

Document Version

Accepted author manuscript

Licence

CC BY-NC-ND

Citation (APA)

de Krijger, J., Rans, C., Van Hooreweder, B., Lietaert, K., Pouran, B., & Zadpoor, A. A. (2017). Effects of applied stress ratio on the fatigue behavior of additively manufactured porous biomaterials under compressive loading. *Journal of the Mechanical Behavior of Biomedical Materials*, 70, 7-16. <https://doi.org/10.1016/j.jmbbm.2016.11.022>

Important note

To cite this publication, please use the final published version (if applicable).
Please check the document version above.

Copyright

In case the licence states "Dutch Copyright Act (Article 25fa)", this publication was made available Green Open Access via the TU Delft Institutional Repository pursuant to Dutch Copyright Act (Article 25fa, the Taverne amendment). This provision does not affect copyright ownership.
Unless copyright is transferred by contract or statute, it remains with the copyright holder.

Sharing and reuse

Other than for strictly personal use, it is not permitted to download, forward or distribute the text or part of it, without the consent of the author(s) and/or copyright holder(s), unless the work is under an open content license such as Creative Commons.

Takedown policy

Please contact us and provide details if you believe this document breaches copyrights.
We will remove access to the work immediately and investigate your claim.

Research article

1
2
3
4
5
6
7
8
9
10
11
12
13
14
15
16
17
18
19
20
21
22
23
24
25
26
27
28
29
30
31
32
33
34
35
36
37
38
39
40
41
42
43
44
45
46
47
48
49
50
51
52
53
54
55
56
57
58
59
60
61
62
63
64
65

Effects of applied stress ratio on the fatigue behavior of additively manufactured porous biomaterials **under compressive loading**

Joep de Krijger¹, Calvin Rans², Brecht Van Hooreweder³, Karel Lietaert^{4,5},
Behdad Pouran^{6,7}, Amir A Zadpoor^{6*}

¹*Department of Materials Science and Engineering, Faculty of Mechanical, Maritime, and Materials
Engineering, Mekelweg 2, Delft 2628CD, The Netherlands*

²*Faculty of Aerospace Engineering, Kluyverweg 1, Delft 2629HS, The Netherlands*

³*Department of Mechanical Engineering, KU Leuven, Leuven, Belgium*

⁴*3D Systems - LayerWise NV, Leuven, Belgium*

⁵*Department of Materials Engineering, KU Leuven, Leuven, Belgium*

⁶*Department of Biomechanical Engineering, Faculty of Mechanical, Maritime, and Materials
Engineering, Mekelweg 2, Delft 2628CD, The Netherlands*

⁷*Department of Orthopedics, UMC Utrecht, Heidelberglaan100, 3584CX Utrecht, The Netherlands*

Word count: 5906 (introduction-conclusions)

* Corresponding author, email: a.a.zadpoor@tudelft.nl, Tel: +31-15-2781021.

ABSTRACT

1 Additively manufactured (AM) porous metallic biomaterials are considered promising
2 candidates for bone substitution. In particular, AM porous titanium can be designed to exhibit
3 mechanical properties similar to bone. There is some experimental data available in the
4 literature regarding the fatigue behavior of AM porous titanium, but the effect of stress ratio
5 on the fatigue behavior of those materials has not been studied before. In this paper, we study
6 the effect of applied stress ratio on the [compression-compression](#) fatigue behavior of selective
7 laser melted porous titanium (Ti-6Al-4V) based on the diamond unit cell. The porous titanium
8 biomaterial is treated as a meta-material in the context of this work, meaning that R-ratios are
9 calculated based on the applied stresses acting on a homogenized volume. After
10 morphological characterization using micro computed tomography and quasi-static
11 mechanical testing, the porous structures were tested under cyclic loading using five different
12 stress ratios, i.e. $R = 0.1, 0.3, 0.5, 0.7$ and 0.8 , to determine their S-N curves. [Feature tracking](#)
13 [algorithms](#) were used for full-field [deformation](#) measurements during the fatigue tests. It was
14 observed that the S-N curves of the porous structures shift upwards as the stress ratio
15 increases. The stress amplitude was the most important factor determining the fatigue life.
16 Constant fatigue life diagrams were constructed and compared with similar diagrams for bulk
17 Ti-6Al-4V. Contrary to the bulk material, there was limited dependency of the constant life
18 diagrams to mean stress. The notches present in the AM biomaterials were the sites of crack
19 initiation. This observation and other evidence suggest that the notches created by the AM
20 process cause the insensitivity of the fatigue life diagrams to mean stress. [Feature tracking](#)
21 [algorithms](#) visualized the [deformation](#) during fatigue tests and demonstrated the root cause of
22 inclined (45°) planes of specimen failure. In conclusion, the R-ratio behavior of AM porous
23 biomaterials is both quantitatively and qualitatively different from that of bulk materials.

24 **Keywords:** Cellular structures, bone grafting, orthopaedic implants, fatigue life, stress ratio

1. INTRODUCTION

1
2 Additive manufacturing (AM) techniques such as selective laser melting (SLM) and electron
3
4 beam melting (EBM) are increasingly used for manufacturing of bone substituting
5
6 biomaterials and orthopaedic implants because of the many advantages they offer including
7
8 design freedom, high precision, and the ability to produce parts directly from a CAD design
9
10 without the need for molds [1]. Additively manufactured porous biomaterials based on lattice
11
12 structures take full advantage of the possibilities offered by AM to maximize the bone
13
14 regeneration performance of bone substituting biomaterials and the longevity of orthopaedic
15
16 implants. The type of repeating unit cell and its dimensions can be chosen so as to adjust the
17
18 mechanical properties of the resulting porous biomaterial [2, 3] in order to more closely match
19
20 the mechanical properties of bone. Achieving a closer match in the mechanical properties of
21
22 bone and the implant is critical in mitigating risks associated with stress shielding [4]. In
23
24 addition, the porosity of such biomaterials can offer a large interconnected volume of space
25
26 for bone ingrowth. The same interconnected volume of space could be used for drug delivery
27
28 purposes to release growth factors [5] and/or anti-microbial agents [6]. Furthermore, porous
29
30 biomaterials often possess much larger surface area as compared to the equivalent solid
31
32 shapes. The area of this surface can be either treated or coated so as to improve bone
33
34 regeneration performance [7, 8] or induce antibacterial properties.

35
36 During recent years, a lot of attention has been paid to manufacturing of porous structures
37
38 based on designs that were impossible to produce using conventional methods. These
39
40 structures are often made using EBM [9-12] or with SLM [13-15]. In this study, we are
41
42 particularly interested in SLM porous structures. SLM is a process that uses a laser to locally
43
44 melt a thin layer of metal powder, which then solidifies in the desired cross-sectional shape. A
45
46 new powder layer is placed on top of the partly solidified cross section, and the process is
47
48 repeated until the full part is built. The most common material that is currently used for this
49
50
51
52
53
54
55
56
57
58
59
60
61
62
63
64
65

1 manufacturing process is Ti-6Al-4V. Several researchers have manufactured porous metallic
2 biomaterials aimed for orthopaedic applications using this titanium alloy [16-18].
3

4 As a consequence of the high temperature gradients experienced during the SLM process,
5 unfavorable microstructures and residual stresses may develop in the material, resulting in
6 fracture toughness and fatigue properties that are inferior to those observed for the parts made
7 with conventional techniques [19-21]. The unfavorable fatigue properties of SLM parts can,
8 however, be improved by subsequent heat and surface treatment. Limited information [11, 22-
9 24] is available in the literature regarding the fatigue behavior of porous biomaterials made by
10 additive manufacturing techniques in general and SLM in particular. In a recent work, it is
11 shown how the porosity and the type of unit cell influence the [compression-compression](#)
12 fatigue behavior of additively manufactured porous biomaterials [22, 23]. They found that the
13 S-N curves normalized with respect to the yield stress of the porous structures conformed
14 very well to one single power law for each type of unit cell. This shows that meta-materials
15 are structures when their small-scale properties are considered, but they behave as materials
16 when their homogenized macroscopic properties are studied [21]. [Compression-compression](#)
17 [loading is often \[7, 11, 12, 22-24\] used when studying the fatigue behavior of such additively](#)
18 [manufactured porous biomaterials, because it is considered the most relevant mode of loading](#)
19 [for bone-mimicking biomaterials.](#)
20
21
22
23
24
25
26
27
28
29
30
31
32
33
34
35
36
37
38
39
40
41
42

43 Although there are advantages to considering the structural behavior of porous metal
44 biomaterials in terms of relating performance to the mechanical behavior of the constituting
45 material, treatment of the structure as a meta-material offers simplicity from a design and
46 application standpoint. In line with this, the authors have decided for simplicity to adopt the
47 meta-material viewpoint of porous metal biomaterials for this paper. This means that the R-
48 ratios determined in this study are calculated based on applied stresses acting on the surface of
49 homogenized material volume rather than the local physical stresses within the structure.
50
51
52
53
54
55
56
57
58
59
60
61
62
63
64
65

1 In mechanical fatigue, a standard sinusoidal stress cycle can be described by its minimum,
2 maximum and mean stress, where the ratio between min and max is defined as the stress ratio,
3
4 *R*. An *R*-value of 0.1 means that the maximum stress is ten times higher than the minimum
5 stress. Previous studies on the fatigue behavior of AM porous biomaterials have all used one
6 single *R*-value, i.e. $R = 0.1$. However, porous biomaterials used in load-bearing orthopaedic
7 applications are often subjected to various types of daily activities such as walking, hopping,
8 and running. These activities are associated with different types of loading profiles [25-27]
9 that might be different in their magnitude, frequency bands, and other characteristics.
10 Designing load-bearing AM porous biomaterials therefore requires information regarding the
11 fatigue response of those materials to different loading regimes including loading profiles
12 with different stress ratios. Studies into the effects of R-ratio on the fatigue behavior of bulk
13 Ti-6Al-4V have found that an increase in stress ratio for the same stress amplitude (i.e.
14 increasing mean stress) results in a lower fatigue [28-30]. However, the dependency of the
15 fatigue behavior on the stress ratio is known to be material-dependent and might be different
16 for SLM porous biomaterials.

17 The current study aims to provide data and insight into the fatigue behavior of SLM porous
18 titanium (Ti-6Al-4V) biomaterials when subjected to loading profiles with different applied
19 stress ratios (from now on referred to as simply R-ratio). After morphological characterization
20 using micro computed tomography (micro-CT), dry weighing, and Archimedes measurements,
21 SLM porous structures based on the diamond unit cell were mechanically tested under
22 compression to determine their quasi-static mechanical properties. The compression-
23 compression S-N curves of the same porous structures were then determined experimentally
24 using loading profiles with different R-ratios.

2. MATERIALS AND METHODS

2.1 Additive manufacturing

Test samples were manufactured using SLM (3D Systems) from Ti-6Al-4V-ELI powder according to ASTM F3001. This alloy has a theoretical density of 4.42 gcm^{-3} . The build chamber had an inert Ar atmosphere with an oxygen level below 50ppm. The samples were built using a similar procedure and similar parameters as described in our previous studies [6-8, 22, 23, 31]. The samples were built on top of a solid titanium build plate from which they were subsequently removed using wire electrical discharge machining (EDM).

Repeating the diamond unit cell in all directions created the porous structures of the cylindrical test specimens with diameter of 15 mm and length of 20 mm. The front view of a test sample and the basic unit cell are displayed in Figure 1. The nominal (i.e. designed) porosity of the specimens was 80%. STL files were created using the Magics software from Materialise (Leuven, Belgium). 3D Systems' DMP Explorer software was used for slicing and hatching of the stl file.

2.2 Morphological characterization

The morphological features of the AM porous structures were characterized using dry weighing, Archimedes measurements, and micro-CT scans. For the Archimedes measurements, the test procedure described in ASTM B311 [32] was followed. This standard describes the procedure for measuring the density of powder metallurgy materials. A batch with a minimum of five samples was first weighed on a balance with a precision of 0.0001g (Denver Instruments AA-160). The 'dry porosity' was then calculated by dividing the actual weight by the theoretical weight of the macro volume. The sample was then submerged in pure ethanol and weighed again, from which the actual volume could be calculated. The Archimedes porosity was then calculated by dividing this actual volume by the total macro volume of the sample.

1
2
3
4
5
6
7
8
9
10
11
12
13
14
15
16
17
18
19
20
21
22
23
24
25
26
27
28
29
30
31
32
33
34
35
36
37
38
39
40
41
42
43
44
45
46
47
48
49
50
51
52
53
54
55
56
57
58
59
60
61
62
63
64
65

Micro-CT scans were performed on a Caliper LifeSciences Quantum FX μ -CT scanner. Five samples were scanned for 120 seconds at 90kV and 180 μ A, at a resolution of 48 μ m per voxel. The image processing method is similar to previous studies from [22], while a more detailed description of the image processing procedures is provided in [31]. The images were processed using the software package Image-J. This was done by first applying an automatic local threshold (Niblack, radius 15) to create a binary image. The same thresholding method was applied for all micro-CT slices. From this binary image, the overall porosity and average pore and strut sizes were determined using the volume fraction algorithm available in the BoneJ plugin.

2.3. Quasi-static mechanical testing

The test procedure for the static compression test was based on ISO 13314:2011 [33]. A Zwick Z100 (100kN) test system with compression plates was used for these tests. A constant **deformation** rate of 1.2 mm/min was applied until 60% strain after which the test was automatically stopped. A total of three specimens were tested. The following parameters were calculated using the obtained stress-strain curves: maximum stress (σ_{\max}) and its corresponding strain (e_{\max}), the plateau stress (σ_{pl}) which is calculated as the arithmetical mean of the stresses between 20% and 40% strain, the quasi-elastic gradient (E_{20-70}) which is the elastic straight line between 20% and 70% of the plateau stress, the compressive offset stress (σ_{off}) which is the compressive stress at 0.2% plastic strain obtained from the quasi-elastic gradient and the energy absorption (E.A.) which is the area under the stress-strain curve up to 50% strain. The offset stress is considered to represent the yield stress of the porous structures to enable comparison with other studies. As mentioned in the introduction, all stresses mentioned in this paper are based on a meta-material viewpoint of the porous biomaterial, and hence based on the total circular area of the cylindrical sample with a diameter of 15 mm.

2.4. Fatigue Testing

1
2 A fatigue test protocol similar to the ones used in our previous studies was used [22, 23]. S-N
3
4 curves were constructed by measuring the force-controlled fatigue life of porous structures at
5
6 ten different maximum stresses between 20% and 90% of the yield (offset) stress. Each test
7
8 was repeated at least two times. If the difference between cycles to failure was larger than 40%
9
10 of their average value, a third sample was tested. The fatigue tests were carried out at a stress
11
12 ratio of $R = 0.1, 0.3, 0.5$ and 0.7 , resulting in an SN curve for each stress ratio. An exponential
13
14 fit to the SN curves was carried out using the MATLAB curve-fitting tool using a [nonlinear](#)
15
16 [least squares criterion](#). The S-N curves were then combined to create a constant life (fatigue)
17
18 diagram, which can be used to visualize the mean stress behavior of the samples and to
19
20 compare this with the literature. A few extra tests were conducted at a stress ratio of $R = 0.8$
21
22 to obtain more data points for constructing the constant life diagram. All tests were carried out
23
24 on an MTS 100kN hydraulic test machine, at a loading frequency of 15Hz with a sinusoidal
25
26 wave shape. [The tests were continued until failure of the specimen, however exceeding \$10^6\$](#)
27
28 [cycles was regarded as a run-out](#). The run-out tests are marked with an arrow in the final S-N
29
30 curve. The point of failure was defined by an increase in displacement of 2 mm. To prevent
31
32 the sample from moving and making sure that the sample was aligned properly during the
33
34 tests, a sample holder as displayed in Figure 2 was used. The specimens were placed between
35
36 two sample holders.

2.5. Full-field [deformation](#) measurements

37
38 For a selected number of fatigue tests, full-field [deformation](#) measurements were performed
39
40 using a digital camera system (Optomotive Velociraptor) at an interval of 100 cycles. In order
41
42 to obtain images at the same point in every cycle, the testing machine was programmed to
43
44 stop at the maximum load after every 100th cycle, and send a signal to the camera system that
45
46 then triggered the camera shutter after which the cycle continued. This process was repeated
47
48
49
50
51
52
53
54
55
56
57
58
59
60
61
62
63
64
65

1 until the sample failed. The obtained images were then processed with MATLAB to visualize
2 the local displacement values of the sample. This was done by using a feature detection
3 algorithm (Speeded Up Robust Features, *detectSURFFeatures*) from the Computer Vision
4 System Toolbox that looks for matching features in two images. A close-up of the sample
5 from the image correlation process is displayed in Figure 3. In this picture, the two compared
6 images are placed on top of each other with the first picture in red, and the displaced image in
7 blue. Corresponding features are then marked with a yellow line to indicate the displacement.
8 The distance in pixels of the two successive pictures is then calculated after which an outlier
9 filter is applied to remove unwanted points. Some of the corresponding features that the MATLAB
10 algorithm recognizes are extremely far away. For example, a point at the upper left corner of the
11 sample may be corresponded to a point at the bottom. Such correspondences in the feature tracking
12 algorithm would result in impossibly and unrealistically large displacements. An outlier filter was
13 therefore applied to removes such ‘impossible’ correspondences. The distances were then
14 normalized by dividing them by the initial length of the sample that was measured with a
15 caliper before each test. The displacement field was then visualized by applying a colored
16 marker to the displaced point, ranging from blue to red with an increasing magnitude of the
17 deformation.

40 2.6. Constant fatigue life diagrams

41 To study the effect of stress amplitude and mean stress on fatigue life, it is customary to plot
42 the so-called constant life diagrams. In a constant life diagram, the combination of stress
43 amplitude and mean stress is displayed for a specific number of cycles that lead to failure.
44

45 A common way of comparing or fitting data in constant life diagrams is by plotting the
46 modified Goodman relationship:
47

$$48 \sigma_a = \sigma_{-1} \left(1 - \frac{\sigma_m}{\sigma_u} \right) \quad (1)$$

1 where σ_{-1} is the fatigue life for complete reverse loading (i.e. $R = -1$), σ_m is the mean stress,
2 and σ_u is the ultimate tensile strength of the material. This relationship predicts a linear
3 descent of the constant life from the fully reversed loading ($R = -1$, $\sigma_m = 0$) to the static
4 ultimate stress of the material, where the amplitude is zero and the mean stress is equal to the
5 ultimate stress.
6
7
8
9
10

11 The choice of fully reversed loading ($R = -1$) as a datum point in the Goodman relationship
12 stems from the prevalence of rotating beam fatigue testing as a means to measure the fatigue
13 resistance of materials at the time. This test was relatively simple and efficient at applying
14 large numbers of fatigue cycles in a short period of time; however, it was limited by the fact
15 that it could only test fully reversed loading. It is possible to reformulate this relationship in
16 terms of an alternative datum while keeping the linear nature of the Goodman relation. Doing
17 so, equation 1 can be reformulated as:
18
19
20
21
22
23
24
25
26
27

$$28 \sigma_a = \frac{\sigma_{aR}\sigma_u}{\sigma_u - \sigma_{mR}} \left(1 - \frac{\sigma_m}{\sigma_u}\right) \quad (2)$$

29 where the subscript R in σ_{aR} and σ_{mR} indicates the R-ratio of the newly selected datum. For
30 this study, as fully reversed loading conditions were not tested, a datum of $R = 0.1$ was
31 selected. This choice was made as the conditions of mean stress and amplitude stress at this
32 R-ratio were closest to the fully reversed loading tested in this study. When using this
33 equation within this study, it will be referred to as the Modified Goodman relation to highlight
34 the change in datum.
35
36
37
38
39
40
41
42
43
44
45
46

47 Another common comparison that is used in fatigue diagrams is the Gerber parabola, which
48 has the same axis intersections as the modified Goodman relation but assumes a parabolic
49 relation for the descent. In order to compare these graphs from the literature with the test
50 results of this study, three curves from the ASM international Fatigue data book [28] were
51 digitized using a plot digitizer tool [34].
52
53
54
55
56
57
58

59 2.7. Optical microscopy

60
61
62
63
64
65

1 The fracture surfaces were examined using an optical microscope (Keyence VHX-5000 series
2 Digital microscope, lens: Z250 dual-light high magnification zoom lens, 250-2500X).
3

4 **3. RESULTS**

5 **3.1. Morphological characterization**

6
7 The actual porosities of the porous structures measured by various techniques were all close
8 to the nominal (design) porosity, i.e. 80% (Table 1). There was relatively small standard
9 deviation in the morphological properties of the different samples such as porosity (<0.5%),
10 strut diameter (60 μm , < 20% of the mean value), and pore size (112 μm , < 15% of the mean
11 value) (Table 1).
12
13
14
15
16
17
18
19
20

21 **3.2. Quasi-static mechanical properties**

22 There was little variation in the measured mechanical properties of the porous structures
23 (Table 1). The struts of the specimens failed close to the compression plates, either at the top
24 or bottom, after which they gradually crushed from this location (Figure 4a). An inclined
25 failure line (45 degrees) was observed during the gradual breakdown (Figure 4a). Struts that
26 were in contact with the compression plate failed first after which the sample gradually
27 crushed from that position.
28
29
30
31
32
33
34
35
36
37

38 **3.3. Fatigue testing**

39 For the same values of normalized stress (max. applied stress / yield stress), loading under
40 higher R-ratios resulted in greater number of cycles to failure (Figure 5a). This is to be
41 expected since for any given maximum stress, the stress amplitude lowers when the R-ratio
42 increases. The S-N curves plotted on a double logarithmic scale show a similar slope for R-
43 ratios 0.7 and 0.8 and for R-ratios 0.1 and 0.3 (Figure 5b). For every R-ratio, the S-N data can
44 be very well represented by exponential trendlines ($R^2 \approx 0.98$) (Table 2). Plotting the number
45 of cycles against the stress amplitude resulted in a single trend for all tested specimens
46 regardless of the stress ratio under which they were tested (Figure 6). However, there was a
47
48
49
50
51
52
53
54
55
56
57
58
59
60
61
62
63
64
65

1
2 slight decrease in the fatigue life for high stress ratios that could be more clearly seen for
3 stress levels below $0.1\sigma_y$ (Figure 6).

4
5 One way of presenting the gradual failure during the fatigue life of this type of samples is to
6
7 plot the stiffness of the specimens in function of the percentage of the total fatigue life (Figure
8
9 7). The stiffness was calculated by dividing the maximum force during a cycle, by the
10 displacement measured by the fatigue machine (both data is measured directly by the
11 machine). So the displacement describes the distance that a sample is compressed at the
12 maximum force during a cycle. This displacement increases during the fatigue test, which can
13 be described as a stiffness decrease. This quantity represents the relative stiffness and this
14 value is different from the actual stiffness, because the displacement at the minimum force
15 also increases over the fatigue life. It can nevertheless be used to observe the gradual failure
16 of the samples. The stiffness values were normalized with respect to the maximum stiffness to
17 enable comparison between different load cases. All stress ratios showed comparable stiffness
18 degradation behaviors (Figure 7). The final failure occurred at a lower stiffness decrease for
19 maximum normalized stresses above 0.4 or mean normalized stresses higher than 0.3 (Figure
20 7). The number of cycles to failure of the experiments presented in Figure7a varied between
21 ≈ 130.000 and 225.000 for $R=0.3$ to $R=0.8$, and was around 560.000 cycles for $R=0.1$. An
22 overview of the normalized loads for each test is displayed in the table in the graph.

23
24 Further analysis showed that the specimen tested at the lowest amplitude ($R=0.7$) had a
25 constant rate of stiffness degradation comparable to the other tests, but over a longer period of
26 the total fatigue life and a more rapid decrease near the end (Figure 7b). The repeated tests
27 that were performed under the same stress conditions showed the same behavior. The tests
28 with stress amplitudes of $0.15\sigma_y$ and $0.245\sigma_y$ showed a very similar rate of stiffness
29 degradation (Figure 7b).

1 The test that is marked with $R=0.3a$ in Figure 7b, shows a stiffness increase during the test,
2 which dropped again after around 50% of the fatigue life. This behavior occurred for four
3 other specimens with different loading conditions. The total number of cycles did not deviate
4 much from the repeated tests at the same conditions.
5
6
7

8 **3.4. Feature tracking for deformation measurement**

9
10 The full-field deformation measurements performed using feature tracking algorithms clearly
11 showed an area of high strain concentration (highlighted by an abrupt change in deformation
12 contour) with angles similar to what was ultimately seen in the failure lines of the specimens
13 (Figures 4, 8-10). The white line marks the direction of the final failure of the samples
14 (Figures 8-10). At 50% of the fatigue life ($R=0.1$), the deformation distributions already
15 indicate increased deformations at an angled orientation, which was more pronounced for the
16 specimens subjected to fatigue loading with lower maximum stress (Figure 8).
17
18
19
20
21
22
23
24
25
26
27
28

29 Three different stress ratios with approximately the same amplitudes were compared (Figure
30 10). For specimens B and C, a cross shape could already be observed halfway the fatigue life
31 (Figure 10). All three specimens showed a similar pattern of stiffness degradation over the
32 fatigue life, except for the test at $R=0.1$, which showed a higher rate of stiffness degradation
33 over the fatigue life (Figure 10). The displacement values measured using feature tracking
34 algorithms were in good agreement with those measured using the fatigue test machine
35 (Figure 10).
36
37
38
39
40
41
42
43
44
45

46 Comparisons between the feature tracking results for different load cases showed only small
47 differences. At high maximum stresses the deformation distribution was more horizontal, but
48 this did not affect the final failure direction. Also no apparent differences were visible
49 between the tests at the same stress ratios, except for one test that is displayed in Figure 9,
50 where a clear upper and lower triangular part was visible in the deformation distribution
51 which did not correspond with the final failure direction. Looking only at inset figure B1, one
52
53
54
55
56
57
58
59
60
61
62
63
64
65

1 might expect a failure direction that starts in the upper left corner, going to the lower right
2 corner, because the strains in the upper right corner of the sample are slightly larger than the
3 lower left. The final failure occurred in the other direction as seen in inset figure B2, indicated
4 with the with a dashed line. This ‘change’ occurred gradually during the cycles between B1
5 and B2.
6
7
8
9
10

11 **3.5. Constant fatigue life diagrams**

12 The constant life diagrams for the tests performed in the current study were plotted by fitting
13 exponential fits to the test data (Figure 11) and are compared with the typical behavior of bulk
14 Ti-6Al-4V reported in the literature [28] (Figure 12). When the normalized mean stress
15 increases from 0.2 to 0.9, the normalized stress amplitude slightly decreases for the constant
16 life diagrams of 50.000 and 100.000 cycles (Figure 11). Increased values of mean stress did
17 not result in any notable decrease of the stress amplitude for the constant life diagram of
18 500.000 cycles (Figure 11). The fit of the modified Goodman relation and the Gerber parabola
19 were not very good for the obtained data set. The modified Goodman relation only fitted our
20 test data at our selected datum of $R = 0.1$ (which by definition it must fit exactly) and its close
21 proximity up to $R = 0.3$ (Figure 11). The Gerber parabola fared better; however, a clear
22 parabolic trend in the obtained data set was not visible (Figure 11).
23
24
25
26
27
28
29
30
31
32
33
34
35
36
37
38
39
40

41 **3.6. Fatigue fracture analysis**

42 During all fatigue tests, failure occurred at a 45° angle (Figures 4b-c). Powder from the SLM
43 process was visible on the surface of the struts and the overall appearance was irregular
44 (Figure 13a). Observation of the fracture surface showed that multiple fatigue cracks were
45 initiated from the rough surface (Figure 13b). Most samples failed along one direction, while
46 a few samples failed at both $+45$ and -45 degrees, resulting in a triangular or cross-shaped
47 failure (Figure 4b-c). No relation was found between the applied loads and this failure
48 appearance.
49
50
51
52
53
54
55
56
57
58
59
60
61
62
63
64
65

4. DISCUSSION

1
2
3
4
5
6
7
8
9
10
11
12
13
14
15
16
17
18
19
20
21
22
23
24
25
26
27
28
29
30
31
32
33
34
35
36
37
38
39
40
41
42
43
44
45
46
47
48
49
50
51
52
53
54
55
56
57
58
59
60
61
62
63
64
65

Compression-compression fatigue tests do normally not cause fatigue failure in continua, but several studies [11, 22, 23] have shown that porous structures fail under compressive-compressive cyclic loading. The fatigue tests performed in the current study confirmed the previous findings on porous materials that the S-N behavior of compressive cyclic loading on porous materials results in the same S-N trend that is characteristic for tension-tension cyclic loading of the parent material. The reason for this is that the compressive loading and the compressive stresses described in this work refer to the homogenized volume of the meta-material (i.e. the cylindrical specimen) and not the struts. When looking at the fatigue samples as structures, it becomes clear that the struts or beams are actually loaded in a combination of cyclic bending and cyclic axial compressive stresses [35]. The cyclic loading of the structure in compression-compression gives rises to both compressive and tensile stresses in the struts. It is most likely that these tensile stress components cause the fatigue failure of the struts, ultimately leading to fracture of the porous sample. This is illustrated in Figure 14 that shows an arbitrary strut of the diamond unit cell, its hyperstatic boundary conditions similar to the free body-diagram as presented in [36], and an approximation of the normal stress distributions that occur [35].

The axial compressive stress S_A and the bending stress S_B can be calculated using strut diameter d , strut length L , strut area A and moment of inertia I . For these diamond unit cells with properties shown in Table 1, the angle $\theta=35,26^\circ$ represents the orientation of the strut force F , as explained more in detail in [35, 36].

$$S_B = \frac{FLd\cos\theta}{4I} \cong 94.3F \text{ with } I = \frac{\pi d^4}{64} \quad (3)$$

$$S_A = \frac{F\sin\theta}{A} \cong 7.8F \text{ with } A = \frac{\pi d^2}{4} \quad (4)$$

$$S_1 = F \left(\frac{Ld\cos\theta}{4I} - \frac{\sin\theta}{A} \right) \cong F(94.3 - 7.8) \quad (5)$$

$$S_2 = F \left(\frac{Ld \cos \theta}{4I} + \frac{\sin \theta}{A} \right) \cong F(94.3 + 7.8) \quad (6)$$

It is important to notice that these formulations are based on several assumptions including linear material behavior, constant and uniform geometrical properties (d , L), absence of stress concentrations and simplified boundary conditions, and are therefore useful only for providing insight into the general state of stress in the struts and not accurate estimation of stress values. It is for instance shown that the load angle θ has an important influence on the ratio of uniform compressive stress S_A compared to the bending stress S_B . For this particular sample, and for assuming θ constant, it is clear from Equations 3 and 4 that the bending stress S_B is much larger than the axial compressive stress S_A , which leads to significant tensile stresses S_I on the surface of the struts. Although the total tensile stress S_I is smaller in absolute value than the total compressive stress S_2 , it is most likely that S_I eventually causes the strut to fail in fatigue. This is also confirmed by analyzing the fractured surfaces, where cracks were mainly found in the upper parts of the struts (Figure 13).

As indicated earlier, the R-ratio in this work is calculated from the minimum and maximum loading that is applied on the whole porous structure and not from the actual local minimum and maximum stresses occurring in a critically loaded point of a strut. When assuming constant load angle θ , the relation between load F and stress S is constant, as shown in Equations 5 and 6, and hence the ratio of loading is equal to the ratio of local stress. This is not the case when load angle θ is not constant. When the sample is subjected to cyclic loading with high load and hence high mean load, the sample will deform, the average load angle θ will decrease and hence S_B will gain more importance over S_A . This geometric non-linearity clearly influences the state of stress, and hence also the stress ratio. This effect might be significant depending on parent material, unit cell type and sample porosity. In the current study, this effect was not taken into account, and R-ratios are hence properties of the structure, and not of the material.

1 S-N curves shifted upwards when loading was performed under higher stress ratios (Figure
2 5a). This is a result of the lower stress amplitudes experienced for higher stress ratios given
3
4 the fact that the tests were based on predefined maximum loads. It was also observed that the
5
6 slope of the S-N curves plotted on a logarithmic scale decreases for higher stress ratios
7
8 (Figure 5b), suggesting that a relatively small change in the maximum stress influences the
9
10 fatigue life more strongly for higher stress ratios. Stress amplitude is clearly the dominant
11
12 factor in determining the S-N curve (Figure 6).
13
14
15

16 Fatigue diagrams of bulk Ti-6Al-4V from literature all show similar behavior, with a clear
17
18 decline of the stress amplitude when the mean stress is increased (Figure 12). The lines in
19
20 Figure 12 represent 10^5 cycles of both notched and smooth specimens for three different heat-
21
22 treatments of bulk Ti-6Al-4V. A significant *R*-ratio effect is observed for this material, which
23
24 shows a similar behavior as predicted by the Gerber or modified Goodman relation. The *R*-
25
26 ratio behavior of the AM porous biomaterials studied here (Figure 11) follows neither the
27
28 Goodman or Gerber predictions and is therefore not only quantitatively but also qualitatively
29
30 different from that of the bulk Ti-6Al-4V material (Figure 12). These observations mark clear
31
32 differences between the fatigue behavior of AM porous biomaterials and that of conventional
33
34 bulk materials.
35
36
37
38
39

40 The relatively low sensitivity of the constant life diagrams obtained in the current study to
41
42 mean stress can be explained by [increased surface roughness](#) and the notches that are present
43
44 in the struts of AM porous biomaterials. In bulk Ti-6Al-4V materials, notches not only reduce
45
46 fatigue strength but also reduce the sensitivity of the fatigue life to mean stress (Figure 12).
47
48 Lanning [37] found similar behavior for notched specimens as compared to smooth specimens.
49
50 A method to quantify the notch effect is discussed in [30], where the (un-notched) data of the
51
52 amplitude in a constant life diagram is reduced by a stress concentration factor, k_t , or a fatigue
53
54 notch factor, k_f . Large values of these factors significantly reduce the slope of the curve,
55
56
57
58
59
60
61
62
63
64
65

1 thereby reducing the sensitivity of the fatigue life to the mean stress, which results in constant
2 life diagrams that are similar to the notched behavior of bulk Ti-6Al-4V (Figure 12) and the
3
4 constant life diagrams obtained in the current study for 50.000 and 100.000 cycles (Figure 11).
5
6 The statement that notches could be the cause of the low mean stress sensitivity of the AM
7 porous biomaterials considered here is supported by the fact that fatigue cracks seemed to
8
9 initiate from the notches present in the struts of the porous structure (Figure 13a). The
10
11 imperfections caused by the manufacturing process have been shown to significantly
12
13 influence the mechanical properties of various types of materials including additively
14
15 manufactured [38] and machined [39] materials. The surface roughness of the struts is
16
17 dependent on the AM process including both laser processing parameters and the size and
18
19 shape of the powder that is used in the powder bed. Increased surface roughness of the struts
20
21 could cause stress concentrations and act as crack initiation sites [7]. One approach for
22
23 improving the fatigue resistance of AM porous biomaterials could therefore be to optimize the
24
25 manufacturing process including the laser processing parameters and the characteristics of the
26
27 powder including its size distribution and flowability such that the size and distribution of the
28
29 surface roughness are more effectively controlled.
30
31
32
33
34
35
36
37

38 The displacement fields obtained by feature tracking show that it is possible to visualize the
39 failure direction and gradual deformation of the specimens using full-field deformation
40
41 measurement techniques. The feature tracking results also did not show significant differences
42
43 between the different R-ratio tests. It can nevertheless be used in the future research to
44
45 improve our understanding of the deformation distribution in AM porous biomaterials, for
46
47 example, by comparing porous structures with different types of repeating unit cell.
48
49 Comparing different lightning conditions or adding non-reflective paint on the specimens
50
51 could further optimize the feature tracking results, because it was found that the samples were
52
53 reflective in the presence of a large light source that is needed in combination with the
54
55
56
57
58
59
60
61
62
63
64
65

1 cameras. The increasing deformations of the sample during the test resulted in a change of the
2 reflections that is unfavorable for the feature detection process.
3

4 Comparing the S-N curves obtained here with those obtained in a previous study [22] in
5 which similar AM porous biomaterials were tested using a stress ratio of $R = 0.1$ shows that
6 the S-N curve from that study corresponds with the S-N curve obtained in the current study
7 for $R=0.3$ (and not $R = 0.1$) (Figure 5). That might be due to the fact that smaller specimens
8 were used in [23] as compared to those used here (10x15mm instead of 15x20mm). This can
9 be an indication of a size effect which is known to occur for both smooth and notched
10 specimens [40, 41] as well as for cellular structures [42, 43]. Tests with different sample sizes
11 should be performed to determine whether a size effect is present in the fatigue behavior of
12 this type of AM porous biomaterials.
13
14
15
16
17
18
19
20
21
22
23
24

25 AM porous biomaterials used for bone grafting or as a part of load-bearing orthopaedic
26 implants are subjected to regular cyclic loading caused by activities such as walking, running,
27 jumping, stair climbing, and various types of sport activities. It is therefore important to
28 design AM porous biomaterials such that they can withstand the experienced fatigue loading.
29 Design for fatigue often requires information regarding the fatigue response of the material
30 under consideration to various loading regimens. For example, it is important to understand
31 the fatigue response of a given material to cyclic loadings with different stress ratios and
32 frequencies. As far as human activities similar to the ones mentioned above are concerned,
33 loading profiles could change considerably from one activity to another [44-49]. A wide range
34 of different parameters including, for example, pathological conditions such as osteoarthritis
35 [44] and psychosocial stress [50] could change musculoskeletal loading. Since it is not
36 possible to determine the S-N curves of different materials, empirical relationships such as
37 Goodman and Gerber are used for interpolating between the experimental data and fatigue
38 design of materials under loading conditions not experimentally tested. Since the R-ratio
39
40
41
42
43
44
45
46
47
48
49
50
51
52
53
54
55
56
57
58
59
60
61
62
63
64
65

1 behavior of AM porous biomaterials does not match those predicted by the empirical
2 relationships used for bulk materials, one may need to develop new empirical relationships for
3 fatigue design of AM porous biomaterials. Further research is needed to determine what the
4 best empirical relationships for fatigue design of AM porous structures are.
5
6
7
8

9 **5. CONCLUSIONS**

10 The influence of the R-ratio on the compression-compression fatigue behavior of additively
11 manufactured porous titanium biomaterials based on the diamond unit cell was studied. These
12 porous metal structures are analyzed in this work as if they behave as materials. This means
13 that, stresses, strains and R-ratios are calculated as properties of the cylindrical porous sample,
14 and not of the parent material. Constructing constant life diagrams and comparing the gradual
15 failure under different loading conditions allowed us to study the effects of mean stress and
16 stress amplitude on the constant life diagrams. [Feature tracking algorithms](#) were used for full-
17 field [deformation](#) measurement during the fatigue tests. Compression-compression S-N
18 curves were found to exhibit the same log-linear trend characteristic of the tension-tension
19 behavior of the bulk material. The S-N curves shifted upwards when the stress ratio increased.
20 The stress amplitude was found to be the dominant factor determining the fatigue lives of the
21 AM porous biomaterials considered here. The constant fatigue life diagrams showed little
22 sensitivity to mean stress, which is very different from what is observed for bulk Ti-6Al-4V
23 and other bulk metals and alloys, meaning that the fatigue behavior of AM porous
24 biomaterials including their R-ratio behavior is not only quantitatively but also qualitatively
25 different from that of bulk materials. [One could therefore conclude that relationships similar to the](#)
26 [Gerber law that are normally used for the fatigue design of continuous materials are not applicable](#)
27 [when designing lattice structures, meaning that new relationships should be developed for that](#)
28 [purpose. This result is generalizable to other materials and lattice structures, as it nullifies the](#)
29 [assumption that the fatigue design principles used for continuous materials could be directly applied to](#)
30 [additively manufactured porous \(bio-\)materials.](#)
31
32
33
34
35
36
37
38
39
40
41
42
43
44
45
46
47
48
49
50
51
52
53
54
55
56
57
58
59
60
61
62
63
64
65

REFERENCES

1. Thijs, L., et al., *A study of the microstructural evolution during selective laser melting of Ti-6Al-4V*. Acta Materialia, 2010. **58**(9): p. 3303-3312.
2. Heintl, P., et al., *Cellular Ti-6Al-4V structures with interconnected macro porosity for bone implants fabricated by selective electron beam melting*. Acta biomaterialia, 2008. **4**(5): p. 1536-1544.
3. Mullen, L., et al., *Selective Laser Melting: A regular unit cell approach for the manufacture of porous, titanium, bone in - growth constructs, suitable for orthopedic applications*. Journal of Biomedical Materials Research Part B: Applied Biomaterials, 2009. **89**(2): p. 325-334.
4. Ratner, B.D., et al., *Biomaterials science: an introduction to materials in medicine*. 2013: Academic press.
5. van der Stok, J., et al., *Full regeneration of segmental bone defects using porous titanium implants loaded with BMP-2 containing fibrin gels*. European cells & materials, 2015. **2015**(29): p. 141-154.
6. Amin Yavari, S., et al., *Antibacterial behavior of additively manufactured porous titanium with nanotubular surfaces releasing silver ions*. ACS applied materials & interfaces, 2016. **8**(27): p. 17080-17089.
7. Amin Yavari, S., et al., *Effects of bio-functionalizing surface treatments on the mechanical behavior of open porous titanium biomaterials*. Journal of the mechanical behavior of biomedical materials, 2014. **36**: p. 109-119.
8. Amin Yavari, S., et al., *Crystal structure and nanotopographical features on the surface of heat-treated and anodized porous titanium biomaterials produced using selective laser melting*. Applied Surface Science, 2014. **290**: p. 287-294.
9. Cansizoglu, O., et al., *Properties of Ti-6Al-4V non-stochastic lattice structures fabricated via electron beam melting*. Materials Science and Engineering: A, 2008. **492**(1): p. 468-474.
10. Cheng, X., et al., *Compression deformation behavior of Ti-6Al-4V alloy with cellular structures fabricated by electron beam melting*. Journal of the mechanical behavior of biomedical materials, 2012. **16**: p. 153-162.
11. Hrabe, N.W., et al., *Compression-compression fatigue of selective electron beam melted cellular titanium (Ti-6Al-4V)*. Journal of Biomedical Materials Research Part B: Applied Biomaterials, 2011. **99**(2): p. 313-320.
12. Li, S., et al., *Compression fatigue behavior of Ti-6Al-4V mesh arrays fabricated by electron beam melting*. Acta Materialia, 2012. **60**(3): p. 793-802.
13. Brenne, F., T. Niendorf, and H. Maier, *Additively manufactured cellular structures: Impact of microstructure and local strains on the monotonic and cyclic behavior under uniaxial and bending load*. Journal of Materials Processing Technology, 2013. **213**(9): p. 1558-1564.
14. Gorny, B., et al., *In situ characterization of the deformation and failure behavior of non-stochastic porous structures processed by selective laser melting*. Materials Science and Engineering: A, 2011. **528**(27): p. 7962-7967.
15. Yan, C., et al., *Evaluations of cellular lattice structures manufactured using selective laser melting*. International Journal of Machine Tools and Manufacture, 2012. **62**: p. 32-38.
16. Chahine, G., et al., *The design and production of Ti-6Al-4V ELI customized dental implants*. JOM, 2008. **60**(11): p. 50-55.
17. Lin, C.Y., et al., *Structural and mechanical evaluations of a topology optimized titanium interbody fusion cage fabricated by selective laser melting process*. Journal of Biomedical Materials Research Part A, 2007. **83**(2): p. 272-279.
18. Sallica-Leva, E., A. Jardini, and J. Fogagnolo, *Microstructure and mechanical behavior of porous Ti-6Al-4V parts obtained by selective laser melting*. Journal of the mechanical behavior of biomedical materials, 2013. **26**: p. 98-108.
19. Cain, V., et al., *Crack propagation and fracture toughness of Ti6Al4V alloy produced by selective laser melting*. Additive Manufacturing, 2014.
20. Leuders, S., et al., *On the mechanical behaviour of titanium alloy TiAl6V4 manufactured by selective laser melting: Fatigue resistance and crack growth performance*. International Journal of Fatigue, 2013. **48**: p. 300-307.
21. Van Hooreweder, B., et al., *Analysis of fracture toughness and crack propagation of Ti6Al4V produced by selective laser melting*. Advanced Engineering Materials, 2012. **14**(1-2): p. 92-97.
22. Amin Yavari, S., et al., *Relationship between unit cell type and porosity and the fatigue behavior of selective laser melted meta-biomaterials*. J Mech Behav Biomed Mater, 2015. **43**: p. 91-100.
23. Amin Yavari, S., et al., *Fatigue behavior of porous biomaterials manufactured using selective laser melting*. Materials Science and Engineering, 2013. **33**(8): p. 4849-58.

24. Zargarian, A., et al., *Numerical simulation of the fatigue behavior of additive manufactured titanium porous lattice structures*. Materials Science and Engineering: C, 2016. **60**: p. 339-347.
25. Caron, R.R., et al., *Musculoskeletal stiffness changes linearly in response to increasing load during walking gait*. Journal of biomechanics, 2015. **48**(6): p. 1165-1171.
26. Hobara, H., et al., *Amputee locomotion: lower extremity loading using running-specific prostheses*. Gait & posture, 2014. **39**(1): p. 386-390.
27. Lohman, E.B., K.S.B. Sackiriyas, and R.W. Swen, *A comparison of the spatiotemporal parameters, kinematics, and biomechanics between shod, unshod, and minimally supported running as compared to walking*. Physical Therapy in Sport, 2011. **12**(4): p. 151-163.
28. Henry, S.D., et al., *Fatigue Data Book: Light Structural Alloys*. 1994: ASM International.
29. Lindemann, J. and L. Wagner, *Mean stress sensitivity in fatigue of α , ($\alpha\beta$) and β titanium alloys*. Materials Science and Engineering: A, 1997. **234-236**: p. 1118-1121.
30. Nicholas, T., *High Cycle Fatigue, a mechanics of materials perspective*. 2006, Oxford: Elsevier Science Ltd.
31. Ahmadi, S.M., et al., *Additively Manufactured Open-Cell Porous Biomaterials Made from Six Different Space-Filling Unit Cells: The Mechanical and Morphological Properties*. Materials, 2015. **8**(4): p. 1871-1896.
32. B311, A., *Standard Test Method for Density of Powder Metallurgy (PM) Materials Containing Less Than Two Percent Porosity*. 2013, ASTM International.
33. ISO, *ISO 13314: Mechanical Testing of metals - Ductility Testing - Compression Test for Porous and Cellular metals*. 2011, ISO.
34. Rohatgi, A., *WebPlotDigitizer*. 2015.
35. Van Hooreweder, B., et al., *Improving the fatigue performance of porous metallic biomaterials produced by Selective Laser Melting*. Acta Biomaterialia, 2016. **in press**.
36. Ahmadi, S.M., et al., *Mechanical behavior of regular open-cell porous biomaterials made of diamond lattice unit cells*. J Mech Behav Biomed Mater, 2014. **34**: p. 106-15.
37. Lanning, D.B., T. Nicholas, and G.K. Haritos, *On the use of critical distance theories for the prediction of the high cycle fatigue limit stress in notched Ti-6Al-4V*. International journal of fatigue, 2005. **27**(1): p. 45-57.
38. Campoli, G., et al., *Mechanical properties of open-cell metallic biomaterials manufactured using additive manufacturing*. Materials & Design, 2013. **49**: p. 957-965.
39. Zadpoor, A.A., J. Sinke, and R. Benedictus, *Experimental and numerical study of machined aluminum tailor-made blanks*. journal of materials processing technology, 2008. **200**(1): p. 288-299.
40. Kloos, K., A. Buch, and D. Zankov, *Pure geometrical size effect in fatigue tests with constant stress amplitude and in programme tests*. Materialwissenschaft und Werkstofftechnik, 1981. **12**(2): p. 40-50.
41. Schijve, J., *Fatigue of Structures and Materials*. 2009: Springer. 621.
42. Andrews, E., et al., *Size effects in ductile cellular solids. Part II: experimental results*. International Journal of Mechanical Sciences, 2001. **43**(3): p. 701-713.
43. Onck, P., E. Andrews, and L. Gibson, *Size effects in ductile cellular solids. Part I: modeling*. International Journal of Mechanical Sciences, 2001. **43**(3): p. 681-699.
44. Liikavainio, T., et al., *Loading and gait symmetry during level and stair walking in asymptomatic subjects with knee osteoarthritis: importance of quadriceps femoris in reducing impact force during heel strike?* The Knee, 2007. **14**(3): p. 231-238.
45. Mundermann, A., et al., *In vivo knee loading characteristics during activities of daily living as measured by an instrumented total knee replacement*. Journal of Orthopaedic Research, 2008. **26**(9): p. 1167-1172.
46. Taylor, W.R., et al., *Tibio - femoral loading during human gait and stair climbing*. Journal of Orthopaedic Research, 2004. **22**(3): p. 625-632.
47. Voloshin, A., *The influence of walking speed on dynamic loading on the human musculoskeletal system*. Medicine and science in sports and exercise, 2000. **32**(6): p. 1156-1159.
48. Voloshin, A.S., et al., *Dynamic loading on the human musculoskeletal system—effect of fatigue*. Clinical Biomechanics, 1998. **13**(7): p. 515-520.
49. Zadpoor, A.A. and A.A. Nikooyan, *A mechanical model to determine the influence of masses and mass distribution on the impact force during running—a discussion*. Journal of Biomechanics, 2006. **39**(2): p. 388-390.
50. Marras, W.S., et al., *The influence of psychosocial stress, gender, and personality on mechanical loading of the lumbar spine*. Spine, 2000. **25**(23): p. 3045-3054.

1
2
3
4
5
6
7
8
9
10
11
12
13
14
15
16
17
18
19
20
21
22
23
24
25
26
27
28
29
30
31
32
33
34
35
36
37
38
39
40
41
42
43
44
45
46
47
48
49
50
51
52
53
54
55
56
57
58
59
60
61
62
63
64
65

Figure captions

Figure 1. Diamond unit cell porous structure, Dimensions: 15x20mm.

Figure 2. Specimen fixture for fatigue tests, dimensions are in mm.

Figure 3. Detection of corresponding points in the [feature tracking](#) code.

Figure 4. Typical sample failure at static compression (a), fatigue failure at one (b) or two directions (c).

Figure 5. Obtained SN-curves at different stress ratios on a linear (a) and logarithmic (b) scale. [The number 2 in subfigure \(a\) indicates the number of run-out specimens.](#)

Figure 6. Normalized stress amplitude vs. number of cycles to failure.

Figure 7. Stiffness decay over lifetime for a constant stress amplitude (a) and increasing amplitudes (b).

Figure 8. Strain development during fatigue tests at $R = 0.1$.

Figure 9. Strain development during fatigue tests at $R = 0.5$.

Figure 10. Strain development during Fatigue tests at equal amplitudes and different mean stresses ($0.675\sigma_y$ (A), $0.52\sigma_y$ (B), $0.275\sigma_y$ (C)).

Figure 11. Constant life diagram constructed from test results.

Figure 12. Constant life diagram comparing different Ti-6Al-4V compositions from the data presented (from different sources) in reference [28].

Figure 13. Close-up of strut at 250x magnification (a) Fracture Surface with crack initiated from notch at a magnification of 1500x.

Figure 14. Approximation of loading and normal stress distribution of one single strut of the diamond unit cell

Figure 1

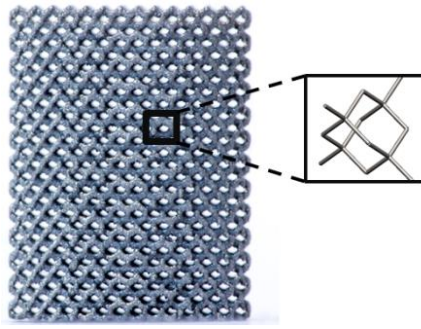

1
2
3
4
5
6
7
8
9
10
11
12
13
14
15
16
17
18
19
20
21
22
23
24
25
26
27
28
29
30
31
32
33
34
35
36
37
38
39
40
41
42
43
44
45
46
47
48
49
50
51
52
53
54
55
56
57
58
59
60
61
62
63
64
65

Figure 2

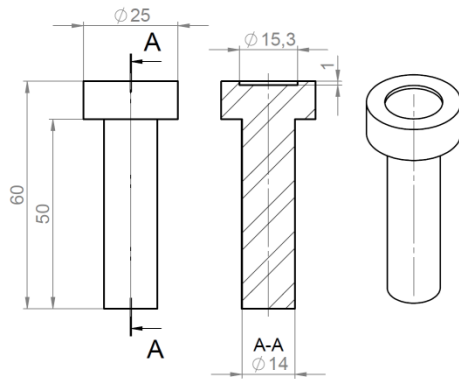

1
2
3
4
5
6
7
8
9
10
11
12
13
14
15
16
17
18
19
20
21
22
23
24
25
26
27
28
29
30
31
32
33
34
35
36
37
38
39
40
41
42
43
44
45
46
47
48
49
50
51
52
53
54
55
56
57
58
59
60
61
62
63
64
65

Figure 3

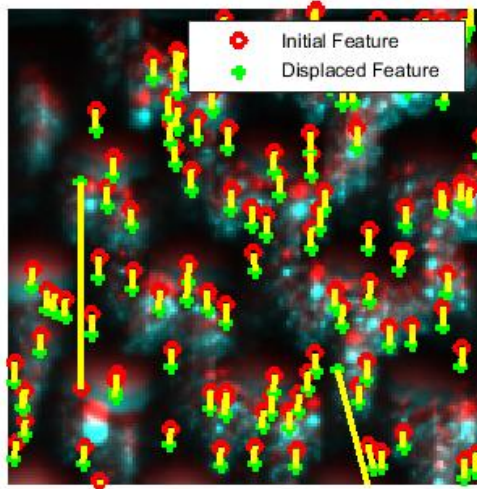

1
2
3
4
5
6
7
8
9
10
11
12
13
14
15
16
17
18
19
20
21
22
23
24
25
26
27
28
29
30
31
32
33
34
35
36
37
38
39
40
41
42
43
44
45
46
47
48
49
50
51
52
53
54
55
56
57
58
59
60
61
62
63
64
65

Figure 4

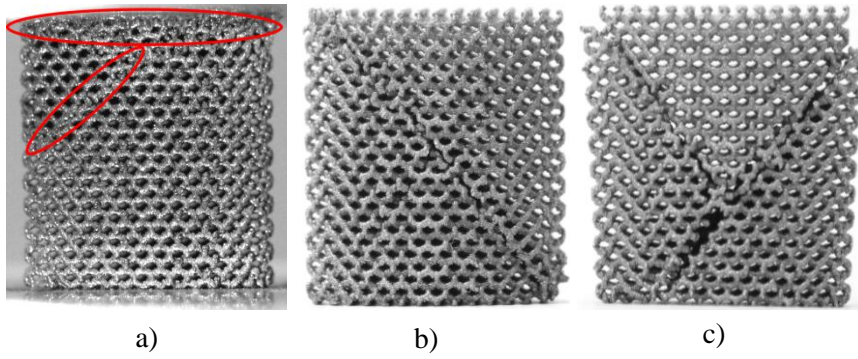

1
2
3
4
5
6
7
8
9
10
11
12
13
14
15
16
17
18
19
20
21
22
23
24
25
26
27
28
29
30
31
32
33
34
35
36
37
38
39
40
41
42
43
44
45
46
47
48
49
50
51
52
53
54
55
56
57
58
59
60
61
62
63
64
65

Figure 5

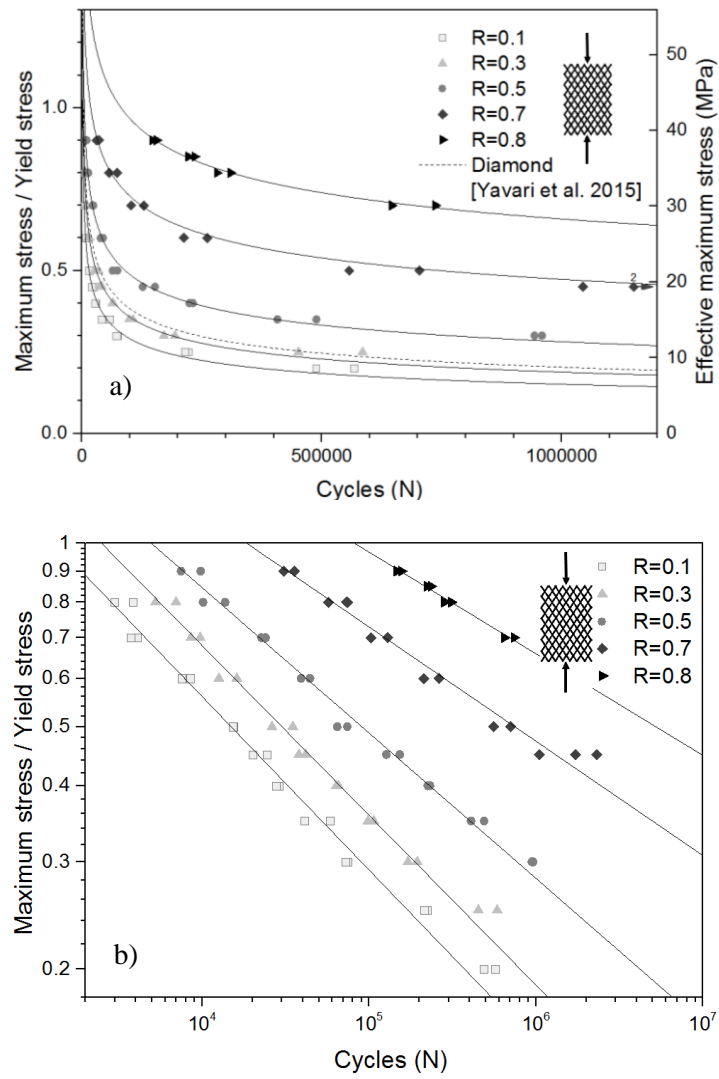
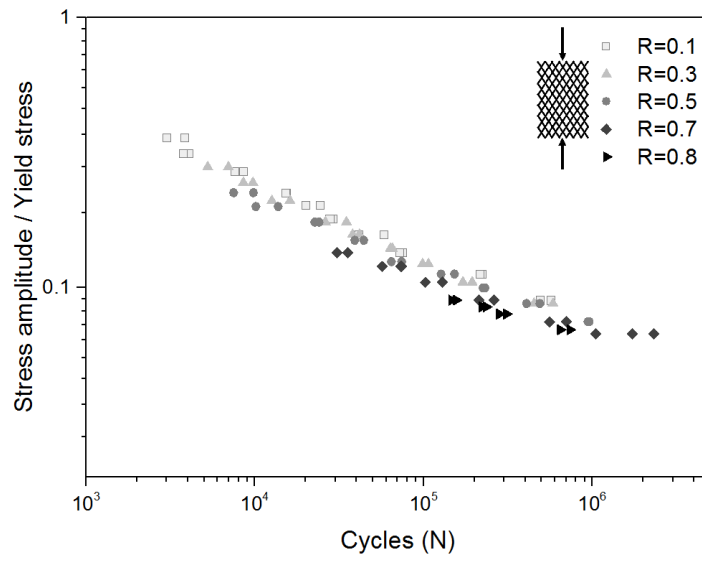

Figure 6



1
2
3
4
5
6
7
8
9
10
11
12
13
14
15
16
17
18
19
20
21
22
23
24
25
26
27
28
29
30
31
32
33
34
35
36
37
38
39
40
41
42
43
44
45
46
47
48
49
50
51
52
53
54
55
56
57
58
59
60
61
62
63
64
65

Figure 7

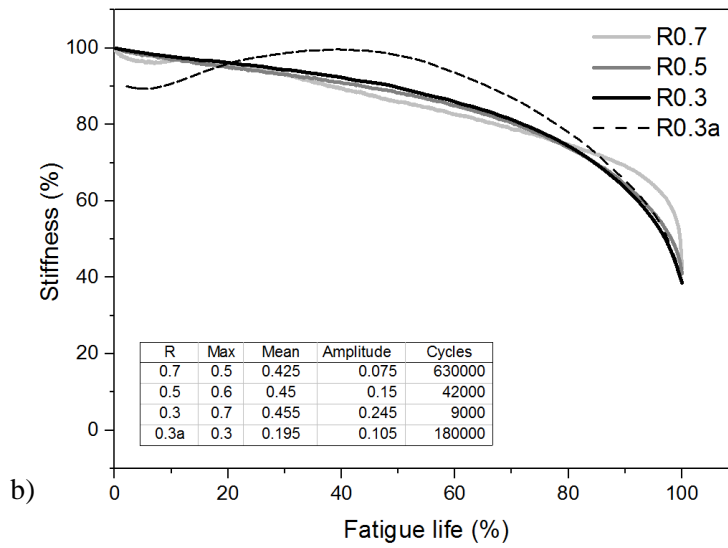
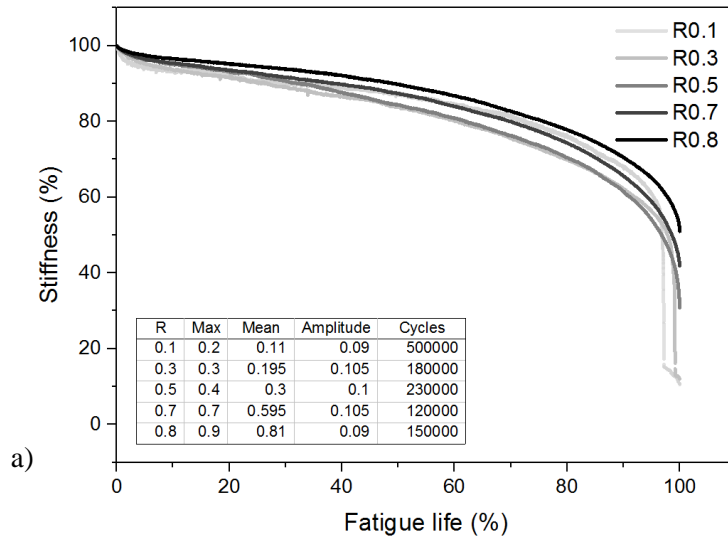

Figure 8

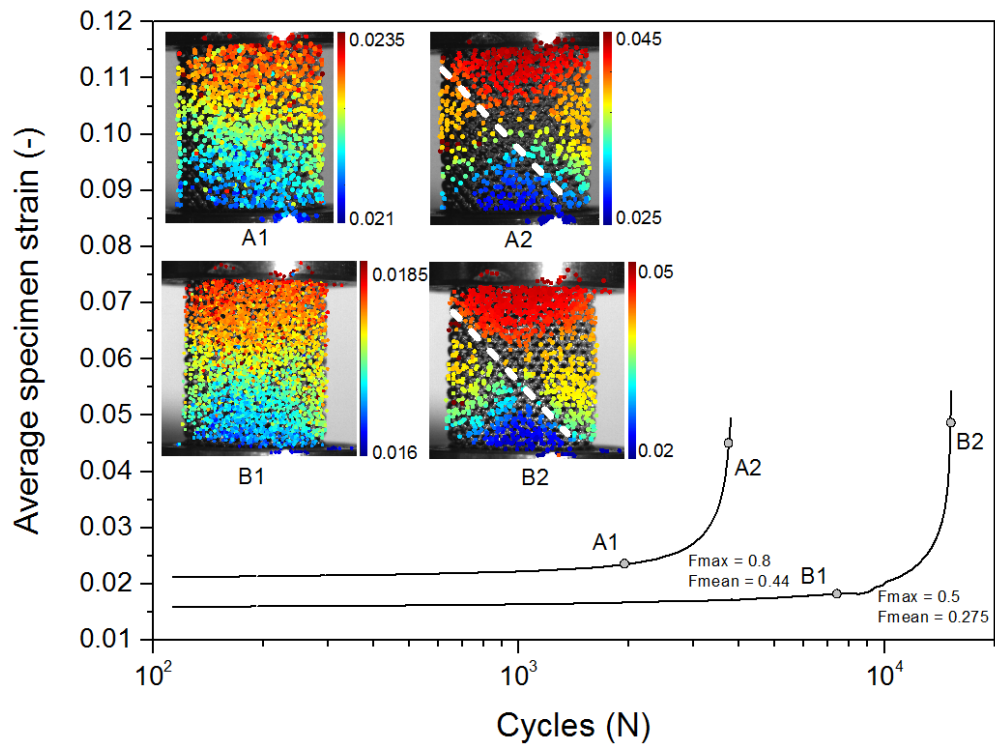

Figure 9

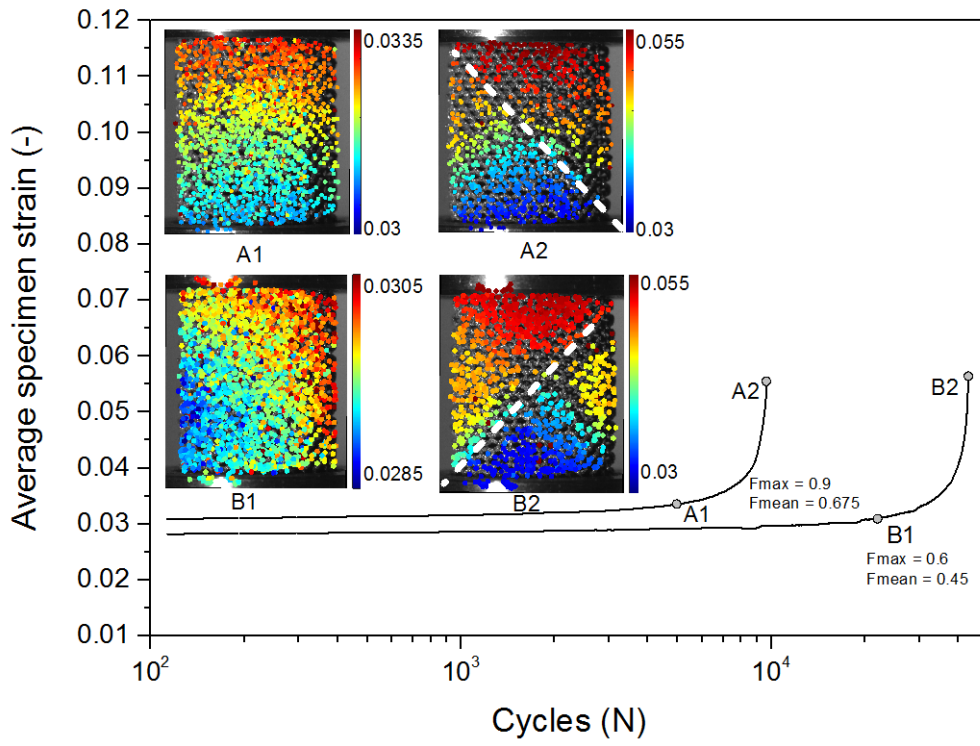

Figure 10

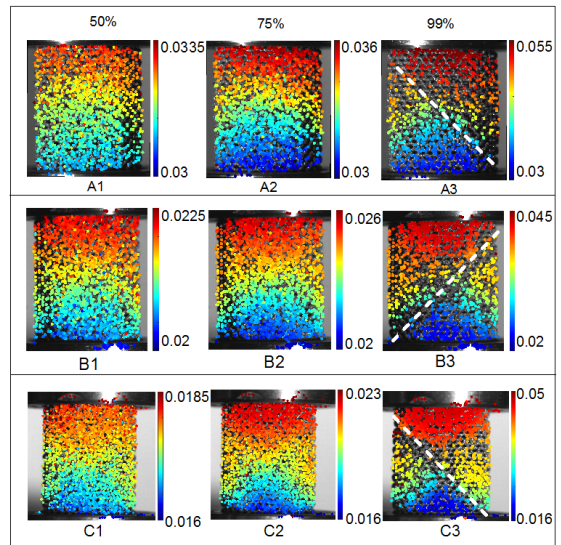
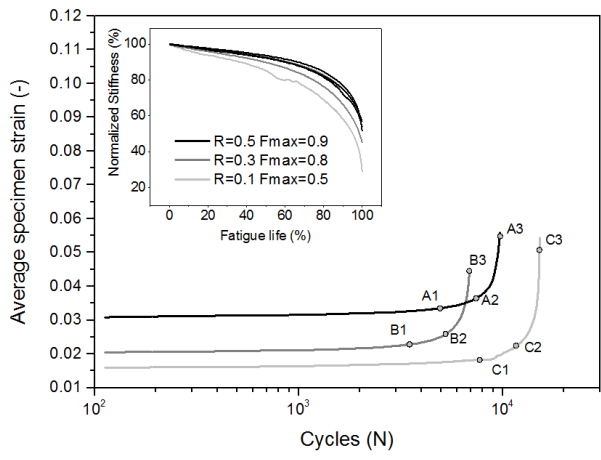

Figure 11

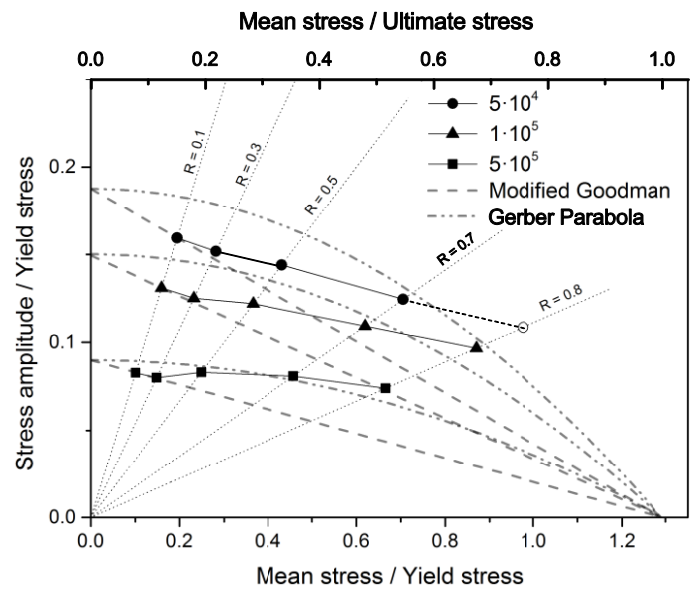
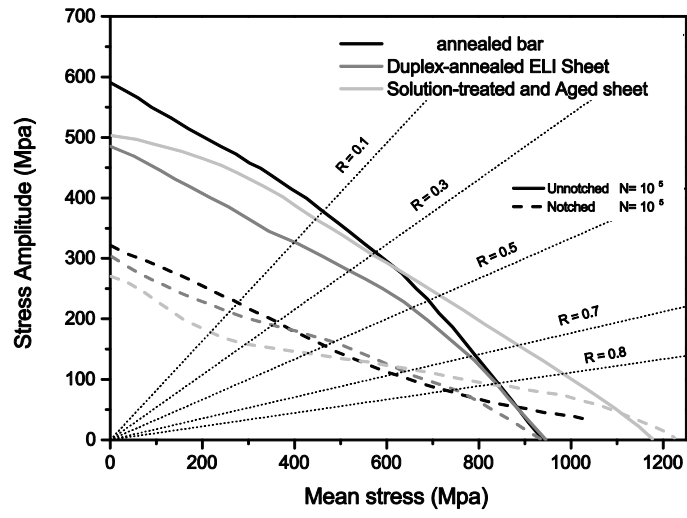
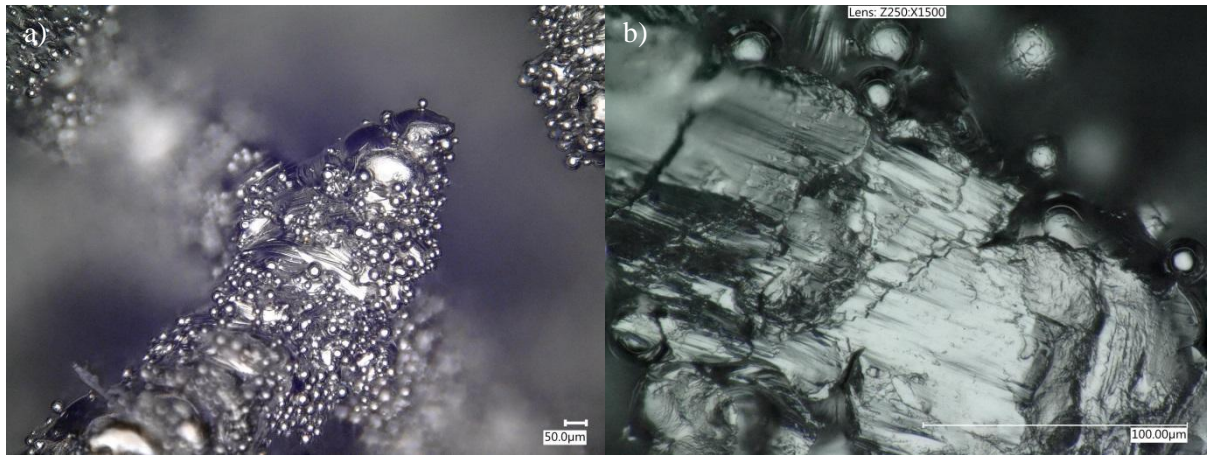

Figure 12



1
2
3
4
5
6
7
8
9
10
11
12
13
14
15
16
17
18
19
20
21
22
23
24
25
26
27
28
29
30
31
32
33
34
35
36
37
38
39
40
41
42
43
44
45
46
47
48
49
50
51
52
53
54
55
56
57
58
59
60
61
62
63
64
65

Figure 13



1
2
3
4
5
6
7
8
9
10
11
12
13
14
15
16
17
18
19
20
21
22
23
24
25
26
27
28
29
30
31
32
33
34
35
36
37
38
39
40
41
42
43
44
45
46
47
48
49
50
51
52
53
54
55
56
57
58
59
60
61
62
63
64
65

Figure 14

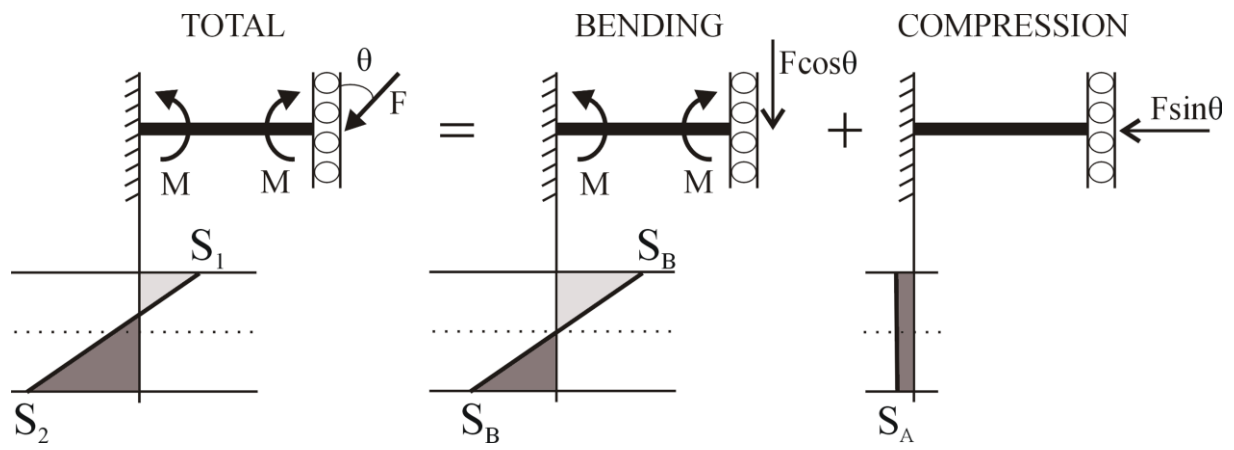

1
2
3
4
5
6
7
8
9
10
11
12
13
14
15
16
17
18
19
20
21
22
23
24
25
26
27
28
29
30
31
32
33
34
35
36
37
38
39
40
41
42
43
44
45
46
47
48
49
50
51
52
53
54
55
56
57
58
59
60
61
62
63
64
65

Table Captions

Table 1. Morphological and compressive mechanical properties (mean \pm standard deviation) of the porous structures.

Table 3. Exponential curve fitting parameters ($y = a x^b$).

Table 1

Property	Measured value
Dimensions, D x L (mm)	15 x 20
Unit cell size (mm)	1.5
Dry weight (g)	3.114 ± 0.079
Porosity, dry weighing (%)	80.1 ± 0.5
Porosity, Archimedes (%)	79.2 ± 0.6
Porosity, Micro-CT (%)	79.8 ± 0.3
Pore size, Micro-CT (μm)	765 ± 112
Strut diameter, Micro-CT (μm)	306 ± 60
σ_{max} (MPa)	55.6 ± 0.8
e_{max} (%)	6.3 ± 0.7
$\sigma_{\text{off}} [\sigma_y]$ (MPa)	43.0 ± 2.1
σ_{pl} (MPa)	35.3 ± 2.2
E_{20-70} (GPa)	1.36 ± 0.46
E.A. (MJm^{-3})	17.3 ± 0.6

Table 2

	<i>a</i>	<i>b</i>	<i>R</i> ²
<i>R</i> =0.1	7.703	-0.2846	0.9854
<i>R</i> =0.3	8.848	-0.2787	0.9876
<i>R</i> =0.5	7.620	-0.2387	0.9880
<i>R</i> =0.7	6.318	-0.1876	0.9792
<i>R</i> =0.8	6.597	-0.1668	0.9886

1
2
3
4
5
6
7
8
9
10
11
12
13
14
15
16
17
18
19
20
21
22
23
24
25
26
27
28
29
30
31
32
33
34
35
36
37
38
39
40
41
42
43
44
45
46
47
48
49
50
51
52
53
54
55
56
57
58
59
60
61
62
63
64
65