

Solutions for the Province of Groningen

Seismic retrofit of historic Amsterdam School houses

Pasquale A. van Dijk

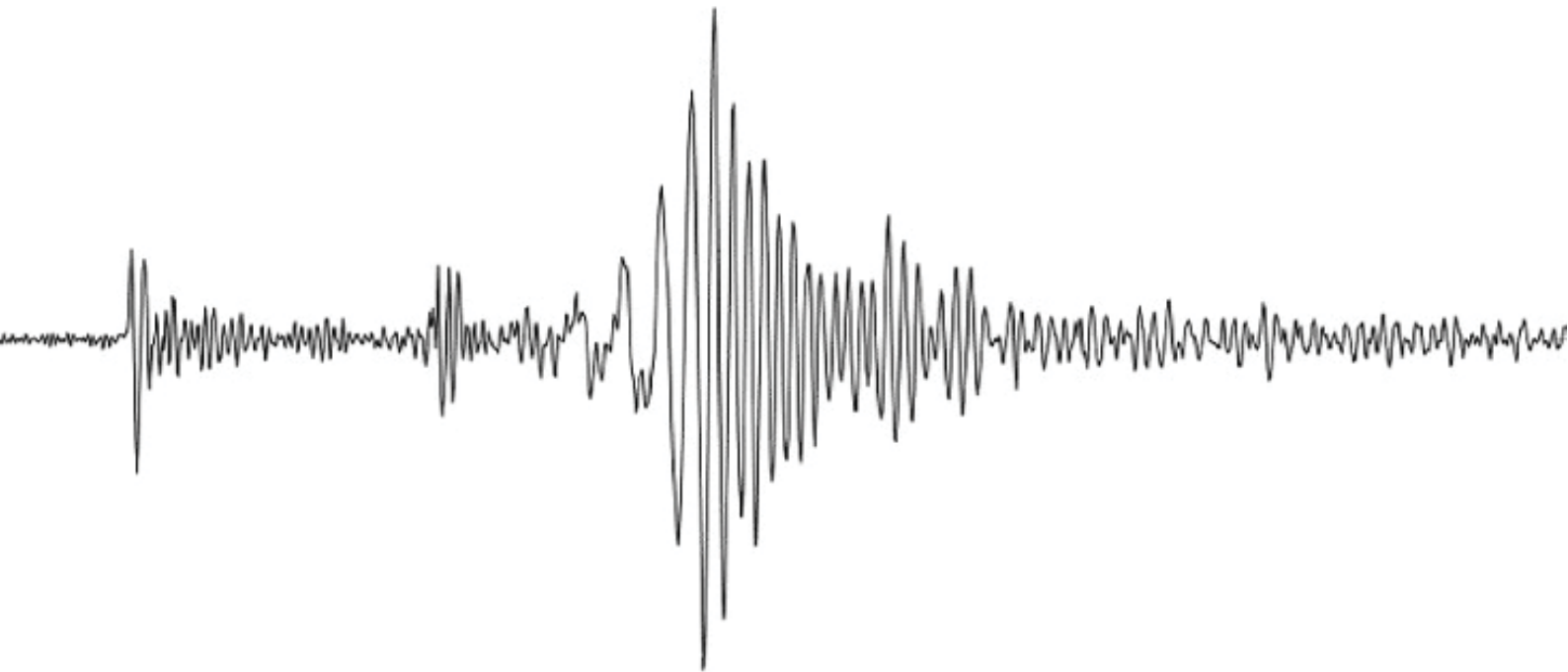

Solutions for the Province of Groningen

Seismic retrofit of historic Amsterdam School houses

Delft University of Technology | Faculty of Architecture
Master track | Building Technology

P5 GRADUATION REPORT

Date | June 26th, 2015
Name | Pasquale (P.A.) van Dijk
Student number | 1502530
First mentor | prof. dr. ir. J.C. Paul MBA
Second mentor | ir. K.B. Mulder
Third mentor | ir. J.E.P. Smits



Preface

This research was conducted for the purpose of finishing my MSc track in Building Technology. The topic, “Earthquake resistant Retrofit for the Province of Groningen”, was introduced to me by one of my mentors, Ir. J.E.P. Smits. Ever since I received his first e-mail with the request whether I wanted to explore this topic, it has had my full attention and dedication. In advance I knew less than zero about earthquakes, but I took the challenge and acquired myself the expertise.

The purpose of the research was to contribute to the earthquake related problems in the Province of Groningen by creating suitable solutions for the reinforcement of existing buildings in the earthquake area. This concerned not only a technical issue, but a social issue as well.

This “journey” has been a very educative experience to me. Solving a technical problem in a social context, with the participation of the end users, the residents of the earthquake area, made this research very real. And the journey won’t end with this research. The topic is very present-day and vivid among the inhabitants in the Region. The social and political issue will continue to exist, the job is not yet done.

During my investigation I was supported by my mentors Prof. Dr. Ir. J.C. Paul MBA and Ir. K.B. Mulder. I couldn’t have found better counselors then these two men. They have always supported my ideas, managed to motivate me during the obstacles that I was confronted with during my research and guided me where necessary. My sincere thanks to you both. And of course my gratitude to my mentor Ir. J.E.P. Smits for bringing me this very interesting topic.

Furthermore I’d like to thank F. Sikkes, J. Sikkes, A. de Bruin, L. Goslinga, H. Poelman, S. Veentjer, and V. Willemsen for showing me their lovely homes, sharing their thoughts, and answering all my questions. I also want to thank Ir. H. Wijbenga and Ir. E. Siemer from Arup for showing me around in the test houses and sharing their expertise with me.

My appreciation also go to J. Rots and M. Wienk, for giving me insight in the points of view of the municipality of Loppersum and Libau regarding the earthquake issue. And to F. Halming for researching the archives of Loppersum for days in the interest of my research.

And last but not least I’d like to thank my dearest dad for his unconditional love, time, effort and support during my research.



Abstract

Earthquakes, as a result of commercial extraction of natural gas out of deep soil, has become a frequently recurring phenomenon in the Province of Groningen. Historically earthquakes have never been an issue in the Netherlands, and the built environment is not prepared for this phenomenon.

The purpose of this research was to find suitable solutions for retrofitting houses in order to protect them against earthquakes. The focus was on Amsterdam School style houses. This pre-war architecture has been very popular in the Groningen region, and there are plenty of these unique heritage houses. The earthquakes, and the strengthening measures, both are a threat for the monumental houses. The aesthetics of the reinforcing measures, for the purpose of preservation of this distinctive architecture, formed the starting point for the research.

This study has resulted in innovative designs for reinforcement measures that suit the style of the Amsterdam School architecture. Designs have been made for earthquake resistant chimneys, embellishments and covers for reinforcing anchor plates, stiff floors and reinforcements for masonry parapets. Extra attention has been paid to the social context. Contact with local residents, encounter their experiences and listening to their wishes regarding the earthquake problems has been of great influence. The designs are the result of a human approach within a technical framework.

All designs are projected on four existing Amsterdam School style houses in Loppersum. In contact with the residents of the case study houses and stakeholders the designs have been evaluated, and drawn into a wider context. The process towards the design and subsequent analysis, are as important as the design itself, and may provide a basis for wider future application.





Contents

1 Introduction.....	9	4 Design preparation.....	44
1.1 Introduction		4.1 Design task	
1.2 Problem statement		4.2 Classification of measures	
1.2.1 Extent of the problem		4.3 Design principles	
1.2.2 Social discontentment		4.4 Design requirements	
1.2.3 Historic/cultural values		4.3.1 Constructive requirements	
1.2.4 Additional problems		4.3.2 Functional/aesthetical requirements	
1.3 Objectives		4.6 Style strategies	
1.4 Research questions		4.6.1 Building specific	
1.5 Methodology		4.6.2 Style specific	
		4.6.3 Period specific	
		4.6.4 Unspecific	
		4.7 Design attitude	
		4.8 Design Strategy	
2 Literature research.....	15	5 Design catalog.....	57
2.1 Earthquakes		Catalog:	
2.1.1 What is an earthquake?		1. Decorative chimney bracing	
2.1.2 Measuring an earthquake		2. Lightweight chimney	
2.1.3 Groningen and earthquakes		3. Lightweight parapet	
2.1.4 The emergence of the induced earthquakes		4. Decorative parapet restraint	
2.1.5 Seismic hazard		5. Planter box parapet restraint	
2.1.6 Building Vulnerability		6. Invisible anchor plate	
2.1.7 Structural stiffness		7. Covered anchor plate 1	
2.2 Seismic design principles		8. Covered anchor plate 2	
2.3 Unreinforced masonry buildings		9. Decorative anchor plate	
2.3.1 Box behavior		10. Strip anchor plate	
2.3.2 Flexible diaphragms		11. Integrated floor heating	
2.3.3 Damage patterns		12. Rigid decorative ceiling	
2.3.4 Arups seismic retrofit approach			
2.4 Levels of intervention			
2.5 Amsterdam School			
2.5.1 What is Amsterdam School?			
2.5.2 Province of Groningen			
2.5.3 Amsterdam school and risks			
2.6 Seismic retrofit of historic buildings			
3 Fieldwork.....	27	6 Stakeholders.....	108
3.1 Case study buildings		6.1 Overview of the stakeholders	
3.2 Recurring riskful elements		6.2 Interviews with stakeholders	
3.2.1 Collapse hazards			
3.2.2 Falling hazards			
3.2.3 Elements picked for further elaboration			
3.3 Structural anatomy		7 Conclusions.....	116
3.3.1 Masonry parapet		7.1 Conclusions	
3.3.2 Chimney		7.2 Recommendations for future research	
3.3.3 Masonry supported beam			
3.3.4 Wooden floor			
3.4 Test houses		Bibliography.....	118
3.4.1 Chimneys			
		Appendices.....	120





1. Introduction

1.1 Introduction

During a search for oil, in 1958 in the municipality of Slochteren in the Province of Groningen, natural gas was found. Since 1963 the NAM (Nederlandse Aardolie Maatschappij) extracts gas from the Groningen gas field. The Groningen gas field since then remains one of the largest gas fields in the world. (Figure 2 shows the location of the Groningen gas field).

The field contained 2800 billion cubic meters of gas. About 60% of this gas has been produced already, but the coming decades there will be enough left to continue pumping. Approximately until 2080 the field will remain in operation (and the earthquakes will remain to happen), although after 2020 the capacity will drop down. (Figure 3 shows the soil subsidence until 2008 and the expected subsidence until 2080) (<http://www.namplatform.nl/gaswinning/het-groningen-gasveld.html>)

The past few years in the North-East of the province of Groningen earthquakes occur more frequently and severe. The earthquakes caused by the gas extraction in the area are so called “induced earthquakes”.

The first identifiable earthquake as a result of the gas extraction dates back to 1991. Ever since earthquakes are a regular phenomenon in the Province of Groningen, and the number of earthquakes is increasing, along with their magnitude. The most severe earthquake measured so far in the Province of Groningen has occurred in Huizinge, on the 16th of August 2012 with 3.6 on the Richter scale. From this moment on serious measures have been taken and many researches have been done regarding to the future gas extraction in this area and the effects of the earthquakes. For example, a new production plan for the Groningen gas field has been drawn up. (<http://www.namplatform.nl/aardbevingen/ervaren-van-aardbevingen.html>)

Figure 4 shows the locations and magnitudes of the earthquakes that occurred in the Province of Groningen in the year 2014.



Figure 1: Province of Groningen, source: www.faat.nl



Figure 2: Groningen gas fields, source: www.namplatform.nl



Figure 3: Groningen gas fields, source: www.namplatform.nl



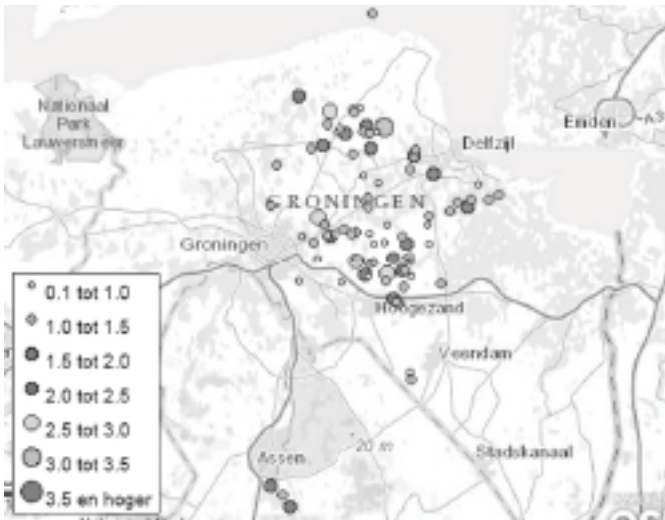

Figure 4: Earthquakes 2014, source: www.namplatform.nl



Figure 5: Earthquake damage, source: www.groninger-bodem-beweging.nl

1.2 problem statement

1.2.1 Extent of the problem

Research (Muntendam-Bos et al., 2013) shows that in the coming 3 years earthquakes with a magnitude of 4.1 on the Richter scale are likely to occur. This does not bring very great risks for the infrastructure, however buildings can get seriously damaged. Reinforcement of existing buildings therefore is necessary.

Many buildings in the Province of Groningen are likely to get damaged by the lately occurring earthquakes, or have been damaged already. In the past earthquakes were never an issue in this part of the Netherlands, so no laws and regulations on this matter are included in the Dutch building decree. The typical Dutch building stock is not prepared for earthquakes at all. These buildings need to be protected against further damage or even collapsing.

“For the Netherlands there is currently no National Annex and NDPs, and Eurocode 8 is not required by the Dutch Legislation (Bouwbesluit 2012). The use of Eurocode 8 in the Netherlands is on a vol-

untary basis, however it would require a National Annex and NDPs. Development of the National Annex and NDPs is foreseen by the NEN institute.” (Arup, 2013)

The typical Dutch detailing, and the use of unreinforced masonry as a predominant building material (75-85% of the stock) makes that the building stock in Groningen responds very vulnerable to earthquakes.

Table 1 and 2 show the damageability of masonry buildings and reinforced concrete/steel buildings. The grading indicates the severity of the damage. Grade 1 represents negligible to slight damage up to grade 5 which represents destruction. The zone represents the chance of an earthquake occurring in that area, ranging from zone 2 which represents moderate-prone areas up to zone 5 which represents very severe-prone areas..

The tables 1 & 2 clearly show the poor performance of masonry in case of an earthquake in comparison to other materials.

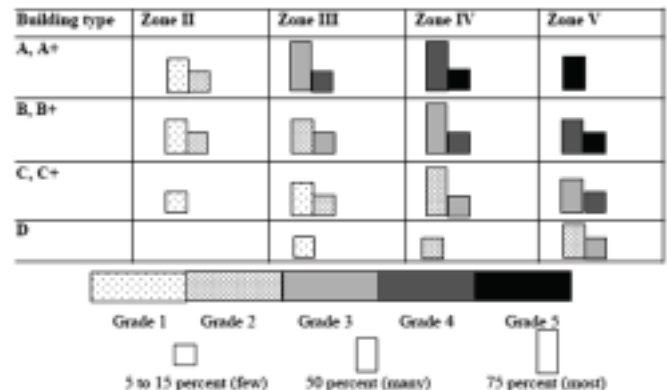

Table 1: Damageability masonry buildings, source: Chakrabati, A.

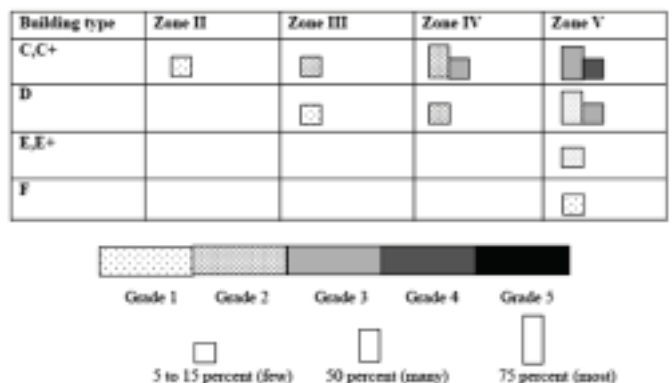

Table 2: Damageability of RC/steel buildings, source: Chakrabati, A. et al)

Approximately 30,000-90,000 buildings need to be reinforced in the coming years (source: www.nrc.nl/nieuws). This indicates the scale of the problem. Finding customized solutions for every single building does not seem feasible, a system-



atic approach is obvious in this case.

The proposed reinforcement measures will focus on structural safety, which includes eliminating the possibility of injury, guided by Eurocode 8.

The figure 9 below shows a quote from Eurocode 8, indicating that the Dutch building stock with all its unreinforced masonry has not been taking this building code into account.

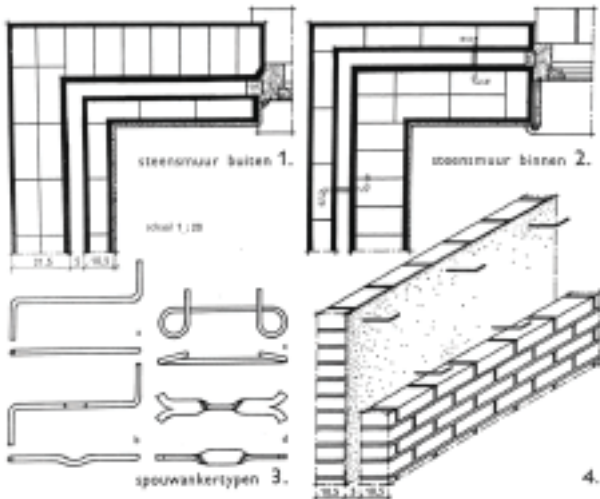

Figure 6: Typical Dutch cavity wall details, source: Jellema, R. et al)

1.2.2 Social discontentment

The earthquakes in Groningen are not caused by natural forces, but provoked by gas extraction. This causes discontentment among the inhabitants of Groningen. Since they do not have direct benefits from the gas extraction, and their properties get damaged and drop value by the damaged image of the region, they feel victimized.

In the year 2014 alone over 17,000 damage reports have been submitted (<http://feitenencijfers.namplatform.nl/>).

The discontentment of the people is stressed almost on a daily base in affairs programs and in the newspapers.



Figure 7: Protest against gas extraction, source: NRC Handelsblad

(2) Due to its low tensile strength and low ductility, unreinforced masonry that follows the provisions of EN 1996 alone is considered to offer low-dissipation capacity (DCL) and its use should be limited, provided that the effective thickness of walls, t_{ef} , is not less than a minimum value, $t_{ef,min}$.

Figure 9: Quote from Eurocode 8, source: Eurocode 8

‘Veiligheid Groningers bij gaswinning genegeerd’

2,8 OP SCHAAL VAN RICHTER

Weer beving in Groningen, op 11 kilometer van hoofdstad

Weer aardbeving in Groningen, 2,7 op Richterschaal bij Wirdum

235 schademeldingen na aardbeving Groningen

Als de stad beeft en er doden vallen

Figure 8: Headlines of national newspapers in 2014, source: own elaboration

1.2.3 Historic/cultural values

Until the end of 2014 189 monumental buildings were reported as being damaged by the earthquakes (<https://veilig-erfgoed.nl/onderwerpen/aardbevingen/aardbevingen-en-rijksmonumenten>). Besides from the risk of personal injury to people, earthquakes can make drastic changes to the face of the built environment as well. Valuable buildings that are noted as part of the provinces' culture heritage are not only in danger of being damaged or even collapse from the earthquakes directly, the measures to reinforce them can disrupt the sight as well.

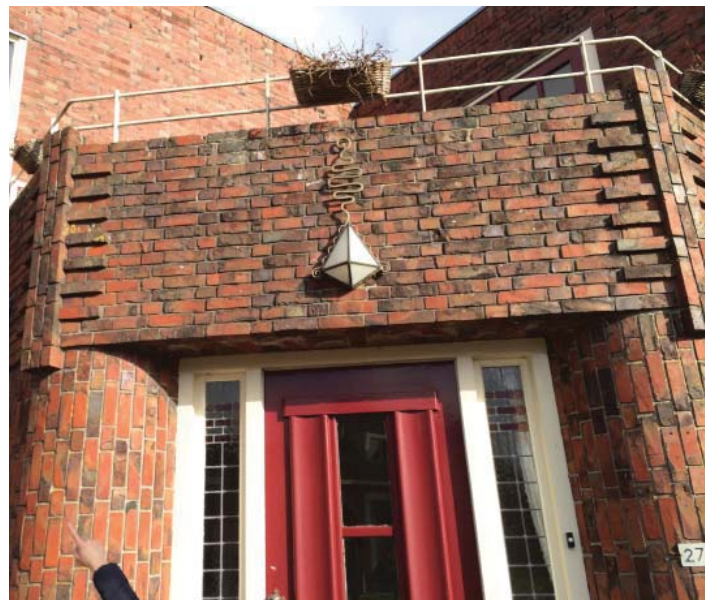

Figure 10: Amsterdam school style building in Loppersum, source: own elaboration



Next to churches, windmills and medieval structures the Province of Groningen holds a significant amount of Amsterdam School style buildings (figure 10). The Province of Groningen, besides Amsterdam, has the largest stock Amsterdam School style buildings in the Netherlands. (Spek & Jong, 2000) This particular style has been very popular in the province of Groningen for a while. During a period of prosperity at the beginning of the 20th Century many of these particular buildings have been built throughout the province of Groningen. These ornately masonry architecture with high architectural design value might be at risk regarding to earthquakes.

Making these typical Amsterdam School buildings earthquake resistant in an aesthetically desirable way will probably require customized solutions. It is to be expected that this high level of customization will make the reinforcement measures highly expensive and time consuming.

1.2.4 Additional problems

1.2.4 Additional problems

Besides the earthquakes Groningen has to deal with, the region unfortunately suffers from additional problems. Due to its geographical location, the economic malaise and the trend of urban migration, the Province of Groningen also suffers from declination of it's population, incomes that are below average and high rates of unemployment. (<http://statline.cbs.nl/>) Therefore the earthquakes hit Groningen particularly hard.

1.3 Objectives

The goal of the research will be finding solutions for making Amsterdam School buildings in the province of Groningen earthquake resistant.

Because of the great variation in form and appearance, and the high architectural value of these buildings, reinforcing them requires some extra attention. Special attention should be paid to the aesthetics of the measures, and the preservation of valuable architectural elements.

In order to make the interventions accessible and affordable, creating a method and cataloging elements and possible solutions for reinforcement will be the main purpose of the research. These kind of tailored solutions can be offered without having to redo the whole research for every building. The catalog will offer examples on how to reinforce Amsterdam School buildings in a aesthetically acceptable and feasible manner.

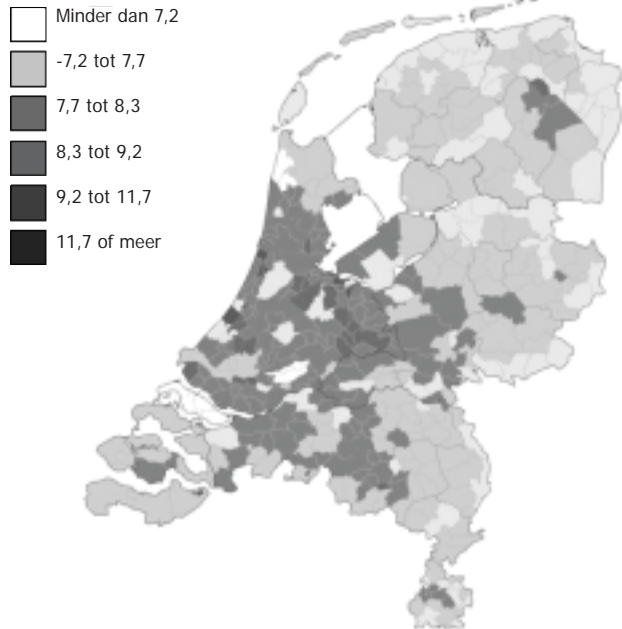

Figure 11: Income November 2014 x 1000, source: www.cbs.nl

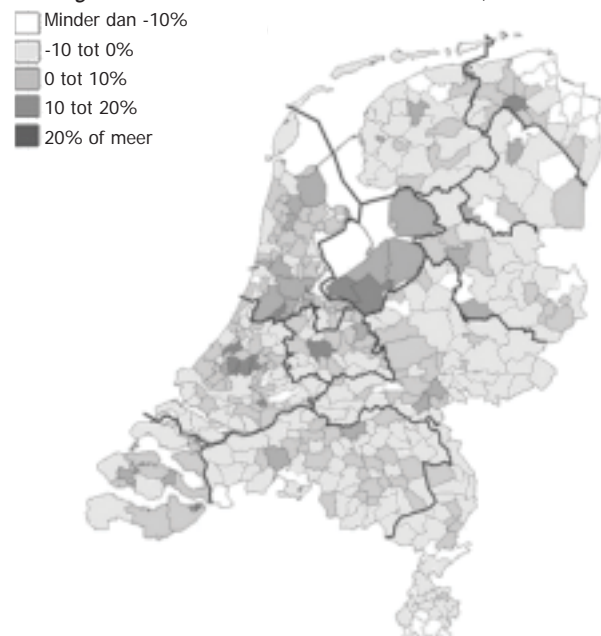

Figure 12: Population growth 2007-2025, source: www.cbs.nl

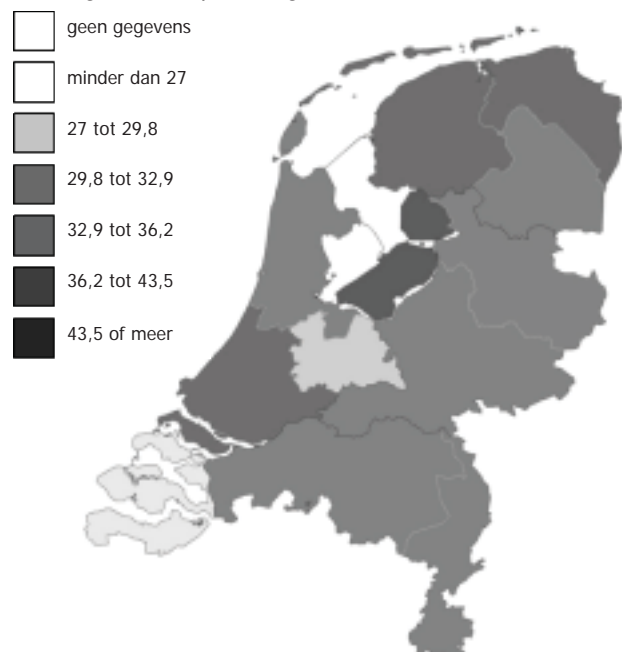

Figure 13: Labor force 1987-2014, source: www.cbs.nl



Within this catalog suitable solutions will be described for reinforcement that match the architectural elements and the typical structure of the Amsterdam School style buildings. Maintaining the current functions and aesthetics will be one of the main points of concern herein.

As a result, research will mainly be focused on the following topics:

- The Amsterdam School typology
- Build-up and detailing of Amsterdam School buildings
- Seismic retrofit of buildings
- Retrofit of heritage buildings

1.4 Research questions

The main research question for the research is:

“How can typical Dutch heritage masonry buildings (Amsterdam school) in the province of Groningen be reinforced to withstand earthquakes with respect for the preservation of the existing appearance and function of the building?”

Additional important questions are:

- *What is the typical build-up of Amsterdam School buildings in Groningen (structure, cladding, foundation, details, etc...)?*
- *What are, within the style of the Amsterdam School, vulnerable recurring elements that need to be reinforced to protect them against earthquakes?*
- *What possible solutions are there (available) to reinforce nonstructural elements in buildings to protect them against earthquakes?*
- *How can the solutions for reinforcement of the nonstructural elements be applied in an aesthetically acceptable way?*
- *How can the solutions for reinforcement be applied on a broader scale (developing a standard/method)?*
- *What are the requirements, both technically and aesthetically, that the design for reinforcements must meet?*

1.5 Methodology

After the determination of the research topic, “Solutions for earthquake resistant retrofit in the province of Groningen” the field of research had

to be narrowed down into a manageable, relevant and interesting inquiry. The starting point of finding a suitable research direction was the current research of Arup, commissioned by the NAM, on possible solutions for protecting buildings against earthquakes.

The intention was to find a research direction that could make use of Arup’s pursuits and investigations, but not doing the exact same thing. After further consideration and research it seemed that Arup’s research mainly focusses on the reinforcement of the structural elements. The testing houses are being tested with the “level 2 and 3 interventions”, in which level 2 interventions include the tying of floors and walls and the level 3 interventions include the stiffening of flexible diaphragms (more detailed information on this follows in later chapters).

As an extension to Arup’s research the main focus will be on the architectural integration of the structural interventions that are needed to protect the buildings against earthquakes.

To have a better overview and understanding, the common basics of earthquakes and earthquake resistant retrofit of buildings need to be researched. To make the research more specific, the research will focus on one specific type of building. After the finding that Groningen has the second largest resource of Amsterdam School style buildings in the Netherlands, this seemed an interesting direction to go. Not only the monumental status and the large variation in form and appearance of this type of buildings forms a challenge, also, the richly decorated masonry architecture seems, in advance, not very resistant against the forces of an earthquake.

A specific (literature) research needs to be done to get an overview of built up of Amsterdam School buildings and the elements within these buildings that form a risk in case of an earthquake, and to find possible solutions to eliminate these risks. This literature research will mainly focus on the Amsterdam School style, masonry, seismic hazards and seismic design and retrofit.

To create a bigger sense of the reality of the problem also some field research needs to be done as well. In the context of the research NAM’s test houses will be visited, to get an idea what mea-



asures can be taken to structurally reinforce a building and what they look like. Also, to get an idea what kind of damages have occurred so far and to get an idea of the needs and wishes of the local house owners some houses within the style of the Amsterdam School will be visited.

In order to create a broader purpose the research will not focus on one specific house or building but on a larger group of buildings in the same style of architecture. A number of case study buildings will be selected for further research.

After an analysis of the selected case study buildings, the field research and the literature research an overview of riskful elements (risk analysis) will be made.

After having an overview of the riskful elements the actual design task can be composed. Based on the found riskful elements and the required reinforcements resulting from the literature research the actual measures that must be designed can be determined.

Before starting the design process some requirements have to be established in order to assess the various solutions for reinforcement. These requirements can be (for example) the aesthetic value, the costs, the structural safety and the ease of installation.

During the design process various solutions for reinforcement will be shown that meet the proposed requirements. The different solutions for reinforcement need to be modified in such a way that the architectural integration is optimal to ensure and protect the aesthetics and historic value of the buildings. The different solutions will be included in the “design catalog”.

In the end the proposed measures need to be validated on their technical and aesthetical qualities. The structural performance needs to be assessed in order to protect the buildings and the people living in it against future earthquakes. Also the feasibility of installation needs to be researched, and the aesthetics of the measures must be judged by the end users.

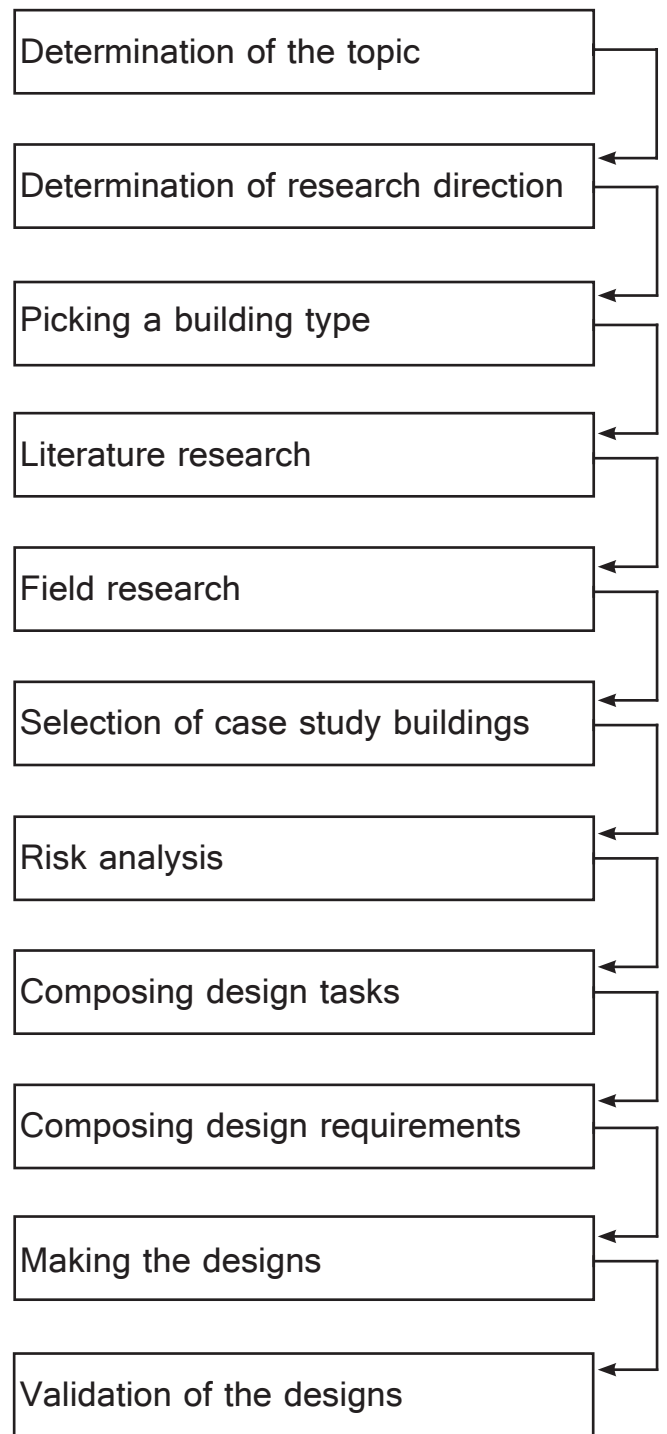

Figure 14: Scheme of the research method, source: own elaboration



2. Literature research

2.1 Earthquakes

2.1.1 What is an earthquake?

Earthquakes are associated with violent shaking of the ground. A natural earthquake is caused by the movement of the tectonic plates. When two adjoining plates collide earthquakes can occur. At the plate's boundaries large amounts of energy build up. The high stress eventually exceeds the strength of the rock along weak regions called failures. This can result in a sudden energy release; an earthquake. (Chakrabarti, A. et al)

2.1.2 Measuring an earthquake

The intensity of an earthquake is best described by its magnitude measured at the epicenter of the quake. The commonly used scale for this purpose is the Richter scale.

The intensity at a particular location is measured by the observation of damage and human reactions. The commonly used scale in Europe to measure intensity is the European Macro seismic Scale (EMS).

The measured intensity (EMS) and the associated damage to buildings usually correlates with the ground acceleration in a geographic area. This acceleration can be measured with accelerographs and is expressed as PGA, Peak Ground Acceleration.

2.1.3 Groningen and earthquakes

Since 1963 natural methane gas has been extracted from the Groningen gas field for decennia without significant problems, until in 1991 the first induced earthquake occurred. In 1993 the relation between the gas subtraction and the quakes was proved by a committee of the NAM and the Rijksgeologische Dienst under supervision of the KNMI. (www.namplatform.nl)

Research conducted in 2013 has revealed the increase of the magnitude and the frequency of the earthquakes with the field running low.

The most severe earthquake so far took place in Huizinge (municipality of Loppersum). This earthquake had a magnitude of 3.6 on the Richter scale. The prognosis is that the coming years (until 2016) earthquakes with a magnitude of 4.1 on the Richter scale can occur. The prognosed ground

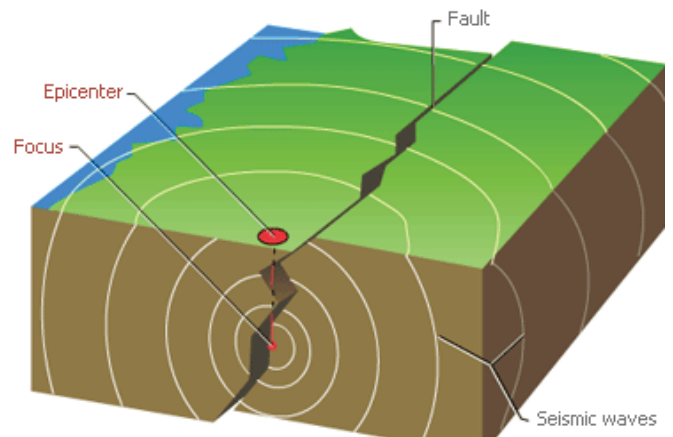

Figure 15: How Earthquakes Work, source: cenvironment.blogspot.com

acceleration (PGA) is 0,12g. With earthquakes of this order of magnitude buildings can get damaged, and people's safety can therefore not be assured. (www.namplatform.nl)

2.1.4 The emergence of the induced earthquakes

The earthquakes in Groningen are caused by the gas extraction. The gas is pumped from about 3km depth towards the surface. The gas is trapped in porous rock layers. Without interference these rock layers are stable and will stay in place. When mining the entrapped gas the porous rock becomes unstable. The rock layers will compact. This compaction can occur slowly and gradually, but the layers can also crack and fracture. When this happens the abrupt subsidence can cause an earthquake. These vibrations can be felt on the earth's surface. (Deltares, 2011)

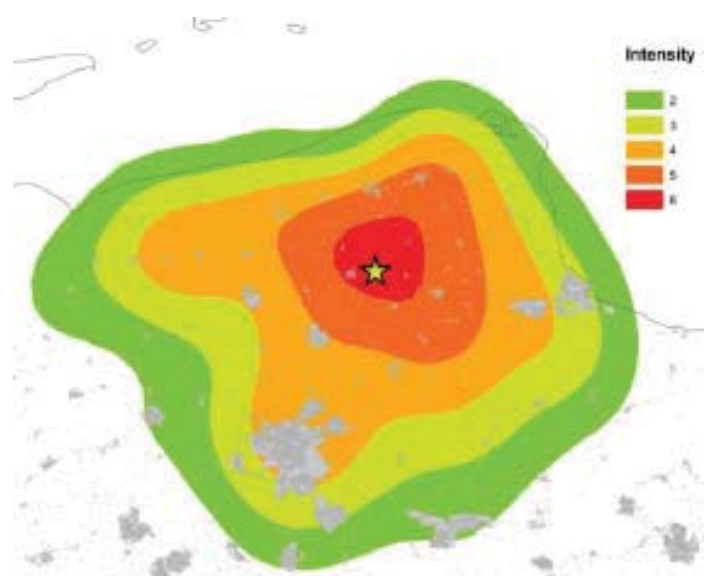

Figure 16: Intensity map from the 2012 Huizinge earthquake (Mw=3.6). The epicentre is displayed with a yellow star, source: Arup, 2013



2.1.5 Seismic hazard

A seismic hazard is the probability of an earthquake occurring within a given period of time in a given geographic area and will exceed a predetermined magnitude .

“Seismic Hazard: The frequency with which a specified level of ground motion (for instance 20% of ground acceleration) is exceeded during a specified period of time.” (Arup, 2013)

Although the exact moment and magnitude of the earthquakes in the Groningen province cannot be predicted the probability of earthquakes of a certain magnitude can be calculated statistically. Research executed by Dr. A.G. Muntendam-Bos and Dr. J.A. de Waal shows that the number of earthquakes in the province of Groningen and their magnitudes are increasing with time. This results in a higher expectation value for the occurrence of higher magnitude earthquakes. The occurrence of earthquakes with a magnitude higher than 3.9 on the Richter scale happening in the upcoming 12 months cannot be predicted.





EMS-98 Intensity	Felt	Impact	Magnitude (Approximat Value)	Building Damage (Masonry)
I	Not felt	Not felt		
II-III	Weak	Felt indoors by a few people. People at rest feel a swaying or light trembling.	2	
			3	
IV	Light	Felt indoors by many people, outdoors by very few. A few people are awakened. Windows, doors and dishes rattle.		
V	Moderate	Felt indoors by most, outdoors by few. Many sleeping people wake up. A few are frightened. Buildings tremble throughout. Hanging objects swing considerably. Small objects are shifted. Doors and windows swing open or shut.	4	
VI	Strong	Many people are frightened and run outdoors. Some objects fall. Many houses suffer slight non-structural damage like hair-line cracks and falling of small pieces of plaster.		
VII	Very strong	Most people are frightened and run outdoors. Furniture is shifted and objects fall from shelves in large numbers. Many well-built ordinary buildings suffer moderate damage: small cracks in walls, fall of plaster, parts of chimneys fall down; older buildings may show large cracks in walls and failure of in-fill walls.	5	
VIII	Severe	Many people find it difficult to stand. Many houses have large cracks in walls. A few well built ordinary buildings show serious failure of walls, while weak older structures may collapse.		
IX	Violent	General panic. Many weak constructions collapse. Even well built ordinary buildings show very heavy damage: serious failure of walls and partial structural failure.	6	
X+	Extreme	Most ordinary well built buildings collapse, even some with good earthquake resistant design are destroyed.	7	

Table 3: Twelve-stage European Macroseismic Scale 1998 (EMS-98), source: www.seismo.ethz.ch



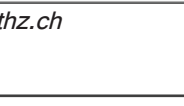
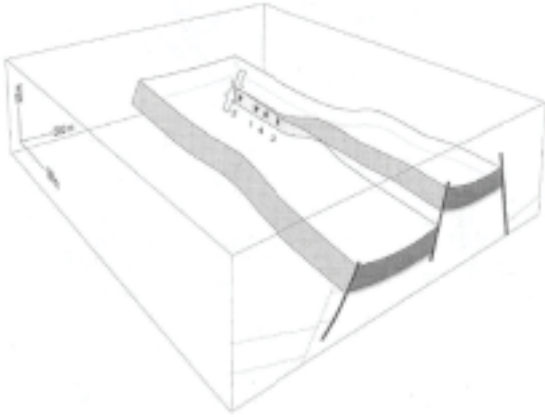

Figure 17: Shear stresses along fractures, source: www.ondergroningen.nl

2.1.6 Building Vulnerability

Earthquakes as well as wind loads acting on a building are so called “lateral loads”. Their effect is mainly in the horizontal direction. The weight of the building, and the occupants in it, act in vertical direction.

Forces due to earthquakes are termed “seismic forces”. These seismic forces in buildings are induced by heavy masses present at the different floor levels. Without mass there is no force. Such forces are called inertial forces. These inertial forces can be calculated by the product of the masses and their respective accelerations.

In case of an earthquake the building behaves like a vertical cantilever, and swings horizontally like an inverted pendulum. The masses at higher levels swing more. The seismic forces increase at higher floor levels, accumulating from top to bottom, acting as a sum of forces on the ground walls/columns.

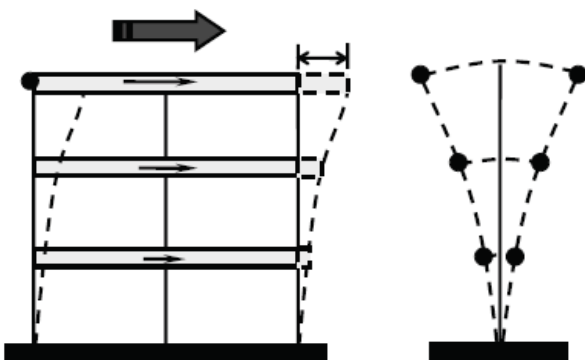

Figure 18: Seismic forces generated by masses vibrating, source: Chakrabarti, A. et al)

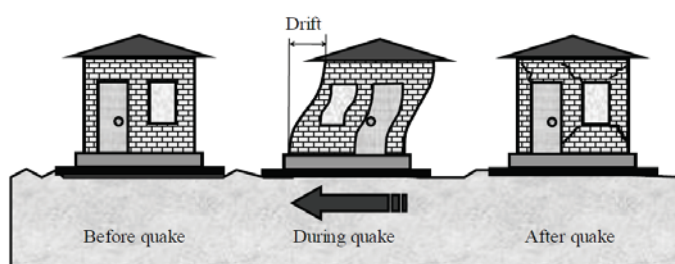

Figure 19: Drift generated by seismic forces, source: Chakrabarti, A. et al)

2.1.7 Structural stiffness

Buildings tend to behave somewhat elastic under service loads. return to the original configuration after an earthquake). How much a building deflects under earthquake loads depends on the stiffness of the building. The stiffer the building, the less it will deflect.

Ideally, it is desirable for the building to behave elastically under lateral loads, but the design of a building that acts elastically under high level earthquake loads is economical not feasible. Therefore, to avoid buildings from collapse, engineers allow the building to behave elastically at high load levels and thus dissipate the energy. To prevent the buildings from getting damaged during earthquakes, the stiffness need to be adequate. If this is not the case already, this stiffness needs to be added afterwards.

2.2 Seismic design principles

The shape and configuration of buildings significantly influences their behavior under earthquake loading. Buildings designed following the general principles of an earthquake resistant building will be less likely to get damaged.

The general principles for seismic resistant design are:

- Limited mass
- Regularity in plan
- Regularity in elevation
- Choice of material and detailing
- Continuity
- Distribution of live loads
- Redundancy
- Distribution of seismic-resisting elements

(Arup, 2013)

Limited mass

In case of an earthquake the mass of the building is accelerated. The multiplication of the acceleration and the mass determine the total force ($F = M.A$). The higher the mass, the bigger the force will be. To decrease the risk of damage in a building reducing the mass in a building is preferred.

$$F = M.A$$



Regularity in plan

During an earthquake the forces act in all directions. When having an unequal distribution of mass and an irregular shape, the buildings' parts are allowed to move in different directions. This movement will cause torsion which can tear apart building elements. The center of the mass and the center of the rigidity should be as close to each other as possible so L, T, U, V or Z shaped building plans should be avoided.



Figure 20: Unfavourable plans, source: Arup, 2013

Regularity in elevation

The horizontal movement that occurs during an earthquake causes forces inside the building that need to be distributed to its foundation. This distribution should be as smooth as possible, which is only possible if all floors are approximately equal in stiffness, or if the changes are gradual. Sudden changes in stiffness should be avoided. Flexible levels, with large openings or open ground floors with columns should also be avoided.

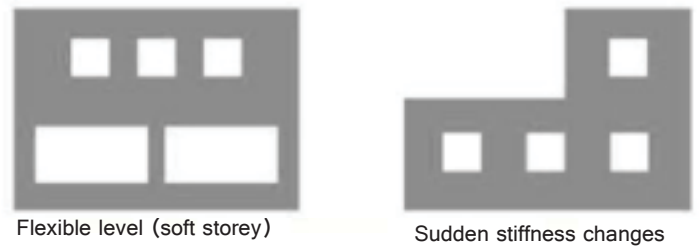

Figure 21: Unfavourable elevations, source: Arup, 2013

Choice of material and detailing

In earthquake design detailing is very important. Adequate connections made of ductile materials are preferred, since ductile materials are less likely to collapse under the displacements due to earthquake loads (figure 22)

Steel, timber, reinforced concrete and reinforced masonry are known to behave well in case of an earthquake. Unreinforced masonry, which behaves more brittle, does not and therefore is vulnerable to earthquakes.

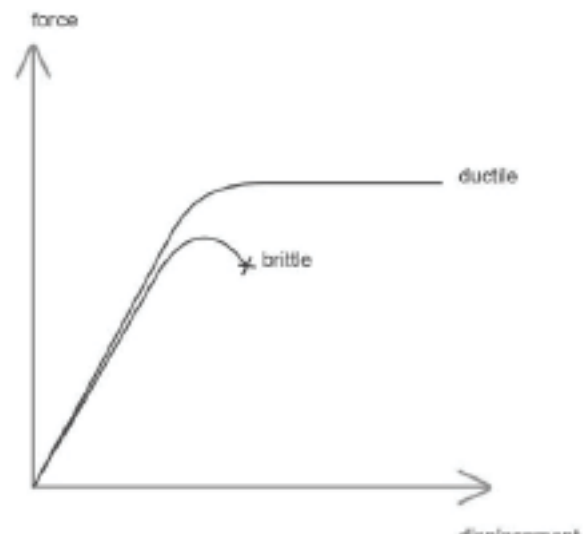

Figure 22: Ductile and brittle behaviour of materials and structure (source: Arup, 2013)

Continuity

To provide proper distributions of loads to load resisting elements throughout the building the elements should be well fixed together. Without these connections elements can move separately from each other, colliding into each other or falling over causing damage.



Figure 23: Discontinuity of walls leads to out-of-plane tipping and floor falling, source: Arup, 2013



Distribution of live loads

Heavy live loads, such as archives and vaults, should be placed lower in the building and close to the center of rigidity. If not, the heavy loads can cause torsion and/or increase the seismic forces in the building. (Figure 24 and 25)

Redundancy

Different load paths will enable the building to resist seismic forces even when some members fail.

Distribution of seismic-resisting elements

Seismic resisting elements should be distributed as close to the perimeter of the building as possible, creating the largest possible lever arm and thereby the largest overall resistance.

2.3 Unreinforced masonry buildings

Since the majority of the Groningen building stock consists of unreinforced masonry some extra attention will be paid to the properties and solutions of this material in relation to earthquakes. The typical behavior, the damage patterns and the possibilities for structural upgrading will be mentioned.

2.3.1 Box behavior

In non-engineered masonry buildings, as we see a lot in the Groningen province, the lateral loads such as wind loads and earthquake loads are resisted by the “box behavior” of the buildings. The forces are resisted by the combination of its elements (floors, roof, walls). The distribution of the horizontal forces ideally acts on the in-plane direction of the walls, since in the out-of-plane direction masonry walls are less stiff and weaker. The buildings in Groningen are resistant to wind loads, but not to earthquake loads. The distribution of the seismic and the wind loads are different, since wind loads are proportional to the size and shape of the building, and seismic loads are proportional to the mass of the building. Reinforcing these buildings against earthquakes therefore might be necessary (figure 26 and 27).

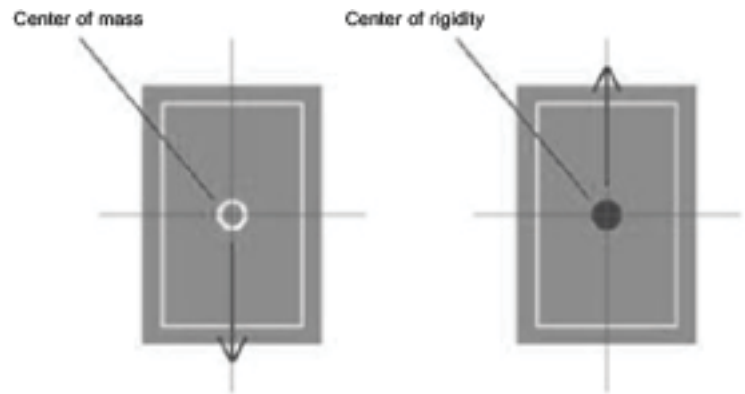

Figure 24: No eccentricity, so no torsion, source: Arup, 2013

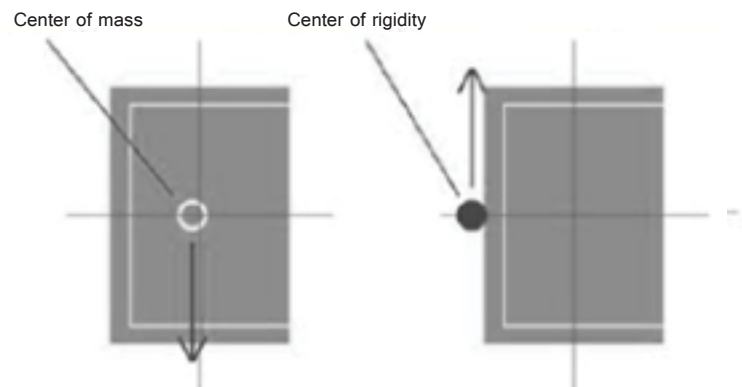

Figure 25: Eccentricity, causing torsion, source: Arup, 2013

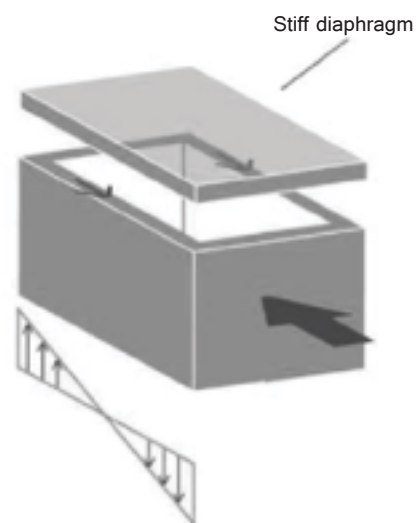
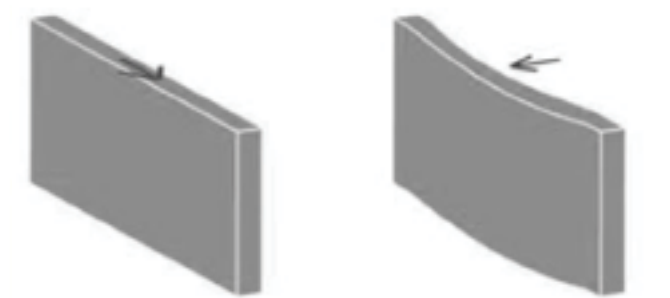

Figure 26: Box behavior, source: Arup, 2013



In plane stiff behavior Out-of-plane plane stiff behavior
Figure 27: In plane and out-of-plane stiff behavior, source: Arup, 2013



2.3.2 Flexible diaphragms

Stiff diaphragms distribute the forces proportional to the stiffness of the walls. In this case the forces act on the in-plane resistance of the wall.

Flexible diaphragms distribute the forces in relation to the tributary mass assigned to each wall. Consequently, some walls have to resist significant loads in the weak out-of-plane direction (Figure 28).

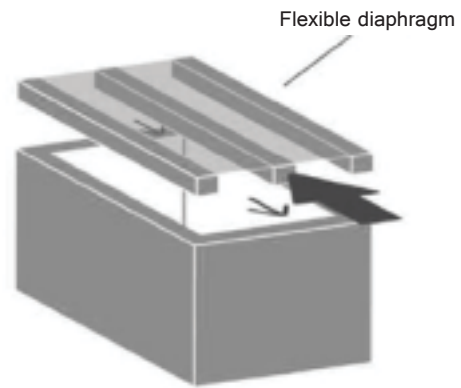

Figure 28: Flexible diaphragms, source: Arup, 2013

2.3.3 Damage patterns

There is a great variety in masonry damage patterns. In many cases it is hard to say whether cracks are caused by an earthquake or not. Cracks can be caused by many factors such as soil compaction, rusty wall ties, thermal expansion, shrinkage, lack of dilatations, weak foundation, insufficient lintels etc. In order to still give an overview, an analysis had been made on basis of research (Vent, de, I., 2011) of damage patterns that could be caused by earthquakes. The damage patterns do not necessarily have to be caused by earthquakes.

To be sure, an inventory of cracks need to be made of a building. If after an earthquake damage has shown up that was not apparent before the earthquake, and the pattern is similar to one of the given examples, than it is very likely that the damage is caused by an earthquake.

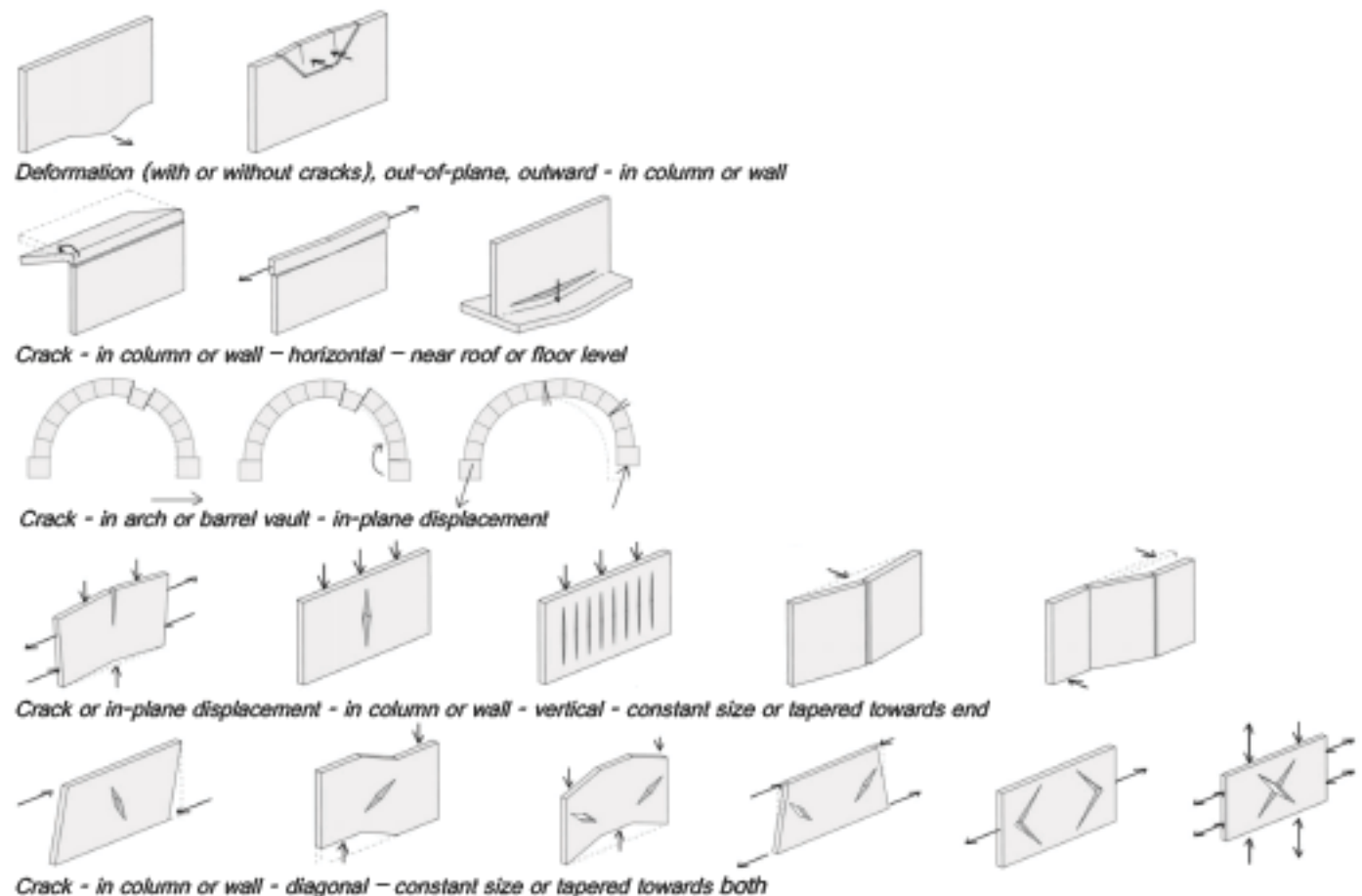

Figure 29: possible seismic damage patterns, source: Vent, de., I. 2011



2.4 Levels of intervention

The structural upgrading of buildings can be distinguished in “levels”. Not all buildings in all locations ask for the same level of intervention. The seismic risk (Figure 30) determines what level of intervention is needed. Depending on the seismic hazard of the location and the seismic resistance (vulnerability) of the building the demanded levels of intervention for a specific project can be picked. This way excessive costs and disruption will be prevented as much as possible.

The levels of intervention are divided in 7 levels of intervention, in which level 1 are the minor interventions and level 7 is demolition. The measures increase in intensity from level 1 to 7.

Permanent upgrading measures – intervention levels:

- Level 1: Mitigation measures for higher risk building elements (potential falling hazards);
- Level 2: Tying of floors and walls;
- Level 3: Stiffening of flexible diaphragms;
- Level 4: Strengthening of existing walls;
- Level 5: Replacement and addition of walls;
- Level 6: Foundation strengthening; and
- Level 7: Demolition.

(Arup, 2013)

In the Groningen Province, due to the nature and size of the earthquakes probably level 1, 2 and 3 will be sufficient for most of the building stock.

$$\text{Seismic Risk} = \text{Hazard} * \text{Exposure} * \text{Vulnerability}$$

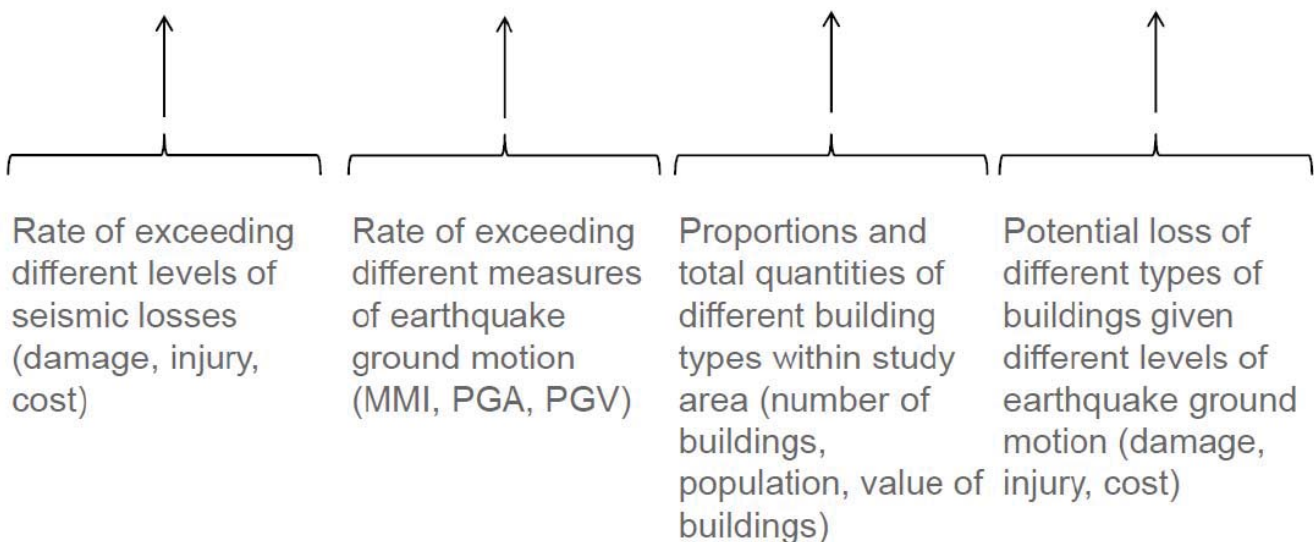

Figure 30: Seismic risk, source: Arup, 2013



Level 1

Level 1 concerns the tying or removal of non-structural elements, that potentially can fall (falling hazards) and cause damage. Often seen falling hazards are chimneys, ornaments, parapets, cantilever walls, and brick veneer cavity walls.



Figure 31: Chimney restraint, source: Arup, 2013

Level 2

Level 2 concerns the tying of floors, roof and walls and checking/installing/replacing wall ties. The floors, roof and the walls need to be connected to provide continuity. The connections should keep the elements from moving/falling over, and make the building work as one rigid system.

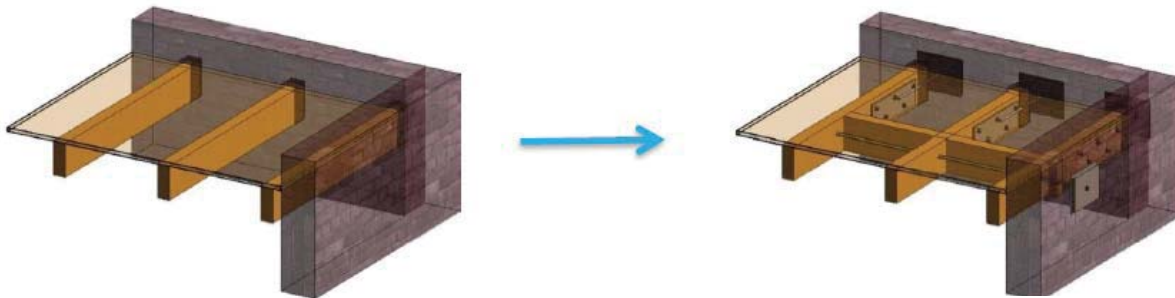

Figure 32: Floor-wall connection, source: Arup, 2013

Level 3

Level 3 concerns the stiffening of flexible diaphragms in order to make the force distribution act on the in plane resistance of the wall, and distribute the forces proportional to the stiffness of the walls.

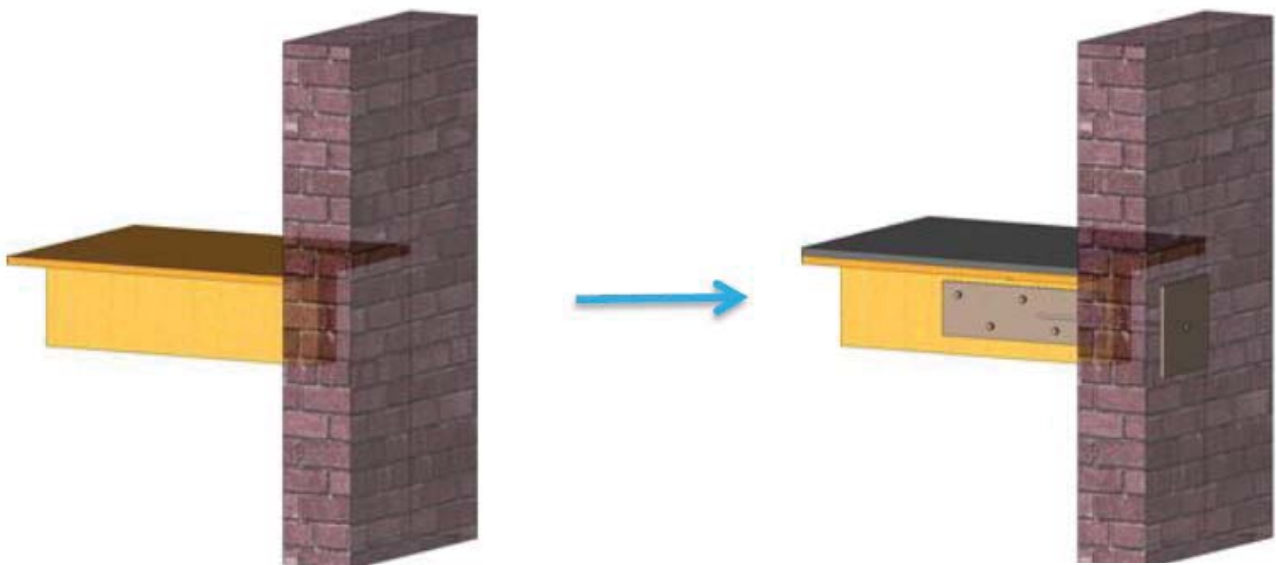

Figure 33: Floor stiffening, source: Arup, 2013

Level 4

Level 4 concerns the strengthening of existing walls to make them better resistant against potential seismic forces.

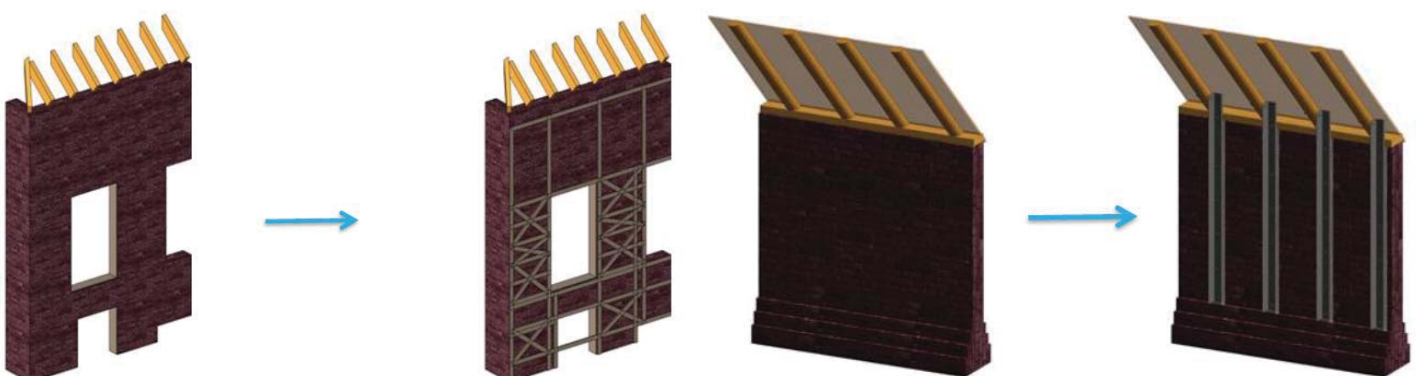

Figure 34: Wall strengthening source: Arup, 2013



Level 5

Level 5 concerns the replacement or addition of walls, to provide the building with more, or more sufficient seismic resistant elements.

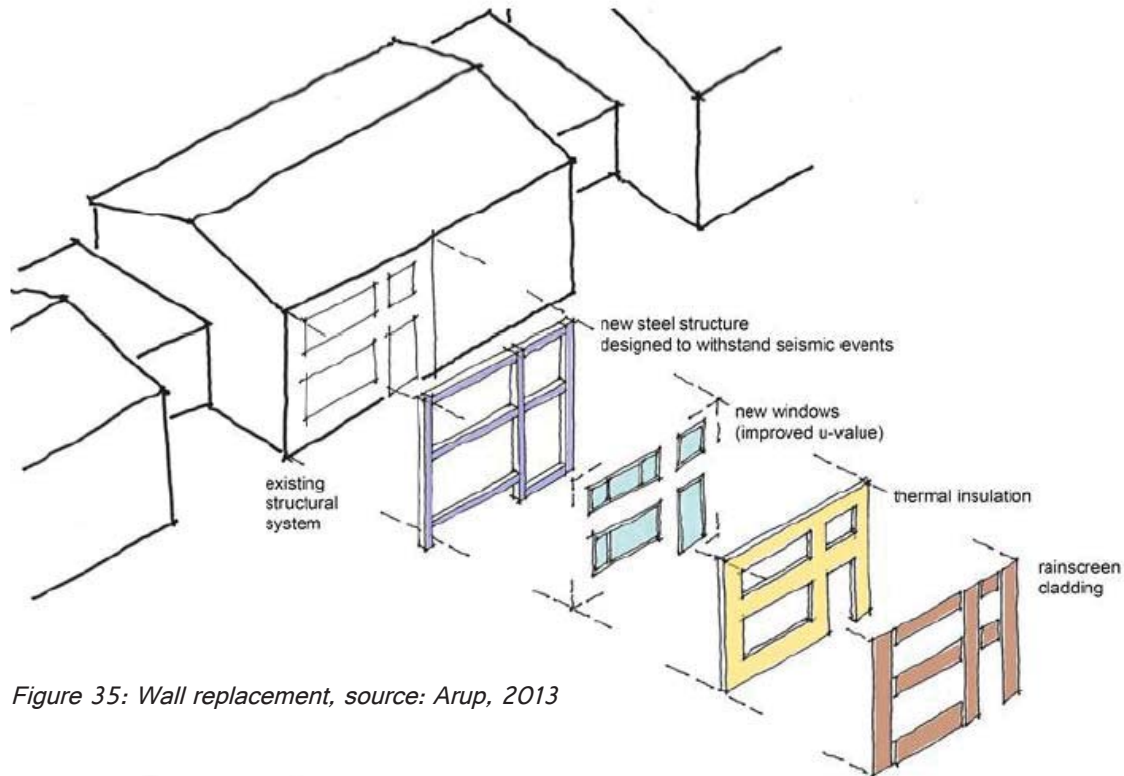

Figure 35: Wall replacement, source: Arup, 2013

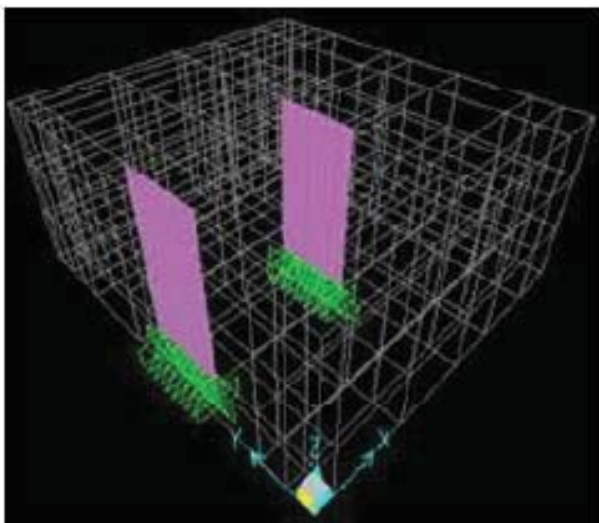

Figure 36: Additional walls, source: Arup, 2013



Figure 37: Additional walls 2, source: Arup, 2013

Level 6

Level 6 concerns the strengthening of the foundation in order to increase the strength and/or stiffness of the existing foundation system.

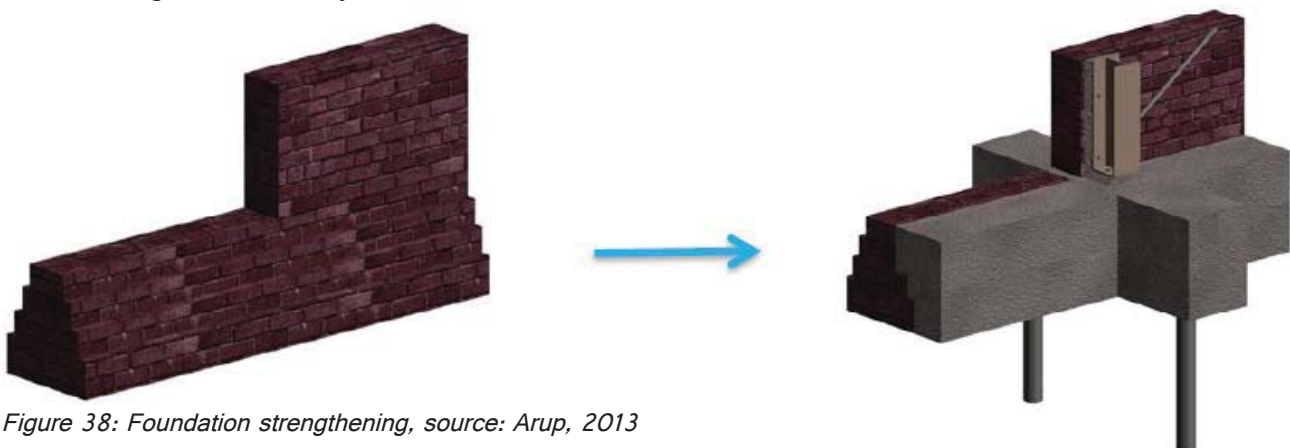

Figure 38: Foundation strengthening, source: Arup, 2013



Level 7

Level 7 concerns demolition and new building. This measure will be taken if reinforcing a building is not possible, wanted or economically feasible.



Figure 39: Demolition source: www.powell-constructors.com

2.5 Amsterdam School

2.5.1 What is Amsterdam School?

Amsterdam school was a new expressive form of architecture that arose around 1911 in Amsterdam in response to the austere rational style of Berlage's "Neue Sachlichkeit". The term "Amsterdam School" was first mentioned in 1916 by the architect "Jan Gratama". Actually "Amsterdam School" is not the right term for what it describes. There has never been a united manifest. Although there were similarities, there was no common consensus within the style. Every architect had its own approach towards and interpretation of the style. The idea of the Amsterdam School is to consider and approach a building as a "sculpture". The shape formed the base, the construction and materials followed afterwards. The preference for its distinctive sculptural masonry is the result of its suitability for modelling and has a typical Dutch nature.

One of the characteristics of the Amsterdam School style is the emphasis on 2 and 3 dimensional plasticity. Expressive colors and deconstructive brick bonds were used a lot. Also glazed tiles and roof tiles were used to decorate the façade.

Another important characteristic of the Amsterdam School style was the aim for a coherent design with lots of attention for the details. The interior and the exterior had to form a unity, a "Gesamtkunstwerk". Every accessory, from furniture till fencing, was designed carefully to fit in the elaborated scheme of elements.

The Amsterdam School style became more modest during the late 20's due to economic recession, the reduction of subsidies and a changed vision on architecture. The tide was turning and Berlage's old school "Neue Sachlichkeit" became more popular again.

(Reenders, A., 2007)



Figure 40: Amsterdam School style building source: www.moulores.net



2.5.2 Province of Groningen

The question whether typical Amsterdam School buildings exist outside Amsterdam can be determined. After research the answer was that it certainly exists outside Amsterdam. The Amsterdam School buildings outside Amsterdam need to be classified in two categories, “Adepts and Derivatives”. The Adepts are seen as typical Amsterdam School. The buildings have all the stylistic features to be allowed under the umbrella of the Amsterdam School style. The Derivatives do have similarities with the Amsterdam School style but not sufficient to be fully accepted within the style. Groningen, as an exception, has to one’s surprise, a large amount of Adepts (and lots of Derivatives as well).

During the early 20’s and the 30’s the Amsterdam School style became very popular in the Province of Groningen. The style was, during this period, popular all over the The Netherlands. But nowhere as popular as in Groningen. Various architects originating from Groningen had brought the style to Groningen after having received their education in Amsterdam. The days of economic prosperity and the progressive economic and cultural upraise in the region made it the ideal conditions for the Amsterdam School style to become very popular.

The variant of the Amsterdam School style in Groningen was more lasting than the Amsterdam origin. The style in Groningen became even more popular when the style in Amsterdam lost it’s popularity. During these days the influences of “De Stijl”, F.L. Wright, Dudok and the “Neue Sachlichkeit” had their impact. This made that the Groningen variant of the Amsterdam School style was more sleek and restrained.

2.5.3 Amsterdam School and risks

The fact that almost all Amsterdam School buildings are built of unreinforced masonry their shape and ornamentation make that they are likely to perform poor in case of an earthquake.

Slender, high chimneys, wide window strips, large openings, cantilevers and deconstructive masonry patterns seem not ideal in case of an earthquake. The images below show examples of Amsterdam School style buildings in the province of Groningen and their possible weaknesses.



Figure 41: Riskful elements, source: own elaboration



Figure 42: Riskful elements, source: own elaboration



Figure 43: Riskful elements, source: own elaboration



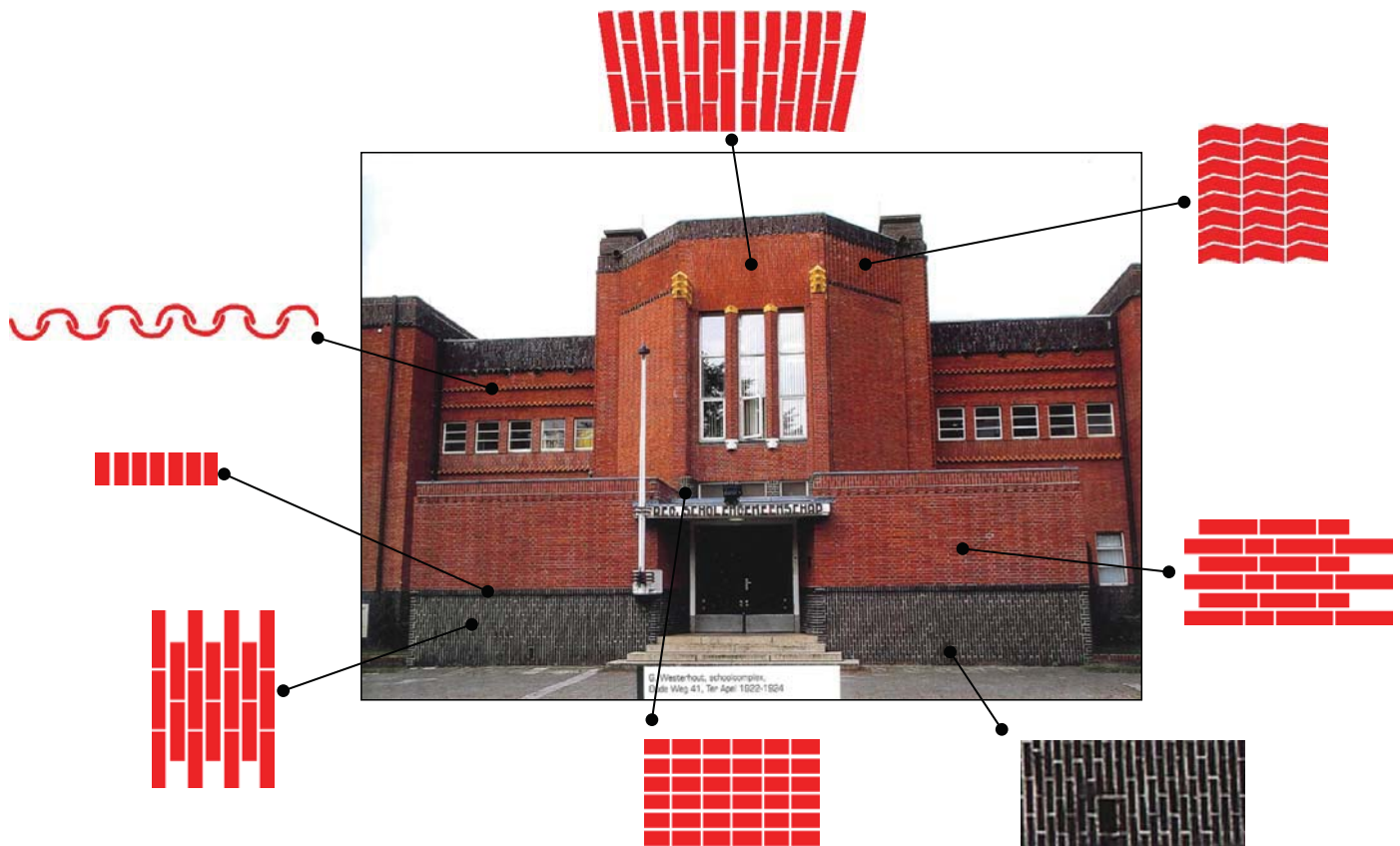

Figure 44: Masonry patterns, source: own elaboration

2.6 Seismic retrofit of historic buildings

In *“Designing for earthquakes: A manual for architects : providing protection to people and buildings”*, is described that the United States regulations for buildings that are of significant importance, like churches, palaces, national monuments etc., vary per region. The designer should investigate what legislation is applied for such building for alterations on the building as well as seismic requirements for them.

Seismic retrofit policies most of the time include special considerations for historic buildings.

The changes that are needed for successful preservation often conflict preservation guidelines. Compromises are needed in both directions to achieve a successful project.

The requirements for the aesthetics included in preservation guidelines often call for distinction between old and new.

“These interventions often fall under historic preservation guidelines that call for clear differentiation of new structural components, or that discourage recreation of historic components that are removed. “

(United, S., & Federal Emergency Management, A., 2006)

The most appropriate solution for each case must be determined individually.

Another conflict is between current preservation and future preservation of the building. A better performance level for the future requires more work and alterations now but gives better prospects for saving the building over a longer period of time. However, most preservation codes allow lower expected seismic performance to reduce construction work and minimize damage.

The use of seismic isolation seems ideal for historic buildings, since it requires not much construction work and also reduces expected damage in the future. Nevertheless this is not applied often because it is expensive and without subsidy not likely to be feasible. Especially for nonpublic buildings.



3. Fieldwork

3.1 Case study buildings

To investigate the typical elements and build-up of Amsterdam School style buildings in the province of Groningen, a selection of case study buildings has been made. The search area for case study buildings was limited to the municipality of Loppersum. The municipality of Loppersum is considered to be the center of the earthquake area, hence, the demand for reinforcement measures is very urgent in its locality.

Also, the municipality of Loppersum is a merger of multiple towns, merged together to a single entity. Therefore, the search for documents (plans) at the city hall can be limited to one location, while having a large area to collect possible buildings.

Based on online research and google street view, an initial selection of twenty-two Amsterdam School style buildings in Loppersum is composed. The following images show pictures of the chosen case study buildings.

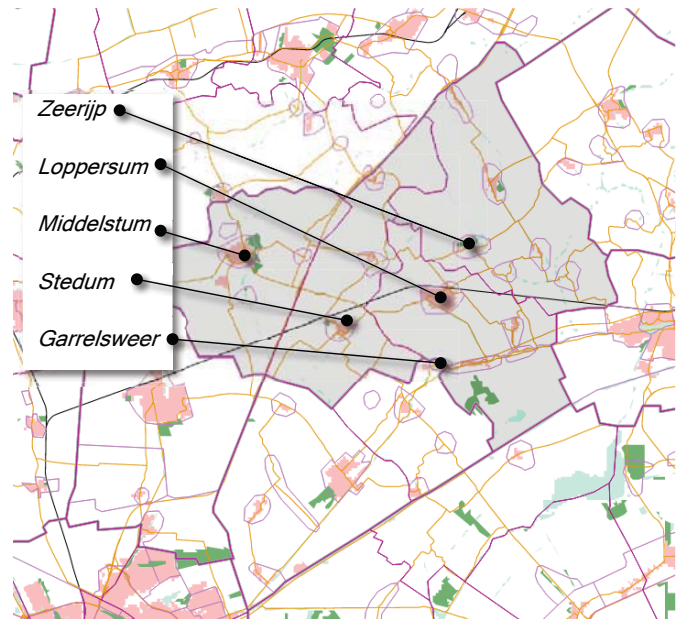

Figure 45: Municipality of Loppersum, source: own elaboration

Case study buildings:



Figure 46: Wijmersweg 15, Loppersum source: own elaboration



Figure 47: Molenweg 25, Loppersum source: own elaboration





Figure 48: Wijmersweg 53, Loppersum, source: own elaboration



Figure 49: Kampweg 21, Stedum, source: own elaboration



Figure 50: Borgweg 33, Zeerijp, source: own elaboration



Figure 51: Stationsweg 10, Stedum, source: own elaboration



Figure 52: Onno van Ewsumlaan 6, Middelstum, source: own elaboration



Figure 53: Borgweg 2, Zeerijp, source: own elaboration



Figure 54: Wirdumerweg 21-23, Loppersum, source: own elaboration



Figure 55: Kerkepad 2, Middelstum, source: own elaboration



In order to be more specific, the set is reduced to twelve buildings. The selection is based on the amount of available information (plans, visits, and contact with residents) and the extent to which they suited the chosen architectural style. The following pictures show images of the remaining buildings after the second selection.



Figure 56: Heerestraat 2, Middelstum, source: own elaboration



Figure 57: Heerestraat 15, Middelstum, source: own elaboration



Figure 58: Menthedalaan 16, Middelstum, source: own elaboration



Figure 59: Molenweg 20, Loppersum, source: own elaboration



Figure 60: Heerestraat 15, Middelstum, source: own elaboration



Figure 61: Molenweg 56, Loppersum, source: own elaboration





Figure 62: Brouwerslaan 4, Middelstum, source: own elaboration



Figure 63: Onno van Ewsumlaan 4, Middelstum, source: own elaboration

After doing research on recurring riskful elements and the typical built up of the case study buildings, the number of case study buildings is reduced to four buildings. These four buildings have been visited, inside and out, interviews with residents have taken place and drawings of plans are available of the houses. Therefore, in the more detailed stage of designing, the focus will be on these four properties. The images below show pictures of the remaining four case study buildings.



Figure 64: Wijmerspad 1, Loppersum, source: own elaboration



Figure 65: Wirdumerweg 27, Loppersum, source: own elaboration



Figure 66: Zeerijperweg 12, Loppersum, source: own elaboration



Figure 67: Stationslaan 7, Loppersum, source: own elaboration



3.2 Recurring riskful elements

In order to find solutions for the reinforcement of Amsterdam School buildings in the province of Groningen, the hazards need to be determined first. To create a broader support for the proposed solutions, the most common risk elements are to be selected. This way the solutions can be applied on a large amount of buildings. This generalization will in the end reduce costs and time, while being able to provide custom solutions. From the twelve remaining case study buildings, all the recurring riskful elements have been mapped.

The riskful elements are divided in two categories:

- Falling hazards, i.e., elements that can fall of the building and cause damage;
- Collapse hazards, i.e., weak spots in the building that may contribute to the collapse of the entire building.

The collapse hazards are further divided into 3 categories:

- Wall in-plane collapse hazards;
- Wall out-of-plane collapse hazards;
- Torsion collapse hazards.

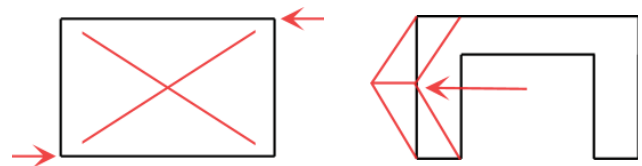

Figure 68: Wall in-plane collapse hazard, source: own elaboration

3.2.1 Collapse hazards



Figure 69: Corner windows, source: own elaboration



Figure 70: Bay windows, source: own elaboration



Figure 71: Large entrances, source: own elaboration



Figure 72: Indoor balconies, source: own elaboration



Figure 73: Strip windows, source: own elaboration



Figure 74: Unreinforced masonry, source: own elaboration



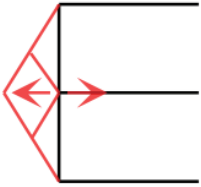

Figure 75: Wall out-of-plane collapse hazard, source: own elaboration

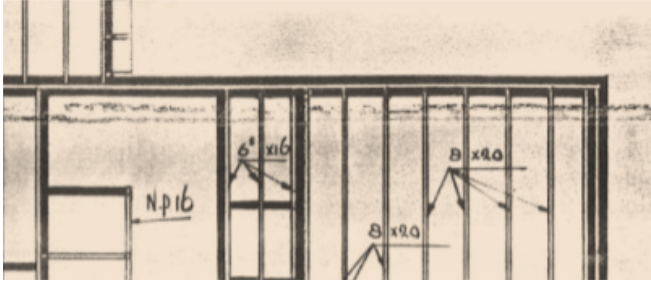

Figure 76: Masonry supported beams, source: own elaboration



Figure 77: Wooden floors, source: own elaboration



Figure 78: Wooden roofs

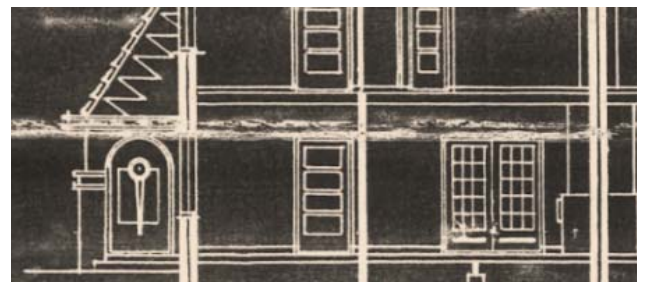

Figure 79: Cavity walls (wall ties), source: own elaboration

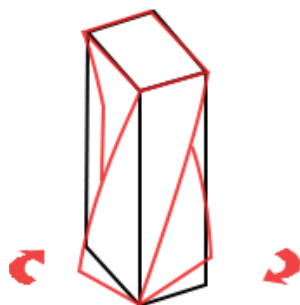

Figure 80: Torsion collapse hazard, source: own elaboration

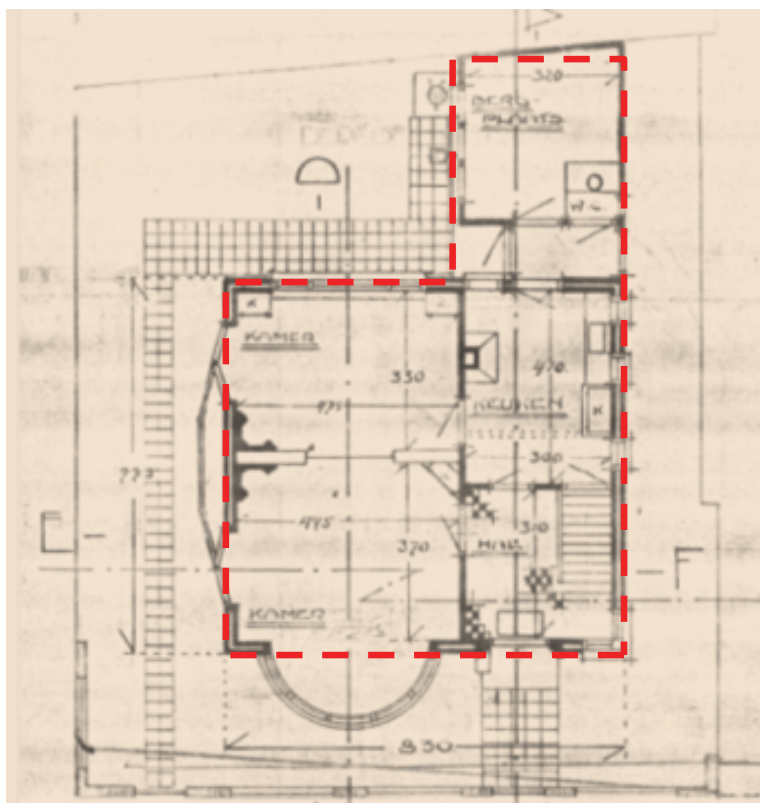

Figure 81: Irregular floor plan, source: own elaboration



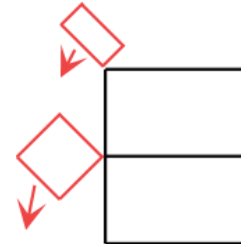

Figure 81: Falling hazards, source: own elaboration

3.2.2 Falling hazards



Figure 82: Balconies, source: own elaboration



Figure 83: Chimneys, source: own elaboration



Figure 84: Sheds, source: own elaboration



Figure 85: Oriel windows, source: own elaboration



Figure 86: Ornaments, source: own elaboration



Figure 87: Box gutters, source: own elaboration



Figure 88: Dormers, source: own elaboration



Figure 89: Masonry parapets, source: own elaboration





Figure 90: Roof overhangs, *source: own elaboration*



Figure 91: Ceramic roof tiles, *source: own elaboration*



Figure 92: Stained glass, *source: own elaboration*



Figure 93: Planter boxes, *source: own elaboration*

3.2.3 Elements picked for further elaboration

From the set of risk elements four have been selected for further elaboration: the chimneys, the masonry parapets, the masonry supported beams and the wooden floors. These elements have been selected because almost without exception they occur in most buildings. Also, they are of such size that they form a major risk in case of an earthquake.

Furthermore, the selected elements have been chosen because they can be reinforced with level 1, 2, and 3 measures. Other riskful elements, such as large openings in walls, require more significant measures. These heavy measures are probably not needed in the Groningen province.

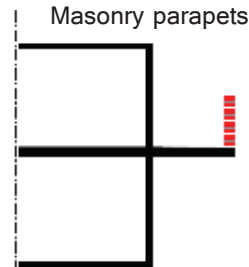

Figure 95: Picked element, *source: own elaboration*

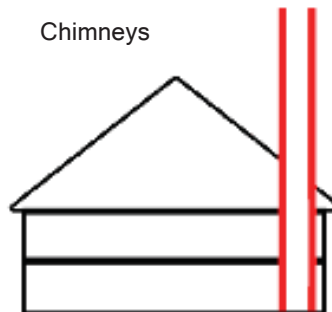

Figure 96: Picked element, *source: own elaboration*

Masonry supported beams



Figure 94: Picked element, *source: own elaboration*

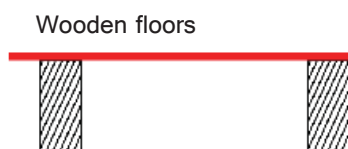

Figure 97: Picked element, *source: own elaboration*



3.3 Structural anatomy

To find suitable reinforcement measures for the Amsterdam School building stock, the structural anatomy of the properties must be figured out. For the four elements (chimneys, parapets, wooden floors, and masonry supported wooden beams) that were chosen for further elaboration the build-up was specified. This has been done with the use of the original blueprints case study buildings, site visits and a literature study in books dating back to the early 20th century.

3.3.1 Masonry parapet

The build-up of the balconies dating back to the early 20th century differs very much. There are examples of wood supported balconies, masonry supported balconies, but by far most balconies were already made of concrete. Within the style of the Amsterdam School, in which masonry design plays a very predominant role, most of the balconies have masonry parapets, which are cemented on top of the concrete balcony platform.

In the case of an earthquake there is a chance on parapets falling down. Since the parapets are made of heavy bricks, this brings major risk. Therefore the parapets need to be reinforced to prevent them from falling down.

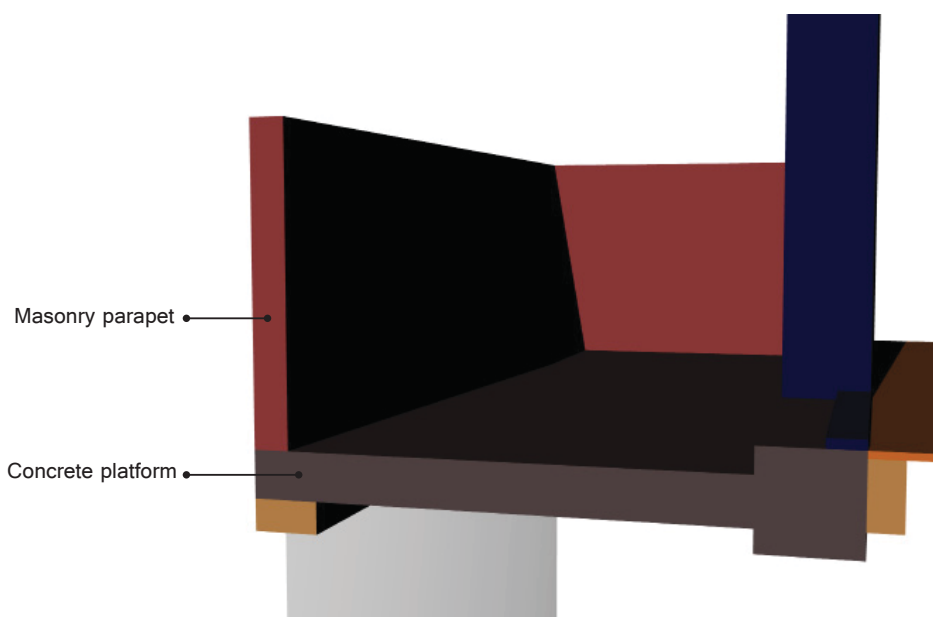
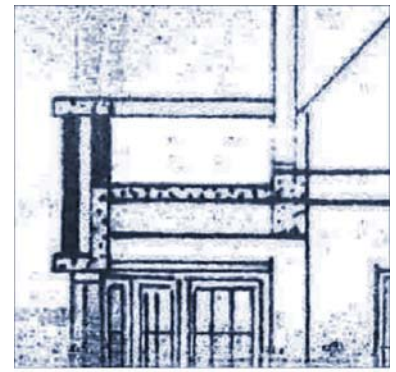
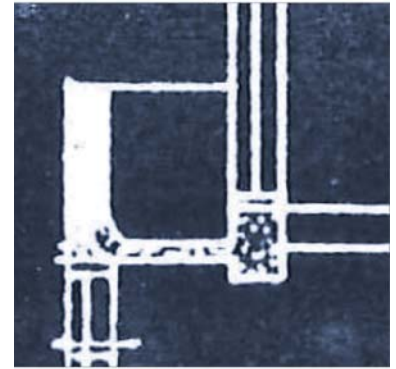

Figure 98: Parapet build-up, source: own elaboration



Menthedalaan 16, Middelstum



Onno van Ewsumlaan 6, Middelstum

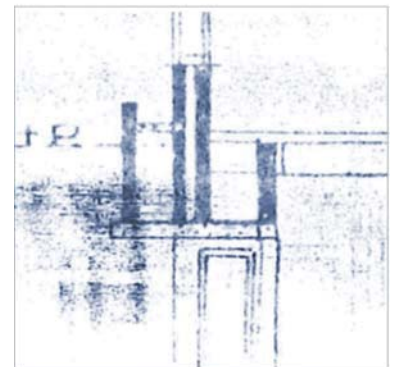

Heerestraat 15, Middelstum

Figure 99: Parapets, building plans, source: gemeente Lop-persum

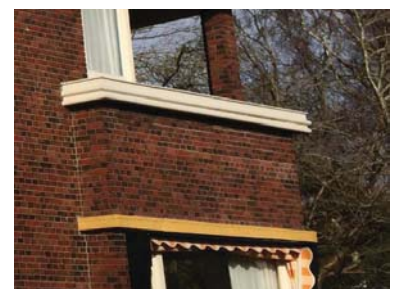

Figure 100: Parapet pictures, source: own elaboration



3.3.2 Chimney

The frequently occurring masonry chimneys in the houses built in the early 20th century form a great risk when earthquakes happen. The brittleness and weight of brick material, the hollow channels and the tall and slender shape of the chimneys makes them incredibly vulnerable for earthquake forces.

The giant and heavy concrete “tubes” are often wedged just between wooden floors and beams, and supported by their own foundation. This wooden support structure is often not strong enough to resist the seismic forces of an earthquake which could result in the break and/or fall over of the chimney.

In other cases, the chimney is connected to the load bearing outer wall. With these chimneys, it is not the support structure that causes the problem, but because the chimney protrudes far above the roof, there is risk of the top part breaking and falling through the roof.

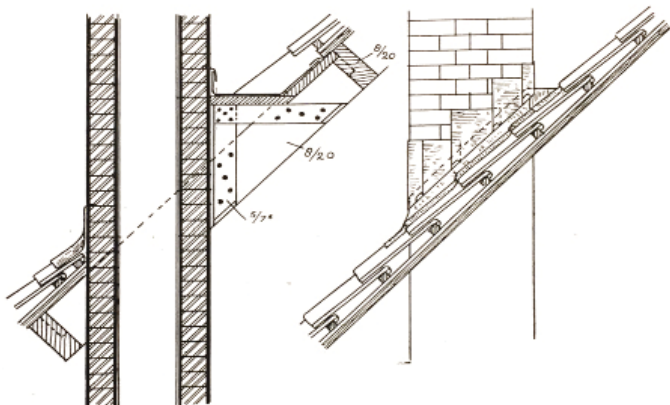

Figure 101: Chimney roof passage, Source: Wattjes, J.G.

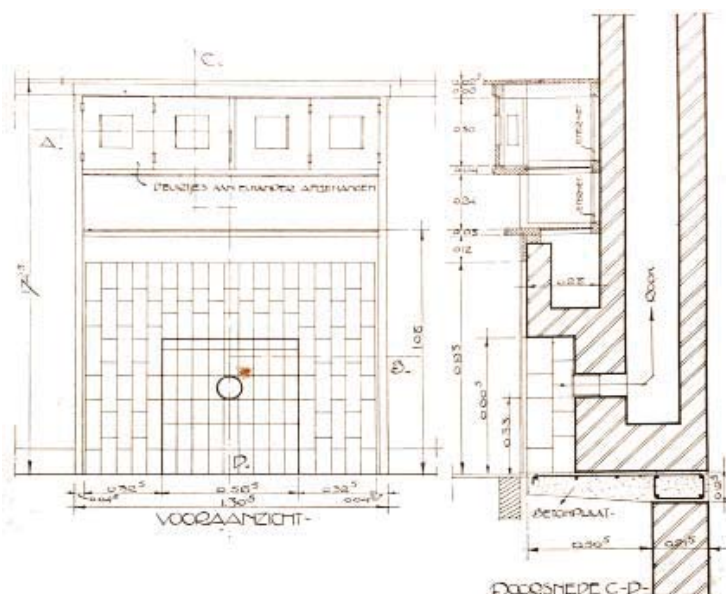

Figure 102: Fireplace, elevation & section, Source: Wattjes, J.G.

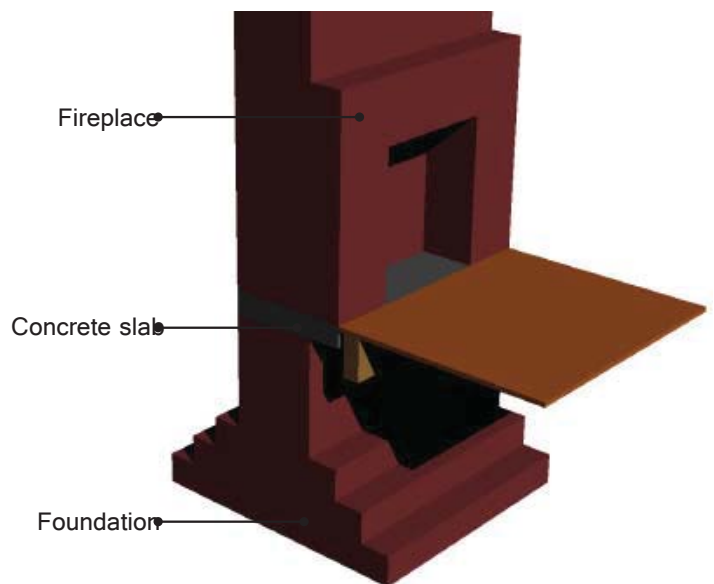

Figure 103: Fireplace build-up, source: own elaboration

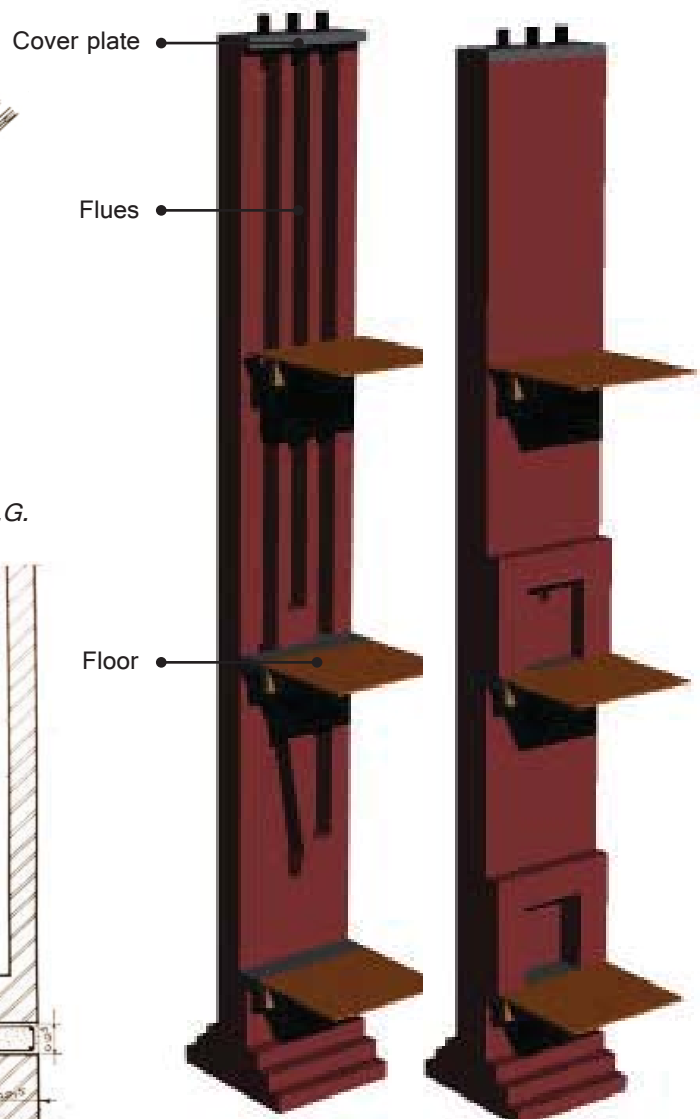
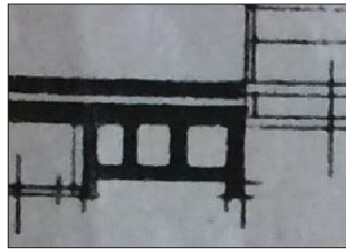
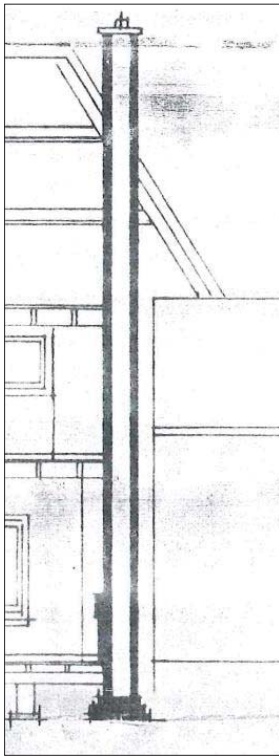
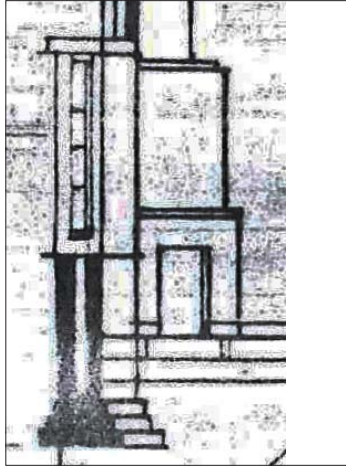

Figure 104: Chimney build-up, source: own elaboration





Zeerijperweg 12, Loppersum



Heerestraat 15, Middelstum Menthedalaan 16, Middelstum

Figure 105: Chimneys, building plans, source: gemeente Loppersum



Figure 106: Replacement of a chimney, Wijmerspad 1, Source: own elaboration

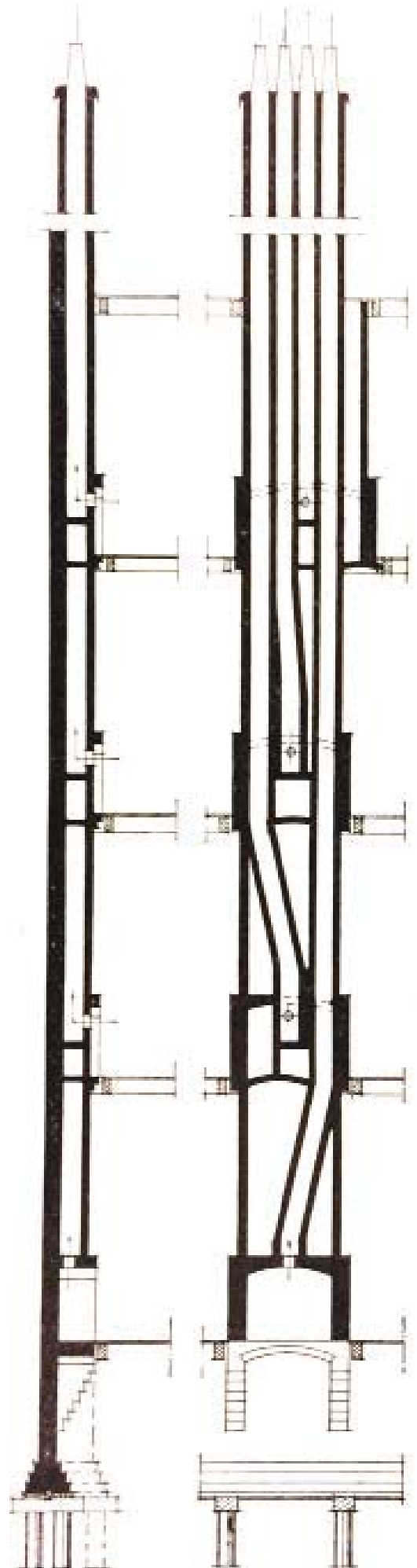

Figure 107: Chimney flues, Source: Wattjes, J.G.



3.3.3 Masonry supported beam

The wooden support beams are often laid loosely in the masonry walls, or are held by a small iron anchor. Although the construction perfectly distributes the static loads and the live loads in the building, it cannot resist the lateral forces caused by earthquakes. Hence, this type of construction responds very poorly to earthquakes. The beams are able to move horizontally, with the risk of colliding into the outer leaf of the wall, and/or breaking the wall. The original anchors have not been calculated on the forces of an earthquake, and are often deteriorated by corrosion.

Not only are the beams likely to cause motion, also the overall construction lacks continuity with the weak masonry-wood connections. To stiffen the construction and to limit displacements during earthquakes, the elements should be well tied together. Since the existing connection does not meet the requirements for earthquake resistance, new anchors should be applied to enhance the structural safety.



Figure 108: Loose masonry at the location of floor beams caused by beams, www.namplatform.nl



Figure 109: Loose masonry at the location of floor beams caused by beams, www.namplatform.nl

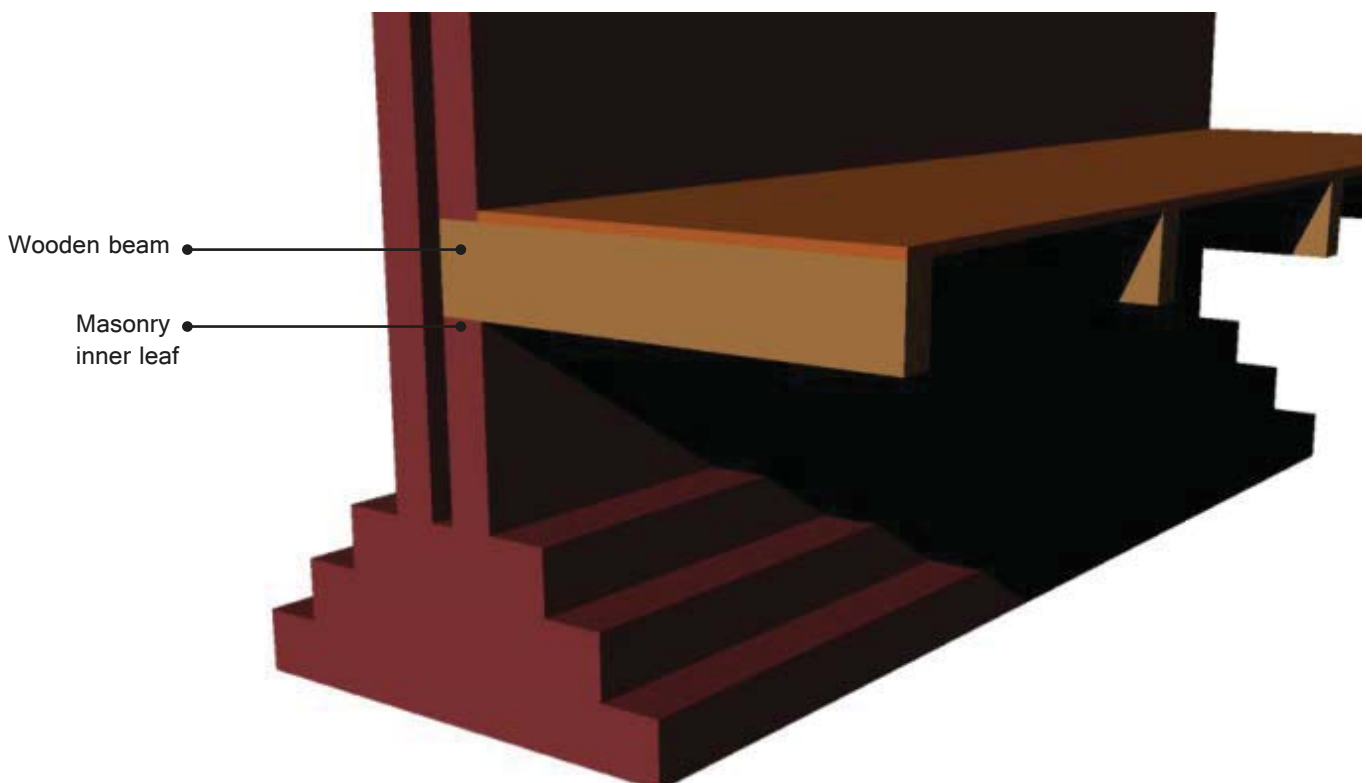
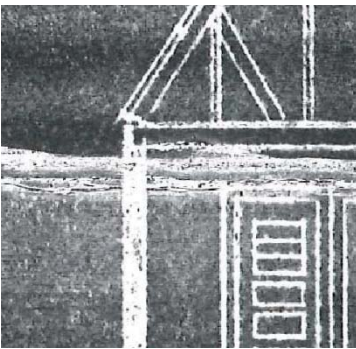

Figure 110: Beam support, source: own elaboration

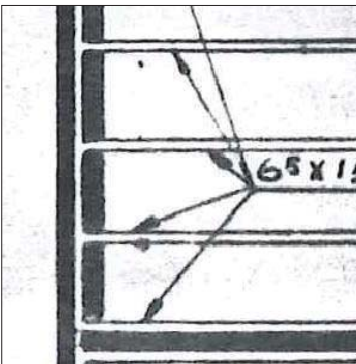



Figure 111: Wooden beams, Source: own elaboration



Heerestraat 2, Middelstum



Grachtstraat 12, Middelstum

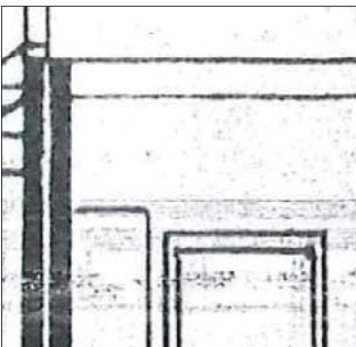

Grachtstraat 12, Middelstum
Figure 112: Beams, building plans, source: gemeente Loppersum

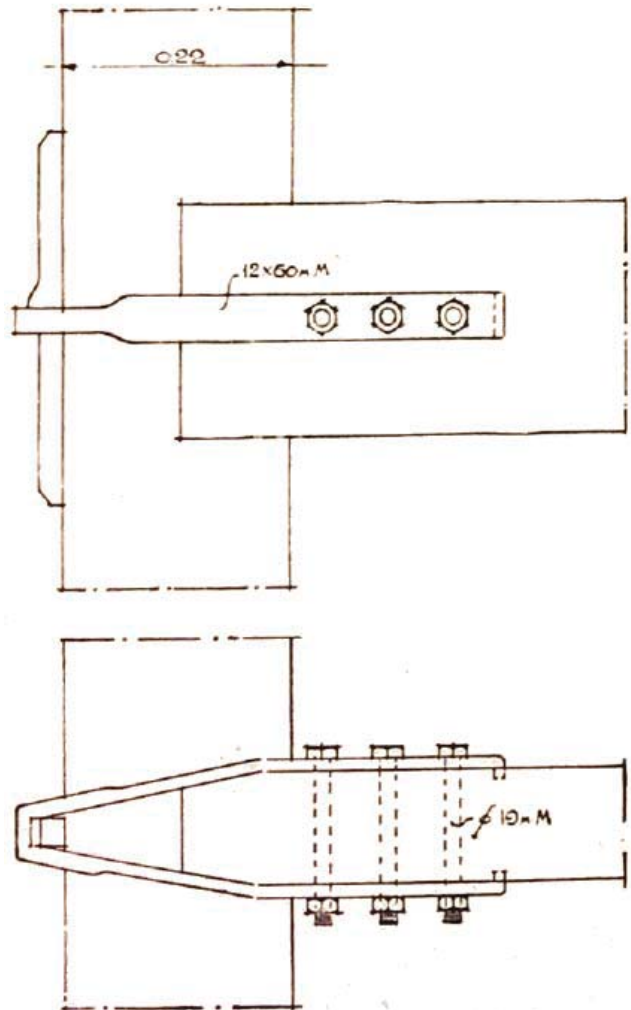

Figure 113: Solid wall anchor, Source: Wattjes, J.G.

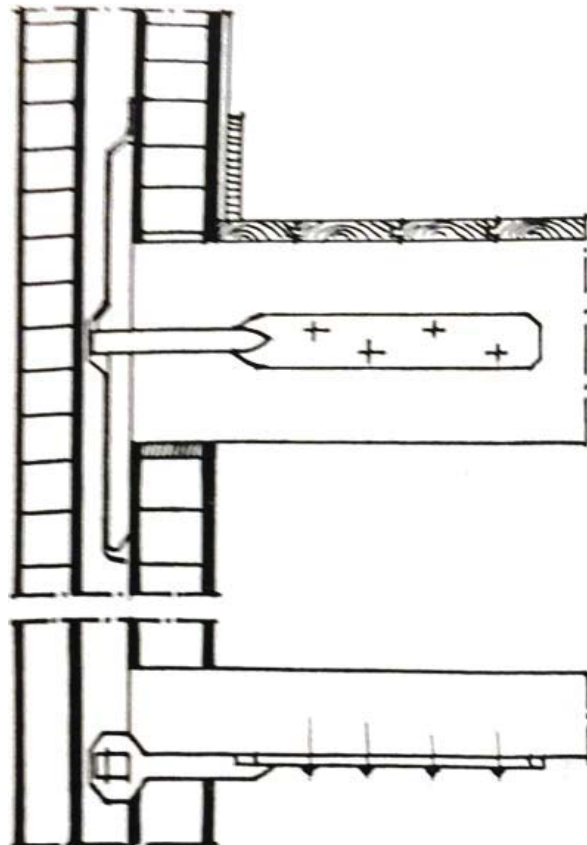

Figure 114: Cavity wall anchor, source: Jellema, R. et al)



3.3.4 Wooden floor

The wooden floors, supported by beams, act as a flexible diaphragm in case of an earthquake. During an earthquake the floor will deflect, which causes an out-of-plane resistance in the walls. Because of the structural properties of masonry walls this is highly undesirable.

In order to make the building better resistant to earthquakes, the wooden floors should be reinforced to make them rigid.

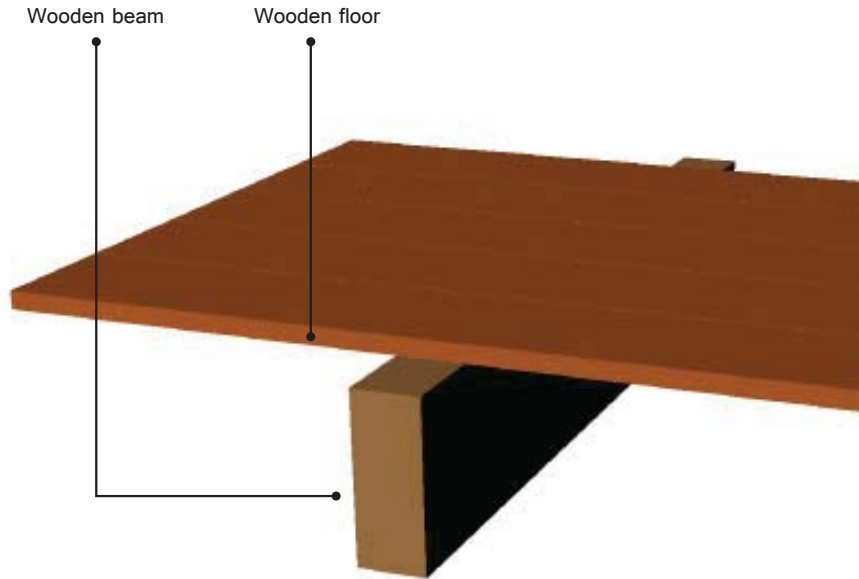

Figure 115: Wooden floor build-up, source: own elaboration

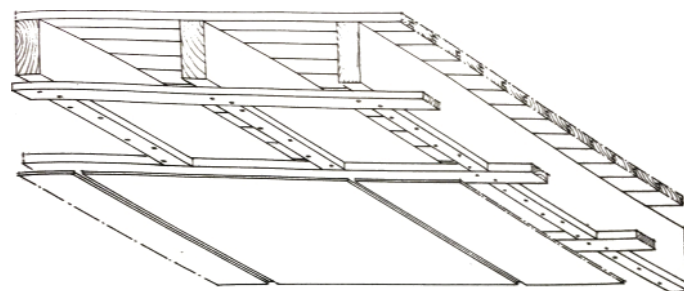
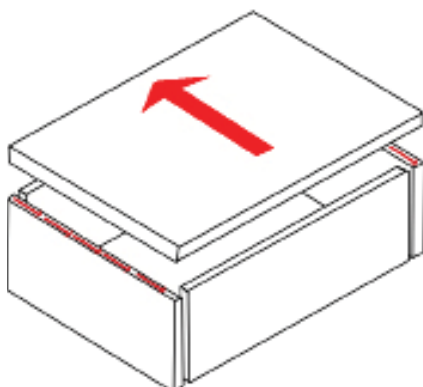
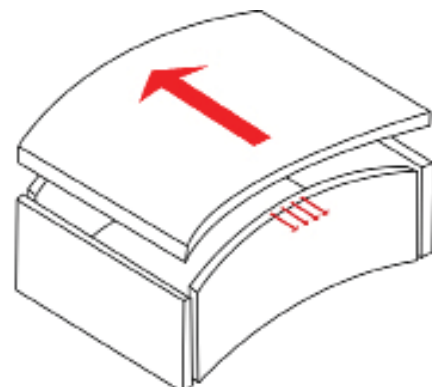

Figure 116: Typical floor detail, source: Jellema, R. et al)



Rigid diaphragm, in plane resistance, source: own elaboration



Flexible diaphragm, out-of-plane resistance, source: own elaboration

Figure 117; In and out-of-plane resistance, source: own elaboration



Wijmerspad 1, Loppersum



Wirdumerweg 27, Loppersum

Figure 118: Wooden floors, source: own elaboration

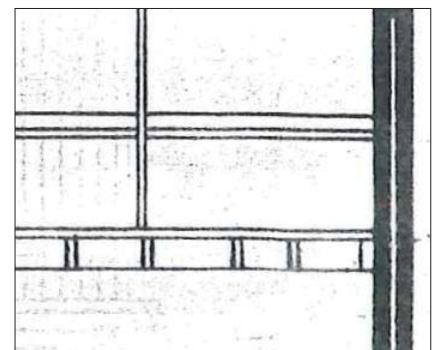
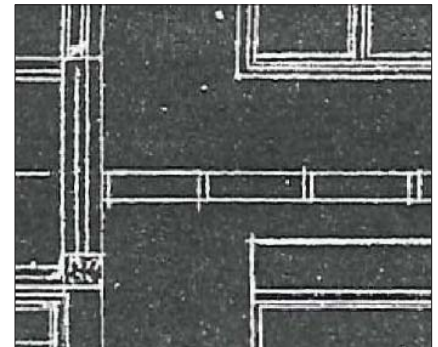

Figure 119: Wooden floors, building plans, source: gemeente Loppersum



3.4 Test houses

The NAM (Nederlandse Aardolie Maatschappij) has bought several test houses in order to test reinforcement measures that in the future are needed to protect the buildings in Groningen. These measures are, or will be, tested on the ease and feasibility of implementation.

Four houses that have structural similarities with the Amsterdam School buildings have been visited recently. In three of the houses level 2 and 3 measures have been implemented. The visit offered a clear insight in the dimensions and the aesthetics of possible reinforcement measures.

3.4.1 Diaphragm stiffening

In the houses various solutions for stiffening the flexible wooden floor diaphragms (level 3) have been conducted. A variety of materials have been used, the shapes, positioning and dimensions differed a lot. This variety might offer potentials when picking suitable solutions for a specific building.

The solutions for stiffening diaphragms that were exposed in the test houses are;

- Short wooden beams under the floors between the joists;
- Layers of poured reinforced concrete;
- Steel plates nailed on the wooden floor;
- OSB (Oriented Strand Board) plates

screwed on the wooden floor;

- Steel strips nailed on the wooden floor;
- CFRP (Carbon Fiber Reinforced Plastic) strips glued to the floor.

The wooden beams between the joists have the benefit that they do not disturb change the floor surface, but they are labor intensive to install.

The poured reinforced concrete has the benefit that the anchors for the floor-wall connection directly can be poured into the concrete. No extra profile or elements is required. The disadvantage of this system is that the floor probably needs extra support to carry the heavy loads of the concrete. Also the addition of mass can increase the seismic loads in the building during earthquakes.

The steel plates nailed on the floor are easy to apply, but a high amount of nails weakens the wooden floor.

The OSB plates are easy to apply and they form a cheap solution. The main issues regarding the OSB plates are their size, because they do not fit through the stairwell, and the thickness of the material (2x 9mm).

The steel strips nailed on the floor are easy, but labor intensive, to install. Because of the high number of needed nails, it takes quite a while to install all the strips.

Joisted bars in-between joists



Poured reinforced concrete layer



Nailed steel plates



Screwed OSB plates



Glued CFRP strips



Nailed steel strips



Figure 120: Test houses diaphragm stiffening, source: own elaboration



The CFRP strips are very thin, which is a benefit. The installation is also quite easy, although it requires some specific knowledge on how to install the strips properly.

3.4.2 Floor-wall connection

Also different measures for the interior fastening of the anchors, to create a proper floor-wall connection, (level 2) have been shown in the test houses.

The tested measures are;

- A steel plate screwed to a joist;
- A wooden beam bolted to the joists;
- A concreted anchor;
- Steel profiles bolted to the floor and glued to the wall;
- A beam shoe bolted to the beam and anchored to the wall.

The steel plate mounted on the joist does not seem to have many disadvantages, however, most of the time, the masonry in-between the beams is not very strong. The structural warranty is secure up to the level of the beams, but the masonry in-between has often been filled with semi-dried grout. Therefore the masonry blocks often lie loosely on the wall. Also the ceiling must be demolished in order to reach the joists.

The wooden beam bolted to the joists prevents the weak area of masonry in-between the joists from crumbling. The forces of the anchors are also spread over a larger surface area. The disadvantage of this method is, again, the need for demolishing the ceiling and the dimensions of the beams limits the possibilities for showing the construction in-between the plates of the ceiling.

The concreted anchor has no major benefits, but the added weight of the concrete layer and the probable need for extra support underneath the floor, makes this solution not very convenient to apply.

The steel profiles bolted/glued to floors and beams offer good solutions. They are slender enough to easily hide them with a neat finish. The forces are nicely spread over a large area, which reduces the chance of crumbling of the masonry. A disadvantage might be that either the ceiling or the floor needs to be demolished. Also placement in-between joists does not offer a very good solution since the profile need to be cut in pieces. Also, in case of placement in-between joists, the profiles should also have flanges in order to connect the pieces to the joists.

A beam shoe offers a good solution, but the design should be altered slightly to avoid fastening in

Screwed steel plate



Wooden beam + bolted steel profiles



Concreted



Bolted and glued steel profile

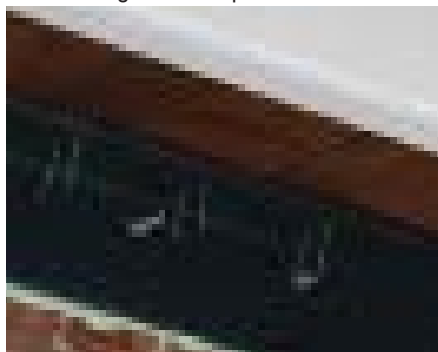

Bolted and glued steel profile



Bolted beam shoe



Figure 121: Test houses floor-wall connections, source: own elaboration



the weak in-between joist area. The solution in the image is quite immense (Figure 121).

3.4.1 Chimneys

Although no level 1 measures had been conducted in the test houses, one example of a riskful chimney was spotted. (Figure 122) shows a chimney that has no secondary support structure. It was struttet with wooden beams to prevent it from falling. In the case of an earthquake this chimney is likely to move like a pendulum under the load of the seismic forces. The heavy weight of the chimney will destroy everything in its path whilst moving, and in case of breakage the fallen part can come down through roofs and floors.

The second (Figure 123) shows a removed flue of a chimney. In order to prevent the seismic risks of the heavy chimneys, removal (and replacement by a light weight variant) offers a good solution. However, without a proper replacement the fireplaces of course lose their function.

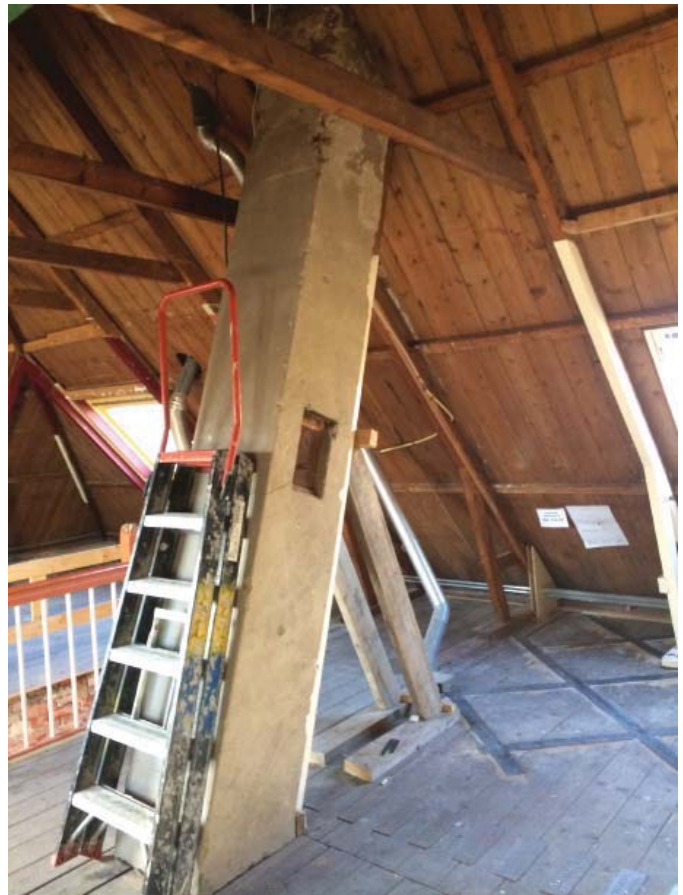

Figure 122: Riskful chimney in test house, source: own elaboration



Figure 123: Removed chimney in test house, source: own elaboration



4. Design preparation

4.1 Design task

Before starting the design first needs to be determined what need to be designed. Four riskful elements have been selected for which reinforcing solutions have to be found. But to create a catalog, one design per element for one single building is not sufficient. More designs and approaches need to be established, and designs for multiple buildings need to be developed.

As a starting point the picked elements can be linked to different levels of intervention (Figure 125). The levels of intervention roughly represent what needs to be done.

After the classification of the required measures per element in levels of intervention, the interventions can be further distinguished in different approaches for intervention. This different approaches will have consequences for the final aesthetics of the building and the implementation.

In this research per element multiple different approaches will be elaborated into designs, as examples. But many more approaches/designs could be developed in the future.

To provide some guidance in the development of the different designs, and to make the solutions measurable, a strategy will be provided. This strategy will help taking decisions during the design process, and makes it possible for others to follow the same strategy.

4.2 Classification of measures

In order to get a basic idea of the needed interventions per element the elements can be classified in levels 1, 2 and 3 for intervention.

The chimney and the parapet do not make part of the main construction of the building. These elements therefore are so called “non-structural elements”. These elements form falling hazard. During an earthquake they can tear down and fall of the building. The chimney and the parapet require level 1 interventions. They need to be tied adequately to the main construction (or be replaced).

The wooden floors within the constructive system

4 elements

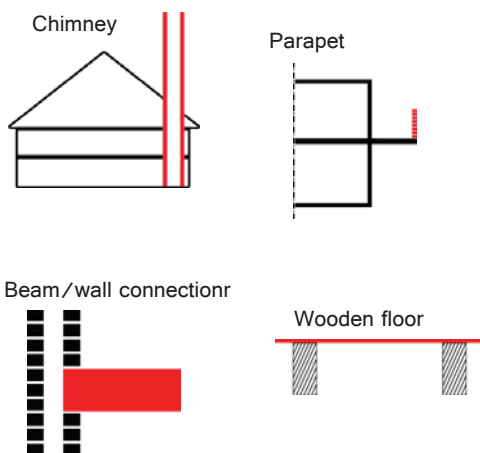

4 houses

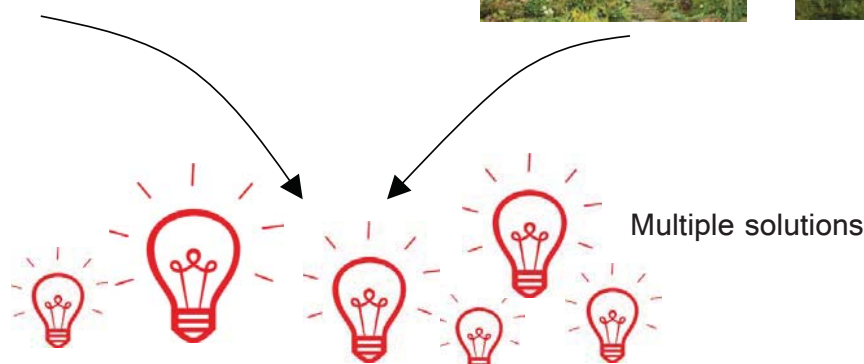

Figure 124: Design task, source: own elaboration



create flexible diaphragms. In case of an earthquake the floors are able to deflect, which can cause undesirable out-of-plane resistance in the masonry walls. To prevent this the floor should be reinforced to act as a rigid surface. The stiffening of flexible diaphragms can be assigned to a level 3 intervention measure.

The wooden beams, if not connected properly, could shift during an earthquake. The beams could possibly collide into the walls, causing damage. Also, in general, inadequate connections between different constructive elements enhances the chance on unwanted deflections and deformations. The brittle materials (brick masonry) are not able to resist these forces. The beams, in order to protect the building from damage or collapse, should be tied to the walls properly. The connection between floors and walls to provide constructive continuity can be assigned to a level 2 intervention.

- Level 1: Mitigation measures for higher risk building elements (potential falling hazards);
- Level 2: Tying of floors and walls;
- Level 3: Stiffening of flexible diaphragms
- Level 4: Strengthening of existing walls;
- Level 5: Replacement and addition of walls;
- Level 6: Foundation strengthening; and
- Level 7: Demolition.

4.3 Design principles

In the process of designing reinforcement measures for the characteristic Amsterdam School style buildings different principles for reinforcement can be adopted.

The first principle is to try to make the reinforcement measures as invisible as possible. This way the existing appearance will endure.

The second strategy is to find an aesthetic that suits the building, but will not be invisible, a matching style. This will change the appearance of the building, but not disrupt it. It must look like it had always been there and embellish the building.

The third strategy is to make the measures reversible. The measures will change the appearance of the building, and possibly disrupt it as well. But the measures will not damage the building and can be removed when they are no longer needed.

After interviews with homeowners in Loppersum it seemed that the reversible approach is considered undesirable. A house should offer comfort and happiness to the people living in it nowadays and not in the far future. This approach seems not suitable for homes, but possibly it is for historic buildings that function that must be remained as national heritage, such as churches, castles and palaces.

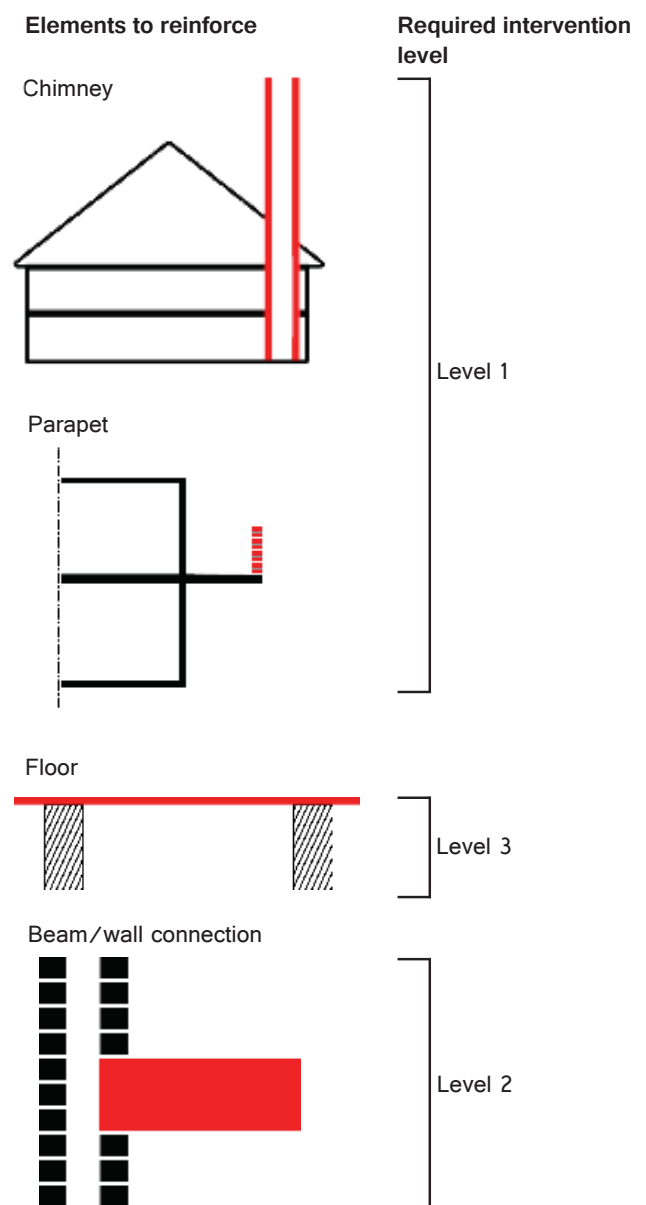

Figure 125: Classification of the required measures in levels of intervention, source: own elaboration



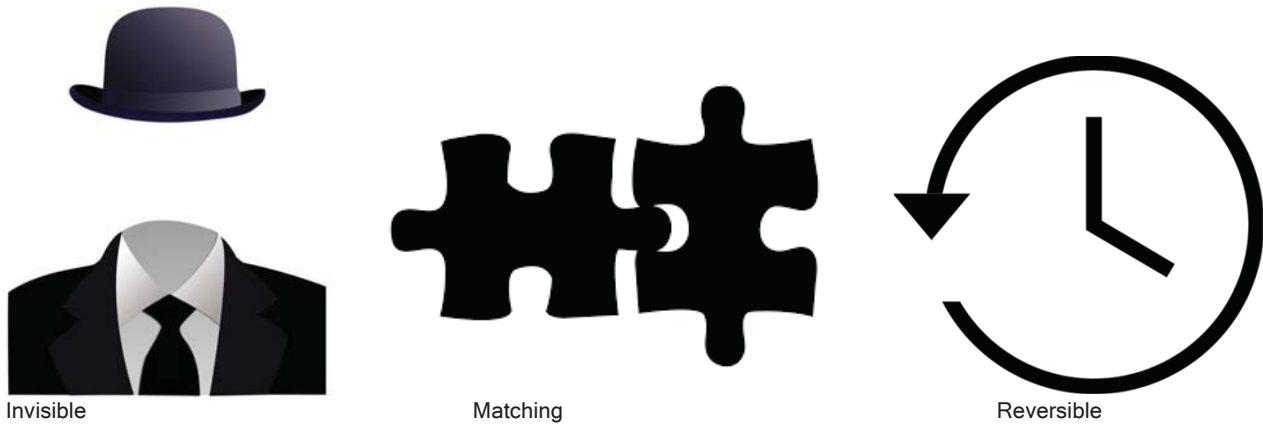

Figure 126: Design principles, source: own elaboration

4.4 Design requirements

In order to make the quality of the final design measurable and to create boundary conditions for the design, requirements have been established.

The requirements have been divided into structural requirements and functional/aesthetical requirements.

4.3.1 Constructive requirements

- The chimneys, wooden floors, masonry supported wooden beams and masonry parapets need to be reinforced adequately following the principles of the level 1,2 and 3 interventions.
- The intervention measures need to have the right dimensions to ensure the needed protection.
- The intervention measures need to have the right structural properties to ensure the needed protection.
- Replacement of elements should be done in a durable way. New additions should not get damaged after minor vibrations. (e.g. floors, ceilings)

4.3.2 Functional/aesthetical requirements:

- Original elements with a significant architectural value should ideally be preserved.
- If preservation of an original iconic element for any reason turns out to be impossible, the element should get an aesthetically pleasing replacement. (e.g. stoves, fireplaces, ceilings, floors, wainscoting, plinths, moldings, chimneys, frames, doors, closets)
- Reinforcement measures should ideally not be visible. If they are, they must have an appearance that suits the style of the building, and this way not disturb the image.
- Affected components should not lose function after the interventions. (e.g. fireplaces)



4.6 Style strategies

The invisible and the reversible measures are quite clear to understand. The invisible measures should be hidden or covered in a such a way that the building keeps its original aesthetics.

The reversible measure must be mounted in a such way that it does not affect the building and the applied materials must be demountable. The measures must be completely demountable.

The matching style is a bit harder to define. To find a matching style you have to understand the characteristics of the building you are altering and the Amsterdam School style in common. To create a bigger sense of what the Amsterdam School style concerns and looks like the following quote can form a good starting point:

“Buildings of the Amsterdam School are characterized by brick construction with complicated masonry with a rounded or organic appearance, relatively traditional massing, and the integration of an elaborate scheme of building elements inside and out: decorative masonry, art glass, wrought iron-work, spires or “ladder” windows (with horizontal bars), and integrated architectural sculpture. The aim was to create a total architectural experience, interior and exterior.” (http://en.wikipedia.org/wiki/Amsterdam_School)

Elements of the Amsterdam School style that without exception appear in each of the case study buildings that have been researched are the complicated and expressive masonry and the elaborated scheme of building elements both in the interior and exterior. But how but how this is elaborated varies per building.

In the process of designing solutions in a matching style different strategies can be distinguished. A possible strategy to find a matching style is to pick one or more existing elements in the building that need reinforcement and create a reinforcement measure in the same shape or style. This way a high level of customization will be reached, and the solution will be inseparable from the building. This measure can, in principle, be applied on the building it was designed for only.

Another strategy is to have a broader look at the Amsterdam School style buildings that have been

built in the same period of time and have a look into frequently recurring typical elements, and create a reinforcement measure in the same shape or style. This leads to a more “common style”, and the elements can be used on more buildings that fit the Amsterdam School style.

A third strategy is to create measures that refer to the time it was built, but are not specifically linked to the Amsterdam School style. For example anchor plates, as they were used in the early 20th century, can be copied and modified into anchor plates that can resist and distribute seismic forces. This historic measures could possibly not only be used on Amsterdam School building but has a much wider application. It could be applied on all buildings dating back to the beginning of the 20th century.

4.6.1 Building specific

The strategy “building specific” is finding a matching style by picking one or more existing elements and create a reinforcement measure in the same shape or style. To be able to do this an inventory of these elements needs to be made. This inventory has been made for four selected case study houses.

These case study buildings (see page 27) have been selected for further elaboration specifically because they fit well within the Amsterdam School style, and because much information is available about these 4 buildings.

All these buildings have been visited during fieldwork, and the residents have been contacted and interviewed.

On the following pages, per house, the elements are described and visualized.



Characteristic elements - Zeerijperweg

1. "Tree of life". The small figurine on the shed above the front door represents "the tree of life". This abstract view is also visible in the pattern of the stained glass. This all refers to the name of the building, "Wråldsbirin", which means something as "life path".



2. The two fireplaces are very iconic items in the interior. The brown colors, and the clean geometric shapes are also recognizable in the exterior of the building.

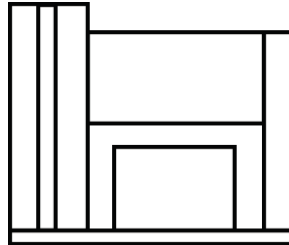

3. The banister aligns perfect with the stained glass. The shape of the "teardrop" and the circles are also visible in the stained glass.

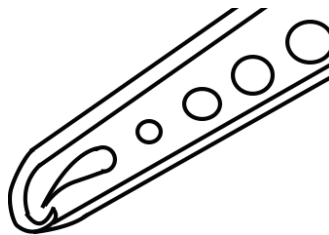

4. As mentioned before the pattern in the stained glass represents the "tree of life". The big stained glass corner window, spread over two floors, is a very prominent iconic element, both for the interior as the exterior appearance of the house.

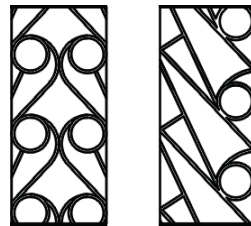

5. The plug boxes on the ceilings align with the clean geometric shapes of the fireplace and the composition of the exterior.

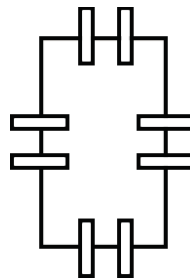

6. The protruding soldier course of red bricks emphasizes the horizontality in the facade and enhances the geometric structure of the exterior.



7. As the fireplace, the plug boxes and the soldier course the ceiling also contains strong geometric shapes.

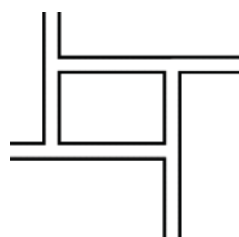
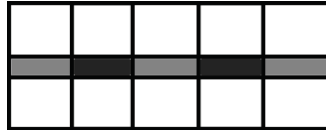

Figure 127: Zeerijperweg details, source: own elabora-



Characteristic elements - Wijmer-spada

1. Two linear decorative slats adorn the door post.



2. The same decorative slats as seen on the door post appear on the ceilings.

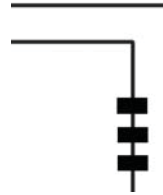

3. Again the pointed slats ornament the paneling beneath the windows.



4. The banister is also adorned with the decorative slats.



5. On the glazing in the door the same slats as elsewhere can be recognized. This time the vertically and horizontally placed slats form a hash.

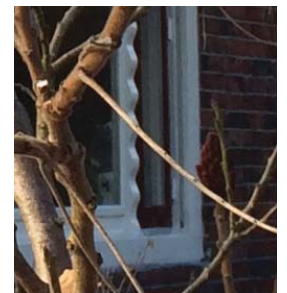
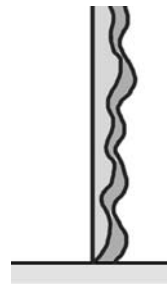

6. The geometric pattern of the stained glass is comparable to the pattern of the slats on the door glazing.

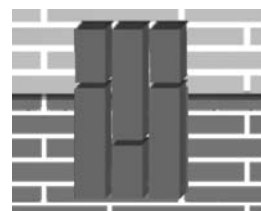

7. The façade is characterized by vertically stacked brickwork in a stretcher bond.

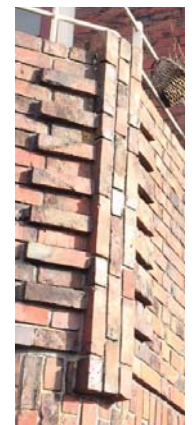
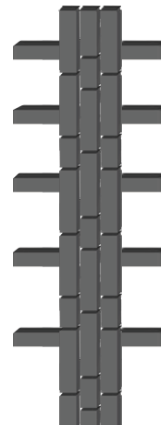
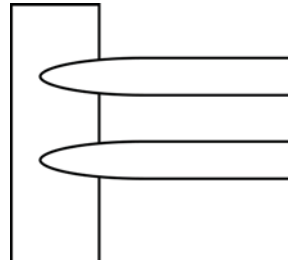

Figure 128: Wirdumerweg details, source: own elaboration



Characteristic elements - Wijmerspad

1. Two linear decorative slats adorn the door post.



2. The same decorative slats as seen on the door post appear on the ceilings.

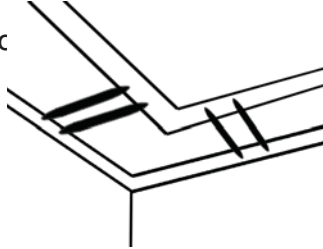

3. Again the pointed slats ornament the paneling beneath the windows.

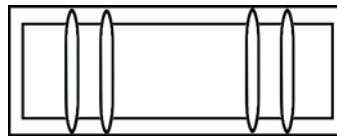

4. The banister is also adorned with the decorative slats.



5. On the glazing in the door the same slats as elsewhere can be recognized. This time the vertically and horizontally placed slats form a hash.

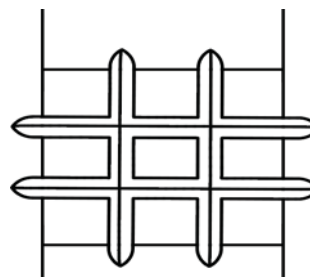

6. The geometric pattern of the stained glass is comparable to the pattern of the slats on the door glazing.



7. The façade is characterized by vertically stacked brickwork in a stretcher bond.



Figure 129: Wijmerspad details, source: own elaboration



Characteristic elements - Stationslaan

1. The façade is characterized by vertically stacked brickwork in a stretcher bond.



2. The vertically placed ceramic roof tiles predominate the appearance of the façade. The whole upper floors are covered under a garment of red tiles.

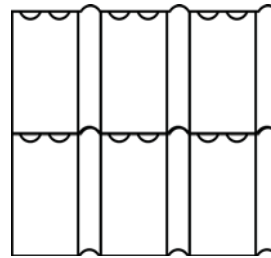

3. Both interior and exterior these typical doors with triangular window and geometrical patches and slats recur.

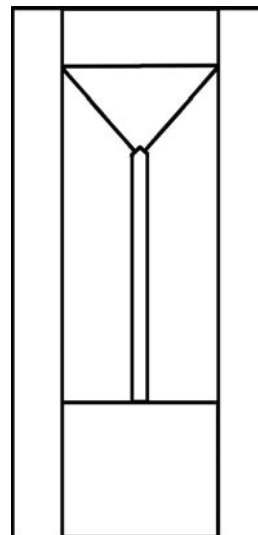

4. The parapets of the balconies are decorated with open-work masonry.



5. Most of the facade is coated with this typical header bond.

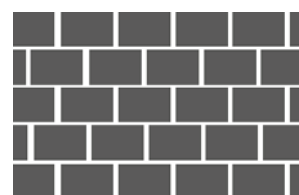

Figure 130: Stationslaan details, source: own elaboration



4.6.2 Style specific

The strategy “style specific”, in which with a broader look at the Amsterdam School style typical elements will be selected, and used to create reinforcement measures in the same shape or style.

For this strategy also typical elements need to be found, but this time the elements will be “harvested” from randomly picked Amsterdam School buildings to find a desired shape.

The images below give examples of how to abstract elements and shapes for further use.

1. A decorative Amsterdam school chimney. Two triangular shaped concrete slabs are holding 3 spheres. A thirds slab frames the text written in the chimney. All together is forms a playful design with emphasis on geometric shapes (square, sphere, rectangle, triangle).



2. The side of the staircase is ornamented with horizontal and vertical placed rectangles. The “consoles” underneath the steps have a more organic shape, which enhances the rigid geometric shapes of the banister



3. Several Amsterdam School buildings have been ornamented with text. During the period the houses were built, there were some very popular fonts that are very recognizable for that time. Also in other disciplines than architecture these fonts can be found, for example in magazines and in art pieces.



Figure 131: Amsterdam School details, source: own elaboration



4.6.3 Period specific

The strategy “period specific” is to create measures that have been used during the time it was built, but are not specifically linked to the Amsterdam School style.

A good example illustrating this strategy is the anchor plate. Many antebellum buildings, also typical Amsterdam School style buildings, are equipped with anchor plates already. (see Figure 132, Heerestraat 2, Loppersum). But not for seismic reasons but for structural reasons.

When protecting buildings against earthquakes anchor plates are used. In this case circular restraints, called “patress plates” are used (Figure 133). The historic anchor/patress plates can be copied and altered in such a way that they are suitable for seismic protection. This way the measure will be visible, but due to the historic character of the anchors will make it look like they are applied decades ago.

4.6.4. Unspecific

The strategy “unspecific” does not take any style or shape into account. It is not linked to any reference. The purpose with this strategy is to connect to the building in a more abstract manner (for instance by stressing the horizontality of the building by the addition of oblong elements). Or to create a discrepancy between the existing building and the new additions. This can, for example, be done by using contemporary, untraditional materials or contrasting colors.

4.7 Design attitude

When altering an existing building different design attitudes can be distinguished. In this case, a division has been made between “contrasting” and “merging”.

In case of the “contrasting” design attitude the purpose it to is create a design that is in contrast with the existing building. This way it stays clear what’s old and what’s new in the building. The new additions must differ from the existing elements in shape, color and/or material.

This attitude can be executed in many ways. It’s mostly up to the designer to create a shape that is respectful towards, and in harmony with, the existing building. Within the new design small references to the original building can be given. If



Figure 132: Heerestraat 2, Middelstum, source: www.rtvnoord.nl



Figure 133: Traditional wall tie patress plates, source: www.redgwick.co.uk



Figure 134: Contemporary wall tie patress plates, source: https://en.wikipedia.org/wiki/Anchor_plate#/media/File:Florenz_-_Mauerbefestigung.jpg

well executed, contrasts in architecture can result in great designs.

In the case of the “merging” design attitude is to “hide” the alterations. The buildings appearance can be changed, but it must seamlessly connect to the existing structure. In the end it must look like the alterations never took place, and the new additions had always been there.

What attitude suits the building best is up to the residents, the designer and the preservation guidelines and the initial appearance of the building.



4.8 Design strategy

When making a design, whether it is for a new design or design for retrofit, many thinkable options are possible. In this case the structural boundary conditions can be determined/ calculated on the basis of the severance of the earthquakes and the buildings resistance to earthquakes before the retrofit. The boundary conditions regarding aesthetics, on the other hand, are a lot harder to define. Of course you do not want to remove valuable characteristic elements, and you do not want the building to deteriorate due to the strengthening measures. But safety comes first and sometimes concessions must be made. What is for sure is that the measures somehow must suit the style of the building. But this can be reached in many ways as well.

The most important condition is in any case that the design must be well thought out. The decisions must be taken carefully, in collaboration with all the stakeholders. Also every building requires its own approach. Within the set boundaries the final execution is up to the designer.

In order to create some guidance and to make the aesthetics of the design more “measurable” some questions can be answered to create a starting point.

The first question that can be asked is whether the reinforcement measure must be visible, invisible or reversible.

The reversible strategy is in this case, when it comes to “permanent” measures and home refurbishment, not desirable. After interviews with

the owners it seemed that the majority wants to live in an aesthetically pleasing house. They want their house to be nice-looking, safe and comfortable now and in the future. This measure seems more suitable for (public) buildings with a special function, such as historic churches that should be kept the way they are. For these buildings, that function as art pieces or as a relic from the past, conservation is important to preserve the national heritage. A house is a utensil, and should meet the requirements of its user.

If the case of “invisible” measures no conditions are required regarding the aesthetics of the measure itself. The condition in this case is that the existing appearance remains unchanged. This requirement is in itself already strict enough to judge the result. No further questions therefore are required. However, one should bear in mind that trying to pursue invisibility is very ambitious, and will not be possible in all cases.

In the case of opting for visible measures there are many different approaches thinkable. To keep things “simple”, some questions have been developed that can help taking decisions during the design process.

The first question you have to ask yourself is whether the measure concerns an addition in order to reinforce the existing element/structure or whether the hazardous element can be replaced in its entirety. This mainly depends on the architectural value of the element, its importance in the overall picture of the building and the wishes of the stakeholders and the preservation guidelines.

A second question is whether the appearance

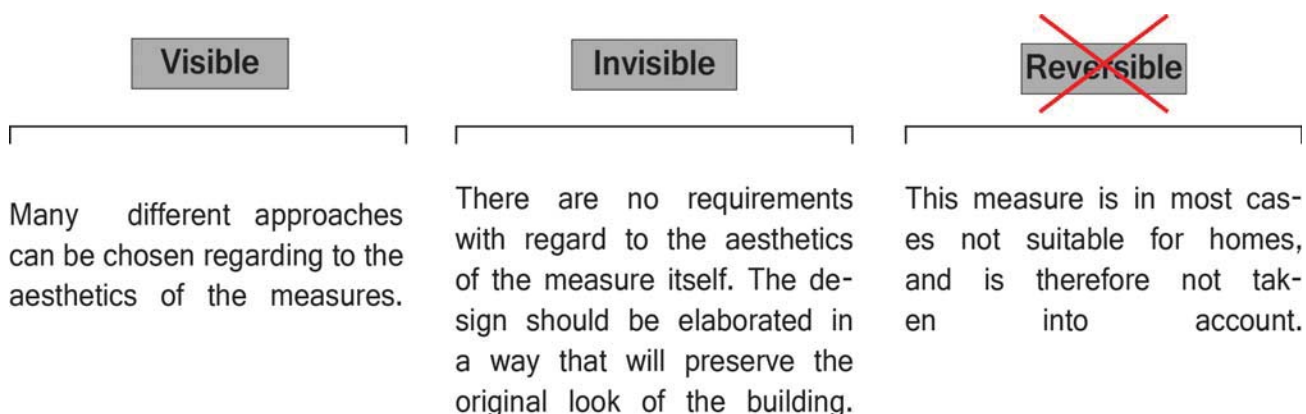

Figure 135: Design strategies: own elaboration



of the measure should be contrasting with the existing building or that it should become one with the building (merging). This can be executed in many ways, and might depend on wishes of stakeholders and on preservation guidelines. In the case of a listed building, preservation guidelines might require a clear distinction between the original structures and the added alterations. This distinction is not very strict. Measures can for example have contrasting colors, but merge with the building by its shape.

As an extreme we can say that the measure merges when it is not immediately apparent that the modification was added later. The other extreme is that it is immediately apparent that something has been added later. In between there is a whole range of conceivable possibilities.

To offer more guidance regarding to “style”, a decision should be taken on how broad your view will be. Four different approaches have been distinguished that can be adopted as a starting point for the design.

To offer made to measure solutions, the design input should be found within the building itself, this approach is called “building specific”. Within the building there must be searched for systems, materials, colors, shapes etc. that are suitable for modification into a design for a reinforcement measure. Mind that the intention is not to copy, but to abstract and transform the elements into a suitable design.

To find a solution that is more broad, and probably has a wider applicability, the style can be specified to “Amsterdam School”. Within this approach, that is called “style specific” in the whole stock of buildings that are classified as Amsterdam School can be searched for inspirational elements that are characteristic within the style of the Amsterdam School. Again, the intention is not to copy, but to abstract and transform the elements into a suitable design. Also there is a great variety in appearance and ornaments within the style of the Amsterdam School. The elements are not all interchangeable, there should always be a consideration if it fits the building for which you are designing

AA third approach is to find your inspiration in buildings built during a specific period. This ap-

proach is called “period specific”. The Amsterdam School style buildings have been built mostly between 1910 and 1935. Within the stock of buildings built during this time there can be searched for elements and solutions.

Because specifying this is quite broad, within this style a more direct approach can be adapted. For example in the case of the search solutions, there can be looked into elements that in itself can offer a solution, such as historic anchor plates, wrought iron parapets or decorative chimney restraints.

In this case, because the elements can offer a solution in itself, copycats might be possible if it fits the image. Also an abstraction of the original can be made.

A last approach is to completely differentiate from the existing style and period. In this case a new design can be developed at the discretion of the designer. A modern style, distinctive from the original building can be adopted. How this should be implemented into the existing building will have to be examined case by case.

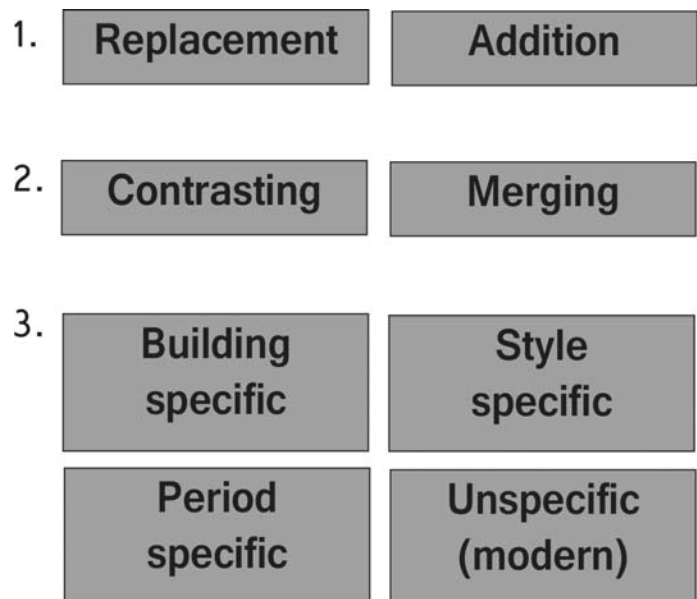

Figure 136: Design choices, source: own elaboration

Designing is no hard science, and in the case of retrofit you always have to deal with an existing situation and the users of the building. There is never one perfect solution, and the choices made during the design process are influenced by many different factors.



To give some structure to the design process some questions can be answered to take some first decisions. Answering these question can form the starting point of the design.

Within the broad range of possible design solutions a starting point for the design can be made by answering the following questions:

- Should the measure be an addition to the element/structure or can the hazardous element be replaced in its entirety.
- Should the appearance of the measure be contrasting or merging with the existing building?
- Should the style of the measure be building specific, style specific, period specific or unspecific (modern)?

The answers on the questions create a position in a spectrum of solutions. To make this positions easily visible the scheme below was designed.

As an example the positions “A, B and C” have been marked.

Position A in this case is a solution in a period specific style, added to the existing element/structure, the appearance of the measure merges with the existing building.

Position B concerns a solution in a building specific style. The measure replaces the existing element/structure. The appearance of the measure is contrasting with the existing building.

Position C concerns a solution that has a style specific appearance, it is an addition to the existing structure/element, the measures presence is contrasting with the existing building.

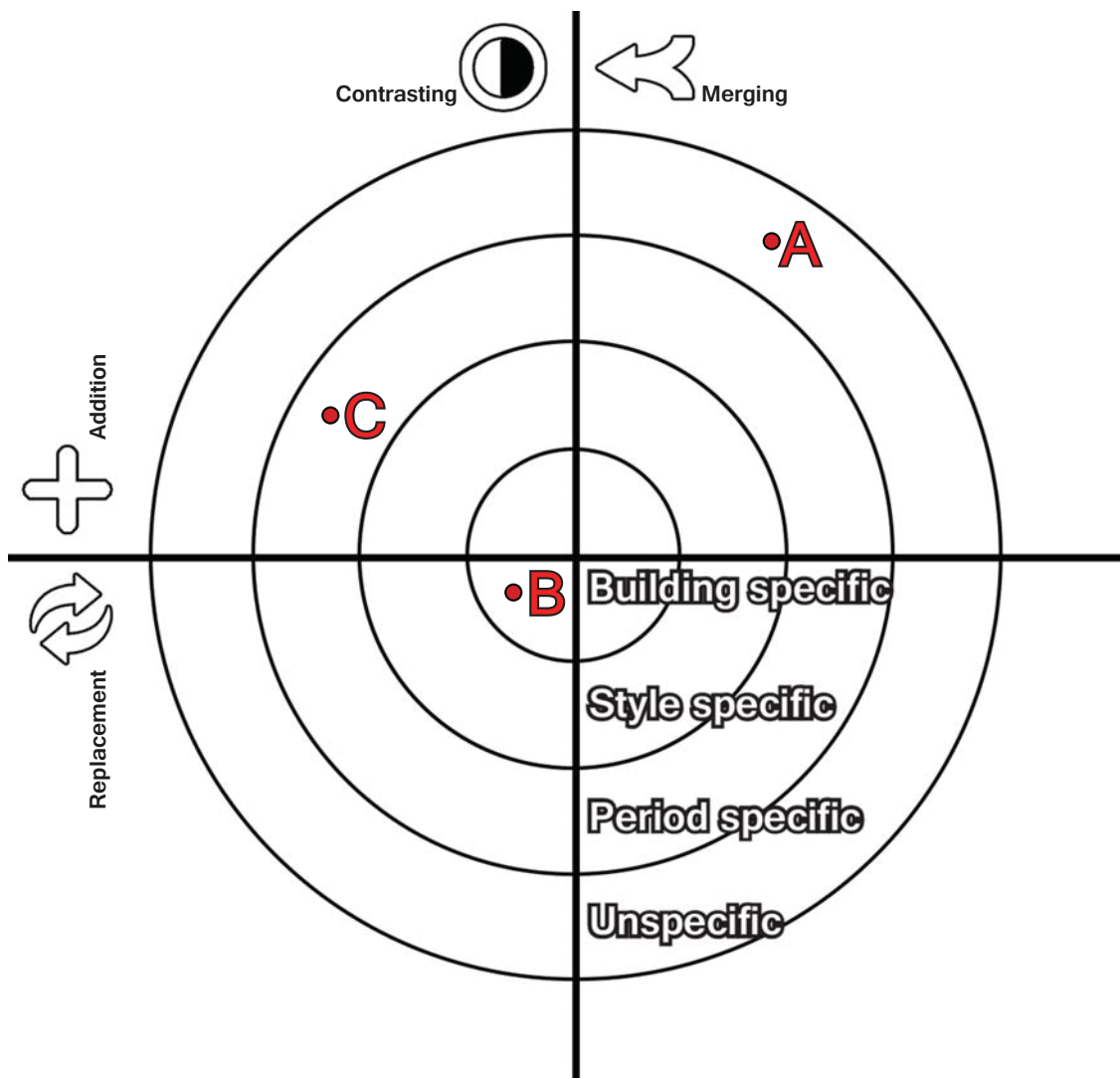

Figure 137: Design decisions spectrum, source: own elaboration

5. Design catalog

In this design catalog 12 designs for reinforcing measures have been included. The designs concern solutions for chimney reinforcements, parapet reinforcements, anchors for the purpose of the floor-wall connection and floor stiffening measures.

The designs have been divided in sections. Each section represents a different elements. The chimney and parapet restraint concern level 1 measures, the wall anchors concern level 2 measures and the floor stiffening solutions are level 3 measures.

To make it easy to navigate through the catalog each section has a color and each design has a label. The front-page of the catalog contains an index which is connected to the labels. Via the index you'll be able to immediately find the page of your choice. The index shows which element it concerns, what case study buildings, the solution it was designed for and what kind of solutions there are.

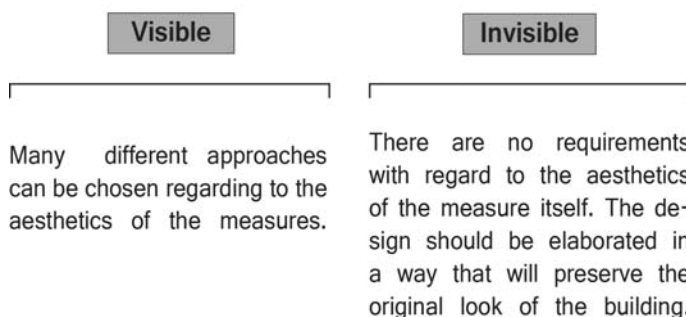

Figure 138: Design strategies, source: own elaboration

The design sheets contain information about the technique, detailing, installation, materialization of the designs and so on. Each first page contains an informative text about the design and an installation manual. The second page contains 3D visualizations and pictures associated with the design. The third page contains a detailed section of the installed design and the fourth page contains additional information and information about the design decisions related to the design strategy (see chapter 4).

To visualize and compare the different design strategies, the choice for visibility or invisibility will be displayed (Figure 138) and in case of a visible design the position of the design within the “design decision spectrum” will be pointed (figure 139).

On the following page the four case study buildings on which the designs have been projected are shown again. Also the 4 elements, chimney, parapet, beam-wall connection and the floor are shown with their corresponding levels of intervention.

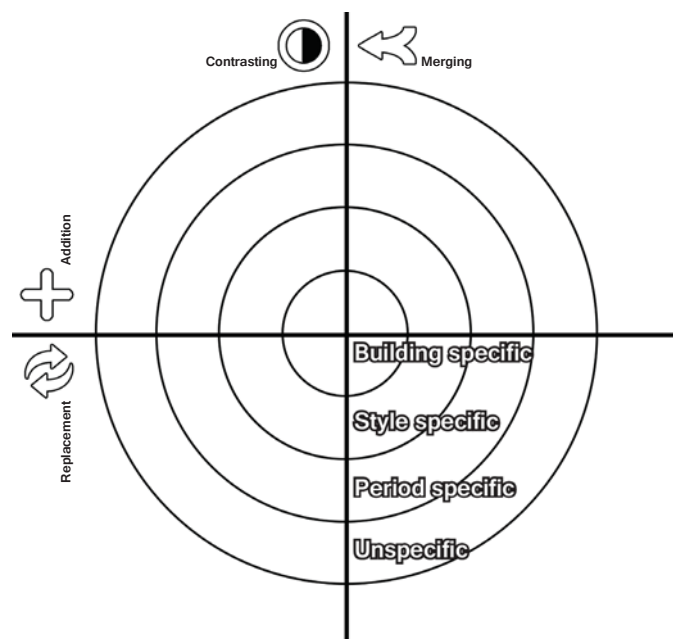

Figure 139: Design decisions spectrum source: own elaboration



Case study buildings:



Figure 140: Wijmerspad 1, Loppersum, source: own elaboration



Figure 141: Wirdumerweg 27, Loppersum, source: own elaboration



Figure 142: Stationslaan 7, Loppersum, source: own elaboration



Figure 143: Zeerijperweg 12, Loppersum, source: own elaboration

Elements to reinforce:

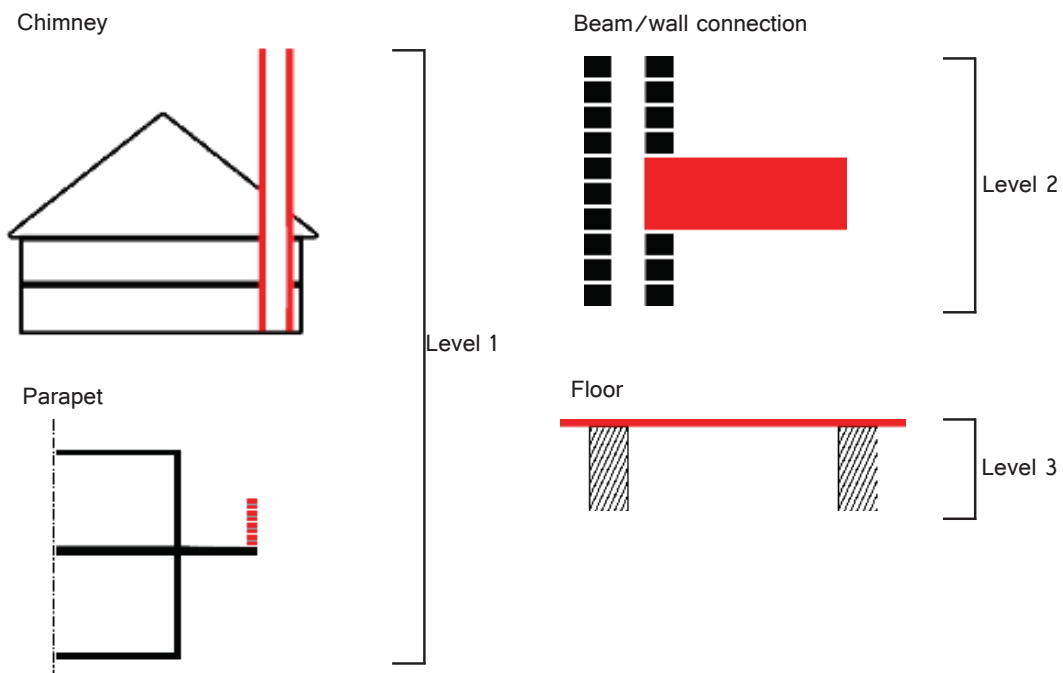

Figure 144: Elements to reinforce, source: own elaboration



Level 1

Chimney - decorative chimney bracing
Zeerijperweg 12

1

Chimney - lightweight chimney
Zeerijperweg 12

2

Parapet - lightweight parapet
Zeerijperweg 12

3

Parapet - decorative parapet restraint
Wirdumerweg 27

4

Parapet - planter box parapet restraint
Stationslaan 7

5

Level 2

Wall anchor - invisible anchor plate
Undefined

6

Wall anchor - covered anchor plate 1
Wirdumerweg 27

7

Wall anchor - covered anchor plate 2
Stationslaan 7

8

Wall anchor - decorative anchor plate
Wijmerspad 1

9

Wall anchor - strip anchor plate
Zeerijperweg 12

10

Level 3

Floor stiffening - integrated floor heating
Undefined

11

Floor stiffening - rigid decorative ceiling
Zeerijperweg 12

12

Decorative chimney bracing

Design

This design is a decorated variant of a traditional chimney bracing. In order to protect the slender protruding part of the chimney above the roof against breaking and falling during earthquakes the chimney is held together by an enclosing "sleeve". Usually these sleeves are very simple in shape, and do not fit the style of the building specifically. It looks like a temporary restraint that can be removed after the danger is subsided. Because the aim in case of home reinforcement is to offer permanent solutions the restraint is decorated to suit the style of the building. This makes the reinforcement inseparable from the building, and the restraint will look like it belongs there. The decorative pattern on the sleeve is the same pattern as the pattern of the stained glass window of the house.

Mechanics

Steel straps wrapped around the chimney post tension the bricks, this improves the flexural strength of the masonry, and prevents the chimney from collapse due to outward bulging. The angle section profiles on the corners of the chimney, held by the steel straps, prevent the chimney from buckling and breakage of parts.

The bracing is attached to the main structure of the building by tie rods that are connected to the wall plate, and a pushing rod that is connected to the roof trusses. This prevents the chimney from moving during an earthquake.

Assembling

First the nonstructural decorative plates must be attached to the chimney. This needs to be done without drilling into the chimney. Best they can be glued or temporarily held by a support structure. After the placement of the decorative plates the corner profiles can be put in place. The corner profiles should have a soft and flexible finish on the inside to prevent point loads on bulges of the rough masonry.

Around the decoration and the corner profiles the steel straps can be wrapped and tensioned.

After the installation of the bracing the tension rods and the push rod can be attached to the bracing and fixed to the wall plate and the roof trusses. The tie rods that connect the wall plate and the chimney bracing need to be tensioned as well to avoid all movement. A push rod will be connected to the roof trusses.

Materials

The best material for the chimney restraint is stainless steel. This material is very ductile, which is preferable in case of an earthquake. It is very strong and does not rust, which is important when exposed to moist weather conditions. The steel can be painted in any color for decorative purposes.

Detailing

The bracing wrapped around the chimney consists of 3 elements, the decorative panels, the corner profiles and the steel straps holding everything together. The corner profiles should have a soft finish on the inside to ensure equal distributions of forces.

Push and tie rods are attached to the sleeve in order to connect the chimney to the main structure of the building. Where the rods and cables hit the roof tiles the waterproofing should be guaranteed by lead plates. The cables must be attached to the (reinforced) wall plate. The push rod should be connected to the roof trusses.

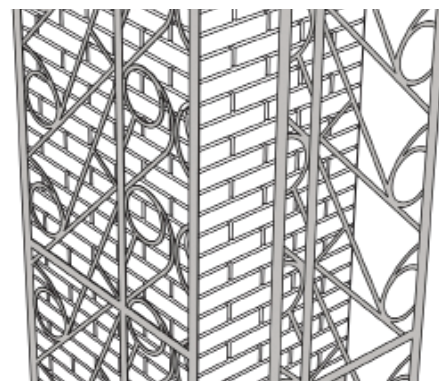

1. Placing decorative plates

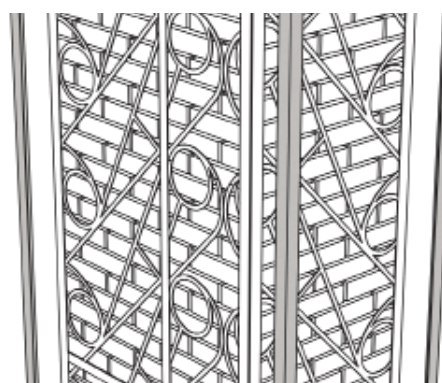

2. Mounting the corner profiles

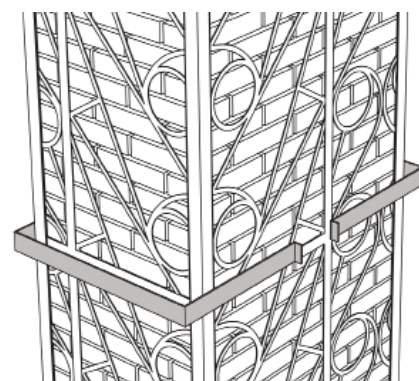

3. Tighten the steel straps

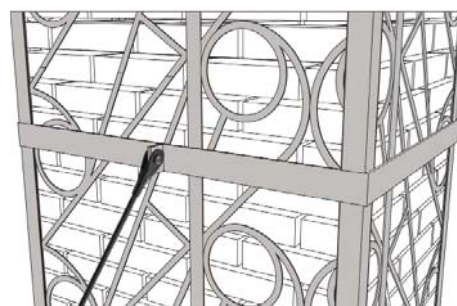

4. Attachment to the main structure

Figure 145: Assembling: own elaboration

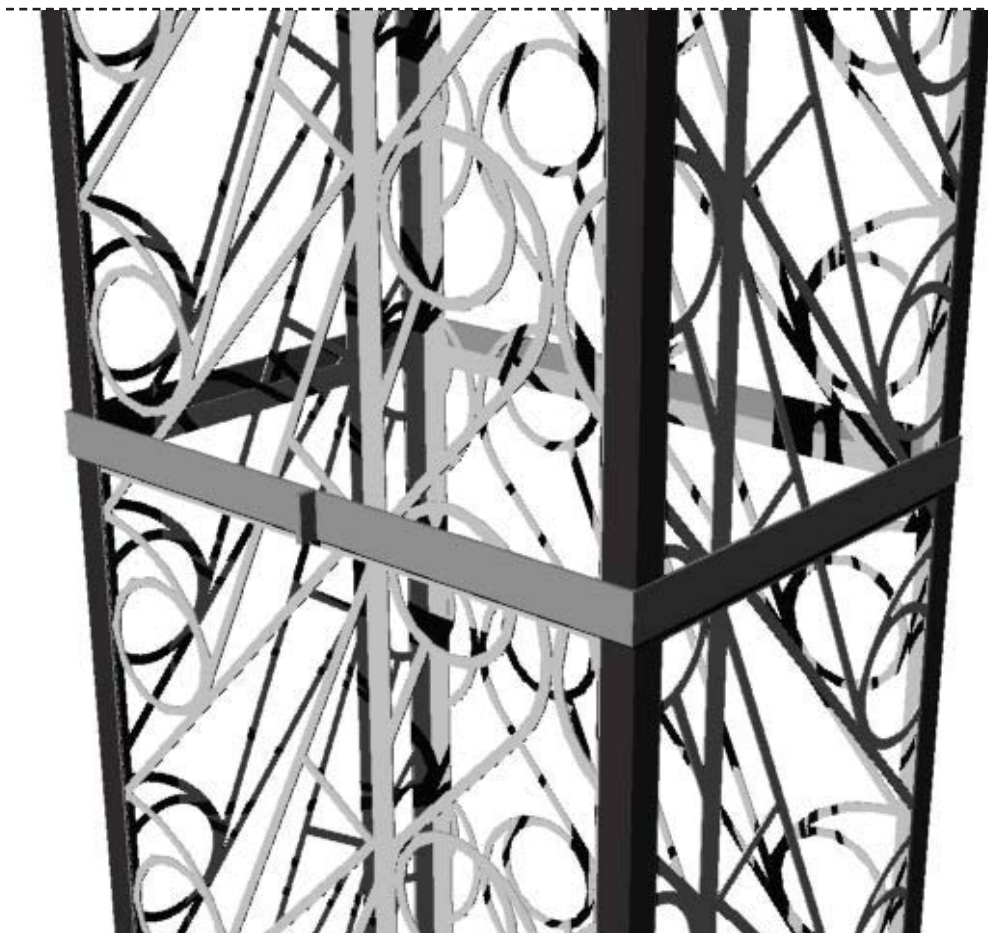

Figure 146: Before assembly, source: own elaboration



Figure 147: stained glass window, source: own elaboration



Figure 148: After retrofit, source: own elaboration



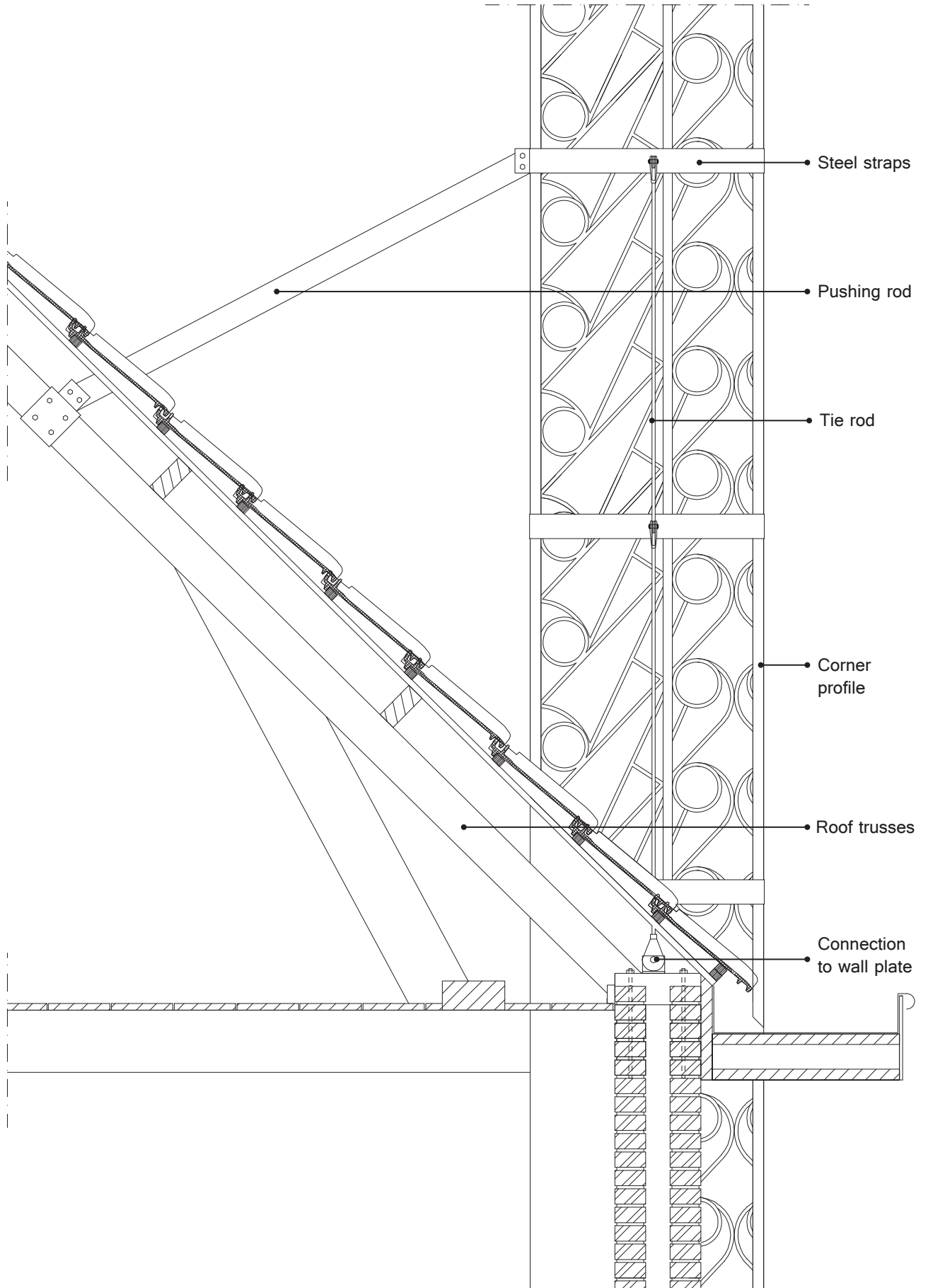

Figure 149: Detail, source: own elaboration



Marginalia:

- A sturdy steel tube of 80x80mm, 4mm thickness, will probably be sufficient as a pushing rod.
- Cables of approximately 16mm thickness will probably be sufficient to transfer the forces to the wall plate.
- The corner profiles should be attached seamlessly to the rough masonry to enable a smooth transfer of forces on the 4 corners of the chimney. To achieve this, a flexible material must be applied against the brickwork or on the inside of the angle sections.
- Instead of diagonal connections between the draw bands, the decorative pattern now fulfills this function. In the case this pattern is lacking in the design diagonal braces must be applied.

Design decisions::

For this design a building specific approach was chosen. The reinforcement measure refers to the stained glass window of the building it was designed for. By picking an existing “element” (the pattern) and turning this into a reinforcement measure a visual merge with the building was pursued. The original chimney will remain intact, the reinforcement concerns an addition.

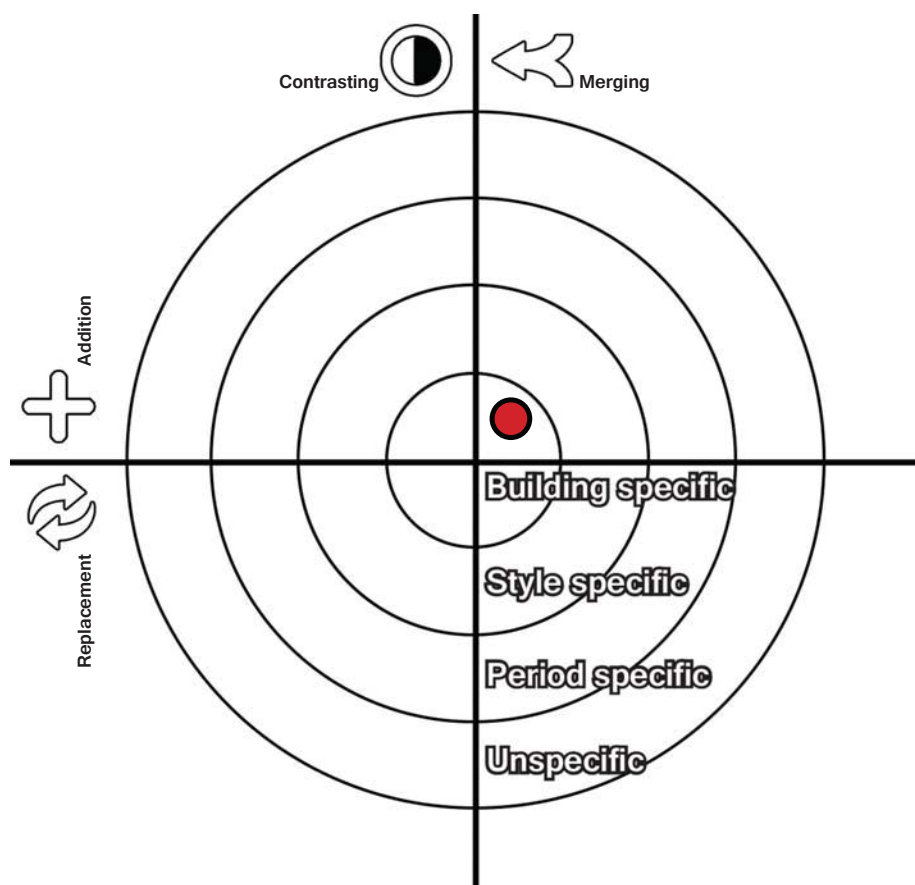

Figure 150: Design decisions spectrum source: own elaboration



Lightweight chimney

Design

Due to the heavy weight, the slender shape and the brittleness of the material the masonry chimney causes great danger in case of an earthquake. By removing the chimney and replacing it by a light-weight variant the chimney will remain its functionality without the danger of breaking or falling.

The usual lightweight chimneys are not very aesthetically pleasing. In many cases one tried to mimic the original aesthetics of the removed chimney by covering the lightweight chimney with brick strips in a similar color as the original masonry. This, in many cases, results in a very odd looking appearance because the color and surface of the brick strips will always differ from the original masonry. Therefore, in this case, was decided to give the chimney a whole new contemporary look with small references to the Amsterdam School style. This way the building and its style will be honored and respected and the chimney suits the style of the architecture.

Mechanics

By the removal of the hazardous heavy protrusion above the roof, the danger in case of an earthquake is reduced to a minimum. The new chimney is built of aluminum and attached to the remains of the old chimney.

Without the huge mass the chimney will cause way less seismic forces in case of an earthquake.

Assembling

In order to be able to install the new chimney the old chimney needs to be removed to the level of the roof. Beneath the level of the roof, the chimney is held by the masonry walls and thus falling or breaking will be prevented. On top of the remains of the old chimney a profile will be attached that will hold the new aluminum chimney. After installing this profile the new chimney can be placed over the profile. New steel flues will provide proper functioning of the fireplaces after the replacement of the chimney. The new flues will function as structural profiles and provide structural integrity of the new chimney as well. The roof around the new chimney must be adequately closed with lead strips in order to provide water tightness. The remaining part of the chimney below the roof will be covered with a matching aluminum piece in to create a unified, slick appearance from top till bottom.

Materials

The new chimney is made of aluminum. This material is very light weight and well resistant to weather circumstances. The new flues are made of steel to withstand the heat of the smoke.

Detailing

The new chimney is attached to a profile that is screwed on top of the remains of the old chimney. New steel flues provide the functioning of the existing fireplaces and they also provide a strong connection between the remains of the old chimney and the new light-weight chimney. The length of the flues provides an equal spread of the wind loads over a larger length of the masonry chimney remains. The roof around the chimney should be covered adequately with lead strips to provide water tightness.

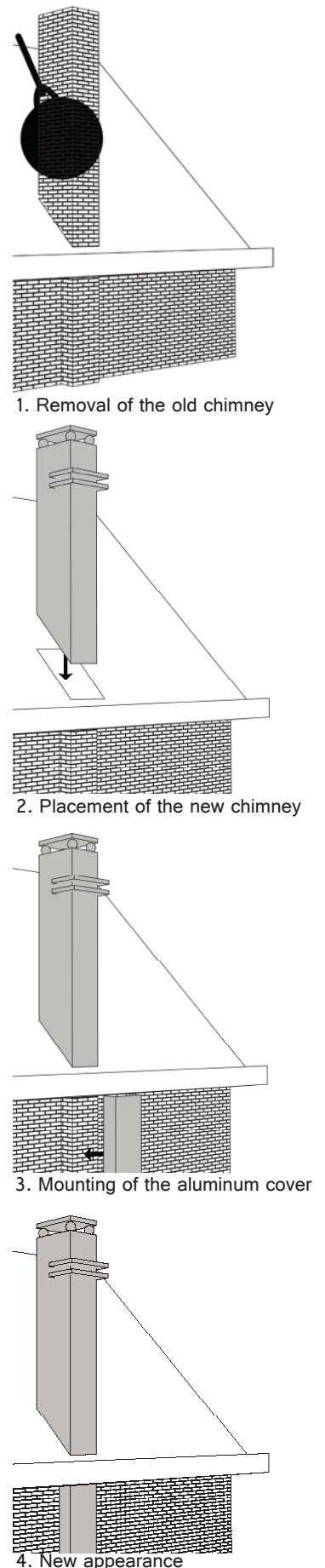

Figure 151: Assembling: own elaboration



Figure 152: After retrofit, source: own elaboration

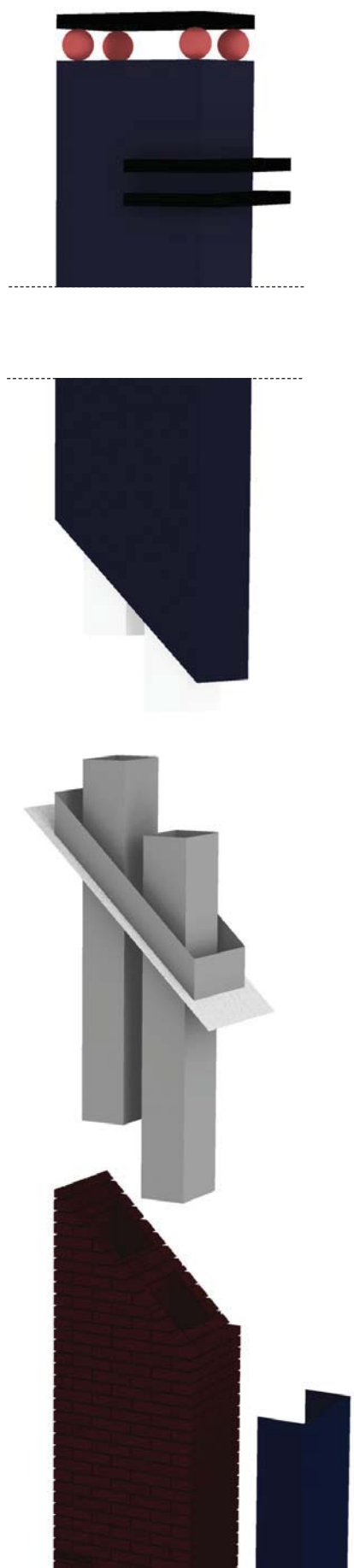

Figure 153: Before assembly, source: own elaboration



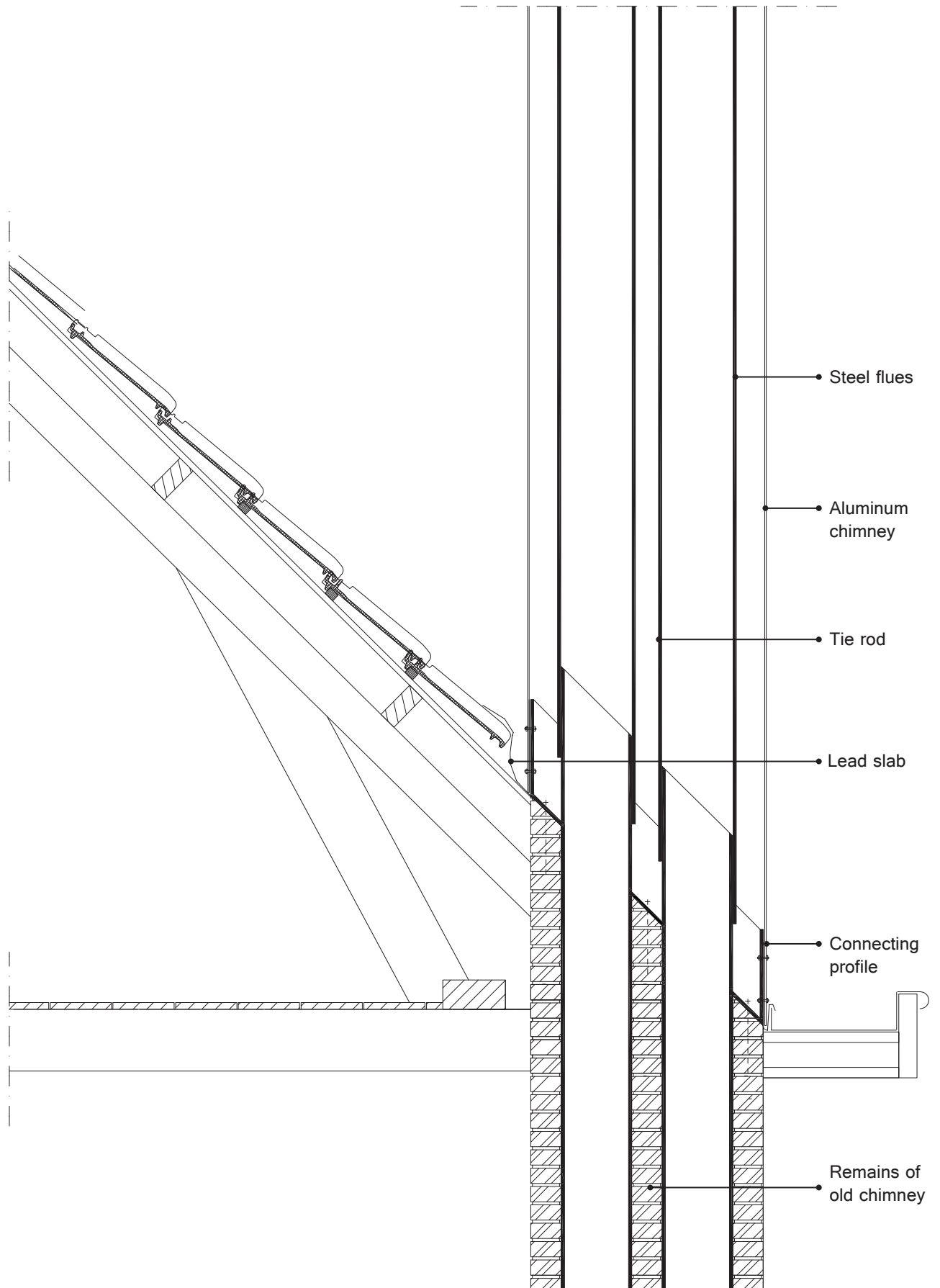

Figure 154: Detail, source: own elaboration



Marginalia:

The current channels in the chimney will probably not be much larger than 90x90mm. In order to keep the heaters usable, with an energy burden of 6KW, a heater pipe with a thickness of at least 150mm is required. The flues must be sufficiently heat-resistant as well. With an inner pipe of 150 mm and an outer pipe of 250mm this probably will be achieved. The remains of the original might not provide sufficient space for the insertion of the new flues. In order to keep the heaters useful the lower part of the chimney probably still needs to be partially degraded.

Design decisions:

For this design a style specific approach was chosen. The reinforcement measure refers to an Amsterdam School style chimney of another building designed by the same architect that designed this building. The chimney connects to the architectural style of the building.

The modern use of material (aluminum) contrasts with the original building. The original chimney will partial be removed, the reinforcement concerns a replacement.

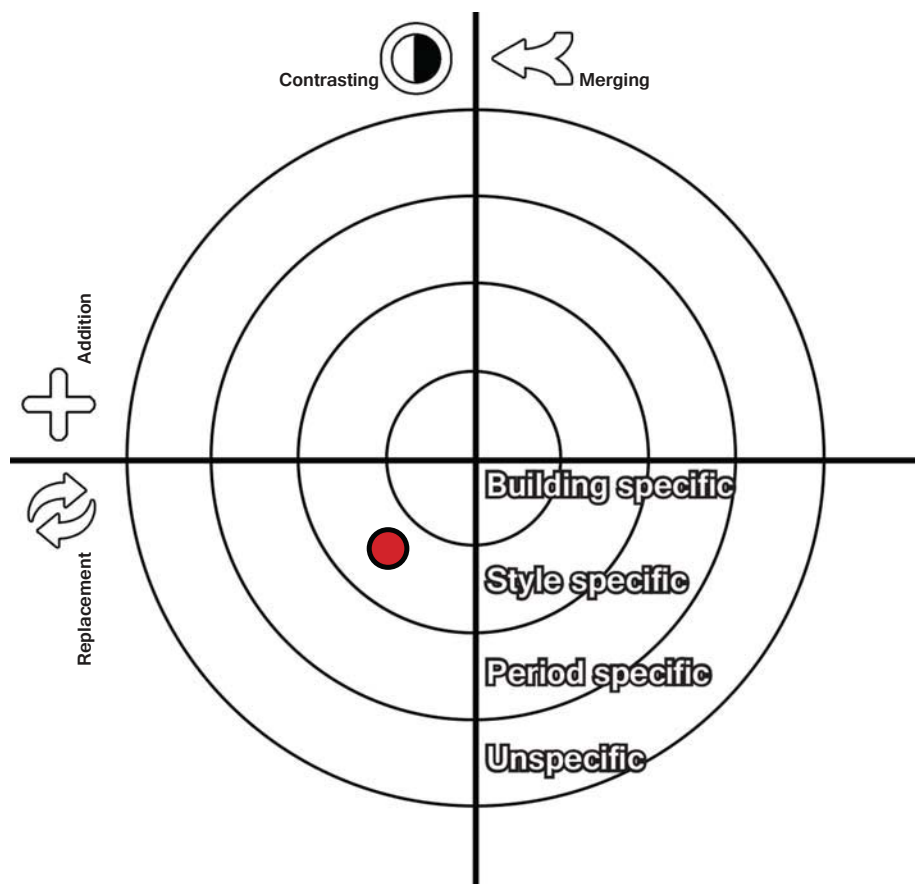

Figure 155: Design decisions spectrum source: own elaboration



Lightweight parapet

Design

Due to the heavy weight and the brittleness of the material the masonry parapet causes great danger in case of an earthquake. By removing the parapet and replacing it by a lightweight variant the parapet will remain its functionality without the danger of breaking or falling.

The plane masonry parapet in this case is replaced by a decorative wrought iron variant that follows the pattern of the expressive stained glass window of the building. This way the expressivity of the stained glass will be emphasized and the repetition of the pattern will enhance the “total architectural experience”, one of the characteristics of the Amsterdam School style.

Mechanics

By the removal of the hazardous heavy masonry parapet, the danger in case of an earthquake is reduced to a minimum. The new parapet is built of wrought iron and attached to balcony and the wall. Without the mass the parapet will cause way less seismic forces.

Assembling

In order to be able to install the new parapet, the old parapet needs to be removed entirely. The new parapet will be attached to the concrete balcony and the masonry wall by the use of chemical anchors that will be bolted to the lightweight parapet.

Materials

The new parapet is made of wrought iron. The openness of the pattern and the slenderness of the elements make the parapet lightweight. Because of the mass reduction the seismic forces will be reduced to a minimum. A colored coating will protect the material against weather influences. The connections will be made of stainless steel in order to prevent them from corroding and because of its favorable structural properties.

Detailing

The new parapet is attached to the concrete balcony and the masonry wall using chemical anchors and bolted nuts.

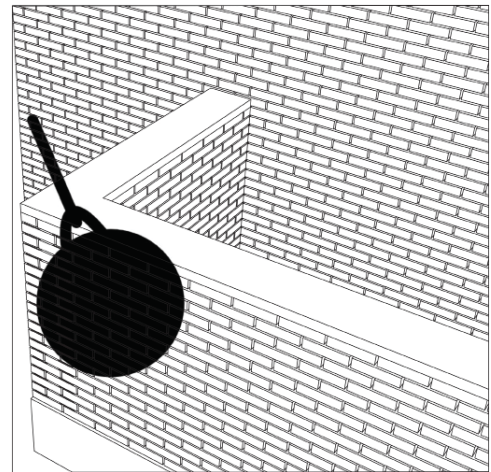

1. Removal of the old parapet

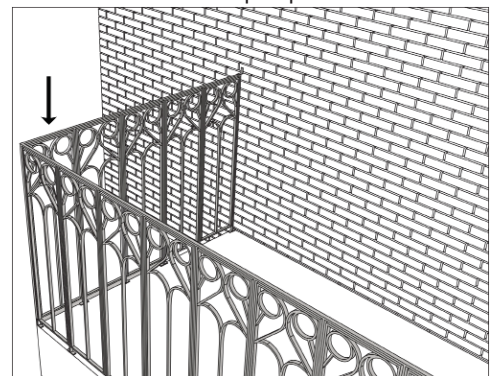

2. Placement of the new parapet

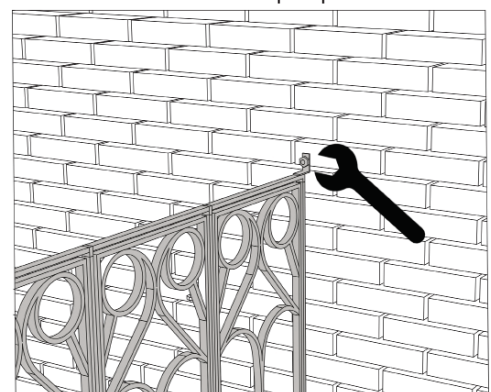

3. Bolting the parapet to the wall

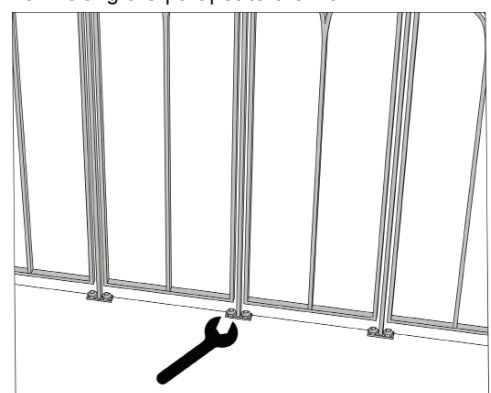

4. Bolting the parapet to the balcony slab

Figure 156: Assembling: own elaboration





Figure 157: Before assembly, source: own elaboration



Figure 158: Before retrofit, source: own elaboration



Figure 159: After retrofit, source: own elaboration



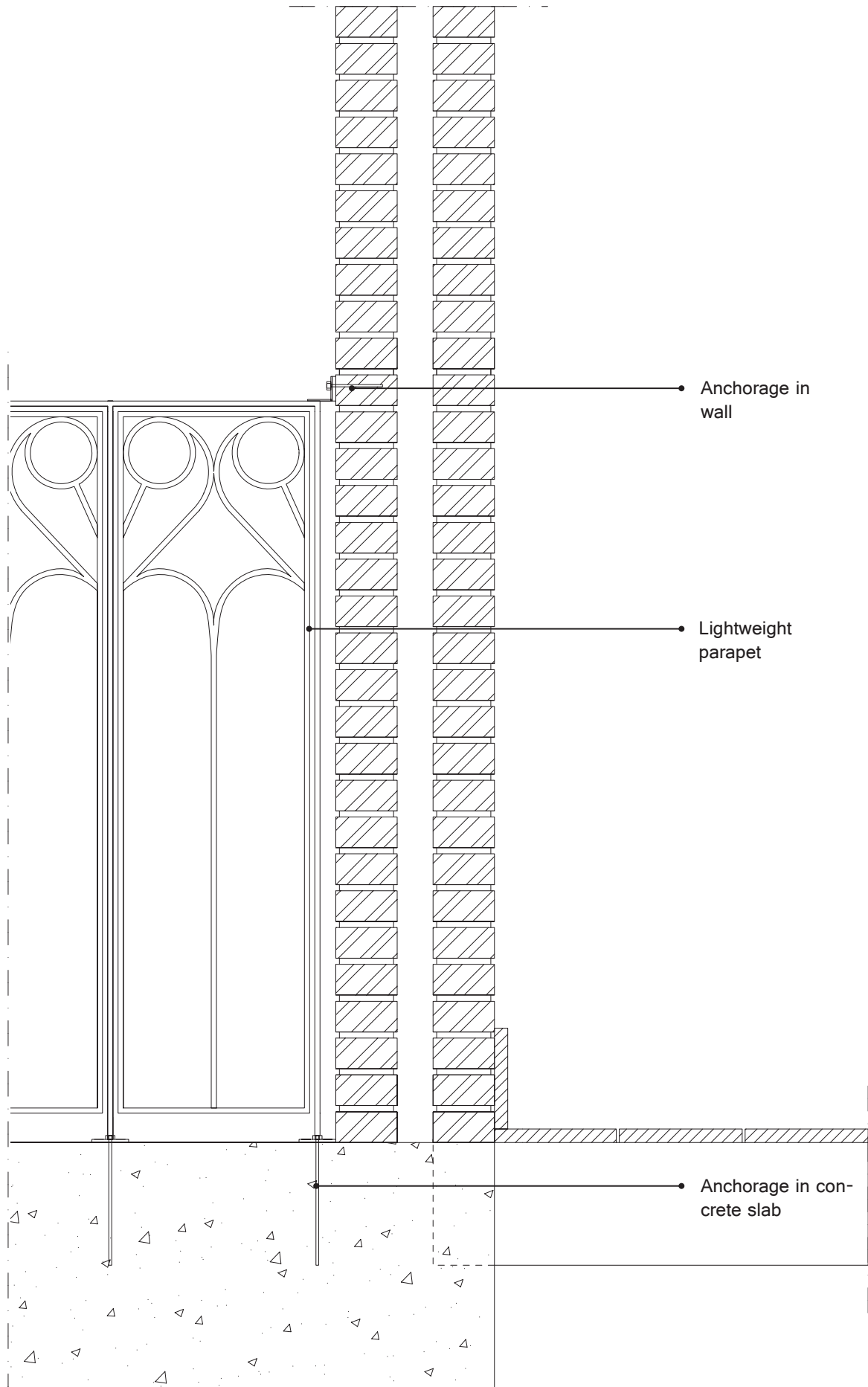

Figure 160: Detail, source: own elaboration



Marginalia:

Every 1000mm length of the parapet a steel profile of at least 30x60 mm must be installed to provide sufficient structural safety. This is included in the Dutch building regulations.

Design decisions:

For this design a building specific approach was chosen. The reinforcement measure refers to the stained glass window of the building it was designed for. By picking an existing “element” (the pattern) and turning this into a reinforcement measure a merge with the building was pursued. The original parapet must be removed, the reinforcement concerns a replacement.

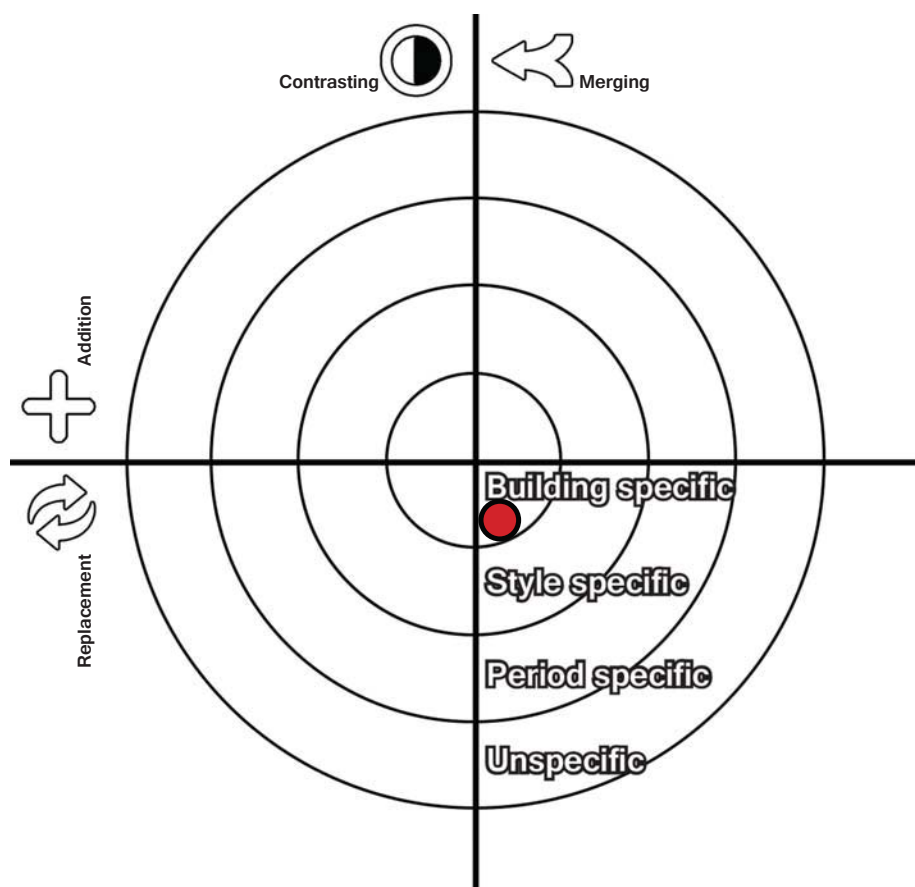

Figure 161: Design decisions spectrum source: own elaboration



Decorative parapet restraint

Design

Due to the heavy weight and the brittleness of the material the masonry parapet causes great danger in case of an earthquake. The parapet can break and fall down. To prevent this from happening a restraint must be attached to the parapet.

In this design the aesthetics of the restraint are inspired on the ornaments of the building in its original state. The masonry garden fencing with wrought iron ornaments is removed in the past, to the regret of the current residents. The fence on top of the masonry parapet of the balcony, on the other hand, was added later on (see Figure 166).

In the design for the restraint the “new” fence was removed and replaced by a structural one, decorated with the ornaments of the old garden fencing.

Mechanics

The fence forms a rigid steel cage that is connected to the walls and the parapet. In case of an earthquake, the cage prevents the parapet from moving back and forth. With the parapet firmly held in place by the steel construction the chance on collapse of the parapet is reduced to a minimum.

Assembling

First the small fence on top of the parapet must be removed. After this, the prefabricated cage can be put in place. After the placement of the cage, the structure must be adequately connected to the parapet and the walls. This can be done by the use of chemical anchors (connection to the parapet) and anchor plates (connection to the walls).

In case of a cavity wall, inside the cavity must be add a padding that can distribute the forces between the leaves, and to prevent the walls from collapsing due to the tension forces of the reinforcement measure. This can for example be reached by using a “socket anchor”. A socket anchor looks like a regular anchor, but around the shaft of the rod an elastic socket is placed. After insertion in the wall, the socket can be filled with grout. Inside the cavity of the wall the socket will be able to expand to a certain extent when being filled, which creates a thickening in between the wall leaves, that connects the two leaves.

Materials

The best material for the cage is stainless steel. This material is very ductile, which is preferable in case of an earthquake. It is very strong and does not rust, which is important when exposed to moist weather conditions. The steel can be painted in any color for decorative purposes

Detailing

The cage can be entirely be prefabricated. The cage must be connected to the walls and the parapet by the use of chemical anchors and anchor plates to ensure adequate distributions and remittance of forces.

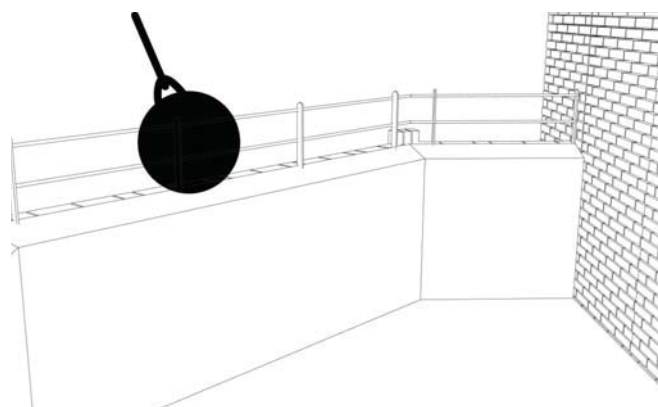

1. Removal of the old fence

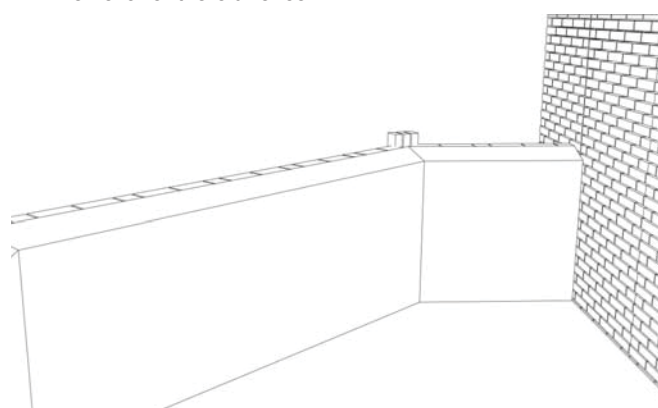

2. Parapet without fence

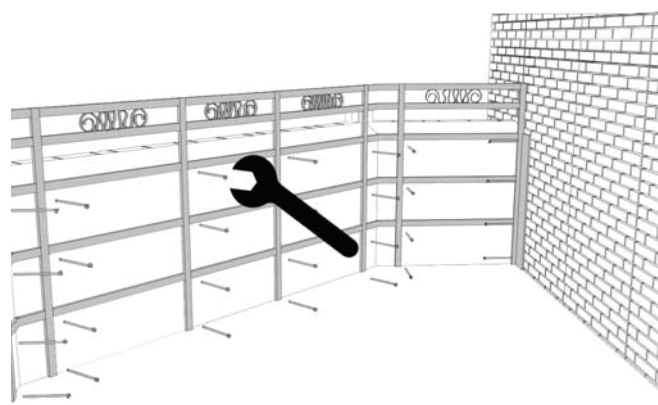

3. Bolting the restraint to parapet and the wall

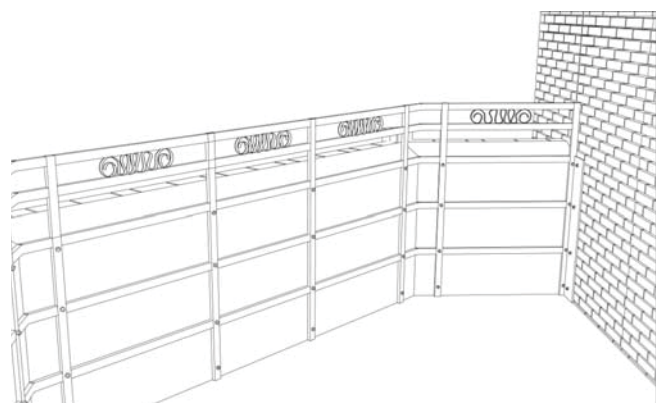

4. New appearance

Figure 162: Assembling: own elaboration



Figure 163: Before assembly, source: own elaboration

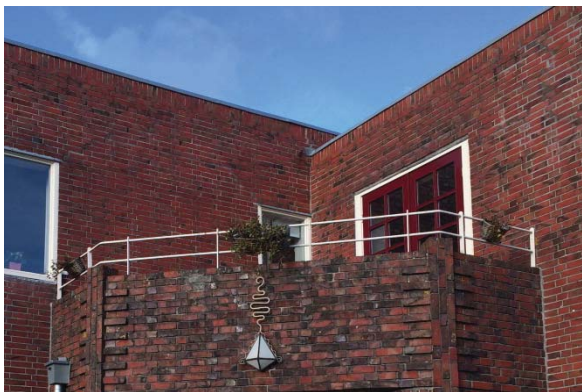

Figure 164: Before retrofit, source: own elaboration

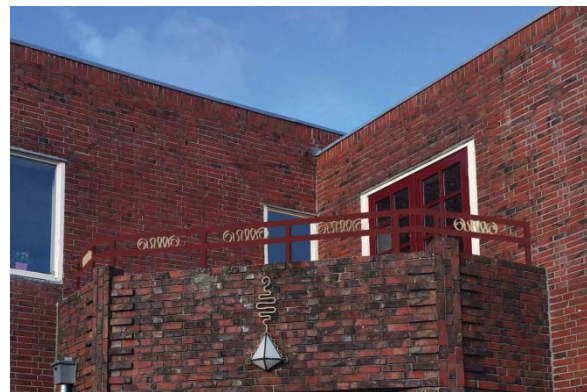

Figure 165: After retrofit, source: own elaboration



Figure 166: Original appearance of the building : own elaboration



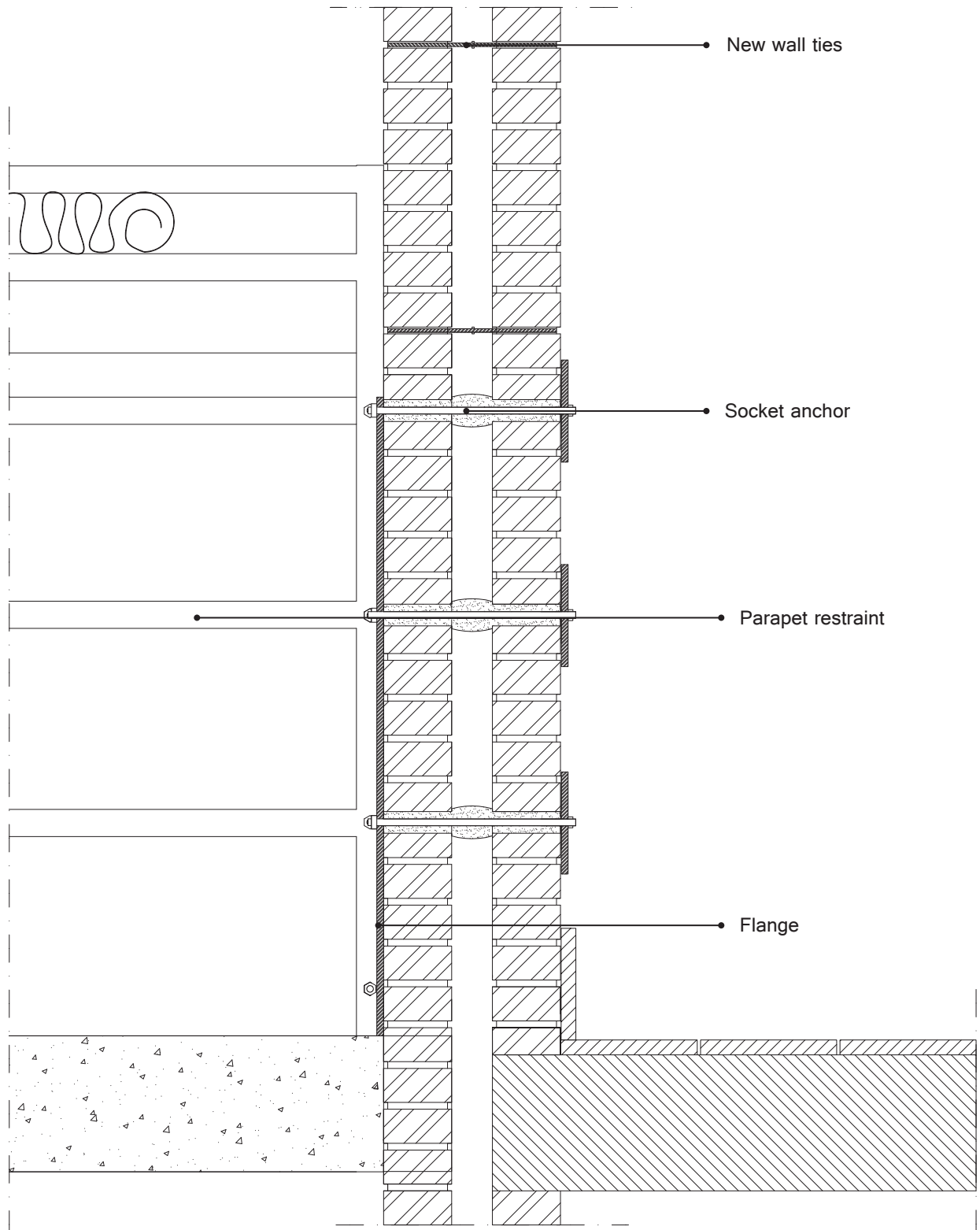

Figure 167: Detail, source: own elaboration



Marginalia:

Extra attention must be paid to the connection with the walls. Because new forces will hit walls that were not necessarily designed to be able to withstand this, the forces must be adequately distributed over a large surface area. On the outside of the wall this will be provided by the flange connected to the cage, on the inside of the building an anchor plate must be attached.

Design decisions:

For this design a building specific approach was chosen. The reinforcement measure refers to the original garden fencing of the building. By picking a building specific element and turning this into a reinforcement measure a visual merge with the building was pursued. The original parapet will remain intact, the reinforcement concerns an addition.

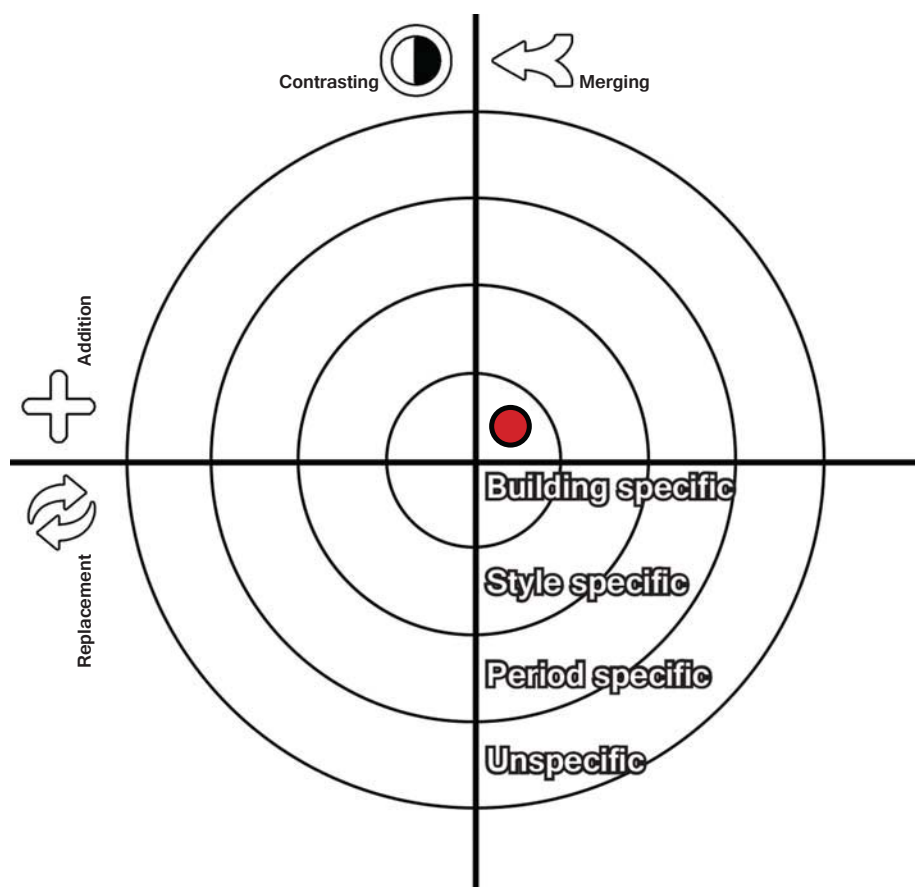

Figure 168: Design decisions spectrum source: own elaboration



Planter box parapet restraint

Design

Due to the heavy weight and the brittleness of the material the masonry parapet causes great danger in case of an earthquake. The parapet can break and fall off the building. To prevent this from happening a restraint must be attached to the parapet.

This design is based on adding an extra function to the parapet restraint. In this case the restraint functions as a planter box; a functionality that many people already have added to their parapets.

Mechanics

The “planter box” in fact is a structural profile that is connected to the main structure. In case of an earthquake, the profile prevents the parapet from moving back and forth. With the parapet firmly held in place by the profile the chance on collapse of the parapet is reduced to a minimum.

Assembling

The planter box profile can simply be placed on top of the parapet. The profile must be attached adequately to the main structure. In this case the underlying structure concerns a wooden beam that makes part of the roof trusses. The parapet can be attached to this beam by the use of a bolted tension rod.

Materials

The best material for the planter box is stainless steel. This material is very ductile, which is preferable in case of an earthquake. It is very strong and does not rust, which is important when exposed to moist weather conditions. The steel can be painted in any color for decorative purposes. In order to prevent the addition of weight, which is unfavorable in case of an earthquake, a lightweight growth medium should be used instead of regular soil in the planter box.

Detailing

The planter box profile is attached to the main structure by the use of bolts.

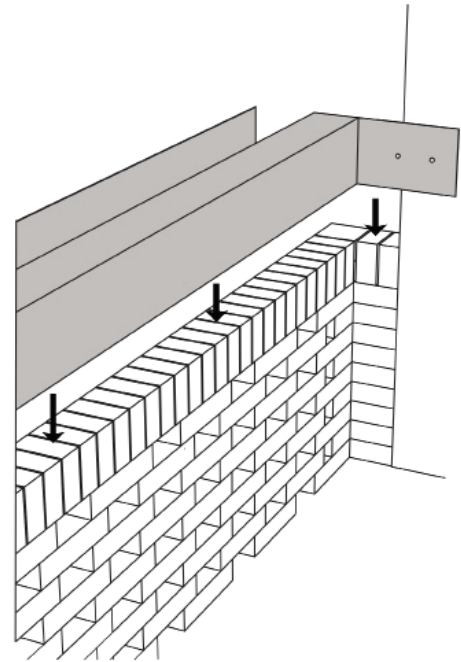

1. Placement of the profile

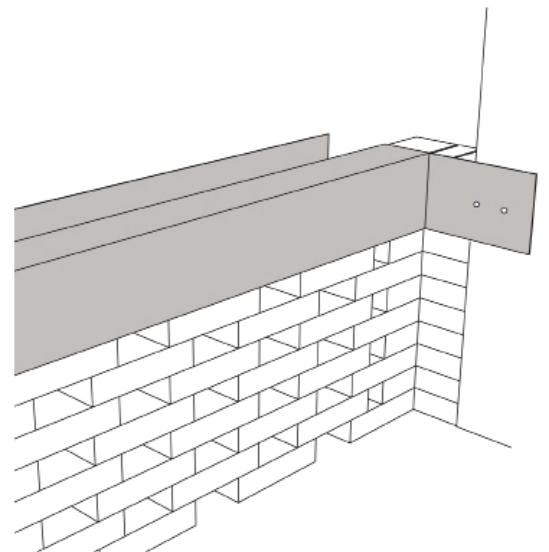

2. Profile in the right place

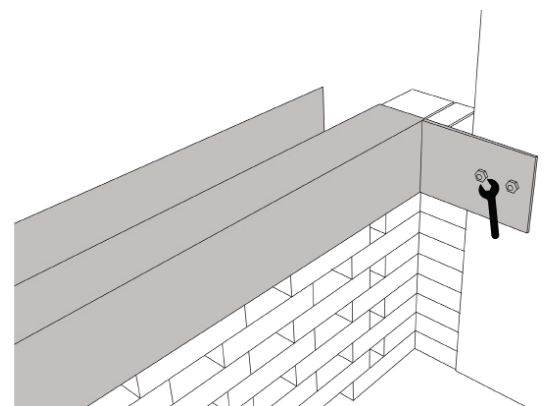

3. Bolting the profile to the wall

Figure 169: Assembling, source: own elaboration



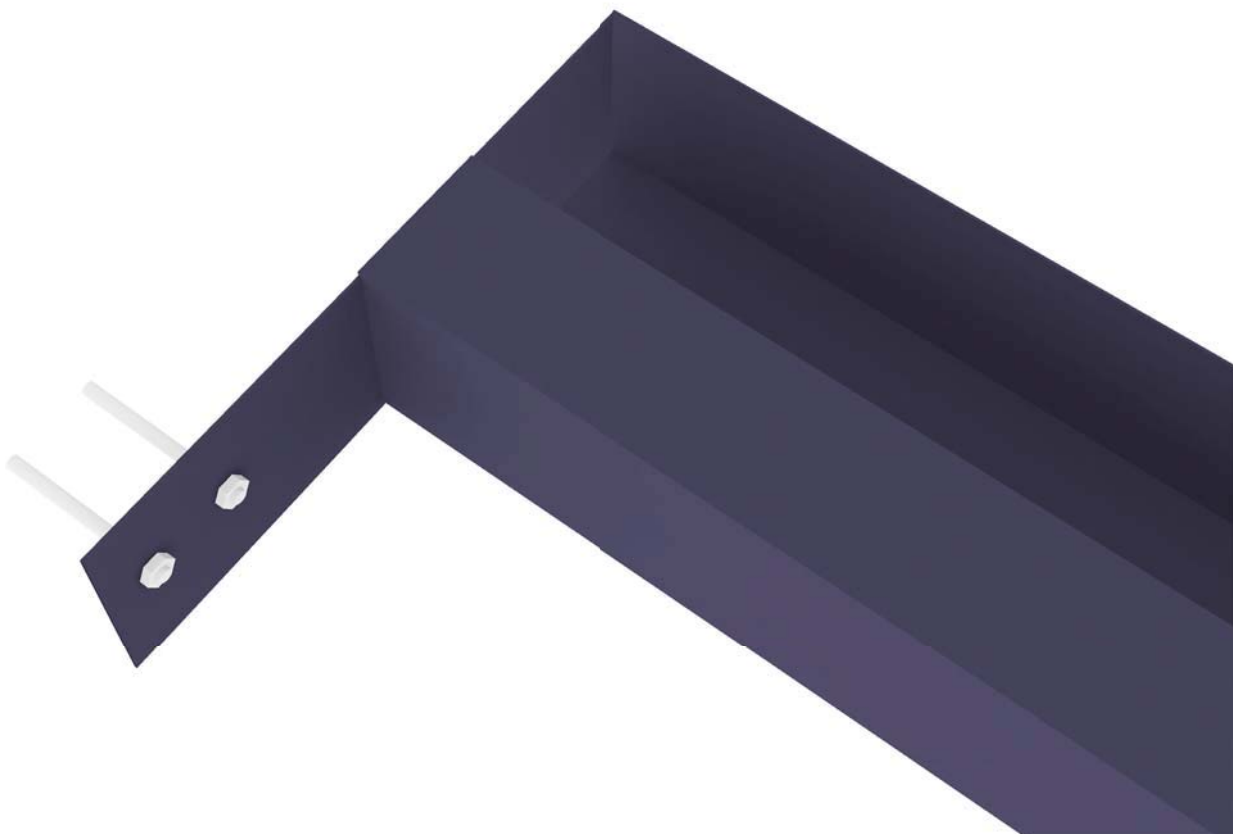

Figure 170: Before assembly, source: own elaboration



Figure 171: Before retrofit, source: own elaboration



Figure 172: After retrofit, source: own elaboration



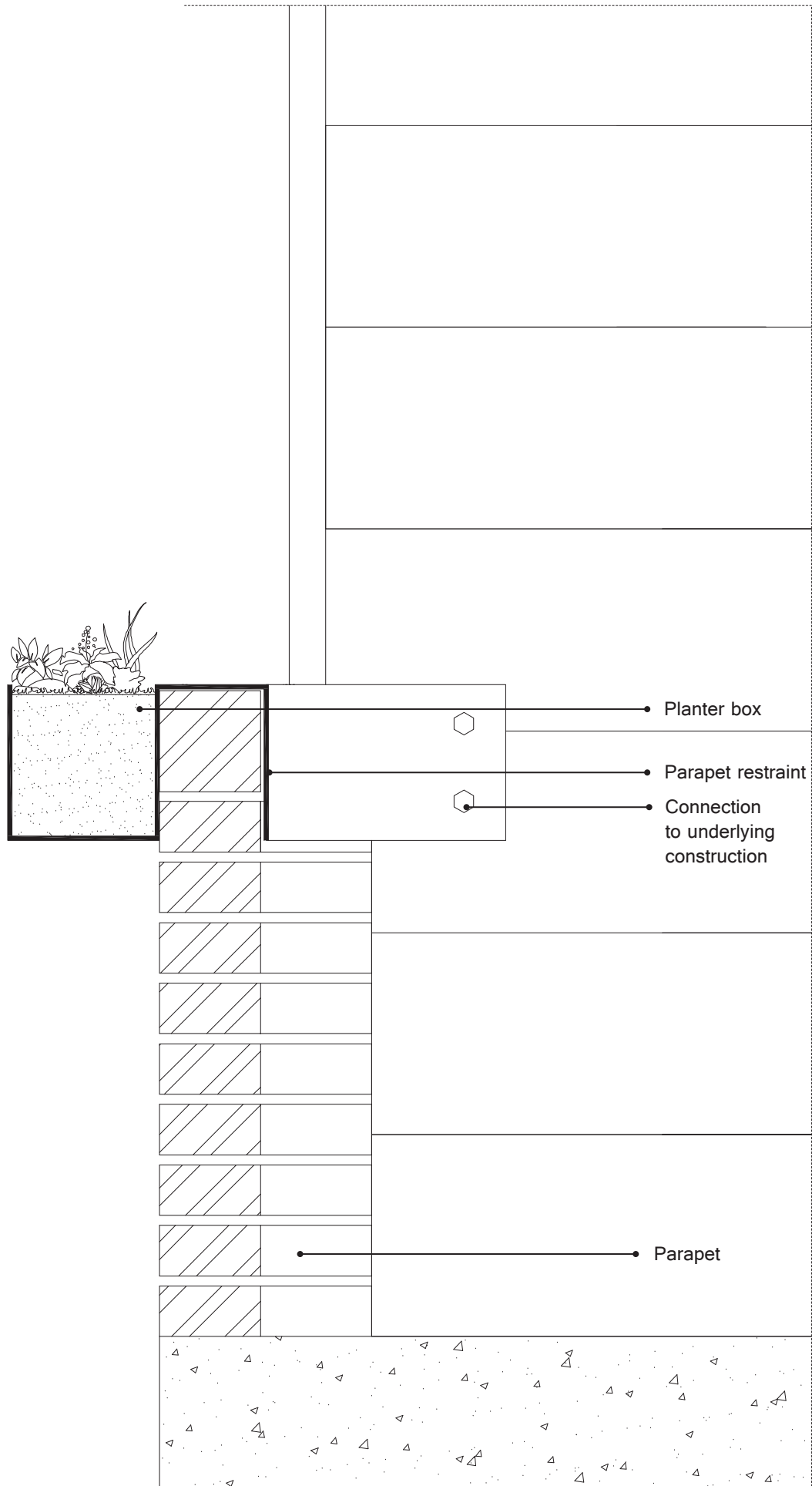

Figure 173: Detail, source: own elaboration



Marginalia:

- The forces caused by the additional mass of the profile and the planter box must be transported through the connections as well. Therefore these connections should have adequate dimensions and structural properties.
- The underlying structure must be strong enough to be able to dissipate the forces of both the parapet and the planters.
- Due to the openwork masonry, in this case, the consistency of the parapet is significantly lower than in traditional masonry. It could happen that the parapet breaks in the middle, beneath the reinforcement measure. In order to prevent this from happening at the rear of the brickwork a fiber mat (glass or carbon) can be glued to the brickwork with an epoxy adhesive. This way the bricks cannot break loose from each other.

Design decisions:

For this design an unspecific approach was chosen. The reinforcement measure does not refer to a specific style or building. The design contrasts with the building due to the use of contemporary materials and shaping. The original parapet will remain intact, the reinforcement concerns an addition.

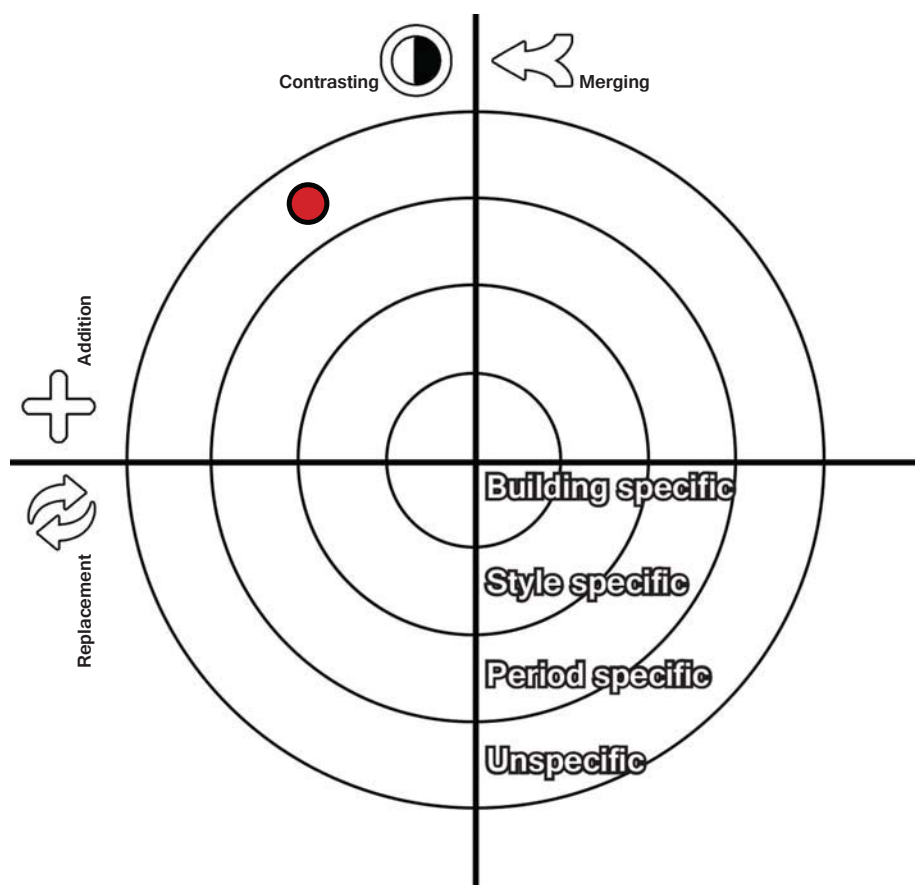

Figure 174: Design decisions spectrum source: own elaboration



Invisible anchor plate

Design

This design intends to pursue invisibility. The anchor plate is inserted inside the cavity wall from the inside, through a machined gap. Inside the cavity wall the anchor must be turned 90 degrees in order to make a connection to the wall. The appearance from the outside of the building will remain unchanged.

Mechanics

In order to be placed inside the wall, the anchor plate is long and slender to fit through a small gap. Inside the wall the anchor must be turned 90 degrees in order to place it perpendicular to the direction of the masonry. This way it can distribute forces over multiple bricks. The part of the anchor that touches the inside of the cavity wall must be covered with a soft foam in order to equalize the rough surface of the masonry.

Assembling

First an L profile with slotted holes must be attached to the floor beams on top of the floor against the wall. Then, in the right location, narrow gaps must be cut in the inner leaf of the cavity wall with a wall cutter. After having the wall cut the anchors can be pushed through the gaps. When reaching the cavity, the anchors must be turned 90 degrees to get stuck in the cavity. By the use of anchor plates and bolts the anchor can be tightened to the L profile.

Materials

The choice of material for the anchor is stainless steel. This material is very ductile, which is preferable in case of an earthquake. It is very strong and does not rust, which is important inside the moist wall.

Detailing

The anchor is T shaped. This is necessary to be able to fit through a narrow hole cut in the longitudinal direction of the masonry, and after turning it 90 degrees, the contact area of the anchor provides distribution of forces over multiple bricks. The contact surface of the anchor must be covered with foam in order to properly connect to all the stones, and to prevent the emergence of unwanted point loads.

Anchor plates placed over the L profiles enable bolting the anchors to the structure.

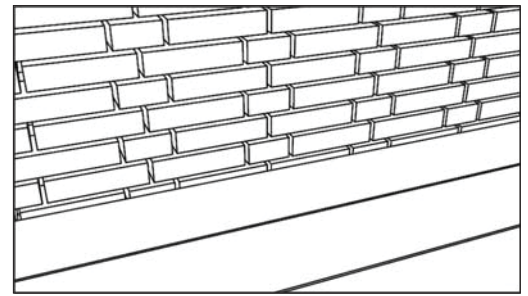

1. Bare wall

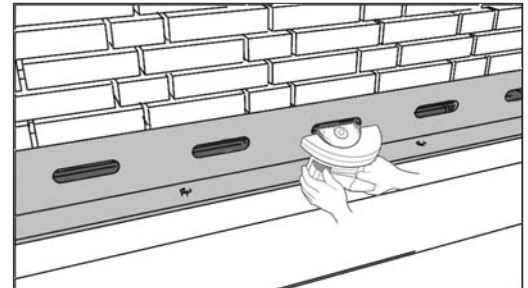

2. Cutting gaps

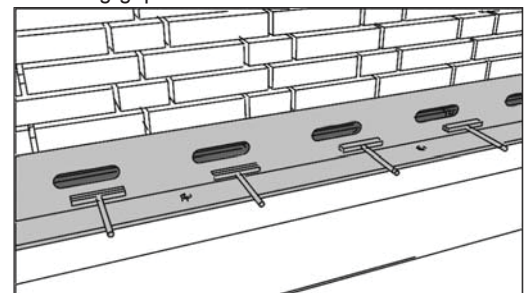

3. Inserting the anchors

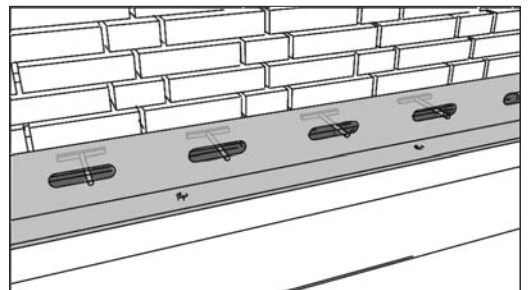

4. Anchors inside the cavity of the wall

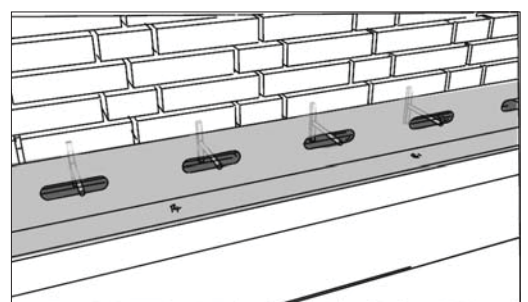

5. Rotated anchors

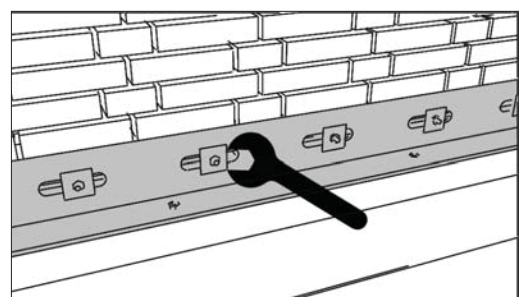

5. Bolting the anchors

Figure 175: Assembling: own elaboration



Figure 176: Before assembly; position 1, source: own elaboration



Figure 177: Before assembly; position 2, source: own elaboration



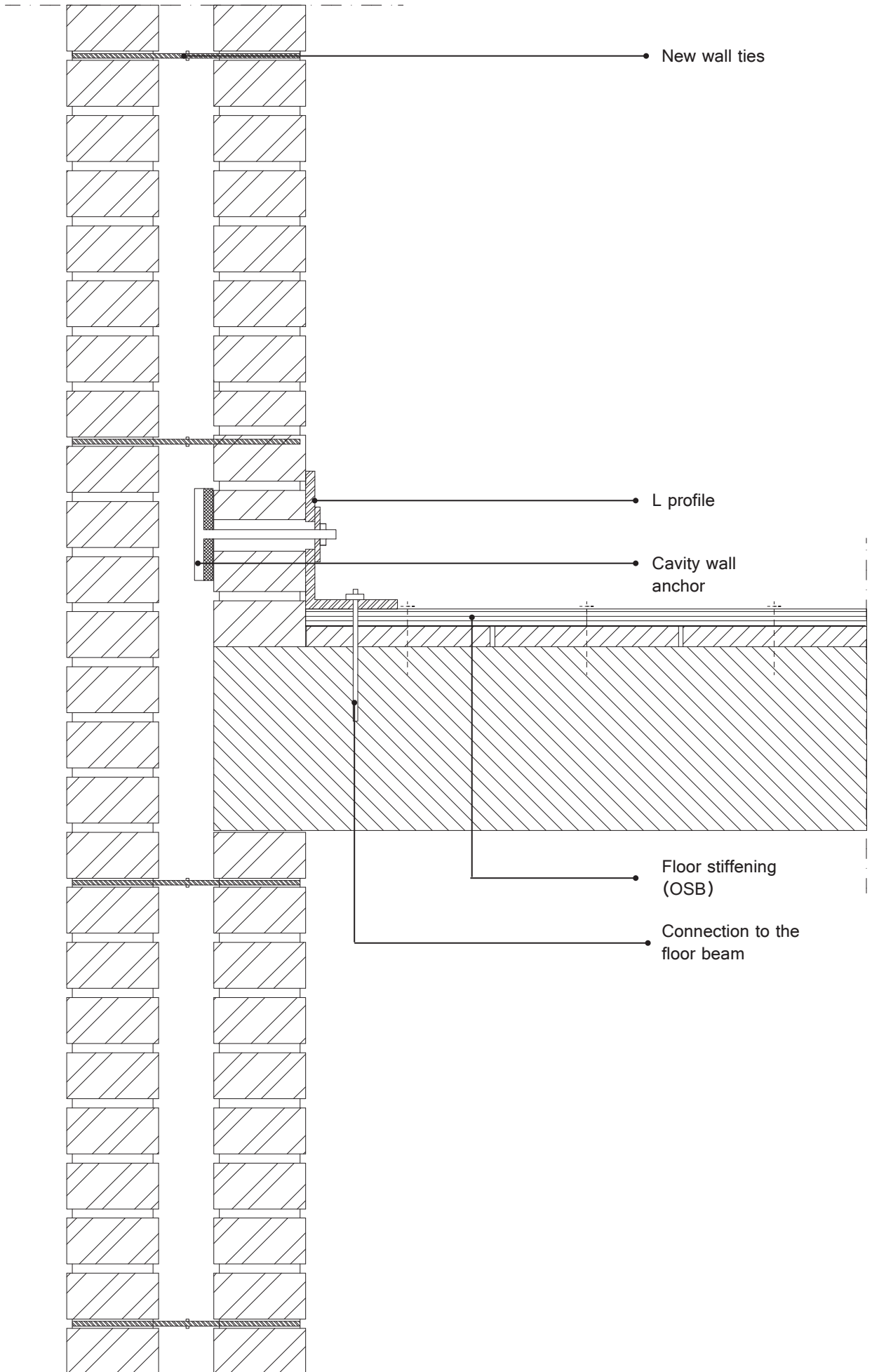

Figure 178: Detail, source: own elaboration



Marginalia:

- The cavity is never smooth inside, it has many bulges due to sloppy jointing. To ensure that the anchor touches the masonry over a large surface area a soft material should be applied on the wall touching side of the anchor.
- The cavity might be narrower than 60mm because of bulges of mortar. This can make it more difficult to implement the anchors. Also old wall ties can disturb the installation of the wall anchors.
- The forces need to be conveyed in a rigid floor surface for the purpose of the transfer of forces (level 3 measure). This rigid surface must be provided as well, and the connection between the rigid surface, the floor beams and the wall should be adequate.
- The two leaves of the cavity wall must be adequately connected by the use of renovation wall ties.

Design decisions:

For this design the purpose was to pursue invisibility.

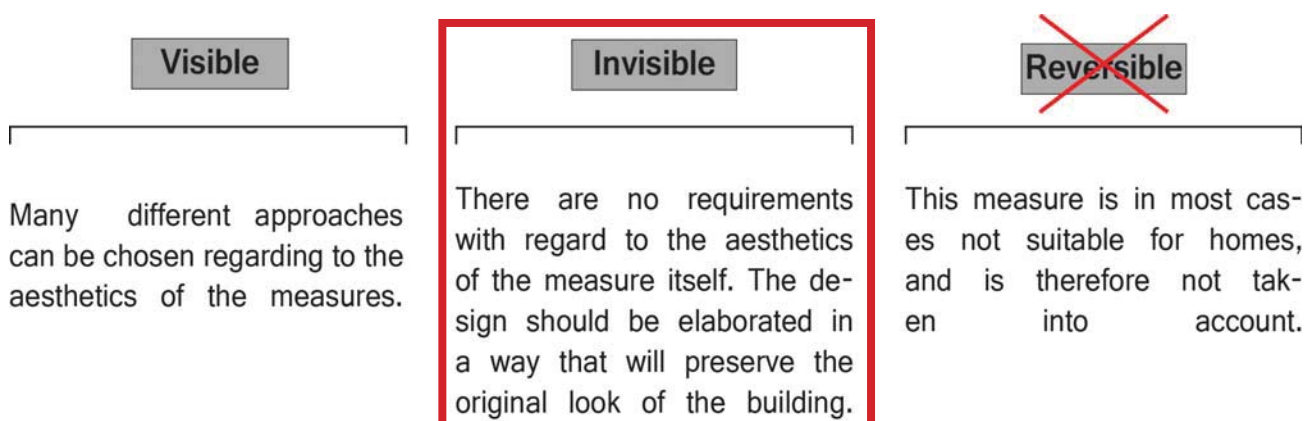

Figure 179: Design strategies: own elaboration



Covered anchor plate 1

Design

This concept is based on the idea of a “total architectural experience”. The ornament on the shed is repeated on the cover of the anchor plate. Over the structural anchor plate a replaceable cover can be hung that fits the style of the architecture of the building. This way the anchor plate itself can be standardized, but its cover can be adjusted to the aesthetics of the building.

Mechanics

The inner anchor plate provides the structural properties of the reinforcement measure, and distributes the forces. The outer anchor “cover” hides the structural anchor plate. The outer anchor plate does not have to be made of a specific material to withstand large forces, but it must withstand weather conditions since it will be exposed to the outside all the time. It also shouldn't weigh too much, or be too brittle, because this enlarges the chance on falling off during earthquakes what can create a new hazard.

Assembling

On the inside of the building an L profile must be attached to the floor, in order to make a rigid connection between wall and floor. Then, after the mounting of the L profile, at appropriate distances holes need to be drilled through the wall (from the inside). From the inside a tie rod than can be stabbed through the L profile and the wall. On the outside a constructive anchor plate can be placed on the end of the tie rod, and bolted together to tension the system.

In case of a cavity wall, inside the cavity must be add a padding that can distribute the forces between the leaves, and to prevent the walls from collapsing due to the tension forces of the reinforcement measure. This can for example be reached by using a “socket anchor”. A socket anchor looks like a regular anchor, but around the shaft of the rod an elastic socket is placed. After insertion in the wall, the socket can be filled with grout. Inside the cavity of the wall the socket will be able to expand to a certain extent when being filled, which creates a thickening in between the wall leaves, that connects the two leaves.

The position of the structural anchor plates will differ slightly in height because of the inaccuracy of the drilling. To remove this difference aesthetically the fixations of the cover plates can be hung on the exact same height from the floor. The fixation will be provided by a bracket to which the cover plates easily can be attached.

Materials

The choice of material for the constructive anchor plate is stainless steel. This material is very ductile,

which is preferable in case of an earthquake. It is very strong and does not rust, which is important when exposed to moist weather conditions.

The aesthetic plate can be best composed of two layers of material, an inner plate that ensures “structural” properties and a top layer that is glued to the steel inner layer. This top layer can be made of any material. In this case the anchor plate looks similar as the decorative concrete of the shed. A tile of concrete for example could be glued to the steel inner layer of the outer plate.

Detailing

On the inside of the building a steel profile is bolted to the floor, and connected to the wall by rods. The rods connect the steel profile to an anchor plate on the outside. The anchor plate on the outside of the wall is covered by a nonstructural aesthetic plate that suits the style of the building. Between the structural anchor plate and the outer wall a layer of grout is added in order to equalize the surface and thus provide a smoother distribution of forces.

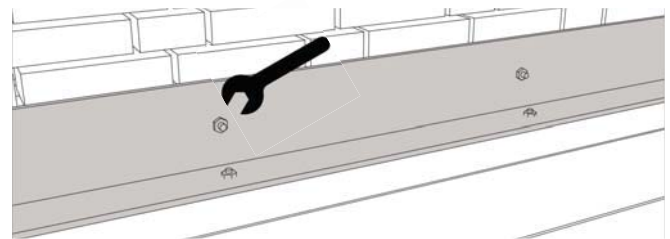

1. Bolting the L profile

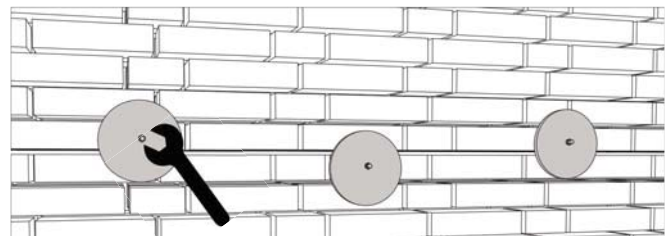

2. Bolting the anchor plates

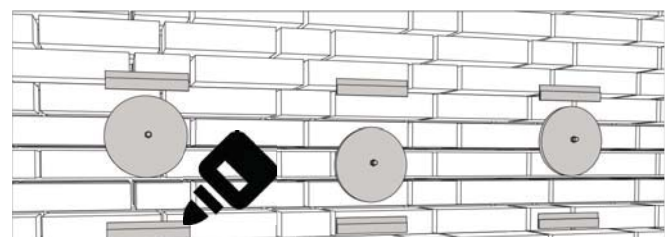

3. Glueing the brackets

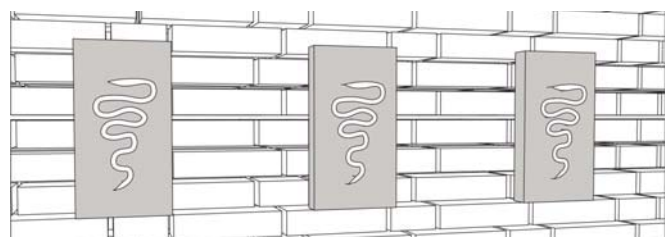

4. Placed cover plates

Figure 180: Assembling: own elaboration

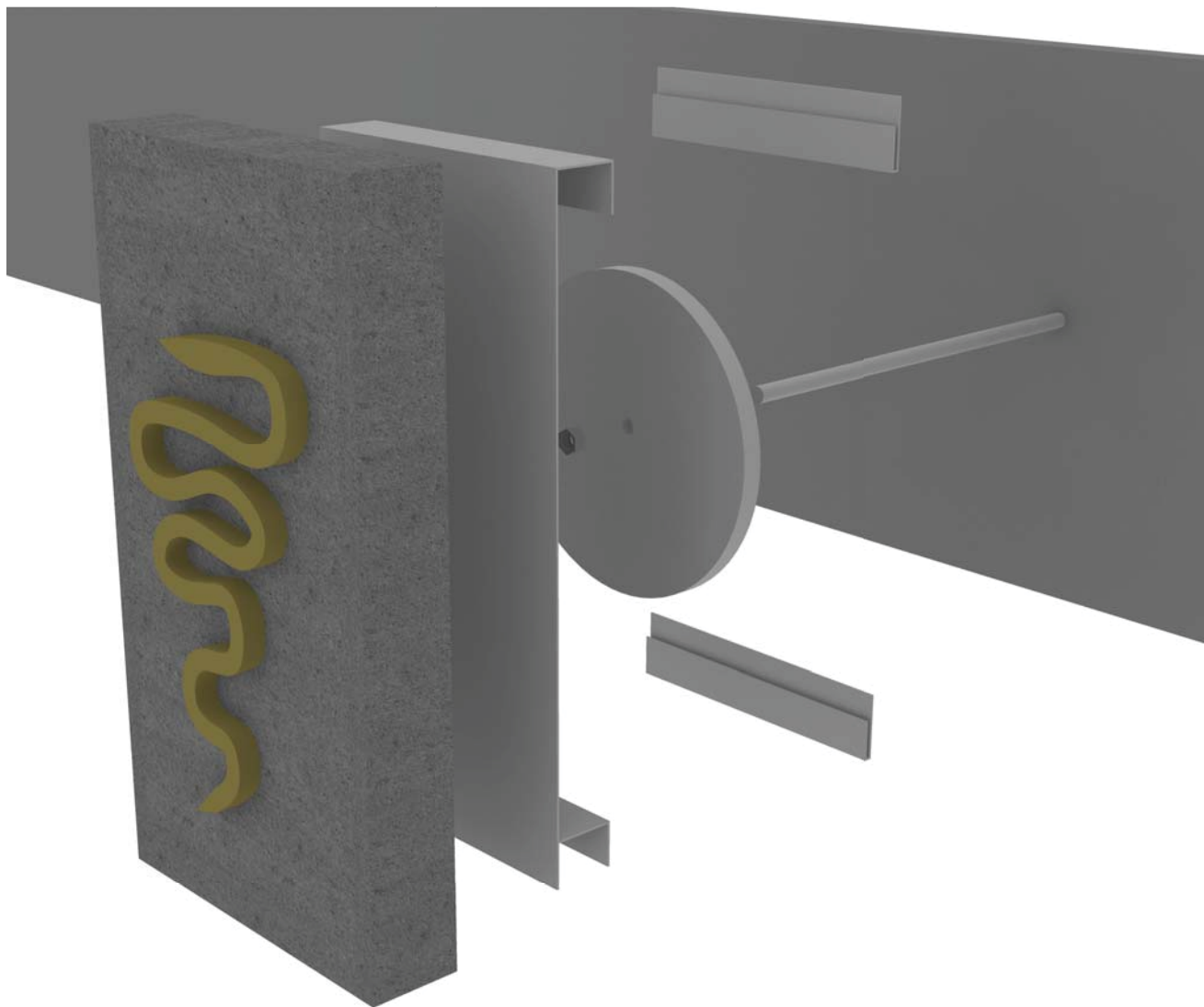

Figure 181: Before assembly, source: own elaboration



Figure 182: Before retrofit, source: own elaboration



Figure 183: After retrofit, source: own elaboration



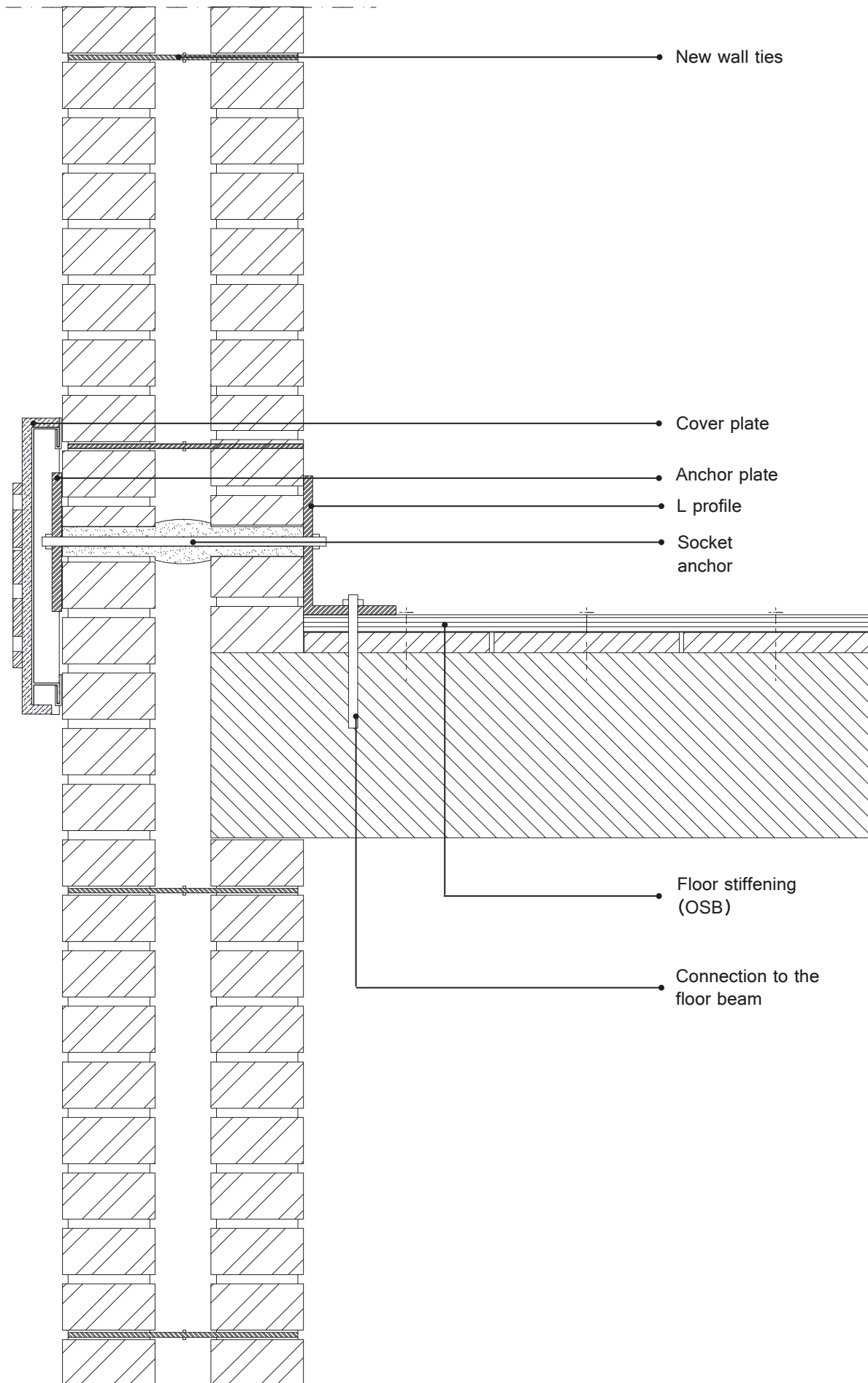

Figure 184: Detail, source: own elaboration



Marginalia:

- For the determination of the thickness of the profile and the anchor plate 2 approaches are possible. You can use a “flexible” profile and utilize the elasticity in order to dissipate the energy of the forces. This is, in the case of naturally caused earthquakes the most favorable. In the case of the induced earthquakes in Groningen the flexibility is of less importance, because the tremors are short-lived. In the case of the induced earthquakes it is better to pursue the highest possible stiffness. A standard L profile, 100x150, 8mm should be sufficiently in this case. For the anchor plate 8 or 10 mm thickness would be sufficient.

- When the anchors are drilled from the inside the anchors will not all end at the exact same height. To equalize this difference in height visually the cover plate should offer enough space for adjustment.

- In case of the use of socket anchors a hole of 32 mm is drilled, the sock will, once filled with grout, expand in the cavity to a thickness of 40mm. This expansion interlinks the inner and outer leaf of the cavity wall.

Design decisions:

For this design a building specific approach was chosen. The reinforcement measure refers to the ornaments on the shed of the building. By picking an existing element and turning this into a reinforcement measure a visual merge with the building was pursued. No elements have to be removed in order to install this measure, the reinforcement concerns an addition.

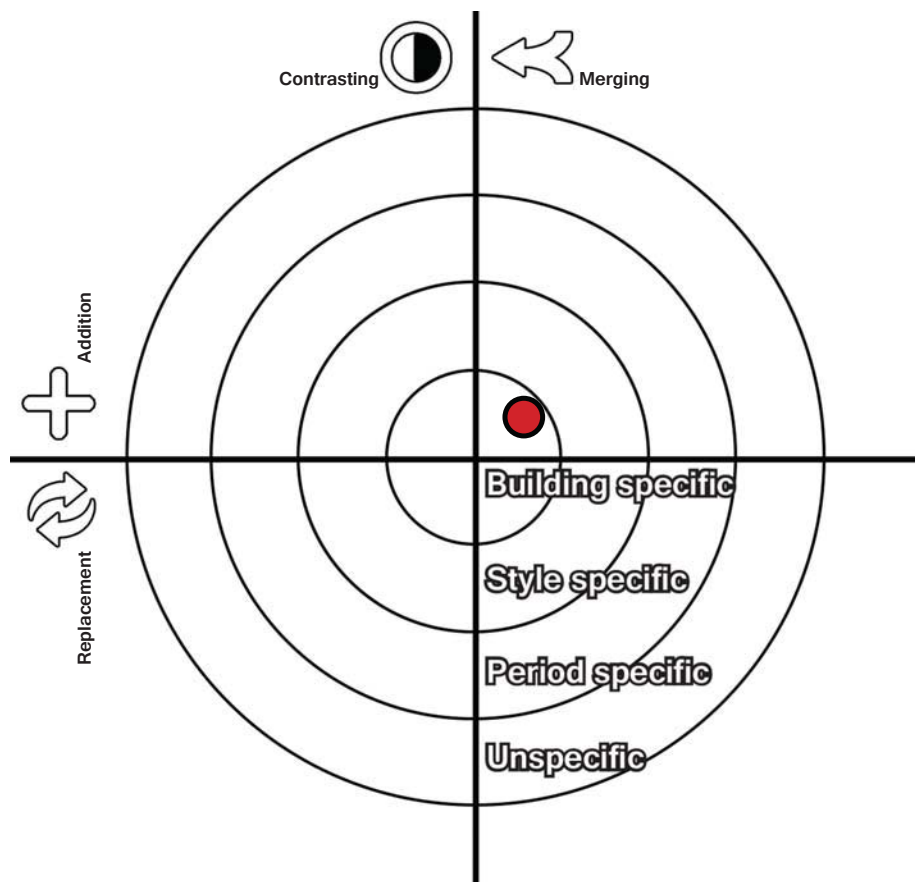

Figure 185: Design decisions spectrum source: own elaboration



Covered anchor plate 2

Design

This concept is based on the idea of a “total architectural experience”. The typical triangular shape of the little window in the doors is repeated as a cover for the anchor plate. Over the structural steel anchor plate a replaceable wooden cover is hung that fits the style of the architecture of the building. This way the anchor plate itself can be standardized, but its cover can be adjusted to the aesthetics of the building.

Mechanics

The inner anchor plate provides the structural properties of the measure, and distributes the forces. The outer cover hides the performing anchor plate. The outer plate does not have to be made of a specific material to withstand large forces, but it must withstand weather conditions since it will be exposed to the outside all the time. It also shouldn't weigh too much, or be too brittle, because this enlarges the chance on falling off during earthquakes what can create a new hazard.

Assembling

On the inside of the building a beam shoe must be attached to the floor beam, in order to make a rigid connection between the wall and the floor. Then, after the mounting of the beam shoe, a hole needs to be drilled through the wall (from the inside). From the inside of the building a tie rod then can be inserted through the wall. On the outside the constructive plate can be placed on the end of the tie rod, and bolted together to tension the system. The position of the structural anchor plates will differ slightly in height because of the inaccuracy of the drilling. To remove this difference aesthetically the fixations of the cover plates must be hung on the exact same height relative to each other. The fixation will be provided by brackets with slotted holes that are mounted on the cover plates. Two screws in the wall provide the attachment to the building.

Materials

The best choice of material for the constructive anchor plate is stainless steel. This material is very ductile, which is preferable in case of an earthquake. It is very strong and does not rust, which is important when exposed to moist weather conditions.

The aesthetic plate was designed in wood to approach the aesthetics of the doors as close as possible. The fastening brackets must be screwed onto the cover plate, and two stainless steel screws must be drilled into the wall in order to mount the cover plate.

Detailing

On the inside of the building a steel beam shoe is connected to the floor beams, and connected to the wall by a rod which connects the profile to an anchor plate on the outside. The anchor plate on the outside of the building is covered by a nonstructural aesthetic plate that suits the style of the building. Between the structural anchor plate and the outer wall a layer of grout is added in order to equalize the surface and thus provide a better distribution of forces.

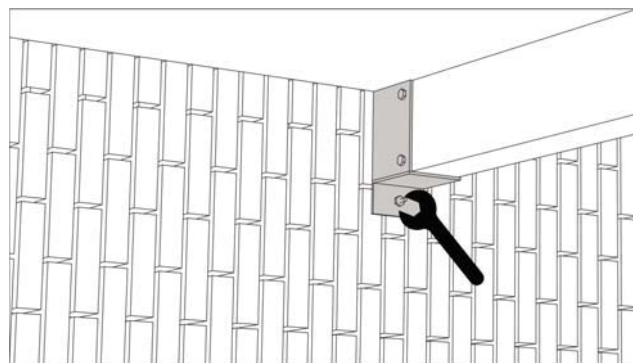

1. Bolting the beam shoe

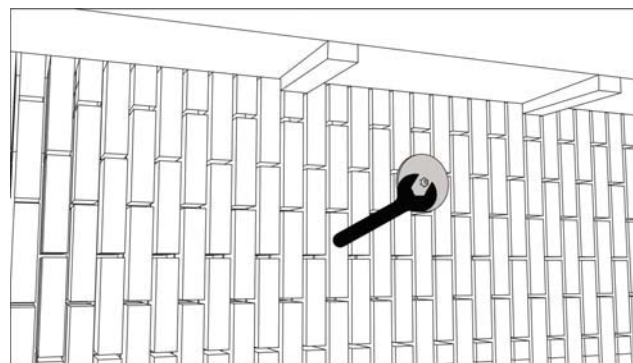

2. Bolting the anchor plate

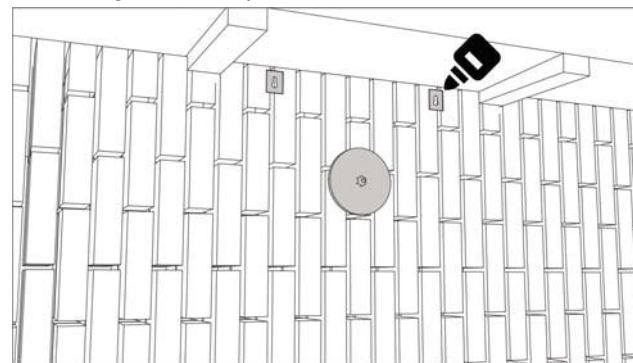

3. Glueing the brackets

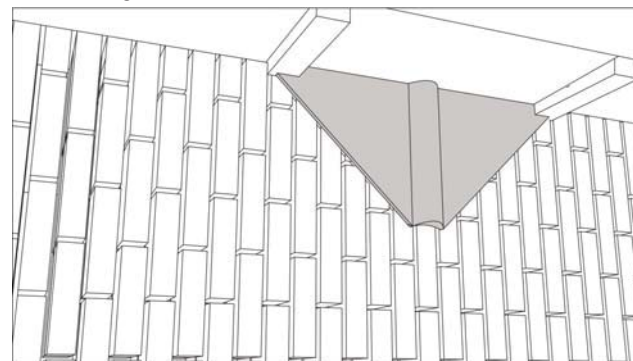

4. Placed cover plate

Figure 186: Assembling: own elaboration

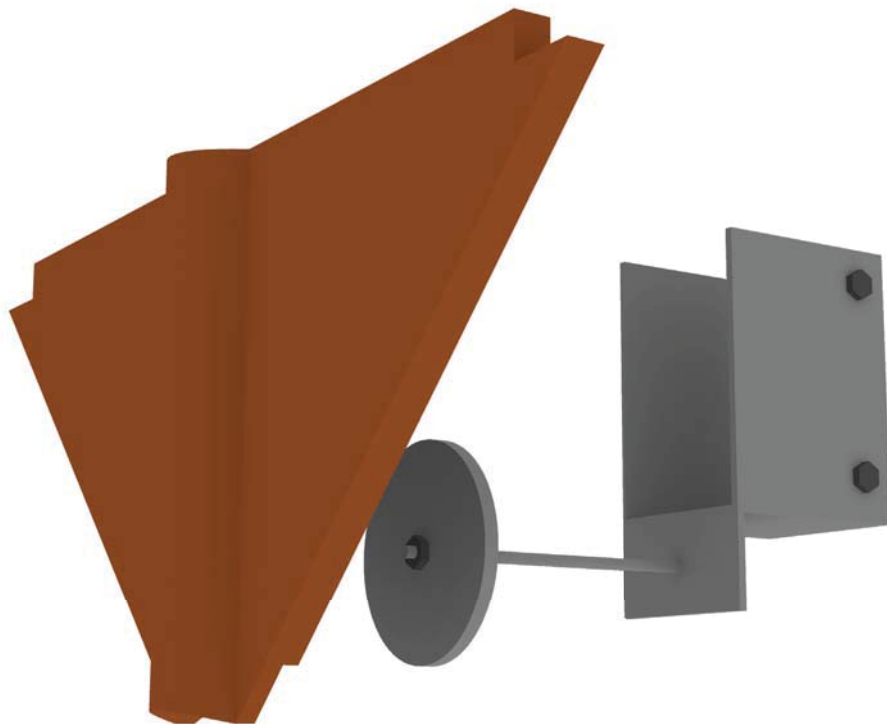

Figure 170: Before assembly, source: own elaboration



Figure 187: Before retrofit, source: own elaboration



Figure 188: After retrofit, source: own elaboration



Figure 189: Ornamental doors, source: own elaboration



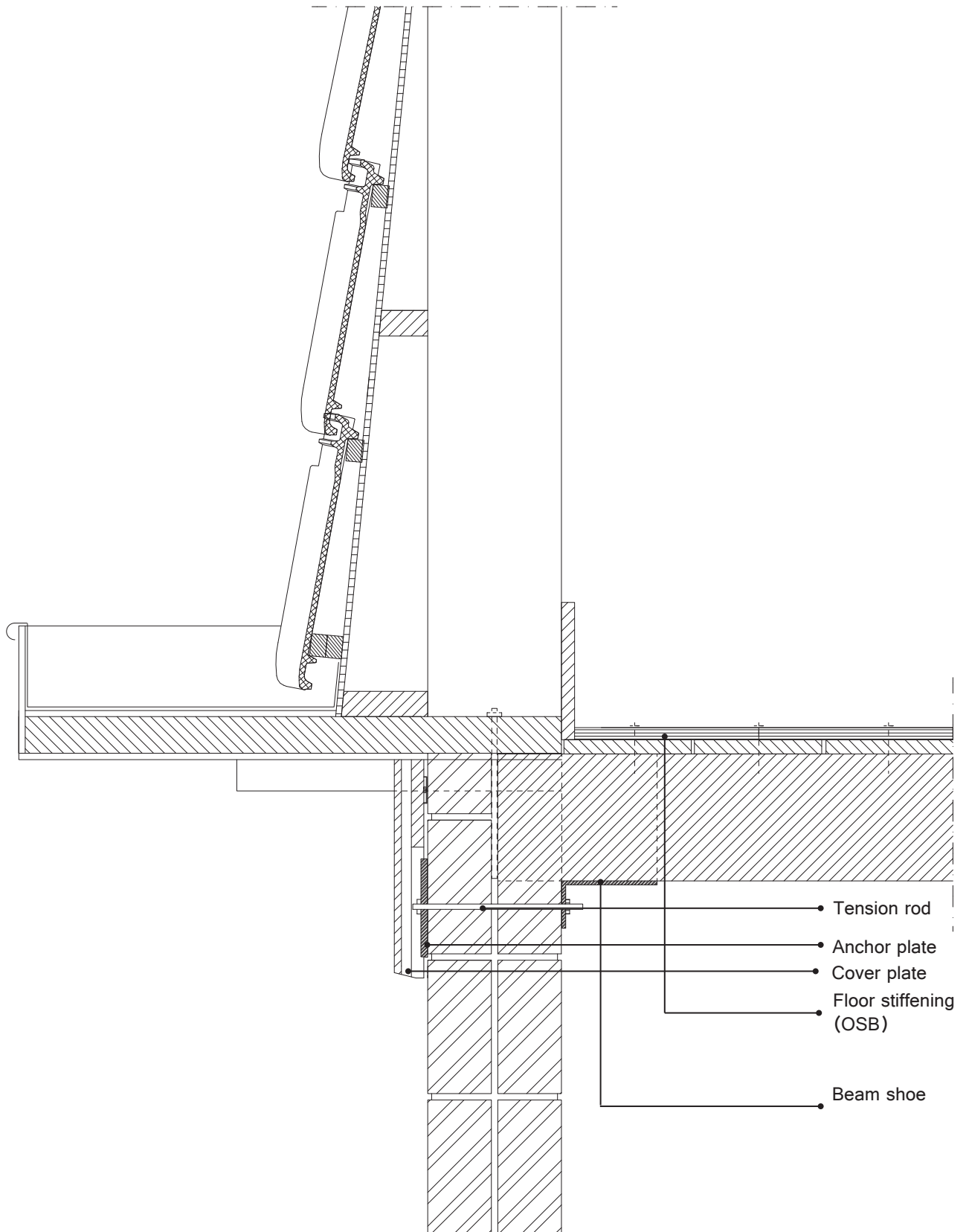

Figure 190: Detail, source: own elaboration



Marginalia:

- A thickness of 8 or 10 mm for the anchor probably would be sufficient.
- When the anchors are drilled from inside the anchors will not all end at the same height. To equalize this difference in height the cover plate should offer enough space for adjustment.

Design decisions:

For this design a building specific approach was chosen. The reinforcement measure refers to the ornamental shape of the doors. By picking an existing “element” and turning this into a reinforcement measure a merge with the building was pursued. No elements have to be removed in order to install this measure, the reinforcement concerns an addition.

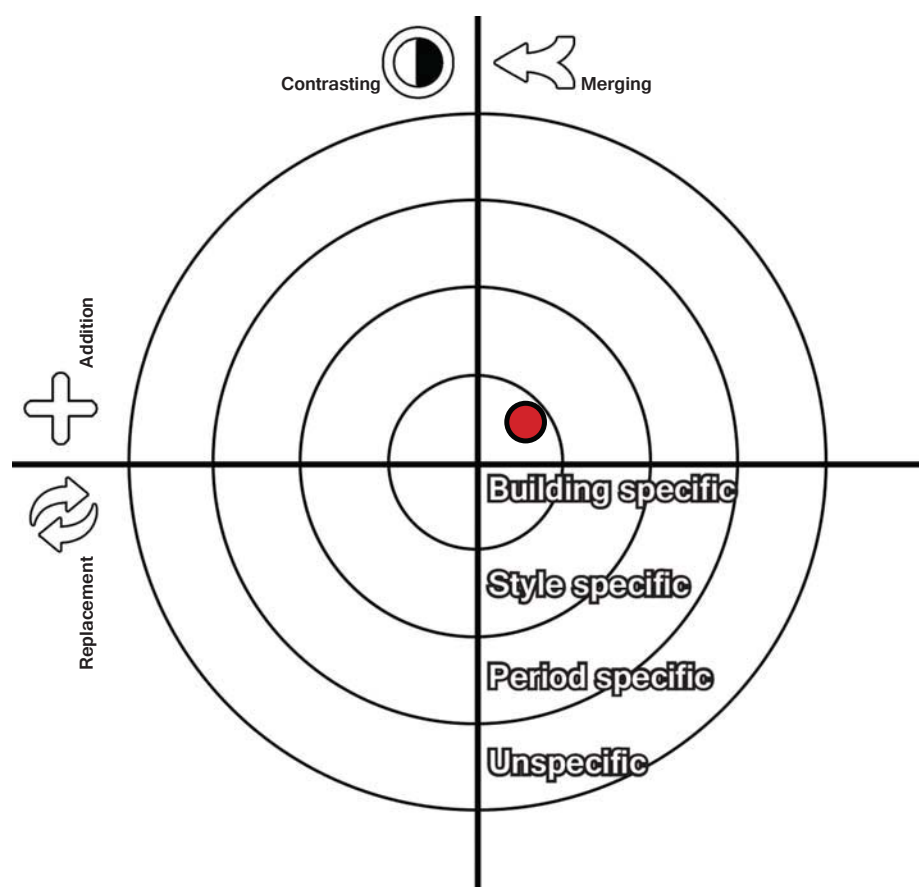

Figure 191: Design decisions spectrum source: own elaboration



Decorative anchor plate

Design

This concept is based on the idea of a “total architectural experience”. The ornamental shape of the crossed slats appears throughout the building. This shape is repeated in the shape of the anchor plate. The anchor plate is custom shaped especially for this specific building. The anchor has not only a functional purpose but it also embellishes the building’s facade.

Mechanics

The crossed slats constitute a large surface area in order to transfer the forces into the wall. The thickness of the customized anchor plate should be sufficient to provide enough stiffness and strength to withstand the forces of an earthquakes. The material should not deteriorate under weather influences in order to maintain the right structural properties.

Assembling

On the inside of the building L profiles must be attached to the floor in order to make a rigid connection between the wall and the floor. Then, after the mounting of the L profile, at appropriate distance holes need to be drilled through the wall. This should be done best from the outside. From the inside the steel profile provides sufficient support for the masonry but from the outside the bricks should be drilled as careful as possible in order to not ruin the masonry. After both drilling the wall and the profile, from the inside a tie rod than can be stabbed through the wall. On the outside the customized anchor plate can be placed on the end of the tie rod, and bolted.

In case of a cavity wall, inside the cavity must be add a padding that can distribute the forces between the leaves, and to prevent the walls from collapsing due to the tension forces of the reinforcement measure. This can for example be reached by using a “socket anchor”. A socket anchor looks like a regular anchor, but around the shaft of the rod an elastic socket is placed. After insertion in the wall, the socket can be filled with grout. Inside the cavity of the wall the socket will be able to expand to a certain extent when being filled, which creates a thickening in between the wall leaves, that connects the two leaves.

Materials

The best material for the anchor plate is stainless steel. This material is very ductile, which is preferable in case of an earthquake. It is very strong and does not rust, which is important when exposed to moist weather conditions. The steel can be painted in any color.

Detailing

On the inside a steel profile is bolted to the floor beams, and connected to the wall by two rods which connects the profile to an anchor plate on the outside. Between the anchor plate and the outer wall a layer of grout is added in order to equalize the surface and thus provide a better distribution of forces. The dimensioning of the anchor plate is made such a way that it suits the pattern of masonry. The two holes in order to mount the anchor plate will always be drilled in the stone, and not in the jointing, for structural reasons.

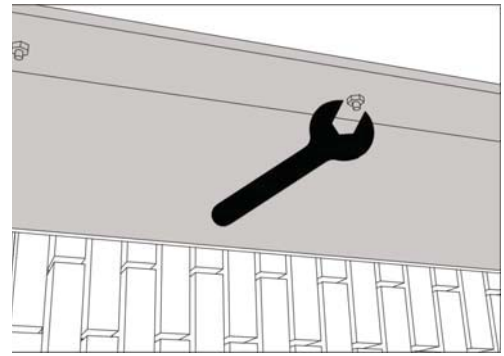

1. Bolting the L profile

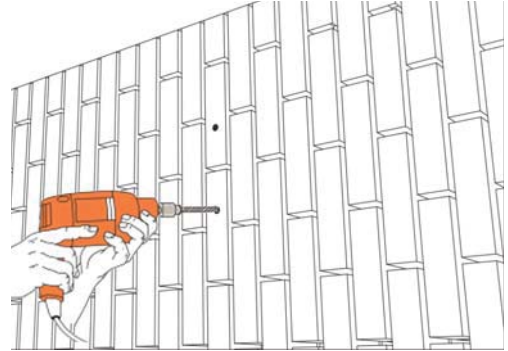

2. Drilling holes from the outside

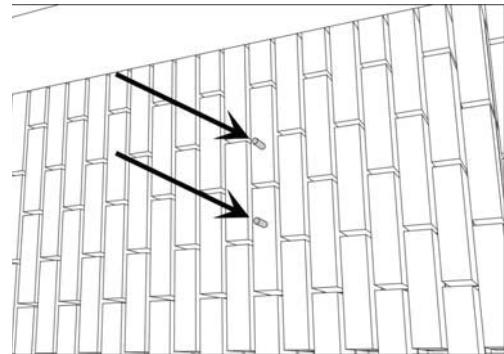

3. Inserting the tie rods

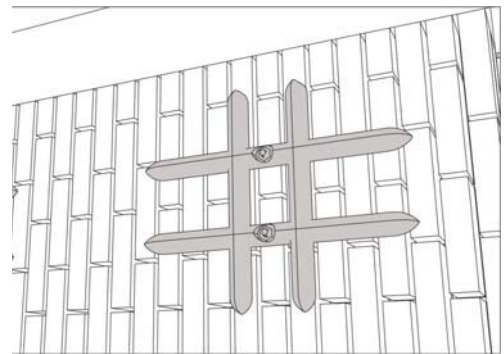

4. Placed anchor plate

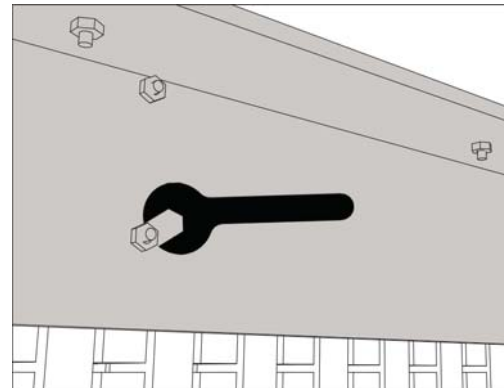

5. Bolting the tie rods

Figure 192: Assembling: own elaboration

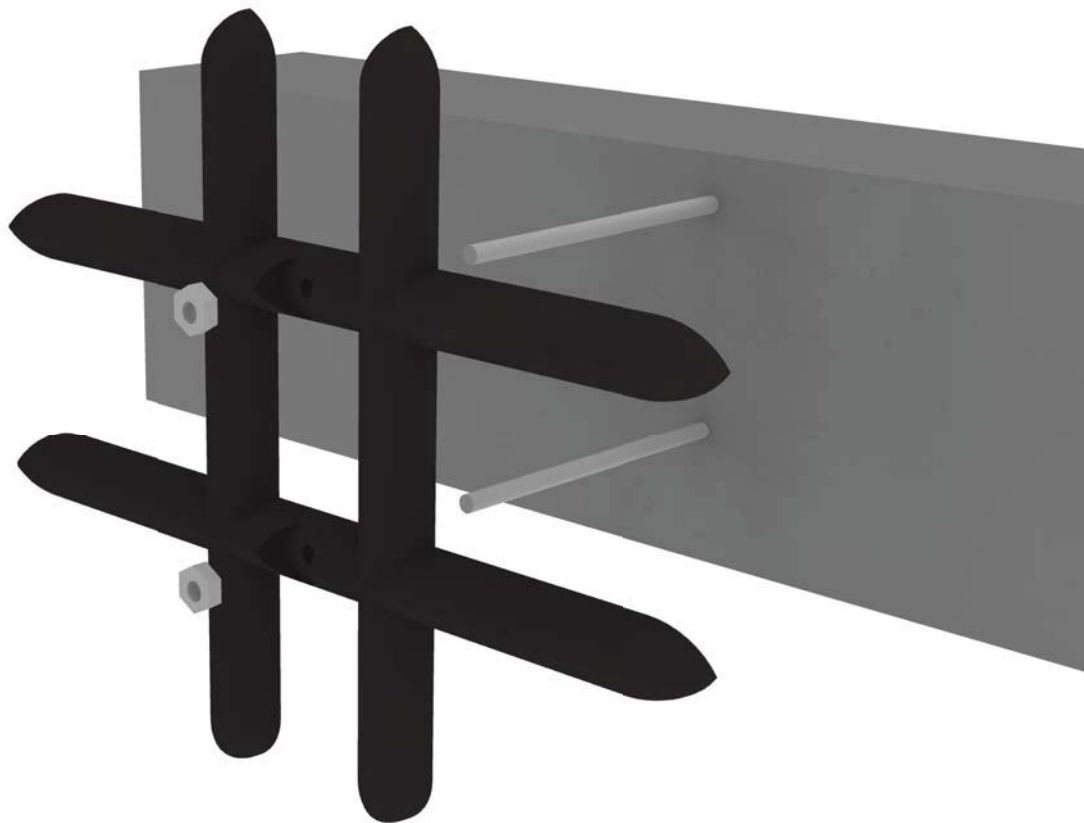

Figure 193: Before assembly, source: own elaboration



Figure 194: Before retrofit, source: own elaboration



Figure 195: After retrofit, source: own elaboration

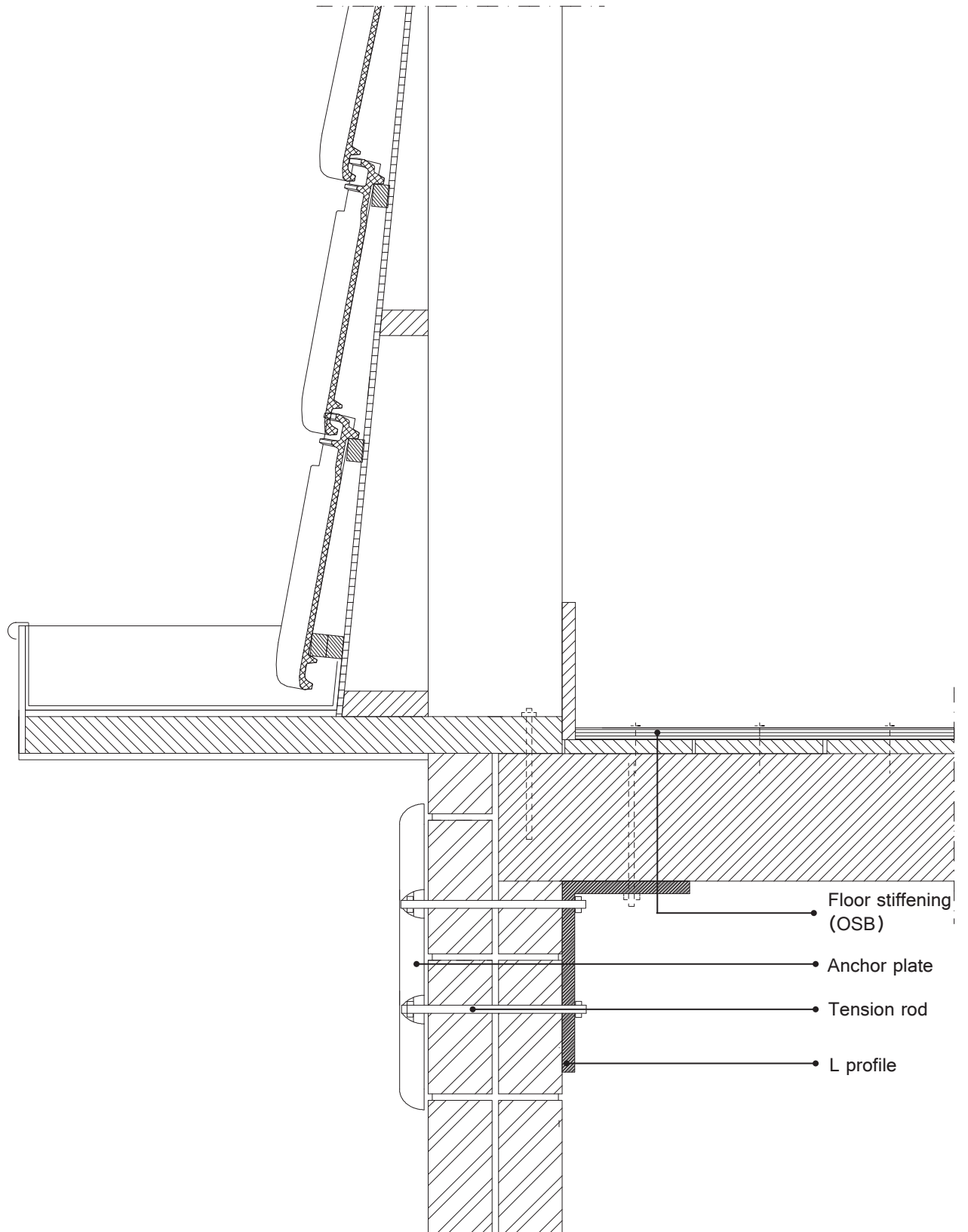

Figure 196: Detail, source: own elaboration



Marginalia:

- The anchor consists of four “bars”. The two bars that provide the load-bearing are the ones transverse to the direction of the masonry (the horizontal bars in this case). These bars must be sufficiently strong.
- It is advantageous to locally reinforce the masonry by the application of the HAS method in order to strengthen the area around the anchors.

Design decisions:

For this design a building specific approach is chosen. The reinforcement measure refers to the ornamental shape of the crossed slats that appears throughout the building. By picking an existing element and turning this into a reinforcement measure a visual merge with the building was pursued. No elements have to be removed in order to install this measure, the reinforcement concerns an addition.

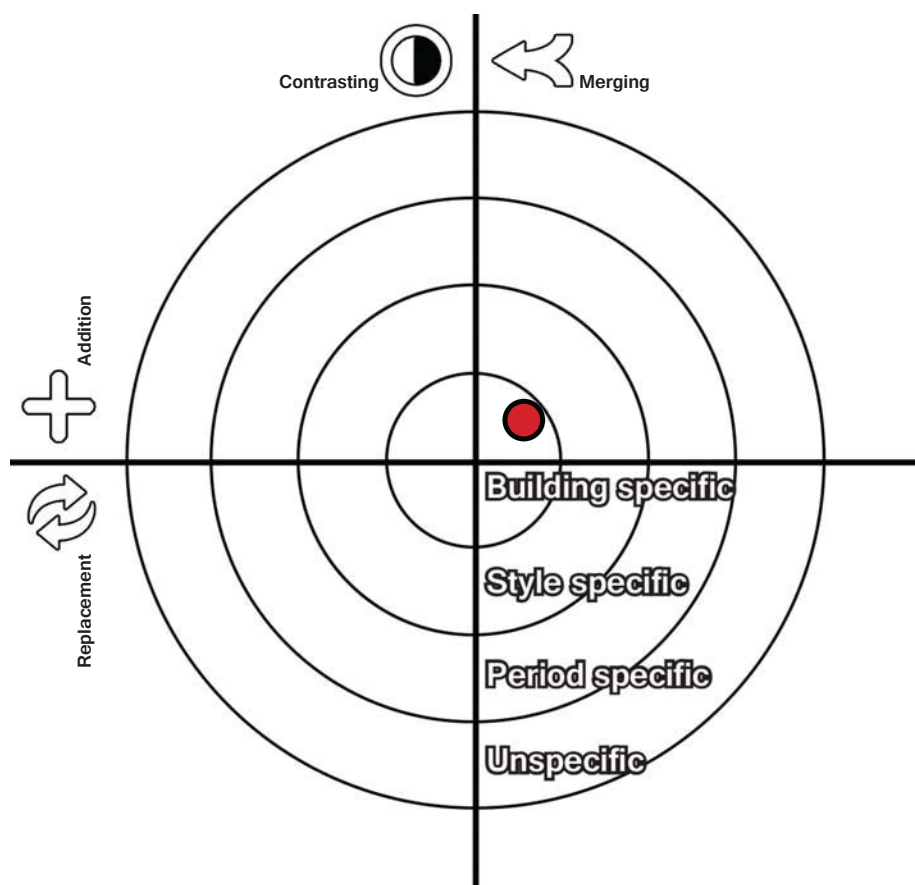

Figure 197: Design decisions spectrum source: own elaboration



Strip anchor plate

Design

Because a plurality of anchor plates on a façade can drastically disturb the appearance of the building, this design concerns an oblong anchor that stretches over the whole length of the façade. This suits the orthogonal shapes in the façade and it emphasizes the horizontality in the building even more. Emphasized horizontality, with a few contrasting vertical elements is a frequent recurring design which is characteristic for the style of the Amsterdam School. Possibly this design therefore is applicable on a wider range of buildings. In itself the anchor plate is not based on any style or building, the layout and materialization is sleek and contemporary.

Mechanics

The oblong anchor plate stretches all over the length of the facade and constitutes a large surface area in order to transfer the forces to the wall. Because the forces during an earthquake will be distributed over the whole length of the façade, local errors in the masonry will be wiped out. This enhances the overall structural integrity of the measure.

At an equal distance from each other the plate will be bolted to the wall and the underlying structure. The thickness of the anchor plate should be sufficient to provide enough stiffness and strength to withstand the forces of the earthquakes. The material should not deteriorate under weather influences in order to maintain the right structural properties.

Assembling

On the inside wooden beams must be installed in-between the joists, against the wall. In order to equalize the surface of the masonry and to provide the structural integrity of the masonry in-between the joists a layer of grout must be poured between the beam and the wall. In general, the masonry in-between the joists is more brittle than the rest of the wall. This piece of masonry is added after the placement of the beams, often with almost dried mortar. The piece of wood and the grout keeps the bricks firmly together which enhances the strength in this part of the wall. The beam is connected to the joists by the use of bolted profiles.

On the outside, the wall surface must be equalized with grout to provide a smooth connection between the anchor plate and the wall. At correct height and distance holes must be drilled in the wall from the outside, through the wall and the beam. This should happen from the outside through the pre drilled anchor plate.

Through the drilled holes, from the inside tie rods can be inserted through the wall. On the outside the customized anchor plate can be placed on the ends of the tie rods, and bolted to the tension the system. In case of a cavity wall, inside the cavity must be added a padding that can distribute the forces between the leaves, and to prevent the walls from collapsing due to the tension forces of the reinforcement measure. This can for example be reached by using a "socket anchor". A socket anchor looks like a regular anchor, but around the shaft of the rod an elastic socket is placed. After insertion in the wall, the socket can be filled with grout. Inside the cavity of the wall the socket will be able to expand to a certain extent when being filled, which creates a thickening in between the wall leaves, that connects the two leaves.

Materials

The best material for the anchor plate is stainless steel. This material is very ductile, which is preferable in case of an earthquake. It is very strong and does not rust, which is important when exposed to moist weather conditions. The steel can be painted in any color.

Detailing

On the inside a wooden beam is connected to the floor, and connected to the wall by the rods which are connected to an oblong anchor plate on the outside. The elements are bolted together and tensioned to provide a strong connection between the floor and the wall. Between the anchor plate and the outer wall a layer, and between the beam and the inner wall leaf a layer of grout is added in order to equalize the surface and thus provide a better distribution of forces. In case of a cavity wall a socket anchor must be used in order to connect the inner and the outer wall leaf and to prevent collapse due to the tension forces caused by the reinforcement measure.

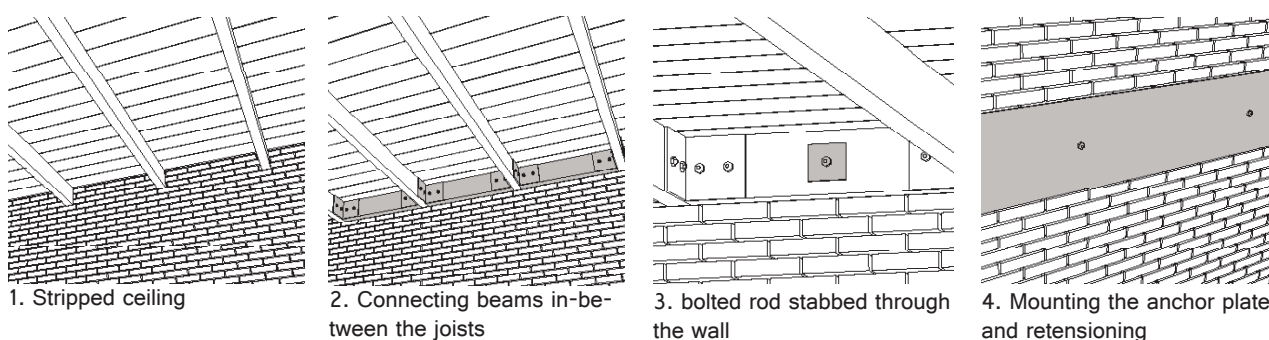

Figure 198: Assembling: own elaboration

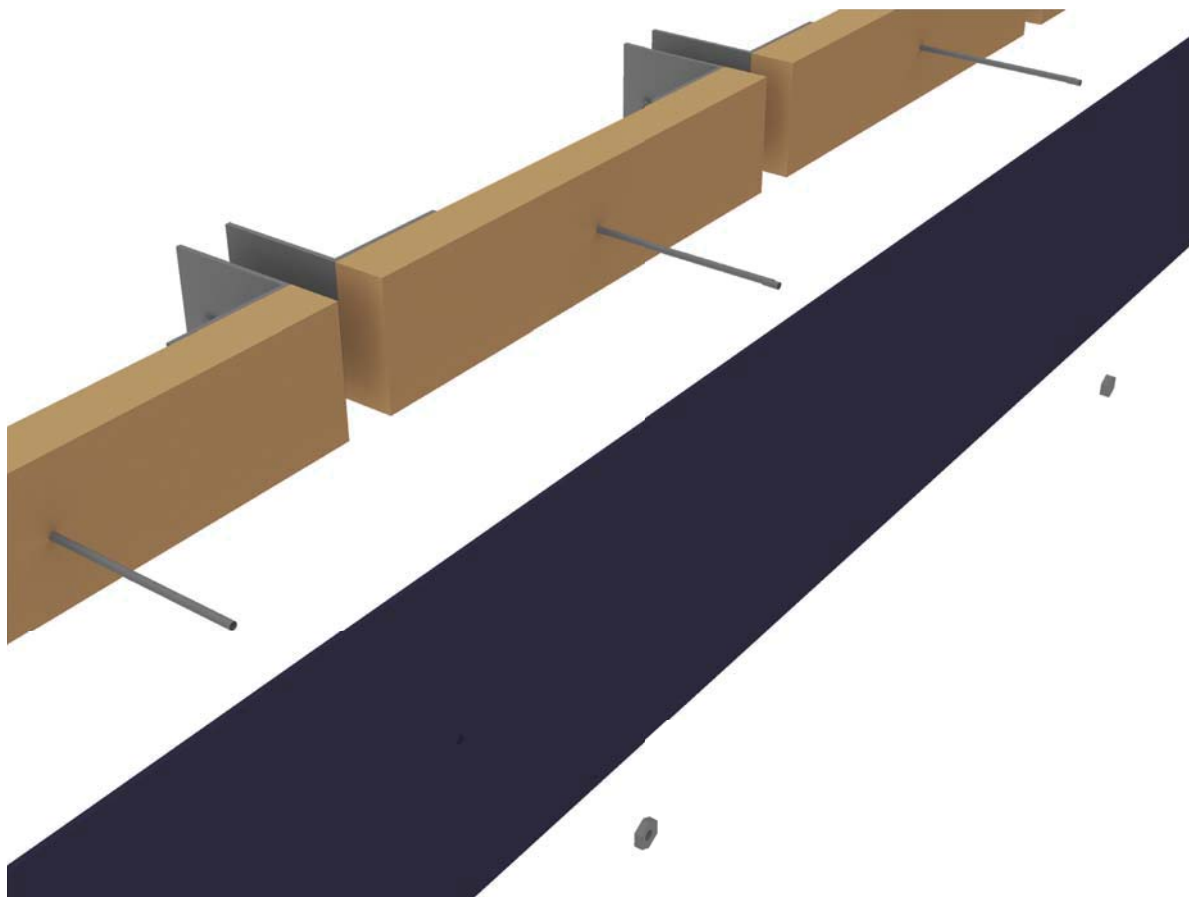

Figure 199: Before assembly, source: own elaboration



Figure 200: Before retrofit, source: own elaboration



Figure 201: After retrofit, source: own elaboration



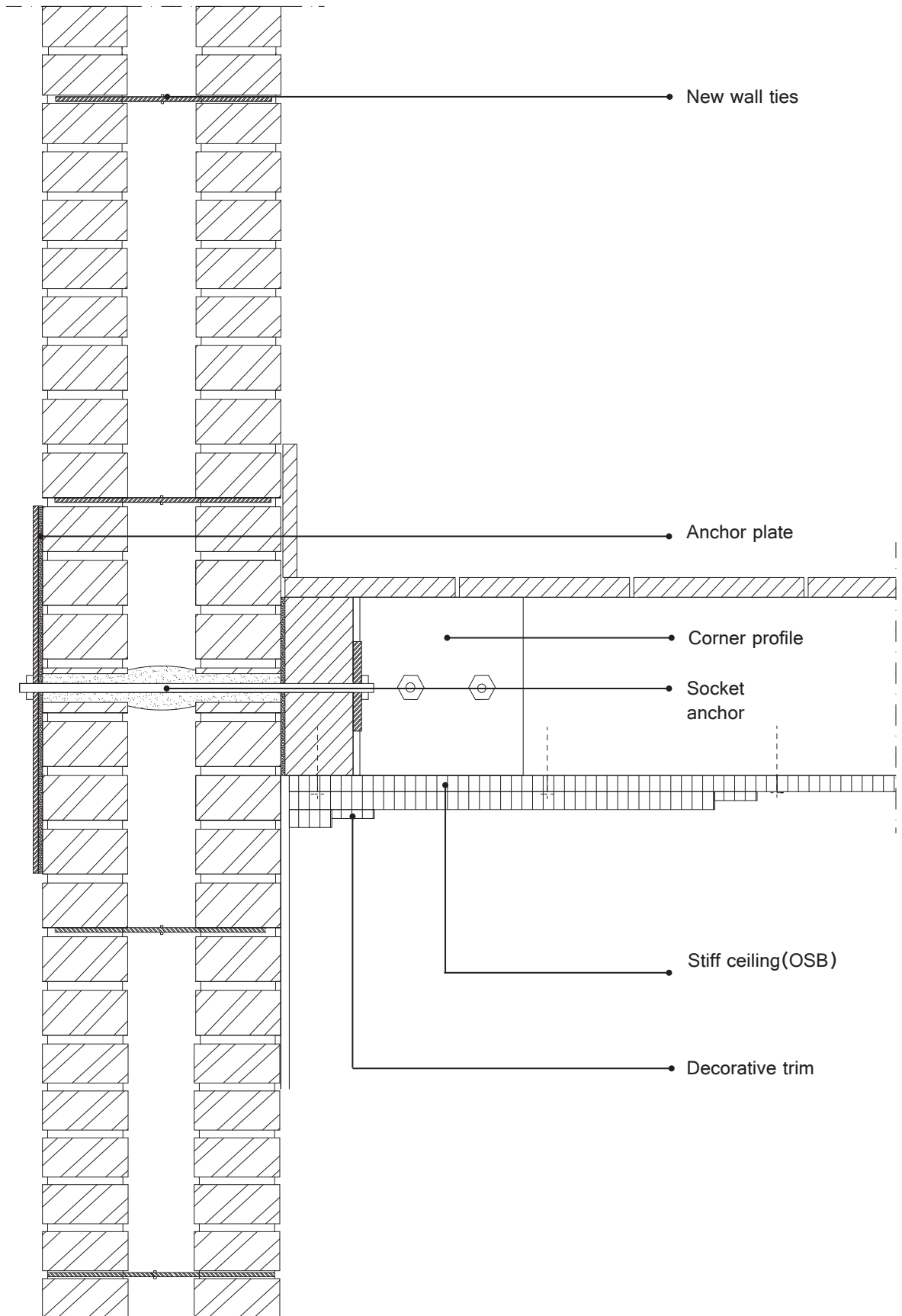

Figure 202: Detail, source: own elaboration



Marginalia:

- The only function of the profiles between the beams and the floor joists is to hold the beams in place during installation. They can be made smaller if that's desired.
- A thickness of 8mm is probably sufficient for the outside anchor plate.

Design decisions:

For this design an unspecific approach is chosen. The reinforcement measure does not refer to a specific style or building. The design merges with the building due to the shaping and the pick of color of the measure. The shape fits the orthogonal shapes in the façade and the color matches the blue painted box gutters and windows. The original elements in the building will remain intact, the reinforcement concerns an addition.

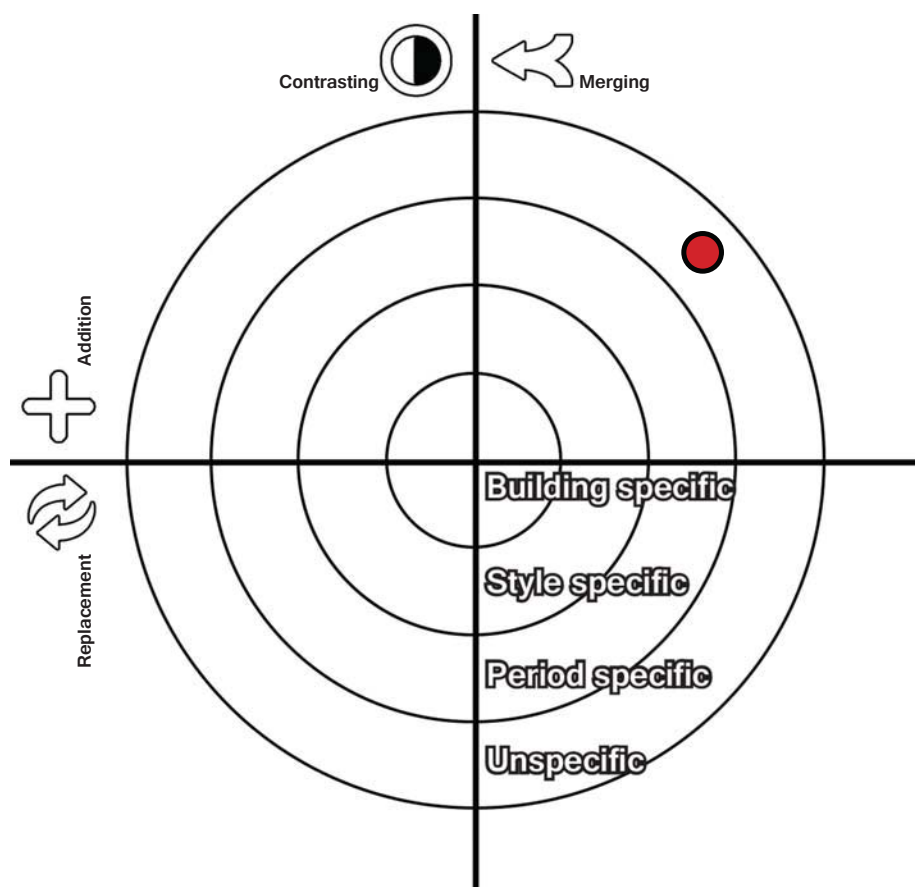

Figure 203: Design decisions spectrum source: own elaboration



Integrated floor heating

Design

This design for the stiffening of a floor has, next to the structural upgrading, an extra function. The perforated steel plates enable the layer of concrete to be thinner whilst providing the same strength in comparison to conventional reinforcing steel. Next to the reduction of thickness the steel plates enable the possibility of installing floor heating inside the added layer.

Mechanics

In order to make a building better resistant to earthquakes flexible diaphragms need to be avoided. The wooden floors in the prewar buildings act as flexible diaphragms. The flexible floors can be stiffened by adding a layer on top of it. A layer of 50mm concrete will be sufficient to stiffen the diaphragm.

Assembling

First a layer of foil must be placed on top of the original wooden floor. On top of the foil the steel plates must be placed, and adequately attached to the floor beams. At the locations where the foil is perforated in order to attach the plates to the beams, the foil must be resealed to avoid leakage of concrete in the end. After the connection of the plates to the structural beams the pipes of the floor heating system can be put in place. Also the level 2 measures (wall anchors) should be installed.

After the application of the foil, the plates, the level 2 measure and the new heating system the concrete can be poured on top of the floor. After the drying of the concrete a floor finish can be applied.

Materials

The reinforcing plates are made of steel, the stiffening material is concrete.

Detailing

A perforated steel plate must be attached to the beams of the wooden floor structured by the use of a sufficient amount of screws. Using a water tight foil underneath the plate before pouring the concrete is necessary to avoid leakage. The level needs to be combined with a level 2 measure, the rods of the anchors can be poured in the concrete to ensure structural integrity in the building.



1. Placing the steel plates on top of the foil



2. Installation of the floor heating



3. Pouring the concrete

Figure 204: Assembling, source: <http://reppel.nl/nl>



Figure 205: Build-up , source: <http://reppel.nl/nl>

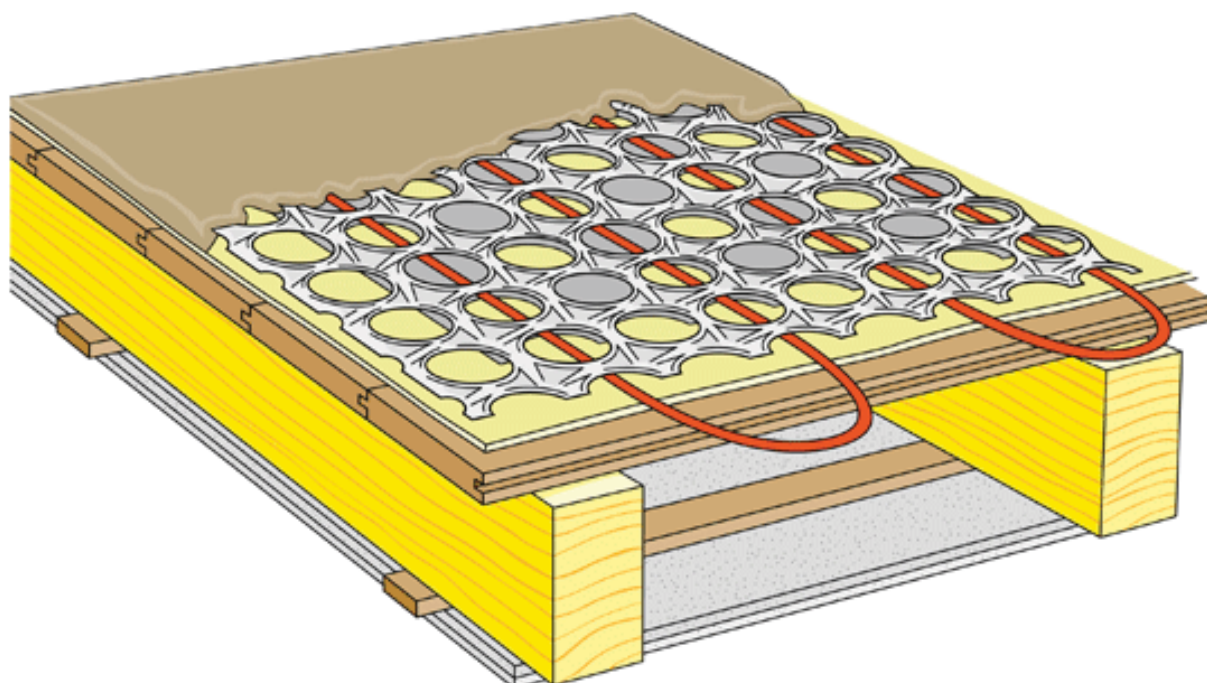

Figure 206: Build-up , source: <http://reppel.nl/nl>



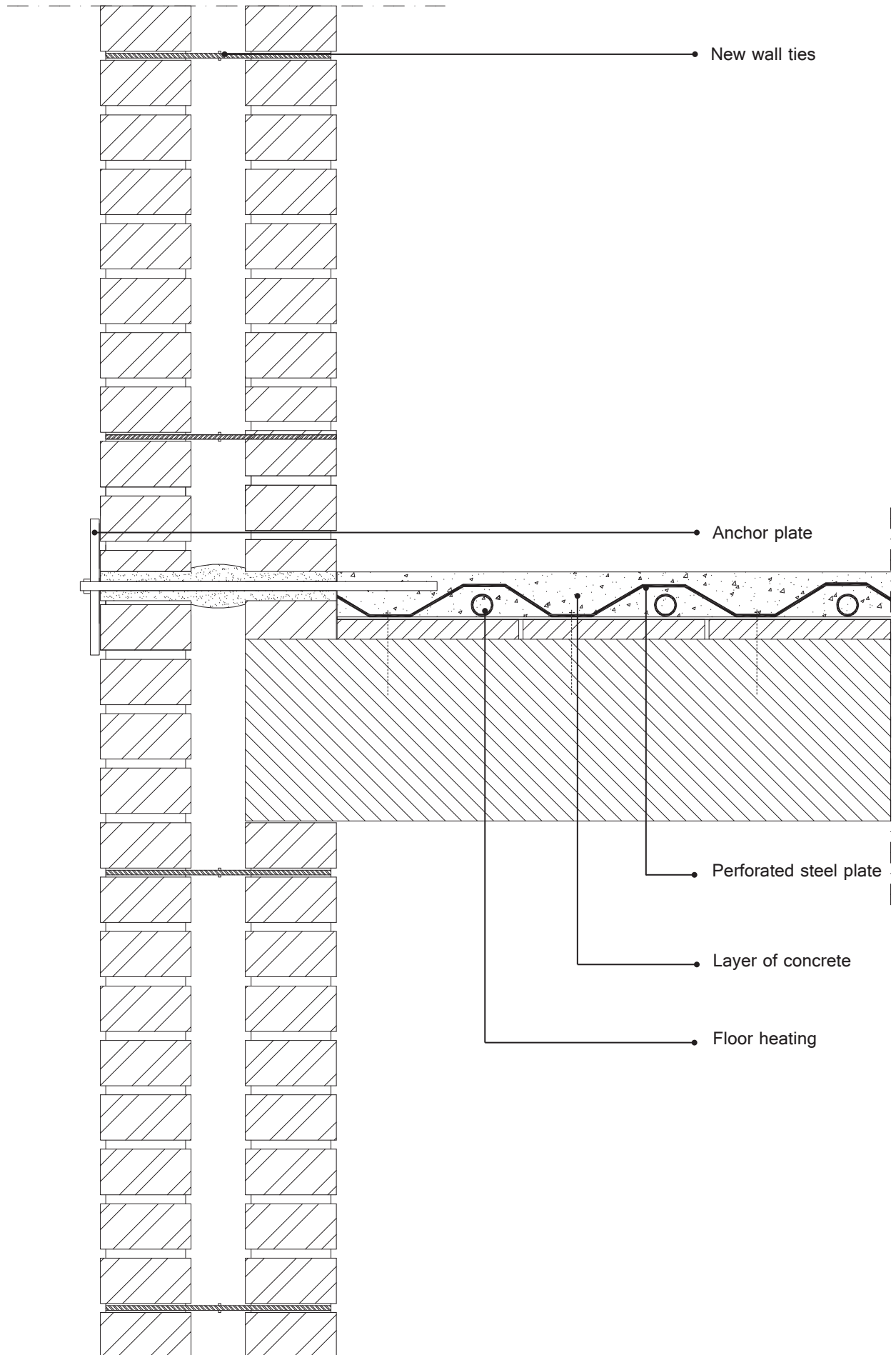

Figure 207: Detail, source: own elaboration



Marginalia:

- In Italy a concrete slab of 50mm seems to be sufficiently rigid to absorb the pressure. The profiled steel sheet will absorb the tensile forces sufficiently. The magnitude of the pressure component that needs to be absorbed by the concrete will depend on the span (buckling length). The floor will buckle up. In order to reduce the buckling length, the steel plates must be attached to the wooden floor beams. If this is executed properly, a thickness of 30 mm of concrete is likely to be sufficient to absorb all the pressure forces. However, when there is a foil applied below the plate, before pouring the concrete, the foil will be punched at the location of the connections. These holes must be sealed properly to prevent leakage of concrete.
- The layer of concrete must be continuous. All the rooms on the floor must therefore be provided with a layer of concrete. The layer of concrete must be connected to the supporting walls with level 2 measures. Nonbearing walls must temporarily be removed to avoid structural interruptions.
- The increased weight of the floor will have to be absorbed by the floor joists. At the location of the supports of the beams, near the masonry walls, the timber can be deteriorated over time. This must be determined whether this is the case. In case the quality of the wood appears indeed reduced the beam should be supported extra near the wall. This can be achieved by the addition of an extra support column underneath the beam. In-between these new supports insulation can be added in order to improve the energy performance of the building.
- At the location of the stairwell possibly an additional construction must be applied in order to create one continuous stiff plate.

Design strategy:

For this design an unspecific approach was chosen. The reinforcement measure does not refer to a specific style or building. Whether the measures merges or contrasts with the building depends on the finish. The original elements in the building will remain intact, the reinforcement concerns an addition.

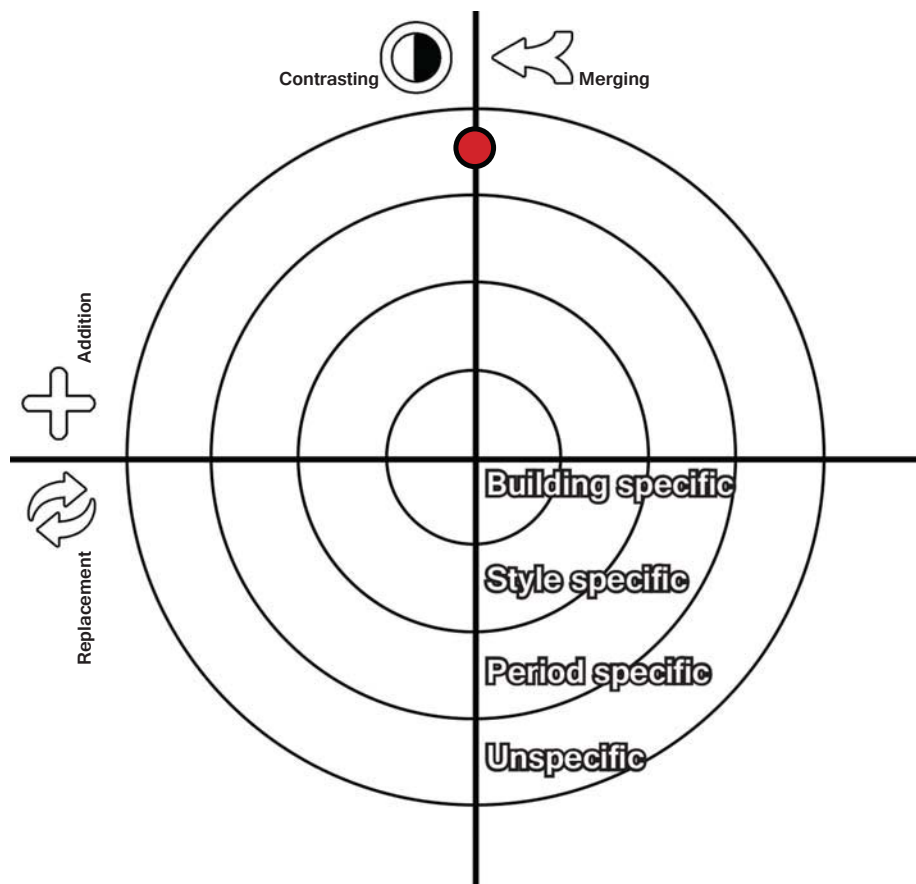

Figure 208: Design decisions spectrum source: own elaboration



Rigid decorative ceiling

Design

In this design, instead of the floor, the ceiling is stiffened. The area underneath the ceiling often offers enough space for the application of a stiff layer.

In addition, it is also more easy to return the ceiling into its original aesthetics. Many ceilings in the researched houses have been replaced during the 70's and their appearance is not very attractive. In other cases the original ceiling was remained, but by the ravages of time the ceiling was deteriorated so much that replacement was desirable anyway.

To make the design fit the style of the building, on top of the OSB (oriented strand board) restraint the geometric pattern of the original ceiling was returned onto the new ceiling.

Mechanics

In order to make a building better resistant to earthquakes flexible diaphragms need to be avoided. The wooden floors in the prewar buildings act as flexible diaphragms. The flexible floors can be stiffened by adding a layer of OSB on top of it. Two layers of 9mm OSB will be sufficient to stiffen the diaphragm. By putting this layer on top of the floor, the original wooden floor and its pleasing aesthetics will be covered. Next to this, the added height of the extra layer will require modifications to doorposts and plinths. Therefore in this design the ceiling is stiffened instead of the floor in order to create a rigid plane.

Assembling

The original ceiling and wall finishing need to be removed. When the ceiling is been removed, the level 2 measure can be applied in-between the joists. On top of the joists two layers of oriented strand board must be screwed to provide stiffness. In the end the wall finish must be reapplied and on the oriented strand board the decorative plates and slats must be glued, nailed or screwed in order to return the ceiling into its original aesthetics.

Materials

To stiffen the diaphragm oriented strand board is used. On top of the oriented strand board slats and plates are mounted for decorative reasons. The wall finish and the decorations should be made of slightly flexible materials preferably in order to prevent them from cracking after minor seismic activity in the future.

Detailing

Two layers of OSB are screwed to the underside of the floor beams. On the OSB plates decorative details can be applied as desired.

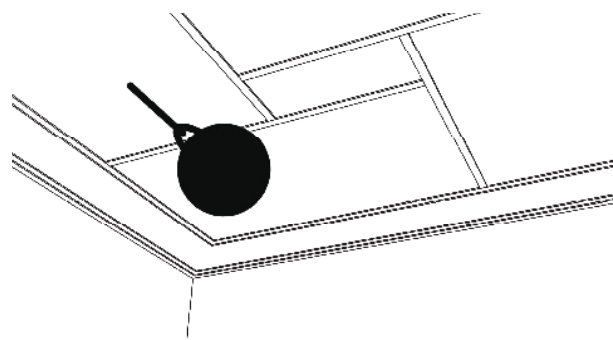

1. Removal of the old ceiling

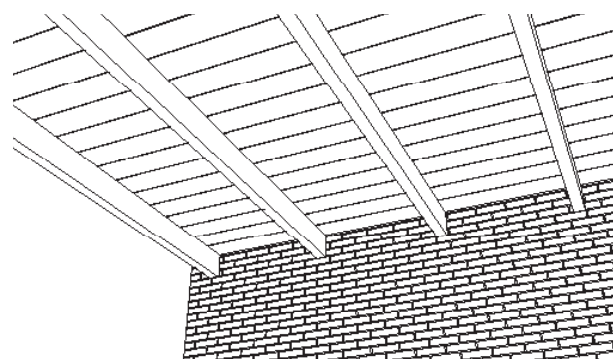

2. Bare ceiling

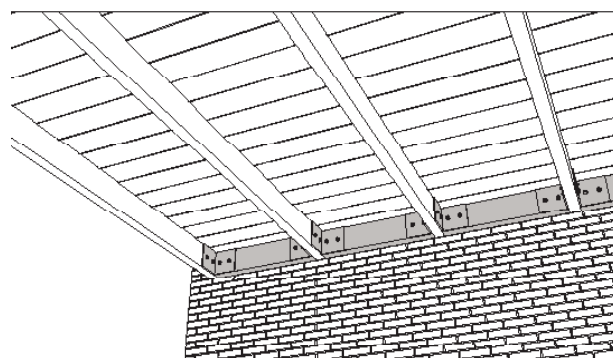

3. Application of the level 2 measure

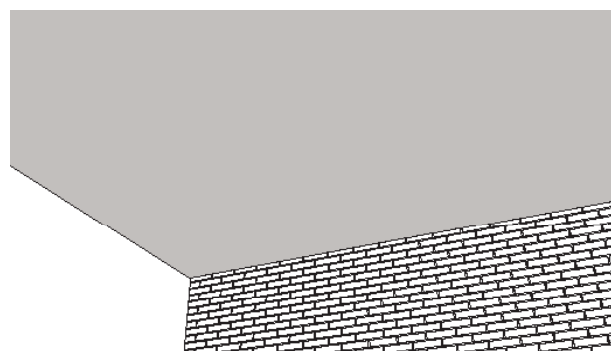

4. Application of the OSB restraint

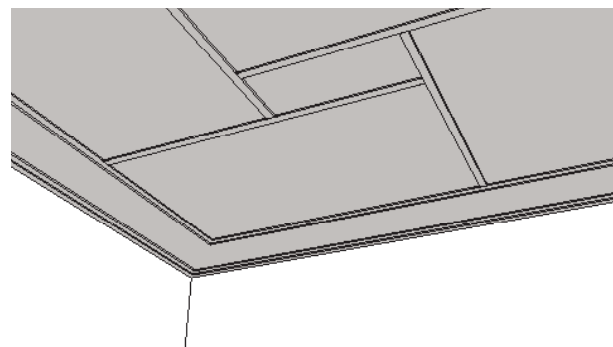

4. Application of the decorative pattern

Figure 209: Assembling: own elaboration



Figure 210: New ceiling, source: own elaboration



Figure 211: Before retrofit, source: own elaboration



Figure 212: After retrofit, source: own elaboration



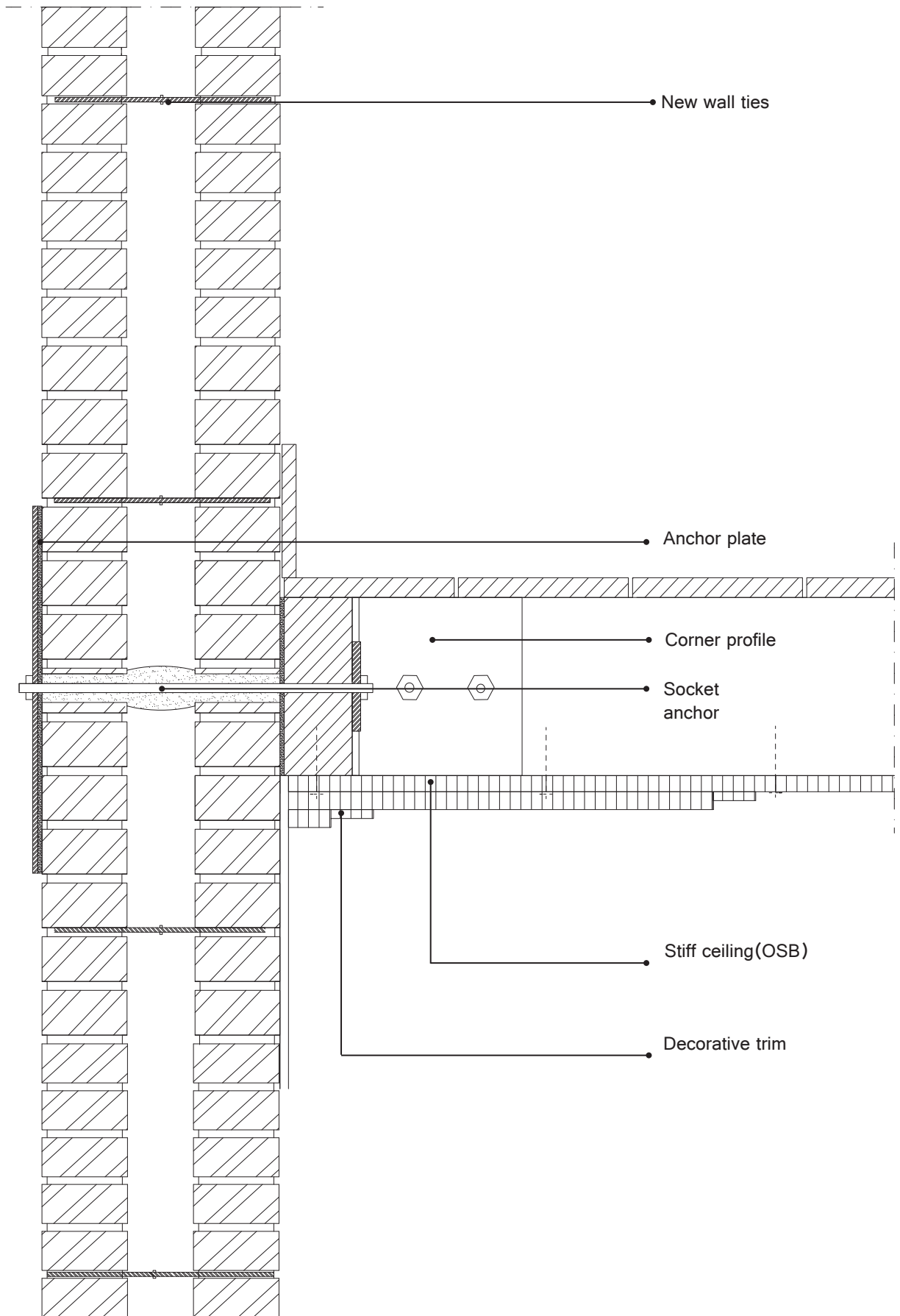

Figure 213: Detail, source: own elaboration



Marginalia:

- In this case the geometric pattern of the old ceiling was used to decorate the measure. This pattern has no influence on the structural properties of the ceiling, other thinkable patterns or decorations are possible as well.
- The connections between the materials, especially near the corners, should be flexible and with enough spacing in between in order to avoid cracks after future earthquakes.

Design strategy:

For this design a building specific approach is chosen. In this design the original appearance of the old ceiling is restored after reinforcement. The design merges visually with the building. The original ceiling in the building will be removed, therefore this measure concerns a replacement.

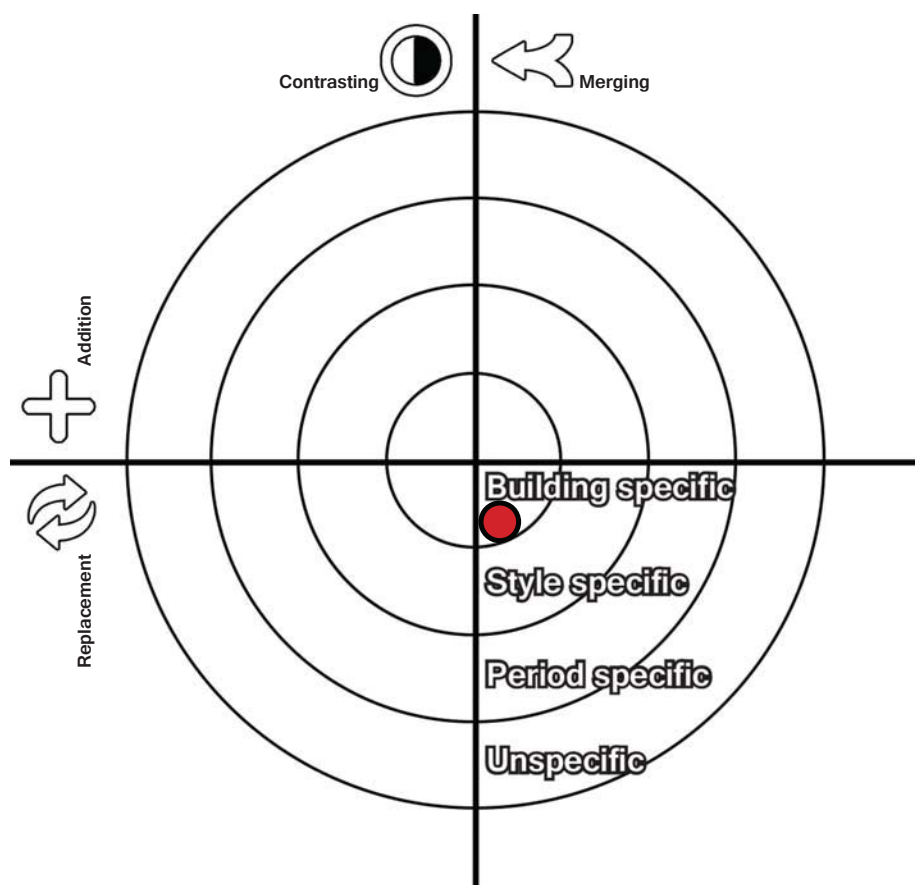

Figure 214: Design decisions spectrum source: own elaboration





6. Stakeholders

Within the process of finding suitable solutions for reinforcement measures for Amsterdam School houses in the Province of Groningen multiple stakeholders are involved. They all have their own interests and function in the process. In order to be able to implement reinforcement measures various stakeholders must agree on the plan.

In the communication with the various parties it is important to have an overview of which people and organizations have which functions and interests.

An indicative list of current stakeholders is:

- The State
- The Government
- The Province of Groningen
- The Municipalities (within the earthquake district)
- Inhabitants
- NAM (Dutch Petroleum Company)
- Engineering Agencies
- Libau / Cultural Heritage Agency
- Contractors
- Centrum Veilig Wonen (CVW)
- Architects

6.1 Overview of the stakeholders

The State

The State represents the Dutch population. It is the owner of the gas field. Their interest is to contribute to the Dutch welfare and provide a sufficient amount of gas to provide the Dutch households. These interests are in conflict with those of the people in Groningen.

The Government (Ministry of Economic Affairs)

The Government should represent the interests of the Dutch people. They have to take a decision on the extent/continuation of the gas extraction. It's the Governments' task to act for the benefits of its citizens. They must ensure safety and well-being of the Dutch inhabitants. However ceasing the gas extraction seems logi-

cal in concern of the people in Groningen, it won't ensure the end of the seismic activity. Also the financial benefits from the gas extraction are of great importance for our national economy.

The Province of Groningen

The Province of Groningen is responsible for the spatial planning in the Province. They create the landscape integration plan. They have to protect the livability of the area.

The Municipalities

The Municipality is the representative of the residents living in the Municipality. They have to ensure the livability of the area. The assessment of aesthetic qualities in the built environment is outsourced to a special "Design Review Committee" (Welstandcommissie). In the Province of Groningen this is done by "Libau", an independent consultant on aesthetic qualities of the built environment and preservation of heritage.

The Municipalities within the earthquake area are responsible for the building permits. In case of adjustments to the structure of a building the Municipality must authorize the request. This is based on the "Dutch Building Decree" (Bouwbesluit) but since this document does not take earthquakes into account they have to adjust to the new situation.

Inhabitants

The inhabitants of the earthquake area worry about the devaluation of their properties and the structural safety of their houses. They suffer long and complex procedures in order to get their lawful right and subsequent financial compensations for repairs and alterations to their houses. They feel often feel misunderstood and unheard. They feel that authorities are not acting in their interest.

In order to be able to carry out alterations to houses the inhabitant does always have the final word (there are exceptions of course). Without their permission it is very difficult to get things done. Therefore keeping contact with them, and listen to their wishes and needs is extremely important. They should be seduced to reinforce their houses, in order to recognize the value of it.

NAM (Dutch Petroleum Company)

The NAM is the company that extracts the gas in the Groningen area. They need the permission



of the Dutch government to continue the drilling. They are blamed for the emergence of the recent earthquakes, and they are held responsible for the damage caused by the earthquakes and the financial consequences that come with it.

Engineering agencies

Engineering agencies are employed by the NAM to perform studies on seismic risks and to find suitable solutions for structural upgrading of buildings in the earthquake area. Their task is to eliminate the risk of personal injury by the collapse of buildings. In order to increase financial feasibility and the practicability of the solutions they look into the possibilities of standardization of the solutions with implementation on a larger scale as a goal.

They conduct inspections of houses and villages and estimate the possible risks.

Libau/Cultural Heritage Agency

Libau is an independent advisory board which advises on the aesthetic qualities of the built environment. Both for contemporary buildings and heritage. In case of a building permit the municipality asks Libau for advice. Libau operates in cooperation with the national "Cultural Heritage Agency". The Cultural Heritage Agency is responsible for the preservation of cultural and historical heritage on a national level of scale.

Libau and the Cultural Heritage Agency had never to deal with earthquakes before. Their policies must be readjusted in order to meet the current demand.

Contractors

The earthquakes in the area create extra employment for local contractors. As most stakeholders did, until recent they knew little about earthquakes and earthquake resistant building. They need to be updated on their knowledge in order to meet the current demand.

Centrum Veilig Wonen (CVW)

CVW, "center for safe living" is an organization that is commissioned by the Ministry of Economic Affairs. They must take over the damage handling from the NAM, since the NAM suffers a damaged reputation. People have lost confidence in the NAM, therefore, the responsibilities regarding to damage handling are taken away from them. They claim to have all the expertise for smoothly handling the damage, and the subsequent finan-

cial claims and structural upgrading of houses.

Architects

Architects so far do not have a very predominant role within the earthquake problem in Groningen. Within the various involved organizations there are some instances with knowledge of architecture (Libau, CVW), but by itself, there is no specific role reserved for the architect. Architects in the Netherlands have no training in earthquake resistant building or retrofit. Educating architects to make them ready to help finding solutions in the Groningen earthquake problem is an unexploited opportunity.

6.2 Interviews with stakeholders

In order to evaluate the used methods in this research and the resulting designs, but also to get insight in the positions of the various stakeholders in respect to the problem, interviews have been executed among different stakeholders.

A structural engineer of engineering office Arup, an employee of Libau, an official of the Municipality of Loppersum and the four inhabitants of the case study buildings in Loppersum have been questioned.

Structural engineer

Mrs. Hinke Wijbenga, structural engineer at engineering agency Arup, had a look at the 12 designs for reinforcement measures. From her point of view she gave her comments and advised on the 12 solutions. She clearly saw a difference in drawing between the structural engineers she is working with and the more architectural elaborated designs.

In principle the designs were, from her point of view, workable. But they all needed some extra attention when it comes to dimensioning, positioning of anchorages, tolerances, etc. Also the principle of installation could have some extra attention.

The approach of the structural engineer is very rational. They assess the design mainly on structural functionalism and the ease of implementation. The "architects' " approach, which includes aesthetics as one of the main points of concern, is in this respect, fairly different.

In a collaboration between an architect and an engineer, in which the architect has expertise of the basic principles of seismic design, it must be possible to come to solutions on which both parties can agree.



Libau

Mr. Merijn Wienk, employee of Libau, has been interviewed. Libau is an advisory agency for the Province and the Municipalities that advises on the design of the built environment and the preservation of monuments. They do not recognize themselves as experts for finding solutions for reinforcement measures.

Libau is actively involved in the Groningen earthquake problem, but more on the background. They have been involved in the establishment of a handbook/protocol, mainly on the parts that concern monuments.

Usually they are only asked for their expertise in a very late stage of the process, to assess the aesthetic quality of planned interventions. But in the case of the earthquake problems they should involve themselves earlier in the process to prevent for worse scenarios. Lots of monuments are in danger now due to the earthquakes.

They entered into a dialogue with the various parties (NAM, Province of Groningen, Municipalities, Cultural Heritage Agency etc.) to acquire themselves a more active role in the process. There is no ready solution yet, and a standardized plan for large-scale implementation is still in the future, but Libau is preparing for the changing future.

Libau often has to deal with conflicting interests. On the one hand they want to protect national heritage, and make buildings safe as soon as possible. But sometimes the reinforcement can cause new problems, in the sense that the measures itself will ruin the building. On the other hand, doing little or nothing can also be undesirable because the building may become unsafe and unusable, or can even collapse.

Within the process of taking the design decisions (contrast/merge, replace/addition, contemporary/ historicizing) Libau does not have a very strong opinion. Every decision from their point of view seems right, if properly substantiated. In case of a monument however, keeping the building in its original state is preferred. But in the case of earthquakes this is not always possible. Before designing reinforcing measures for heritage buildings an adequate assessment of the valuable elements needs to be made to make clear what parts of the building should be preserved.

Temporary measures, which seems undesirable from an inhabitants point of view, is seen as a good solution for the time being. This offers the opportunity for “watchful waiting” until better technologies for preservation become available. But, probably this is more feasible for non-residential buildings since livability and safety are predominant in the case of housing.

A scheme, or strategy, as used during the development of the designs in this study, can be helpful in the conversation with the stakeholders which was mentioned by Mr. Merijn Wienk. However, the scheme could be extended to a larger level of scale, in which besides the building scale level also the urban (and social) context is taken into account.

On the designs itself Mr. Wienk could not give a clearly defined opinion from the Libau point of view. He stressed that every case independently must be assessed by their design review committee in case of implementation.

Municipality of Loppersum

Mr. Jinko Rots, “Project Secretary Earthquakes and Gas Production” was interviewed as representative of the Municipality of Loppersum. The Municipality acts mainly in favor of the inhabitants, and they ensure the livability of the area. The assessment of aesthetic qualities in the built environment is outsourced to a special “Design Review Committee” (Welstandcommissie) of Libau.

Safety is most urgent in their decision making, this can overrule the preservation of environmental qualities. In urgent situations the municipality overrules Libau’s advice in order to get things done quickly.

On the long term new approaches need to be established for dealing with the earthquake problems because the conventional methods and procedures are not sufficient. For example the authorization for a building permit takes too long for the sometimes urgent situations and the scale of the problem is too large for the Municipalities’ capacity. All stakeholders must adapt to the new situation, and be open to new ideas. Communication between stakeholders is important to view the different perspectives. Maintaining a close relationship with the inhabitants is import-



ant. Not only to be able to act in their best interests. Without their collaboration it's very hard to get things done. The people need to be persuaded to take action.

Mr. Rots did not have a strong opinion on the designs, though he liked them. His question was however, who will be responsible for the extra costs of the extra ornamentation added to the measures. Nevertheless, from the viewing point of fairness, paying some extra attention to the aesthetics of the measures in order to satisfy the people and preserve the environmental quality seems a good idea to him.

Inhabitants

The inhabitants of the four case study homes in Loppersum have been questioned on the twelve design solutions projected on their homes. The interviewed people are: H. Poelman (Wijmerspad 1), J. Sikkes (Zeerijperweg 12), A. de Bruin (Stationslaan 7), S. Veentjer (Wirdumerweg 27). Their overall reaction was very positive. They really liked the fact that there had been paid some special attention to their houses and their personal situation. Also the significant level of customization in the designs pleasantly surprised them.

Per design the reactions of the four inhabitants will be described and the grading they gave for the designs are shown in Tables.

Design 1

The people liked the idea of the use of the pattern of the stained glass in the restraint. However, the use of the pattern on the chimney looked a bit too chaotic to their opinion.

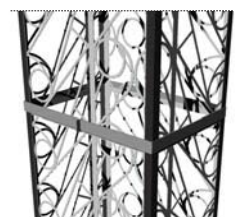

Design 1	--	-	±	+	++
S. Veentjer		•			
J. Sikkes		•			
A. de Bruin		•			
H. Poelman				•	

Table 4: Assessment by residents, source: own elaboration



Design 2

People liked this design better than the previous solution for the chimney. The chimney is very different from the original, but it fits well in the picture. Most people find this a better solution than the lightweight chimneys with the brick strips. Trying to mimic the original almost never results in a satisfying result because the rehash will always look different than the original.



Design 2	--	-	±	+	++
S. Veentjer				•	
J. Sikkes			•		
A. de Bruin			•		
H. Poelman					•

Table 5: Assessment by residents, source: own elaboration

Design 3

In general the people liked this design. Only J. Sikkes, the owner of the building it was designed for, was somewhat critical. He liked the appearance of the heavy masonry parapet. The design changes the appearance of the building, but most people think the change is positive. One of the frequently heard remarks was that the privacy will be affected because of the openness of the fence.



Design 3	--	-	±	+	++
S. Veentjer				•	
J. Sikkes		•			
A. de Bruin				•	
H. Poelman				•	

Table 6: Assessment by residents, source: own elaboration



Design 4

The questioned people really liked this design. They were really charmed by the idea of the reference to the past. They even said the result looks better than the original situation.



Design 4	--	-	±	+	++
S. Veentjer					•
J. Sikkes				•	
A. de Bruin					•
H. Poelman					•

Table 7: Assessment by residents, source: own elaboration

Design 5

Without exception the people really liked this design. Even without the constructive function they would be open to have such a planter box on their balconies. The design does not remind them of a reinforcement measure, it is seen as a nice addition.



Design 5	--	-	±	+	++
S. Veentjer					•
J. Sikkes					•
A. de Bruin					•
H. Poelman					•

Table 8: Assessment by residents, source: own elaboration

Design 6

The residents were very pleased with the pursuit of invisibility of the measure.



Design 6	--	-	±	+	++
S. Veentjer					•
J. Sikkes				•	
A. de Bruin					•
H. Poelman					•

Table 9: Assessment by residents, source: own elaboration



Design 7

The opinions on this design differed much. The plurality of the anchors made that some people were of the opinion that the design disturbed the image a bit. But in general they were enthusiastic about the idea of covering the anchor plates with an aesthetic plate that suits the building.

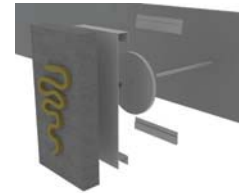

Design 7	--	-	±	+	++
S. Veentjer		•			
J. Sikkes				•	
A. de Bruin					•
H. Poelman					•

Table 10: Assessment by residents, source: own elaboration

Design 8

Most residents liked this design. But as the previous design they were afraid that the plurality of the anchors would create an odd appearance. Also because of the size they expressed the opinion that the cover plates are a bit dominant in the image.

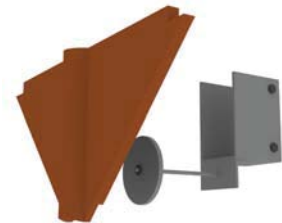

Design 8	--	-	±	+	++
S. Veentjer			•		
J. Sikkes			•		
A. de Bruin				•	
H. Poelman				•	

Table 11: Assessment by residents, source: own elaboration

Design 9

Most people liked this design. They noticed similarities between the traditional wall anchors and this design. They liked the repetition of the crossed slats. Its suits the building well in their opinion.

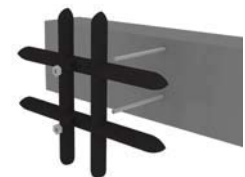

Design 9	--	-	±	+	++
S. Veentjer			•		
J. Sikkes				•	
A. de Bruin				•	
H. Poelman				•	

Table 12: Assessment by residents, source: own elaboration



Design 10

Besides the owner of the building this anchor plate was designed for the questioned people liked this design. However, some people were of the opinion that the anchor plate would have been even better if it was slightly more slender. The owner has the preference for an invisible solution.

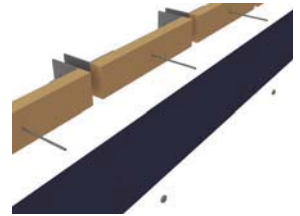

Design 10	--	-	±	+	++
S. Veentjer				•	
J. Sikkes		•			
A. de Bruin				•	
H. Poelman					•

Table 13: Assessment by residents, source: own elaboration

Design 11

The floor heating as an extra feature besides the structural upgrade was much appreciated. Only the fact that a new layer is added on top of the wooded floors was disliked. The people are very attached to their original wooden floors, the new layer of concrete in their opinion does not suit their houses. So in itself they were enthusiastic about it, but for another house.



Design 11	--	-	±	+	++
S. Veentier					•
J. Sikkes				•	
A. de Bruin			•		
H. Poelman				•	

Table 14: Assessment by residents, source: own elaboration

Design 12

This, without exception, is seen as a good solution. The fact that the ceiling will be returned to its original aesthetics was very welcome. People also saw possibilities in the embellishment of their ceilings in case they did not have a pretty Amsterdam School variant.

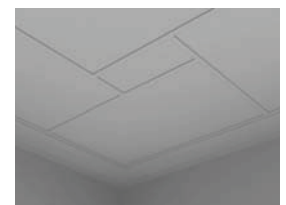

Design 12	--	-	±	+	++
S. Veentjer					•
J. Sikkes					•
A. de Bruin					•
H. Poelman					•

Table 15: Assessment by residents, source: own elaboration



7. Conclusions

7.1 Conclusions

The main research question of this study is;

“How can typical Dutch heritage masonry buildings (Amsterdam school) in the Province of Groningen be reinforced to withstand earthquakes with respect for the preservation of the existing appearance and functioning of the building?”

Purpose

The purpose of the research was to find solutions for making Amsterdam School buildings in the Province of Groningen earthquake resistant. This had to be done with extra attention for the aesthetics of the measures, and the preservation of valuable architectural elements in order to protect the appearance of the buildings.

In order to make the interventions more accessible and feasible a catalog with examples of possible design solutions has been compiled and the method which lead towards various solutions has been described. This way the method and the solutions can be used for a wider range of buildings.

In order to find suitable solutions, literature research and field research have been executed. The basics of earthquakes and earthquake design and retrofit has been researched. Also the Amsterdam School style and the seismic retrofit of historic buildings have been examined.

Also field research had been done. During this research buildings in the earthquake area were visited that meet the characteristics of the Amsterdam School style. Also the test houses of the NAM have been visited to have a look at the implemented reinforcement measures in the buildings.

Also the municipality of Loppersum was visited to collect construction drawings of selected case study buildings.

To gain insight into the more social aspects of the problem residents and other stakeholders have been questioned in order to get an idea of the needs and wishes of the local people.

In order to find the risk in the case study buildings the construction of the building was researched by examining maps, visual screenings and literature on early 20th century building methods. Comparing this information with the general rules of earthquake resistant building the riskful elements have been selected. From the list of riskful elements the 4 most common riskful elements; chimneys, parapets, floor-wall connections and wooden floors, have been selected for further elaboration. These elements can be reinforced with level 1, 2 and 3 measures.

Design strategy

The level 1, 3 and 3 interventions describe the basic principles of the needed measures, but the actual design can be executed in many ways. To find a suitable solution, requirements regarding structural safety and aesthetics have been drawn.

The structural framework is quite clear and is the same for all buildings and can be tested. Within the aesthetic framework a broad range of approaches are possible. Therefore 3 design principles, “invisible”, “matching” and “reversible” have been distinguished. It soon became clear that in the case of the retrofit of homes the “reversible” design strategy was not suitable because it would cause nuisance to residents for an indefinite period of time.

The invisible design principle has very strict boundary conditions, namely, that the reinforcement measure should not be visible. However, trying to pursue invisibility is very ambitious, and will not be possible in many cases.

For the “visible” design principle a strategy was constructed to make it easier to form a starting point for the design. By answering a couple of questions the boundary conditions, from a broad range of possibilities, can be drawn. The answers on these questions depend on the wishes of the stakeholders and the preconditions of the building in question.

Design

The design solutions in the catalog are the result of the followed design strategy. The designs include different measures that are adapted to the buildings they were designed for.



Typical Dutch heritage masonry buildings (Amsterdam school) in the province of Groningen can be reinforced to withstand earthquakes with respect for the preservation of the existing appearance and functioning of the building. The best way to do this is to offer a certain level of customization. Within the style of the Amsterdam School no building looks like one other. In order to offer solutions that really respects the building and its appearance, a bespoke solution is best.

Structurally lots of the buildings are quiet similar since they are built during the same period, and the riskful elements recur in different buildings, most of the required measures can be determined on forehand or after a quick screening. In finding the basic structural needs a standardized method can be applied here.

Stakeholders

In order to achieve a desired result collaboration between the different stakeholders in the process is a must. The importance of the end user as a stakeholder, the residents of the affected buildings, should not be underestimated. Without their approval the implementation of measures is not possible. The home owners need to be tempted to collaborate in the shaping of a safer environment.

The bodies that create the preconditions for the reinforcement measures (engineers, inspectors, the NAM, the Municipalities, etc.) must interact with each other in order to allow the process to run smoothly. This preconditions can't be ignored. But in the end, when the preconditions have been set, within the constraints, a more flexible approach should be welcomed.

The architect until now did not have a very significant role. In listening to the wishes and needs of the end users, and finding creative solutions within a strict program of requirements, there is an excellent role for the architect. This research can help the architect understand the basics of the issues of earthquake resistant retrofit.

The document can also function as an aid to help the stakeholders communicate more easy. The design decisions can be made with the use of the selection tool to come to a result in which all can find satisfaction. The used strategies in this research can be applied to other styles of architecture as well.

7.2 Recommendations for future research

The designs in the catalog, if one puts them into practice, need more examination. Complex calculations need to be performed to prove its efficiency. Prototyping and testing the solutions in a pilot study might be required.

The proposed designs in the catalog are samples of a wider range of possible solutions. This catalog can be supplemented infinitely. Thereby 4 picked elements, for 4 picked case study buildings designs, have been developed. The method can be repeated on a larger amount of buildings (and even other styles of architecture), and for more different elements. The architect can be a key figure in achieving this.

Only the level 1, 2 and 3 measures have been taken into account during this research. There is a large probability that tougher measures will be required in parts of the Province of Groningen. Because these measures have not been taken into account it might be possible that these measures cause conflict with the proposed designs in the current catalog. Also, these heavier measures might be harder to design in a way that ensures the preservation of the existing appearance and functioning of the building.

The positions of many stakeholders is not very clear yet. All parties have to deal with new problems that in the past never has been an issue in the Province of Groningen. The clarification of functions might help making the process more efficient. All stakeholders should recognize and implement their own expertise, but share their knowledge in a dialogue. Within the network of stakeholders the role of the architect can be much more significant as a designer of new solutions. Future research should be executed to clarify the specific role of each stakeholder and to define the role of the architect within the network.



Bibliography

Books and articles:

- Architectuur, M. (1979). *De Amsterdamse School : 1910-1930*. Amsterdam: Van Genneep/Stichting Architectur Museum.
- Arup. (2013). *Groningen 2013 Implementation Study*. Amsterdam.
- Asselbergs, A. L. L. M. (1975). *Nederlandse architectuur 1910-1930 : Amsterdamse school*. Amsterdam.
- Chakrabarti, A., Menon, D., Sengupta, A. K., India, Central Public Works, D., Indian Buildings, C., & Indian Institute of, T. (2008). *Handbook on seismic retrofit of buildings*. New Delhi: Narosa Publishing House.
- Charleson, A. (2008). *Seismic design for architects : outwitting the quake*. Amsterdam; Boston; London: Elsevier/Architectural Press.
- Eurocode 8 (EN 1998) *Design of structures for earthquake resistance, European Standard (English version)*
- Groninger_Bodem_Beweging. (2014). *Gescheurd vertrouwen - bedreigd wonen*.
- Hunen, M. v. (2012). *Historisch metselwerk : instandhouding, herstel en conservering*. Zwolle; [S.l.]: WBooks ; Rijksdienst voor het Cultureel Erfgoed.
- Jellema, R., Meischke, M. C. A., & Muller, J. A. (1948). *Bouwkunde: : voor het middelbaar technisch onderwijs*. Delft: Waltman.
- Lagorio, H. J. (1990). *Earthquakes : an architect's guide to nonstructural seismic hazards*. New York: Wiley.
- Loon, P. J. v. *Metselen, materialen, gereedschappen en uitvoering*. Dl. 1, Dl. 1. 's-Hertogenbosch: Malmberg.
- Mulder, B., & Luursema, E. (1995). *Handboek renovatie Gordel 20-40 : architectuurherstel in Amsterdam*. Bussum: Thoth.
- Muntendam-Bos, A. G., Waal, de, J.A. . (2013). *Re-assessment of the probability of higher magnitude earthquakes in the Groningen gas field*.
- NAM. (2013). *Winningsplan Groningen*. Assen.
- NPR 9998 (2015), *Beoordeling van de constructieve veiligheid van een gebouw bij nieuwbouw, verbouw en afkeuren - Grondslagen voor aardbevingsbelastingen: Geïnduceerde aardbevingen (in Dutch)*
- Schiebroek, C. J. M., & Berens, H. (1991). *Baksteen in Nederland : de taal van het metselwerk*. De Steeg; 's-Gravenhage: Koninklijk Verbond van Nederlandse Baksteenfabrikanten ; SDU uitgeverij Koninginnegracht.
- Spek, J. v. d., & Jong, M. d. (2000). *Schoonheid van het detail : Amsterdamse School in de provincie Groningen*. Groningen: Regio-Projekt Uitgevers.
- Stenvert, R., & Stichting Uv, A. V. (2012). *Biografie van de baksteen : 1850-2000*. Zwolle; Amersfoort: WBooks ; Rijksdienst voor het Cultureel Erfgoed.
- Syngellakis, S. (2013). *Retrofitting of heritage structures : design and evaluation of strengthening techniques*. Southampton: WIT Press.
- Tomazevic, M. (1999). *Earthquake-resistant design of masonry buildings*. London: Imperial College Press.
- United, S., & Federal Emergency Management, A. (2006). *Designing for earthquakes a manual for architects*. Washington, D.C.: U.S. Dept. of Homeland Security, FEMA.
- Veldman-Reenders, A., Stolk, C., & Horst, N. v. d. (2007). *Versteende welvaart : Amsterdamse School op het Groninger Hoogeland*. Groningen: Noordboek.
- Vent, de, I.A.E. (2011), *Structural damage in masonry: Developing diagnostic decision support*, PhD Dissertation, Delft University of Technology, Faculty of Architecture
- Vent, de, I.A.E. (2011), *Prototype of a diagnostic decision support tool for structural damage in masonry*, Supplement to the PhD thesis of Ilse A.E. de Vent: *Structural damage in masonry: Developing diagnostic decision support* Delft University of Technology Faculty of Architecture
- Wattjes, J. G. (1942). *Constructie van gebouwen: Dl. I. (Constructie van gebouwen.)* Amsterdam: Kosmos.
- Wattjes, J. G. (1926). *Constructie van gebouwen: Dl. 3. (Constructie van gebouwen.)* Amsterdam: N.V. Wed. J. Ahrend & Zoon.
- Weijde, F. (1936). *Metselen*. Utrecht: Hoonte].



Websites:

www.cbs.nl

cenvironment.blogspot.nl

en.wikipedia.org/wiki/Amsterdam_School

www.fagt.nl

www.groninger-bodem-beweging.nl

www.moulures.net

www.namplatform.nl

www.nrc.nl

www.ondergroningen.nl

www.powell-constructors.com

www.seismo.ethz.ch

reppel.nl

www.rijksoverheid.nl

www.rtvnoord.nl

statline.cbs.nl

veilig-erfgoed.nl

en.wikipedia.org/wiki/Amsterdam_School



Appendices



Figure A1: Front façade, Stationslaan 7



Figure A2: Right façade, Stationslaan 7



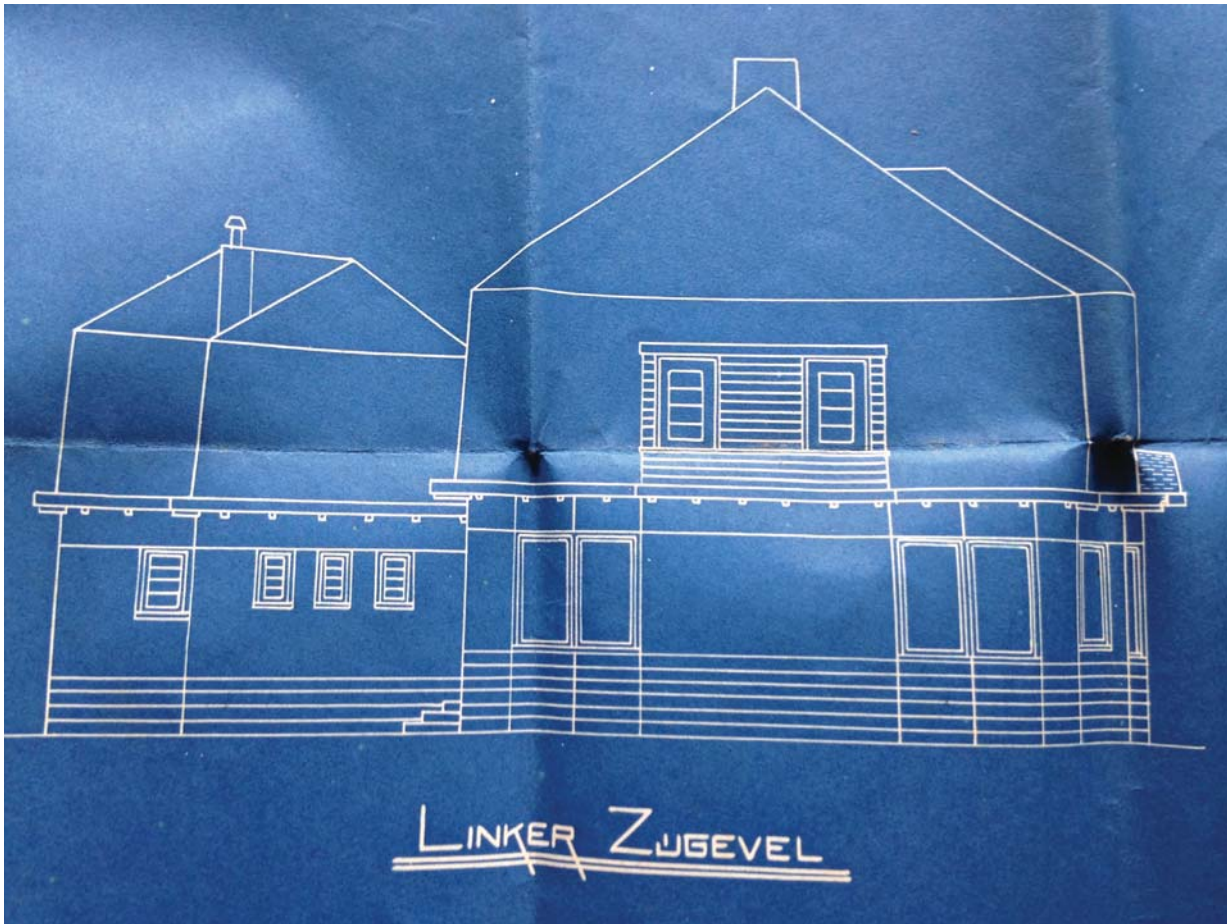

Figure A3: Left façade, Stationslaan 7

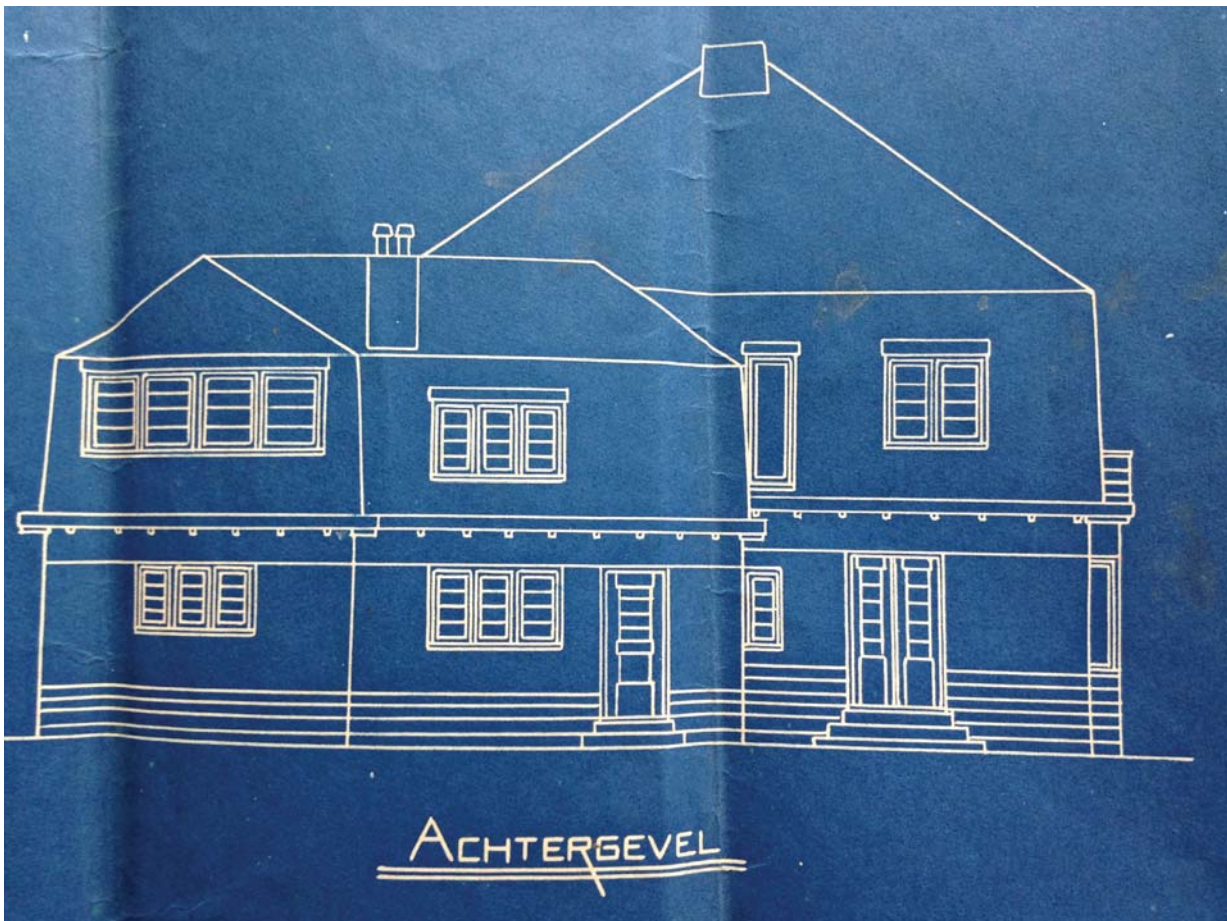

Figure A4: Rear façade, Stationslaan 7



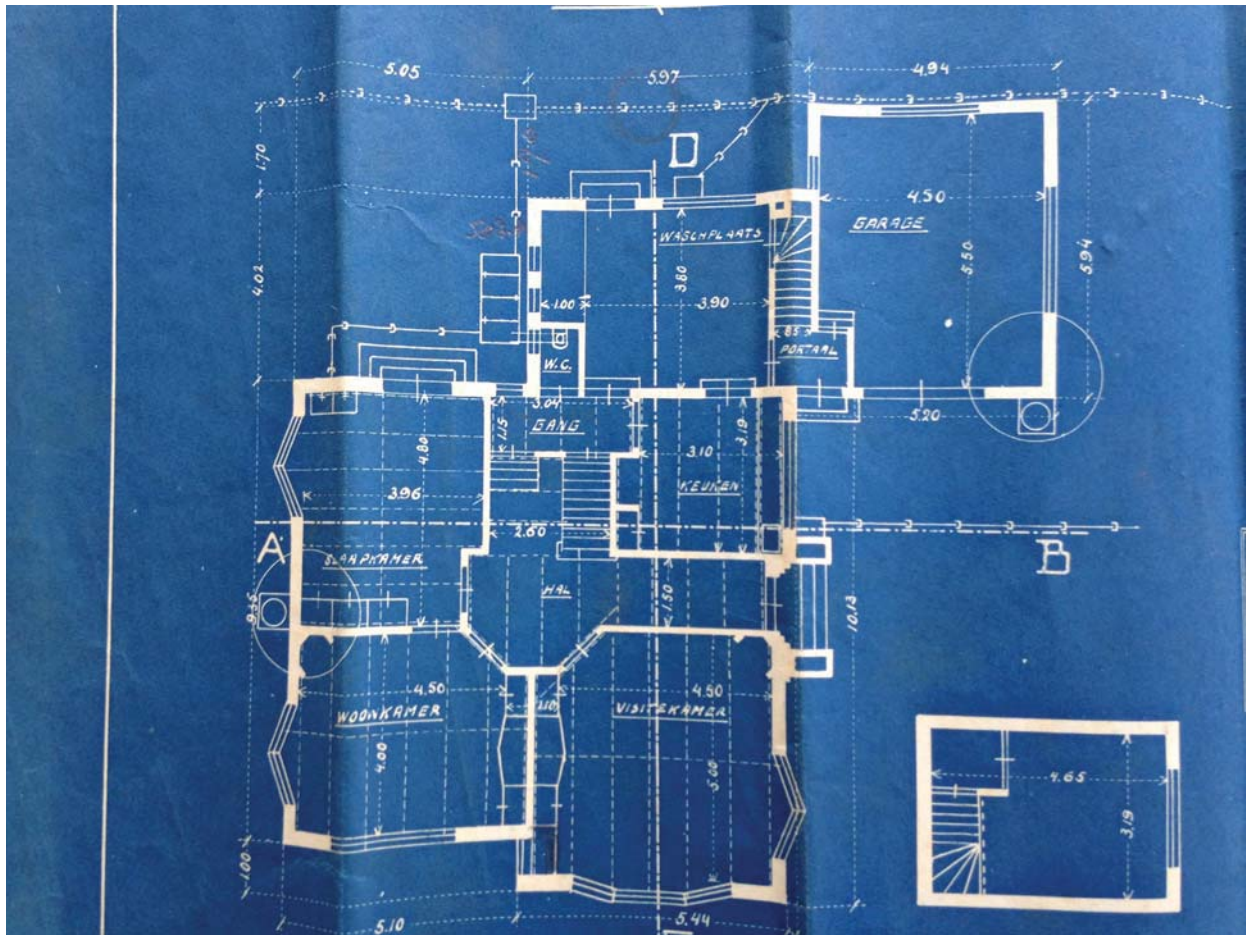

Figure A5: Ground floor, Stationslaan 7

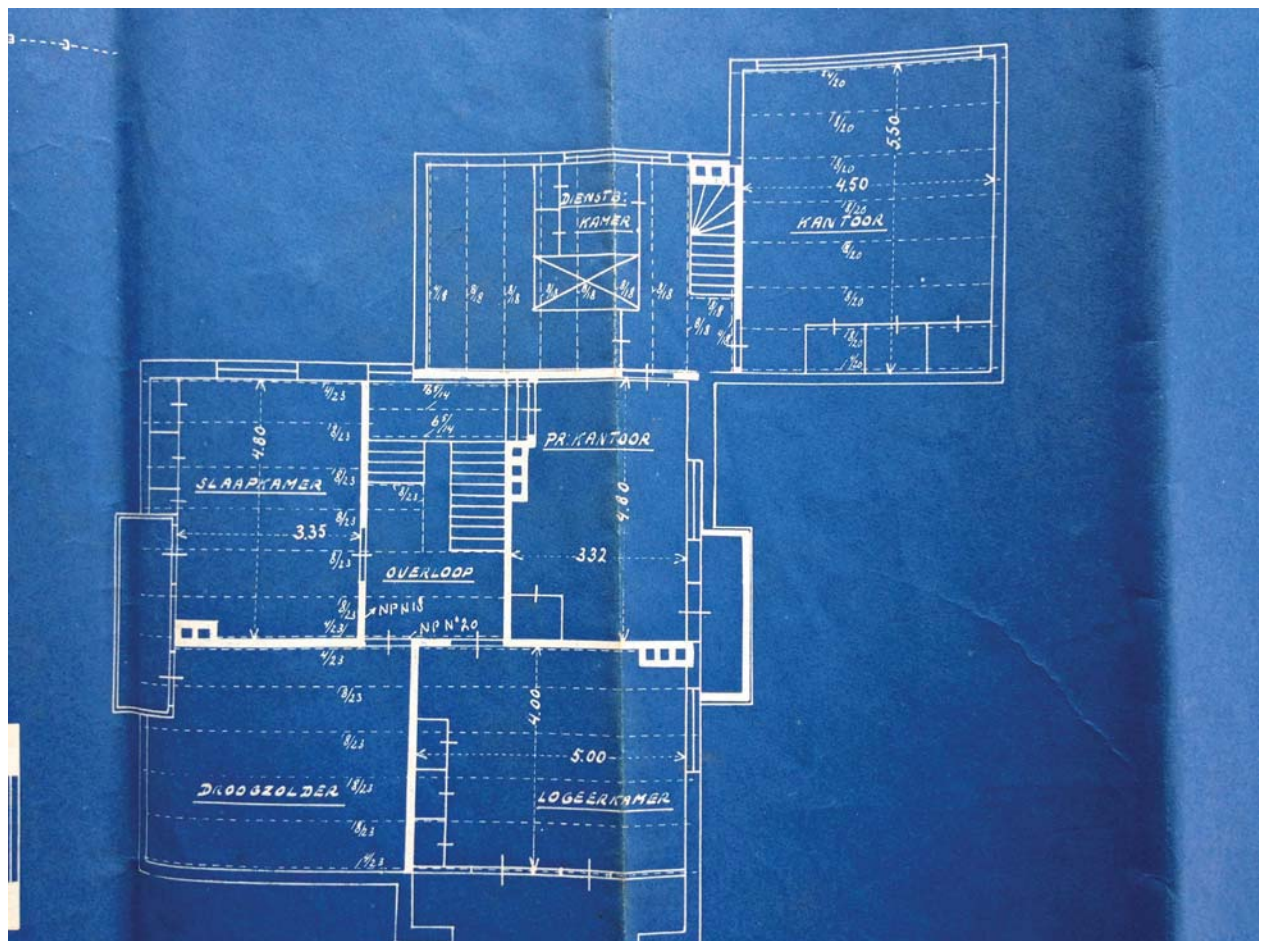

Figure A6: First floor, Stationslaan 7



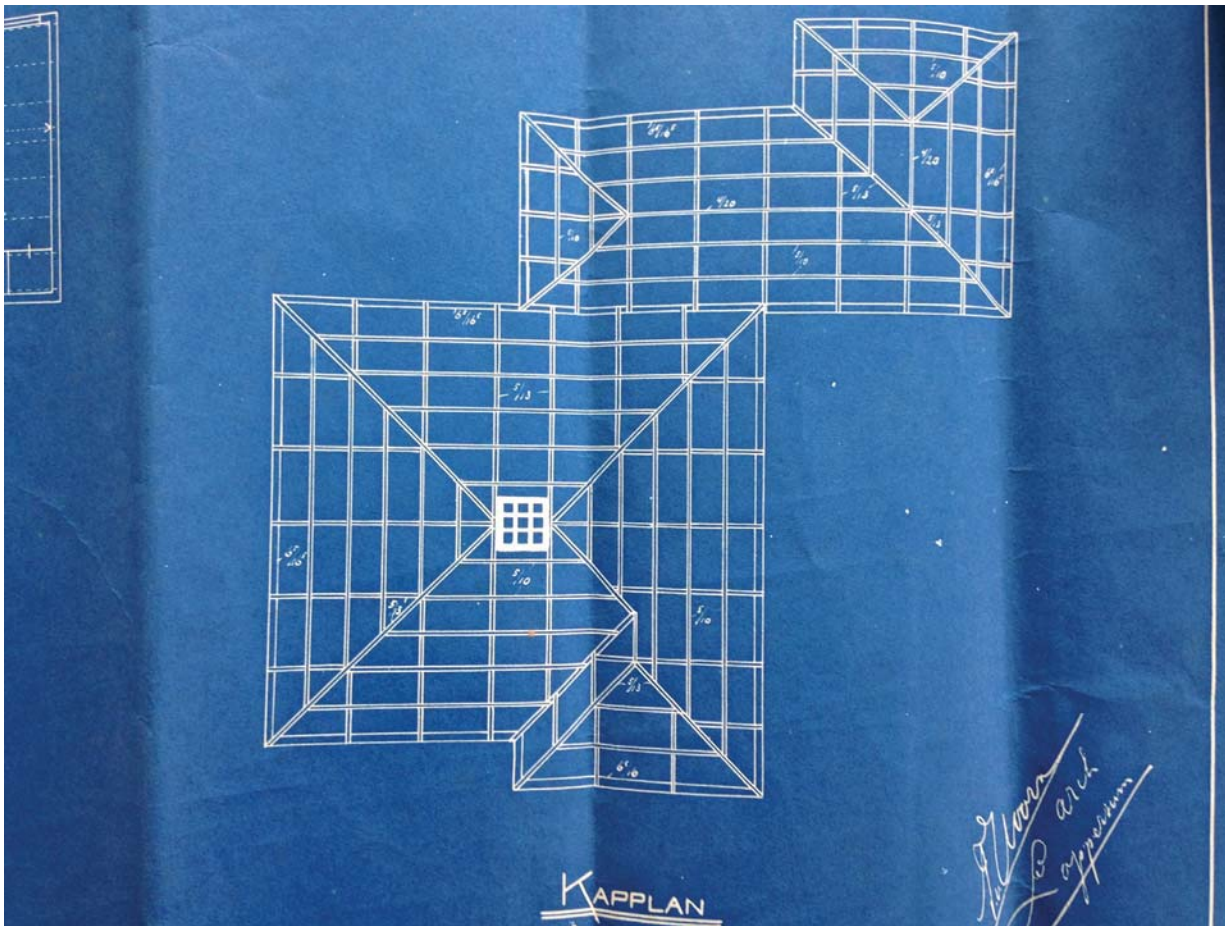

Figure A7: Roof plan, Stationslaan 7



Figure A8: Section A-B, Stationslaan 7





Figure A9: Section C-D, Stationslaan 7



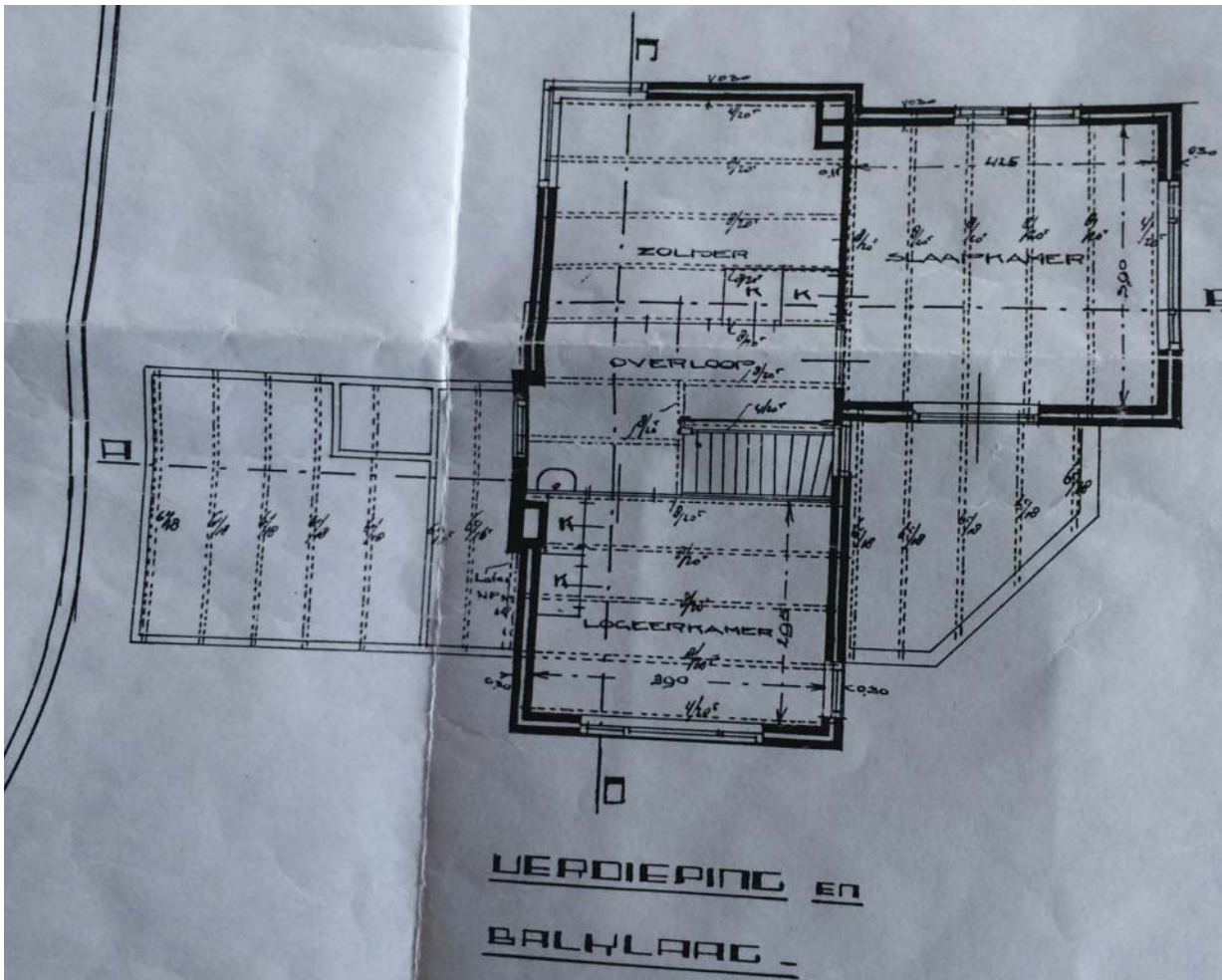

Figure A10: First floor, Wirdumerweg 27

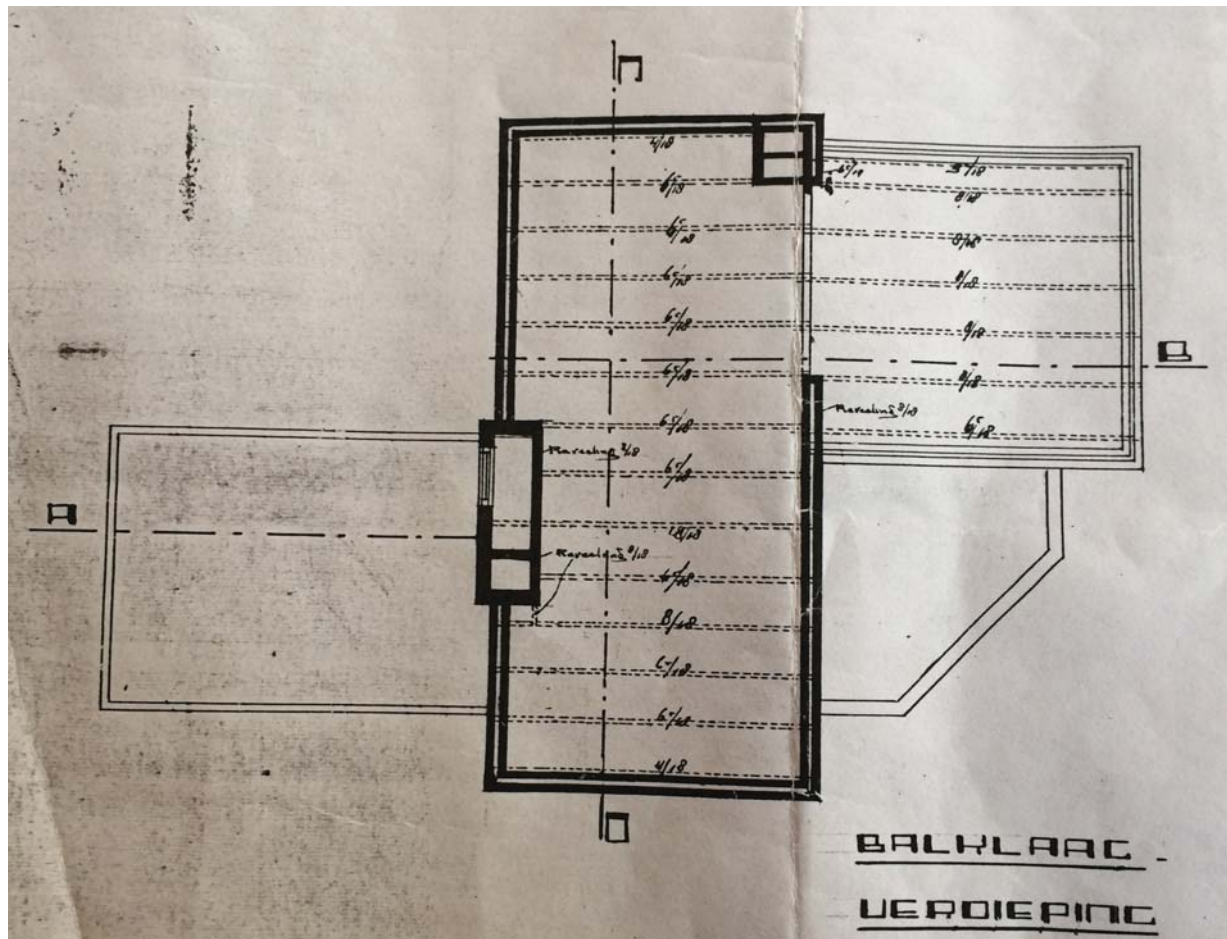

Figure A11: beams, Wirdumerweg 27



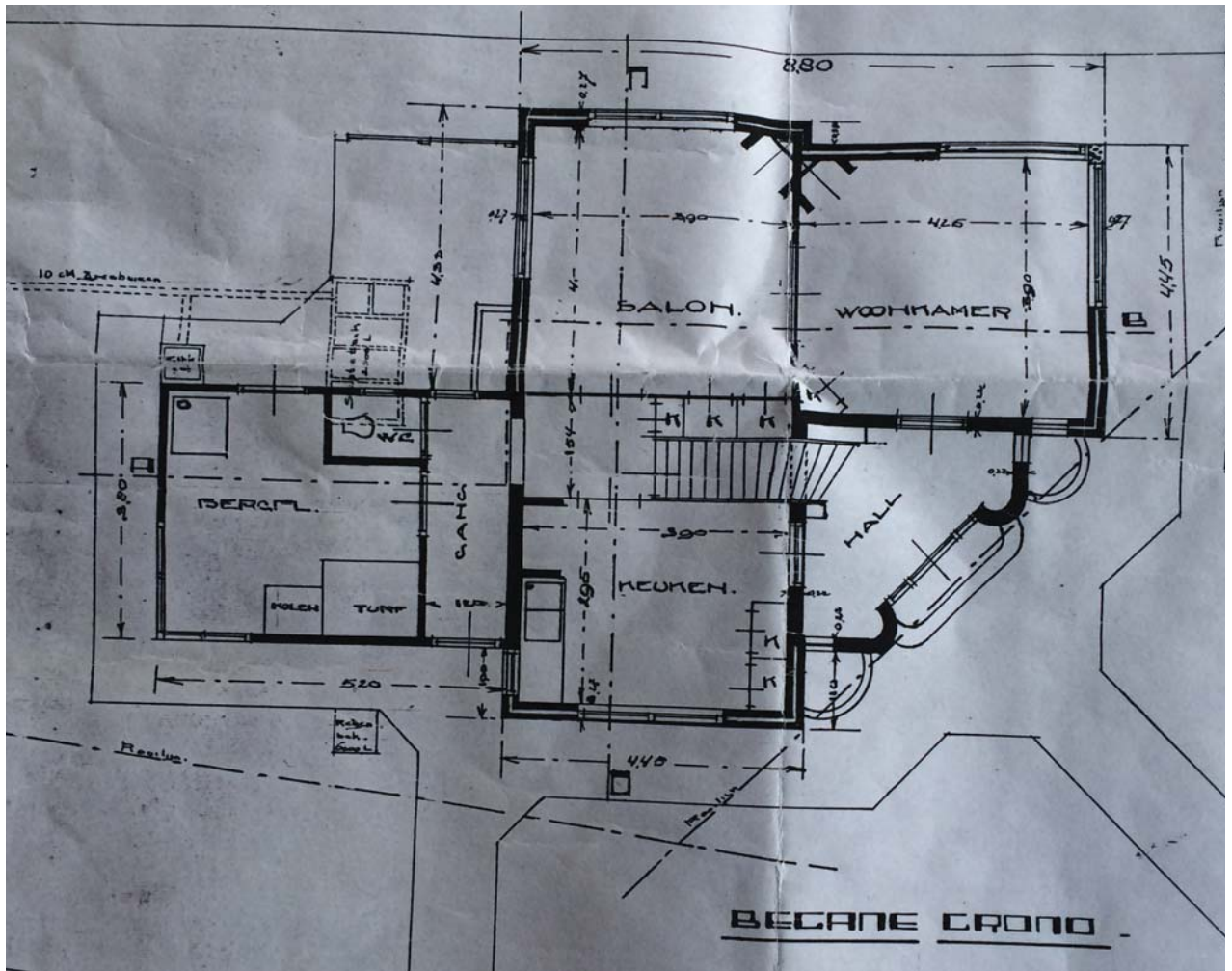

Figure A12: Ground floor, Wirdumerweg 27

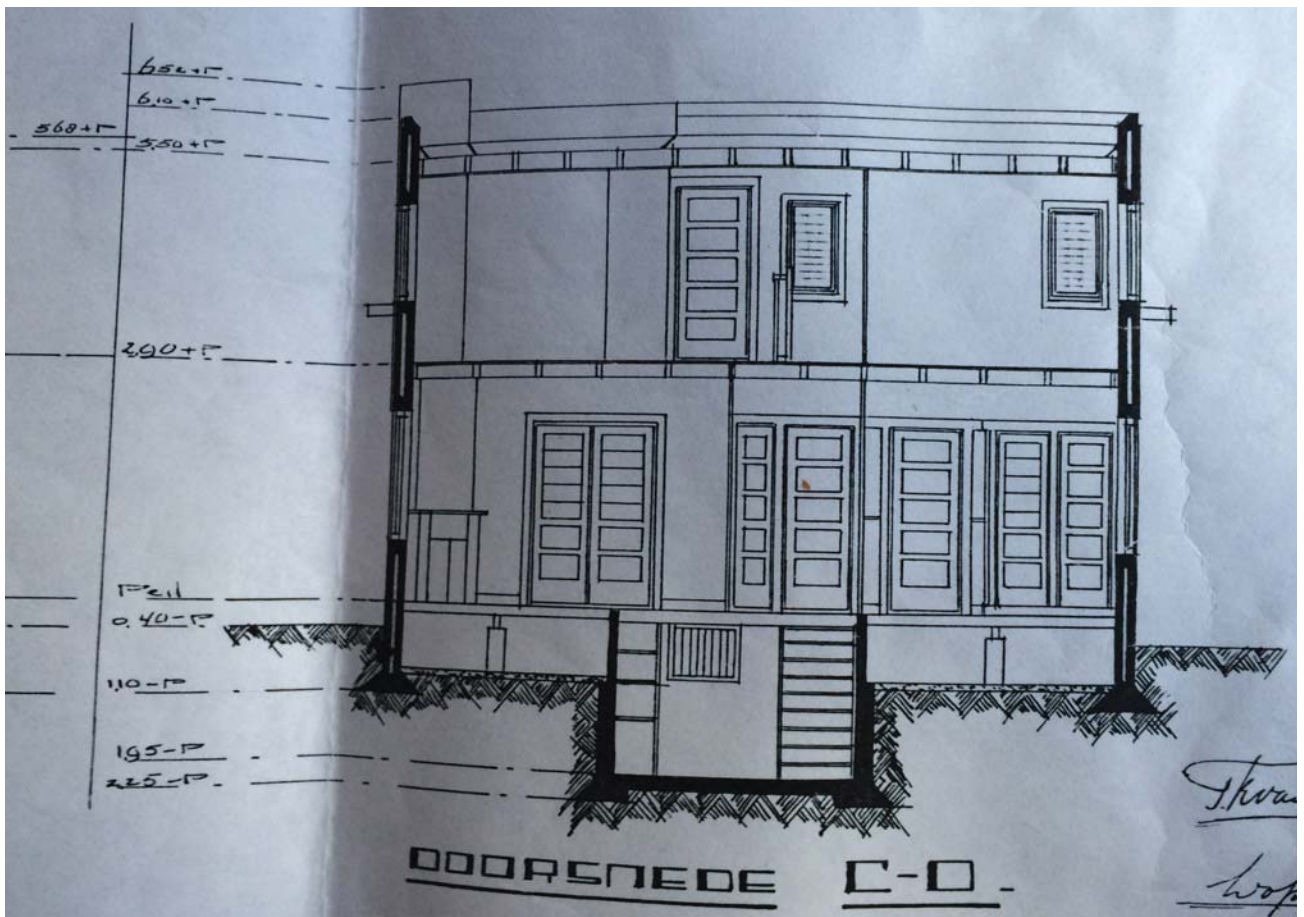

Figure A13: Section C-D, Wirdumerweg 27



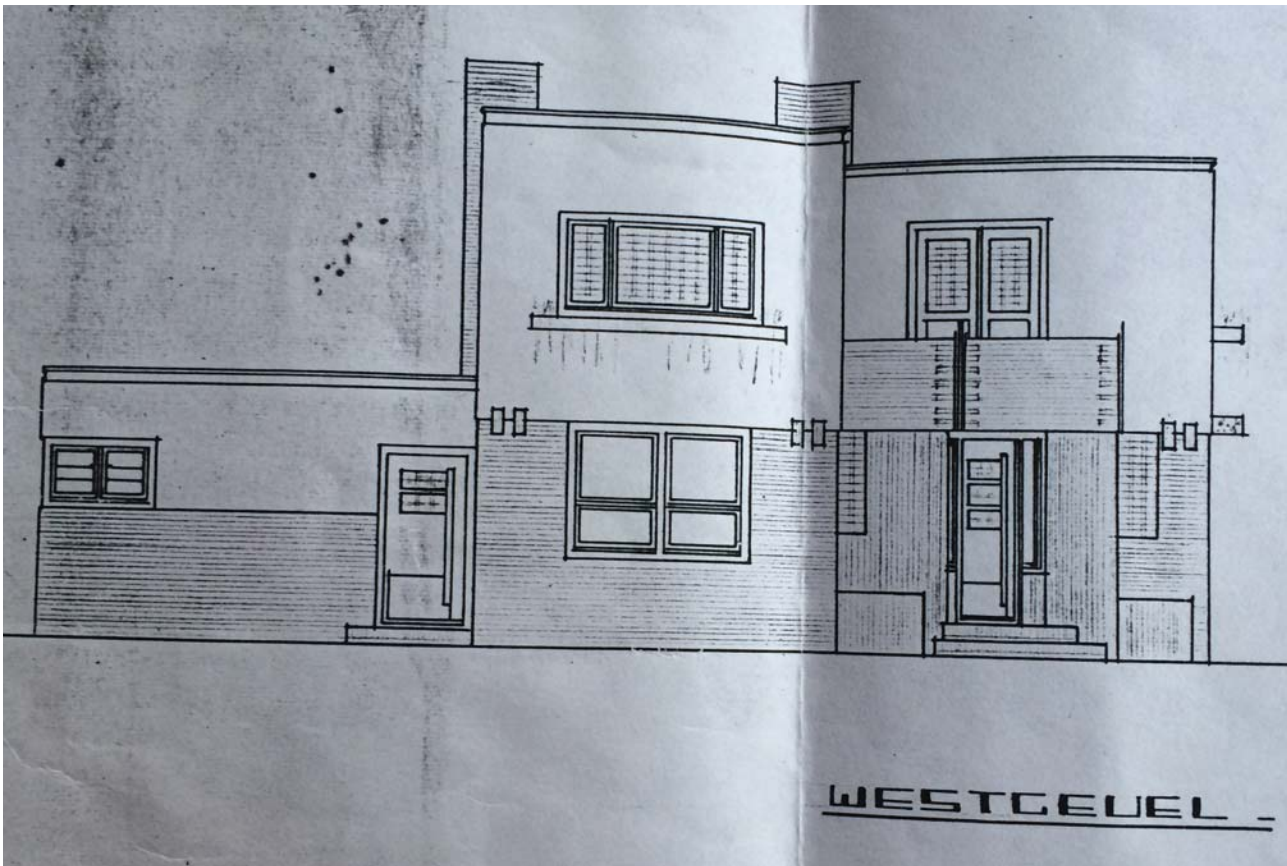

Figure A14: West façade, Wirdumerweg 27

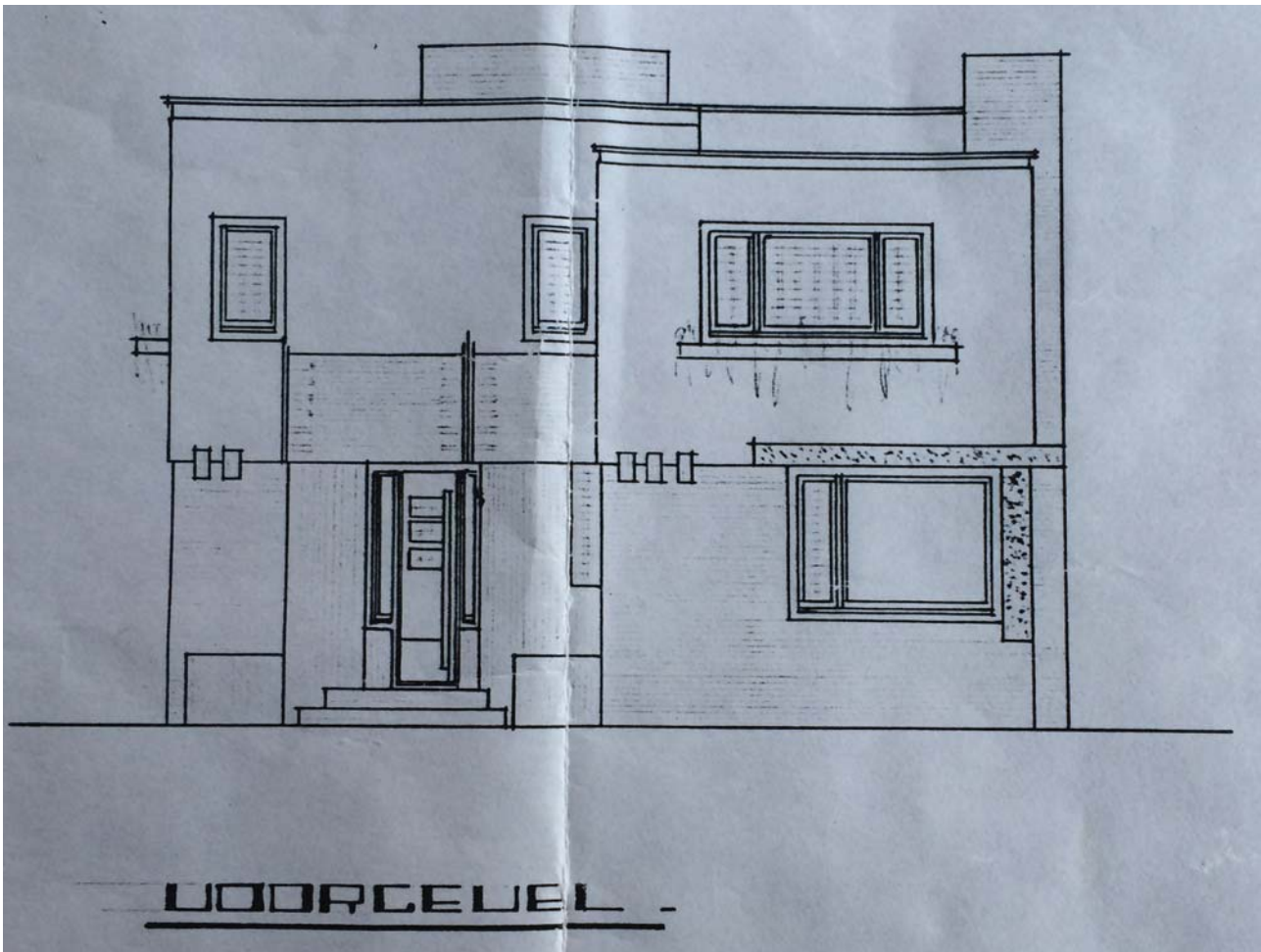

Figure A15: Front façade, Wirdumerweg 27



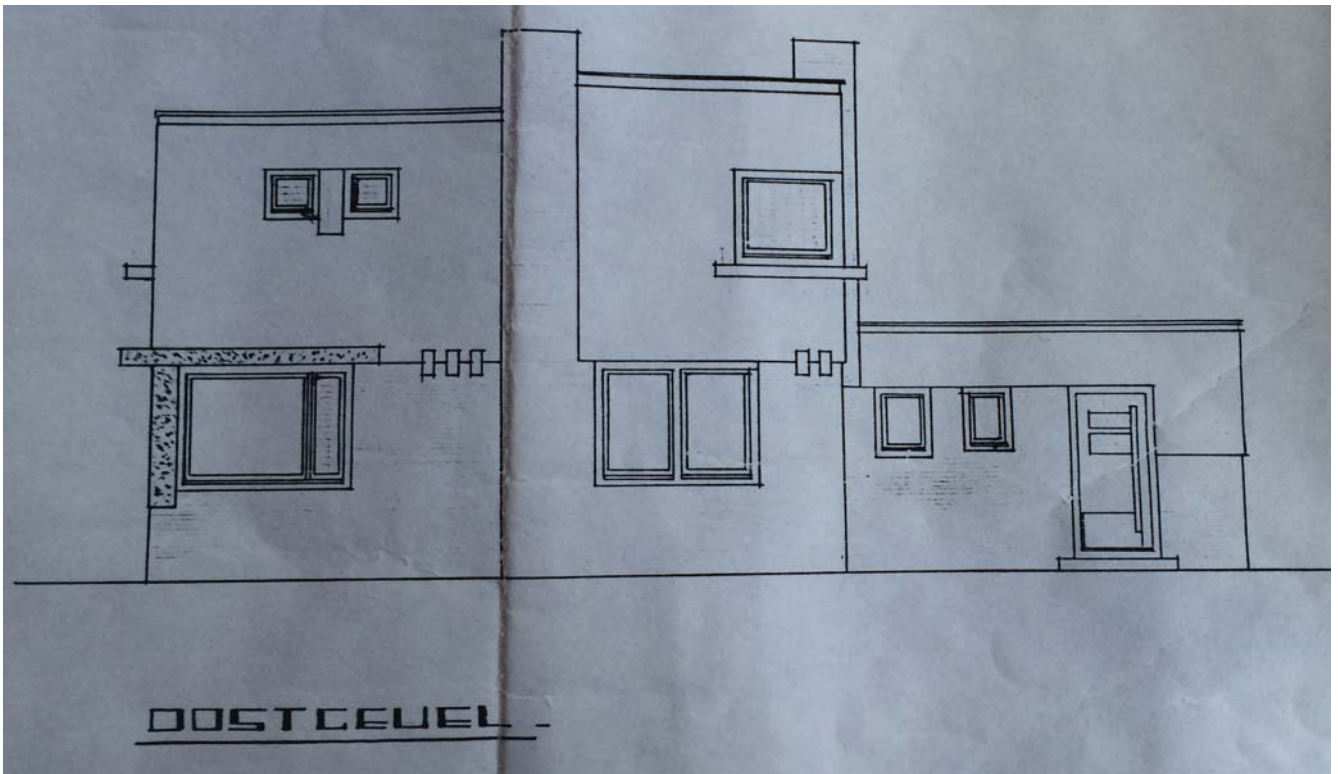

Figure A16: East façade, Wirdumerweg 27

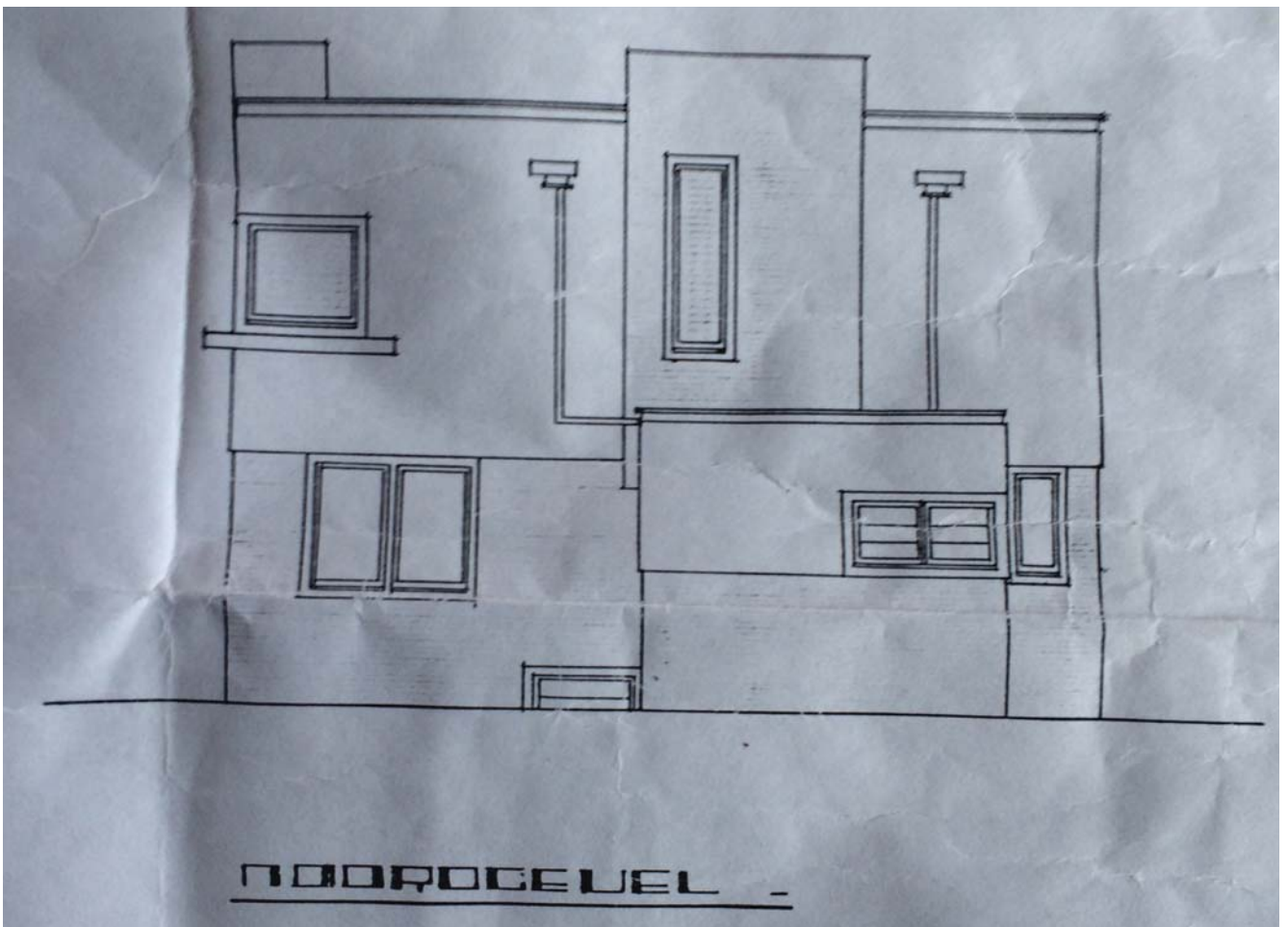

Figure A17: North façade, Wirdumerweg 27



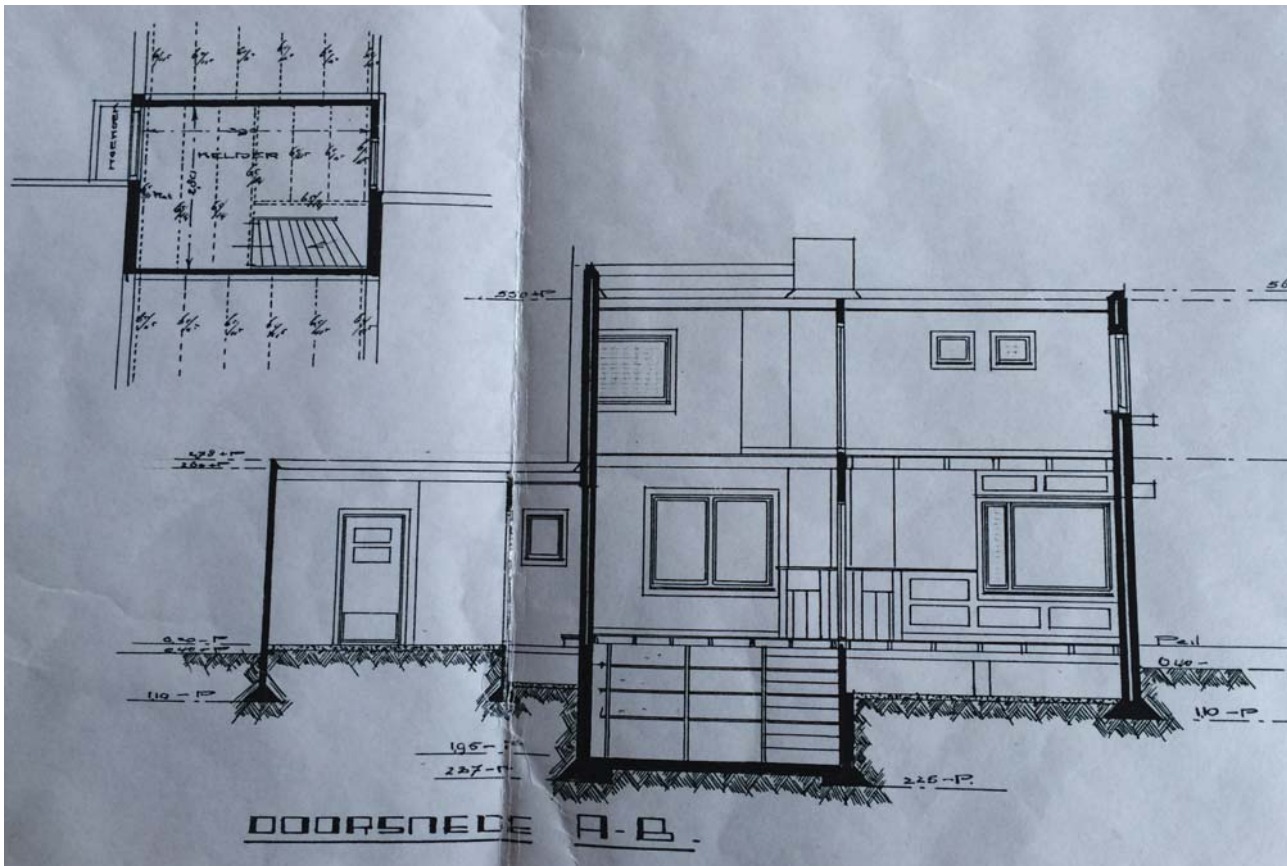

Figure A18: Section A-B, Wirdumerweg 27



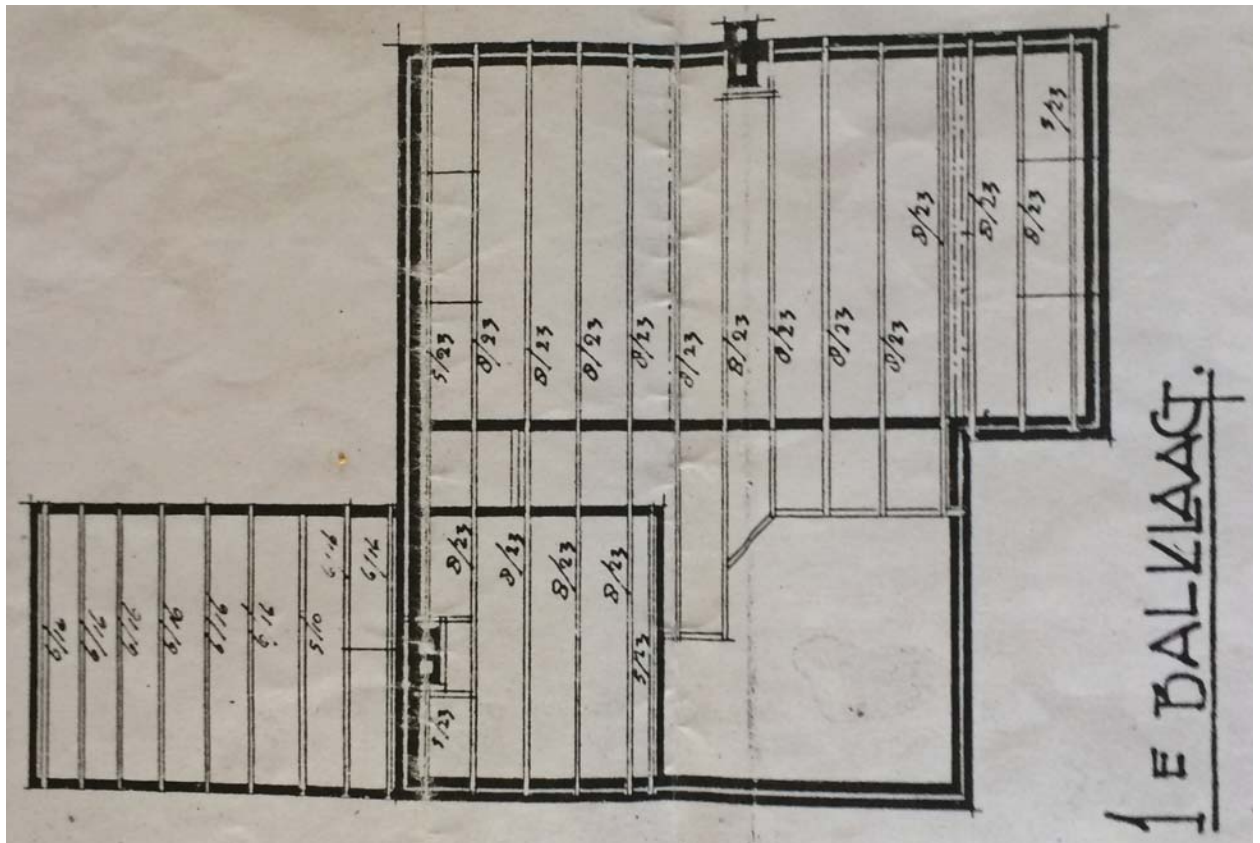

Figure A19: Beams, Zeerijperweg 12

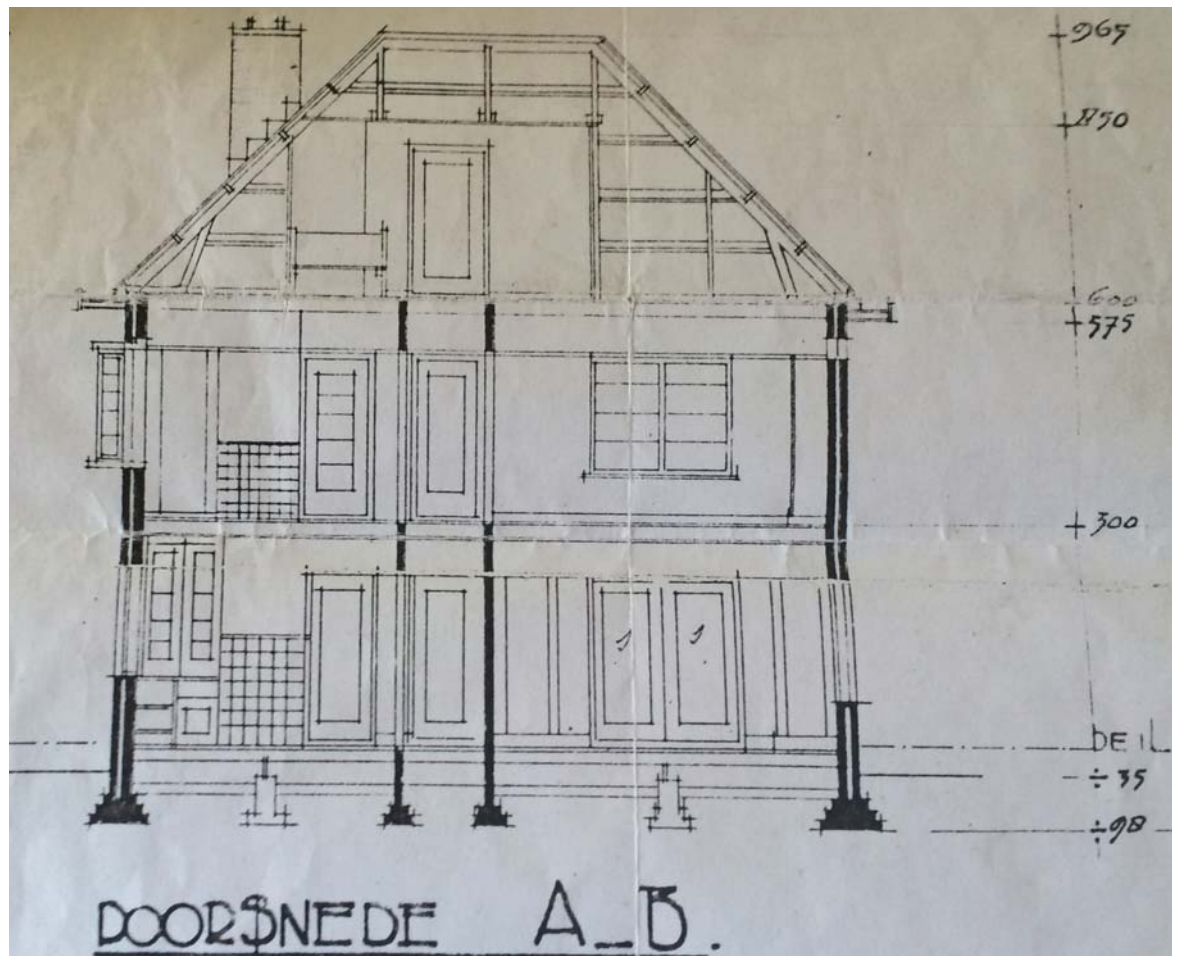

Figure A20: Section A-B, Zeerijperweg 12



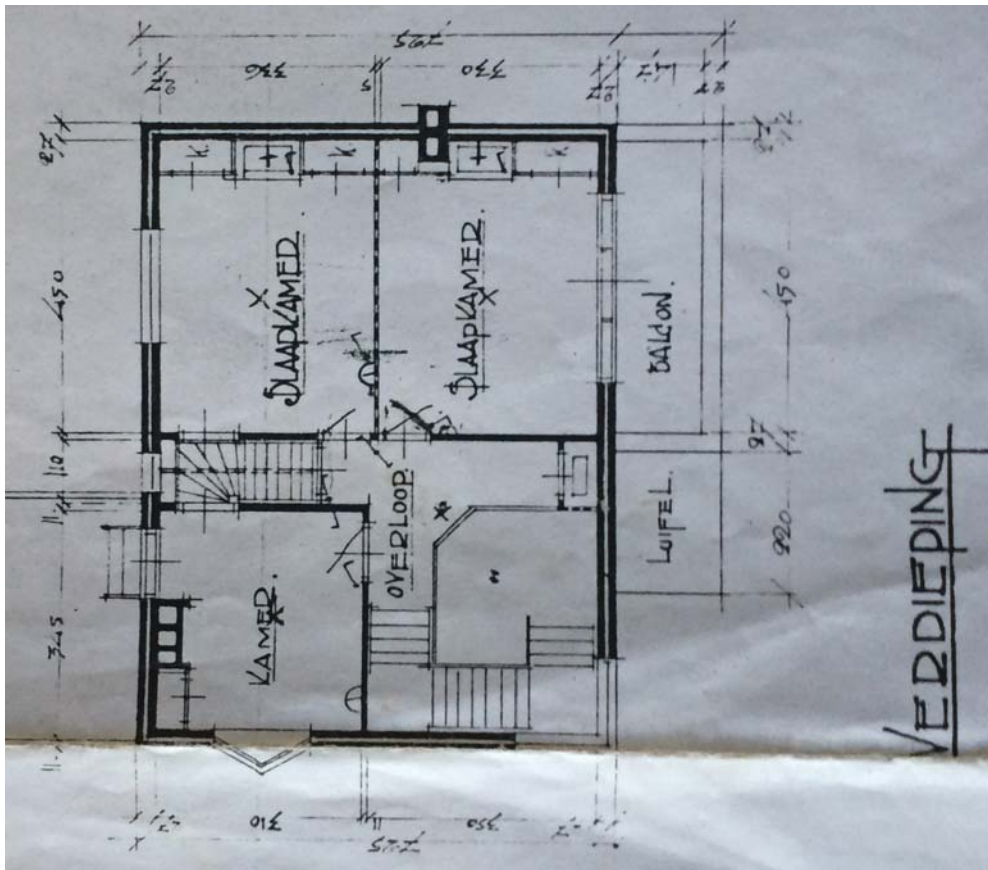

Figure A21: First floor, Zeerijperweg 12

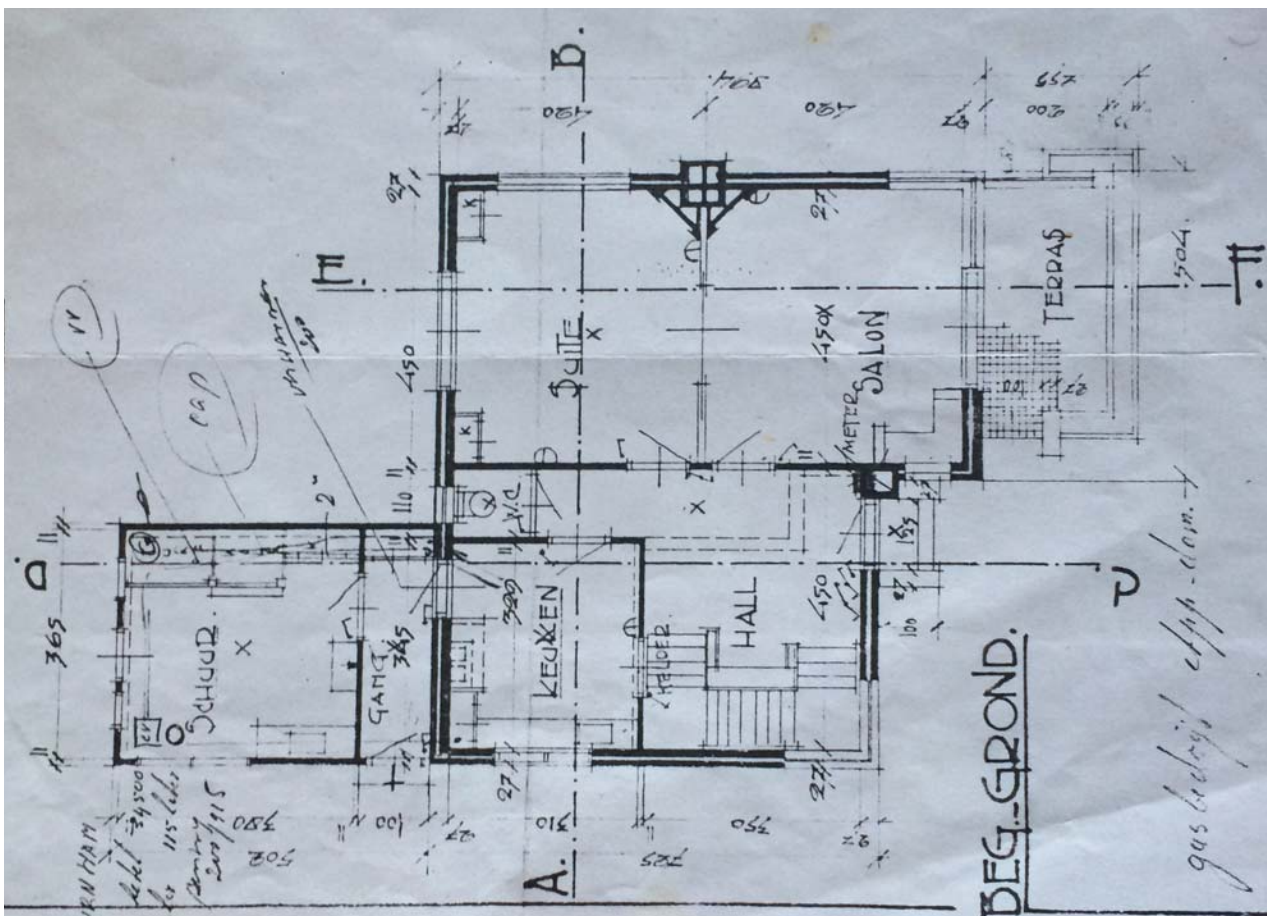

Figure A22: Ground floor, Zeerijperweg 12

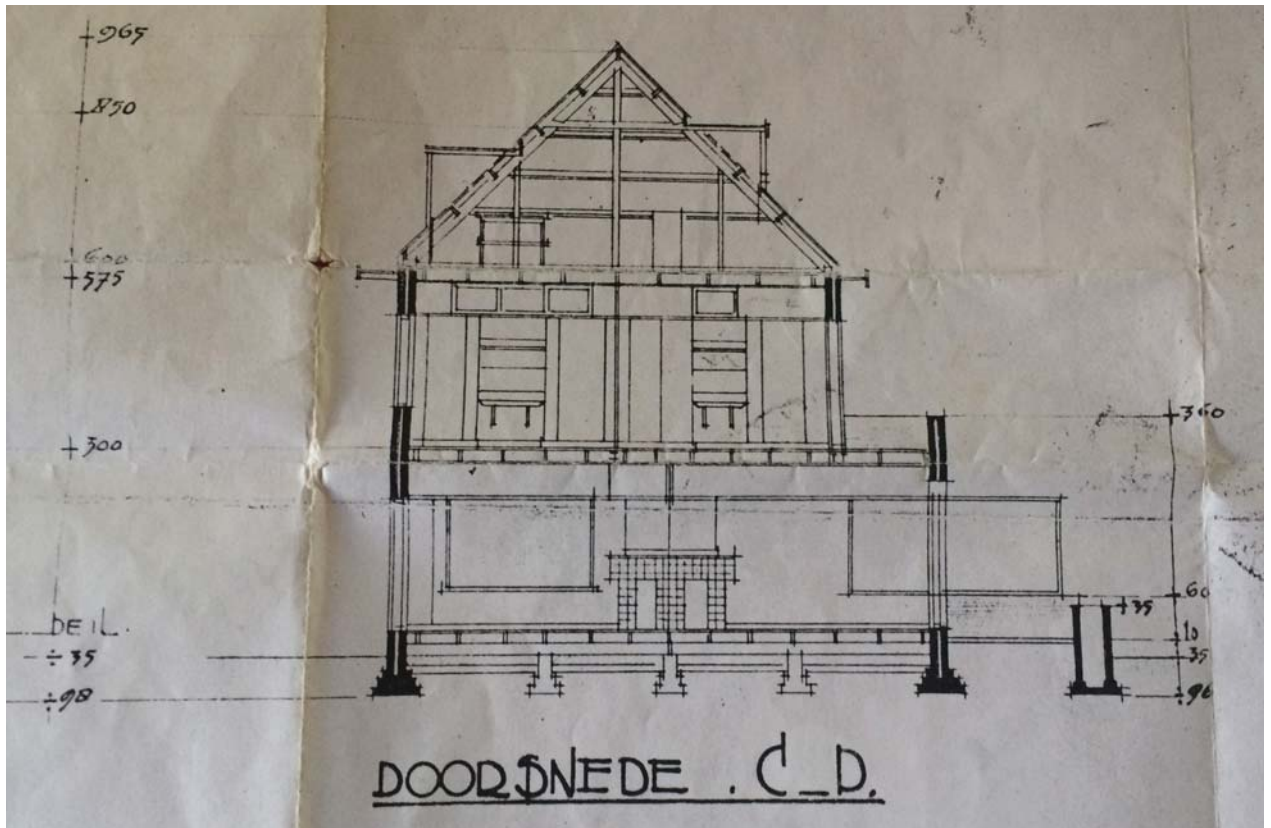

Figure A23: Section C-D, Zeerijperweg 12

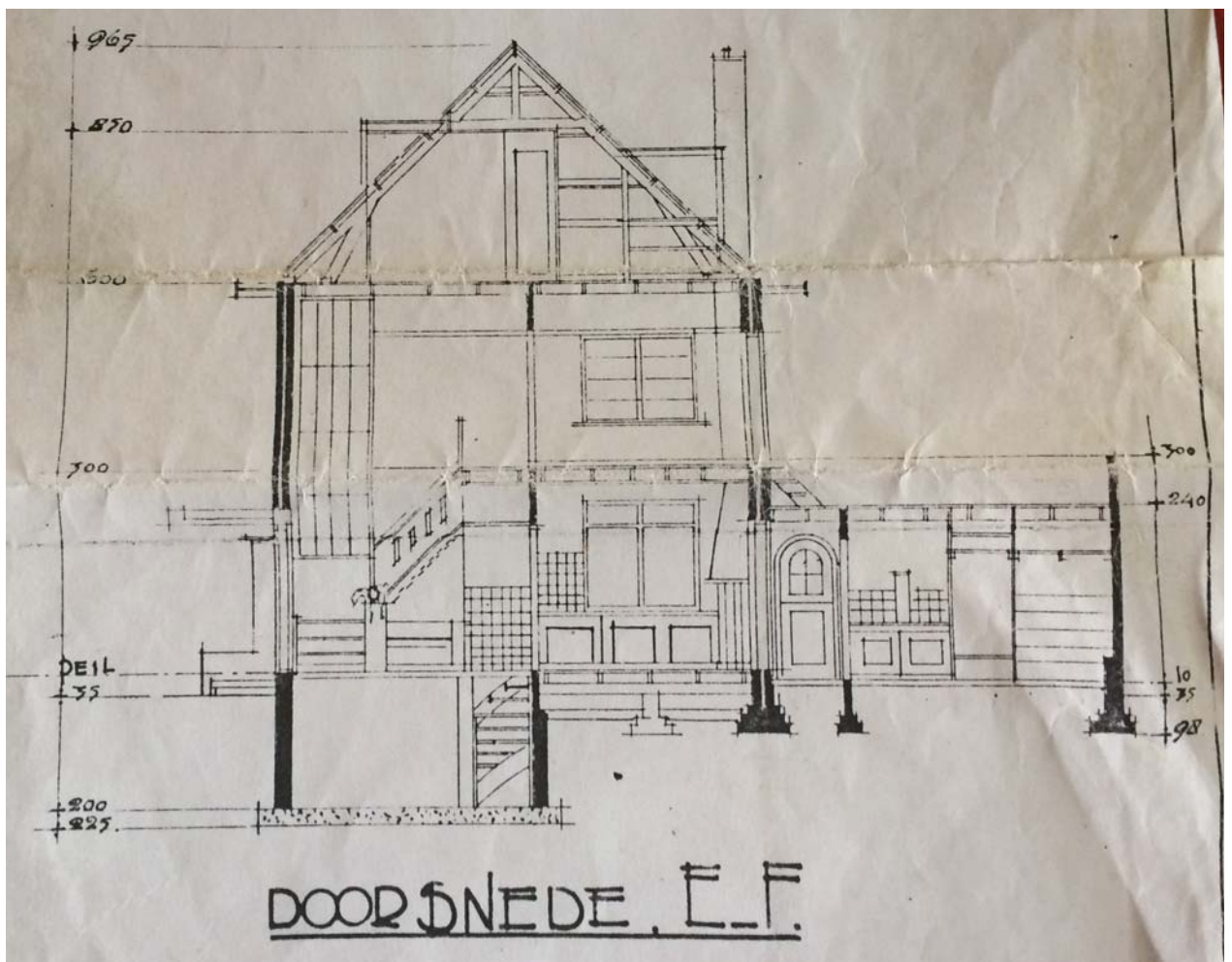

Figure A24: Section E-F, Zeerijperweg 12



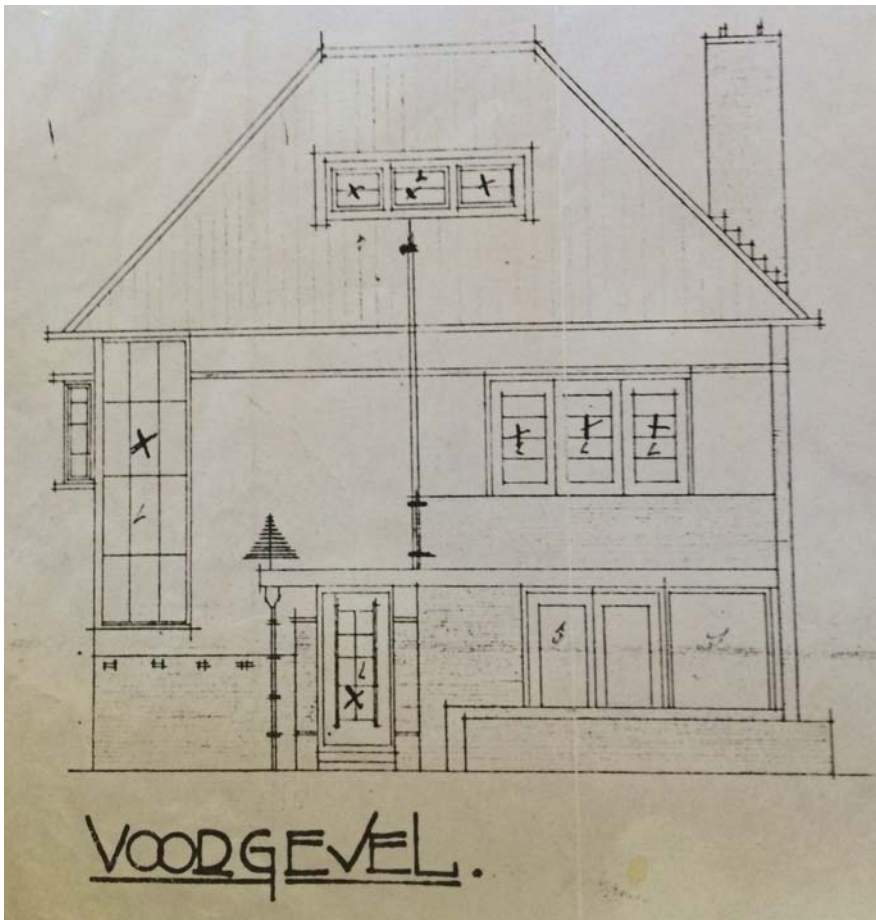

Figure A25: Front façade, Zeerijperweg 12

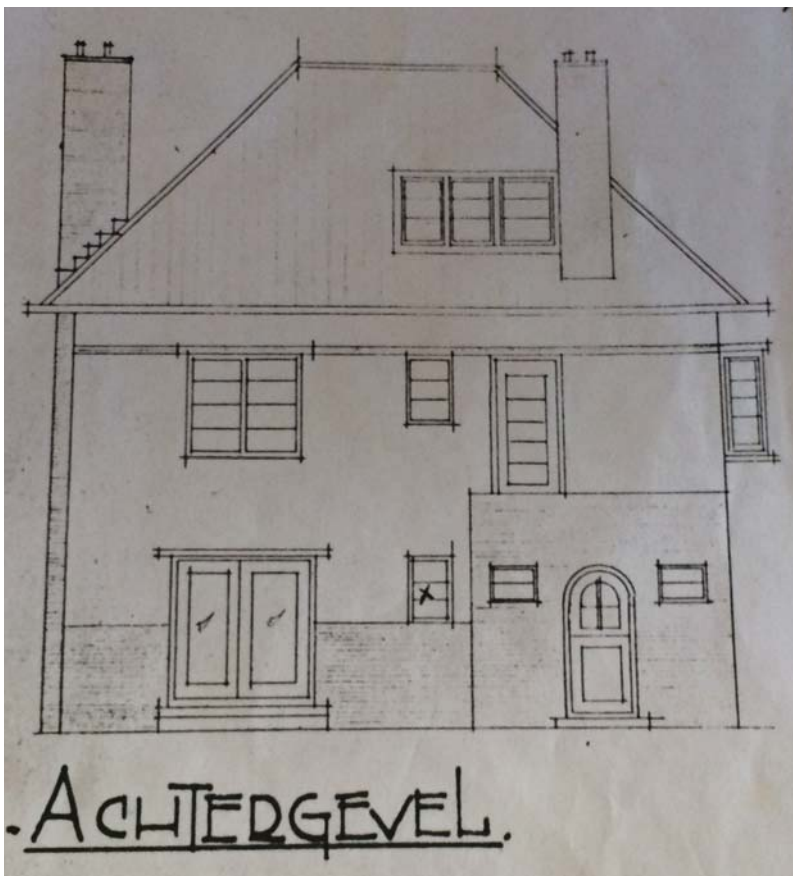

Figure A26: Rear façade, Zeerijperweg 12



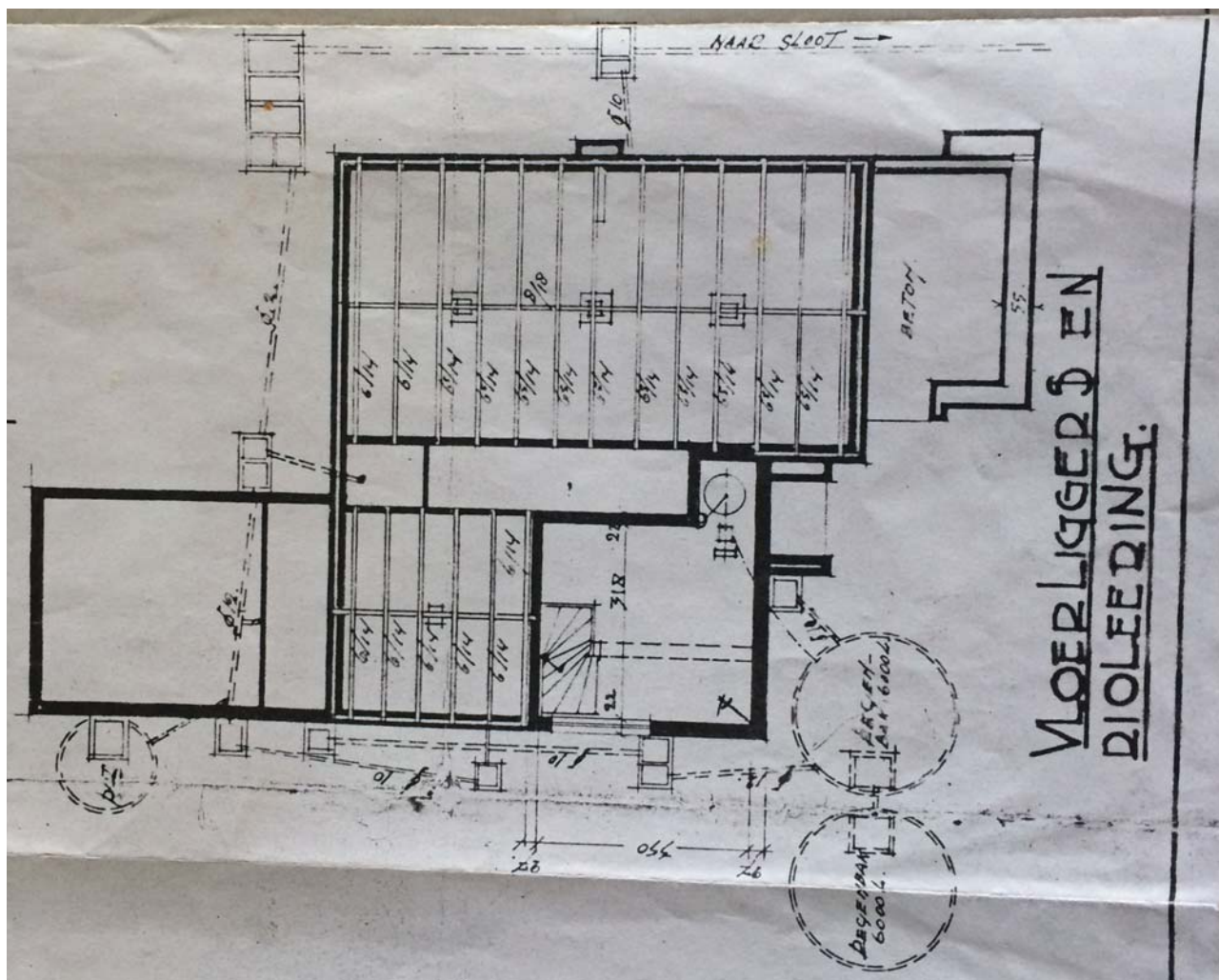

Figure A27: Beams and sewerage, Zeerijperweg 12

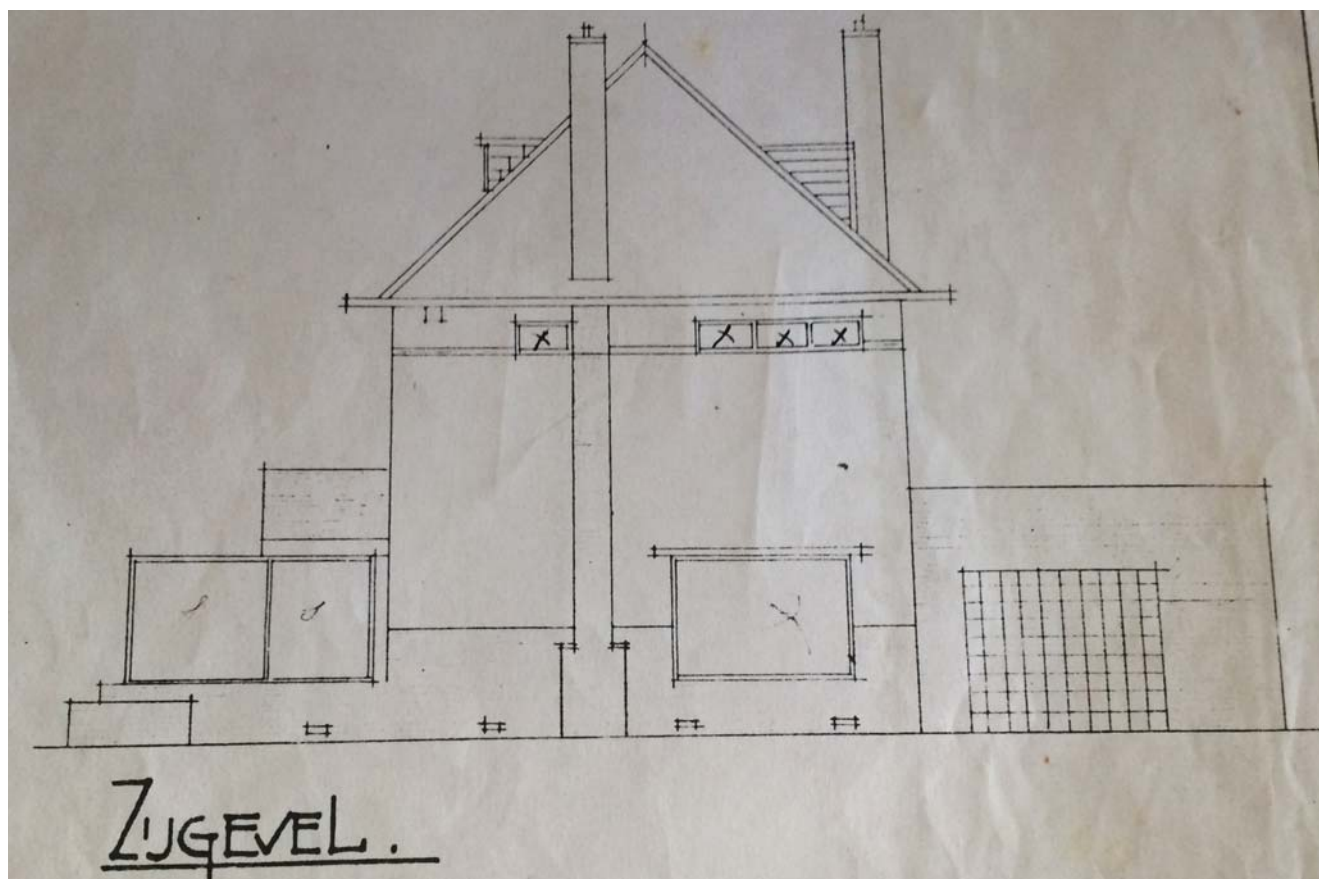

Figure A28: Right façade, Zeerijperweg 12



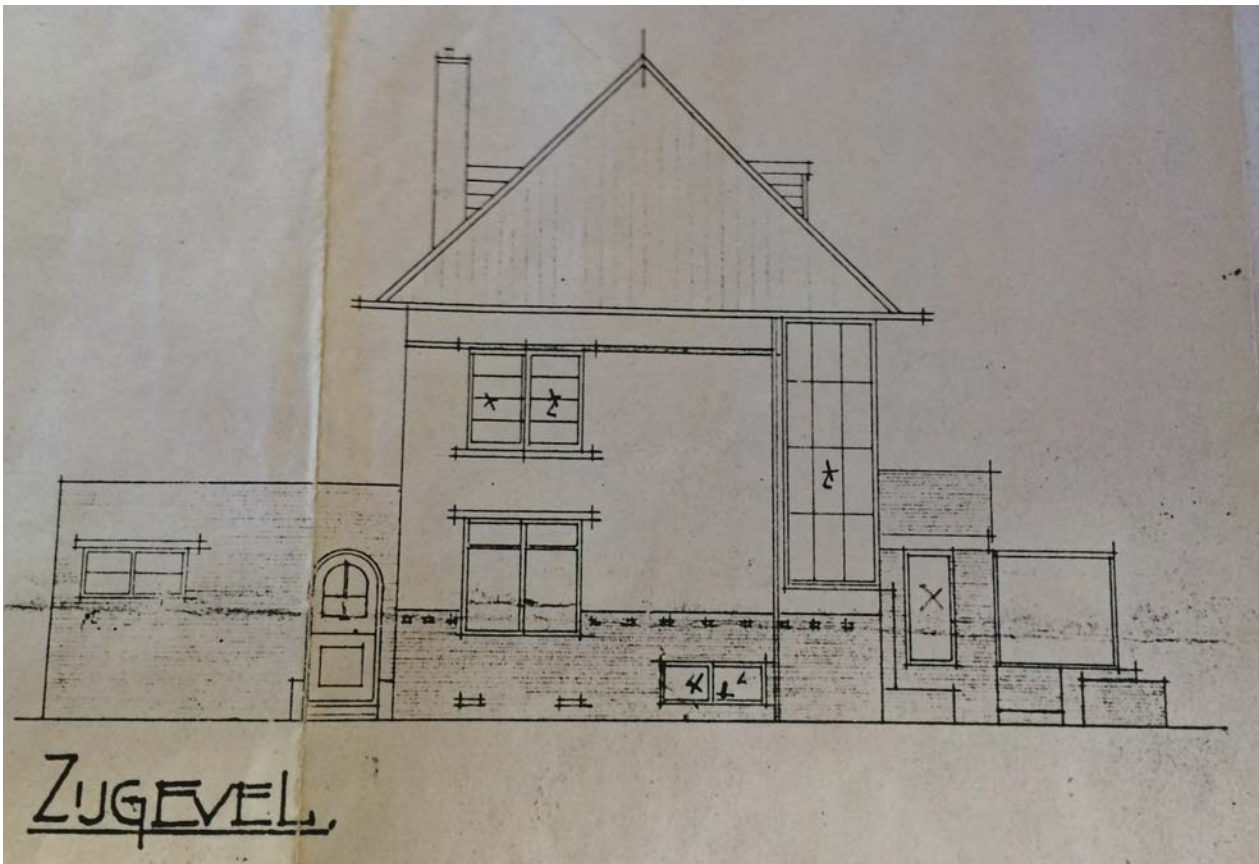

Figure A29: Left façade, Zeerijperweg 12

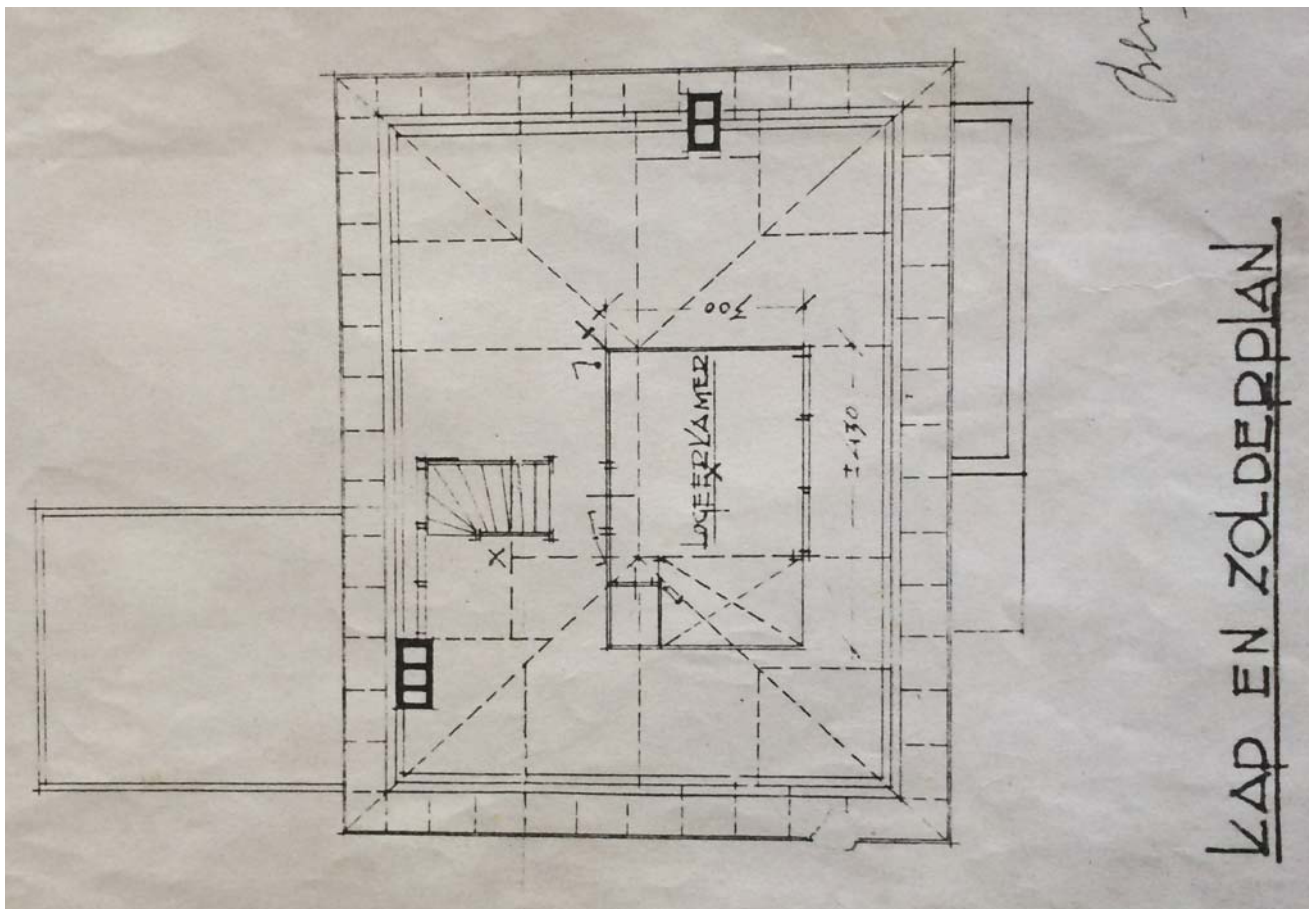

Figure A30: Roof plan, Zeerijperweg 12