

Stopping patterns of train services

An integral approach in network design

Daimen Darryll Ramsing

4261127



STOPPING PATTERNS OF TRAIN SERVICES

An integral approach in network design

by

D. D. Ramsing

July 2020

Master of Science
in Transport, Infrastructure & Logistics
Faculty of Civil Engineering & Geosciences
Delft University of Technology

Supervisors: Prof. Dr. ir. B. van Arem TU Delft
Dr. ir. N. van Oort TU Delft
Dr. W.W. Veeneman TU Delft
ir. N. Guis Nederlandse Spoorwegen

To be defended on July 7, 2020 from 13.00 hour (MET) in a Zoom-meeting.

Source of the image on the front page:

NS 2020 © <https://nieuws.ns.nl/spoorkaart-2020-hier-te-downloaden/>



PREFACE

Dear Reader,

I want to thank you a lot for reading my thesis, as this is in front of you right now. For the last couple of months, I have been writing this research at the Netherlands Railway to obtain my Master of Science in Transport, Infrastructure and Logistics at Delft University of Technology.

As long as I know, I have been extremely fond of trains and - in smaller extent - other rail-bound transport modes. So I already knew at the beginning of my masters, that I wanted to graduate on a rail topic. Eventually, I got the chance to take a look within a company which is operating the Dutch Main Rail network, one of the most dense and widely used national train networks in the world.

This would not have been possible without many people surrounding me. First, I would like to thank my Graduation Committee. Wijnand, thank you for helping me with structuring the process of my thesis and continuously reminding me of the main line of my research. Furthermore, I want to thank you for the tea during every meeting. I would like to thank Bart for the pleasant meetings and providing me with helpful feedback. Niels, I want to thank you for the guidance throughout the whole process. Even before I really started the thesis project, you helped me with your time and advice. Additionally, I want to thank you for the fun meetings that we had, I remember ending a meeting talking about a soccer game once. At last, but not least, I want to thank Niek for our weekly meetings and the constant guidance, even during the whole Covid-19 situation. Additionally, I want to thank you for the pep talks when I needed them.

Secondly, I want thank my family, as without them I would not be at the place I am now. I want to thank my mother and Kees, for their unconditional support, their help and telling me everything would be fine. My aunts and uncle, I want to thank for being such examples for me. I want to thank my father for the gym visits together while writing my thesis.

Now, I want to take the time to thank my friends. Pieter, for the regular meetings, help with Python and feedback. Yasmin, for reading my thesis and supporting when she could. Sebastiaan and Frederik, for kickstarting my Python knowledge and helping structuring my Python files. And of course, my roommates, Lennart, Roel and Joris, who listened to every struggle and idea I had during the process.

At last, I want to thank the department at NS, Klant- en Marktadvies, for the welcoming atmosphere at the office. More specific, I want to thank Team Vervoer for the fun pubquizes and overwhelming me with all their knowledge on the train network.

This thesis is finalized during a world wide pandemic, where most of the world is in a sort of lock down, including the Netherlands. This made some parts of the research extra challenging, yet I am still very proud of what I achieved with the help of all them mentioned above - and many more.

With writing these words, I will officially end my time as a student in Delft. It was an exciting time, where I found group of friends that will remain my whole life. It was a time that shaped me to the person that I am today and I am very grateful for the whole experience. Thanks to all who joined me along this journey.

Enjoy reading my thesis!

D. D. Ramsing

July, 2020

MANAGEMENT SAMENVATTING

De trein is een belangrijk onderdeel in de verplaatsingen van mensen, functionerend als de ruggegraat van de mobiliteitsketen. De trein is gebonden aan specifieke infrastructuur, zoals het spoor en de stations. De locatie van deze stations is vaak historisch bepaald en het veranderen van de statussen van deze stations ligt vaak gevoelig. Daarnaast zijn de operatie van de trein diensten over het hele land gelijk, terwijl er duidelijke regionale verschillen zijn in het gebruik van het trein netwerk. Daarbij zijn er in het aanbod in het voor- en natransport enige zaken aan het veranderen, zoals deelmobiliteit. Dit maakt dat het trein netwerk in een veranderende omgeving ligt, maar zelf weinig veranderd.

De veranderingen om het trein netwerk niet meer aansluit bij het gebruik van de passagier, wat de keuze voor de trein minder aantrekkelijk kan maken. Dit onderzoek wil inzichten verkrijgen in de effecten van het netwerk ontwerp op de passagier. Het onderzoek zal gedaan worden in opdracht van de Nederlandse Spoorwegen.

Hoe zouden de stoppatronen van treindiensten gepland moeten worden, gegeven verschillende netwerk- en vraagkenmerken?

Een literatuurstudie, een kwalitatieve en kwantitatieve netwerk analyse en interviews zijn onderdelen van de methodiek in het onderzoek. Tijdens de kwantitatieve netwerk analyse zal er gebruik gemaakt worden van data beschikbaar gesteld door de Nederlandse Spoorwegen.

De literatuurstudie is gericht zijn op de belangrijke aspecten in het reisgedrag van passagier, het netwerk ontwerp en het maken van transport modellen.

Het reisgedrag van passagiers wordt beïnvloed door het netwerk ontwerp en het netwerk wordt ontworpen gebaseerd op het reisgedrag van de passagier, wat maakt dat het een tweezijdige wisselwerking is tussen beiden aspecten. Het reisgedrag van de passagier omvat de keuzes die gemaakt worden voor of tijdens de reis. Hieronder vallen de transportmiddel, station en route keuze. Tijdens het onderzoek is aangenomen dat de passagier de keuze heeft gemaakt voor de trein en deels dat de station keuze ook bekend is. De route keuze op het trein netwerk zal worden gemodelleerd door middel van een logit-model gebaseerd op de reistijden van de verschillende routes.

Het proces in het netwerk ontwerp kent verschillende stappen, waarbij dit onderzoek zich meer focust op de strategische stappen. Het netwerk ontwerp leent zich, door de verschillende belangen, niet om geoptimaliseerd te worden voor een enkele waarde. Deze ontwerp dilemma's kunnen een andere uitkomst hebben afhankelijk van het doel beoogd met het netwerk. Dit onderzoek zal voornamelijk benaderd worden met vanuit het perspectief van de passagier, welke een zo kort mogelijke reistijd beoogt. Echter worden de varianten ook beoordeeld op de benodigde vloot en infrastructuur capaciteit.

Netwerk varianten

Een routekeuze model is gebruikt om de invloed van verschillende varianten in netwerk ontwerp te testen. Hierbij kwamen de volgende punten naar boven:

1. Na een bepaald aantal draagt een extra Intercity station niet meer bij aan een snellere reistijd.
2. De Zone en Skip-stop Sprinter resulteren in een snellere reistijd, maar leggen voor sommige herkomst en bestemmingsparen een verplichte overstap op.
3. Een hogere frequentie van de Sprinter draagt meer bij dan een hogere frequentie van de Intercity.

Case studies

Om de verschillende varianten in netwerk ontwerp te testen op cijfers uit de realiteit, zijn twee verschillende case studies uitgekozen. De Stedenbaan Zuid, van Dordrecht tot Den Haag Centraal, en de

Veluwelijn, van Utrecht Centraal tot Zwolle. De netwerk varianten worden eerst gestest met de initiële herkomst en bestemmingen matrix en vervolgens op een andere stationskeuze.

Initiële station keuze

De Stedenbaan Zuid is een relatief korte lijn met veel Intercity stations gelegen in relatief verstedelijkt gebied. Er zijn veel aanvullende openbaar vervoerssystemen aanwezig bij de stations en reiziger lijken zich over meerdere stations te verdelen.

De nieuwe varianten op de Stedenbaan Zuid resulteren allen in een slechtere reistijd voor passagiers. Daarnaast presteren de Zone en Skip-stop Sprinter veel slechter vergeleken met de huidige situatie. De spreiding van de passagiers over de verschillende stations zorgt voor deze uitkomsten. Sommige stations hebben een extra functie buiten de treinverbinding, zo is Schiedam Centrum door de opening van de Hoekse lijn een nog belangrijkere overstappunt geworden. Dit maakt dat er tijdens het netwerk ontwerp ook naar veel andere aspecten gekeken moet worden dan alleen het trein netwerk.

De Veluwelijn is een langere lijn gelegen in minder verstedelijkt gebied met een verbindende functie tussen de Randstad en de noordelijke gebieden van Nederland. Langs de lijn zijn op dit moment drie Intercity stations, dit zijn ook meteen de stations die het meest gebruikt worden door de passagiers.

De uitkomsten voor de Veluwelijn presteren allen beter dan de huidige situatie. Zeker de Zone en Skip-stop Sprinter presteren beter op de Veluwelijn, omdat de reistijd van bijna alle stations naar de grote stations wordt versneld. Een van de doelen omtrent de Veluwelijn is het faciliteren van een snellere verbinding met het Noorden. Alle varianten voor deze lijn hadden Harderwijk aan de Intercity dienst toegevoegd, wat de verbinding met het Noorden vertraagt.

Beiden lijnen laten duidelijke verschillen zien in de prestaties van de verschillende netwerk ontwerpen. Dit verschil komt grotendeels door het verschil in de vervoerspatronen op de lijnen. Dit bevestigt het feit dat invulling van de treindiensten per regio dient te verschillen, gebaseerd op de vervoerspatronen van de passagier. Daarnaast laten de uitkomst van de modellen en de beoogde doelen omtrent de lijn zien dat het netwerk ontwerp hetzelfde doel moet uitdragen.

Nieuwe station keuze

Het veranderen van de stop patronen van de trein diensten kan het aantal directe verbindingen tussen stations en de reistijd van deze verbindingen veranderen, wat de station keuze van de passagier kan beïnvloeden.

Gebaseerd op de reistijd naar stations, de afstand tussen stations en de frequentie en reistijd tussen herkomst- en bestemmingstation wordt er bepaald of passagiers een andere herkomststation zullen kiezen voor de verschillende varianten in netwerk ontwerp. Passagiers kunnen alleen een andere station keuze maken als hun initiële station een andere status heeft dan in de huidige situatie van het netwerk ontwerp. De uitkomsten gebaseerd op het model met de huidige aannames, laten zien dat de verandering in station keuze relevanter is voor de Stedenbaan Zuid dan voor de Veluwelijn. Dit komt overeen met de realiteit, waar op de Stedenbaan Zuid de stations dichtbij elkaar liggen en er aanvullende transport systemen zijn om de station keuze te faciliteren. Het veranderen van het netwerk ontwerp in een meer verstedelijkt gebied kan leiden tot een andere station keuze, daarin dient er wel gefaciliteerd worden in aanvullende transport middelen om deze keuze te maken. De Nederlandse Spoorwegen kan de negatieve effecten verminderen door het aanbieden van leen scooters, of andere transport middelen voor middellange afstanden, of samen te werken met partners die dit kunnen faciliteren.

Conclusie

Het succes van het netwerk ontwerp is voornamelijk afhankelijk van de vervoerspatronen van de passagiers. Het veranderen van de stop patronen van trein diensten zal dan allereerst moeten richten op het voldoen aan de vervoersvraag. Daarnaast zal het netwerk ontwerp ook getoetst moeten zijn op de doelen die samen met de stakeholders zijn opgesteld en andere randvoorwaarden, als de knooppunt functie van stations. Daarnaast hebben de omgevingsfactoren in combinatie met de stop patronen een effect op de station keuze kan de passagier, welke beter gefaciliteerd wordt in meer verstedelijkt gebied.

Stopping patterns of train services

Daimen Ramsing

July 2020

Abstract

The train network is a vital link within the mobility chain. Several aspects in the mobility chain are changing, for example the alternatives in modes and the trip types of passengers. The rail network with the vital locations as stations and the operation of the services on the network seem to be less adaptive, while the travel behaviour of passengers seem to change due to developments in access and egress. Additionally, the use of the train network differs per region. This could result in a mismatch between the network design and the way passengers use the network, i.e. the travel behaviour of passengers. This research will perform a qualitative and quantitative network analysis on two different case studies to obtain insights into influence of the network design on the travel times and station choice. These case studies are the Stedenbaan Zuid and the Veluwelijn, which both show different demand and network characteristics. Both case studies reveal different results in terms of travel times for the network variants, due to the differences in demand characteristics. The differences in the effect of the network design of the case studies could be assigned to the demand characteristics. In network design, the usage by the passenger should be leading. Yet, the location of the network and the stop density could contribute to passengers changing their travel behaviour based on the network design. Additionally, the intended goals of the operator and relevant stakeholders should be known, as this can change the evaluation of the network design.

1 Introduction

National and regional train services contribute in larger extent to the accessibility of Dutch cities and the Netherlands as a whole. In the daily commute, the train is used for approximately 62% as the main mode within multi-modal trips (13). In addition, the average length of these commuting trips have increased, from 14,6 kilometres to 19,0 kilometres and 33% of the commuters in the Netherlands travels between cities contrary to 27% in 1997 (14). Combining these aspects, it is clear that the train holds a vital place within the whole public transport chain and perhaps even more in the years to come.

The location and amount of railway stations are mostly historically grown. Additionally, the train services in the Netherlands are operated equally throughout the country, while De Bruyn et al. (5) state that the services could be adjusted to the use per region. Furthermore, emerging modes lay hold on an increasing share within Europe, changing the dynamics within the whole public transport chain (18). As this changing environment affects the mode choice, i.e. traditional versus contemporary modes, it could also influence other

aspects of the access and egress trips, like the catchment areas of public transportation (17). In line with these recent developments, the passenger opts for a more integrated public transport system (18).

The operations of the train services and stopping patterns could be reviewed to better fit the purpose of the passenger. Changes could be made in the amount of stops and the location of these stops in certain services considering the current network. In the Netherlands, a more integrated and hierarchical rail network is desired to provide smoother multi-modal trips for all trip lengths. Providing new services and a new distribution of stations on the current network can be helpful while improving the system.

This research will focus on the effects of different variants in network design on the main rail network, given different demand and network characteristics.

First, Section 2 will introduce the used methodologies. Subsequently, relevant concepts will be stated in Section 3. Thereafter, the results will be shown in Section 4. At last, Section 5 will state some conclusions and Section 6 will elaborate on recommendations.

2 Methodology

This research builds upon several methods in order to answer the research question. These methods are literature, network and interview analysis.

2.1 Literature analysis

The basis of this research will be a literature study. The literature study will be used to find the societal and research gaps. In addition, the relevant aspects of network design and travel behaviour be addressed, including the bi-level problem.

2.2 Network analysis

Two approaches in network analysis are used in this research. The qualitative network analysis is used for the case studies and focuses on assessing the external boundary conditions of the network, as location and other public transport connections. The quantitative network analysis will calculate the travel time and amount of transport of the variants in network design, which is applied on both the case studies and the network variants.

The route choice model built for the quantitative network analysis is a macroscopic, frequency based route choice model. The station choice model is compiled complement to the route choice model.

The origin and destination data is provided by the Netherlands Railways and represents an average Tuesday.

2.3 Interview analysis

Stations and the main rail network have a natural complexity among them. To obtain insights in the goals and interests of the stakeholders certain interviews are conducted. Among the interviews are municipalities, a travellers interest group and market managers of the Netherlands Railways. The outcomes of the interviews will be used to put the outcomes of the model within a broader context.

3 Literature review

This research has as main goal to determine the influence of the network design on travel behaviour and vice versa. These two concepts are highly intertwined. The network design set the boundaries conditions for the use by the passenger. While the travel behaviour determines the success of the network design. If the travel behaviour changed a lot,

the network design might have to change too. [Figure 1](#) shows the bi-level problem of network design and travel behaviour.

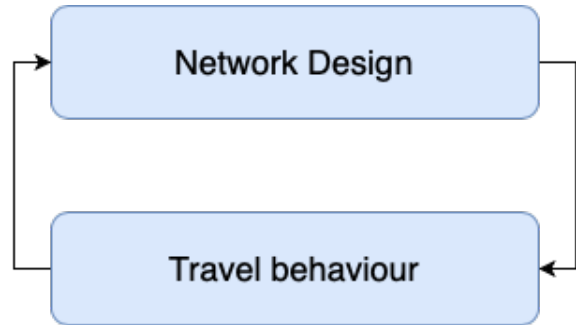

Figure 1: Bi-level problem: Network Design and Travel Behaviour

3.1 Travel behaviour

Travel behaviour combines the choices of passengers in their daily commute or more occasional trips. These choices can consider different aspects during the trip, as the mode, station and route choice, where some of these choices are made simultaneously. Ben-Akiva and Bierlaire (1) describe that choices need to be made by a decision-maker, which is the passenger. There need to be several alternatives with different attributes and a certain process of choosing the preferred alternative by the passenger. These choices are influenced by the attitude and perceptions of the passengers (Ben-Akiva et al.).

3.1.1 Mode choice

The choice for the mode, either main or access and egress mode, is influenced by several different factors (8). First, Bhat (3) and Bhat and Sardesai (4) state that socio- demographics of the individual and households influence the the choice of the main mode. This factor determines for example the availability of the amount of cars per household. Secondly, Ye et al. (23) and Hensher and Reyes (11) declare that the complexity of the journey has an significant impact on the mode choice. Thirdly, the location of the residents could indicate the preferred travel mode (Wee et al. (22); Frank et al. (9); Pinjari et al. (15)). Passengers with the train or other public transport mode as their preferred mode are more likely to move to an area with a good accessibility to those modes, same counts for other modes. This implies that the mode and partially the station choice are determined by the residential location of the passengers.

Emerging modes have an impact on the alternatives passengers can choose from which can have an impact on the choices passengers make.

3.1.2 Station choice

Among the important factors in station choice are the operational characteristic of the services calling at a station. Debrezion et al. (7) add the train services and the frequency of trains calling at a station as relevant factors in the station choice. The services capture the amount of destinations that could be reached from that certain station (7), as Intercity services mostly are operated for a longer distance than Sprinter services. The higher the frequency at a station, the higher the probability for that station to be chosen. The frequency has more effect on resident nearby than residents living further from the station. The factor with the highest effect on the station choice is the Intercity status of a station (7). When considering the last two findings of Debrezion et al. (7), a status alteration of station might be intercepted by increasing the frequency of the services offered at that station. For example, when changing the status of a station, the possible loss of passengers could be leveled by increasing the frequency of the sprinter service at that station.

3.2 Route choice

This research will focus on the route choice on the main rail network, which are the different travel possibilities between station pairs. This choice will be modelled based on the travel time of certain routes. The presence of a transfer in a route is very important in the route choice.

Concluding, the addition of new alternatives in routes, stations and modes can change the travel behaviour of the passenger. Additionally, changing the stopping patterns of trains, i.e. changing travel times and frequencies, can have an impact on the station choice of the passengers.

To include the disadvantage of a transfer within the trip, a transfer penalty is used. For trips with one transfer the transfer penalty is assumed to be 13,36 minutes, which is rounded to 14 minutes (6). This value will be used for this research too, as only travel option with a maximum of 1 transfer are considered during the route choice.

3.3 Network design

The main focus of this research are different variants of network design in terms of the stopping patterns of different train services. The way a transport network is designed can influence the use of the system

by the passenger, i.e. the travel behavior, and vice versa.

Network design involves different stages of planning. Guihaire and Hao (10) describe five different steps in public transport planning.

1. design of the routes
2. setting the frequencies
3. timetabling
4. vehicle scheduling
5. crew scheduling

As rail-bound transit requires specific infrastructure, Schöbel (16) include infrastructure planning as the first step of the network design. This research will focus on line planning, more specific in stopping patterns of different train services. The infrastructure will be assumed a boundary condition. Other operational and tactical planning aspect will not be considered during this research.

Kepaptsoglou and Karlaftis (12) outcomes of the network design process are influenced by the objectives attributed to the network, the operational characteristics and the environmental conditions.

3.3.1 Design dilemma

van Oort and van Nes (21) describe three different main variables in network design: frequency, line density and stop density. Where frequency is the amount of vehicle operated in a given time period, the line density is the total line length in a certain area and the stop density is the amount of stops along the line.

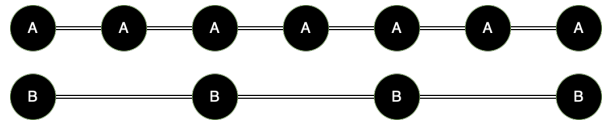

Figure 2: Design dilemma: stop density

In Figure 2 two different lines are shown. Both are operated for the same length, where line A has a higher stop density than line B. More stops increase the accessibility of the line for the passengers, as it shortens the access and egress trips (20). Including more stops decreases the operational speed of the line, resulting in longer travel times (20). During this research, the stopping patterns of different train services will be adjusted. This implies that the stop density of the different services will be changed. Outcomes as the travel time of the passengers based on these stopping patterns will be reviewed.

3.3.2 Design objectives

Van Nes and Bovy (19) discussed several objective functions respecting the design variables as frequency, and line and stop spacing. These objective functions differ per party involved in public transport, e.g. passengers, operators and authorities.

The total travel time of the passengers will have a prominent place in this research, this implies that the main focus of the research will be based on the passenger' perspective. However, the case studies will be - in lesser extent - evaluated on the fleet requirements and infrastructure capacity. The latter factors represent the interests of the operator and infrastructure manager. In addition, lower travel times in the system can be linked to the attractiveness of the system, which is a point of view of the transport authorities.

4 Results

This section will present the outcomes of different network variants. Subsequently, the case studies will be introduced and their outcomes will be shown. First, the outcomes of the different network variants will be shown in Section 4.1. Subsequently, the results of the case studies will be shown in Section 4.2.

4.1 Network variants

To determine the effect of stopping patterns, frequencies of the services and origin and destination patterns, different variants in network design are calculated based on networks as shown in Figure 3.

The main findings of the analysis of the network variants are:

1. The addition of an extra Intercity station does not always contribute to better travel times. The addition of an extra stop slows the service for passengers not using that new stop. The time savings usually obtained with an Intercity, can diminish while adding too much stations to that service.
2. A high frequent Sprinter is more beneficial for the travel times than a high frequent Intercity. The Sprinter is beneficial for all station pairs, while an Intercity contributes to some station pairs being better connected.
3. the Zone and Skip-stop variants result in faster travel time between some station pairs, but impose mandatory transfers for other pairs.

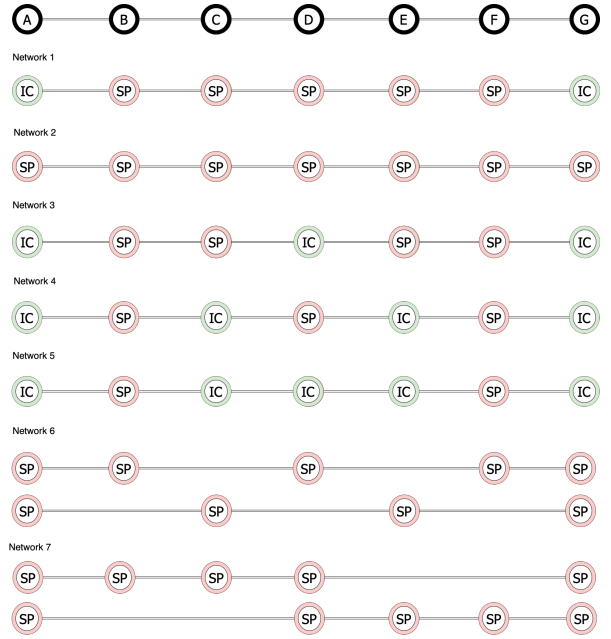

Figure 3: Network variants

4.2 Case studies

During this research two different case studies are used, the Stedenbaan Zuid and the Veluwelijn. The case studies are used to test the network designs on real demand relations.

The Stedenbaan Zuid between Dordrecht and Den Haag Centraal counts 14 stations over a length of about 45 kilometres. The line is located in the province of South-Holland, in one of the more urbanised regions of the Netherlands and connecting the bigger cities of Rotterdam and Den Haag. Half of the stations, have an IC status.

The Veluwelijn is a line in the more central regions of the Netherlands, connecting three somewhat bigger cities. These cities are Utrecht, Amersfoort and Zwolle, which are the only three cities with a station with an IC status. The line is approximately 88 kilometres long with 15 stations located along the line.

The names of the variants for both case study are given in Table 1.

Variant	Stedenbaan Zuid	Veluwelijn
1	Current	Current
2	'Minimal IC'	'IC Harderwijk'
3	'Important nodes'	'Zone Sprinter'
4	'Zone Sprinter'	'Skip-stop Sprinter'
5	'Skip-stop Sprinter'	

Table 1: Variants for the case studies

The visual representations of the different variants for the case studies are shown in [Section 7](#). The outcomes presented further on will be based on these variants in network design.

4.2.1 Initial station choice

First, the performance of the different variants in network design are tested with the initial origin and destination matrix, as provided by the Netherlands Railways. The outcomes will be presented as a ratio compared to the current situation. Values above 1 perform worse compared to the current situation and values below 1 perform better compared to the current situation. The outcomes are presented in perceived and actual travel times of all passengers combined. The outcomes for the Stedenbaan Zuid are shown in [Figure 4](#) and for the Veluwelijn in [Figure 5](#).

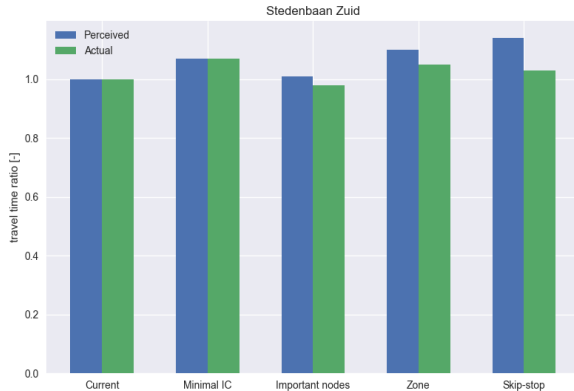

Figure 4: Outcomes Stedenbaan Zuid

The outcomes of the variants for the Stedenbaan Zuid show that most variants perform worse than the current situation. Except for 'Important nodes', which performs better in actual travel time, but worse in perceived travel time.

In a broader context, the current situation of the Stedenbaan Zuid includes lots of stations in the Intercity service. [Section 4.1](#) shows that too much stations in the Intercity service result in less time savings. Yet, the current situation performs best compared to the new variants. Stations should also be evaluated on connections to other public transport systems. Rotterdam Blaak and Schiedam Centrum are excluded as Intercity stations in most of the variants, affecting a significant part of the passengers. The addition of an extra layer in the train system, with a fast service just connecting several important stations along the line and providing for longer trips can be beneficial for the system.

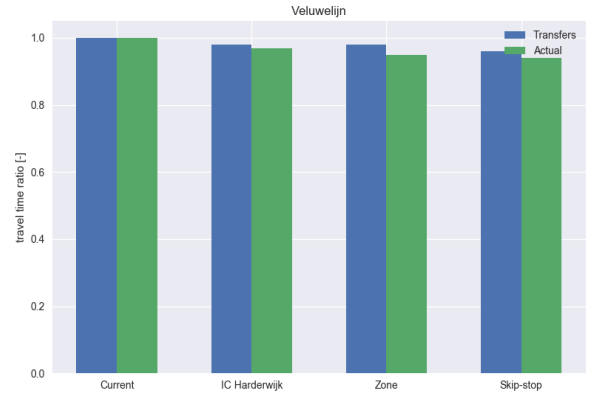

Figure 5: Outcomes Veluwelijn

The outcomes for the Veluwelijn show that all variants perform better in both perceived as actual travel time. Especially the Zone and Skip-stop Sprinter perform better, as these variants result in shorter travel times towards the important stations along the line.

In a broader context, the demand characteristics result in better performing Zone and Skip-stop Sprinter compared to the Stedenbaan Zuid. All variants for the Veluwelijn perform better compared to the current situation. Yet, all variants include Harderwijk in the Intercity service. The Veluwelijn is important in the connection between the Randstad and the Northern parts of the Netherlands. The Netherlands Railways and different layers of the government want to reduce the travel time between these regions, which is not the case when including Harderwijk as an Intercity station. This addresses the formulation of clear goals with relevant stakeholders in the network design process.

The performance of the variants in network design differ significantly per case study, which is caused by the different demand characteristics of the lines. The initial origin and destination matrix is used for this section, which represents travel behaviour under the current network design.

4.2.2 New station choice

Passengers can change their initial station choice based on a new network design. This section will give insights in passengers changing their initial station choice based on a new network design. A choice model will be used for stations with different statuses than in the current situation. The choice model accounts for the following aspects:

1. the travel time of passengers to their access station

2. the distance between successive stations
3. the frequency and travel time from the access to the egress station

Due to the assumptions made, especially about the distance categories, passengers changing their initial station choice is more relevant for passengers on the Stedenbaan Zuid than for passengers on the Veluwelijn. The Veluwelijn will be excluded from this part of the analysis. In reality, the Stedenbaan Zuid facilitates the station choice better, as passengers have the choice among different stations while making a trip.

Scenarios

Three different scenarios are compiled to check their effects on the amount of passengers changing their initial station choice. These scenarios all adjust the access travel time of the passengers.

1. 'Captured passengers'
2. 'Spread of passengers'
3. 'Shared mobility'

'Captured passengers' is a scenario where passengers are housing near their preferred station only. Subsequently, the passengers are more spread over the catchment of the stations in 'Spread of passengers'. Thereafter, 'Shared mobility' will look into the effects of short and mid length shared mobility modes.

The station choice is mostly influenced by the network characteristics, where more urbanised regions can facilitate the station choice better. When adjusting the network design, a relevant option as used in the current situation should be in the proximity and mid-length trips should be facilitated, for a new station choice.

5 Conclusion

This research aims to identify the effect of different stopping patterns of the train services on the main rail network on the travel times of passengers. Based on the quantitative and qualitative network analysis, it can be concluded that the demand characteristics are leading in the success of the network design. New variants in network design were compiled for two different case study lines, the Stedenbaan Zuid from Dordrecht to Den Haag Centraal and the Veluwelijn from Utrecht Centraal to Zwolle. Both the case studies showed different results for the variants in network design. These results were

obtained with the original origin and destination matrices, which represents the travel behaviour under the current situation. Both case studies resulted in different performances for the variants in network design.

Additionally, passengers can change their initial station choice based on the new network design. Where the location of the line and the network characteristics play an important role.

At last, the interviews showed that the intended goals of the operator and other relevant stakeholders should be known, as this can highly influence the evaluation of the network design. The Veluwelijn shows better performing networks with Harderwijk as an Intercity station, but it affects the connection of the Randstad and the Northern regions of the Netherlands, which is an important interest of the Netherlands Railways and different governmental parties.

6 Recommendations

This section will state several recommendations based on the outcomes of the research. These recommendations could be used by the Netherlands Railways in their current network design, or while considering new stopping patterns.

1. add a extra layer in the train system to provide a suitable service for all trip lengths
2. align the goals intended for the train services with relevant stakeholders
3. determine demand patterns of the considered lines
 - (a) more spread demand benefits more from high frequent Sprinter service
 - (b) focused demand benefits from zone and skip-stop Sprinter
4. Intercity could be combined with Zone Sprinter to provide for more and faster direct connections

References

- Ben-Akiva, M. and Bierlaire, M. (1999). *Discrete Choice Methods and their Applications to Short Term Travel Decisions.* pages 5-33. Springer, Boston, MA.
- Ben-Akiva, M., Walker, J., Bernardino, A., Gopinath, D., Morikawa, T., and Polydoropoulou, A. *Integration of Choice and Latent Variable Models.*

- Bhat, C. R. (1997). Work travel mode choice and number of non-work commute stops. *Transportation Research Part B: Methodological*, 31(1):41–54.
- Bhat, C. R. and Sardesai, R. (2006). The impact of stop-making and travel time reliability on commute mode choice. *Transportation Research Part B: Methodological*, 40(9):709–730.
- De Bruyn, M., Guis, N., Hogenberg, J., and Meijers, J. (2019). Next Step Dienstregeling. Technical report, Nederlandse Spoorwegen.
- De Keizer, B., Geurs, K. T., and Haarsman, G. H. (2012). Interchanges in timetable design of railways: A closer look at customer resistance to interchange between trains NS (Dutch Railways). Technical report.
- Debrezion, G., Pels, E., and Rietveld, P. (2007). Choice of departure station by railway users. Technical report.
- Eluru, N., Chakour, V., and El-Geneidy, A. M. (2012). Travel mode choice and transit route choice behavior in Montreal: Insights from McGill University members commute patterns. *Public Transport*, 4(2):129–149.
- Frank, L., Bradley, M., Kavage, S., Chapman, J., and Lawton, T. K. (2008). Urban form, travel time, and cost relationships with tour complexity and mode choice. *Transportation*, 35(1):37–54.
- Guihaire, V. and Hao, J. K. (2008). Transit network design and scheduling: A global review. *Transportation Research Part A: Policy and Practice*, 42(10):1251–1273.
- Hensher, D. A. and Reyes, A. J. (2000). Trip chaining as a barrier to the propensity to use public transport. *Transportation*, 27(4):341–361.
- Kepaptsoglou, K. and Karlaftis, M. (2009). Transit Route Network Design Problem: Review. *Journal of Transportation Engineering*, 135(8):491–505.
- KiM (2019). Mobiliteitsbeeld 2019. Technical report.
- PBL (2020). Afstanden woon-werk verkeer nemen toe.
- Pinjari, A. R., Pendyala, R. M., Bhat, C. R., and Waddell, P. A. (2007). Modeling residential sorting effects to understand the impact of the built environment on commute mode choice. In *Transportation*, volume 34, pages 557–573.
- Schöbel, A. (2012). Line planning in public transportation: Models and methods.
- Shaheen, S. and Chan, N. (2016). Mobility and the sharing economy: Potential to facilitate the first-and last-mile public transit connections. *Built Environment*, 42(4):573–588.
- Standing, C., Standing, S., and Biermann, S. (2019). The implications of the sharing economy for transport. *Transport Reviews*, 39(2):226–242.
- Van Nes, R. and Bovy, P. (2000). Importance of Objectives in Urban Transit-Network Design. *Transportation Research Record: Journal of the Transportation Research Board*, 1735(1):25–34.
- Van Oort, N. and Van Nes, R. (2009). Line length versus operational reliability: Network design dilemma in Urban public transportation. *Transportation Research Record*, (2112):104–110.
- van Oort, N. and van Nes, R. (2009). Regularity analysis for optimizing urban transit network design. *Public Transport*, 1(2):155–168.
- Wee, B. V., . . . , H. H. E. J. o., and 2002, u. (2002). Preferences for modes, residential location and travel behaviour. *superheroscitech.tudelft.nl*.
- Ye, X., Pendyala, R. M., and Gottardi, G. (2007). An exploration of the relationship between mode choice and complexity of trip chaining patterns. *Transportation Research Part B: Methodological*, 41(1):96–113.

7 Appendix

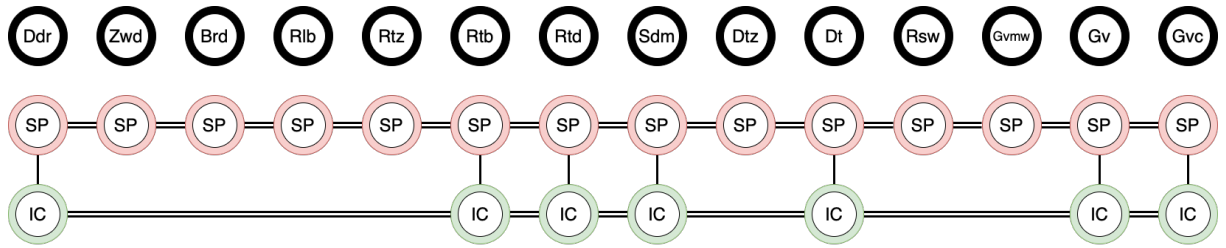

Figure 6: Stedenbaan Zuid: Current situation

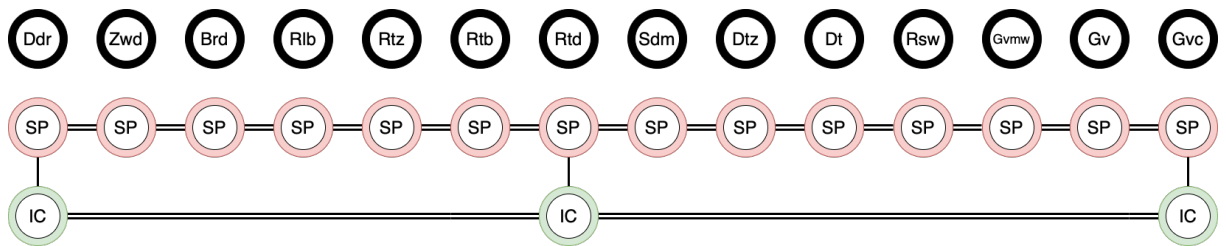

Figure 7: Stedenbaan Zuid: 'Minimal IC'

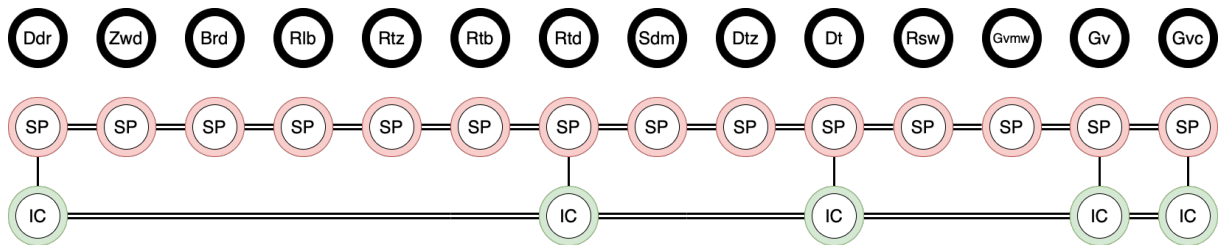

Figure 8: Stedenbaan Zuid: 'Important nodes'

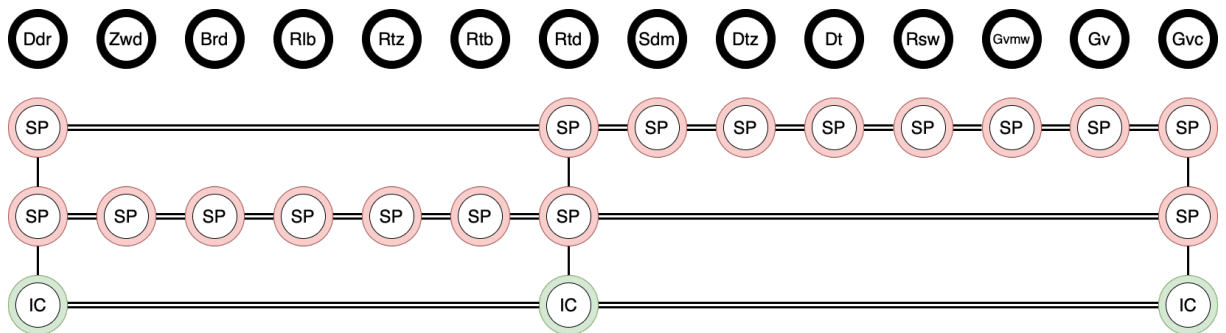

Figure 9: Stedenbaan Zuid: Zone Sprinter

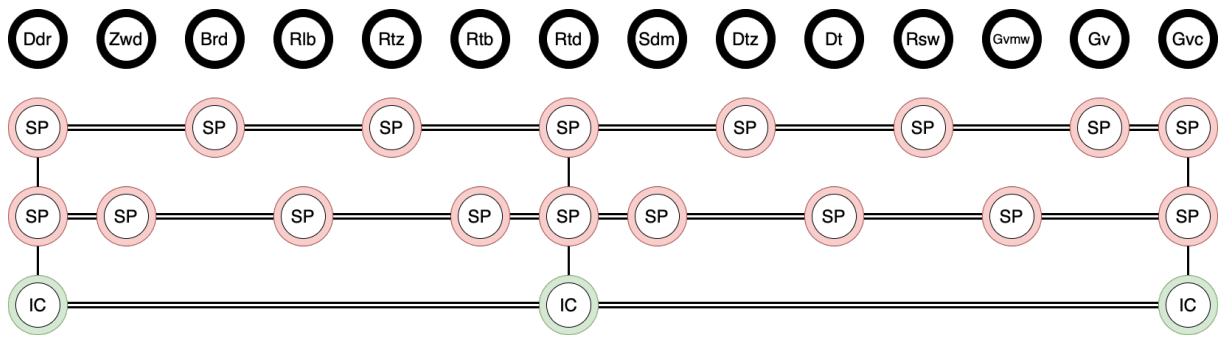

Figure 10: Stedenbaan Zuid: Skip-stop Sprinter

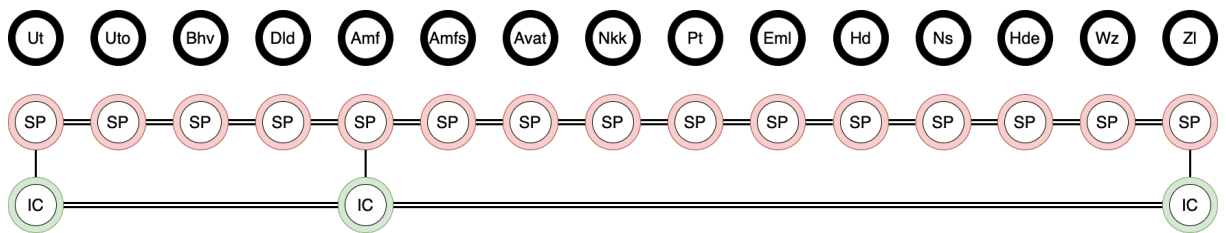

Figure 11: Veluwelijn: Current situation

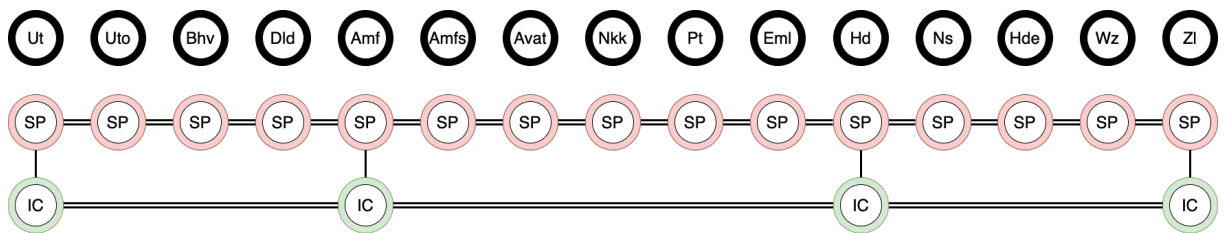

Figure 12: Veluwelijn: IC Harderwijk

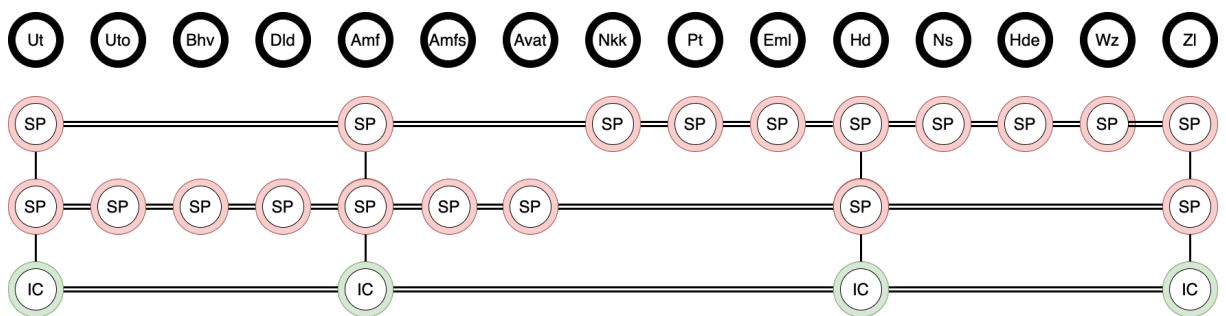

Figure 13: Veluwelijn: Zone Sprinter

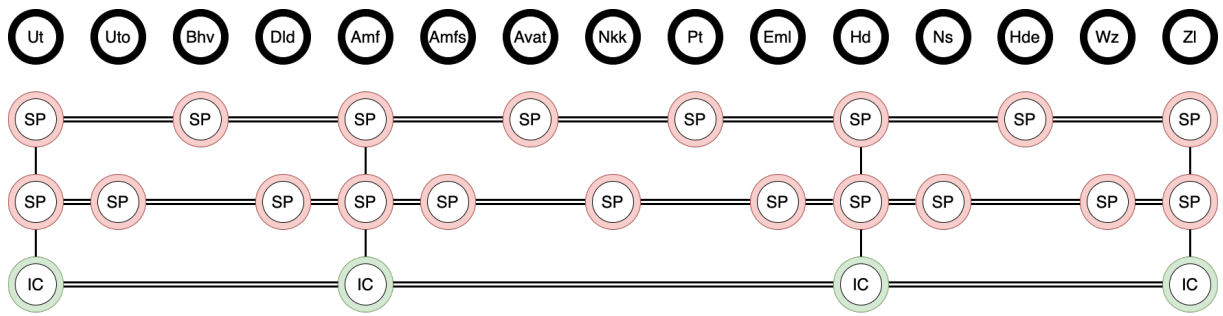

Figure 14: Veluwelijn: Skip-stop Sprinter

CONTENTS

1	INTRODUCTION	3
1.1	Context	3
1.2	Problem statement	4
1.3	Research questions	4
1.4	Research and Societal gaps	5
1.5	Practical relevance	5
1.6	Scope	5
1.7	Readers guide	5
2	METHODOLOGY	7
2.1	Literature analysis	7
2.2	Network analysis	7
2.2.1	Quantitative network analysis	7
2.2.2	Micro vs Macro	7
2.3	Interview analysis	8
2.4	Case studies	9
2.5	Data	10
2.6	Limitations of the methodologies	10
3	LITERATURE ANALYSIS	11
3.1	Classification of services and stations	11
3.1.1	Services	11
3.1.2	Stations	12
3.2	Travel behaviour	13
3.2.1	Mode choice	13
3.2.2	Station choice	14
3.2.3	Route choice	15
3.3	Emerging modes	15
3.3.1	Modes	16
3.4	Network design	16
3.4.1	Design dilemmas	16
3.4.2	Design objectives	17
3.4.3	Research in Network Design	18
3.5	Transport models	19
3.5.1	Transit models	19
3.5.2	Public Transport assignment	20
3.5.3	Generalised travel time	21
3.6	Conclusion	22
4	MODEL SETUP	25
4.1	Network representation	25
4.1.1	links and travel times	26
4.2	Route choice model	27
4.3	Operational costs	28
4.4	Distribution of passengers among stations	29
4.4.1	Current ridership estimation	30
4.4.2	Determining passengers changing stations	30
4.4.3	Choice model	33
4.4.4	Limitations	33
4.4.5	Test case: Stedenbaan 'minimal IC'	33

5	NETWORK ALTERNATIVES	35
5.1	The network	35
5.1.1	Origins and destinations	37
5.2	Frequencies and OD-Patterns	38
5.2.1	Network 1	38
5.2.2	Network 2	39
5.2.3	Network 3	40
5.2.4	Network 4	40
5.2.5	Network 5	41
5.2.6	Network 6	42
5.2.7	Network 7	43
5.2.8	Conclusion	43
5.3	Verification	44
5.3.1	Sensitivity analysis	45
5.3.2	Bigger network: Station A to M	45
5.3.3	Conclusion	46
5.4	Validation	46
6	CASE STUDIES	49
6.1	Network Design	49
6.2	Stedenbaan Zuid	49
6.2.1	Ridership	50
6.2.2	Results	52
6.2.3	Current situation	52
6.2.4	Minimal IC	53
6.2.5	Important nodes	55
6.2.6	Zone sprinter	57
6.2.7	Skip-stop sprinter	59
6.2.8	Broader context of the variants	61
6.2.9	Conclusion	61
6.3	Veluwelijn	62
6.3.1	Ridership	64
6.3.2	Results	64
6.3.3	Current situation	65
6.3.4	IC Harderwijk	66
6.3.5	Zone sprinter	68
6.3.6	Skip-stop sprinter	70
6.3.7	Broader context of the variants	72
6.3.8	Conclusion	72
6.4	Validation	73
6.5	Conclusion	75
7	PASSENGER STATION CHOICE	77
7.1	Introduction	77
7.2	Application on the case studies	77
7.3	Scenarios	79
7.3.1	Capturing passengers	79
7.3.2	Spread of passengers	80
7.3.3	Shared mobility	80
7.4	Conclusion	82
8	DISCUSSION	85
8.1	Results	85
8.2	Limitations	86
8.3	Recommendations for further research	87

9	CONCLUSION	89
10	PRACTICAL RECOMMENDATIONS	93
10.1	General recommendations	93
10.1.1	Regional differences	93
10.1.2	Hierarchy and layers	93
10.1.3	Align goals with stakeholders	93
10.1.4	Zone Sprinter and Intercity	94
10.2	Stedenbaan Zuid	94
10.2.1	High frequent Sprinter	94
10.3	Veluwelijn	94
10.3.1	Special Sprinter	94
A	INTERVIEWS	99
A.1	Municipality: Pijnacker-Nootdorp	99
A.2	Municipality: Lansingerland	100
A.3	Rover: Network Design	101
A.4	Netherlands Railways: Product market managers	102
A.4.1	Stedenbaan Zuid	102
A.4.2	Veluwelijn	102
B	MODELS	105
B.1	Model parameters	105
B.1.1	Distances	105
B.1.2	Origins of passengers	106
B.2	Sensitivity analysis	107
C	DATA ANALYSIS: ACCESS AND EGRESS	111
C.1	Introduction: Multi-modality and Catchments	111
C.2	Data: Multi-modality and Catchments	112
C.2.1	Trip times per station	112
C.2.2	Mode choice and trip times	115

LIST OF FIGURES

Figure 1.1	Outline of the thesis	6
Figure 2.1	The stations of the case studies on a map	9
Figure 3.1	Spatial and network scales (based on Van Nes (2007))	11
Figure 3.2	Bi-level problem: Network Design and Travel Behaviour	13
Figure 3.3	Design dilemma: stop density	17
Figure 3.4	Design dilemma: line density	17
Figure 4.1	Example of the network representation	25
Figure 4.2	A station and its catchment rings	31
Figure 4.3	Stations with their catchments	31
Figure 4.4	Overlapping influence areas	32
Figure 5.1	The hypothetical network	35
Figure 5.2	All network variants	36
Figure 5.3	Network 1	39
Figure 5.4	Network 2	39
Figure 5.5	Network 3	40
Figure 5.6	Network 4	41
Figure 5.7	Network 5	41
Figure 5.8	Network 6	42
Figure 5.9	Network 7	43
Figure 6.1	Stedenbaan Zuid	50
Figure 6.2	Stedenbaan: Current situation	52
Figure 6.3	Stedenbaan: Minimal IC	53
Figure 6.4	Stedenbaan: Base versus 'minimal IC'	54
Figure 6.5	Stedenbaan: Important nodes	55
Figure 6.6	Stedenbaan: Base versus 'important nodes'	56
Figure 6.7	Stedenbaan: Zone sprinter	57
Figure 6.8	Stedenbaan: Base versus 'zone sprinter'	58
Figure 6.9	Stedenbaan: Skip-stop sprinter	59
Figure 6.10	Stedenbaan: Base versus 'skip-stop sprinter'	60
Figure 6.11	Veluwelijn	64
Figure 6.12	Veluwelijn: Current situation	65
Figure 6.13	Veluwelijn: IC Harderwijk	66
Figure 6.14	Veluwelijn: Base versus 'IC Harderwijk'	67
Figure 6.15	Veluwelijn: Zone sprinter	68
Figure 6.16	Veluwelijn: Base versus 'zone sprinter'	69
Figure 6.17	Veluwelijn: Skip-stop sprinter	70
Figure 6.18	Veluwelijn: Base versus 'skip-stop sprinter'	71
Figure 6.19	Travel times on the Stedenbaan Zuid from the NS app	74
Figure 6.20	Travel times on the Veluwelijn from the NS app	74
Figure 7.1	Share of passengers over different rings	78
Figure C.1	Visualisation of catchment area of a station	111

LIST OF TABLES

Table 2.1	Case study description	9
Table 3.1	Classification of stations based on (De Bruyn and van Hagen, 2002)	12
Table 4.1	Distance categories for station choice	32
Table 4.2	Passengers changing stations for different values for relevant share parameters	34
Table 5.1	Networks for the ridership models	37
Table 5.2	OD-matrix for equal demand	37
Table 5.3	OD-matrix for asymmetric demand	38
Table 5.4	OD-matrix for asymmetric demand	38
Table 5.5	Parameters used for the models	38
Table 5.6	Travel times and transfers for different frequencies under network 1	39
Table 5.7	Travel times and transfers for different OD-patterns under network 1	39
Table 5.8	Travel times and transfers for different frequencies under network 2	39
Table 5.9	Travel times and transfers for different OD-patterns under network 2	40
Table 5.10	Travel times and transfers for different frequencies under network 3	40
Table 5.11	Travel times and transfers for different OD-patterns under network 3	40
Table 5.12	Travel times and transfers for different frequencies under network 4	41
Table 5.13	Travel times and transfers for different OD-patterns under network 4	41
Table 5.14	Travel times and transfers for different frequencies under network 5	41
Table 5.15	Travel times and transfers for different OD-patterns under network 5	42
Table 5.16	Travel times and transfers for different frequencies under network 6	42
Table 5.17	Travel times and transfers for different OD-patterns under network 6	42
Table 5.18	Travel times and transfers for different frequencies under network 7	43
Table 5.19	Travel times and transfers for different OD-patterns under network 7	43
Table 5.20	Amount of transfers for different frequencies for network 8	46
Table 6.1	Current situation on the Stedenbaan Zuid	51
Table 6.2	Results for the base situation of the Stedenbaan Zuid	52
Table 6.3	Required fleet for the current situation on the Stedenbaan Zuid	53
Table 6.4	Run times for the current situation on the Stedenbaan Zuid	53
Table 6.5	Results for 'minimal IC' of the Stedenbaan Zuid	53
Table 6.6	Required fleet for 'minimal IC' on the Stedenbaan	55
Table 6.7	Run times for 'minimal IC' on the Veluwelijn	55
Table 6.8	Results for 'important nodes' of the Stedenbaan Zuid	55
Table 6.9	Required fleet for 'important nodes' on the Stedenbaan Zuid	56
Table 6.10	Run times for 'important nodes' on the Stedenbaan Zuid	57
Table 6.11	Results for 'zone sprinter' of the Stedenbaan Zuid	57
Table 6.12	Required fleet for 'zone sprinter' on the Stedenbaan Zuid	58
Table 6.13	Run times for 'zone sprinter' on the Veluwelijn	59
Table 6.14	Results for 'skip-stop sprinter' of the Stedenbaan Zuid	59
Table 6.15	Required fleet for 'skip-stop sprinter' on the Stedenbaan Zuid	60
Table 6.16	Run times for 'skip-stop sprinter' on the Stedenbaan Zuid	60
Table 6.17	Stedenbaan Zuid: Overview of the outcomes	61
Table 6.18	Current situation on the Veluwelijn	63
Table 6.19	Results for the current situation on the Veluwelijn	65
Table 6.20	Required fleet for the current situation on the Veluwelijn	65
Table 6.21	Run times for the current situation on the Veluwelijn	65
Table 6.22	Results for 'IC Harderwijk' on the Veluwelijn	66

Table 6.23	Required fleet for 'IC Harderwijk' on the Veluwelijn	67
Table 6.24	Run times for 'IC Harderwijk' on the Veluwelijn	68
Table 6.25	Results for 'zone sprinter' on the Veluwelijn	68
Table 6.26	Required fleet for 'zone sprinter' on the Veluwelijn	69
Table 6.27	Run times for 'zone sprinter' on the Veluwelijn	70
Table 6.28	Results for 'skip-stop sprinter' on the Veluwelijn	70
Table 6.29	Required fleet for 'skip-stop sprinter' on the Veluwelijn	71
Table 6.30	Run times for 'skip-stop sprinter' on the Veluwelijn	71
Table 6.31	Veluwelijn: Overview of the outcomes	72
Table 7.1	Passengers changing stations based on the network design	78
Table 7.2	Passengers changing stations based on the network design	79
Table 7.3	Passengers changing stations for scenario 1	80
Table 7.4	Passengers changing stations for scenario 2	80
Table 7.5	Passengers changing stations for scenario 3a	81
Table 7.6	Passengers changing stations for scenario 3b	82
Table B.1	Distances between stations on the Stedenbaan Zuid	105
Table B.2	Distances between stations on the Veluwelijn	106
Table B.3	Share of passengers originating among the catchment rings of stations on the Stedenbaan Zuid	106
Table B.4	Share of passengers originating among the catchment rings of stations on the Veluwelijn	107
Table B.5	Amount of transfers for different choice parameter values	107
Table B.6	Actual travel time in minutes for different choice parameter values	108
Table B.7	Amount of transfers for different values for the transfer resistance	108
Table B.8	Actual travel time in minutes for different values for the transfer resistances	108
Table B.9	Amount of transfers for different distances	109
Table B.10	Actual travel time in minutes for different distances	109
Table C.1	Distribution of the travel times for access and egress trips	112
Table C.2	Distribution of access trip times on the Stedenbaan Zuid	113
Table C.3	Distribution of egress trip times on the Stedenbaan Zuid	113
Table C.4	Distribution of access trip times on the Veluwelijn	114
Table C.5	Distribution of egress trip times on the Veluwelijn	114
Table C.6	Mode choice for access trip times	115
Table C.7	Mode choice for egress trip times	116
Table C.8	Clustered mode choice for access trip times	116
Table C.9	Clustered mode choice for egress trip times	117

1

INTRODUCTION

This chapter will introduce the research. Firstly, background information regarding the rail network and multi-modal trips is given. Secondly, the problem statement and research questions are stated. Subsequently, the research and societal gaps are addressed together with the practical relevance of this research. Thereafter, the scope of the research will be set. At last, the readers guide and outline of the thesis will show the structure of this document.

1.1 CONTEXT

National and regional train services contribute in larger extent to the accessibility of Dutch cities and the Netherlands as a whole. In the daily commute, the train is used for approximately 62% as the main mode within multi-modal trips (KiM, 2019). Implying, that the train is one of the most used public transport modes during the daily commute. In addition, the average length of these commuting trips have increased, from 14,6 kilometres to 19,0 kilometres and 33% of the commuters in the Netherlands travels between cities contrary to 27% in 1997 (PBL, 2020). Combining these aspects, it is clear that the train holds a vital place within the whole public transport chain and perhaps even more in the years to come.

As the train is an important link within the multi-modal trips, i.e. trips using more than one mode, it highly depends on other modes for access and egress trips. More traditional modes could be used for the access and egress trip, just as walking and bus, tram and metro, or more contemporary modes, as shared bicycles, scooters and MaaS-like platforms. The choice for multi-modal trips is influenced by several factors including the characteristics of the journey, station and the system and services (Van Mil et al., 2018).

The more contemporary modes lay hold on an increasing share within Europe, changing the dynamics within the whole public transport chain (Standing et al., 2019). As this changing environment affects the mode choice, i.e. traditional versus contemporary modes, it could also influence other aspects of the access and egress trips, like the catchment areas of public transportation (Shaheen and Chan, 2016). In line with these recent developments, the passenger opts for a more integrated public transport system (Standing et al., 2019).

Given this changing environment in access and egress modes, it is time for the Netherlands Railways to critically review the way its operating lines and servicing stations. The place where intercity and sprinter services stop and interact with the urban or regional public transport systems and other transport systems are vital places within the network, contributing to both the network as the city (Bertolini, 1999). Yet, the location, amount of stations in a certain area and the statuses of stations (Intercity or Sprinter) are mostly historically grown. Providing many stations comes at a cost, it slows the service for all those not using that particular station and adds extra operational costs (Givoni and Rietveld, 2014). The national and regional railway rely on two types of services, respectively Intercity and Sprinter. Where the first is intended for national and inter-regional trips and the latter for regional trips. These services are operated in the same way throughout the whole country, while De Bruyn et al. (2019) state that the needed services might differ per region.

The operations of the train services and stopping patterns could be reviewed to better fit the purpose of the passenger. Changes could be made in the amount of stops and the location of these stops in certain services considering the current network. In the Netherlands, a more integrated and hierarchical rail network is desired to provide smoother multi-modal trips for all trip lengths. Providing new

services and a new distribution of stations on the current network can be helpful while improving the system.

1.2 PROBLEM STATEMENT

The way the train services are operated are mostly historically grown and is not adapted that often. Due to the dependency on specific infrastructure, the locations of the stations are fixed and located a long time ago. In addition, the Intercity and Sprinter service are operated equally throughout the country, while the usage and demand patterns can be different for the different regions in the country. Changing the statuses of stations - i.e. the stopping patterns of services - are difficult by the complex nature of stations and deep interests of different stakeholders. Furthermore, the travel behaviour of passengers could be changed by the changing environment in access and egress modes. Altogether, the rail network with the vital locations as stations and the operation of the services on the network seem to be less adaptive, while the travel behaviour of passengers seem to change due to developments in access and egress and differ per region. This could result in a mismatch between the network design and the way passengers use the network, i.e. the travel behaviour of passengers. If the services are not composed to fit the use of the passengers, the passenger satisfaction could drop and eventually passengers could avoid the main rail network, resulting in a loss of revenue for the Netherlands Railways. It is the interest of the Netherlands Railways to evolve to a more integrated public transport system with the railways as its backbone, suited for different trips and regions. Most of the current research considers bus, tram and/or metro combinations. Furthermore, the amount of researches focusing on the stopping patterns of train services on the national rail network is limited. Additionally, emerging modes in first- and last- mile transport are changing the environment of public transport. Combining the above it can be concluded that a fresh look upon the way services are offered is needed. This research will explore the influence of new network designs in terms of stopping patterns on the travel time and transfers of passengers, and operational costs. Additionally, an estimation about the effects of the stopping patterns on the station choice will be explored. The effects of different stopping patterns and frequencies will be reviewed in a broader context of urban and regional transport structures by using two different case studies.

1.3 RESEARCH QUESTIONS

The following research question is formulated in order to carry out this research:

How should the stopping patterns of the train services be organised, given different network and demand characteristics?

The main research question can be divided in the following sub-questions:

- SQ1: *What are important aspects of travel behaviour and network design in the usage by the passenger?*
- SQ2: *What is the effect of different stopping patterns on the total travel time and the amount of transfers?*
- SQ3: *What is the effect of new network designs, in terms of stopping patterns, on Stedenbaan Zuid and the Veluwelijn?*
- SQ4: *What is the effect of new network designs on the station choice of passengers? and what is the possible influence of emerging modes?*

1.4 RESEARCH AND SOCIETAL GAPS

As stated in the problem statement, current research mostly focuses on the effect of emerging modes on the access and egress trips and not so much on the effect of these modes on the railway system. Additionally, the research on stopping patterns and hierarchy on main rail lines is very limited. These researches mostly consider bus, tram or metro and combinations of these modes. From a societal point of view, the implications and possible benefits of more integrated transport systems, considering both main rail and access and egress modes, or changing current operations are not known.

1.5 PRACTICAL RELEVANCE

The research will be done in collaboration with the Netherlands Railways. The company sees a changing environment around them and feels the urge to obtain knowledge about the times to come. The company directs to provide a more integrated mobility instead of just train services. During this integration, emerging modes and whole multi-modal trips, i.e. door-to-door, could not be left out. Which creates chances for new options in network design on the main rail network. This research will focus on how the current stopping patterns and hierarchy in services could be changed given the emerging modes. The research will be tested on its practical implications by using two case studies, the Stedenbaan Zuid and Veluwelijn. The insights provided by this research are expected to be applicable for the Dutch main rail network. And eventually for regions abroad with the similar characteristics as the dutch network and passenger.

1.6 SCOPE

As the goal of this research is to get insights about global system outcomes due to strategic changes in operations, some decisions are made in what is included or not. These decisions are stated in this part. Firstly, the lines operated by the Netherlands Railways will be included, with the exception of the international services. Secondly, the demographic characteristics, trips and activities will be assumed to be constant during the network analysis. This implies that the demand changes due to a better service will not be accounted for. However, passengers swapping their initial access station will be included in a part of this research. Thirdly, the existing network will be used as a starting point, the lines and infrastructure will not be changed initially. Additionally, the influence of stations on passenger experience will be left out of scope during this project. This research will include different service types, this will be Intercity services and Sprinter services. Different stopping patterns per service type and corridor will be defined. While compiling the variants assumptions could be made about the needed infrastructure, these assumptions will be stated clearly when made. Additionally, the needed capacity of the trains, thus the length of the trains in the system, will not be included. This is seen as a tactical measure, while this research mainly focuses on strategic measures.

1.7 READERS GUIDE

The structure of the research is as follows. First, the methodologies are introduced in Chapter 2. In Chapter 3, different aspects of travel behaviour, network design and transport modelling are addressed. Subsequently, the setup of different modelling modules, as the route and station choice models, are explained in Chapter 4. In Chapter 5, different hypothetical network designs will be modelled and evaluated based on their outcomes. Thereafter, Chapter 6 will focus on the implications of different network design on the case studies. Then, Chapter 7 will elaborate on passengers changing their initial

station choice. Subsequently, Chapter 8 and Chapter 9 will discuss the results and state the obtained conclusions. At last, some practical recommendations will be stated in Chapter 10. In Figure 1.1, the outline and structure of the thesis is visualised.

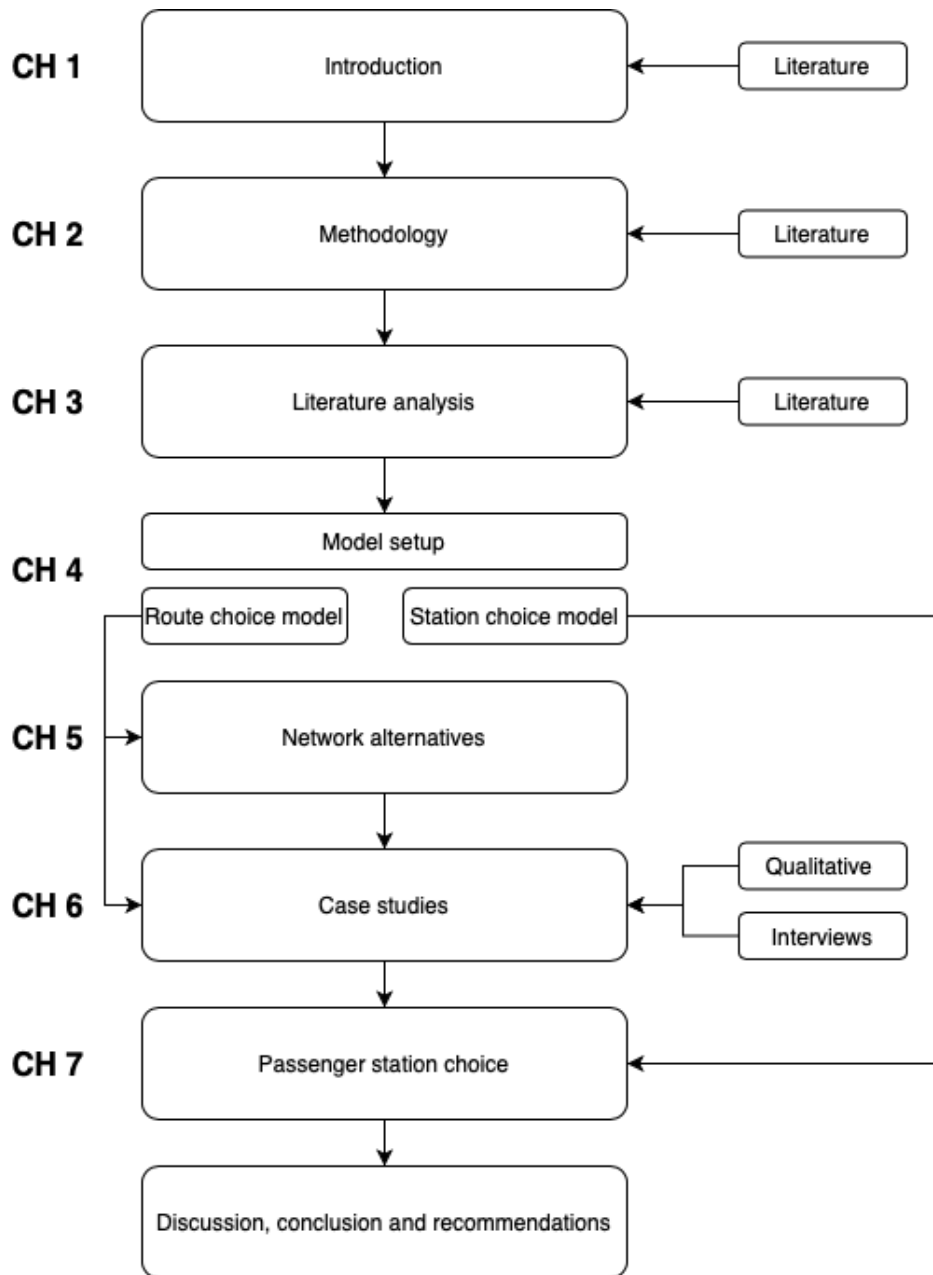

Figure 1.1: Outline of the thesis

2 | METHODOLOGY

In this chapter, different methods used during this research are highlighted. Subsequently, the requirements for data to answer the research questions are discussed.

2.1 LITERATURE ANALYSIS

The basis of this research will be a literature study. The literature study will be used to find the societal and research gaps. In addition, the literature will be used to get familiar with the current state of network design for national and regional train services and the appropriate models for transit assignment. Subsequently, the criteria, which have an influence on the function of stations, will be abstracted from the literature too.

2.2 NETWORK ANALYSIS

A network analysis will be performed in order to get insights in the dynamics of current existing networks and the effects of providing different train services with different stopping patterns. This network analysis will be carried out based on some theoretical networks and the case studies described in Section 2.4.

2.2.1 Quantitative network analysis

The ridership models will be made to determine the effects of different frequencies and stopping patterns on the general travel time in the system. In these theoretical models a part of a railway line will be simulated with different types of stations. During the simulations, the statuses of the stations will be changed. The total travel time, perceived and actual, of all travellers combined, the amount of transfers and operational costs will be calculated. The quantitative network analysis, will be used for the network variants in Chapter 5 and the case studies as described in Section 2.4.

2.2.2 Micro vs Macro

Transport modelling could be done in several level of detail. Microscopic models include a high level of detail, where separate and even individual passengers could be modelled. In contrast, macroscopic models are in a way less detailed and mostly focuses on aggregate outputs as average flows. First, the advantages of micro and macro demand models will be stated followed by the advantages of network supply models.

Demand models

Micro

- high predictive power
- give deep insights into travellers' behaviour

Macro

- low data requirements
- applicable at large scale, low computational power

In terms of travel behaviour, this research is less focused on individual behaviour and more on the travel behaviour on a higher level.

Network supply models

Micro

- applicable for detailed local analyses
- easy to incorporate heterogeneity in travellers and modes
- strong in traffic flow modelling

Macro

- applicable for large regional analyses
- give 'average' conditions, no need for multiple simulations
- strong in route choice modelling

As this research include rail networks serving a broader region, average system conditions are desired and route choice modelling is important, the macro level network supply modelling fits the purposes of this research extremely well.

2.3 INTERVIEW ANALYSIS

Stations have a natural complexity among themselves. This results in lots of different stakeholders having different interests in stations. The actor analysis will be carried out to identify the relevant factors for the value of stations by relevant stakeholders. [Enserink et al. \(2010\)](#) state that actor analysis provides insights in the involved actors and their networks. Additionally, the method is suitable as support for project management and design activities ([Enserink et al., 2010](#)).

The main question of this research would be linked to the "design and recommend" aspects as stated in [Enserink et al. \(2010\)](#), as this research is focusing on a new design of stopping patterns for national and regional train services. Thus, the actor analysis in this research will have as goal to create ideas for alternative strategies and tactics, due to mapping interests and options of different actors. This eventually helps to identify common interest and shared fundamental values among the different actors. It will help to identify what actors could contribute to these shared values and possibilities for compensation or mitigating measures for particular actors ([Enserink et al., 2010](#)).

During the interviews, the interviewee will be confronted with factors giving stations value and the role of the main rail network relative to other public transport systems. This will give an broader view upon the the topic, rather than just a transport engineering point of view.

Additionally, the interviews will be used to validate the model outcomes and review them from a broader context.

Among the interviewees are municipalities with and without stations on the main rail network and people within the Dutch Railways linked to the lines of the case studies, mentioned in Section 2.4, or linked to the department managing stations. Due to the sudden COVID-19 situation, the amount of conducted interviews is lower than expected.

2.4 CASE STUDIES

In order to link the previous findings to real world examples, two case studies will be used. The network analysis will be performed based on two corridors in the Netherlands. The network analysis will include simulations using real board and alighting data from the Netherlands Railways. These case studies will be used as a guideline throughout this project. The case studies are chosen based on the assumption that both corridors reveal different characteristics of the network, thus will represent a certain contrast within the case studies. The maps with the locations of the stations of both case studies are shown in Figure 2.1 and the two case studies are described in Table 2.1.



Figure 2.1: The stations of the case studies on a map

Case study	Description
Stedenbaan Zuid	Dordrecht to The Hague CS Relatively short corridor (approx. 45 km) in (mostly) high urbanised areas 15 stations (7 stations with IC status)
Veluwelijn	Utrecht to Zwolle A longer line (approx. 88 km) connecting three big cities (Utrecht - Amersfoort - Zwolle) in a not so urbanised area 14 stations (3 stations with IC status)

Table 2.1: Case study description

The **Stedenbaan Zuid** is a short corridor in the Southern part of the Randstad. The part from Dordrecht to The Hague will be considered. This line connects two major cities, Rotterdam and The Hague, and serves several of average sized cities along the line. There is a lot of travel interaction among all the stations and the distances travelled are relatively short (De Bruyn et al., 2019).

The **Veluwelijn** is a longer corridor connecting the bigger cities of Utrecht and Amersfoort with Zwolle. Along the line lots of smaller municipalities are located. The trips along this line are mostly long and are focused on the bigger stations at both ends of the line (De Bruyn et al., 2019).

Several relevant variants per case study will be compiled and will be tested for different criteria. Quantitative outcomes will be generated through the simulation of the defined variants for the case studies. The variants will be compiled based on the outcomes of the quantitative network analysis for the network variants in Chapter 5 qualitative network analysis at the beginning of Chapter 6. For each variant, some indicators will be calculated as total travel time in the system, amount of transfer weighed for the amount of travellers, and operational costs, expressed in fleet requirements and infrastructure capacity.

When the outcomes of the network analysis are obtained, these outcomes will be generalised based on the characteristics of the corridor. This will be done in order to formulate recommendations for other (similar) corridors in the Netherlands too under specific conditions.

2.5 DATA

For this research, the availability of data plays a main role. Especially, in compiling the ridership model and linking the case studies by empirical data. For the ridership models, some assumptions are made for the operational speed of the services. These assumptions could be made closely to the current operational speeds of the different services. For the case studies, real origin and destination data on those lines is needed, as this data represents the most accurate information for the current network design. This will be provided by the Netherlands Railways.

Additionally, data is needed of the origins of the passengers for the station choice model. This will be derived from a data set, provided by the Netherlands Railways.

2.6 LIMITATIONS OF THE METHODOLOGIES

The proposed methodologies can raise certain limitations. While modelling tries to mimic the real world, it is hard to represent real people's behaviour in these models. To capture some of these behavioural factors, assumptions need to be made that simplify their nature or will not capture all aspects, due to the macroscopic nature of this research. The feasible route set of passengers could differ by their preferences for transfers, services and even access stations, which is a part of the station choice.

Enserink et al. (2010) state two main limitations for actor analysis. The first one being the validity of the information sources, meaning that actors could frame their information resulting in wrong depictions of the problem and interests. Another case could be that the information available is not sufficient, this means that the researcher will have to estimate certain aspects with the network of actors. This is why it is better to state when information is not widely available. Another limitation is that the actor analysis is a snapshot, it could differ over time. That is something to be aware of while interpreting the results of the interviews.

3

LITERATURE ANALYSIS

The literature analysis will focus on different relevant parts having an impact on the train system. First, the classification of stations and services is discussed. Subsequently, the factors influencing the station choice and catchment will be discussed. Thereafter, the influence of emerging modes on the multi-modal trips. Thereafter, relevant aspects in network design will be addressed. At last, basic aspects of transport modelling and choices for this research are stated.

3.1 CLASSIFICATION OF SERVICES AND STATIONS

This part will state current classifications of services and stations. Additionally, it will address the two-way interaction between these concepts, making it vulnerable for political interference.

3.1.1 Services

The connection between stations is also determined by the type of services provided at a certain station. Some stations are served only by regional trains and other are also served by inter-regional services. The stations could act as a major junction of several lines and service type or as a feeder station. This has a influence on the level of service offered at a certain station. In Figure 3.1, the different spatial and corresponding train services are shown.

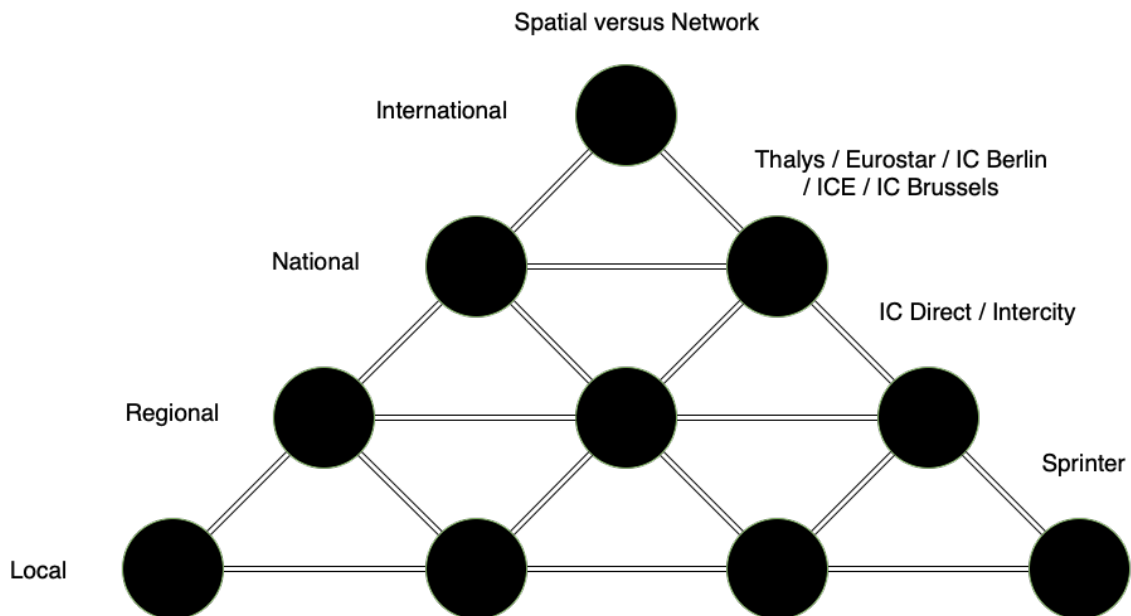

Initially, train services are classified on their stopping patterns, and in smaller extent their operational speed, as train services higher in hierarchy usually include less stops in their service.

The services clearly show a hierarchy, with the international services being an higher service than the other services. Yet, the practice commonly deviates from the this clear hierarchy. In some sections, higher level services as IC have same stopping patterns as SP services. This can be due to political or operational reasons.

The different services can be operated with different frequencies, stopping patterns and line lengths. Currently, two distinctions are made. The Intercity is supposed to call only at major cities and have a longer line length to provide for inter-regional transport. While the Sprinter calls at every station it passes.

The way a train service is used can depend on the type of area which it is serving. In their paper [Van Nes et al. \(1988\)](#) state that the design of the network determines the service offered and that the network design should meet the area it is located in. This implies that the usage of the network could differ in different area types, thus different service characteristics are needed.

3.1.2 Stations

Stations could be classified in different ways. The Netherlands Railway composed one of these classification based on transport and spatial characteristics. This is described in [De Bruyn and van Hagen \(2002\)](#). Six different types are formulated and given in Table 3.1. Only the services highest in hierarchy are given. Subsequently, the characteristics of the different station types, based on [De Bruyn and van Hagen \(2002\)](#), will be described.

	Centre	Suburb	Rural
HST	1		
IC	2	3	
SP	4	5	6

Table 3.1: Classification of stations based on [De Bruyn and van Hagen \(2002\)](#)

- Type 1 Among this category are the stations located in the centres of the main cities. With a significant part of train-train transfers and from other high level of service public transport, thus being an important transfer node between train lines and networks. An extra feature to these types of stations are the international connections. For example, Amsterdam Centraal, Utrecht Centraal and Rotterdam Centraal.
- Type 2 This category represents the stations in the centres of medium sized cities. These could be characterised as stations with major flows from other public transport and again lots of internal transfers (train-train), thus being an important transfer node between train lines and networks. Most of the trip are inter-regional orientated. For example, Den Bosch and Nijmegen.
- Type 3 Stations in this category are mostly located out of the city centres. These stations produce and attract a significant amount of passengers. Yet, flows from other public transport modes are lower than with the previous types. The usage of these stations is mostly focused on the rush hour. For example, Rotterdam Alexander and Amsterdam Bijlmer Arena.
- Type 4 Looking at the stations in this category, their locations could be mostly found in the centre of small villages or cities. These stations play a role in the transfers from (regional) public transport services and are mostly used as a departing (home-end) station. For example, Zwijndrecht and Harderwijk.
- Type 5 The location of the stations in this category are mostly in the suburbs, sometimes near their centres. They are supplementing a main station that is located in its surroundings. It serves mostly the regional trips and has no transfer node purpose. The usage is mostly focused on the rush hour. For example, De Vink and Almere Poort.

Type 6 This is the type of station lowest in terms of hierarchy. These stations could be found outside of the centres of cities or villages. These stations are mostly well accessible for cars. For example, Lage Zwaluwe.

The hierarchy of stations is determined based on the services calling at a station and the spatial characteristics of the area surrounding the station. Classifications could also be made based on the ridership produced by a certain station. The ridership counts, thus the importance, of stations could be strengthened by investing in station districts. Cities highly invest in these districts, and sometime negotiate for increased frequencies or even status upgrades. The determination of station statuses and services calling at stations is not that clearly stated. A station could be assigned to a certain class due the services stopping at that station or it could be decided for a for a certain certain service to stop at a certain station due to the location of that station. This emphasizes the devious determination of the stopping patterns of services, making it very sensitive for political interference.

3.2 TRAVEL BEHAVIOUR

This research focuses on the bi-level problem, network design and travel behaviour. These two concepts are highly intertwined. The network design set the boundaries conditions for the use by the passenger. While the travel behaviour determines the success of the network design. If the travel behaviour changed a lot, the network design might have to change too. Figure 3.2 shows the bi-level problem of network design and travel behaviour.

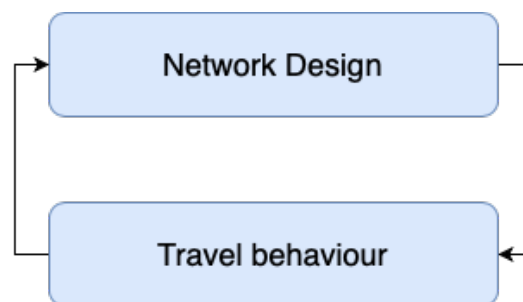

Figure 3.2: Bi-level problem: Network Design and Travel Behaviour

Travel behaviour combines the choices of passengers in their daily commute or more occasional trips. These choices can consider different aspects during the trip, as the mode, station and route choice, where some of these choices are made simultaneously. Ben-Akiva and Bierlaire (1999) describe that choices need to be made by a decision-maker, which is the passenger. There need to be several alternatives with different attributes and a certain process of choosing the preferred alternative by the passenger. These choices are influenced by the attitude and perceptions of the passengers (Ben-Akiva et al.). This section will elaborate on the possible choices made during a trip, which will be mode, station and route choice, and the factors that could influence these choices. Note that these choices are stated separately, yet it is not uncommon for passengers to considers these choices with more than one at the same time.

3.2.1 Mode choice

The choice for the mode, either main or access and egress mode, is influenced by several different factors (Eluru et al., 2012). First, Bhat (1997) and Bhat and Sardesai (2006) state that socio- demographics of the individual and households influence the the choice of the main mode. This factor determines for example the availability of the amount of cars per household. Secondly, Ye et al. (2007) and Hensher

and Reyes (2000) declare that the complexity of the journey has a significant impact on the mode choice. Thirdly, the location of the residents could indicate the preferred travel mode (Wee et al. (2002); Frank et al. (2008); Pinjari et al. (2007)). Passengers with the train or other public transport mode as their preferred mode are more likely to move to an area with a good accessibility to those modes, same counts for other modes. This implies that the mode and partially the station choice are determined by the residential location of the passengers.

This research will assume the main mode choice to be known, which will be the train. Additionally, people are assumed to not change their initial mode choice based on the changes in stopping patterns of the train services. Adding mandatory transfers within the trips of passengers can increase the complexity of the trip itself and eventually affect the mode choice of passengers. This can have impacts on the interpretation of the outcomes to real world recommendations.

3.2.2 Station choice

Another important choice within a trip of a passenger using the train is the station choice. The choice for a certain station can be influenced by several factors. First, the accessibility of a station plays an important role in the choice for a station (Brons et al., 2009). A better accessibility could be found in a wider coverage of the access modes, lower travel times to the station and a better quality of service of the access mode (Brons et al., 2009). Increasing the quality of these facilities will likely increase the use of rail and that station. Secondly, improving the journey to the station has more effect than the transfer between modes. Additionally, improving the access trip to the station will have a different effect depending on the location within the network. This could be in line with the findings of De Bruyn et al. (2019) where different service types per region are promoted. These aspects address the network characteristics of the access and egress stations.

Other important factors in the station choice are the operational characteristics of the services calling at a station. Debrezion et al. (2007) add the train services and the frequency of trains calling at a station as relevant factors in the station choice. The services capture the amount of destinations that could be reached from that certain station (Debrezion et al., 2007), as Intercity services mostly are operated for a longer distance than Sprinter services. The higher the frequency at a station, the higher the probability for that station to be chosen. The frequency has more effect on residents nearby than residents living further from the station. The factor with the highest effect on the station choice is the Intercity status of a station (Debrezion et al., 2007). When considering the last two findings of Debrezion et al. (2007), a status alteration of a station might be intercepted by increasing the frequency of the services offered at that station. For example, when changing the status of a station, the possible loss of passengers could be leveled by increasing the frequency of the sprinter service at that station. Other characteristics influencing the mode choice of passengers are the price, image and comfort (Van Oort and Van Nes, 2009).

While making their station choice passengers include the connection to their destination as an attribute (Verschuren, 2016). The aspects assigned to this attribute are the travel time, frequency and amount of transfers to the interchanges (Verschuren, 2016).

Catchment areas

The magnitude of a catchment area of a railway station can indicate the importance and usage of that particular station, it presents the station choice of passengers from a certain area. Catchment areas, according to Blainey and Evens (2011), can be identified in several ways. The first method uses Simple Catchments. In which a specified distance around the station is considered. The second method uses Discrete Catchments. While using the last method, overlapping catchments of stations will be assigned to only one of the stations. The catchment areas of the stations can differ per station and can depend on the connection with other modes. For example, the catchment area for stations with a high frequency public transport mode might be larger than one without such connections.

Guerra et al. (2012) built upon the first method described by Blainey and Evens (2011). In the paper the half-mile catchment area's are questioned. This is a simple catchment, as the 'half-mile' is a predefined distance. The difference in predicting ridership between a 0.25 mile and 0.5 mile catchment are very small (Guerra et al., 2012), this implies that the catchment does not require a certain size. It is found that 0.25 mile catchment areas more sufficient while considering jobs and the 0.5 mile catchment areas while considering population (Guerra et al., 2012).

While changing the level-of-service and frequency at a station, the catchment area of that station, compared to other stations, could change. This is also the case while adding or erasing stations within a transit line or in a certain service.

Initially, the station choice is assumed to remain the same as in the current situation when changing the stopping patterns. Changing the statuses and stopping patterns influence the destinations that could directly be reached and the frequency to the destination. Which can ignite a different station choice.

3.2.3 Route choice

This research will focus on the route choice on the main rail network, which are the different travel possibilities between station pairs. This choice will be modelled based on the travel time of certain routes. The presence of a transfer in a route is very important in the route choice.

De Keizer et al. (2012) researched the influence of transfers on the customer resistance of passengers. Choice experiments were used to determine the transfer resistance, containing four different factors, transfer time, frequency of the connecting train, and the number of transfers (De Keizer et al., 2012). Passenger characteristics, just as motives, travelling alone and with or without luggage, were also collected during the surveys (De Keizer et al., 2012). They observed that longer journeys have lower travel resistances and commuters react more to the length of the journey than socio-recreational passengers (De Keizer et al., 2012). Additionally, they stated that both extremely long and short transfer times are appraised negatively. The 'ideal' transfer time is estimated at 4 minutes, lower transfer times can cause stress to passengers and longer transfer times increases the waiting time (De Keizer et al., 2012). Other outcomes are that transferring from a low frequency service to an high frequency service the resistance will be lower than the other way around and that cross-platform transfers are appraised better (De Keizer et al., 2012). Schakenbos et al. (2016) also did a valuation of the transfers on a stated preference, checking the influence of travel time, transfer time, headway, costs and station facilities. This research did not only consider train to train transfers, but also from BTM-modes to the train. Their main findings are: bus-train transfers are value worse than metro/tram-train transfers, transfer times have a significant influence on the disutility and the trip purposes show a different reaction on the transfers (Schakenbos et al., 2016).

3.3 EMERGING MODES

New developments as shareable modes could also have an influence on the usage of other transportation systems, as the railway system. Shared mobility, i.e. emerging modes, can be seen as the shared use of bicycles, cars or scooters (Shaheen and Chan, 2016). Scooters and bicycles are assumed to have more an influence on the multi-modal trips using the train. As cycling is one of the main used mode in combinations with the train (KiM, 2019), it is assumed the increasing availability of bicycles will have a positive effect on the use of the train. Shaheen and Chan (2016) state that scooter sharing could likely be beneficial for public transport ridership, as scooters are bounded in the urban context, due to their low speed, and require little parking space, which makes it possible to facilitate parking near stations. Standing et al. (2019) state that there is a need for integrated transport systems, which will even be more relevant due to sharing transport modes. Additionally, it is stated that emerging modes could be used to complement current transportation modes (Standing et al., 2019).

3.3.1 Modes

Several modes could be used in the multi-modal trip, these are mostly used for the access and egress trip. [Rietveld \(2000\)](#) did a study about non-motorised modes in the multi-modal chain for the Netherlands. Walking and cycling have a high share in the short distance trips (25%) ([Rietveld, 2000](#)). In the report of the [KiM \(2019\)](#) a part is devoted to multi-modal trips. The bicycle train combination is the most common combination of modes in multi-modal trips in the Netherlands, especially at the home end of the trip ([KiM, 2019](#)). Additionally, the shares of the access and egress modes did not barely change from 2011 to 2017 ([KiM, 2019](#)).

Emerging modes could have several implications on the travel behaviour of passengers. For the mode choice, emerging modes could add extra alternatives in the access and egress modes or even compete with the train for certain trip lengths. For the station choice, emerging modes could contribute to the choice for other stations as new modes could facilitate longer trips. Additionally, passengers are less bound to specific stations, which is the case with public transport and most of the private modes.

3.4 NETWORK DESIGN

The main focus of this research are different variants of network design in terms of the stopping patterns of different train services. The way a transport network is designed can influence the use of the system by the passenger, i.e. the travel behavior, and vice versa.

Network design involves different stages of planning. [Guihaire and Hao \(2008\)](#) describe five different steps in public transport planning.

1. design of the routes
2. setting the frequencies
3. timetabling
4. vehicle scheduling
5. crew scheduling

As rail-bound transit requires specific infrastructure, [Schöbel \(2012\)](#) include infrastructure planning as the first step of the network design. This research will focus on line planning, more specific in stopping patterns of different train services. The infrastructure will be assumed a boundary condition. Other operational and tactical planning aspect will not be considered during this research.

[Kepaptsoglou and Karlaftis \(2009\)](#) outcomes of the network design process are influenced by the objectives attributed to the network, the operational characteristics and the environmental conditions.

[van Oort and van Nes \(2009\)](#) describe three different main variables in network design: frequency, line density and stop density. Where frequency is the amount of vehicle operated in a given time period, the line density is the total line length in a certain area and the stop density is the amount of stop along the line.

3.4.1 Design dilemmas

During transit network design it is common to face trade offs between the main design variables, which are line density, stop density and frequency ([Van Oort and Van Nes, 2009](#)). This section will point these design dilemma's out.

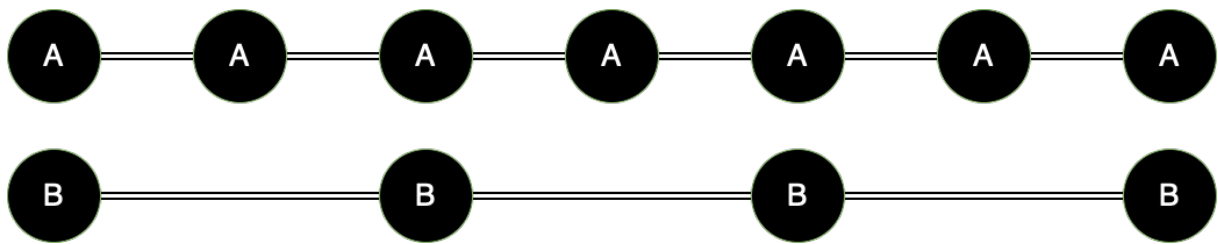

Figure 3.3: Design dilemma: stop density

The first dilemma is the stop density versus travel time, where the stop density can be a measure for the accessibility of the transit line. In Figure 3.3, two different lines are shown. Both are operated for the same length, where line A has a higher stop density than line B. More stops increase the accessibility of the line for the passengers, as it shortens the access and egress trips (Van Oort and Van Nes, 2009). Including more stops decreases the operational speed of the line, resulting in longer travel times (Van Oort and Van Nes, 2009).

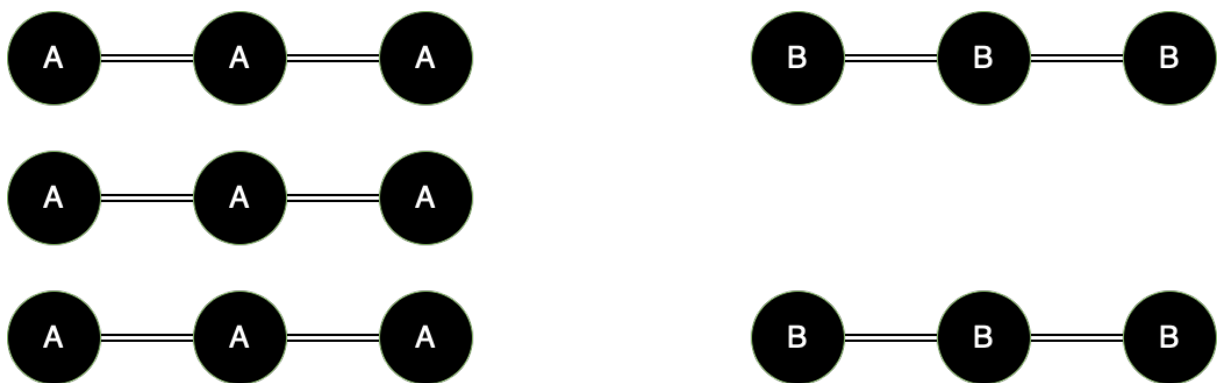

Figure 3.4: Design dilemma: line density

The second dilemma is the line density versus frequency. Figure 3.4 shows two areas, where area A includes three lines and area B includes two lines. Assumed an equal availability of vehicles and same line lengths, the design with more lines imply lower frequencies compared to designs with less lines (Van Oort and Van Nes, 2009).

Van Oort and Van Nes (2009) introduce a third design dilemma, which is line length versus reliability. At the basis of this dilemma is the fact that lines operated for a longer distance are imposed to more variability along the way than shorter lines (Van Oort and Van Nes, 2009).

During this research, the stopping patterns of different train services will be adjusted. This implies that the stop density of the different services will be changed. Outcomes as the travel time of the passengers based on these stopping patterns will be reviewed. Thus will mostly focus on the first design dilemma, stop density versus travel time. When adding or erasing a station in a certain train service, the travel time of the service along the line will increase or decrease. A clear trade-off for the passenger needs to be made in terms of access time and travel time. The frequency and line density dilemma will not be that relevant, as a corridor will be considered with one line. The same explanation holds for the line length and reliability dilemma.

3.4.2 Design objectives

Van Nes and Bovy (2000) discussed several objective functions respecting the design variables as frequency, and line and stop spacing. These objective functions differ per party involved in public transport, e.g. passengers, operators and authorities.

Taking the point of view of the passenger, the main objective would be to minimise its total travel time, as travelling can be seen as a disutility. Two objective functions are described in [Van Nes and Bovy \(2000\)](#). Both functions consider minimising the weighted travel time. While the first considers a fixed frequency, than the balance between access and in-vehicle time will be found. While the latter accounts for fixed operational costs, which will try to optimise the both the line and stop spacing.

The operator will clearly represent other objectives while designing transportation networks. They will try to maximise the ratio between the revenues and the operational costs, i.e. cost-effectiveness ([Van Nes and Bovy, 2000](#)). Either, the operators tries to maximise the profits ([Van Nes and Bovy, 2000](#)).

From the authorities' point of view, the patronage needs to be maximised or the total costs need to be minimized ([Van Nes and Bovy, 2000](#)). The first objective function can be translated to minimising the total travel time, as lower travel times will attract more potential passengers ([Van Nes and Bovy, 2000](#)).

The total travel time of the passengers will have a prominent place in this research, this implies that the main focus of the research will be based on the passenger' perspective. However, the case studies will be - in lesser extent - evaluated on the fleet requirements and infrastructure capacity. The latter factors represent the interests of the operator and infrastructure manager. In addition, lower travel times in the system can be linked to the attractiveness of the system, which is a point of view of the transport authorities.

3.4.3 Research in Network Design

This section will include several studies concerning network design and their outcomes. The importance of network design in public transport systems for urban and rural districts is addressed by [Nielsen and Lange \(2007\)](#). In the paper it is mentioned that the properties of successful public transport is set by the frequency and the network factor. They state that the frequency can be beneficial for the patronage of the network. The network factor describes the structure of the network. They propose that a hierarchy in the system with an high frequent 'trunk' line contributes to the total network, as the waiting time during transfers decreases. Although, this division of the networks is only beneficial in larger towns and cities ([Nielsen and Lange, 2007](#)). Additionally, the frequency for passengers to arrive without planning their departure time is about 6 - 12 departures per hour on a working day ([Nielsen and Lange, 2007](#)).

[Farahani et al. \(2013\)](#) reviewed the urban transportation network design problem (UTNDP). This is a combination of the road network design problem and public transit network design problem. The first focuses on the construction of new roads, the capacities of streets or scheduling the traffic lights. The latter mostly takes route, frequency and timetable setting into account. The UTNDP is able to determine the optimal location of facilities to be added in a transportation network ([Farahani et al., 2013](#)). These facilities could be links and nodes.

In their paper [Enrique Fernández L. et al. \(2008\)](#) present a method to solve the Public Transport Network Design Problem, based on the metro and bus network in Santiago de Chile. The objective chosen is to maximize the social benefit subject to network, demand and behavioural constraints. The variables used in paper of [Enrique Fernández L. et al. \(2008\)](#) represent the itineraries, frequencies and the capacities of the public transport lines in the network. The model specified is based on two levels. Firstly, on the level of the transport authority by maximizing the social benefits. Secondly, on the level of the user which is maximizing its individual benefits. The goal of the model is that consistent results are obtained from both levels. Two different typologies are distinguished based on different public transport systems around the world. The first typology is based on direct services between (most of) the OD-pairs. The second typology is based on integrated systems with a clear hierarchy among the present systems, proving a high level of service with transfers. [Enrique Fernández L. et al. \(2008\)](#) address the importance for differentiating the characteristics of the public transport services provided. Otherwise the systems, in this case a bus and metro system, would compete in stead of complementing

each other. [Enrique Fernández L. et al. \(2008\)](#) conclude that the newly structured system, due to the clear hierarchy, will operate more profitably.

Concluding, the frequencies of the services is addressed by most of the researches as an important aspect in the success of the network design, where higher frequencies increase comfort for the passengers. Additionally, the location and connections of stations is mentioned as important. In a part of the research, the influence of frequencies will be tested on different variants in network design. Subsequently, the different stations in the case studies will be analysed for their location in the main rail network and their connections with other public transport systems.

3.5 TRANSPORT MODELS

This part will elaborate about general transport models, their characteristics and the adjustments or special parts while modelling transit networks and their use. This research is not accounting for congestion on routes or vehicles, this implies that the uncongested assignment methods are being used. This can be divided in the all-or-nothing assignment and the stochastic assignment - based on probit or logit models.

When analysing and modelling transportation systems, it is very common to do so by using a four stage model. A description of the four stage model is given by [Mcnally \(2000\)](#) with the following four stages:

1. **Trip Generation:** During this stage, the frequencies of the trips will be determined.
2. **Trip Distribution:** Given the production and attraction of each zone, the number of trips from a all zones to all other zones is determined, and vice versa.
3. **Mode Choice:** Given the number of trips between each OD-pair, the number of trips using a certain mode between each OD-pair is calculated.
4. **Route Choice:** The last stage is assigning passengers to routes given a transport network and OD matrix, i.e. the assignment. This stage will result in travel times and traffic flows on routes.

The described stages are common for most generic transport models, for all modes. Every stage has different types of models that could be applied. For this research, not every stage might be relevant. Both the trip generation and trip distribution will be assumed to be known, for the ridership models a fictitious OD-matrix will be compiled and for the case studies the boarding and alighting data of the Netherlands Railways will be used. Considering the mode choice, it is assumed to be made by the passenger. The main mode is assumed to be the train for every passenger in the system and passengers are not assumed to change their mode choice. For the case studies, the access and egress trips will be addressed too. This will be done by input of data made available by the Netherlands Railways. Based on different variants in network design, routes and travel times could change for passengers. This is captured in the route choice, or assignment. This will be the main block of this research. The influence of a (slightly) different network on the travel times and route choice will be looked into, given a certain OD-matrices.

The previous described stages are for transport systems in general. Every type of model can have its own specific characteristics. This research will focus on transit systems, more specific on rail bound transit systems. These systems add extra complexity in terms of infrastructure dependency, station choice and timetables or frequencies.

3.5.1 Transit models

Different ways of building transit models are described by [Gentile et al. \(2016\)](#). A differentiation has been made between scheduled and frequency based models. The scheduled based models aim at

determining the passenger loads on single runs or separate vehicles, which are more suitable for real-time management purposes (Gentile et al., 2016). While frequency based models aim at determining average loads on the lines, which are mostly used for the offline planning of services (Gentile et al., 2016).

As the name already implies, frequencies of the lines are important aspects for frequency based models. Based on the frequencies of the lines, the headways of the lines will be determined, which will result in the average waiting times of the passengers (Gentile et al., 2016). When assuming that passengers arrive uniformly distributed at the stations, the average waiting time for the passengers is half the headway time of the service Gentile et al. (2016). The network representation will be separate for each line connected to a generic stop node with arcs to the line stops with a weight for the waiting time of the lines (Nuzzolo, 2002). This way of representing the network allows for transfers between the different lines.

The scheduled based models assume that passengers do consider the timetable during their route choice, the passenger opts for a certain path to its destination (Gentile et al., 2016). This way of modelling public transport can account for dynamic network loading.

The aim of this research is to determine the optimal setting of services and their stopping patterns, i.e. the network design, thus the focus will be on the frequency based models.

3.5.2 Public Transport assignment

As described in Section 3.5, the assignment methods not accounting for congestion are the all-or-nothing assignment and the stochastic assignment. The first method only considers one route per OD-pair. While the stochastic assignment method also accounts for different routes. The stochastic assignment can be based on logit and probit models.

Nielsen (2000) states four different factors for using stochastic assignment methods.

1. Passengers tend not to have full knowledge of the networks, which implies that they can only choose rationally based on their perceived utilities.
2. Travel times of the routes can differ given different time periods.
3. Different routes can be chosen for variation.
4. Different passengers can have different preferences.

During this research, it is from a great value to capture the different perceptions of the passengers based on their knowledge, this implies that the stochastic assignment methods are better applicable. Furthermore, Nielsen (2000) state that the use of stochastic models is mostly focused on car traffic assignment, as public transport assignment tend to be more complex. The complexity of public transport assignment could be found in the organisational network of routes, stops and transfers (Nielsen, 2000).

The research of Nielsen (2000) focuses on the use of the probit method for stochastic traffic assignment. One of the main reasons for using probit assignment methods stated by Nielsen (2000) is that not every passenger is aware of the full feasible route set due to the complexity of the public transport networks.

In this research, only a line is considered where only a distinction is made between services and their stopping patterns. Each origin and destination will be directly connected by either one of the services or all of the services. It will be assumed that the complexity will be highly reduced by considering a line instead of a network, what will reduce the urge to use a probit assignment model. Additionally, due to computational reasons and that aggregate outcomes are desired, the logit assignment model will be used during this research.

Logit models

Mcfadden (1973) described the principles of the logit models to describe people's choice behavior as one of the first. A study into the choice behavior can be distinguished into the following factors (Mcfadden, 1973):

- the objects of choice and set of alternatives available to the decision-maker
- the observed attributes by the decision-maker
- the model of individual choice and behavior, and the distribution patterns of behavior in the population

This implies, while modelling choice behavior, the researcher needs to obtain knowledge upon the choices that have been made by the decision-makers and what the alternatives were. That means the full choice set needs to be present. Additionally, the attributes that people take into account while making a choice need to be known by the researcher, which can significantly differ per decision-maker. Subsequently, an appropriate choice model needs to be chosen and the distribution of certain choice patterns in the population need to be known.

Mcfadden (1973) presented an equation to determine the utility (U) of a certain alternative based on the attributes of that certain alternatives, that counts for every individual exposed to that certain choice set.

$$U = V + \epsilon$$

Where V is representative for the tastes of the population based on the present attributes in the choice set and ϵ is a stochastic element that represents the personal sensitivity to alternatives with certain attributes, e.g. the unobserved utility (Mcfadden, 1973). The utility of every known alternative could be calculated based on its attributes. While considering the principles of Random Utility Maximisation, it is assumed that an individual will choose the alternative with the highest utility.

Based on the utility of all alternatives, the probability of choosing a certain alternative could be determined by the following equation. Where the probability of choosing of alternative i is based on the utility of alternative i and the sum of the utilities of all alternatives.

$$P_i = \frac{e^{U_i}}{\sum * e^U}$$

Using logit for route choice models, the utility or - more accurate - disutility could be found in travel time and costs. Where the travel time and cost will be expressed in negative figures. The alternative with the lowest travel time or cost, i.e. the alternative with a value closest to zero, will be chosen.

For this research, different travel options between a certain OD-pairs using different services will be considered for the route choice. The Netherlands Railways considers a standard value for the tariffs between a certain OD-pair independent of the chosen route, except for the high speed section between Rotterdam CS and Schiphol Airport. This consolidates the choice for only taking travel times into account during this research. However, costs could be more relevant when considering the mode choice too.

3.5.3 Generalised travel time

Travel time will have a central place within this research. The travel time can be divided in different parts of the journey. The choices made by passengers will be based on these travel times. To model the passengers' preferences in timetable studies Guis and Nijënstein (2015) describe three different aspects that describe the attractiveness of trips for a passenger:

1. the actual trip time from origin to destination
2. the amount of transfers, the duration and ease of the transfers and the consequences of missing a transfer
3. the amount of trains leaving in an hour and the deviation of these trains over that time period

These three components together depict the level-of-service of the timetable. The different parts of the trip can be weighted differently to determine the attractiveness of the timetable for the passengers. The different parts of the trip can relatively differ in disutility, for example during the in-vehicle time passengers might be able to work while this is not that common during the waiting time. In this research, different configurations of network design will be reviewed on the total travel time of all passengers combined. Some of these variants in network design will include (obligatory) transfers. To test the attractiveness of all travel possibilities, the transfer resistance will be included. Additionally, the amount of transfers and their duration, and the actual trip time will be included in this research. The deviation of departing trains over a certain time period will be left out of scope, due to the macroscopic character of this research.

Transfer resistance

Ideally, passengers would prefer direct services between their origin and destination station. Yet, transfers could be present due to line planning or it is shortening travel times by transferring to a faster service. The discomfort of a transfer is extensively researched by [De Keizer et al. \(2012\)](#), based on stated preference survey. The time penalty considered for transfers highly depends on the transfer time, the frequency of the connecting train service and whether the transfer is cross-platform or cross-station ([De Keizer et al., 2012](#)). The research states that too short and too long transfer times are less appreciated, a transfer time of 5 minutes seem to be most optimal from a passengers' perspective. For trips with one transfer the transfer penalty is assumed to be 13,36 minutes, which is rounded to 14 minutes [De Keizer et al. \(2012\)](#). This value will be used for this research too, as only travel option with a maximum of 1 transfer are considered during the route choice.

3.6 CONCLUSION

The literature analysis has identified several important factors concerning travel behaviour, network design and transport modelling. Firstly, to obtain knowledge in the classification of services and stations, where the latter will be adjusted during this research. Train services are classified based on their stopping patterns, where the Intercity stops at the major stations and the Sprinter stops everywhere. Stations are classified based on the train services stopping at that station and the spatial characteristics of the area it is located in. Additionally, the ridership generated by a certain station can play a role in classifying stations. This research will include the ridership and location of station while compiling new variants in network design.

Secondly, the travel behaviour of passengers involve the choice passengers make before or during their trip. Among these choices are the mode, station and route choice. This research will assume the mode and choice to be known, the route choice on the rail network will be modelled. However, the travel behaviour is changing due to the availability of other modes, as shared mobility. This can influence the mode and station choice. Subsequently, changing frequencies and stopping patterns can influence the mode and station choice of passengers. In order to obtain insights in the effects on the station choice, a quick estimation in passengers making another station choice will be given.

Thirdly, the network design process knows several steps. This research will focus on the strategic parts of this process, as stopping patterns will be changed. Public transport networks could not be optimised for one factor, due to the different interests, resulting in trade-offs. This research will focus on the stop density and travel time dilemma, taking the total travel time of the passengers into account.

Additionally, the influence of frequencies will be tested on different variants in network design. Subsequently, the different stations in the case studies will be analysed for their location in the main rail network and their connections with other public transport systems.

At last, different aspects in transport modelling are addressed. This research will mostly focus on the route choice of passengers on the rail network, this means that the assignment in transport modelling will be important. As passenger' preferences and knowledge about the network is assumed to be different, a stochastic assignment method, which will be a logit model, is used. The logit model is based on the travel time of the routes and routes including a transfer will include a transfer resistance of fourteen minutes.

The following chapter will focus on the setup and mathematical formulations of the route and the station choice model. Different findings of the literature analysis will be used.

4

MODEL SETUP

This chapter will elaborate on the important and relevant aspect while compiling the model units as used in this research. First, the core of the modelling the network will be addressed, the network representation. Subsequently, the distribution of passengers over routes and calculating the total travel times and transfers will be explained. Additionally, the determination of the costs, in terms of fleet requirements and infrastructure capacity, will be stated. At last, a module for defining the amount of passengers opting for a new access station is explained.

4.1 NETWORK REPRESENTATION

One of the most important aspects in modelling the trips of passengers is the network representation. The network representation determines the way the network will be built in the model. The network representation should accommodate for transfers between services and should be able to include extra restrictions for compiling the feasible route set. This network will be used to determine the feasible routes from origin to destination.

While modelling public transport systems several types of network representations could be used, line based and route section based. The latter accounts for 'non-transfer'-links, while the first accounts for transfers either in its algorithm or by transfer links. Another method is the use of hyperpaths. Yet, the focus will be more on specific passengers travel behaviour (Noh et al., 2012). This research focuses on more aggregate travel behaviour. As transfer are highly relevant for answering the research question a representation accounting for these transfers is chosen. This representation is based on the line specific representation. In Figure 4.1, the chosen network representation is given. All lines are represented as aspects of the travel time, as waiting, in-vehicle or transfer time.

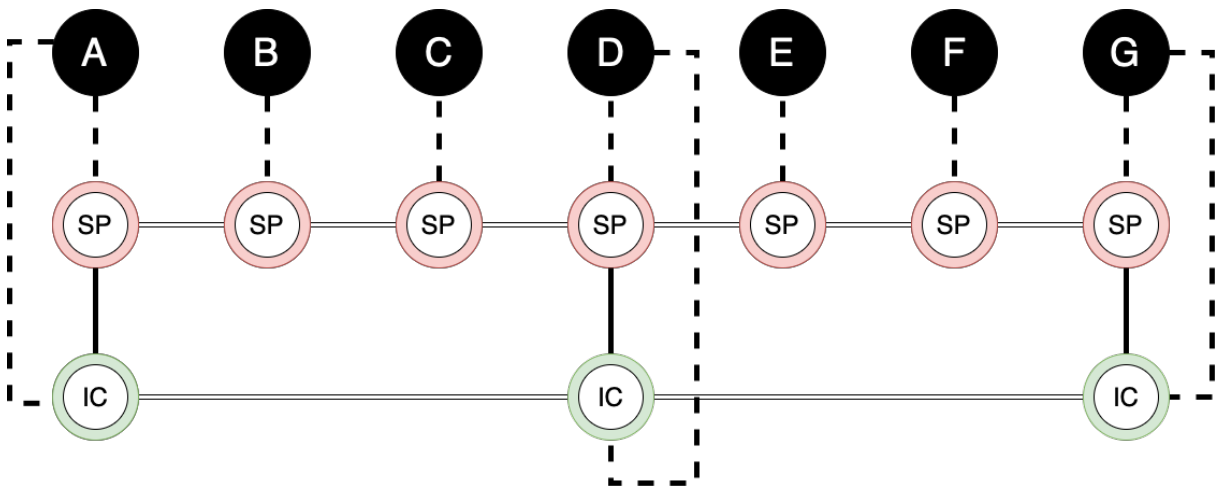

Figure 4.1: Example of the network representation

The example network has three IC stations at A, D and G. The station, the black dots with the white letters, is the place where the passengers will start their journey, with one of the train services. The dashed lines represents the waiting time and depends on the frequency of the service it is connected to. The double, horizontal lines represent the connection between stations by one service and is in fact

the in-vehicle time. The lines connecting SP and IC stations directly are the transfer links. These links are presented by the transfer time and, if it is the perceived travel time, by an added transfer penalty (with an initial value of 14 minutes). The passengers are able to travel between stations - letters - using the different routes by one or a combination of services.

This method of network representation is chosen to facilitate transfers between services more easily in the trip of passengers. Yet, some restrictions or exceptions are included into the links to eliminate irrelevant trips. First, the dotted lines can be passed for a maximum of 2 times in one trip. Thus, one time to one of the train services and one time from one of the train services. This should prevent the appearance of transfers through station nodes in the route set. Additionally, the dotted lines to the train services have a waiting time implemented on them. While, the dotted lines from the train services do not have a weight implemented, as these stations are seen as destinations on the rail network.

4.1.1 links and travel times

The stations are given a tag of the following set. Subsequently, the distances between successive stations are given.

$$\{A, B, C, D, E, F, G\} \quad (4.1)$$

$$\{d_1, d_2, d_3, d_4, d_5, d_6\} \quad (4.2)$$

The distances between stops for every service will be calculated, based on the network representation. For the SP service the distance between successive stations will be used, unless presented otherwise in the network design. The calculation for the IC service is given below with Figure 4.1 as an example:

$$A_{IC} \leftrightarrow D_{IC} = d_1 + d_2 + d_3 \quad D_{IC} \leftrightarrow G_{IC} = d_4 + d_5 + d_6 \quad (4.3)$$

The distances are converted into time by dividing the distance by the speed of the service operated on that link. Keeping the purpose of this model in mind, the average operational speed is used. Detailed acceleration and speed curves are more relevant for microscopic models. Additionally, the dwell time per service is added to the link for modelling purposes.

$$t_x = \frac{d_x}{v_k} + t_{dwell_k} \quad (4.4)$$

where:

- t_x = travel time on link x [s]
- d_x = distance between successive stations [m]
- v_k = operational speed of service k [m/s]
- t_{dwell_k} = dwell time of service k [s]

The transfer links are given a weight with the transfer resistance and with the half of the headway of the service transferring to. The latter is applied under the assumption that passengers arrive randomly at the station. For the actual travel time, the travel resistance is omitted.

$$t_{x_{transfer}} = R_T + \frac{60/f_k}{2} \quad (4.5)$$

where:

$$\begin{aligned}
t_{x_{transfer}} &= \text{transfer time on link } x \text{ [s]} \\
R_T &= \text{transfer resistance of passengers [s]} \\
f_k &= \text{frequency of service } k \text{ [trains/hour]}
\end{aligned}$$

Now that all the time values for the links are known, a path generator is defined to determine all paths between every pair of stations. The route set generation should be logical, have sensible variation in characteristics and include the chosen route (Hoogendoorn-Lanser et al.). The compilation of the routes between a given origin and destination is based on the all-path algorithm, which finds all paths between that origin and destination. To convert that route set to a feasible route set, two different assumptions are made. First, the maximum amount of transfers taken in one trip is assumed to be 1. This implies that no more than one transfer is possible on the same line. Secondly, the longest route to be added to the route set is not more than twice as long as the shortest route from the origin to the destination.

1. Routes with more than 1 transfer
2. Routes more than twice as long as shortest route

This will provide a route set with feasible routes for passengers to choose from. In this part, the restrictions of only using the dotted line when departing from or arriving to a station are included.

This part has shown the compilation of the perceived travel time for certain routes. The actual travel time will be compiled similar as the perceived travel time, except for the transfer resistance not being included during transfers.

4.2 ROUTE CHOICE MODEL

This section will elaborate on the aspect assigning passengers to certain routes. The routes and feasible route set are determined based on the networks, as represented in Section 4.1.

Modelling objective

The model is intended to calculate the total travel time, amount of transfers and the operational costs of a certain configuration of station statuses, given a specified amount of services and their stopping patterns, origin and destination data, and travel times and waiting times.

Now, the feasible routes are collected in a route set, the passengers should be allocated to certain routes. Based on the travel times from origin i to destination j , the probability of choosing a certain route from that particular station will be calculated. This calculation will be done based on Equation 4.6.

$$P_{ijr} = \frac{e^{\beta_r * t_{ijr}}}{\sum e^{\beta_r * t_{ijr}}} \quad (4.6)$$

where:

$$\begin{aligned}
P_{ijr} &= \text{probability of choosing route } r \text{ between origin } i \text{ and destination } j \text{ [-]} \\
\beta_r &= \text{route choice parameter [-]} \\
t_{ijr} &= \text{travel time of route } r \text{ between origin } i \text{ and destination } j \text{ [s]}
\end{aligned}$$

The probability of choosing a certain route from origin i to destination j will be multiplied with the demand from i to j .

$$T_{ijr} = q_{ij} * P_{ijr} \quad (4.7)$$

where:

T_{ijr} = passengers using route r between origin i and destination j [pax]

q_{ij} = travel demand between origin i and destination j [pax]

P_{ijr} = probability of choosing route r between origin i and destination j [-]

The total travel time, both perceived and actual, of the passengers in the system will be calculated by the amount of passengers opting for a certain route between origin i and destination j multiplied with the corresponding travel time of that route between origin i and destination j .

$$t_{total} = T_{ijr} * t_{ijr} \quad (4.8)$$

t_{total} = total travel time of all passengers combined [s]

T_{ij} = passengers using route r between origin i and destination j [pax]

t_{ijr} = travel time of route r between origin i and destination j [s]

The total amount of transfers will be calculated similarly to the total travel time. The amount of passengers opting for a route between origin i and destination j will be multiplied with the amount of transfers in that route. The values of tf_{ijr} could either be 0, if no transfers occur in that route, or 1, as that is the maximum amount of transfers of the feasible routes.

$$tf_{total} = T_{ijr} * tf_{ijr} \quad (4.9)$$

tf_{total} = total amount of transfers of all passengers combined [#]

T_{ij} = passengers using route r between origin i and destination j [pax]

tf_{ijr} = amount of transfers in route r between origin i and destination j [#]

4.3 OPERATIONAL COSTS

The main focus of this research will be on the travel time of the passengers. The operational costs will be determined to obtain knowledge in the costs to operate the considered network design. Operational costs can be determined in several ways. It can be based on the real cost parameters per kilometre, the occupancy of passengers per route segment or on the cycle times of the vehicles. The first method relies on confidential numbers of the Netherlands Railways, and as the considered lines during this research are not identical to the lines as operated by the Netherlands Railways, this will provide hard to interpret numbers. The second method relies on the passenger occupancy per route segment, i.e. between each station. Considering the capacity of a train segment and maximum passenger occupancy per route segment, the length of the train could be determined. This will provide the train lengths needed given a origin and destination matrix (OD-matrix). Yet, the length of the train is very variable, due to differences of the OD-matrix during the day, making it more suitable for microscopic modelling purposes. The last method will include the time needed for a vehicle to make a full cycle and the frequency of that service. This will provide a global indication about the amount of vehicles per service needed to operate the lines for a given stopping pattern. In essence, the combination of the last two methods would be preferred, as it would provide both the train lengths and the amount of trains needed. Yet, as the second method is really sensitive for changing occupancy along the line, it is left out of the cost determination.

The operational costs will be determined by the cycle times of the services and the frequencies. The cycle time include the running, dwell and turnaround times.

$$t_{cyclek} = \frac{d_{total}}{v_k} + t_{dwellk} + t_{tat} \quad (4.10)$$

where:

$$\begin{aligned}
 t_{cyclek} &= \text{total cycle time of service } k \text{ [s]} \\
 d_{total} &= \text{total operating distance [m]} \\
 v_k &= \text{operating speed of service } k \text{ [m/s]} \\
 t_{dwellk} &= \text{dwell time of service } k \text{ [s]} \\
 t_{tat} &= \text{turnaround time of service } k \text{ [s]}
 \end{aligned}$$

To determine the amount of needed vehicles of a certain service, the cycle time is multiplied by the frequency and divided by 60 minutes. This way the vehicle lengths are not determined.

$$N_k = \frac{f_k * t_{cyclek}}{60} \quad (4.11)$$

where:

$$\begin{aligned}
 N_k &= \text{required amount of vehicles [trains]} \\
 f_k &= \text{frequency of service } k \text{ [trains/hour]} \\
 t_{cyclek} &= \text{total cycle time of service } k \text{ [s]}
 \end{aligned}$$

Another cost restriction could be found in the infrastructure occupancy, as the infrastructure capacity is not infinite. This is not really suitable for the conceptual models as defined in this part of the research. It might be suitable during the assessment of the options in the case studies to be found in Chapter 6. [Dingler et al.](#) state that different operating characteristics of services can have implications on the track capacity. One of the delay-causing situations [Dingler et al.](#) address is a delay caused by an averagely slower preceding train. Differences in run time can result in faster services to endure delays or decrease the track capacity significantly due to differences in speed profiles. This should be accounted for during this research, as the Intercity and Sprinter services do show differences in operational characteristics. [Ramunas et al. \(2011\)](#) add several factors as traction & stopping characteristics, speed limitations by technical reasons and stoppage duration.

The infrastructure capacity will be assessed based on the homogeneity of the run times of the services. To calculate the run time of a service, the same formula as for the cycle time is used, except for the turn around times.

$$t_{runk} = \frac{d_{total}}{v_k} + t_{dwellk} \quad (4.12)$$

where:

$$\begin{aligned}
 t_{runk} &= \text{running time of service } k \text{ [s]} \\
 d_{total} &= \text{total operating distance [m]} \\
 t_{dwellk} &= \text{dwell time of service } k \text{ [s]}
 \end{aligned}$$

4.4 DISTRIBUTION OF PASSENGERS AMONG STATIONS

This part will elaborate on the method to estimate the passengers opting for a new access station based on new network designs.

Modelling objective

The model is intended to estimate the amount of passengers opting for a new access station bases on a new network design. This estimation will only consider successive stations in the station choice. The determination of the relevant share of passenger to make a new station choice is based on the distance between successive stations,

the origin of passengers among the catchment rings of the access stations, and the frequency and travel time from stations in the choice set to the destination.

The origin and destination matrix as provided by the Netherlands Railways depict the station choice for the current network design, i.e. the choice of the passengers based on the current attributes. While changing the design of the network, passengers can change their choice based on these new attributes. These changes can eventually change the choice for the stations, which will result in a new origin and destination matrix while considering stations.

While changing the design of the network, it is valuable to map the magnitude of this change in station choice due to changing statuses of stations. If some flexibility is possible in this section of the travel behavior of the passengers, other network variants will score better due to a more optimal station choice. This can result in lower travel times on the rail network.

As described in Section 3.2, the choice for a certain station can be influenced by several factors. Passengers tend to choose their origin station based on the destination station. Another important aspect in the station choice is proximity of the station and the connections with access and egress modes, this can be public transport connections or bicycle lanes and roads.

Changing the station choice is only relevant in several cases. The status of the station, Intercity or Sprinter, should differ from the current network. Additionally, the frequency from origin station A and B to the destination should be different, as the service offered should be different. Subsequently, only consecutive stations are considered for changing the station choice.

The following sections will elaborate on the chosen choice model, the access and egress trips for stations on the case study, the proximity of the stations and will end with the determination of the relevant share of passengers for changing the station choice.

4.4.1 Current ridership estimation

The Netherlands Railways developed a model which returns an estimation of the ridership of a certain station. The model also can give an estimation of the newly generated ridership of a station.

This section will summarize the considered aspects of that model, this will be used as a basis for the model developed for this research. The following aspects are included in the model of the Netherlands Railways:

- the catchment areas of the stations
- the quality of access and egress modes
- the quality of public transport connections
- the degree of urbanisation
- the accessible destinations
- the frequency

The station choice model should be complement to the route choice model. During this research, different variants in network design will be compiled. These new variants have an impact on the travel time of passengers and the direct connections among stations. Which will be the starting point of the station choice model. The other included aspects will be explained in the following sections.

4.4.2 Determining passengers changing stations

Before handling new station choices for passengers, first the amount of passengers who are expected to be relevant to make this choice should be determined. Passengers do not just randomly spawn at

train stations, assumable they have a origin near the access station of their choice. Figure 4.2 presents a station with its catchment rings.

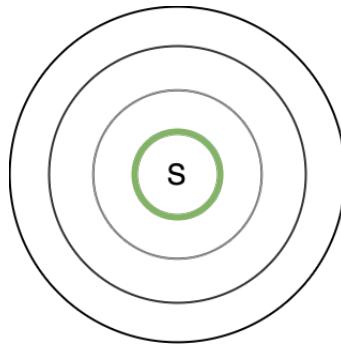

Figure 4.2: A station and its catchment rings

Passengers are assumed to be distributed among these rings, while the exact distributions could differ highly per station. Some stations could have a larger influence area due to several reasons, resulting in larger shares of passengers originating from more outer rings. When knowing the distribution of the passengers over these rings, the amount of passengers easily could be determined by knowing the amount of passengers boarding at that station.

Example Rotterdam Centraal:

Consider the passengers from Rotterdam Centraal to another station, which is assumed to be 100 passengers for this example. In Table B.3, the distribution of the origins of passengers is given for five rings. In the case of Rotterdam Centraal the distribution is as follow: Ring 1 = 28%, Ring 2 = 37%, Ring 3 = 19%, Ring 4 = 12% and Ring 5 = 5%. Resulting in the following amount of passengers per ring, 28 passengers for Ring 1, 37 passengers for Ring 2, 19 passengers for Ring 3, 12 passengers for Ring 4 and 5 passengers for Ring 5.

The Netherlands Railways provided data set with information about access and egress trips, which is analysed in Section C.2 and resulted in the distribution over catchment rings for the stations on the case studies. The further line of reasoning as used in this research is explained along a line with four stations and their catchments, as presented in Figure 4.3.

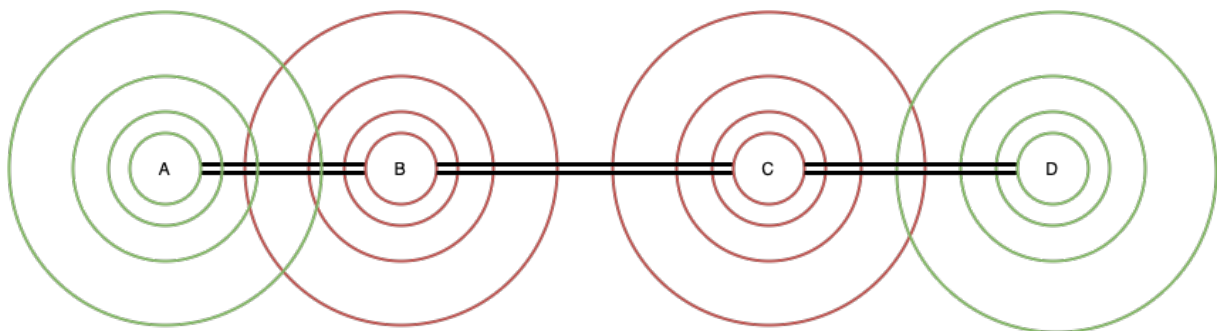

Figure 4.3: Stations with their catchments

When looking at Figure 4.3, two things should stand out. Stations being more proximate to each other have higher chance of overlapping catchments and the outermost catchment rings have a higher chance of overlapping. These two principles are used further on to determine the amount of passengers to make the choice for swapping stations. yet, not every passenger from every ring is not expected to make a relevant choice for a new starting station. Figure 4.4 shows the overlapping catchment area

of station A and B. This is in general the part between the blue arrow - areas outside this arrow are assumed to be less likely to change to a station to the other side of the black line, roughly half of the catchment ring.

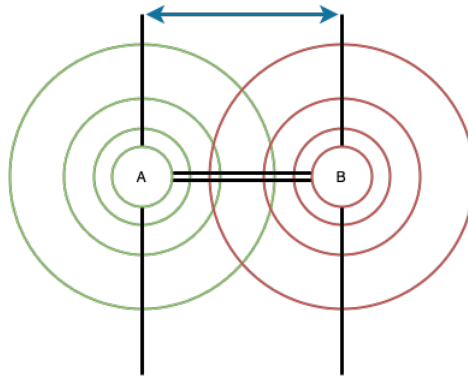

Figure 4.4: Overlapping influence areas

Proximity of stations

The proximity of the stations is an important part in a possible shift in station choice. Stations more distant from each other are less likely to be in each others area of influence, i.e. to be in the same choice set for stations. The proximity of the station is determined based on the physical distance as presented in Table B.1 and Table B.2.

Access and egress trips

To determine the new station choice based on the network design, it is important to represent the access trips of the passengers. In Appendix C, a data set about access and egress trips of passengers using the train as their main mode provided by the Netherlands Railways is analysed. This data is used to map the catchment areas of stations for both the access as egress sides, where passengers are assumed to . These catchment areas could give valuable insights in the areas of influence of the stations.

The data set gives a distribution of passengers choosing for a certain station over five different rings based on their travel times. These travel times are categorised in rings for maximum 5, 15, 25, 45 and 75 minutes. This gives an insight in the travel times of the passengers choosing for certain stations. Additionally, the data set includes the mode used for the these trips. This gives insights in the most observed modes per catchment ring. Both of these categorisations could be determined for every station in the case studies.

Based on the distances between stations, a categorisation of influence of other stations per catchment ring is made. This categorisation is given Table 4.1, where the 0,5 term is derived from Figure 4.4 and the second term is to be determined in ???. The probability term (P) is determined as described in Section 4.4.3.

Distance [m]	1 - 2000	2001 - 4000	4001 - 6000
Ring 1	0	0	0
Ring 2	$0,5 * d * P$	0	0
Ring 3	$0,5 * e * P$	$0,5 * d * P$	0
Ring 4	$0,5 * f * P$	$0,5 * e * P$	$0,5 * d * P$
Ring 5	$0,5 * g * P$	$0,5 * f * P$	$0,5 * e * P$

Table 4.1: Distance categories for station choice

4.4.3 Choice model

The model developed for this research accounts for frequencies and travel time from origin to destination stations. The choice for another access station should be expressed in the frequency and the travel time from the considered stations to the egress station. There is chosen for a logit which accounts for both of these aspects. The logit for line choice as described in Brands et al. (2014) is chosen for determining the station choice. Where the frequency and travel time from both station i_a and i_b , either left or right of the current station, to station j .

$$P_{station} = \frac{f_{ij} * e^{-\beta * t_{ij}}}{\sum f_{xj} * e^{-\beta * t_{xj}}} \quad (4.13)$$

where:

- $P_{station}$ = probability of choosing a certain station [-]
- β = choice parameter [-]
- f_{ij} = frequency of trains from origin i to destination j [trains/hour]
- t_{ij} = travel time from origin i and destination j [s]

For this part of the research, the travel times are used as generalised costs, which are represented by the travel time of the shortest path between origin station i to destination station j .

4.4.4 Limitations

The module as described previously, is a practical method to identify passengers making a new station choice based on a changing station statuses, based on the available data. This part will elaborate on the limitations of this method. Ideally, a distribution over postal codes for every station was used. This would give insights in the physical location of passengers to different stations. When considering station choice, distance decay functions could be used to determine the amount of passengers changing stations based on their distance to stations. As for some stations, the observations for the postal codes were not sufficiently enough, this method could not be applied.

For this method, several practical assumptions were made. First, the passengers are assumed to be distributed uniformly among the rings they are originating from. In reality, the catchments of stations are not perfect circles and the density of origins in those rings could differ, due to difference in urbanisation or natural boundaries as rivers. Secondly, this method diminish the effects of underlying public transport systems. Passengers originating from more outer rings are assumed to be more flexible in their station choice. While, their initial choice could be influenced by another public transport system that provides a fast or high frequent connection to their initial station, making them captured passengers. In general, this method excludes the access and egress trip as a whole. The choice for a new station is only made based on frequency and travel time differences between origins and destinations, where an interaction between both the main trip as the access and egress trip is expected.

4.4.5 Test case: Stedenbaan 'minimal IC'

Before using this module for all networks, the parameters should be determined. This will be done by using network 'minimal IC' for the Stedenbaan Zuid. It is from a great importance that the values for d , e , f and g are chosen carefully. These terms determine the share of relevant passengers for every ring which will be able to change their starting station. In line with the previous stated assumption, that passengers having a origin in a more outer ring have a higher chance of changing stations, the terms should be equal or ascending from d to g . While running the module, the value of the choice parameter is set on 0,4, as this value should show less attraction to only the shortest travel time. Table 4.2 shows the amount of changing passengers for different values for d , e , f and g in five sets of parameter values.

Set	1	2	3	4	5
d	0,7	0,4	0,3	0,2	0,8
e	0,8	0,5	0,5	0,2	0,8
f	0,9	0,6	0,7	0,8	0,2
g	1	0,8	0,9	0,8	0,2
Changers [pax]	1059	626	528	328	1117

Table 4.2: Passengers changing stations for different values for relevant share parameters

As the amount of passengers decline over the rings as the travel time increases, the values for d and e have a greater influence on the share of relevant passengers to opt for a new station. Yet, it is assumed that the passengers originating from those rings are less sensitive for choosing a new station as the travel time to their original station implies that they are already near that station. The values as presented in **set 1** are chosen, as it meets the assumption as explained previously and the share of passengers seems to be plausible.

5 | NETWORK ALTERNATIVES

This chapter will elaborate further on the effect of different network designs on the travel times and amount of transfers. Thereafter, the working mechanisms of the model will be tested. At last, the outcomes of the model will be compared to real life numbers.

5.1 THE NETWORK

For the models, a hypothetical network is considered from node A to G, which is presented in Figure 5.1. Every node represents a station and the lines represent a connection between the stations.



Figure 5.1: The hypothetical network

For different network designs, shown in Figure 5.2 and explained in Table 5.1, different input parameters will be adjusted to identify their effects on the travel times of passengers. These parameters are the origin and destination matrix and frequencies. The calculations will result in the total travel time, the amount of transfers in the system and the operational costs. The total travel time represents the total travel time of all the passengers in the system combined, which includes the transfer time and waiting time. This will give an insight of the travel time of passengers in the system. The amount of transfers are calculated to determine the extra transfers that are made by the passenger for a certain configuration of station statuses. This more clearly provides the amount of passengers affected by this configuration. The operational costs are calculated to determine the capital resources needed to operate the system as designed.

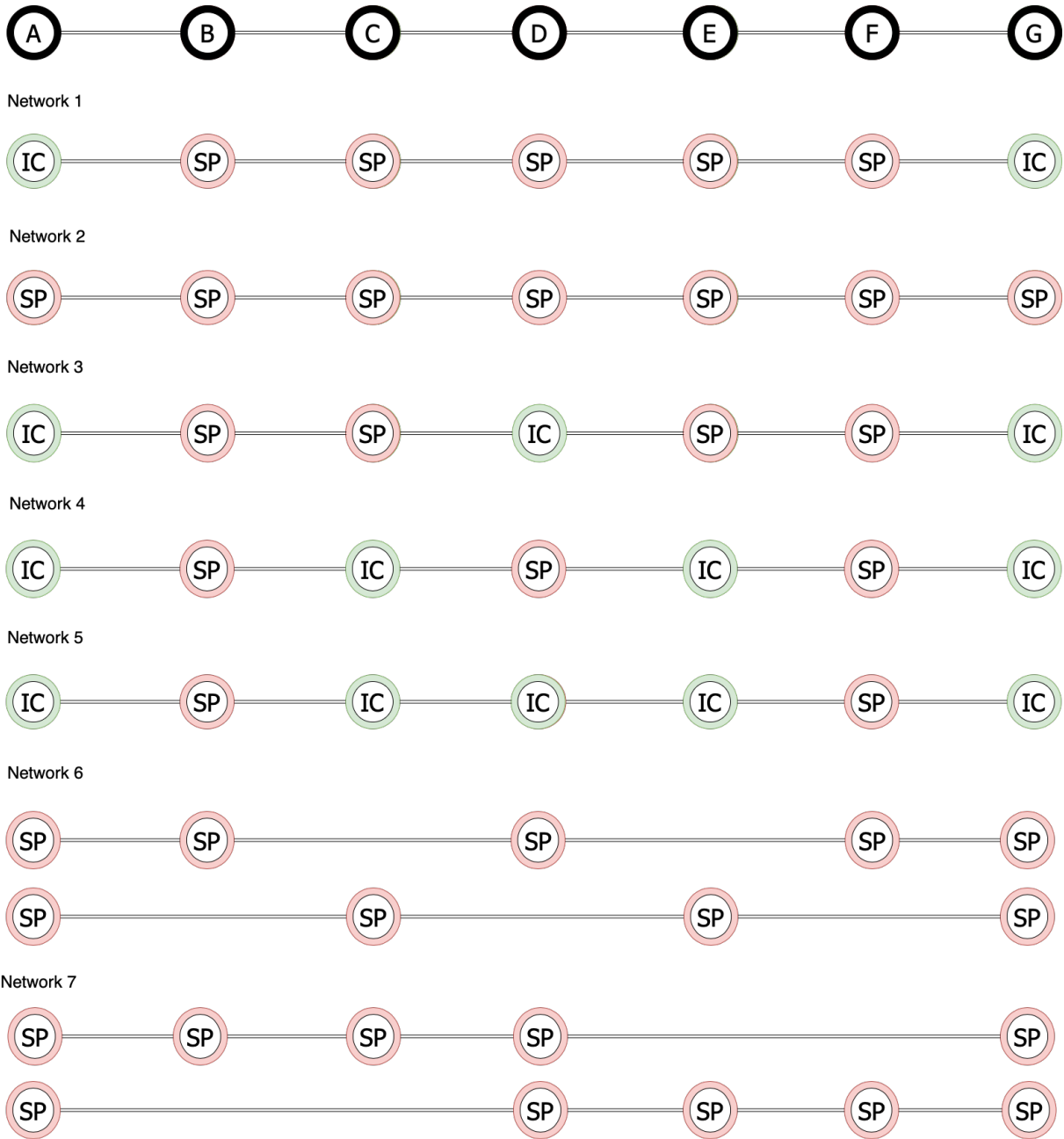

Figure 5.2: All network variants

Network	Explanation
1	In this case, two IC statuses are present at the end of the line. Shorter travel time are expected for travellers between those stations and some transfers might be present.
1	On this line only SP statuses are present. No transfers possible.
3	In addition on the previous variant, an extra IC status is added in the middle of the line. In this case, more transfers might be present.
4	In case SP and IC statuses are alternated starting with IC statuses at both ends. In this variant, more transfer possibilities are present, which might result in more actual transfers.
5	This variant is a combination of the previous two variants. The assumption is that less transfers will be observed due to the increased direct destinations in the IC service.
6	This variant represents a skip-stop operation of two sprinters, the first serving the upper line and the second serving the lower line. The outer stations are possible transfer stations. To reach certain stations a transfer might be needed.
7	The zone sprinter was an inspiration for this variant. In this case one sprinter serves one half of the line and continues to the end. Three different transfer stations are present in this variant.

Table 5.1: Networks for the ridership models

5.1.1 Origins and destinations

Origins and destinations are an important aspects of modelling trips, as this are the start and the end of the trips. The origins are mostly near the start station and the destinations at near the end station. Based on their origin and destination, passengers choose their station. Other relevant factors could be found in Section 3.2. This research focuses on the network design of sections of the railway system, this is the reason that stations will be seen as origins and destinations. The origin and destination matrix will represent the station choice, as passengers choose their start and end station based on attributes that are important to them.

For the ridership models in this chapter, three different type of OD-patterns will be used to simulate different situations. All three OD-patterns have a total sum of 8400 passengers in the system, this provides a better comparison of the variants as the amount of people is equal. In Table 5.2, the basic matrix is given. In this case, **'Equal'**, the OD-matrix is fully symmetric. Every origin and destination has respectively the same production and attraction. In Table 5.3 the second OD-pattern is given, **'Outer stations'**. In this case, the attraction of station A and G are substantially higher than the other stations. In Table 5.4, the third OD-pattern is presented. In this OD-pattern, **'Inner stations'**, the attraction of station D, in the middle is higher than the attraction of the other stations.

	A	B	C	D	E	F	G
A	0	200	200	200	200	200	200
B	200	0	200	200	200	200	200
C	200	200	0	200	200	200	200
D	200	200	200	0	200	200	200
E	200	200	200	200	0	200	200
F	200	200	200	200	200	0	200
G	200	200	200	200	200	200	0

Table 5.2: OD-matrix for equal demand (Equal)

	A	B	C	D	E	F	G
A	0	150	100	100	100	150	400
B	400	0	100	100	100	150	400
C	400	150	0	100	100	150	400
D	400	150	100	0	100	150	400
E	400	150	100	100	0	150	400
F	400	150	100	100	100	0	400
G	400	150	100	100	100	150	0

Table 5.3: OD-matrix for asymmetric demand (Outer stations)

	A	B	C	D	E	F	G
A	0	140	200	520	200	140	100
B	100	0	200	520	200	140	100
C	100	140	0	520	200	140	100
D	100	140	200	0	200	140	100
E	100	140	200	520	0	140	100
F	100	140	200	520	200	0	100
G	100	140	200	520	200	140	0

Table 5.4: OD-matrix for asymmetric demand (Inner stations)

5.2 FREQUENCIES AND OD-PATTERNS

In this part, the results of the outcomes of the different calculations of the models will be presented. The results for the different variants in network design will be presented by changing several factors, as OD-matrices and frequencies, and evaluated based on the effects of these changes. The outcomes will be presented as the cumulative perceived travel time of all passengers combined, cumulative actual travel time of all passengers combined and the amount of transfers taken in that variant.

The parameters used during the calculations are presented in Table 5.5, which remain equal unless stated differently. For determining the effects of different frequencies, the demand patterns as presented in Table 5.2. When adjusting the OD-matrices, the frequencies are set on four vehicles per hour for both the Sprinter as Intercity services.

Parameter	Value
Speed IC	140 km/h
Speed SP	120 km/h
Dwell IC	120 s
Dwell SP	60 s
Route choice parameter	- 0,4
Transfers penalty	14 min
Distance	2 km

Table 5.5: Parameters used for the models

5.2.1 Network 1

The first variant in network design considers two IC stations, one at both ends of the network. The visual representation is shown in Figure 5.3.

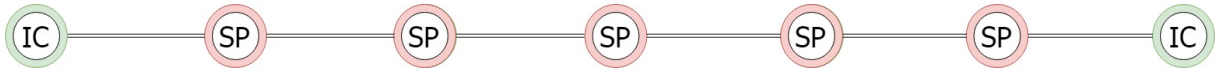

Figure 5.3: Network 1

Variant 1	4 SP 4 IC	8 SP 8 IC	10 SP 10 IC	4 SP 8 IC	8 SP 4 IC
Perceived [min]	105857	74357	68057	104357	75859
Actual [min]	105857	74357	68057	104357	75859
Transfers [pax]	0	0	0	0	0

Table 5.6: Travel times and transfers for different frequencies under network 1

When varying the frequencies of the services, both the perceived and actual travel times drop with a higher frequency. Due to a higher frequency, the waiting time for the passenger will drop. The asymmetric frequencies with different frequencies for both services show that it is more beneficial for the system when the SP service has a higher frequency than the IC service. This results from the fact that more passengers benefit from a more frequent SP service as it serves all stations. Network 1 does not show any transfers. In Table 5.7, the outcomes for varying OD-patterns under network 1 are shown.

Network 1	Equal	Outer stations	Inner stations
Perceived [min]	105857	109914	102269
Actual [min]	105857	109914	102269
Transfers [pax]	0	0	0

Table 5.7: Travel times and transfers for different OD-patterns under network 1

When analysing the outcomes for different OD patterns, still no transfers are observed for this network. The different OD-patterns have different effects on this network. This network performs best for 'Inner stations', as the stations with the highest demands are connected with a fast, direct IC service.

5.2.2 Network 2

The second network will only consider SP stations. Network 2 is presented in Figure 5.4.

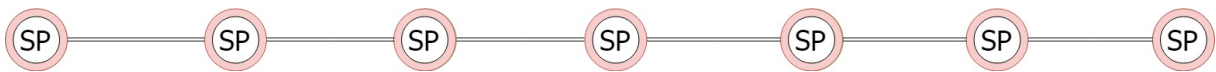

Figure 5.4: Network 2

Network 2	4 SP 4 IC	8 SP 8 IC	10 SP 10 IC	4 SP 8 IC	8 SP 4 IC
Perceived [min]	107800	76300	70000	107800	76300
Actual [min]	107800	76300	70000	107800	76300
Transfers [pax]	0	0	0	0	0

Table 5.8: Travel times and transfers for different frequencies under network 2

Setting different frequencies for network 2 result in lower travel times for higher frequencies. Due to the lack of IC services in this network, the amount of transfers for this network is zero.

Network 2	Equal	Outer stations	Inner stations
Perceived [min]	107800	113800	103240
Actual [min]	107800	113800	103240
Transfers [pax]	0	0	0

Table 5.9: Travel times and transfers for different OD-patterns under network 2

When analysing the effects of different OD-patterns, the outcomes only show the differences in passenger trip lengths for the OD-patterns. The pattern where the passengers are travelling mostly to the outer stations shows the highest travel time, as the trips of the passengers are longer in that case. The pattern where passengers travel to the middle station shows the lowest value.

5.2.3 Network 3

Network 3 considers the same IC stations as network 1, yet an extra IC station is added in the middle at station D. This extra IC station provides better connections for passengers from station A or G to station D, and vice versa. Yet, the service between station A and G has been slowed down due to the extra stop in D. A visual representation of network 3 can be found in Figure 5.5.

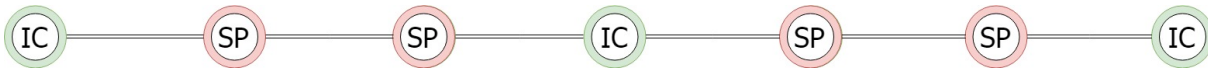

Figure 5.5: Network 3

Network 3	4 SP 4 IC	8 SP 8 IC	10 SP 10 IC	4 SP 8 IC	8 SP 4 IC
Perceived [min]	105514	74014	67714	101014	76305
Actual [min]	105514	74014	67714	101014	76305
Transfers [pax]	0	0	0	0	0

Table 5.10: Travel times and transfers for different frequencies under network 3

Increasing the frequencies of the services result in a lower total travel time for both the perceived and actual travel time. A higher frequency for the SP service than the IC service again provides a better outcome than vice versa. The amount of transfers for this network is equal to zero.

Network 3	Equal	Outer stations	Inner stations
Perceived [min]	105514	110086	100900
Actual [min]	105514	110086	100900
Transfers [pax]	0	0	0

Table 5.11: Travel times and transfers for different OD-patterns under network 3

The OD-pattern with the most demand for station D performs by far the best under this network. By adding a IC station at station D, the trips from A and G to D become significantly lower. This results in benefits in terms of travel time for a large group of passengers. The amount of transfers is still zero.

5.2.4 Network 4

For this network, an alternating pattern for IC stations is assumed, where the IC stations start at both ends. This network provides better connections from station A and G to stations C and E, but increases the travel time from station A to G by adding two extra IC stops. Additionally, this network presents more transfer possibilities. The network design is presented in Figure 5.6.

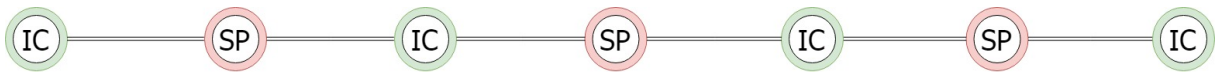

Figure 5.6: Network 4

Network 4	4 SP 4 IC	8 SP 8 IC	10 SP 10 IC	4 SP 8 IC	8 SP 4 IC
Perceived [min]	106758	75258	68958	97657	76300
Actual [min]	106758	75258	68958	97657	76300
Transfers [pax]	0	0	0	0	0

Table 5.12: Travel times and transfers for different frequencies under network 4

A higher frequency of services result in lower travel times in the system by reducing the waiting time. This network again shows benefits for a higher frequency of the SP service over a higher frequency of the IC service. None of the runs show any transfers.

Network 4	Equal	Outer stations	Inner stations
Perceived [min]	106758	112314	102521
Actual [min]	106758	112314	102521
Transfers [pax]	0	0	0

Table 5.13: Travel times and transfers for different OD-patterns under network 4

The OD pattern where station D has the most demand, 'Inner stations', performs best in for this network design too. This is the result of shorter trip lengths for this network. The amount of transfers is again zero.

5.2.5 Network 5

Network 5 uses the IC stations of network 4 as a starting point and adds an extra IC station at D. This addition increases the travel time for passengers of the initial IC stations. As station D is surrounded by IC stations, the IC station might not as beneficial as expected. The IC service is stopping just as much as the SP service. The assumption for this network is that transfers would become less attractive as the IC service is connecting more stations directly. A visual representation of network 5 is given in Figure 5.7.

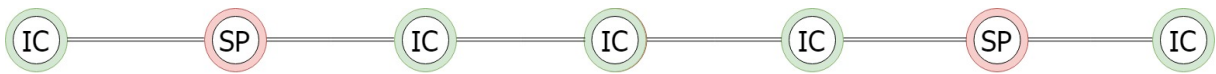

Figure 5.7: Network 5

Network 5	4 SP 4 IC	8 SP 8 IC	10 SP 10 IC	4 SP 8 IC	8 SP 4 IC
Perceived [min]	107657	76157	69857	96000	76300
Actual [min]	107657	76157	69857	96000	76300
Transfers [pax]	0	0	0	0	0

Table 5.14: Travel times and transfers for different frequencies under network 5

Just as expected, this network shows lower travel times for increasing frequencies. Additionally, a higher frequency for the SP service provides a better performance based on travel times than a higher frequency for the IC service. This network also does not show transfers.

Network 5	Equal	Outer stations	Inner stations
Perceived [min]	107657	113618	103164
Actual [min]	107657	113618	103164
Transfers [pax]	0	0	0

Table 5.15: Travel times and transfers for different OD-patterns under network 5

The OD-pattern which is focused on station D, 'Inner stations', reacts best under this network. The passengers under this OD-patterns have an shorter average trip length. Again, no transfers are present in this case.

5.2.6 Network 6

This network considers two skip-stop sprinter services, these sprinters do not stop on every successive stations. This implies that not every OD-pair is not directly connected in this network, resulting in mandatory transfers at one of the outer stations. The amount of transfers will differ per OD-pattern. Network 6 is presented in Figure 5.8.

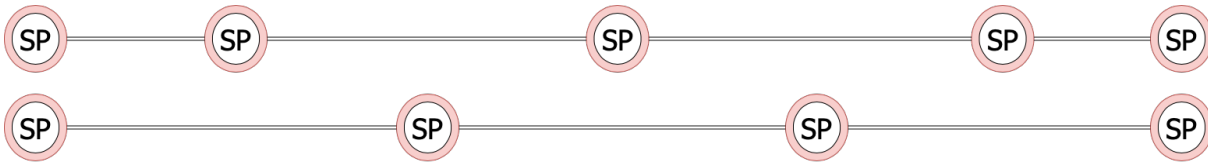

Figure 5.8: Network 6

Network 6	4 SP 4 IC	8 SP 8 IC	10 SP 10 IC
Perceived [min]	160204	119704	111604
Actual [min]	107657	76157	69857
Transfers [pax]	2400	2400	2400

Table 5.16: Travel times and transfers for different frequencies under network 6

This network does show transfers, as they are mandatory for passengers travelling between certain stations. This means that the perceived and actual travel time differ for this network. The performance of this network increases by setting higher frequencies. The amount of transfers are 2400 passengers in total.

Network 6	Equal	Outer stations	Inner stations
Perceived [min]	160204	138906	168602
Actual [min]	107657	113618	103164
Transfers [pax]	2400	1400	2800

Table 5.17: Travel times and transfers for different OD-patterns under network 6

The performance of this network should differ per OD-pattern. 'Outer stations', where most of the passengers travel to the outer stations, performs best under this network as both SP services are directly connect the outer station. For 'inner stations', the opposite is true, as the middle station is just connected by one SP service. This results in a mandatory transfer for most of the passengers. This network could perform better with an extra transfer possibility at the center of the line.

5.2.7 Network 7

Network 7 introduces a zone sprinter. This sprinter operates along the whole line, but only stops at every station for one section of the line. This increases the speed of the SP services but deteriorates the connections from on side of the network to the other by adding a mandatory transfer to those trips. Three different transfer stations are present in this network. A visual representation of network 7 could be found in Figure 5.9.

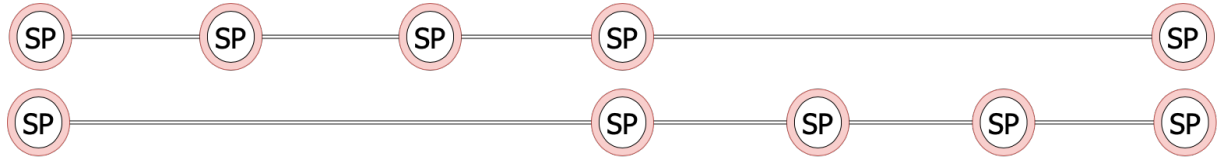

Figure 5.9: Network 7

Network 7	4 SP 4 IC	8 SP 8 IC	10 SP 10 IC
Perceived [min]	136600	99100	91600
Actual [min]	114200	76700	69200
Transfers [pax]	1600	1600	1600

Table 5.18: Travel times and transfers for different frequencies under network 7

The travel times decrease by increasing the frequencies of the services. Due to the presence of transfers in this variant, the perceived and actual travel times differ. The amount of transfers is 1600 for every run.

Network 7	Equal	Outer stations	Inner stations
Perceived [min]	136600	127500	127440
Actual [min]	114200	113500	108400
Transfers [pax]	1600	1000	1360

Table 5.19: Travel times and transfers for different OD-patterns under network 7

The differences in travel times and the amount of transfers for every OD-patterns are relatively low under this network. The network connects both the outer stations and the station in the center, resulting in less mandatory transfers, as these important stations are connected by both SP services.

5.2.8 Conclusion

Now that different frequencies and demand patterns are used as an input for the model, some conclusions could be derived from the outcomes. For all networks applies that increasing the frequency results in lower travel times, as a higher frequency imposes shorter travel times. Additionally, the runs where higher frequencies for SP services than IC services were used, performed better than runs where opposite was applied. The SP service stops at every station, thus every OD-pair benefits from a higher frequency, resulting in more passengers benefit from this frequency increase. In general, for all combinations of frequencies, network 1, 3 and 4 perform best on the both perceived as actual travel times, implying that less Intercity stations is more beneficial for the system. While increasing the frequencies, thus reducing waiting times, of the zone and skip-stop sprinter, their performance approximates the performance of the other variants. Yet, it should be addressed that those networks are operated with two SP services with the same frequency and the other networks are operated with one SP service and an IC service.

When considering different OD-patterns in the model, the best scoring networks do not seem to differ that significantly in terms of perceived and actual travel times. For all three different OD-patterns - only differing in order - network 1, 3 and 4 are the most beneficial variants. The OD-patterns do show an effect in the amount of transfers, 'outer stations' shows the least amount of transfers for network 6 & 7. Variant 7 is more beneficial in perceived travel time for 'inner stations', as both SP-service call at station D with the highest attraction. Network 6 scores less beneficial in perceived travel time, as only one SP service calls at station D.

5.3 VERIFICATION

Model verification is a way to check if the mechanisms in the model are implemented correctly (Sargent, 2013). Two types of verification are distinguished, static and dynamic testing (Sargent, 2013). Static testing is for example based on structured walkthroughs and correctness proofs. On the other hand, dynamic testing based on testing under different conditions. One of the dynamic techniques is checking the input and output relations, while changing the input (Sargent, 2013).

The input and output relations is tested in this section. First, the goal of the model will be addressed. Subsequently, the working mechanism of the model and the input is explained. Thereafter, adjustments are made to check whether the outcomes meet the expectations.

The mechanism assigning passengers to specific routes is based on the logit principle, as presented in Equation 4.6. Which accounts for the difference in travel time. It assigns the highest share to the shortest route and proportional to successive routes based on the relative difference in travel time.

Given that the shortest route is in most cases a direct connection, as most of the networks are not branched, and the transfer penalty that is included on transfer links, the amount of transfers in the ridership models will be fairly low. Due to the transfer penalty, the transfers will be more present in this model, when either the amount of stations will be increased or the distances between stations is increased. Both have an effect of increasing the travel time, which will imply that the transfer penalty will be a relatively smaller part of the total travel time. Thus, this will provide a higher probability of passengers being assigned to routes with transfers. Increasing the amount of stations will also provide extra transfer possibilities, if more IC stations are added to the line.

Looking at the outcomes in the Section 5.2, most of the variants lack in transfers. Except for variants where certain origins and destinations are not directly connected, as for these pairs transfers are required for trips between these stations. This is in line with the statement made previously.

The lack of transfers could be assigned to different factors. First, the choice parameter (β_r) could be chosen to be very sensitive on travel times. The values for β_r could vary between zero and one, values approximating one result in a higher share for the shortest route, while values near zero result in a wider distribution. Secondly, the chosen value for the transfer penalty could be too high, as this value depicts the passengers' resistance to routes with transfers. A route with a transfer should compensate the transfer penalty by having other travel time benefits. Thirdly, the distances between stations and the amount of stations is not sufficient enough. When the distances between the stations is relatively low, the trip lengths on the networks are lower too. This means that the transfer penalty is a relative big part of the travel time, making routes with transfers less attractive. In reality, passengers are more willing to include a transfer when making longer trips instead of shorter trips. Increasing the amount of stations, increase the average length of the trips made on the network and add extra transfer possibilities. This results in a higher chance of having routes with transfers in the route set. At last, the amount of passengers in the considered networks could be too low. Passengers are assigned to routes by a logit model, which assigns passengers to the shortest route and proportional to successive routes. Cases can occur, where the routes with transfers have such low values for probabilities, approximating zero, that the amount of transferring passengers remain zero. This is due to the rounding of values in the model, as passengers need to be full integers. In the previous networks, 200 passengers travelled between

every pair of stations. This value is increased to 1000 passengers per station pair for the sensitivity analysis in Section 5.3.1

5.3.1 Sensitivity analysis

In the ridership models, some parameters will be used which have a great effect on the way the choices of passengers are modelled. These parameters could not be changed by the Dutch Railways, but could differ over time, as they might be part of the nature of the passengers. This section will investigate the influence of changes in those parameter on the outcomes of the model.

Choice parameter

As stated previously, one of the reasons in the lack of transfers could be the chosen value for the choice parameter. This parameter determines the sensitivity for travel time changes. The initial chosen value for the chose parameter was 0.4. To check the working mechanisms of the model, the choice parameter is varied in four different values, 0,4, 0,2, 0,1 and 0,05.

The transfers over these four values for the choice parameter remained the same over every network, as is visible in Table B.5. This implies that the other aspects could still be limiting the outcomes of this model. The choice parameters should not only be seen in the amount of transfers, but could also have implications on the total travel time of the passengers in the system. In Table B.6, an increasing total travel time for lower values for β could be seen. This implies that passengers are also assigned to slightly slower routes. For the following runs, a value of 0,05 is used to avoid that this parameter could be a limiting factor in checking the working mechanisms of the model.

Transfer resistance

Now that the performance of the model for different values for the choice parameter have been tested, the transfer resistance is varied. The amount of transfers for different values for the transfer resistance seem not to change, except for network 1. Network 1 shows an increase of transferring passengers for a transfer resistance of 1 minute. It should be expected Differing the transfer resistance should not have any effect on the actual travel time as it is not included in the calculations for the actual travel time. For the following runs, the transfer resistance is held on 1 minute.

Distances

The distance between successive stations is varied with different values. The amount of transfers per network are given in Table B.9. While all other networks show no changes in the amount of transfers, network 1 shows increasing values for decreasing distances. This contradicts previous statements about increasing station distances resulting in more transfers. Network 1 knows transfer stations in the outermost stations, station A and G. The transfers occurring in this network are mostly from station B to G and from F to A. Shorter distances result in increasing attractiveness for passengers to opt for a route with the faster IC service to their destination. While decreasing the distances, this phenomenon also accounts for extra passengers from station E to G and from E to A.

5.3.2 Bigger network: Station A to M

In the standard network with 7 stations, from A to G, the amount of transfers was zero for almost every variant. One of the options was due to the limited amount of stations considered. More stations, i.e. longer networks, could result in more observed transfers. To check this statement, the network considered in network 3, as depicted in Figure 5.5, is extended to 13 stations and 1000 passengers per OD-pair are assumed. All other parameters where held similar to the last case of the verification, while running the model. For this network, both the distances, where only a distance of 10 km showed 3781

transfers, and frequencies were varied. The amount of transfers for the varied frequencies are given in Table 5.20.

	4 IC	8 IC	12 IC	4 IC	6 IC
Frequency [# /h]	4 SP	8 SP	12 SP	8 SP	8 SP
Actual travel time [min]	2233925	1734769	1562036	1768143	1753065
Transfers [pax]	0	843	5386	0	24

Table 5.20: Amount of transfers for different frequencies for network 8

The outcomes show an increasing amount of transfers for increasing frequencies. Implying that the waiting time, which is exposed twice to transferring passengers, was a limiting factor. Additionally, a frequency of 4 IC and 8 SP trains and 6 IC and 8 SP trains was used. The latter resulted in more transfers, implying that a big difference in frequencies makes passengers choose the more frequent service initially. At last, to check what a high distance would result to, a distance of 10 km is used simultaneously with a frequency of 12 IC and 12 SP trains. This resulted in 23,526 passengers opting for a route including a transfer. This suggests that both the frequency of the services and the distances could be limiting factors. In smaller extent, the magnitude of the network could be addressed as a limiting factor. The outcomes could differ for different configurations in network design for a network with 13 stations.

5.3.3 Conclusion

Concluding, the model as used in this chapter is not fairly sensitive to changes of the input parameters and is assigning most of the passengers to the shortest routes. For every influencing parameter in the route choice of passengers different values were implemented. Subsequently, values for these parameters were chosen that were not assumed to be limiting the outcomes of the model. At last, only network 1 showed changing amount of transfers with differing values for distances. The lack of sensitivity could either be assigned to the magnitude of the considered networks or to the waiting times, as transferring passengers are exposed to the waiting time twice. When applying the model for a network with thirteen stations, the model remained fairly insensitive while varying the distances. For changing frequencies, the model showed different amount of transfers, identifying this as one of the limiting factors. At last, extreme values for both the distance as the frequency were used and showed an enormous increase in transfers. Implying, that both factors are limiting with the waiting time in a larger extent. The model is used with normal parameters in Chapter 6 and displays non-mandatory transfers when applied to both case studies.

5.4 VALIDATION

After the working mechanisms of the model are tested in Section 5.3, this part will demonstrate the validity of comparing the outcomes of the model with the real world. Two important factors are the amount of transfers and the actual travel time, as this depicts the route choices of the passengers. It is hard to compare the considered network with real world numbers, as the network is relatively short, it is more similar to metro network, and the network is not branched, every OD-pair is directly connected by either one or both of the train services. This results in a real small group of passenger opting for a transfer. In reality, the group of passengers opting for a transfer in that case would be fairly low too, only when the travel time savings weigh up to the disadvantage of a transfer a route with a transfer is chosen. This makes it hard to find comparable network sections where a significant amount of transfers is observed.

The validation based on travel time and mimicking other real life numbers will be done based on the current situations of the case studies as described in Chapter 6. This will be done by discussing

the outcomes of the base situation and the new network variants of the case studies with experts of the Netherlands Railways.

6

CASE STUDIES

This chapter will focus on the qualitative and quantitative analysis of the networks of the case studies. The focus will be on the effect of different variants in network design on the travel times of passengers. Yet, the different variants will be assessed on the fleet requirements and infrastructure capacity too. First, the stations along the case studies will be analysed based on the connections to other modalities, their location and the current services calling at that certain station. Secondly, the ridership of the stations are analysed for both case studies. These analysis will be used as an input for the network variants of the case studies. Subsequently, the network variants for the case studies will be quantitatively analysed. The chapter will conclude based on the findings of both case studies.

6.1 NETWORK DESIGN

Changing the stopping patterns of train services can have certain implications for the stations that are connected by these services. This research focuses on the Intercity and Sprinter services, with their current operations as a starting point.

While upgrading a station to an Intercity status, this station will obtain certain advantages in terms of direct connections and travel time to other stations. The latter counts when the Intercity has a lower stop density than the Sprinter service on that section. Contrary, it slows the Intercity service for the initial Intercity stations. Downgrading a station has the opposite effect, the considered station will obtain certain disadvantages and the remaining Intercity stations will have a faster connection through that service.

A deviation from the current stopping patterns of the Sprinter could be made too, as the Zone and Skip-stop Sprinter. The skip-stop operation in network design is one of several measures that show positive effects on the track capacity (Fröidh et al., 2014). The skip-stop operations imply that trains are not stopping at every station along the line. This can be divided in zones, where trains call at every station in a line segment, or successive stations, where trains stop at alternating stations for a certain segment. Additionally, these types of Sprinters impose travel time savings to certain important stations in the network.

Chapter 5 showed that the more Intercity stations do not always contribute to improving the travel times.

6.2 STEDENBAAN ZUID

The Stedenbaan Zuid between Dordrecht and Den Haag Centraal counts 14 stations over a length of about 45 kilometres. The line is located in the province of South-Holland, in one of the more urbanised regions of the Netherlands and connecting the bigger cities of Rotterdam and Den Haag. Seven stations on the line, thus half of all stations, have an IC status. Most of the IC stations are near between Rotterdam and Den Haag. Two stations are a part of international services, where Rotterdam is a stopping station for every international train to Belgium and Den Haag HS has a few international trains passing it every day.

The connections with BTM modes are sufficient, as most of the stations are connected to one of the different modes, except for Delft Campus. Additionally, four of the stations are connected by metro, which can account for more passengers from the outer city regions. Besides, most of the stations do

provide access to the tram services of Rotterdam or Den Haag. Some stations do play a significant role in the accessibility of the region its laying in by either regional busses, tram or metro.

The stations at the Stedenbaan Zuid provide four different stations which function as a junction providing transfers among different lines on the railways. These stations are Dordrecht, Rotterdam Centraal, Den Haag HS and Den Haag Centraal. These stations could be more important places for transfers by passengers as they provide more possibilities for destinations to reach. Until recently, Schiedam Centrum functioned as a junction too. Yet, the line to Hoek van Holland has been converted to a metro line.

6.2.1 Ridership

The ridership per station, i.e. the alighting and boarding passenger, are also an important factor while assessing the importance of the stations. In this section, the relative production and attraction of both lines are analysed. Eventually, the relative production will be used to fill the OD matrix for the calculations of the model. During the analysis, only the stations of each case study line have been included - the passengers travelling through the lines are not included. The values for the Stedenbaan Zuid are shown in Figure 6.1.

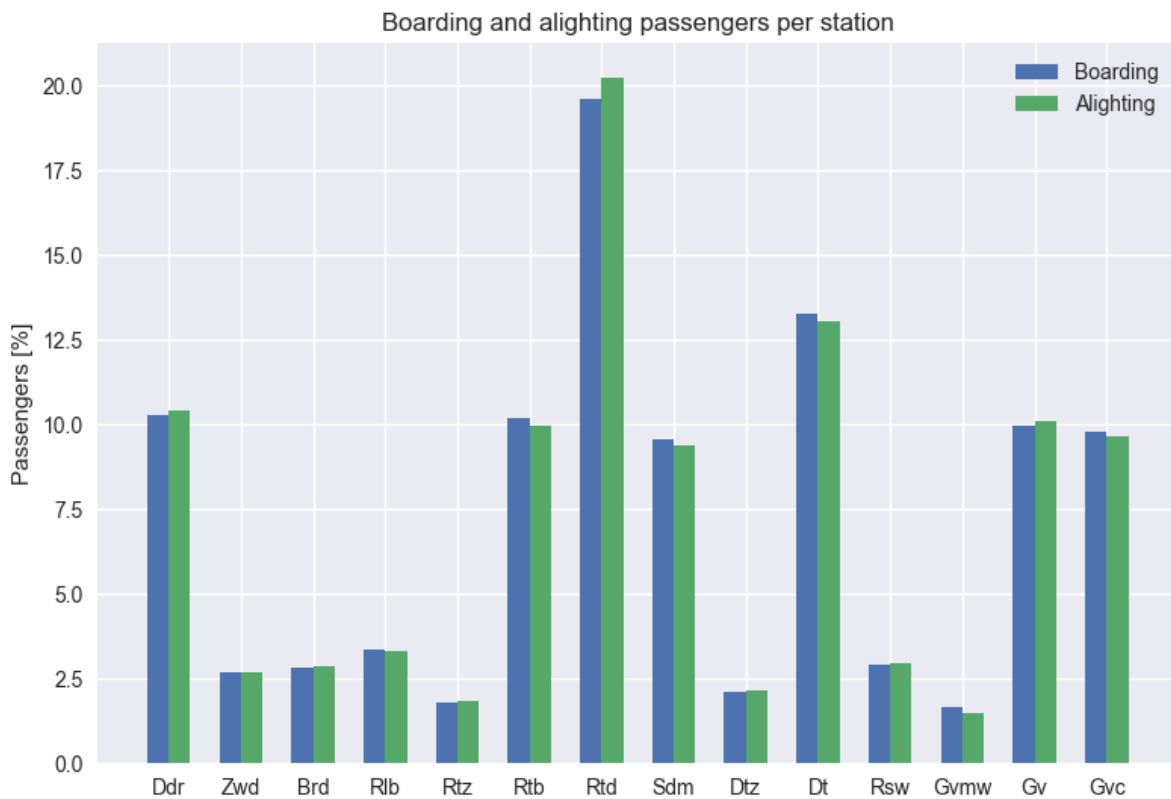

Figure 6.1: Stedenbaan Zuid

While considering the relative ridership of the stations along the Stedenbaan Zuid, the stations with an IC status show a significantly higher ridership. This are also the stations functioning as an junction with several lines. Rotterdam Centraal has the highest relative ridership with a value of 19,6%, followed by Delft with a value of 13,28% and Dordrecht with a value of 10,2 %. Both Den Haag Centraal and Den Haag HS show values of around 10%, which is much lower than Delft. Due to the selection of the stations of the case studies only, the through travelling passengers and passengers destined for

Station	BTM	Train services	Function	KIS
Dordrecht	Local busses Regional busses	Intercity Sprinter	Junction with several lines	1
Zwijndrecht	Local busses Regional busses	Sprinter	Line	4
Barendrecht	Local busses Regional busses	Sprinter	Line	4
Rotterdam Lombardijen	Local busses Regional busses Tram	Sprinter	Line	5
Rotterdam Zuid	Local busses	Sprinter	Line	5
Rotterdam Blaak	Local busses Tram Metro	Intercity Sprinter	Line	3
Rotterdam Centraal	Local busses Regional busses Tram Metro	International IC Direct Intercity Sprinter	Junction with several lines	1
Schiedam Centrum	Local busses Regional busses Tram Metro	Intercity Sprinter	Line	3
Delft Campus		Sprinter	Line	5
Delft	Local busses Regional busses Tram	Intercity Sprinter	Line	2
Rijswijk	Local busses Regional busses Tram	Sprinter	Line	4
Den Haag Moerwijk	Local bus Tram	Sprinter	Line	5
Den Haag HS	Local busses Tram	International Intercity Sprinter	Junction with several lines	2
Den Haag Centraal	Local busses Regional busses Tram Metro	Intercity Sprinter	Junction with several lines	1

Table 6.1: Current situation on the Stedenbaan Zuid

stations outside of the case studies. This value implies the importance of the station within the case studies. In other words, the unexpected lower scoring stations could be of a greater importance for passengers traveling outside the defined case studies. The stations with the lowest values are Den Haag Moerwijk and Rotterdam Zuid with values of respectively 1,65% and 1,81%. This can be due to proximity of better connected stations in the area. The distribution of the ridership per station could be resulted from the underlying transport systems, the proximity of the stations and the amount of Intercity stations along this line, implying that the network characteristics do influence the demand characteristics.

6.2.2 Results

In this section, the results of the different variants of the Stedenbaan Zuid will be presented. First, the current situation will be analysed by use of the model. Subsequently, the new variants in network design will be introduced and analysed.

6.2.3 Current situation

The current network design for the Stedenbaan Zuid will be used as a starting point for the interpretation of the outcomes of the model. The network with the stopping patterns as described in Table 6.1 will be used. The OD-matrix used as a input for the model, is derived from this situation. Thus, it depicts the station choice under this network design. A visual presentation of the current network is shown in Figure 6.2.

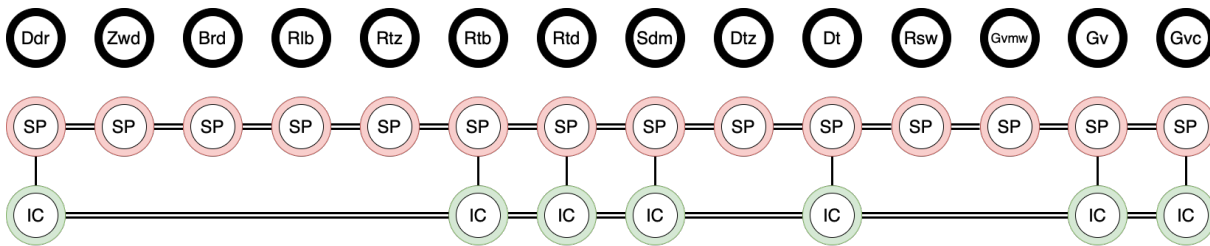

Figure 6.2: Current network design on the Stedenbaan Zuid

Based on the network as presented in Figure 6.2, the model generated the outcomes as presented in Table 6.2. The perceived and actual travel time are given as a total, mean and ratio. The total travel times are the travel times of all passengers combined, the mean travel times are the total travel times divided by the amount of passengers and the ratio is the total travel time of this variant divided by the total travel time of the base variant. The amount of transfers is calculated by summing the amount of passengers opting for a route with a transfer.

Base variant	total [min]	mean [min/pax]	ratio [-]
Perceived travel time	1.812.723	23,00	1,0
Actual travel time	1.812.723	23,00	1,0
Transfers [pax]	0		

Table 6.2: Results for the base situation of the Stedenbaan Zuid

The perceived and actual travel time is in total 1.812.723 minutes and is as average 23 minutes per passenger. The ratio for both travel times is equal to one as it is only compared to the base variant.

Base variant	Cycle time [s]	Fleet [#]
Sprinter	3892	4,32
Intercity	3141	3,49

Table 6.3: Required fleet for the current situation on the Stedenbaan Zuid

To determine the costs of operating a certain timetable, the amount of vehicles required and the run times per service are analysed per variant in network design. Table 6.3 shows the amount of vehicles per service required to operate a timetable given the frequencies and stopping patterns of the services. The values should be interpreted by rounding them up to a full integer. The base variant requires five sprinters and four IC vehicles to operate on the current network design. In reality, especially for IC services, the amount of stations served by a train service is higher than during this research. The figures shown are only representing effects given the considered network, without interaction with other parts of the network.

Base variant	Sprinter	Intercity
Run time [s]	3292	2541

Table 6.4: Run times for the current situation on the Stedenbaan Zuid

The difference in run time for the services operated determine the amount of vehicles that are able to pass a certain track section in a given time period. As the difference in speed between the trains decrease, the more trains could pass a track section. Table 6.4 shows the run times for both services given their stopping patterns in the current situation. The IC service is almost one-third faster than the SP service.

6.2.4 Minimal IC

The first variant on the network design of Stedenbaan Zuid, is a version where the amount of IC station is reduced to three in total. These three IC stations are located in Dordrecht, Rotterdam Centraal and Den Haag Centraal. Stations with a lot of alighting and boarding passengers, like Delft and Den Haag HS are excluded as IC stations. A visual presentation of the network design of 'minimal IC' is shown in Figure 6.3.

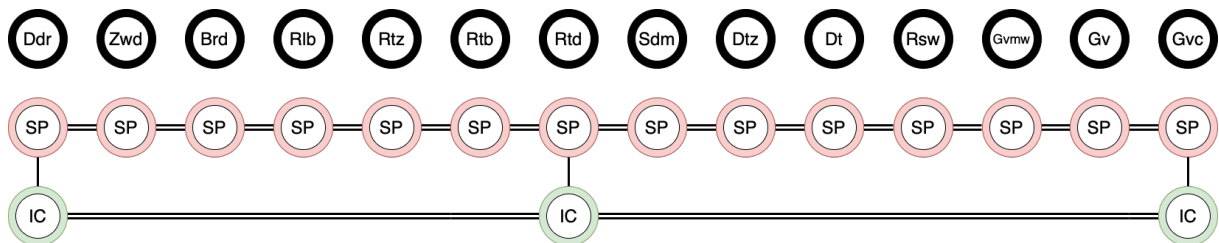

Figure 6.3: Stedenbaan: Minimal IC

Variant 1	total [min]	mean [min/pax]	ratio [-]
Perceived travel time	1.936.384	24,57	1,07
Actual travel time	1.936.356	24,57	1,07
Transfers [pax]	2		

Table 6.5: Results for 'minimal IC' of the Stedenbaan Zuid

The perceived travel time is in total 1.936.384 for all passengers combined and is as average 24,57 minutes per passenger. The actual travel time just slightly differs due to the low amount of transfers for

this variant. Both the perceived as the actual travel time increased with about 7% compared to the base variant. In total two passengers op for a route with a transfer. These transfers occur for Zwijndrecht - Den Haag HS and vice versa.

Compared to the current situation, this variant differs the most where the stations had lost their IC status. These stations are Rotterdam Blaak, Schiedam Centrum, Delft and Den Haag HS. In Figure 6.4, the change in travel time between every origin and destination station is given, compared to the current situation. For the calculation, the travel time of the shortest route is used for both networks.

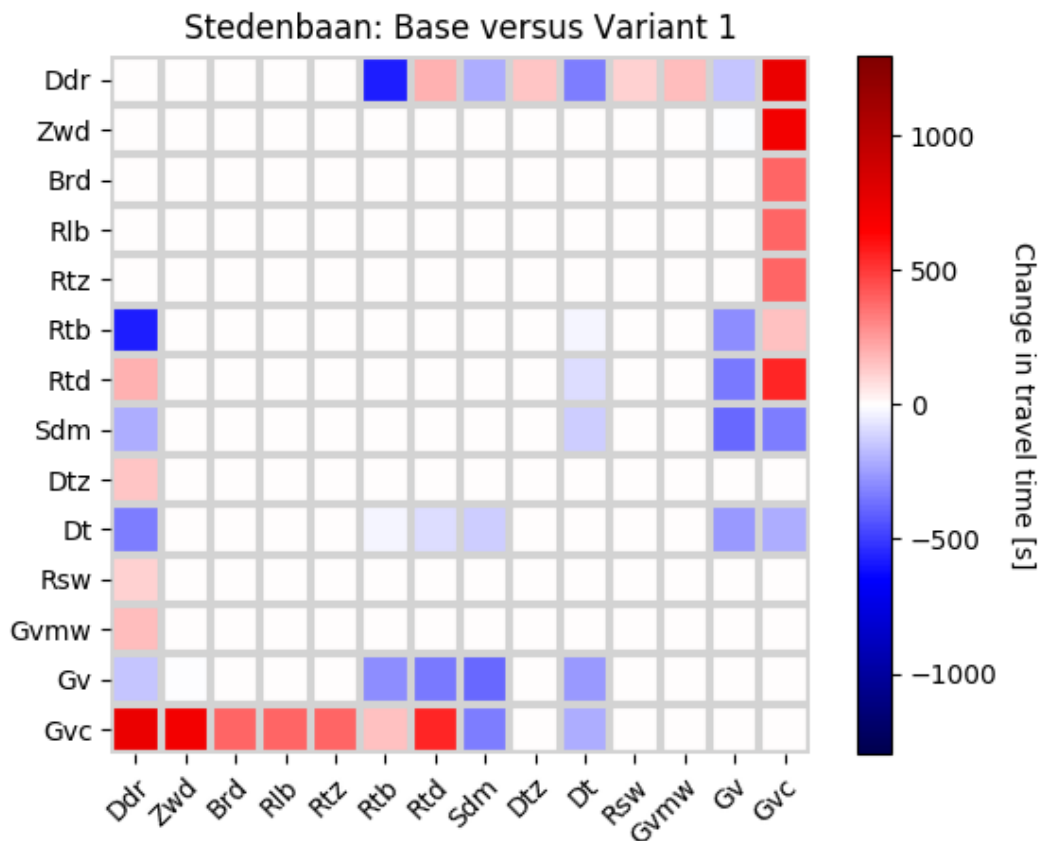

Figure 6.4: Stedenbaan: Base versus 'minimal IC'

The reduction in the amount of IC stations has a clear positive effect on the OD-pairs with both stations with an IC-status, as the travel time between those stations clearly drop in the new network design. Contrary, the stations which lost their IC-status show a increase of travel time mostly to stations with an IC-status, as the travel time between those stations was lower in base situation. Where, the travel time between Rotterdam Blaak and Dordrecht is affected the most. Remarkably, this variant in network design is beneficial for OD-relations of some stations without an IC-status. The travel time between Zwijndrecht and Den Haag Centraal drastically changes. A faster connection between Dordrecht and Den Haag Centraal is beneficial for the passengers between Zwijndrecht and Den Haag Centraal too. In smaller extent, this principle also accounts for stations as Barendrecht, Rotterdam Lombardijen, Rotterdam Zuid to Den Haag Centraal.

Base variant	Cycle time [s]	Fleet [#]
Sprinter	3892	4,32
Intercity	2342	2,60

Table 6.6: Required fleet for 'minimal IC' on the Stedenbaan

The required amount of vehicles per service for 'minimal IC' are given in Table 6.6. This network variant requires five sprinters and three intercity vehicles. The amount of intercity vehicles needed is reduced by the shorter cycle time of the IC service due to less stops.

Base variant	Sprinter	Intercity
Run time [s]	3292	1741

Table 6.7: Run times for 'minimal IC' on the Veluwelijn

Table 6.7 shows the run times for both train services. As the stopping patterns of the SP service did not change its run time will be the same as in the current situation. Meanwhile, the IC service has less stops, making that service quicker. This result in a significantly faster IC service. As the run time differences increase compared to the base variant, the track capacity significantly drops in this variant.

6.2.5 Important nodes

For network design 'important nodes', IC-statuses are assigned to stations either functioning as a transfer junction or with a high share in alighting and boarding passengers. This resulted in IC-stations at Dordrecht, Rotterdam Centraal, Delft, Den Haag HS and Den Haag Centraal. Figure 6.5 shows a representation of this new network design.

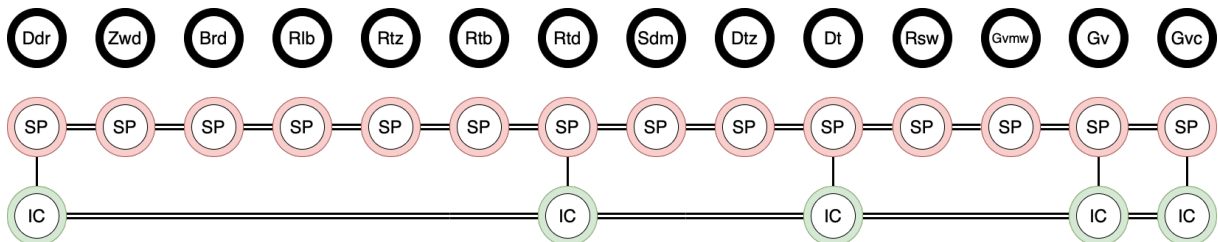

Figure 6.5: Stedenbaan: Important nodes

Variant 2	total [min]	mean [min/pax]	ratio [-]
Perceived travel time	1.825.354	23,16	1,01
Actual travel time	1.792.958	22,75	0,98
Transfers [pax]	2314		

Table 6.8: Results for 'important nodes' of the Stedenbaan Zuid

The perceived travel time is in total 1.825.354 minutes for all passengers combined and is as average 23,16 minutes per passenger. The actual travel time is in total 1.792.958 minutes and has a mean of 22,75 minutes per passenger. These values approach the values of the base variant more than the other variants. This results in a ratio for perceived travel time of 1,01 and for the actual travel time is 0,98. In terms of actual travel time, this variant is performing better than the base variant, implying that more people are having a shorter actual travel time than longer travel times for this network design.. The amount of passengers opting for a route with a transfer is 2314. Overall, this variant in network design approximates the outcomes of the current situation in terms of travel times with more transfers.

The transfers are mostly occurring for Dordrecht, Zwijndrecht and Barendrecht to the range of stations between Delft Campus and Den Haag Centraal. For some of the cases Delft is a strategic transfer point, for other cases travelling from Zwijndrecht and Barendrecht to Dordrecht is more beneficial due to the fast, direct connection to Delft and Den Haag HS and Centraal.

This variant in network design will result in a slightly faster IC service by excluding Rotterdam Blaak and Schiedam Centrum. The remaining IC stations will benefit from this faster service. Figure 6.6 shows the change in travel time between every pair of stations compared to the base situation.

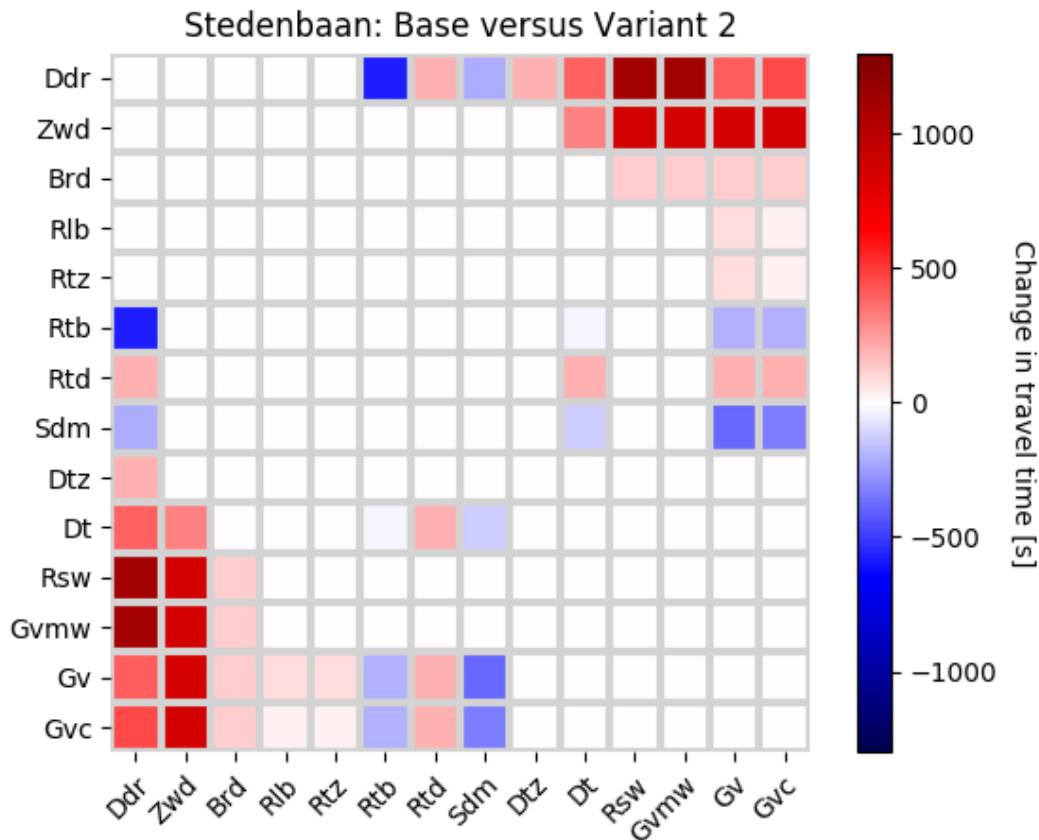

Figure 6.6: Stedenbaan: Base versus 'important nodes'

This variant in network design is mostly beneficial for trips between Dordrecht and Rijswijk or Den Haag Moerwijk. These trips will be reduced in travel time due to the faster service between Dordrecht and Delft, where most of the travellers will transfer for their destination. Rotterdam Blaak and Schiedam Centrum are stations where the travel times increase, especially from and to the IC stations. The trips between Dordrecht and Rotterdam Blaak are affected the most. Again, this variant show benefits for Zwijndrecht due to the faster connection from Dordrecht and to the other IC stations.

Base variant	Cycle time [s]	Fleet [#]
Sprinter	3892	4,32
Intercity	2742	3,05

Table 6.9: Required fleet for 'important nodes' on the Stedenbaan Zuid

In Table 6.9, the required fleet for operating under this network design. The amount of sprinter vehicles are five and four intercity vehicles are needed. The amount of intercity vehicles is similar as

needed in the current situation. Yet, it was expected for this variant to score better than the current situation due to less IC stops. The required amount of intercity vehicles just surpasses the three. By changing some operational parameters as dwell and turn around times, this value could be dropped.

Base variant	Sprinter	Intercity
Run time [s]	3292	2141

Table 6.10: Run times for 'important nodes' on the Stedenbaan Zuid

The run time of both services are shown in Table 6.10. Again, the SP service is operated similar as in the base variant. The IC service is faster than in the current situation and slower than in variant 1. With a run time of 2141 seconds, it will result in a track capacity between those variants.

6.2.6 Zone sprinter

This network design introduces a new concept of a zone sprinter. This sprinter only calls at stations on a certain section of the network. All sprinters call at the stations at IC stations too, this results in a faster connection to IC stations from the sprinter stations. The network for 'zone sprinter' is shown in Figure 6.7.

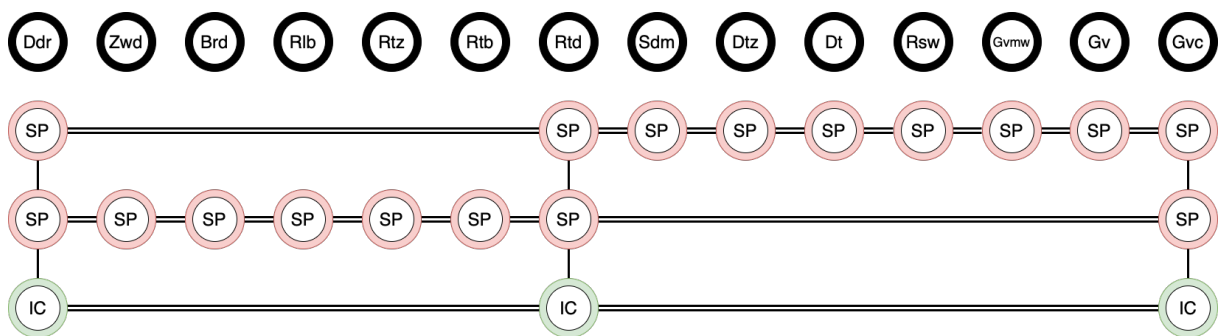

Figure 6.7: Stedenbaan: Zone sprinter

Variant 3	total [min]	mean [min/pax]	ratio [-]
Perceived travel time	2.001.332	25,40	1,10
Actual travel time	1.894.778	24,04	1,05
Transfers [pax]	7611		

Table 6.11: Results for 'zone sprinter' of the Stedenbaan Zuid

The perceived travel time is in total 2.001.332 minutes and has a mean value of 25,40 minutes per passenger. The actual travel time has a value of in total 1.894.778 minutes and is in average 24,04 minutes per passengers. The relatively high difference between the perceived and actual travel time can be explained by the amount of transfers present in this variant. The ratio for perceived travel times shows an increase of approximately 10% compared to the base variant, which makes this variant less attractive for passengers. The total actual travel time is about 5% higher, meaning that the travel time for some of the passenger is slower in this variant. The amount of passengers opting for a route with a transfer in this variant is 7611. The transfers are occurring on the origin and destination pairs that are not directly connected in this variants.

When considering the IC-connections, this variant should show similar results as 'minimal IC', as exactly the same IC-stations are present. This variant should show more changes on the SP-connections,

as this service significantly differs in this case. In Figure 6.8, the change in travel time per station pair is given compared to the base situation.

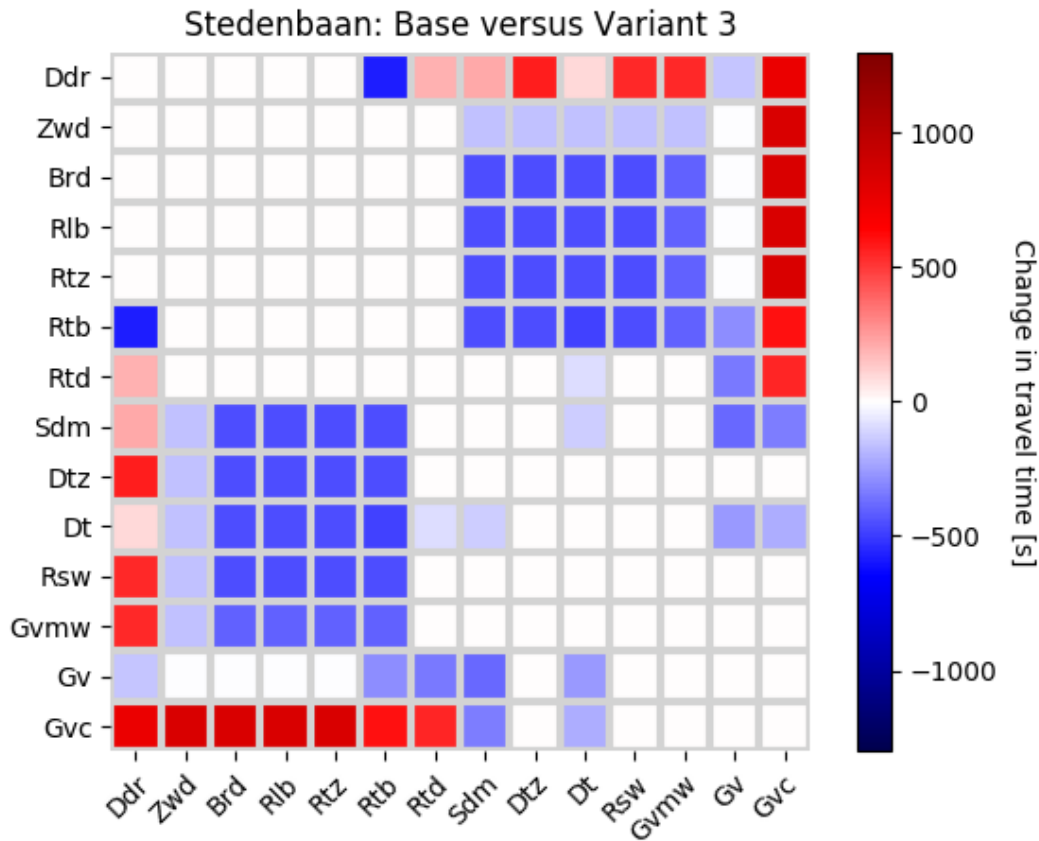

Figure 6.8: Stedenbaan: Base versus 'zone sprinter'

Remarkably, the stations from the one side of Rotterdam Centraal and the other side of Rotterdam Centraal are poorer connected than in the base situation. In this variant of network design passengers have to transfer between SP services when their trip is starting at a SP-station at one side of Rotterdam Centraal to a SP-station to the other side. The stations between Dordrecht and Rotterdam Zuid seem to benefit the most, especially to Den Haag Centraal, in this variant. They will be still directly connected by the SP service, but will skip the stops North from Rotterdam Centraal, resulting in a faster connection to Den Haag Centraal. In the opposite direction, the same phenomenon should be expected. Delft and Schiedam Centrum used to be IC-stations, thus passengers between those stations to Dordrecht do not really benefit from this variant. Trips between Rijswijk, Delft Campus and Den Haag Moerwijk to Dordrecht do benefit from the zone sprinter.

Base variant	Cycle time [s]	Fleet [#]
Sprinter 1	3192	3,54
Sprinter 2	3052	3,39
Intercity	2342	2,60

Table 6.12: Required fleet for 'zone sprinter' on the Stedenbaan Zuid

This variant distinguishes two SP service and one IC service. The required amount of vehicles is shown in Table 6.12. For both SP services four vehicles per hour are needed. The amount of IC vehicles

is three for this network design. This makes it, in terms of fleet requirements, a very demanding variant in network design.

Base variant	Sprinter 1	Sprinter 2	Intercity
Run time [s]	2592	2452	1741

Table 6.13: Run times for 'zone sprinter' on the Veluwelijn

By reducing the amount of stops per SP service, the run times should become lower resulting in less run time differences. Table 6.13 the run times of the services are given. The running time of both SP services are almost equal while the IC service is significantly faster. Yet, the run time difference between the different services is highly reduced compared to variant 1.

6.2.7 Skip-stop sprinter

This variant of network design will include a skip-stop sprinter. The sprinter services will not stop at every successive station, but will call at the stations at IC stations to facilitate transfers. Passengers travelling between successive SP-stations are highly affected, as they will have a mandatory transfer in their trip. In Figure 6.9, a visual representation of this variant in network design is shown.

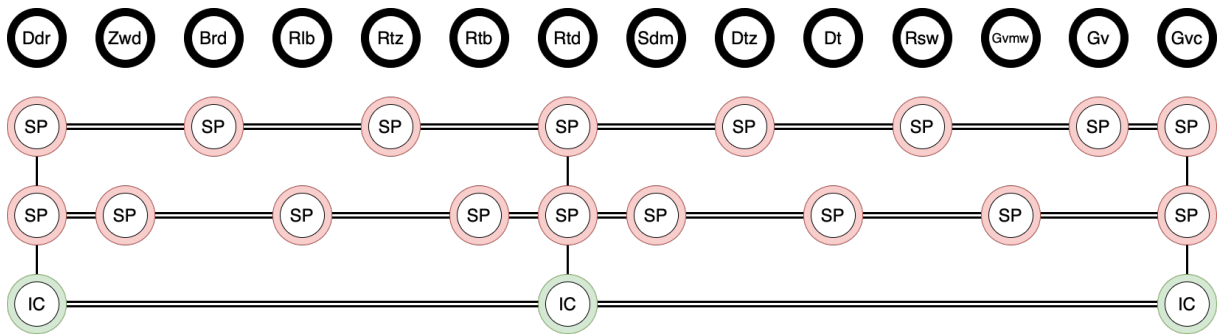

Figure 6.9: Stedenbaan: Skip-stop sprinter

Variant 4	total [min]	mean [min/pax]	ratio [-]
Perceived travel time	2.064.433	26,20	1,14
Actual travel time	1.864.149	23,65	1,03
Transfers [pax]	14.306		

Table 6.14: Results for 'skip-stop sprinter' of the Stedenbaan Zuid

The perceived travel time is in total 2.064.433 minutes for all passengers combined and is as average 26,20 minutes per passenger. The actual travel time is in total 1.864.149 minutes and has a mean of 23,65 minutes per passenger. Compared to the base variant, the total perceived travel time increased with 14% and the actual travel time with 3%. The increase in perceived travel time can be certified by the amount of transfers present compared to the base variant. The increase in actual travel time shows that this variant in network design resulted in slower services for some of the passengers. The amount of transfers taken in this variant is 14.306. The transfers occur on the pairs of stations which are not directly connected in this variant of network design. Figure 6.10 shows the change in travel time between station pairs compared to the base situation.

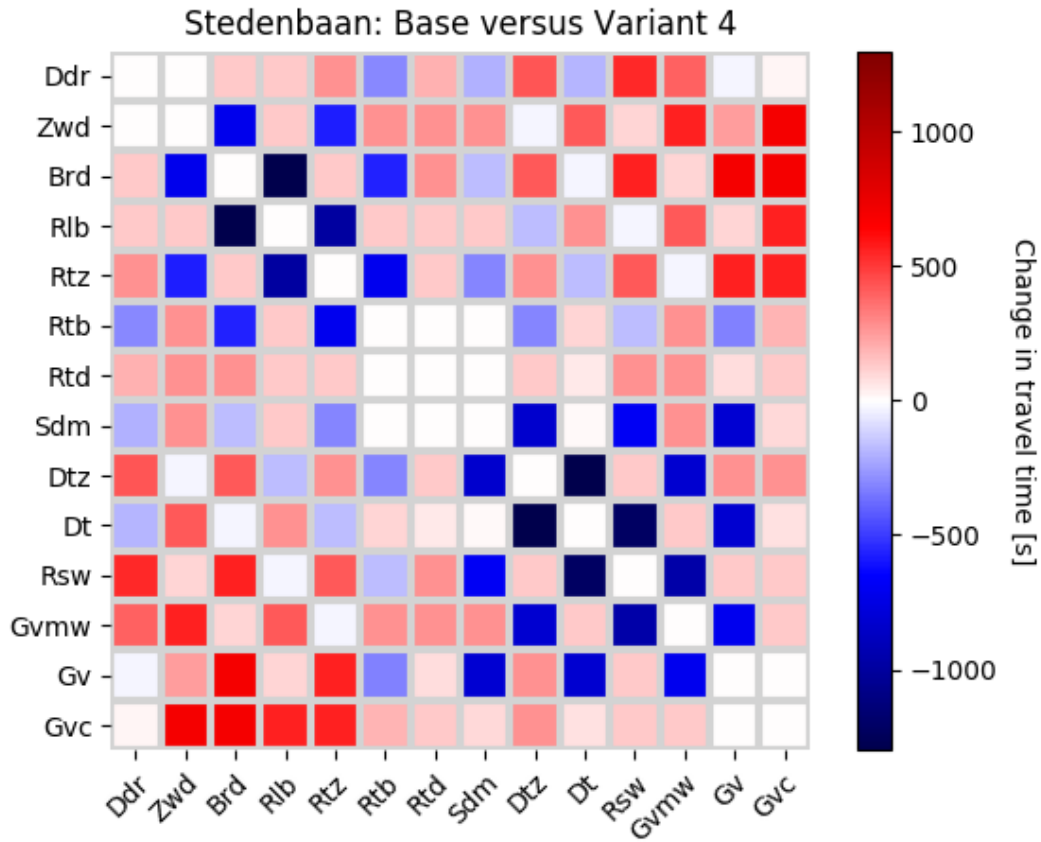

Figure 6.10: Stedenbaan: Base versus 'skip-stop sprinter'

Successive stations are less well connected with each other. Passengers travelling between successive stations do have to transfer at one of the transfer stations. Stations located more in the middle of one of the sections between Dordrecht - Rotterdam Centraal and Rotterdam Centraal - Den Haag Centraal, are affected the most. The travel time between Delft and Delft Campus highly increase. In the previous variants, the travel time between Dordrecht and Rotterdam Blaak was highly affected. In this case, the travel time seems not to be affected at all. The faster SP service seem to equalize the lose of the IC service at Rotterdam Blaak.

Base variant	Cycle time [s]	Fleet [#]
Sprinter 1	3052	3,39
Sprinter 2	3192	3,55
Intercity	2342	2,60

Table 6.15: Required fleet for 'skip-stop sprinter' on the Stedenbaan Zuid

The skip-stop variant for the Stedenbaan Zuid also distinguish two SP services and one IC service. The required fleet is shown in Table 6.15. Once again, the SP services both require four vehicles per hour and the IC service three vehicles per hour.

Base variant	Sprinter 1	Sprinter 2	Intercity
Run time [s]	2452	2592	1741

Table 6.16: Run times for 'skip-stop sprinter' on the Stedenbaan Zuid

The run times for every service is given in Table 6.16. The outcomes are almost similar to the outcomes as for the 'zone sprinter'. The difference in run times between the SP services and the IC service could be reduced by adding more stops in the IC service or erase more stations in the SP services.

6.2.8 Broader context of the variants

The model outcomes are primarily evaluated based on the passengers perspective. The stopping patterns of train services and statuses of stations involve a more complex environment, than just passengers. This section will elaborate in a broader context about the different variants in network design. The interviews with the product manager managers of the Netherlands Railways, as summarised in Section A.4, will be used as input for this section.

The Stedenbaan Zuid includes different transfer hubs among its stations, where Schiedam Centrum is a major metro hub, serving the greater metropolitan area of Rotterdam. This makes that Schiedam Centrum is a very important stop for generating ridership on the main rail network, even more than the figures show in this case. All the new variants in network design exclude two of these hubs, Rotterdam Blaak and Schiedam Centrum, as Intercity stations. This will affect a significant part of the passengers and may increase the pressure on Rotterdam Centraal, which is also serving for trips in other directions.

The Zone and Skip-stop Sprinter could are not preferred as they impose mandatory transfers between several station pairs. The Stedenbaan Zuid has a more spread travel demand, which results in longer travel times for these variants. This is in line with the outcomes of the model.

The addition of an extra layer in the train system, with a fast service just connecting several important stations along the line and providing for longer trips can be beneficial for the system. Currently, a certain faster Intercity is operated between Den Haag Centraal and Eindhoven Centraal twice an hour. This could be accompanied with a service between Rotterdam and a destination more North.

6.2.9 Conclusion

After stating the outcomes for the different variants in network design for the Stedenbaan Zuid, this section will elaborate on conclusions based on these outcomes. The outcomes are presented as an overview in Table 6.17.

Variant	Perceived ratio [-]	Actual ratio [-]	Transfers [pax]	Fleet [trains]	Max. run time difference [s]
Current	1,00	1,00	0	5 SP 4 IC	751
'Minimal IC'	1,07	1,07	2	5 SP 3 IC	1551
'Important nodes	1,01	0,98	2314	5 SP 4 IC	1151
'Zone'	1,10	1,05	7611	4 SP 4 SP 3 IC	951
'Skip-stop'	1,14	1,03	14306	4 SP 4 SP 3 IC	851

Table 6.17: Stedenbaan Zuid: Overview of the outcomes

First, in terms of passenger travel times, none of the new variants outperform the base variant. 'Important nodes' approximates the base variant in these terms. One of the reasons are the demand

characteristics for this section of the train network. The Stedenbaan Zuid shows a more spread distribution in terms of boarding and alighting passengers per station, especially between Rotterdam and Den Haag. When changing an IC status to a SP status, passengers arriving from or destined to this station are immediately affected by a longer travel time than in the current situation. As the share of passengers negatively affected will be relatively high, thus not perform better in these terms. The zone and skip-stop sprinter are not performing that well on the Stedenbaan Zuid. They both show a significant increase in perceived and actual travel times. Yet, the zone sprinter performs a little better than the skip-stop sprinter. This implies that the demand on the Stedenbaan Zuid mostly focuses on nearby stations.

When considering the fleet requirement. The base variant and 'minimal IC' and 'important nodes', respectively require eight, nine and eight vehicles per hour. Where some of the numbers could be reduced by changing operational parameters as dwell and turn around times. The zone and skip-stop sprinter both require eleven vehicles per hour. These figures are a slightly higher than the other variants.

In terms of infrastructure capacity, the base variant is performing well, as the IC service includes lots of stops on this section. 'minimal IC' and 'important nodes' include less IC stops, this results in a faster IC service than in the base variant. The faster IC services impose greater differences between the run times of the SP and IC services, resulting in a lower infrastructure capacity than in the base variant. The zone and skip-stop sprinter include faster SP services. This results in smaller differences between the SP and IC services, thus imposing more homogeneity on the track. The homogeneity could be improved further by including extra IC stops in the network designs of 'zone sprinter' and 'skip-stop sprinter'.

Concluding, given the current origin and destination matrix, the current network design performs best. This is a result of the demand characteristics for this section in the network. Passengers tend to spread among different origin and destination stations, i.e. it is not focused on a few stations. This phenomenon implies that downgrading a station' status will have a relatively high impact on the travel time within the system in total. 'Important nodes' includes stations at junctions and major stations on the line, this variant performs almost similar as the current situation. Yet, some passengers are imposed with a longer travel time, especially from and to Rotterdam Blaak and Schiedam Centrum. 'Zone sprinter' and 'skip-stop sprinter' result in very long travel times due to the demand characteristics on this line. Thus, given the current station choice of passengers. i.e. the original OD-matrix, the current situation of network design performs best. In terms of fleet requirements, all variants require between eight to eleven vehicles per hour to be operated. For 'zone sprinter' and 'Skip-stop Sprinter', where two Sprinter services and one Intercity service are included, the requirements are not much higher than the versions with just one SP and one IC service. Additionally, the Zone and Skip-stop Sprinters result in a higher service on the IC stations in both frequency and travel time. Subsequently, these variants decrease the differences in run time between the services, increasing the infrastructure capacity. The demand characteristics on this line provide for less beneficial outcomes of new variants in network design, while the zone and skip-stop sprinter impose benefits in terms of fleet requirements and infrastructure capacity.

6.3 VELUWELIJN

The current situation of the Veluwelijn is analysed in terms of connections with BTM modes, the train services stopping at the stations, their function in the network and the KIS-classification of the Netherlands Railways and is shown in Table 6.18.

The Veluwelijn is a line in the more central regions of the Netherlands, connecting three somewhat bigger cities. These cities are Utrecht, Amersfoort and Zwolle, which are the only three cities with a station with an IC status. The line is approximately 88 kilometres long with 15 stations located along the line. Utrecht Centraal (to Cologne and Dusseldorf) and Amersfoort Centraal (to Berlin) are both

stations where international trains are calling. The Veluwelijn is also an important line for connecting the Randstad to the Northern regions of the Netherlands.

While observing the BTM connections at the stations of the Veluwelijn, the absence of the metro connections is remarkable. Additionally, Utrecht Centraal is the only station connected by the tram. This region is highly dependent on both local and regional busses. This substantiated the statement that the Veluwelijn is located in less urbanised region of the Netherlands. Furthermore, all of the stations are serviced by either local or regional busses (or both). The local busses are more important for use within the municipality and the regional busses are more important for longer trips into the region. Naturally, the bigger stations as Utrecht Centraal, Amersfoort Centraal and Zwolle have a more regional spread. Yet, other smaller stations along this line are more important for regional accessibility too.

Remarkably, the Veluwelijn has five station functioning as junctions with several lines. These are not only the larger stations of Utrecht Centraal, Amersfoort Centraal and Zwolle. Utrecht Overvecht and Den Dolder, both Sprinter stations, are functioning as junctions with several lines. These stations might play a less significant role for transfers in the trips of the passengers than the bigger cities on the line.

Station	BTM	Train services	Function	KIS
Utrecht Centraal	Local busses Regional busses Tram	International Intercity Sprinter	Junction with several lines	1
Utrecht Overvecht	Local busses Regional busses	Sprinter	Junction with several lines	5
Bilthoven	Local busses Regional busses	Sprinter	Line	4
Den Dolder	Regional busses	Sprinter	Junction with several lines	4
Amersfoort Centraal	Local busses Regional busses	International Intercity Sprinter	Junction with several lines	1
Amersfoort Schothorst	Local busses Regional busses	(Intercity) Sprinter	Line	3
Amersfoort Vathorst	Local busses Regional busses	Sprinter	Line	5
Nijkerk	Local busses Regional busses	Sprinter	Line	4
Putten	Regional busses	Sprinter	Line	4
Ermelo	Regional busses	Sprinter	Line	4
Harderwijk	Local busses Regional busses	Sprinter	Line	4
Nunspeet	Regional busses	Sprinter	Line	4
't Harde	Local busses Regional busses	Sprinter	Line	4
Wezep	Regional busses	Sprinter	Line	4
Zwolle	Local busses Regional busses	Intercity Sprinter	Junction with several lines	2

Table 6.18: Current situation on the Veluwelijn

6.3.1 Ridership

The ridership per station, i.e. the alighting and boarding passenger, are also an important factor while assessing the importance of the stations. In this section, the relative production and attraction of both lines are analysed. Eventually, the relative production will be used to fill the OD matrix for the calculations of the model. During the analysis, only the stations of each case study line have been included - the passengers travelling through the lines are not included. The values for the Veluwelijn are shown in Figure 6.11.

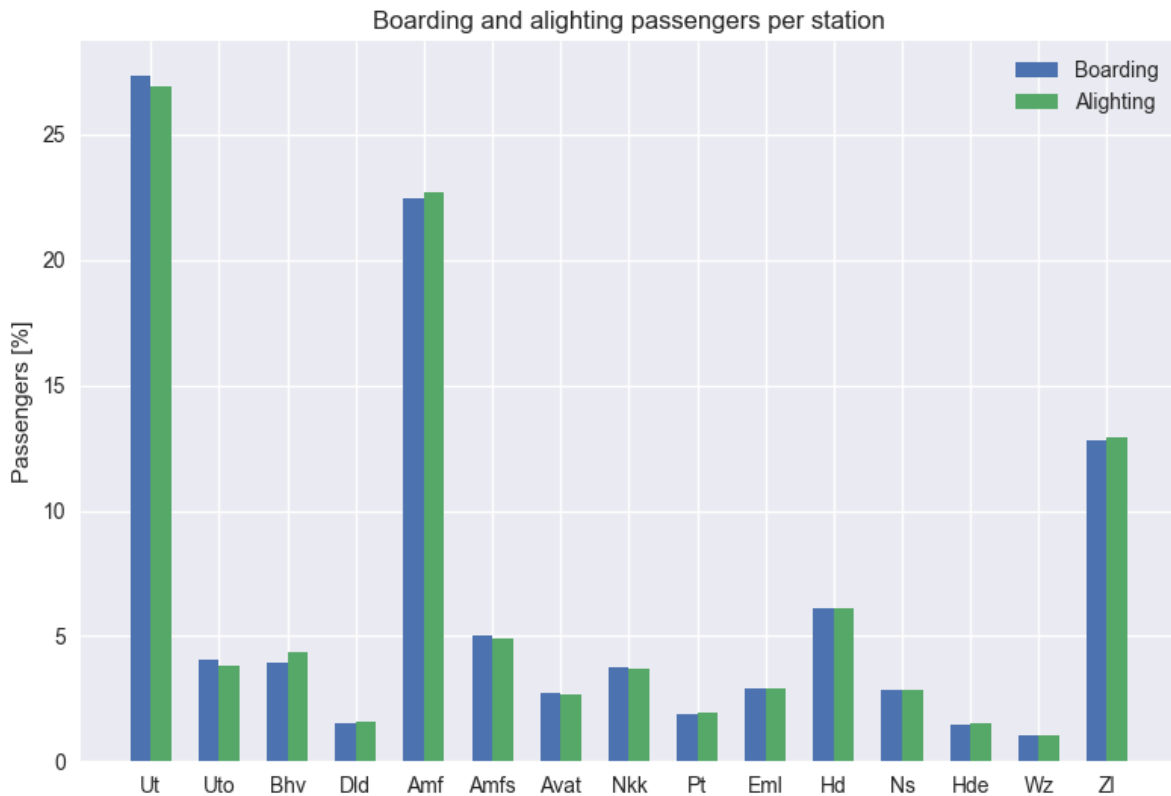

Figure 6.11: Veluwelijn

The Veluwelijn shows even more diverse values while considering the statuses of stations. The IC stations of Utrecht Centraal, Amersfoort Centraal and Zwolle show values of respectively 27,34%, 22,48% and 12,48%, which are by far the highest values for the Veluwelijn. The station following these stations with a value of 6,08% is Harderwijk, which is the highest value not located in the urban regions of Utrecht, Amersfoort and Zwolle. Due to the high ridership counts and the location somewhere half between Amersfoort Centraal and Zwolle, in station count, this could be a promising candidate for a status upgrade or possibly an important transfer location.

6.3.2 Results

This section will show the outcomes of the different types of network design on the Veluwelijn. First, the outcomes of the current network design will be shown. Subsequently, the new variants will be explained and elaborated on their outcomes.

6.3.3 Current situation

The current situation in network design as described in Table 6.18 is used as the base variant for the model input. This variant will be used as a starting point for the interpretation of the outcomes of the model for other variants in network design. The alighting and boarding table, i.e. the OD-matrix, that is used for this line is obtained from a network design similar to this. Thus, it depicts the station choice under this network design. In Figure 6.12 the current network design is presented.

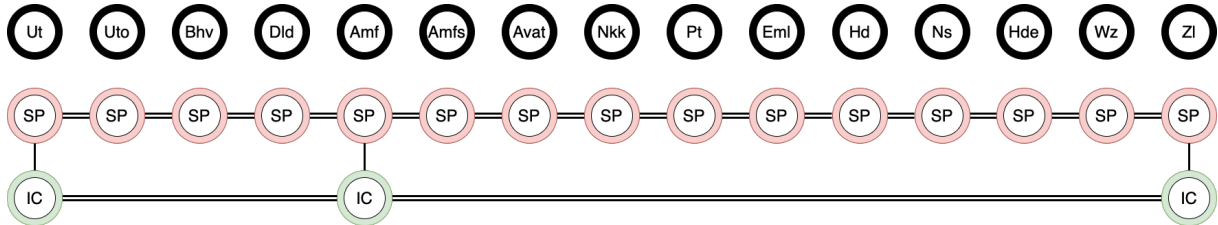

Figure 6.12: Veluwelijn: Current situation

Base variant	total [min]	mean [min/pax]	ratio [-]
Perceived travel time	1.054.017	28.06	1,0
Actual travel time	1.050.811	27,97	1,0
Transfers [pax]	229		

Table 6.19: Results for the current situation on the Veluwelijn

The perceived travel time is in total 1.054.017 minutes and shows an average of 28.06 minutes per passenger. For the actual travel time a value of total 1.050.811 minutes and a mean of 27,97 minutes per passengers is obtained. The ratio for both the perceived as the actual travel time are set to 1,0 as this is the network design where other variants will be compared with. The amount of transfers found in this variant is 229. The transfers are occurring for the pairs Utrecht Centraal - Wezep, implying a transfers at Zwolle, and from Utrecht Overvecht, Bilthoven and Den Dolder to Zwolle, implying transfers at Utrecht Centraal. On the mentioned pairs transfers are occurring in both ways.

Base variant	Cycle time [s]	Fleet [#]
Sprinter	5340	5,93
Intercity	3463	3,85

Table 6.20: Required fleet for the current situation on the Veluwelijn

While running the model with the current network design implemented, the required amount of vehicles per service is calculated and given in Table 6.20. Six sprinter trains and four intercity trains are needed.

Base variant	Sprinter	Intercity
Run time [s]	4740	2863

Table 6.21: Run times for the current situation on the Veluwelijn

The run times of both services for the current situation are given in Table 6.21. While comparing both run times, it can be concluded that the SP service is significantly slower than the IC service. This is not very beneficial for the infrastructure capacity.

6.3.4 IC Harderwijk

This is the first variant of network design for the Veluwelijn. For this variant, a status upgrade is chosen for Harderwijk. After Utrecht Centraal, Amersfoort Centraal and Zwolle, Harderwijk has most of the alighting and boarding passengers of the stations located on this line. Besides, Harderwijk is located rather strategically in the network, thus stations around are likely to profit too from the upgrade. Other stations as Utrecht Overvecht and Bilthoven are located at junctions, so could accommodate transfers for other destinations. Yet, due to the characteristics of the transport demand on this line and the low amount of alighting and boarding passengers for these stations, they are not chosen for an upgrade. The visual representation of this variant in network design is shown in Figure 6.13.

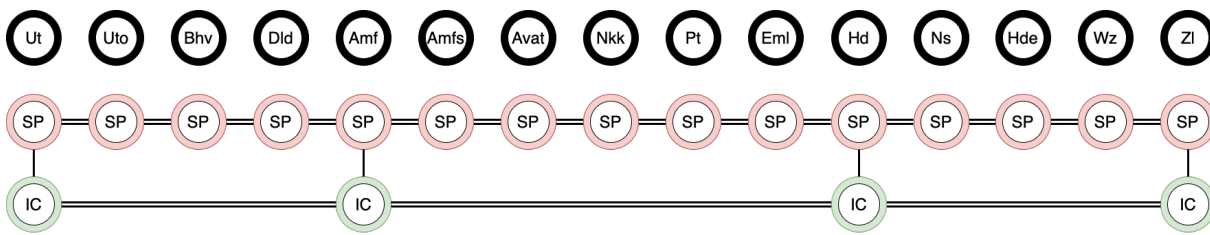

Figure 6.13: Veluwelijn: IC Harderwijk

Variant 1	total [min]	mean [min/pax]	ratio [-]
Perceived travel time	1.032.573	27,49	0,98
Actual travel time	1.024.453	27,27	0,97
Transfers [pax]	580		

Table 6.22: Results for 'IC Harderwijk' on the Veluwelijn

The perceived travel time has a value of total 1.032.573 minutes and an average of 27,49 minutes per passenger. The actual travel time is 1.024.453 minutes in total and a mean of 27,27 minutes per passenger. While comparing these outcomes with the outcomes of the base variant, the perceived travel time decreases with approximately 2% and the actual travel time increases with 3%. The latter value shows that the service is actually slowed down for a significant group of the passengers, compared to the base variant.

Through travelling passengers:

The Veluwelijn is very important for through travelling passengers from the Randstad to the Northern part of the Netherlands. These passengers are using the Intercity service on this line. Including an extra stop in this service increases the travel time for every passenger using this line. To get familiar with the amount of additional travel time for these passengers a short calculation is made. Assume that 10.000 passengers are travelling to the north and back on this line, their trip is increased with the dwell time of the Intercity service in this model of 200 seconds (= 3 minutes and 20 seconds). Multiplying these terms, give value that should be added tot the actual and perceived travel time for all variants including an extra Intercity stop at Harderwijk. The value is approximately 3% of the actual travel time in the base variant, implying that the ratio of 'IC Harderwijk' compared to the base variant should be 1,01 for the perceived travel time and 1,06 for the actual travel time.

The amount of transfers is 580 passengers for this variant. Transfers are shown for the pairs from Utrecht Centraal to 't Harde, Wezep and Zwolle, implying that Harderwijk is used as transfer point, and from Utrecht Overvecht, Bilthoven and Den Dolder to Zwolle, for these pairs different transfer points could be used. This variant scores better than the base variant on the perceived travel time, making this variant in network design, overall, more attractive for passengers. To obtain insights in

OD-pair which benefit or suffer under this new network design, the shortest routes for each pair for both the new and old network design are compared. The change in travel time is shown in Figure 6.14.

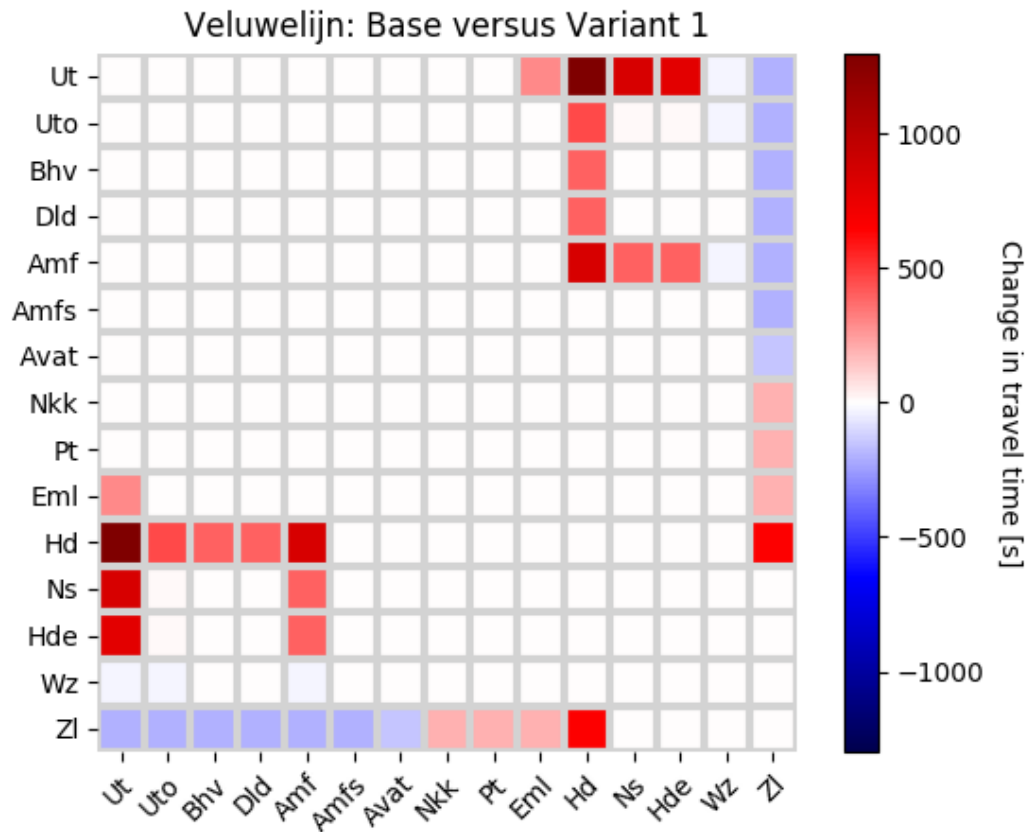

Figure 6.14: Veluwelijn: Base versus 'IC Harderwijk'

The status upgrade at Harderwijk shows, as expected, benefits from this station to the other stations as Utrecht Centraal, Amersfoort Centraal and Zwolle. The trips to these stations decrease in travel time by the faster service to and from Harderwijk. Thereby, the trips from Harderwijk to stations as Den Dolder, Bilthoven and Utrecht Overvecht will have a shorter travel time to. Trips between these station pairs could use the transfer possibility at Amersfoort Centraal. Conversely, the trips from Amersfoort Centraal to Nunspeet and 't Harde benefit from the transfer possibility at Harderwijk. In contrary, the service from Zwolle to Amersfoort Centraal and Utrecht Centraal is slower due to the extra stop in Harderwijk - this also counts for through travelling passengers. The stations between Amersfoort Centraal and Utrecht Centraal are also affected by the slower operations from and to Zwolle.

Base variant	Cycle time [s]	Fleet [#]
Sprinter	5340	5,93
Intercity	3663	4,07

Table 6.23: Required fleet for 'IC Harderwijk' on the Veluwelijn

Changing the stopping patterns of services will affect their cycle times, thus changing the amount of required vehicles for operating under a certain network design. The outcomes as calculated for 'IC Harderwijk' are given in Table 6.23. For 'IC Harderwijk', six sprinter trains and five intercity trains.

The extra stop in the IC service results in a whole extra vehicle per hour. This can be reduced by changing operational parameters as dwell and turn around times.

Base variant	Sprinter	Intercity
Run time [s]	4740	3063

Table 6.24: Run times for 'IC Harderwijk' on the Veluwelijn

Table 6.24 shows the run time of the services under the network design as in 'IC Harderwijk'. In terms of homogeneity in run times, the differences are slightly reduced by adding an extra stop in the IC service. Yet, the differences are still significant.

6.3.5 Zone sprinter

This variant introduces the zone sprinter on the Veluwelijn, which only directly connects a certain section of the network and IC stations to each other. The IC stations of the current situation have been retained and Harderwijk is included as strategic transfer point. A visual representation of the network design of this variant is shown in Figure 6.15.

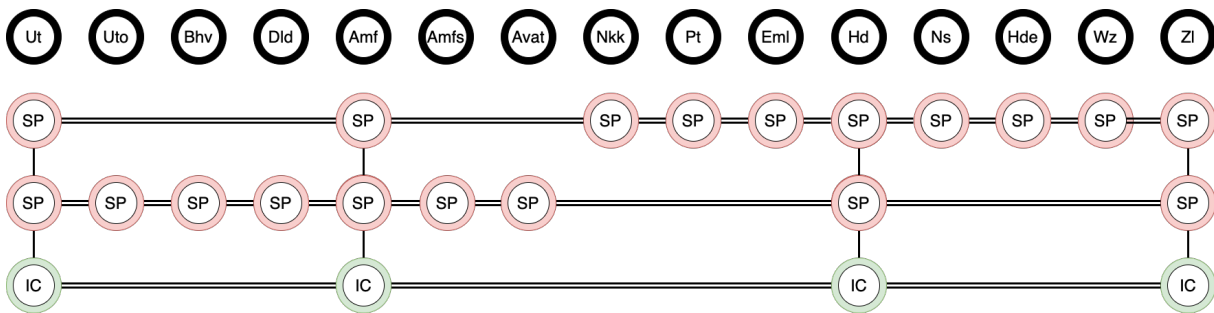

Figure 6.15: Veluwelijn: Zone sprinter

Variant 2	total [min]	mean [min/pax]	ratio [-]
Perceived travel time	1020101	27,16	0,97
Actual travel time	1002153	26,68	0,95
Transfers [pax]	1282		

Table 6.25: Results for 'zone sprinter' on the Veluwelijn

Considering the travel times, the perceived travel time is in total 971.600 minutes in total and has an average of 25,87 minutes per passenger. The actual travel time is in total 953.652 minutes and shows an average of 25,38 minutes per passenger. Compared to the base variant, this variant shows a decrease of approximately 3% in perceived travel time and a decrease of 5% in actual travel time. This in this variant 1282 passengers opt for a route including a transfer, where the transfers are occurring on the origin and destination pairs which are not directly connected. This value is rather low, as this variant includes mandatory transfers for certain OD-pairs. Yet, the demand characteristics on this line is mostly focused on the main stations, which are all connected faster to all stations with this new SP service. The change in travel time per OD-pair is shown in Figure 6.16.

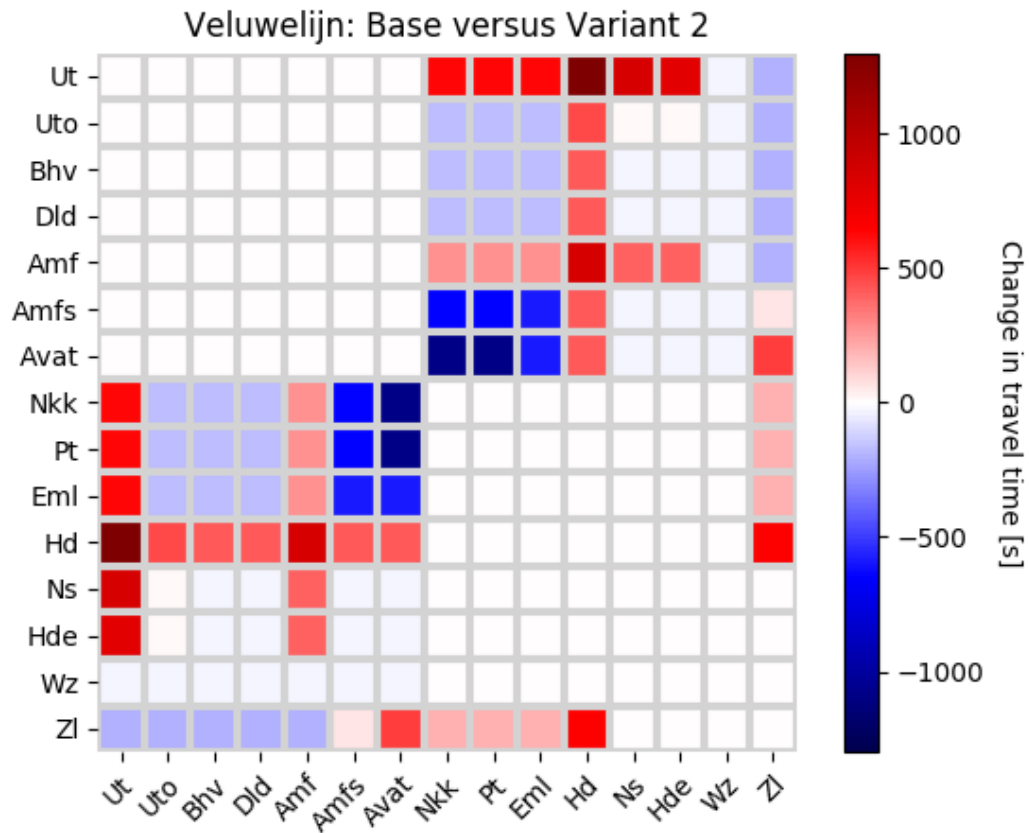

Figure 6.16: Veluwelijn: Base versus 'zone sprinter'

When considering the change in travel time, the trips between Nijkerk - Amersfoort Vathorst and Putten - Amersfoort Vathorst are affected the most negative in terms of travel time. Passengers travelling between these stations are mandatory to take an transfer at either Amersfoort Centraal or Harderwijk, extending their trip significantly. This negative effect in travel time change could be eliminated by facilitating a transfer possibility between both SP services at Nijkerk. Stations around Harderwijk see a better service to Utrecht Centraal, and vice versa, in this variant of network design. Trips from and to Harderwijk are again having benefits from its IC status. Contrary, other stations, at both sides of the line, are not affected that negatively as could have been expected. This can be due to the location of the transfer possibilities in this variant of network design.

Base variant	Cycle time [s]	Fleet [#]
Sprinter 1	4640	5,16
Sprinter 2	4500	5,00
Intercity	3663	4,07

Table 6.26: Required fleet for 'zone sprinter' on the Veluwelijn

Table 6.26 shows the cycle times of the services and the required fleet for 'zone sprinter'. The zone sprinter requires two different sprinter services, where both require six sprinter trains per hour. Additionally, five intercity trains are needed.

Base variant	Sprinter 1	Sprinter 2	Intercity
Run time [s]	4040	3900	3063

Table 6.27: Run times for 'zone sprinter' on the Veluwelijn

In Table 6.27, the run times for the different services under the network design of 'zone sprinter' are shown. What can be concluded from the run time values is that the differences highly dropped compared to other variants. This could result in a higher infrastructure capacity under this variant of network design.

6.3.6 Skip-stop sprinter

This network design includes a skip-stop sprinter, which alternately connects stations - all IC stations are included in all services. Again, the initial IC stations are retained and Harderwijk is added as strategic transfer location. The network design as described can be found in Figure 6.17.

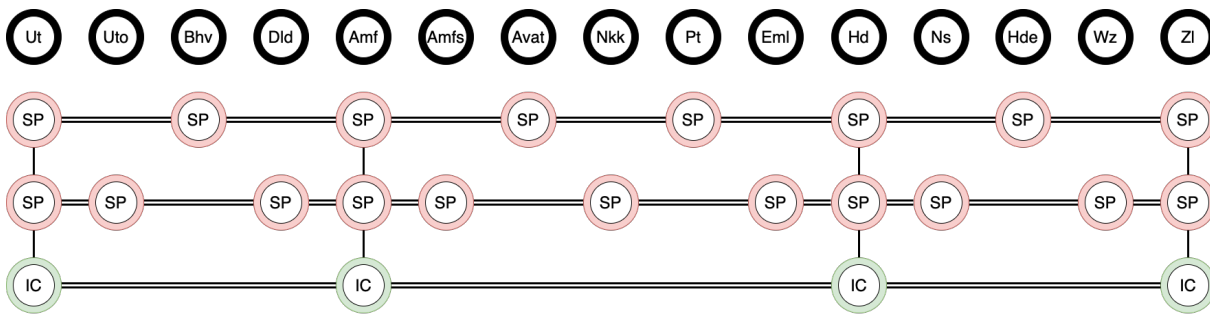

Figure 6.17: Veluwelijn: Skip-stop sprinter

Variant 3	total [min]	mean [min/pax]	ratio [-]
Perceived travel time	1.014.895	27,02	0,96
Actual travel time	991.417	26,39	0,94
Transfers [pax]	1677		

Table 6.28: Results for 'skip-stop sprinter' on the Veluwelijn

The perceived travel time is in total 1.014.895 minutes for all passengers combined with a mean of 27,02 minutes per passenger. The actual travel time is in total 991.417 minutes and shows a value of 26,39 minutes per passenger. In terms of perceived travel time and actual travel time, this variant shows a decrease in travel time of respectively 4% and 6%. The amount of passengers opting for a route with a transfer is 1677, which are occurring on the not directly connected pairs. Again, this value is lower than expected, as this variant imposes mandatory transfers for some OD-pairs. This can be allocated to the demand characteristics on this line.

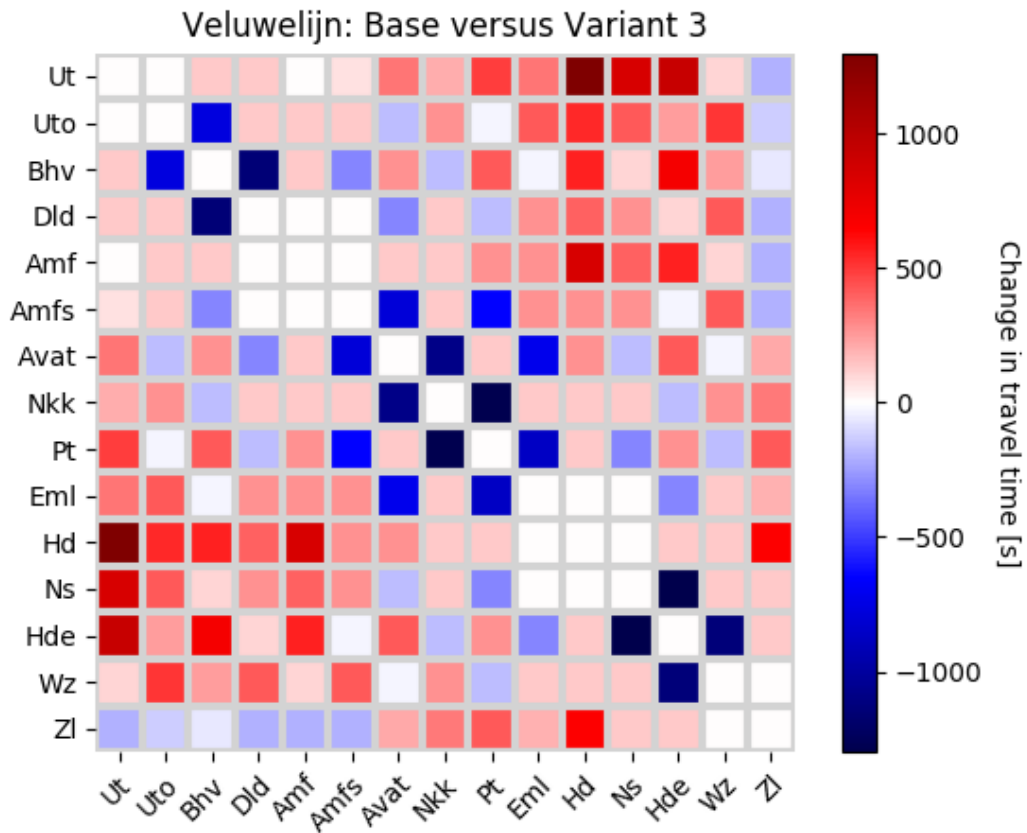

Figure 6.18: Veluwelijn: Base versus 'skip-stop sprinter'

As expected, the service between successive stations became slower, due to the mandatory transfer at one of the IC stations. Harderwijk benefits from the change in status compared to the current situation. Yet, the service from SP stations to IC stations are faster due to the alternating sprinters, this results in lower travel times. At one side, the service between successive stations has been slowed down, the other way shows a beneficial effect for most of the SP stations to the IC stations.

Base variant	Cycle time [s]	Fleet [#]
Sprinter 1	4360	4,84
Sprinter 2	4780	5,31
Intercity	3663	4,07

Table 6.29: Required fleet for 'skip-stop sprinter' on the Veluwelijn

Table 6.29 presents the cycle time of the services and the required amount of vehicles for 'skip-stop sprinter'. This variant requires five sprinter trains for one of the SP services and six for the other SP service. For the IC service, five intercity trains are needed.

Base variant	Sprinter 1	Sprinter 2	Intercity
Run time [s]	3760	4180	3063

Table 6.30: Run times for 'skip-stop sprinter' on the Veluwelijn

From the values presented Table 6.30, it could be concluded that the differences in travel time really dropped compared to the current situation.

6.3.7 Broader context of the variants

The model outcomes are primarily evaluated based on the passengers perspective. The stopping patterns of train services and statuses of stations involve a more complex environment, than just passengers. This section will elaborate in a broader context about the different variants in network design. The interviews with the product marker managers of the Netherlands Railways, as summarised in Section A.4, will be used as input for this section.

The Veluwelijn is a very important connection between the Randstad and the Northern regions of the Netherlands. The Netherlands Railways have set a goal together with the national and regional governments to reduce the travel times between these regions, i.e. improve the Intercity service. All variants considered for this line include Harderwijk as additional stop in the Intercity service, slowing that service down. This is not in line with the goal among the line and the services. The upgrade of Harderwijk will be beneficial for the area, yet will affect the through travelling passenger with longer travel times. Additionally, the extra Intercity stop in Harderwijk will result in more passengers opting for the Intercity service, which is already very crowded.

Improving the Sprinter service is another goal for the Veluwelijn. This could be achieved by a variant of the Zone Sprinter. A three layered train system with an extra faster Intercity could contribute to the faster connection with the Northern parts of the Netherlands. Yet, the capacity on the Veluwelijn already is at its limits.

The success of certain designs in network variants is also influenced by the actual timetable, which is not included currently.

6.3.8 Conclusion

Now that the outcomes of all variants are presented, this part will state some conclusions for the network design on the Veluwelijn derived from these outcomes. The outcomes are presented in an overview in Table 6.31.

Variant	Perceived ratio [-]	Actual ratio [-]	Transfers [pax]	Fleet [trains]	Max. run time difference [s]
Current	1,00	1,00	229	6 SP 4 IC	1857
'IC Harderwijk'	0,98	0,97	580	6 SP 5 IC	1677
'Zone'	0,97	0,95	1282	6 SP 5 SP 5 IC	977
'Skip-stop'	0,96	0,95	1677	6 SP 5 SP 5 IC	1117

Table 6.31: Veluwelijn: Overview of the outcomes

When upgrading the status of Harderwijk to an IC station (IC Harderwijk), the perceived and actual travel time of all separate passengers summed is lower than in the current situation. This means that the system as a whole will benefit from 'IC Harderwijk' in network design. This does not imply that every passenger will have shorter travel time, especially travellers from the Utrecht and Amersfoort area to Zwolle, and vice versa, are affected with a slightly longer travel time by an extra IC stop in Harderwijk. Yet, 'IC Harderwijk' imposes a benefit for such a group of passengers that is shows lower travel times

in total, as stations around Harderwijk benefit from the upgrade too. The new types of SP services, the zone sprinter and skip-stop sprinter, both show a significant decrease for both the perceived and actual travel time. The success of these variants could be assigned to the demand characteristics of the line. When looking to the values for boarding and alighting passengers in Figure 6.11, it can be seen that the stations of Utrecht Centraal, Amersfoort Centraal, Harderwijk and Zwolle account for approximately 70% of the passengers. In 'zone sprinter' and 'skip-stop sprinter' these four stations are connected in all services, which implies that passengers arriving from or destined to these stations are not likely to take a transfer, as there is already a fast direct connection to these stations. On the other hand, the passengers who were using both services - IC and SP - in the base variant and 'IC Harderwijk' are less likely to transfer between these services, as the SP services provided a better service by calling at less stations. For example, trips starting at an IC station and ending at an SP station usually could opt for a direct route with the SP service and a route with a transfer using both the IC and SP service. As the SP was stopping at every station, the SP was much slower than the IC, thus a group of passengers would opt for the latter option too. In the case of the zone and skip-stop sprinter, the direct SP service is faster by stopping at less stations. This makes the transfer option less attractive for passengers than the direct route.

When considering the required fleet, the base variant and 'IC Harderwijk' significantly require less vehicles than the other two variants. The base variant requires ten vehicles in total and 'IC Harderwijk' requires eleven vehicles. Adding one IC stop at Harderwijk raises the amount of vehicles needed by a whole number. By changing operational parameters as dwell and turn around times, this requirement in vehicles could be reduced. For both variants with two SP services, 'zone sprinter' and 'skip-stop sprinter', sixteen vehicles are needed. To perform - in terms of passenger travel times - even a little worse than in the original situation significantly more vehicles are needed.

Where 'zone sprinter' and 'skip-stop sprinter' perform not that well on the required vehicles, they decrease the difference in running times of the services on the track. Homogeneity in terms of running times of services sharing the same track section results in a higher infrastructure capacity, thus more trains could be operated in the same time period. The base variant and 'IC Harderwijk' still show significant running time differences, where 'IC Harderwijk' performs a little better.

Concluding, 'IC Harderwijk' is performing very well in terms of passenger travel times and required fleet. Thus implies that an extra IC station at Harderwijk would be beneficial for the whole system. Yet, the Veluwelijn is an important part in the network for passengers travelling from the Randstad to the North of the Netherlands and vice versa. After considering their time loss, this variant could be very promising as other stations near Harderwijk also profit from its upgrade. The trip of these through travelling passengers is slowed down, which is not accounted for in this research. The zone and skip-stop sprinters are very high demanding in terms of fleet requirements but do impose significant travel time benefits for the system as a whole. Meanwhile, it reduces the travel time between the main stations to the SP stations by accelerating the SP services and improve the infrastructure capacity compared to the other variants. For the main stations, as Utrecht Centraal, Amersfoort Centraal, Harderwijk and Zwolle, the service is upgraded. This is not only in terms of travel time, but in frequency too, as all services call at these stations. This is some thing that could be considered in the decision-making process too.

6.4 VALIDATION

This research focuses on the travel behaviour of passengers and their choices based on the travel times as a result from the different variants in network design. This section is checking the outcomes of the models to real world numbers and mechanisms. First, the travel times of the current situation, as found in the Netherlands Railways app, will be compared to the run times of the services from the model. Subsequently, the evaluation by the experts as shown in Section A.4 will be given.



Figure 6.19: Travel times on the Stedenbaan Zuid from the NR app

Figure 6.19 shows the travel time on the Stedenbaan Zuid for the Sprinter and Intercity service as found on the app of the Netherlands Railways. A trip from Dordrecht to Den Haag Centraal will take about 54 minutes by Sprinter and 42 minutes by Intercity, including transfer at Den Haag HS. The run times of the Sprinter is 3292 seconds which is about 55 minutes, as calculated in the model. For the Intercity, the model returns a run time of 2541 seconds, which is about 42 minutes. These two figures approximate the values as given by the Netherlands Railways very well.



Figure 6.20: Travel times on the Veluwelijn from the NS app

In Figure 6.20, the travel time from Utrecht Centraal and Zwolle is given for the Sprinter and Intercity, as found from the Netherlands Railways app. The Sprinter takes about one hour and fifteen minutes, while the Intercity shows a travel time of 51 minutes. The model returns a run time of 4740 seconds, which is equivalent to one hour and eighteen minutes, for the Sprinter. For the Intercity, a run time of 2863 seconds is returned by the model, which is the same as 47 minutes. The differences between travel time from the Netherlands Railways app and the model are higher for the Veluwelijn. The outcomes of the model are compared to the current situation, this means that consistency between the modelled variants should be applied. The new variants in network design use the same operational parameters as the modelled current situation, which maintains the consistency among the variants.

The interviews with the Product Market Managers of the Stedenbaan Zuid and the Veluwelijn from the Netherlands Railways were conducted to check the outcomes of the model with the reality. The interviews could be found in Section A.4. The interviewees were asked to evaluate the outcomes of both case studies based on their knowledge.

The working mechanisms seem to implement correctly. For the Veluwelijn, passengers are using Harderwijk as a transfer station in the new variants. This is a relatively small share of the passengers. Passengers are not expected to use Harderwijk as a transfer point in reality. Yet if it is a possibility to use Harderwijk as transfer station, some passengers will do so. Which is the small share taking the transfer in Harderwijk.

One of the main improvements is to change the model from a frequency based to a scheduled based model. The way a timetable is constructed determines an important part of the success of the network design. The timetable is explicitly important for the points where passengers will take their transfer, as passengers will try to minimize waiting times. So the arrival and departure times of the services at certain stations are very important.

6.5 CONCLUSION

Now that both the Stedenbaan Zuid as the Veluwelijn are analysed, some conclusions are drawn derived from both lines. The Stedenbaan Zuid and the Veluwelijn show differences on several aspects. First, the length of the lines and the area it is located in. The Stedenbaan Zuid is almost half as long as the Veluwelijn and is located in a more urbanised region of the Netherlands with almost half of its stations having a IC status, where the Veluwelijn is located in a more rural part of the Netherlands but is connecting two urbanised regions. In terms of demand characteristics, some differences occur. The demand on the Veluwelijn focuses mainly on three stations, Utrecht Centraal, Amersfoort Centraal and Zwolle, accounting for almost 60% of the ridership on the line. The Stedenbaan Zuid show a more spread values for the ridership among its stations. These differences in characteristics could lead to different effects of new variant of network design.

Generally, all new variants for the Stedenbaan Zuid score less on travel times, implying that the current network design is best for the current demand characteristics. However, the ridership demand per station could have been shaped to its current network design, which is not accounted for in this case. Additionally, the special types of Sprinters, as the Zone and Skip-stop Sprinter, perform significantly worse on these lines. Meanwhile for the Veluwelijn, all variants score better than the current situation. This upgrade of Harderwijk resulted in lower travel times for stations near Harderwijk to Amersfoort Centraal too. Additionally, the Zone and Skip-stop Sprinter are performing significantly better compared to the similar network designs for the Stedenbaan Zuid. This is the result from the demand characteristics of this line, the three main stations are connected in both the Zone as Skip-stop Sprinter, thus most of the passengers still are able to travel directly between their origin and destination.

In terms of fleet requirements, the Stedenbaan Zuid requires less vehicles than the Veluwelijn. This is the result from the line length of the Stedenbaan Zuid. Remarkably, where the zone and skip-stop sprinter are relatively vehicle consuming variants for the Veluwelijn with a difference compared to the base variant of five to six vehicles extra, these variants are less consuming on the Stedenbaan Zuid with just four extra vehicles. For most of the cases, for both the Stedenbaan Zuid as the Veluwelijn, changing some operational parameters as turn around and dwell times could improve this aspect a little.

An important factor in railway capacity is the homogeneity in run times on the track. The initial difference in run times are highest for the Veluwelijn, as the Intercity service includes just three stops and the Sprinter service includes fifteen. On the Stedenbaan Zuid, the Intercity service more than double in quantity. Resulting in a slower Intercity service, but providing more run time homogeneity and thus a better track capacity. These differences remain lower for the Stedenbaan Zuid than for the Veluwelijn. Yet, both the Zone as Skip-stop Sprinter improve the performance of the network design based on this aspect. The homogeneity in terms of run times on the Stedenbaan Zuid could be improved even more by adding extra stops in the Intercity service.

Concluding, the new variants for the Zone and Skip-stop Sprinter are more applicable for lines with the demand characteristics as the Veluwelijn, thus mainly focused on some stations, as these variants

improved the services to these main points in the network. In contrast, the demand characteristics on the Stedenbaan Zuid shaped itself to the current network design, as the amount of stations with an Intercity status are located in a relatively small area. This resulted in passengers spreading over several stations instead of just one station with an Intercity status in the area, making new variants in network design perform worse than the current situation. When considering the fleet size, the Zone and Skip-stop Sprinter are highly consuming but these outcomes could be improved by changing some operational parameters. Additionally, the Zone and Skip stop Sprinter reduce the differences in run times on the track, which result in a higher capacity on the track. Altogether, when the demand is focused on a few main points, as the Veluwelijn, within the network, the Zone and Skip-stop Sprinter could be applicable to reduce travel times and improve track capacity. When the demand is more scattered over several stations, the deterioration in travel time outweighs the benefits obtained by more run time homogeneity.

7

PASSENGER STATION CHOICE

While previous chapters reviewed the network designs based on given origins and destinations, representing current station choices, this chapter will include the influence new network design on passengers changing their initial station choice. First, the

7.1 INTRODUCTION

This change in station choice will be based on some aspects that are also represented in the model. As stated before, the OD-matrix provided by the Netherlands Railways depict the station choice of passengers based on the current network design. While choosing a departing or arriving station, several factors or attributes are weighed and eventually leads to a choice. These choices are visible in the OD-matrix and are based on the current network design. Stations with a higher frequency, serving more directions or are more central located, will have higher ridership values.

When changing the services offered at a station, passengers can opt for a new station. This choice can be based on several attributes, but this research will take the distances between stations, the origins of the passengers relative to their current station and the frequencies and travel times from the starting stations in the choice set to the destination station. The exact working principles are described in Section 4.4. In reality, the networks and availability of access and egress modes play an important role in the station choice.

If passengers will opt for a new starting station depends on the statuses of stations in the variants of network design. Passengers are only expected to swap if their starting station has another status than in the current network design. This will be used as a starting point for this module. The passengers are assumed to only consider adjacent stations for a new station choice. Additionally, the passengers are expected to consider this choice only while there is a difference in frequency between the stations in the choice set to the destination.

If all requirements as stated before are met, relevant amount of passengers who would considers the new station choice are determined by the distance between the stations and the origin of passengers over the catchment rings. The distances for successive stations on the Stedenbaan Zuid are given in Table B.1 and for the Veluwelijn in Table B.2. The distribution of the origins of passengers over the catchment rings are given in Table B.3 for the Stedenbaan Zuid and in Table B.4 for the Veluwelijn.

7.2 APPLICATION ON THE CASE STUDIES

This part will focus on the application of this new station choice module on the case studies. The first estimation is based on the model as described in Section 4.4 and the initial access times of the passengers as visualised in Figure 7.1, where ring 1 to 5 correspond with the the following access times to the stations, 5 minutes, 15 minutes, 25 minutes, 45 minutes and 75 minutes. The network variants as presented in Section 6.2 are used for the Stedenbaan Zuid and from Section 6.3 for the Veluwelijn.

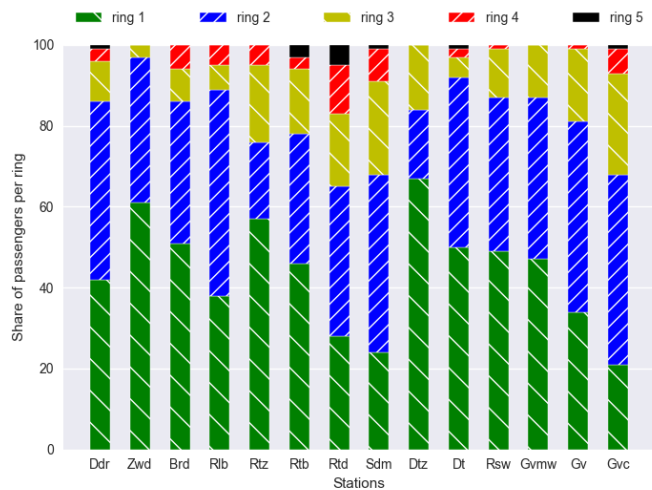

(a) Stedenbaan Zuid

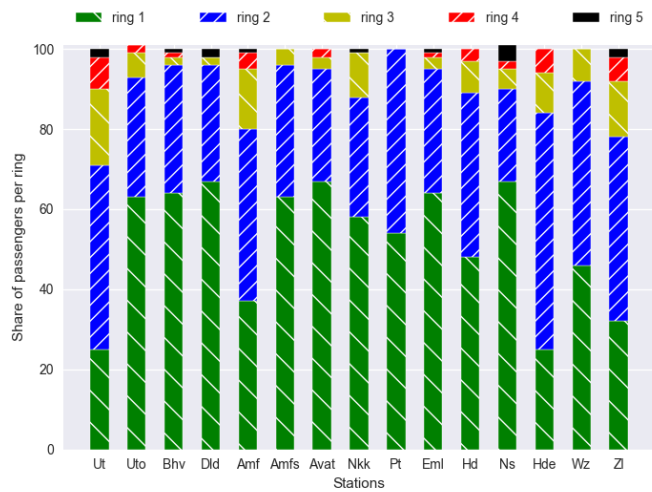

(b) Veluwelijn

Figure 7.1: Share of passengers over different rings

Stedenbaan Zuid	Changers [pax]
'minimal IC'	1060
'important nodes'	906
'zone sprinter'	1060
'skip-stop sprinter'	1567

Table 7.1: Passengers changing stations based on the network design

As every variant for the network design of the Stedenbaan Zuid includes several stations with different statuses than in the base variant, it seems that every variant includes some passengers change their starting station. For 'important nodes' the amount of passengers opting for a new starting station is lowest with a value of 906, as it has the least amount of stations with a different status as in the base variant. 'minimal IC', 'zone sprinter' and 'skip-stop sprinter' have the same amount of stations with another status. Where 'minimal IC' and 'zone sprinter' show the same amount of passengers opting for a new starting station. Remarkably, the highest value is for 'skip-stop sprinter'. This variant includes

the skip-stop sprinter, which does not connect successive stations anymore - thus including mandatory transfers for some origin and destination pairs. As passengers also base the choice for their starting station on the travel time to the end station, passengers are expected to opt more for another station when that new station is directly connected to the end station. In Table 7.2, the passengers opting for a new station on the Veluwelijn are presented.

Veluwelijn	Changers [pax]
'IC Harderwijk'	0
'zone sprinter'	0
'skip-stop sprinter'	7

Table 7.2: Passengers changing stations based on the network design

The amount of passengers changing their station on the Veluwelijn is drastically lower than on the Stedenbaan Zuid. Passengers are only supposed to swap stations when a status change occurred compared to the base situation. For the Veluwelijn, just one stations subject to a different status, that is Harderwijk. Additionally, the distances between successive stations on the Veluwelijn is higher than on the Stedenbaan, resulting in less overlap in influence areas of stations. Subsequently, the choice for a new station only becomes relevant for just a few origin and destination pairs - mostly for Intercity connections. Passengers on the Veluwelijn could be more captured by their initial starting station due to the network characteristics of the line, as distances between stations, and their origins to the stations. In reality, passengers on the Stedenbaan Zuid could be more likely to change their initial station choice, as the sequence of stations is more dense and the underlying networks of access and egress modes serve more train stations at once. As the influence of new station statuses, as delineated in this research, is not that relevant for the Veluwelijn, this line will not be included in further analyses.

7.3 SCENARIOS

The environment in urban transport modes is changing very rapidly. As these urban transport networks are complementing the rail network, implying these changes also affect the rail network as operated by the Netherlands Railways. This part will illustrate the influence of changes in access modes and trips for passengers changing their initial station choice based on several scenarios. Starting with a scenario, 'Captured passengers', where passengers are housing near their preferred station only. Subsequently, the passengers are more spread over the catchment of the stations in 'Spread of passengers'. Thereafter, 'Shared mobility' will look into the effects of short and mid length shared mobility modes.

7.3.1 Capturing passengers

Explanation *The trend in urbanisation pursues and passengers highly focus on areas near stations.*

Goal *To identify the outcomes of passengers making a new station choice while most of the passengers originate from areas in the proximity of their initially preferred station.*

Modelled *All passengers originate from the first two rings around the station (Ring 1: 0,5 and Ring 2: 0,5).*

Urbanisation and transit-oriented development are two phenomena that are present in the current day moving patterns of people, they tend to opt for housing in urban areas near station to reduce their access and egress travel time. Passengers using the train as their main transport mode are assumed to settle in the first two catchment rings of the stations - thus within 5 and 15 minutes travel time to the stations. This implies that passengers are less likely to swap their starting station after a status change.

Thus a new network design will have less effects in this scenario. Table 7.3 shows the outcomes for this scenario, where 50% of the passengers originate from the first ring and 50% from the second ring.

Scenario 1	Changers [pax]
'minimal IC'	473
'important nodes'	0
'zone sprinter'	473
'skip-stop sprinter'	766

Table 7.3: Passengers changing stations for scenario 1

In line with the expectations, all variants show less passengers who opt for a new starting station as every most passengers have such a travel time that they are more or less bound to their initial station. 'Important nodes' does not show any passengers opting for a new station. This is the result from the low amount of new statuses in this variant.

7.3.2 Spread of passengers

Explanation *Passengers tend to spread more evenly among the catchment rings.*

Goal *To identify the effects of passengers spreading among the catchment rings on the amount of passengers making a new station choice.*

Modelled *All catchment rings do account for 20% of the passengers.*

This scenario accounts for passengers to spread more among the catchment rings, this could be the result of different causes. The scenario is analysed to emphasize the possibilities in cases where passengers choosing for the train as their main mode are not that bound to the proximity of train stations. As passengers are evenly spread over all five rings, i.e. 20% per ring, the amount of passengers that are not bound to a certain station increases. This should result in more passengers that would be willing to change their starting station. The outcomes are presented in Table 7.4.

Scenario 2	Changers [pax]
'minimal IC'	1981
'important nodes'	2209
'zone sprinter'	1981
'skip-stop sprinter'	2316

Table 7.4: Passengers changing stations for scenario 2

The amount of passengers changing their starting station did increase, as the passengers who can make this relevant choice did increase due to this new distribution over the catchment rings. Remarkably, 'important nodes' shows an enormous increase in passengers opting for a new station. This is the result of the amount of the amount of relevant connections for choosing a new station. 'Important nodes' includes the most amount of IC stations after the base variant, these are the most relevant connections for passenger to opt for a new station. Yet, the probability that the passenger opt for a new station are based on the frequency and travel times to the destination. As 'important nodes' includes relatively a lot IC stations, it slows the IC service, thus the travel time difference decreases. This results in a lower probability of choosing a new station.

7.3.3 Shared mobility

Shared mobility are obtain a more prominent place in the urban transport environment. Shared mopeds, bicycles and cars are commonly used modes for trips within the city' boundaries. As stated

by Brons et al. (2009), a better accessibility could be found in a wider coverage of the access mode, lower travel time to the station and better quality of service of the access mode. This phenomenon can be strengthened by emerging modes. The effects of new network designs in terms of stopping patterns, could be complemented by these new modes, as passenger are ought to be more flexible. Based on shared mobility, two different scenarios are compiled.

Active modes

Explanation *Shared active modes are increasing their market share as access mode.*

Goal *To identify the effects of more use of active modes for access trips to the station.*

Modelled *The share of passengers originating from ring 1 and 2 are increased by 80%.*

The first scenario includes active modes to obtain more market share. During this scenario in greater extend bicycles and in smaller extend steps will be meant. Steps could be electrically driven, yet the distances travelled are comparable with bicycle trips. During the calculations of this scenario, the amount of passengers for the first and second ring are assumed to increase with 80%. The rest of the rings will remain the same share as in the current situation. The outcomes are presented in Table 7.5.

Scenario 3a	Changers [pax]
'minimal IC'	866
'important nodes'	571
'zone sprinter'	866
'skip-stop sprinter'	1344

Table 7.5: Passengers changing stations for scenario 3a

The influence of this scenario has most of its impact on the first two rings, passengers originating from these rings are more bound to their initial station. This scenario show a slightly lower amount of passengers opting for a new starting station. As the shares of passengers originating from the first two rings are raised, the relative shares of passengers originating from more outer rings decline, as the sum of shares should remain equal to one. As the outer rings have could be more sensitive for choosing new stations, the outcomes decline as the amount of passengers from these rings declined.

Mopeds and cars

Explanation *Shared moped and cars are increasing their market share as access mode.*

Goal *To identify the effects of more use of faster modes for access trips to the station.*

Modelled *The share of passengers originating from ring 2 and 3 are increased by 80%.*

Mopeds and cars are serving a new segment of shared mobility by Felyx and Lev. As previously, these modes where mostly serving the private owned segments, nowadays passengers are not bound by their car or moped and thus are not that bound to the station where they have to leave their property. These modes are used within cities and are more relevant for serving mid-length trips. This scenario will include more trips from the second and third ring to the stations. The passengers departing from these rings are relatively less captured by a station and more flexible, by the use of shared mobility. For this scenario, the amount of passengers originating from the second and third ring gained 80% compared to the current situation. Table 7.6 presents the outcomes for this scenario.

Scenario 3b	Changers [pax]
'minimal IC'	1203
'important nodes'	954
'zone sprinter'	1203
'skip-stop sprinter'	1703

Table 7.6: Passengers changing stations for scenario 3b

This scenario shows an increase of mid-length access trips, implying that less passengers are captured by their initial starting station. The values are all higher than for the current access trips. The moped and car as access mode, especially as shared mobility modes, impose more flexibility from passengers when choosing stations.

7.4 CONCLUSION

A new network design does have implications on passengers and their choice for a new starting stations. This chapter elaborated on a pragmatic module to determine the amount of passengers opting for a new starting station based on new statuses of stations and the frequency and travel times to the destination. It is assumed that passengers swapping their starting station will have a (slight) benefit from their new departing station.

While considering the current situations in access trips on both the Stedenbaan Zuid as Veluwelijn, their differences in network and demand characteristics are shown. The Veluwelijn has the almost the same amount of stations as the Stedenbaan Zuid, yet spread over a length almost twice as long. This means that averagely seen, there is more distance between every station, resulting in less overlapping between stations. Eventually, resulting in significantly less passengers that are changing their departing station, also caused by the chosen variants for the network design.

The Stedenbaan Zuid is located in a more urbanised area of the Netherlands, where other public transport networks and the availability of other modes are more present, which can imply that the Stedenbaan Zuid would be more resilient to changes in network design. The choice for a new departing station based on new network designs is more relevant for passengers using stations along this line. Additionally, the distances between successive station is relatively low and the amount of IC stations is very high, which gives room for station downgrades and thus a new station choice by passengers. This line is made subject to three different scenarios, where the first two assumed a whole new distribution of access trips.

The first scenario 'Capturing passengers' display the least amount of passengers opting for new stations, as this scenario assumed of a increasing urbanisation around existing stations. As passengers are expected to choose their hoses near their preferred departing stations, they are less expected to swap their departing station based on a new network design.

'Spread of passengers' accounts for a even spread of passengers over the five catchment rings. The amount of passengers changing their departing station is significantly higher than in the previous scenario, as the share of passengers that are more flexible in their station choice increased.

For 'Shared mobility' two different sub-scenarios are formulated, one for 'Active modes' and another for 'Mopeds and cars'. For both sub-scenarios, the distributions for shares access trip lengths are preserved. The 'Active modes' scenario includes an increase for the first and second catchment rings, which results in less passengers who change their departing station. While 'Mopeds and cars' focus on the second and third catchment ring, inevitably resulting in more changing passengers.

When introducing a new network design with new station statuses, the Netherlands Railways should keep several factors in mind - especially when downgrading a station' status. First, another station with another status should be in a sufficient distance from the station of the passengers initial choice. Additionally, the catchment area of the station considered should cover a sufficient domain and the

distribution of passengers among these rings, as the share of passengers captured by a certain station will become lower in this case.

For the access trips and modes in combination with new network variants, the Netherlands Railways could better focus on complementing their services with faster shared modes as cars and mopeds, as they impose the most flexibility of the passengers. This implies that passengers are ought to more easily change their preferred departing station, due to the presence of these modes. Thus while implementing a new network design and minimizing the disadvantages for the passengers, the Netherlands Railways could offer mopeds as a new service of collaborate with new partners in this domain.

8

DISCUSSION

This chapter will provide the interpretation of the main findings of this research, found in previous chapters. Subsequently, the limitations of the used methods and their impact on the interpretation of these results. At last, recommendations for future research will be given.

8.1 RESULTS

The goal of this research is to align the network design of the main rail network to the usage by the passengers. This section will provide guidelines in the interpretation of the key findings of this research. Firstly, the performance of new stopping patterns highly depend on the usage, i.e. the travel behaviour, by the passengers. The new variants in network design are first calculated based on the original origin and destination matrices, as provided by the Netherlands Railways. On the Stedenbaan Zuid, which shows more spreading in ridership among the stations, new variants in network design performed less compared to the current situation, based on the original origin and destination matrix. While, the Veluwelijn, where the ridership is focused on a few stations, the new variants performed better compared to the current situation. The reason that new variants on the Veluwelijn performed better is that all new variants provided better connections to the main stations along this line, which resulted in shorter travel time from most of the stations to these main points, imposing benefits for a significant group of passengers. When adjusting the network design on the Stedenbaan Zuid, downgrading a station or new stopping patterns, as Skip-stop and Zone Sprinter, impose travel time disadvantages for such group of passengers that is outweighs the benefits for other groups of passengers. It is commonly known that travel behaviour and network design have a two sided influence on each other. In this research, the network design is interpreted as the stopping patterns of train services, which are measures that could be changed relatively quick. On the other hand, travel behaviour comprises the choices of passengers, which is also influenced by several personal characteristics, besides just the network design. Additionally, structural changes in the behaviour of passengers take time to evolve. This justifies the choice to use the initial origin and destination matrix as provided by the Netherlands Railways to initially test the new variants in network design. The initial origin and destination matrix depicts the revealed station choice of the passenger based on the attributes the passengers take into account, including the current network design. Passengers are not assumed to drastically change their travel behaviour over night.

Secondly, the change in travel behaviour of the passengers is influenced by the network characteristics. As previously stated, the original origin and destination matrices depict the choices of passengers under the original situation in network design. The choices of passengers can change by changes in the network design and other aspects considering travel behaviour. The results of this research show that, based on changed stopping patterns, the Stedenbaan Zuid is facilitating new station choices better than the Veluwelijn. The Stedenbaan Zuid is located in a relatively more urbanised region and is shorter than the Veluwelijn with almost an equal amount of stations. Additionally, the area of the Stedenbaan Zuid facilitates more complementing public transport systems. In reality, the passengers on the Stedenbaan Zuid have more relevant stations to choose from while making a trip. This makes the outcome of this research in line with the reality. For this part of the research some assumptions are made in order to determine the passengers that would opt for a new access station, based on new stopping patterns. These assumptions were based on the distance between successive stations, the flexibility of passengers in the station choice based on their travel time to their initial access station

and the choice set of access stations. A shorter distance between stations imply that the choice between those stations could be more relevant for passengers, resulting in a higher share of passengers who could opt for a new access station. Passengers with longer travel times to their access station could be less fixed on their initial access station. The choice set considers just two stations in the determination of passengers changing their access station, these stations are the access station of their initial choice and the station direct to the right or the left of their initial access station. Due to the assumptions, the outcomes could either be over or under estimated, depending on the geographical boundaries and transportation connections.

Thirdly, facilitating for mid-length trips contribute to passengers changing their initial station choice. The scenarios made to check the effect of different distributions of the origins of passengers to their initial starting stations revealed that scenario's with more mid-length travel times showed more passengers changing their initial station choice. The passengers with mid-length travel times to their initial station could be less fixed to their initial station. In a broader context, if mid-length trips are facilitated for, passengers could more easily travel to the station of their choice, even if it is slightly further than the station of their initial choice. The flexibility of the passengers in their station choice depends on the network characteristics too, as stated previously.

Fourthly, Intercity and Sprinter services both have different functions, in operation and according to stakeholders. The interviews with different stakeholders pointed out that different functions are assigned to the train services. Where the Intercity should provide for the inter-regional trips and the Sprinter for the regional trips. [De Bruyn et al. \(2019\)](#) state that the characteristics of the trips differ per region. The outcomes of the case studies confirm this statement, as the Stedenbaan Zuid and the Veluwelijn show different results for the Zone and Skip-stop Sprinter. The difference in performance of these variants on the case studies imply that the implementation of the services should differ per region.

At last, the different goals and interests among the main rail network result in a complex environment. The model outcomes should be interpreted in a broader context considering the goals of the different relevant stakeholders. Changing the stopping patterns of train services do have an influence outside the area of the considered line. The variants in network design on the Veluwelijn all included a Intercity stop in Harderwijk and performed better than the current situation in terms of travel time. Yet, one of the main interests among the Veluwelijn is the connection between the Randstad and the Northern regions of the Netherlands. This connection is established by the Intercity services, which is slowed in all variants of the network design by the addition of Harderwijk in the service. This can result in a different valuation of the variants than only based on the outcomes of the model. This statement emphasizes the importance of stating clear objectives while adjusting the network design, as this significantly influences the interpretation of the outcomes, which is in line with the statements from [Van Nes and Bovy \(2000\)](#).

8.2 LIMITATIONS

Just as any other research, the chosen methodologies imply certain limitations. This section will discuss the impact of these limitations on interpreting the results. First, the considered networks are modelled to be fully independent from the outside world. This research does not account for through travelling passengers, which should be included when determining the advantages and disadvantages in terms of travel times. Additionally, the train is very important for longer trips too, especially the Intercity service. When adjusting a station status from Intercity to Sprinter, it could have an impact on passengers originating further down the network, which is not accounted for currently. Both aspects are impacting the results in a way that they can not be fully representative when assessing based on the travel times, i.e. the benefits distorted. Secondly, the considered networks are could not be representative, one major characteristic of the train network is that it is a branched network with lots of different lines.

This characteristic is fully diminished during this research, making it more a metro network. In a more branched network, it could be more beneficial to transfer due to the nature of the network.

For determining passengers changing their access station, lots of practical assumptions were made, especially, about the distribution of passengers over the catchment rings, the share of passenger who were able to make a relevant station choice and their willingness to travel to a new station. All these assumptions, can make that the amount of passengers making a new station choice could have been under- or overestimated. First, the assumption about the flexibility of passengers increasing over the rings could be different. Passengers travelling longer to a certain station could have chosen that particular station due to the service connecting to that station, which makes them less flexible. Secondly, the passengers were assumed to be uniformly distributed among the different catchment rings. Totally, ignoring natural and other geographical boundaries. In some cases it would have overestimated the amount of passengers swapping stations, in other cases this would have been underestimated. Thirdly, complementing transport were neglected. Some public transport networks connect two train stations, making the station choice between those stations fairly relevant - for example for Rotterdam Blaak and Schiedam, which are connected with the same metro service. While this research only accounted for station choice between successive stations. The overflow from these stations could have been overestimated. At last, passengers are assumed to be willing to change their station based on new designs of the network. Yet, in reality, passengers can opt for other modes based on the disadvantages of the new design based compared to the old situation. This does not only account for the station choice, but for the mode choice too. In both cases, the ridership is overestimated and the loss of passengers should be concluded as a disadvantage.

8.3 RECOMMENDATIONS FOR FURTHER RESEARCH

This section will elaborate on recommendations for further research. It is desirable to obtain more insights in different aspects concerning the rail network and its design. The combination of emerging modes and the rail system, in greater extent the willingness to use emerging modes as an access mode and the willingness to consider a new station with the availability of these emerging modes. Insights in this aspect could provide a more realistic determination of passengers willing to change their initial station choice. This will map the flexibility of passengers under the availability of alternative modes.

Secondly, the catchment areas of Intercity and Sprinter stations in different regions could be investigated more in depth. This gives insights in the influence areas of stations for different regions and could result in a more tailored recommendations based on the characteristics of the region and the status of the station. This could also give a better look into the effects of changing station statuses per region, not only based on travel times on the network, but for the areas around the station too.

Thirdly, in this research it is assumed that emerging modes would complement the train network, while it could be a competitive mode. More insights in the overflow of train passengers to emerging modes, especially for short distance trips.

Fourthly, this study used a frequency based model, this means that lots of information is generalised, as waiting and transfer times. A follow up study using a operable timetable is recommended. This way the success of the variants in network design could be determined more accurately. Additionally, to determine the effects of changing the statuses of stations should be determined by using a bigger network, as the inter-regional trips are not that represent in this research. The inter-regional trips are most relevant for the Intercity services and thus the Intercity stations.

9

CONCLUSION

The train network is the backbone of the mobility chain, accounting for approximately 62% of the multi-modal trips, i.e. trips using more than one mode. The train is still obtaining extra market share in the Netherlands, considering the amount of trips and trip lengths. Due to the multi-modal trips, the train system is highly dependent on access and egress modes. Currently, lots of developments are taking place with the access and egress modes, as for example shared mobility and MaaS-platforms. In line with these developments, passengers may opt for a more integrated public transport system. As the mobility environment, surrounding the train system, is highly changing, the train services and their stopping patterns are mostly historically grown. The operations of the train services and their stopping patterns could be reviewed to fit the purposes of the passenger better in this changing environment, improving the train system.

This research focuses on the stopping patterns of train services and the statuses of stations, summarized as the network design. First, the categorisation and hierarchy of stations and services need to be known. Train services are categorised based on their stopping patterns, where Intercity only includes the important stations and the Sprinter includes every station it passes. International trains are classified as most important and their services mostly includes - mostly - the most important stations. In the Netherlands, the Intercity is used as a service for inter-regional trips and the Sprinter for more regional trips, the latter includes every station it is passing, resulting in a slower service, while the operational speed does not significantly differ from the Intercity. Stations are classified based on the characteristics of the area its located in and the services stopping at that station. This implies that the train services calling at that station determine the hierarchy of that station, which should mean that the services are normative. Stations could be classified based on their ridership too, thus the amount of passengers opting for a station could determine the importance of the station and which services are stopping at that station. This elucidates the ambiguous interaction between stations and train services, making it very sensitive to political interference.

As stated previously, the train is one of the most used main modes in multi-modal trips. This implies that the train system could not be seen separately from the other modes. Travel behavior and network design are two important aspects in this research. Travel behaviour depicts the choices of passengers based on the attributes of the network. Important aspects of travel behaviour are route choice, including travel times, and station choice, including frequencies, passenger' experience and train services stopping at the station. The station choice could be transformed to the catchment area. In terms of network design, several aspects are important. Among these aspects are the stopping patterns, or stop densities, of services and the frequencies of the services. More stops in a service, increase the accessibility of the service but do slower the service for passengers not using that station, which is a common network design dilemma. Additionally, networks could be designed to fit different purposes from different perspectives, as from passenger', authority' and operators' perspective.

Different variants in network design do have implications on travel times. Networks including less Intercity stops performed better on the total travel time. When networks included more Intercity stops, the performance dropped as the travel time advantages of the faster IC service diminished. The zone and skip-stop sprinters, resulted in higher perceived travel times due to the higher amount of transfers. When increasing their frequencies, the actual travel times approached the values for the better scoring networks. While displaying the networks to different OD-patterns, no particular difference between networks was shown. Yet, the demand characteristics of the line should be included while compiling a new network design. An important factor for transfers to occur in the considered system are the frequencies of the services, as passengers opting for a route with a transfer are exposed to waiting times twice. Additionally, transfers are more relevant for passengers making a longer trip on the

network, as for these passengers the travel time benefits equalize the disadvantages of the transfer itself.

Network and demand characteristics do influence the performance of variants in network design. Networks where the ridership is more spread among different stations, as the Stedenbaan Zuid, are performing less, in terms of travel time, when exposed to new variants of network design. The ridership seemed to form itself to the current network design by the statuses of stations and the complementing public transport system, which resulted in a wider spread of passengers among the available stations. Changing the network design of networks with ridership more focused on a few main point in the network, as the Veluwelijn, are more resilient for new network designs, if those main points are included in the new services. The zone and skip-stop sprinters are more relevant for networks with a more focused demand, for networks with shorter distances, as the detour distances will be lower for these networks, and reduce the difference in run times, increasing the track capacity. Thus, these new sprinters types could be applied on lines where track capacity needs to be increased, given a suiting demand pattern, and where track expansions are not easily possible. The Stedenbaan Zuid and Veluwelijn, show major differences on the performance of different variants in network design due to their network and demand characteristics. This research did not account for through travelling passengers, this can have an impact on the discussed outcomes.

Passengers can include attributes of the network design in their choice for access and egress stations. Therefore, other choices in access and egress stations could be made based on a new network design. Based on the distance between successive stations, the origins from passengers, and the frequency and travel time from the stations - in the choice set - to the destination, an estimation of the passengers opting for a new access station due to a new network design. Passengers opting for a new access station are assumed to have a lower travel time on the rail network, as they also choose their station bases on the travel time. The Stedenbaan Zuid showed more passengers opting for a new access station due to the network characteristics, as distances between successive stations. This outcome is very plausible, as the Stedenbaan Zuid knows a very high level of complementing public transport systems to initiate this new station choice, making it a more resilient network when exposed to new network designs. Changing network designs will result in more passengers changing their access station when passengers are not mostly originating from the direct area of the station, as these passengers are less flexible in their station choice. When considering emerging modes, active modes will have less influence on the station choice at the access side, as they mostly serve the area more near to the station, and the passenger tend to own these modes already. Modes serving a more wide area around the station, as mopeds and shareable cars, will be more promising in facilitating a new station choice at the access side. For the egress side, emerging modes could obtain more successes, as passengers do not tend to have private modes available at that side of the journey. To reduce the negative effects of new network design in more rural areas, the focus should lay on faster access and egress modes too.

When the demand characteristics tolerate new types network design, several opportunities arise. For example, the travel times could be highly reduced and track capacity could increased by different sprinter operations. Additionally, emerging modes could be used as an extension of the rail network. Changes in network design could be strengthen by accommodating more flexibility of the passenger, in terms of station choice and travel times. Challenges occur during the elaboration of the network new network design and complementing transport systems. Travel behaviour could indeed be influenced by network design. The reality is that passengers are not that flexible in real life and almost every change in network design knows negatively affected passengers. These passengers could decide to reduce their trip frequency and even avoid the main rail network. Every aspect in planning new network designs should focus on minimising the disadvantages of the passenger, for example by remain the same level of service as before the adjustment in network design.

Concluding, This research aims to identify the effect of different stopping patterns of the train services on the travel time of the passengers. An unambiguous answer about the network design in the Netherlands as a whole could not be given. Yet, several parts could be stated. First, while considering a new network design, the demand characteristics should be known. The success of the network design is initially dependent on the transport patterns of the passengers. Changing the stopping patterns of

train services should first be focused on meeting the demand characteristics. Secondly, the demand and network characteristics significantly differ per region in such way that different operation per region should be justified. This research included two case studies, the Stedenbaan Zuid and the Veluwelijn, which show very different demand and network characteristics. The outcomes for the network variants were different for both case studies. Thirdly, the location of the network and the network characteristics have an influence on passengers changing their initial station choice. The lines for which a new network design is considered should also be analysed in broader context, as other public transport connections and the distances between stations, to determine the relevant stations for passengers to choose from. At last, the interviews showed that the intended goals of the operator and other relevant stakeholders should be known, as this can highly influence the evaluation of the network design.

Altogether, the Netherlands Railways is recommended to provide a more custom network design per region in their journey to a more integrated transport system with the rail network as its backbone.

10

PRACTICAL RECOMMENDATIONS

This chapter will state several recommendations based on the outcomes of this research. The focus of this research was on different configurations of network design and their impact on the passengers. This chapter will start with some general recommendations. Subsequently, some recommendations for the case study lines will be stated.

10.1 GENERAL RECOMMENDATIONS

This research tested different stopping patterns of train services on two case studies, which showed different network and demand characteristics. This section will elaborate on general recommendations for the Netherlands Railways.

10.1.1 Regional differences

The outcomes of the research show that the demand characteristics are leading in the success of the network design. The demand characteristics differ per region, while the stopping patterns of the services are equal throughout country. The Netherlands Railways is recommended to consider a tailored network design per region based on the demand and network characteristics.

While changing the network design, passengers could eventually change their initial station choice. This change is dependent on the the location of the network and the network characteristics, addressing the importance of the regional differences. The choice for a new access and egress station could be facilitated by different emerging modes, especially at the egress side, due to the lack of private modes at that side of the trip. The Netherlands Railways is recommended to check the network characteristics, including complementing transport networks, and to facilitate more types of shared access and egress modes at stations.

10.1.2 Hierarchy and layers

The research showed that the performance of the network design on a certain line is dependent on the demand characteristics of the line. The demand characteristics, i.e. trip lengths, can highly differ per region, yet the train services are identically operated throughout the Netherlands. The Netherlands Railways should look into the possibilities of a three layered train system to provide better alignment for all trip lengths. An extra layer in the train system would provide the possibility to customize the stopping patterns more aligned with the demand characteristics on the different lines. The differentiation of the train services throughout the country can impose ambiguity for the passengers, yet the current information systems, as apps and information signs on the station, could contribute in coping with this uncertainty.

10.1.3 Align goals with stakeholders

The main rail network is a complex environment, in terms of stakeholders and goals. Every stakeholder can have different interest in certain lines, stations and even train services. Especially, the Intercity services impose extra interests from all kind of stakeholders. The goals intended for certain lines can have a big influence in the way certain variants in network design are evaluated. The outcomes of

the new variants for the Veluwelijn performed better in terms of travel time, compared to the current situation. Yet, all variants slowed the Intercity service by including Harderwijk in that service. This changed the evaluation of the outcomes drastically.

10.1.4 Zone Sprinter and Intercity

A promising combination could be the Zone Sprinter within an Intercity service, where an Intercity is stopping as a Sprinter for a section of the line. This increases the amount of fast direct connections for the sprinter stations to the Intercity stations.

The zone should connect a part of the section with a high ridership, as it will contribute to the capacity along that section of the line. Additionally, the service should connect stations where passengers usually where mandatory to make a transfer.

10.2 STEDENBAAN ZUID

The Stedenbaan Zuid is located in a highly urbanised region of the Netherlands with a relatively high station density and a high ridership along the line. Additionally, the line knows a more evenly spread ridership among the different stations. This section state the recommendations for this line and could applied for lines with the same characteristics.

10.2.1 High frequent Sprinter

The ridership on the Stedenbaan Zuid is spread among several stations and already knows a relatively high frequency of train services among its stations. Due to the demand characteristics, the travel time savings of passengers could not be found in the variants as the Zone and Skip-stop Sprinter. The focus should be on a high frequent Sprinter on the Stedenbaan Zuid, this reduces the waiting time of the passengers substantially and all origin and destination pairs encounter advantages of the increased frequency. In addition, the increased frequency of the Sprinter can decrease the disadvantages of transfers for passengers originating from stations out of the region.

10.3 VELUWELIJN

The Veluwelijn is located in more rural part of the Netherlands and functioning as an important connection between two regions. The ridership along the line is focused on several stations. This section state the recommendations for this line and could applied for lines with the same characteristics.

10.3.1 Special Sprinter

Travel time savings on the line could be achieved by the special variants in network design, as the Zone and Skip-stop Sprinter. The demand characteristics contribute to the success of these variants. The Zone Sprinter would be preferred, as it still directly connects neighbouring stations. The main stations along the line should be included in both Sprinter services and strategic transfer points should be included from one zone to another zone.

Additionally, the operation of the services as a Zone or Skip-stop Sprinter can result in more track capacity due to more homogeneity in run times on track.

BIBLIOGRAPHY

- Ben-Akiva, M. and Bierlaire, M. (1999). Discrete Choice Methods and their Applications to Short Term Travel Decisions. pages 5–33. Springer, Boston, MA.
- Ben-Akiva, M., Walker, J., Bernardino, A., Gopinath, D., Morikawa, T., and Polydoropoulou, A. Integration of Choice and Latent Variable Models.
- Bertolini, L. (1999). Spatial Development Patterns and Public Transport: The Application of an Analytical Model in the Netherlands. *Planning Practice and Research*, 14(2):199–210.
- Bhat, C. R. (1997). Work travel mode choice and number of non-work commute stops. *Transportation Research Part B: Methodological*, 31(1):41–54.
- Bhat, C. R. and Sardesai, R. (2006). The impact of stop-making and travel time reliability on commute mode choice. *Transportation Research Part B: Methodological*, 40(9):709–730.
- Blainey, S. and Evens, S. (2011). Local station catchments: reconciling theory with reality.
- Brands, T., De Romph, E., Veitch, T., and Cook, J. (2014). Modelling Public Transport Route Choice, with Multiple Access and Egress Modes. In *Transportation Research Procedia*, volume 1, pages 12–23. Elsevier.
- Brons, M., Givoni, M., and Rietveld, P. (2009). Access to railway stations and its potential in increasing rail use. *Transportation Research Part A: Policy and Practice*, 43(2):136–149.
- De Bruyn, M., Guis, N., Hogenberg, J., and Meijers, J. (2019). Next Step Dienstregeling. Technical report, Nederlandse Spoorwegen.
- De Bruyn, M. and van Hagen, M. (2002). Bepaling stationstypes. Technical report, Nederlandse Spoorwegen.
- De Keizer, B., Geurs, K. T., and Haarsman, G. H. (2012). Interchanges in timetable design of railways: A closer look at customer resistance to interchange between trains NS (Dutch Railways). Technical report.
- Debrezion, G., Pels, E., and Rietveld, P. (2007). Choice of departure station by railway users. Technical report.
- Dingler, M. H., Lai, Y.-C., and Barkan, C. P. Effect of train-type heterogeneity on single-track heavy haul railway line capacity.
- Eluru, N., Chakour, V., and El-Geneidy, A. M. (2012). Travel mode choice and transit route choice behavior in Montreal: Insights from McGill University members commute patterns. *Public Transport*, 4(2):129–149.
- Enrique Fernández L., J., de Cea Ch., J., and Malbran, R. H. (2008). Demand responsive urban public transport system design: Methodology and application. *Transportation Research Part A: Policy and Practice*, 42(7):951–972.
- Enserink, B., Kwakkel, J., Bots, P., Hermans, L., Thissen, W., and Koppenjan, J. (2010). *Policy analysis of multi-actor systems*. Eleven International Publ.
- Farahani, R. Z., Miandoabchi, E., Szeto, W. Y., and Rashidi, H. (2013). A review of urban transportation network design problems. *European Journal of Operational Research*, 229(2):281–302.

- Frank, L., Bradley, M., Kavage, S., Chapman, J., and Lawton, T. K. (2008). Urban form, travel time, and cost relationships with tour complexity and mode choice. *Transportation*, 35(1):37–54.
- Fröidh, O., Sipilä, H., and Warg, J. (2014). Capacity for express trains on mixed traffic lines. *International Journal of Rail Transportation*, 2(1):17–27.
- Gentile, G., Florian, M., Hamdouch, Y., Cats, O., and Nuzzolo, A. (2016). The theory of transit assignment: Basic modelling frameworks. In *Springer Tracts on Transportation and Traffic*, number 9783319250809, pages 287–386. Springer International Publishing.
- Givoni, M. and Rietveld, P. (2014). Do cities deserve more railway stations? The choice of a departure railway station in a multiple-station region. *Journal of Transport Geography*, 36:89–97.
- Guerra, E., Cervero, R., and Tischler, D. (2012). Half-Mile Circle Does it Best represent Transit station Catchments? *Transportation Research Record: Journal of the Transportation Research*, 2276:101–109.
- Guihaire, V. and Hao, J. K. (2008). Transit network design and scheduling: A global review. *Transportation Research Part A: Policy and Practice*, 42(10):1251–1273.
- Guis, N. and Nijenstein, S. (2015). Modelleren van klantvoorkeuren in dienstregelingsstudies. *Colloquium Vervoerplanologisch Speurwerk*.
- Hensher, D. A. and Reyes, A. J. (2000). Trip chaining as a barrier to the propensity to use public transport. *Transportation*, 27(4):341–361.
- Hoogendoorn-Lanser, S., Bovy, P., and van Nes, R. Application of constrained enumeration approach to multi-modal choice set generation. 31(0):1–21.
- Kepaptsoglou, K. and Karlaftis, M. (2009). Transit Route Network Design Problem: Review. *Journal of Transportation Engineering*, 135(8):491–505.
- KiM (2019). Mobiliteitsbeeld 2019. Technical report.
- Mcfadden, D. (1973). Conditional logit analysis of qualitative choice behavior.
- Mcnally, M. G. (2000). The Four Step Model. Technical report.
- Nielsen, G. and Lange, T. (2007). Network Design for Public Transport Success - Theory and Examples. *Trebo 10 Conference*.
- Nielsen, O. A. (2000). A stochastic transit assignment model considering differences in passengers utility functions. *Transportation Research Part B: Methodological*, 34(5):377–402.
- Noh, H., Hickman, M., and Khani, A. (2012). Hyperpaths in Network Based on Transit Schedules. *Transportation Research Record: Journal of the Transportation Research*, 2284:29–39.
- Nuzzolo, A. (2002). Transit Path Choice and Assignment Model Approaches (°). In *Advanced Modeling for Transit Operations and Service Planning*, pages 93–124. Emerald Group Publishing Limited.
- PBL (2020). Afstanden woon-werk verkeer nemen toe.
- Pinjari, A. R., Pendyala, R. M., Bhat, C. R., and Waddell, P. A. (2007). Modeling residential sorting effects to understand the impact of the built environment on commute mode choice. In *Transportation*, volume 34, pages 557–573.
- Ramunas, V., Gailiene, I., and Podagelis, I. (2011). Increment of railway line capacity ENVIRONMENTAL ENGINEERING INCREMENT OF RAILWAY LINE CAPACITY.
- Rietveld, P. (2000). Non-motorised modes in transport systems: A multimodal chain perspective for The Netherlands. *Transportation Research Part D: Transport and Environment*, 5(1):31–36.

- Sargent, R. G. (2013). Verification and validation of simulation models. *Journal of Simulation*, 7:12–24.
- Schakenbos, R., Paix, L. L., Nijenstein, S., and Geurs, K. T. (2016). Valuation of a transfer in a multi-modal public transport trip. *Transport Policy*, 46:72–81.
- Schöbel, A. (2012). Line planning in public transportation: Models and methods.
- Shaheen, S. and Chan, N. (2016). Mobility and the sharing economy: Potential to facilitate the first-and last-mile public transit connections. *Built Environment*, 42(4):573–588.
- Standing, C., Standing, S., and Biermann, S. (2019). The implications of the sharing economy for transport. *Transport Reviews*, 39(2):226–242.
- Van Mil, J. F. P. ., Leferink, T. S., Annema, J. A. ., and Van Oort, N. (2018). Insights into factors affecting the combined bicycletransit mode. Technical report.
- Van Nes, R. (2007). Notes on hierarchy in spatial systems and transport systems. Technical report.
- Van Nes, R. and Bovy, P. (2000). Importance of Objectives in Urban Transit-Network Design. *Transportation Research Record: Journal of the Transportation Research Board*, 1735(1):25–34.
- Van Nes, R., Hamerslag, R., and Immers, B. (1988). Design of Public Transport Networks.
- Van Oort, N. and Van Nes, R. (2009). Line length versus operational reliability: Network design dilemma in Urban public transportation. *Transportation Research Record*, (2112):104–110.
- van Oort, N. and van Nes, R. (2009). Regularity analysis for optimizing urban transit network design. *Public Transport*, 1(2):155–168.
- Verschuren, M. (2016). *An origin-destination based train station choice model for new public transport connections to train stations*. PhD thesis.
- Wee, B. V., . . . , H. H. E. J. o., and 2002, u. (2002). Preferences for modes, residential location and travel behaviour. *superheroscitech.tudelft.nl*.
- Ye, X., Pendyala, R. M., and Gottardi, G. (2007). An exploration of the relationship between mode choice and complexity of trip chaining patterns. *Transportation Research Part B: Methodological*, 41(1):96–113.

A | INTERVIEWS

This appendix will include summaries of the conducted interviews for this research.

- A.1 Municipality: Pijnacker-Nootdorp
- A.2 Municipality: Lansingerland
- A.3 Rover: Network Design
- A.4 Netherlands Railways: Product market managers
 - A.4.1 Stedenbaan Zuid
 - A.4.2 Veluwelijn

A.1 MUNICIPALITY: PIJNACKER-NOOTDORP

The municipality, Pijnacker-Nootdorp, focuses on sustainable mobility as its first solution. Yet, the car is still a solution for people where other options are not that convenient. It is their goal to make people think about their choices for mobility, but choice should be logical in terms of costs and time (for the passenger). The municipality searches for direct motives to help people and companies in changing their behaviour in mobility choices, for example in time and cost savings. The choice for public transport should be as intuitive as the choice for the car.

The municipality is represented along with 22 other municipalities in the MRDH, which covers regional issues in the metropolitan area of Rotterdam and The Hague combined, just as public transport. The MRDH sets the requirements for the concessions on the public transport lines. All 23 members have a vote in the conditions for these concessions.

The municipality is located along a rail line, which is recently converted to a metro line. Several stations are added in its area and the frequency is increased since the conversion.

Since the conversion, the amount of stations in the municipality increased from one to three, this result in a better accessibility of the line for the inhabitants. This increment in accessibility provides a better comfort and more ease in use of the new metro line, as the distances needed to access the metro are less than before. At once, the frequency of the line increased. More vehicles per hour provides for a better comfort, as the inhabitants are more able to take the meter near its preferred departure time.

The municipality sees it as an chance to combine policy on mobility and spatial planning. For the municipality it makes more sense to develop housing near the stations, as the inhabitants will be more likely to use this mode of transport. Yet, the growth of the amount of housing should be simultaneous with the availability of the transport modes.

The three stations are in essence equally, even the station with a higher frequency in the rush hour to Rotterdam. The stations are important as not every inhabitant works within the boundaries of the municipality. The connections to both The Hague and Rotterdam are important. Thus a frequency increase along the whole line is desired. The choice for housing is influenced by the metro and the fast connections.

The line was expected to perform better after the conversion. Spatial policy was formed to benefit from and contribute to the new line. Yet, the current ridership numbers were not that expected. In order to prevent that its success will be its destruction, the frequency from Pijnacker-Zuid to Rotterdam is increased.

Concluding, the value in the stations could be found in the frequency, amount of vehicles per hour, and the accessibility, the distance to the stations. Both leading to more comfort. The access and egress from the line will be lower and the due to the high frequency people could use the service when they want. While connecting both cities located near the municipality, the conversion added valuable stations and lines.

A.2 MUNICIPALITY: LANSINGERLAND

There is a policy for mobility within the municipality, dating from 2010. Which was clearly a different time, shared mobility did not have big share within the mobility chain and public transport was not that growing as nowadays. Currently, new policy is being formulated, where bicycle and public transport will have priority. Yet, the facilities for car usage should be sufficient too. Public transport is in the spotlight, especially in combination with spatial planning. This combination also is provided the success of the metro line (E-lijn). Due to the high level of service of the public transport line, the usually Rotterdam oriented municipality becomes a home for people more dependent on The Hague too.

A station environment has a node function within its surroundings, in other words transfer function from other public transport modes, the bicycle or the car. But also needs to address other functions than just transferring people. For example station Westpolder, where also other functions are realised. A live-able place is created and not just a place where people could transfer. Contrary, Rodenrijs has a good transfer function, yet other functions are not existent. The quality of the places is very important in these days. From a transportation point of view, the quality could be found in the frequency of the line and the relatively short travel times. The travel times to the center of Rotterdam are very short.

The new train station has been designed very well, certainly when considering the surroundings. It is connected well by bicycle lanes, roads and the bus lines are rerouted to call at that station. It has a good allure for that spot, providing a nice place to stay during the transfers between the different modes. To increase the amount of passengers at that station, allocating a new function of the area is one of the options. The new station is located at a place where the tram of Zoetermeer - The Hague was nearly touching the railway track. Thus it was clear that the station should have been located there. The new station provided a growth of travellers destined to the more eastern places in the Netherlands, then just Rotterdam or the Hague. It provides extra possibilities to travel to these locations from that municipality.

The transport demand needs to grow, it is not there immediately when opening a station. Currently, the municipality is mostly focused on Rotterdam, yet the other destinations will become more in attention with the inhabitants. The ZoRo is also a main key in growing the travel demand. It has been developed for growth and when successful, it could be converted to a new line.

The value of stations could be found in the accessibility of the municipality with other places in the Netherlands. A function is that people could reach other places with station. Yet, the other functions are very important. The new train station as a line to Utrecht, it has provided a broader scope in destinations that could be reached from the municipality. The station currently has a frequency of four vehicles per hour. Possibilities are being explored to increase this frequency. Or in the distant future, even a IC status. For the latter, the required transport demand need to be generated. The municipality will assign the right function to the area to achieve that.

Concluding, the municipality focuses on stations as just more than just the connectivity between different modes. The frequency of the transport services offered are certainly a added value for a station too. Yet, the municipality tried to offer a bigger scope of destinations reachable with public transport by the new train station. Which implies that the possibility of reaching other places in the Netherlands is also an added value of a station.

A.3 ROVER: NETWORK DESIGN

Rover is an organisation representing the interest of travellers using public transport system and has an advisory role in the decision making process. The parties involved, like the Netherlands Railways or ProRail, can make the final call on decisions. Yet, the minister responsible for mobility assigns great value to the opinion of organisations like Rover during the decision making process. Implying that their knowledge and opinion is always consulted on beforehand. Rover can use both formal and informal channels to influence the decision making process. Additionally, they carry out their own researches and can lobby at the house of representatives.

The focus of Rover is shifting towards a broader few than only public transport, like sustainable mobility and chances for spatial planning and mobility combined. A great value is assigned to the right shares in modal shift. Some highly used corridors show traffic jams on the freeways, but the trains tend to be not that full. Shifting passengers from the car to the train would be beneficial in these cases, as the infrastructure is already present. Mostly, the reason that passengers do not opt for the train on those corridors is due to a lack of quality in terms of frequency, reliability and speed. Smart adjustments in the network may have a huge effect on the ridership on those corridors.

The rail network in the Netherlands is the backbone of the mobility chain. The long haul services as the Intercity services are important, yet the inter-regional services as the Sprinters should be of a sufficient service level too. Currently, the Sprinter seems subordinated to the Intercity services as the Sprinter services have to wait for Intercity services to overtake or the transfer times for sprinters are not that attractive due to the scheduled timetable.

One of the problems in modelling public transport models is that they tend to underestimate the transport demand, especially for new cases. Newly opened stations near the city of Apeldoorn all have a higher ridership than that was accounted for by the transport models. The Hoekse lijn, Valleilijn and Randstadrail also show more success than when they were previously operated and the estimations of the transport models. The cost benefit analyses are based on the estimations of these models, which are underestimating ridership values. This implies that these cost benefit analyses could be debatable.

A standard norm is needed for both the Intercity and Sprinter services. Where both services obtain a sufficient basis timetable with minimum transfer times, a sufficient frequency and operational speed. The Dutch Note on Mobility sets a hard standard norm for traveling speeds on the Dutch freeways. This kind of norms are not present for the railway sector, which results in a loss of quality. When such norm is present, it is more clear when and where some investments need to be made.

The Veluwelijn was the center of attention in the plan Randstadspoor, where more stations near the city of Utrecht would be realised and an increased frequency to station Harderwijk. Eventually, it was expected that the trains would not fit the infrastructure. Thus the plans were not realised. There is a fair chance that the plans were canceled based on miscalculations. Yet, a huge step in terms of increasing the service level on the Veluwelijn still can be made by releasing a turning track at station Harderwijk. Implying that with relatively low investment, a huge impact could be made.

The railway system could show differences per region. Currently, the different services have a very important role within the operations. When leaving this philosophy a little, the alignment with the usage per region could more easily be found. One of the possibilities is a system with three service types. With a three layered system, the medium sized nodes could be better connected. The completion of this system could be tailor-made for every region. Concepts like zonal trains could benefit the traveller and increase capacity on the infrastructure. Another way to increase infrastructure capacity is to split and combine trains. This can result in high capacity on certain busy corridors and sufficient capacity on less busy sections with direct connections to more destinations. Reviewing the services on the railways could help improve the system without too much investments.

The Stedenbaan Zuid has a more diffuse transport demand and the Veluwelijn has a more direct demand towards a few cities. In the case of Stedenbaan Zuid, station Schiedam Centrum is very important due to the metro connections. When a three layered system is applied, the Intercity status might be downgraded to another status. Where all calling services should have a sufficient standard norm. This provides a quicker Intercity service and better fine-meshed transport system.

In the railway sector there is a clear lack of long term decision making and is restraint for investments. While these investments could clearly be beneficial for the sector and the Netherlands as a whole. Projects like a light rail line between Haarlem and Schiphol Airport to contribute to a modal shift towards public transport, should be a real option.

Concluding, a standard norm of services should be applied in the rail sector. This could contribute in assessing investments to be made. This standard norm is embodied by frequency, operational speed and reliability. Additionally, small investment can already have a huge impact on the quality of services offered. Subsequently, adjusting to a three layered system could also be beneficial for improving the quality and provides chances for tailor-made operations per region.

A.4 NETHERLANDS RAILWAYS: PRODUCT MARKET MANAGERS

Interviews have been conducted with the product market managers of the case study lines to validate the outcomes of the model and review the variants of network design in a broader context. The interviewees were asked questions about their impression about the network design, the outcomes of the model and the stakeholders involved and their opinion about the proposed network designs. The overall conclusion about these interviews is that the outcomes of the model are as expected and the outcomes should be reviewed in a broader context.

A.4.1 Stedenbaan Zuid

The Intercity status is very important for the stakeholders, adjusting the status will affect the accessibility the area the station is located in. The current situation is beneficial, as the amount of Intercity and Sprinter stops seem to work for this line. The new variants in network design all consider less Intercity stations, which result in a significant group imposed to disadvantages in travel time and direct connections.

The current situation is preferred, the occupancy of the Intercity and Sprinter service seem to be in balance. Additionally, the Intercity stops at stations of a great importance in the connectivity for the greater metropolitan area of Rotterdam and Den Haag. For example, Schiedam Centrum is a very important hub for the metro. This functions has been strengthened by the opening of the Hoekse line. Stations clearly have other functions beside the train. The current situation could be complemented with a three layered system with a faster, less stopping Intercity service to provide for faster trips on longer distances.

The outcomes of the variants in network design are as expected by the product market manager. Improvements could be made by including through travelling passengers and an extra layer in the train services.

A.4.2 Veluwelijn

New variants in network design always show proponents and opponents. The Veluwelijn plays a significant role in the connection between the Randstad and the Northern regions of the Netherlands. The Netherlands Railways and the Dutch government both have the goal to provide for a faster connection between these regions. All new variants include an extra Intercity stop in Harderwijk, which slow the service resulting in longer travel times. Other variants excluding Harderwijk and even Amersfoort Centraal as Intercity station could be more preferred to achieve this goal. In this case, the three layered train system could be promising by adding a faster Intercity service. It is a goal of Netherlands Railways to improve the Sprinter product, a variant of the Zone Sprinter could be promising in this case. The Veluwelijn has some capacity issues, the amount of trains per track section is already at its maximum. Implying that the three layered system could not be applied directly.

The model outcomes are as could be expected. The model is frequency based, which is more relevant for high frequent corridors, which does not counts for the Veluwelijn. Additionally, some factors considering the timetable and departure times are not considered in the model, which are very important for the success of the timetable. The occurrence of Harderwijk as interchange station is very particular, yet if their is a possibility for passengers to use that station in their route, it could occur. The amount of passengers taking that route could be influenced by the departure times of the different services. The model could be improved by adding the through travelling passenger during the calculation, which is a very important group on this line.

B | MODELS

This chapter will state different inputs for the model. Additionally, the outcomes for the sensitivity analysis will be shown.

B.1 MODEL PARAMETERS

This part will include certain model parameters used as input for the case studies.

B.1.1 Distances

The distances used to compile the networks of the case studies are given in Table B.1 for the Stedenbaan Zuid and in Table B.2 for the Veluwelijn.

Station from	Station to	Distance [km]	Distance [m]
Den Haag CS	Den Haag HS	1,9	1900
Den Haag HS	Moerwijk	1,9	1900
Moerwijk	Rijswijk	1,9	1900
Rijswijk	Delft	4,5	4500
Delft	Delft Campus	1,9	1900
Delft Campus	Schiedam	8,4	8400
Schiedam	Rotterdam CS	4	4000
Rotterdam CS	Rotterdam Blaak	1,9	1900
Rotterdam Blaak	Rotterdam Zuid	2,4	2400
Rotterdam Zuid	Lombardijen	2,8	2800
Lombardijen	Barendrecht	3,1	3100
Barendrecht	Zwijndrecht	7,6	7600
Zwijndrecht	Dordrecht	2,1	2100
Total			44400

Table B.1: Distances between stations on the Stedenbaan Zuid

Station from	Station to	Distance [km]	Distance [m]
Utrecht CS	Utrecht Overvecht	2,9	2900
Utrecht Overvecht	Bilthoven	6,1	6100
Bilthoven	Den Dolder	2,8	2800
Den Dolder	Amersfoort CS	9,2	9200
Amersfoort CS	Amersfoort Schothorst	3,3	3300
Amersfoort Schothorst	Amersfoort Vathorst	2,5	2500
Amersfoort Vathorst	Nijkerk	5,7	5700
Nijkerk	Putten	7,5	7500
Putten	Ermelo	4,8	4800
Ermelo	Harderwijk	4,5	4500
Harderwijk	Nunspeet	12,1	12100
Nunspeet	Harde 't	8,6	8600
Harde 't	Wezep	9	9000
Wezep	Zwolle	9	9000
Total			88000

Table B.2: Distances between stations on the Veluwelijn

B.1.2 Origins of passengers

Passengers do not randomly spawn at stations just before their train trip. In Section C.2, a data set with access and egress trip data is analysed. After erasing the missing observations, two tables are compiled for the case studies to use as an input. In Table B.3, the input for the Stedenbaan Zuid is presented and for the Veluwelijn in Table B.4.

Access	5 [min]	15 [min]	25 [min]	45 [min]	75 [min]
Ddr	0,42	0,44	0,11	0,03	0,01
Zwd	0,61	0,36	0,02	0	0
Brd	0,51	0,35	0,08	0,06	0
Rlb	0,38	0,51	0,06	0,05	0
Rtz	0,57	0,19	0,19	0,05	0
Rtb	0,47	0,32	0,16	0,03	0,03
Rtd	0,28	0,37	0,19	0,12	0,05
Sdm	0,24	0,44	0,23	0,08	0,01
Dtz	0,69	0,17	0,15	0	0
Dt	0,5	0,42	0,05	0,02	0,01
Rsw	0,49	0,39	0,12	0,01	0
Gvmw	0,47	0,4	0,13	0	0
Gv	0,34	0,47	0,18	0,01	0
Gvc	0,21	0,47	0,25	0,06	0,01

Table B.3: Share of passengers originating among the catchment rings of stations on the Stedenbaan Zuid

Access	5 [min]	15 [min]	25 [min]	45 [min]	75 [min]
Ut	0,25	0,46	0,19	0,08	0,02
Uto	0,63	0,3	0,06	0,02	0
Bhv	0,64	0,32	0,02	0,01	0,01
Dld	0,67	0,29	0,02	0	0,02
Amf	0,37	0,44	0,15	0,04	0,01
Amfs	0,63	0,33	0,04	0	0
Avat	0,67	0,29	0,03	0,02	0
Nkk	0,58	0,3	0,1	0	0,01
Pt	0,54	0,46	0	0	0
Eml	0,64	0,31	0,03	0,01	0,01
Hd	0,48	0,41	0,08	0,03	0
Ns	0,67	0,23	0,05	0,02	0,04
Hde	0,25	0,59	0,1	0,06	0
Wz	0,46	0,46	0,08	0	0
Zl	0,32	0,46	0,14	0,05	0,02

Table B.4: Share of passengers originating among the catchment rings of stations on the Veluwelijn

B.2 SENSITIVITY ANALYSIS

This section will present the outcomes for the sensitivity analysis as presented in Section 5.3.1. The goal of this section is to test the relevant working mechanisms of the model and is applied for all seven networks as presented in Chapter 5. For every changed parameter both the total actual travel time and the amount of transfers are analysed. The choice parameter is used as a starting point. Subsequently, the transfer resistance has been varied. At last, different values for the distances between successive stations are used.

Table B.5 shows the amount of transfers per network for different values for the choice parameter. Remarkably, for every value of β , the outcomes remain equal. This implies that other factors are limiting the outcomes.

	β [-]	0,05	0,1	0,2	0,4
Network 1	1	0	0	0	0
2	2	0	0	0	0
3	3	0	0	0	0
4	4	0	0	0	0
5	5	0	0	0	0
6	6	12000	12000	12000	12000
7	7	8000	8000	8000	8000

Table B.5: Amount of transfers for different choice parameter values

When decreasing the value of the choice parameter, passengers could also opt for a slightly shorter route. The actual travel times are shown in Table B.6. The highlighted cells show differences in travel time compared to the initial situation with a choice parameter of 0,4. For network 4-5, slight difference in travel times could be observed from values for the choice parameter of 0,2 and below. These networks include relatively slower IC services due to the amount of stops included in those services in the networks. This results in less travel time differences between the shortest route and the second shortest route. A slight increase of travel time is visible in every run, implying that a small share of passengers is assigned to routes with longer travel times. The same counts for network six but with lower value for the choice parameter. A value of 0,05 is used further on this sensitivity analysis.

	β [-]	0,05	0,1	0,2	0,4
Network	1	529285	529285	529285	529285
	2	539000	539000	539000	539000
	3	527571	527571	527571	527571
	4	534267	533629	533341	533287
	5	538962	538125	537894	537858
	6	633094	633000	633000	633000
	7	571000	571000	571000	571000

Table B.6: Actual travel time in minutes for different choice parameter values

In Table B.7, the amount of transfers for different values of the transfer resistance are shown. Remarkably, the amount of transfers do not really increase by lower transfer resistances. This could have as a reason that passengers who are making a transfer are exposed twice to the waiting time, which is half the headway (7,5 minutes). This value does not include the transfer resistance. While decreasing the transfers resistance, passengers are still facing this additional travel time compared to direct routes. When using a value of one, the transfers for network 1 increase.

	Transfer resistance [min]	14	10	5	3	1
Network	1	0	0	0	0	486
	2	0	0	0	0	0
	3	0	0	0	0	0
	4	0	0	0	0	0
	5	0	0	0	0	0
	6	12000	12000	12000	12000	12000
	7	8000	8000	8000	8000	8000

Table B.7: Amount of transfers for different values for the transfer resistance

Table B.8 shows the total actual travel times for different transfer resistances. The following runs will use a transfer resistance of 1 minute.

	Transfer resistance [min]	14	10	5	3	1
Network	1	529285	529285	529285	529285	529293
	2	539000	539000	539000	539000	539000
	3	527571	527571	527571	527571	527571
	4	534267	534267	534267	534267	534267
	5	538962	538962	538962	538962	538962
	6	633094	633094	633094	633094	633094
	7	571000	571000	571000	571000	571000

Table B.8: Actual travel time in minutes for different values for the transfer resistance

In Table B.9, show the amount of transfers for varying distances between successive stations. Only network 1 shows different amount of transferring passengers. Contrary to the expectations, these values become higher for lower distances between stations. For network 1, the only transfer points are in the outermost stations of the network, thus transfers are only assumable for passenger departing from B (for lower distances, also C) to G or from F (for lower distances, also E) to A. When the distance is lower, the choice for a route with a transfer to the faster IC service becomes more relevant.

	Distance [m]	500	1000	2000	4000	10000
Network	1	2044	1338	486	168	156
	2	0	0	0	0	0
	3	0	0	0	0	0
	4	0	0	0	0	0
	5	0	0	0	0	0
	6	12000	12000	12000	12000	12000
	7	8000	8000	8000	8000	8000

Table B.9: Amount of transfers for different distances

When the distances are changed, the travel times will also increase. In Table B.10, the total actual travel times are shown. Nothing particular could be determined from these values for checking the working mechanisms of the model.

	Distance [m]	500	1000	2000	4000	10000
Network	1	444621	473273	529293	639626	970518
	2	455000	483000	539000	651000	987000
	3	446302	473416	527571	636172	961857
	4	454136	481007	534267	640258	958548
	5	455334	483223	538962	650042	969699
	6	525226	561126	633094	777094	1209094
	7	487573	515342	571000	683016	1019016

Table B.10: Actual travel time in minutes for different distances

C

DATA ANALYSIS: ACCESS AND EGRESS

This appendix will provide insights in the catchments of the stations in the case studies. Data representing the origins and destinations of passengers will be analysed. This will result in distributions of travel times to and from stations, the modes used and their origin and destination area based on postal codes.

C.1 INTRODUCTION: MULTI-MODALITY AND CATCHMENTS

Trips using the train as one of its modes, usually don't start or end at the station. Most of the times, the passengers have another origin and destination somewhere near the starting or end station. These origins and destinations are within the catchments of the stations. The catchment area of a station is visualised in Figure C.1.

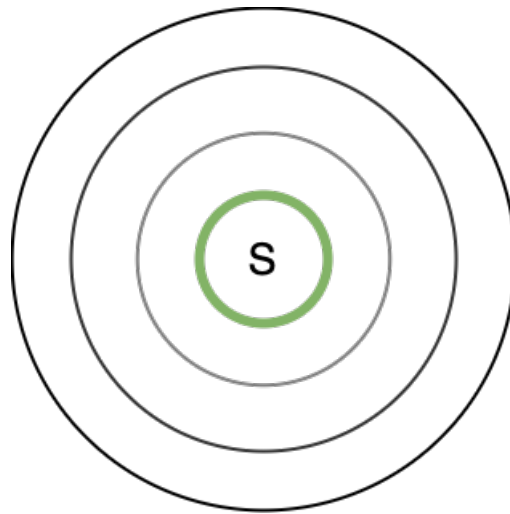

Figure C.1: Visualisation of catchment area of a station

While considering catchments of stations, the access catchment could be different from the egress catchment due to different factors. The probability of using a certain station decreases with the distance from the station. Thus, the expectation is that the longer access and egress trip times will be less observed than the shorter travel times. Another assumption is that the larger stations will have a bigger catchment area. This will result in more observations of longer travel times. This could also be distorted by the fact that the larger stations will have evidently more observations for every category, due to the amount of passengers using the station. When modelling the multi-modal trips, it is of great importance to obtain insights in the travel times and mode choice of the passengers to and from the stations.

C.2 DATA: MULTI-MODALITY AND CATCHMENTS

The Netherlands Railways has some data about the travel times, mode choice and origin and/or destination area based on postal codes. This is available for both the access as the egress side of the trip. A little remark, the data at the egress side tend to be less reliable due to missing observations. The data is analysed based on the stations in both case studies, the Stedenbaan Zuid and the Veluwelijn.

The travel time to and from the stations are categorised in 6 different categories. In 5 minutes, 15 minutes, 25 minutes, 45 minutes, 75 minutes and missing. The amount of observations need to be sufficient per station and - desirable - per category. Each time category could be interpreted as a separate ring as visualised in Figure C.1. In Table C.1, the distribution over all observations in the data set.

Trip	5 min [%]	15 min [%]	25 min [%]	45 min [%]	75 min [%]	- [%]
Access	41,55	40,82	11,90	4,03	1,16	0,53
Egress	36,08	37,13	10,32	4,09	5,33	7,04

Table C.1: Distribution of the travel times for access and egress trips

While considering all 42.723 observations of the data set, the distributions for the travel times of the access and egress time is found. For the egress trips, about 7% of the observations show a missing value for travel times opposite to 0,5% for the access trips. The first two time categories show for both the access and egress trip about the same share of observations, the difference is within the range of 1% per trip type. Comparing the share of the access and egress trips per time category, the first two time categories are significantly different, this can be assigned to the missing values. Analysing the distribution overall, it seems almost equal for both the access and egress trips. The biggest differences are:

1. The sequence of the most observed time categories is for the **access trips** time category 1 and 2, while for the **egress trips** it is time category 2 and 1.
2. The highest time category is significantly more observed for **egress trips** than for **access trips**. This can be a result of the lack of availability of faster private modes at the egress side.

When analysing the travel times of the access trips on the Stedenbaan Zuid, the lowest amount of observation per station is for station Rotterdam Zuid with 22 observations and the highest amount is for station Rotterdam CS with 1138 observations. The total amount of observations at the access side is 4543 observations for the Stedenbaan Zuid, with 27 missing values. The observations for the same line and the egress trip provide as lowest value 16 observations for station Den Haag Moerwijk and 2150 observations for Den Haag CS. The total amount of observations at the egress side is 5660, with 310 missing values.

For the access side of the trips on the Veluwelijn, the total amount of observations is 4099 with 30 missing values. The lowest value is for station Wezep with a value of 26 and the highest value is for station Utrecht CS with a value of 1801. The total amount of observations on the egress side is 6592 with 439 missing values. The lowest value is 15 observations for station Wezep and the highest value is 4273 for station Utrecht CS.

c.2.1 Trip times per station

The Stedenbaan Zuid from station Dordrecht to station Den Haag CS, is a line in a fairly urbanised region in the Netherlands. Most of the stations can rely on other profound transportation systems for the access and egress trips of the passengers. In Table C.2 and Table C.3, the distribution of observations of trip times over the different stations for the access and egress trips are presented.

Stations	5 min	15 min	25 min	45 min	75 min	-	Total
Den Haag HS	100	139	53	4	1	3	300
Den Haag CS	227	513	278	67	14	7	1106
Rijswijk	54	43	13	1	0	0	111
Delft	254	214	27	9	3	0	507
Delft Campus	37	9	8	0	0	0	54
Schiedam Centrum	95	177	91	34	5	2	404
Rotterdam CS	311	414	217	130	54	12	1138
Rotterdam Blaak	86	58	30	5	5	0	184
Rotterdam Zuid	12	4	4	1	0	1	22
Rotterdam Lombardijen	30	40	5	4	0	0	79
Barendrecht	71	48	11	8	0	1	139
Zwijndrecht	74	44	3	0	0	0	121
Dordrecht	145	152	37	9	4	1	348
Den Haag Moerwijk	14	12	4	0	0	0	30
Total	1510	1867	781	272	86	27	4543

Table C.2: Distribution of access trip times on the Stedenbaan Zuid

For the access trips, the total amount of observations is 4543 with a total of 27 missing values. Most of the observed trips are within the first two time categories, where the second category is the biggest. The stations with the highest amount of observations are station Rotterdam CS and Den Haag CS with respectively 1138 and 1106 observations. These stations also have the most observations for the highest time category, this can be clarified by the possibilities for faster transport modes or the destinations that are reachable from those stations, thus providing a larger attraction of that station.

Stations	5 min	15 min	25 min	45 min	75 min	-	Total
Den Haag HS	111	127	54	8	5	14	319
Den Haag CS	791	857	279	80	38	105	2150
Rijswijk	31	20	1	2	0	1	55
Delft	170	175	40	10	9	25	429
Delft Campus	20	13	1	1	0	0	35
Schiedam Centrum	62	80	44	16	8	8	218
Rotterdam CS	511	655	205	91	80	96	1638
Rotterdam Blaak	134	107	20	11	5	22	299
Rotterdam Zuid	33	14	1	6	3	15	72
Rotterdam Lombardijen	32	19	10	2	3	3	69
Barendrecht	15	11	4	0	1	1	32
Zwijndrecht	16	11	4	1	0	0	32
Dordrecht	77	138	38	12	12	19	296
Den Haag Moerwijk	8	6	1	0	0	1	16
Total	2011	2233	702	240	164	310	5660

Table C.3: Distribution of egress trip times on the Stedenbaan Zuid

The total amount of observations on the egress side of the trip for the stations on the Stedenbaan Zuid is 5660 with 310 missing values. In this data set, the stations on the Stedenbaan Zuid are more observed as destination stations than origin stations. The first two time categories are mostly observed, with the second category being the maximum. Again, Den Haag CS and Rotterdam CS are the stations with the most observations. Stations Rotterdam CS and Den Haag CS show the most observations for the highest time category. This could imply the regional importance for these stations. Station Dordrecht and Schiedam Centrum are runner ups in this case.

The Veluwelijn is located in a less urbanised region of the Netherlands. Where some of the stations could not rely on high quality transportation systems. The ridership is mostly focused on three stations, Utrecht CS, Amersfoort CS and Zwolle. In Table C.4 and Table C.5, the access and egress trips are presented over the trip times per station.

Stations	5 min	15 min	25 min	45 min	75 min	-	Total
Zwolle	222	318	97	35	17	2	691
Wezep	12	12	2	0	0	0	26
Harde 't	13	30	5	3	0	0	51
Nunspeet	38	13	3	1	2	1	58
Den Dolder	33	14	1	0	1	0	49
Bilthoven	67	34	2	1	1	1	106
Amersfoort CS	261	313	104	25	7	4	714
Amersfoort Schothorst	107	57	7	0	0	0	171
Nijkerk	45	23	8	0	1	0	77
Putten	22	19	0	0	0	0	41
Ermelo	64	31	3	1	1	0	100
Harderwijk	58	50	10	4	0	1	123
Utrecht Overvecht	79	37	7	2	0	0	125
Utrecht CS	448	820	346	138	28	21	1801
Amersfoort Vathorst	44	19	2	1	0	0	66
Total	1449	1759	594	210	57	30	4099

Table C.4: Distribution of access trip times on the Veluwelijn

The total amount of observations for the access side of the trips is 4099 with 30 missing values. The first two time categories are mostly observed, where the second time category is most observed. Stations Utrecht CS is mostly observed with 1801 observations and is followed by station Amersfoort CS with 714 observations and Zwolle with 691 observations. Stations Zwolle and Utrecht CS show the most observations for the highest time category, where Zwolle shows the highest relative share. This addresses the regional importance of these stations.

Stations	5 min	15 min	25 min	45 min	75 min	-	Total
Zwolle	274	445	77	36	44	64	940
Wezep	4	4	1	0	6	0	15
Harde 't	4	10	2	3	2	2	23
Nunspeet	26	11	5	0	6	3	51
Den Dolder	9	11	1	1	3	3	28
Bilthoven	55	30	12	3	8	0	108
Amersfoort CS	338	301	74	25	25	45	808
Amersfoort Schothorst	36	14	7	2	0	3	62
Nijkerk	22	13	1	1	3	1	41
Putten	7	12	8	1	3	3	34
Ermelo	23	18	1	0	1	3	46
Harderwijk	24	21	17	3	3	6	74
Utrecht Overvecht	58	30	3	0	2	7	100
Utrecht CS	1630	1691	456	121	74	301	4273
Amersfoort Vathorst	21	9	3	1	0	1	35
Total	2508	2602	667	197	179	439	6592

Table C.5: Distribution of egress trip times on the Veluwelijn

The total amount of observations for the egress side of the trips is 6592 with 439 missing values. The amount of observations at the egress side is substantially larger than at the access side. Again, the first two time categories are mostly observed, where the second time category is most observed. Yet, the difference with the first time category is less than 100 observations. Station Utrecht CS has 4273 observations, followed by Zwolle with 940 observations and Amersfoort with 808 observations. Where station Zwolle and Utrecht CS show the most observations in the highest time category.

For both the Veluwelijn as the Stedenbaan Zuid, the distribution of the observations over the time categories seem fairly similar. Most of the trips are present in the first two time categories. This could be in line with the residential self-selection phenomenon, that people tend to choose their home based on the mode they frequently use. That could clarify the access side of the trips. The egress side of the trips should be clarified by the trip purpose. Most of the people using the train for the daily commute tend to work near the station or have a sufficient connection with other transportation modes. Some of the stations show observations in the highest time category, assuming that faster transportation modes are used for these trips, the catchment areas of these stations is fairly large. These stations do mostly have a substantial amount of boarding and alighting passengers or are the bigger stations in the area.

c.2.2 Mode choice and trip times

In Table C.6 and Table C.7, the mode choice for different trip times respectively for the access and egress trips. For both cases, all observations in the data set are included. The mode choice for different trip times could differ per region. For example, the availability of underlying transport systems, as bus/tram/metro, or the availability of private modes, as a bicycle or car. The mode choice, especially at the egress side of the trip could be influenced by the emerging shared mobility.

Mode	5 min	15 min	25 min	45 min	75 min	-	Total
Station was destination	0	0	0	1	0	124	125
Walking	5870	3704	567	120	85	31	10377
Bike	5755	4809	808	174	35	7	11588
E-bike	444	584	175	49	8	1	1261
Passenger (bike, moped)	36	34	10	2	0	0	82
Folding bike	217	126	21	7	1	1	373
Folding E-bike	5	9	5	1	2	1	23
Moped	46	54	10	2	3	1	116
Car (driver)	1749	2060	678	216	76	5	4784
Car/motor (passenger)	1791	1525	390	128	68	8	3910
Motor (driver)	6	13	0	2	0	0	21
BTM	1702	4359	2370	980	189	27	9627
Taxi	106	124	26	10	1	3	270
Different	24	34	21	25	23	8	135
-	10	13	6	6	5	11	51
Total	17761	17448	5087	1723	496	228	42743

Table C.6: Mode choice for access trip times

At the access side of the trip, walking, cycling and the BTM option are mostly used. Remarkably, 85 observations did walk for a maximum of 75 minutes, which is very unlikely. Most of the observations are using a bicycle for the access trip with a value of 11.588. The bicycle is mostly used for the first two time categories and in a smaller extent for the third time category. Walking shows a similar distribution over the time categories as cycling, with a total number of observations of 10.377. The bus, tram and metro account for 9627 of the observations. These observations are mostly distributed over the first three time categories. Overall, the higher categories in trip times are less observed in the access trips. The active modes are widely used, followed by other public transport. The car, both as passenger and

driver, is also more widely used for the lower travel time categories, while it might be expected that this mode will be more convenient for the longer trip times.

Mode	5 min	15 min	25 min	45 min	75 min	-	Total
Station was destination	0	0	1	0	1	2477	2479
Walking	10156	7460	1556	519	635	241	20567
Bike	1002	1295	287	93	122	16	2815
E-bike	24	44	26	13	37	5	149
Passenger (bike, moped)	26	22	4	5	1	0	58
Folding bike	159	163	39	11	4	0	376
Folding E-bike	3	6	5	1	1	1	17
Moped	4	8	4	1	2	1	20
Car (driver)	85	91	40	33	33	4	286
Car/motor (passenger)	1387	1501	436	237	246	29	3836
Motor (driver)	3	2	0	1	0	0	6
BTM	2272	4988	1917	763	300	88	10328
Taxi	84	129	40	16	14	6	289
Airplane	125	36	14	16	740	75	1006
Different	80	107	34	27	126	30	404
-	13	18	9	14	18	35	107
Total	15423	15870	4412	1750	2280	3008	42743

Table C.7: Mode choice for egress trip times

One of the most outstanding changes is the increasing amount of observations walking to their destination at the egress side. The value nearly doubled to 20.567. The passengers cycling and driving a car decrease enormously. This can be clarified by the fact that these transportation methods mostly use privately owned modes, which are less available at the destination station. The use of bus, tram and metro increased a little compared to the access side of the trip to 10.328 observations, where almost half of the trips will be at maximum 15 minutes. A new mode is observed at the egress side, this is the airplane. This explains the increasing observations of the longer travel times.

While using the mode choice in the calculations, some of the modes might be excluded or merged. As not every mode is relevant for representing the daily multi-modal trips and some of the categories could easily be combined to elucidate the distribution of mode choices.

Clustered mode choices and trip times

To obtain more relevant structures in the access and egress modes and their usage per catchment ring, the modes have been clustered by similarities. The following clusters have been selected, walking, bike, e-bike, mopeds, cars and BTM. Most of the categorisations are based on speed and the distinguished between drivers and passengers has been diminished.

Mode	5 [min]	15 [min]	25 [min]	45 [min]	75 [min]	Total
Walking	5297	3298	500	108	69	9272
Bike	5669	4673	792	171	32	11337
E-bikes	420	548	169	45	10	1192
Moped	39	47	10	2	2	100
Car	3123	3189	969	305	118	7704
BTM	1498	3859	2145	882	161	8545

Table C.8: Clustered mode choice for access trip times

For the access trips, the bike and walking are the most observed modes and more dominant over the first two rings (see Table C.8). BTM follows and is more observed over the second and third ring.

Mode	5 [min]	15 [min]	25 [min]	45 [min]	75 [min]	Total
Walking	10142	7445	1553	517	634	20291
Bike	1181	1476	329	109	127	3222
E-bikes	27	50	31	14	38	160
Moped	4	8	4	1	2	19
Car	1551	1718	514	283	292	4358
BTM	2267	4977	1907	761	299	10211

Table C.9: Clustered mode choice for egress trip times

For the access trips, walking is the most observed modes and more dominant over the first two rings (see Table C.9). A huge drop in the usage of bicycles is observed, this can due to the lack in availability of this - originally - private mode at the egress side. BTM seems to take the share of bicycles over.