

'EENHEID IN VERSCHIEDENHEID'

AFSTUDEERSTUDIO ARCHITECTURE & DWELLING

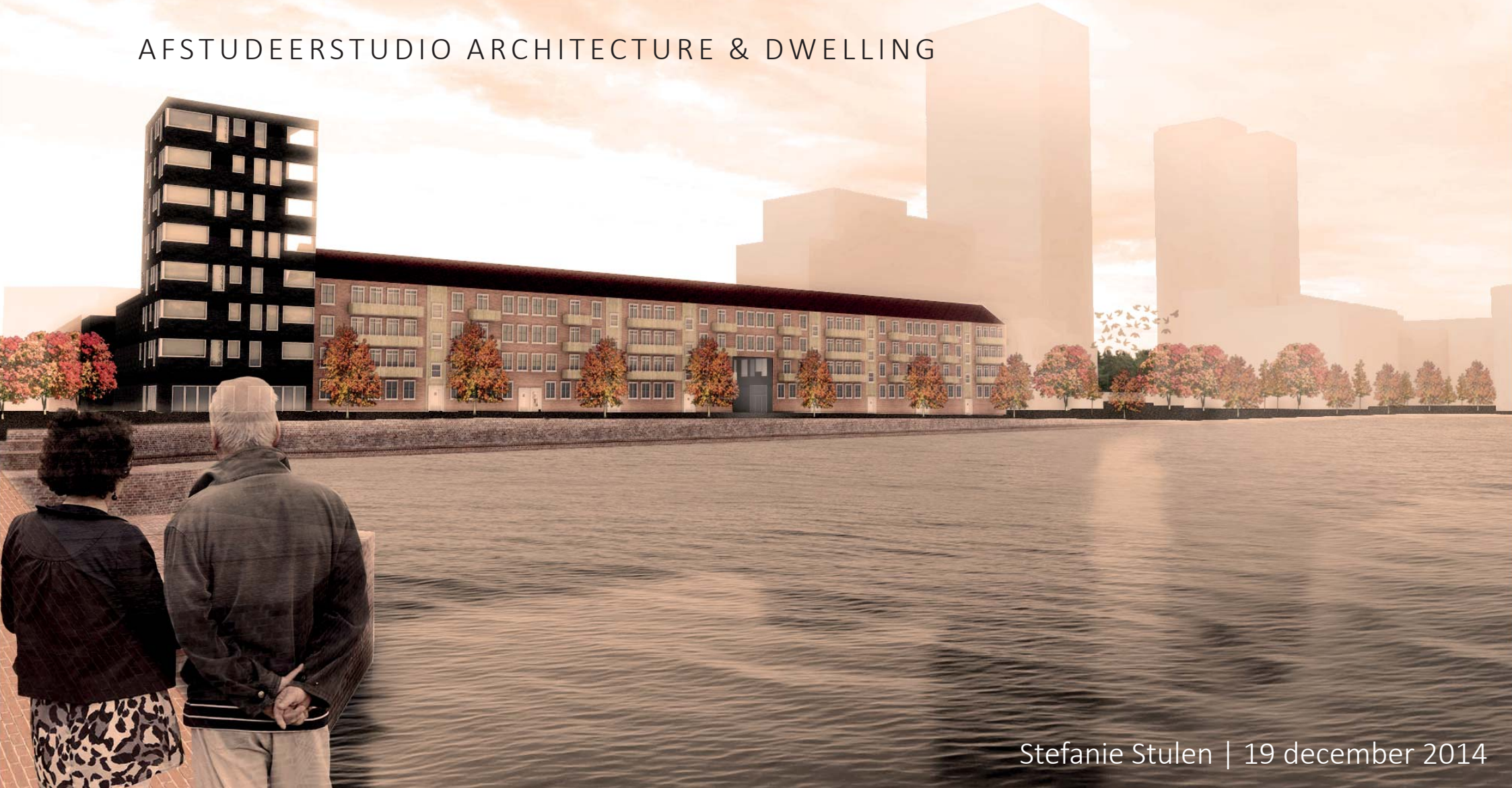

Stefanie Stulen | 19 december 2014

INHOUDSOPGAVE

IMPRESSIE

INLEIDING LOCATIE

PROBLEEMSTELLING

ONTWIKKELINGEN

ONTWERPOPDRACHT

THEMA ONDERZOEK

ROUTE DOOR HET ONTWERP

STEDENBOUWKUNDIG ONTWERP

OPDELING

WONINGEN

KLIMAATSYSTEEM

DETAILLERING





coffeecompany



treub

let's go!





INDOS .NL

INSPIRATIE

EMMA GIES

Handwritten graffiti on a wall, including colorful abstract shapes and the text "LIP" and "DRS 05/11".

Handwritten graffiti on a wall, including the word "ace" in black, "KUR" in blue, and a large white abstract tag on a black background.

Two men standing on a sidewalk, one in a dark jacket and jeans, the other in a black coat, looking at something together.

A person standing on the sidewalk near a bicycle, wearing a grey jacket and blue jeans.

Two people walking on the sidewalk, a man in a blue shirt and a woman in a black dress.





14



13







LOCATIE



LOCATIE



LOCATIE



AMSTERDAM CENTRAL STATION M

NIEUWMARKT M

WATERLOOPLEIN M

WEESPERPLEIN M

WIBAUTSTRAAT M



LOCATIE



LOCATIE



LOCATIE



VAN DER KUNBUURT



VAN DER KUNBUURT

ONTWERPLOCATIE

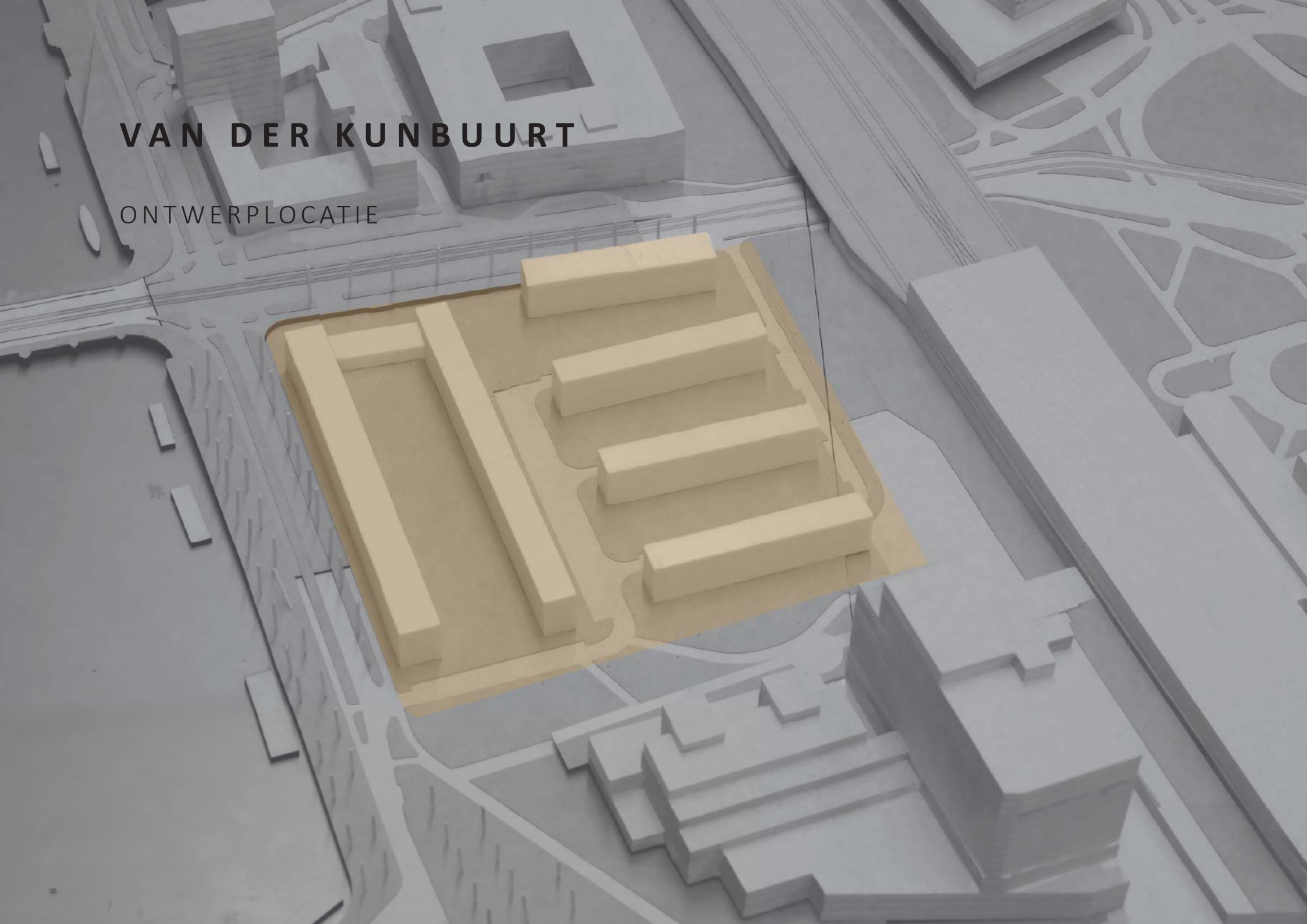

VAN DER KUNBUURT

SOCIALE WONINGBOUW

284

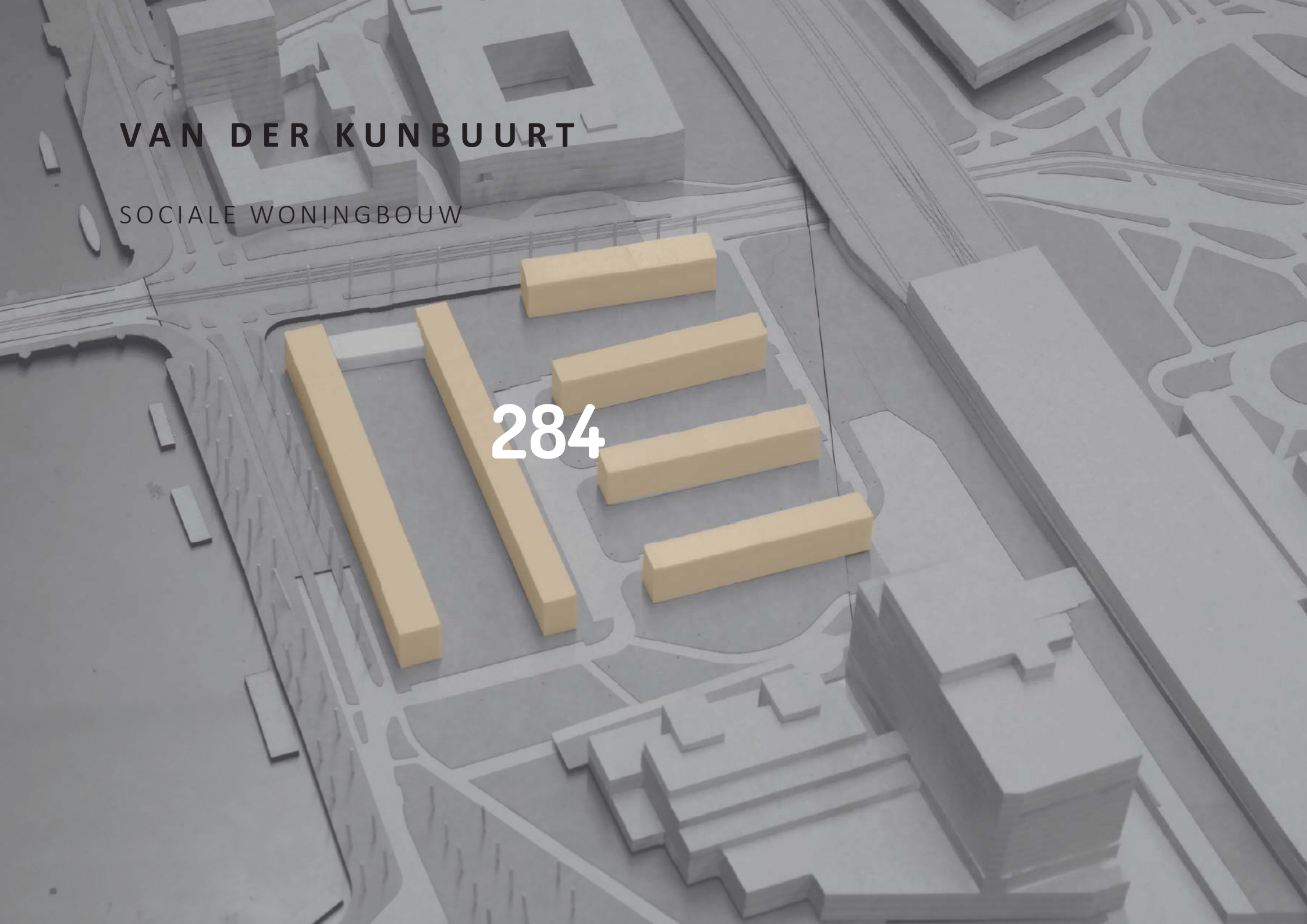

VAN DER KUNBUURT

ORIËNTATIEPUNTEN

BERLAGEBRIDGE

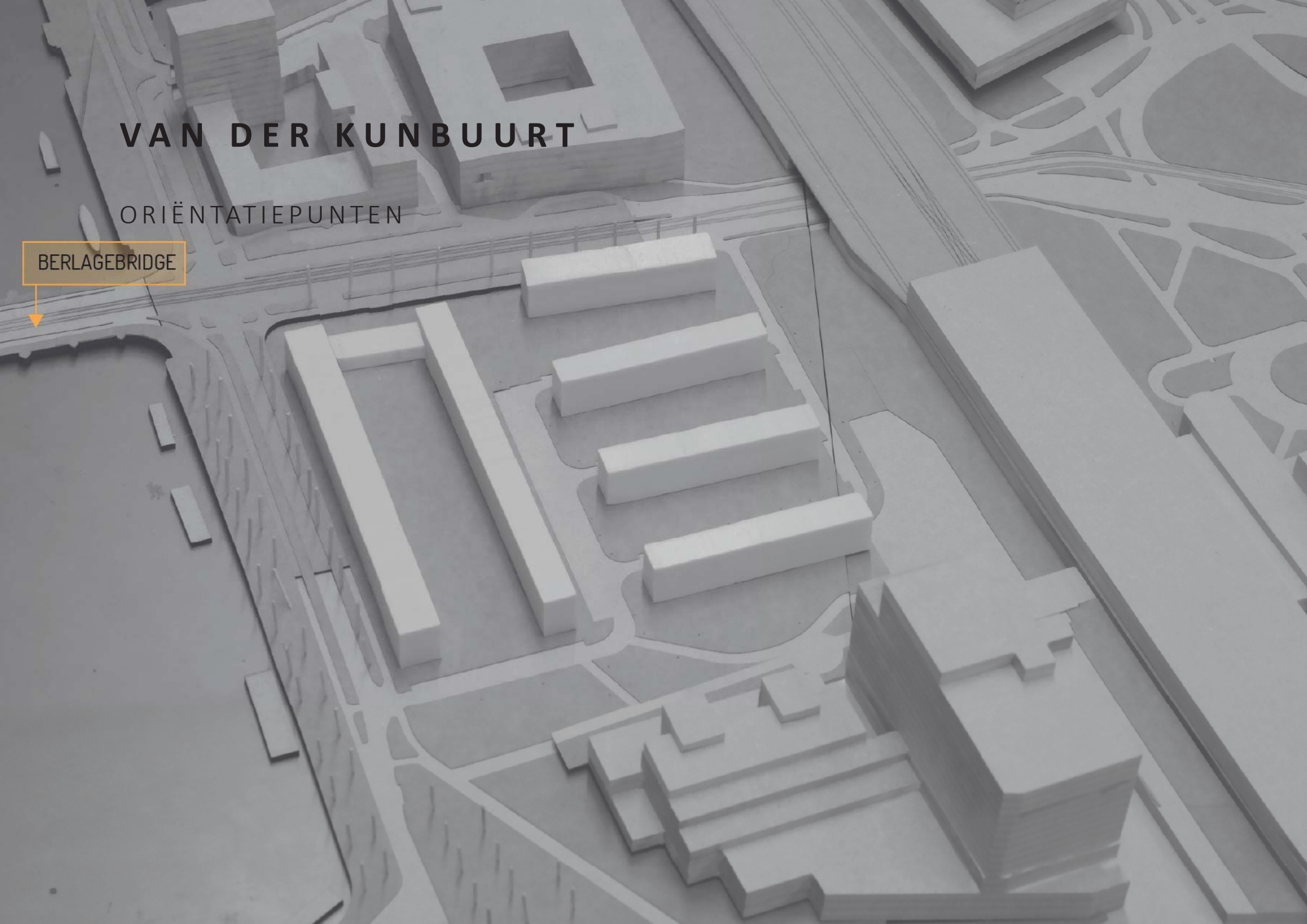

VAN DER KUNBUURT

ORIËNTATIEPUNTEN

BERLAGEBRIDGE



AMSTEL



VAN DER KUNBUURT

ORIËNTATIEPUNTEN

BERLAGEBRIDGE



AMSTEL



STATION AMSTEL

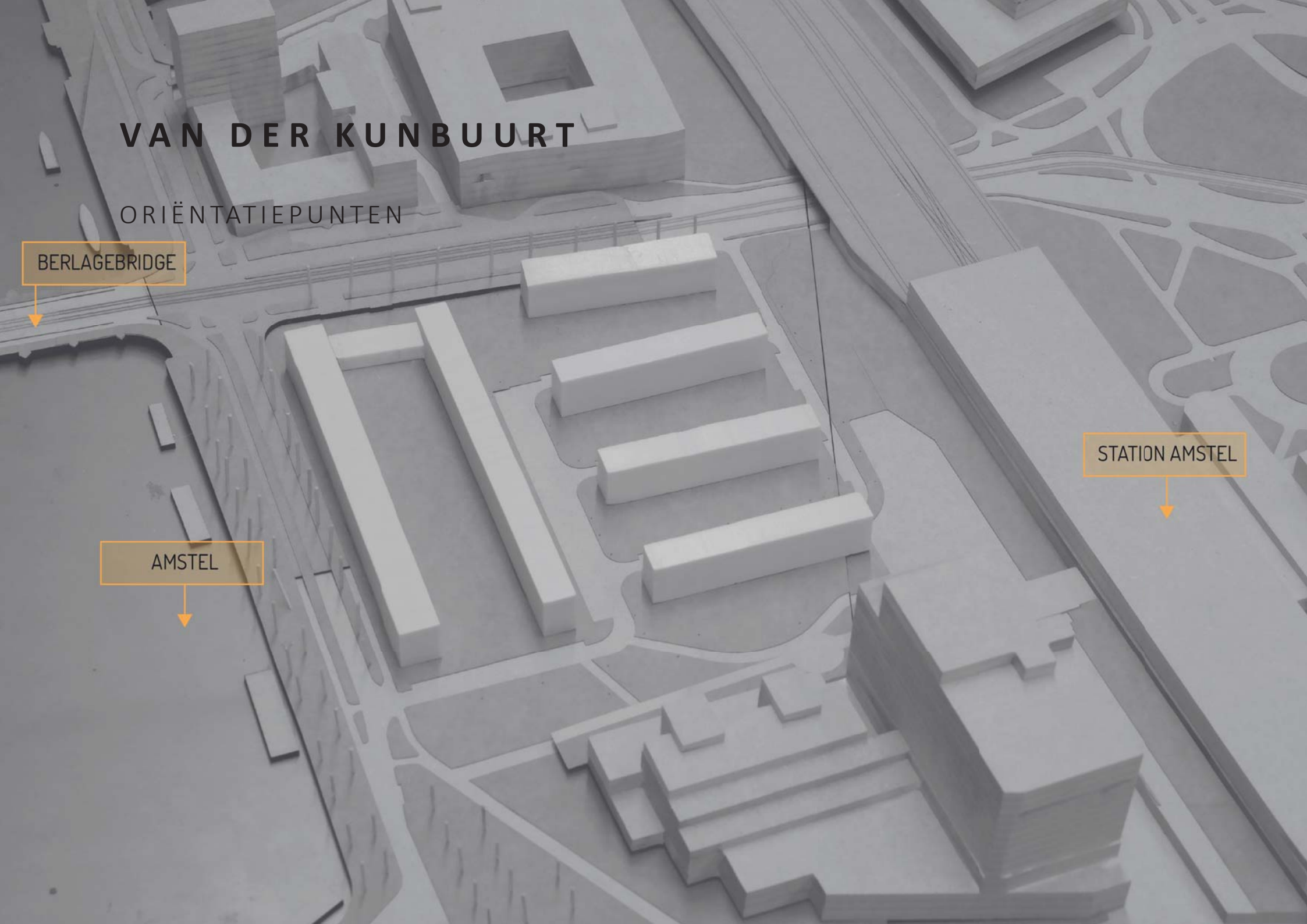

VAN DER KUNBUURT

FUNCTIES



VAN DER KUNBUURT

FUNCTIES



VAN DER KUNBUURT

FUNCTIES



VAN DER KUNBUURT

FUNCTIES



VAN DER KUNBUURT

FUNCTIES



VAN DER KUNBUURT

HOOGTEVERSCHILLEN

255+

70+

70+

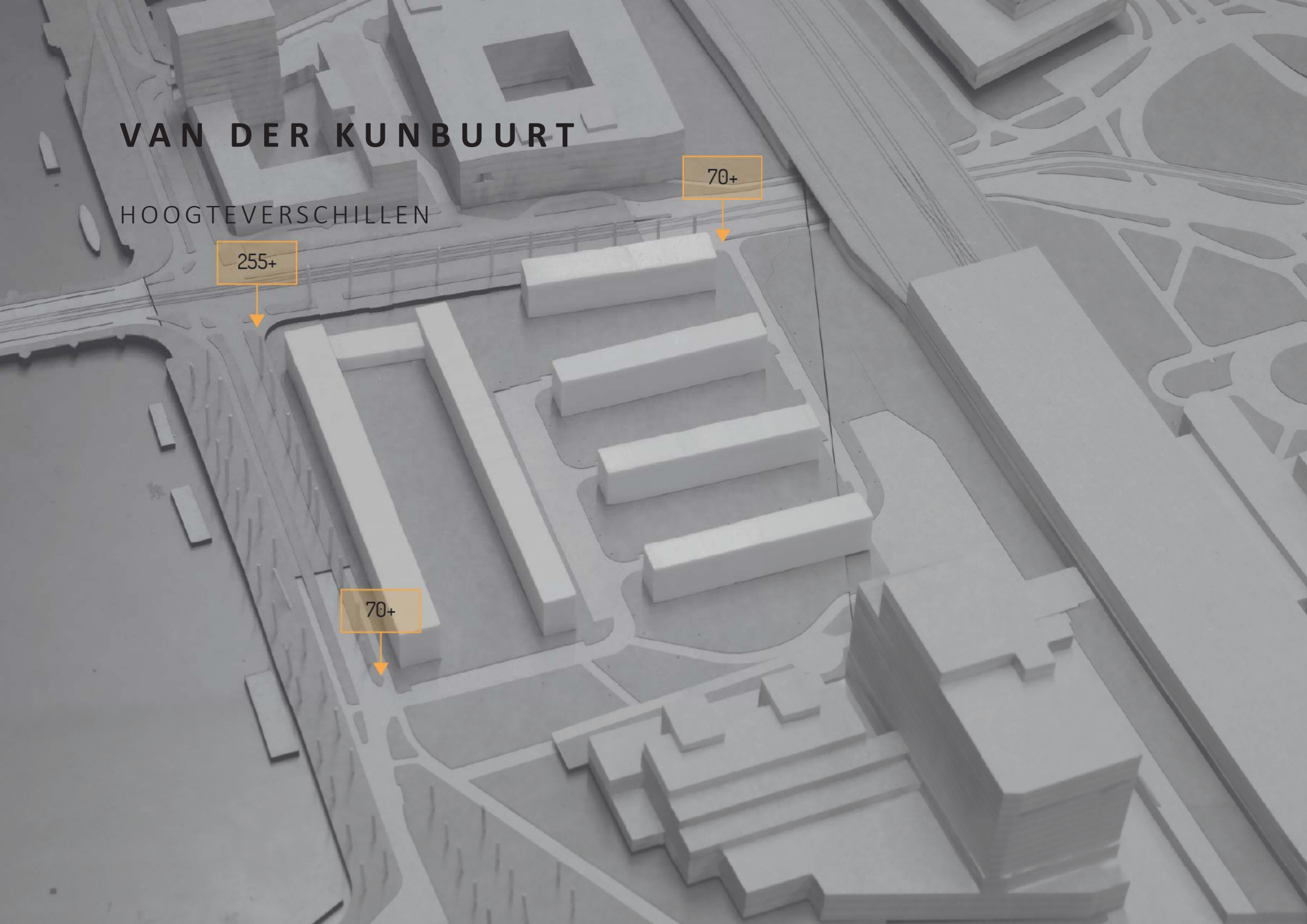

VAN DER KUNBUURT

ONTSLUITING



VAN DER KUNBUURT

ONTSLUITING



VAN DER KUNBUURT

ONTSLUITING



STEDENBOUWKUNDIGE ANALYSE

CONCLUSIE

+

-

STEDENBOUWKUNDIGE ANALYSE

CONCLUSIE



Ontsluiting

Faciliteiten zijn dichtbij

Kwaliteits-prijsverhouding van de woningen

Naast de Amstel

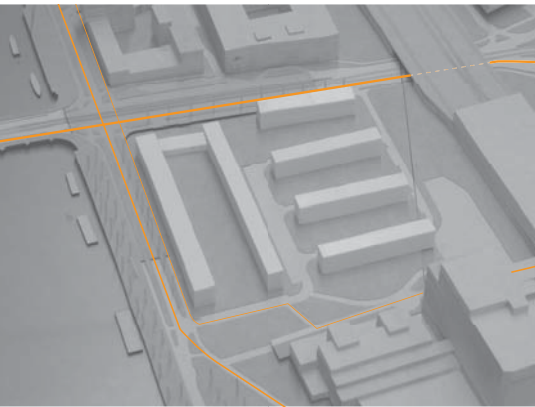

STEDENBOUWKUNDIGE ANALYSE

CONCLUSIE



Ontsluiting

Faciliteiten zijn dichtbij

Kwaliteits-prijsverhouding van de woningen

Naast de Amstel

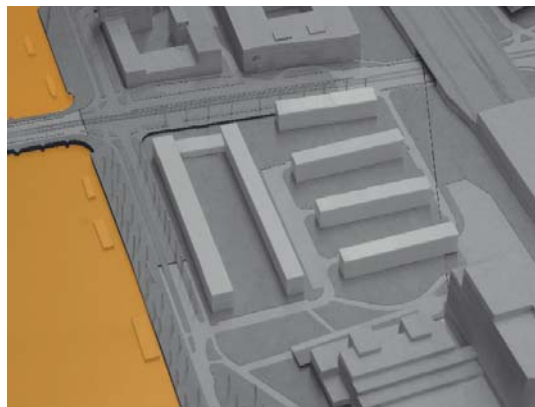

STEDENBOUWKUNDIGE ANALYSE

CONCLUSIE



Ontsluiting

Faciliteiten zijn dichtbij

Kwaliteits-prijsverhouding van de woningen

Naast de Amstel



Functioneel geïsoleerd

Ongebruikte buitenruimte

Geen samenhang in de buurt

Levendigheid mist

Gesloten plint

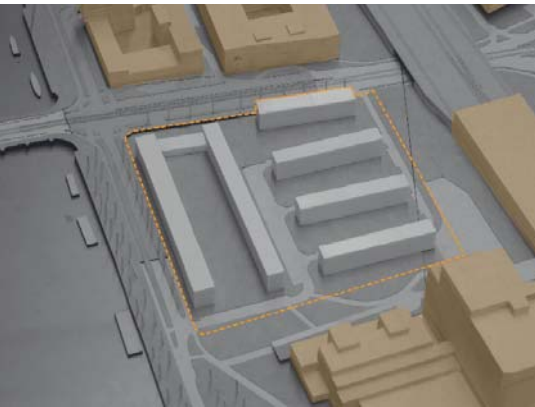

STEDENBOUWKUNDIGE ANALYSE

CONCLUSIE



Ontsluiting

Faciliteiten zijn dichtbij

Kwaliteits-prijsverhouding van de woningen

Naast de Amstel



Functioneel geïsoleerd

Ongebruikte buitenruimte

Geen samenhang in de buurt

Levendigheid mist

Gesloten plint

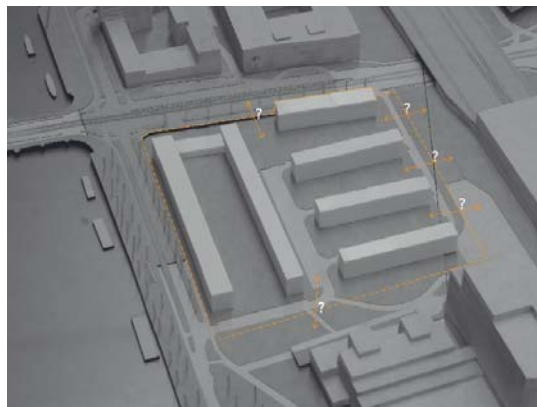
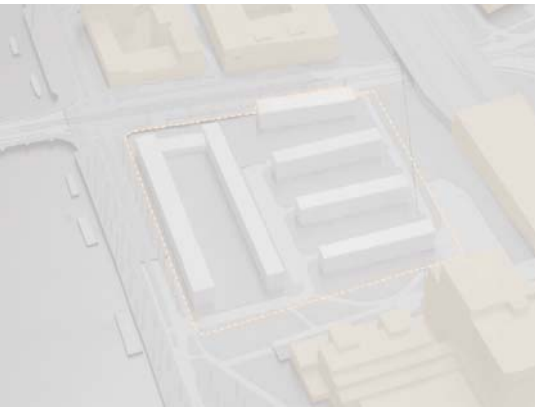

STEDENBOUWKUNDIGE ANALYSE

CONCLUSIE



Ontsluiting

Faciliteiten zijn dichtbij

Kwaliteits-prijsverhouding van de woningen

Naast de Amstel



Functioneel geïsoleerd

Ongebruikte buitenruimte

Geen samenhang in de buurt

Levendigheid mist

Gesloten plint

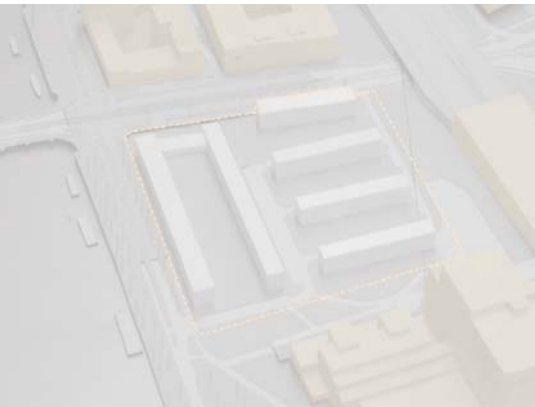

STEDENBOUWKUNDIGE ANALYSE

CONCLUSIE



Ontsluiting

Faciliteiten zijn dichtbij

Kwaliteits-prijsverhouding van de woningen

Naast de Amstel



Functioneel geïsoleerd

Ongebruikte buitenruimte

Geen samenhang in de buurt

Levendigheid mist

Gesloten plint

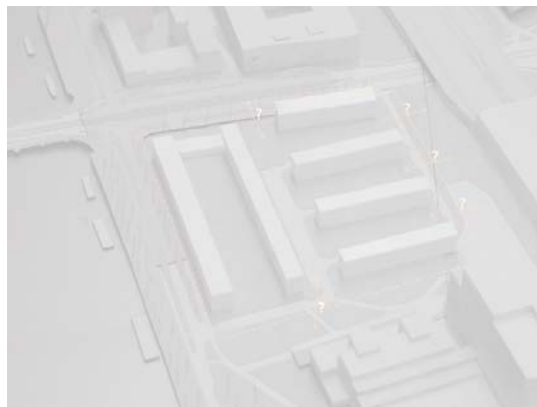
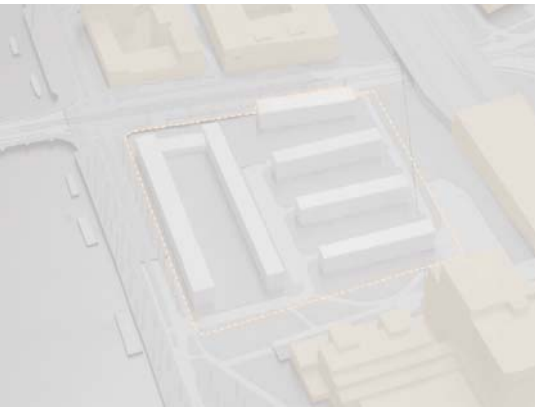

PROBLEMSTELLING

PROBLEEMSTELLING

SAMENHANG ONTBREEKT

In de **functioneel geïsoleerde** Van der kunbuurt is de samenhang in en om de Van der Kunbuurt gering. De bewoners van de gedecontextualiseerde buurt hebben niet of **nauwelijks (ver)binding met hun directe leefomgeving**. De huidige wooncondities **voldoen niet meer aan de woonbehoefte** van het leven in de **21ste eeuw**.

PROBLEEMSTELLING

SAMENHANG ONTBREEKT

In de **functioneel geïsoleerde** Van der kunbuurt is de samenhang in en om de Van der Kunbuurt gering. De bewoners van de gedecontextualiseerde buurt hebben niet of **nauwelijks (ver)binding met hun directe leefomgeving**. De huidige wooncondities **voldoen niet meer aan de woonbehoefte** van het leven in de **21ste eeuw**.

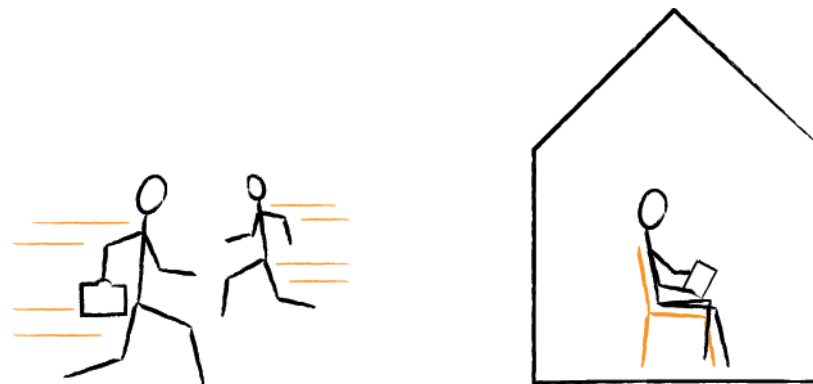

SOCIAAL EN MAATSCHAPPELIJKE ONTWIKKELEN

SOCIAAL EN MAATSCHAPPELIJKE ONTWIKKELEN

DECONTEXTUALISERING

Flexibilisatie van de arbeidsmarkt



Globalisering



Verstedelijking



SOCIAAL EN MAATSCHAPPELIJKE ONTWIKKELEN

DECONTEXTUALISERING

Flexibilisatie van de arbeidsmarkt



Globalisering



Verstedelijking



SOCIAAL EN MAATSCHAPPELIJKE ONTWIKKELEN

DECONTEXTUALISERING

Flexibilisatie van de arbeidsmarkt



Globalisering



Verstedelijking



SOCIAAL EN MAATSCHAPPELIJKE ONTWIKKELEN

DECONTEXTUALISERING

Flexibilisatie van de arbeidsmarkt



Globalisering



Verstedelijking



ONTWERPOEDRACHT

ONTWERPOPDRACHT

TRANSFORMATIE

Het transformeren van Van der Kunbuurt, met zoveel mogelijk **behoud van bestaande bouw**, zodat het zowel in de stedenbouwkundige context als op schaal van de woning voldoet aan de **leef-en woonbehoeftes van de 21ste eeuw**.

ONTWERPOPDRACHT

TRANSFORMATIE

Het transformeren van Van der Kunbuurt, met zoveel mogelijk **behoud van bestaande bouw**, zodat het zowel in de stedenbouwkundige context als op schaal van de woning voldoet aan de **leef-en woonbehoeftes van de 21ste eeuw**

THEMA ONDERZOEK

'LEESBAARHEID VAN DE RUIMTE'

LEESBAARHEID VAN DE RUIMTE

THEORIE

THEMA ONDERZOEK: 'LEESBAARHEID VAN DE RUIMTE'

THEORIE

Jane Jacobs (binding directe leefomgeving)



THEMA ONDERZOEK: 'LEESBAARHEID VAN DE RUIMTE'

THEORIE

Jane Jacobs (binding directe leefomgeving)

Jan Gehl



THEMA ONDERZOEK: 'LEESBAARHEID VAN DE RUIMTE'

THEORIE

Jane Jacobs (binding directe leefomgeving)

Jan Gehl

Herman Hertzberger



LEESBAARHEID VAN DE RUIMTE

REFERENTIES



BEGIJNHOF
Leuven

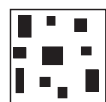

LE MEDI
Rotterdam

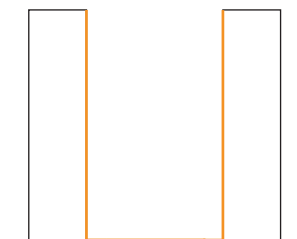

POPTAHOF, AKROPOLIS
Delft
RESIDENCE LE POINT DU JOUR
Parijs



JUSTUSKWARTIER
Rotterdam



8-TALLET
Copenhagen

LEESBAARHEID VAN DE RUIMTE

HET VORMEN VAN EEN LEESBAAR GEHEEL



LEESBAARHEID VAN DE RUIMTE

WONINGDIFFERENTIATIE

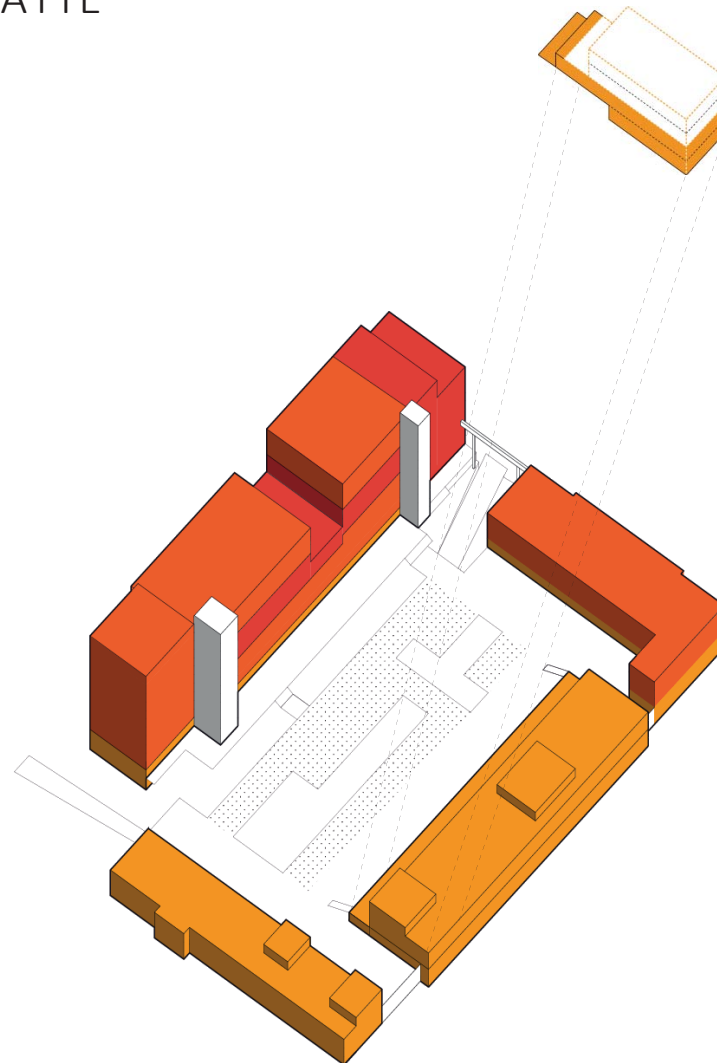

LEESBAARHEID VAN DE RUIMTE

BETROKKENHEID

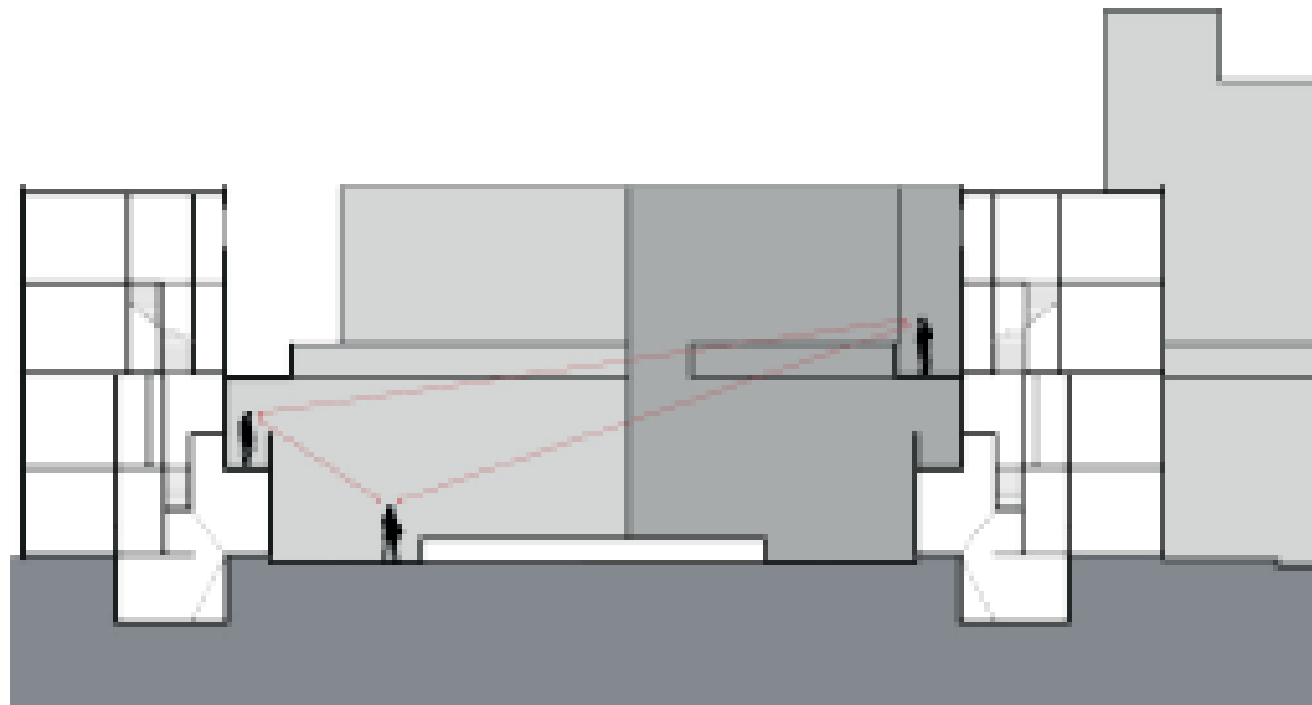

LEESBAARHEID VAN DE RUIMTE

TOEËIGENEN



LEESBAARHEID VAN DE RUIMTE

MOGELIJKHEID VOOR VERSCHILLENDE ACTIVITEITEN

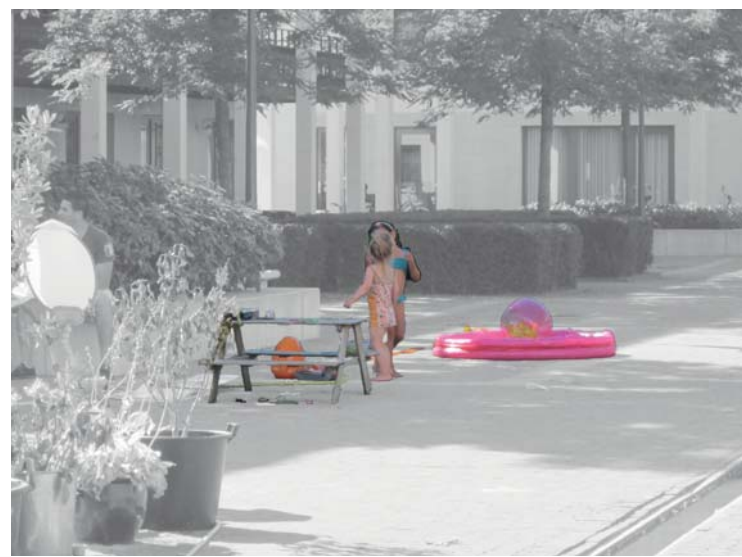

LEESBAARHEID VAN DE RUIMTE

EIGEN INTERPRETATIE



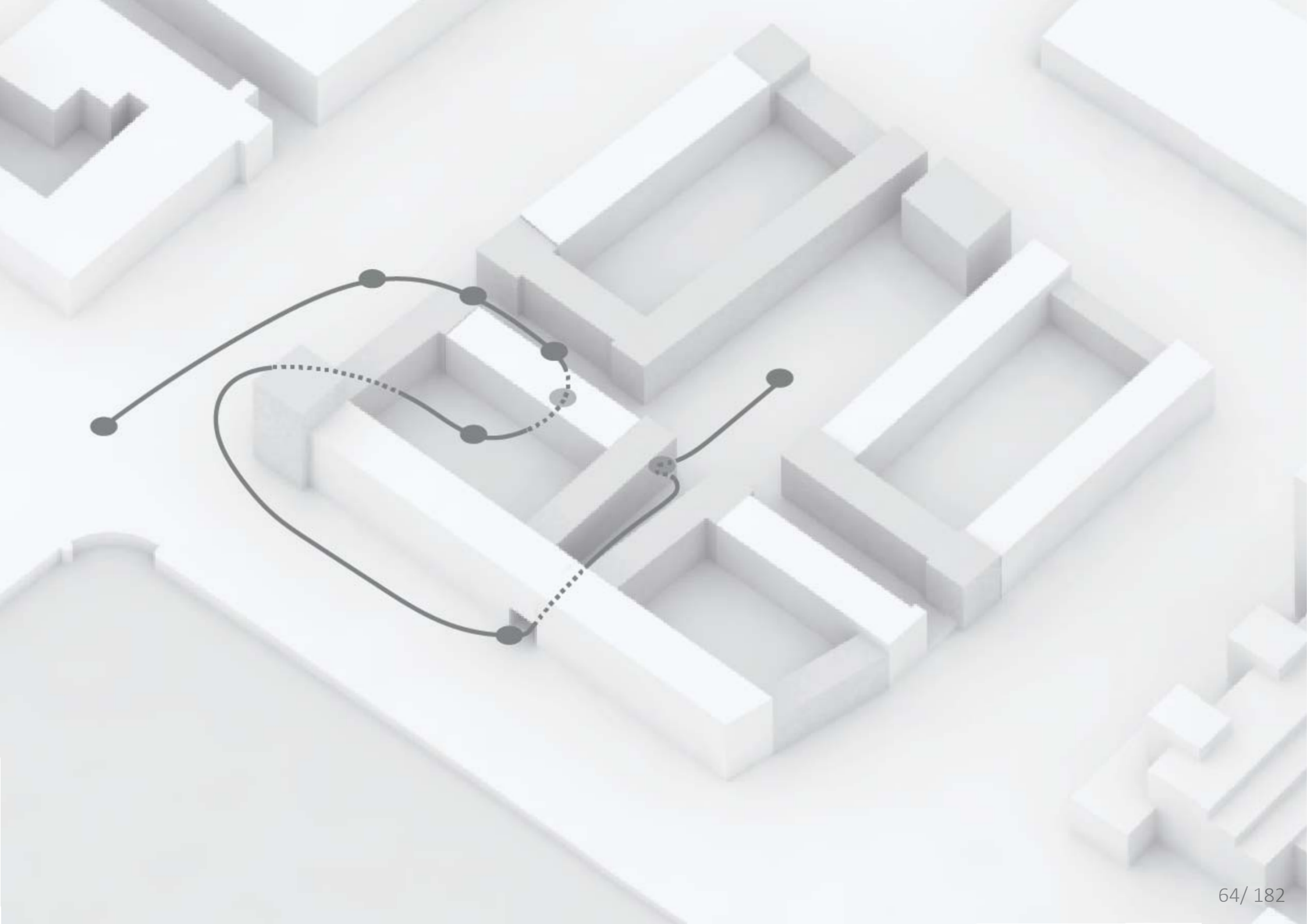

STEDENBOUWKUNDIG ONTWERP



STEDENBOUWKUNDIG ONTWERP

HUIDIGE SITUATIE

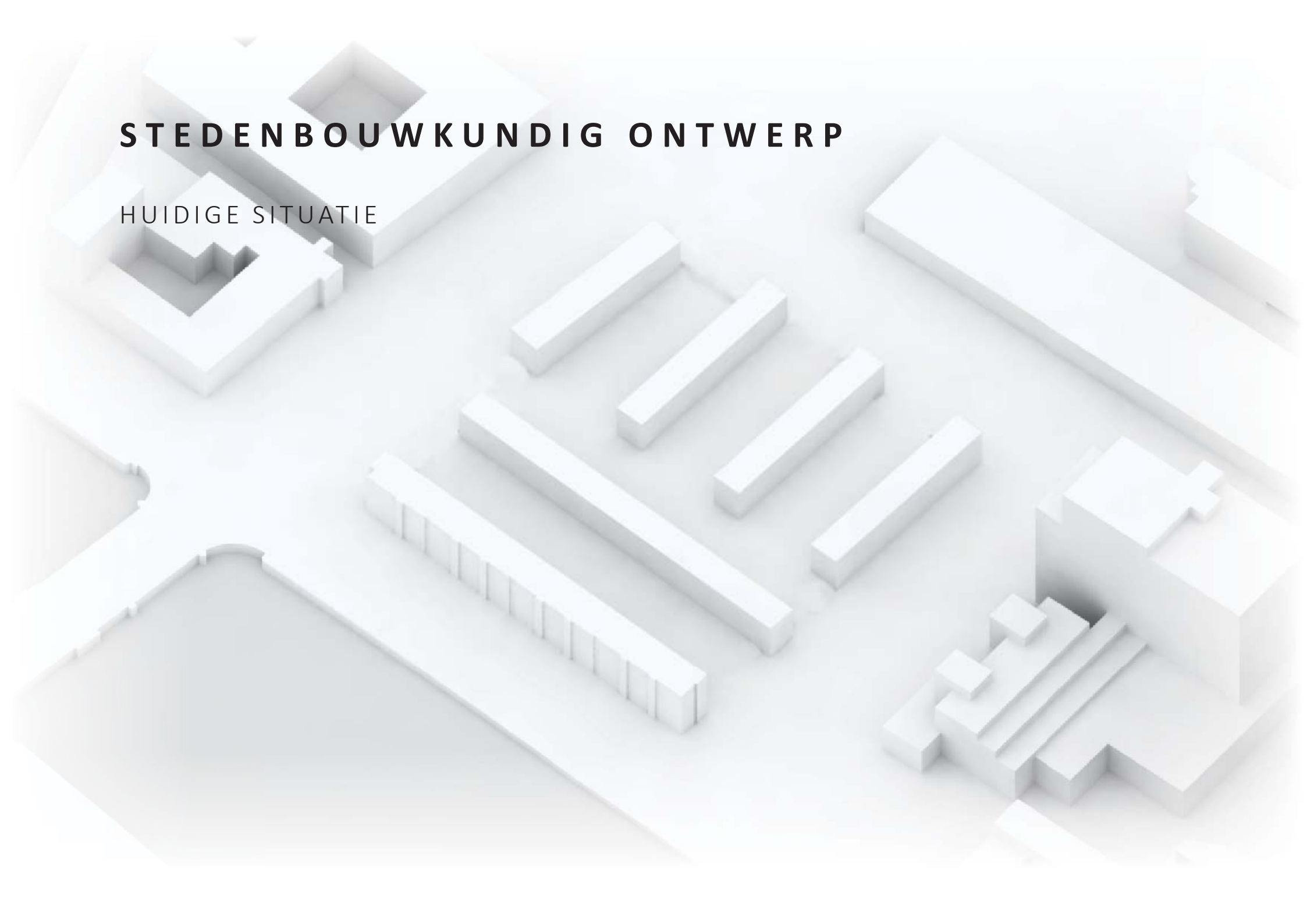

AFBAKENING VAN DE WOONWIJK

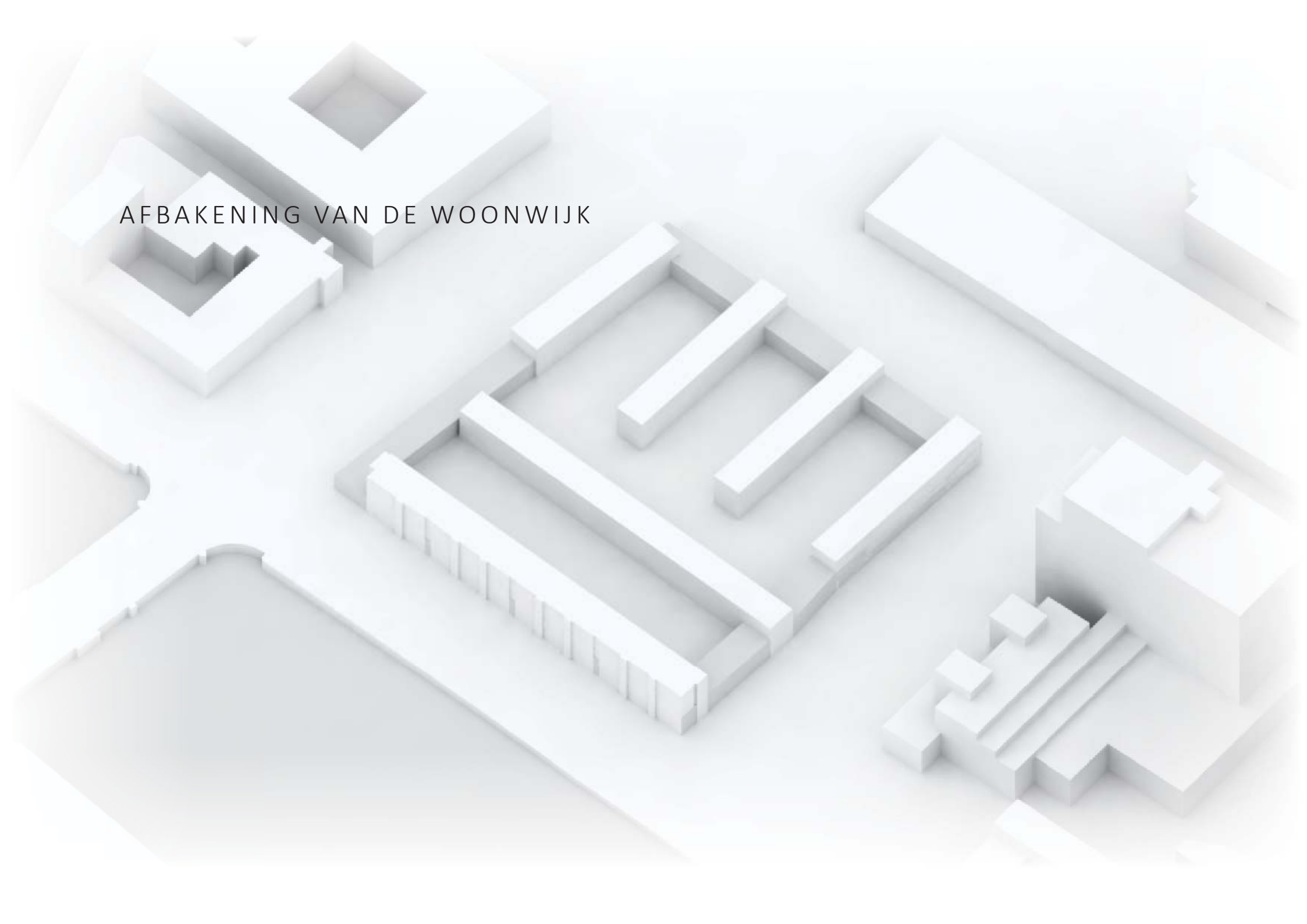

OPDELEN VAN DE SCHAAL

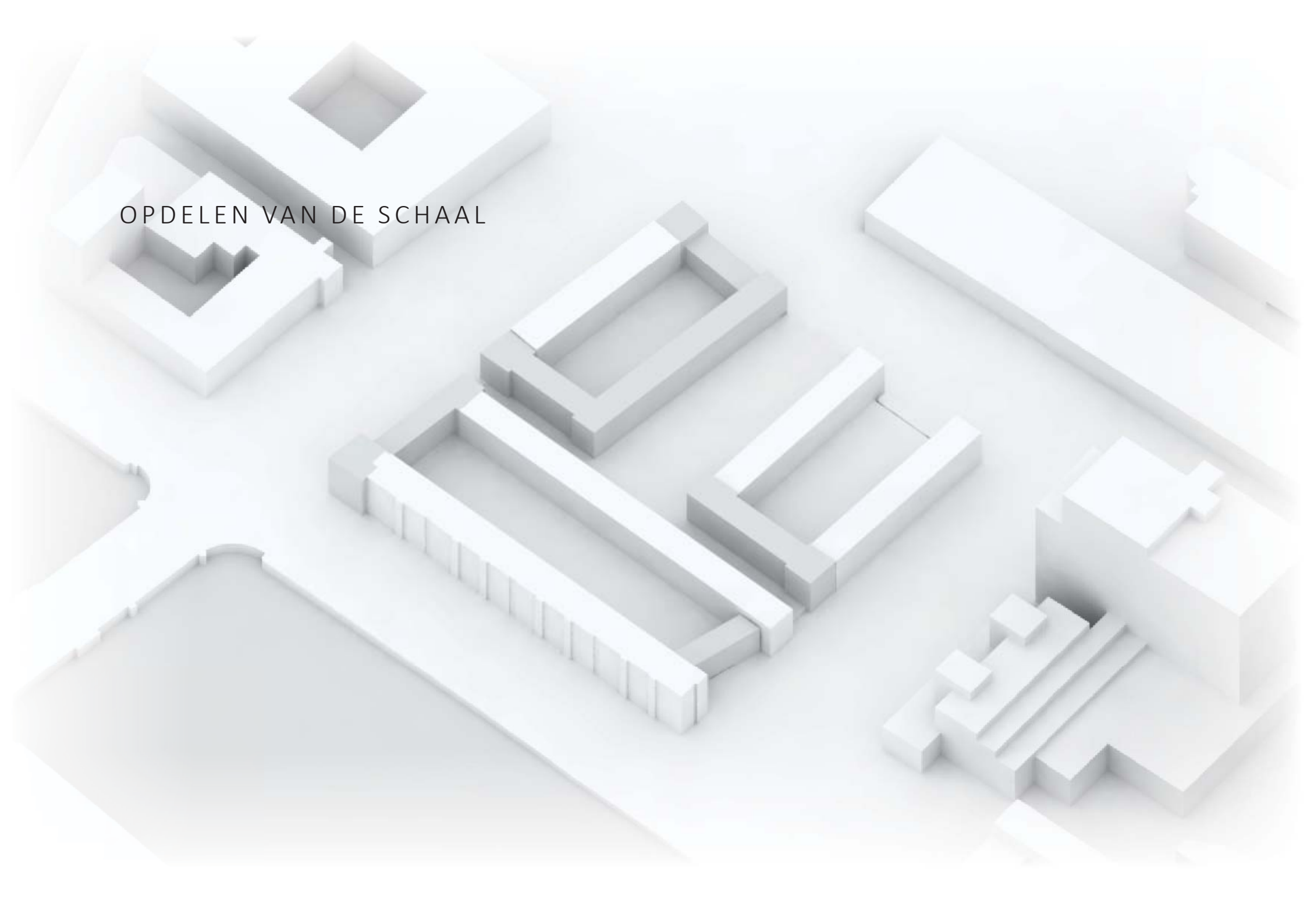

RELATIE STEDENBOUWKUNDIGE CONTEXT

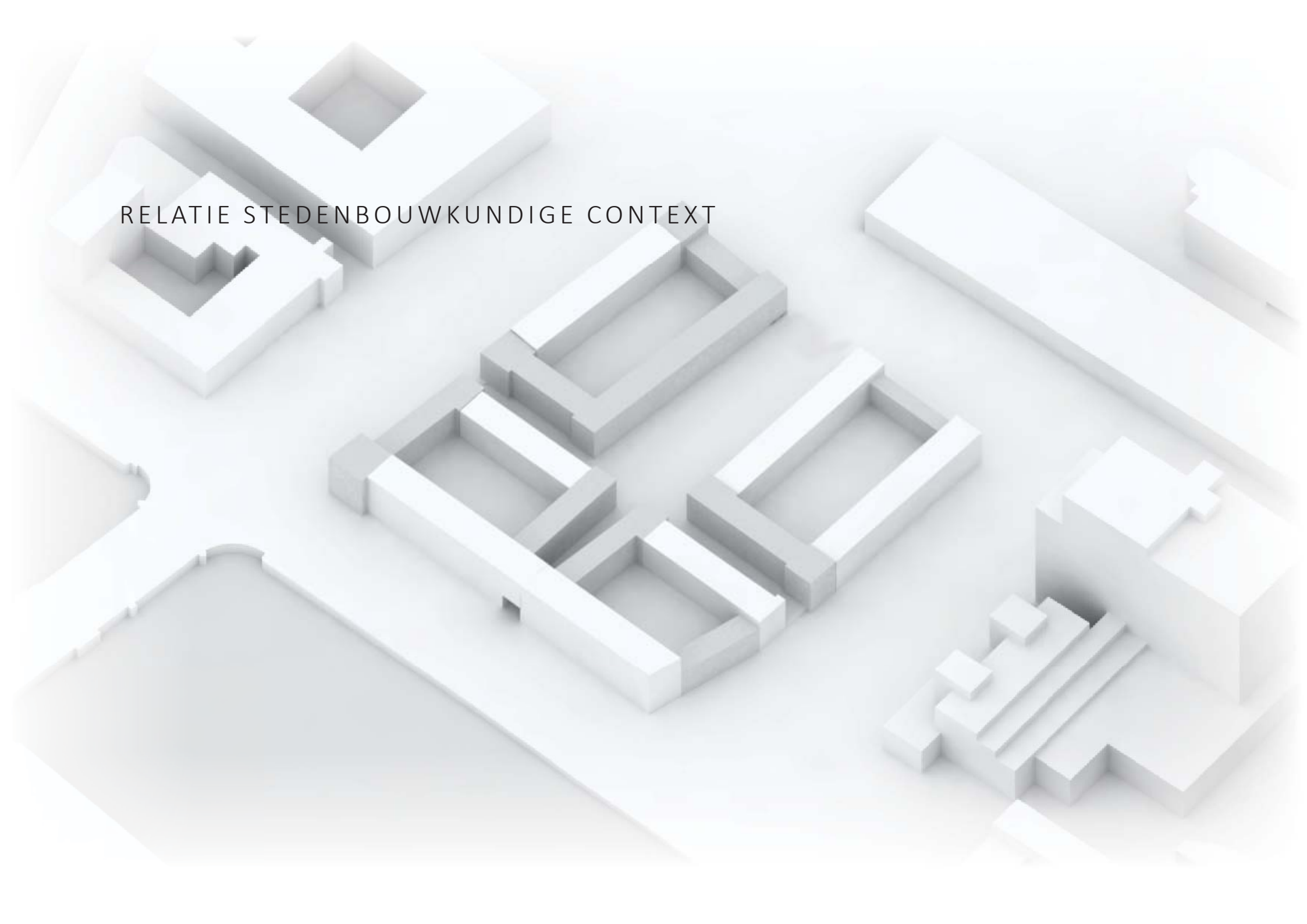

ORIËNTATIEPUNTEN TOEVOEGEN

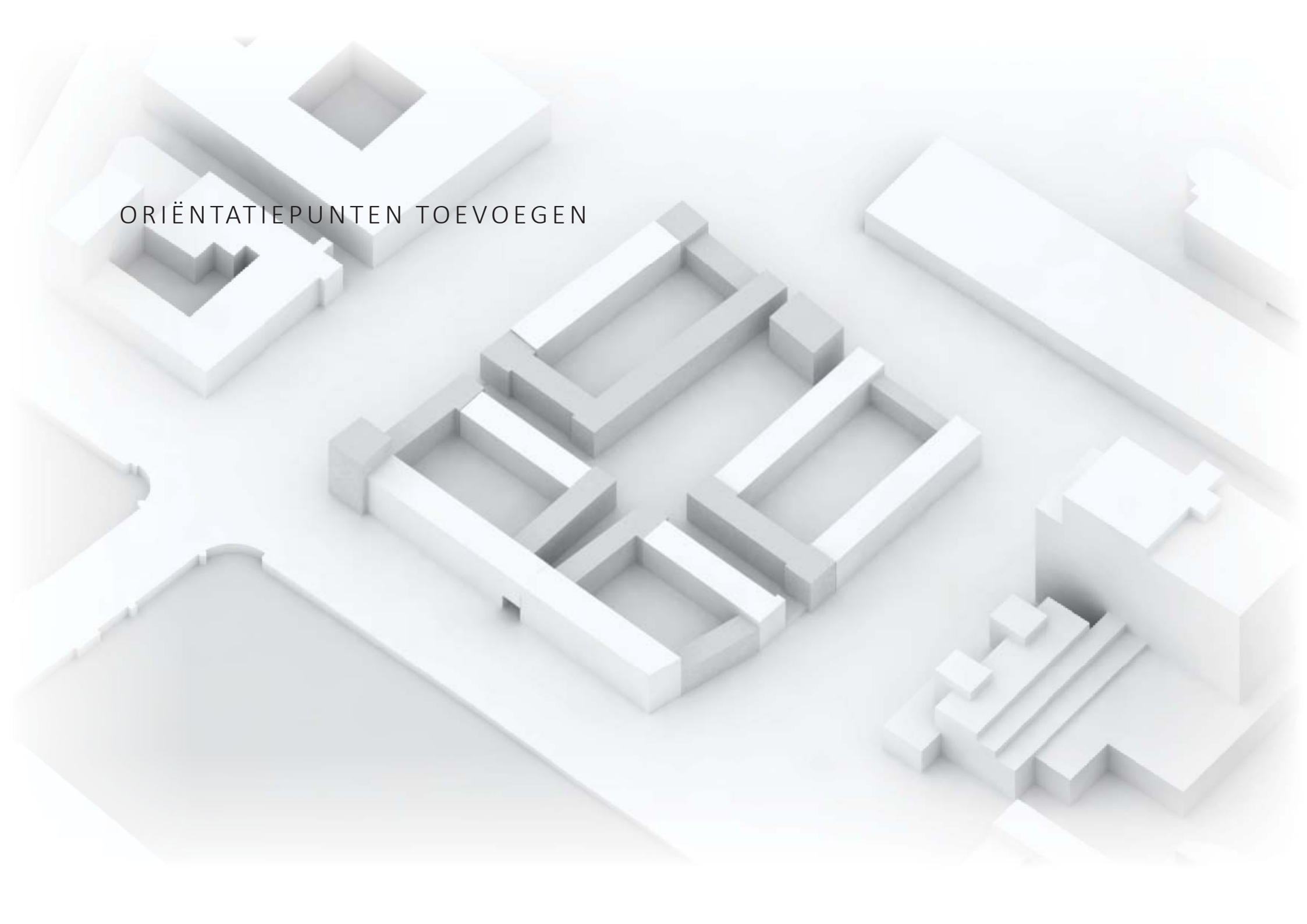



OPDELING

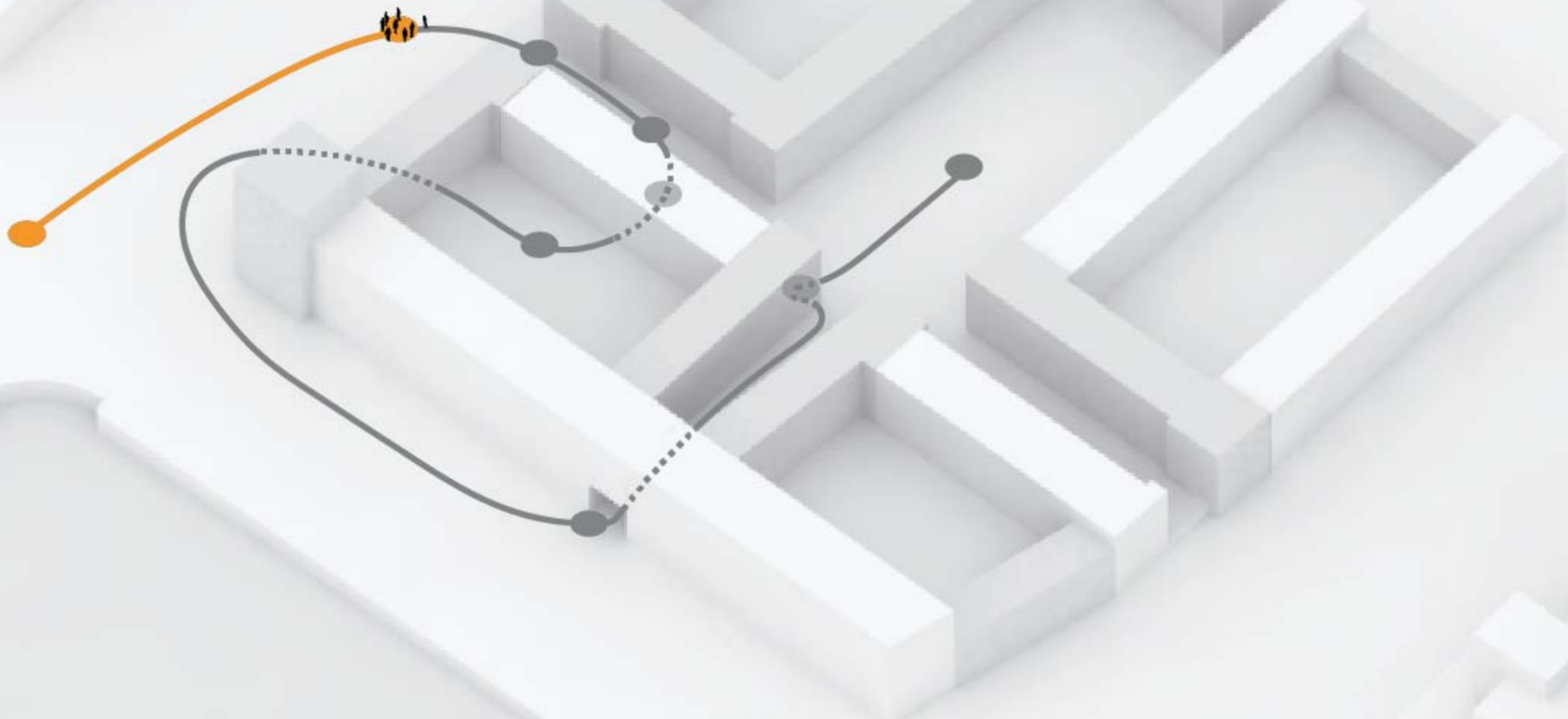

OPDELING

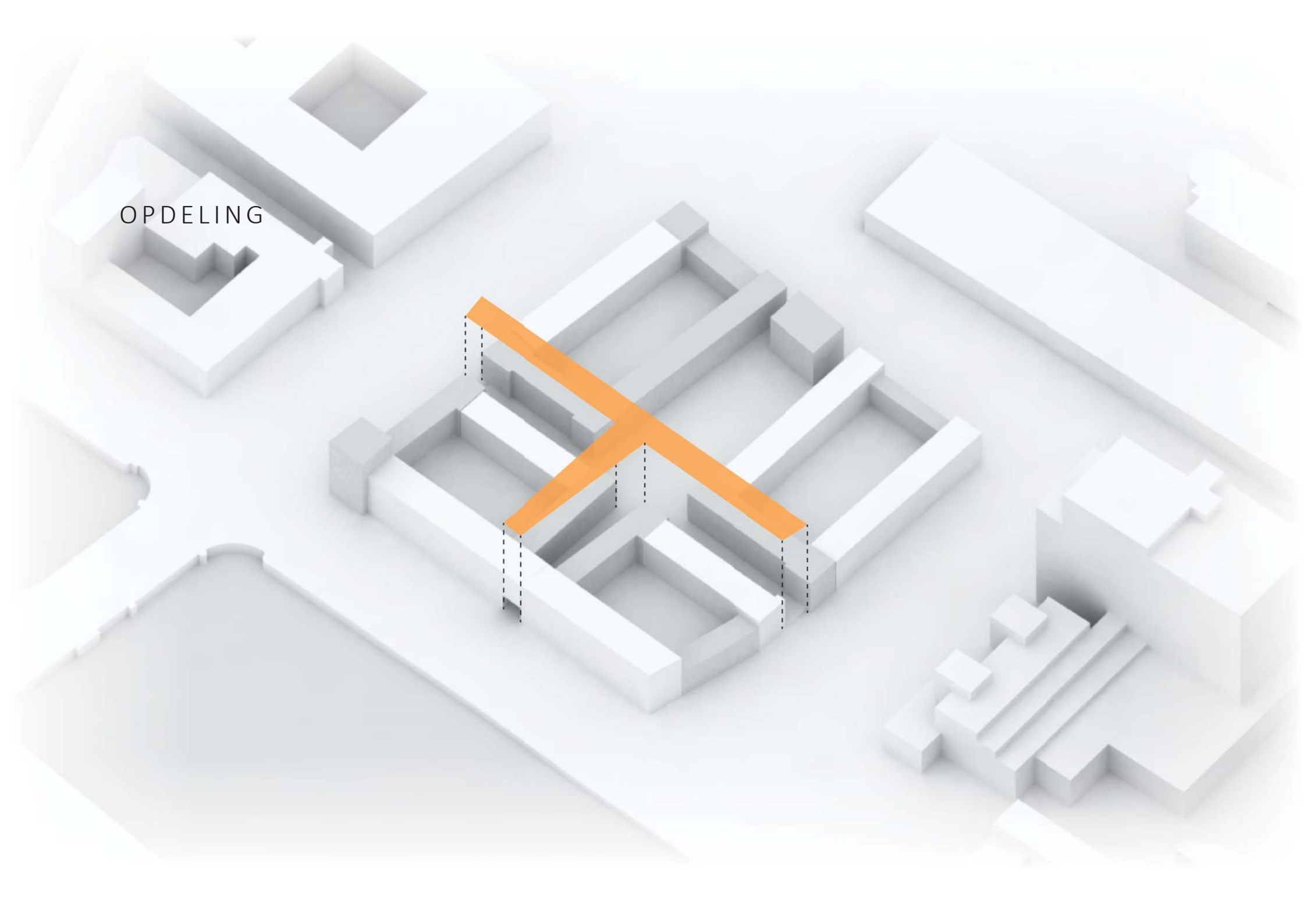

OPDELING

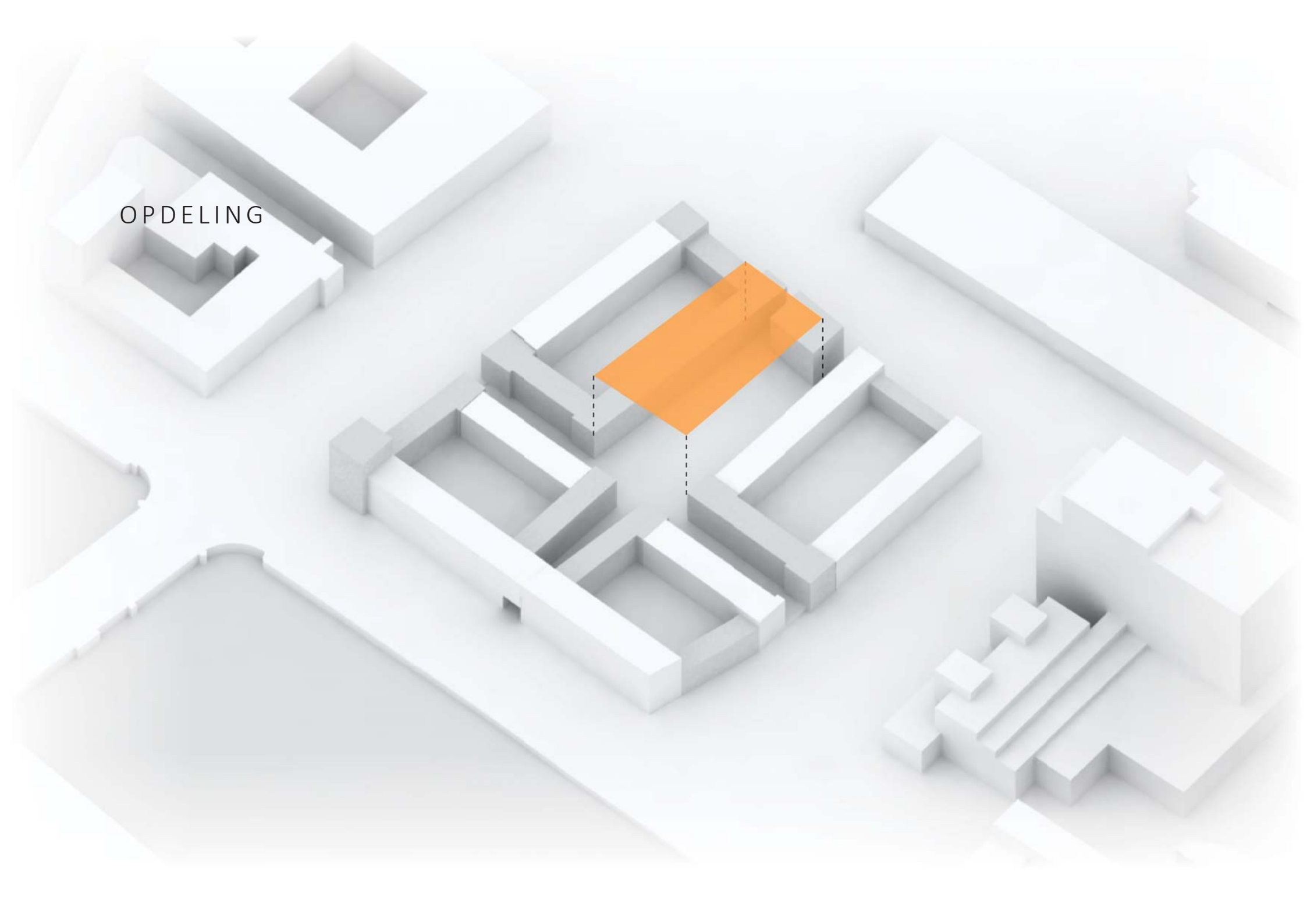

OPDELING

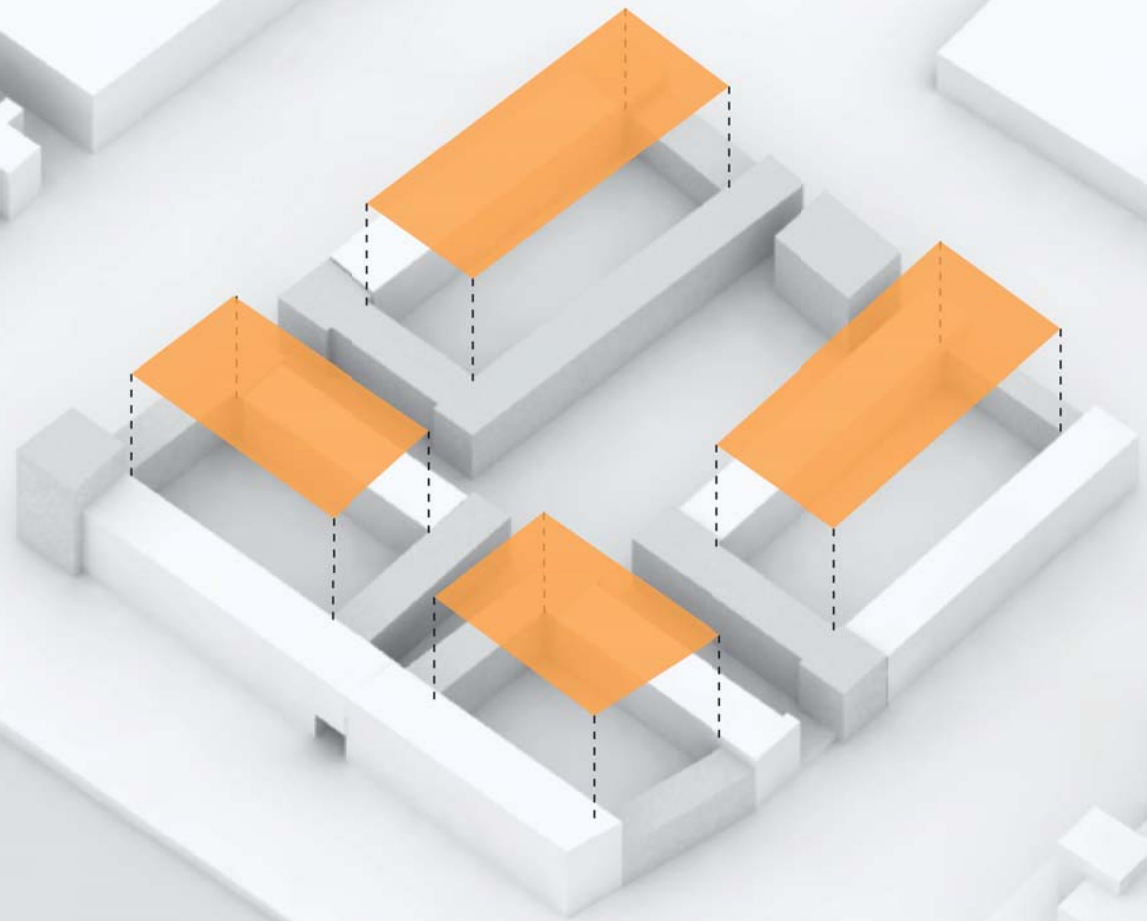

ENTREE'S

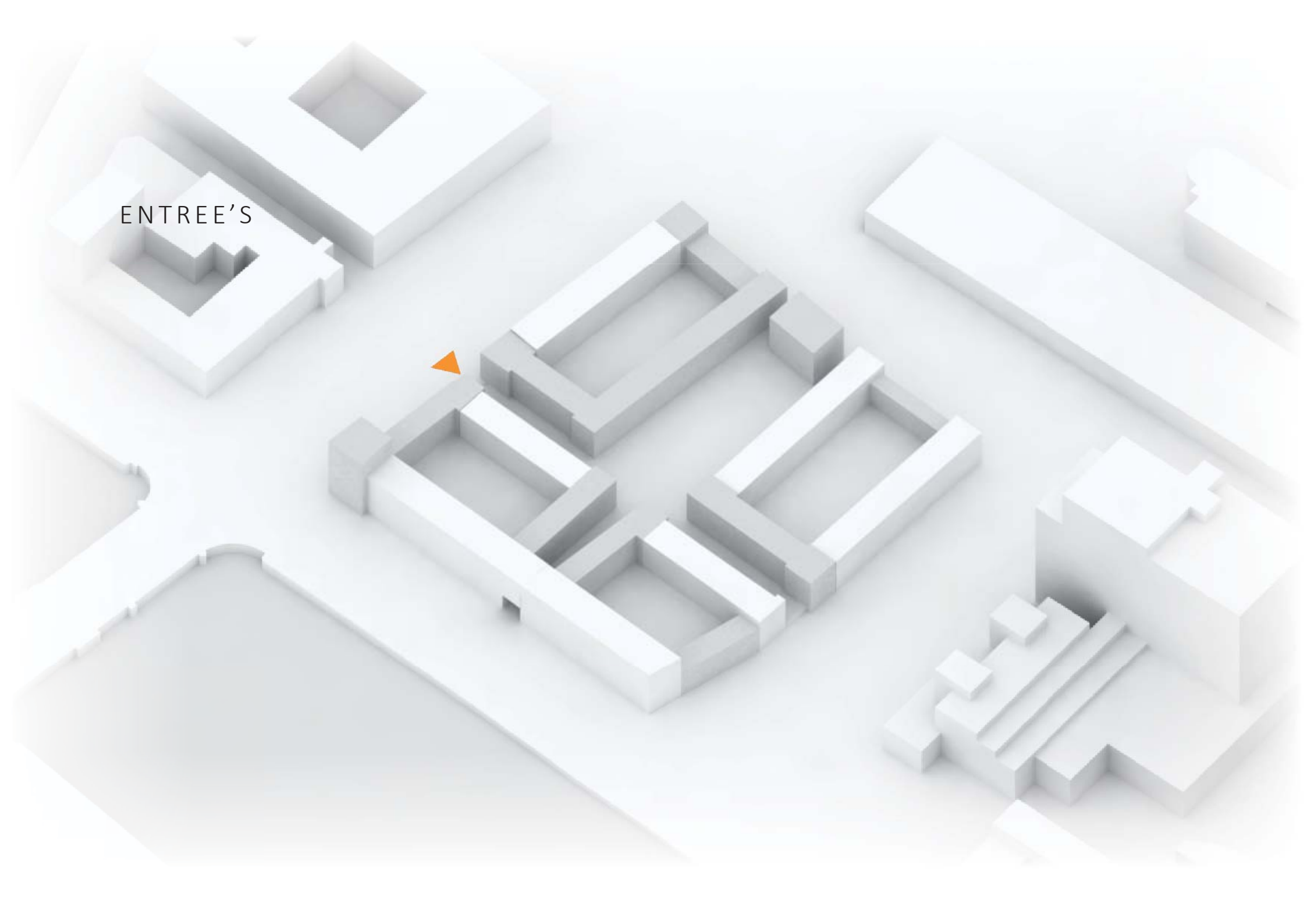

ENTREE'S

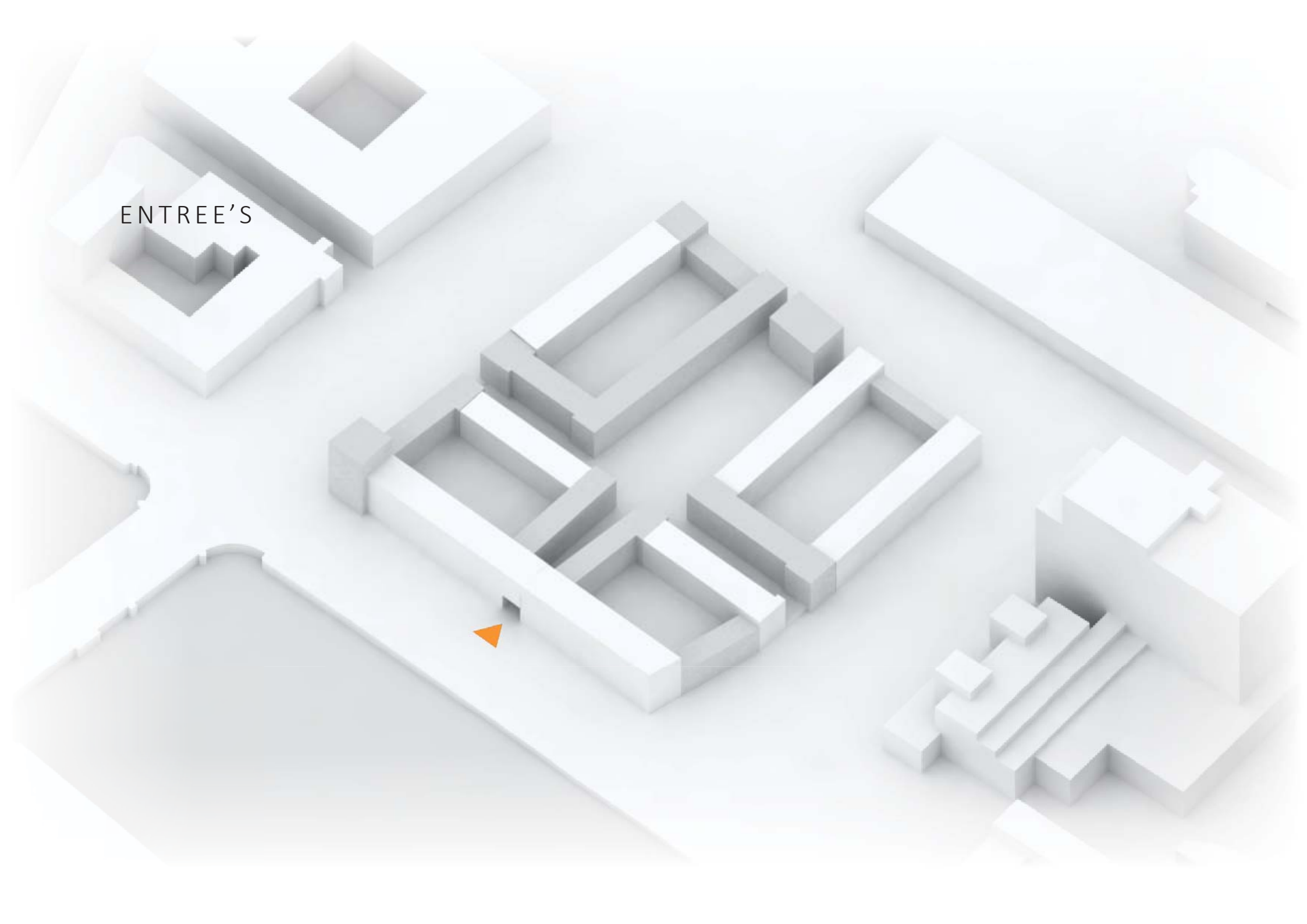

ENTREE'S

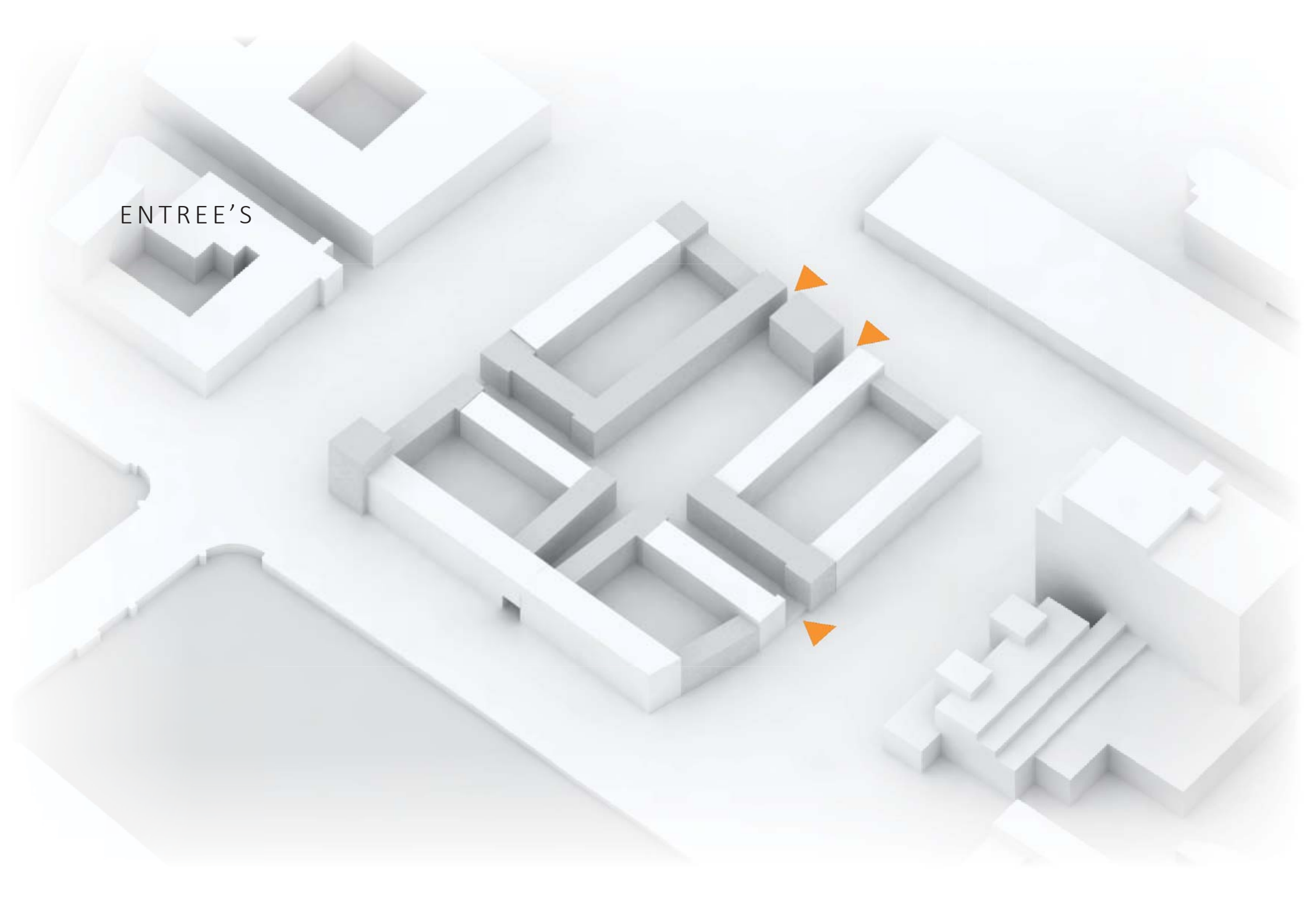

ROUTING

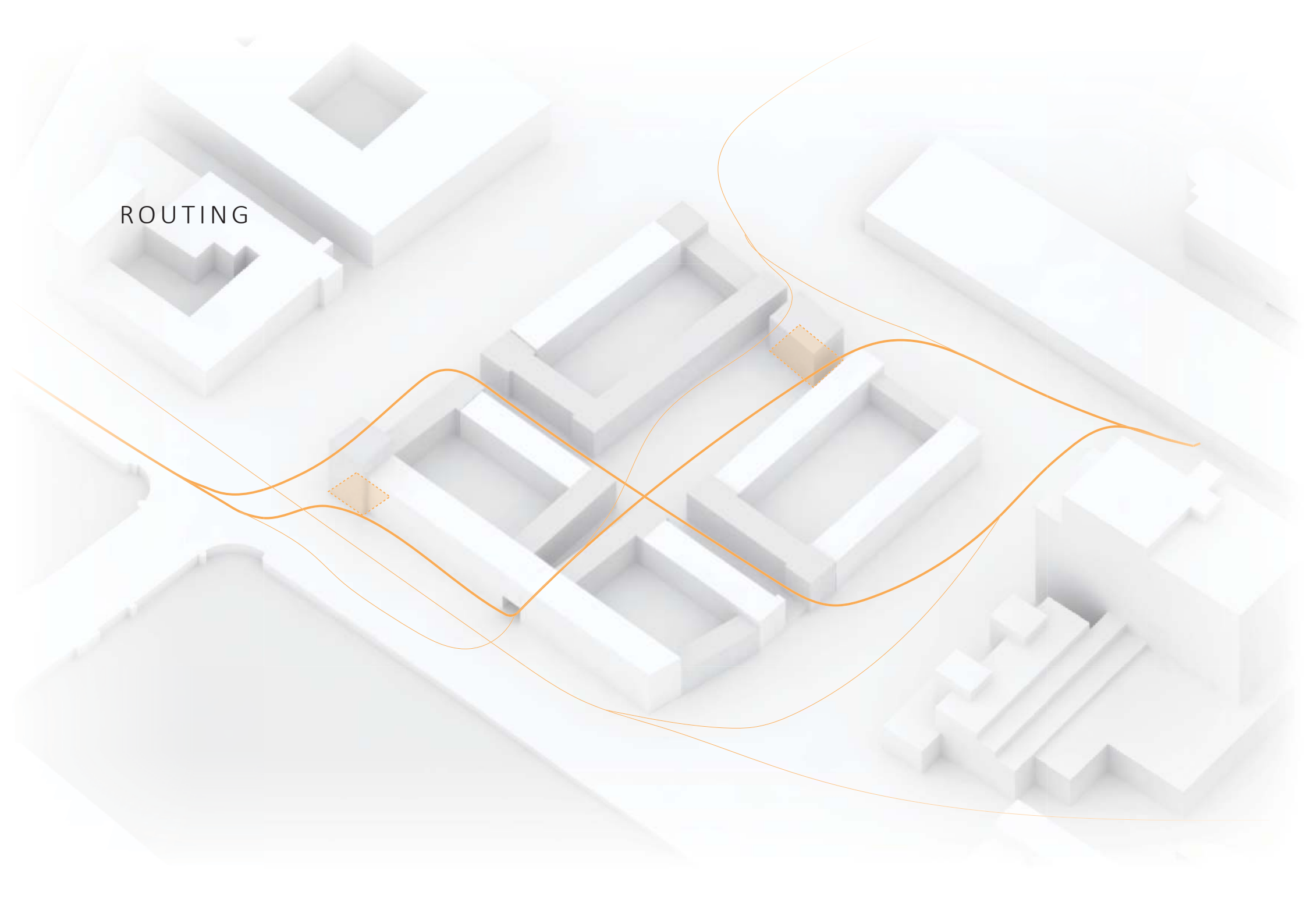

ONTSLUITING WONINGEN

PORTIEK

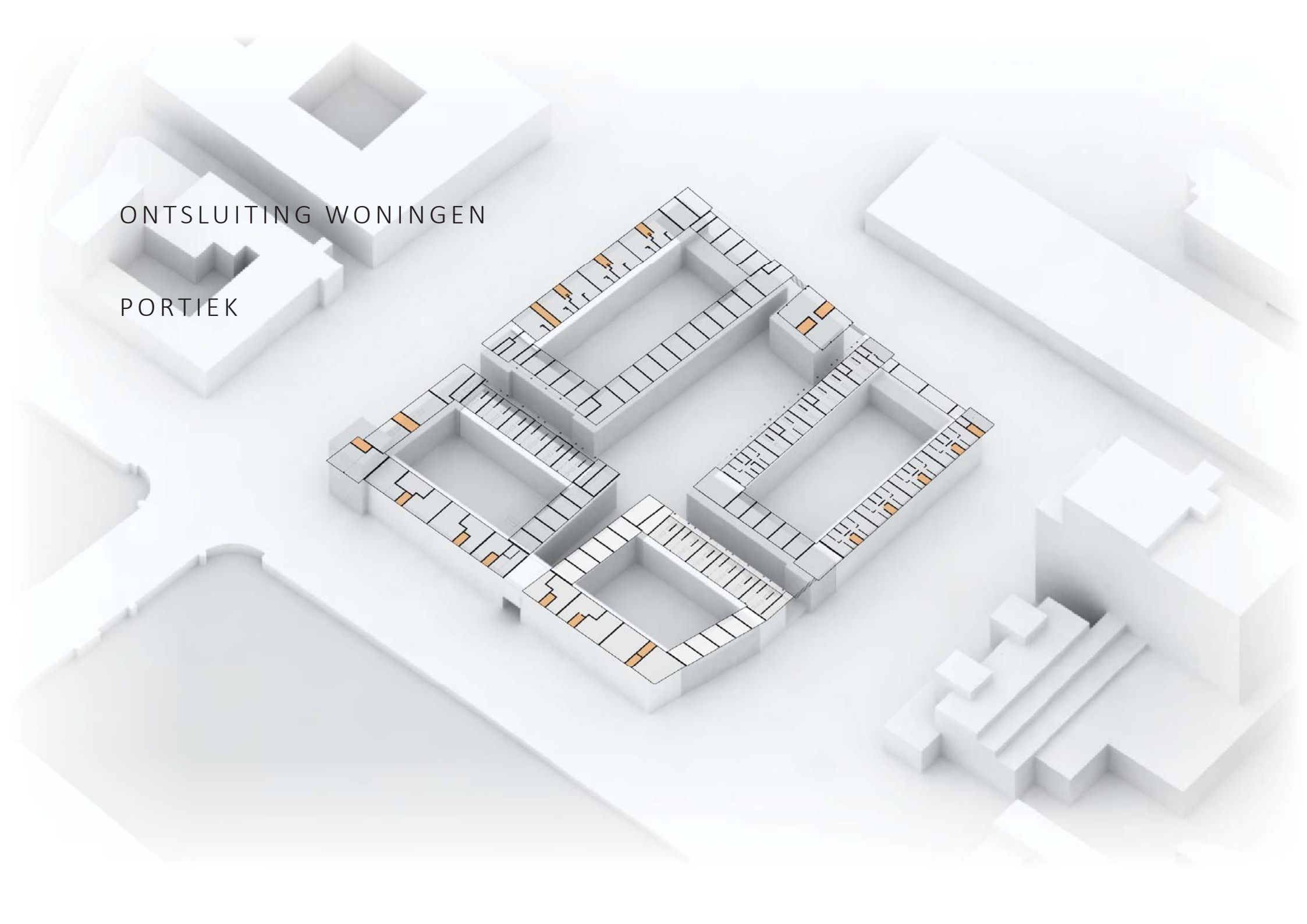

ONTSLUITING WONINGEN

GALLERIJ

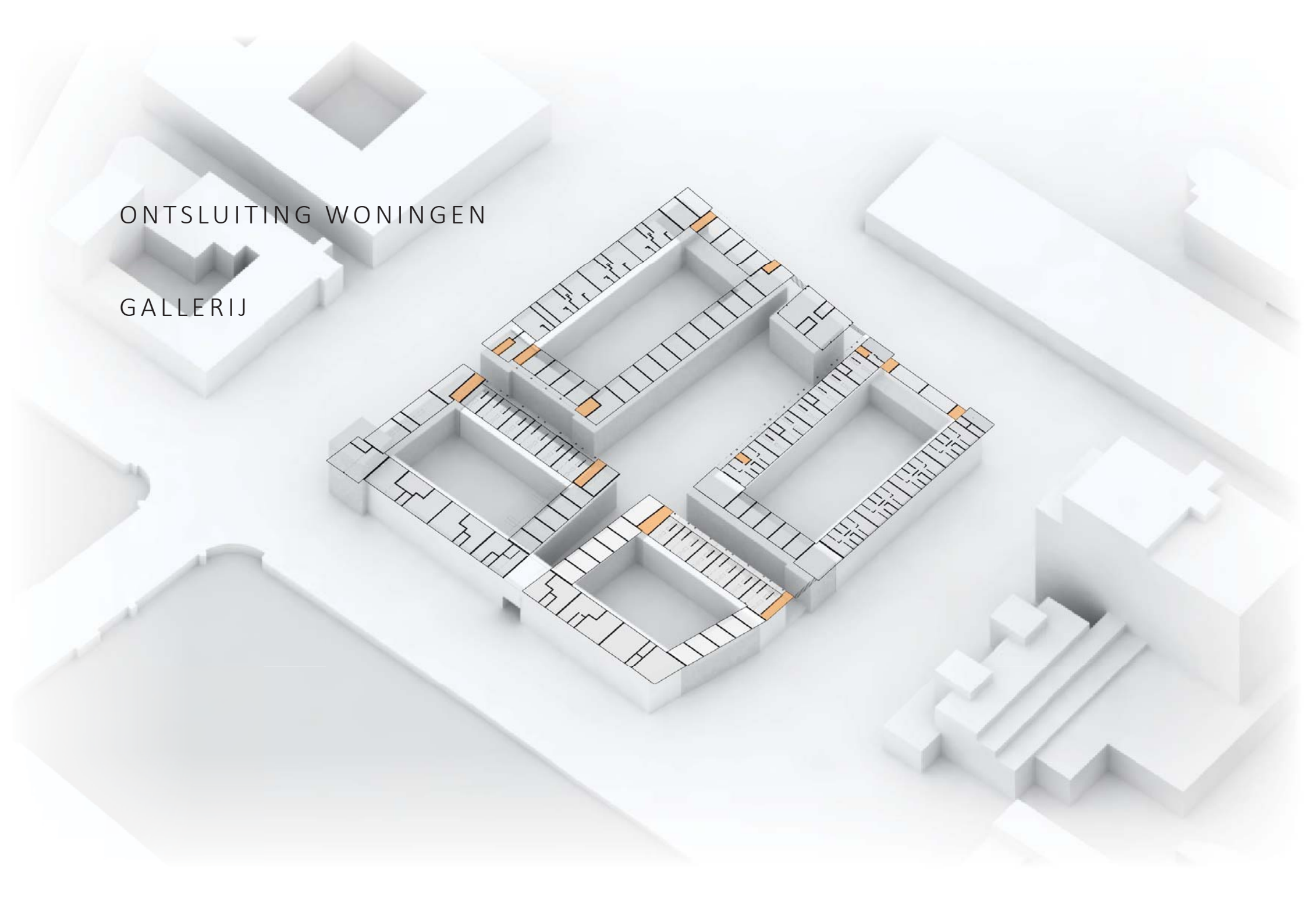

ONTSLUITING WONINGEN

BEGANE GROND

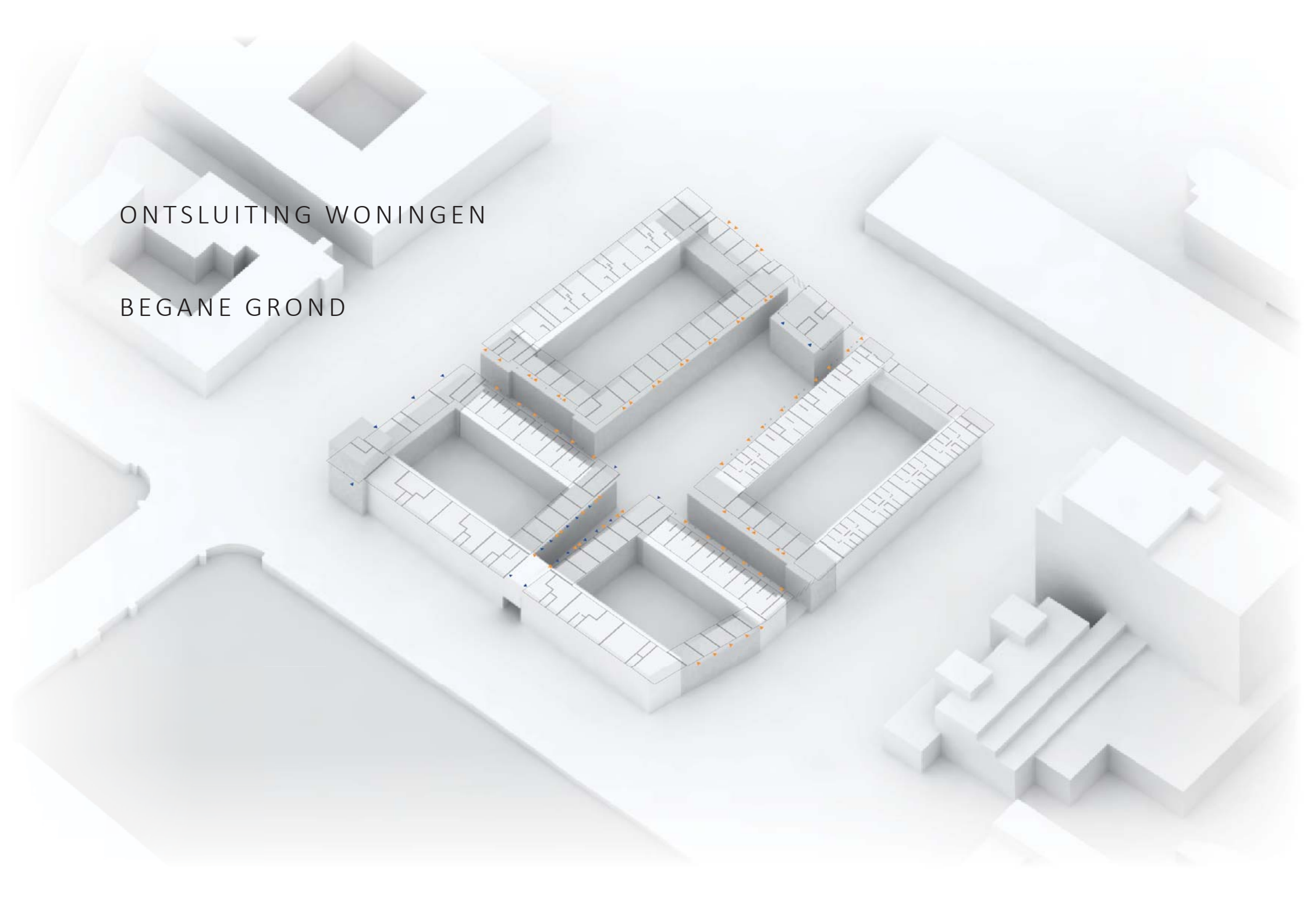

BINNENLOPEN VAN DE WOONWIJK

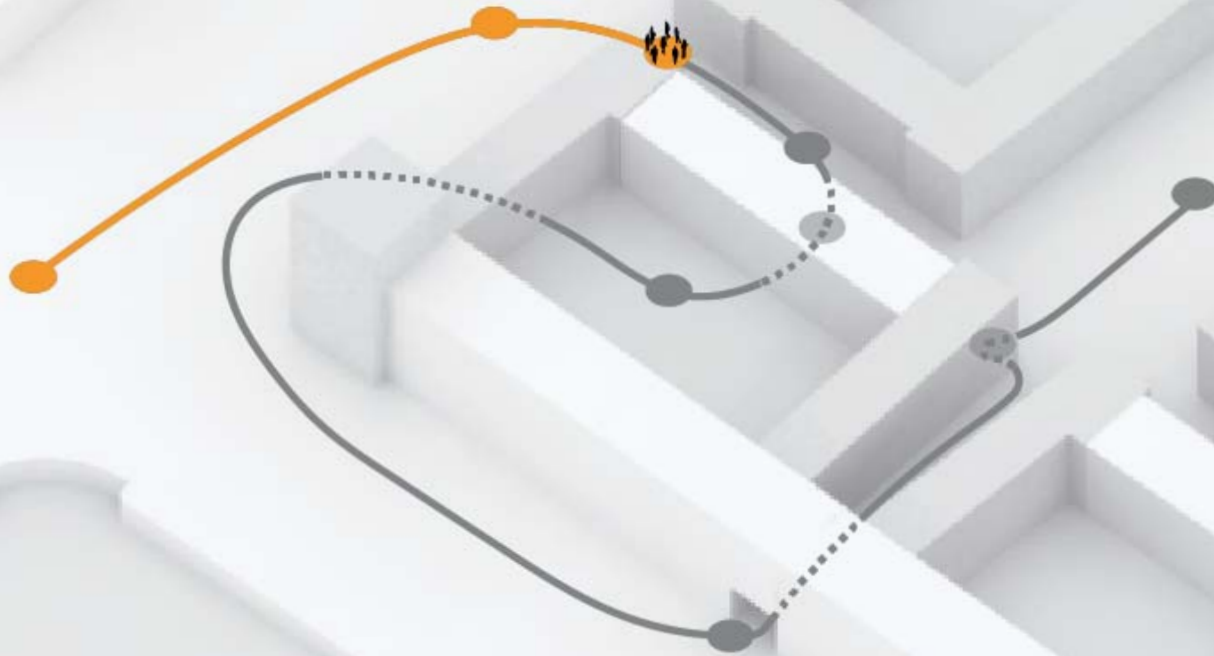

NOORD ENTREE

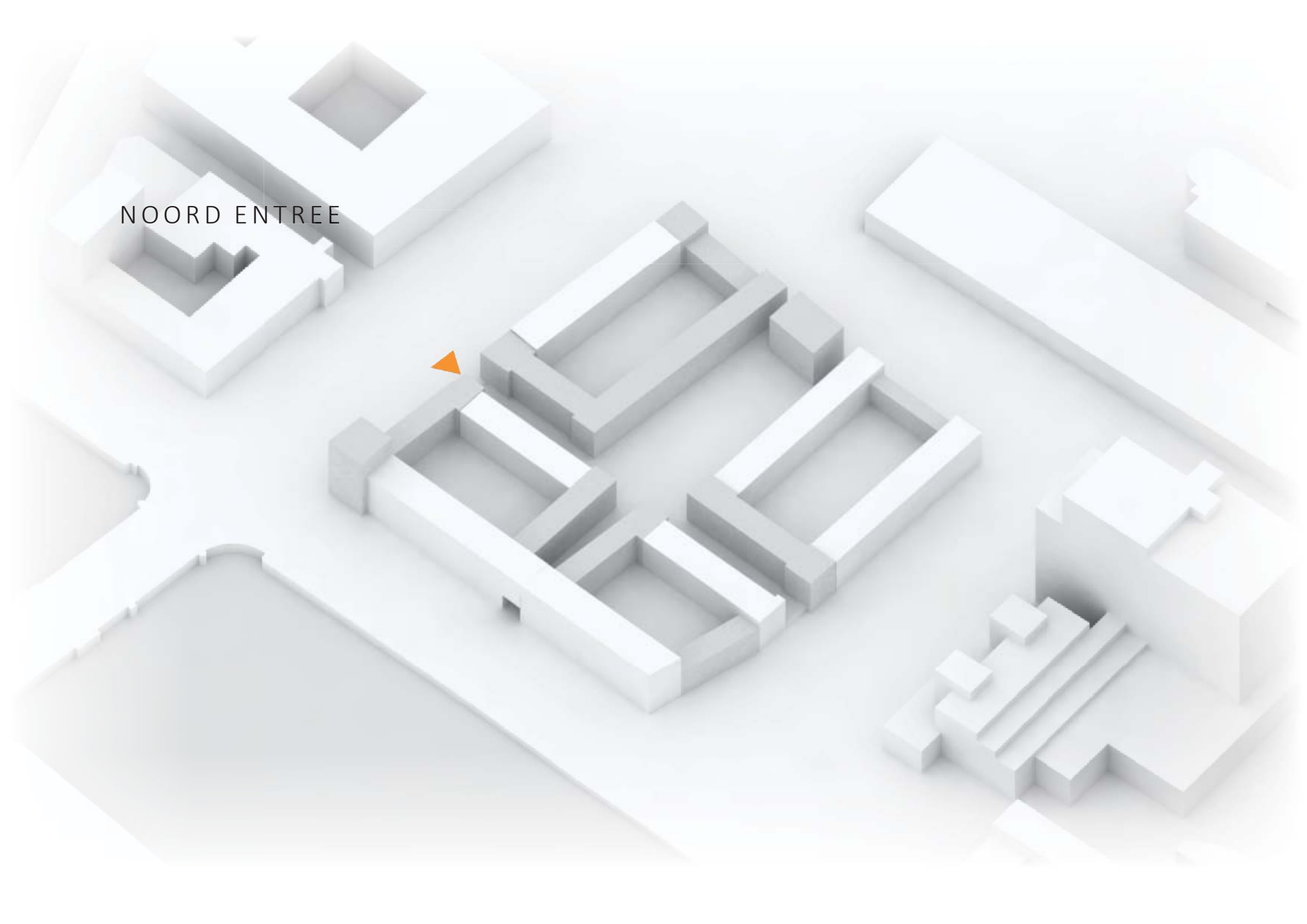



OOSTGEVEL VAN DER KUNSTRAAT

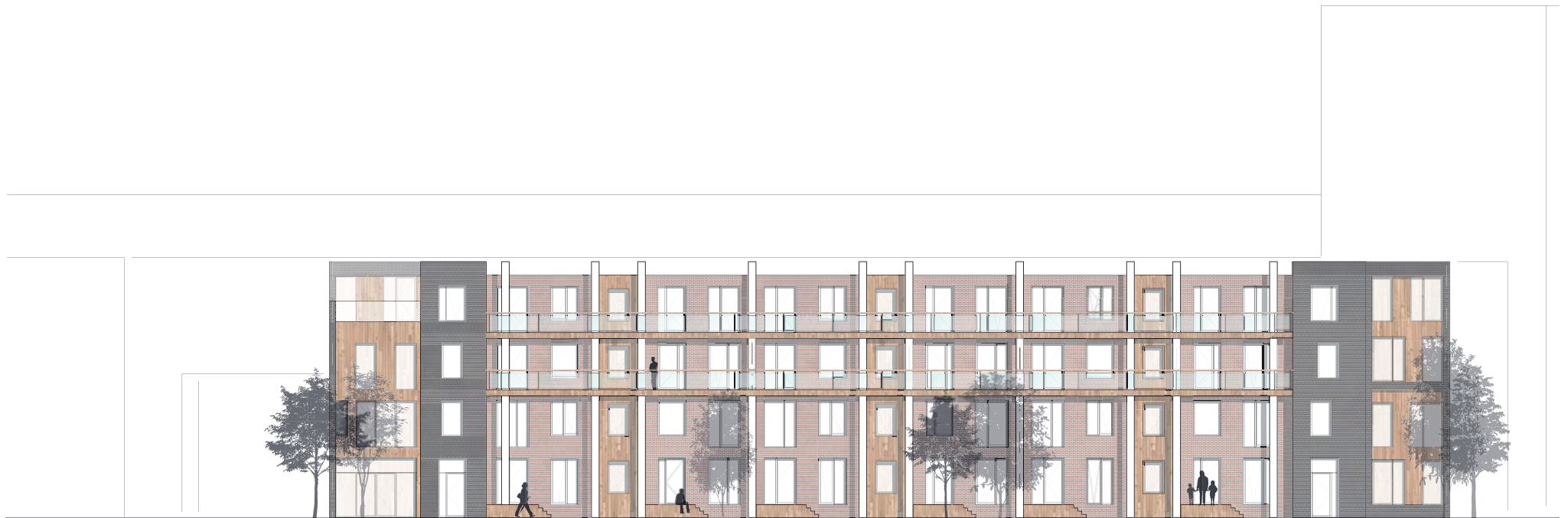

GEVELCONCEPT

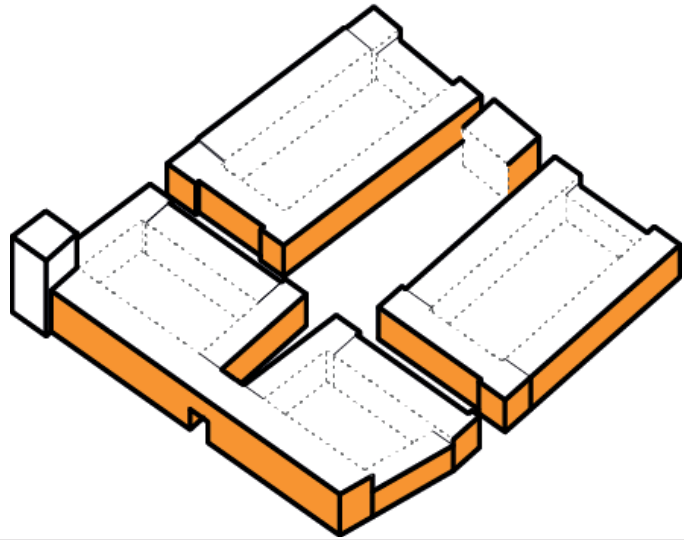

GEVELCONCEPT

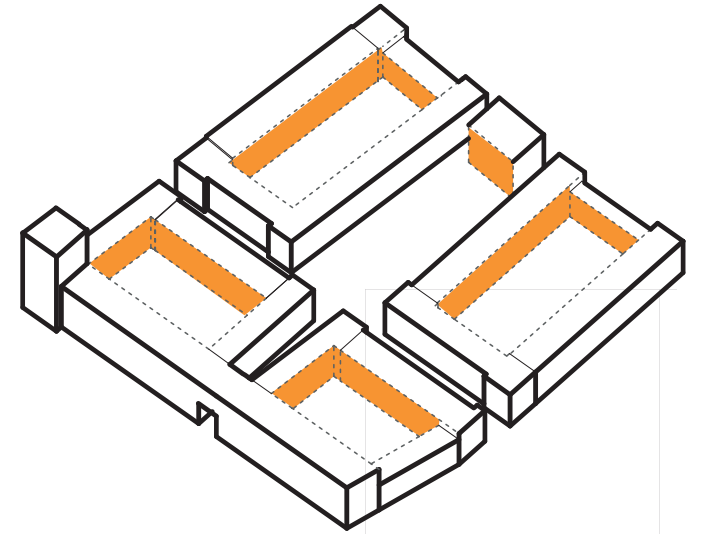
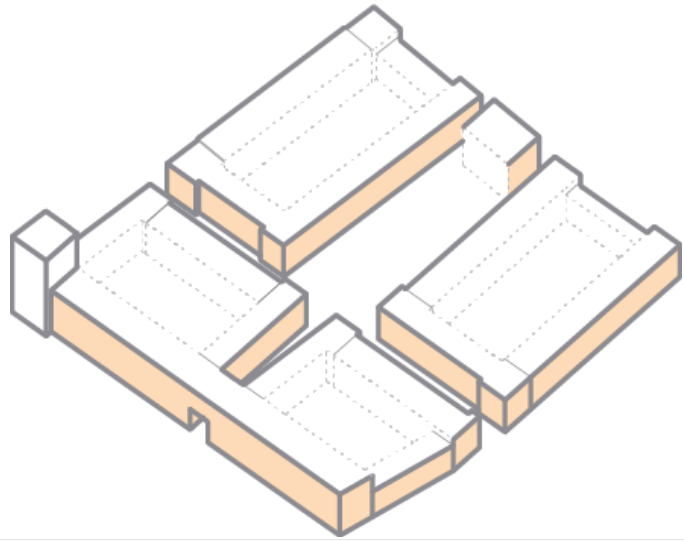

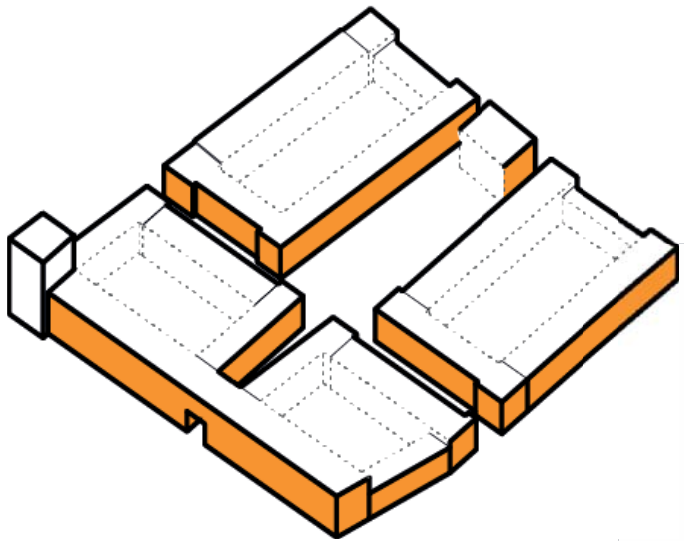

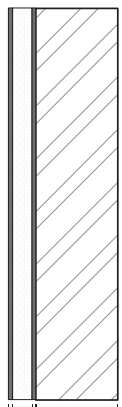
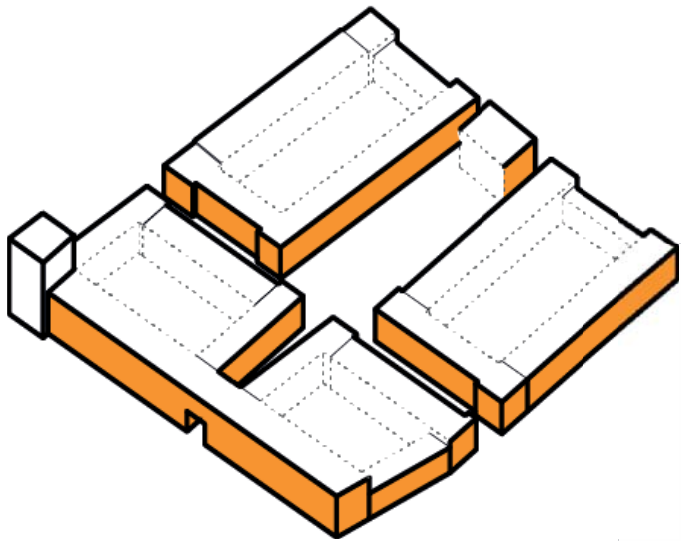

1010 210
50

BESTAAND

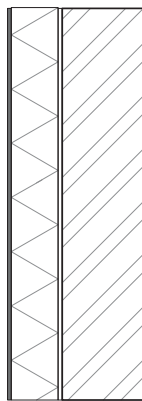

BUITENGEVEL



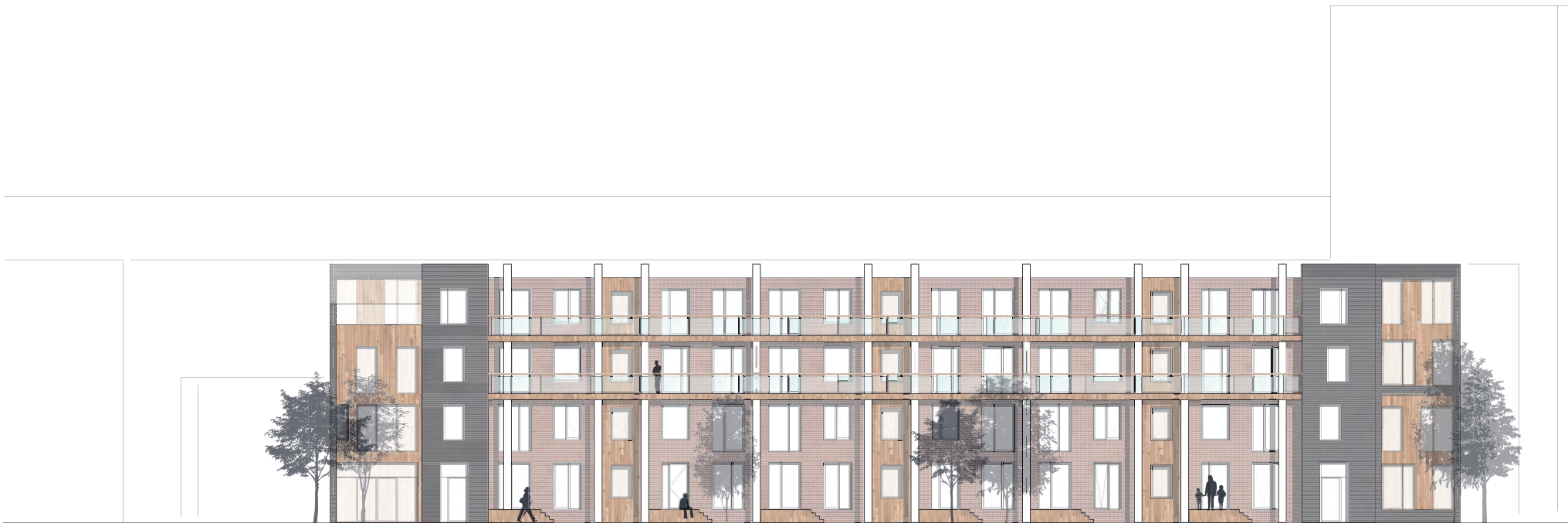

MATERIALISATIE

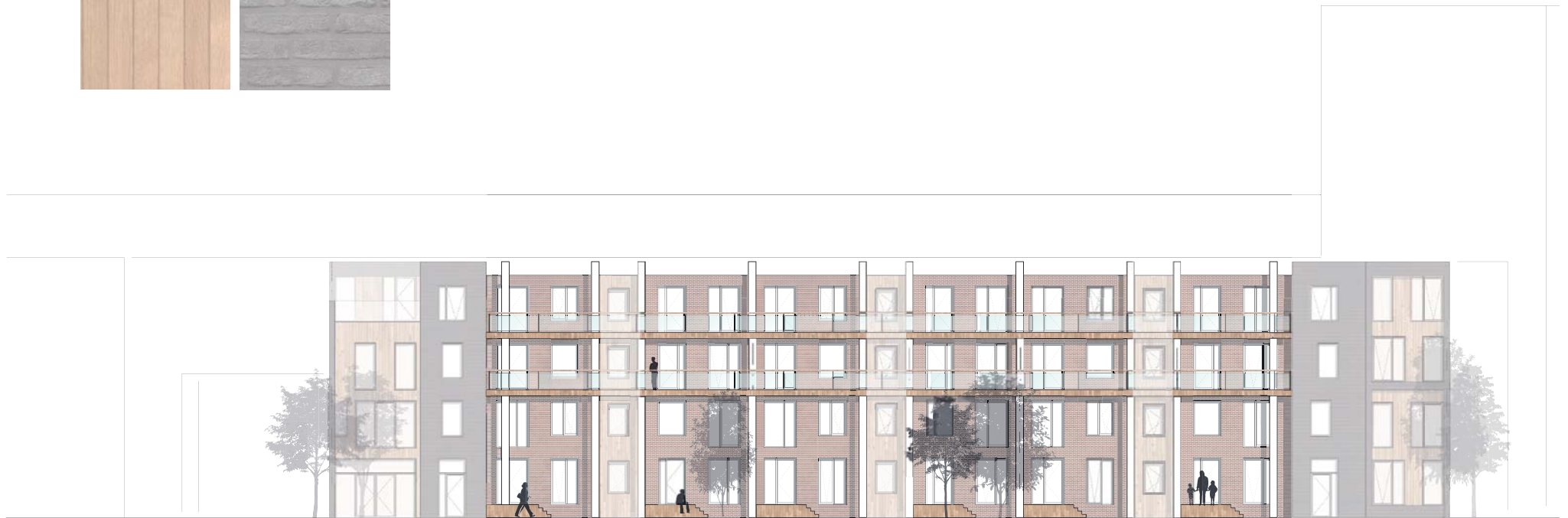

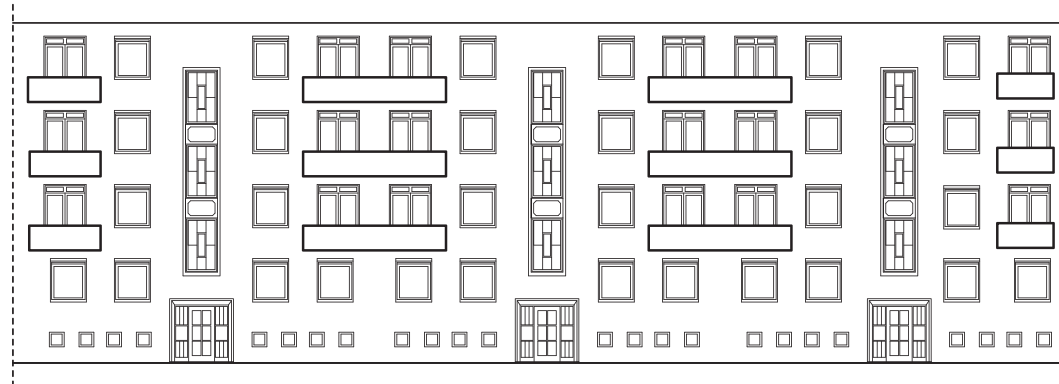

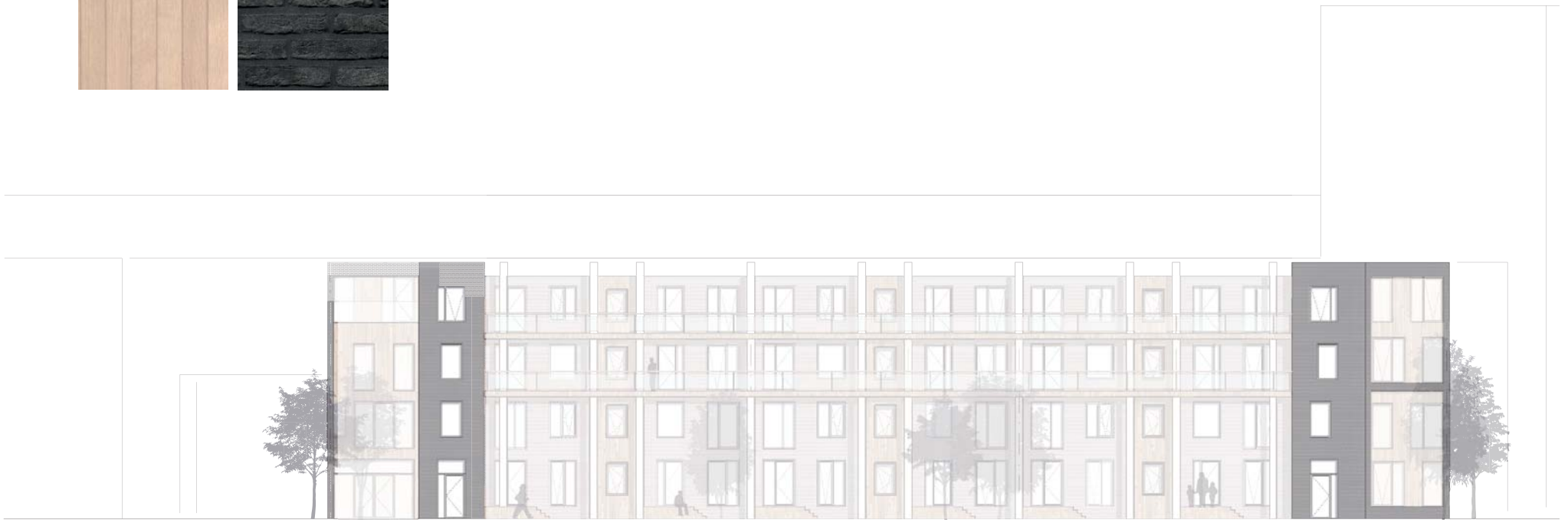

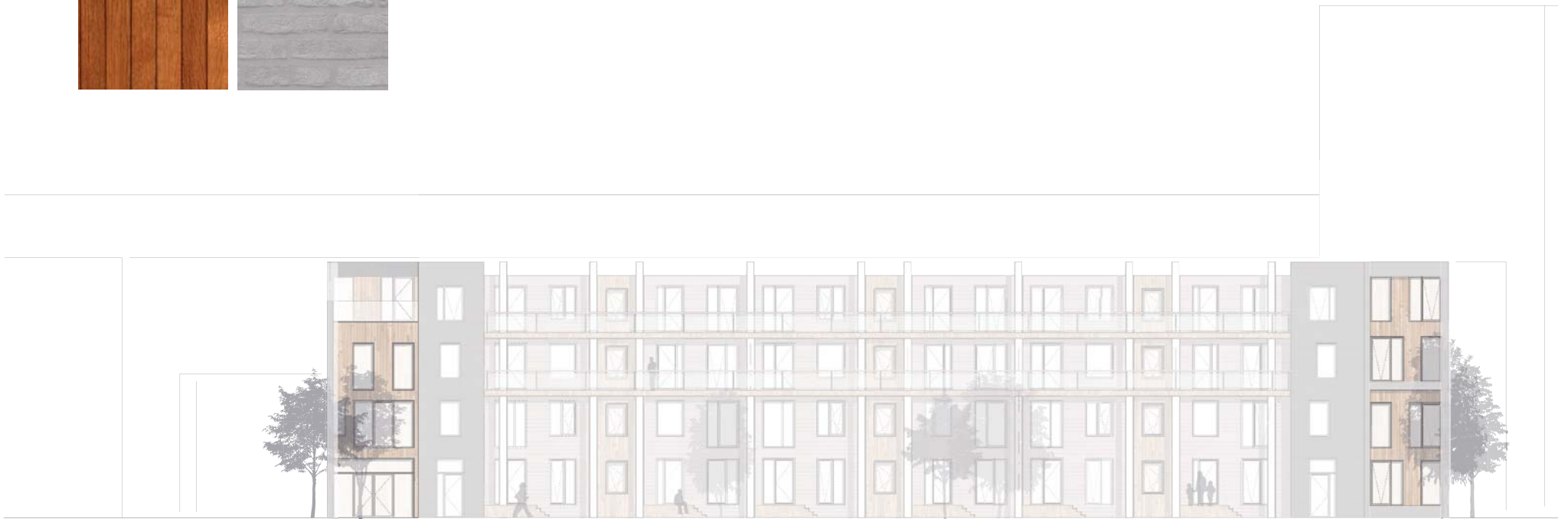

DETAILLERING

AANSLUITING BESTAAND EN NIEUW

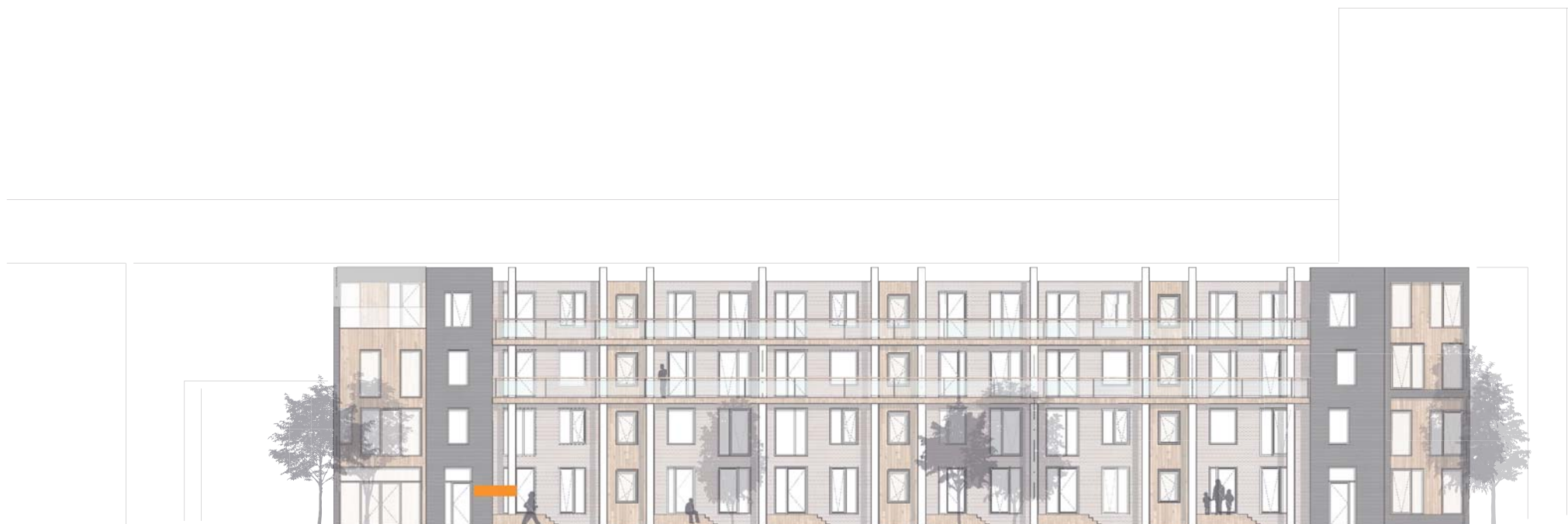

DETAILLERING

AANSLUITING BESTAAND EN NIEUW

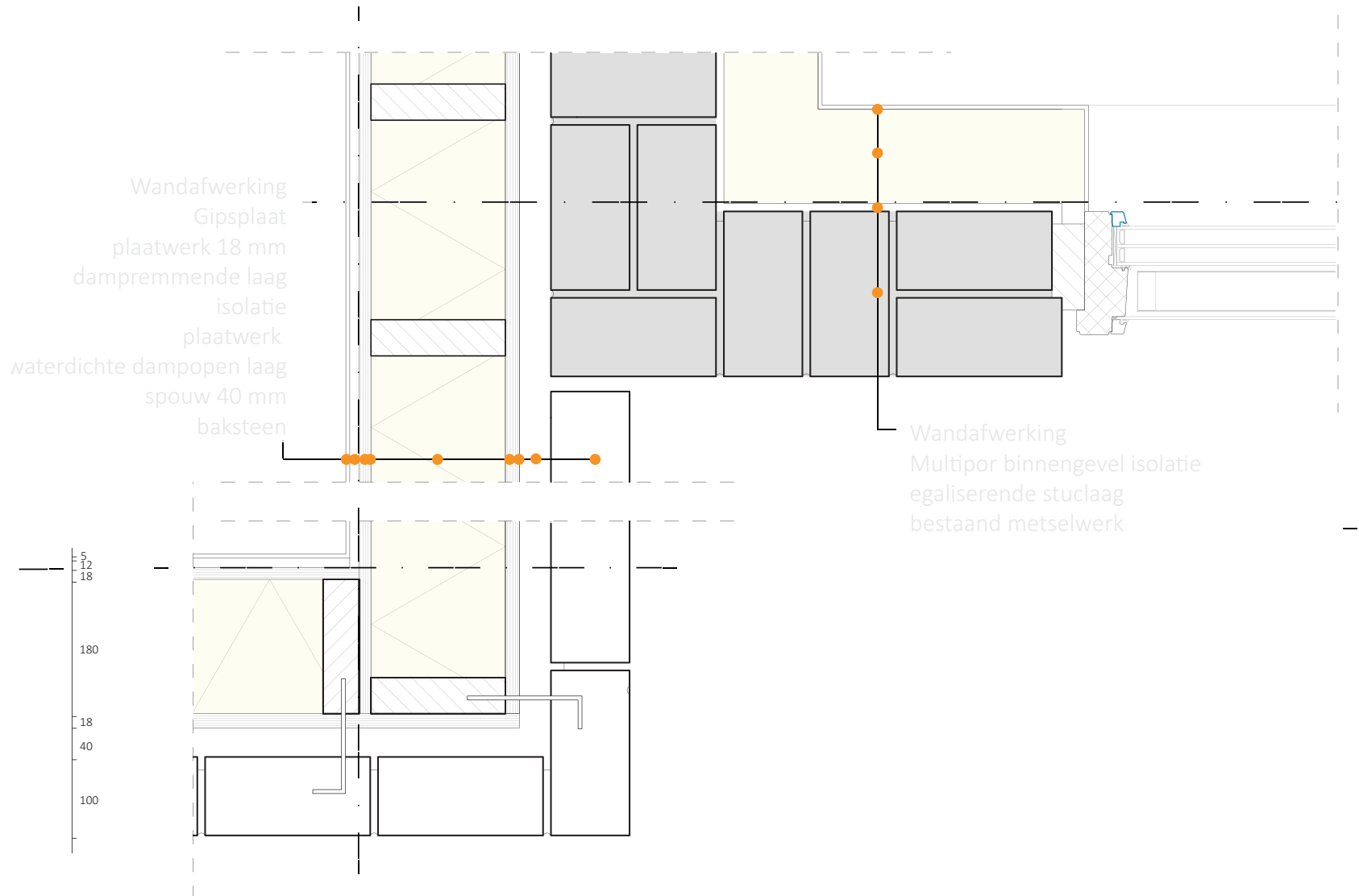

VISIE VOOR DE WONING

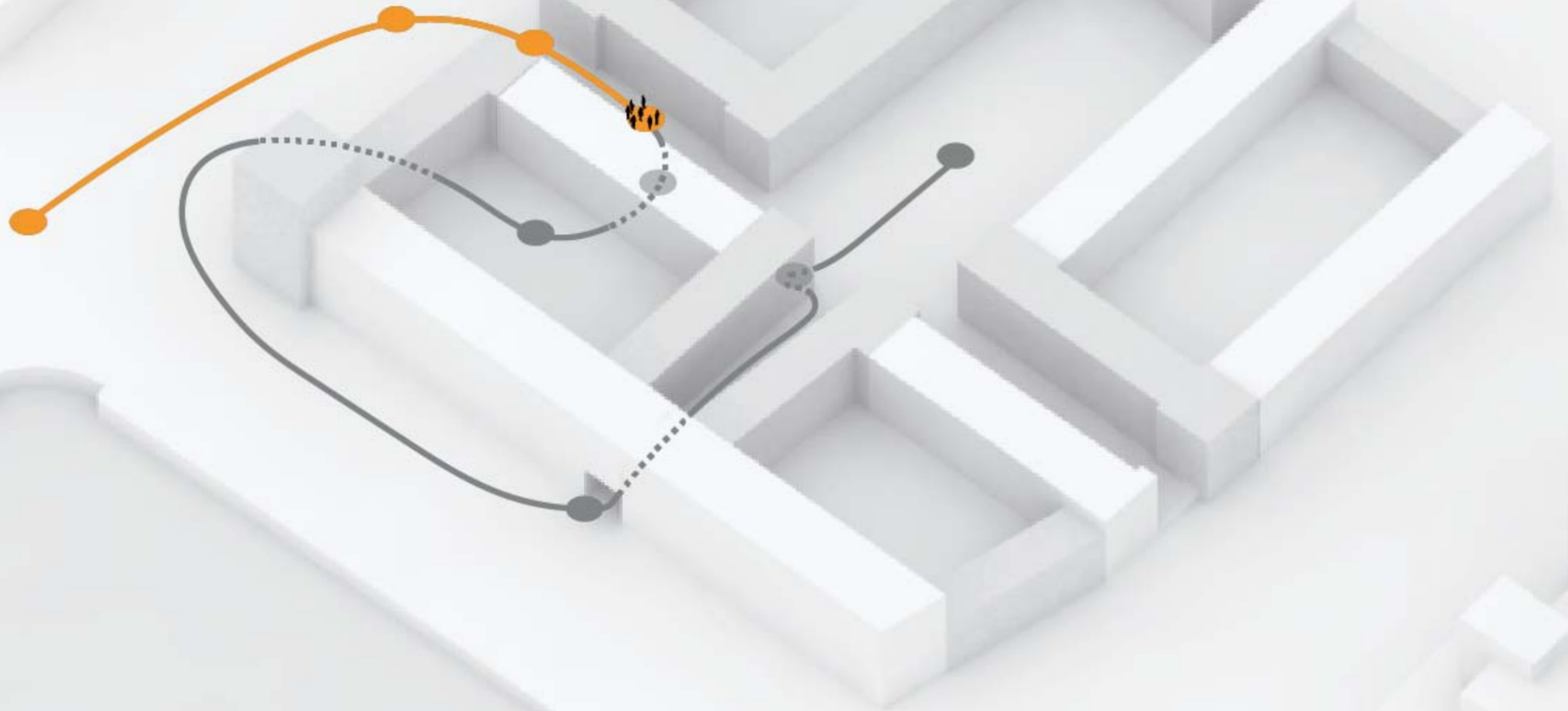

VAN DER KUNWONING 1

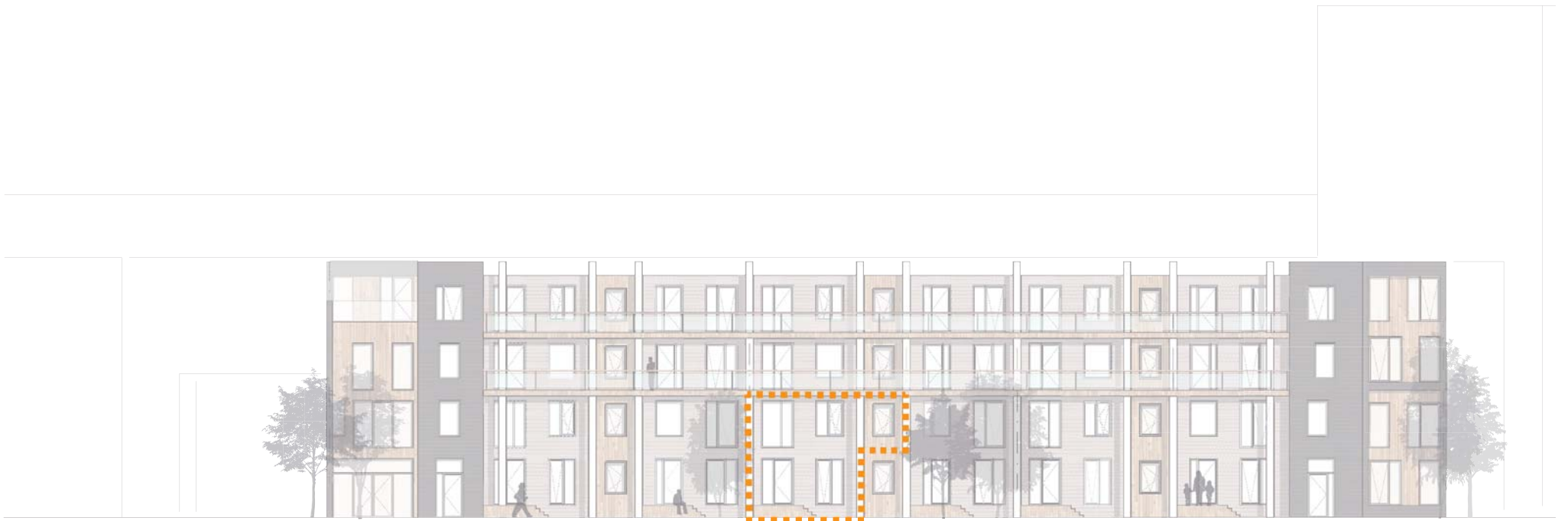

WONING CONCEPT

DE ERVARINGSROUTE

Bewoners

A dotted orange line representing a path. It starts as a horizontal line, then curves downwards in a series of steps, ending at the bottom right of the page.

WONING CONCEPT

DE ERVARINGSROUTE



WONING CONCEPT

DE ERVARINGSROUTE



WONING CONCEPT

DE ERVARINGSROUTE

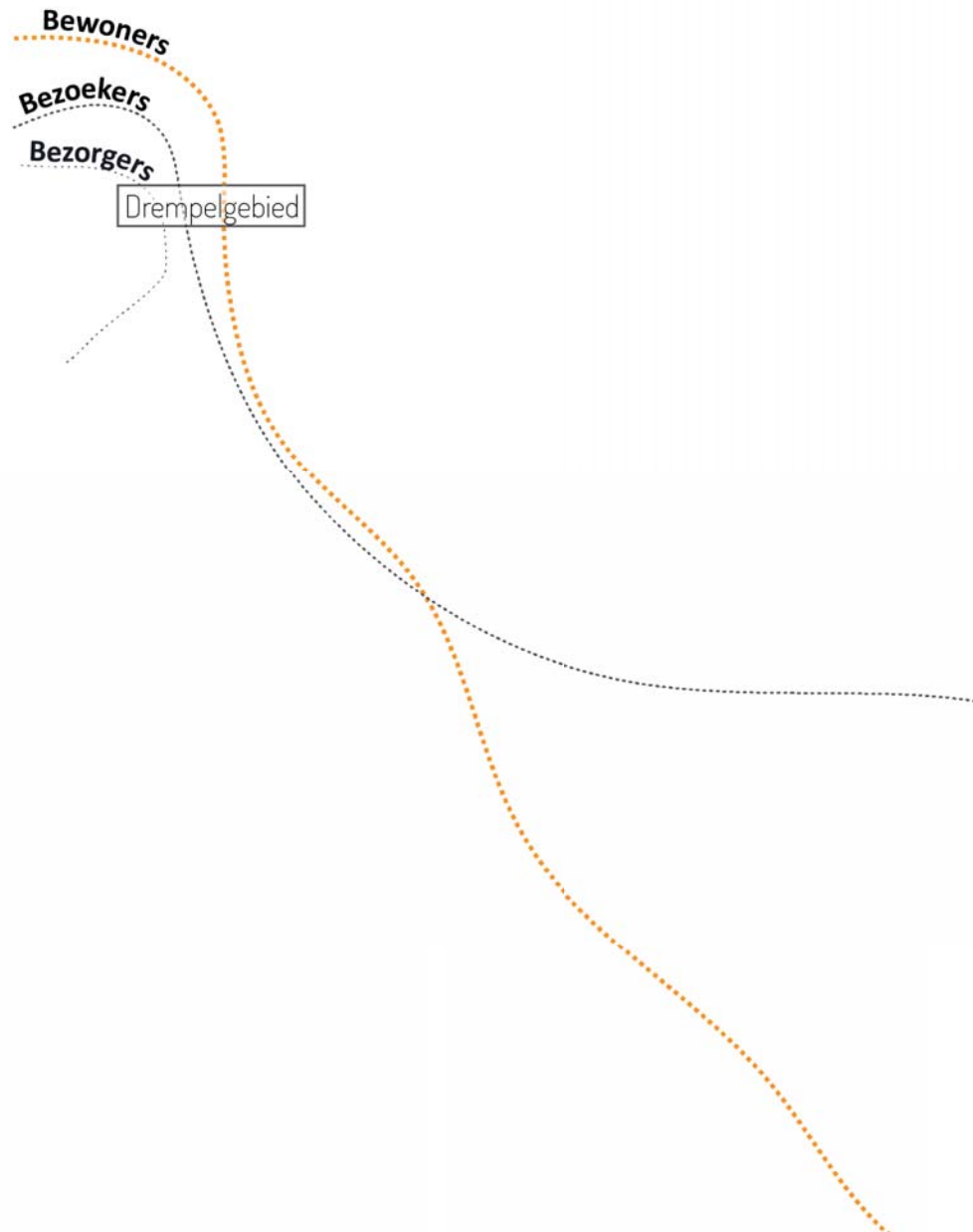

WONING CONCEPT

DE ERVARINGSROUTE

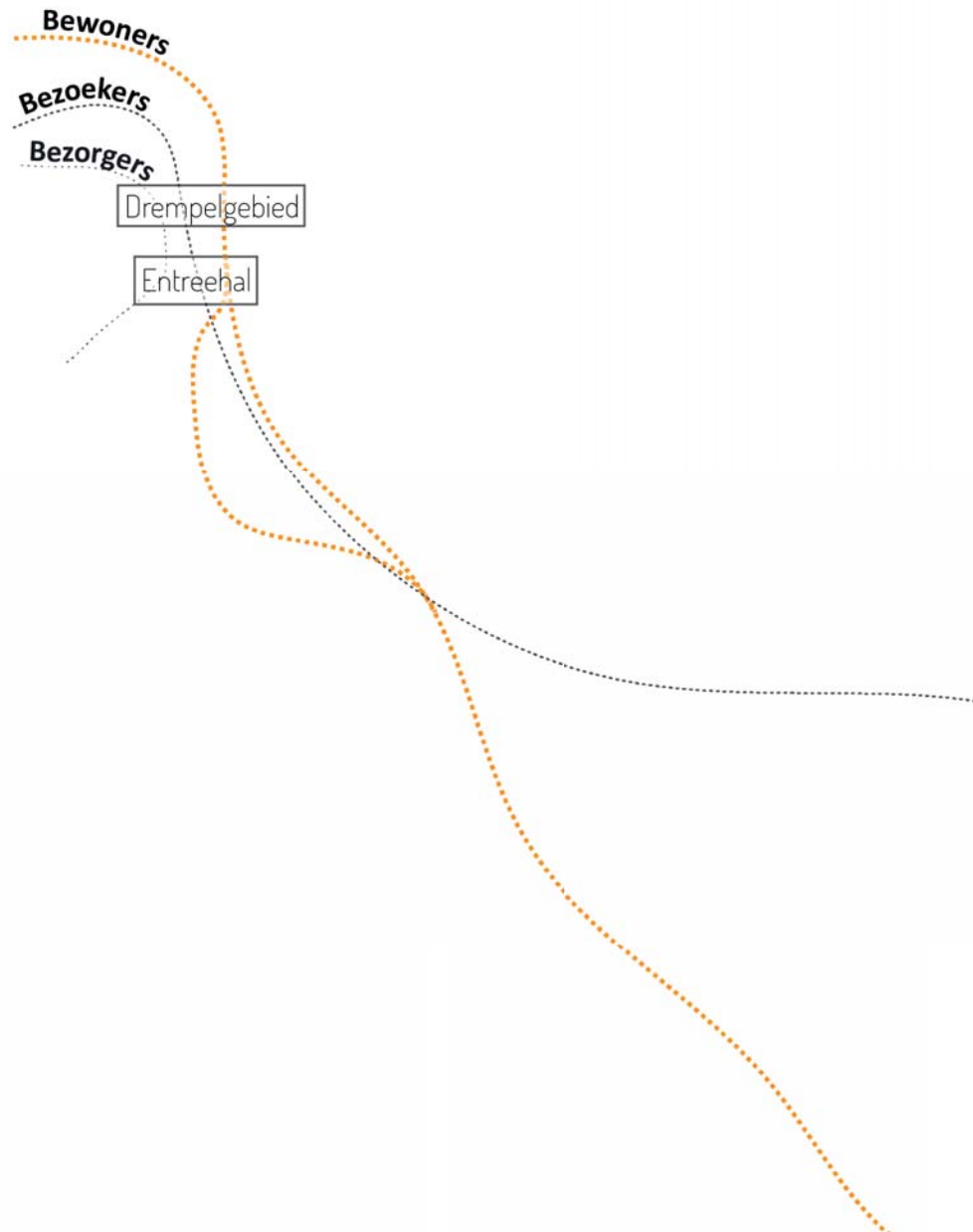

WONING CONCEPT

DE ERVARINGSROUTE

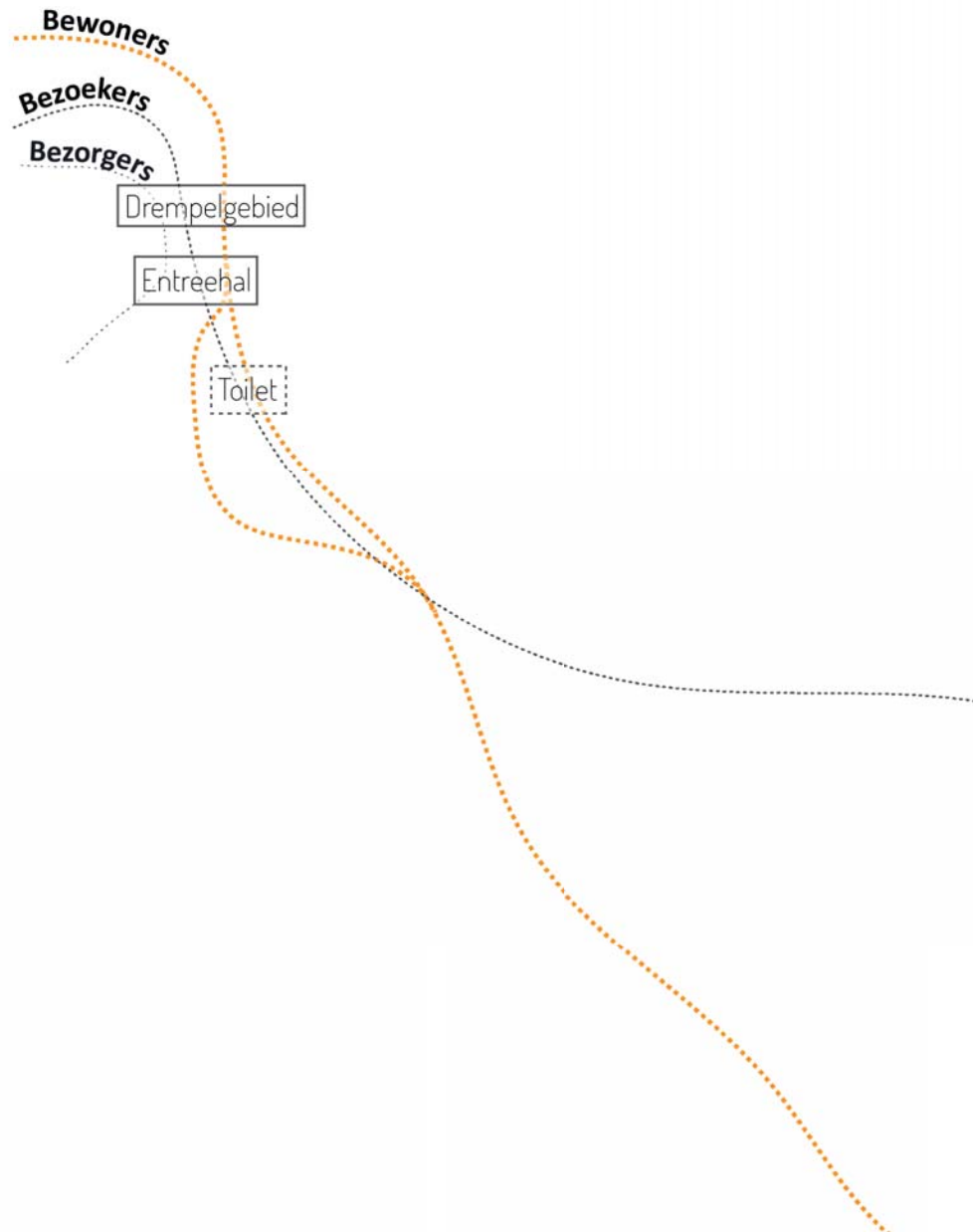

WONING CONCEPT

DE ERVARINGSROUTE

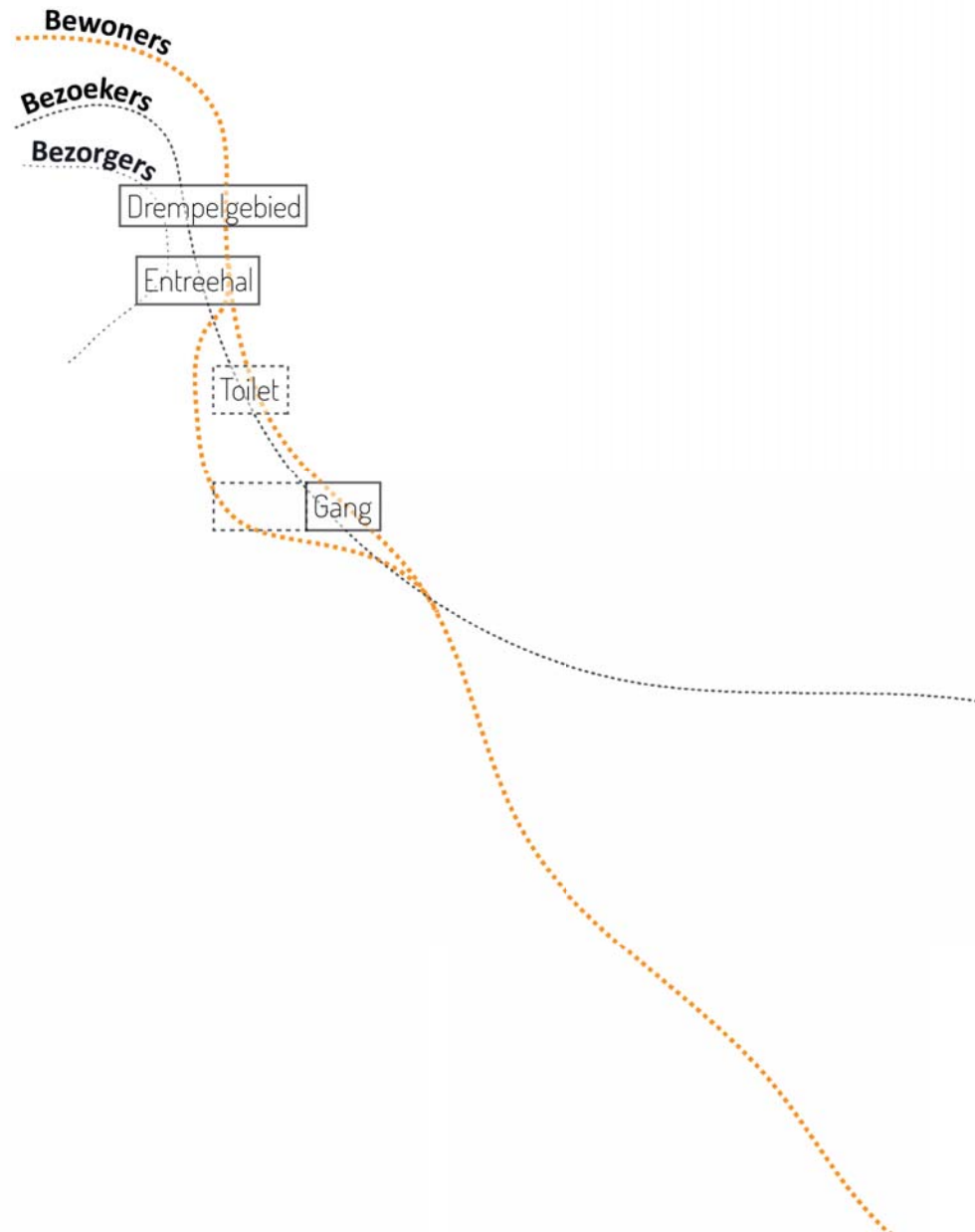

WONING CONCEPT

DE ERVARINGSROUTE

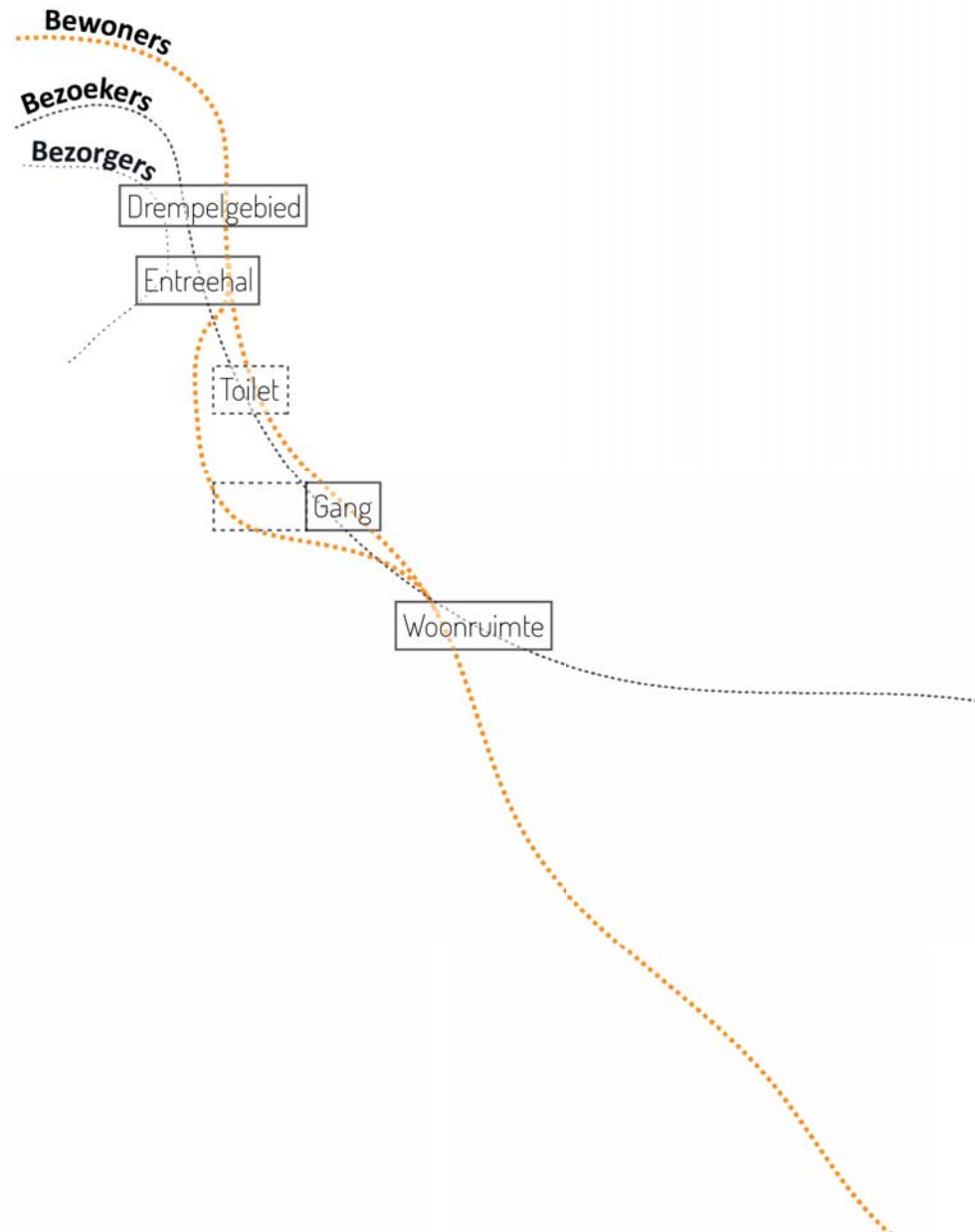

WONING CONCEPT

DE ERVARINGSROUTE

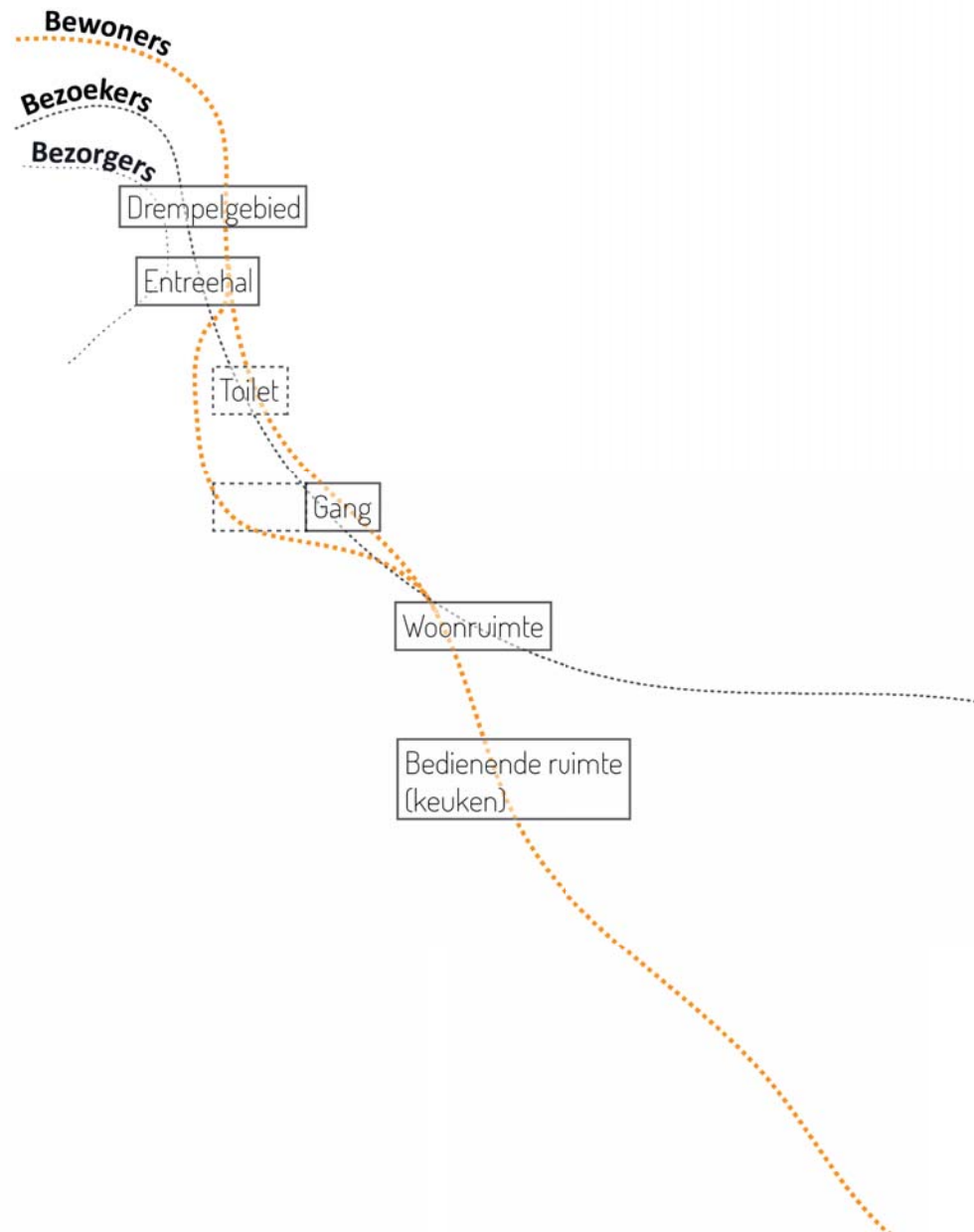

WONING CONCEPT

DE ERVARINGSROUTE

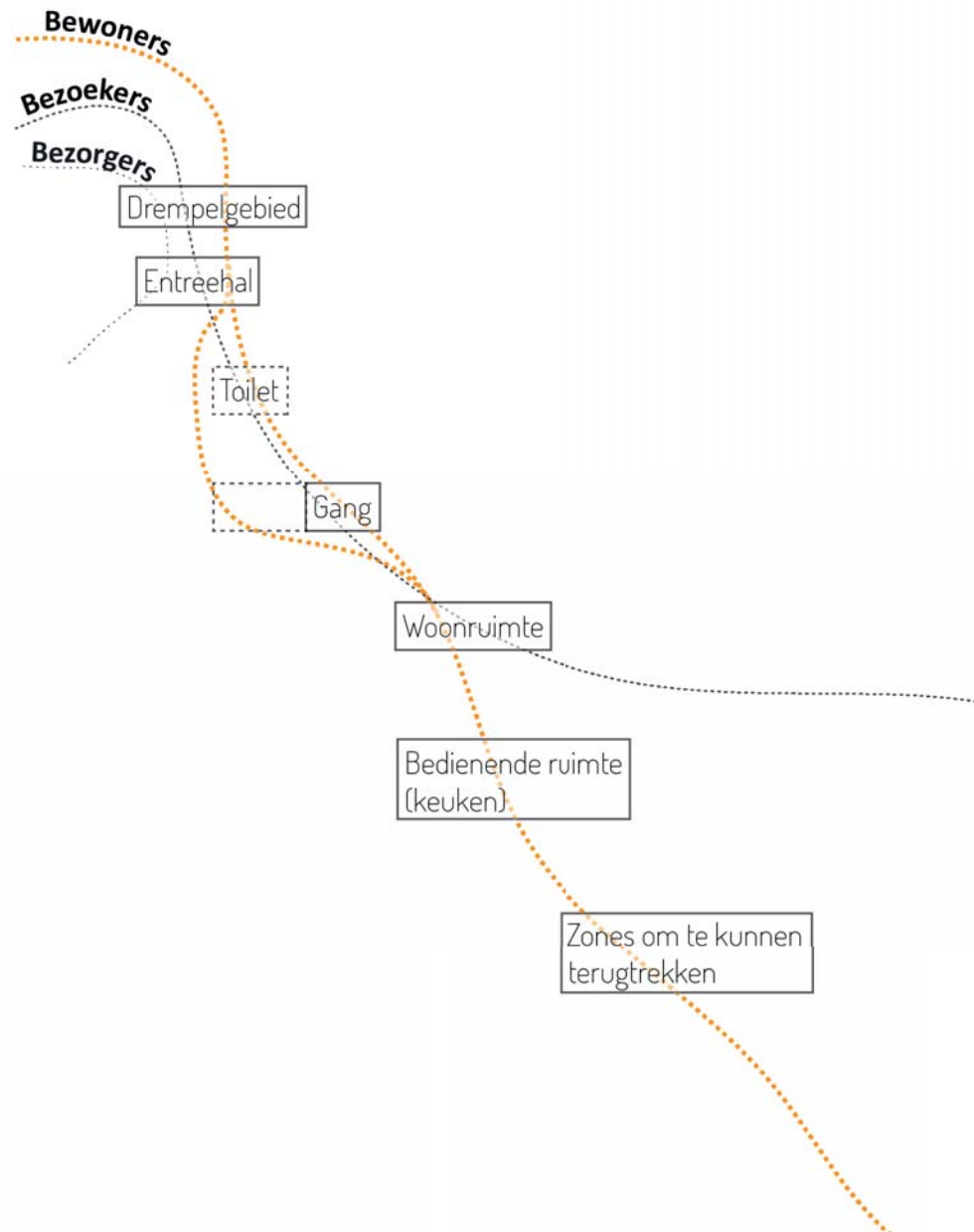

WONING CONCEPT

DE ERVARINGSROUTE

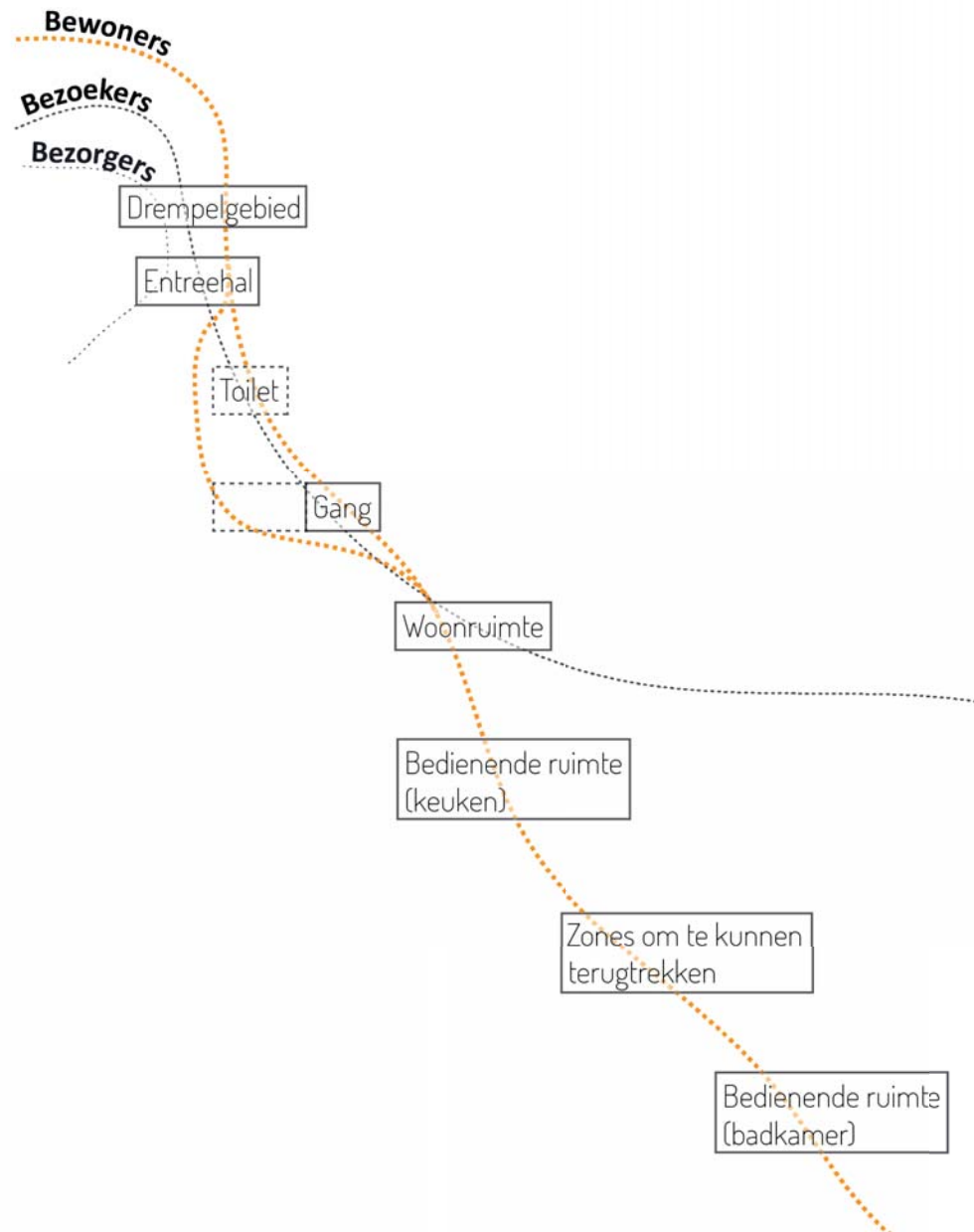



ONDERZOEK 'ATMOSPHERES'

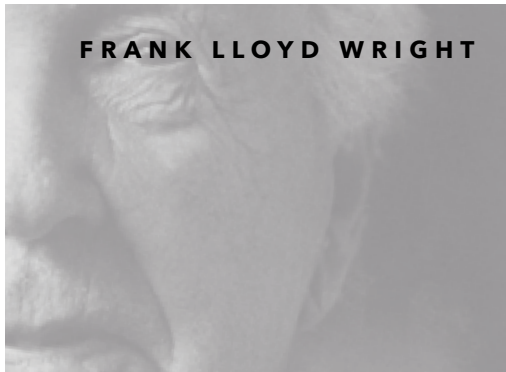
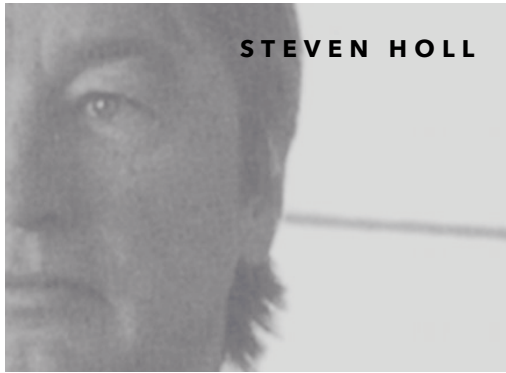

ONDERZOEK 'ATMOSPHERES'

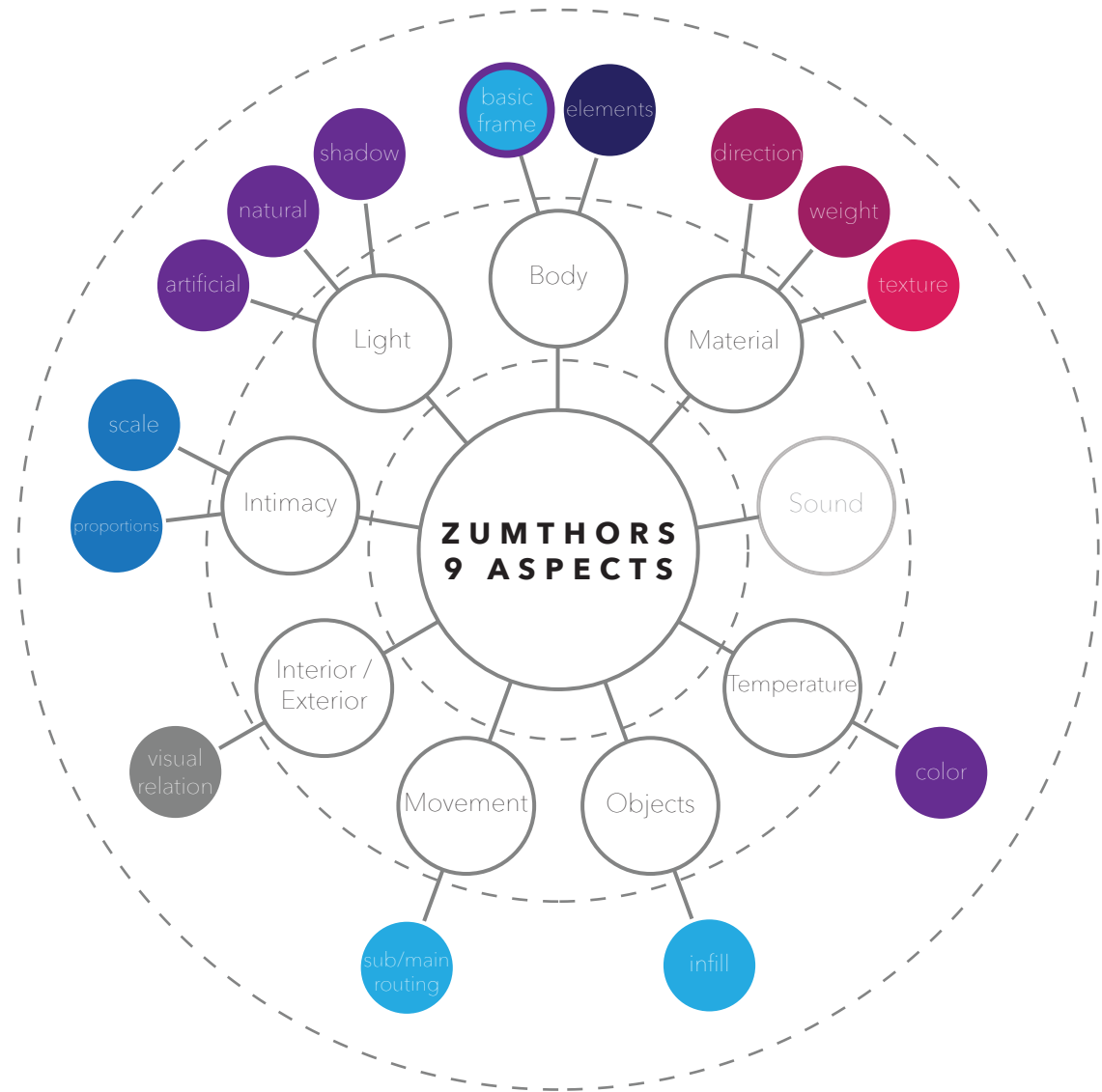
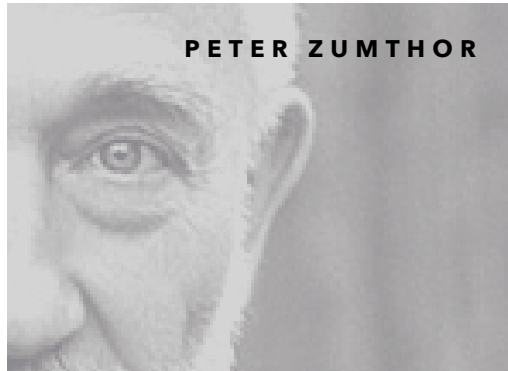

ONDERZOEK 'ATMOSPHERES'

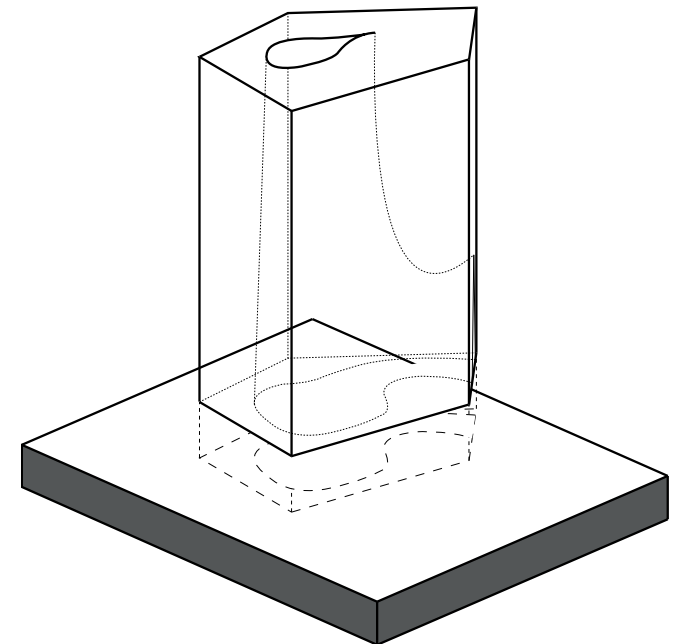
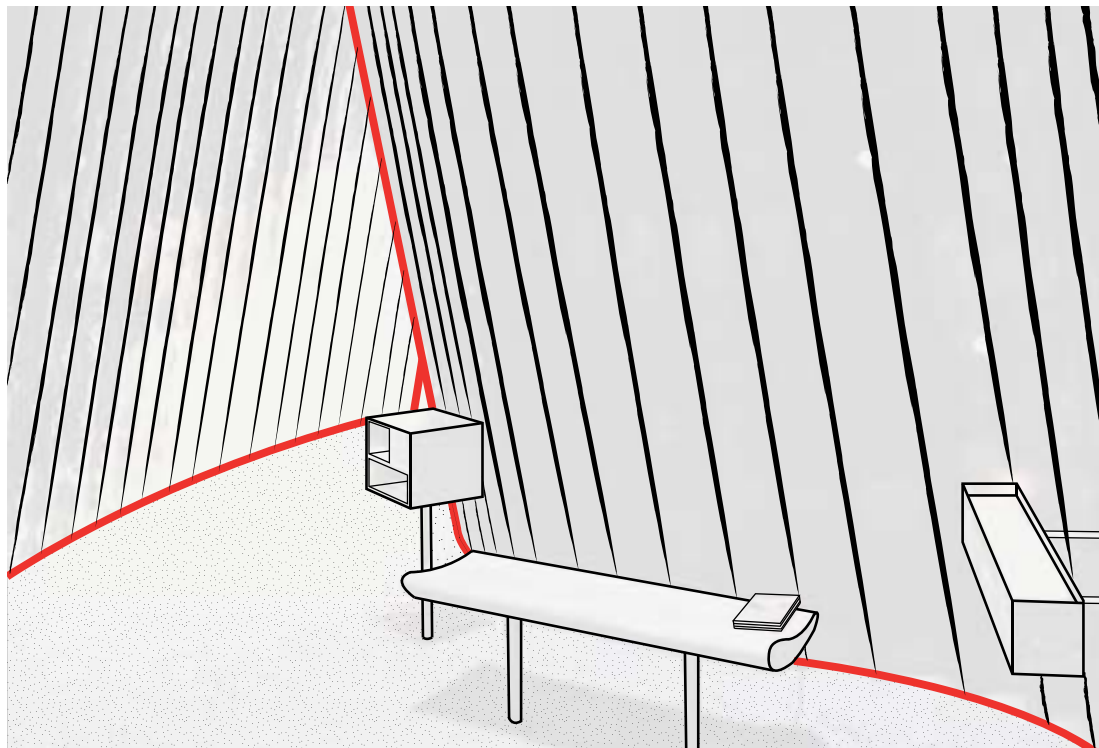
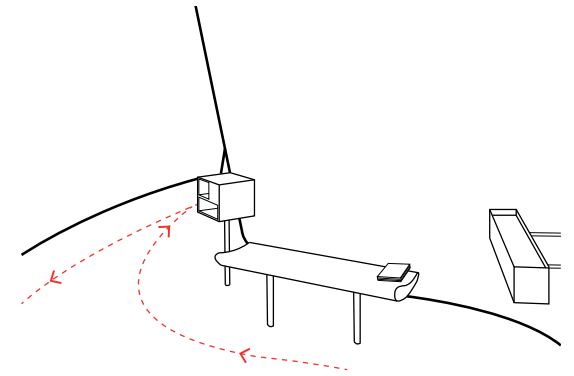
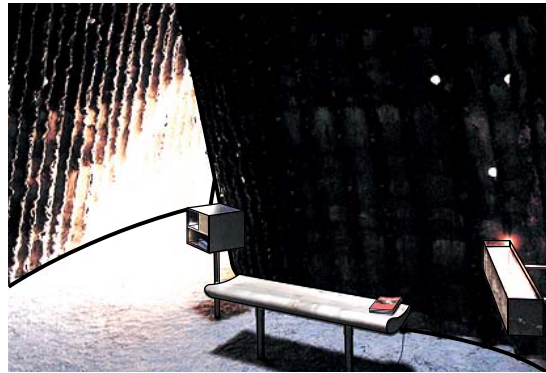
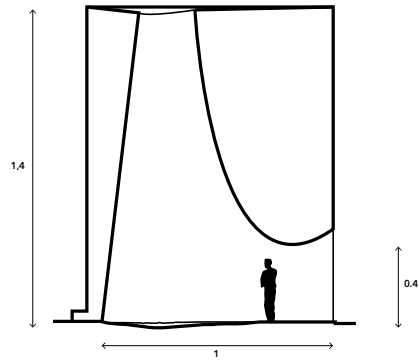

ONDERZOEK 'ATMOSPHERES'

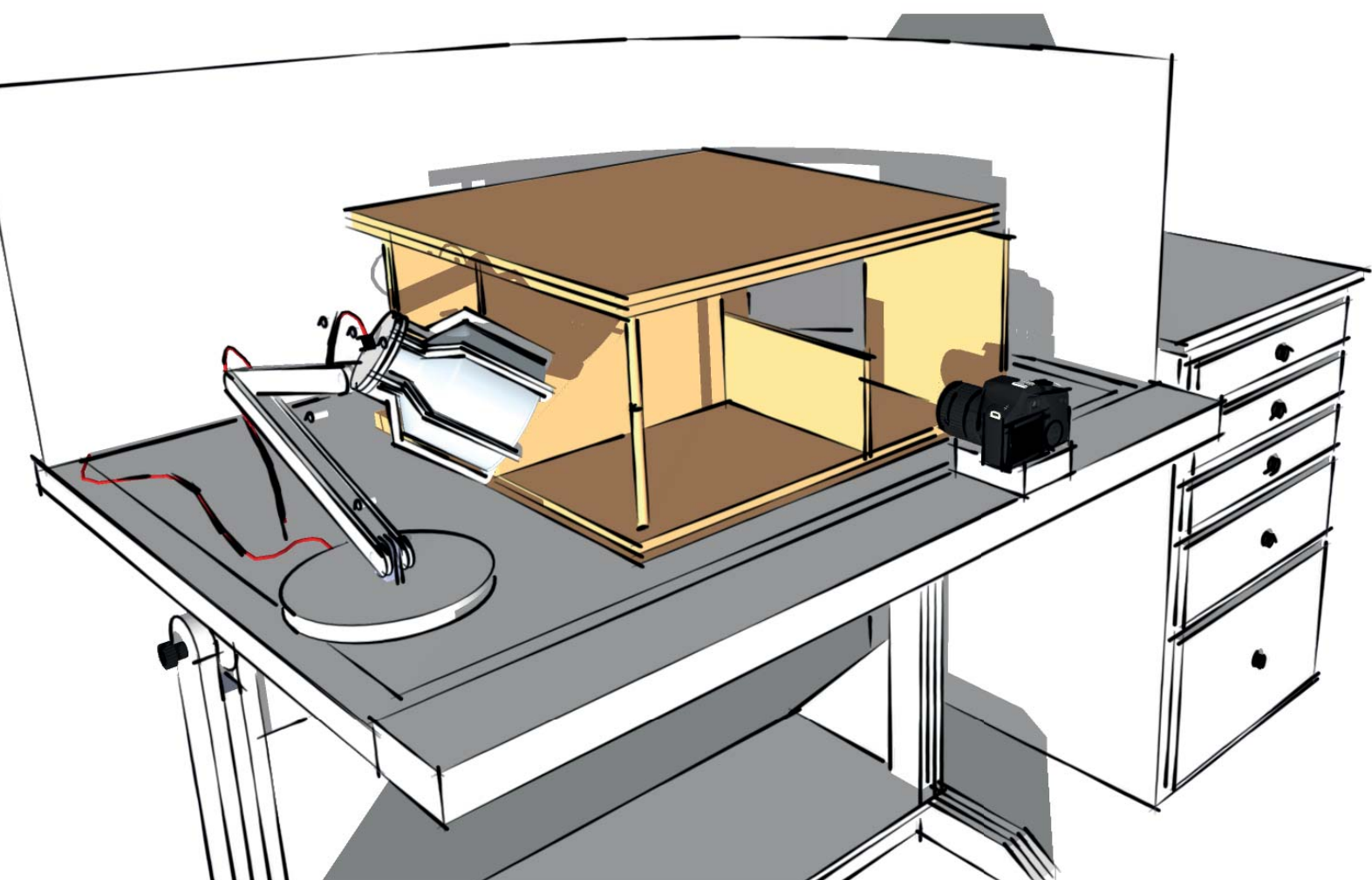





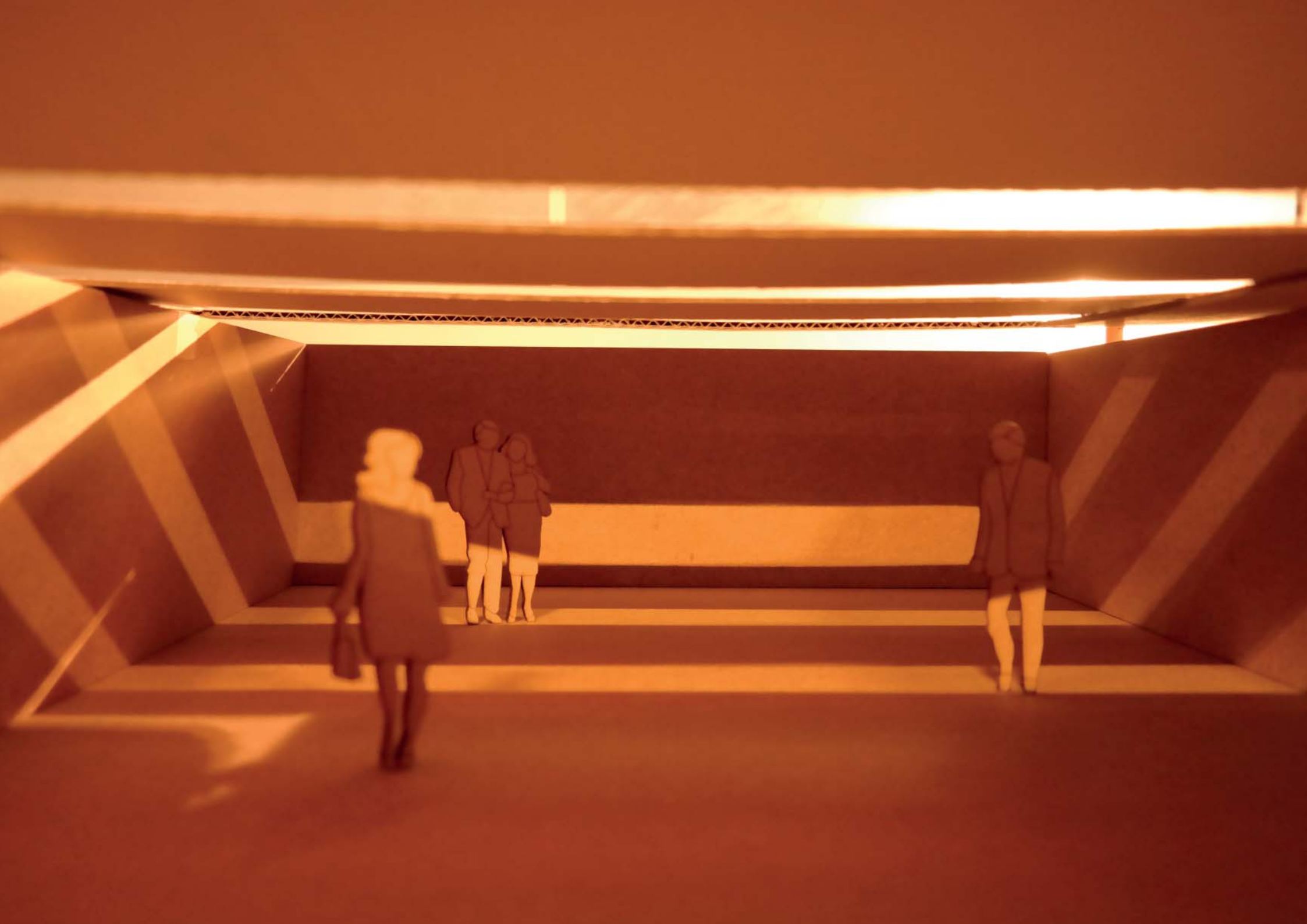

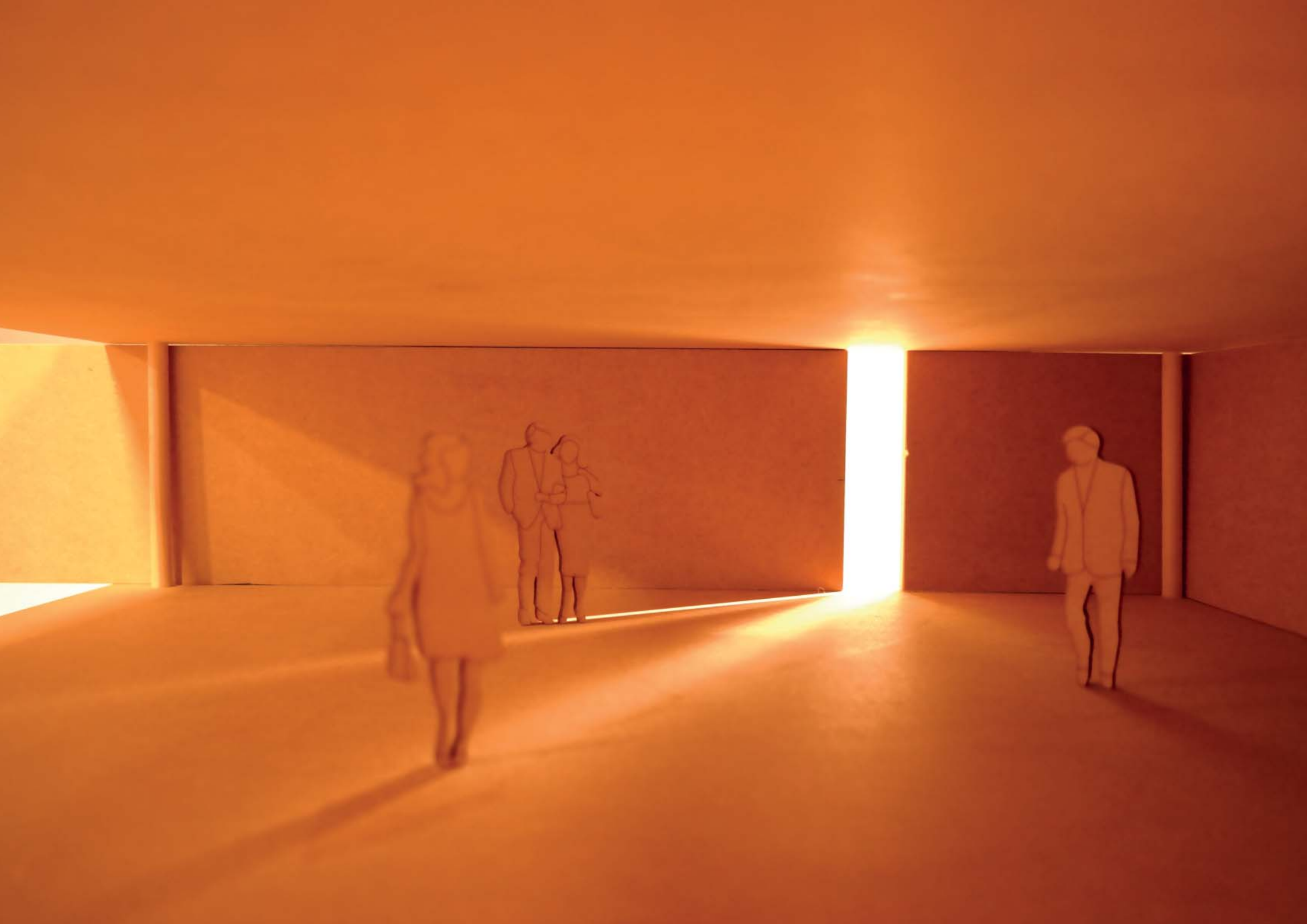







VAN DER KUNWONING

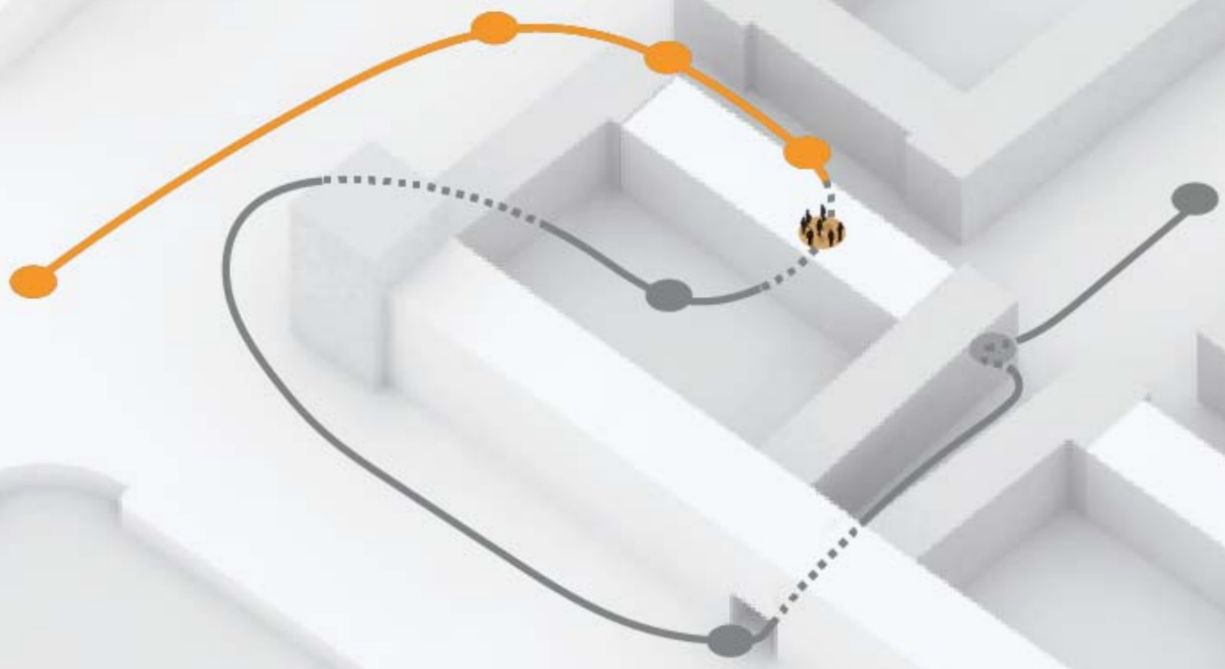

VAN DER KUNWONING

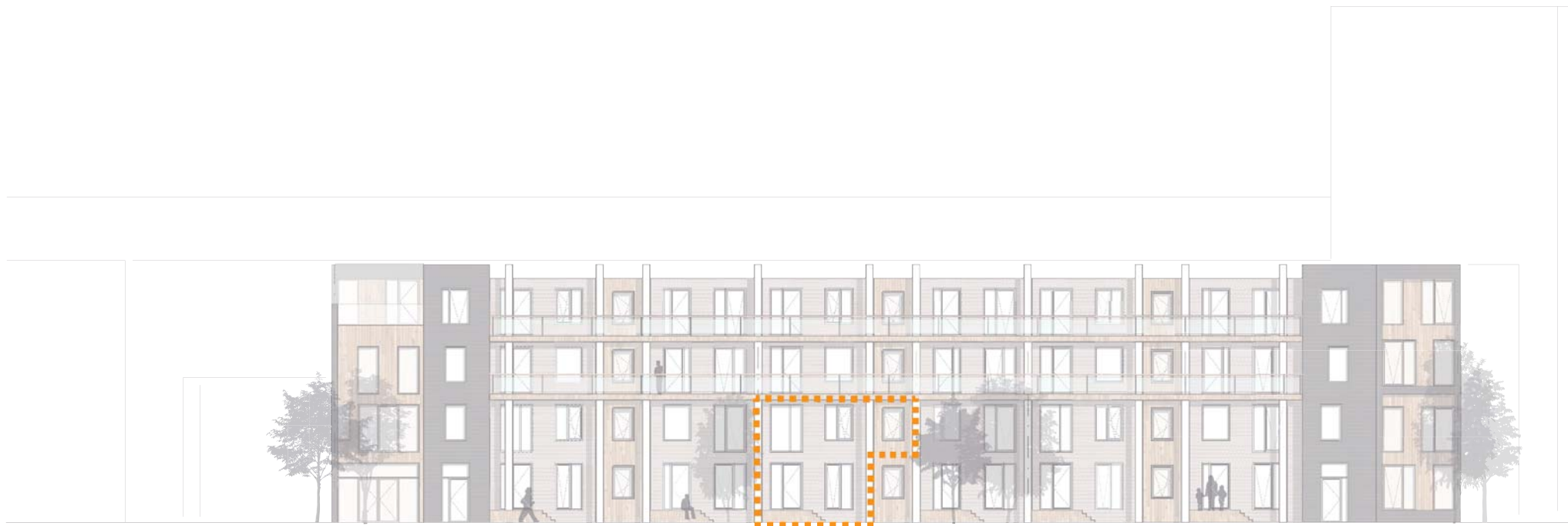

WONINGCONFIGURATIE

BESTAAND

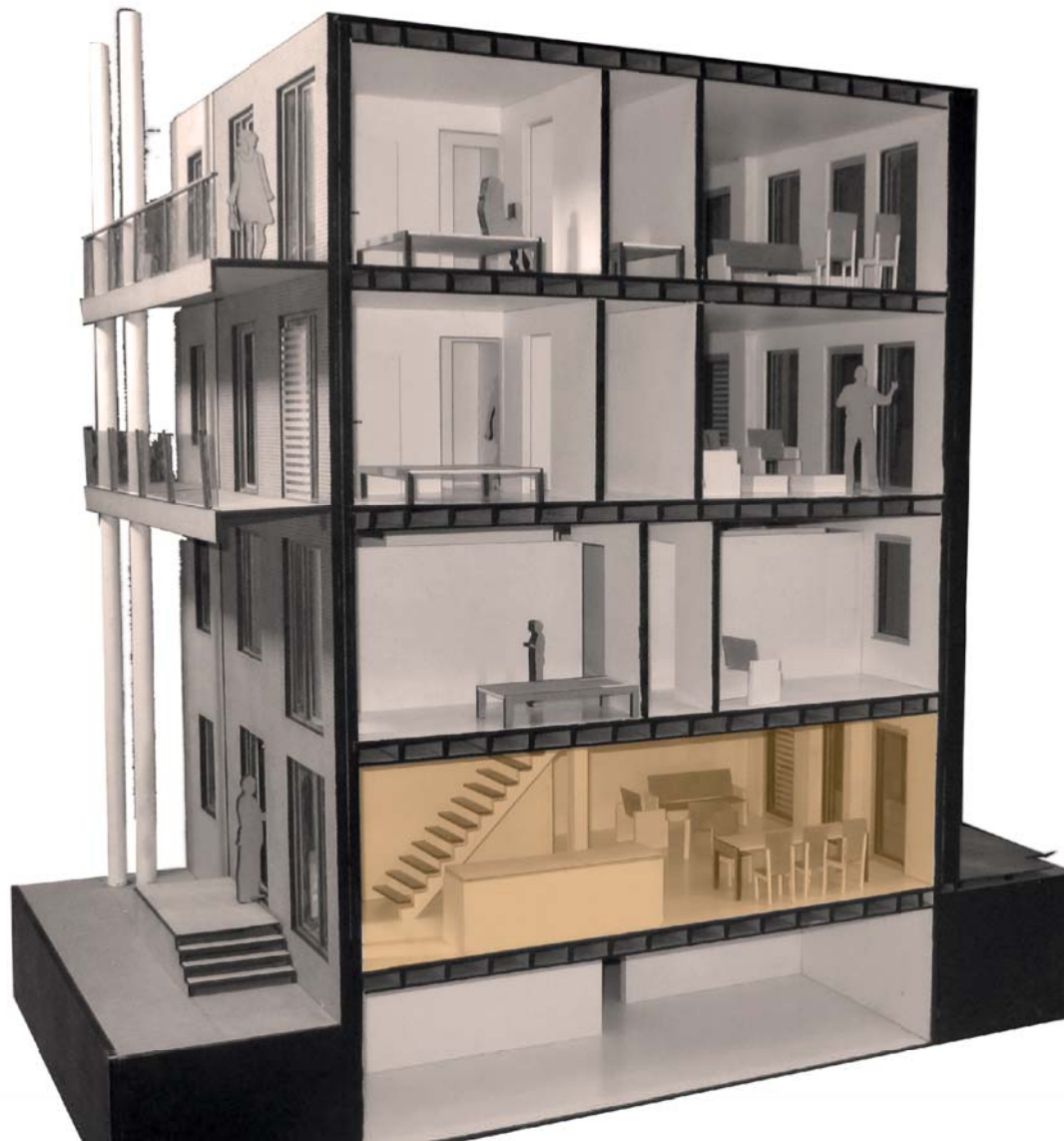

WONINGCONFIGURATIE

BESTAAND



WONINGCONFIGURATIE

NIEUW



VAN DER KUNWONING



110 M²

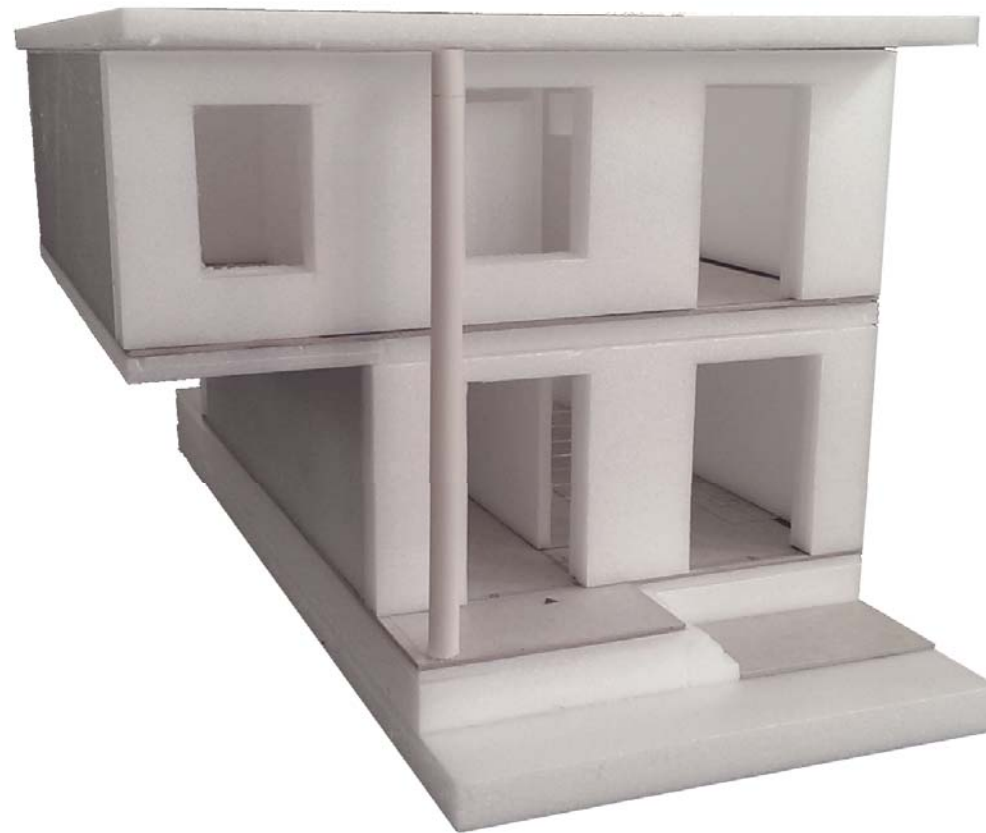

VAN DER KUNWONING



110 M²

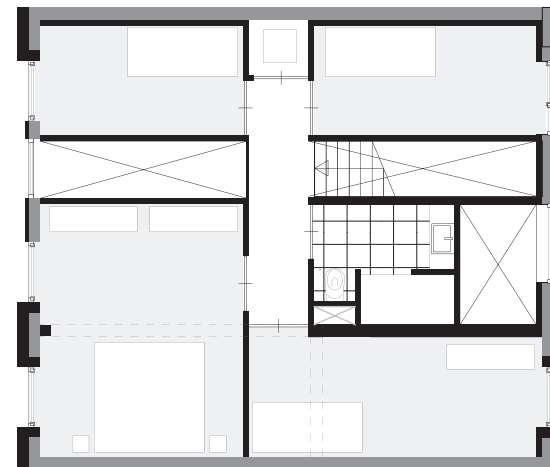
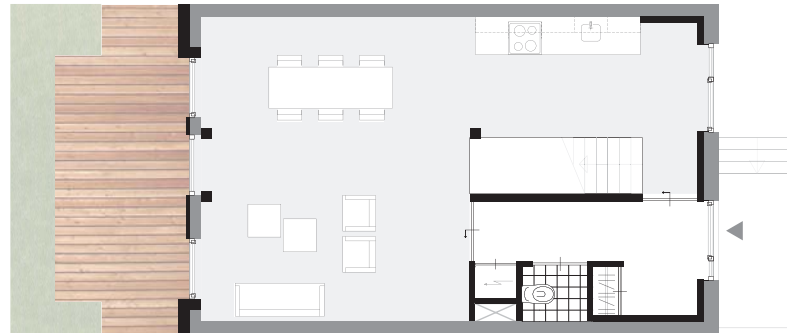

VAN DER KUNWONING

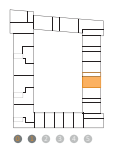

110 M²

VAN DER KUNWONING

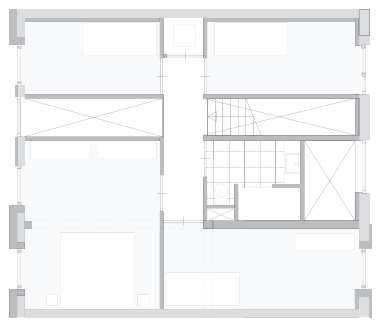
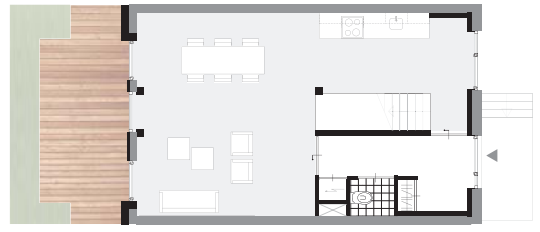

VAN DER KUNWONING

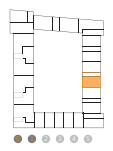

110 M²

VAN DER KUNWONING

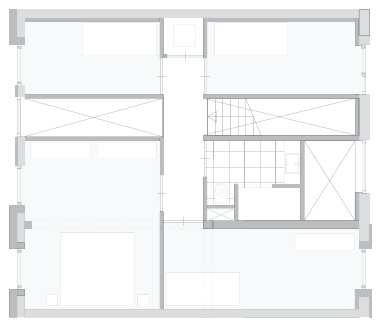

VAN DER KUNWONING



110 M²

VAN DER KUNWONING

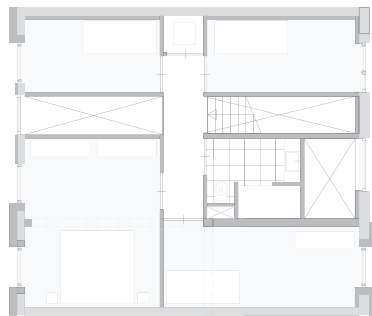
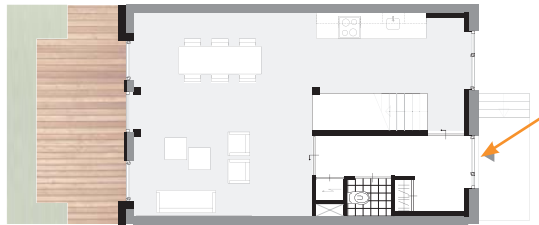

VAN DER KUNWONING

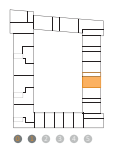

110 M²

VAN DER KUNWONING

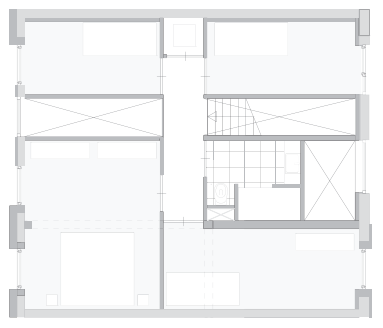
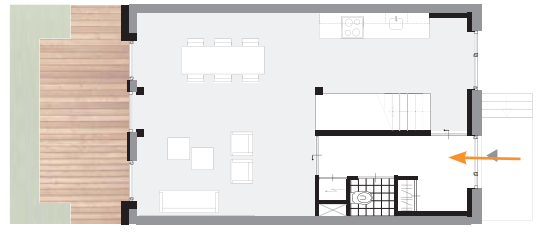

VAN DER KUNWONING

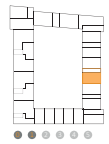

110 M²

VAN DER KUNWONING

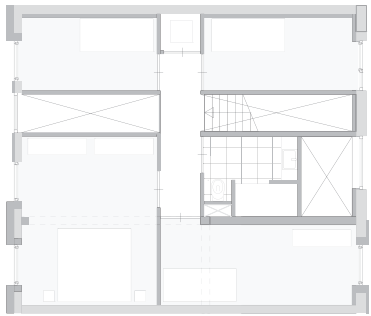
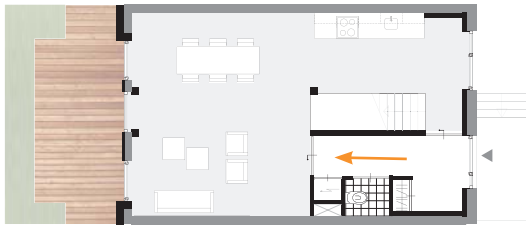

VAN DER KUNWONING



110 M²

VAN DER KUNWONING

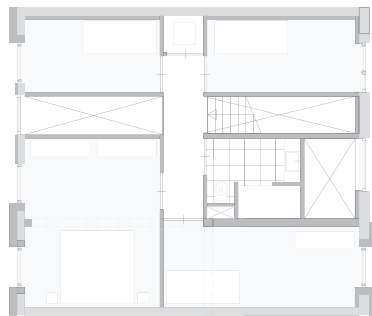
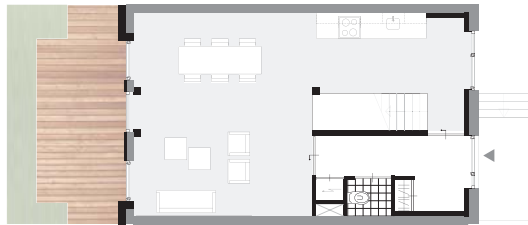

VAN DER KUNWONING

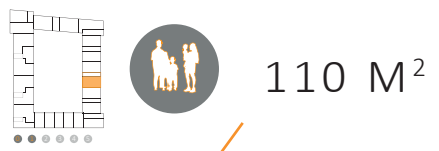

110 M²

VAN DER KUNWONING

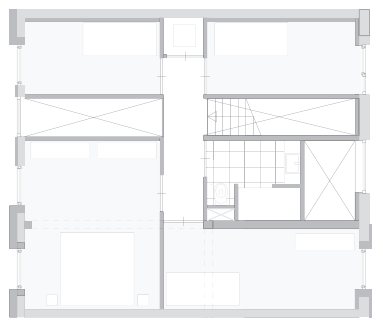
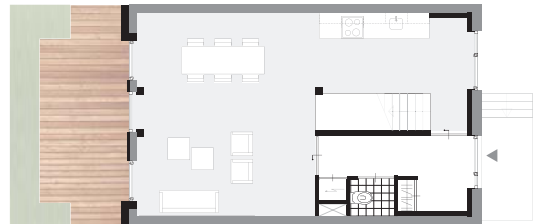

VAN DER KUNWONING

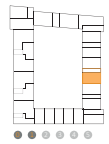

110 M²

VAN DER KUNWONING

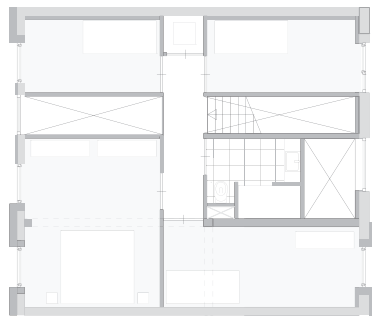
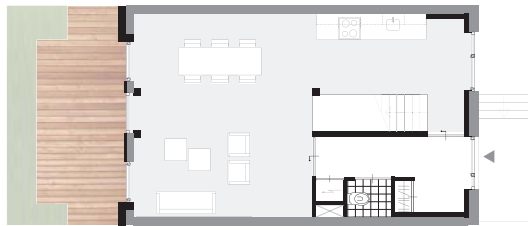

VAN DER KUNWONING



110 M²

VAN DER KUNWONING

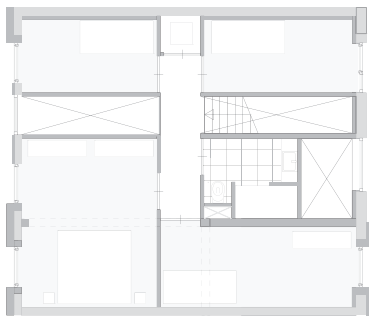
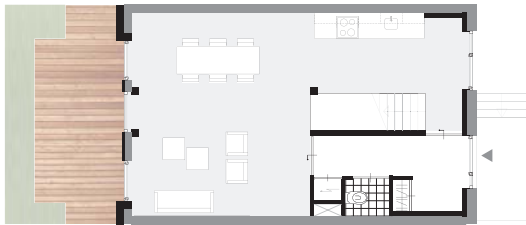

VAN DER KUNWONING



VAN DER KUNWONING

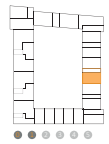

110 M²

VAN DER KUNWONING

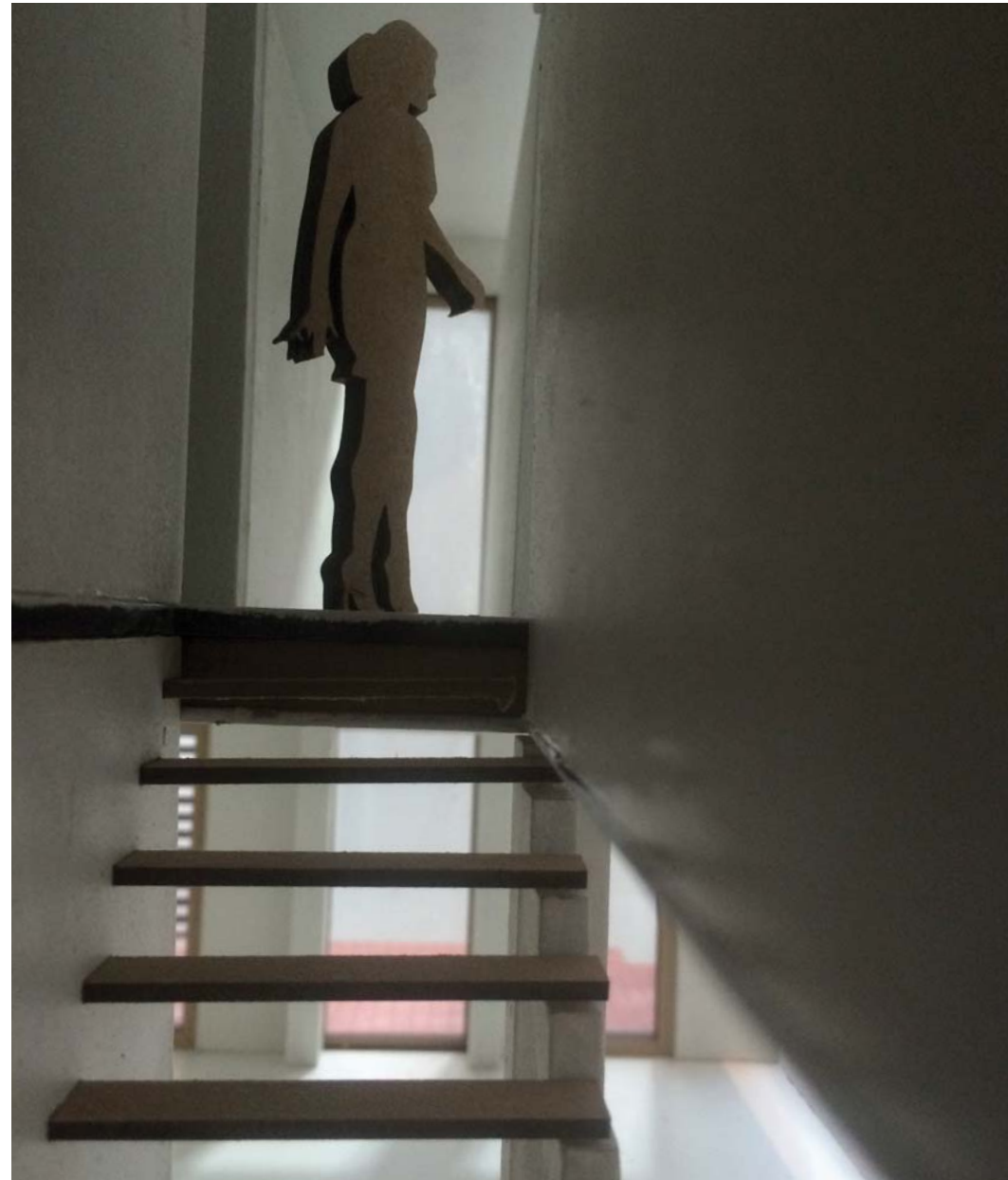
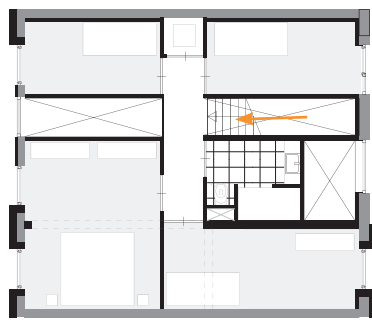
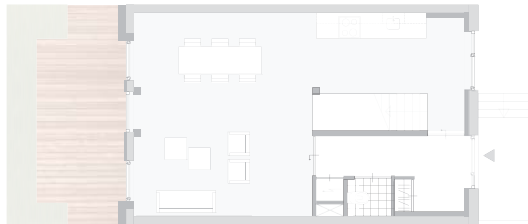

VAN DER KUNWONING



110 M²

VAN DER KUNWONING

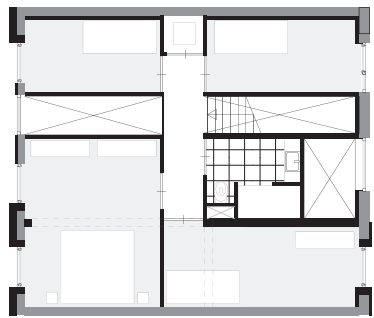
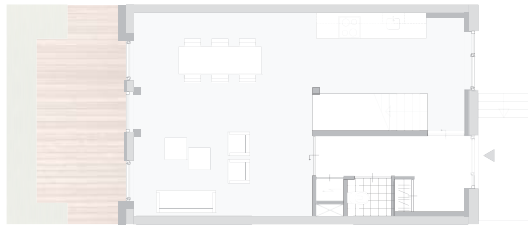

VAN DER KUNWONING

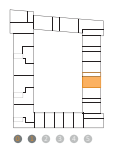

110 M²

VAN DER KUNWONING

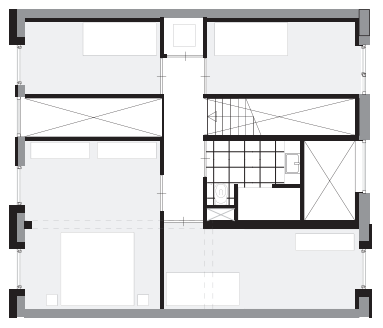
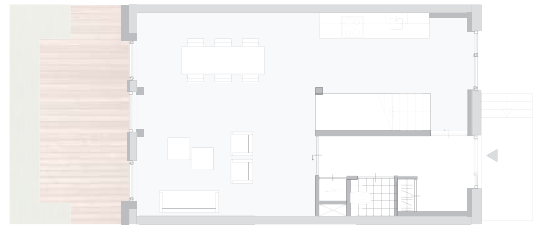





VAN DER KUNWONING 1

DETAIL KOZIJN

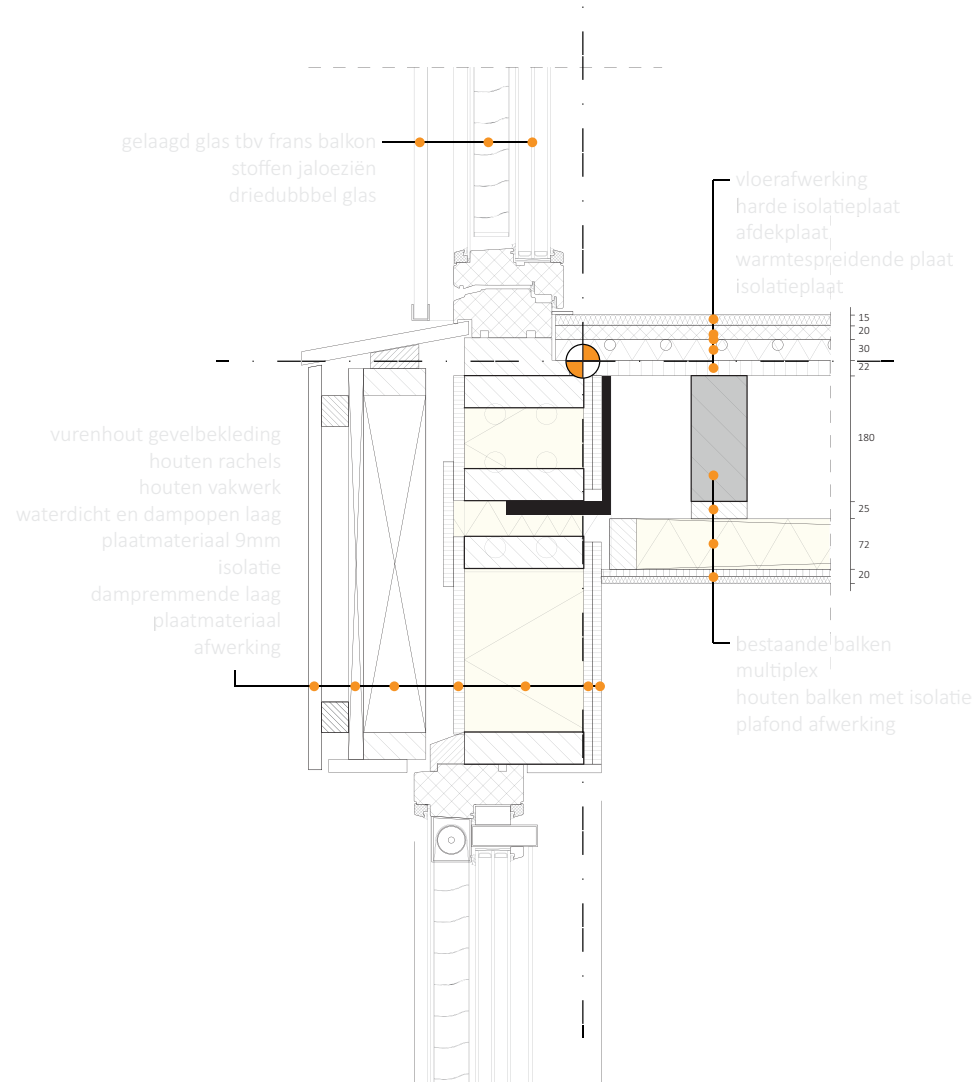

VAN DER KUNWONING

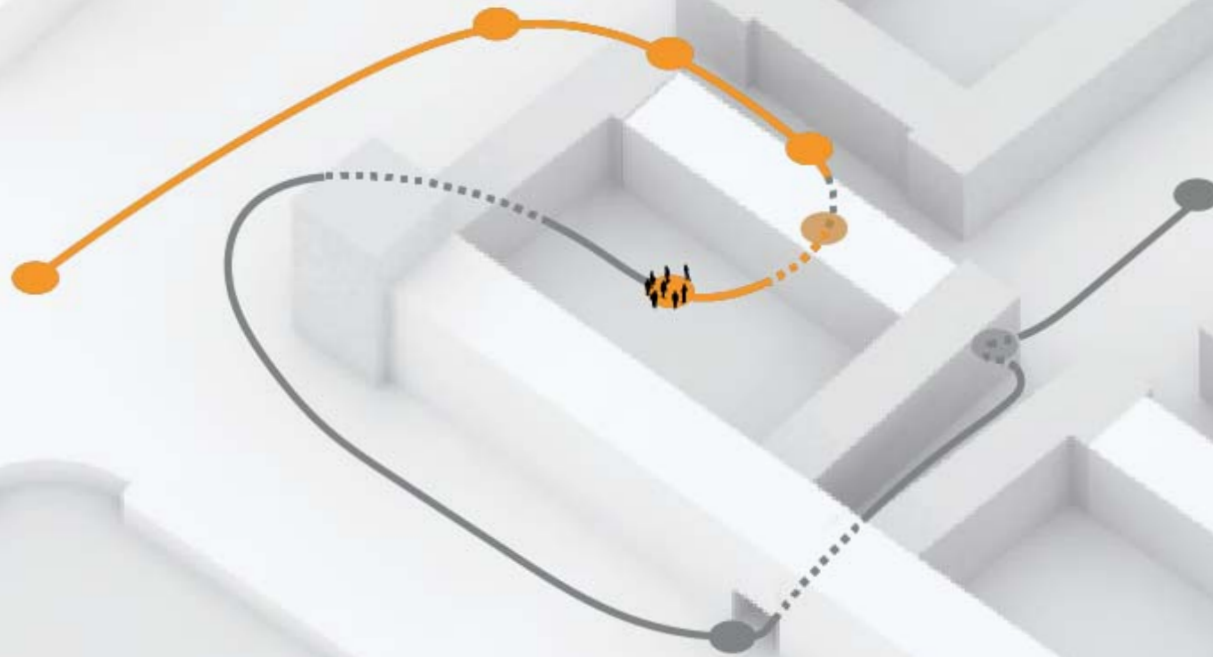

COURTYARD GEVEL

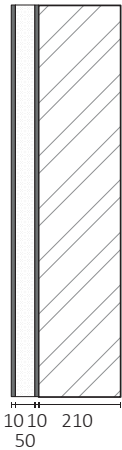
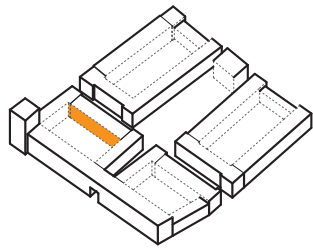

BESTAAND

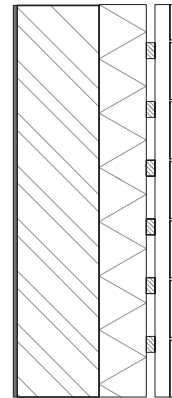

BINNENGEVEL



COURTYARD GEVEL

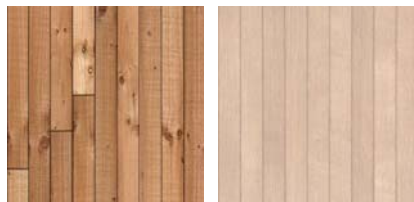
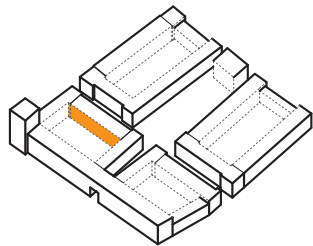

COURTYARD GEVEL

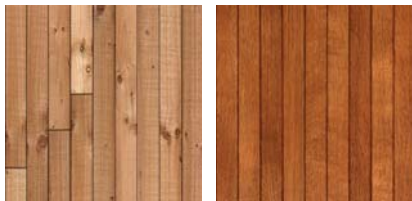
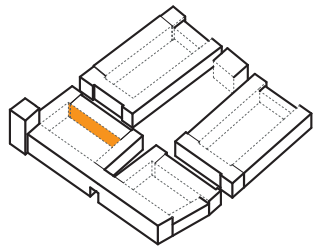

CONSTRUCTIE GEVEL

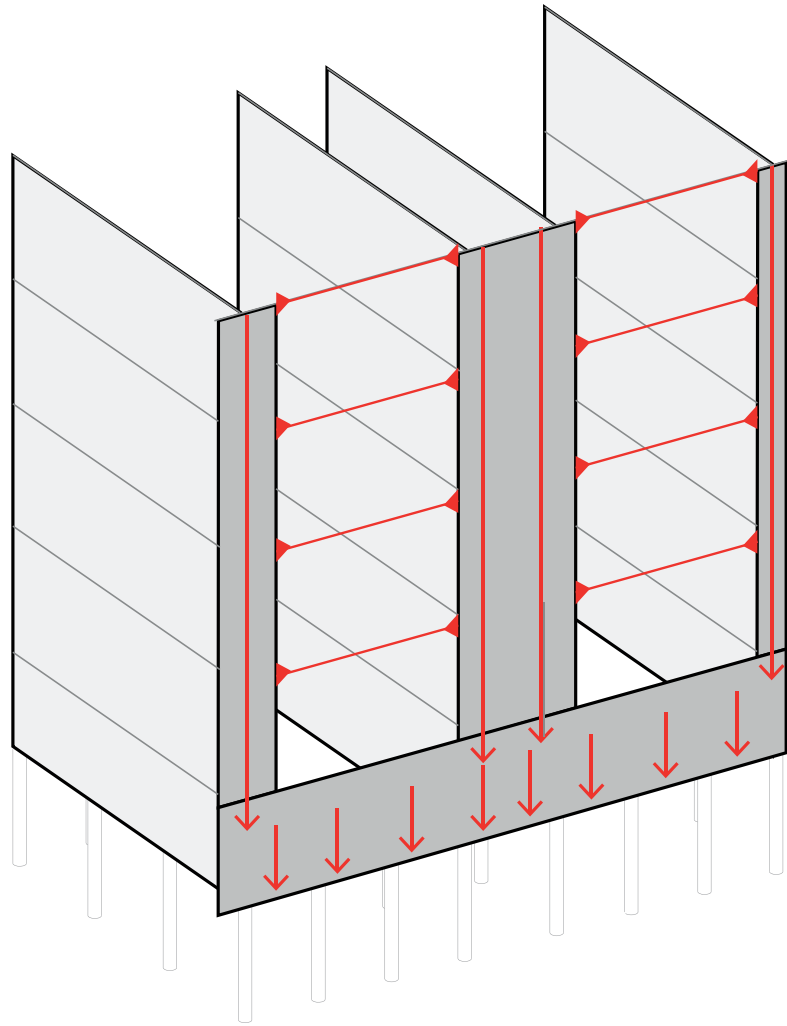





VAN DER KUNWONING

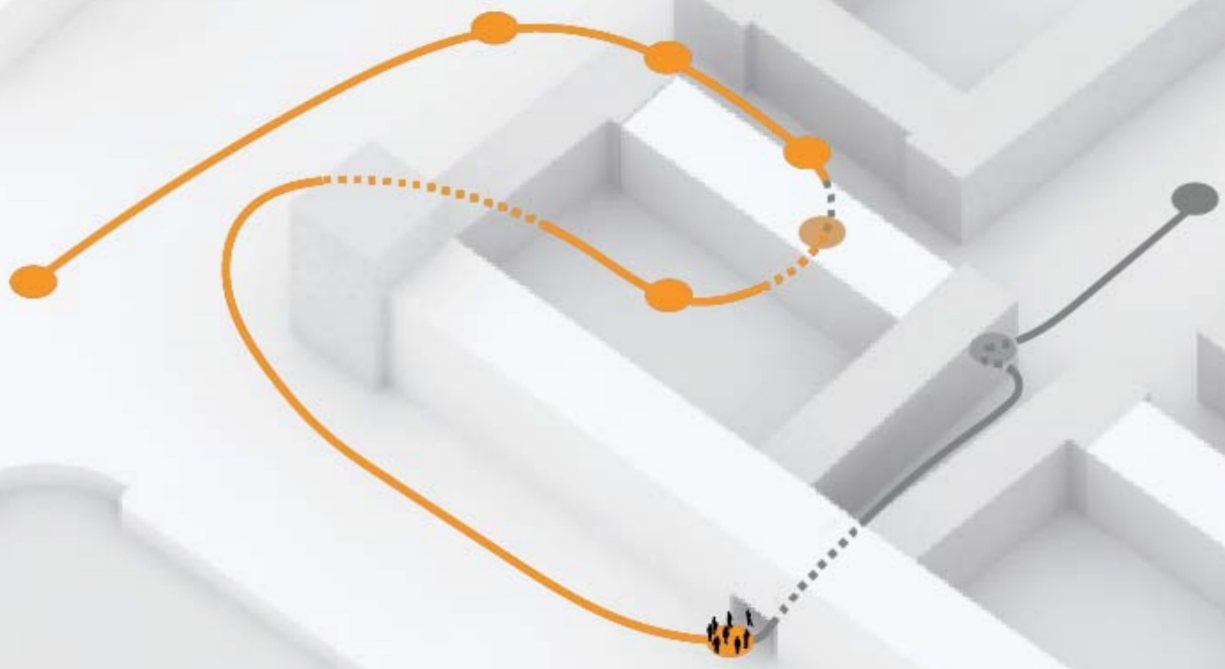

WEST ENTREE

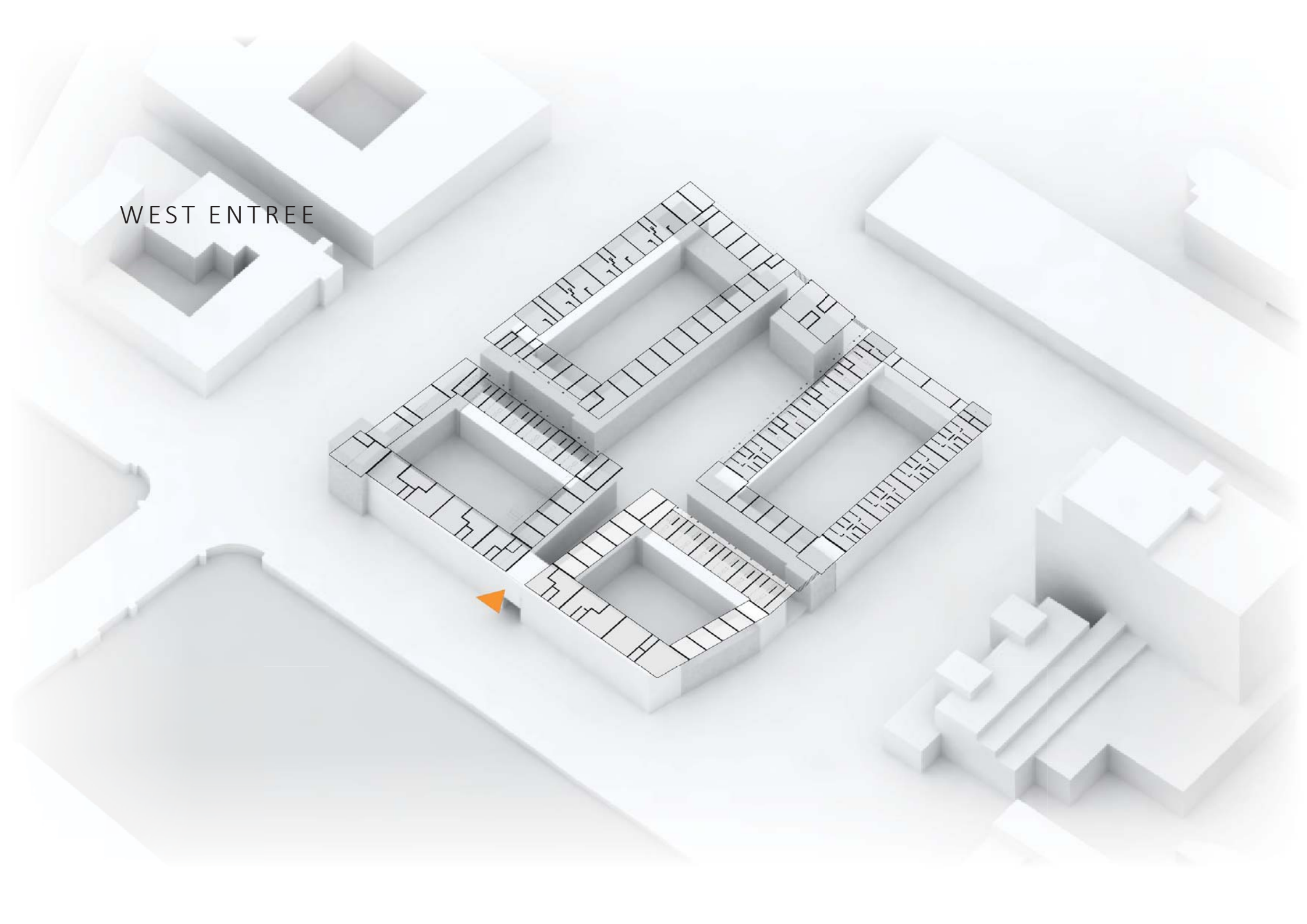





COURTYARD GEVEL

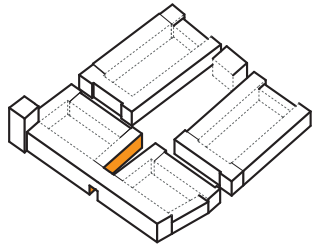

DETAIL

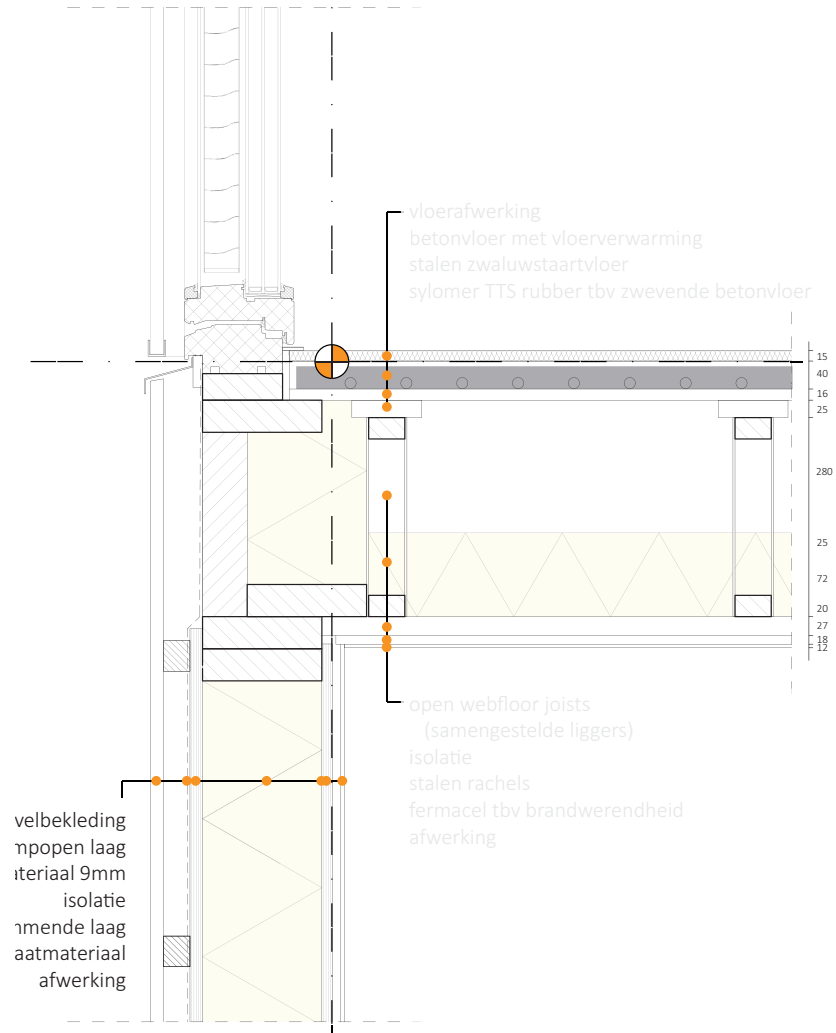

DETAIL

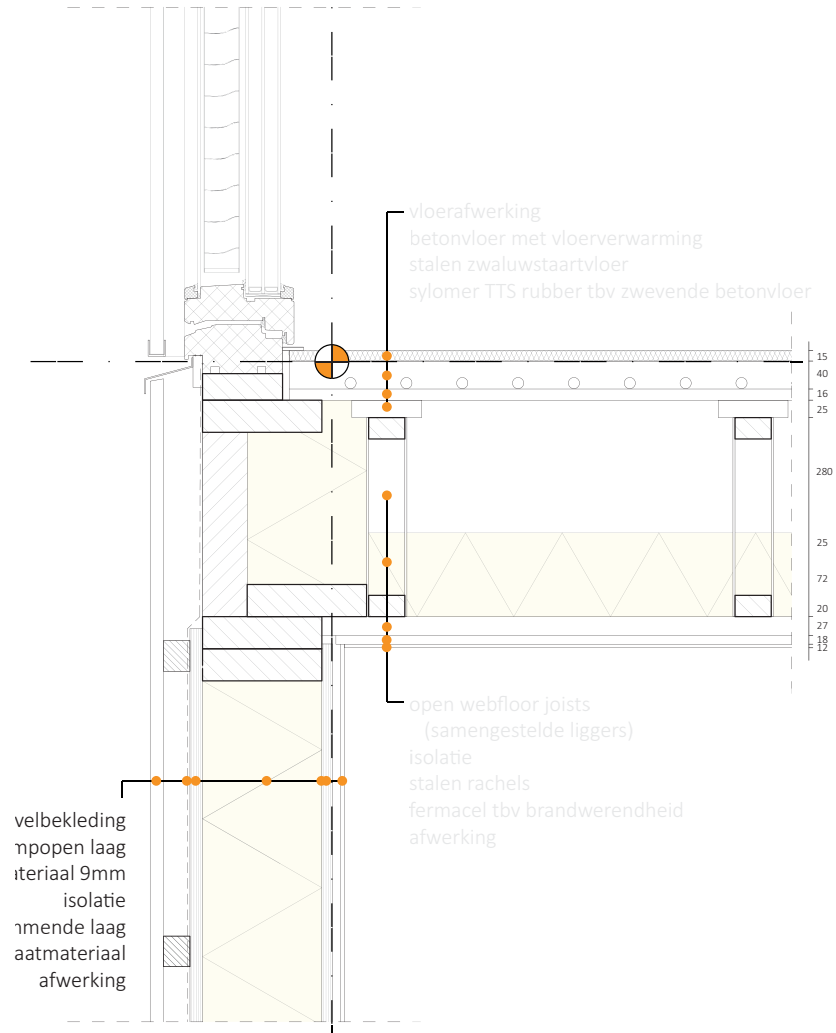

KLIMAAT

AANPASSINGSVERMOGEN

Daglichttoetreding

Zonwering

Luchtreinheid

Luchtbeweging

Temperatuur



EIGEN REKENING
Bewustzijnsgevoel

BEHAAGLIJKE TEMPERatuur

Zomer; koelen

Winter; verwarmen

DAGLICHT

Gradaties van daglicht

KLIMAAT NIEUW

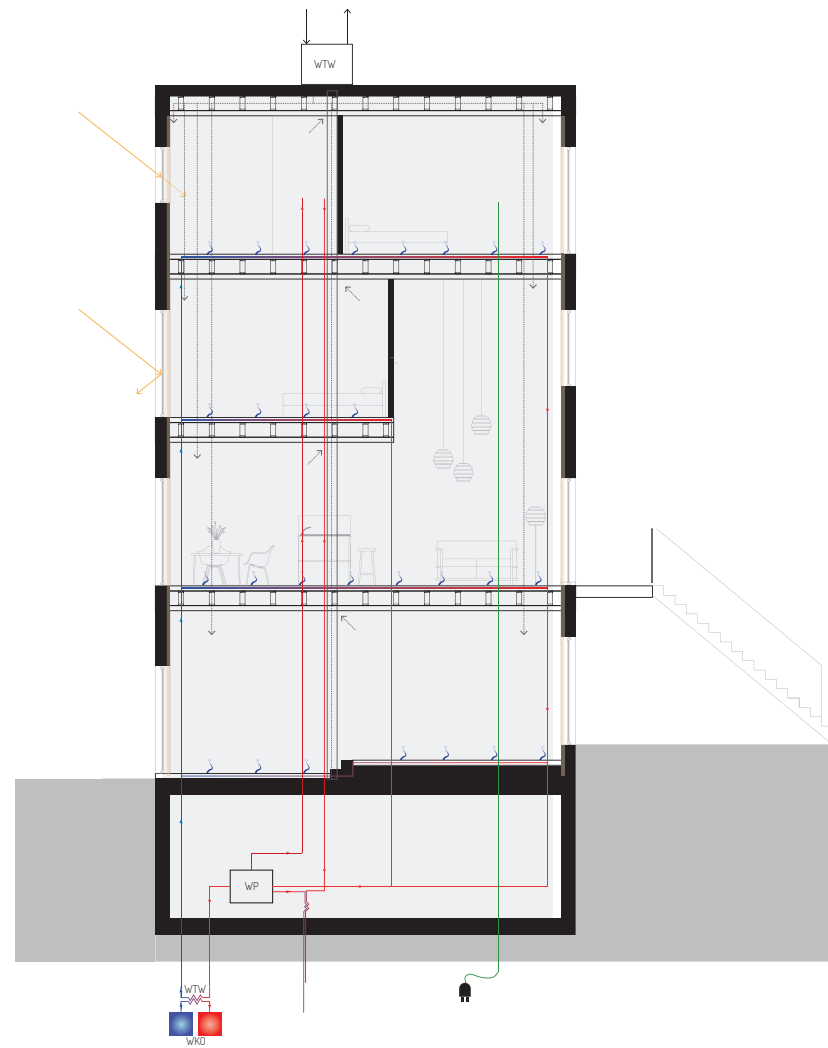
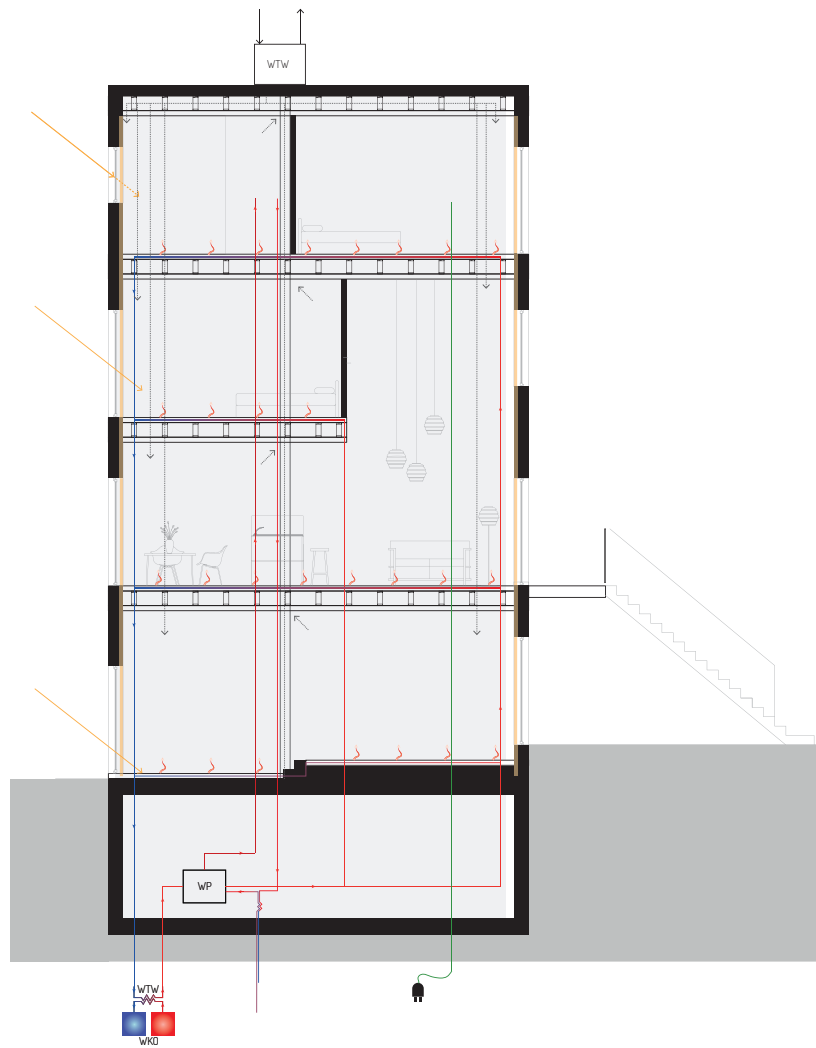

KLIMAAT BESTAAND

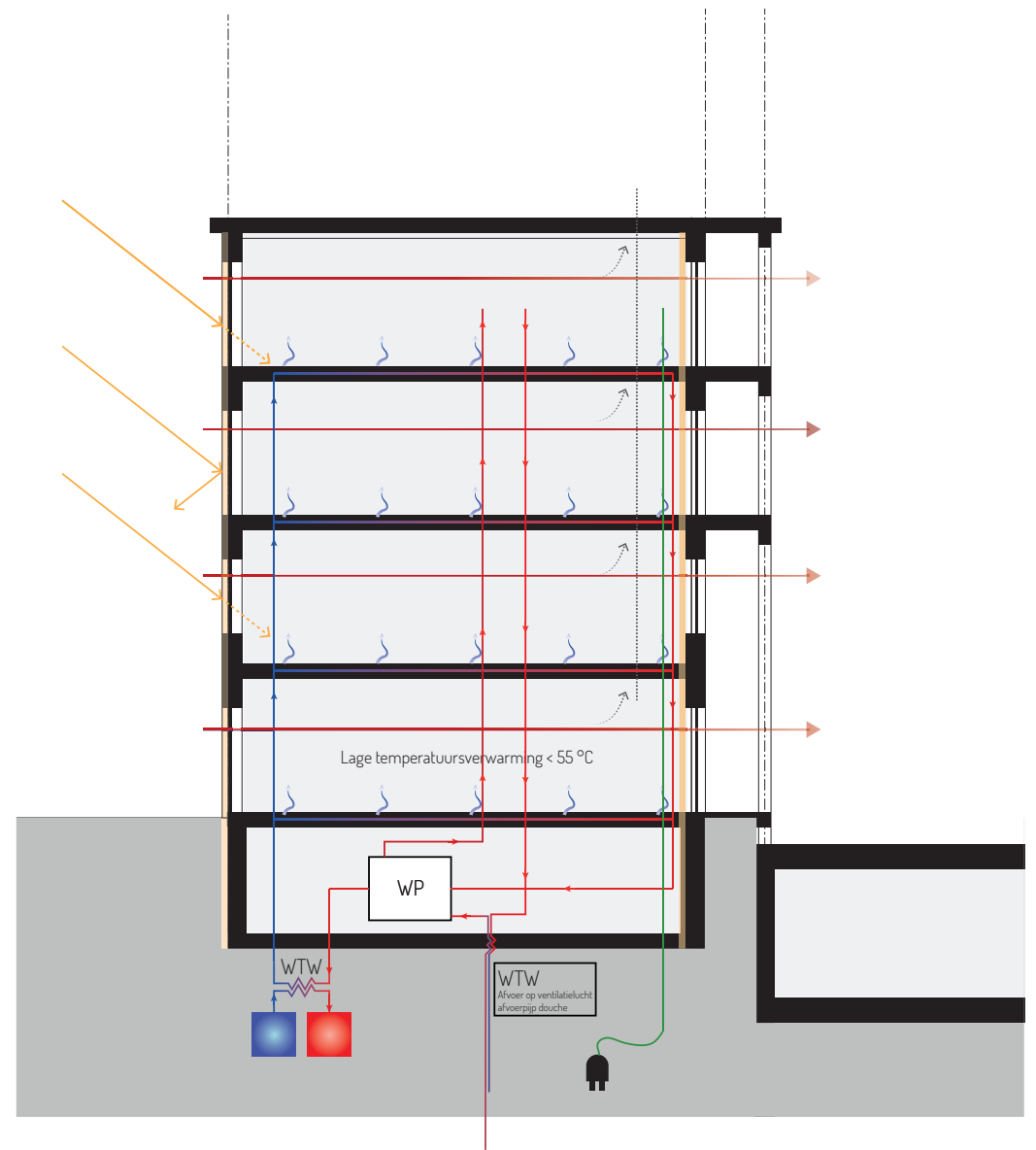
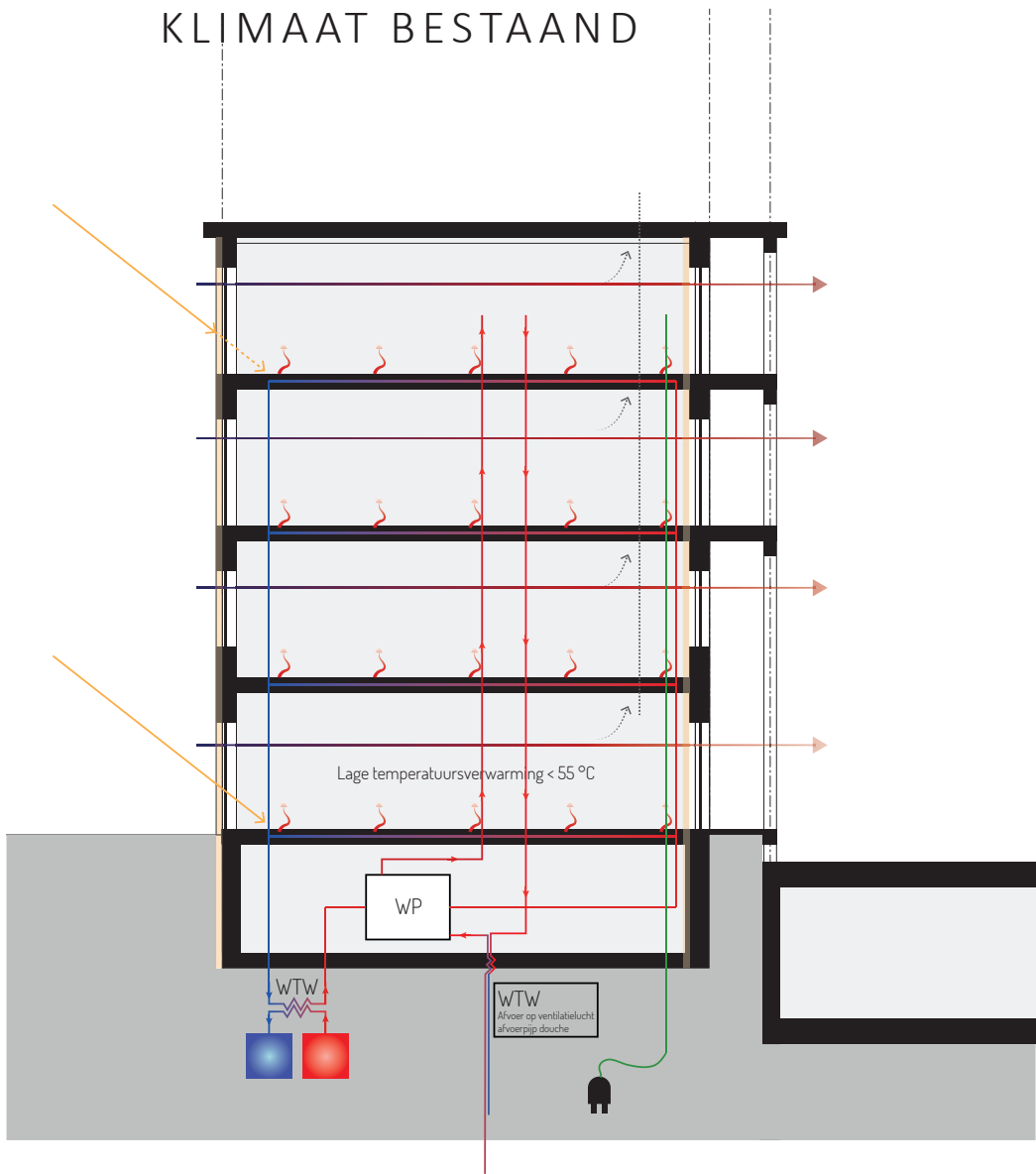

AMSTELLAAN HOEKWONING

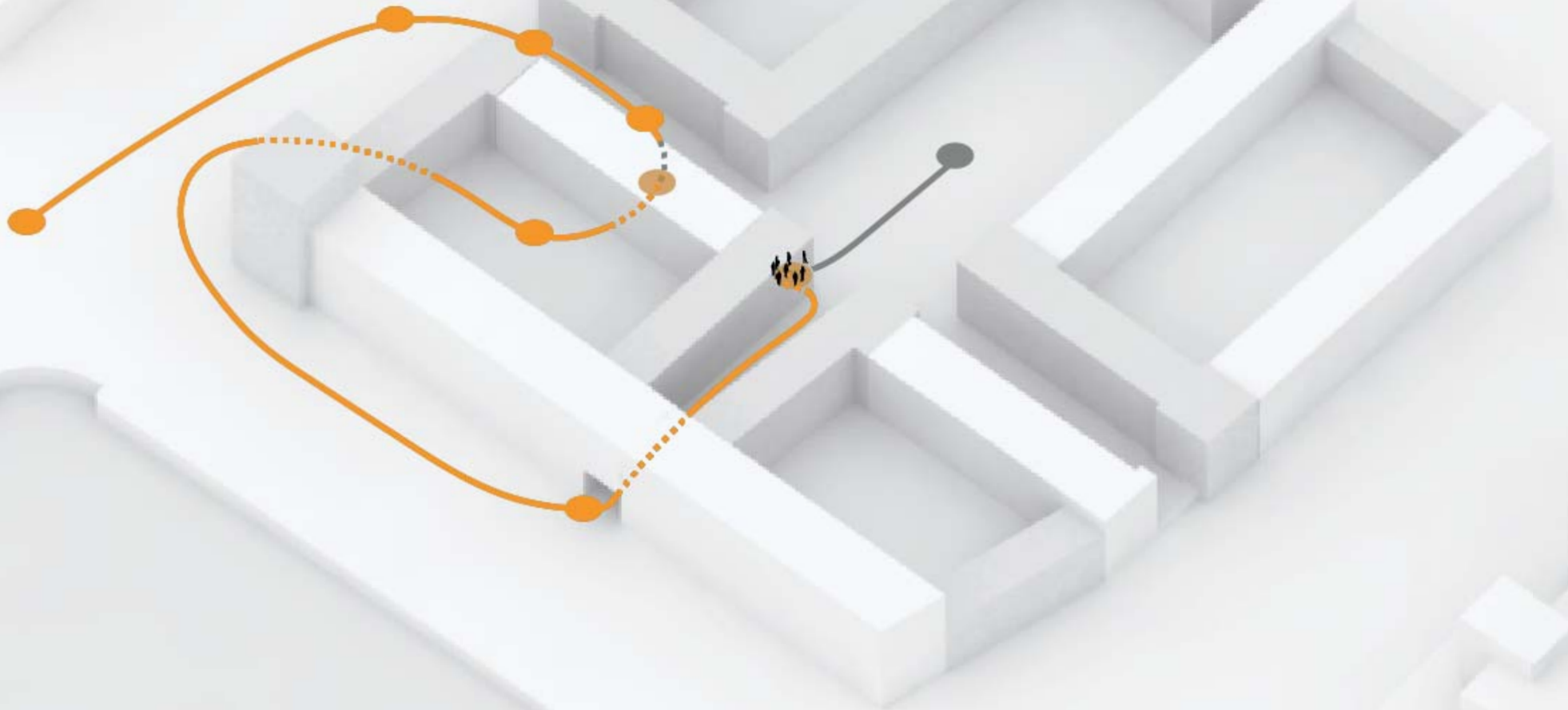

ATELIERWONINGEN

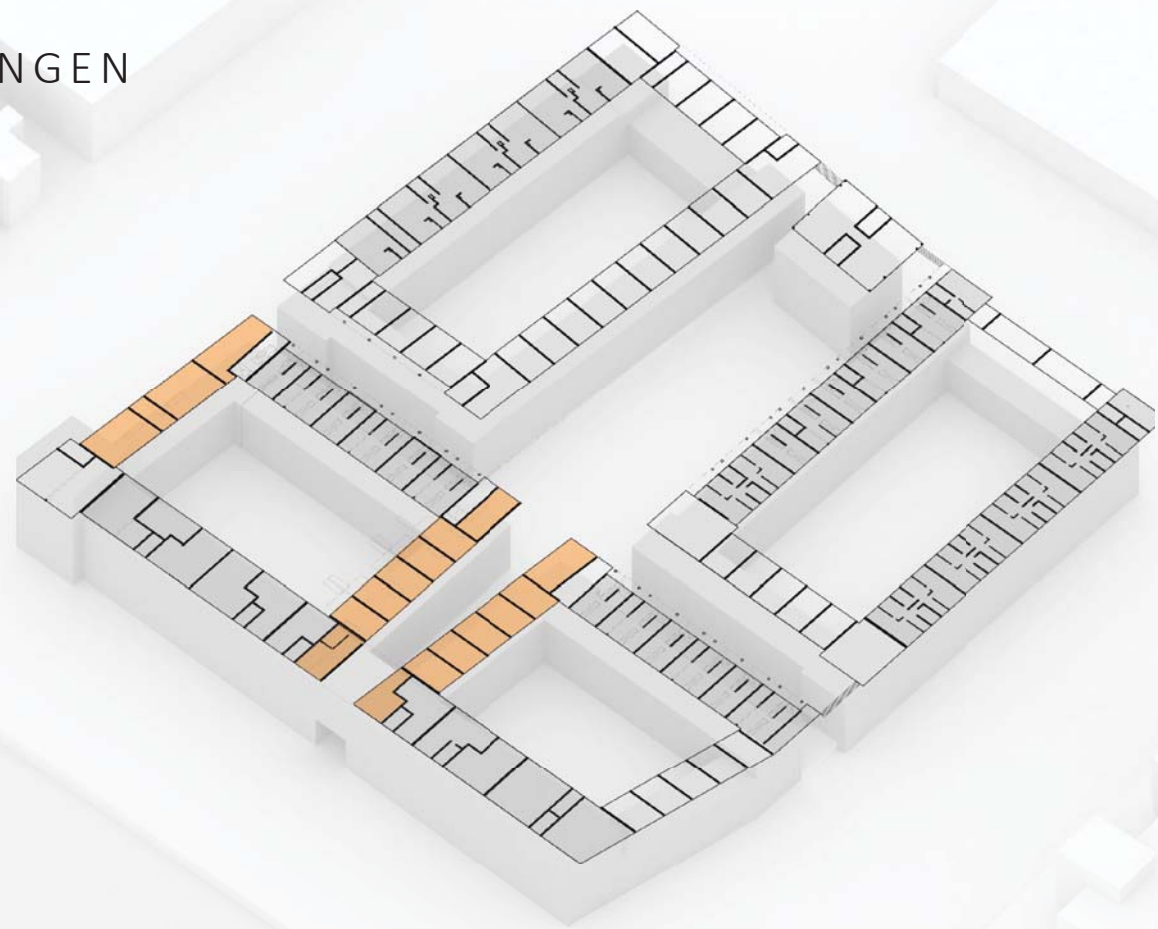

AMSTELLAAN HOEKWONING



AMSTELLAAN WONING

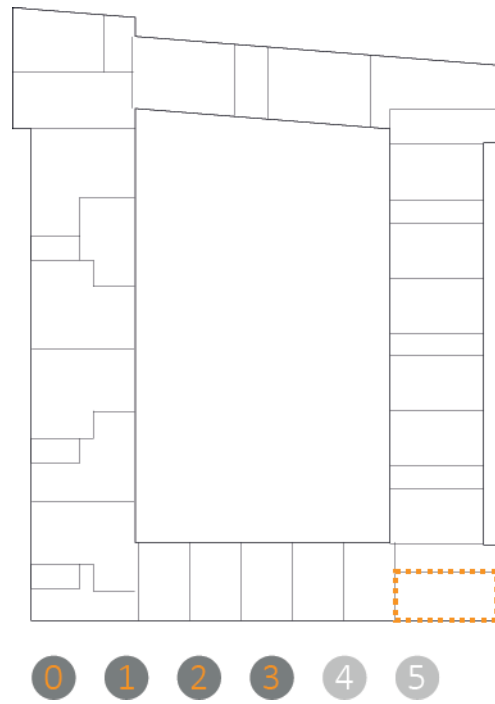

AMSTELLAAN WONING



130 M²



AMSTELLAAN WONING



130 M²

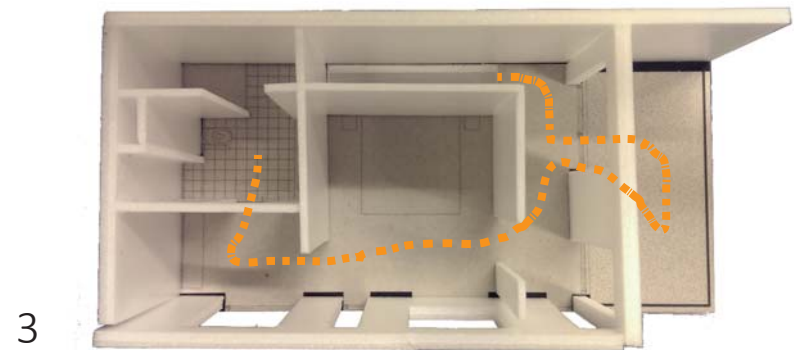
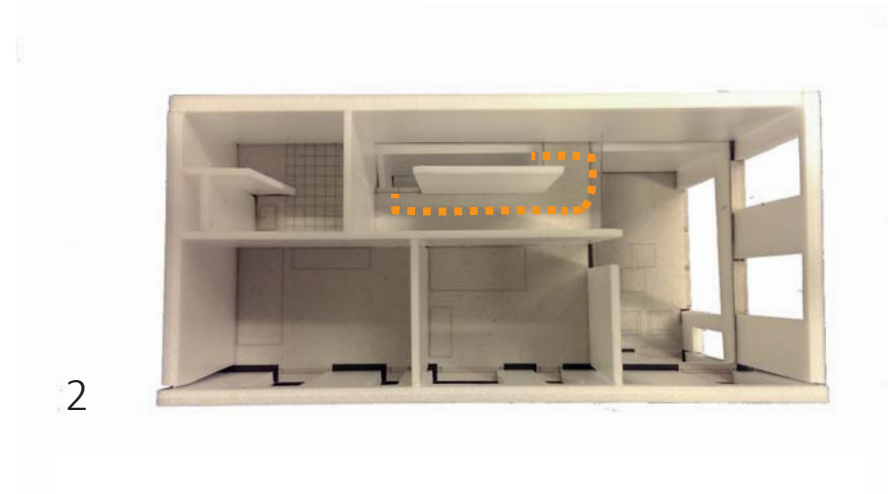
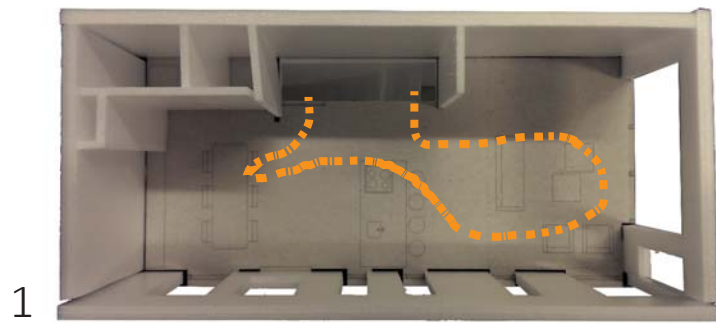
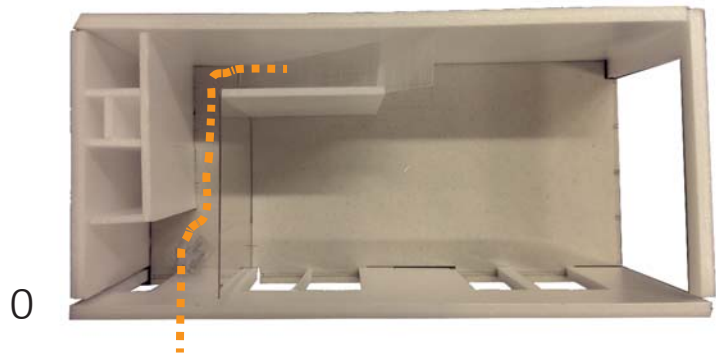

AMSTELAAN WONING



130 M²



AMSTELLAAN WONING



130 M²



AMSTELLAAN WONING



130 M²



AMSTELLAAN WONING



130 M²



AMSTELLAAN WONING



130 M²



AMSTELLAAN WONING



130 M²

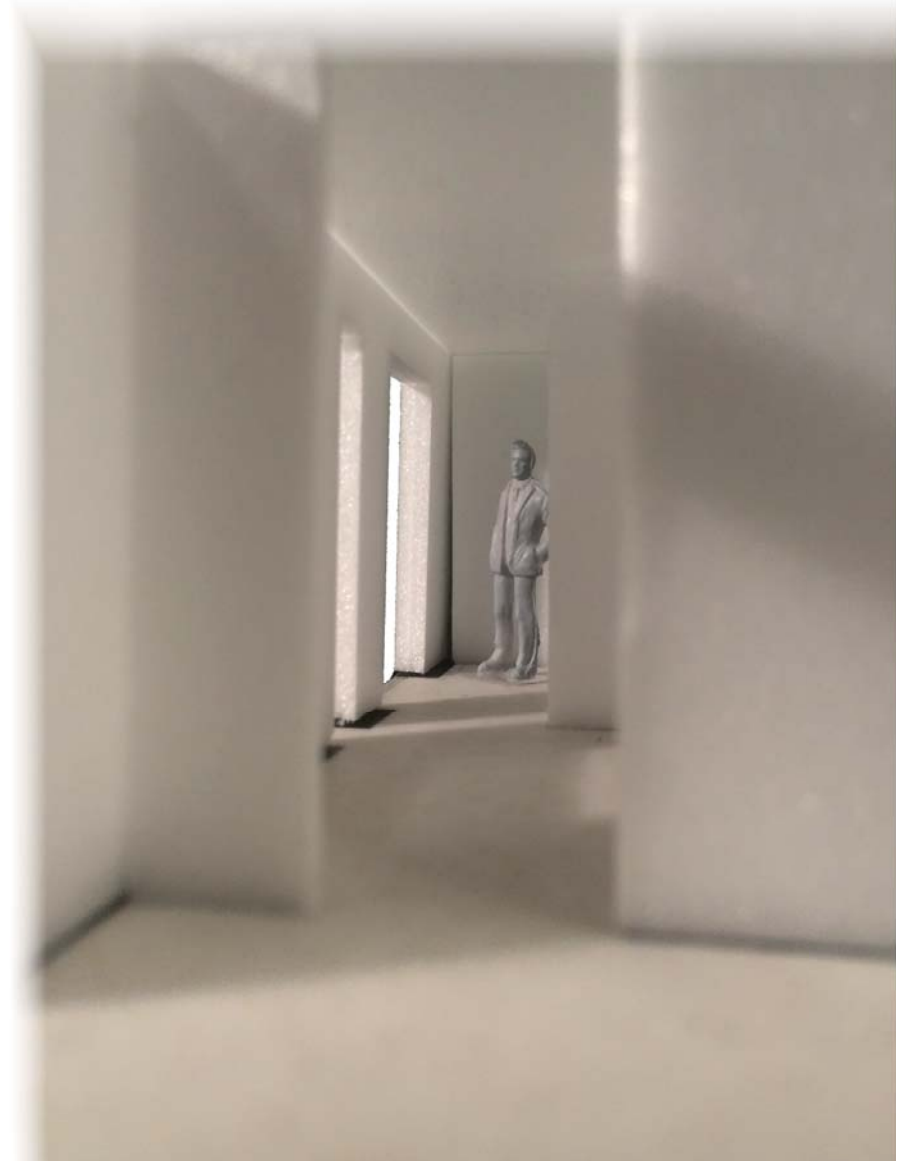
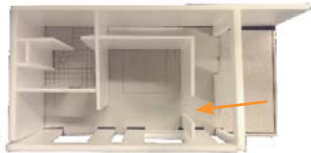

PLEIN

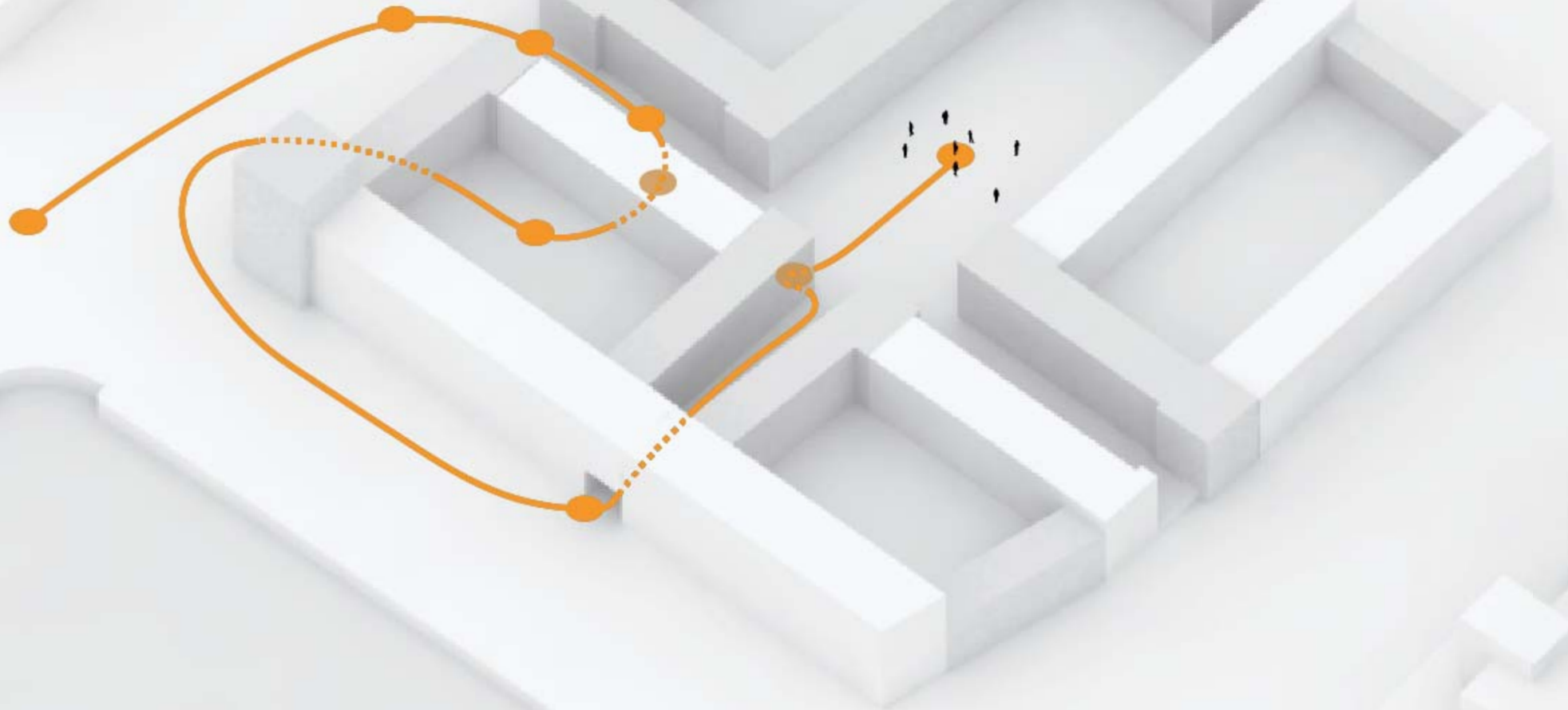











An architectural rendering of a modern residential complex. In the foreground, two people are seen from behind, looking across a wide canal. The canal is bordered by a low brick wall. In the middle ground, a long, multi-story building with a mix of dark and light facades stretches across the frame. To the left, a taller, dark-colored building with a grid of windows stands out. In the background, several tall, modern skyscrapers rise against a hazy, orange-tinted sky, suggesting a city skyline. The overall atmosphere is calm and urban.

De woonwijk **'EENHEID IN VERSCHIEDENHEID'** biedt de bewoners een **thuisgevoel** in een vertrouwelijke buurt op, die **bestaand en nieuw met elkaar verenigd**. Dit op een **menselijke schaal** en op een **dynamische en grootschalige locatie**.

'EENHEID IN VERSCHEIDENHEID'

BEDANKT VOOR UW AANDACHT



MET DANK AAN:

Hans Stolwijk

Hans Witterholt

Martin van Lent

Karina Wilting

Eline Kolken

Rinke Feenstra

Yordi Paasman