

Growing Dwellings

The explorative design of
a dwelling supporting biodiversity

4538382
Lian Blok





EGO



ECO

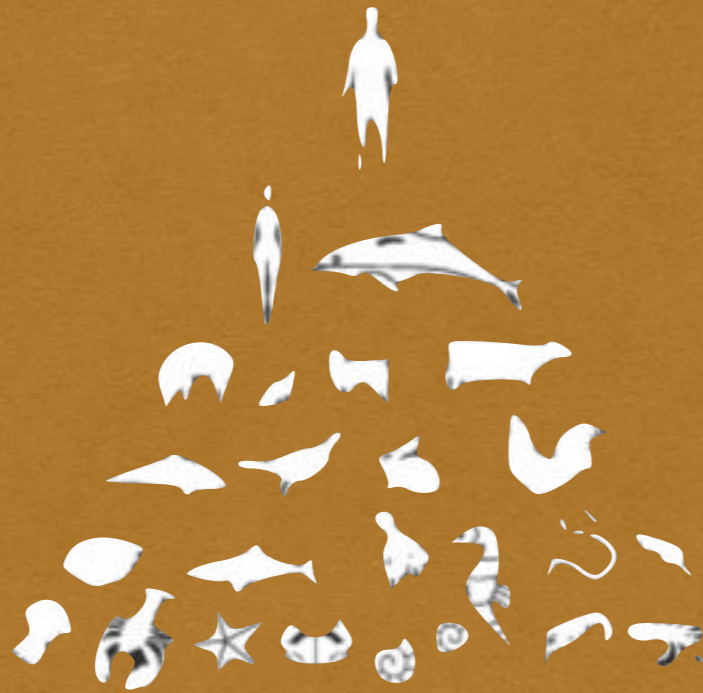

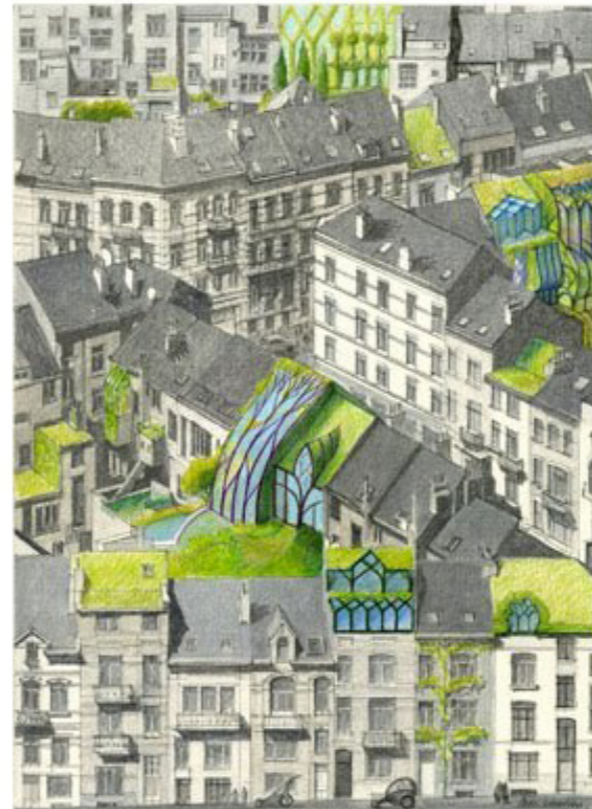

the future of cities by integrate organism in dwellings (Schuiten & Labrique, 2009)

inhoudsopgave

research

- locatie
- materials
- design requirements

design

- dwelling
- scenario's
- technique
- transformation

Research

How can a dwelling contribute to
biodiversity in a low biodiverse context?

*How can a dwelling contribute to
biodiversity in a low biodiverse context?*

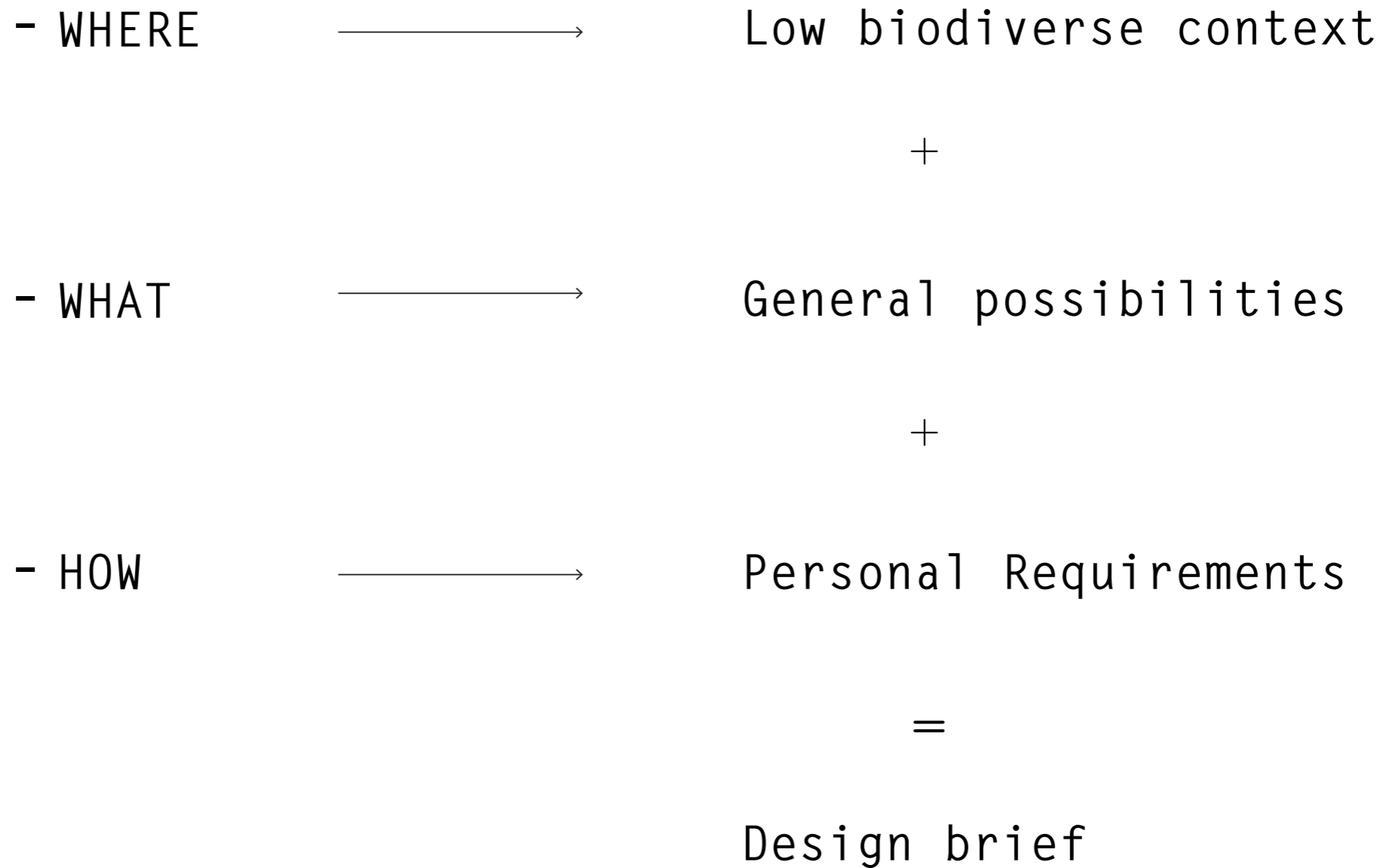

- WHERE

- WHAT

- HOW



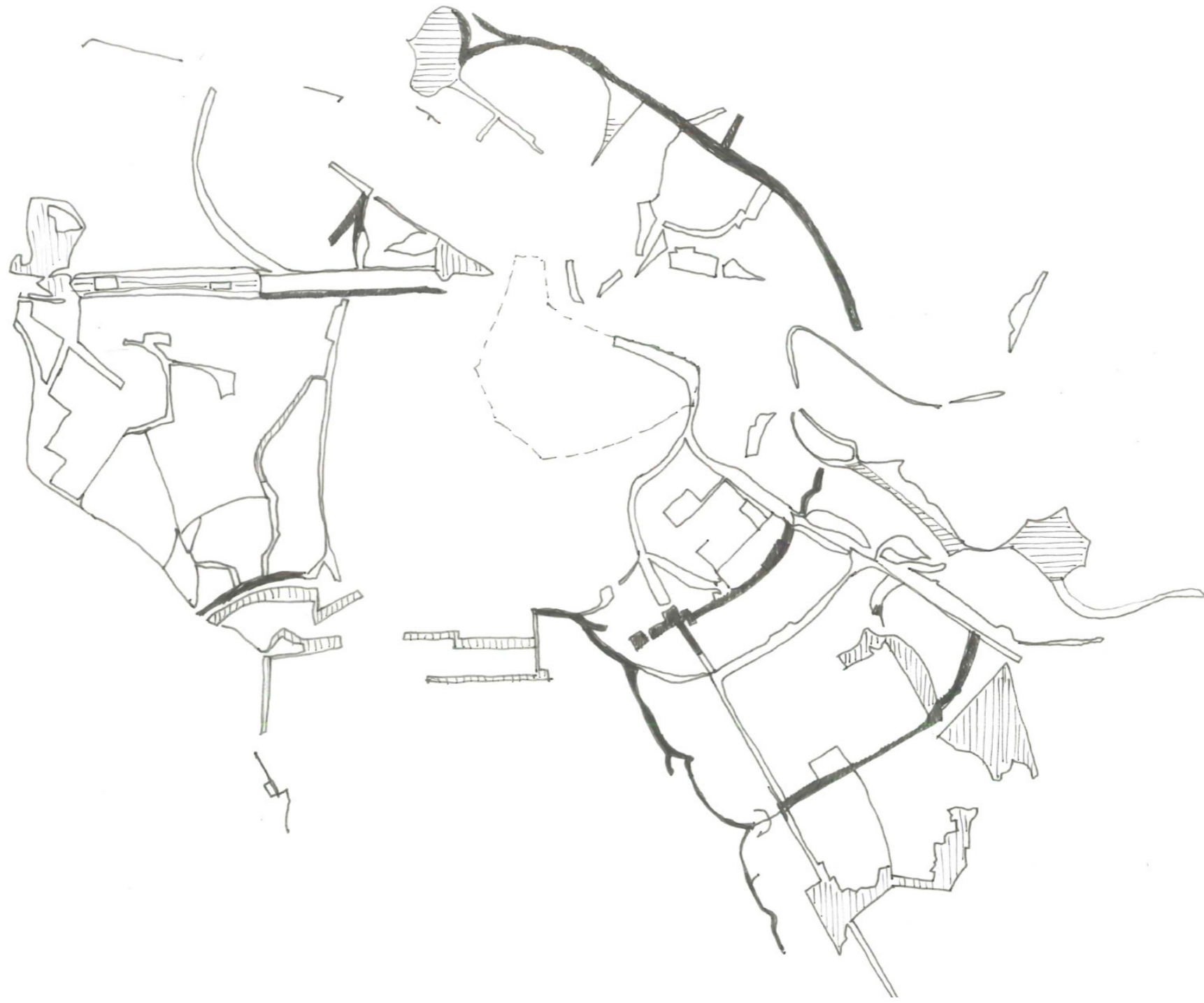

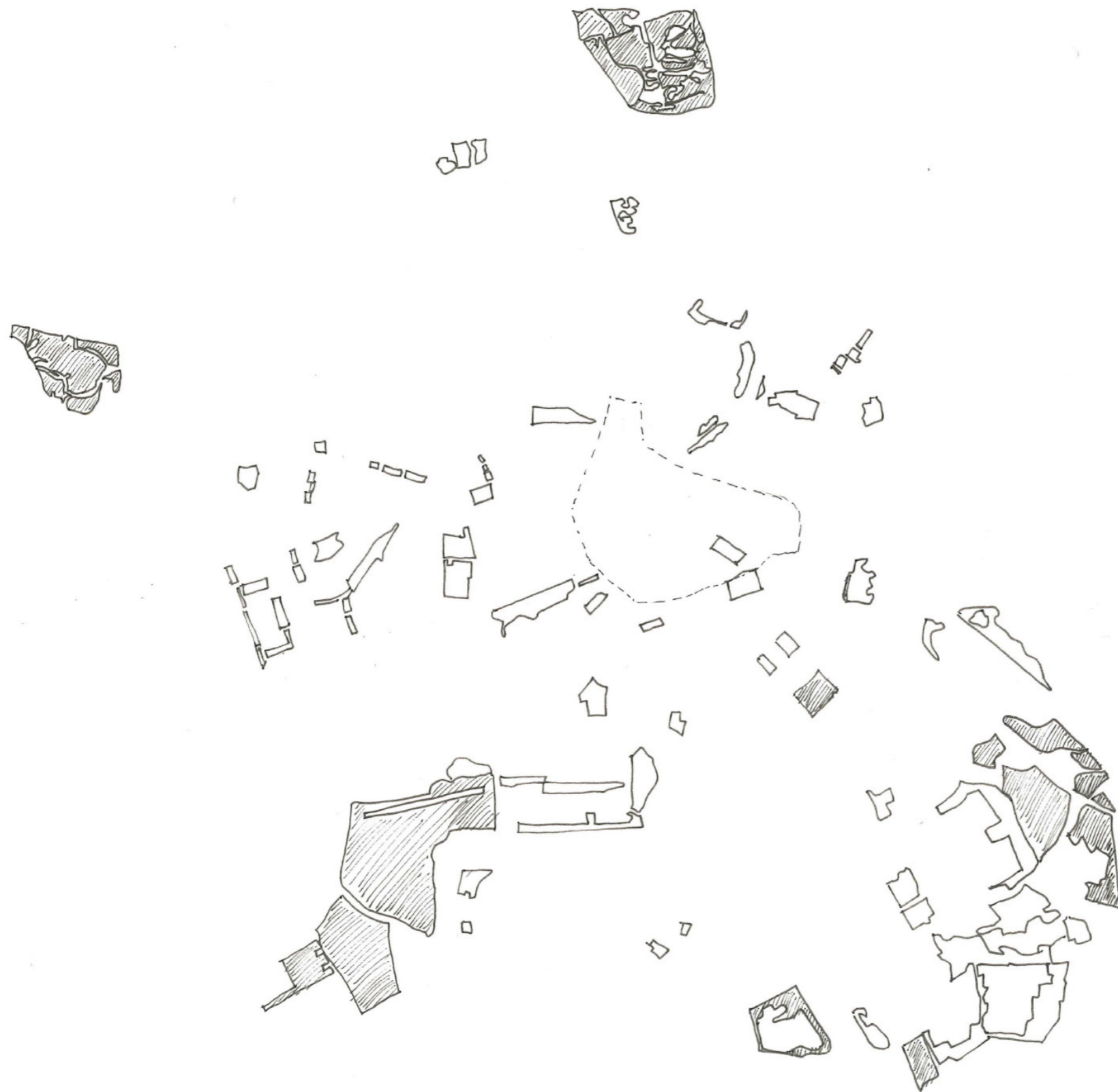



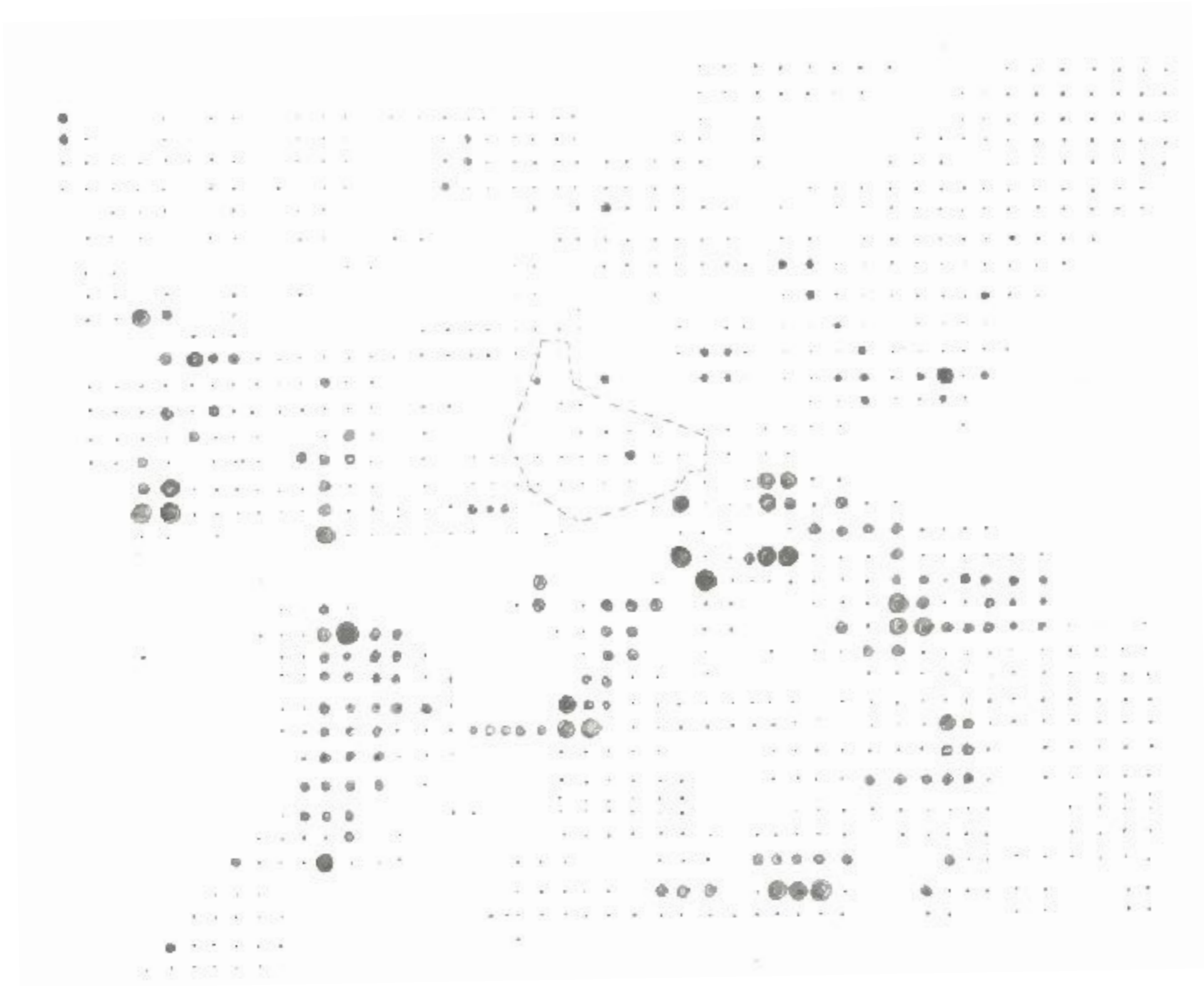

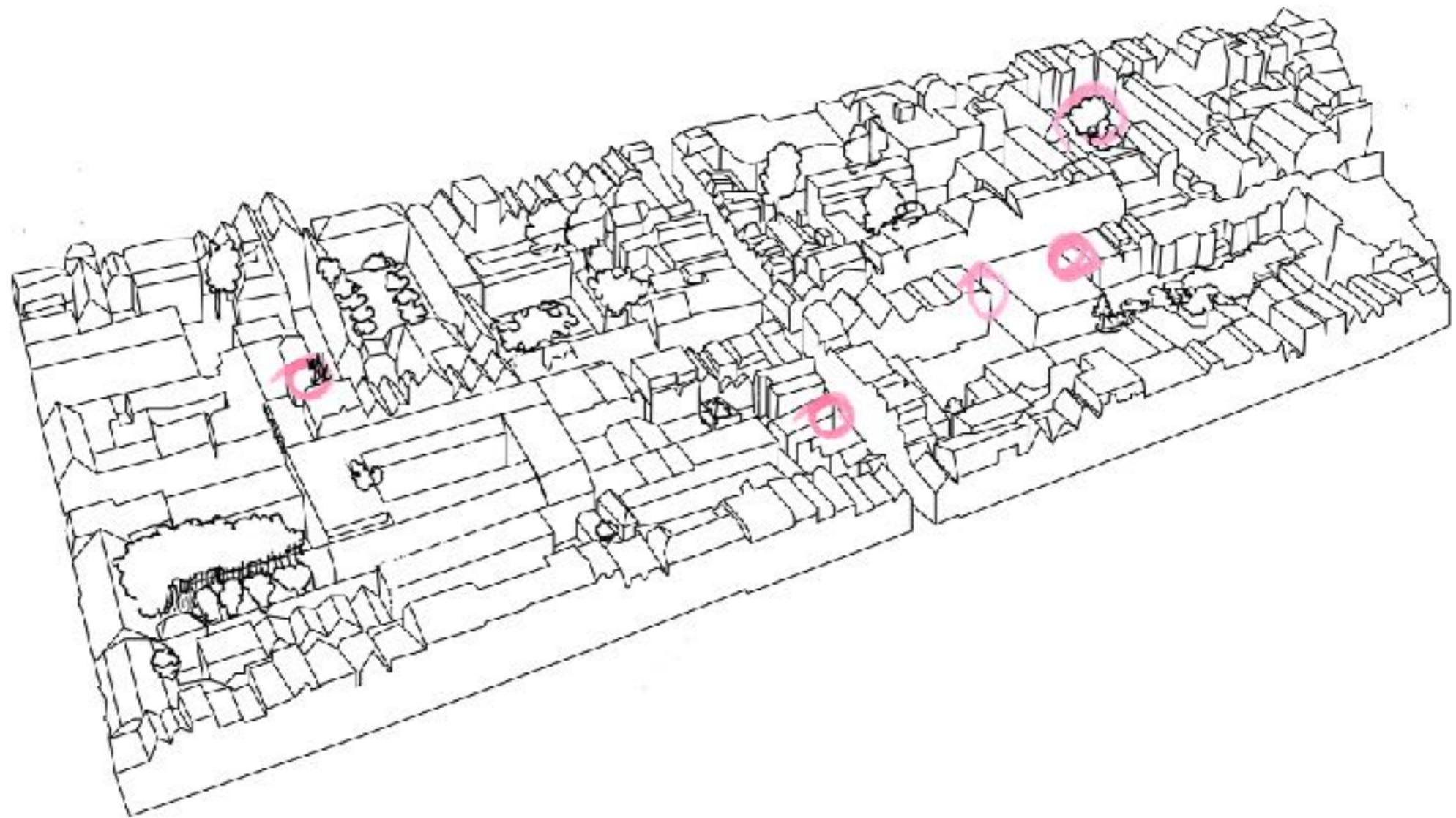

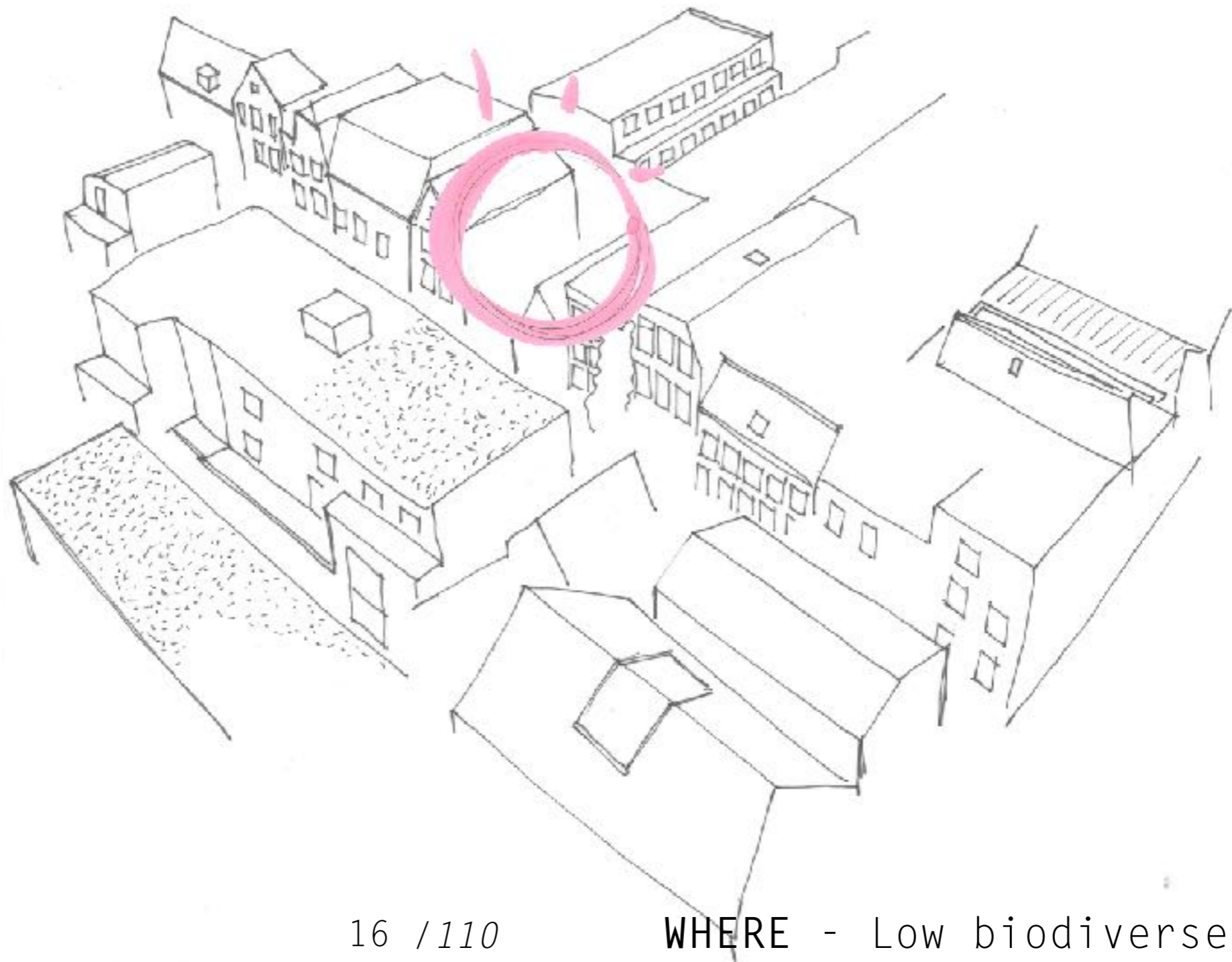

restaurants, bar, handmade shoe store, handmade jewellery store, clothing store, laundry, gym

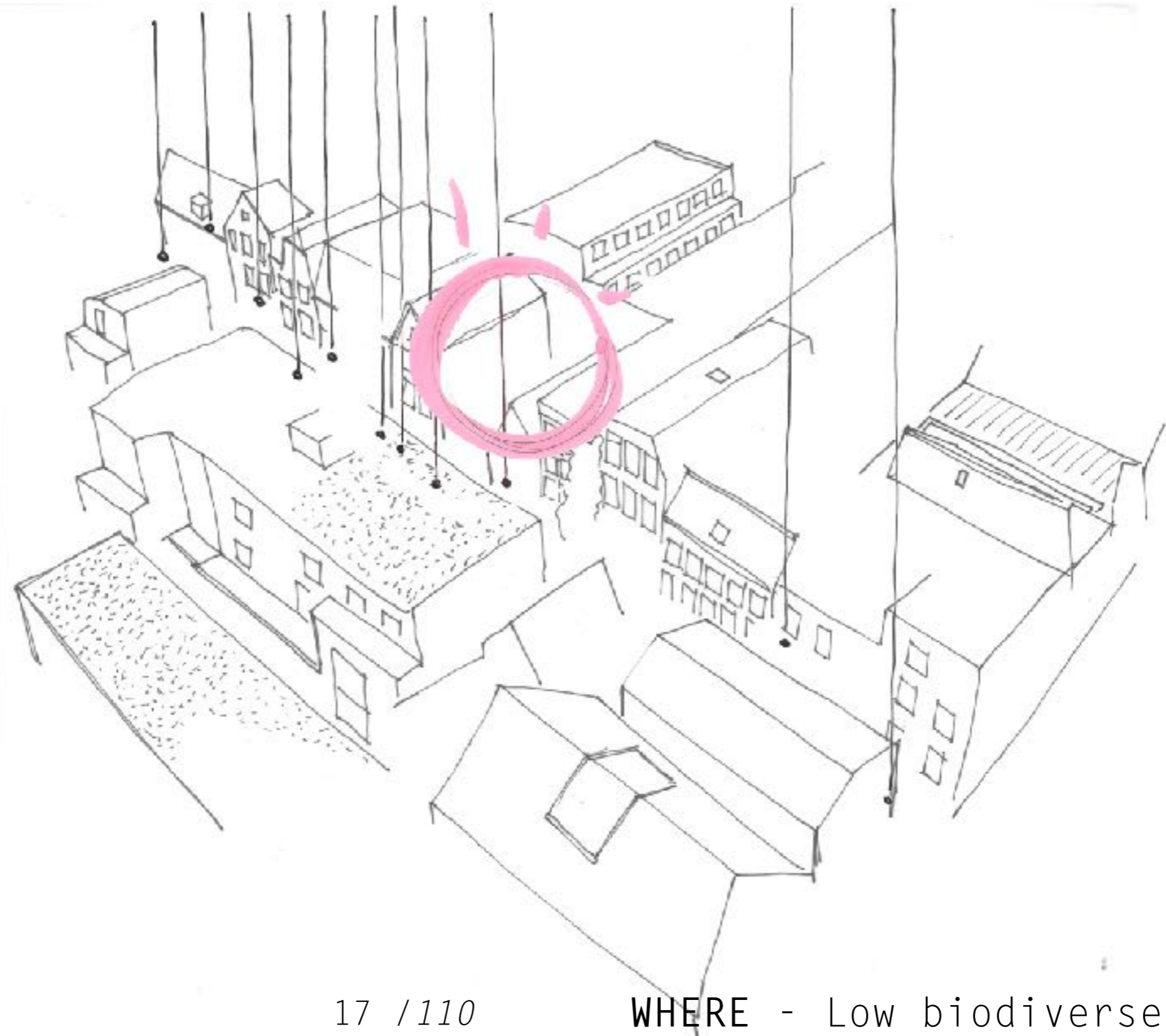

- WHERE

- WHAT

- HOW

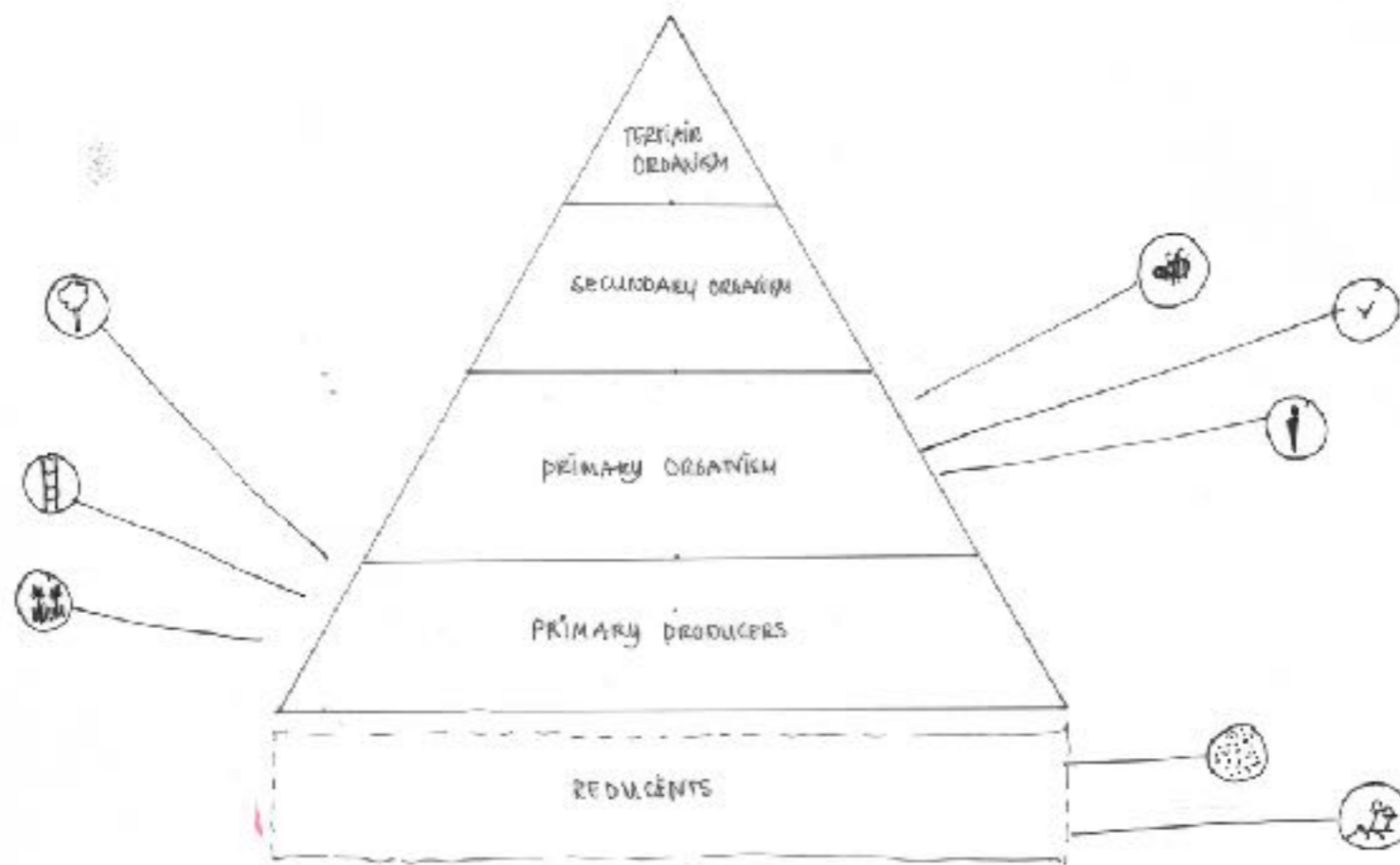

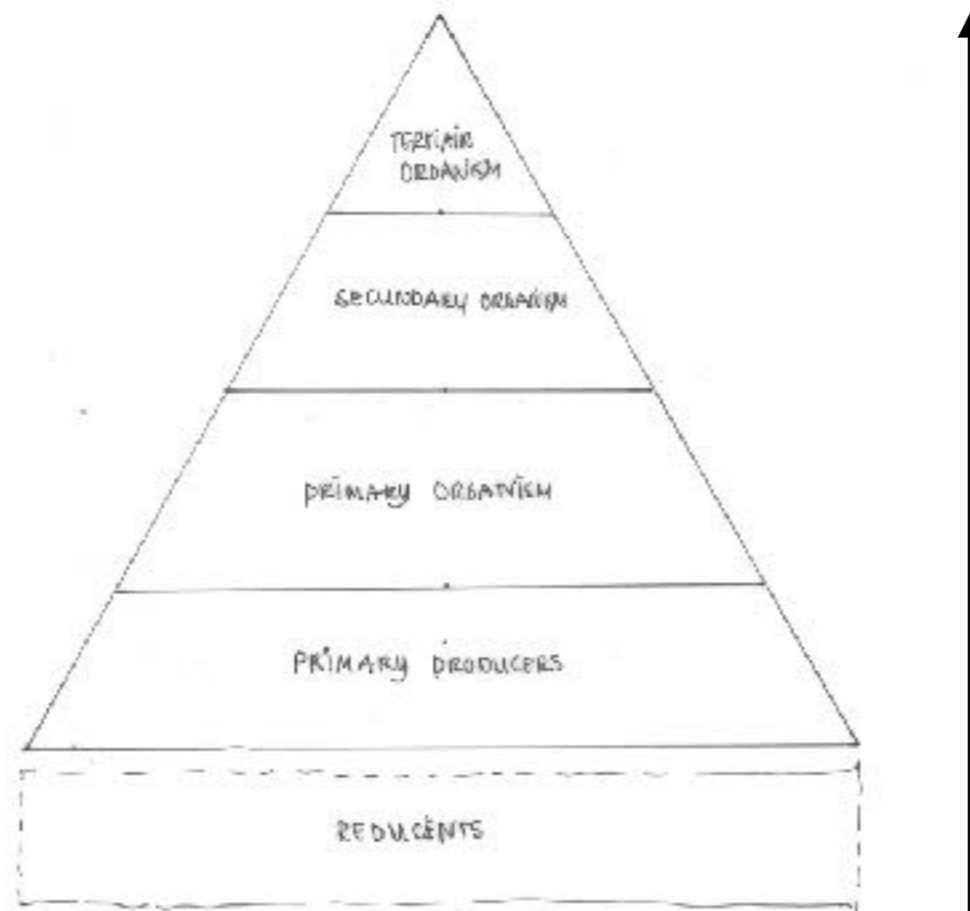

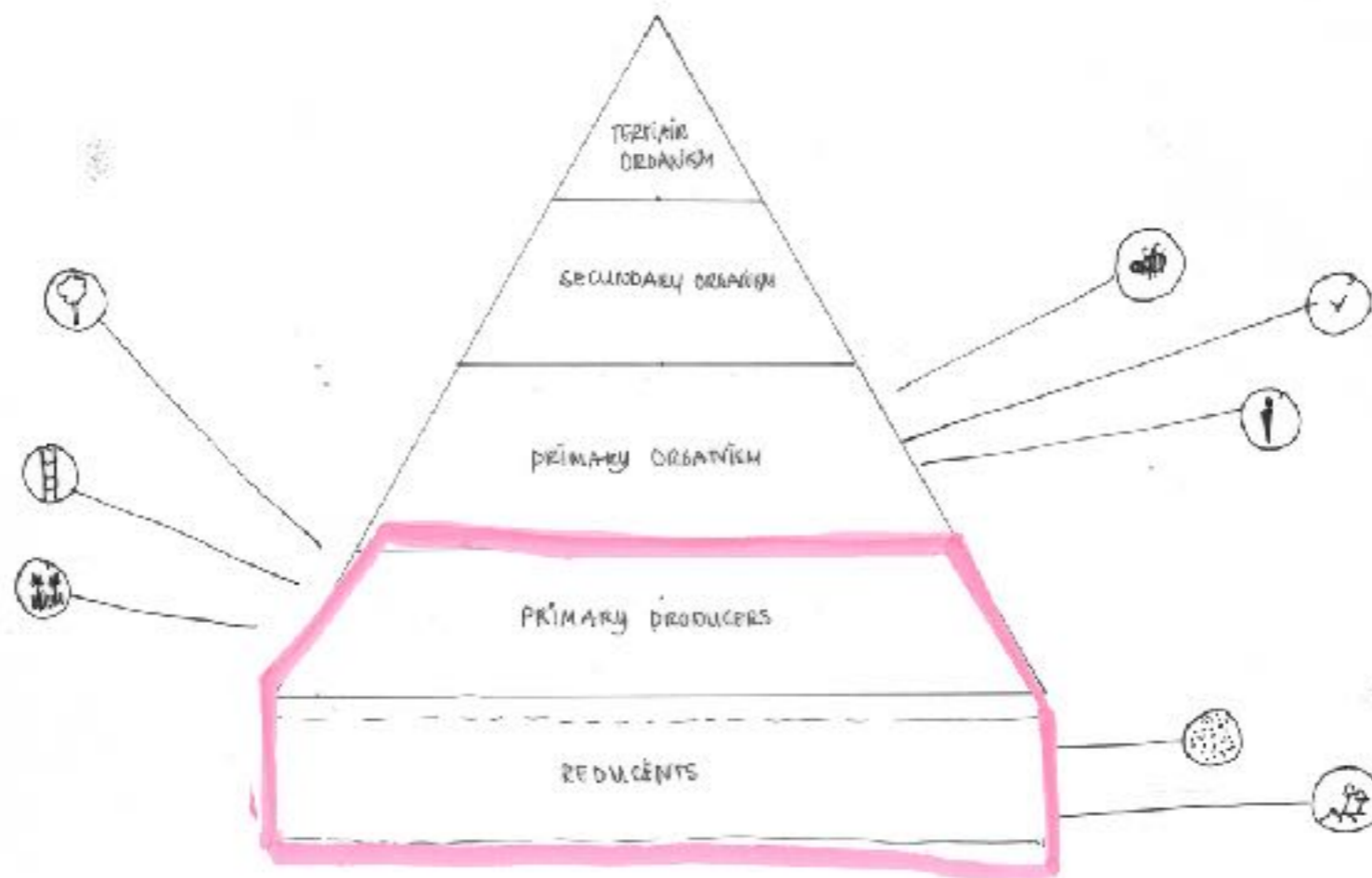

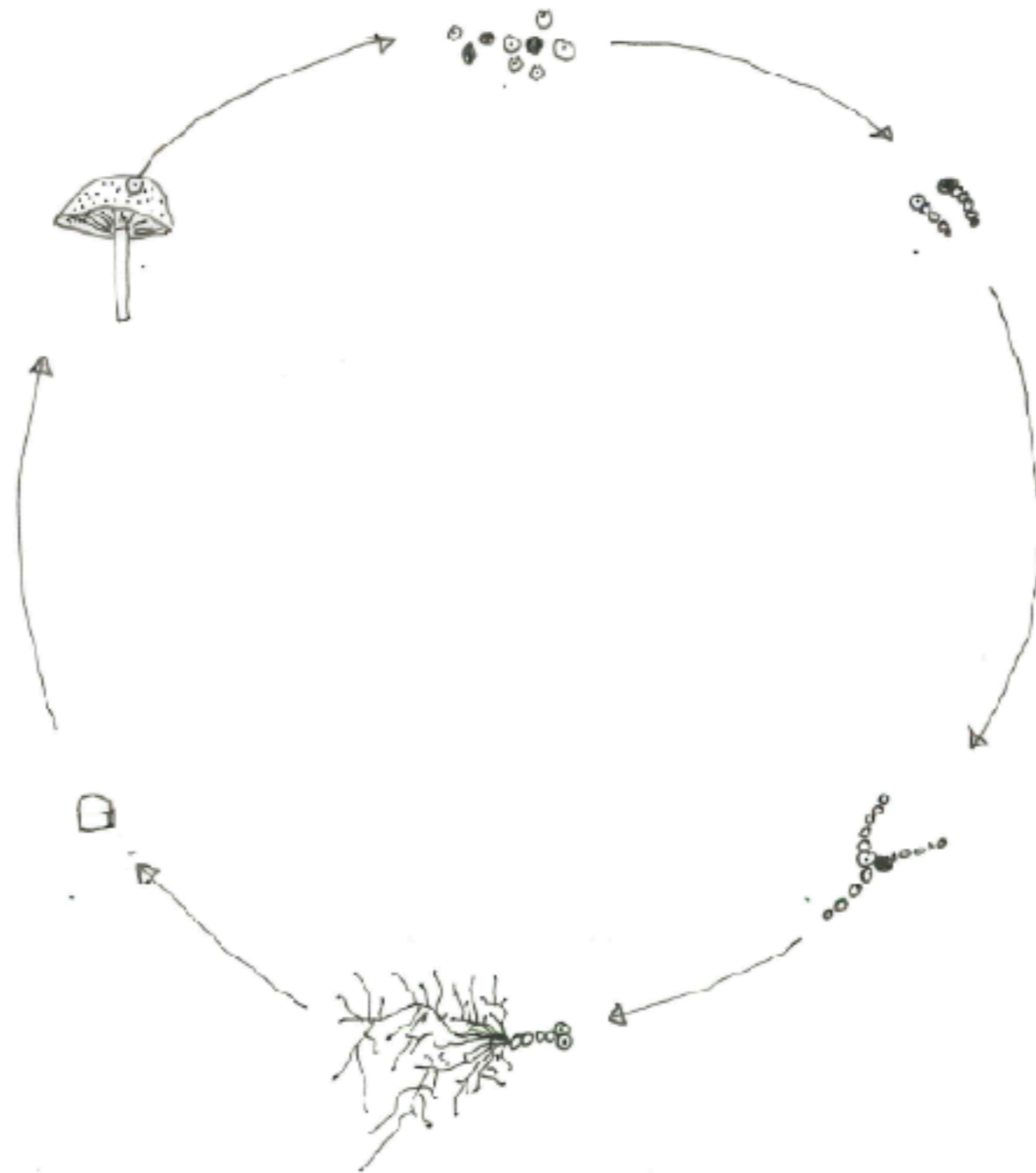



Mycelium (Officina Corpuscoli, the Growing Lab/Mycelia)



Foot bridge (Ferdinand Ludwig, 2005)



Foot bridge (Ferdinand Ludwig, 2005)



Bamboo theatre (DnA, 2015)



Meghalaya, India

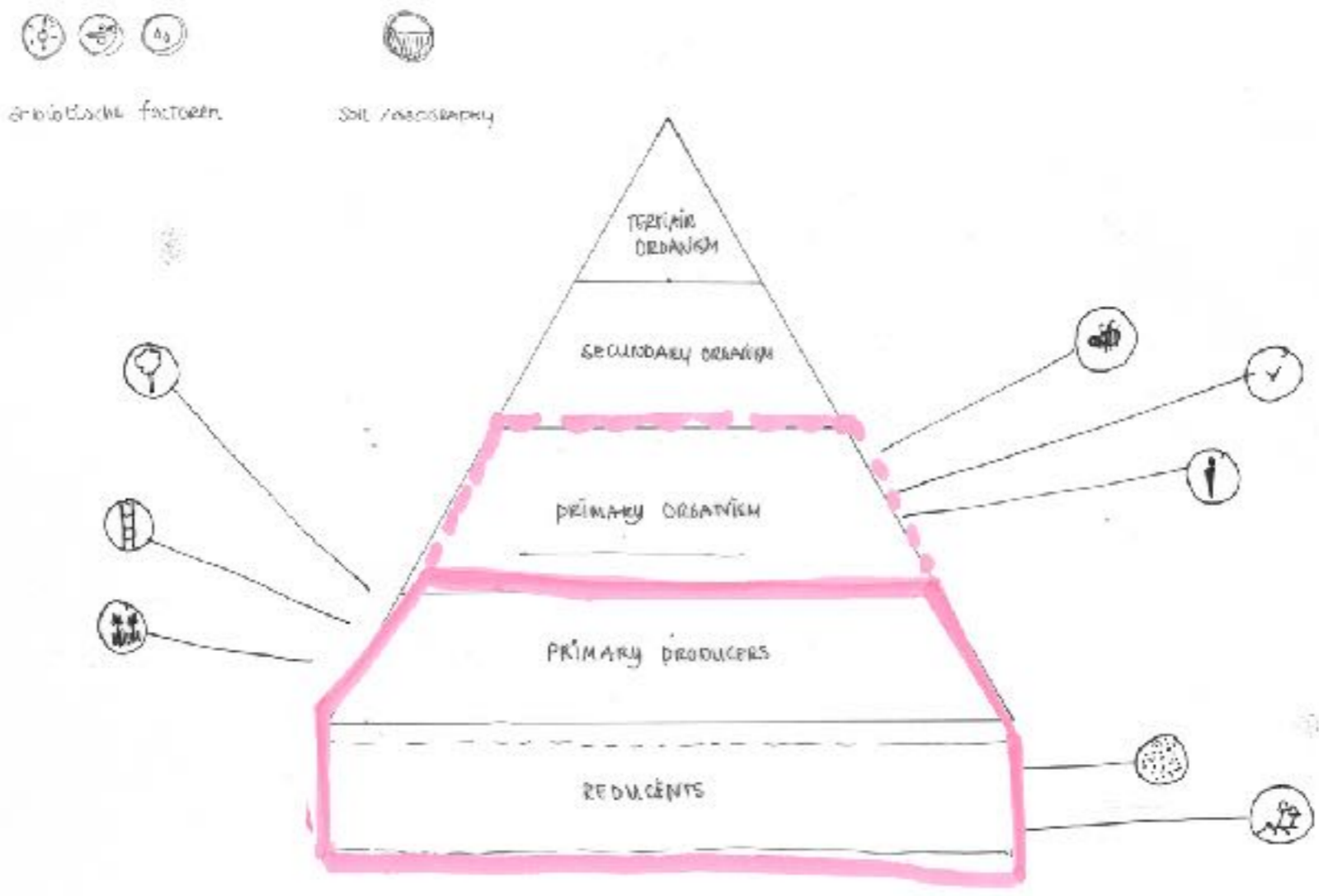

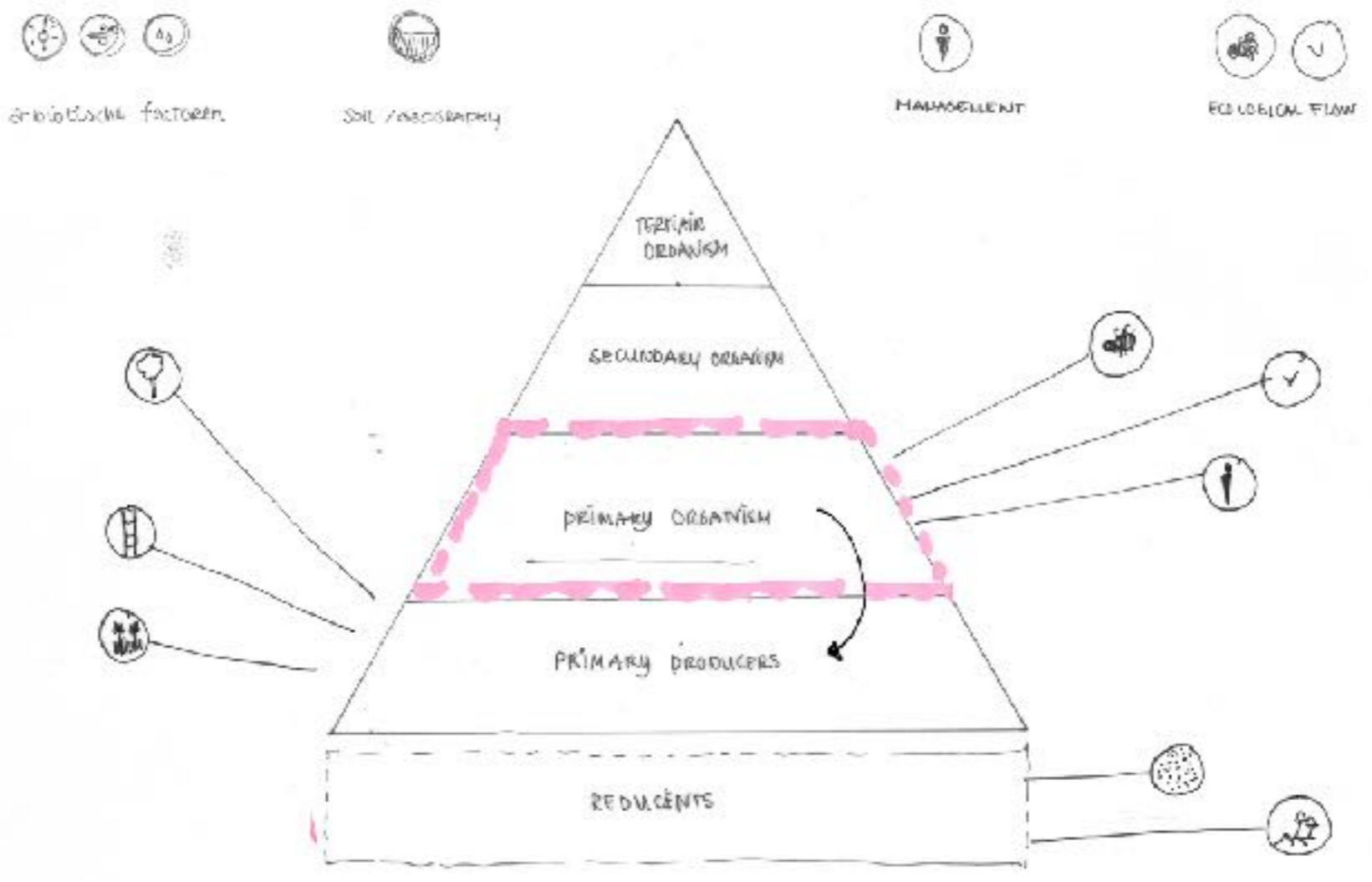

- WHERE

- WHAT

- HOW



- 1 Alle elementen van het gebouw hebben een invloed op het ecosysteem
- 2 Primaire organismen zijn belangrijker dan secundaire organismen
- 3 aantal primaire organismen groeit gedurende de levensduur van de woning
- 4 secundaire organismen zich aanpassen aan de a-biotische factoren[zon, wind, regen, etc]
- 5 geologie wordt beschermd en zo mogelijk verbeterd.

Design



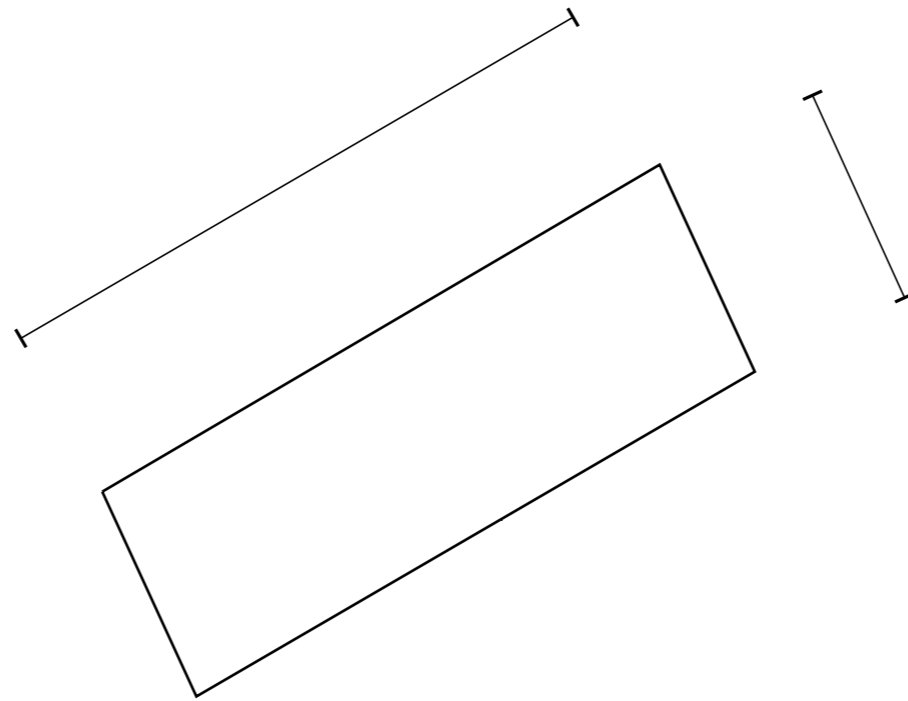

34 / 110

PLOT

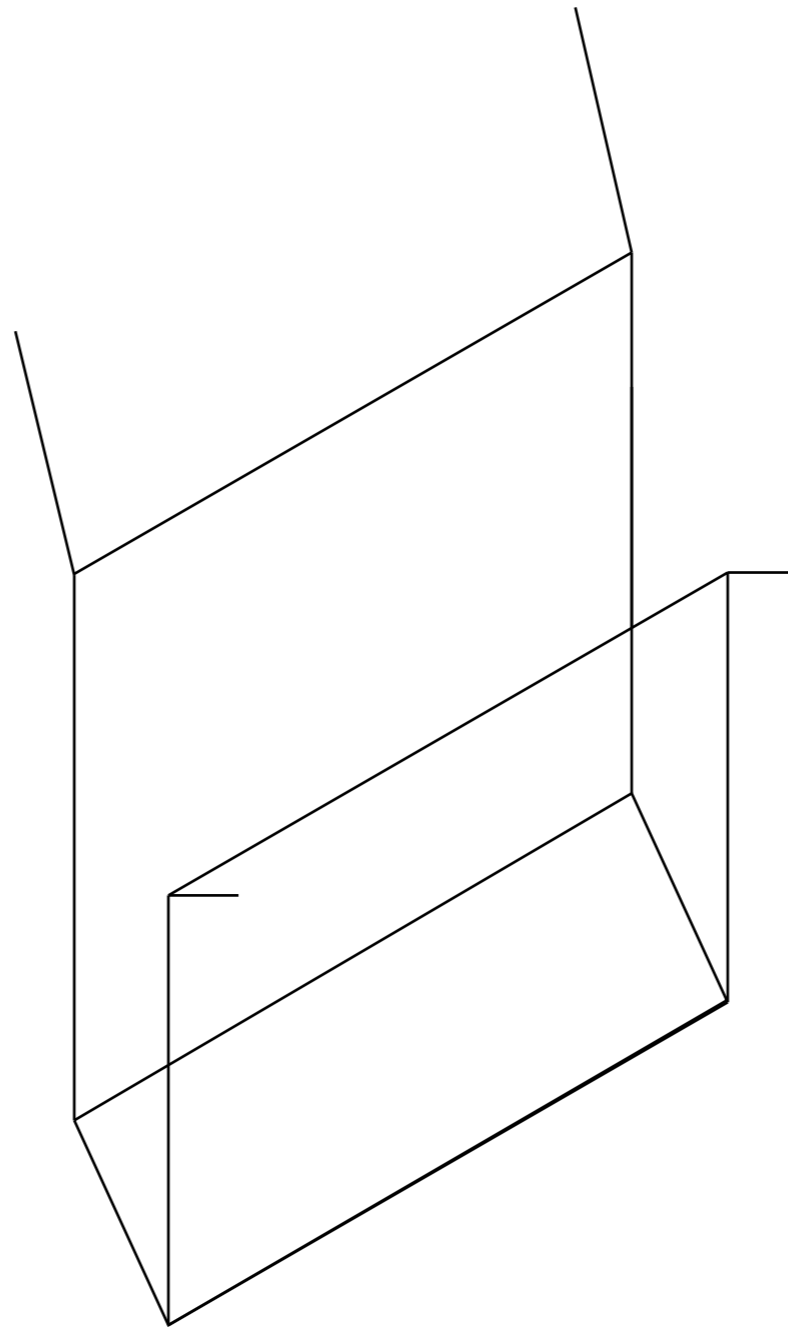

35 / 110

PLOT - neighbours

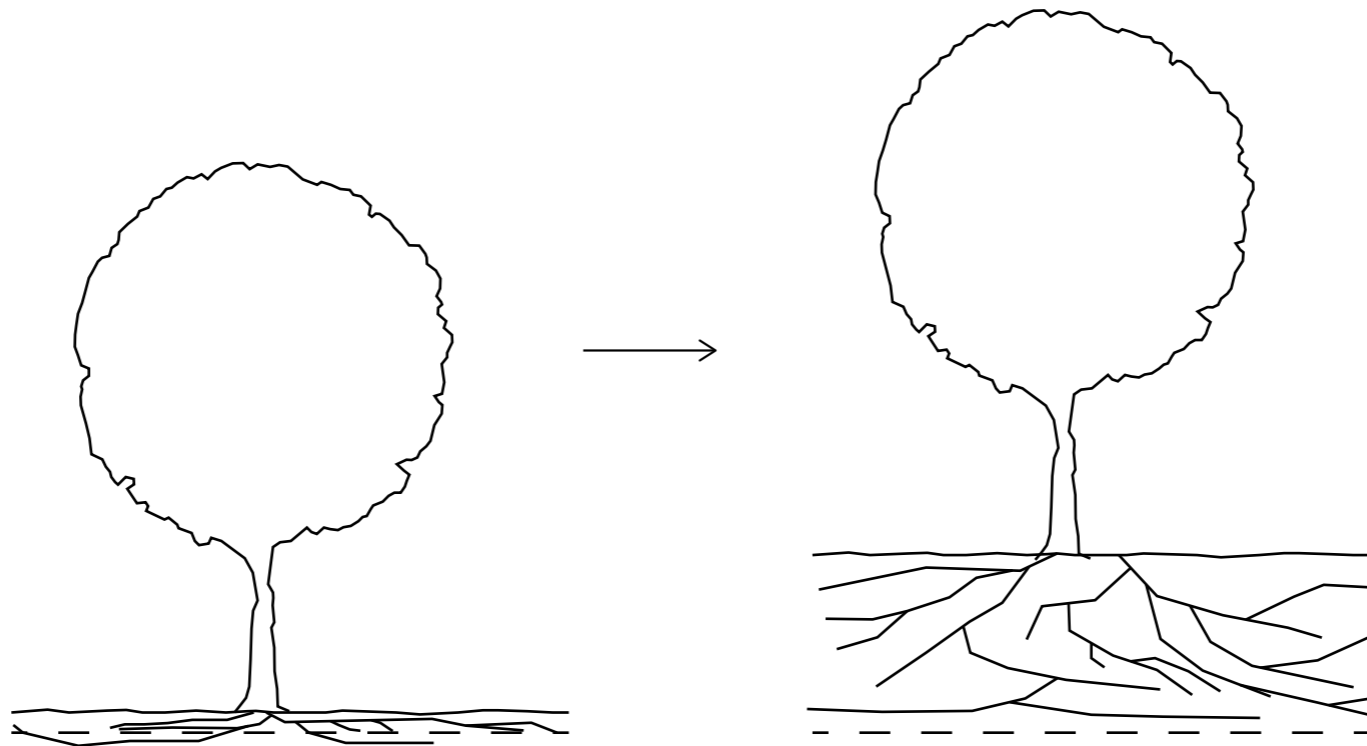

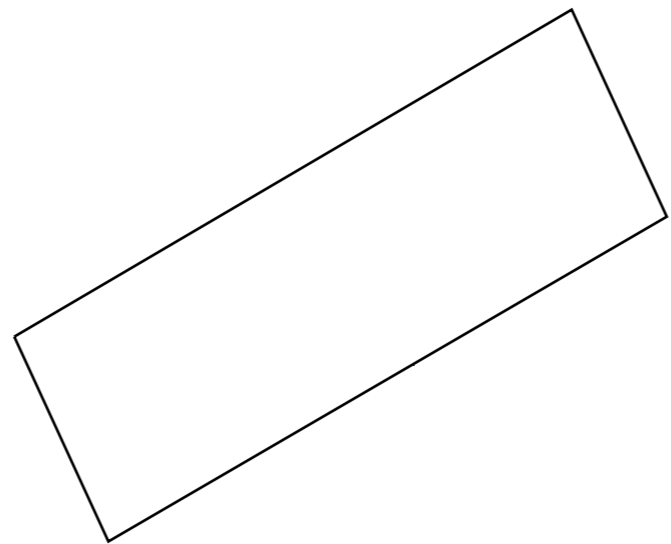

37 / 110

PLOT

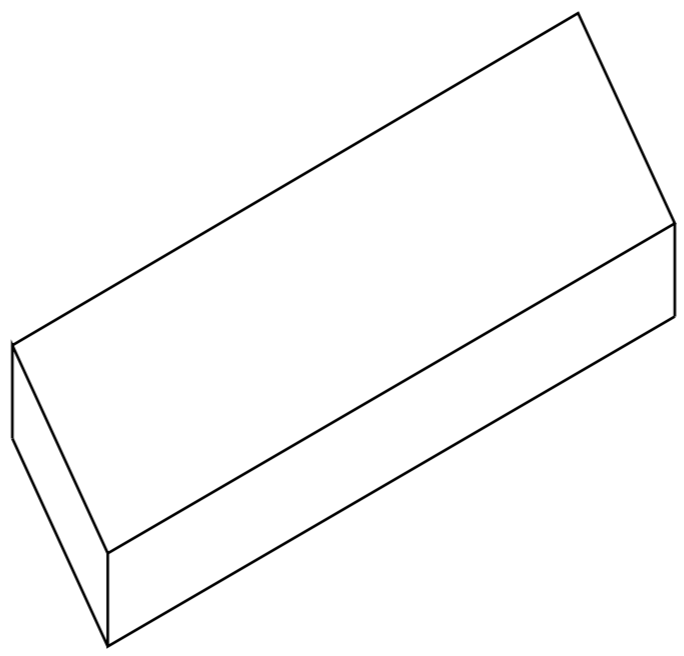

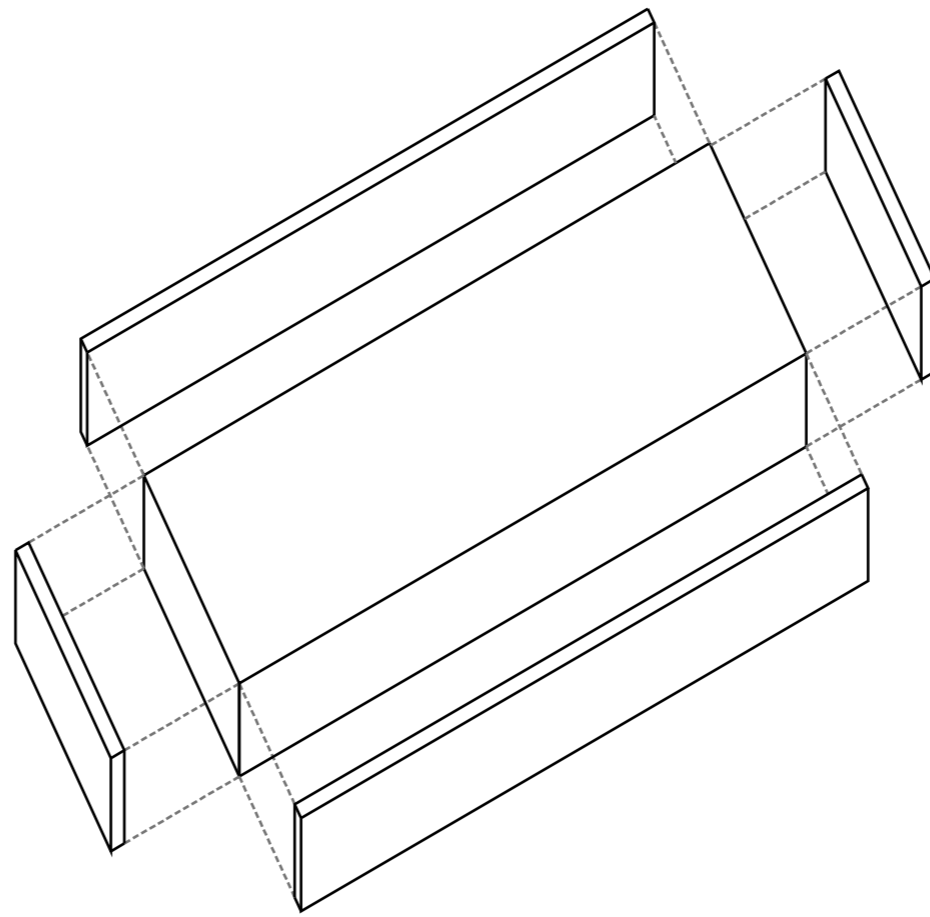

39 / 110

PLOT - rammed earth

in/out of the wind, wet/dry ground,
views, less/more surrounded sound

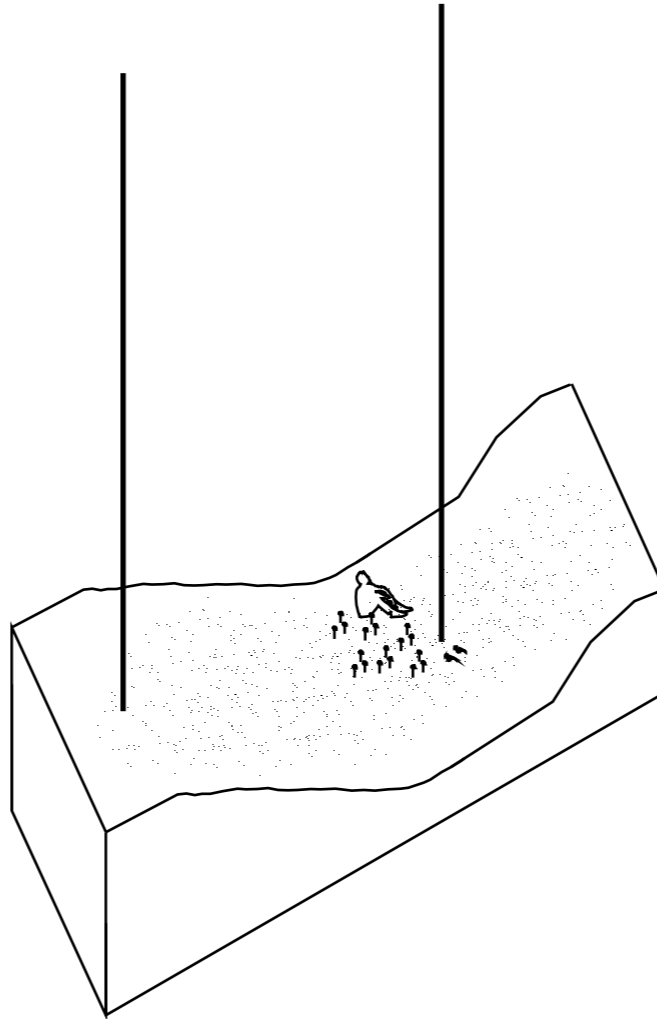

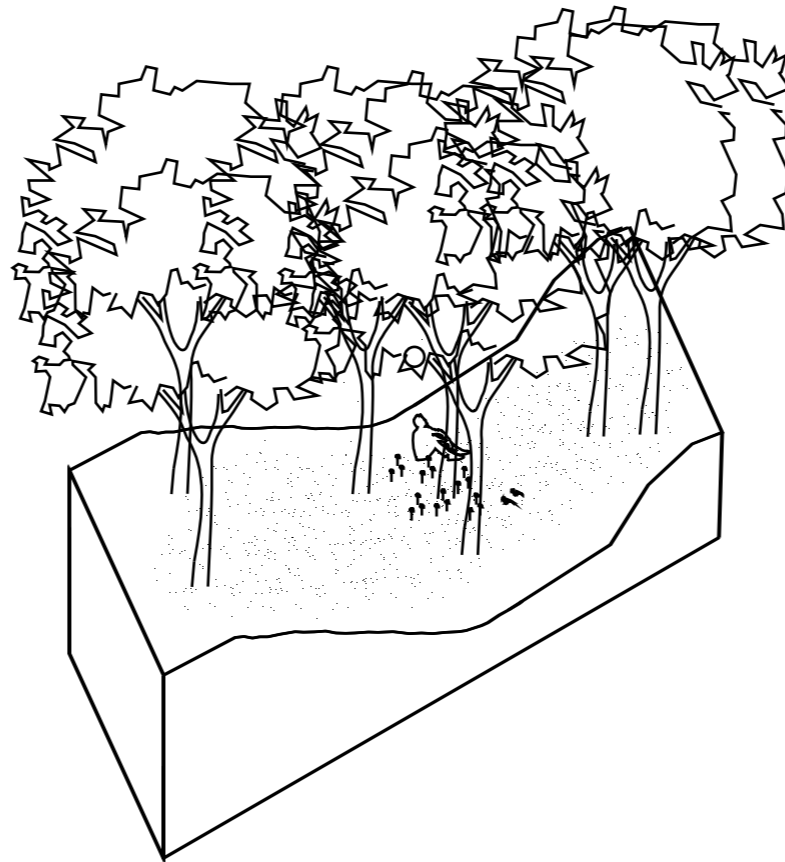

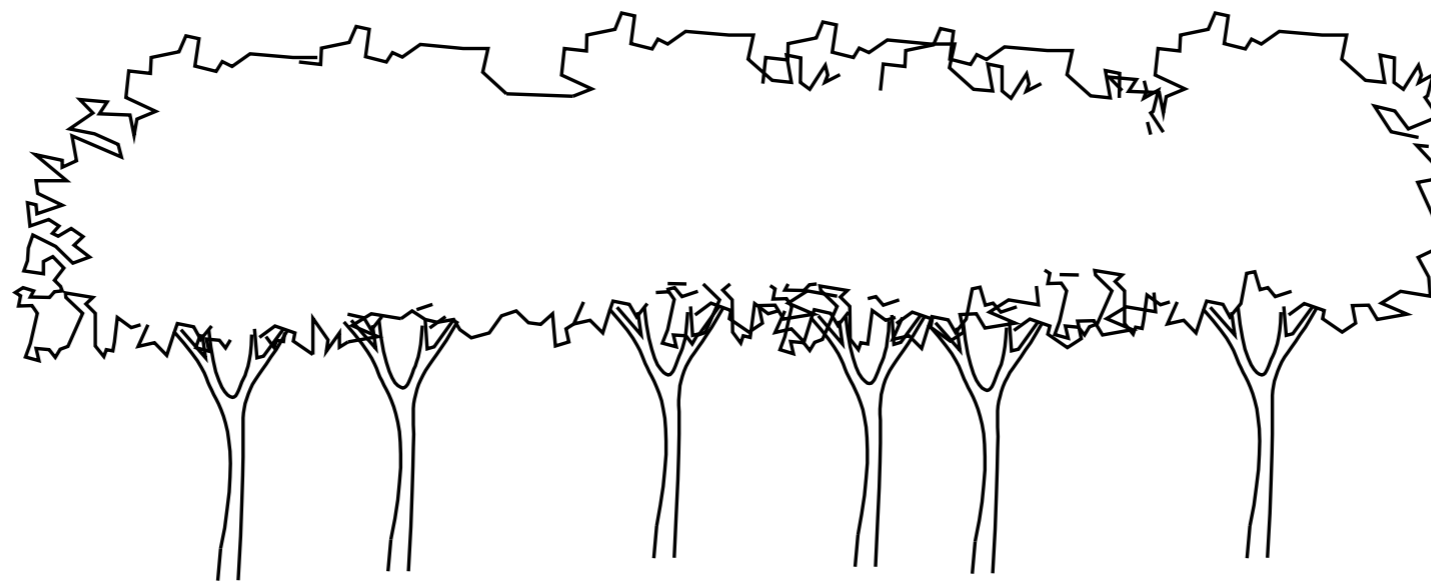



Winterlinde (wikipedia)



Tanzlinde in Sachsenbrunn(wikipedia)



Leiboom (Ten Hoven Bomen)



Linde in bloei (Natuurwijzer Naturalis)

winterlinde,
kleinbladige linde



June-September

3-5 cm

slow growing

+150year

zomerlinde,
grootbladige linde



April-June-September

6-15cm

quick growing

+120/150year

krimlinde



June-Juli-November

5-10cm

quick growing

+150year

krimlinde
+15m

kleinbladige linde
+25m

grootbladige linde
+35m

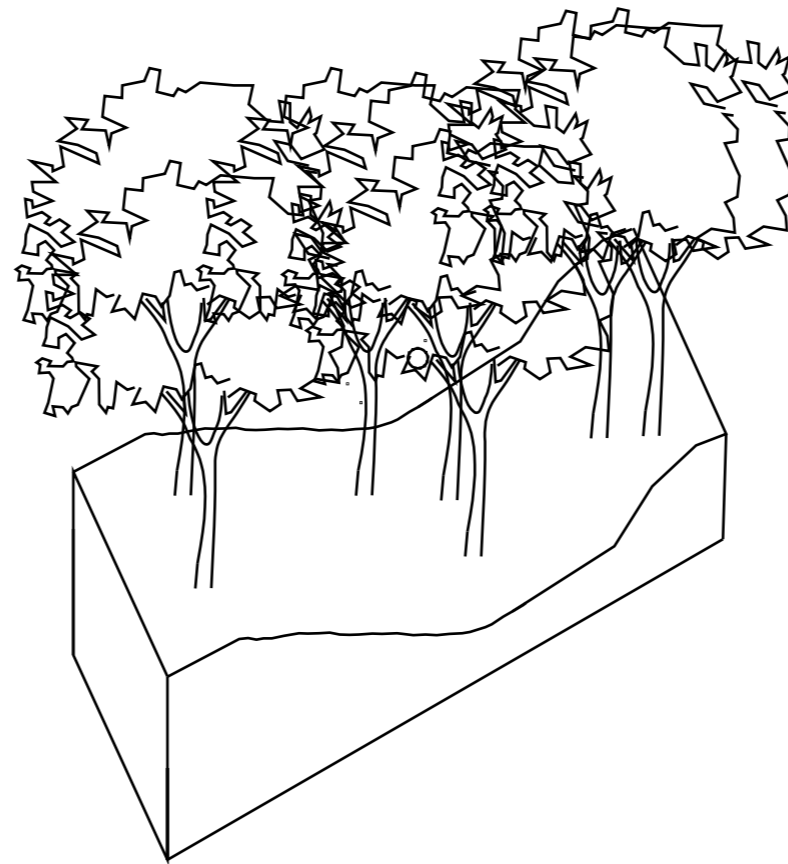

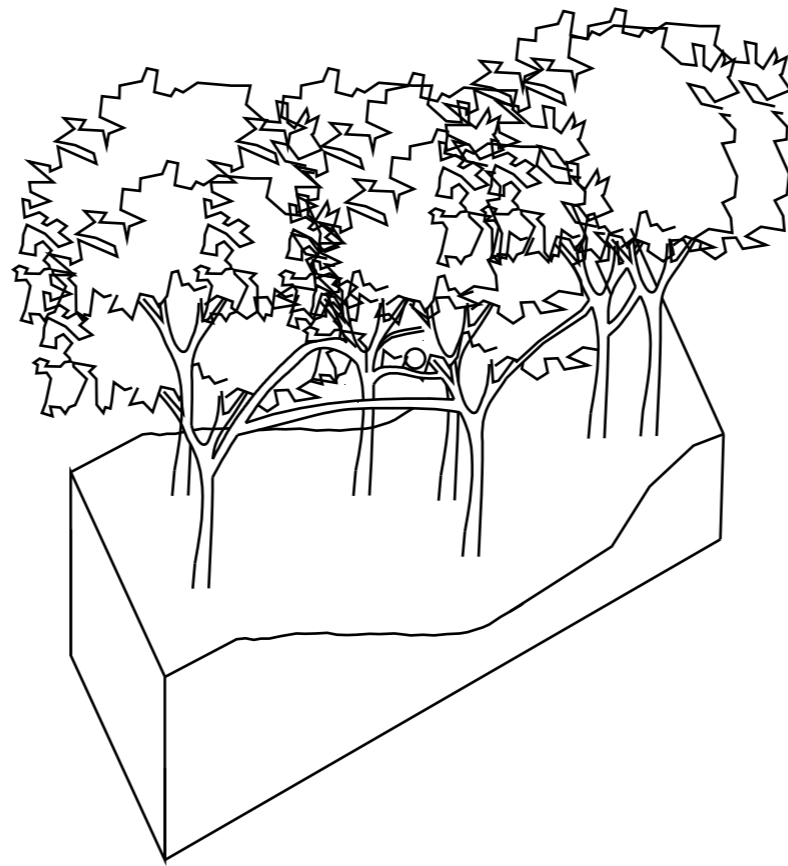



(Janice Dunn, 2005)

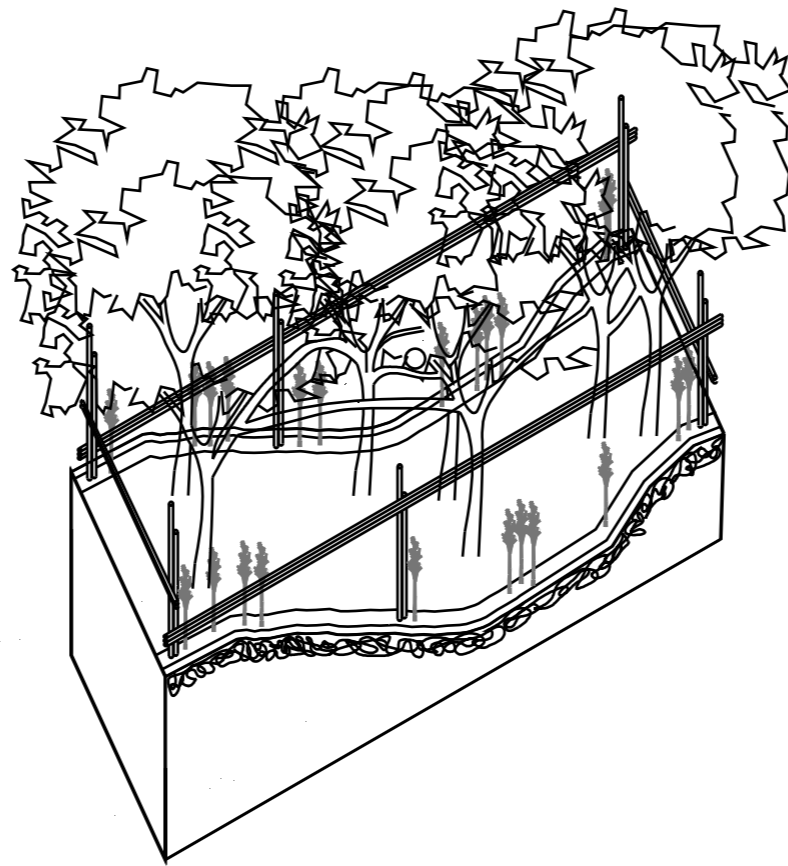

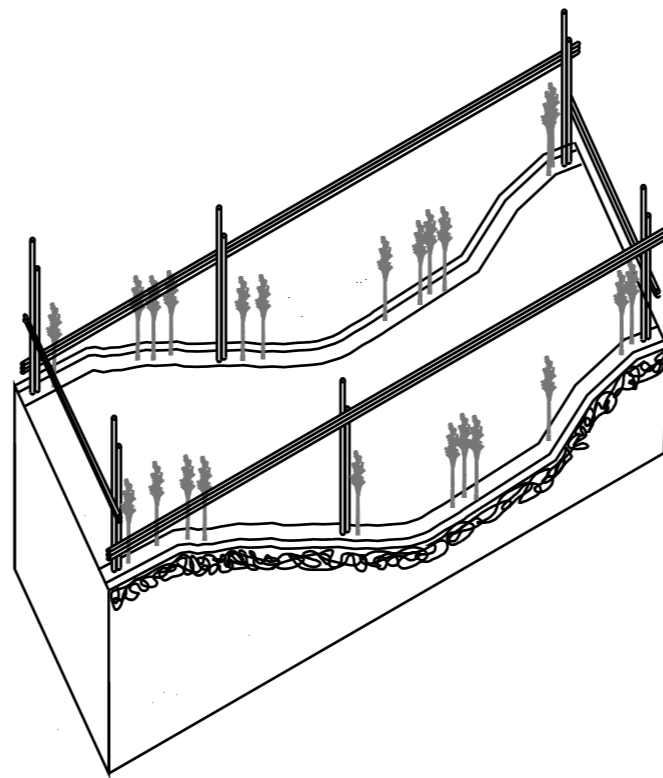

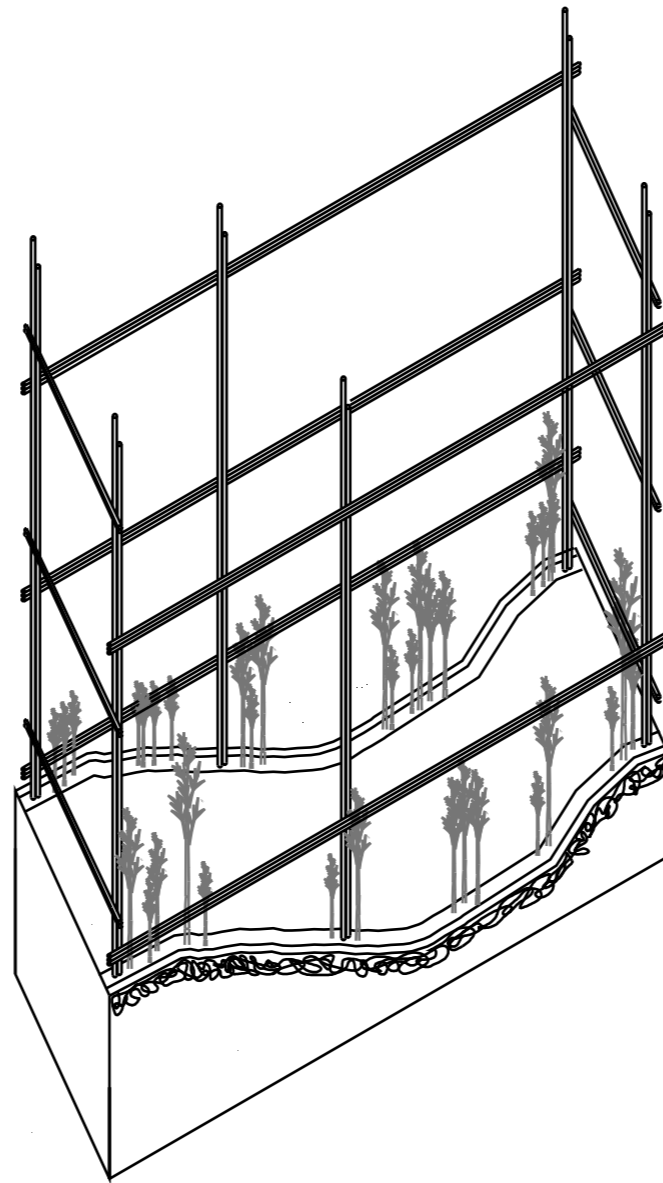

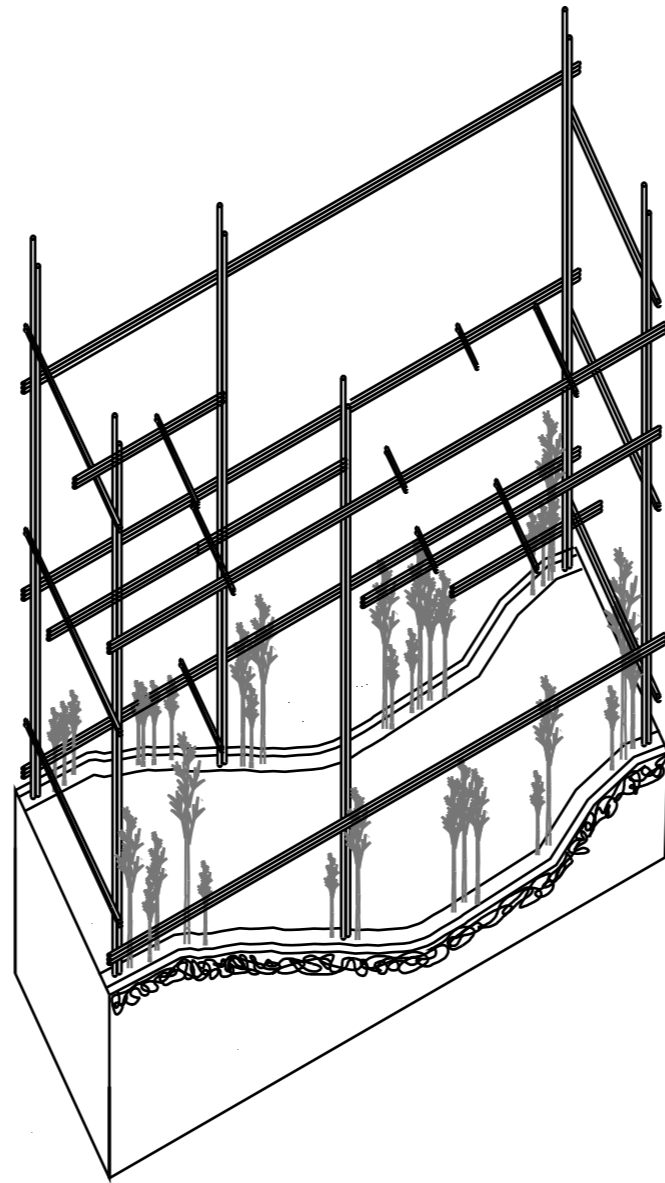





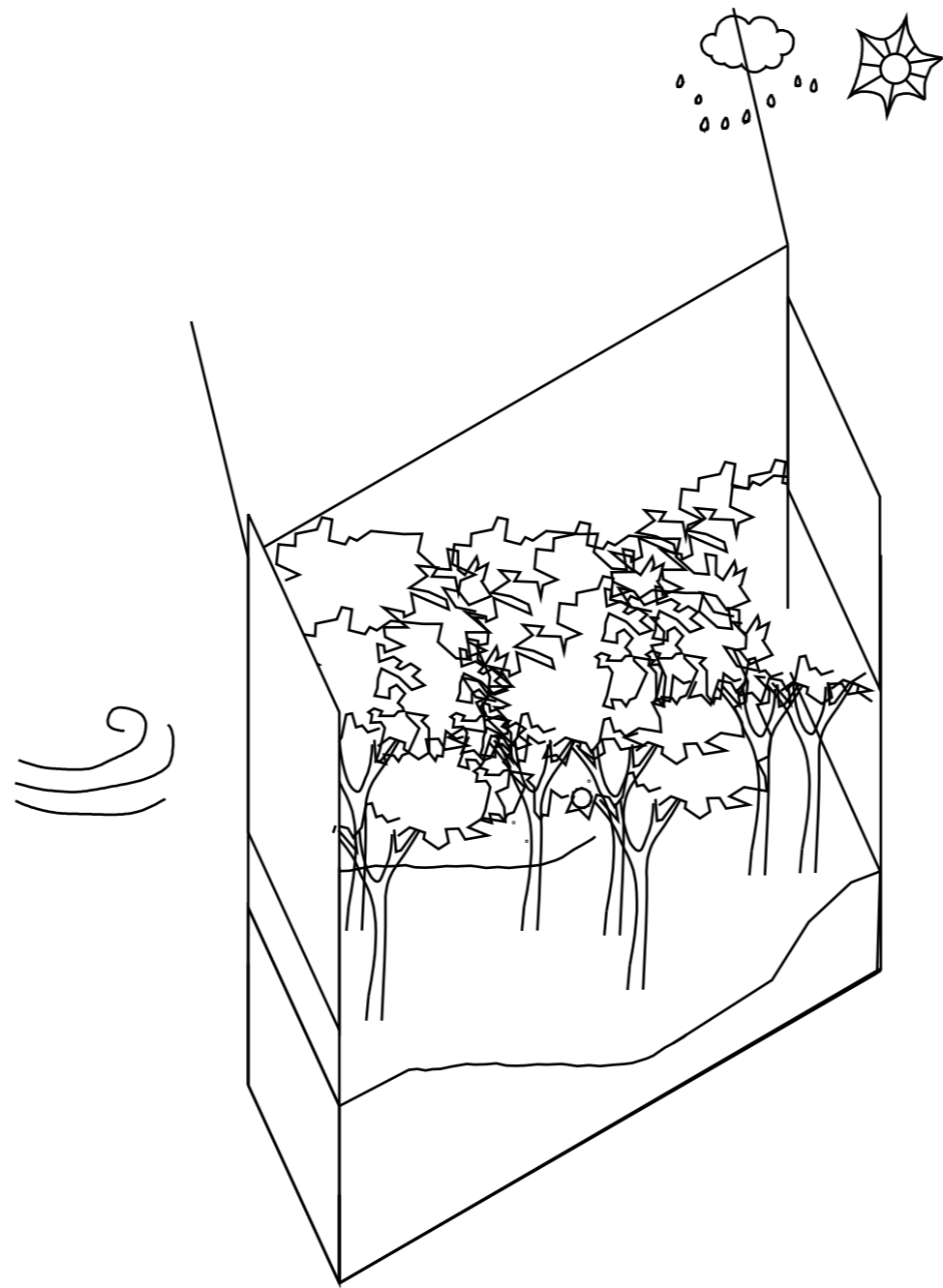



58 / 110

FRONT FACADE

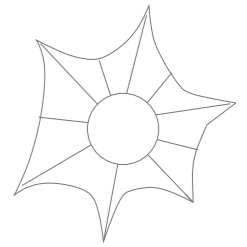
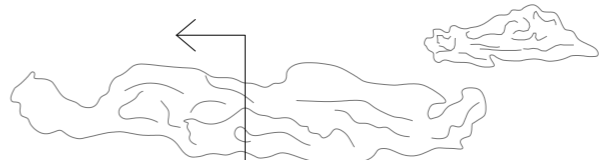
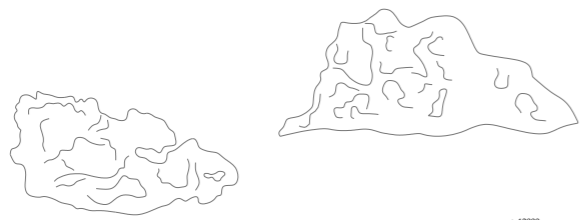

+ 12000

+ 9300

+ 8100

+ 6950

+ 4200

+ 2850

+ 2100

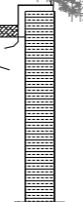
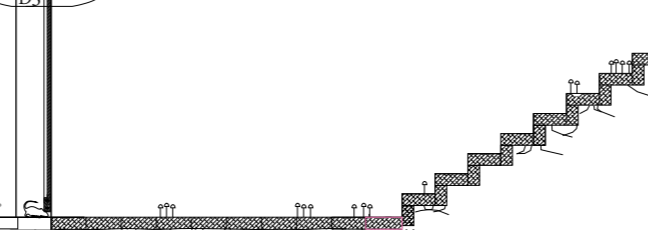
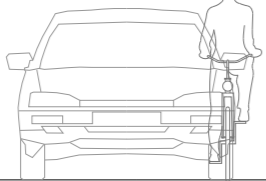
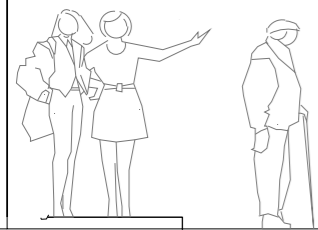

Scenario





61 / 110

FRONT FACADE



62 / 110

FRONT FACADE



63 / 110

FRONT FACADE

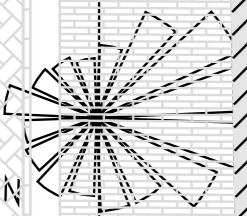
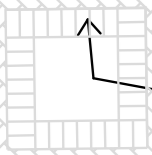
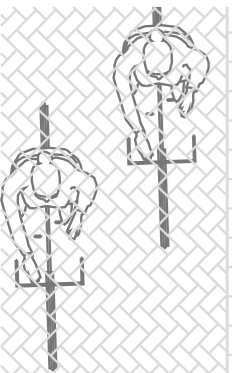
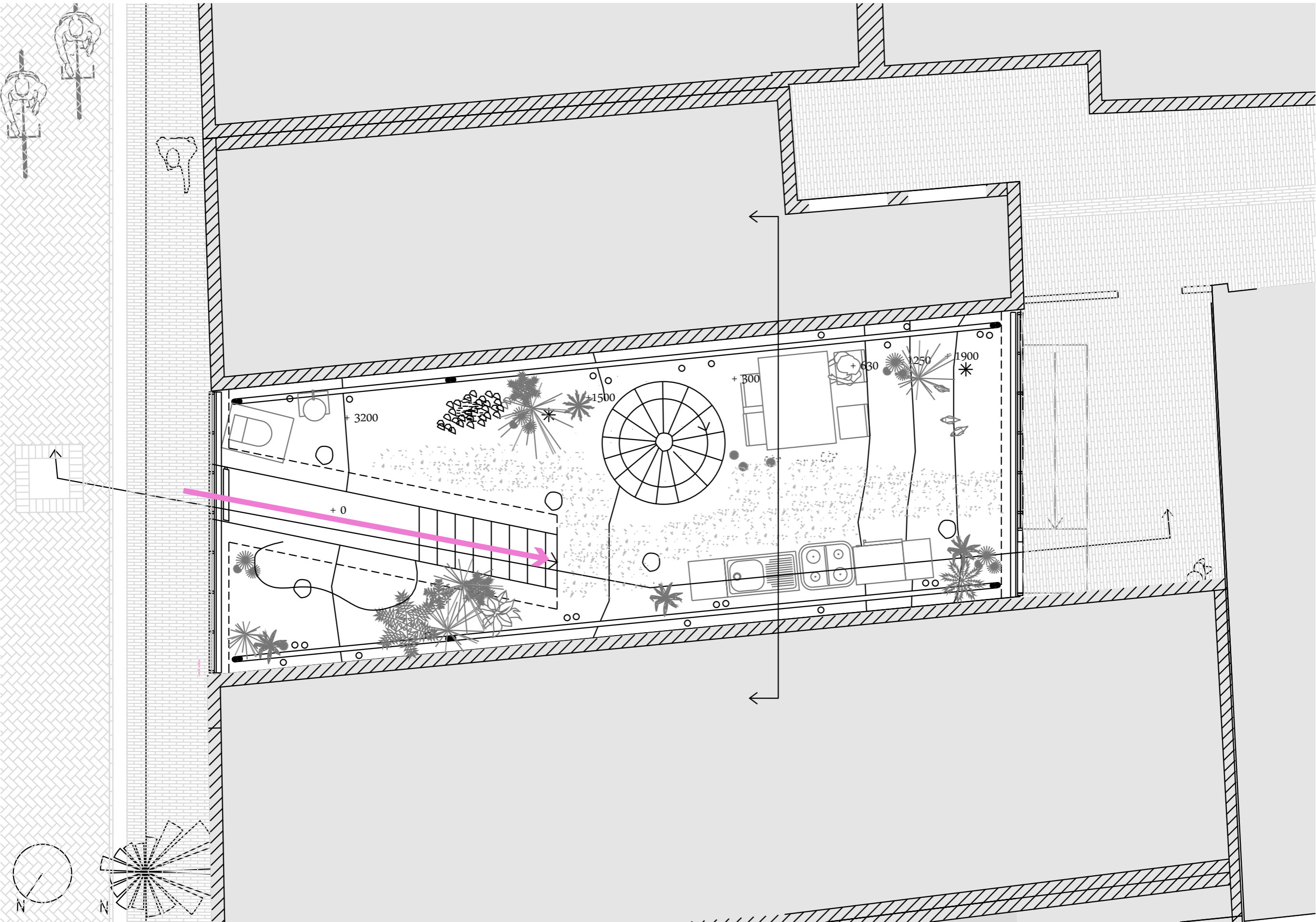

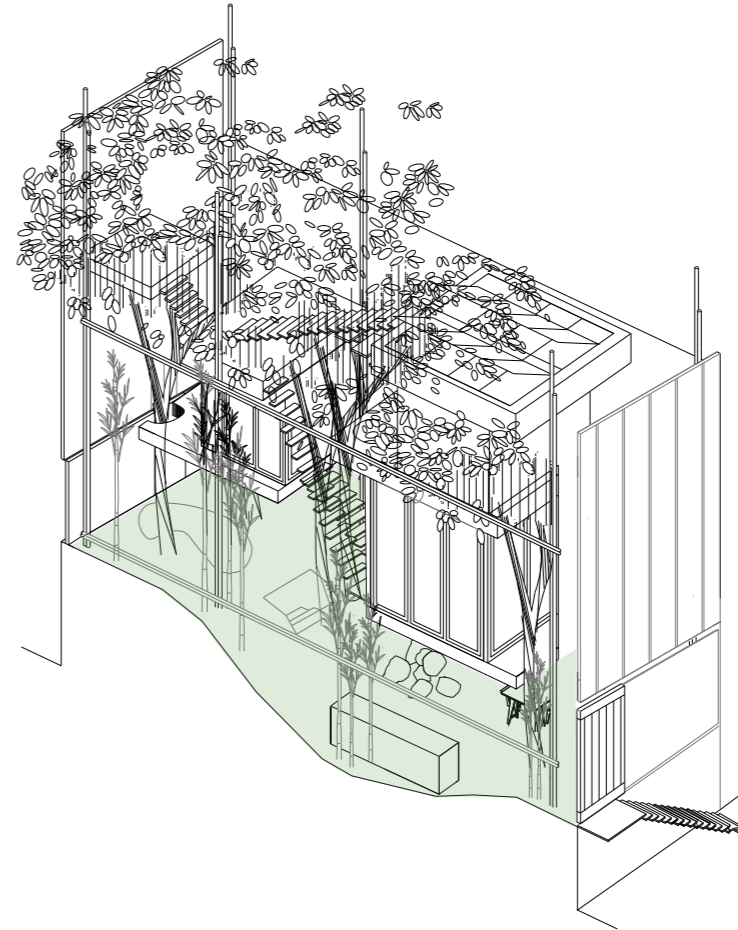

Entrance
Eating room
Kitchen
Toilet

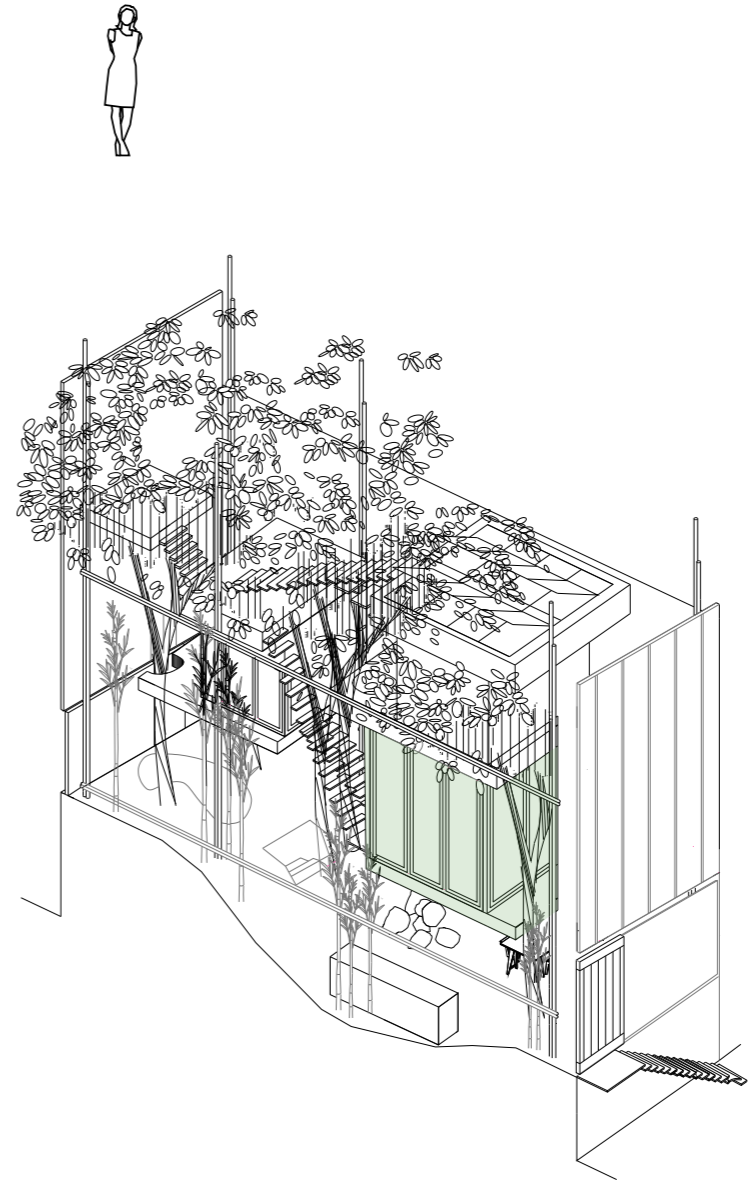

Living room

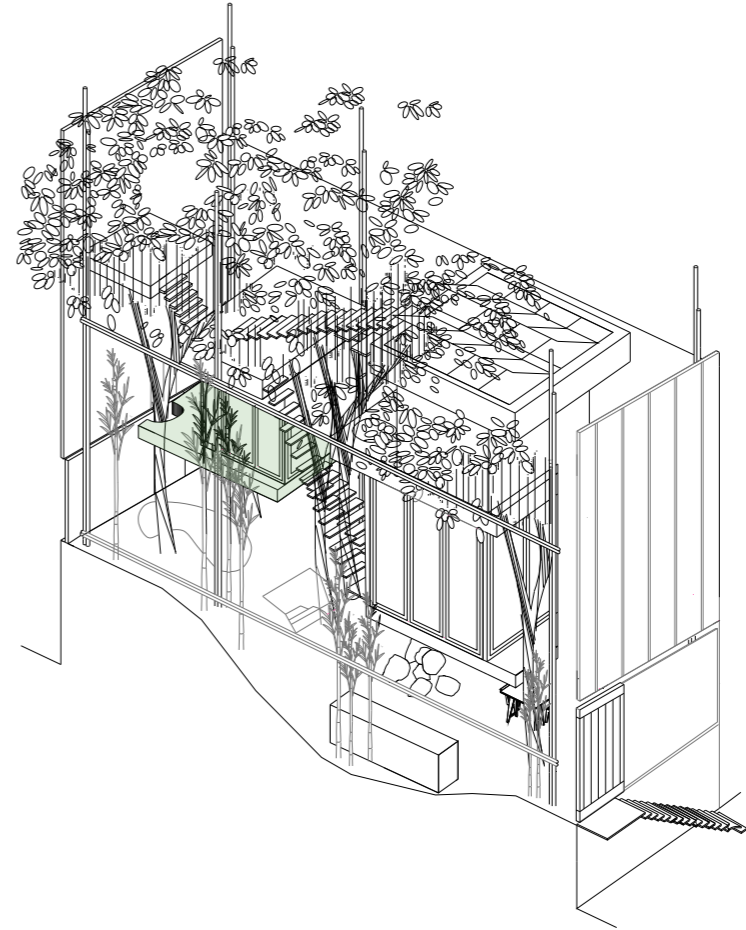

Sleeping room

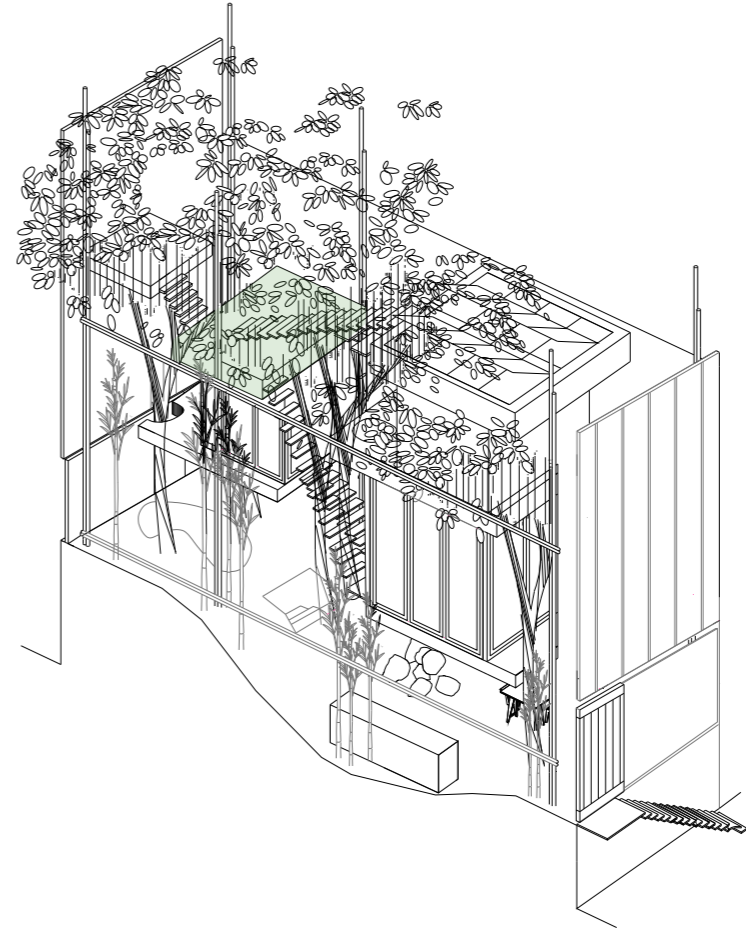

Living room

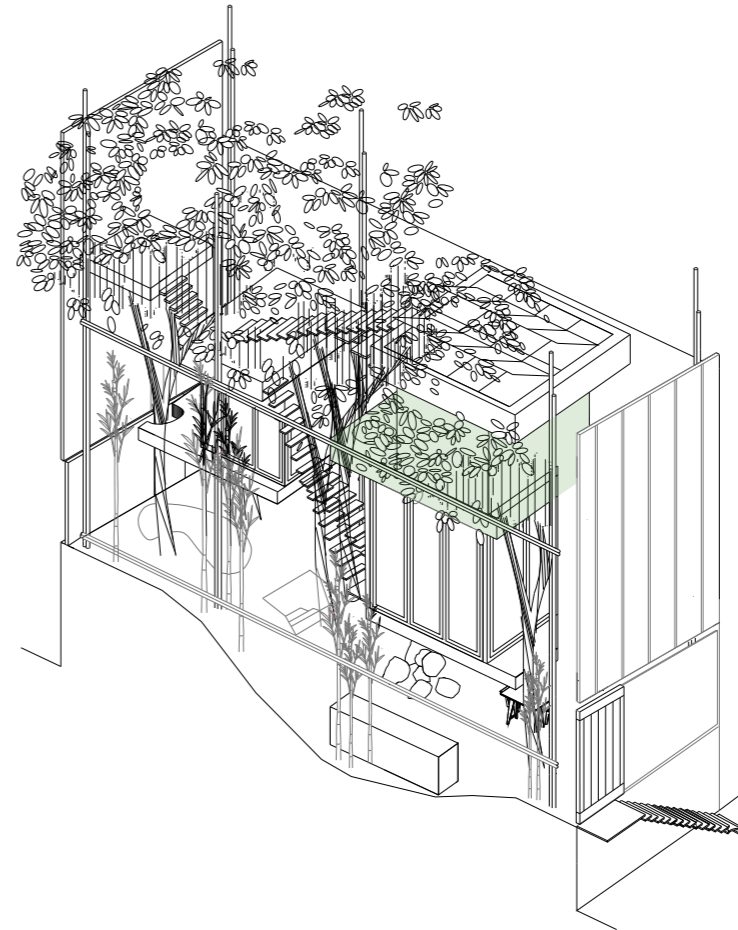

Sleeping room

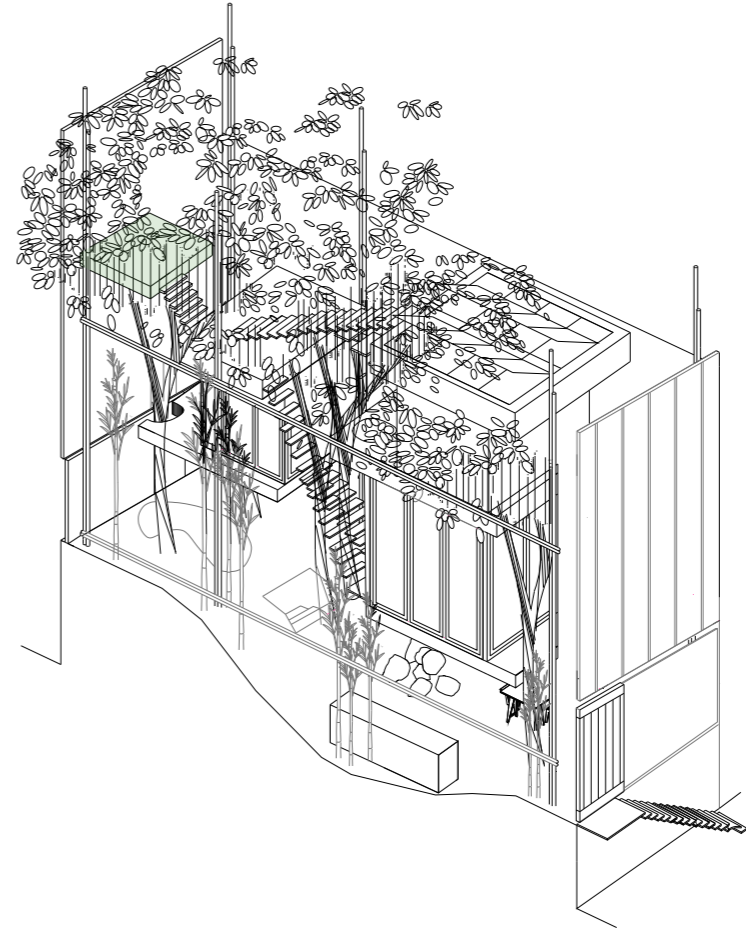

Shower

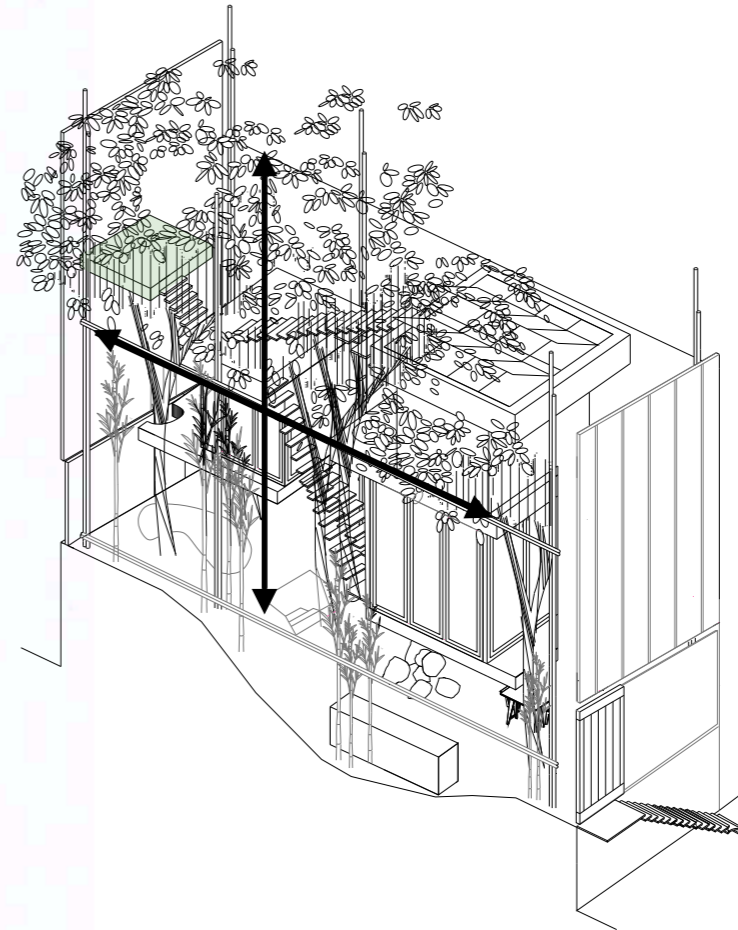

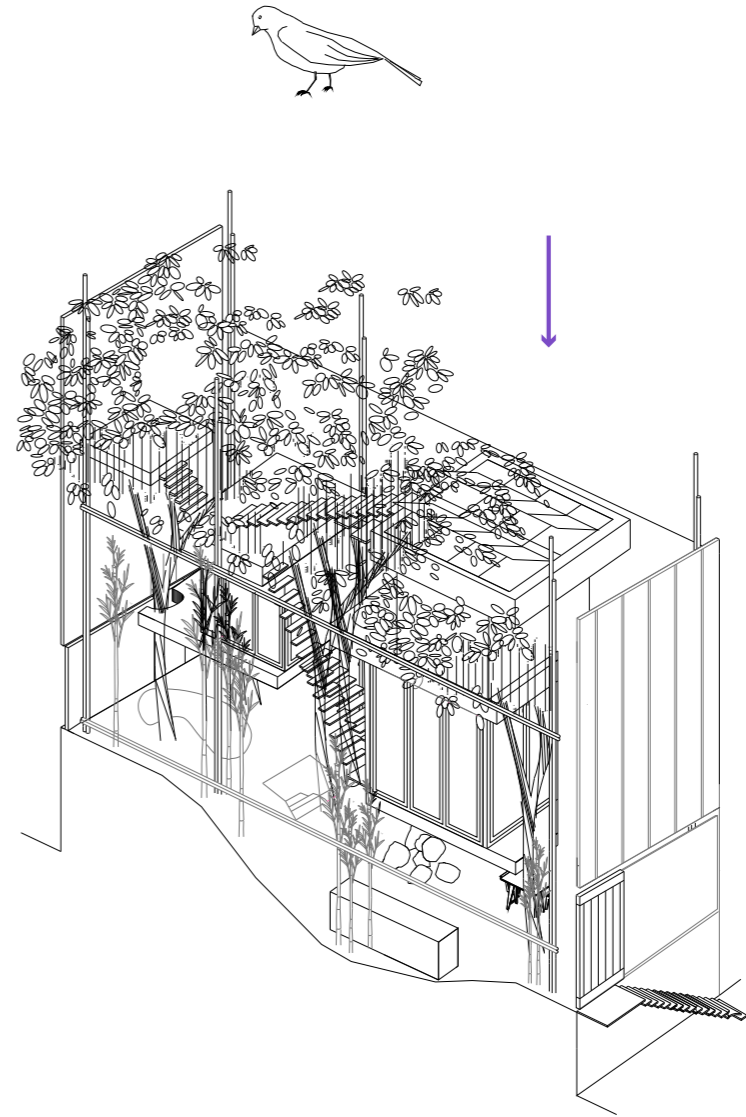

Entrance

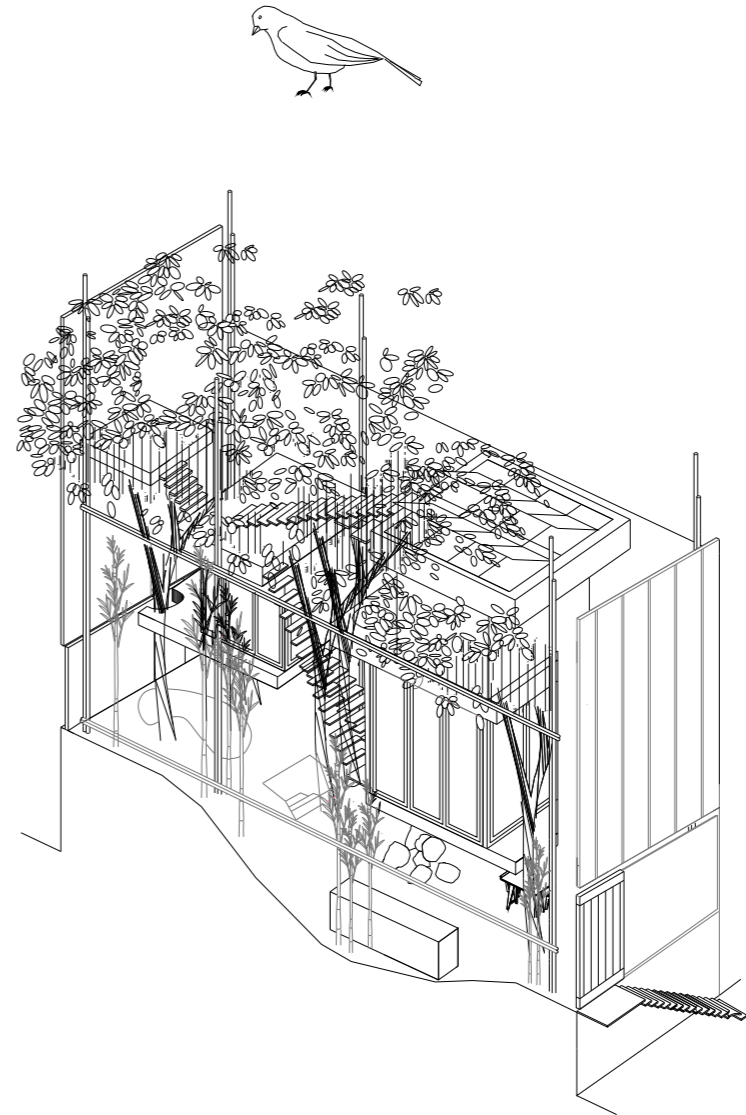

Living room
Dining room

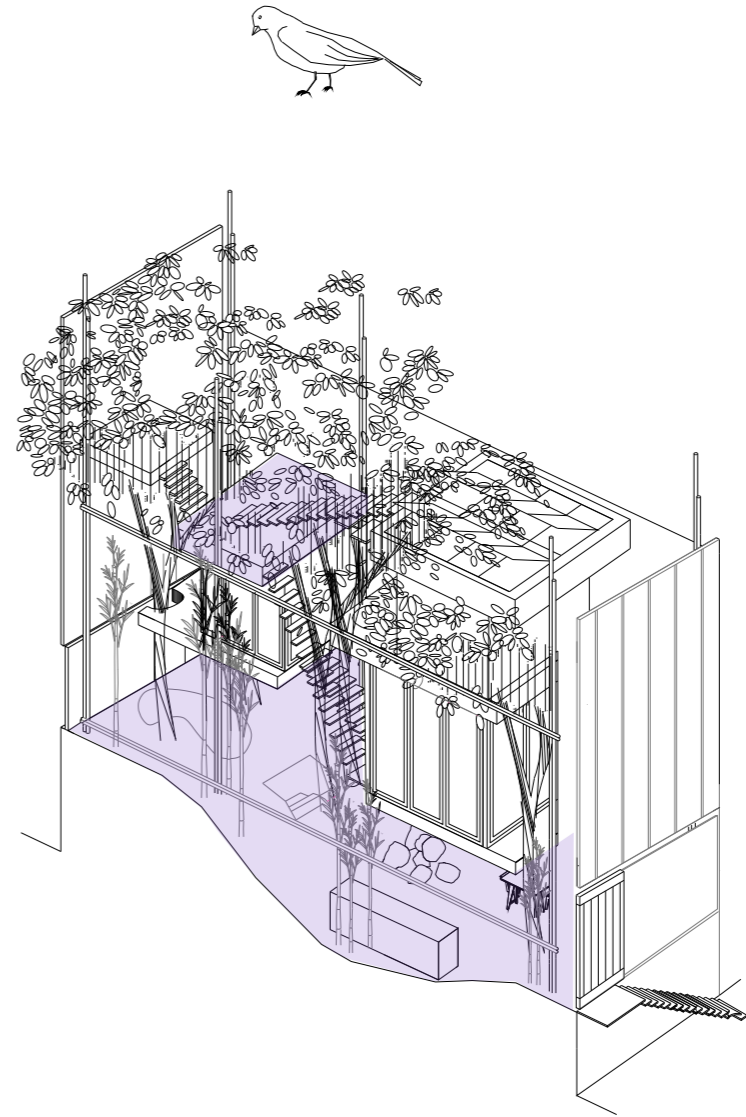

Dining room
Bathroom
Shower

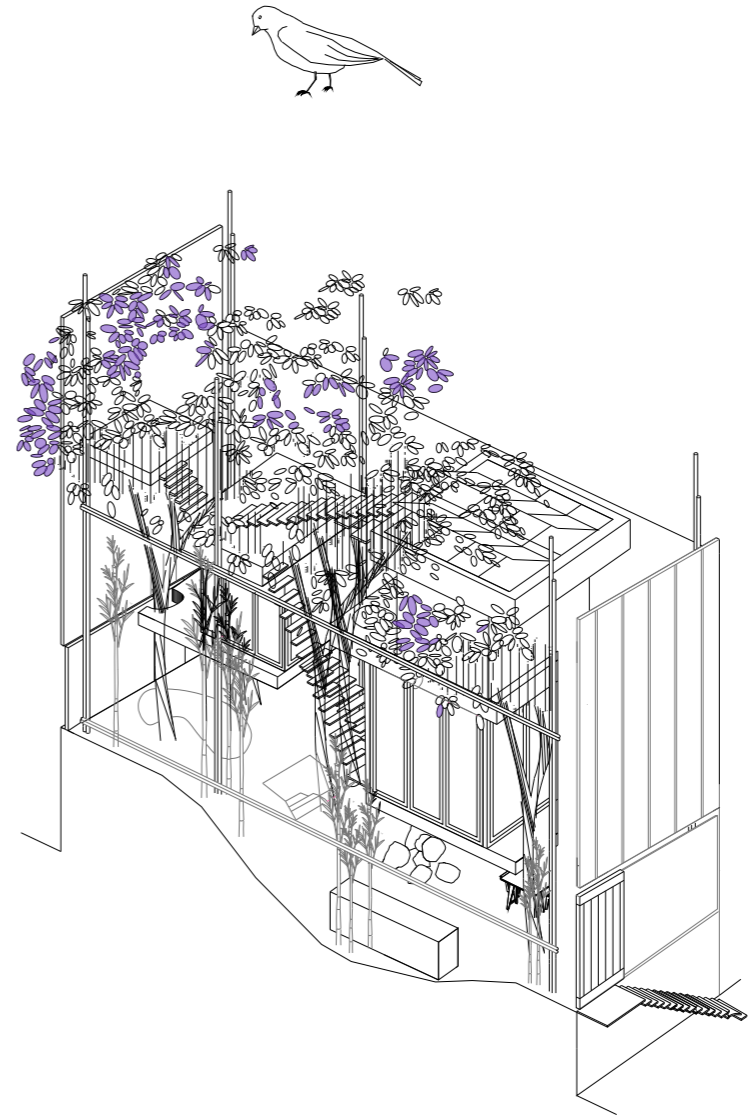

Dining room

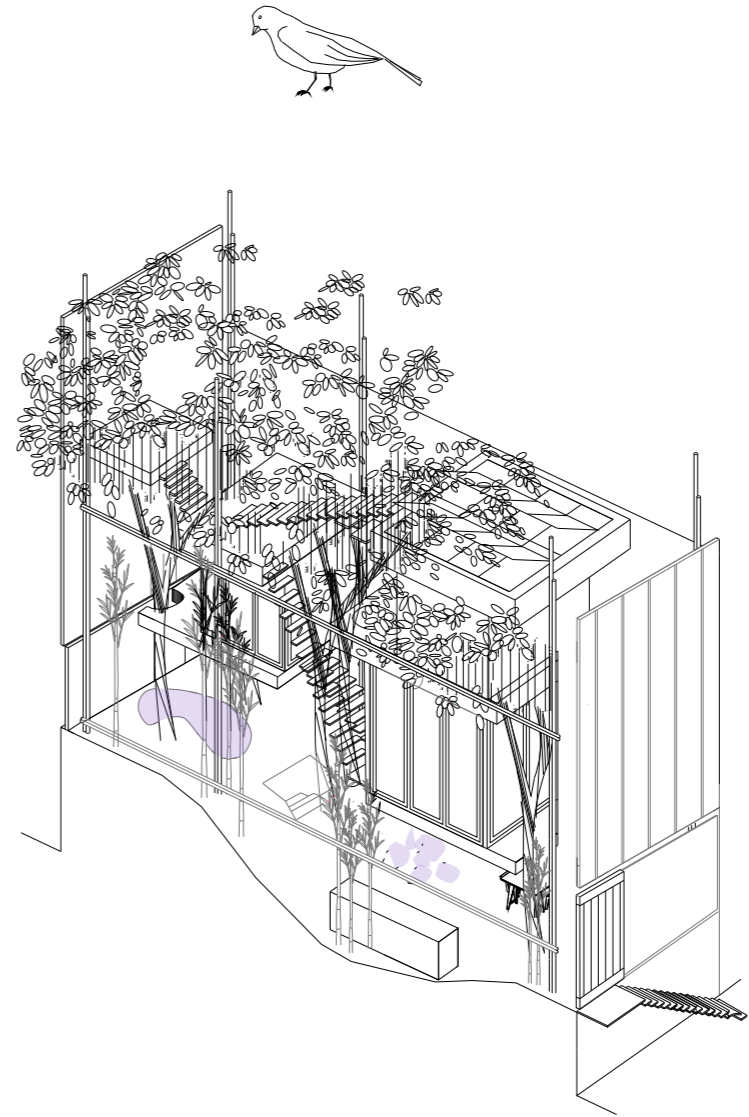

Drink area

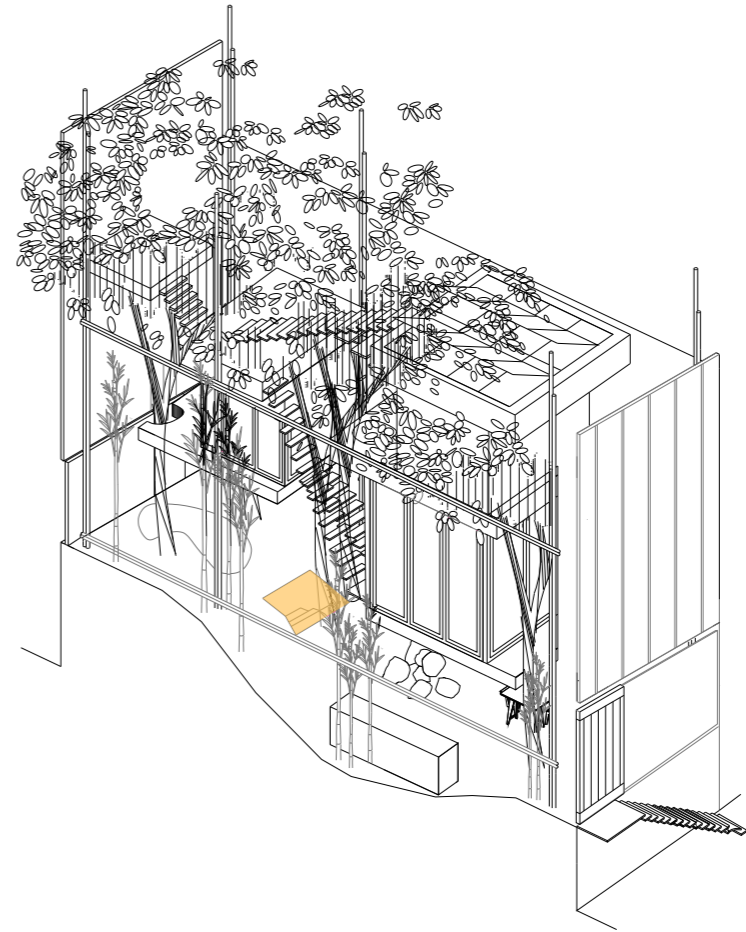

Entrance

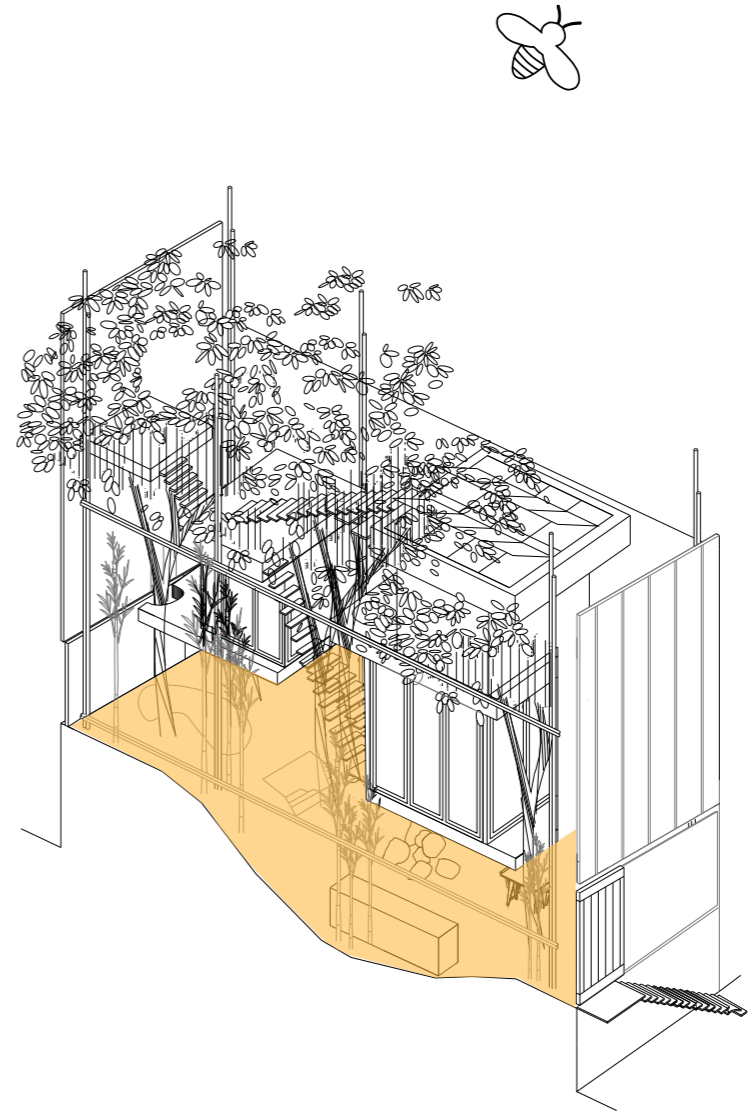

Living room
Dining room

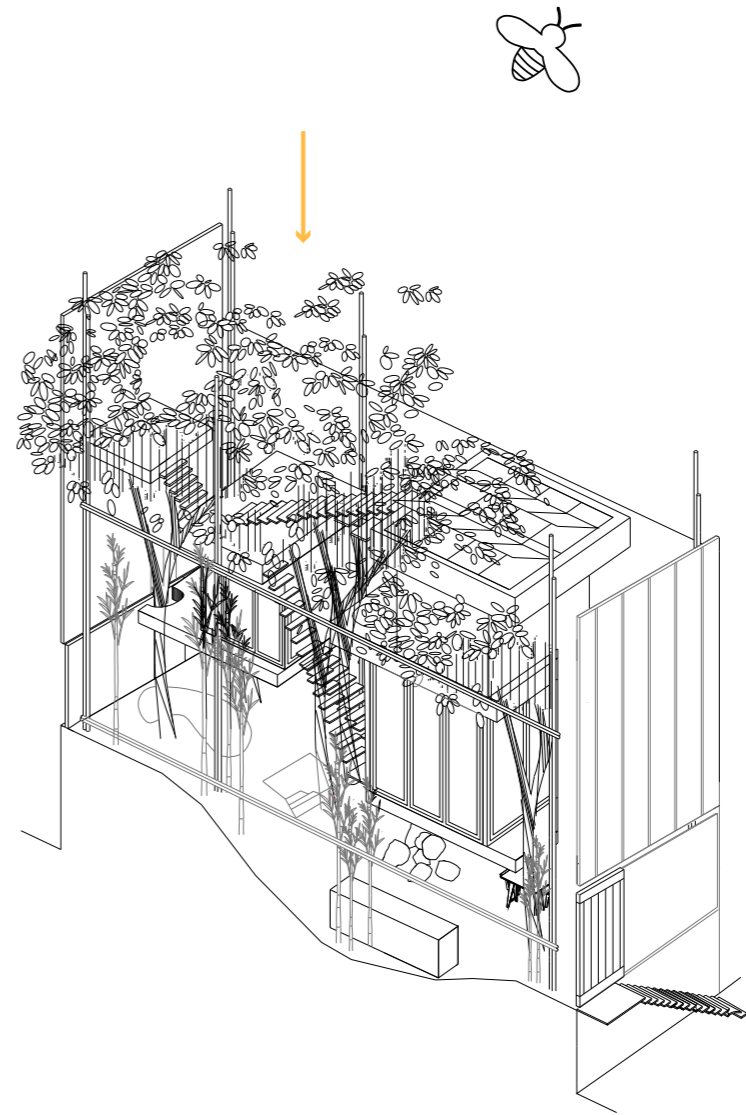

Entrance 2

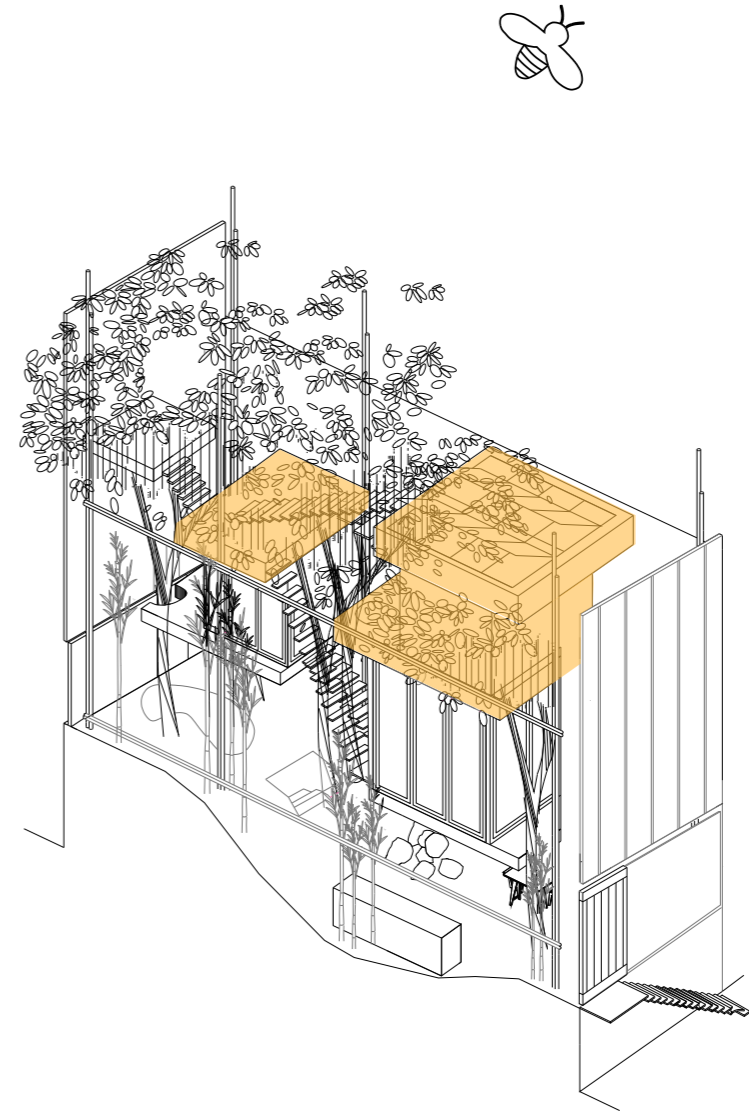

Living room
Dining room

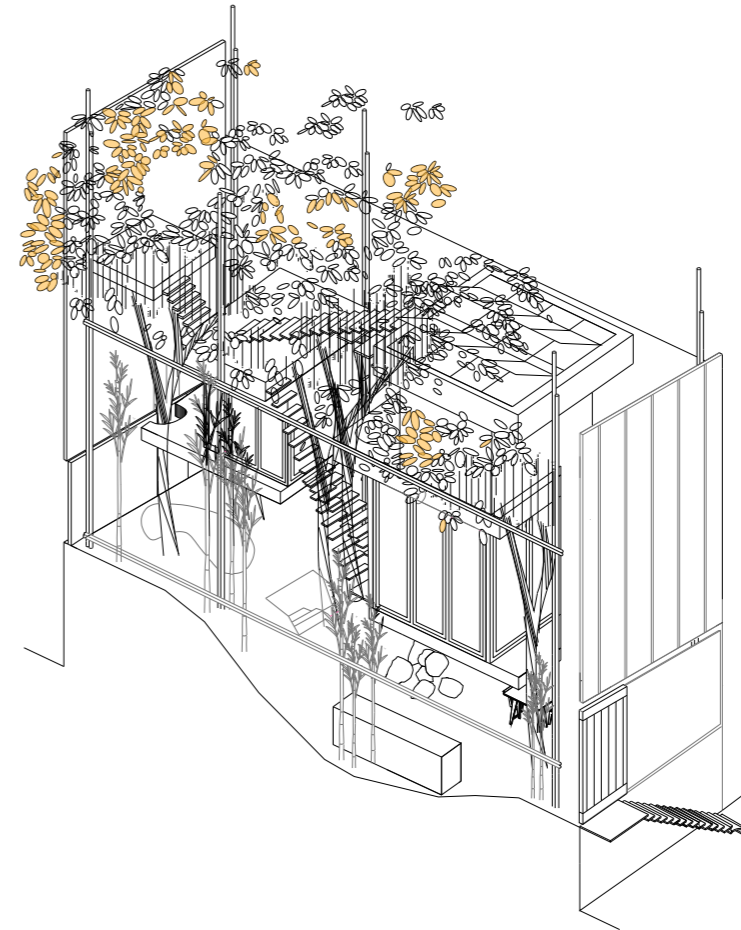

Extra dinner in
July/August

Technique

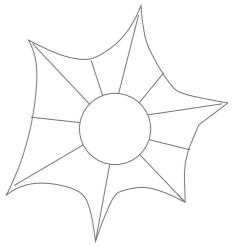
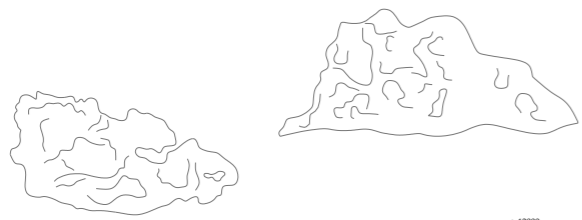

+ 12000

+ 9300

+ 8100

+ 6950

+ 4200

+ 2850

+ 2100

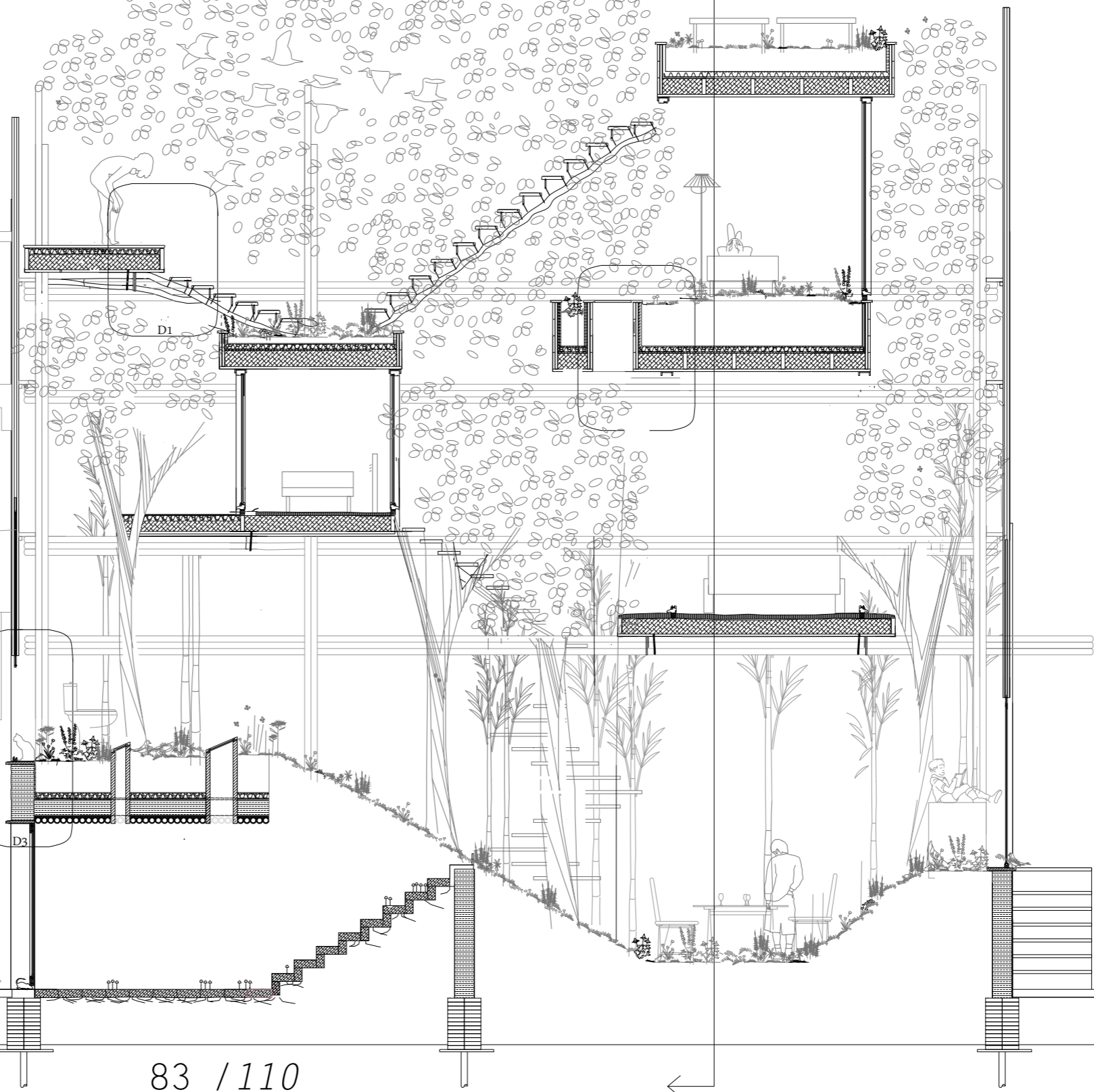
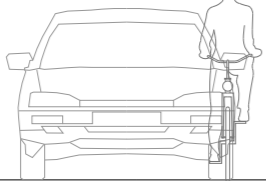
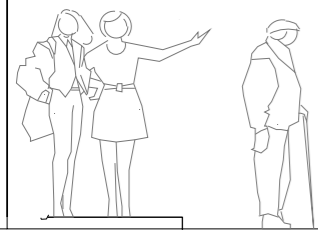



- **Constructive:** Living Trees and bamboo
- **Acoustic/isolation :** mycelium
- **Close lifecycle:** living bacteria
- **Protection:** open, half open and closed living area
- **Non-constructive:** use sun, wind and rain; transparent stiff materials and specific tools
- **Improve geology:** add soil
- **Protect geology:** bamboo construction, living foundation, no pipes in the ground

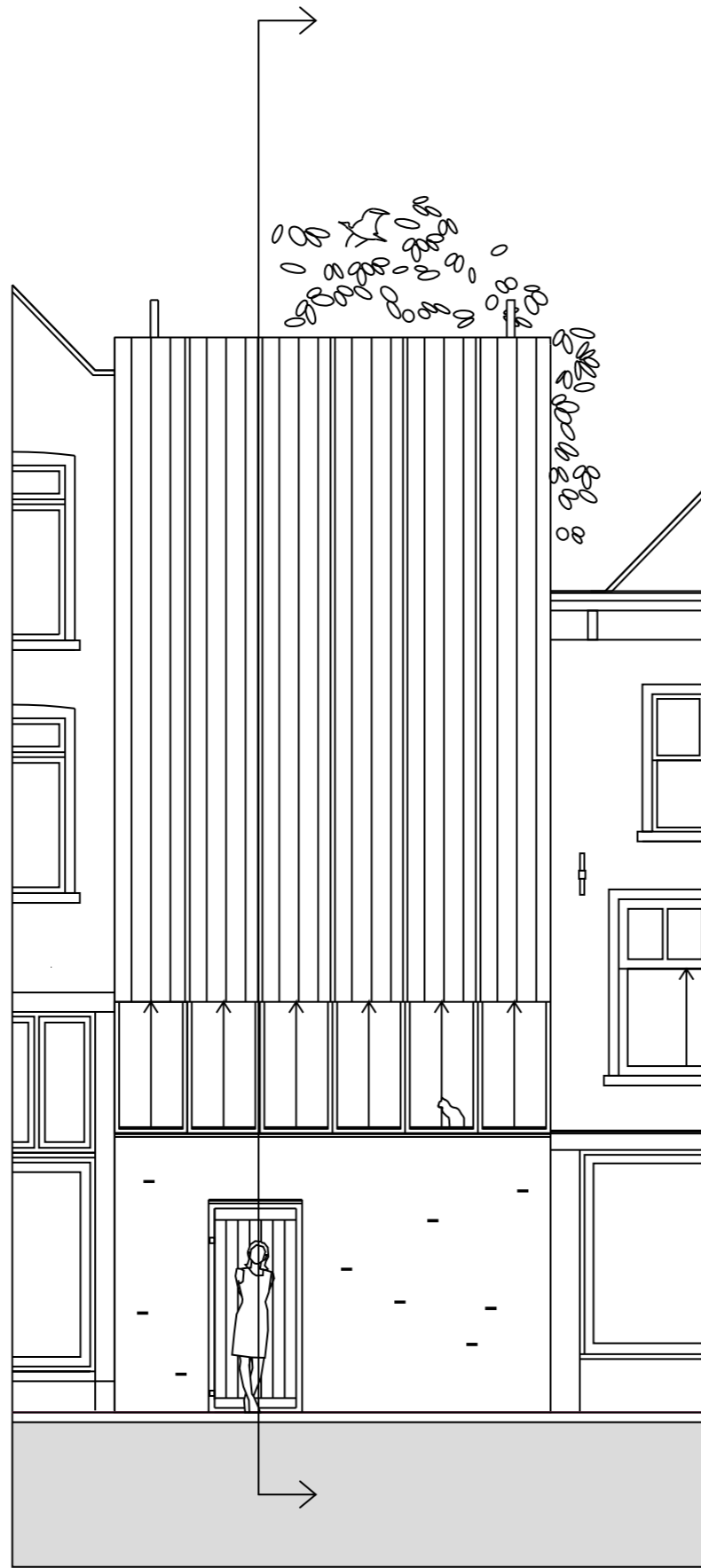

85 / 110

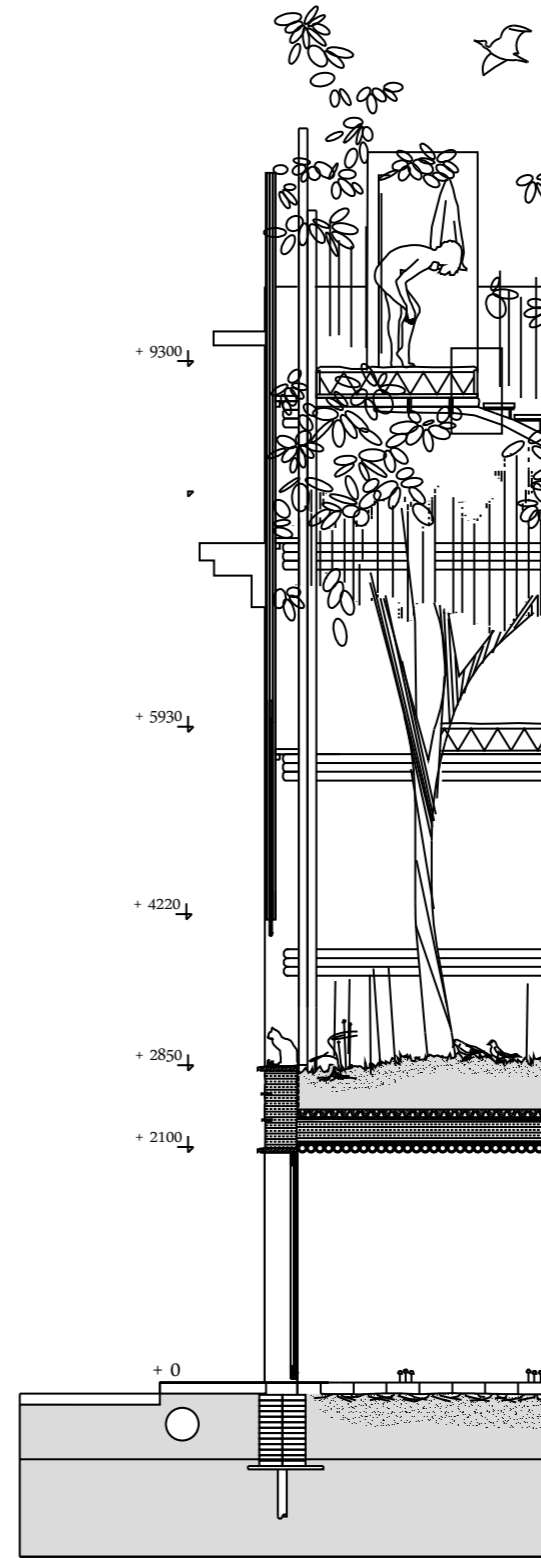

FRONT FACADE

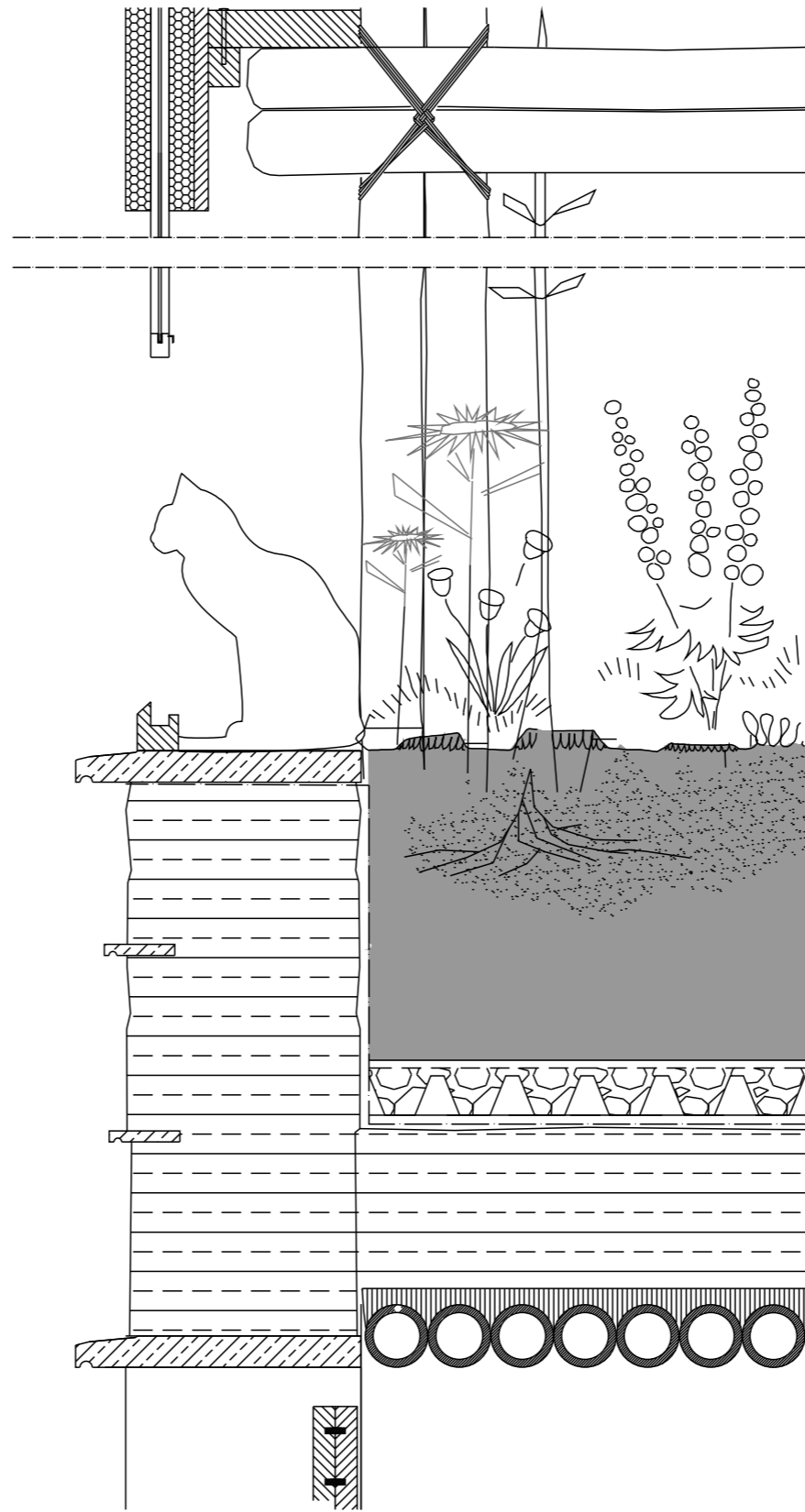

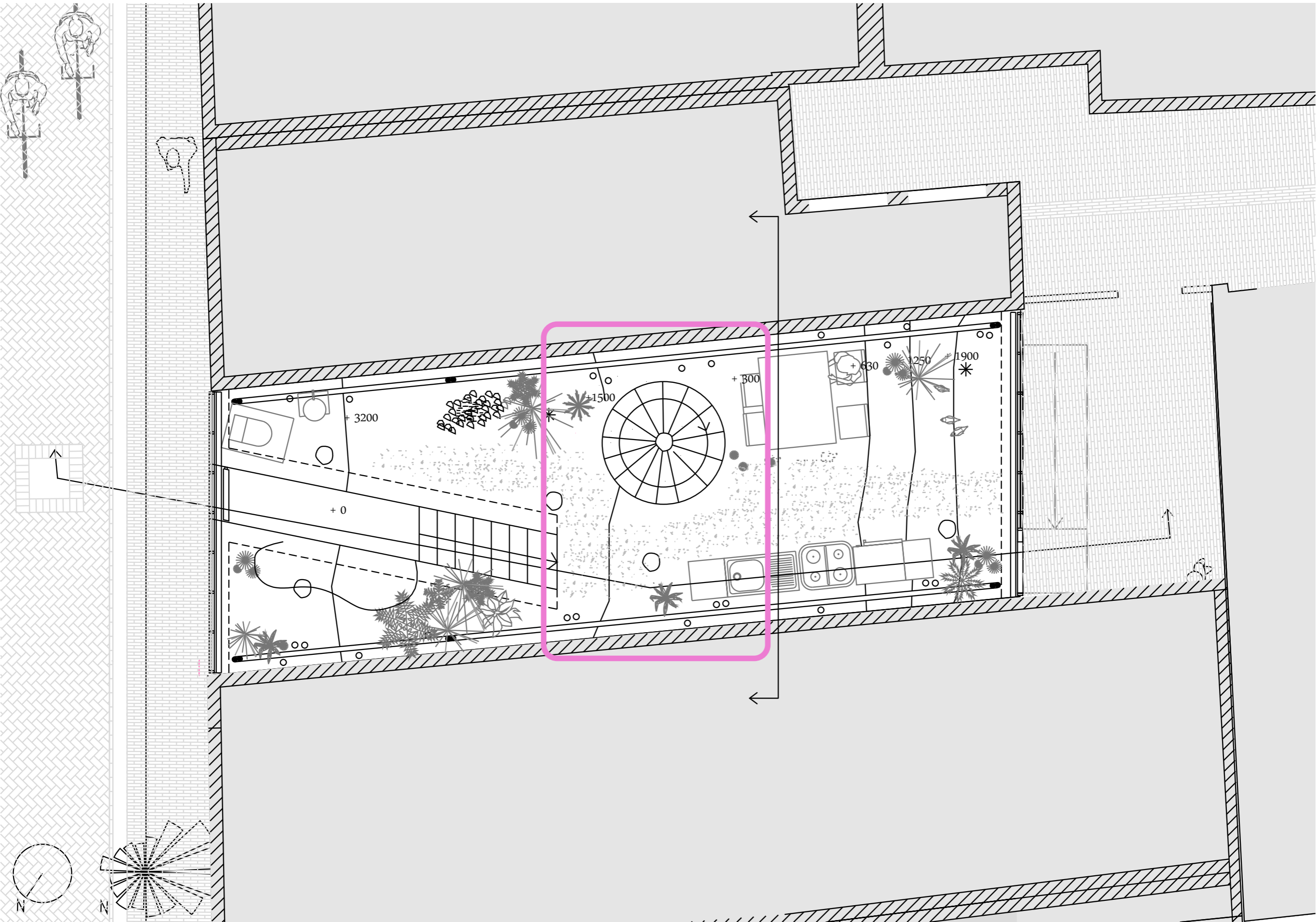



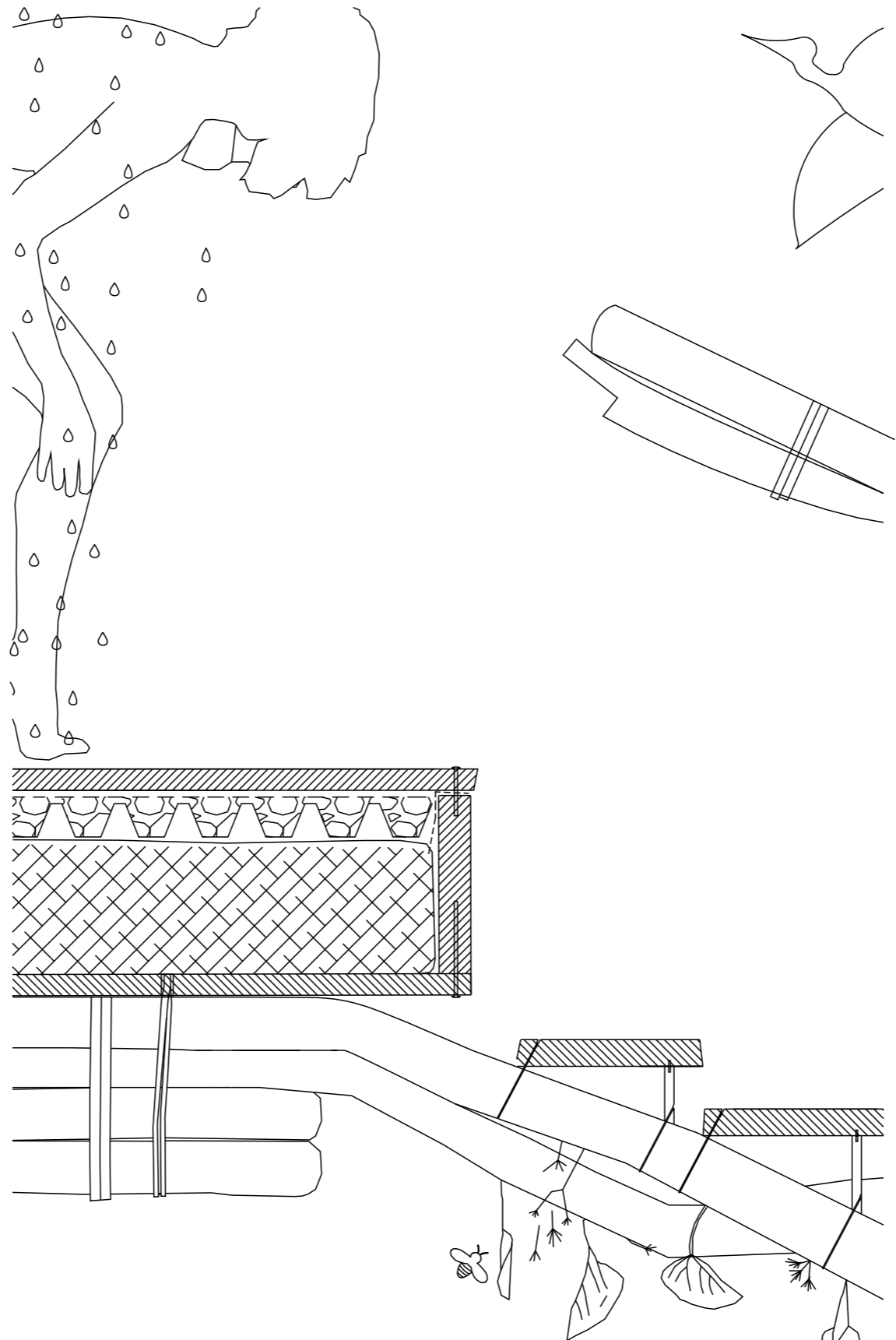

89 / 110

SECTION - detail



Foot bridge (Ferdinand Ludwig, 2005)



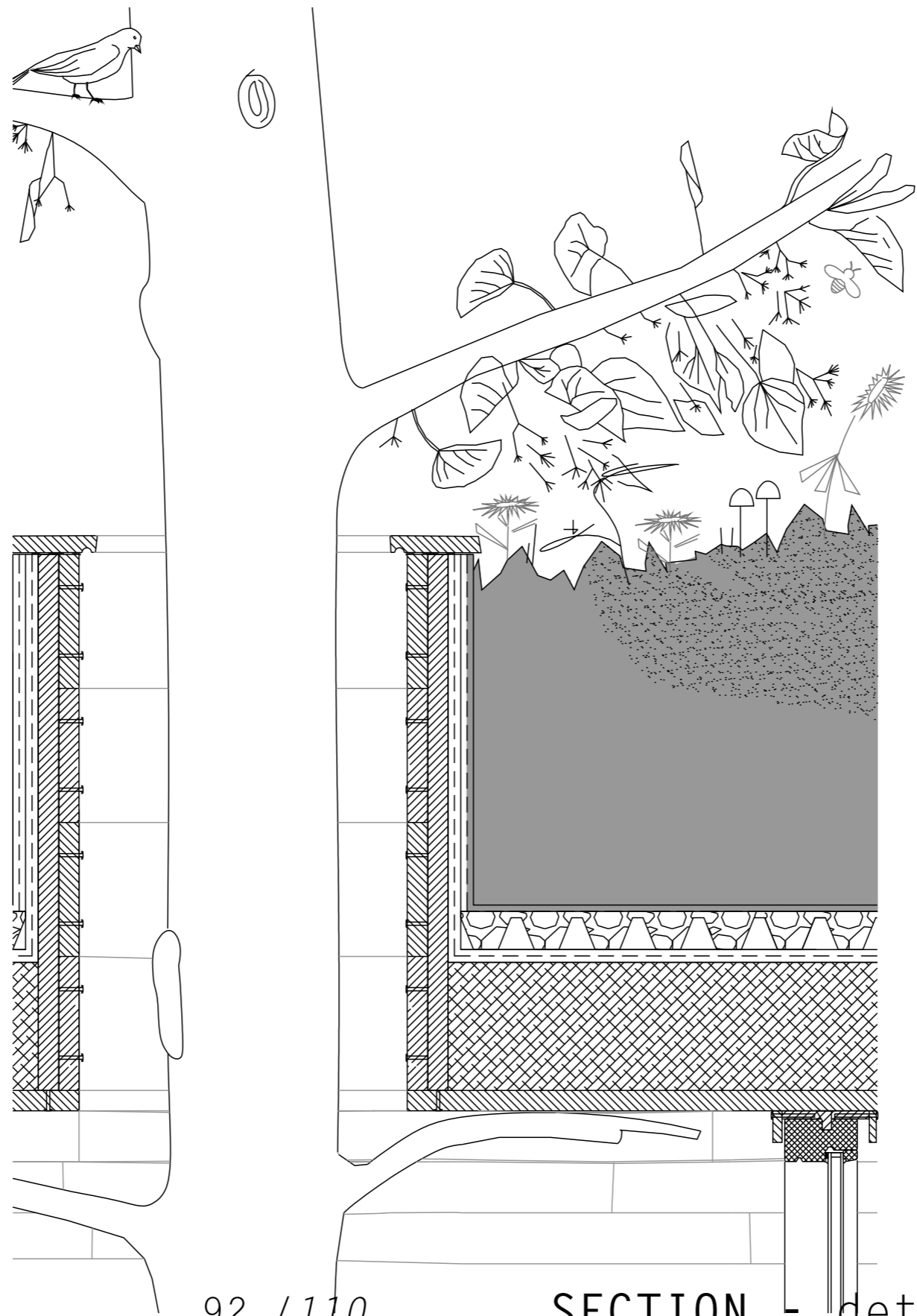

92 / 110

SECTION - detail

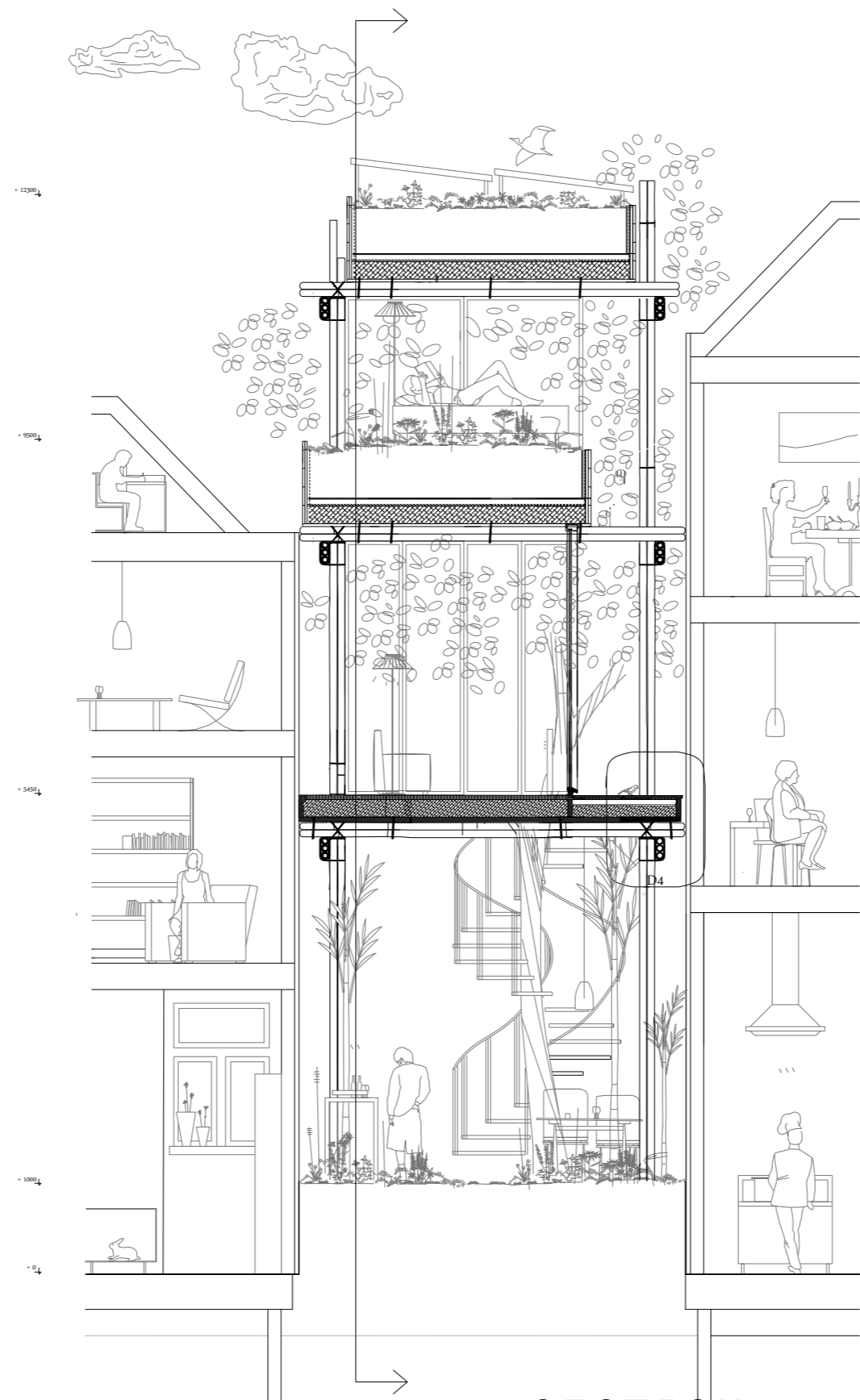

93 / 110

SECTION - walls

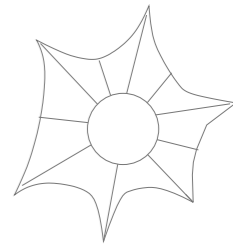
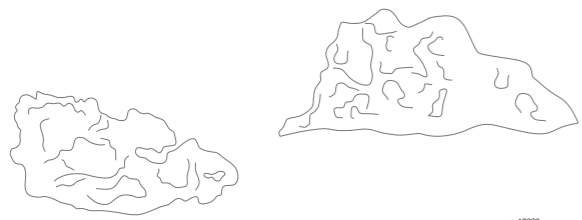

+12000
+9300
+8100
+7065
+4220
+2850
+2100

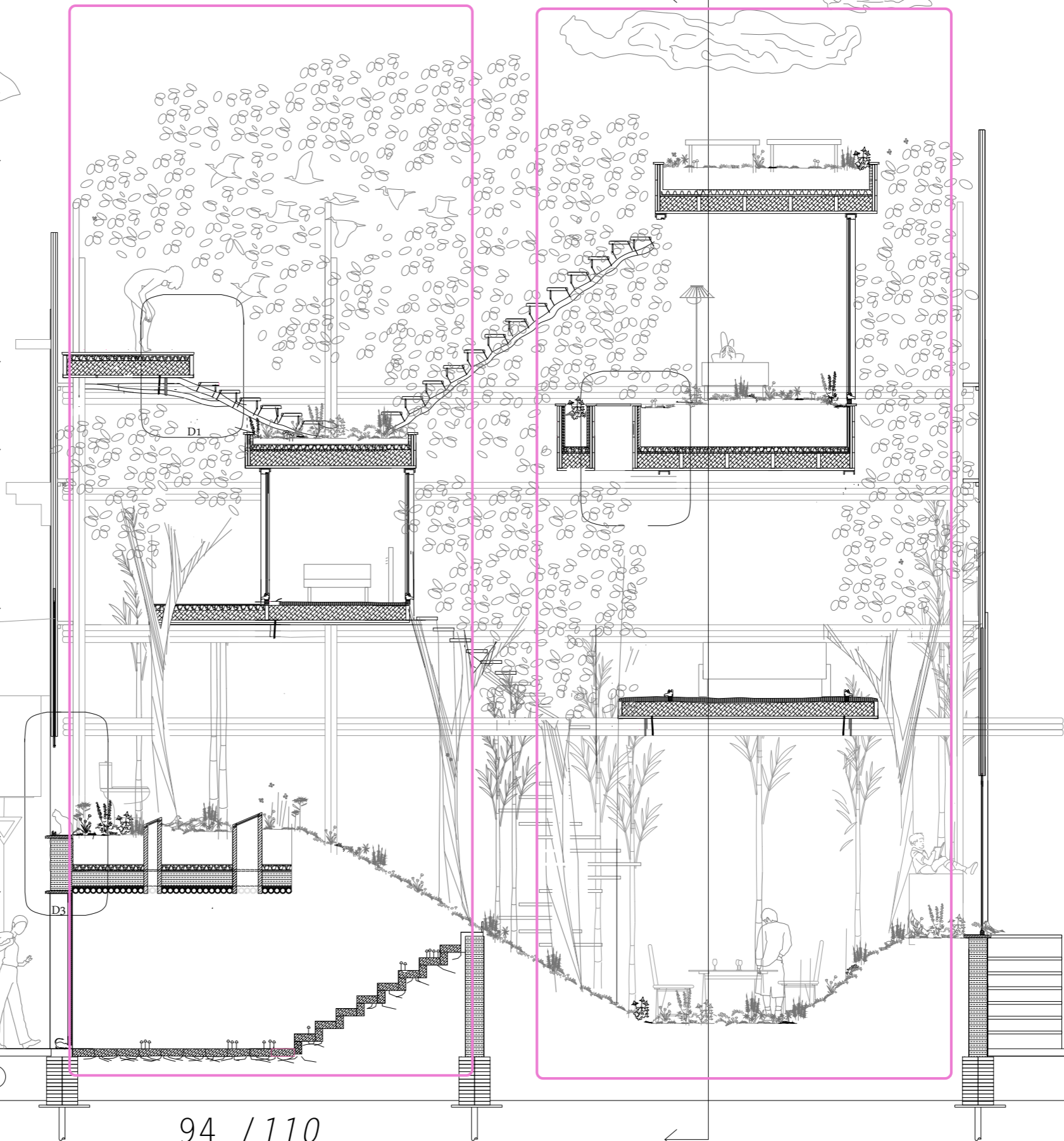

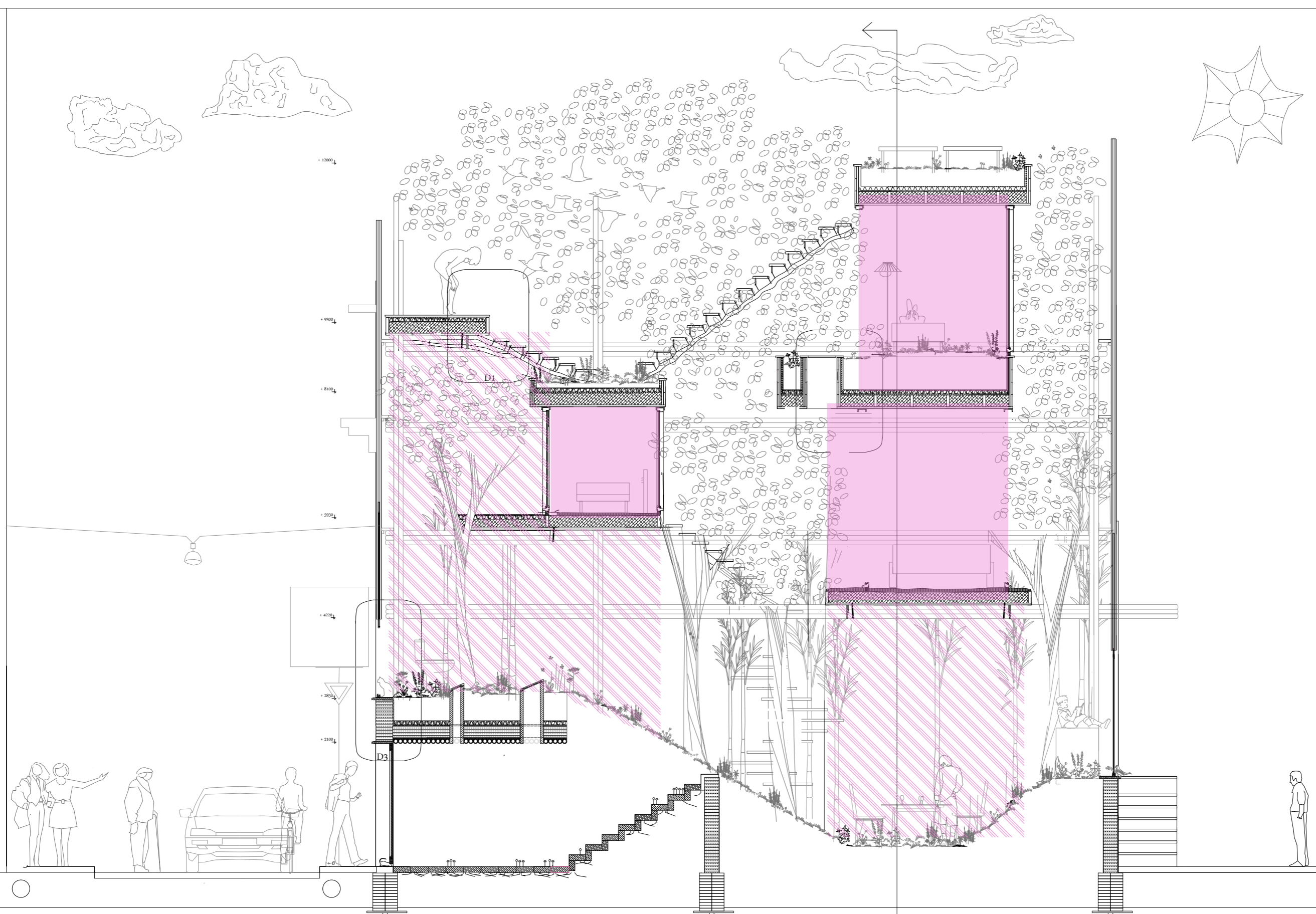

95 / 110

SECTION ← indoor/outdoor

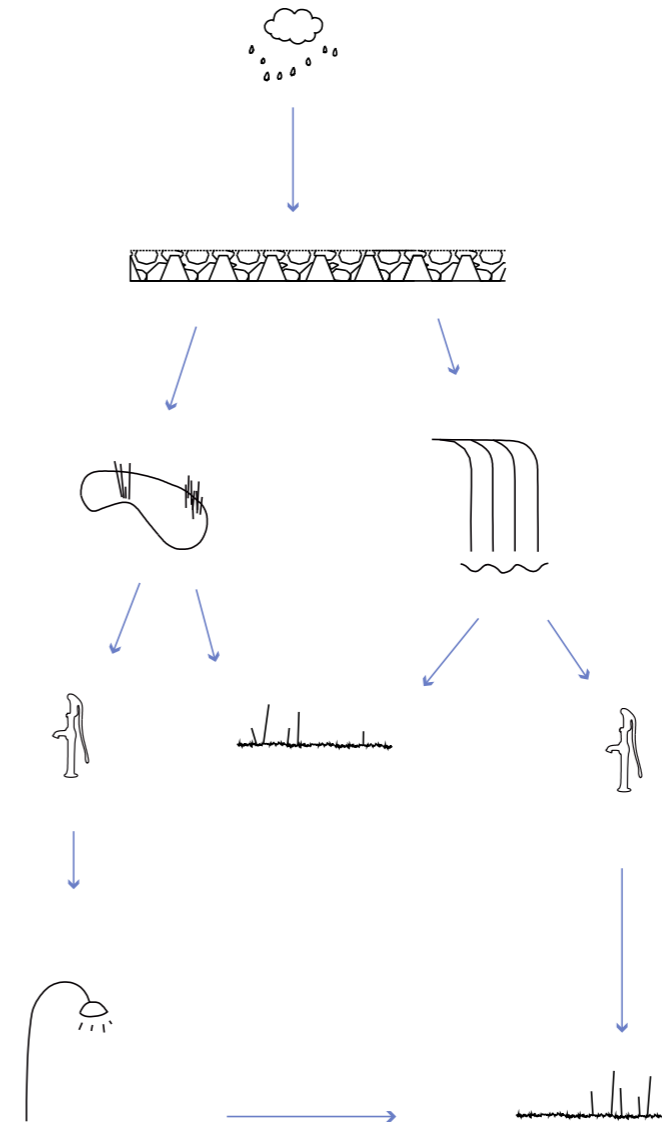

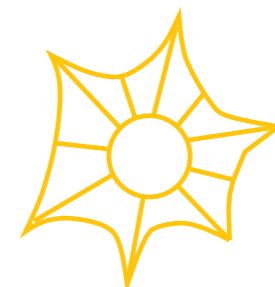

+ 12000 ↓

2250 kwh/year

+ 9300 ↓

+ 8100 ↓

+ 5930 ↓

+ 4220 ↓

+ 2850 ↓

+ 2100 ↓

+ 0 ↓

1150mmx755mm
x1555mm

97 / 110

ELEKTRICITY

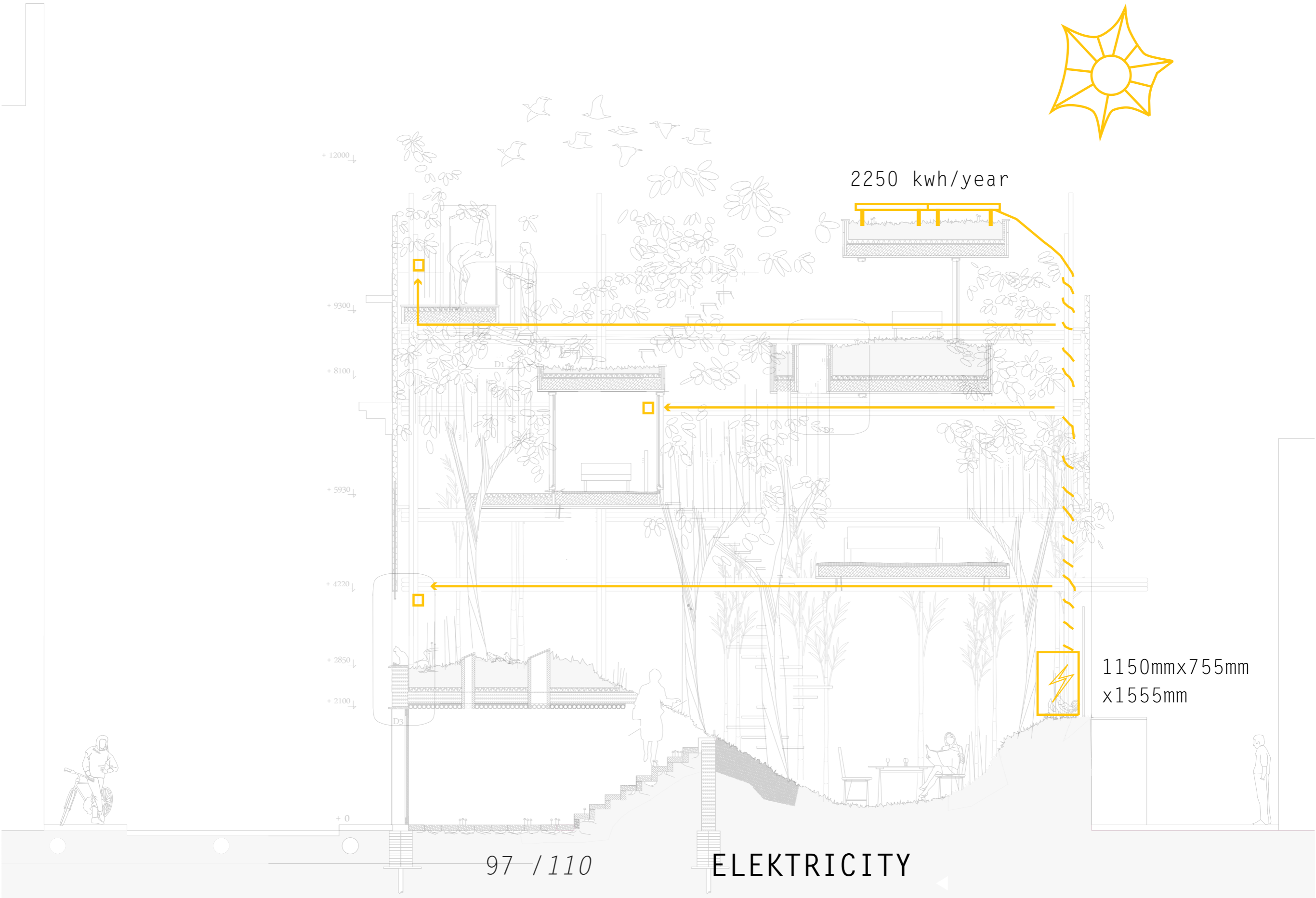

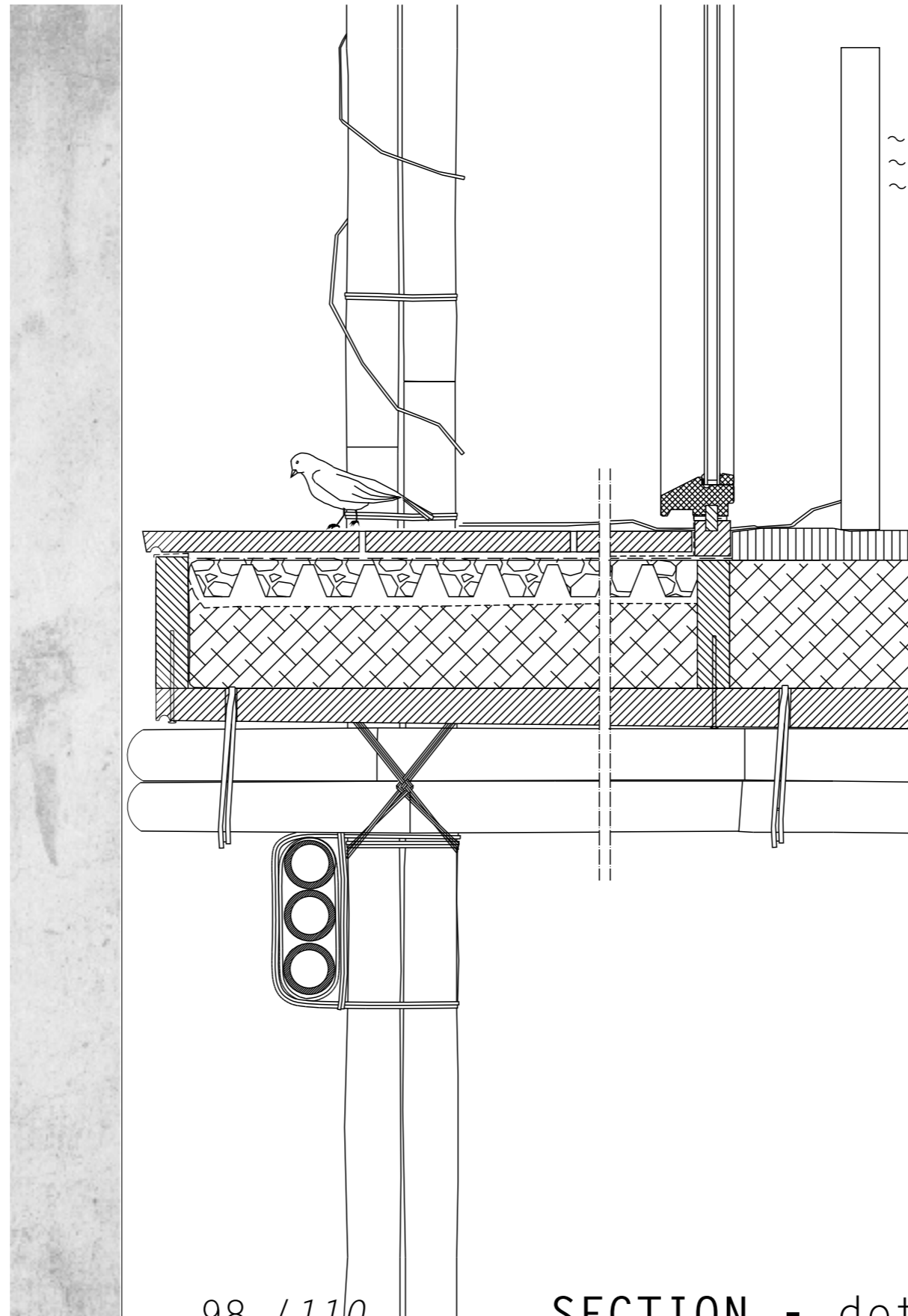

98 / 110

SECTION - detail

Transformation
during the time

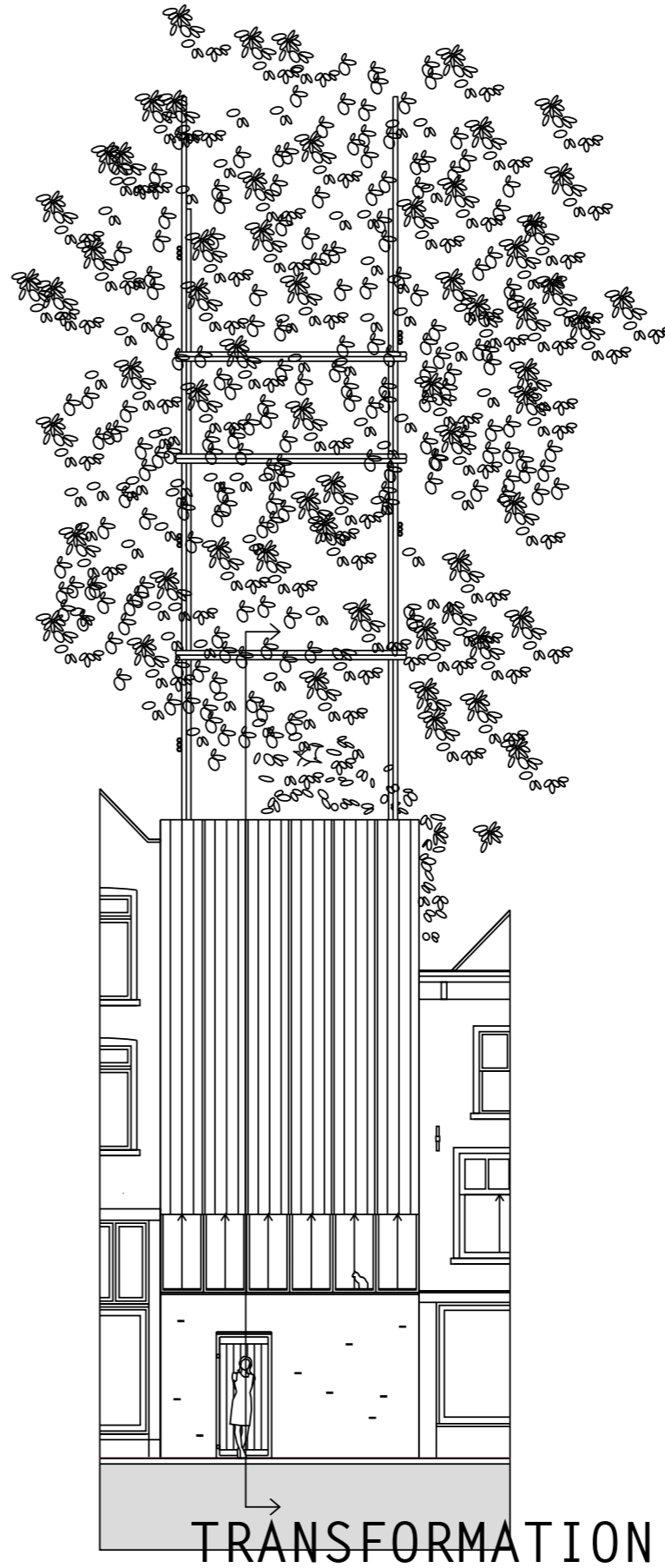
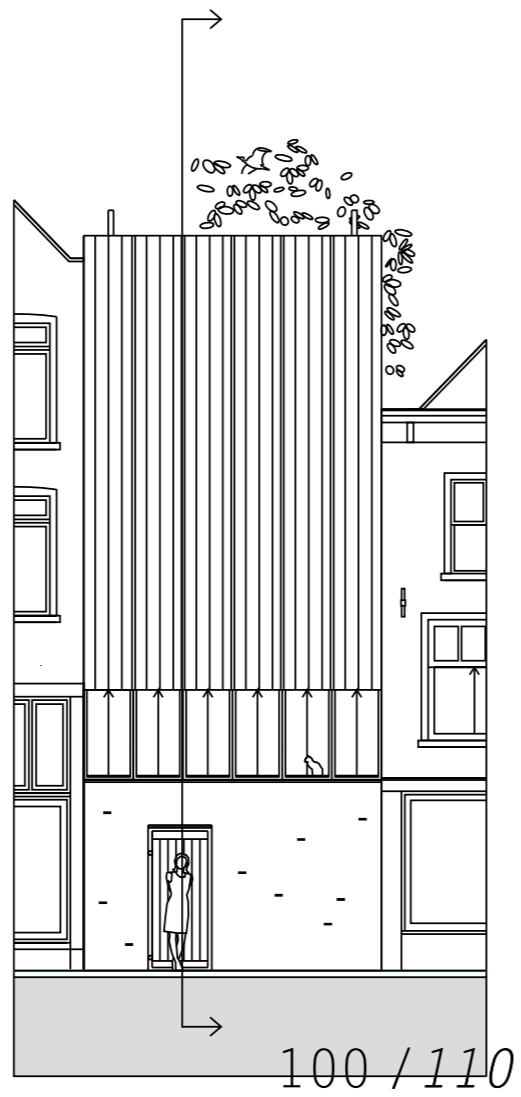

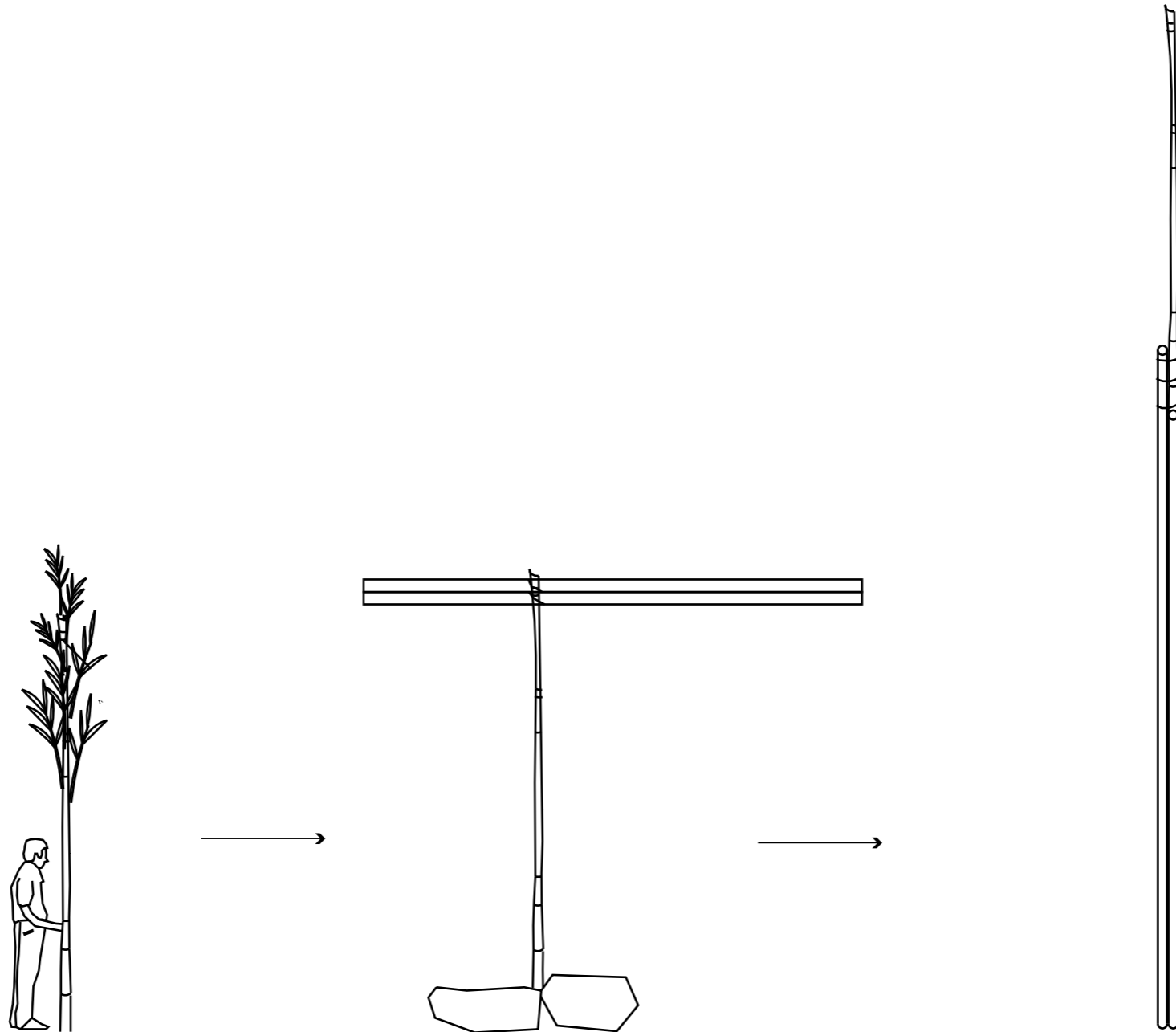

101 / 110

TRANSFORMATION - rebuild

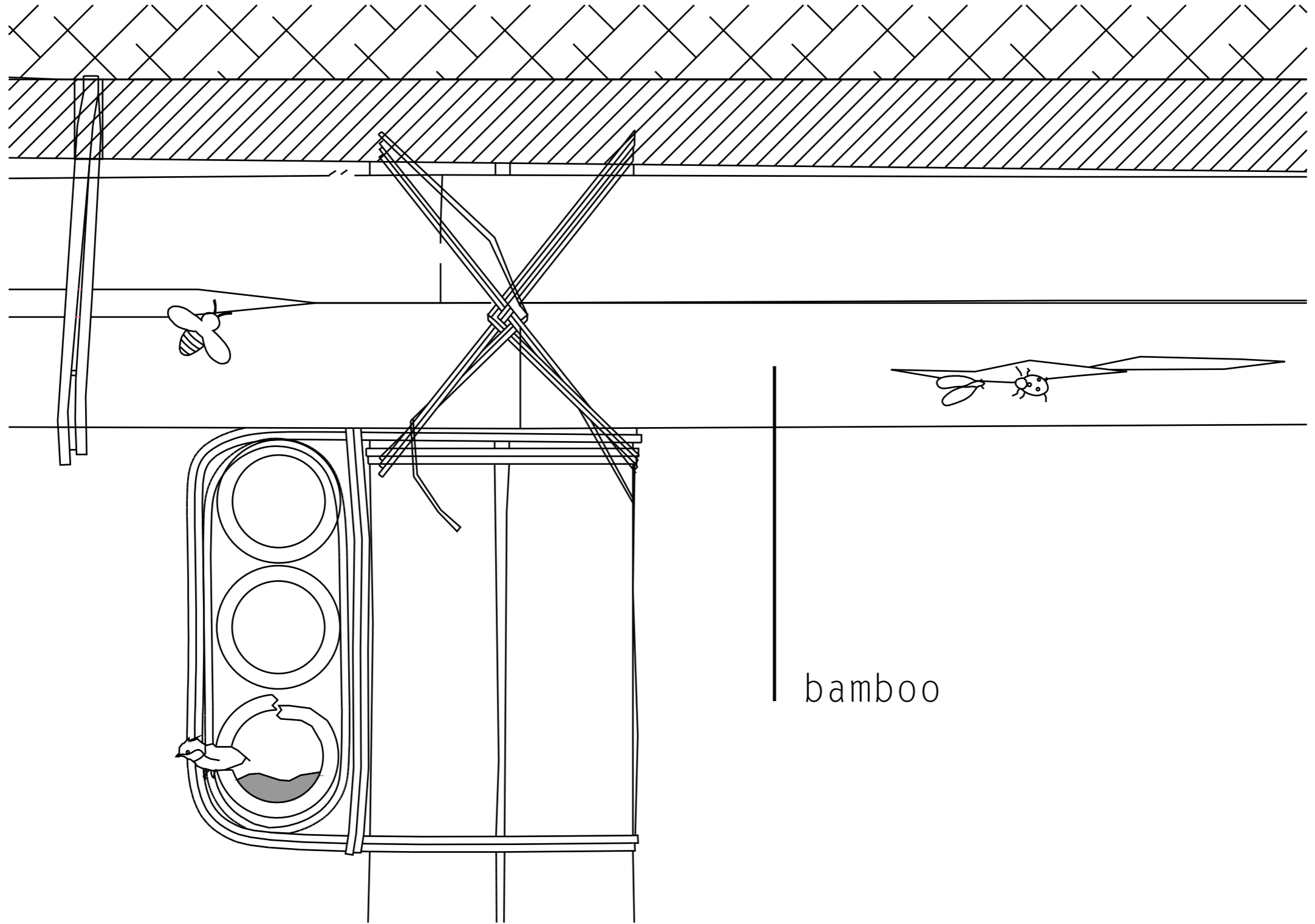

102 / 110

TRANSFORMATION - living areas

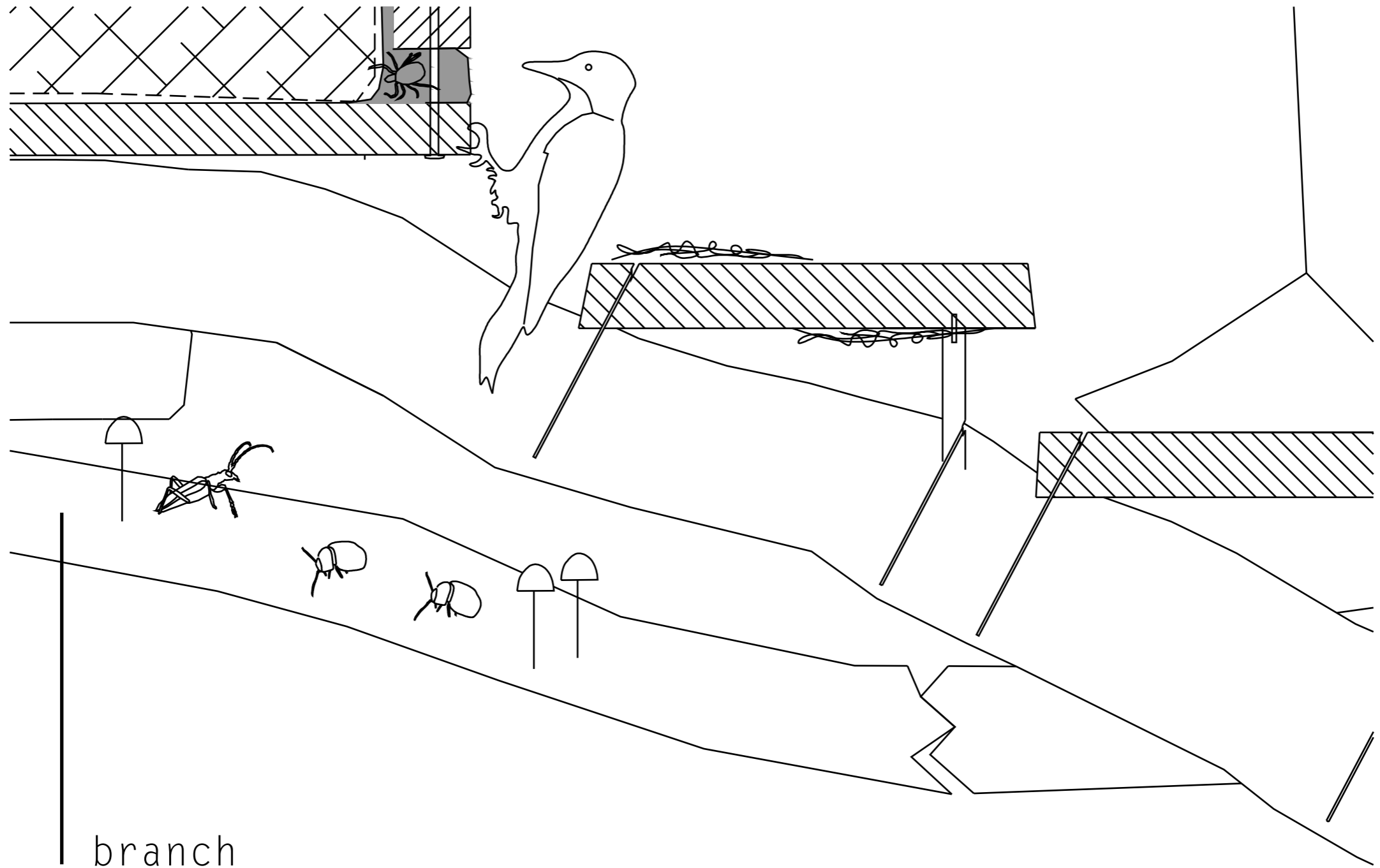

branch





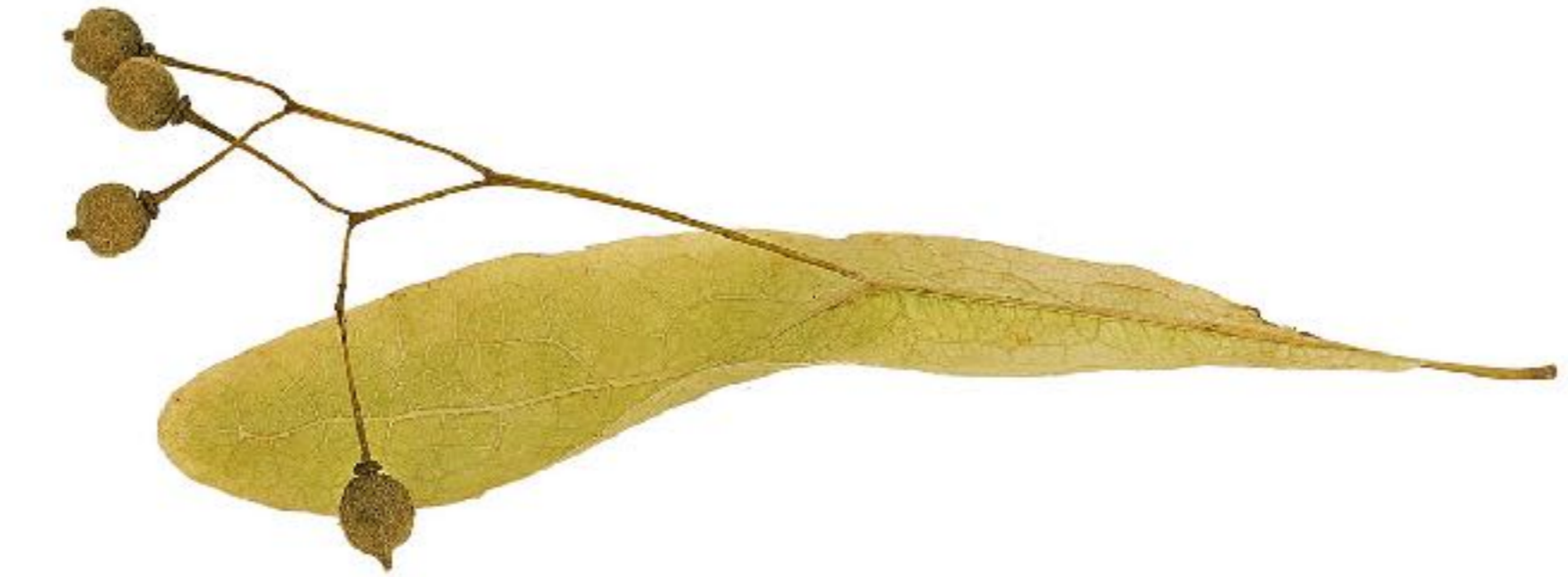

1 cm

106 / 110

TRANSFORMATION - reproduction



new volumes add organism
 + expanding ecostructure
 + connection between public and private outdoor spaces

ecostructure
 + surviving of organism
 + visual jungle in street
 + plant 10 long lived trees in area
 + less concrete/ less heat

collective district heating
 + small pipes

add water basins
 + fun for kids
 + attracts algae, frogs and other
 + plant 10 long lived trees in area





Bedankt

Ps: tot zo in de botanische tuinen?