

CT5306

# Capacities of Inland Waterways

Ports, waterways and inland navigation

May 1999

ir. R. Groenveld



CT 5306

## Capacities of Inland Waterways

ir. R. Groenveld

310252



# CONTENTS

<b>1. INTRODUCTION</b> .....	<b>2</b>
<b>2. EXPLANATION OF TERMS USED</b> .....	<b>4</b>
2.1. OPERATIONAL CAPACITY .....	4
2.2. INTENSITY .....	4
2.3. DENSITY .....	5
2.4. WATERWAY RESISTANCE .....	5
2.5. SHIP SPEED .....	8
<b>3. OPEN WATERWAYS</b> .....	<b>10</b>
3.1. INTRODUCTION .....	10
3.2. CALCULATING ON THE BASIS OF KNOWLEDGE AND EXPERIENCE .....	11
3.3. CALCULATION ON THE BASIS OF THE VIRTUAL AREA AROUND A SHIP .....	12
3.4. CALCULATION ON THE BASIS OF A SIMULATION .....	16
<b>4 CLOSED WATERWAYS</b> .....	<b>20</b>
4.1 INTRODUCTION .....	20
4.2 4.2 LOCKS .....	20
4.2.1 <i>Locking cycle</i> .....	22
4.2.2 <i>Lock capacity</i> .....	24
4.2.3 <i>Passage time individual ship</i> .....	24
4.2.4 <i>The operating time (<math>T_b</math>)</i> .....	26
4.2.5 <i>Entry and exit following times</i> .....	37
4.2.6 <i>The loop times</i> .....	48
4.2.7 <i>Maximum number of ships in the lock chamber</i> .....	49
4.2.8 <i>Calculation example for lock capacity</i> .....	53
4.2.9 <i>Traffic intensity patterns and the influence on capacity</i> .....	56
4.2.10 <i>Lock dimensions according to the CVB</i> .....	59
<b>5 VESSEL TRAFFIC SERVICE</b> .....	<b>64</b>
5.1 INTRODUCTION .....	64
5.2 HISTORY .....	65
5.3 RADAR SYSTEMS OVER THE YEARS .....	66
5.4 VESSEL TRAFFIC SERVICE AMSTERDAM-TIEL .....	67
5.5 REGISTRATION AND UTILISATION OF THE NETHERLANDS' INLAND WATERWAY NETWORK .....	70
<b>6 SAFETY</b> .....	<b>71</b>
6.1 INTRODUCTION .....	71
6.2 RISK ANALYSIS .....	73
6.3 PROBABILITY OF FAILURE IN PRACTICE .....	74
6.4 CODES .....	77
<b>REFERENCES</b> .....	<b>79</b>
<b>APPENDIX I: THE FUTURE OF THE RIVER MAAS</b> .....	<b>81</b>
<b>APPENDIX II: AN ARTICLE FROM 'DE VOLKSKRANT'</b> .....	<b>85</b>
<b>FROM: 'DE VOLKSKRANT', SATURDAY 21 NOVEMBER 1998</b> .....	<b>85</b>



## 1. Introduction

The lecture “Capacities of Inland Waterways” builds further on the lecture “Inland Waterways”, CTwa4330, and is in fact an upgrade of the lecture notes written by Ir. J. Bouwmeester in 1988.

As apparent from the title, attention will be focused on the capacity of inland waterways. A great deal of research has been performed in this area in the past. In the Netherlands that research was carried out mainly by the Directorate-General for Public Works and Water Management (RWS) and the regional departments of this directorate, with Delft Hydraulics also being frequently involved.

A considerable amount of attention has been given to the standardisation of inland waterways, both at a national and international level.

At international level, the CEMT<sup>1</sup> has accepted a classification system in which inland waterways are divided into 5 classes that correspond with 5 standard ships, a 6<sup>th</sup> class was subsequently added in 1961.

In the period 1958- 1969 the ECE<sup>2</sup> drew up a classification which also included the East European countries. As the inland waterways in Eastern and Western Europe differ considerably, this classification was never actually implemented.

In 1977 the CVB<sup>3</sup> commenced the adaptation of the design standards for Dutch waterways to the developments in the fleet of Dutch inland navigation vessels.

In the eighties it became clear that as a result of the increase in shipping traffic, the CEMT classification was beginning to become out-of-date.

Following a Dutch initiative, at the 1985 PIANC congress held in Brussels it was decided that a new classifications system be introduced; this was subsequently completed in 1992.

In 1996 the CVB published the complete rules and regulations with respect to the dimensions, design and organisation of inland waterways and structures [11].

Although little consideration was given to the capacity of inland water systems in this standardisation, at present increasingly more use is being made of probabilistic simulation models for dealing with inland waterway traffic.

The Civil Engineering Division of the RWS, for example, now have the SIVAK model at its disposal, whilst on several occasions in the past use was made of the Prodim model for the dimensioning of inland waterways.

---

<sup>1</sup> Conference Europeenne des Ministres des Transport

<sup>2</sup> Economic Committee of the United Nations for Europe

<sup>3</sup> Inland Waterway Management Committee

With an inland waterway load of greater than 15000 passages per year it can no longer be considered responsible to draw up cross-sections on the basis of empirical rules, therefore making it necessary to carry out supplementary research with the aid of traffic-flow simulation models and navigation simulation models.

Following a description of the terms used, this lecture will address the capacities of open inland waterway sections. Next the capacity of inland waterways restricted by locks will be discussed. This distinction has been made because locks are a determining factor for the capacity of closed inland waterways.

Further significant aspects in the determination of capacity and safety are the traffic regulation systems (chapter 5)

Finally, in chapter 6 consideration is given to registering inland waterway network utilisation in the Netherlands, and in chapter 7, trends and future expectations are discussed.

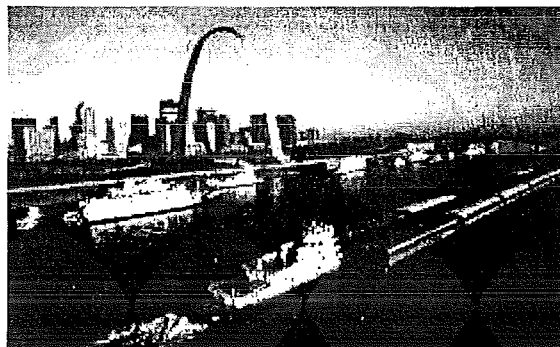
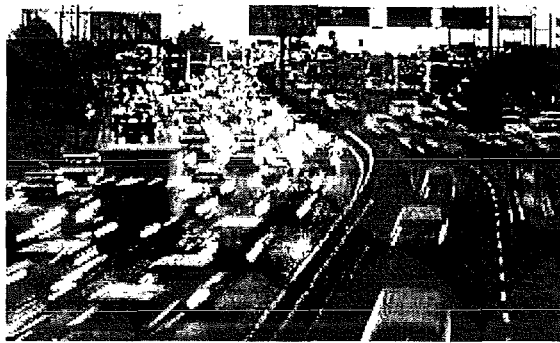

Figure 1-1: *a motorway and an inland waterway*

With an inland waterway load of greater than 15000 passages per year it can no longer be considered responsible to draw up cross-sections on the basis of empirical rules, therefore making it necessary to carry out supplementary research with the aid of traffic-flow simulation models and navigation simulation models.

Following a description of the terms used, this lecture will address the capacities of open inland waterway sections. Next the capacity of inland waterways restricted by locks will be discussed. This distinction has been made because locks are a determining factor for the capacity of closed inland waterways.

Further significant aspects in the determination of capacity and safety are the traffic regulation systems (chapter 5)

Finally, in chapter 6 consideration is given to registering inland waterway network utilisation in the Netherlands, and in chapter 7, trends and future expectations are discussed.



Figure 1-1: *a motorway and an inland waterway*



## 1. Introduction

The lecture "Capacities of Inland Waterways" builds further on the lecture "Inland Waterways", CTwa4330, and is in fact an upgrade of the lecture notes written by Ir. J. Bouwmeester in 1988.

As apparent from the title, attention will be focused on the capacity of inland waterways. A great deal of research has been performed in this area in the past. In the Netherlands that research was carried out mainly by the Directorate-General for Public Works and Water Management (RWS) and the regional departments of this directorate, with Delft Hydraulics also being frequently involved.

A considerable amount of attention has been given to the standardisation of inland waterways, both at a national and international level.

At international level, the CEMT<sup>1</sup> has accepted a classification system in which inland waterways are divided into 5 classes that correspond with 5 standard ships, a 6<sup>th</sup> class was subsequently added in 1961.

In the period 1958- 1969 the ECE<sup>2</sup> drew up a classification which also included the East European countries. As the inland waterways in Eastern and Western Europe differ considerably, this classification was never actually implemented.

In 1977 the CVB<sup>3</sup> commenced the adaptation of the design standards for Dutch waterways to the developments in the fleet of Dutch inland navigation vessels.

In the eighties it became clear that as a result of the increase in shipping traffic, the CEMT classification was beginning to become out-of-date.

Following a Dutch initiative, at the 1985 PIANC congress held in Brussels it was decided that a new classifications system be introduced; this was subsequently completed in 1992.

In 1996 the CVB published the complete rules and regulations with respect to the dimensions, design and organisation of inland waterways and structures [11].

Although little consideration was given to the capacity of inland water systems in this standardisation, at present increasingly more use is being made of probabilistic simulation models for dealing with inland waterway traffic.

The Civil Engineering Division of the RWS, for example, now have the SIVAK model at its disposal, whilst on several occasions in the past use was made of the Prodim model for the dimensioning of inland waterways.

---

<sup>1</sup> Conference Europeenne des Ministres des Transport

<sup>2</sup> Economic Committee of the United Nations for Europe

<sup>3</sup> Inland Waterway Management Committee

## 2. Explanation of terms used

### 2.1. Operational capacity

The “operational capacity” of an inland waterway is defined as the maximum number of ships that can pass through a specific cross-section of an inland waterway per time unit, taking account of safety and waiting times (service level).

Waiting times may for example occur at a lock or bridge, or may be imposed by a VTS<sup>4</sup>.

Considering the subjectivity of the term, safety, and the acceptable waiting time, the principal should first obtain some insight in this respect before operational capacity can be established unequivocally<sup>5</sup>.

In addition to the points of departure named, capacity is also dependent on the following limiting conditions:

- The infrastructure of the waterway. Not only the depth and width of the canal, but irregularities such as bends, constrictions and civil engineering structures also affect operational capacity.
- The fleet characteristics (dimensions, type, together with the volume pattern) are also of importance. For example, it is quite obvious that the irregularity of the volume pattern greatly influences waiting times.
- Lastly, the traffic rules and weather conditions also play a role.

### 2.2. Intensity

Intensity is defined as the number of ships or tonnes of dead-weight capacity that pass through a specific cross-section of an inland waterway per time unit (see figure 2-1a)

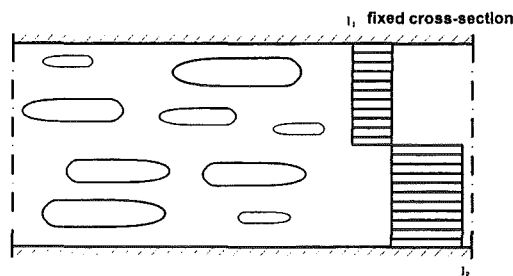

Figure 2-1a

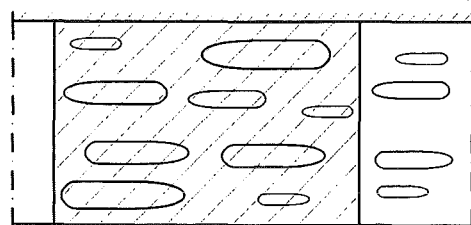

Figure 2-1b

Figure 2-1: *The intensity and density of an inland waterway*

<sup>4</sup> Vessel Traffic System

<sup>5</sup> on dubbelzinnig

### 2.3. Density

The density is the quantity of shipping traffic, expressed in numbers of ships, carrying capacity or otherwise, per unit of surface area or waterway length at a specific time (see figure 2-1b)

### 2.4. Waterway resistance

The resistance of an inland waterway is determined by the time required for a ship to pass a waterway section (traveling time + waiting time of the waterway). The total resistance of the inland waterway is equal to the sum of the sub-resistances of the various waterway sections, whereby the resistances can be considered to be connected in series (see fig. 2.2).

If the maximum acceptable waiting time is known, the “operational capacity” of the inland waterway can be determined.

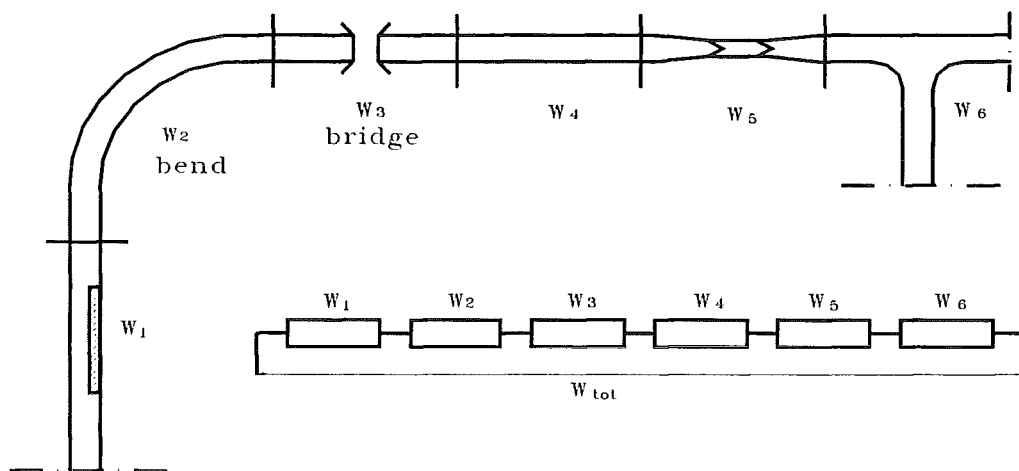

Figure 2-2: Resistances in a waterway

The resistance of an inland waterway can be subdivided into:

- a constant part ( $W_c$ ) and
- a variable part ( $W_v$ ), the waiting time at for instance bridges or locks.

The constant part, with no other traffic depends on:

- a ship speed if possible of  $V_s = 0.8 * V_{lm}$  to  $0.9 * V_{lm}$  ( $V_{lm}$ = limit speed vessel);
- shape and dimensions of the cross-section of the inland waterway;
- lay-out of the inland waterway with bends and other discontinuities;
- engine capacity of the ship under consideration and
- conditions such as wind, current, visibility etc.

The variable part of the resistance ( $W_v$ ) is the extra time loss that results from the interaction of the ship under consideration with any other shipping traffic. This  $W_v$  is determined by:

- Delays during overtaking and encountering manoeuvres with other ships, which are dependent on:
  - The number of shipping lanes
  - The speed differences and diversity of the various ships
  - The reaction and behaviour of the individual ship captains
- Temporary or total inability to overtake as a result of:
  - Excessive traffic density on the waterway
  - Safety traffic rules, e.g. overtaking prohibited.

In making a choice between routes A and B the ship's captain will obviously have to take the resistance of the different routes into account (see fig 2.3).

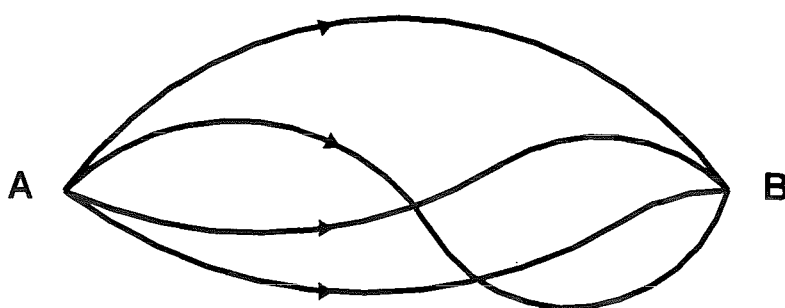

Figure 2-3: *Different routes*

**Example** (see figure2-4)

If ship 1 could continue travelling undisturbed at a speed of  $0.8 * V_{lm}$  then the resistance would be equal to  $W_c = L/(V_{lm}*0.8)$ . As ship 2 is travelling at a lower speed, ship 1 wishes to overtake this ship. This is however prevented due to the approaching ship 3. As a result ship 1 has to reduce speed (time  $t = t_1$ ) down to the speed of ship 2 until ship 3 has passed (time  $t = t_2$ ). Ship 1 can subsequently commence the overtaking manoeuvre. However, the speed at which that can now be achieved is lower than ship 1's original speed. That is caused by the increased resistance that ship is subjected to in the limited cross-section. Furthermore, in most cases ship 2 should reduce its speed, as otherwise the overtaking ship would not be able to get out of the 'water level-depression' created by ship 2.



## 2.5. Ship speed

As stated before in addition to the dimensions and shape of the inland waterway and the dimensions of the ship, the speed of ships on inland waterways also depends on the volume of traffic on the inland waterway and weather conditions. A traffic-load curve has been determined experimentally, whereby a general relationship was found between the average speed and the traffic load ( $I/C$ ), namely:

$$V_s = V_0 - a(I/C)^3 \quad (2.1)$$

Where  $I$  = traffic intensity and  $C$  = capacity (number ships/ time unit)

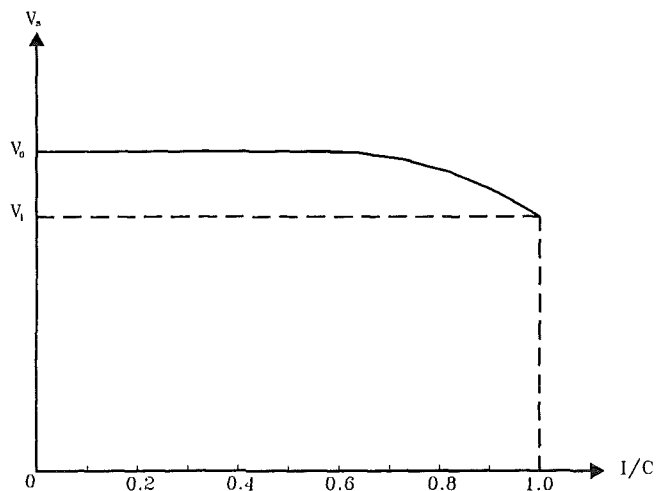

Figure 2-5: Navigation speed as a function of the traffic load

Two points of this curve are striking:

1. The maximum navigation speed on the unburdened inland waterway ( $V_0$ ), and
2. The speed that can be realised when reaching capacity ( $V_1$ ).

The latter speed is normally the speed of the slowest ship. Of course these speeds are also dependent on the limiting speed, the maximum speed that a ship can achieve (see also Ctw 4330).

In practice, it appears that the theoretical maximum speed, calculated with Schijf, is virtually never achieved. There are a number of reasons for this:

- The one-dimensional approach that is used in calculating the limiting speed does not apply on extremely wide waterways;
- In bends and in blind areas of the waterway, speed will be reduced in connection with safety;
- Ship's engines are sometimes too small to enable the ship to travel at the limiting speed;
- Waterway regulations prescribe a lower speed to prevent damage to banks and moored shipping;

- Due to economic considerations, navigating at the limiting speed is unattractive. This leads to ships travelling at an average speed of  $0.8 * V_{lm}$  (see figure 2.6).

In connection with its length the ship also has a maximum speed, which is in general higher than the limiting speed derived from the Schijf diagram (see Ctwa4330).

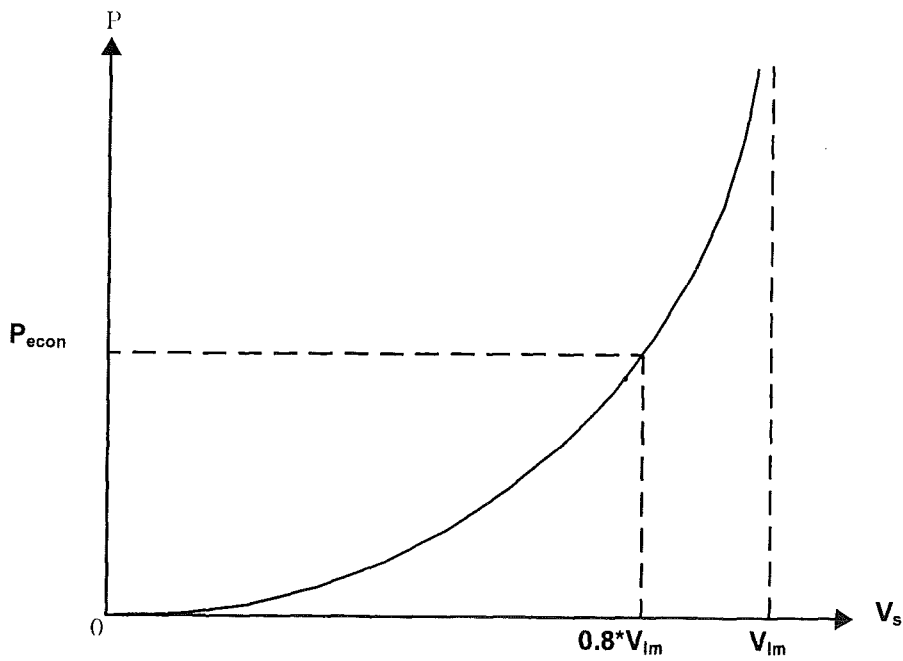

Figure 2-6: *Speed versus engine capacity*

### 3. Open waterways

#### 3.1. Introduction

It has already been stated that the capacity of an inland waterway is determined by the following factors:

- the resistance of the inland waterway (the longitudinal cross-section and the cross-section of the waterway),
- ship characteristics (speed and pattern of use) and
- external factors (traffic rules and weather conditions).

All these factors are also dependent on one another (see figure 3.1 for an explanation).

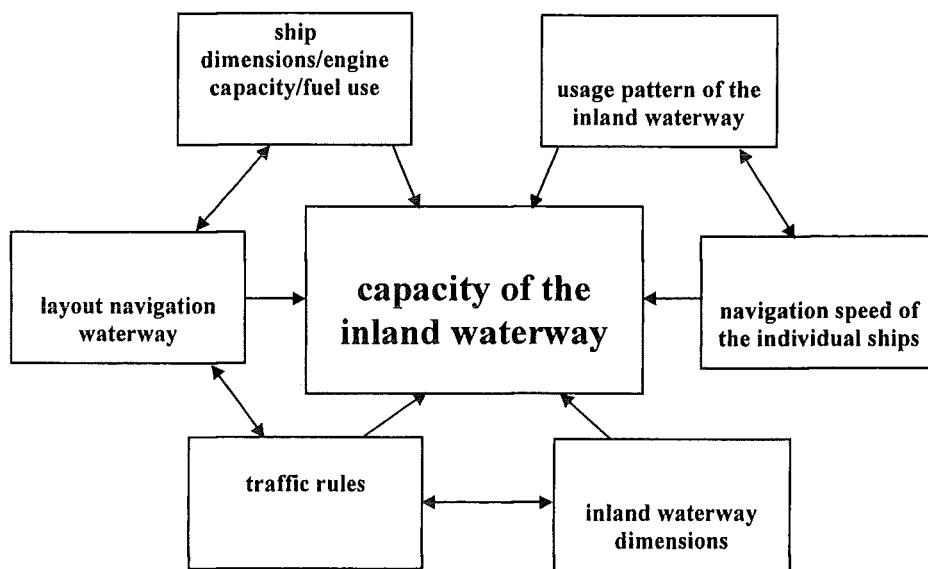

Figure 3-1: Factors that exert an influence on waterway capacity

The term capacity has already been discussed in chapter 2.

Three methods with which capacity can be determined are dealt with in these lecture notes.

#### *The first method (see par. 3.2)*

In the first and simplest method, used in the past, was based on experience. In this case a traffic situation was submitted to experts. They examined whether the situation described was possible and whether it was safe enough. The traffic intensity variation of the inland waterway did not come under discussion (see figure 3.2).



*The second method (see par. 3.3)*

In the second method, that has a somewhat more scientific approach, the virtual area around a ship is considered. No account is taken of the traffic intensity variation of the inland waterway with this method either. The inland waterway is 'built up' with blocks, representing area's occupied by the individual ships, moving at a specific speed. This schematization used as the basis for calculating the capacity of the waterway (see also figure 4.26).

*The third method (see par 3.4)*

In order to determine capacity nowadays, use is nearly always made of simulation models. In this probabilistic method, uncertain factors such as the number of ships making use of the waterway in the time (the usage pattern) is described using distribution functions. In fact, by using these computer simulation models, the manner in which the shipping traffic is dealt with in terms of the time is simulated.

**3.2. Calculating on the basis of knowledge and experience**

In the 1970s, this method was used in the preparation of the "Vaarwegennota", in which a policy for the future of the waterway network in the Netherlands had to be drawn up.

A survey was used to establish capacity. This survey was carried out by 'practical' experts, such as waterway managers, river masters, captains and other concerned parties.

A number of ships with a variety of speeds and dimensions were hypothesised over a specific length L of the inland waterway. A number of similar situations in the form of drawings were then submitted to the participants. The respondents were then requested to assess the situation for safety from a nautical point of view. In addition, the traffic load could also be increased or decreased at the discretion of the respondent.

A submitted situation was considered acceptable in a nautical sense in the event that a significant majority had assessed it accordingly.

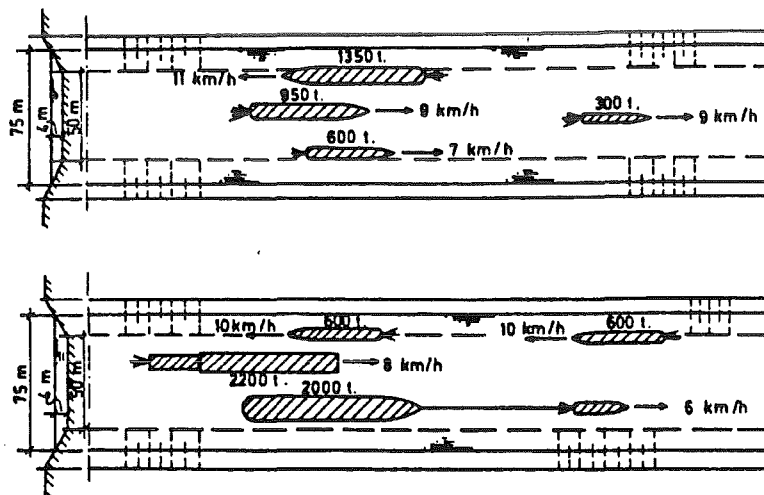

Figure 3-2: *Examples of traffic situations for assessment*

### 3.3. *Calculation on the basis of the virtual area around a ship*

The virtual area is defined as the area around a moving ship into which other ships will not enter for safety reasons.

In order to be able to determine this virtual area, a statement will have to be made regarding the mutual lengthwise and widthwise distances that individual ships have to maintain from one another.

#### *Lengthwise distance or lacunal distance*<sup>6</sup>

The lacunal distance is distance between the stern of the ship travelling in front and the bow of the ship travelling behind. In 1975, the RWS performed a study into this distance at Ewijk on the River Waal. By narrowing the river a forced river traffic obstruction was created, resulting in slow-moving, heavy traffic and delays. The normal width of 260 metres was reduced to 130 metres by means of derelict boats<sup>7</sup> and supplementary buoyage<sup>8</sup>. Furthermore, overtaking was prohibited and enforced by a patrol boat. For each boat passing, the time of passage, the level of loading and other details were noted in two cross sections. In addition, a photograph was taken every thirty seconds, 1500 in total. With those 1500 photographs several conclusions could be drawn:

- There appeared to be no connection between the lacunal distance and the navigation speed of the ships concerned.
- Unloaded ships displayed a marginally smaller lacunal distance comparison with loaded ships.
- The lacunal distance on a straight inland waterway appeared to be greater between ships travelling downstream ( $S_e = 1.45 L$ ) than those travelling upstream ( $S_e = 1.05 L$ ). This was related to the fact that ships travelling downstream are more difficult to steer at low navigation speeds, such as when suddenly being forced to stop as a result of a calamity.
- The influence of a bend was only noticeable when travelling upstream. In that case the ships maintained a greater lacunal distance. ( $S_e = 1.25 L$ ).

---

<sup>6</sup> hiaatafstand

<sup>7</sup> wrakboten

<sup>8</sup> aanvullende betonning

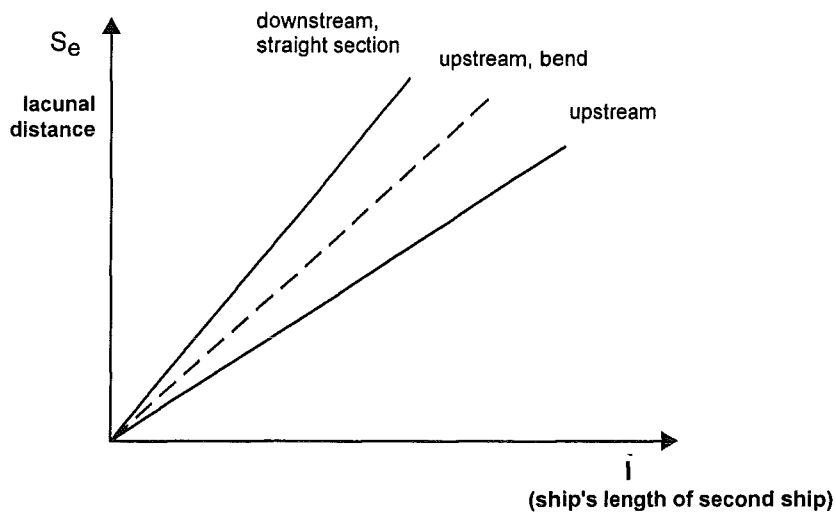

Figure 3-3: Relationship between lacunal distance and the length of the ship travelling behind

The following distance of the ships appeared to vary in time as a subdued<sup>9</sup> sinus wave in the narrowed river. Ships that noticed that the ships in front were travelling slowly only appeared to react once they reached the minimum following distance ( $S_{min}$  in figure 3.4). The ship captains subsequently attempted to adjust their speed to that of the ship travelling ahead, which in the first instance was often achieved by a drastic reduction in speed. The ship captain then allowed his speed to increase once more, resulting in a sinus shaped swing around the equilibrium value ( $S_e$ ).

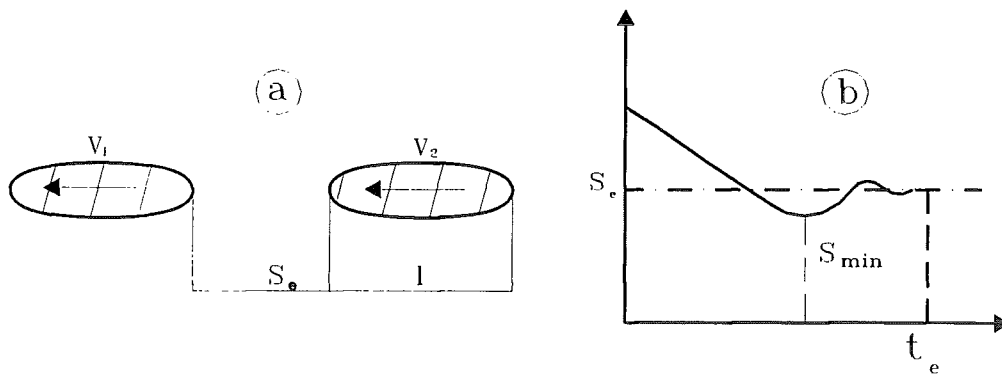

Figure 3-4: sinus-shaped following distance

<sup>9</sup> gedempte

### *Measuring the virtual area*

This method is chiefly applied on wide waterways in coastal areas and at sea. The virtual area of a given ship is determined with the aid of a large number of photographs taken of a radar screen on which that ship is continually visible (see figure 3.5).

A virtual area forms around the ship in question, that other ships will not risk entering due to safety considerations. In this manner, a virtual space can be created for every type of ship. Here too, this virtual area is related to the traffic intensity at the time of the measurement. With increasing activity on the inland waterway, people will have a tendency to take more risks, which will result in the reduction of the virtual area.

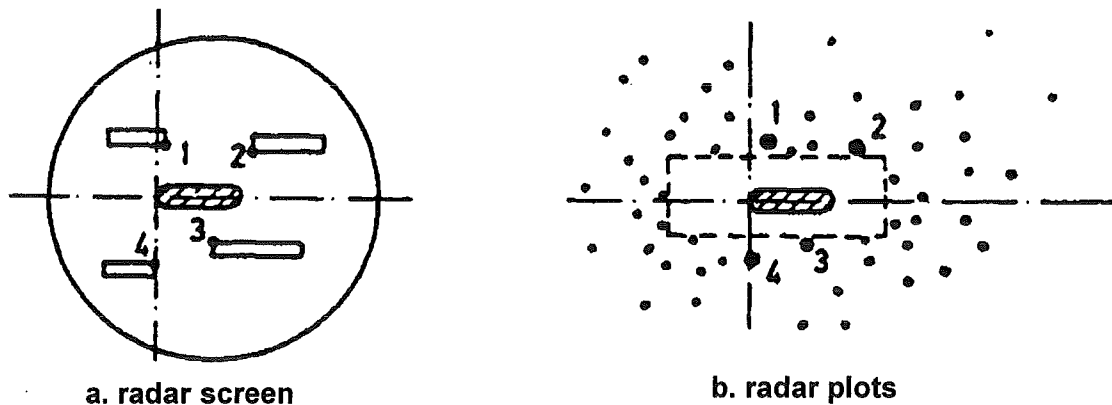

Figure 3-5: *virtual area of space around a ship*

The RWS has also used this method to establish the interaction between the recreational and the commercial shipping sector. According to regulations, pleasure craft (< 20 metre) are obliged to give way to larger vessels. This means that speed must be reduced and/or the course has to be changed. A study into this interaction resulted into the following conclusions being drawn:

- Commercial traffic does not give way to pleasure craft;
- The navigation speed of the commercial traffic remains constant;
- The area of influence around commercial vessels is dependent on the size of the ship;
- The area of influence is the same for laden and unladen ships;
- The area of influence is significantly greater on spacious waters than on relatively small canals.

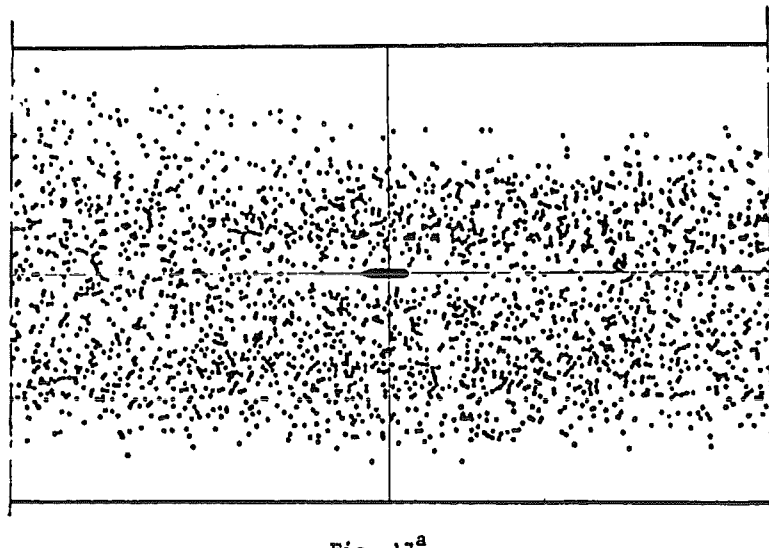

Fig. 17<sup>a</sup>

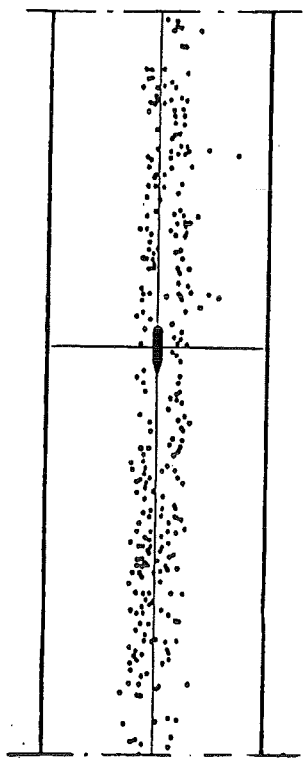

Fig. 17<sup>b</sup>

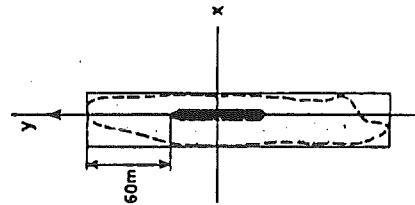

Fig. 17<sup>c</sup>

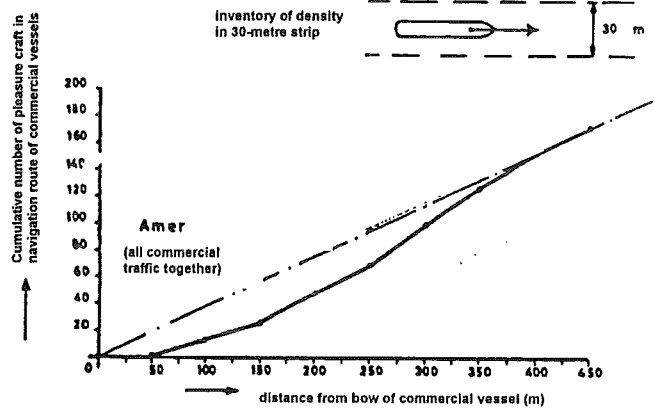

Fig. 17<sup>d</sup>

Figure 3-6 Disruption of pleasure traffic due to passage of a commercial vessel

From the results above, a virtual area of space ( $L_v$  and  $B_v$ ) has been established for every category of ship. For the sake of simplicity it has also been assumed that the virtual areas are rectangular in shape.

If it is now assumed that the virtual areas of two or more ships never overlap one another for a single moment (see figure 3.7) and that the average speed is  $v$ , then the capacity of a section of waterway can be established.

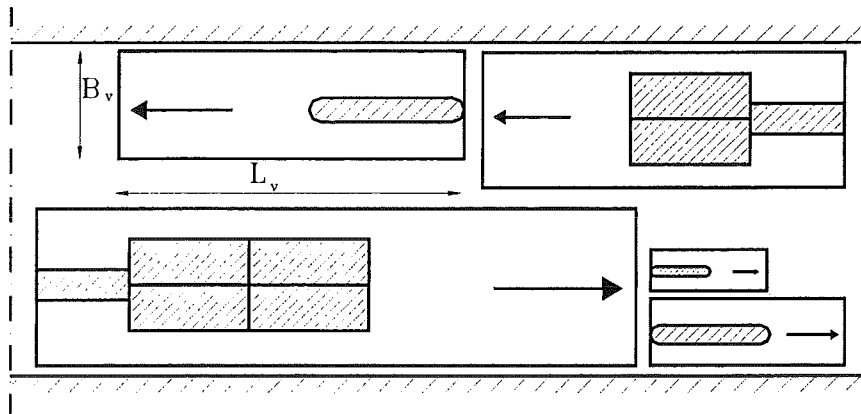

Figure 3-7: *Virtual areas*

### 3.4. Calculation on the basis of a simulation

As stated in the introduction, in order to assess proposed designs for capacity and safety requirements, simulation models are used for high traffic intensities of more than 15000 passages per year,

When using simulation models it is possible to include parameters that are subject to random functions (stochastic variables). In this manner, it is possible to simulate the dynamic behaviour of the ship traffic for a specific canal.

An important stochastic variable is for example the arrival pattern of ships that want to make use of a part of an inland waterway. In a simulation model, these variables are usually entered with the aid of distribution functions, e.g. to simulate ship arrivals use is often made of the distribution functions of intermediate<sup>10</sup> arrival times. It is, however, also possible to enter the ship type and dimensions into the model in this manner.

Other important stochastic entry parameters are:

- a. navigation speeds;
- b. weather conditions.

<sup>10</sup> tussenliggende

Very often the process description method is used.

The process description method specifies the dynamic behaviour of the system by describing the activities of the “live components” in the model. ‘Live’ means that these components are executing activities. The dynamic section of a model will contain a process description for each “live component” and will formulate the interactions between the components (see lecture notes on Service Systems in Ports and Inland Waterways) etc.

For instance, a model of an inland waterway could comprise generators of the different ship types (creating vessel arrivals), a process description of a ship, traffic control (handling the ship traffic with traffic rules).

The components are specified by the attributes of the components. For example, the attributes of a ship are type, length, width, draught, cargo etc. An overview of typical model components is given in the table below.

Table 3-1: *Model components*

Component	Description	Section
<b>Define</b>	defines: Components with attributes, queues, tables, random streams, time unit, input files, output files	Definition
<b>Main</b>	Creates the system by reading the initial values of attributes from input files	Initial
<b>Generator of ships</b>	generates ships, according to distribution functions, and assesses the values of the relevant attributes of these ships	Dynamic
<b>Traffic Control</b>	Manages the ship traffic in the canal by applying the traffic rules related to canal sections, bridges, locks and other obstacles	Dynamic
<b>Ship (class of Components)</b>	carries out the process of the class component ship	Dynamic

The flow chart of the process of the component ship in the model of canal Gent-Terneuzen is given as an example. Three main obstacles hinder the ship traffic between Terneuzen and Gent: the Sluiskil, Sas van Gent and Zelzate bridges. The flow chart shows the interaction between the ship and the component “Traffic Control” for permission to pass a bridge and to enter a new canal section.

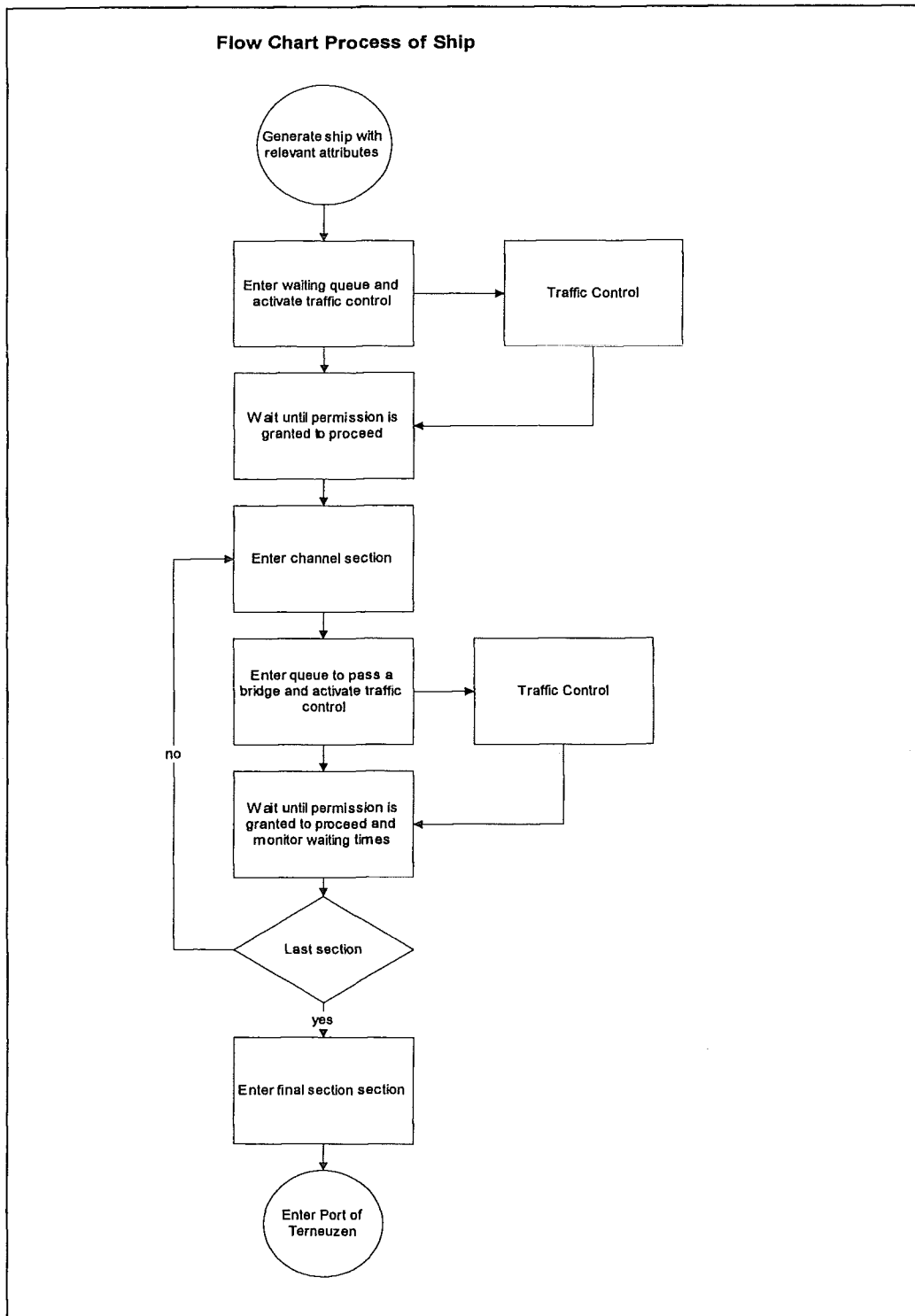

*Figure 3-8: Flow Chart Process of Ship*



*The output should characterise the performance of a system.*

As the input data show random variability, the output of simulation runs will also demonstrate random variability. This means that a statistical analysis should be applied.

Important results include distribution of waiting times, ship turnaround times in relation to the canal dimensions. A financial evaluation can be carried out on the basis of this information.

For alternative canal dimensions and layouts, traffic flow simulation reveals:

- the maximum canal capacity using acceptable waiting times and turnaround times as criteria (operational capacity)
- the impact of operational traffic rule changes resulting from safety demands

The results of real time manoeuvring simulation models are often used to formulate the traffic rules.

*Evaluation of simulation results.*

Evaluation is dependent on the final objectives

If the objective is pure economic efficiency, then the results indicate how to minimise the cost or maximise the benefits.

Within the framework of canal design, this means that it is necessary to weigh the costs of the canal dimensions and related structures (bridges, locks etc) against the costs of waiting times.

If, however, the objective is reliability and security, then the risk of failure should be minimised. This may result in the formulation of traffic rules.

For the optimisation of the design of a canal, a balanced deliberation of both criteria should be carried out.

## 4 Closed waterways

### 4.1 Introduction

In chapter 3 it was stated that if structural works such as bridges and locks are present on a section of inland waterway, then they will be significant factors in determining capacity, generally speaking. The determination of that capacity will be discussed in this chapter.

In its guidelines the “Commissie Vaarweg Beheerders (CVB)”, in The Netherlands prescribe regulations for headroom, width of passage, underwater profile and above surface profile.

For the calculation of the resistance and capacity of moveable bridges, is referred to the calculation methods applied for a lock. A bridge passage, whereby the bridge has to be opened, can be simply derived from a lock passage in which the operating time, consisting of the opening and closing of the lock gates and the chamber turnaround, is reduced to the opening of the bridge, whereby entry is coupled directly to exiting, without the ship having to come to a standstill in the chamber.

### 4.2 Locks

Locks are structural works that separate waterways. The two waterways may have differences in water levels or in water quality (saltwater/freshwater). Related to this and ship traffic directions is whether a lock has to operate in its separate function in one or two directions, which is in turn important to the type of lock doors used (mitre gates<sup>11</sup>, vertical lift gates<sup>12</sup> or sliding gates<sup>13</sup>). A lock may consist of a single locking chamber (1), one lock chamber with an intermediate head, through which in principle three different chamber surfaces can be used for the locking process (2), or a lock complex consisting of two or more adjacent<sup>14</sup> chambers (3), with or without the same dimensions.

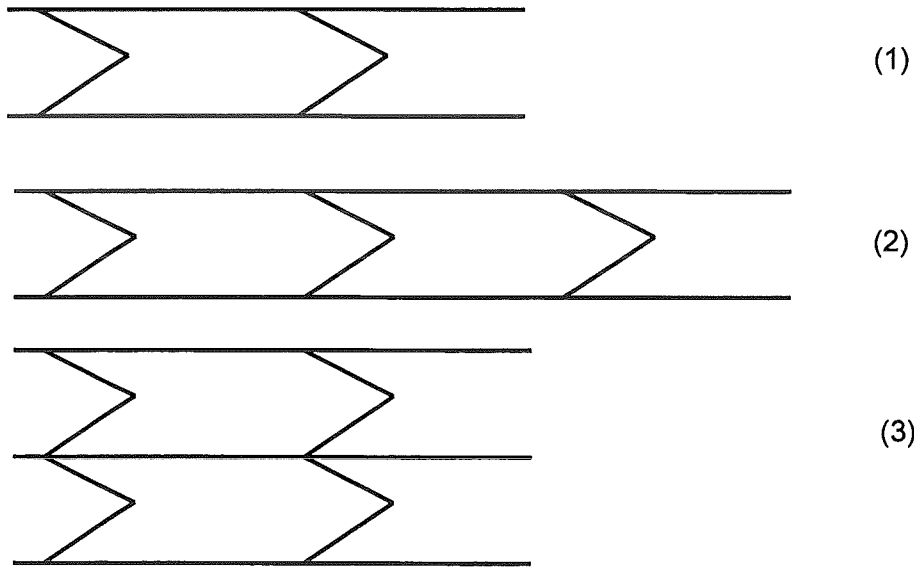

<sup>11</sup> puntdeuren  
<sup>12</sup> hefdeuren  
<sup>13</sup> roldeuren  
<sup>14</sup> aangrenzende

When approaching the lock one of three possible situations will apply:

1. The lock gates are open enabling the ship to travel directly into the lock chamber;
2. The lock gates are (still) closed and the ship will have to moor up behind the ships already present to await the next lock operation;
3. The volume of traffic is so great that the ship will have to wait in the waiting area (moored for at least one lock operation (cycle time) before being able to enter the lock.

In establishing the capacity of the lock it is assumed that there are sufficient ships present each time to fill the chamber completely. However, it is clear that the waiting times created in this way will be unacceptable to the shipping traffic. In such cases, the operational capacity of the lock should be used in calculating the capacity of the inland waterway.

The operational capacity is the capacity whereby the waiting times are just about acceptable to the shipping traffic.

The locking process can be viewed in two ways, i.e. through the eyes of the waterway user and through the eyes of the lockkeeper.

In the eyes of a waterway user, a lock is an obstacle on the inland waterway that has to be negotiated.

Passing through a lock can then be seen as a waiting time problem with the following components:

- Waiting areas;
- The service point, that for a lock is translated into lock chambers.

The lockkeeper, however, sees a repeating entity (the locking cycle). In the following paragraphs the locking cycle and the resultant capacity are discussed, followed by the passage time of the ship and, finally, the various components of the locking process will be explained further.

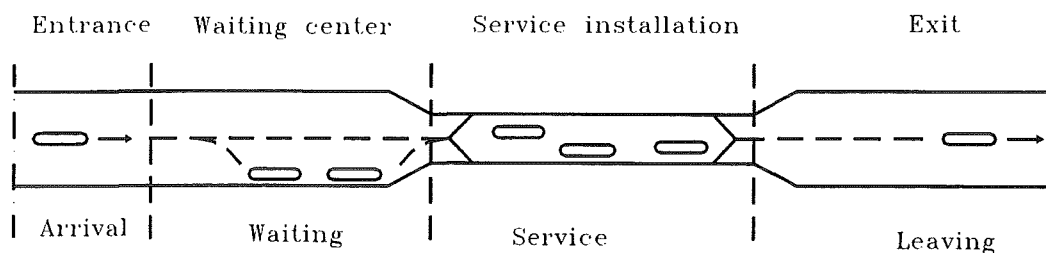

Figure 4-1: *Waiting time system at a lock*

### 4.2.1 Locking cycle

The first distinction within the locking cycle concerns one or two-way traffic. In case of two way traffic, the cycle time  $T_c$  (the time to complete a locking cycle), can be presented in formula form:

$$T_c = T_{d(\text{upstream})} + T_{d(\text{downstream})} \quad (4. 1)$$

The locking duration in upstream direction and the locking duration in downstream direction can both be subdivided into the total entry time ( $T_i$ ), the operating time ( $T_b$ ) and the total leaving time ( $T_u$ ). In formula form:

$$T_d = T_i + T_b + T_u \quad (4. 2)$$

or:

$$T_c = (T_i + T_b + T_u)_{\text{upstream}} + (T_i + T_b + T_u)_{\text{downstream}} \quad (4. 3)$$

On further examination, it can be seen that the *arrival time* consists of two parts: the loop time  $t_l$  and the sum of the entry following times ( $\sum t_i$ ). The loop time connects the upstream lockage with the downstream lockage or vice versa. The loop time is defined as the time that elapses between the moment that the last ship leaves the lock and the moment at which the first ship enters the lock. In this case the moment of lock entry is defined as the moment that the stern of the ship passes the dock sill<sup>15</sup>, and the moment of leaving the lock as the moment that the stern of the ship once again passes the dock sill, but in the other direction.

The summation of the entry following times should therefore be taken over (n-1) ships where n is the total number of ships entering the lock. The first ship and the time taken to get the ships moving is included in the loop time.

The *operating time* can also be subdivided into various parts. The operating time commences when the last ship entering is located within the lock. The operating time is equal to the time required to close the doors ( $T_{\text{doors, closed}}$ ), the time required to fill or empty the chamber ( $T_{\text{chamber}}$ ), and the time required to open the doors ( $T_{\text{doors, open}}$ ). From observations it appears that the leaving time of the first ship does not differ greatly from the following leaving time ( $t_u$ ), applicable to the other ships. The leaving time is therefore calculated as the summation of all ship leaving times (n).

To summarise, the following now applies for the total cycle time:

$$T_c = (t_l + \sum t_i + T_{\text{gates, closed}} + T_{\text{chamber}} + T_{\text{gates, openen}} + \sum t_u)_{\text{upstream}} + (t_l + \sum t_i + T_{\text{gates, closed}} + T_{\text{chamber}} + T_{\text{gates, open}} + \sum t_u)_{\text{downstream}} \quad (4. 4)$$

In paragraph 3.3 the numeric values that apply to the components above will be examined further.

---

<sup>15</sup> sluisdrempeel

If a lock only operates in one direction, a slightly different formula will be applicable, since in one in every two operations an empty chamber is locked. This time is practically the same as the operating time for a full chamber. The loop time will be slightly shorter, as it is not necessary to wait for ships to leave. The following therefore applies to the cycle time in a lock operating in only one direction:

$$T_c = t_l^1 + \sum_{i=2}^m t_i + \sum_{u=1}^m t_u + 2T_b \quad (4.5)$$

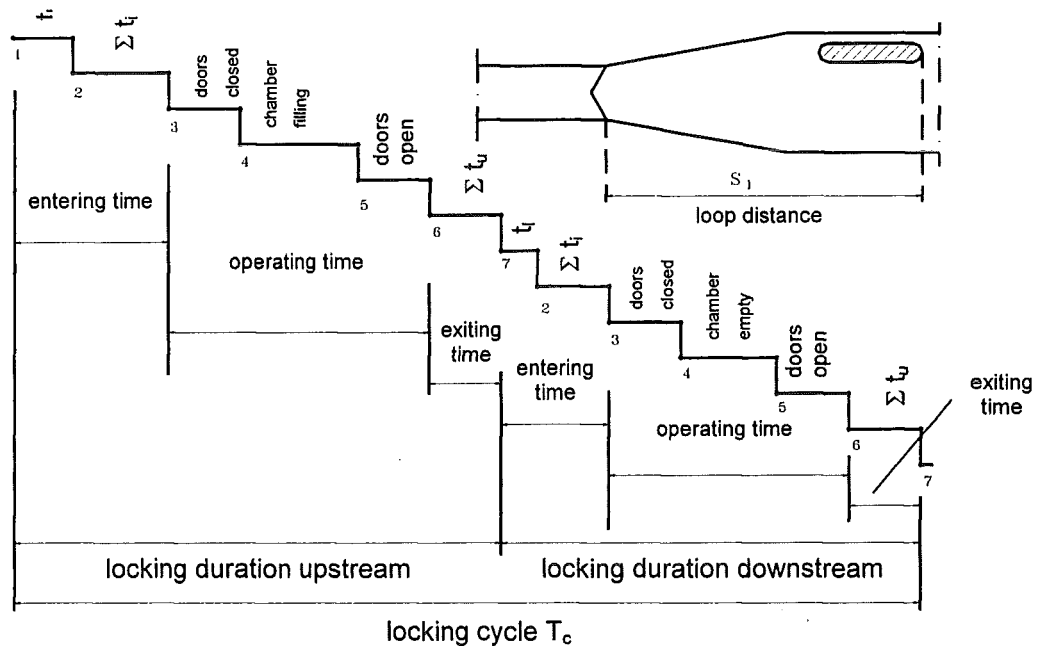

Figure 4-2: *Components of the locking cycle*

In figure 4.2, seven points in time can be distinguished in the locking cycle, whereby the stern of the ship is continuously followed in the time:

1. The stern of the last ship from the previous locking operation passes dock sill;
2. The stern of the first ship in the locking operation under consideration passes the dock sill on the entry side;
3. The stern of the last ship in the locking operation under consideration passes the dock sill on the entry side, after which the doors can be closed;
4. The gates on the entry side are closed and the locking operation can commence;
5. The locking operation is (virtually) complete and the gates on the exit side can be opened;
6. The gates on the exit side are opened, the stern of the first ship leaving passes the exit dock sill;
7. The stern of the last ship leaving passes the dock sill (this point in time is simultaneous with the point in time 1 of the following lock operation).

As apparent from the figure, the loop time is determined by points in time 1 and 2. These are highly dependent on the so-called 'loop distance' (see par. 4.2.6)

### 4.2.2 Lock capacity

If a lock chamber is constantly filled to capacity over a longer period then the lock capacity can be determined as an average of that amount. The capacity of a lock can then be defined as follows:

*The capacity of a lock is the maximum quantity of traffic, expressed in numbers of ships, dead-weight capacity or otherwise, that can be locked through under the prevalent conditions<sup>16</sup> per time unit if the lock operators work continuously.*

In general the capacity of a lock is expressed in the number of ships per hour ( $C_s$ ) or the tonnes of carrying capacity per hour ( $C_T$ ). In the case of two-way traffic the following comparisons apply

$$C_s = (2 * n_{\max} / T_c) \quad [\text{ships/time unit}] \quad (4. 6)$$

$$C_T = C_s * T \quad [\text{tonnes carrying capacity/hour}] \quad (4. 7)$$

In this case  $n_{\max}$  is the average over a large number of maximum capacity locking operations and  $T_c$  is the corresponding average cycle time.  $\frac{Q_s}{T}$  is the average carrying capacity of the ships.

As stated earlier, this capacity will be accompanied by unacceptable waiting times, especially when the arrival pattern is irregular.

### 4.2.3 Passage time individual ship

In addition to be being viewed through the eyes of the lockkeeper, whereby the locking process is conceived as a cyclic process, the lock can also be viewed through the eyes of the ship captain. He only sees the lock as obstacle, a resistance that has to be overcome. From his standpoint, the so-called passage time can be defined as follows:

*The passage time of an individual ship ( $t_p$ ) is equal to the total extra time that a locking operation requires, in comparison to an imaginary situation without a lock, in which the ship can continue travelling at its cruising speed.*

The total passage time can be divided into various components:

$$t_p = t_w + t_s \quad (4. 8)$$

In which  $t_w$  is the waiting time and  $t_s$  the locking time. The waiting time  $t_w$  may contain several lock cycle times when the ship arriving at the lock can not be included in the next locking operation because the chamber is continually being filled to capacity:

$$t_w = k * T_c + t_w \quad (k = 0, 1, 2, \dots) \quad (4. 9)$$

where  $t_w$  = remaining waiting time prior to entering.

---

<sup>16</sup> voorkomende omstandigheden

In the figure below, the time-progress diagram is illustrated for a ship in a lock into which only one ship fits and for which the waiting time is equal to zero.

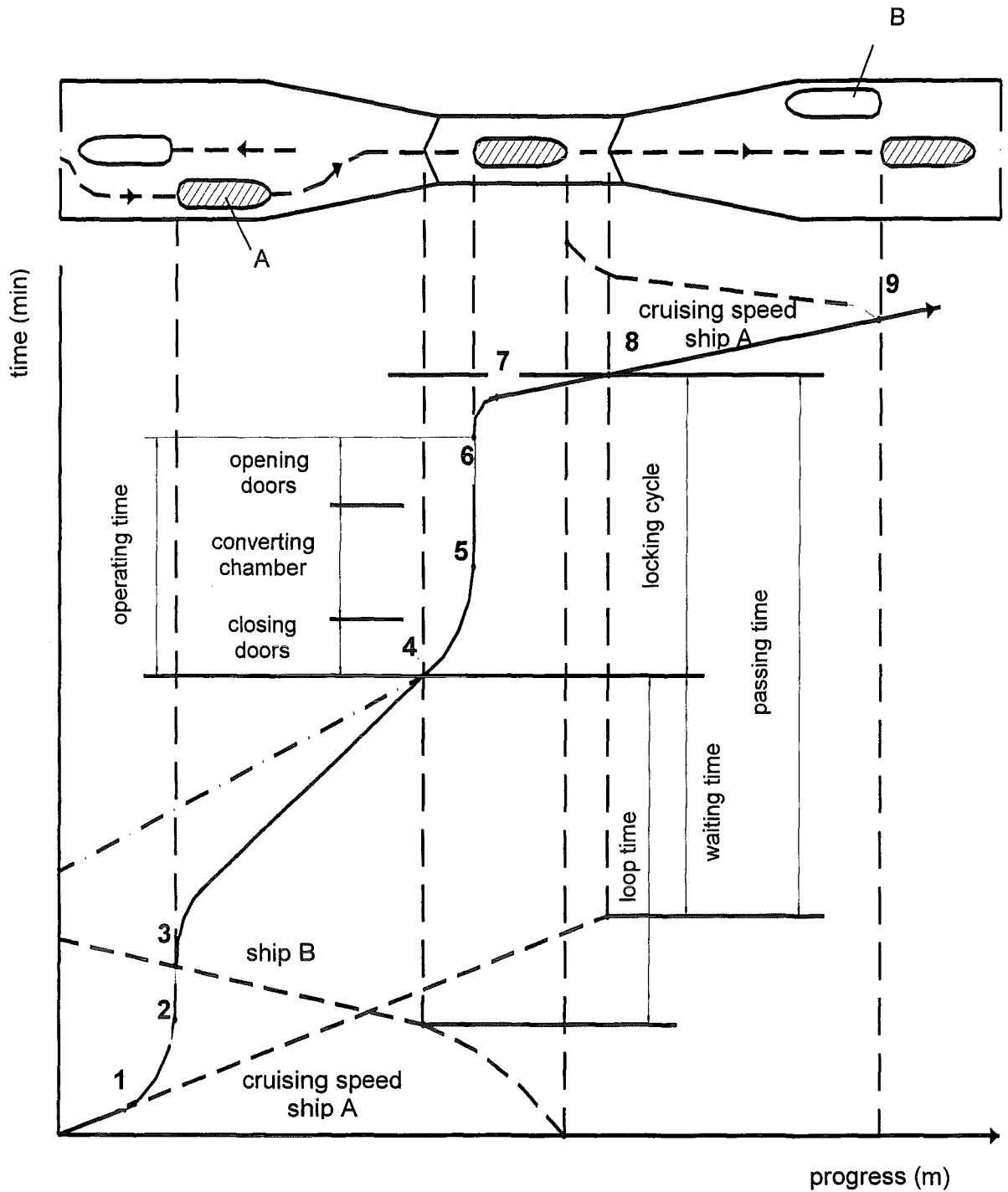

Figure 4-3: time-progress diagram

The following steps can be distinguished in the diagram:

- (0-1) ship A approaches the lock at cruising speed
- (1-2) ship A reduces speed and stops at the waiting area (A1)
- (2-3) ship A remains in the waiting area
- (3) ship B passes ship A, ship A can now proceed
- (3-4-5) ship A leaves the waiting area, proceeds into the lock
- (4) the stern of ship A passes the entrance dock sill
- (4-5-6) operating time ( $T_b$ ), position ship (A2)
- (6-7) ship A increases speed until cruising speed is reached
- (7-8-9) ship A leaves the lock (at cruising speed)
- (8) the stern of ship A passes the exit dock sill
- (9) ship A passes ship C (A3), so that ship C can proceed

The passage time resulting from this is the time between point of time 1, at which ship A arrives at the lock and point of time 8, at which ship A leaves the lock.

The extra time required due to the presence of the lock is therefore the passage time minus the time taken to travel this course if the ship had been able to continue travelling at cruising speed. (see figure 4.3).

#### 4.2.4 The operating time ( $T_b$ )

The following components can be distinguished in the locking process: *the loop times, the entry following times, the operating time and the exit following times.*

As has already been stated earlier, the operating time consists of three parts:

- closing the entrance gates
- filling or emptying the chamber
- opening the exit gates

##### *Opening and closing the gates*

The time required for opening the gates is dependent on the type of gate. Several examples of the times observed for three types of electrically-operated gates are given in the table below. From the table it can be seen that the operating times for the vertical gate are the longest; furthermore the passage height is also limited with this type of gate.

Table 4.1: lock gate operating times

Gate type	Chamber width (m)	Closing gate (min.)	Opening gate (min.)	Total (min.)
Sliding gate	12	1.2	0.7	1.9
Vertical lift gate	14 to 18	3 to 3.3	2 to 2.3	5 to 5.6
Mitre gate	16 to 24	1.3 to 2.5	1.2 to 1.6	2.5 to 4.1

The gates can be opened when the water level difference on both sides of the gate has practically been reduced to zero. The gates are also sometimes opened when a so-called remaining head drop is still present. Among other things this is dependent on



the sealing system used between the gate and the lock (friction) and the operating mechanism (opening against the head drop). This is often possible for a vertical gate with a pillar mechanism.

#### *Filling or emptying the chambers*

The emptying or filling of the chamber can be effected in three ways:

1. By opening sluices in the gates (possible in all three variants);
2. By opening the valves in bypass<sup>17</sup> or longitudinal drains<sup>18</sup> that discharge through one or more openings in the chamber walls or chamber floor;
3. By lifting or tilting the gate (for example, of a vertical lift or pivot gate) slightly allowing water to pass by the gate.

When filling the chamber there is a considerable dissipation of energy as the water in the chamber is held back. This can cause a great nuisance to the ships in the chamber, especially if the chamber is filled rapidly; in that case the hawser forces<sup>19</sup> in particular become extremely great.

When emptying the chamber, the reverse applies: the water in the chamber is accelerated, but this is less of a nuisance to ships in the chamber. Immediately outside the chamber the water is once again slowed down. At this point an apron<sup>20</sup> is often applied to prevent river bed erosion.

The transitory wave caused by filling or emptying the chamber sometimes causes a nuisance to shipping traffic.

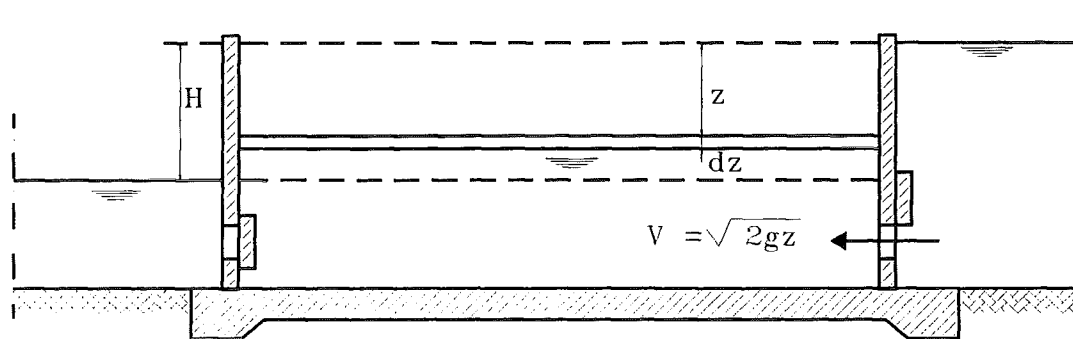

Figure 4-4: *chamber filling by means of sluices in the gates*

---

<sup>17</sup> omloop  
<sup>18</sup> langsriolen  
<sup>19</sup> troskrachten  
<sup>20</sup> stortebed

*Determining the filling and emptying time (turnaround time) in slowly changing chamber water levels*

If the sluice is opened suddenly (with sluice surface area  $A_s \text{ m}^2$ ), the quantity of water entering per time unit will be  $m \cdot A_s \cdot \sqrt{2 \cdot g \cdot z}$ . See figure 4.5 for explanation. The discharge coefficient  $m$  will then be determined by the shape and curvature of the discharge opening and will vary between 0.6 and 0.9. For a chamber area of  $O_k \text{ m}^2$  the following continuity equation is applicable:

$$m \cdot A_s \cdot \sqrt{2gz} \cdot dt + O_k \cdot dz = 0 \quad (4.10)$$

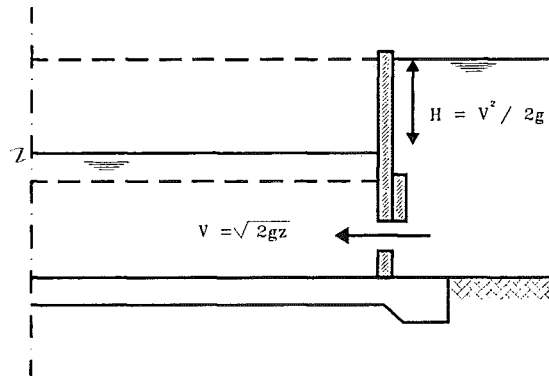

Figure 4-5: *Speed of the water entering the lock*

By integrating the equation (4.10) with an initial value of  $z = H$  for  $t = 0$ , the development of the water level in the chamber can be found with the time:

$$t = \frac{2 \cdot O_k}{m \cdot A_s \cdot \sqrt{2g}} \cdot (H^{1/2} - z^{1/2}) \quad (4.11)$$

The total filling time  $T$  ( $t = T$  for  $z = 0$ ) is then:

$$T = \frac{2 \cdot O_k \cdot H}{m \cdot A_s \cdot \sqrt{2gH}} \quad (4.12)$$

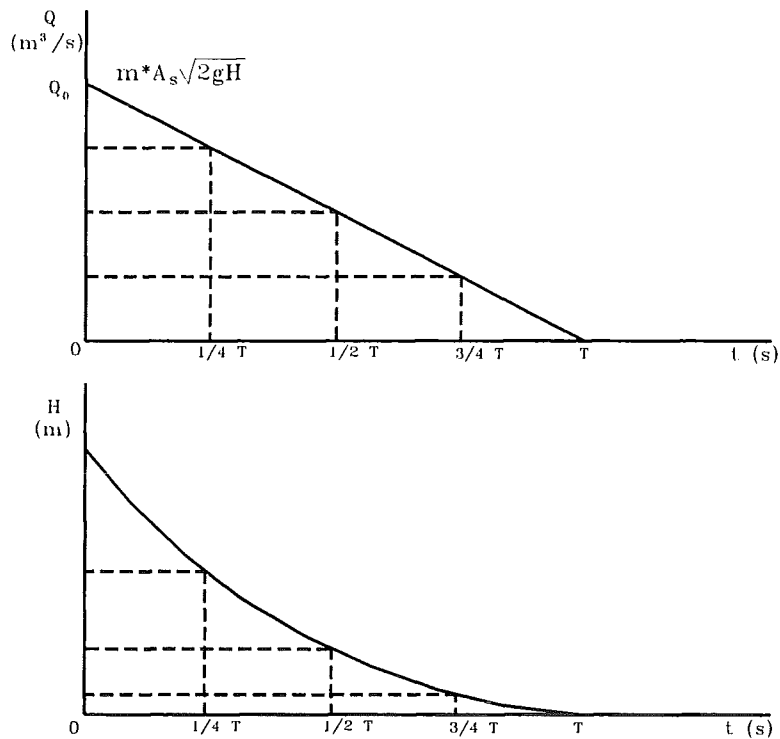

Figure 4-6: Chamber filling development if sluice is opened suddenly

*Establishing filling and emptying time on the basis of translatory waves*

In the previous observation it was assumed that the level in the lock chamber rises equally as a whole. In reality that will, however, not be the case. When the sluice is suddenly fully opened at point of time  $t = 0$ , a positive translatory wave will run through the chamber. A negative translatory wave will be created in the canal, which in connection with its extremely small height can be omitted from any further considerations here. The lock chamber will in principle be filled in 'slices' (see figure 4.7).

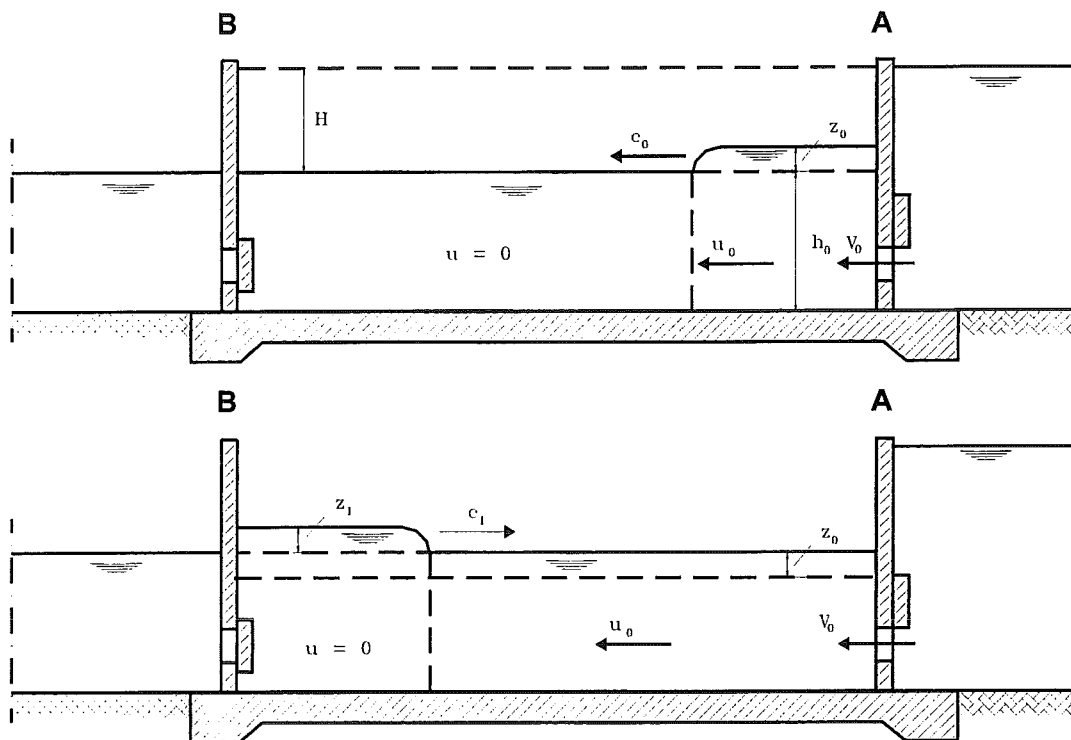

Figure 4-7: Translation wave as a result of lock filling

At point of time  $t = 0$  a positive transitory wave begins to run from A with a height  $z_0$  that travels with a speed of:

$$C_0 = \sqrt{gh_0} \cdot \left(1 + \frac{3}{4} \cdot z_0/h_0\right) \quad (4.13)$$

The water discharge through the sluice opening in the door, during the period that the rise in water level in the chamber at the location A has a value of  $z_0$ , appears to be equal to:

$$Q'_0 = m \cdot A_s \cdot \sqrt{2g(H - z_0)} \quad (4.14)$$

From continuity considerations this quantity has to be equal to:

$$Q'_0 = C_0 \cdot z_0 = U_0(h_0 + z_0) \quad (4.15)$$

When this wave reaches the end of the lock (lock gate B), a complete rebound takes place, whereby the kinetic energy is fully converted to potential energy ( $U = 0$ ) and then back into kinetic energy. If the speed of travel remains equal to  $C_0$ , the height of this rebound wave should once again equal  $z_0$ . This speed changes, however, due to the increase in the depth of the water ( $h_0 + z_0$ ) and becomes  $C_1$ . According to the continuity condition the new height of the wave is then  $z_1$  (see figure 4.8):

$$Q_0 = C_0 \cdot z_0 = C_1 \cdot z_1 = \dots enz \quad (4.16)$$

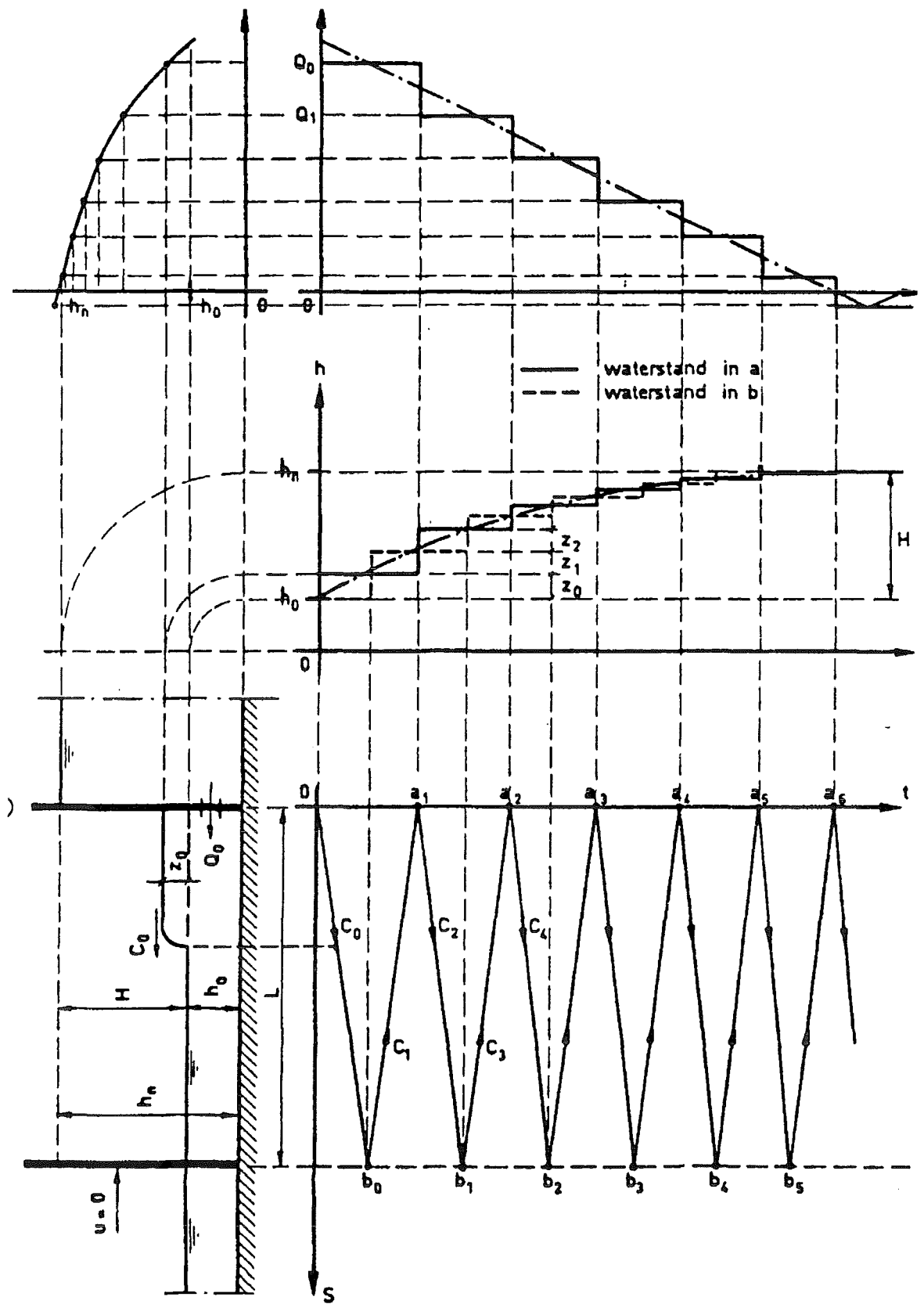

Figure 4-8 Development of filling of chamber with translatory waves

If there are ships in the lock chamber, a completely different situation is created. A complicated interplay<sup>21</sup> of hydraulic forces on the ships is created during filling. As a result of the longitudinal filling, the ships hawsers are predominantly loaded<sup>22</sup> by longitudinal forces. Furthermore, an extra rebound is created when the translatory waves reaches the ships and the water flows faster because the presence of the ship causes a smaller current profile. At the point when the translatory wave meets the ship, a sudden longitudinal force is exerted as a result of the current. See figure 4.9. The magnitude of this longitudinal force is approximately:

$$F = 1/2 \cdot \rho \cdot g \cdot b \cdot (z^2 + 2zd) \quad (4.17)$$

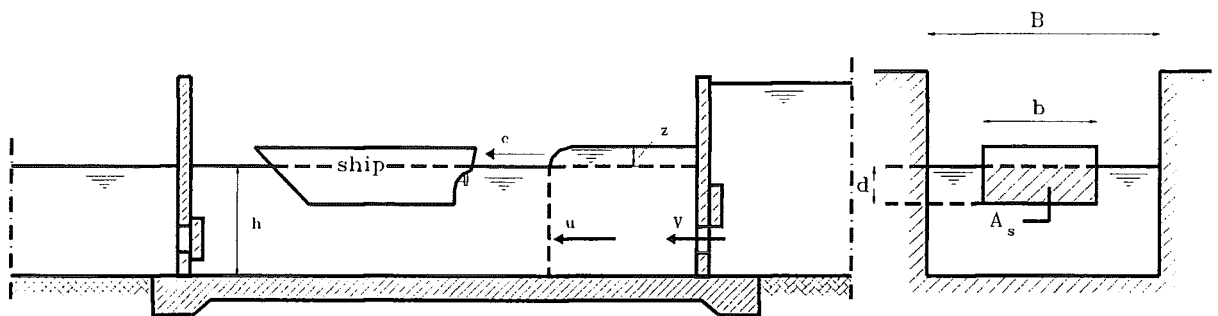

Figure 4-9: Translation wave in lock chamber if ships are present

The force must be transferred through the hawsers to the bollards<sup>23</sup>. On the return of the translatory wave, hawser forces are created once again, but then in the opposite direction. As a result, only one hawser is ever constantly taut<sup>24</sup>, whilst the other remains slack<sup>25</sup> (see figure 4.10). When the force changes direction, the ship is given a slight speed and thus kinetic energy which can be absorbed by slipping the hawser. Without this slipping possibility, excessive hawser forces could be created.

<sup>21</sup> krachtenspel  
<sup>22</sup> voornamelijk belast  
<sup>23</sup> bolders  
<sup>24</sup> strak  
<sup>25</sup> slap

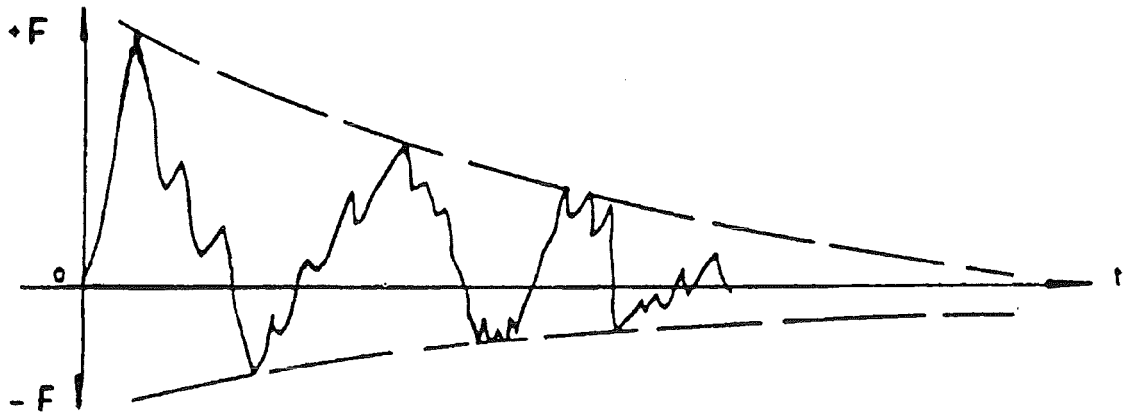

Figure 4-10: *Development of hawser force*

In the past steel cables were used as hawsers. Nowadays nylon hawsers are more popular because they stretch more and therefore require less work and attention. Opening the sluices more gradually will reduce hawser forces.

*Filling or emptying the chamber by opening the sluice with a uniform speed.*

By opening the sluice with a uniform speed the sluice opening will increase linearly with time:  $A = t / (T_1 \cdot A_s)$  (see figure 4.11).

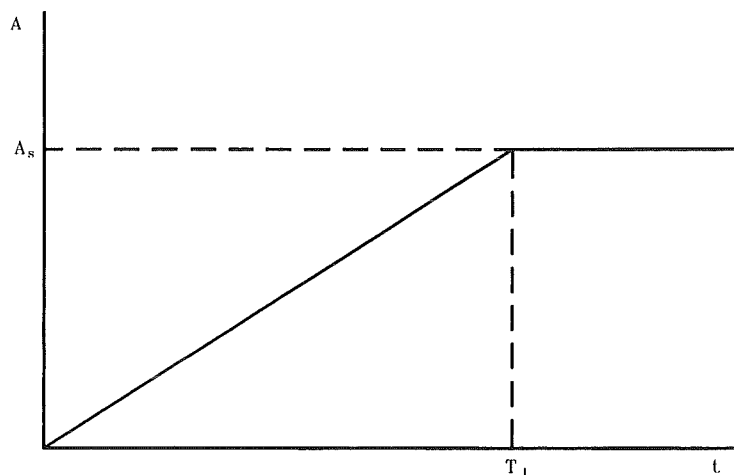

Figure 4-11: *sluice opening development during lifting time*

In this case  $T_1$  is the total lifting time of the sluice. If it is once again assumed that the chamber surface level rises evenly, the following must apply:

$$m \cdot (t/T_1 \cdot A_s) \cdot \sqrt{2gz} \cdot dt + O_k \cdot dz = 0 \quad (4.18)$$

From which it follows:

$$t \cdot dt = - \frac{O_k \cdot T_1}{m \cdot A_s \cdot \sqrt{2g}} \cdot \frac{dz}{\sqrt{z}} \quad (4.19)$$

By integrating the equation (4.19) with an initial value of  $z = H$  for  $t = 0$ , the development of the water level in the chamber can be found with the time:

$$t^2 = \frac{4 \cdot O_k \cdot T_1}{m \cdot A_s \cdot \sqrt{2g}} \cdot (H^{1/2} - z^{1/2}) \quad (4. 20)$$

Now by substituting the total opening time of the sluice:

$$T_1 = \frac{4 \cdot O_k}{m \cdot A_s \cdot \sqrt{2g}} \cdot (H^{1/2} - H_1^{1/2}) \quad (4. 21)$$

The remaining head drop<sup>26</sup>  $H_1$ , after  $T_1$  seconds, additionally requires a filling time analogous to equation (4.12) of:

$$T_2 = \frac{2 \cdot O_k \cdot H_1}{m \cdot A_s \cdot \sqrt{2gH_1}} = \frac{2 \cdot O_k \cdot H_1^{1/2}}{m \cdot A_s \cdot \sqrt{2g}} \quad (4. 22)$$

The total filling time then becomes:

$$T = T_1 + T_2 = \frac{2 \cdot O_k}{m \cdot A_s \cdot \sqrt{2g}} [2(H^{1/2} - H_1^{1/2}) + H_1^{1/2}] \quad (4. 23)$$

Which is equal to:

$$T = \frac{T_1}{2} + \frac{2 \cdot O_k \cdot H}{m \cdot A_s \cdot \sqrt{2gH}} \quad (4. 24)$$

From this it therefore appears that with uniform sluice opening procedure, the total filling time in relation to the sudden sluice opening is increased with half of the opening time ( $T_1 / 2$ ).

The hawser forces are greatly reduced in the initial period due to the extremely weak wave front. Due to the inertia<sup>27</sup>, a light rocking motion is created that causes practically no danger to the hawsers.

---

<sup>26</sup> verval

<sup>27</sup> traagheid



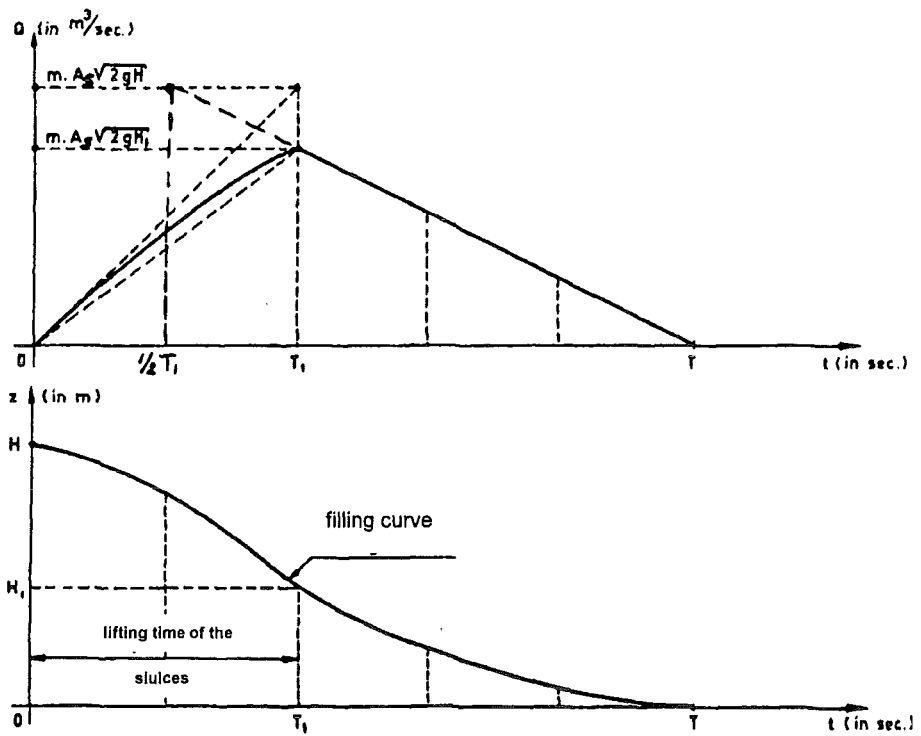

Figure 4-12: Lock filling development with uniformly opened sluice

In figures 4.6 and 4.12 it can clearly be seen that the time required to fill the last section of the chamber is disproportionate in relation to the total filling time. It is for that reason that in practice the gates are opened when a specific head drop (5 to 10 cm) still remains. A considerable time saving can be made in this way.

A system with bypass drains and drains with transverse culverts<sup>28</sup> are often chosen for both increased head drop and increased chamber surface areas (see figure 4.13). The water is then let in or let out by means of adjustable openings in the heads or walls of the lock. The most favourable situation for shipping traffic is when the openings are distributed evenly throughout the chamber.

<sup>28</sup> zijspuiten

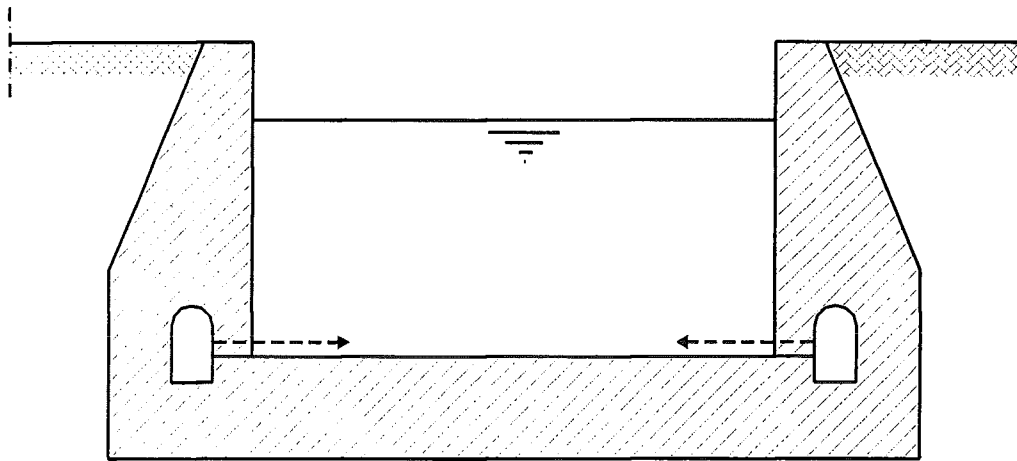

Figure 4-13: *Drain with transverse culverts*

The great difference with the sluice opening is the domination of friction losses in the drains, amplified by the deceleration losses caused by bends and outflows. Discharge through the drains is approximately equal to:

$$Q = \mu \cdot A_r \cdot \sqrt{2gz} \quad (4.25)$$

In which  $A_r$  represents the cross-section of the drain measured in  $m^2$  and  $\mu$  represents the discharge coefficient of the entire drain system. This coefficient is equal to  $\sqrt{(1 / \Sigma \varphi)}$ , in which  $\Sigma \varphi$  is the sum of all friction and deceleration losses (drain sluice, entry, exit and bend losses) in the entire drain system.

In order to reduce hawser forces, the quantity of water is often regulated by sluices. The transverse culverts can also be placed opposite one another, resulting in the energy becoming spent. The construction with circulating drains<sup>29</sup> requires much extra concrete work and furthermore also has to be correctly dimensioned.

When vertical lift gates are used, they are often combined with so-called stilling chambers<sup>30</sup>. It is in these stilling chambers that the essential energy conversion takes place. Furthermore, one or more jet breakers and flow guides are installed in the stilling chamber. These ensure that the lock current is immediately forced to distributed itself over the entire height of the chamber, resulting in the creation of an even longitudinal flow (see figure 4.14).

<sup>29</sup> omloopriolen

<sup>30</sup> woelkamers

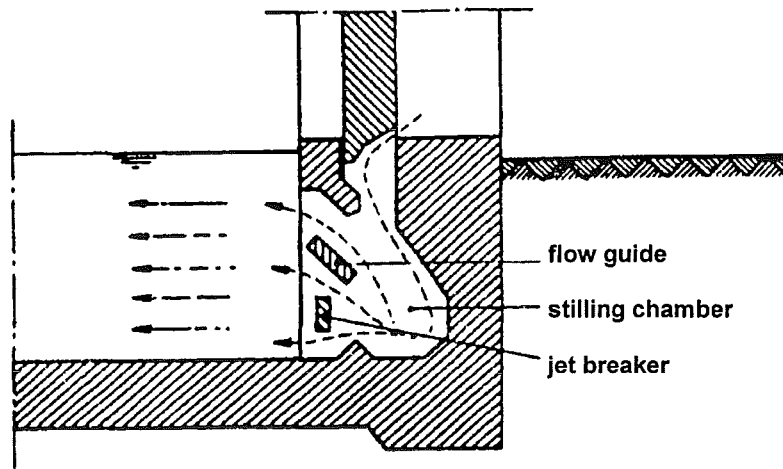

Figure 4-14 Lock chamber filling under vertical lift gate

#### 4.2.5 Entry and exit following times

The entry and exit (following) times of ships are determined on the basis of a large number of measurements made in the practical situation, as a theoretic approach is barely possible, if at all. In the past a major study was conducted in which the entry and exit (following) times were determined in a large number of locks (16 lock complexes and 23 lock chambers). A considerable spread can be seen, particularly as a result of the influence of human behaviour and the great differences with respect to the manoeuvrability characteristics of the various ships. Figure 4.15 illustrates two practical examples. The first graph concerns the entry times of laden motor vessels in the 'Hartelshuizen' (chamber dimensions 24\*280 m and 12\*120 m, now out of service). The second concerns the exit following times of laden motor vessels at the 'Volkeraksluizen' (chamber dimensions 24\*325 m).

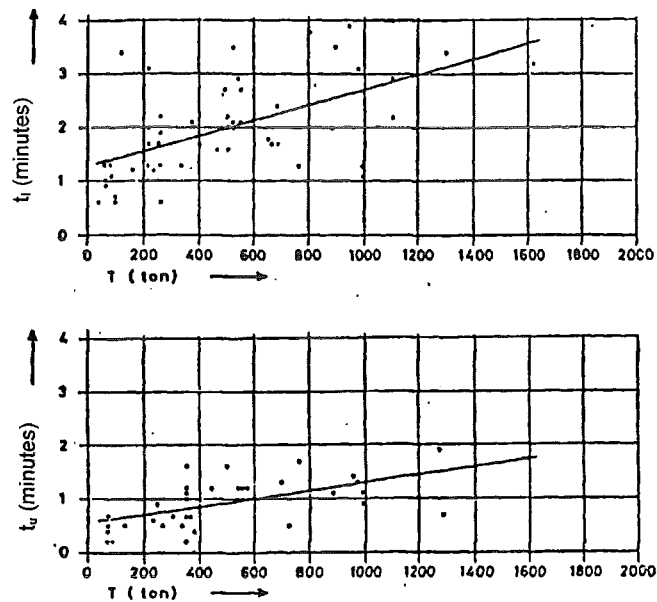

Figure 4-15: entry times and exit times

From the measurements and observations applicable to motor vessels the following conclusions can be drawn:

1. The entry and exit (following) times increase with the carrying capacity of the ships.
2. The entry and exit (following) times of unladen ships are significantly shorter than those applicable to laden ships, for which reason a distinction is made between them in the further processing of the results.
3. The entry and exit (following) times of a ship with a specific carrying capacity clearly increases as the surface area of the wet chamber cross-section ( $A_k = B_k \cdot h$ ) decreases.
4. The entry and exit (following) times for towed barges, that are rarely seen nowadays, are clearly longer than those for motor vessels or pushed convoys.
5. The entry and exit (following) times are unfavourably influenced by chamber shapes that deviate from the trough barge profile (lock chamber width greater than the lock and head width, such as in a so-called 'green' chamber) and by blindly situated waiting areas (bends etc.).
6. The loop time is directly dependent on the so-called loop distance (see also figure 4.22).

The resistance when entering or leaving a lock is taken into account by the dimensionless quantity  $A_s / A_k$ , which is the ratio of the submerged midship section area of the ship to the area of the wet chamber cross-section.

At the point of crossing from the lock approach into the relatively narrow lock, as a result of this change a ship is confronted with adaptation phenomena with respect to navigation speed and the associated return current velocity and water-level depression. In an extremely sudden transition in cross section area the following phenomena occur:

- A positive translatory wave that enters the lock chamber;
- A great increase in the return current velocity along the ship;
- A negative translatory wave that runs into the lock approach.

The greater the navigational speed and the smaller  $A_s / A_k$  ratio, the stronger these phenomena become (see figure 4.17)

During the actual lock entry the development of the navigation speed and the resulting phenomena such as reflecting translatory waves and current velocities appear to be capable of displaying an extremely irregular character. In practice however, it appears that if the ratio  $A_s / A_k < 0.4$  there is generally little cause for concern.

A further problem applies to laden pushed convoys in pushed convoy locks and the largest maritime vessels in maritime locks ( $A_s / A_k = 0.7$  to  $0.8$ ). The initial speed ( $V_0$ ) may not be too great or the translatory waves created by the ships can cause damage the first time they reflect off the closed gates. The maximum height of the translatory wave ( $Z_{max}$ ) appears to be directly proportional to the square of the initial vessel speed and with the ratio of the area of the wet chamber cross-section ( $A_k - A_s$ ) through which the return current has to take place to that of the ship  $A_s$ . According to figure 4.17, the following applies approximately:

$$\frac{Z_{max}}{h} = 1,44 \cdot \frac{V_0^2}{gh} \cdot \frac{A_s/A_k}{1 - A_s/A_k} \quad (4.26)$$

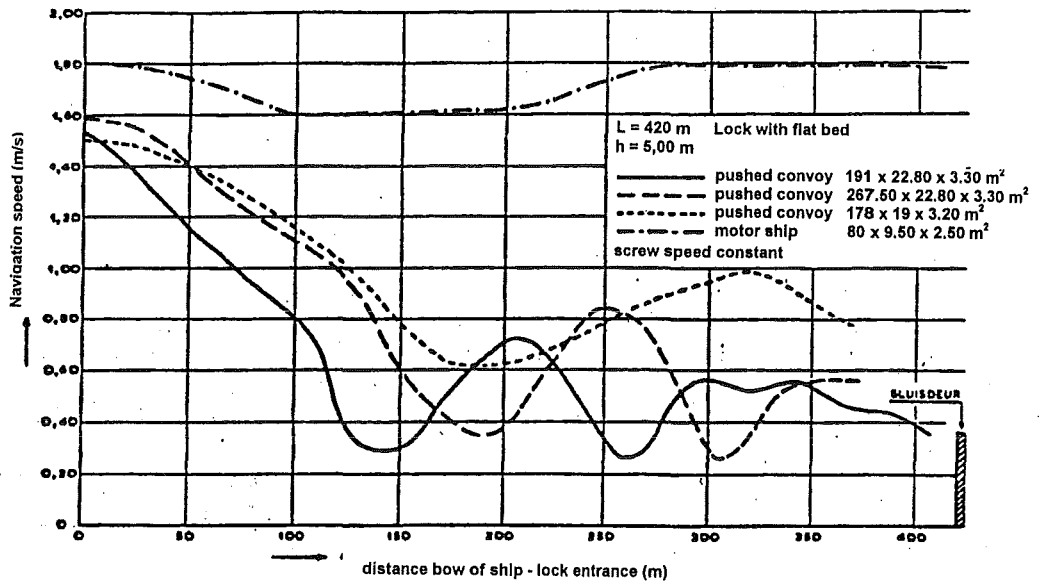

Figure 4-16: *Development of navigation speed in the lock for various ships*

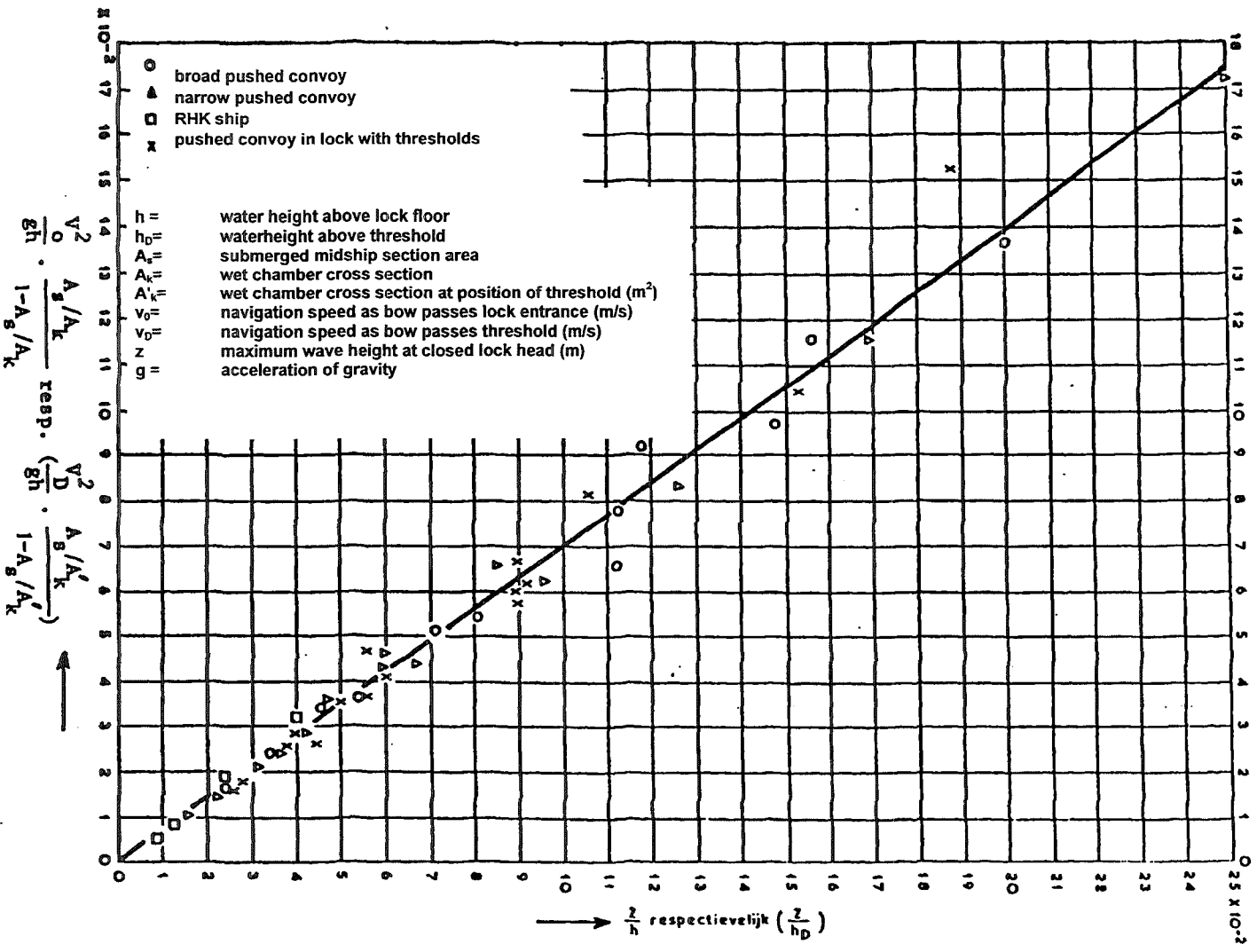

Figure 4-17: Maximum transitory wave heights at the location of the closed lock head

By introducing so-called standard (inland navigation) ships, that are representative for carrying capacity classes (0 to 7), a certain relationship between  $A_s$  and  $t_l$  and  $t_u$  can be determined.

Table 4.2: *Ship classes*

No	Dead-weight capacity (tonnes)	Standard ship			
		T (tonnes)	l (m)	b (m)	d (m)
0	50 – 199	125	25	4,6	1,6
1	200 – 449	325	39	5,1	2,2
2	450 – 749	550	50	6,6	2,5
3	750 – 1149	925	67	8,2	2,5
4	1150 – 1549	1350	80	9,5	2,6
5	1550 – 2549	2000	95	11,5	2,7
6	2550 – 4999	4100	175	11,4	3,0
7	≥ 5000	8800	185	22,8	3,2

In figure 4.18 this relationship is illustrated for both laden and unladen standard ships with the aid of the dimensionless parameter  $A_s/A_k$  for locks with a modern design (lock head width = lock chamber width) and a conveniently arranged situation. For deviations such as towed barges, deviant lock shapes, wind nuisance and inconveniently arranged situation, corrections should be applied.

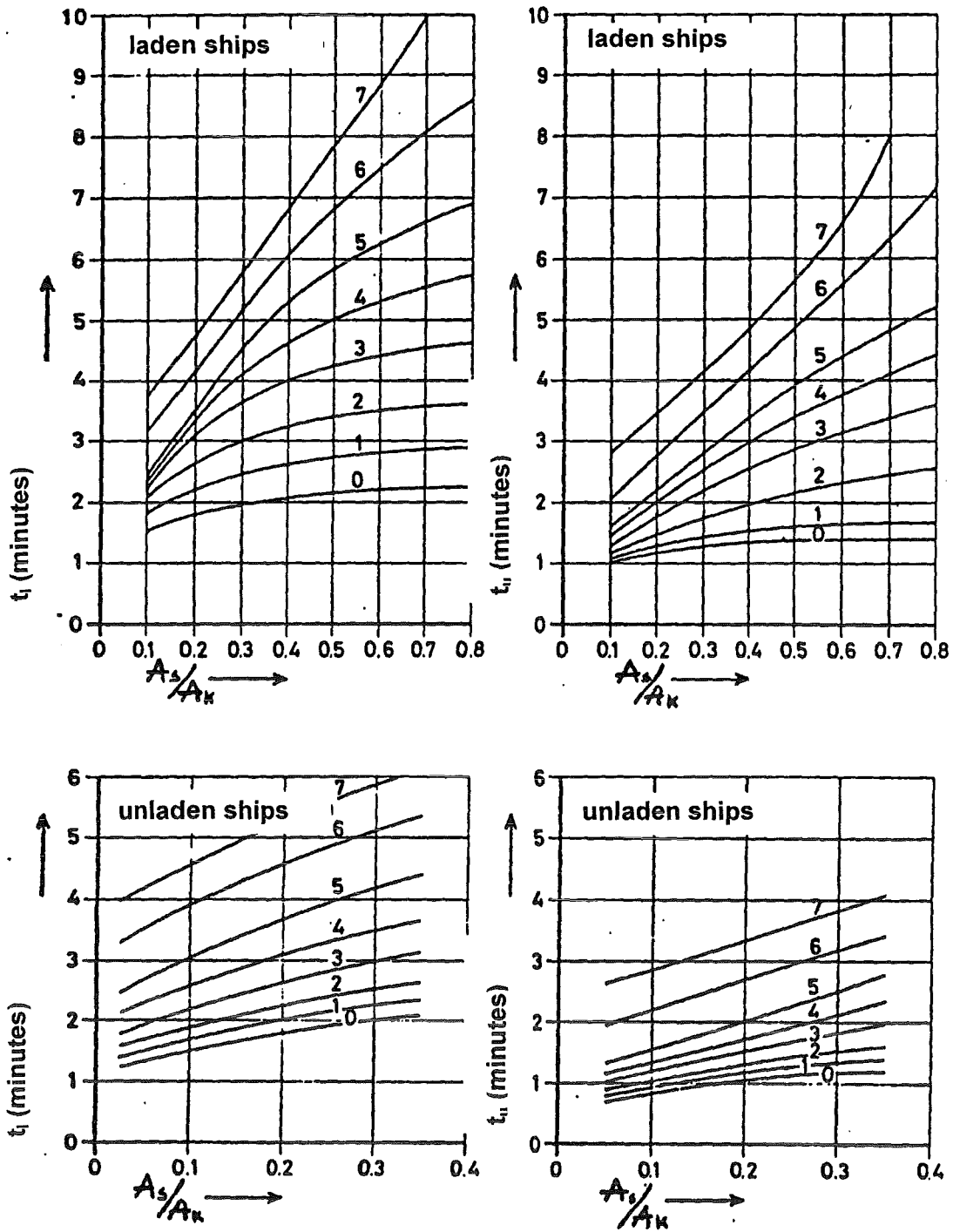

Figure 4-18 Entry and exit times for laden and unladen standard ships



The values from the figures above can be used as input for a simulation model. The "Commissie Vaarweg Beheerders" dictates that with a large volume of traffic (>10000 passages per year) the number of chambers and the dimensions thereof must be determined with the aid of simulation models. In order to gain an initial impression use can be made of the average values of  $t_i$  and  $t_u$  for a given traffic composition. Assuming a fixed (known) area of the chamber cross-section ( $A_k$ ), the average carrying  $T$  per class, and the  $A_s/A_k$  ratio per standard ship class, then  $t_{is}$  (entry following time class  $s$ ) and  $t_{us}$  (exit following time class  $s$ ) can be established. The average values of the entire fleet are then:

$$t_i = \sum_{s=0}^m (P_s \cdot t_{is}) \quad (4.27)$$

and

$$t_u = \sum_{s=0}^m (P_s \cdot t_{us}) \quad (4.28)$$

In this case  $P_s$  is the percentage of the carrying capacity class  $T_s$  within the given traffic composition, whereby  $m$  is the highest occurring dead-weight capacity class.

In 1972-1973 fleet divisions were established according to the average carrying capacity  $T$  on an inland waterway for the situations prevailing in The Netherlands. This relationship is given in figure 4.19.

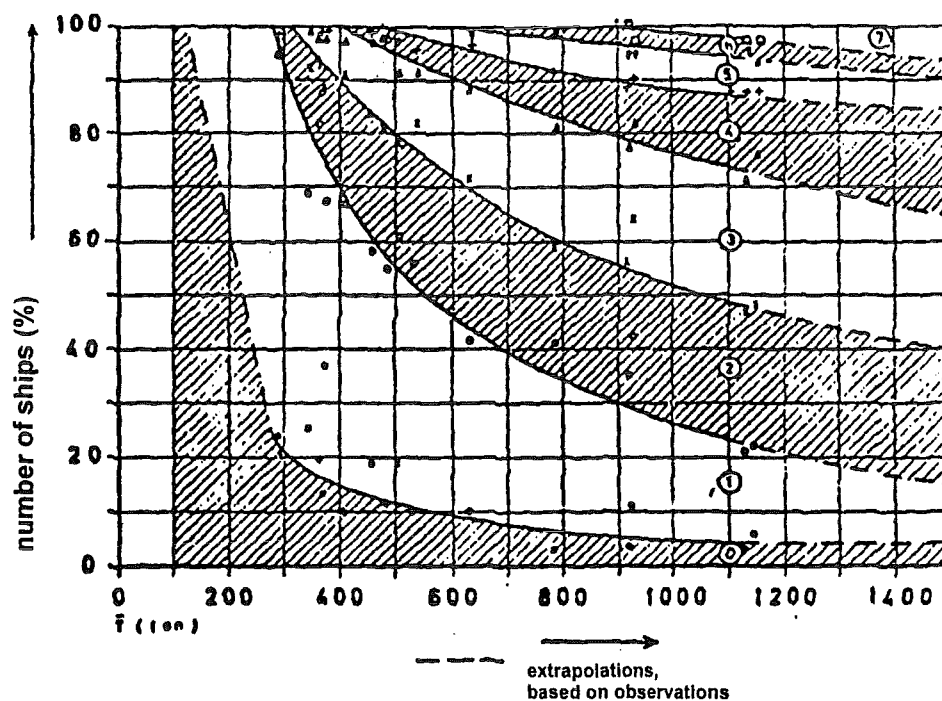

Figure 4-19: Relationship between the relative share of the dead-weight capacity classes of the fleet under consideration and the average dead-weight capacity

The fleet composition for the various average dead-weight capacities T is given on this basis, for the standard frequency distribution in table 4.3. Table 4.4 shows an alternative fleet composition for 'lower' navigability classes.

In many cases this standard classification for ships was insufficient, and a more far-reaching classification had to be applied, as is the case for traffic control studies on the major rivers (see table 4.5).

Table 4.3: *Composition of the fleet in standard ships*

<b>T<sub>average</sub></b> <b>(tonnes)</b>	<b>Share of the standard ships (in %)</b>							
	<b>0</b>	<b>1</b>	<b>2</b>	<b>3</b>	<b>4</b>	<b>5</b>	<b>6</b>	<b>7</b>
125	100,0	-	-	-	-	-	-	-
160	82.5	17.5	-	-	-	-	-	-
200	62.5	37.5	-	-	-	-	-	-
240	42.5	57.5	-	-	-	-	-	-
280	22.5	77.5	-	-	-	-	-	-
300	20.0	73.0	7.0	-	-	-	-	-
350	17.5	62.5	16.0	4.0	-	-	-	-
400	15.4	54.2	20.9	9.0	0.5	-	-	-
450	13.5	48.0	24.5	11.0	3.0	-	-	-
500	12.0	43.2	26.1	13.0	4.6	0.9	-	-
600	9.3	36.7	27.0	17.0	5.6	4.4	-	-
700	7.2	33.0	25.4	20.4	7.3	5.6	1.1	-
800	6.0	30.0	24.0	22.5	9.0	6.4	2.1	-
900	5.0	26.2	24.5	23.8	10.5	6.5	2.9	0.6
1000	4.5	23.0	24.7	24.3	12.5	6.5	2.9	1.6
1100	4.5	19.5	25.0	25.0	14.0	6.5	3.0	2.5
1200	4.5	16.5	24.5	26.0	15.0	7.0	3.0	3.5
1300	4.5	14.5	25.0	25.0	16.5	7.2	2.8	4.5
1400	4.5	12.5	25.0	24.5	18.0	7.0	3.0	5.5
1500	4.5	10.5	25.0	23.5	20.0	7.0	3.0	6.5

Table 4.4 *Alternative fleet composition in standard ships for various 'lower' navigability classes*

T <sub>average</sub> (tonnes)	Share of the standard ships (in %)							
	0	1	2	3	4	5	6	7
	A. navigability class 4							
500	12.0	42.0	27.0	13.0	6.0	-	-	-
600	8.5	32.0	31.0	17.0	11.5	-	-	-
	B. navigability class 5							
700	7.0	29.0	27.0	22.0	8.0	7.0	-	-
800	5.0	24.0	25.0	25.0	10.5	10.5	-	-
900	4.0	18.5	23.0	27.0	13.5	14.0	-	-
1000	3.0	14.0	21.0	28.0	16.0	18.0	-	-
	C. navigability class 6							
1000	3.0	22.0	24.0	26.0	11.0	8.0	6.0	-
1200	2.0	16.0	22.0	29.0	11.0	10.0	10.0	-
1400	2.0	10.0	19.0	32.0	11.0	12.0	14.0	-

Table 4.5: *Fleet division and percentage occurrence of the various categories of ships*

Description	category	% of the weekly total		
		1972	1973	
Motor cargo or motor tanker vessel	< 450 tonne	1	18.9	13.5
	450-750 tonne	2	23.9	20.9
	750-1149 tonne	3	23.4	23.5
	1150-1549 tonne	4	11.2	15.9
	1550-2549 tonne	5	3.8	3.9
	> 2550 tonne	6	0.1	0.5
Pushed convoy or pushing motor vessel	< 5000 tonne	7	4.0	3.0
	Cargo or motor tanker vessel >= 5000 tonne	8	3.6	4.4
Single towed cargo or towed tanker ship or adjacently coupled towed ships	<1000 tonne	9	0.4	0.4
	>= 1000 tonne	10	3.6	1.9
Motor vessel with towed ship or Motor vessel adjacently coupled	< 1000 tonne	11	0.2	0.6
	>= 1000 tonne	12	0.0	1.9
Ocean-going vessel		13	1.8	1.8
Working vessel, towed object		14	0.3	0.2
Individual towing, pushing service or fishing vessel		15	2.1	1.6
Passenger vessel		16	0.9	1.2
Pleasure craft		17	1.8	4.8

The weekly total observed for both navigation directions on the river Waal east of Nijmegen in the period 12 to 19 June 1972 amounted to: 3598 ships, and in the period 19 to 26 June 1973: 3562 ships.

For various dead-weight capacities  $T_{\text{average}}$  with the aid of the standard frequency distribution in table 4.3, the average entry following times ( $t_i$ ) and exit following times ( $t_u$ ) are determined as a function of the area of the wet chamber cross-section ( $A_k$ ), (see figures 4.20 and 4.21). This has been performed for both laden and unladen ships. From these graphs it is apparent that for an average ship with the given  $T$  :

$$t_i (\text{laden ship}) > t_i (\text{unladen ship}) > t_u (\text{laden ship}) > t_u (\text{unladen ship})$$

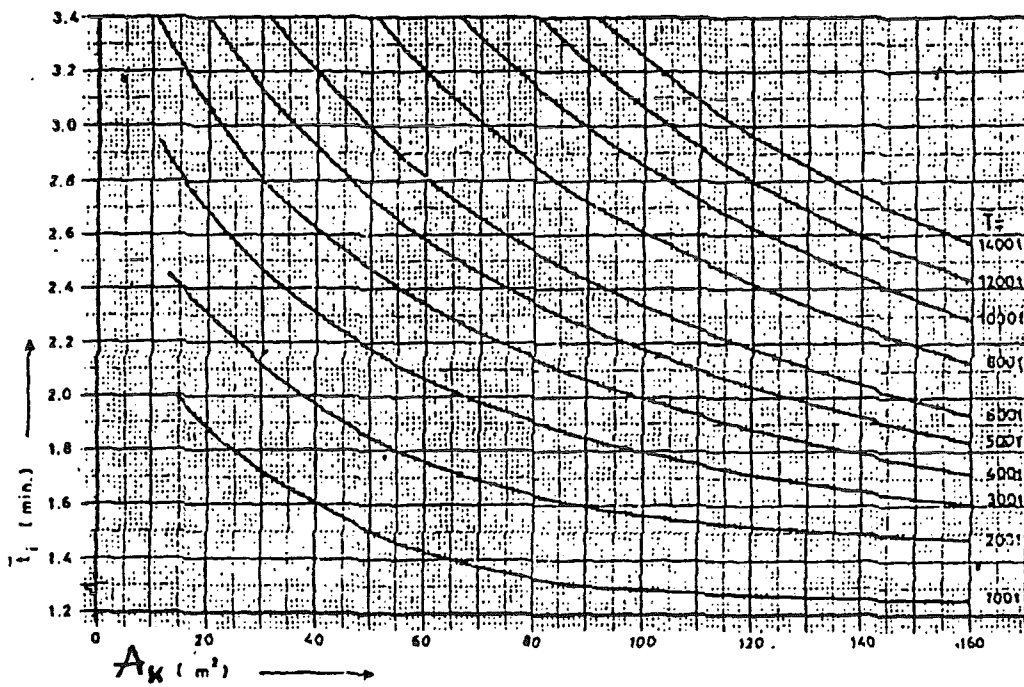
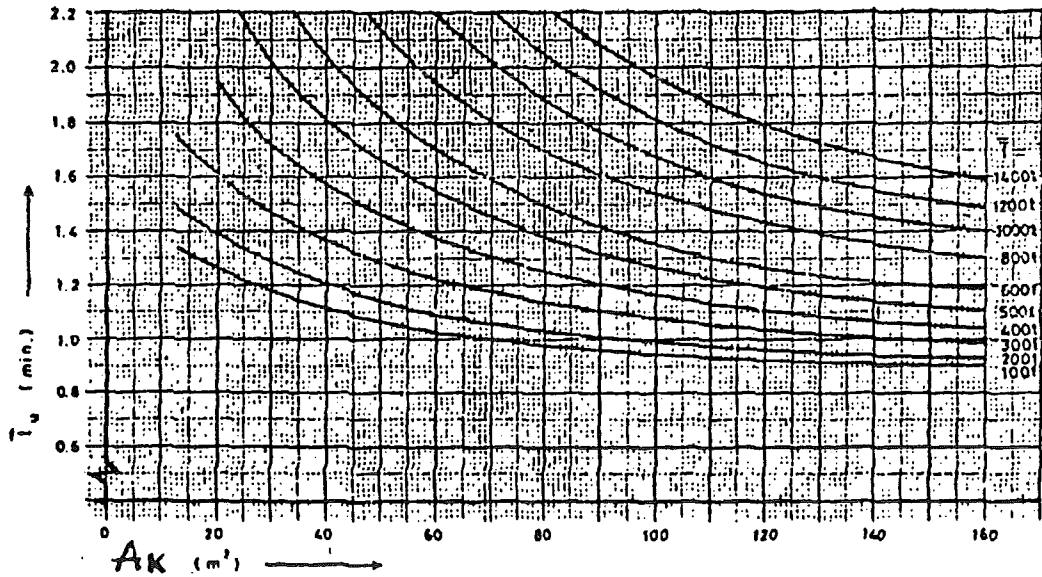

Figure 4-20: The relationship between entry and exit following times and the area of the chamber (laden ships)

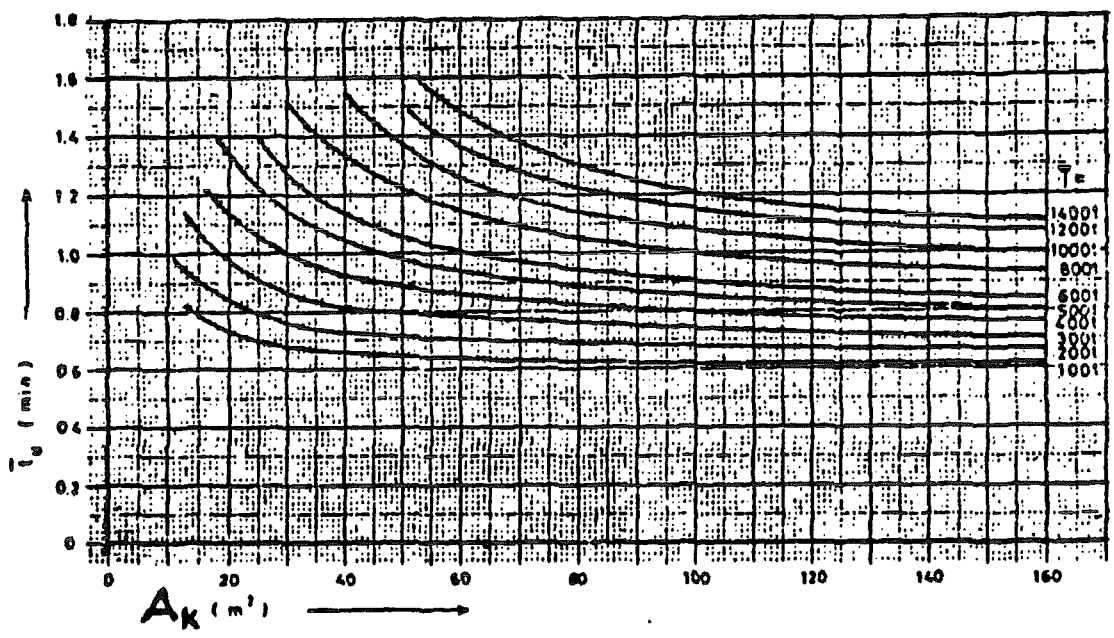
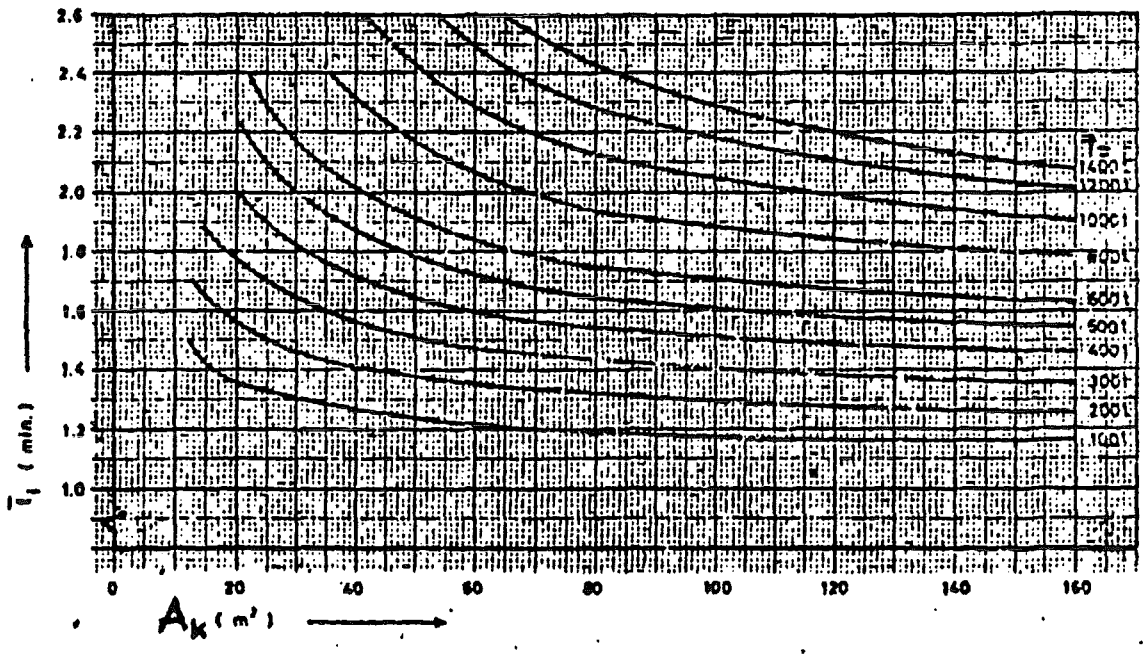

Figure 4-21: The relationship between entry and exit following times and the area of the chamber (unladen ships)

Although the values in these graphs are clearly dated with respect to the current circumstances in the Netherlands, they can however be applied for an initial approach. Obviously an investigation will have to be made regarding the applicability of these values when designing or modifying a lock.

#### 4.2.5 The loop times

As stated before the loop time is defined as the time that elapses between the moment that the last ship leaves the lock and the moment at which the first ship enters the lock.

Just as for the individual entry and exit (following) times, the loop time is also a function of the loading status of a ship (laden or unladen), the dead-weight capacity  $T$  and the chamber cross-section  $A_k$ . Furthermore, the loop time  $t_l$  is also dependent on the distance from the stern of the first ship in the waiting area to the entrance gates and actually consists of two parts:

$$t_l = t_{l \text{ (exiting ship)}} + t_{l \text{ (entering ship)}} \quad (4. 29)$$

From observations it appears that  $t_{l \text{ (entering ship)}}$  is much greater than  $t_{l \text{ (exiting ship)}}$ . The release and acceleration of the entering ship, whereby immediate account has to be taken with slowing down of this ship in connection with taking up a position in the lock chamber, proceeds far more slowly and easily takes up the greatest part of the loop time.

For that reason in practice the loop time is approximated to the following function of the loop distance  $S_l$  :

$$t_l = f(S_l, A_s/A_k)_{\text{entering ship}} \quad (4. 30)$$

The entry following times are functions of the  $A_s/A_k$  ratio, as are the loop times. In determining the average loop time ( $t_l$ ) for locking operations with standard ships (see figure 4.22) the average entry following time  $t_i$  is therefore used, with a time correction being added that is dependent on the average loop distance ( $S_l$ ).

$$t_l = t_i + \text{time correction } \Delta t [f(S_l)]$$

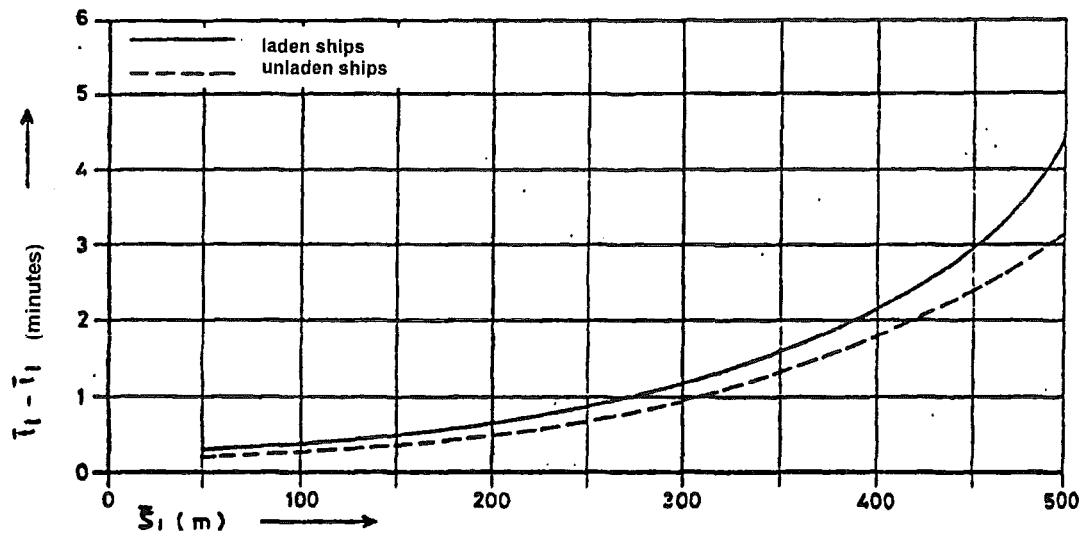

Figuur 4.21: *correction graph for the average loop time*

#### 4.2.7 Maximum number of ships in the lock chamber

It is possible to establish the maximum number of ships in the lock chamber with the aid of a simulation on the basis of a specific fleet distribution.

Some locks make use of a computer program to determine the optimum lock arrangement. If this is case, lock operators try to maintain a distance between ships of 3% of the ship's width in the longitudinal direction and 1 to 2% of the chamber width in the transverse direction.

Different criteria apply for establishing the maximum number of ships in the lock chamber of a maritime lock. Maritime vessels are for example always moored<sup>31</sup> immediately alongside the lock walls.

The figures below give the maximum number of ships as a function of the average dead-weight capacity, and the width and length of the chamber. In this case use is made of the fleet composition as a function of the average dead-weight capacity as given in paragraph 4.2.5.

<sup>31</sup> afgemeerd

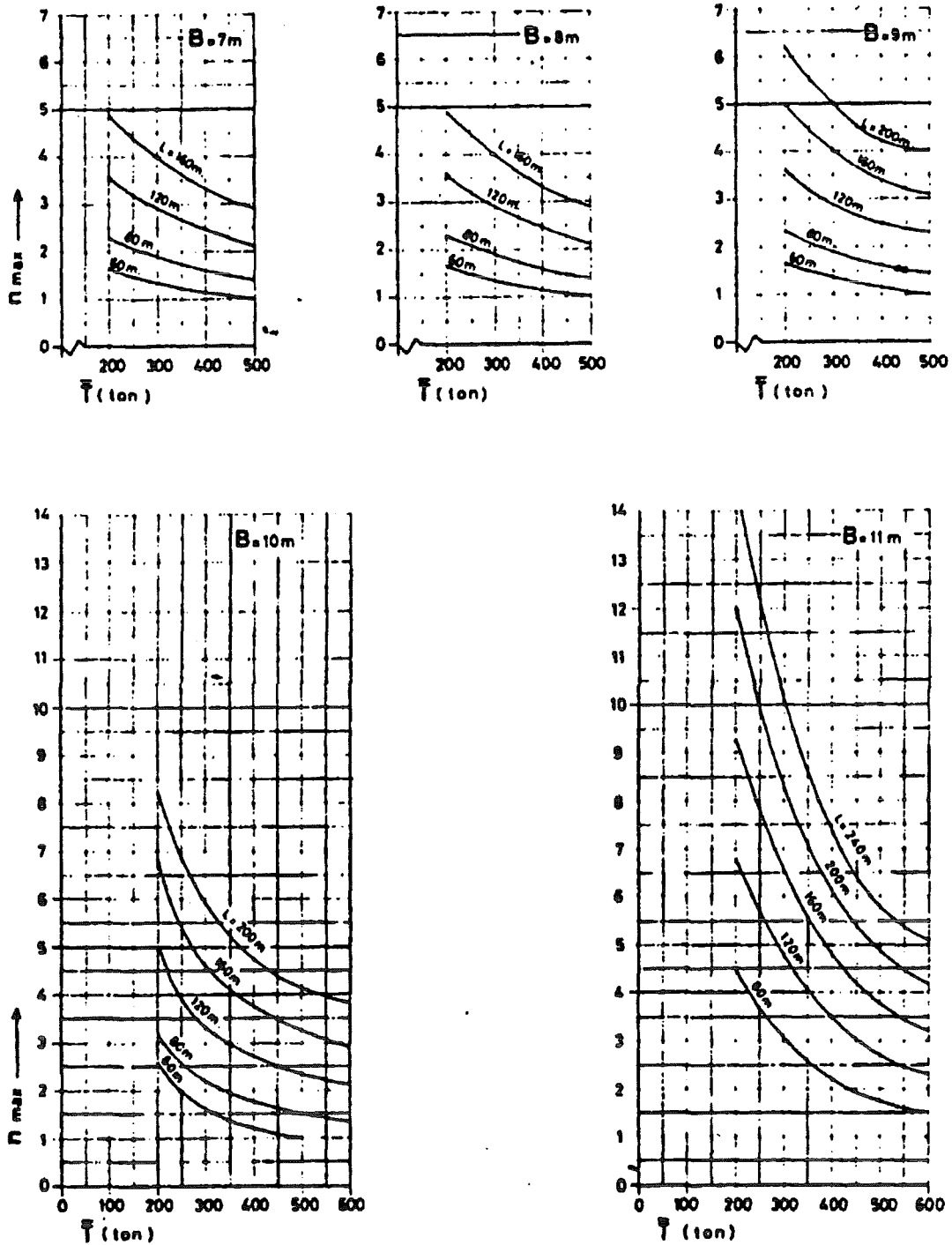

Figure 4-23: Maximum number of ships that the lock chamber can accommodate ( $n_{max}$ ) as a function of the average dead-weight capacity ( $T$ ) for various chamber dimensions



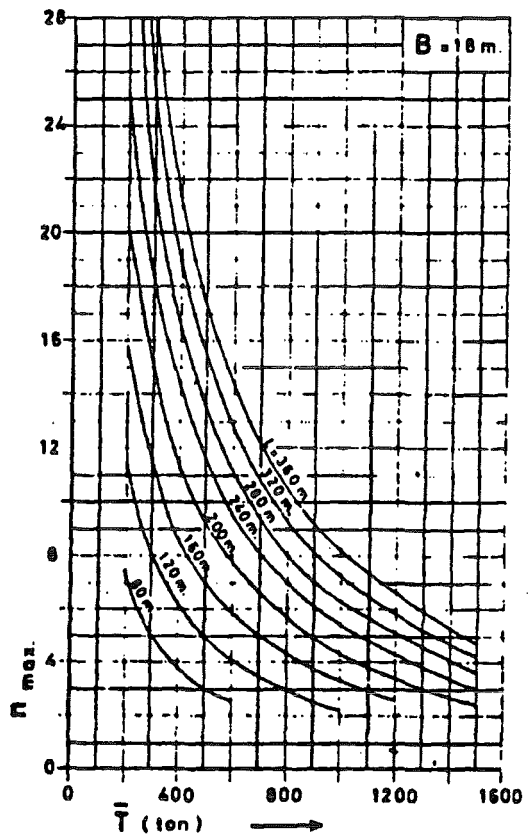
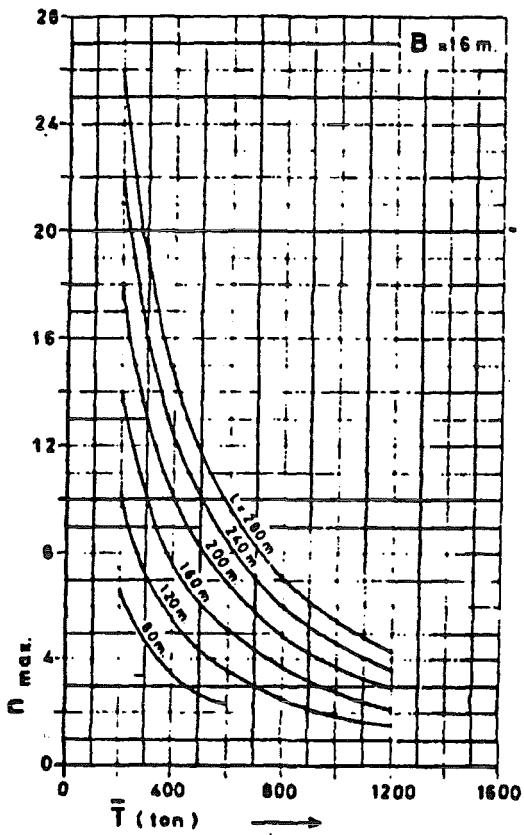
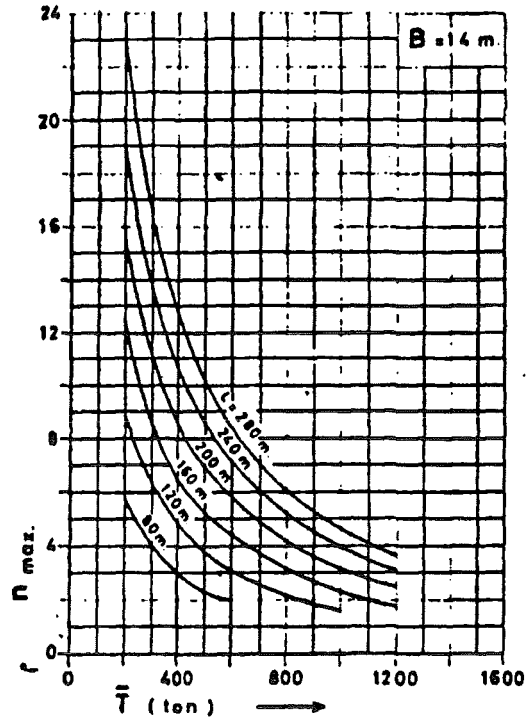
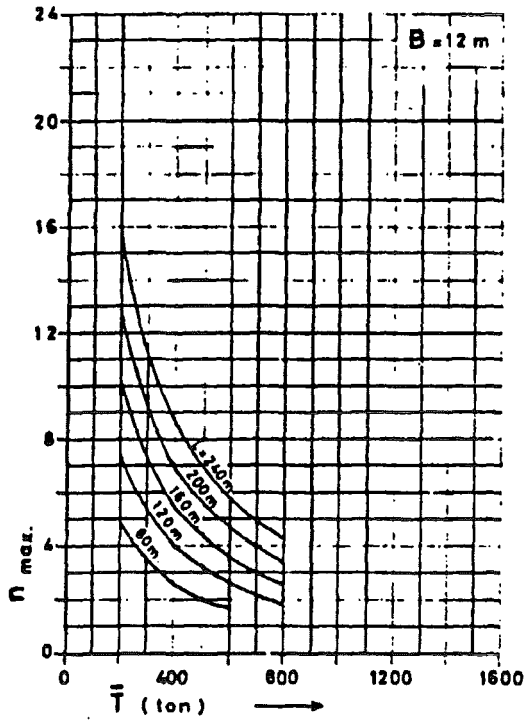

Figure 4-24: : Maximum number of ships that the lock chamber can accommodate ( $n_{max}$ ) as a function of the average dead-weight capacity ( $T$ ) for various chamber dimensions

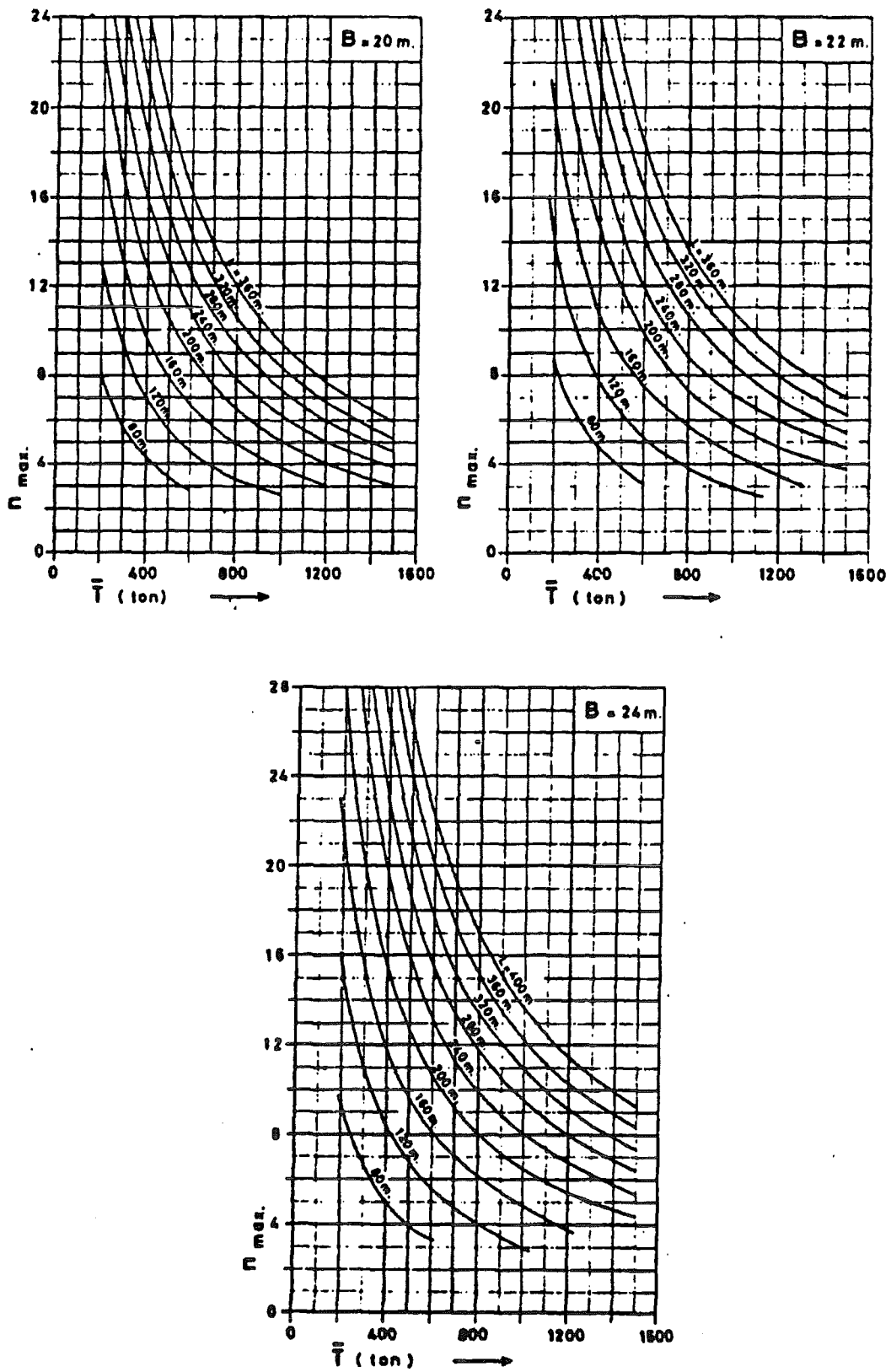

Figure 4-25: : Maximum number of ships that the lock chamber can accommodate ( $n_{max}$ ) as a function of the average dead-weight capacity ( $T$ ) for various chamber dimensions

#### 4.2.8 Calculation example for lock capacity

Three cases can be distinguished in calculating the locking capacity of inland waterways:

1. Always locking in two directions with fully occupied chambers;
2. Always locking in one direction with fully occupied chambers and in the other direction with partially occupied chambers;
3. Always locking in one direction with fully occupied chambers (one-way traffic).

The calculation method for case 1 will be dealt with first, Following that an indication will be given of the changes to be made in this calculation for calculating the capacity for case 2 or 3.

#### A. Lock data

##### a. Data regarding the fleet

The composition of the fleet has to be known (specified according to the dead-weight capacity with the corresponding percentage). From this the average tonnage per ship can be calculated (see table below).

Table 4-6: Fleet data

	% ( $P_s$ )	$T_{AVERAGE}$ [TONS]	$T_{AVERAGE} * P_s$ [TONS]
	6	125	7.5
	30	325	97.5
	24	550	132
	22.5	925	208.1
	9	1350	121.5
	6.4	2000	128
	2.1	4100	86.1
<b>Total</b>	<b>100</b>		<b>780.7</b>

##### b. Data regarding the lock

An indication of the chamber dimensions is given in the sketch below:

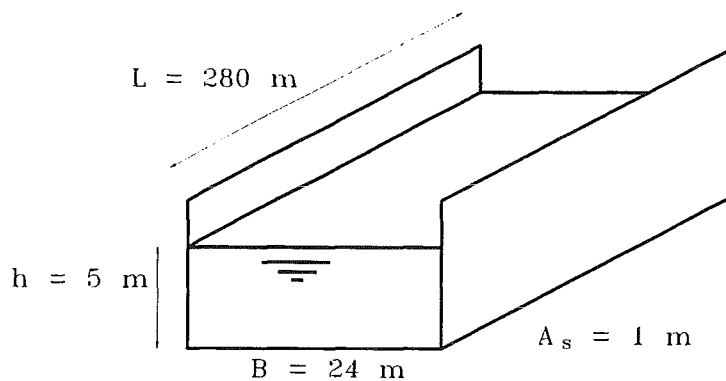

The lock is fitted with mitre gates.  
 The total area of the sluice opening in the gates in the lower head and in upper head both amount to  $A = 4 \text{ m}^2$   
 The loop distance is  $S_l = 400 \text{ metres}$ )

### **B. Determination $n_{\max}$**

The value  $n_{\max}$  can be determined for the various values of  $T_{\text{average}}$  with the aid of the figures that provide an indication of the relationship between the width of the lock, the length of the lock and the average tonnage.

From the above information it is possible to derive that  $n_{\max}$  is equal to 12 ships (work this out for yourself!)

### **C. Determining the operating time on the entry of the ships $T_b$**

#### *a. Determining gate operation time*

The operating time for opening and closing is 3.3 minutes (the lock has a mitre gate and chamber width of 24 metres, according to table 4.1 the average opening is about 3.3 minutes)

#### *b. Determining filling/emptying time*

According to the formula below, the time required for chamber turnaround is:

$$T = \frac{2 \cdot O_k \cdot H}{m \cdot A_s \cdot \sqrt{2 \cdot g \cdot H}}$$

This appears to be approx. 14 minutes

### **D. Determination of the entry time $t_i$ and exit time $t_u$ and the loop time in the direction of the lower reach**

#### *a. Determination $t_i$*

From figures 4.20 and 4.21 in which the relationship between the chamber area, the average tonnage and  $t_i$  is given,  $t_i$  can be determined. In the example this results in the following:

$A_k = 5 \text{ m} \cdot 24 \text{ m} = 120 \text{ m}^2$ ; thus  $t_{i, \text{laden}} = 2.42 \text{ minutes}$  and  $t_{i, \text{unladen}} = 1.85 \text{ minutes}$ . Given that 70% is laden, thus  $t_{i, \text{average}}$  is equal to  $0.7 \cdot 2.42 + 0.3 \cdot 1.85 = 2.25 \text{ minutes}$ .

#### *a. Determination $t_u$*

$A_k = 4 \text{ m} \cdot 24 \text{ m} = 96 \text{ m}^2$ ; thus  $t_{u, \text{laden}} = 1.57 \text{ minutes}$  and  $t_{u, \text{unladen}} = 1 \text{ minute}$ . Given that 70% is laden, thus  $t_{u, \text{average}}$  is equal to  $0.7 \cdot 1.57 + 0.3 \cdot 1 = 1.4 \text{ minutes}$ .

#### *b. Determination loop time $t_l$*

The difference between the  $t_i$  and  $t_l$  is a function of the loop distance. In the example this difference is equal to 2 min (see fig 4.22).

The loop time is thus  $2.25 + 2 \text{ min.} = 4.25 \text{ min.}$

### **E. The locking duration $T_d$ in the direction of the lower reach**

This is a summation of the loop time, the number of ships minus 1x the (average) entry time, the turnaround time for time for the chamber, the opening and closing times of the gates and the number of ships multiplied by the (average) exit time. In the example this is:

$$T_d = t_l + (n-1) * t_i + T + T_b + n * t_u$$

$$= 4.25 + (12-1) * 2.25 + 14 + 3.3 + 12 * 1.4 = 63.1 \text{ minutes}$$

#### **F. Determination of the locking duration of entry**

##### a. *Determination operation time $T_b$*

Opening and closing gates: 3.3 min. (see C.)

##### b. *Determination filling/emptying time*

The turnaround time is the same as calculated in C (work this one out yourself!)

##### c. *The determination of the entry following times*

Determination  $t_i$  (see fig.4.20 and fig 4.21)

$A_k = 4 \text{ metre} * 24 \text{ metre} = 96 \text{ m}^2$ ; thus  $t_{i, \text{laden}} = 2.66 \text{ minutes}$  and  $t_{i, \text{unladen}} = 1.9 \text{ minutes}$ . Given that 70% is laden, thus  $t_{i, \text{average}}$  is equal to  $0.7 * 2.66 + 0.3 * 1.9 = 2.43 \text{ minutes}$ .

Determination  $t_u$

$A_k = 5 \text{ metre} * 24 \text{ metre} = 96 \text{ m}^2$ ; thus  $t_{u, \text{laden}} = 1.42 \text{ minutes}$  and  $t_{u, \text{unladen}} = 0.96 \text{ minutes}$ . Given that 70% is laden, thus  $t_{u, \text{average}}$  is equal to  $0.7 * 1.42 + 0.3 * 0.96 = 1.28 \text{ minutes}$ .

Determination loop time  $t_l$

The difference between the  $t_i$  and  $t_l$  is a function of the loop distance. In the example, this difference is equal to 2 minutes.

The loop distance is thus  $2.43 \text{ minutes} + 2 \text{ minutes} = 4.43 \text{ minutes}$

##### d. *Locking duration upstream*

This is a summation of the loop time, the number of ships minus 1x the (average) entry time, the filling and emptying times for the chamber, the opening and closing times of the gates and the number of ships (average) multiplied by the exit time. In the example this is:

$$T_d = t_l + (n-1) * t_i + T + T_b + n * t_u$$

$$= 4.43 + (12-1) * 2.43 + 14 + 3.3 + 12 * 1.28 = 63.57 \text{ minutes}$$

#### **G. Determination of the cycle time**

This time is equal to the sum of the lock gates downstream and upstream:

$$T_c = 63.1 + 63.57 = 126.92 \text{ minutes} = 2.11 \text{ hours}$$

#### **H. Determination of capacity**

$$C_s = 2 * n_{\text{max}} / T_c = 2 * 12 / 2.11 \text{ hours} = 11.37 \text{ ships/hr.}$$

$$C_t = T_{\text{average}} * C_s = 780 * 11.37 = 8872 \text{ tonne/hr.}$$

### **I. Changes that apply to locking of a chamber which is always fully occupied and one which is partially occupied**

The changes that apply to locking of a chamber which is always fully occupied and one which is partially occupied are as follows:

- a. For the navigation direction for which the capacity is to be calculated  $n_{\max}$  applies; for the opposite direction  $n < n_{\max}$  applies;
- b.  $T_c$  is calculated for the first direction on the basis of  $n_{\max}$  and for the opposite direction on the basis of  $n$ ;
- c. The capacity is determined with the aid of the following comparison:  
 $C_s = 1 * n_{\max} / T_c$

### **J. The changes for locking in only one direction are as follows:**

- a. The loop time has to be replaced by the shorter entry time of the first ship.
- b.  $T_c = T_d$ , in the lock direction +  $T_b$  (opposite direction)
- c. The capacity is determined with the aid of the following comparison:  
 $C_s = 1 * n_{\max} / T_c$

### **K. Information minimum lock dimensions**

The minimum chamber dimensions for lock chambers as a function of the waterway class for commercial shipping as drawn up by the C.V.B. in 1996 are given in section 4.3

#### **4.2.9 Traffic intensity patterns and the influence on capacity**

In the previous paragraph the maximum capacity was determined.

It should be stressed that if the maximum capacity is allowed as the average capacity, unacceptable waiting times will arise which are caused by the variation of the traffic intensity.

Variations in traffic intensity can be partially systematic and partially stochastic. The systematic build up of the intensity pattern can be described in daily cycles (24 hours) and weekly cycles (7 days).

The 24-hour cycle is characterised by relatively low traffic intensity during the night and relatively high traffic intensity during the day.

The week cycle is characterised by low intensities during Saturday and Sunday and higher intensities during the working days

In addition to these systematic variations, there are also the stochastic variations that have a random character.

The waiting times for ships can be registered with the aid of simulation models. A general impression of the relationship between intensities and waiting times is given in fig 4.26.

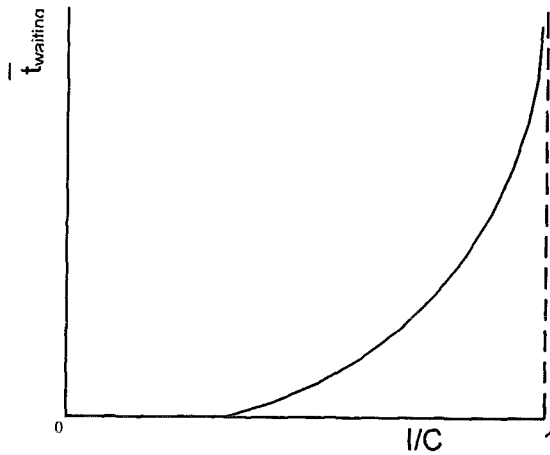

Figure 4-26: *The relationship between the average time ( $t_w$ ) and the intensity-capacity ratio  $I/C$ )*

As a result of the great differences in intensity between day and night and the stochastic character, a delay may already occur at low  $I/C$  values.

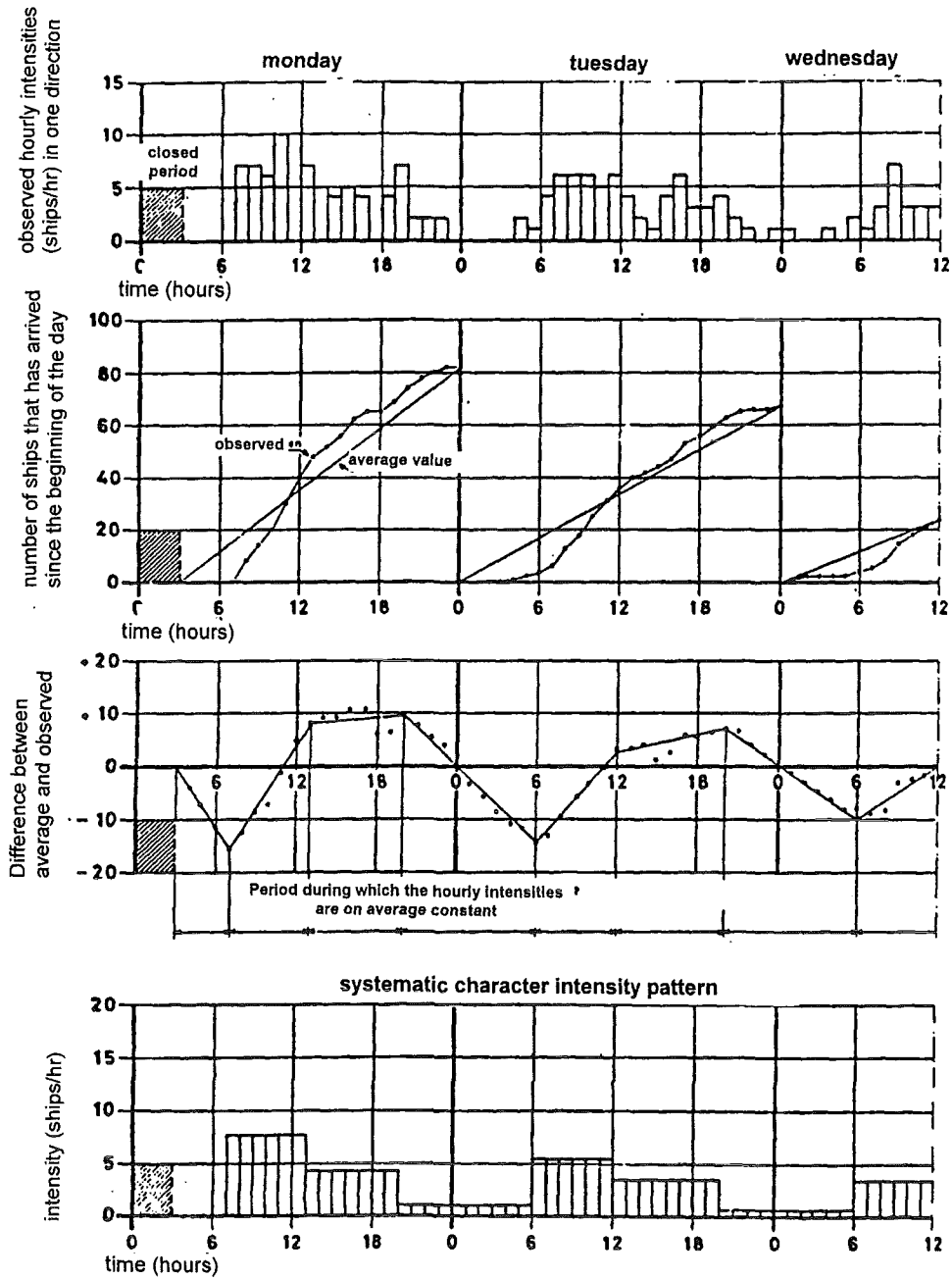

Figure 4-27: Determination of the systematic character of an observed intensity pattern



### 4.3 Lock dimensions according to the CVB

The CVB [Commissie Vaarweg Beheerders] in its publication 'Waterway Guidelines' in 1996 has established the dimensions of locks, including the lay-by/waiting area. These concern the dimensions of locks for commercial shipping, locks for recreational traffic, and locks for mixed traffic. These guidelines will be dealt with in succession.

#### 4.3.1 Locks for commercial traffic

Figure 4.28 shows an overview drawing with the most important characteristics of a lock.

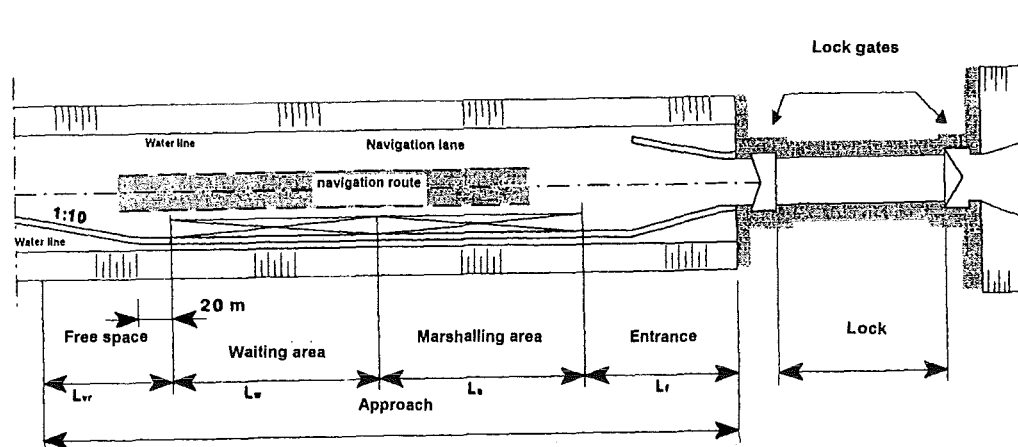

Figure 4-28: Lock arrangement following the CVB

The dimensions of the lock are of course dependent on the design ship in the lock. Table 4-8 shows the relationship between the normative ship that makes use of the lock (divided into classes) and the lock length, chamber width and threshold depth (= design draught + keel clearance).

Table 4-8: Lock dimensions for commercial shipping

Class	Lock length [m]	Chamber width [m]	Threshold depth [m]
I	43	6.0	2.2 + 0.6 = 2.8
II	62	7.5	2.5 + 0.6 = 3.1
Iia	75	8.0	2.5 + 0.6 = 3.1
III	75	9.0	2.5 + 0.6 = 3.1
IIIa	90	9.0	2.5 + 0.6 = 3.1
IV	95	10.5	2.8 + 0.7 = 3.5
Va	125	12.5	3.5 + 0.7 = 4.2
Vb	210	12.5	4.0 + 0.7 = 4.7

In this case the width is somewhat limited and therefore the presence of strong guide fenders<sup>32</sup> is assumed as a corrective measure for entry. If these guide fenders are insufficient the lock entrance will have to be wider.

### **The lock approach**

The CVB recommends laying the axis of the lock approach in the extension of the axis of the lock. Furthermore, the lock approach should be straight. The lock approach in figure 4.28 consists of four parts. These will be dealt with in succession.

The lock entrance fulfils three functions for the ships entering and leaving:

- the provision of a visual guide;
- the provision of physical support/guidance of the front of the ship if the ship is not correctly aligned with the lock;
- the prevention of a ship that is a little askew becoming trapped in the lock head.

The angle between the guide fenders and the axis of the canal can vary from 1:6 to 1:4. Curved guide fenders are recommended for locks that have to be suitable for class Va and Vb rather than straight ones.

The marshalling area<sup>33</sup> must offer space to the same number of ships that can be locked in one operation. The width of the marshalling area must therefore be equal to the width of the lock chamber. For the relationship between the length of the marshalling area and the length of the chamber a value of 1.0 -1.3 can be assumed.

The waiting area/lay-by is optional according to the CVB. This facility is only necessary if mooring up is necessary on a regular basis. An exception is made if a separate marshalling or waiting area has to be constructed for ships with hazardous cargo and suchlike. Given that the waiting area has to be constructed in line with the marshalling area, the width of the waiting area is equal to the width of the marshalling area.

The length of the free space must be sufficient to allow the ship entering the lock approach from the inland waterway to lose speed and is dependent on local circumstances. In general, a distance of least  $2.5 * L$  must be available, with L being equal to the length of the design ship.

The depth of the entire lock approach must be equal to that of the connecting waterway and, in order to prevent sedimentation, greater than the threshold depth..

---

<sup>32</sup> geleidewerken

<sup>33</sup> opstelruimte

### 4.3.2 Locks for recreational traffic

The CVB recommends building a separate yacht lock when there are more than 10,000 commercial passages on an inland waterway with mixed traffic. The dimensions of the yacht lock will be dependent on:

- the intensity of the recreational traffic;
- the dimensions of the yachts;
- the dimensions of the maintenance equipment;
- the character of the inland waterway with respect to the recreational traffic; motor, sail or combined route;
- a possible function as a reserve lock for commercial shipping.

As is the case in commercial shipping, recreational shipping also includes so-called classes into which the normative ships are divided. Contrary to commercial shipping, due to the wide variety of dimensions that prevail in recreational shipping, no standard ships (such as the 'Spits' or 'Kempenaar' in commercial shipping), have been established in this case. As a result, the only division made is on the basis of average yacht dimensions. The dimensions have been selected in such a manner that per waterway class only 5% of the vessels have either a greater length, width or draught.

Table 4-9: normative ship dimensions for the recreational fleet and the brown fleet

Class	Sailing boats			
	Height	Draught	width	length
1	8.50	1.25	3.00	9.00
2	12.00	1.50	3.50	10.00
3	12.00	1.75	3.75	11.00
4	>12.00	1.90	4.00	12.00

Class	Motor boats			
	Height	Draught	width	length
1	-	0.90	3.50	10.00
2	2.25	1.10	3.75	12.00
3	2.75	1.40	4.00	14.00
4	3.40	1.50	4.25	15.00

Class	Brown fleet			
	Height	Draught	width	length
BV1	>12.00	1.20	5.50	25.00
BV2	>12.00	1.40	6.50	30.00

In the case of locks intended for commercial shipping, simulation models only have to be used when the volume of traffic exceeds 10,000 ships. According to the CVB, a simulation should always be performed when designing yacht locks. Nevertheless, the CVB still provide a number of dimensions as an indication.

- The threshold depth = the draught + 0.4 metres.
- For 10,000 recreational vessels per year, the lock must be suitable for four ships, (two wide and two long). The length and width dimensions used here are exceeded by approximately 30% of the ships.
- In the event of a traffic volume of 10,000 to 25,000 ships per year, the length should first be extended to a maximum length of 60 metres. The recommended width in this case being 8 metres.
- When more than 25,000 ship pass through the lock per year, a chamber width of 10-12 metres can be chosen for a length of 80-120 metres.

### **The lock approach**

The arrangement of a lock approach for a lock for recreational shipping is in general the same as that for a lock approach for commercial shipping. In this case however different dimensions apply:

- The lock entrance legs can be constructed at a slope of 1:3;
- The marshalling area is equal in width to the lock chamber;
- The length of the marshalling area for a chamber width of 7 metres is equal to 1.2 times the lock length. At a chamber length of 8 to 10 metres, this ratio would be 1.5 to 1.8;
- In small locks, the length of the free space must be a minimum of 60 metres; when 6 yachts are in the chamber the free space must be at least 10 times the length of the normative ship;
- The depth of the lock approach must be equal to the threshold depth.

### **4.3.3 Locks for mixed traffic**

With a mixed volume of commercial shipping and recreational shipping, in the first instance the possibility of constructing a separate yacht lock should be examined (see *lock for recreational shipping*). When that is not possible (financially or physically) a lock for mixed traffic will have to be considered.

Due to the small dimensions of yachts in relation to the commercial shipping, the ship size of pleasure craft does not cause a problem. For comparison: all recreational shipping can be locked in a lock for class I commercial shipping.

The only problem in mixed locking is the number of yachts in the lock chamber. This large volume of traffic requires that measures be taken to allow the lock to function. Chamber enlargement is a good solution. The question however is whether to increase the chamber width or the chamber length. The advantages of a widened chamber over a lengthened chamber are:

- The capacity for separate commercial shipping (in the winter 6 months) becomes significantly larger;
- Recreational shipping suffers less from water turbulence caused by the propellers of the commercial shipping

The disadvantages of a widened chamber over a lengthened chamber are:

- The construction of the lock is more expensive;
- The safety of the recreational shipping becomes an issue earlier.

Due to the increased safety, the CVB recommends an extended lock in which case the commercial shipping would be expected to depart slowly, thus enabling propeller water turbulence to be kept to a minimum.

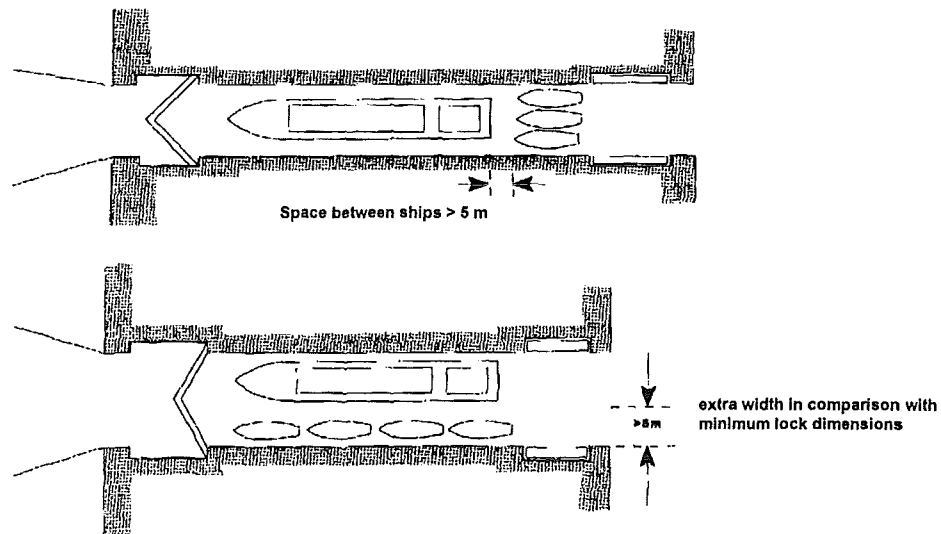

Figure 4-29: two types of lock enlargement

### The lock approach

Several modifications to the lock approach are required for commercial shipping:

- If there is a lot of recreational shipping, it is advisable to provide a separate marshalling area with a minimum length of 30 metres.
- With a single sided marshalling area for commercial shipping, the marshalling area for the recreational traffic on the other side should be as close to the lock as possible.

## 5 Vessel Traffic Service

### 5.1 Introduction

A Vessel Traffic Service (VTS) can be described as follows:

*“A VTS is a service implemented by a competent authority, designed to improve the safety and efficiency of vessel traffic and to protect the environment. The service has the capability to interact with the traffic”.*

A VTS comprises a total package of people, resources and rules of conduct that, in interaction with the traffic participants, is aimed at promoting the smooth and safe handling of shipping traffic and protecting the environment in a specific area. The primary task of a VTS is of a *preventive* and *curative* nature. The preventive task of traffic supervision consists of the prevention of accidents and the promotion of smooth traffic handling. That means that individual barge captains must remain informed with respect to the traffic situation, that traffic supervisors must anticipate vessels meeting and that the flow of traffic should be well-regulated.

The curative task of traffic supervision consists of limiting the consequences of accidents or incidents. This means that a VTS must always be capable of making an immediate analysis of an accident in order to subsequently alert the emergency services. A VTS must also be able to inform the remaining vessels with respect to any problems that have arisen. Furthermore, a VTS should also ensure that in case of an accident, traffic is still handled in an orderly manner. The Shipping Traffic Act offers two legal instruments to support the tasks described above:

- The issuing of traffic information
- The provision of traffic directions

Legally, a traffic direction is an order given by a duly authorised person to one or more traffic participants in order to effect a specific result in the flow of traffic. A barge captain must therefore always obey the traffic directions given by a traffic supervisor.

Furthermore, the VTS's also fulfil several other functions, such as the issuing of lock and harbour information and the gathering of shipping data.

## 5.2 History

During the last ten years Vessel Traffic Services have become increasingly important on the inland waterways. Following the example of ocean shipping, VTS has now also been introduced in specific shipping areas of inland navigation. This has become particularly necessary due to the increase of shipping traffic, scale increases and a rise in the volume of hazardous substances being transported.

The somewhat dated government measures appeared to be far from sufficient, and it is for that reason that nowadays the authorities act far more assertively in striving to remedy traffic bottlenecks on waterways. That initially began with patrol boats. However, as a result of essential cutbacks the preventative task of these patrol boats was shifted to a curative task (acting in case of calamities), and with the subsequent implementation of traffic posts it became apparent that the preventative task could be carried out more cost-effectively from the shore.

The first real 'traffic post' was established in Brienoord in 1966. In contrast to the 'bad weather posts' that had existed up until that time, this post provided shipping with continuous radar information. Following this, in 1974 the post in Dordrecht was established, which during the 80's grew into a fully-fledged vessel traffic service. Tiel and Nijmegen followed shortly after. In the early 90's the VTS in Dordrecht was given a facelift, and in 1997 the VTS on the Amsterdam Rhine Canal was completed.

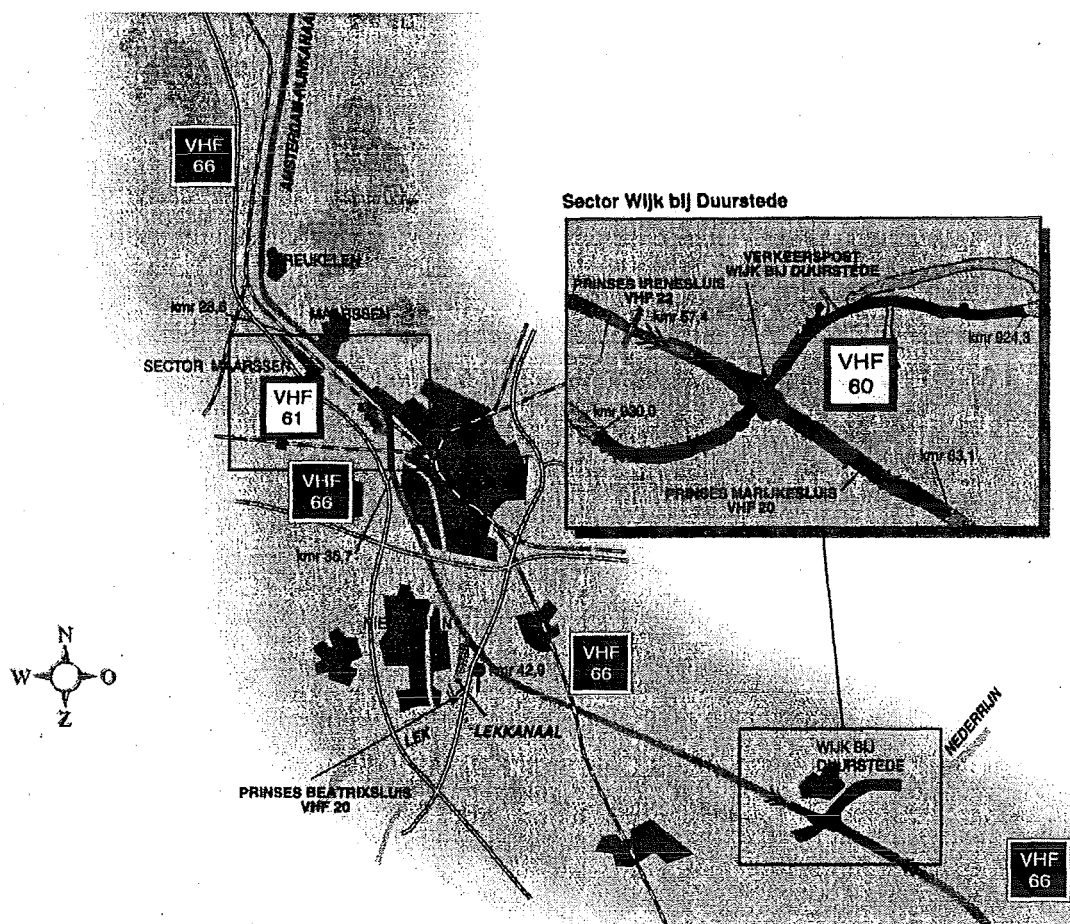

Figure 5-1: VTS area

Up until the year 2000 the main priority will be the modernisation and optimisation of the VTS in 'de Waal' region (see also figure 2.8 below). The development of the radar system has had an important influence on the realisation of the present VTS system.

### 5.3 Radar systems over the years

- *First generation of shore radar systems*

During the 70's these radar systems had two advantages in comparison to the first radar systems of the early 50's. With this new system it was possible to make use of the radar under daylight conditions. Furthermore, the area served was much greater as a result of establishing unmanned radar stations that were coupled to the VTS by microwave radio links.

- *Second generation of shore radar systems*

At the end of the 80's two things changed with respect to the first generation of shore radar systems. With the aid of new technology (digital scan conversion), the monitors obtained greatly improved picture quality. Additionally, due to the use of telephone lines instead of the expensive microwave radio links to distribute the radar information, it also became possible to obtain all radar information during bad weather conditions.

- *Third generation of shore radar systems*

Nowadays radar images are 'translated' by a computer into an attractive computer image of the waterway. Furthermore, identification data on the radar monitors is coupled to the vessels displayed. Vessels are also labelled, enabling a traffic post to directly couple data from a specific vessel to the system. All information is then simply passed on, so that the other traffic posts can call up all the data required about a specific inland waterway vessel on the screen immediately, without any further loss of time.



Figure 5-2: modern radar screens



## 5.4 *Vessel Traffic Service Amsterdam-Tiel*

By way of illustration, in this paragraph the VTS area Amsterdam-Tiel is discussed, (see fig. 5.3).

Traffic control was implemented at the junction of the river Lek with the Amsterdam-Rhine canal at *Wijk bij Duurstede* as long ago as 1952. In 1958 a permanent post was established at *Wijk bij Duurstede*.

The location of the post was chosen due to the excellent view offered for good visual contact between the post and the barge captains (despite advanced radar equipment visual contact remains important).

In 1992 the safety standards were established. This resulted in three problem areas on the Amsterdam-Rhine canal:

- The barrage<sup>34</sup> at Amsterdam
- At Maarsen (at this point the canal is only 70 metres wide, whilst a width of 100 m is available everywhere else)
- At the junction of the canal with the river Lek (*Wijk bij Duurstede*)

The first two points were new, whilst the post at *Wijk bij Duurstede* required upgrading. At present clear radar images of the shipping traffic are generated in the traffic post by having a computer interpret radar images that originate from radar posts located along the shore.

Separate channels are used for the various segments to which everybody is required to report.

### ***Safety***

There is a total of approximately 100,000 shipping movements per year. In a bad year there are only five collisions. For that reason, instead of supervising the shipping traffic, the main task of the post has become the provision of information to barge captains. As instructions can be given to vessels approaching locks, for example, the post has a perceivable influence on shipping traffic. As such vessels can easily enter a lock at the right moment (resulting in reduced fuel consumption).

In the future it is expected that there will be a computer on board every inland waterway vessel, thereby enabling every vessel to also see what the post can see.

In order to promote safety, traffic post personnel are instructed to be brief, businesslike and precise, with re-examinations being held once every three years. As from May 1<sup>st</sup> there will always be 2 people working in shifts in the post 24 hours a day.

### **Interaction with pleasure cruising**

Whilst there are only 9000 commercial vessels, there are some 250,000 yachts in The Netherlands, for which reason interaction with the pleasure cruising traffic is extremely important. That has resulted in as much technical jargon as possible being removed from communications (this now also forms part of the new training scheme). Every vessel must indicate the name of the vessel, its position and its destination. However this does not always work in practice. More than 50% of the yachts do not

---

<sup>34</sup> keerschuij

possess a marine telephone, but the post nevertheless still provides inland shipping with details of pleasure craft positions on the waterway. Inland shipping most certainly finds pleasure craft a hindrance. For the varsity, for example, the canal may not be navigated for one hour beforehand due to the surge created as a result of the straight vertical sheet-pile walls.

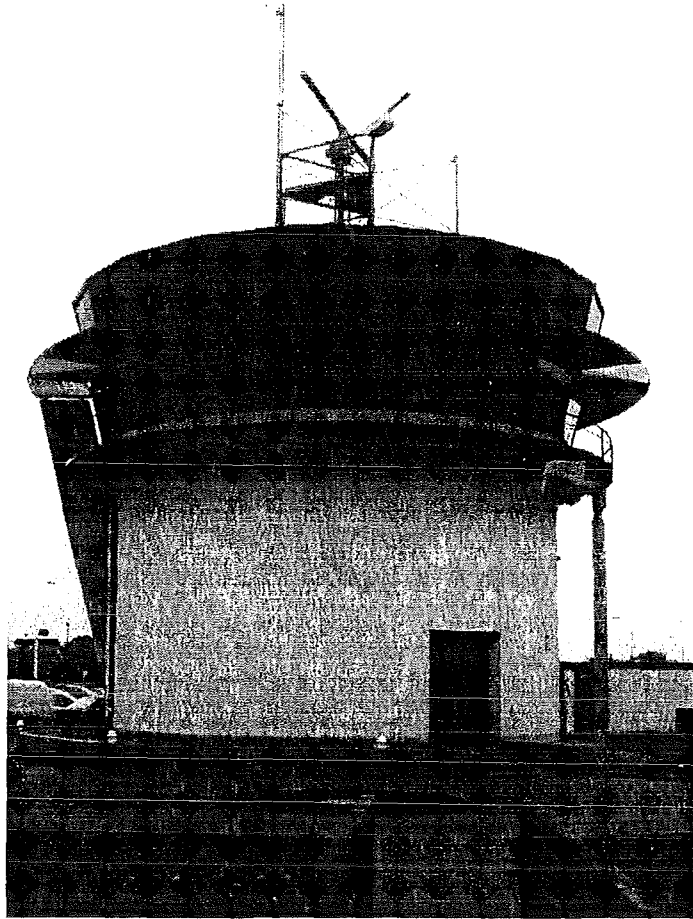
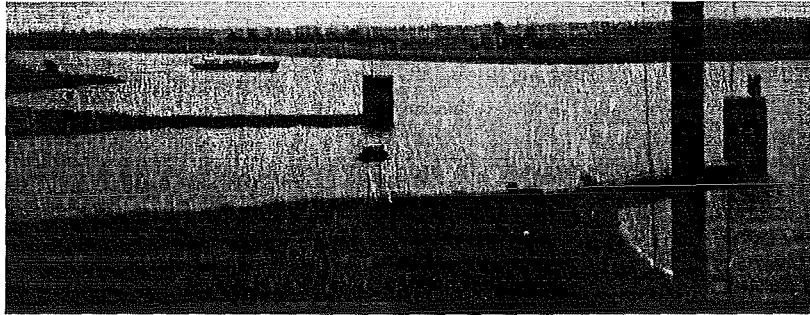
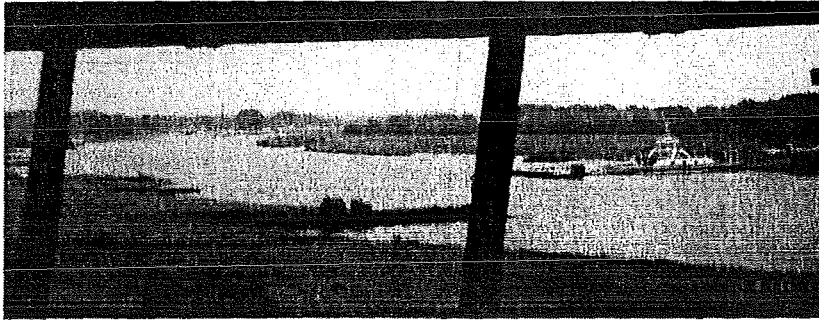

Figure 5-3: *Views from the outside of the Post at 'Wijk bij Duurstede'*



*Figure 5-4: The view from left to right*

### **5.5 Registration and utilisation of the Netherlands' inland waterway network**

The government has been engaged in analysing the flow of traffic and transport in the shipping industry for many years. As such the government has been using information and tracing systems in an attempt to provide answers to questions such as *How is the inland waterway network utilised?* and *Where do what types of ships operate and with what loads and draught?*. On the basis of the information obtained it will be possible to adjust policy, thereby enabling future bottlenecks to be recognised well in time. Since 1994 the IVS90 system has been in operation. IVS stands for '*Informatie Verwerkend Systeem*' [Information Processing System]. This system covers 80% of The Netherlands' main inland waterway network and operates as follows. Ships report in when entering the IVS90 area and are followed during their journey. During that time interim progress reports are made. The IVS90 area consists of a collection of so-called IVS90 blocks. These blocks together form the IVS90 network. The IVS90 network is configured by the regional IVS90 managers, and each IVS90 block is allocated a unique number. This unique number subsequently provides a correlation between the shipping data in IVS90 and the digital inland waterway network. A considerable amount of data with respect to transport over water is therefore available. However, these figures are always related to just one area in the network. By correlating the information from the various IVS90 blocks to one another information can then be obtained with respect to the route chosen per journey. With this travel information it is possible to obtain shipping traffic statistics regarding all IVS90 journeys made during a specific period. It is then possible to plot and illustrate those journeys on a chart. Using the VOIR (View Of IVS90 Routes) system it is then possible to view the current shipping traffic intensity on IVS90 waterways. All data regarding ships travelling in The Netherlands are fed through to this system every five minutes.

## 6 Safety<sup>35</sup>

### 6.1 Introduction

An important contributory factor to the capacity of a waterway is the level of safety required on that waterway. After all, safety promoting measures such as reductions of navigational speed, prohibiting overtaking or the introduction of one-way traffic all have an influence on the capacity of a waterway.

The Netherlands is one of the most densely populated industrialised countries in the world, where space for living, working and nature is scarce. Choices often have to be made whereby economic advantages, environmental issues and safety all have to be weighed up against one another. In the transport sector that is aimed at the transportation of 'hazardous substances' in particular. In the Netherlands the question as to whether and to what extent the handling of hazardous substances could conflict with the safety of the immediate environment is one that is constantly dwelled upon at great length.

As a result of the extensive chemical and petrochemical industry in The Netherlands and the surrounding countries, there is a question of widespread distribution and transit of hazardous substances. At least 10% of the total flow of goods consists of hazardous substances. For road transport that is approximately 5%, between 25 and 40% for rail transport and some 25 to 30% on the inland waterways. (Transportation through pipelines has not been taken into consideration in this case). Table 6.1 illustrates the annual transport volume per transportation mode.

Table 6.1: *Transport of hazardous substances*

Mode of transport	Transport flow (million tonnes/year)	No. of loads per year
Road	20	0.8 million vehicles
Inland waterway	55	0.06 million vessels
Rail	5	0.2 million railway tank wagons

In this case a distinction is made between:

- a. *External risks, which include:*
  - the individual risk
  - the group risk
- b. *Internal risks, which include:*
  - the risk to shipping traffic itself.

As far as the external risk is concerned, in The Netherlands attention is focused on the problematic nature of the risk faced by the surrounding population should an accident occur in which an explosive, flammable or toxic substance is released.

<sup>35</sup> Adapted from 'Kansen in de Civiele Techniek, deel 1: probabilistisch ontwerpen in theorie'

The following factors play a role:

- The extent of the flow of transport, which is a determining factor in the chance of accidents with an effect on the immediate environment
- The type of hazardous substances, which is a determining factor in the effects on the immediate environment
- Traffic safety, which is a determining factor in the risk of major accidents
- The number of people that live, work, recreate, etc. along the route, which is a determining factor for the number of possible fatal casualties

The combination of these factors determines the risk level for specific locations along transportation routes.

Due the great volume of international transport, the demands made on ships to limit these risks to a minimum are often drawn up on an international level. The international regulations can be seen as a precondition for a certain level of safety.

On the basis of the general acceptable risks, an assessment can be made as to whether locally applicable risks are acceptable, and if necessary various measures for limiting such risks can be considered.

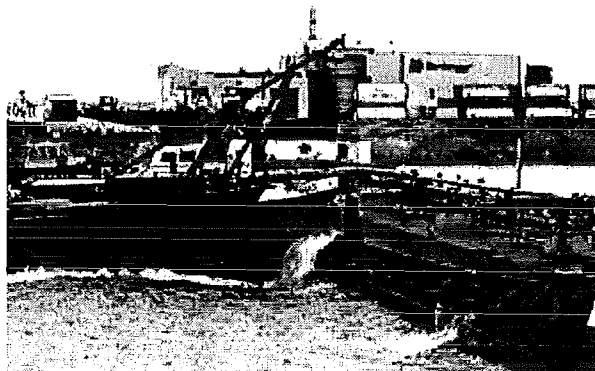

Figure 6.1: *a colliding ship*

In calculating the risk, standardisation of the calculation method applied is extremely important. Only then can a specific decision be made objectively and without prejudice. In this risk calculation chance multiplied by consequence is assumed, i.e. the chance of an accident and the damaging effect that such an accident could have on the immediate environment are the most important factors used in calculating the risk.

As stated, a distinction is made between the risk that one person faces (the so-called individual risk: the possibility of fatal injury) and the total seriousness of an accident (to so-called group risk: the possibility of a specific number of casualties). The individual risk gives rise to a possibility of a fatal situation arising at a specific location due to the performance of a specific activity. By increasing the distance of the activity being considered, the risk of (fatal) injury is reduced. Locations with equal risk can be indicated on a chart by means of so-called risk contours (in a manner similar to that used for height contours on a topographical map). With that the individual risk factor is well-suited for use in establishing a safety zone between the route and vulnerable destinations.

The group risk provides an assessment of the risk of a disaster with a specific number of fatal casualties. Therefore the number of persons residing in the vicinity of the route consequently also determines the extent of the group risk. Accordingly, the group risk thereby focuses specific attention in terms of possible disaster situations, and can subsequently be put to great advantage in a 'disaster plan'. The group risk can also be used for comparing route alternatives, whereby the total group risk is calculated for each route alternative, and the results obtained then compared in relation to one another.

Another important fact is that people face many risks in daily life, but interpret them differently. As such, the risk of death as a result of illness, although dependent on age, nevertheless remains substantial. The risk of death is to a much lesser degree determined by road traffic accidents. The risk of death as result of accidents in which hazardous substances are involved is in turn even smaller than death as a result of road traffic accidents for example. Of far greater importance however is the magnitude such an accident may have, with the possibility of multiple victims, or even hundreds of victims in the event of major disasters. Society considers the latter risk far less acceptable.

In the risk analysis a number of possible chance-consequence combinations have been drawn up. In most cases this number runs into hundreds. Account is taken of diversity in loads, the prevailing types of ships, differences in the strengths of ships, the prevailing weather conditions and the accident data up to the present. A calculation is then made of what damage might occur in the vicinity with respect to all possible accident situations.

Of course, in addition to external safety, the safety of shipping traffic also plays an important role.

## **6.2 Risk analysis**

Before an analysis of risks can be made it is necessary to give further consideration to the definition of risk. The risk of an activity is calculated as the product of the probability of an undesired event, occurring when performing the activity, and the consequences of that event. A risk analysis can be used for a number of purposes, such as for assessing safety, or the economic optimisation of processes and objects. A general objective of risk analysis is to provide a basis for making rational decisions.

The first step in the risk analysis is to map out all possible undesirable events and the consequences thereof. If a system or one of its components no longer fulfils one or more required functions, we speak of a failure. The condition of failure can be realised by following a number of different approaches. Such an approach, that eventually leads to failure, is known as a failure mechanism. The condition whereby failures are precisely at the point of occurring, is known as a limit state. It is extremely important that the most comprehensive overview possible is available of all failure mechanisms, before a quantitative analysis can be started. In fact, in practice more accidents result due to failure to recognise mechanisms than as a result of incorrectly analysing a mechanism.

In this quantitative risk analysis the following probabilities should be established:

- The probability of undesirable events occurring
- The probability of an undesirable event leading to a possible effect
- The probability that this event will lead to the contemplated consequences

In the risk analysis use is made of a so-called reliability function. Reliability is defined as the probability of the limit state not being exceeded. The general form taken by a reliability function is:

$$Z = R - S \quad (6.1)$$

in which R is the strength or resistance to failure and S is the load, that which promotes failure. Z is the reliability function of the system.

In figure 6.2 this reliability function is in the RS plane, with the indicated latitude for failure. The border condition is the line  $Z=0$ .

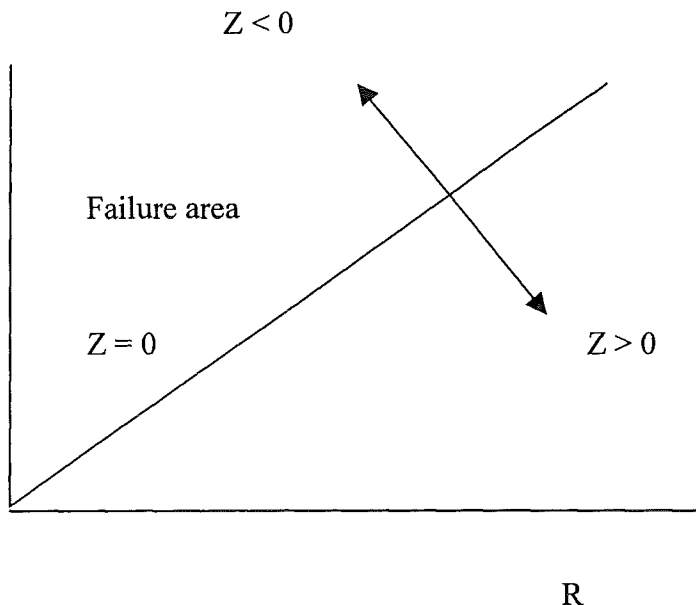

Figure 6.2: Reliability function in the RS plane

### 6.3 Probability of failure in practice

One of the possible failures of a canal system is the exceeding of the canal's limits on both sides. Calculations could be based on the assumption of a normal distribution of extreme ship positions in the cross-section of a canal.

In figure 6.3 an example is given of the manner in which the extremes on both sides of the ship are measured. Both Y-PT and Y-SB are measured with reference to the canal axis. To estimate the chance of failure the ship's positions in the canal should be registered. The mean and standard deviations then have to be calculated in order to estimate the probabilities of exceedance on both sides.



In figure 6.4 an example of the probability of exceedance on the port and starboard sides is given, based on a normal distribution. The probability of exceedance on the starboard side, for example, for one canal passage can now be calculated. This is achieved by first computing the z value and integrating the normal distribution between this z value and infinity.

$$z = \frac{\text{channel\_limit(SB)} - \text{mean\_YSB}}{\text{sigma\_YSB}} \quad (6.2)$$

The probability of exceedance will be:

$$\int_z^{\infty} \frac{1}{\sqrt{2\pi}} e^{(-z^2/2)} dz \quad (6.3)$$

If this chance is too high, measures should be taken to reduce the probability of exceedance.

The chance of failure of the canal system when considering ship collisions is not easy to estimate. Figures with respect to the chance of collisions in case of an overtaking or an encountering manoeuvre should be available, and would have to be monitored in practice. Nevertheless, it is quite clear that this chance is highly dependent on the intensity of traffic.

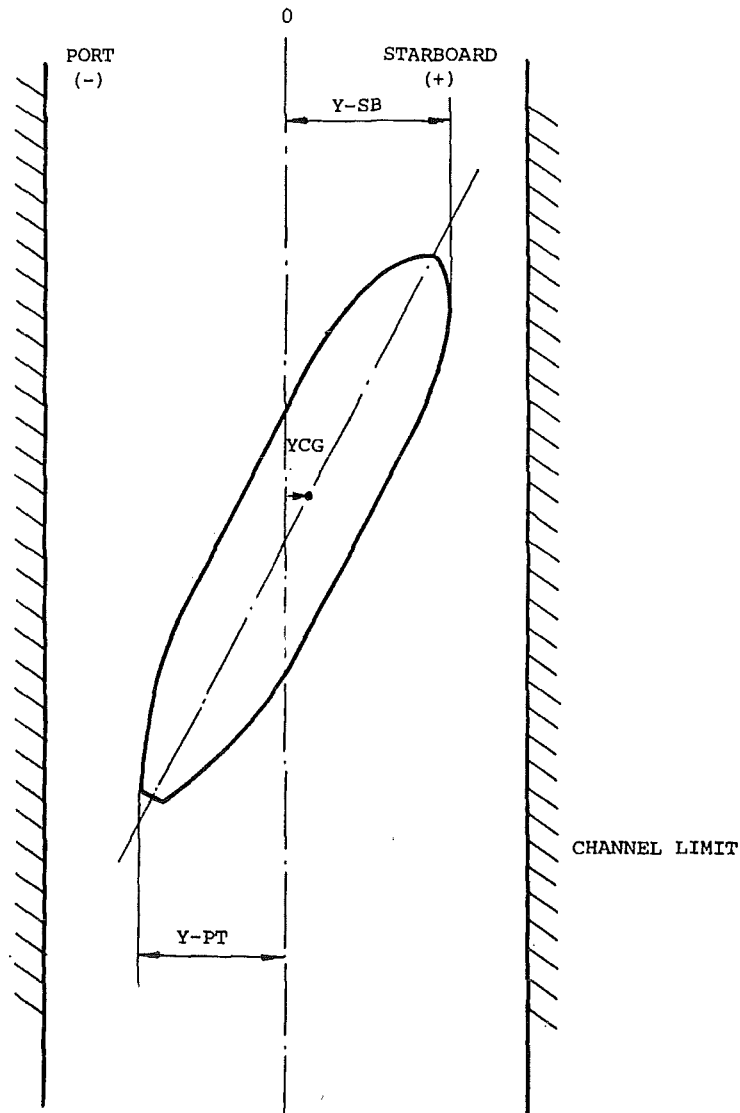

Figure 6.3: measuring extreme values of the position of a ship

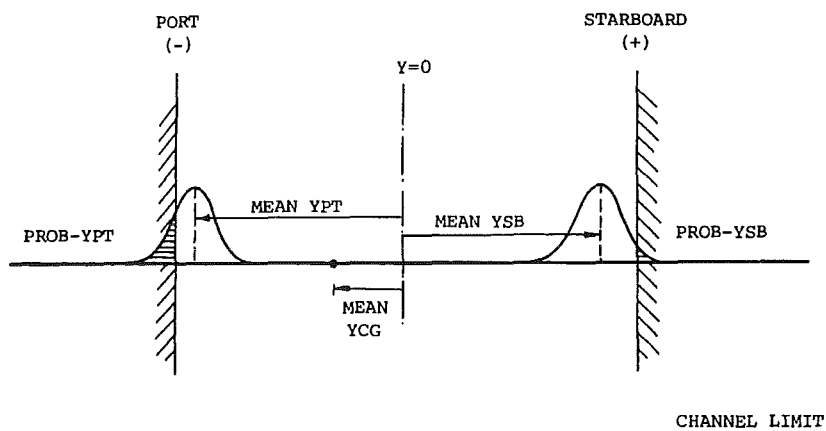

Figure 6.4: probability of colliding with the shore with the aid of the normal distribution

## 6.4 Codes

The purpose of using risk codes is to be able to approach risks in a consistent manner. As these codes quite simply did not yet exist, the competent authorities decided to set up a study for this purpose. That study was carried out in the mid 90's, by order of the Ministry of Housing, Physical Planning and Environment and the Ministry of Transport, Public Works and Water Management.

The choice of norm level was based on a calculation of the risk levels for a large number of locations. The final choice for the norm level was on the one hand determined by the endeavour to keep risk levels in transport sector as low as possible, and on the other hand by the desire to limit the number of possible future situations in which codes might be exceeded. This requires further explanation: If only the first demand is examined, the safety standards would have to set quite a high level, resulting in adjustments being required for virtually all dangerous points in inland navigation.

However, if only the feasibility and affordability of the adjustments were taken into consideration, the codes would have to remain as low as possible.

As a result, the choice of norm was determined in the field of tension between these two demands.

The study consisted of three phases:

- The development of calculation methods, in particular for the assessment and evaluation of the group risk, whereby the dynamic character of the transport was taken into account.
- A comparative study to assess the practical application of the possible norm options.
- A study into the consequences of risk codes for this transport. This involved an examination of the number of possible locations for which measures would have to be considered in order to meet the codes chosen, including the costs involved and any possible environmental consequences.

Rough calculations were made for relevant locations throughout the Netherlands. The risk level was calculated for a total of 3000 locations, following with an estimation could be made of the number of locations with a risk higher than a specific norm value. The measures that would be necessary to reduce the risk levels to a sufficient degree subsequently provided an illustration of the consequences connected to a specific norm value. The norm was then determined on the basis of the consequences, and at a value whereby the number of locations exceeding that norm remained limited.

In practice these values boil down to the following. As far as the individual risk is concerned, the limit value has been established at  $10^{-6}$  fatal accidents per year (only permitted for vulnerable destinations at locations whereby the chance of a death resulting from an accident involving hazardous substances on the route under consideration is no greater than one in a million per year). For new situations this value is the limit. For some existing situations the chance of an accident appears to be higher than  $10^{-6}$ . For situations such as those the *standstill* principle applies for new developments, until such a time that the norm is satisfied. As in these cases there is often a question of a situation that has developed, in such cases it will not always be possible to satisfy the proposed norm in the future. It has therefore been proposed that only those areas that have an individual risk of more than  $10^{-5}$  require urgent reorganisation. Such situations were not indicated in the study.

In exceptional cases the limit values may be departed from. This consideration does however have to be submitted to the ministries involved for approval. As a result the State then becomes partially responsible for situations in which a higher individual risk is accepted. Among the matters that may play a role in this consideration are:

- Disproportionate costs involved with satisfying the norm
- International interests
- Alternatives bearing greater risks
- The low level of exceeding limits in a specific area, with attention also being given to the developments in transport

On the basis of the individual risk, adjustments were found to be necessary in 5% of the cases studied as a result of the risk norm being exceeded. In 95% of the 'points of attention' a 100 metre zone on both sides of the route on which vulnerable destinations were unable to be realised, or only realised to a limited extent, was sufficient to bring safety back within the limits set out in the norm.

Different figures apply as far as the group risk is concerned. Firstly a measure of distance is required to which the group risk applies. Research has revealed that a length of 1 kilometre is more than adequate for this purpose. This consequently results in an orientation value being arrived at for the group risk per km. of route of  $10^{-4}$  per year for 10 victims;  $10^{-6}$  per year for 100 victims, etc.

One unusual aspect, however, is that the local and regional authorities are free to deviate from these orientation values. If that is the case it must be shown that a public and perceptive examination in weighing up rights and obligations has been made, based on the basic situation that meets the orientation value for the group risk, and in which an indication is given as to why in that specific case a departure from the norm is necessary.

In practice this group risk norm means that in the most extreme case, limitations may be applicable with respect to the possible density of building developments in a maximum zone of 200 metres on each side of the routes concerned..

## References

- [1] 'Lock capacity and traffic resistance of locks', ir. C. Kooman & P.A. de Bruijn, 1975
- [2] 'Praktijkwaarnemingen van vaarsnelheden voor een Kempenaar op de Zuid-Willemsvaart', Rijkswaterstaat, 1980
- [3] 'Vaarwegennota', Ministerie van Verkeer en Waterstaat, 1981
- [4] 'Struktuurschema Vaarwegen, deel d: regeringsbeslissing, Ministerie van Verkeer and Waterstaat, Ministerie van Volkshuivering en Ruimtelijke ordening, 1981
- [5] 'Struktuurschema Vaarwegen, partiële herziening inhoudende toevoeging hoofdvaarwegen i.v.m. recreatievaart, deel a: beleidsvoornemen', Ministerie van Verkeer and Waterstaat, Ministerie van Volkshuivering en Ruimtelijke ordening, 1981
- [6] 'Capaciteit van binnenscheepvaartwegen m.b.v. simulatiemodellen', Stichting Postacademiale Vorming Verkeerskunde, A.J. Bekendam and W. de Ruiter, 1981
- [7] 'The use of simulation techniques as a tool for vessel traffic management', (Schip en Werf, jrg. 48, no. 12, pp. 195-199), P.P. Noë en W. Veldhuyzen, 1981
- [8] 'Guyana navigability study', Marin (Maritime Research Institute Netherlands), july 1984
- [9] 'Weerstand en capaciteit van scheepvaartwegen' (f13N), Ir. J. Bouwmeester, 1988
- [10] 'Zeevaart op binnenwateren', TRAIL research school, november 1995
- [11] 'Richtlijnen Vaarwegen', Commissie Vaarwegbeheerders, june 1996
- [12] 'Kansen in de Civiele Techniek, deel 1: probabilistisch ontwerpen in theorie', CUR (Civieltechnisch Centrum Uitvoering Research en Regelgeving), march 1997
- [13] PAO-course november 1997:
  - 'Veiligheid vervoer over water', R.Ph.A.C. Saveneije
  - 'Infranetwerken, prognoses en ruimtelijke analyse', J.U. Brolsma / R. Visser
  - 'Verkeersbegeleiding en telematica', C.P.M. Willems / L. Kluiters
  - 'Verladerseisen aan vervoer en binnenvaart', J. Tjalma
  - 'Vaarwegenbeleid Rijksoverheid en CCR', A.J. Veraart
- [14] 'Het binnenschip ontwikkelt vaart', Volkskrant, 21 november 1998



## Appendix i: The future of the River Maas

### The history of the Maas

The Maas was canalised in the middle of the 20's. Important projects have included the Juliana Canal (a 35 kilometre long canal that runs parallel to the river), the Maas-Waal Canal and the St. Andries Canal, that both form a connection between the Maas and the Rhine.

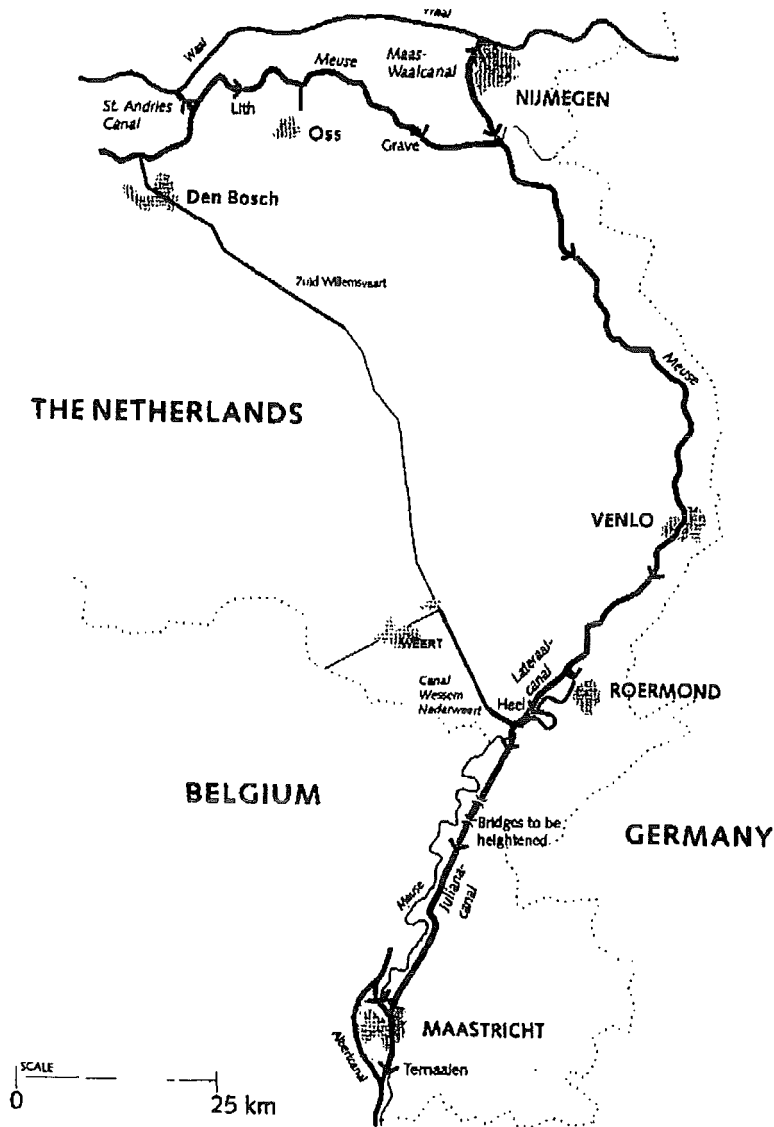

Figure i.1: *The Maas basin in the Netherlands*

The Maas forms good connections between the Port of Rotterdam, the German Ruhr area, the industrial region around Liège and the Port of Antwerp. This 'circuit' offers excellent opportunities for the Maas, especially in the area of container shipping.

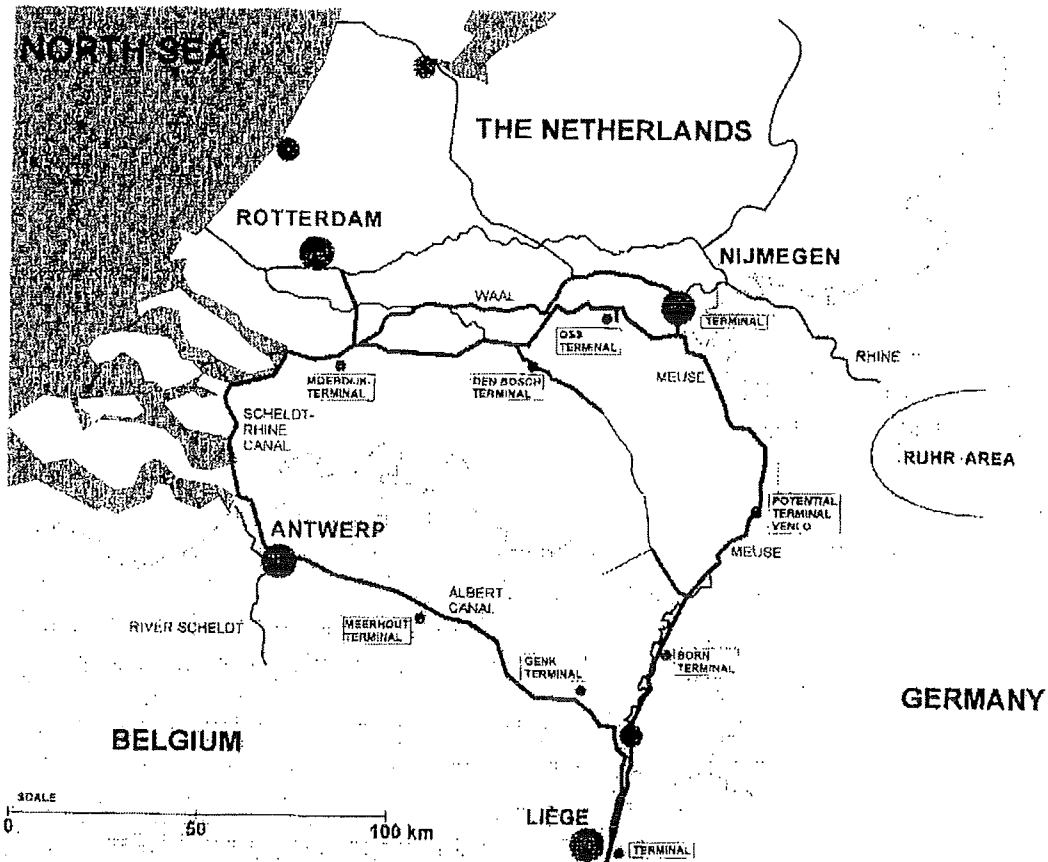

Figure i.2: The 'circuit' through the Netherlands, Germany and Belgium

The most important goods transported over the Maas are sand, gravel, and other raw building materials. The prognosis is that the transport of gravel will decline, but that this will be accompanied by a rise in the levels of other goods, and to such an extent that the volume of transport will remain the same. The transport of containers in particular will see an increase. It is expected that a total of approximately 100,000 TEU per year will be transported in the year 2010.

### Government plans

The intention of the government to make the Netherlands a distribution country, or to maintain it as such, has several consequences for inland shipping. The fact that roads are increasingly contributing to congestion and environmental problems is creating additional opportunities for inland shipping. The government is stimulating this with the SVV-II plan, which states that the Maas must be made suitable for 'Rhine sized' ships (110 x 11.40 x 3.5 metres) and double barge convoys (190 x 11.40 x 4 metres).



### The Maas after 2010

As a result of the extent of the government's plans it will take at least 10 years before they are implemented. For that reason the Department of Public Works is looking many years ahead in their plans for the future. In this framework the Department of Public Works has developed three visions for the future, which are intended to predict what will occur in inland shipping between 2010 and 2050.

In the first scenario ('Innovative Inland Shipping') it is expected that the market will begin to operate in a far more customer orientated manner. This scenario was underlined by an article that was published in 'de Volkskrant' in November 1998 (see appendix ii).

The second scenario is entitled 'Tariffs and Incentives', and is based on the expectation that the change in the market predicted in scenario will be financially supported by the government, with consideration for example being given to imposing extra surcharges on road transport.

The third and last scenario, named 'distance rule / obligation', assumes that in the future it will no longer be possible to transport goods over distances of more than 150 kilometres via motorways. This will cause explosive growth in the transportation of goods over water.

The consequences of these various scenarios are described in tables i.1 to i.3 below.

Table i.1: *Expected volume of traffic in millions of tonnes whereby modernisation is not taken into account*

Year	1994	2010	2050
<b>Scenario</b>			
1	38	41	41
2	38	41	51
3	38	41	70

Table i.2: *Expected volume of traffic in millions of tonnes whereby modernisation is taken into account*

Year	1994	2010	2050
<b>Scenario</b>			
1	38	41	62
2	38	41	77
3	38	41	105

Table i.3: *Reduction in the growth of goods transport on motorways.*

Year	1994	2010	2050
<b>Scenario</b>			
1			38%
2			46%
3			64%

Other developments to be expected in inland shipping are an increase in the size of the average ship and the modernisation of ships. At present it is the locks in particular that create bottlenecks in the waterway system. With some level of adaptation it is expected that the average capacity of a ship will increase to 1500 or even 2000 tonnes by the year 2020.

When all of these developments are taken into consideration, a number of predictions can be made with respect to the Maas should no improvements be made to the river:

- The level of safety on the Maas would possibly be reduced
- Traffic congestion would occur on the Juliana Canal and at locks
- The required number of larger ships and innovation would remain unattainable

For that reason the Department of Public Works wishes to introduce several improvements that can be divided in to three groups.

1. *Infrastructural work to be carried out up to the year 2000*

This concerns capacity enlargements of locks, bridge heightening and maintenance work (total costs: 400 million guilders).

2. *Infrastructural work to (probably) be carried out between 2000 and 2010*

In this case consideration is being given to a widening of Juliana Canal, the enlargement of a number of locks and the heightening of some 15 bridges in the southern part of the Juliana Canal (total costs: 500 million to 1 billion guilders).

3. *Non-infrastructural improvements*

These can be split up into active stimulation of inland shipping by the government, the plans for industrial areas located in the vicinity of waterways, so that it becomes financially more attractive to make use of inland shipping as a means of transport and expanding the use of telematics, thereby providing inland shipping with an advantage over road transport from a technical point of view (e.g. consider VTS and IVS-90).

## Appendix ii: An article from 'de Volkskrant'

From: 'de Volkskrant', Saturday 21 November 1998

### Inland shipping building up steam

*Inland shipping is becoming more innovative and professional. Without subsidies, whilst the government is pumping billions into the High Speed Rail Link (de Betuwelijn). According to the Ministry of Transport, Public Works and Water Management, transport over water has increased by 30% during the last five years.*

'Big? Huh! In a manner of speaking a ship like this could still be navigated through a ditch', says skipper Henk Wanders., standing proudly on the superstructure of his new container ship. At his feet lies the 135 metre long and 17 metre wide 'Amistade'. It is Wanders second container giant intended for the inland shipping network.

Less than six months ago the inland shipping captain caused a great deal of commotion by introducing the 'Jowi' onto the waterways, an inland shipping colossus capable of carrying twice as many containers as other ships. The Jowi brought inland shipping, which has been saddled with a bad image for many years, right back into the picture. Transport economists and shippers expressed their great admiration for the innovative strength and efficiency of the inland shipping captains.

The contrast with the cumbersome, expensive and monopolistic railway system could not be greater. 'As progressive and revolutionary as inland shipping is, so conservative is the railway system', says Rotterdam consultant Nico de Raadt, who works for the American shipping line 'SeaLand', among others.

'The railway system is extremely inefficient. Even if you were to charge-on the cost of road construction in form of tolls or suchlike, roads would still be cheaper than rail', states distribution manager E. van der Werff of Shell Chemicals in the publication 'Transportvisie'. For that reason Shell transports 60% of its products by road..

According to Van der Werff the infrastructure is not being utilised in the correct manner. Shell has therefore closed a covenant to intensify transport via inland shipping.

During the last five years inland shipping has become extremely efficient, contends consultant De Raadt. 'They are all independent entrepreneurs. You can see that with the Jowi. The owner, Wanders, is continually occupied with modernisation. These people have their own capital invested in the ships, the owners themselves can often be found at the helm and they continue trying to improve their effectiveness every minute of the day'.

In De Raadt's opinion larger ships constructed from lighter materials are one of the most important characteristics of the wave of modernisation sweeping through inland shipping, 'A skipper is no longer a man with a sailor's hat and a pipe. He has become an entrepreneur with a considerable bank loan.'

Wanders supports this story. 'The Jowi sails 365 days a year, 24 hours a day. We earn a reasonable wage, but we have to work extremely hard'. Together with his wife, two

sons and future daughter-in-law he lives and works on the container giant. 'If you don't support one another, you just can't survive'.

In addition to his family, Wanders is also happy with the support and cooperation given by the banks and the Combined Container Service (CCS). Whilst the High Speed Rail Link (*de Betuwelijn*) has been of no interest to any private parties, investors have placed a considerable amount of money in the ships costing a total of 22 million guilders. CCS, who transport 230,000 standard containers over the Rhine, and has a third of the market in its hands, charters ships and guarantees the cargo. 'They are just as important as the ship, because you cannot arrange the loads yourself', says Wanders.

With the Jowi, which is able to operate at even lower costs due to its enormous capacity, inland shipping appears to be making a substantial comeback. From 1980 to 1995 the growth of goods transport in Europe was completely swallowed up by road transport. Although rail and inland shipping transport dropped slightly, in recent years inland shipping transport has been undergoing tempestuous development. According to figures from the Department of Transport and Public Works, the transport of goods over water has increased by 30% over the last five years. In particular the liberalisation of inland shipping has made the barge captains more innovative and professional according to the Central Bureau For the Rhine and Inland Shipping (CBRB), the most important pressure group representing ship owners and captains. The CBRB expects that growth will continue and that container transport over water will have doubled by 2010.

One striking aspect is that the captains have realised all this completely under their own power, without a single penny of government support. 'Subsidy?', Wanders breaks out laughing, 'We are ones that pay out subsidies, I shortly have to pay 1.9 million guilders to Brussels in order to allow the *Amistade* to sail'.

According to the Ministry of Transport, Public Works and Water Management, this regulation was introduced because until recently inland shipping was characterised by structural overcapacity. In order to create a healthy market it was necessary to create a balance between supply and demand'.

On the basis of this regulation Wanders has to pay 155 Euros (344 guilders) for every tonne of loading capacity that he introduces into the market. Another option is to purchase old ships and exchange the old tonnage for new.

Wanders just can't understand it. Together with his business partners, Henk Middelkoop, who together with his two brothers will be responsible for sailing the *Amistade*, can only look on in envy whilst the government pumps billions of guilders into the '*Betuwelijn*' High Speed Rail Link. In their opinion inland shipping could cater for a great deal of the flow of goods. 'There's more than enough capacity on the water, and furthermore, the *Betuwelijn* follows the same route that we follow over the river Waal'.

Nevertheless, the barge captains do not want to become dependent on government support. 'In the long run you gain far more strength if you do it yourself', says Middelkoop.

Due to the level of congestion on the roads, inland shipping is running with the wind. The barge captains have no competitors to fear wherever water destinations are concerned. For the load carried by one Jowi alone you would need a convoy of trucks four kilometres in length. Despite this, many shippers do not always make the choice for water transport as a matter of course. Its old, negative image still continues to haunt inland shipping.

In addition to that, a great number of destinations in Europe do not lie on the water, making it necessary to transfer the cargo onto trains or trucks, which raises costs considerably. A great many shippers are also deterred by the long journey times over water, which is unnecessary according to the CBRB, as the majority of the containers carried by inland shipping have been shipped from overseas. 'A container from America or Asia has been underway for weeks. What difference does it make if the last leg of the journey to Germany takes a day longer?', says the CBRB.

The shippers however are of a different opinion. The American shipping company SeaLand, that books containers that have to travel from Chicago to Mannheim on a virtually daily basis, clearly do bear that in mind. 'Goods that have to arrive at their destination quickly are usually forwarded by truck or by rail. If there is less urgency a choice is made for the less expensive inland shipping system', says Nico de Raadt. An inland shipping vessel takes fifty hours to cover the distance from Rotterdam to Mannheim. A truck can cover the same distance in eleven hours, and a train can reach Mannheim in fifteen hours.

Most containers (50%) that arrive in Rotterdam via SeaLand are forwarded to the final destination by truck. Some 30% are transported by rail and the remaining 20% are carried by inland shipping.

Despite all the improvements, inland shipping also has a down side, according to De Raadt. Along the Rhine, between Rotterdam and Basel there are approximated forty inland shipping terminals. "Those colossal ships that carry up to four hundred standard containers are however not able to load and unload everywhere. Although apparently everyone is now busily occupied in investing, in a few years time such ships will be able to be handled at three locations, in Duisburg, Mainz en Germersheim'.

The problem with the transshipment points has been recognised by the Ministry of Transport, Public Works and Water Management. Minister Netelenbos is currently working on a subsidy scheme for the construction of domestic terminals. The scheme should be implemented in the middle of 1999. A shift in the transport of goods from the road to rail or inland shipping is a matter of great importance to the Ministry.

According to a study carried out by the Department of Transport and Public Works the level of transport on offer in 2020 will have risen by 50 to 150%.

Business consultant De Raadt is of the opinion that inland shipping still has an entire world to gain. The entrepreneurs in this branch of industry orient themselves virtually exclusively towards maritime transport, goods that arriving or leaving the Port of Rotterdam. 'The extent of continental transport is nine times greater', says the business consultant. That involves goods that are manufactured in the Netherlands and then have to be transported to countries such as Austria or Italy.

In continental transport the truck is still by far the favourite. Inland shipping should look towards this market, says De Raadt. After all, barge captains tow a hundred thousand empty containers through Europe.

Although inland shipping usually carries full containers, they also often carry empty containers destined for factories and harbours where they are filled.

A creative inland shipping entrepreneur could carry goods for continental transport in those empty containers, such as the bars of chocolate manufactured in Veghel and which have to be transported to distribution centres in Southern Germany. Or German car components destined for Dutch garages. 'Of course not all products are suitable, but if you only take 10% of the continental transport, you would gain an enormous increase in turnover'.