

The Ministry of Global Movement

Reconfiguring the monolith towards postcolonial repair

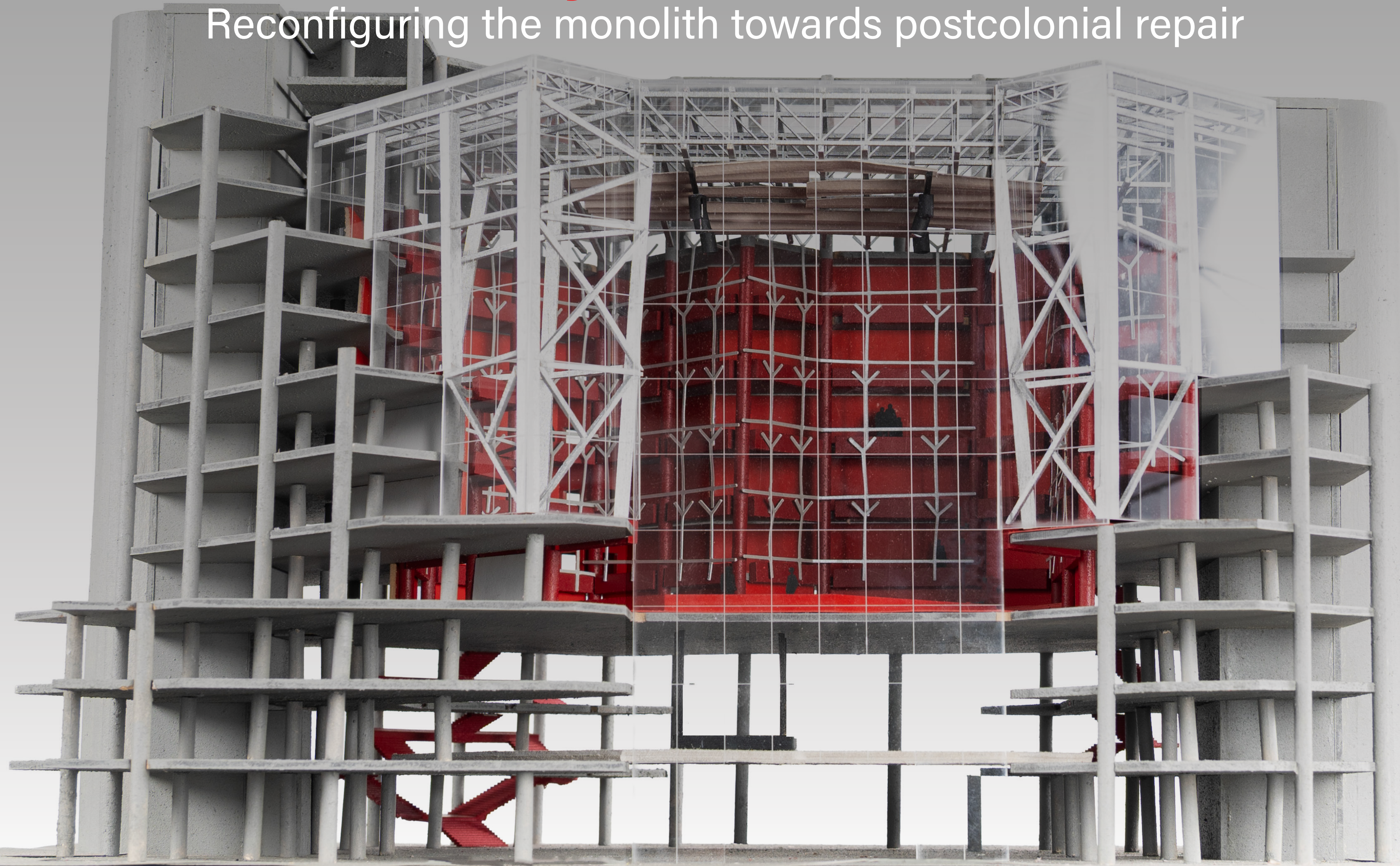

The Power of Paper



Picture of World Passport by author in the Fenix Museum, Rotterdam.

The construction of borders



Still from *Centro di Permanenza Temporanea*. From Paci (2007). Via Fenix.

The construction of borders

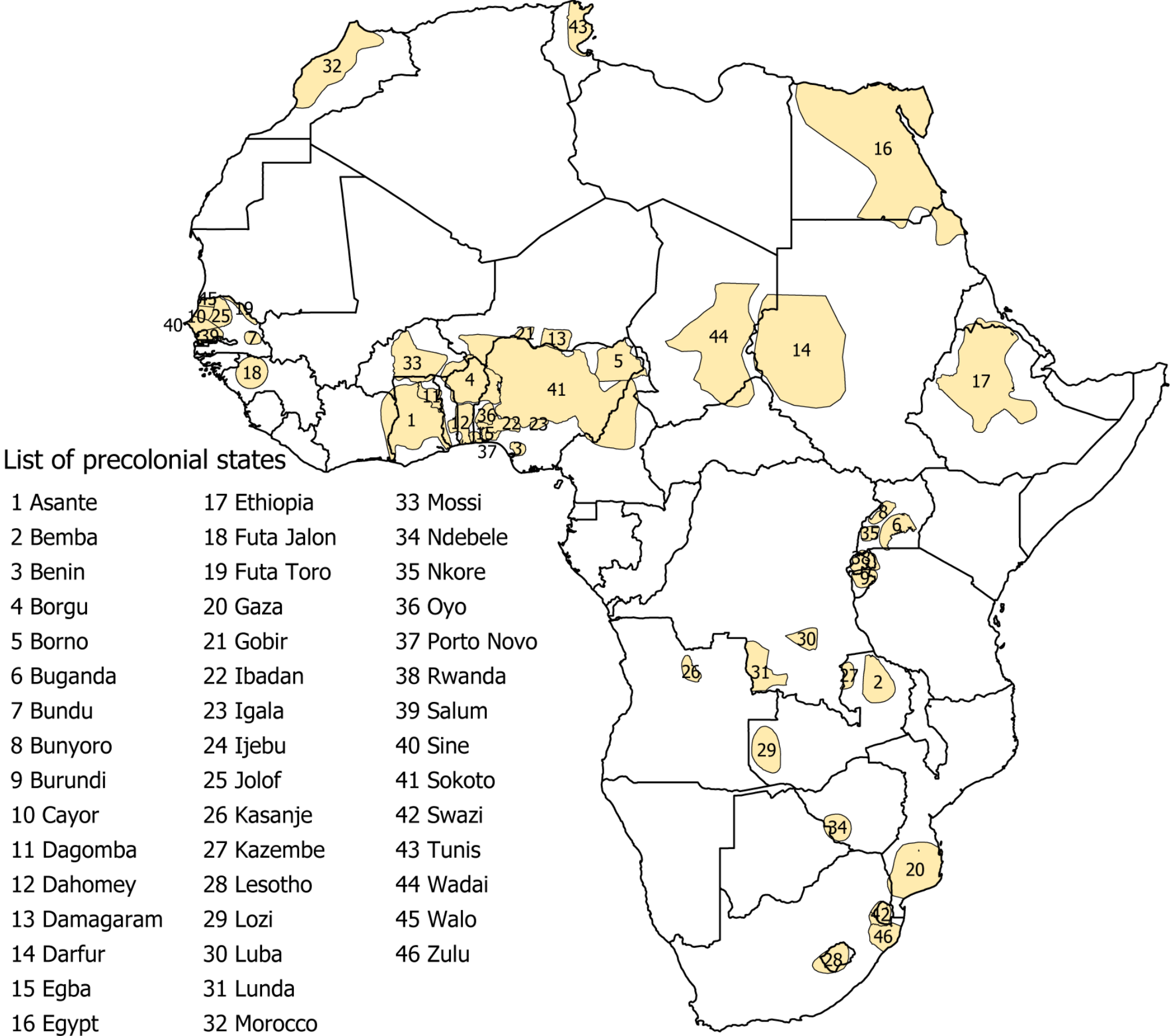

Map of precolonial states and boundaries. From American Political Science Review (2024). Via ZME Science.

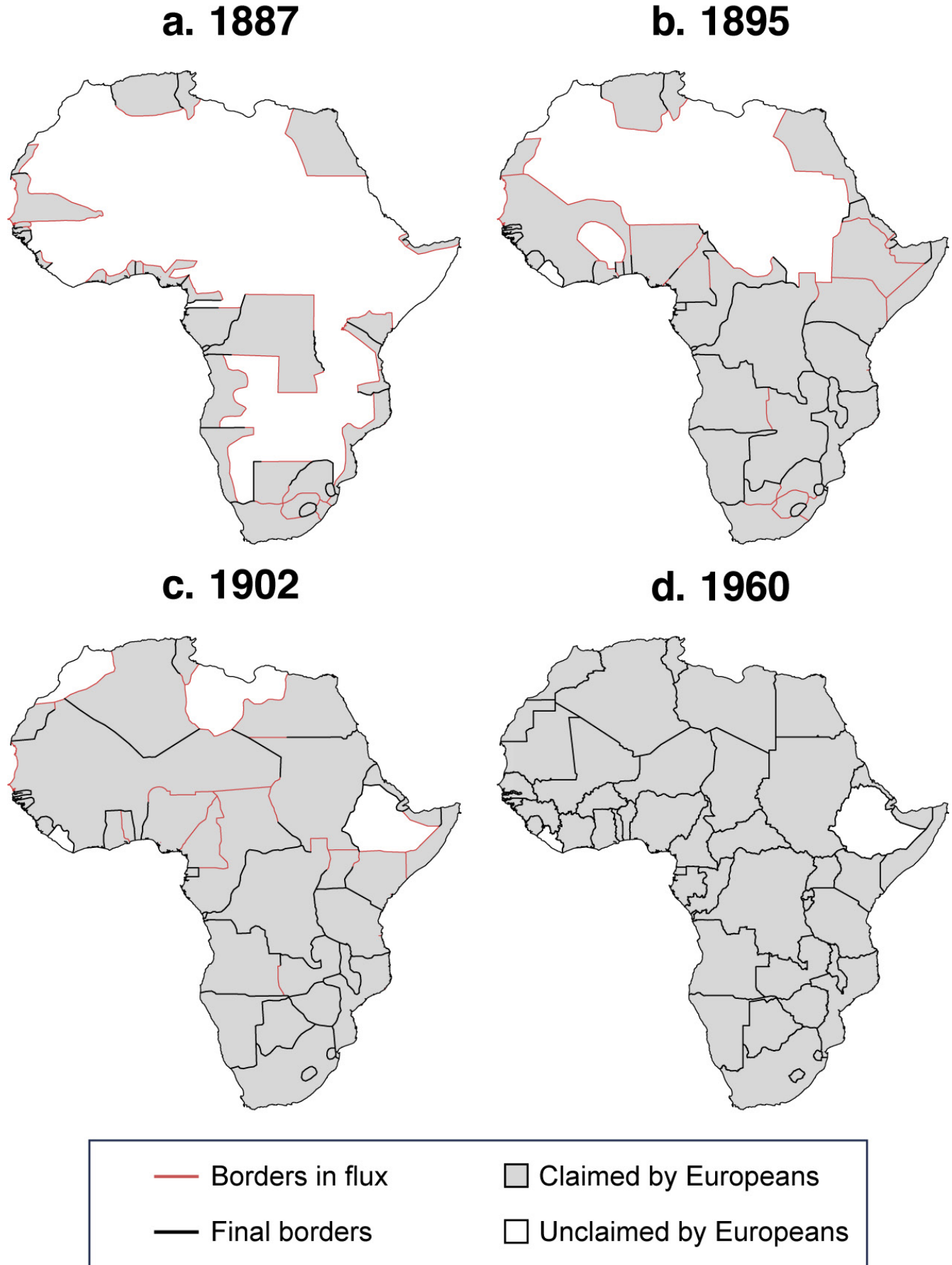

The evolution of the political map of Africa, largely shaped by European colonizers. From American Political Science Review (2024). Via ZME Science.

The standardisation of the passport

European overseas colonies and their colonizers over time, 1920

Only countries that are independent today are considered. Current country borders are used across time.

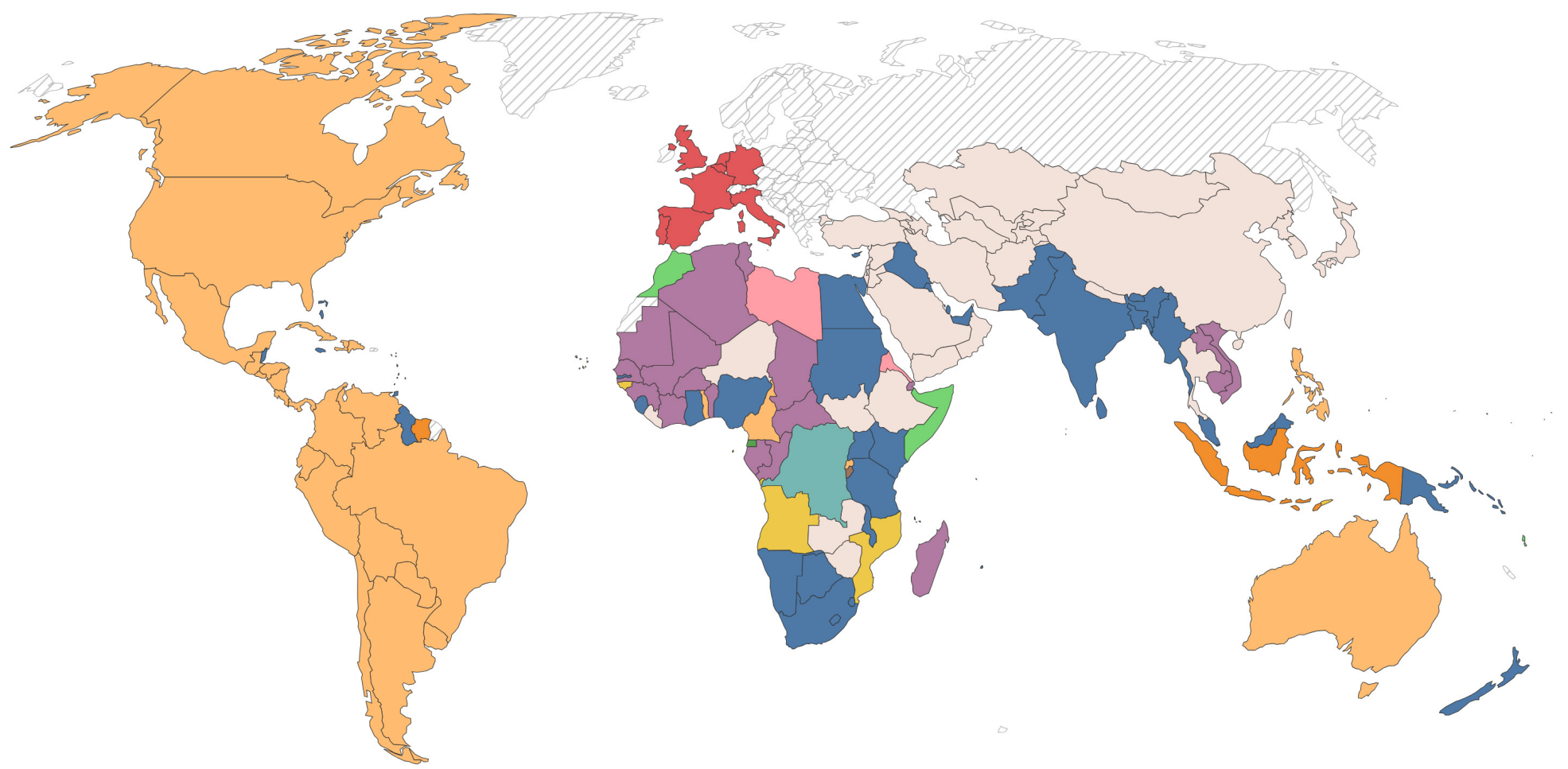

- Belgium
- France
- Germany
- Italy
- Netherlands
- Portugal
- Spain
- United Kingdom
- Multiple colonizers
- Colonizer
- Not colonized
- No longer colonized
- No data

Data source: Bastian Becker (2023)

OurWorldinData.org/state-capacity | CC BY

















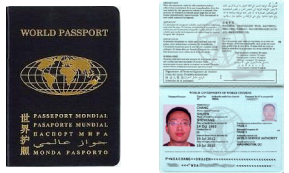
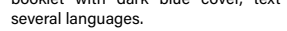



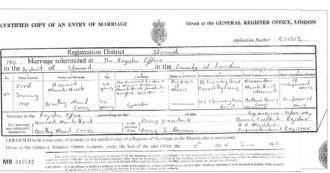

European overseas colonies and their colonizers over time, 1920. From Becker (2023). Via Our World in Data.

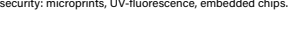
TYPE OF "INTERNATIONAL" OR "STANDARD" PASSPORT RECOMMENDED BY THE LEAGUE OF NATIONS PASSPORT CONFERENCE HELD IN PARIS IN OCTOBER 1920. (The model is that of a passport such as would be delivered by the Spanish Government.)

<p style="font-size: small;">Este pasaporte contiene 20 páginas Ce passeport contient 20 pages</p> <div style="border: 1px solid black; width: 30px; height: 30px; margin: 5px auto; text-align: center; font-size: x-small;">Lugar de Emisión</div> <p style="text-align: center; font-weight: bold; font-size: small;">PASAPORTE PASSEPORT NOMBRE DEL PAIS NOM DU PAYS</p> <p style="font-size: x-small;">No del pasaporte / Nº de passeport / Nombre del portador / Nom du porteur / Acompañado de su esposa / Accompagné de sa femme / y de hijos / et de enfants</p> <p style="font-size: x-small;">NACIONALIDAD / NATIONALITÉ</p>	<p style="text-align: center; font-weight: bold; font-size: small;">SEÑAS PERSONALES SIGNALEMENT</p> <table style="width: 100%; font-size: x-small;"> <tr> <td style="width: 80%;">Profesión / Profession / Lugar y fecha del nacimiento / Lieu et date de naissance / Domicilio / Domicile / Raza / Race / Color de los ojos / Couleur des yeux / Color del cabello / Couleur des cheveux / Señas particulares / Signes particuliers</td> <td style="width: 20%; vertical-align: top;">Esposa - Femme</td> </tr> </table> <p style="text-align: center; font-weight: bold; font-size: x-small;">HIJOS - ENFANTS</p> <table style="width: 100%; font-size: x-small;"> <tr> <td style="width: 33%;">Nombre / Nom</td> <td style="width: 33%;">Edad / Age</td> <td style="width: 33%;">Sexo / Sexe</td> </tr> </table>	Profesión / Profession / Lugar y fecha del nacimiento / Lieu et date de naissance / Domicilio / Domicile / Raza / Race / Color de los ojos / Couleur des yeux / Color del cabello / Couleur des cheveux / Señas particulares / Signes particuliers	Esposa - Femme	Nombre / Nom	Edad / Age	Sexo / Sexe
Profesión / Profession / Lugar y fecha del nacimiento / Lieu et date de naissance / Domicilio / Domicile / Raza / Race / Color de los ojos / Couleur des yeux / Color del cabello / Couleur des cheveux / Señas particulares / Signes particuliers	Esposa - Femme					
Nombre / Nom	Edad / Age	Sexo / Sexe				
<p style="text-align: center; font-weight: bold; font-size: small;">Esposa femme</p> <table style="width: 100%; font-size: x-small;"> <tr> <td style="width: 50%; text-align: center;">(photo)</td> <td style="width: 50%; text-align: center;">(Foto)</td> </tr> </table> <p style="text-align: center; font-size: x-small;">timbre 300</p> <p style="text-align: center; font-size: x-small;">FIRMA DEL PORTADOR SIGNATURE DU TITULAIRE Y DE SU ESPOSA ET DE SA FEMME</p> <p style="font-size: x-small;">Firma del Expedido / Signature de l'agent délivrant le passeport</p>	(photo)	(Foto)	<p style="text-align: center; font-size: x-small;">Países en los cuales este pasaporte es válido Pays pour lesquels ce passeport est valide</p> <p style="text-align: center; font-size: x-small;">La validez de este pasaporte termina - Ce passeport expire le</p> <p style="text-align: center; font-size: x-small;">a menos que se renueve, à moins de renouvellement</p> <p style="font-size: x-small;">expedido en / délivré à / fecha / date</p> <p style="text-align: center; font-weight: bold; font-size: x-small;">RENOVACIONES RENOUVELLEMENTS</p> <p style="font-size: x-small;">1º 2º 3º 4º</p>			
(photo)	(Foto)					

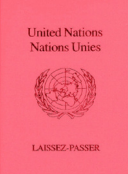
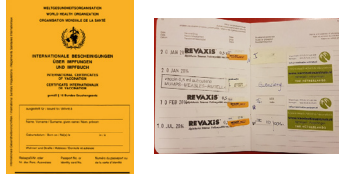
Passport conferences territory issues by the League of Nations. From League of Nations Archive (2025). Via Passport-collector.com.

Research: The passport catalogue

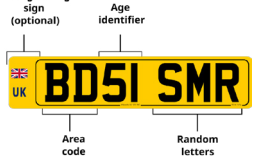
<p>legal identity national passport</p>  <p>legal & civic function Proof of identity and certification for travel. Citizenship is a common prerequisite. Issuing authority: national government and obligatory for international travel.</p> <p>history & temporality Valid for 5-10 years. First versions of passports date back to 450BC, but current form of passport dates back to WWI (Read the short history of the passport for more).</p> <p>materiality & form 40 page booklet with hard plastic cover.</p>  <p>security: micro & raised print, anti-counterfeit paper, watermark, qr-code, readable chip, uv-fluorescence, kinegram, 3D-photo</p> <p>identity markers Full name, birth date and place, gender, photograph, citizen number, signature.</p>	<p>national ID</p>  <p>legal & civic function Proof of identity and certification for travel within certain regions such as the EU/EEA or MERCOSUR states. Obligatory in some countries. Same requirements and issuing authority as passport.</p> <p>history & temporality Valid for 5-10 years. Its precedent was the European Identity Card, but after discontinuation issuing for identity cards became a national state responsibility.</p> <p>materiality & form Plastic card.</p>  <p>security: micro & raised print, tilted laser image, qr-code, readable chip, uv-fluorescence, kinegram, 3D-photo</p> <p>identity markers Full name, birth date and place, gender, photograph, citizen number, signature.</p>	<p>driver's license</p>  <p>legal & civic function Proof of identity within issued state and authorizes to operate motorized vehicles. Issued by the state's vehicle authority. Requirements: residency for minimum period and usually minimum age of 18</p> <p>history & temporality Usually valid for 5-10 years, but depends on age (over a certain age validity becomes shorter). Introduced in the beginning of 20th century. It can be obtained without a nationality.</p> <p>materiality & form Plastic card.</p>  <p>security: micro & raised print, tilted laser image, readable chip, uv-fluorescence, optic variable ink</p> <p>identity markers Full name, birth date and place, gender, photograph, citizen number, signature.</p>	<p>legal identity fantasy passport</p>  <p>legal & civic function Document resembling passport, to make political statement. The World Passport is an example of such a document by the World Service Authority (non-profit organisation). Accepted by six countries.</p> <p>history & temporality The WSA sells passports with different validities depending on price. It was founded in 1954 and has both notable acceptances and rejections in its use by various people.</p> <p>materiality & form Resembling national passports. 42-page booklet with dark blue cover, text in several languages.</p>  <p>security: "ghost" photo and alphanumeric code bar in MRZ-zone.</p> <p>identity markers Full name, birth date and place, gender, photograph.</p>	<p>legal identity diplomatic/service/public passport</p>  <p>legal & civic function Legal travel and identity document for individuals travelling on government business. Reduces amount of border control inspections and grants immunity. Issued by national government.</p> <p>history & temporality Valid to use only for diplomatic missions. Historically stemming from the Vienna Convention on Diplomatic Relations (1961).</p> <p>materiality & form 66 page booklet, different front page than regular passport. Other features same as regular passport.</p> <p>identity markers Same as regular passport.</p>	<p>family passport</p>  <p>legal & civic function Legal travel and identity document for family members included in the passport. Not valid since most countries require individual passports for travellers.</p> <p>history & temporality Not valid in most countries. More common during first period of passports when women were inscribed in their husband's passport.</p> <p>materiality & form Paper booklet, different cover than regular passport. Other features same as regular passport.</p> <p>identity markers Full names of family members, often other descriptive markers and birthdate and place noted.</p>	<p>emergency passport</p>  <p>legal & civic function Temporary document for persons with urgent need to travel (i.e. stolen passport). Issued by state's embassy or government. Not every country accepts emergency passports.</p> <p>history & temporality Valid for short duration, granting temporary travel.</p> <p>materiality & form Paper booklet, different cover colour than regular passport. Clearly states emergency status. Other features same as regular passport.</p> <p>identity markers Same as regular passport.</p>	<p>legal identity birth certificate</p>  <p>legal & civic function Vital record to document birth of a person, often required for obtaining other legal documents, healthcare and education. Issued by local governmental authority.</p> <p>history & temporality Permanently valid. Originally introduced for tax purposes and determining military manpower in the 19th century. Often regarded as crucial document to opening door to human rights.</p> <p>materiality & form On paper, but often registered digitally. Security: often secured digitally, sometimes watermarked paper.</p> <p>identity markers Long/short formats showing child's full names, parents' names, gender, birthdate and place.</p>	<p>death certificate</p>  <p>legal & civic function Legal document stating person's death. Issued by medical practitioner or governmental office. Often required when applying for probate and administration of the deceased.</p> <p>history & temporality Permanently valid. Historically kept records by churches. Standard modern death certificate was developed around the 20th century.</p> <p>materiality & form On paper, but often registered digitally. Security: often secured digitally, sometimes watermarked paper.</p> <p>identity markers Often full name, age, birth date, marital status.</p>	<p>marriage/divorce papers</p>  <p>legal & civic function Validating document for marriages or changes in personal status. Issued by a governmental official.</p> <p>history & temporality Marriage document valid until divorce. Marriage licenses became pervasive in the late 19th century, as contracts between families. Links to history of same-sex marriage and female emancipation.</p> <p>materiality & form On paper, but often registered digitally. Security: officiated with stamp, watermark and microprints.</p> <p>identity markers Full names, birthdate and place, parents' full names, witness names and signatures.</p>
<p>movement authorisation residence permit</p>  <p>legal & civic function Required to reside and work in country of which person is not a state's citizen. Issued by national government or decided authority of that state (immigration service).</p> <p>history & temporality Validity dependent on temporariness (usually 5 years) or permanence. Created shortly after introduction of passports to register "aliens" for residence around 1940 (i.e. Green cards and Schengen Visa).</p> <p>materiality & form Can be a biometric chipped card, or digital document.</p>  <p>security: microprints, UV-fluorescence, embedded chips.</p> <p>identity markers Full names, birthdate and place, gender, photograph.</p>	<p>visa / stamps</p>  <p>legal & civic function Sometimes required for entering, remaining or leaving countries. Issued by entering country's assigned authority.</p> <p>history & temporality Validity dependent on type of visa or stamp, but always temporary and dependent on traveler's stay duration. Dependent on power of passport whether granted, see the Henley Index for power of passports.</p> <p>materiality & form Sticker or stamp in passport / digital document. Style highly differs from state to state.</p> <p>identity markers Sometimes no identity markers, otherwise stating full name, birthdate and place, gender, nationality.</p>	<p>asylum application</p>  <p>legal & civic function Application for protection to remain within a state. Issued by the state and assigned immigration authority of the state in which person applies.</p> <p>history & temporality Highly dependent on state, but varies between 6 months and 10 years. Became common after the 1999 European Asylum System, but has evolved over the years in the midst of political debates.</p> <p>materiality & form Printed or digital document.</p> <p>identity markers Usually supported by other proofs of identity. Often includes full name, birthdate and place, gender, nationality.</p>	<p>movement authorisation refugee travel document</p>  <p>legal & civic function Travel document required for traveling to countries except home country. Can be used as proof of identity. Issued by state in which applied for.</p> <p>history & temporality Valid for 1-5 years, historically linked to the Asylum Application. The precedent for the refugee travel document was the Nansen passport (1922-1938).</p> <p>materiality & form Often resembling a national passport, often different color (blue or green).</p> <p>identity markers Full name, birthdate and place, gender.</p>	<p>laissez-passez</p>  <p>legal & civic function One-way travel document, issued by United Nations. Can be used for emergencies or traveling deceased persons.</p> <p>history & temporality Valid for one journey, to be used within six years of issue. Originally introduced after WWII in the midst of the first cooperations within Europe.</p> <p>materiality & form Pink or blue printed document, resembling passport. Can be digital</p> <p>identity markers Similar to national passport.</p>	<p>supporting documents vaccination passport</p>  <p>legal & civic function Sometimes required document for traveling when certain vaccinations are compulsory. Issued by medical practitioner or ministry related to health.</p> <p>history & temporality Booklet is permanently valid, vaccinations registered within vary highly in validity. Introduced for international travel in 1930s and became an important document for controlling movement of (un)vaccinated during COVID-19.</p> <p>materiality & form Digital or booklet. Often includes QR-codes, sometimes stamps or stickers from vaccinations.</p> <p>identity markers Sometimes only QR-code, otherwise name, birthdate and place, gender, nationality and signature.</p>	<p>proof of deregistration</p>  <p>legal & civic function Proof that a person has moved abroad. Issued by local government authority. A certificate sometimes required for residence permit.</p> <p>history & temporality Valid until end of deregistration. Linked history to residence permit.</p> <p>materiality & form Mostly digital documents.</p> <p>identity markers Supported by other proof of identity. Full name, birthdate and place, gender, nationality, citizen number, civil status.</p>	<p>more than human pet passport</p>  <p>legal & civic function Document required for domesticated animals to travel with an EU-resident to travel to another EU country. Issued by official veterinarian.</p> <p>history & temporality Valid for life as long as animal's health can be ensured. Introduced in 2001 during the PETS Pet Travel Scheme.</p> <p>materiality & form Blue booklet with photograph of animal. Printed on paper with microprints.</p> <p>identity markers Photograph, name, species, breed, gender, date of birth, coat description, chip number, chipping date and location of microchip or possible tattoo.</p>	<p>plant passport</p>  <p>legal & civic function Vital information required for trade of seeds, cuttings, plants, and trees between EU businesses. Issued by National Plant Protection Organisation or authorised businesses.</p> <p>history & temporality No fixed expiration date. Introduced in 2019 for the Plant Health Regulation.</p> <p>materiality & form Rectangular shaped sticker with European Union flag, in colour or black and white.</p> <p>identity markers Botanical name and plant traceability code.</p>	<p>license plate</p>  <p>legal & civic function Required for operating motorised vehicles. Issued by national vehicle authority.</p> <p>history & temporality In some countries permanently assigned to vehicles for lifetime, plate numbers can be retired or reused. Some countries require deregistration from state. Emerged around the same time as driver's license.</p> <p>materiality & form Rectangular plate made of enamel or metal (usually aluminum). Standardisation of sizing.</p> <p>identity markers Random letters and numbers assigned to vehicle. Sometimes distinguishing national flag or abbreviation.</p>

Research: Transcoding racism on paper

Rank	Passport	Visa-free score	Rank	Passport	Visa-free score	Rank	Passport	Visa-free score
1	Singapore	192	8	Iceland	181	31	Peru	142
2	Japan	188		Lithuania		32	Macao (SAR China)	141
	South Korea		9	Malaysia	180	33	Taiwan (Chinese Taipei)	139
3	Denmark	186	10	United States	179	34	Serbia	136
	Luxembourg		11	Bulgaria	178	35	El Salvador	132
	Spain			Romania			Guatemala	
	Sweden		12	Monaco	177	36	Solomon Islands	131
	Switzerland		13	Chile	175	37	Colombia	130
4	Austria	185	14	Cyprus	174		Honduras	
	Belgium		15	Andorra	171	38	Marshall Islands	128
	Finland			Hong Kong (SAR China)			Montenegro	
	France		16	Argentina	169		North Macedonia	
	Germany			Brazil			Samoa	
	Greece		17	San Marino	168	39	Tonga	127
	Ireland		18	Israel	165	40	Nicaragua	125
	Italy		19	Barbados	162	41	Tuvalu	124
	Netherlands			Brunei		42	Bosnia and Herzegovina	122
	Norway		20	The Bahamas	158		Georgia	
5	Hungary	184	21	Mexico	157	43	Kiribati	121
	Portugal		22	St. Vincent and the Grenadines	156		Micronesia	
	Slovakia			Uruguay			Palau Islands	
	Slovenia		23	St. Kitts and Nevis	155	44	Moldova	120
	United Arab Emirates		24	Antigua and Barbuda	154	45	Venezuela	118
6	Croatia	183		Seychelles		46	Russian Federation	113
	Czechia		25	Vatican City	152		Türkiye	
	Estonia		26	Costa Rica	148	47	Qatar	111
	Malta			Panama		48	South Africa	101
	New Zealand		27	Grenada	147	49	Belize	99
	Poland			Mauritius		50	Kuwait	96
7	Australia	182	28	Trinidad and Tobago	146	51	Ecuador	94
	Latvia		29	Dominica	145		Timor-Leste	
	Liechtenstein			Paraguay		52	Maldives	92
	United Kingdom			St. Lucia		53	Vanuatu	89
8	Canada	181	30	Ukraine	143			
						54	Fiji	88
							Guyana	
							Saudi Arabia	
						55	Bahrain	87
						56	Jamaica	86
						57	Nauru	85
							Oman	
						58	Papua New Guinea	83
						59	Botswana	81
							China	
							Kosovo	
						60	Belarus	79
							Thailand	
						61	Bolivia	78
							Kazakhstan	
							Suriname	
						62	Namibia	76
						63	Lesotho	74
						64	Indonesia	73
						65	Dominican Republic	72
							Morocco	
							eSwatini	
						66	Malawi	71
						67	Azerbaijan	70
						68	Kenya	69
							The Gambia	
						69	Ghana	68
							Tanzania	
						70	Benin	67
							Rwanda	
							Tunisia	
						71	Armenia	66
							Uganda	
						72	Cape Verde Islands	65
						72	Zambia	65
						73	Mongolia	64
							Philippines	
						74	Sierra Leone	62
							Zimbabwe	
						75	Kyrgyzstan	61
							Uzbekistan	
						76	Mozambique	60
							Sao Tomé and Príncipe	
						77	Cuba	58
							Togo	
						78	Burkina Faso	57
							Côte d'Ivoire	
							Gabon	
							Madagascar	
							Senegal	
						79	Mauritania	56
						80	Algeria	55
							India	
							Niger	
						81	Equatorial Guinea	54
							Guinea	
							Tajikistan	
						82	Mali	53
						83	Chad	52
							Guinea-Bissau	
						84	Comoro Islands	51
							Jordan	
						85	Bhutan	50
							Cambodia	
							Egypt	
							Haiti	
						86	Angola	49
							Burundi	
						86	Central African Republic	49
							Liberia	
							Vietnam	
						87	Cameroon	47
							Congo (Rep.)	
							Laos	
							Turkmenistan	
						88	Djibouti	46
						89	Myanmar	44
							Nigeria	
						90	Congo (Dem. Rep.)	43
							Ethiopia	
							Lebanon	
						91	South Sudan	41
							Sudan	
						92	Iran	40
						93	Libya	39
							Sri Lanka	
						94	Eritrea	38
							North Korea	
							Palestinian Territory	
						95	Bangladesh	37
						96	Nepal	35
						97	Somalia	33
						98	Pakistan	31
							Yemen	
						99	Iraq	29
						100	Syria	26
						101	Afghanistan	24

Global Passport Ranking 2026. From Henley & Partners (2026). Via Henley & Partners.

**How can we reframe the institution
of the mobility order?**

Typology: Ministry of Migration and Asylum

Typology: Ministry of Global Movement

Concept: Institutional pillars

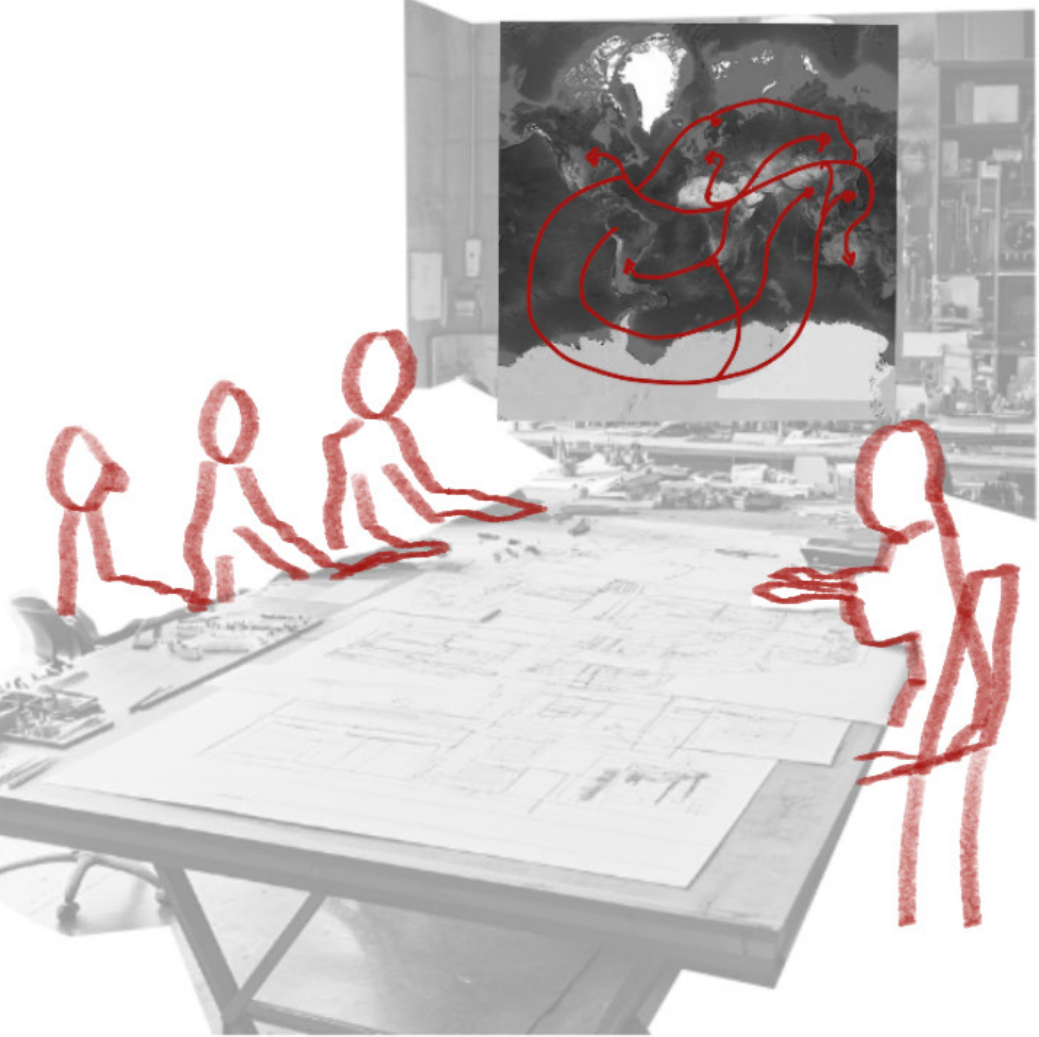

Information: By dedicating space for research and rewriting policy, the institution shifts from state-centric migration toward "movement".

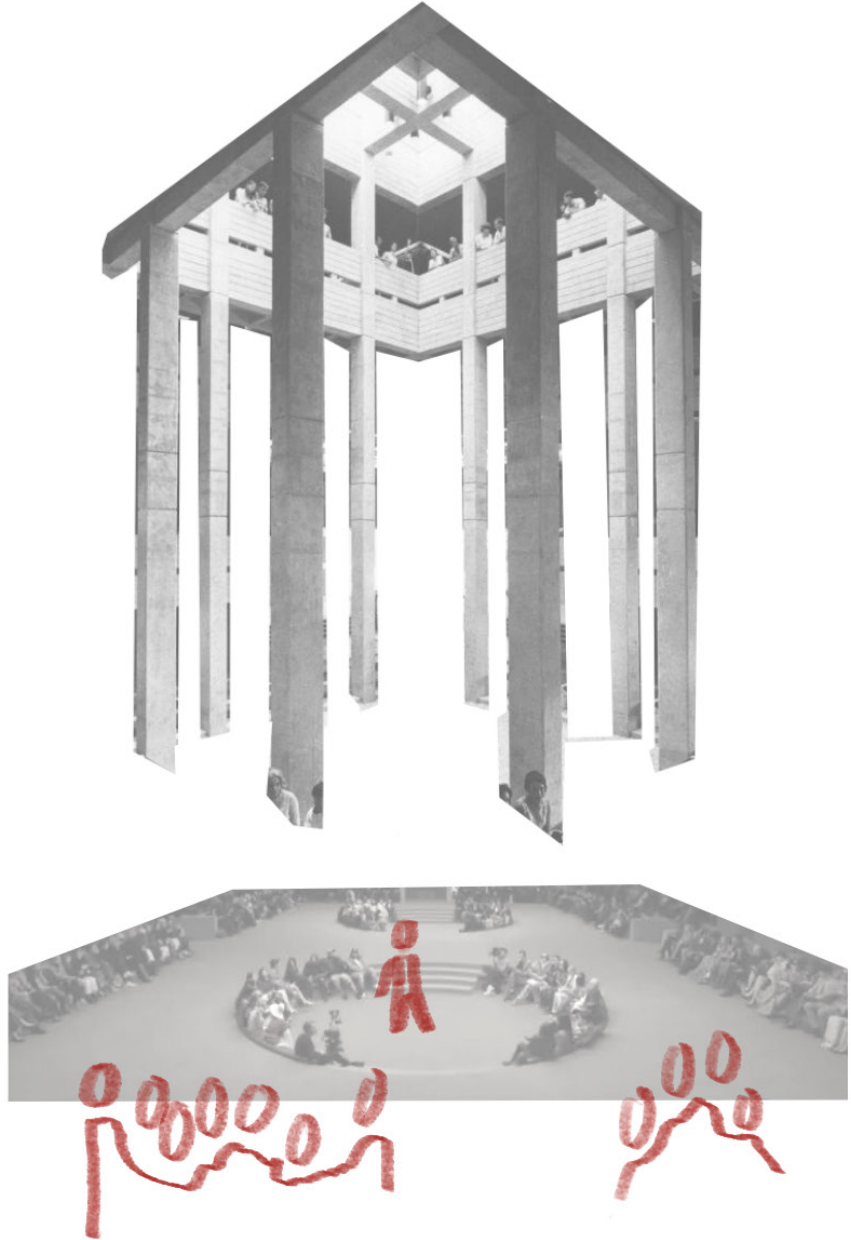

Inspiration: The establishment of a theatre empowers and celebrates the cultural diversity that results from global movement.



Identity: The institution provides an archival space centred around the storing and rewriting of identities, moving toward a more plural approach to human documentation.

Site: The Hague



Site: The Hague



Ministry of Colonies in the Hague. From Haags Historisch Museum (1904). Via Haags Historisch Museum.

Site: The building BZ67



Images of BZ67 by author.

Site: The building BZ67 as material kit of parts



Architectural documentation: Nieuwbouw Ministerie van Buitenlandse Zaken, 's-Gravenhage (1974-1984). Projectarchitect: D.C. Apon. *Archief ABBTd18, Het Nieuwe Instituut, Rotterdam.*

Research: Spatial reconfiguration as architectural representation for rewriting history

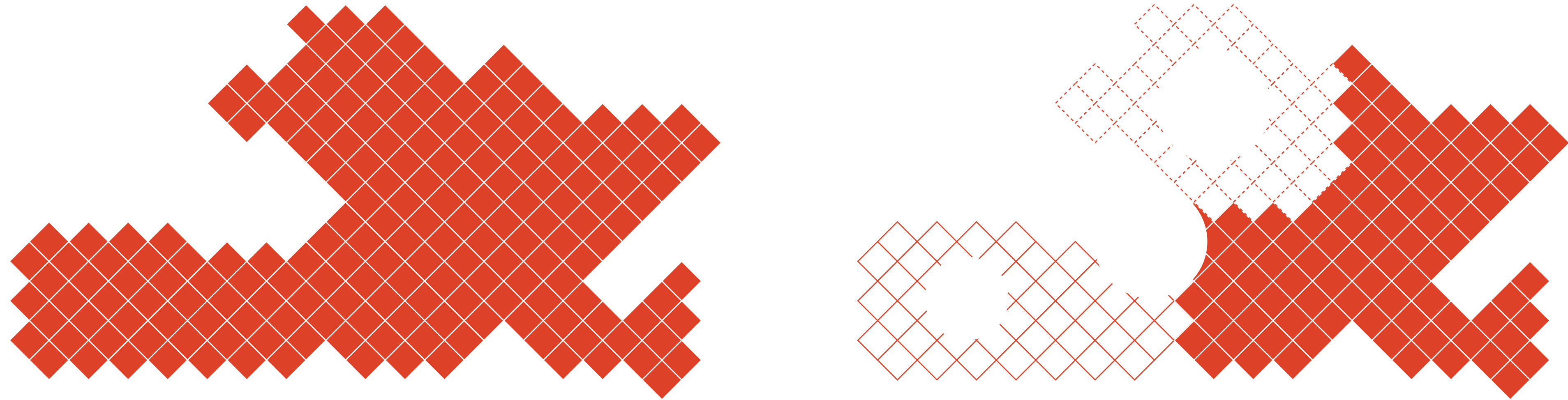

Final design results

THE MINISTRY OF GLOBAL
MOVEMENT





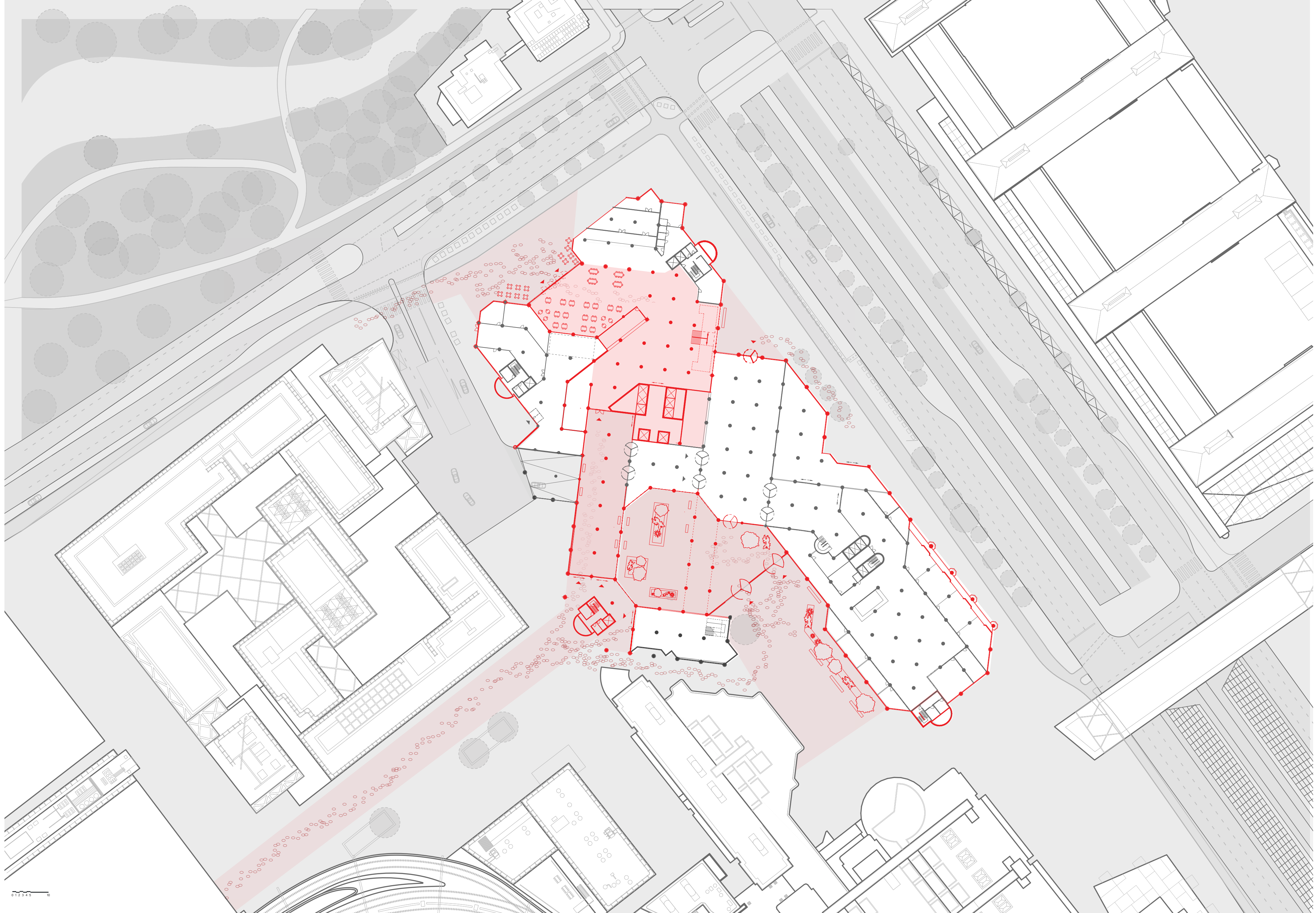

Current situation: Approach from the Hague Central



View: Public entrance



Plans: Ground floor

- 0.01 main public entrance
- 0.02 exhibition hall cultural centre
- 0.03 shared walkway
- 0.04 atrium of exchange
- 0.05 corridor to ministry
- 0.06 lobby ministry
- 0.07 bike parking
- 0.08 hall
- 0.09 coffee corner
- 0.10 sanitary
- 0.11 entrance theatre
- 0.12 foyer
- 0.13 box office
- 0.14 cloakroom
- 0.15 café/restaurant
- 0.16 bar
- 0.17 kitchen
- 0.18 stage door
- 0.19 back office
- 0.20 changing rooms
- 0.21 entrance logistics
- 0.22 air caster for trap stage
- 0.23 entrance parking

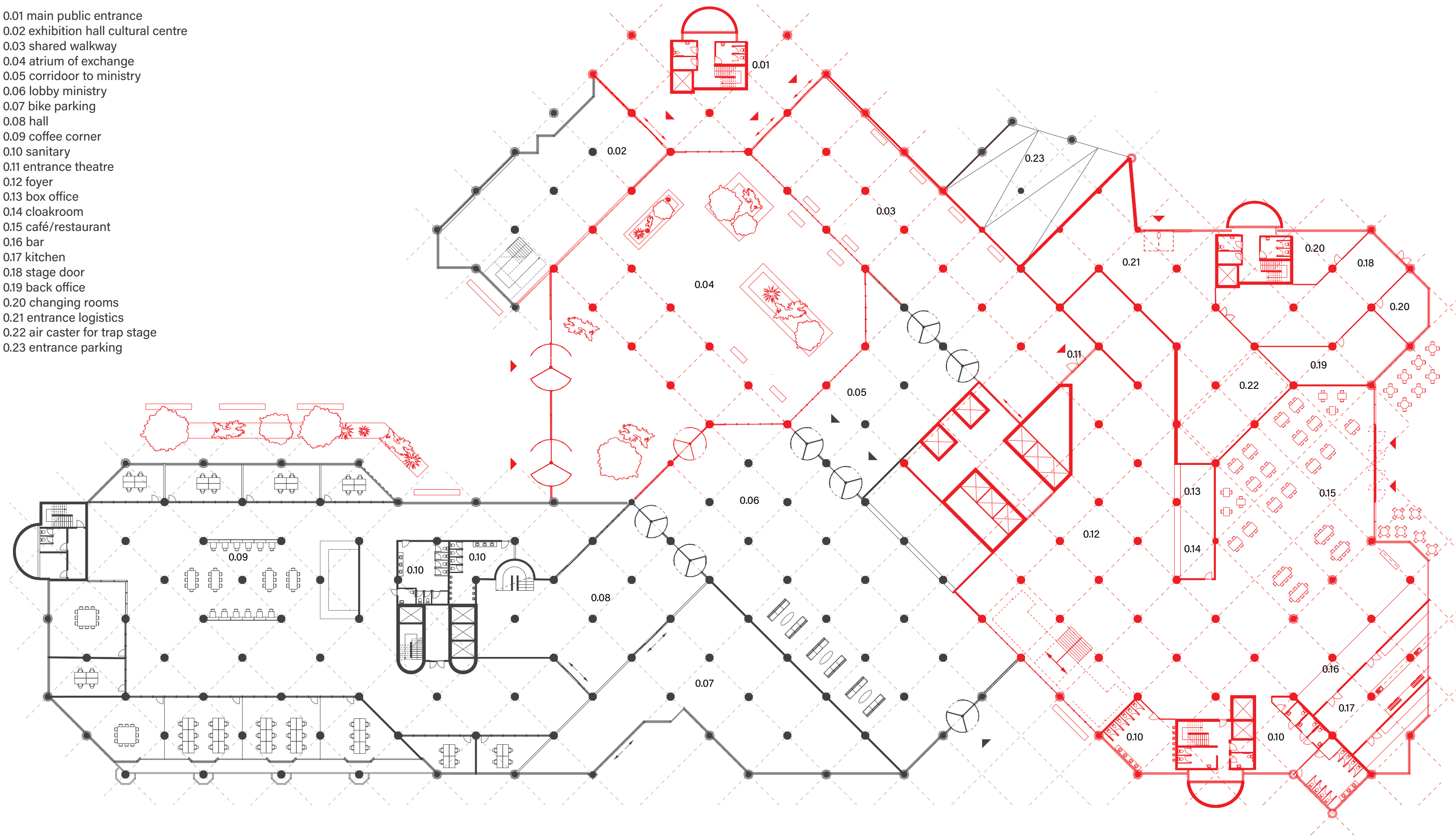

0 1 2 3 4 5 10



Plans: Ground floor

- 0.01 main public entrance
- 0.02 exhibition hall cultural centre
- 0.03 shared walkway
- 0.04 atrium of exchange
- 0.05 corridor to ministry
- 0.06 lobby ministry
- 0.07 bike parking
- 0.08 hall
- 0.09 coffee corner
- 0.10 sanitary
- 0.11 entrance theatre
- 0.12 foyer
- 0.13 box office
- 0.14 cloakroom
- 0.15 café/restaurant
- 0.16 bar
- 0.17 kitchen
- 0.18 stage door
- 0.19 back office
- 0.20 changing rooms
- 0.21 entrance logistics
- 0.22 air caster for trap stage
- 0.23 entrance parking

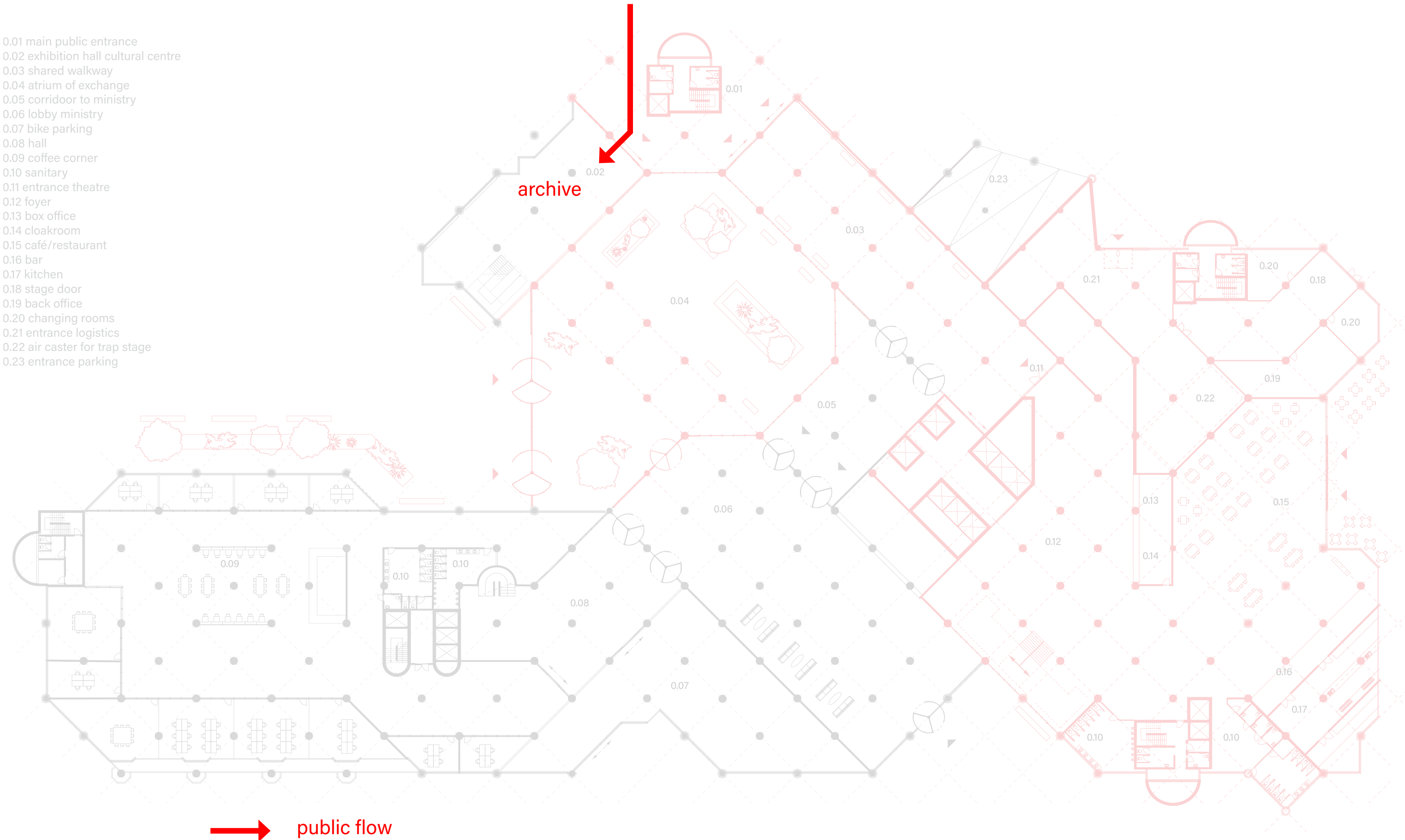

→ public flow

0 1 2 3 4 5 10



Plans: Ground floor

- 0.01 main public entrance
- 0.02 exhibition hall cultural centre
- 0.03 shared walkway
- 0.04 atrium of exchange
- 0.05 corridor to ministry
- 0.06 lobby ministry
- 0.07 bike parking
- 0.08 hall
- 0.09 coffee corner
- 0.10 sanitary
- 0.11 entrance theatre
- 0.12 foyer
- 0.13 box office
- 0.14 cloakroom
- 0.15 café/restaurant
- 0.16 bar
- 0.17 kitchen
- 0.18 stage door
- 0.19 back office
- 0.20 changing rooms
- 0.21 entrance logistics
- 0.22 air caster for trap stage
- 0.23 entrance parking

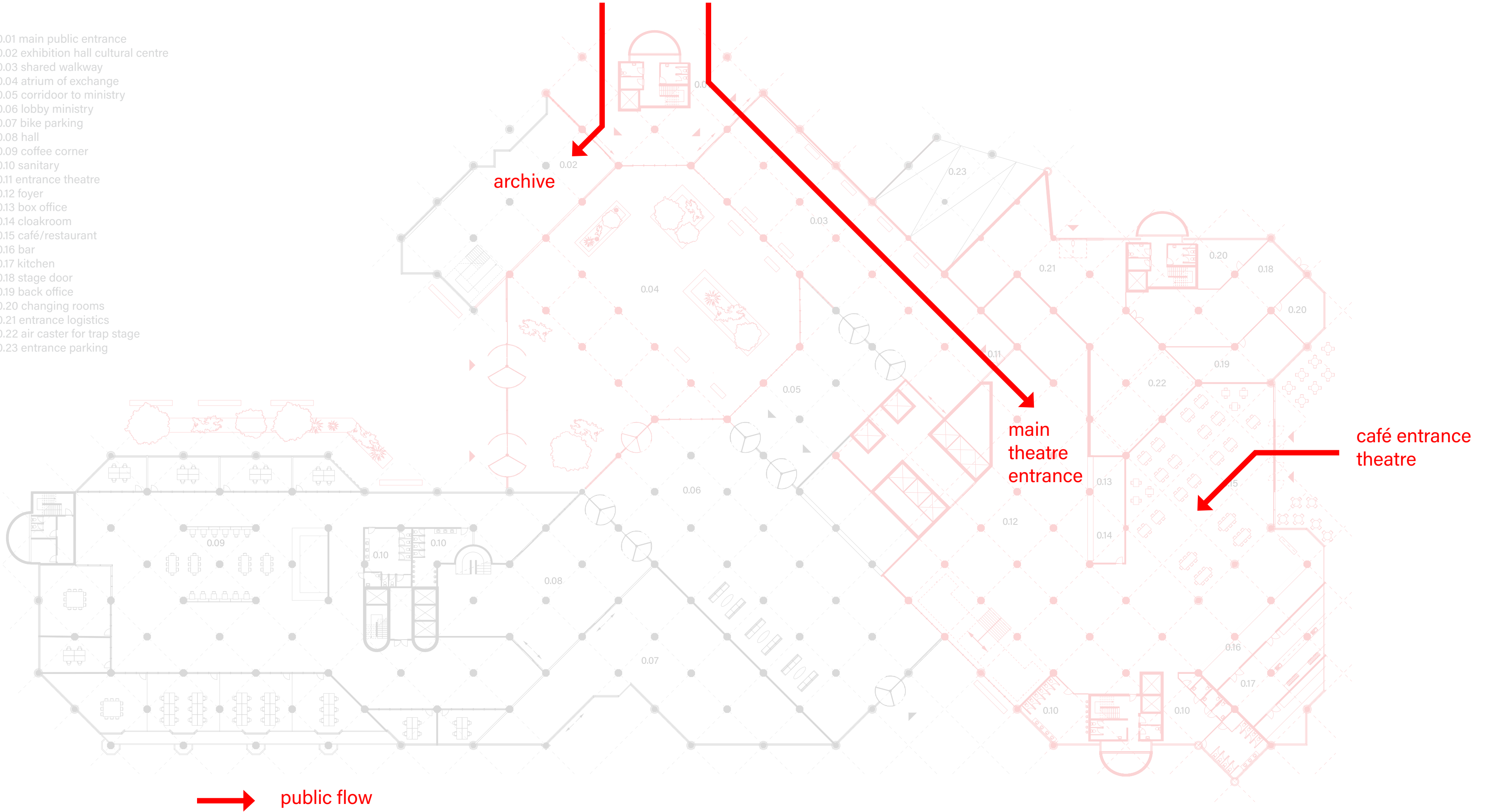

Plans: Ground floor

- 0.01 main public entrance
- 0.02 exhibition hall cultural centre
- 0.03 shared walkway
- 0.04 atrium of exchange
- 0.05 corridor to ministry
- 0.06 lobby ministry
- 0.07 bike parking
- 0.08 hall
- 0.09 coffee corner
- 0.10 sanitary
- 0.11 entrance theatre
- 0.12 foyer
- 0.13 box office
- 0.14 cloakroom
- 0.15 café/restaurant
- 0.16 bar
- 0.17 kitchen
- 0.18 stage door
- 0.19 back office
- 0.20 changing rooms
- 0.21 entrance logistics
- 0.22 air caster for trap stage
- 0.23 entrance parking

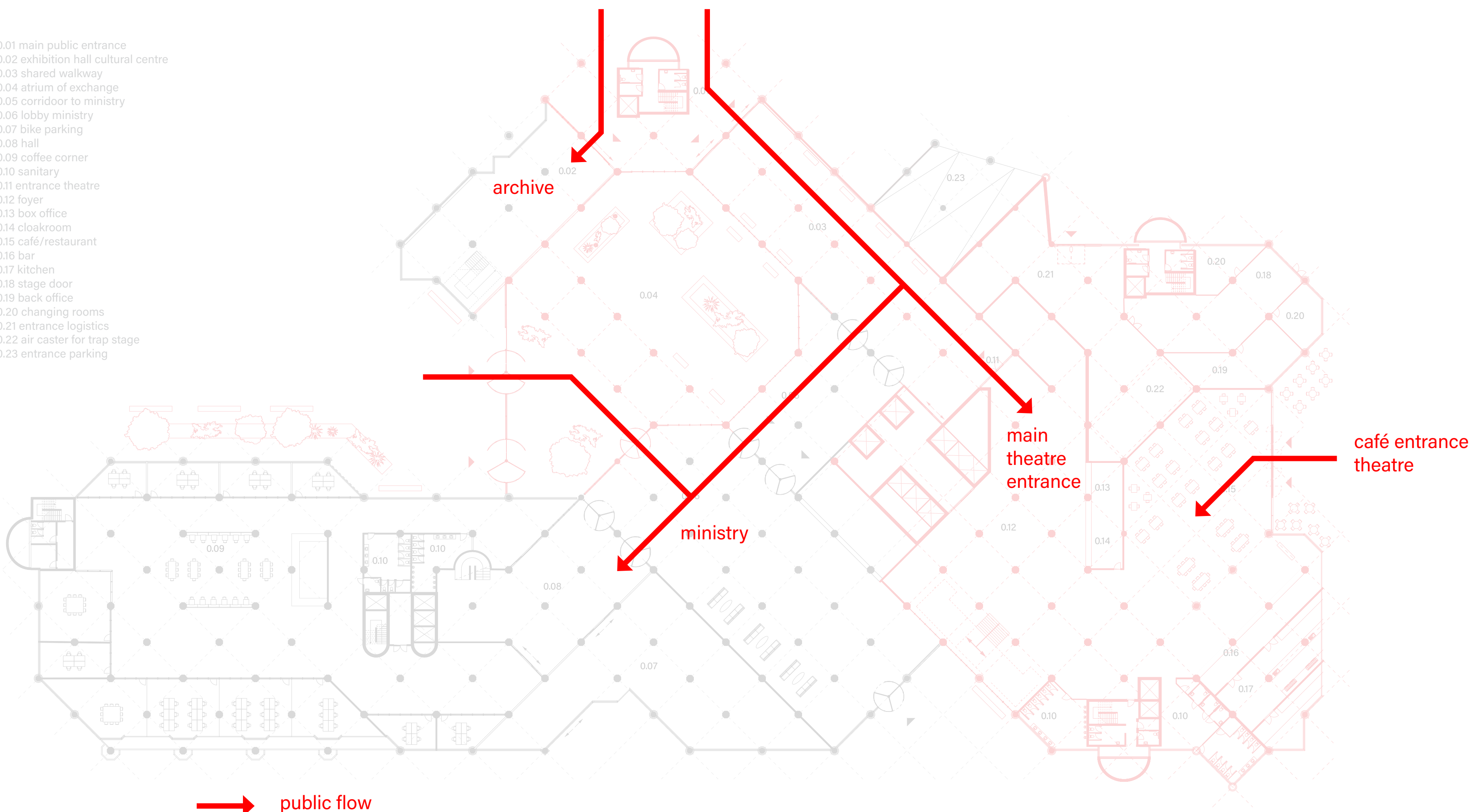

→ public flow

0 1 2 3 4 5 10



Plans: Ground floor

- 0.01 main public entrance
- 0.02 exhibition hall cultural centre
- 0.03 shared walkway
- 0.04 atrium of exchange
- 0.05 corridor to ministry
- 0.06 lobby ministry
- 0.07 bike parking
- 0.08 hall
- 0.09 coffee corner
- 0.10 sanitary
- 0.11 entrance theatre
- 0.12 foyer
- 0.13 box office
- 0.14 cloakroom
- 0.15 café/restaurant
- 0.16 bar
- 0.17 kitchen
- 0.18 stage door
- 0.19 back office
- 0.20 changing rooms
- 0.21 entrance logistics
- 0.22 air caster for trap stage
- 0.23 entrance parking

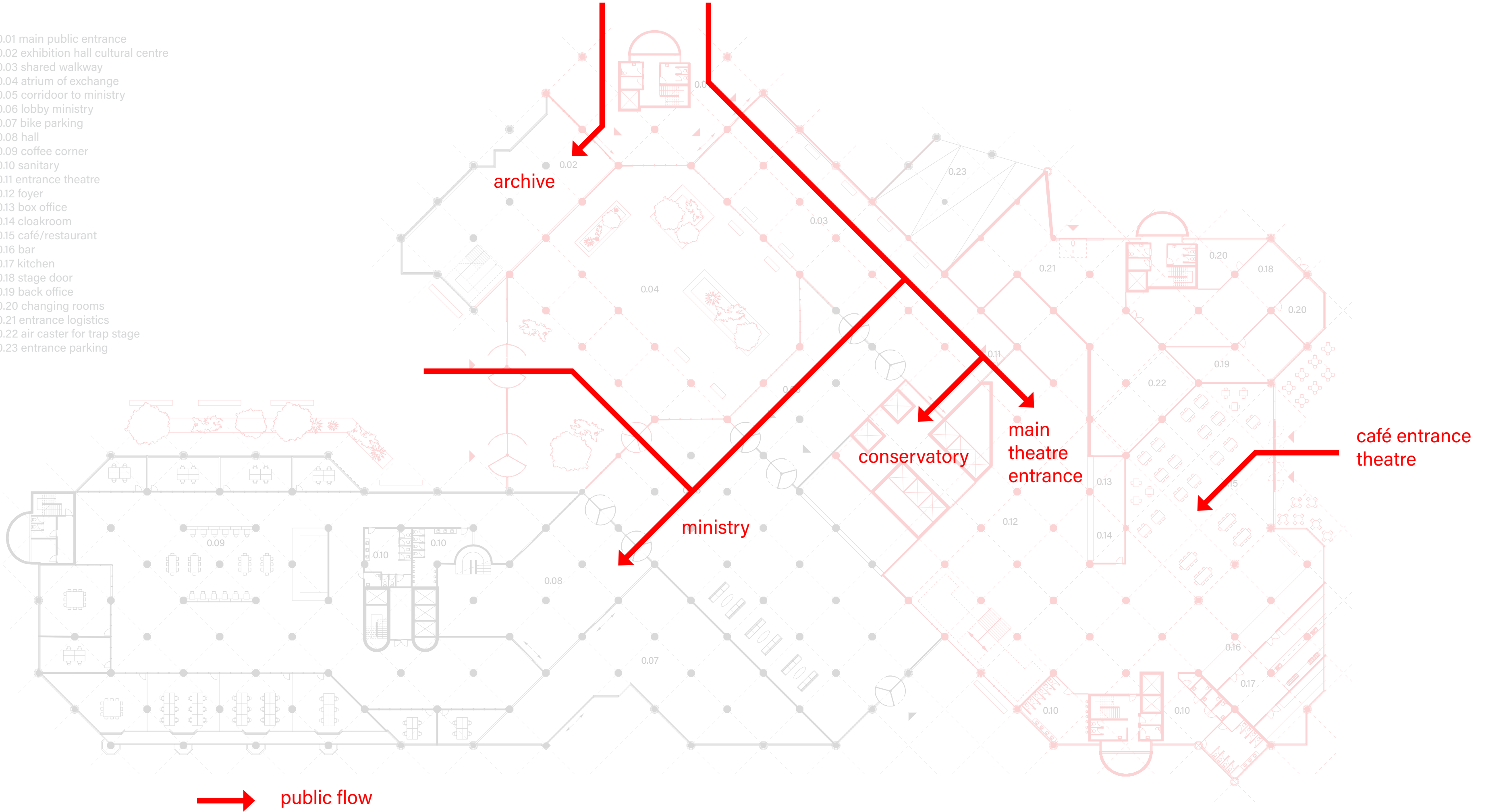

→ public flow

0 1 2 3 4 5 10



Views: The Ministry and the Atrium

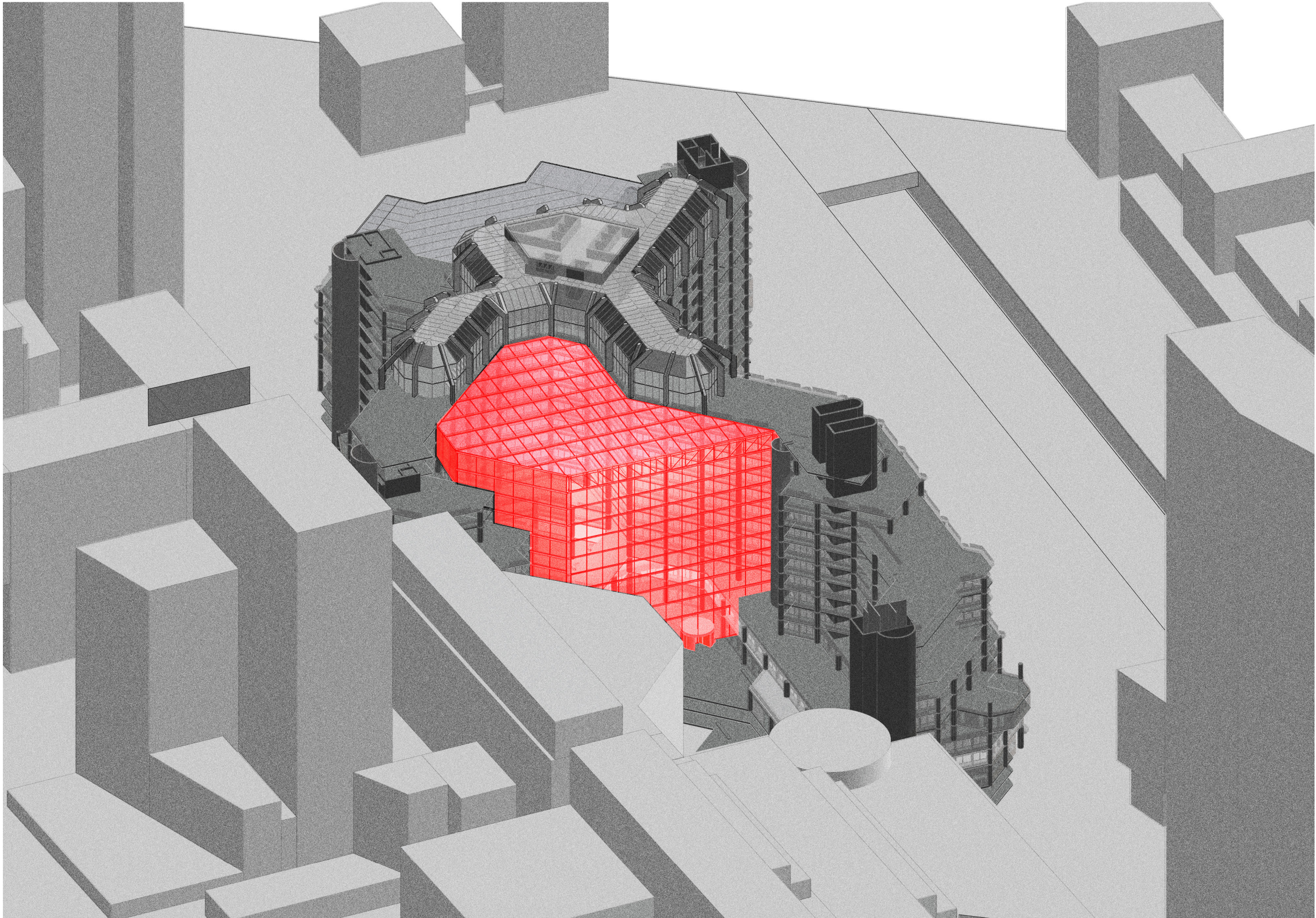

Reconfiguration

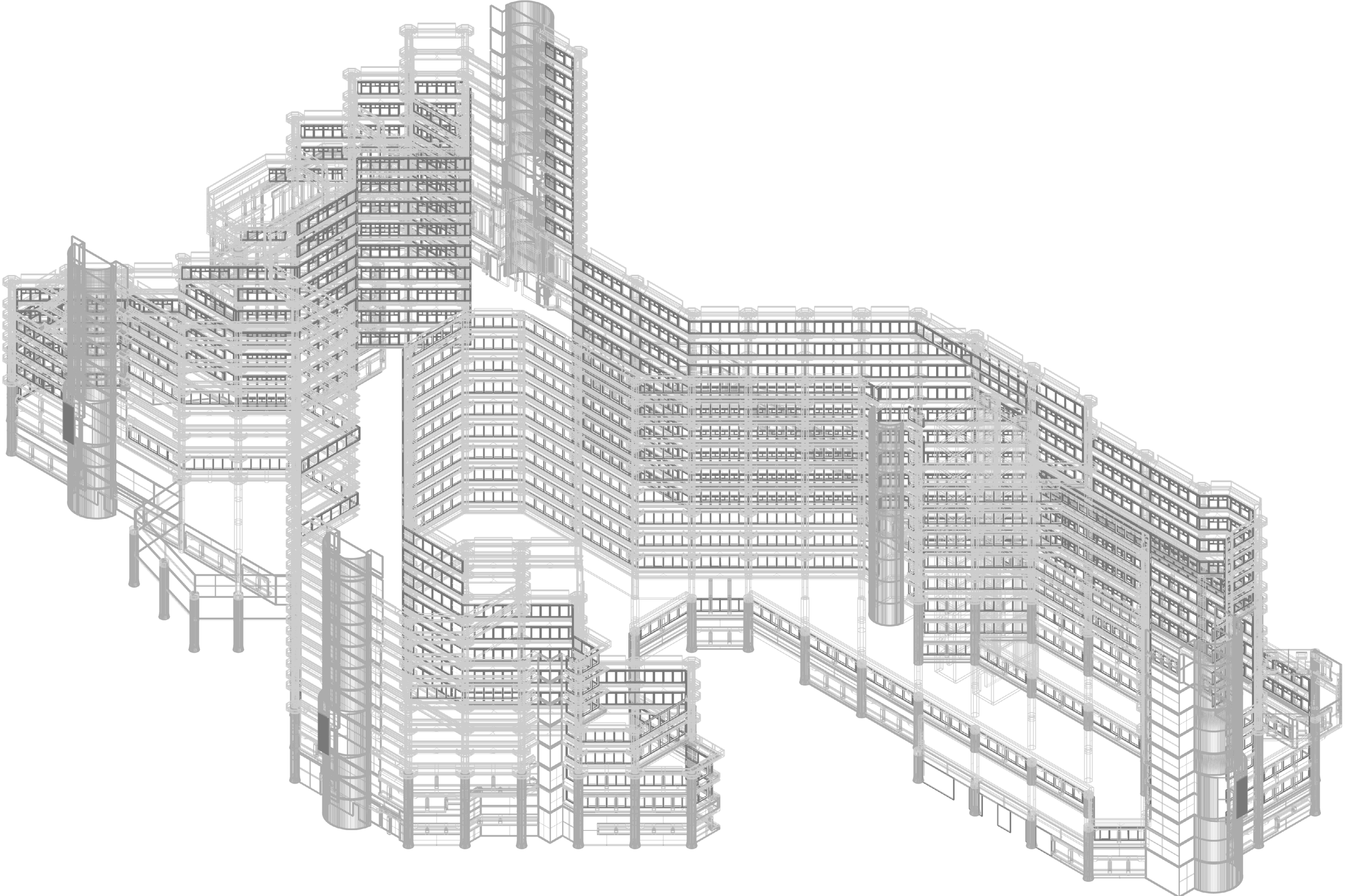

Reconfiguration: Removal

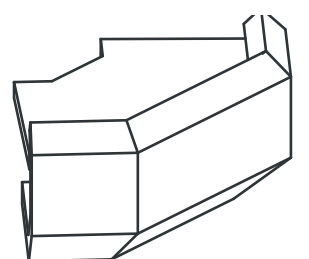

O-03 element
dimensions: 700x850x1400
material type: prefab concrete
amount mined: 126

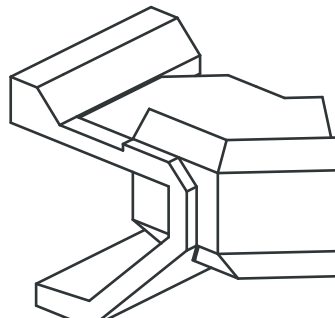

O-02/04 element
dimensions: variable
material type: prefab concrete
amount mined: 252

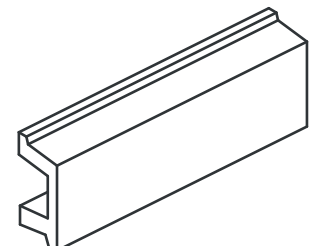

P-element parapet
dimensions: 610x330xvariable
material type: prefab concrete
amount mined: 138

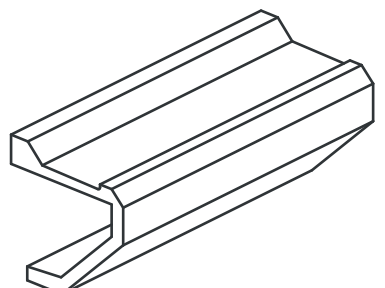
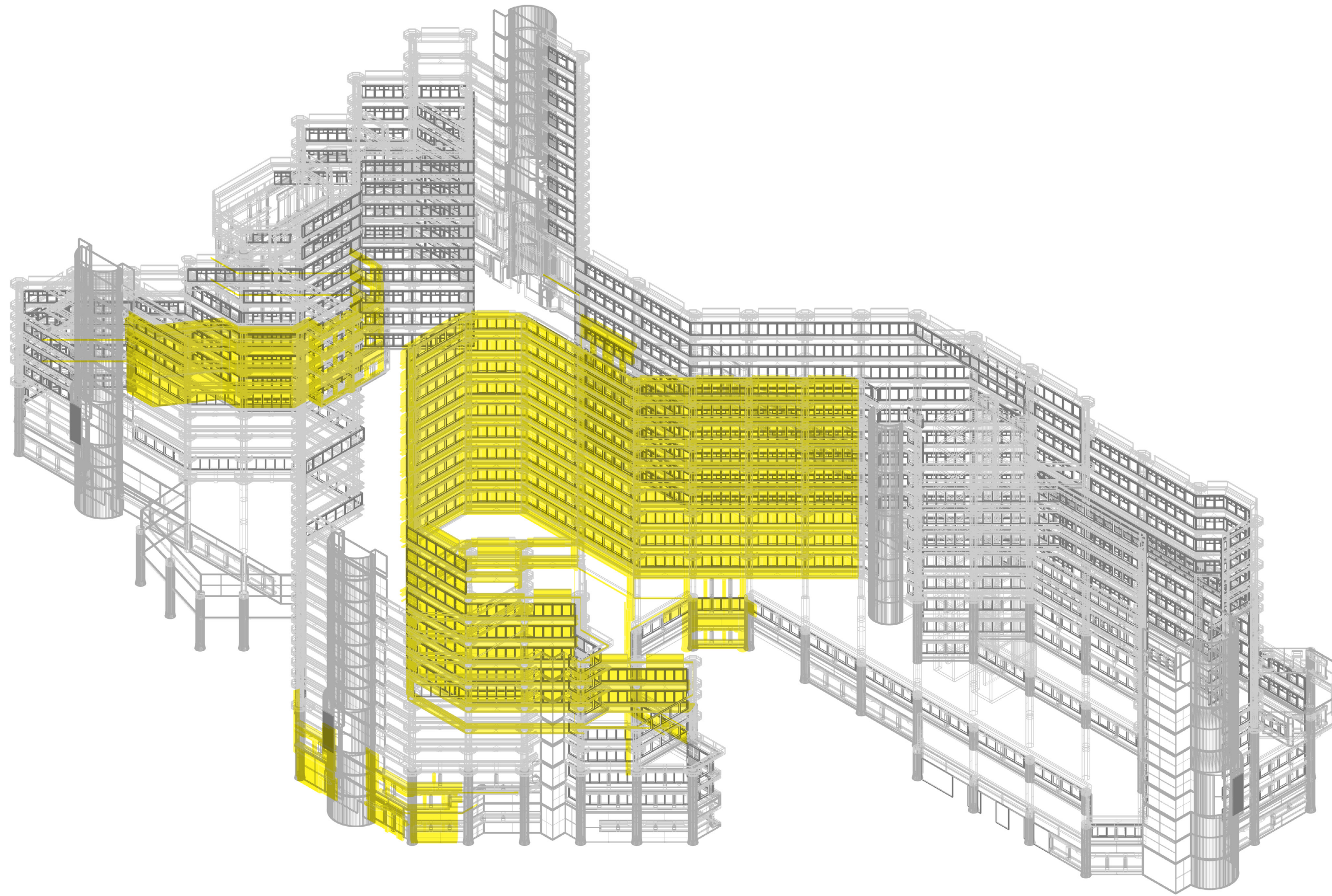

X-element
dimensions: 900x650xvariable
material type: prefab concrete
amount mined: 138

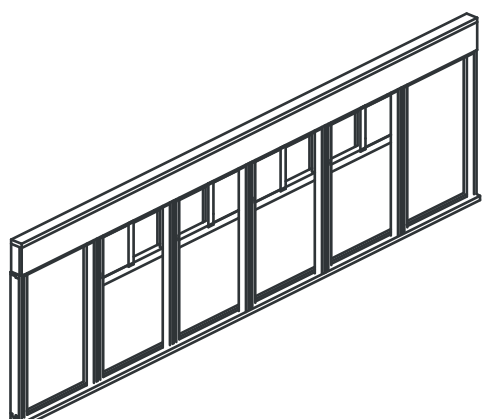

window frame
dimensions: 1700x120xvariable
material type: glass and aluminum
amount mined: 138

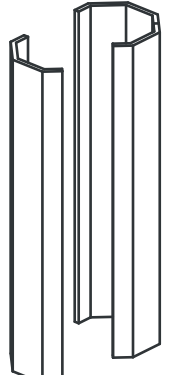

column shells
dimensions: 900mm diameter,
50mm thickness
material type: prefab concrete
amount mined: 126

Reconfiguration: Addition

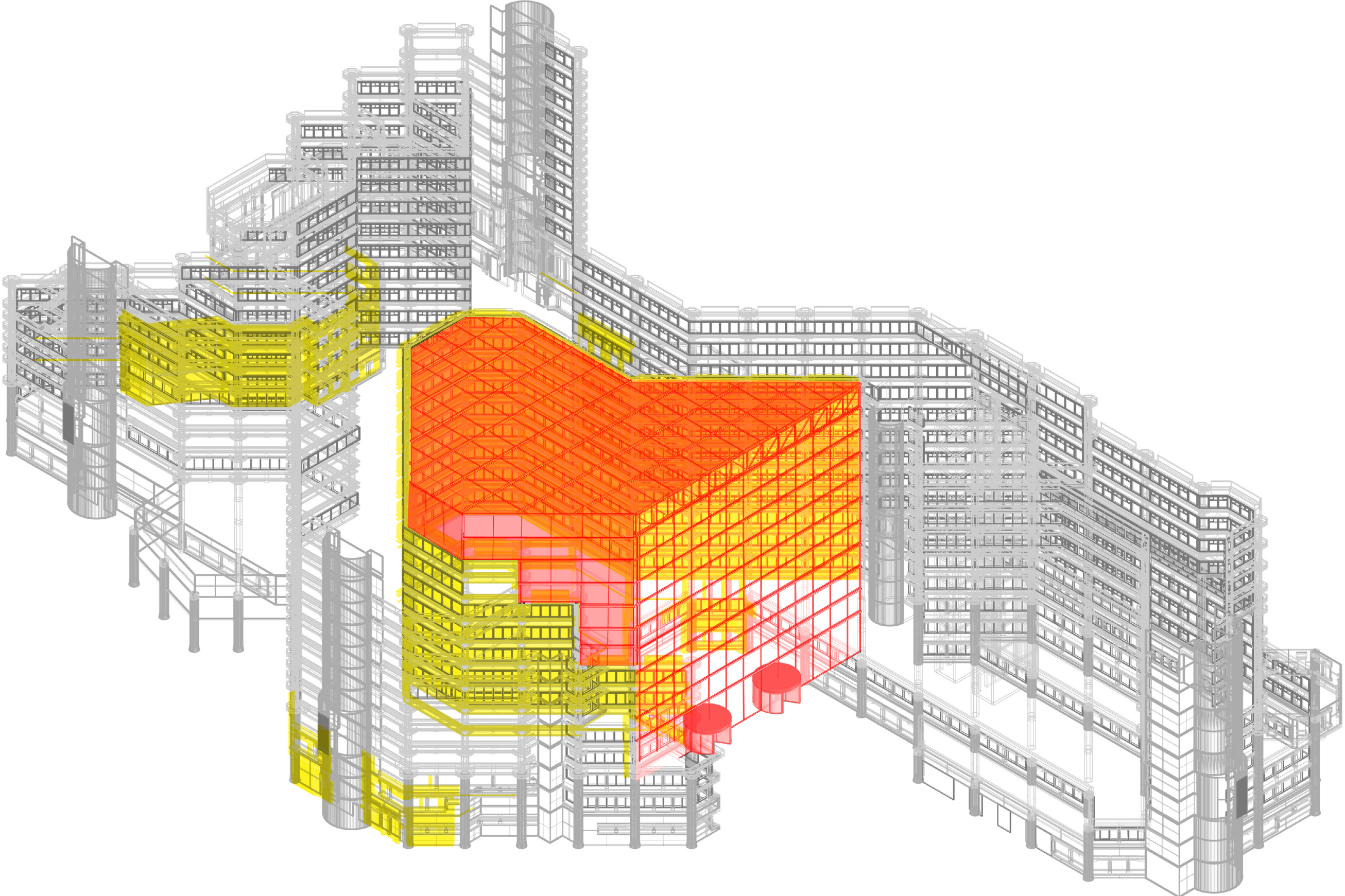

Section: Ministry Atrium

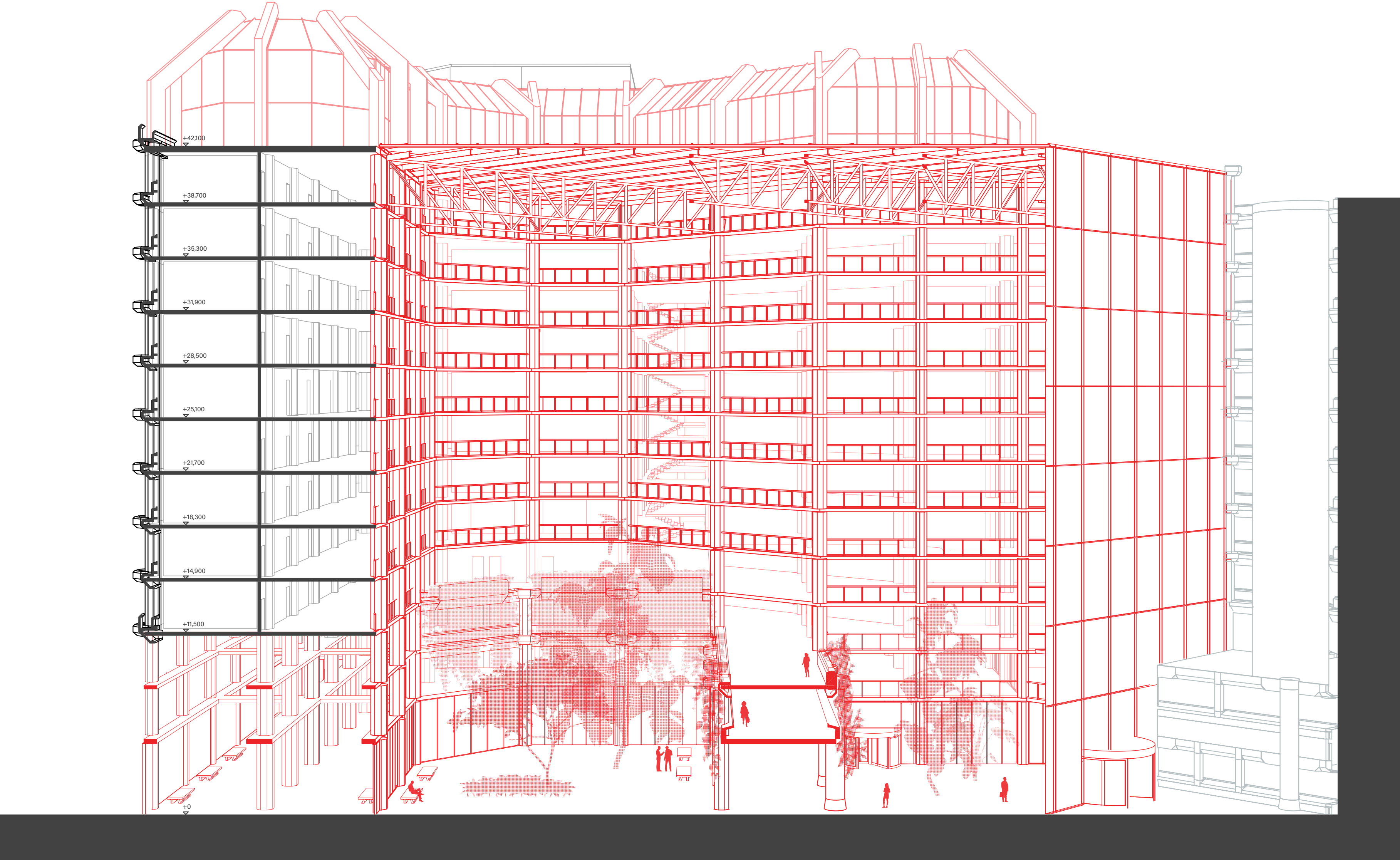

View: Ministry Atrium



Views: The Theatre

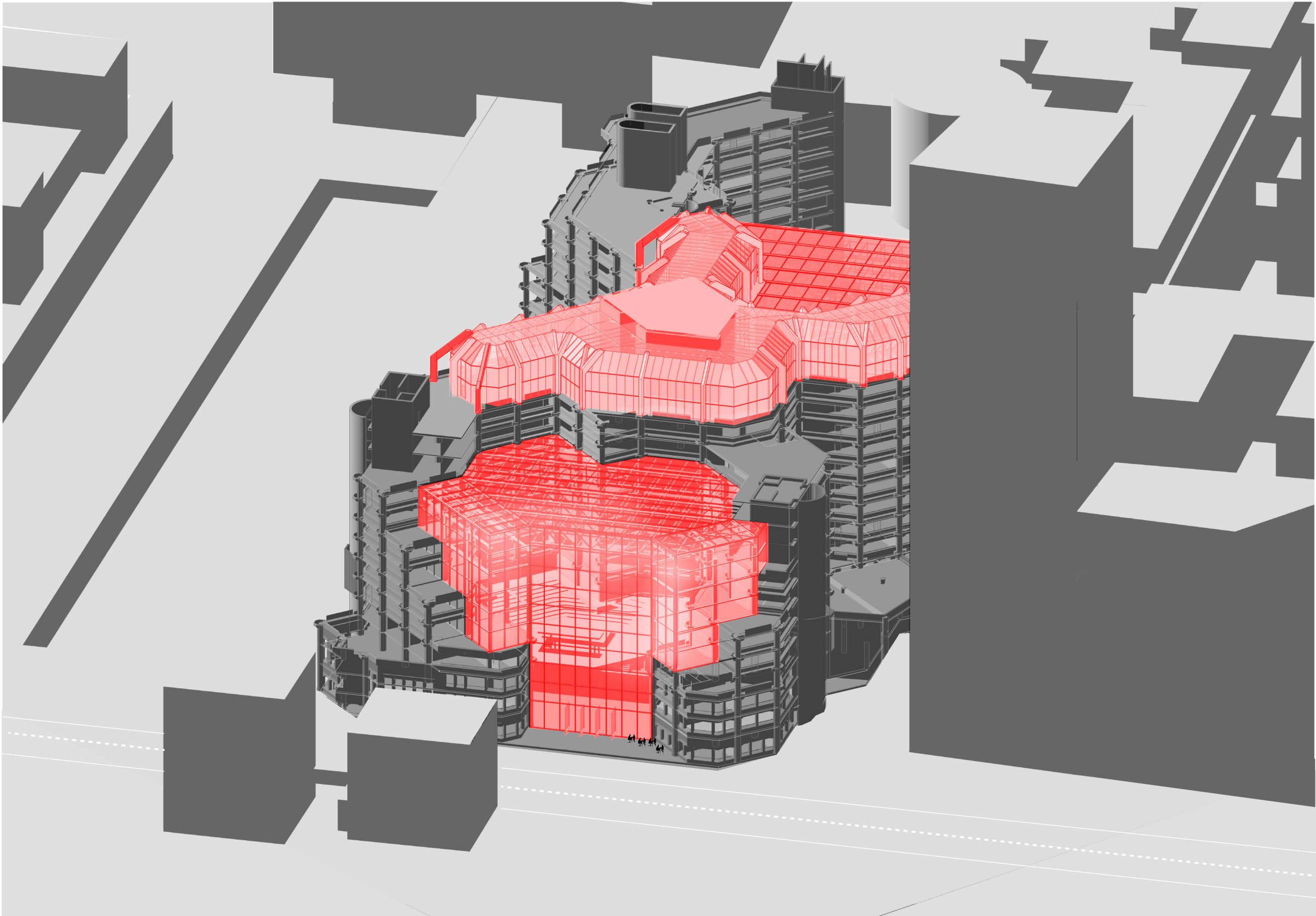

Plans: Level 3

- 3.04 atrium of exchange void
- 3.10 sanitary
- 3.20 changing rooms
- 3.24 exhibition space
- 3.29 copy/print station
- 3.30 meeting rooms
- 3.31 office
- 3.33 storage
- 3.34 flexible office space
- 3.35 archival storage
- 3.36 preservation room
- 3.37 reading room
- 3.38 minister's office
- 3.39 stage level foyer
- 3.40 sound lock (vomitory)
- 3.41 auditorium
- 3.42 backstage

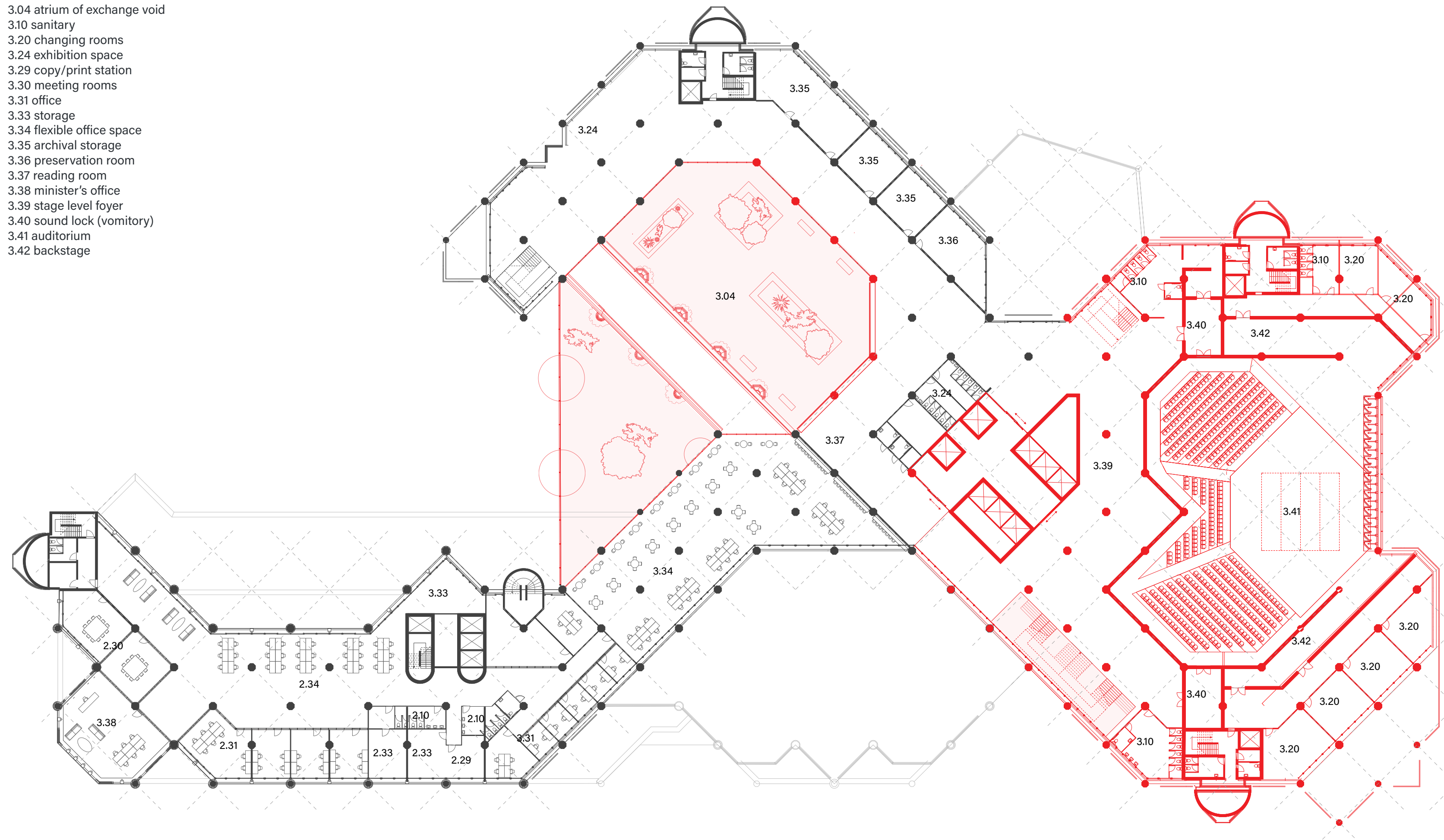

0 1 2 3 4 5 10









Section: Theatre of Transformations

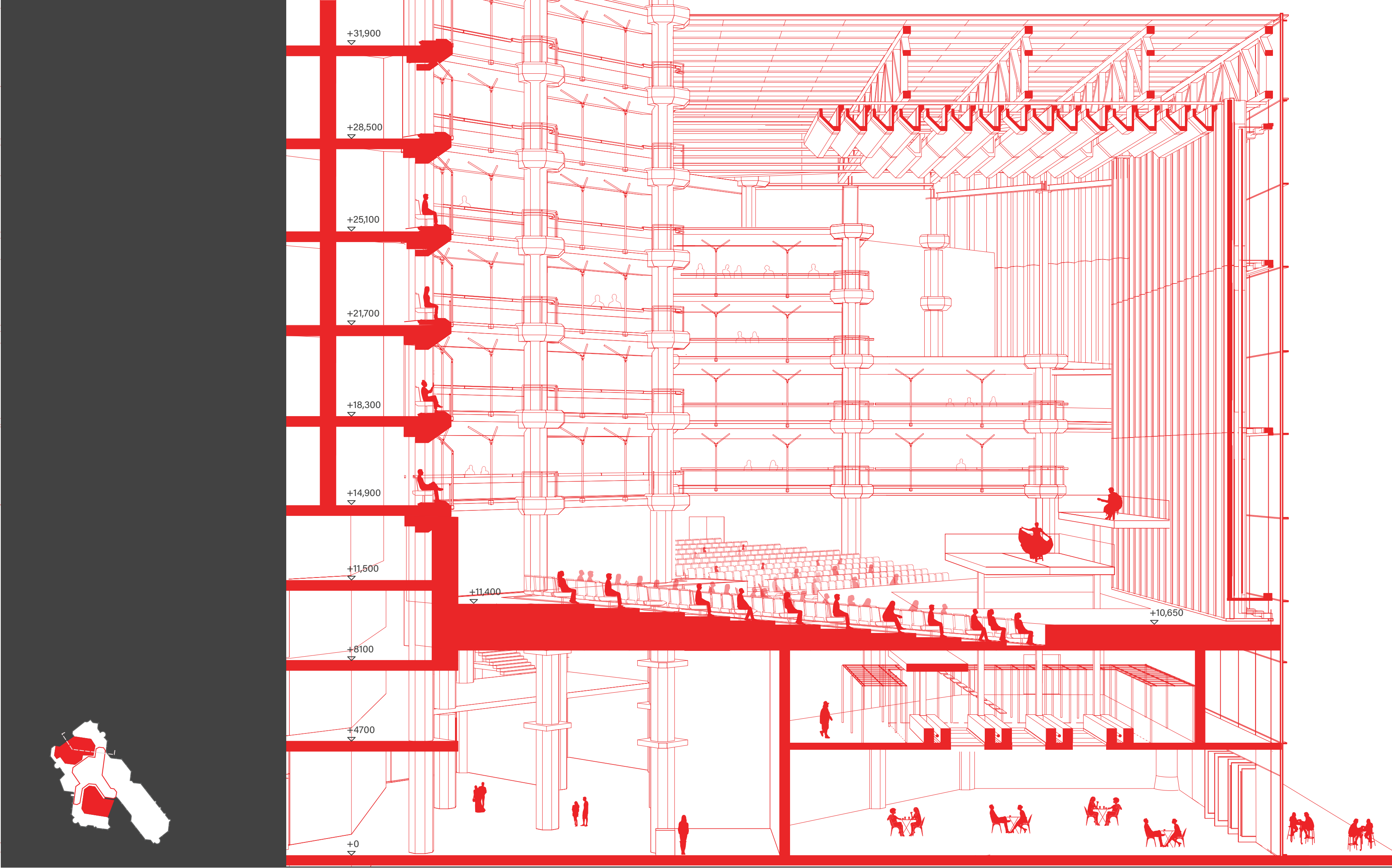

View: Theatre foyer

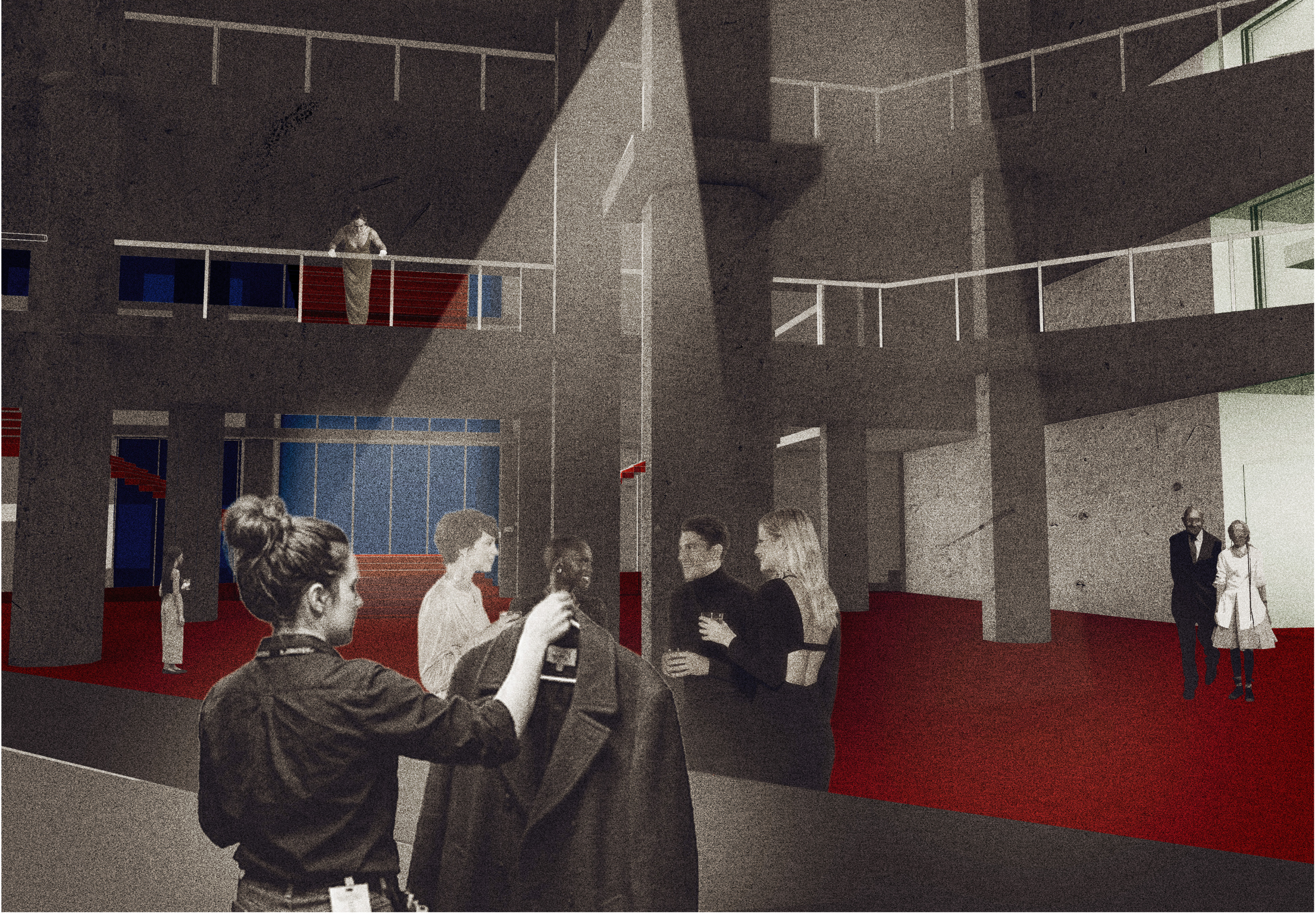





View: Theatre auditorium

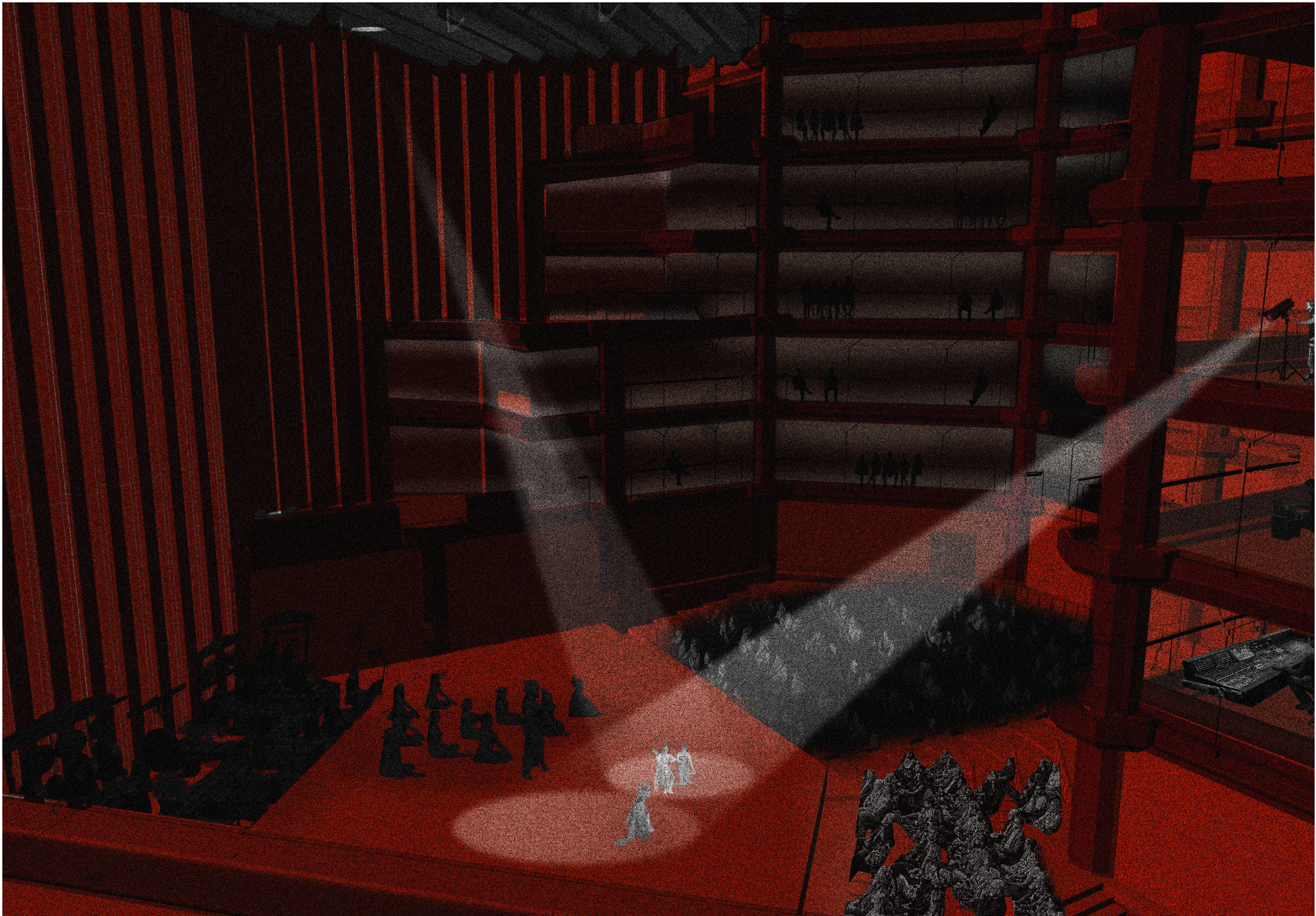

Plans: Level 13

13.48 elevator core to conservatory of belonging
13.49 café
13.50 waiting room
13.51 ceremonial space

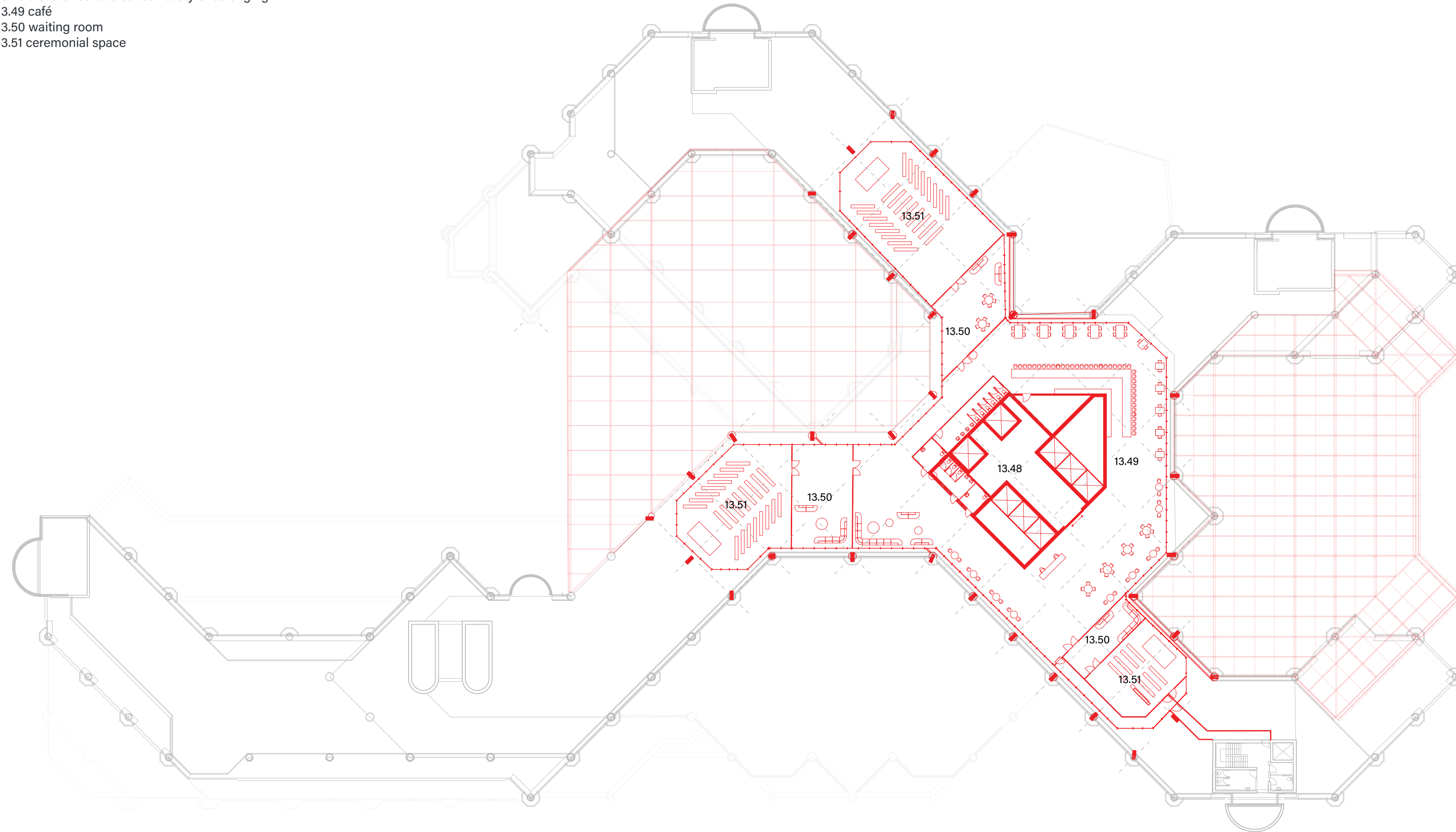

0 1 2 3 4 5 10





Section: Conservatory of Belonging

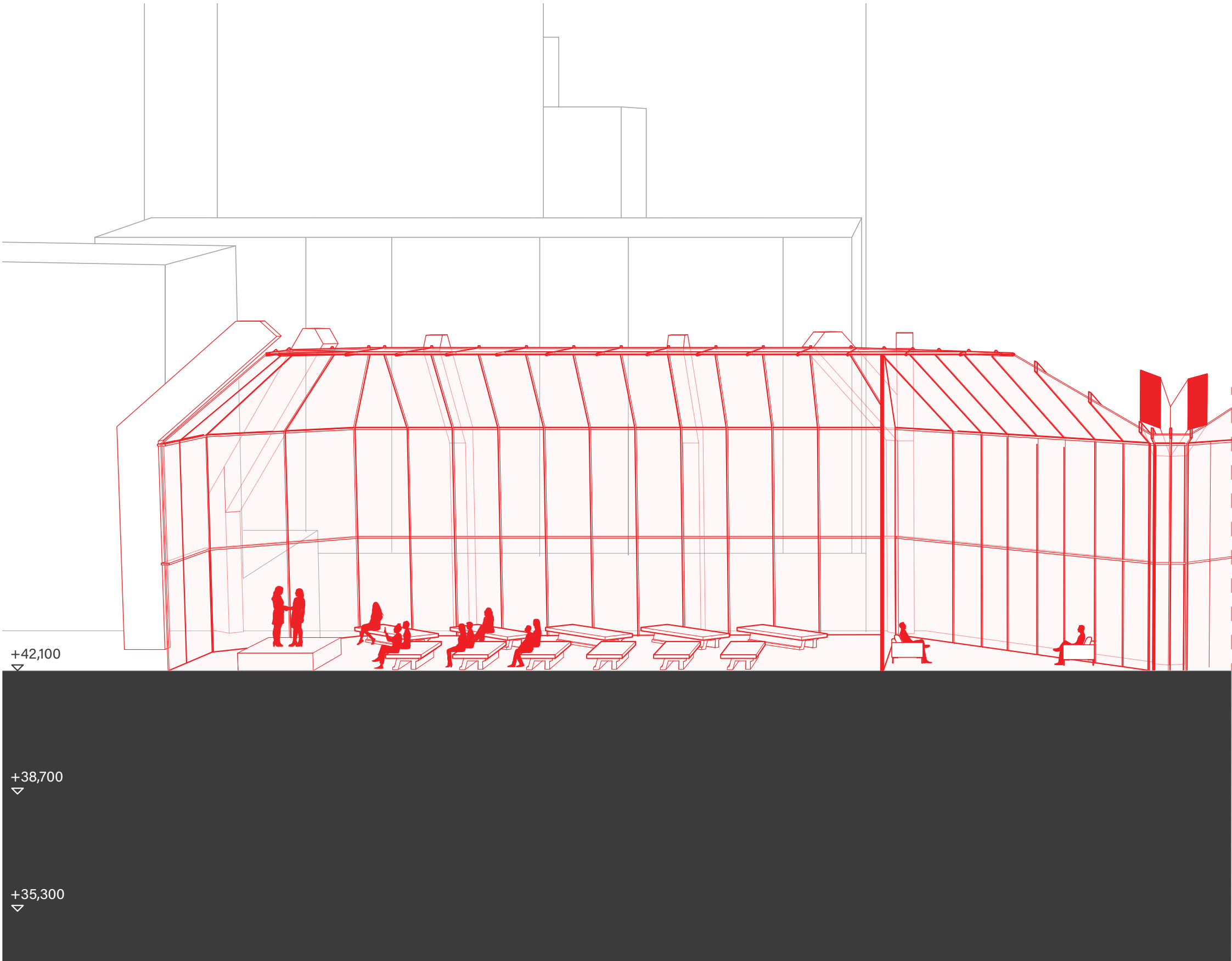

View: Conservatory ceremonial space



Plans: Level 7

- 7.04 atrium of exchange void
- 7.10 sanitary
- 7.24 exhibition space
- 7.30 meeting rooms
- 7.31 office
- 7.33 storage
- 7.34 flexible office space
- 7.35 archival storage
- 7.37 reading room
- 3.38 minister's office
- 7.39 get-round corridor
- 7.40 sound lock (vomitory)
- 7.41 auditorium void
- 7.43 digitization space archive
- 7.44 recording room
- 7.45 archival storage large pieces
- 7.46 theatre balcony
- 7.47 follow-spot room

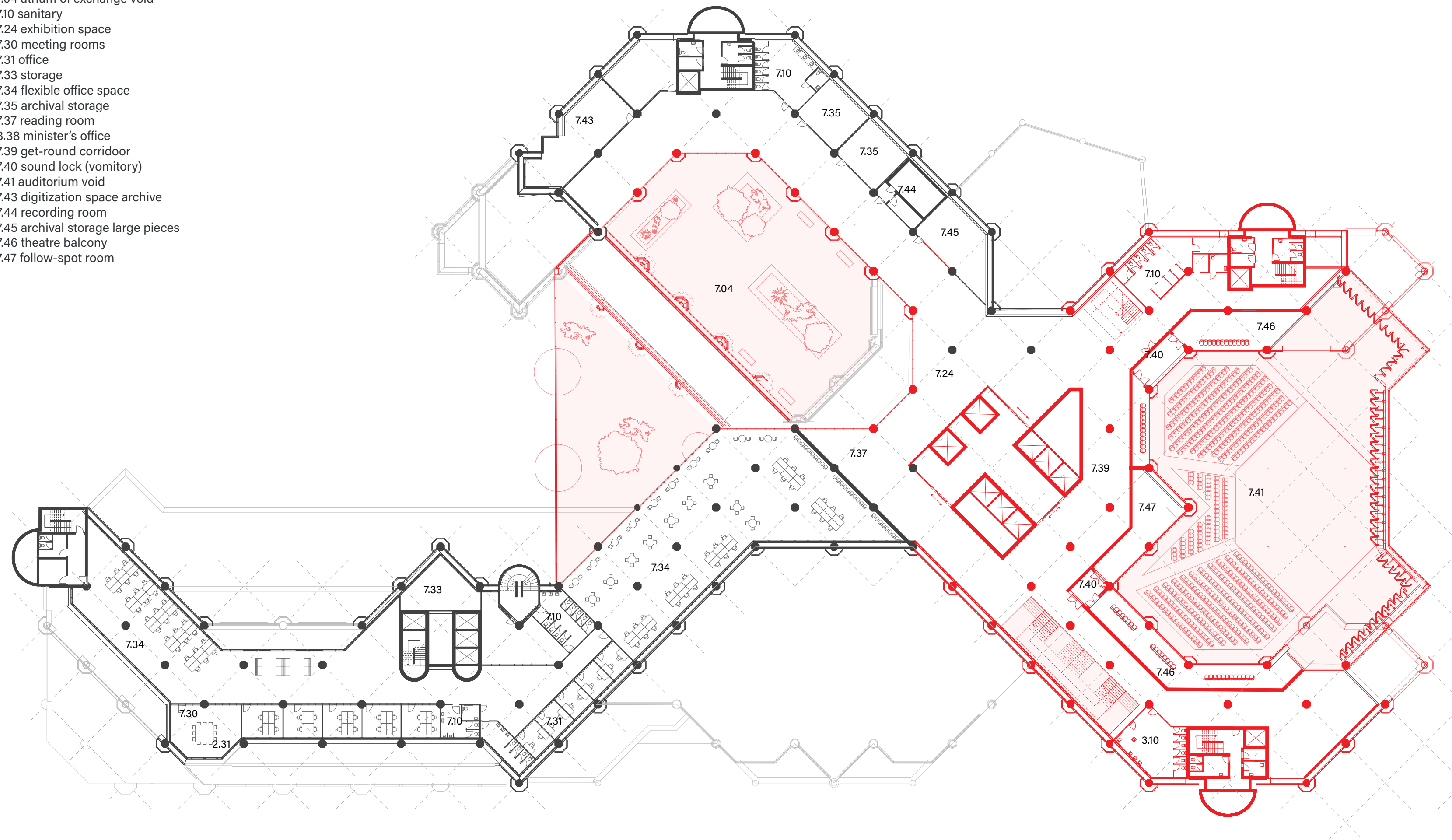

Conclusion

Methodology: Rewriting a building's logic

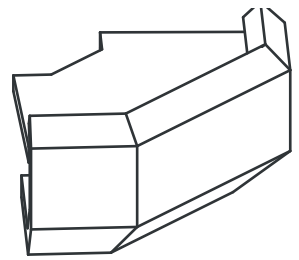

O-03 element
dimensions: 700x850x1400
material type: prefab concrete
amount mined: 126

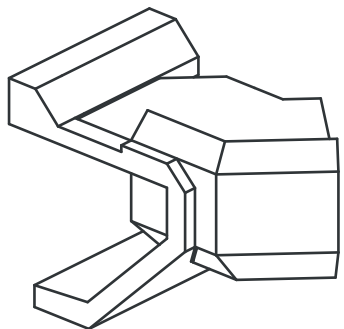

O-02/04 element
dimensions: variable
material type: prefab concrete
amount mined: 252

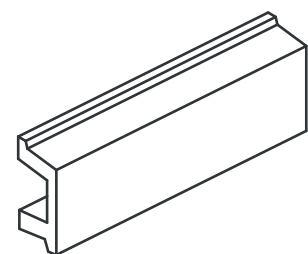

P-element parapet
dimensions: 610x330xvariable
material type: prefab concrete
amount mined: 138

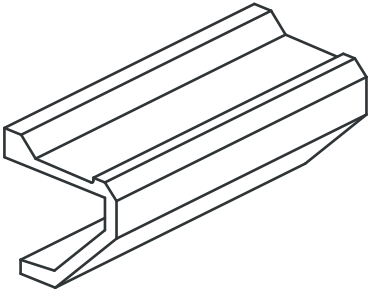
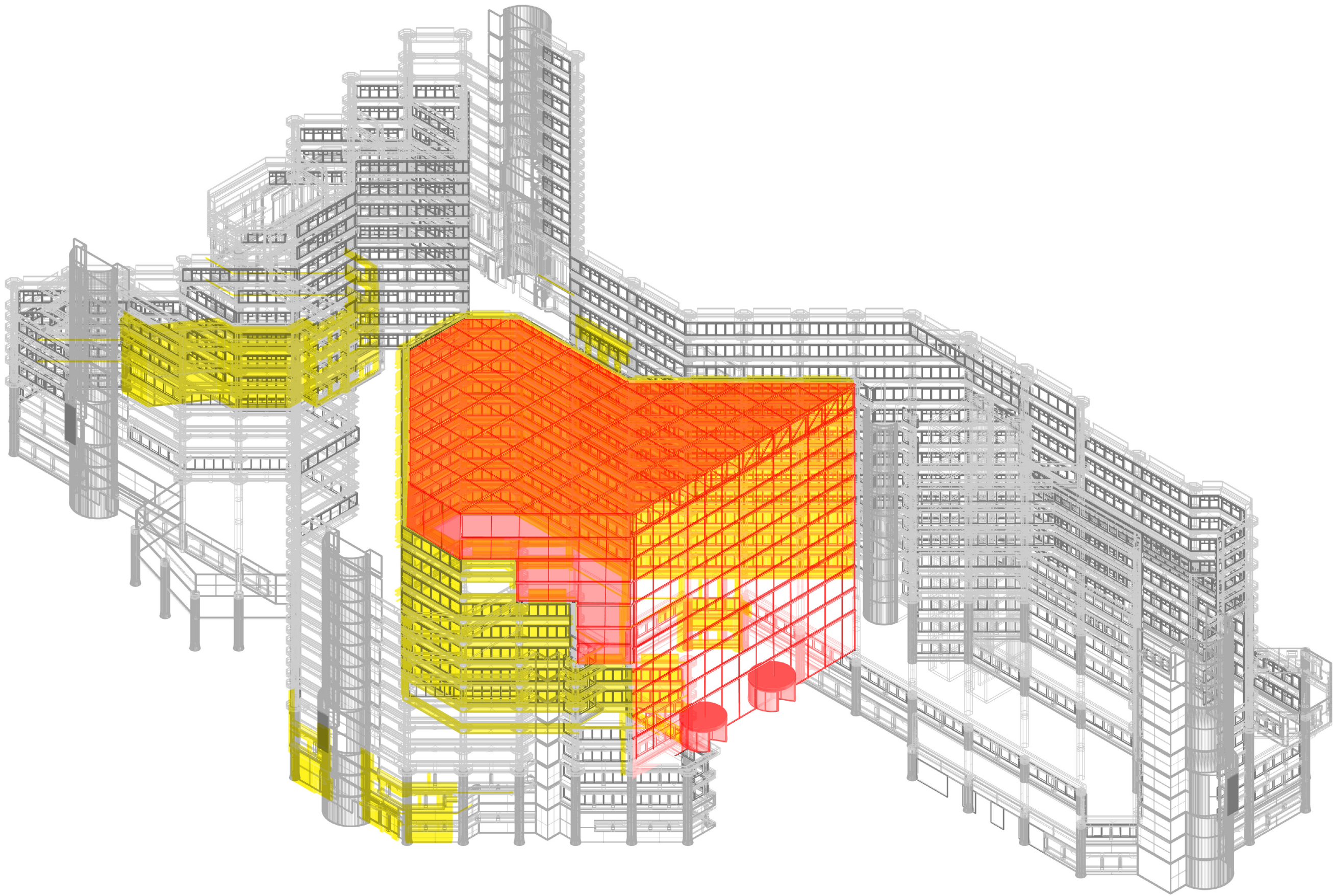

X-element
dimensions: 900x650xvariable
material type: prefab concrete
amount mined: 138

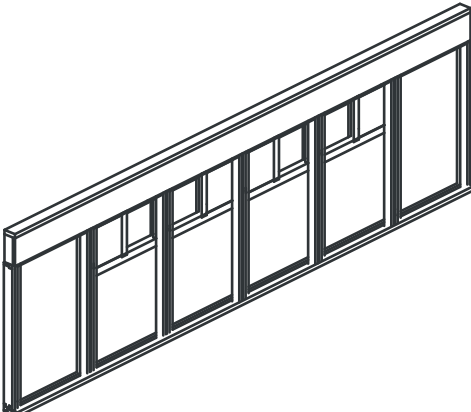

window frame
dimensions: 1700x120xvariable
material type: glass and aluminum
amount mined: 138

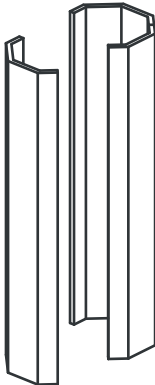

column shells
dimensions: 900mm diameter,
50mm thickness
material type: prefab concrete
amount mined: 126

Reflection: Institutional pillars

Reflection: Institutional pillars

INFORMATION Ministry Atrium



Reflection: Institutional pillars

INFORMATION Ministry Atrium



INSPIRATION Theatre

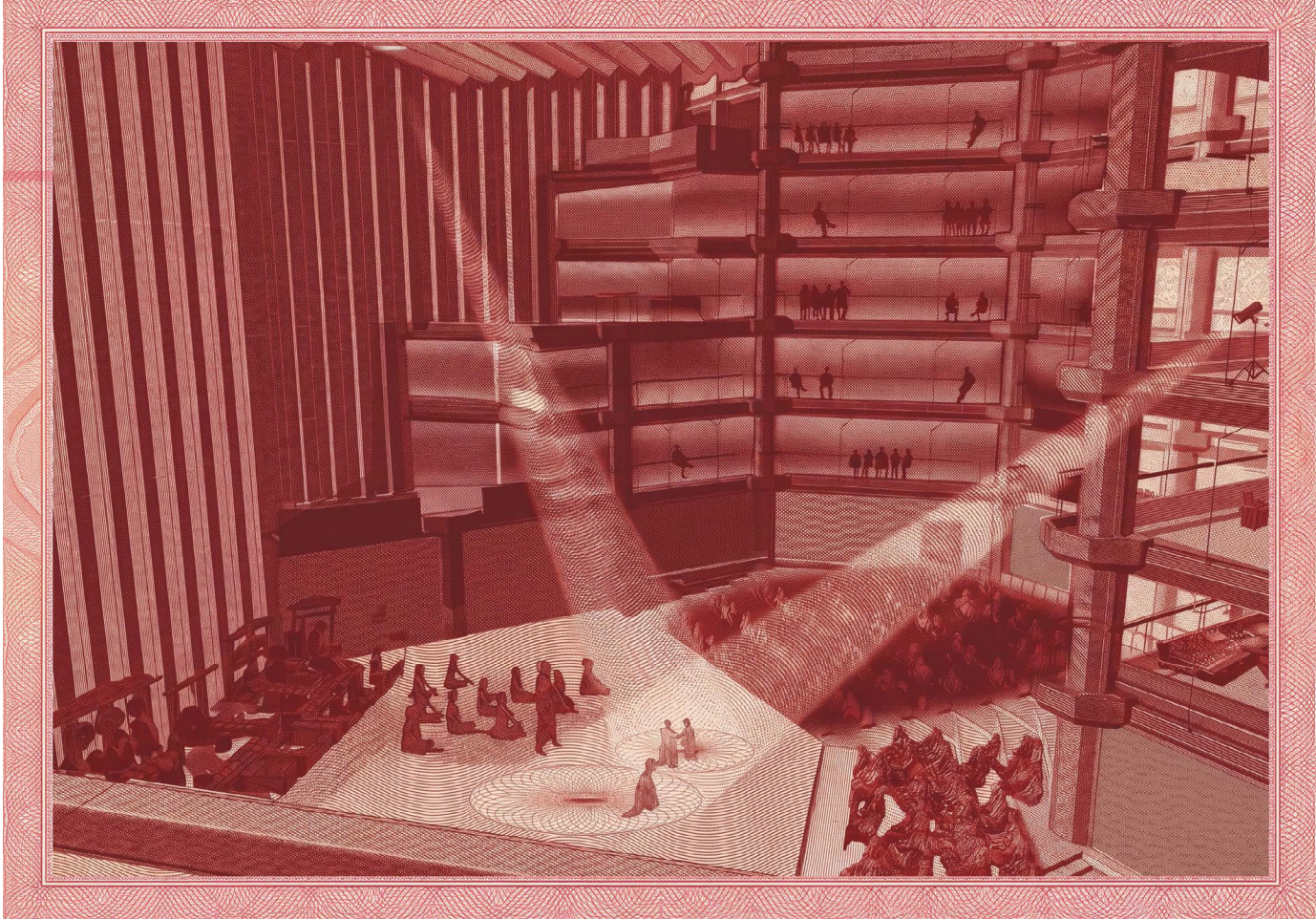

Reflection: Institutional pillars

INFORMATION Ministry Atrium



INSPIRATION Theatre

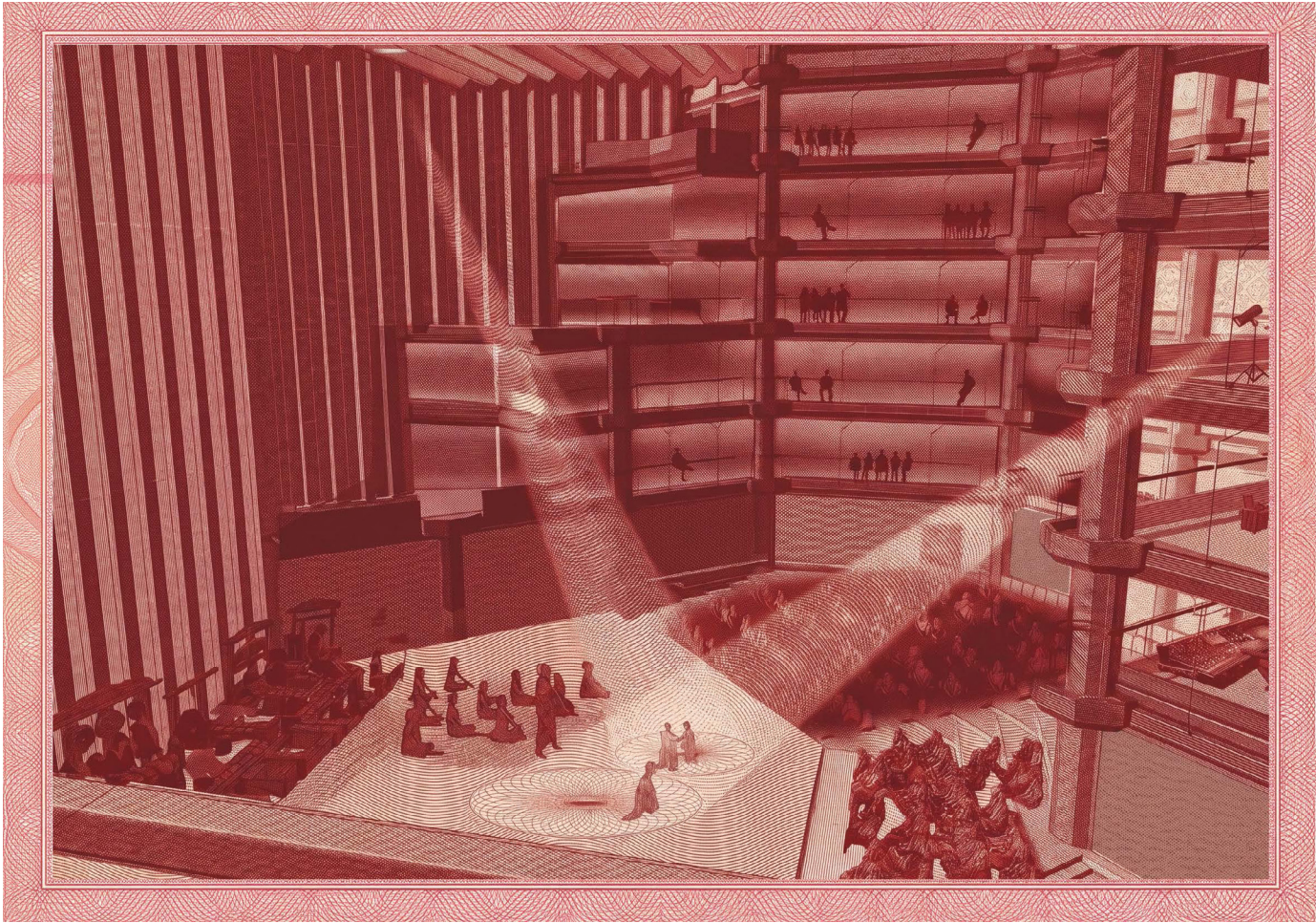

IDENTITY Conservatory/Archive

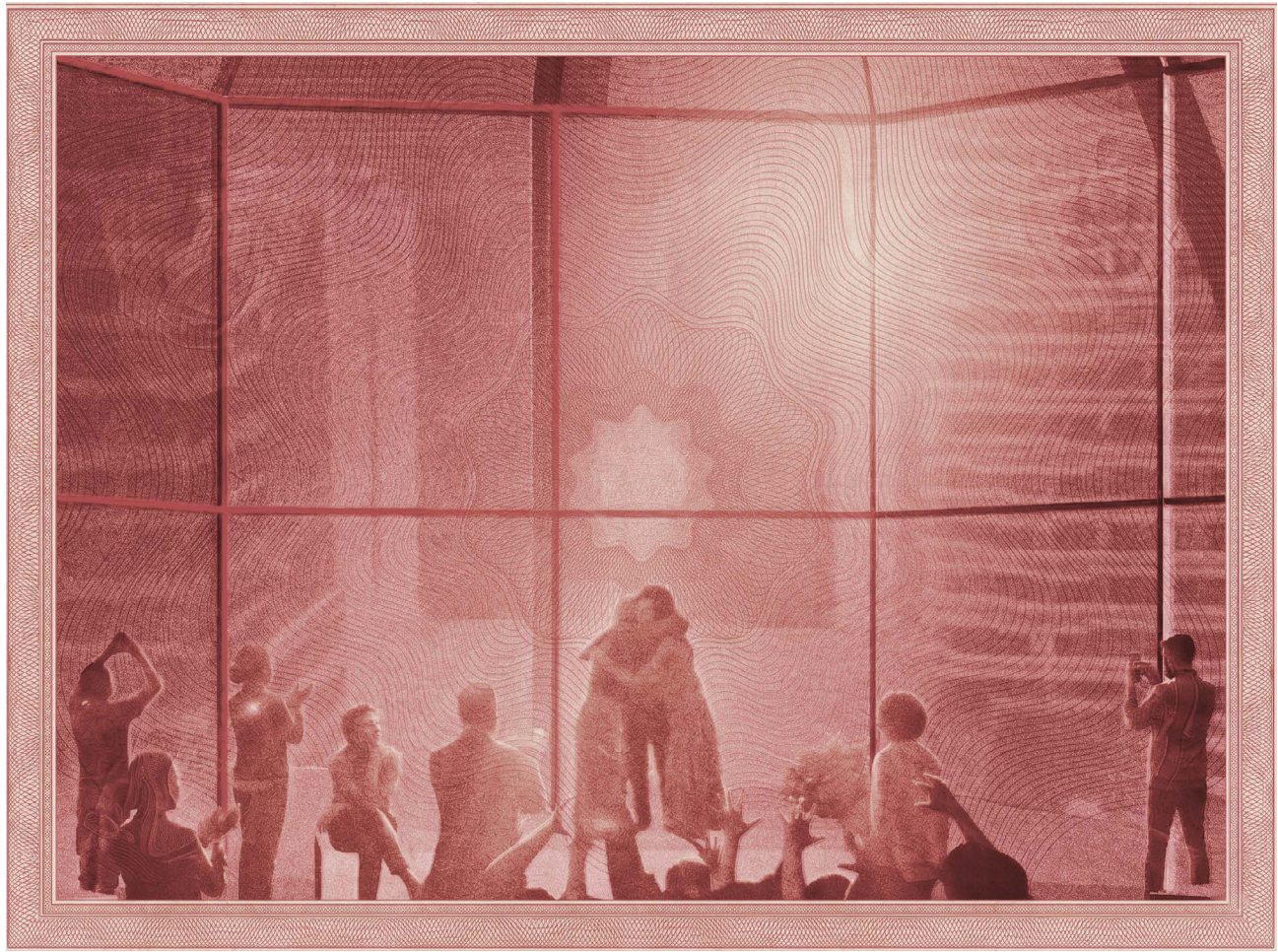

Reflection: Institutional pillars

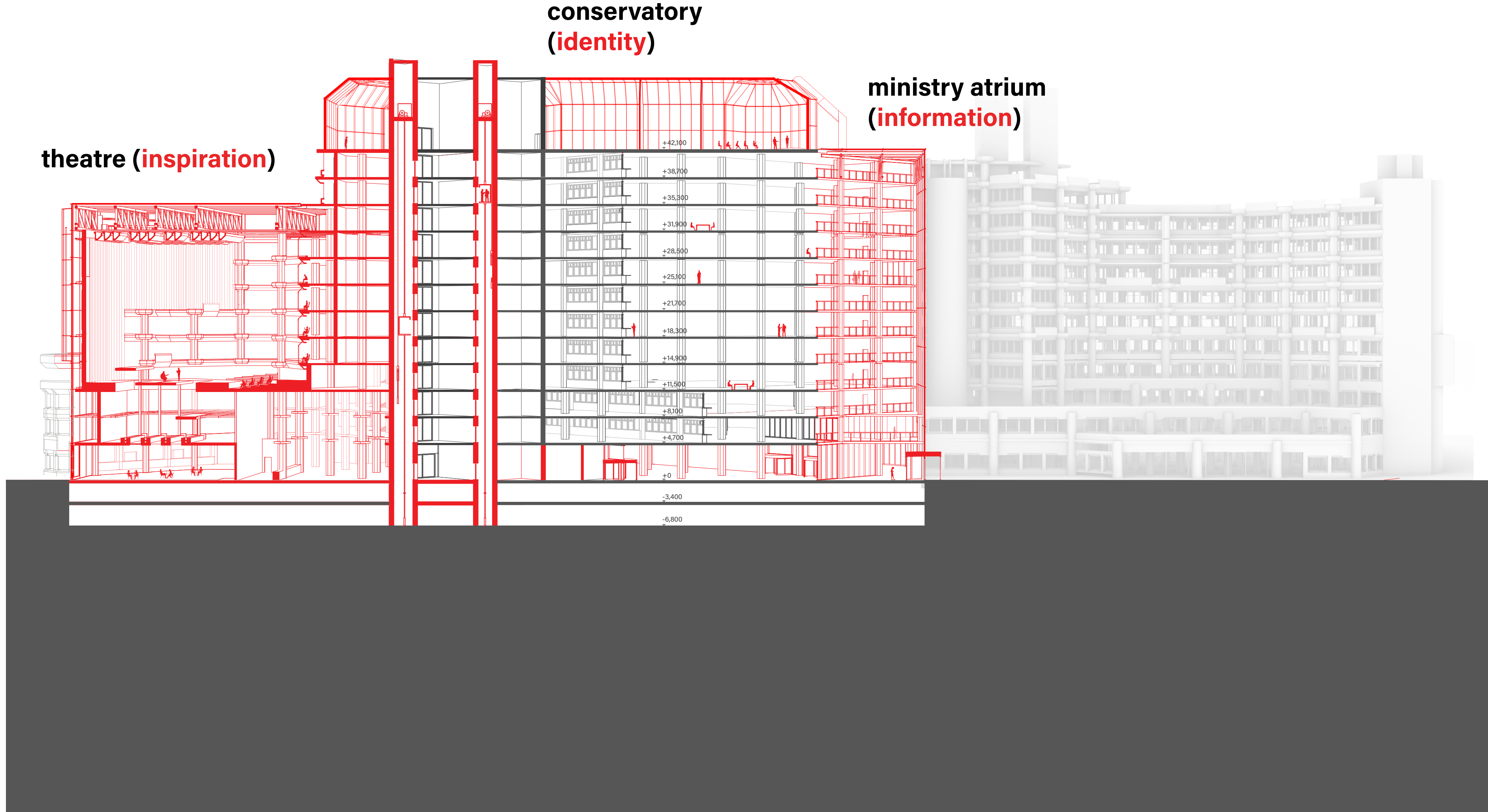

Thank you.

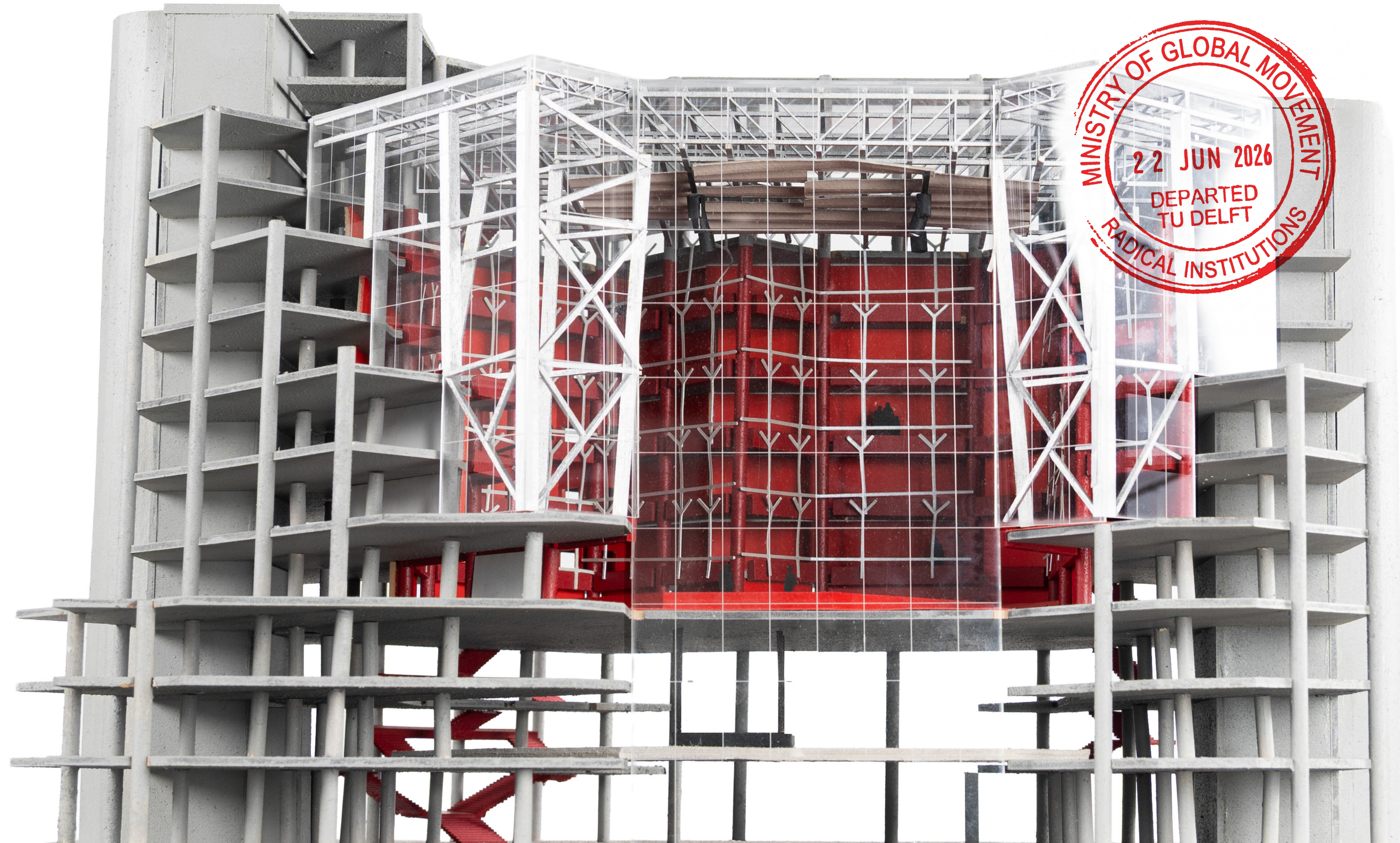

THE MINISTRY OF GLOBAL MOVEMENT

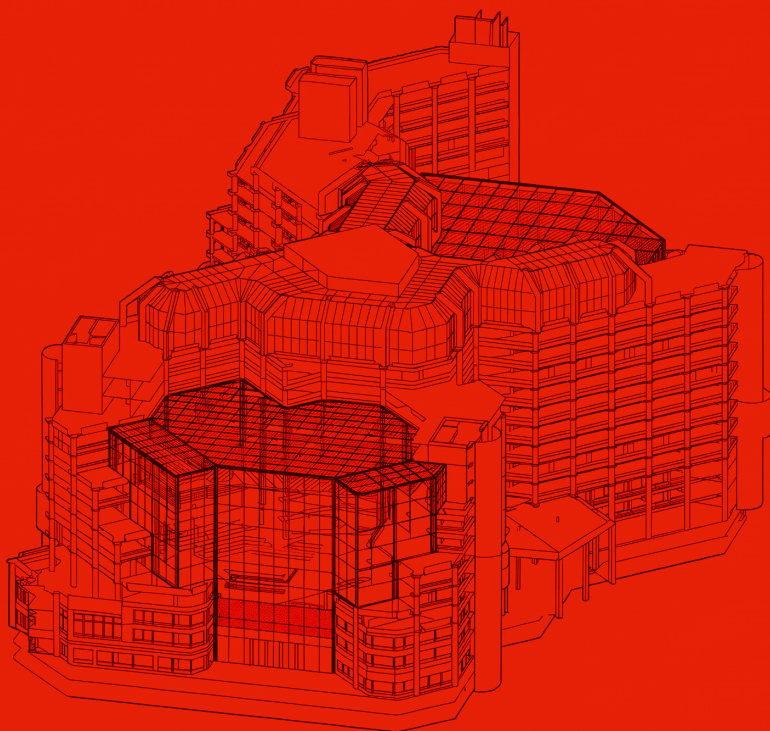

IN NAAM VAN DE INGESCHREVEN STUDENT

DE STUDIO BEGELEIDERS) VAN DE GROEP DESIGN, DATA AND SOCIETY AAN DE TECHNISCHE UNIVERSITEIT DELFT VERZOEKEN ALLE BETROKKENEN DE HOUDER VAN DIT ARCHITECTUURPASPOORT VRIJ EN ONGEHINDERD DOOR TE LATEN. HIERBIJ WORDT BEKENDGEMAAKT DAT DE „APONROTS“ (BZ67) ZIJN MONOLITHISCHE AUTORITEIT HEEFT VERLOREN.

BESCHERMING, VEILIGE DOORGANG EN EEN ZITPLAATS IN HET THEATER VAN TRANSFORMATIES WORDEN VERLEEND AAN ALLE BEWEGENDE LICHAMEN, ONGEACHT NATIONALE AFKOMST, PAPIEREN VOLMACHTEN OF COMPUTATIONELE DATAFICATIE.

IN NAME OF THE MATRICULATED UNDERGRADUATE

THE STUDIO TUTORS OF THE DESIGN, DATA AND SOCIETY GROUP AT DELFT UNIVERSITY OF TECHNOLOGY REQUEST ALL THOSE WHOM IT MAY CONCERN TO ALLOW THE BEARER OF THIS ARCHITECTURAL PASSPORT TO PASS FREELY WITHOUT LET OR HINDRANCE. NOTICE IS HEREBY GIVEN THAT THE "MONKEY ROCK" (BZ67) HAS BEEN STRIPPED OF ITS MONOLITHIC AUTHORITY.

PROTECTION, SAFE PASSAGE, AND A SEAT IN THE THEATRE OF TRANSFORMATIONS ARE GRANTED TO ALL MOVING BODIES, REGARDLESS OF NATIONAL ORIGIN, PAPER PROXIES, OR COMPUTATIONAL DATAFICATION.

AU NOM DE L'ÉTUDIANT DE PREMIER CYCLE INSCRIT

LES TUTEURS DU GROUPE « DESIGN, DATA AND SOCIETY » DE L'UNIVERSITÉ TECHNIQUE DE DELFT DEMANDENT À TOUTES LES PERSONNES CONCERNÉES DE PERMETTRE AU PORTEUR DE CE PASSEPORT ARCHITECTURAL DE CIRCULER LIBREMENT, SANS ENTRAVE NI OBSTRUCTION. PAR LA PRÉSENTE, NOUS INFORMONS QUE LA « ROCHE DE SINGES » (BZ67) A ÉTÉ DÉPOUILLÉE DE SON AUTORITÉ MONOLITHIQUE.

PROTECTION, LIBRE PASSAGE ET UNE PLACE AU THÉÂTRE DES TRANSFORMATIONS SONT ACCORDÉS À TOUS LES CORPS EN MOUVEMENT, INDÉPENDAMMENT DE LEUR ORIGINE NATIONALE, DE LEURS PROCURATIONS SUR PAPIER OU DE LEUR DATIFICATION INFORMATIQUE.



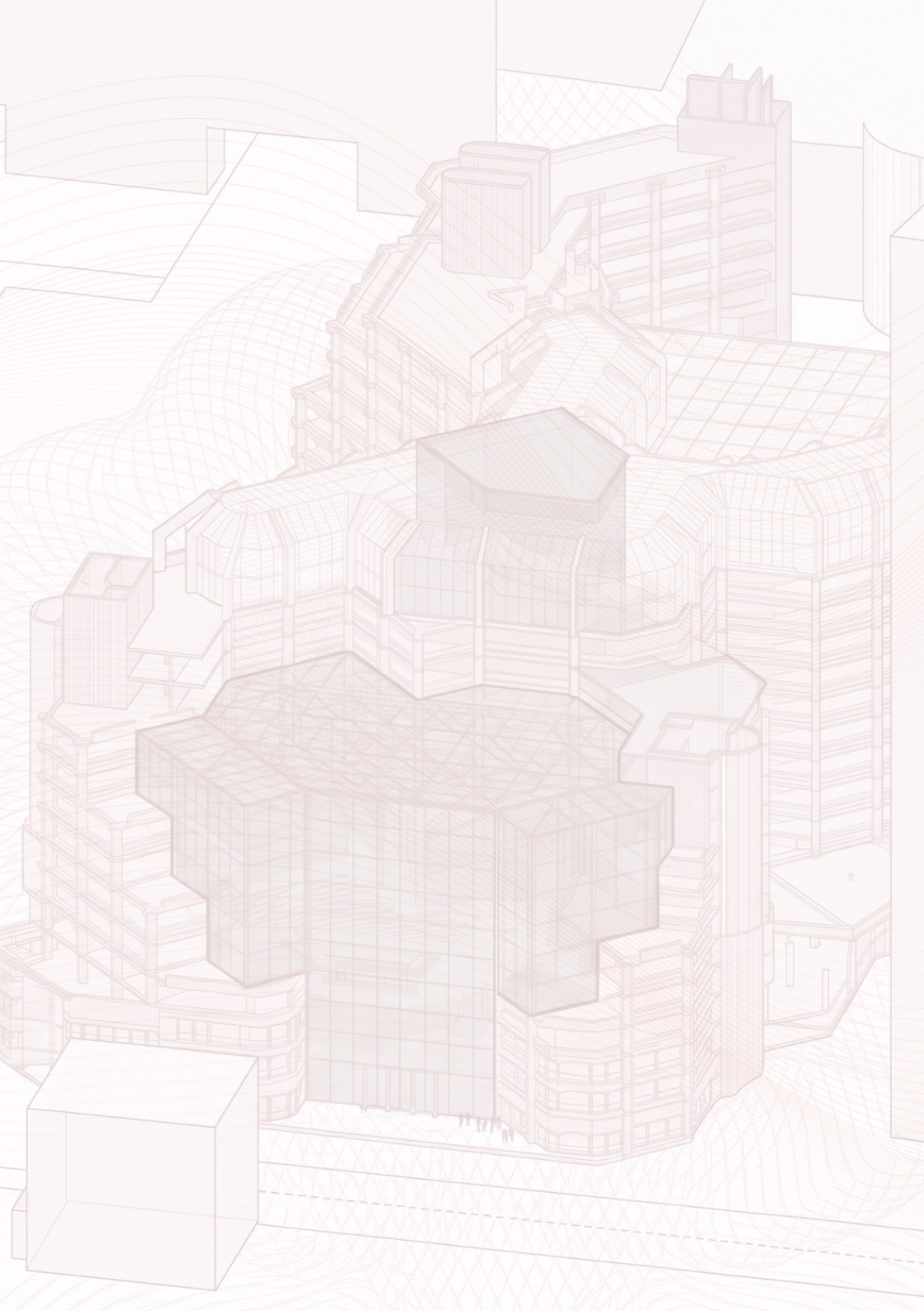

PASPOORT
PASSPORT
PASSEPORT



DELFT UNIVERSITY OF TECHNOLOGY

student number
4684125

type code 2-nationaliteit/nationality/nationalité
P NLD Nederlandse

3 naam/surname/nom

Fung Fen Chung

4 voornamen/given names/prénoms

Lisanne Maja

5 afstudeerdatum / date of graduation / date d'obtention du diplôme

22 JUN 2026

6 afstudeerplaats/place of graduation/lieu date d'obtention du diplôme

Hall C, Faculteit Bouwkunde, Delft

7 master

MSc Architecture, Urbanism and Building Sciences

8 begeleiders/tutors/tuteurs

Angela-Rout & Marija Mateljan

9 studio

Design, Data, and Society - Radical Institutions



ACKNOWLEDGEMENTS

I want to thank my tutors Angie and Marija for their immense help in framing the narrative of this project, and for always prompting me with inspiring ideas to push my design process. I want to thank my peers for their refreshing perspectives and advice during the whole process. I want to thank my mom Yvette, dad Henk, brother Jesse, Duncan and all my friends for supporting me throughout this entire journey. Lastly, I want to thank my grandfather, without you, I would have never studied architecture. This one is for you.

ABSTRACT

Modern migration policies use the passport, a tool rooted in 1920s colonial-era logic, to control human mobility. The *Ministry of Global Movement* challenges this hierarchical system by transforming a closed institutional typology into a hybrid model that celebrates cultural diversity.

Using postcolonial spatial theory and adaptive reuse, the project reconfigures the structuralist “Monkey Rock” building (BZ67) in The Hague into a combined ministry, theatre, and archive. The design centers on three radical spatial interventions: stripping the monolithic façade to create a public Ministry Atrium; establishing the Theatre of Transformations within the stepped structure of the northern wings; and re-envisioning the top structure as the Conservatory of Belonging for naturalisation ceremonies. Ultimately, the project demonstrates how a sovereign building can be spatially reactivated to support plural cultural identities.

THE POWER OF PAPER



PROBLEM STATEMENT

Passports and border controls aren't neutral; they carry a colonial history that uses paper to restrict human mobility based on national origin, often acting as a proxy for discrimination. Today, as these systems shift toward digital tech, we risk entirely forgetting our mobility order was built upon exclusion and oppression. While governments dictate these “open” or “closed” borders, architects design the physical spaces that enforce them—making architecture complicit in the control of movement.

PROJECT

Situated in The Hague, the historic heart of Dutch national politics, and thus colonial decision-making, this project challenges that control. By physically transforming an existing sovereign building, the design actively dismantles bureaucratic architecture to make room for a future that empowers postcolonial voices.



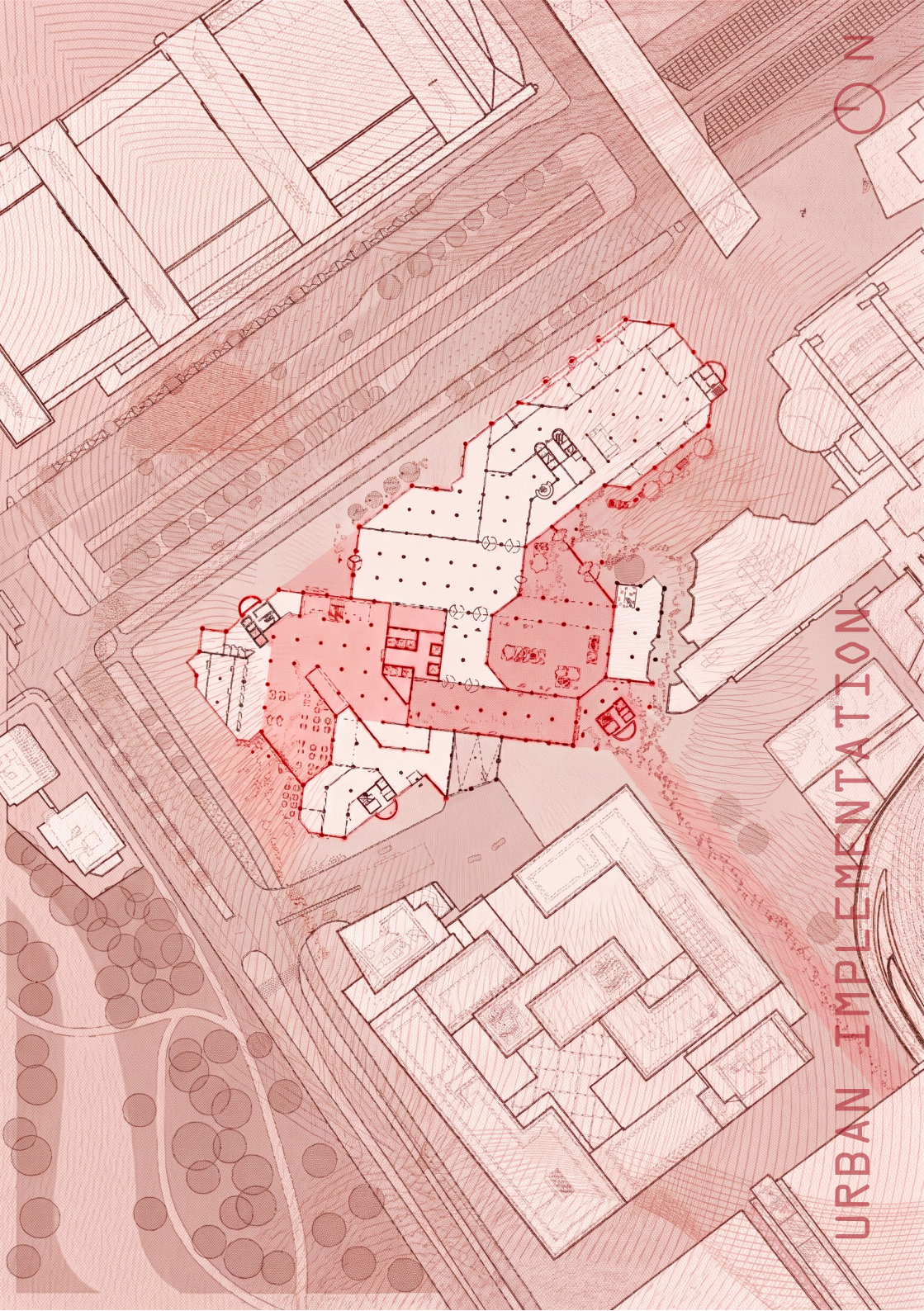

COLONIAL HISTORY OF THE HAGUE



MINISTRY OF COLONIES
1861 - 1969 THE HAGUE

The Hague forms the seat of the Dutch national government. Historically, the state orchestrated its colonial policies from within this city.

As a direct effect of decolonisation, waves of citizens from the former colonies migrated to the Netherlands because of uncertainty for safety of political and economic stability. Many people from the former colonies settled in the Hague, especially people originating from the Indies.

The Hague displays many architectural traces of its colonial wealth and exploitation. It manifests clearly in the architecture of the *Mauritshuis*, or through naming of neighbourhoods like the *Zeeheldenkwartier* and the *Laan van Nieuw-Oost-Indië*. More importantly, the history lives on through the everyday experiences of communities that experience systemic inequality and discrimination to this day.

ZONE 1: INFORMATION

Arriving outside the building, you perceive an opened up facade. By completely carving out the lower three floors of the archive wing, the entrance is transformed into a highly visible, welcoming public portal easily seen when approaching from The Hague Central Station.

The Ministry of Global Movement is positioned within the longest wing of the building. Guided by programmatic drivers of visual transparency and accessibility, the design proposes a strong visual connection and tension between the public and governmental side within the Ministry Atrium. Within the Atrium, a semi-outdoor green area fulfills the desire for a restorative space for the wellbeing of civil servants, allowing them to coexist and see one another alongside citizens.

PUBLIC ENTRANCE



MINISTRY ATRIUM



GROUND

FLOOR

- 0-01 main public entrance
- 0-02 exhibition hall cultural centre
- 0-03 shared walkway
- 0-04 atrium of exchange
- 0-05 corridor to ministry
- 0-06 lobby ministry
- 0-07 bike parking
- 0-08 hall
- 0-09 coffee corner
- 0-10 sanitary
- 0-11 entrance theatre
- 0-12 foyer
- 0-13 box office
- 0-14 cloakroom
- 0-15 café/restaurant
- 0-16 bar
- 0-17 kitchen
- 0-18 stage door
- 0-19 back office
- 0-20 changing rooms
- 0-21 entrance logistics
- 0-22 air caster for trap stage
- 0-23 entrance parking

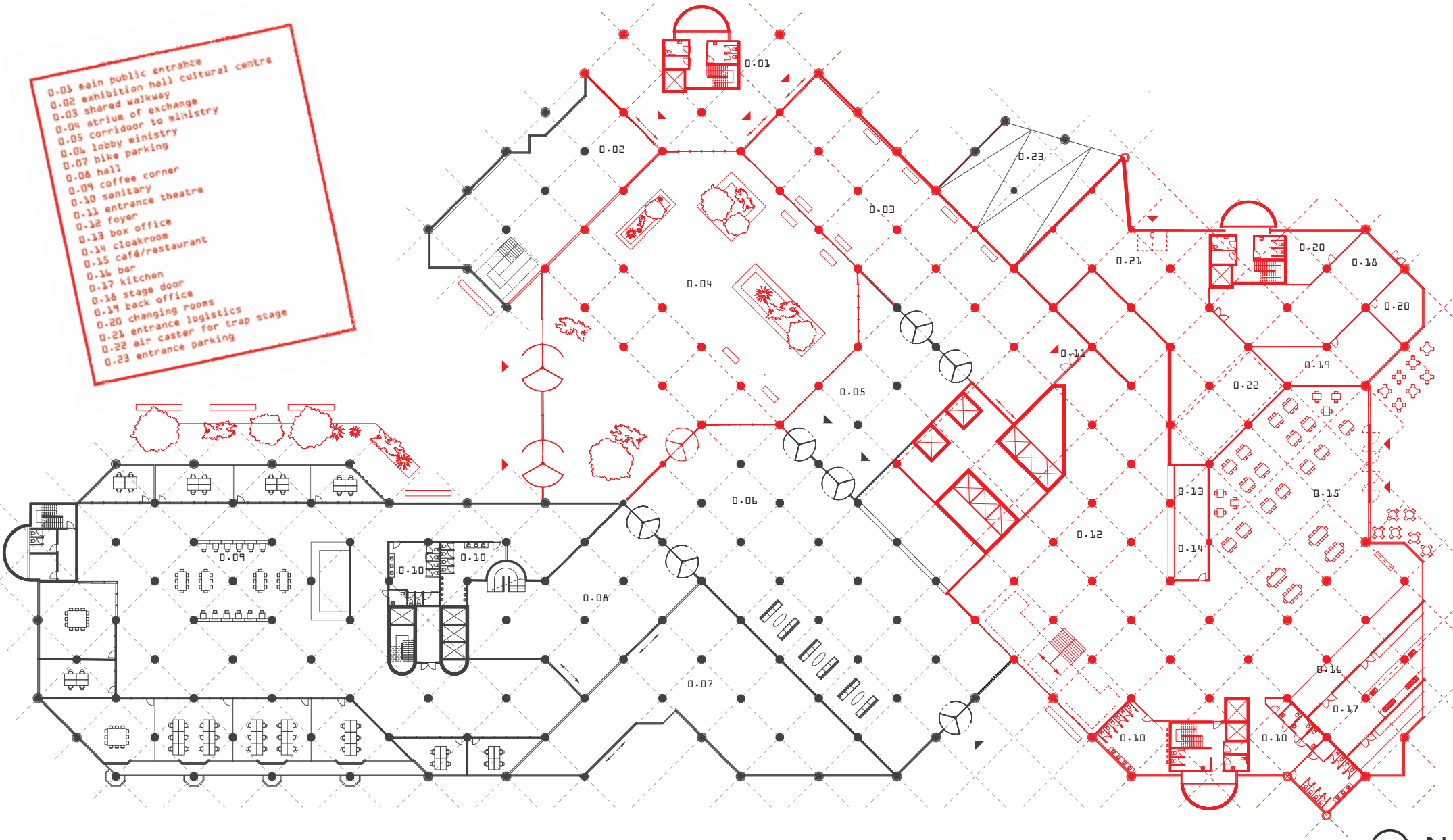

0 1 2 3 4 5 10



MINISTRY

ATRIUM

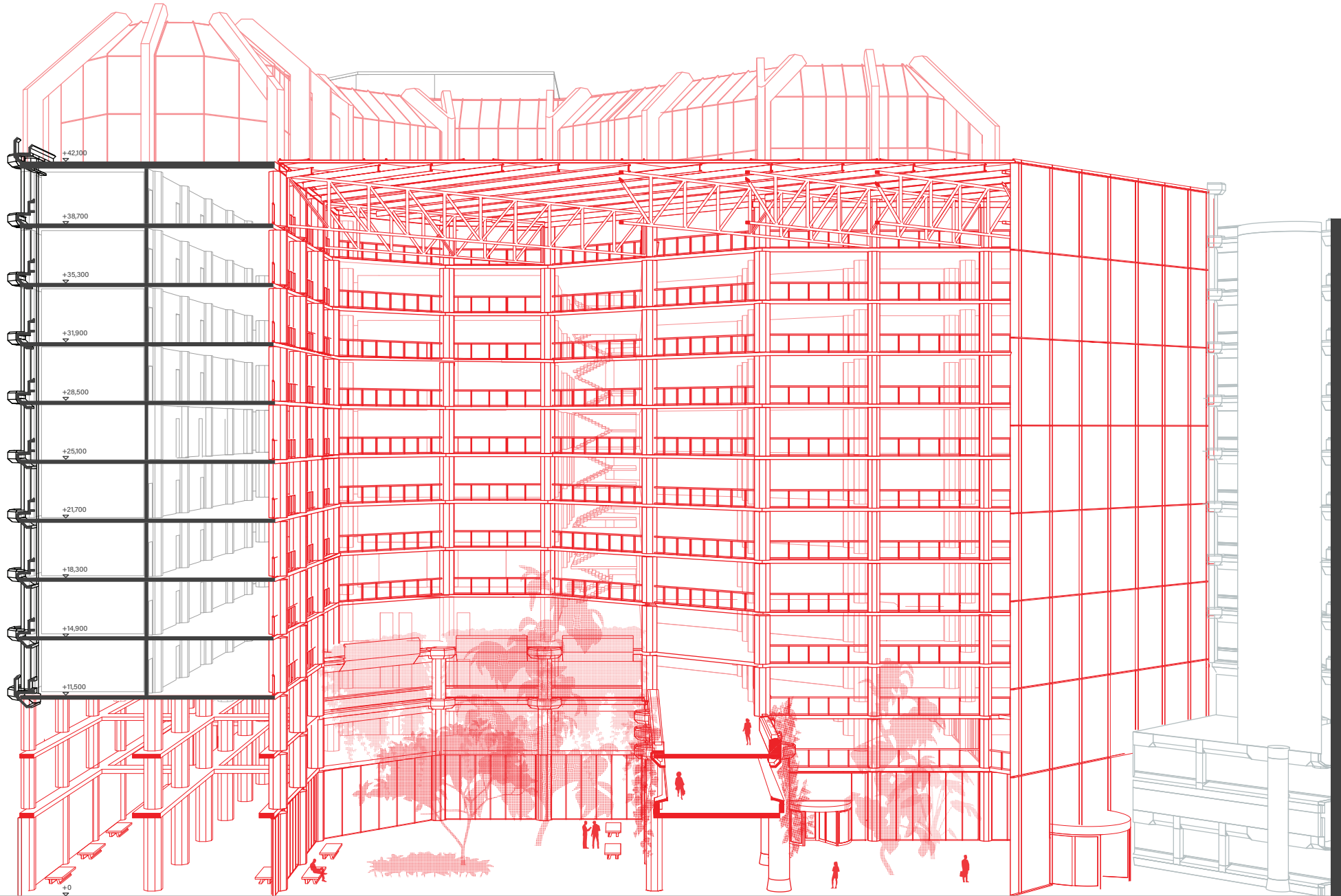

ZONE 2: INSPIRATION

The cultural function of the project focuses heavily on the design of a performance theatre. The design reimagines the original structuralist stepped structure as public seating facing a central stage, with possibilities to transform for other stage designs. A newly introduced glass roof encloses this stepped structure, transforming the existing roof into an internal floor to fully re-envision the building for the theatre typology.

Within the theatre, full light blackouts and specific acoustic treatments are required during live performances. To meet these needs, the design repurposes the concrete façade shells mined from the ministry's atrium. In the roof of the auditorium, these concrete shells function as light louvers, while the roof beams are left bare, leveraging their outer convex shape to reflect sound upward toward the balconies.

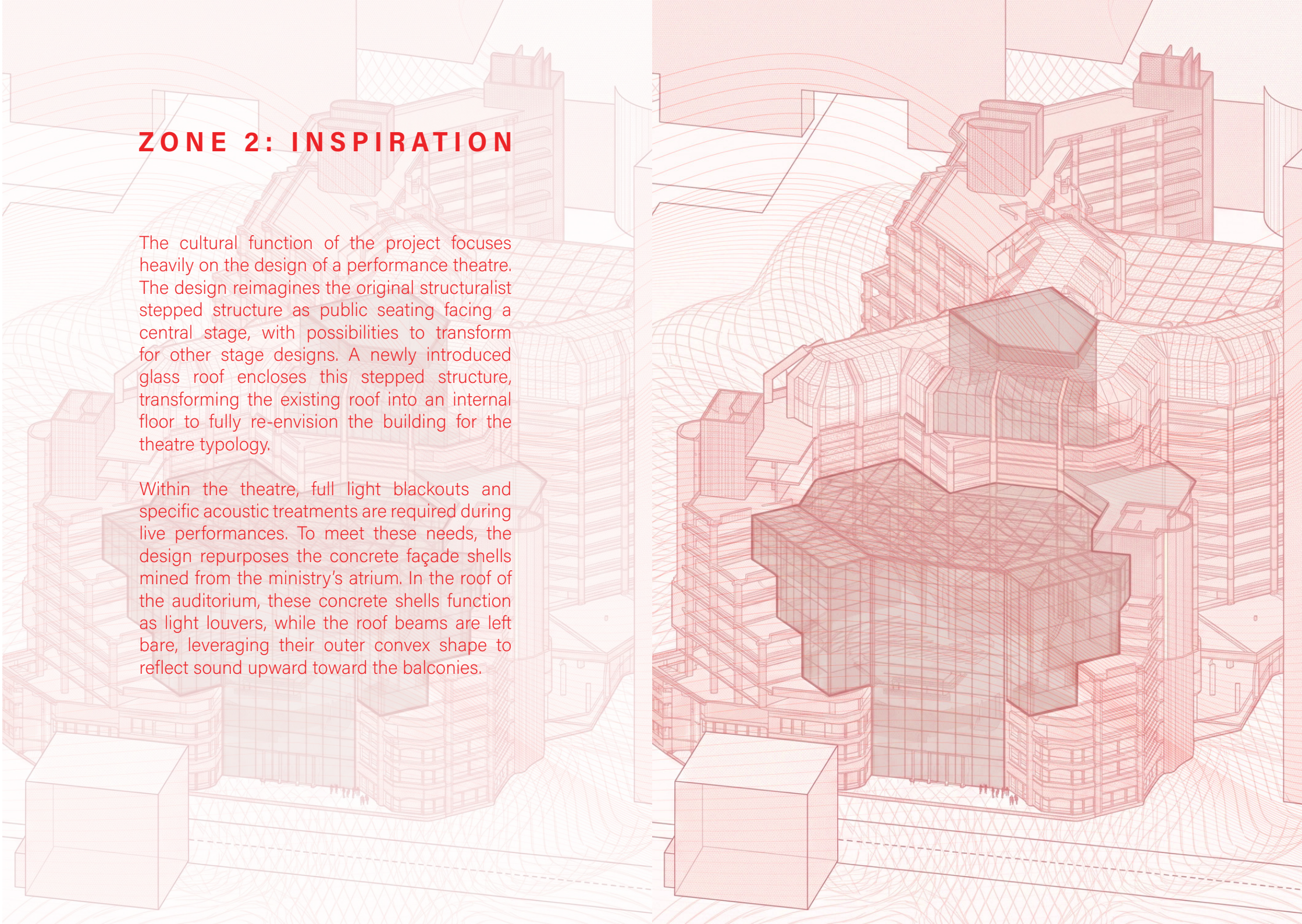

THEATRE AUDITORIUM

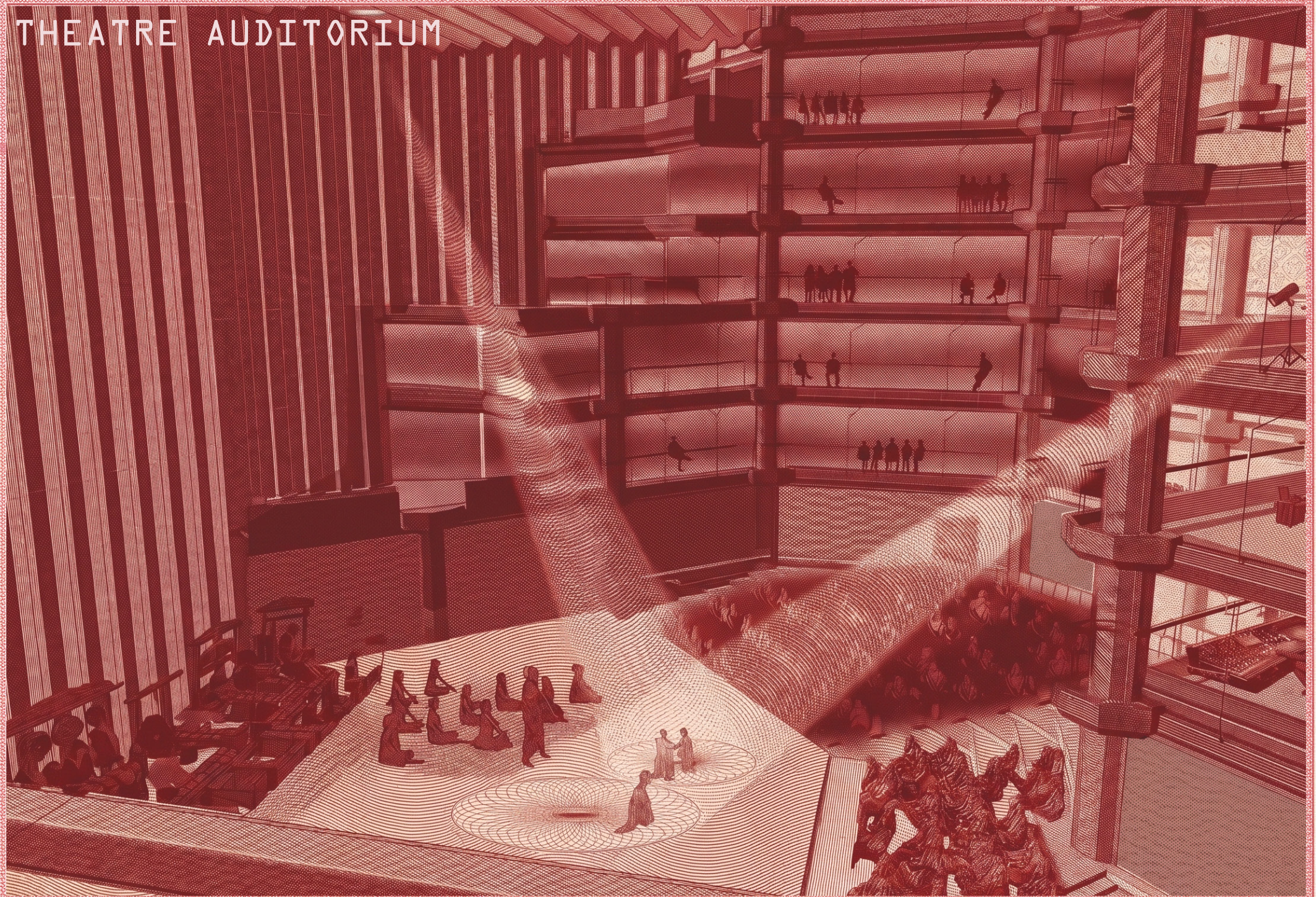

THEATRE FOYER

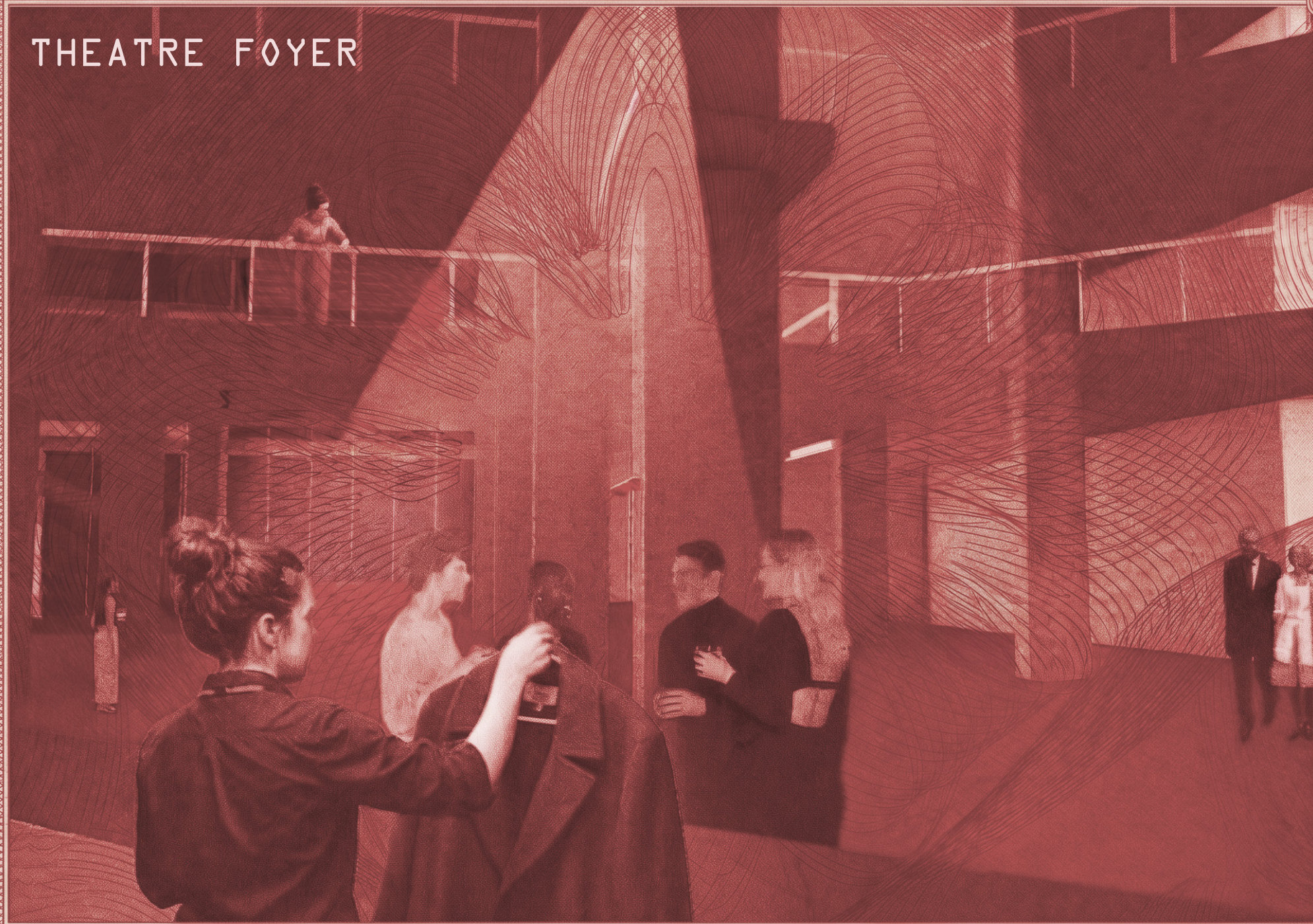

LEVEL

SEVEN

- 7.04 atrium of exchange void
- 7.10 sanitary
- 7.24 exhibition space
- 7.30 meeting rooms
- 7.31 office
- 7.33 storage
- 7.34 flexible office space
- 7.35 archival storage
- 7.37 reading room
- 7.38 minister's office
- 7.39 get-round corridor
- 7.40 sound lock (vomitory)
- 7.41 auditorium void
- 7.43 digitization space archive
- 7.44 recording room
- 7.45 archival storage large pieces
- 7.46 theatre balcony
- 7.47 follow-spot room

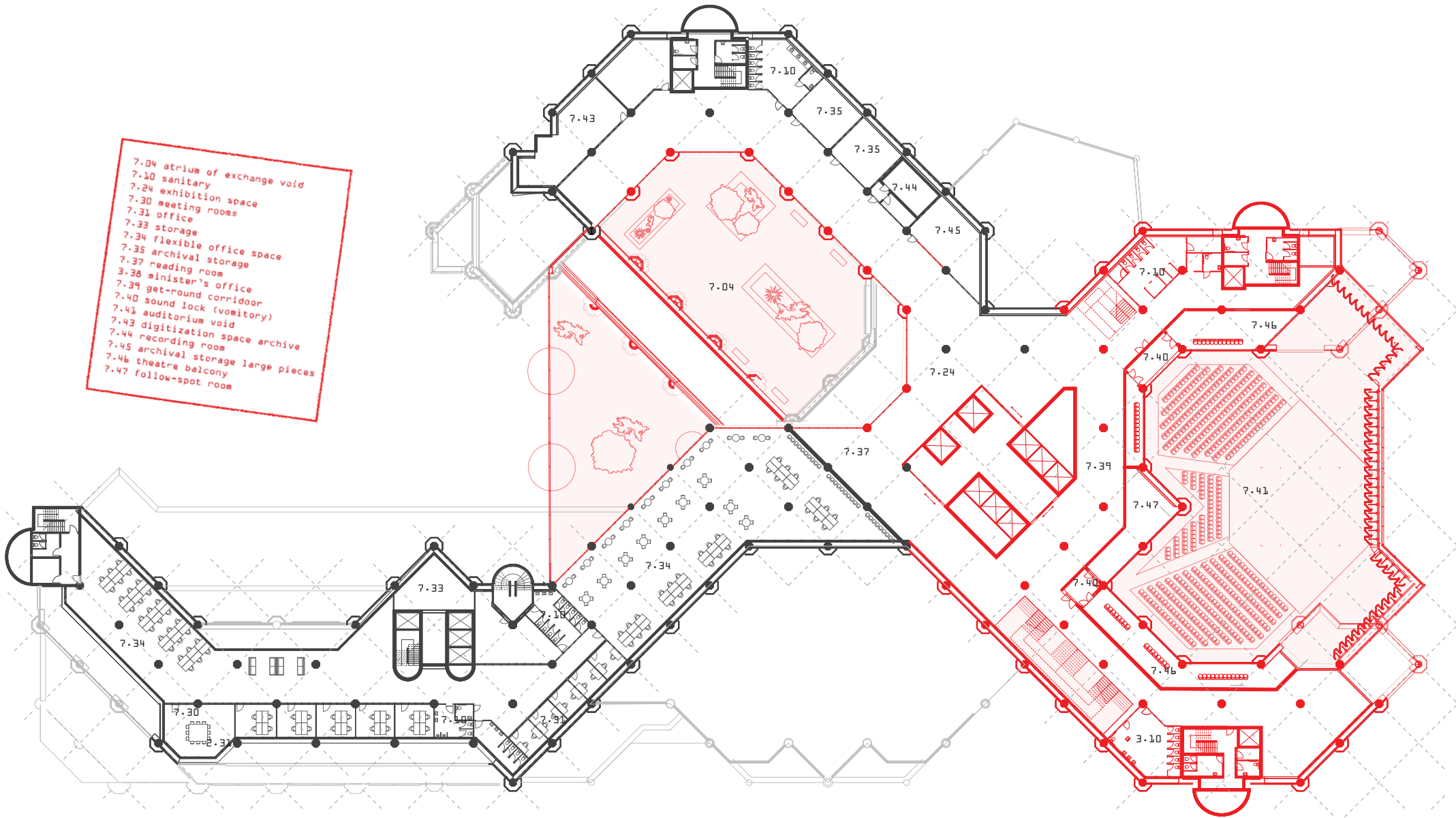

0 1 2 3 4 5 10



THEATRE OF

TRANSFORMATIONS

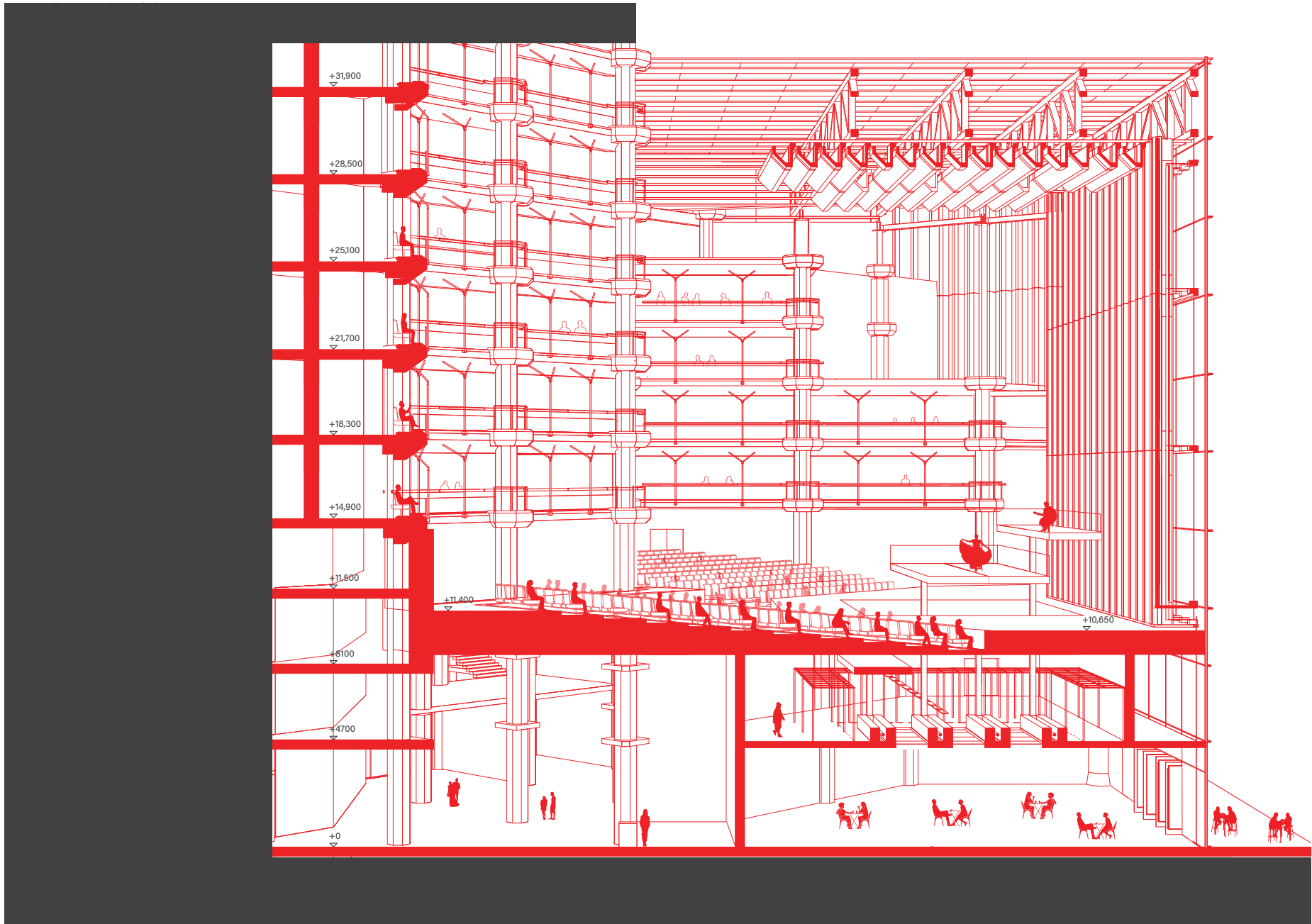

ZONE 3: IDENTITY

In the redesign of the crown, the space is re-envisioned as an open, greenhouse-like structure that accommodates spaces for the naturalization ceremony. This celebratory spatial sequence fundamentally transforms the building's most private, top installation layer into a welcoming, panoramic public asset for new citizens.

Traveling through the heart of the building between the archive, the theatre, and the ministry, the Conservatory physically stitches the hybrid institution together and holds values central to all three. It connects the ministry, enabling and empowering global movement through policy; the archive, storing the ever-increasing, diverse cultural stories of the people who moved to the Netherlands; and the theatre, empowering different communities in their traditions.



CONSERVATORY



LEVEL

THIRTEEN

13.48 elevator core to
conservatory of belonging
13.49 café
13.50 waiting room
13.51 ceremonial space

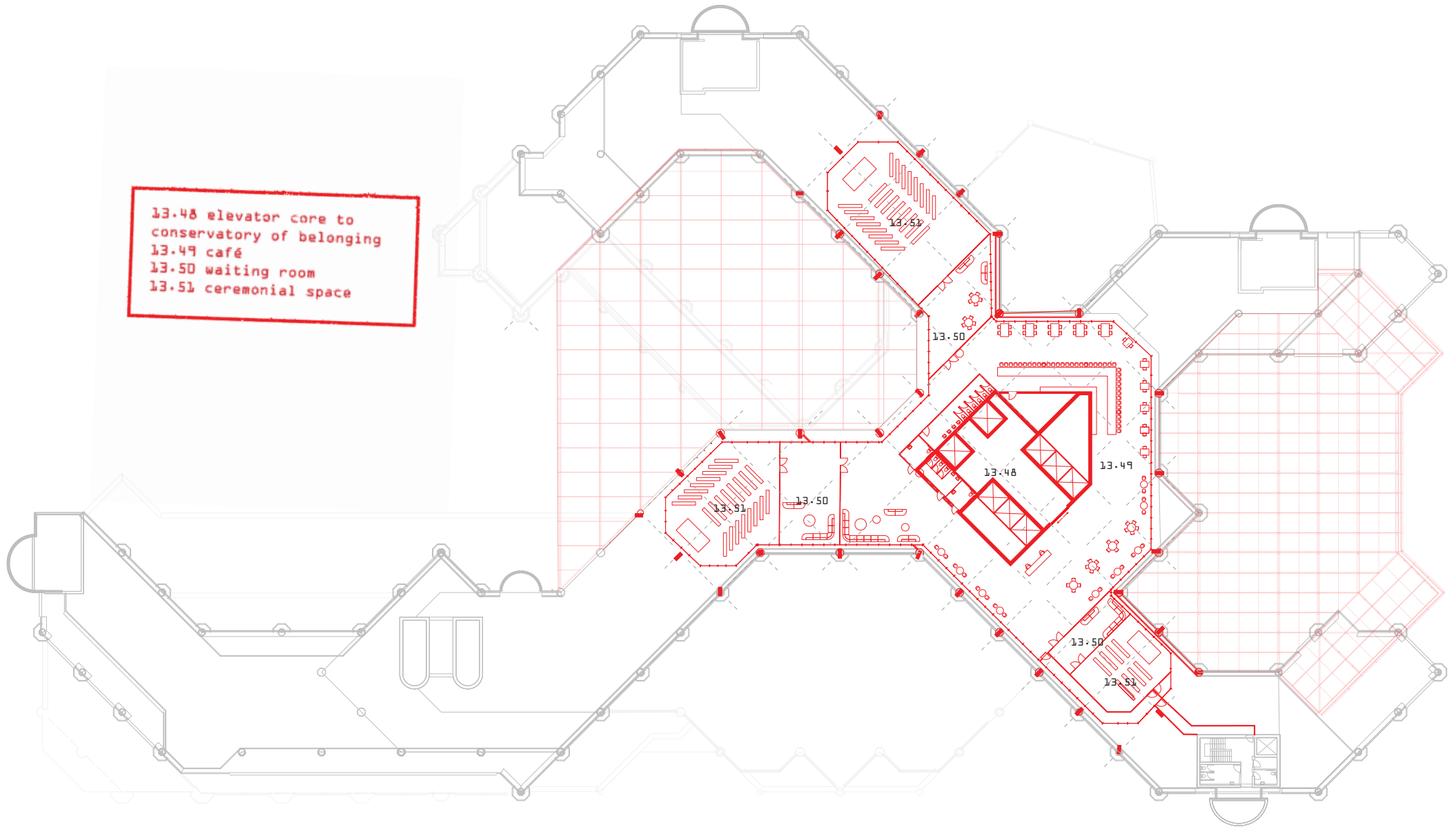

0 1 2 3 4 5 10



CONSERVATORY OF

BELONGING

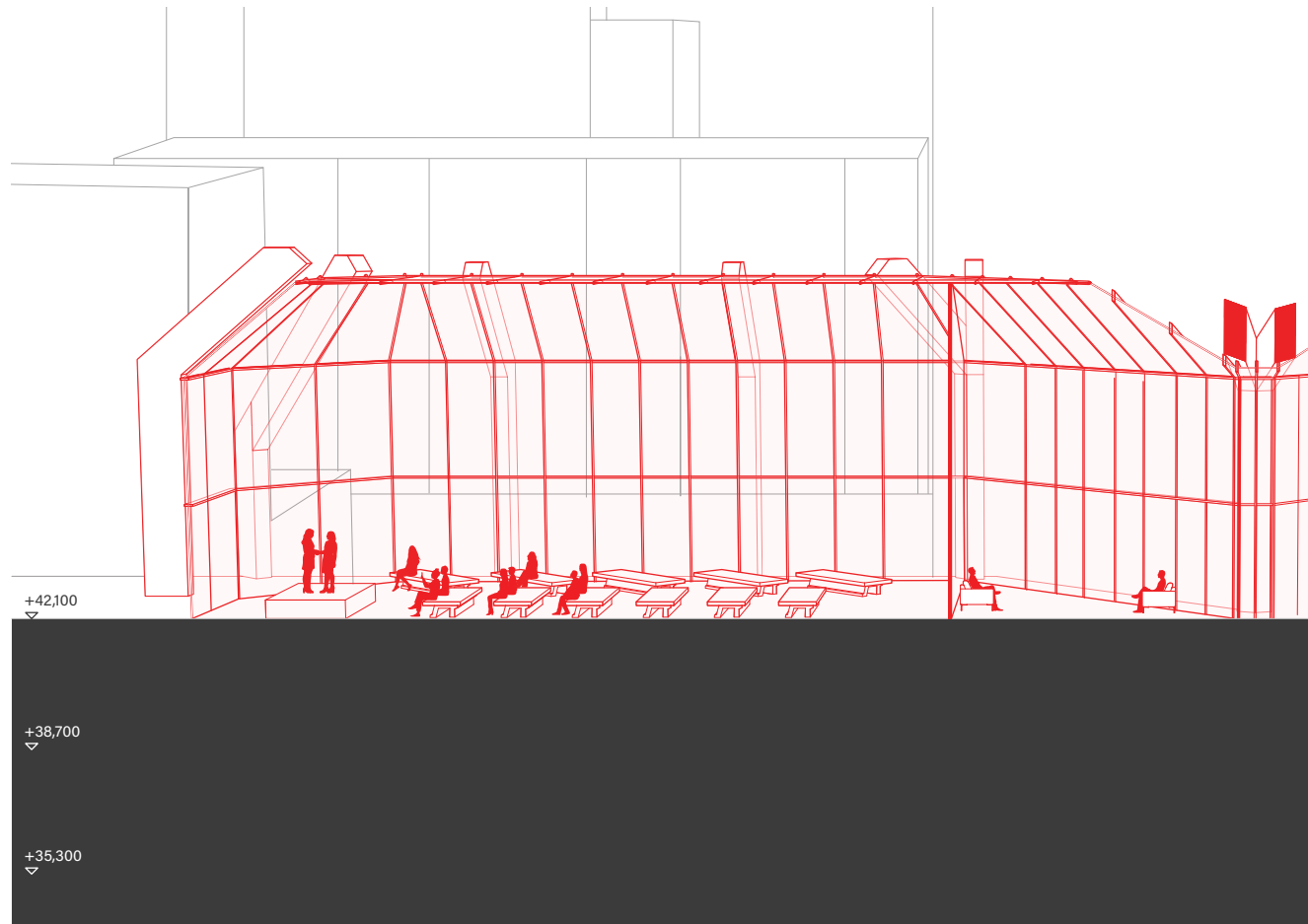

CONCLUSION

This thesis explores how reconfiguring a dense, monolithic building can embody a postcolonial future for a governmental institution. The passport and its paper governance manifest a colonial-era logic. For a more just future, our built institutions must adapt to celebrate global movement.

Through an adaptive reuse strategy of “negotiating with the grid,” the architectural acts of subtraction, exchange, and addition break the building’s repetition. Mined façade elements become light louvers for the Theatre of Transformations, the stripped façade creates a transparent Ministry Atrium, and the crowning Conservatory of Belonging becomes an open greenhouse for naturalisation ceremonies.

This hybrid institution directly untangles the tension between the passport and the individual. The public entrance becomes a welcoming “stamp of arrival.” Inside, the Ministry represents written transparency, the Atrium honors the human face behind the paperwork, and the Archive of Identities preserves the rich stories that history so often leaves unheard. Much like a passport booklet’s binding holds distinct pages together, this architecture binds people across cultural differences, where identity is continuously shared, negotiated, and celebrated.



