

MSC-THESIS

# CONSTRUCTING A PARKING GARAGE UNDERNEATH HISTORICAL CITY CANALS

A CASE STUDY

2008 – 2009

PIETER SCHOUTENS

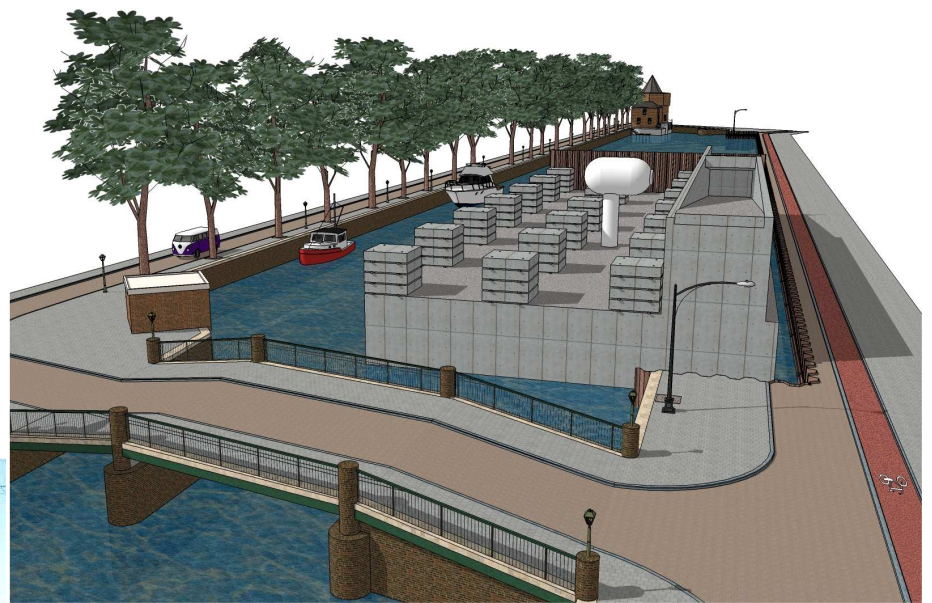



MSC-THESIS

*CONSTRUCTING A PARKING GARAGE  
UNDERNEATH HISTORICAL CITY CANALS*

*A CASE STUDY*

2008 – 2009

PIETER SCHOUTENS

**Delft University of Technology**

Faculty of Civil Engineering and Geosciences

Department of Hydraulic Engineering

Stevinweg 1 | PO-box 5048

2628 CN Delft | 2600 GA Delft

Phone: +31 (0)15 2785440

Fax: +31 (0)15 2787966

**Witteveen+Bos**

Office of Amsterdam

Hoogoorddreef 56F | PO-box 12205

1101 BE Amsterdam | 1100 AE Amsterdam

Phone: +31 (0)20 3125555

Fax. +31 (0)20 6974795

Contact information of the author:

Pieter Schoutens  
Pijlstaartpad 9  
2623 MH Delft  
E-mail: [pieterschoutens@gmail.com](mailto:pieterschoutens@gmail.com)  
Phone: +31 (0)6 41820626 | +31 (0)15 2616060

Graduation committee:

Prof. drs. ir. J.K. Vrijling	TU Delft – CEG, department of Hydraulic Engineering
Ir. W.F. Molenaar	TU Delft – CEG, department of Hydraulic Engineering
Ing. H.J. Everts	TU Delft – CEG, department of Geo-engineering
Drs. ir. J.L.C.M. van Daelen	Witteveen+Bos
Ir. H. de Waardt	Witteveen+Bos

Cover photograph of the Gelderse kade: Witteveen+Bos, 2008.

Copyright © 2009 by P. Schoutens.

All rights reserved. No part of this thesis may be reproduced, stored in a database or retrieval system, or published, in any form or by any means, electronically, mechanically, by print, photocopying, microfilm or any other means without prior written permission from the author.



# Preface

This thesis is the final part in completing my study of Civil Engineering at Delft University of Technology in the Netherlands. It is the result of a research project conducted in association with the department of Hydraulic Engineering at the faculty of Civil Engineering and Geosciences in Delft, and with the engineering firm Witteveen+Bos in Amsterdam.

This company has initiated research on multifunctional use of bodies of water in densely urbanised city centres, such as old harbour basins and canals. It is primarily focussed on the construction of underwater parking garages by application of prefabricated immersible elements. A dry excavation is thereby eliminated in an attempt to reduce adverse effects of the construction process on adjacent buildings.

During the period of October 2008 until July 2009 I have worked at Witteveen+Bos to determine the feasibility of a parking garage underneath the Geldersekaade canal in the centre of Amsterdam. This study mainly concerns the viability of an innovative construction method that both applies prefab immersion elements and pneumatic caissons. Although designed for a specific case study, its principles may well be applicable at similar sites elsewhere in the Netherlands or abroad.

Many people assisted, supported or otherwise aided me during the past nine months, some of whom I would like to mention here in particular. First of all, I express my gratitude to Klaas Jan Bakker for inciting my enthusiasm about the project and showing me how to approach it from new angles. I also thank Henk Vlijm for explaining to me the social relevance of decisions made from a structural point of view, and for his personal involvement in the project overall. I am grateful to my colleagues at Witteveen+Bos, who were always eager to help or discuss the many design aspects I ran into, and for providing distraction at times when it was most welcome. Last but not least I give thanks to my graduation committee for their constructive criticism and feedback, and for the time and dedication they showed me during my entire thesis project.

Pieter Schoutens

Delft, June 2009



# Table of contents

<b>ABSTRACT .....</b>	<b>VII</b>
<b>1 INTRODUCTION .....</b>	<b>1</b>
<b>2 PROBLEM ANALYSIS .....</b>	<b>3</b>
2.1 GENERAL PROBLEM DESCRIPTION .....	3
2.2 CASE-STUDY: GELDERSEKADE.....	5
<b>3 OBJECTIVE .....</b>	<b>9</b>
3.1 MOTIVATION.....	9
3.2 THESIS OBJECTIVE .....	9
3.3 APPROACH STRATEGY .....	10
<b>4 STARTING POINTS.....</b>	<b>11</b>
4.1 REQUIREMENTS BY THE COMMISSIONER.....	11
4.2 BOUNDARY CONDITIONS.....	13
4.3 STARTING ASSUMPTIONS .....	13
<b>5 SPATIAL INTEGRATION .....</b>	<b>15</b>
5.1 PRESENT SITUATION .....	15
5.2 TRAFFIC ACCESS SYSTEM .....	18
5.3 PARKING FLOOR CONFIGURATION .....	21
<b>6 CONSTRUCTION METHOD .....</b>	<b>29</b>
6.1 CONSTRUCTION METHOD 1: TRADITIONAL .....	29
6.2 CONSTRUCTION METHOD 2: DIAPHRAGM WALLS .....	31
6.3 CONSTRUCTION METHOD 3: PNEUMATIC CAISSONS.....	32
6.4 CONSTRUCTION METHOD 4: IMMERSSED PREFAB ELEMENTS.....	34
6.5 CONSTRUCTION METHOD 5: PREFAB ELEMENTS/PNEUMATIC CAISSON HYBRID .....	36
6.6 CONCLUSIONS .....	38
<b>7 RISK ASSESSMENT .....</b>	<b>41</b>
7.1 METHODOLOGY.....	41
7.2 RISKS OF CONSTRUCTION METHOD 1 .....	44
7.3 RISKS OF CONSTRUCTION METHOD 2 .....	46

7.4	RISKS OF CONSTRUCTION METHOD 5 .....	47
<b>8</b>	<b>COST ESTIMATE.....</b>	<b>49</b>
8.1	METHODOLOGY .....	49
8.2	COSTS OF CONSTRUCTION METHOD 1 .....	51
8.3	COSTS OF CONSTRUCTION METHOD 2 .....	52
8.4	COSTS OF CONSTRUCTION METHOD 5 .....	54
8.5	CONCLUSIONS AND EVALUATION .....	55
<b>9</b>	<b>ELABORATION OF CHOSEN DESIGN .....</b>	<b>57</b>
9.1	INTERNAL LAY-OUT <sup>[11]</sup> .....	57
9.2	CROSS-SECTIONAL DIMENSIONS.....	60
9.3	PNEUMATIC CAISSON PROVISIONS.....	62
9.4	RESULTS .....	66
<b>10</b>	<b>PREFAB IMMERSION ELEMENTS .....</b>	<b>69</b>
10.1	STARTING POINTS AND REQUIREMENTS .....	69
10.2	BEARING CAPACITY .....	71
10.3	FLOATABILITY .....	77
10.4	COUPLING PROVISIONS .....	85
10.5	CONCEPTUAL DESIGN OF TWO ALTERNATIVES .....	90
10.6	CONCLUSIONS .....	92
<b>11</b>	<b>SOIL DEFORMATIONS DURING CONSTRUCTION .....</b>	<b>95</b>
11.1	TEMPORARY RETAINING WALLS .....	96
11.2	CONSTRUCTION OF CAISSON ON CANAL BED .....	98
11.3	INFLUENCE ON ADJACENT STRUCTURES .....	100
11.4	BENTONITE VOID STABILITY DURING IMMERSION .....	102
11.5	CONCLUSIONS .....	103
<b>12</b>	<b>CONCLUSIONS AND RECOMMENDATIONS.....</b>	<b>105</b>
12.1	CONCLUSIONS .....	105
12.2	RECOMMENDATIONS .....	110
<b>13</b>	<b>REFERENCES .....</b>	<b>111</b>
13.1	LITERATURE .....	111
13.2	WEBSITES.....	112
13.3	EXPERTS .....	113
<b>APPENDIX A</b>	<b>PARKING ZONES IN AMSTERDAM-CENTRE.....</b>	<b>115</b>
<b>APPENDIX B</b>	<b>SOIL RETAINING METHODS.....</b>	<b>117</b>

<b>APPENDIX C</b>	<b>RISK ASSESSMENT .....</b>	<b>125</b>
<b>APPENDIX D</b>	<b>COST ESTIMATE .....</b>	<b>127</b>
<b>APPENDIX E</b>	<b>CROSS-SECTIONAL DIMENSIONS OF THE GARAGE.....</b>	<b>131</b>
<b>APPENDIX F</b>	<b>DESIGN OF THE PREFAB ELEMENTS.....</b>	<b>137</b>
<b>APPENDIX G</b>	<b>GEOTECHNICAL PROFILE OF THE GELDERSEKADE-AREA .....</b>	<b>145</b>
<b>APPENDIX H</b>	<b>CALCULATIONS ON SOIL DEFORMATIONS .....</b>	<b>147</b>
<b>APPENDIX I</b>	<b>ARTIST IMPRESSION OF CONSTRUCTION PHASING.....</b>	<b>155</b>



# Abstract

In an attempt to improve the value of public space on street level, the municipality of Amsterdam Centre has requested feasibility studies on several parking garages to be built underneath city canals. Three of these are to be constructed within the Singelgracht and one underneath the Geldersekkade canal. This thesis is focussed on the feasibility of a parking garage underneath the Geldersekkade, which should accommodate 350 parking places.

Two aspects play a major role in the design of the garage as elaborated in this thesis. One is a binding requirement by the local municipality that the historical appearance of the old quaywalls is to be maintained or restored, and the canal profile is not to be obstructed in any way after completion of the garage. The second aspect is the fact that this study is conducted in consultation with Witteveen+Bos Amsterdam, who are researching the application of immersed tunnelling techniques in the construction of underwater parking garages. The emphasis of this thesis is therefore on an innovative construction method that applies prefabricated immersible elements.

A survey with respect to spatial integration and alternative floor plans leads to five alternative construction methods, three of which are subjected to a cost estimate and risk analysis. These provide the following results:

- 1) Traditional bottom-up method using a temporary cofferdam and an underwater concrete floor (two levels):       € 28.4 million
- 2) Bottom-up method using diaphragm walls and an underwater concrete floor (two levels):                               € 34.9 million
- 3) Pneumatic caisson method, using prefabricated immersible elements to form a dry construction platform in the canal, on top of which the caissons are built (three levels):                       € 31.8 million

It turns out that adverse events with the highest risk profile are structural damage to historical quaywalls, adjacent buildings or to the Schreierstoren, caused by sheetpile driving or leaking retaining walls. These risks do not hold for the pneumatic caisson method, which is situated at a greater distance from these structures and does not apply a dry excavation. The pneumatic caisson method on the other hand has a high



risk concerning project delays as a result of its innovative nature and lack of experience on various design aspects.

The pneumatic caisson/immersed elements construction method is selected for further evaluation. A preliminary design is made to determine the main dimensions of the garage, and to check whether it can actually accommodate the required 350 parking places.

In this design the prefabricated immersible elements form the cutting edges and foundation structure of the pneumatic caissons, but should also function as a dry working platform in the canal, on top of which the caissons are built. A study with respect to functional and structural requirements results in the conceptual design of two alternative prefab immersion elements, which both measure 21 x 5.85 x 3.5m. The main difference between these is the primary construction material used: concrete versus steel. Both alternatives have a draft of 2.7-2.8m, so the canal needs to be dredged up to a depth of at least 3m. The concrete elements are slightly less expensive than the steel alternative, have a shorter on-site construction time but are more costly to transport.

From calculating the expected soil deformations as a result of the construction process, the most severe deformations seem to be caused by the great loads imposed by the caissons on top of the canal bed, before pneumatic immersion is commenced. Pile foundations of adjacent buildings may settle approximately 5mm if no mitigation measures are applied. The easiest way to reduce this problem is to reduce the loads on the subsoil by constructing and immersing the caissons in multiple stages. The western quaywall will also be influenced by the construction process. Especially the dredging works in the canal may cause it to displace, so this should be done at a maximum distance from the quay. Mitigating measures, such as soil/foundation improvement, may be required as it has significant historical value.

All in all, the regarded construction method turns out to be very promising in an urban environment. The absence of a dry cofferdam is a significant advantage over traditional bottom-up methods, especially regarding soil deformations and the risk of leaking retaining walls. No insurmountable problems have been found, but it is nonetheless advised to monitor the soil deformations of a reference project. The last caisson of the North/South metro line, to be constructed and immersed at the Station Island in Amsterdam, is a very suitable test case. Other recommendations mainly concern research on the foundation of adjacent structures: can the Schreierstoren and the Hoofdbrug cope with the required dredging works, and can grout anchors be placed underneath the pile foundations of adjacent buildings.

# 1 Introduction

Increasing parking problems in densely urbanised city centres has incited research on multifunctional use of public space. Especially underground there is plenty of space available, but exploiting this space is a laborious, expensive and in most cases hazardous ordeal.

Typical Dutch historical city centres are characterised by the presence of canals. These canals make promising locations for the construction of large underground spaces such as parking garages, as there are no significant buildings overhead and they are often close to their target users (tourists, commuters and residents). Possibly, specific properties such as the navigability of these canals can also be used to aid in the construction process.

This thesis is focussed on the feasibility of a parking garage underneath the Geldersekkade canal in the centre of Amsterdam. The garage should house 350 parking places, partly to compensate for parking space lost on ground level, partly to relief local queues for parking permits. Although this thesis is aimed at a specific case study, the elaborated construction method may well be applicable in a much broader sense as the characteristics of the Geldersekkade are very similar to other city canals in the Netherlands.

The main body of this thesis can be subdivided into four parts:

The first part, chapters 2 to 4, provides the problem analysis and a framework for the case study. First, a general problem analysis is conducted in a broad sense, followed by a more specific one focussed on the project area of the case study. The problem analysis is concluded with a problem statement, followed by a thesis objective and an approach strategy on how to attain this objective. A list of requirements and boundary conditions is provided wherewith the produced solutions must comply.

The second part of this thesis starts with a generation of alternative solutions regarding spatial integration, internal layout design of the garage and different construction methods (chapters 5 and 6). Risk analyses and cost estimates of three promising alternatives are made to allow for an objective evaluation (chapters 7 and 8 respectively).

In the third section (chapters 9 to 11), one construction method is selected for further elaboration. The centre of excellence here is on the design of prefab immersible elements, which form an integral part of the chosen construction method. Also, a chapter is dedicated to soil deformations caused by the construction of the parking garage in this specific way. Special attention is paid to adverse effects such as damage to the structural integrity of adjacent buildings.

This thesis is concluded with all prominent findings on the case study (chapter 12): general conclusions are drawn on the feasibility of a parking garage underneath a city canal, and more specifically regarding the chosen construction method. Recommendations are provided on how the research on this subject can be improved, how the chosen design itself can be improved, and where gaps in knowledge are to be found.

# 2 Problem analysis

## 2.1 General problem description

### 2.1.1 Socio-topographical framework

The city centre of Amsterdam is characterised by several core functions, the most important of which are tourism (ranging from regional to international), entertainment, residential, small businesses and retail. Each of these functions puts different demands on the transportation facilities provided in the city centre.

Foreign tourists mostly arrive by train or taxi and use the public transports system (e.g. bus, tram, metro) or taxi to get to their destinations. Tourists from the Netherlands might also take the train to Amsterdam, but often go by car. Inhabitants of Amsterdam tend to use their bicycle or go by public transport while travelling within the city, and take their cars or the train when leaving it.

During the past century, both private and public motorised traffic increased dramatically, resulting in a clogged city centre with poor accessibility. Not only for cars, busses and trams but even for cyclists and pedestrians. Another issue arose with increasingly high values of air pollutants such as NO<sub>x</sub> and microscopic dust.

In an attempt to improve the value of public space, the municipality of Amsterdam has started discouraging non-necessary traffic<sup>1</sup> within the city centre. This has been done by improving distribution roads, limiting the accessibility of the centre by car, increasing downtown parking-fees, providing cheap parking space outside of the centre at public transport hubs, etc. It should result in reduced noise, stench and air pollution, less congestion and improved provisions for public transport, cyclists and pedestrians. The strategy has proven quite successful during recent years: car traffic within the centre of Amsterdam has been reduced by 25% between 1991 and 2005.<sup>[1]</sup>

---

<sup>1</sup> According to a bill on accessibility of the city centre,<sup>[1]</sup> necessary traffic is defined as that which is required for the proper functioning of the city centre (e.g. public transport, taxis, distribution traffic, emergency services) as well as traffic by permit-holders (residents, entrepreneurs, disabled, etc.).

### 2.1.2 Present problems

Apart from hindrance caused by non-necessary traffic, a fair share of the nuisance nowadays is caused by necessary traffic, especially parking permit-holders. Despite the relatively low number of car owners in the centre of Amsterdam, parking pressure is very high, mostly during evening hours. On average 90% of the parking places are occupied, resulting in three main problems:

- Loss of public space on street level as a result of parked cars;
- Visual hindrance causing an aesthetic problem;
- Increased traffic caused by people seeking parking places.

Additionally, the demand for parking permits far exceeds the supply (which is limited by the number of available parking places). In 2007 there were 3200 residents/companies waiting for a parking permit in the Amsterdam-Centre district, resulting in a queue of up to 5 years.<sup>[2]</sup>

### 2.1.3 Proposed solutions

The municipality of Amsterdam-Centre is intent on decreasing the total number of general parking places on street level to 11500<sup>[3]</sup>: a reduction of 3000 in total. Most of these should be compensated for to ensure accessibility. In fact, according to the local municipality, more parking places should be created to reduce the waiting lists for parking permits.

All of the new parking places will have to be constructed indoors, mostly below ground level due to lack of space. They should also be constructed close to their target users (no more than 300m apart) and have a lower tariff than street level parking to encourage their utilisation. An integral dynamic parking-reference system should direct people to a garage with sufficient space, reducing 'search-traffic'.

The municipality of Amsterdam-Centre has initiated preparations for 15 parking garages, some of which are already under construction. A special fund has been commissioned to cover for possibly unprofitable exploitation of these garages.<sup>[1]</sup>

## 2.2 Case-study: Geldersekkade

### 2.2.1 Problem description

The parking pressure in the core area of the city centre (permit zone CE-01)<sup>1</sup> is even higher than in the rest of the Amsterdam: in 2006 there was an occupation rate of 97% during daytime, and 93% in the evening.<sup>[2]</sup> Nonetheless, in accordance with the municipality's policy on parking places at street level, parking space is scheduled for removal.

To compensate for this, a parking garage underneath the Geldersekkade canal, or in its immediate vicinity (figure 2-1 and figure 2-2), is one of four garages being actively investigated by the local municipality. The others are Westeinde (bordering Oud Zuid), the vicinity of Leidseplein (bordering Oud West) and along the Marnixkade (near Westerpark). The latter three are all to be situated underneath the Singelgracht, which is outside of the core area. A similar construction method may however be applicable for all four garages as they are all to be constructed underneath a shallow body of water with adjacent buildings and which is enclosed by narrow bridges.

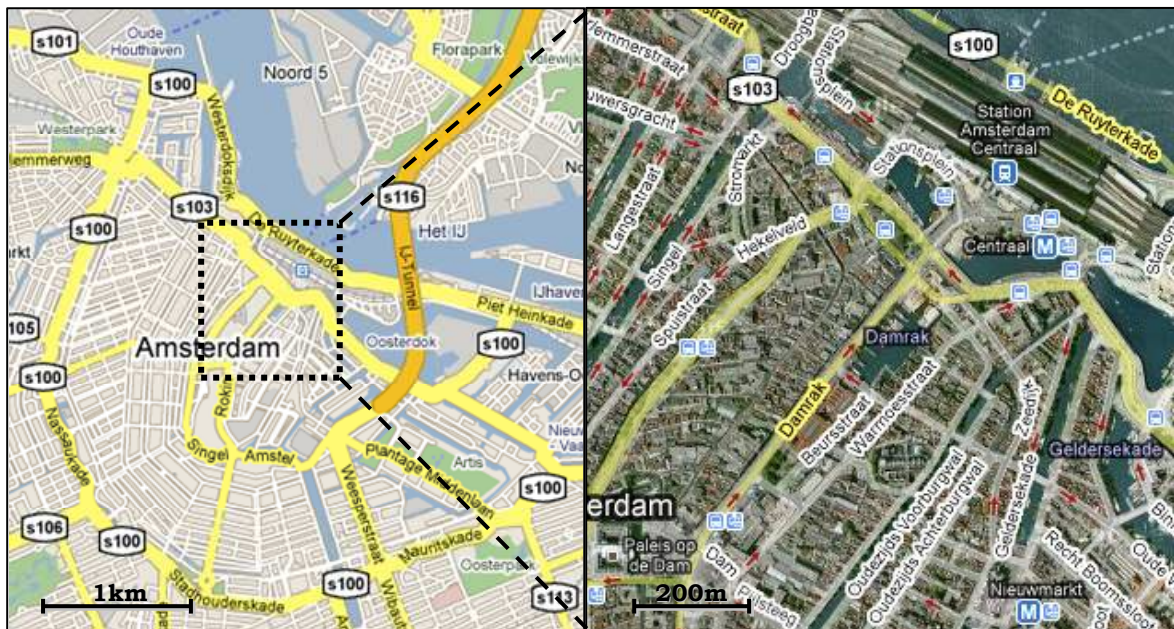

Figure 2-1: Map of Amsterdam Centre (left), with a magnification of the core area (right). The Geldersekkade is at the lower right hand side of the enlargement. (Source: GOOGLE MAPS)

<sup>1</sup> For a detailed map of Amsterdam Centre, parking zones and tariffs, refer to Appendix A.



According to a report on potential revenues of a parking garage at the Geldersekkade,<sup>[4]</sup> the area around the Geldersekkade can be characterised by several specific activities:

- Catering industry (Zeedijk, Nieuwmarkt)
- Small-scale retail, mainly Chinese stores (Zeedijk, Nieuwmarkt)
- Prostitution related (Wallen area)
- Tourism (Wallen area, Waag)
- Residential



*Figure 2-2: Photograph of the Geldersekkade as viewed from the north (Prins Hendrikkade), towards the Nieuwmarkt (photo by WITTEVEEN+BOS)*

As can be expected from these activities, peak hours with respect to car traffic/parking are early in the evening: residents arrive from work, people go out for dinner and tourism is still active. However, radical changes are planned with respect to car parking:

- Refurbishment of the Noordelijke Burgwallen (120 parking places to be removed);
- The Noordelijke Burgwallen will become inaccessible for cars between 20:00 and 7:00 hours (except the Zeedijk and Geldersekkade. 43 Parking places need to be compensated for);



- Rearrangement of the Geldersekade and Nieuwmarkt (57 parking places to be removed);
- Demolition of a car park at the Oosterdokskade (65 car parking places and 23 places for coaches will be removed, although possibly outside area of influence of the Geldersekade).

Also, some 100 additional parking places need to be constructed to cover for a parking lot on the Nieuwmarkt, which has been removed several years ago. Altogether this amounts to a parking garage with room for 320-350 cars, of which permit holders take a share of at least 70% (as decreed by the municipality of Amsterdam-Centre in its Plan of Approach).<sup>[5]</sup> The aforementioned report on potential revenues states that this ratio might not be profitable. A budget shortage will have to be covered by the so-called Garage Fund.

### 2.2.2 Problem definition

The problem statement as derived from this chapter is defined as:

“The functional and structural design of a parking garage underneath the Geldersekade canal, which accommodates 350 parking places and meets the boundary conditions and requirements imposed by the municipality of Amsterdam-Centre.”

This problem definition forms the basis for any content provided in this thesis. An objective and approach strategy on how it is attempted to find adequate answers to this problem, are provided in the next chapter.



# 3 Objective

## 3.1 Motivation

The construction of a parking garage in densely urbanised areas, such as historical city centres, inevitably causes serious impact to the surroundings. Witteveen+Bos has initiated research on a construction method that puts the nature of Dutch historical city centres (the presence of navigable canals) to good use. This research mainly focuses on the application of immersed tunnelling techniques in other fields of engineering (courtesy of Vlijm, H.<sup>[3]</sup>). By application of prefab immersible elements, the need for a dry building pit can be eliminated, reducing on-site construction time and the influence of the construction process on its surroundings.

Experience with this construction method applied as such is virtually non-existent, making a parking garage underneath the Geldersekade an ideal test case. Naturally, due to the innovative aspects of this method, and especially in the scope of recent calamities in the historical centre of Amsterdam<sup>1</sup>, public objections can be expected. To counter these, a thorough investigation of the feasibility of this method and its specific advantages/disadvantages is therefore required.

## 3.2 Thesis objective

The objective of this thesis is to provide satisfactory answers to the problem statement expressed in paragraph 2.2.2. The main focus of the design will be on an innovative construction method, which makes use of prefabricated immersible elements. The functional design will be limited to the strictly necessary to form a sound basis for the structural design and construction process.

---

<sup>1</sup> During the construction of the North-South metro line in 2008, soil settlements resulting from a leaking diaphragm wall caused serious structural damage to adjacent buildings. Since this was one of several stains on the project, the construction of the entire metro line was put to a halt. Civil unrest, parliamentary enquiries, the commissioning of a dedicated advisory committee, departure of municipal councillors and a huge budget exceedance were the result.

The final product of this thesis will not be a completely worked out detailed design of the parking garage. Instead it will provide adequate estimations of common design parameters, and distinct itself by in-depth consideration and calculations of exceptional design aspects.

### 3.3 Approach strategy

In order to achieve a broad understanding of this specific problem, and the construction of underground parking garages in general, a wide approach is taken by starting with a spatial layout design (integration into the present traffic distribution system and spatial boundary conditions). Five alternative construction methods are briefly evaluated. The three most promising ones are subjected to a risk analysis and costs estimate to allow a more objective evaluation of the different designs. The underlying principles of the second part of this thesis (chapters 5-8) are roughly based on a feasibility study on the Geldersekkade parking garage as produced by Witteveen+Bos.<sup>[6]</sup>

Disregarding the possibility that the evaluation of alternative construction methods may point out a certain method to be the cheapest, safest, or generally most promising alternative, the elaborated design focuses on a method that makes use of prefabricated immovable elements (as mentioned in the thesis objective). An extensive feasibility study is conducted regarding the construction phasing, soil-structure interaction and its influence on adjacent buildings.

# 4 Starting points

## 4.1 Requirements by the commissioner

Summarising the draft Program of Requirements on parking garages in Amsterdam,<sup>[7]</sup> and more specifically the shortened version focussed on the Geldersekkade,<sup>[8]</sup> a rough list of requirements is made. Only the requirements that may influence the structural design are listed here.

### 4.1.1 Requirements with respect to garage layout

1. Capacity: 350 parking places, no bicycle storage.
2. Pedestrian/emergency exits: At least two main entrances/exits with elevators should be included (at the northern and southern side), as well as an emergency exit. Distance from any point in the garage to the nearest escape exit should never exceed 40m.
3. Managers' office:  $\geq 20m^2$ , to be situated near the entry/exit ramps. Preferably shaped rectangular with a short edge of at least 3.5m. Should also include a toilet unit and a pantry.
4. Storage room:  $\geq 10m^2$
5. Technical equipment room: Size not specified, estimated at  $\geq 35m^2$ . Should accommodate various provisions such as an emergency power supply, pumping system, elevator, ventilation system, etc.
6. Layout of traffic provisions: According to NEN 2443
7. Parking angle:  $70^\circ$ - $80^\circ$
8. Provisions for disabled: At least 1% of the parking places should be suitable for disabled, of which at least 1 on each level at close proximity of an elevator.
9. Garage clearance height: 2.3m

4.1.2 Requirements with respect to car accessibility

10. Ramp slope: 10%
11. Ramp width: 4m (one way) including 0.25m object clearance. 4.5m in curves.
12. Inner radius of curves:  $\geq 4.5m$ .
13. Number of entry/exit ramps: At least two entries and exit ramps to avoid clogging in case a ramp is blocked.
14. Buffer space: Straight horizontal buffer space of 10m in front of parking equipment.
15. Connection to public road: To be designed in consultation with Amsterdam-Centre district.

4.1.3 Structural requirements

16. Loads and calculations: According to Dutch codes (or sufficiently proven valid otherwise).
17. Floor top layer:  $\geq 5cm$  of unreinforced concrete to allow for installation of detection coils. Surface treatment by power floating<sup>1</sup> (except on ramps).
18. Columns: Round(ed) cross-section and as slender as possible.

4.1.4 Requirements with respect to the Geldersekkade canal

19. Navigable depth of canal:  $\geq 2m$  (top of structure at  $\geq 3m$  below mean water level to allow for dredging tolerances).
20. Minimum canal discharge:  $20m^2$  wet cross-section to be maintained at all times (equivalent to the discharge capacity through the culvert underneath the Nieuwmarkt).
21. Existing quay wall: Historical appearance to be maintained or restored. Several historical sandstone blocks of the old ramparts have been incorporated in the western quaywall. These must be preserved.

---

<sup>1</sup> Power floating = vlinderen (Dutch)

22. Trees: Healthy trees should be preserved if possible, or replanted after construction of the garage.
23. Existing bridges: Bridges 297 (Gelderschebrug), 298 (Bantammerbrug) and 299 (Hoofdbrug) to be maintained.

## 4.2 Boundary conditions

1. Water level in canal: Mean water level of NAP  $-0.40m$ . Can rise up to NAP  $+0.0m$ .
2. Navigable width of bridge 299:  $7m$ <sup>[9]</sup>
3. Head clearance of bridge 299:  $2.37m$  (relative to mean water level).<sup>[10]</sup>
4. Topography of project area: According to figure 5-1.
5. Geographical profile: According to drawing ASD1150.1.1900 (refer to Appendix G).
6. Existing quay wall design: Masonry wall with relief slab and wooden piles at a 1:10 rake, founded on 1<sup>st</sup> sand layer.
7. Pile foundation clearance: Horizontally a distance of  $2.5m$  should be maintained between new structure and existing pile foundations to avoid settlements.

## 4.3 Starting assumptions

1. Automated car entrance: Not possible due to insufficient peak capacity or high number of entrance/exit units.
2. Parking places: Parking angle of  $30^{\circ}$ - $80^{\circ}$  can be applied (as opposed to  $70^{\circ}$ - $80^{\circ}$  prescribed by the municipality of Amsterdam) to reduce garage width.
3. Ramp slope: Up to 12% (instead of 10% as prescribed) can be applied to fit the length of the ramps within the canal profile.
4. Entry/exit: The commissioner prescribes that there should be at least two entries and exit ramps. However, as a result of the limited space, multiple entry/exit



ramps are probably not possible. It should nonetheless be possible to use an alternative exit in case the main exit ramp is blocked.

5. Car buffer space:

Due to limited space, it will most likely be impossible to have 10m of straight buffer space in front of the parking meters and garage exit. The design will nonetheless take into account demands with respect to ergonomics and comfort.

# 5 Spatial integration

The garage will need to be integrated into the present situation of the Geldersekkade: positioning with respect to existing buildings and foundations, connection to the traffic distribution system, etc. Also, several changes are planned with respect to the traffic distribution on, and in the vicinity of, the Geldersekkade. These are also taken into account.

Two aspects dominate the spatial integration of the garage. Both are both treated in this chapter:

- Traffic access system (positioning of entrance/exit ramps)
- Garage floor configuration (footprint of the garage and excavation depth, related to the number of floors and layout of parking provisions on each floor)

## 5.1 Present situation

The Geldersekkade is about 365 meters long. On the northern side, the canal is connected to the Open Havenfront (a body of water separating the Station Island from Amsterdam Centre) at the monumental Schreierstoren. The Prins Hendrikkade bridges this connection by means of the Hoofdbrug (bridge 299). At the southern side the canal branches to the southeast (Recht Boomsloot) and has a dead end at the Nieuwmarkt. In the middle, the canal is bridged by the Bantammerbrug (bridge 298), separating it into two parts. The northern part has a length of approximately 250m, whereas the southern part is only 100m long. Figure 5-1 provides a topographical map of the area.

The Geldersekkade is accessible by car on both sides. The western side is characterised by a narrow one-way traffic lane, some room for parking on the canal side and very limited space for pedestrians (figure 5-2): the distance between facades and quay is approximately 6.5 meters. The road can only be accessed from the north (Prins Hendrikkade/Central Station) or the Stormsteeg, and leads to the Nieuwmarkt.

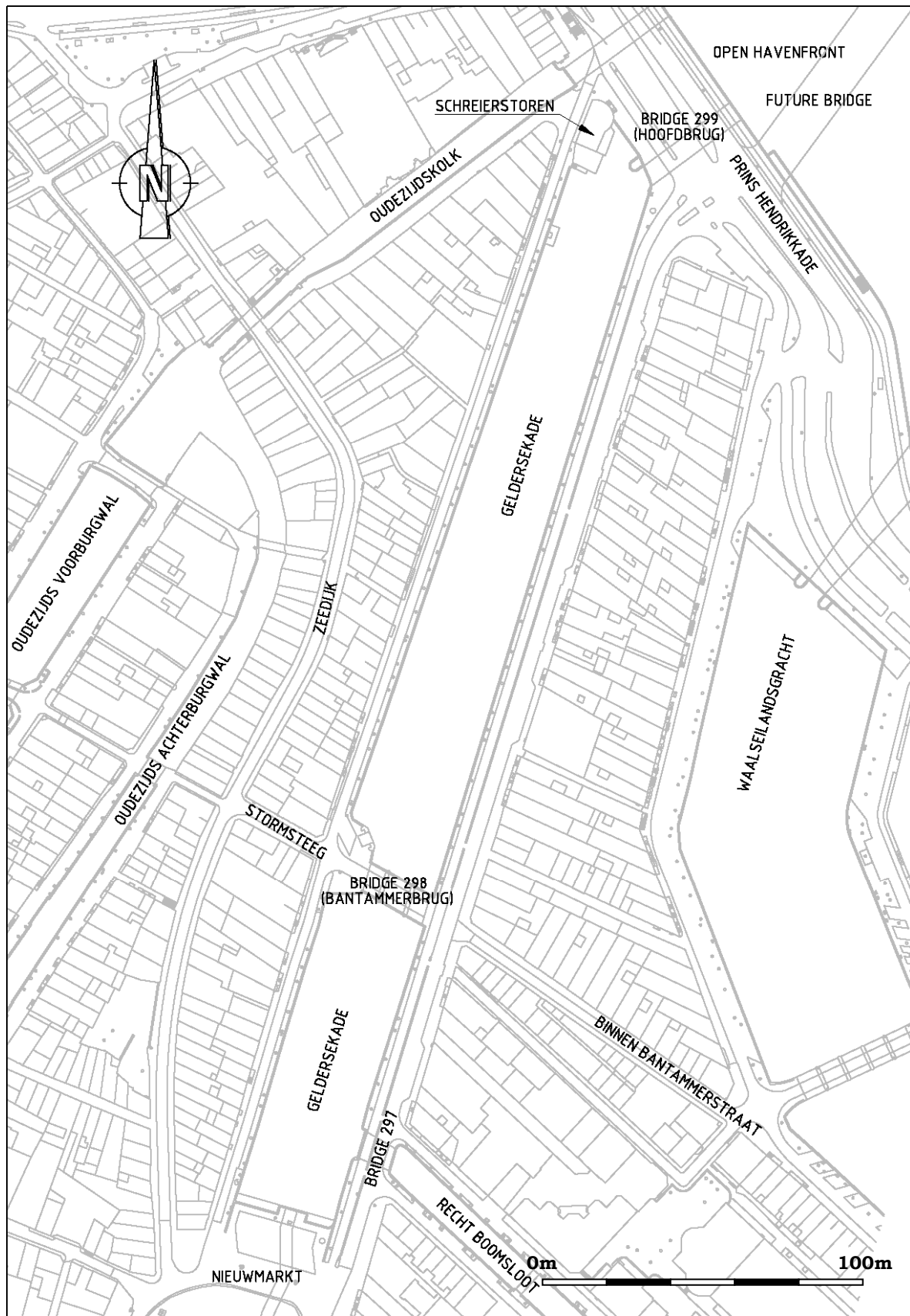

Figure 5-1: Detailed map of the Gelderse kade



Figure 5-2: Western side of the Geldersekkade, as seen from the north (Photo by WITTEVEEN+BOS)

The eastern side is considerably wider, with a distance between facades and quay of 12.5 to 15 meters. It features a narrow road with traffic in two directions, a separate, two-directional cycle-track and a walkway (figure 5-3).



Figure 5-3: Eastern side of the Geldersekkade, as seen from the Bantammerbrug to the north (Photo by WITTEVEEN+BOS)

Future plans are to rearrange the eastern side however, to accommodate just a one-way traffic lane (to the north), and a one-way cycle-track (to the south). Also, a bridge will be constructed between the eastern Geldersekkade/Prins Hendrikkade junction

and the Station Island. This bridge will have a large impact on the traffic distribution at the junction, which will then be regulated by traffic lights.

More implications are imposed by the fact that turning left onto the Geldersekkade while driving north along the Prins Hendrikkade will no longer be possible. Turning left from the Geldersekkade onto the Prins Hendrikkade will also be prohibited.

## 5.2 Traffic access system

For the configuration of the entrance and exit ramps, several options are available: They can be positioned along the eastern and/or western side of the garage, and traffic can enter and leave the garage either to the North or to the South. The main design criteria are:

- Accessibility
- Traffic safety (for garage users, pedestrians, cyclists, other car traffic, etc.)
- Possibilities for integration in existing / future traffic distribution system
- Design demands imposed by the commissioner (municipality of Amsterdam Centre)

Three alternatives are explained in this chapter, which have been thoroughly investigated by Witteveen+Bos with regard to traffic flow and safety.<sup>[9]</sup> A fourth alternative is not mentioned here. This alternative has an entrance at the northern side by means of a tunnel underneath the Prins Hendrikkade, but is technically not feasible due to the presence of the Eastline metro underneath bridge 299.

### 5.2.1 Alternative 1: Entrance West from the North. Exit East to the North

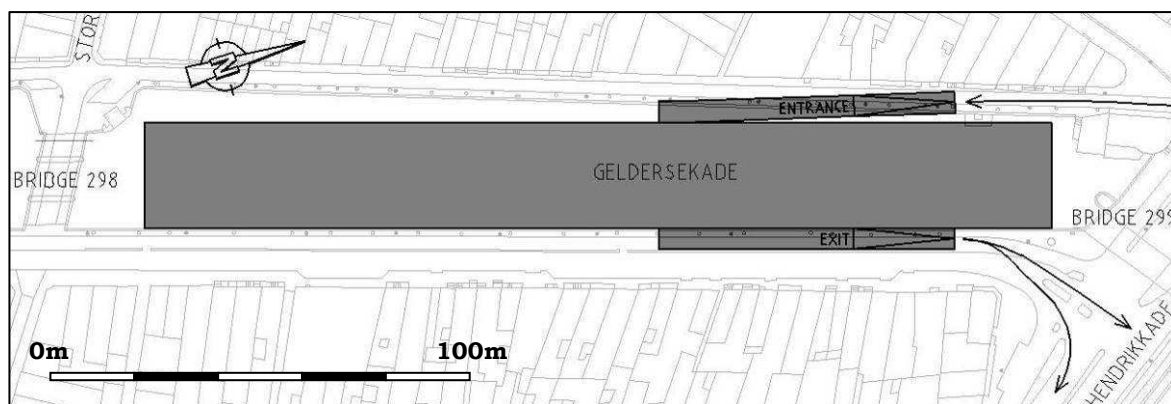

Figure 5-4: Traffic comes from the North and enters the garage from the western side of the Geldersekkade. The exit is on the eastern side, to the North.

The first alternative is based on the one-directional traffic along the Geldersekkade. The entrance is situated on the western side, with traffic entering from the north. The exit is on the eastern side with cars leaving the garage to the north.

Advantages:

- Integration in one-directional traffic along both sides of the Geldersekkade

Disadvantages:

- Limited space on western side of the Geldersekkade requires the entrance ramp to be (partly) constructed inside of the canal profile if through-traffic is not to be obstructed.
- Poor accessibility of the entrance: cars cannot enter the garage when coming from the south on the Prins Hendrikkade and have to make a detour.

#### 5.2.2 Alternative 2: Entrance East from the North. Exit East to the North

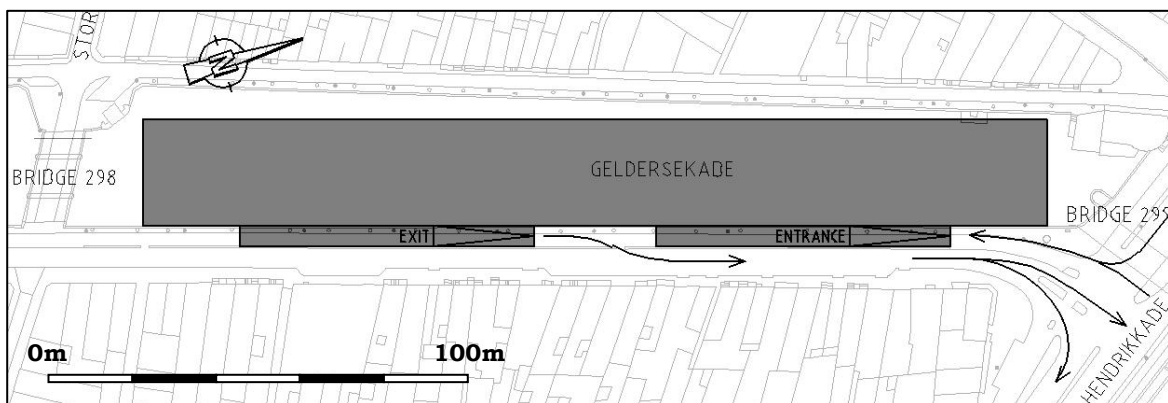

Figure 5-5: Entrance and exit are both on the eastern side. Traffic enters from the North, and leaves to the North as well.

In the second alternative both the entrance and the exit are situated on the eastern side of the Geldersekkade. Cars can enter the garage from the Prins Hendrikkade when coming from the north, or when coming from the Station Island. Cars leaving the garage head northward along the Geldersekkade and can turn right onto the Prins Hendrikkade or cross over to the Station Island. This alternative implies that the northernmost part of the Geldersekkade has two-way traffic.

Advantages

- Good accessibility for cars coming from the northwest (Prins Hendrikkade) as well as for those coming from the Station Island.

- Exit at considerable distance from the Prins Hendrikkade reduces the risk of queuing on the ramp by cars waiting for the traffic lights.

#### Disadvantages

- Little space available for two-way traffic along the eastern Geldersekkade. Possibly the entrance will have to be (partly) constructed within the canal profile.
- Traffic accidentally entering the eastern Geldersekkade from the North, or when facing a full garage, may get 'locked up', forcing it to make a U-turn or drive through the garage.
- The garage is not directly accessible by cars coming from the south-east along the Prins Hendrikkade, whereas this will likely be the main supply route.
- The present cycle-track will need to be moved to the eastern side of the road or to the canal side to avoid dangerous conflict-points with the garage entrance/exit.

#### 5.2.3 Alternative 3: Entrance East from the South. Exit east to the North

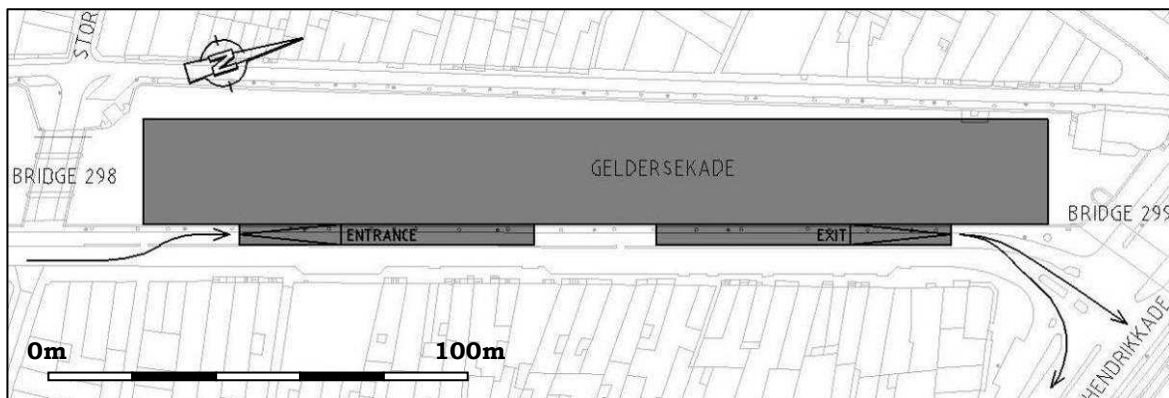

Figure 5-6: Traffic comes from the south and enters the garage on the eastern side. The exit is also on the eastern side, to the north.

In the third alternative both the entrance and the exit are at the eastern side of the Geldersekkade, similar to the second alternative. The difference is that the entrance is situated at the southern end and cars enter from the south instead of from the north.

#### Advantages

- Most suitable spatial use: entrance and exit can both be constructed within the quay.
- Fits well into future traffic distribution system (one-way traffic on Geldersekkade).



### Disadvantages

- Not directly accessible from the Prins Hendrikkade: traffic will have to take a detour through the city centre to reach the garage.
- Garage will be hard to find for visitors if it is not accommodated in the IDP.
- Exit close to the Prins Hendrikkade junction may lead to obstructions on the exit ramp by queuing traffic.

#### 5.2.4 Conclusions

The first alternative does not seem feasible: It requires the entrance ramp to be mostly constructed within the canal. However, according to the requirements by the commissioner,<sup>[8]</sup> it is not allowed to obstruct the view on the historical quay by any means.

The second alternative has two main disadvantages: it is not directly accessible by cars coming from the south-east (Prins Hendrikkade), as turning left onto the Geldersekade will not be possible. A considerable detour via the Station Island will have to be made in this case. Also, the one-directional traffic on the eastern Geldersekade is partly disturbed. This puts a larger claim on public space, and causes inconvenient situations for cars accidentally entering the eastern Geldersekade from the north: they are forced to either make a U-turn or enter the garage.

The third alternative turns out to be the best with respect to traffic safety, as it fits perfectly into the one-way traffic system on the eastern Geldersekade and it has only limited spatial demands as the entrance and exit are in line. A main disadvantage of this alternative is the fact that the exit will be close to the Geldersekade/Prins Hendrikkade junction. This creates a risk of a queue in front of the traffic lights that extends onto the exit ramp. Another disadvantage is that the entrance cannot be approached directly from the Prins Hendrikkade, and traffic will have to be directed through a part of the city centre. Search traffic is considered to be of a minor issue, as the garage will mainly be used by permit holders that are familiar with the area.

## 5.3 Parking floor configuration

The configuration of the garage floors (number of floors, garage width, lay-out of parking provisions, etc) determines to a large extent which construction method is suitable. Several garage floor configurations are investigated to determine whether a specific design is sensible.

Various floor plans are available, of which the most common types are:

- Horizontal floor
- Split-level
- Sloped floors
- Spiralling floors

The first three plans usually have a rectangular foundation, the fourth has a circular. Since the Geldersekkade canal has a rectangular shape, the fourth alternative does not seem viable.

In case of an underground parking garage, the first plan has a considerable advantage over the second and third. It has the shallowest depth (the split-level garage is half a level deeper on one side, the garage with sloped floors even a full level) and the horizontal basement floors can function as a strut or bracing in all directions. For this reason only the horizontal floor plan is investigated.

The alternative floor configurations investigated in this paragraph differ in the number of floors, the layout of the parking provisions and the surface area required for their construction.

### 5.3.1 Calculation method

For each alternative, a preliminary calculation is made to determine how many parking places can be constructed in the Geldersekkade. It assumes the following parameters:

- Width of parking places (b): 2.4m
- Total usable length of the Geldersekkade canal: 340m
- Length used by the Bantammerbrug: 35m
- Minimum width of the Geldersekkade canal: 29m
- Construction clearance from quaywall 2.5m  
(according to article 4.2:7 of the starting points)
- Surface loss due to garage facilities: 30%  
(ramps, curves, maintenance room, exit shafts/staircases, etc.)

In this calculation, the Dutch code NEN 2443:2000<sup>[11]</sup> is used. This code provides values for traffic lane width and parking place length, depending on the parking angle  $a$  and the width of the parking places  $b$  (refer to table 5-1 and figure 5-7).

**Table 5-1: Parking place dimensions and single-direction lane width according to Table 6A of NEN 2443-2000, for  $b = 2.4\text{m}$**

$\alpha$ [°]	$P_1$ [m]	$P_2$ [m]	$w$ [m]
30	4.20	6.55	4.00
45	4.85	8.20	4.00
60	5.15	9.25	4.00
65	5.20	9.45	4.00
70	5.20	9.60	4.00
80	5.00	10.00	4.70
90	5.00	10.00	5.65

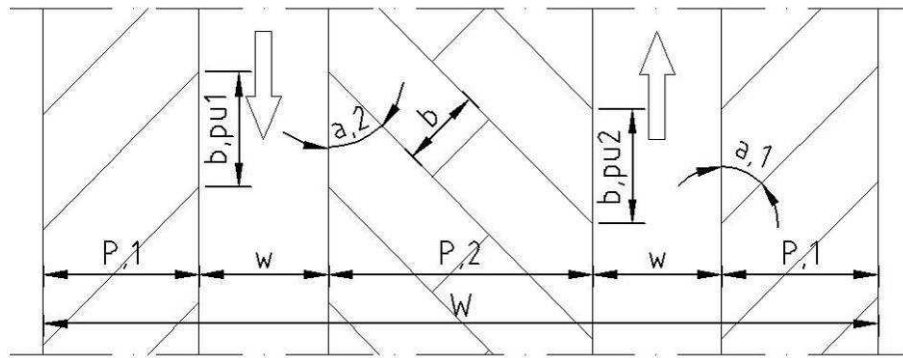

Figure 5-7: Parking place dimensions in garage, showing  $P_1$  (length of single-sided parking unit),  $P_2$  (length of double-sided parking unit),  $w$  (traffic lane width),  $b$  (width of parking place),  $b_{pu}$  (width of parking unit),  $\alpha$  (parking angle) and  $W$  (internal width of garage).

The width of the parking units  $b_{pu(1,2)}$  follows from  $b_{pu(1,2)} = \frac{b}{\sin(\alpha_{(1,2)})}$ .

The parking capacity of the garage is determined by subtracting the relative length lost due to facilities from the gross garage length. The remaining length is divided by  $b_{pu(1,2)}$  to determine the number of single- and double-sided parking units. Multiplying these by the amount of single- and double-sided parking rows gives the total number of parking places.

The detailed results of this calculation for the various floor configuration alternatives can be found in paragraph 5.3.5.

### 5.3.2 Alternative 1: Single level

The first configuration alternative considers a single level garage: all parking places have to be accommodated on a single floor. The idea behind this alternative is to limit the costs of the garage by limiting the excavation depth.

This alternative has a large claim on surface area and consequently it is required to use both parts of the Geldersekkade canal for the construction of the garage. Preferably, the Bantammerbrug (bridge 298) is maintained, as removing it would mean considerable hindrance during construction and extra costs for its reconstruction. A tunnel will have to be built underneath the bridge, allowing cars to cross over from the northern part of the garage to the southern side and vice-versa.

Furthermore, there will only be enough space available if at least one quaywall is (temporarily) removed. The eastern quaywall seems to be most suitable for this, since it is relatively far from existing buildings and the entrance/exit shafts can be incorporated in the reconstruction of the quaywall. Also, the western quaywall has much more historical significance. Removing the eastern quay will allow construction of a garage with an external width of approximately 27m. Assuming the ramp configuration as mentioned in paragraph 5.2.3, the foundation plan of the garage can be depicted as in figure 5-8.

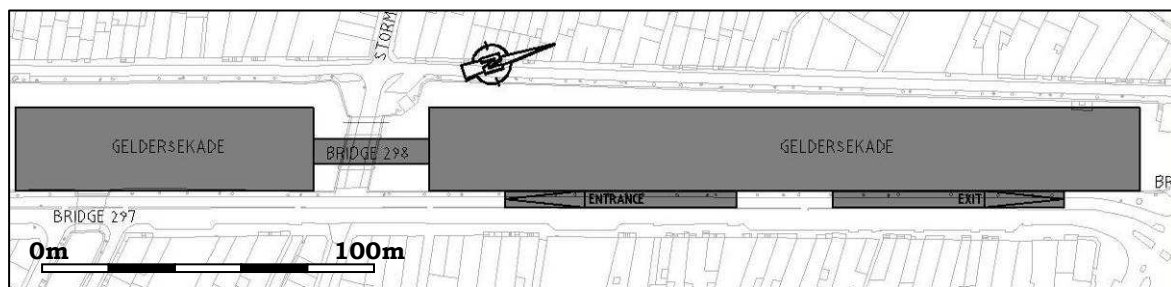

Figure 5-8: Garage footprint 1A (single level, maintaining bridge 298)

From iteration it follows that the maximum number of parking places in this configuration equals approximately 290, and has a typical layout as shown in figure 5-7. A double-sided parking row in the middle, encompassed by a single-direction traffic lane on either side and two single-sided parking rows along the periphery of the garage. The outer (single-sided) parking places have an angle of 70° whereas the inner (double-sided) parking places have an angle of 45°. Increasing the parking angle increases the number of parking places, but also increases the width of the garage. This is done most economically in the single-sided parking rows. The ramps that connect the different floors are at both extreme ends of the garage, making a sloped U-turn.

Because of the fact that this alternative does not produce the desired number of parking places, a variant on this alternative (1B) is created which assumes that the Bantammerbrug is removed during construction. This would allow the full length of the Geldersekkade to be used for the garage, increasing its effective length by approximately 35m (figure 5-9).

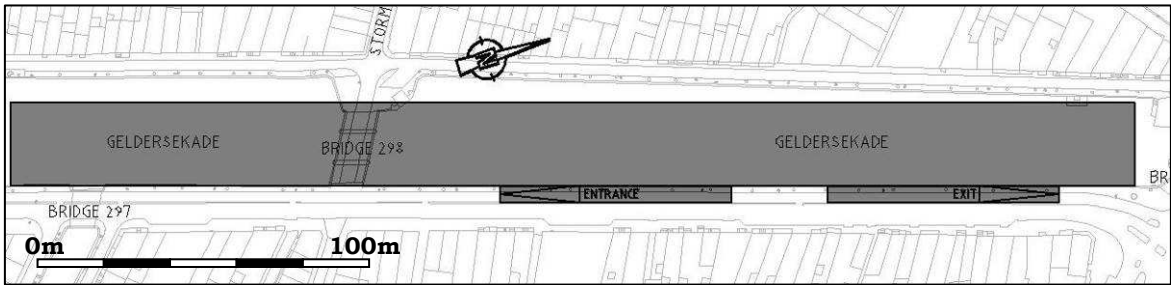

Figure 5-9: Garage footprint 1B (single level, reconstruction of bridge 298)

It turns out that the extra length can accommodate approximately 36 more parking places. This brings the total to 326, which is still not sufficient with regard to the required 350 places.

### 5.3.3 Alternative 2: Two levels

The second alternative is based on the intention of maintaining bridge 298. From calculations on the first alternative it follows that the corresponding *internal* garage width is 26.6m, while it is stated in paragraph 5.3.1 that the maximum *outer* garage width was 27m, leaving very little room for construction. In the second alternative, an attempt is made to reduce the garage width by applying a smaller parking angle.

The two goals stated above can only be achieved by constructing a parking garage with multiple levels. Since the northern part of the Geldersekaide is the longest, a garage in this part of the canal would require the least amount of levels. The length available for a garage in this canal is estimated at 215m (staying clear of the foundations of the Schreierstoren and bridge 298).

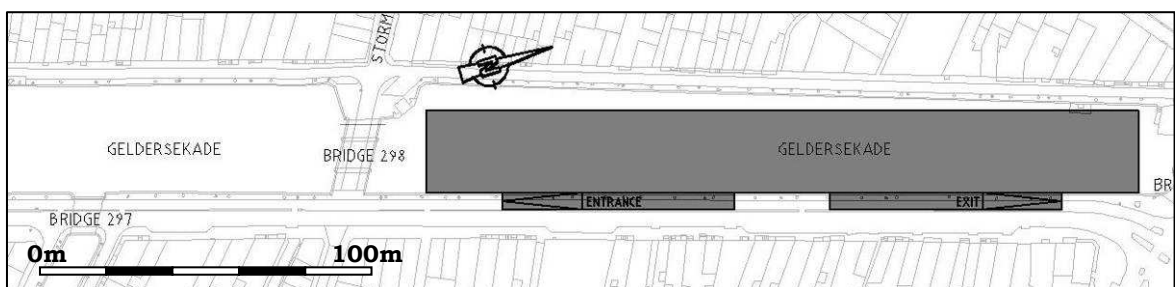

Figure 5-10: Garage footprint 2 (two levels)

Using the same layout as alternative 1, but with a parking angle of 45° for both the single- and double-sided parking rows, results in an internal garage width of 25.9m and 352 parking places.

### 5.3.4 Alternative 3: Three levels

A third alternative is to maintain both the Bantammerbrug and the quaywalls on either side of the canal. This should result in minimal risk to surrounding buildings (as the distance between buildings and garage is as large as possible) and minimal hindrance during construction of the garage. It also implies that the footprint of the garage will be even smaller, with a maximum width of approximately 21m. A garage with at least three levels will be required to suit these demands.

Within this narrow profile, it is no longer possible to fit four parking places in the width of the garage. Since there have to be at least two one-directional lanes, at most two parking places can be placed side by side, perpendicular to the longitudinal axis of the garage. To create a maximum amount of parking places, the parking angle will have to be large. With an angle of 70°, a garage with three levels can accommodate 348 parking places, at an internal garage width of 18.4m.

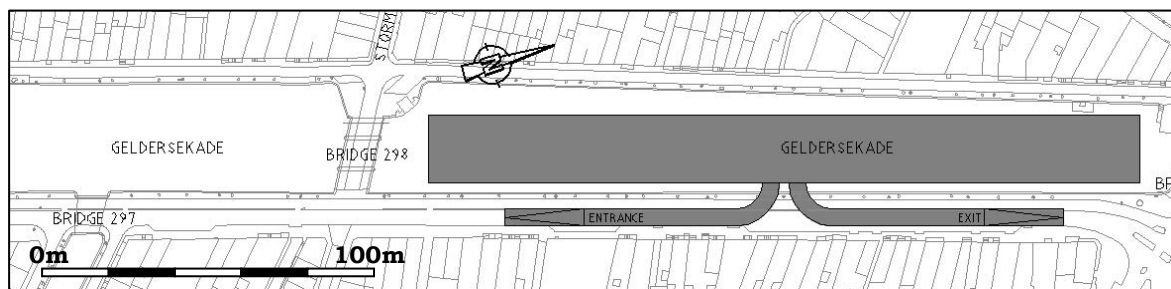

Figure 5-11: Garage footprint 3 (three levels)

### 5.3.5 Lateral ramp positioning

The construction method for the entrance/exit ramps as suggested for alternative 3 (figure 5-12 C) may be unfeasible due to the limited width of the profile between quay and facades. The entire road will be obstructed during construction of the ramps, and a building pit with groundwater drainage may still be required. Even after its construction, the ramps are inconveniently situated in the middle of the road, leaving little room for the bicycle track, through road and sidewalk. Inevitably, a part of the old quaywall will need to be demolished to allow construction of the cross-connections from the ramps to the garage.

From the above statements it follows that the construction of the ramps may seriously negate most advantages of a construction method that maintains both quaywalls. Alternatively, the ramps can be constructed on top of the garage (figure 5-12 A) inside the canal profile. In this way the entire quaywall can be preserved and the present road profile is barely influenced. The main disadvantage is that this

method would seriously alter the historical identity of the canal, as the view on the old quaywall is blocked by the ramps, and ships will no longer be able to dock along the quay. As the municipality of Amsterdam Centre already stated in its programme of requirements, this is considered highly undesirable.

A third alternative is to place the ramps on top of the garage and entirely moving it eastward so that the western wall of the ramps coincides with the position of the present quaywall (figure 5-12 B). Eventually, a new wall would partly replace the eastern quaywall, as with alternatives 1 and 2. Disadvantages are that the old quaywall will need to be demolished and trees removed. Advantages are that the road will stay (partly) accessible during construction and the final situation provides a convenient spatial layout. Trees can be replanted on top of the garage and ramps.

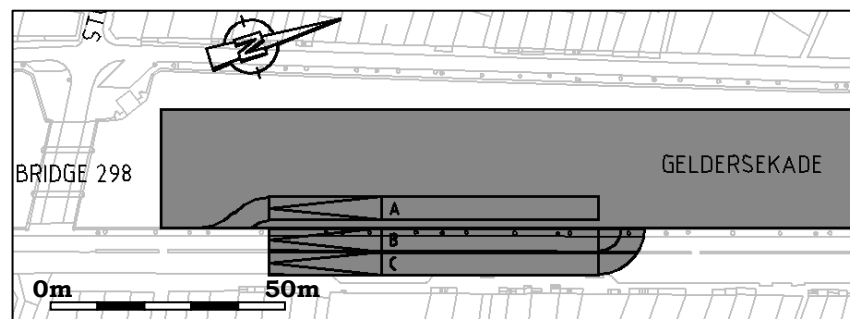

Figure 5-12: Alternative positioning of ramps: A) inside the canal profile; B) at the present quaywall; C) behind the present quaywall

### 5.3.6 Calculation results and conclusions

Calculations on the alternative configurations of the floor plan are summarised in Table 5-2. The first alternative does not seem to be very promising as it can't house enough cars, even if bridge 298 is demolished and reconstructed on top of the garage. The local municipality considers demolishing of this bridge highly undesirable, and it will also add considerably to the costs of the entire project.

The second alternative seems to be more viable: it can almost accommodate sufficient parking places and leaves bridge 298 intact. It still requires the replacement of most of the eastern quaywall nonetheless.

The third alternative is constructed in between of both quaywalls and consequently leaves most of the present structures intact. Only the entrance/exit ramps and pedestrian exits will have to cross the quay in some way. Just like the second alternative it facilitates sufficient parking places. Alternatively, as stated in paragraph 5.3.5, the entire three-storey garage can be constructed approximately 8m eastward, replacing the present quaywall.

**Table 5-2: Calculation of garage dimension for different floor configuration alternatives**

		Symbol	Alternative				Unit
			1A	1B	2	3	
Input	Width of parking place	$b$	2.4	2.4	2.4	2.4	[m]
	Width of traffic lane	$w$	4	4	4	4	[m]
	Number of lanes	$n_{lane}$	2	2	2	2	[-]
	Number of 1-sided parking rows	$n_{row1}$	2	2	2	2	[-]
	Number of 2-sided parking rows	$n_{row2}$	2	2	2	0	[-]
	Parking angle 1-sided parking rows	$a_1$	70	70	45	70	[°]
	Parking angle 2-sided parking rows	$a_2$	45	45	45	0	[°]
	Length of garage	$L$	305	340	215	215	[m]
	Surface loss due to facilities	$\Delta A$	30	30	30	30	[%]
	Number of floors	$n_{floor}$	1	1	2	3	[-]
Output	Length of 1-sided parking unit	$P_1$	5.20	5.20	4.85	5.20	[m]
	Length of 2-sided parking unit	$P_2$	8.20	8.20	8.20	0.00	[m]
	Internal width of garage	$W$	26.60	26.60	25.90	18.40	[m]
	Width of 1-sided parking unit	$b_{pu1}$	2.55	2.55	3.39	2.55	[m]
	Width of 2-sided parking unit	$b_{pu2}$	3.39	3.39	3.39	0.00	[m]
	Number of 1-sided parking places	$n_1$	166	186	176	348	[-]
	Number of 2-sided parking places	$n_2$	124	140	176	0	[-]
	Number of parking places in garage	$n$	<b>290</b>	<b>326</b>	<b>352</b>	<b>348</b>	[-]

A remark is made with respect to the calculation method used in this paragraph: The surface loss due to facilities has a large influence on the available garage space. A rough estimate is made which is assumed equal for all alternatives. Likely however, a garage with multiple floors will have a smaller net available surface area (due to the presence of more ramps, more curves, more emergency/pedestrian exits, etc), reducing the number of parking places. A detailed floor plan will have to verify the actual amount of parking places that fit into a particular floor plan.



# 6 Construction method

The construction of the Geldersekkade parking garage implies that a deep excavation (up to 15m below ground level) has to be realised in close vicinity of existing buildings and foundations. Due to the densely urbanised nature of the site and the high groundwater level, it requires a procedure that puts a low demand on spatial use, which is capable of retaining (ground)water and sufficiently stiff to prevent significant soil deformations. Other aspects associated with a specific construction method, such as costs, risks, noise/vibration/traffic hindrance, environmental effects etc., also govern its viability.

Alternative methods that may qualify for construction of the garage are produced based on the specific properties of retaining wall and floor types, as well as integrated methods, as mentioned in Appendix B. <sup>[25],[1]</sup> Specific construction methods are, by nature, more promising for a specific garage layout. In this paragraph, five construction methods for the carcass of the garage are specified:

- |                                                        |                |
|--------------------------------------------------------|----------------|
| 1) Traditional bottom-up (using a temporary cofferdam) | (Two levels)   |
| 2) Diaphragm walls + underwater concrete floor         | (Two levels)   |
| 3) Pneumatic caissons                                  | (Three levels) |
| 4) Immersed prefab elements (box caissons)             | (Three levels) |
| 5) Prefab elements/pneumatic caissons hybrid           | (Three levels) |

## 6.1 Construction method 1: Traditional

The first construction method uses the bottom-up procedure: first, a dry excavation is created by placing steel sheetpile walls and an UWC-floor. Within this cofferdam, the carcass of the garage is constructed using traditional reinforced concrete. Once finished, the cofferdam is backfilled and the temporary walls are removed.

This method is most suitable for floor configuration alternative 2 (two levels), as this alternative already requires temporary walls to be placed around the eastern quaywall in order to remove it. Also, a deeper excavation increases the risk of leakage and settlements. Roughly, the construction stages can be identified as follows:

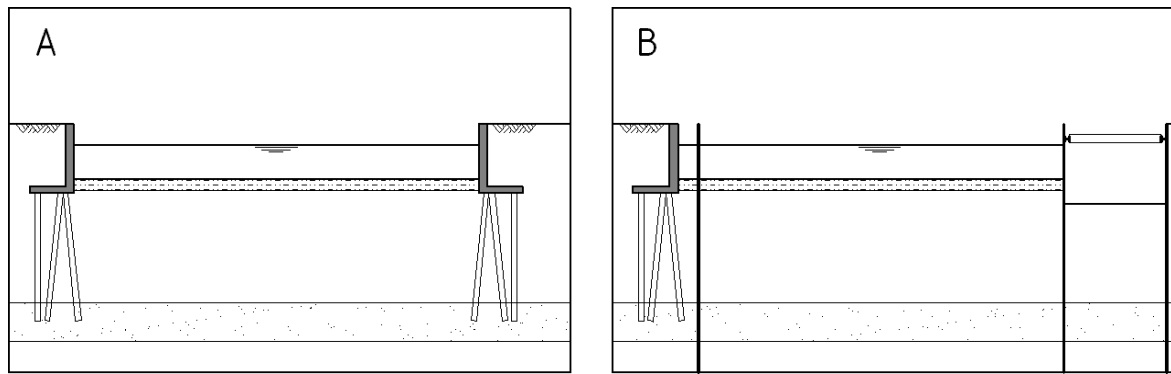

Figure 6-1: Traditional method using a cofferdam with temporary walls. A) Original situation. B) Installation of temporary (sheetpile) walls; removal of eastern quaywall and trees.

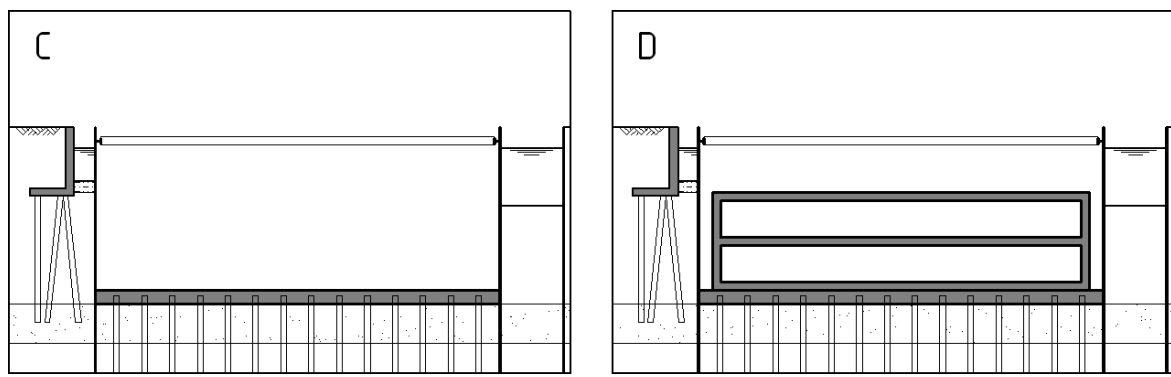

Figure 6-1: C) Moving middle sheetpile wall; mounting of struts; excavation of cofferdam up to construction depth; placing of vertical tension elements in subsoil; construction of UWC-floor; drainage of cofferdam. D) Construction of basement floor, walls, intermediate floor and roof.

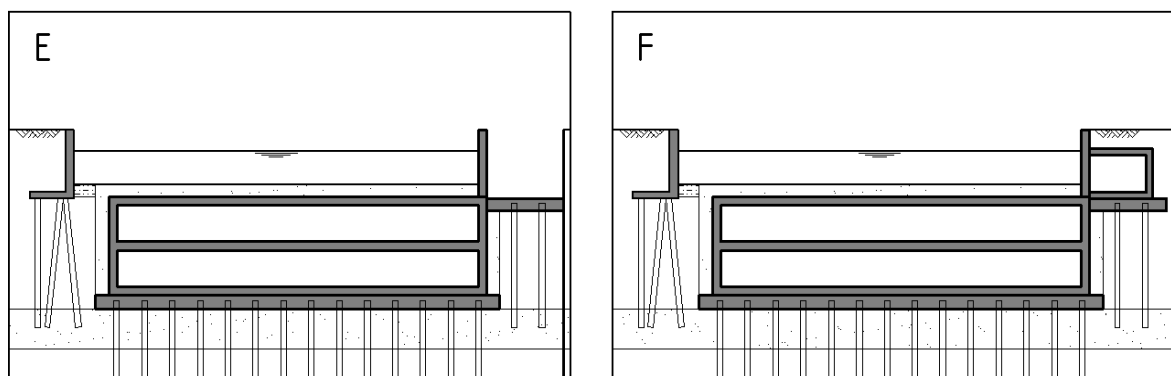
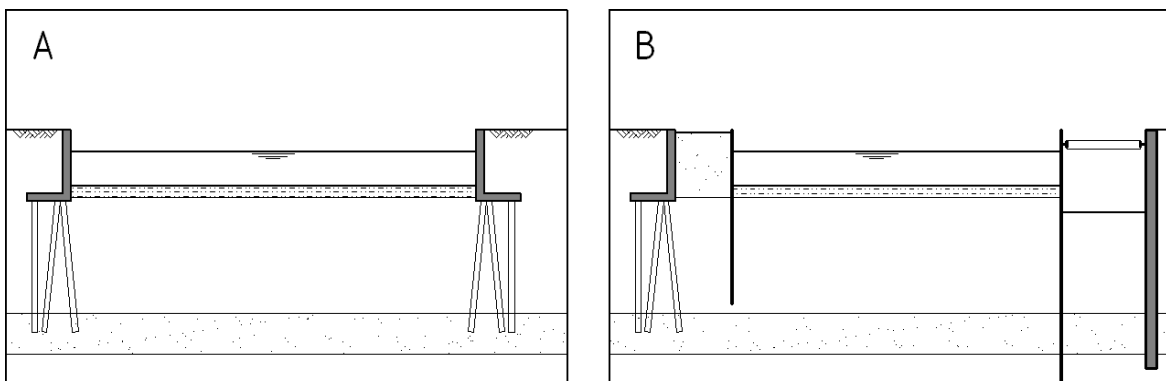

Figure 6-1: E) Covering of roof with ballast material; removal of temporary walls and struts. F) Construction of entry/exit ramps and shafts; reconstruction of eastern quaywall and replanting trees.

## 6.2 Construction method 2: Diaphragm walls

As with the first method, this method is most suitable for floor configuration alternative 2. The difference is that this method uses permanent walls for the construction of the cofferdam instead of temporary walls: they will also be used as the final walls of the garage. Temporary struts will be applied, which are replaced by the intermediate floors as soon as these are in place.

The permanent cofferdam walls can be made of coated sheetpile, secant pile or diaphragm walls. Advantage of a permanent sheetpile wall is that it can be driven in the canal in wet conditions. Disadvantage is that it can hardly carry any vertical loads. A secant pile/diaphragm wall on the other hand still requires temporary walls to be able to construct the permanent wall in the canal in dry conditions. Secant pile walls are relatively cheap but tend to have a higher risk of cracks and leakage than diaphragm walls. Construction of a garage using concrete diaphragm walls can be summarised as follows:



*Figure 6-2: Construction method using a cofferdam with permanent walls. A) Original situation. B) Installation of temporary (sheetpile) walls; filling of space between western quay and temporary wall with sand; construction of diaphragm wall behind eastern quaywall; removal of eastern quaywall and trees.*

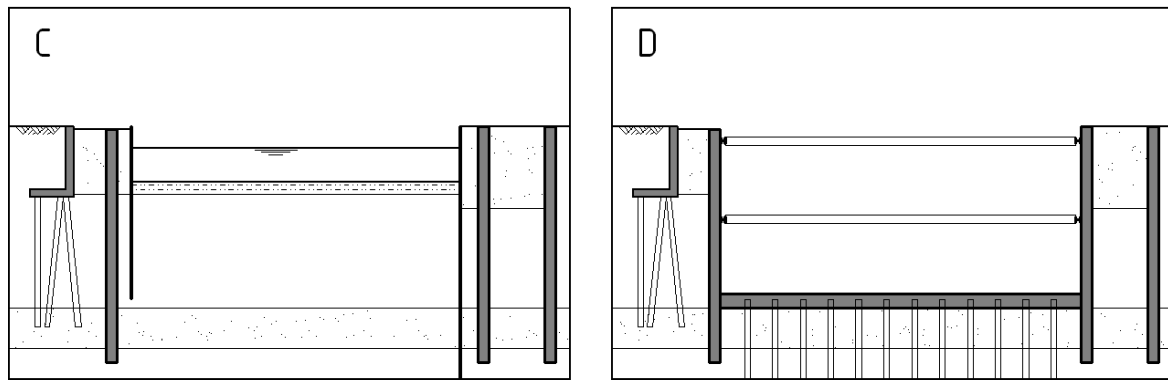

Figure 6-2: C) Backfilling of the excavation at the quaywall; construction of permanent (diaphragm) walls. D) Removal of temporary walls; mounting of struts; excavation of cofferdam up to construction depth; placing of vertical tension elements in subsoil; construction of UWC-floor; drainage of cofferdam.

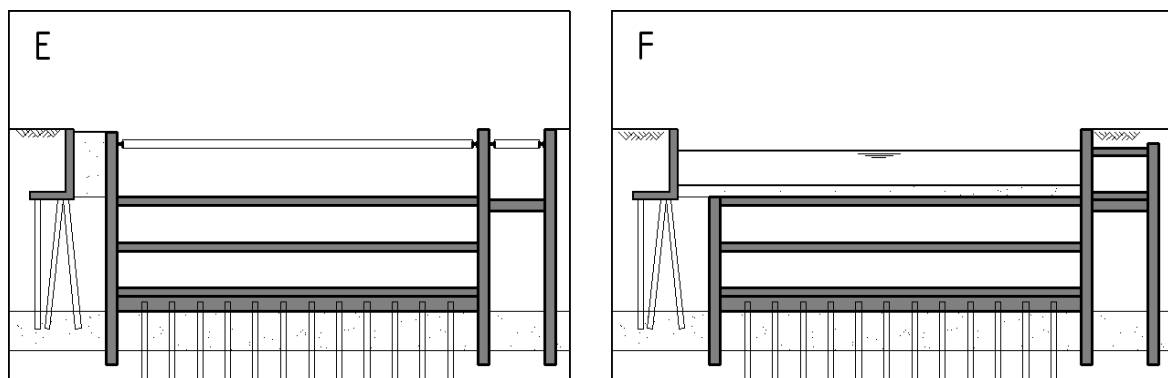

Figure 6-2: E) Construction of basement floor, intermediate floor and roof; removal of intermediate struts. F) Covering of roof with ballast material; removal of upper struts; demolishing of diaphragm wall above bed level in canal profile; construction of entry/exit ramps and shafts; reconstruction of eastern quaywall and replanting trees.

### 6.3 Construction method 3: Pneumatic caissons

The main advantage of the pneumatic caisson method is that it does not require a deep construction pit with drainage system. Thus it reduces the risk of settlements of the surrounding soil during excavation or due to leakage of the retaining walls. A dry construction site in the canal profile is still required to construct the cutting edges and basement floor of the caisson. This can be achieved by a sandfill in the canal which is sufficiently high above the water table. To reduce the volume of the sandfill (and consequently, the loads on the subsoil) a geomembrane covered with sand may prove an economically favourable alternative in this case.

It is unlikely that the garage can be immersed as a single caisson with a total length of 215m. Therefore, it is subdivided into several sections that are constructed and immersed separately.

Once an entire garage section, except the ramps, is completed above ground, it is immersed into the ground between the quaywalls by excavating the soil underneath. After consecutively immersing the different garage sections up to the desired level, the working chambers underneath the caissons are filled with concrete to provide a solid foundation and permanent ballast. The connections between the caissons are constructed in-situ, as are the ramps.

This method seems most suitable for alternative 3 (three levels). Schematically, the different construction stages are as show in figure 6-3.

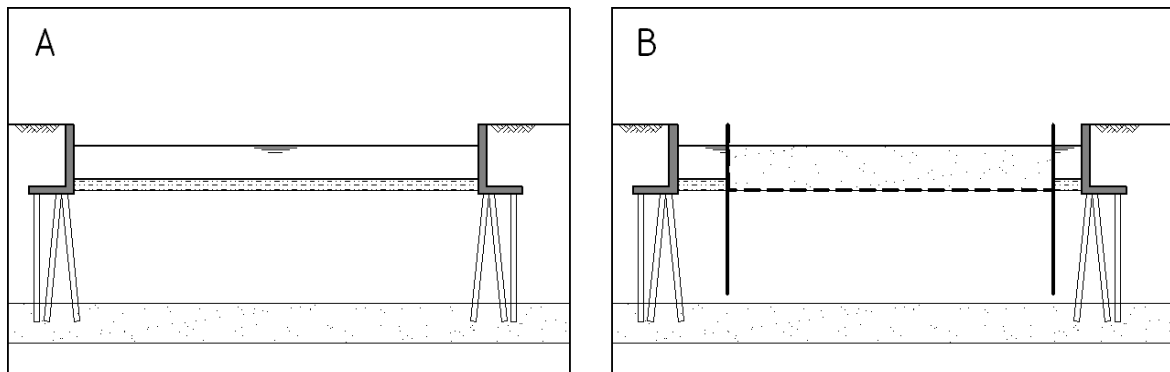

Figure 6-3: Pneumatic caisson method. A) Original situation. B) Installation of temporary walls; dredging of silt in cofferdam; placing of temporary impermeable layer; filling of cofferdam with sand.

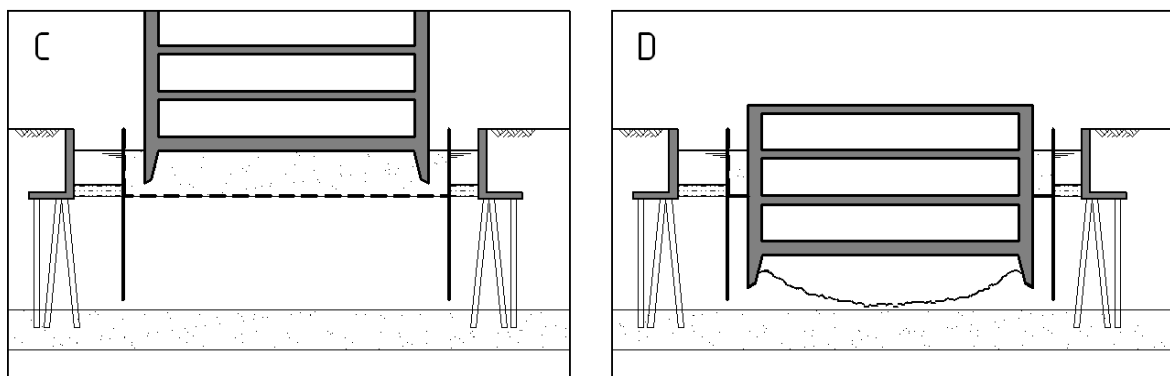

Figure 6-3: C) In-situ construction of first caisson element. D) Pneumatic immersion of first caisson element

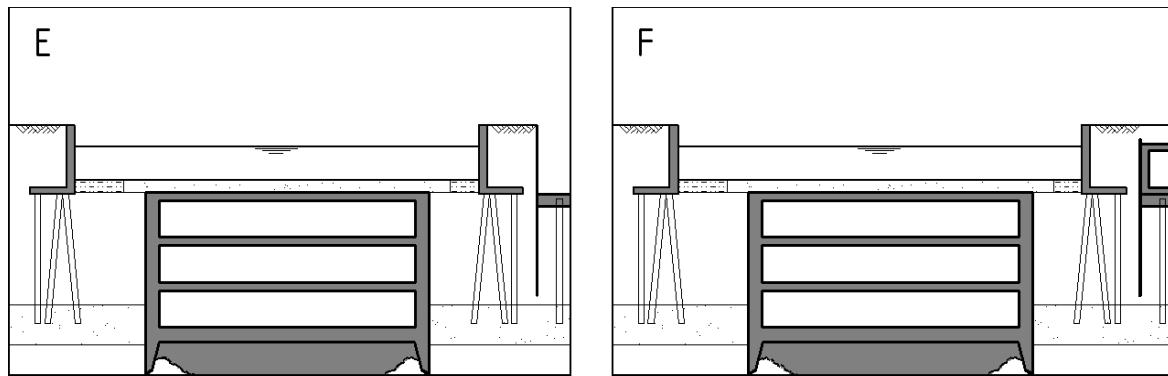

Figure 6-3: E) Filling of working chamber with concrete; covering of caisson element with ballast material; removal of temporary walls. F) Repetition of phase B–E for consecutive elements; construction of joint between caissons; in-situ construction of entry/exit ramps and shafts.

## 6.4 Construction method 4: Immersed prefab elements

The idea has been put forward to adopt immersed tunnelling techniques for the construction of underwater parking garages (Vlijm, H.<sup>[1]</sup>) However, unlike traditional immersed tunnels, the dimensions of the prefab elements applicable in the Geldersekkade canal are very limited: the normative cross-section is bridge 299, between the Geldersekkade and the Open Havenfront, which has a maximum width of 7m and total head clearance of approximately 5m (wet cross-section included).

As with the caisson method, the immersed elements method seems most suitable for floor plan alternative 3. An advantage is that prefabricated elements may reduce the construction time and hindrance at the site of the garage.

An important implication of this limited profile is that the floor plan needs to be adapted. Situating the parking places under an angle  $\alpha$  of  $90^\circ$  produces a minimum value of the parking unit width  $b_{pu}$ . According to NEN 2443:2000 this results in a width of  $w = 5.65m$  for a one-directional access lane and a parking unit length  $P_1$  of 5m. A single element can thus accommodate 4 parking places, with the following internal dimensions:

- Width:  $2 \cdot 2.4 = 4.8m$
- Length:  $2 \cdot 5 + 5.65 + 4 = 19.65m$
- Height:  $= 2.6m$

Assuming a wall thickness of  $0.5m$  and a thickness of the watertight joints of  $0.1m$ , the external dimensions are:

- Width:  $\sim 5.9m$
- Length:  $\sim 20.65m$
- Height:  $\sim 3.7m$

The total number of parking places deviates from the layout assumed for floor configuration alternative 3 in chapter 5: with a parking unit width  $b_{pu}$  of  $5.9/2=2.95m$ , the total number of parking places is now estimated at 306. This is far less than the required 350 places.

Special elements may need to be constructed for the cross-level ramps, or automated car elevators can be applied. Anyhow special provisions are required for the cross-connections between floors. The following construction phases can be identified, assuming the application of automated car elevators within the canal profile:

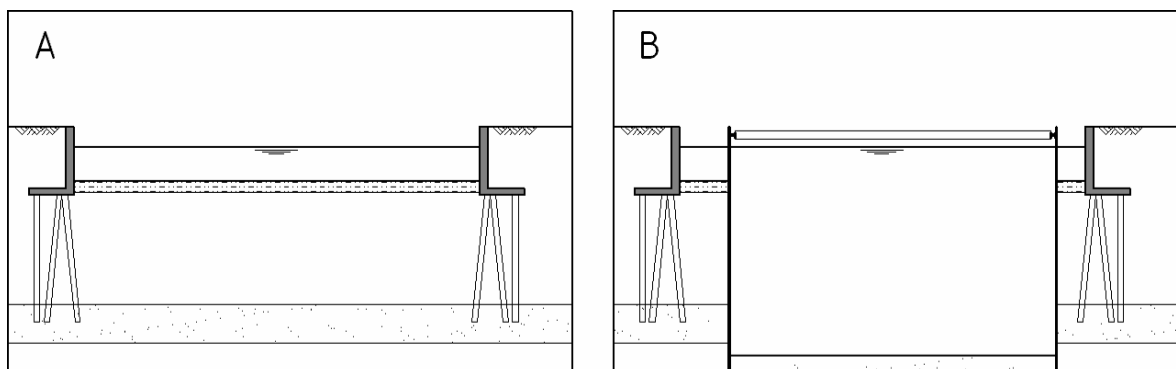

Figure 6-4: Immersed prefabricated elements method. A) Original situation. B) Off-site construction of prefabricated elements; installation of temporary walls; mounting of struts; wet excavation of immersion trench; placing of foundation layer.

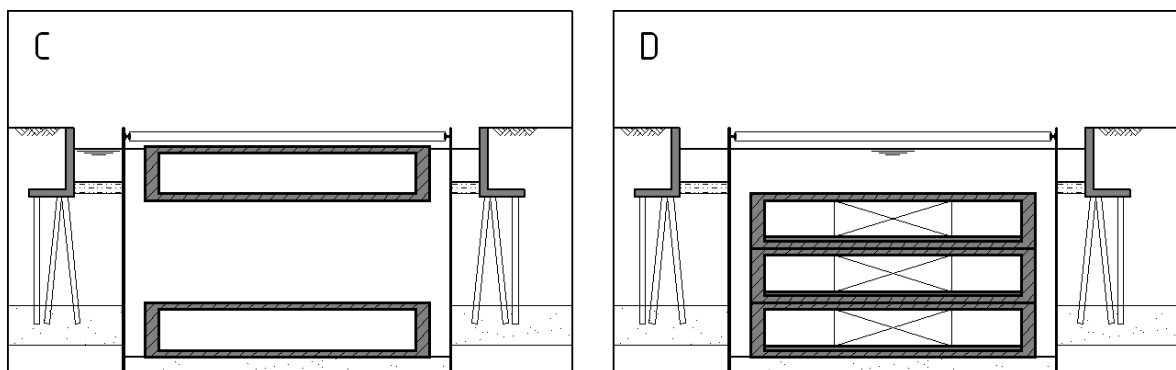

Figure 6-4: C) Immersion of prefabricated elements. D) Placing of permanent ballast concrete inside the elements; establishment of watertight joints between elements; removal of bulkheads.

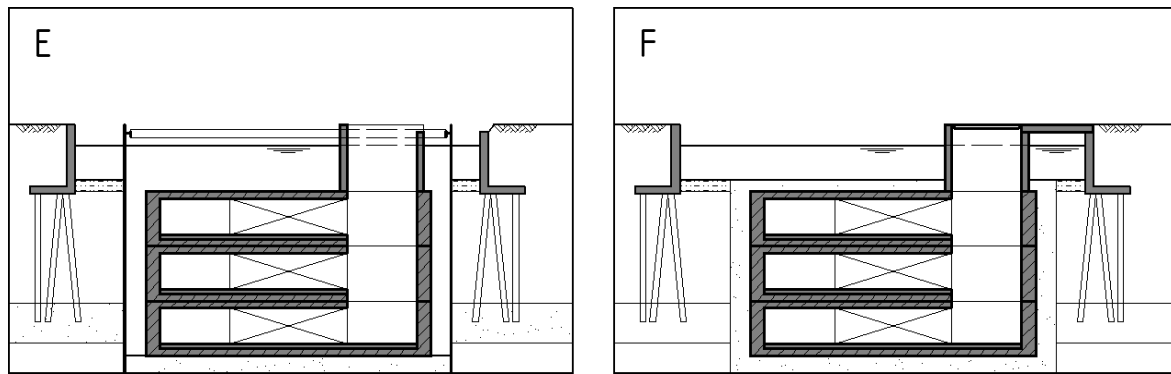

Figure 6-4: E) Construction of elevator shaft. F) Covering of elements with ballast material; removal of temporary walls and struts; construction of quay bridge and installation of automated elevator and equipment.

## 6.5 Construction method 5: Prefab elements/pneumatic caisson hybrid

A construction method that employs the advantages of both the pneumatic caisson method and the immersed elements method may result in a hybrid with unique characteristics:

The cutting edges and working chamber roof of the caissons are prefabricated and towed to the construction site over water. There, they are interconnected (e.g. by using post-tensioning cables and watertight seals) and immersed onto the canal bed. The elements are constructed such that, once immersed, their roofs will still be above water. Construction of the rest of the caissons can thus proceed above the water table, eliminating the need for a sandfill or cofferdam. Once the individual caissons are constructed, immersion and connection of consecutive caisson elements can proceed according to the regular pneumatic caisson method.

The pneumatic caisson/immersed elements hybrid method with replacement of the eastern quaywall has the following construction phasing:



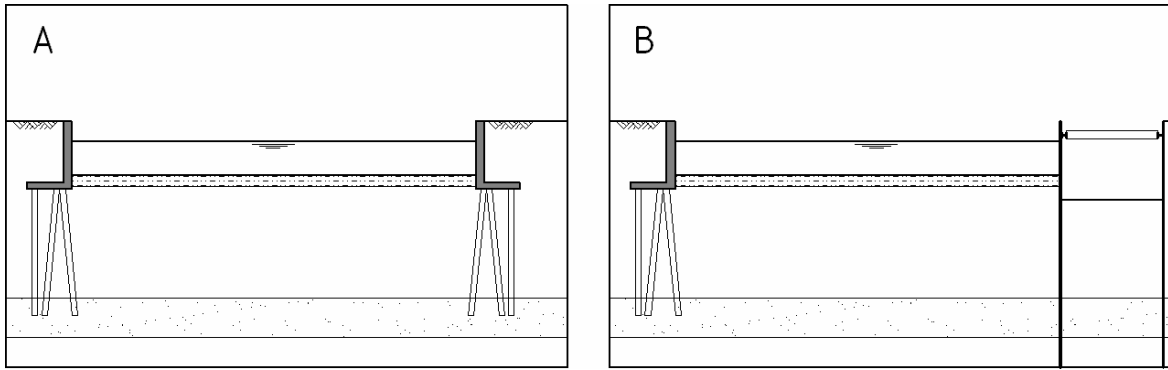

Figure 6-5: Prefab elements/pneumatic caisson hybrid method. A) Original situation. B) Off-site construction of prefab elements; installation of temporary retaining walls; removal of eastern quaywall.

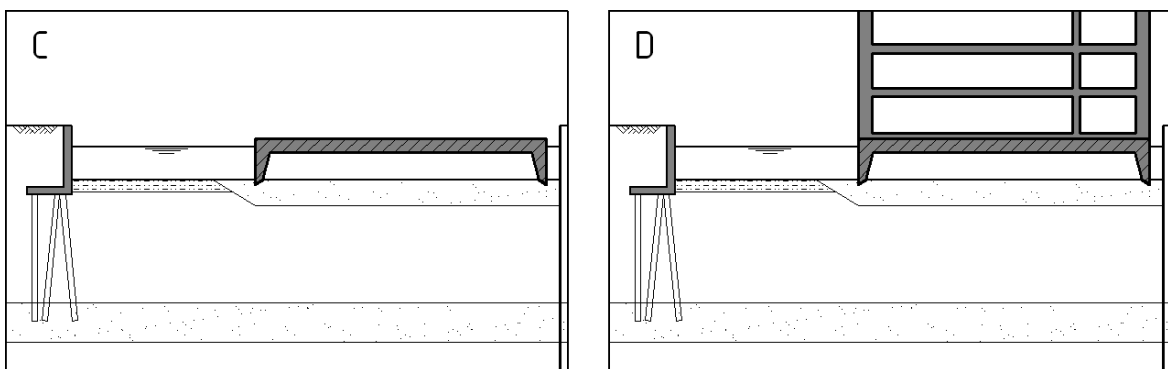

Figure 6-5: C) Dredging of silt in canal; placing of sand layer; coupling of elements; immersion of prefab elements onto canal bed. D) In-situ construction of first caisson on top of prefab elements.

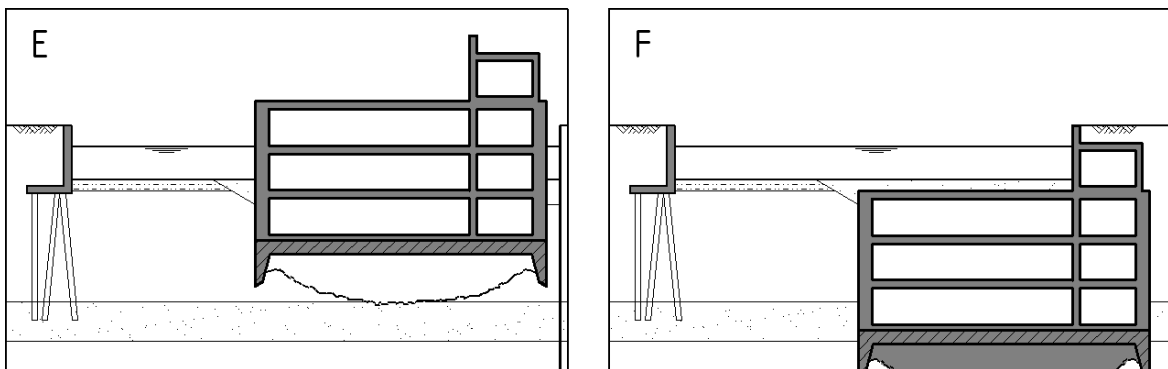

Figure 6-5: E) Pneumatic immersion of first caisson F) Filling of working chamber with concrete; covering of caisson element with ballast material; repetition of step B-E for consecutive caisson elements; construction of joint between caissons; removal of temporary retaining wall; reconstruction of eastern quaywall and replanting trees.

## 6.6 Conclusions

For the different construction methods discussed in this chapter, a number of main advantages and disadvantages can be listed:

**Table 6-1: Advantages and disadvantages of alternative construction methods**

Construction method	Advantages	Disadvantages
<p><b>1</b> Traditional, using a temporary sheetpile cofferdam</p> <p>Two levels</p>	<ul style="list-style-type: none"> <li>• Proven and reliable method</li> <li>• Very accurate results with respect to positioning</li> <li>• Short driving distances in garage due to fewer levels</li> </ul>	<ul style="list-style-type: none"> <li>• Noise/vibration hindrance due to heavy sheetpile driving</li> <li>• Loss of eastern quaywall</li> <li>• Dry excavation increases risk of leakage and deformations</li> </ul>
<p><b>2</b> Traditional, using diaphragm walls</p> <p>Two levels</p>	<ul style="list-style-type: none"> <li>• Limited noise/vibration hindrance</li> <li>• Reduced construction time by applying permanent walls</li> <li>• Short driving distances in garage due to fewer levels</li> </ul>	<ul style="list-style-type: none"> <li>• Heavy equipment on eastern Geldersekaade will cause obstructions</li> <li>• Limited quality control before excavation increases risk of deficiencies</li> <li>• Dry excavation increases risk of leakage and deformations</li> <li>• May cause political unrest due to recent problems</li> <li>• Loss of eastern quaywall</li> <li>• Discharge through canal blocked during construction</li> </ul>
<p><b>3</b> Pneumatic caisson</p> <p>Three levels</p>	<ul style="list-style-type: none"> <li>• Limited noise/vibration hindrance</li> <li>• No groundwater drainage required</li> </ul>	<ul style="list-style-type: none"> <li>• Visual obstruction when caisson is above ground</li> <li>• Only applicable in subsoil with homogeneous, horizontal strata</li> <li>• Labour-intensive with health risk</li> <li>• Ramp positioning unfeasible</li> </ul>
<p><b>4</b> Prefab immersion elements</p> <p>Three levels</p>	<ul style="list-style-type: none"> <li>• Rapid assembly on site reduces construction time</li> <li>• No groundwater drainage required</li> </ul>	<ul style="list-style-type: none"> <li>• Noise/vibration hindrance due to sheetpile driving of the immersion trench</li> <li>• Insufficient parking places</li> <li>• Inconvenient parking layout: 90° parking angle</li> <li>• Large number of watertight connections to be realised under water</li> <li>• Ramp positioning unfeasible</li> </ul>

<p><b>5</b> Pneumatic caisson/ prefab elements hybrid Three levels</p>	<ul style="list-style-type: none"> <li>• Reduced construction time due to absence of cofferdam and partial prefabrication</li> <li>• No groundwater drainage required</li> </ul>	<ul style="list-style-type: none"> <li>• Visual obstruction when caisson is above ground</li> <li>• Significant number of watertight connections to be realised, partly under water</li> <li>• Only applicable in subsoil with homogeneous, horizontal strata</li> <li>• Labour-intensive with health risk</li> <li>• Noise/vibration hindrance due to sheetpile driving</li> <li>• Loss of eastern quaywall</li> </ul>
--------------------------------------------------------------------------------	----------------------------------------------------------------------------------------------------------------------------------------------------------------------------------	-------------------------------------------------------------------------------------------------------------------------------------------------------------------------------------------------------------------------------------------------------------------------------------------------------------------------------------------------------------------------------------------------------------------------

It turns out that the 4<sup>th</sup> construction method (immersed prefab elements) does not provide adequate answers to the requirements by the commissioner: it cannot accommodate enough cars, and an automated car elevator/parking system has insufficient peak capacity for this particular case. Also, the presence of the car elevator in the canal profile is considered highly undesirable for aesthetical reasons. This alternative therefore is not evaluated any further.

Construction methods 3 and 5 are largely similar. Apart from the positioning, they differ mainly in the fact that the latter shows some promising innovations, which makes it an interesting research subject. For this reason, the traditional pneumatic caisson method (alternative 3) will not be evaluated any further. Should the immersible elements as applied in method 5 prove unfeasible, the base of the caisson can still be constructed using a traditional sandfill.

Construction methods 1, 2 and 5 will be further elaborated in the next two chapters.



# 7 Risk assessment

## 7.1 Methodology

The risk assessment as performed in this chapter is based on the following definition of causal risk:

- Consequences x Probability → Risk

For each construction method (alternative 1, 2 and 5 as explained in chapter 6), a number of potential causes of risks is determined. The consequences (damage inflicted, translated into monetary terms) of each event are determined and multiplied by its probability of occurrence. Disregarding correlation between different events, the sum of the risks related to each construction method results in the total expected project risk. For the full risk assessment, refer to Appendix C.

In this chapter, only the total risk of each alternative is presented, as well as the causes of the highest risks (not necessarily the causes with the highest consequences). Also, an estimated spread of the total risk is discussed.

### 7.1.1 Purpose of risk assessment

There are several reasons to conduct a risk assessment in an early design stage:

- Mapping of the execution risks tied to different construction methods should result in a more detailed knowledge base and allows a more objective evaluation of each alternative;
- Creating a basis for risk control measures and future research to inhibit specific risks;
- Validating the cost estimate of the contingencies (chapter 8): the total project risk should not exceed this item.

### 7.1.2 Identification of causes

The causes for specific risks are identified by consultation of various specialists and are based on a survey by Witteveen+Bos.<sup>[12]</sup> Only construction risks or risks related to technical failures are treated in this chapter: legal/procedural risks, risks related

to safety issues, financial risks, etc. are not taken into account. However, a distinction is made between regular technical risks and cases where individuals or society may suffer from the potential effects of a risk, part from any delays caused. Society-affecting risks tend to be less acceptable.

Ideally, all main causes for failure or other sources of damage/negative effects are listed for each alternative. Inevitably, chances are considerable that specific aspects are overlooked or neglected. A risk assessment therefore is a process that remains in constant development until execution of a project, and sometimes even continues after the project itself has been completed. It develops as knowledge increases.

#### 7.1.3 Estimating probabilities of occurrence

A risk assessment can only be done sensibly if the probabilities of adverse events can be quantified. At this design stage the risks can only be determined qualitatively so a translation of qualitative probabilities into quantitative ones is needed. This is done by the following classification for the probabilities of occurrence:

- Highly unlikely 1%
- Unlikely 5%
- Possibly 10%
- Likely 25%
- Very likely 50%
- Certain 100%

#### 7.1.4 Estimating consequences

Similar to its probability, the damage caused by a hazardous event can hardly be fathomed in advance if not all effects, and their costs, are exactly determined quantitatively. For now, the following classification of potential consequences (damage) is used:

- Small € 0.25 million
- Medium € 0.5 million
- Large € 1 million
- Very large € 2.5 million

This is based on the idea that large consequences are in the order of magnitude of 5%–10% of the direct costs of the project budget (refer to chapter 8).

### 7.1.5 Expected risk and deviation

The estimated risk related to a certain adverse event should not be regarded as an absolute value. It should rather be seen as the mean of the probability distribution of the risk.

The probability of occurrence of each event is described by a Bernoulli distribution: Let  $p_i$  be the probability of occurrence of event  $E_i$ . The probability of non-occurrence then becomes  $1 - p_i$ . If  $C_i$  is the consequence of  $E_i$ , the expected value of the risk  $R_i$  is defined by:

- $R_i = p_i \cdot C_i$  (Risk = Probability x Consequence)

The variance of the probability of occurrence of  $E_i$ ,  $\sigma_i^2$ , is defined by:

- $\sigma_i^2 = p_i(1 - p_i) \quad \rightarrow \quad \sigma_i = \sqrt{p_i(1 - p_i)}$

The standard deviation of the expected risk  $R_i$  then becomes:

- $\sigma(R)_i = \sqrt{p_i(1 - p_i)} \cdot C_i$

The expected total risk of a combination of  $n$  events is the sum of the risk of each individual event:

- $M = \sum_{i=1}^n R_i = \sum_{i=1}^n p_i \cdot C_i$

The standard deviation of this expected total risk is determined as follows:

- $\Sigma(M) = \sqrt{\sum_{i=1}^n \sigma(R)_i^2} = \sqrt{\sum_{i=1}^n p_i(1 - p_i) \cdot C_i^2}$

This value should give an idea of the spread around the expected total risk, within which the actual project risk will likely be: the range of  $M - \Sigma(M) \dots M + \Sigma(M)$  gives a confidence interval of 68% for the actual project risk.

It should be born in mind that in this calculation only the spread of the probability distribution is regarded; not the uncertainty in the estimate of the probability itself (paragraph 7.1.3) or the estimate of the consequences (paragraph 7.1.4). Considering the large uncertainties in these estimates, the actual spread in the total project risk will be much larger.

## 7.2 Risks of construction method 1

### 7.2.1 Results of risk assessment

Total risk: € 3.1 million

Standard deviation: € 1.8 million

Certain risk: € 0.5 million (to be accounted for in direct project costs)

Risk to be covered by the contingency allowance:

€ 2.6 million

### 7.2.2 Top risks and mitigating measures

#### 1) Structural damage to quaywalls due to vibrations of sheetpile driving

Probability: 25%

Consequences: € 2.5 million

Risk: € 0.625 million

Several historical sandstone blocks of the old ramparts have been incorporated in the western quaywall. Vibrations caused by driving and pulling of heavy sheetpile walls in close vicinity of the quay will likely cause subsidence of its foundation and/or cracking of the masonry walls.

Conducting an extensive geological survey and making geotechnical calculations may help prevent unexpected damage to the quay. If required according to these calculations, soil/foundation improvement measures can be applied.

#### 2) Damage to the Schreierstoren

Probability: 10%

Consequences: € 2.5 million

Risk: € 0.25 million

The historical Schreierstoren is the oldest and only remaining rampart fortification tower of Amsterdam. Even though its foundation is in good condition, it is poorly documented. Construction works in close vicinity of the tower may cause deformations of the subsoil with potentially severe results.

Damage to the Schreierstoren caused by construction works is considered highly unacceptable. Investigation of the foundation of the tower and calculations on its



bearing capacity are required. Possibly soil improvements around the piles may be needed as well as measures to locally reduce the impact of construction works.

3) Cosmetic damage to adjacent buildings due to vibrations of sheetpile driving

Probability: 25%

Consequences: € 1.0 million

Risk: € 0.25 million

Vibrations in the subsoil due to driving and removing of sheetpiles may cause cosmetic damage to adjacent buildings, such as cracks in brickwork or plaster and deformations of stairheads.

Mitigating measures are similar to those preventing damage to the quaywalls. Another option is to apply smaller sheetpile sections, which require less heavy vibrations.

4) Problems during sheetpile driving caused by unexpected obstacles

Probability: 50%

Consequences: € 0.5 million

Risk: € 0.25 million

The historical centre of Amsterdam is notorious among contractors for the large concentrations of undocumented rubble and old foundation elements in the subsoil. Driving of sheetpiles may be slowed or hampered by these obstacles, or sheetpiles may be damaged.

Examining historical maps of the area may help predict the presence of obstacles, but does not prevent damage or delays caused by these obstacles. A certain budget should be reserved to cover for this.

5) Archaeological discovery of objects

Probability: 100% (certain)

Consequences: € 0.25 million

Risk: € 0.25 million

It is almost certain that there will be archaeological findings on the construction site, as the garage is constructed in an old city moat. This will result in some delays and extra costs. This should be taken into account in the project budget estimate.

## 7.3 Risks of construction method 2

### 7.3.1 Results of risk assessment

Total risk: € 2.5 million

Standard deviation: € 1.5 million

Certain risk: € 0.5 million (to be accounted for in direct project costs)

Risk to be covered by the contingency allowance:

€ 2.0 million

### 7.3.2 Top risks and mitigating measures

#### 1) Structural damage to quaywalls due to vibrations of sheetpile driving

Probability: 10%

Consequences: € 2.5 million

Risk: € 0.25 million

As in paragraph 7.2.2-1, however the sheetpiles are less heavy and driven at a greater distance from the quaywall.

#### 2) Problems during excavation of diaphragm walls due to unexpected obstacles

Probability: 50%

Consequences: € 1 million

Risk: € 0.5 million

Excavation of the diaphragm wall trenches may be slowed due to the presence of obstacles in the subsoil. Also, the removal of these obstacles may lead to (partial) collapse of a trench.

Excavation should be done with great care. Examining historical maps of the area may help predict the presence of obstacles.

#### 3) Archaeological discovery of objects

Similar to paragraph 7.2.2-5.

## 7.4 Risks of construction method 5

### 7.4.1 Results of risk assessment

Total risk: € 3.1 million

Standard deviation: € 1.8 million

Certain risk: € 0.5 million (to be accounted for in direct project costs)

Risk to be covered by the contingency allowance:

€ 2.6 million

### 7.4.2 Top risks and mitigating measures

#### 1) Delays due to innovative construction method

Probability: 25%

Consequences: € 2.5 million

Risk: € 0.625 million

Constructing an underground garage in a narrow canal using pneumatic caissons is an innovative method. Even more so because this method makes use of prefab elements that have never been applied as such. Unforeseen deficiencies may show up or e.g. the authority for supervision of building works may express concerns, which can not immediately be reassured.

Extensive preliminary research and perhaps model tests are advisable before execution to confine delays. These delays are primarily of concern to the contractor and commissioner, but may cause civil unrest if they are long-lasting.

#### 2) Cosmetic damage to adjacent buildings due to vibrations of sheetpile driving

Similar to paragraph 7.2.2-3.

#### 3) Archaeological discovery of objects

Similar to paragraph 7.2.2-5.



# 8 Cost estimate

## 8.1 Methodology

Objective evaluation of the three alternative construction methods as discussed in the previous chapters can partly be done by a cost estimate per alternative. For this estimate of the project costs, a standard template (SSK) by CROW<sup>[13]</sup> is applied. Also, the costs estimate for the Geldersekkade parking garage as produced by Witteveen+Bos<sup>[14]</sup> is used as a guideline for unit prices and rough figures. The reference level of prices is July 2008, in accordance with this report.

Quantities and volumes, which provide the input for the cost estimate, are based on the findings of chapters 5 and 6. Specific quantities or assumptions regarding a specific construction method are listed in this chapter.

### 8.1.1 Composition of costs estimate

According to the SSK, the cost estimate is to be split up into several main budget items:

- Direct costs

Estimate of costs that are directly related to volumes of construction materials, materiel and labour, or to project-specific works. The direct costs are subdivided into:

- A. Preparatory works

Setting up of the work area, demolishing of existing quaywall and removal of pavement and trees.

- B. Temporary provisions

Installation of sheetpile retaining walls and related excavations, relocation of boats and provisions to ensure the discharge capacity of the canal.

- C. Soil works

Excavation and disposal of soil and silt, and refill of sand where necessary. It is assumed that hydraulicking<sup>1</sup> of soil in a pressurised working chamber underneath the caisson is three times as expensive as regular wet excavation, e.g. using an earth grab.

D. Foundation works

Tension piles underneath the main structure and piles to bear the loads of the entrance/exit ramps onto the subsoil.

E. Concrete works

Underwater concrete floor, structural floors, walls and roof, columns and levelling layers.

F. Remaining provisions

Pedestrian exits, ducts and wiring, restoration of the quaywall and pavement, replanting trees.

G. Yet to be detailed

Budget item to account for the low level of detail in the present design. It is expected that with increasing knowledge and level of detail, the direct project costs also increase. This budget item is estimated at 10% of A-F combined.

- Indirect costs

Costs related to activities that are not directly tied to the project itself, but which are nonetheless required for its execution, e.g. operational costs of the site hut. A profit/risk budget for of the contractor is also included in this item.

- Additional costs

Engineering costs, project supervision, etc. A budget for project risks, the contingency allowance, is also listed under additional costs.

In this chapter only the total sums per budget item are listed. For the full cost estimates, refer to Appendix D.

---

<sup>1</sup> Also known as hydraulic mining: Excavation method that employs water to dislodge rock material or move sediment.<sup>[a]</sup> For the pneumatic immersion of caissons, generally a water jet is used to loosen the soil whereupon the suspended sediment is pumped out of the working chamber.

### 8.1.2 Exclusions

Several potential cost-items are not taken into account in this estimate:

- Purchase of real estate / property
- Expropriation
- Participation / objection procedures
- Environmental Impacts Assessment
- Remediation of polluted soil/sludge
- Interest loss
- Value Added Tax

## 8.2 Costs of construction method 1

### 8.2.1 Preliminary dimensioning

External dimensions:

- Length:  $215m$
- Width:  $28m$
- Excavation depth:  $NAP -11.6m$
- Top of garage roof:  $NAP -3.4m$
- Top of quaywall:  $NAP +1.5m$
- Sheetpile length:  $20m$  (propped at  $+0.5m$  NAP, applied along the full circumference of the garage)

Concrete works:

- UWC-floor:  $t = 1500mm$
- Construction floor:  $t = 800mm$
- Outer walls:  $t = 600mm$
- Intermediate floors:  $t = 500mm$  (prefab)
- Roof:  $t = 800mm$
- Columns:  $\varnothing 700mm$
- Tension piles: Grout injection piles, C.T.C  $3000mm$

## 8.2.2 Cost estimate of construction method 1

**Table 8-1: Cost estimate of construction method 1**

Item	Description	Qty.	Unit	Unit price	Total	Margin
1A	Preparatory works				€ 135,000.00	30%
1B	Temporary provisions				€ 1,337,600.00	30%
1C	Soil works				€ 742,500.00	40%
1D	Foundation works				€ 2,017,000.00	30%
1E	Concrete works				€ 9,633,600.00	15%
1F	Remaining provisions				€ 2,055,000.00	30%
<b>Subtotal direct costs</b>					<b>€ 15,920,700.00</b>	<b>21%</b>
1G	Yet to be detailed	10%	€	15,920,700.00	€ 1,592,070.00	
<b>Direct costs</b>					<b>€ 17,512,770.00</b>	
One-time costs / construction site costs / execution costs		10%	€	17,512,770.00	€ 1,751,277.00	
General costs / profit and risk / contributions		13%	€	17,512,770.00	€ 2,276,660.10	
<b>Indirect costs</b>					<b>€ 4,027,937.10</b>	
Contingency allowance		10%	€	21,540,707.10	€ 2,154,070.71	
Engineering, administration and supervision		20%	€	23,694,777.81	€ 4,738,955.56	
<b>Additional costs</b>					<b>€ 6,893,026.27</b>	
<b>Subtotal total costs</b>					<b>€ 28,433,733.37</b>	
<b>Round off</b>					<b>€ 266.63</b>	
<b>Total costs (VAT excluded)</b>					<b>€ 28,434,000.00</b>	

## 8.2.3 Check with risk assessment

Total project costs: € 28.434 million ±21%

Contingency allowance: € 2.154 million

Estimated risk: € 2.6 million

The contingencies budget is too small. The highest risk for this construction method (€ 0.625 million) is caused by structural damage to the western quaywall. This risk has influence on society, but is not strictly unacceptable. If proper measures are taken beforehand, the quay can be restored later. Adopting these works in the cost estimate reduces the project risk by € 0.625 million but increases its direct costs.

## 8.3 Costs of construction method 2

### 8.3.1 Preliminary dimensioning

External dimensions:

- Length: 215m
- Width: 28m



- Excavation depth: NAP -11.6m
- Top of garage roof: NAP -3.4m
- Top of quaywall: NAP +1.5m
- Sheetpile length: 15m (applied behind the eastern quaywall and to make a filled cofferdam in the canal around the rest of the outer garage walls)
- Diaphragm wall 1.: 17m (propped at +0.5m NAP)

Concrete works:

- UWC-floor:  $t = 1500mm$
- Construction floor:  $t = 800mm$
- Diaphragm walls:  $t = 800mm$
- Intermediate floors:  $t = 500mm$  (prefab)
- Roof:  $t = 800mm$
- Columns:  $t = \text{Ø}700mm$
- Tension piles: Grout injection piles, C.T.C 3000mm

### 8.3.2 Cost estimate of construction method 2

**Table 8-2: Cost estimate of construction method 2**

Item	Description	Qty.	Unit	Unit price	Total	Margin
2A	Preparatory works				€ 135,000.00	30%
2B	Temporary provisions				€ 895,200.00	30%
2C	Soil works				€ 686,250.00	40%
2D	Foundation works				€ 2,017,000.00	30%
2E	Concrete works				€ 13,753,700.00	15%
2F	Remaining provisions				€ 2,055,000.00	30%
<b>Subtotal direct costs</b>					<b>€ 19,542,150.00</b>	<b>20%</b>
2G	Yet to be detailed	10%	€	19,542,150.00	€ 1,954,215.00	
<b>Direct costs</b>					<b>€ 21,496,365.00</b>	
One-time costs / construction site costs / execution costs		10%	€	21,496,365.00	€ 2,149,636.50	
General costs / profit and risk / contributions		13%	€	21,496,365.00	€ 2,794,527.45	
<b>Indirect costs</b>					<b>€ 4,944,163.95</b>	
Contingency allowance		10%	€	26,440,528.95	€ 2,644,052.90	
Engineering, administration and supervision		20%	€	29,084,581.85	€ 5,816,916.37	
<b>Additional costs</b>					<b>€ 8,460,969.26</b>	
<b>Subtotal total costs</b>					<b>€ 34,901,498.21</b>	
<b>Round off</b>					<b>€ 498.21-</b>	
<b>Total costs (VAT excluded)</b>					<b>€ 34,901,000.00</b>	

### 8.3.3 Check with risk assessment

Total project costs: € 34.901 million  $\pm 20\%$

Contingency allowance: € 2.644 million

Estimated risk: € 2.0 million

The budget for contingencies properly covers the estimated project risk. Special mitigating measures may not be required.

## 8.4 Costs of construction method 5

### 8.4.1 Preliminary dimensioning

External dimensions:

- Length: 215m
- Width: 22m
- Excavation depth: NAP -17.2m
- Top of garage roof: NAP -3.4m
- Top of quaywall: NAP +1.5m
- Sheetpile length: 17m (braced at +0.5m NAP, applied behind the eastern quaywall)

Concrete works:

Due to the increased excavation depth, the required rigidity of the caisson and to facilitate the immersion process, the concrete thickness is increased in most parts of the structure with respect to the previous two construction methods:

- Basement floor:  $t = 1000mm$
- Outer walls:  $t = 1000mm$
- Prefab floors:  $t = 500mm$
- Roof:  $t = 1000mm$
- Columns:  $\varnothing 700mm$
- Concrete fill  $t = 2000mm$  (poured into working chamber after immersion of a caisson has completed)
- Prefab elements:  $V = 115m^3$

## 8.4.2 Cost estimate of construction method 5

**Table 8-3: Cost estimate for construction method 5**

Item	Description	Qty.	Unit	Unit price	Total	Margin
5A	Preparatory works				€ 135,000.00	30%
5B	Temporary provisions				€ 819,000.00	30%
5C	Soil works				€ 1,373,095.00	40%
5D	Foundation works				€ 170,000.00	30%
5E	Concrete works				€ 10,998,300.00	15%
5F	Remaining provisions				€ 2,135,000.00	30%
<b>Subtotal direct costs</b>					<b>€ 15,630,395.00</b>	<b>20%</b>
5G	Yet to be detailed	10%	€	15,630,395.00	€ 1,563,039.50	
<b>Direct costs</b>					<b>€ 17,193,434.50</b>	
One-time costs / construction site costs / execution costs		10%	€	17,193,434.50	€ 1,719,343.45	
General costs / profit and risk / contributions		13%	€	17,193,434.50	€ 2,235,146.49	
<b>Indirect costs</b>					<b>€ 3,954,489.94</b>	
Contingency allowance		10%	€	21,147,924.44	€ 2,114,792.44	
Engineering, administration and supervision		20%	€	23,262,716.88	€ 4,652,543.38	
<b>Additional costs</b>					<b>€ 6,767,335.82</b>	
<b>Subtotal total costs</b>					<b>€ 27,915,260.25</b>	
<b>Round off</b>					<b>€ 260.25-</b>	
<b>Total costs (VAT excluded)</b>					<b>€ 27,915,000.00</b>	

## 8.4.3 Check with risk assessment

Total project costs: € 27.915 million ±20%

Contingency allowance: € 2.115 million

Estimated risk: € 2.6 million

The contingency allowance is too small. When examining the highest causes of risks, those with influence on society are fairly limited. The most important risk is caused by delays due to the innovative construction method, estimated at € 0.625 million. A solution can be searched in reducing the risk by increasing the engineering budget during the design stage.

## 8.5 Conclusions and evaluation

Recapitulating, the total estimated project costs for the different alternatives equal:

- 1) Traditional method, bottom-up: € 28.434 million
- 2) Diaphragm walls with UWC-floor: € 34.901 million
- 3) Pneumatic caisson with prefab elements: € 27.915 million

The costs of alternative 1 are dominated by the great quantities of sheetpile walls to be applied, and the risks related to a dry excavation close to the historical quaywall and Schreierstoren.

Alternative 2 is by far the most expensive one. This is primarily caused by the expensive diaphragm walls that are applied. Also, the inconvenient cofferdams to be constructed in the canal profile, required for the dry excavation of the diaphragm walls, contribute significantly to the total costs.

Alternative 5 turns out to be the cheapest method, despite the great costs related to the soil works. The biggest gain is achieved by omission of the tension piles underneath the main garage structure. A remark is made that a rough estimate is done for the costs of the prefab elements (€40,000/element). In case these turn out to be more expensive, the economical advantages of this method may be lost.<sup>1</sup> Costs for transportation of the prefab elements, which are highly variable depending on the manufacturing site of the elements, are also not taken into account. Rental of tugboats and e.g. a dry-dock may considerably add to the costs.

Throughout the rest of this thesis, the structural design and construction phasing aspects of alternative 5 are elaborated more thoroughly. This is in consistence with the thesis objective expressed in paragraph 3.2.

---

<sup>1</sup> As a result of progressing knowledge, in chapter 10 it indeed turns out that the price estimated for a prefab element, as done in paragraph 8.4.2, is way off: approximately €100,000 versus €40,000. The estimated project cost of construction method 5 then becomes €31.7 million, making it more expensive than the traditional bottom-up method but still considerably less expensive than diaphragm walls.

# 9 Elaboration of chosen design

All considerations explained in this chapter contribute to a functional and structural design of the selected construction method. This design is used as a starting point for further research in chapters 10 and 11.

## 9.1 Internal lay-out<sup>[11]</sup>

### 9.1.1 Ramps

Requirements with respect to the ramps between street level and level -1:

- Slope: 1:10 (transition gradient not required)
- Width: 4m
- Level difference: 8.5m (from top of quay to upper garage floor)
- Length: 85m

It is possible to fit the two ramps in line within the length of the garage, but it is not possible to create more than one entrance and one exit ramp. In case of a blocked ramp, the entrance will need to be used as an alternative exit.

For spatial optimisation reasons, the cross-level connections are positioned at the extreme ends of the garage, making a sloped U-turn. These must comply with the following:

- Slope: 1:10 (transition gradient not required)
- Width: 4.5m
- Minimum inner radius: 4.5m
- Level difference: 3.1m
- Length: 31m (measured along the inner curve)

The diameter of the outer bend of the ramp thus equals at least 18m. Table 5-2 states that the parking layout requires an internal width of 18.4m. With some reserve for internal walls and/or columns (estimated at 0.4m) the total internal garage width becomes 18.8m.

### 9.1.2 Pedestrian exits and elevators

From a safety point of view, the distance from any point inside the garage to the nearest exit or fire door may never exceed 40m. Consequently, the distance between two points of escape may never be more than 80m, resulting in a minimum of three exit shafts.

At least two elevators should be included in the design, positioned in the vicinity of parking places for disabled people. These will be mainly located at the top parking floor, at the extreme ends of the garage: positions with a good compromise between ease of parking manoeuvres and accessibility. There will be a staircase without an elevator at the centre of the garage and a staircase with elevator on either end of the garage. Since the structure already protrudes into the eastern quay, it seems sensible to also construct the exit shafts along the eastern side of the canal.

Although the actual design and construction of the staircases and elevators requires significant research with respect to spatial integration, it is considered to be outside the scope of this thesis. The design and positioning of the exit shafts will therefore only be considered indicatively.

### 9.1.3 Parking places / column placement

The internal load distribution of the garage and the layout of the parking provisions are mutually dependent. Considering the large internal width of the garage (18.8m), internal walls or columns are unavoidable. From a user point of view, there should be no internal walls, and columns should be far apart to maximise the transparency inside the garage. From a structural point of view, the spans inside the garage should be limited and loads should be transferred vertically to the foundation.

For levels -2 and -3, the spatial layout is not bound to as much constraints as level -1: at level -1, cars coming from street level enter the garage along the eastern outer wall and make a U-turn to cross over to the western side. This manoeuvre requires free space in the centre of the garage over its full width. The same holds at both extreme ends of the garage. Another constraint at level -1 is that on top of it, the new quaywall is constructed. This wall imposes a considerable load onto the roof of the garage.

Two alternatives are investigated, of which one is optimised from a structural point of view (figure 9-1), and one from a user point of view (figure 9-2). Both turn out to provide similar numbers of parking places on levels -2 and -3.

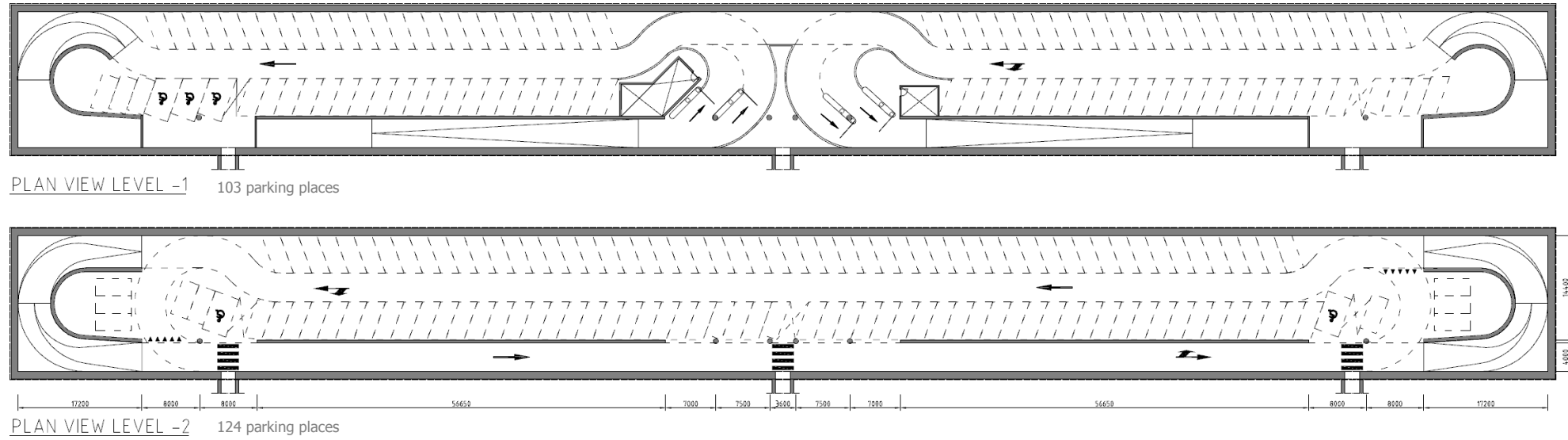

Figure 9-1: Parking places and column placement, alternative 1

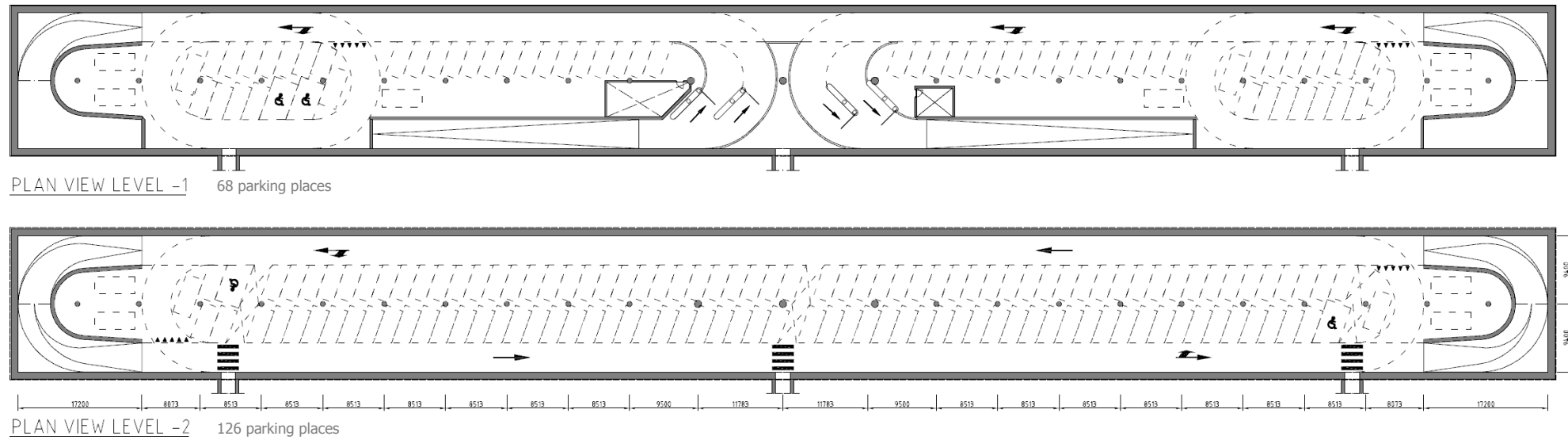

Figure 9-2: Parking places and column placement, alternative 2

The load distribution of the second alternative however seems highly inconvenient: the vertical load from the quaywall and entrance/exit ramps has to be transferred horizontally by about 5m to the outer walls and central row of columns. Also, the C.T.C. distance between the columns in the centre of the garage is fairly large (11.8m) to provide enough space for two cars to pass side-by-side at level -1. A third disadvantage of alternative 2 is that on the top floor, some space is wasted due to the presence of the ramps: the empty space can not be reached by car, and therefore can not be used for parking places. Because of this lost space, in total this alternative provides 30 less parking places.

Considering the above, despite its advantages regarding user comfort, the second alternative does not appear viable, and is therefore discarded.

## 9.2 Cross-sectional dimensions

### 9.2.1 Summary of calculations

For the full design and calculations on structural elements of the garage,<sup>[15],[16]</sup> refer to Appendix E. The results are summarised in figure 9-3.

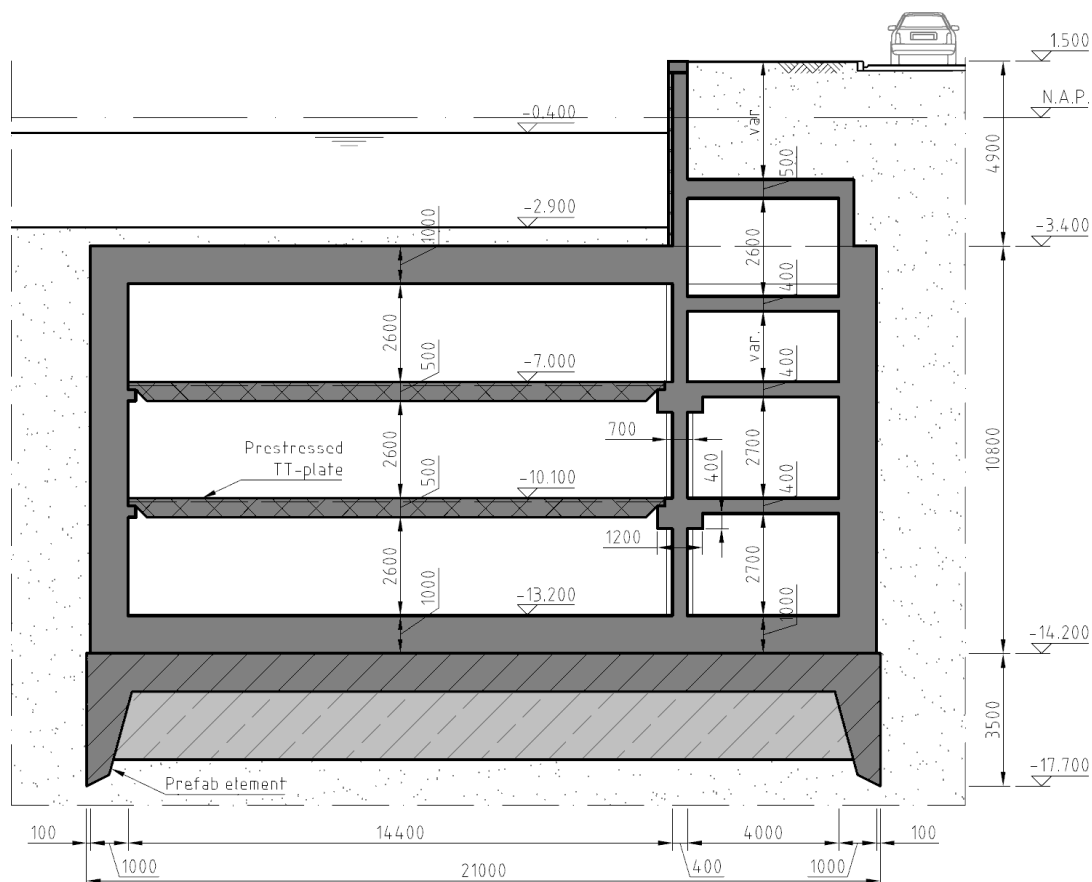

Figure 9-3: Cross-sectional dimensions of parking garage. (Dimensions in mm, levels in m)



### 9.2.2 Immersibility of caissons

To allow immersion of the caisson elements, the self-weight of the element, possibly increased by ballast material, should be heavier than the displaced groundwater. If the element is too heavy, it may sink into the subsoil too rapidly, resulting in poor controllability of the process. If the element is too light, it will start to float at some point during the immersion stage.

After immersion, the working chamber underneath the caissons is filled with concrete. This concrete is attached to the garage floor, ensuring the permanent ballasting of the garage and also creating a firm foundation layer. In the final stage a foundation pressure is required that exceeds the water pressure by 10% to ensure the vertical stability of the garage at all times.<sup>[17]</sup> During immersion this surplus should be approximately 5% to enable a smooth descent of the structure.

Given the cross-sectional dimensions as mentioned before, and assuming the prefab immersion elements to have a theoretical concrete thickness of 1.1m, the required ballast weight during immersion can be determined. A dry working chamber with a height of 2m underneath the caisson will also add to the required ballast material:

- $W_{caisson} = 2306kN / m$
- $A_{foundation} = 20.8m^2 / m$
- $P_{foundation} = 110.9kN / m^2$
- $h_{caisson} = 11.8m$
- $d_{immersion} = 11.8 + 2 = 13.8m$
- $\frac{P_{foundation} + W_{ballast}}{\rho_w \cdot g \cdot 105\%} = d_{immersion} \rightarrow W_{ballast} = 13.8 \cdot 1.05 \cdot 1 \cdot 9.81 - 110.9 = 31.2kN / m^2$

This corresponds to approximately 1.30m of ballast concrete, 2.0m of sand or 3.1m of water. In the final stage a dry working chamber is no longer required. When the working chamber is flooded and in open connection to the groundwater, the ballast weight must be equal to:

- $\frac{P_{foundation} + W_{ballast}}{\rho_w \cdot g \cdot 110\%} = h_{caisson} \rightarrow W_{ballast} = 11.8 \cdot 1.10 \cdot 1 \cdot 9.81 - 110.9 = 16.4kN / m^2$

According to the above, roughly 0.7m of ballast concrete is required in the final stage to ensure vertical equilibrium.

## 9.3 Pneumatic caisson provisions

### 9.3.1 Caisson dimensions

From the previous paragraph it follows that the external width of the garage is  $20.8m$ . The total external length is approximately  $215m$ . To accommodate the manageability of the immersion process, and to reduce the stresses and structural deformations (due to bending, thermal expansion, shrinkage, etc), the garage is subdivided into several sections. These sections are constructed and immersed separately, and interconnected once they have reached their final position.

Experience has taught that (depending on circumstances) caisson elements with a length ranging from  $35$  to  $60m$  provide a technically and financially sound compromise. Increasing the length results in more structural concrete per cross-section to ensure the rigidity of the caisson, and reduces manageability of the caisson immersion process. Decreasing the length causes longer construction times, as more immersion operations are required. Also, the construction of the caisson joints is quite an expensive procedure so the number of joints should be limited.

According to paragraph 9.3.3, the width required for the caisson joints is  $1.3m$ . Using the following formula, the dimensions of the caisson can be determined:

- $$L_{caisson} = \frac{215 - (n - 1) \cdot 1.5}{n}$$

In which  $n$  is the number of caisson elements. This results in the following:

- 3 caissons (2 joints):  $L_{caisson} = 70.8m$
- 4 caissons (3 joints):  $L_{caisson} = 52.8m$
- 5 caissons (4 joints):  $L_{caisson} = 42.0m$

Based on experience, the application of four caissons will likely provide the optimum solution.

To accommodate the immersion procedure of a pneumatic caisson, a void/trench is created along the circumference of the caisson by making its base several centimetres wider than the main width. During immersion, this void is injected with bentonite slurry to reduce skin friction and to prevent jamming of the caisson when it slightly tilts.

### 9.3.2 Prefab caisson shoe elements

The dimensions of the prefab elements, which will compose the so-called ‘shoe’ of the caisson, are determined by several factors:

- Height of the working chamber:  $2m$
- Height of the cutting edge:  $\sim 0.5m$
- Freeboard after immersion onto the canal bed:  $\sim 0.5m$
- Caisson width:  $20.8m$
- Width of bentonite slurry void:  $\sim 0.1m$
- Normative navigable cross-section:

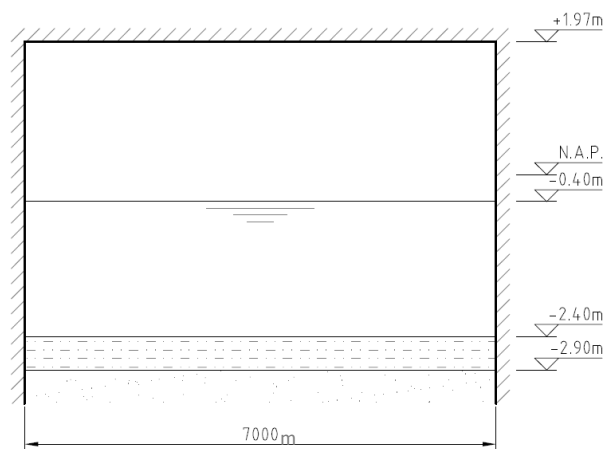

Figure 9-4: Navigable cross-section of bridge 299

The normative navigable cross-section is determined by bridge 299 (Hoofdbrug). This bridge has a width of  $7m$  and a head clearance of nearly  $2.4m$  above mean water level. The canal is approximately  $2.5m$  deep, the lower  $0.5m$  of which has likely silted up. Dredging away this silt (and possibly some extra soil) may be required to allow passage of the elements.

To avoid damage to the elements or the bridge as a result of collision, some extra clearance on either side of the elements is required. A clearance of at least  $0.5m$  is considered acceptable. The elements should nonetheless be as wide as possible to reduce the number of joints and floating operations, and to increase the floating stability of the elements.

Dividing the length of the caisson into 9 elements results in an element width of  $5.85m$ . The external dimensions of the elements thus become:

- $L \times W \times H = 21 \times 5.85 \times 3.5m$

Schematically, the floating, coupling and immersion procedure of the prefab elements on the construction site can be depicted as in figure 9-5.

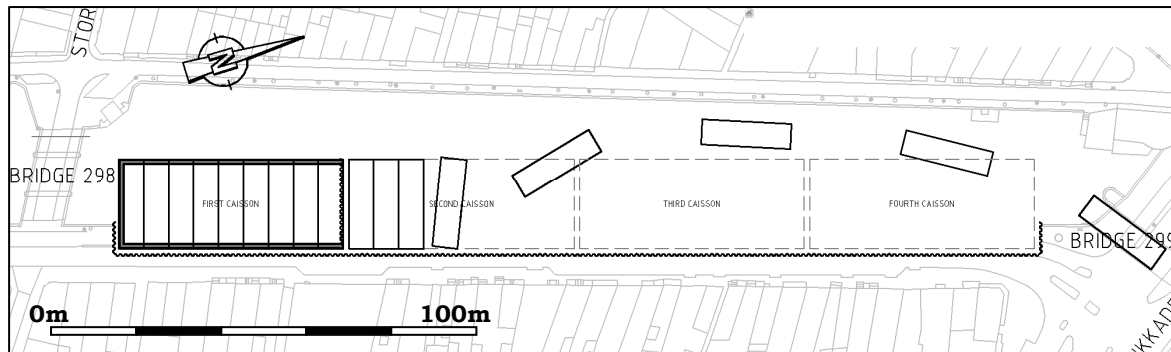

Figure 9-5: Schematisation of transport and coupling of the prefab elements

### 9.3.3 Joints between caissons

Several methods are available to create the underground connections between the different caisson elements:

- Frozen soil

Injecting liquid nitrogen into a body of water-bearing soil will cause it to freeze. Frozen soil, if sufficiently thick, is highly impermeable to water and strong enough to resist active soil pressures.

This principle can be applied to create a wall of frozen ground between two consecutive caissons. Once this lump of frozen soil has reached its required thickness, the bulkheads of the caissons can be demolished and the frozen soil can be excavated from the inside. A ring of frozen soil around the caisson joint makes a temporary water/soil-retaining barrier. The connection of the joint can then be constructed from the inside using traditional concrete.

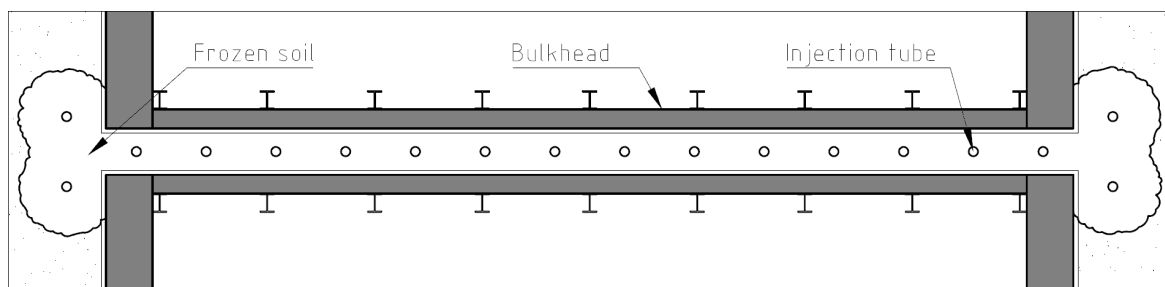

Figure 9-6: Caisson joint by use of frozen soil

The main disadvantages of this system are that it can hardly be applied in subaqueous environments (as it will cause a large body of water to freeze around the injection pipes, on top of the structure) and that it bears a high risk with respect to failure of the freezing system. Also, during construction of the Eastline metro in Amsterdam, it turned out to be an excessively expensive procedure.<sup>[18]</sup> After several

caisson joints (although successful) it was decided to construct the remaining joints in a different manner:

- Diaphragm walls + UWC-floor

Another method to construct the connection between two caissons is by use of the diaphragm wall method:

Two vertical trenches are excavated perpendicular to, but overlapping the caisson joint, adjacent to either side of the caissons. The trenches are stabilised with bentonite slurry, and consecutively filled with reinforcement meshes and concrete. Once the diaphragm walls are in place, the space between the two caissons can be excavated up to the foundation depth. At that level an underwater concrete floor is poured which interlocks with a notch in both caisson floors, so that vertical tension elements are not required. After the UWC-floor has cured, the void of the joint can be pumped dry and a permanent connection can be made.

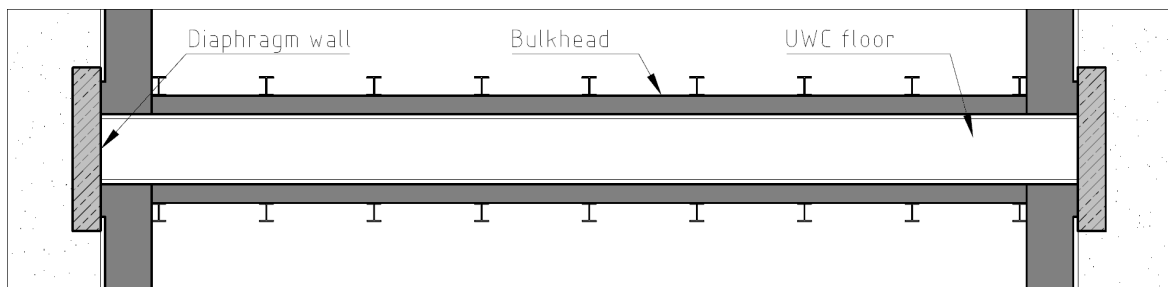

Figure 9-7: Caisson joint by use of diaphragm walls and UWC floor

Unfortunately, as stated in paragraph 6.2, diaphragm walls can not be applied in case the excavation is to be carried out under water. There is also a considerable risk of leakage through the seam between the diaphragm walls and caisson walls.

- Sheetpile walls + UWC-floor

A third option is to use steel sheetpiles instead of diaphragm walls to temporarily retain water and soil around the caisson joint. A sheetpile lock is incorporated in the concrete walls on either side of the joint so a watertight connection can be established. Once the sheetpiles around the joint are in place, the joint can be excavated and construction can proceed similar to the method with diaphragm walls. Possibly, the steel sheetpile walls can be retrieved after completion of the joint.

The main disadvantage of this method is that it requires heavy vibration equipment to drive the sheetpiles. It may however be the only possible option in this specific case.

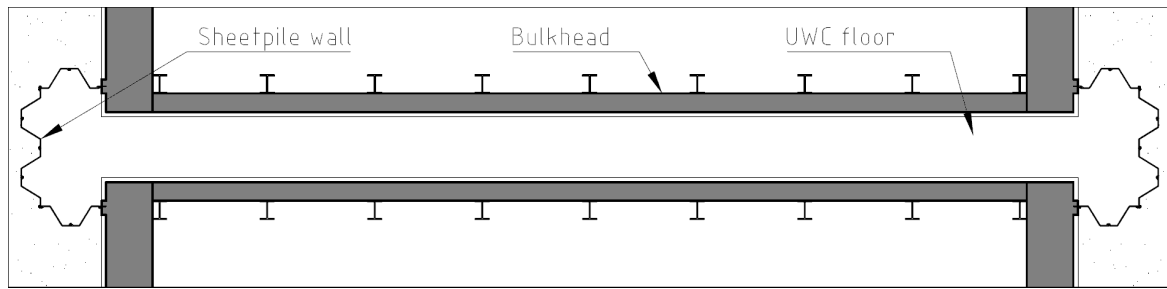

Figure 9-8: Caisson joint by use of an open sheetpile cofferdam with UWC-floor

The design width of the joints is determined by two main factors:

- Width required for construction of the joint
- Construction/immersion tolerances of the caissons

The width required for construction of the joint again depends on the construction method: in case of frozen soil, this width only needs to be in the order of 0.5m to allow the injection tubes to be placed. The soil excavation and concrete casting is done from the inside.

In case an open cofferdam is applied for construction of the joint, more space is needed: the soil is excavated from ground level so an earth-grab needs to be able to pass through. Also there needs to be enough space to install formwork for the concrete works. At least 1m is estimated to be required for this procedure.

The tolerances need to be added to the minimum joint width to ensure that the required width is actually achieved. Several factors contribute to these tolerances: measurement deviations, construction tolerances and immersion tolerances. For the Eastline metro, these tolerances combined were estimated at 0.175m for the longitudinal direction of the caissons. In practice, it turned out that the final structure fitted well within these tolerances. Taking into account the progression of knowledge and science since then, the tolerances are now estimated at 0.15m.

The construction tolerances as mentioned above need to be added twice to the structural width of the joint, as two consecutive caissons may both be constructed at either extreme end of these tolerances. From this it follows that the design width of the joint is  $1 + 2 \cdot 0.15 = 1.3m$ .

## 9.4 Results

The combined results of all considerations and calculations of this chapter can be summarised as shown in figure 9-9.

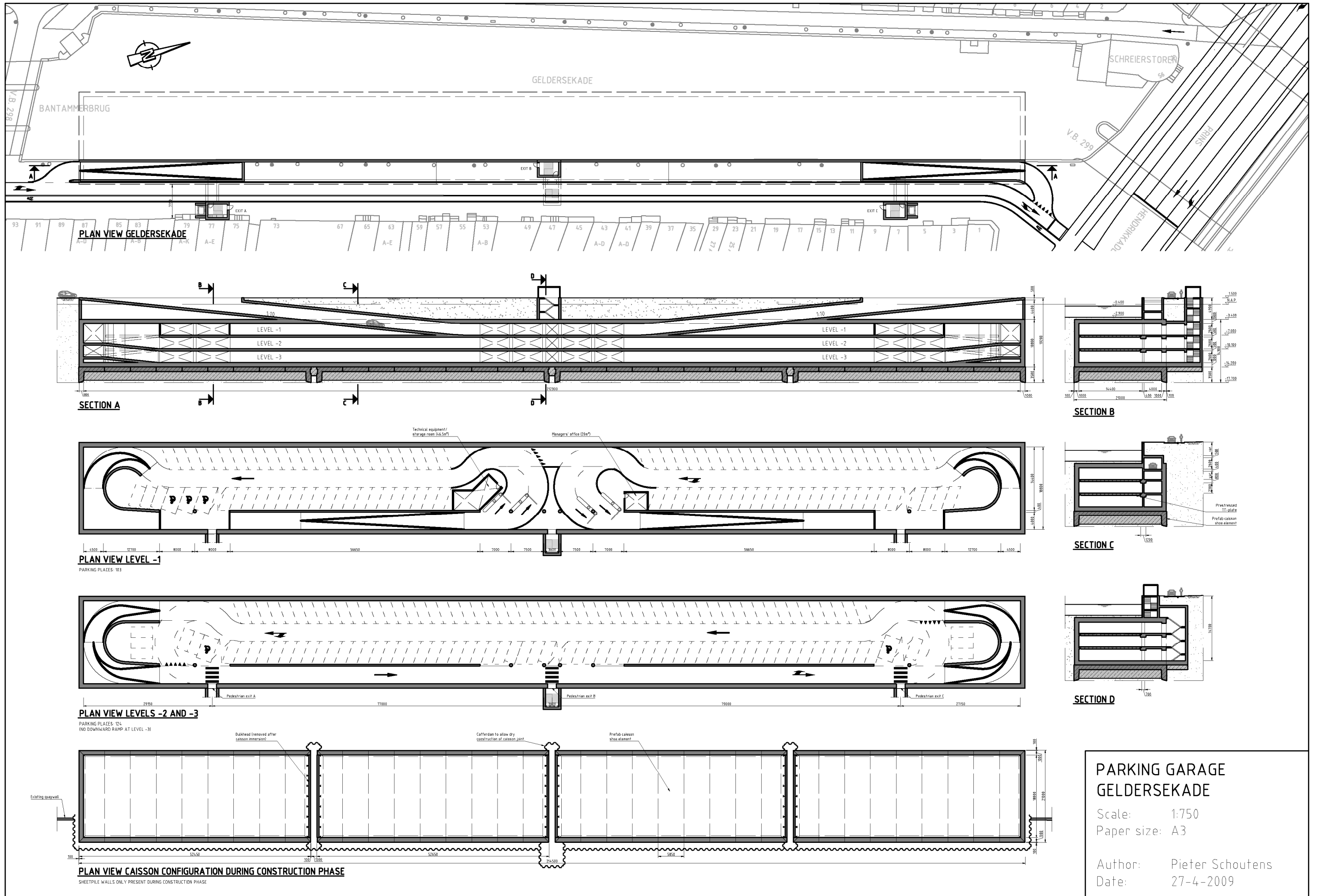

Figure 9-9: Preliminary design of the parking garage (Units in mm)





# 10 Prefab immersion elements

## 10.1 Starting points and requirements

The design of the prefab immersion elements is bound to a large number of boundary conditions, functional and structural requirements. The main requirements, which form the basis for the design of the prefab elements as discussed in this chapter, are listed below.

### 10.1.1 Starting points

#### 1. External dimensions

- Length x width x height = 21 x 5.85 x 3.5m;
- During transport on open water these external dimensions may be larger, e.g. for added buoyancy.

#### 2. Loads on the prefab elements.

- Refer to figure 10-1 and figure 10-2.

### 10.1.2 Functional requirements

#### 1. Floatability during transportation

- The elements should have sufficient buoyancy to keep them afloat;
- Stability (especially of asymmetrical elements): the metacentric height should be sufficiently high to prevent the elements from turning over;
- The elements should have sufficient keel clearance.

#### 2. Dry working platform after immersion

- The height of the prefab elements minus settlement due to loading should be larger than the water depth plus freeboard;
- The platform should be sufficiently flat and horizontal to allow even and accurate construction of the superstructure;

- Fixation/coupling between elements should be such that uneven settlements of individual elements are prevented (e.g. due to unequal loading, inhomogeneous soil layers, etc.).
3. Dry working chamber underneath platform
    - The sealing between the joints of adjacent prefab elements should be water/airtight and be able to cope with a pressure difference over the joint to prevent the working chamber from depressurising;
    - The working chamber should be accessible by labourers, so several manholes should be incorporated in the basement floor.

### 10.1.3 Structural requirements

1. Rigidity during transport
  - The elements should be sufficiently strong and stiff to cope with wave action etc.
2. Strength to support first structural layer
  - The basement floor of the garage, as well as the lower structural walls, is cast on top of the prefab elements. These should be sufficiently strong to cope with these loads.
  - The elements should be able to transfer shear forces to adjacent elements to avoid unequal settlements/deformations.
3. Design of cutting edges
  - The design of the cutting edges should be such that a delicate balance between ease of soil cutting and controllability of the sinking process is found.
  - The strength of the cutting edges should be sufficient to withstand high concentrated loads, e.g. due to the presence of unexpected foundation elements or boulders in the subsoil.
4. Contribution to caisson strength/stiffness
  - After construction of the basement floor and lower wall sections, shear forces and torsion loads are no longer carried by the prefab elements. They may however still be able to contribute to the strength and stiffness of the caisson, especially in the lateral direction of the basement floor.

## 10.2 Bearing capacity

### 10.2.1 Definition of loads

Based on figure 9-3, the loads on the foundation of the prefab elements can be determined. A distinction should be made between different construction stages:

After coupling and immersion of the prefab elements, the newly formed 'construction platform' rests on the cutting edges. The basement floor is then cast on top of the platform. This means that the top of the elements should stay above water, limiting the depth they may sink into the soil. After casting the basement floor, the outer walls and bulkheads are constructed. Once these are in place, they take over the water-retaining function of the prefab elements. In this stage it is no longer required that the top edges of the elements are above the water table. The intermediate walls, columns and floors can then be constructed in a dry environment in which the outer walls ensure the water retention. Finally, the roof can be built on top, completing the caisson structure. The loads on the construction platform can be schematised as:

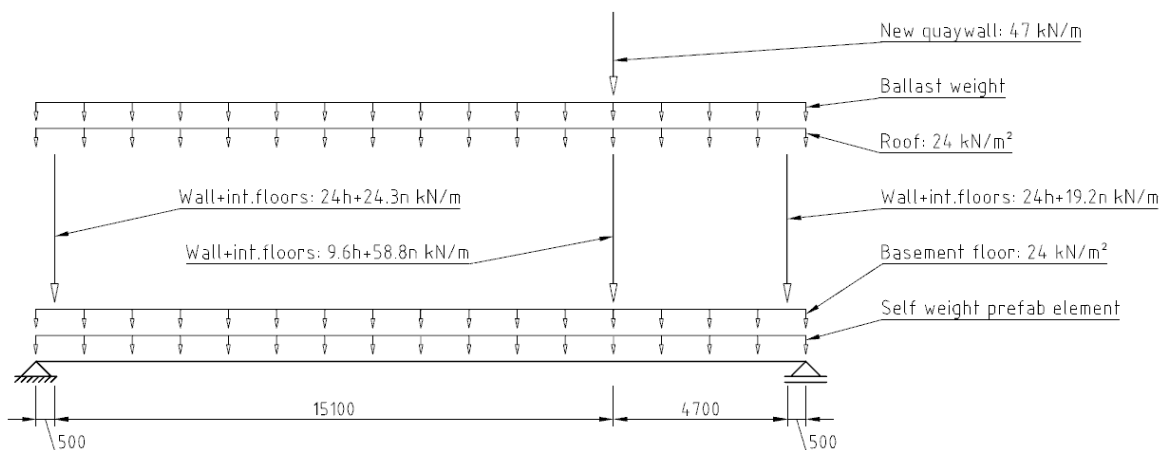

Figure 10-1: Downward forces acting on prefab elements as a function of construction phasing, in which:  $h$  = height of walls in meters, measured from the top of the basement floor;  $n$  = number of intermediate floors installed.

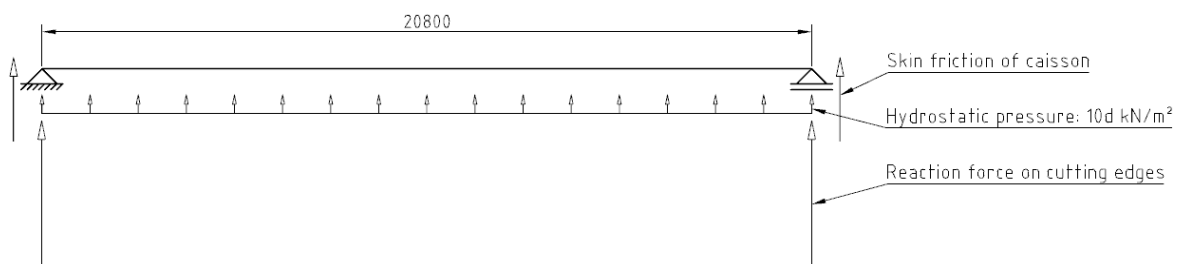

Figure 10-2: Upward forces acting on caisson, in which:  $d$  = immersion depth below water table.

### 10.2.2 Bearing capacity of the cutting edges

A preliminary calculation is made to determine whether the basement floor can be constructed on top of the prefab elements while maintaining the clearance above water. This calculation is based on a shallow strip foundation model according to the method of Brinch Hansen.<sup>[20],[21]</sup> Assumptions made:

- The loads are only carried by the cutting edges in the longitudinal axis of the garage  $\rightarrow F_{s;v;d} = \frac{(1.0 \cdot 24 \cdot 20.8 + (1.1 \cdot 24 - 0.6 \cdot 10) \cdot 21)}{2} = 463.8kN$  per running meter;
- The foundation strip can be considered as infinitely long;
- Homogeneous, single-layered subsoil;
- Drained soil behaviour;
- Loads: SLS of basement floor + self-weight of semi-submerged prefab element (0.5m clearance above water table);
- A soil improvement is applied in the vicinity of the foundation strip. This sand layer has a minimum thickness of 1.5 times the width of the cutting edge, and a width of at least 4 times the width of the cutting edge.

The full calculation is explained in Appendix F. The main result of this calculation is that the maximum bearing capacity of the cutting edges is in the order of 10-20% of the imposed load. Obviously this is far from satisfactory, even though it is an estimate of the representative lower boundary value. Also it is found that the bearing capacity is highly sensitive to variations in the inclination of the cutting edge and the angle of internal friction of the subsoil.

### 10.2.3 Solutions to satisfy bearing capacity

A solution to the insufficient bearing capacity of the cutting edges can be found by enlarging the foundation area. Increasing the width of the cutting edges does not seem sensible, as this gives only a minor increase in the bearing capacity and a large increase in the structural volume. Making the base of the cutting edges horizontal does not seem viable either, as the soil needs to collapse inward into the working chamber during immersion of the caisson. Excavation of the soil underneath the cutting edges would also become very laborious.

Increasing the total length of the cutting edges, e.g. by creating one or several cutting edges inside the working chamber, perpendicular to the longitudinal axis of the caisson, can also enlarge the foundation area. Two of such transverse ridges per caisson, and taking into account the edges at both extreme ends of the caisson,

roughly double the foundation area. This however is still insufficient. Further increase of the number of internal cutting edges, e.g. by installing them along the full circumference of each individual prefab element (providing 8 intermediate edges per caisson), may just be sufficient. It would inevitably also mean a high degree of partitioning of the working chamber, resulting in unfavourable working conditions.

Another option is to adopt the method of spreading the loads during the construction phase before immersion, as is done in the traditional way of pneumatic caisson construction. In the traditional method a sandfill is placed on top of the foundation level. The cutting edges are cast in excavated trenches and the basement floor of the caisson is cast on top of the sandfill. Since it is decided that the sandfill will not be applied (refer to paragraph 6.5), different measures must be taken to spread the load. Some alternatives are:

#### 1. Pressurised air

As soon as the cutting edges have protruded deep enough into the subsoil, a more or less airtight sealing can be achieved. The working chamber can then be subjected to pressurised air, reducing the foundation pressure on the cutting edges.

As mentioned in the previous paragraph, the cutting edges can carry approximately 15% of the weight of the superstructure. Consequently, the required load reduction per running meter of cutting edge equals approximately  $400\text{kN}$ . Distributing this load over the roof of the working chamber results in a pressure of  $43\text{kN}/\text{m}^2$ , roughly  $4.3\text{m}$  of water pressure. Since the roof of the working chamber is already  $0.6\text{m}$  below the water surface (reducing its effective weight), the required overpressure is  $3.7\text{m}$  of water column ( $37\text{kN}/\text{m}^2$  or  $0.37\text{bar}$ ).

A risk of this method is that the sealing may not be fully airtight. If too much air slips through at once, the air bubbles may transport sand grains and a blow-out can occur. This results in a sudden burst of air to leave the working chamber, causing a large hole in the foundation layer underneath the cutting edge. In the most fortunate case, this only causes some of the prefab elements to settle unequally. If this happens during construction of the basement floor however, the entire platform may sink uncontrollably due to loss of balancing pressure and foundation capacity, and the entire construction platform is lost.

A possibility to prevent this from happening is to contain the air in some sort of bag or balloon, much like the principle of a pneumatic tyre. Possibly this pocket of air can also be used during transport of the elements to provide buoyancy, although it

will be harder to keep it in place during this stage and it can be damaged more easily.

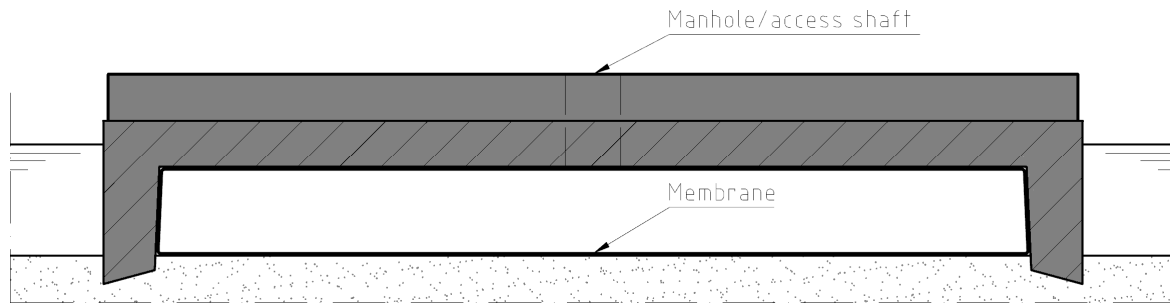

Figure 10-3: Reduction of the foundation pressure and distribution of the loads to the subsoil by means of a bellow filled with pressurised air inside the working chamber.

## 2. Ping-Pong balls

Other filling materials can be used that are easier to contain and don't need to be pressurised. As with compressed air, these filling materials can also add buoyancy during transport of the elements, e.g. Ping-Pong balls or EPS.

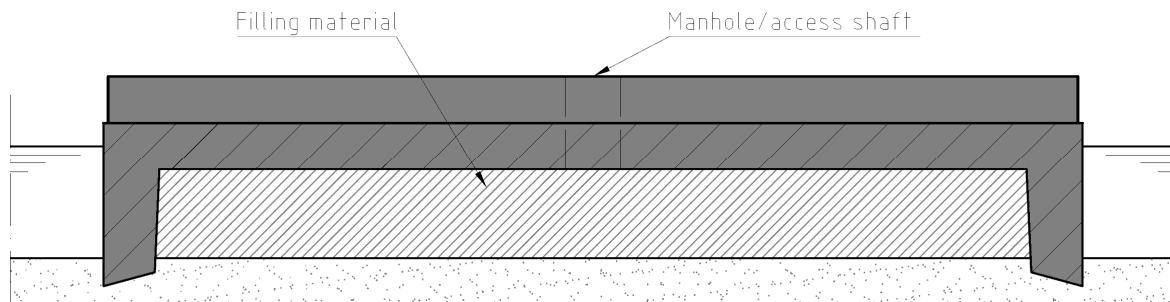

Figure 10-4: Increase of the foundation area (and possibly a reduction of the foundation pressure) by means of a filling material in the working chamber

Ping-Pong balls have limited compressive strength but due to their ability to redistribute in space, the top load will be distributed very evenly to the foundation layer. It will also be quite easy to remove the balls from the working chamber once the superstructure is completed. The buoyancy is limited by the maximum packing of spheres, having a minimum void ratio (porosity) of about 0.3. A standard-size Ping-Pong ball has a radius of 20mm and a mass of 2.7g.<sup>[b]</sup> Assuming the voids are filled with water, the combined density equals  $0.7 \cdot \frac{0.0027}{\frac{4}{3}\pi 0.02^3} + 0.3 \cdot 1000 = 356\text{kg}/\text{m}^3$ .

The disadvantage of this method is that vast quantities of Ping-Pong balls are required: roughly 4 million balls per element, or 36 million per caisson. Fortunately these can be recycled for each consecutive caisson.

### 3. EPS

EPS (Expanded PolyStyrene) has great properties with respect to buoyancy (density of  $15\text{-}50\text{kg}/\text{m}^3$ ), compressive strength ( $90\text{-}400\text{kN}/\text{m}^2$  at 10% compression) and is fairly impervious to water.<sup>[22]</sup> On the downside it is also quite expensive, and laborious to remove from underneath the working platform. A possibility to easily remove the EPS is by dissolving the foam (e.g. by using thinner or acetone), but this could result in environmental issues or uncontrollable loss of foundation capacity. Either way, the EPS must likely be processed before it can be reused, if at all.

### 4. Sandfill

Another option is to fill the working chamber with sand. Similar techniques are applied in the construction of immersed tunnels: once immersed, the tunnel elements are underflowed with sand to create a stable foundation.

This resembles the effect of the sandfill burrow used in traditional caisson-construction as discussed earlier: it distributes the loads to the subsoil during construction of the superstructure, and can be easily removed once completed. The difference with this traditional method is that the volume of sand required is much smaller (reducing the loads on the subsoil) and no temporary retaining walls are required to stabilise the sandfill: the cutting edges take care of this.

Disadvantages of this method are that the filling material cannot be used for added buoyancy during transport.

### 5. Waterfilled bellow

A rather exquisite solution might be to use the water inside the working chamber itself to transfer the loads to the foundation layer: due its poor compressibility and equally distributed pressure, water seems like a suitable filling material. Just like compressed air, the water should be contained to prevent it from flowing out of the working chamber. An inflatable bellow can be fixed to the bottom of each prefab element. After immersion, these bellows are filled with water from the canal until all water underneath the prefab elements is contained. This should ensure stability of the working platform, and prevent the bellow membranes from bursting as a result of pressure build-up and high strains. After construction of the superstructure, the water can be gradually released from the bellows to smoothly immerse the structure into the soil. The empty bellows are then extracted and possibly reused for the next caisson.

Disadvantages of this method are that the bellow-membranes will be quite costly, especially if they cannot be reused for consecutive caissons. Also, the membranes are quite vulnerable and exposed to risk of tearing, e.g. due to damage by sharp objects, improper inflation/filling, etc. If one bellow tears, the adjacent bellows will lose their support pressure and also collapse.

## 6. External floats

Fixing large floats, such as pontoons, to the circumference of the working platform should reduce the foundation pressure. As mentioned with the first method however (pressurised air) it is stated that roughly 3.7m of water pressure needs to be carried by the 'foundation aiding accessory'. Obviously this would result in excessively large floats. Also, at the eastern side, the platform is constructed right next to a sheetpile wall. Consequently, there is no space at this side to attach external floats.

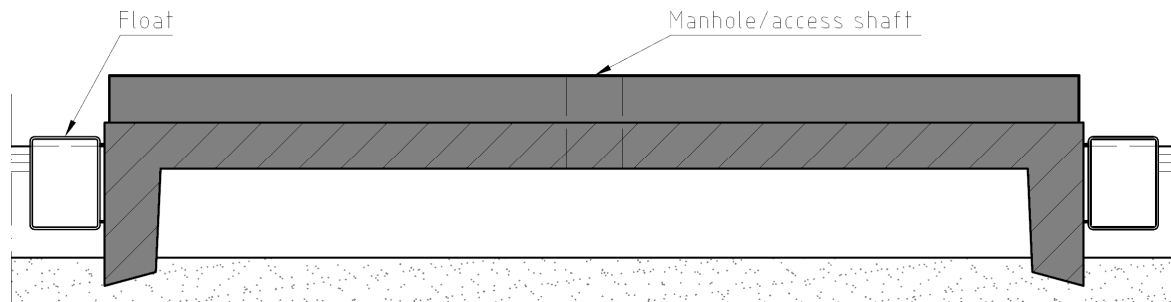

Figure 10-5: Reduced foundation pressure by adding external floats

### 10.2.4 Conclusions

From the different alternatives discussed in the previous paragraph it can be concluded that the most promising solutions are to fill the working chamber with sand after immersion (if the prefab elements have sufficient buoyancy by themselves) or to use EPS blocks in the working chamber (if added buoyancy is required). Both methods have proven themselves in practice and can be applied relatively easy.

Ping-pong balls may also prove a suitable filling material, but more research on the compressive properties would be required to determine the modulus of elasticity and compressive strength.



## 10.3 Floatability

### 10.3.1 Methodology

The floatability of the elements is mainly determined by the buoyancy (do the elements actually float?) draft (ground-, or 'keel' clearance) and the stability of the elements which keeps them from rolling over. External influences, such as wind and wave action, are considered to be of lesser importance: the governing conditions regarded in this chapter are at the moment that the elements are navigated underneath a narrow bridge at controllable conditions. On open water, external floats can be fixed to the elements to provide added buoyancy and stability.

Due to the mutual dependence of buoyancy and stability of the prefab elements with regard to their dimensions and materials used, they are considered jointly in one iterative optimisation process. The underlying principles are first discussed separately and then applied to two different alternative designs.

### 10.3.2 Buoyancy

The buoyancy of the prefab elements is determined by the self-weight of the elements and the water displacement. The required buoyancy on the other hand is governed by the minimum keel clearance in the normative cross-section: at a water depth of 3m, the minimum clearance should still be maintained to ensure navigability of the elements and prevent them from grounding on the canal bed.

Due to the high blocking of the flow profile underneath bridge 299, it can be expected that passage of the elements will cause a local depression of the water table. Under normal circumstances, water is being discharged through the canal from the south to the north. This means that the elements are also subjected to a current opposite to the direction of transportation, increasing the relative velocity between the water and the prefab elements. It may be the case that due to this counter-current, the elements cannot be transported upstream if the so-called limit speed (determined by the maximum return current) is lower than the normal flow velocity. It may also happen that the local depression of the water table is so great that the elements tend to ground. This depression should be added to the static draft of the elements to determine the actual keel clearance.

To determine the limit speed and maximum draft increment, the corrected theory of Schijf is applied, which is based on super-critical flow of the return current:<sup>[23]</sup>

- $Fr = \frac{V_{lim}}{\sqrt{gh}}$
- $1 - \frac{A_s}{A_c} + \frac{1}{2} Fr^2 - \frac{3}{2} Fr^3 = 0$
- $Z_{lim} = \bar{h} \frac{1}{3} \left( 1 - \frac{A_s}{A_c} - \frac{V_{lim}^2}{gh} \right)$

In which:

- $Fr$  = Froude-number [-]
- $V_{lim}$  = Limit velocity of prefab element relative to water [m/s]
- $A_c$  = Wet cross-sectional area of undisturbed canal (=  $3 \cdot 7 = 21 m^2$ )
- $A_s$  = Underwater amidships<sup>1</sup> cross-section of prefab element (=  $5.85 \cdot D m^2$ )
- $D$  = Static draft of element [m]
- $Z_{lim}$  = Maximum water level depression at amidships section [m]
- $g$  = Gravitational acceleration (=  $9.81 m/s^2$ )
- $\bar{h}$  = Average waterway depth (=  $3 m$ )

The prefab elements should provide enough buoyancy such that  $D + Z$  are no greater than  $\bar{h}$  plus a safety margin. To determine the actual water level depression  $Z$ , it is first needed to determine the return current for a certain velocity  $V_s$ :

- $\frac{(V_s + U)^2 - V_s^2}{2gh} - \frac{U}{V_s + U} + \frac{A_s}{A_c} = 0$
- $Z = \alpha \frac{(V_s + U)^2}{2g} - \frac{V_s^2}{2g}$
- $\alpha = 1.4 - 0.4 \frac{A_s}{A_c}$

In which:

- $V_s$  = Velocity of the prefab element relative to the water [m/s]
- $U$  = Return current along element at amidships section [m/s]
- $Z$  = Water level depression at amidships section [m]
- $\alpha$  = Correction factor for non-uniform flow [-]

---

<sup>1</sup> Amidships: Generally a point at approximately half the length of a vessel where its breadth is the largest. In this particular case, due to the odd shape of the elements, not the actual amidships section is used but the section with the largest cross-sectional area and draft.

These formulas can be evaluated iteratively, but in this case they have been solved analytically using the software package *MAPLE*. Refer to Appendix F for an example calculation.

### 10.3.3 Stability

To prevent the prefab elements from rolling over and sinking during transportation, it is required that they are hydrostatically stable. This means that if an element heels<sup>1</sup>, it should be able to right itself again due to a shift in the centre of buoyancy. Generally, increasing the relative breadth of a vessel, or lowering the centre of gravity, improves its stability.

In terms of hydrostatics, stability means that the centre of gravity of a vessel is below the so-called metacentre. The position of the metacentre is determined by use of the Scribanti-formula<sup>[24]</sup>, which reads:

- $\overline{BN}_\varphi = \frac{I_T}{V_{displ}} \left(1 + \frac{1}{2} \tan(\varphi)^2\right)$

In which:

- $B$  = Centre of buoyancy
- $N_\varphi$  = Metacentre
- $I_T$  = Moment of inertia of the water plane intersection [ $m^4$ ]
- $V_{displ}$  = Displacement volume of the prefab element [ $m^3$ ]
- $\varphi$  = Angle of heel [ $^\circ$ ]

For a stable design, the distance  $\overline{BN}_\varphi$  should be positive. To simplify this calculation, some assumptions are made:

- The elements are wall-sided<sup>2</sup>;
- The elements are symmetrical (this seems acceptable for the standard elements, but is especially not the case for the end-elements, which have an extra cutting-edge along the full length at one side);
- The angle of heel is small ( $<10^\circ$ ).

---

<sup>1</sup> Heel (also known as roll): the transverse inclination of a vessel due to the action of the waves, the wind, a greater weight upon one side, etc., usually transitory.<sup>[c]</sup>

<sup>2</sup> A floating structure is said to be wall-sided if, for the angles of heel to be considered, those portions of the hull covered or uncovered by the changing water plane are vertical when the structure is upright.<sup>[24] p2-15</sup>

### 10.3.4 Alternative 1: Concrete

The first alternative design of the prefab immersion elements is based on concrete as a main construction material. This seems sensible, as the entire caisson structure will eventually be made of concrete. Also, the prefab elements form an integral part of the foundation of the caisson, and need to provide sufficient rigidity to the first structural layer.

Due to the high density of concrete, the application of added buoyancy will be inevitable. The maximum available volume for lightweight filling material is the entire working chamber. If loose filling material is used (e.g. Ping-Pong balls), temporary bulkheads can be placed alongside the working chamber to contain the material. Another way of saving weight is to make the roof of the elements less thick, and making them ‘bathtub’-shaped by placing a small retaining wall alongside the circumference of the roof (see figure 10-6).

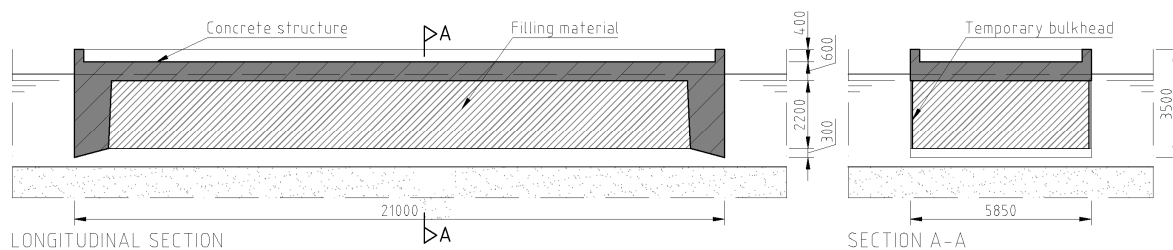

Figure 10-6: Concrete prefab element with lightweight filling material (Units are in mm)

The spreadsheet as used for the calculation of the draft and hydrostatic stability is shown in Appendix F.2.1. From iteration with respect to the different design parameters, it follows that Ping-Pong balls cannot be applied as a filling material due to the high combined density of the Ping-Pong ball/water mixture: they do not provide sufficient buoyancy. It will be a challenge to make the elements light enough with any other filling material, but EPS seems most suitable.

It also turns out that the concrete elements tend to be unstable due to the combination of a high centre of gravity and a low centre of buoyancy. The metacentric height  $G-N_{\phi}$  is in the order of 0.5m or less, which in practice is considered to be undesirable. Due to the short route of transportation where this value is valid (assuming that on open water external floats are attached to the element), it is nonetheless considered to be acceptable. It should be noted here that if an element capsizes underneath bridge 299, it will be unreachable by e.g. a pontoon crane and it will block the entire waterway.

Another serious design issue with respect to floatability is caused by the end-elements: the extra cutting edge increases the self-weight, reduces the space available for buoyant material and the asymmetry may cause the element to tilt during transportation. Possibly, attaching air-filled floats to either side of the element such that they counterbalance with the asymmetry can solve this problem. This can only be done if the end-elements are made less wide to comply with the navigable cross-section underneath bridge 299. After passing this bridge, the floats must be detached to allow coupling with the rest of the platform. Obviously this will result in a cumbersome operation. In total, the platform will then be composed of 10 elements instead of 9.

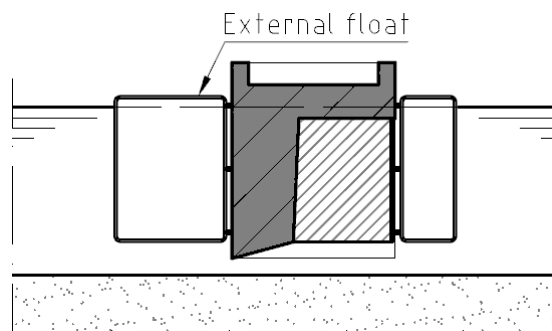

Figure 10-7: End-element made of concrete (cross-sectional view)

Advantages:

- Quick assembly on-site due to a high degree of prefabrication.

Disadvantages:

- Temporary lightweight filling material required to provide sufficient buoyancy;
- Removal of filling material and bulkheads from inside the working chamber will be laborious;
- Due to the high self-weight of the elements, the filling material also needs to act as a temporary foundation for the superstructure;
- Due to the high centre of gravity, the elements tend to be just barely stable;
- The end-elements require drastic adjustments to the design, and have serious consequences regarding the coupling operation to preceding elements.

#### 10.3.5 Alternative 2: Steel

The second alternative is based on the concept of immersed tunnel construction as primarily done in the USA: a lightweight hollow formwork made of steel is prefabricated and transported to the construction site. Once there, it is filled with

concrete and immersed. Eventually the steel formwork offers no (or little) structural contribution if applied in this traditional manner. In Japan however, several tunnels have been constructed using the so-called Steel-Concrete-Steel (SCS) method: structural elements consist of an outer and an inner steel shell fitted with stiffeners and stud connectors. The void between these shells is filled with highly fluid concrete. Eventually the steel contributes considerably to the strength of the structure (no or little additional reinforcement is needed), but is susceptible to corrosion.<sup>[17]</sup>

Deterioration is not really an issue for the steel formwork when applied for the caisson footing. Corrosion will be limited as the element is positioned in fresh water, it always stays submerged after completion of the garage and the caisson footing is allowed to somewhat deteriorate, provided that the concrete stays connected to the garage for ballast. This makes steel seem like a reasonable alternative for concrete elements.

In this application, steel ‘pontoons’ are created that have such a low self-weight that no additional buoyancy is needed (see figure 10-8). After connection of consecutive prefab elements, reinforcement is placed inside (if required) and the elements are filled with concrete so that they just immerse onto the canal bed. Then a foundation layer (sandfill) is placed to ensure that the elements do not sink into the soil too much when loaded. When the foundation bed is in place, the main superstructure can be constructed on top of the elements.

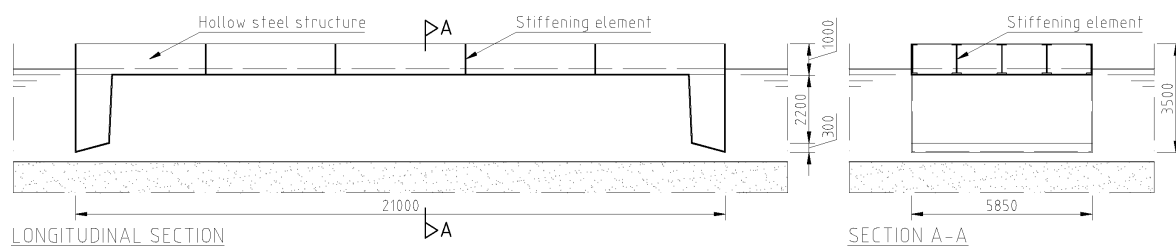

Figure 10-8: Hollow steel prefab element (Units are in mm)

As expected it turns out that these elements are much lighter than the concrete alternative (70-80t as opposed to 260-300t, refer to Appendix F.2.2). They may even be so light that they can be transported by barge. Nonetheless it will still barely be possible to make the elements light enough for the required keel clearance.

Hydrostatically they are very stable, unlike the concrete elements, and will therefore not require any external floats on open water. This stability is also of importance when an element is transported laterally, as required for coupling of consecutive elements. Due to the absence of filling material and bulkheads, the blocking ratio of

the steel alternative is also much smaller in this direction. This contributes to the manoeuvrability in lateral direction.

Unlike their concrete counterparts, the steel elements actually create buoyancy by adding volume. Therefore, the end-elements that are rigged with an extra cutting edge tend to heel in the exact opposite direction from the concrete elements. Extra ballast must be applied to keep them horizontal.

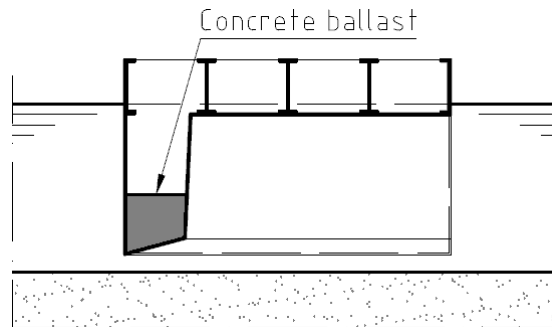

Figure 10-9: End-element made of steel (cross-sectional view)

#### Advantages:

- No added buoyancy required: the elements float by themselves;
- Transportable by barge if the manufacturing plant is at a greater distance;
- Low centre of gravity versus high centre of buoyancy makes the elements very stable during transportation;
- The end-elements require only minor adjustments to the design and no extensive procedures are required during coupling of these elements;
- Low blocking ratio when transported laterally allows for easier manoeuvring during the coupling procedure. This does not hold for the end-element.

#### Disadvantages:

- The elements have a relatively low rigidity so they may easily deform until they are filled with concrete;
- On the construction site some work is needed to install all the reinforcement and pour the concrete inside the elements before the basement floor can be constructed;
- A sandfill must be made underneath the elements to distribute the load of the superstructure to the subsoil;
- The prefabricated steel hull, as applied in the SCS-method, is a relatively expensive means of reinforcing concrete.

### 10.3.6 Conclusions

Summarising the previous two paragraphs, it can be concluded that the steel alternative has a considerable number of advantages over the concrete alternative, mainly with respect to manoeuvrability of the elements. The main disadvantages of the steel alternative are that it results in a longer on-site construction time and that it may prove to be more expensive due to the amount of 'wasted' steel.

Some specific conclusions with respect to the draft, keel clearance and limit velocity can be drawn, which hold for both alternatives:

The static ground clearance, at a water depth of 3m, is in the order of 20-40cm. When passing underneath bridge 299 this gives a very high blocking ratio  $A_s/A_c$  of about 0.75, resulting in a limit velocity of 0.35-0.40m/s and a water level depression of 10cm. Consequently, if the counter-current is greater than about 0.35m/s, transportation of the elements upstream will not be possible at all. The safety margin with respect to the keel clearance is also very small: a trim angle of 1.5-2% will cause the elements to run aground.

It therefore seems advisable to dredge a trench with a water depth of 3.5m to allow for smoother transportation of the elements. Research should be done to determine if the foundation of bridge 299 can cope with a bed level drop of 1m (0.5m of dredging was already assumed in this calculation: the mean water depth is 2.5m). It should also be investigated whether it is possible to temporarily restrict the discharge through the canal so the elements can be transported at a higher velocity.

At the immersion/construction site on the other hand, the canal should be as shallow as possible to ensure a large freeboard after immersion of the elements. Possibly a catamaran-pontoon can be used to slightly lift the elements out of the water so a larger freeboard of the construction platform can be achieved.



## 10.4 Coupling provisions

### 10.4.1 Shear connection

After coupling of the elements and before construction of the basement floor, it should be prevented that the elements move laterally or vertically with respect to one another. This can be achieved by installing shear connections in the joint between consecutive elements.

These shear connections must be able to cope with forces that result from unequal settlements of adjacent elements, either caused by inhomogeneous strata in the subsoil or by unequal loading on top of the elements. Other causes of shear forces may be wave/wind action when the entire platform is still afloat, or collision by a (construction) vessel or uncoupled element.

A simple way of solving this is by installing dowels on the face of one element, and matching slots/sockets in the next. If these dowels and slots are made cone- or trapezoid-shaped, they can even aid in the positioning of the elements during the coupling procedure.

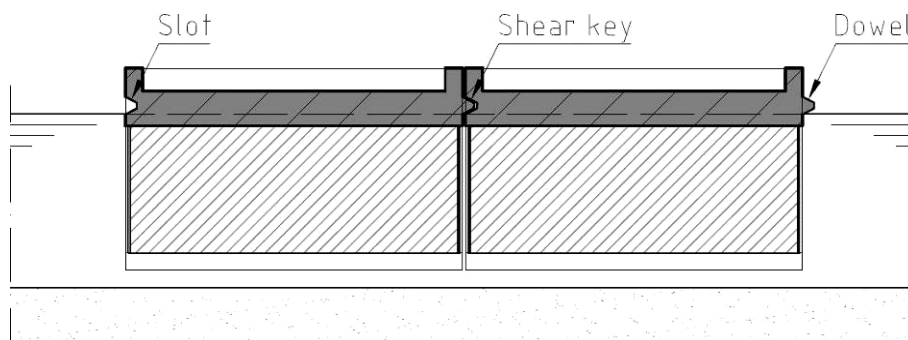

Figure 10-10: Shear key by means of a dowel connection (cross-sectional view).

### 10.4.2 Water/airtight sealing

After immersion of the prefab elements and construction of the superstructure of a caisson, the foundation layer is removed from the inside of the working chamber. This will cause the structure to sink into the subsoil as the foundation loses its bearing capacity.

Once the caisson has sunk sufficiently deep into the soil and the connection between the outer surface of the structure and the soil is more or less airtight, the air in the working chamber can be pressurised. As the air pressure reaches values close to the hydrostatic pressure outside the working chamber, the groundwater will cease to

flow into the working chamber. During this procedure, it must be prevented that water or air can seep through the joints between the prefab elements. If this is not sufficiently taken care of, too much air may leak out of the working chamber and it may prove hard to keep the air pressure at the appropriate level.

A traditional method of solving this problem is to install a rubber sealing (gasket) along the circumference of the connected parts. The dimensions of this gasket are determined by the expected pressure difference over the joint and the required freedom of motion: if some relative movement or rotation between elements is to be expected, a compressible gasket is needed that can follow these motions. In most cases however, expansion of the gasket must be prevented as it may lead to leakage.

A long continuous gasket can be installed which starts at the tip of one cutting edge, runs along the top of the element and continues down the cutting edge at the other side (total length of about 27m per element). Another option is to install two separate sealings that are placed only at both cutting edges and extend vertically beyond the top of the element. When the basement floor is cast, these ends are adopted into the concrete. In this way the length of the gasket is reduced by about 18.5m. The concrete basement floor ensures the airtightness on the upper side of the joint.

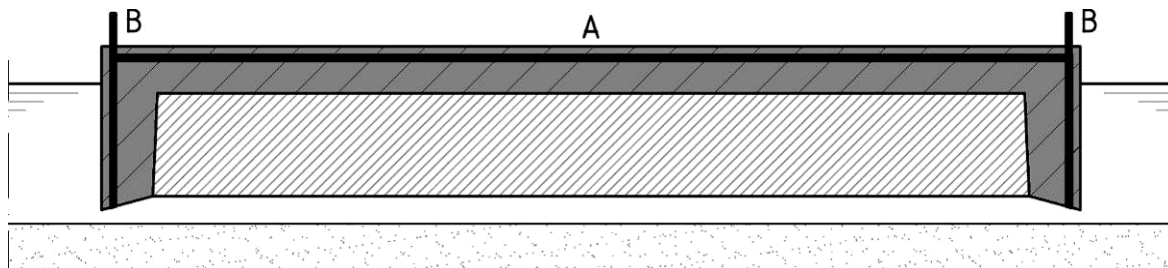

*Figure 10-11: Gasket on the face of a prefab element, showing option A) continuous, and option B) protruding from top of element (side view)*

An alternative that can only be applied with the steel element is to weld consecutive elements together. This may ensure both the water-/airtightness and the shear connection. A disadvantage of this method is that it makes the entire platform very stiff. Some deformations of the foundation bed or the platform may result in high stresses in the welded seams, potentially causing cracks. Another disadvantage is that most welds need to be made under water, requiring an expensive and poorly controllable operation.

### 10.4.3 Longitudinal tensioning

A requirement for the gaskets to function properly is that they are compressed between the adjacent elements that are to be sealed. In traditional immersed tunnelling, gaskets installed between elements are compressed by the water pressure pushing against the bulkhead of the last element. Sealings applied in the lining of bored tunnels are compressed by the jacking forces of the TBM and the groundwater and soil pressures acting on the outside of the ring-shaped lining.

Unfortunately, groundwater can not be applied for compression of the gaskets in this particular case as they are subjected to the same (hydrostatic) pressure on all sides. Special provisions need to be applied to make sure that the gaskets remain compressed. These provisions should also prevent the dowels from disconnecting and keep the elements in place. Only after construction of the basement floor and lower structural walls, the longitudinal tensioning and rigidity versus shear deformation is taken over by the caisson structure. The tensioning provisions and shear keys in the elements then lose their functionality.

One possibility for the longitudinal tensioning is to use post-tensioned prestressing cables. Each newly placed prefab element is stringed to the previous: after running the cable through the new element, it is tensioned and anchored to ensure that the new element is pressed against the previous one. Disadvantages of this method are that it is very expensive (especially when considering that it is only a temporary provision) and that it needs to be applied in wet conditions while prestressing tendons and anchors have very low tolerance with respect to moisture.

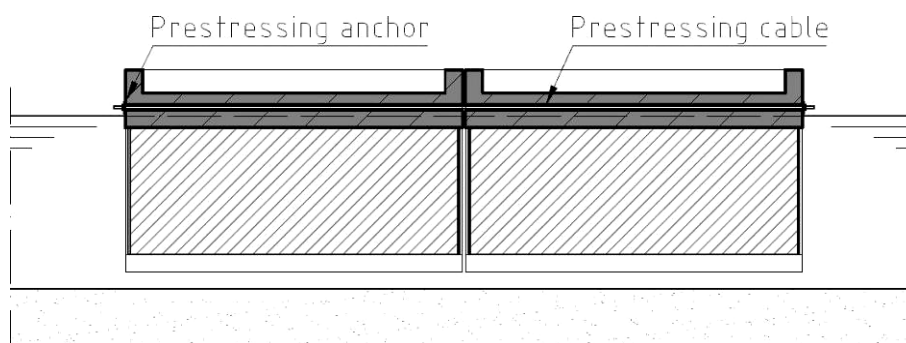

Figure 10-12: Longitudinal tensioning by prestressing (cross-sectional view)

Another possibility is to use stud bolts. Instead of stringing all elements together with several long cables, each new element is bolted and tensioned to the previous by means of stud bolts running through a hole in both elements. Since bolting through concrete (as shown in figure 10-13) is undesirable, a steel flange needs to be applied

along the face of an element. Adjacent flanges can then be bolted against one another. Several of these bolts need to be applied under water.

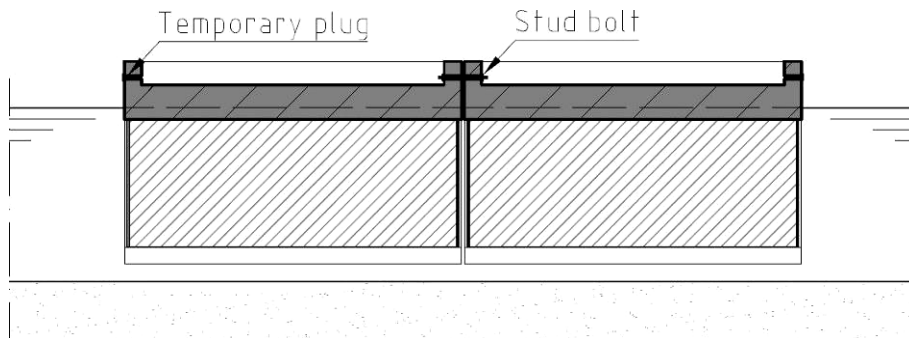

Figure 10-13: Longitudinal tensioning by means of stud bolts (cross-sectional view)

A third option is to install a hinge on each corner of an element. When the elements are coupled, first one corner is brought into position and its hinge is aligned with the hinge of the previous element. A bolt is slid through to fix this hinge in place. It now acts as a pivot and the new element can rotate around this point to bring the second hinge in place. With both hinges bolted, the new element is fixed in place relative to the previous element. A disadvantage of this method might be that the hinges are hard to align, especially in water with some wave action. The pivots are also very weak points if the elements rotate in any other degree of freedom than around the vertical axis. It also seems likely that the pivot bolt method is only applicable if the 'short' version of the gasket (figure 10-11, configuration B) is applied, as it will otherwise not be possible to keep the sealing in the middle span of the prefab elements compressed.

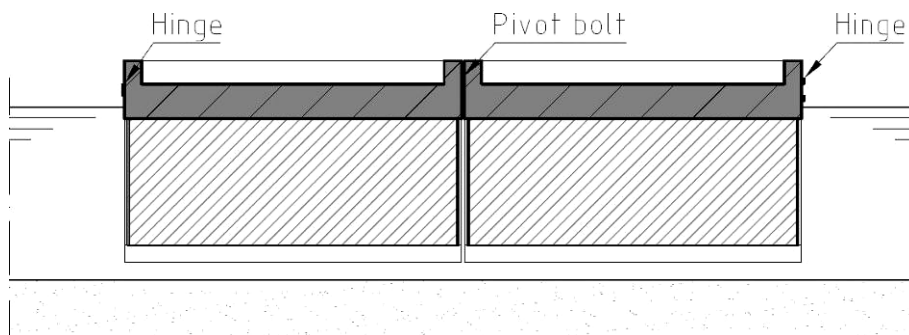

Figure 10-14: Longitudinal tensioning by means of a pivot bolt (cross-sectional view).

Whichever method is used, it should be ensured that the centroidal axis of the longitudinal tensioning provisions is at the same height as the centre of gravity of the gasket. If it is applied higher or lower, the gasket is compressed unevenly at the upper and the lower end, and a slight curvature of the platform will be the result. With the short gaskets, this point is at half the element height. With the continuous

sealing, this point is approximately  $\frac{2 \cdot 3 \cdot 1.5 + 20 \cdot 0}{2 \cdot 3 + 20} = 0.35m$  below the horizontal part of the gasket. The second alternative has the advantage that this point is above the water table before immersion of the elements, allowing for easier coupling.

#### 10.4.4 Connection to other structural elements

Apart from the coupling provisions mentioned in the previous paragraphs, the elements must also be connected to the structural- and ballast concrete (refer to Figure 10-15). Of primary concern are:

1. Connection to the main walls of the garage to transfer bending moments from the basement floor to the walls;
2. Fixation to the basement floor to reduce the upward bending moments due to water pressure, and to help distribute the bending moments in lateral direction of the garage;
3. Connection to the ballast concrete, which is eventually poured into the working chamber underneath the basement floor;
4. Connection of the cutting edges to the basement floor, to transfer the horizontal component of the passive soil forces acting on the inclined cutting edges to the basement floor. This may also help reduce the upward bending moments.

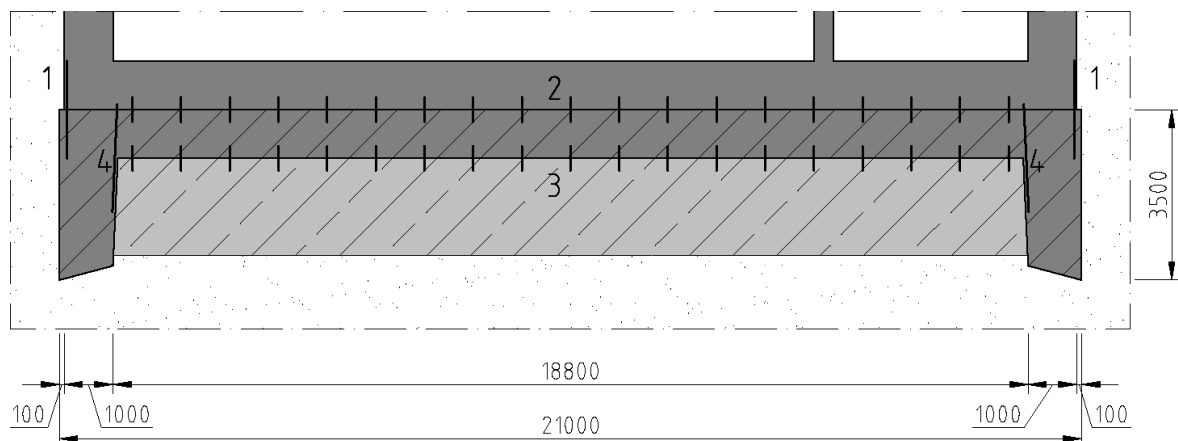

Figure 10-15: Various types of reinforcement bars protruding from the prefab elements, to connect these to adjacent structural elements. 1) Connection to outer caisson walls; 2) connection to basement floor; 3) connection to ballast concrete; 4) connection to inner sides of the cutting edges. (Units are in mm)

For calculations on these types of connections, refer to Appendix F.3. The results can be summarised as follows:

1. A row of protruding bars  $\text{Ø}28\text{--}180$ ,  $l_a = 700\text{mm}$  along the short edge of the prefab elements. These bars should have a coverage of  $142\text{mm}$  ( $1.5 \cdot \text{Ø}_k$  plus  $100\text{mm}$  to allow for the bentonite slurry void next to the caisson);
2.  $\text{Ø}20\text{--}2000$  in the horizontal plain,  $l_a = 360\text{mm}$ ;
3.  $\text{Ø}20\text{--}2000$  in the horizontal plain,  $l_a = 360\text{mm}$ , preferably applied as anchor-bars to allow free working space underneath the caisson.
4. Can be distributed internally in the element so no protruding bars required.

With the concrete prefab elements, most of the reinforcing steel mentioned above should already be installed in the manufacturing plant in the form of protruding bars, or anchor-bars should be incorporated into the elements. This is not the case with the elements made of steel, which are hollow and reinforcement must be added on-site to save weight.

## 10.5 Conceptual design of two alternatives

Recapitulating all considerations and calculations of this chapter, two alternative designs are made for the standard prefab elements. Elements that deviate from this standard design, such as the end-elements and those fitted with a manhole for access to the working chamber, are not considered here.

The main distinction between the two alternatives is the primary construction material used (concrete or steel). Other differences can be found in the application of added buoyancy, the shape of the gasket, the means of horizontal tensioning of consecutive elements and the presence/absence of reinforcement bars.

### 10.5.1 Alternative 1: Concrete

The first alternative uses concrete as a primary construction material. It has vertical cutting edge walls to reduce its weight and increase the space available for buoyancy material. Temporary steel bulkheads are applied along both sides of the void underneath the element, partly to help contain the buoyancy material, partly to increase the longitudinal bending stiffness of the element during transportation. As a buoyancy material, EPS with a specific density of  $40\text{kg}/\text{m}^3$  is used.

Longitudinal prestressing does not seem viable as a provision for longitudinal tensioning, as there is no internal space available for the tensioning device and anchorage plate. It may be possible to apply the anchorage behind the lateral cutting edge of the last element, but then it has to be tensioned in wet conditions. As

mentioned before, the use of prestressing tendons is also a very expensive provision. Instead it is chosen to use stud bolts. Mainly because of its ease of application, the flexibility it allows and the low costs involved. Nonetheless a large number of sizeable bolts need to be installed to ensure sufficient rigidity of the joint. Also, the bolts that connect the cutting edges need to be applied below the water table.

Protruding reinforcement bars are applied as mentioned in paragraph 10.4.4. This results in figure 10-16. For further details on this design, refer to Appendix F.2.1.

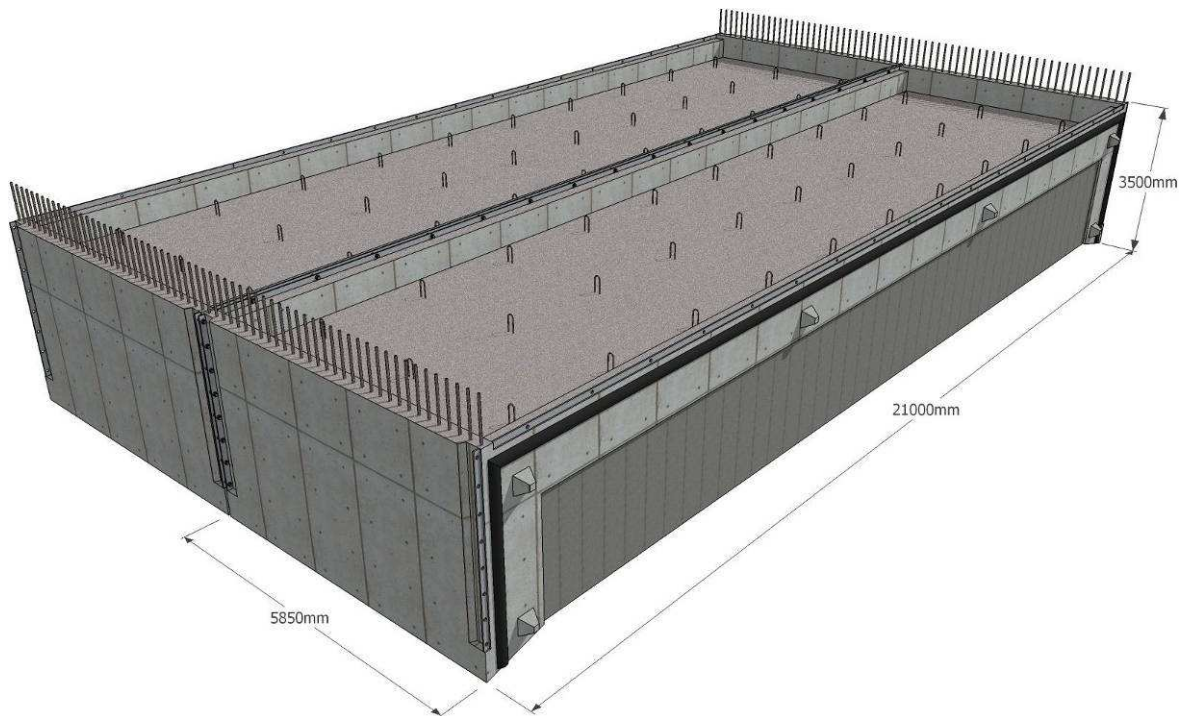

*Figure 10-16: Artist impression of two coupled concrete prefab elements*

#### 10.5.2 Alternative 2: Steel

The second alternative is one entirely made of steel. The walls of the cutting edges are slightly sloping inward to add volume, and thereby buoyancy. 21m Long steel beams (e.g. HE1000B), laterally braced by welded plates, provide rigidity to the platform. Bolts are used to temporarily keep a new element in place while a steel strip is welded over the joint, along the outer circumference of the previous and the next element. If required for increased watertightness or rigidity, another strip can be welded against the inner circumference underneath the platform, as the platform is still afloat and no buoyancy-material is in the way. The holes required for the bolts need to be plugged during transportation, or they need to be drilled on-site.

Dowel pins are welded onto the steel shell structure to ensure the fixation and cooperation between prefab steel and the concrete cast on-site (according to the SCS-

method). Protruding reinforcement bars for coupling to the basement floor and outer caisson walls are placed after immersion of the platform onto the canal bed. Altogether this results in a prefab element as schematically depicted in figure 10-17. For more details on this design, refer to Appendix F.2.2.

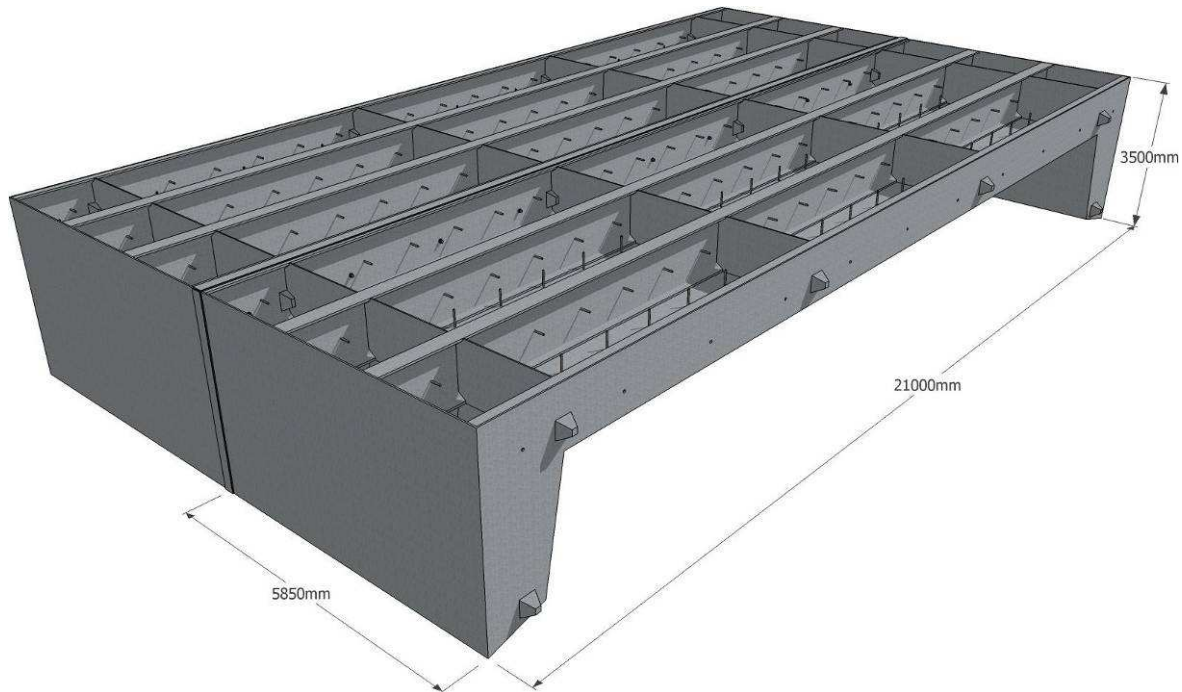

Figure 10-17: Artist impression of two coupled steel prefab elements

## 10.6 Conclusions

The most important design aspects and characteristics of both alternatives for the prefab caisson footing elements can be summarised as shown in table 10-1.

It turns out that the draft of both elements is fairly similar, but the steel element has better properties with respect to stability during floating, can easily be floated sideways and can even be transported by barge and lifted by a crane. This allows for much more freedom with respect to the construction site of the prefab elements.

The main advantage of the concrete alternative is that it has a shorter on-site construction time. Immediately after coupling of the elements and immersion of the platform onto the canal bed, it can be used as a foundation for the lower structural elements of the garage. With the steel alternative on the other hand, firstly all prefab sections need to be welded together, then the platform can be immersed and finally some  $1850m^2$  of sand need to be sluiced underneath the platform to make a foundation bed. Once this foundation layer is in position, all reinforcement bars can be installed and only then can the lower structural elements of the garage be cast.



Cost-wise the concrete prefab elements are more expensive than the steel alternative. However, when also taking into account the concrete cast on-site, the concrete alternative is again in favour.<sup>1</sup> Since transportation of the elements is not taken into account and considering the fact that the steel elements will be cheaper to transport, an economical optimum can be found by comparing manufacturing-, transportation- and building site costs.

Altogether both alternatives are very competitive and each has unique advantages and disadvantages over the other. Due to the difference in costs, and since on-site construction time is a main factor in adverse effects on the surroundings of the building site, preference is given to the concrete alternative.

**Table 10-1: Properties and characteristics of two alternative prefab element designs**

	1) Concrete	2) Steel
Draft of element	2.73m	2.77m
Stability during transportation	-	+
On-site construction time	+	-
Steel mass per element	12t (bulkheads/stiffeners)	80t
Concrete mass per element	261t (+129t in-situ)	0 (+383t in-situ)
EPS mass per element	9t	0
Material costs per element <sup>2</sup>	€ 55,350 (€ 74,700 incl. in-situ)	€ 48,000 (€ 86,300 incl. in-situ)
Other pros/cons	<ul style="list-style-type: none"> <li>- Environmentally unfriendly due to EPS waste</li> <li>- Inconvenient coupling procedure of end-element</li> </ul>	<ul style="list-style-type: none"> <li>+ Transportable by barge due to low self weight</li> <li>- Watertight welds need to be made in a sub-aqueous environment</li> </ul>

When reflecting back on the cost estimate of chapter 8, it can now be stated that the price estimated for a prefab element is way off (€40,000 versus approximately €100,000, including labour but transportation excluded). Using this progressing knowledge, the estimated project cost of this construction method becomes almost €32 million (versus €28 million as calculated in paragraph 8.4.2).

<sup>1</sup> It should be kept in mind here that the price of steel is highly susceptible to market fluctuations and is based on a price level of February 2009. Just for reference: just half a year before (July 2008) prices were over 60% higher.<sup>[d]</sup>

<sup>2</sup> Prices used: Concrete (regular reinforced): €150/*t*<sup>[a]</sup>, concrete (as applied in SCS-structure) €100/*t*, steel: €600/*t*<sup>[d]</sup>, EPS: €1000/*t*<sup>[e]</sup>.



# 11 Soil deformations during construction

The primary aim of the pneumatic caisson/immersed elements construction method is to significantly reduce adverse effects caused by the construction works, especially when compared to traditional methods. The main causes of adverse effects are considered to be vibrations and soil settlements, but also hindrance due to obstruction of infrastructure. Several construction phases can be identified that may be a cause of hindrance or damage:

- Driving of sheetpile walls (vibrations)
- Demolishing of the eastern quaywall and dredging of the canal (soil deformations due to displacements of the adjacent soil/active wedge)
- Immersion and loading of the prefab elements, construction of the entire caisson on top of the canal bed (soil deformations due to consolidation/squeezing of the subsoil)
- Pneumatic immersion of the caisson (horizontal soil displacements due to the presence of the caisson 'tail void' in the passive soil wedge behind the sheetpile wall)
- Pulling of sheetpile walls (vibrations)

Each of these construction phases is discussed in this chapter. For calculations on the different construction phases, the finite element model *PLAXIS* is used. The numerical calculation mesh as applied in this model is shown in figure 11-1. For the composition and properties of the subsoil, refer to Appendix G and H.1.<sup>[26]</sup> Because of the unloading-reloading nature of the construction process as described here, the hardening soil model is used to predict the deformations.

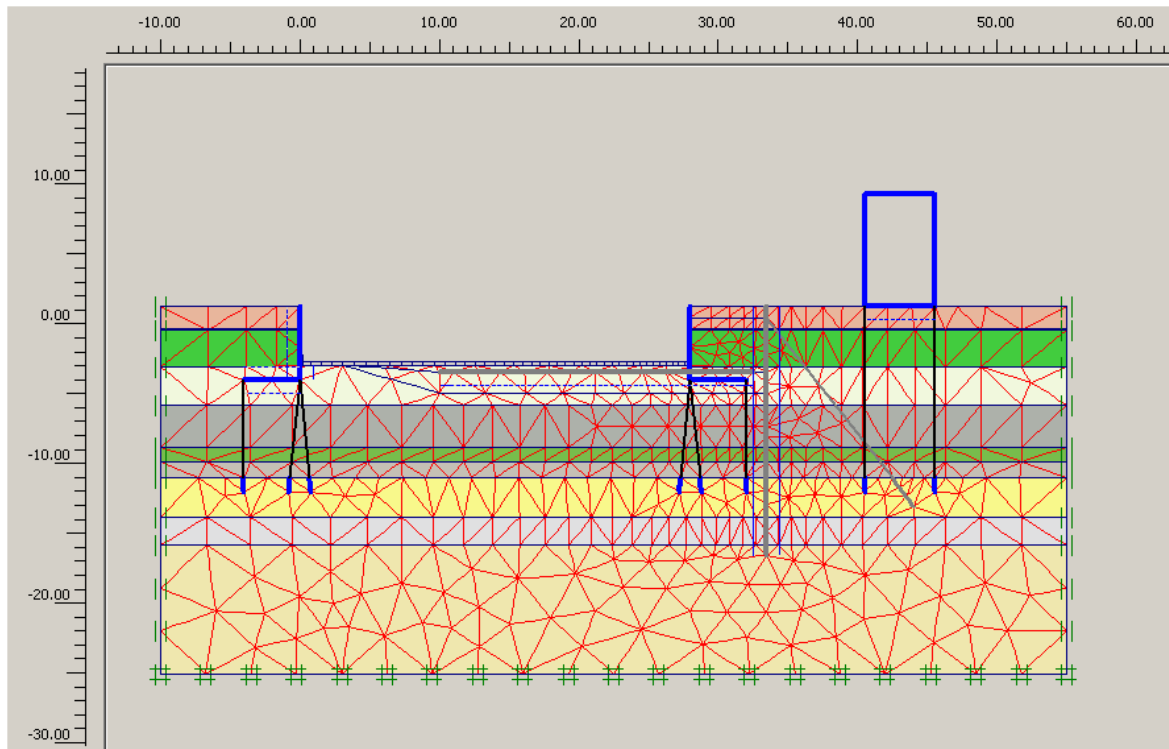

Figure 11-1: Initial calculation mesh as used in PLAXIS. 0-Reference level is equal to NAP. (Units are in meters)

## 11.1 Temporary retaining walls

### 11.1.1 Wall bracing

To allow demolishing of the eastern quaywall and to temporarily take over its retaining function, a sheetpile wall is driven between the present quay and the adjacent buildings on the eastern side of the Geldersekaade. Once this wall is in place, the old quaywall can be demolished and the canal bed is dredged up to  $-4.9\text{m}$  NAP ( $4.5\text{m}$  below mean water level). By doing so, contaminated sludge is removed and a  $1.5\text{m}$  thick layer of sand can be placed to improve the bearing capacity of the caisson foundation.

The sheetpile wall should be sufficiently rigid to prevent damage to adjacent buildings as a result of soil deformations. Two types of soil deformation can be distinguished that may cause damage to these buildings: displacement of shallow layers, causing cosmetic damage to facades and porches, and settlement of deep layers, possibly causing pile foundations to displace. Although both types of soil displacement are undesirable, the latter type is far less acceptable as it may have very severe consequences for the structural integrity of buildings.

In normal circumstances a sheetpile wall is braced (refer to appendix B.1.3). In this particular case however, only a single retaining wall is applied rather than a cofferdam. Another problem is that the caissons are built and immersed in the area where normally the struts are applied. Considering the above, struts do not qualify for wall bracing. Soil anchors can be used, but as some buildings are founded approximately 7m from the wall, chances are good that the anchor plate/grout body needs to be placed beyond the first row of foundation piles.

#### 11.1.2 Retaining walls without anchorage

If a temporary retaining wall is to be applied without anchorage, the wall should be very rigid. The disadvantage of a rigid sheetpile wall is that it has a larger cross-sectional area, and therefore requires heavier vibration materiel to drive it into the ground. Since the sheetpile walls are driven at a distance of only 7m from adjacent buildings, severe vibration hindrance is to be expected. Sheetpiles with a larger cross-section than AZ36 or equivalent are therefore to be avoided.

As a rule of thumb, a sheetpile length of three times the retaining height (6m) is assumed. Using AZ36 sheetpiles with a length of 18m, a maximum horizontal deflection of 40mm at the top of the wall is found. This is just after demolishing of the eastern quaywall and dredging of the canal.

#### 11.1.3 Retaining walls with anchorage

In an attempt to reduce vibration nuisance and soil deformations, a lighter sheetpile section, e.g. AZ26, can be used in combination with ground anchors. After an initial shallow excavation, anchor rods are driven into the soil until they protrude into a sandy layer. A grout body is formed around the tips of the hollow rods by injecting grout into the soil under high pressure. Once this lump has hardened, it acts as an anchor. A horizontal girder, or wale, is placed along the sheetpile wall. The anchor rods are tensioned to a desired prestressing force, and fixed to the wale. By carefully adjusting this prestress force, the deflection of the sheetpile wall can be accurately controlled.

Using AZ26 sheetpiles with a length of 18m and a prestressing force of 40kN/m, deformations are almost entirely avoided. At the canal bed level, the sheetpiles deflect 3.5mm towards the canal. At the top, they deflect 2mm in the other direction. Due to these deformations, the total force in the anchor rods increases to approximately 59kN/m.

The disadvantage of this method is that it may be hard to place the anchor rods due to the presence of a large number of foundation piles. Another disadvantage is that when a grout body is formed in the vicinity of a pile tip, the pile temporarily loses its bearing capacity. A third disadvantage is that when large forces act on the anchors, they may cause soil deformations near foundation piles.

Due to the relatively low prestressing force, only few ground anchors are required. With a centre to centre distance of  $8m$ , a total of 27 anchors with a capacity of  $\sim 500kN$  per anchor are needed. To minimise the influence on existing pile foundations, the grout bodies should be placed at least  $2m$  below the foundation level of adjacent buildings.

#### 11.1.4 Conclusions

Although the calculations of the unanchored retaining wall show fairly limited deformations, it is highly sensitive to changes in the loads (e.g. caused by heavy construction equipment on the quay). Local deformations may therefore be considerably larger than predicted. Because of the unpredictability of this behaviour, it is considered preferable to apply anchored sheetpile walls.

## 11.2 Construction of caisson on canal bed

### 11.2.1 Drained or undrained soil behaviour

Various clay layers are present in the subsoil, which are poorly permeable to water. It can therefore be expected that for short construction phases the influence of undrained soil behaviour may be of influence. Possibly vertical drainage needs to be applied to speed up the consolidation process.

From calculations it follows that most deformations increase if drained behaviour, or long-term conditions, are assumed. The consolidation process is of considerable influence on the construction of the caissons, which impose large loads onto the subsoil: full consolidation leads to an increase of up to 85% in soil settlements when compared to undrained behaviour. Since this construction phase may take several months, it seems advisable to assume drained soil behaviour.

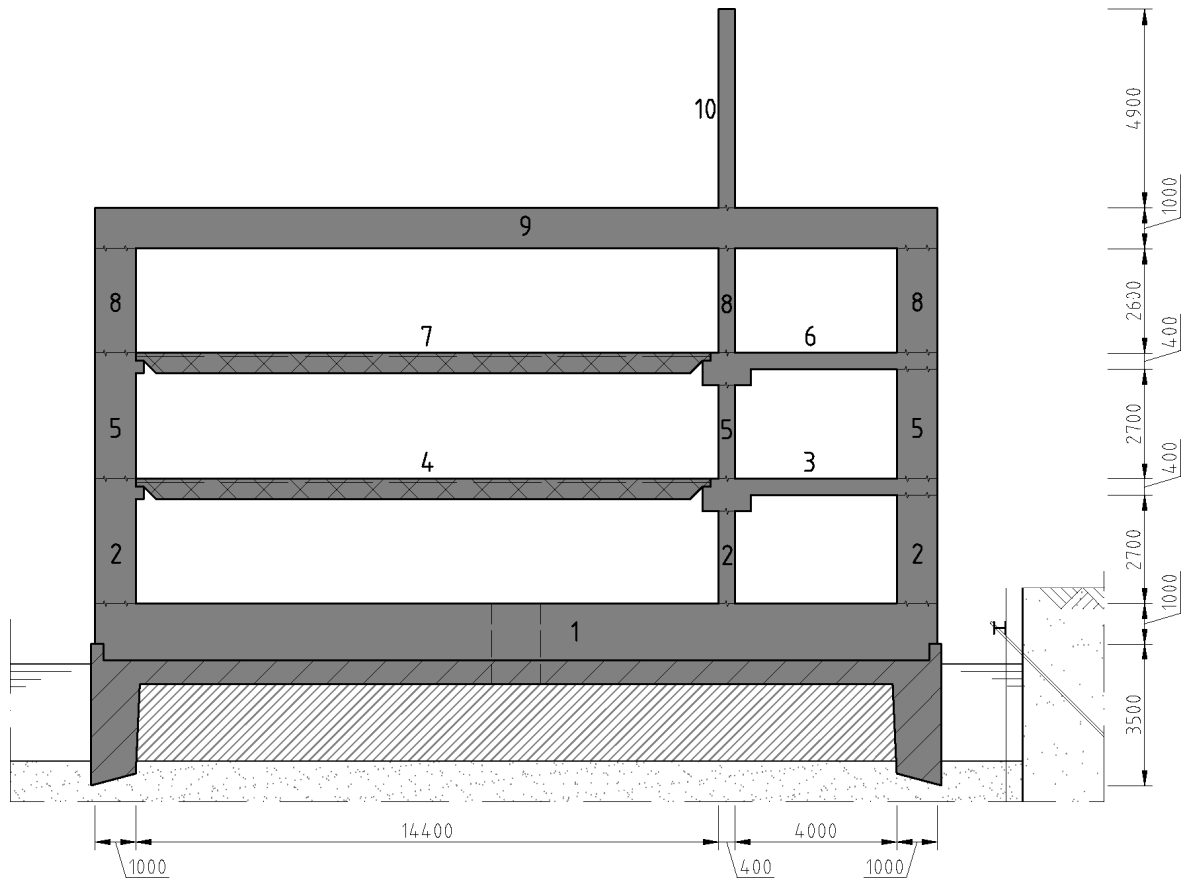

Figure 11-2: Construction phasing of the caisson on top of the prefab elements. The numbers denote the casting order of the structural concrete. (Units are in mm)

### 11.2.2 Prefab elements and basement floor

It can now be determined how much the prefab elements settle when the basement floor of the garage is cast on top (figure 11-2: 1). Since the initial freeboard is just 0.5m, this settlement may only be very limited.

In this calculation it is assumed that the cutting edges carry a maximum load of  $55\text{kN/m}^2$ , as determined in Appendix F. The rest of the weight of the basement floor is transferred to the subsoil by the EPS-blocks underneath the prefab elements. This load equals  $28.8\text{kN/m}^2$ . It turns out that the maximum settlement of the prefab elements equals 105 to 110mm.

The compression of the EPS-blocks should be added to this settlement to determine the actual level drop of the dry construction platform. With a Young's-modulus of  $3.2\text{N/mm}^2$ <sup>[22]</sup> and an EPS layer thickness of 2.1m, the compression of the EPS amounts to 17mm. This means that after immersion of the prefab elements and casting of the basement floor, the freeboard of the platform is reduced by about 125mm. The remaining freeboard thus becomes 0.35-0.40m.

### 11.2.3 Caisson superstructure

The construction of the rest of the caisson (figure 11-2: 2-10) will cause the distributed load on the canal bed to increase up to  $91.7kN/m^2$ . It is assumed that this load is distributed uniformly over the footprint of the caisson, as the cutting edges have exceeded their bearing capacity.

Calculations point out that the maximum settlement of the prefab elements during this construction phase will be in the order of  $250mm$ . The presence of the sheetpile wall, as well as the preconsolidated soil underneath the old quaywall, slightly restricts deformations on the eastern side. Some tilting of the caisson may be the result.

## 11.3 Influence on adjacent structures

### 11.3.1 Displacements of facades of adjacent buildings

Cosmetic damage to facades and porches of adjacent buildings is generally caused by displacements of the top soil layers near the sheetpile wall. Since the deformation of these soil layers is mostly determined by the type of soil retention, two cases are considered: with and without anchorage, as discussed in paragraph 11.1.

The displacements of the investigated structures are in the order of  $6-7mm$  if AZ36 sheetpiles without anchorage are applied, and  $1-2mm$  for AZ26 sheetpiles with ground anchors. Once more it turns out that the application of ground anchors is advisable. If necessary, in the second case the displacement can even be influenced by re-adjusting the prestressing force of the anchors. In both cases the buildings slightly shift towards the canal.

### 11.3.2 Displacements of foundation piles

A risk of structural damage to adjacent buildings is primarily determined by displacements of the wooden pile foundations. Especially vertical displacement of the pile tips or the foundation layer is of great concern. Due to the great loads imposed by the caisson onto the subsoil, and the presence of a relatively compressible layer (Alleröd) underneath the first sand layer, vertical displacements can be expected.

Calculations tell that horizontal displacements of the pile tips are negligible, but the row of foundation piles closest to the caisson may settle up to  $5mm$ . Likely this will not cause any major structural damage, but should nonetheless not be taken lightly. A solution to this problem is to construct and immerse the caissons in multiple



phases. By doing so, the foundation pressure, and thereby the soil settlements, can be reduced by approximately 50% (refer to figure 11-3).

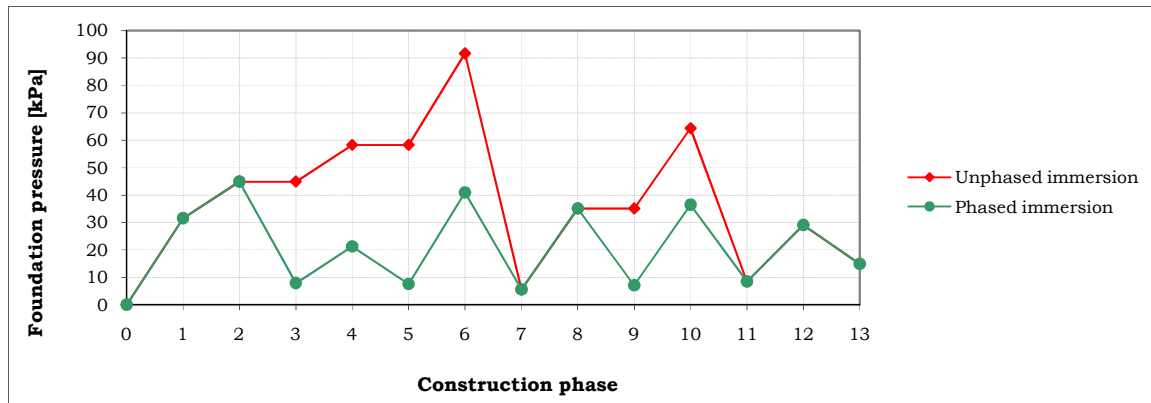

Figure 11-3: Foundation pressure as a function of construction phase. (0) Initial condition; 1) Placement of caisson footing and construction of basement floor; 2) Construction of second floor; 3) 3.7m immersion [phased]; 4) Construction of third floor; 5) 1.4m immersion [phased]; 6) Construction of caisson roof; 7) Full immersion without ballast; 8) Ballasting; 9) 2.9m immersion [phased]; 10) Ballasting; 11) Immersion onto foundation level; 12) Flooding + ballasting of working chamber; 13) Final situation, after removal of temporary ballast.

It should be kept in mind here that the rigidity of the caisson is very limited when the roof is not yet constructed. Struts are needed to prevent the outer walls from bending inward due to the hydrostatic- and soil pressure acting on the outside of the caisson.

### 11.3.3 Displacements of western quaywall

The western quaywall is at approximately 10m from any construction works, but might nonetheless be influenced by it. The western quay has significant historical value. Any damage caused to this structure will require restoration and will likely be of serious influence on the project costs.

From numerical calculations it follows that the western quaywall may slightly topple over, move 15mm towards the canal and settle by about 6mm. This is partly caused by dredging of the canal bed, partly by the great loads imposed on the subsoil. To reduce these deformations, any dredging works should be done at a maximum distance from the western quaywall. Phased construction and immersion of the caissons will also help. On the positive side, the canal profile as used in the numerical model is the narrowest part of the canal. At wider parts (southward) the distance between dredging works and the western quaywall increases.

## 11.4 Bentonite void stability during immersion

After commencement of the pneumatic immersion of a caisson, a void or trench is established along the circumference of the structure. This void should prevent contact between the caisson and the surrounding soil to minimise skin friction and thereby ease the immersion process.

The void is created by the cutting edges that protrude 0.1 m beyond the main walls of the caisson. Injection tubes run along the caisson perimeter, just above the protruding edge. Simultaneously with the immersion process, bentonite slurry is injected in the trench between the caisson walls and the soil to prevent the soil from collapsing inward (refer to figure 11-4 for a graphical representation). The bentonite slurry also acts as a lubricant.

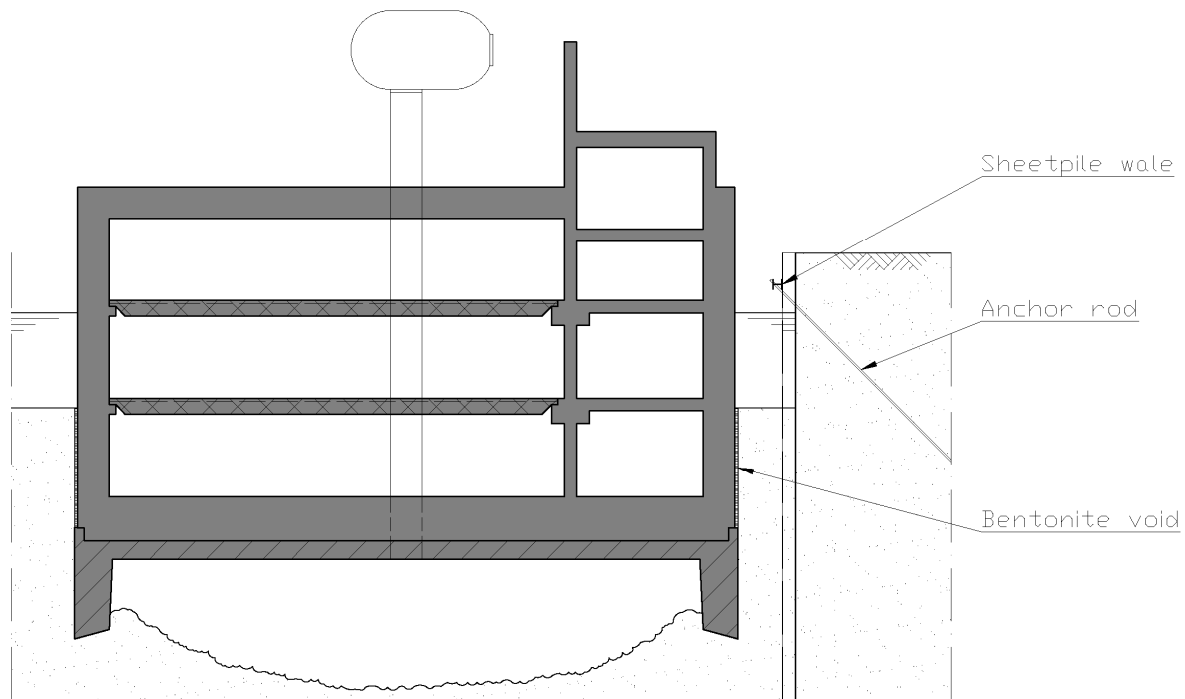

Figure 11-4: Pneumatic caisson during immersion, showing the bentonite filled trench on either side of the structure.

Key to the success of this procedure is that the hydrostatic pressure of the bentonite slurry balances with the horizontal soil pressure. This is where a problem arises in the presented construction process: the bentonite-filled trench on the eastern side of the caisson has to pass through the ground that ensures the stability of the sheetpile wall. Due to the relatively high passive soil pressures active here, it is doubtful that bentonite slurry can provide enough counter-pressure to balance this out. If the bentonite void collapses, the sheetpile wall may bend outward by up to 100 mm.

In bored tunnelling techniques, where bentonite slurry is also applied as a stabilising fluid, this problem is solved by establishing overpressure in the bentonite slurry. Unfortunately, in this case the bentonite slurry is in open connection to the surrounding environment so overpressure can not be created.

The bentonite pressure can be improved by increasing the density of the slurry. Assuming that the bentonite trench runs from  $-3.4\text{m}$  NAP (canal bed level) to  $-14.2\text{m}$  NAP (after full immersion of the caisson), and based on the soil parameters in Appendix H.1, it can be calculated that a bentonite slurry with a density of  $12.6\text{kN}/\text{m}^3$  is sufficient. General bentonite slurry does not come in such high densities, so a special mixture is required.

Another option to increase the slurry pressure is by increasing the height of the trench. As can be seen in figure 11-4, the space between the caisson and the sheetpile wall can easily be backfilled with sand. Even when the roof of the caisson is below the water table, the new quaywall can be used to retain this sand. Doing so will also reduce the passive soil pressures on the caisson-side of the sheetpile wall. If the fill level of the slurry trench is made equal to the height of the sheetpile wall ( $1.3\text{m}$  NAP), a slurry density of  $10.7\text{kN}/\text{m}^3$  is adequate. Standard bentonite slurry will suffice in this case. It should be kept in mind that if this method is applied, the trench may not be continuous along the full circumference of the caisson, as different fill levels are used ( $-3.4\text{m}$  NAP on the western side,  $+1.3\text{m}$  NAP on the eastern side).

For details on these calculations, refer to Appendix H.4.

## 11.5 Conclusions

Anchorage of the temporary sheetpile retaining walls next to the caisson is highly recommended to reduce soil deformations and vibration hindrance, and to increase the controllability of the displacements in the upper soil layers.

Displacements of pile foundations may however prove a bigger threat. These are in the order of  $5\text{mm}$  vertically, and can not be solved by adjusting the prestressing force in the anchors; the displacements are primarily caused by settlements in the Alleröd layer, underneath the first sand layer. They can only be reduced by constructing and immersing the caissons in multiple stages to reduce the loads on the subsoil. Doing so will require special measures to ensure the rigidity of the caissons in the early immersion stages.

The northernmost part of the western quay is also subjected to some deformations. This part of the western quay is closest to the construction activities and the canal will be dredged close by. Mitigating measures, such as soil/foundation improvements, may be required as this quay has significant historical value. Likely however, these displacements are also caused by settlements in deep soil layers. In this case phased construction of the caissons will also help reduce deformations.

With respect to the stability of the bentonite slurry trench between the caisson and the sheetpile wall, two options are available. One is to apply high-density slurry and simply start the trench at the bed level of the canal. If this method is applied, anchored sheetpiles are for sure required as the trench may be unstable at the top. Another option is to backfill the space between the sheetpile wall and the caisson with sand so a higher slurry level can be achieved. Regular bentonite slurry will then suffice. During immersion of the caisson, constant backfilling with sand is needed to ensure that the trench maintains its required height.

Regarding the prefab elements it can be said that the initial clearance height of  $0.5m$ , just after immersion, will be reduced by about  $0.10-0.15m$  as a result of soil settlements when the basement floor is cast, and compression of the EPS-blocks. The remaining  $0.35-0.40m$  of clearance above water seems fairly limited and puts serious demands on dredging, construction and element coupling tolerances. Ship waves may also cause issues as they can easily overtop the platform.

# 12 Conclusions and recommendations

## 12.1 Conclusions

### 12.1.1 Spatial integration of the garage

Conclusions regarding the entry/exit ramps:

- There is only enough space available for a single entry and a single exit ramp, which are both to be positioned in line;
- The ramps should be placed along the eastern quaywall. The western quay is half as wide and does not provide adequate space and traffic capacity. It also has significant historical value so this quay should be maintained as much as possible;
- The ramps can either be positioned within the canal (disadvantages: disturbance of the navigable canal profile and devaluation of historical character of the canal) or at the position of the eastern quaywall (loss of trees and replacement of eastern quay). The spatial profile between the eastern quaywall and adjacent buildings is too narrow to allow construction of the entry/exit ramps behind the quaywall;
- Entrance from the south and exit to the north fits best in the future one-way traffic plan and traffic distribution system in the vicinity of the Geldersekade. In this case, the entrance is not directly accessible from a main distribution road, but since the garage is designed mostly for permit-holders, search-traffic is considered to be of a minor problem.

Conclusions regarding the floor plan of the garage:

- Because of the presence of the Bantammerbrug, it is advisable to use only the northern part of the canal for the garage. This section of the Geldersekade allows for a garage length of 215m. Furthermore, a single-level garage can not accommodate enough parking places, even if both the southern and the northern part of the Geldersekade are used;

- When using only the northern part of the canal, a garage with either two levels at an internal width of 25.9m, or three levels with an internal width 18.4m do provide adequate solutions to the required parking capacity.

#### 12.1.2 Alternative construction methods

- Three construction methods seem feasible for construction of the garage:
  - 1) Traditional bottom-up method using a temporary cofferdam and an underwater concrete floor (two levels);
  - 2) Bottom-up method using permanent diaphragm walls and an underwater concrete floor (two levels);
  - 3) Pneumatic caissons built on top of the canal bed and subsequently immersed (three levels).
- To avoid the need for a large sandfill and sheetpiles in the canal profile, required for the dry in-situ construction of the caissons, a method using prefabricated immersible elements to form the basis of the pneumatic caissons seems viable;
- The estimated costs for the alternative construction methods are:
  - 1) Traditional method, bottom-up: € 28.4 million
  - 2) Diaphragm walls with UWC-floor: € 34.9 million
  - 3) Pneumatic caisson with prefab elements: € 31.8 million(VAT excluded, price level 2008)
- The primary risk related to construction methods 1 and 2 is the fact that a dry excavation is to be made in close proximity of the historical western quaywall. The Schreierstoren (the oldest remaining rampart tower of Amsterdam) is also exposed to potential damage. Structural damage to the Schreierstoren caused by construction works will result in severe public objections and budget exceedances;
- The main risk of the pneumatic caisson/prefab elements method is in the fact that it is an innovative method with unknown design aspects, and it has likely to be made by construction workers lacking specific experience. Unforeseen deficiencies may show up during execution of the project, causing delays.

## 12.1.3 Internal lay-out of the garage (pneumatic caisson, 3 levels)

- Two alternative internal lay-outs have been investigated for the construction method using pneumatic caissons. The internal lay-out and the internal load distribution of the structure show great mutual dependence:
  - From a user point of view, short driving distances and a surveyable spatial layout with wide viewing angles are preferable. This results in large C.T.C.-distances between columns and few internal walls;
  - From a structural point of view, a design has been made that has a convenient load distribution and internal walls wherever possible.
- It turns out that the user-friendly design does not provide the required number of parking places and has such an inconvenient load distribution that it is discarded. Nonetheless, the spatial lay-out of this design has considerable advantages over the other.

## 12.1.4 Prefabricated immersible elements

Two types of prefab immersion elements are investigated (being one mainly of concrete and one made of steel), which form the cutting edges and foundation structure of the pneumatic caissons. Conclusions with respect to the navigability of these elements are:

- The draft of the elements is in the order of 2.7 to 2.8m. This should be taken into account with respect to navigability in the Geldersekkade canal, which has an average depth of 2.5m (at a mean water level of -0.4m NAP). The depth at the construction site should be only just larger than the draft (~2.9m) to ensure a maximum freeboard. On open water, dredging up to a bed level of at least -3.4m NAP is required;
- Navigation of the elements underneath the Hoofdbrug at the Prins Hendrikkade should be done with care. Due to the high blocking ratio here, the elements tend to sag slightly and may run aground. If the foundation of this bridge allows it, the local water depth should be increased to 3.5m (-3.9m NAP);
- Another consequence of this high blocking ratio is that the velocity of the elements relative to the water is limited to about 0.3m/s. The discharge through the culvert underneath the Nieuwmarkt must temporarily be halted during transportation of the elements, which is in contradiction with the program of requirements. Another option is to install a pumping system to bypass the Hoofdbrug;

- The concrete prefab elements have poor hydrostatic stability due to the high centre of gravity. On open water, external stabilisers need to be attached to the element, but at the Hoofdbrug-passage these can not be present. This is not the case with the steel prefab element, which has great stability properties;
- The end-elements have an extra cutting edge perpendicular to the longitudinal axis of the garage. With the concrete alternative, this edge adds a huge off-centred weight. The shape of the element must be adjusted and external floats must be attached to it to compensate for this. This edge does not cause problems with the steel alternative, where it adds buoyancy which can simply be compensated by ballasting.

Other conclusions with respect to both alternative designs of the prefab elements:

- The working chamber underneath the platform, after coupling and immersion of the elements, needs to be filled with a temporary foundation material. This should prevent the platform from setting too much when loaded by the first structural layers built on top of it;
  - In case of the concrete element it is advisable to use the buoyancy material already present underneath the element for this purpose. EPS seems like a very suitable material to fulfil both purposes;
  - With the steel element, added buoyancy material is not needed and foundation material can be applied on the construction site. After immersion of the coupled elements, the working chamber can be filled with sand to form an excellent foundation layer. The considerable weight of this sand layer may however cause some extra soil settlements.
- After immersion of the coupled prefab elements and pouring the basement floor of the garage on top of these, the freeboard is just 0.35-0.40m, putting serious demands on dredging, construction and element coupling tolerances. It seems advisable to construct the formwork of the basement floor such that it can retain small waves, to prevent the platform from overtopping.
- Due to the high degree of prefabrication, the concrete elements will help in a shorter on-site construction time when compared to the elements made of steel;
- Weighing 800kN, the steel elements are four times as light as the concrete alternative. Likely they can even be transported from the manufacturing plant to the construction site by barge, considerably reducing the transportation costs.



- The concrete element is 10-20% cheaper than the steel element, when also taking into account all on-site construction works and added material. The concrete elements roughly cost €100,000 a piece.

#### 12.1.5 Influence on adjacent buildings

- Anchorage of the temporary sheetpile retaining walls next to the caisson is required to reduce soil deformations and vibration hindrance as lighter sheetpile profiles can be used. Only few ground anchors are needed, but they do need to be applied in between/underneath wooden foundation piles of adjacent buildings.
- Pile foundations of adjacent buildings will likely settle approximately 5mm if no mitigation measures are applied. These displacements are primarily caused by compression of the Alleröd soil layer, underneath the first sand layer, and result from the great loads imposed by the caissons constructed on top of the canal bed.
- A solution to this problem is to construct and immerse the caissons in multiple phases. By doing so, the foundation pressure, and thereby the soil settlements, can be reduced by approximately 50%. Doing so will require special measures to ensure the rigidity of the caissons in the early immersion stages.
- The northernmost part of the western quay is subjected to some deformations. This part of the western quay is closest to the construction activities and the canal needs to be dredged close by. Mitigating measures, such as soil/foundation improvement, may be required as this quay has significant historical value. Phased immersion of the caissons will also help to reduce deformations.
- The fact that deformations of this quaywall are already expected pleads for ensuring a maximum distance between caisson construction and the western quaywall/Schreierstoren. This is of consequence for an alternative design where both quaywalls are maintained by immersing the caissons in between.
- To avoid soil settlements due to collapse of the bentonite slurry trench, situated between the caisson and surrounding soil during pneumatic immersion, two options seem feasible. One is to use high-density slurry to balance the passive soil pressures of the adjacent sheetpile wall. The other option is to backfill the space between the caisson and the temporary retaining wall to allow a higher bentonite fill level and reduce passive soil pressures underneath the caisson.

For an artist impression of the entire construction of the garage, and a visualisation of most conclusions and research results of this thesis, refer to Appendix I.

## 12.2 Recommendations

Although no insurmountable problems have been found during this feasibility study, additional research on several design aspects is highly recommendable to improve the viability of the project, and to reduce the number of unknown factors:

- Although the produced garage design does fulfil the requirements by the commissioner with respect to parking capacity (350 parking places), it has a very inconvenient internal lay-out from a user point-of-view. Optimisation with respect to user requirements and internal load distribution may result in a more satisfactory design. Possibly some parking places need to be sacrificed for this (e.g. making a U-turn next to the upward ramp on level -2 cuts the driving distance from level -3 to the exit by approximately 350m, at the cost of 3 parking places).
- It should be investigated whether the foundations of the Hoofdbrug (bridge 299) can cope with a drop of the bed level in the canal by approximately 1 to 1.5m, to allow passage of the prefab immersion elements. The same holds for the Schreierstoren.
- Research is needed on the influence of grout anchors underneath the pile foundations of buildings on the eastern side of the Geldersekade: is it possible to place the anchor rods between the piles, and to what degree do the grout anchors negatively affect the bearing capacity of the piles?
- Phased construction and immersion of the pneumatic caissons is advisable, but negatively affects the rigidity of the caisson during early immersion stages. Structural calculations are needed to determine what measures, and consequently what costs, are needed to ensure the structural integrity of the caisson and to limit its deformations.
- To increase the certainty with respect to predicted soil deformations, monitoring of reference projects is highly advisable. An ideal test case is the last pneumatic caisson of the North/South metro line, to be immersed in the Open Havenfront, Amsterdam. The geographical profile here is highly similar to the Geldersekade and settlement-measurements may prove invaluable for a parking garage underneath the Geldersekade, or any other parking garage to be constructed in Amsterdam using a pneumatic caisson method.

# 13 References

## 13.1 Literature

- [1] Bureau of Public Space (2004). *Nota Bereikbaarheid Binnenstad 2004 – 2009*. Amsterdam: Amsterdam-Centre district.
- [2] Smit, S. (2007). *Parkeergarages in Amsterdam Centrum, Notitie*. Amsterdam: Amsterdam-Centre district.
- [3] Municipality of Amsterdam [2006]. *Programmakkoord 2006 – 2010*. Amsterdam: Amsterdam-Centre district.
- [4] Huis in het Veld, T.P., Heide, W.H. van der (2005). *Parkeergarage Geldersekaade, Studie naar de opbrengsten*. Amersfoort: Grontmij Parking Consultants BV.
- [5] Bureau of Public Space, department of Policy (2008). *Parkeergarage Geldersekaade, Plan van Aanpak*. Amsterdam: Amsterdam-Centre district.
- [6] Daelen, J.L.C.M. van (2009). *Haalbaarheidsstudie parkeergarage Geldersekaade, nota voorontwerp*. Amsterdam: Witteveen+Bos.
- [7] Municipality of Amsterdam, department of Parking Garages (2008). *Programma van Eisen, Parkeergarages Centrum Amsterdam (Concept v1)*. Amsterdam: Municipality of Amsterdam.
- [8] Daelen, J.L.C.M. van (2008). *Verkort Programma van Eisen, Parkeergarage Geldersekaade (Concept)*. Amsterdam: Witteveen+Bos.
- [9] Daelen, J.L.C.M. van (2008). *Nota van Uitgangspunten, Parkeergarage Geldersekaade (Concept)*. Amsterdam: Witteveen+Bos.
- [10] Datacharter / Blokplan (2008). *Varen in en rond Amsterdam – Vaarwijzer Amsterdam 2008*. p5,13. Haarlem: Datacharter
- [11] NEN 2443 (2000). *Off-street and multi-storey car parks*. Delft: Nederlands Normalisatie-instituut.
- [12] Daelen, J.L.C.M. van (2008). *Risicodossier, Parkeergarage Geldersekaade*. Amsterdam: Witteveen+Bos.

- [13] CROW-publicatie 137 (2002). *Wat kost dat? Standaardsystematiek voor kostenramingen in de GWW (herziene uitgave)*. Ede: CROW.
- [14] Daelen, J.L.C.M. van (2008). *Kostenramingen, Parkeergarage Geldersekaade (Concept)*. Amsterdam: Witteveen+Bos.
- [15] Betonvereniging (2006). *GTB 2006, Complete Uitgave. Grafieken en tabellen voor beton*. Rijswijk: Quantas.
- [16] NEN 6702 (2007). *Technical principles for building structures – TGB 1990 – Loadings and deformations*. Delft: Nederlands Normalisatie-instituut.
- [17] Bakker, K.J., Huijben, J.W., Kooijman, G. and Vrijling, J.K. (2008) *Bored and immersed tunnels (CTwa5305)*. Delft: TU Delft, Faculty of Civil Engineering and Geosciences.
- [18] Stiksma, K. (ed.) (1987). *Tunnels in the Netherlands, underground transport connections*. Den Haag: Rijkswaterstaat.
- [19] Kraneveld, M.R., Vonk, R.A., Wit, J.C.W.M. de. *Tunneldeel Open Havenfront en Natte Damrak – Uitvoering in pneumatische caissons*. Cement 2 (2004): p41-45. 's-Hertogenbosch: Stichting ENCI Media.
- [20] Verruijt, A. (1983). *Grondmechanica*. Delft: Delft University Press.
- [21] NEN 6744 (2007). *Geotechnics – Calculation method for shallow foundations*. Delft: Nederlands Normalisatie-instituut.
- [22] Eaves, D. (2004). *Handbook of polymer foams*. iSmithers Rapra Publishing.
- [23] Groeneveld, R. (2002). *Inland waterways*. Delft: TU Delft, Faculty of Civil Engineering and Geosciences.
- [24] Journée, J.M.J. and Massie, W.W. (2001). *Offshore hydromechanics*. Delft: Delft University Press.
- [25] Puller, M. (2003). *Deep excavations: a practical manual (2<sup>nd</sup> ed.)*. London: Thomas Telford.
- [26] Herschleb, J. (2000). *Grondonderzoek Noord/Zuidlijn. Parameterset definitief ontwerp*. Amsterdam: Adviesbureau Noord/Zuidlijn.

## 13.2 Websites

- [a] Hydraulic mining – Wikipedia, the free encyclopedia (December 2008). <[en.wikipedia.org/wiki/Hydraulic\\_mining](http://en.wikipedia.org/wiki/Hydraulic_mining)>

- [b] School for Champions: online lessons for those seeking success (March 2009).  
<[www.school-for-champions.com/sports/tabletennis.htm](http://www.school-for-champions.com/sports/tabletennis.htm)>
- [c] Mijn Woordenboek. Online vertaling en synoniemen (October 2008 – June 2009). <[www.mijnwoordenboek.nl](http://www.mijnwoordenboek.nl)>
- [d] Steel industry news and information portal (May 2009).  
<[www.steelonthenet.com/prices.html](http://www.steelonthenet.com/prices.html)>
- [e] Expandable Polystyrene (EPS) Prices and Pricing Information (May 2009).  
<[www.icis.com/v2/chemicals/9076007/polystyrene-expandable/pricing.html](http://www.icis.com/v2/chemicals/9076007/polystyrene-expandable/pricing.html)>
- [f] Deep foundation – Wikipedia, the free encyclopedia (December 2008)  
<[en.wikipedia.org/wiki/Deep\\_foundation](http://en.wikipedia.org/wiki/Deep_foundation)>

### 13.3 Experts

- [i] Vlijm, Ing. H.M. (Henk). Amsterdam: Witteveen+Bos
- [ii] Bakker, Dr.ir. K.J. (Klaas Jan). Delft: TU Delft, Gouda: COB
- [iii] Buykx, Ir. S.M. (Stefan). Amsterdam: Witteveen+Bos
- [iv] Koek, Ir. A.J. (Sander). Amsterdam: Witteveen+Bos
- [v] Kerssens, Ing O. (Oscar). Amsterdam: Witteveen+Bos



# Appendix A Parking zones in Amsterdam-centre





**Legenda**

- Vergunninggebieden
- A** Vergunningen zijn niet geldig van maandag t/m zaterdag van 09.00 uur tot 18.00 uur
- B** Vergunningen zijn niet geldig van maandag t/m zaterdag van 09.00 uur tot 18.00 uur en op zondag van 12.00 uur tot 18.00 uur
- €** Straattariefgebieden met daarin het bijbehorende uurtarief

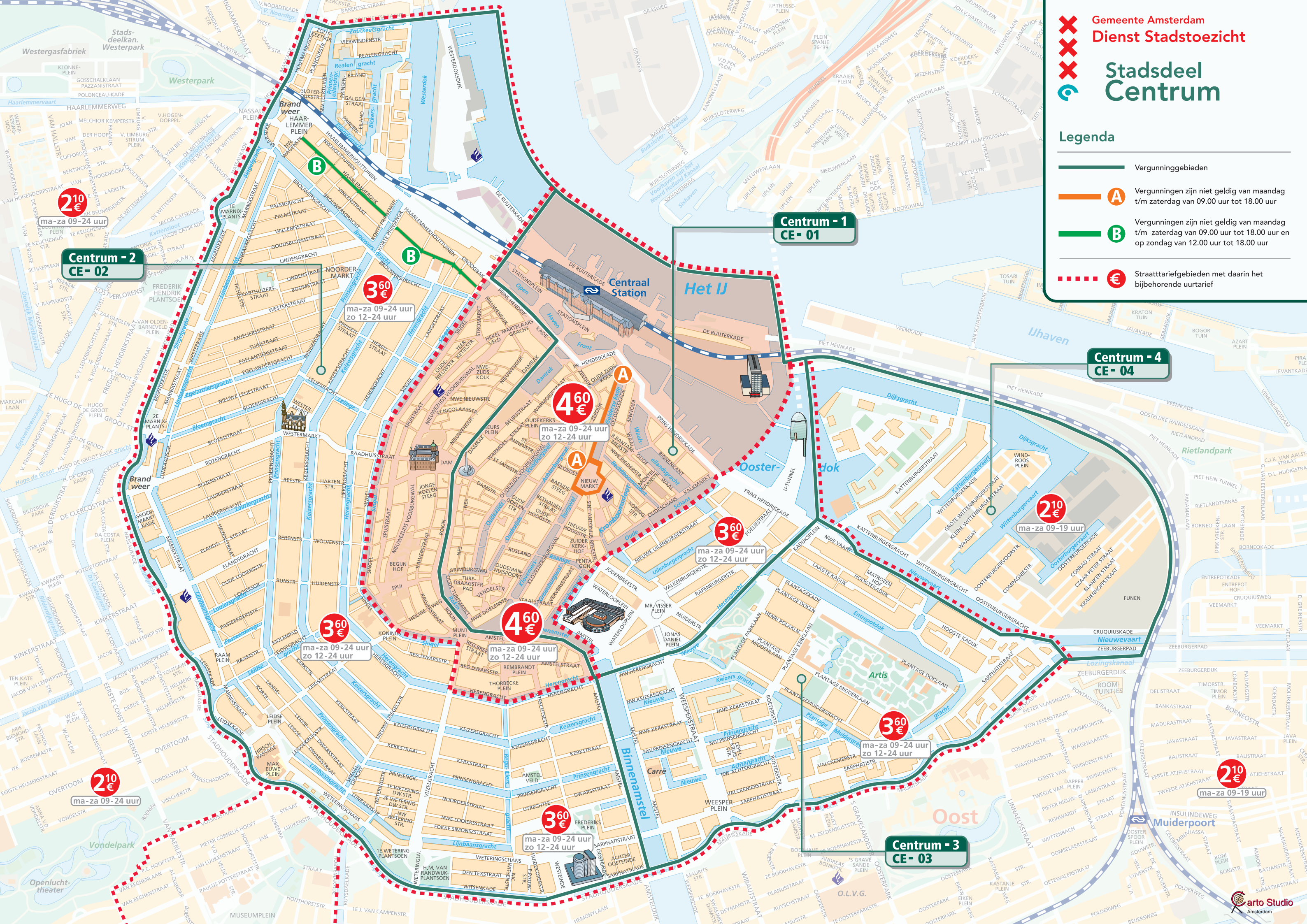

**Centrum - 2**  
CE-02

**Centrum - 1**  
CE-01

**Centrum - 4**  
CE-04

**Centrum - 3**  
CE-03

**2.10€**  
ma-za 09-24 uur

**B**

**3.60€**  
ma-za 09-24 uur  
zo 12-24 uur

**4.60€**  
ma-za 09-24 uur  
zo 12-24 uur

**4.60€**  
ma-za 09-24 uur  
zo 12-24 uur

**3.60€**  
ma-za 09-24 uur  
zo 12-24 uur

**2.10€**  
ma-za 09-19 uur

**3.60€**  
ma-za 09-24 uur  
zo 12-24 uur

**4.60€**  
ma-za 09-24 uur  
zo 12-24 uur

**3.60€**  
ma-za 09-24 uur  
zo 12-24 uur

**3.60€**  
ma-za 09-24 uur  
zo 12-24 uur

**2.10€**  
ma-za 09-19 uur

**2.10€**  
ma-za 09-24 uur





# Appendix B Soil retaining methods

This appendix provides an overview of most common types of soil retention, both in the vertical and horizontal sense. Firstly, a number of basic soil retaining wall types are discussed (classified by means of obtaining stability), followed by methods to retain vertical soil and groundwater pressures, and concluded by some integrated construction methods.<sup>[25],[1]</sup>

## B.1 Horizontal soil retention

### B.1.1 Gravity wall

A gravity wall consists of a structure that primarily depends on its own weight to counterbalance the active soil pressure on the wall. Horizontal stability is mainly obtained by friction between the bottom of the wall and the subsoil, and can be increased by entrenching the wall into the ground or constructing a shear key to mobilise a passive soil wedge (Figure B-1).

In general gravity walls have a large surface area. They require extensive drainage or watertight provisions to ensure stability and prevent leakage when applied in water-bearing soil. Various types of gravity walls exist:

- Solid concrete wall

Generally in-situ cast concrete. Both reinforced and plain concrete can be applied. This type is commonly used in hydroelectric dams with retaining heights exceeding 100m.

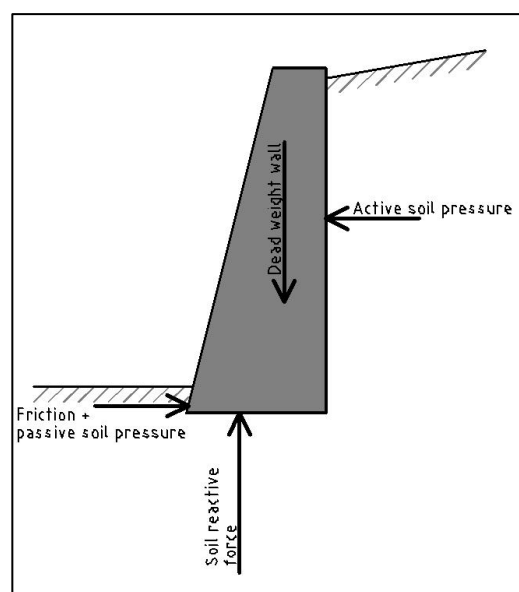

Figure B-1: Gravity wall principle

- Masonry wall

Monolithic bricks, stones or concrete blocks stacked on top of each other.

- Composite gravity wall

May consist of various materials. Usually built by stacking 'boxes' filled with ballast material, such as gabions (steel mesh baskets filled with rock), crib walls (cells built up log cabin style from concrete elements or timber and filled with soil) and geosynthetic bags.

- Cantilever/counterfort wall

A cantilever wall (also known as L-wall) is usually constructed of precast concrete elements and uses the dead weight of the soil to counterbalance the soil pressure. A horizontal slab (footing) is fixed to the bottom of the wall and positioned underneath the active soil wedge, preventing the wall from overturning. Higher resistance against toppling over can be achieved by extending the footing or the toe of the wall, to increase the leverage arm of the counterbalancing moment. This also reduces the vertical soil stress underneath the wall. A shear key underneath the wall can increase horizontal stability.

A counterfort wall is principally similar to a cantilever wall, however the main retaining wall is braced to the horizontal footing by perpendicular triangular walls (counterforts). Increased strength and stiffness results in greater retaining heights.

### B.1.2 Cantilevering wall

Not to be confused with a cantilever wall, cantilevering walls generally consist of long stiff elements protruding deep into the subsoil. Passive soil pressures induced by the fixing moments have to cover for stability (Figure B-2).

There is a large variety of cantilevering wall types, of which the most common ones are listed below:

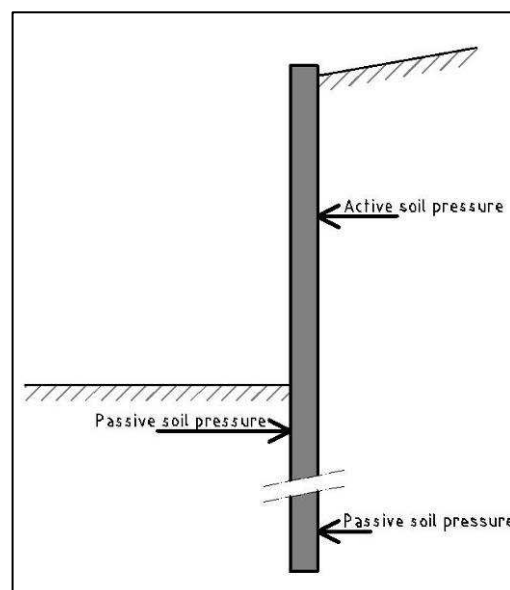

Figure B-2: Cantilevering wall principle

- Soldier pile wall

A soldier pile wall (also known as Berlin wall) consists of wide flange steel H-sections driven into the ground at regular distances (usually 2-3m). During excavation, horizontal timber or concrete beams (lagging) are placed in between the soldier piles to retain the soil. It cannot be applied in water-bearing soil. Typical retaining height: 5m.

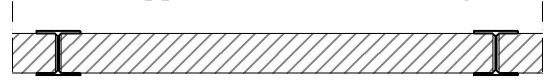

Figure B-3: Soldier pile wall cross-section

- Sheet pile wall

Sheet pile walls consist of interlocked, thin-walled section elements driven (or vibrated) into the ground. Sheet pile elements may be made of steel, timber, glassfiber, plastic or concrete. Typical retaining height: 5m.



Figure B-4: Sheet pile wall cross-section

- Combi-wall

A combined wall (combi-wall) consists of regular steel (Z- or U-section) sheetpiles, alternated by stiffening piles, or king piles. These may be tubular piles, box sections or I-sections. Due to the high bending stiffness of the king piles, the retaining height can be significantly increased: up to 10m of non-braced excavation.



Figure B-5: Combi-wall cross-section

- Contiguous bored/secant piles

Boring a vertical hole into the ground, stabilising the soil with a steel tube or bentonite slurry, placing reinforcement (or a steel section) into the hole and backfilling it with concrete makes a bored pile. Placing a series of piles next to one another creates a contiguous bore pile wall. A secant pile wall is constructed by making an overlap between consecutive piles: first a series of piles is made with some space (less than a pile diameter) in between, later followed by piles in between of the first piles. Typical retaining height: 5-7m (depending on pile diameter and the steel sections/reinforcement used).

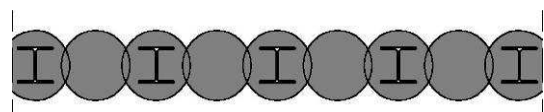

Figure B-6: Secant pile wall cross-section

- Concrete diaphragm wall

A diaphragm wall is built in much the same way as a bored pile wall. The main difference is that the pile sections have a rectangular shape instead of circular (the excavation is done with an earth grab or cutter instead of an auger) and stabilisation of the excavated shaft is nearly always done with bentonite slurry. The joint between consecutive walls is made watertight by placing a rubber seal along the full height of the wall, or by creating an overlap. With sufficient bracing and proper equipment, in practice the diaphragm wall can attain large depths (over 100m).

### B.1.3 Braced wall

Nearly all the wall types mentioned above can be executed as (partially) braced walls: horizontal soil anchors are placed at some distance from the wall (beyond any potential failure plane) and fixed to the wall by means of a rod or cable. This increases the horizontal stability of the wall and reduces deformations (Figure B-7). Another type of wall bracing is the application of struts to transfer horizontal loads either to the ground or to an opposing wall, creating a cofferdam.

Bracing of pile walls can be applied very economically to reduce the length of the piles, as well as the required section stiffness: the fixing moments and passive pressures in the subsoil can be considerably reduced, as well as horizontal deformations of the wall. For deep excavations, multiple levels of wall bracing may be applied (either struts or anchors). A concrete basement (or intermediate) floor may also act as a horizontal bracing. The maximum excavation depth of pile walls can thus be increased by up to 10 to 20 meters, in practice only limited by the equipment used.

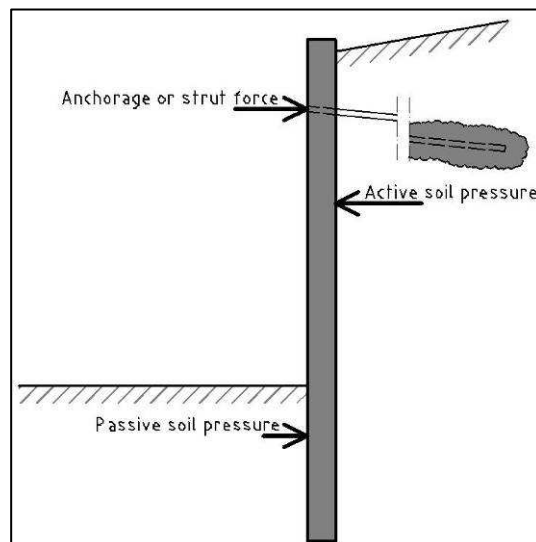

Figure B-7: Braced wall principle (e.g. by application of a grout anchor)

## B.2 Vertical soil retention

### B.2.1 Impermeable soil layer and ballast

In alluvial areas, there is usually a silt or clay layer present at a certain depth. These layers tend to be poorly permeable to water, especially in the vertical sense. When a pile wall is driven into the silt or clay layer to create a cofferdam, the area within is virtually cut off from the surrounding groundwater. Consecutively, it can be pumped dry and/or excavated to create a construction pit. Ballast material may need to be placed (or kept) at the bottom to resist vertical uplift forces underneath the clay layer. Not doing so might lead to bursting of the impermeable layer.

### B.2.2 Artificial impermeable layer and ballast

If a natural impermeable layer is absent or insufficient, an artificial layer may be created to retain groundwater. These can be made by:

- Chemical injection

A water-soluble polymer is injected into the subsoil at multiple locations at close intervals. Once the polymer enters the soil, it starts reacting with ions naturally present there, converting into an insoluble substance. When done with care, a watertight screen is created at the injection depth.

- Jet grouting

Instead of a polymer, cement is injected into the soil. This is done through a nozzle at high pressure, mixing the soil, cement and groundwater. After some time the mixture hardens, forming a grout column at the injection spot. When done at overlapping intervals (usually 0.6 – 0.8m), a watertight grout curtain is created. This curtain may be constructed in a downward arched shape between two retaining walls to better resist some of the uplift forces. It also helps distributing these uplift forces to the adjacent retaining walls so a shorter wall length can be applied.

- Geomembrane

A geomembrane is a sheet of impermeable synthetic polymer that is placed at the bottom of an excavated pit and subsequently backfilled with ballast material. This is done to protect the sheet from damage, to keep it in place and to prevent it from uplifting.

### B.2.3 Artificial soil retaining layer

- Concrete floor

A concrete floor, when sufficiently thick, is generally impermeable to water and heavy enough to resist uplift forces. It can be constructed in dry conditions when a temporary impermeable layer is installed in the cofferdam, but it is generally constructed using non-reinforced underwater concrete poured in wet conditions. To reduce the height of the concrete floor, tension elements may be driven into the subsoil. The upper tips of these elements are fixed in the floor and transfer vertical uplift forces to the subsoil by means of shaft friction or anchorage plates, reducing the need for ballast material.

- Frozen ground

By pumping liquid nitrogen or highly cooled salty water through the ground using pressure pipes, it is possible to freeze the subsoil. This results in a watertight lump around the pipeline, but if done at several locations, a floor (or wall) of frozen ground can be created. Frozen ground is generally very stiff and has a high compressive strength.

## B.3 Combined methods

### B.3.1 Sloped excavation

The cheapest way to make a building pit is to simply excavate the soil under a slope. The angle of internal friction and cohesion of the subsoil determine the maximum inclination of the slope. Consequently, in weak soils it will be very mild, resulting in a large claim on area in case of a deep excavation. Also, when excavating below the groundwater table, the slopes may become unstable, or the pit may be flooded if the soil is relatively permeable.

### B.3.2 Bottom-up method

In the bottom-up method a cofferdam is created first. Usually a sheet pile wall is used for watertight horizontal soil retention. Combiwall and/or bracing can be applied in case of deep excavations. Vertical soil retention can be achieved by any of the methods mentioned in paragraph B.2, however a geomembrane is usually not



used as it requires a lot of earthworks and another (temporary) watertight layer or extensive drainage before it can be applied.

Once a dry excavated cofferdam is created, construction of the final structure commences, starting at the bottom with a basement floor and followed by walls, possibly intermediate floors and a roof. Afterwards the soil is backfilled, the temporary walls are removed and the roof is covered.

### B.3.3 Top-down method

Top-down construction has been developed to either allow for rapid continuation of activities (Cut and Cover method) above ground, or enable simultaneous construction above and below ground level on the same site.

The general idea is that permanent soil retaining walls (usually sheet pile, secant pile or diaphragm wall), as well as structural foundation elements and columns, are constructed from ground level. Once these are in place, the topsoil is excavated and a first level of bracing is installed. As soon as the excavation is sufficiently deep, construction on top of the site can commence while work continues below ground. With the Cut and Cover method, a roof is placed on top of the excavation pit to allow traffic to pass over it again, minimising hindrance to infrastructure.

### B.3.4 Prefabricated immersion elements (box caisson)

Originally developed in the USA at around 1900, this method was primarily used for tunnel construction. Nowadays it is used for various projects that incorporate a submerged, watertight structure.

Prefab immersion elements (also known as box caissons) generally are concrete or steel elements that are not constructed on site. Instead, they are constructed elsewhere (e.g. at a dry-dock or casting basin), launched and towed to the construction site over water. Once there, they are weighted by ballast water and sunk onto the bed or into a dredged immersion trench. In case there is insufficient space for a sloped excavation, temporary walls may be required to create a stable trench.

Several immersion elements can be connected to form a larger structure. Once a watertight joint is established, the bulkheads between elements are removed, enabling passage from one element into the other. The outer walls, floors and roofs of the elements cover for the final soil/water retention, and non-structural ballast concrete is poured inside or on top of the elements to ensure vertical stability.

### B.3.5 (Pneumatic) caisson method

A caisson is a large box, usually made of concrete or steel, which is sunk into the ground by excavation of the soil underneath it. The circumference of the bottom of the caisson is shaped as a cutting edge, causing the soil to fail under the weight of the caisson and collapse inward.

In an open-well caisson, excavation usually takes place in wet conditions as the working area is connected to the outside environment. In a pneumatic caisson on the other hand, the working chamber is sealed off from the environment and put under overpressure (Figure B-8).

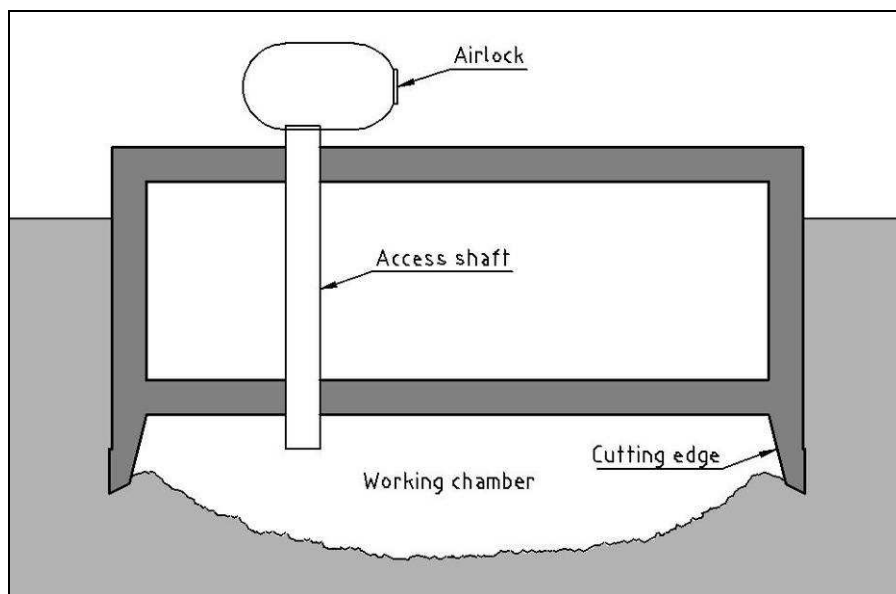

Figure B-8: Schematic visualisation of the pneumatic caisson method

The objective is to counterbalance the (ground)water pressure by the pressurised air, establishing a dry working chamber. Caisson workers enter and leave the chamber through an airlock. Hydraulic guns are used to loosen the soil, allowing the material to be excavated or pumped out of the caisson. If needed, caisson workers can remove obstacles such as rocks or old foundation works.

Once the caisson has reached its desired depth, the working chamber is filled with low-strength concrete and becomes part of the foundation.

# Appendix C Risk assessment

Undesired event (E)		Conseq. M EUR.	Constr. method 1			Constr. method 2			Constr. method 5			Societal [Y/N]
Nr.	Description		p(E)	$\sigma(R)$	R	p(E)	$\sigma(R)$	R	p(E)	$\sigma(R)$	R	
1	Structural damage to quaywalls due to vibrations of sheetpile driving	2.5	25%	1.083	0.625	10%	0.750	0.250	5%	0.545	0.125	Y
2	Damage to the Schreierstoren	2.5	10%	0.750	0.250	5%	0.545	0.125	1%	0.249	0.025	Y
3	Structural damage to adjacent buildings due to vibrations of sheetpile driving	2.5	5%	0.545	0.125	1%	0.249	0.025	5%	0.545	0.125	Y
4	Changing groundwater table due to obstruction of aquifer by garage structure	2.5	1%	0.249	0.025	1%	0.249	0.025	1%	0.249	0.025	Y
5	Damage to adjacent buildings due to leakage of structural walls	2.5	1%	0.249	0.025	5%	0.545	0.125	1%	0.249	0.025	Y
6	Damage to quaywalls due to soil stress relief during sinking of caisson	1	N/A	0	0	N/A	0	0	5%	0.218	0.050	Y
7	Damage to adjacent buildings due to soil stress relief during sinking of caisson	1	N/A	0	0	N/A	0	0	10%	0.300	0.100	Y
8	Cosmetic damage to adjacent buildings due to vibrations of sheetpile driving	1	25%	0.433	0.250	5%	0.218	0.050	25%	0.433	0.250	Y
9	Damage to adjacent buildings due to leakage of sheetpile walls	1	10%	0.300	0.100	1%	0.099	0.010	N/A	0	0	Y
10	Deformations due to improper design of sheetpile wall	1	5%	0.218	0.050	1%	0.099	0.010	5%	0.218	0.050	Y
11	Deformations due to failure of struts / wall bracing	1	1%	0.099	0.010	1%	0.099	0.010	1%	0.099	0.010	Y
12	Inaccessibility of buildings due to obstruction of roadways	0.5	25%	0.217	0.125	25%	0.217	0.125	25%	0.217	0.125	Y
13	Damage to Bantammerbrug	0.5	5%	0.109	0.025	5%	0.109	0.025	1%	0.050	0.005	Y
14	Damage to, or disturbance of, ecology on/in quaywall	0.25	100%	0.000	0.250	100%	0.000	0.250	100%	0.000	0.250	Y
15	Damage to quay wall due to construction traffic	0.25	50%	0.125	0.125	50%	0.125	0.125	50%	0.125	0.125	Y
16	Damage due to unexpected cables and pipelines	0.25	50%	0.125	0.125	50%	0.125	0.125	50%	0.125	0.125	Y
17	Damage to adjacent buildings due to construction traffic	0.25	25%	0.108	0.063	25%	0.108	0.063	25%	0.108	0.063	Y
18	Jamming/tilting of caisson element during sinking	2.5	N/A	0	0	N/A	0	0	5%	0.545	0.125	N
19	Flooding of caisson working chamber due to dropout of air pressure system	2.5	N/A	0	0	N/A	0	0	1%	0.249	0.025	N
20	Delays due to innovative construction method	2.5	N/A	0	0	N/A	0	0	25%	1.083	0.625	N
21	Design not executable without additional measures	2.5	5%	0.545	0.125	5%	0.545	0.125	5%	0.545	0.125	N
22	Problems during excavation of diaphragm walls due to unexpected obstacles	1	N/A	0	0	50%	0.500	0.500	N/A	0	0	N
23	Archeological discovery of buildings	1	10%	0.300	0.100	10%	0.300	0.100	10%	0.300	0.100	N
24	Flooding of cofferdam due to dropout of pumping system	1	1%	0.099	0.010	1%	0.099	0.010	N/A	0	0	N
25	Leakage of joint between caisson elements	0.5	N/A	0	0	N/A	0	0	10%	0.150	0.050	N
26	Loss of prefab elements during transportation over water	0.5	N/A	0	0	N/A	0	0	1%	0.050	0.005	N
27	Disfunctional watertight sealing between prefab elements	0.5	N/A	0	0	N/A	0	0	10%	0.150	0.050	N
28	Problems during driving of sheetpiles due to unexpected obstacles	0.5	50%	0.250	0.250	5%	0.109	0.025	25%	0.217	0.125	N
29	Problems during main excavation due to unexpected obstacles	0.5	25%	0.217	0.125	25%	0.217	0.125	25%	0.217	0.125	N
30	Insufficient bearing capacity of subsoil resulting in more foundation elements	0.5	5%	0.109	0.025	5%	0.109	0.025	N/A	0	0	N

CONSTRUCTING A PARKING GARAGE UNDERNEATH HISTORICAL CITY CANALS

31	Archaeological discovery of objects	0.25	100%	0.000	0.250	100%	0.000	0.250	100%	0.000	0.250	N
32	Bursting of UWC-floor due to failure of tension elements	0.25	5%	0.054	0.013	5%	0.054	0.013	N/A	0	0	N
33	Bursting of UWC-floor due to UWC malfunctioning	0.25	5%	0.054	0.013	5%	0.054	0.013	N/A	0	0	N
34	Delays due to violation of noise regulations	0.25	5%	0.054	0.013	1%	0.025	0.003	5%	0.054	0.013	N
<b>Σ(M) Estimated standard deviation of total risk</b>			<b>1.766</b>			<b>1.477</b>			<b>1.821</b>			
<b>M Total estimated risk (Million EUR)</b>			<b>3.095</b>			<b>2.530</b>			<b>3.095</b>			

# Appendix D Cost estimate

## D.1 Construction method 1

Item	Description	Qty.	Unit	Unit price	Total	Margin
5A1	Setting up work area	1 -	€	10,000.00	€ 10,000.00	
5A2	Breaking up of existing pavement	1 -	€	5,000.00	€ 5,000.00	
5A3	Demolishing of existing quaywall	220 m <sup>1</sup>	€	500.00	€ 110,000.00	
5A4	Removal of trees	1 -	€	10,000.00	€ 10,000.00	
<b>5A</b>	<b>Preparatory works</b>				€ 135,000.00	30%
5B5	Street level provisions	2 -	€	25,000.00	€ 50,000.00	
5B2	Application of temporary sheetpiles AZ26-700	4,000 m <sup>2</sup>	€	80.00	€ 320,000.00	
5B3	Application of girders and props	30 ton	€	1,000.00	€ 30,000.00	
5B4	Application of grout anchors	46 -	€	4,000.00	€ 184,000.00	
5B5	Relocation of boats	7 -	€	30,000.00	€ 210,000.00	
5B6	Provisions to accomodate discharge Waternet	1 -	€	25,000.00	€ 25,000.00	
<b>5B</b>	<b>Temporary provisions</b>				€ 819,000.00	30%
5C1	Wet excavation of soil	5,500 m <sup>3</sup>	€	2.00	€ 11,000.00	
5C2	Disposal of soil, 10km one-way	5,500 m <sup>3</sup>	€	7.50	€ 41,250.00	
5C3	Backfilling sand fill between structure and sheetpiles	2,500 m <sup>3</sup>	€	12.50	€ 31,250.00	
5C4	Removal and disposal of silt	5,500 m <sup>3</sup>	€	15.00	€ 82,500.00	
5C5	Acceptance costs of disposed silt	8,250 ton	€	30.00	€ 247,500.00	
5C6	Application of sandfill on top of structure	5,250 m <sup>3</sup>	€	12.50	€ 65,625.00	
5C7	Hydraulicking soil underneath caisson	66,220 m <sup>3</sup>	€	6.00	€ 397,320.00	
5C8	Disposal of soil underneath caisson, 10km one-way	66,220 m <sup>3</sup>	€	7.50	€ 496,650.00	
<b>5C</b>	<b>Soil works</b>				€ 1,373,095.00	40%
5D1	Application of groutinjection piles, l=11m	40 -	€	3,500.00	€ 140,000.00	
5D2	Application of steel tubular piles Ø500x6mm, l=15m	10 -	€	3,000.00	€ 30,000.00	
<b>5D</b>	<b>Foundation works</b>				€ 170,000.00	30%
5E1	Application of underwater concrete floor, t=1500mm	340 m <sup>3</sup>	€	120.00	€ 40,800.00	
5E2	Application of levelling layer UWC, t=100mm	60 m <sup>3</sup>	€	150.00	€ 9,000.00	
5E3	Application of concrete floor, t=1000mm	4,730 m <sup>3</sup>	€	300.00	€ 1,419,000.00	
5E4	Application of prefab floor, t=500mm	3,225 m <sup>3</sup>	€	600.00	€ 1,935,000.00	
5E5	Application of concrete walls, t=600mm	6,160 m <sup>3</sup>	€	450.00	€ 2,772,000.00	
5E6	Application of concrete roof, t=1000mm	4,730 m <sup>3</sup>	€	350.00	€ 1,655,500.00	
5E7	Application of floor entrance/exit ramps, t=500mm	400 m <sup>3</sup>	€	350.00	€ 140,000.00	
5E8	Application of columns, Ø700mm	18 -	€	600.00	€ 10,800.00	
5E9	Application of cement screed	12,600 m <sup>2</sup>	€	35.00	€ 441,000.00	
5E10	Application of concrete fill underneath caisson	9,460 m <sup>3</sup>	€	120.00	€ 1,135,200.00	
5E11	Prefab caisson elements	36 -	€	40,000.00	€ 1,440,000.00	
5E12	Application of concrete diaphragm walls, t=800mm	0 m <sup>3</sup>	€	550.00	€ -	
<b>5E</b>	<b>Concrete works</b>				€ 10,998,300.00	15%
5F1	Installations for water and electricity	1 -	€	755,000.00	€ 755,000.00	
5F2	Staircases, elevators, etc.	1 -	€	250,000.00	€ 250,000.00	
5F3	Restoring old quaywall	20 m <sup>1</sup>	€	7,500.00	€ 150,000.00	
5F4	Reconstruction of quaywall	200 m <sup>1</sup>	€	2,500.00	€ 500,000.00	
5F5	Replanting trees	1 -	€	90,000.00	€ 90,000.00	
5F6	Restoring pavement on quay	1 -	€	20,000.00	€ 20,000.00	
5F7	Ducts and cables (3rd parties)	1 -	€	20,000.00	€ 20,000.00	
5F8	Research of excavated soil on archaeological findings	1 -	€	100,000.00	€ 100,000.00	
5F9	Immersion provisions	1 -	€	250,000.00	€ 250,000.00	
<b>5F</b>	<b>Remaining provisions</b>				€ 2,135,000.00	30%
	<b>Subtotal direct costs</b>				€ 15,630,395.00	20%
<b>5G</b>	<b>Yet to be detailed</b>	10%	€	15,630,395.00	€ 1,563,039.50	
	<b>Direct costs</b>				€ 17,193,434.50	
	<i>One-time costs / construction site costs / execution costs</i>	10%	€	17,193,434.50	€ 1,719,343.45	
	<i>General costs / profit and risk / contributions</i>	13%	€	17,193,434.50	€ 2,235,146.49	
	<b>Indirect costs</b>				€ 3,954,489.94	
	<i>Contingency allowance</i>	10%	€	21,147,924.44	€ 2,114,792.44	
	<i>Engineering, administration and supervision</i>	20%	€	23,262,716.88	€ 4,652,543.38	
	<b>Additional costs</b>				€ 6,767,335.82	
	<b>Subtotal total costs</b>				€ 27,915,260.25	
	<b>Round off</b>				€ 260.25-	
	<b>Total costs (VAT excluded)</b>				€ 27,915,000.00	

## D.2 Construction method 2

Item	Description	Qty.	Unit	Unit price	Total	Margin
2A1	Setting up work area	1	-	€ 10,000.00	€ 10,000.00	
2A2	Breaking up of existing pavement	1	-	€ 5,000.00	€ 5,000.00	
2A3	Demolishing of existing quaywall	220	m <sup>1</sup>	€ 500.00	€ 110,000.00	
2A4	Removal of trees	1	-	€ 10,000.00	€ 10,000.00	
<b>2A</b>	<b>Preparatory works</b>				€ 135,000.00	30%
2B1	Street level provisions	1	-	€ 25,000.00	€ 25,000.00	
2B2	Application of temporary sheetpiles AZ26-700	7,440	m <sup>2</sup>	€ 80.00	€ 595,200.00	
2B3	Application of girders and props	0	ton	€ 1,000.00	€ -	
2B4	Application of grout anchors	0	-	€ 4,000.00	€ -	
2B5	Relocation of boats	7	-	€ 30,000.00	€ 250,000.00	
2B6	Provisions to accomodate discharge Waternet	1	-	€ 25,000.00	€ 25,000.00	
<b>2B</b>	<b>Temporary provisions</b>				€ 895,200.00	30%
2C1	Wet excavation of soil	50,000	m <sup>3</sup>	€ 2.00	€ 100,000.00	
2C2	Disposal of soil, 10km one-way	50,000	m <sup>3</sup>	€ 7.50	€ 375,000.00	
2C3	Backfilling sand fill between structure and sheetpiles	2,500	m <sup>3</sup>	€ 12.50	€ 31,250.00	
2C4	Removal and disposal of silt	3,000	m <sup>3</sup>	€ 15.00	€ 45,000.00	
2C5	Acceptance costs of disposed silt	4,500	ton	€ 30.00	€ 135,000.00	
2C6	Application of sandfill on top of structure	6,350	m <sup>3</sup>	€ 12.50	€ 79,375.00	
2C7	Hydraulicking soil underneath caisson	0	m <sup>3</sup>	€ 5.00	€ -	
2C8	Disposal of soil underneath caisson, 10km one-way	0	m <sup>3</sup>	€ 7.50	€ -	
<b>2C</b>	<b>Soil works</b>				€ 686,250.00	40%
2D1	Application of groutinjection piles, l=11m	665	-	€ 3,000.00	€ 1,995,000.00	
2D2	Application of steel tubular piles Ø500x6mm, l=15m	8	-	€ 2,750.00	€ 22,000.00	
<b>2D</b>	<b>Foundation works</b>				€ 2,017,000.00	30%
2E1	Application of underwater concrete floor, t=1500mm	9,030	m <sup>3</sup>	€ 120.00	€ 1,083,600.00	
2E2	Application of levelling layer UWC, t=100mm	600	m <sup>3</sup>	€ 150.00	€ 90,000.00	
2E3	Application of concrete floor, t=800mm	4,820	m <sup>3</sup>	€ 300.00	€ 1,446,000.00	
2E4	Application of prefab floor, t=500mm	6,020	m <sup>3</sup>	€ 600.00	€ 3,612,000.00	
2E5	Application of concrete walls, t=600mm	0	m <sup>3</sup>	€ 450.00	€ -	
2E6	Application of concrete roof, t=800mm	4,820	m <sup>3</sup>	€ 350.00	€ 1,687,000.00	
2E7	Application of floor entrance/exit ramps, t=500mm	400	m <sup>3</sup>	€ 350.00	€ 140,000.00	
2E8	Application of columns, Ø700mm	56	-	€ 600.00	€ 33,600.00	
2E9	Application of cement screed	12,000	m <sup>2</sup>	€ 35.00	€ 420,000.00	
2E10	Application of concrete fill underneath caisson	0	m <sup>3</sup>	€ 120.00	€ -	
2E11	Prefab caisson elements	0	-	€ 40,000.00	€ -	
2E12	Application of concrete diaphragm walls, t=800mm	9,530	m <sup>3</sup>	€ 550.00	€ 5,241,500.00	
<b>2E</b>	<b>Concrete works</b>				€ 13,753,700.00	15%
2F1	Installations for water and electricity	1	-	€ 1,025,000.00	€ 1,025,000.00	
2F2	Staircases, elevators, etc.	1	-	€ 250,000.00	€ 250,000.00	
2F3	Restoring old quaywall	0	m <sup>1</sup>	€ 7,500.00	€ -	
2F4	Reconstruction of quaywall	220	m <sup>1</sup>	€ 2,500.00	€ 550,000.00	
2F5	Replanting trees	1	-	€ 90,000.00	€ 90,000.00	
2F6	Restoring pavement on quay	1	-	€ 20,000.00	€ 20,000.00	
2F7	Ducts and cables (3rd parties)	1	-	€ 20,000.00	€ 20,000.00	
2F8	Research of excavated soil on archaeological findings	1	-	€ 100,000.00	€ 100,000.00	
2F9	Immersion provisions	0	-	€ 250,000.00	€ -	
<b>2F</b>	<b>Remaining provisions</b>				€ 2,055,000.00	30%
	<b>Subtotal direct costs</b>				€ 19,542,150.00	20%
<b>2G</b>	<b>Yet to be detailed</b>	10%		€ 19,542,150.00	€ 1,954,215.00	
	<b>Direct costs</b>				€ 21,496,365.00	
	One-time costs / construction site costs / execution costs	10%		€ 21,496,365.00	€ 2,149,636.50	
	General costs / profit and risk / contributions	13%		€ 21,496,365.00	€ 2,794,527.45	
	<b>Indirect costs</b>				€ 4,944,163.95	
	Contingency allowance	10%		€ 26,440,528.95	€ 2,644,052.90	
	Engineering, administration and supervision	20%		€ 29,084,581.85	€ 5,816,916.37	
	<b>Additional costs</b>				€ 8,460,969.26	
	<b>Subtotal total costs</b>				€ 34,901,498.21	
	<b>Round off</b>				€ 498.21-	
	<b>Total costs (VAT excluded)</b>				€ 34,901,000.00	

## D.3 Construction method 5

Item	Description	Qty.	Unit	Unit price	Total	Margin
5A1	Setting up work area	1	-	€ 10,000.00	€ 10,000.00	
5A2	Breaking up of existing pavement	1	-	€ 5,000.00	€ 5,000.00	
5A3	Demolishing of existing quaywall	220	m <sup>1</sup>	€ 500.00	€ 110,000.00	
5A4	Removal of trees	1	-	€ 10,000.00	€ 10,000.00	
<b>5A</b>	<b>Preparatory works</b>				€ 135,000.00	30%
5B5	Street level provisions	2	-	€ 25,000.00	€ 50,000.00	
5B2	Application of temporary sheetpiles AZ26-700	4,000	m <sup>2</sup>	€ 80.00	€ 320,000.00	
5B3	Application of girders and props	30	ton	€ 1,000.00	€ 30,000.00	
5B4	Application of grout anchors	46	-	€ 4,000.00	€ 184,000.00	
5B5	Relocation of boats	7	-	€ 30,000.00	€ 210,000.00	
5B6	Provisions to accomodate discharge Waternet	1	-	€ 25,000.00	€ 25,000.00	
<b>5B</b>	<b>Temporary provisions</b>				€ 819,000.00	30%
5C1	Wet excavation of soil	5,500	m <sup>3</sup>	€ 2.00	€ 11,000.00	
5C2	Disposal of soil, 10km one-way	5,500	m <sup>3</sup>	€ 7.50	€ 41,250.00	
5C3	Backfilling sand fill between structure and sheetpiles	2,500	m <sup>3</sup>	€ 12.50	€ 31,250.00	
5C4	Removal and disposal of silt	5,500	m <sup>3</sup>	€ 15.00	€ 82,500.00	
5C5	Acceptance costs of disposed silt	8,250	ton	€ 30.00	€ 247,500.00	
5C6	Application of sandfill on top of structure	5,250	m <sup>3</sup>	€ 12.50	€ 65,625.00	
5C7	Hydraulicking soil underneath caisson	66,220	m <sup>3</sup>	€ 6.00	€ 397,320.00	
5C8	Disposal of soil underneath caisson, 10km one-way	66,220	m <sup>3</sup>	€ 7.50	€ 496,650.00	
<b>5C</b>	<b>Soil works</b>				€ 1,373,095.00	40%
5D1	Application of groutinjection piles, l=11m	40	-	€ 3,500.00	€ 140,000.00	
5D2	Application of steel tubular piles Ø500x6mm, l=15m	10	-	€ 3,000.00	€ 30,000.00	
<b>5D</b>	<b>Foundation works</b>				€ 170,000.00	30%
5E1	Application of underwater concrete floor, t=1500mm	340	m <sup>3</sup>	€ 120.00	€ 40,800.00	
5E2	Application of levelling layer UWC, t=100mm	60	m <sup>3</sup>	€ 150.00	€ 9,000.00	
5E3	Application of concrete floor, t=1000mm	4,730	m <sup>3</sup>	€ 300.00	€ 1,419,000.00	
5E4	Application of prefab floor, t=500mm	3,225	m <sup>3</sup>	€ 600.00	€ 1,935,000.00	
5E5	Application of concrete walls, t=600mm	6,160	m <sup>3</sup>	€ 450.00	€ 2,772,000.00	
5E6	Application of concrete roof, t=1000mm	4,730	m <sup>3</sup>	€ 350.00	€ 1,655,500.00	
5E7	Application of floor entrance/exit ramps, t=500mm	400	m <sup>3</sup>	€ 350.00	€ 140,000.00	
5E8	Application of columns, Ø700mm	18	-	€ 600.00	€ 10,800.00	
5E9	Application of cement screed	12,600	m <sup>2</sup>	€ 35.00	€ 441,000.00	
5E10	Application of concrete fill underneath caisson	9,460	m <sup>3</sup>	€ 120.00	€ 1,135,200.00	
5E11	Prefab caisson elements	36	-	€ 100,000.00	€ 3,600,000.00	
5E12	Application of concrete diaphragm walls, t=800mm	0	m <sup>3</sup>	€ 550.00	€ -	
<b>5E</b>	<b>Concrete works</b>				€ 13,158,300.00	15%
5F1	Installations for water and electricity	1	-	€ 755,000.00	€ 755,000.00	
5F2	Staircases, elevators, etc.	1	-	€ 250,000.00	€ 250,000.00	
5F3	Restoring old quaywall	20	m <sup>1</sup>	€ 7,500.00	€ 150,000.00	
5F4	Reconstruction of quaywall	200	m <sup>1</sup>	€ 2,500.00	€ 500,000.00	
5F5	Replanting trees	1	-	€ 90,000.00	€ 90,000.00	
5F6	Restoring pavement on quay	1	-	€ 20,000.00	€ 20,000.00	
5F7	Ducts and cables (3rd parties)	1	-	€ 20,000.00	€ 20,000.00	
5F8	Research of excavated soil on archaeological findings	1	-	€ 100,000.00	€ 100,000.00	
5F9	Immersion provisions	1	-	€ 250,000.00	€ 250,000.00	
<b>5F</b>	<b>Remaining provisions</b>				€ 2,135,000.00	30%
	<b>Subtotal direct costs</b>				€ 17,790,395.00	20%
<b>5G</b>	<b>Yet to be detailed</b>	10%		€ 17,790,395.00	€ 1,779,039.50	
	<b>Direct costs</b>				€ 19,569,434.50	
	<i>One-time costs / construction site costs / execution costs</i>	10%		€ 19,569,434.50	€ 1,956,943.45	
	<i>General costs / profit and risk / contributions</i>	13%		€ 19,569,434.50	€ 2,544,026.49	
	<b>Indirect costs</b>				€ 4,500,969.94	
	<i>Contingency allowance</i>	10%		€ 24,070,404.44	€ 2,407,040.44	
	<i>Engineering, administration and supervision</i>	20%		€ 26,477,444.88	€ 5,295,488.98	
	<b>Additional costs</b>				€ 7,702,529.42	
	<b>Subtotal total costs</b>				€ 31,772,933.85	
	<b>Round off</b>				€ 66.15	
	<b>Total costs (VAT excluded)</b>				€ 31,773,000.00	



# Appendix E Cross-sectional dimensions of the garage

## E.1 Roof

Preliminary estimate for concrete plates without prestressing, according to GTB 2006<sup>[15]</sup>:

$$\bullet \quad \frac{l}{t} = \frac{225}{l} \quad \rightarrow \quad t = \sqrt{\frac{l^2}{225}} \quad (\text{for } l > 7m)$$

With  $l \approx 15m$ , this results in  $t = 1m$ .

## E.2 Outer walls

It is assumed that the outer walls are propped by the intermediate floors, reducing their effective span and maximum bending moments. Rigid walls are required to retain water and soil pressures in the final stage. In the construction stage, they must also ensure the torsional and bending stiffness of the entire caisson during the immersion process.

For now, a similar thickness as the roof is adopted, 1m.

## E.3 Intermediate floors

According to NEN 6702, the representative distributed load on the parking floors equals  $2kN/m^2$  for cars with a weight of less than  $25kN$ , with a transient load factor of  $\psi = 0.7$ .<sup>[16]</sup>

The intermediate floors should be constructed as slender as possible to limit the excavation depth of the caissons. The floors consist of two parts: a main span of  $14.8m$ , and a smaller span of  $4m$  at the ramps and parking road on the eastern side of the garage. Since the main span is quite large, the application of prefabricated prestressed floor elements seems advisable here.

Renowned Dutch suppliers of prestressed concrete elements produce certified TT-plates with a height of 430-450mm that can span up to 16m.<sup>1</sup> In case these plates are applied, special provisions for bracing the outer walls need to be applied, as the prestressed TT-plates can't transfer large axial forces. The props can be conveniently placed in between of the webs underneath the TT-plates.

The short spans need to carry the same load, but more importantly, connect the node where columns/intermediate walls meet with the bearing of the prestressed plates, with the outer wall. A thickness of 400mm is assumed.

## E.4 Basement floor

The basement floor is constructed on top of the prefab immersion elements, which then temporarily rise above the water table. But even though it is fixed to the elements, the elements don't necessarily contribute to the strength and stiffness of the caisson floor in all directions. The elements are placed perpendicular to the longitudinal axis of the garage, so without special provisions, the elements only contribute to the bending stiffness in lateral direction; not in longitudinal.

After pouring, the basement floor should already be stiff enough to prevent cracking due to unequal settlements of the elements. Constructing stiffening walls in longitudinal direction before pouring the entire floor may help solve this issue.

## E.5 Columns

A coarse calculation of the load distribution in the final stage of construction can now be made. The submerged weight of the soil is assumed conservatively at  $\rho = 20kN/m^3$ . Also, a reduction of the Young's modulus is used to account for cracking of the concrete. It assumed to be approximately  $10 \cdot 10^6 kN/m^2$ . Including soil- and water-pressures and a variable load of  $2kN/m^2$  on the parking floors, the axial forces in the structure are as shown in Figure E-1 for the Ultimate Limit State.

---

<sup>1</sup> Source: WWW.BETONSON.NL, WWW.SPANBETON.NL

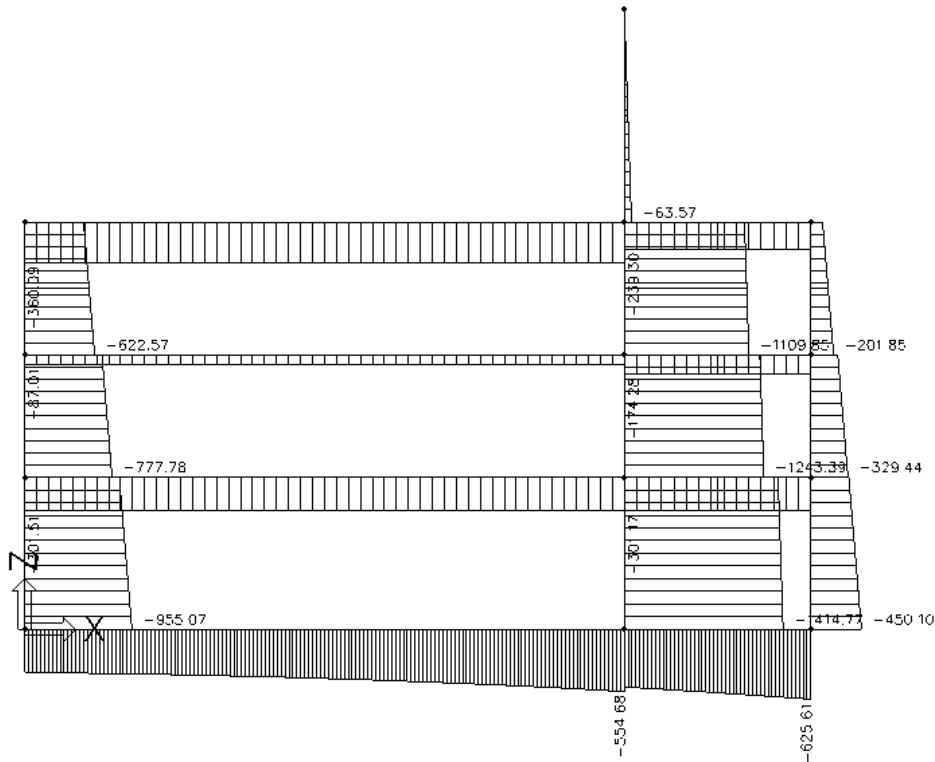

Figure E-1: Axial forces, ULS, per running meter (kN, as determined using a 1<sup>st</sup> order 2D linear static model in SCIA ENGINEER)

The maximum axial force on the intermediate walls equals  $1414.77\text{ kN}$ . This is the load on the walls with a thickness of  $0.4\text{ m}$ . The corresponding column load can be found by subtracting the self-weight of the walls, multiplying by the C.T.C.-distance of the columns and adding the self-weight of the columns. As a preliminary estimate, it is assumed that the columns have a diameter of  $700\text{ mm}$ . The maximum C.T.C.-distance of the columns is  $8\text{ m}$  (refer to figure 9-1).

- $$\left( N'_{d,\text{wall}} - \frac{\gamma_w \cdot l \cdot t \cdot \rho g}{1000} \right) \cdot \text{C.T.C.} + \frac{\gamma_w \cdot l \cdot \frac{1}{4} \pi D^2 \cdot \rho g}{1000} = N'_{d,\text{column}}$$
- $$\left( 1414.77 - \frac{1.2 \cdot 10.3 \cdot 0.4 \cdot 2500 \cdot 9.81}{1000} \right) \cdot 8 + \frac{1.2 \cdot 10.3 \cdot \frac{1}{4} \pi 0.7^2 \cdot 2500 \cdot 9.81}{1000} = 10469\text{ kN}$$

2<sup>nd</sup> Order bending moments don't need to be evaluated if:

- $\lambda_n \leq 15 - 10\alpha_n$  for  $0.5 < \alpha_n < 1.0$

With:

$$\lambda_n = l_c / h$$

$l_c$  = buckling length, estimated at  $0.7l$  (some freedom of rotation at both ends).

$$h = i\sqrt{12} \quad (\text{Equivalent section height})$$

$$i = \sqrt{I / A_c} \quad (\text{Primary radius of gyration})$$

$$I = \frac{1}{4} \pi r^4 \quad (\text{Moment of inertia})$$

$$A_c = \pi r^2 \quad (\text{Concrete cross-sectional area})$$

$$\rightarrow h = \sqrt{12 \frac{\frac{1}{4} \pi r^4}{\pi r^2}} = \sqrt{3r^2}$$

$$\alpha_n = \frac{N'_d}{A_c f'_b}$$

For  $l = 2.6m$ , and assuming concrete strength class C45/55, this results in:

$$h = \sqrt{3 \cdot 0.35^2} = 0.606m$$

$$\lambda_h = 0.7 \cdot 2.6 / 0.606 \approx 3.0$$

$$\alpha_n = \frac{10.469 \cdot 10^6}{384.8 \cdot 10^3 \cdot 33} \approx 0.824$$

Unity check:

$$\frac{\lambda_h}{15 - 10\alpha_n} \leq 1 \quad \rightarrow \quad \frac{3.0}{15 - 10 \cdot 0.824} \approx 0.444 \leq 1$$

A column diameter of 700mm seems to be sufficient. It may be possible to decrease the width of the columns by taking into account the diaphragm action of the new quaywall. This wall, built on top of the garage structure, bridges the spans between the columns and will effectively reduce the loads on the columns. Linear static 3D-analysis of a half-space of the garage results in the following axial column forces:

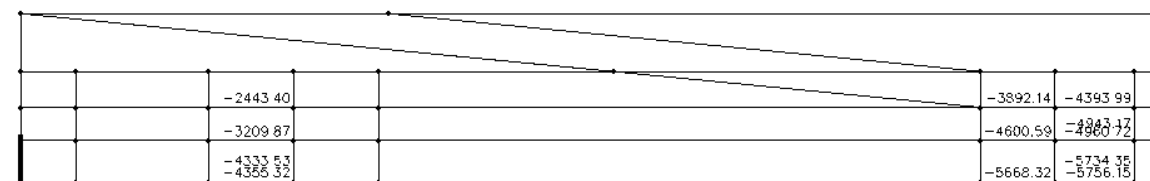

Figure E-2: Axial forces in columns, ULS (kN, as determined using a 1<sup>st</sup> order 3D linear static model in SCIA Engineer)

It can be seen in Figure E-2 that the axial forces in the columns on the left are more than halved, indicating the importance of the diaphragm action of the new quaywall. The diaphragm action of the wall on the right-hand side of this figure is of less influence: the effective span of the wall is larger so it acts less stiff.

The large deviations in axial forces on the columns could also be caused by a modelling error. In order to validate the 3D-model, the bending moments in the roof

of the garage are compared with those found in the 2D-model. As can be derived by comparing Figure E-3 and Figure E-4, these are almost similar.

Arguably, the diaphragm action of the quaywall can not be used to increase the slenderness of the quaywall for two reasons:

- The garage is subdivided into several sections: the caisson elements. These elements are immersed separately, so the diaphragm action may not yet be fully developed at the end of a caisson element.
- The caissons are built from the bottom up, so the columns and the roof of the garage are completed before the quaywall on top is constructed. Consequently, the columns must at least be able to carry the weight of the roof of the garage.

Optimisation studies on this subject in a later design stage may allow for reduction of the column diameter, but is considered to be outside the scope of this research.

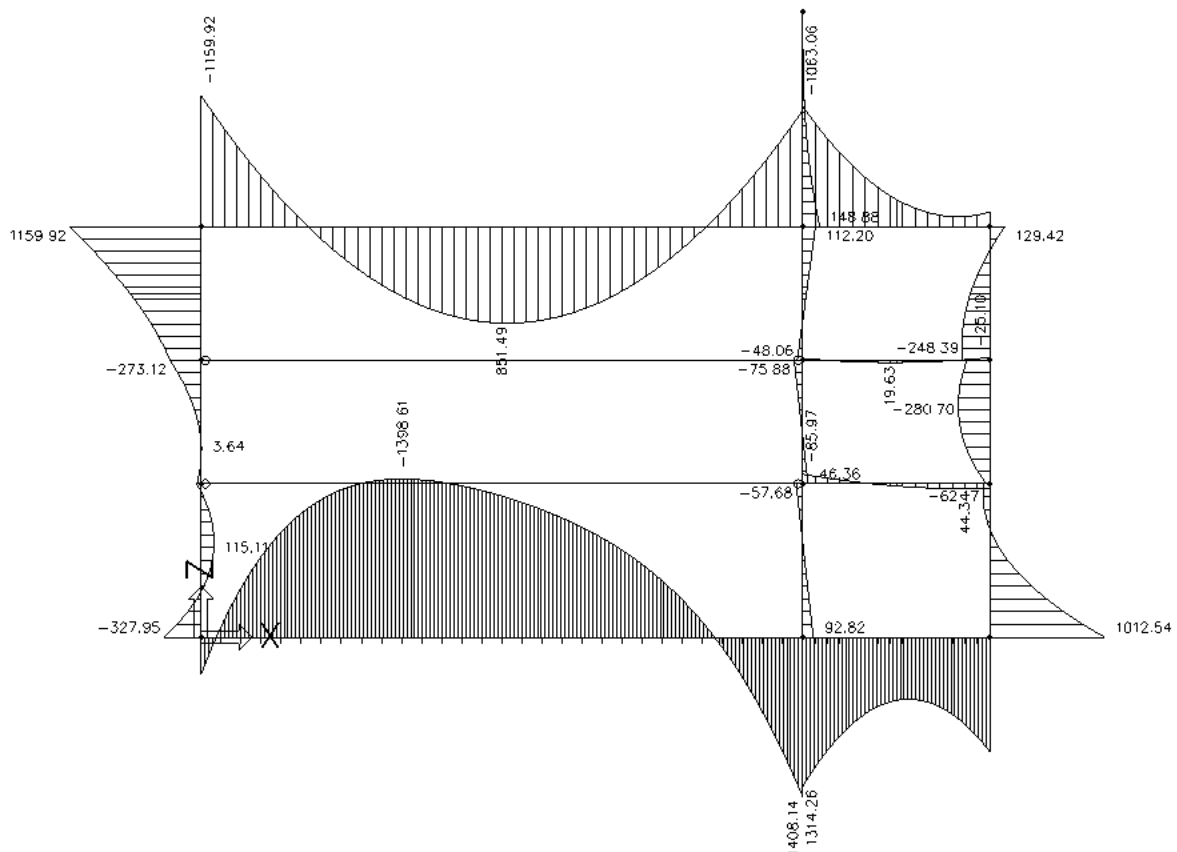

Figure E-3: Bending moments, ULS (kNm, as determined using a 2D linear static model in SCIA ENGINEER)

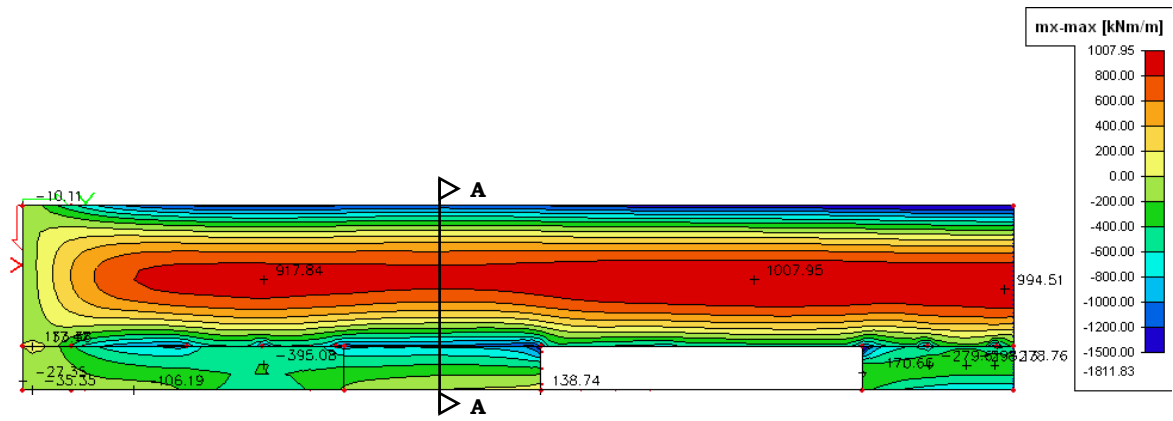

Figure E-4: Bending moments in roof, ULS (as determined using a 3D linear static model in SCIA ENGINEER). The section of the 2D-model is denoted by A-A.

# Appendix F Design of the prefab elements

This appendix provides several *EXCEL*-spreadsheets as used for the calculations and iteration process on the design of the prefab immersion elements, as well as the code used for the software package *MAPLE*. It also provides some calculations done on the protruding reinforcement bars of the prefab elements.

## F.1 Bearing capacity of cutting edges

**CUTTING EDGE BEARING CAPACITY: STRIP FOUNDATION ACCORDING TO NEN6744:2007 / BRINCH HANSEN**

**Loads and foundation strip dimensions**

Effective width of cutting edge	$w'$	1.1 m
Angle of cutting edge with horizontal plane	$\varphi_{edge}$	15 °
Cutting depth	$z$	0.50 m
Vertical force	$F_{s;v;d}$	463.8 kN/m
Effective area of foundation	$A'$	1.10 m <sup>2</sup>
Height of cutting edge	$h_{edge}$	0.29 m
Effective soil coverage	$d$	0.21 m
Horizontal reactioning force	$F_{r;h;d}$	124.27 kN/m
Ratio between horizontal and vertical forces	$F_{r;h}/F_{rv}$	0.27 -
Resulting reaction force	$F_{r;d}$	480.16 kN/m

**Soil parameters**

Effective angle of internal friction	$\varphi'_{avg;d}$	30 °
Effective volumetric weight near foundation strip	$\gamma'_{avg;d}$	8 kN/m <sup>3</sup>
Effective cohesion	$c'_{avg;d}$	0 kN/m <sup>2</sup>

**Influence zone**

Width ratio for $F_{s;h}/F_{s;v}=0$	$a_e/w'$	1.62 -
Width ratio for $F_{s;h}/F_{s;v}=1$	$a_e/w'$	4.26 -
Depth ratio for $F_{s;h}/F_{s;v}=0$	$z_e/w'$	0.59 -
Depth ratio for $F_{s;h}/F_{s;v}=1$	$z_e/w'$	1.58 -
Influence width	$a_e$	2.56 m
Influence depth	$z_e$	0.94 m

**Load factors**

Bearing capacity factor (soil coverage)	$N_q$	18.40 -	
Bearing capacity factor (cohesion)	$N_c$	30.14 -	
Bearing capacity factor (soil weight)	$N_\gamma$	20.09 -	
Shape factor (soil coverage)	$s_q$	1 -	
Shape factor (cohesion)	$s_c$	1 -	
Shape factor (soil weight)	$s_\gamma$	1 -	
Reduction factor for oblique load (soil coverage)	$i_q$	0.54 -	0.29 -
Reduction factor for oblique load (cohesion)	$i_c$	0.51 -	0.54 -
Reduction factor for oblique load (soil weight)	$i_\gamma$	0.39 -	0.15 -
Effective vertical soil stress at foundation level	$\sigma'_{v;z;d}$	1.64 kN/m <sup>2</sup>	
Maximum foundation pressure	$\sigma'_{max;d}$	50.89 kN/m <sup>2</sup>	22.28 kN/m <sup>2</sup>

**Foundation bearing capacity**

$F_{max;d}$	<b>55.98 kN</b>	<b>24.51 kN</b>	<b>Insufficient bearing capacity!</b>
-------------	-----------------	-----------------	---------------------------------------

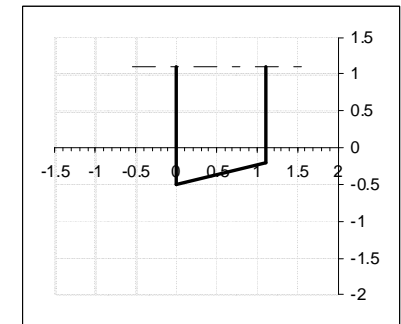
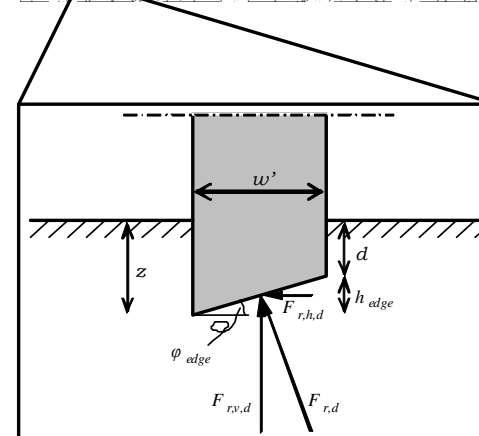
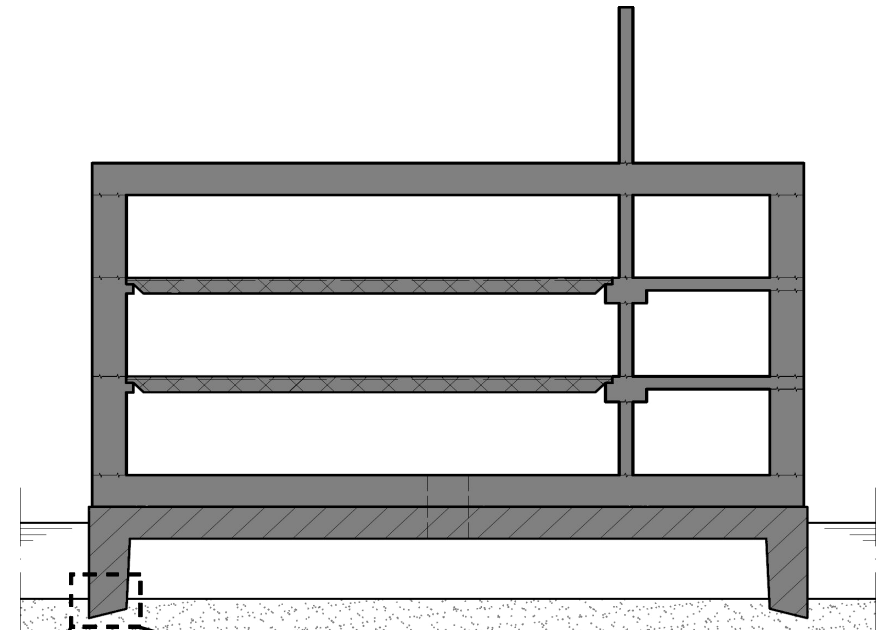

Verruijt:



## F.2 Element buoyancy and stability

### F.2.1 Alternative 1: Concrete

**FLOATING STABILITY OF PREFAB CONCRETE CAISSON SHOE WITH ADDED BUOYANCY IN WORKING CHAMBER**

**Input**

Length of element	$l_{element}$	21 m
Width of element	$w_{element}$	5.85 m
Height of floor	$h_{floor}$	0.6 m
Height of retaining wall	$h_{ret}$	0.5 m
Width of retaining edge wall	$w_{ret}$	0.3 m
Height of cutting edge wall	$h_{wall}$	2.1 m
Inner wall angle	$\varphi_{wall}$	0°
Height of cutting edge	$h_{edge}$	0.295 m
Cutting edge angle	$\varphi_{edge}$	74.99°
Density of filling material	$\rho_{fill}$	40 kg/m <sup>3</sup>
Thickness of bulkhead	$t_{bulkhead}$	0.02 m
Volumetric steel content	$\omega_s$	2%
Water depth	$d_w$	3 m

**Consequential input**

Height of element	$h_{element}$	3.50 m
Height of working chamber	$h_{chamber}$	2.40 m
Width of wall at floor	$w_{wall}$	1.10 m
Tangent of wall	$\tan(\varphi_{wall})$	0.00 -
Width of wall at cutting edge	$w_{edge}$	1.10 m
Tangent of cutting edge	$\tan(\varphi_{edge})$	3.73 -

**Output**

Volume of element excl. filling material	$V_{element}$	110.52 m <sup>3</sup>	
Mass of steel	$m_s$	31488.78 kg	
Mass of concrete	$m_c$	259931.84 kg	
Mass of filling material	$m_{fill}$	9174.97 kg	
Mass of element	$m_{element}$	300595.59 kg	
Volume of water displacement	$V_{displ}$	300.60 m <sup>3</sup>	
Draught (rel. to water table)	$D$	-2.73 m	
Clearance above water (freeboard)	$h_{clearance}$	0.77 m	
Center of buoyancy (rel. to water table)	$B$ [•]	-1.22 m	
Center of gravity (rel. to water table)	$G$ [•]	-0.40 m	
Moment of inertia of water table intersect.	$I_{water}$	350.35 m	
Initial metacentre (rel. to $B$ )	$EM$	1.17 m	
Tilt check: distance $GM > 0$	$GM$	0.34 m	No tilting
Tilt angle (rel. to vertical)	$\varphi_{tilt}$	0.00°	
Real metacentre (rel. to $B$ )	$BN_\varphi$	1.17 m	
Real metacentre (rel. to water table)	$N_\varphi$ [•]	-0.06 m	
Stability check: distance $GN_\varphi > 0$	$GN_\varphi$	0.34 m	Stable floating

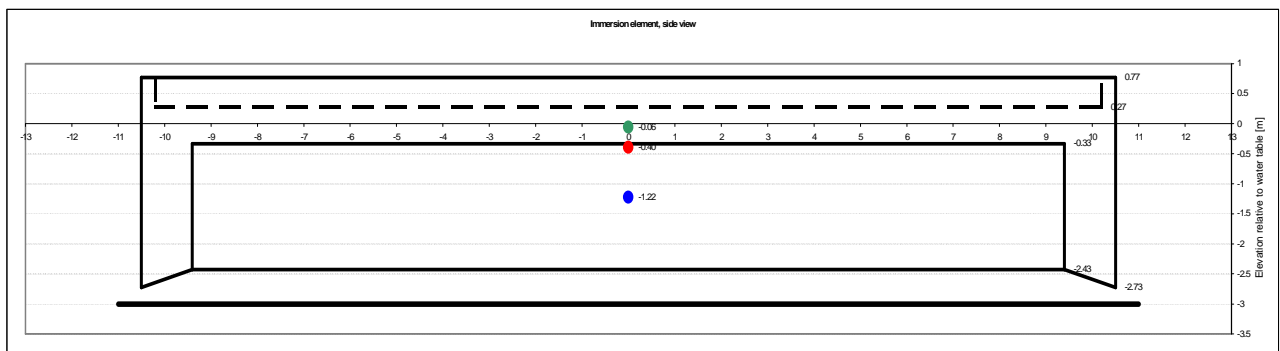
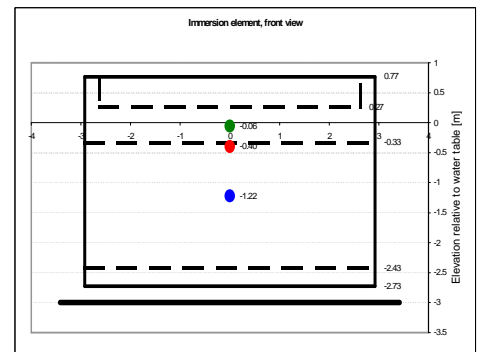

F.2.2 Alternative 2: Steel

**FLOATING STABILITY OF PREFAB STEEL CAISSON SHOE FILLED WITH CONCRETE**

**Input**

Length of element	$l_{element}$	21	m
Width of element	$w_{element}$	5.85	m
Height of floor	$h_{floor}$	1.1	m
Height of wall	$h_{wall}$	2.1	m
Inner wall angle	$\varphi_{wall}$	10.8	°
Height of cutting edge	$h_{edge}$	0.295	m
Cutting edge angle	$\varphi_{edge}$	75	°
Ballast fill material density	$\rho_{fill}$	2400	kg/m <sup>3</sup>
Concrete fill level (rel. to bottom)	$h_{fill}$	0	m
Volumetric steel content	$\omega_s$	6	%
Water depth	$d_w$	3	m

**Consequential input**

Height of element	$h_{element}$	3.50	m
Height of working chamber	$h_{chamber}$	2.40	m
Width of wall at floor	$w_{wall}$	1.50	m
Tangent of wall	$\tan(\varphi_{wall})$	0.19	-
Width of wall at cutting edge	$w_{edge}$	1.10	m
Tangent of cutting edge	$\tan(\varphi_{edge})$	3.73	-

**Output**

Volume of element	$V_{element}$	169.01	m <sup>3</sup>
Mass of steel	$m_s$	79602.19	kg
Mass of ballast material	$m_{ballast}$	0.00	kg
Mass of element	$m_{element}$	79602.19	kg
Volume of water displacement	$V_{displ}$	79.60	m <sup>3</sup>
Draught (rel. to water table)	$D$	-2.77	m
Clearance above water (freeboard)	$h_{clearance}$	0.73	m
Center of buoyancy (rel. to water table)	$B$ [•]	-0.72	m
Center of gravity (rel. to water table)	$G$ [•]	-0.15	m
Moment of inertia of water table intersect.	$I_{water}$	350.35	m <sup>2</sup>
Initial metacentre (rel. to $B$ )	$BM$	4.40	m
Tilt check: distance $GM > 0$	$GM$	3.83	m
Tilt angle (rel. to vertical)	$\varphi_{tilt}$	0.00	°
Real metacentre (rel. to $B$ )	$BN_{\varphi}$	4.40	m
Real metacentre (rel. to water table)	$N_{\varphi}$ [•]	3.68	m
Stability check: distance $GN_{\varphi} > 0$	$GN_{\varphi}$	3.83	m
			Stable floating

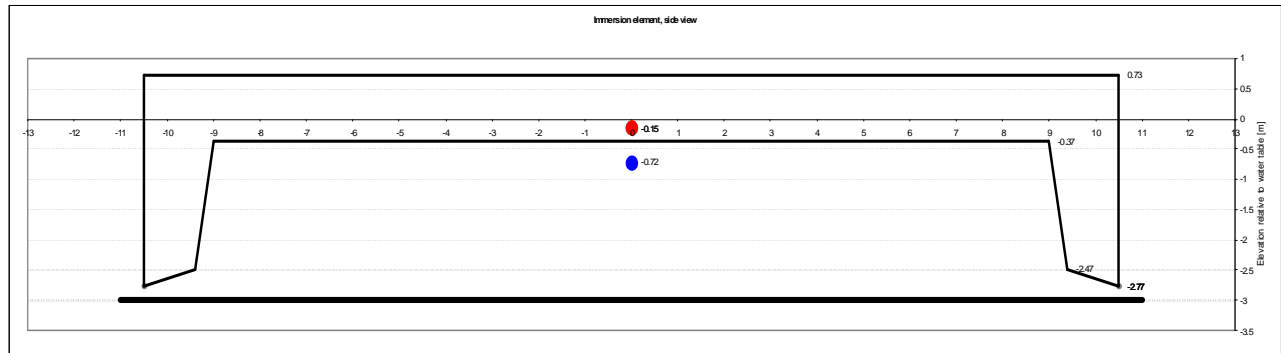
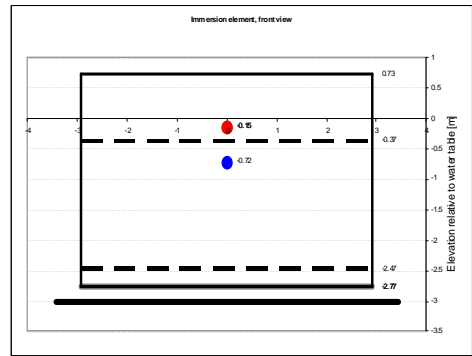

F.2.3 MAPLE-code used to determine limit speed and depression of the water table during transportation of the prefab elements

```

> restart:
> EQ1:=1-As/Ac+(1/2)*(Vlim/(gh)^(1/2))^2-
(3/2)*(Vlim/(gh)^(1/2))^(2/3)=0;

```

$$EQ1 := 1 - \frac{As}{Ac} + \frac{Vlim^2}{2gh} - \frac{3 \left( \frac{Vlim}{\sqrt{gh}} \right)^{(2/3)}}{2} = 0$$

```

> EQ2:=((Vs+U)^2-Vs^2)/(2*gh)-U/(Vs+U)+As/Ac=0;
EQ2 := \frac{(Vs+U)^2 - Vs^2}{2gh} - \frac{U}{Vs+U} + \frac{As}{Ac} = 0
> B0:=7:h:=3:b:=5.85:d:=2.75:g:=9.81:Vs:=0.3:
> Ac:=B0*h;As:=b*d;gh:=g*h;
Ac := 21
As := 16.0875
gh := 29.43
> Vsolve:=solve(EQ1,Vlim):
> Vlim:=Vsolve[2];
Vlim := 0.3382788256
> Zlim:=h*(1/3)*(1-As/Ac-Vlim^2/gh);
Zlim := 0.2300402750
> Usolve:=solve(EQ2,U):
> U:=Usolve[2];
U := 1.235174614
> alpha:=1.4-0.4*Vs/Vlim;
alpha := 1.045263047
> Z:=alpha*(Vs+U)^2/(2*g)-Vs^2/(2*g);
Z := 0.1209701978

```

### F.3 Protruding bars of prefab elements

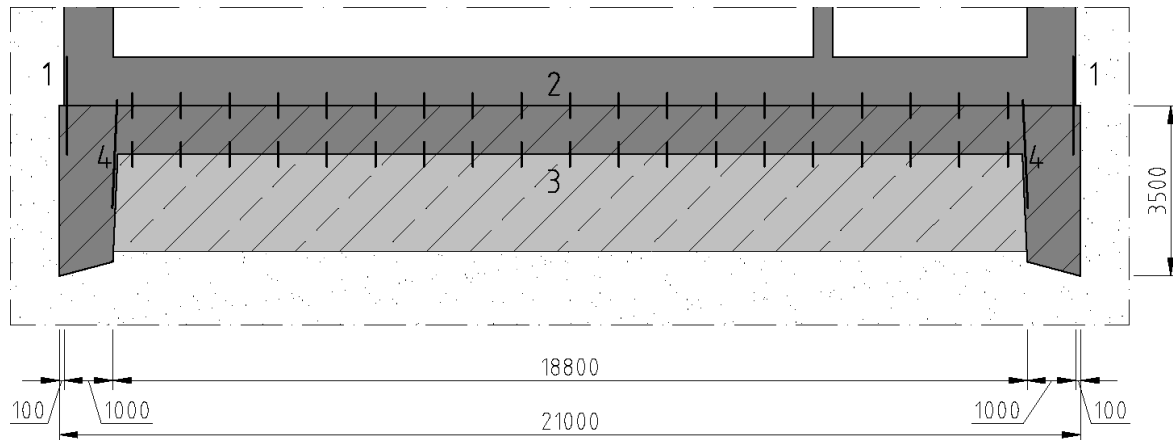

Figure F-1: Various types of reinforcement bars protruding from the prefab elements, to connect these to adjacent structural elements. 1) Connection to outer caisson walls; 2) connection to basement floor; 3) connection to ballast concrete; 4) connection to inner sides of the cutting edges. Units in mm.

#### F.3.1 Connection to outer caisson walls

The connection of the caisson footing to the outer walls of the garage is done by means of straight, vertical bars. These should be set back about 0.15m from the edge of the prefab element to allow for a tail void between the caisson footing and the outer walls of the caisson. A preliminary calculation is made to determine the maximum bending moment to be transferred from the basement floor (caisson footing) to the outer walls. This calculation is based on figure 10-1 and figure 10-2, using  $d = 15.2m$  and a span of  $15.1m$ . It is also assumed that the floor is fixed at both ends of the main span of the basement floor (at the outer wall and at the intermediate wall). This results in:  $M_d = \frac{1}{24}(15.2 \cdot 10 - 0.9 \cdot 2 \cdot 24)15.1^2 = 1234kNm/m$

As a first estimate, an internal leverage arm of 0.85m and reinforcing steel with yield strength of  $435N/mm^2$  is assumed. This results in a reinforcement section of  $3337mm^2/m$ .  $\varnothing 28-180$  with  $1.5 \cdot \varnothing_k = 42mm$  coverage and an anchorage length of 700mm will suffice.

#### F.3.2 Connection to basement floor

Stirrups protruding from the upper sides of the prefab elements will make the connection between the span of the elements and the basement floor. It is assumed

here that the connection between the prefab element and the basement floor is not watertight, so after a considerable time the hydrostatic pressure start acting directly on the bottom of the basement floor. The stirrups must then transfer the weight of the prefab elements and ballast concrete to this floor. From figure 10-1 it can be derived that the maximum buoyancy force (ULS) in the final stage equals  $665.2kN/m$  (disregarding the weight of the prefab elements and ballast concrete). This corresponds to  $32kN/m^2$ . A single bar  $\varnothing 10$ , with an anchorage length of  $0.20m$ , per square meter will be sufficient to transfer this load.

### F.3.3 Connection to the ballast concrete

Underneath the horizontal slab of the prefab element some stirrups are also required to fix the ballast concrete in the working chamber to the basement floor. The reinforcement required for this is very limited, and can only be applied at the very end of the caisson immersion process to allow freedom of movement for the caisson workers. Anchor-bars can be installed in the prefab element to connect these stirrups in a later stage, or they can be drilled into the caisson floor manually. For convenience sake this reinforcement is taken equal to that of the fixation between the prefab elements and the basement floor.

### F.3.4 Connection to inner sides of the cutting edges

Due to the inclination of the face of the cutting edges, there will be a sizeable horizontal component of the soil reactive force acting on this face. Especially when the caisson hits a solid object during immersion (e.g. an old foundation element), local reaction forces may reach high values. To prevent the cutting edge from bending outward and breaking, reinforcement on the inside of the cutting edge is required. As a preliminary estimate, it is assumed that on an area of  $0.10 \times 0.10m$  the concrete compressive strength is reached as a result of collision with a solid object. The resulting horizontal component of this force equals  $100^2 \cdot 33 \cdot \tan(15^\circ) = 88.4kN$ . This results in a maximum bending moment of  $88.4 \cdot 3 = 265.2kNm$ . With an internal leverage arm of  $0.85m$ ,  $\varnothing 12-160$  will suffice if this load is distributed over 1 meter. These bars require an anchorage length of  $0.22m$ . It turns out that this load can be distributed internally in the element, and no protruding bars are required.



# Appendix G Geotechnical profile of the Geldersekkade-area





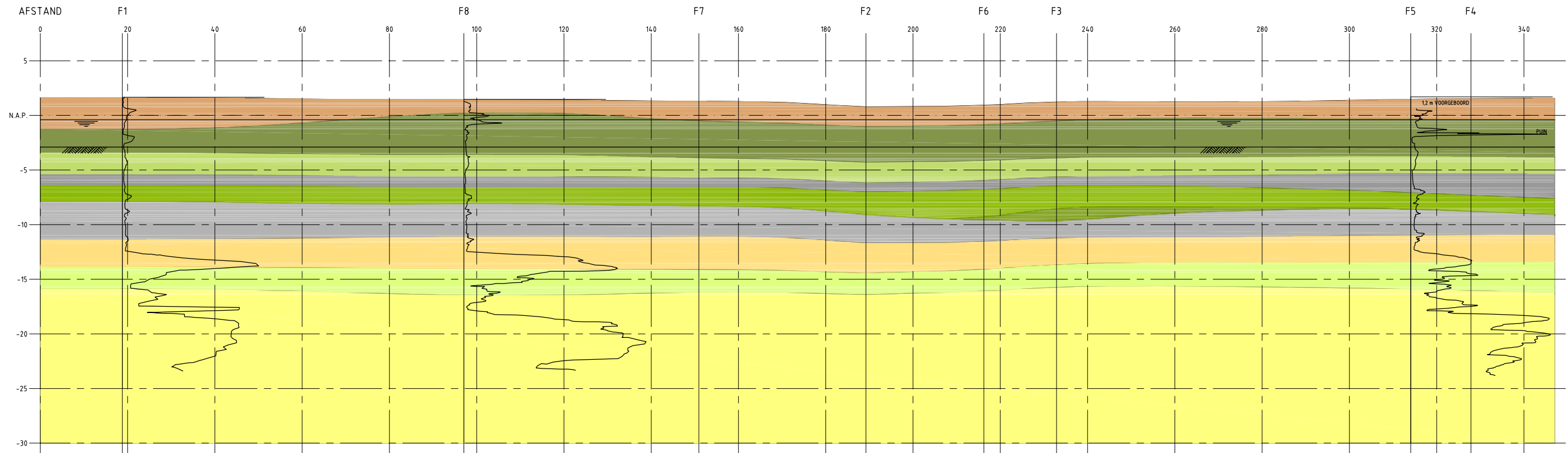

**GRONDPROFIEL GELDERSCHE KADE**

SCHAAL VERTICAAL 1: 200  
SCHAAL HORIZONTAAL 1: 500

CONUS WEERSTAND MN/M<sup>2</sup>

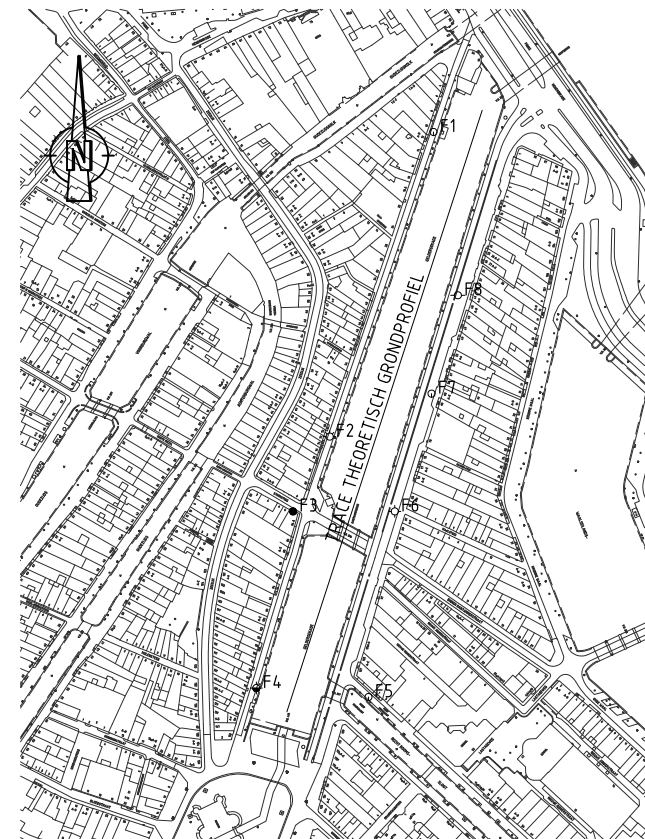

**LOCATIE SONDERINGEN**  
SCHAAL 1: 2000

**DOCUMENT IN BEWERKING** 0  
xx-xx

**LEGENDA:**

- OPHOOGLAAG-ZAND
- AANVULLING: PUIN / ZAND / KLEI / ^
- HOLLANDVEEN
- OUDE / ZEEKLEI
- WADAFZETTING / ZANDHOUDEND
- SILT
- BASISVEEN
- WADAFZETTING-HYDROBIA KLEI
- EERSTE ZANDLAAG
- TUSSENLAAG ALLEROD
- TWEEDE ZANDLAAG

**OPMERKINGEN:**

MAATEN IN mm, TENZIJ ANDERS VERMELD  
HOOGTEMATEN IN m t.o.v. N.A.P.  
HOEKEN IN 90 GRADEN STELSEL

Gemeente Amsterdam  
Parkeergarage Gelderskade  
Geotechnisch lengte profiel

**Witteveen Bos**  
Postbus 12205  
1100 AE Amsterdam  
Telefoon 020 312 55 55  
Telefax 020 697 47 95

Getekend O.C. Kerssens  
Gecontroleerd S. Slob  
Goedgekeurd J.L.C.M. v. Daalen  
Datum -

G	_____
F	_____
E	_____
D	_____
C	_____
B	_____
A	_____
Wijzigingen	_____
Schaal	1: 500 / 1: 200
Formaat	A1

ASD1150.1.1900



# Appendix H Calculations on soil deformations

## H.1 Input parameters

This data set originates from a survey done for the construction of the North/South metro line.<sup>[26]</sup> Values are determined by means of a tri-axial shear test until failure (15% strain).

**Table H-1: Input parameters used for geotechnical calculations**

Layer			Density		Strength		
Nr.	Description	Lvl (upper) [m NAP]	$\gamma_m$ [kN/m <sup>3</sup> ]	$\gamma_{m,sat}$ [kN/m <sup>3</sup> ]	$c'$ [kPa]	$\phi'$ [°]	$\psi$ [°]
1	Fill layer (debris, sand, clay)	+1.3	12,9	15,0	0	25	0
2	Holland peat	-0.4	10,5	10,5	5	20	0
3	Old/Seaclay	-4.0	13,4	16,5	7	33	0
4	Wadden deposition (containing sand)	-5.8	15,7	17,9	2	35	0
5	Silt	-6.5	15,7	17,9	2	35	0
6	Basispeat	-8.8	11,7	11,7	6	21	0
7	Wadden deposition / hydrobia clay	-9.8	11,5	15,2	8	34	0
8	First sand layer	-11.3	18,7	19,8	0	33	3
9	Alleröd	-13.8	16,7	18,5	0	33	0
10	Second sand layer	-15.8	17,9	19,0	0	35	5

Lay. Nr.	Permeability		Additional			Hardening soil model		
	$k_x$ [m/day]	$k_y$ [m/day]	$\nu$ [-]	$K_0$ [-]	POP [kPa]	$E_{ref}^{50}$ [kPa]	$E_{ref}^{oed}$ [kPa]	$E_{ref}^{ur}$ [kPa]
1	1.0E+00	1.0E+00	0.15	0	0	10000	8000	30000
2	2.0E-03	1.0E-03	0.15	0.65	10	2000	1000	10000
3	1.3E-04	1.3E-04	0.15	0.5	10	9000	3000	25000
4	1.0E-02	1.0E-02	0.20	0.4	0	12000	5000	33000
5	1.0E-02	1.0E-02	0.20	0.4	0	12000	5000	33000
6	2.0E-02	1.0E-02	0.15	0.65	10	2000	1000	10000
7	9.0E-05	9.0E-05	0.15	0.59	10	9000	3000	15000
8	1.3E+01	1.3E+01	0.20	0.4	0	40000	30000	200000
9	2.6E+00	2.6E+00	0.20	0.4	0	17000	13000	45000
10	8.6E+00	8.6E+00	0.20	0.4	0	35000	35000	190000

## H.2 PLAXIS calculation mesh

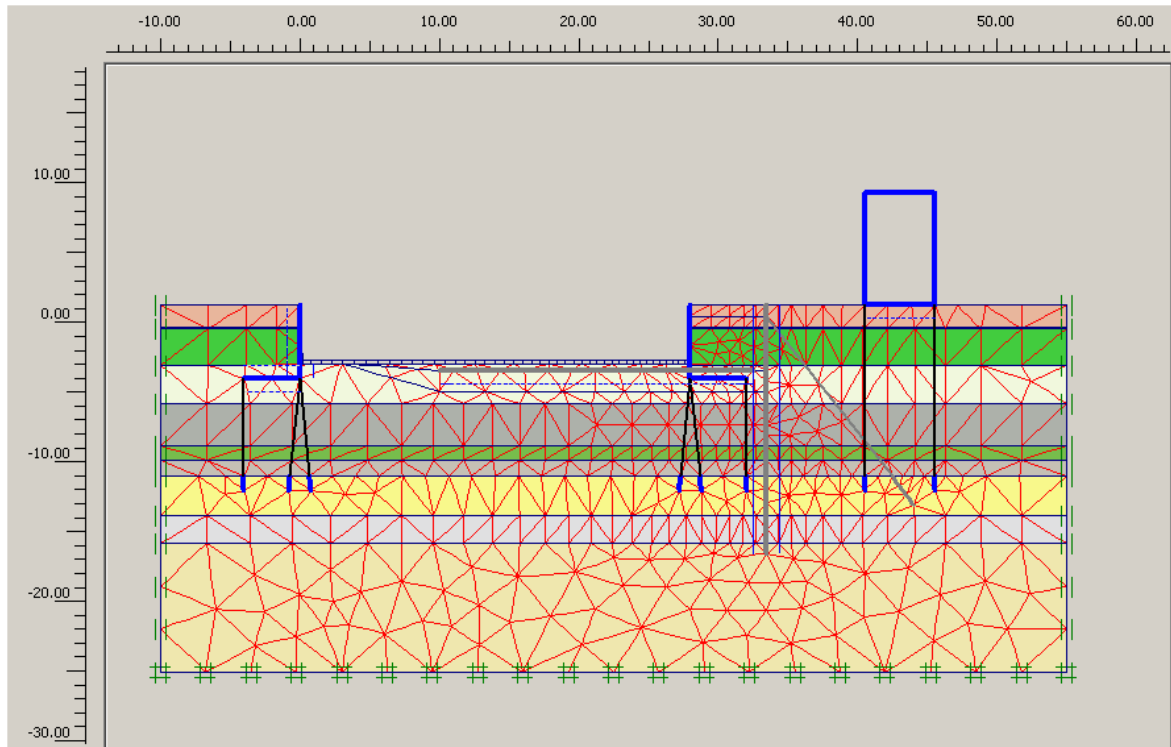

Figure H-1: Initial PLAXIS model and calculation mesh (units in meters)

### H.3 Output

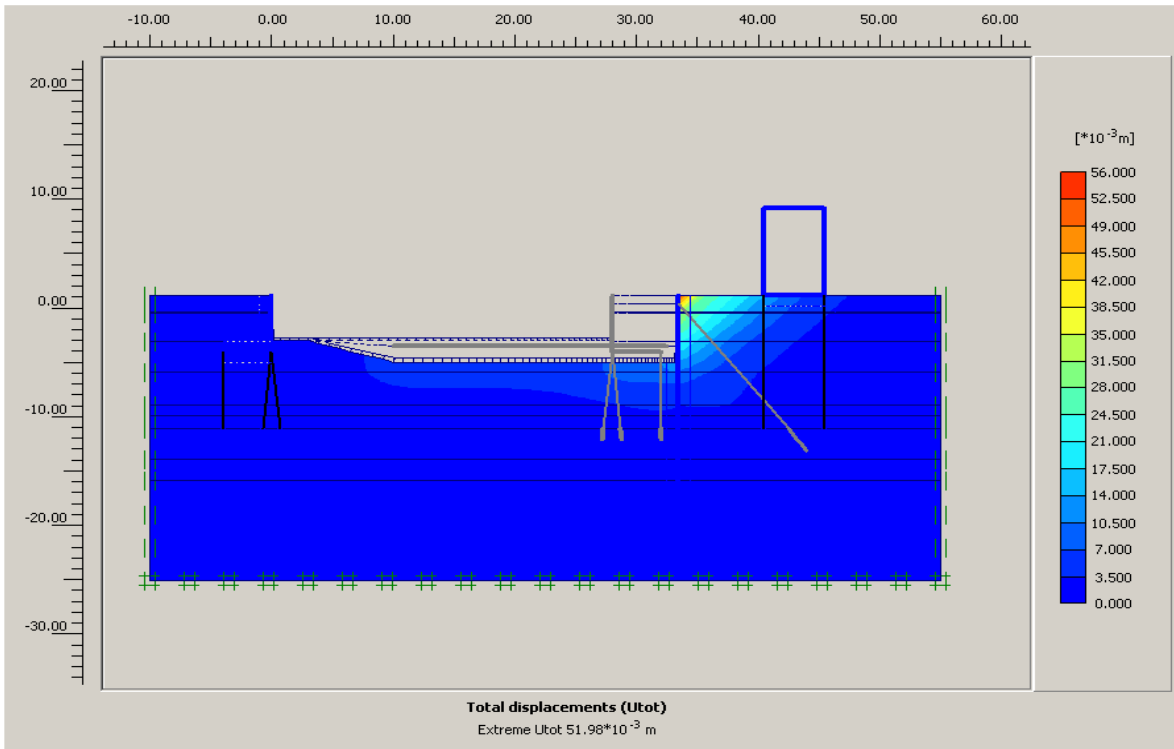

Figure H-2: Total displacements after demolishing the old quaywall and dredging the canal, using AZ36 sheetpiles without anchorage

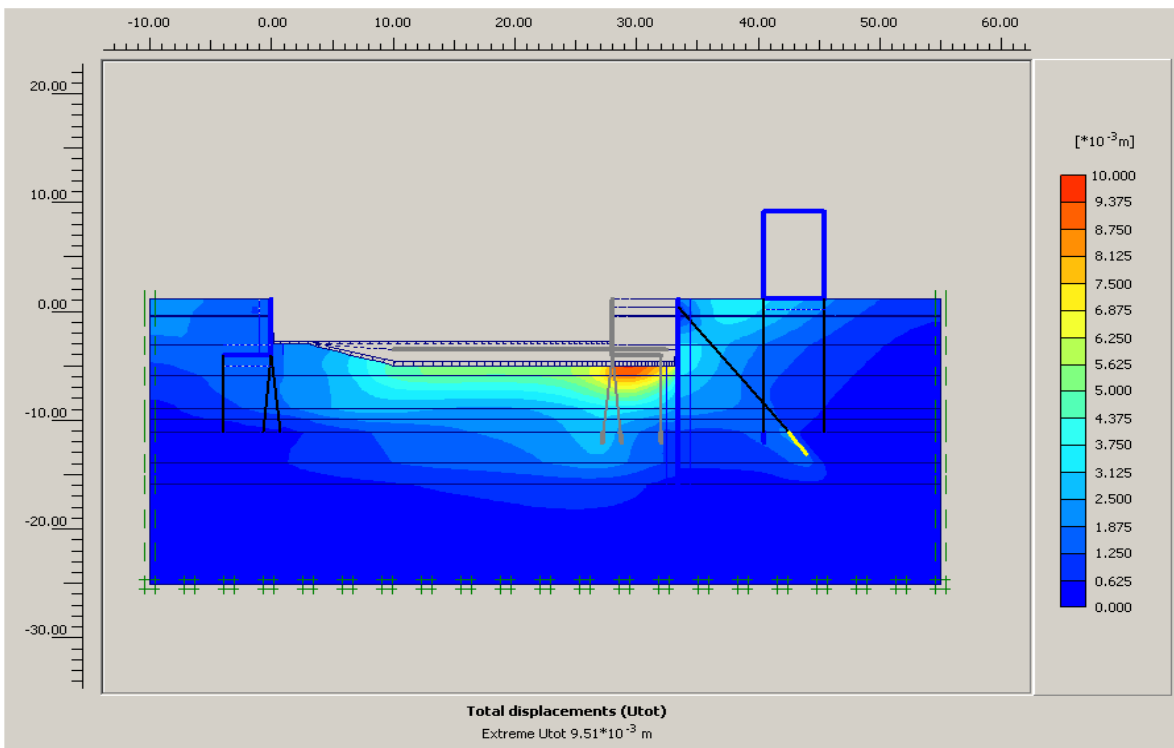

Figure H-3: Total displacements after demolishing the old quaywall and dredging the canal, using AZ26 sheetpiles with anchorage

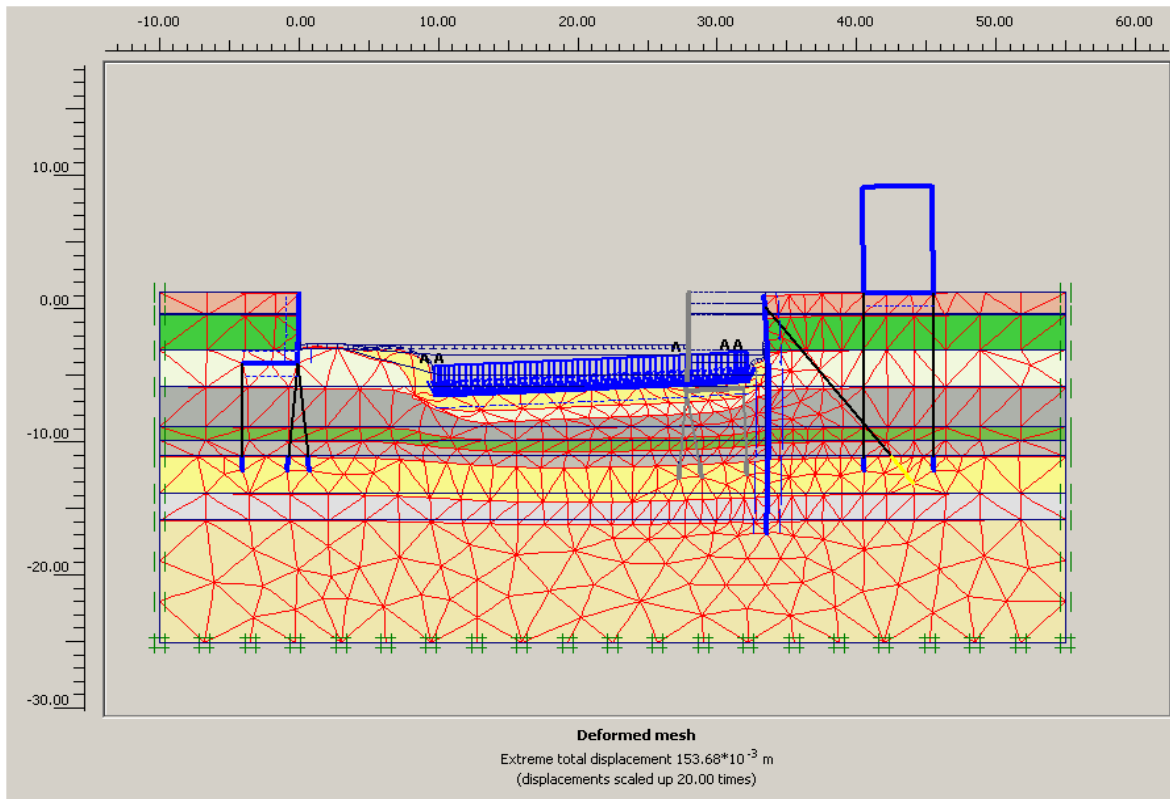

Figure H-4: Deformed mesh showing the influence of caisson construction on top of the canal bed, assuming undrained soil behaviour

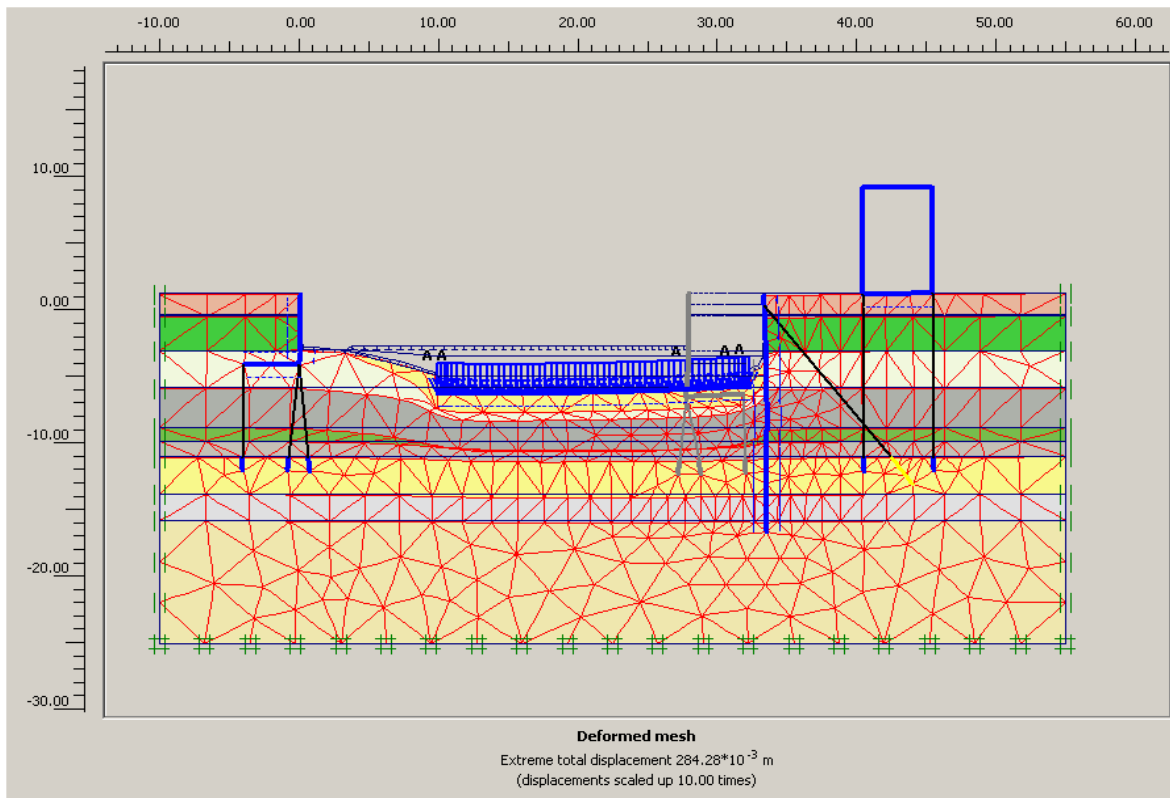

Figure H-5: Deformed mesh showing the influence of caisson construction on top of the canal bed, assuming drained soil behaviour

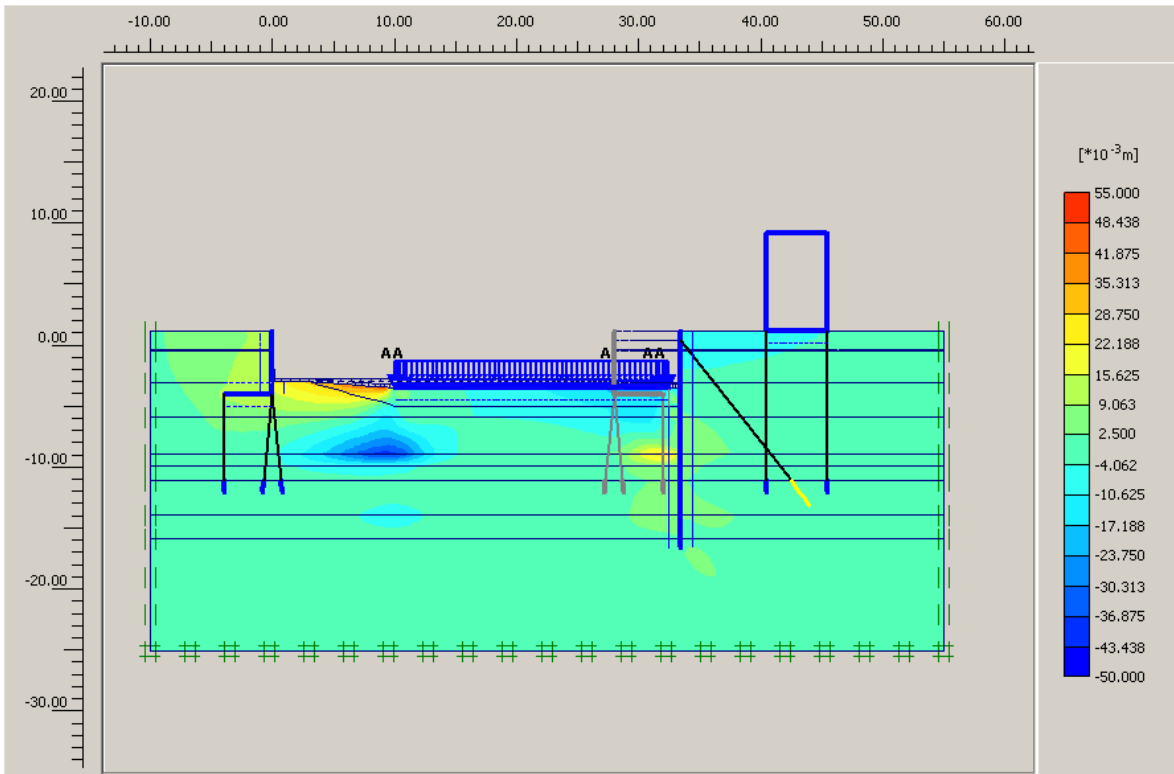

Figure H-6: Horizontal displacements after construction of caisson using AZ26 sheetpiles with anchorage (drained soil behaviour)

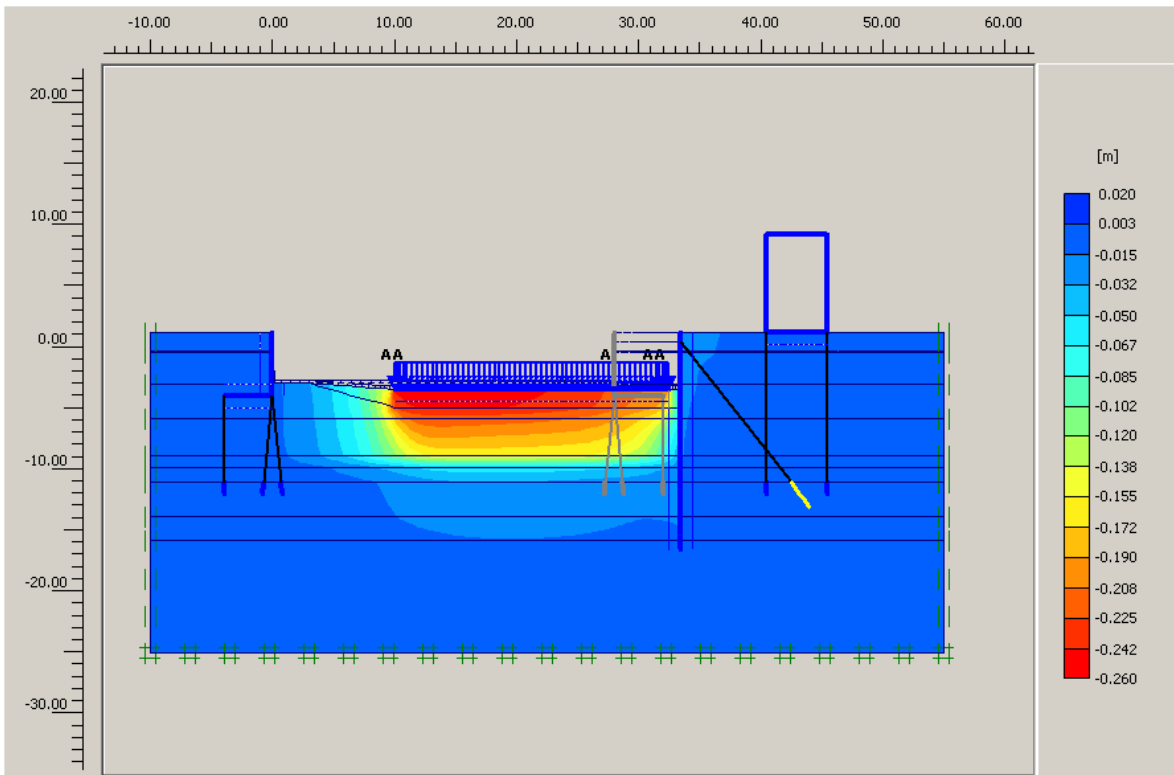

Figure H-7: Vertical displacements after construction of caisson using AZ26 sheetpiles with anchorage (drained soil behaviour)

## H.4 Calculations on bentonite slurry trench

For these calculations, a water level of  $-0.4\text{ m NAP}$  is assumed

**Table H-2: Calculation of horizontal soil pressures**

Layer Nr. Description	Lvl (bottom) [m NAP]	Density		Strength		Soil pressure				
		$\gamma_m$ [kN/m <sup>3</sup> ]	$\gamma_{m,sat}$ [kN/m <sup>3</sup> ]	$c'$ [kPa]	$\varphi'$ [°]	$K_a$ [-]	$\sigma_{zz}$ [kN/m <sup>2</sup> ]	$\sigma'_{zz}$ [kN/m <sup>2</sup> ]	$\sigma'_{xx}$ [kN/m <sup>2</sup> ]	$\sigma_{xx}$ [kN/m <sup>2</sup> ]
0 Air	1,3	0,0	0,0	0	0	1	0	0	0	0
1 Fill layer (debris, sand, clay)	-0,4	12,9	15,0	0	25	0,41	21,93	21,93	8,90	8,90
2 Holland peat	-4,0	10,5	10,5	5	20	0,49	59,73	23,73	4,63	40,63
3 Old/Seaclay	-5,8	13,4	16,5	7	33	0,29	89,43	35,43	2,84	56,84
4 Wadden deposition (containing sand)	-6,5	15,7	17,9	2	35	0,27	101,96	40,96	9,02	70,02
5 Silt	-8,8	15,7	17,9	2	35	0,27	143,13	59,13	13,94	97,94
6 Basispeat	-9,8	11,7	11,7	6	21	0,47	154,83	60,83	20,49	114,49
7 Wadden deposition / hydrobia clay	-11,3	11,5	15,2	8	34	0,28	177,63	68,63	10,90	119,90
8 First sand layer	-13,8	18,7	19,8	0	33	0,29	227,13	93,13	27,45	161,45
9 Alleröd	-15,8	16,7	18,5	0	33	0,29	264,13	110,13	32,47	186,47
10 Second sand layer	-20,0	17,9	19,0	0	35	0,27	343,93	147,93	40,09	236,09

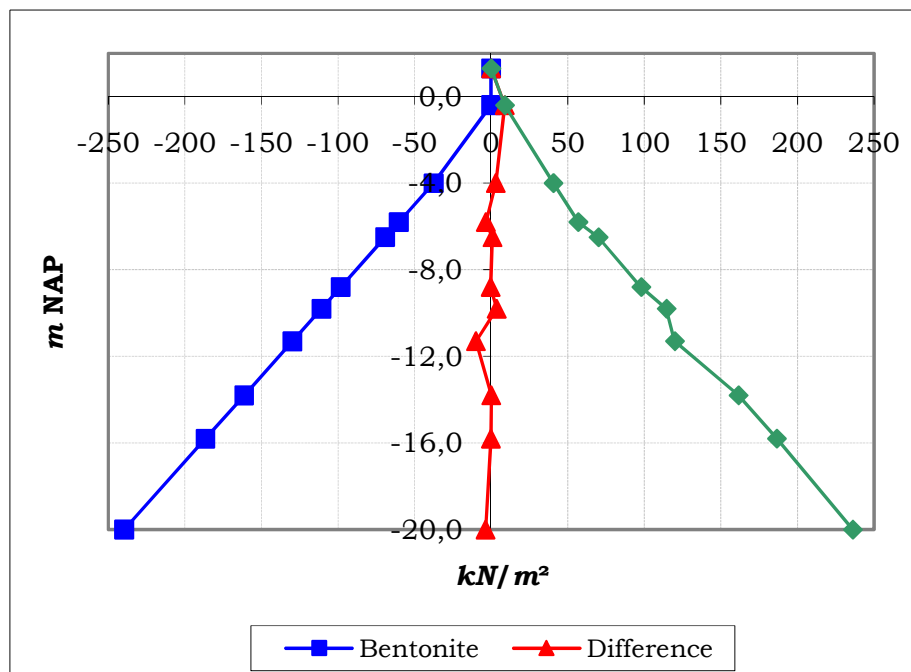

Figure H-8: Horizontal pressures on sheetpile wall using a bentonite fill level of  $-3.4\text{ m NAP}$  and a slurry density of  $12.6\text{ kN/m}^3$



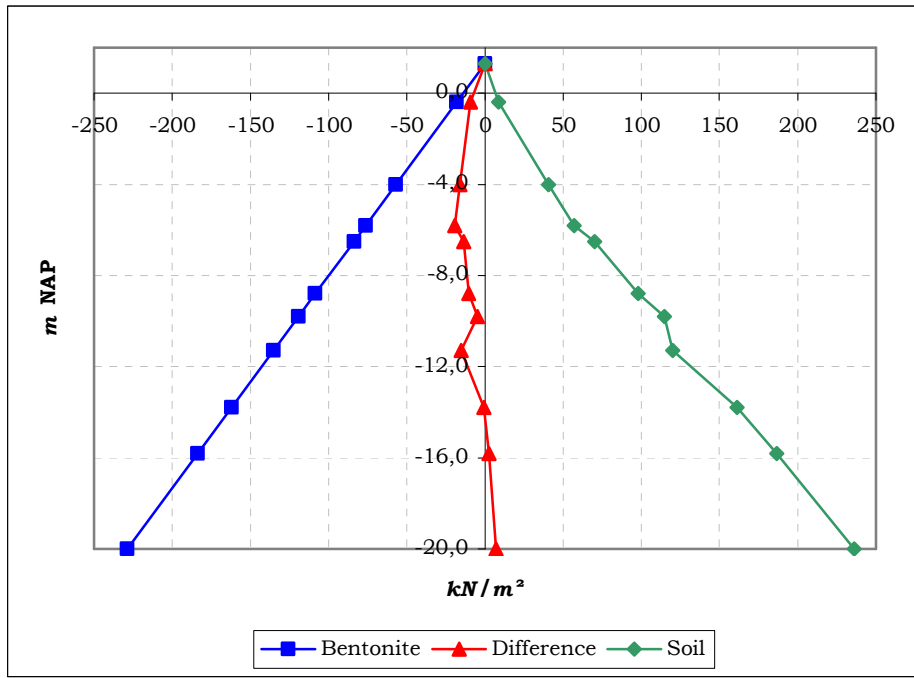

Figure H-9: Horizontal pressures on sheetpile wall using a bentonite fill level of 1.3m NAP and a slurry density of 10.7kN/m³



# Appendix I Artist impression of construction phasing



*Figure I-1: Initial situation, showing the Gelderse kade from south to north. (The bridge in the lower left corner represents the Bantammerbrug (bridge 298). Adjacent buildings on the western and eastern side are not shown, but their facades are positioned there where the drawing ends. For convenience sake the road setting is already shown as it will be after completion of the garage.)*





*Figure I-2: After installing the sheetpile walls behind the eastern quaywall, trees are removed and the old quay is demolished. Traffic will temporarily be diverted several meters eastward, closer to the facades of adjacent buildings. (The tower at the far end of the canal represents the Schreierstoren.)*

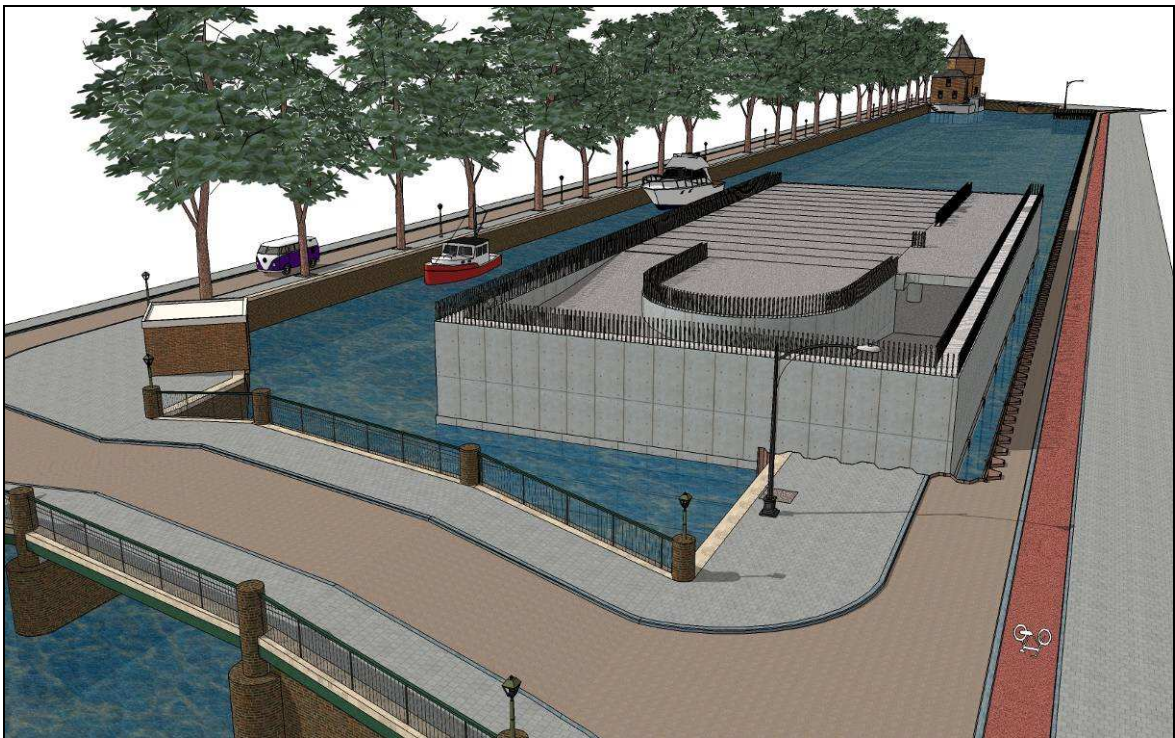

*Figure I-3: The prefabricated elements are constructed off-site. After dredging of the canal, the elements are transported to the construction site over water. Once there, they are positioned and coupled with the aid of several spud piles.*





*Figure I-4: When the prefabricated platform is fully assembled, it is immersed onto the canal bed and construction of the basement floor of the garage can commence on top of it.*



*Figure I-5: Construction of the garage proceeds on top of the platform, rising above the water table. The intermediate floors are constructed by means of prefabricated floor panels.*





Figure I-6: If the caisson is not constructed and immersed in stages, the structure will rise up to +15m above street level. Besides the concrete works that shape the caisson, also some sheetpiles and locks are incorporated in the structure. These are needed in a later stage.

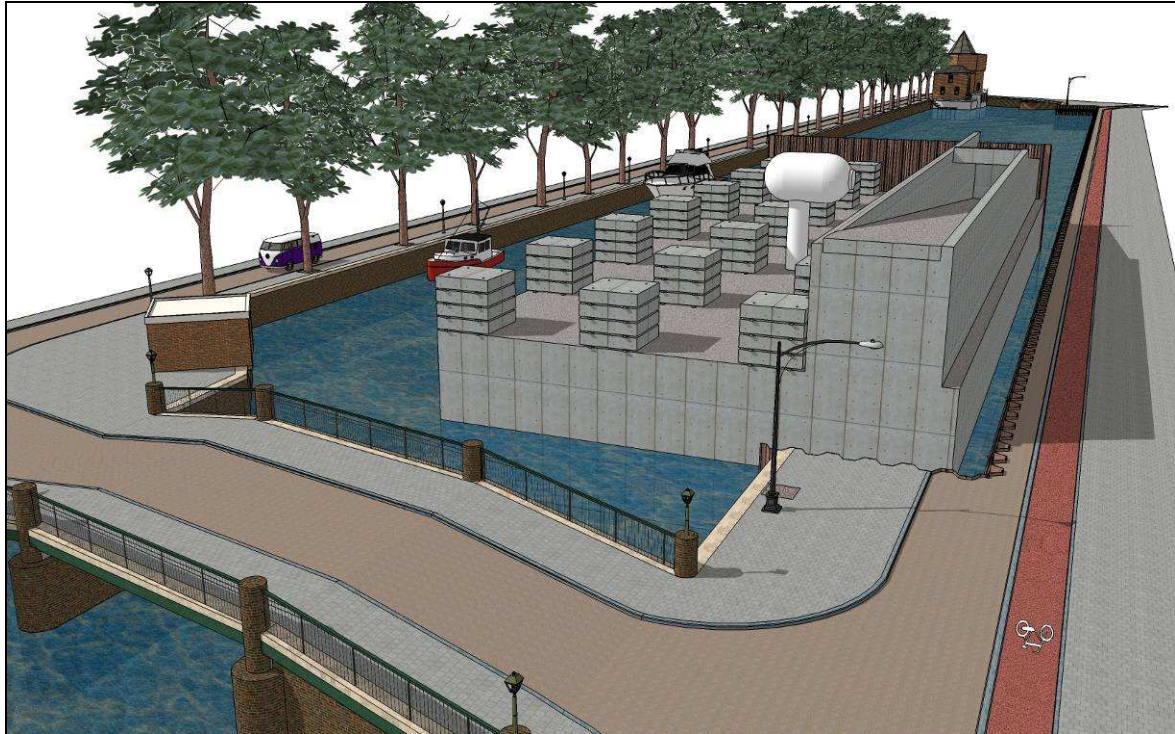
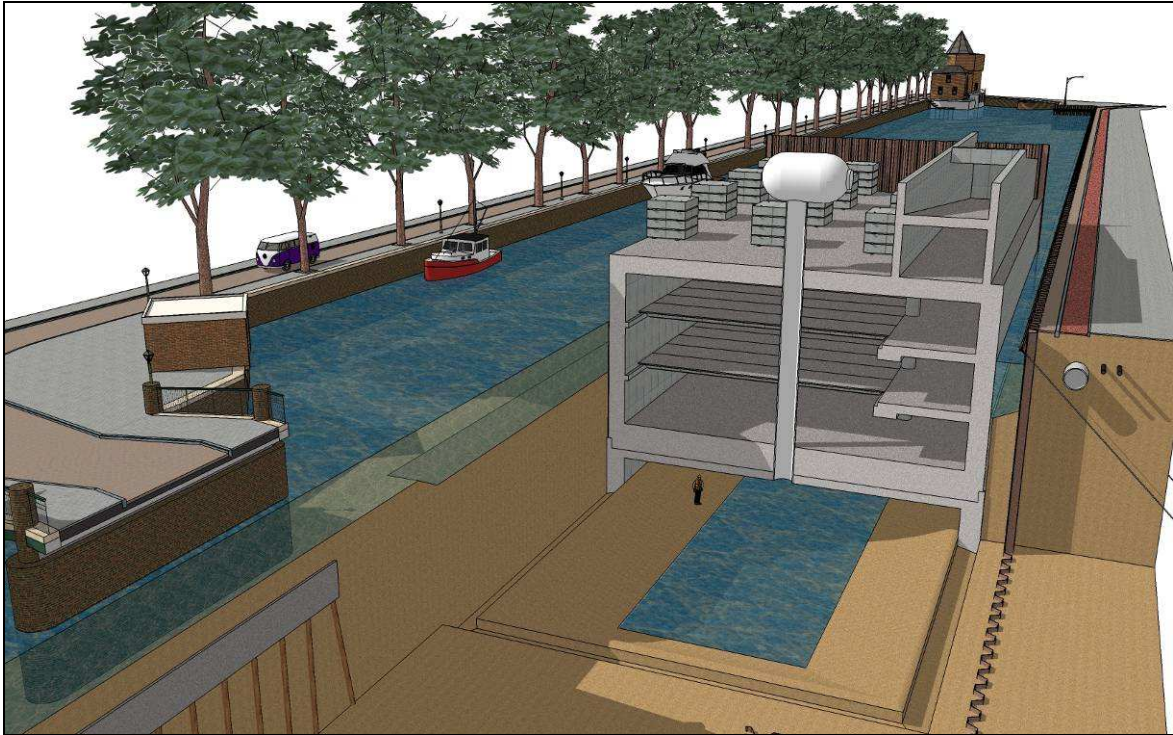

Figure I-7: After completion of the caisson, temporary ballast is placed on top and an airlock is installed. By manually and hydraulically excavating the soil underneath, the caisson will start to sink into the ground.





*Figure I-8: Cross-sectional view showing the working chamber underneath the caisson. The working chamber is subjected to pressurised air, balancing the hydrostatic pressure of the groundwater to prevent it from flowing in. Caisson workers enter the caisson through the airlock to ensure that the working chamber stays pressurised.*



*Figure I-9: Just before full immersion of the caisson, bricks and stones are placed applied on the new quaywall in dry conditions. After it is completely immersed, only the new quaywall, the ramps, the airlock and the sheetpiles rise above water.*





*Figure I-10: The working chamber is filled with ballast concrete so the temporary ballast can be removed. The airlock and access shaft can also be removed. Construction of the second to fourth caissons proceeds in a similar manner as the first.*



*Figure I-11: After construction and immersion of two adjacent caissons, several sheetpiles are placed around the caisson joint to complete a small cofferdam. The joint is excavated and an underwater concrete floor is cast. The construction of the joint can then proceed in dry conditions, allowing formwork and reinforcement to be placed.*





*Figure I-12: As soon as the joints are made and the bulkheads are removed from within the caissons, the temporary retaining walls can also be removed. The carcass of the garage is now completed.*



*Figure I-13: A layer of sand is placed on top of the garage in the canal profile to protect it from damage. The space between the garage structure and the sheetpile walls is also filled up. After compacting of this sand, the sheetpile walls can be removed and pavement can be restored.*





*Figure I-14: The Geldersekkade in the final situation, after replanting of trees and construction of the pedestrian exits. (The positioning of the pedestrian exits is only shown indicatively here, and their construction method is not elaborated.)*



