

Document Version

Final published version

Citation (APA)

Bhandia, R., van der Meer, A., Widl, E., Strasser, T. I., Heussen, K., Jensen, T. V., Steinbrink, C., Nguyen, V. H., Bourry, F., Syed, M., Chodura, P., Besanger, Y., Nguyen, T. L., Mantafounis, P., & Davros, A. (2019). *D-JRA2.3 Smart Grid Simulation Environment*. European Commission H2020. https://erigrd.eu/wp-content/uploads/2019/01/DL_D-JRA2.3_Smart_Grid_simulation_environment_2018-12-23.pdf

Important note

To cite this publication, please use the final published version (if applicable).
Please check the document version above.

Copyright

In case the licence states "Dutch Copyright Act (Article 25fa)", this publication was made available Green Open Access via the TU Delft Institutional Repository pursuant to Dutch Copyright Act (Article 25fa, the Taverne amendment). This provision does not affect copyright ownership.
Unless copyright is transferred by contract or statute, it remains with the copyright holder.

Sharing and reuse

Other than for strictly personal use, it is not permitted to download, forward or distribute the text or part of it, without the consent of the author(s) and/or copyright holder(s), unless the work is under an open content license such as Creative Commons.

Takedown policy

Please contact us and provide details if you believe this document breaches copyrights.
We will remove access to the work immediately and investigate your claim.



European Research Infrastructure supporting Smart Grid Systems Technology Development, Validation and Roll Out

Work Package 08

JRA2 - Co-Simulation based Assessment Methods

Deliverable D8.3

D-JRA2.3: “Smart Grid simulation environment”

Grant Agreement No:	654113
Funding Instrument:	Research and Innovation Actions (RIA) – Integrating Activity (IA)
Funded under:	INFRAIA-1-2014/2015: Integrating and opening existing national and regional research infrastructures of European interest
Starting date of project:	01.11.2015
Project Duration:	54 months

Contractual delivery date:	31/10/2018
Actual delivery date:	23/12/2018
Name of lead beneficiary for this deliverable:	16 Delft University of Technology
Deliverable Type:	Other (O)
Security Class:	Public (PU)
Revision / Status:	released

Document Information

Document Version: 04
Revision / Status: released

All Authors/Partners

Rishabh Bhandia, Arjen van der Meer / TUD
Edmund Widl, Thomas Strasser / AIT
Tue Vissing Jensen, Kai Heussen / DTU
Van Hoa Nguyen, Franck Bourry / CEA
Cornelius Steinbrink / OFFIS
Yvon Besanger, Tung Lam Nguyen / GINP
Panagiotis Mantafounis, Andreas Davros / ICCS-NTUA
Mazheruddin Syed / USTRATH
Przemyslaw Chodura / DNVGL

Distribution List ERIGrid Consortium Members

Document History

Revision	Content / Changes	Resp. Partner	Date
1	Document structure generated	TUD	17.09.18
2	Draft inputs, first version for internal review	TUD, AIT, DTU, CEA, OFFIS, GINP, ICCS-NTUA, USTRATH, DNVGL	30.10.18
3	Final version for internal review	TUD	18.11.18
4	Included feedback from internal reviews and Security Advisory Group (SAG)	TUD, AIT, DTU	07.12.18

Document Approval

Final Approval	Name	Resp. Partner	Date
Review Task Level	Rishabh Bhandia	AIT	19.09.18
Review WP Level	Evangelos Rikos	CRES	27.11.18
Review WP Level	Merkebu Zenebe Degefa	SINTEF	29.11.18
Review Security Adv. Group (SAG)	Kieran McLaughlin	QUB	28.11.18
Review Security Adv. Group (SAG)	Thomas Bleier	BSEC	06.12.18
Review Steering Com. Level	Thomas Strasser	AIT	23.12.18

Disclaimer

This document contains material, which is copyrighted by certain ERIGrid consortium parties and may not be reproduced or copied without permission. The information contained in this document is the proprietary confidential information of certain ERIGrid consortium parties and may not be disclosed except in accordance with the consortium agreement.

The commercial use of any information in this document may require a licence from the proprietor of that information.

Neither the ERIGrid consortium as a whole, nor any single party within the ERIGrid consortium warrant that the information contained in this document is capable of use, nor that the use of such

information is free from risk. Neither the ERIGrid consortium as a whole, nor any single party within the ERIGrid consortium accepts any liability for loss or damage suffered by any person using the information.

This document does not represent the opinion of the European Community, and the European Community is not responsible for any use that might be made of its content.

Copyright Notice

© The ERIGrid Consortium, 2015 – 2020

Table of contents

Executive Summary	6
1 Introduction	7
1.1 Purpose of the Document	7
1.2 Scope of the Document	7
1.3 Structure of the Document	7
2 Research Motivation and Proposed Approach	8
2.1 Background	8
2.2 Large-Scale System Assessment Approach	9
2.3 Contributions	11
3 Integrated Simulation Environment for Large-Scale Systems.....	12
3.1 Smart Grid Large-scale Systems	12
3.2 Definition of Smart Grid Large-Scale Systems	12
3.3 Properties of Smart Grid Large-scale Systems	13
3.4 Qualification and Assessment of Large-scale Phenomena	16
3.5 Collective Phenomena at System Level.....	16
3.6 Modelling Artefacts and Numerical Issues	19
3.7 Simulation-based Assessment of Smart Grid Large-Scale Systems	19
3.8 Integrated Simulation Toolchain.....	20
3.9 Smart Grid Model Library.....	23
4 Large-Scale System Scenarios.....	24
4.1 Assessment of the FRT Capability of Distributed Wind Turbine Generators (TC1-LSS1)	24
4.2 Assessment of the Remote Real-Time Coord. Voltage Control for Distr. Grids (TC3-LSS2)	28
5 Implementations and Results.....	34
5.1 Assessment of the FRT Capability of Distributed Wind Turbine Generators (TC1-LSS1)	34
5.2 Remote real-time coordinated voltage control for distribution grids (TC3-LSS/LSS2).....	37
5.3 Technical Assessment of the Overall System	41
6 Conclusions	43
7 References	44
8 Annex	45
8.1 List of Figures	45
8.2 List of Tables	45
8.3 Test Case Specification for LSS1.....	46
8.7.2.....	48
8.7.2.....	48
8.7.2.....	50
8.4 Test Case Specification for LSS2.....	51
8.7.2.....	54
8.7.2.....	54
8.7.2.....	56

Abbreviations

<i>ARP</i>	Address Resolution Protocol
<i>API</i>	Application Program Interface
<i>CPES</i>	Cyber-Physical Energy System
<i>DER</i>	Distributed Energy Resource
<i>DES</i>	Discrete Event Simulation
<i>FRT</i>	Fault Ride Through
<i>FMU</i>	Functional Mock-up Unit
<i>FMI</i>	Functional Mock-up Interface
<i>HIL</i>	Hardware-in-the-Loop
<i>HTD</i>	Holistic Test Description
<i>ICT</i>	Information and Communications Technology
<i>IEC</i>	International Electrotechnical Commission
<i>JRA</i>	Joint Research Activity
<i>LSS</i>	Large Scale System
<i>LV</i>	Low Voltage
<i>MAC</i>	Media Access Control
<i>MV</i>	Medium Voltage
<i>ODE</i>	Ordinary Differential Equation
<i>OLTC</i>	On-Load Tap Changer
<i>OuI</i>	Object under Investigation
<i>PCC</i>	Point of Common Coupling
<i>PLL</i>	Phase Locked Loop
<i>PV</i>	Photovoltaic
<i>RMS</i>	Root Mean Square
<i>SuT</i>	System under Test
<i>TC</i>	Test Case
<i>UC</i>	Use Case
<i>UDP</i>	User Datagram Protocol
<i>WP</i>	Work Package
<i>WPP</i>	Wind Power Plant
<i>WTG</i>	Wind Turbine Generator

Executive Summary

This report summarizes the work conducted within ERIGrid related to an integrated simulation environment for large-scale systems. The main goal of the JRA2 is to develop advanced simulation-based tools and methods to validate Smart Grid scenarios, configurations and applications in context of co-simulation. The work done in D-JRA2.1 involved assessment of specialized simulation packages for Smart Grids and to develop tools to couple these simulation packages for co-simulation.

New tools and models were also developed as some of the existing tools were not sufficient enough to achieve the appropriate couplings. In D-JRA2.2 co-simulation-based assessment methods were developed to compare the performance between monolithic and co-simulations. In D-JRA2.3 we aim to combine all the work done under WP JRA2 to present an integrated simulation package that can be applied to Large Scale systems. The assessment methods developed in D-JRA2.2 have been tested initially in small systems to measure the performance and identify possible flaws. However, the complexity increases significantly in large scale realistic systems.

This report documents the challenges faced when the systems and their models grow larger (i.e., upscaled) and how different large scale specific phenomena and issues were identified. After the identification of the challenges, the assessment methods were modified and packaged into an integrated simulation environment which can be used for scaled out systems. The simulation packages are provided as an addendum along with this report while their details are concisely documented in this report.

1 Introduction

1.1 Purpose of the Document

This report provided an overview of the ERIGrid simulation environment. The work focuses on developing an integrated simulation environment for facilitating large-scale smart grid system assessment. The work involved analysis of large scale phenomena and the challenges faced in setting up an adequate co-simulation framework dealing with such phenomena. The analysis leads to a definition of large scale smart grid system in the form of a non-exhaustive list of characteristic properties that serve as criteria to distinguish a Large-Scale System (LSS) from one at traditional scale. Additionally, a large-scale smart grid system may exhibit different characteristics and related issues compared to a system built by just linear scaling up of parameters of a small system.

Thus, co-simulation of a large scale smart grid system adds another layer of complexity and challenges. Accordingly, the simulation environment needs to be designed such that it can address those issues. Previous Joint Research Activity (JRA) JRA2 work provides the input in form of test cases, model libraries, and simulation environment while work documented in this deliverable shows the implementation and results obtained of such an integrated simulation environment for two upscaled test cases that have been adopted for prototyping the co-simulation coupling methods as described in D-JRA2.1.

1.2 Scope of the Document

One of the major focus areas of JRA2 was to assess the potentials and limits of scalable co-simulation. The scope of this document is to show the capabilities of developed libraries and tools in the context of large scale systems assessment. In this deliverable, we define what constitutes a LSS and what the different phenomenon's they can exhibit are. We also assess the performance of our co-simulation framework in two LSS test-cases. These systems are developed by extending two test cases discussed before in D-JRA2.1 and D-JRA2.2. That is, the model of the physical system will be scaled out (same system size, higher granularity of components) whereas the co-simulation of this system model is scaled up (larger overall model to be simulated). The tools developed in previous works of JRA2 have also been extended/modified to implement in case of LSS simulations.

1.3 Structure of the Document

Section 1 provides an overview of the subjects addressed in this document, including its scope and structure. Section 2 presents the research motivation and background for the work presented in this document. The section discusses in detail the assessment approaches proposed for LSS. Section 3 discusses the factors behind the formation of an integrated simulation environment. The section starts by defining Smart Grid large-scale systems and their unique properties. The assessment of LSS based on the phenomena's exhibited is discussed and key modelling artefacts and issues are listed. The section finally discusses the various simulation tools used and how they were used/modified to create an integrated simulation environment for LSS Assessment. Section 4 gives an overview of the large-scale systems simulated and evaluated in this deliverable. The details of the model like system and test configurations are discussed. Finally, the challenges faced for implementation of LSS were listed and the solutions were explained. Section 5 discusses in detail the implementation results two LSS systems simulated in an integrated simulation network. The implementation results are benchmarked against the results obtained from small scale system simulations. Section 6 presents the conclusions for the work presented in this document.

2 Research Motivation and Proposed Approach

During the last decade, one can observe a great transformation of the power system. On the one hand, increased consumption of electricity along with electrification of transport leads to increase in loads on the existing infrastructure; on the other hand, high penetration of distributed and renewable energy resources (levels of 15% to 20%) to reduce carbon emission, makes it increasingly difficult to ensure the reliable and stable management of electricity systems. Smart metering infrastructure, shifting from demonstration phase to large scale deployment, marks an important milestone for the already strong impact of communication network and automation technology to the power grid. The Cyber-Physical Energy System (CPES, or Smart Grid) has increased in both scale and complexity.

Smart Grid is the backbone of the smart city. Adding more cross domain applications, not limited to the boundary of the traditional power system but also having socio-technical impacts: smart education and healthcare, smart transportation traffic light control, etc. the CPES helps to optimize, automate and enhance the global social system operations, to improve the quality of service and impact on personal life. A Smart City is more than just developing infrastructures. It involves the whole ecosystem, improving human condition and advancing the society. Smart cities can be seen as integrated living solutions that link many life aspects such as power, transportation, and buildings in a smart and efficient manner to improve the quality of life of its citizens, with focus on the future by emphasizing the importance of sustainability of resources and applications for the future generations.

Smart Grids and Smart Cities exhibit growing reliance on increasingly interoperable and interdependent systems to provide functionalities not achieved by the individual stand-alone systems. This system of systems crossing traditional boundaries are large scale and potentially complex. It is noteworthy that the concept of large scale system of systems is inherently different from engineering large-scale but essentially well-bounded monolithic systems. While it is also important to consider the organizational and functional aspects, in terms of engineering, these large systems demand equal consideration on increasing program scale and on complexity of system interactions. A smart city requires the physical infrastructure and computational cyber-infrastructure to holistically and consistently coordinate to ensure its efficient and reliable functionality.

It is however not trivial to assess these large-scale systems of systems with current tool sets because complexities of system and of the tools for system assessment and evaluation increase manifold in large scale realistic systems. From the evaluation and testing point of view, one of the main challenges in designing, validating, and rolling out smart grid innovations is the size and the strong coupling of the electric energy system. Changes on individual components might be harmless in small numbers but can cause a significant impact when getting popular and large in numbers -- an aspect that is not easy to discover in complex systems. Additionally, the size puts the simulation packages under stress: performance and accuracy are often traded against each other, which is undesirable.

Work Package (WP) JRA2 has approached these challenges via:

- 1) Scenario handling and system modelling via specialized software.
- 2) Modular system of systems architecture with clean boundaries for separate optimization.
- 3) Cyber-security assessment.

2.1 Background

Smart Grids and smart cities are commonly multi-domain systems involving the power system dynamics, communication as well as control and supervision applications at various operational times scales. Their development brings new requirements and new functionality to the power systems domain and associated Information and Communication Technology (ICT) systems. More than just increasing in "scale", this means functionality is to be provided beyond the boundaries of components and across different technology domains. Model-based design methods are essential for the

validation and assessment of such systems due to the large scale and huge complexity involved with inter-domain interaction. The existing tool sets are however domain oriented and cannot fulfil this emerging necessity. On one hand, as the system evolves in complexity and interdependency, the smart grid can be viewed as a system of systems. In assessment of the smart grid as system-of-systems, the scope would shift from direct technical assessments to investigations on the modularity structure and resiliency of the overall energy infrastructure.

Simulation-based assessment of complex and large scale multi-domain systems does not aim at this level of abstraction, and instead focuses on explicit representation of technical elements and their assessment in a system context. On the other hand, assessment at higher levels of maturity (e.g., pre-deployment) and system integration requires that the solution components and functionality are accurately represented. The factors influencing this solution can be of physical, ICT or algorithmic and computational aspects, accordingly the assessment methodology and simulation has to account for the domain specific representations and procedures. The assessment of a smart grid needs to account for such requirements beyond the capacity of a single simulation framework. A smart grid simulation environment has to be established with accordingly accurate models for intra and inter-domain elements as well as interfaces and framework for coordination of those models in a holistic scenario. It must allow seamless cross-domain integration and consistent configuration and functionality of the master algorithm so that the system of systems can be analysed in its completeness with correct interdependency and interconnection among systems.

While preliminary efforts towards such smart grid simulation environment were accomplished in previous work of JRA2 (i.e. smart grid model library, co-simulation interface with cyclic dependencies between the simulated models, and continuous/discrete event coupling), this deliverable focuses on the large-scale deployment of co-simulation approach for smart grid assessment and investigates the behaviour of such models in an upscaling context. Understanding these characteristics allows identifying the key properties that influence the correctness and consistency of an assessment framework for LSS. Note that formally upscaling a system yields the complexity of the models and simulation of a system whereas expanding the system size to be assessed is regarded scale out. In the two main test cases for LSS we do, however, apply the term upscaling for both.

The consideration of large scale systems is important in developing a smart grid assessment environment due to two main reasons: in terms of system behaviours and in terms of simulator's capacity. The behaviour of a model, a function, hardware may change significantly or eventually switch to another regime when it is upscaled beyond a certain threshold (e.g., tail latency). The same principle goes for the inter-model interaction (e.g., convergence time in a multi-agent system as the system scaled up, cascading of control oscillations). Large scale behaviour of a model/hardware needs further analysis and investigation than just assuming linear scaling of parameters.

Another important aspect is that once the system is scaled up, the computational load on the simulators rarely increases linearly with the system and model scale. This can be due to poor management of threading and parallel processes, exponential increasing of dynamic memory, bottleneck of bandwidth, and synchronization constraints upon execution of co-simulation, amongst others. Studying the system in large scale requires also a study on the simulator's capacity and behaviour on handling such complex framework, as the validation set up becomes a large-scale system itself. This study allows the system designer to foresee the necessity in terms of physical equipment to diagnose the problematic points.

2.2 Large-Scale System Assessment Approach

In order to access the necessary requirements of large scale simulation environment, we employ an approach considering two important pillars: the definitions and methodological analysis and assessment for LSS as seen in Figure 1.

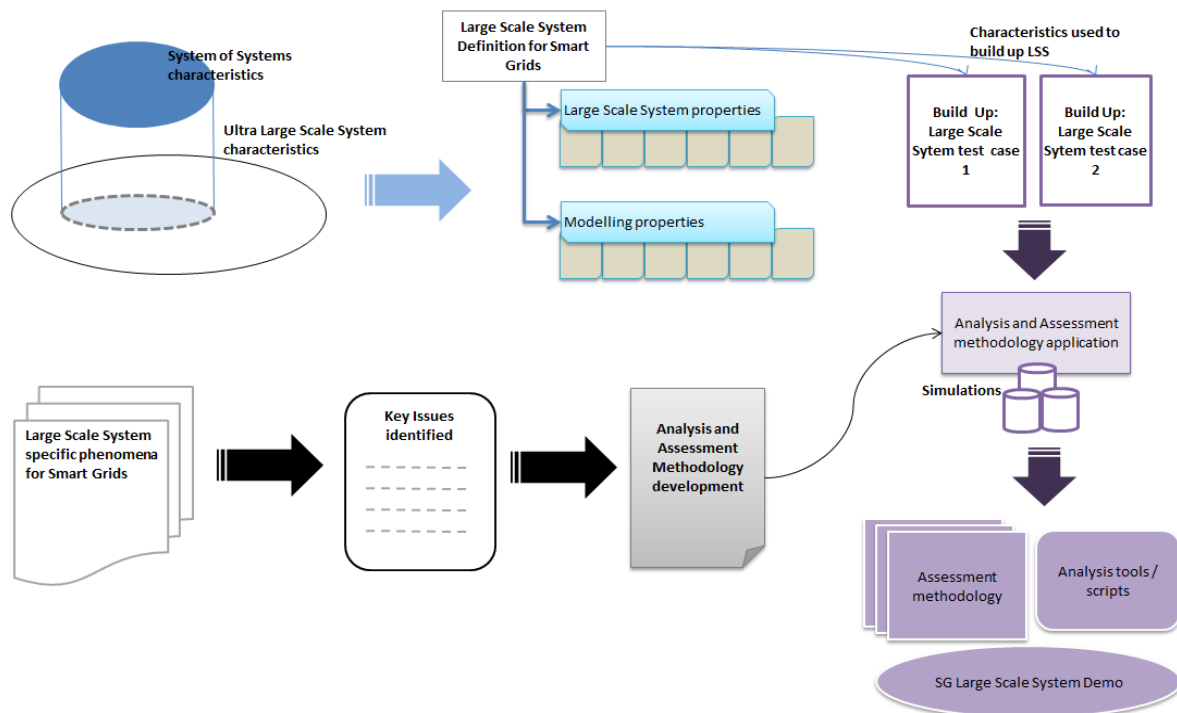

Figure 1: Large-scale system assessment workflow

Addressing the needs of a large-scale system simulation environment, we have carried out a questionnaire and an analysis on phenomena that only come into presence when the system reaches a certain threshold in context of upscaling. The study considers large scale phenomena in both senses: the system under test and the large-scale simulation framework for CPES. The singular phenomena of a large-scale system with respect to a normal one need to be taken into account to avoid unwanted scenarios in mass deployment in reality. On the other hand, the large-scale simulation framework for CPES considers the methods and tool-boxes for correct and seamless integration of large scale co-simulation. The latter aspect is often linked to the first one as a large scale CPES is an integrated multi-domain system that requires appropriately sophisticated but holistic environment for testing and validation for which large scale co-simulation appears to be a reasonable approach.

The two considerations cover different but complementary aspects of large scale system assessment. An analysis of underlying issues of such phenomena was also carried out leading to a definition of LSS in the context of JRA2 with a table of notable phenomena that appears once the system reaches a certain threshold, becomes large scale and requires an appropriate change in assessment approach. This definition allows the determination whether a system has reached large scale status and if it is necessary to adjust the assessment approach.

Based on these considerations, tools and interfaces were developed to demonstrate the proposed workflow via two upscaled versions on the principal test-cases developed in previous work of JRA2, mainly tasks JRA2.1 and JRA2.2. The development and implementation of the tools and interfaces present an important contribution in terms of technical implementation and improves the expertise of the ERIGrid consortium.

2.3 Contributions

In the context of LSS assessment, the contributions of JRA2.3 documented in this deliverable are:

- Identification and classification of large scale system phenomena
- Identification of underlying issues/causes of such phenomena
- Analysis on the phenomena and the issue, leading to a definition of LSS. This allows the determination of the metrics and thresholds at which the system becomes LS and will require appropriate changes in assessment approach.
- The assessments approach (upscaling, simulation) is then defined.
- Tools developed for LSS assessment.
- Test-cases defined, prototyped, and demonstrated.

3 Integrated Simulation Environment for Large-Scale Systems

3.1 Smart Grid Large-scale Systems

There is no official definition for smart grid large-scale system in literature. A system can be large scale for one situation but might not be under other assumptions. In this work, we avoided trying to find a formal “correct for all situations” definition for large scale system, as this is both hard (if possible at all) and does not yield any practical benefit. Instead we investigated and prototyped notable characteristics of a LSS that are distinct and can serve as indication to separate LSS from normal system in a particular scenario. These characteristics are classified into properties exhibited when the system surpasses the large-scale threshold and the phenomena that require appropriate adaptation of assessment methods with respect to a normal system, particularly in the context of JRA2, adaptation of co-simulation framework in a large-scale set-up.

The definition of smart grid large-scale system is then presented as a non-exhaustive list of properties that a LSS may exhibit and that may require an adjustment of assessment approach. Particular attention was also given to the implementation of test setups to deal with such systems that are potentially adequately large-scale system themselves.

3.2 Definition of Smart Grid Large-Scale Systems

The concept of LSS finds precedence in computer science and systems engineering. In that view, a LSS was defined monolithically and “large scale” could be quantified in terms of number of code lines or number of components. In Smart Grid LSS, both criteria are applicable, but it can be argued that the scales are somewhat different, mainly due to the aforementioned strong coupling and fast dynamics observable in electric power systems.

The motivation for defining LSS as a separate problem category in a computer science context has been the qualitative difference in methodology and technology required to deal with systems “... formed by integration of separately developed systems to provide functionality beyond that achievable by their component systems.” [3]. Relevant smart grid systems are also formed as integration of separately developed systems. The concept of “large” is of course relative. Key to the work in ERIGrid in the context of smart grid testing is to identify those conditions under which a “larger” system requires a *qualitatively different approach to testing technology and qualification methods*.

Large-scale systems can be defined as systems composed of multiple components/devices working together to complete a task. The complexity of the system itself can depend on number of components involved, different functionality requirements, or lines of code as noted above. However, large scale can also be the types and number of testing equipment and software infrastructure required to perform an experiment. Considering these dimensions of scale, in context of ERIGrid, *Smart Grid LSS* are systems for which testing needs exceed laboratory-scale, and conventional simulation environments are insufficient. This testing need may be driven either by the properties of the *real-world system under test*, or by qualities of the required *testing infrastructure* employed in an experiment setup.

A *real-world system* or problem is considered large scale if at least one of the following properties exceeds the acceptable complexity for present-day study methods

- Number of nodes and components exceeds conventional computing strategies.
- Interdependencies across multiple domains, due to non-linearity of phenomena or multiple representation contexts (e.g., need for model & data translation).
- Complexity through number of stakeholder systems and interfaces; e.g. conflicting implementation of standards, complicated data specification, etc.

An experiment setup can become a large-scale system itself. Testing infrastructure/testbeds can be considered large-scale in a sense of simulation complexity, and hardware can be large-scale in both direct physical scales and complexity in phenomena and multi-domain issues exceeds the practically feasible complexity for present-day study methods, considering

- Co-simulation setups where multiple instances of simulation models require scaling up computational resources and cause numerical challenges. This has been implemented in LSS1, which has been further detailed in latter part of this document (Section 4).
- Integration of simulated and hardware laboratory (power system in the loop) addressed in [4].
- Management and assessment of experiment events and results across domains are further discussed in development of upscaled test systems defined in latter part of this document (see Section 5).

The features discussed here are summarised in Table 1.

Table 1: Large Scale System in Context of JRA2

Focus on specific aspects: <ul style="list-style-type: none"> • focus on Smart Grid systems • focus on implementation of test setups • focus on systems that (potentially) feature complex technical/physical behaviour Below are the criteria for properties of a test case and experiment setup in view of large-scale systems that are relevant in the context of JRA2.		
real-world (investigated phenomena)	physical (laboratory)	virtual (simulation)
<ul style="list-style-type: none"> • Scale in number of nodes and components • Complexity through interdependencies across multiple domains • complexity through stakeholder interpretations 	<ul style="list-style-type: none"> • number of nodes/ buses/ components • number of domains (power, heat, ICT etc.) • number of relevant layers (business, information, communication, components etc.) • geographical size 	<ul style="list-style-type: none"> • number of equations • number of simulation tools and instances • variety of models of computation (time-continuous, event-driven etc.)

3.3 Properties of Smart Grid Large-scale Systems

A real-world system or problem is considered large scale if one of the following scaling parameters exceeds the complexity acceptable to present-day study methods. Hence a change of assessment needs to be done due to increase in scale. In general, it is hard to determine an absolute threshold for LSS; it rather depends on the application. What can be formulated are scaling rules and criteria for when a change of methodology is required.

In this section, we present a list of large scale smart grid system properties that are subjected to upscaling and need to be taken into account in a LSS assessment. We consider two main aspects: real smart grid phenomena and issues of large scale simulation. Based on those aspects the possible LSS properties are then determined and categorized as seen in Figure 2.

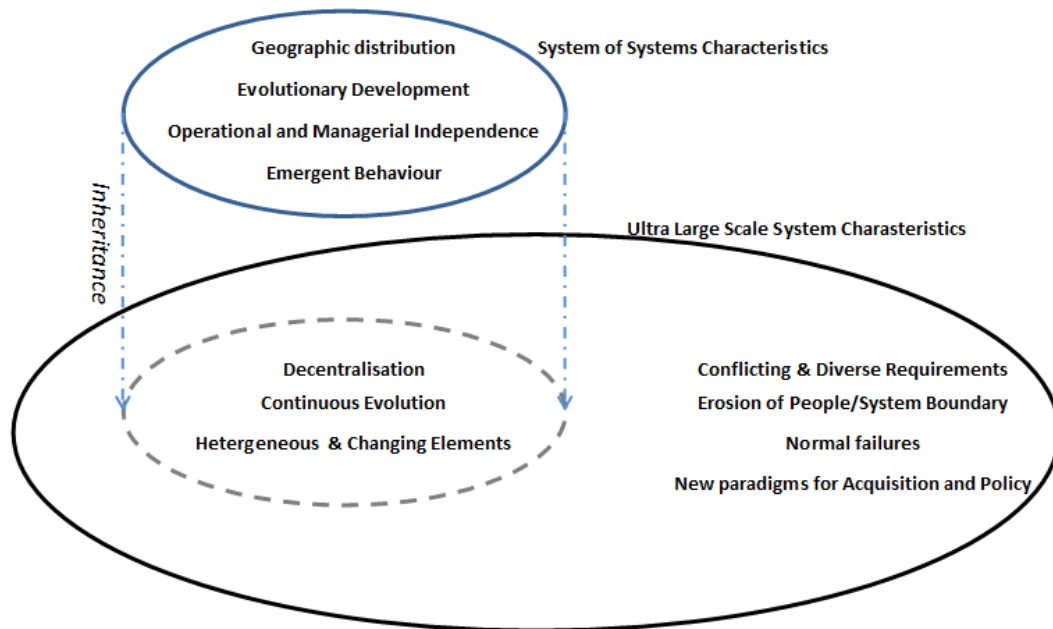

Figure 2: Smart Grid Large scale system properties

In terms of real smart grid LSS, the following properties are supposed to be in consideration when upscaling as seen in Table 2.

Table 2: Potential LSS properties in real world smart grid

No. of Nodes/buses	System size
System Size in geographical scale	(with more components linked via ICT)
Domains involved	Electrical, power, heat, control, ICT
Coupling strength	No. of connections and interdependencies
Semantic Complexity	No. of functions under test
No. of layers	Business Function, information, communication
No. of hardware elements	Components at various levels
No. of Computational elements	Components with computational requirements
No. of people involved	People involved at various levels of the System under Test
No. of overlapping policy domains and mechanisms	How different mechanism interact with each other

A smart grid can be defined as a multi-domain system of systems. In our discussions so far, we have talked about complexities involved in large scale simulation across various smart grid components and their properties. However, each domain has its own set of challenges which necessitates the need for domain specific scaling law. These challenges and this scaling law have to be met by modifying and/or extending the domain specific simulators. Hence, a list of domain-based potential properties subjected to upscaling issues has also been established in JRA2 work.

1. Power System

- a. Number of buses
- b. Time scale of exhibited phenomena
- c. Time scale of the simulator/solver

2. *Communication Simulator*

- a. Number of packets sent and received
- b. Total data to be transferred per packet
- c. Type of communication (wired, wireless)
- d. Number of nodes communicating

3. *Orchestrator Aspects*

- a. Mix of discrete and continuous simulators
- b. Number of interfaces (connections)
- c. Frequency of data exchange
- d. Equivalent source and interface techniques

4. *Automation and Control*

- a. Level control implementation - model fidelity (common to all)
- b. Complexity of subroutines – runtime complexity
- c. Control structure (decentralised, distributed)
- d. Frequency of interactions
- e. Delays from translations
- f. Diversity of the functions

5. *Multiphysics Simulators*

- a. Mix of discrete & continuous dynamics
- b. Model fidelity
- c. Stiffness – diversity of timescales
- d. Number of parameters

It is noteworthy to clarify that “large” and “simple” are not per se opposites. A system may be “large” in absolute scale but not necessarily complex in terms of number of domain and interconnection/interdependency. Hence, it can be modelled in a simplistic way and does not require an adaptation or adjustment of classical assessment method. From a modelling point of view, such a system therefore does not exhibit a large-scale property. To this understanding, in our scope, we consider also the modelling complexity as a large-scale property for analysis. In terms of modelling and large-scale simulation, a list of potential properties for analysis is identified.

- Level of Disaggregation
- Explicit Modelling of Functions (frequency/voltage control)
- Operating Boundary Conditions
- Instability Phenomenon
- Resolution

Depending on the application and its requirement of details in models, it is up to the user to decide the necessary “scaling up” of the considered model. For example, in order to test the behaviour of a centralized secondary controller (voltage or frequency) in a distribution network, the user needs to adapt the algorithm to the real-life scale model of a distribution grid (i.e. the matrices of buses and branches, the input and output matrices). While the augmentation in size of these matrices may lead to slowing down the optimization process, it does not require any change in assessment method until the size of the assessed matrices exceeds the limitation of the operating system or the simulation software. That can be considered as a boundary at which the system becomes large scale. On the other hand, when the application requires detailed consideration on the effect of communication latency among the elements and the centralized controller to the convergence of the algorithm; it is necessary not only to view the system topology through their matrices, but also to simulate the latency between them. In this case, the communication network is considered in its integrity and the number of attributes to process is huge. The “breakthrough” limitation may therefore be earlier.

As the large-scale properties are different and can eventually disrupt from the corresponding small-scale expectation, it is of great interest to analyse the system in real-life scale before implementing.

This allows timely detection of altered functionality due to system scale as well as analysis and determination of potential bottleneck in real-life scale implementation. As for modelling and simulation aspect, it provides the possibility to determine the requirements of an assessment test-bench and to verify whether an assessment result is credible (i.e., appropriate testing approach was used).

3.4 Qualification and Assessment of Large-scale Phenomena

As discussed above, criteria or thresholds for large-scale systems cannot directly be derived for the specific properties that enumerate the scaling. Instead, this section considers an approach that describes the LSS-phenomena in terms of behavioural metrics of either the domain or the testbed and qualifies a complexity threshold/transition for these metrics. We seek to delineate the types of large-scale phenomena which occur in a smart grid real-world and its simulation complement. Specifically, we seek to distinguish these phenomena by whether their occurrence is intrinsic to the system under test - in which case they are “true” collective phenomena (see Section 3.2.1) – or a result of the particular implementation choices made for the experiment system - in which case they are modelling or simulator artefacts (see Section 3.2.2). Distinguishing these phenomena is difficult in general, as their influence on experiment outputs appears similar, resulting in, e.g., oscillations of an output signal. Common for these phenomena are, that as a control parameter, such as those outlined in Section 3.1, is varied, they influence observation parameters in some critical way.

The purpose of this section is to point out and classify several sources of emergent phenomena of each category. The classification supports analysis of test results for larger test systems and simulation experiments. The classification of observed scaling phenomena aims to support the further design optimization, either of the system under test, or the experiment setup (model, simulator).

3.5 Collective Phenomena at System Level

Collective phenomena at the system level are intrinsic to the system under test. That is, they are implied by the system configuration parameter choice – their *occurrence is independent of the chosen implementation of the test*, these phenomena occur even when the test is implemented correctly. Thus, even though the phenomena may yield counterintuitive results, their occurrence does not indicate a fault in the test implementation. In other words, collective phenomena at the system level scale under transformation of (parts of) the specific test system configuration.

These phenomena can thus yield false negatives when deciding whether a test is implemented correctly. Conversely, implementing a test known to exhibit these phenomena, can serve as verification that the test infrastructure is appropriately constructed, as these phenomena are typically sensitive to parameters of the test system under consideration. System-level phenomena can be observed in the behaviour of system parameters as well as in the evaluation of performance metrics, together which can be called *observation parameters*.

To distinguish phenomena, we can group them by their effects on system parameters. The effects can be characterized by the relation between *observation parameters* and *control parameters*. The dependence of phenomena under variation of *control parameters* can be classified as:

- *Scale with the system size* (linear, logarithmic, exponential, and polynomial)
- *Appear at certain critical system sizes* (i.e. phenomenon appears and remains beyond a certain control parameter value.
- *Appear and disappear at certain ‘islands’ of control parameters* or parameter combinations (i.e. the phenomenon is not persistent both with respect to increase or decrease of the control parameter beyond the island)

Phenomena of interest are characterized by significant observation parameter variations, such as:

- a) *Inadvertent oscillations,*
- b) *Extreme values (e.g. performance increase or decay; system failure)*
- c) *Intermittent performance degradation.*

Intermittency may occur as a result of system nonlinear dynamics, but also as a result of increased model fidelity, i.e., reflecting additional manifesting when the system fidelity is high (e.g., wake effect). In this work, the working group identified a number of phenomena associated with smart grid use cases under which scaling may lead to critical increases in behaviour complexity; a single use case can exhibit a number of upscaling challenges, some more intuitive (e.g. optimization slower with more nodes), others of a surprising nature (e.g. congestion sometimes more likely due to link addition). The latter type is more discussed in systems sciences, and thus is named:

- *Coordinated Voltage Control with active local control devices (UC1)*
 - [UC1-1] Scalability limits of CVC algorithm for increasing number of units.
 - [UC1-2] effect of communication time lags on control behaviour.
 - [UC1-3] Inverter Crosstalk in distribution/collection grid.
- *Fault-ride through function of DER inverters (UC2)*
 - [UC2] FRT-Infeed current to “blind” the overcurrent relay [5].
- *Collective response under real-time pricing (indirect control) (UC3)*
 - [DTU-2] “Cobweb effect”: power oscillations due to controller hunting prices, and prices getting adjusted [6].
 - [DTU-3] “Crowding effect”: homogeneous control laws cause crowding that would not happen if decisions were not (implicitly) synchronized, e.g. “Start charging when prices are lowest” [7].
- *Congestion effects (UC4)*
 - [UC4] “Braess paradox”: adding lines to a grid configuration may reduce transfer capacity or cause de-synchronization [8-9].

These scaling scenarios are further categorized by phenomena of interest and control parameters and observables in Table 3:

Table 3: Classification of Smart Grid LSS phenomena

	(a) Inadvertent Oscillations	(b) Extreme Values	(c) Intermittent Performance Degradation
<i>I. Scale</i>	<i>(e.g. auditory feedback amplification; not represented among smart grid cases here)</i>	Crowding Effect [UC2-1] The more units become synchronized, the stronger the effect	Coordinated Voltage Control [UC1-1] Convergence of optimization algorithm may depend on network topology, less on unit count
<i>II. Threshold</i>	Inverter Crosstalk [UC1-3] Inverter crosstalk can cause oscillatory instability	Crowding Effect [UC2] Collapse of throughput when line limits reached	Comm. Network Delays [UC1-2] Time lags can cause instability, depending on control architecture
<i>III. Islands</i>	Cobweb Effect [UC3-1] Cobweb effect (price/ power oscillation) occurs at specific combinations of delay and response gain	Cross-Functional Effect [UC2] Inverter droop control causes (narrow) non-detection zones for protection system	Braess Paradox [UC4] Braess does occur at specific combinations of load, and disappears at other neighbouring combinations

The example phenomena classification is discussed with further detail below. Here, each relevant *control parameters* and possible *observables* are listed.

I-(c): [UC1-1] Coordinated Voltage Control (CVC)

A central controller computes set points and communicates with specific system devices (OLTC, DER units, and storage systems). *Control Parameter*: number of units and topology of distribution grid. *Observables*: Deviations of bus nominal voltage level / increased power losses due to malfunction of system parts.

II-(c): [UC1-2] Communication network delays

Delays in communicating the voltage measurements of geographically widespread distributed control applications can impact the control performance. *Control parameter*: Length of time lag OR Jitter of communication channel delay. *Observable*: Test objective-specific performance measurements – e.g., voltage deviations from nominal operation.

II-(a): [UC1-3] Inverter Crosstalk in distribution/ collection grid

Oscillatory instabilities due to (delays, Eigen modes, etc.). When multiple inverters are present, their combined control modes may induce an unstable oscillation in inverter set points. As the number of inverters, n , increases, the potential number of oscillatory modes scales exponentially in n . *Control parameters*: number of inverters (≥ 2), electrical distance between PCCs, PLL control parameters (P/f droop); *observable*: inverter power injections.

II-(c): [UC2] Non-detection zones

Cross-functional effect: inverter control functionality leads to protection failure (due to non-detection zones) and for specific control parameters and selected control functions [7]. *Control parameters*: active control modes and inverter parameters; *Observable*: failure of anti-islanding protection triggering when it is expected.

III-(a): [UC3-1] Cobweb effect

Control via dual variables (e.g., prices) can, when delays are included, become unstable and lead to oscillations. Relevant in the context of large-scale systems, as the possible modes of oscillation increase exponentially in the number of units, and thus it quickly become impractical to validate the absence of such unstable models.

III-(b): [UC3-2] a/b Crowding effect

When a fleet of homogenous controllers receive the same control signal, their response will be amplified. Result: increased coincidence factors and potential overload situations. It may lead to Cobweb effect due to overcorrection of control signal when delays are present.

III-(c): [UC4] Braess' Paradox: oscillatory islands.

Network effect/Phenomenon; *Control parameter*: "infrastructure improvement" (additional lines or increased transfer capacity of existing ones); *observable*: e.g., "Throughput capacity reduction" (change of flows could go through more critical lines)

The described phenomena are of different nature with respect to the ease of detection and how easily reproducible they are, but also very different in their potential risk for the system and the applicability of mitigation strategies.

For example, a LSS phenomenon of *Extreme Values* caused by Crowding Effect (threshold control parameter, with “extreme” observables) can be benign if one can control the system size or the control parameters to alleviate the symptoms. It can however be challenging if the control parameter cannot be controlled in the real-world (e.g., PV penetration level) and the observable is a rare and catastrophic event (e.g. the massive triggering of PV disconnection due to a single higher frequency excursion). It is obviously difficult to reproduce *Intermittent Performance Degradation* by Braess’ Paradox Effect (where multiple control parameters or narrow parameter ‘islands’ are required, for that matter), as these require both extensive screening of parameters and systematic ranking of observables to identify such situations (cf. [6]).

Note that a given classification depends on the choice of control parameters and observables: it could be imagined that “islands” could be turned into “thresholds” for appropriate parameter transformations, and similarly, observables may be transformed into specific residuals, turning an Intermittent Performance Degradation-observable into category Extreme Values, more suited for detection. The taxonomy provided here is therefore rather a guideline for reasoning about phenomena in scaling of scenarios.

3.6 Modelling Artefacts and Numerical Issues

Here we will discuss the phenomena that occur as a result of a particular choice of simulation orchestrator or simulation tool and numerical issues arising due to the choice.

- *Phenomena as result of choice of particular orchestrator*
Performance issues due to sequential scheduling: Scheduling of simulator execution within a co-simulation setup may be realized in either a parallel or sequential setup. In a sequential setup, the current execution step is scheduled for each simulator one after another. This obviously can lead to decreasing performance for very large numbers of partly expensive simulators simulating long periods of time. Moreover, simply employing a parallel setup instead may not suffice to counter the loss of performance. After all, depending on the types of simulators and the causal chain of their interaction, the setup may provide little to no potential for parallelism. Such an issue would thus need to be resolved via adjustment of scheduling, simulators and scenario modelling in combination.
- *Phenomena as result of choice of particular simulation tool*
Aggregation of uncertainty sources: Simulation models are by definition afflicted with uncertainty (in respect to the behaviour of the modelled real-world systems). In co-simulation, models are coupled via data exchange so that uncertain output of one model serves as input for the next. This way, data may be propagated through sets of interconnected models and aggregate an increasing degree of uncertainty. As a consequence, quantification of the output uncertainty may become challenging for large-scale co-simulation setups with large numbers of interconnected simulators. Especially those simulators are afflicted that either directly or indirectly receive input from other simulators since the number of uncertainty sources is especially high.

3.7 Simulation-based Assessment of Smart Grid Large-Scale Systems

Methodology

In order to consider and to propose appropriate assessment methods for the two aforementioned categories of LSS and modelling properties, we adopted in JRA2.3 two principal methodologies:

- *Upscaling in terms of properties (i.e., scale out)*: this method targets phenomena directly related to real large scale smart grid system.
- *Upscaling in terms of modelling (i.e., scale up)*: this method targets large scale implementations for validation of smart grid.

These methodologies are consequences of the drivers identified in Sections 2 and 3.1.

Furthermore, to sustain these methodologies in the framework of the ERIGrid holistic testing framework, an integrated simulation toolchain has been developed. Particularly, the simulation toolchain aims to have a combination of domain-specific tools in relevant domains and to provide good coverage of relevant use cases. Significant emphasis was given to the standard FMI as a base for interfacing simulators.

In the first methodology involving the upscaling of physical phenomena related to real large-scale smart grid system, we are investigating the adaptation of the proposed toolchain by increasing the model's scale in simulation, which does not necessarily increase the complexity of the model. For example, in Test Case 1 (TC1) of JRA2, the wind turbine model is rescaled to the size of a real-life wind power plant. While it does not increase the complexity of the model, the influence of the wind turbine on the grid is now much more important and it becomes a crucial factor to consider in the grid stability.

The second methodology involves the upscaling in terms of modelling. It allows consideration of the test bench design and validity. For example, in TC1 of JRA2, in parallel with augmenting the size of the wind turbine, we can divide the single WT model into a combination of multiple small WTs. On the one hand, it can help to investigate potential bottlenecks (power and communication), on the other hand, the stress load test on communication interfaces can give invaluable information for dimensioning the real network.

3.8 Integrated Simulation Toolchain

In this subsection, we discuss how domain specific tools are combined to provide an integrated simulation environment

Mosaik as a co-simulation master

The mosaik co-simulation framework is especially employed in JRA2 to provide a sense of improved transparency in smart grid co-simulation. This can be achieved due to the open-source character of the mosaik and its high usability. Accordingly, researchers do not need to employ proprietary middleware like MATLAB or the PSCAD API to replicate results of complex simulation studies.

In the context of JRA2 it has been shown how mosaik can serve as a master for FMUs via a generic interface based on the FMI++ library. Combining the FMI standard with mosaik allows researchers to reuse standard-compliant simulation components without the need to implement new, dedicated interfaces for them. Furthermore, simulators can be provided via the *FMI for Co-Simulation* standard without a need to share the source code. This allows institutions to provide access to their simulation tools while still preserving confidentiality.

Neither mosaik nor FMI are linked to special application domains in their specification of simulation components. Therefore, interdisciplinary co-simulation can be established by simply mapping the data provided or needed by different simulators. Furthermore, mosaik provides a data exchange algorithm on a discrete time basis. However, in contrast to classical discrete time modeling, mosaik allows variable time steps between different simulators as well as for one and the same simulator. This way, multi-domain co-simulation is supported by flexible stepping of heterogeneous simulators and the potential to combine different timescales without a decrease of performance.

Finally, mosaik provides a flexible *Scenario-API* that allows easy specification of executable co-simulation setups. Due to the script-based setup description, upscaling of any co-simulation experiment is rather trivial, given that the employed simulators support it.

FMI-compliant simulation interfaces

Work package JRA2 covers not only the extension of the mosaik environment to include FMI-compliant simulators and models, but also includes the development (or extension) of FMI-compliant interfaces for simulation tools for which no (or only limited) FMI support was available yet. These developments are essential to provide a complete FMI-based simulation toolchain for smart grid assessments, making essential functionality of domain-specific simulators available for the co-simulation.

As such, the resulting output from work package JRA2 should be considered as a prototype implementation for an FMI-based smart grid co-simulation toolchain that serves as proof-of-concept and basis for further development. For this reason, attention has been paid that these developments were carried out in a sustainable way, which allows future reproduction and extension:

- *Extensibility*: All FMI-compliant simulator interfaces developed in JRA2 are based on functionality provided by the FMI++ Library [10]. Hence, future developments of the FMI++ Library (e.g., due to new versions of the FMI standard) can be included into these interfaces with relatively little effort.
- *Reproducibility*: All FMI-compliant simulator interfaces developed in JRA2 are publicly available (open source). As such, they serve as best practice examples to developers of other simulation tools for how the FMI++ Library can be applied in this context.

More specifically, the following domain-specific tools have been successfully integrated based on developments (or extensions) carried out as part of work package JRA2 (refer to deliverable D-JRA2.2 for details):

- *Electrical power systems*: A previously existing FMI-compliant interface for the DiGSILENT PowerFactory tool has been extended to provide access to electro-mechanical simulations (also referred to as stability, or RMS simulations) [11].
- *Communication*: A first prototype of a FMI-compliant interface for the ns-3 tool has been implemented. This development is especially interesting because it demonstrates how an FMI-compliant interface can be used to interact with an event-based simulator.
- *Automation and control*: An FMI-compliant interface for the MATLAB tool has been implemented. Even though there exist several approaches to export Simulink models as FMUs, this interface is the first attempt to provide direct access to the full functionality of scripted MATLAB.

Together with other existing FMI-compliant interfaces (especially for Simulink and Modelica models) the resulting combination of domain-specific tools provides a toolchain that covers all relevant domains for assessing smart grid applications. Moreover, its application within work package JRA2 has demonstrated that this toolchain covers a large spectrum of relevant use cases (see details further down and test cases provided in deliverable D-JRA2.2).

Application layer models developed and used for the ns-3 large scale scenario

For the purpose of work package JRA2, several application layer models were developed in order to meet the specific demands of the co-simulation scenarios. In the following, the application layer models used for test case TC3 LSS (also known as LSS 2) are listed as an example:

- *Dummy smart meter custom server*: This application layer model simulates UDP server functionality similar to the Controller server or the OLTC custom server. It was created in order to simulate the co-channel interference phenomenon. It constitutes the server in which the dummy smart meters connect and transmit their packets to create network channel congestion. Please note that the choice of using UDP server functionality for dummy smart meter custom server is not a recommendation of this technology for similar real-world systems. It was rather a

convenient choice for the purpose of modelling an ICT network, resulting in simple yet realistic models for proof-of-concept validation in test case LSS 2.

- *Dummy smart meter custom client*: This application layer model simulates UDP client functionality similar to the smart meter custom client. It was created in order to simulate the co-channel interference phenomenon. The application's role is to connect to the dummy server and transmit excessive amount of packet, in order to create increase traffic in the network channel. Please note that the choice of using UDP server functionality for dummy smart meter custom client is not a recommendation of this technology for similar real-world systems. It was rather a convenient choice for the purpose of modelling an ICT network, resulting in simple yet realistic models for proof-of-concept validation in test case LSS 2

Generic virtual component tools

For various tools in the integrated simulation toolchain, FMI realizations are available or have been developed. To leverage the vendor-neutral FMI in coupling external hardware, an interface program which instantiates generic virtual components was implemented. The interface application, called *FMITerminalBlock*, allows loading an FMI-based model, to obtain the simulation results, and to synchronize exposed variables via a network connection. The use of off-the-shelf computing hardware and automation systems is enabled by implementing a best effort-approach which synchronizes the simulation time with the notion of real-time whenever communication is triggered. Data exchange is performed via industrial communication protocols which can be configured to fit into existing applications. In particular, a set of event-based protocols as defined in IEC 61499 are supported. A user must configure the mapping of exposed model variables and provided network variables. Additionally, *FMITerminalBlock* allows configuring various algorithmic aspects such as the synchronization algorithm and the numerical integration method. To support dissemination and a broad availability of FMI-based virtual components, the interface program is released under an open-source license [12].

For efficient control and interface logic development in large-scale distributed systems, Eclipse 4diac [13] is included into the toolchain. Eclipse 4diac consists of several components such as an IEC 61499-compliant integrated development environment which can be used to design distributed systems. A runtime environment executing the previously designed control logic is also provided. Figure 3 shows the user interface of the Eclipse 4diac development environment on editing control logic implemented as a function block network.

Since *FMITerminalBlock* natively supports the event-based communication protocol of Eclipse 4diac, virtual components can be efficiently integrated into IEC 61499-based automation systems. Additionally, the Eclipse 4diac tools support a broad variety of communication protocols and hardware controllers. One can flexibly realize complex data transformations within the Eclipse 4diac framework which go well beyond the representational mapping of *FMITerminalBlock*. Such data transformations include the mapping of one single status code as delivered by an external hardware controller to multiple Boolean output signals as requested by a virtual component. Hence, connected Eclipse 4diac controllers can be deployed for protocol translation and control function implementations alike.

Within ERIGrid Task JRA 2.2, the generic virtual component toolchain was examined in Test Case 2 (TC2). Several experiments in a proof-of-concept were performed by interfacing an industrial On Load Tap Changer (OLTC) and *FMITerminalBlock* using an industrial communication protocol. The experiments have been carried out successfully and results can be consulted in the corresponding reports of D-JRA 2.2.

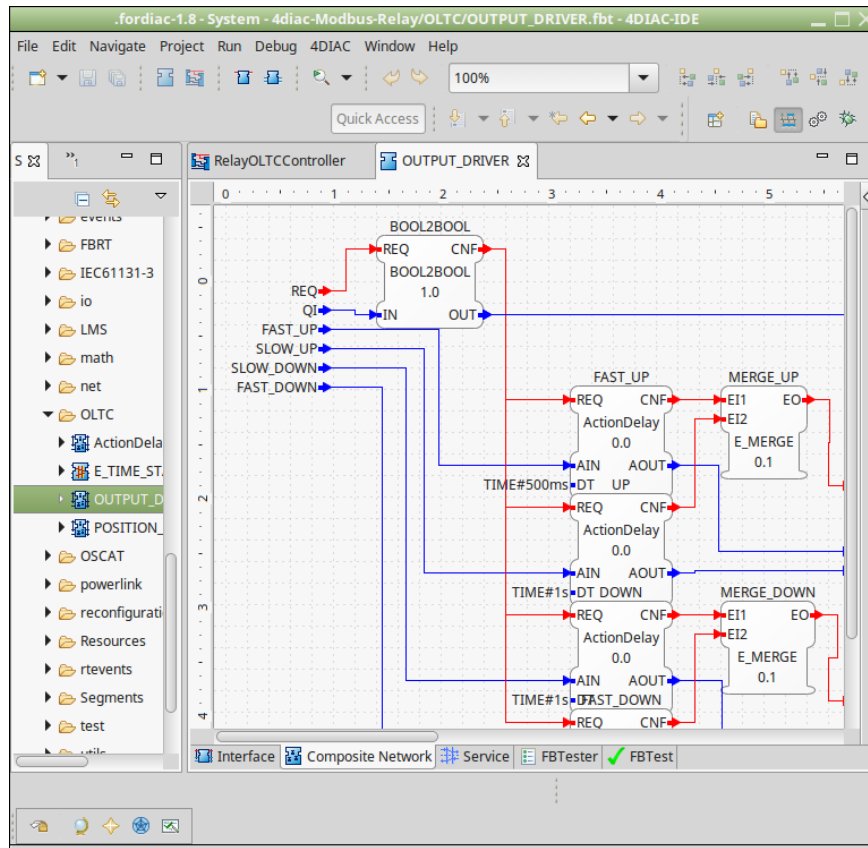

Figure 3: Eclipse 4diac user interface

3.9 Smart Grid Model Library

To complement and expand the functionality of FMI-based co-simulation, a dedicated FMI-ME compliant Smart Grid library has been developed within the ERIGrid project. The developed model library provides three simulation domain sets of models carefully selected and developed for validation and acceleration of novel smart grid solutions. The three simulation domains, namely power systems, communications, and controls, and the choice of models across the domains have been driven by their importance, supported by the shared interest and widespread expertise of the consortia partners.

The models have been originally developed in MATLAB/Simulink or OpenModelica due to the availability of tools within the platform that allow for model exportation as FMUs for ME. The models developed and exported as FMUs have been tested for their compliance to FMI-ME specification, proving and demonstrating their tool-independent implementation (interoperability) and facilitation of their reusability. Furthermore, all the models have been thoroughly tested for their representative behaviour by means of integration tests, i.e., an FMU exported from MATLAB/Simulink was imported within OpenModelica and vice-versa for testing the model performance. Each FMU was also tested within mosaik where the performance of the imported FMU was verified against a predefined input-output relationship obtained within simulation tool utilized for model development.

Two of the models developed in the smart grid model library have been used in the upscaled version of TC 1 also referred as LSS 1. The models used are the convertor controller model and the Gault Ride-Through (FRT) controller model. The models were used to control the wind turbine FRT support and recovery during and after short circuit conditions. The implementation results are discussed further in the subsequent sections. Successful large-scale co-simulation enhances the validity of the developed models. The models will be released as open source along with this deliverable.

4 Large-Scale System Scenarios

4.1 Assessment of the FRT Capability of Distributed Wind Turbine Generators (TC1-LSS1)

4.1.1 Motivation

The fault ride through capability of distributed wind turbine generators was referred to as Test Case 1 (TC1) in earlier JRA2 deliverables. In DJRA2.1 and DJRA2.2, the evaluation of cyclic dependencies between different models in TC1 has been documented. This test case was chosen to be up-scaled, bearing the name Large Scale System 1 (LSS1). It includes several components with a mix of discrete and continuous nature. TC1 consists of a Wind Power Plant (WPP) connected to the grid at transmission level. The use case is the fault ride through (FRT) capability of the entire system (i.e., the WPP) so that the compliance to grid codes, usually dictated at the high-voltage side of the connection transformer, are maintained. The entire system is co-simulated which leads to cyclic dependencies among the components of the system model. Hence, maintenance of synchronism between the simulators is of utmost importance for proper functioning of the system. In today's power system with higher penetration of DERs and an increasing role of the ICT infrastructure, TC1 becomes an instrumental study case for upscaling and validation of its performance.

4.1.2 System Configuration

TC1 consisted of a transmission grid and the WPP as the main components. The transmission grid is a standard IEEE 9-bus test system [14] where the generator G3, transformer T3 and Bus 3 have been replaced by the WPP (Figure 4).

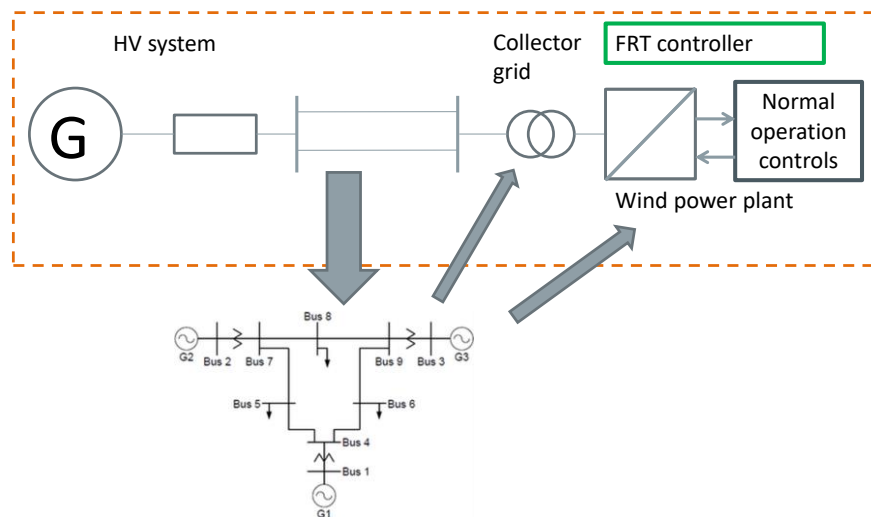

Figure 4: Modified IEEE 9-bus system as applied in the grid configuration of TC1

The minute details of the system can be found in DJRA2.1. The test case focussed on the interaction between the WPP and the transmission grid. The point at which both are connected is referred to as Point of Common Coupling (PCC). The PCC is important because during three phase short circuits, the FRT capability is tested and the PCC is the point where legal compliance to grid codes is required, among other requirements. Previous deliverables, DJRA2.1 and DJRA2.2 documented how the monolithic simulation and small-scale co-simulation of TC1 performed in Simulink [15] and DGSilent PowerFactory [16] platforms respectively. The results are benchmarked to each other and are found to be tracing almost similar patterns for FRT and post-FRT recovery. In the small-scale co-simulation between Simulink and PowerFactory, an aggregated WPP is used with a rating of 100 MVA at a power factor of 0.85 leading, hence 85 MW. For the simulation of this system model tree FMUs are generated: one for dictating the FRT actions (the FRT controller), one for

modelling the converter controls of the wind turbine, and one for the power system model in PowerFactory using the FMI for co-simulation specification]. The FMUs are exported from Simulink using the FMI exporter plugging [10] and coupled to the main system simulated in PowerFactory. FMI++ is the orchestrator of this FMU interaction and an intuitive Python script is used to execute the overall co-simulation. Figure 5 shows the described interactions.

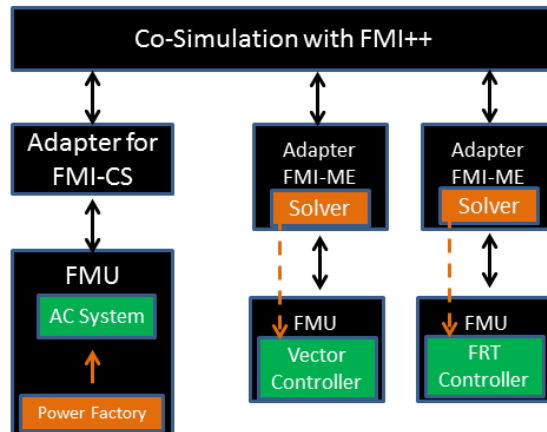

Figure 5: Co-simulation interaction with FMI++ as orchestrator

Scaling Up

Based on scaling-up laws and properties discussed in above sections, we scale up TC1 by splitting the aggregated WPP into a layout of 32 wind turbines with 4 strings of 8 wind turbines each. The rated power is distributed equally among all 32 turbines, with each having a rating of 3.75 MVA and power factor of 0.70. The Wind Park is assumed to have ideal wind turbine spacing of 700m with underground cable connections. The parameter selection for the cables is applied as seen in Table 4 [17].

Table 4: Parameter selection for 33 kV cables

Irat [A]	r [ohm/km]	l [mH/km]	c [uF/km]
270	0.342	0.46	0.155
320	0.247	0.437	0.16
360	0.196	0.4	0.17
410	0.159	0.38	0.18
530	0.098	0.36	0.22
690	0.063	0.33	0.26

Hence, 32 wind turbines lead to increased number of nodes and buses, which adds a layer of complexity. Additionally, each wind turbine will have its own FRT controller and converter controller. This local/distributed approach is considered a plausible assumption because of the high bandwidth and reliability needed. This implies that the co-simulation needs the generation of 32x2=64 FMUs. This leads to a considerable increase in simulator interactions, which will also test the robustness of the developed coupling interfaces. Thus, the scaling up of TC1 is done in such a way that we add two layers of complexity, one from the increased system size point of view (increased nodes, buses etc.) and the second from more complex co-simulation point of view (i.e., scale out: increased simulator interactions). The FRT voltage support and recovery is tested in the scaled-up simulation to benchmark the results against the small-scale co-simulation. The grid interfaces of the 32 wind turbines are inserted into Power Factory and can be seen in Figure 6.

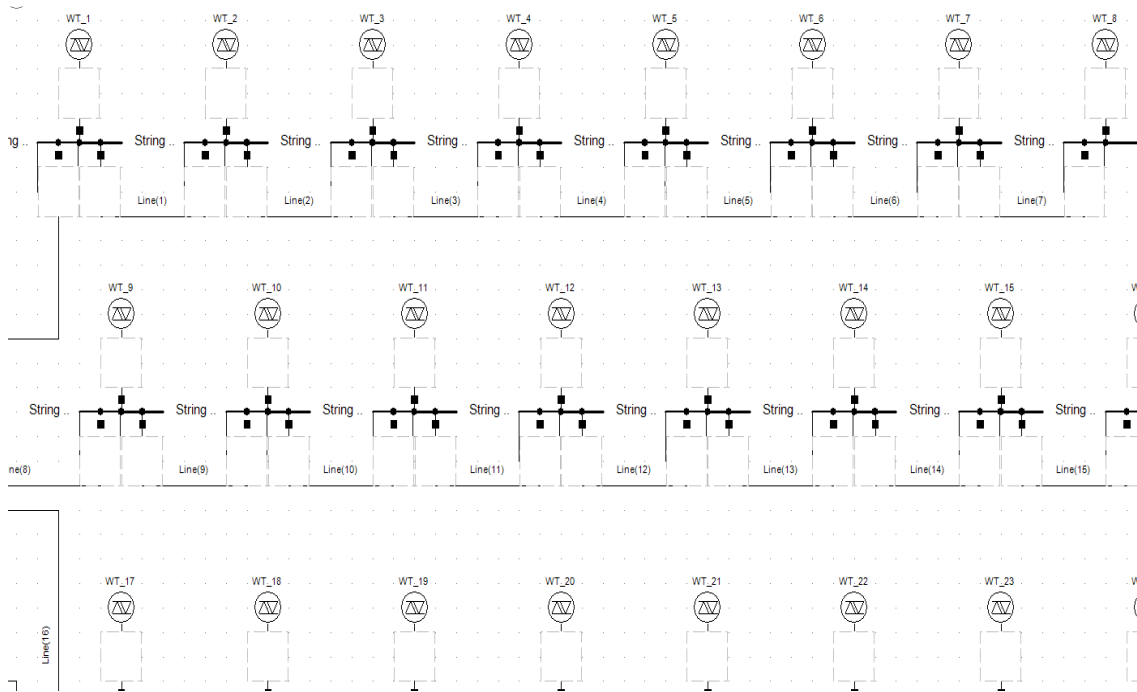

Figure 6: Scaled up WPP (32 Wind Turbines) in PowerFactory

4.1.3 Test Specification

The System under Test (SuT) for TC1-LSS1 can be seen in Figure 7. The main feature is 32 instances of converter controller and FRT controller of the 32 wind turbines interacting across simulators. The more detailed version of the test specification can be found in Annex 9.3. The main test objective is to verify the behaviour of the 32 wind turbines at the PCC during and after a voltage dip that occurs at the PCC. In order to reproduce this situation, a 3-phase-to-ground fault is triggered in a transmission grid node with the FRT controller enabled. The success of the test depends on whether all the wind turbines remain connected and no further overcurrent's, voltages, and over-frequency occur after fault isolation. The voltage recovery due to FRT support at the PCC should trace the same as we obtained from the previous small-scale co-simulation.

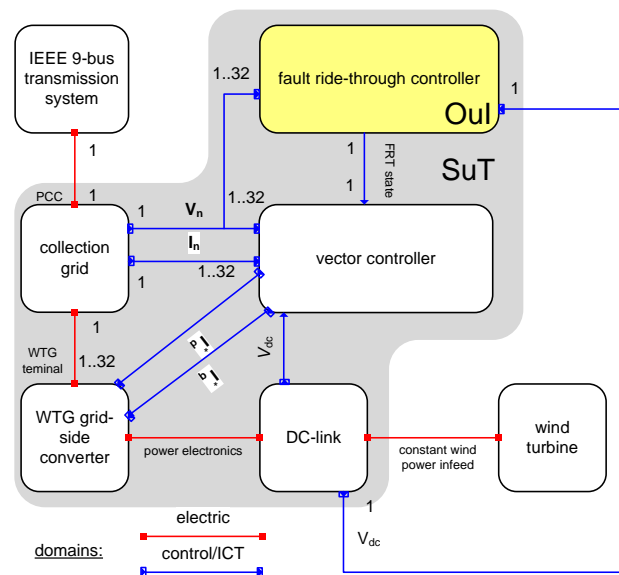

Figure 7: SuT (System under Test) of upscaled TC1 (LSS 1), accompanied with component interface variables

4.1.4 Implementation Challenges

An important PowerFactor functionality is to associate objects with user-defined DSL models via a composite model (type *ElmComp*). By sending a so-called *parameter event* (type *EvtParam*) to such a DSL model, the input parameters of the model can be changed. This change of input parameters can be easily propagated to the parameters of any object by connecting the DSL model with the corresponding object in a *composite model*. For sending events to a composite model, a dedicated compiled DSL block called *FMIAdapter* is provided. To use this DSL block it must be included into a composite frame (as can be seen in Figure 8). The block does not have to be connected directly to any other block, instead it sends events to other blocks (in the example to the block called *Controller*) to change their input parameters.

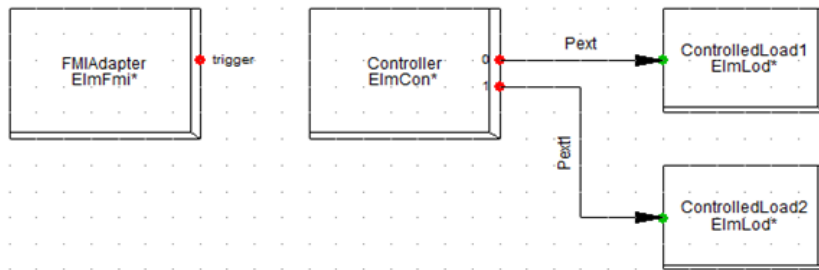

Figure 8: Example of a composite frame including DSL model FMIAdapter

In case of the small-scale co-simulation there existed only one aggregated WPP. Hence the abovementioned setup was enough for the FMUs from Simulink to communicate with the FMU of the aggregated wind turbine model. However, in the upscaled version, we have 32 wind turbines with each having their own set of 2 FMUs each. This translates into the PowerFactory requirement to make 32 composite frames for 32 wind turbines. However, we need only one *FMI Adapter* block to request the event parameter for the entire system. Hence 32 composite frames cannot have an individual *FMI adapter* block. Moreover, in PowerFactory, the composite frames cannot communicate with each other without thorough non-trivial adjustments. This leads to a challenge as to how to have all the composite frames communicate with the single FMI Adapter block. The solution to this challenge was to design one single big composite frame with the FMI adapter block and replication of all other 32 composite frames. This workaround makes the design process more time-consuming and complex. The single big composite frame as designed for upscaled TC1 simulation can be seen in Figure 9.

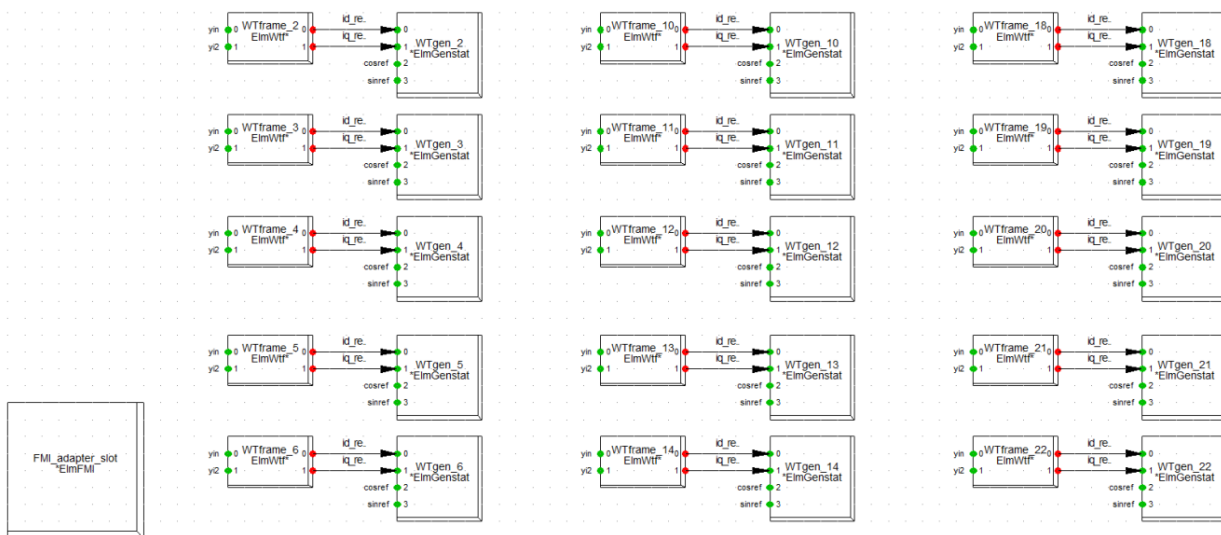

Figure 9: Single composite frame encompassing 32 individual wind turbine frames (PowerFactory modelling)

4.2 Assessment of the Remote Real-Time Coord. Voltage Control for Distr. Grids (TC3-LSS2)

4.2.1 Motivation

As distribution grids become increasingly observable, through the use of smart grids, and increasingly controllable, by the ubiquity of DERs, combining these new resources to enhance system resilience and decrease operational costs is a major topic in current research. Since information in these distributed systems are typically sent over public communication networks rather than the dedicated networks used prior, delays in communication and dropped packages are of concern in testing controllers intended for deployment in distribution systems. The use of public networks further leads to concerns on cybersecurity, as communication may be intentionally distorted. The work undertaken in LSS2 intends to develop and demonstrate test bed features which allow testing controllers with remote sensors and action points. Particular emphasis is placed on the technology required to allow the system under test to scale to a large number of access points, and techniques for control of ICT network operation.

Within this context, a test case has been designed that deals with the impact of ICT-related aspects in a radial low voltage distribution grid that extends over a relatively large geographical area. Remote sensors – referred to as smart meters in this test case – are installed towards the ends of the network's feeders and regularly send information about the local voltage levels via a communication network to a controller. Based on these meter readings, the controller actuates the tap position of an OLTC transformer.

Each smart meter is connected to the communication network through a wireless connection. Due to the geographical size of the overall system and the resulting distances between the ends of the feeders, each smart meter is connected to a separate wireless local network. For this specific test case, the focus of interest are ICT-related effects arising from co-channel interference in these wireless local networks, especially long communication delays and packet loss.

The aim of this test case is to demonstrate and assess the effect of communication networks on the actuation pattern of the controller and the resulting physical effects in the low voltage distribution system. For this assessment, the size of the wireless network (in terms of connected devices) is scalable. This allows determining the critical size of this communication network for supporting stable and reliable operating conditions.

4.2.2 System Configuration

Figure 10 provides a conceptual overview of the main components of the system configuration of this case. In the following, the individual parts are described in detail.

Electrical Network

A large radial low voltage distribution network with an OLTC MV/LV transformer (see Figure 11) has been chosen for this test case. It has been adapted from the reference networks provided in [15] and is large in terms of connected loads and geographical size compared to typical low voltage distribution networks. The tap changer is configured such that switching from one tap position to the next decreases (step up) or increases (step down) the voltage level at the LV side by 2,5%.

Towards the end of each feeder a smart meter is located, respectively. These meters send measurement data (local voltage level) in regular intervals to the voltage controller via a wireless local network. The sending of the data is synchronized among these smart meters, i.e., they all send their data at the same time.

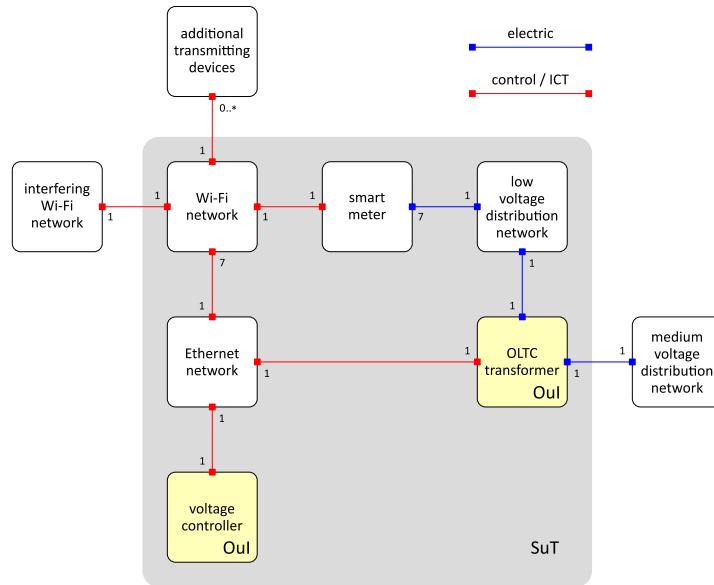

Figure 10: Overview of the system configuration of test case LSS2

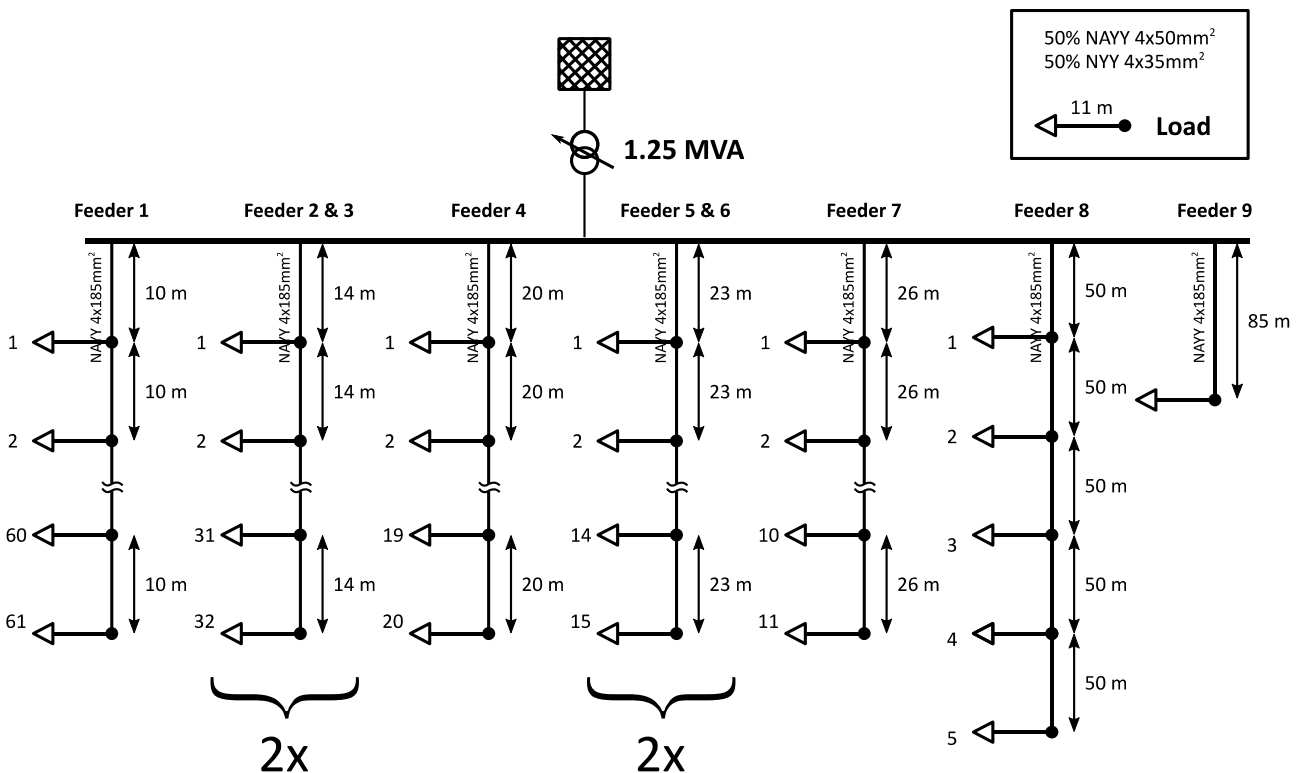

Figure 11: Schematic diagram of the low voltage distribution network of test case LSS2

Communication Network

With a growing demand for networking resources also the probability of interference between two or more networks or components in the same network (e.g., two access points) increases. Co-channel interference, as the name implies, is the type of interference which occurs when two or more Wi-Fi access points that share the same coverage cell operate on the same frequency channel. The resulting performance degradation causes communication delays, packet loss and throughput deterioration. This phenomenon is more frequent in the 2.4 GHz band, where the non-overlapping channels are limited to 1, 6, 11 or 14. Therefore, as network densities increase, the

reuse of the same channels is virtually unavoidable. In the 5 GHz band this is less common, because the number of non-overlapping channels increases to 24 due to the higher spectrum range. However, in this case also the propagation range is decreased due to the high signal frequency.

For the purpose of this test case, each smart meter is connected to a wireless local network (Wi-Fi, networking standard 802.11ac, coding scheme index 3, and short guard interval disabled). In addition to the smart meters, several other (unrelated) devices are connected to the same wireless local networks, which use the wireless local networks simultaneously to the smart meters. Furthermore, each of these local networks has another additional Wi-Fi network close to it, transmitting at the same frequency and causing co-channel interference (frequency channel: 5180 Mhz, channel width: 40 Mhz).

In order to observe the impact of the co-channel interference, the additional Wi-Fi networks overload the frequency by sending packets at very small intervals (in the order of 10µs) with a packet size of 972 bytes. Wireless conversations are managed using CSMA/CA (Carrier-sense multiple access with collision avoidance) and every station is sending frames only when the medium is idle. As the smart meter’s local network is congested due to the overload from the additional Wi-Fi network, the shared channel is always busy. This results in augmented waiting times and more packet collisions, reducing the performance of the smart meter’s local network significantly. In addition, an Ethernet network (bandwidth: 100 Mbps, channel delay: 6560 ns) connects the Wi-Fi networks to the voltage controller and the OLTC.

Voltage Controller

For the voltage controller a simple rule-based control algorithm is used, which calculates tap position set-points for the OLTC transformer depending on the smart meter readings (see Figure 12). This controller runs on a dedicated server, separate from the transformer and the smart meters, to which it is connected through the communication networks (both Wi-Fi and Ethernet). The controller actuation is synchronized with the smart meters, i.e., it is always actuated directly after the smart meters send their data (but delayed by a short amount of time).

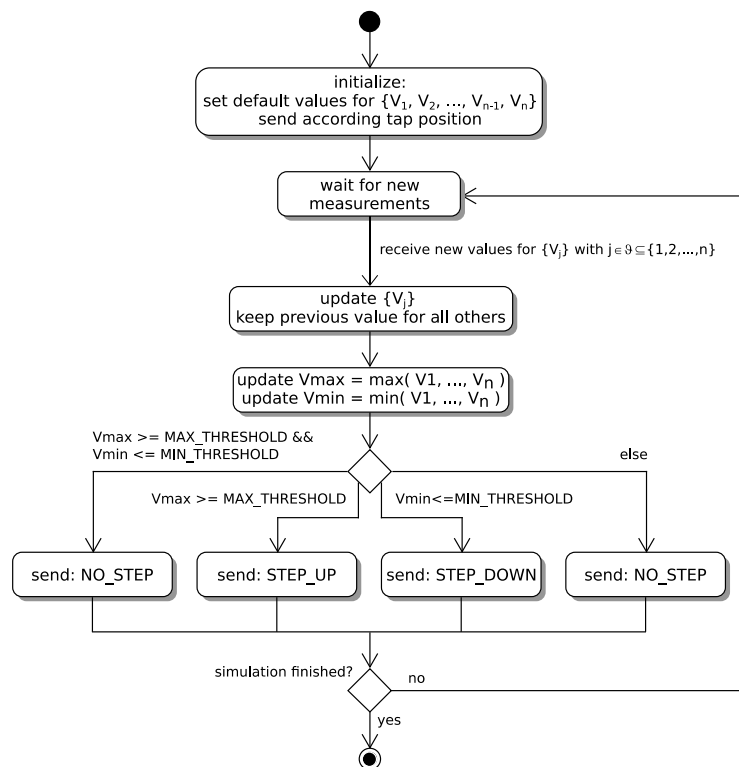

Figure 12: Schematic diagram of the voltage control algorithm used for test case LSS2

4.2.3 Test Specification

Overview

This test aims at a simulation-based assessment of the impact of communication delays and packet loss due to co-channel interference on the actuation pattern of the OLTC and the voltage levels. The impact is evaluated by comparing the final realized tap position with the expected tap position, i.e., the final tap position resulting from the actuation in an idealized test case without communication delays or packet loss. The voltage levels at the end of the simulation are expected to be within the operational limits. Figure 13 provides an overview of the involved simulation components.

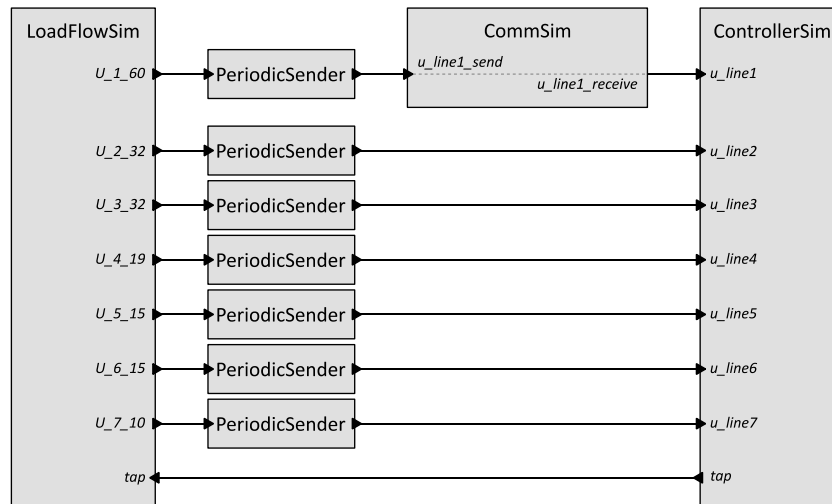

Figure 13: Overview of the individual simulation components for test case LSS2

Test Design

The test takes 2 minutes of simulation time. Within this time, the meters send their measurements to the controller in regular intervals ($T_{\text{sender}}=60$ s) in perfect synchronization, beginning at the start of the simulation ($t=0$ min). The controller receives new measurements, calculates a new tap position setpoint, and sends this value to the OLTC. This calculation is delayed with respect to the smart meters sending their data ($\Delta t_{\text{ctrl}}=1$ s).

The transmission of data from the meter at the end of feeder 1 is affected by co-channel interference from another Wi-Fi. The size (in terms of connected devices) of the Wi-Fi network is determined by the number of other devices (n_{device}). They all transmit data at approximately the same time, i.e., the meter and the devices send randomly within the interval $[t, t+\delta t_{\text{device}}]$, with $\delta t_{\text{device}}=0.01$ s. The transmission delays for data from the other meters to the controller and from the controller to the OLTC's are assumed to be negligible.

The voltage at the end of the longest feeder is expected to fall beyond the lower threshold within one minute, and a change in the tap position is expected to happen the next time the meters transmit their measurements to the controller ($t=1$ min). More precisely, the OLTC is expected to switch from the neutral tap position (position 0) one step down (position -1), increasing the voltage level at the LV side by 2,5%. All other voltages are expected to stay within the operational limits throughout the test.

As this test involves an uncertain element through the interference in the ICT network, each test run will yield different results. To deal with this, the results from a (large) sample of individual simulation run need to be combined and statistically analysed (Monte Carlo approach).

Large-Scale Aspects of the Test Case

The test case incorporates two different aspects of large-scale systems:

- *Geographical size of distribution network:* The low voltage distribution network used in this test case is comparable large in size. At the same time, the range of wireless communication networks is limited, and is in practice far below the scale of the electrical network. Therefore, the smart meters (located at the end of the feeders) use separate local networks to connect to the voltage controller.
- *Number of devices in the communication network:* The size of the Wi-Fi networks in terms of connected devices (n_{device}) is a free parameter of this test case. Given the fact that this parameter reflects only the number of devices sending simultaneously, a moderate value already implies a large number of devices located within the range of the Wi-Fi network (that do not transmit within the short duration of a single simulation step).

4.2.4 Implementation Challenges

As for implementation challenges we first consider the challenges related to upscaling the models then the challenges related to the co-simulation aspect (i.e. scheduling, coordination of master algorithm, and handling simulator infrastructure).

First and foremost, the implementation challenge is related to the fact that the CVC controller uses a mixed-real-integer optimization that is based on the topology of the grid (i.e. the matrices of buses and branches, the inputs and outputs matrices). It is therefore not trivial to linearly upscale the controller as a function of number of actuation points. It is required to adapt the related matrices to the new topology. Every time the number of actuation points increases, it is necessary to adapt the algorithm to the new topology. Moreover, the configuration on the communication network is not fixed either and needs to be adjusted accordingly. While it is theoretically possible to design an adaptive controller that takes into account the topological change of the grid; it requires a full integration of a semantical information model which is presently not available in the electrical engineering field. Common Information Model (IEC 61970/61968) is the closest to such an information model; however, it has not fully supported the whole smart grid yet. It also requires time and effort to build and implement such a semantical controller, which exceeds the scope of the test-case.

Another implementation challenge in a co-simulation context is given by the fact that the communication simulation introduces a delay into the message exchange of the system. Consequently, a simulator cannot predict when it will receive its next input. This translates to a discrete event simulation (DES). DES can be realized in different ways in a co-simulation setup. The most general solution is to employ a co-simulation master that supports event-based scheduling. However, there are different possibilities to implement such a master. A conservative scheduling algorithm bounds the period of simulation time every simulator can advance into the future. This prevents simulators from producing events that are already in the past for other simulators. Progressive scheduling, on the other hand, allows simulators to advance as fast as possible, but requires them to do a roll-back once an event occurs that would influence their past state. This type of scheduling can lead to an improvement in performance but is not supported by all types of simulators.

The co-simulation framework mosaik contains scheduling on a discrete time basis. The typical solution for such a master to deal with DES is to define a minimal time step n that lies between any two events. Then all simulators are advanced in increments of this time step to ensure that no event is missed. Obviously, this can lead to performance issues based on the underlying application case. A solution to mitigate such problems can be established with a rather simple extension of the scheduler: Before the data for a given time-step is sent to a simulator, it is screened within the scheduling algorithm. If the input does not exceed a given interval, the stepping of the simulator

is skipped since no new results are expected. In other words, simulators are only “woken up” when their inputs actually change (due to events).

This solution provides a reasonable approach to address the problem of synchronization of unpredictable time steps in DES and the problem of integrating Discrete Event Simulation (DES) with continuous simulation. However, it requires an augmentation of number of time steps and introduces higher computational complexity.

The feasibility of such solutions has been tested in JRA2 in the context of mosaik. In the long run, however, mosaik is expected to be extended with a conservative DES scheduling module to allow more flexible solutions to event-based simulation problems. A discussion based on it can be found in the outlook of the Deliverable D-JRA2.2 [2].

5 Implementations and Results

5.1 Assessment of the FRT Capability of Distributed Wind Turbine Generators (TC1-LSS1)

5.1.1 Implementation Details

Upscaled TC1 (LSS1) as described in previous sections was implemented in an integrated simulation environment as a co-simulation between Simulink and PowerFactory. The converter controller (Figure 15) and FRT controller model (Figure 14) for each of the wind turbines were designed in Simulink while the main transmission system was implemented in PowerFactory. FMI-compliant simulator interfaces developed in JRA2 based on functionality provided by the FMI++ library was used for coupling the two tools. The converter and FRT controller are then exported as FMUs. A total of 64 FMUs are generated and exported for 32 wind turbines. The PowerFactory model is converted to and FMU according to FMI for co-simulation. A python script is used to execute the co-simulation. Co-simulation is facilitated by FMI++ python interface wrapper for FMI++ library [14].

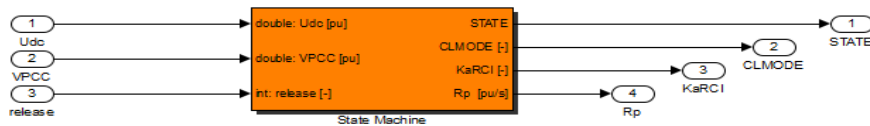

Figure 14: FRT controller developed in Simulink, along with interface variables and types

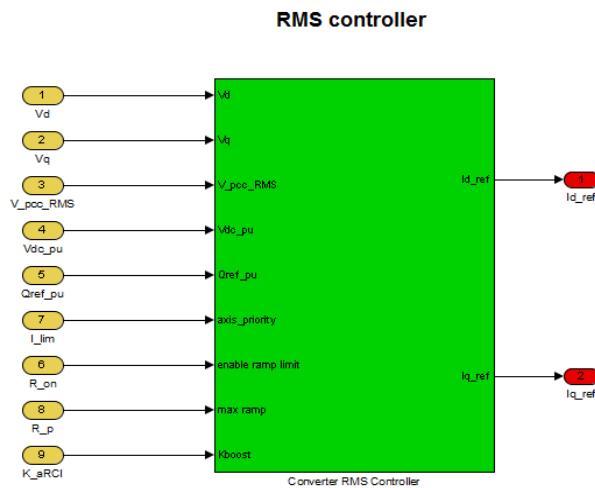

Figure 15: RMS converter controller (Simulink) along with interface variable names

5.1.2 Experimental Results

The time-domain simulation results obtained for all the 32 wind turbines as seen in Figure 16 and 17 are tracing almost same. The FRT support and voltage recovery at the PCC can be seen in Figure 17. Figure 18 shows the output power. In principle the waveforms trace the same pattern but the slight difference in waveforms is due to the different system scale of the experiments. The event simulated is a three-phase-to-ground short circuit at 1 s, which is cleared after 20 ms. Both time-domain plots are compared with the small-scale co-simulation results and we can see that they trace very similarly. Hence, the upscaled co-simulation presents satisfactory results (both qualitatively and quantitatively) and the tools and interfaces developed in this work can be used as an integrated simulation environment for other test cases, both for scale out of the system size and for scale up of the model size to be addressed.

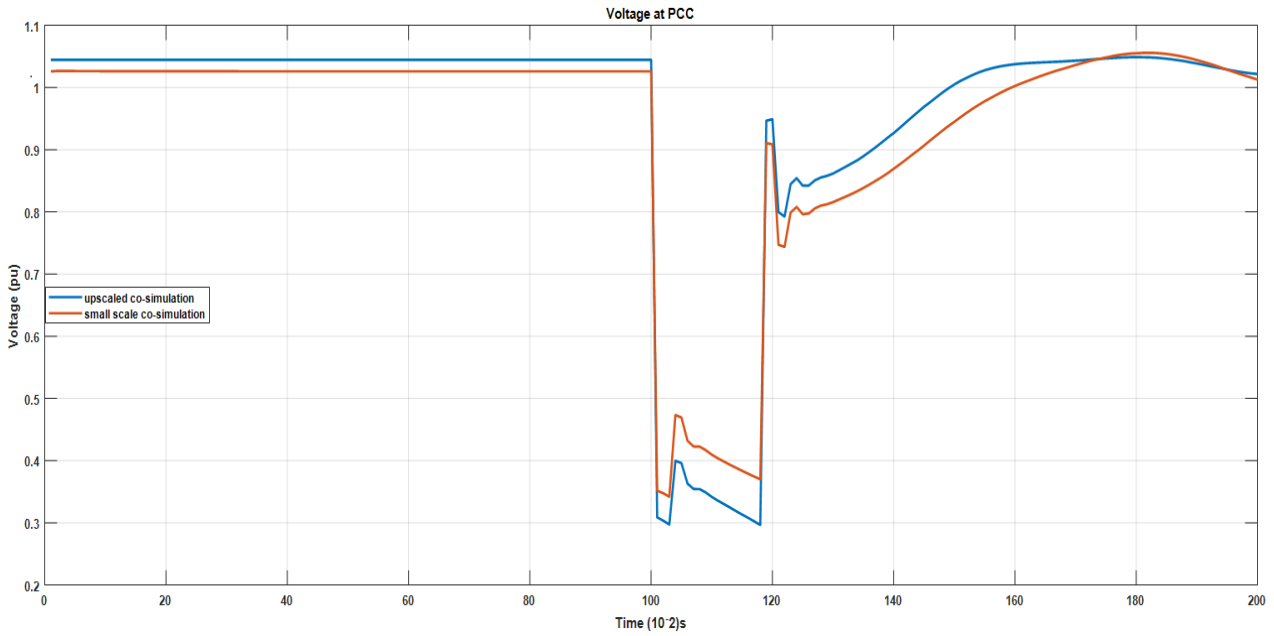

Figure 16: time domain results for FRT support and voltage recovery for both small-scale (red) and upscaled co-simulation (blue) respectively

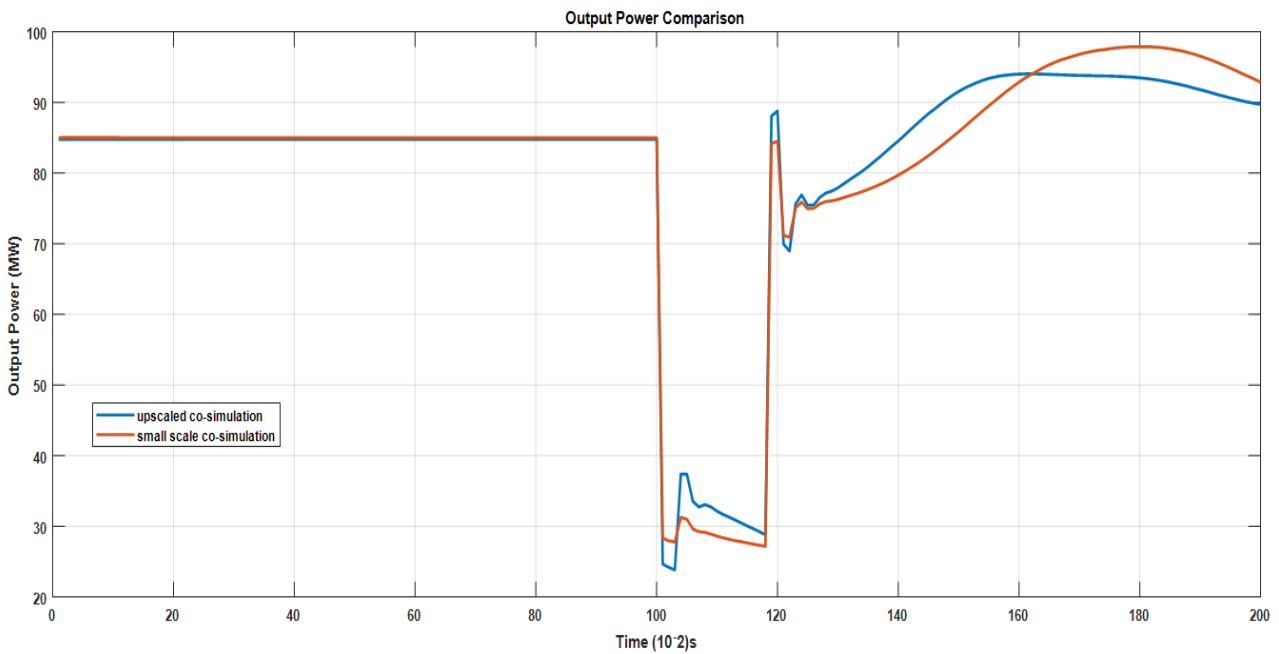

Figure 17: Output Power Comparison Plot

Figure 18, 19 and 20 shows the simulation results of output power, output voltage and FRT controller state respectively for one of the wind turbines (Wind Turbine 10) in the 32-wind turbine simulation setup. As one can observe the waveforms trace the same pattern as the overall system (Figure 16 and 17) albeit in the range of their ratings.

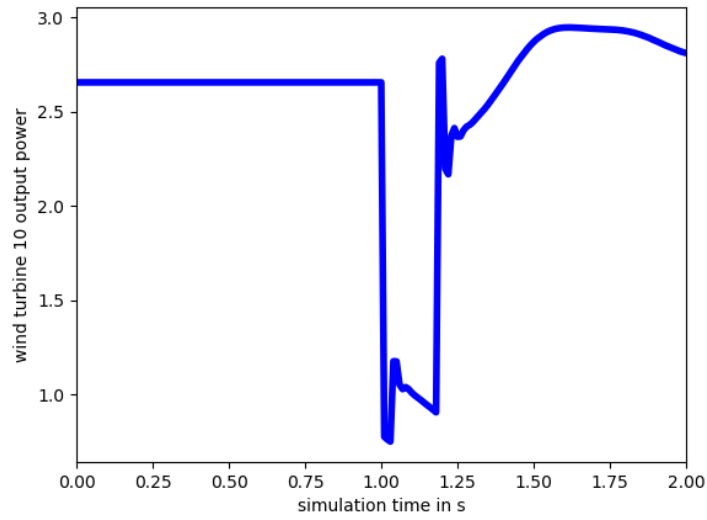

Figure 18: Wind Turbine (number 10) power output (MW)

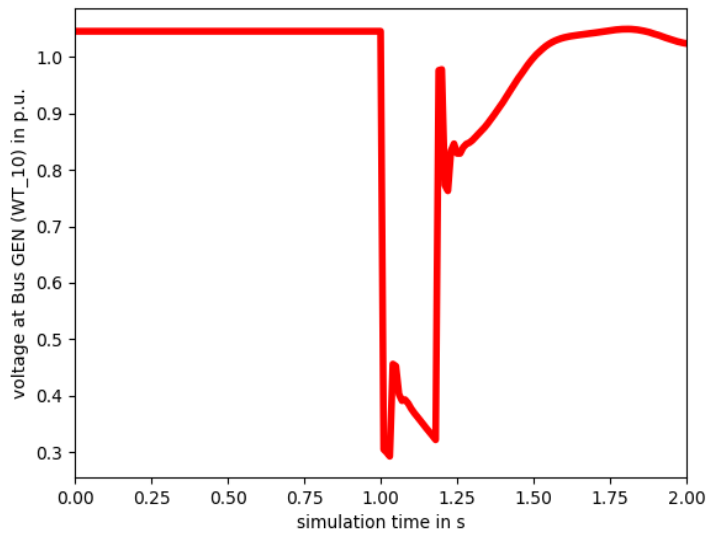

Figure 19: Wind Turbine (number 10) voltage output

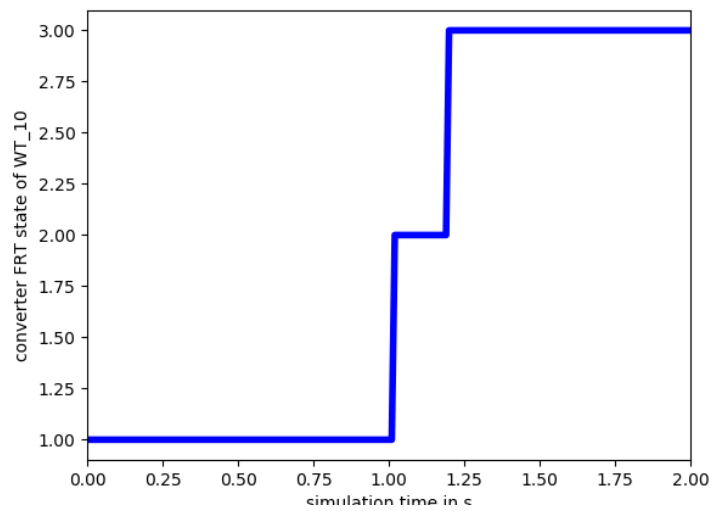

Figure 20: FRT controller state variation with event (Wind Turbine 10)

5.2 Remote real-time coordinated voltage control for distribution grids (TC3-LSS/LSS2)

5.2.1 Implementation Details

Overview

This test case has been realized in an advanced co-simulation setup using FMUs for Co-Simulation to encapsulate the domain-specific models (see Figure 21):

- *Power system simulation:* The low voltage distribution network is implemented as PowerFactory model, using consecutive power flow calculations to simulate the power system.
- *Communication network simulation:* The effects of the co-channel interference (communication delays, packet loss) are simulated with the help of ns-3.
- *Controller:* The algorithm for calculating the tap position setpoint is implemented as a (simple) MATLAB script.

The periodic sender and the FMI-compliant adapters are implemented in Python on top of mosaik's high level API. The use of PowerFactory requires this simulation to use Windows as operating system. However, since ns-3 is developed for Linux operating systems, it is run in a Cygwin environment.

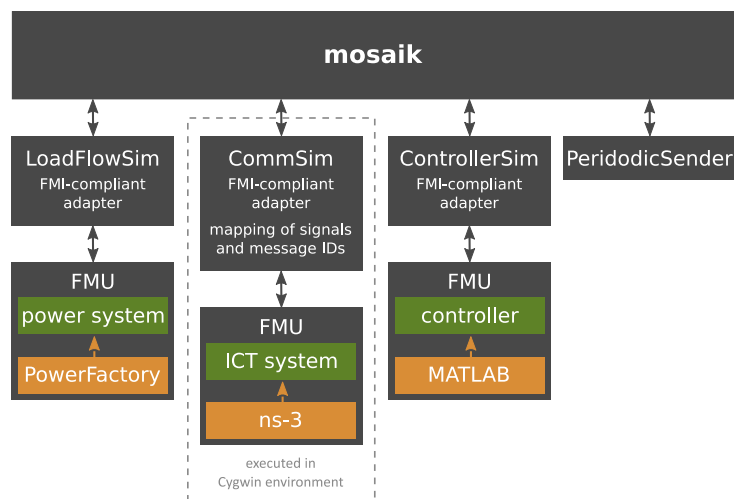

Figure 21: Overview of the experimental implementation of test case LSS2 in the mosaik framework

The communication network model uses message IDs as inputs and outputs, with a message ID equal to 0 indicating that no signal is present. Inside the ns-3 model, these message IDs are associated to dummy messages (of configurable size), which are used to simulate the processing of the message within the communication network. However, the power system model and the voltage controller expect real-valued numbers as inputs and outputs and the corresponding tools (i.e., PowerFactory and MATLAB). Therefore, the mosaik wrapper for the ns-3 FMU implements a mapping between message IDs and signal values. Furthermore, all FMU wrappers and mosaik simulators are implemented such that they understand an input of type none as absent signal and react accordingly (e.g., remain idle in case the signal is absent).

Electrical Network Model

Figure 22 shows a snapshot of the PowerFactory's graphical representation of the low voltage distribution network model used in this test case. Due to the large number of loads connected to this network (192 loads in total), it depicts the loads only as barely visible dots, connected through the

radial feeder lines. Please note that this is only a topological representation of the network, displaying the nodes at more or less random positions (i.e., the displayed length of the lines does not represent the actual length of the lines).

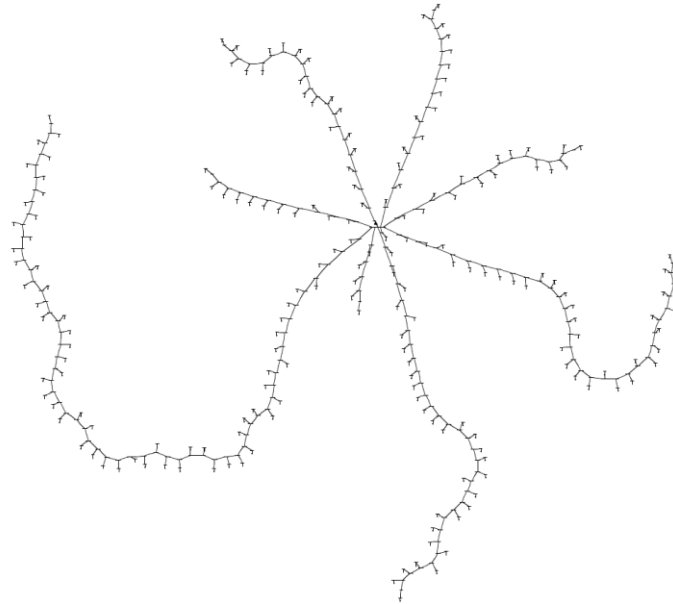

Figure 22: Snapshot of the single-line diagram of the low voltage distribution grid used for test case LSS2

Communication Network Model

Each Wi-Fi network is modelled in a cyclic shape with its access point at the centre of the cycle. Smart meters and other transmitting devices can be grouped and associated with different Wi-Fi networks. In addition, a jitter is added to the sending times of each transmitting device in every Wi-Fi network. The values of this jitter are drawn from a uniform random distribution in the interval $[0, \delta t_{\text{device}}]$

Wi-Fi access points form a circle with the voltage controller at the centre of the topology. The OLTC transformer resides in the last Wi-Fi network. Each Wi-Fi network has a dummy Wi-Fi network in close vicinity, which is used to introduce the co-channel interference. For example, 400 smart meters connected in groups of 100 plus 1 voltage controller and 1 OLTC would result in the network model shown in Figure 23.

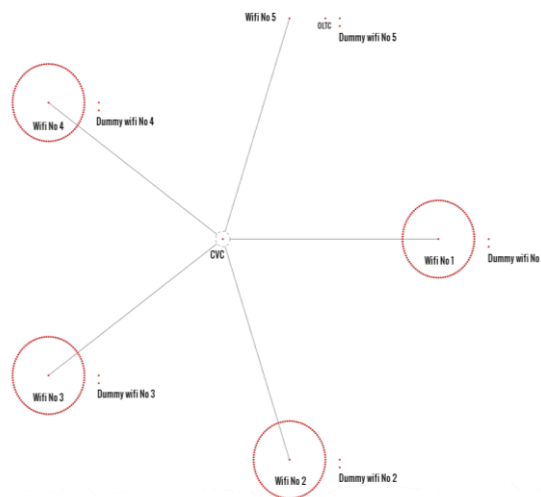

Figure 23: Example topology for the communication network model used in test case LSS2

5.2.2 Implementation Challenges

One challenge of the implementation in a co-simulation context is given by the fact that the communication simulation introduces a delay into the message exchange of the system. This translates to a DES, which can be realized in different ways in a co-simulation setup. The co-simulation framework mosaik contains scheduling on a discrete time basis. The typical solution for such a master to deal with DES is to define a minimal time step that lies between any two events. Then all simulators are advanced in increments of this time step to ensure that no event is missed. Obviously, this can lead to performance issues based on the underlying application case. In the context of test case LSS2, this solution provides a reasonable approach to address the problem of synchronization of unpredictable time steps in DES and the problem of integrating DES with continuous simulation. However, it introduces an augmentation of the number of time steps and degrades computational performance. Therefore, mosaik is expected to be extended with a new DES scheduling module to allow more flexible solutions to event-based simulation problems.

In the ns-3 simulation tool, the process of configuring the routing table of a communication network component is usually done with the help of a specific static function (*PopulateRoutingTables* of class *Ipv4GlobalRoutingHelper*). This method uses the *Dijkstra SPF* algorithm to calculate the shortest path between all the nodes of the topology, updating the corresponding routing tables. When simulating a small-scale scenario this requires negligible time. However, when transitioning to large-scale scenarios, this procedure has a dramatic effect in the execution time of the simulation script. To avoid this issue, it is preferable to use static routing, where the user is in charge of declaring the routes (and therefore the routing tables) for every component in the topology.

5.2.3 Experimental Results

Validation of Network Communication Models

Several stand-alone simulation experiments including only the communication network have been carried out in order to test and validate the ns-3 models developed for test case LSS2.

In order for a network component to communicate with another one, it is required to know its physical address (MAC). Within this context, the *Address Resolution Protocol* (ARP) is a communication protocol used to identify the MAC address from an IP address. When a component wants to send a packet to a given IP address in a network, it searches its ARP cache for the corresponding physical address bound to it. If this entry does not exist, it broadcasts a packet (*ARP request*) to every component asking for the physical address of the destination component.

Figure 24 shows an example of a successful ARP stage and subsequent transmission stage in the example topology. The ARP request is sent by the access point and is answered by the voltage controller, since this is the component that the smart meters send their packets to. The same rules and procedures are applied for all the other Wi-Fi networks in the topology. Please note that the choice of using ARP functionality for resolving IP-MAC addresses is not a recommendation of this technology for similar real-world systems. It was rather a convenient choice for the purpose of modelling an ICT network, resulting in simple yet realistic models for proof-of-concept validation in test case LSS 2

In order to simulate interference, the dummy networks initiate their operation before any transmission from a smart meter (or any other device) occurs. This is done in order to forestall the congestion of the network before any transmission takes place. Figure 25 visualizes such an initialisation of a dummy Wi-Fi network.

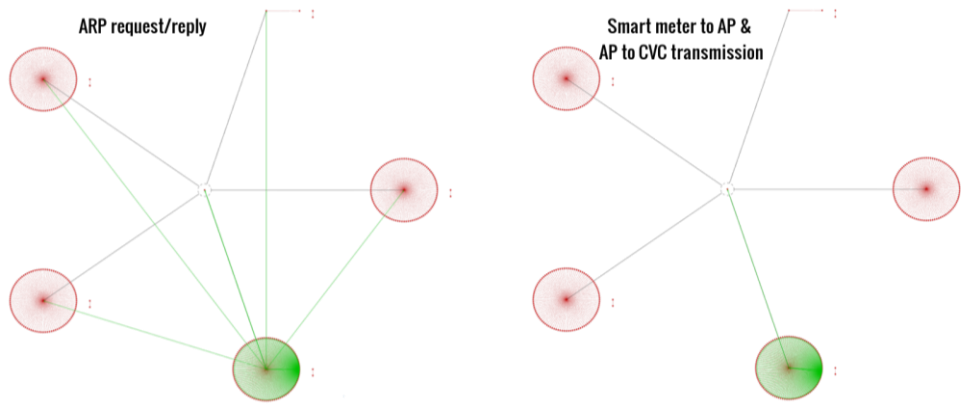

Figure 24: Visualization of an isolated ARP request/reply and transmission in the example topology

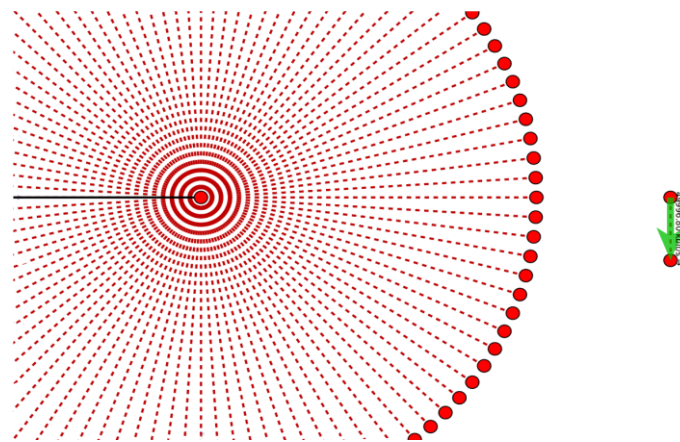

Figure 25: Snapshot of the initialisation of a dummy Wi-Fi network

To observe the impact of co-channel interference as the topology gets larger, the network model was simulated for different numbers of smart meters. To this end, a topology analogous to the one shown in Figure 23 was used, where smart meters were connected to Wi-Fi networks in groups of 100. The simulations were executed with and without co-channel interference. The number of smart meters was parameterized starting from 100 and reaching up to 5000 in steps of 100.

Figure 26 shows how the co-channel interference degrades the performance of the network concerning the end-to-end delay. The delays without co-channel interference range between 6.0 ms and 6.4 ms, whereas with the phenomenon between 1.06 s and 1.29 s. This is a significant degradation of 19010% on average. Similarly, the average packet loss rate went from 0% to an average of 3.8%.

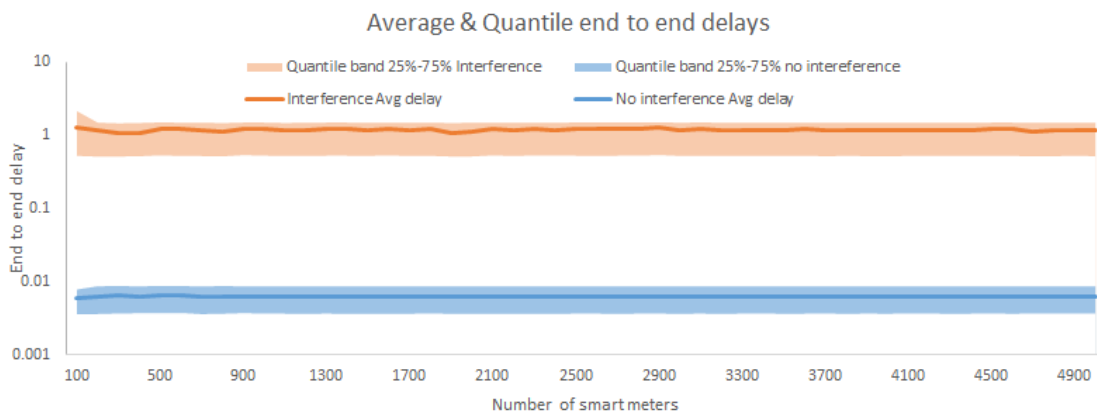

Figure 26: Average end-to-end delay in the example topology as a function of the number of smart meters

5.3 Technical Assessment of the Overall System

All simulations are compared to an idealized reference case, where no communication delays or packet loss are present. The voltage at the end of the longest feeder is expected to fall beyond the lower threshold within one minute, and a change in the tap position (from 0 to -1) is expected to happen the next time the meters transmit their measurements to the controller ($t=1$ min). All other voltages are expected to stay within the operational limits throughout the test. Figure 27 shows the according actuation pattern of the transformer's tap.

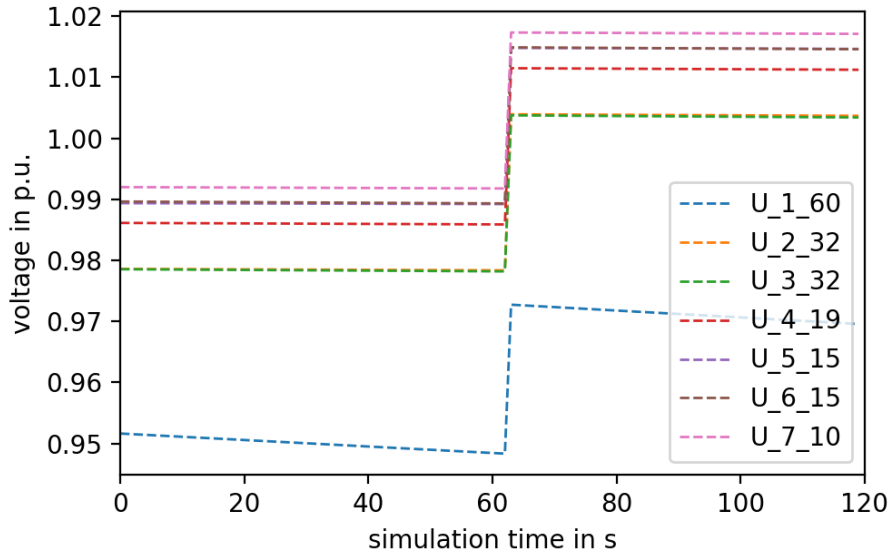

Figure 27: Expected actuation of the transformer's tap used as reference for test case LSS2

The size of the wireless network in terms of connected devices (n_{device}) has been used as scaling parameter for the test case. This allows determining the critical size of the communication network for supporting stable and reliable operating conditions.

Furthermore, the test case assumes that only the Wi-Fi network at the end of the longest feeder (in which the voltage violation occurs) is affected by co-channel interference. Hence, the topology of the communication network model is configured to contain only one Wi-Fi network, whose access point is connected to the voltage controller through an Ethernet network. All other delays in the overall system are neglected, as they are negligible in comparison to the delay between the smart meters sending and the actuation of the voltage controller ($\Delta t_{\text{ctrl}}=1$ s), compare with Figure 28. Also, only one of the devices in this single Wi-Fi network is considered to be a smart meter, whereas all others are considered to be unrelated devices that only coincidentally transmit data at the same time.

In order to incorporate the randomness of the communication delays and packet loss, an ensemble of simulation runs with different random number generator seeds has been evaluated using a Monte Carlo approach. 700 simulations were run for each different scaling scenario, totalling in 2800 simulation runs. An overview of the corresponding results is given in Figure 28. The bar chart in the figure shows the probability of ending up with a certain final tap position depending on the number of other devices in the Wi-Fi network. Bars labelled "okay" represent the probability to end up with the expected final tap position. Bars labelled with "delay" and "packetloss" represent the probability to end up with a different tap position, either due to a communication delay longer than the delay of the controller (Δt_{ctrl}) or because the transmission did not succeed at all, respectively. The results show that in this specific test case, the reliability of the control scheme degrades significantly with even only a moderate number of other transmitting devices within the same Wi-Fi network. With just 60 other devices, the probability of an erroneous (lack of) actuation due to very long communication delays is close to 60%, and around 4% due to packet loss.

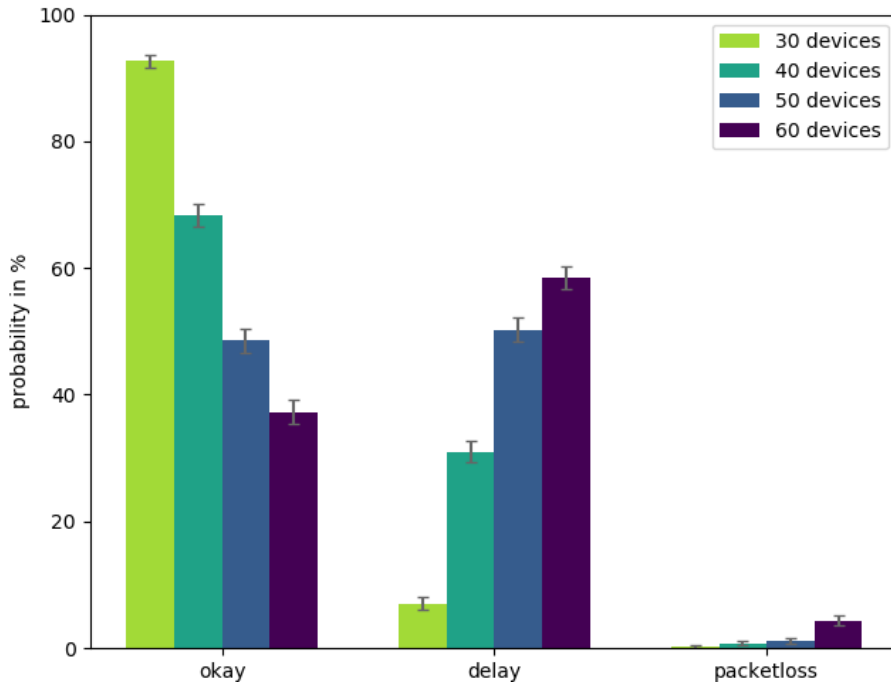

Figure 28: Overview of simulation results for test case LSS2

Figure 29 shows the corresponding computation times for simulating a test case depending on the scaling parameter. As expected, the simulation time increases linearly with the number of considered devices. In each case, the simulation of the communication network took the most time, with the simulation of the remainder of the system taking about 20 s (including computational overheads such as initializing the simulators or storing the results). Moreover, each simulation run only comprised 2 ns-3 simulations (i.e., when the smart meters sends data at t=0 s and t=60 s), demonstrating how computationally expensive the simulation of the co-channel interference in the communication network is.

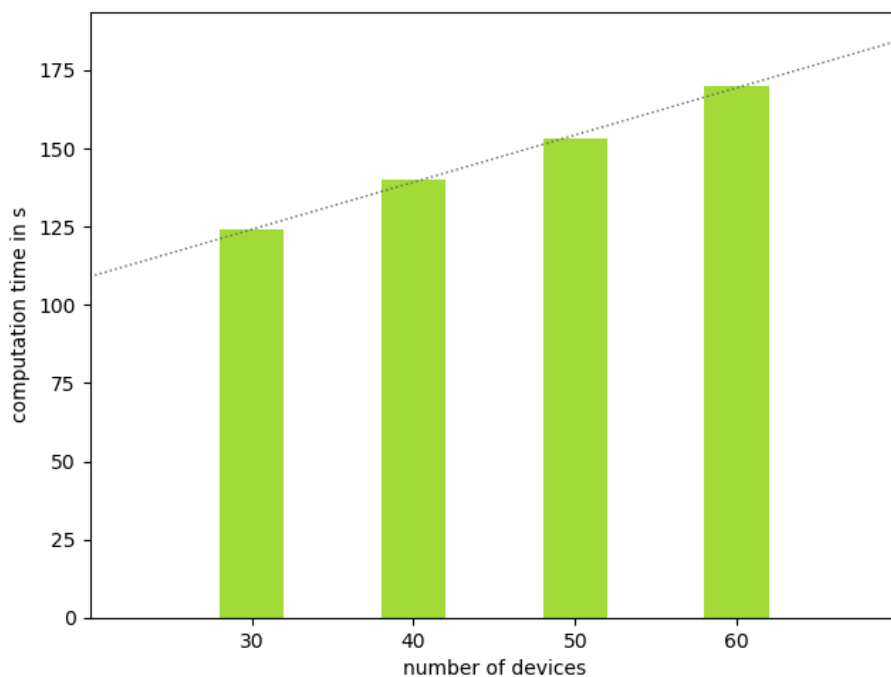

Figure 29: Average simulation time for test case LSS2 depending on the scaling parameter

6 Conclusions

This document presented the scalability in both system size and system model size of two previously developed co-simulation test cases that had been prototyped for exemplary test systems. We started by defining a set of upscaling laws, which are dependent on factors like large scale phenomena, domain-based upscaling issues, simulator interactions, and modelling properties, among others. We then discussed these phenomena in detail and provided a general guideline on parameters to consider when upscaling a large-scale system for co-simulation purposes.

The tools used and modified along with model library created to design specific models and interfaces were introduced. These tools and models were used to conduct simulations and it was explained how they are combined to form an Integrated Simulation Environment. The domain specific best suited simulators were connected to each other via couplings and interfaces developed in JRA2 work. The co-simulation is then implemented by assigning parts of entire test system simulation to best suited simulators. The entire system simulation is orchestrated by either FMI++ or mosaik and results are collected and verified. Hence, the *Integrated Simulation Environment* helps us in achieving simulations which couldn't have been achieved through a single simulator.

The working of this integrated simulation environment was addressed through two LSS, each one of which exhibiting different large-scale phenomena. The implementation details and challenges were listed and their solutions discussed. Finally, the results of the LSS simulation were presented and interpreted. The results were satisfactory in terms of scalability (complexity and size) of the simulation interfaces developed earlier in D-JRA2.1 and D-JRA2.2. The tools, interfaces and models developed will be released in an open source platform as part of ERIGrid's contribution to the scientific community.

7 References

- [1] Widl, E. et al. (2017), DJRA2.1 Simulator coupling and Smart Grid libraries, Technical Report, ERIGrid (2018).
- [2] Widl, E. et al. (2018), DJRA2.2 Smart Grid ICT Assessment, Technical Report, ERIGrid (2018).
- [3] Stevens, R. (2004). Systems engineering in the information age: the challenge of mega-systems. MITRE CORP MCLEAN VA.
- [4] Nguyen, Van Hoa et al. (2018), D-JRA3.2 Extended Real-Time Simulation and Hardware-in-the-loop Possibilities, Technical Report, ERIGrid (2018).
- [5] Sgarbossa, Riccardo. "Unintentional Islanding in Distribution Networks with Large Penetration of Power Electronics and Renewable Energy Systems." (2017).
- [6] Larsen, Emil Mahler, et al. "The Cobweb Effect in Balancing Markets with Demand Response." 12th International Conference on the European Energy Market. IEEE, 2015.
- [7] Roozbehani, Mardavij, Munther A. Dahleh, and Sanjoy K. Mitter. "Volatility of power grids under real-time pricing." IEEE Transactions on Power Systems 27.4 (2012): 1926-1940.
- [8] Tchuisseu, Eder Batista Tchawou, et al. "Curing Braess' Paradox by Secondary Control in Power Grids." New Journal of Physics, vol. 20(8) (2018).
- [9] Dirk Witthaut and Marc Timme, "Braess's paradox in oscillator networks, desynchronization and power outage." New Journal of Physics, Volume 14, August 2012
- [10] "The FMI++ Library: A High-level Utility Package for FMI-based Software Development," [Online]. Available: <http://fmipp.sourceforge.net>
- [11] "The FMI++ PowerFactory FMU Export Utility," [Online]. Available: <http://powerfactory-fmu.sourceforge.net>.
- [12] <https://github.com/AIT-IES/FMITerminalBlock> (Accessed on 2018-07-20)
- [13] <https://www.eclipse.org/4diac/> (Accessed on 2018-07-20)
- [14] The Illinois Centre for a Smarter Electric Grid (ICSEG), "WSCC 9-Bus System," *Power Cases*. [Online]
- [15] "MATLAB," [Online]. Available: <http://www.mathworks.com>.
- [16] "DlgSILENT PowerFactory," [Online]. Available: <http://www.digsilent.com/>.
- [17] E. Muljadi, C. P. Butterfield, A. Ellis, J. Mechenbier, J. Hochheimer, R. Young, N. Miller, R. Delmerico, R. Zavadil und J. C. Smith, "Equivalencing the collector system of a large wind power plant," in *IEEE Power Engineering Society General Meeting*, Montreal, Canada, 2006.
- [18] G. Kerber, *Aufnahmefähigkeit von Niederspannungsverteilsnetzen für die Einspeisung aus Photovoltaikkleinanlagen*, Technische Universität München, 2011.
- [19] "The FMI++ Python Interface for Windows," [Online]. Available: <https://pypi.python.org/pypi/fmipp>.

8 Annex

8.1 List of Figures

Figure 1: Large-scale system assessment workflow	10
Figure 2: Smart Grid Large scale system properties	14
Figure 3: Eclipse 4diac user interface	23
Figure 4: Modified IEEE 9-bus system as applied in the grid configuration of TC1	24
Figure 5: Co-simulation interaction with FMI++ as orchestrator	25
Figure 6: Scaled up WPP (32 Wind Turbines) in PowerFactory	26
Figure 7: SuT (System under Test) of upscaled TC1 (LSS 1), accompanied with component interface variables.....	26
Figure 8: Example of a composite frame including DSL model FMIAdapter	27
Figure 9: Single composite frame encompassing 32 individual wind turbine frames (PowerFactory modelling)	27
Figure 10: Overview of the system configuration of test case LSS2	29
Figure 11: Schematic diagram of the low voltage distribution network of test case LSS2	29
Figure 12: Schematic diagram of the voltage control algorithm used for test case LSS2.....	30
Figure 13: Overview of the individual simulation components for test case LSS2.....	31
Figure 14: FRT controller developed in Simulink, along with interface variables and types	34
Figure 15: RMS converter controller (Simulink) along with interface variable names.....	34
Figure 16: time domain results for FRT support and voltage recovery for both small-scale (red) and upscaled co-simulation (blue) respectively	35
Figure 17: Output Power Comparison Plot.....	35
Figure 18: Wind Turbine (number 10) power output (MW)	36
Figure 19: Wind Turbine (number 10) voltage output	36
Figure 20: FRT controller state variation with event (Wind Turbine 10)	36
Figure 21: Overview of the experimental implementation of test case LSS2 in the mosaik framework.....	37
Figure 22: Snapshot of the single-line diagram of the low voltage distribution grid used for test case LSS2.....	38
Figure 23: Example topology for the communication network model used in test case LSS2.....	38
Figure 24: Visualization of an isolated ARP request/reply and transmission in the example topology	40
Figure 25: Snapshot of the initialisation of a dummy Wi-Fi network.....	40
Figure 26: Average end-to-end delay in the example topology as a function of the number of smart meters.....	40
Figure 27: Expected actuation of the transformer's tap used as reference for test case LSS2	41
Figure 28: Overview of simulation results for test case LSS2.....	42
Figure 29: Average simulation time for test case LSS2 depending on the scaling parameter	42

8.2 List of Tables

Table 1: Large Scale System in Context of JRA2.....	13
Table 2: Potential LSS properties in real world smart grid.....	14
Table 3: Classification of Smart Grid LSS phenomena.....	17
Table 4: Parameter selection for 33 kV cables	25

8.3 Test Case Specification for LSS1

8.3.1 Test Case

Name of the Test Case	JRA2-LSS1
Narrative	<p>The test case (JRA2-LSS1) aims to study and evaluate cyclic dependencies between the continuous simulators in an upscaled network. The interaction between electricity network and converter interfaced devices is of main interest in this test case as converters generally exhibit non-linear behaviour during faults. The converter and FRT controllers are designed in Simulink which are exported as FMU. The transmission system is designed in PowerFactory. The co-simulation is facilitated by FMI++ o-simulation is facilitated by python interface wrapper for FMI++ library.</p> <p>The experiments in the test case verify the low-voltage ride through capability of the 32 wind turbines that are interconnected to a small transmission system. They comprise of type 4 wind turbines, which have a fully rated converter interface. The wind power plant must comply with the grid code specification of a low-voltage ride through time against voltage profile. This profile stipulates at the coupling location the minimum profile at which the WPP must stay connected.</p>
Function(s) under Investigation (FuI) "the referenced specification of a function realized (operationalized) by the object under investigation"	The fault ride-through capability of the converter, fast reactive power support, active power recovery by the WTGs.
Object under Investigation (Oul) "the component(s) (1..n) that are to be qualified by the test"	The fault ride-through capability of the converter, fast reactive power support, active power recovery by the WTGs
Domain under Investigation (Dul): "the relevant domains or sub-domains of test parameters and connectivity."	<ul style="list-style-type: none"> • Electrical • Control/ICT • Environment
Purpose of Investigation (Pol) formulation of the test purpose in terms of Characterization, Verification, or Validation	Verification of the converter dynamics and the converters' capability to comply to the FRT curves after a 3-phase short circuit upstream in the (sub-)transmission system, causing a voltage dip at the coupling point of the upscaled wind power plant (32 wind turbines)
System under Test (SuT): A list of systems, subsystems, components included in the test case or test setup.	<p>The wind park (collection system+wind turbine generators (WTG)) is treated by the system operator as one single entity, the wind power plant. The fault ride-through (FRT) curve is enforced at the coupling point, whereas the grid interface of the converter, its controls, protection, and electromechanical conversion components ensure the compliance to this curve. Hence the SuT comprises:</p> <ul style="list-style-type: none"> • the coupling point • the collection grid, • the step up transformers, • the converters, • the WTG converters • the WTG FRT controller • the WTG protection schemes • the WTG DC links

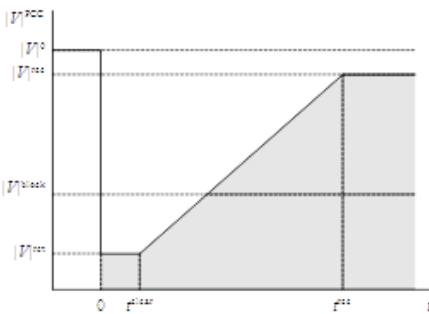
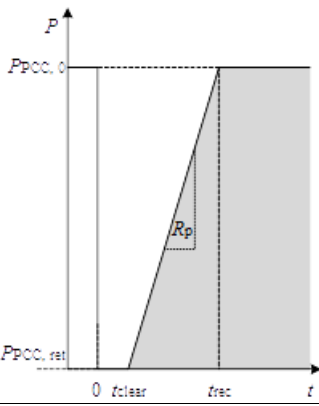
	<ul style="list-style-type: none"> the WTG electrical machine
<p>Functions under Test (FuT) Functions relevant to the operation of the system under test, including Ful and relevant interactions btw. Oul and SuT..</p>	<ul style="list-style-type: none"> The fault ride-through functionality of the converter fast reactive power support The physical response of external system interacting with Oul post fault active power recovery functionality normal operating controls of the WTGs Current Limit of the converters Direct voltage control of the DC link of the wind turbine
<p>Test criteria: "the measures of satisfaction that a need to be evaluated for a given test to be considered successful. Formalization of the Pol wrt. SuT and FuT attributes.</p>	<ul style="list-style-type: none"> Converter must stay connected during and after the fault direct voltage operating region is not violated WTGs remain synchronised to the grid Transient and frequency stability must be maintained
<p>target metrics (test factors): A numbered list of measures to quantify each identified Purpose of Investigation</p>	<p>FRT Curve: A: WPP must stay connected, B: WPP may temporarily disconnect from transmission system active power recovery curve: minimum ramping active power rate the WTG has to comply to</p> <p>FRT Curve:</p>  <p>Active Power Recovery Curve:</p> 
<p>variability attributes identification of the sets of attributes (controllable or uncontrollable parameters) and qualifi-</p>	<p>Short circuit duration (primary versus backup protection)</p>

<p>cation of the required variability; includes reference to purpose of investigation.</p>	
<p>quality attributes (thresholds): reference to POI and target metrics, the threshold level required to pass a test and precision level.</p>	<p>FRT curve tests:</p> <ul style="list-style-type: none"> • short duration (200ms), deep dip <p>Criteria is fulfilled in case FRT controls keep direct voltage and WTG speed within design boundaries, and phase locked loop (PLL) maintains synchronisation.</p>

8.3.2 Qualification Strategy

8.3.2.1 Test Specification JRA2-LSS1.TS1

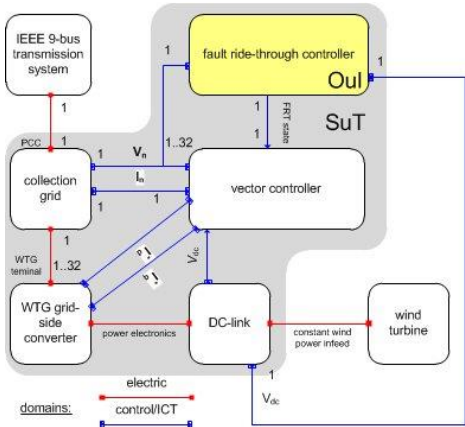
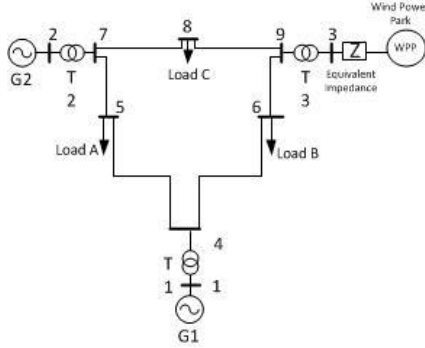
<p>Reference to Test Case</p>	<p><i>JRA2-LSS1</i></p>
<p>Title of Test</p>	<p><i>Upscaled Co-simulation</i></p>
<p>Test Rationale</p>	<p><i>To perform and evaluate monolithic TC 1.1 on the Power Factory simulator platform</i></p>
<p>Specific Test System (graphical)</p>	<p>The test specific SuT:</p>  <p>The test system setup:</p>  <p>In the grid configuration above, the generator G3 has been replaced in the PowerFactory monolithic design by an aggregated Wind Power Park via an equivalent impedance.</p> <p>Please consider the grid configuration in the test case descriptions as a reference. The variables between the components are the domain specific interface variables. The connections in the control domain have a directional component. The type, descriptions, and units of the interfac-</p>

	<p>ing variables inside the test system are described below.</p> <ul style="list-style-type: none"> • <input type="checkbox"/> V_{pcc}: 3x1 array with nodal voltages [V] • <input type="checkbox"/> I_t: 3x1 array with equivalent branch currents [A] • <input type="checkbox"/> I_d: 3x1 array with converter currents [A] • <input type="checkbox"/> I_q: 3x1 array with converter currents [A] • <input type="checkbox"/> V_{dc}: voltage between + and – pole [V] • <input type="checkbox"/> I_{lim}: limiting scheme (0=no limiting, 1=d-axis priority, 2=q-axis priority, 3=proportional limiting) [-] • <input type="checkbox"/> K_{aRC}: additional reactive current injection gain [pu] • <input type="checkbox"/> R_p: active power recovery ramp rate [pu/s] • <input type="checkbox"/> R_{on}: ramp rate on/off [-] • <input type="checkbox"/> $prot$: chopper on/off [-]
Target measures	<ul style="list-style-type: none"> • <i>FRT curve compliance</i> • <i>WPP remain synchronized to transmission grid</i> • <i>Correct initialization of converter controller and FRT controller</i> • <i>Direct Voltage operating region is not violated</i>
Input and output parameters	<p>Controllable input parameters: fault duration, fault location, FRT control mode (on/off)</p> <p>Uncontrollable parameters: voltage at coupling point implicitly set by the fault characteristics, wind turbine rotor speed</p> <p>Measured parameters: DC voltage, phase angle of PLL</p>
Test Design	<ul style="list-style-type: none"> • Determine operating point • Set short circuit location to x • Initiate short circuit at t=1 • Clear fault at t=y • Assess test criteria
Initial system state	<i>WPP replaces G3 from IEEE 9 bus system inheriting its operating point (P, Q at coupling point)</i>
Evolution of system state and test signals	<p><u>Test events:</u> See test design.</p> <p><u>Target metrics:</u> All deterministic cases (so all test criteria for all parameter variations) must be successful.</p> <p><u>Internal boundary conditions:</u> The IGBT current limit of the converter is 110% of the rated current, the minimum active power recovery rate is 5pu/s, i.e., in 200 ms the wind turbines must be able to recover to the pre-fault power output. The wind turbine speed and the corresponding pitch controller are not modelled. Their boundaries and time constants are hence not taken into consideration for FRT operation.</p>
Other parameters	
Temporal resolution	<ul style="list-style-type: none"> • Time constants inside SuT in between 50 μs and 5 s • Continuous simulation, time step size depends on software experiment • Components exhibit physical behaviour, the FRT controller is a discrete controller (state machine)
Source of uncertainty	
Suspension criteria / Stopping criteria	<ul style="list-style-type: none"> • Violation of WTG synchronism with grid • If transient and frequency stability is violated

8.3.3 Mapping Strategy

8.3.3.1 Experiment Specification JRA2-LSS1.TS1.Upscaled Co-simulation

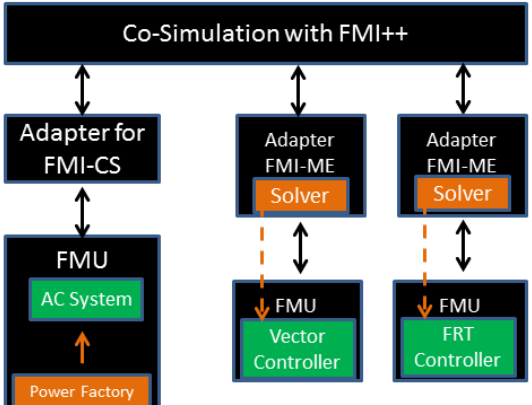
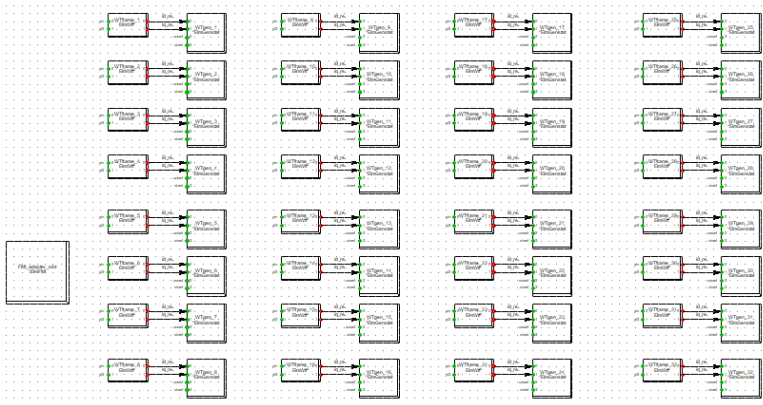
Reference to Test Specification	<i>JRA2-LSS1.TS1</i>
Title of Experiment	<i>Upscaled co-simulation</i>
Research Infrastructure	<i>DNVGL, TUD</i>
Experiment Realisation	<p>A co-simulation-based approach is used by using FMI++ to conduct co-simulation between Simulink and PowerFactory. The power system is a upscaled version of experiments conducted in previous work</p> <p>The Controller converter and FRT controller are modelled in Simulink. The IEEE 9-bus system, the collection grid, and the grid interface of the aggregated wind turbine are modelled in the RMS partition of PowerFactory, while underlying controls are FMUs</p>
Experiment Setup (concrete lab equipment)	<p>Experiment Simulator Interaction Overview:</p>  <p>The Combined Large-Scale System Frame model in PowerFactory:</p> 
Experimental Design and Justification	<ul style="list-style-type: none"> • Three Phase short circuit location: bus 4 • Variation of fault duration: 200ms

8.4 Test Case Specification for LSS2

8.4.1 Test Case

<p>Name</p>	<p>Remote real-time coordinated voltage control for distribution grids</p>
<p>Narrative</p>	<p>This test case deals with the impact of ICT-related aspects in a radial low voltage distribution grid that extends over a relatively large geographical area. Remote measuring units – referred to as <i>smart meters</i> in this test case – are installed towards the ends of the network’s feeders and regularly send information about the local voltage levels via a communication network to a controller. Based on these meter readings, the controller actuates the tap position of an OLTC transformer.</p> <p>Each smart meter is connected to the communication network through a wireless connection. Due to the geographical size of the overall system and the resulting distances between the ends of the feeders, each smart meter is connected to a separate wireless local network. Within this context, ICT-related aspects of interest are effects arising from co-channel interference in these wireless local networks, especially due to long communication delays and packet loss.</p> <p>The aim of this test case is to demonstrate and assess the effect of communication networks on the actuation pattern of the controller and the resulting physical effects in the low voltage distribution system. For this assessment, the size of the wireless network (in terms of connected devices) is scalable. This allows determining the critical size of this communication network for supporting stable and reliable operating conditions.</p>
<p>Function(s) under Investigation (Ful)</p>	<p>Focus of this investigation is the actuation pattern of the voltage controller in the presence of communication delays and packet loss. The controller calculates setpoints for the tap position of the OLTC transformer based on the readings of the smart meters located at the end of the feeders.</p> <pre> graph TD Start(()) --> Init[initialize: set default values for {V1, V2, ..., Vn-1, Vn} send according tap position] Init --> Wait[wait for new measurements] Wait --> Recv[receive new values for {Vj} with j in {1,2,...,n}] Recv --> UpdateV[update {Vj} keep previous value for all others] UpdateV --> UpdateMinMax[update Vmax = max(V1, ..., Vn) update Vmin = min(V1, ..., Vn)] UpdateMinMax --> Decision{Vmax >= MAX_THRESHOLD && Vmin <= MIN_THRESHOLD} Decision -- "Vmax >= MAX_THRESHOLD" --> SendNoStep1[send: NO_STEP] Decision -- "Vmin <= MIN_THRESHOLD" --> SendStepUp[send: STEP_UP] Decision -- "else" --> SendStepDown[send: STEP_DOWN] Decision -- "else" --> SendNoStep2[send: NO_STEP] SendNoStep1 --> Wait SendStepUp --> Wait SendStepDown --> Wait SendNoStep2 --> Wait Decision --> Finished{simulation finished?} Finished -- no --> Wait Finished -- yes --> End((())) </pre>

Object under Investigation (<i>Oul</i>)	<ul style="list-style-type: none"> • Voltage controller • OLTC transformer
Domain under Investigation (<i>Dul</i>)	<ul style="list-style-type: none"> • Electrical (voltage levels) • ICT (data transmission, cyber-attacks) • Control (calculation of setpoints, OLTC actuation)
Purpose of Investigation (<i>Pol</i>)	Characterize the response of the voltage controller in the presence of co-channel interference in the wireless local networks, resulting in communication delays and/or packet loss for the smart meter measurement data.

System under Test (*SuT*)

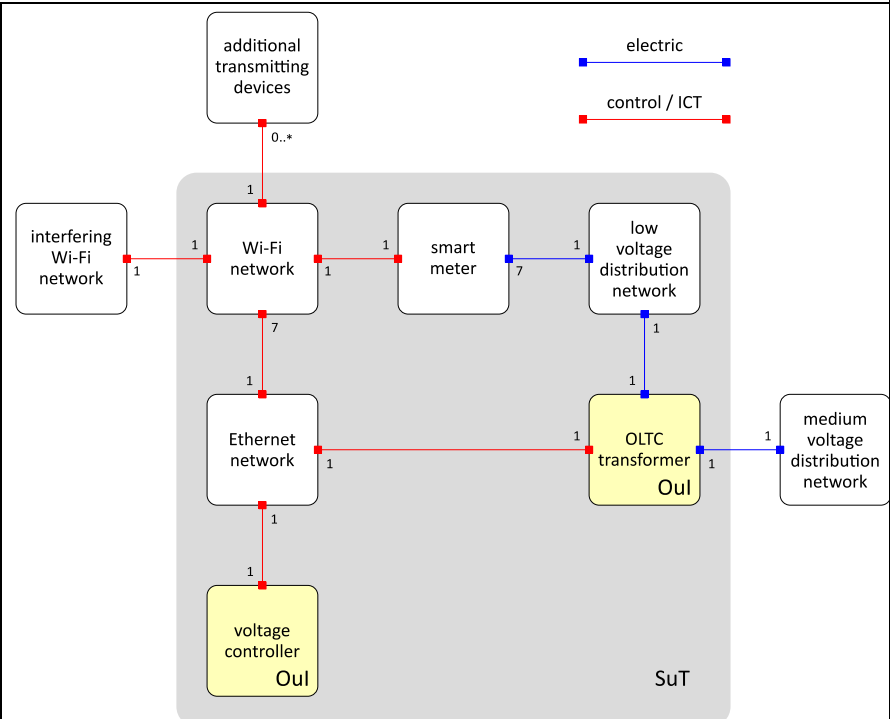

- Smart meters:
- located toward the end of each feeder
 - send measurement data (local voltage level) in regular intervals to the controller via a wireless local network
 - the smart meters are synchronized, i.e., they all send their data at the same time
- Additional transmitting devices:
- in addition to the smart meters, several other (unrelated) devices are connected to the same wireless local networks
 - these devices use the wireless local networks simultaneously to the smart meters
- Voltage controller:
- simple rule-based control algorithm, calculating tap position setpoints for the OLTC transformer depending on the smart meter readings
 - runs on a dedicated server, separate from transformer and smart meters
 - the controller actuation is synchronized with the smart meters, i.e., it is always actuated directly after the smart meters send their data (but delayed by a short amount of time)
- Communication network:
- each smart meter (together with the other additional transmitting devices) is connected to a wireless local network (Wi-Fi, networking standard 802.11ac, coding scheme index 3, short guard interval disabled)

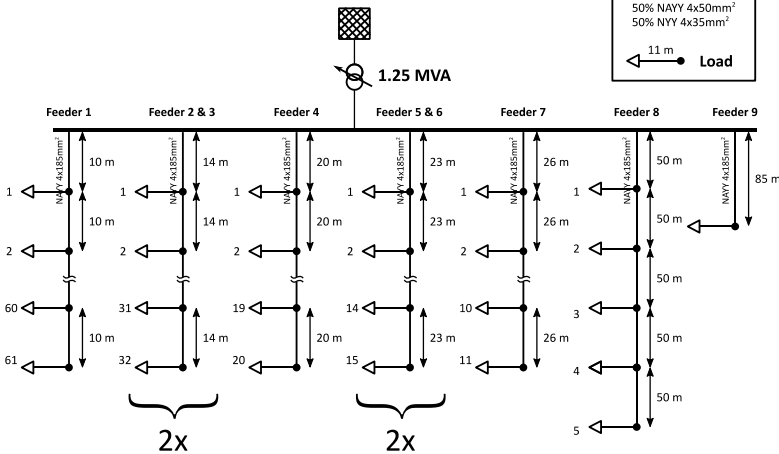
	<ul style="list-style-type: none"> each of these Wi-Fi networks has another Wi-Fi network close to it, transmitting at the same frequency and causing the co-channel interference (frequency channel: 5180 Mhz, channel width: 40 Mhz) an Ethernet network (bandwidth: 100 Mbps, channel delay: 6560 ns) connects the Wi-Fi network to the voltage controller <p><u>Low voltage distribution system:</u></p> <ul style="list-style-type: none"> large radial low voltage distribution network with OLTC MV/LV transformer (see diagram below) compared to typical low voltage distribution networks this system can be considered large in terms of connected loads and geographical size 7 buses with smart meters towards the end of feeders 1 to 7 (bus 1-60, bus 2-32, bus 3-32, bus 4-19, bus 5-15, bus 6-15, bus 7-10)  <p>adapted from: G. Kerber, <i>Aufnahmefähigkeit von Niederspannungsverteilnetzen für die Einspeisung aus Photovoltaikkleinanlagen</i>, PhD thesis, Technische Universität München (2011)</p>
<p>Functions under Test (FuT)</p>	<ul style="list-style-type: none"> setpoint calculation from voltage controller setpoint actuation at OLTC data transmission of meter readings and controller setpoints
<p>Test criteria</p>	<p>Even in the presence of communication delays and packet-loss, the actuation of the OLTC transformer should result in acceptable operational conditions (voltage levels according to grid codes). More specifically, the tap position should coincide with the “idealized” base case, where no communication delays, controller dead times or cyber-attacks are present.</p>
<p>target metrics (test factors)</p>	<ul style="list-style-type: none"> Tap position Voltage levels
<p>variability attributes</p>	<p><u>attributes for upscaling:</u></p> <ul style="list-style-type: none"> n_{device}: number of interfering devices in the wireless local networks <p><u>intrinsic system attributes:</u></p> <ul style="list-style-type: none"> T_{sender}: time offset between voltage measurements Δt_{ctrl}: delay between meters sending and controller actuation δt_{device}: max. jitter of additional transmitting devices random number generator seed for ICT network simulator
<p>quality attributes (thresholds)</p>	<p>acceptable operational conditions for the voltage levels are between 0,95 p.u. and 1,05 p.u.</p>

8.4.2 Qualification Strategy

8.4.2.1 Test Specification JRA2-LSS2.TS1_baseline

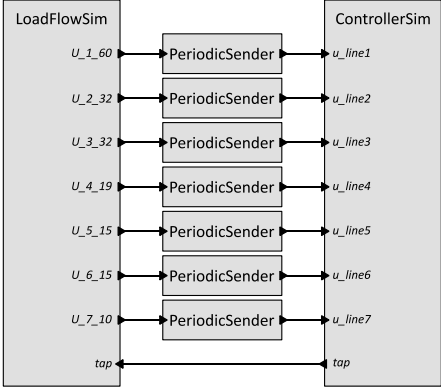
Reference to Test Case	JRA2-LSS2
Title of Test	baseline simulation without co-channel interference
Test Rationale	The outcome of this test is the reference for test spec. JRA2-LSS2.TS1. By neglecting ICT-related effects this represents the “idealized” case.
Specific Test System (graphical)	<p>overview of individual simulation components:</p> 
Target measures	This test serves as baseline for reference for test specification JRA2-LSS2.TS1. As such, there is no qualification strategy for the output of this test itself.
Input and output parameters	<p><u>controllable input parameters:</u></p> <ul style="list-style-type: none"> tap position <p><u>measured parameters:</u></p> <ul style="list-style-type: none"> voltages at selected busses <p><u>uncontrollable parameters:</u></p> <ul style="list-style-type: none"> $T_{\text{sender}} = 60 \text{ s}$ $\Delta t_{\text{ctrl}} = 1 \text{ s}$
Test Design	<ul style="list-style-type: none"> The test takes 2 minutes of simulation time. The meters send their measurements to the controller in regular intervals ($T_{\text{sender}}=60 \text{ s}$) in perfect synchronization, beginning at the start of the simulation ($t=0 \text{ min}$). The controller receives new measurements, calculates a new tap position setpoint and sends this value to the OLTC. This calculation is delayed with respect to the smart meters sending their data (Δt_{ctrl}). The transmission of data from the meters to the controller (voltage measurements) and from the controller to the OLTC’s tap actuator (tap position setpoint) happens without delays. The voltage at the end of the longest feeder (U_{1_60}) is expected to fall beyond the lower threshold within 1 minute, and a change in the tap position (from 0 to -1) is expected to happen the next time the meters transmit their measurements to the controller ($t=1 \text{ min}$). All other voltages are expected to stay within the operational limits throughout the test.
Initial system state	<ul style="list-style-type: none"> initial tap position (at $t=0 \text{ min}$): 0
Evolution of system state and test signals	<ul style="list-style-type: none"> loads 5, 9, 13, 15 and 17 of feeder 1 linearly ramp from 0 to 10 kW within 2 minutes all other remaining loads linearly ramp between two random values within the range $2 \pm 0,2 \text{ kW}$

Other parameters	none
Temporal resolution	<ul style="list-style-type: none"> 1 second
Source of uncertainty	<ul style="list-style-type: none"> load profiles
Suspension criteria / Stopping criteria	none

8.4.2.2 Test Specification JRA2-LSS2.TS1

Reference to Test Case	JRA2-LSS2
Title of Test	assessment of impact of co-channel interference depending on the size of the wireless local network
Test Rationale	This test assesses the impact of communication delays and packet loss due to co-channel interference on the actuation pattern of the OLTC and the voltage levels. The impact is evaluated by comparing the final realized tap position with the expected tap position (from the base line simulation JRA2-LSS2.TS1_baseline). The voltage levels at the end of the simulation are expected to be within the operational limits.
Specific Test System (graphical)	<p><u>overview of individual simulation components:</u></p>
Target measures	<ul style="list-style-type: none"> expected final tap position (at t=2 min): -1 voltage levels are expected to be within operational limits
Input and output parameters	<p><u>upscaling parameters:</u></p> <ul style="list-style-type: none"> $n_{device} \in \{30, 40, 50, 60\}$ <p><u>controllable input parameters:</u></p> <ul style="list-style-type: none"> tap position <p><u>measured parameters:</u></p> <ul style="list-style-type: none"> voltages at selected busses <p><u>uncontrollable parameters:</u></p> <ul style="list-style-type: none"> $T_{sender} = 60 \text{ s}$ $\Delta t_{ctrl} = 1 \text{ s}$ $\delta t_{device} = 0,01 \text{ s}$
Test Design	<ul style="list-style-type: none"> The test takes 2 minutes of simulation time. The meters send their measurements to the controller in regular intervals ($T_{sender}=60 \text{ s}$) in perfect synchronization, beginning at the start of the simulation ($t=0 \text{ min}$). The controller receives new measurements, calculates a new tap position setpoint and sends this value to the OLTC. This calculation is delayed with respect to the smart meters sending their data (Δt_{ctrl}). The transmission of data from the meter at the end of feeder 1 is affected by co-channel interference from another Wi-Fi. The size (in terms of connected devices) of the Wi-Fi network is determined by the number of other devices (n_{device}). They all transmit

	<p>data at approximately the same time, i.e., the meter and the devices send randomly within the interval $[t, t+\delta t_{\text{device}}]$.</p> <ul style="list-style-type: none"> The transmission delays for data from the other meters to the controller and from the controller to the OLTC's are assumed to be negligible. The voltage at the end of the longest feeder (U_{1_60}) is expected to fall beyond the lower threshold within 1 minute, and a change in the tap position (from 0 to -1) is expected to happen the next time the meters transmit their measurements to the controller ($t=1$ min). All other voltages are expected to stay within the operational limits throughout the test.
Initial system state	<ul style="list-style-type: none"> initial tap position (at $t=0$ min): 0
Evolution of system state and test signals	<ul style="list-style-type: none"> loads 5, 9, 13, 15 and 17 of feeder 1 linearly ramp from 0 to 10 kW within 2 minutes all other remaining loads linearly ramp between two random values within the range $2 \pm 0,2$ kW
Other parameters	<ul style="list-style-type: none"> random generator seed of communication simulator
Temporal resolution	<ul style="list-style-type: none"> 1 second
Source of uncertainty	<ul style="list-style-type: none"> communication delays and packet loss load profiles
Suspension criteria / Stopping criteria	none

8.4.3 Mapping Strategy

8.4.3.1 Experiment Specification JRA2-LSS2.TS1_baseline.mosaik

Reference to Test Specification	JRA2-LSS2.TS1_baseline
Title of Experiment	implementation of base line simulation in mosaik
Research Infrastructure	N/A
Experiment Realisation	<p>The experiment is implemented as co-simulation using mosaik with a constant simulation step size of 1 second.</p>
Experiment Setup (concrete lab equipment)	<p>Dedicated simulation components are implemented as FMUs for Co-Simulation:</p> <ul style="list-style-type: none"> power system simulation: the power system is implemented as PowerFactory model, using consecutive power flow calculations to simulate the power system controller: the algorithm for calculating the tap position setpoint is implemented as a (simple) MATLAB script

	The periodic sender and the FMI-compliant adapters are implemented in Python on top of mosaik's high level API. The use of PowerFactory requires this simulation to use Windows as operating system.
Experimental Design and Justification	This is a basic co-simulation setup using the mosaik environment with FMUs.
Precision of equipment	N/A
Uncertainty measurement	N/A
Storage of data	The output from the individual simulation components is stored as time series data (HDF5 data format).

8.4.3.2 Experiment Specification JRA2-LSS2.TS1.mosaik

Reference to Test Specification	JRA2-LSS2.TS1
Title of Experiment	assessment of impact of co-channel interference using mosaik
Research Infrastructure	N/A
Experiment Realisation	
Experiment Setup (concrete lab equipment)	<p>Dedicated simulation components are implemented as FMUs for Co-Simulation:</p> <ul style="list-style-type: none"> power system simulation: the power system is implemented as PowerFactory model, using consecutive power flow calculations to simulate the power system controller: the algorithm for calculating the tap position setpoint is implemented as a (simple) MATLAB script communication network simulation: the effects of the co-channel interference (communication delays, packet loss) are simulated with the help of ns-3 <p>The periodic sender and the FMI-compliant adapters are implemented in Python on top of mosaik's high level API. The use of PowerFactory requires this simulation to use Windows as operating system. However, since ns-3 is developed for Linux operating systems, it is run in a Cygwin environment.</p>
Experimental Design and Justification	<p>This is an advanced co-simulation setup using FMUs. In order to incorporate the “randomness” of the communication delays and packet loss, an ensemble of simulation runs with different random number generator seeds has to be evaluated (Monte Carlo approach).</p> <p>The communication network model uses message IDs as inputs and outputs, with a message ID equal to 0 indicating that no signal is pre-</p>

	<p>sent. Inside the ns-3 model, these message IDs are associated to dummy messages (of configurable size), which are used to simulate the processing of the message within the communication network. However, the power system model and the voltage controller expect real-valued numbers as inputs and outputs and the corresponding tools (i.e., PowerFactory and MATLAB). Therefore, the mosaik wrapper for the ns-3 FMU implements a mapping between message IDs and signal values. Furthermore, all FMU wrappers and mosaik simulators are implemented such that they understand an input of type None as absent signal and react accordingly (e.g., remain idle in case the signal is absent).</p>
Precision of equipment	N/A
Uncertainty measurement	N/A
Storage of data	The output from the individual simulation components is stored as time series data (HDF5 data format).