

# THE HOUSE OF IMAGINATION\*

A DESIGN PROPOSAL BASED ON THE RESEARCH 'RE-ENVISION THE PUBLIC LIBRARY: SEARCHING FOR THE NEW LIBRARY IDENTITY'.  
DORINE VOS P5 PRESENTATION APRIL 19TH 2018









▲ Foto Kees Martens

## **Bibliotheek Nuenen als eerste op de schop**

**NUENEN - Bezoekers van de bibliotheek in Nuenen gaan volgende maand als eersten de gevolgen van de bezuinigingen bij bibliotheek Dommeldal merken.**

Inge Lepelaars 19-04-13, 16:20 Laatste update: 14-03-17, 17:26







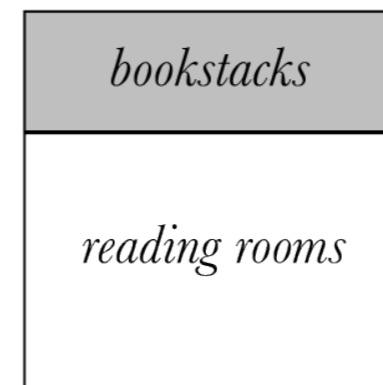
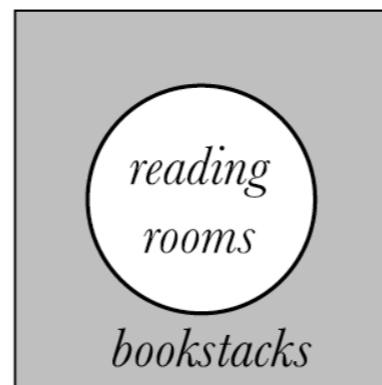
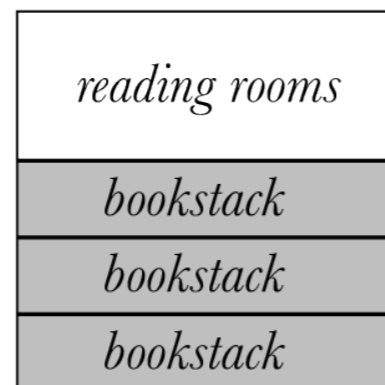

*The original library design Main division in the building*





*Example of the central reading room: The library of the British Museum*



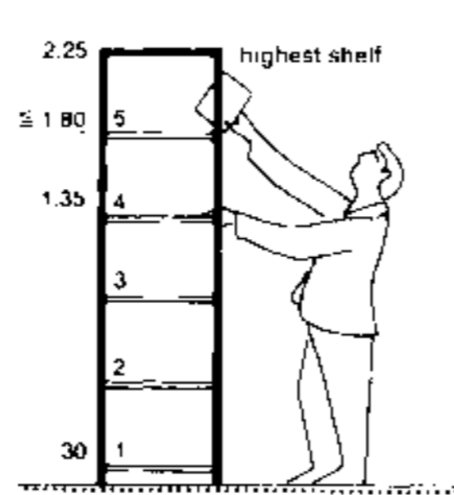

⑩ Height of five-shelf unit

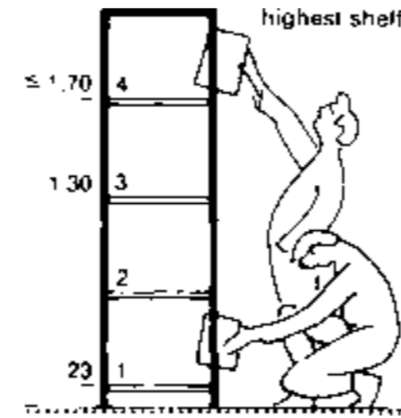

⑪ Bookshelf for schoolchildren

standing users

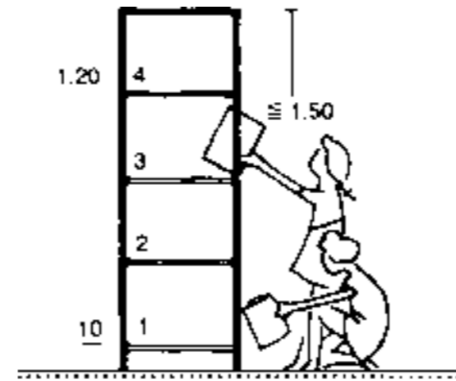

@ Height of four-shelf unit for small children

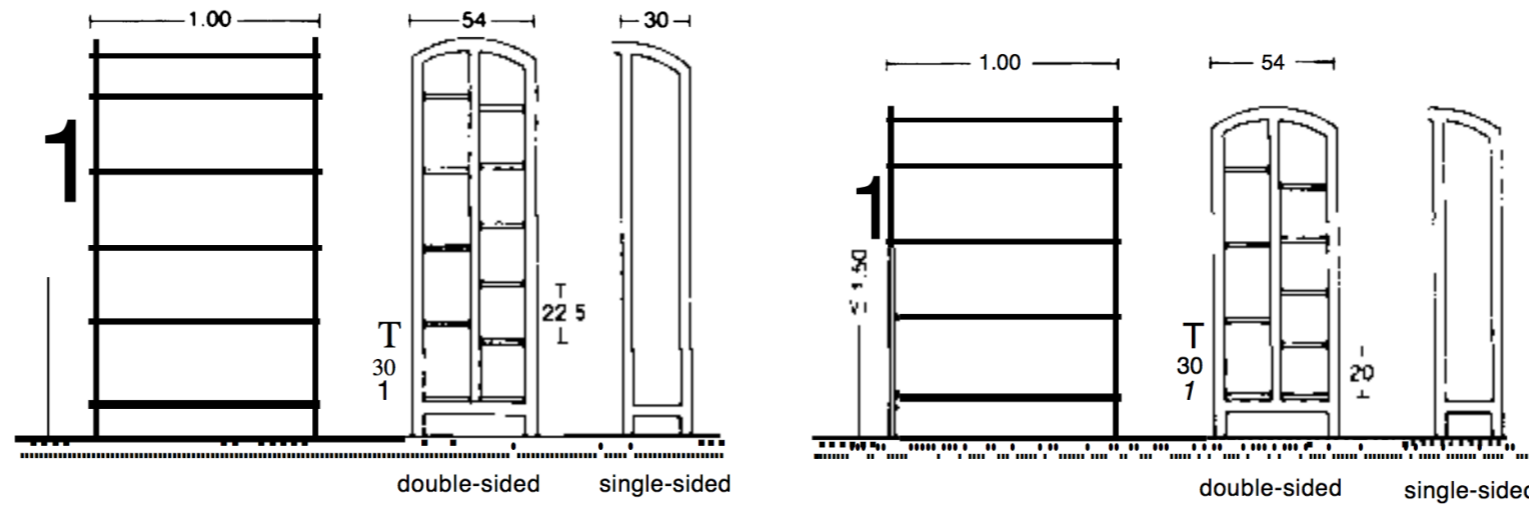

⑭ Shelf units: for adults, 5--6 shelves; for children 4--5 shelves → ⑫

*Library design according to Neufert*



# CONTEXT OF CHANGE





*New ways of knowledge transfer*



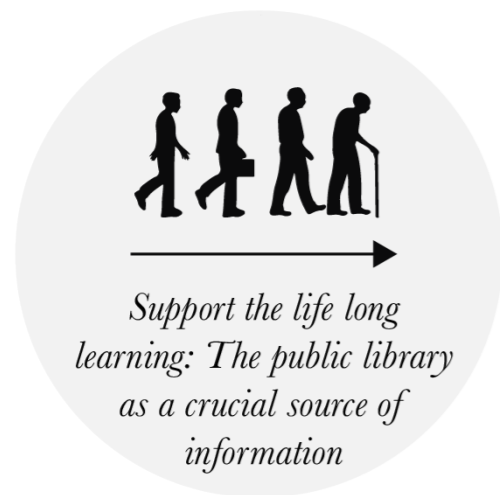

*Opportunities for the public library in relation to the context of change*

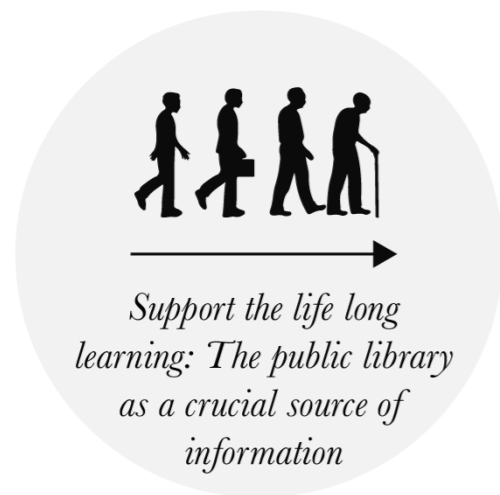

*Opportunities for the public library in relation to the context of change*



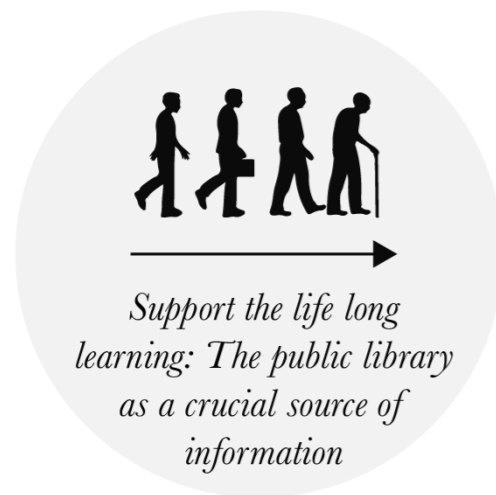

*Opportunities for the public library in relation to the context of change*

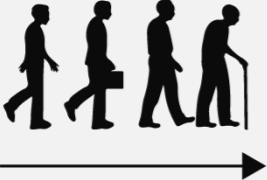

*Support the life long learning: The public library as a crucial source of information*



*The mobilization of talent: Create meeting places for creation*



*Include the excluded population by supporting extra educational functions*



*The public library can function as a hub of connection and integration*

*Opportunities for the public library in relation to the context of change*



*The Library as Workingspace*

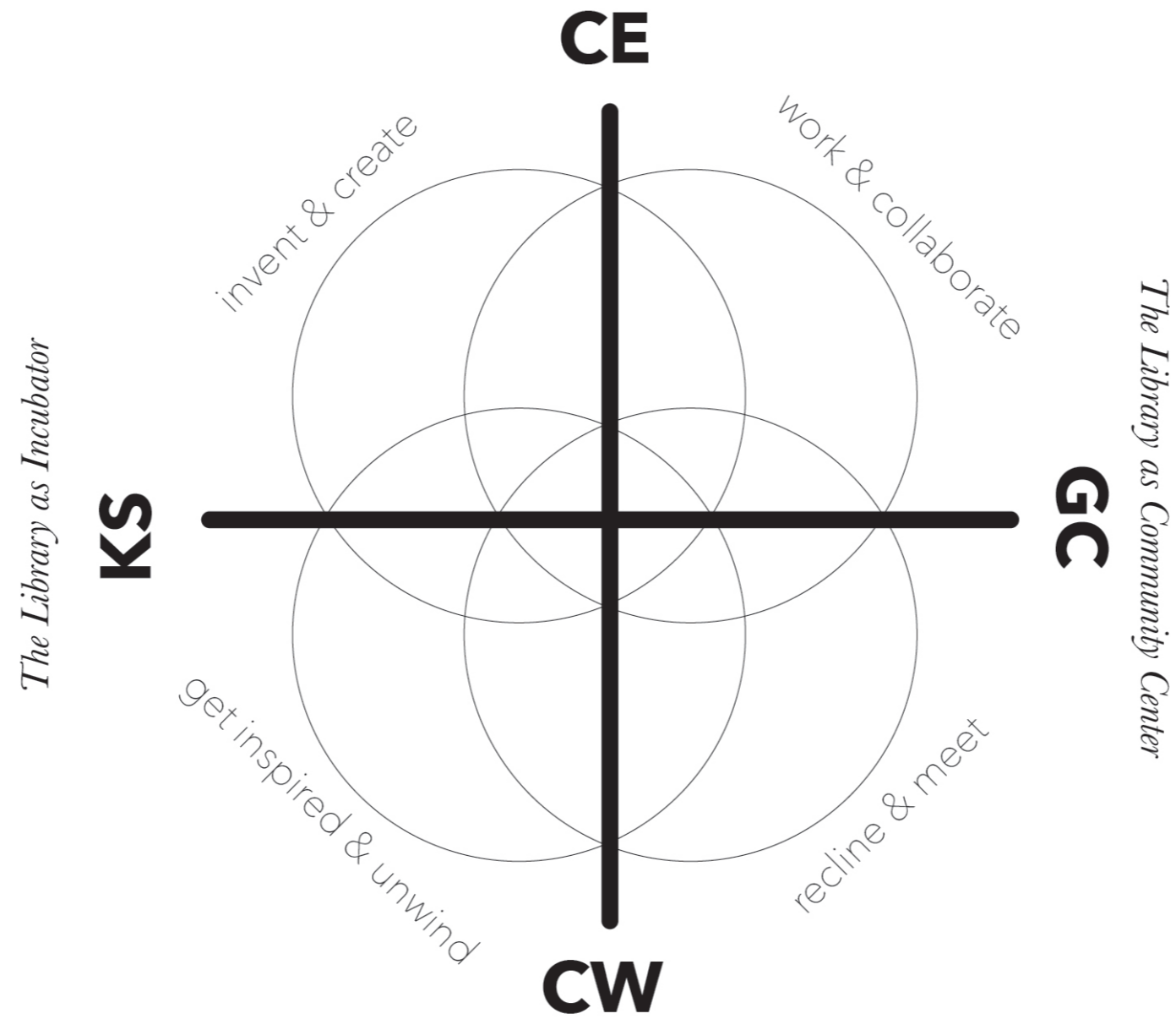

*The Library as Second Home*

*Conclusion of the research*

**BUT HOW TO CREATE IDENTITY?**



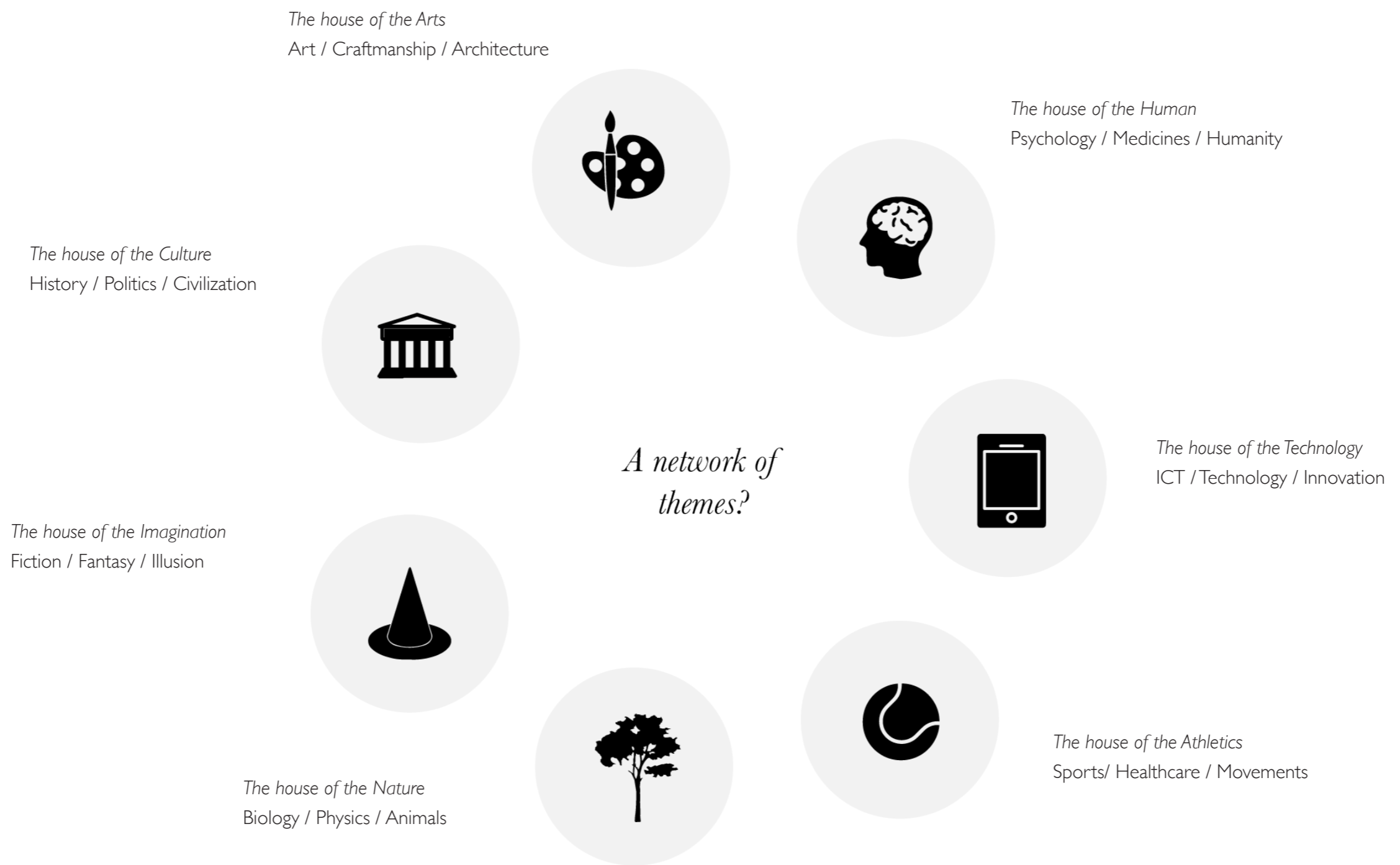

*Cluster of different themes for enhancement of the library identity*







*A network of themes through the city of Rotterdam*

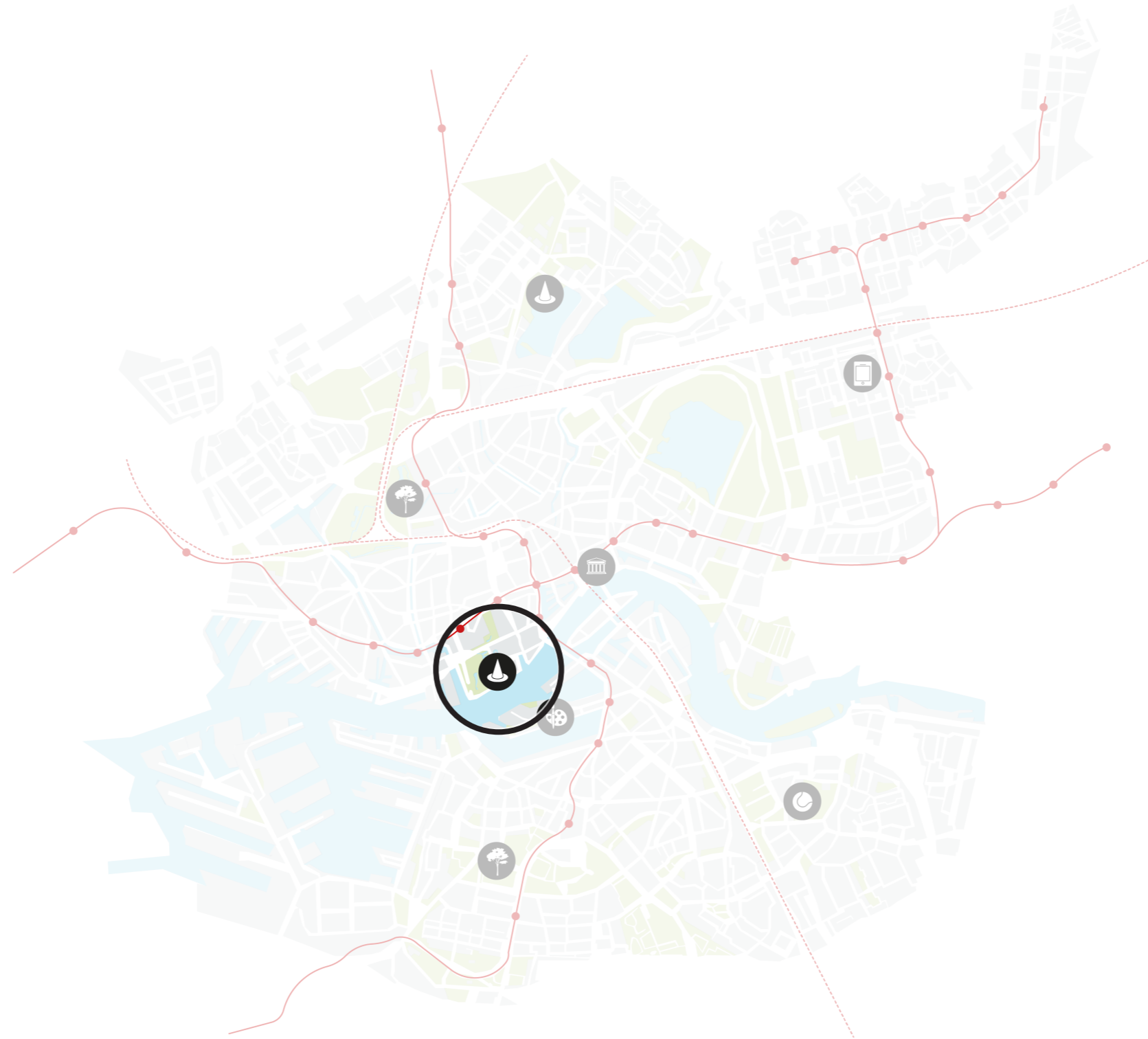

*Chosen location: The House of Imagination in 'Het Park'*







# THE HOUSE OF IMAGINATION\*

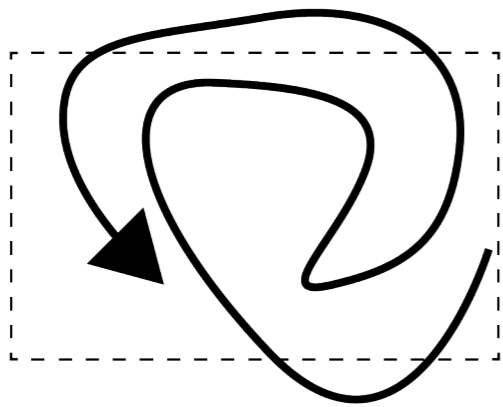

*General concept towards the house of Imagination*

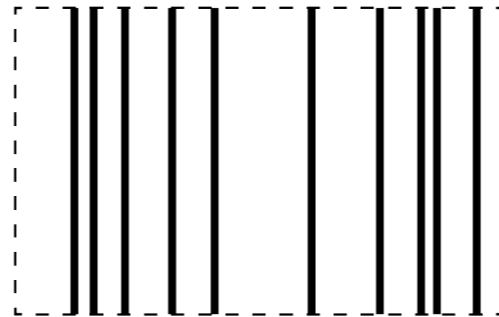
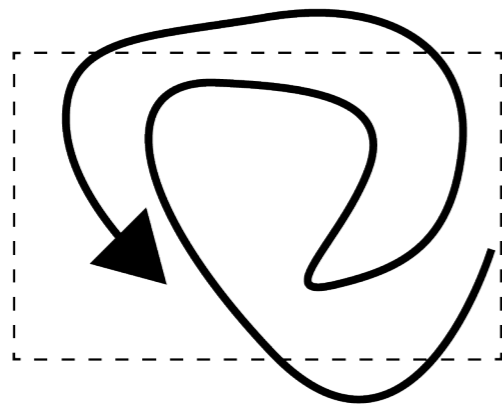

*General concept towards the house of Imagination*



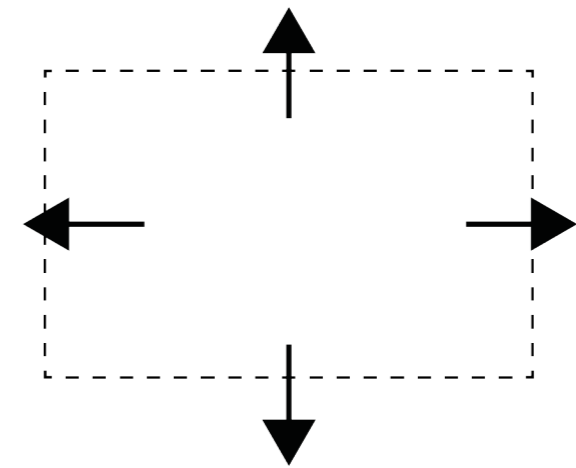
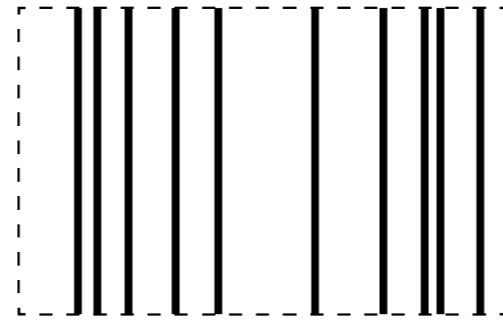
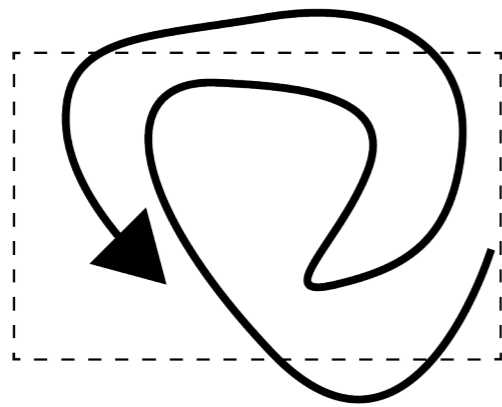

*General concept towards the house of Imagination*

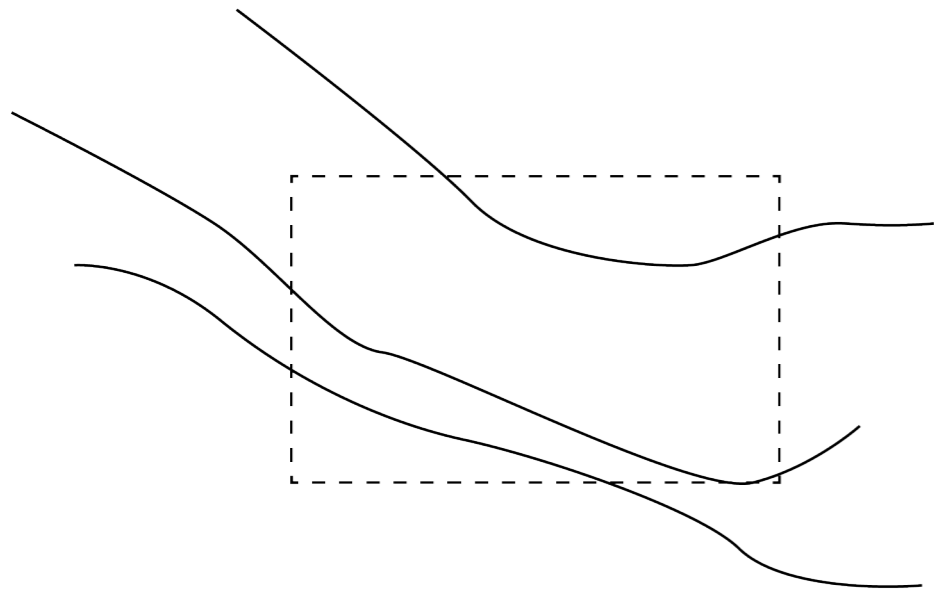

*Design Elements*

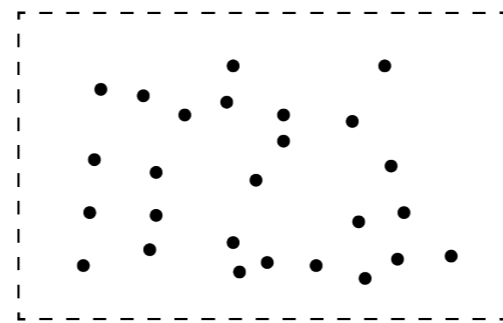
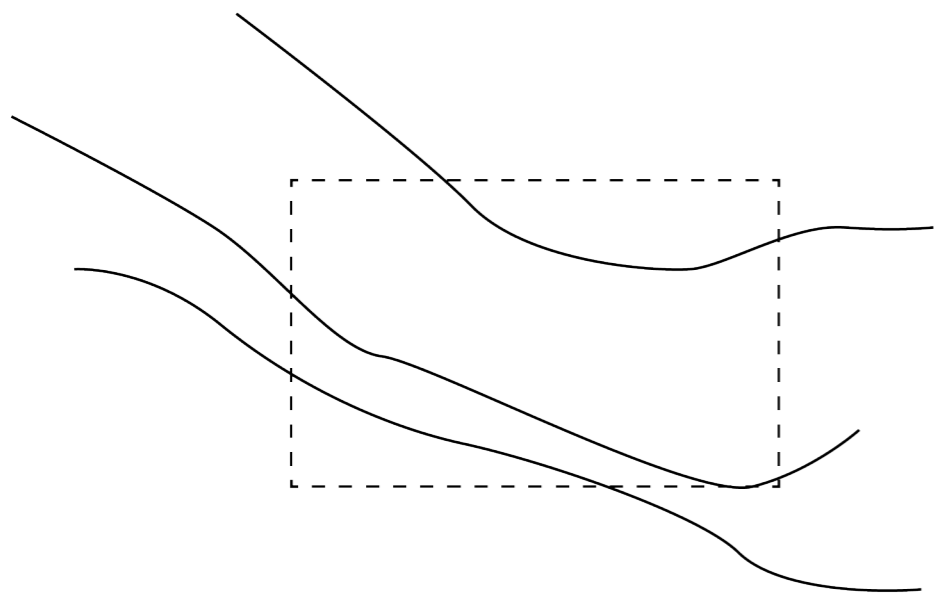

*Design Elements*



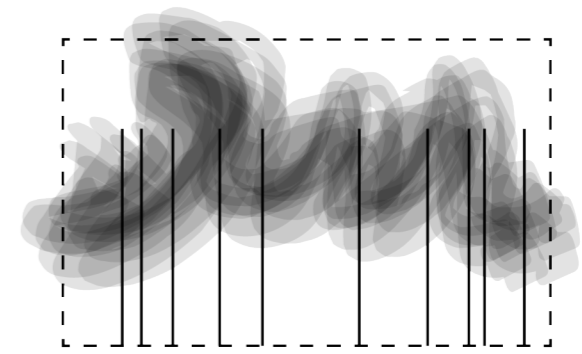
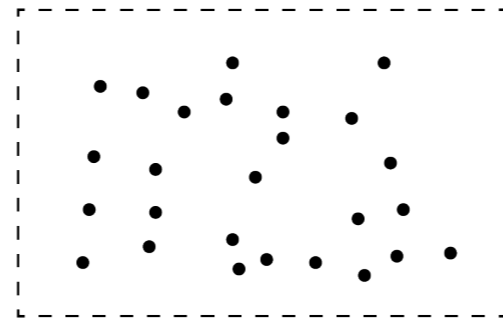
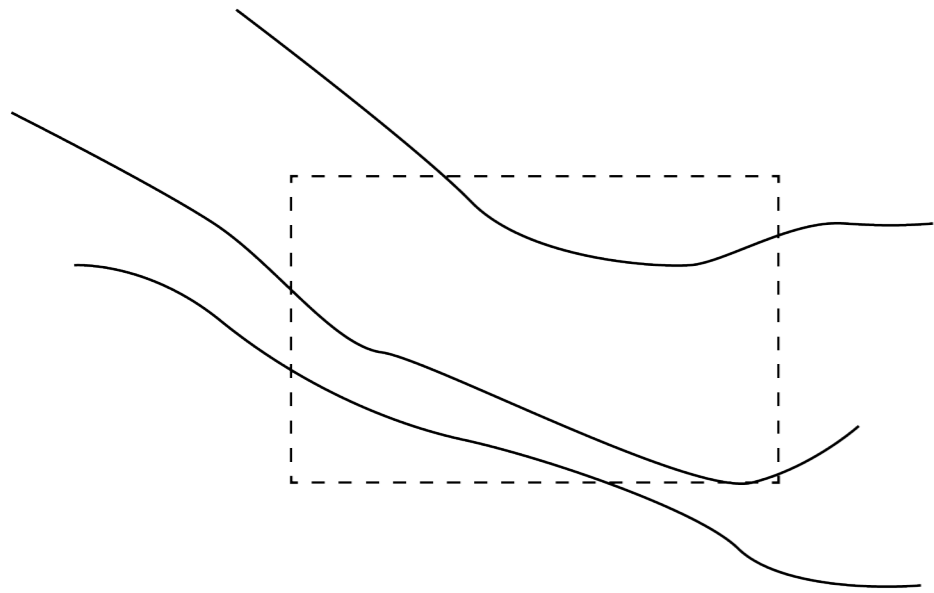

*Design Elements*

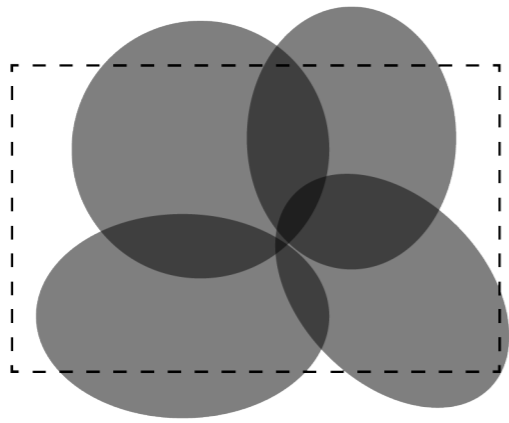

*Approach of Space program*

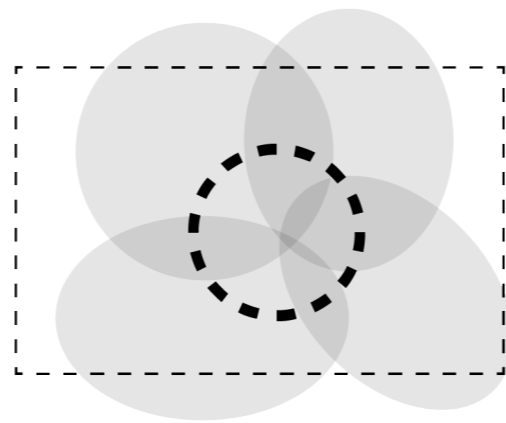
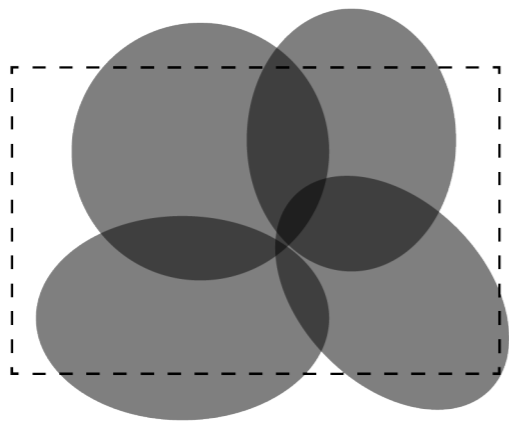

*Approach of Space program*



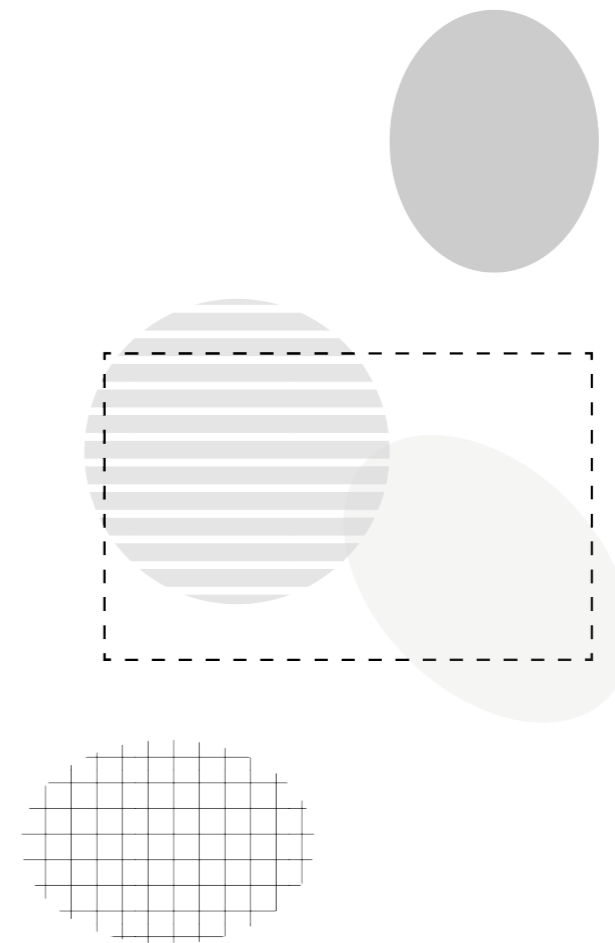
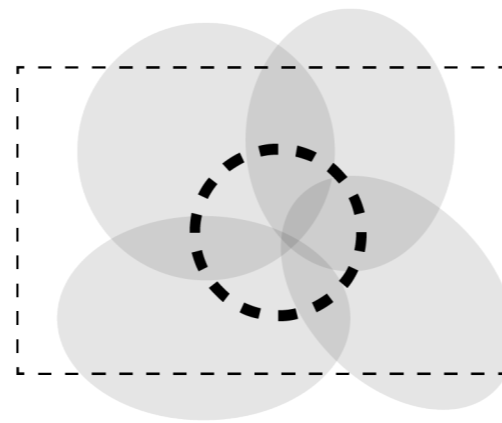
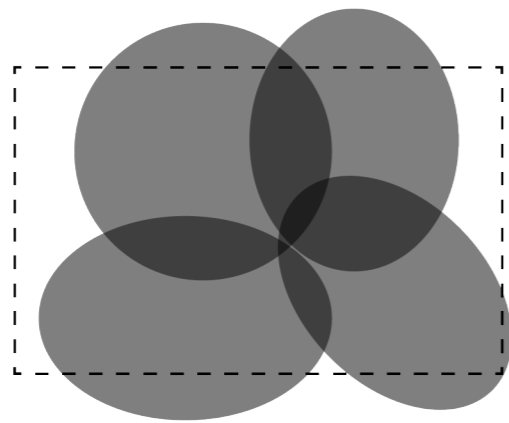

*Approach of Space program*



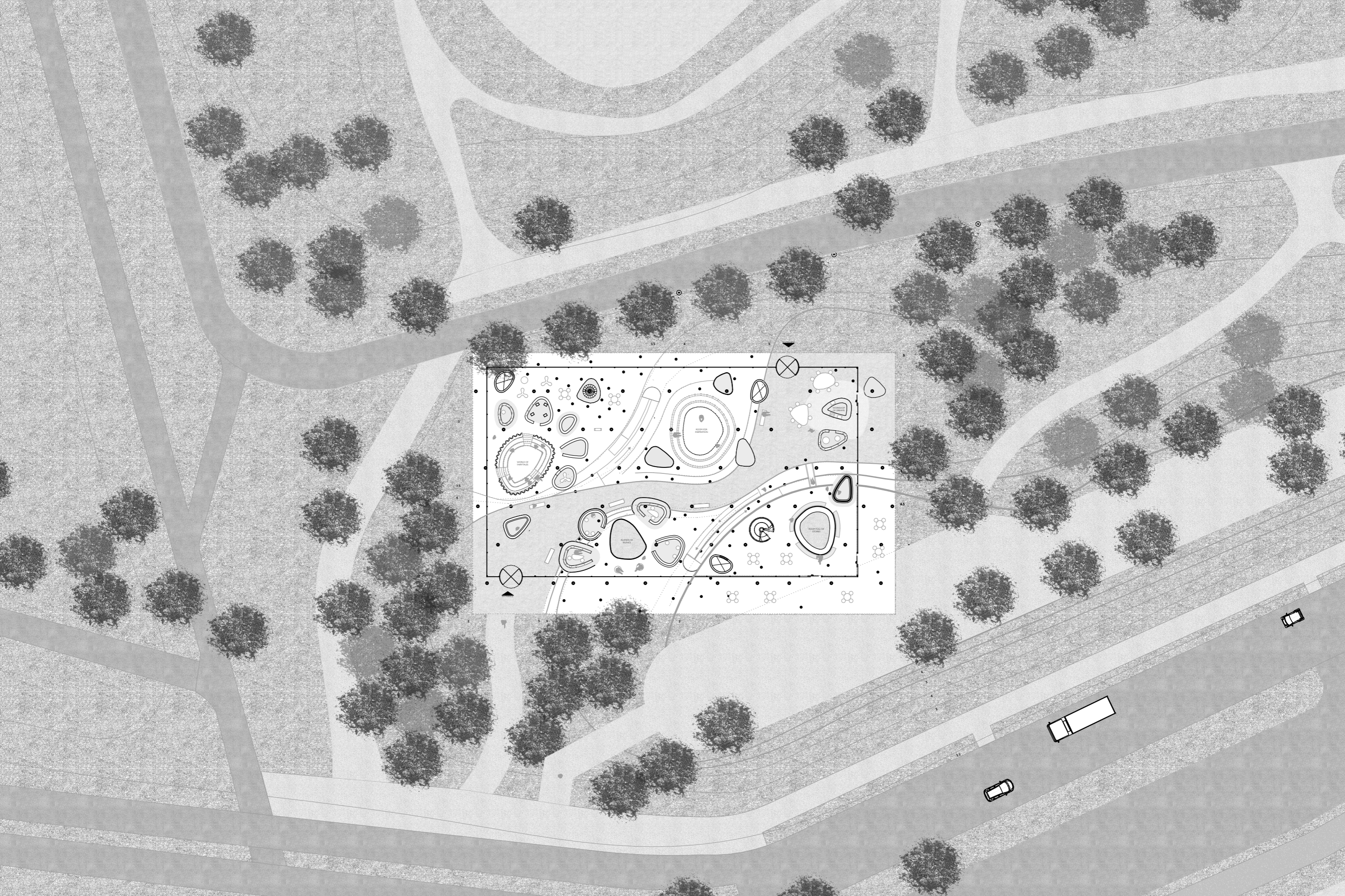



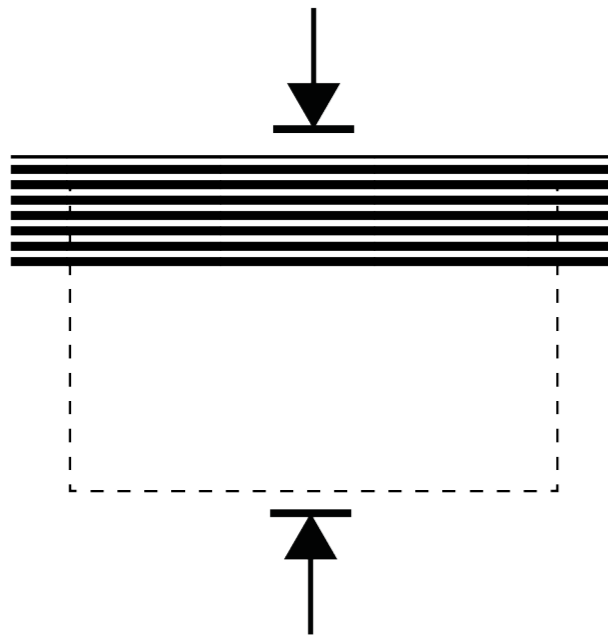

*Context approach*



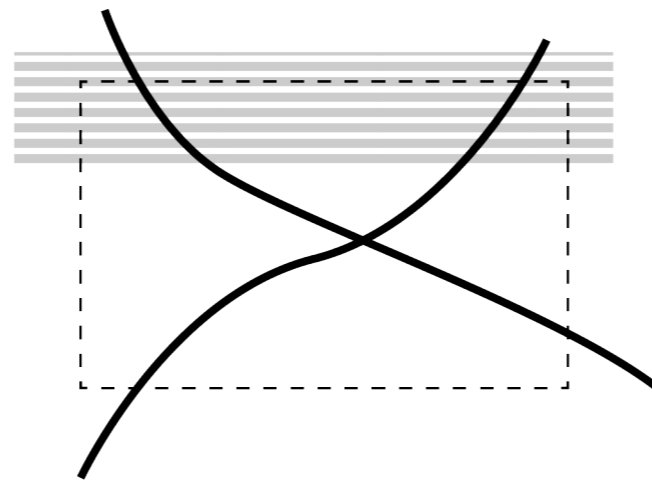
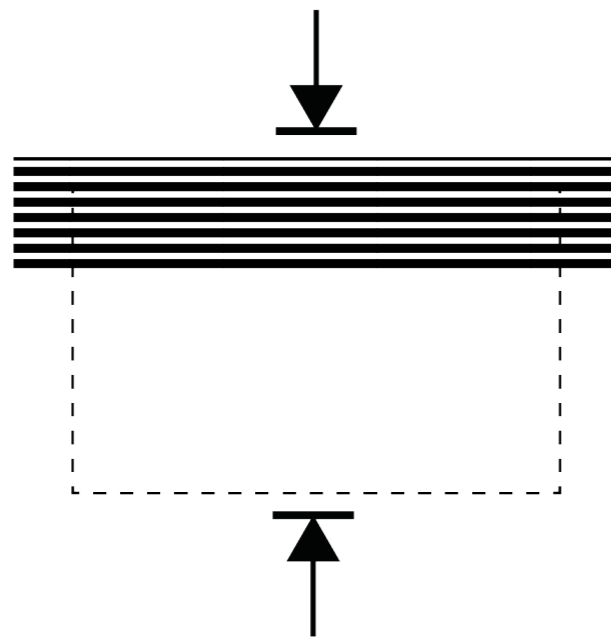

*Context approach*

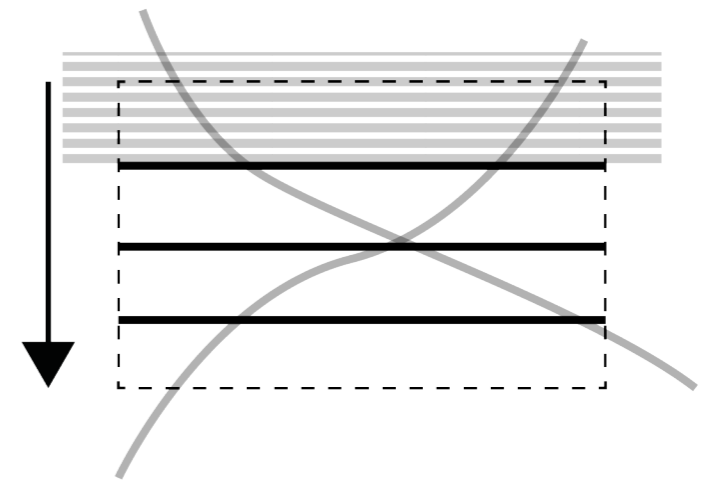
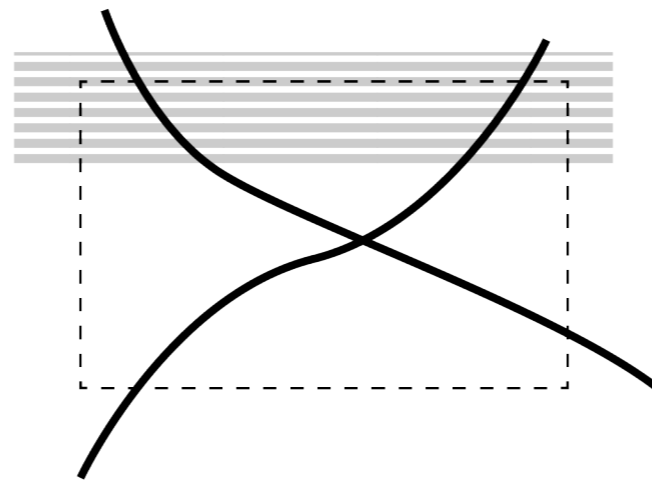
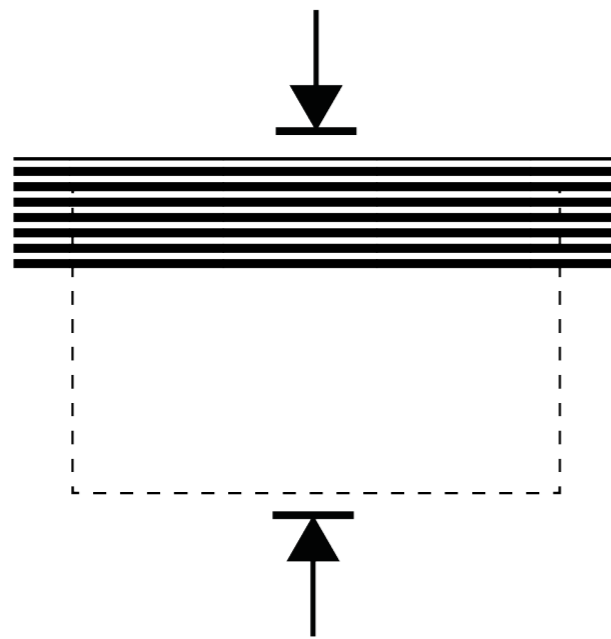

*Context approach*





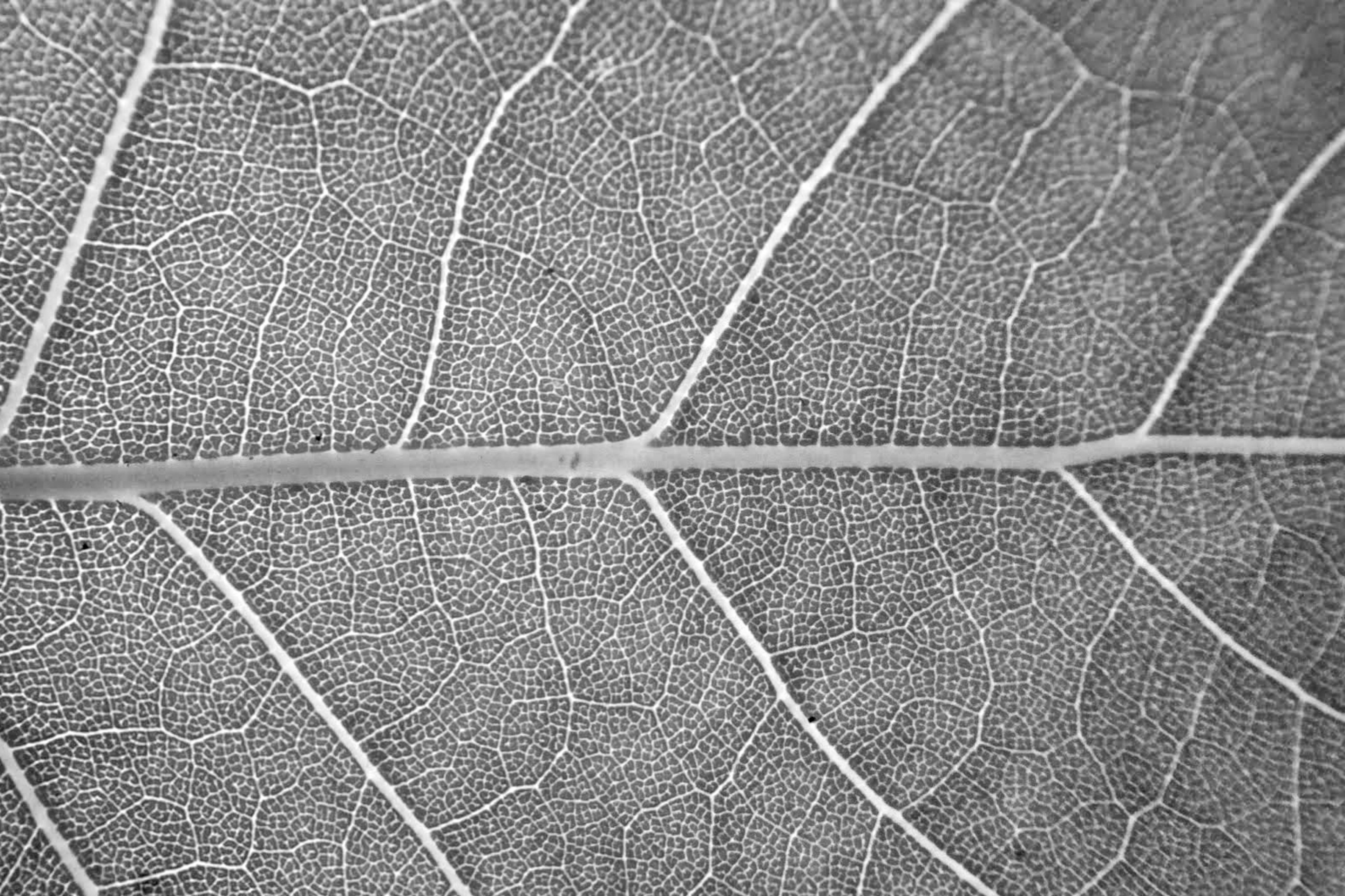



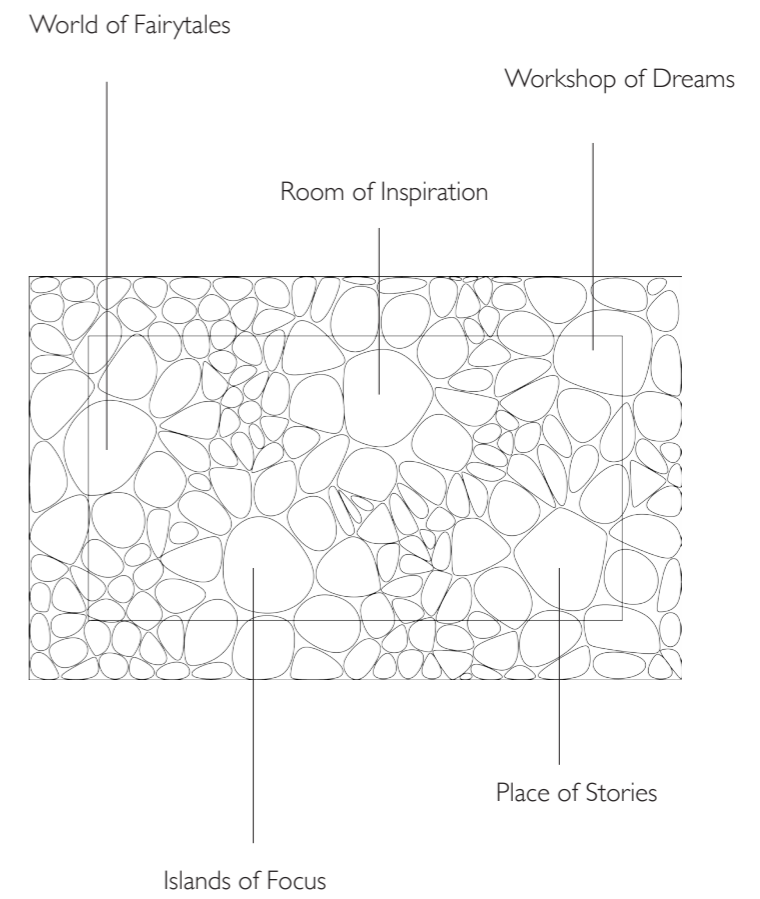
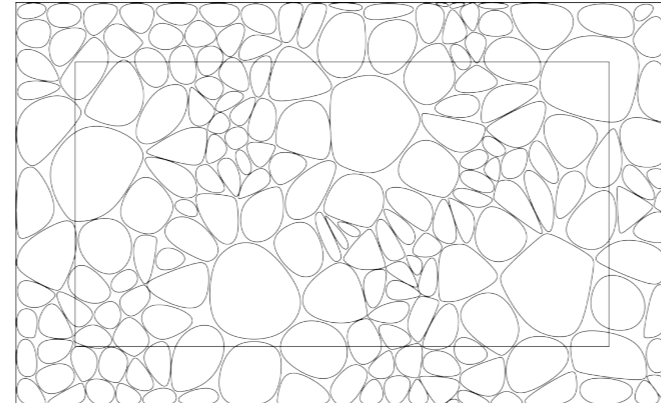
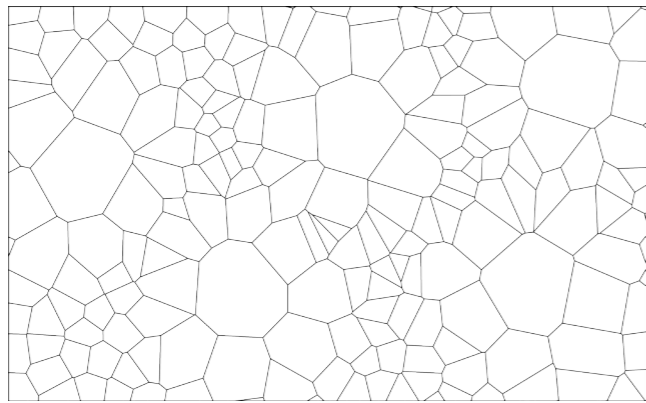

*Development of the Voronoi pattern*

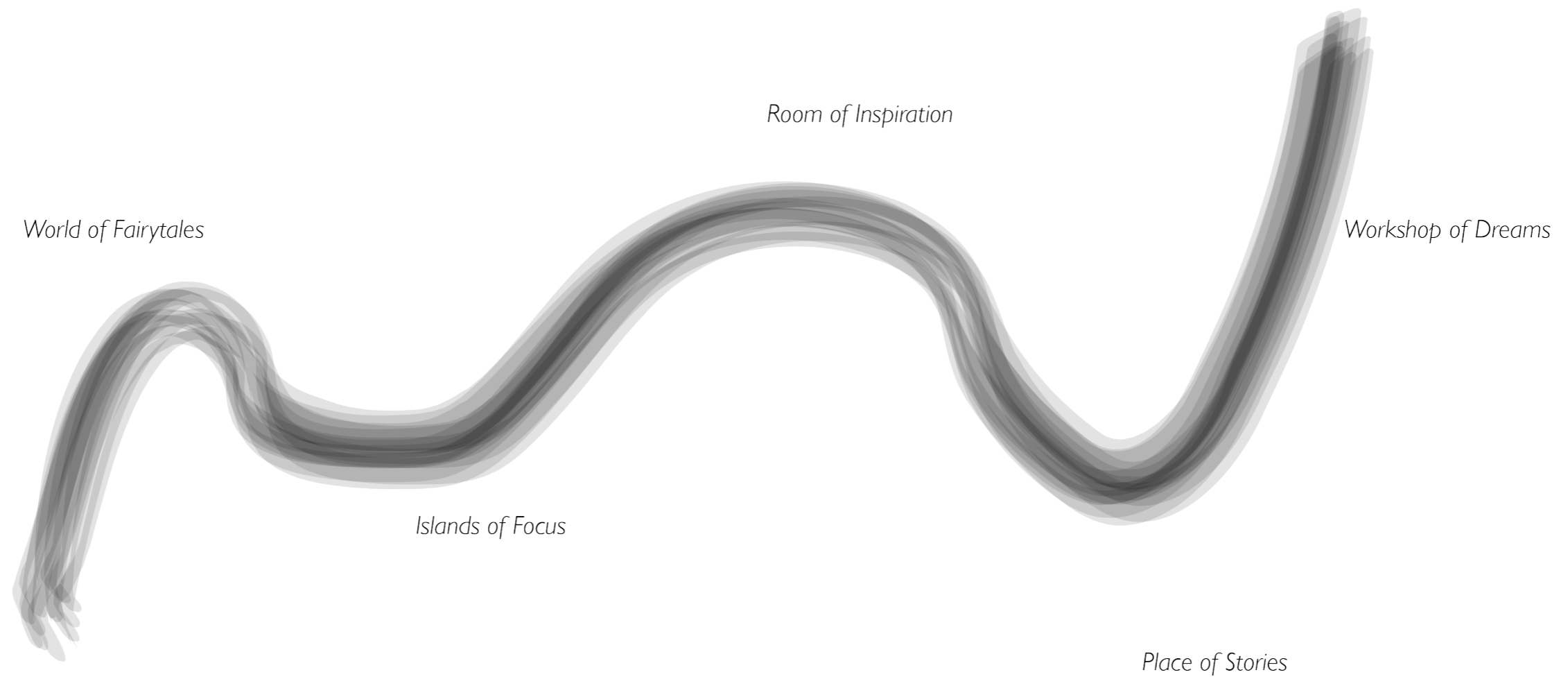

*5 zones of design connected by a boulevard through the woods*

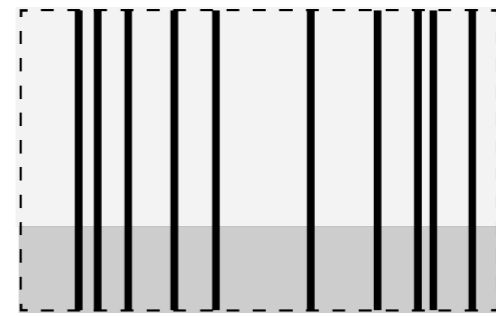
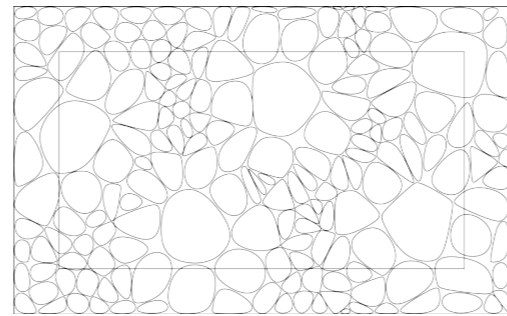
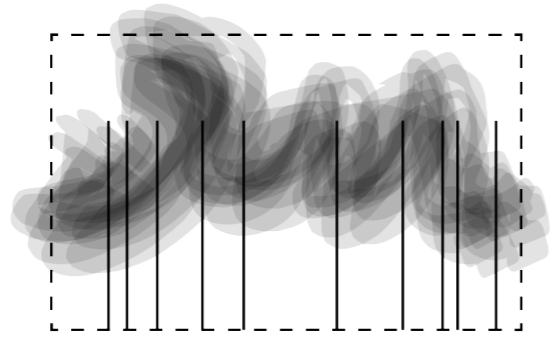

*Key Principles*



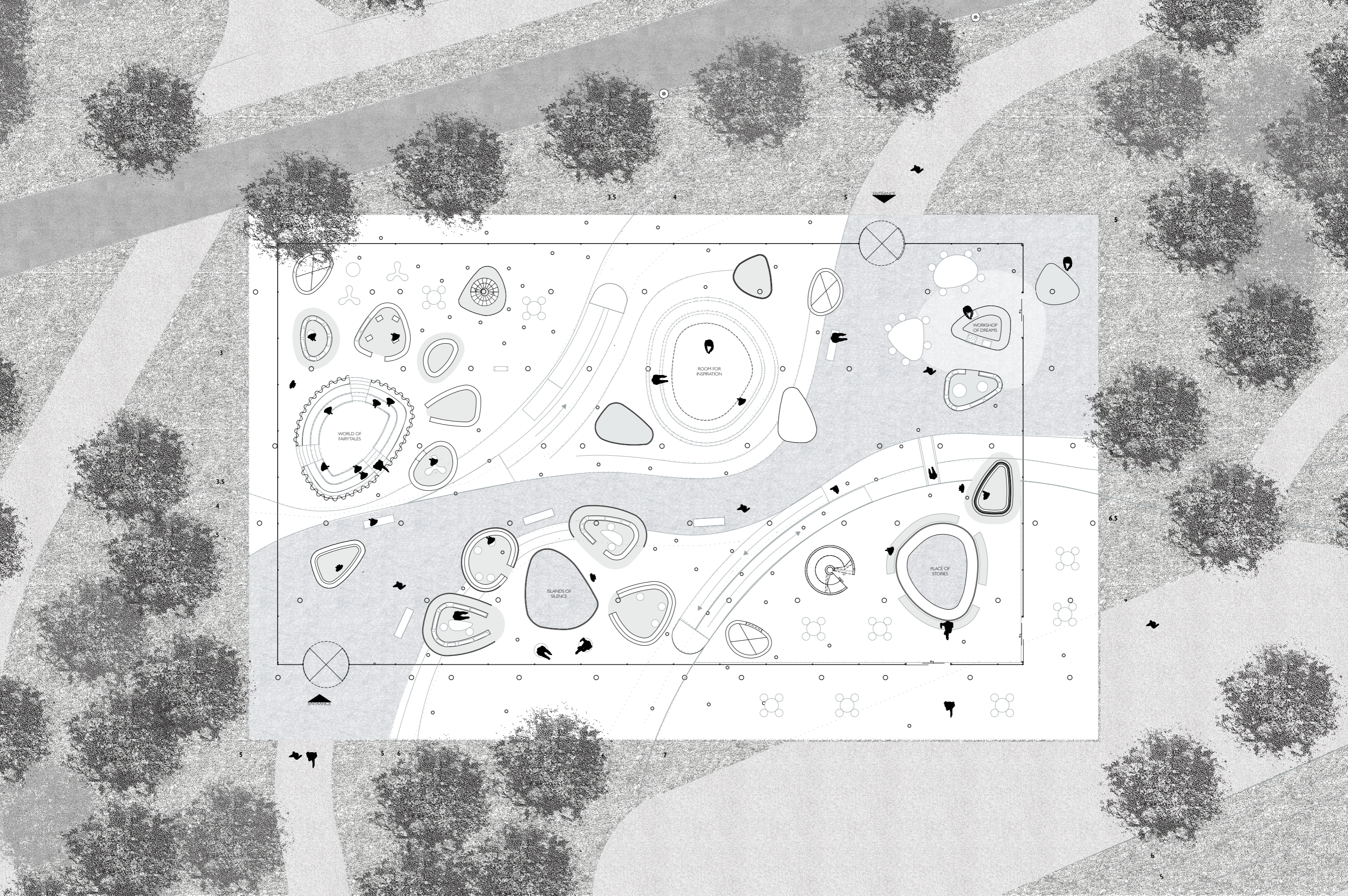







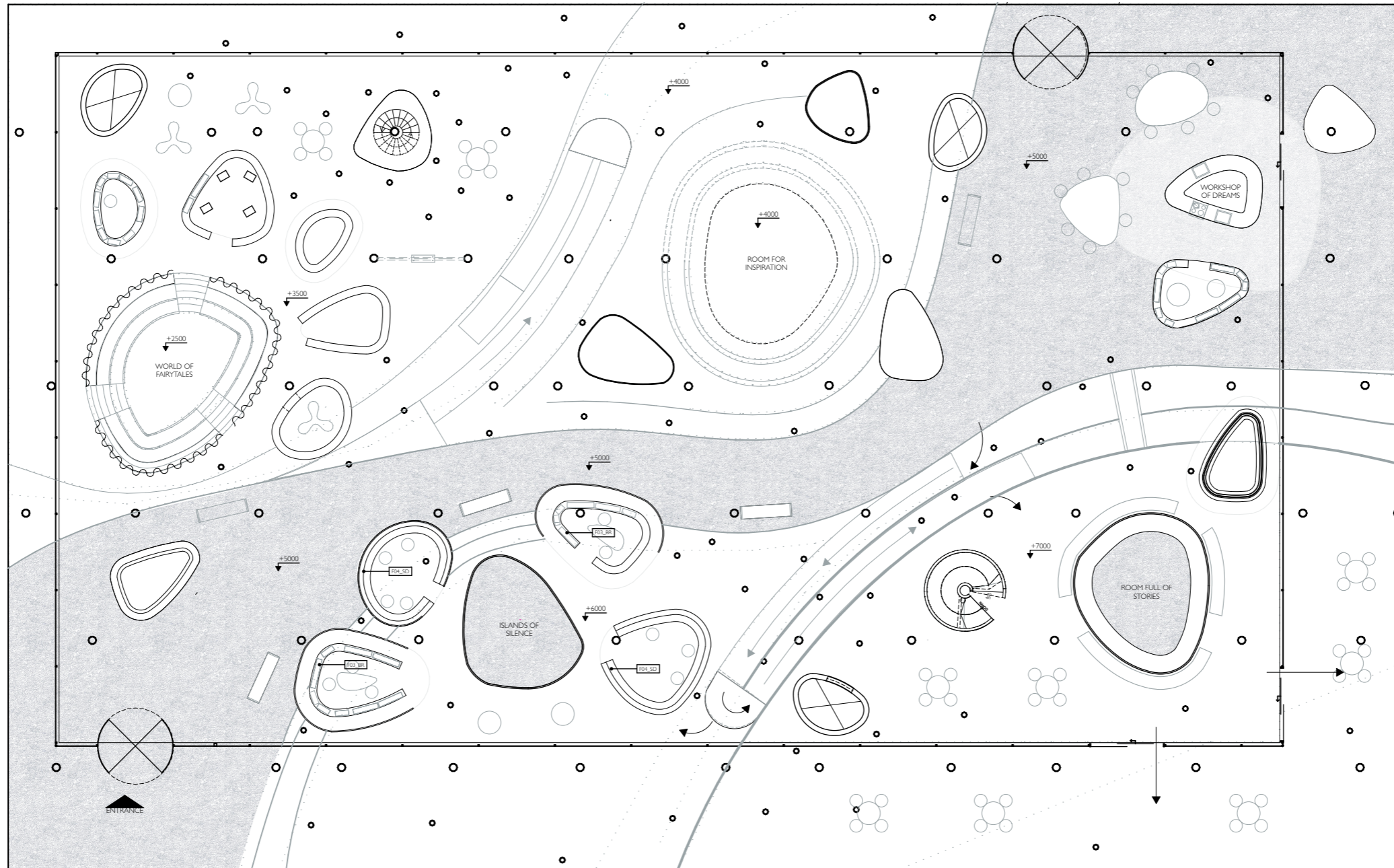

# 01 INSPIRE







01 INSPIRE

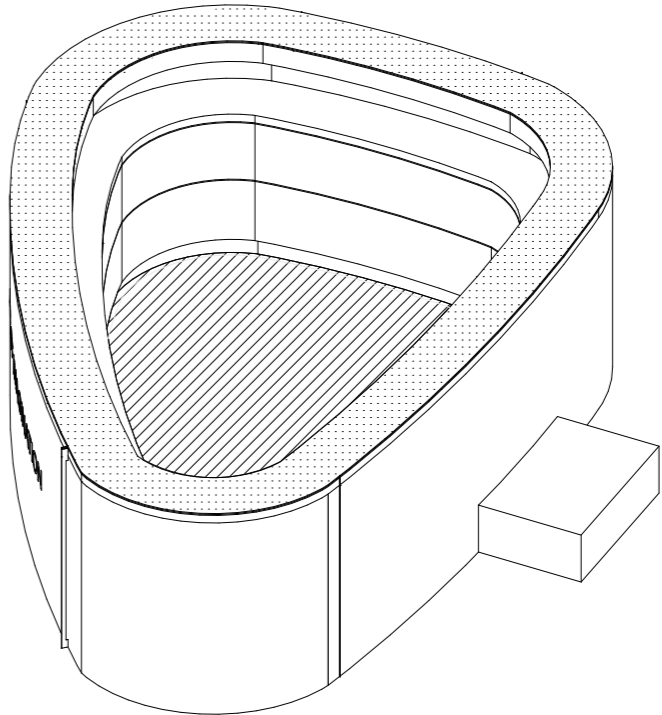
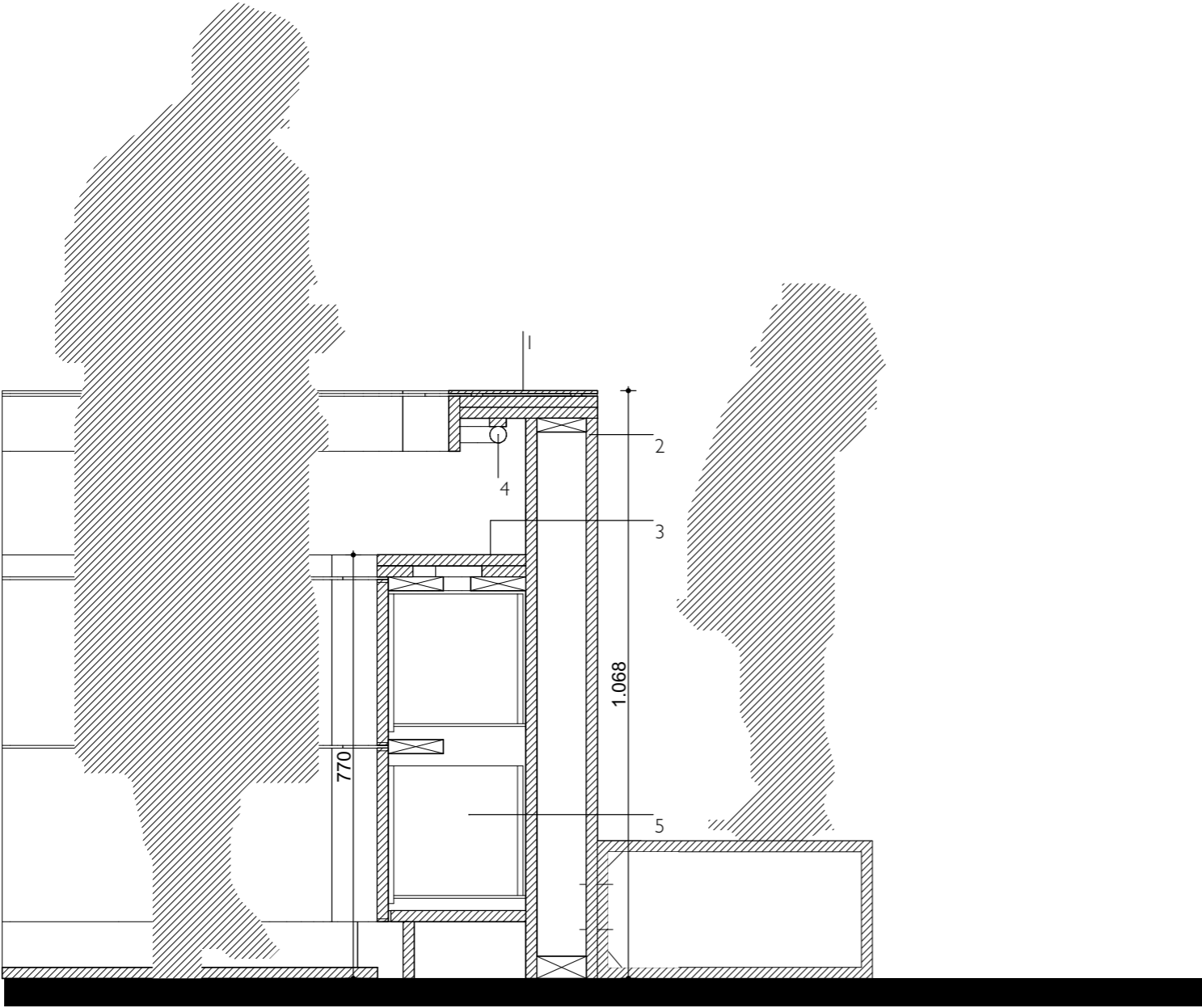

*Detail of the information desk*

**01 INSPIRE**



*Route of Light in the model*



## 01 INSPIRE

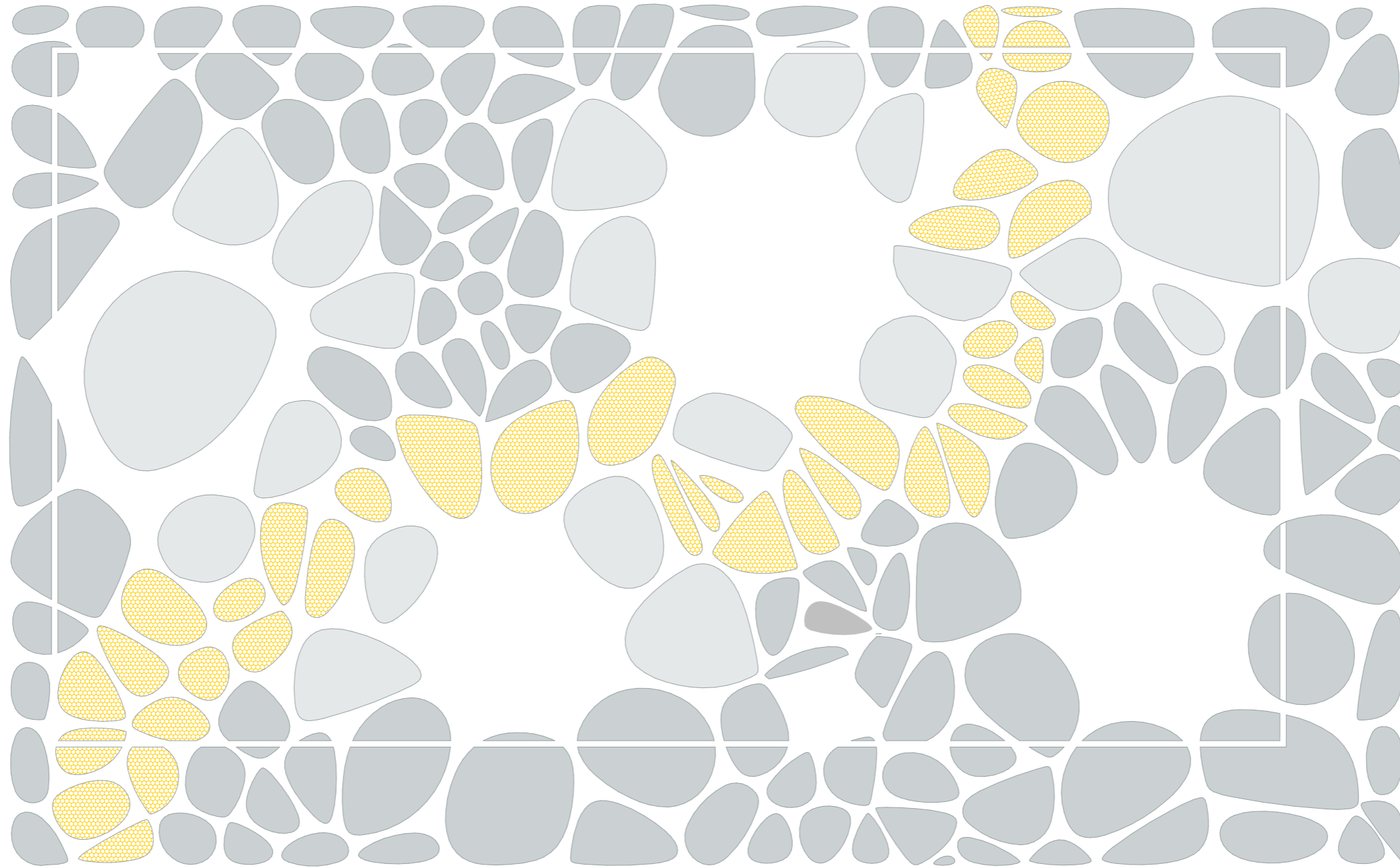

*Reflection of the boulevard in the ceiling*

**01 INSPIRE**

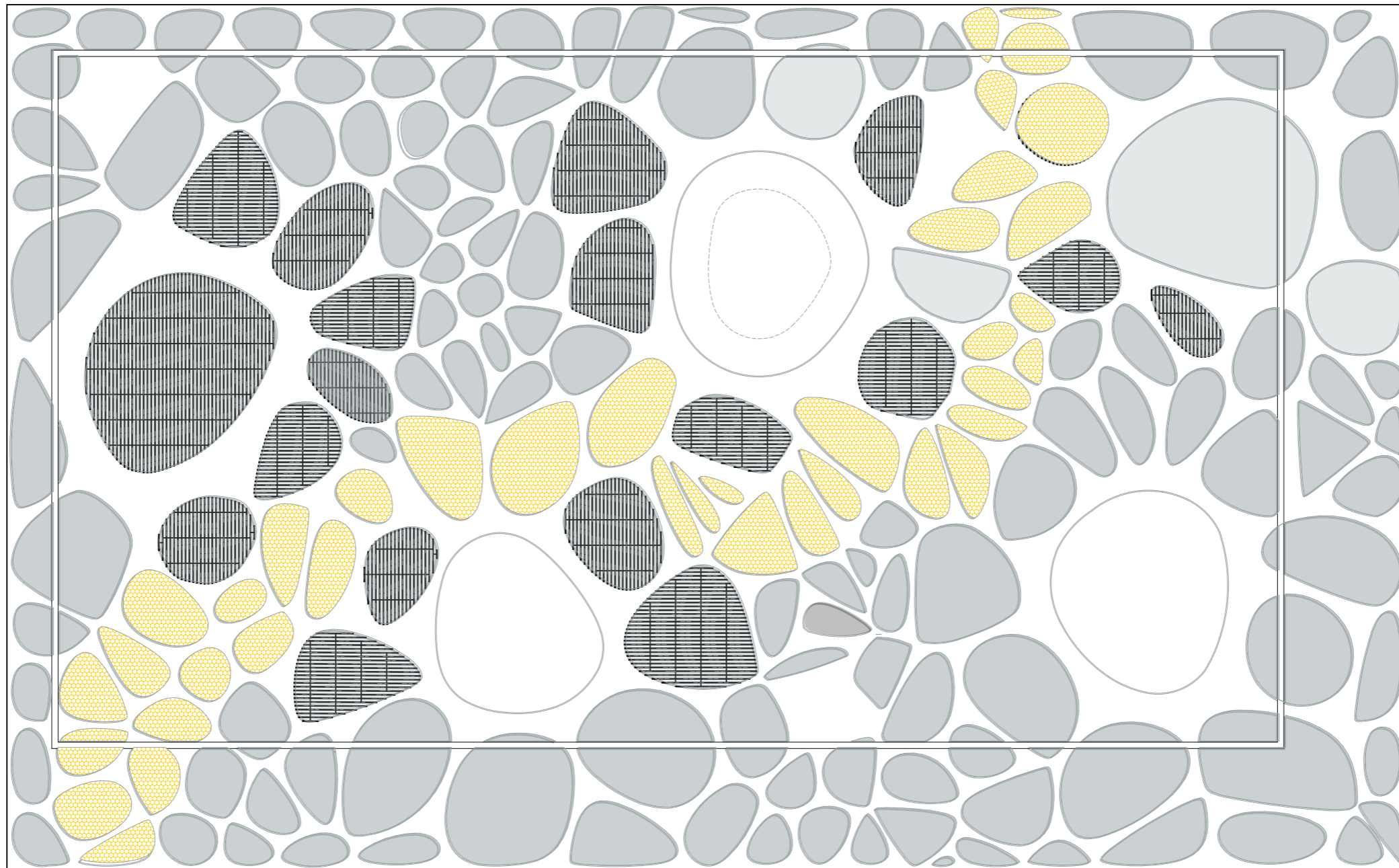

*Reflection of the boulevard in the ceiling*



# 01 INSPIRE

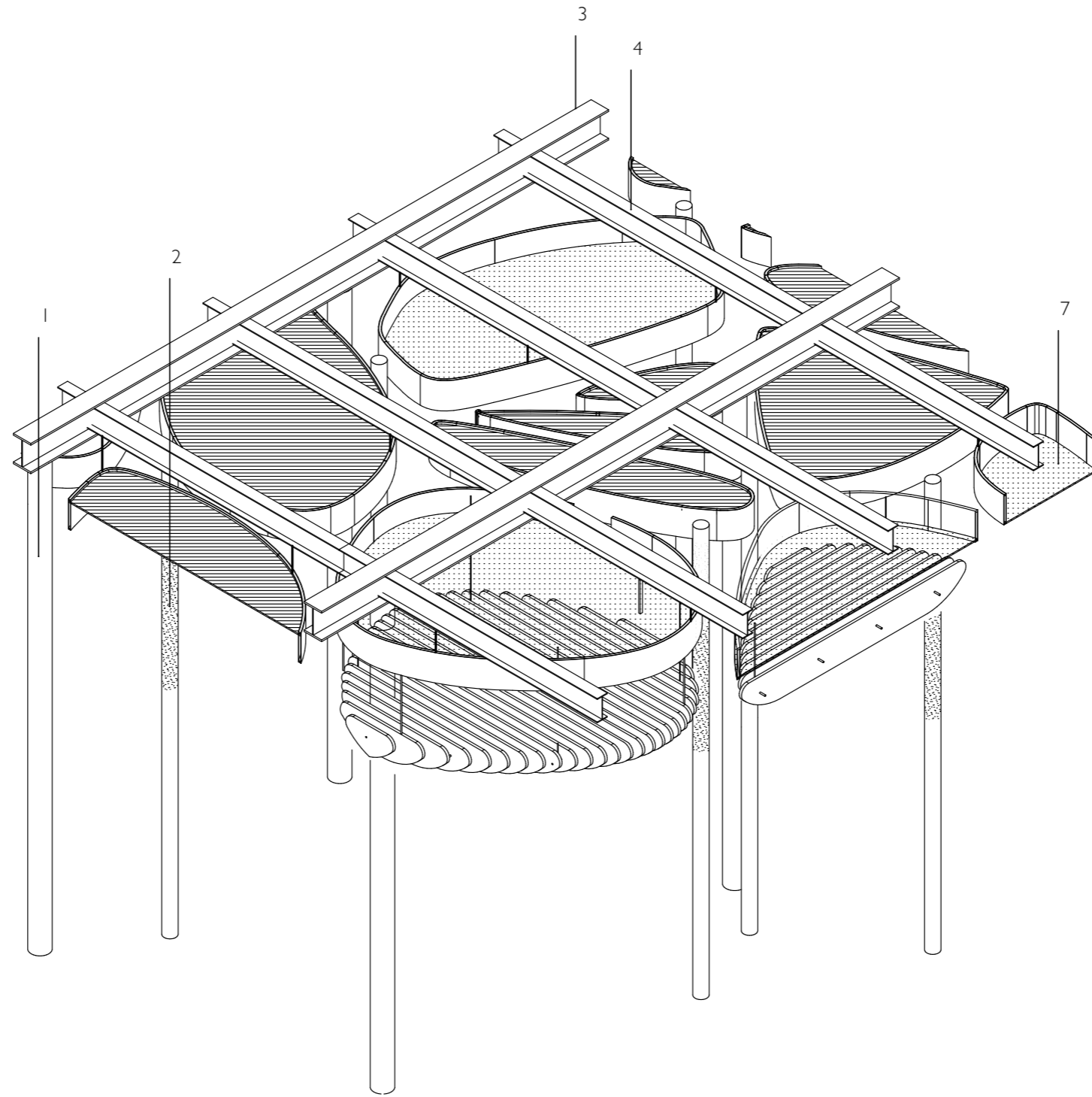

*Axonometric view of the ceiling*



1:200



# 02 DREAM







## 02 DREAM

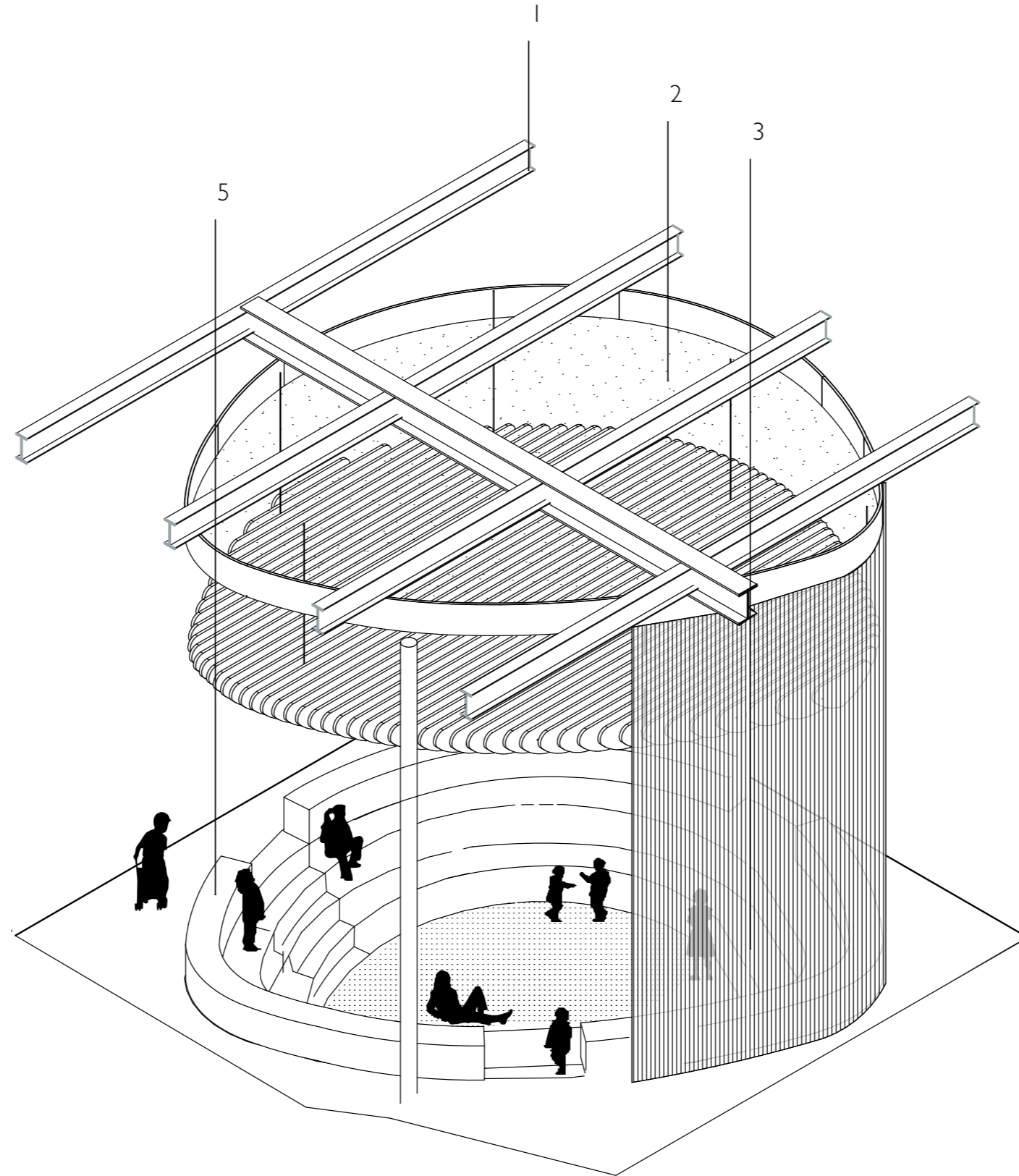

*3D impression of the Story telling hole*

## 02 DREAM

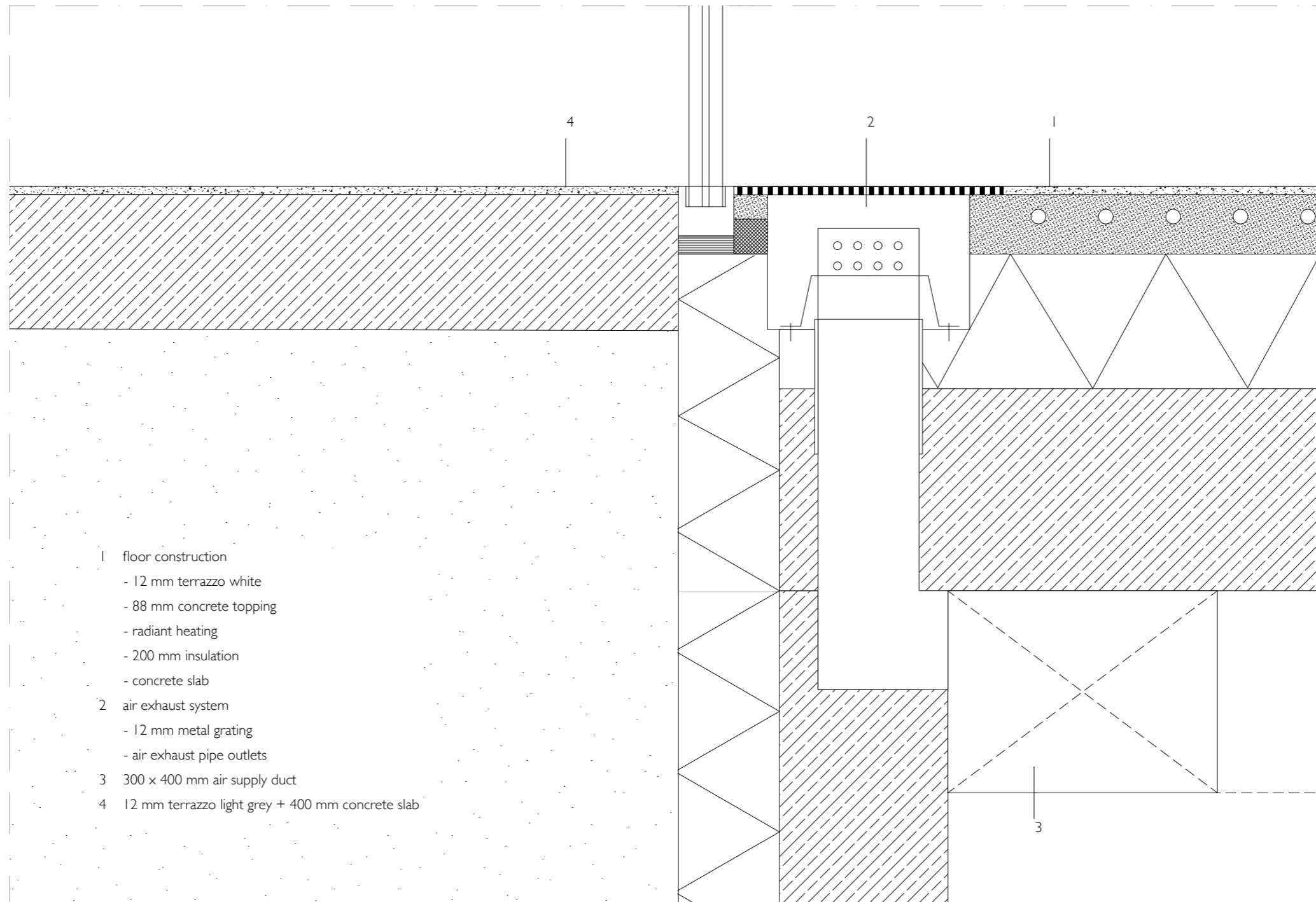

*3D impression of the Story telling hole*



## 02 DREAM

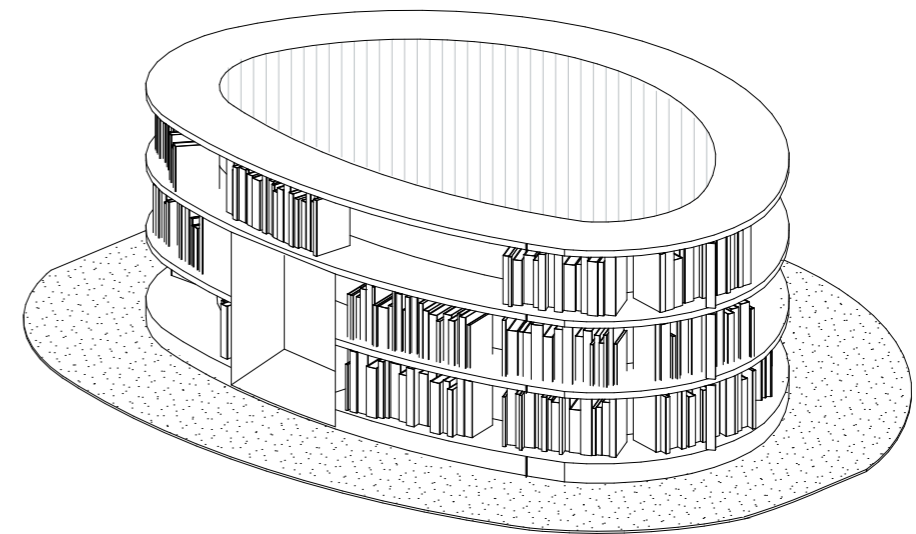
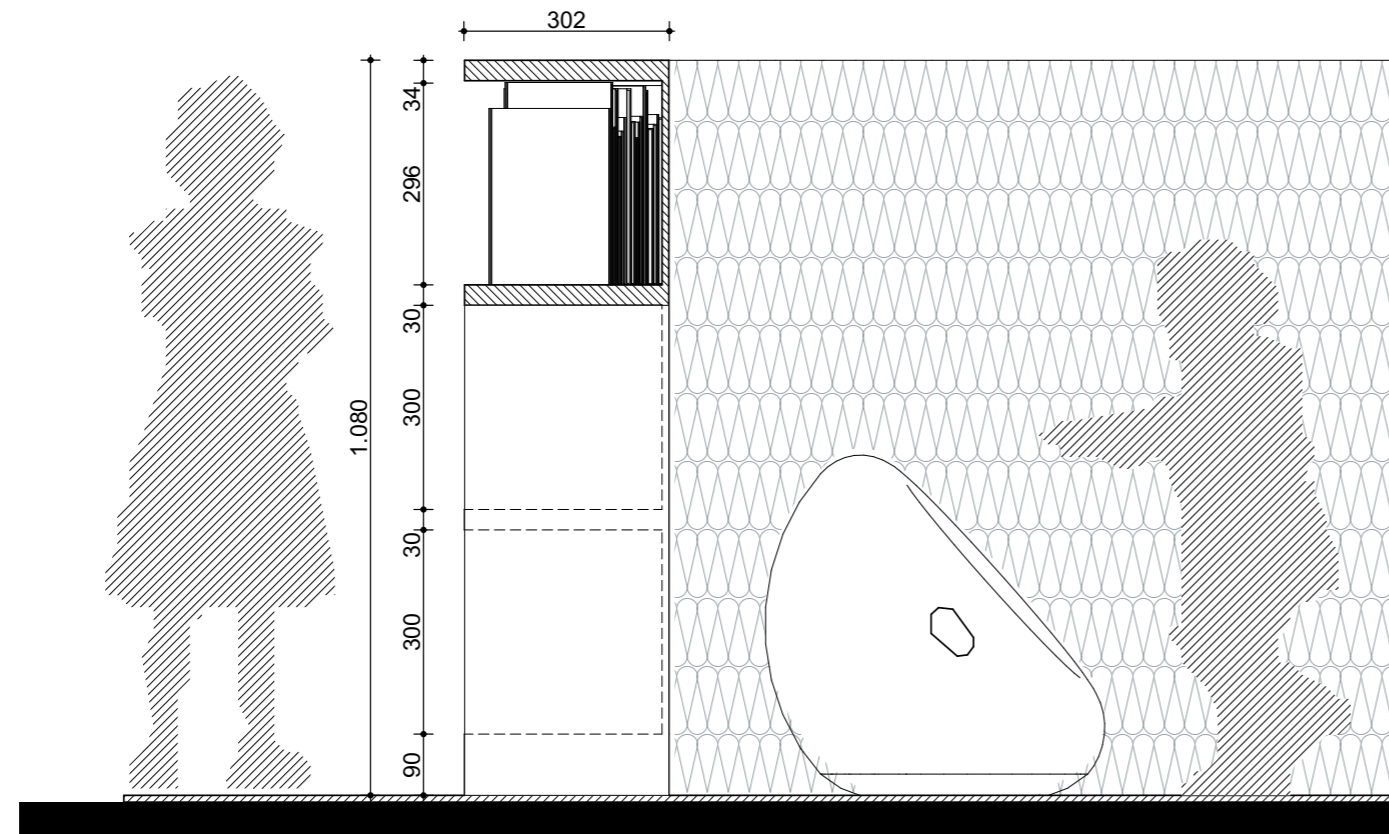

*Book shelf element children*





# 03 EXPOSE







### 03 EXPOSE



*Tribune in Model*

### 03 EXPOSE

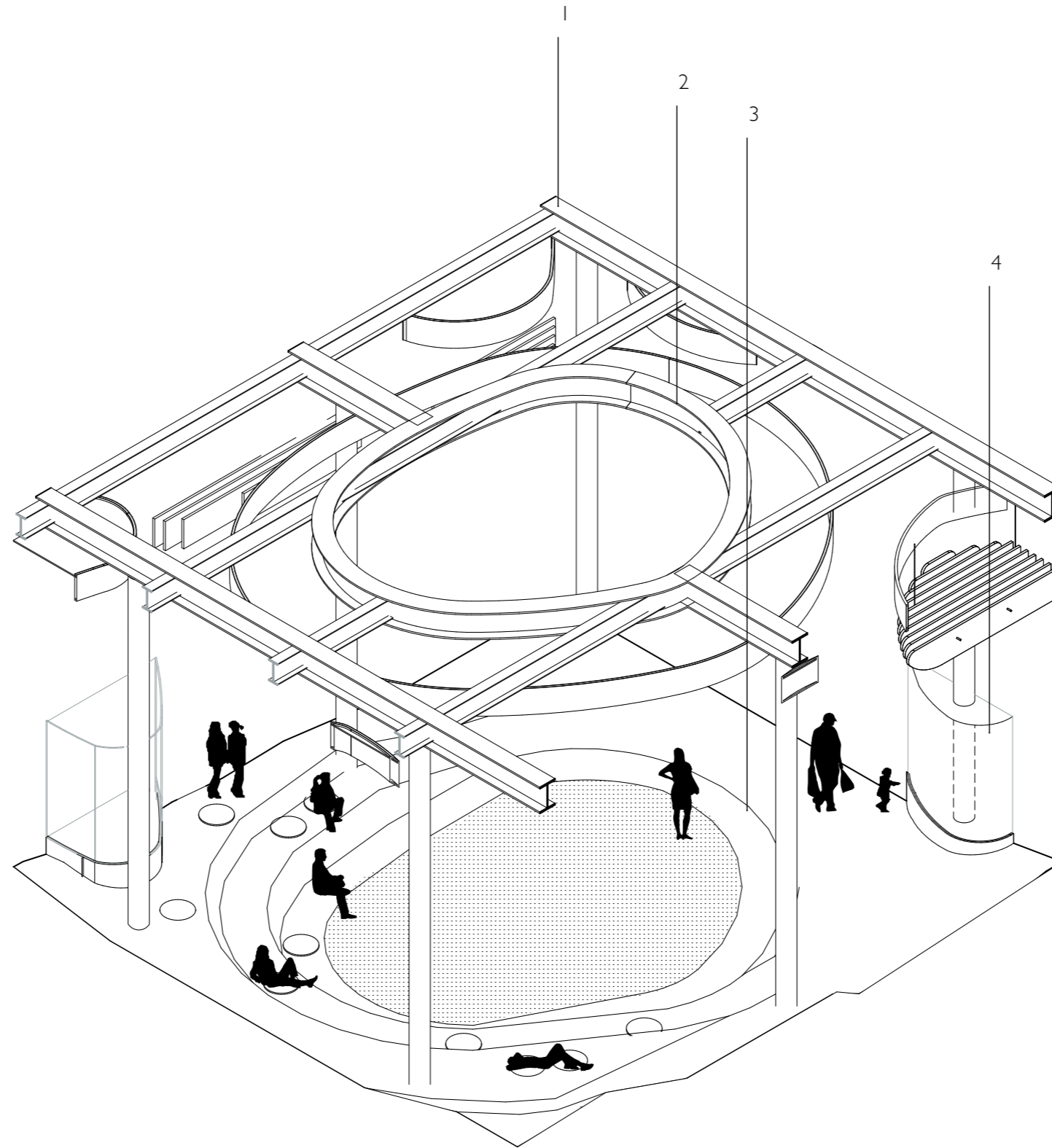

*3D impression of the tribune*



### 03 EXPOSE

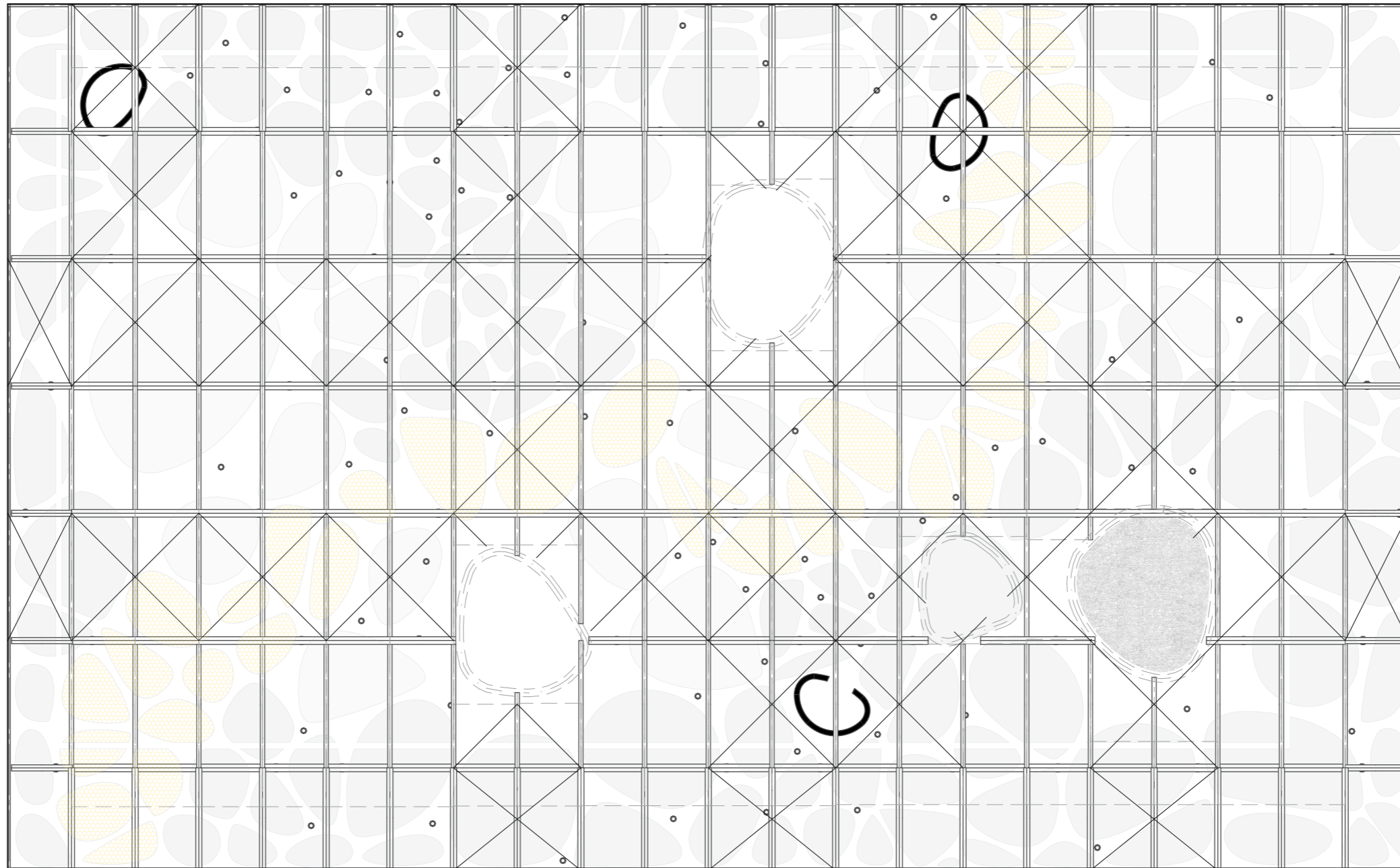

*Construction floorplan in combination with the Voronoi forms*

## 03 EXPOSE

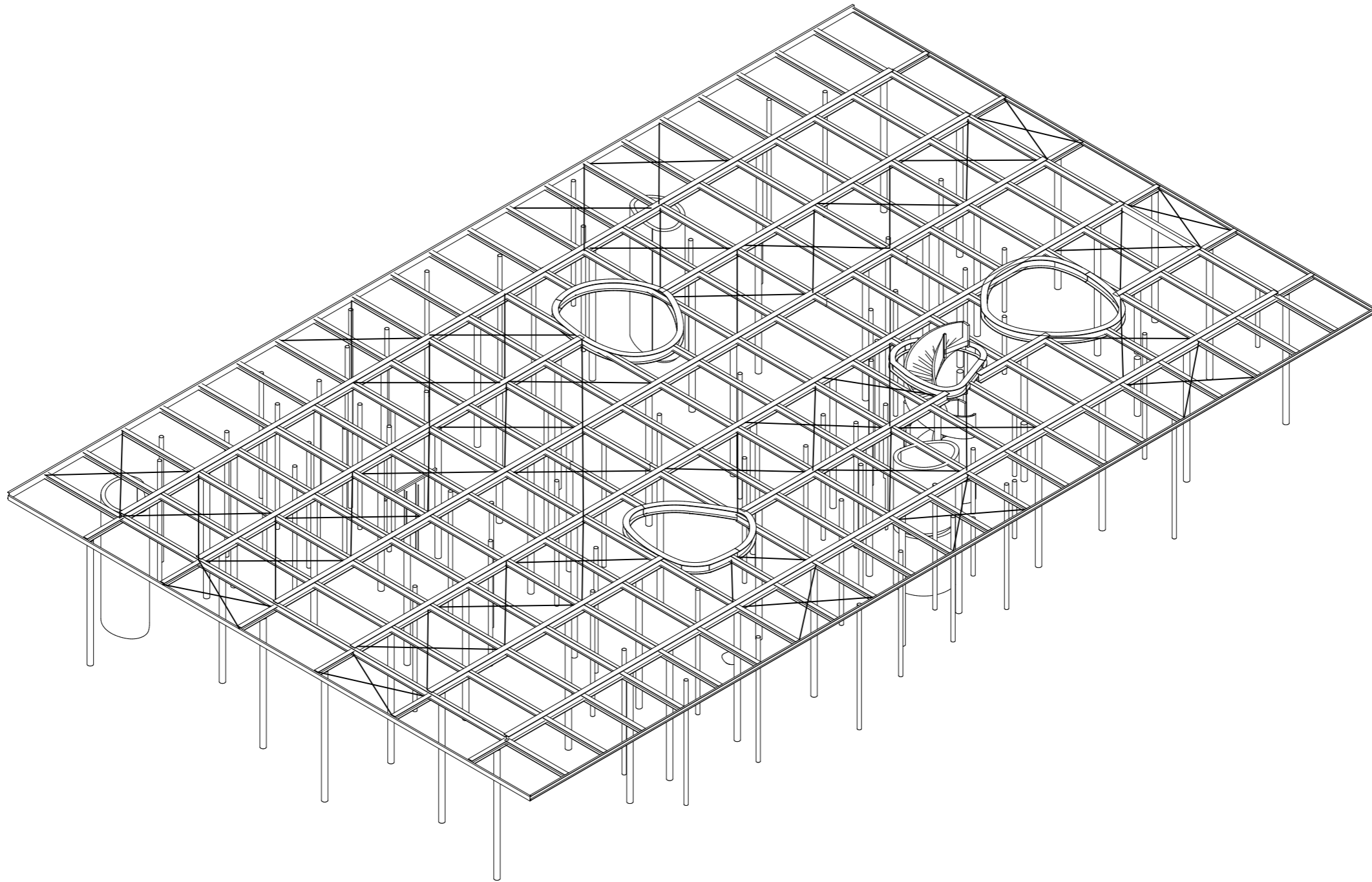

*Construction Axonometry*



# 03 EXPOSE

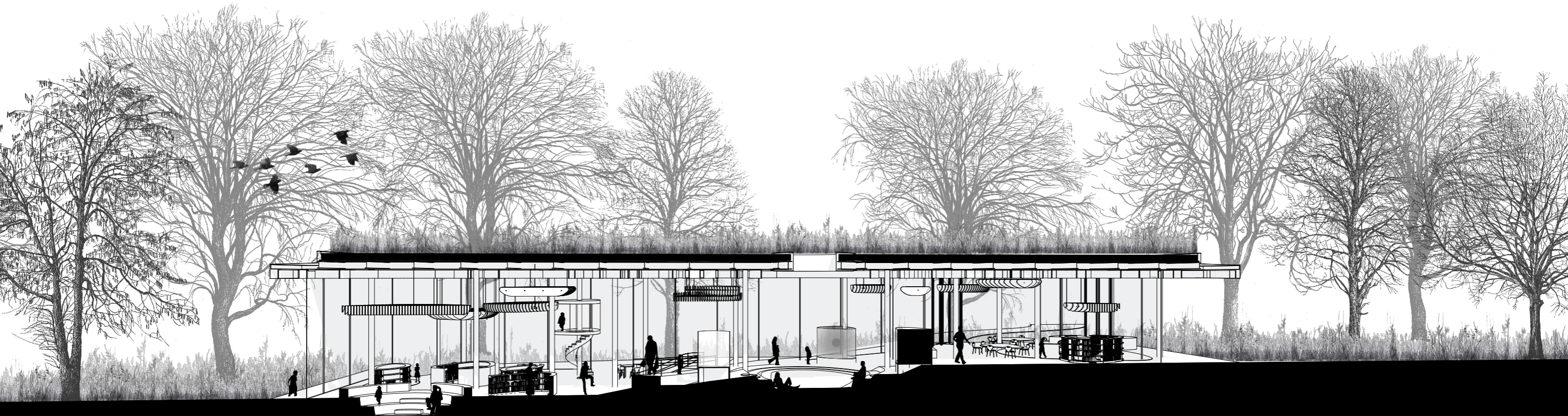



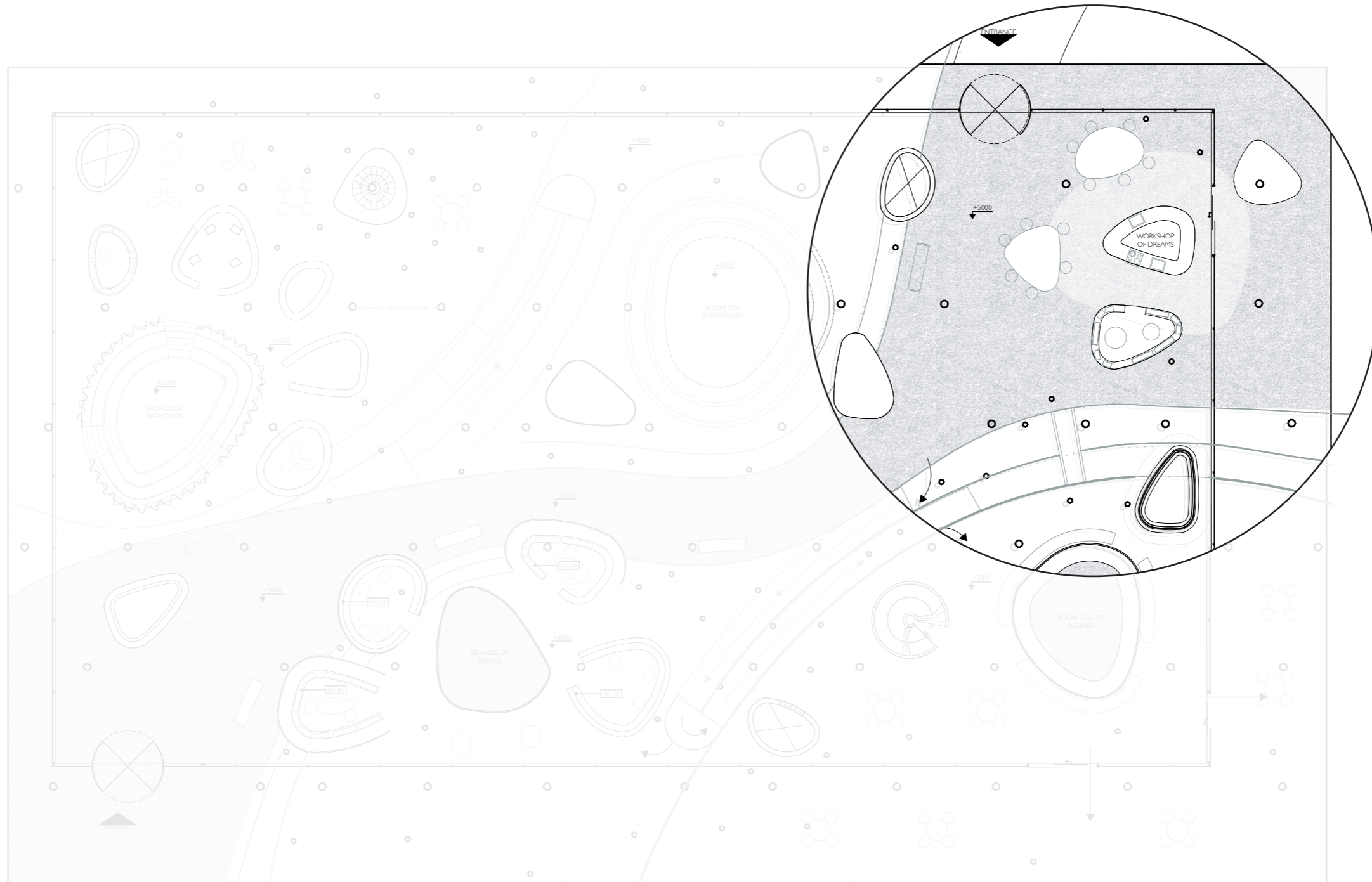



# 04 CREATE





## 04 CREATE

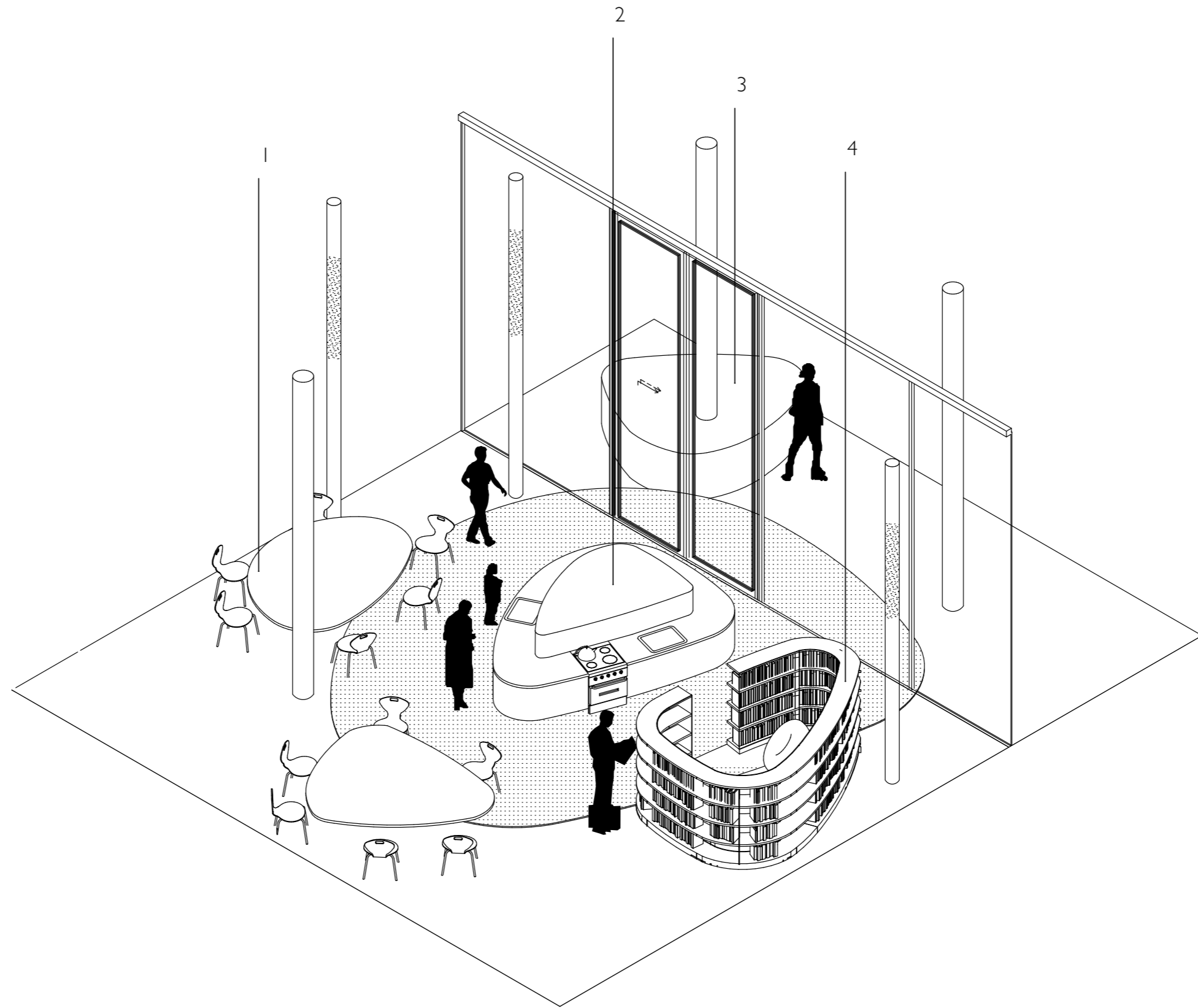

*3D impression of the workshop place*

**04 CREATE**

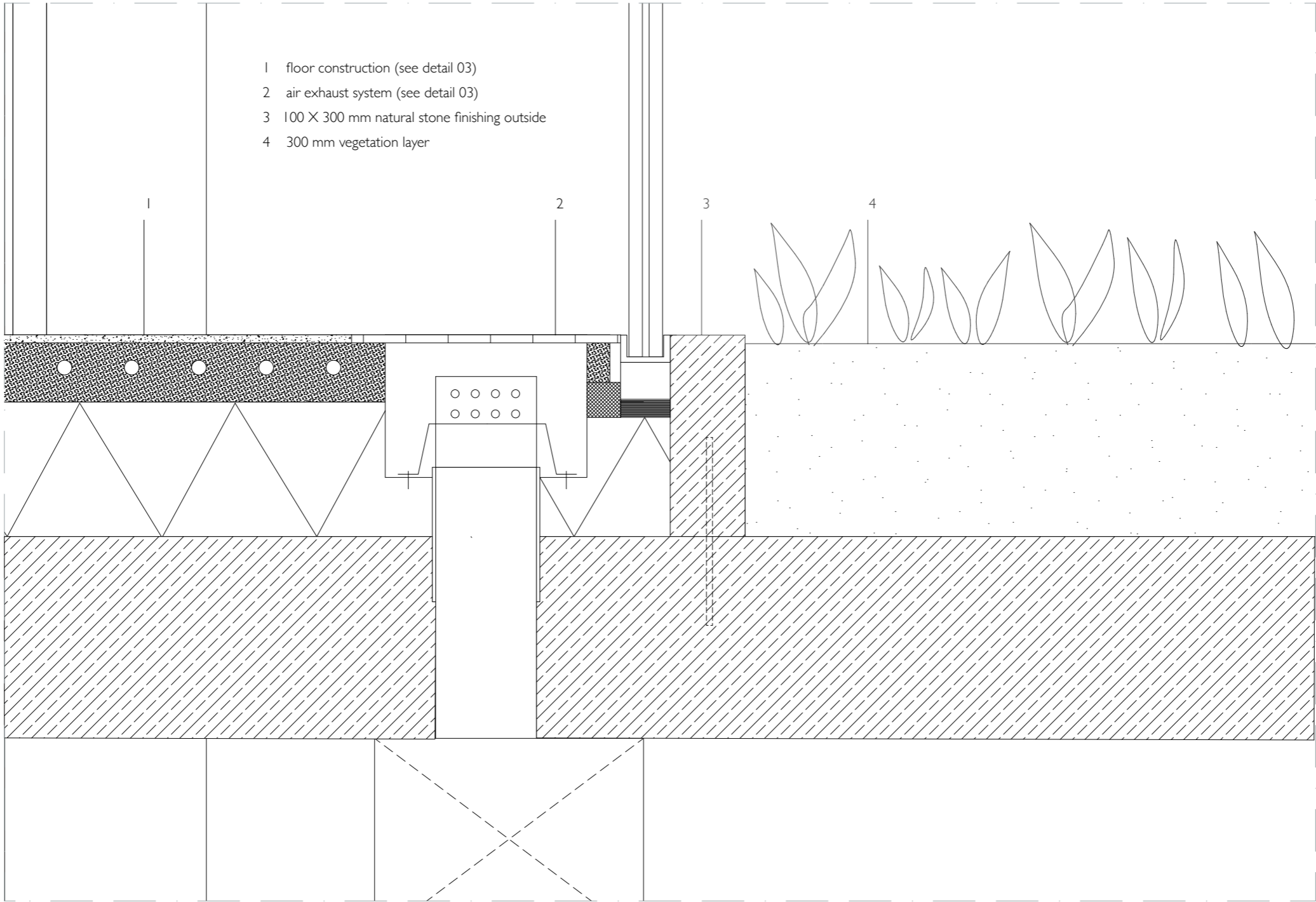

*Detail of the air exhaust filter*



## 04 CREATE

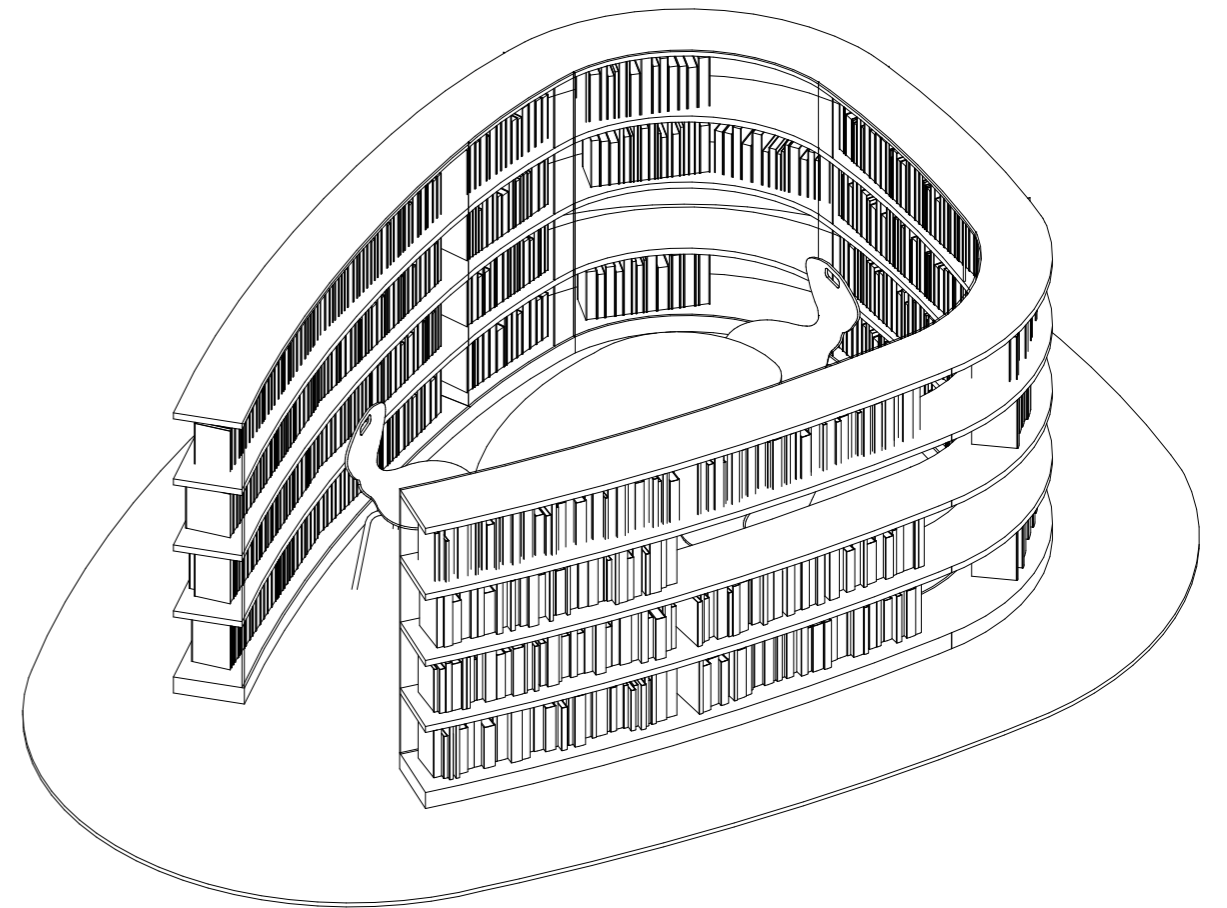
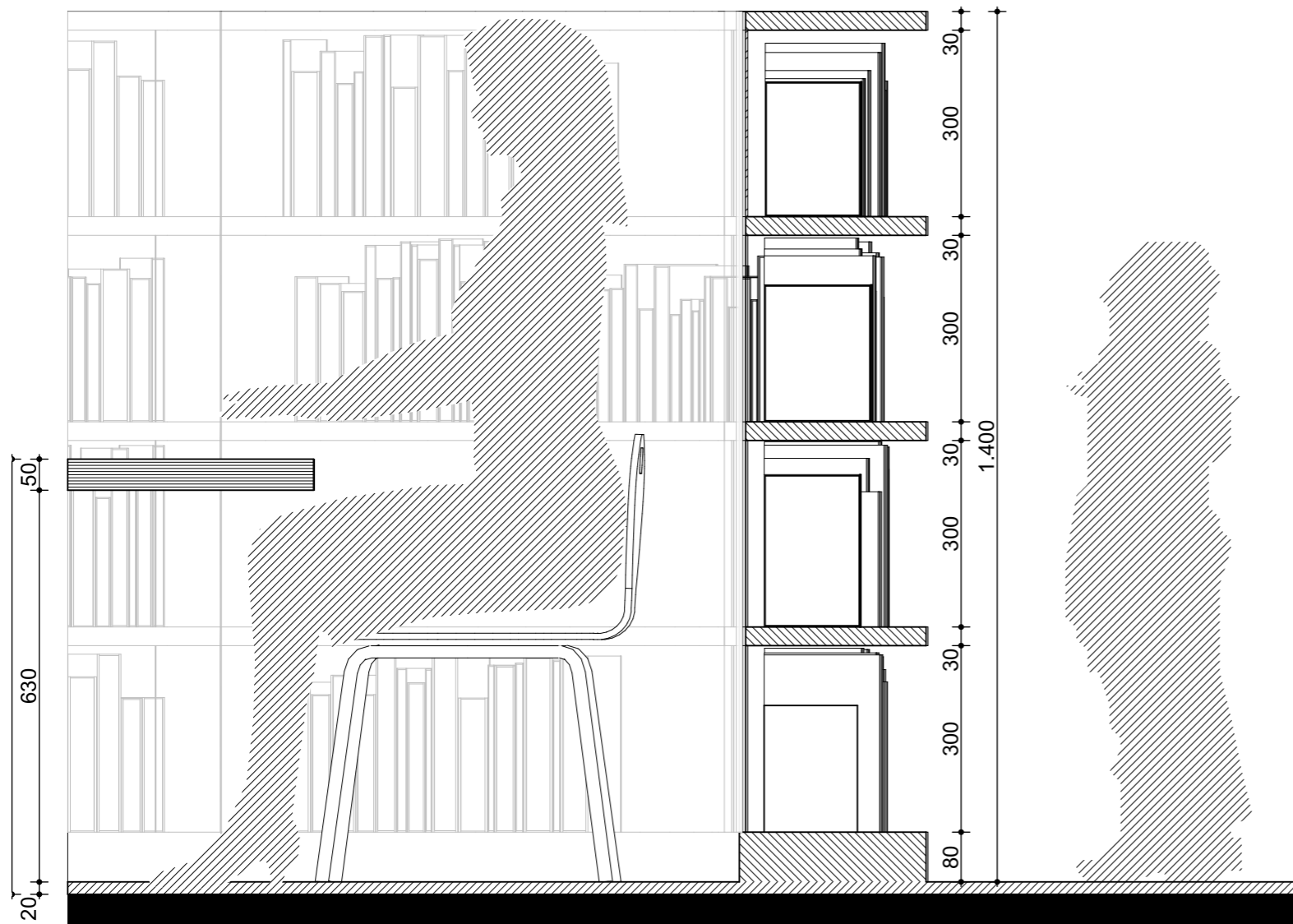

*Book shelf element*





# 05 FOCUS







# 05 FOCUS

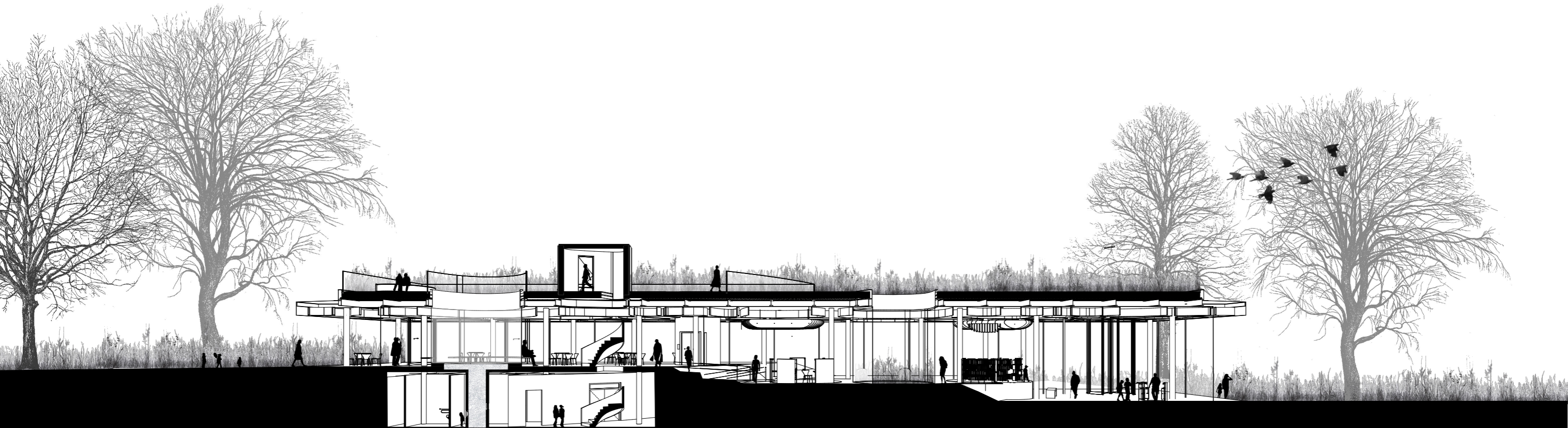

## 05 FOCUS

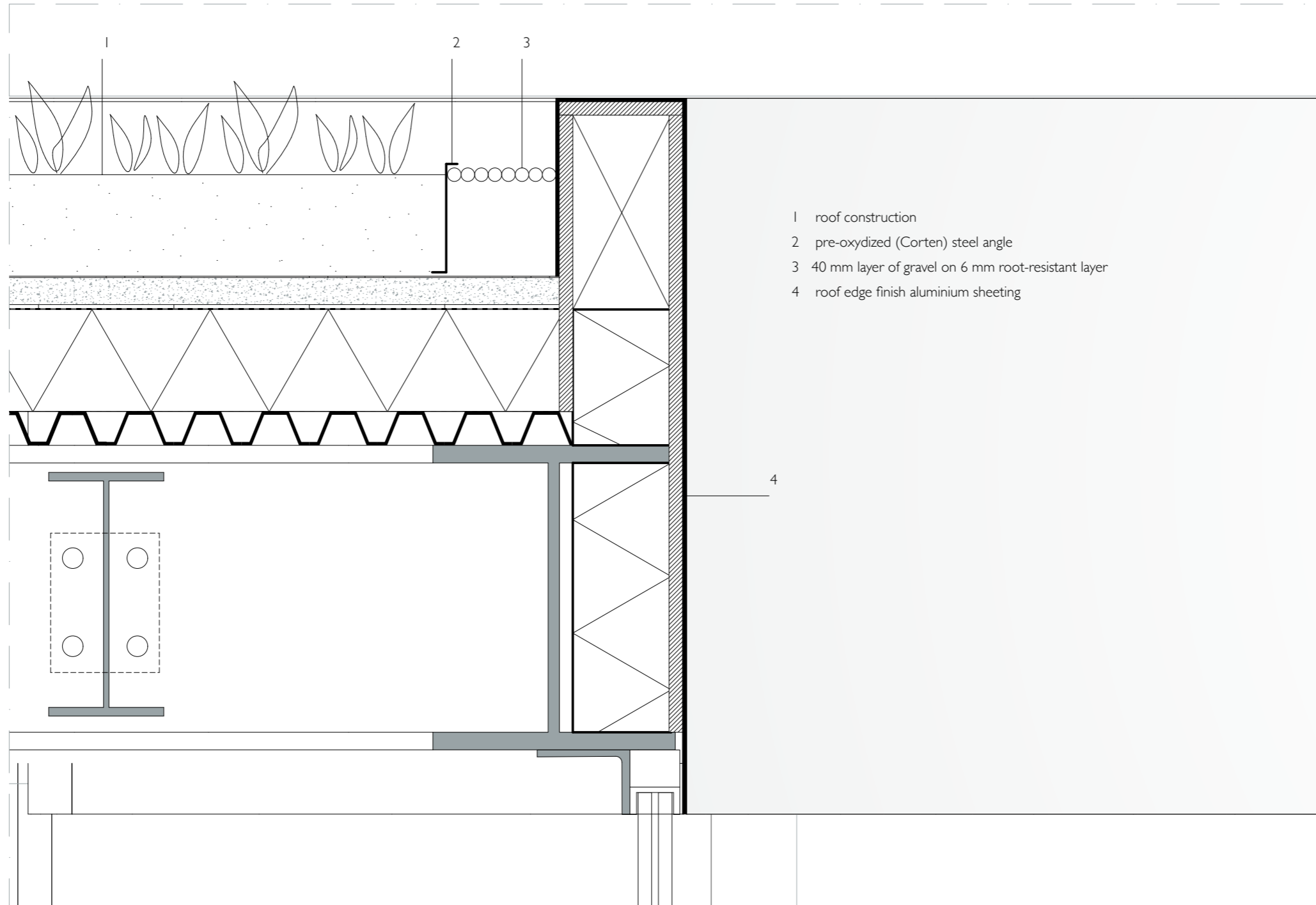

*Detail of the Roof - Impluvium*



# 05 FOCUS

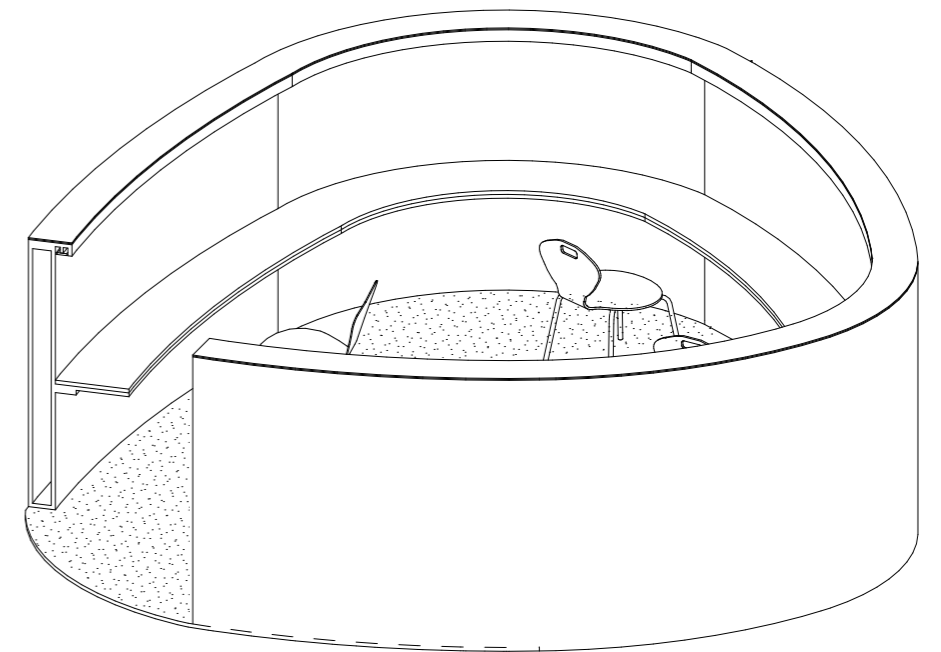
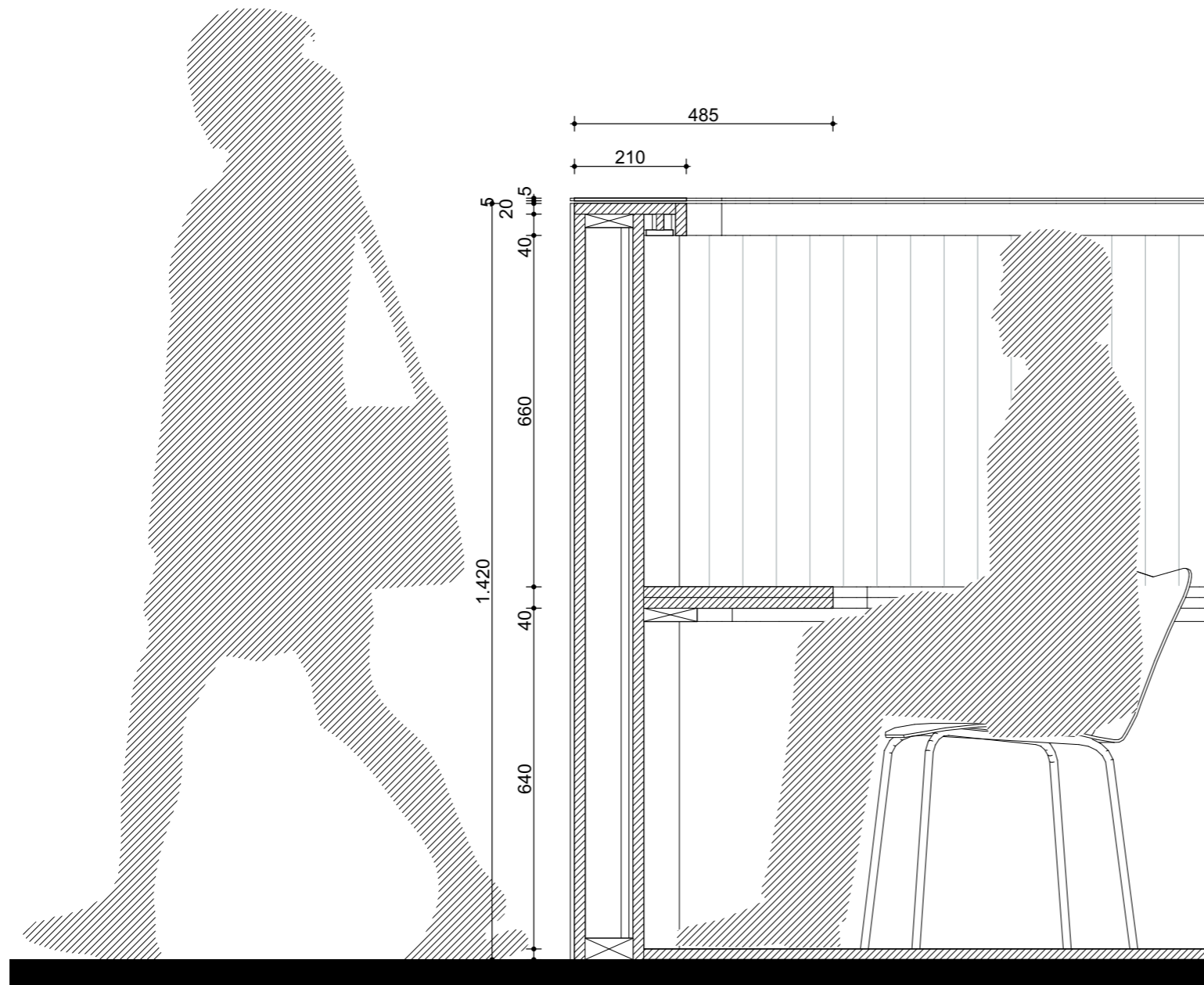

*The reading element*





# 06 CONNECT





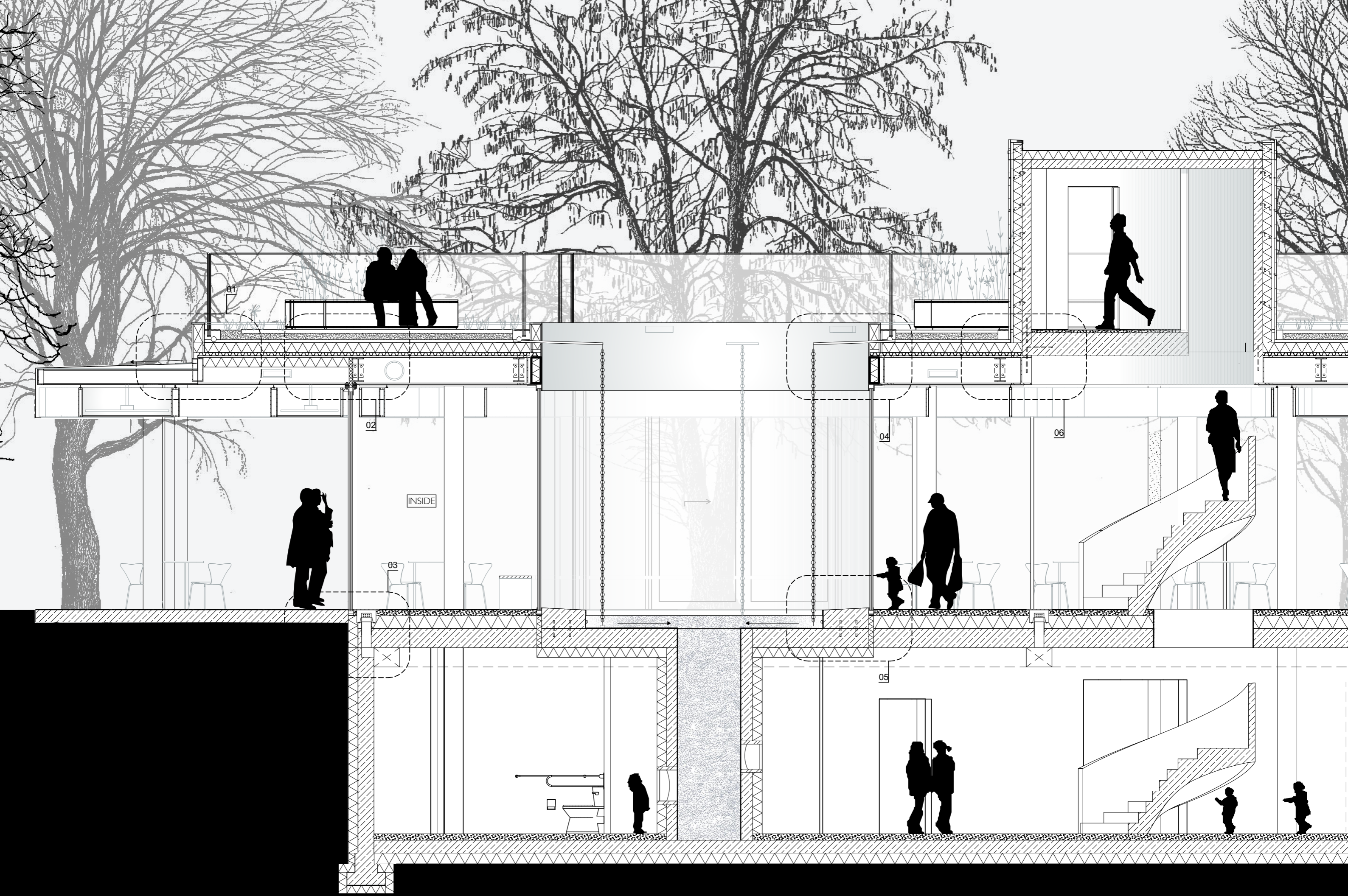



## 06 CONNECT

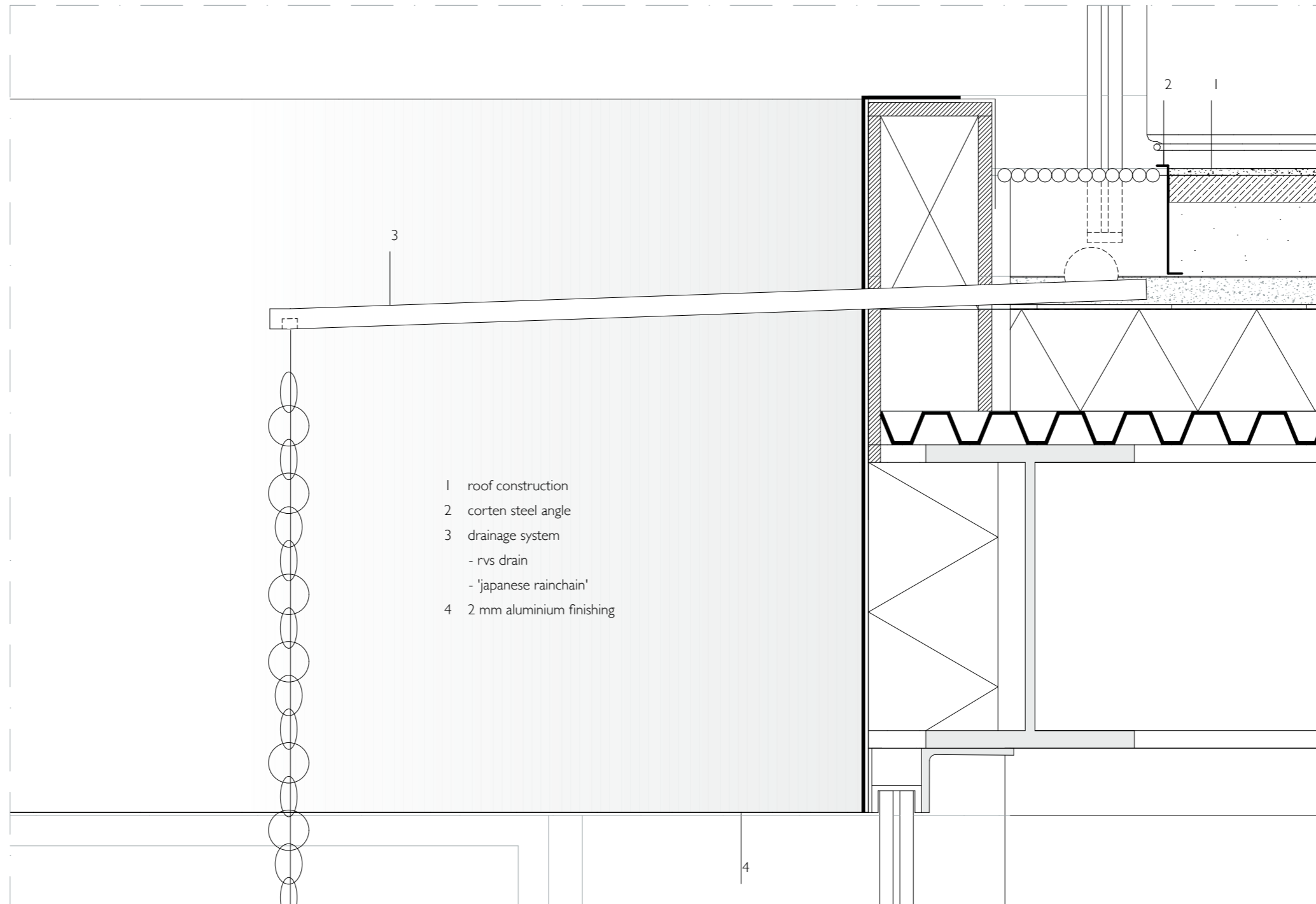

*Detail Japanese Rainchain*



## 06 CONNECT



*Impression Outside Model*

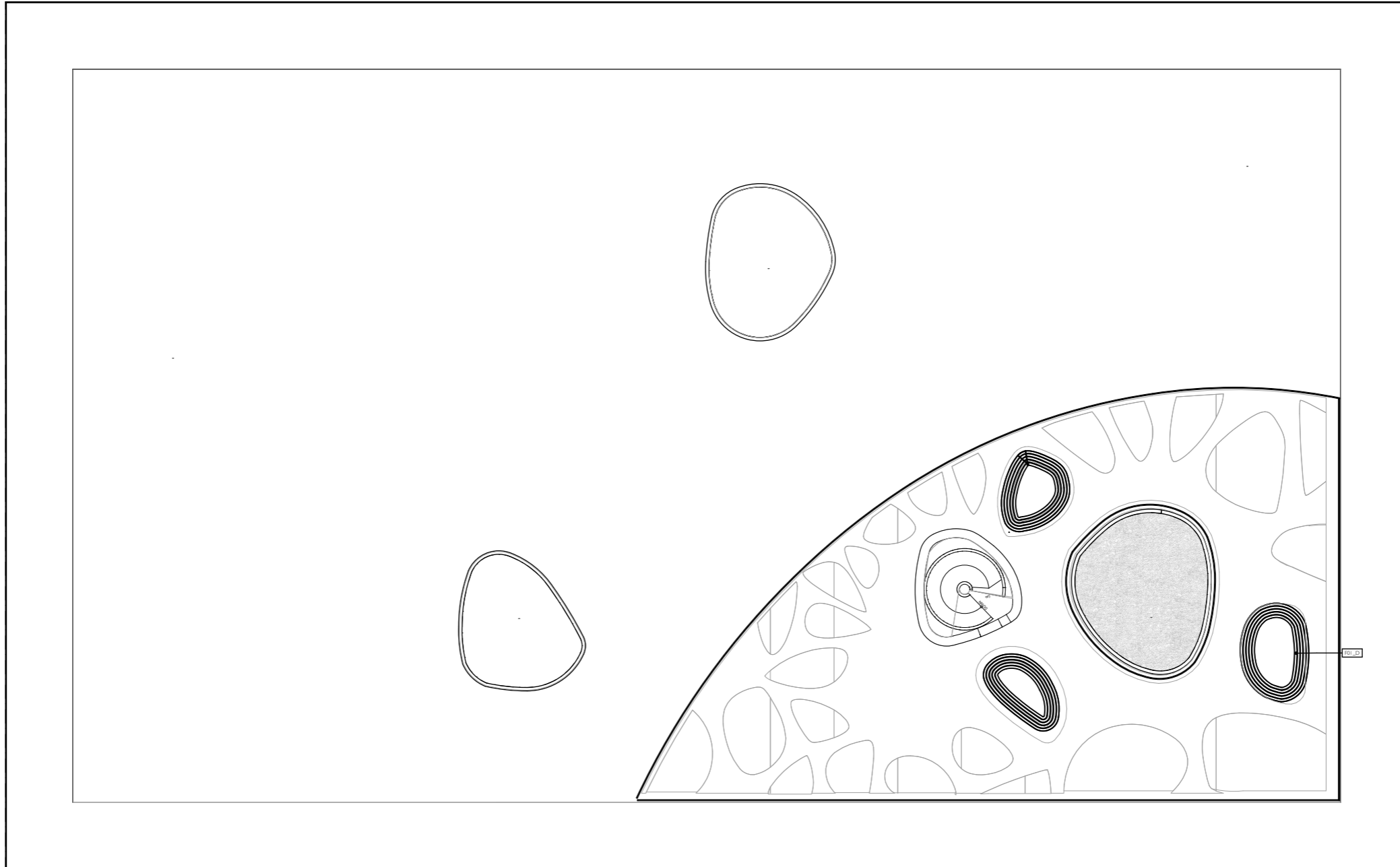



# 07 OVERVIEW





# 07 OVERVIEW

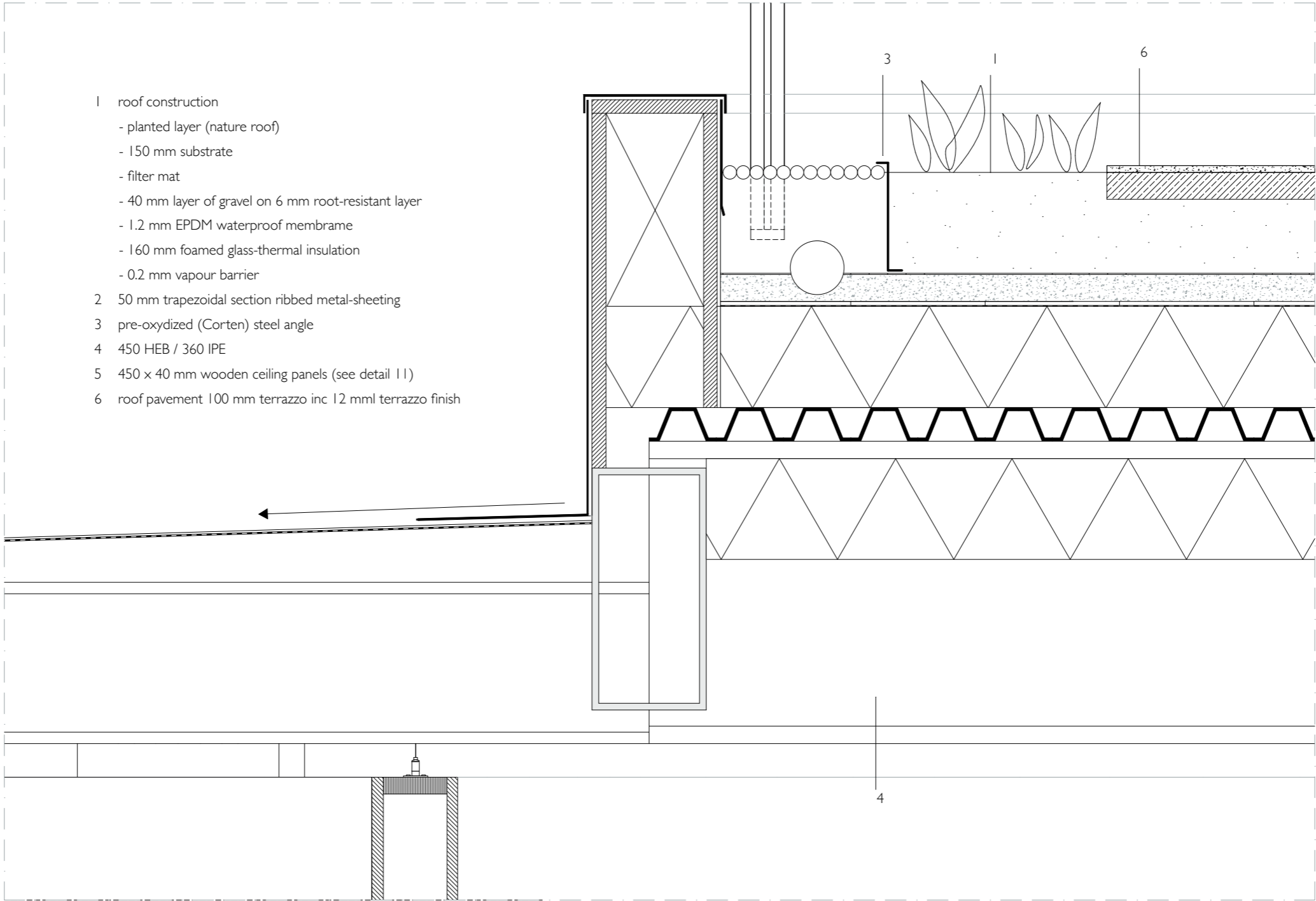

- 1 roof construction
  - planted layer (nature roof)
  - 150 mm substrate
  - filter mat
  - 40 mm layer of gravel on 6 mm root-resistant layer
  - 1.2 mm EPDM waterproof membrane
  - 160 mm foamed glass-thermal insulation
  - 0.2 mm vapour barrier
- 2 50 mm trapezoidal section ribbed metal-sheeting
- 3 pre-oxidized (Corten) steel angle
- 4 450 HEB / 360 IPE
- 5 450 x 40 mm wooden ceiling panels (see detail 11)
- 6 roof pavement 100 mm terrazzo inc 12 mml terrazzo finish

*Detail roof structure (U=0.10)*

**07 OVERVIEW**

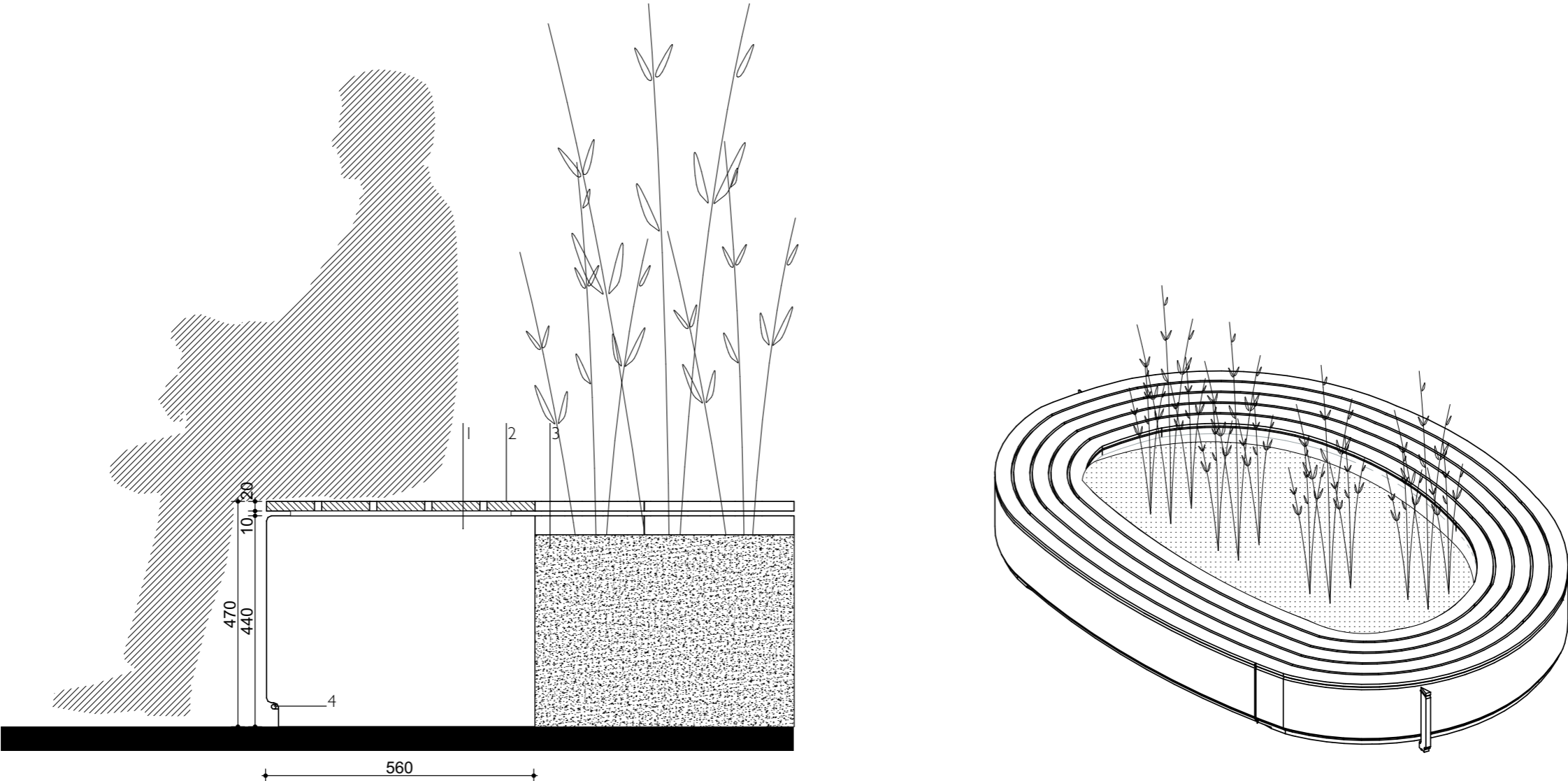

*The roof seating element*



**FUTURE?**

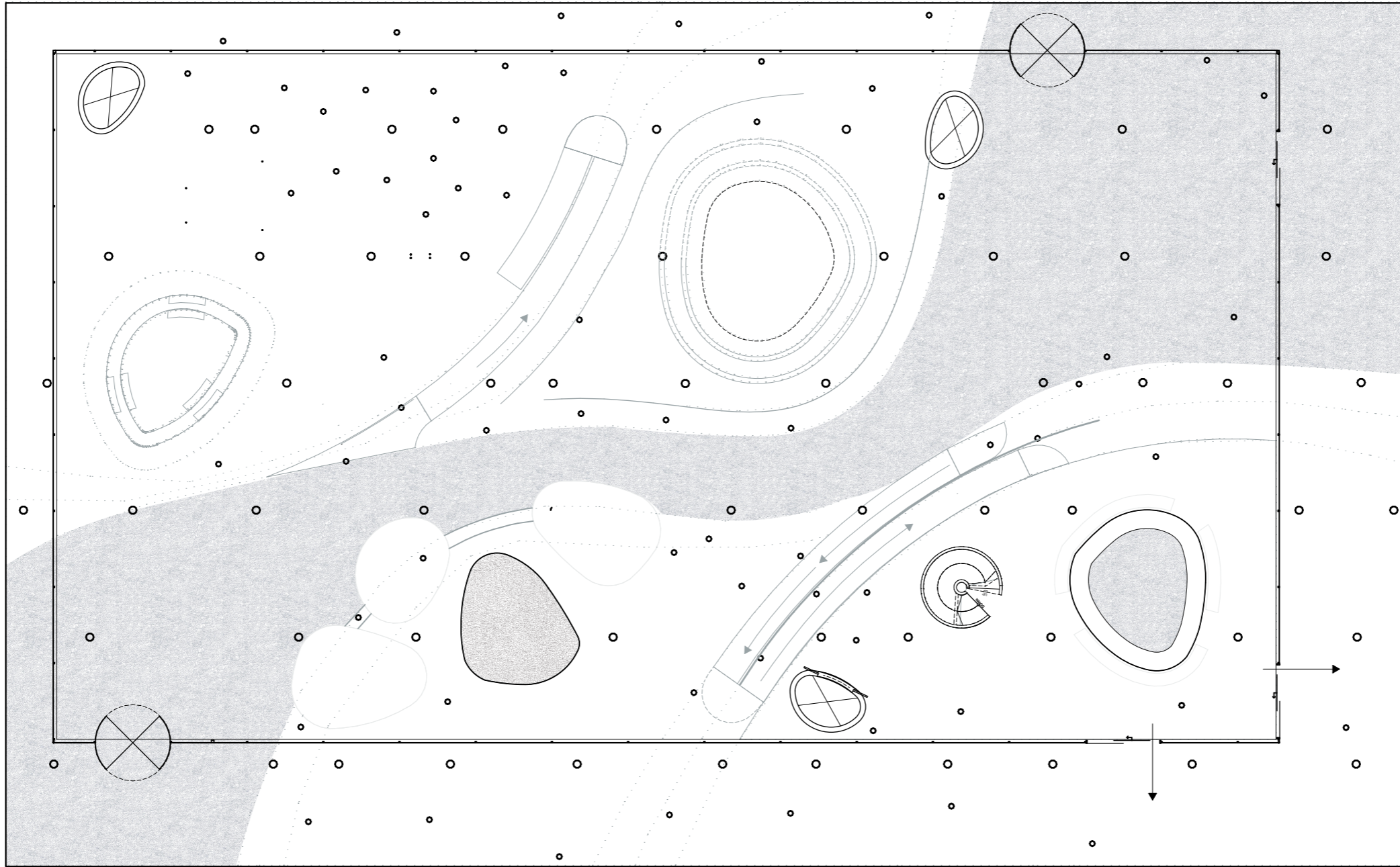

*Flexibility*



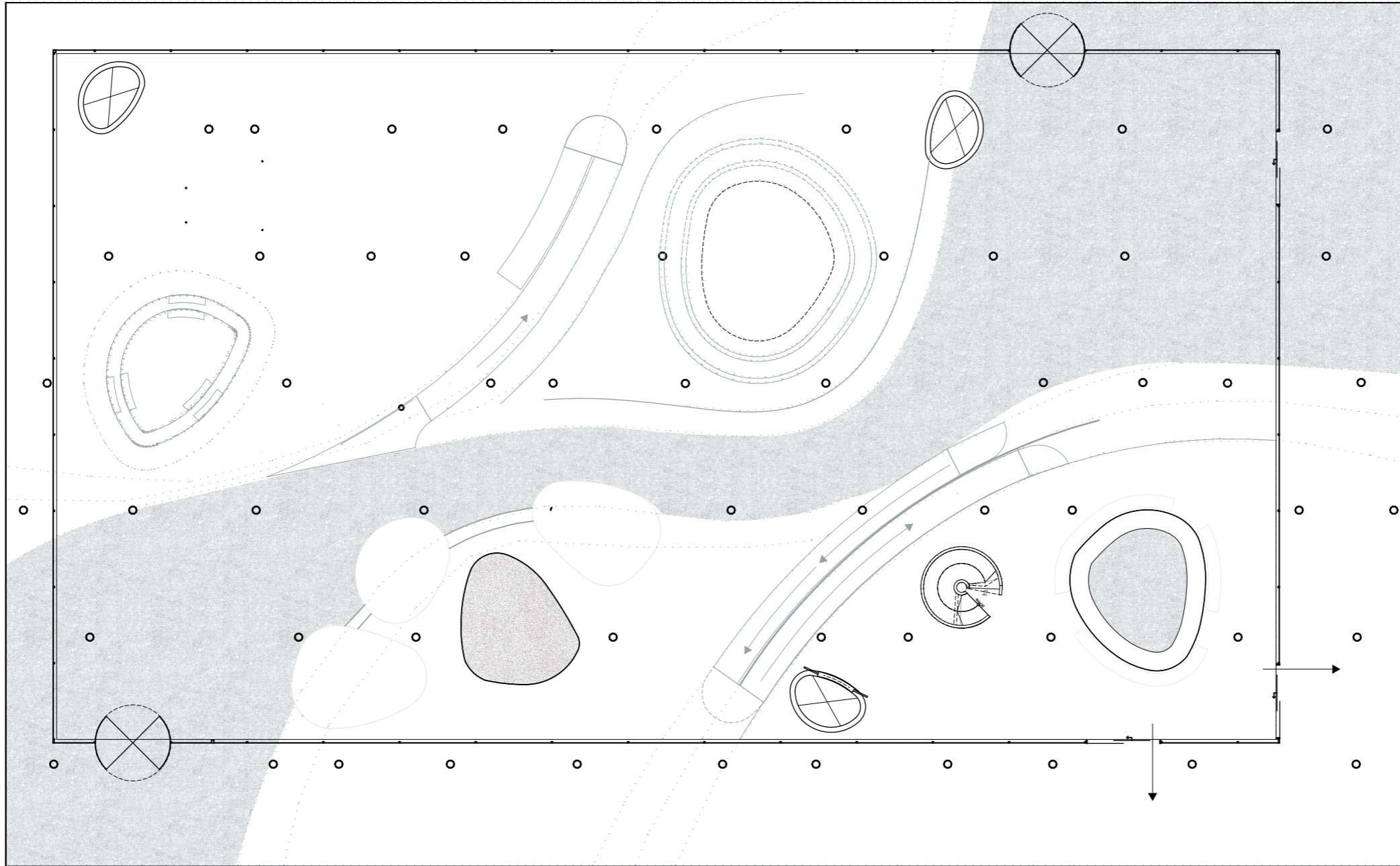

*Flexibility*

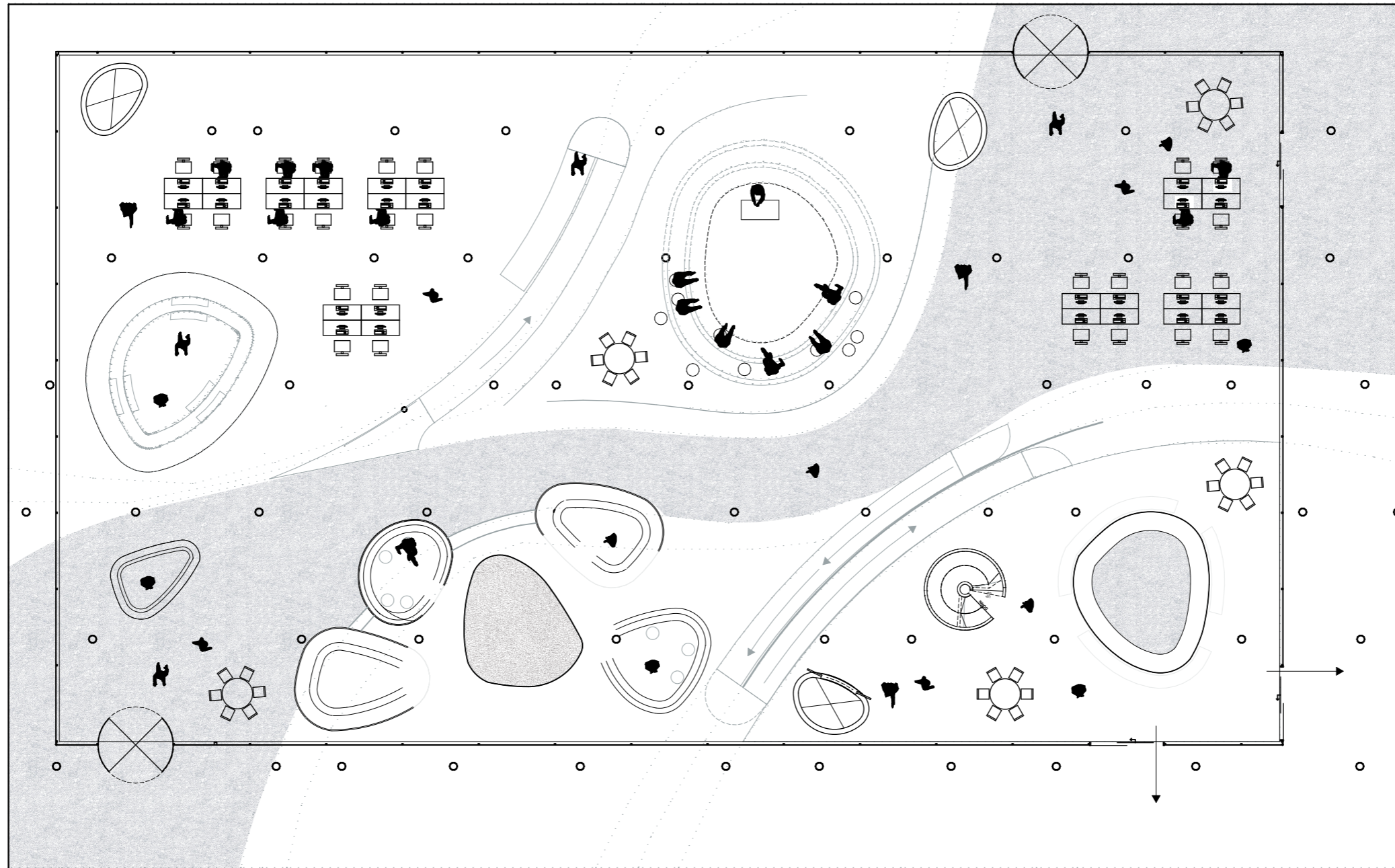

*An Office*



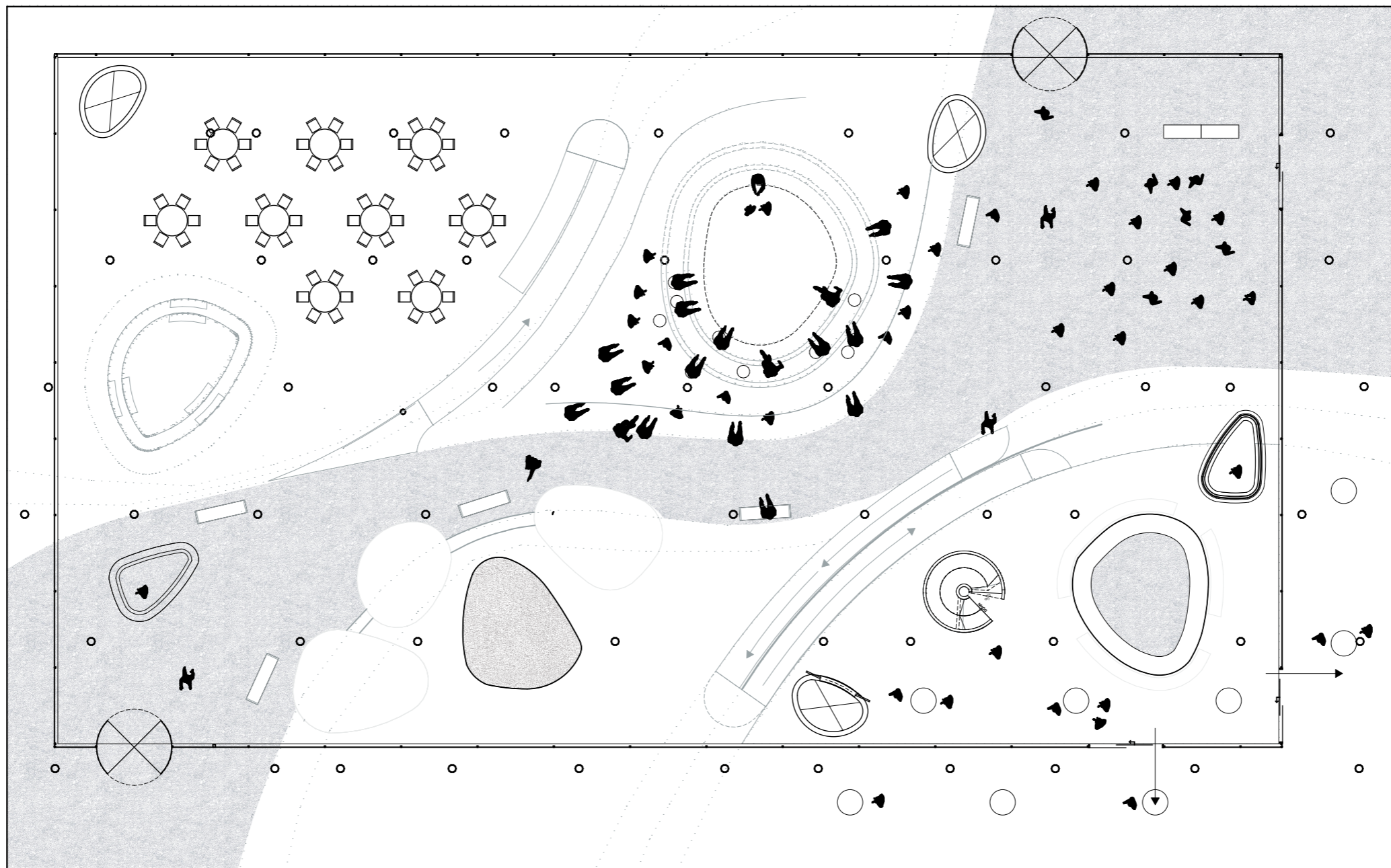

*An Event Center*

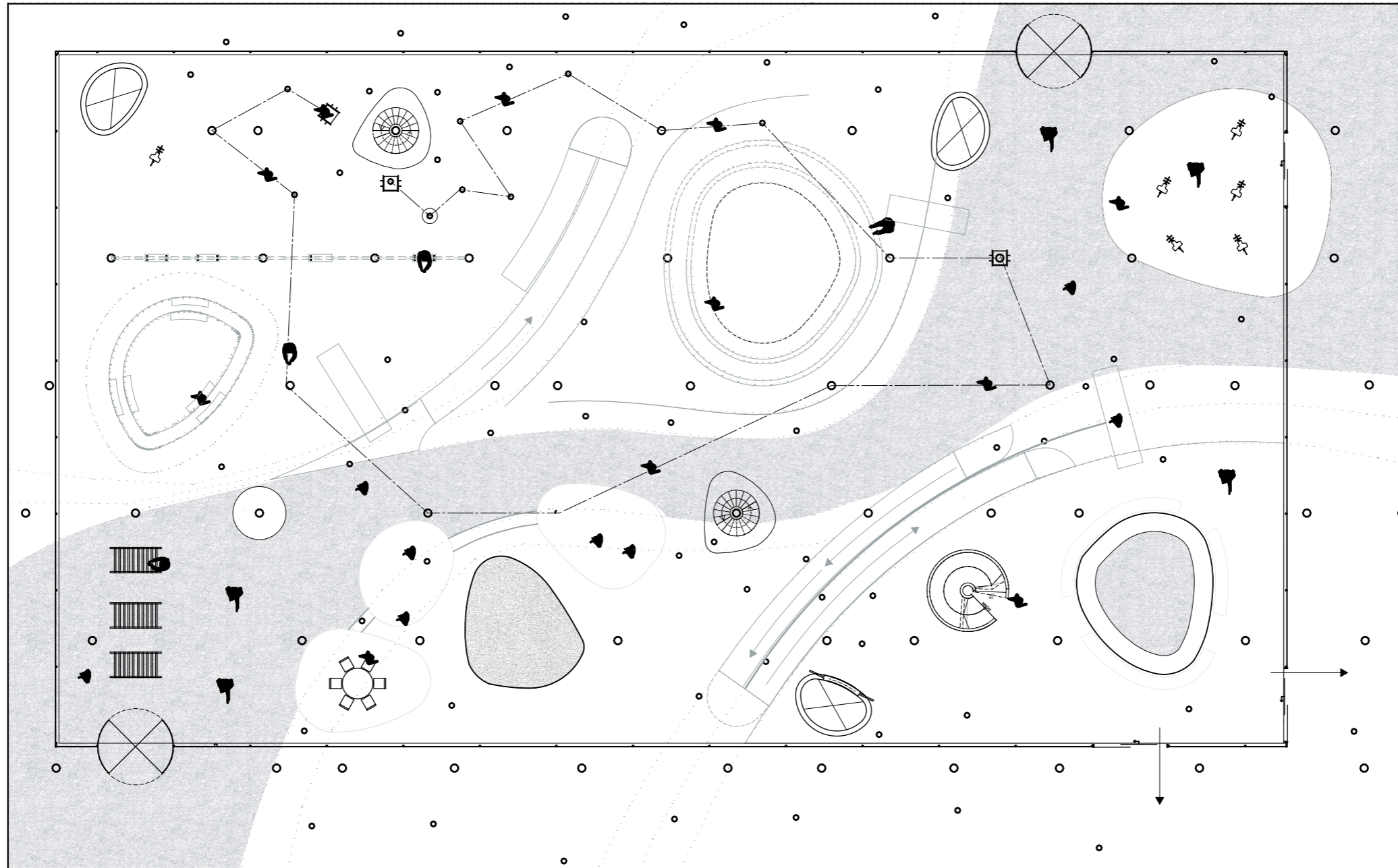

*A Playground for Children*









*01 The Underworld: Foundation & Installation*



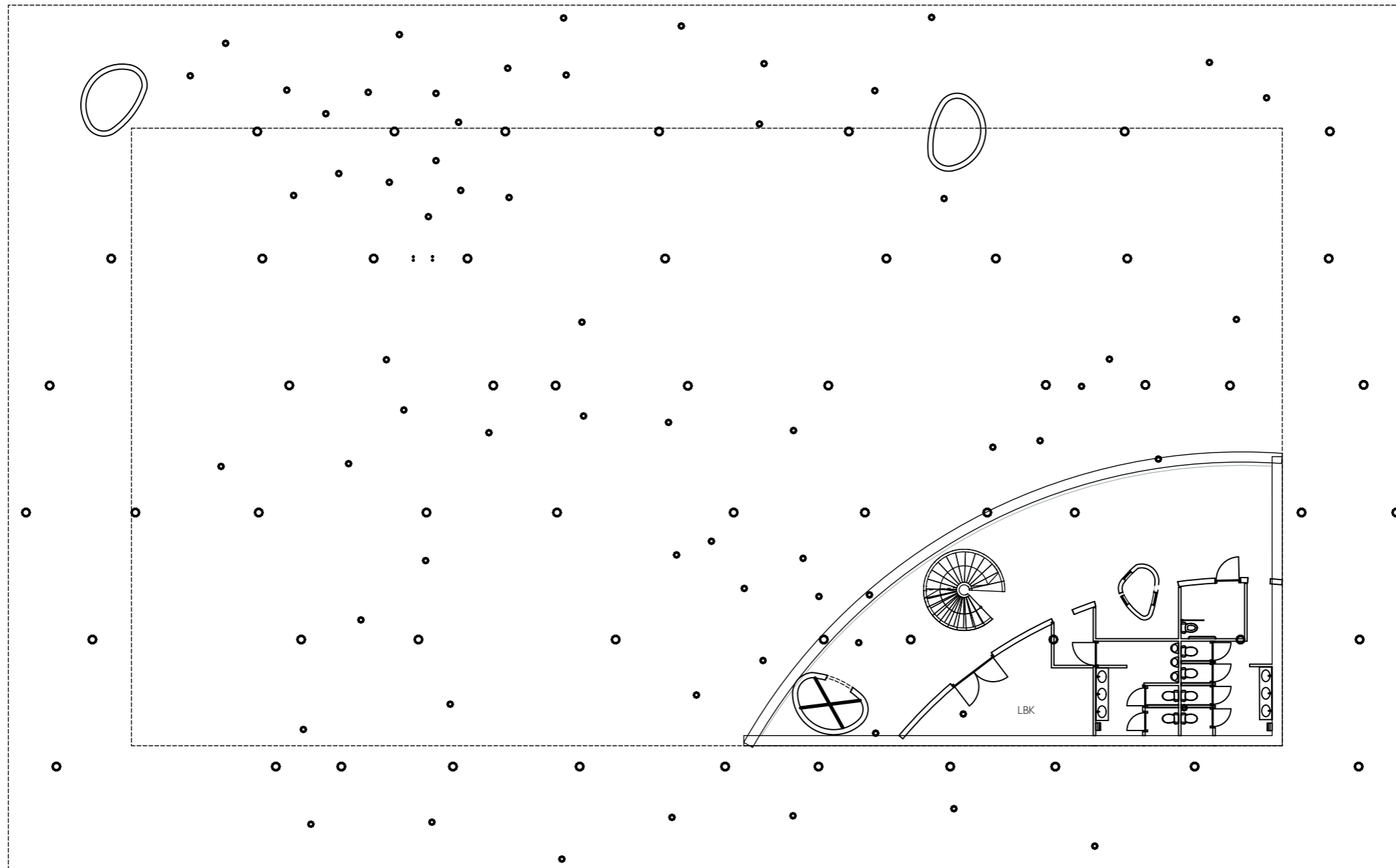

*02 The Soil: Morphology & Diffusion*

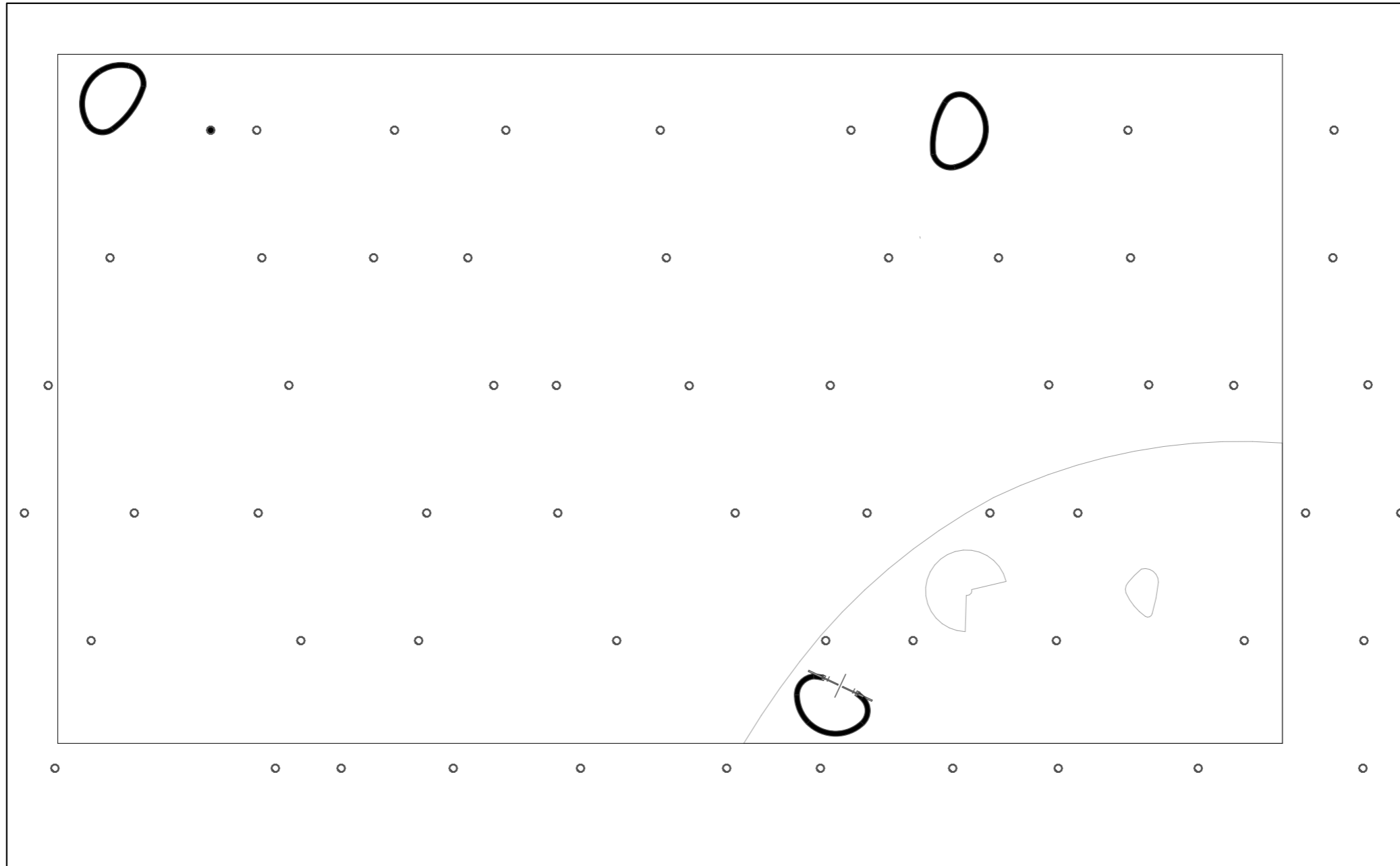

*03 The Tree Trunks: Structure & Transportation*



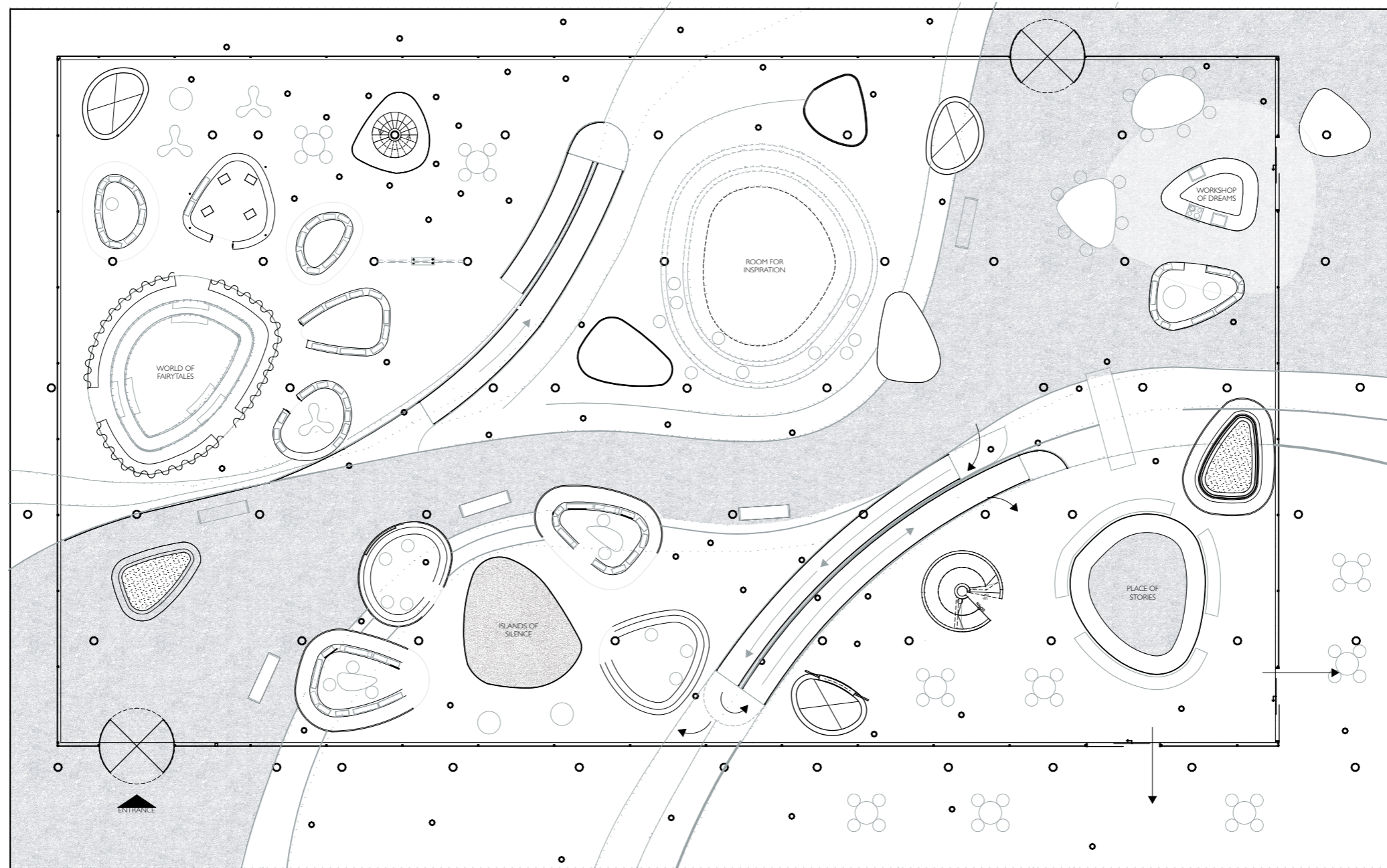

*04 The Open Space: Function & Division*

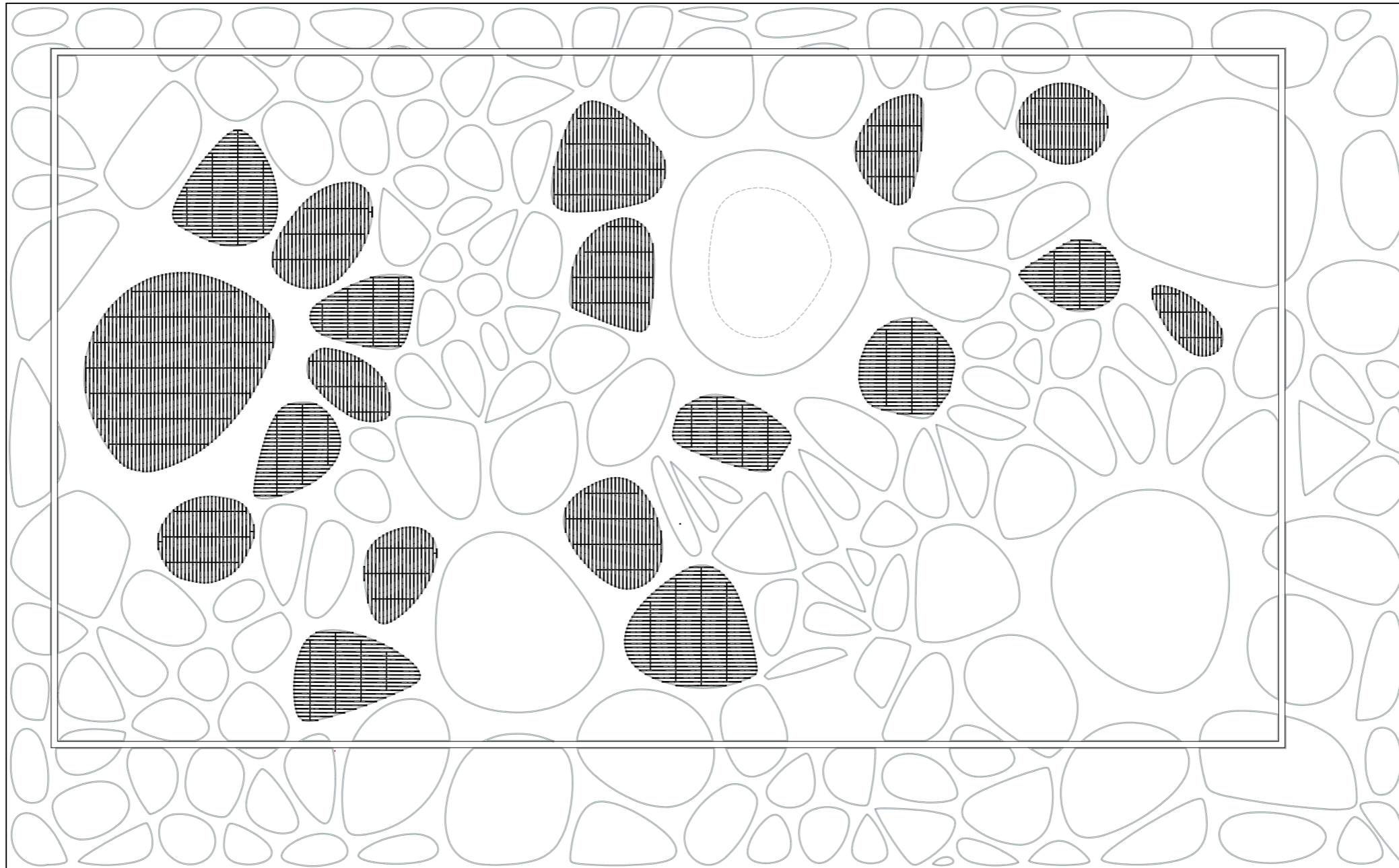

*05 The Leaves: Orientation & Light*



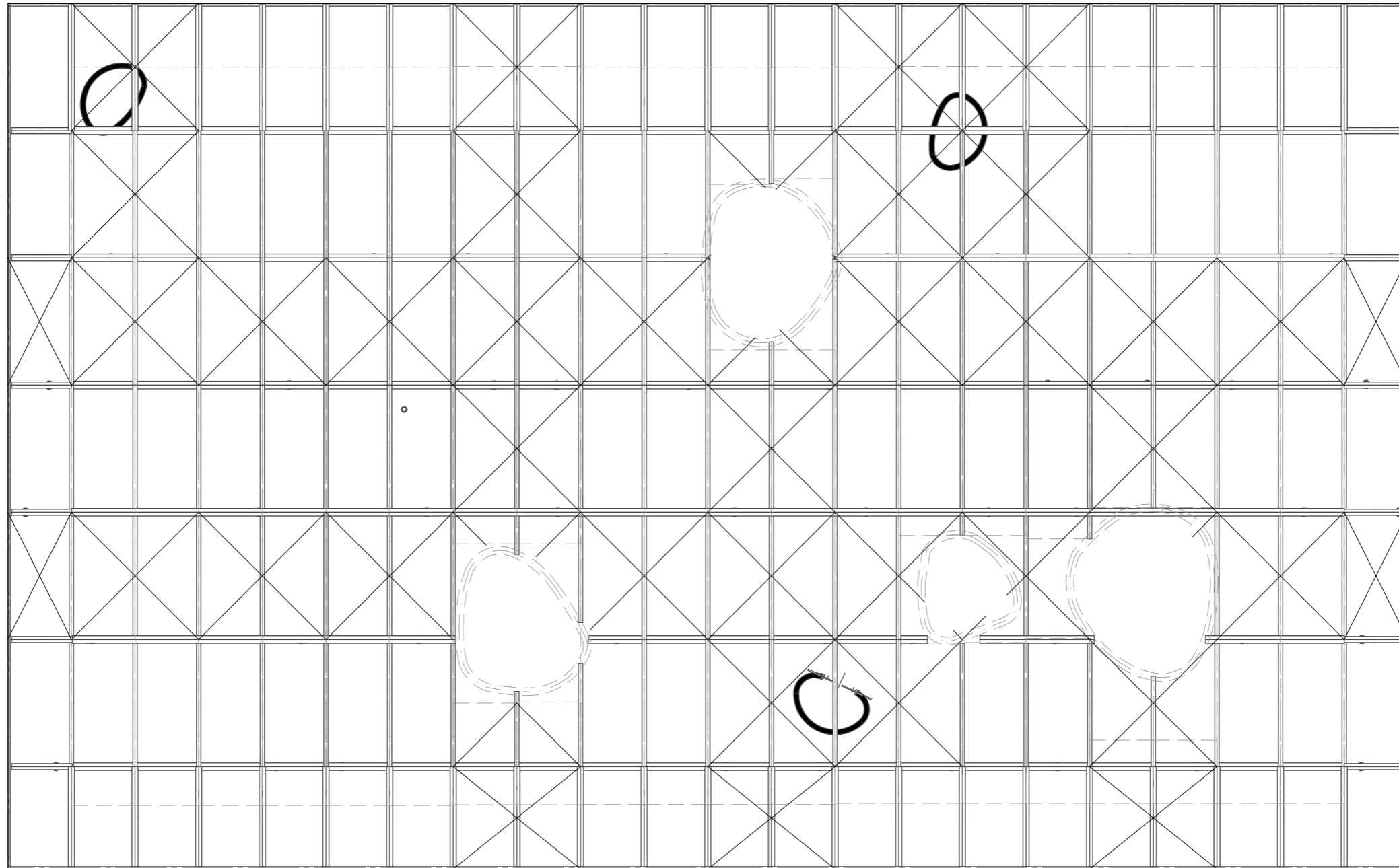

*06 The Branches: Construction & Installation*

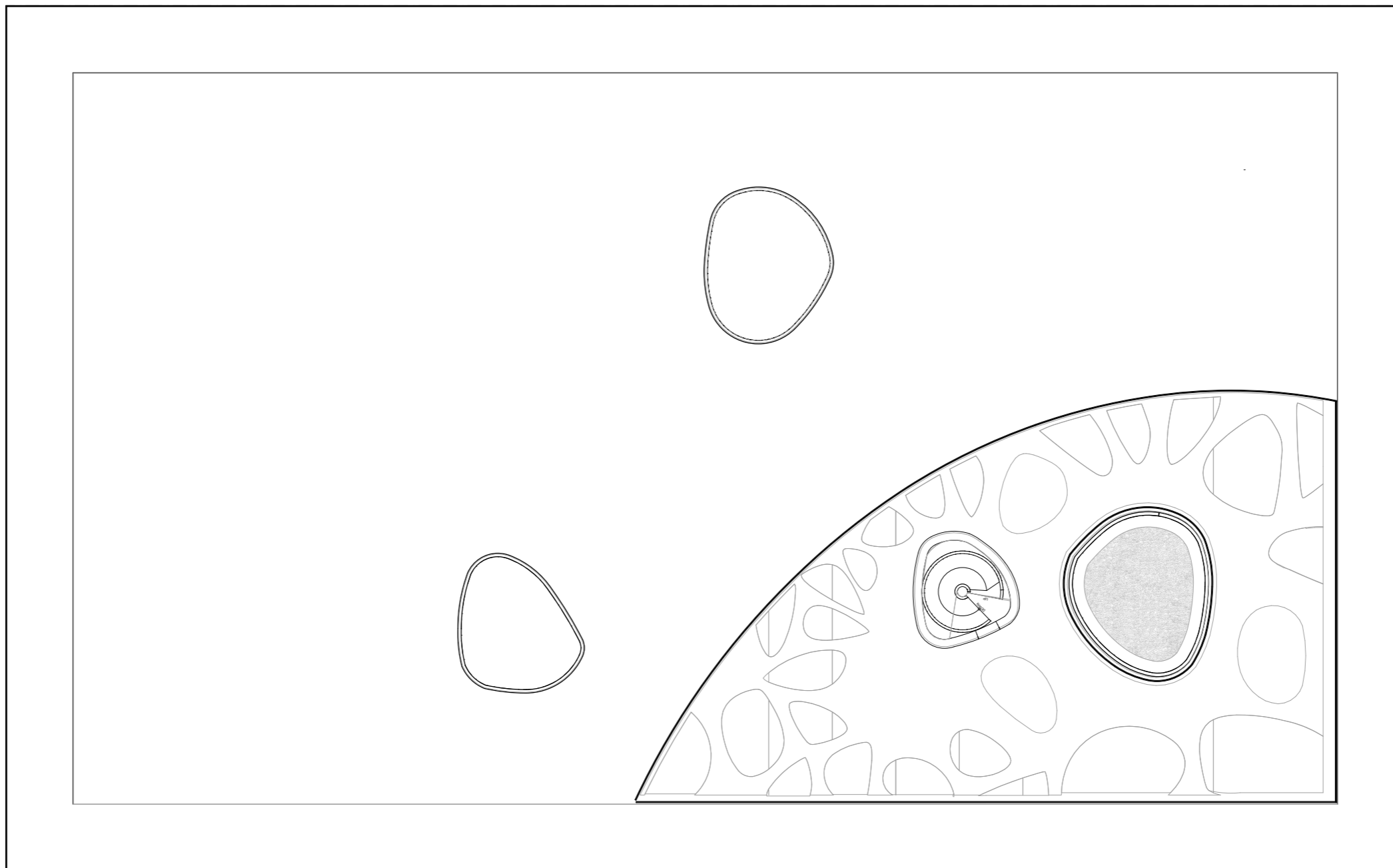

*The Panorama: Protection & Collection*



