

Research question

How can *desire* (both individual and collective) as expressed in the current form of entertainment park help in re-evaluating the *value* of *play*?

Problems

1. Consumption oriented entertainment
2. Enclosed, fixed environment
3. Scripted and repetitive behaviour
4. Invariable experience
5. Subjects are absent and reactive
6. Privileging individual over collective
7. Objects are not completely fixed
8. Bodies in various positions
9. Memory of the day
10. Machinic

Sub-questions

- How is the site organized?
What is the site doing?
What are the potentials of the site?
- Why one wants to be absent and reactive?
Why one has the desire to suppress oneself?
What are the forces that are imposing the rules?
- Where and when in the entertainment park you suppress yourself?
What is the main element that makes entertainment park?

Method

- = island - layers - field
- = park - game - rules
- = ride - element - constraint

Method

Conclusions

What if?

Design questions

island - layers - field

1. Architecture **captures and control the flows**
2. Territories are formed in encounter of different forces
3. Forces overflow the territories

... we follow the flows instead of controlling them?
... territories shift?
... forces of one territory overflow to another?

How to intuit the following of flows and break them accordingly in order to produce the potentials?

park - game - rules

1. Architecture is a **rule giver and a referee**
2. Rules create habits and rituals
3. Subjects suppress themselves because of the desires

... there are no rules?
... the rules are shifted?
... door, fence, walls are removed?

How to create architecture where subjects generate their own rules depending on their own activity and complying to them?

ride - element - constraint

1. Architecture is a **producer of constraints**
2. Constraint affords experience
3. Constraint can lead to production and / or consumption

... this experience is introduced somewhere else?
... the shape is translated into something else?

How can a constraint connect production and consumption of the subject that undergoes it?

Design questions

How to intuit the following of flows and break them accordingly in order to produce the potentials?

How to create architecture where subjects generate their own rules depending on their own activity and complying to them?

How can a constraint connect production and consumption of the subject that undergoes it?

Purpose

different reality

new subjectivity

play

Proposal

performative architecture

event

deviant objects

Theory

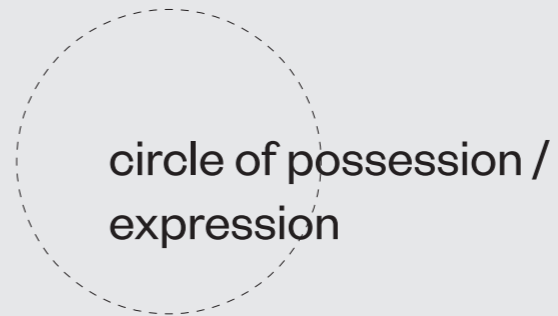

line of light

●
point of stability



Design

membrane / skin

movement

markers

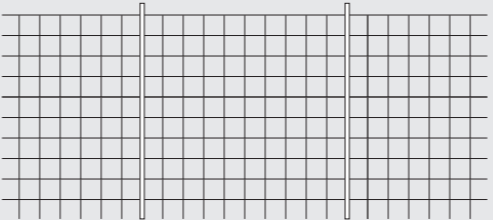
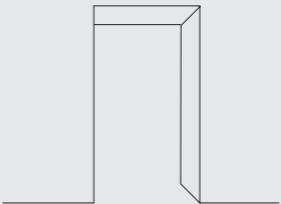
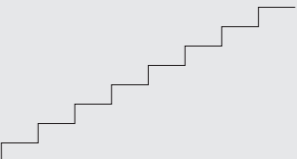
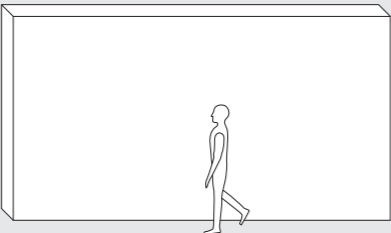
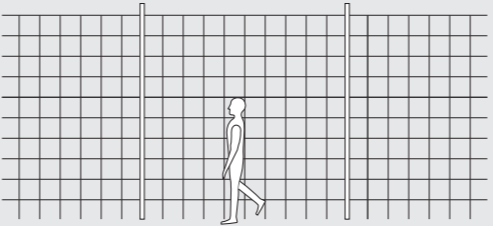
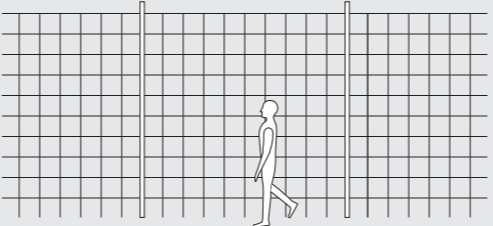
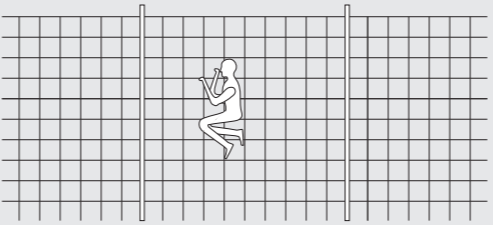
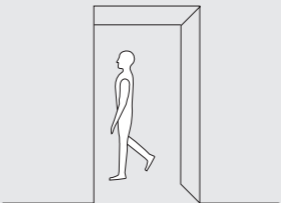
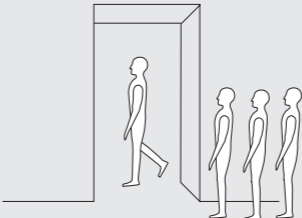
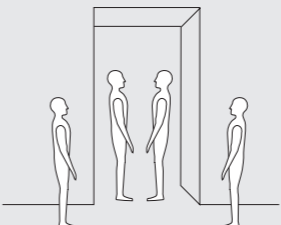
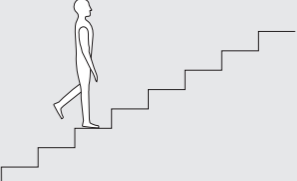
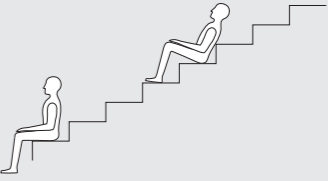
Elements

	wall	fence	entrance	stairs
elements				
habits		  	  	  

Rides

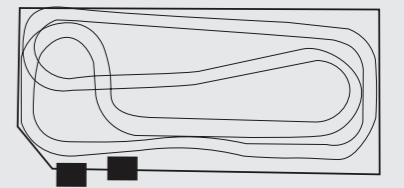
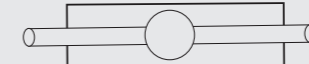
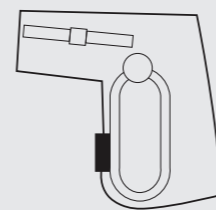
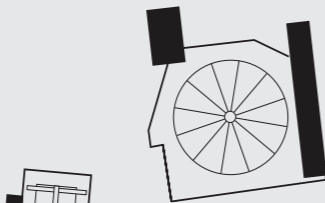
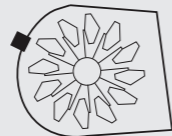
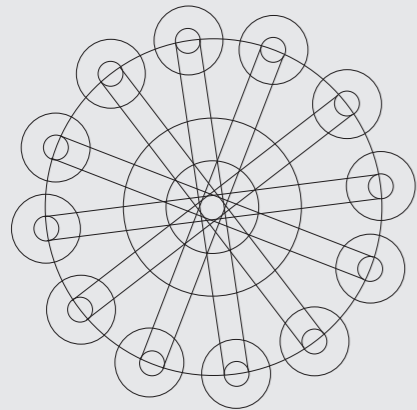
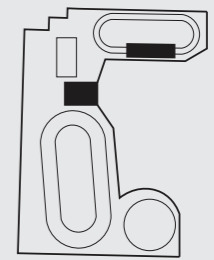
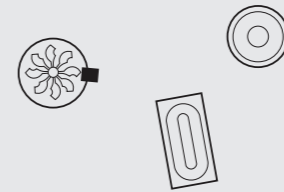
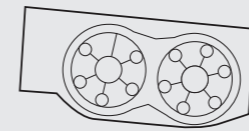
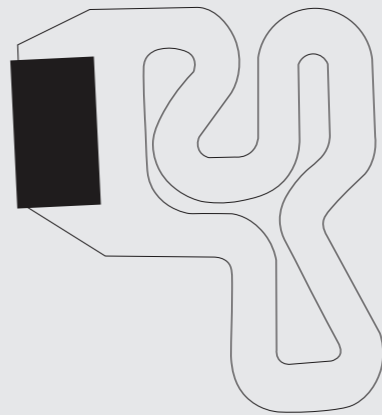
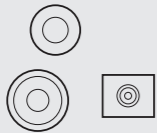
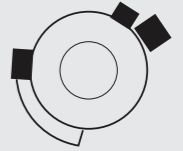
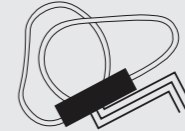
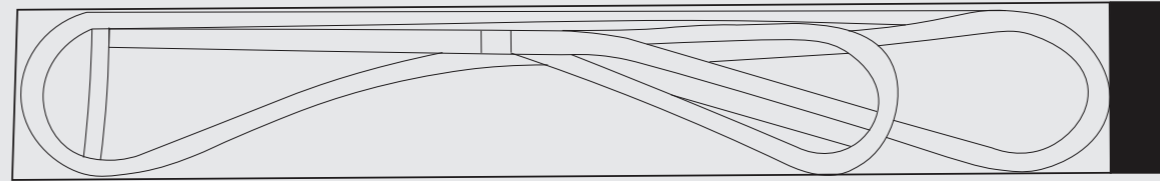
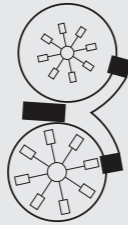
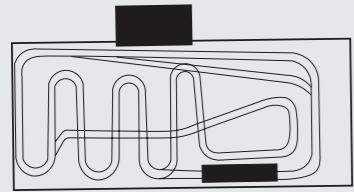
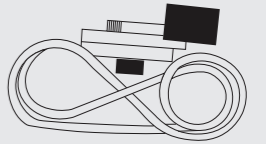
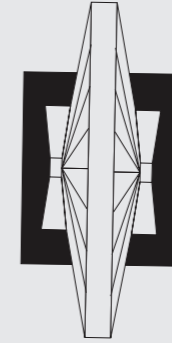
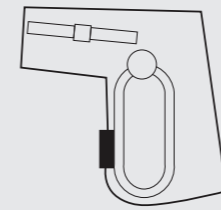
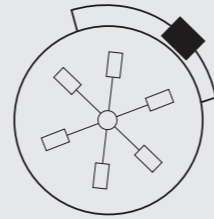
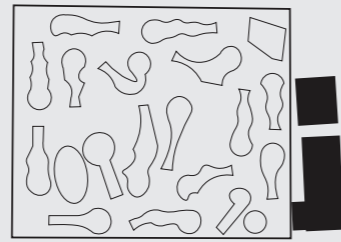
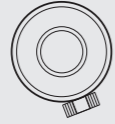
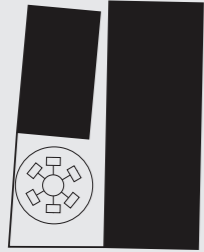
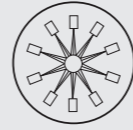
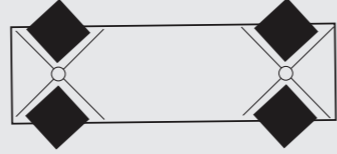
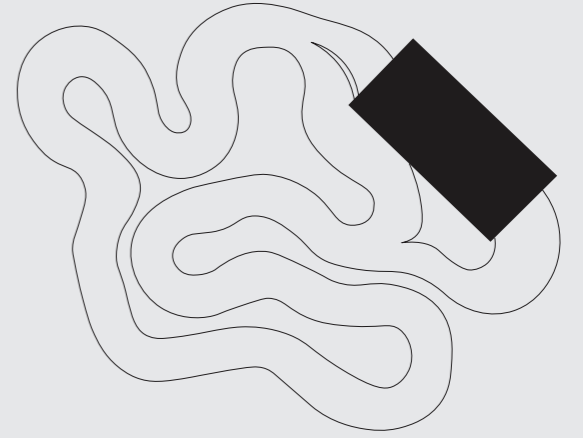
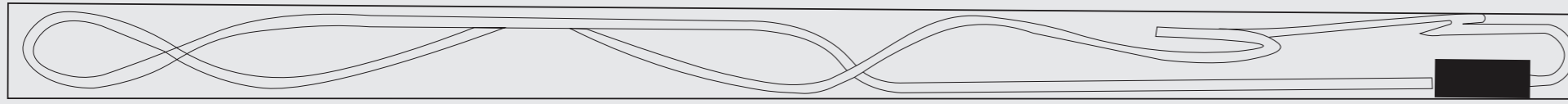

Ride

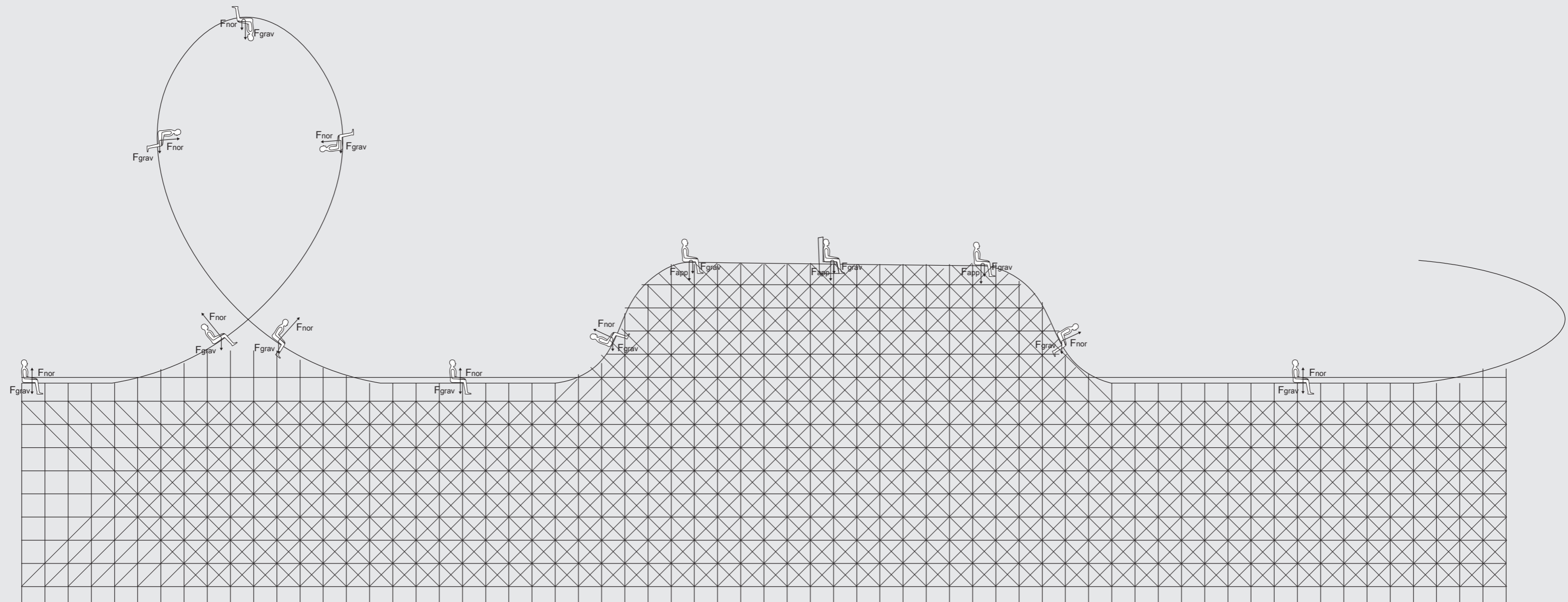

Bodies



Brief

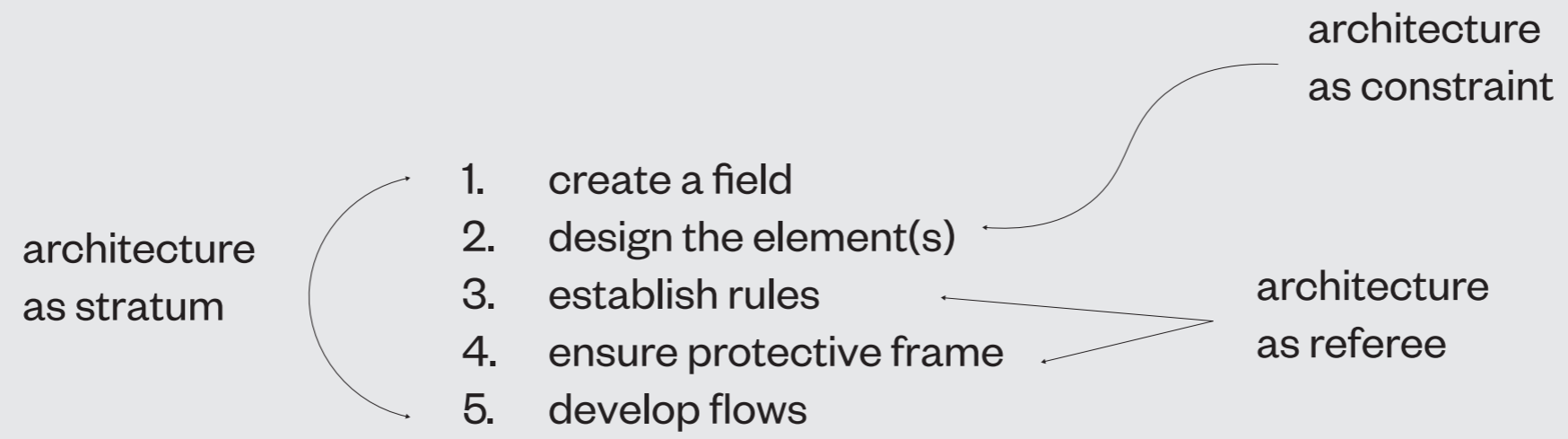

Chapters

Chapter 1 **Island**
Mapping the strip
Layers - architecture as stratum

Chapter 2 **Park**
Mapping the game
Rules - architecture as referee

Chapter 3 **Ride**
Mapping the furniture
Element - architecture as constraint

Membrane
Creating the field
Layers - architecture as stratum

Movement
Transforming the ways
Rules - architecture as referee

Markers
Introducing the intensities
Element - architecture as constraint

Membrane

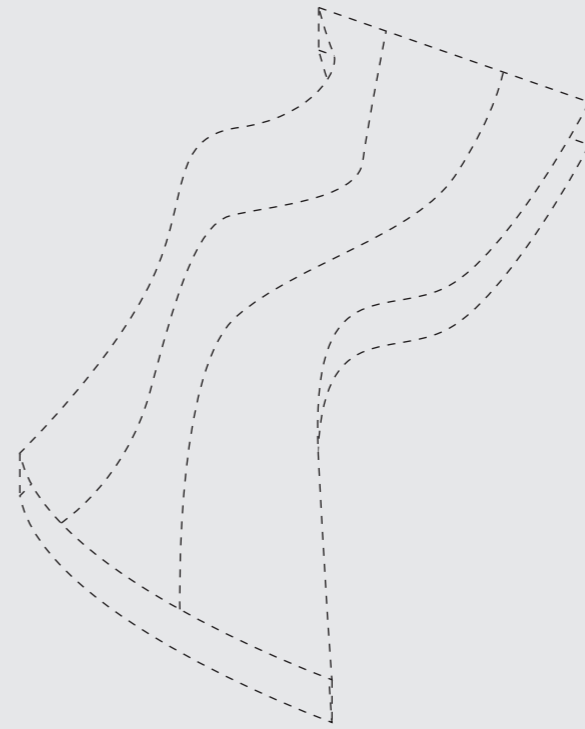

Movement

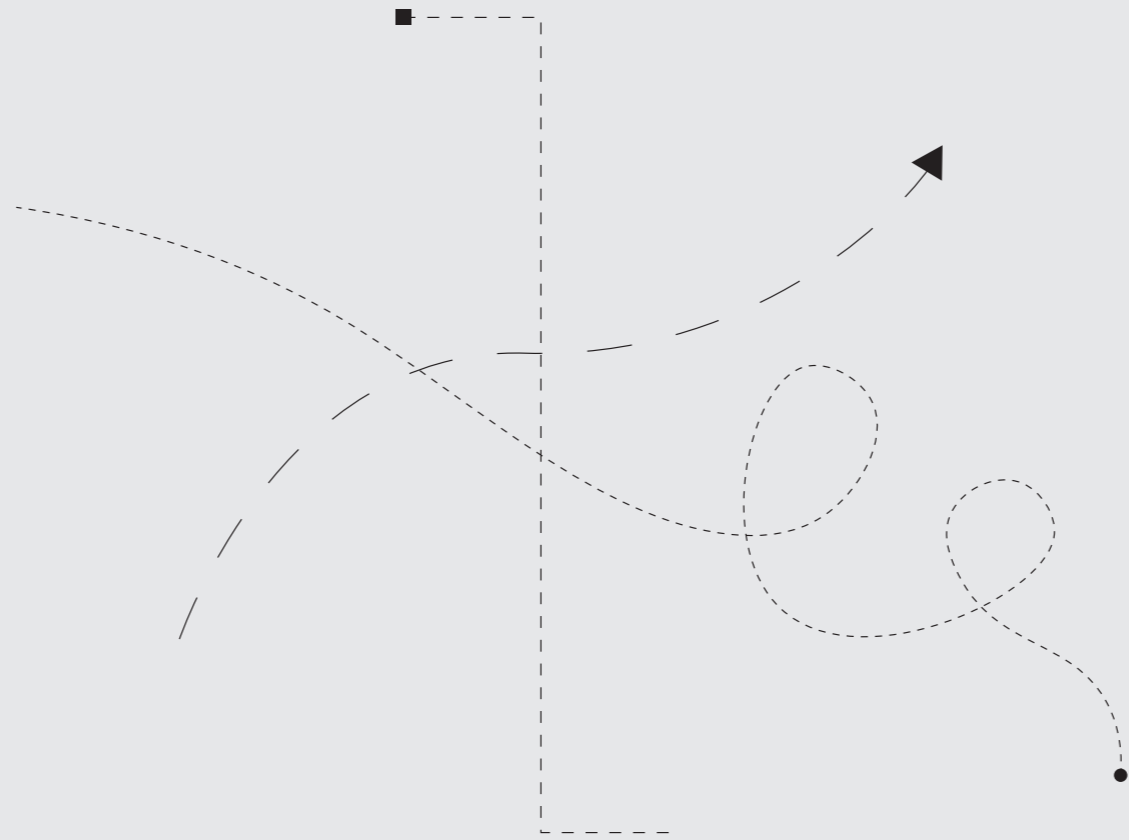

Markers

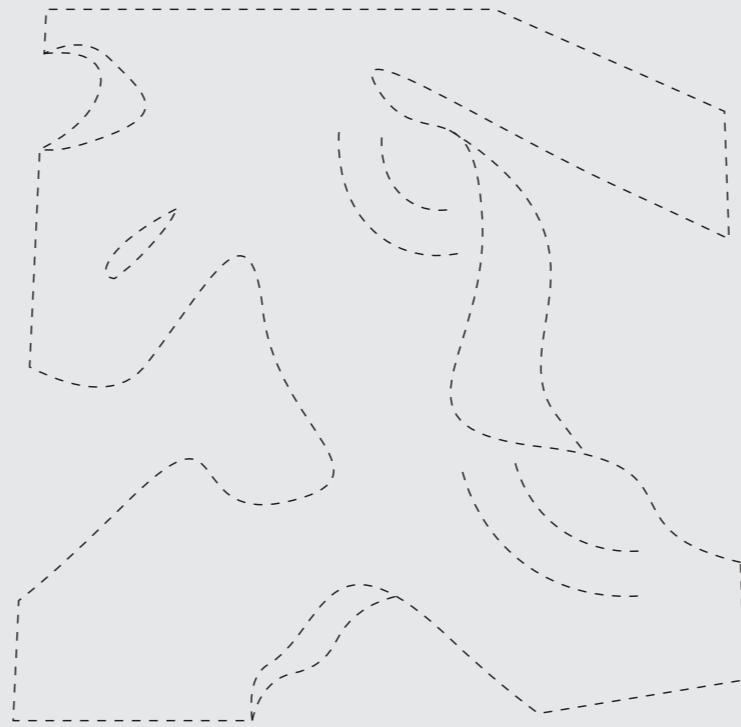

Conceptual collage



membrane

markers

movement

Conceptual collage

movement

movement

markers

markers

membrane

membrane



Conceptual collage

movement

markers

membrane



movement

membrane

markers

Membrane

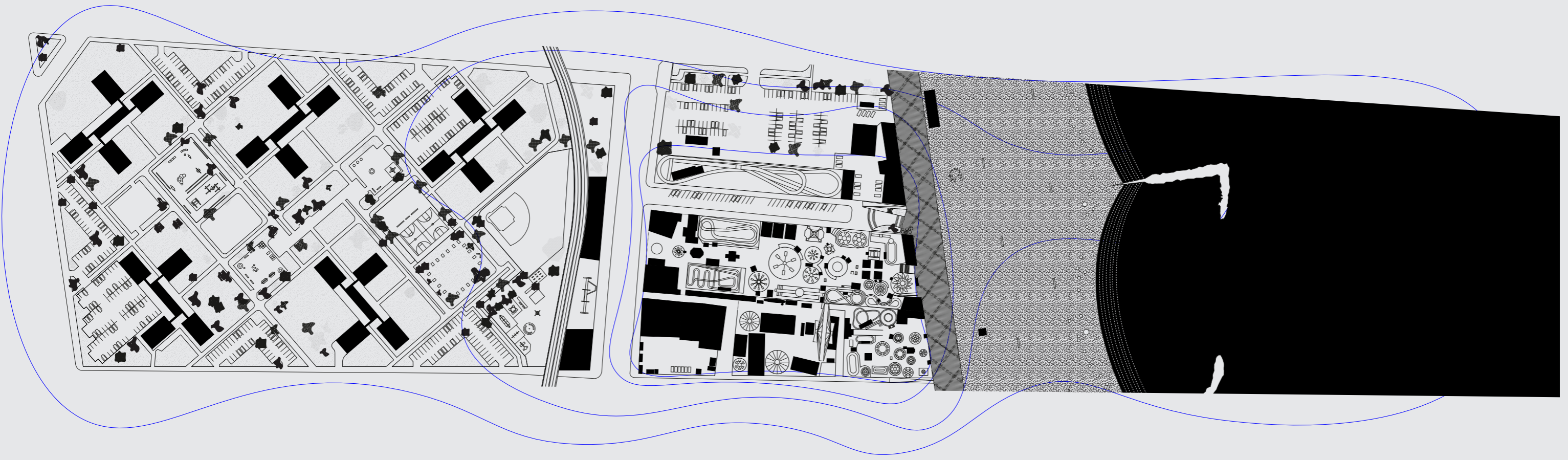

Membrane

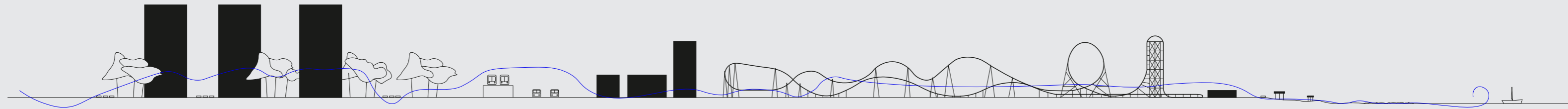

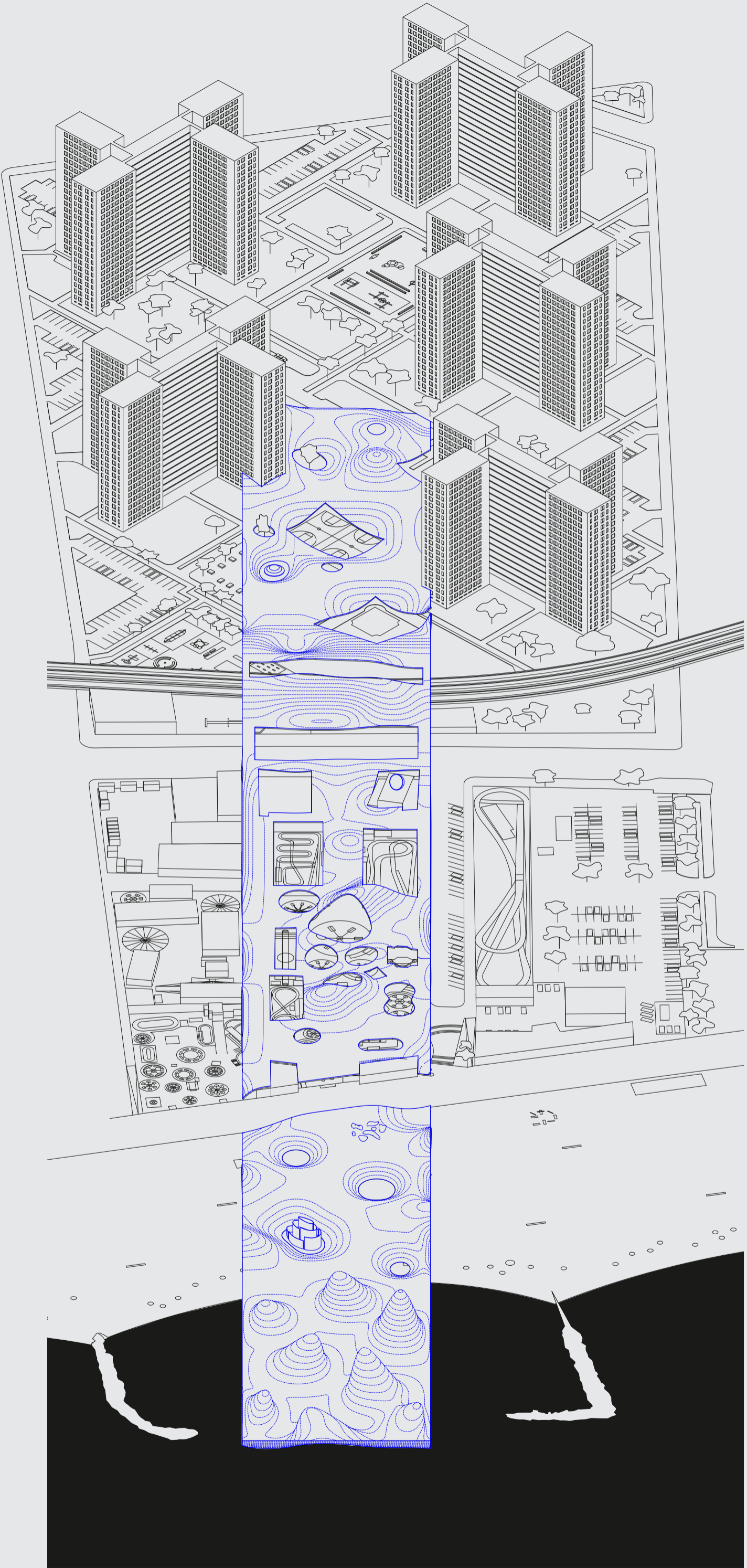

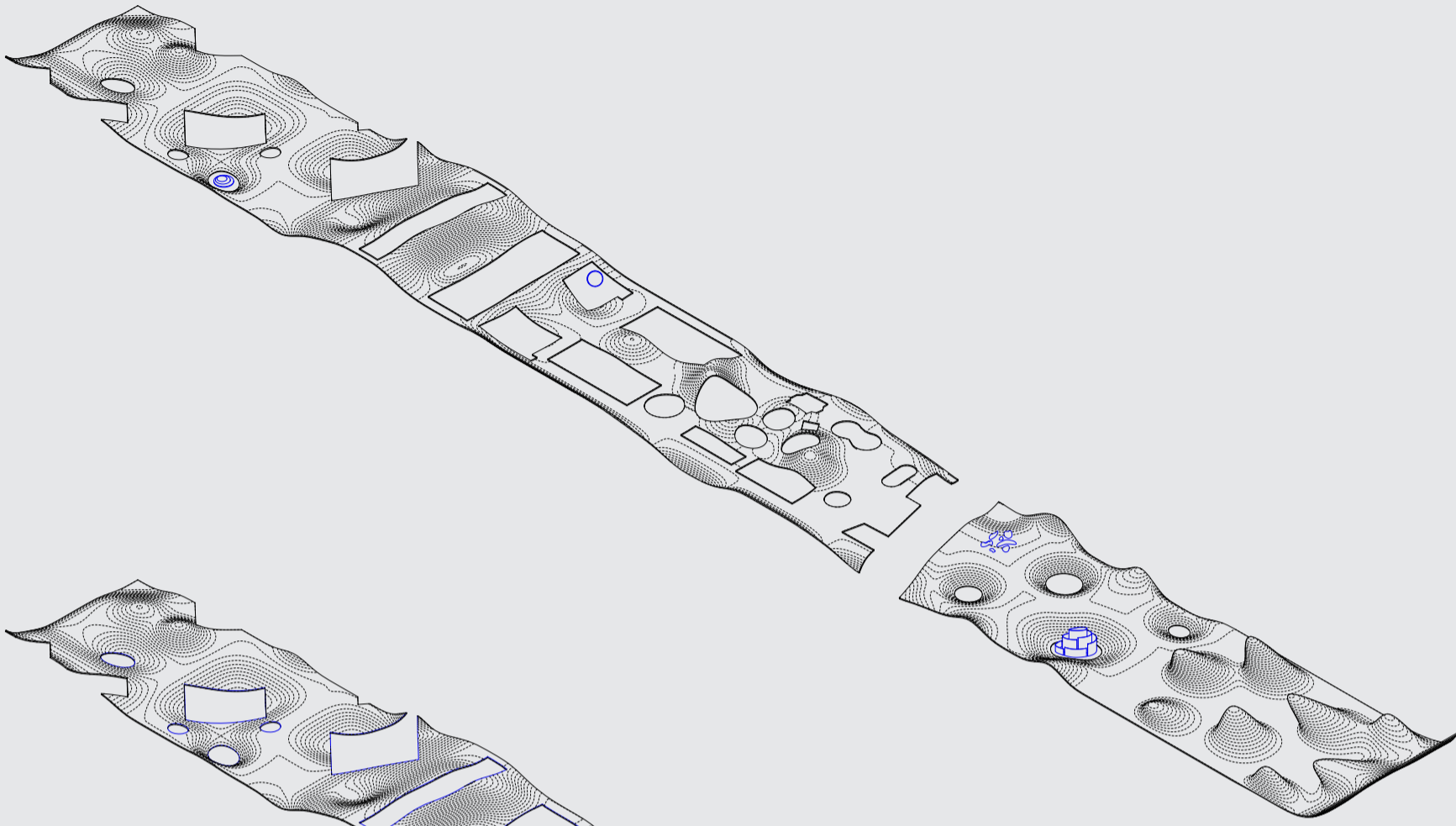

markers

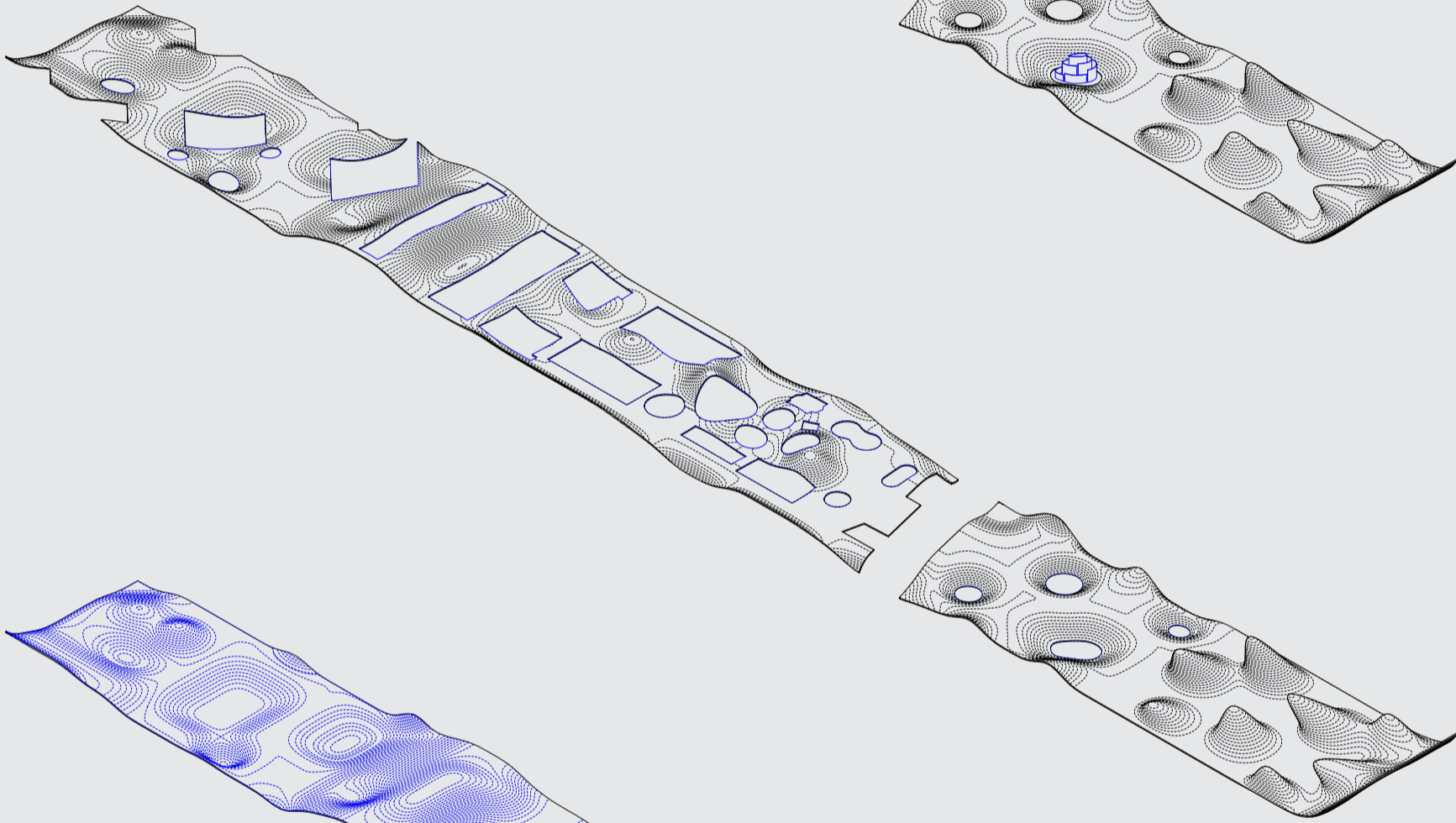

movement

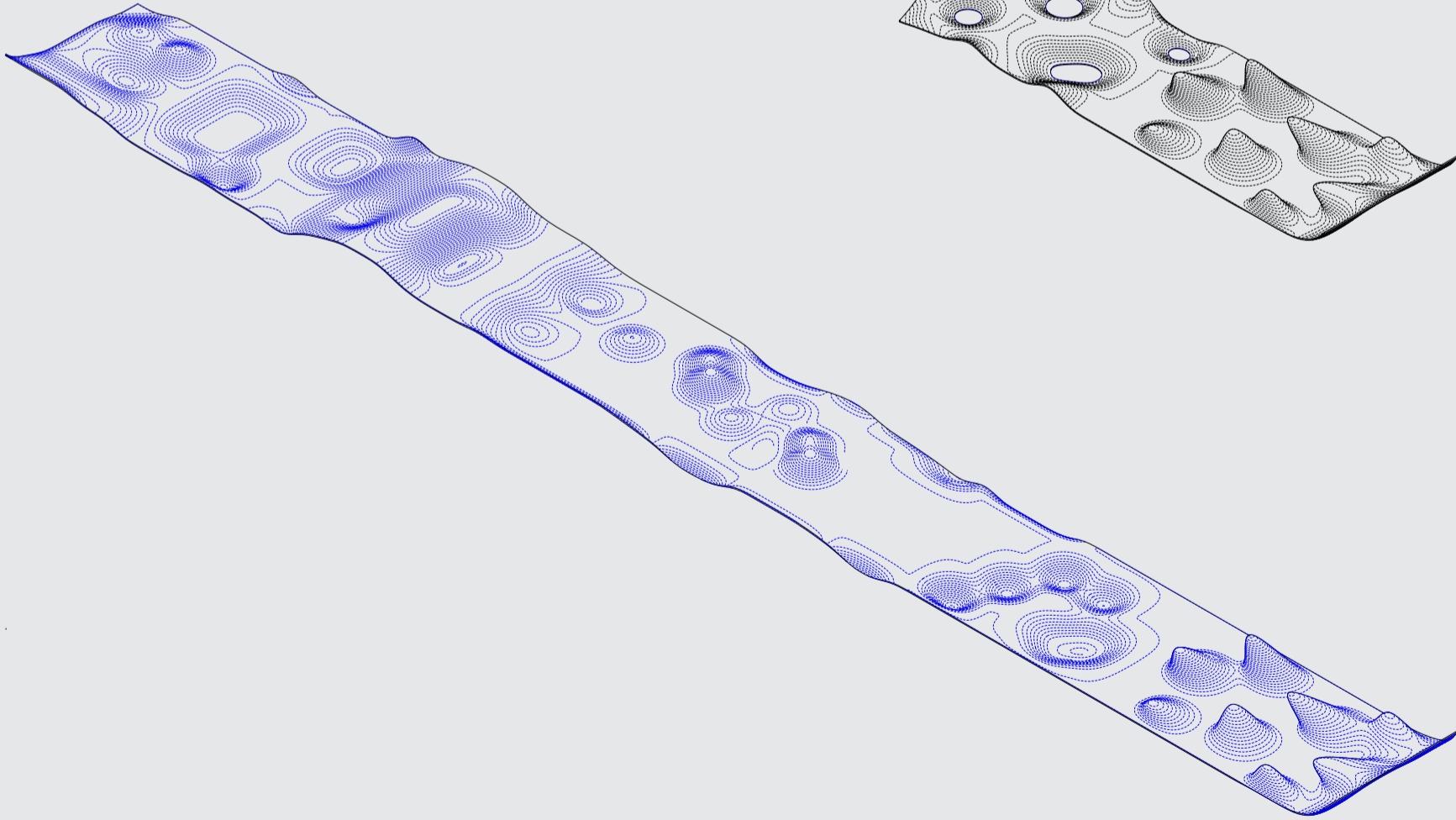

membrane

Membrane

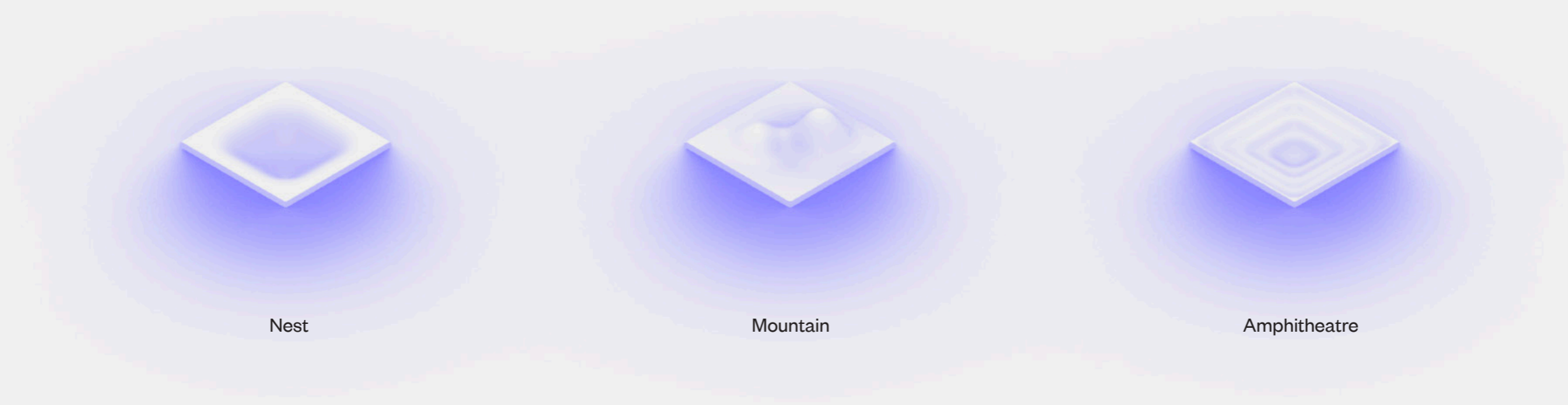
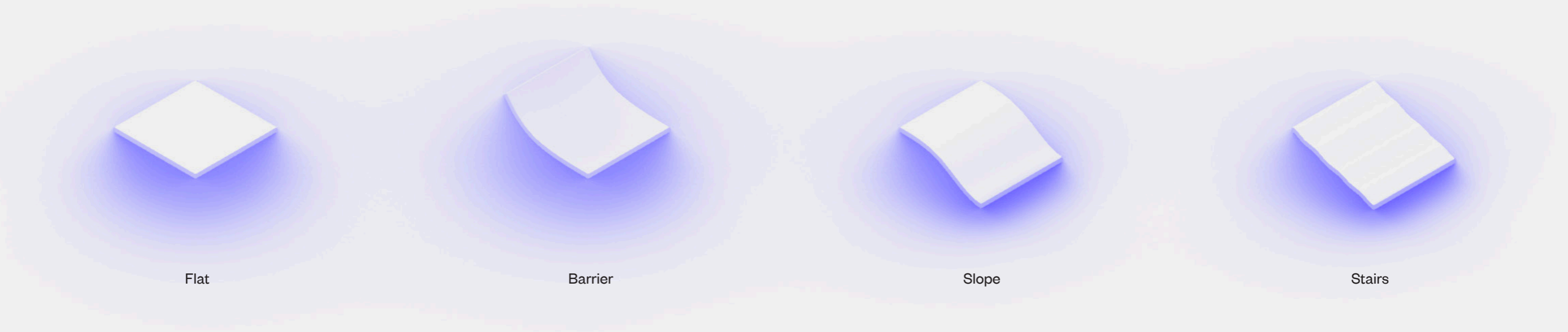

Movement



Hole



Bridge



Glass

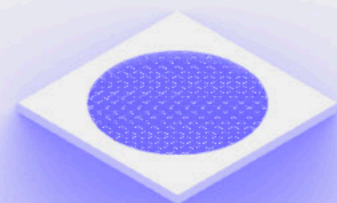

Net

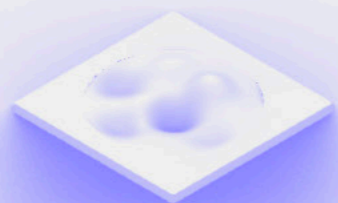

Topo



Tramp

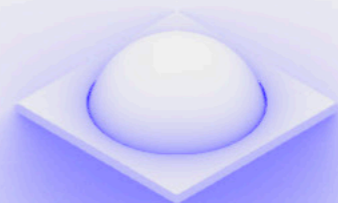

Bubble

Markers

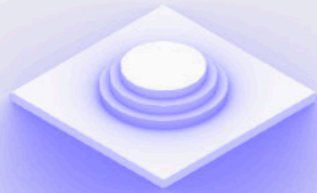

Stage



Maze



Amplifier



Elements



Tunnel



BUCKLE UP! TRAVEL
SMOOTHLY. AND
ENJOY THE VIEW.
WE'VE GOT YOU
COVERED.
BUCKLE UP!
BUCKLE UP!

BUCKLE UP! TRAVEL
SMOOTHLY. AND
ENJOY THE VIEW.
WE'VE GOT YOU
COVERED.
BUCKLE UP!
BUCKLE UP!

BUCKLE UP! TRAVEL
SMOOTHLY. AND
ENJOY THE VIEW.
WE'VE GOT YOU
COVERED.
BUCKLE UP!
BUCKLE UP!



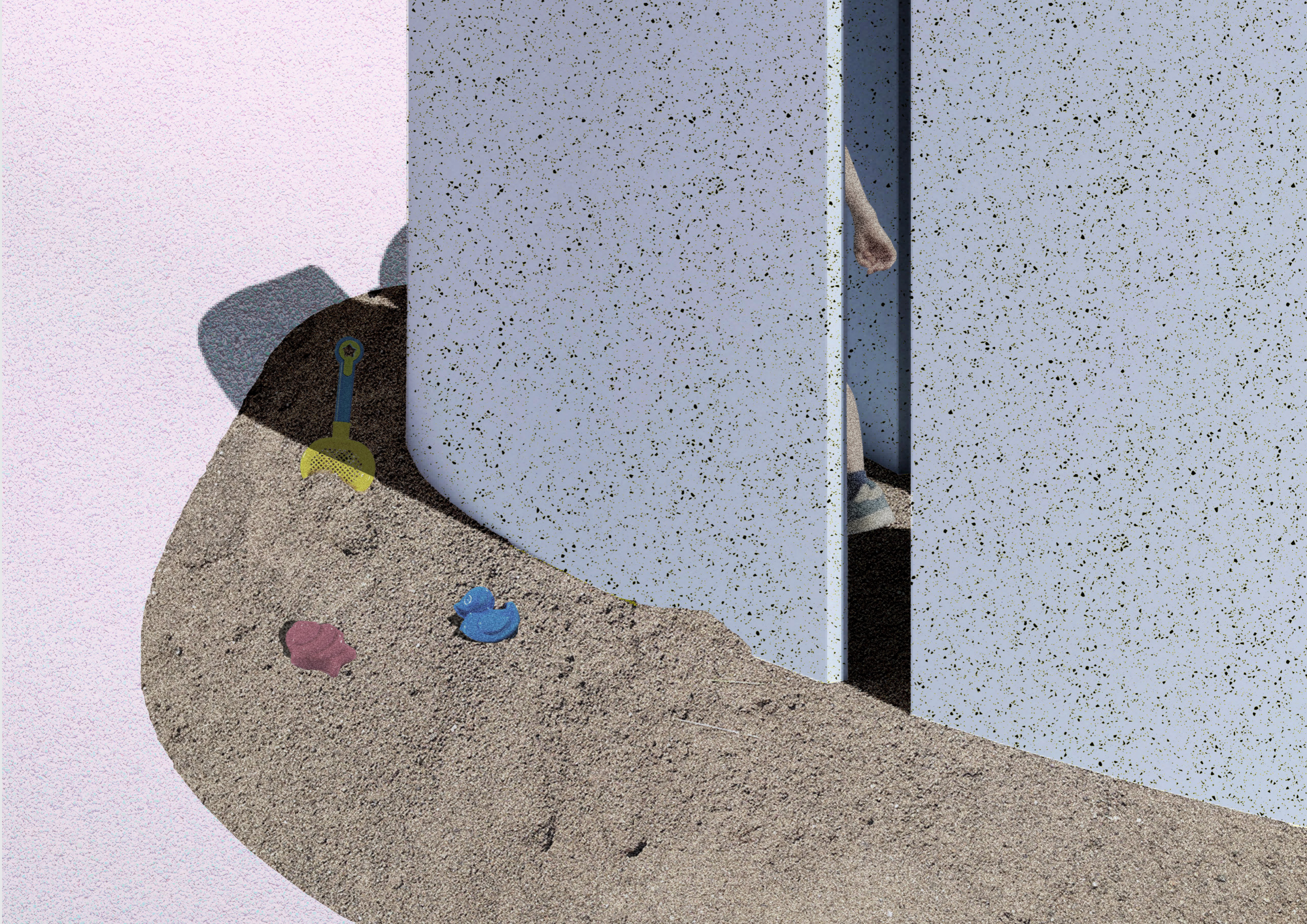



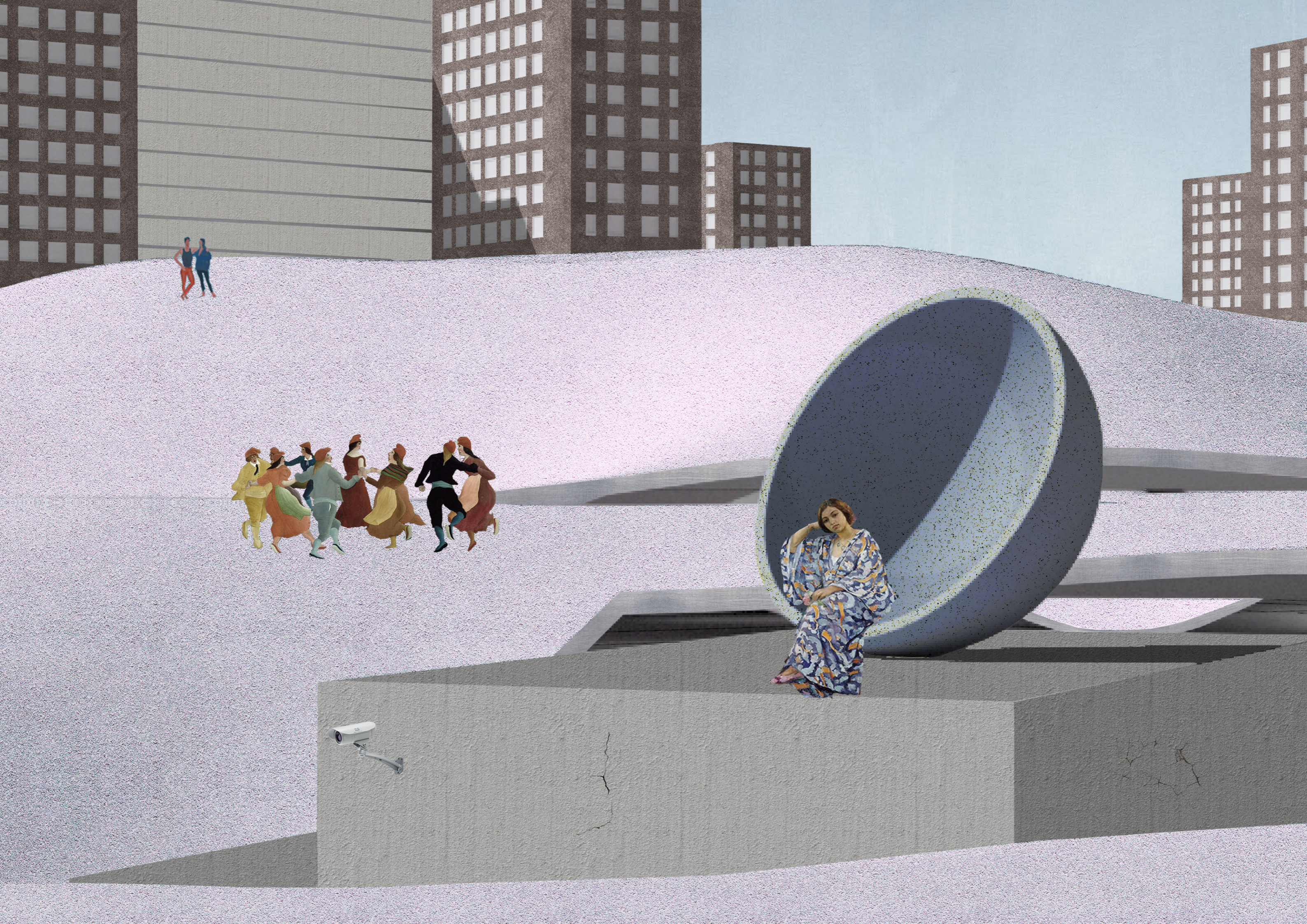

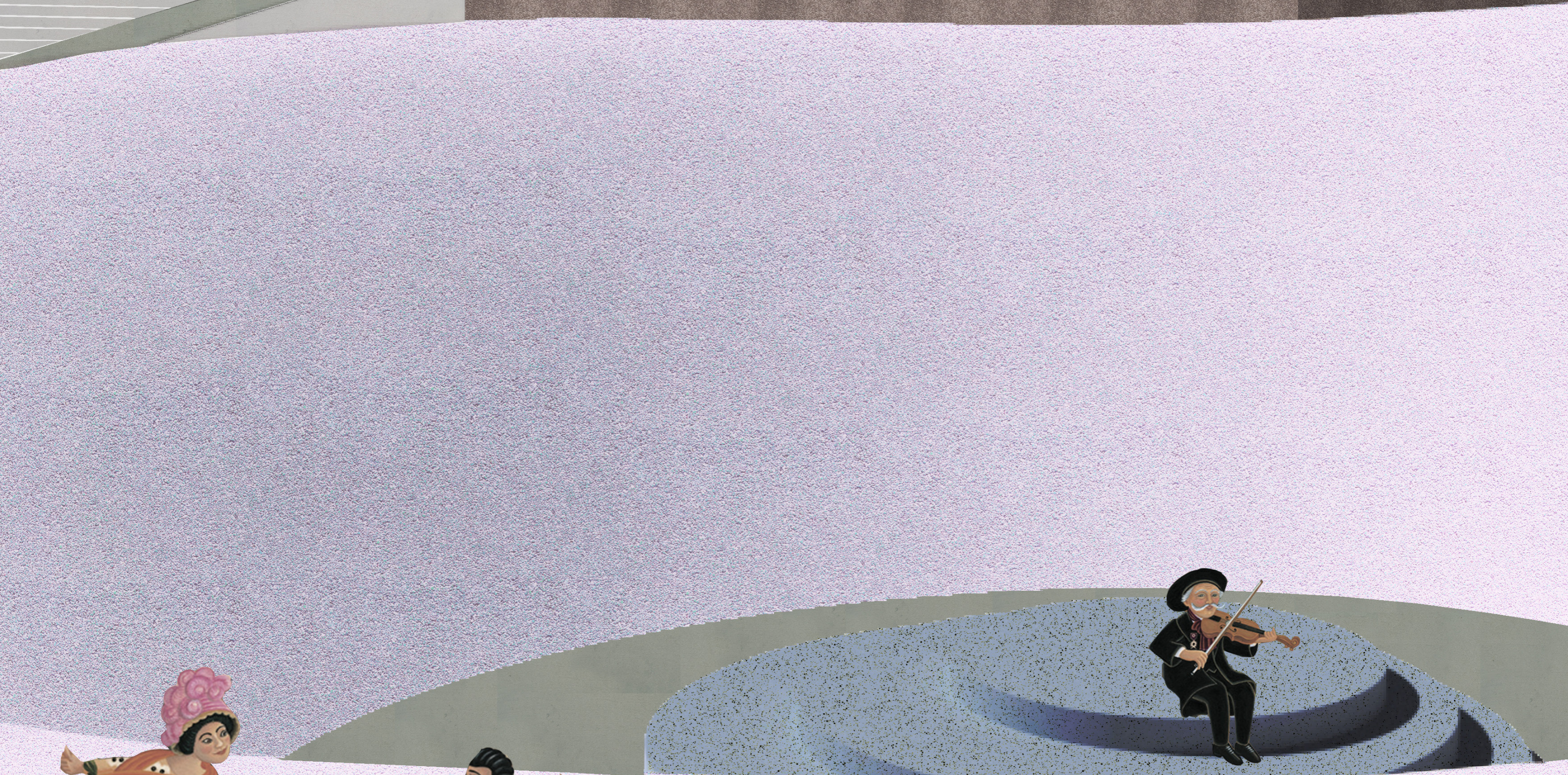
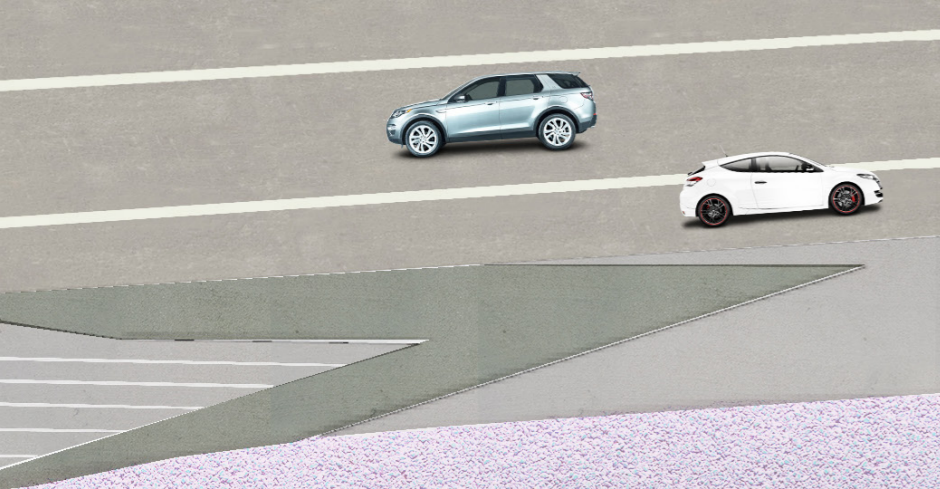







Brief

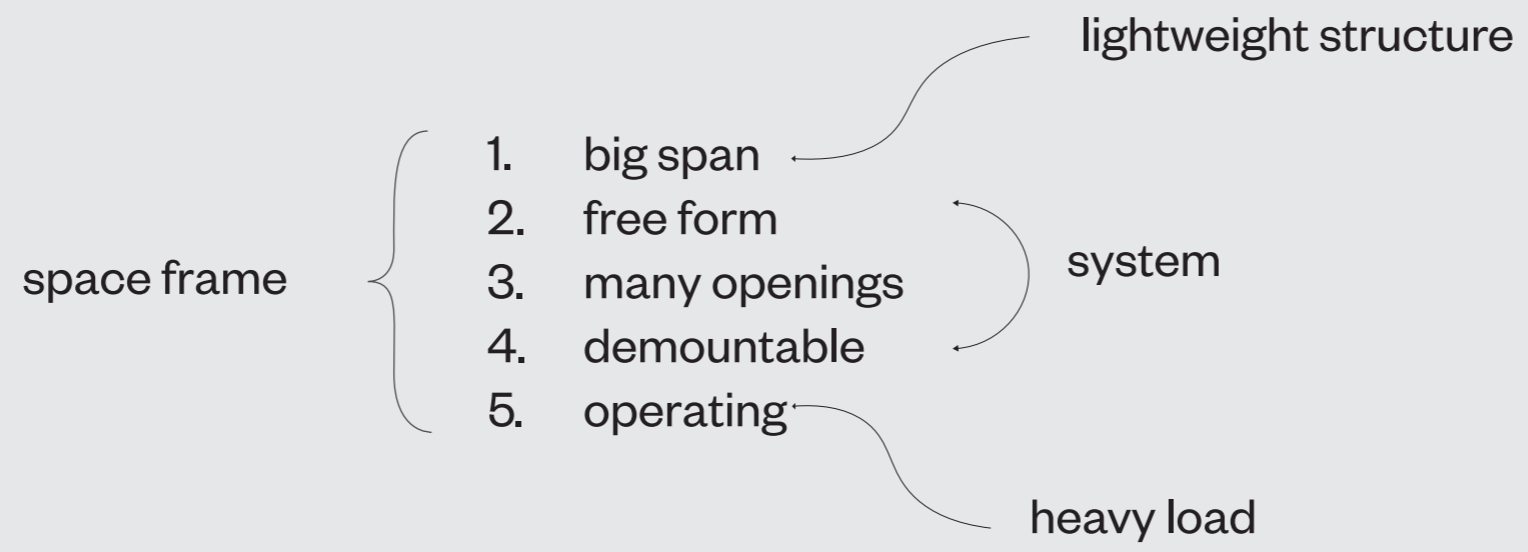

Structure

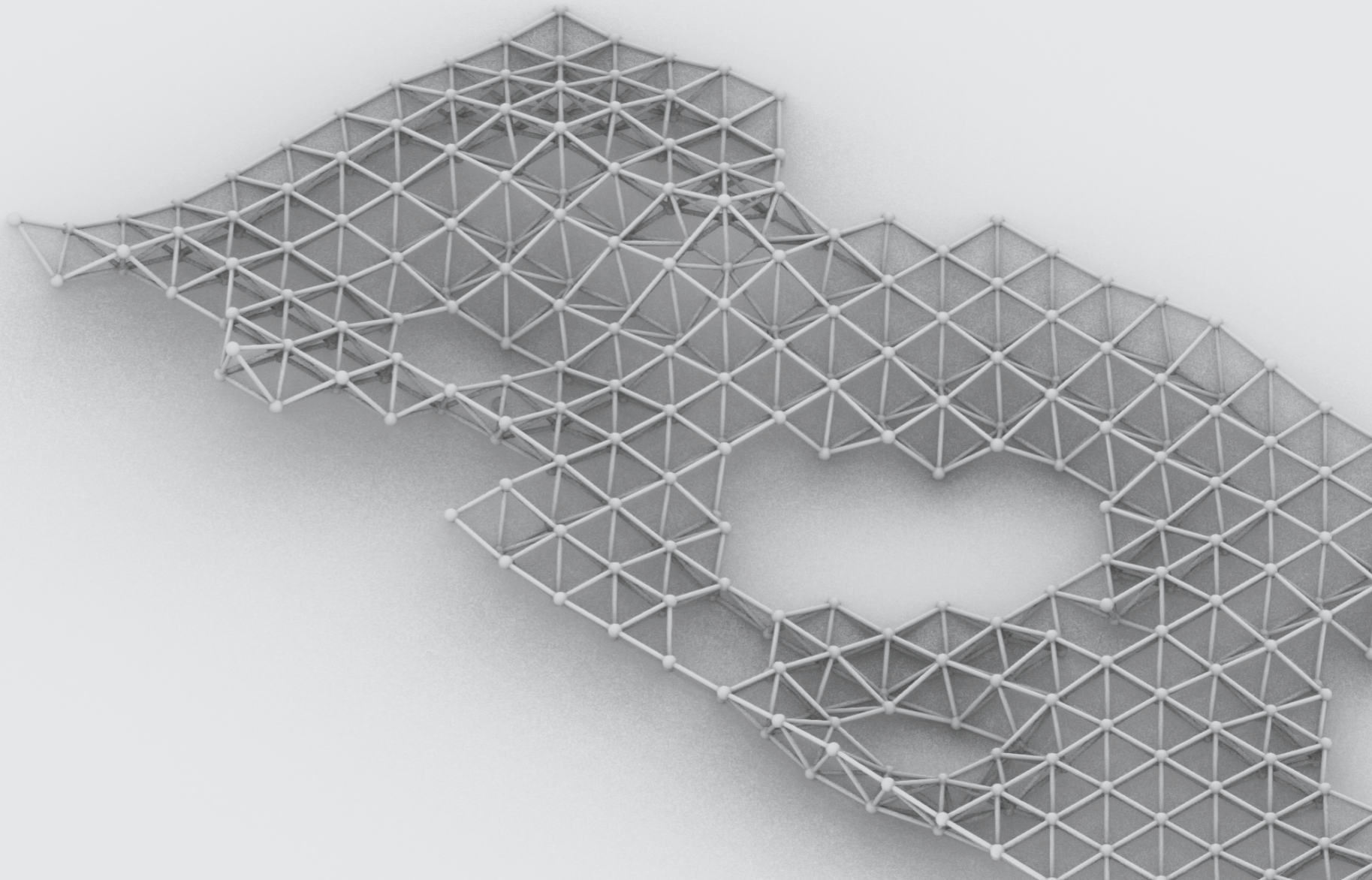
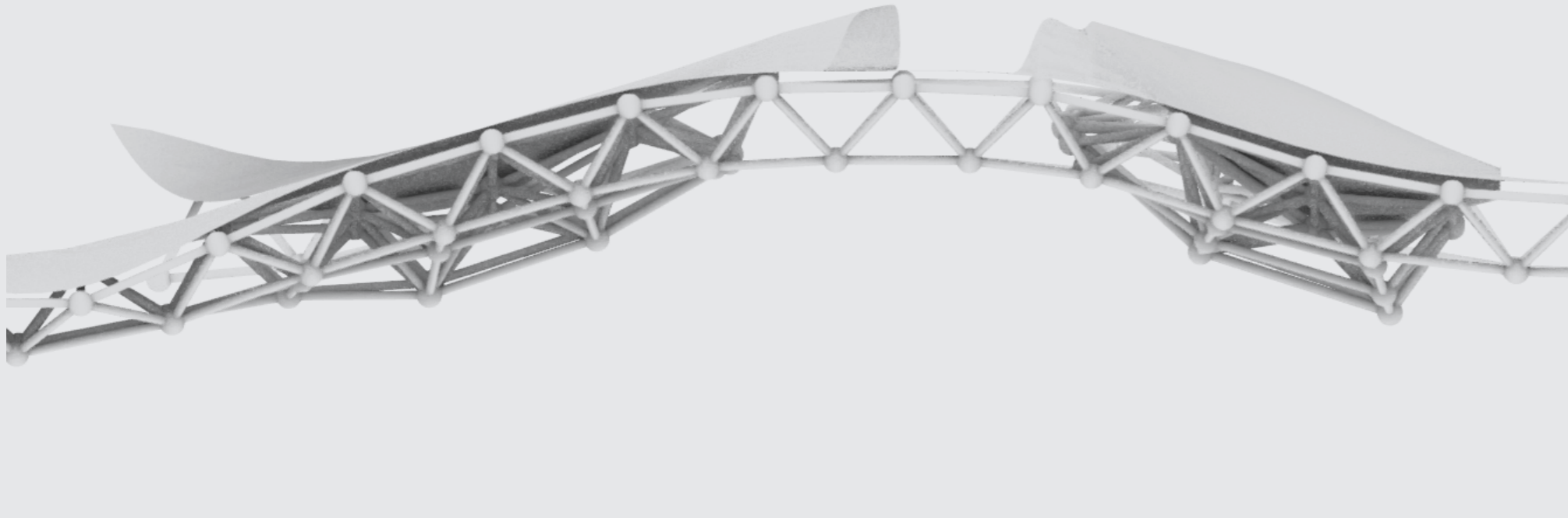

Structure

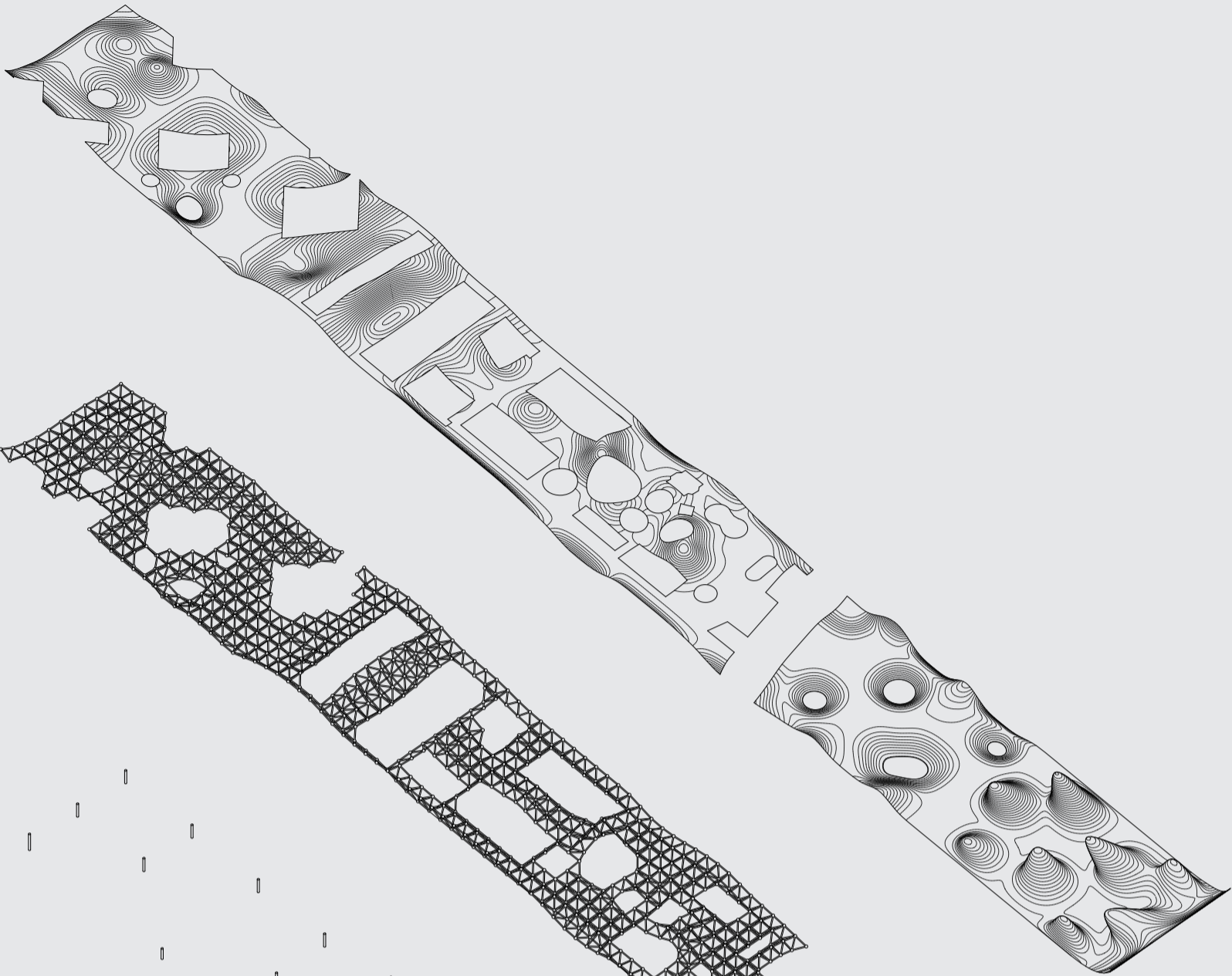

roof

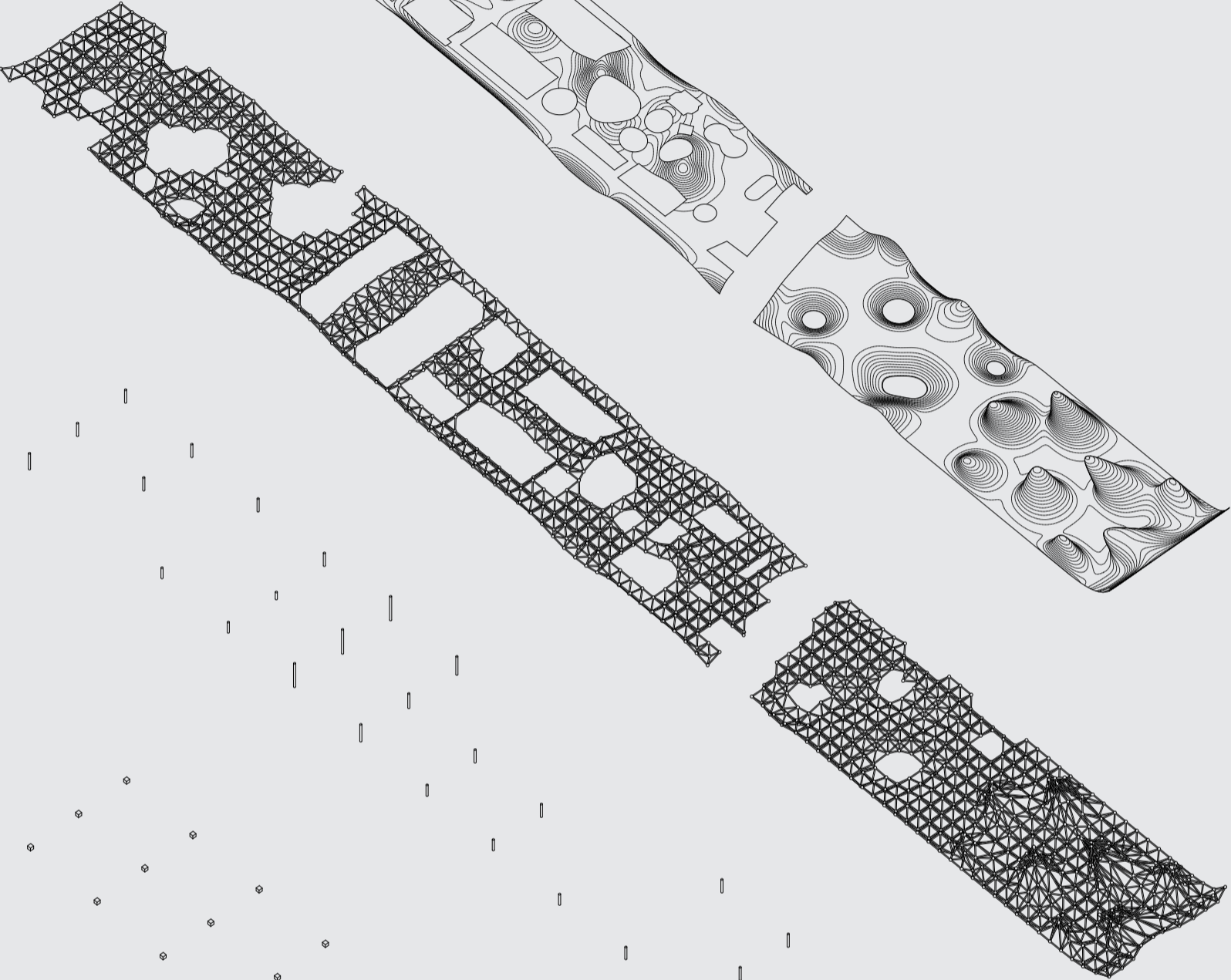

space frame

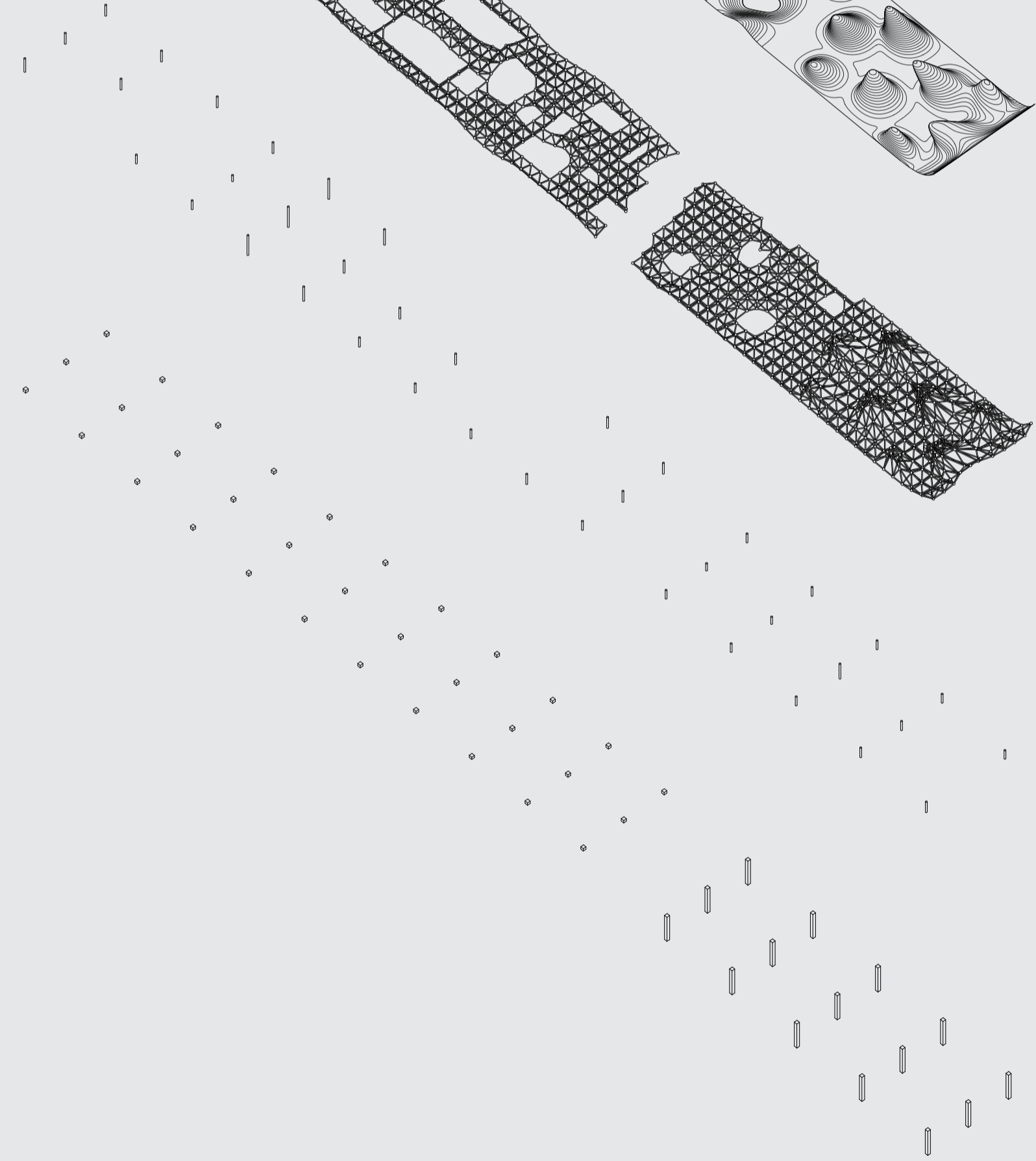

columns

foundation

Phases

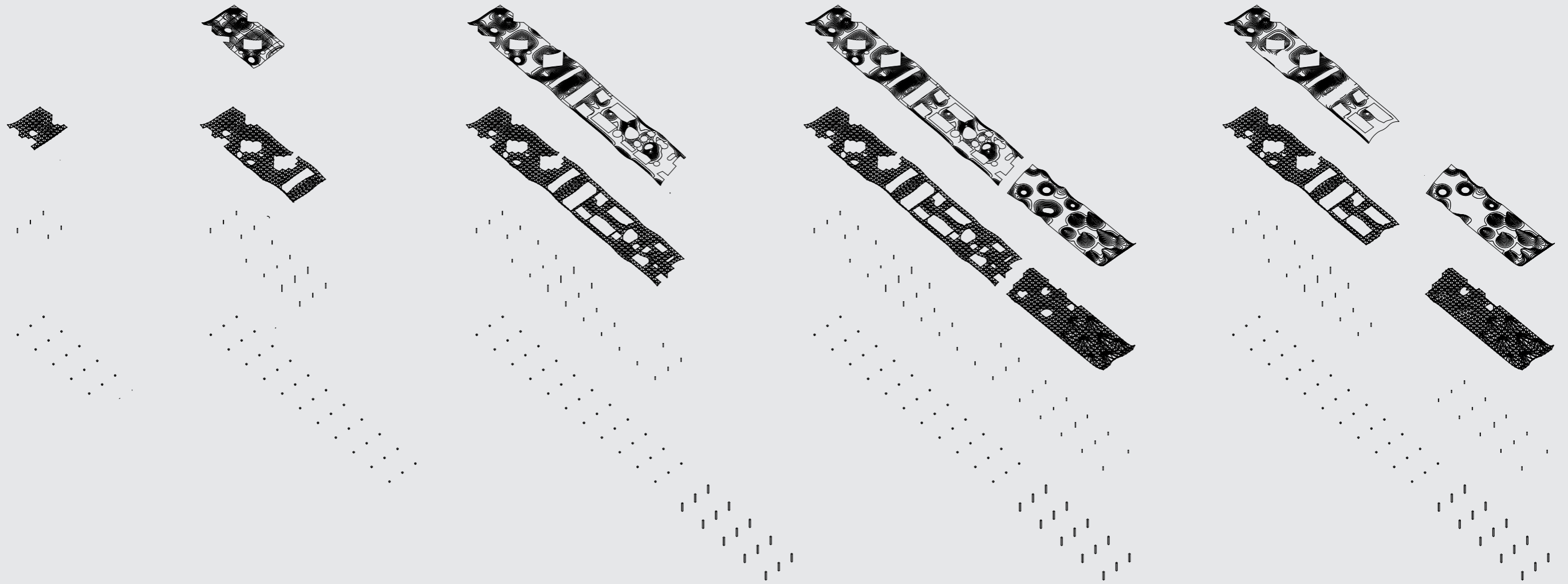

Stage 1:
foundation - columns - space frame

Stage 2:
roof layers in parts

Stage 3:
pile foundation in the ocean

Stage 4:
final arrangement

Stage 5:
removing / changing / adding

Floor plans

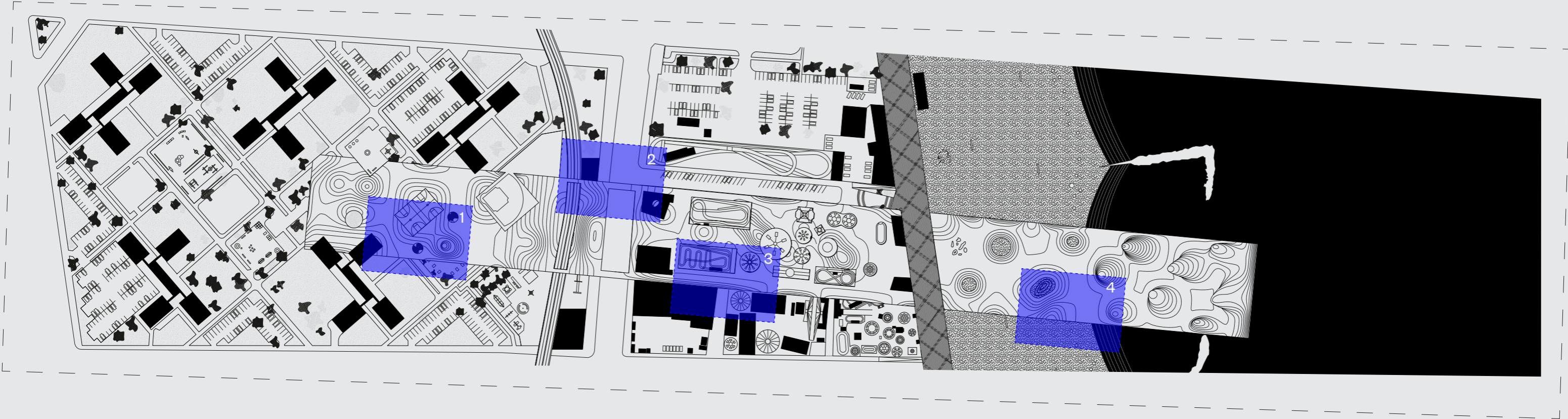

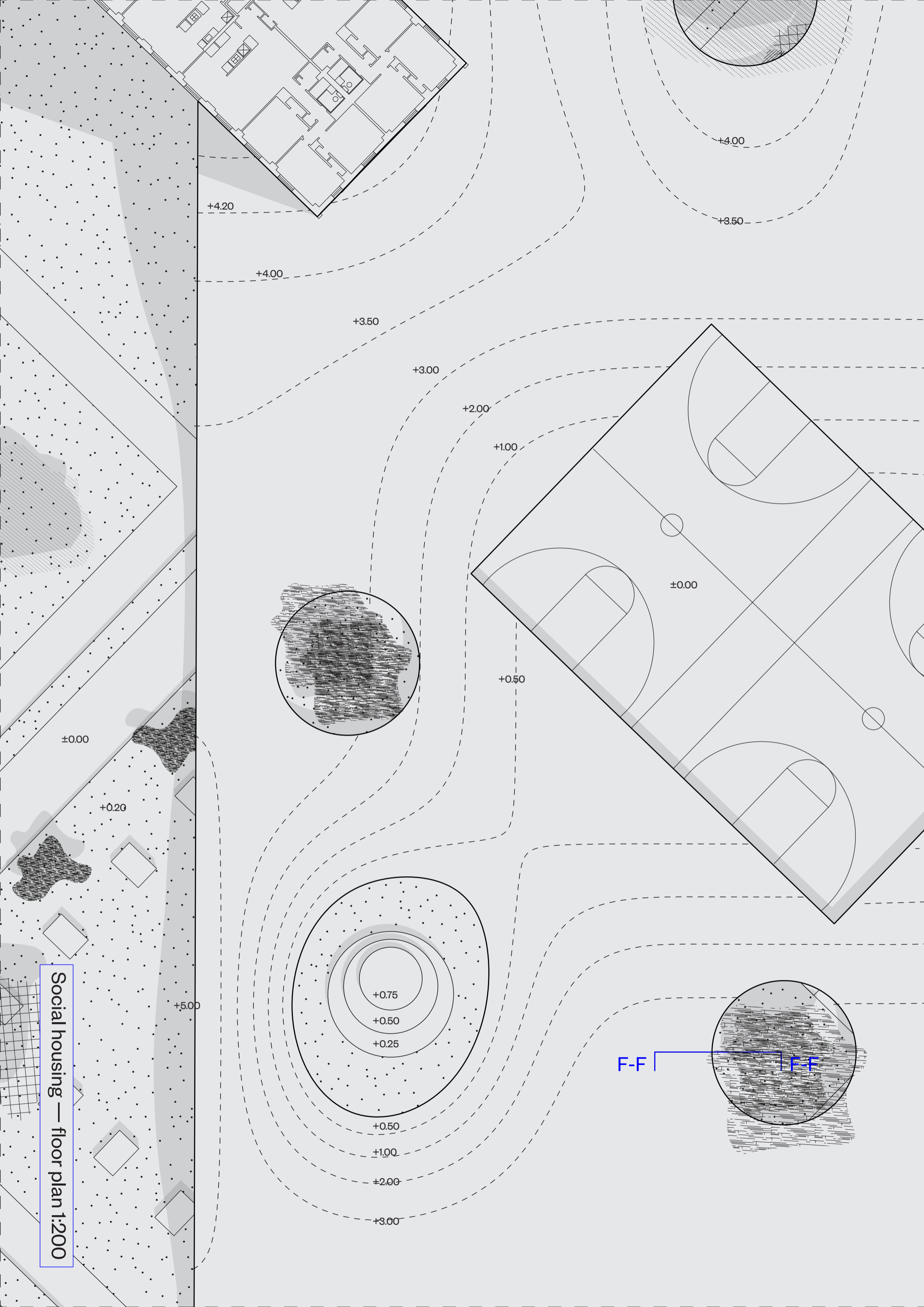

Social housing — floor plan 1:200

F-F

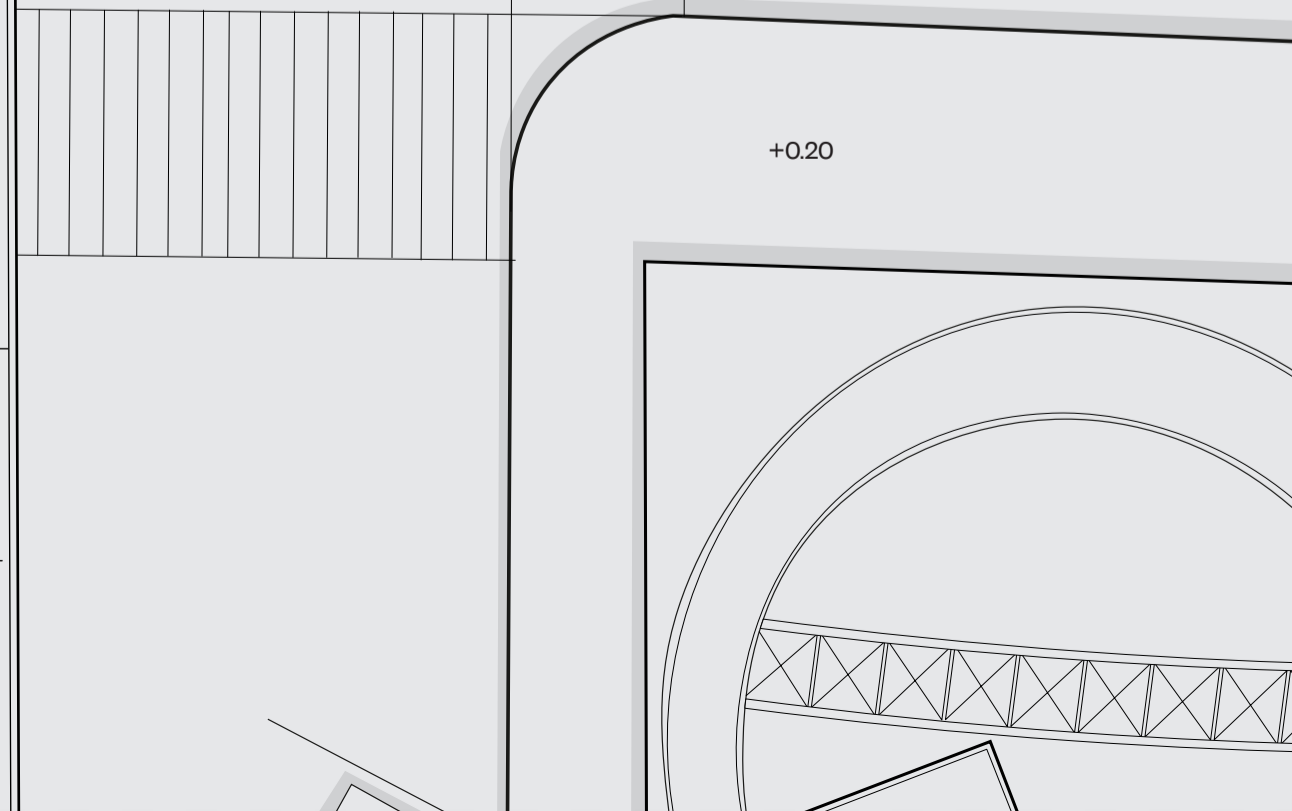
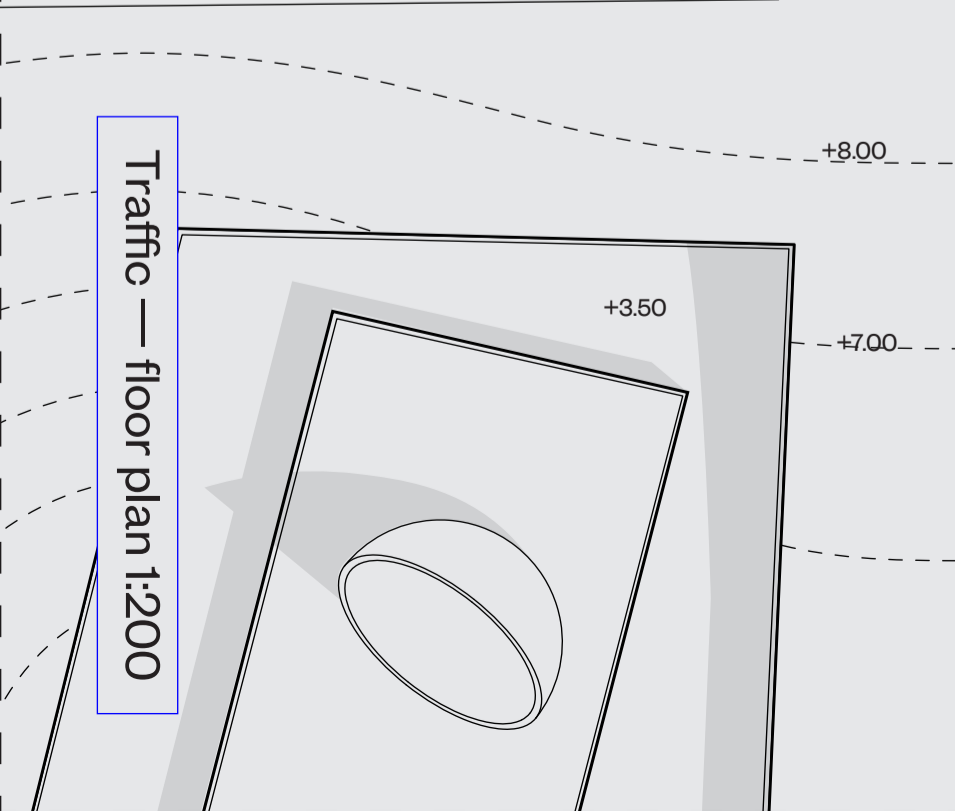
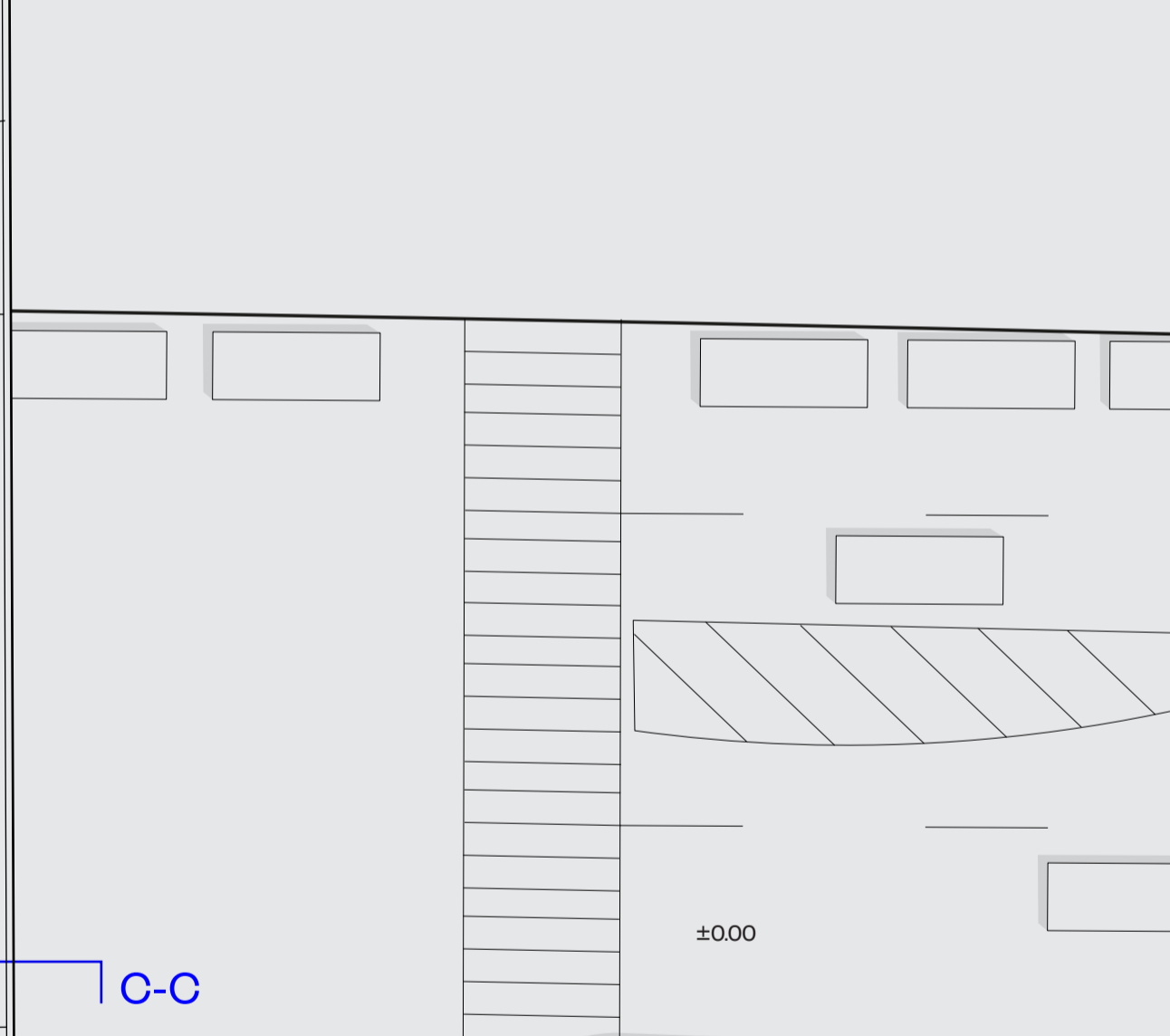
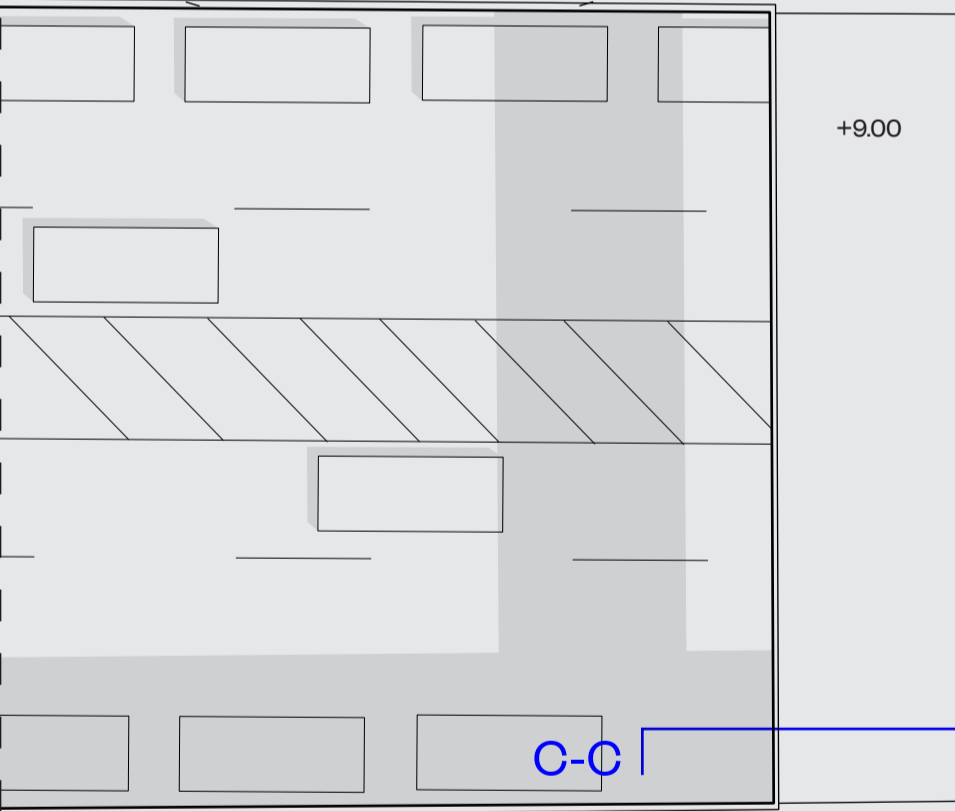
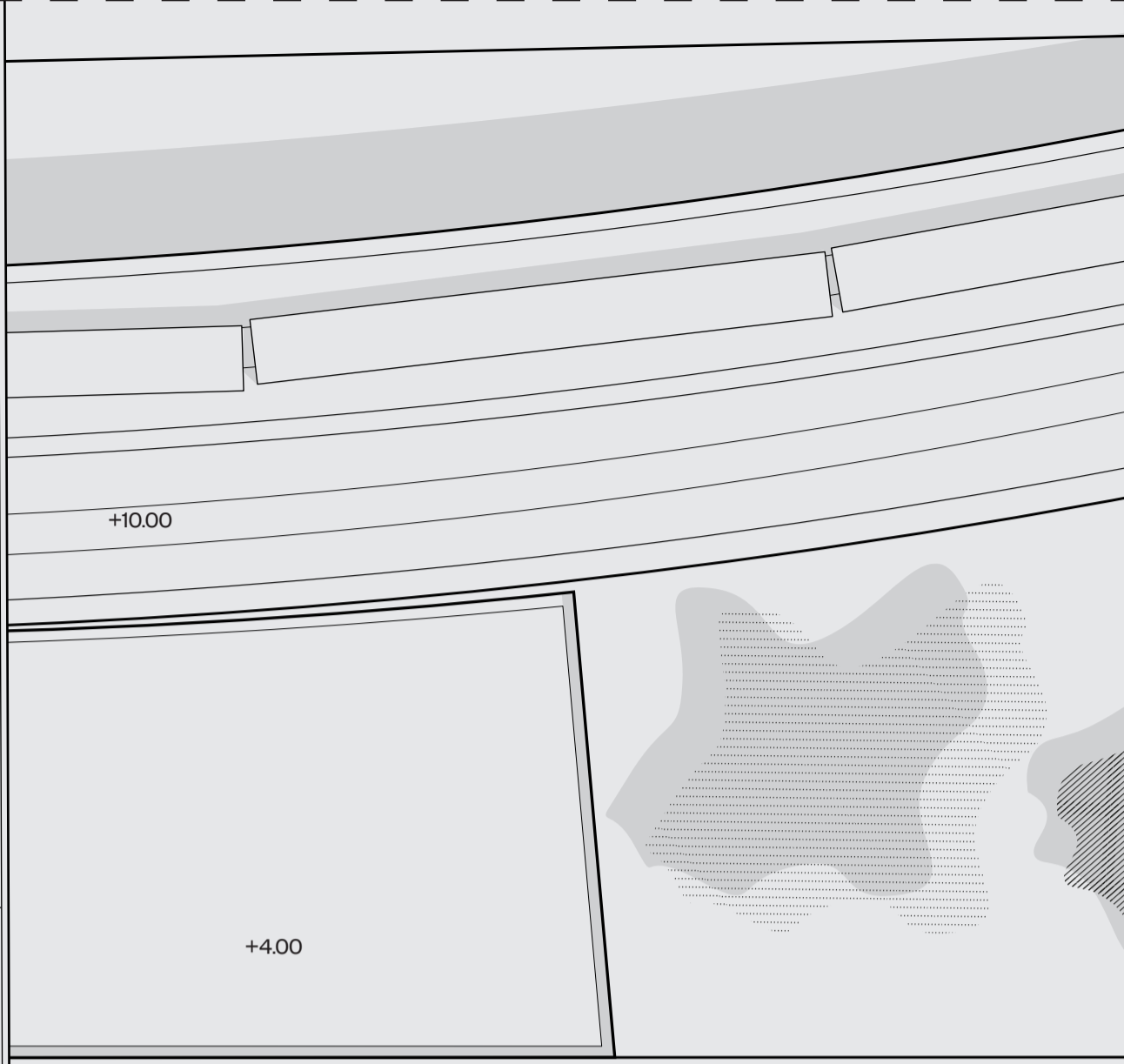
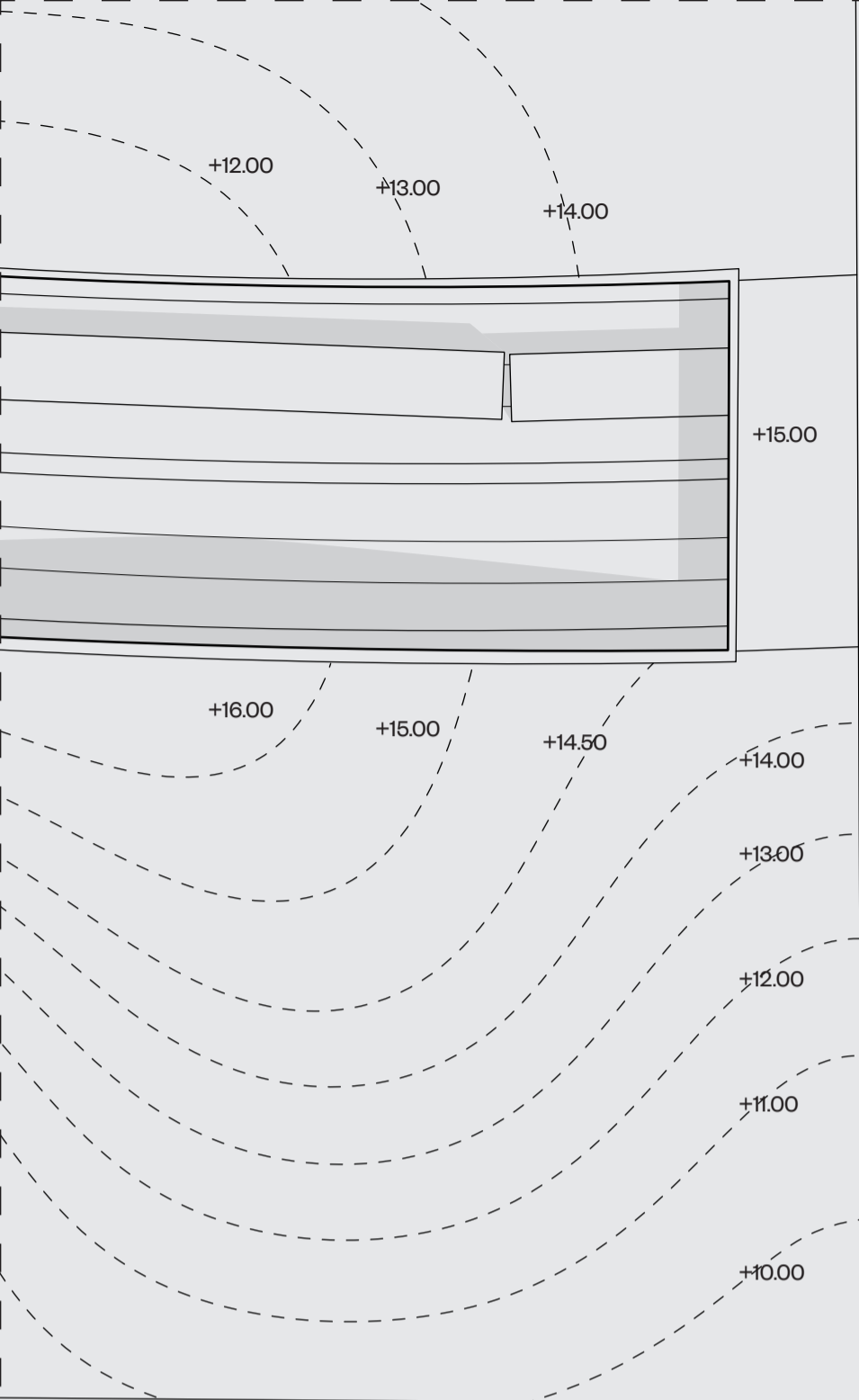

Traffic — floor plan 1:200

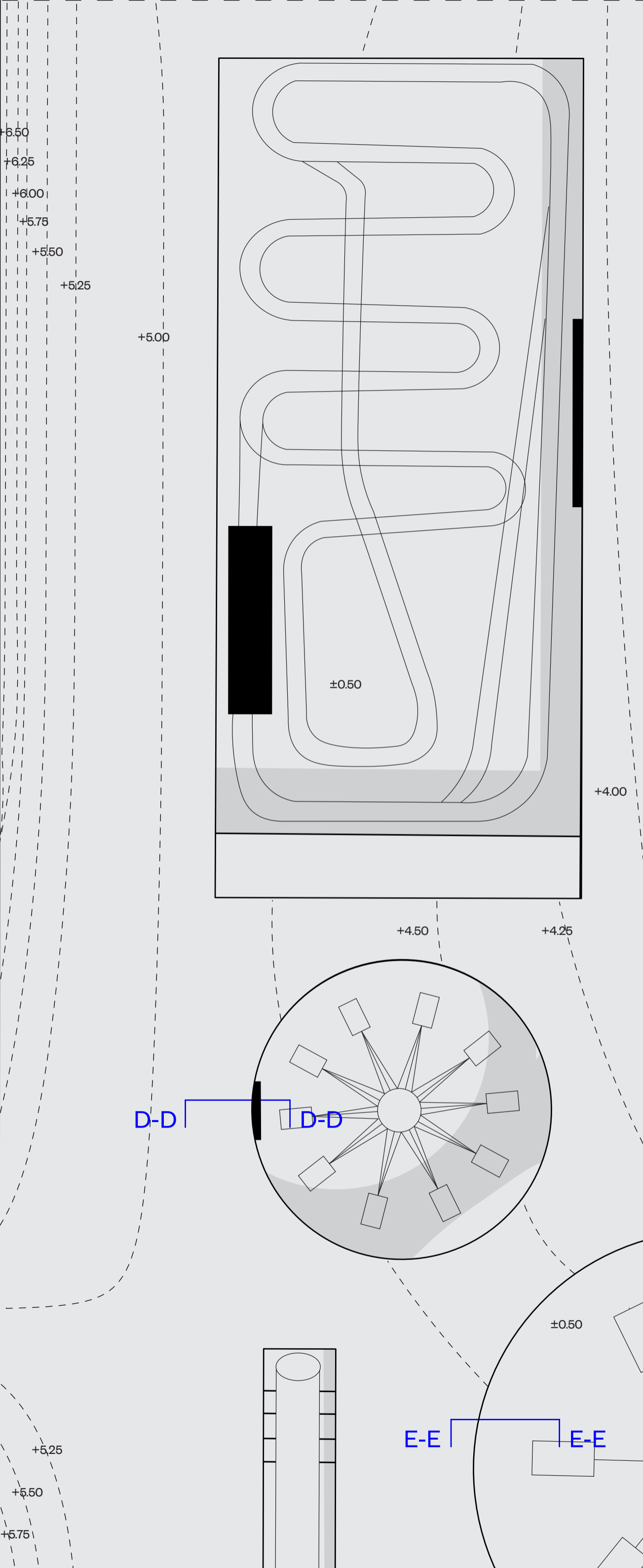
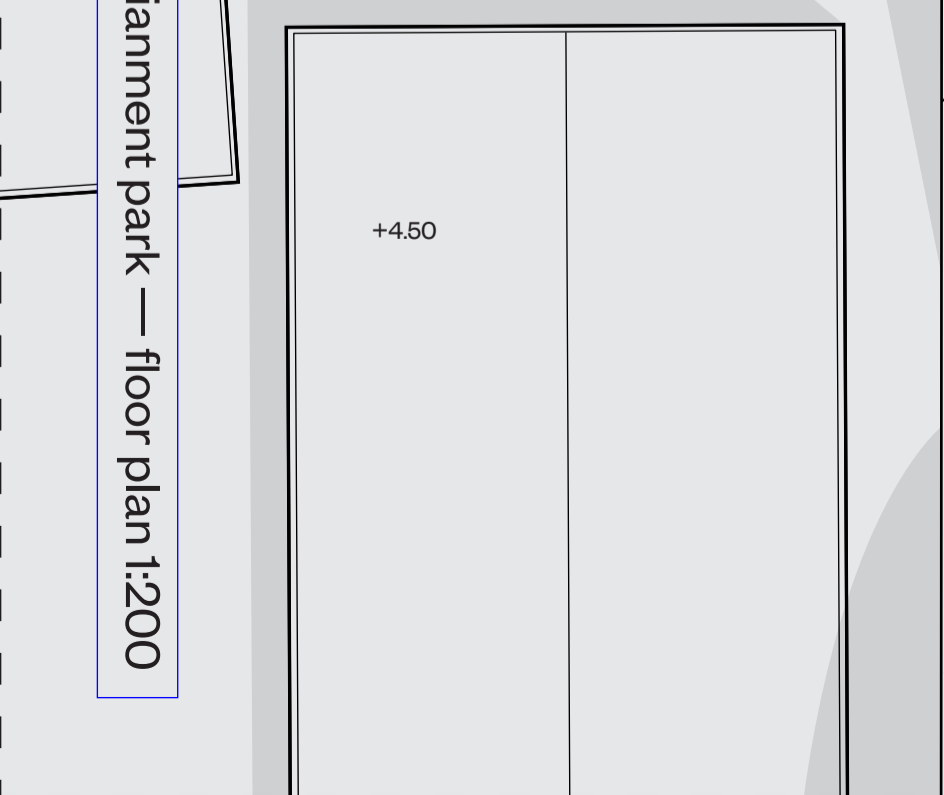
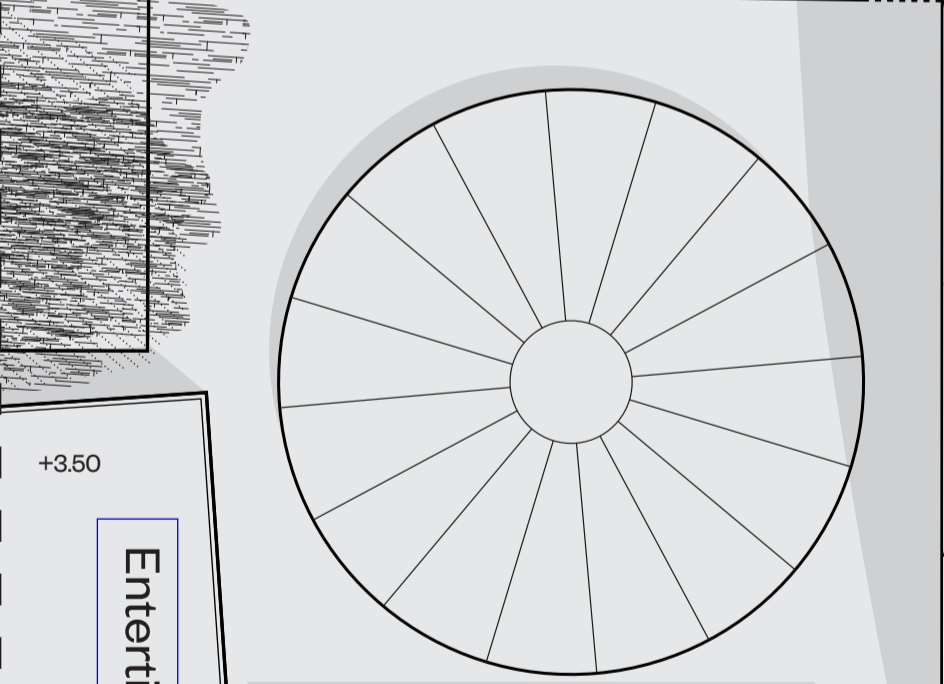
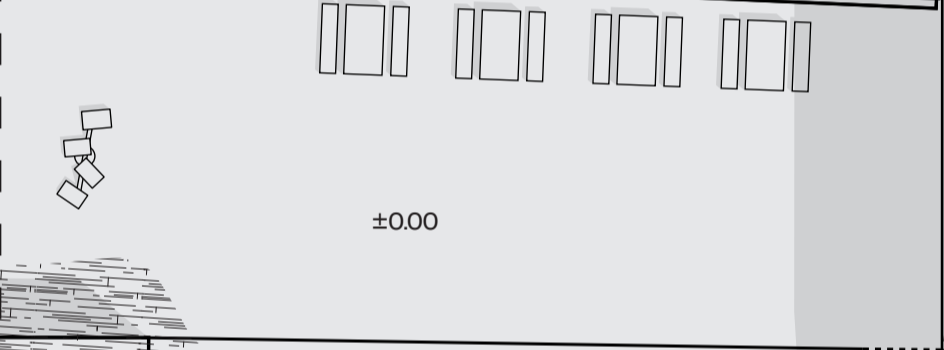
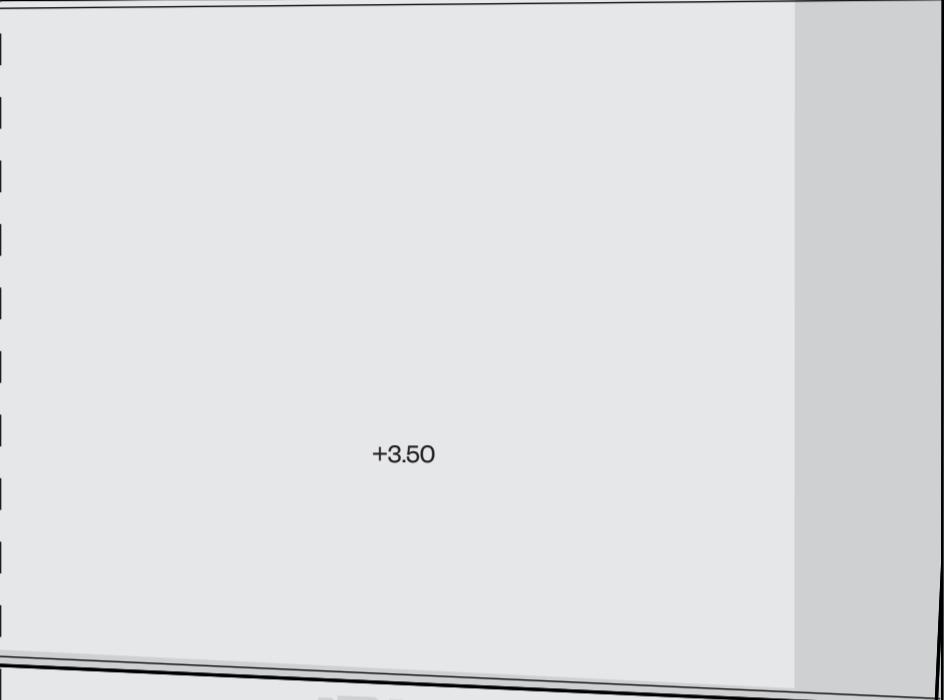

Entertainment park — floor plan 1:200

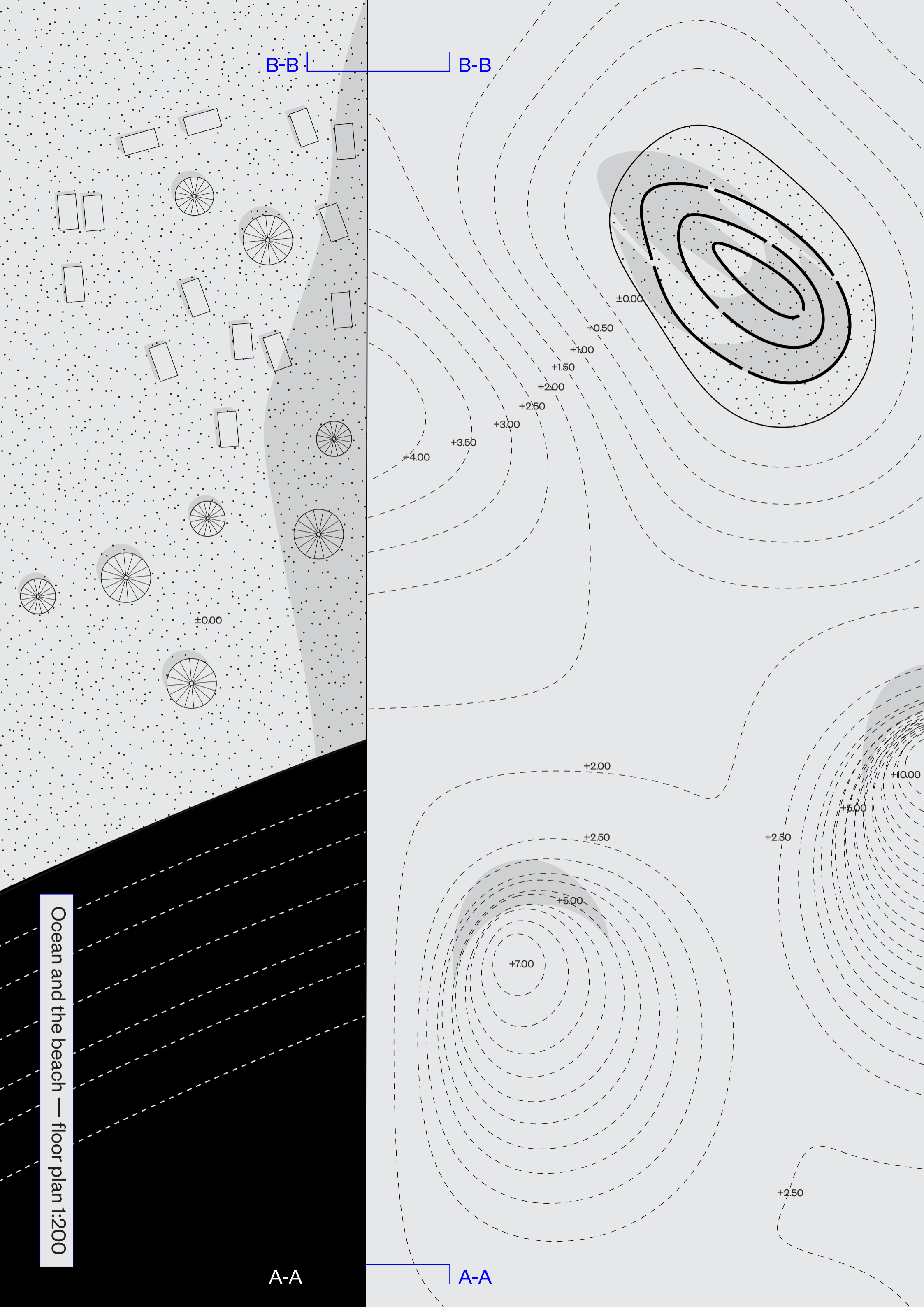

B-B

B-B

±0.00

+4.00

+3.50

+3.00

+2.50

+2.00

+1.50

+1.00

+0.50

±0.00

+2.00

+2.50

+5.00

+7.00

+10.00

+5.00

+2.50

+2.50

Ocean and the beach — floor plan 1:2000

A-A

A-A

Barrier — Section A-A, 1:20

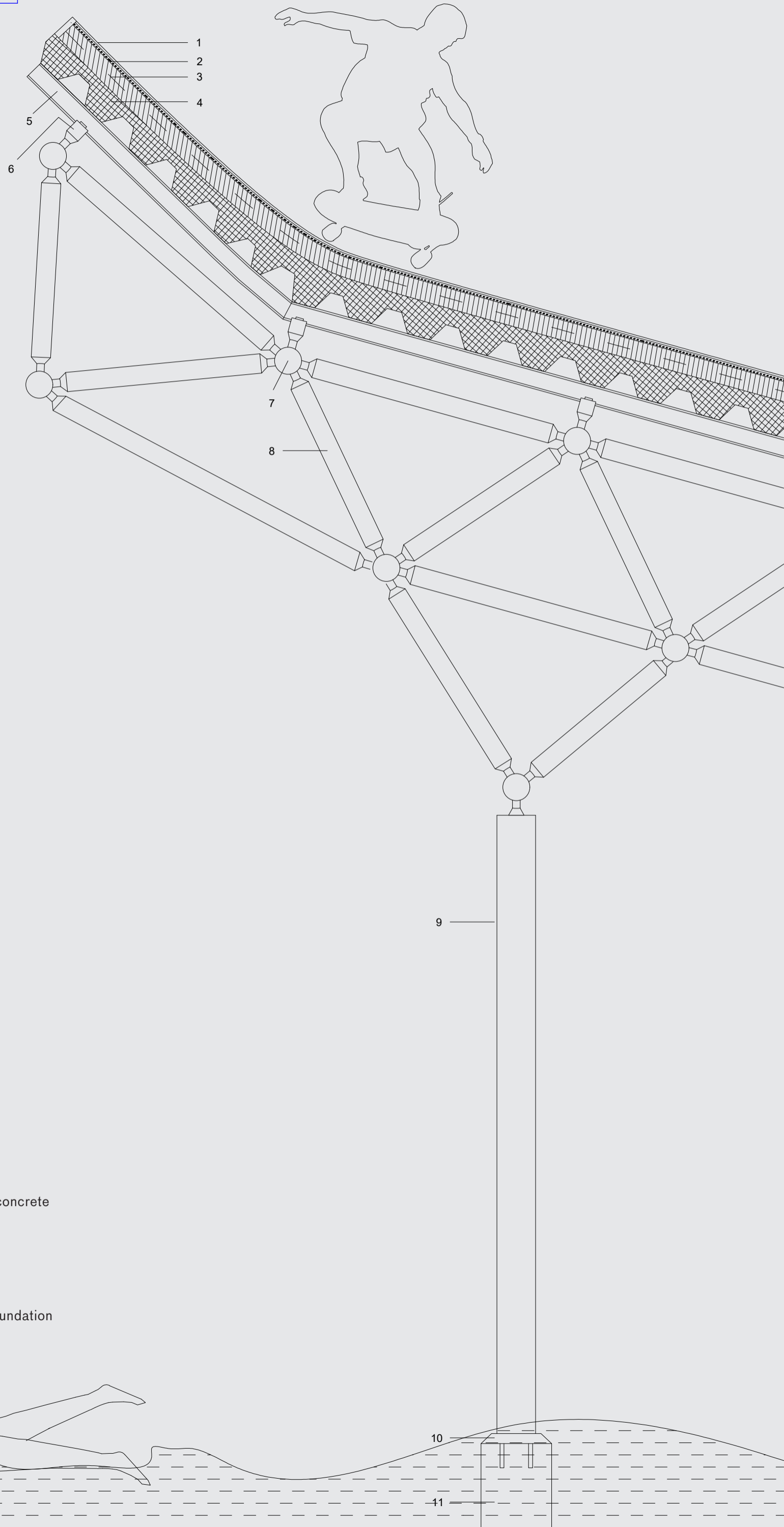

1. rubber tiles made from recycled granulate
2. bitumen waterproof sheets
3. smooth concrete in tilt 1,5%
4. trapezoidal metal deck filled with reinforced concrete
5. secondary L shaped steel structure
6. steel connector - nod
7. connecting joints of primary steel structure
8. main tubes of primary steel structure
9. tube steel column
10. steel connector with steel plate bolted into foundation
11. pile foundation

Mountain — Section G-G, 1:20

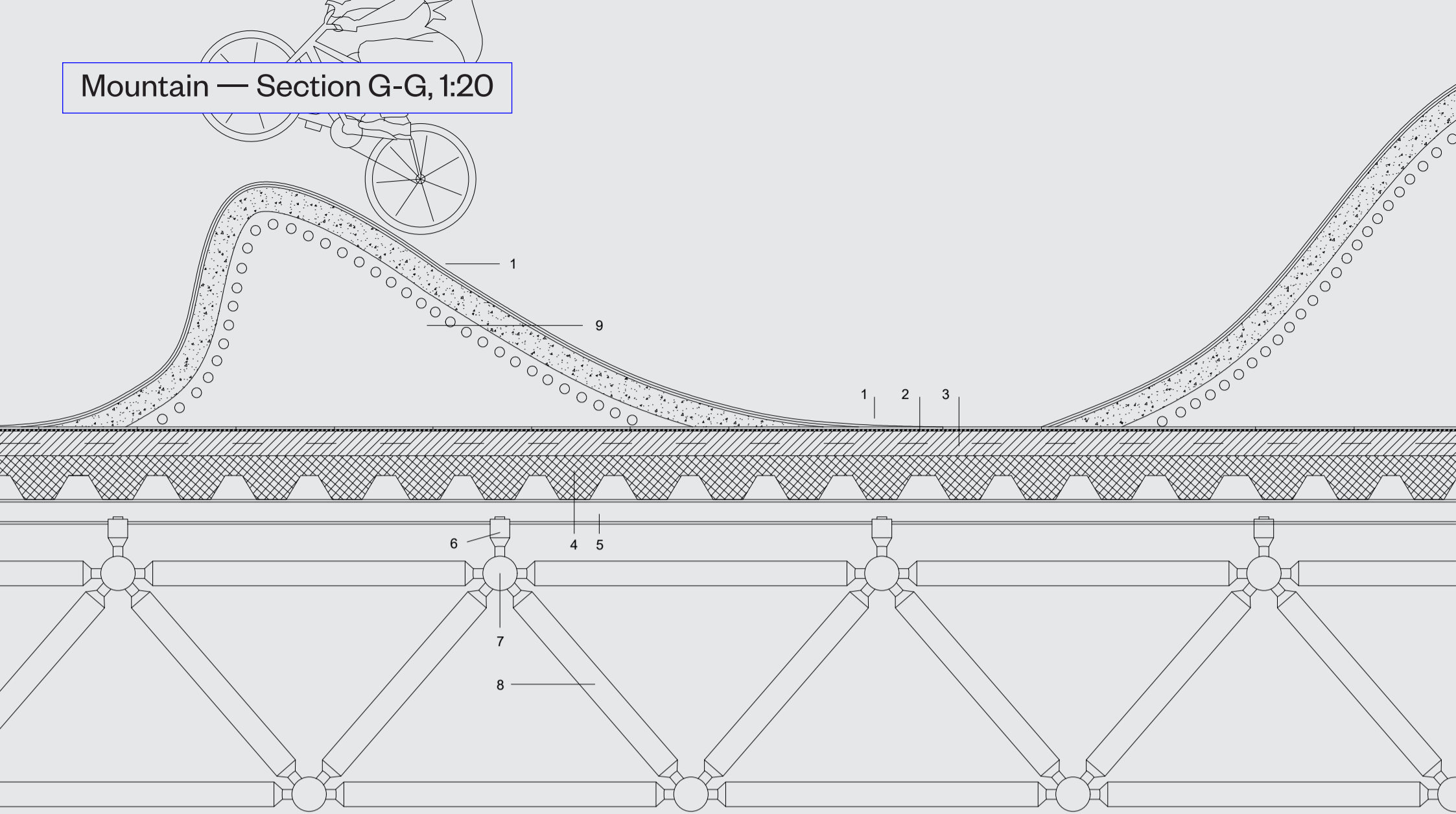

1. rubber tiles made from recycled granulate
2. bitumen waterproof sheets
3. smooth concrete in tilt 1,5%
4. trapezoidal metal deck filled with reinforced concrete
5. secondary L shaped steel structure
6. steel connector - nod
7. connecting joints of primary steel structure
8. main tubes of primary steel structure
9. mound - rubber granulate covering, loose rubber granulates, gravel

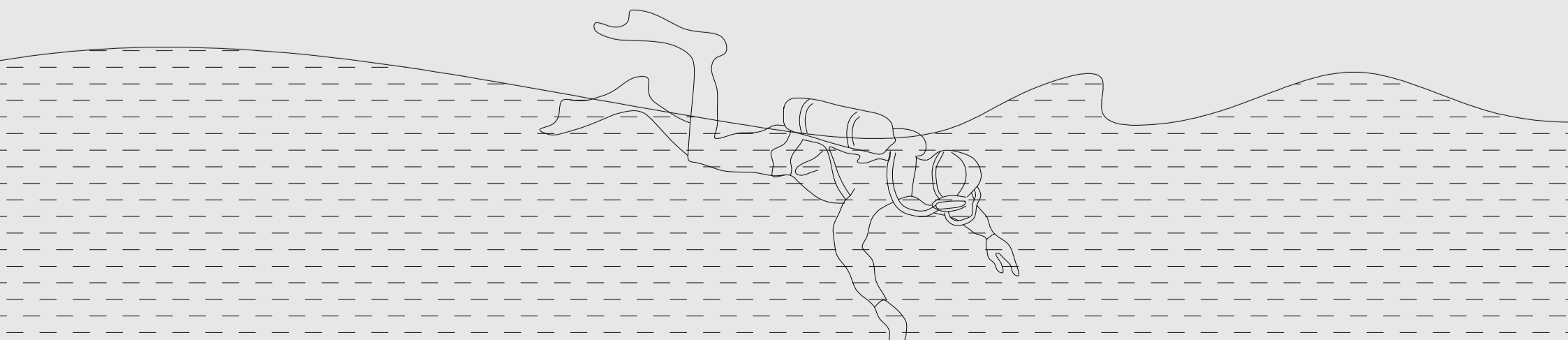

Slope — Section B-B-1, 1:20

1. rubber tiles made from recycled granulate
2. bitumen waterproof sheets
3. smooth concrete in tilt 1,5%
4. trapezoidal metal deck filled with reinforced concrete
5. L shaped steel profile
6. secondary L shaped steel structure
7. steel connector - nod
8. connecting joints of primary steel structure
9. main tubes of primary steel structure
10. steel connector with steel plate bolted into foundation
11. foundation, individual square footing

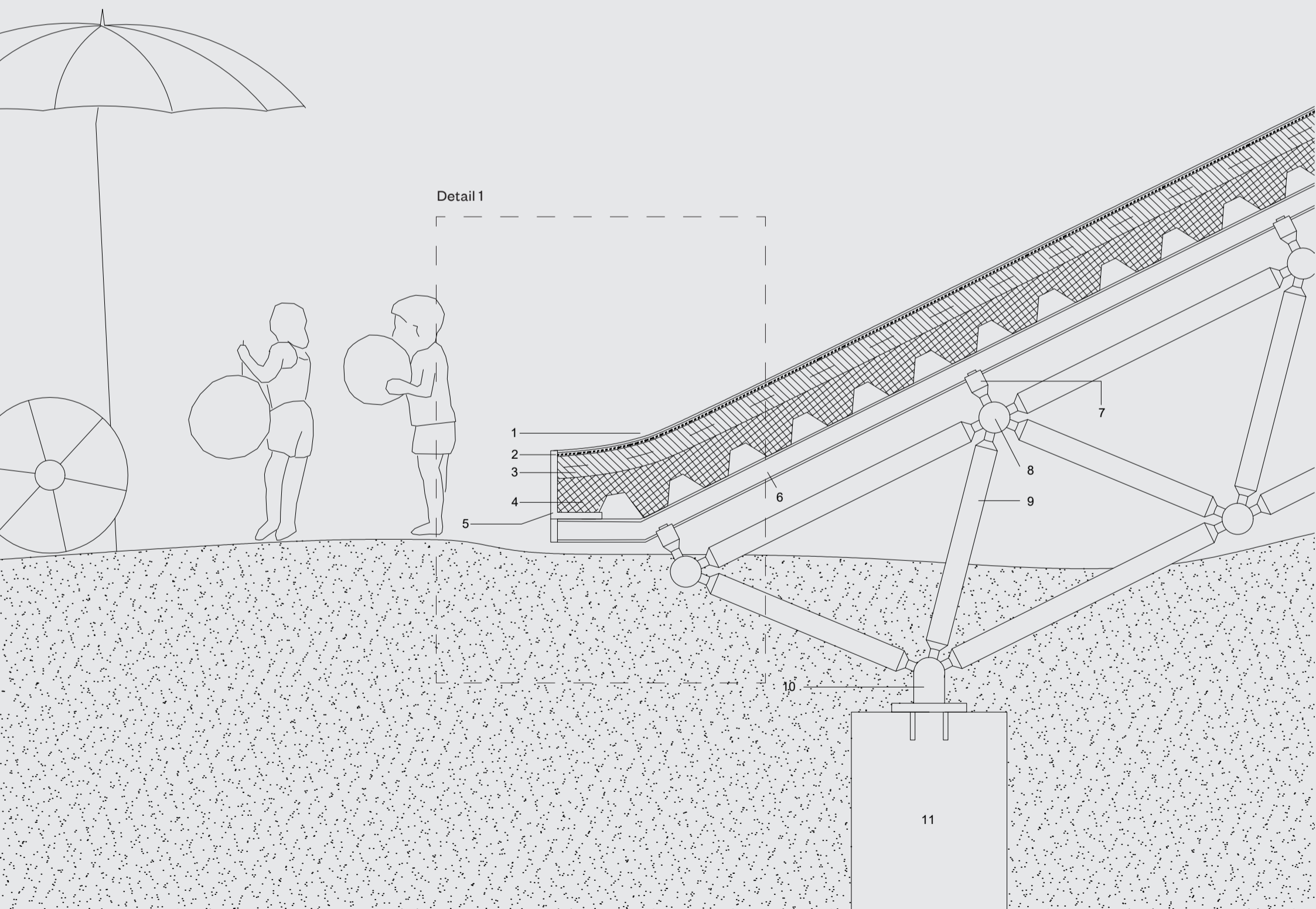

Slope — Section B-B-2, 1:20

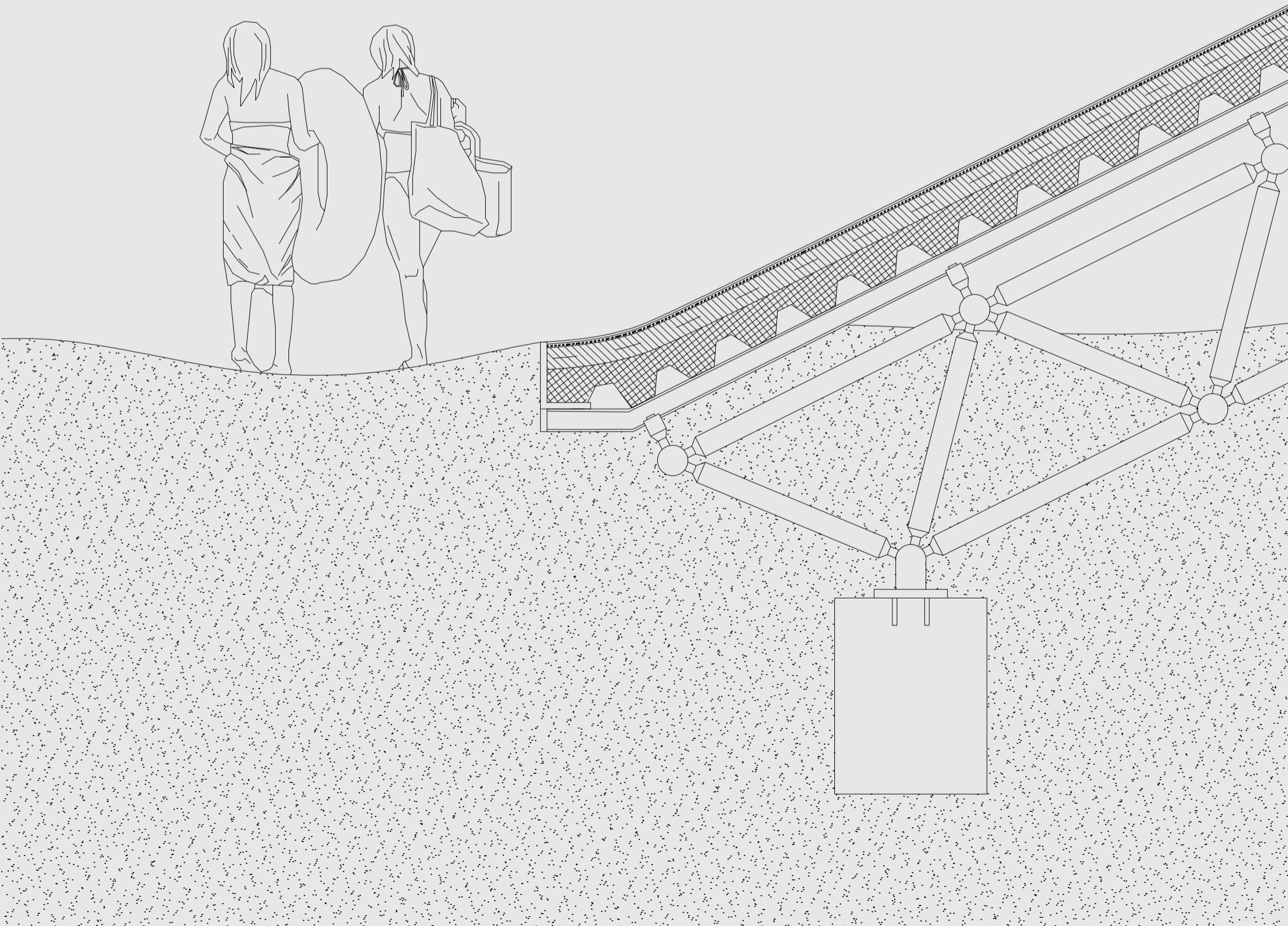

Slope — Section B-B-3, 1:20

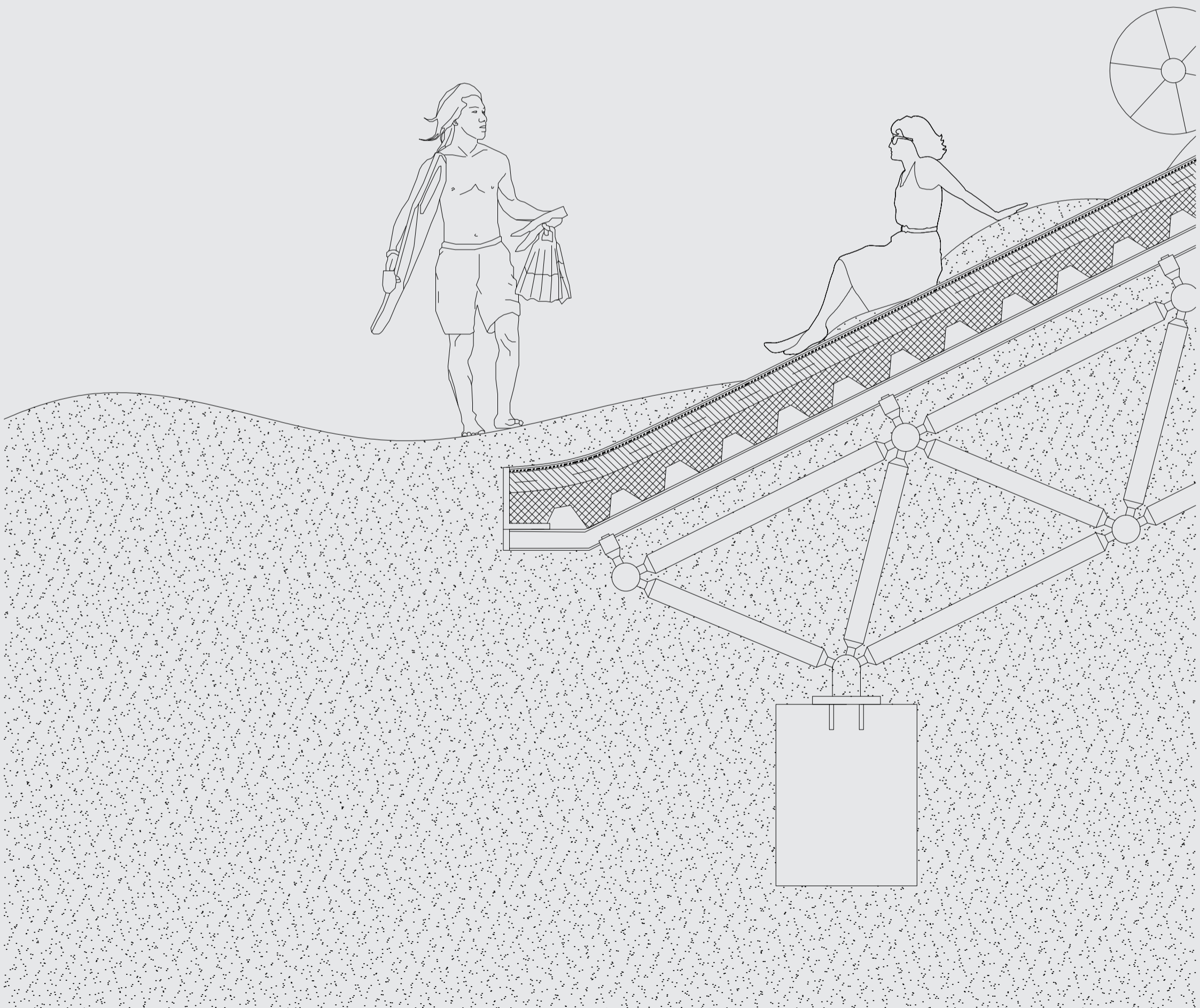

Flat — Section C-C, 1:20

1. rubber tiles made from recycled granulate
2. bitumen waterproof sheets
3. smooth concrete in tilt 1,5%
4. trapezoidal metal deck filled with reinforced concrete
5. secondary L shaped steel structure
6. steel connector - nod
7. connecting joints of primary steel structure
8. main tubes of primary steel structure
9. glass fence
10. aluminium handrail
11. steel column I profile
12. poured concrete
13. smooth concrete in tilt 1,5%
14. bedding sand
15. existing soil sub-grade
16. concrete curb

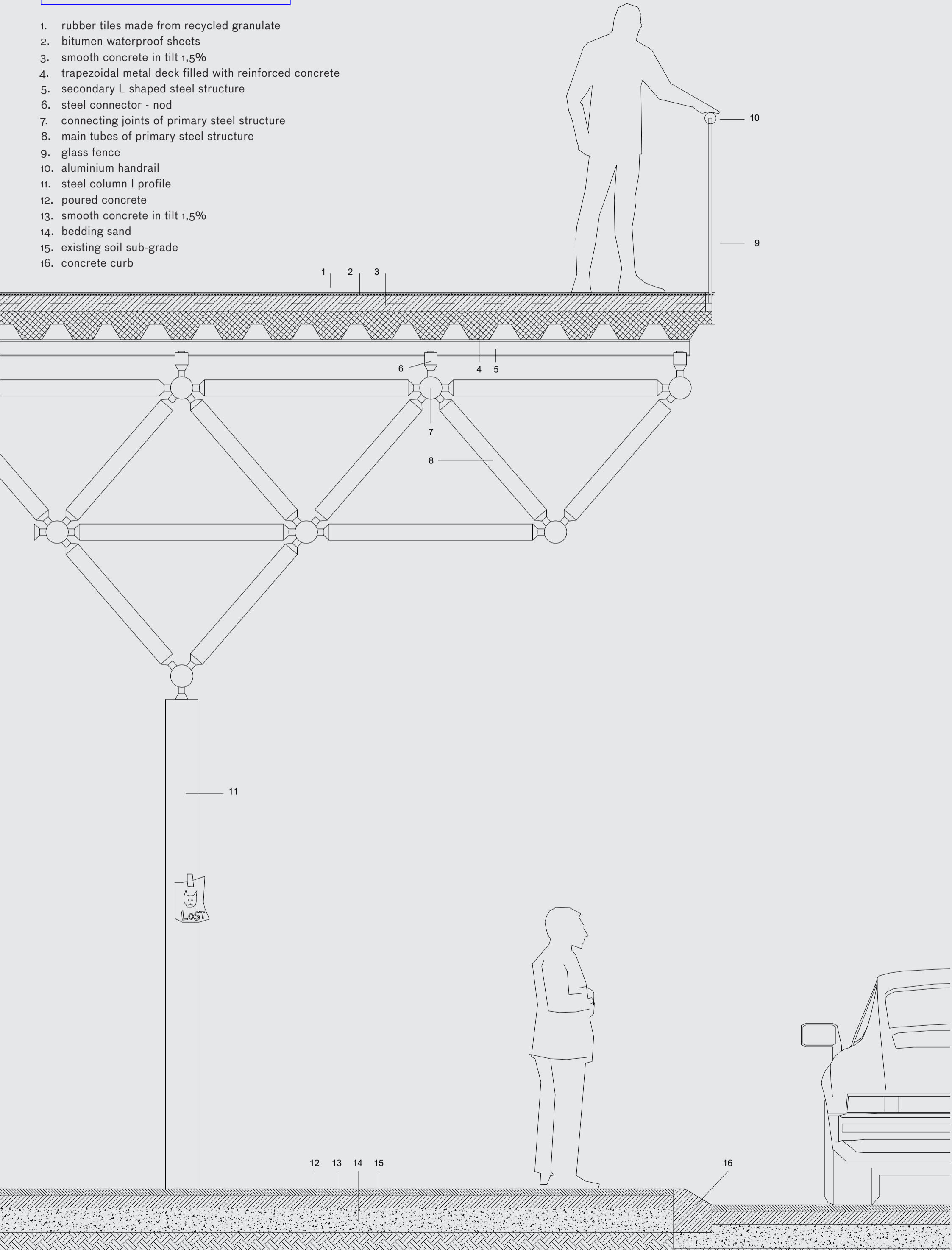

Hole - net — Section D-D, 1:20

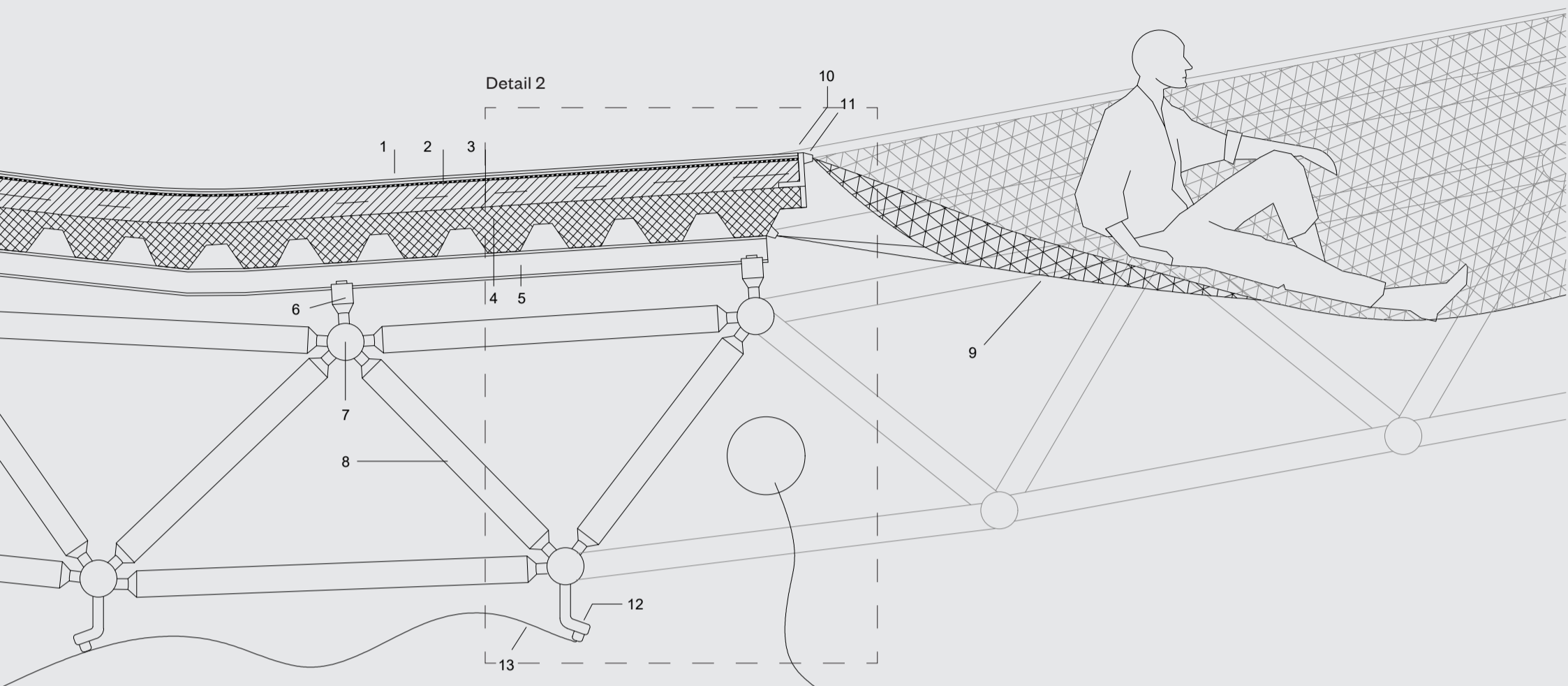

1. rubber tiles made from recycled granulate
2. bitumen waterproof sheets
3. smooth concrete in tilt 1,5%
4. trapezoidal metal deck filled with reinforced concrete
5. secondary L shaped steel structure
6. steel connector - nod
7. connecting joints of primary steel structure
8. main tubes of primary steel structure
9. net for sitting
10. L shaped steel profile
11. metal connector for the net
12. angled aluminium bracket
13. glass fibre fabric with silicone coating
14. concrete floor tiles
15. mortar bed
16. concrete slab
17. compact aggregate base
18. existing soil sub-grade

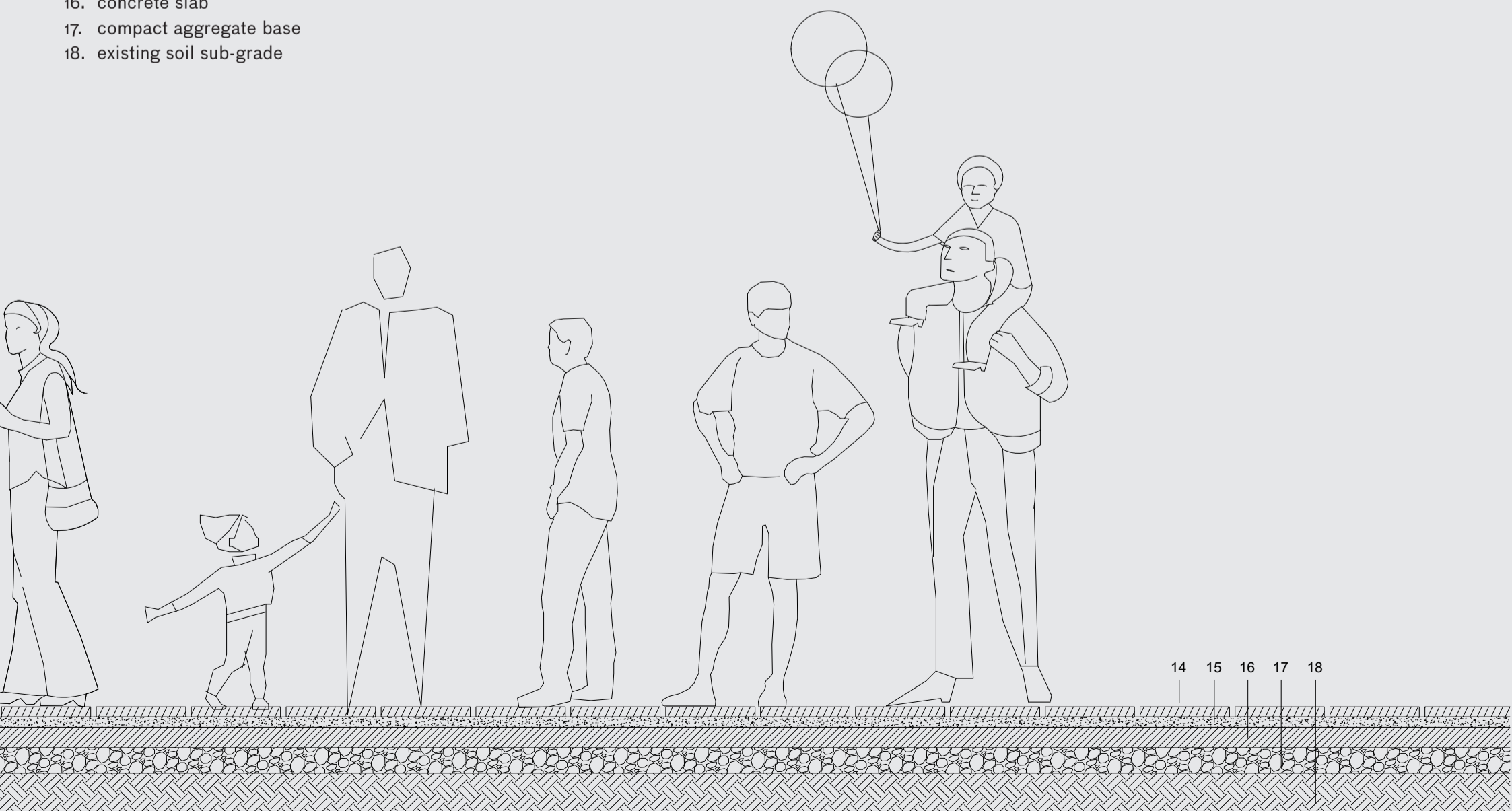

Hole - glass — Section E-E, 1:20

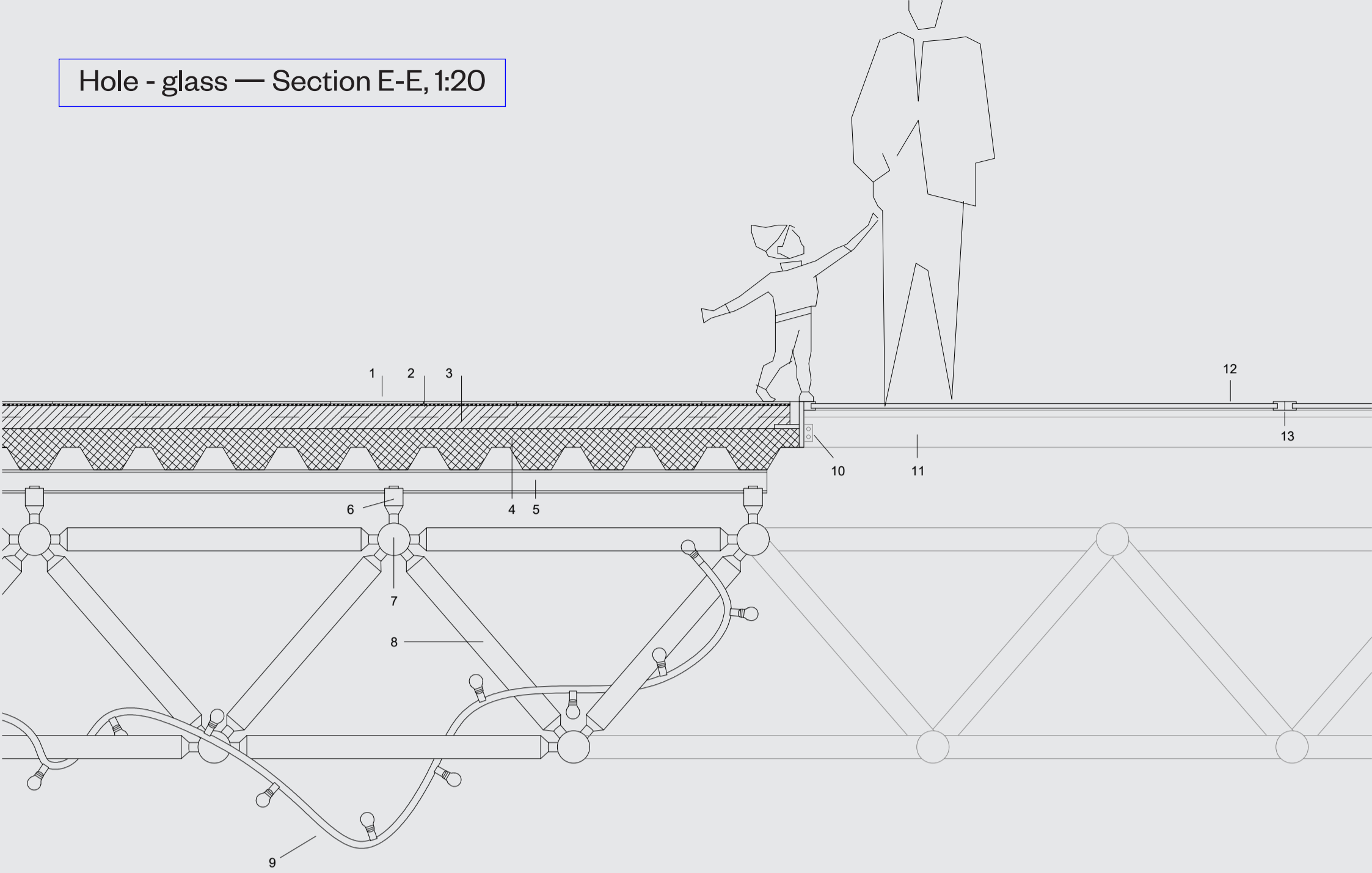

1. rubber tiles made from recycled granulate
2. bitumen waterproof sheets
3. smooth concrete in tilt 1,5%
4. trapezoidal metal deck filled with reinforced concrete
5. secondary L shaped steel structure
6. steel connector - nod
7. connecting joints of primary steel structure
8. main tubes of primary steel structure
9. LED string / rope lights
10. steel connecting plate
11. steel I profile supporting window structure
12. aluminium window frame
13. reinforced tripple walking glass
14. concrete floor tiles
15. mortar bed
16. concrete slab
17. compact aggregate base
18. existing soil sub-grade

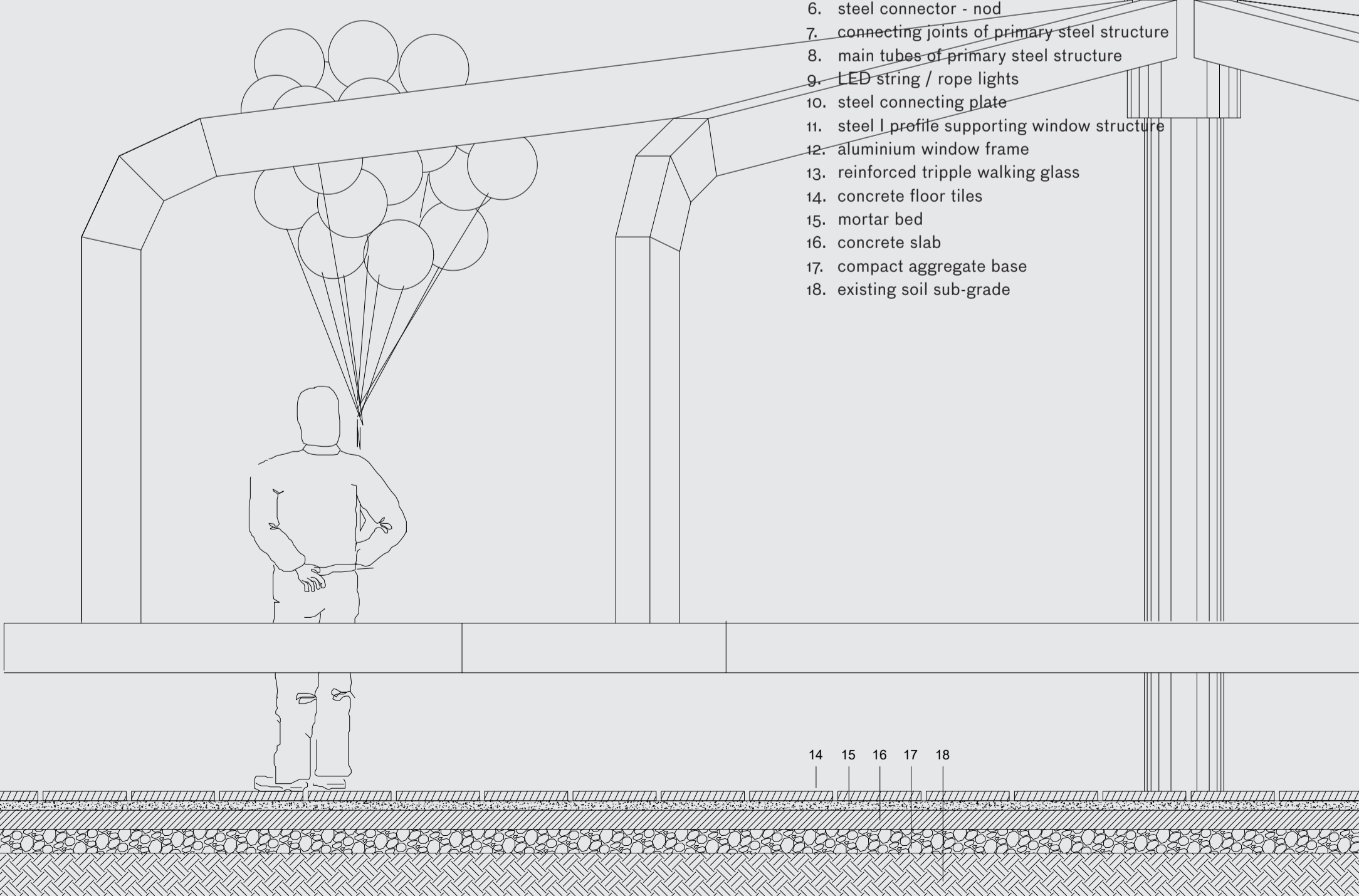

Hole - fence — Section F-F-1, 1:20

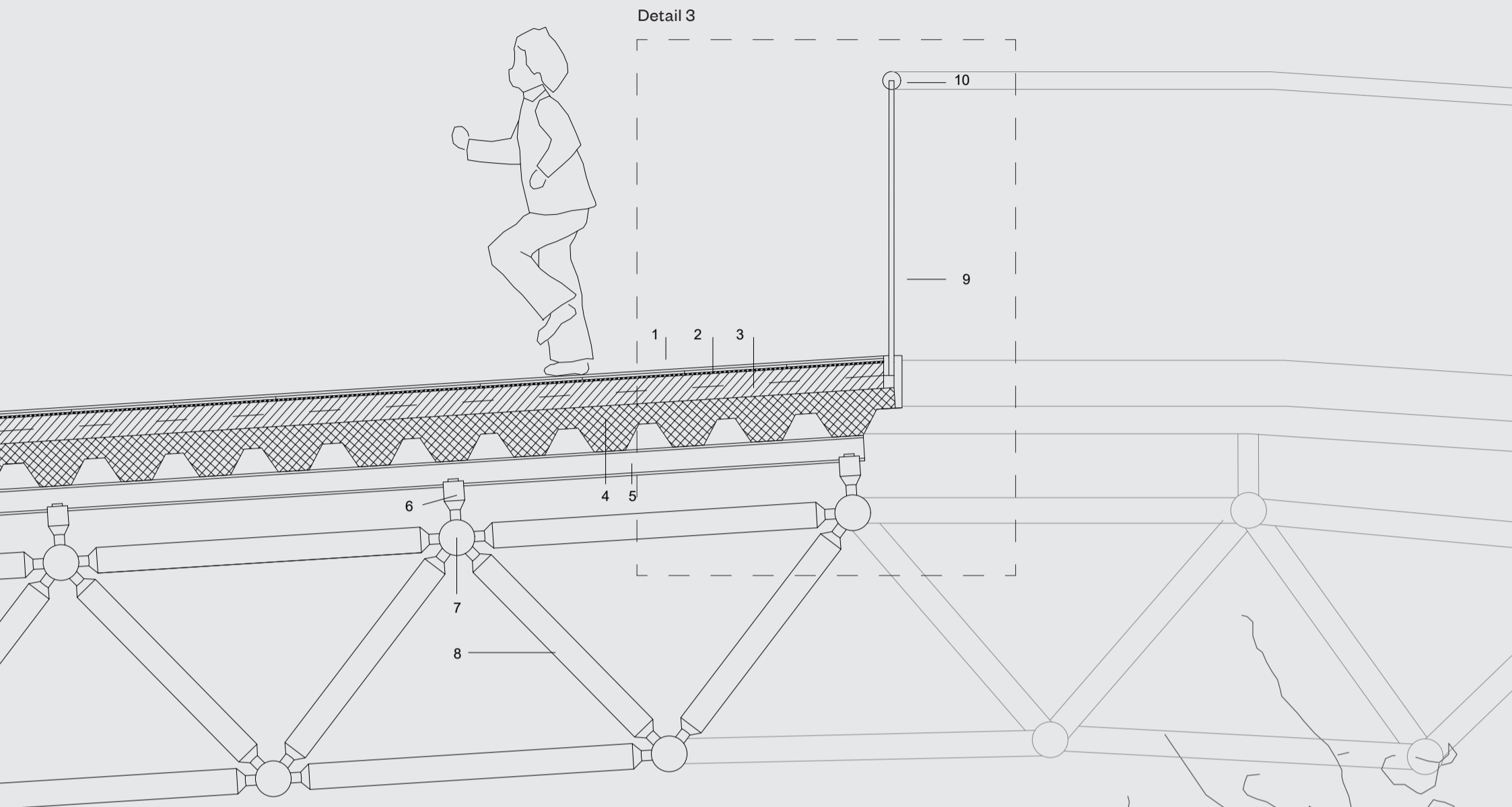

1. rubber tiles made from recycled granulate
2. bitumen waterproof sheets
3. smooth concrete in tilt 1,5%
4. trapezoidal metal deck filled with reinforced concrete
5. secondary L shaped steel structure
6. steel connector - nod
7. connecting joints of primary steel structure
8. main tubes of primary steel structure
9. glass fence
10. aluminium handrail

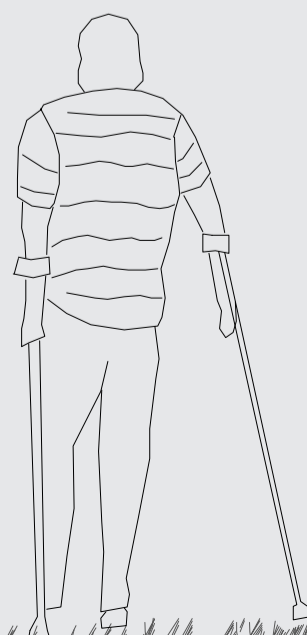

Hole - fence — Section F-F-2, 1:20



Hole - fence — Section F-F-3, 1:20

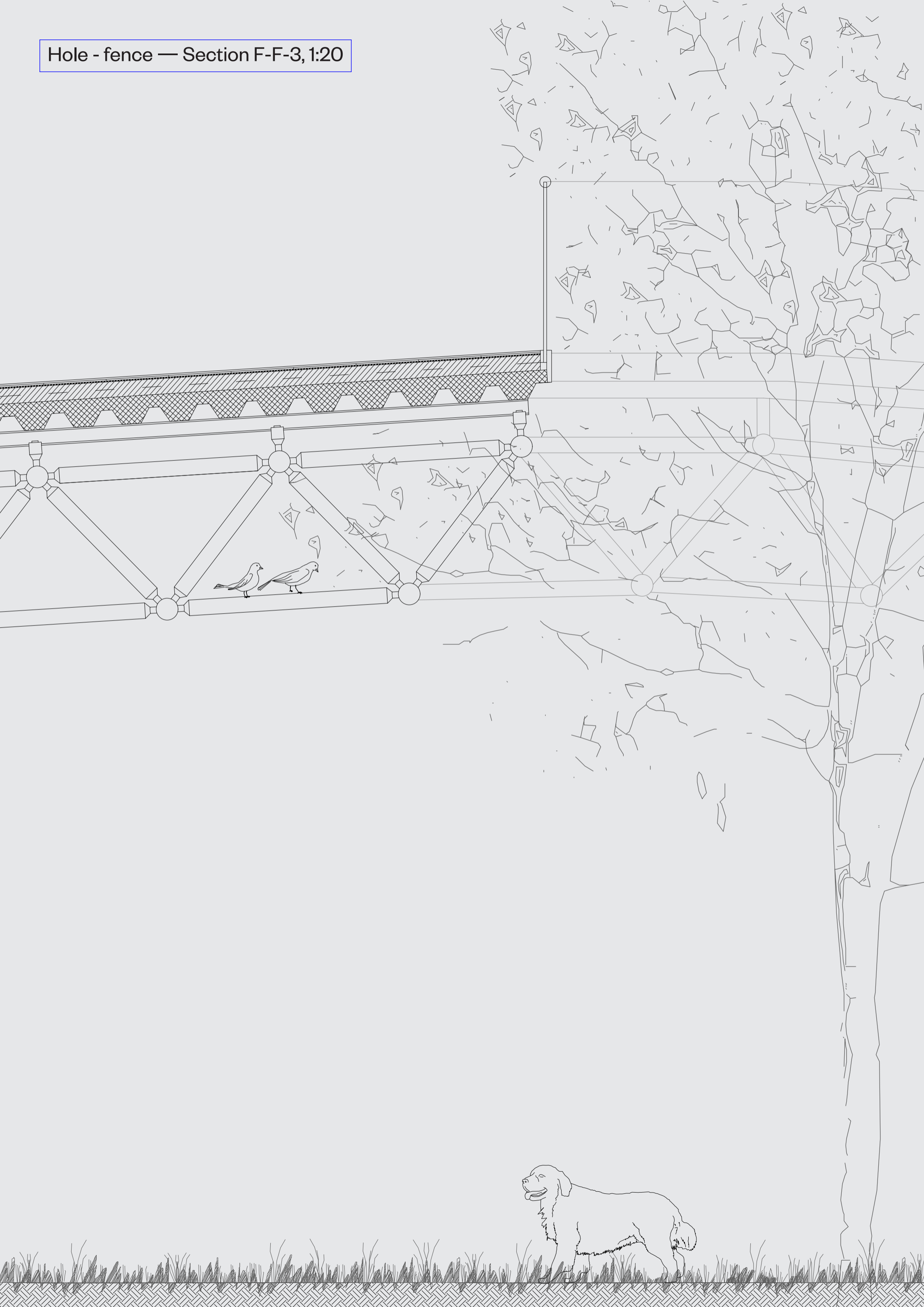

Hole - fence — Detail 1, 1:5

1. LED light
2. gutter
3. drain
4. L shaped steel profile protecting the floor layers
5. secondary L shaped steel structure

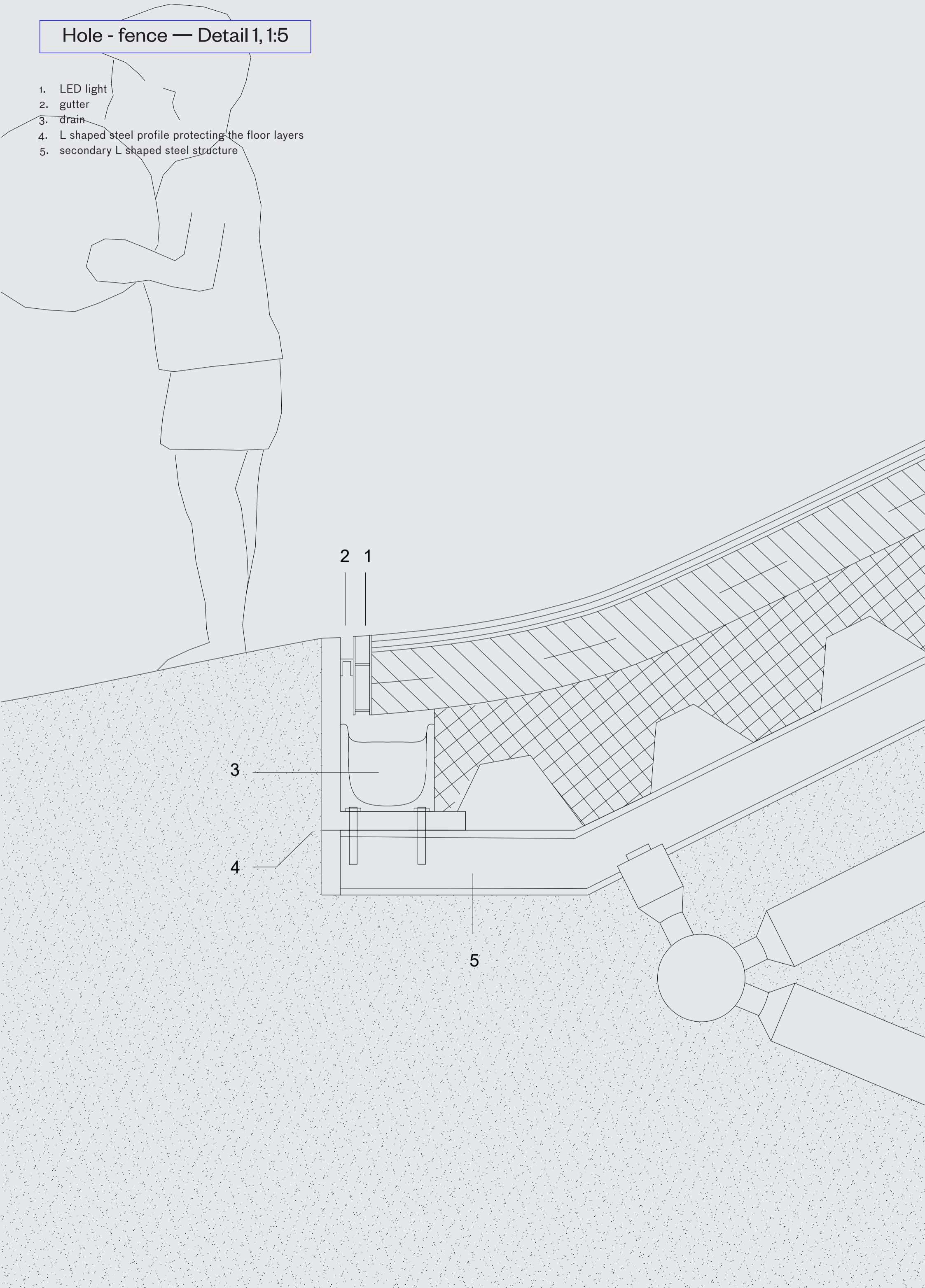

Hole - fence — Detail 2, 1:5

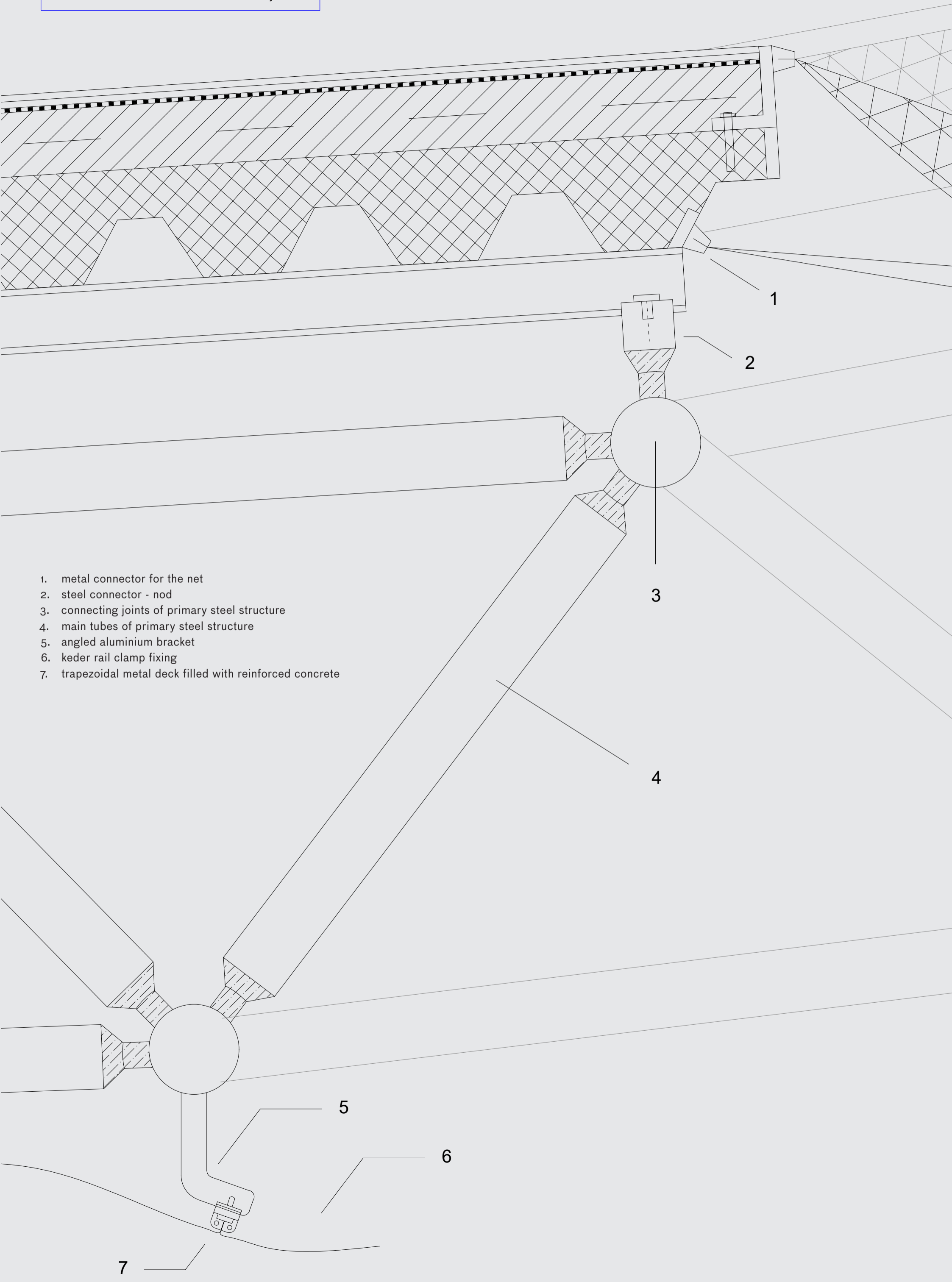

- 1. metal connector for the net
- 2. steel connector - nod
- 3. connecting joints of primary steel structure
- 4. main tubes of primary steel structure
- 5. angled aluminium bracket
- 6. keder rail clamp fixing
- 7. trapezoidal metal deck filled with reinforced concrete

Hole - fence — Detail 3, 1:5

1. 80 mm diameter stainless steel top rail silicone-fixed to glass
2. structural toughened and heat - soaked glass, held in base clamp
3. glass set in Arbocal to a minimum depth of 80 mm, then pointed with silicone sealant
4. continuous metal clamping system fixed to the slab using
5. stainless steel trim
6. plaster finish to slab

