

# Repurposing wind turbine blades as a construction material

A method to extract valuable elements from a decommissioned wind turbine blade for applications in the construction industry

Master Thesis

Simon Pronk

# Repurposing wind turbine blades as a construction material

**A method to extract valuable elements from a decommissioned wind turbine blade for applications in the construction industry**

by

Simon Pronk

Student number:	4305140	
Thesis Committee:	Prof. Dr. Henk Jonkers	TU Delft
	ir. Hoessein Alkisaie	TU Delft
	ir. Peter Eigenraam	TU Delft
	Tom Borst	Arcadis
Institution:	Delft University of Technology	
Place:	Faculty of Civil Engineering, Delft	
Graduation company:	Arcadis N.V.	
Project start:	September, 2021	

Cover Image: Wind Turbine in Gunn's Hill - North America, 2020 ProWind GmbH

# Preface

Writing the preface of a master thesis means the last miles on the study road are about to take place. The thesis has been the last challenge to obtain my degree in the master studies Building Engineering at the Delft University of Technology. This research is conducted in collaboration with Arcadis and has been an interesting ride since the start of the research, in September 2021.

In search of a thesis topic, I came up with multiple ideas which I pitched during my first interview with Arcadis. The people of the Structural Design and Engineering department were enthusiastic about my proposals, but informed me that they potentially had another interesting thesis topic. At that time, a preliminary design for a large canopy was submitted for a tender and this design contained wind turbine blades as roof beams. Based on this design I came in touch with the experienced structural engineer Tom Borst. We met in the summer holiday in an empty office at Arcadis in Rotterdam to discuss the possibilities to conduct my master thesis at Arcadis with a topic related to the repurposing of wind turbine blades.

When I started investigating the problem of blade waste materials, I learned how big the waste problem will become the coming decade and that a first step towards large scale repurpose possibilities had to be taken. During my kick-off meeting, I proposed a research that, in retrospect, could take up an entire career. Luckily, my committee members and I had a productive discussion which helped me to further narrow down the scope of the research. This, in combination with the further meetings, has led to a research that turned out manageable and at the same time could add a significant contribution to the waste problem.

Looking into the future, I hope that the value of the material in end-of-life blades will be recognized soon and that in a few years it is achievable to incorporate wind turbine blade elements in a wide variety of construction projects. I am aware of the fact it is not yet the most straight forward method, and maybe even not the most economical option, to incorporate turbine blade elements in a project. Therefore I hope that with the rising awareness and the necessity to design circular, a visionary client has the courage to take this challenge.

In order to make this happen, I hope my research demonstrates the possibilities of decommissioned wind turbine blades and the value they contain, even after decades of spinning around. Moreover, I hope that from now on turbine blade elements will be a serious alternative for current building materials. I look forward to the future developments regarding this topic.

*Simon Pronk  
Delft, April 2022*

# Abstract

Wind turbines are decommissioned when they reach their end-of-life. The reason for reaching end-of-life varies per wind turbine, but they all have in common that the wind turbine blades can not be recycled and thus end up as waste. Since a growing amount of wind turbines will reach their end-of-life the coming decade, the waste problem will increase. To solve or limit this problem, the lifetime of a blade can be extended, or a sustainable end-of-life treatment can be established. This is currently not available yet.

This research focuses on repurposing wind turbine blades. The objective is not to find one application, but rather to propose a method that enables large scale processing of wind turbine blades, for applications in the construction industry.

Since to date it is uncommon to repurpose wind turbine blades, Two processes are proposed to give guidance on how to repurpose wind turbine blades. The first process is meant to repurpose as many blades as possible, by sawing the blade in plates and beams that can be applied to construction projects. The second process gives guidance to a project team that wants to incorporate wind turbine blades in their construction project, which can raise awareness for the waste problem.

Both processes are supported by a grasshopper script. This script enables the user to either find an efficient mapping of elements that can be extracted from the blade, or gives design freedom depending on the aim of the repurpose project.

The first process is further worked out. A geometry model of an actual wind turbine blade is analyzed and categorized in panels with a homogeneous material layup. On this panels, a nesting pattern of plates and beams, as commonly used in the construction industry, is projected which can later be sawn into relative flat plates and beams. With this, almost half of the blade panels can be turned into useful construction elements.

The cross section of a blade consists of various functions, and thus various material structures. Three categories are distinguished: Spar caps, shell panels and the shear web. For each of these categories, the material layup and properties are analysed, which has led to an advice on possible applications. Spar caps are strong, stiff and have a homogeneous cross section. They can be repurposed as structural beams. Shell panels are light and stiff and can be repurposed as partition walls, formwork or flooring. The shear web is light, stiff, and entails good insulation properties. This can be repurposed as building cladding. Although this research does not contain sample tests, the material properties of the blade are provided and are of significant value, despite their 27 years of service.



# Acknowledgements

First of all, I would like to thank the committee members for their supervision and guidance during my thesis. I am thankful for the willingness of Professor Jonkers to chair the thesis committee.

I am very grateful for the input, effort and support of Tom Borst. Next to his work at Arcadis he was willing to give feedback on my ideas, attend meetings, comment my work and provide information regarding the topic.

Also, I appreciate very much the motivational and guiding discussions I had with Hoessein Alkisaie. Our meetings always encouraged me to proceed and were useful to check if I didn't lose track of the objective of the research.

Moreover, I would like to thank Peter Eigenraam for his guidance related to the modelling in Grasshopper. He was able to grasp my modelling struggles and explained very clearly how I could proceed.

I would also like to thank Jelle Joustra, Phd candidate at the faculty of Industrial Design, who demonstrated that it is actually possible to extract flat elements from a blade and even provided me with a few blade elements.

Special thanks goes out to Lawrence Bank and Russell Gentry, principal investigators at the Re-wind Network, for their extensive knowledge on wind turbine blades, for their willingness to meet often and comment on my work and last but definitely not least, for providing me the GE37 blade model which has been used as a case study in this research.

Credit also go out to my friends and girlfriend, who took the time to read my thesis, tried to grasp what I was working on, sent me en masse examples of repurposed blade projects and criticized my research plans when necessary.

Finally, my greatest thanks go to my parents. Without their support and guidance I could never have been where I am today.

# Contents

<b>Preface</b>	<b>i</b>
<b>Abstract</b>	<b>ii</b>
<b>Acknowledgements</b>	<b>iii</b>
<b>Nomenclature</b>	<b>vi</b>
<b>List of Figures</b>	<b>vii</b>
<b>List of Tables</b>	<b>ix</b>
<b>1 Introduction</b>	<b>1</b>
1.1 Relevance of the research	1
1.2 Research question	2
1.3 Objective	2
1.4 Research methodology	2
1.5 Scope and limitations	3
1.5.1 Scope	3
1.5.2 Limitations	4
1.6 Literature review	5
1.6.1 Background on wind turbine design	5
1.6.2 Geometry of available reference wind turbine blades	5
1.6.3 Damages in wind turbine blades	5
1.6.4 Recycling and repurposing of decommissioned wind turbine blades	6
1.6.5 Material properties of materials used in wind turbine blades	6
<b>2 State-of-the-art</b>	<b>7</b>
2.1 Wind turbines	7
2.1.1 Wind turbine design	7
2.1.2 Main elements of a wind turbine	7
2.2 Wind turbine blade design	8
2.2.1 Geometry of a wind turbine blade	8
2.2.2 Used methods and theories for wind turbine blade design	11
2.2.3 Wind classes	12
2.2.4 Blade materials and properties	13
2.2.5 Manufacturing process	15
2.3 Overview of installed wind turbines in the Netherlands	15
2.4 Possible end-of-life strategies of wind turbine blades	16
2.4.1 Prevention	17
2.4.2 Reuse	17
2.4.3 Repurpose	17
2.4.4 Recycling	18
2.4.5 Recovery	18
2.4.6 Disposal	18
<b>3 Assessment Method</b>	<b>19</b>
3.1 Why blades are decommissioned	19
3.1.1 Turbine reaches its end of service life	19
3.1.2 Economical reasons	21
3.2 A method to repurpose wind turbine blades	21
3.3 Disposal costs at this moment	22

<b>4</b>	<b>Repurpose Method</b>	<b>24</b>
4.1	Objectives and methodology . . . . .	24
4.1.1	Objectives . . . . .	24
4.1.2	Methodology . . . . .	25
4.2	Input for the repurpose model . . . . .	25
4.2.1	Boundary conditions for extracting the elements . . . . .	27
4.3	Efficient extraction algorithm . . . . .	28
4.3.1	Algorithm for efficient repurposing of wind turbine blades . . . . .	29
4.3.2	Expected efficiency range of the repurposed panels . . . . .	31
4.3.3	Nesting patterns on blade panels . . . . .	32
4.3.4	Maximum element dimensions from blade panels . . . . .	35
4.3.5	Assigning thickness to resulting elements . . . . .	36
4.4	Algorithm for repurposing wind turbine blades on demand . . . . .	36
4.4.1	Approach for on-demand algorithm . . . . .	37
4.4.2	Description of on-demand algorithm . . . . .	37
4.4.3	Possible outcomes of on demand algorithm . . . . .	37
4.5	Element properties . . . . .	38
4.5.1	Spar caps . . . . .	38
4.5.2	Shell panels . . . . .	38
4.5.3	Shear Web . . . . .	39
4.6	Advise on possible applications . . . . .	40
4.6.1	Shear Web . . . . .	41
4.6.2	Spar Cap . . . . .	41
4.6.3	Shell Panels . . . . .	41
4.6.4	Out-of-the-box . . . . .	42
4.6.5	Practical tips and implications . . . . .	42
4.7	Results . . . . .	43
<b>5</b>	<b>Discussion</b>	<b>46</b>
5.1	Answer to the research question . . . . .	46
5.2	Conclusions . . . . .	46
5.3	Discussion . . . . .	47
5.3.1	Research approach . . . . .	47
5.3.2	Value quantification . . . . .	47
5.3.3	This research in a broader context . . . . .	48
5.4	Recommendations . . . . .	49
5.5	Further research . . . . .	49
	<b>Bibliography</b>	<b>51</b>
	<b>References</b>	<b>54</b>
<b>A</b>	<b>Manufacturers of wind turbines in the Netherlands</b>	<b>55</b>
<b>B</b>	<b>Method to repurpose wind turbine blades</b>	<b>57</b>
B.1	Repurpose as many wind turbine blades as possible . . . . .	57
B.2	Incorporate wind turbine blades in project design . . . . .	59
<b>C</b>	<b>Grasshopper scripts</b>	<b>61</b>
C.1	Preparing the model . . . . .	61
C.2	Optimized for material use . . . . .	62
C.3	On-demand extracting of elements . . . . .	65
C.4	Adding thickness . . . . .	66
<b>D</b>	<b>Catalog</b>	<b>68</b>
<b>E</b>	<b>Building elements</b>	<b>70</b>

# Nomenclature

## Abbreviations

Abbreviation	Definition
BEM	Blade Element Momentum
CAD	Computer Aided Design
CFRP	Carbon Fiber Reinforced Polymer
EoL	End-of-Life
GE37	General Electric 37 meter long wind turbine blade
GFRP	Glass Fiber Reinforced Polymer
HAWT	Horizontal Axis Wind Turbine
LEHP	Leading Edge High Pressure
LELP	Leading Edge Low Pressure
MW	Mega Watt
NREL	National Renewable Energy Laboratory
RWT	Reference Wind Turbine
SCHP	Spar Cap High Pressure
SCLP	Spar Cap Low Pressure
TEHP	Trailing Edge High Pressure
TELP	Trailing Edge Low Pressure
VAWT	Vertical Axis Wind Turbines



# List of Figures

1.1	Schematic overview of research methodology and structure of the report . . . . .	3
1.2	Visualisation of repurpose methods and research gap . . . . .	4
2.1	Schematic overview of a wind turbine (Posco, 2016) . . . . .	8
2.2	Aerodynamic parameters for outer geometry of a blade (Kanshal, 2018) . . . . .	9
2.3	Characteristic cross sections. Retrieved from Nijssen and Van Delft (2003) . . . . .	9
2.4	A cross section at 22m from the root of a 47 meter long composite rotor blade for 2MW wind turbines including the materials used (Chen, 2019) . . . . .	10
2.5	Exploded view of the DTU 10MW RWT (Bortolotti et al., 2019) . . . . .	10
2.6	Standard design wind turbine blade (Schubel and Crossley, 2012) . . . . .	11
2.7	Illustration of the loads acting on a wind turbine blade. The blade is a GE37 blade model provided by the Re-Wind Network . . . . .	11
2.8	Illustration of the fiber lay-up in uni-axial, bi-axial and tri-axial laminates . . . . .	13
2.9	Hatched regions of the structural and aerodynamic part in a blade cross section (Chen, 2019) . . . . .	14
2.10	Blade mould at the Siemens blade factory in Hull. Retrieved from Manufacturer (2018) . . . . .	15
2.11	Installed wind turbines in the Netherlands on shore. Data provided by Bosch and van Rijn (2021) . . . . .	16
2.12	Average power capacity of installed wind turbines in the Netherlands per year. Data provided by Bosch and van Rijn (2021) . . . . .	16
2.13	Waste hierarchy according to circular economy principles (Schmid Marylise et al., 2020) . . . . .	17
3.1	Current disposal costs and benefits of wind turbine blades . . . . .	22
3.2	A theoretical cost/profit range in case a GE37 blade is repurposed . . . . .	23
4.1	GE37 Blade model and legend, received from Georgia Insitute of Technology . . . . .	26
4.2	Leading edge and trailing edge of the blade . . . . .	26
4.3	Five cross sections of the GE37 blade . . . . .	26
4.5	Possible deviations in timber. Curved, crooked, scoundrel and hollow. (Van de Kuilen et al.) . . . . .	27
4.4	Inhomogeneity in parts of the blade. The following is illustrated: Leading edge reinforcement, Trailing edge reinforcement & extra shear web . . . . .	27
4.6	All seven blade panels set out individually. From left to right: TEHP, SCHP, LEHP, LELP, SCLP, TELP, Shear Web . . . . .	29
4.7	TELP Panel divided over 500 points . . . . .	29
4.8	Projection of plates with global coordinate system . . . . .	29
4.9	Projection of plates on local principal curvature coordinate system . . . . .	30
4.10	Illustration of bounding box of one element . . . . .	30
4.11	All possible panels projected on the TELP panel . . . . .	30
4.12	All possible beams projected on the TELP panel . . . . .	31
4.13	Range in obtained efficiency per blade panel . . . . .	32
4.14	TELP Panel with only beams. This leads to a lower efficiency than the combination of plates and beams . . . . .	33
4.15	TELP Panel final nesting pattern . . . . .	33
4.16	TEHP Panel final nesting pattern . . . . .	33
4.17	LELP Panel final nesting pattern . . . . .	34
4.18	LEHP Panel final nesting pattern . . . . .	34
4.19	SCLP Panel final nesting pattern . . . . .	34
4.20	SCHP Panel final nesting pattern . . . . .	35

4.21 Shear Web final nesting pattern . . . . .	35
4.22 Maximum available dimensions . . . . .	36
4.23 Cross sections of the blade at 16 different stations. Pictures of the blade are provided by the Re-Wind Network . . . . .	36
4.24 Examples of results from on demand algorithm . . . . .	38
4.26 Detailed picture of the spar cap. Picture provided by the Re-Wind Network . . . . .	38
4.25 Cross sections of the blade at station 15, 8 and 2. Pictures received from the Re-Wind Network . . . . .	39
4.27 Spar cap information. Retrieved from Alshannaq et al. (2022b) . . . . .	40
4.28 Detailed picture of a shell panel. Picture provided by the Re-Wind Network . . . . .	40
4.29 Detailed picture of the shear web. Picture provided by the Re-Wind Network . . . . .	41
4.30 The isolated I beam (left) and the shear web cut as triangle (right) . . . . .	42
4.31 Overview of all the plates and beams with their dimension, origin and material category . . . . .	44
4.32 Renders of the resulting materials in a possible application . . . . .	45
B.1 Step 1 of the mass reuse process . . . . .	57
B.2 Step 2 of the mass reuse process . . . . .	58
B.3 Step 3 of the mass reuse process . . . . .	58
B.4 Step 4 of the mass reuse process . . . . .	58
B.5 Step 1 of the project oriented process . . . . .	59
B.6 Step 2 of the project oriented process . . . . .	59
B.7 Step 3 of the project oriented process . . . . .	59
B.8 Step 4 of the project oriented process . . . . .	60
B.9 Step 5 of the project oriented process . . . . .	60
C.1 Prepare the model by setting the individual panels apart . . . . .	62
C.2 Input parameters for efficiency script . . . . .	63
C.3 Three steps of the grasshopper script . . . . .	63
C.4 Script that checks and filters the allowable deviation in terms of curvature . . . . .	63
C.5 Two steps in the script . . . . .	64
C.6 Final steps in the script . . . . .	64
C.7 The entire grasshopper script for one blade panel . . . . .	64
C.8 Script for all seven blade panels . . . . .	65
C.9 Option 2 for the on-demand script: taking a section of the blade by determining a cutting plane in the X, Y and Z plane . . . . .	65
C.10 The input surface from the blade panel and input form to be projected on that panel in option 3 of the on-demand script . . . . .	66
C.11 The entire script for option 3 . . . . .	66
C.12 The script to assign thickness to the extracted elements. This script is able to assign one thickness . . . . .	66
C.13 All scripts to assign thickness to all the elements . . . . .	67
D.1 Catalog of elements extracted from the GE37 blade, following from the efficiency algorithm as described in Chapter 4. Catalog includes dimensions, deviation, flexural stiffness and estimated value. . . . .	69
E.1 Beam sizes available in wholesale market. Retrieved from <a href="http://www.stiho.nl">www.stiho.nl</a> . . . . .	70
E.2 Plate sizes available in wholesale market. Retrieved from <a href="http://www.stiho.nl">www.stiho.nl</a> . . . . .	71

# List of Tables

2.1	Wind classes from IEC 61400-1 standard . . . . .	13
2.2	Elastic properties for the materials used in the SNL-100-01 (Todd Griffith and Ashwill, 2011), retrieved from Arias (2017) . . . . .	14
2.3	Manufacturers and the amount of wind turbines in the Netherlands on-shore (Bosch and van Rijn, 2021) . . . . .	15
4.1	dimensional deviations based on NEN 5461 . . . . .	28
4.2	Dimensions and wholesale market prices of construction elements. Wholesale market prices extracted from <a href="http://www.gadero.nl">www.gadero.nl</a> . . . . .	28
4.3	Residual material properties of spar cap in GE37 blade (Alshannaq et al., 2022b) . . . . .	38
4.4	Material properties of the shell panel skin, shear web skin and the foam core material. . . . .	40
4.5	Percentage of material used, set out per blade panel, for the overall blade panels. . . . .	43
A.1	Overview of wind turbine manufacturers in the Netherlands . . . . .	56

# Introduction

Wind energy is an important clean energy source in the fight against climate change. Yet, with the rapid rise of installed wind turbines, the inevitable downside is that the required material is rising as well. Wind turbines do have a limited service life of usually 20-25 years ([WindEurope, 2020](#)), and when their end-of-life stage is reached, the residual material should be processed as sustainable as possible to minimize the climate impact. However, especially the blades of wind turbines are challenging to repurpose or recycle, due to their non-biodegradable composite materials. This is extra unfortunate since the design of wind turbine blades is very sophisticated. At the same time, a repurpose method applicable on industrial scale does not exist ([WindEurope, 2020](#)). Research shows that the estimated cumulative weight of disposed wind turbine blades world wide in 2050 will be between 21,4 Mt and 69,4 Mt ([Liu and Barlow, 2017](#)).

To assess which waste treatment method is desired, the waste hierarchy can be consulted ([defra, 2011](#)). In this hierarchy, prevention is on top, followed by re-use, repurpose, recycling, recovery and disposal. Currently, the most viable waste treatment methods of wind turbine blades are incineration, landfill and recycling. These waste treatment methods perform bad in the waste hierarchy. This is why it is fundamental to come up with solutions for waste treatment of turbine blades that perform better in the waste hierarchy and reduce the environmental impact of the waste.

The focus of this research is on the repurposing of decommissioned wind turbine blades. Repurposing is a waste treatment method that aims to find new use for products that are written off. Since no large scale repurpose method is present yet, the focus will be on standard elements that can be applied in a wide variety of applications. This research is done in at TU Delft, Civil Engineering in collaboration with engineering firm Arcadis. Therefore, the industry of focus for new applications will be the construction industry.

## 1.1. Relevance of the research

As of 2020, 34.000 turbines in Europe are 15 years or older ([WindEurope, 2020](#)). Since wind turbines usually have three blades, over 100.000 wind turbine blades will have to be processed over the next decade in Europe alone. ([WindEurope, 2020](#)). To reduce waste, it is important to have a strategy for the processing of decommissioned wind turbine blades. This strategy should be as sustainable as possible to minimize the impact on the environment.

Most of the wind turbine blades consist of composite materials. Composite materials consist of various materials with different properties. In blade design this is a combination of reinforcing fibers, usually glass fibre, and thermosets such as epoxy. A common term for this material is Glass Fiber Reinforced Polymer (GFRP). These materials generate the strength and flexibility of the blade while minimizing the weight. Furthermore, the composites provide resistance to corrosion, fatigue, and electrical conductivity, which makes it an excellent material for the blades ([Schmid Marylise et al., 2020](#)). The downside of the material properties of composites is that it is an extremely strong material which is hard to dismantle or recycle.

Although there are some initiatives related to the repurposing of blades, for example a bike shed or pedestrian bridges, no large-scale applicable solutions are present yet. Even though conform the waste



treatment hierarchy, repurposing is more desirable than recycling, recovery, or disposal. To come up with alternatives for repurposing, industries other than the wind industry should investigate how wind turbine blades can be incorporated in their industry so that more applications for repurposing emerge. To tackle the problem, these applications should ideally be applicable on large scale. This research examines the possibilities of repurposing wind turbine blades in the construction industry.

## 1.2. Research question

*How can a decommissioned wind turbine blade be repurposed as construction elements?*

## 1.3. Objective

The main objective of this research is to extract building elements from a wind turbine blade model and to investigate whether the extracted elements can be useful in the construction industry. Furthermore, this research gives insight in how to assess whether wind turbine blades can be repurposed.

## 1.4. Research methodology

The research starts with a literature study to gain more insight in the state-of-the-art. People in the field are interviewed to gain more insight in the current end-of-life strategies of decommissioned wind turbine blades and to find out why these turbine blades are actually decommissioned. The purpose of this research is to demonstrate to what extent it is possible to extract elements, that can be used in the construction industry, from a decommissioned wind turbine blade. This will be investigated by means of a case study. A scanned turbine blade model, the so called GE37 blade, will be used as case study and is available in the CAD program Rhino. In the visual programming tool Grasshopper, which is an extension from Rhino, the algorithm will be written to extract elements from model. The aim of this algorithm is to provide a nesting pattern that maximizes the material yield with the highest possible value. From this nesting pattern follows a catalog with all the extracted elements, including their dimensions and material properties. Based on this catalog, advice is given on the possible applications of the repurposed elements.

Figure 1.1 shows a visualisation of the research methodology and the structure of the research with corresponding chapter numbers. This section states the sub research questions of every chapter, which together will lead to answering the main research question.

### Chapter 2 - State-of-the-art

The purpose of this chapter is to gain insight in the state-of-the-art of the wind turbine industry. Design methods for wind turbine blade design are investigated to gain insight in the aerodynamic and structural design of turbine blades. Research is done on wind turbines currently installed in the Netherlands and current end-of-life strategies of wind turbine blades are investigated. The following sub-questions are formulated:

1. What is the general design of wind turbine blades
2. Which methods and theories are used for the design of wind turbine blades?
3. How old are on-shore wind turbines in the Netherlands?
4. What are current end-of-life strategies of wind turbine blades?

### Chapter 3 - Assessment method

The purpose of this chapter is to investigate what reasons exist for decommissioning wind turbines. Further, a step by step method is developed to assess whether a wind turbine blade is suitable to repurpose. This is done by a combination of interviewing professionals working in the wind turbine industry and by means of a literature study. The following sub-questions are formulated:

5. Why are blades decommissioned?
6. How to assess whether a blade can be repurposed?

### Chapter 4 - Repurpose method

The purpose of this chapter is to investigate which useful building materials can be extracted from the GE37 blade model. Building materials are defined as plates and beams, comparable to those available in wholesale markets. The objective is to present a catalog of useful building materials that are extracted from the GE37 blade. To structure this research, the following sub-questions are formulated:

7. What type of standard building materials can be extracted from a GE37 wind turbine blade?
8. Which advice can be given based on the possible application of the extracted elements?

### Chapter 5 - Results and discussion

In this final chapter the results of the research will lead to answering the main research question and provide a conclusion on the research. Also, recommendations for further research will be given.

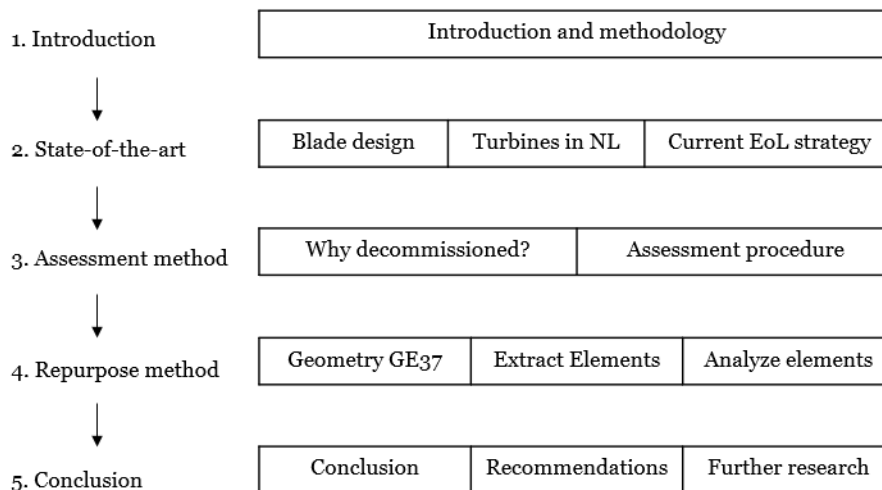


Figure 1.1: Schematic overview of research methodology and structure of the report

## 1.5. Scope and limitations

This section describes the scope, the main focus of the research. Due to the limited time available, not all aspects can be investigated. Therefore, limitations of this research are described in this section.

### 1.5.1. Scope

This research will mainly focus on extracting useful building elements, such as plates and beams, from a wind turbine blade that can be repurposed in the construction industry. Furthermore, a general method description will be introduced that can be either useful for (new) owners of wind turbine blade that want to repurpose the blade material or project teams that want to incorporate (parts of) a wind turbine blade in their construction project. The scope is to demonstrate to the industry which valuable materials can be extracted from a decommissioned blade, and what the characteristics of these materials are.

The blade model used in this research is from a GE37 turbine. This turbine type is manufactured by General Electric. The wind blade models used in this research were provided by Georgia Institute of Technology produced using proprietary software (BladeMachine). This case study will demonstrate if it is feasible to extract construction elements from a wind turbine blade.

In the field of repurposing, multiple levels of repurpose are possible. One can aim to repurpose the entire wind turbine blade at once, for example to use them as transmission poles or bridge structures. This field of repurposing is where the Re-Wind network focuses on (McDonald and Bank, 2021). The advantage is that little processing is necessary to obtain the desired dimensions. Also, the value of the material is conserved. The disadvantage is that applications on an industrial scale are harder to achieve. The opposite of this approach is to shred the blade material to a certain size or extracting the glass fiber from the polymer and use this material as raw material for new applications. One can

argue whether this is more a form of recycling, but in the industry this method is often labeled as repurposing. This method gives a wide variety of application possibilities. However, the downside is that the material value is almost entirely lost and intensive post-processing of the material is needed. This research focuses on the right balance between the two earlier stated methods. Namely, extracting useful elements from a blade so that the elements can be repurposed for applications in the construction industry. This research does not focus on exploring possible applications, but rather aims to deliver an overview of which useful elements can be extracted from a blade, in the form of a catalog. The performance of this method in terms of application possibilities, material value conservation and post-processing is the mean of the earlier stated methods. The application possibilities are wide, the material value is relatively good conserved and necessary post-processing is limited.

To clarify the possible repurpose routes, and to show how this research fills a research gap, a visualisation is made and shown in figure 1.2. Here, also the performance of the methods in terms of application possibilities, material value conservation and post-processing is indicated.

This research compared to other repurpose possibilities

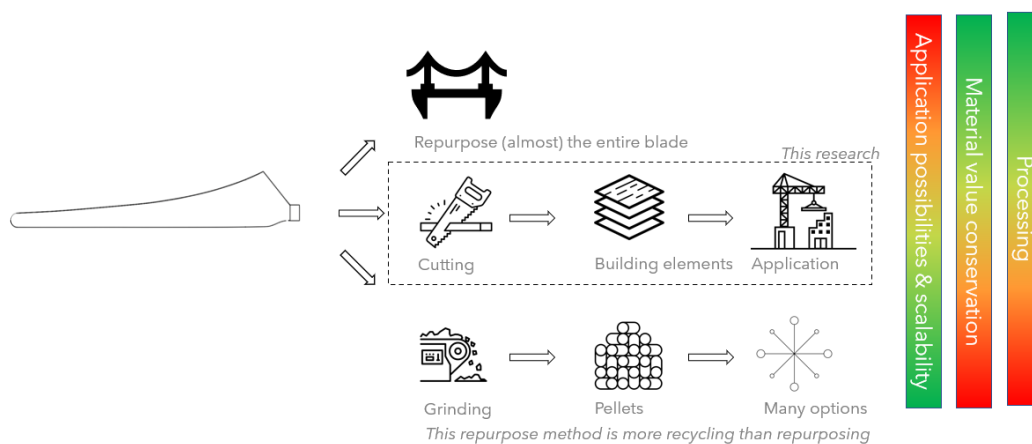


Figure 1.2: Visualisation of repurpose methods and research gap

### 1.5.2. Limitations

The limitations of the research are set out point by point

- The algorithm for extracting building elements focuses on one single model. The algorithm process can, however, be copied and applied to other types of blades. Since the designs of different blade types vary, it is not feasible to develop an algorithm in advance that works for every type of blade.
- Reference wind turbines published by research institutes are used to learn more about the aerodynamic design and structural properties of wind turbine blades. This is done because the availability of technical specifications of installed wind turbines is scarce, due to reluctance in disclosing information by the relevant companies.
- Only a high-level assessment method can be delivered that gives guidance on how to repurpose a blade. This is due to the lack of information available regarding maintenance reports and residual quality of turbine blades.
- The research will mainly focus on onshore wind turbines since the vast majority of wind turbines reaching their end-of-life stage are onshore wind turbines.
- The advise on possible applications of extracted blade elements focuses on applications in the construction industry. Other industries could be relevant as well but will remain out of the scope of this research.
- No research is done on the residual quality of decommissioned blades due to the lack of available data and material.

## 1.6. Literature review

This section gives an overview of the consulted literature. First, literature that provide knowledge on the general design guidelines is explored, to gain understanding in the background of wind turbines, aerodynamics and wind turbine blade design. For research- and educational purposes, a number of reference wind turbines (RWT) is published. These RWT's give insight in the parameters necessary to obtain a wind turbine blade geometry, the materials used throughout the blade and the strength- and stiffness properties. To gain insight in the damages generally occurring in wind turbine blades, literature is reviewed on investigations in this field. Next, the current processes for recycling, and initiatives for repurposing of decommissioned wind turbine blades are investigated. Eventually, comparable materials as present in the wind turbine blade are investigated to gain insight in the structural behaviour and possible applications of elements present in the blade.

### 1.6.1. Background on wind turbine design

The following books are reviewed to gain knowledge on the design of wind turbine blades, wind turbines in general and the forces and circumstances the blade must be designed for. In the *Wind Energy Handbook* (Burton et al., 2001) a complete overview is given of aerodynamics and design loads on wind turbines. Also the design of wind turbine components, of which wind turbine blades is described. The book stems from 2001, but since the wind turbines designed in that period are now about to reach end-of-life, and the laws of aerodynamics are not time dependent, the book retains its relevance. In the book "Aerodynamics of Wind Turbines" (Hansen, 2015), the definitions and necessary theory to understand the Blade Element Momentum (BEM) Theory are described. Further, aerodynamics, dynamic structural models and sources for loads on a wind turbine are handled. Also the beam theory to design the structural part of the blade is explained. In *Norske Veritas* (2010) and *Norske Veritas (Organization) and Forskningscenter Risø*. (2002) it is described how to design and manufacture wind turbine blades.

This literature gains insight in the design of turbine blades and broadens the knowledge on wind turbines in general. This provides a foundation for the rest of the research.

### 1.6.2. Geometry of available reference wind turbine blades

One of the most well known RWT was developed in 2005 by the National Renewable Energy Laboratory (NREL), located in the United States. The RWT is developed using a combination of commercial turbine data and parameters. This RWT is often referred to in research and remains a relevant RWT to this day. It is a 5MW RWT for offshore system development described in *Jonkman et al.* (2009). In 2011, Sandia National Laboratories published a 100 meter long RWT blade, described in *Todd Griffith and Ashwill* (2011). In 2013, the Denmark Technical University (DTU) published a 10 MW RWT for offshore siting, which was meant to be a baseline for benchmarking new technologies. Offshore was chosen because this size of wind turbines will be mainly installed offshore. The 10MW RWT is described in *Bak et al.* (2013). In 2019, the IEA Wind Task 37, consisting of the NREL, DTU, Technische Universität München and SINTEF Enerfy Research, updated the 10MW RWT published in 2013, and at the same time published a 3.4MW land-based RWT. The latter is developed because the earlier published offshore RWT has been used extensively for land-based research studies due to the lack of alternatives. Therefore, there was a need for new RWT's. The two RWT's are described in *Bortolotti et al.* (2019). The most recent RWT is published in 2020 by the IEA Wind Task 37 and describes a 15 MW offshore RWT. The RWT is described in *Gaertner et al.* (2020) and serves as a baseline for new technologies.

### 1.6.3. Damages in wind turbine blades

Several research studies are conducted on the damages and failure modes in wind turbine blades, both experimental studies and studies on decommissioned, failed blades. *Chen* (2018) investigated the failure of two blades from two wind turbines that failed in the same wind farm sequentially. *Chen* (2019) reports experimental observation of structural degradation in a wind turbine blade subjected to fatigue loading. In this study the maximum stiffness decreases are 2,2%. *Chen and Eder* (2020) give a comprehensive overview of damage and failures in wind turbine blades and reviews recent advances in the field of the structural integrity. In the report of *Yeh and Wang* (2017), the 5MW NREL RWT is analyzed. Here it is concluded that maximum stress occur at the junction of the circular root airfoil and the first aerodynamic airfoil. In the research study of *Marín et al.* (2009), the reason lying behind



detected damages in a blade are investigated. Concluded is that the detected damages seems to be due to a fatigue mechanism, and that the fatigue life could have been decremented by diverse manufacture defects.

From the reviewed literature, no conclusions can be drawn on the residual quality of turbine blades in general. Based on literature, the influence of fatigue on the residual strength seems limited. However, in practice the blades should always be tested to approximate the real strength of the blade.

#### **1.6.4. Recycling and repurposing of decommissioned wind turbine blades**

The amount of blade waste material will increase significantly the coming years. This is substantiated by [Liu and Barlow \(2017\)](#) and [Lichtenegger et al. \(2020\)](#). A lot of research has been performed on the recycling of composite materials already, [Amaechi et al. \(2020\)](#) gives an extensive description of current recycling technologies and applications for the recycled GFRP material. [Jensen and Skelton \(2018\)](#) gives an overview of the best available waste treatment technologies in Europe. [Yazdanbakhsh et al. \(2018\)](#) describes how small GFRP elements can be used as reinforcement in concrete. WindEurope published a paper that discusses how to manage composite blade waste in [Skelton \(2017\)](#). [Topham and McMillan \(2017\)](#) propose how a wind farm can be decommissioned sustainable. Since the problem of wind turbine blade waste will grow the coming decades, more initiatives to repurpose decommissioned wind turbine blades are coming up. Providing more initiatives is something this research is aiming to contribute to. One of the leading examples for repurposing decommissioned wind turbine blades is the Re-wind project. This is an organization consisting of students and professionals from four universities in Ireland and the USA. Their objective is to compare sustainable end-of-life repurposing and recycling strategies for decommissioned wind turbine blades, coupled with Life-Cycle Sustainability Assessments. They mainly focus on repurposing the entire blade (or a large share of it) in one go and published multiple papers with repurpose solutions. [Gentry et al. \(2020\)](#) proposes to use parts of wind turbine blades as roofs for housing. [Alshannaq et al. \(2021\)](#) proposes to use wind turbine blades as electrical transmission poles. [Bank et al. \(2019\)](#) performed a structural analysis on GFRP parts from decommissioned wind turbine blades for building reuse applications. [Tasistro-Hart et al. \(2019\)](#) presented a method for the digital reconstruction of the geometry of a wind turbine blade from a point-cloud model to polysurface model. [Deeney et al. \(2021\)](#) investigated Sustainability Indices for end-of-life alternatives for wind turbine blades based on the UN sustainable development goals. Next to the Re-wind project, more research studies investigate the repurpose possibilities. [André et al. \(2020\)](#) proposes to re-use wind turbine blades for construction and infrastructure. [Goodman \(2010\)](#) explores the possibilities for architectonic re-use of wind turbine blades. [Joustra et al. \(2021\)](#) gives a more holistic approach on how to repurpose wind turbine blades through segmentation. While a lot of ongoing research relates to recycling blades, the literature regarding repurposing blades is limited. Also, the repurpose applications vary. The research on blade segmentation ([Joustra et al., 2021](#)) is a good starting point for this research and demonstrates the possibility of extracting flat panels from a RWT.

#### **1.6.5. Material properties of materials used in wind turbine blades**

Wind turbine blades are mainly made of a combination of solid GFRP and sandwich panels, where GFRP is the skin material and foam or balsawood is the sandwich material. ? investigated experimentally and analytically the structural performance of sandwich panels composed of GFRP skins and a soft polyurethane foam core. [Landesmann et al. \(2015\)](#) aimed to determine the mechanical properties of GFRP elements to classify it for structural applications. [Sharaf and Fam \(2011\)](#) investigated the behaviour of large scale sandwich panels subjected to out-of-plane loading for cladding of buildings. [Thomsen \(2009\)](#) presents an overview of current design principles, materials and technology in wind turbine blades. [Correia et al. \(2012\)](#) investigated the structural behaviour of composite sandwich panels for civil engineering applications. [Landesmann et al. \(2015\)](#) investigated the structural behaviour of GFRP to classify it for civil engineering applications. This knowledge gains insight in how extracted elements from a blade can eventually be applied in practice.

# 2

## State-of-the-art

In this chapter the following research questions will be answered:

- What is the general design of wind turbine blades?
- Which methods and theories are used for the design of wind turbine blades?
- How old are on-shore wind turbines in the Netherlands?
- What are current end-of-life strategies of wind turbine blades?

### 2.1. Wind turbines

This section gives a high level introduction on wind turbines and the main elements a wind turbine consists of.

#### 2.1.1. Wind turbine design

In the design of wind turbines, Vertical Axis Wind Turbines (VAWT) and Horizontal Axis Wind Turbines (HAWT) can be distinguished. Since the majority of the commercial wind turbines installed today are HAWT's, this research will only focus on the latter. Within the HAWT's, various design options are possible. A distinction can be made between upwind and downwind rotors. Also, the number of blades can vary, usually between one and three. A downwind rotor means the rotor is behind the tower and follows the direction of the wind automatically. This has as advantage that no yaw mechanism is necessary, but a great disadvantage is the fluctuation of wind power since the wind has to pass the tower first. Therefore, downwind rotors are not commonly used. Upwind rotors on the other hand face the wind in front of the tower, creating a better wind flow on the rotors. In order to operate efficiently, the upwind rotors need a yaw mechanism. This mechanism keeps the rotor axis aligned with the wind. For the rotor blades, usually three blades are used. One-bladed and two-bladed turbine designs exist, where one-bladed turbines are not widespread and two-bladed turbines occur sometimes. However, despite saving blade material, they have the disadvantage that at the same rotational speed less energy is generated. Also more fluctuating loads occur because of the variation of the moments of inertia, being either horizontal or vertical. Due to its dominance in the wind turbine industry, this research focuses on upwind HAWT's with three rotor blades. (Burton et al., 2001)

#### 2.1.2. Main elements of a wind turbine

HAWT's usually consists of a foundation, a tower, a nacelle, a hub and blades attached to the hub. All elements will briefly be clarified. A schematic overview of the different parts is shown in Figure 2.1. (Burton et al., 2001)

##### Foundation

The foundation supports the entire wind turbine and distributes all the acting forces to the soil. The type of foundation depends on the soil conditions where the turbine is placed. Onshore wind turbines are usually supported by a slab foundation or pile foundation. Offshore wind turbines are usually supported by a monopile, tripod or a floating structure, depending on the water depth. Since the foundation must

be able to withstand bending moments from all directions, the foundation is usually circular with a larger diameter than the bottom tower diameter. (Schubel and Crossley, 2012)

### Tower

The tower supports the nacelle and rotor and is connected to the foundation. Wind speeds increase higher above the ground and therefore the tower enables the rotor to generate energy in a higher wind stream. Usually the tower is a conical, tubular steel tower which is manufactured in sections of 20-30 meters, due to transport limitations. The sections are constructed and bolted together on site. The diameter of the tower is largest at the base and decreases with the height. This is because the largest bending moments occur at the base of the tower (Schubel and Crossley, 2012).

### Hub

The rotor hub is the central part of the rotor and connects the blades to the nacelle. The blades and nacelle are connected to the hub with steel bolts and the hub usually consists of cast iron. This is used because the hub must be able to resist metal fatigue. The hub is also connected to the rotor shaft and transfers the forces caught by the blade through the shaft, which drives the generator in the nacelle. Depending on the turbine type, the hub can contain a pitch control mechanism which enables the blades to catch the right angle of the wind to get the most power output. (Schubel and Crossley, 2012)

### Nacelle

The nacelle is on top of the tower and houses the equipment to control the turbine. Main components in the nacelle are the main shaft, main gear, main bearing, couplings, mechanical brakes, hydraulic systems, generator and yaw system. Also, it carries the hub and rotor blades. Sensors detect the wind speed and wind direction. The nacelle is placed on a gear wheel so that it can turn the rotor in the direction of the wind (yaw system) in the nacelle. In the nacelle the mechanical power is converted into electricity.

The main gear converts the rotational speed of the wind to a higher rotational speed to generate electricity and from the generator this is transferred to the grid via the tower (Schubel and Crossley, 2012). A schematic overview of the different parts is shown in Figure 2.1.

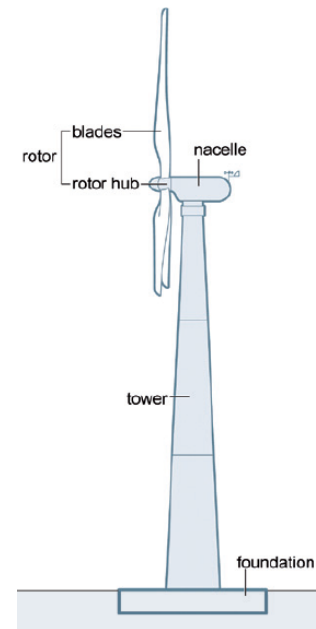


Figure 2.1: Schematic overview of a wind turbine (Posco, 2016)

## 2.2. Wind turbine blade design

In this section an overview will be given of the design of wind turbine blades. First, the standard geometry of a wind turbine blade will be described. Subsequently, the used methods and theories for wind turbine blade design are described. Lastly, the wind classes used in the design codes are described.

### 2.2.1. Geometry of a wind turbine blade

The function of a wind turbine blade is to create a rotational velocity to maximize energy generation, while maintaining its structural integrity. The design objectives can be summarized as follows (Burton et al., 2001):

1. Maximize annual energy yield
2. Limit maximum power output
3. Resist extreme and fatigue loads
4. Restrict tip deflection to avoid blade-tower collisions
5. Avoid resonances
6. Minimize weight

## 7. Minimize cost

Some of the objectives are in conflict. When designing wind turbine blades, there must be a balance between these objectives. The design process can be divided in two stages: aerodynamic design (objective 1 & 2) and structural design (objective 3-6). The outer surface geometry of a wind turbine blade, which accounts for the aerodynamic part of the structure, is shown in Figure 2.2 and can be described with the following parameters (Kanshal, 2018):

- **Airfoils**

The upper part of the blade is the suction side, and the lower part of the blade is the pressure side, because wind presses at this side. The upper and lower side together form a profile, which varies throughout the blade. This profile is called an airfoil and can be described as a set of points that describe the form of a blade section. A blade consists of multiple airfoils throughout the length of the blade

- **Chord**

This is the distance between the trailing edge and leading edge. Adjusting the chord length enables the airfoil to be scaled

- **Pitch**

To face the blade to the optimal wind flow, a pitch has to be inserted in the design of the blade because the relative wind velocity differs throughout the length of the blade. The pitch is the angle between the chord of the blade and the rotor plane and usually increases from 0 degrees at the root to around 25 degrees at the tip.

- **Length of the blade**

- **Location of the airfoils**

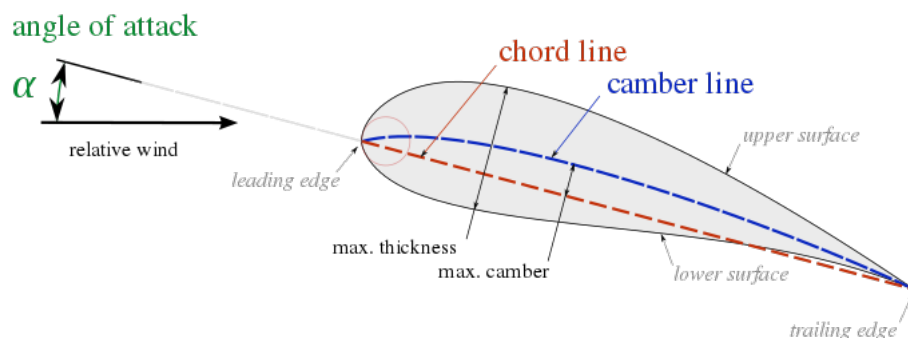


Figure 2.2: Aerodynamic parameters for outer geometry of a blade (Kanshal, 2018)

To reinforce the blade, in a way that it can maintain its structural integrity, a shear web is placed at the inside of the shell throughout the blade. The function of the shear web is to resist out-of-plane shear loads, which can not be resisted well by the hollow shell structure. This shear web acts as a beam, which simplifies the structural analysis. The shear web can have different configurations. Usually an I-beam spar, Box spar or Wound D-spar is used, which is illustrated in Figure 2.3. The web is connected to the spar caps, which are the reinforcing elements at the outer surface of the blades. The spar caps have a thicker material cross section than the rest of the outer surface material since their function is both structural and aerodynamic. Due to the limited access to the design of wind turbine types, it is not clear which web configuration is most common. The

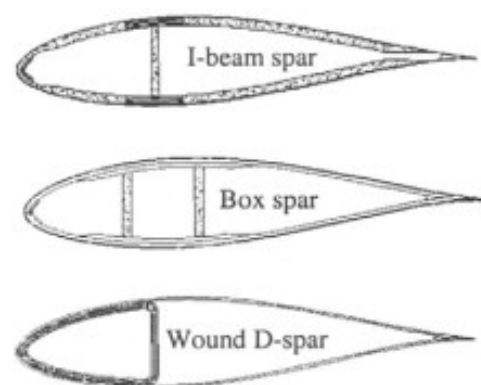


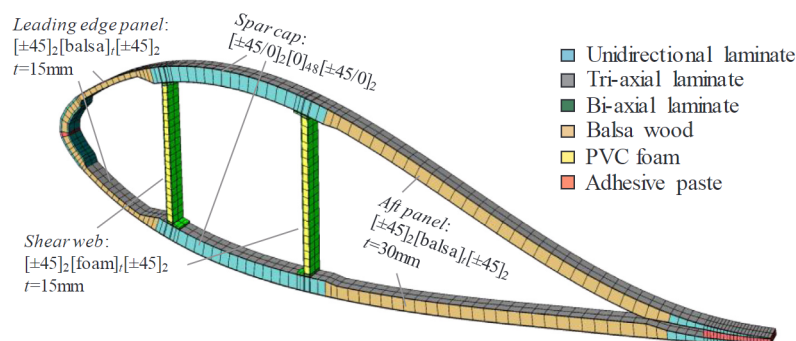
Figure 2.3: Characteristic cross sections. Retrieved from Nijssen and Van Delft (2003)



material build up of the shear webs differs per blade type. Often, a sandwich structure is used, where the outer material is GFRP and the sandwiched material is foam or balsa wood to prevent buckling. The shear web follows the tracing of the blade and, as a result, has a certain twist throughout its length (Nijssen and Van Delft, 2003).

The blades are usually made of layers of fibreglass, which are embedded in a resin matrix. This is generally known as Glass Fibre Reinforced Polymer, or GFRP. The resin used is usually epoxy or polyester. Newer types of wind turbines also use Carbon Fiber Reinforced Polymer (CFRP) since carbon has a higher stiffness and a lower weight. It is, however, more expensive than glass fiber. In general, a balsa wood or foam layer is present as sandwich core material in the shell panels (located at the leading edge and trailing edge) and in the shear web or shear box. Many manufacturers and designs exist in the wind turbine industry, and blade requirements are dependent on the size and location of the turbine. Therefore, the choice of design and materials can vary for different types of blades. Next to the external GFRP panels and the spar caps, other material is also present in the blade. Inserts such as bolts are present in the root to transfer forces from the blade to the hub. Further, lightning protection, usually in the form of a conductor cable from the tip to the root, is present in the blade. Lastly, a mechanical system is present that enables the tip to turn enabling it to function as an aerodynamic brake (Chen, 2019).

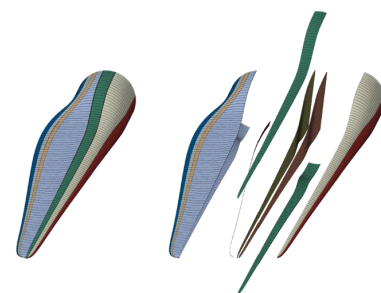
Figure 2.4 shows a typical section of a wind turbine blade with the materials used. At the left the leading edge is present, facing the wind. The tip of the leading edge, as well as the trailing edge at the right side, are reinforced to account for flapwise bending due to gravitational force. The spar caps and shear webs form the structural core of the blade and remain the structural integrity. The spar caps are reinforced to account for edgewise bending, resulting from the wind force acting on the blade. Following from the functions, the blade can be subdivided in panels with separate materials and corresponding material properties.



**Figure 2.4:** A cross section at 22m from the root of a 47 meter long composite rotor blade for 2MW wind turbines including the materials used (Chen, 2019)

Resulting from the functions in the blade, the blade can be subdivided in panels with separate materials and corresponding material properties. The exact subdivision varies per blade design, but always comprises a reinforced leading- and trailing edge, spar caps, a shear web (in different versions) and aerodynamic panels in between. An exploded view of the DTU 10MW RWT model (Bortolotti et al., 2019) is shown in Figure 2.5.

Now that the sections of a wind turbine blade are treated, the entire structure of the blade is taken into consideration. A blade can be divided into three main parts over its length: the root, mid span and tip. The root has to withstand the highest forces, moments and stress due to its one sided inclination. Therefore, the material and profile are thicker in



**Figure 2.5:** Exploded view of the DTU 10MW RWT (Bortolotti et al., 2019)

the root than in other parts of the blade. The structural integrity governs the aerodynamic properties. The mid span has an aerodynamic profile to generate movement. The height of the blade, also known as chord length, decreases further in the blade. This is due to the fact that further in the blade the speed is higher and less lift has to be generated, so the blade tapers towards the tip. The tip is the part where the velocity is the highest, and most of the energy is generated. Also, the tip can, depending on the design, function as an aerodynamic brake by tilting it in the direction of the wind. Figure 2.6 shows a standard design of a wind turbine blade.

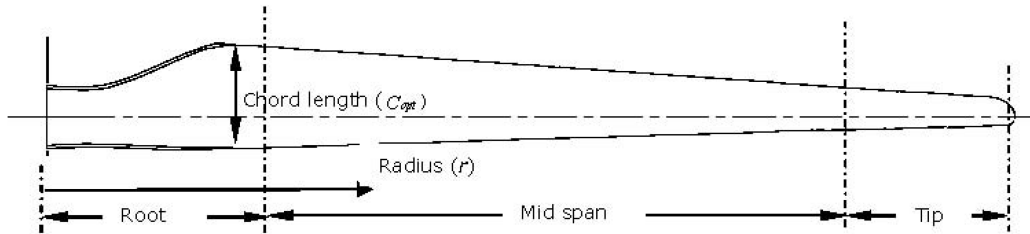


Figure 2.6: Standard design wind turbine blade (Schubel and Crossley, 2012)

### 2.2.2. Used methods and theories for wind turbine blade design

The loads acting on a wind turbine blade are illustrated in Figure 2.7 and are as follows Schubel and Crossley (2012):

- Flapwise and edgewise bending due to the pressure load on the blade
- Gravitational loads from the self-weight of the blade
- Torsional loading, because the shear resultants of the flap- and edgewise loads do not go through the shear centre of the blade section
- Normal loading due to the rotation of the blade

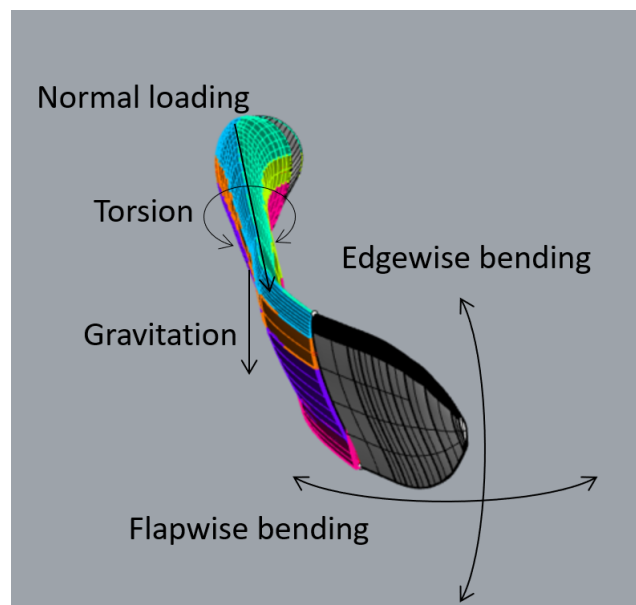


Figure 2.7: Illustration of the loads acting on a wind turbine blade. The blade is a GE37 blade model provided by the Re-Wind Network

A part of the design is to analyse which load cases are likely to occur in the wind turbine during its design life. The design load cases vary between different codes, but mainly consist out of a combination of a load case type, a design situation and a wind condition. A load case type can be normal, extraordinary or accidental. A design situation varies between normal power production and serious failure. Wind

conditions vary between normal and extreme conditions. Lastly, the different combinations are subdivided into the limit states fatigue, ultimate and/or accident. The loads wind turbine blades must resist are the gravity due to self weight, aerodynamic loads, and centrifugal forces due to rotation. The force resulting from selfweight is simply the mass multiplied by the acceleration of gravity. Centrifugal load at the root is the mass times the radius of the blade times the angular rotor speed squared. Aerodynamic loads are subdivided into a lift force and a drag force. A lift force acts in the direction of the rotating blades, a drag force acts perpendicular to this motion. The lift and drag forces can be calculated as follows:

$$F_L = 1/2 * C_L * \rho * c * W^2$$

$$F_D = 1/2 * C_D * \rho * c * W^2$$

Where  $C_L$  and  $C_D$  are lift and drag coefficients,  $\rho$  is the density of air and  $c$  is the chord length of the blade. (Burton et al., 2001)

### BEM Theory

The Blade Element Momentum (BEM) Theory is one of the first and still the most commonly used methodologies to investigate rotor aerodynamics and to calculate the forces acting on a wind turbine blade. It is the combination of Blade Element Theory and Momentum theory. The theory calculates the thrust and torque contributions of all elements in a blade all along the blade length and adds them up. It considers two-dimensional aerodynamics. With this, insight can be gained in the forces acting on the wind turbine blade under different wind speeds. (Hansen, 2015)

### Design verifications

Full-scale blade tests are carried out to verify the fatigue strength and static strength of the design of a wind turbine blade (Zhou et al., 2014). Usually, a full-scale test is performed for every new wind turbine blade type. The static and dynamic blade tests consist out of the following aspects:

- A static load test is performed on all sides of the blade, thus in two opposite directions in the flapwise and edgewise configuration
- A dynamic load test is performed on the same sides. In this test a number of load cycles is imitated
- Also a residual static strength test can be performed in the test phase. Here, first the blade is bent once by a very large force and then a residual static strength test is done

### 2.2.3. Wind classes

Wind is highly variable, both geographically and temporally. Generally, higher wind speeds are present off-shore than on-shore. Parameters influencing the wind are, amongst others, the latitude, the presence of mountains, the proportion of land and sea and the size of land masses. When a wind turbine is designed, it must be able to withstand the wind forces acting on the location of operation. However, it is not necessary to design the wind turbine for loads it will not be exposed to. Therefore, different wind classes are distinguished. The parameters defining the wind class are annual average wind speed at hub-height, extreme 50-year gust, and turbulence.

Annual average wind speed is the average of an ever varying wind. Seasonal characteristics, as well as daily weather variations cause the wind climate to change throughout the year. Although it is hard to predict the annual variation, an approximation can be done using a Weibull distribution. The formula for this distribution is

$$F(U) = \exp(-(U/c)^k)$$

Where  $F(U)$  is the fraction of time where the wind speed exceeds  $U$ .  $c$  is a scale parameter related to the annual mean wind speed and  $k$  is a shape factor which describes the variability about the mean. The annual average wind speed is considered at hub-height.

Turbulence is the variation of wind speed, mainly generated by friction with the surface of the earth and thermal effects, which can cause air masses to move vertically as a result of different air densities. It refers to fluctuations in wind speed on a time-scale of typically ten minutes. The turbulence intensity depends on the roughness of the ground surface and the height above the surface. Also, it depends on topographical features such as mountains and local features such as trees and buildings. The

turbulence decreases with increasing height above the ground. Above a certain height, the air flow can be considered laminar, which gives ideal circumstances for wind turbine drive. Off-shore wind turbines currently in development aim to operate in this laminar flow, but on-shore wind turbines will remain too small for this. Turbulence is an important parameter since varying wind speeds can lead to dynamic loading and with that, fatigue loads can occur.

Extreme 50-year gust is an extreme condition that appears on average only once every 50 years. The wind turbine must be able to withstand extremes of wind speed, this can occur with the turbine operating, parked or during a particular operation such as a shut-down event. The IEC standard specifies a reference wind speed  $V_{ref}$  which is five times the annual average wind speed. The extreme 50-year gust is 1.4 times  $V_{ref}$  at hub height. (IEC61400-1, 1999)

With the parameters defining the wind classes, seven different wind classes are distinguished in the standard, which are set out in table 2.1

Wind Class	Turbulence	Annual avg. wind speed	Extreme 50-year gust
IA High Wind	Higher Turbulence 18%	10 m/s	70 m/s
IB High Wind	Lower Turbulence 16%	10 m/s	70 m/s
IIA Medium Wind	Higher Turbulence 18%	8,5 m/s	59,5 m/s
IIB Medium Wind	Lower Turbulence 16%	8,5 m/s	59,5 m/s
IIIA Low Wind	Higher Turbulence 18%	7,5 m/s	52,5 m/s
IIIB Low wind	Lower Turbulence 16%	7,5 m/s	52,5 m/s
IV	-	6,0 m/s	42 m/s

Table 2.1: Wind classes from IEC 61400-1 standard

#### 2.2.4. Blade materials and properties

Figure 2.3 and 2.4 give an impression of the intersection of a typical wind turbine blade. A blade has multiple functions, resulting from structural requirements (high strength-to-weight ratio, fatigue life and stiffness) and aerodynamic optimisation. Also, the weight and cost of the blade must be minimized and the ability must exist to form the blade into the desired aerofoil shape. These objectives lead to the choice for the materials used in wind turbine blades. First, an introduction is given in the materials used. Then, the blade materials are subdivided in the structural part and aerodynamic part.

##### Materials

The materials present in a wind turbine blade are usually:

- Uni-axial laminates, where all glass fibers are parallel to each other
- Bi-axial laminates, where glass fibers are oriented in [+45/-45] or [0/90]
- Tri-axial laminates, where glass fibers are oriented in three directions, [-45/0/45]
- Resin to glue the glass fiber laminates, such as polyester or epoxy
- Sandwich core material such as foam or balsawood
- Gelcoat to coat the outer surface

The lay-up of the glass fiber laminates is illustrated by Figure 2.8.

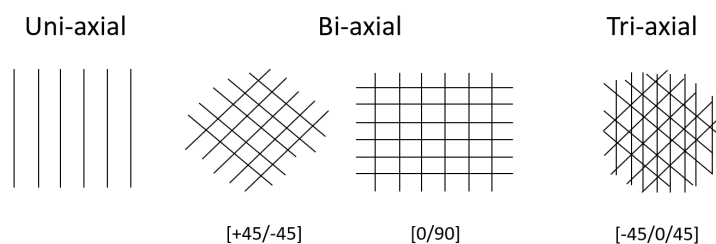
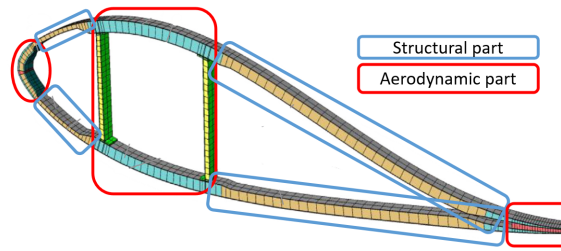


Figure 2.8: Illustration of the fiber lay-up in uni-axial, bi-axial and tri-axial laminates



**Figure 2.9:** Hatched regions of the structural and aerodynamic part in a blade cross section (Chen, 2019)

A material can either be isotropic or orthotropic. An isotropic material behaves with the same mechanical properties in every direction, as is the case with the gelcoat, resin, and foam. On the other hand, the material properties of orthotropic materials depend on the direction in which they are arranged. Orthotropic materials are subsets of anisotropic materials. The glass fibers are orthotropic and vary in orientation from unidirectional to tri-axial (Arias, 2017). To give insight in the magnitude of the material properties related to wind turbine blades, the blade materials used in the RWT SNL-100-01 (Todd Griffith and Ashwill, 2011) are used shown in table 2.2.

Materials	$E_{11}$ (MPa)	$E_{22}$ (MPa)	$G_{12}$ (MPa)	$\nu_{12}$ [-]	Density $kg/m^3$
Gelcoat	3440		1380	0,3	1235
Resin	3500		1400	0,3	1100
Foam	256		22	0,3	200
Uni-axial laminate	41.800	14.000	2630	0,28	1920
Bi-axial laminate	13.600	13.300	11.800	0,49	1780
Tri-axial laminate	27.700	13.650	7200	0,39	1850

**Table 2.2:** Elastic properties for the materials used in the SNL-100-01 (Todd Griffith and Ashwill, 2011), retrieved from Arias (2017)

The used material in the wind turbine blade is a combination of multiple of the material types stated in table 2.2. The outermost layer is the gelcoat, which gives the blade its white color and protects the blade materials against the environment. The laminates are stacked in multiple layers and impregnated with the resin. the amount of laminates stacked is dependent on the thickness of the cross section. The thickness decreases throughout the length of the blade since less structural demands are needed further in the blade. Impregnating the fiber laminates with resin leads to a combined material. This is indicated by the fiber volume fraction,  $V_f$ , which states the volume of the laminate as a percentage of the total volume. The remaining percentage is the resin.

### Structural part

The structural parts are pointed out from Figure 2.4. The structural part consists of the spar caps, shear web and reinforcement at the leading- and trailing edge tips. The spar caps and reinforcement are formed with unidirectional laminates, which can account for the overall stiffness and the load carrying mechanism. The reinforcement in the leading and trailing edge resists the edgewise bending and the spar caps and shear web resist the flapwise bending. The shear webs are placed to increase the resistance against out-of-plane shear loads. Shear webs are usually a sandwich panel in which the sandwich skins consist of bi-axial laminates and the sandwich core material consists of foam or balsawood. The core material is a low strength and light weight material, but the increase in thickness provides the shear web a high bending stiffness with low overall density. The spar caps are thick, solid GFRP sections with strong elastic properties in the longitudinal direction.

### Aerodynamic part

The aerodynamic part has a limited structural function, and must be a stiff part with low density. This leads to shell panels that follow the airfoil curvature and connect the structural parts. Usually, the shell

panels are sandwich panels as well. The skin material consist of multidirectional fibers (bi-axial or tri-axial) impregnated with resin to approximate an isotropic material. The sandwich core usually is balsa wood or foam, with a near constant thickness throughtout the length of the blade. The sandwich core can also be reinforced with GFRP ribs to increase the strength and prevent delamination.

### 2.2.5. Manufacturing process

In general, two negative molds are made for the low pressure side and the high pressure side of the blade. Gelcoat is the first layer that is laid in the mold. This is a thin film that gives the blade a white finish. Then, multiple glass fiber mats are laid in. The making of composite materials involves several layers stacked on top of each other. On each mat a layer of epoxy or polyester is rolled to bind the mats into a hard matrix of fibers. The fiber mats have varying orientations: unidirectional, bi-axial or triaxial. Foam panels are glued on the shell panels to increase the stiffness. The sandwich shell panels are finished with again layers of fiber mats. The shear web is placed in one mold and is connected to the mold with an adhesive. Subsequently, the second mold is placed on top of the first mold and the shear web and is connected with an adhesive to the shear web and leading- and trailing edge of the first mold. Lastly the adhesive edge is polished and the blade is ready for transport. (Hansen, 2015).



**Figure 2.10:** Blade mould at the Siemens blade factory in Hull. Retrieved from [Manufacturer \(2018\)](#)

## 2.3. Overview of installed wind turbines in the Netherlands

At this moment in the Netherlands 2204 wind turbines are installed on-shore. The oldest wind turbine still in operation dates from 1982 and has a rated power of 0,015MW. From WindStats ([Bosch and van Rijn, 2021](#)) a data set is retrieved with all installed wind turbines on-shore. In this data set the location, manufacturer, type, hub-height, diameter, power capacity and start date are given. With the use of this data set, insight is given in the following questions:

- Which manufacturers produced the wind turbines?
- Which percentage is older than 20 years?
- What is the average power capacity per year of the installed wind turbines

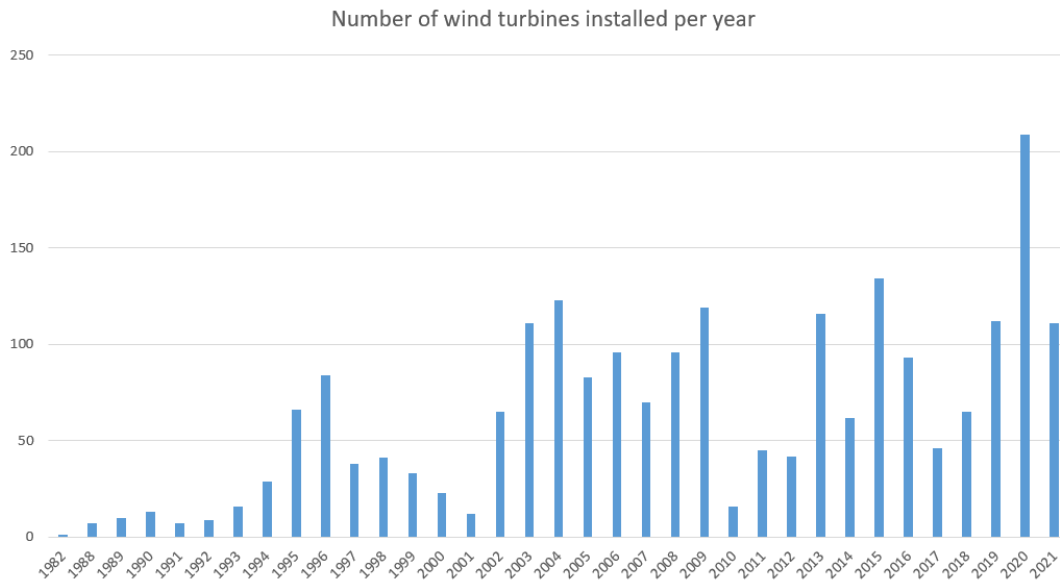
Table 2.3 gives an overview of the manufacturers and the amount of wind turbines in operation in the Netherlands. The amount of wind turbines older than 20 years is given in a separate column. Throughout the years, many manufacturers are acquired by larger companies. The list with original manufacturers therefore is more elaborate and is given in Appendix A.

Manufacturer	Total amount of wind turbines	Wind turbines older than 20 years
2-B Energy	1	0
Enercon	704	131
EWT	48	1
GE Wind	25	5
Leitwind	1	0
Nordex	274	9
Siemens Gamesa	238	55
Vestas	909	185
Total	2200	386

**Table 2.3:** Manufacturers and the amount of wind turbines in the Netherlands on-shore ([Bosch and van Rijn, 2021](#))

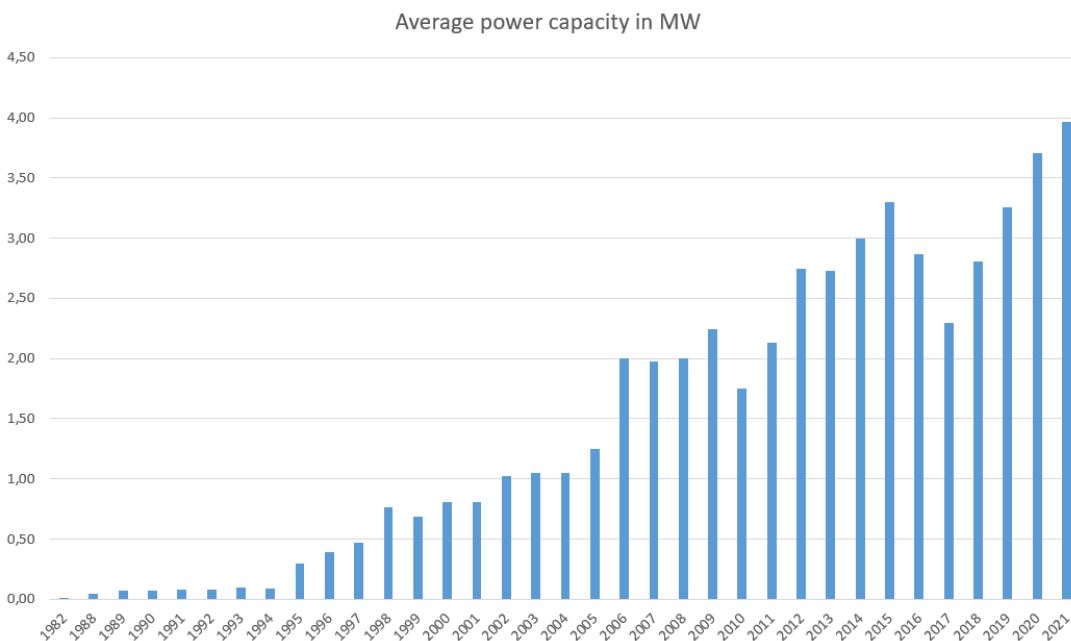
From the 2204 wind turbines currently installed on-shore in the Netherlands, 386 wind turbines are installed before 2001. So, the percentage of wind turbines older than 20 years is 18%. The amount of wind turbines that is installed each year from 1982 until now is shown in Figure 2.11. This gives insight in the amount of wind turbines that are likely to reach their end of service life in the coming years.





**Figure 2.11:** Installed wind turbines in the Netherlands on shore. Data provided by [Bosch and van Rijn \(2021\)](#)

From the wind turbines installed, the average power capacity is calculated and set out in a graph, which can be seen in Figure 2.12. The rising trend of power capacity can clearly be seen. In the years until 1994, the power capacity was around 0,08 MW. From that moment on, the power capacity started to increase, which resulted in an average power capacity of 3 MW over the last couple years. This means a multiplication of 37 times the power output in 25 years, a tremendous increase.



**Figure 2.12:** Average power capacity of installed wind turbines in the Netherlands per year. Data provided by [Bosch and van Rijn \(2021\)](#)

## 2.4. Possible end-of-life strategies of wind turbine blades

In this section the possible end-of-life strategies are described. The waste treatment methods are pictured in the waste hierarchy in Figure 2.13 to give insight in their performance according to circular economy principles for sustainable waste management. Unfortunately, data is lacking on which waste

treatment method is most common in practice. The problem with current waste treatment methods is their available scale, profitability or a combination of the two. Therefore, turbine blades often are recovered, disposed, or used as landfill. The available technologies will be described per waste treatment method.

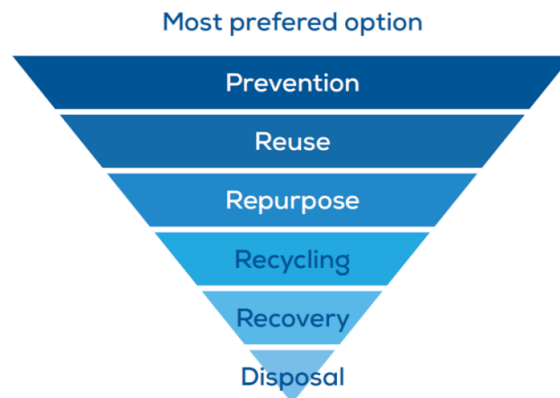


Figure 2.13: Waste hierarchy according to circular economy principles (Schmid Marylise et al., 2020)

### 2.4.1. Prevention

Prevention is not an end-of-life strategy. Prevention rather focuses on the optimization of design and performance in order to decrease the amount of materials needed. This can include mass reduction resulting in less material to recycle, lifetime extension design and decreasing failure rates (Schmid Marylise et al., 2020). Radical different approaches, such as modular design or using biobased materials are currently under investigation, but this is not standard design yet and is not expected to be applied on large scale in the coming decade.

### 2.4.2. Reuse

Reuse takes place when the entire wind turbine is decommissioned and the turbine or parts of it are reused in other locations (Beauson et al., 2022). Nowadays, on-shore wind turbines deliver around three MW's of power, which is a big increase compared to wind turbines that are installed 20 years ago, as already is shown in Figure 2.12. Therefore, it can be economical interesting to replace the older wind turbines with newer ones, and thus generate more power while using the same amount of land. In this case the reason for decommissioning does not necessarily relate to the quality and residual strength of the wind turbine. Thus, the wind turbines are able to operate for a longer period of time. Another reason for decommissioning the wind turbines and transporting it to customers is that regulations in western Europe are more strict than in other parts of the world. This may require major investments to again meet the regulations, which makes life-time extension economically unattractive. Selling the wind turbines in that case can be more economical. In the case of re-use, the wind turbines are inspected, offered to the market and transported to the customers, for example in eastern Europe. The reason that customers are still interested in these relatively old wind turbines is that, in addition to the attractive price, wind turbines of this size are easy to maintain and they can be constructed with relatively small cranes (Robbertsen, 2021). Reuse seems technically and economically affordable for older generations of wind turbine blades, which are relatively small and may have significant residual life. However, for larger and more recent wind turbine blades, transport may become challenging and involve higher cost (Beauson et al., 2022).

### 2.4.3. Repurpose

The circular economy guide (201, 2018) defines repurposing as "the use of a product or material for different function than it was originally produced for." The advantages of repurpose are that it reuses the structure and the quality of the composite material without requiring significant reprocessing (Beauson et al., 2022). This extends the lifetime of the composite material and reduces the environmental impact. Multiple research groups are currently working on solutions for repurposing wind turbine blades. Gentry et al. (2020) proposes to use parts of wind turbine blades as roofs for housing. Alshannaq

[et al. \(2021\)](#) proposes to use wind turbine blades as electrical transmission poles. [Bank et al. \(2019\)](#) performed a structural analysis on GFRP parts from decommissioned wind turbine blades for building reuse applications. [Tasistro-Hart et al. \(2019\)](#) presented a method to obtain the geometry of a wind turbine blade. This is useful because manufacturers of wind turbine blades are reluctant in disclosing information regarding the blades. The problem with current repurpose is that to date many of the repurposing examples represent demonstration projects that are unlikely to be a large-scale solution for future expected volumes ([WindEurope, 2020](#)). This is partly because blade geometries vary per wind turbine type. Also, it may be difficult to ensure consistent material specifications with wind turbine blades available at different ages and conditions ([Beauson et al., 2022](#)). New initiatives must be generated to scale up the repurposing of decommissioned wind turbine blades.

#### **2.4.4. Recycling**

Recycling techniques for GFRP material are commonly divided in three categories: mechanical recycling, thermal recycling and chemical recycling ([Oliveux et al., 2015](#)). The technologies related to the recycling categories are at different levels of maturity. Mechanical grinding is a commonly used and recycling method because it is low cost, effective and requires low energy. The recycled products are short fibres and ground matrix (powder). These can be used respectively as reinforcement or fillers respectively. To date, cement co-processing is the main recycling technology. The glass fiber is used as raw material for the cement mixes and the polymer matrix is burned as fuel for the process, which reduces the carbon footprint of cement production ([Schmid Marylise et al., 2020](#)). The disadvantage of recycling is that all the material properties of the blade are lost. Also, recycling requires intensive post-processing before new products can be made. Manufacturers are currently improving designs of wind turbine blades to make them fully recyclable ([Menendez, 2021](#)).

#### **2.4.5. Recovery**

Recovery means turning waste into a fuel or thermal energy after removing all individual components that can be used again ([Schmid Marylise et al., 2020](#)).

#### **2.4.6. Disposal**

Disposal is often related to land-filling. This has been a major waste treatment method since other methods are not profitable or applicable on large scale. In several countries landfilling is already forbidden, and from 2025 decommissioned wind turbine blades are banned from landfilling in Europe ([Bhatti, 2021](#)).

# 3

## Assessment Method

In this chapter the following research questions will be answered:

- Why are blades decommissioned?
- How to assess whether a blade can be repurposed?

### 3.1. Why blades are decommissioned

The service life of a wind turbine usually is 20-25 years ([WindEurope, 2020](#)). However, the exact service life is different for each wind turbine. In this section an overview is given of possible reasons why wind turbines are decommissioned. Due to the lack of publicly available information it is not possible to set out the specific reasons for decommissioning wind turbine blades. However, based on interviews with professionals in the field and literature study, a general description for this inquiry can be given. The two main reasons for decommissioning wind turbines are reaching the end of service life and economical reasons ([Ortegon et al., 2013](#)). Reaching the end of service life can be a technical matter, with the risk of causing failure, or the permit for the wind turbine can be expired. For economical reasons, usually it can be profitable to replace older wind turbines with new wind turbines with a higher yield. Exact numbers regarding the reason for decommissioning wind turbines are not present in literature. Both aspects will be further elaborated on in the following sections.

#### 3.1.1. Turbine reaches its end of service life

One of the reasons for decommissioning wind turbine blades is that the entire wind turbine reached its end of service life. This stage can be divided in two parts: failure causes and expiration of the permit. Failure causes imply that part of the turbine did not meet its demands. In case failure occurred at the turbine blades, this can affect the repurpose possibilities. Expiration of the license is more a bureaucratic matter and does not necessarily relate to the condition of the wind turbine.

The residual strength of wind turbine blades after reaching end-of-life is expected to be quite good. This is substantiated by the full scale flexural testing of a 27 year old blade to determine load-deflection behavior, ultimate capacity, strain history and failure modes. The results of the testing revealed that the GFRP material was still in excellent conditions ([Ruane et al., 2022](#)). This case study cannot give conclusions on all the blades presents, but shows that after 27 years of service life, the material still has significant material properties, which is a promising finding.

#### General damage and failure causes

In this section the general damage and failure causes related to wind turbine blades are investigated. It is important to note that a distinction can be made between the wind turbine blades and other parts of the turbine, that eventually can lead to decommissioning. The latter does not necessarily relate to the condition of the turbine blades. Due to the high competition in the wind industry, relevant companies are reluctant in disclosing information about wind turbine blades, including the reasons for failure. GCube Insurance services has estimated that of the 700.000 blades installed worldwide in 2014, on average 3800 incidents of blades occur each year, which is an annual amount of 0,5% ([GCube, 2014](#)). These

incidents vary in degree of seriousness, from manageable incidents to serious failure. This report sums up the incidents that, alone or in a combination, cause failure. The failure causes related to wind turbine blades are as follows:

- Failure at root connection leading to blade throw
- Extreme load buckling
- Lightning damages, including subsurface effect and moisture ingress thereafter
- Manufacturing effects leading to debonding
- Blade overspeed striking the tower
- Environmental events outside design envelopes
- Incorrect design for fatigue loads
- Poor manufacturing quality control leading to delamination

Since field investigations are scarce, a good method is to check experimental investigations to find out more about the failure modes. [Chen and Eder \(2020\)](#) state that from multiple full-scale testing studies two common conclusions can be drawn on the damage and failure modes:

- The governing failure phenomenon is primarily buckling driven whereby structural non linearity plays an important role in the failure process.
- The ultimate failure is typically characterized by a sequence of multiple failure modes, in which three-dimensional stresses/strain states may play an important role.

The failure modes that are most likely to occur in a wind turbine blade (except the total collision, in which a blade is not suitable for repurposing) and that can influence the remaining quality of a blade are fatigue, excessive bending stress, buckling and large deformation. Fatigue failure modes are complex to assess in advance. Wind turbines are designed to carry a high number of loading cycles, typically up to a magnitude of 1000 million cycles during their designed service life of 20-25 years. The risk exists that structural properties of turbine blades degrade with time, leading to reduced stiffness in the materials. A fatigue life is designed with a certain length, generally according to the service life. In this fatigue life, three phases exist:

- |                                   |  |
|-----------------------------------|--|
| Phase 1: Fast initial degradation | Matrix cracking                                    |
| Phase 2: Gradual degradation      | Matrix cracking coupled with interfacial debonding |
| Phase 3: Fast final degradation   | Fiber breakage                                     |

To investigate the degree of fatigue degradation and the impact this has on the bending stiffness, an experimental observation is carried out by [Chen \(2019\)](#). Here a full-scale 47 meter long blade is subjected to two million load cycles, with increased fatigue load to compensate for the real life amount of load cycles. The material used in the blade is mainly GFRP and balsa wood panels, as can be seen in [Figure 2.4](#). Looking at the results of the experiment, it can be concluded that the maximum stiffness decrease in the blade is 2.2%. Also, the third fatigue phase does not occur in the blade, which suggests that the blade might have a longer fatigue life and possibly a sufficient residual structural strength. Lastly, post-test visual inspection is conducted, where a few structural damages are found in the blade. These damages are very local and are regarded as too minor to affect the overall structural strength of the blade. The outcomes of this experiments deliver a positive outlook for the residual strength of blade material and its repurposing possibilities. However, eventually tests must be performed to substantiate the quality of the blades that will be repurposed.

### Expiration of the permit

Every wind turbine must meet certain standards. The design guidelines wind turbines have to meet are written by certification authorities, such as the international operating company Det Norske Veritas. Once the design guidelines are met, a permit is issued that enables the wind turbine to operate for a certain period of time. If the duration of this time is exceeded, the permit expires. It is possible to extend the duration of the permit. However, this requires an investment and possible modifications to the wind turbine. If it is economically more profitable to re-power the wind farm, with generally larger turbines with a higher power output, involved parties can decide to decommission the wind turbines.

### 3.1.2. Economical reasons

Another reason for decommissioning wind turbines is economical (Ortegon et al., 2013). This reason can stand on its own, but can also be in conjunction with expiration of the permit or damages on the wind turbine. The product of wind turbines is power, which can be sold to the commercial market. The returns from this power production can cover initial investment costs and maintenance costs. If the returns exceeds this costs, profit is made. Since the stakeholders related to the exploitation of wind farms are commercial businesses, the profitability factor is of importance. Subsidizing the wind industry has been necessary in recent years to overcome the gap between costs and returns, which implies the margins are tight in this industry. As can be seen in Figure 2.12, the power output of on-shore wind turbines has shown a tremendous increase, as a result of research, optimization and increasing sizes of wind turbines. A wind turbine with a higher power output can generate more returns and increase the profitability of a wind farm. At the same time, more green energy can be produced. In many countries, especially in the Netherlands, space is limited. Therefore, the amount of wind farms that can be placed are limited as well. As a result, the current wind farm location can be the most optimal location to install new wind turbines with a higher power output. This substantiates the economical reasons for decommissioning wind turbines.

## 3.2. A method to repurpose wind turbine blades

In this section a stepwise method is described that can be used if an initiator wants to repurpose wind turbine blades and wants to offer them to other parties. The goal here is to demonstrate which steps are needed to undertake in order to extract useful and safe building elements. The method consists of five steps and is briefly described in this section. It can be found in its entirety in Appendix B.

### Step 1: Collect general information

The first step is to learn more about the relevant wind farm and turbine blades. Therefore, general questions are established. The location of the wind farm, turbine type, amount of turbine blades and period in which they become available are asked. Further, an inventory is made of the relevant stakeholders, such as the farm owner and decommissioning party.

### Step 2: Collect blade information

It is recommended to collect the available information about the blade. The first question is why the blades are decommissioned. This can give an indication of the quality of the blades. Next, maintenance reports should be collected. It can occur that maintenance reports are not available or non-existent. In this case damages and repairs must be investigated. To assess the quality, strength and stiffness of the blade, visual inspections and sample test must be performed.

### Step 3: Determine blade geometry

To be able to extract elements from the blade, first the blade geometry has to be obtained. There are multiple options to find the blade geometry. These options are set out from easy to more complex. The first step is to check if the blade model already exists in the database. If not, the manufacturer can be asked to provide documentation regarding the geometry and properties of the blade. Since the design information about wind blades is strictly confidential, this often cannot be disclosed. The third option is to scan the blade to obtain an outer geometry of the blade. For the inner geometry and thickness, construct an internal point cloud. If all steps above are not possible, the airfoil sections can be measured by hand and modelled in a Computer Aided Design (CAD) program.

### Step 4: Extract useful elements from the blade

This step can be performed using Rhino. In this research, this step is worked out in Chapter 4. Once the model is finished following the procedure in Chapter 4, the modelling can be put into practice. The cutting surfaces can be extruded using a water jet cutter. This cutter is able to cut precise and smooth. Depending on the application, post-processing can be done. For example sanding, coating or sealing seams to prevent moisture inlet. After post-processing the elements can be delivered to the client, or sent to a storage location in case there is not a client yet.

### 3.3. Disposal costs at this moment

To give insight in the disposal costs of wind turbine blades at this moment, Cora Burger is interviewed. She is the former CEO of Demacq Design, a recycling company in the Netherlands, and is currently an independent recycling consultant with a proven track record of recycling wind turbine blades. In this interview, insight is given in the current course of events and common prices for wind turbine blades disposal. The given range of amounts in euros can differ per period of time and region and should be interpreted merely as an indication.

Once a wind turbine is going to be decommissioned, processing parties receive a budget from former owners of the wind turbines, such as energy companies, to dispose the blades. The budget they receive is very divergent and differs from €400 to €900 per ton. The blades that are currently EoL have a length of 30-100 meters. They must be segmented to transport with normal trucks. This is done using a waterjet cutter, which uses water in combination with sand, and has a cutting loss of circa one millimeter. The costs of hiring a sawing company are €2000, - per day. On average, two blades with a weight of six to seven tons can be sawn per day, giving a total of twelve to fourteen tons per day. The costs of transporting one blade, which fits on one truck after sawing, is approximately €600, - within the Netherlands. Transporting an entire blade on an exceptional convoy will cost around €30.000, -, which happens in the commission phase. Thus, it is not at all economical beneficial to saw the blade after transporting. A recycling option that is currently used is providing the cement industry in Germany with the blade material. In this case, the blade material can be used as raw input material in the cement production process. The blade must be delivered in pieces of at least 20 centimeters and with a maximum of 1x2 meter pieces, so must be segmented further. The sawing or shredding must take place on the yard of the decommissioning party and will cost around €150 per ton. Providing the cement industry with the blade material costs €350 per ton.

Another option is to dispose the blade material. First, the blades are shredded, which costs €100 to €200 per ton and afterwards the shredded material is disposed, at a price of circa €80 per ton. What is striking is that disposing the blades is a much cheaper option for the processing parties than delivering it to the cement industry. Obviously, disposal is less desired than recycling. However, in practice the economical profit will preponderate over the environmentally desired option. Incentives such as grants, or regulations could influence this. Figure 3.1 gives an overview of the disposal costs and benefits of wind turbine blades. It must be said that the numbers give a rough estimate and that factors such as scale of the decommissioned wind farm, incentives from former owners to recycle the material instead of disposing it, oil prices etc. can significantly influence the actual magnitude of costs and benefits.

Disposal costs of wind turbine blades				
Action	Costs	amount range [ton]	cost range per ton	Description
Budget for disposal	€ -900,00	1	2,2 € -900 € -409	Former owners pay 400-500 euros per ton for outsourcing the disposal
Sawing for transport	€ 2.000	12	14 € 167 € 143	Sawing the blade in transportable segments costs 2000 per day. 12-14 ton can be sawn per day
Transport	€ 600	6	7 € 100 € 86	Approximately one blade fits on a usual truck
1 Cement industry	€ 350	1	1 € 350 € 350	The cement industry can use blade materials as raw material, in case it is delivered in 1x2m pieces. This costs 350 euros per ton
Sawing for cement industry	€ 150	1	1 € 150 € 150	The blades must first be sawn in 1x2m pieces
2 Shredding	€ 1.000	5	10 € 200 € 100	A shredder costs 30.000 euros and is often already present on disposal yards. Renting it will cost 1.000 euros per day
Disposal	€ 80	1	1 € 80 € 80	Dumping the blades as waste material costs 80 euros per ton
1	Raw material for cement production		€ -133 € 319	
2	Shredding and disposal		€ -353 € -1	

Figure 3.1: Current disposal costs and benefits of wind turbine blades

In this research a method is proposed to repurpose wind turbine blades. A GE37 blade is used as case study and this blade has a weight of five tons. In Chapter 4 it is described how the blade is repurposed and what percentage of the blade can actually be repurposed. It has been found that an estimated efficiency of 38-50% of the input material can be repurposed. This means that parts of the



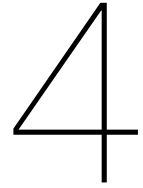
blade can be sold as repurposed materials, but that the remaining material still must be recycled or disposed. An indication of the costs and benefits is given in case 40% of the blade material can be sold as repurposed materials.

To approximate the possible yield of selling plates and beams, the extracted elements are compared to elements sold in wholesale markets, which is elaborated on in Chapter 4. This gives a potential yield of €4380, -. Since this is a best-case scenario, the range for yield is set to €1000 - €4000. Costs that are involved in the selling process are scanning and sawing of the blade, and storage of the blade elements. The remaining 60% of the blade material is offered to the cement industry or disposed.

Figure 3.2 gives an overview of the possible costs and benefits. It must be said that the actual values can vary significantly in practice. This is dependent on multiple factors as stated above. Further, no market research is performed on the need of blade elements instead of general elements. It is most likely that other factors than economical factors will eventually give the incentive to incorporate blade elements in projects. That could be factors like PR, circularity demands or special demands from the client.

Cost/profit range for a repurposed GE37 blade with a weight of five tons							
Action	Costs	amount range [ton]		cost range per ton		Cost/profit range GE37 blade	
Budget for disposal	€ -900,00	2,2	1	€ -409	€ -900	€ -2.045	€ -4.500
Sawing for transport	€ 2.000	14	12	€ 143	€ 167	€ 714	€ 833
Transport	€ 600	7	6	€ 86	€ 100	€ 429	€ 500
Scanning the blade	€ 100	1	0,5	€ 100	€ 200	€ 500	€ 1.000
sawing the blade	€ 200	1	0,5	€ 200	€ 400	€ 1.000	€ 2.000
Storage	€ 20	1	0,5	€ 20	€ 40	€ 100	€ 200
selling the blade	€ -1.000	1	0,25	€ -1.000	€ -4.000	€ -1.000	€ -4.000
1 Cement industry	€ 350	1	1	€ 350	€ 350	€ 1.050	€ 1.050
Sawing for cement industry	€ 150	1	1	€ 150	€ 150	€ 450	€ 450
2 Shredding	€ 1.000	10	5	€ 100	€ 200	€ 300	€ 600
Disposal	€ 80	1	1	€ 80	€ 80	€ 240	€ 240
1				Sell and cement	€ 1.197	€ -2.467	
2				Sell and dispose	€ 237	€ -3.127	

Figure 3.2: A theoretical cost/profit range in case a GE37 blade is repurposed



# Repurpose Method

In this chapter the following research questions will be answered:

- What type of standard building materials can be extracted from a GE37 wind turbine blade?
- Which advice can be given based on the possible application of the extracted elements?

This chapter describes how elements can be extracted from a wind turbine blade. The steps in the process will be performed on the basis of a case study. An existing wind turbine blade will be used and elements will be extracted from this model using the parametric design tool Grasshopper. Two approaches are distinguished; an efficient process and a process with more design freedom. The latter is published to give project initiators an incentive to incorporate wind turbine blades in their design. The efficient process is worked out further to give insightful advice on the possible applications. Once the elements are extracted, a catalog of the elements will be presented including their properties, possible applications and eventual necessary post-processing based on their application characteristics. Finally, a showcase will be presented to demonstrate a possible application.

## 4.1. Objectives and methodology

In this section the objectives, methodology and approach of this repurpose method will be described. The objectives describe the purpose of this method and what must be achieved. The methodology describes how the objectives are achieved.

### 4.1.1. Objectives

No large scale applications for the repurposing of wind turbine blades are present yet. To contribute to a solution for this problem, it is fundamental to demonstrate which valuable materials can be extracted from a wind turbine blade and what the properties of these materials are. Once this is demonstrated in this research, the threshold for using repurposed wind turbine blade material in construction projects is lowered. The elements that will be extracted from the blade in this research are kept straight forward on purpose, so a wide variety of applications can be thought of, and many wind turbine blades can be repurposed. The goal of this research is to demonstrate what kind of material can be extracted from a wind turbine blade, and what the value of these materials is. This is pursued in two approaches. In paragraph 3.2 an assessment method is set up from two starting points, of which the repurpose method will be a follow-up. The first method is constructed for an owner of wind turbine blades that can saw the blade into panels and beams and eventually sell them. The second method is constructed for a project team that wants to incorporate elements of wind turbine blade(s) in their project.

For an owner of decommissioned wind turbine blades, the goal is to saw the blade as efficient as possible, and at the same time extract the highest possible economical value out of the blade. These two main objectives can conflict, so the optimum between the efficiency of the blade material used and the economical value must be found. This approach also contributes to the large scale applicability of repurposed wind turbine blades, something that has not yet been achieved at this moment. Also, the potential economic benefits this method proposes can give a tremendous incentive to repurpose blades instead of current end-of-life strategies.

For a project team that wants to incorporate elements of wind turbine blades in their project, a model must be available in which the project team is able to extract "on demand" elements from an available wind turbine blade. The goal is to provide future users with a useful model in which free-form elements can be extracted from the blade. Providing this model lowers the threshold to incorporate wind turbine blades in building projects and can contribute to the creation of landmarks, which, in their turn, can contribute to creating awareness of this waste problem.

### 4.1.2. Methodology

The repurpose method is modelled on the basis of a case study, the model of the GE37 wind turbine blade as depicted in Figure 4.1. The blade is divided in six surface panels and a shear web. The material composition in one panel is assumed homogeneous in terms of material composition. Slight variations in the material composition, or additional materials can be present in the panels, but this remains out of scope for this research. Every blade panel will be treated independently of the adjacent panels. In this way, the resulting elements consist of a homogeneous material composition.

The elements that will be projected on the blade panels are standard construction materials. Straight-forward plates and beams with dimensions that are most commonly used in the construction industry are chosen to keep a wide range of possible applications.

The goal of the model is two-fold. First, the goal is to repurpose as much of the blade material as possible. This is called the efficiency and is defined as the percentage of material used, calculated by dividing the used area over the total area of a blade panel. Second, the goal is to turn the blade into elements with the highest possible economical value. To meet both demands, construction elements are set out with their dimensions and wholesale market price. The dimensions and prices are based on timber beams and plates, because the material properties of the shell panels in the blade are comparable to timber (Joustra et al., 2021) and timber has a wide variety of dimensions. The plates and beams with a thickness analogous to the blade, and with the most commonly used dimensions are taken as input for the model. The output of the model is a catalog of plates and beams including their dimensions and wholesale market price. The material properties belonging to the blade panels will be assigned to the plates and beams and a structural analysis is performed on the elements to give advice on the possible applications. Each panel will receive an "efficiency score" to quantify the amount of material that can be extracted from a panel. This percentage is the area of the extracted elements divided by the total panel area.

The method proposed in this research requires a blade geometry model. The method can be performed both on blade models with assigned thicknesses and on blade models with surface lofts. Further, the blade panels in the geometry model are already divided. If this is not the case in another available blade model, it can simply be done using Rhino if the division lines between the different materials are known. Therefore, the proposed method is easily applicable to all types of blades.

## 4.2. Input for the repurpose model

For this research, the blade geometry model of the wind turbine type GE37 is used. This turbine type is manufactured by General Electric. The wind blade model used in this research was provided by Georgia Institute of Technology produced using proprietary software (BladeMachine). This institute has produced the models in Rhino and based the geometry mainly on LiDaR scans. The GE37 turbine is a 1,5MW wind turbine designed for wind class 1 (See section 2.2.3 for more information regarding wind classes). The rotor diameter is 77 meters and the blade has a length of 37 meters. The turbine was replaced by a larger turbine before reaching its end-of-design-life for the purpose of increasing power generation, also known as repowering. (Alshannaq et al., 2022a)

The objective of the repurpose method is to demonstrate that valuable elements can be extracted out of a wind turbine blade. Five GE37 wind turbines are located in the Netherlands, and have been installed in 2005. The procedure designed in this research can be copied and applied to other models to extract elements from other blades. This can be done if a geometry file of a blade is present in Rhino. The grasshopper script can be connected to this geometry file and in this way the procedure can be copied. This can contribute to finding large scale repurpose solutions for decommissioned blades.

To give insight in the material composition, Figure 4.3 shows five cross sections of the GE37 blade throughout the length of the blade. In the model, the blade will be divided in individual panels, as illustrated in Figure 4.1.

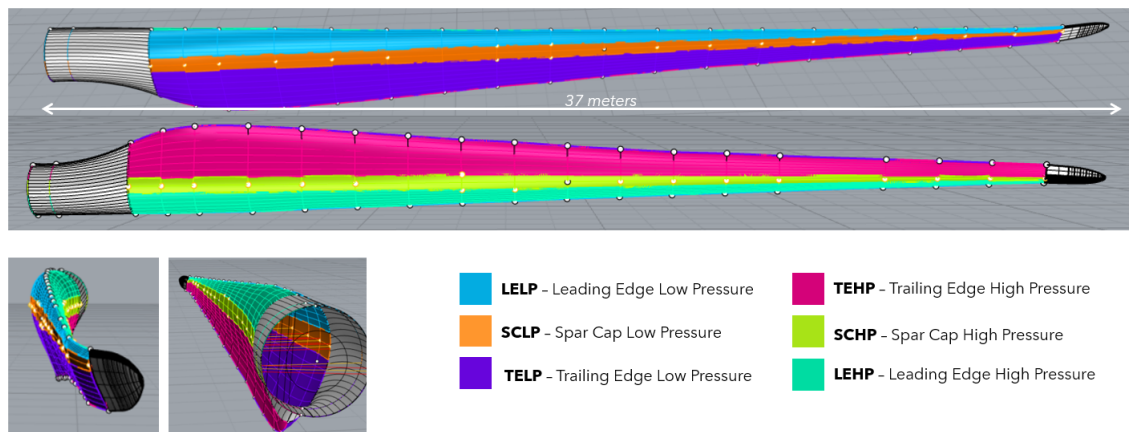


Figure 4.1: GE37 Blade model and legend, received from Georgia Insitute of Technology

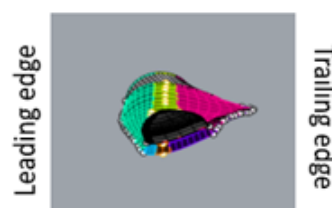


Figure 4.2: Leading edge and trailing edge of the blade

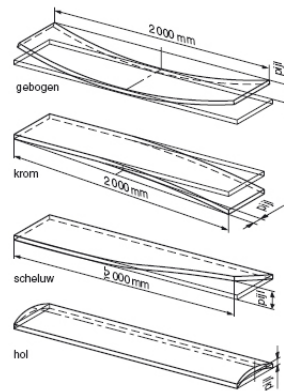


Figure 4.3: Five cross sections of the GE37 blade

The shell panels, shear web and spar caps are homogeneous in terms of material composition. The only variation throughout their length is the thickness.

Certain parts in the cross section of the blade are not homogeneous. They are elaborated on point by point:

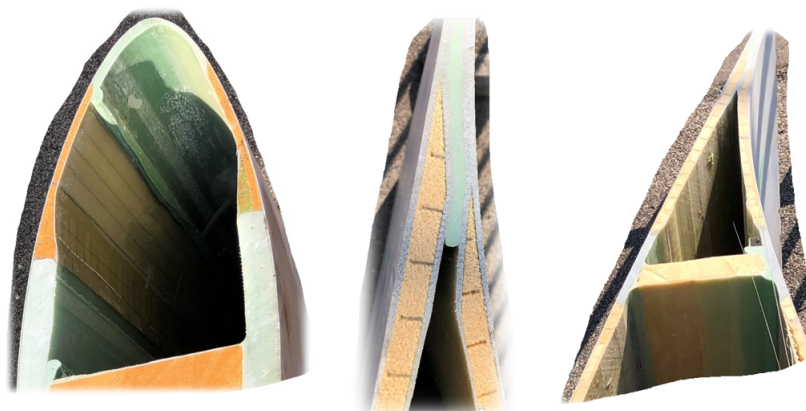
- The transition from shell panel to spar cap is not homogeneous. The spar cap is thicker than the shell panel, so more foam is added towards the spar cap, while the GFRP skin layer has a smooth transition.
- The leading edge (top of the left picture in Figure 4.4) is reinforced with GFRP. The dimensions



**Figure 4.5:** Possible deviations in timber. Curved, crooked, scoundrel and hollow. (Van de Kuilen et al.)

of this reinforcement are constant throughout the blade. This means that further in the blade, the width of the leading edge shell panels decreases.

- The trailing edge (central picture in Figure 4.4) is reinforced with GFRP as well. A transition area is present between the homogeneous shell panels and the reinforcement.
- In the wider section of the blade, the first 10 meters, an extra shear web is present (right picture in Figure 4.4). Because no pictures of cross sections earlier in the blade are present, limited information is available. However, it can clearly be seen that the second shear web is like the main shear web and is designed as an I-beam. The little spar caps intersect the homogeneous shell panel. This could influence the homogeneity in case plates are extracted from the shell panel.



**Figure 4.4:** Inhomogeneity in parts of the blade. The following is illustrated: Leading edge reinforcement, Trailing edge reinforcement & extra shear web

#### 4.2.1. Boundary conditions for extracting the elements

Boundary conditions will be established to have guidelines on extracting the elements. One of the challenges in the process is to extract elements that are flat enough to act as a comparable element, such as a plate. This is challenging since the aerodynamic design of a wind turbine blade leads to a curved and twisted geometry. Joustra et al. (2021) discovered that the materials from a turbine blade behave comparable to timber for stiffness limited design. Therefore, the guidelines for the design of timber regarding twist and curvature are taken into consideration in determining the boundary conditions. This gives guidance to the quantification of allowable deviations in the blade material. The guidelines for timber design are extracted from NEN5461 (Van de Kuilen et al.) and are set out in Table 4.1. Here, the dimensional deviations over a one meter span are shown. The smallest deviation possible is desired, but also using as many material from the original blade as possible. Therefore, the allowed deviation



is a variable parameter in the model. The goal is to not exceed a deviation of 16mm per meter so that the dimensional deviation is at most "Large" according to NEN5461.

Description	dimensional deviation per meter (d)
Extremely small	$d \leq 1 \text{ mm}$
Very small	$1 \text{ mm} \leq d \leq 2 \text{ mm}$
Small	$2 \text{ mm} \leq d \leq 4 \text{ mm}$
Mediocre	$4 \text{ mm} \leq d \leq 8 \text{ mm}$
Large	$8 \text{ mm} \leq d \leq 16 \text{ mm}$
Very large	$d \geq 16 \text{ mm}$

**Table 4.1:** dimensional deviations based on NEN 5461

The types of deviations that can occur for timber are illustrated in Figure 4.5. The deviations in Table 4.1 apply to curved, crooked and scoundrel. For hollow, the deviations from the eurocode are defined different. The deviations reach from zero to four millimeters over a width of 100 millimeter (Van de Kuilen et al.). Since the allowed deviations for hollow deviations are higher than the other deviation types, the allowed deviations for hollow deviations cannot be exceeded and thus can be disregarded.

When looking at standard building materials, the most straight forward building elements are plates and beams. Research is performed on the available sizes in hardware stores. A complete overview can be found in Appendix E. The dimensions of plates and beams used in this model are set out in Table 4.2. For plates, the width is between 1250 and 4200 millimeters, the length is between 600 and 3050 millimeters and the height or thickness is between 3,6 and 40 millimeters. For beams, the width is between 19 and 100 millimeters, the height is between 100 and 300 millimeters and the length is between 1850 and 7500 millimeters.

The goal is to find the highest possible economical value in the blade. The 2440x1220 mm plate has the highest value and thus will be projected first, followed by the 4,8m long beam and the 3,6m long beam (see Table 4.2). The blade panel can be filled up with the smaller beams and half plate to optimize the material use. The exact procedure for extracting the elements will be described in paragraph 4.3. In conclusion, the beams and plates set out in Table 4.2 are used as input for the model, and the boundary condition is the allowed deviation, which aims to remain as low as possible, but can be increased to optimize the material use.

### 4.3. Efficient extraction algorithm

In this section, the step by step modelling process from a wind turbine blade to a set of building elements is explained. Building elements are defined as plates and beams with standard dimensions, as offered in the construction industry. This modelling process is performed in Grasshopper, a Rhinoceros plugin. The entire script can be found in Appendix C. From a structural point of view, the blade can be divided in three parts as shown in Figure 2.6. The parts are the root, mid span and tip. The root and tip are disregarded because the midspan accounts for the majority of the material, and due to a lack of available data. This section focuses on the efficient processing of blades, the first scenario as described in section 4.1.1. The goal is thus to repurpose as much of the blade material as possible, while maximizing the economical value of the eventual products.

The material properties are added afterwards, and a structural analysis is performed on the resulting

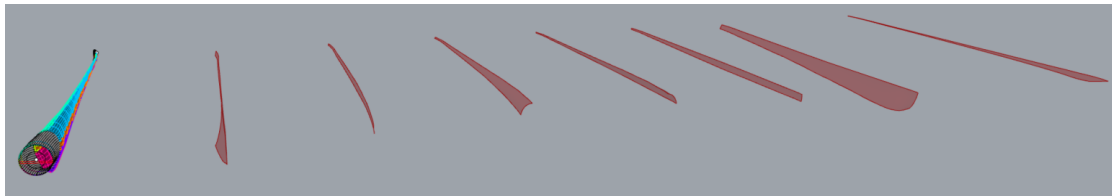
Type	Construction element dimensions [mm]	Wholesale market price
Plate	2440 x 1220	€89,95
Half plate	2440 x 610	€35,95
Beam	4800 x 15	€57,95
Beam	3600 x 15	€43,45
Beam	2800 x 15	€32,35
Beam	1850 x 15	€16,95

**Table 4.2:** Dimensions and wholesale market prices of construction elements. Wholesale market prices extracted from [www.gadero.nl](http://www.gadero.nl)

elements.

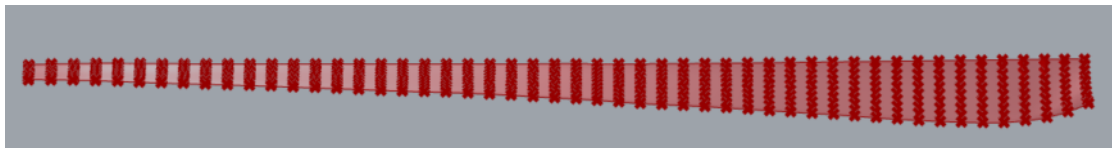
### 4.3.1. Algorithm for efficient repurposing of wind turbine blades

The blade is divided into seven panels, six surface panels and a shear beam, as shown in Figure 4.1. The blade panels have labels that relate to the location of the panel in the blade. Figure 4.2 indicates the leading edge and trailing edge. The top of the blade in Figure 4.1 faces the wind and experiences high pressure. The bottom of the blade experiences low pressure. This explains the origin of the labels. Every panel will be treated independently. The panels are divided in this way because the material composition in every individual panel is homogeneous. Figure 4.6 shows the original blade and all the individual panels.



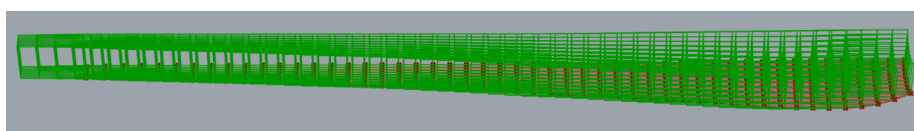
**Figure 4.6:** All seven blade panels set out individually. From left to right: TEHP, SCHP, LEHP, LELP, SCLP, TELP, Shear Web

The first input of the algorithm is the surface of one of the seven blade panels. The surface is divided by a grid of 500 points, 50 points in the length and 10 points in the height. A more dense grid will lead to more specific results, but on the other hand requires more computational power. At



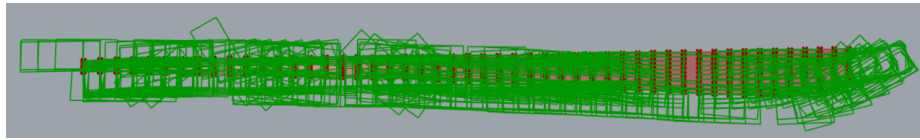
**Figure 4.7:** TELP Panel divided over 500 points

every single point, an origin of a coordinate system is placed. This origin is oriented in either the global coordinate system, or in a local principal curvature coordinate system. In a local principal curvature coordinate system, the curvature at the origin is zero, which can be beneficial since the curvature must be limited. The global coordinate system has a more straight forward orientation that enables a more dense grid. The choice for a local or global coordinate system can be considered for every element type individually. The second input is the X and Y dimension of the plate or beam that will be projected on the panel. At every point in the surface, this plate or beam is now projected, resulting in a projection of 500 elements. Figure 4.8 and 4.9 show this projection for the two coordinate systems. The global coordinate system leads to plates in the same orientation, while the local principal curvature coordinate system has a different orientation for all the plates. As can be seen clearly, some elements are falling out of the blade surface panel. This will be filtered in a later stage. First, the projected elements must be projected in the blade, instead of on the blade, so that they receive the curvature of the blade panel. This is done by extracting the elements through the blade panel, leading to an element that intersects with the blade panel. All that is not intersected by the blade panel is removed, and only the part of the element that is located at the blade panel is left. Now all the projected elements follow the course of the blade panel and have a three dimensional geometry, including the curvature of the blade panel (although no thickness is assigned to the blade panel yet).



**Figure 4.8:** Projection of plates with global coordinate system

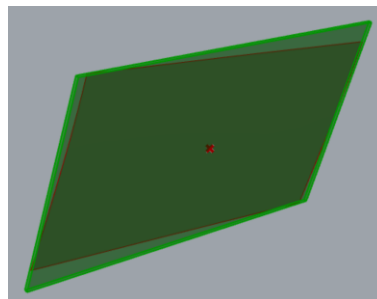




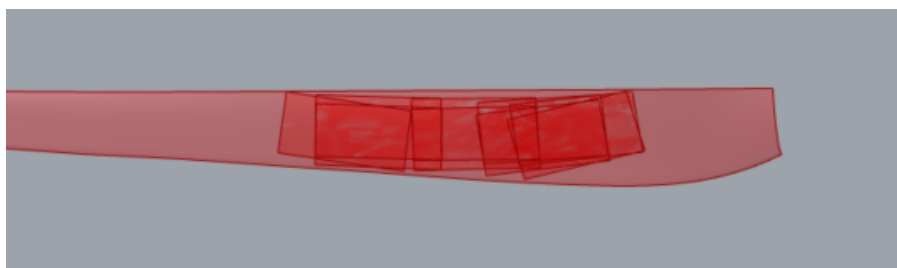
**Figure 4.9:** Projection of plates on local principal curvature coordinate system

The next step is to filter elements in a way that only elements remain which can actually be extracted from the blade panel in practice. Elements that exceed the surface area of the blade panel are filtered first. This is done by comparing the actual area of an element with the theoretical area. The theoretical area is the x-coordinate multiplied with the y-coordinate, with a small deviation upwards due to the curvature of the blade panel. The actual area of an element is equal or slightly higher than the theoretical area if the element fits to the blade panel, and is smaller than the theoretical area if a part of the element exceeds the surface of the blade panel. A "Larger than" component, with actual area is larger than the x-coordinate multiplied by the y-coordinate of the elements provides this filter.

The second filter is the maximum allowed deviation. In Table 4.1 the dimensional deviations for timber plates from the Eurocode are set out. The allowed deviation is a parameter in the grasshopper model that can be set with five possibilities. "0" represents an extremely small deviation, "1" represents a very small deviation, "2" represents a small deviation, "3" represents a mediocre deviation and "4" represents a large deviation. The deviation is calculated by adding a "bounding box" to the element. This is a box in which the element fits exactly, as illustrated in Figure 4.10. Due to the curvature of the blade panel, the bounding box has a certain thickness. Although the thickness of the bounding box is limited, the top part of the Figure clearly shows the third dimension of the box. To find the deviation, the dimensional deviations from Table 4.1 are converted to radians. The bounding box can be evaluated on the angle between the box corners in X- and Y-direction. If the deviation is higher than the allowed deviation, the element is culled. After filtering, all possible configurations of the inserted element can be projected on the blade panel. These possible configurations are illustrated in Figure 4.11 and 4.12 for plates and beams on the TELP panel.



**Figure 4.10:** Illustration of bounding box of one element



**Figure 4.11:** All possible panels projected on the TELP panel

The approach follows from the methodology and aims to find the highest possible efficiency, as well as the highest possible economical value. Therefore, first the panels with dimension 2,44x1,22 m are

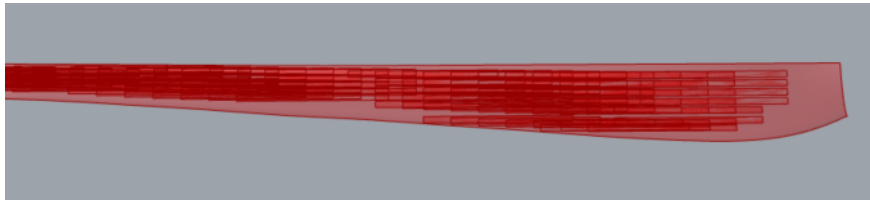


Figure 4.12: All possible beams projected on the TELP panel

projected on the blade panels. After all possible plates are projected on the blade panel, beams are projected on the blade panel. The sequence of this projections is from large beams to smaller beams, because large beams have a higher possible economical value, and smaller beams can fill up the blade panel, allowing for a high efficiency. In the last stage of the algorithm, the desired panels and beams can be selected so that no overlapping occurs. This results in a nesting pattern. Nesting refers to the process of placing cutting pattern to minimize the raw material waste, which are the blade panels in this case. In the nesting patterns the thickness and material properties are not included yet, these are assigned to the plates and beams after nesting.

#### 4.3.2. Expected efficiency range of the repurposed panels

In this section is described what the expected range is of the material percentage that can be repurposed. This percentage is dependent on which element dimensions are projected on the blade panels. To find out which percentage of the material can be repurposed, multiple approaches have been tested. These approaches all aim to find a high percentage of material that can be repurposed to decrease the amount of waste material. The approaches are as follows:

1. Start with projecting large beams, with a length of 3,6 or 4,8 meter and a deviation of "1", then project the same beams with a higher allowed deviation and repeat this process for smaller beams until no more beams fit in the grid. The smaller beams have a length of 2,15, 1,85 or 1 meter.
2. Start with panels and then beams. Three panels are suitable for this approach
  - (a) In case of the TELP and TEHP, plates with a size of 2,44x1,22 can be projected on the panel. First a deviation of "1" is allowed after which a deviation of "4" is allowed. The grid is then filled with beams, of which two approaches are tested
    - i. Beams with a length of 3,6 meter
    - ii. Beams with a length of 2,15 meter
  - (b) In case of the Shear Web, one plate with a size of 2,44x1,22 and deviation "1" can be projected. Then, half plates with a size of 2,44x0,61m and deviation "1" are projected. The grid is filled up with 4,8m long beams with a deviation "1".
3. Project only beams with a length of 2,8 meter. The allowed deviation is first set to "1", and then the grid is filled up further with a deviation that allows more beams to be projected. The deviation is usually set to "4", but this also includes the beams that have a lower deviation.
4. Project only smaller beams with a length of 1,85 meter. The allowed deviation is first set to "1", and then the grid is filled up further with a deviation that allows more beams to be projected. The deviation is usually set to "4", but this also includes the beams that have a lower deviation.
5. Project very small beams, with a length of 1 meter, to check if this increases the efficiency significantly.

For every blade panel, a resulting efficiency range is found. These ranges vary from a minimum of 33% to a maximum of 57%. The ranges per blade panel are set out in figure 4.13. Overall, 38-50% of the blade can be repurposed as construction elements.

Panel	Approach description	A				B				C				Efficiency	Range
		First input dim.	dev	sub-efficiency	# of elements	Second input dim.	dev	sub-efficiency	# of elements	Third input dim.	dev	sub-efficiency	# of elements		
TELP	1 large beams to smaller beams	3,6x0,15	1	30%	19	2,15x0,15	1	8%	8					38%	38-48%
	2 only smaller beams	2,15x0,15	1	39%	41									39%	
	3 only medium beams	2,8x0,15	1	38%	31									38%	
	4 Panels, then large beams	2,44x1,22	1	8%	1	2,44x1,22	4	16%	2	3,6x0,15	1	22%	14	46%	
	5 Panels, then small beams	2,44x1,22	1	8%	1	2,44x1,22	4	16%	2	2,15x0,15	1	24%	25	48%	
TEHP	1m mini beams	1,0x0,15	1	45%	101	1,0x0,15	4							45%	37-57%
	1 large beams to smaller beams	3,6x0,15	1	22%	14	2,15x0,15	4	31%	32					53%	
	2 only smaller beams	2,15x0,15	1	16%	17	2,15x0,15	4	30%	31					46%	
	3 only medium beams	2,8x0,15	1	14%	14	2,8x0,15	4	30%	24					44%	
	4 Panels, then large beams	2,44x1,22	1	9%	1	2,44x1,22	4	18%	2	3,6x0,15	1	11%	11	37%	
LELP	5 Panels, then small beams	2,44x1,22	1	9%	1	2,44x1,22	4	18%	2	2,15x0,15	3	30%	30	57%	
	1 large beams to smaller beams	3,6x0,15	1	29%	8	1,85x0,15	2	8%	4	1,85x0,15	3	4%	2	40%	
	2 only smaller beams	1,85x0,15	1	33%	17	1,85x0,15	4	4%	2					37%	
	3 only medium beams	2,8x0,15	1	32%	11	2,8x0,15	4	3%	1					34%	
	4 1m mini beams high dev	1,0x0,15	4	36%	34									36%	
LEHP	5 1m mini beams	1,0x0,15	1	28%	27	1,0x0,15	4	5%	5					33%	36-45%
	1 large beams to smaller beams	4,8x0,15	1	27%	7	3,6x0,15	1	3%	1	1,85x0,15	3	12%	8	42%	
	2 only smaller beams	1,85x0,15	1	32%	21	1,85x0,15	3	14%	9					45%	
	3 only medium beams	2,8x0,15	1	25%	11	2,8x0,15	2	11%	5					36%	
	4 1m mini beams	1,0x0,15	1	27%	33	1,0x0,15	4	15%	18					41%	
SCLP	1 large beams to smaller beams	4,8x0,15	1	48%	9	1,85x0,15	2	4%	2					52%	44-52%
	2 only smaller beams	1,85x0,15	1	52%	25									52%	
	3 only medium beams	3,6x0,15	1	48%	12	1,85x0,15	2	4%	2					52%	
	4 1m mini beams	1,0x0,15	1	44%	39									44%	
SCHP	1 large beams to smaller beams	4,8x0,15	1	27%	5	1,85x0,15	3	19%	9					46%	46-55%
	2 only smaller beams	1,85x0,15	1	32%	16	1,85x0,15	3	16%	8					50%	
	3 only medium beams	3,6x0,15	1	36%	9	1,85x0,15	3	19%	9					55%	
	4 1m mini beams	1,0x0,15	1	29%	26	1,85x0,15	3	17%	15					46%	
Shear Web	1 Panels, then beams	2,44x1,22	1	13%	1	2,44x0,61	3	19%	3	4,8x0,15	1	15%	5	47%	39-52%
	2 Large beams	4,8x0,15	1	52%	17									52%	
	3 Medium beams	2,8x0,15	1	48%	27									48%	
	4 smaller beams	1,85x0,15	1	46%	39									46%	
	5 mini beams	1,0x0,15	1	39%	61									39%	
Overall														38-50%	

Figure 4.13: Range in obtained efficiency per blade panel

It is expected that projecting small beams, with a size of one meter, would increase the efficiency of the blade panels, because this could lead to a denser grid and less curvature will occur in the blade panels. Although the latter is true, the efficiency score never reached its maximum when one meter span beams were used. Because the area of these beams is small, a lot of beams are needed to reach a dense grid. The amount of points the panel is divided in, which is limited due to available computing power, leads to open spaces where no beams are projected. At the same time, longer span beams are already able to cover quite a significant area of the blade. The parts of the panel where longer span beams can't be projected, aren't always suitable for small beams due to their curvature which exceeds the allowable curvatures.

Panels have a high area compared to beams due to their width. Projecting a panel also leaves no open spaces in its own area. However, it has turned out to be difficult to reach a high efficiency in the area around the panels, because they are usually projected in the local coordinate system as this gives the panels the smallest deviation. The approach that has led to the highest efficiency in all blade panels, is to first project large beams, with a span of 3,6-4,8 meter. Then, the grid can be filled up with smaller beams and eventually a higher allowable deviation can be set to the smaller beams to fill up the grid even further. With this approach, also the highest economical value can be obtained.

The approach where large beams are projected first, after which smaller beams are projected to fill up the grid, leads to a realistically high efficiency. With this approach, first the largest available beams (3,6-4,8m span) are projected with a deviation "1". Then, the allowable deviation is increased, or the size of the input beams is decreased, and the process is repeated. The efficiency does not grow when very small beams, with a length of one meter, are projected.

### 4.3.3. Nesting patterns on blade panels

In this section is described how the nesting patterns for the seven blade panels are obtained. Nesting refers to the process of laying out cutting patterns to minimize the raw material waste. Thus, in this section the highest possible efficiency is sought for. Every panel is treated individually and an efficiency score is given to the panel. When analysing the beam projections in Figure 4.15 to 4.21, some empty space can be observed. This is a result from limited available computing power. The blade panel is divided over 500 points, of which 50 in the longitudinal direction. Over a length of 32 meter, there is a projected point at every 0,64 meter. Increasing the amount of points and the required computational power can have a positive effect on the efficiency score of the nesting pattern.

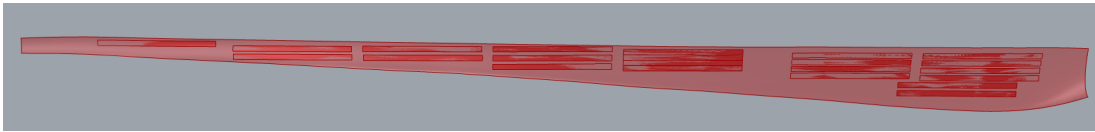
#### TELP - Trailing Edge Low Pressure Panel

The TELP panel has a transition from spar cap to constant panel thickness at the spar cap side, and a lamination at the trailing edge. Therefore, on both edges a margin of 100mm is taken into account where no elements are projected.

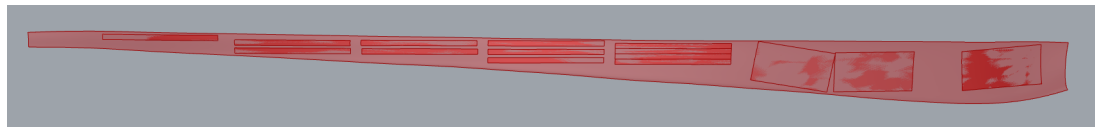
First, panels of 2,44x1,22m are projected with an allowed deviation of "1" and a local principal curvature

coordinate system. This leads to two suitable panels. As a next step the 2,44x1,22m panels are projected again, but now with an allowed deviation of "4". One panel is suitable in this setting. The panels are located at the root section side. All three panels together cover 24% of the panel area. Now the beams are projected. First must be considered which coordinate system is the most suitable, the local principal curvature axis or the global coordinate system. For the TELP panel the global axis is most suitable for all beams because this enables a denser grid than the principal curvature axis. Two beam sizes of 3,6 meters and of 4,8 meters are projected on the panel, with an allowed deviation of "1". Both 4,8m beams and 3,6m beams can be projected. A higher efficiency can be achieved with 3,6m beams because this gives a denser grid. The total economical value is also slightly higher with 3,6m beams. The eventual efficiency score of the TELP surface is 43%. The plates and beams that can be extracted are high-value elements.

Since from the nesting patterns it seems that the panels take a lot of space, an attempt is made to increase the efficiency using only beams. This has led to an efficiency of 34% and thus is significantly lower. Therefore, the combination of beams and plates is chosen as final nesting pattern



**Figure 4.14:** TELP Panel with only beams. This leads to a lower efficiency than the combination of plates and beams



**Figure 4.15:** TELP Panel final nesting pattern

#### **TEHP - Trailing Edge High Pressure Panel**

First, plates with a size of 2,44x1,22m and an allowed deviation "1" are projected on the panel. Only one panel can be projected in the local principal curvature coordinate system. Increasing the allowed deviation to "2" and "3" creates one more panel for both allowed deviations. So in total three panels can be extracted, with deviations "1, 2 and 3". For projecting panels, both local and global coordinate systems are explored. The global coordinate system can produce the most beams since this enables the grid to be dense. Beams with a length of 4,8m and deviation "1" can be extracted from this panel. After this step, 3,6m beams with a maximum allowed deviation of "2" are inserted. The eventual achieved efficiency is 51%



**Figure 4.16:** TEHP Panel final nesting pattern

#### **LELP - Leading Edge Low Pressure Panel**

The Leading Edge Low Pressure Panel has an inhomogeneous thickness at the leading edge side, due to reinforcement and adhesion. The width of this inhomogeneous layer is approximately 100mm. This area will be excluded from the model. Extracting plates from the LELP panel is not possible due to its curvature, so only beams can be projected. First, an attempt is done to project 4.8x0.15m beams on the LELP with a deviation "1". The local principal curvature is used since this allows for a denser grid. Since not many beams can be projected, the size is lowered to 3.6 meter long beams. Eight beams are projected with a total efficiency of 29,35%. Next, 3.6m panels are projected with a higher allowed deviation, but no beams of this size fit in the remaining grid. The rest of the grid is filled with smaller beams of size 1,85x0,15m and deviation 2-3. This leads to an eventual efficiency of 40%



Figure 4.17: LELP Panel final nesting pattern

#### LEHP - Leading Edge High Pressure Panel

The Leading Edge High Pressure is comparable to the LELP in terms of material composition. Extracting plates from the LELP panel is not possible due to its curvature, so only beams will be projected. First, an attempt is done to project 4,8x0,15m beams on the LELP with a deviation "1". This leads to 7 possible beams, with an efficiency of 27,4%. An attempt is made to fill the grid further with 3,6m panels, but this is not possible. Therefore, small 1,85x0,15m beams are projected to increase the efficiency. The allowed deviation is given as 1 and 3, which gives 2 and 8 possible beams respectively. The eventual efficiency is 42%



Figure 4.18: LEHP Panel final nesting pattern

#### SCLP - Spar Cap Low Pressure Panel

The spar caps consist of a different material than the shell panels. GFRP is used in this case. The thickness of the spar caps decreases throughout the length. The thickness at the root is approximately 58mm and at the tip 25 mm. The course of the thickness is approximated as linear. The width of the beams is again set to 150mm since this follows from the beam sizes available in wholesale markets. The beam thickness with a width of 150mm can vary between 22-58mm. First, beams with a length of 4,8m and a width of 0,15m are presented. The global coordinate system leads to more outcomes and less overlap, so this orientation will be used, with an allowed deviation of "1". Due to the relative flatness and limited curvature, beams can be projected straight forward on the panel. Therefore, the 4,8m beams with a small deviation can already achieve an efficiency of 48,3%. Since the grid is filled quite dense already, the width of the panels will be increased to check if a higher efficiency is possible. 200mm width is inserted, this however leads to a lower efficiency of 42%. Also, beams with a length of 3,6m and a width of 0,15m are inserted. The efficiency here is the same as the 4,8m beams, 48%. Since the beams with a longer length have a higher value, the 4,8m beams are used. The value per meter for these beams is the same so different outcomes could also be possible. To fill the grid further, two small beams of 1,85m with a deviation of "2" are placed. This leads to an eventual efficiency of 52%



Figure 4.19: SCLP Panel final nesting pattern

#### SCHP - Spar Cap High Pressure

The Spar Cap High Pressure panel is located on the opposite of the SCLP. The shear web is located in between these two panels. Together the spar caps and shear beam form an "I-beam". The SCHP panel consists of the same material as the SCLP. The thickness near the root is approximately 57mm and this decreases to 28mm at the tip. The course of the thickness is approximately linear. First, 4,8m long beams are projected on the panel with allowed deviation "1". With this, five beams can be projected, which leads to an efficiency of 27%. Since overlapping panels limit the number of panels that can be projected, beams with a length of 3,6m are projected to challenge the efficiency. For both options, the global coordinate system is used since this leads to a denser possible grid. Beams of 3,6m with deviation "1" achieve an efficiency of 36% so they're chosen over the 4,8 beams. The next step is to increase the deviation to "3" for 3,6m beams to allow a denser grid. Two more beams can be projected leading to a total efficiency of 44%. Since a large gap is left open, smaller beams with a length of 2,8m will be projected to fill the grid. Two beams are projected, with a deviation of 2 and 3. The eventual efficiency is 50%



Figure 4.20: SChP Panel final nesting pattern

### Shear Web

The shear web is a sandwiched panel consisting of two thin GFRP layers with foam in between. It has a constant thickness of 80 mm. This is thicker than general plate- and beam thicknesses. Since the thickness is not straight forward, effort will be put into finding plate-like material, that can be used as for example partition walls. First, an attempt is made to extract a 2,44x1,22m panel from the shear web. One panel with a deviation “1” can be extracted. Increasing the allowed deviation does not lead to more panels, so half panels are used with dimensions 1,22m by 0,61m. This gives three more panels. The rest of the grid is filled with 4,8x0,15m beams. The efficiency score is 47%



Figure 4.21: Shear Web final nesting pattern

#### 4.3.4. Maximum element dimensions from blade panels

In case a project team wants to incorporate certain elements from a blade into their project, it is important to have insight in the maximum available dimensions that can be extracted from the blade. To give this insight, the blade panels are considered individually. The range of available dimensions for rectangular elements is sought out. This is done for an allowed deviation of “one” to “four”. First, the maximum X value is found, after which its corresponding Y value is found. Then, first the maximum Y value is found, after which its corresponding X value is found. The results are the maximum dimensions of elements that can be extracted from the blade panels.

The method described above demonstrates the maximum dimensions for a maximum X value and a maximum Y value respectively. This method has some restrictions since stretching one value (X or Y), can decrease the range of the other value (Y or X respectively). Thus, this approach gives a range and an indication, but is not comprehensive. To give more insight on the maximum possible sizes of elements that can be extracted from the blade, the maximum area of an element is found. This is first done using Galapagos, a component in grasshopper that can optimize a shape so that it best achieves a user defined goal. However, the required computing time turned out to be significant. Therefore, it is decided to find the maximum area manually.

Figure 4.22 gives an overview of the maximum XY dimension, YX dimension and maximum area. With this, a potential user has insight in the maximum sizes and areas the elements can cover. To find out whether the exact desired dimensions a user has, can indeed be extracted from the blade panel, the model can be used.

What is remarkable, is that the maximum area is less sensitive for the allowed deviation. This is because a panel-like element covers more area than a slender beam, while covering less length of the blade panel.



Panel	Deviation	Maximum X dimension	Maximum Y dimension	Amount of elements	Maximum Y dimension	Maximum X dimension	amount of elements	Maximum area	X dimension	Y dimension
TELP	1	10	0,2	1	1,2	7	1	2,24	8	0,9
	2	10,5	0,25	1	1,2	8	1	7,49	8	0,9
	3	10,7	0,2	1	1,2	8	1	7,49	8	0,9
	4	10,7	0,2	1	1,4	8,5	1	7,49	8	0,9
TEHP	1	19	0,25	1	0,8	12	1	8,15	10	0,8
	2	21	0,3	1	1,1	7,5	1	11,68	11	1
	3	24	0,35	1	1,1	7,5	1	11,68	11	1
	4	26	0,3	1	1,1	7,5	1	11,68	11	1
LELP	1	8	0,25	1	0,4	5,5	1	2,22	5	0,4
	2	9	0,2	1	0,45	4,5	1	2,65	6	0,4
	3	9	0,2	1	0,45	4,5	1	2,65	6	0,4
	4	9,5	0,15	1	0,45	4,5	1	2,65	6	0,4
LEHP	1	12	0,15	1	0,5	10	1	4,54	10	0,45
	2	14	0,15	1	0,5	10	1	4,54	10	0,45
	3	14	0,15	1	0,55	6	1	4,54	10	0,45
	4	14	0,15	1	0,6	5	2	4,54	10	0,45
SCLP	1	10,5	0,2	1	0,3	9	1	3,52	10	0,35
	2	10,5	0,2	1	0,35	10	1	3,52	10	0,35
	3	11	0,15	1	0,35	10	1	3,52	10	0,35
	4	11	0,15	1	0,35	10	1	3,52	10	0,35
SCHP	1	18	0,2	1	0,35	13	1	4,544	15	0,3
	2	22	0,2	1	0,5	10	1	6,03	15	0,4
	3	25	0,2	1	0,5	12	1	6,03	15	0,4
	4	25	0,2	1	0,5	12	1	6,03	15	0,4
Shear Web	1	22	0,2	1	1,4	1,5	1	6,49	13	0,5
	2	23	0,15	1	1,4	1,5	1	6,49	13	0,5
	3	23	0,17	1	1,4	1,5	1	6,49	13	0,5
	4	23	0,17	1	1,4	1,5	1	6,49	13	0,5

Figure 4.22: Maximum available dimensions

### 4.3.5. Assigning thickness to resulting elements

The GE37 blade is measured at multiple locations throughout the length, so the thickness of the blade panels is known. Due to confidentiality, these measurements cannot be disclosed, but with this information, thickness can be assigned to the surface elements resulting from the efficiency algorithm. In Figure 4.23 sixteen cross sections and their original location are shown.

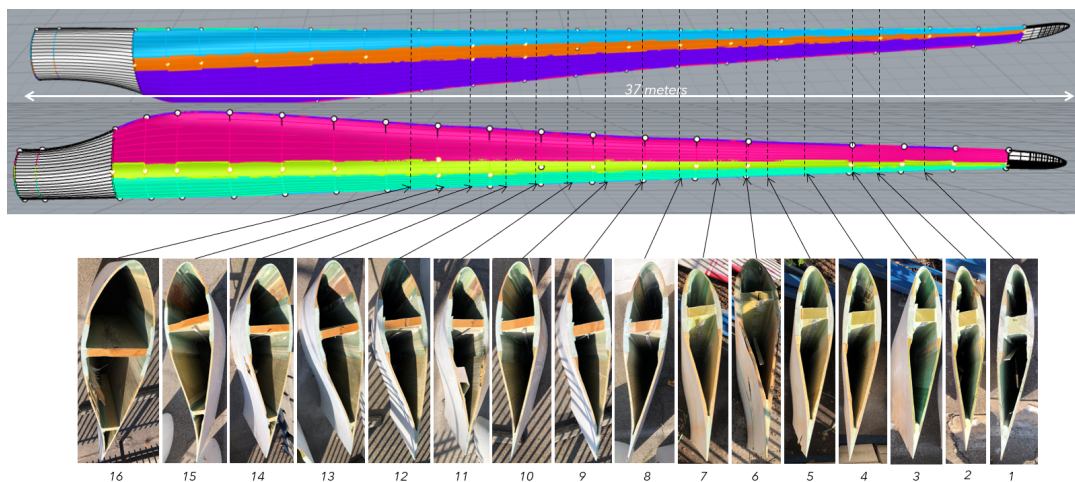


Figure 4.23: Cross sections of the blade at 16 different stations. Pictures of the blade are provided by the Re-Wind Network

To model the thickness, the surface panels are taken as input in Grasshopper. The center point is defined and at this location the local principal curvature is found. A plane is constructed on the surface frame where the local principal curvature is zero, and the surface is extruded along the Z-axis of the plane to add the thickness. The procedure in grasshopper is shown for the TELP panel in Appendix C.

All elements are tabulated with their dimensions and deviations. In the Table also the estimated cost per item, as summarized in Table 4.2, are shown to give an indication of the potential total yield of one blade. The complete catalog with all dimensions can be found in Appendix D. Following the process described above, a total of 96 building elements can be extracted from a 37 meter long wind turbine blade, with an estimated value of €4.497,00 based on comparable timber materials. The costs to scan the blade and saw it in the desired elements, as well as the costs to dispose the residual material, are not quantified within this research.

## 4.4. Algorithm for repurposing wind turbine blades on demand

This section describes how a model is designed that can be used if project teams want to incorporate wind turbine blades in their construction project. The goal of delivering this model is to provide a

first step for architects and engineers to explore with the possibilities of using wind turbine blades in construction projects. Since the demands can differ per project, a high flexibility in design freedom is required. The model is designed with this flexibility in mind. First, the general approach is described after which is described how the algorithm works. Lastly, examples of possible outcomes are given.

#### 4.4.1. Approach for on-demand algorithm

In this section the approach for the algorithm is described. To cover most of the possible applications, three approaches are distinguished:

1. Reuse the entire blade
2. Repurpose blade sections
3. Extract freeform elements

If a project team wants to use entire wind turbine blades in their project, the blade geometry can be directly copied to the project model. No post-processing in this model is necessary. To determine the orientation, structural function and support points, it is advised to gain insight in the structural characteristics of the blade, which are described in section 2.

To repurpose blade sections, the model users must have the ability to cut the blade in multiple planes. Therefore, cutting planes are modelled in X, Y and Z direction. The possible inputs are the entire blade, or one of the seven blade panels. For extracting freeform elements, the blade is again divided in the seven panels as described in section 4.2, to have a homogeneous material. The users can then project multiple types of free forms on the blade panels.

#### 4.4.2. Description of on-demand algorithm

In this section, the algorithm to extract blade sections or free forms from the blade is described. Reusing the entire blade does not require a separate algorithm, so this will not be discussed.

##### Repurpose blade sections

The input for blade sections is either the entire blade or one of the seven blade panels. The parameters are the X, Y and Z coordinates of cutting planes. To construct a cutting plane, first a plane is made with the origin at the root end of the blade. On this plane a surface is projected which can be moved over the X, Y or Z axis by changing the parameters. With the split brep component, and the surfaces as cutting shape, the input model is splitted. Since after splitting two breps remain, the desired brep must be selected. Selecting the desired brep must be performed after every cut, in X, Y and Z direction.

##### Extract freeform elements from the blade model

For extracting freeform elements from the blade model, the methodology set up in the efficiency algorithm is reproduced. The input is one of the seven blade panels. To prepare the model, the surface is divided over 500 points. Again the local plane, where the local principal curvature is zero at the origin, and the global plane are constructed. In one of these origins, the free forms are projected. Four forms are distinguished, which all have different input parameters. The input forms are set out in the following list:

- Rectangular form - The input parameters are the X- and Y-coordinate
- Circular form - The input parameter is the radius of the circle
- Free form - The free form is constructed by a four point surface. For every input point, one of the 500 points projected on the surface can be selected.
- Ellipse - The input parameters are two radii that together lead to the ellipse

For the rectangle, circle and ellipse, the selected form is projected on all the 500 surface points just like the efficiency algorithm in section 4.3. The forms that fall outside the surface are filtered and an allowed deviation can be set. The result is a list with all forms that can be projected in the blade panel. The user has the freedom to choose one or more forms by selecting them.

#### 4.4.3. Possible outcomes of on demand algorithm

In the following Figure examples of possible outcomes are given. On the left the entire blade is shown. In the middle the blade with different cutting planes is shown and on the right the ellipse, freeform and circle are projected in the blade.

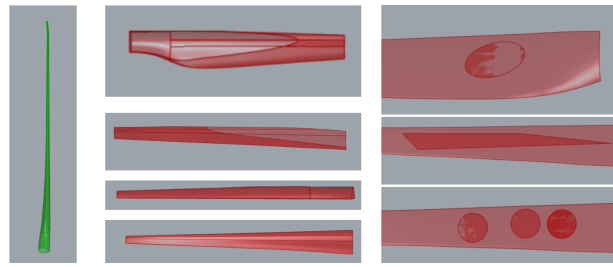


Figure 4.24: Examples of results from on demand algorithm

Property	Unit	Value
Longitudinal Tensile Strength	MPa	597
Longitudinal Compressive Strength	MPa	504
Shear Strength	MPa	55
Longitudinal Young's Modulus	MPa	36.800
Longitudinal Compressive Modulus	MPa	41.900
Volume fraction	%	50

Table 4.3: Residual material properties of spar cap in GE37 blade (Alshannaq et al., 2022b)

## 4.5. Element properties

The wind turbine blade can roughly be divided in three groups: spar caps, shell panels and the shear web. All three groups have their own characteristic properties, which will be elaborated on in this section. Figure 4.25 illustrates the material lay-up and variation of the cross section throughout the length of the blade. First, the spar cap will be elucidated, then the shell panels and finally the shear web.

### 4.5.1. Spar caps

A detailed picture of the spar cap is shown in Figure 4.26. The spar caps are responsible for the main load bearing of the blade. The spar caps are faced perpendicular to the wind direction and provide stiffness to the blade. Together with the shear web a beam is created. The spar cap has a high strength-to-weight ratio and a high stiffness-to-weight ratio. The spar cap mainly consists of uni-axial fibers. The outer laminates consist of bi-axial laminates with a thickness of 1,78 mm. The outer laminate thickness is constant over the length of the blade and the thickness (amount of laminates) of the uni-axial fibers decreases with the length of the blade. Figure 4.27a shows the lay-up of the glass fibers in the cross section of the spar cap. The stacking sequence of the fiber layer is characterized as  $[(\pm 45)_2/Mat/0_n/(\pm 45)_2]$ , where "n" represents the number of uni-axial layers, which can add up to 100 layers. Alshannaq et al. (2022b) determined the residual properties of the spar caps in the GE37 blade by means of multiple sample tests. Tensile, compressive, shear, bearing, and pull-through properties are obtained in the research. The tensile stress-strain diagram is shown in Figure 4.27b, including the test set-up.

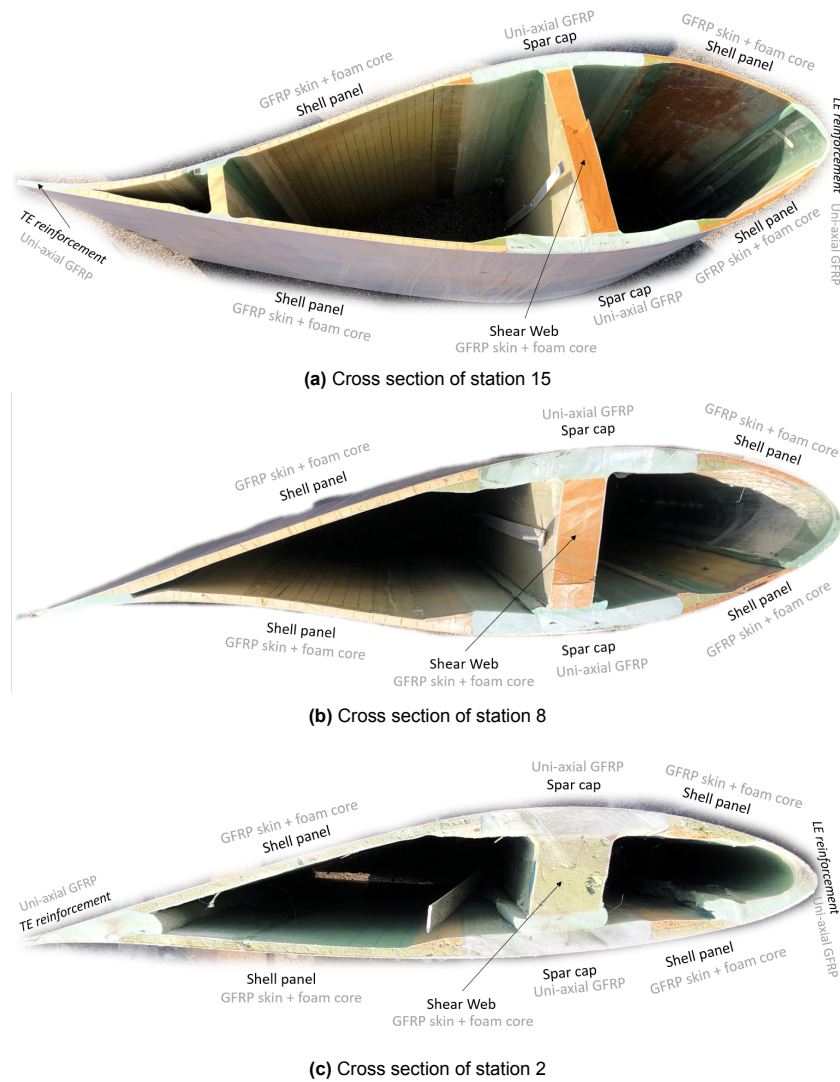


Figure 4.26: Detailed picture of the spar cap. Picture provided by the Re-Wind Network

The material properties of the GE37 spar cap obtained in Alshannaq et al. (2022b) are shown in Table 4.3

### 4.5.2. Shell panels

A detailed picture of a shell panel is shown in Figure 4.28. The shell panels form the aerodynamic shape of the blade. The shell panels are sandwich material, where the skin is tri-axial GFRP to resist torsional effects. The core material is foam, reinforced with ribs of GFRP perpendicular to the skin. These ribs significantly increase the stiffness and strength of the panels. The foam used in the shell panels, as well as in the shear web, is "Divinycell H". The material properties are retrieved from its brochure (Diab Groupe, 2022). This PVC material is ideal for applications subject to fatigue, slamming or impact loads. Further it includes consistent high quality, excellent adhesion/peel strength, excellent chemical



**Figure 4.25:** Cross sections of the blade at station 15, 8 and 2. Pictures received from the Re-Wind Network

resistance, low water absorption and good thermal/acoustic insulation. The Divinycell H comes in multiple densities, but the density used in the core is  $130 \text{ kg/m}^3$ . The material properties of the skin are provided by Re-Wind and an overview of the material properties in the shell panel is given in Table 4.4.

### 4.5.3. Shear Web

A detailed picture of the shear web is shown in 4.29. The shear web is located inside the blade and provides support to the shell and resists shear forces. The shear web is a sandwich material with a bi-axial GFRP skin and a thick foam core. The foam used in the core is the same as used in the shell panels. The material properties of the skin are provided by Re-Wind. Since no information regarding the behaviour of the shear web of the GE37 blade is present, literature of comparable materials is consulted. [Correia et al. \(2012\)](#) performed a full-scale flexural test on multiple 2,50 long x 0,50 wide x 0,104 thick sandwich panels in a four-point bending configuration. These dimensions are comparable to the shear web in the GE37 blade. All tested panels showed an approximately linear behaviour up to failure, with a slight stiffness reduction. Collapse was due to shear failure of the core, followed by skin-core delamination. [Sharaf and Fam \(2011\)](#) performed experiments on a (9.145 x 2.440 x 78 mm) sandwich panel with polyurethane core and GFRP skins. The materials and thickness dimensions used in this research are comparable to the shear web, the foam core has a thickness of 75mm and the GFRP skins of the shear web are slightly thicker than the experimental panel. Ribs reinforce the



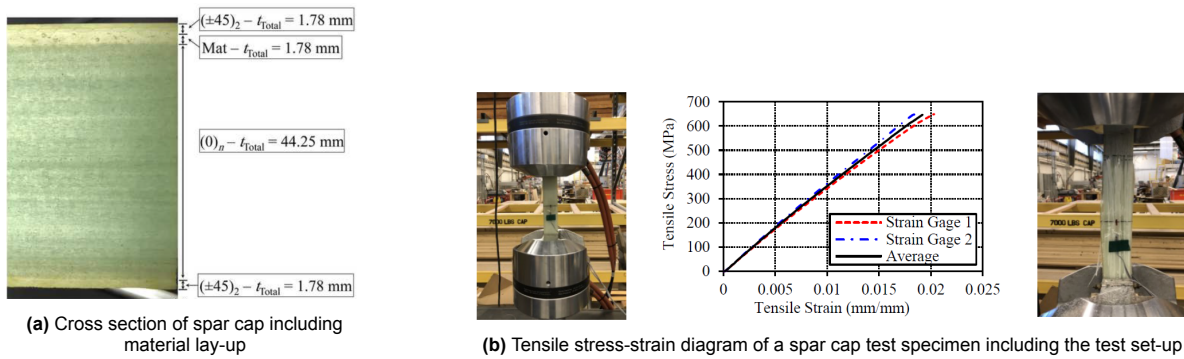


Figure 4.27: Spar cap information. Retrieved from Alshannaq et al. (2022b)



Figure 4.28: Detailed picture of a shell panel. Picture provided by the Re-Wind Network

large test panel, two in the longitudinal direction and three in the transverse direction. These can also be added to the smaller shear web sections extracted from the blade in case multiple shear web plates or beams are connected. Full-scale panels were tested under both uniform air pressure, to model out-of-plane bending under wind loading, and mechanical loading to failure. The panels showed a linear flexural response and achieved a maximum pressure of 7,5 kPa, which is 2,6 times higher than the maximum factored design wind pressure in Canada. The deflection of the panel under maximum service wind pressure did not exceed span/360. At ultimate, failure occurred in a successive manner, at three stages. First, failure occurred by outward local buckling of the GFRP skin in compression adjacent to the midheight supports. The second failure occurred by shear of the polyurethane core and the final failure occurred by outward wrinkling and crushing of the GFRP compression skin near midspan.

### 4.6. Advise on possible applications

In this section the possible applications for repurposed blade elements are set out. To come up with possible applications for the elements extracted from the blade, a brainstorm is set up with the Structural

Property	unit	Shell panel skin	Shear Web skin	Foam core
Stacking sequence at 31,7m	[-]	[(+/-45)s]	[(+/-45)6]	-
Stacking sequence at 13,4m	[-]	[(+/-45)2s]	[(+/-45)7]	-
Tensile Strength	MPa	146	146	4,8
Shear Strength	MPa	193	193	2,2
Young's Modulus	MPa	10100	10100	175
Shear Modulus	MPa	10500	10400	50
Density polymer matrix	kg/m <sup>3</sup>	1190	1190	-
Density fibers	kg/m <sup>3</sup>	2600	2600	-
Fiber content	%	46	60	-
Density	kg/m <sup>3</sup>	1838,6	2036	130

Table 4.4: Material properties of the shell panel skin, shear web skin and the foam core material.



**Figure 4.29:** Detailed picture of the shear web. Picture provided by the Re-Wind Network

Design & Engineering section of Arcadis. For the three material compositions Shear Web, Spar Cap and Shell Panels, the question is asked “How can you use this material in a project?”. This has led to a wide variety of outcomes. The applications are set out for the Shear Web, Spar Cap and Shell Panels, and also for out-of-the-box ideas. Boundary conditions for the applications are included as well. This collection of possible applications can be used as an inspiration for repurposing the blade elements. A wide variety of applications can be conceived, so this section is certainly not commonly exhaustive.

#### **4.6.1. Shear Web**

The thickness of the foam is 75 mm and its thermal conductivity has a value of 0,036 W/mK. This is equal to the thermal conductivity of stone wool and lower than foam glass and fiberboard (Kono et al., 2016), making it an excellent insulation material with a thickness that is within the range of insulation thicknesses offered by wholesale markets. The plates have sufficient strength to resist out-of-plane bending under wind loading (Sharaf and Fam, 2011) and thus can be used for building cladding applications. The shear web plates can be stacked to reach a desired height, and in this case it is recommended to connect a layer to both elements that can operate as a rib and increase the buckling capacity of the cladding. Also insulating floors are a possible application. In this case the deflection of the foam and the connection to the load bearing floor are points of interest. Roof plates can also be made, where the foam must be sealed to prevent water inlet and the connection with the roof beams must be investigated.

#### **4.6.2. Spar Cap**

The Spar Cap beams have a thickness between 33-53 mm. Due to the uni-axial material composition the beams have a high strength. The spar cap beams can be used as sheet piling as an alternative for ground retaining sheet piles. Here, the beams must be wide to easily span large distances, and large holes between piles must be avoided. Further, it must be checked whether deterioration can impair the soil. A fence can be constructed with the spar cap beams as poles, or side by side as a railing. The connection between the spar cap and cover must then be further investigated. The spar caps can be used to construct a roof, or roof beams. In case wide elements are used with an overlap, such as roof tiles, a roof can be established on an inclined roof. For both a flat and inclined roof, cladding must be added to ensure water tightness and connection with the rest of the construction must be designed. The strength of the spar caps enables it to be used as floor beams. Here, the connection between walls and other floor materials, as well as strength verification, must be investigated.

#### **4.6.3. Shell Panels**

The shell panels can be used as a light-weight roof construction with aluminum pack. The curvature of the shells is used as an advantage because water slides off the curved panels and the panels are connected using an aluminum pack, as is currently done in the Amsterdam ArenA. The foam must be sealed to prevent water inlet. The panels can be used as cladding of a pitched roof. Just like roof tiles, the shell panels can overlap to let water slide off. The foam must be sealed and a connection with the roof must be designed. The panels can be used as fences. Together with poles (potentially spar cap beams) and mounting material, the panels can form an opaque fence. As a variation on the currently widely used suspended ceiling, the shell panels can be used as ceiling plates. Small plates with a limited curvature can be used to insert in a standard aluminum rack. The last and most straightforward option is to use the panels as interior walls. Here, a connection must be designed to connect the wall panels to the floor and/or the ceiling.



#### 4.6.4. Out-of-the-box

The brainstorm is performed based on the proposed plates and beams resulting from the blade. However, many other forms can be extracted from the blade as well. Three out-of-the-box ideas arised during the brainstorm:

1. Use the I-beam.
  - (a) The spar caps and shear web together form a large I-beam. Although it decreases in size through its length, part of it can be used as I-beam to cover large spans. It can be suitable for applications where a curvature in the beam is allowed.
2. Cut shear web as triangle to cover large area.
  - (a) If multiple shear webs are present, large triangles can be sawn out. These can be stacked to get large rectangular plates that can cover a large area.
3. Large, curved architectural walls from the shell panels.
  - (a) The original curvature of the blade can be used to create partitioning walls with an architectural desired curvature

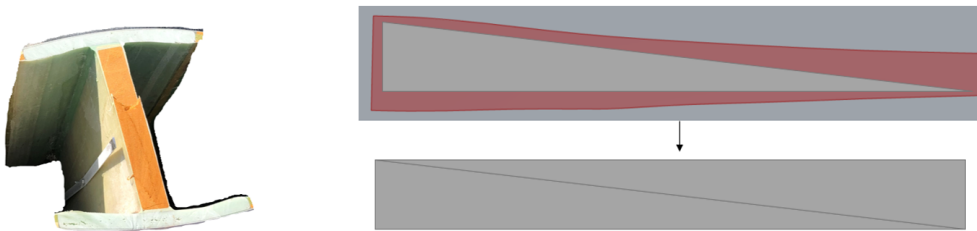


Figure 4.30: The isolated I beam (left) and the shear web cut as triangle (right)

#### 4.6.5. Practical tips and implications

In this section, practical tips and implications that can be encountered in the repurposing process are set out.

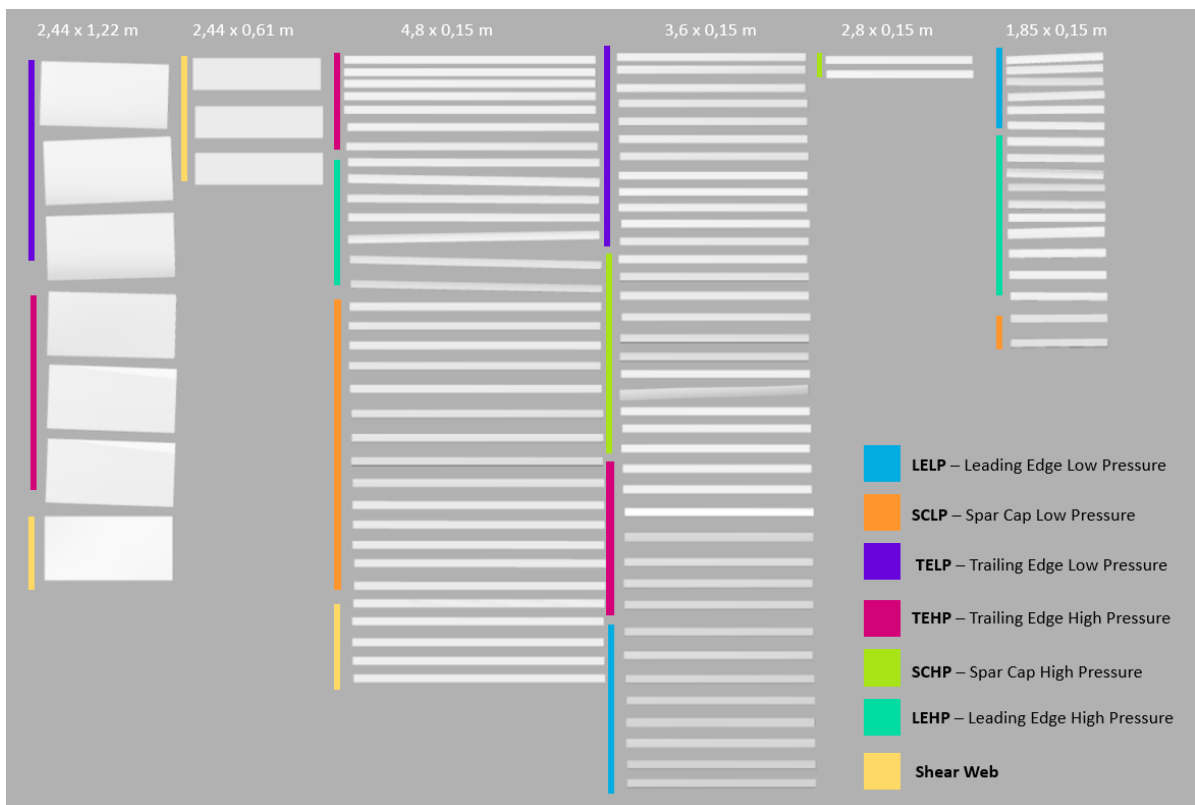
- In this research the blade is divided in panels. When a blade is decommissioned the entire blade becomes available. The blade can be sawn on site with a water jet cutter. The water jet cutter generally has a limited jet diameter of 0.5-1 millimeter, so cutting losses from the water jet cutter are negligible.
- To transport the blade on regular trucks, the blade must be sawn in multiple pieces, depending on the length of the blade. This can have consequences for the available cutting pattern. Either the blade must be scanned on site to propose the cutting pattern, or the blade is sawn on site and scanned in pieces on a storage location.
- In the storage location, the blade panels must be separated. This can be done using a diamond-tipped circular saw. Excess material, such as the bonding material between the panels, must then be removed. This can be done with an electric planer. The desired plates and beams can now be extracted from the panels using a waterjet cutter. the shell panels and shear web can be sawn with a mechanical saw as well, but this is less precise, leads to more cutting losses due to the width of the saw blade, and can be difficult to apply to the shear web because of its thickness.
- Inserting bolts can cause a local reduction of the material properties since the fibers are intersected. overall this is expected to have a limited impact. Standards recommend the use of the gross cross-sectional area of the element for stress calculations and disregard the hole. Also, no significant effects from inserting bolts are found in specimen testing (Alshannaq et al., 2022b).
- To prevent the foam from degrading as a result of moisture inlet, the edges of the shear web and shell panel elements must be sealed off when used in outside conditions.

## 4.7. Results

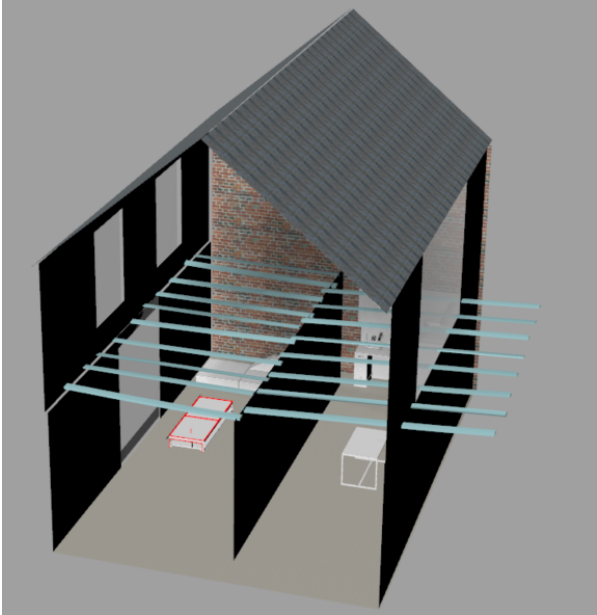
The repurpose method has demonstrated that it is possible to extract building elements from a decommissioned wind turbine blade. Following the procedure as described in this chapter, around half of the blade panel material can be useful as plates and beams. The resulting efficiency per blade panel is set out in Table 4.5. The blade material can be subdivided in three categories, with their own characteristics. These categories are the spar caps, shear web and shell panels. The entire selection of plates and beams is demonstrated in Figure 4.31. Although further research is required to assess the residual quality of blades, the tests carried out on the GE37 blade show promising results. Since the elements extracted from the blade are straight forward, a wide variety of applications can be conceived. The spar caps have a three times higher elastic modulus than structural timber, and can be used as structural beams. The shear web has a thick foam layer with excellent insulation properties and a high stiffness due to the GFRP skin, making it an interesting material for building cladding, insulation and partition walls. The shell panels are a well performing material for lightweight constructions loaded in bending, and can be applied as formwork, partition walls or floor covers. To give an impression of the possible applications, some renders are made. The spar caps are modelled as structural beams in a residential setting, with 3,6 m beams spanning two walls, and 4,8m beams overhanging partly as balcony. The shear web plates and beams are rendered as building cladding, where the plates and beams are stacked on top of each other. The shell panels are rendered as partition wall element and floor cladding. This is illustrated in Figure 4.32

Results from the Repurpose method		
Extracted from	Number of elements	Efficiency
TELP	15	38-48%
TEHP	17	37-57%
LELP	14	33-40%
LEHP	17	36-45%
SCLP	11	44-52%
SCHP	13	46-55%
Shear Web	9	39-52%
Total efficiency		38-50%

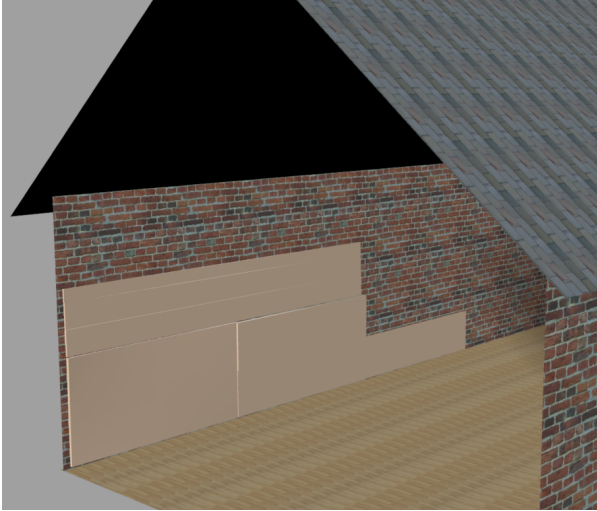
**Table 4.5:** Percentage of material used, set out per blade panel, for the overall blade panels.



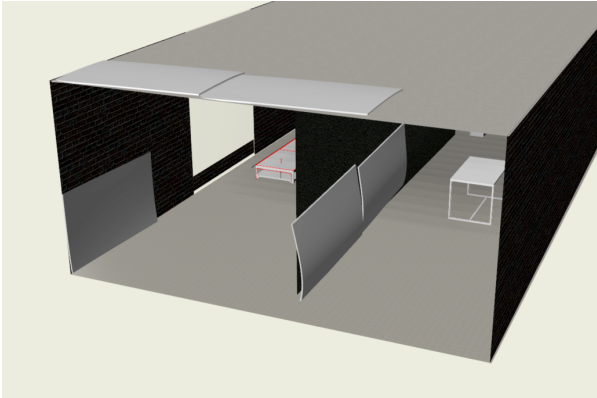
**Figure 4.31:** Overview of all the plates and beams with their dimension, origin and material category



(a) Spar caps rendered as structural beams



(b) Shear web plates and beams rendered as building cladding



(c) Shell panel plates rendered as flooring and wall cladding

**Figure 4.32:** Renders of the resulting materials in a possible application

# 5

## Discussion

### 5.1. Answer to the research question

This study aims to contribute to a solution for an increasing waste problem of decommissioned wind turbine blades. This is structured by the following research question:

*How can a decommissioned wind turbine blade be repurposed as construction elements?*

The following answer to the research question has derived from the research.

A decommissioned wind turbine blade can be repurposed as construction elements by projecting desired dimensions on the blade panels, resulting in a nesting pattern. The blade can be sawn in the pattern obtained using the method proposed in this research. The resulting elements can be used in a wide variety of applications. It will be challenging to put this proposed method into practice since the profitability of the method is questionable. On the one hand, the created construction elements will result in economic value. On the other hand, this method concerns considerable overhead costs and residual materials to dispose.

### 5.2. Conclusions

In this paragraph the answer to the research question of Paragraph 5.1 is explained in more detail. Point by point, the following is concluded:

- The reason for decommissioning wind turbines does not necessarily relate to the quality of the wind turbine blades. Eventually, the blades take up a limited part of the business case in wind farm exploitation. Economical or regulatory reasons, such as repowering the wind farm or expiration of the wind turbine permit, determine to a large extent whether a wind turbine will be decommissioned.
- Although limited research has been done on the residual strength and properties of wind turbine blades, the available literature shows promising results. It is expected that the overall residual strength of wind turbine blades is significant.
- A nesting pattern can be obtained using the grasshopper model that was created during this research. With this model, a significant part of the double curved blade can be cut into highly accurate slabs and beams with limited curvature.
- Spar caps are made out of GFRP with uni-axial fibers. This material has a high strength and stiffness in the longitudinal direction. The modulus of elasticity is around three times higher than structural timber. The spar caps used in the investigated blade are therefore appropriate to use as structural beams
- The shear web is a sandwich material with GFRP skins. The sandwich lay-up is characterized by a high stiffness and a low weight and the foam has good thermal conductivity properties. The shear web elements are suitable to use as building cladding or (partition) walls. Further, they can be used as flooring although concentrated loading is not advised since this can cause delamination of the layers.

- The shell panels perform comparable to timber for design in bending. They can, amongst others, be applied as formwork, floor plates, partition walls or floor cladding. Due to the significant double curve in the shells, especially near the root of the blade, the amount of flat material that can be extracted from the shell panels is limited.
- The optimal percentage of material that can be repurposed in the investigated blade parts, following from the approach described in this study, is in the range of 38% to 50%

## 5.3. Discussion

Certain assumptions were made during the research. In addition, the research has certain limitations. In this section, the approach of the research is critically questioned. Further, the study is put into a broader context after which the other relevant issues are reviewed.

### 5.3.1. Research approach

The discussion points of the research itself are set out point by point.

- The elements extracted from the blade in this research are compared to plates and beams that are currently used in the construction sector. To limit the curvature of the element, an allowable deviation can be set. To find a significant percentage of material that can be repurposed, the curvature in certain panels, especially the shell panels, is significant. This can be a limiting factor for actually incorporating the elements in construction projects.
- Prices from comparable timber elements are used to estimate the economic value of elements that are extracted from the blade. The material properties of shell panels, shear web and spar cap vary and are not the same as material properties for timber. Also, the curvature of the elements, and the impact this has on the economical value is not taken into account. Therefore, the actual economic value can differ from the estimated value
- The proposed method assumes the entire blade can be repurposed. In practice, the blades are sawn on site to ease transportation. This can affect the available blade panels and the resulting nesting pattern. As a result, the percentage of material that can be repurposed could be lower.

### 5.3.2. Value quantification

In this research the possible yield of repurposing a blade is stated in economic value. This approximation is based on comparable building materials. To quantify the possible yield of repurposing a blade, the economic value of the resulting blade elements is approximated, based on comparable building materials. However, next to economic value, other forms of values exist, that can even be decisive for the actual implementation of blade panels in construction.

Repurposing part of the blade means less waste has to be disposed. Since no large-scale recycling options exist, the entire material is lost when disposed. Avoiding this by, at least, extending the lifetime of a part of the material has an environmental value. At the same time, if the blade is used for a beam for example, that beam doesn't have to be produced from another source. In this way it can reduce the amount of necessary raw materials.

Incorporating repurposed blade in construction projects can also have a social value. If blade elements are visible in repurposed projects, people can become aware of the fact that after a turbine's EoL, materials are leftover. Also, demonstrating a part of a blade incorporated in construction projects can give an impression of the actual size of blades, which is hard to imagine if no reference is present. Lastly, it can contribute to awareness of the materials used in blades.

For an architect, a blade has a potentially enormous architectural value. Curved elements or non-standard forms can be quite expensive to manufacture. A blade already is curved and also consists of structural sufficiently strong material, depending on the application. An architect can demonstrate the original forms of the blade to contribute to the social value but can also use the blade as input material for an architecture project. At the same time, this can contribute to the portfolio of the architect and potentially attract new clients.

For a client it can have an additional value to its project to make use of waste materials. Depending on the background of the client it can be interesting to show the blade materials in its project, for example if the client is related to the wind industry or composites industry. Also, if a client is not related to such an industry, using waste materials can positively affect the reputation of the project.



### 5.3.3. This research in a broader context

The problem is that the amount of decommissioned wind turbine blades will grow tremendously the coming decade and no recycling options are available yet. However, in practice the quality of the blades is not normative in deciding when a wind turbine will be decommissioned. In fact, the blades are only a limited part of the exploitation of a wind farm. More important is the energy output which generates energy as well as revenue. It can not be expected that the quality of the blades become normative since other concerns simply are of higher importance. This being said, it must be the concern of every sector and every business to use natural resources responsibly and to limit the climate impact as much as possible. Currently, research is going on to design fully recyclable blades, but these will only become EoL in at least 25 years and are not even the standard. This endorses that solutions must be conceived to reduce the waste material of wind turbine blades the coming decades, of which repurposing can be one.

In this research the prices for extracted elements are estimated based on comparable building materials. Due to limited reference material this approach is acceptable, but in practice it will be challenging to guarantee the homogeneity in terms of size, curvature and material composition of the elements. This can lead to the necessity of using flexible joints or customized designs which could influence the economic value of the elements. Regulations and codes in the building sector could make it difficult to quickly adopt the use of repurposed blade elements. It is fundamental to guarantee the strength and behaviour of materials used in construction. To guarantee this for blade elements, multiple tests must be performed. Since many wind turbine blade types exist, with different designs and material compositions, it could be required that all different types must be tested individually. It is of importance to show regulators the need to adopt repurposed materials, while of course at all times the safety of structures must be ensured. Therefore, communication and collaboration between regulators and structural engineers is necessary.

It differs per element to what extent the curvature is. However, in almost all elements, at least a slight curvature is present. This must be considered, and measures must be taken depending on the application. To find out which measures must be taken, first the allowable deviations for connection mechanisms and mounting system must be known. Based on this it can be estimated which elements need a custom-made connection. For load carrying beams, it must be checked whether the strength or another failure mode is normative. If a significant deviation is present, it is possible that general connections do not fit. A flexible mounting system or a custom-made mounting system then must be established. It is unlikely that contractors will now choose for blade panels and beams instead of commonly used construction materials if only the economic aspect is considered. Panels have a deviation, the stock is not yet centralized and thus unknown, and blade material is not yet common practice in the building sector. Therefore, a first step towards implementing blade panels in construction projects will most likely be in collaboration with the client. The client can make certain demands which can make it attractive to incorporate the blade panels in projects.

It would currently be a challenge to bridge the period between decommissioning the blade and actually using the blade elements. Also, acquiring a blade for a project can be challenging and must be done in advance to take the geometry of the specific blade into the design of the project. It would be useful to establish a platform that provides information on which blade will become available, their amount and type. The latter is even more challenging since the geometry of blade types is not public. In order to create a large scale offer of wind turbine blade elements the following steps must be taken. First, a location must be found that can house the blade sections. Second, a scanner must be purchased to load the blades in the computer. Thirdly, the algorithm created in this research must be used to find the desired nesting pattern of the blade sections. Fourthly, a water jet cutter must be installed and connected to the computer model to saw the blade sections in the desired elements. Lastly, a platform must be developed with a database of all the available blade elements. Depending on the costs for storage, scanning, sawing, developing the platform and disposing the residual material on the one hand, and the yield from taking over the blades and selling the blade elements, a business case can be set up to turn this repurposing into a profitable business. Eventually demand is key for such a business case. A realistic first step towards this demand is to find a client with sustainability ambitions and to take the repurposed blades in the project as a demonstrative application.

## 5.4. Recommendations

Recommendations can be made for the wind industry, decommissioning parties and engineers.

### Wind industry

It would be recommended to:

- Disclose information regarding the design of wind turbine blades from wind turbine types that are soon to be decommissioned. This enables engineers to construct detailed models of the blades and this can help the wind industry with solving the increasing problem of blade waste.
- Disclose maintenance reports and repair history of a wind turbine at the time of decommissioning. These reports can improve the assessment of the blade quality and can help solving the blade waste problem as well.

### Decommissioning parties

It would be recommended to:

- Get in touch with parties interested in repurposing the blades before decommissioning and sawing the blades. This can prevent the blades from being disposed and can help these parties with finding suitable blades for their project.
- Decompose the blade into usable element and offer the to the market. The residual material can be shredded in usable fibers as raw material for other products.
- Look for repurpose opportunities instead of transporting the blades to waste plants. Generally circa €400,- to €1.000,- per tonne of blade material is offered to decommissioning parties, but if the blades are sawn like the method described in this study, the blade material can yield money again. Depending on the processing costs and eventual yield, the profit can be increased

### Engineers & Contractors

It would be recommended to:

- Incorporate wind turbine blades in construction projects to contribute to a solution for the waste problem. Also, innovative choice of materials can contribute to the publicity of the project. Although margins are tight in the construction industry, it could be possible to incorporate blades if a client has sustainability ambitions and is willing to free up budget for this.
- Be aware of the (limited) curvature of the extracted elements. Due to the blade's double curvature a slight curvature will always be present in the elements, so the elements cannot be replaced with standard elements without checking the effects of this action.
- Perform sample tests on a blade to substantiate the material properties of the repurposed blade. In this way the actual strength and material properties can be guaranteed, and with this, the use of these elements can be approved by regulators.
- Use wind turbine blade elements as temporary construction material, building fences and form-work to save on currently used materials

## 5.5. Further research

This study focuses on the construction industry. In order to solve the blade waste problem, other sectors could investigate a similar approach to repurpose turbine blades in their industry.

Different steps will be required to eventually incorporate elements extracted from wind turbine blades in construction projects. In this study a first step towards repurposing wind turbine blade elements in the construction industry is set out.

In order to actually use blade material, the strength and stiffness of the material must be assured. At this moment, the Eurocodes, which set the standards for building requirements to ensure safety, do not mention blade material yet. Therefore, in order to realise a construction project containing turbine blade elements, the safety of the elements must be proven. To achieve this, extensive testing on multiple wind turbine blades will need to be performed.

Future studies will contribute to the feasibility of repurposing wind turbine blades in the construction industry. The following topics require future research:

- 
- Obtaining the geometry of various turbine blade models by connecting a LiDAR scanner to a CAD program
  - Perform tests on the shear web, spar cap and shell panels to substantiate their material properties and to check behaviour of the elements under different load configurations than the blade is initially designed for. Amongst others, the following tests can be performed: Transverse- and longitudinal tension and compression, open-hole tension and shear tests.
  - Perform research to the fire resistance of wind turbine blade elements.

# Bibliography

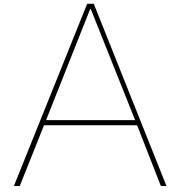
- Repurpose definition, 2018. URL <https://www.ceguide.org/Strategies-and-examples/Dispose/Repurposing>.
- A. Alshannaq, J. Respert, L. Bank, T. Gentry, and D. Scott. Properties of a 37m long FRP wind turbine blade after 11 years service. 2022a.
- A. A. Alshannaq, L. C. Bank, D. W. Scott, and T. R. Gentry. Structural Analysis of a Wind Turbine Blade Repurposed as an Electrical Transmission Pole. *Journal of Composites for Construction*, 25(4), 8 2021. ISSN 1090-0268. doi: 10.1061/(asce)cc.1943-5614.0001136.
- A. A. Alshannaq, S. Asce, J. A. Respert, L. C. Bank, D. Asce, M. Asce, T. Russell Gentry, and A. Professor. As-Received Physical and Mechanical Properties of the Spar Cap of a GE37 Decommissioned GFRP Wind Turbine Blade. 2022b. doi: 10.1061/(ASCE)MT.1943-5533.0004410.
- C. V. Amaechi, C. O. Agbomerie, A. Sotayo, F. Wang, X. Hou, and J. Ye. Recycling of Renewable Composite Materials in the Offshore Industry. In *Encyclopedia of Renewable and Sustainable Materials*, pages 583–613. Elsevier, 2020. doi: 10.1016/b978-0-12-803581-8.11445-6.
- A. André, J. Kullberg, D. Nygren, C. Mattsson, G. Nedev, and R. Haghani. Re-use of wind turbine blade for construction and infrastructure applications. In *IOP Conference Series: Materials Science and Engineering*, volume 942. IOP Publishing Ltd, 10 2020. doi: 10.1088/1757-899X/942/1/012015.
- F. Arias. NuMAD Modeling and Finite Element Analysis of SNL-100-01 Wind Turbine Blade Shells. Technical report, 2017.
- C. Bak, F. Zahle, R. Bitsche, T. Kim, A. Yde, L. Christian Henriksen, A. Nata-rajana, and M. Hartvig Hansen. Department of Wind Energy I-Report Description of the DTU 10 MW Reference Wind Turbine. Technical report, 2013.
- L. Bank, F. Arias, T. Russel Gentry, T. Al-Haddad, B. Tasistro-Hart, and J.-F. Chen. Structural analysis of FRP parts from waste wind turbine blades for building reuse applications. Technical report, 2019.
- J. Beauson, A. Laurent, D. P. Rudolph, and J. Pagh Jensen. The complex end-of-life of wind turbine blades: A review of the European context. *Renewable and Sustainable Energy Reviews*, 155:111847, 3 2022. ISSN 1364-0321. doi: 10.1016/J.RSER.2021.111847.
- J. Bhatti. Europe bans disposal of decommissioned wind turbine blades in landfills: A step towards life cycle sustainability. 2021. URL <https://www.downtoearth.org.in/blog/energy/europe-bans-disposal-of-decommissioned-wind-turbine-blades-in-landfills-a-step-towards-life-cycle>
- P. Bortolotti, H. Canet Tarres, K. Dykes, K. Merz, L. Sethuraman, D. Verelst, and F. Zahle. IEA Wind TCP Task 37 Systems Engineering in Wind Energy-WP2.1 Reference Wind Turbines Technical Report. Technical report, IAE Wind TCP Task 37, 2019. URL [www.nrel.gov/publications](http://www.nrel.gov/publications).
- Bosch and van Rijn. Windstats.nl / Bosch en van Rijn, 11 2021. URL <https://www.boschenvanrijn.nl/>.
- T. Burton, D. Sharpe, N. Jenkins, and E. Bossanyi. WIND ENERGY HANDBOOK. Technical report, John Wiley & Sons, Chichester, 2001.
- X. Chen. Fracture of wind turbine blades in operation—Part I: A comprehensive forensic investigation. *Wind Energy*, 21(11):1046–1063, 11 2018. ISSN 10991824. doi: 10.1002/we.2212.
- X. Chen. Experimental observation of fatigue degradation in a composite wind turbine blade. *Composite Structures*, 212:547–551, 3 2019. ISSN 0263-8223. doi: 10.1016/J.COMPSTRUCT.2019.01.051.

- X. Chen and M. A. Eder. A Critical Review of Damage and Failure of Composite Wind Turbine Blade Structures. In *IOP Conference Series: Materials Science and Engineering*, volume 942. IOP Publishing Ltd, 10 2020. doi: 10.1088/1757-899X/942/1/012001.
- J. R. Correia, M. Garrido, J. A. Gonilha, F. A. Branco, and L. G. Reis. GFRP sandwich panels with PU foam and PP honeycomb cores for civil engineering structural applications: Effects of introducing strengthening ribs. *International Journal of Structural Integrity*, 3(2):127–147, 2012. ISSN 17579864. doi: 10.1108/17579861211235165.
- P. Deeney, A. J. Nagle, F. Gough, H. Lemmertz, E. L. Delaney, J. M. McKinley, C. Graham, P. G. Leahy, N. P. Dunphy, and G. Mullally. End-of-Life alternatives for wind turbine blades: Sustainability Indices based on the UN sustainable development goals. *Resources, Conservation and Recycling*, 171, 8 2021. ISSN 18790658. doi: 10.1016/j.resconrec.2021.105642.
- defra. Guidance on applying the Waste Hierarchy. Technical report, 2011. URL [www.defra.gov.uk](http://www.defra.gov.uk).
- Diab Group. Technical Data Divinycell H. Technical report, 2022.
- E. Gaertner, J. Rinker, L. Sethuraman, F. Zahle, B. Anderson, G. Barter, N. Abbas, F. Meng, P. Bor-tolotti, W. Skrzypinski, G. Scott, R. Feil, H. Bredmose, K. Dykes, M. Shields, C. Allen, and A. Viselli. Definition of the IEA Wind 15-Megawatt Offshore Reference Wind Turbine Technical Report. Technical report, 2020. URL [www.nrel.gov/publications](http://www.nrel.gov/publications).
- GCube. breaking blades: global trends in wind turbine. Technical report, 2014. URL <http://www.gcube-insurance.com/>.
- T. R. Gentry, T. Al-Haddad, L. C. Bank, F. R. Arias, A. Nagle, and P. Leahy. Structural Analysis of a Roof Extracted from a Wind Turbine Blade. *Journal of Architectural Engineering*, 26(4):04020040, 12 2020. ISSN 1076-0431. doi: 10.1061/(asce)ae.1943-5568.0000440.
- J. Goodman. ARCHITECTONIC REUSE OF WIND TURBINE BLADES. Technical report, 2010. URL <https://www.researchgate.net/publication/343403060>.
- M. O. L. Hansen. Aerodynamics of Wind Turbines. Technical report, Abingdon, 2015.
- IEC61400-1. IEC, Wind turbine generator systems – Part 1: Safety requirements, International Standard IEC61400-1, 2nd edition. Technical report, 1999.
- J. P. Jensen and K. Skelton. Wind turbine blade recycling: Experiences, challenges and possibilities in a circular economy, 12 2018. ISSN 18790690.
- J. Jonkman, S. Butterfield, W. Musial, and G. Scott. Definition of a 5-MW Reference Wind Turbine for Offshore System Development. Technical report, 2009. URL <http://www.osti.gov/bridge>.
- J. Joustra, B. Flipsen, and R. Balkenende. Structural reuse of wind turbine blades through segmentation. *Composites Part C: Open Access*, 5, 7 2021. ISSN 26666820. doi: 10.1016/j.jcomc.2021.100137.
- S. Kanshal. Airfoil Terminology and Definitions, 2018.
- J. Kono, Y. Goto, Y. Ostermeyer, R. Frischknecht, and H. Wallbaum. Factors for eco-efficiency improvement of thermal insulation materials. *Key Engineering Materials*, 678:1–13, 2016. ISSN 16629795. doi: 10.4028/www.scientific.net/KEM.678.1.
- A. Landesmann, C. A. Seruti, and E. D. M. Batista. Mechanical properties of glass fiber reinforced polymers members for structural applications. *Materials Research*, 18(6):1372–1383, 11 2015. ISSN 15161439. doi: 10.1590/1516-1439.044615.
- G. Lichtenegger, A. A. Rentizelas, N. Trivyza, and S. Siegl. Offshore and onshore wind turbine blade waste material forecast at a regional level in Europe until 2050. *Waste Management*, 106:120–131, 4 2020. ISSN 18792456. doi: 10.1016/j.wasman.2020.03.018.

- P. Liu and C. Y. Barlow. Wind turbine blade waste in 2050. 2017. doi: 10.1016/j.wasman.2017.02.007. URL <http://dx.doi.org/10.1016/j.wasman.2017.02.007>.
- Manufacturer. From fishing to fibreglass: Hull embraces blade production, 2018. URL <https://www.themanufacturer.com/articles/fishing-fibreglass-hull-embraces-blade-production/>.
- J. C. Marín, A. Barroso, F. París, and J. Cañas. Study of fatigue damage in wind turbine blades. *Engineering Failure Analysis*, 16(2):656–668, 3 2009. ISSN 1350-6307. doi: 10.1016/J.ENGFAILANAL.2008.02.005.
- A. McDonald and L. Bank. Re-Wind Design Catalog Fall 2021. Technical report, 2021. URL [www.re-wind.info](http://www.re-wind.info).
- M. Menendez. Siemens Gamesa pioneers wind circularity: launch of world's first recyclable wind turbine blade for commercial use offshore, 9 2021. URL <https://www.siemensgamesa.com/newsroom/2021/09/launch-world-first-recyclable-wind-turbine-blade>.
- R. P. Nijssen and D. R. Van Delft. Alternative Fatigue Formulations for Variable Amplitude Loading of Fibre Composites for Wind Turbine Rotor Blades. *European Structural Integrity Society*, 32(C): 563–574, 1 2003. ISSN 1566-1369. doi: 10.1016/S1566-1369(03)80125-5.
- D. Norske Veritas. STANDARD DET NORSKE VERITAS DESIGN AND MANUFACTURE OF WIND TURBINE BLADES, OFFSHORE AND ONSHORE WIND TURBINES. Technical report, 2010. URL <http://www.dnv.com>.
- Norske Veritas (Organization) and Forskningscenter Risø. *Guidelines for design of wind turbines*. Det Norske Veritas, 2002. ISBN 8755028705.
- G. Oliveux, L. O. Dandy, and G. A. Leeke. Current status of recycling of fibre reinforced polymers: Review of technologies, reuse and resulting properties, 7 2015. ISSN 00796425.
- K. Ortegon, L. F. Nies, and J. W. Sutherland. Preparing for end of service life of wind turbines. *Journal of Cleaner Production*, 39:191–199, 1 2013. ISSN 09596526. doi: 10.1016/j.jclepro.2012.08.022.
- Posco. Steel Solutions in Wind Power, 1 2016. URL <https://newsroom.posco.com/en/steel-solutions-in-wind-power/>.
- W. Robbertsen. Verwijderen van oude windmolens. Dit komt er allemaal bij kijken, 3 2021. URL <https://windplanblauw.nl/blog/verwijderen-van-oude-windmolens-dit-komt-er-allemaal-bij-kijken/>.
- K. Ruane, Z. Zhang, A. Nagle, A. Huynh, A. Alshannaq, A. McDonald, P. Leahy, M. Soutos, J. McKinley, R. Gentry, and L. Bank. Material and Structural Characterization of a Wind Turbine Blade for use as a Bridge. Technical report, 2022.
- Schmid Marylise, Gonzalez Ramon Nieves, Dierckx Ann, and Wegman Thomas. Accelerating Wind Turbine Blade Circularity. Technical report, 5 2020.
- P. J. Schubel and R. J. Crossley. Wind turbine blade design, 2012. ISSN 19961073.
- T. Sharaf and A. Fam. Experimental Investigation of Large-Scale Cladding Sandwich Panels under Out-of-Plane Transverse Loading for Building Applications. *Journal of Composites for Construction*, 15(3):422–430, 6 2011. ISSN 1090-0268. doi: 10.1061/(asce)cc.1943-5614.0000176.
- K. Skelton. Discussion paper on managing composite blade waste. *WindEurope*, 2017. doi: 10.13140/RG.2.2.22748.90248. URL <https://www.researchgate.net/publication/321081335>.
- B. Tasistro-Hart, T. Al-Haddad, . Lawrence, C. Bank, and R. Gentry. Reconstruction of Wind Turbine Blade Geometry and Internal Structure from Point Cloud Data. Technical report, 2019. URL [www.re-wind.info](http://www.re-wind.info).
- O. T. Thomsen. Sandwich materials for wind turbine blades - Present and future. *Journal of Sandwich Structures and Materials*, 11(1):7–26, 1 2009. ISSN 10996362. doi: 10.1177/1099636208099710.



- D. Todd Griffith and T. D. Ashwill. SANDIA REPORT The Sandia 100-meter All-glass Baseline Wind Turbine Blade: SNL100-00. Technical report, 2011. URL <http://www.ntis.gov/help/ordermethods.asp?loc=7-4-0#online>.
- E. Topham and D. McMillan. Sustainable decommissioning of an offshore wind farm. *Renewable Energy*, 102:470–480, 3 2017. ISSN 18790682. doi: 10.1016/j.renene.2016.10.066.
- J. W. Van de Kuilen, G. Buitenhuis, J. Dubelaar, A. van Eckevelde, and W. Gard. NEN5461\_ontwerpeisen\_hout.
- WindEurope. Decommissioning of Onshore Wind Turbines. Technical report, 2020.
- A. Yazdanbakhsh, L. C. Bank, K. A. Rieder, Y. Tian, and C. Chen. Concrete with discrete slender elements from mechanically recycled wind turbine blades. *Resources, Conservation and Recycling*, 128:11–21, 2018. ISSN 18790658. doi: 10.1016/j.resconrec.2017.08.005.
- M. K. Yeh and C. H. Wang. Stress analysis of composite wind turbine blade by finite element method. In *IOP Conference Series: Materials Science and Engineering*, volume 241. Institute of Physics Publishing, 11 2017. doi: 10.1088/1757-899X/241/1/012015.
- H. F. Zhou, H. Y. Dou, L. Z. Qin, Y. Chen, Y. Q. Ni, and J. M. Ko. A review of full-scale structural testing of wind turbine blades. *Renewable and Sustainable Energy Reviews*, 33:177–187, 5 2014. ISSN 1364-0321. doi: 10.1016/J.RSER.2014.01.087.



# Manufacturers of wind turbines in the Netherlands

In this Appendix an overview is given of all manufacturers that have built wind turbines in the Netherlands, and the amount of wind turbines they built. In the meantime, a lot of manufacturers are acquired by larger companies. Therefore, the time span in which the manufacturers have been active is also given.

Manufacturer	# turbines	# turbines 20+ years old	First built	Last built
2-B Energy	1	0	2016	2016
Alstom	12	0	2014	2015
Bonus	54	53	1995	2002
Bouma	1	1	1993	1993
Enercon	549	6	1997	2017
EWT	48	1	1999	2018
GE Wind	8	0	2005	2019
Lagerwey	155	125	1982	2020
Leitwind	1	0	2013	2013
Micon	21	21	1994	1996
NedWind	19	19	1995	1998
Neg Micon	218	35	1998	2005
Nordex	274	9	1998	2021
Nordtank	59	59	1995	1997
Senvion	58	0	2010	2018
Siemens	72	2	2000	2019
Siemens Gamesa	54	0	2017	2020
Tacke	5	5	1995	1995
Vestas	591	50	1995	2021
Total	2200	386		

**Table A.1:** Overview of wind turbine manufacturers in the Netherlands

# B

## Method to repurpose wind turbine blades

In Chapter 4 is described on high level how wind turbine blades can be repurposed. In this Appendix the complete process is represented. Two processes are distinguished. The first process describes how an owner of wind turbine blades can repurpose wind turbine blades with the objective to repurpose as many wind turbine blades as possible, by extracting standard building elements from the blades, which eventually can be sold. The second process describes which steps project teams can undertake in order to incorporate wind turbine blades, or elements of one or more blades, in their project.

### B.1. Repurpose as many wind turbine blades as possible

<b>Step 1 - Collect general information</b>		
<i>One or more wind turbine blades are becoming available. Please answer the following questions to obtain an overview of the general information:</i>		
1.	What is the location of the wind farm?	
2.	What is the type of the wind turbine?	
3.	What is the power output of the wind turbine?	
4.	How many wind turbine blades of this type are becoming available?	
5.	Who is the manufacturer of the wind turbine?	
6.	Which party is the owner of the wind turbine?	
7.	Which party is responsible for the decommissioning of the blades?	
8.	When will the blades be decommissioned?	
9.	Are the blades available immediately after decommissioning?	
10.	If question 8 is answered "no", when are the blades available?	

Figure B.1: Step 1 of the mass reuse process

Step 2 - Collect blade information		
<i>Now that the general information is collected, we have to inventorize which information regarding the blade, blade history and its quality can be collected.</i>		
Step 2a - Service- and maintenance reports		
1.	Why are the blades decommissioned?	<p><b>Technical</b> If the blades are decommissioned for technical reasons, related to damage in the blades, thorough research must be performed to find the exact residual value of the mechanical and physical properties. If the blade is seriously fractured, repurposing is not advised. If blade damage was not the cause of decommissioning, answer the following questions to find out what the quality of the blade is.</p> <p><b>Economical</b> This implies the turbine blade is still permitted to operate, but it is economically interesting to repower the wind farm. Answer the following questions to find out what the quality of the blade is</p> <p><b>Permit</b> If the permit is expired, the turbine is not allowed to operate anymore. However this does not mean the turbine blades are worthless. Answer the following questions to find out what the quality of the blade is</p>
2.	Are service- or maintenance reports available?	<p>yes proceed to the next question</p> <p>no go to step 2b.</p>
3.	Are there any damages detected?	<p>yes exclude the damages from the cutting pattern.</p> <p>no proceed to the next question</p>
4.	Have there been repairs in the blade?	<p>yes exclude the repairs from the cutting pattern, proceed to step 2b</p> <p>no proceed to step 2b</p>
Step 2b - Inspection and sample testing		
1.	Conduct a visual inspection to find eventual damages or repairs	If any damages or repairs are found, exclude these parts of the blade from the repurposing process
2.	Conduct a sample test of the blade material to approximate the physical and mechanical properties of the blade	Depending on the application of the repurposed elements, the required accuracy of the physical and mechanical properties can vary. In this phase it is advised to give an approximation of the strength based on sample testing. In a later phase, more accurate tests can be performed if necessary

Figure B.2: Step 2 of the mass reuse process

Step 3 - determine blade geometry			
<i>To be able to create a model of the blade, in which the repurposed elements can be extracted, the geometry of the blade has to be determined. The goal of this step is to obtain the geometry in Rhino. Depending on the available resources, multiple options exist. Start with the first option and walk through the possibilities in order.</i>			
	A	B	C
1.	Check if the model of the wind turbine type is already present. Herefore, check the database	Database	Contact the owner of the model to receive the Rhino model
2.	Ask the manufacturer of the blade to provide you with documentation regarding the geometry and properties of the blade. Since the design information about wind blades is strictly confidential, this often cannot be disclosed.	If the documentation is disclosed, model the parameters of the documentation in Rhino to create the geometry that can be connected to the grasshopper script in the next step	To keep it manageable, start with modelling the outer geometry of the blade based on the prescribed airfoils. In a later stadium the thickness can be added
3.	Scan the blade to obtain an outer geometry of the blade. For the inner geometry and thickness, construct an internal point cloud	Export the scans to Rhino to create the geometry model that can be connected to the grasshopper script in the next step	
4.	If none of the options above is possible, measure the geometry by hand and model it in Rhino	A wind turbine blade always consists of multiple airfoils throughout the length of the blade, so it is advised to divide the blade in 10-30 segments depending on the length of the blade, and to model the airfoils. A surface can be lofted	In a next step, add thickness to the blade model, measured from the blade. Also, add the internal structure.

Figure B.3: Step 3 of the mass reuse process

Step 4 - Extract valuable construction elements from the blade	
<i>To find the repurpose elements, a grasshopper script is made. Here one can input various parameters to find desired elements. The input parameters are described here. The algorithm to extract the elements while optimizing the blade material used is described in chapter 4 of the report.</i>	
1.	Insert the dimension of the most valuable element
2.	Insert the dimension of the second most valuable element. Repeat this until the grid of the blade panel is full
3.	Divide the actual blade in its homogeneous panels, just like in the Grasshopper model, using a waterjet cutter
4.	Cut out the elements that follow from the Grasshopper model, using a waterjet cutter
5.	Store the elements
6.	Promote the elements, and make sure they can be found online, for example on a platform or webshop
7.	Sell as many elements as possible

Figure B.4: Step 4 of the mass reuse process

## B.2. Incorporate wind turbine blades in project design

Step 1 - Determine project demands		
<i>The first step is to determine how a wind turbine blade should be incorporated into the desired project. Based on this, a targeted search for one or more suitable wind turbine blades can be started</i>		
1.	Describe the project	
2.	Describe wind turbine blade demands	
3.	Which dimensions are demanded?	
4.	What kind of elements/blades are demanded?	
5.	How many of those elements/blades?	
6.	How will the elements/blades be loaded?	
7.	Where will the elements/blades be located? (inside/outside)	
8.	What building physics properties are demanded?	
9.	What are the structural demands of the elements/blades?	
10.	Any other specific demands?	

Figure B.5: Step 1 of the project oriented process

Step 2 - Find a suitable wind turbine blade		
<i>Now that the demands are set out clearly, a targeted search can be started. The answers from step 1 can influence the applicability of available blades. In this step a suitable blade will be searched for the project and an inventory of the stakeholders is made.</i>		
1.	Inventarise which wind turbines will be decommissioned in the near future	
2.	Find out which of these turbines is most suitable for the project	
3.	Find out the location of the wind turbine(s)	
4.	Determine the type of the turbine	
5.	(If multiple blades are needed) Find out how many blades will become available	
6.	Find out who is the manufacturer of the wind turbine	
7.	Find out which party is the owner of the wind turbine	
8.	Find out which party is responsible for the decommissioning of the blades	
9.	Find out when the blades will be decommissioned	
10.	What is the (negative) price for each blade? (usually €1000 per tonne)	
11.	(How) should the blades be sawn on site?	
12.	If so, arrange a sawing company to saw the blades (in cooperation with the decommissioning party who usually is responsible for the sawing)	
13.	What kind of transport is necessary	
14.	Where will the blade (elements) be stored?	

Figure B.6: Step 2 of the project oriented process

Step 3 - Collect information about the blade quality		
<i>Now that the general information is collected, we have to inventorize which information regarding the blade, blade history and its quality can be collected. In the previous steps the demands are stated in terms of structural performance, building physics, sizes and quality. Based on this it can be decided whether the quality of the collected blades is sufficient. That will be found out in this step.</i>		
Step 3a - Service- and maintenance reports		
1.	Why are the blades decommissioned?	<p>Technical</p> <p>Economical</p> <p>Permit</p> <p>If the blades are decommissioned for technical reasons, related to damage in the blades, thorough research must be performed to find the exact residual value of the mechanical and physical properties. If the blade is seriously fractured, repurposing for structural applications is not advised. If blade damage was not the cause of decommissioning, answer the following questions to find out what the quality of the blade is.</p> <p>This implies the turbine blade is still permitted to operate, but it is economically interesting to repower the wind farm. Answer the following questions to find out what the quality of the blade is.</p> <p>If the permit is expired, the turbine is not allowed to operate anymore. However this does not mean the turbine blades are worthless. Answer the following questions to find out what the quality of the blade is</p>
2.	Are service- or maintenance reports available?	<p>yes</p> <p>no</p> <p>proceed to the next question</p>
3.	Are there any damages detected?	<p>yes</p> <p>no</p> <p>exclude the damages from the cutting pattern.</p> <p>proceed to the next question</p>
4.	Have there been repairs in the blade?	<p>yes</p> <p>no</p> <p>exclude the repairs from the cutting pattern, proceed to step 3b</p> <p>proceed to step 3b</p>
Step 3b - Inspection and sample testing		
1.	Conduct a visual inspection to find eventual damages or repairs	<p>If any damages or repairs are found, exclude these parts of the blade from the repurposing process.</p>
2.	Conduct a sample test of the blade material to approximate the physical and mechanical properties of the blade	<p>Depending on the application of the repurposed elements, the required accuracy of the physical and mechanical properties can vary. In this phase it is advised to give an approximation of the strength based on sample testing. In a later phase, more accurate tests can be performed if necessary.</p>
3.	Determine whether the quality of the blade is sufficient for the project	

Figure B.7: Step 3 of the project oriented process

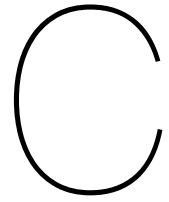


Step 4 - Incorporate blade in project model		
In case it is necessary for the project to incorporate the blade(s) or element(s) in the model, first the geometry of the blade must be obtained. The goal of this step is to obtain the geometry in Rhino. Depending on the available resources, multiple options exist. Start with the first option and walk through the possibilities in order. After the geometry is obtained, incorporate the blade(s) or element(s) in the model of the project.		
A	B	C
1. Check if the model of the wind turbine type is already present. Herefore, check the database	Database	Contact the owner of the model to receive the Rhino model
2. Ask the manufacturer of the blade to provide you with documentation regarding the geometry and properties of the blade. Since the design information about wind blades is strictly confidential, this often cannot be disclosed.	If the documentation is disclosed, model the parameters of the documentation in Rhino to create the geometry that can be connected to the grasshopper script in the next step.	To keep it manageable, start with modelling the outer geometry of the blade based on the prescribed airfoils. In a later stadium the thickness can be added.
3. Scan the blade to obtain an outer geometry of the blade. For the inner geometry and thickness, construct an internal point cloud	Export the scans to Rhino to create the geometry model that can be connected to the grasshopper script in the next step	
4. If none of the options above is possible, measure the geometry by hand and model it in Rhino	A wind turbine blade always consists of multiple airfoils throughout the length of the blade, so it is advised to divide the blade in 10-30 segments depending on the length of the blade, and to model the airfoils. A surface can be lofted between the airfoils to obtain the geometry.	In a next step, add thickness to the blade model, measured from the blade. Also, add the internal structure.
5. Extract the desired elements from the geometry model	Do this by following the steps of "Repurpose Method" in chapter 4 of the report	
6. Incorporate the extracted blade elements in the project model		
7. Perform a structural analysis of the elements if necessary		

Figure B.8: Step 4 of the project oriented process

Step 5 - perform post-processing	
Prepare the blade(s) or element(s) such that they can be incorporated into the project	
1.	In case smaller element are used, divide the blade in its homogeneous panels with a waterjet cutter
2.	Saw the blade in the desired elements with a waterjet cutter
2.	Based on the application, determine if post-processing is necessary
3.	Incorporate the blade(s) or element(s) in the project

Figure B.9: Step 5 of the project oriented process



# Grasshopper scripts

This appendix shows the grasshopper scripts used in this research.

## **C.1. Preparing the model**

First, the blade geometry is collected and the blade panels are set out individually

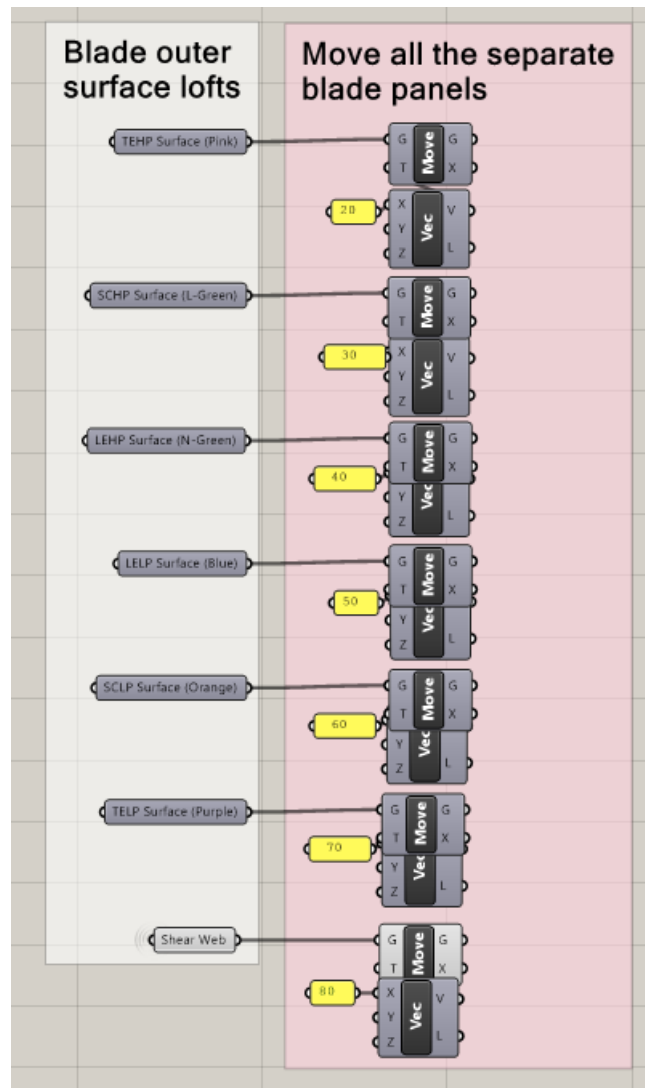


Figure C.1: Prepare the model by setting the individual panels apart

## C.2. Optimized for material use

Here, the steps for the "efficiency algorithm" are set out. First the input parameters are given. These are the dimensions of the desired elements, and the allowed deviation.

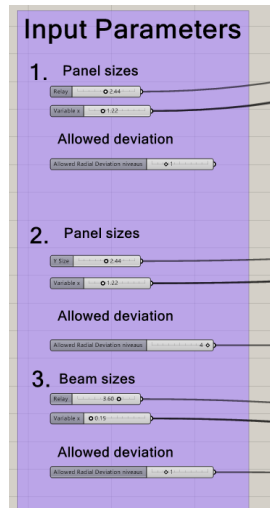


Figure C.2: Input parameters for efficiency script

The following Figures show the steps that enable elements to be extracted from the blade surface.

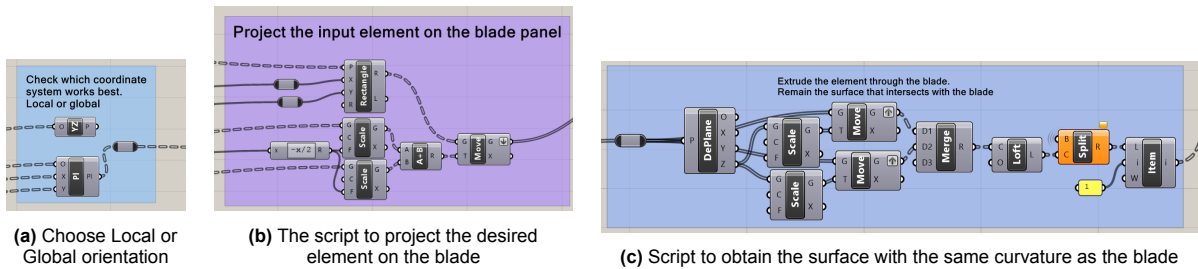


Figure C.3: Three steps of the grasshopper script

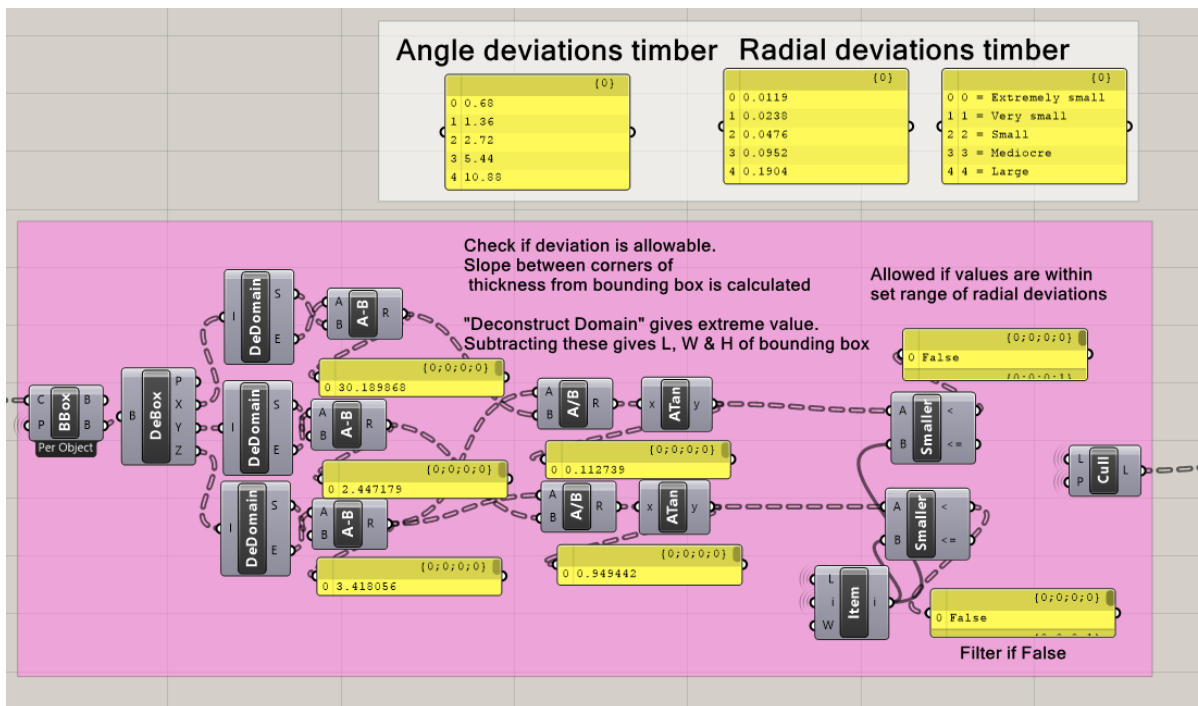
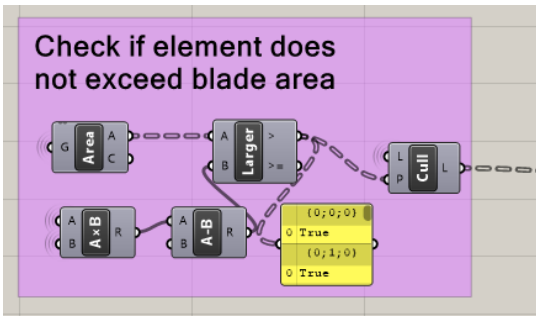
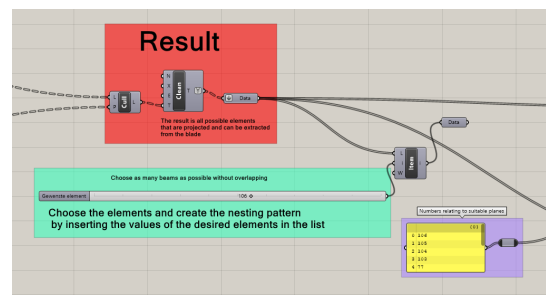


Figure C.4: Script that checks and filters the allowable deviation in terms of curvature

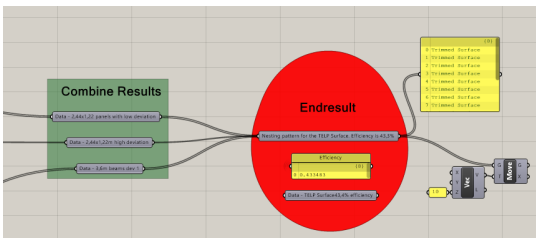


(a) Script that filters elements exceeding the blade panel area

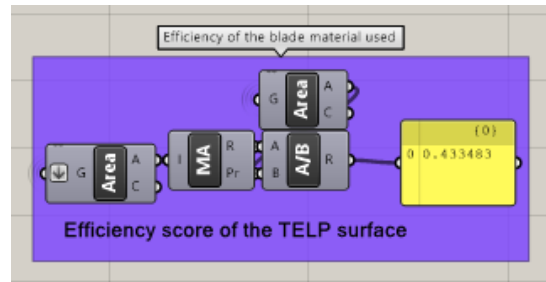


(b) All the resulting elements from one type of element. The number slider can be used to selected desired elements

Figure C.5: Two steps in the script



(a) The combined result of all element types, resulting in a nesting pattern as shown in Chapter 4



(b) Script to calculate the efficiency score

Figure C.6: Final steps in the script

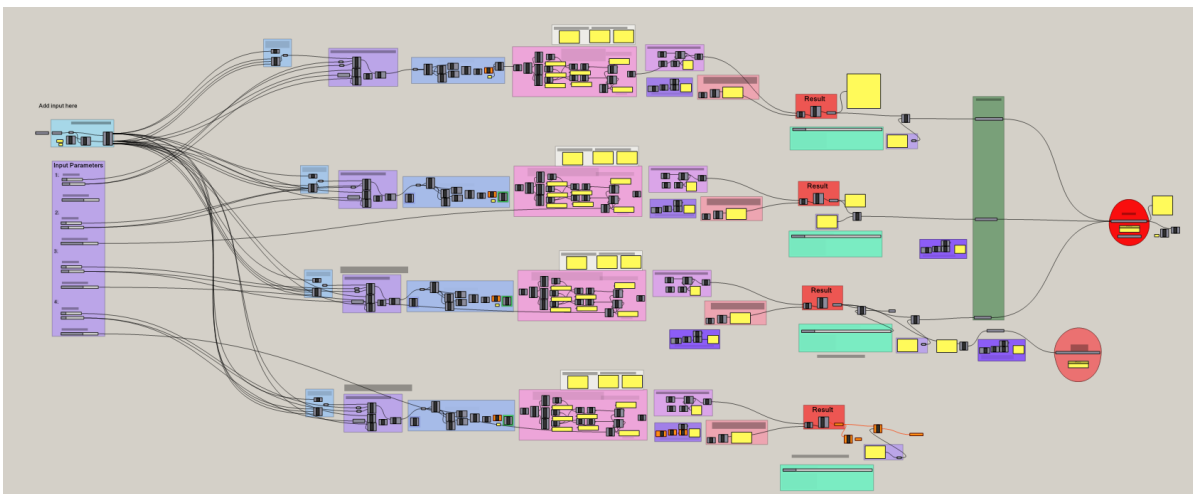


Figure C.7: The entire grasshopper script for one blade panel

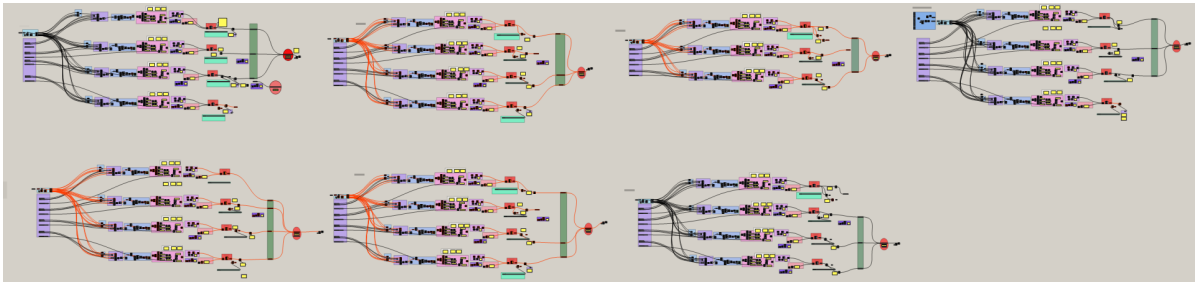


Figure C.8: Script for all seven blade panels

### C.3. On-demand extracting of elements

Three approaches are distinguished. The first approach is simply incorporating the entire blade in a project. The second approach is selecting a section by cutting the blade with three cutting plates. The third and last approach is extracting free form shapes from the blade panels.

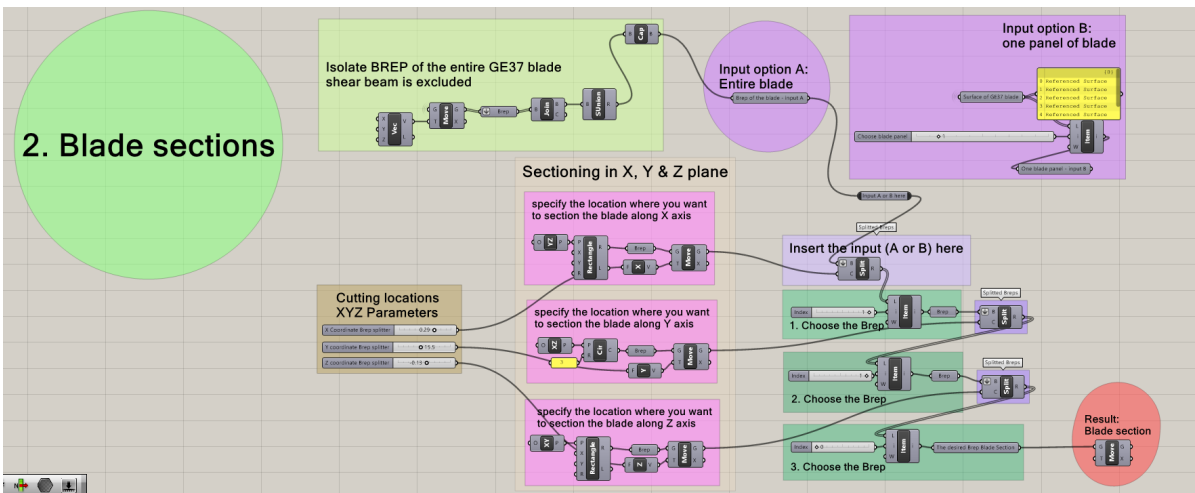


Figure C.9: Option 2 for the on-demand script: taking a section of the blade by determining a cutting plane in the X, Y and Z plane

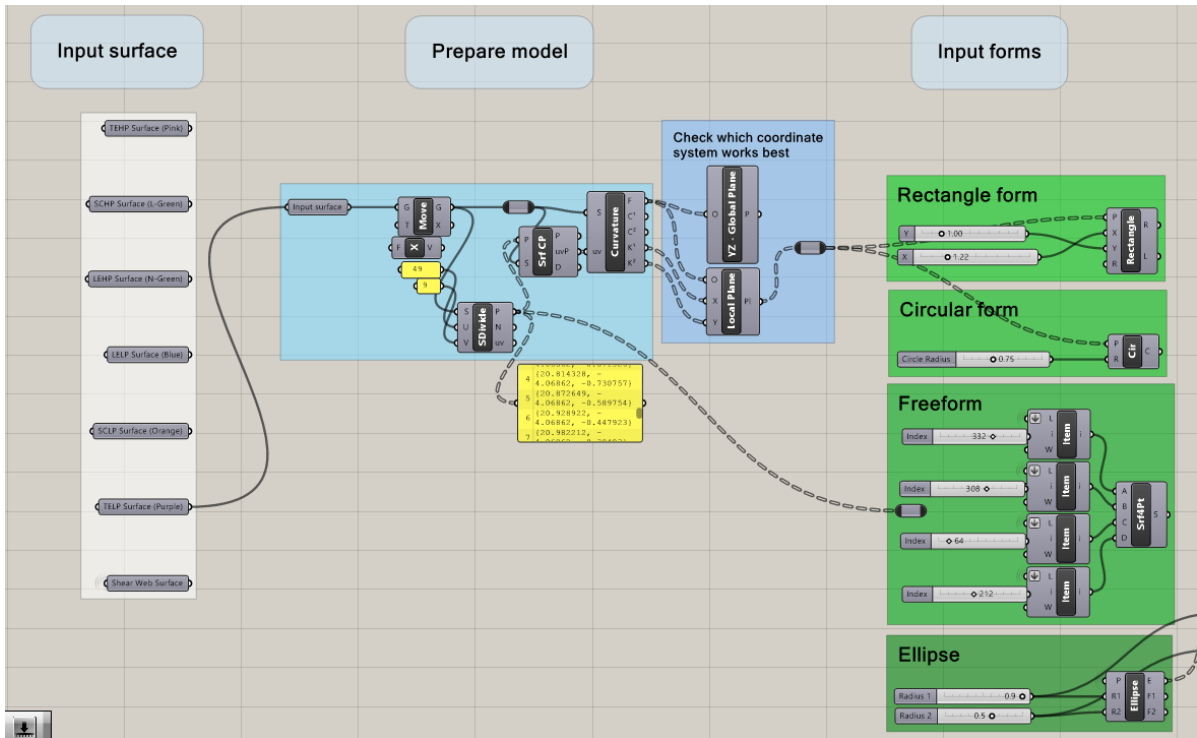


Figure C.10: The input surface from the blade panel and input form to be projected on that panel in option 3 of the on-demand script

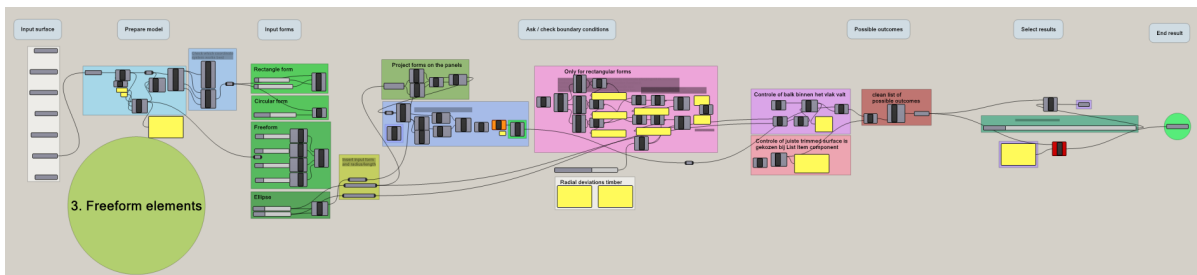


Figure C.11: The entire script for option 3

## C.4. Adding thickness

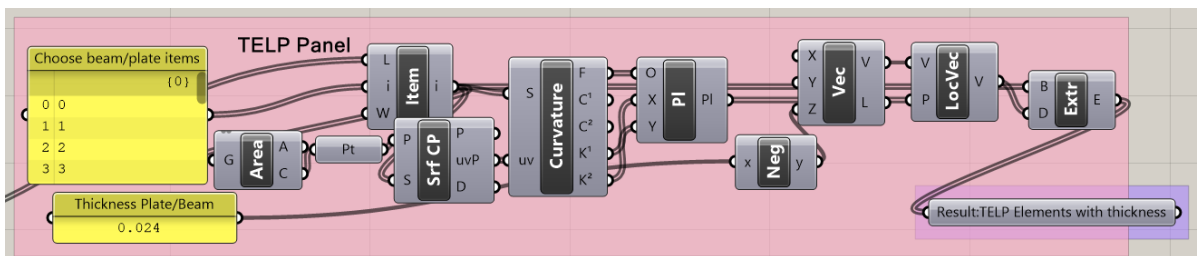


Figure C.12: The script to assign thickness to the extracted elements. This script is able to assign one thickness



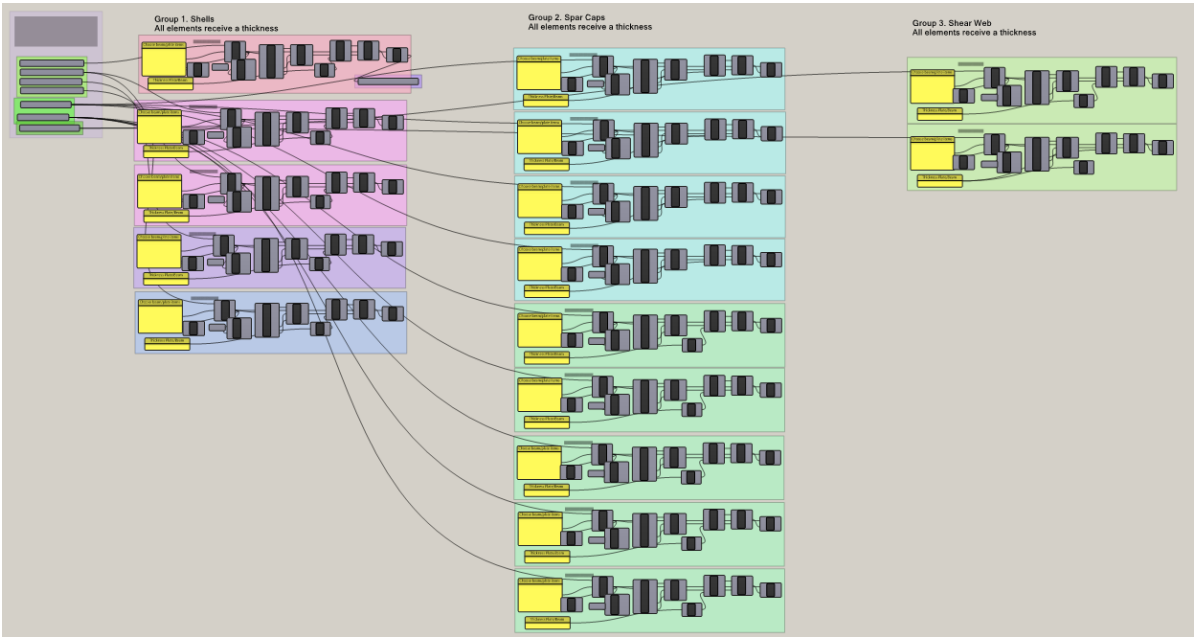
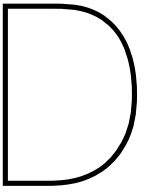


Figure C.13: All scripts to assign thickness to all the elements





# Catalog

Catalog of elements from the blade, efficient algorithm

Extracted from #	Type	Dimensions X [mm]	Dimensions Y [mm]	Thickness [mm]	Amount	Deviation	Material	I (skin) [mm <sup>4</sup> ]	E (skin) [MPa]	EI Skin [Nm <sup>2</sup> ]	Cost per item	Total yield
TELP	1 Plate	2440	1220	24	2		1 Foam + GFRP shell	708108.33	10100	7151.89	89.95	179.90
TELP	2 Plate	2440	1220	24	1		4 Foam + GFRP shell	708108.33	10100	7151.89	89.95	89.95
TELP	3 Beam	3600	150	24	12		1 Foam + GFRP shell	87062.50	10100	879.33	43.45	521.40
TEHP	4 Plate	2440	1220	24	1		1 Foam + GFRP shell	708108.33	10100	7151.89	89.95	89.95
TEHP	5 Plate	2440	1220	24	2		4 Foam + GFRP shell	708108.33	10100	7151.89	89.95	179.90
TEHP	6 Beam	4800	150	22	7		1 Foam + GFRP shell	71687.50	10100	724.04	57.95	405.65
TEHP	7 Beam	3600	150	22	7		2 Foam + GFRP shell	71687.50	10100	724.04	43.45	304.15
LELP	8 Beam	3600	150	16	8		1 Foam + GFRP shell	34562.50	10100	349.08	43.45	347.60
LELP	9 Beam	1850	150	16	4		2 Foam + GFRP shell	34562.50	10100	349.08	16.95	67.80
LELP	10 Beam	1850	150	16	2		3 Foam + GFRP shell	34562.50	10100	349.08	16.95	33.90
LEHP	11 Beam	4800	150	16	7		1 Foam + GFRP shell	34562.50	10100	349.08	57.95	405.65
LEHP	12 Beam	1850	150	16	2		1 Foam + GFRP shell	34562.50	10100	349.08	16.95	33.90
LEHP	13 Beam	1850	150	16	8		3 Foam + GFRP shell	34562.50	10100	349.08	16.95	135.60
SCLP	14 Beam	4800	150	53	2		1 solid GFRP	1860962.50	36800	68483.42	57.95	115.90
SCLP	15 Beam	1850	150	53	1		2 solid GFRP	1860962.50	36800	68483.42	16.95	16.95
SCLP	16 Beam	4800	150	50	2		1 solid GFRP	1562500.00	36800	57500.00	57.95	115.90
SCLP	17 Beam	1850	150	50	1		2 solid GFRP	1562500.00	36800	57500.00	16.95	16.95
SCLP	18 Beam	4800	150	43.5	4		1 solid GFRP	1028910.94	36800	37863.92	57.95	231.80
SCLP	19 Beam	4800	150	30	1		1 solid GFRP	337500.00	36800	12420.00	57.95	57.95
SCHP	20 Beam	3600	150	53	2		1 solid GFRP	1860962.50	36800	68483.42	43.45	86.90
SCHP	21 Beam	2800	150	49	1		2 solid GFRP	1470612.50	36800	54118.54	32.35	32.35
SCHP	22 Beam	2800	150	49	1		3 solid GFRP	1470612.50	36800	54118.54	32.35	32.35
SCHP	23 Beam	3600	150	49	1		2 solid GFRP	1470612.50	36800	54118.54	43.45	43.45
SCHP	24 Beam	3600	150	49	5		1 solid GFRP	1470612.50	36800	54118.54	43.45	217.25
SCHP	25 Beam	3600	150	40	2		1 solid GFRP	800000.00	36800	29440.00	43.45	86.90
SCHP	26 Beam	3600	150	33	1		2 solid GFRP	449212.50	36800	16531.02	43.45	43.45
Shear Web	27 Plate	2440	1220	80	1		1 Foam + GFRP shell	9162708.33	10100	92543.35	89.95	89.95
Shear Web	28 Plate	2440	610	80	3		1 Foam + GFRP shell	4581354.17	10100	46271.68	35.95	107.85
Shear Web	29 Beam	4800	150	80	5		1 Foam + GFRP shell	1126562.50	10100	11378.28	57.95	289.75
Total					96							€ 4,381.00

**Figure D.1:** Catalog of elements extracted from the GE37 blade, following from the efficiency algorithm as described in Chapter 4. Catalog includes dimensions, deviation, flexural stiffness and estimated value.



# Building elements

Beams	Height [mm]	Width [mm]	Length [mm]	Beams	Height [mm]	Width [mm]	Length [mm]
Hardwood	25	125	2450-6700	Spruce C planed	44	70	2400-5400
	32	150	2450-6700		19	70	2400-5100
	32	200	1850-6100		44	95	2400-5400
	25	150	2750-6700		70	170	2400-6000
	25	300	1850-5800		19	45	2400-5100
	32	200	2450-5500		38	140	3000-5400
	32	250	2450-5800		70	195	2400-6000
	22	150	1850-5200		44	145	2400-5400
	25	250	2450-6100		44	120	2400-5400
	25	300	1850-5500		38	89	2400-5400
	100	200	2450-6400		58	155	2400-6000
	19	100	3050-6100		38	120	3000-5400
	25	200	2750-6700		44	44	2700-5400
	25	250	2450-7000		19	96	2700-5400
	32	300	2450-6100		38	184	3600-6000
	32	250	2150-3650		70	220	2700-6000
	32	300	1850-4000		38	170	4200-6000
	22	200	1850-5500		28	45	2700-4800
	100	200	2450-7300		70	245	3000-6000
	32	150	2450-6100		28	195	3600-5400
	44	200	1850-4900		28	145	3600-4800
	44	150	1850-5800		38	235	3600-6000
	100	250	2450-6100		95	195	3000-6000
Fine wood	20	245	2500		95	220	3000-6000
	40	205	2400	Spruce C finger joint	44	70	3000-4800
	25	220	2500		70	195	6600-7500
	50	175	3350		70	170	6600-7500
	20	180	2500		38	235	7500
	20	125	2500		70	270	7500
	20	140	2400		70	245	6600-7500
					70	220	6600-7500
					58	155	6600-7500
					95	195	6600-7500
					95	245	6600-7500

Figure E.1: Beam sizes available in wholesale market. Retrieved from [www.stiho.nl](http://www.stiho.nl)

Plates	Width [mm]	Length [mm]	Height [mm]
Real wood panels	2500	1210	38
	4200	800	38
	4200	800	27
	4200	600	38
	4200	625	40
	4200	600	19
	4200	800	19
Chipboard	2500	1250	18
	3050	1250	18
Poplar concrete plywood	2500	1250	18-22
Birch concrete plywood	1250	2500	4 tot 18
	1530	3050	9 to 18
	2500	1250	9 to 18
	1530	3050	18
	305	125	18
Radiplex concrete plywood	2500	1250	18
Okoume plywood	2500	1220	18
	2150	950	40
	3100	1530	4 to 40
Poplar plywood	2500	1220	5 to 18
	3100	1530	9
Hardwood plywood	2440	1220	9 to 18
	2750	1000	3,6

Figure E.2: Plate sizes available in wholesale market. Retrieved from [www.stiho.nl](http://www.stiho.nl)