

**Document Version**

Final published version

**Licence**

CC BY

**Citation (APA)**

Li, K., Friebel, M., & Pluymakers, A. M. H. (2026). Thermo-mechanical behaviour of the sealant-steel interface under thermal cycling for CCS. *International Journal of Greenhouse Gas Control*, 153, Article 104642. <https://doi.org/10.1016/j.ijggc.2026.104642>

**Important note**

To cite this publication, please use the final published version (if applicable). Please check the document version above.

**Copyright**

In case the licence states "Dutch Copyright Act (Article 25fa)", this publication was made available Green Open Access via the TU Delft Institutional Repository pursuant to Dutch Copyright Act (Article 25fa, the Taverne amendment). This provision does not affect copyright ownership. Unless copyright is transferred by contract or statute, it remains with the copyright holder.

**Sharing and reuse**



Other than for strictly personal use, it is not permitted to download, forward or distribute the text or part of it, without the consent of the author(s) and/or copyright holder(s), unless the work is under an open content license such as Creative Commons.

**Takedown policy**

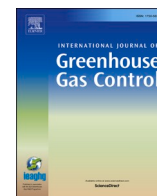
Please contact us and provide details if you believe this document breaches copyrights. We will remove access to the work immediately and investigate your claim.



## Thermo-mechanical behaviour of the sealant-steel interface under thermal cycling for CCS

Kai Li <sup>\*</sup> , Marc Friebel, Anne M.H. Pluymakers 

Geoscience & Engineering Department, Delft University of Technology, the Netherlands

### ARTICLE INFO

#### Keywords:

CCS  
Sealants  
Thermal cycling  
Sealant-steel bonding  
Thermo-mechanical behaviour

### ABSTRACT

In CCS wells, cyclic injection of cold CO<sub>2</sub> into the hot subsurface may lead to debonding between sealant and steel casing. We test how thermal cycling affects the sealing ability of five different types of sealant (S1 to S5) surrounding a simulated steel wellbore. We use cylindrical sealant samples with a stainless steel (AISI 316 L) pipe in the centre, cured at 150°C and 30 MPa for 28 days. Using 3 bar N<sub>2</sub> leak tests at room temperature, we test how much the sealant-steel interface leaks before and after thermal cycling under unconfined and confined (1.5 MPa) conditions. We also conduct push-off experiments using a 500 kN loading frame before and after. For the unconfined test, we place the sample on a custom-built jig, whereas for confined tests we have a similar assembly inside a conventional triaxial vessel. The samples are brought to 60°C. Subsequently, we inject 5°C water through the central pipe at 80 mL/min for 2 mins, and let the sample reheat for 12 mins. We repeat this 16 times. Afterwards, we allow the sample to cool to room temperature, and repeat the N<sub>2</sub> leak test in-situ. The results show that under unconfined conditions, the interface leaks more for all sealant types except S3. The key parameter controlling performance is the linear thermal expansion coefficient, where an expansion coefficient closer to that of steel indicates better performance. Under confinement, all sealant types perform better post-thermal cycling, due to the prolonged exposure to confining pressure.

### 1. Introduction

In carbon capture and storage (CCS), the in-situ temperatures at storage depths between 2 and 4 km typically range from 60°C to 120°C (Eiken et al., 2011; Lescanne et al., 2011; Yoo et al., 2013). However, the temperature of injected CO<sub>2</sub> can be as low as 5°C (Shell, 2016; Vilarrasa and Rutqvist, 2017), particularly in offshore projects (such as the Dutch Portos project or the Norwegian Northern Lights project), where CO<sub>2</sub> is transported to the injection point on the sea-floor using pipelines. This suggests that the periodic injection of cold CO<sub>2</sub> into the warmer subsurface could induce temperature fluctuations of up to 115°C. Under such temperature fluctuations, the wellbore and subsurface formations may experience repeated shrinkage during cold CO<sub>2</sub> injection and subsequent expansion after injection when the system equilibrates back to reservoir temperature. As a result, formation of leakage pathways may occur, which potentially includes fractures within the sealant itself (Vilarrasa and Rutqvist, 2017; Carey et al., 2007; Roy et al., 2016; Li and Pluymakers, 2024), and/or debonding between sealant sheath and casing due to the mismatch in their thermo-mechanical properties

(Albawi et al., 2014; De Andrade et al., 2015; Lund et al., 2015). Given that the wellbore provides the shortest path from the storage reservoir to the surface, the formation of such wellbore-related leakage pathways would pose significant risks to the long-term viability of CO<sub>2</sub> storage underground (Celia et al., 2005). Therefore, understanding the effects of thermal cycling on the integrity of the sealant sheath and on the annulus between sealant and wellbore steel is crucial to ensuring the security and thus long-term sustainability of CO<sub>2</sub> storage systems. Understanding the key properties determining performance will also be fundamental to the design of more resilient sealant compositions that can withstand the dynamic temperature conditions in future CCS operations.

In most depleted oil and gas wells considered for CCS (“legacy wells”), ordinary Portland cement (OPC) is the most common sealant, due to its effective performance as a zonal isolation material and low cost (Parker et al., 2009; Lesti et al., 2013). However, the sealing integrity of OPC-based sealants can be compromised under thermal fluctuations induced by cyclic CO<sub>2</sub> injection and subsequent storage. Albawi et al. (2014) investigated the impact of thermal cycling on wellbore integrity using micro-computed tomography (micro-CT). Their

\* Corresponding author at: Department of Geoscience & Engineering, Stevinweg 1, 2628 CN Delft, the Netherlands.

E-mail address: [likai201509@gmail.com](mailto:likai201509@gmail.com) (K. Li).

<https://doi.org/10.1016/j.ijggc.2026.104642>

Received 25 August 2025; Received in revised form 13 March 2026; Accepted 18 March 2026

Available online 31 March 2026

1750-5836/© 2026 The Authors. Published by Elsevier Ltd. This is an open access article under the CC BY license (<http://creativecommons.org/licenses/by/4.0/>).

scaled-down model, consisting of casing pipe, OPC-based sealant, and rock, revealed that slow temperature variations of 75°C caused debonding at the sealant-steel and sealant-rock interfaces, creating leakage pathways up to several millimeters wide in a cm-scale system. Lund et al. (Lund et al., 2015) simulated the study by Albawi et al. (2014) and found that the thermal properties of the casing, sealant, and rock significantly influenced the wellbore integrity during thermal cycling. They concluded that large temperature fluctuations could induce sufficient thermal stresses to damage the sealant. Similarly, De Andrade et al. (2015) replicated Albawi et al.'s experiments and identified shear failure as the primary mechanism for debonding at interfaces. They also noted that shale exhibited better resistance to thermal cycling than sandstone due to its higher stiffness, making it less prone to shear failure.

Besides OPC-based sealants, novel compositions with modified thermo-mechanical properties are gaining more attention for CCS purposes in recent years, such as calcium aluminate cement (CAC)-based and geopolymers-based sealants. CAC possesses higher early strength and greater heat of hydration compared to OPC (Barborak, 2010), making it a promising candidate for CCS applications. In addition, Dugonjic-Bilic et al. (2011) evaluated a CAC-based sealant composition with a retarder in a CO<sub>2</sub> environment and found it effective in controlling water loss, which is beneficial for CCS. Geopolymer-based sealants are becoming increasingly recognized in the wellbore community, because they can be synthesized from waste materials such as fly ash and biomass ash (Nasvi et al., 2014; Freire et al., 2022), making their obtainment eco-friendly. They exhibit favorable properties such as high ductility, low shrinkage, and strong resistance to carbonation (Hajiabadi et al., 2023), hence show great potential for future CCS applications. However, the performance of these two types of sealants under thermal cycling relevant for CCS is currently unexplored.

In this paper, we investigate five sealant compositions, labeled S1 through S5 using novel methodologies. For reference purposes, these include two conventional OPC-based sealants, commonly used in aged oil and gas reservoirs targeted for CCS (S1 and S2), as well as more novel sealants designed for future CCS (S3 to S5). S1 and S2 are standard OPC-based blends, where S2 contains an expansion agent and demonstrates ultra-low permeability for field applications. S3 is also OPC-based but incorporates CO<sub>2</sub>-sequestering additives and hence possesses modified mechanical properties. S4 is a CAC-based blend specifically formulated for high acid resistance in a CO<sub>2</sub> storage environment. S5 is a granite-based geopolymer blend with enhanced carbonation resistance for CCS. These are the same sealants previously tested by Li and Pluymakers (Li and Pluymakers, 2024), Li et al. (Li et al., 2025) and van Noort et al. (R. van Noort et al., 2024; R. van Noort et al., 2024) S1 through S5 possess significantly different thermo-mechanical properties, spanning a wide range in tensile and compressive strengths, thermal expansion coefficient, and thermal diffusivity, etc.

To examine the thermo-mechanical behaviour of the sealant-steel interface specifically, we conduct thermal-cycling experiments on cylindrical sealant samples with a steel pipe in the middle. These composite samples are custom-designed to mimic the sealant sheath surrounding the steel casing in a wellbore, whilst still having dimensions that fit a conventional triaxial apparatus. Our experiments are performed either without confinement (worst case scenario) or at a relatively low confinement of 1.5 MPa. Under in-situ conditions, confining pressure can reach tens of MPa, depending on the CO<sub>2</sub> storage depth (Kirby et al., 2001; Alnes et al., 2011). We also performed tests under unconfined conditions to represent the worst-case scenario and evaluate whether the added experimental complexity of confinement is worth the additional time required for testing. Note that the thermal cycling used in this study is on the extreme side: we apply an instantaneous temperature drop of 55°C with 12 min intervals between cycles. Whilst the absolute temperature difference is plausible for a scenario where cold CO<sub>2</sub>, transported over the seafloor is injected into a hot reservoir, the rapid temperature change and short cycle intervals are atypical in an

engineering scenario. Moreover, the number of cycles in our experiments is limited to a maximum of 16. Mechanics dictates that more loading cycles lead to greater damage accumulation (Miner, 1945; Fatemi and Yang, 1998; Suresh, 1998). Regardless, we use our bespoke sample type, assembly and experimental protocol to investigate which thermo-mechanical properties control the performance of the sealant-steel interface in a thermo-mechanical regime resembling CO<sub>2</sub> storage conditions.

## 2. Experimental materials, apparatus, and methodologies

### 2.1. Sample description

In our study, we employ composite samples with cylindrical sealant sheath (diameter 3 cm, length 7 cm) bonded to a steel pipe (ID 4 mm, wall thickness 1 mm, AISI 316 L stainless steel, Swagelok Nederland) in the centre to mimic the wellbore section. As shown in Fig. 1, the steel pipe sticks 1.5 cm out of both ends of the sealant sheath.

We test five sealants of different compositions as shown in Table 1, which includes their Technology Readiness Levels (TRLs) defined by API. (Institute, 2009). These compositions include conventional sealants representative in aged oil and gas reservoirs targeted for CCS (S1 and S2), and more novel sealants newly designed for future CCS (S3 to S5). S1 and S2 are standard OPC-based blends, where S2 exhibits an ultra-reduced permeability for field design. S3, designed by Restone (Kvassnes et al., 2020; Kvassnes and Clausen, 2021) is also OPC-based but with CO<sub>2</sub>-sequestering additives and modified mechanical properties. S4 is a CAC-based blend specifically designed to be highly acid resistant for CO<sub>2</sub> storage environment. S5, designed by University of Stavanger (Hajiabadi et al., 2024), is a geopolymer-based blend with high resistance against carbonation for CCS.

S1 to S4 are also used by Li and Pluymakers (Li and Pluymakers, 2024) and Li et al. (Li et al., 2025), who worked on the same sealant batch, but with different sample configurations and a protocol targeting the thermo-mechanical performance of the sealant material alone. All samples are cast and cured by Halliburton AS Norway, following API Recommended Practice 10B-2 (API, 2013). Sealant slurry is mixed with a water/cement ratio of 0.4, and cast into a Teflon mould with a steel pipe (AISI 316 L) pre-mounted as the central axis of the sample cylinder. Then the whole sample is cured at 150°C and 30 MPa for 28 days. Under such elevated temperature and pressure during curing, the chemical reactions of the sealant and the bonding process between the sealant sheath and the steel pipe will be near completion during the curing itself. This minimizes variation in the mechanical and thermal properties of our samples in the time between curing and usage. They are stored in

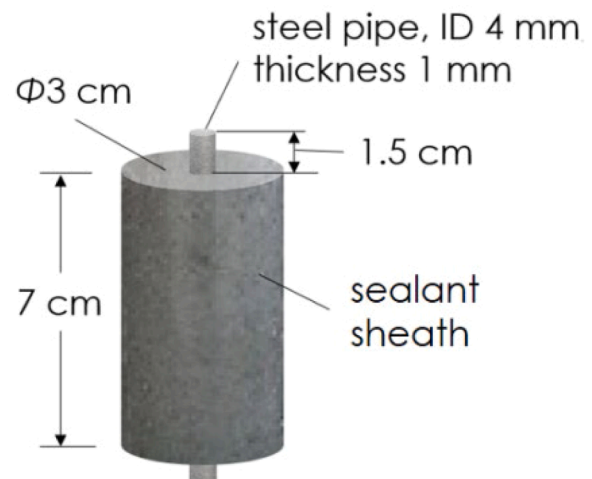

Fig. 1. Schematic of the composite sample.

**Table 1.**

An overview of four sealant compositions and their TRLs. Thermomechanical properties are in Table 2.

Sealant	Composition	TRL
S1	1.90 SG class G cement with 35% BWOC silica flour	7: Proven technology
S2	1.90 SG ultra-reduced permeability class G cement with 35% BWOC silica flour, with high silica fume concentration and expansion agent in form of dead-burnt MgO	7: Proven technology
S3	1.90 SG class G cement with 35% BWOC silica flour, with silica fume, expansion agent in form of dead-burnt MgO, and CO <sub>2</sub> -sequestering additives based on olivine minerals	3: Prototype tested
S4	1.80 SG highly acid-resistant calcium aluminate-based blend	7: Proven technology
S5	1.90 SG granite-based (feldspar rich type of rock as a precursor) geopolymer for CCS	3: Prototype tested

fresh water at room temperature and pressures throughout the study period. Unconfined Compressive Strength (UCS) tests performed at 1 month intervals confirm that mechanical properties do not evolve during storage, see also (Li and Pluymakers, 2024). Before use, the samples are dried in an air-circulated oven (model UF75, Memmert) at 60°C (ramping rate of 0.5°C/min from room temperature to 60°C). Afterwards, the samples are completely dry, which is confirmed by no weight reduction after two days. Note that the slow ramping rates minimizes the damage induced by the drying process, since thermal stresses that built up during heating and cooling have time to slowly dissipate instead of leading to mechanical damage. This is confirmed by microtomography measurements of the samples before thermal cycling.

## 2.2. Pre- and post-thermal cycling thermomechanical analysis

The thermomechanical properties of S1 to S4 are reported by Li and Pluymakers (Li and Pluymakers, 2024). In this study, we also report the mechanical and thermal properties of post-curing and post-drying sealant S5 before any thermal-cycling experiments, performed in the exact same manner as the previously reported measurements on S1 to S4. To summarize, we used a 500 kN loading frame to conduct uniaxial compressive tests on three solid cylindrical S5 samples (diameter 3 cm, length 7 cm) to measure the unconfined compression strength (UCS), Young's modulus, and Poisson's ratio. We used a 50 kN loading frame to conduct Brazilian disc tests on S5 disc samples (diameter 3 cm, thickness 1.5 cm) to measure the indirect tensile strength. Bulk density of S5 is calculated by the weight of the sample (weighed using a laboratory balance, Model VIC-303, Acculab Sartorius Group) divided by its volume. A thermal constants analyzer (Hot Disk® TPS 2200) is used to measure the thermal conductivity and specific heat capacity. Then thermal diffusivity of sealant S5 is calculated by thermal conductivity

**Table 2**

Mechanical and thermal properties of the five sealants, as measured before thermal treatment. Note that properties of sealants S5 are measured in this study. Those of S1 to S4 were measured by Li and Pluymakers (Li and Pluymakers, 2024) and Li et al. (Li et al., 2025).

Sealant	Unconfined compressive strength [MPa]	Young's modulus [GPa]	Poisson's ratio [-]	Tensile Strength [MPa]	Bulk density [kg/m <sup>3</sup> ]	Thermal conductivity [W/(m·K)]	Specific heat capacity [J/(kg·K)]	Thermal diffusivity [mm <sup>2</sup> /s]	Linear thermal expansion coefficient [10 <sup>-6</sup> K <sup>-1</sup> ]	Effective porosity by helium pycnometer [%]
S1	99.8 ± 1.1	13.4 ± 0.2	0.143 ± 0.005	3.63 ± 0.35	1455	0.82 ± 0.04	878 ± 18	0.64	6.89 ± 0.20	35.6 ± 1.9
S2	81.1 ± 1.3	12.0 ± 0.2	0.162 ± 0.010	5.51 ± 0.32	1507	0.93 ± 0.03	936 ± 11	0.66	10.93 ± 0.62	26.8 ± 2.1
S3	33.4 ± 0.7	6.1 ± 0.1	0.139 ± 0.009	6.79 ± 0.15	1374	1.04 ± 0.02	684 ± 13	1.11	9.40 ± 0.12	42.2 ± 0.9
S4	34.3 ± 1.3	6.6 ± 0.1	0.172 ± 0.014	3.92 ± 0.10	1497	0.89 ± 0.02	970 ± 21	0.61	12.32 ± 0.53	37.5 ± 1.6
S5	61.4 ± 2.07	9.5 ± 0.39	0.163 ± 0.001	8.11 ± 0.24	1417	0.79 ± 0.02	527 ± 23	1.06	8.15 ± 0.14	35.5 ± 0.9

divided by density and specific heat capacity. In addition, we used a thermomechanical analyzer (PerkinElmer, TMA 4000) to measure the linear thermal expansion coefficient and a helium gas pycnometer (Anton Paar, Ultrapyc 5000) to measure the effective porosity. All thermomechanical properties are provided in Table 2.

In our study, we also designed bespoke push-off experiments on intact composite samples of sealants S1 to S5 to quantify the strength of the bonding between the sealant sheath and the steel pipe. This has some similarity to conventional bond strength measurements on steel-sealant interfaces (Suryanto et al., 2024), but the geometry of our composite samples differs. As shown in Fig. 2, we mount reference composite samples (i.e. that have not undergone any thermal cycling) on our 500 kN loading frame, which is fit with a customized steel top cap with similar bottom base. The outer surface of the sealant sheath is not in contact with the inner surface of either cap. We apply loading in displacement control mode (rate of 0.0005 mm/s) to push the pipe from the top off the sealant sheath while the sheath is supported by the bottom base, i.e. similar to a standard UCS test. We record the force profile against the displacement of the pipe to obtain the push-off force  $F_{po}$  beyond which the force gets stable or slowly decreases in spite of further

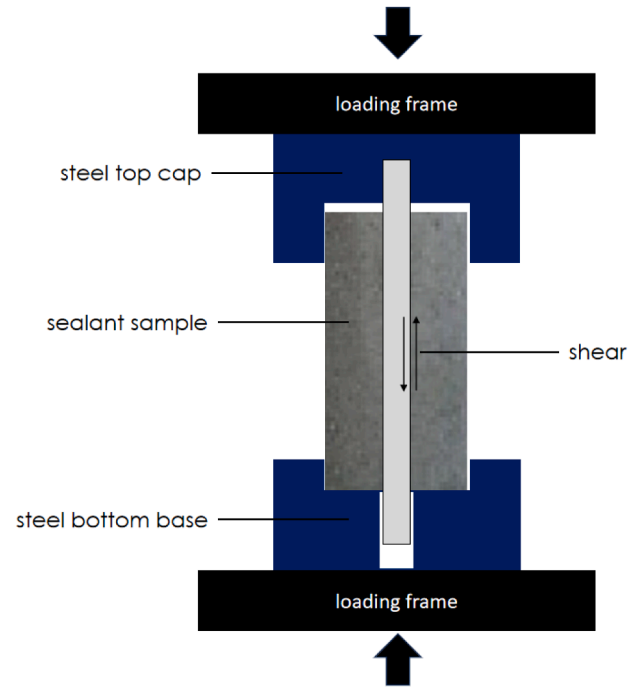

Fig. 2. Schematic of experimental setup for push-off experiments on composite samples. The drawing does not adhere to the actual scale.

displacement. We then calculate the push-off shear stress  $\sigma_{po}$  through division of the push-off force by the bonding area  $A_b$  between sealant sheath and the steel pipe. The equation is given below,

$$\sigma_{po} = \frac{F_{po}}{A_b} = \frac{F_{po}}{\pi d H} \quad (1)$$

where  $d$  is outer diameter of the steel pipe (6 mm), and  $H$  is the length of the sealant sheath (7 cm).

To ensure our procedures are reliable and we obtain repeatable measurements, we conduct push-off experiments on three intact samples (post-curing and post-drying, but without thermal treatment) for each sealant S1 to S5. These three measurements per each sealant are obtained at one month intervals during three months. We also perform similar push-off experiments to all composite samples after thermal treatment to study how thermal cycling affects the mechanical efficacy of the bonding at the sealant-steel interface.

To further determine how thermal cycling affects the integrity of our composite samples including sealant sheath and bonding between sealant sheath and steel pipe, we scan one sample per each sealant S1 to S5 after thermal treatment in unconfined experiments using a micro-CT scanner (CoreTOM, TESCAN UniTom XL, voxel resolution of 32  $\mu\text{m}$ ). Images are post-processed with Panthera software (version 1.4, TESCAN) to detect the possibility of crack formation in sealant or debonding at sealant-steel interface after the experiments. Due to technical limitations, any cracks smaller than 32  $\mu\text{m}$  cannot be detected (i.e. the voxel size), nor would any aperture be visible close to the steel pipe due to the high density of the steel compared to the sealant.

### 2.3. Thermal cycling procedure

In our study, we carry on thermal cycling experiments on composite samples of sealants S1 to S5 either without or with 1.5 MPa confinement. All composite samples tested in this study and the experimental scheme are outlined in Table 3.

#### 2.3.1. Unconfined experiments

For the unconfined experiments we designed a jig, shown in Fig. 3. To mount the sample, we first apply a 5 mm-thick layer of hardened glue (cured under ambient conditions for two days, industrial adhesives 3720A, Permacol B.V.) on the outer surface of the sealant sheath of the sample (1.5 cm height from both ends). We then firmly attach the composite sample with customized steel top cap and bottom base with built-in flowlines. The whole sample assembly is then secured by three bolts over the entire assembly length and placed in a laboratory oven (model UF75, Memmert).

During the unconfined experiment, we first use a syringe pump (model 1000D, Teledyne ISCO, range: 0.001 to 408 mL/min, accuracy: 0.5% of setpoint) to apply 3 bar  $\text{N}_2$  on the top surface of the sealant sheath for 30 mins without confinement and at room temperature. We monitor the volume decrease of  $\text{N}_2$  after 30 mins, based on which we calculate the penetration rate, which will occur through the matrix of sealant sheath as well as the sealant-steel interface. Note that, in this study, the penetration rate of  $\text{N}_2$  is reported with the upstream gas pressure maintained at 3 bar. We apply leak detector solution (Swagelok Snoop) on the seams between sealant sheath and the steel caps, as well as on the joints of flowlines to ensure the  $\text{N}_2$  doesn't leak. When there is no bubble foam observed, it confirms there is no leakage from the sample assembly and we proceed with the next steps. We then heat the whole sample assembly (unjacketed and unconfined) at a ramping rate of 1.3°C/min to 60°C. Then the sample assembly is maintained at this temperature for 30 mins to be fully heated. We next use another syringe pump (model 1000D, Teledyne ISCO) to inject 5°C water at a rate of 80 mL/min for 2 mins through the steel pipe of the sample from top to bottom to apply a rapid temperature drop. We then halt for 12 mins before the next injection to allow the sample assembly to re-equilibrate

**Table 3**

An overview of all composite samples to be tested and the experimental scheme.

No.	Sample name	Sealant composition	Confinement	Experiment type	Experimental scheme
1	S1C-1	S1, OPC			3 bar $\text{N}_2$
2	S1C-2	blend			penetration test
3	S2C-1	S2, OPC			test
4	S2C-2	blend with ultra-reduced permeability			↓ thermal cycling
5	S3C-1	S3, OPC		unconfined	↓
6	S3C-2	blend with $\text{CO}_2$ -sequestering additives	0 MPa	thermal-cycling experiment	3 bar $\text{N}_2$ penetration test
7	S4C-1	S4, CAC			↓
8	S4C-2	blend			micro-CT (on one sample per each sealant)
9	S5C-1	S5, geopolymer blend			↓
10	S5C-2	blend			push-off shear experiment
11	S1C-3	S1, OPC			confinement loading
12	S2C-3	S2, OPC			↓
		blend with ultra-reduced permeability			3 bar $\text{N}_2$ penetration test
13	S3C-3	S3, OPC		confined	↓
		blend with $\text{CO}_2$ -sequestering additives		thermal-cycling experiment	thermal cycling
14	S4C-3	S4, CAC			↓
15	S5C-3	S5, geopolymer blend	1.5 MPa		3 bar $\text{N}_2$ penetration test
		blend			↓
					confinement unloading
					↓
					push-off shear experiment
16	S4C-4	S4, CAC			same as for confined
		blend			thermal-cycling experiment,
17	S5C-4	S5, geopolymer blend		reference loading experiment	only without thermal-cycling treatment

back to 60°C. We repeat the injection followed by reheating for 16 cycles. As shown in Fig. 3, two thermocouples (type K, NI-9219, National Instruments rated to 700°C with an accuracy  $\pm 1^\circ\text{C}$ ) are installed to measure the temperature during the experiment on the outer surface of the sample centre ( $T_{is}$ ), as well as on the top surface of the sealant sheath adjacent to the steel pipe ( $T_{ut}$ ). After the thermal treatment, we allow the sample assembly to cool down to room temperature naturally. Then we apply 3 bar  $\text{N}_2$  on the top surface of the sealant sheath for 30 mins again, to calculate the post-treatment  $\text{N}_2$  penetration rate. Combined with the additional post-treatment shear-off experiment, we deem this in-house designed protocol sufficient to study the effects of thermal cycling on the integrity of the sealant sheath and sealant-steel interface. We test two samples for each sealant composition of S1 to S5.

#### 2.3.2. Confined experiments

In confined experiments, we use a standard triaxial deformation apparatus (Fig. 4), where a composite sealant sample is placed in a pressure vessel. The confining pressures can be maximum 70 MPa, and axial force can be maximum up to 300 kN (equivalent to 442 MPa axial stress on our composite sample). As shown in Fig. 4, it is equipped with an internal furnace. During the experiments, the triaxial vessel is filled with heat transfer oil (Shell Thermia oil B) that provides the confining

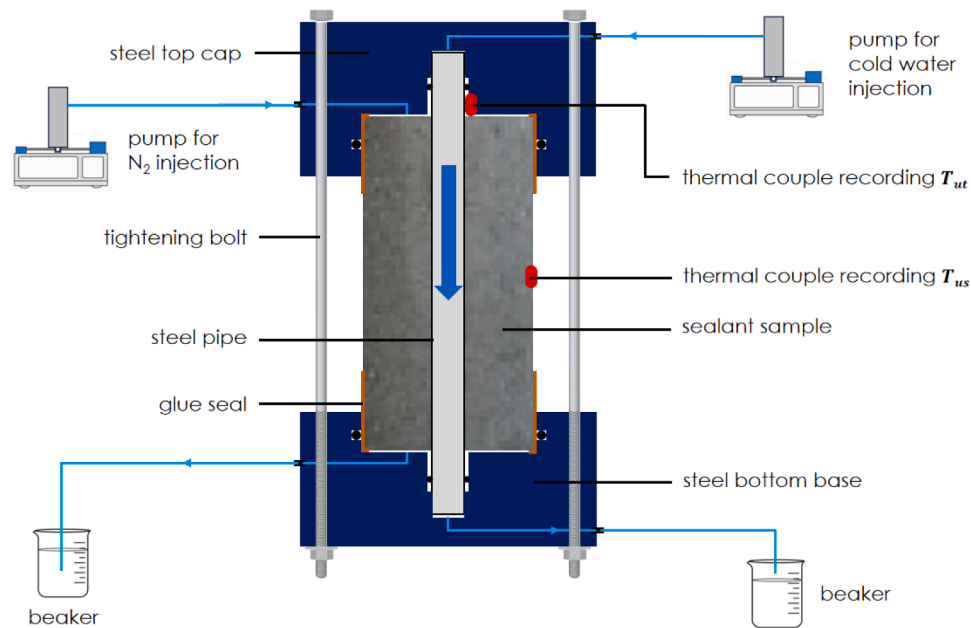

Fig. 3. Schematic of experimental setup for unconfined thermal-cycling experiments. The setup is placed in an laboratory oven. The drawing does not adhere to the actual scale.

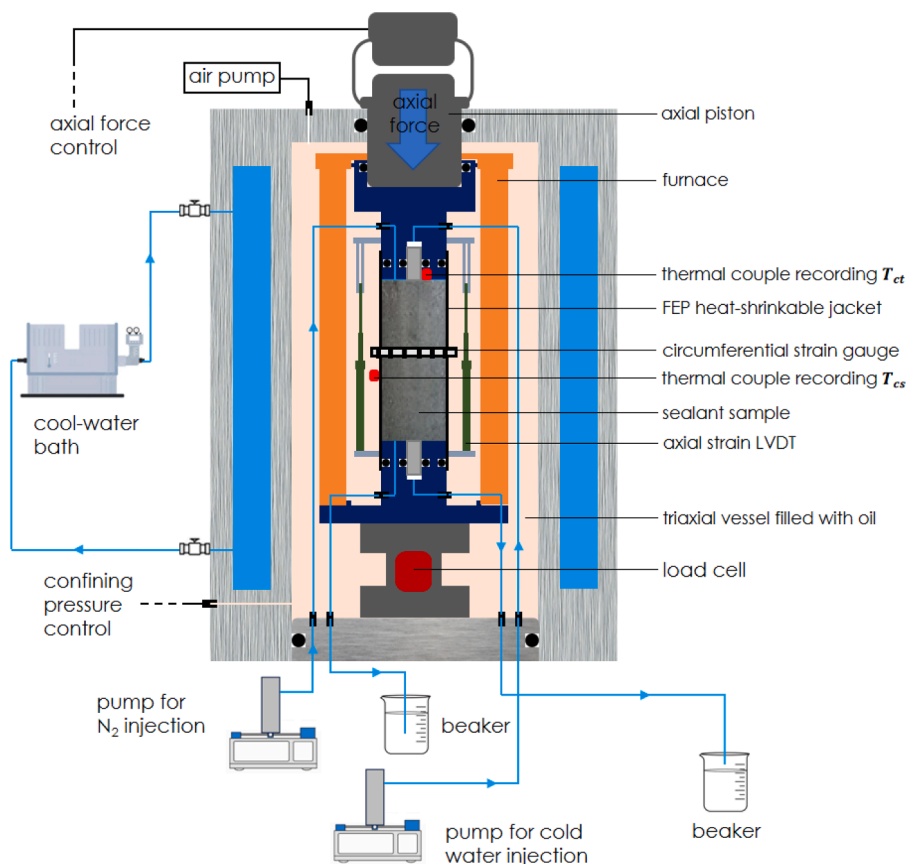

Fig. 4. Schematic of experimental setup for confined thermal-cycling experiments. The setup is a standard triaxial deformation apparatus with the composite sample mounted inside the pressure vessel. The drawing does not adhere to the actual scale.

pressure and transmits the heat. During thermal cycling experiments, a water bath is running through the annulus in the vessel shell to cool and protect the electronics of the apparatus from elevated temperature.

The sample, jacketed by a heat-shrinkable FEP (fluorinated ethylene

propylene) tube (thickness 0.5 mm), is mounted between the upper and lower axial pistons. In both pistons, flowlines are fitted to allow water injection through the steel pipe of the composite sample. Moreover, there are additional flowlines to provide access to the sealant surface,

similar to the unconfined experiments. Two high-precision linear variable differential transformers (LVDTs, 2 mm range) mounted parallel to the sample, and one circumferential strain gauge (10 mm range) mounted around the sample are used to monitor axial and radial deformation, respectively. Two thermocouples (same model as used in unconfined experiments) are installed to measure the temperature on the outer surface in the sample centre ( $T_{cs}$ ), as well as on the top surface of the sealant sheath adjacent to the steel pipe ( $T_{ct}$ ).

In confined thermal-cycling experiments, to mimic an in-situ state of stress, we load the sample close to a hydrostatic condition at a confining pressure of 1.5 MPa with an axial stress of 4 MPa. Then similar to unconfined experiments, we use a syringe pump (model 260D, Teledyne ISCO, range: 0.001 to 107 mL/min, accuracy: 0.5% of setpoint) to apply 3 bar  $N_2$  to the top surface of the sealant sheath for 30 mins while the composite sample is under 1.5 MPa confinement and room temperature. The penetration rate of  $N_2$  through the matrix of sealant sheath and the sealant-steel interface is then calculated. Afterward we heat the pressure vessel to 60°C at a ramping rate of 1.3°C/min (whilst maintain 1.5 MPa confining pressure), and allow temperature to equilibrate for 30 min, to allow the sample assembly to be heated through and through. We apply the same thermal cycling protocol as in the unconfined experiments. In 16 cycles, we inject 5°C water from top to bottom through the central steel pipe using a syringe pump (model 1000D, Teledyne ISCO; 80 mL/min for 2 mins). Then we pause 12 min before the next cycle starts. Afterwards, we shut down the furnace and the temperature of the system gradually decreases to room temperature whilst maintaining 1.5 MPa confining pressure. Subsequently, we perform the 30 min post-treatment penetration test. This is followed by unloading. Afterward the sample is retrieved and the post-treatment push-off experiment is performed. Due to the complexity of the procedure, only one sample can be tested for each sealant composition. However, in addition, we carry out reference experiments to investigate the effects of confinement alone. We use the triaxial deformation apparatus to apply 1.5 MPa confinement and 4 MPa axial stress on the composite sample without thermal treatment. These experiments are conducted at room temperature and the duration of the application of confining pressure is 6 hrs, the same as in confined thermal-cycling experiments (see Fig. 6). We test one sample for sealant S4 and S5. After the reference loading experiments, we perform push-off

experiments on these two composite samples.

### 3. Results and discussions

#### 3.1. Temperature profile and thermal stress

Fig. 5 illustrates the temperature variations at the different positions of sample S1C-1 during a representative unconfined thermal-cycling, and Fig. 6 illustrates the temperature variations at the different positions of sample S1C-3 during a representative confined thermal-cycling experiment. In Fig. 6, the circumferential strain,  $\epsilon_\theta$ , of the composite sample S1C-3 throughout the experiment duration is also plotted. As depicted in both Figs., temperatures on the outer surface,  $T_{us}$  or  $T_{cs}$ , and on the top surface,  $T_{ut}$  or  $T_{ct}$ , of the samples reach 60°C after the initial gradual heating. These temperatures remain constant at 60°C until thermal cycling commences. Upon initial water injection,  $T_{ut}$  and  $T_{ct}$  quickly decrease to 41°C and 45°C respectively within 2 min, while  $T_{us}$  and  $T_{cs}$  decreases to 55°C and 57°C. The discrepancy in temperature drop between unconfined and confined experiments arises primarily from the difference in experimental procedure. There is a diminished temperature drop experienced under confinement during thermal cycling, since in the triaxial deformation setup (Fig. 4), the path that the injected water must traverse through the apparatus to reach the sample is relatively long, which means that the water that reaches the sample is not 5°C anymore. Nonetheless, in both cases, the temperature drops are abrupt. After cold water injection is halted, all temperatures equilibrate back to the system temperature at 60°C within 12 min, and the system is ready for the next cycle. Also note that the thermal cycles applied in this study, though relatively brief with limited temperature drops, are intended to provide a controlled and reproducible proxy for thermal shock at the sealant-steel interface. Previous studies on solid sealant samples of the same compositions have shown that even such modest temperature variations can induce measurable effects (Li and Pluy-makers, 2024, Li et al., 2025).

In the confined experiment (Fig. 6), throughout the whole process, sample S1C-3 is exposed to 1.5 MPa confinement, and circumferential strain is tracked. The sample exhibits an overall decrease in circumferential strain, indicating compaction, with superimposed fluctuations

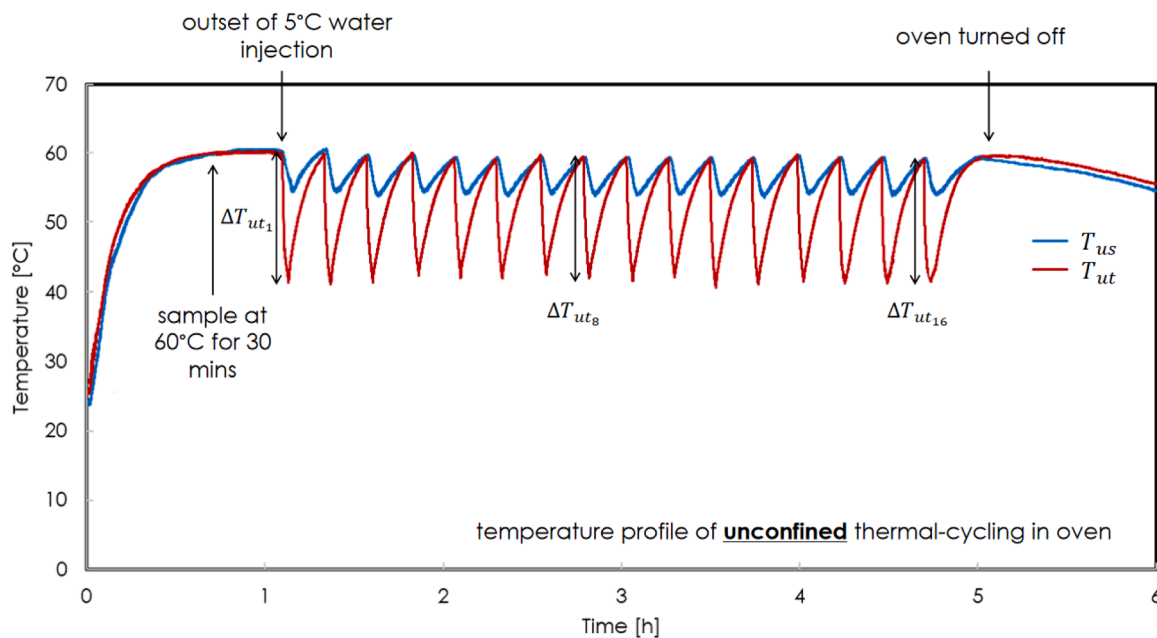

Fig. 5. Temperature variations at the outer surface in the sample centre ( $T_{us}$ ), as well as on the top surface of the sealant sheath adjacent to the steel pipe ( $T_{ut}$ ) of composite sample S1C-1 during unconfined thermal-cycling experiment. These variations are representative for all unconfined thermal-cycling experiments conducted on two samples per each sealant S1 to S5 (see Table 3).

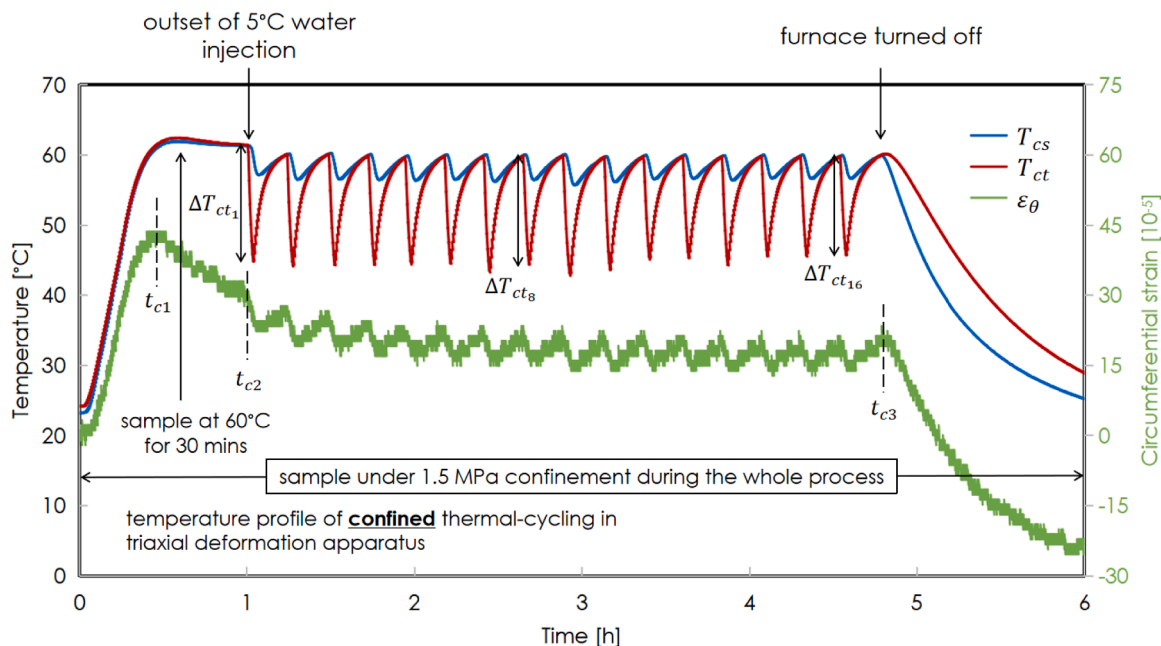

Fig. 6. Temperature variations at the outer surface in the sample centre ( $T_{cs}$ ), as well as on the top surface of the sealant sheath adjacent to the steel pipe ( $T_{ct}$ ) of composite sample S1C-3 during confined thermal-cycling experiment. The circumferential strain,  $\epsilon_{\theta}$ , of the sample throughout the experiment duration is also plotted. These variations are representative for all confined thermal-cycling experiments conducted on one sample per each sealant S1 to S5 (see Table 3).

that are in tune with the temperature fluctuations at the outer surface  $T_{cs}$ .

As shown in Figs. 5 and 6, the most significant temperature fluctuation on the sealant sheath of the composite samples is observed on its top surface adjacent to the steel pipe, which is  $\Delta T_{uti}$  for unconfined experiments, or  $\Delta T_{cti}$  for confined experiments respectively;  $i$  is the order of the thermal cycling. At this position of the sealant sheath, the thermal cycling induces the highest thermal stress throughout the sample. We determine this maximum thermal stress either in unconfined or confined experiments,  $\sigma_{T_{u,c}}$ , using the below equation (Carter and Paul, 1991, Callister et al., 2007):

$$\sigma_{T_{u,c}} = E \cdot \gamma \cdot \Delta T_{ut,ct} \tag{2}$$

where  $E$  is Young's modulus,  $\gamma$  the thermal expansion coefficient of the sealant, and  $\Delta T_{ut,ct} = \frac{\sum_{i=1}^{16} \Delta T_{ut,ct_i}}{16}$  is the average temperature drop on the top surface of the sealant sheath adjacent to the steel pipe of the sample within one injection cycle.

### 3.2. Thermo-mechanical behaviour under unconfined thermal cycling

Fig. 7 presents 3 bar  $N_2$  penetration rates of composite samples of sealants S1 to S5 (two samples per each sealant) before and after unconfined thermal-cycling experiments.

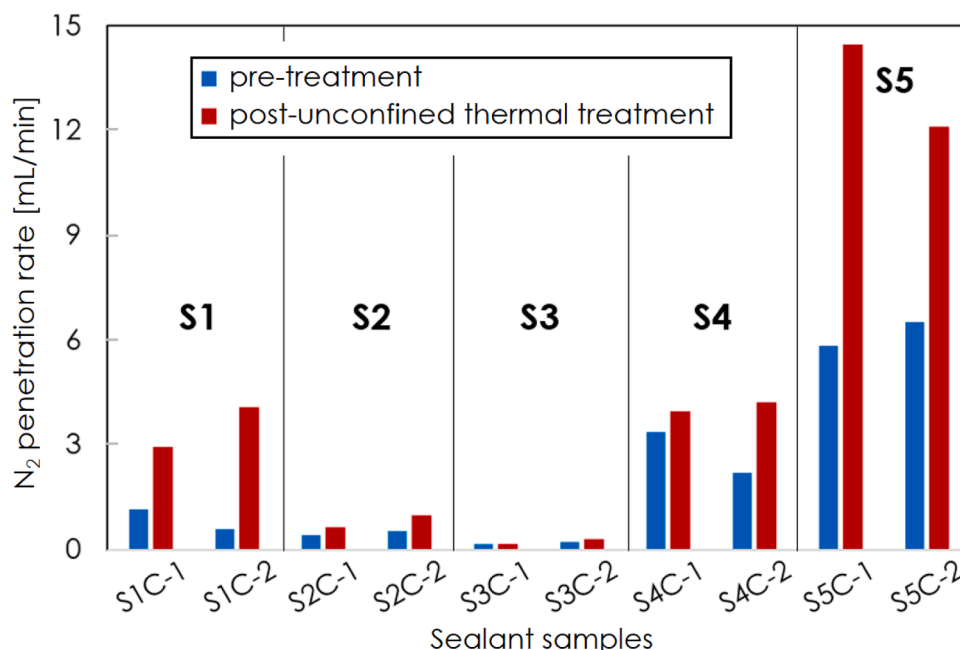

Fig. 7.  $N_2$  penetration rates of composite samples of sealants S1 to S5 (two samples per each sealant) before and after unconfined thermal-cycling experiments.

unconfined thermal-cycling experiments. Penetration rates increase after thermal treatment for samples of all sealants except S3. For S3, the post-treatment changes of penetration rate are insignificant. These indicate that thermal cycling has induced leaking effects on samples for all sealants except S3 through either the matrix of sealant sheath, or the sealant-steel interface, or both. The consistency in results from the two samples for each sealant S1 to S5 ensures that our experimental design (Fig. 3) and protocols are reliable and reproducible. Compared to S2 and S4, samples of sealants S1 and S5 experience a more significant increase in penetration rate, meaning that the thermal-induced leaking effect is more severe for samples of these two sealants. Note that, even though the qualitative trends are similar, the absolute penetration rates pre- and post-thermal treatment are different, indicating that overall there is also significant initial variation in the bond quality.

Fig. 8 displays micro-CT images of S1 to S5 samples after unconfined thermal-cycling experiments. This shows there are no cracks in the sealant sheath for any of the samples following the thermal treatment. However, it is challenging to evaluate the bonding integrity of sealant-steel interface after thermal cycling from our images, due to the dispersion effect as a result of the high density contrast between sealant and steel.

Fig. 9 shows the cycle-averaged temperature drop at outer surface ( $\Delta T_{us}$ ) in unconfined experiments, compared to the thermal expansion coefficient and thermal diffusivity of the five sealants. Compared to S1 and S5, S2 and S4 sealants possess higher thermal expansion coefficient, closer to that of the steel pipe ( $15.85 \times 10^{-6} \text{ K}^{-1}$  for AISI 316 L stainless steel, reported by Desai and Ho (Desai and Ho, 1978)). This suggests that the sealant sheath of S2 and S4 would shrink and expand in a similar range as the steel. We interpret this as the main cause for the less pronounced thermal-induced leaking effects on S2 and S4 compared to S1 and S5 (Fig. 7).

For all sealants, the cycle-averaged temperature drop correlates positively with thermal diffusivity. Note that the thermal diffusivity of the steel pipe is much higher than our sealants ( $3.43 \text{ mm}^2/\text{s}$  for AISI 316 L stainless steel, measured by Kim (Kim, 1975); Ferreira-Oliveira et al. (Ferreira-Oliveira et al., 2022)). Increased thermal diffusivity means that a material can conduct heat more efficiently and rapidly during thermal cycling. Despite its moderate thermal expansion coefficient, S3 exhibits the highest thermal diffusivity. This implies that it can react faster to temperature differences and therefore result in less potential of debonding between sealant and the steel pipe.

Fig. 10 shows the tensile strength of the sealants and the cycle-

averaged thermal stress on S1 to S5 samples induced in unconfined thermal-cycling experiments. The thermal stress is lower than tensile strength for all sealants indicating that the stress is insufficient to initiate mode I cracks (displacement is normal to the cracking plane) by tensile failures in the sealant sheath (Paterson and Wong, 2005). This is supported by CT images (Fig. 8), and further implies that the observed thermal-induced leaking of all sealants except S3 in unconfined experiments mainly occurred through the sealant-steel interface.

### 3.3. Thermo-mechanical behaviour under confined thermal cycling

Fig. 11 presents 3 bar  $\text{N}_2$  penetration rates of S1 to S5 composite samples before and after confined thermal-cycling experiments. Penetration rates before and after reference confined experiments (without thermal cycling) on S4 and S5 samples (S4C-4 and S5C-4) are also displayed in Fig. 11. The rate decreases after confined thermal treatment for samples of all sealants except S3. The change after thermal treatment for S3 sample is insignificant. These imply a sealing effect by confined thermal cycling on composite samples of all sealants except S3. Compared to S1 and S2, S4 and S5 samples experience greater decrease in penetration rate. After reference experiments on samples S4C-4 and S5C-4 with only confinement but no thermal treatment, the samples also undergo a reduction in the penetration rate indicating that sealing occur on these two samples as well. The penetration rate decreases on all samples except S3C-3 in confined thermal-cycling experiments and confined reference experiments validates that confinement alone leads to sealing, which dominates over any potential leaking effects induced by thermal cycling. This is confirmed by the overarching compactive trend in circumferential strain under confinement (Fig. 6).

### 3.4. Push-off shear stress of S1 to S5 samples after unconfined and confined thermal cycling

Fig. 12 shows the push-off shear stress  $\sigma_{po}$  of untreated S1 to S5 composite samples and all other tested samples listed in Table 3. After unconfined thermal treatment,  $\sigma_{po}$  decreases for all S1 to S5 samples. This implies that the bonding at the sealant-steel interface was deteriorated by unconfined thermal cycling. S1 and S5 samples went through the biggest de-bonding with the greatest reduction in  $\sigma_{po}$ , while S3 samples experienced the least. This reflects the observation in the changes of the  $\text{N}_2$  penetration rates in unconfined thermal-cycling experiments (Fig. 7), where the rates increased the most for S1 and S5, and

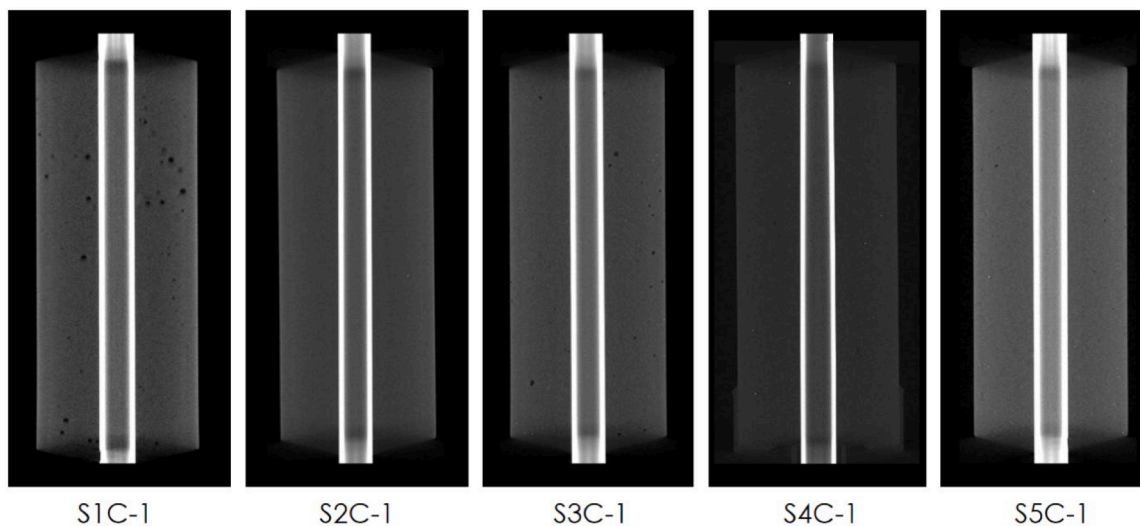

Fig. 8. Micro-CT images of S1 to S5 samples after unconfined thermal-cycling experiments. Voxel resolution of  $32 \mu\text{m}$ . Air is portrayed in black, sealant sheath in grey, steel in white. No cracks are observed in sealant sheath of either sample following thermal treatment. Black pores inside sealant sheath of S1 and S3 samples are pre-existing voids.

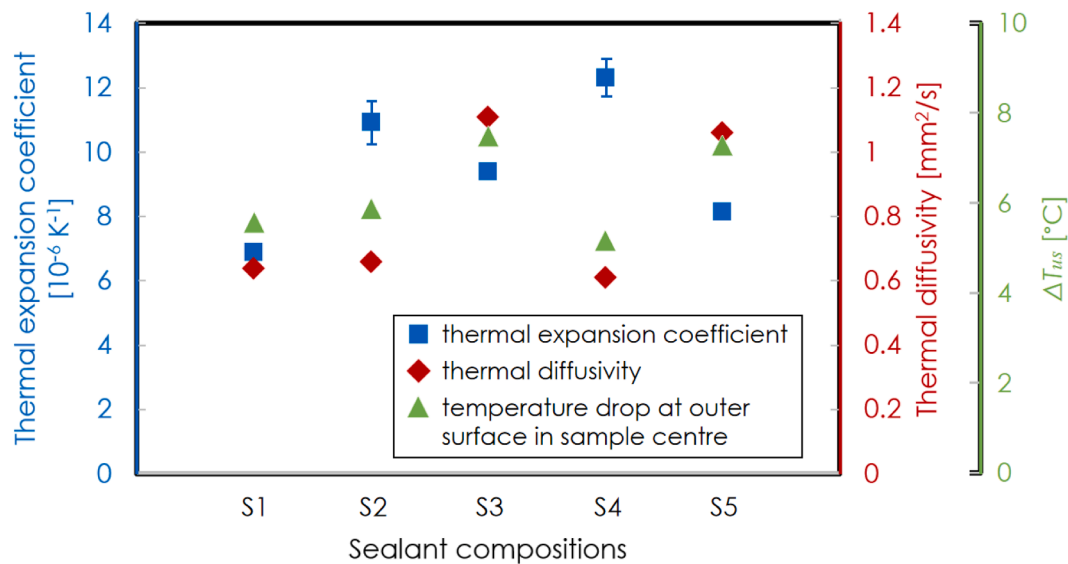

Fig. 9. Thermal expansion coefficient and thermal diffusivity of S1 to S5 sealants, and cycle-averaged temperature drop at outer surface ( $\Delta T_{us}$ ) of S1-S5 sample in unconfined thermal-cycling experiments. The temperature drop is also averaged on measurements of two samples per each sealant.

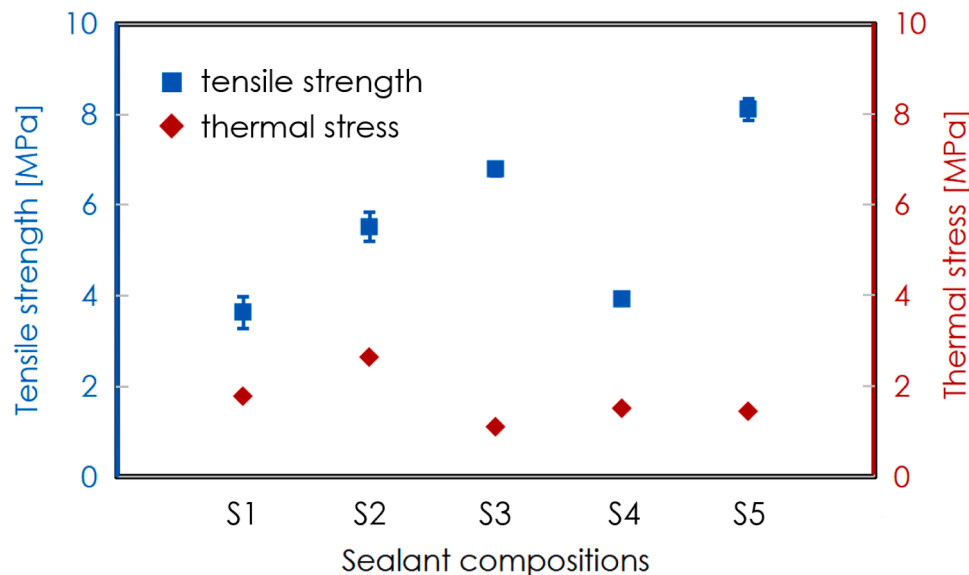

Fig. 10. Tensile strength of S1 to S5 sealants and cycle-averaged thermal stress on their samples induced in unconfined thermal-cycling experiments. The thermal stress is also averaged on measurements of two samples per each sealant.

the least for S3.

After confined thermal-cycling experiments,  $\sigma_{po}$  increases for S1, S2 and S5 samples, while it doesn't change for S3 and S4 samples. The  $\sigma_{po}$  also increases for S4 and S5 samples after confined reference experiments. The increase in  $\sigma_{po}$  of samples in these two types of experiments is attributed to enhanced sealing at the sealant-steel interface by confinement, which is also evidenced by the decreased  $\text{N}_2$  penetration rates (Fig. 11). Note that the increase in  $\sigma_{po}$  of S1 and S2 samples after confined thermal cycling is the greatest.

Fig. 13 shows the Young's modulus of the five sealants and the end-point circumferential strain of S1 to S5 samples after their confined thermal-cycling experiments. Compared to our sealants, the steel pipe is much more rigid with a high Young's modulus (200 GPa for AISI 316 L stainless steel reported by Rehmer et al. (Rehmer et al., 2023)). The deformation of the steel pipe during confined experiment is hence negligible. Compared to other sealants, S1 and S2 possess high Young's modulus, i.e. they are relatively stiff. However, they have undergone the

most compaction, i.e. have undergone the most permanent deformation and also exhibit the biggest increase in push-off shear stress, which would imply improved sealing. Moreover, their change in penetration rate was low. So even though the overall sealant sample compacted, the pathways along the steel tubing remained very similar, which could be explained by their high stiffness.

### 3.5. Implications for $\text{CO}_2$ storage

In the context of CCS, two categories of sealants are typically encountered: existing sealant compositions in legacy wells and new sealant designs specifically for CCS conditions. Often, these sealants are OPC-based or similar, with our S1 and S2 sealants as representatives. Our results demonstrate that, in addition to understanding the mechanical properties, it is crucial to consider the thermal properties of both the sealant and steel to assess the risk of forming leakage pathways along the steel annulus of the wellbore. When the linear expansion

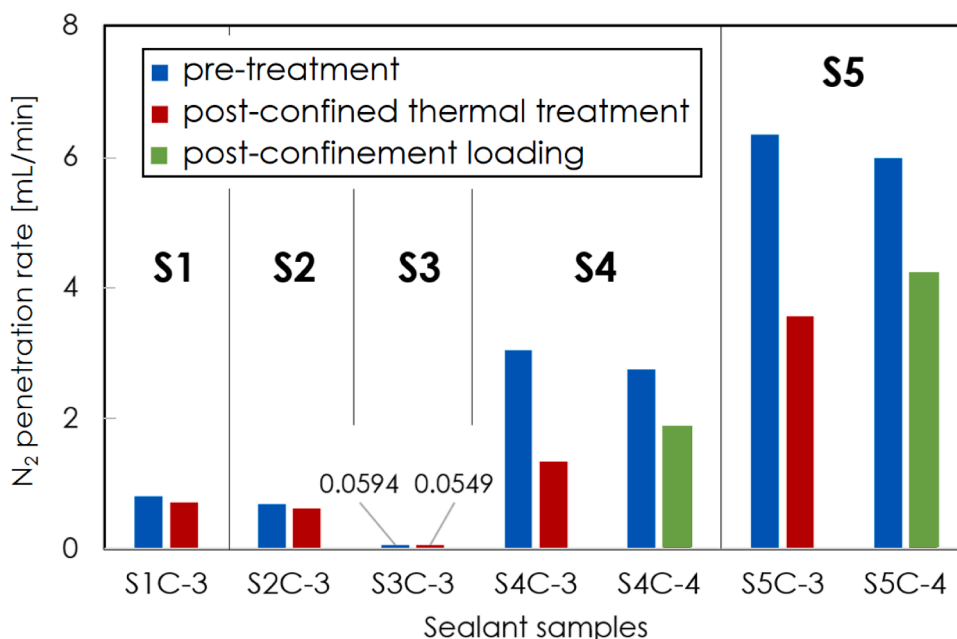

Fig. 11. N<sub>2</sub> penetration rates of composite samples of sealants S1 to S5 (one samples per each sealant) before and after confined thermal-cycling experiments. Penetration rates before and after reference confined experiments (without thermal cycling) on S4 and S5 samples (S4C-4 and S5C-4) are also displayed. Compaction due to confinement is the main reason for the enhanced seal.

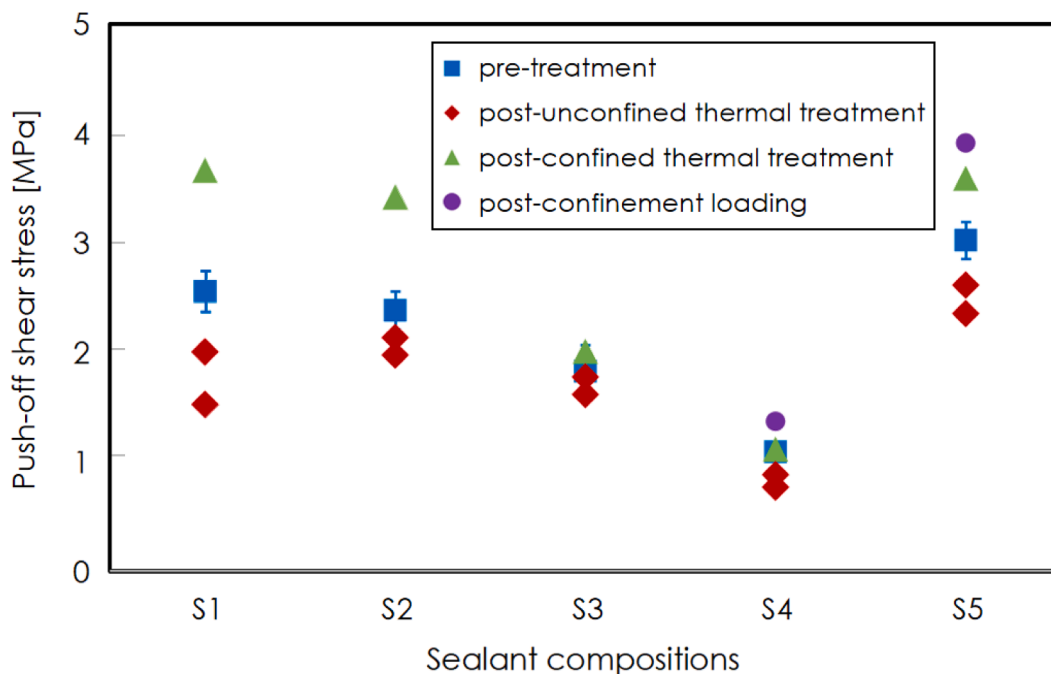

Fig. 12. Push-off shear stress of untreated S1 to S5 composite samples and all other tested samples (listed in Table 3).

coefficient of the sealant is close to that of steel, good bonding at the interface is expected, even if local confinement is low or non-existent. The presence of confinement further reduces the risk of debonding. Drawing from the example of the fracture-resistant S3 in our study, for new sealant designs, apart from any chemical resistance (van Noort et al., 2025), high tensile strength and high thermal diffusivity indicate a lower susceptibility to deterioration by thermal stress accumulation. Such sealants are therefore better suited for CCS environments where thermal cycling is anticipated.

We are aware of the thermal pressurization effects that occur in wet, low-porosity media. However, this study was specifically designed to

isolate and evaluate the combined influence of the thermal and mechanical properties of five different sealants. The use of dried samples was a deliberate methodological choice to eliminate thermal pressurization effects, which would otherwise dominate the thermomechanical response due to variations in porosity and permeability. This would have obscured the very material-dependent differences we aimed to investigate. Understanding how mechanical and thermal properties interact under confining conditions is scientifically relevant both for assessing the performance of existing sealants in legacy wells and for guiding the design of new materials for CCS applications.

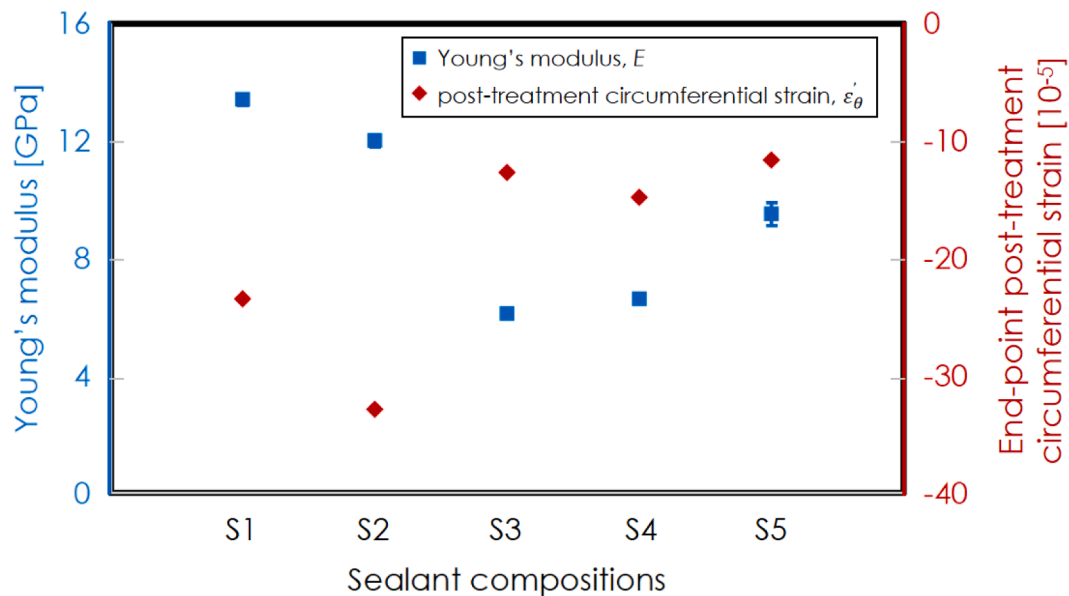

Fig. 13. Young's modulus of the five sealants and the end-point circumferential strain of S1 to S5 samples after their confined thermal-cycling experiments.

#### 4. Conclusions

This study evaluates the effects of thermal cycling on the thermo-mechanical behaviour of five different sealants (S1 to S5) in simulating the sealant-steel interface of CCS wells. Our results demonstrate that under unconfined conditions, thermal cycling negatively impacts the sealing ability of all sealants except S3, with increased leakage at the sealant-steel interfaces and reduced push-off shear stress. The critical factor influencing the performance is the linear thermal expansion coefficient, where sealants with a coefficient closer to that of steel show better bonding and less damage after thermal cycling. Under confined conditions (1.5 MPa), all sealants exhibit improved performance, with no increase in leakage and, in some cases, higher push-off shear stress post-cycling. Confinement helps to reduce the risk of debonding by enabling the sealant sheath to contract in closer proximity to the steel casing during cooling, thus enhancing sealing integrity. These findings underline the importance of considering both thermal and mechanical properties when designing sealants for CCS applications. Sealants with high tensile strength, high thermal diffusivity, and a thermal expansion coefficient similar to that of steel are recommended for future CCS applications, where temperature fluctuations are expected.

#### CRedit authorship contribution statement

**Kai Li:** Writing – review & editing, Writing – original draft, Visualization, Methodology, Formal analysis, Data curation, Conceptualization. **Marc Friebel:** Resources, Methodology, Conceptualization. **Anne M.H. Pluymakers:** Writing – review & editing, Supervision, Project administration, Methodology, Funding acquisition, Conceptualization.

#### Declaration of competing interest

The authors declare that they have no known competing financial interests or personal relationships that could have appeared to influence the work reported in this paper.

#### Acknowledgements

This study is a part of the CEMENTTEGRITY project (project number: 327311) funded through the ACT program (Accelerating CCS Technologies, Horizon2020 project number 691712). The CEMENTTEGRITY

project aims to develop and test novel sealants that can better maintain wellbore integrity during CO<sub>2</sub> injection and storage afterward. Financial contributions from the Research Council of Norway (RCN), the Netherlands Enterprise Agency (RVO), and the Department for Business, Energy & Industrial Strategy (BEIS, UK) are gratefully acknowledged. We thank our consortium partners (IFE (Institutt for Energiteknikk), Halliburton AS Norway, ReStone AS, Universitet i Stavanger, EBN B.V., Heriot-Watt University, and Harbour Energy) for their kind support to our study.

We thank Jan Etienne, Ellen Meijvogel-de Koning, and Jens van den Berg in Geoscience & Engineering Laboratory at Delft University of Technology, the Netherlands, for their technical support.

#### Data availability

Data will be made available on request.

#### References

- Albawi, A., De Andrade, J., Torsæter, M., Opedal, N., Stroisz, A., Vrålstad, T., 2014. Experimental set-up for testing cement sheath integrity in arctic wells. In OTC Arctic Technology Conference. OnePetro.
- Alnes, H., Eiken, O., Nooner, S., Sasagawa, G., Stenvold, T., Zumberge, M., 2011. Results from Sleipner gravity monitoring: Updated density and temperature distribution of the CO<sub>2</sub> plume. Energy Procedia 4, 5504–5511.
- API, R.P., 2013. Api Recommended Practice 10B-2, Recommended Practice for Testing Well Cements, 2nd edition, p. 111. 10B-2.
- Barborak, R., 2010. Calcium aluminate cement concrete (class cac concrete) txdot special specification ss-4491 tip sheet. Construction and Bridge Divisions. Texas Department of Transportation: Austin, TX, USA.
- ... & Callister, W.D., Rethwisch, D.G., Blichblau, A., Bruggeman, K., Cortie, M., Long, J., Mitchell, R., 2007. Materials Science and Engineering: An Introduction, 7. John Wiley & sons, New York, pp. 665–715.
- Carey, J.W., Wigand, M., Chipera, S.J., WoldeGabriel, G., Pawar, R., Lichtner, P.C., Wehner, S.C., Raines, M.A., Guthrie Jr, G.D., 2007. Analysis and performance of oil well cement with 30 years of CO<sub>2</sub> exposure from the SACROC Unit, West Texas, USA. Int. J. Greenh. Gas Control 1 (1), 75–85.
- Carter, G.F., Paul, D.E., 1991. Materials science and engineering. ASM international.
- Celia, M.A., Bachu, S., Nordbotten, J.M., Gasda, S.E., Dahle, H.K., 2005. Quantitative estimation of CO<sub>2</sub> leakage from geological storage: Analytical models, numerical models, and data needs. In: In Greenhouse Gas Control Technologies, 7. Elsevier Science Ltd, pp. 663–671.
- De Andrade, J., Sangesland, S., Todorovic, J., Vrålstad, T., 2015. Cement sheath integrity during thermal cycling: a novel approach for experimental tests of cement systems. In SPE Bergen one day seminar. OnePetro.
- Desai, P.D., Ho, C.Y., 1978. Thermal linear expansion of nine selected AISI stainless steels. Cindas Rep. 51.

- Dugonjic-Bilic, F., Tiemeyer, C., Plank, J., 2011. Study on admixtures for calcium aluminate phosphate cement useful to seal CCS wells. In SPE International Symposium on Oilfield Chemistry. *OnePetro*.
- Eiken, O., Ringrose, P., Hermanrud, C., Nazarian, B., Torp, T.A., Høier, L., 2011. Lessons learned from 14 years of CCS operations: Sleipner, In Salah and Snøhvit. *Energy Procedia* 4, 5541–5548.
- Fatemi, A., Yang, L., 1998. Cumulative fatigue damage and life prediction theories: a survey of the state of the art for homogeneous materials. *Int. J. Fatigue* 20 (1), 9–34.
- Ferreira-Oliveira, J.R., De Lucena, L.R.R., Dos Reis, R.P.B., De Araújo, C.J., Bezerra-Filho, C.R., 2022. Thermal diffusivity measurement of stainless-steel alloys through use of the Angstrom's method. *Exp. Heat Transf.* 35 (4), 419–439.
- Freire, A.L., José, H.J., Moreira, R.D.F.P.M., 2022. Potential applications for geopolymers in carbon capture and storage. *Int. J. Greenh. Gas Control* 118, 103687.
- Hajiabadi, S.H., Khalifeh, M., Van Noort, R., Silva Santos Moreira, P.H., 2023. Review on geopolymers as wellbore sealants: state of the art optimization for CO<sub>2</sub> exposure and perspectives. *ACS Omega* 8 (26), 23320–23345.
- Hajiabadi, S.H., Li, K., Pluymakers, A., van Noort, R., Khalifeh, M., 2024. Exploring the Durability of a Granite-Based Geopolymer Sealant for Carbon Capture and Storage: Evaluating Sealing Performance Under Thermal Shocks in Brine Environments. Available at SSRN 5010201.
- Institute, American Petroleum, 2009. Recommended practice for subsea production system reliability and technical risk management. APIRP 17N.
- Kim, C.S., 1975. Thermophysical Properties of Stainless Steels (No. ANL-75-55). Argonne National Lab., Ill. (USA).
- Kirby, G.A., Chadwick, R.A., Holloway, S., 2001. Depth mapping and characterisation of the utsira sand saline aquifer, central and northern north Sea: *British Geological Survey Report* CR/01/218N. British Geological Survey.
- Kvassnes, A., Clausen, J.A., 2021. U.S. Patent No. 11,014,851. U.S. Patent and Trademark Office, Washington, DC.
- Kvassnes, A., Clausen, J.A., 2020. U.S. Patent No. 10,774,001. U.S. Patent and Trademark Office, Washington, DC.
- Lescanne, M., Hy-Billiot, J., Aimard, N., Prinnet, C., 2011. The site monitoring of the Lacq industrial CCS reference project. *Energy Procedia* 4, 3518–3525.
- Lesti, M., Tiemeyer, C., Plank, J., 2013. CO<sub>2</sub> stability of Portland cement based well cementing systems for use on carbon capture & storage (CCS) wells. *Cem. Concr. Res.* 45, 45–54.
- Li, K., Pluymakers, A.M., 2024. Effects of thermal shocks on integrity of existing and newly-designed sealants for CCS applications. *Int. J. Greenh. Gas Control* 133, 104103.
- Li, K., van Noort, R., Pluymakers, A., 2025. Effects of confined thermal cycling on sealants with different thermomechanical properties for CCS. *Sci. Rep.* 15 (1), 32586.
- Lund, H., Torsæter, M., Munkejord, S.T., 2015. Study of thermal variations in wells during CO<sub>2</sub> injection. In SPE Bergen One Day Seminar. *OnePetro*.
- Miner, M.A., 1945. Cumulative damage in fatigue. *J. Appl. Mech.* 12 (3), A159–A164. <https://doi.org/10.1115/1.4009458>.
- Nasvi, M.C.M., Ranjith, P.G., Sanjayan, J., Bui, H., 2014. Effect of temperature on permeability of geopolymer: a primary well sealant for carbon capture and storage wells. *Fuel* 117, 354–363.
- Parker, M.E., Meyer, J.P., Meadows, S.R., 2009. Carbon dioxide enhanced oil recovery injection operations technologies. *Energy Procedia* 1 (1), 3141–3148.
- Paterson, M.S., Wong, T.F., 2005. Experimental Rock Deformation: the Brittle Field, 348. Springer, Berlin.
- Rehmer, B., Bayram, F., Ávila Calderón, L.A., Mohr, G., Skrotzki, B., 2023. Elastic modulus data for additively and conventionally manufactured variants of Ti-6Al-4V, IN718 and AISI 316 L. *Sci. Data* 10 (1), 474.
- ... & Roy, P., Walsh, S.D., Morris, J.P., Iyer, J., Hao, Y., Carroll, S., Torsæter, M., 2016. Studying the impact of thermal cycling on wellbore integrity during CO<sub>2</sub> injection. In 50th US Rock Mechanics/Geomechanics Symposium. *OnePetro*.
- Shell, P.C.C.S., 2016. Project: FEED Summary Report for Full CCS Chain, Revision K03. Document No. PCCS-00-MM-AA-7180-00001 2016.
- Suresh, S., 1998. Fatigue of materials. *Cambridge University Press google schola* 2, 1–7.
- Suryanto, B., Starrs, G., Kvassnes, A.J., 2024. Bonding performance of cement sealants designed for CCS applications. *Disco. Concrete and Ceme.* 1 (1), 25.
- van Noort, R., Pluymakers, A., Li, K., Suryanto, B., Starrs, G., 2024. Development of tailored wellbore sealants for CCS and other geological storage applications. *First Break* 42 (9), 89–94.
- ... & van Noort, R., Gupta, M., Hajiabadi, S.H., Khalifeh, M., Kvassnes, A., Li, K., Ye, G., 2024. Development and Testing of Novel Cement Designs for Enhanced CCS Well Integrity. In 17th Greenhouse Gas Control Technologies Conference.
- van Noort, R., Svenningsen, G., Li, K., Pluymakers, A., 2025. Exposure of five cementitious sealant materials to wet supercritical CO<sub>2</sub> and CO<sub>2</sub>-saturated water under simulated downhole conditions. *Int. J. Greenh. Gas Control*.
- Vilarrasa, V., Rutqvist, J., 2017. Thermal effects on geologic carbon storage. *Earth-Sci. Rev.* 165, 245–256. <https://doi.org/10.1016/j.earscirev.2016.12.011>.
- Yoo, B.Y., Choi, D.K., Kim, H.J., Moon, Y.S., Na, H.S., Lee, S.G., 2013. Development of CO<sub>2</sub> terminal and CO<sub>2</sub> carrier for future commercialized CCS market. *Int. J. Greenh. Gas Control* 12, 323–332.