









Figure 1: Leeuwen, E. V. (n.d.). A typical dutch view of Kinderdijk. hardlopen.nl. <https://www.hardlopen.nl/artikelen/beleving/aanschouw-ty-pisch-hollands-aanzicht-op-de-kinderdijk/>



Figure 2: photo taken from googlemaps



Figure 2: photo taken from googlemaps

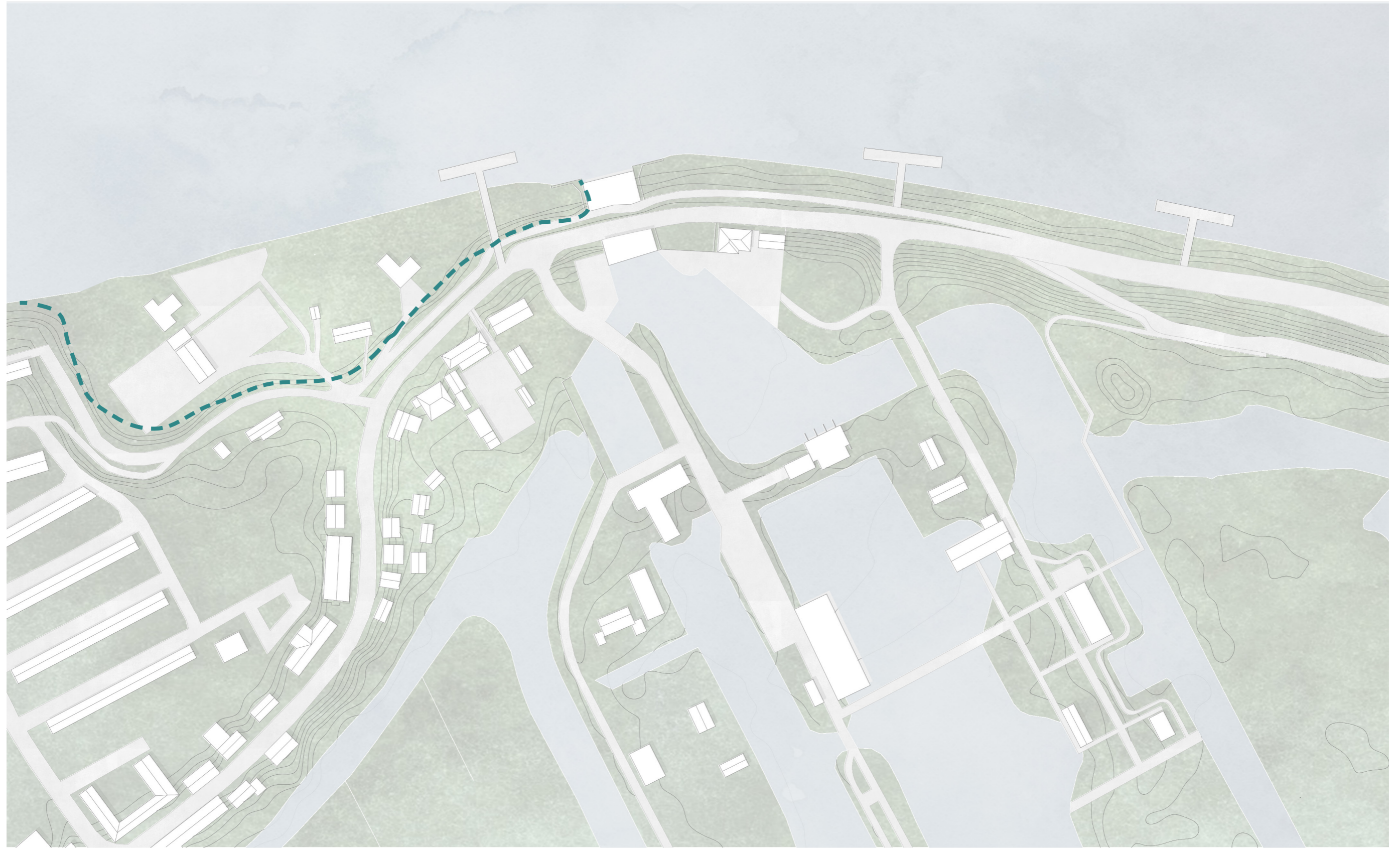


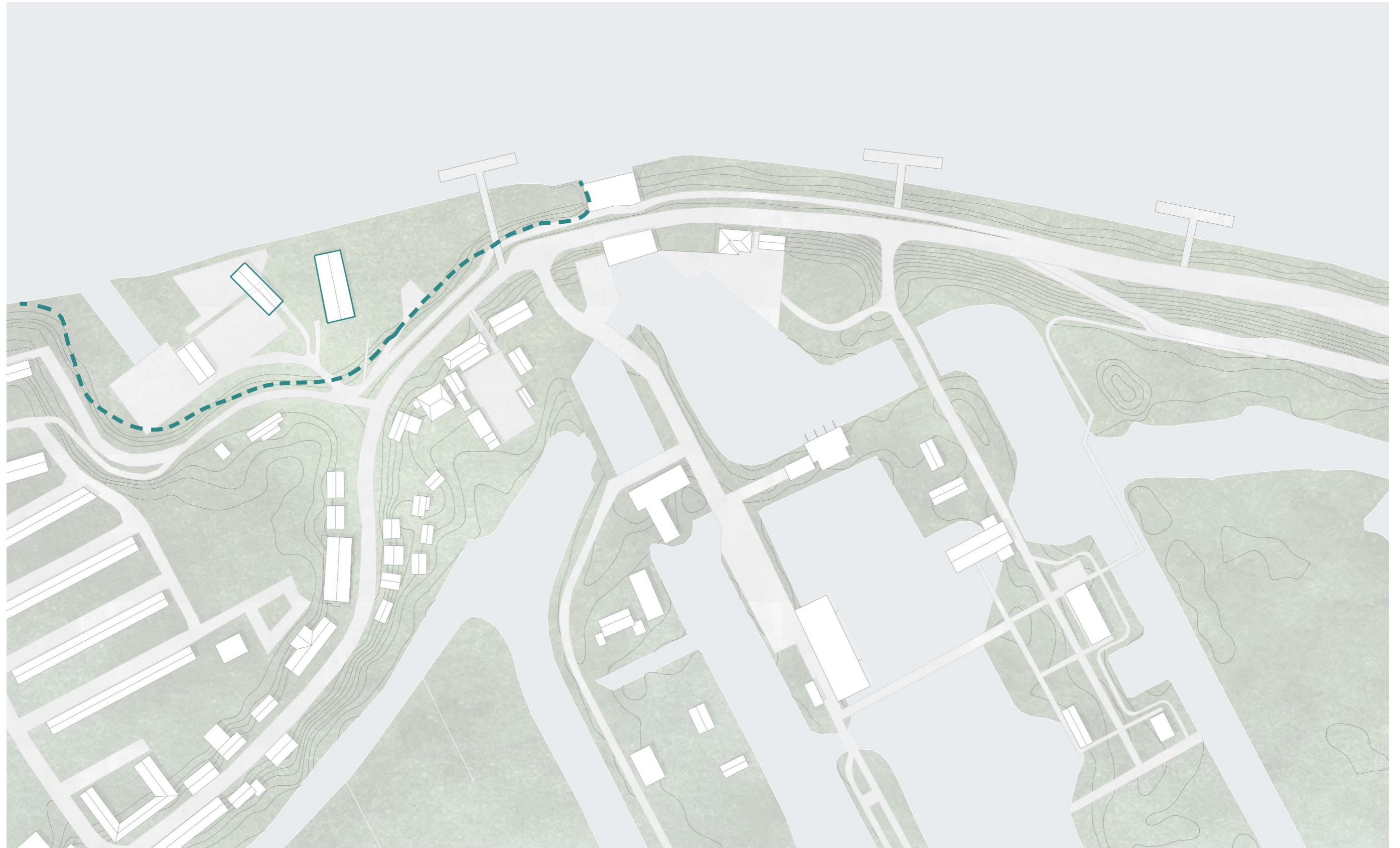


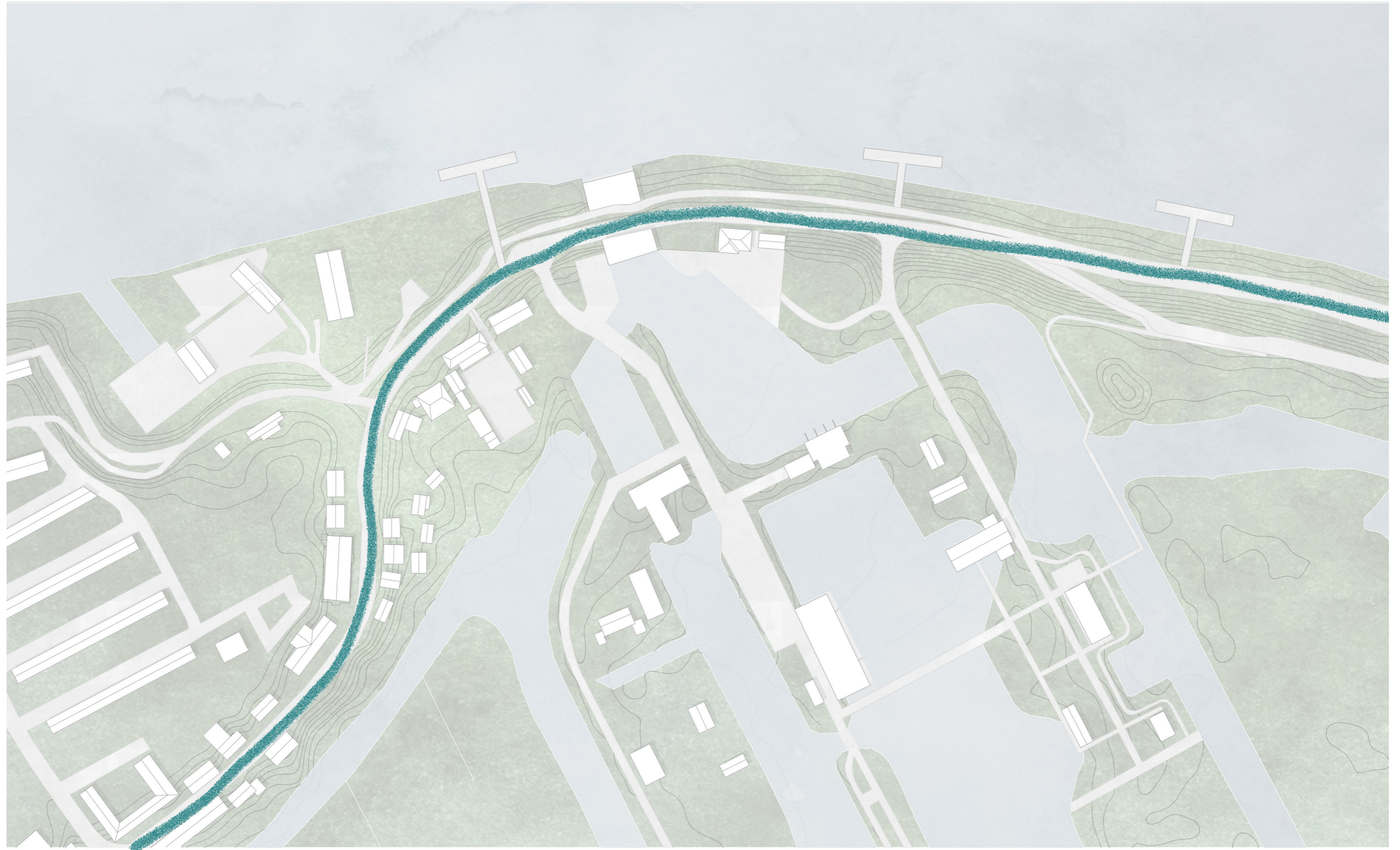
Figure 5: photo taken from googlemaps

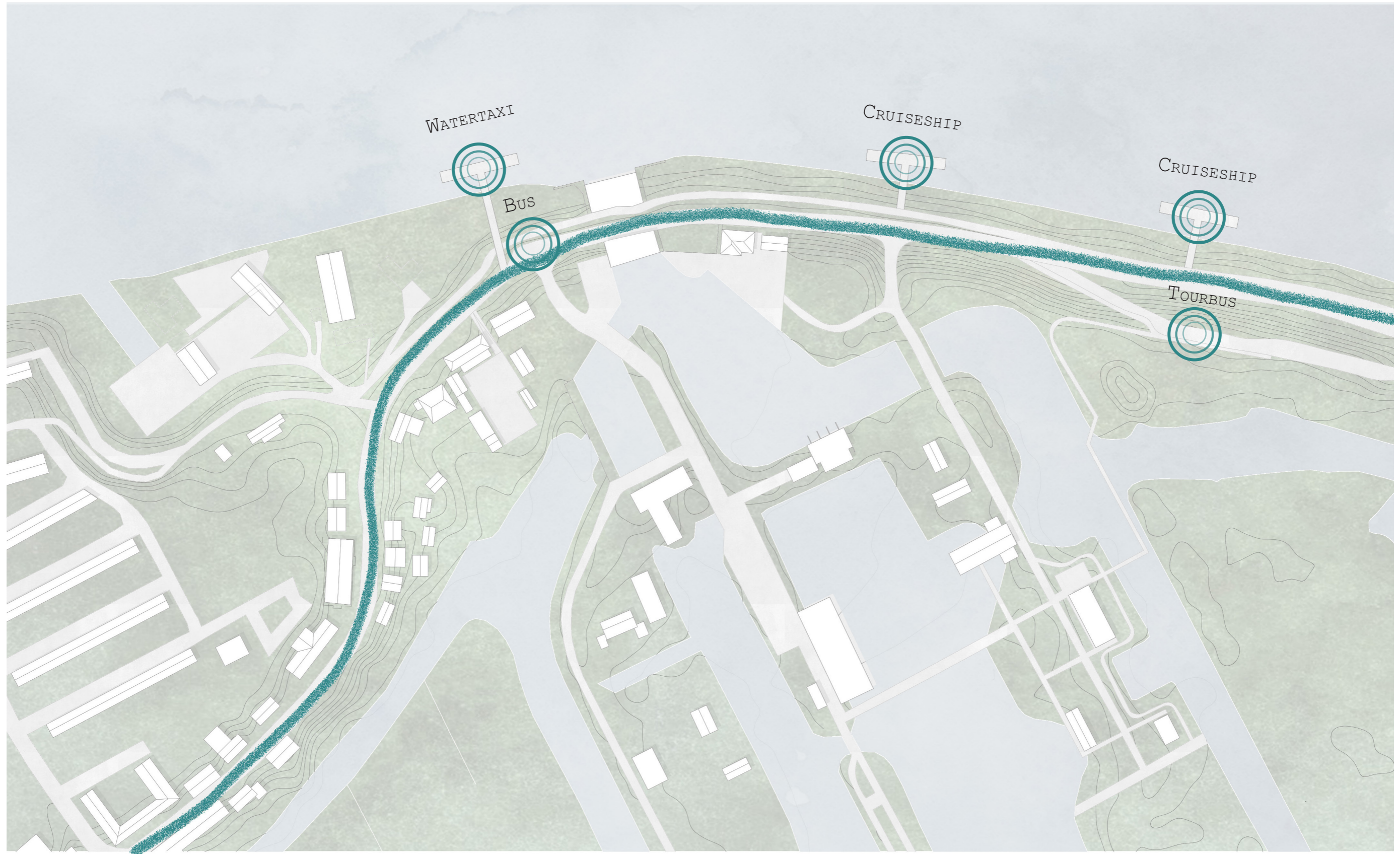


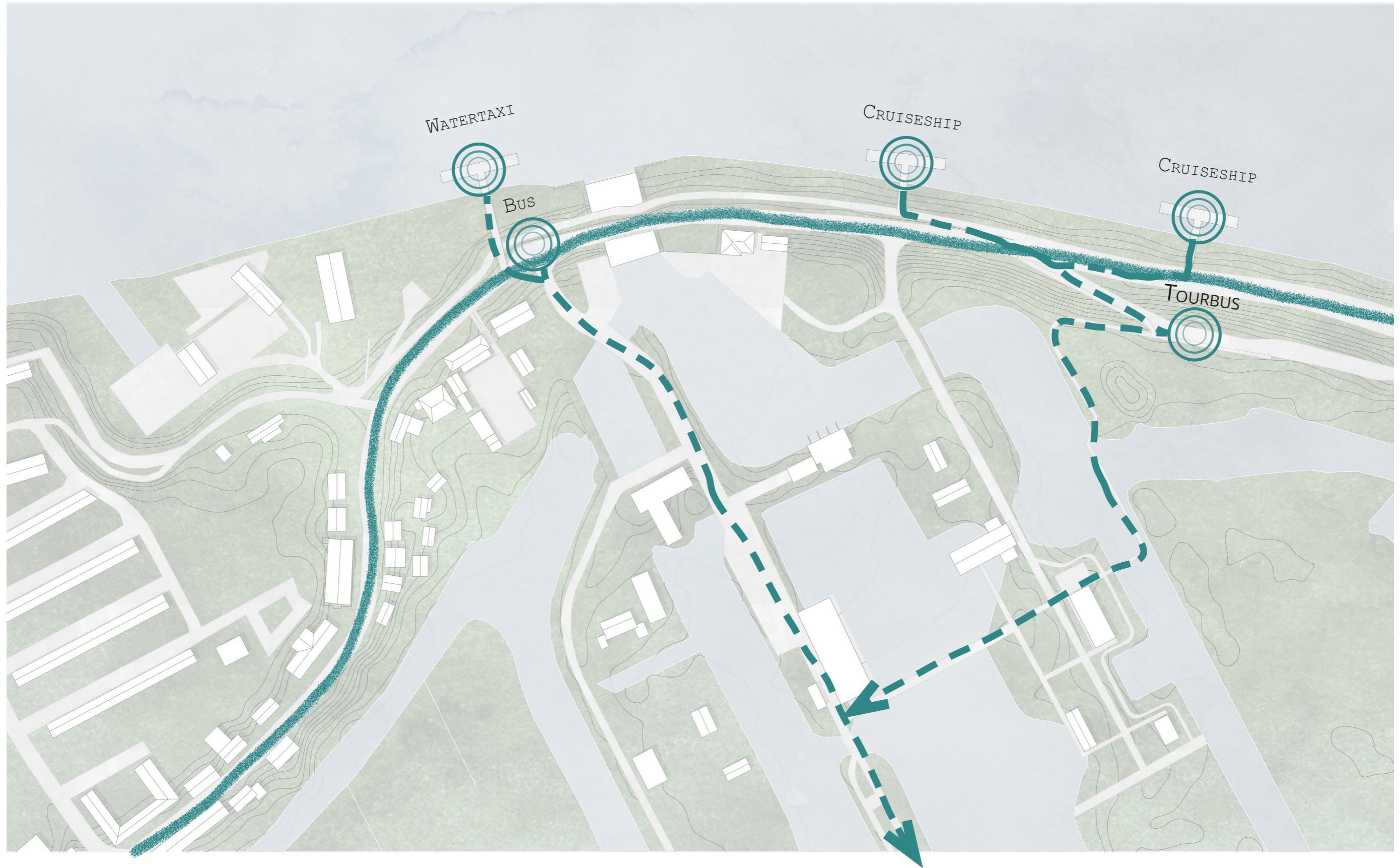
Figure 4: De Winter, J. W. (2023). Pot Terrain before destruction.

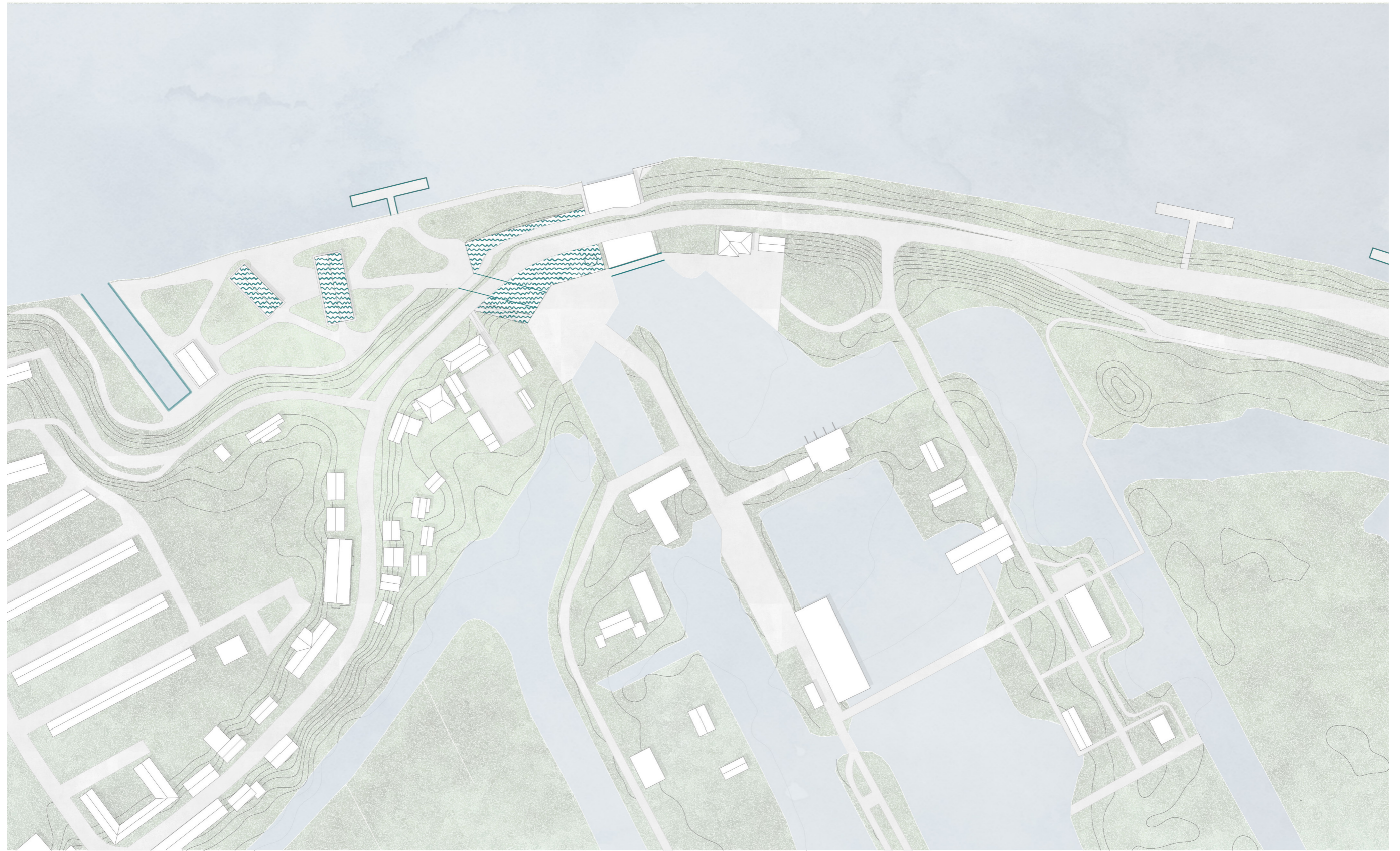




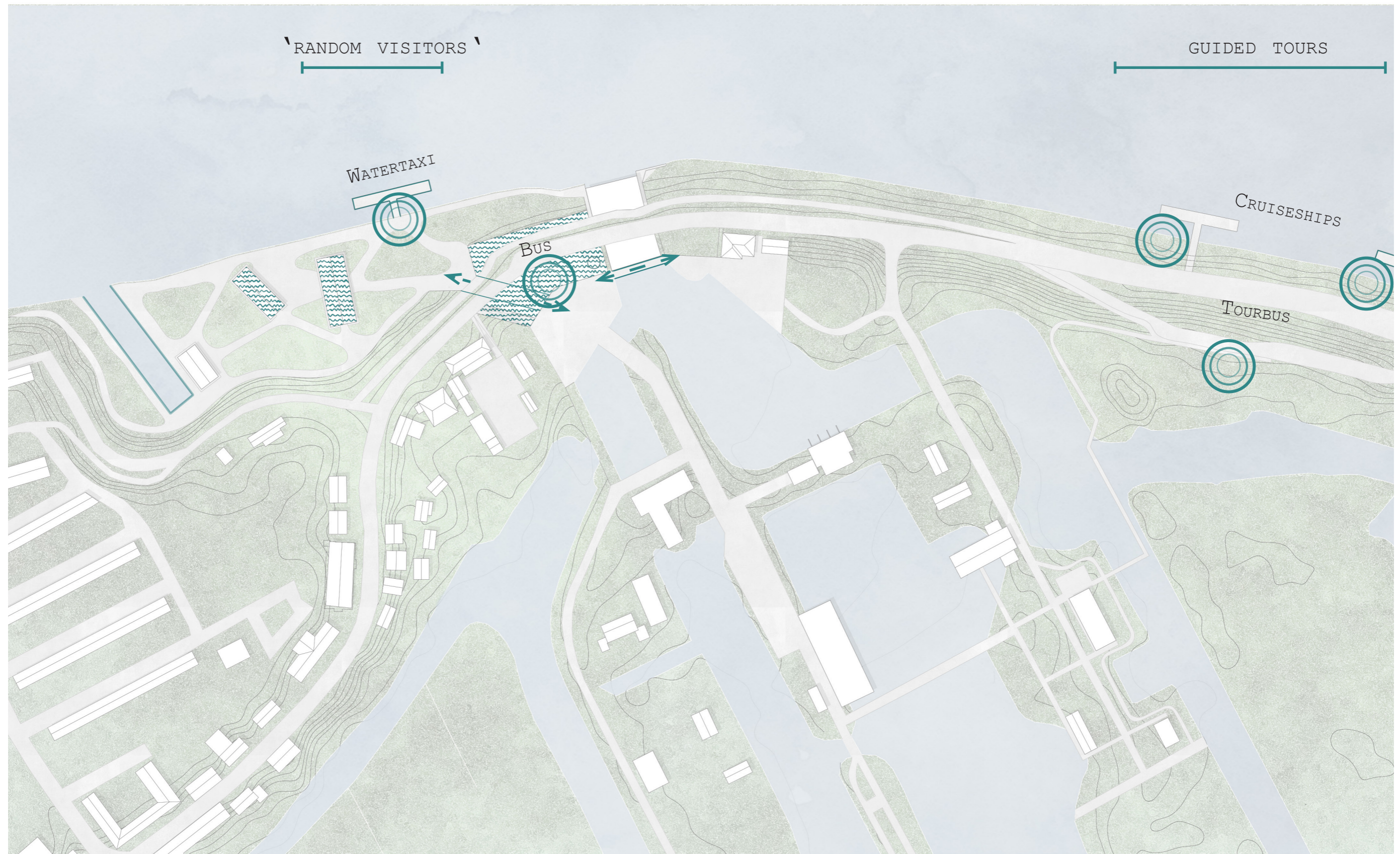


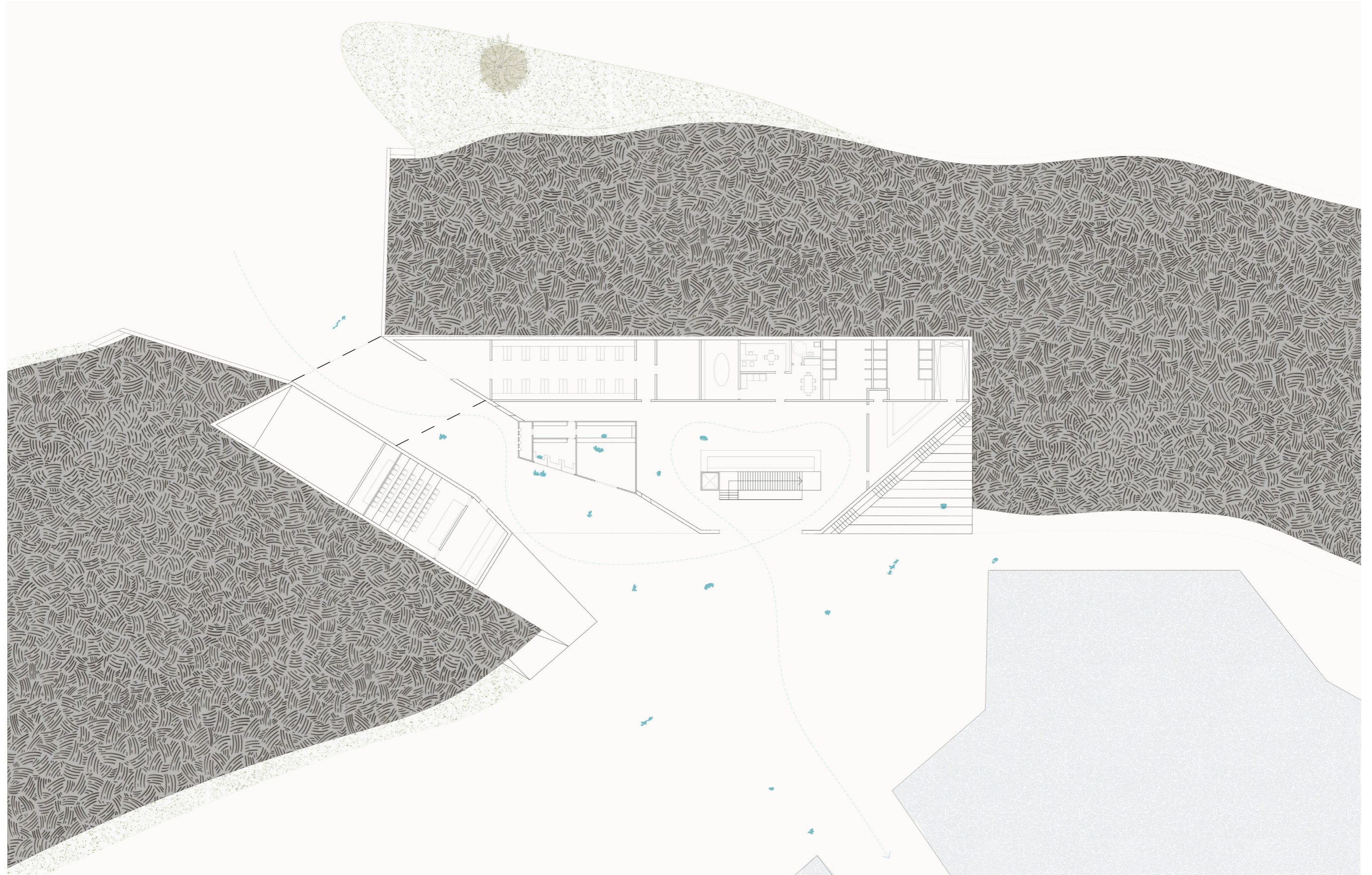


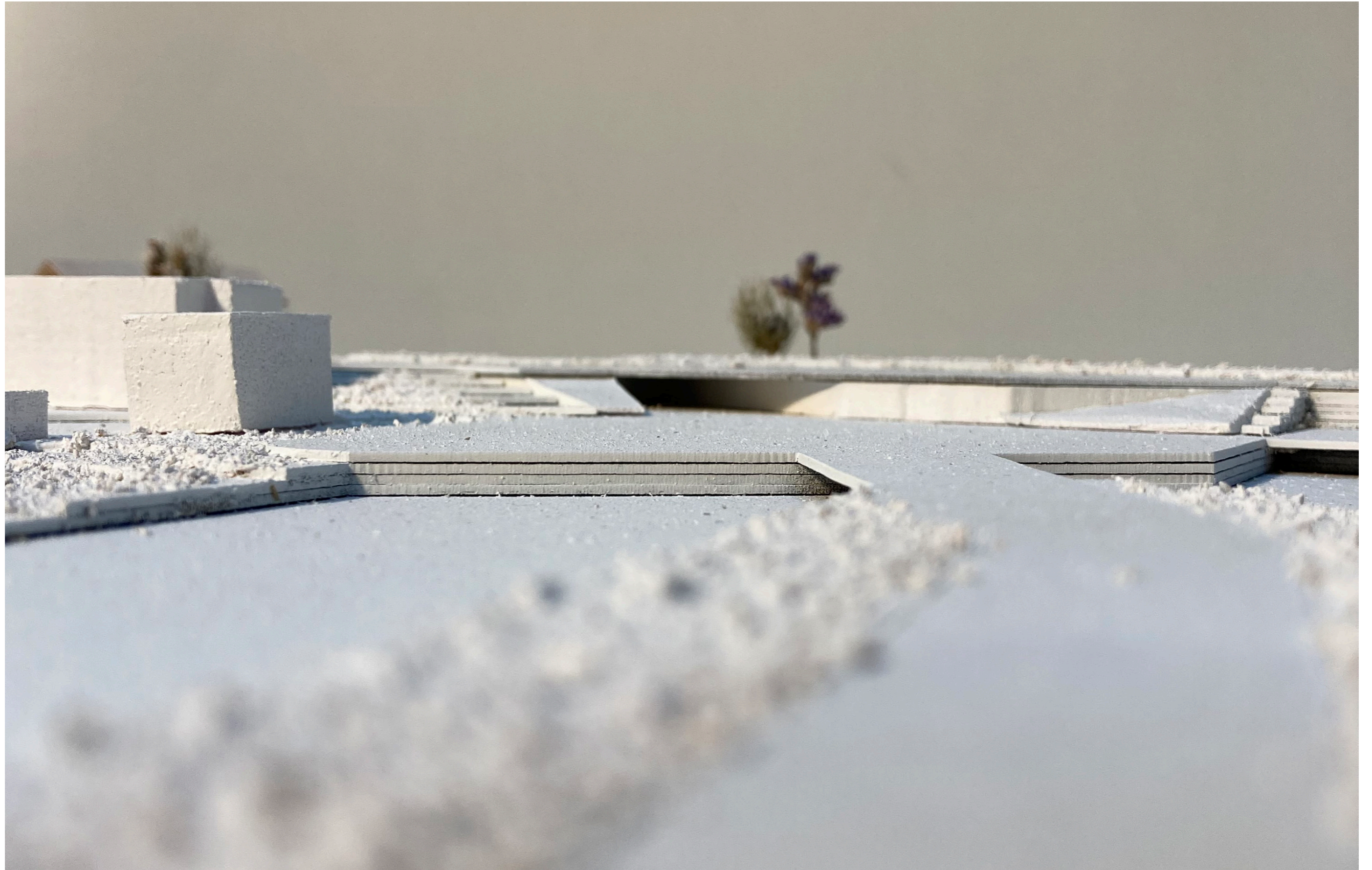


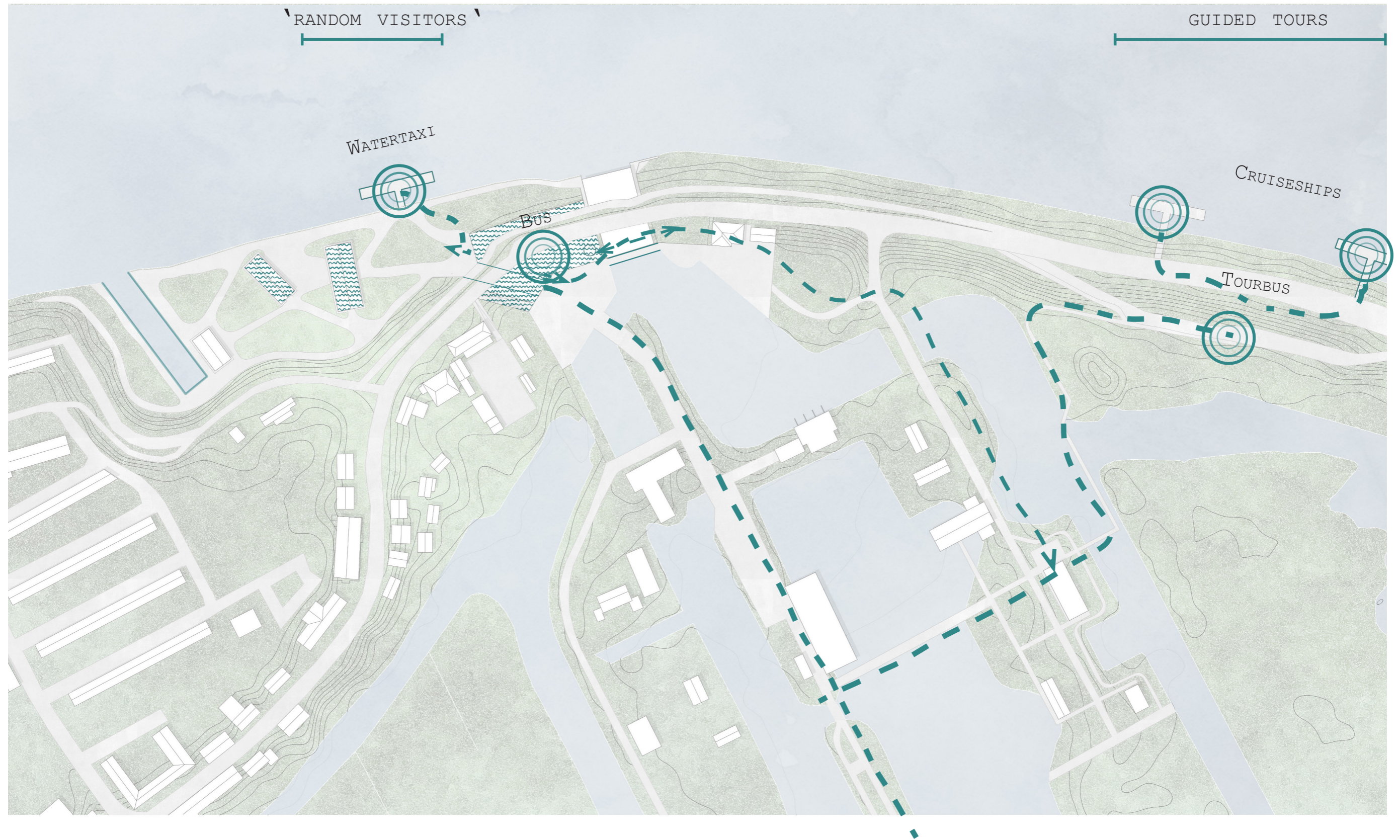


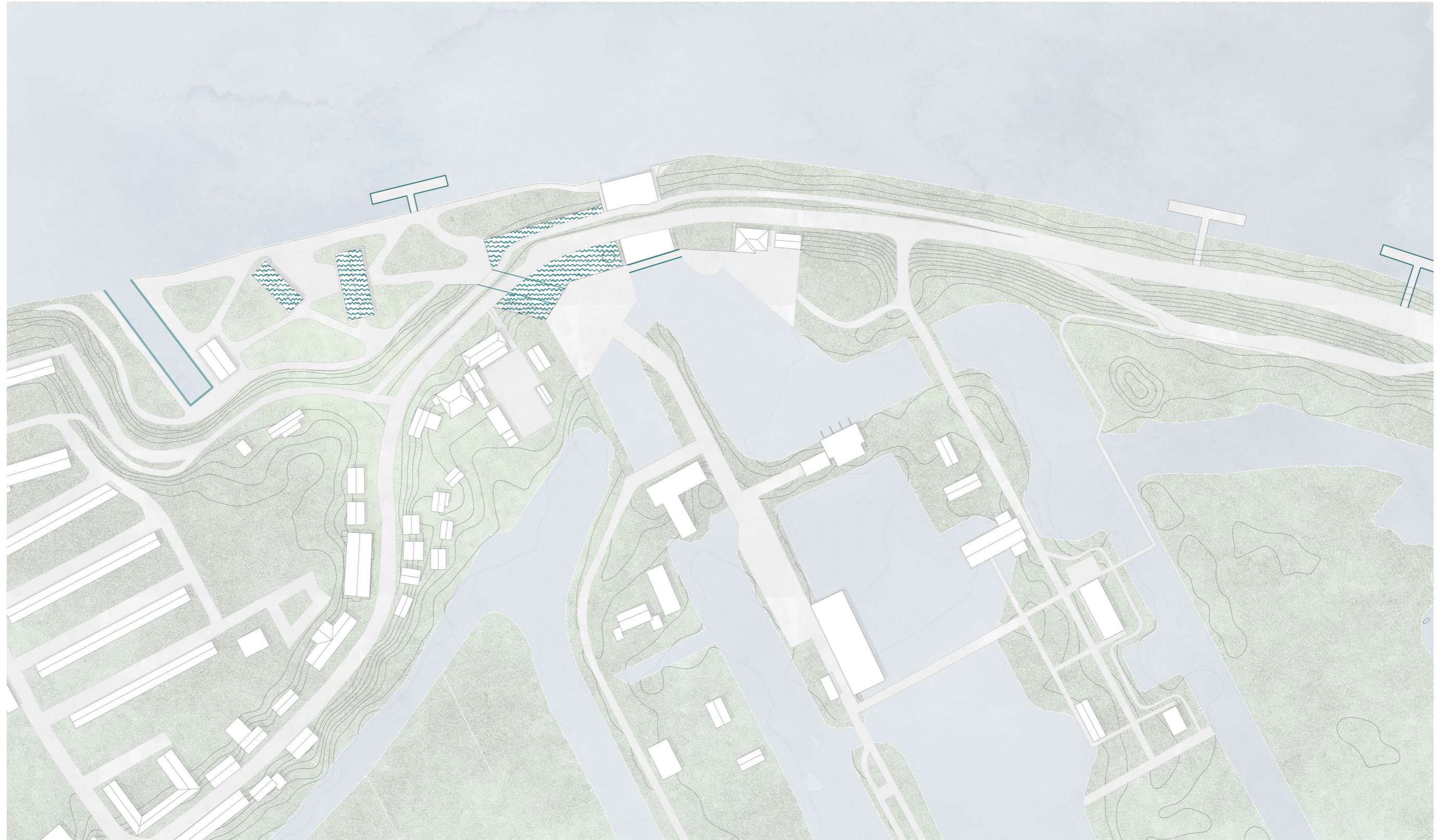






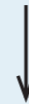




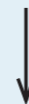


RESEARCH QUESTION

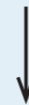
How can we ensure authenticity in reconstructive projects, of structures that have been lost, to remind us of the real history that once was?



What are the regulations and guidelines for reconstruction?



How can authenticity be defined in the reconstructive field?



What are the commonly applied methods and perspectives on the reconstruction of lost architecture?

'Cultural heritage, and its cultural context, properties may be understood to meet the conditions of authenticity if their cultural values (as recognized in the nomination criteria proposed) are truthfully and credibly expressed through a variety of attributes including:

- form and design;
- materials and substance;
- use and function;
- traditions, techniques and management systems;
- location and setting;
- language, and other forms of intangible heritage;
- spirit and feeling; and
- other internal and external factors.

PROJECT ASPECT OF AUTHENTICITY				
				...
FORM & DESIGN				
MATERIAL & SUBSTANCE				
USE & FUNCTION				
TRADITIONS & TECHNIQUES				
LOCATION & SETTING				
LANGUAGE & OTHER FORMS OF INTANGIBLE HERITAGE				
SPIRIT & FEELING				
OTHERS				

Figure 6: Matrix to identify the degree of authenticity in a reconstruction, illustrated by author Note: Aspects of authenticity have been adapted from the Operational Guidelines for the World Heritage Committee




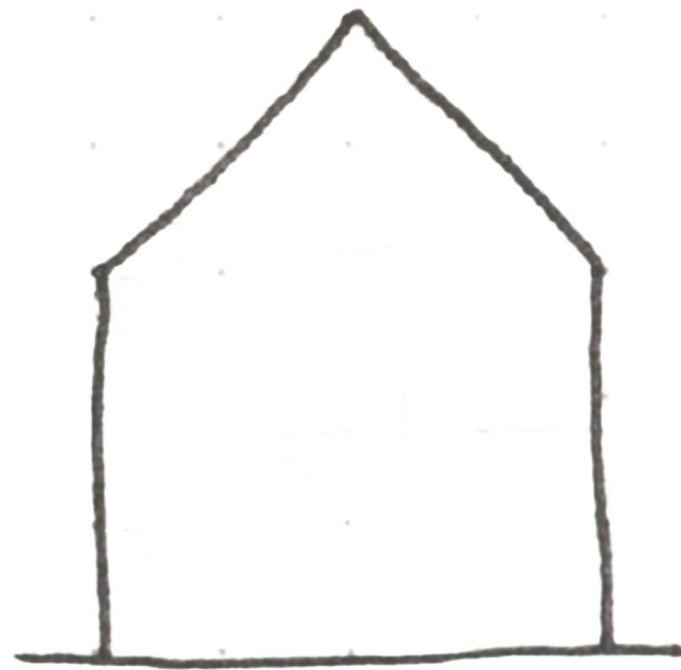
PROJECT ASPECT OF AUTHENTICITY				...
FORM & DESIGN	X	X	X	
MATERIAL & SUBSTANCE	X			
USE & FUNCTION	X			
TRADITIONS & TECHNIQUES	X	X		
LOCATION & SETTING	X	X	X	
LANGUAGE & OTHER FORMS OF INTANGIBLE HERITAGE				
SPIRIT & FEELING	X	X	X	
OTHERS				

Figure 6: Matrix to identify the degree of authenticity in a reconstruction, illustrated by author Note: Aspects of authenticity have been adapted from the Operational Guidelines for the World Heritage Committee



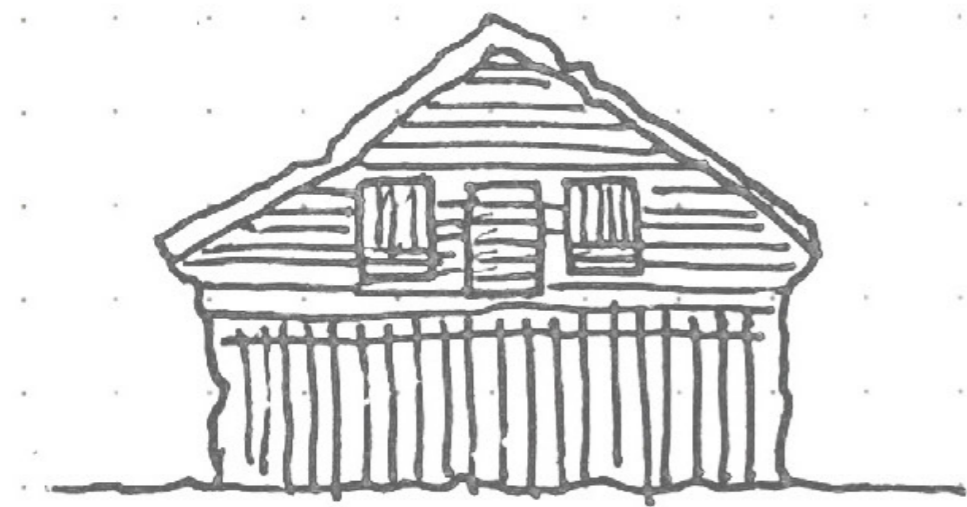
CONSTRUCTION



ABSENT



RECONSTRUCTION



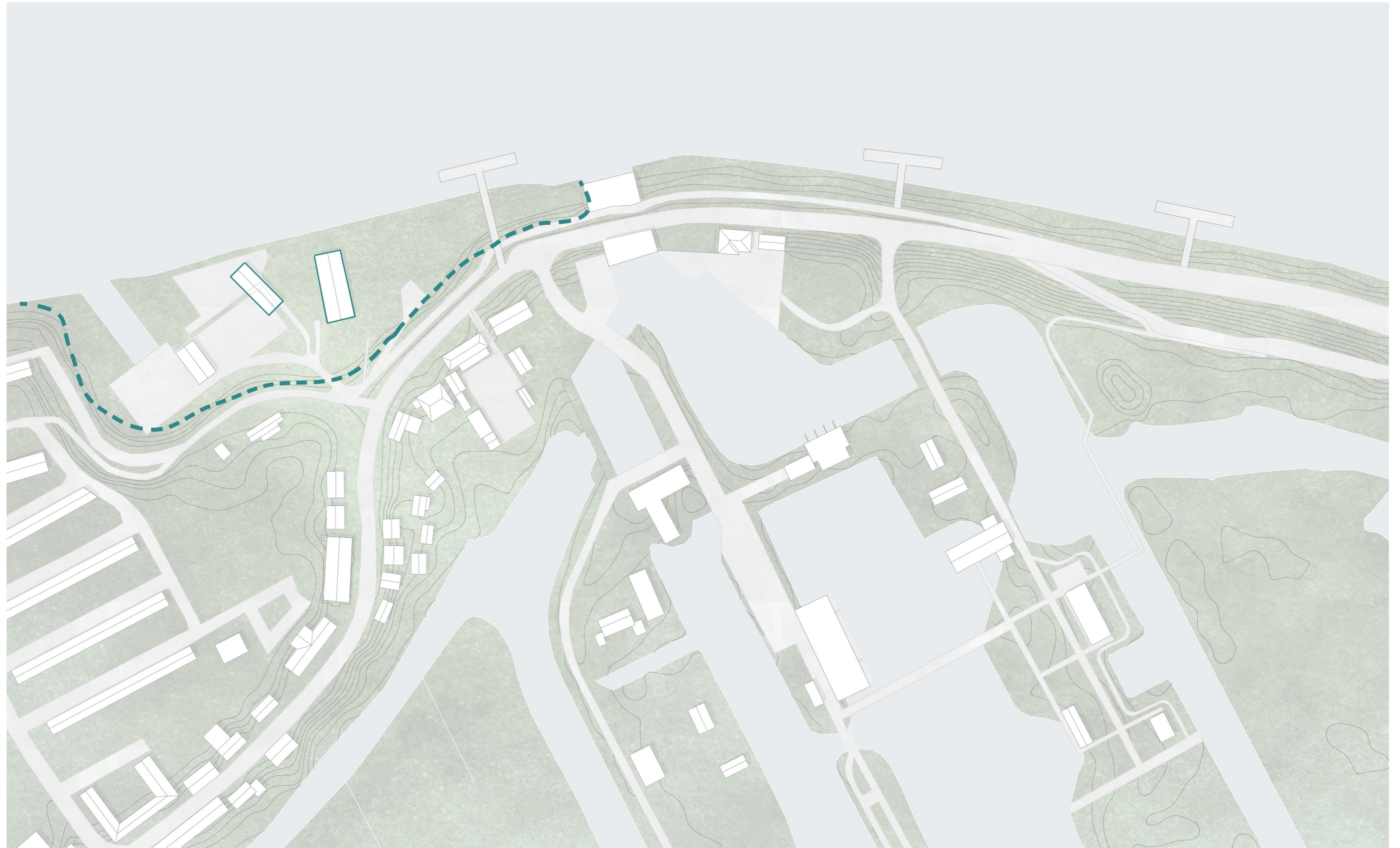
DETERIORATING



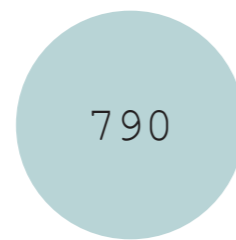
ABSENT



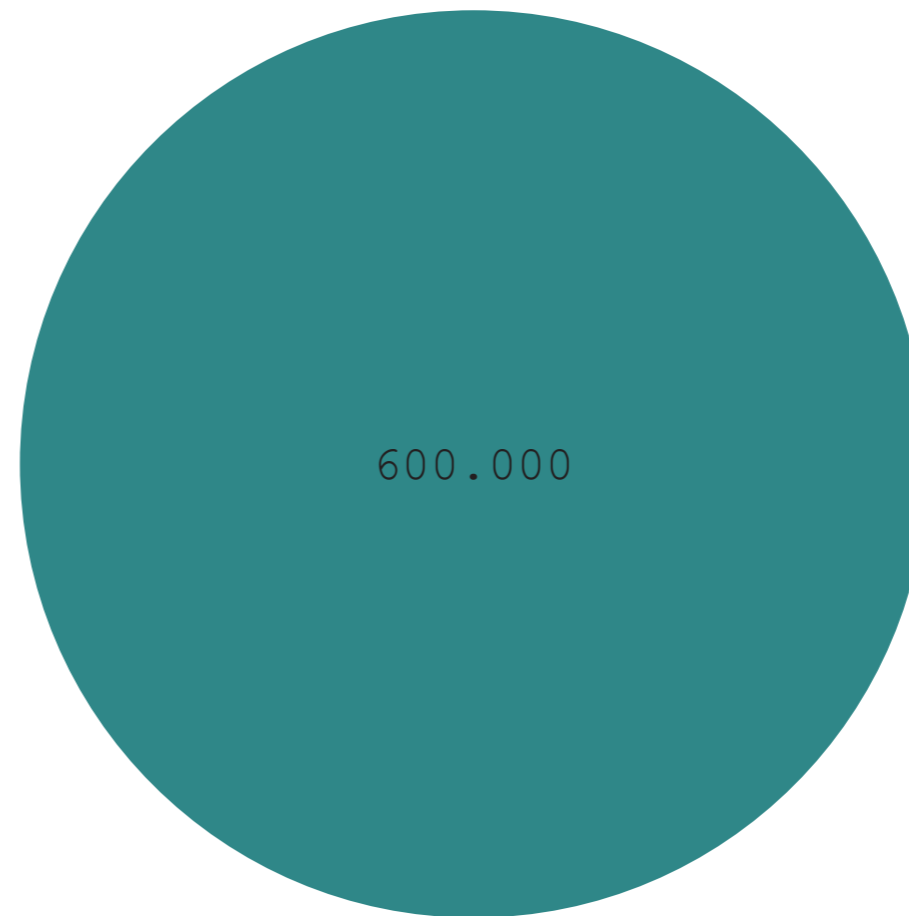
ABSENT

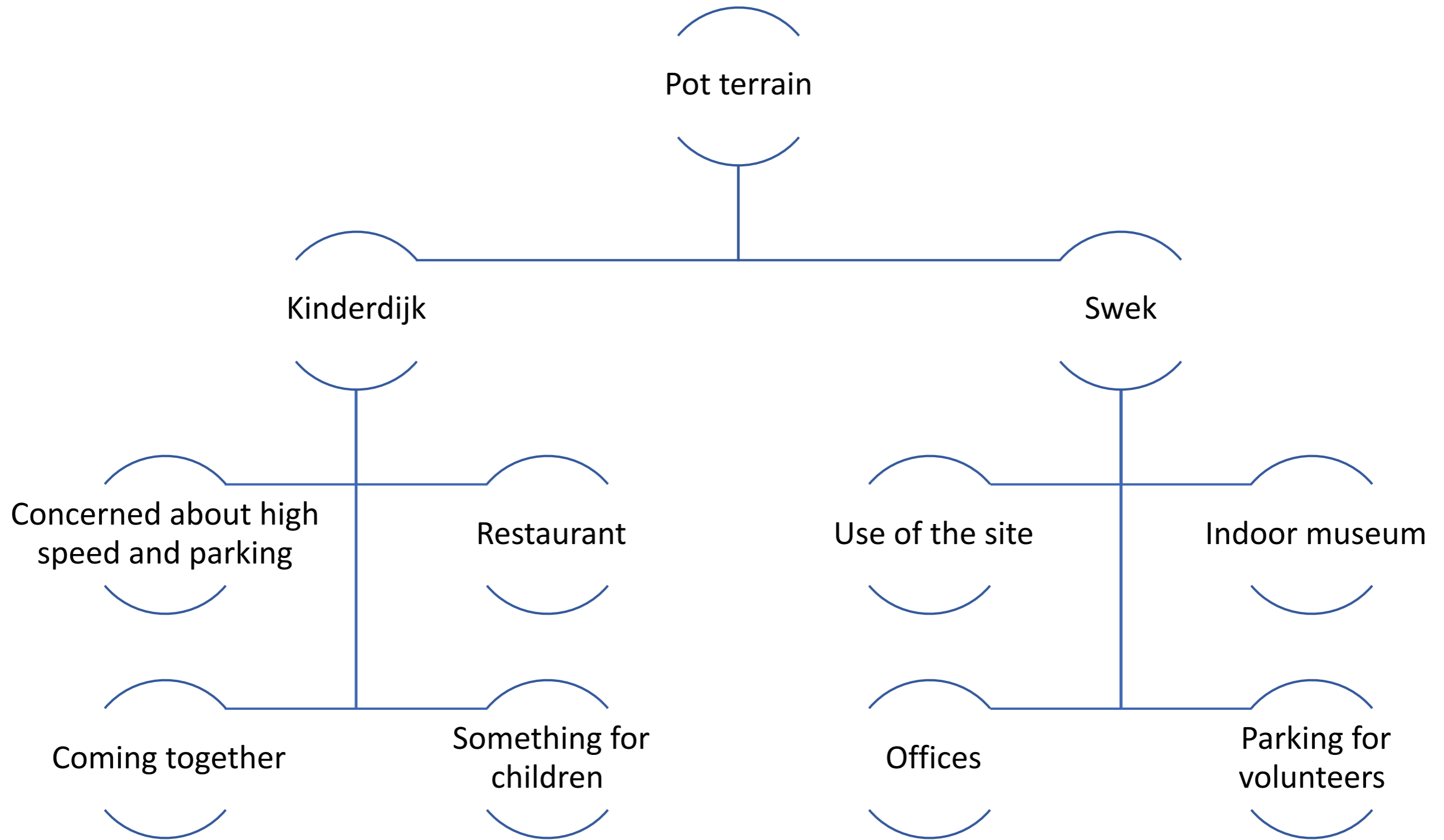


KINDERDIJKS RESIDENTS



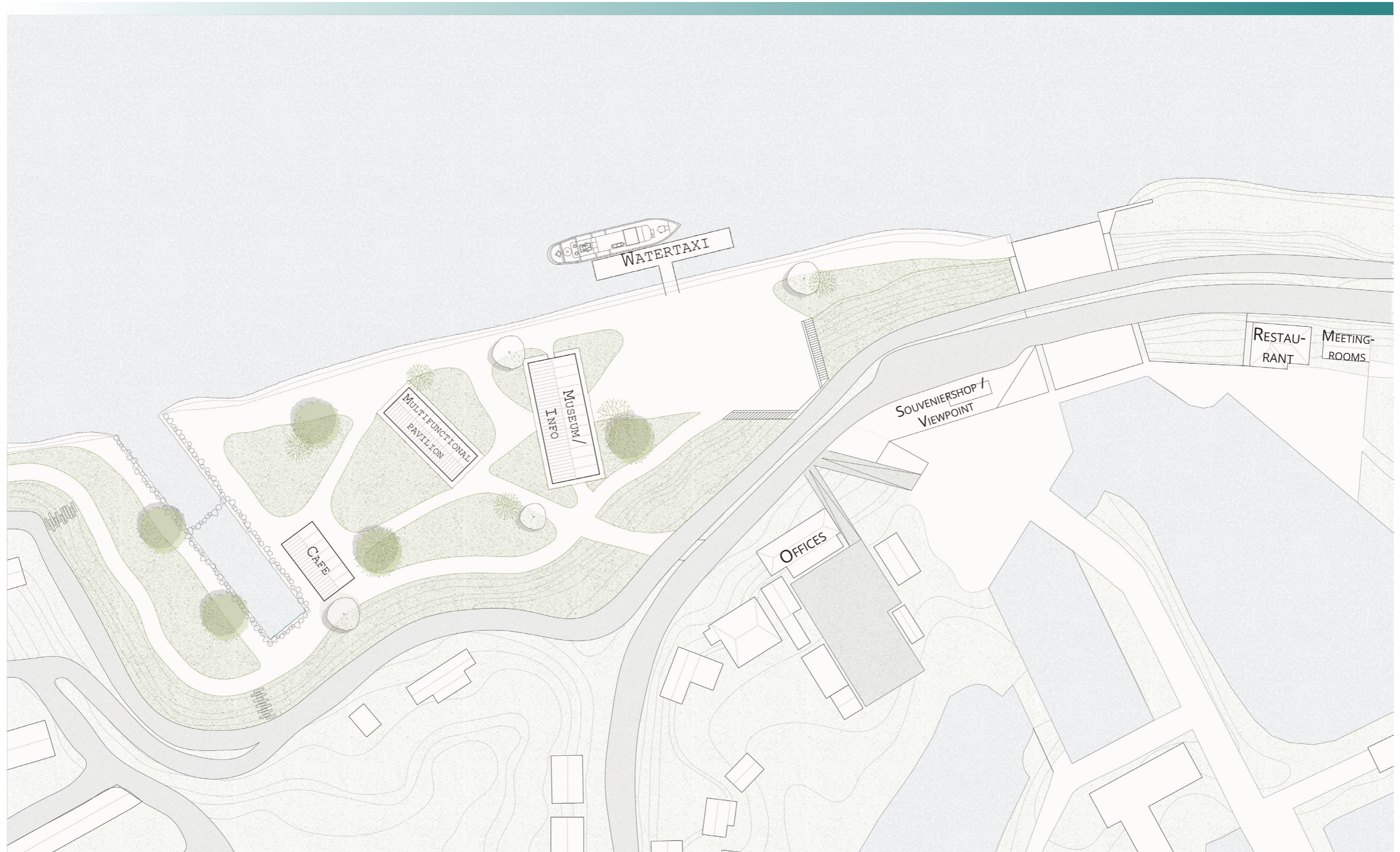
KINDERDIJKS VISITORS

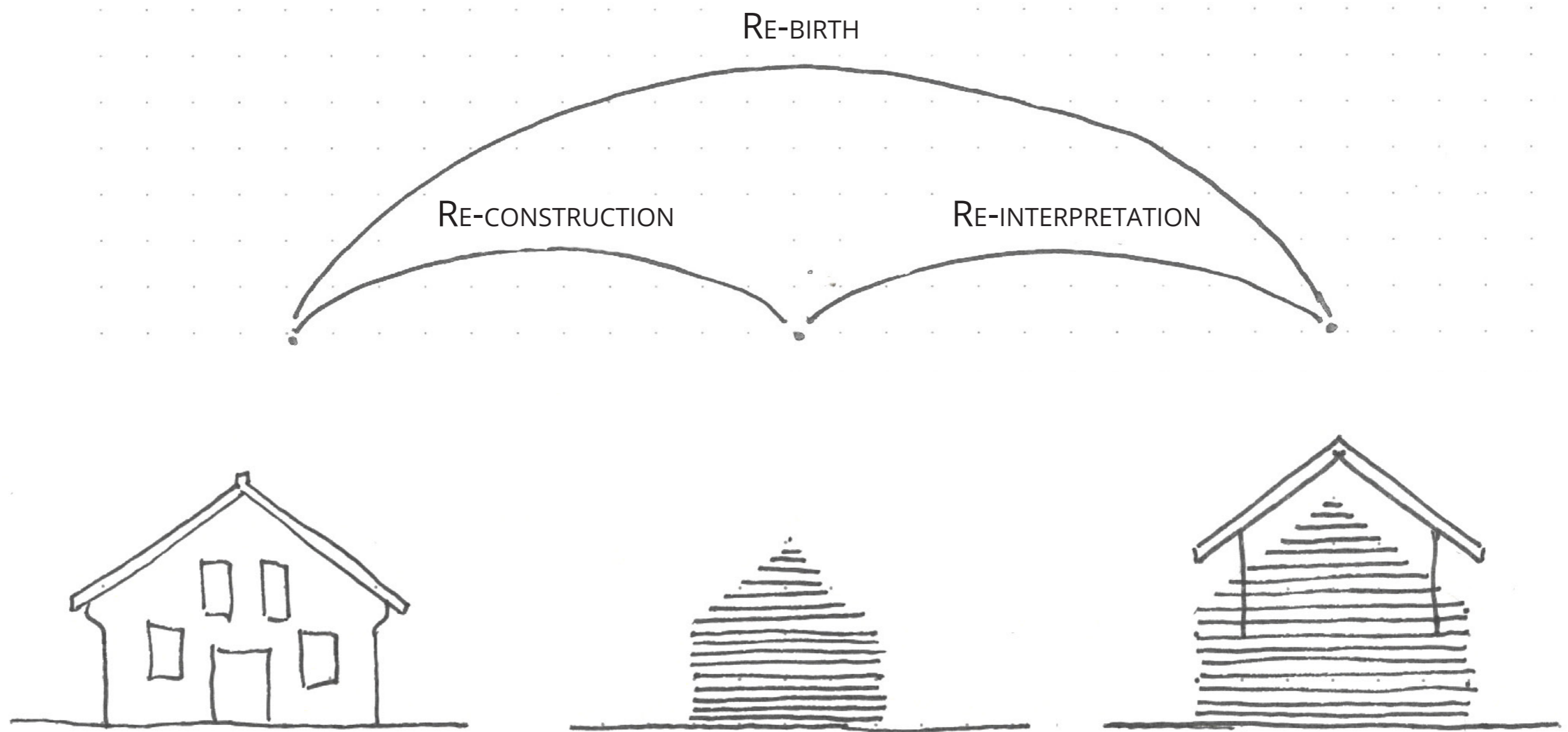


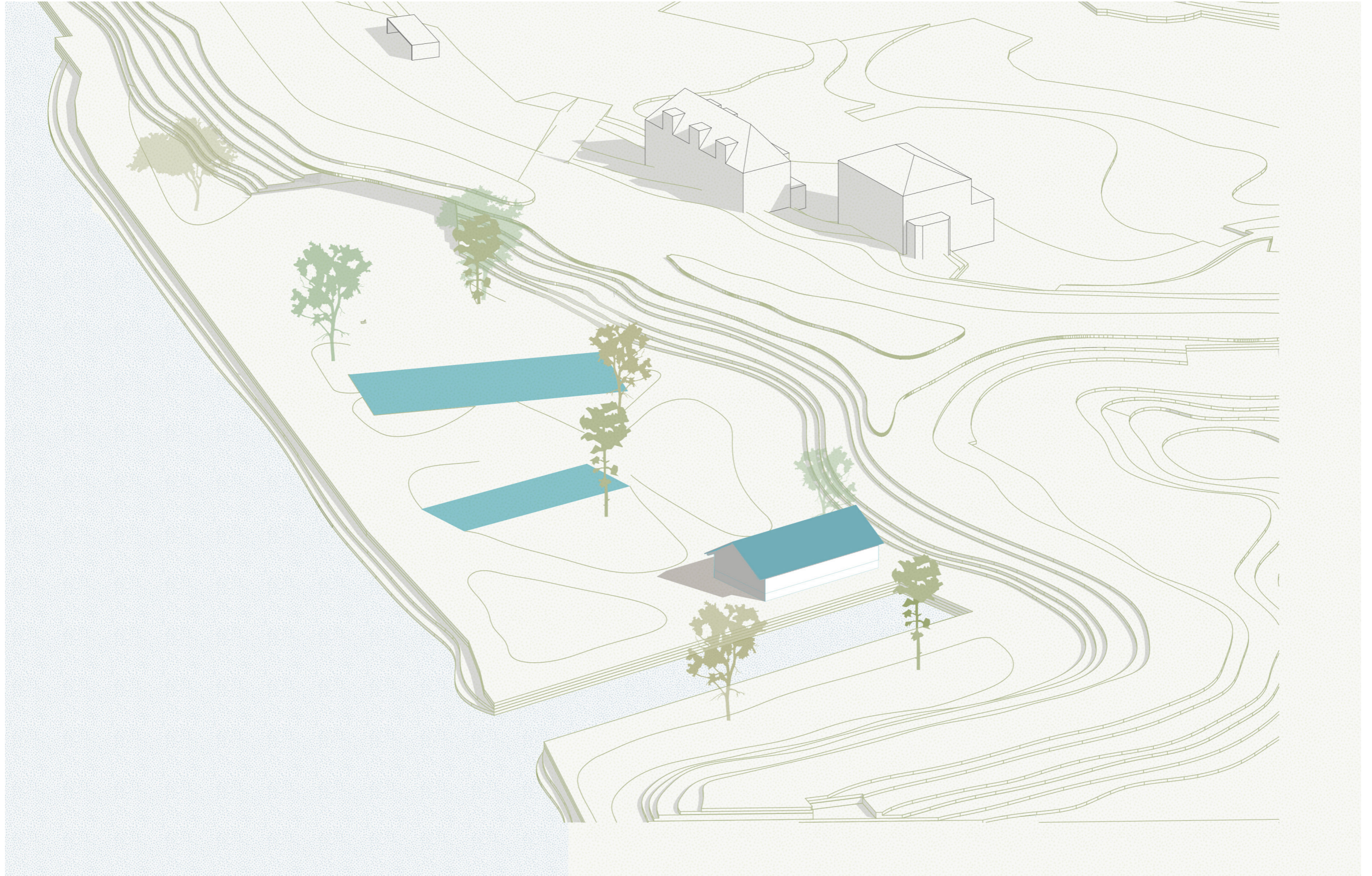


KINDERDIJK

SWEK

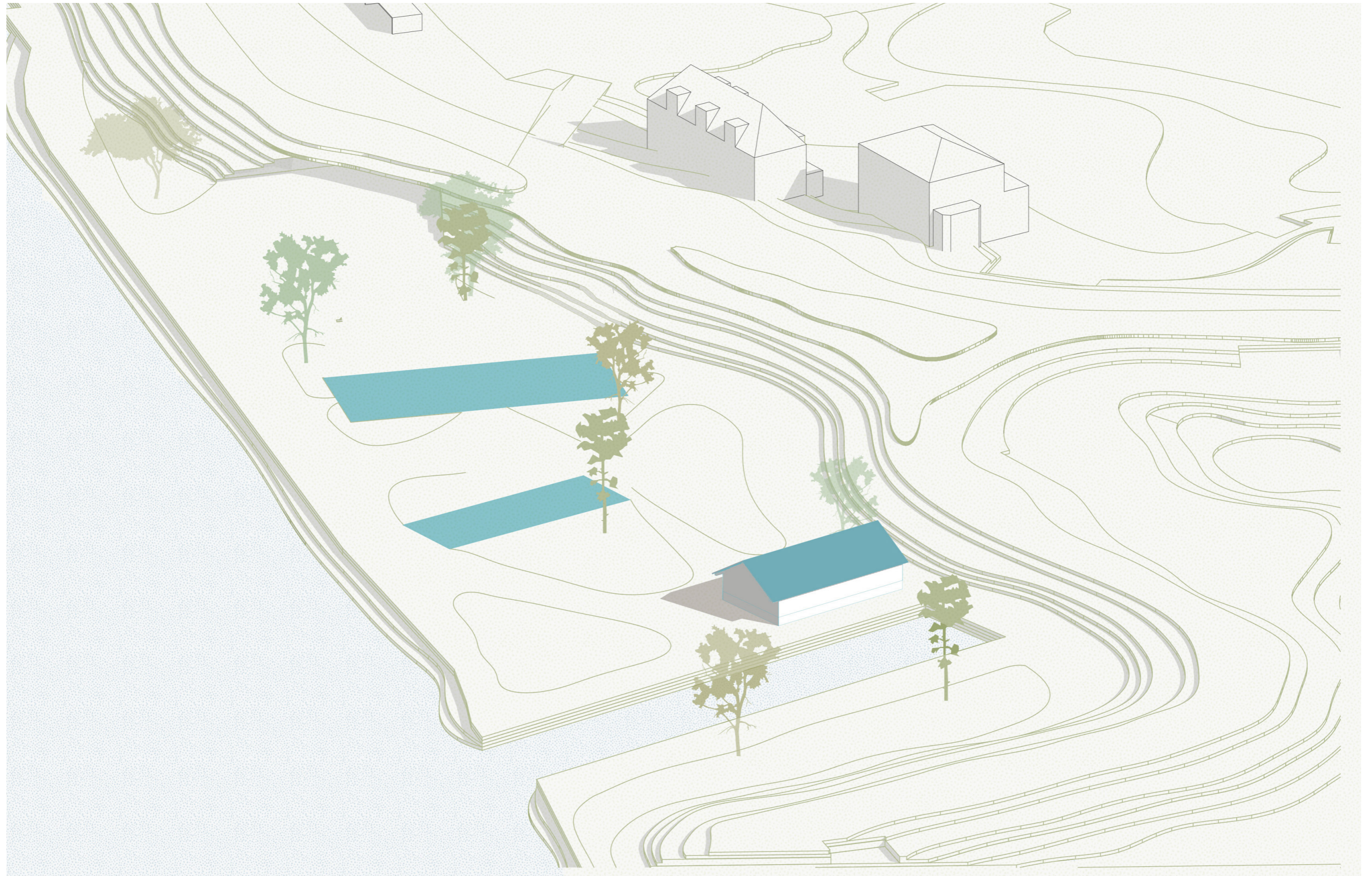


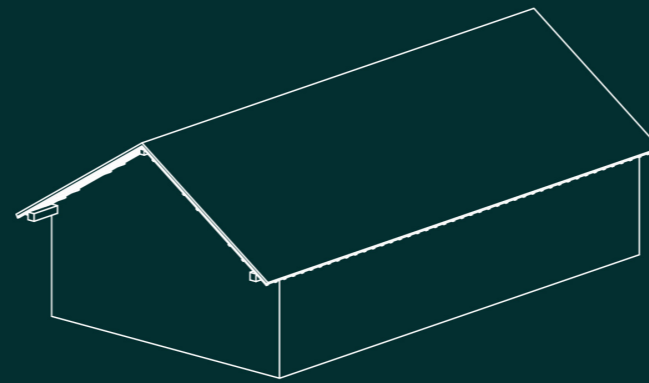


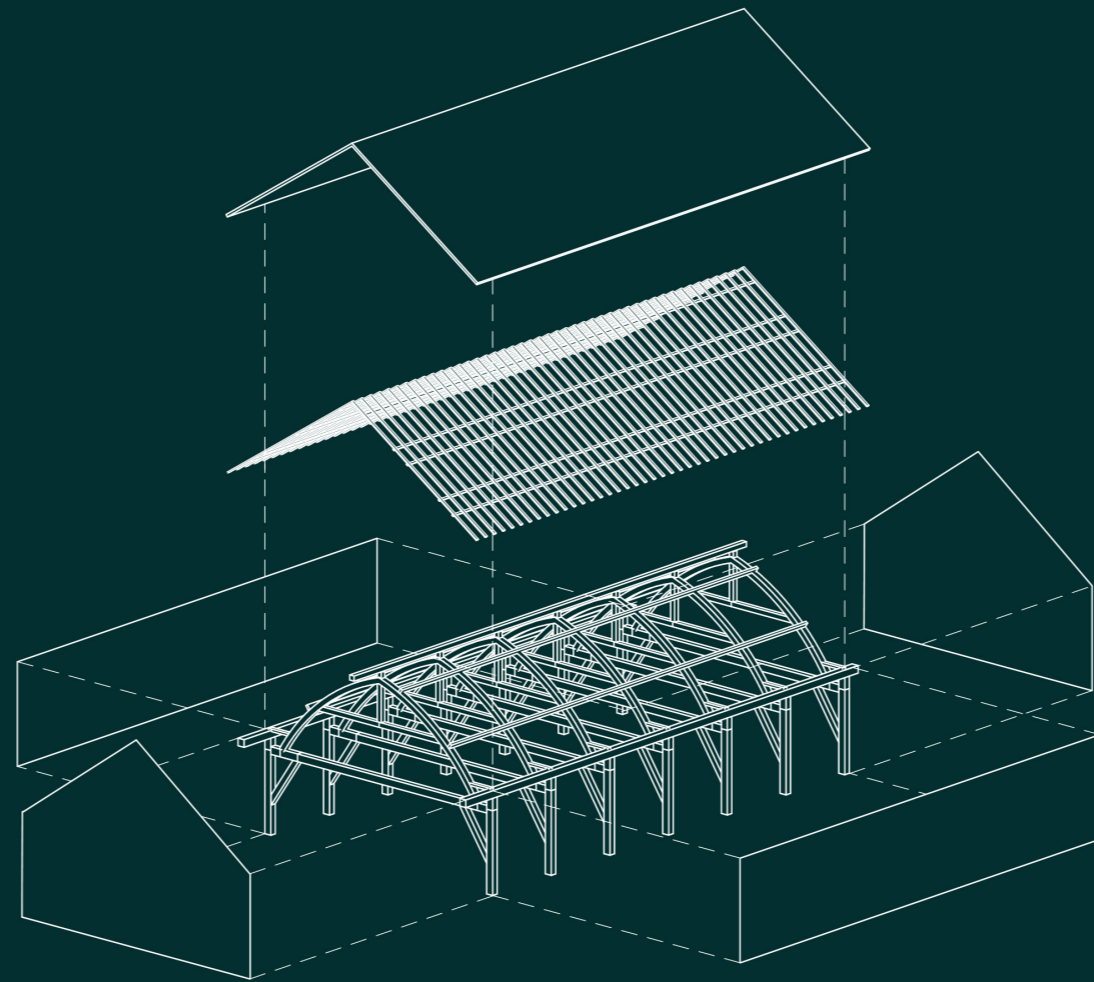


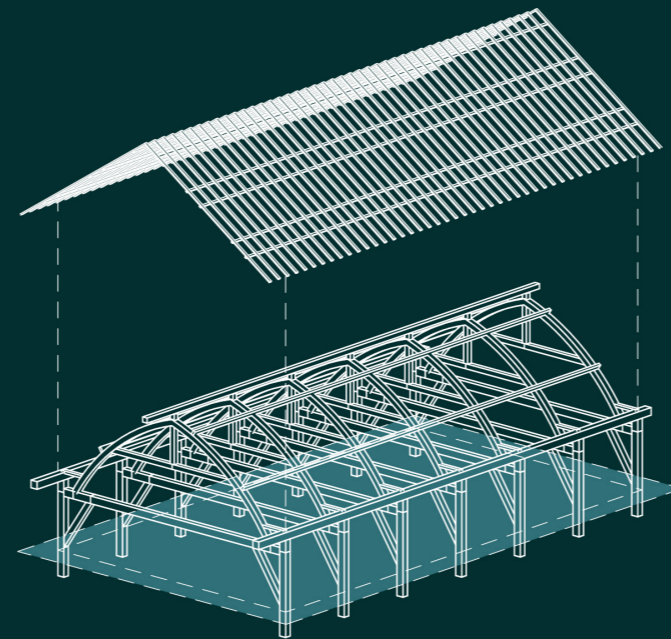


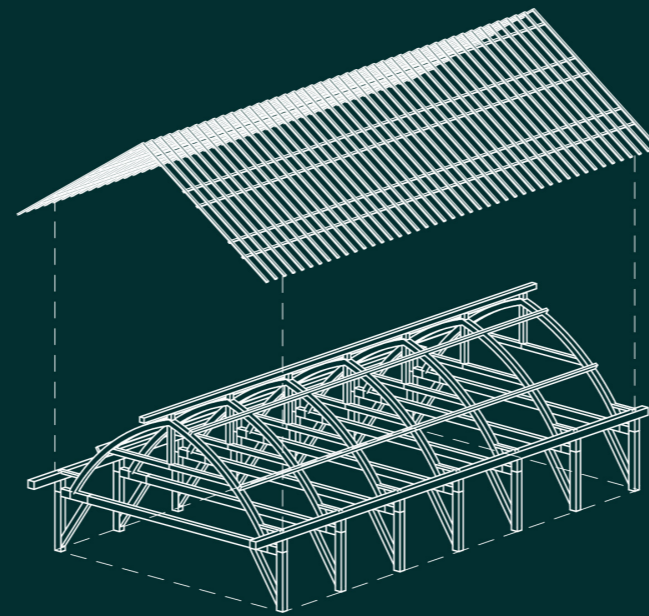


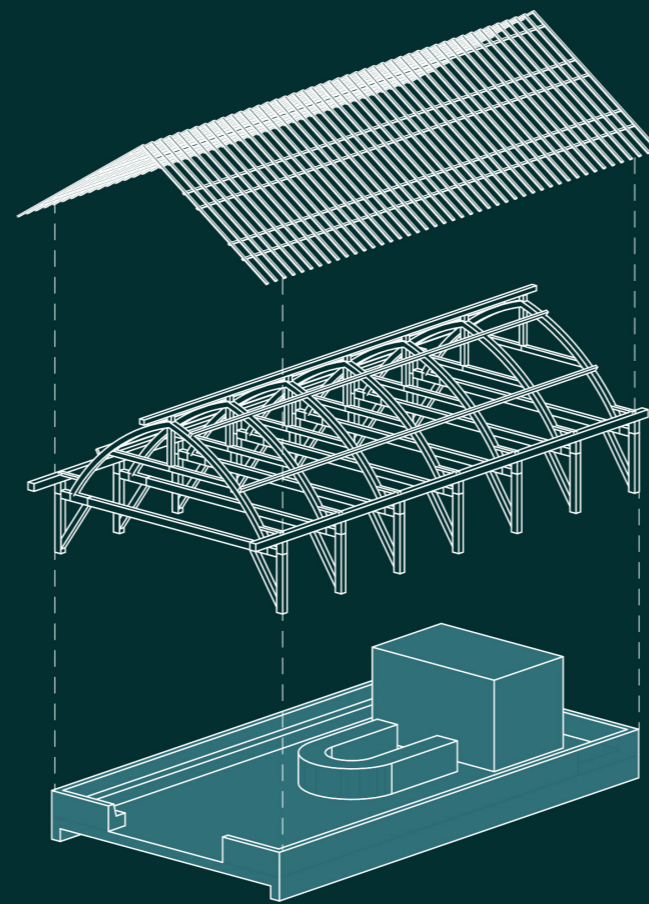


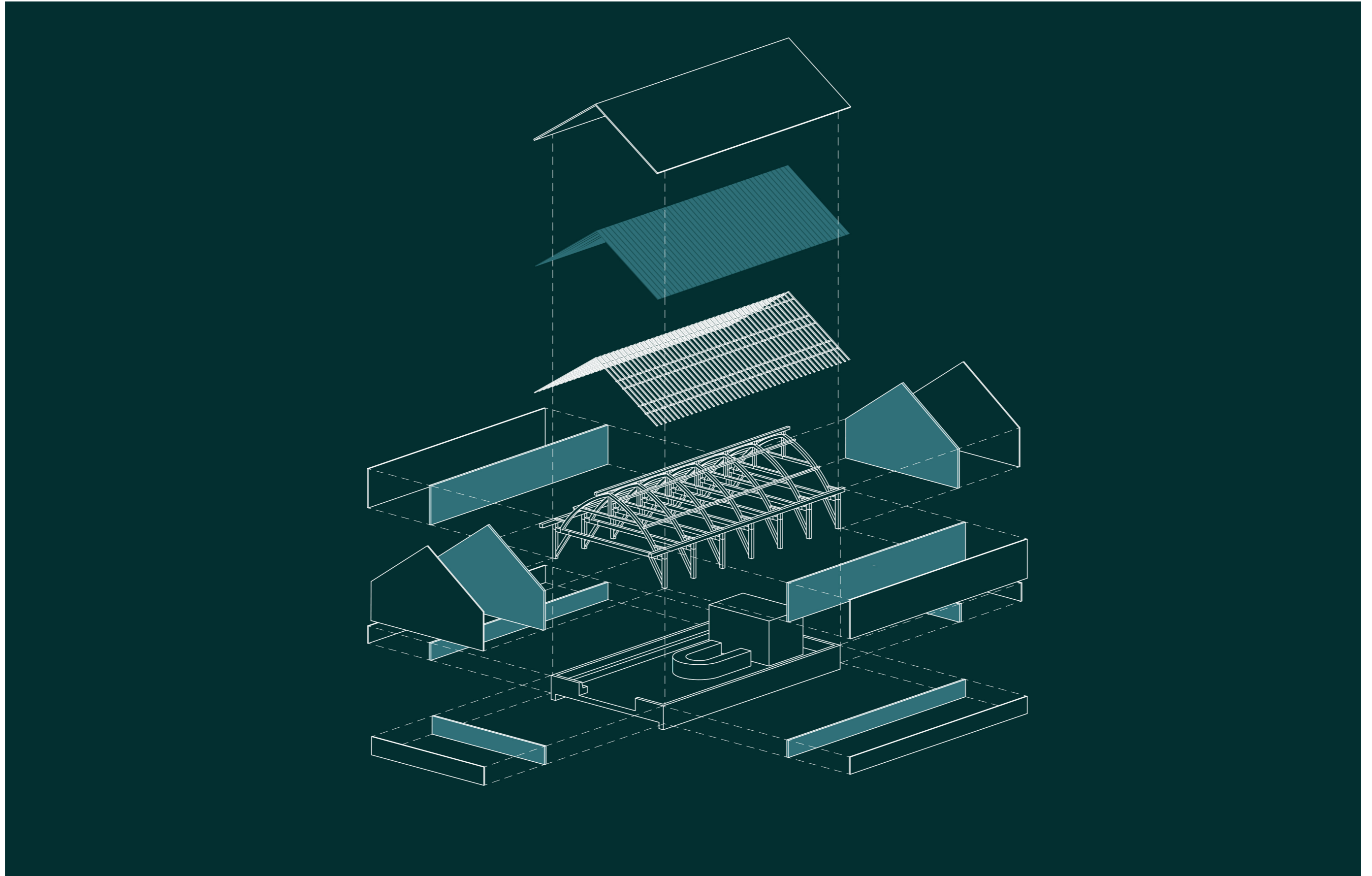


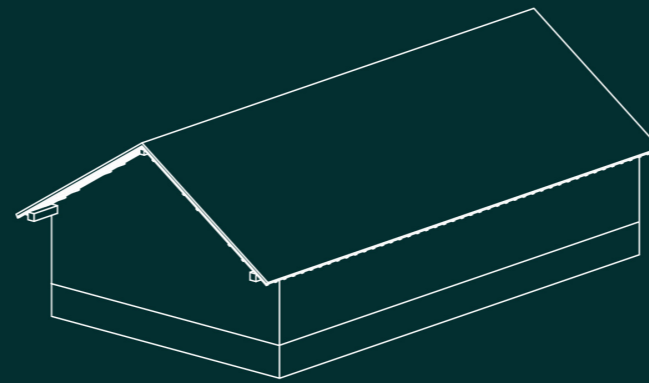










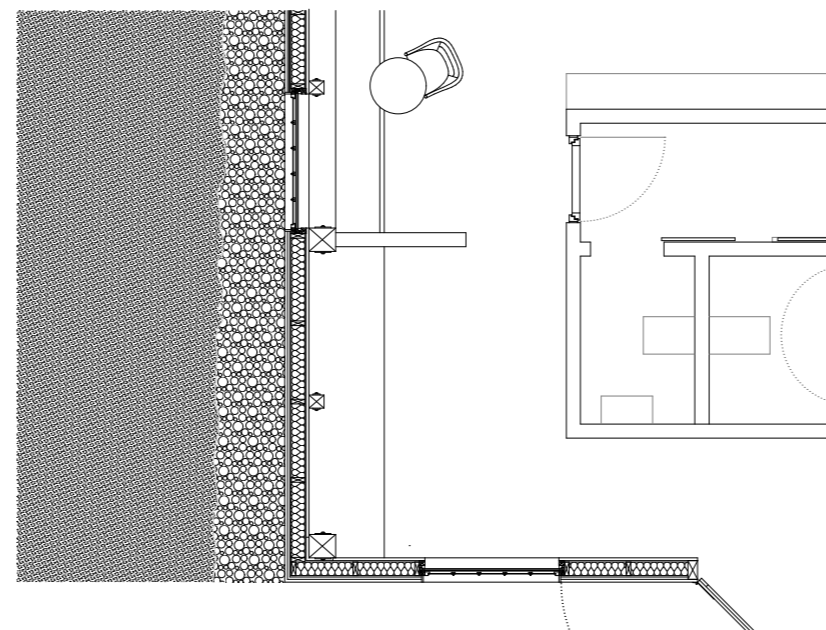
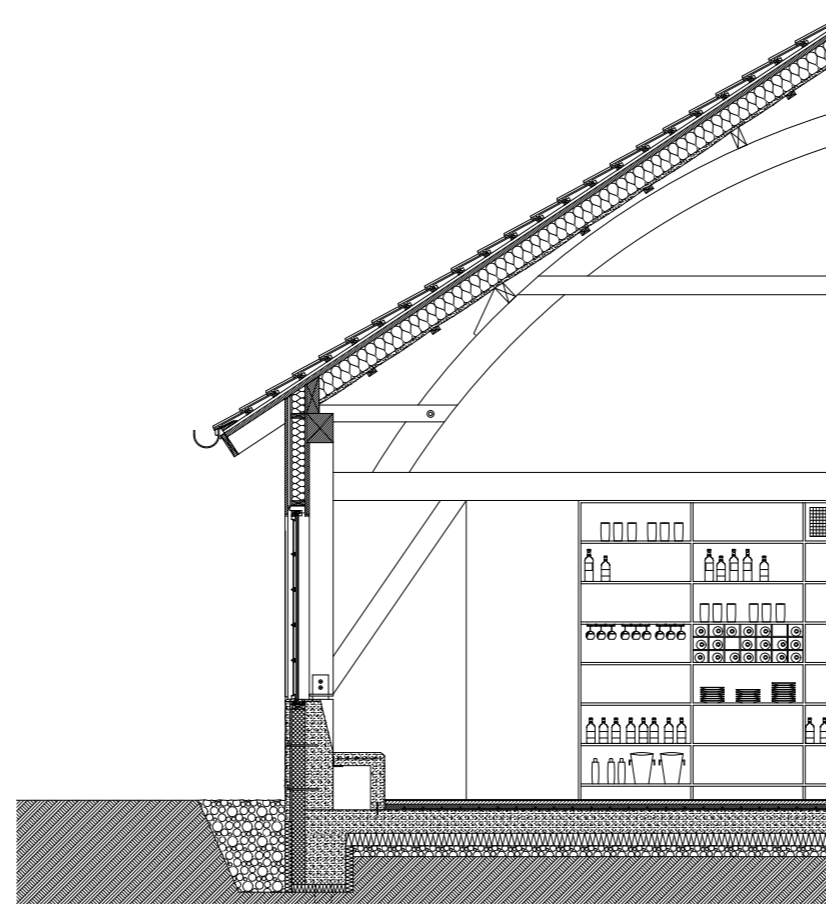


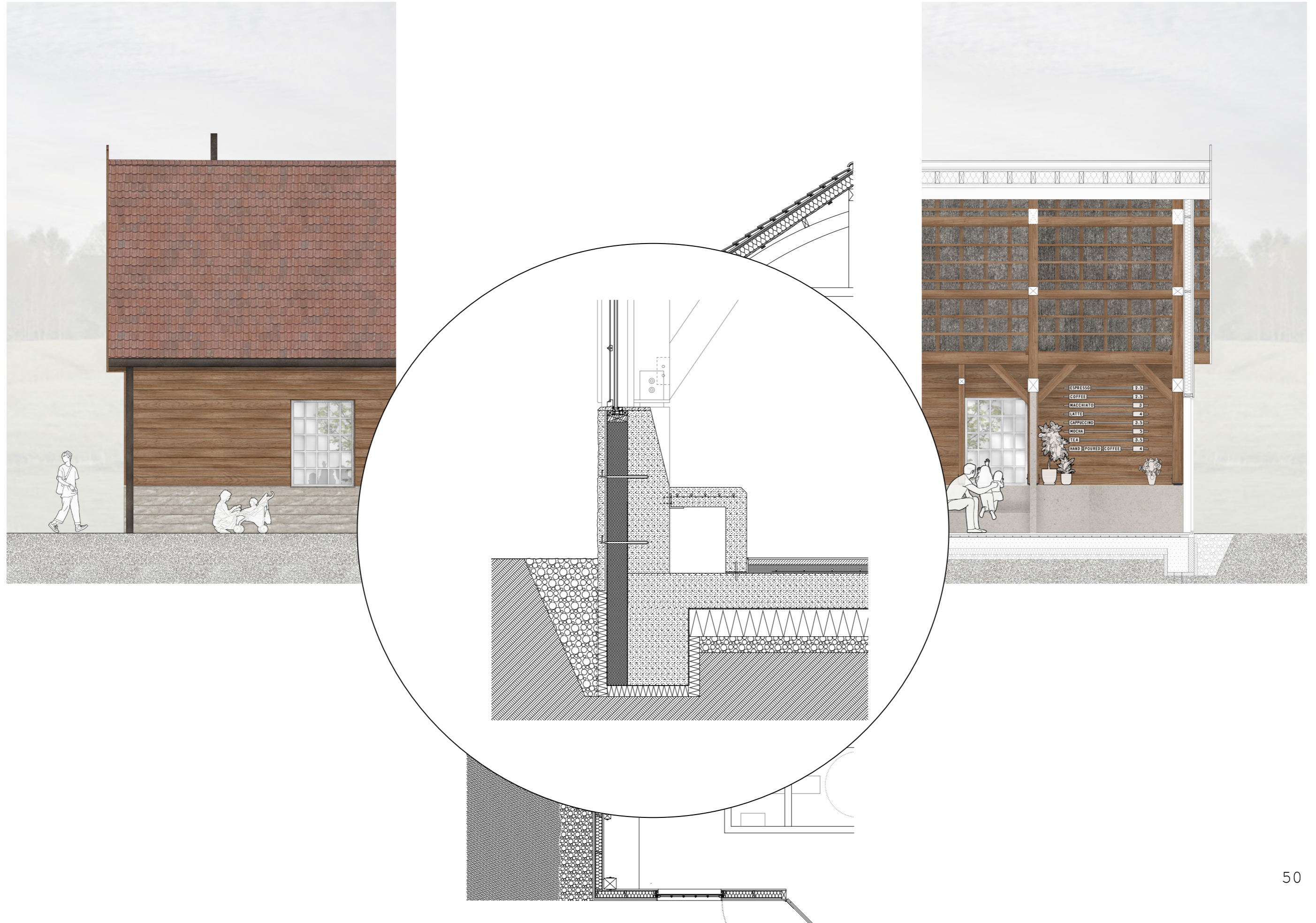


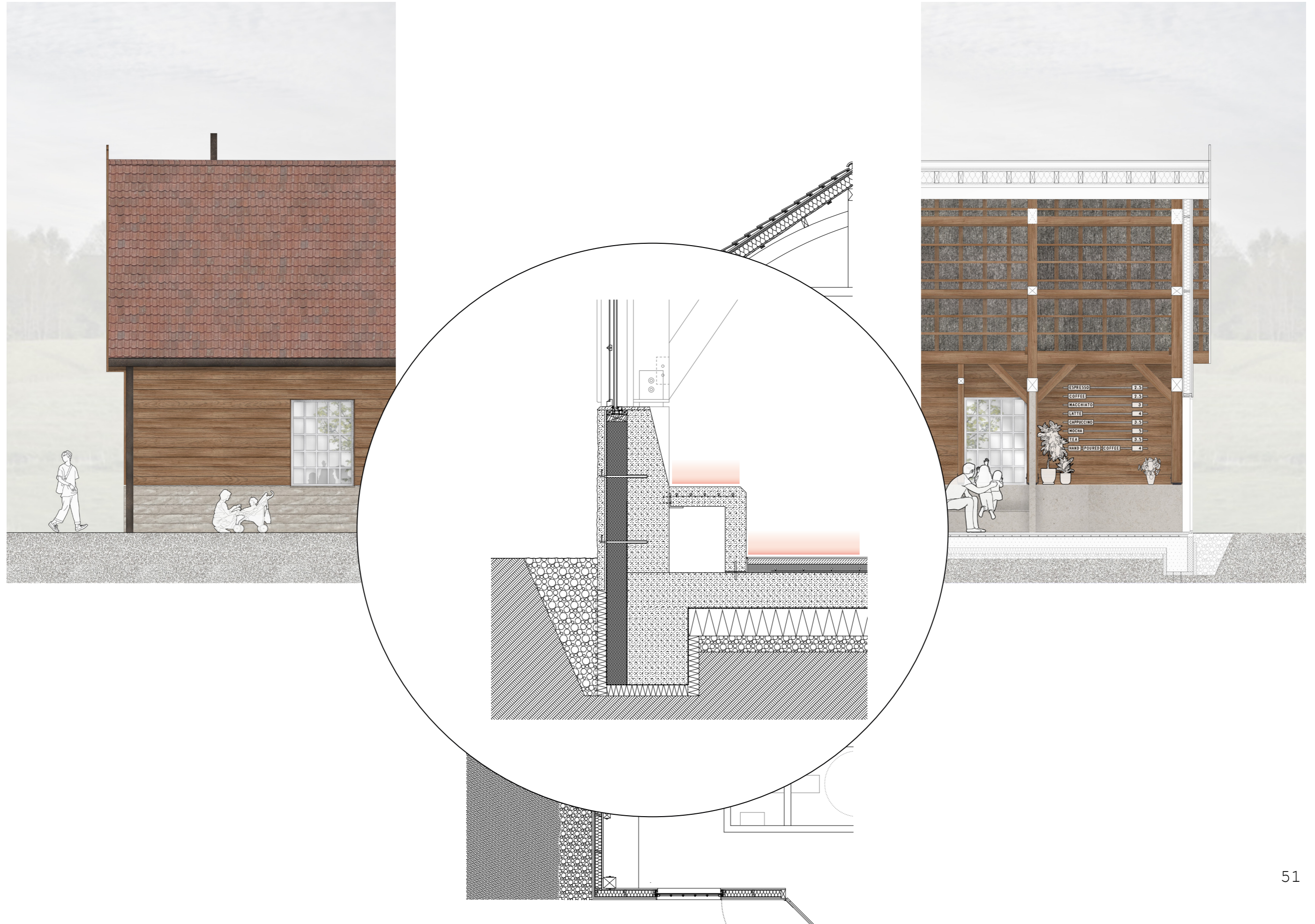


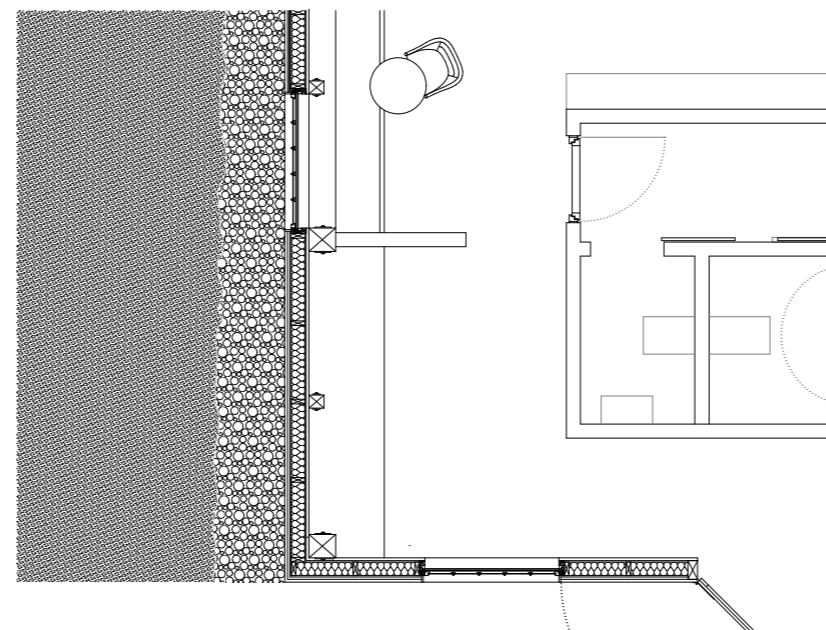
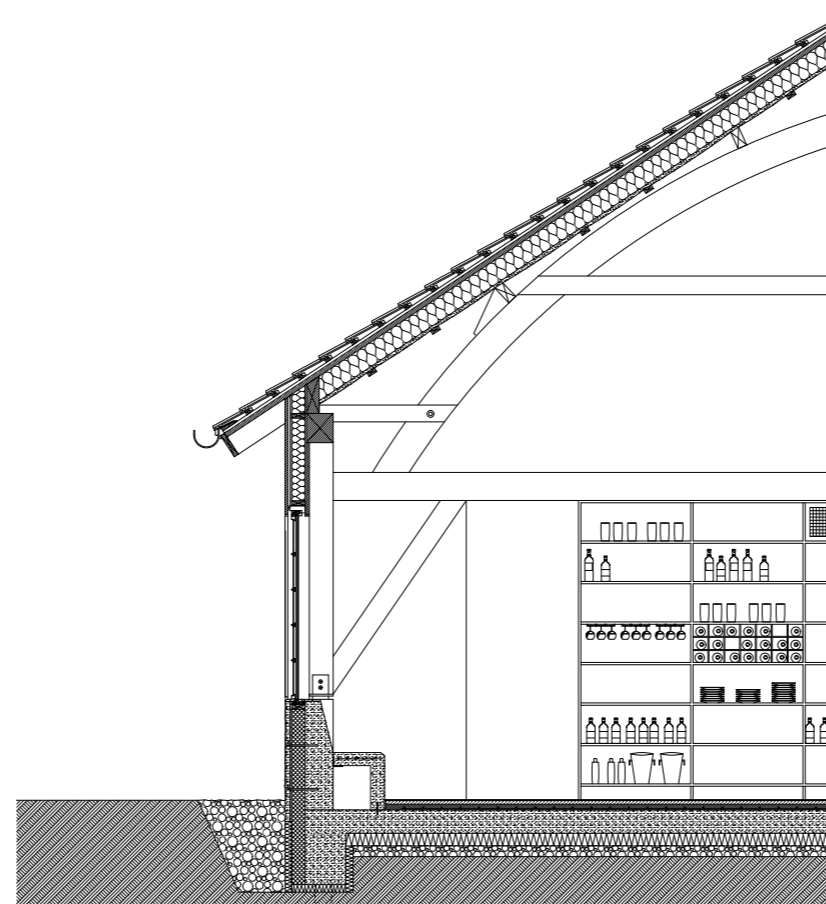


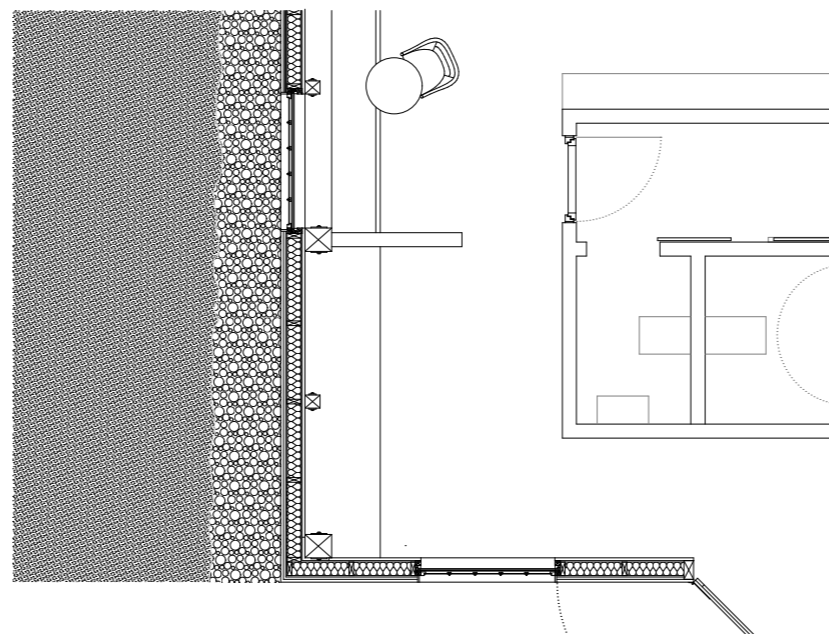
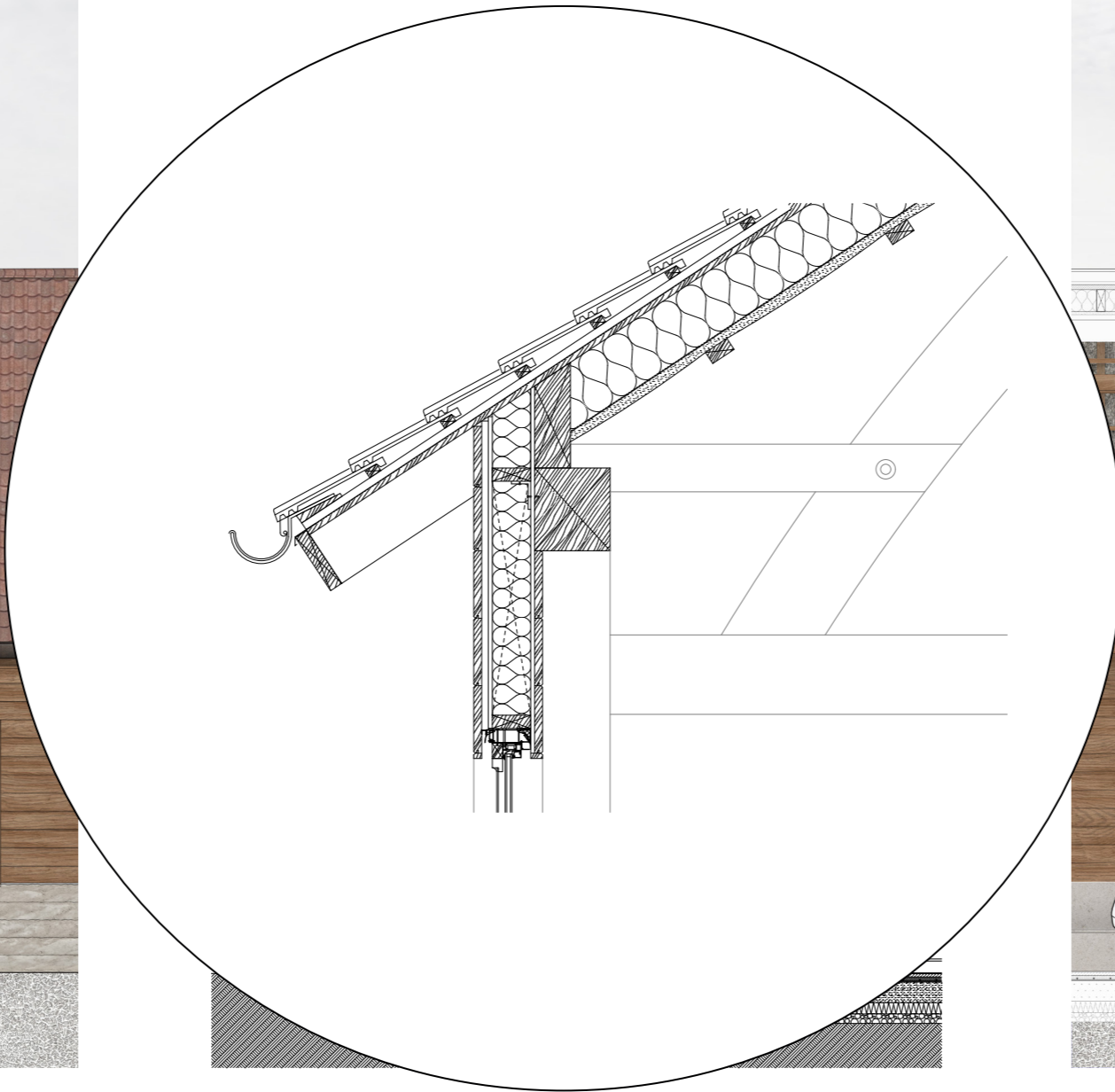


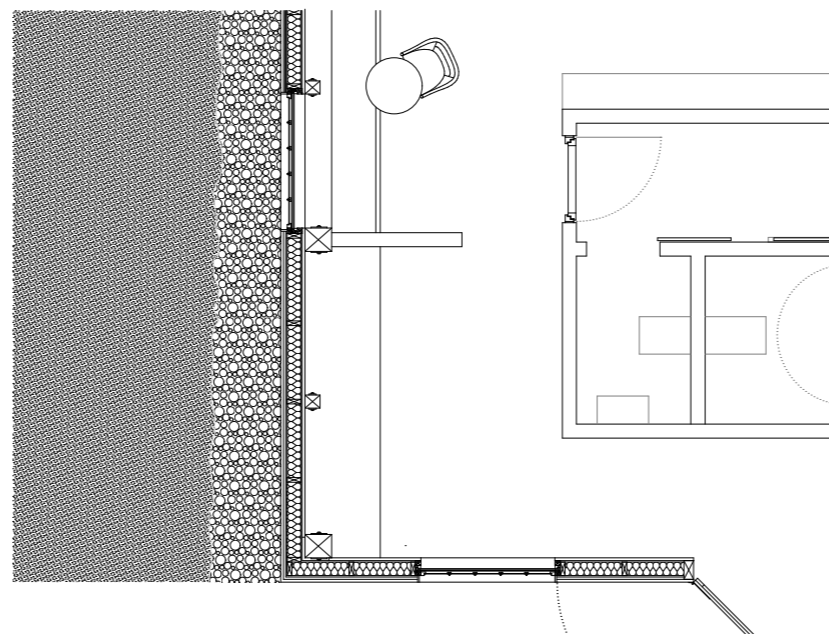
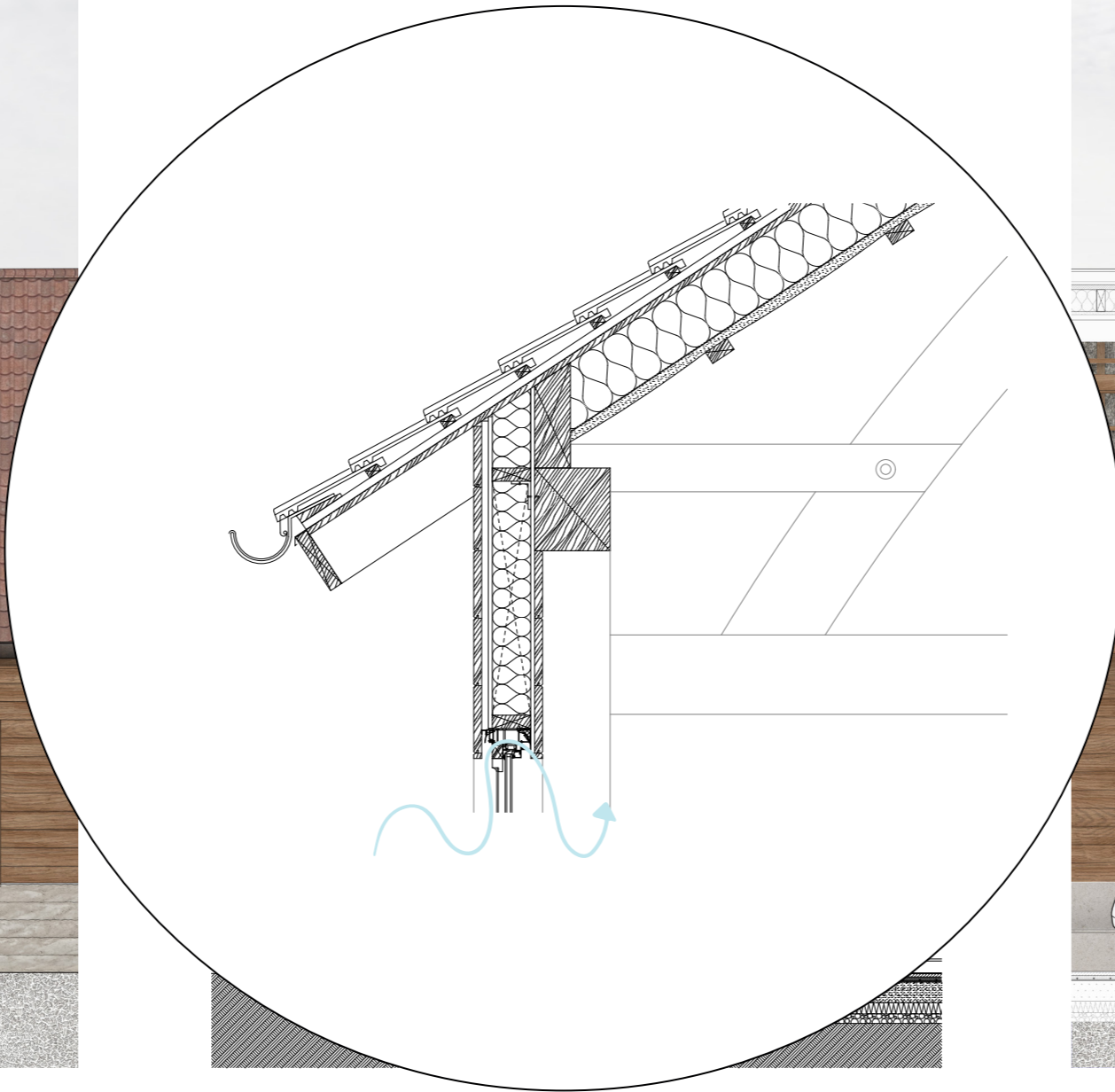


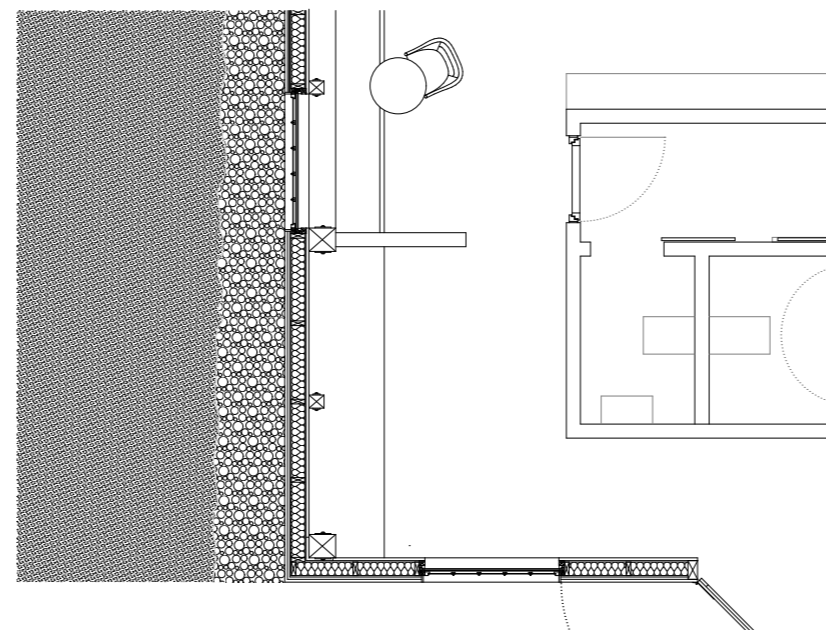
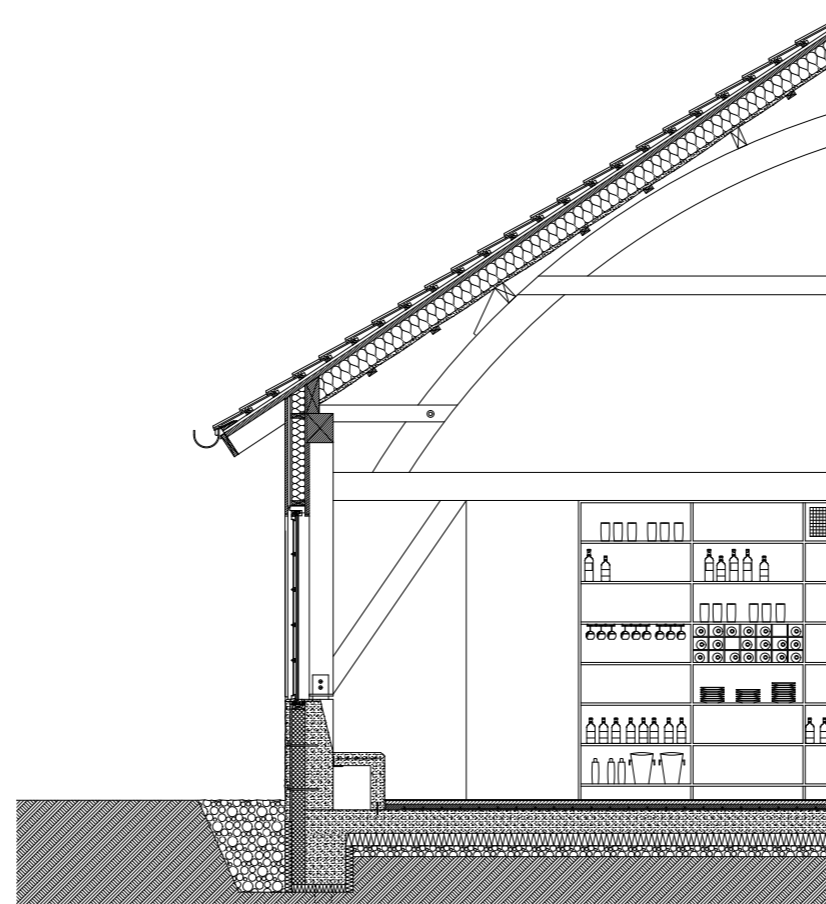


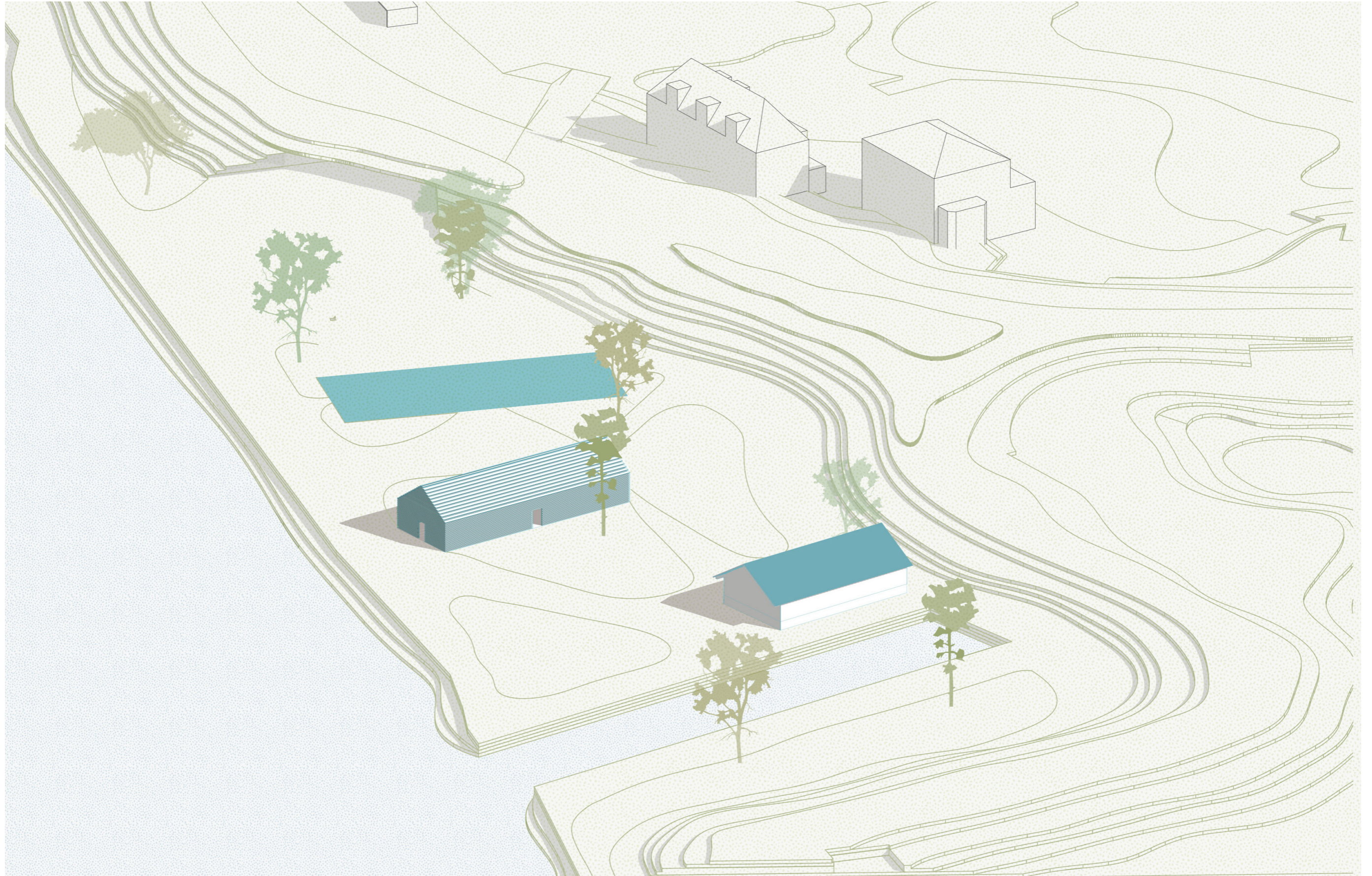












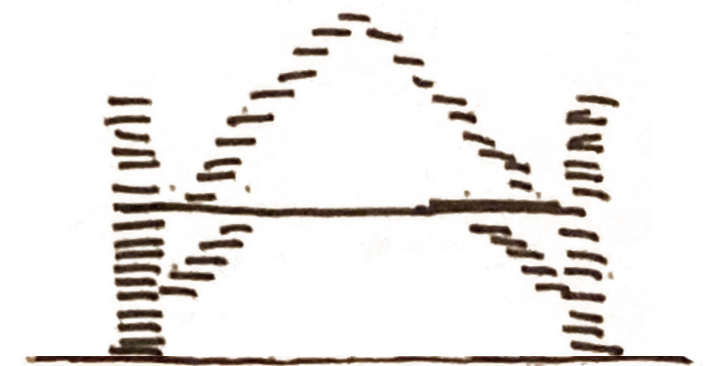
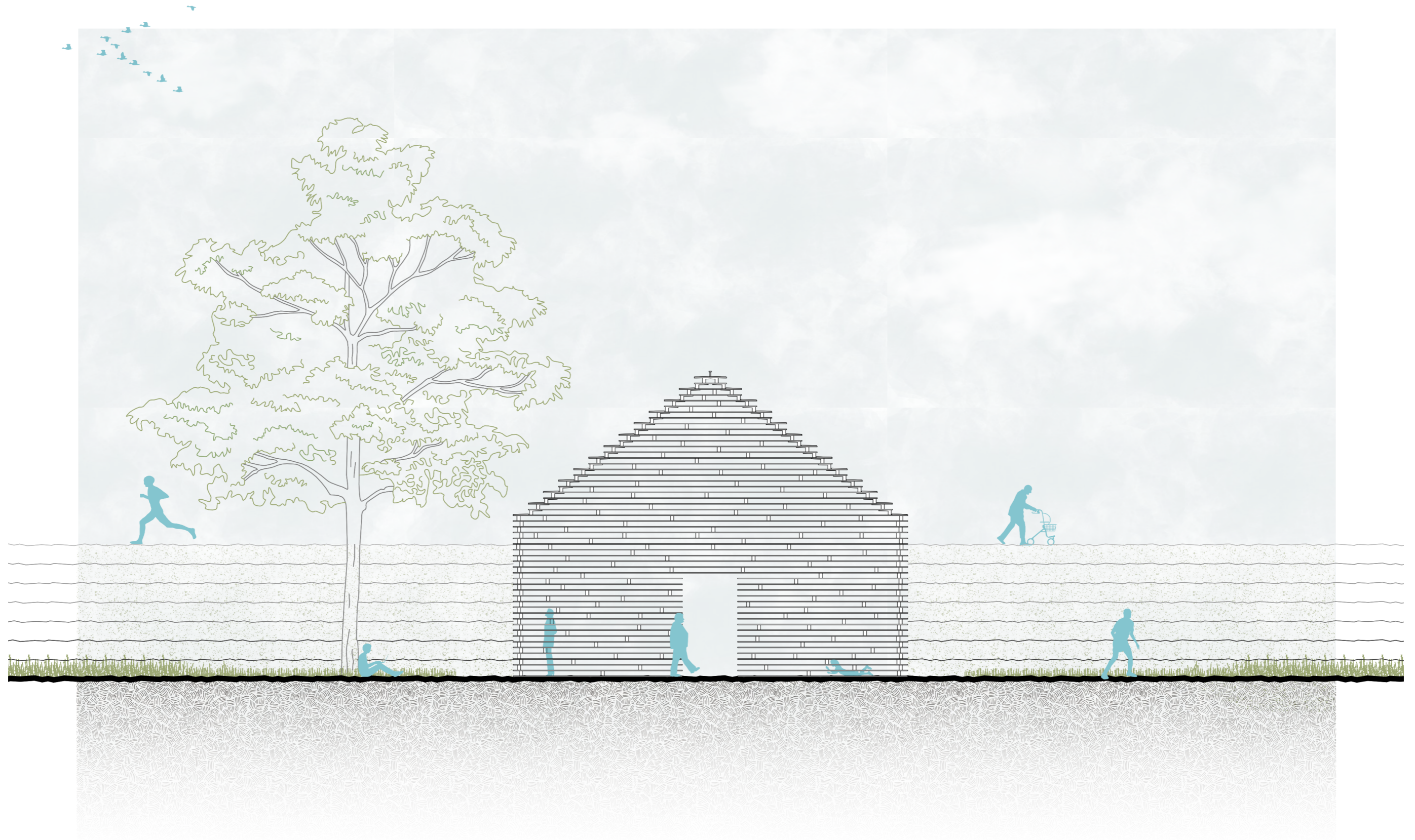
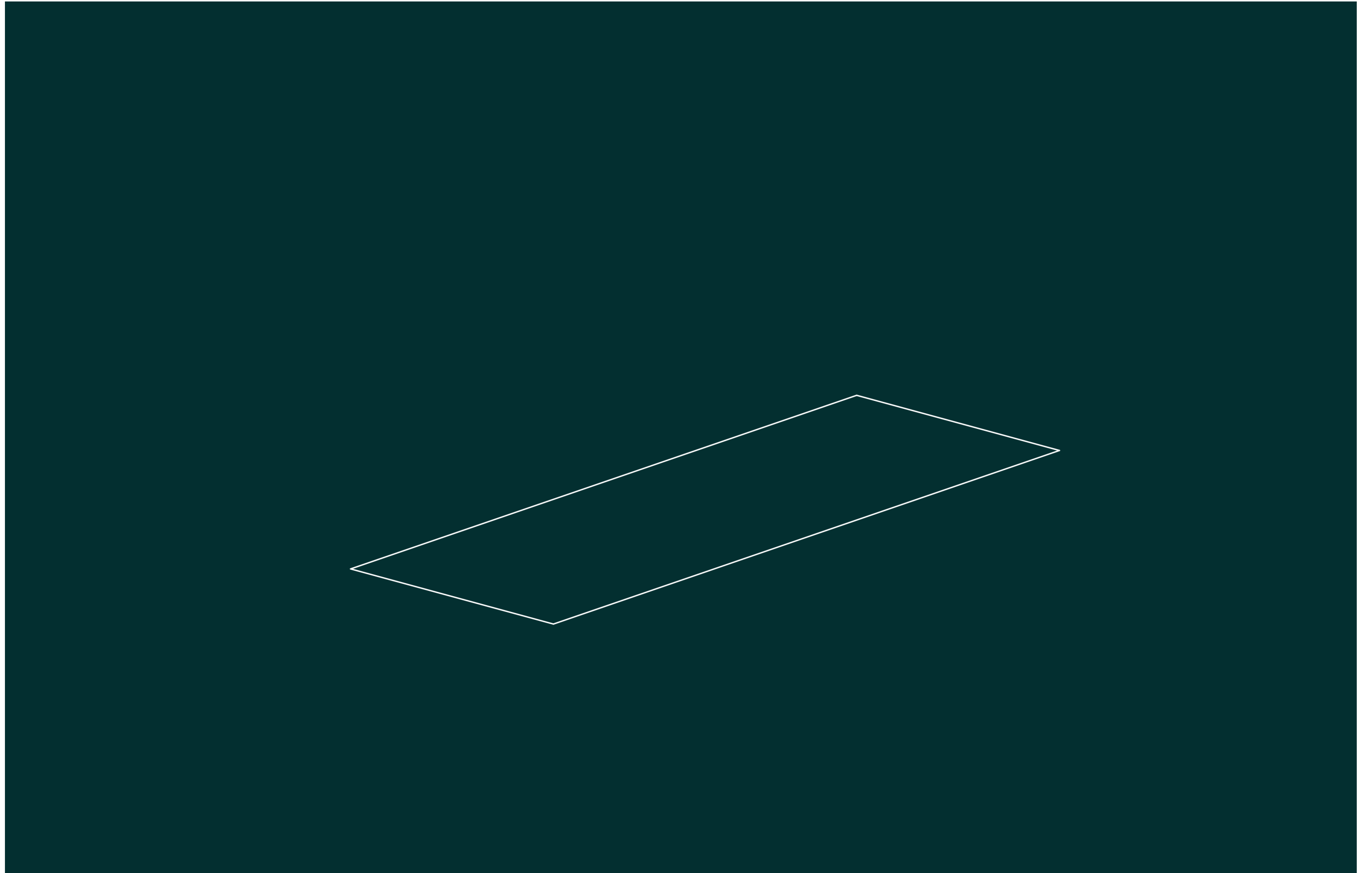
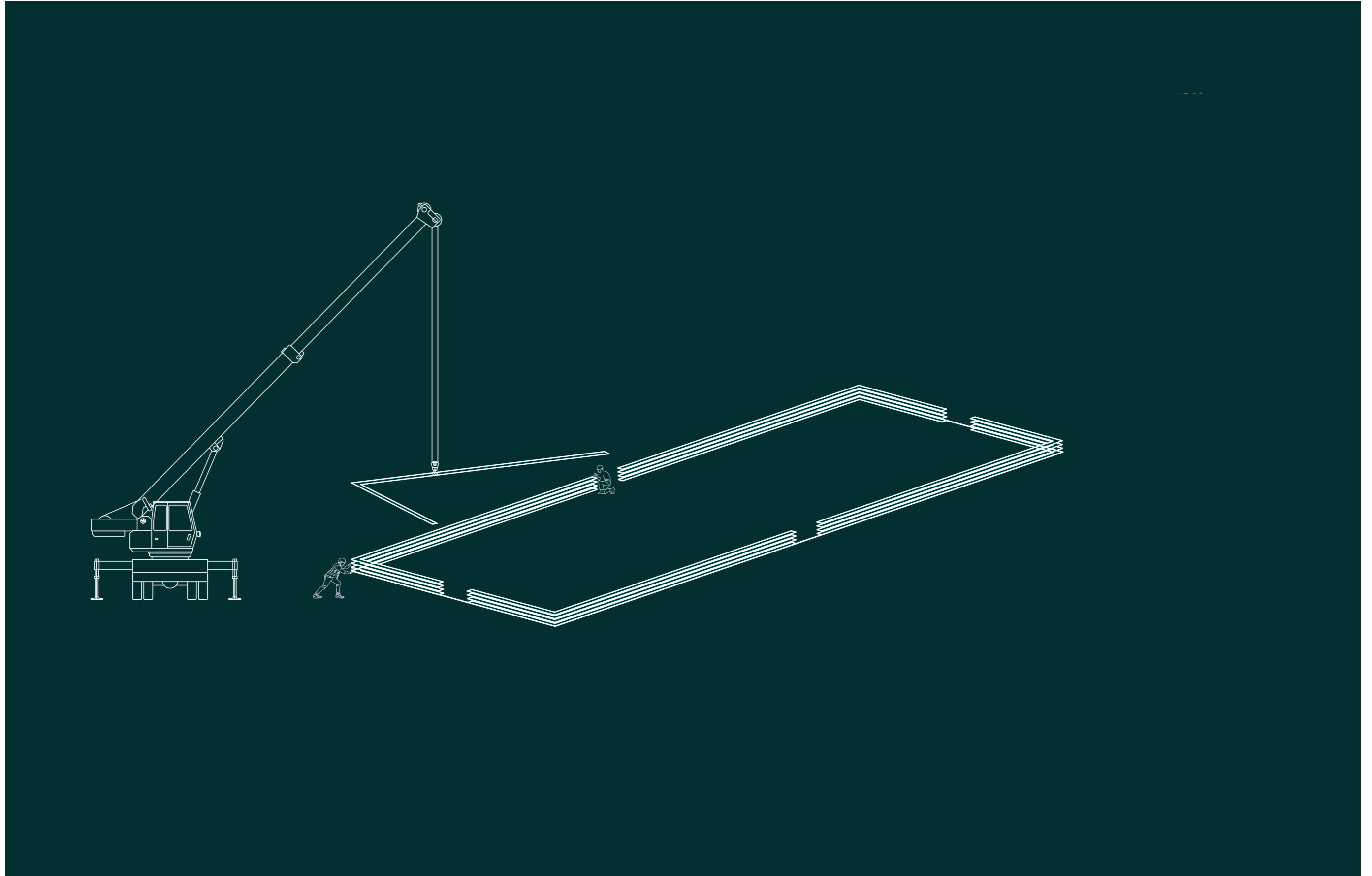


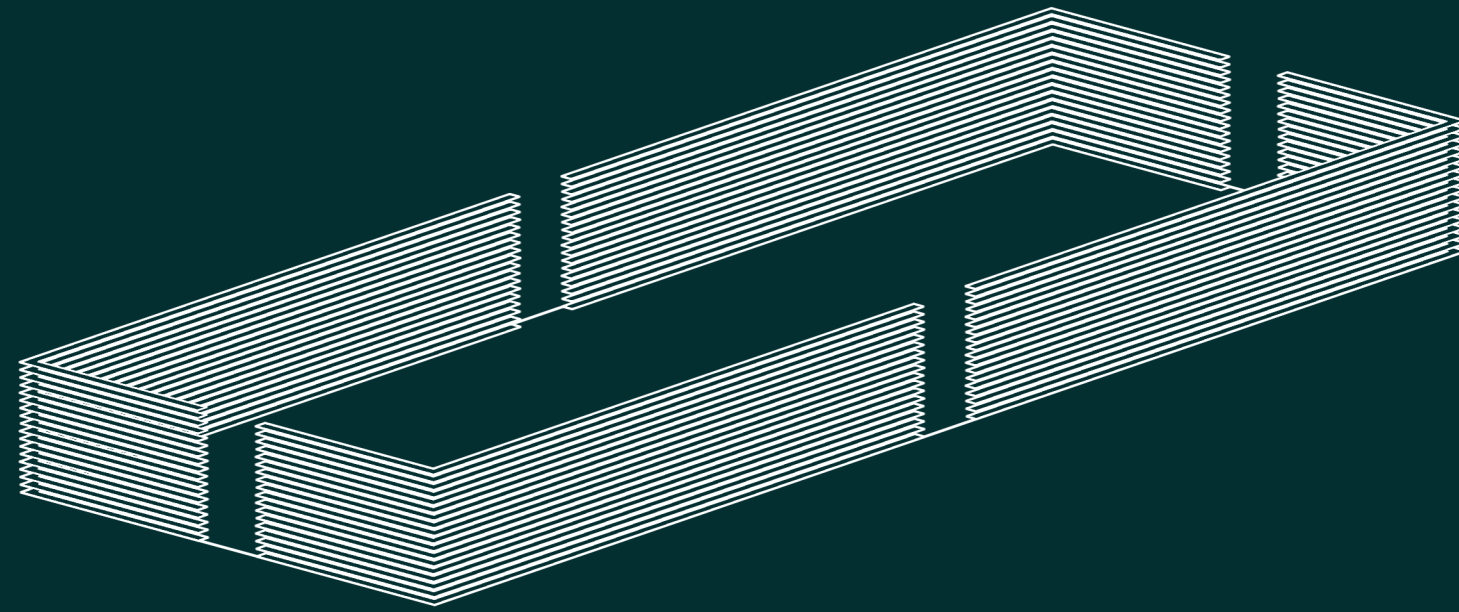


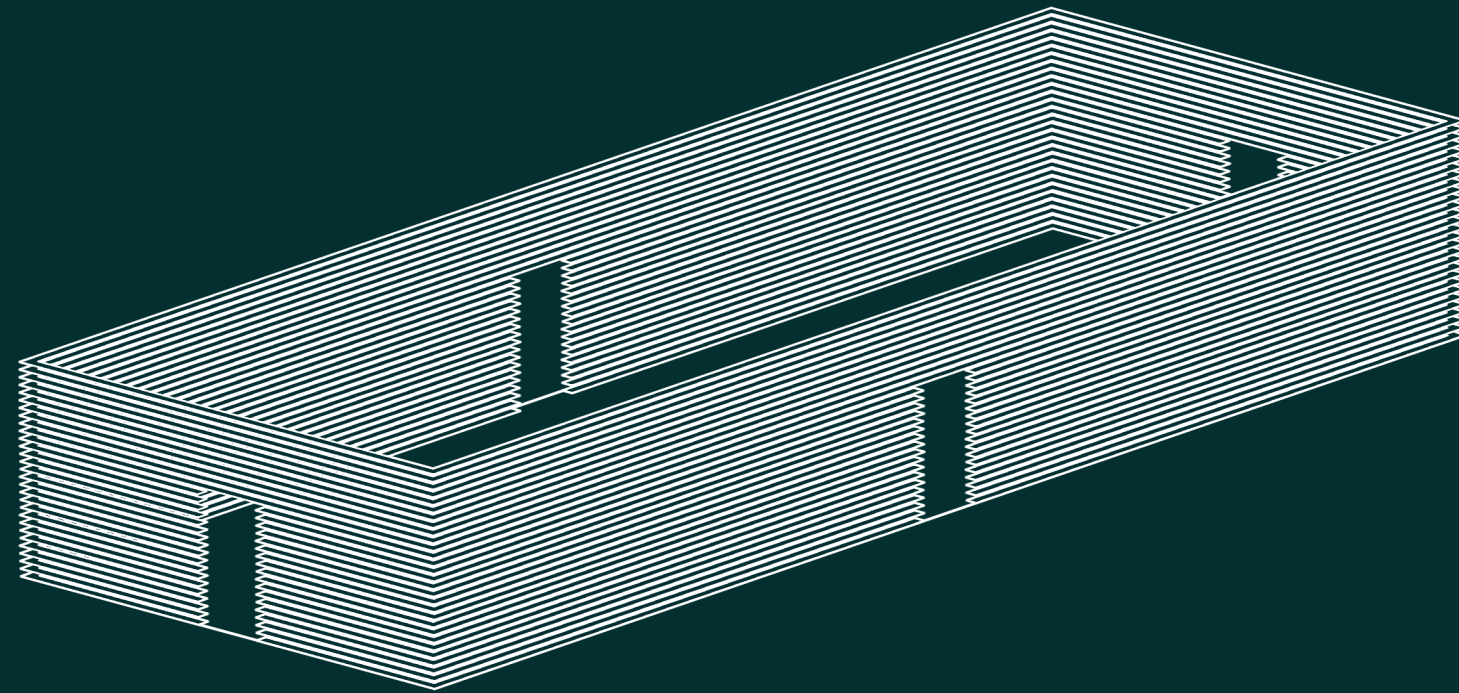
Figure 5: Reading between the lines, Belgium, Solosophie (2024)

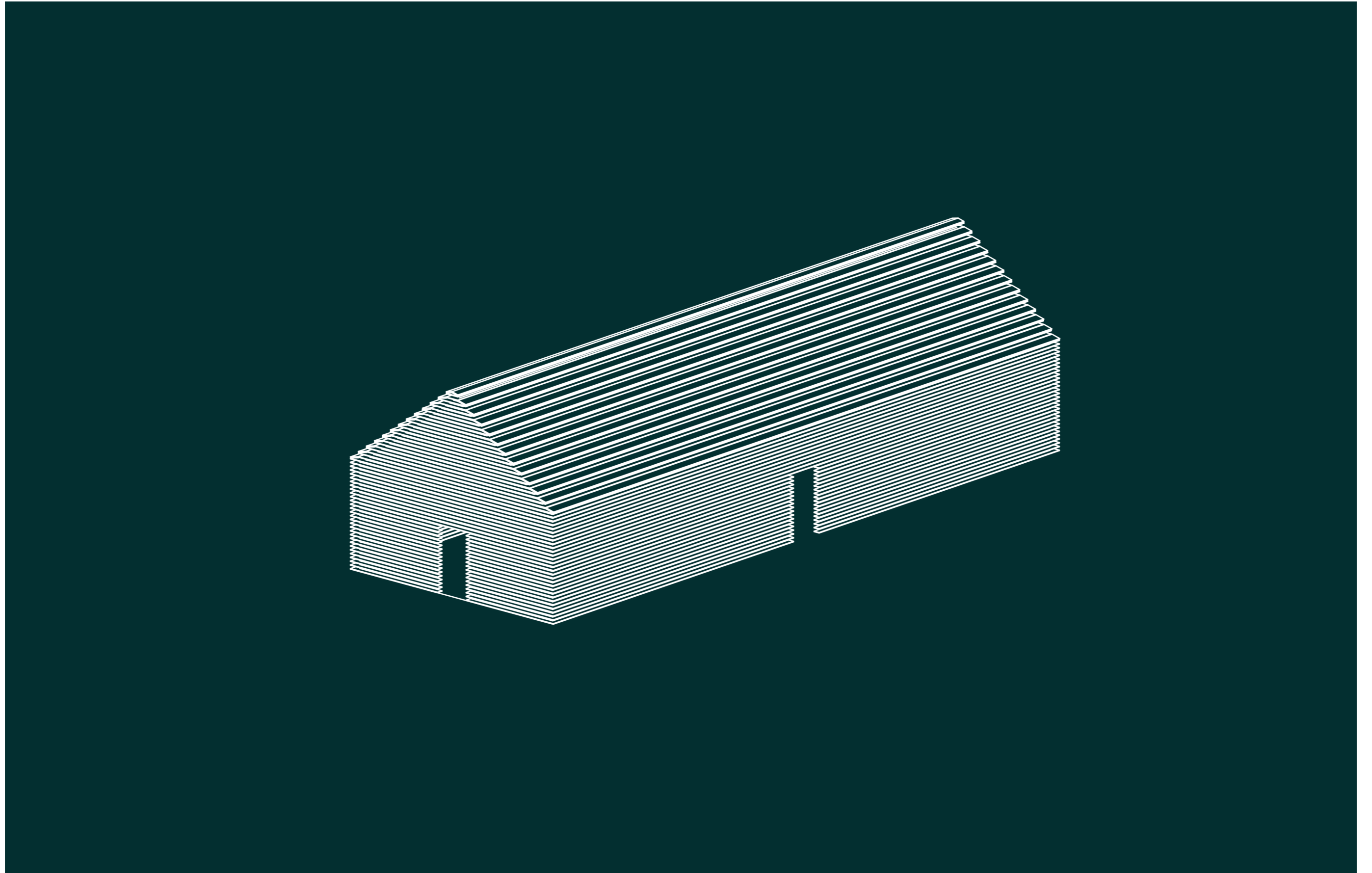


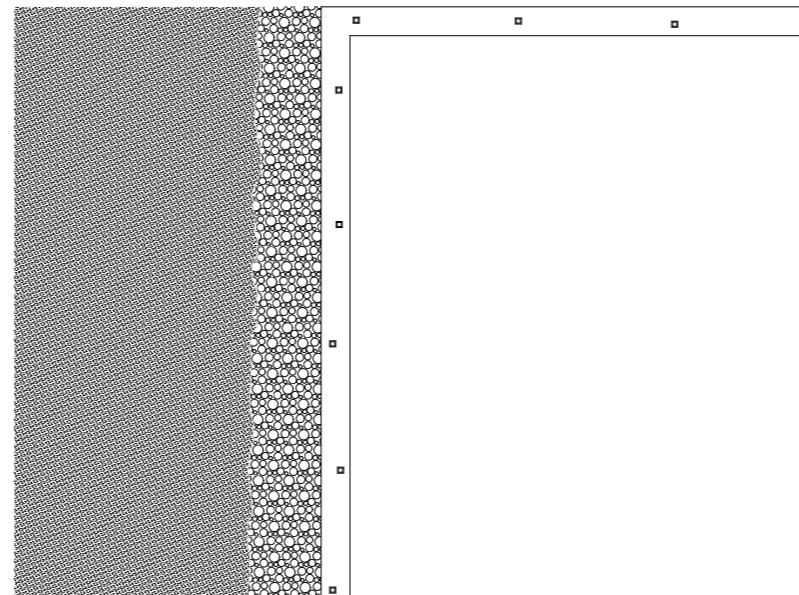
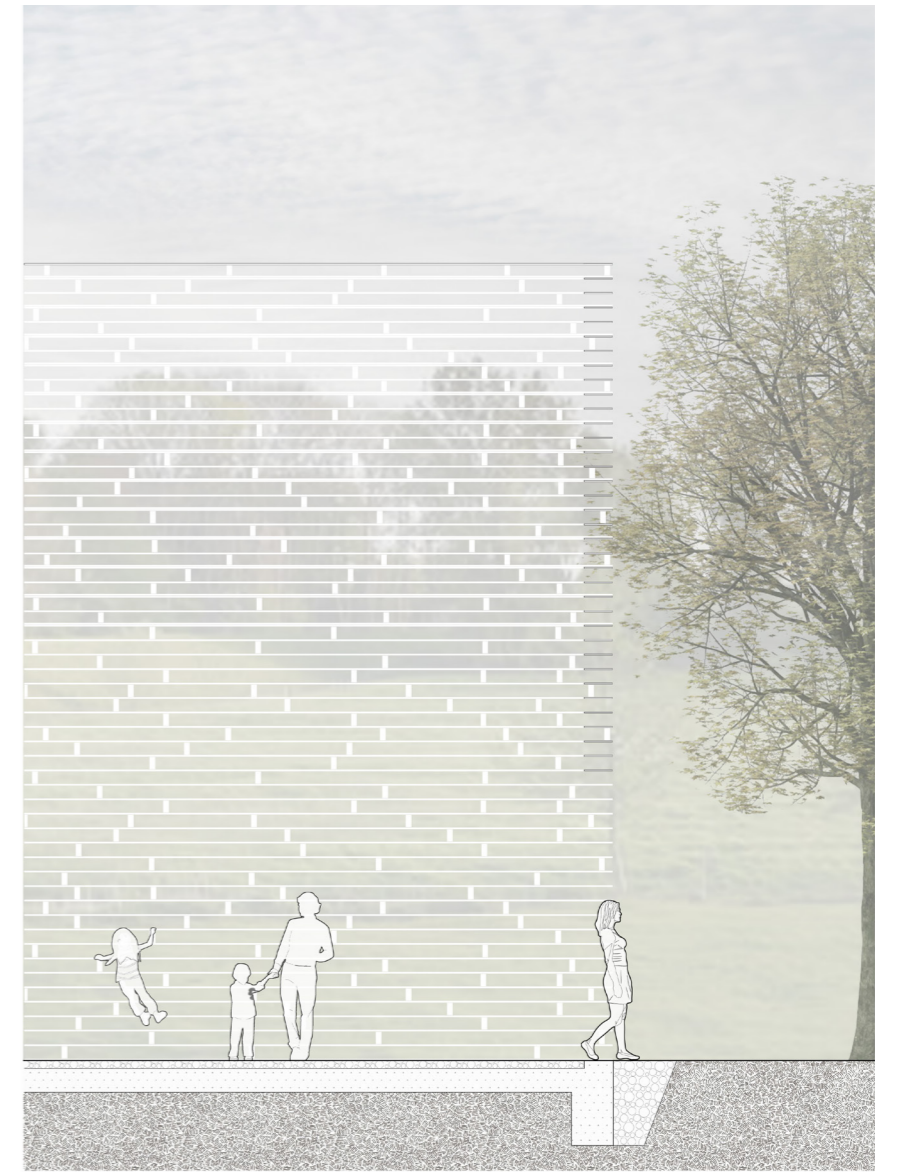
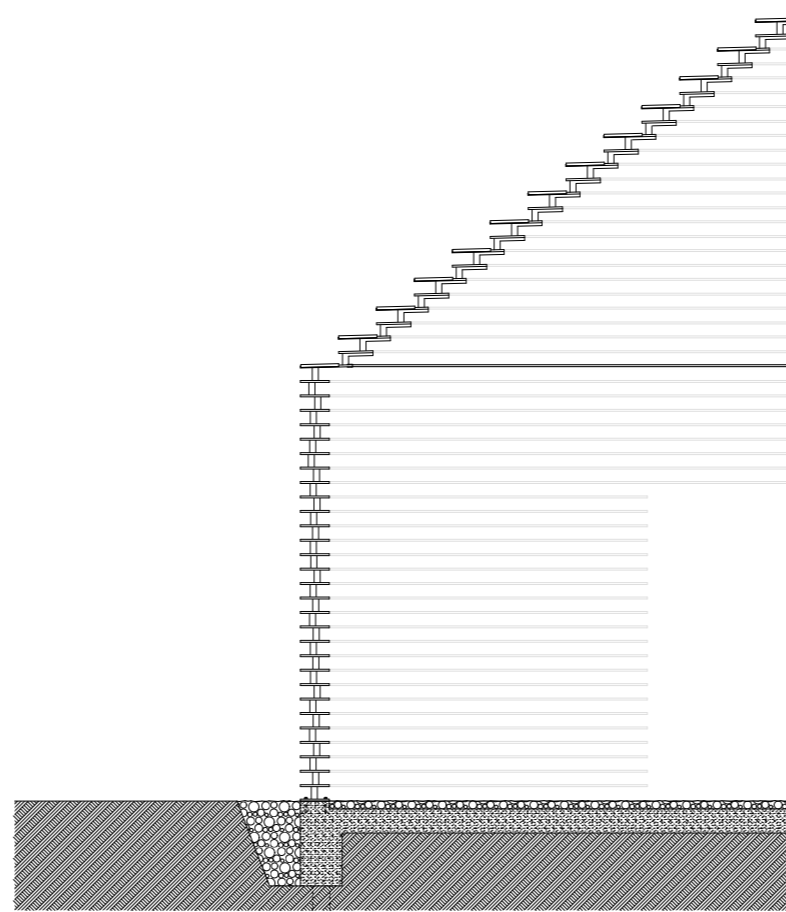


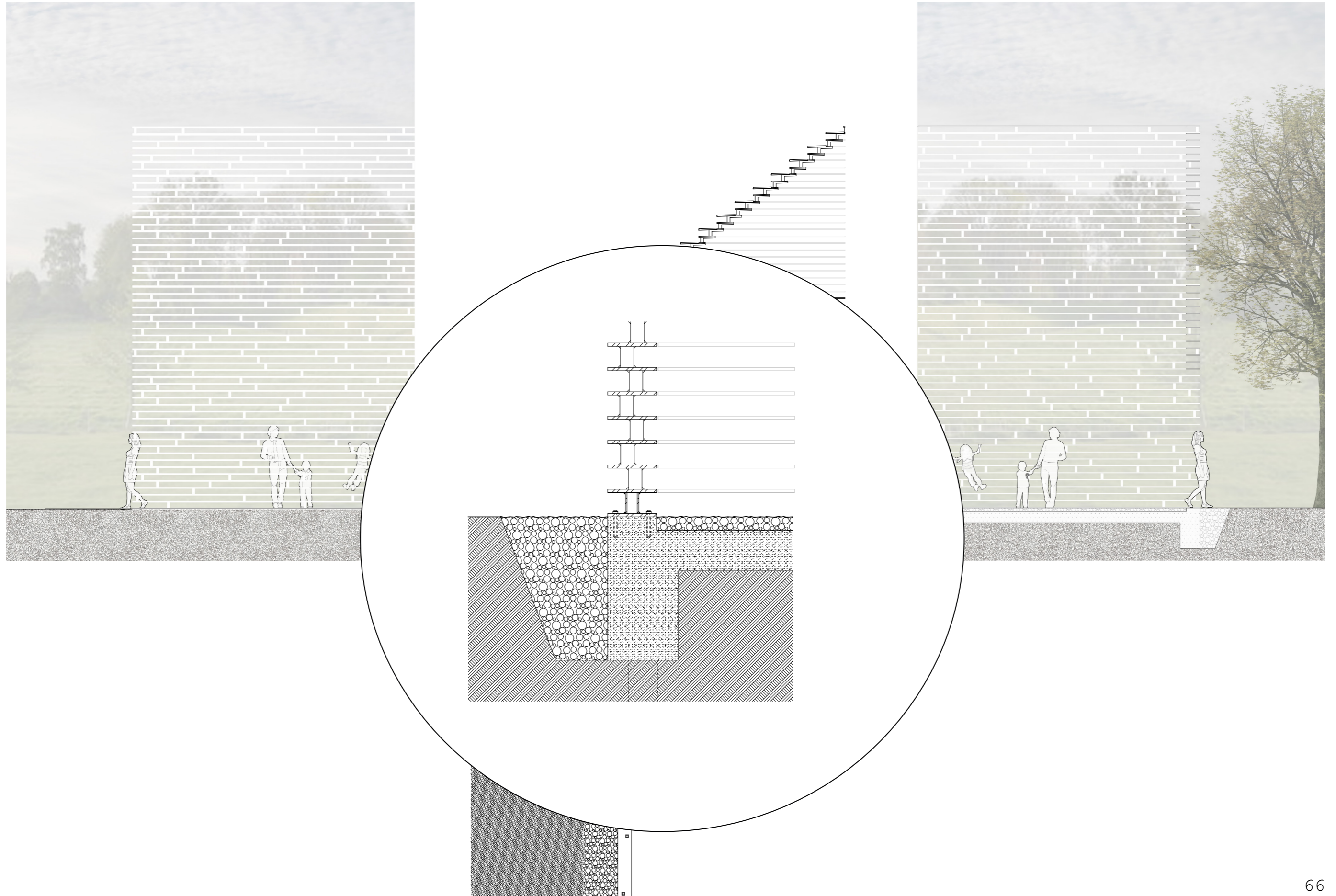


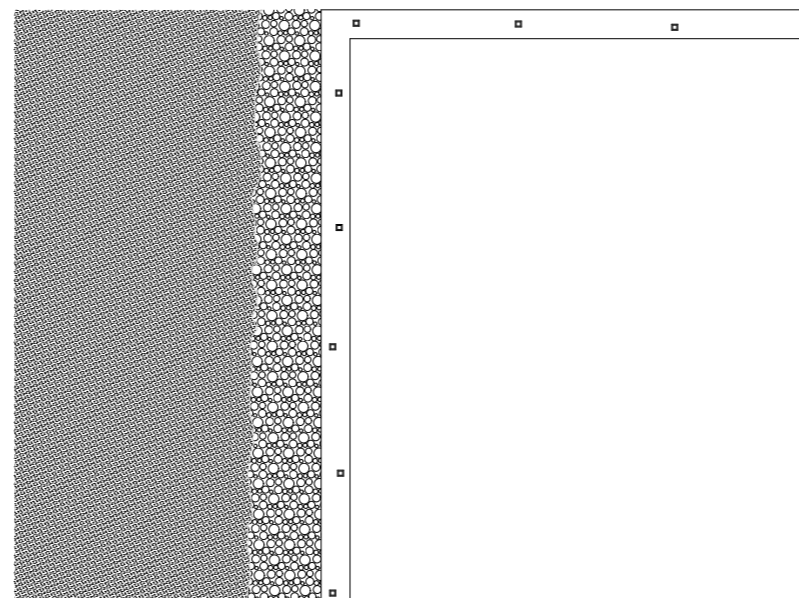
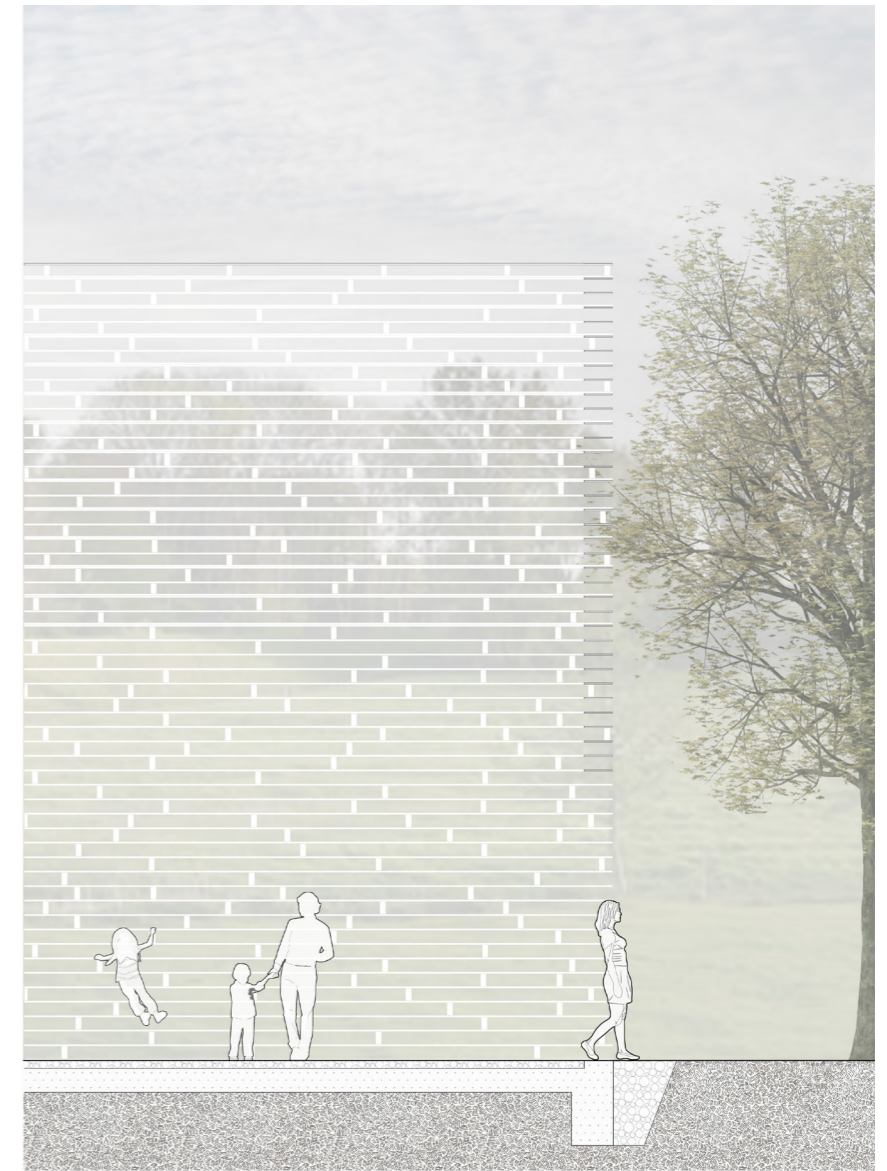
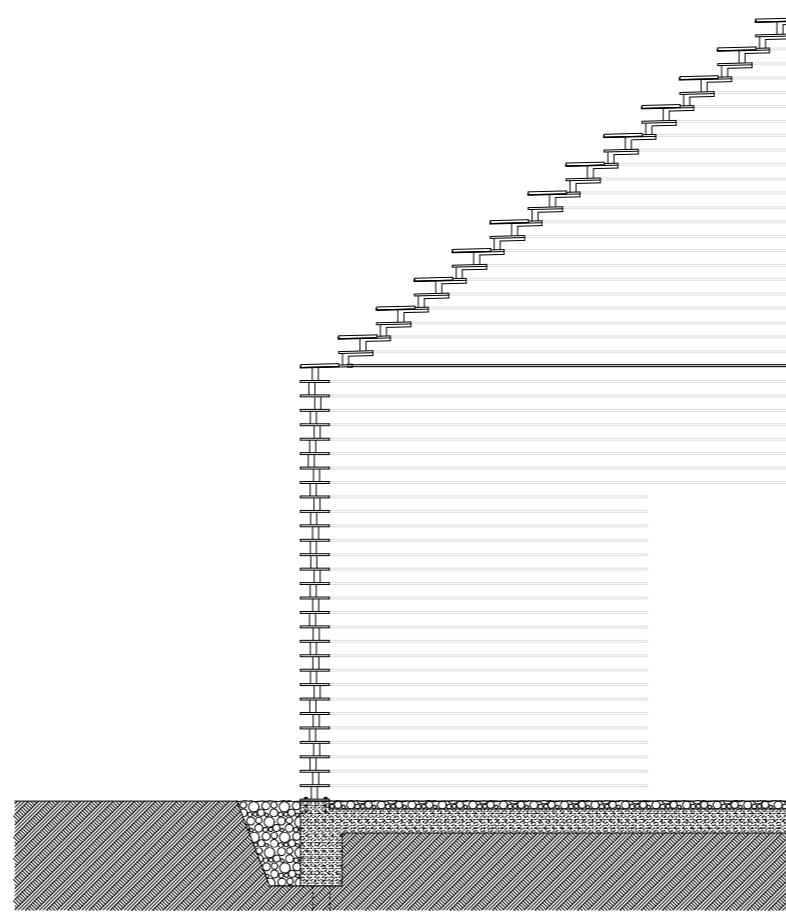


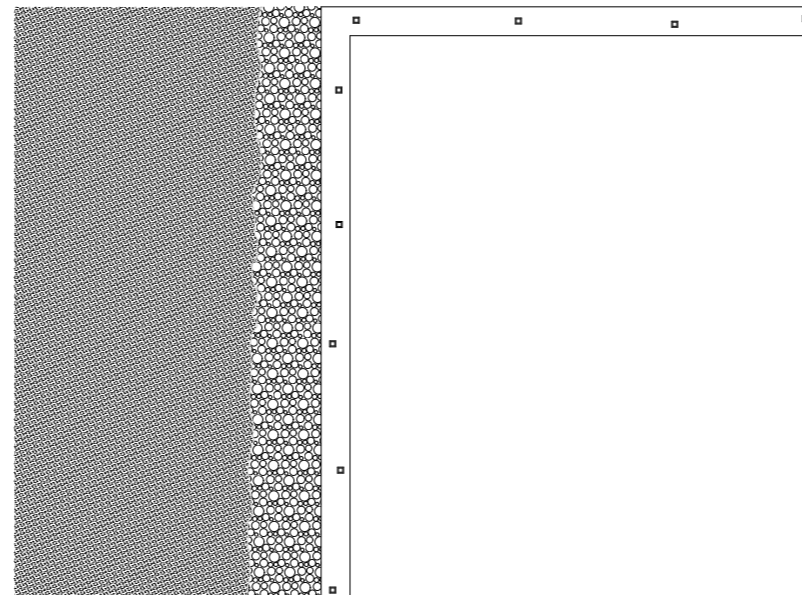
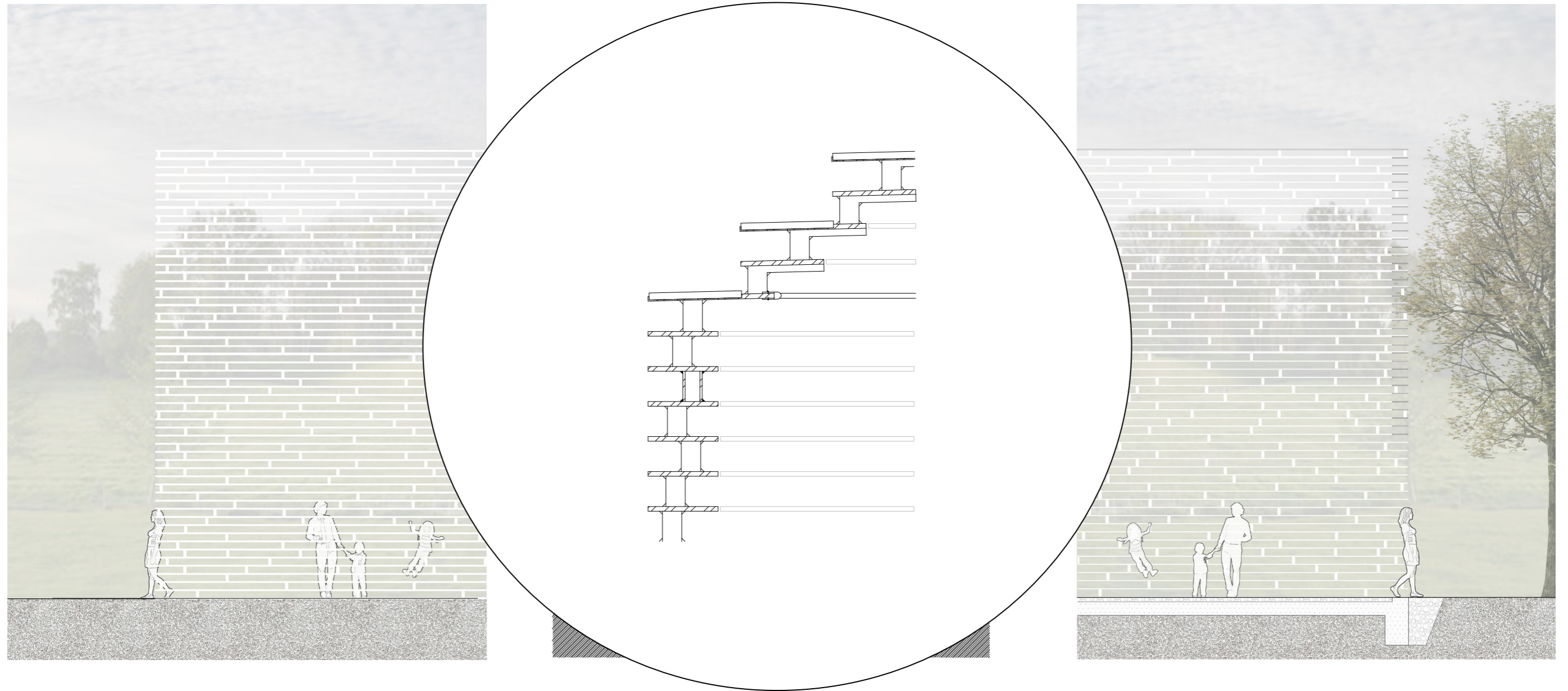


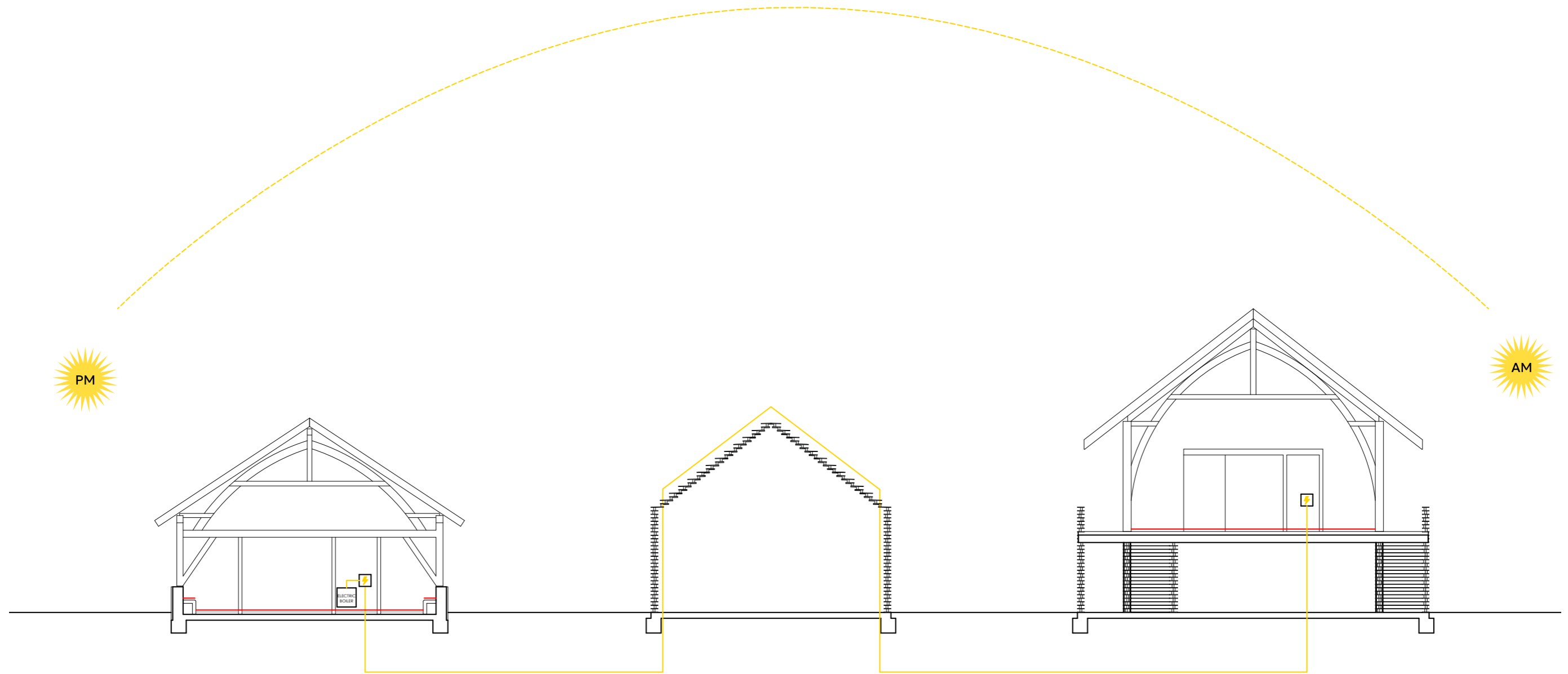


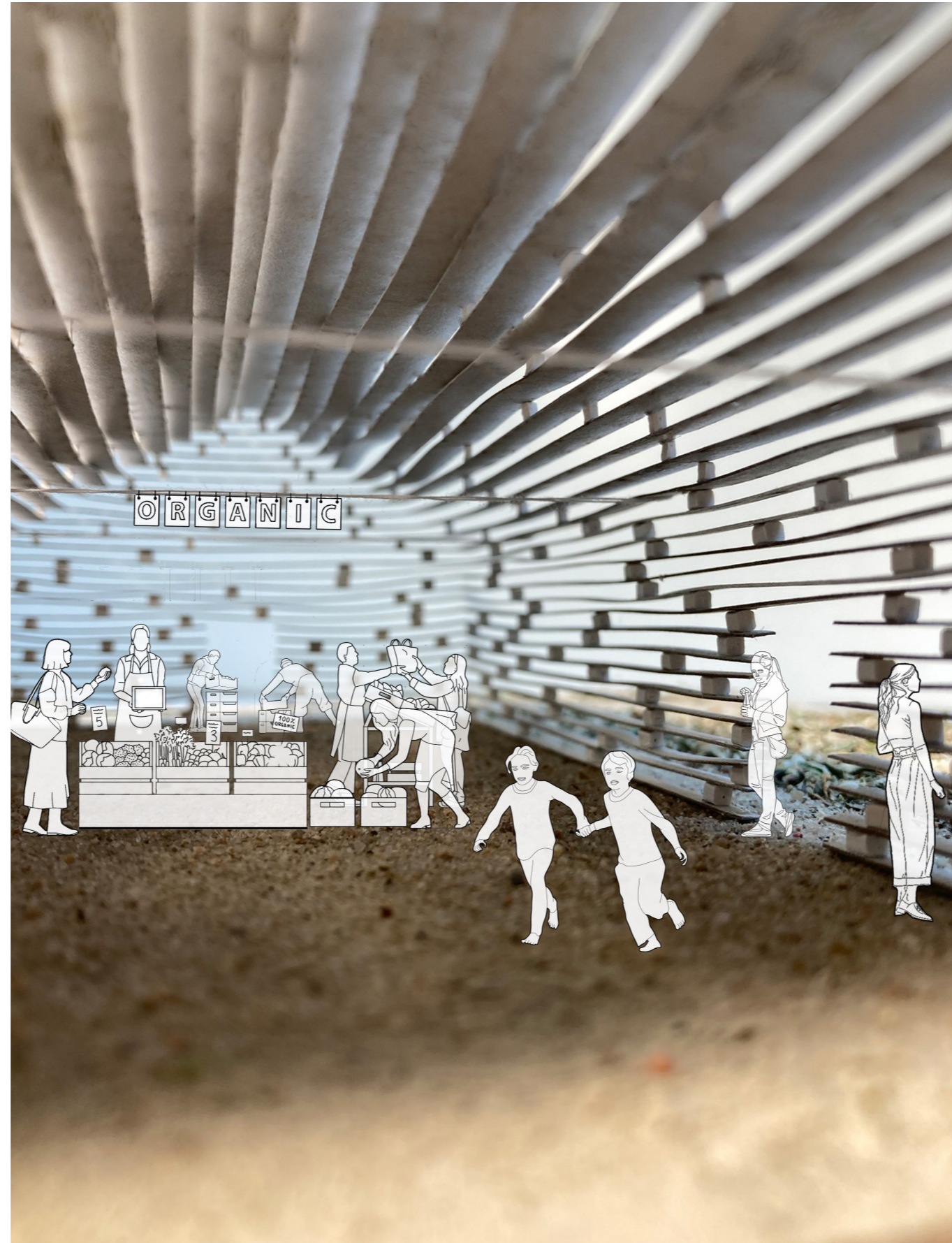


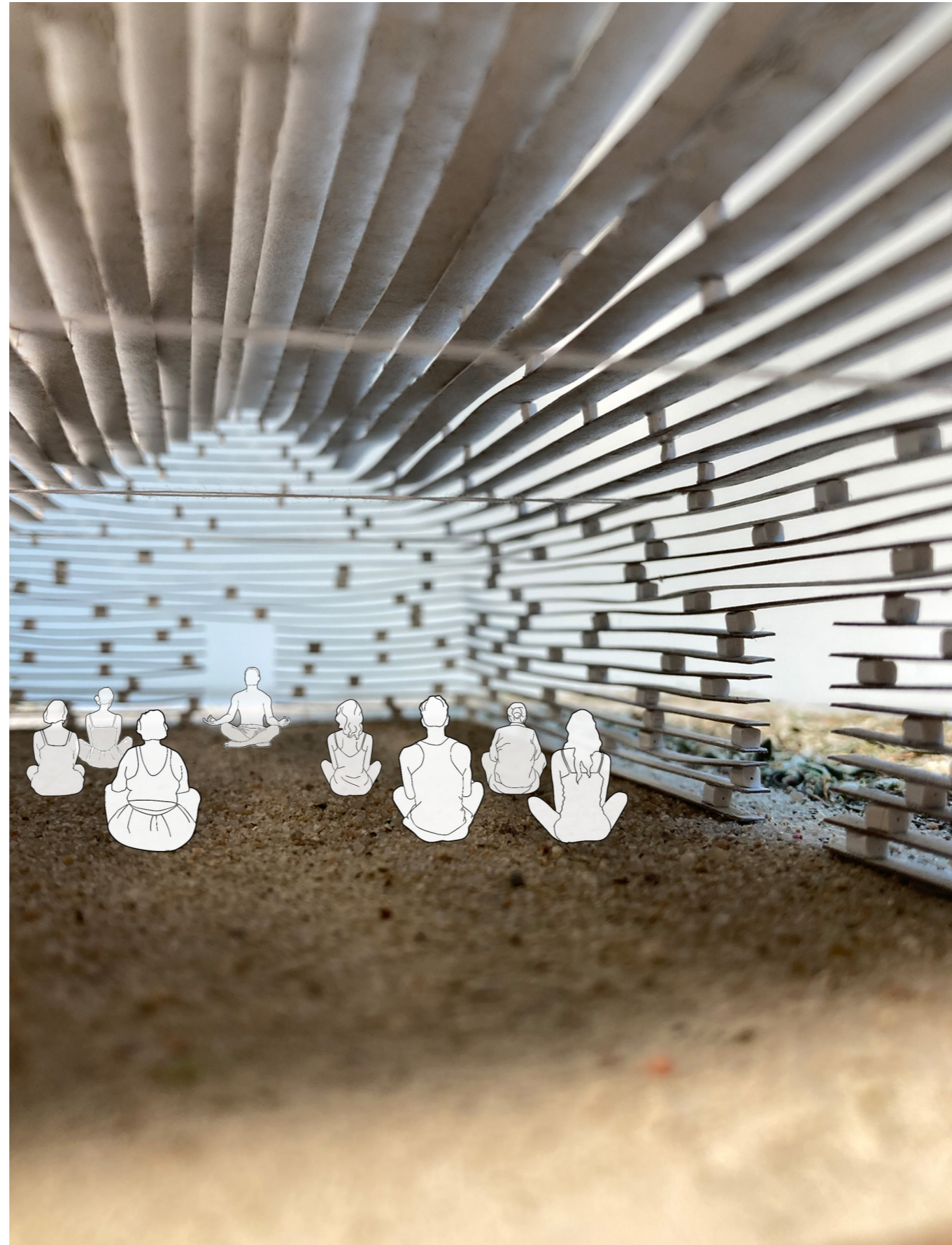


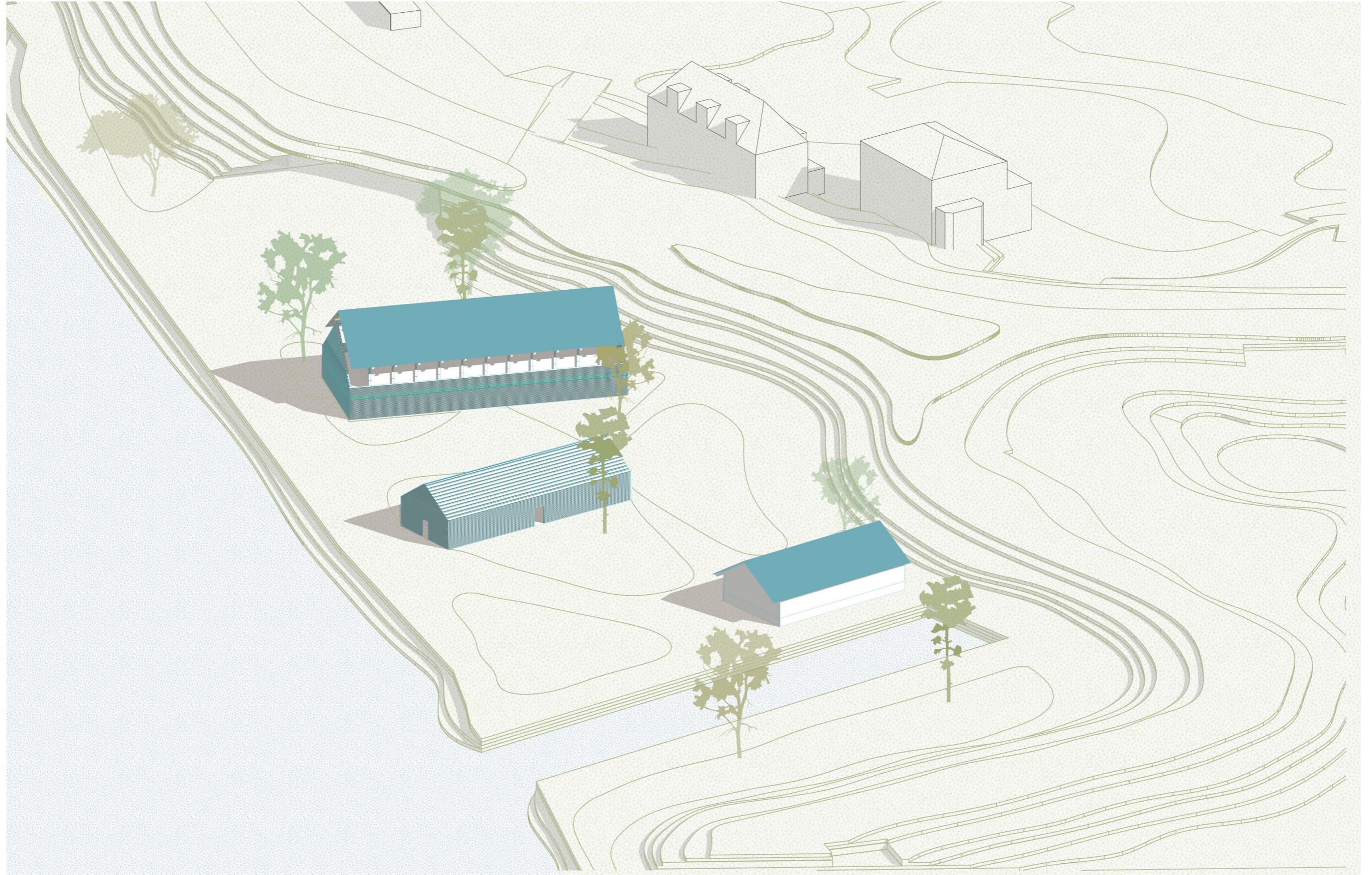




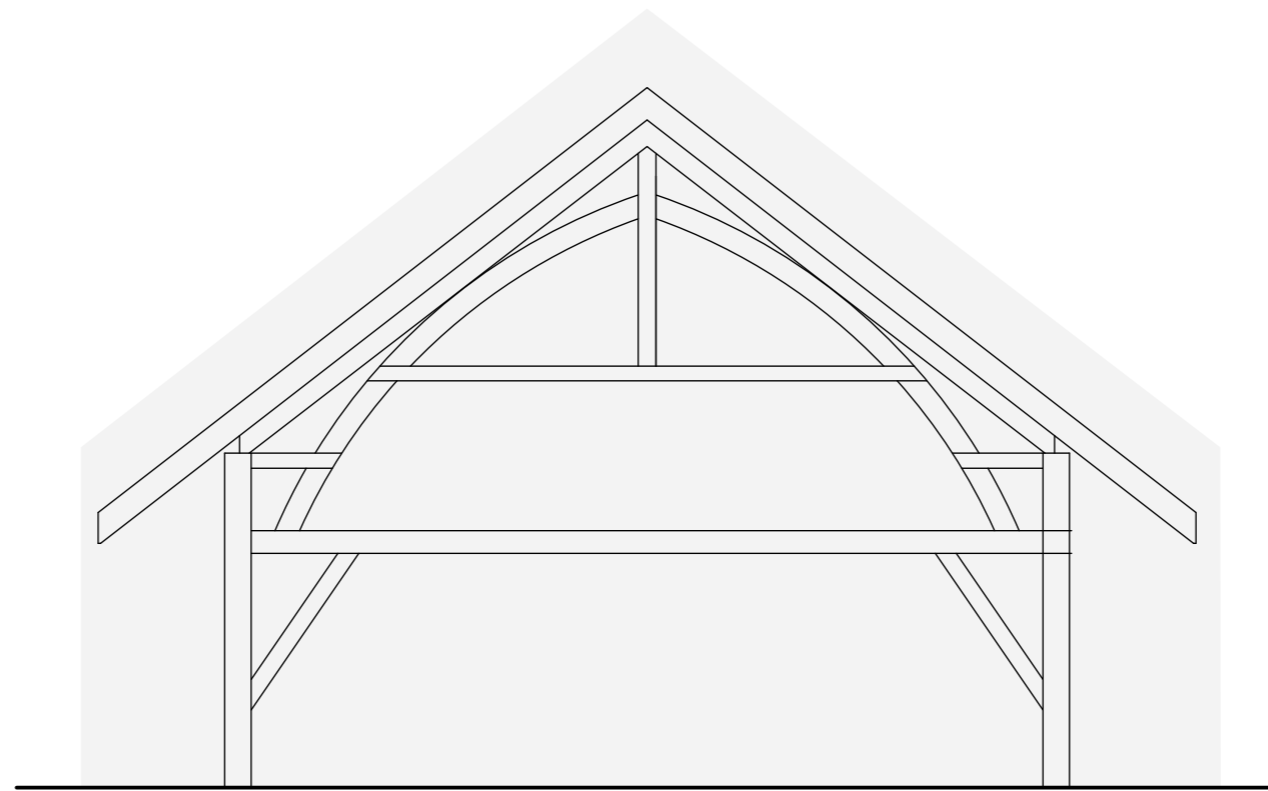


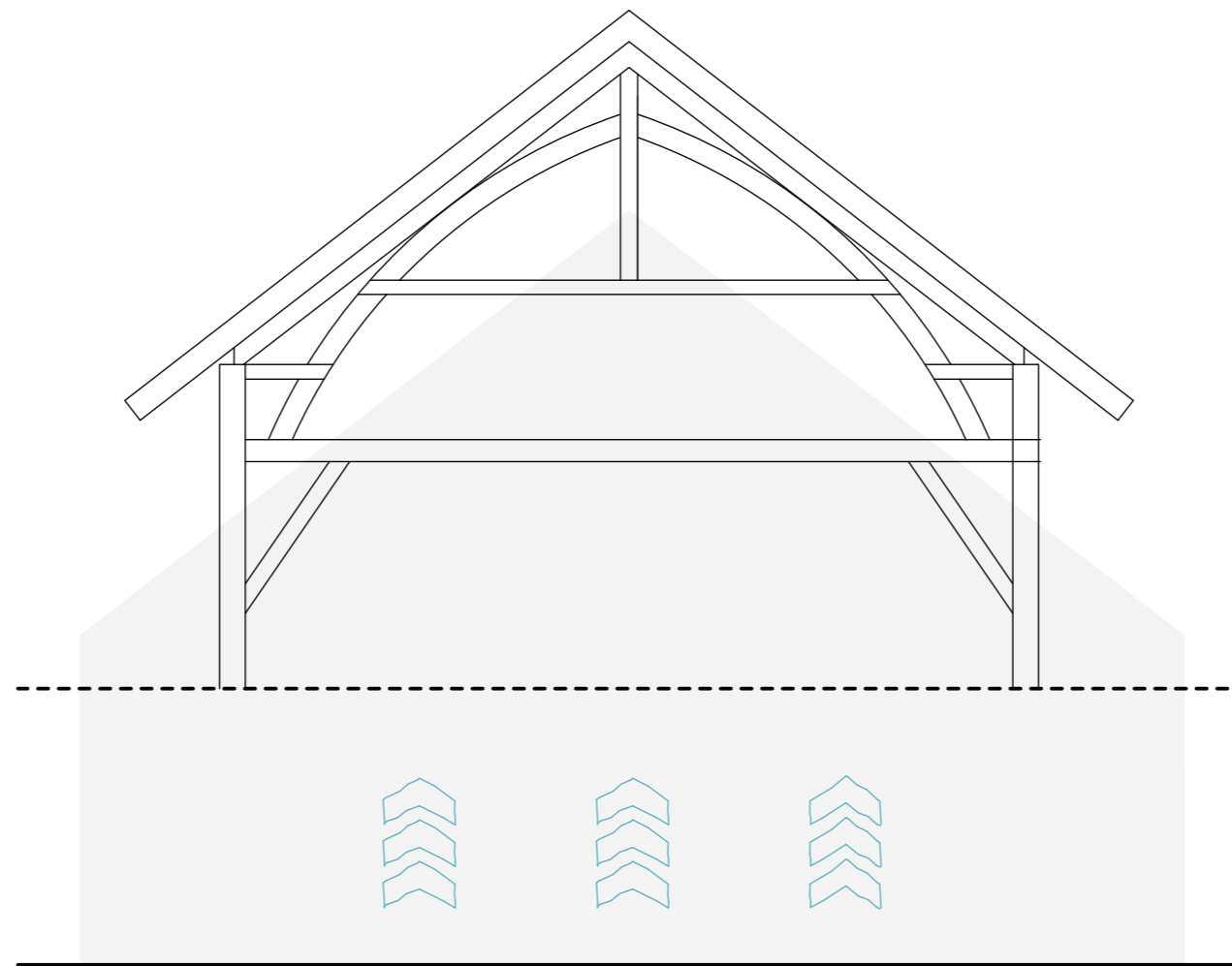


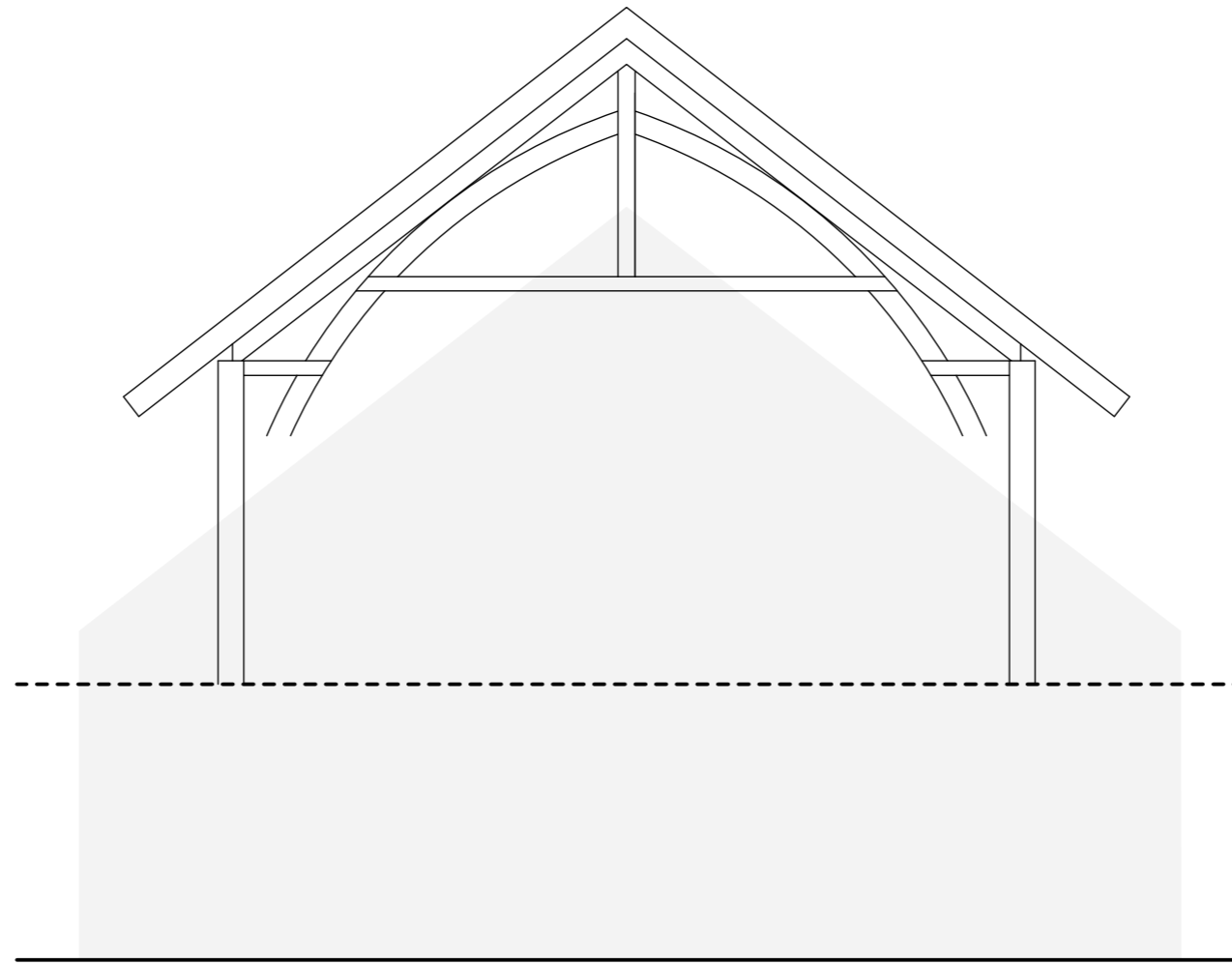


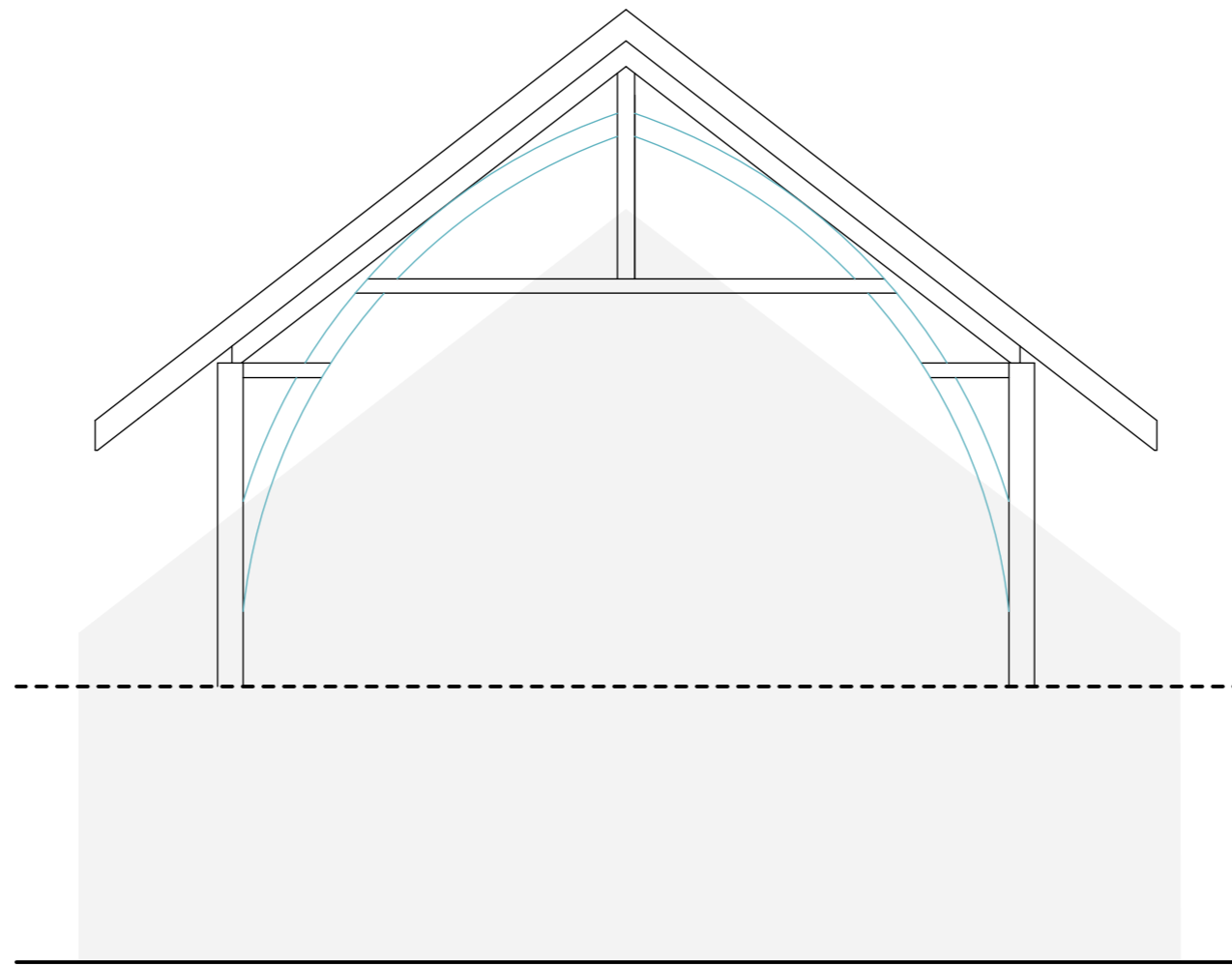


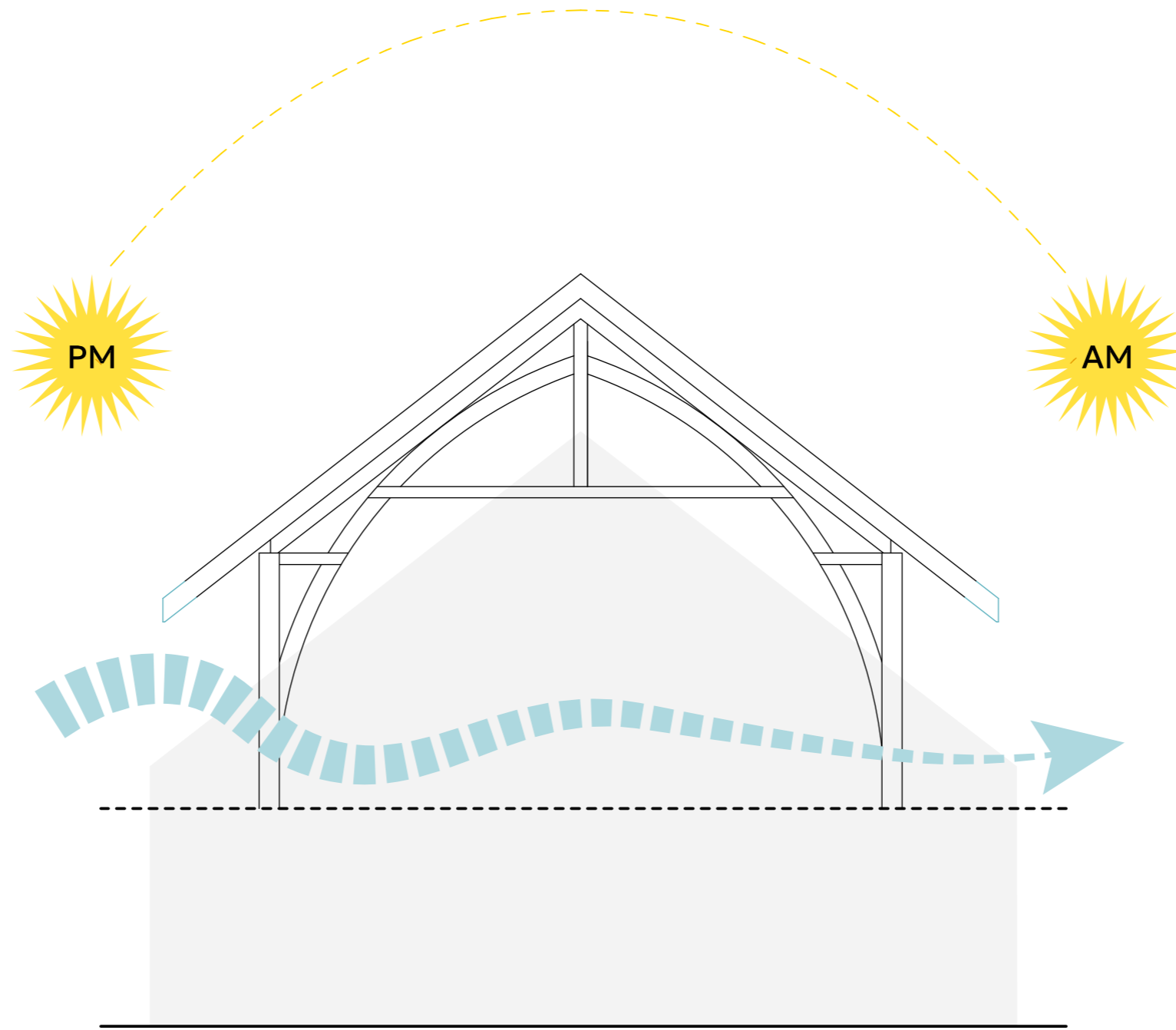


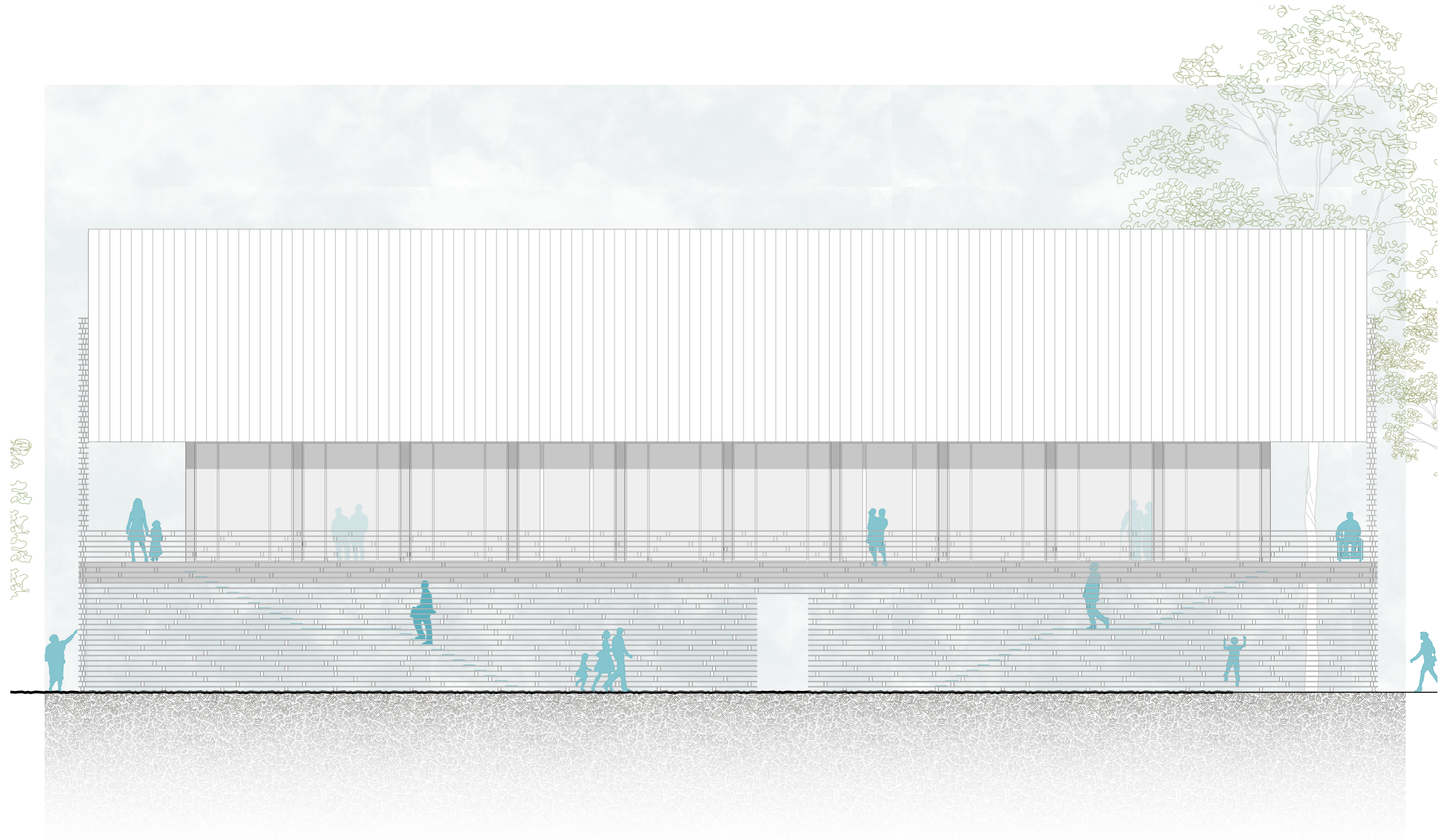




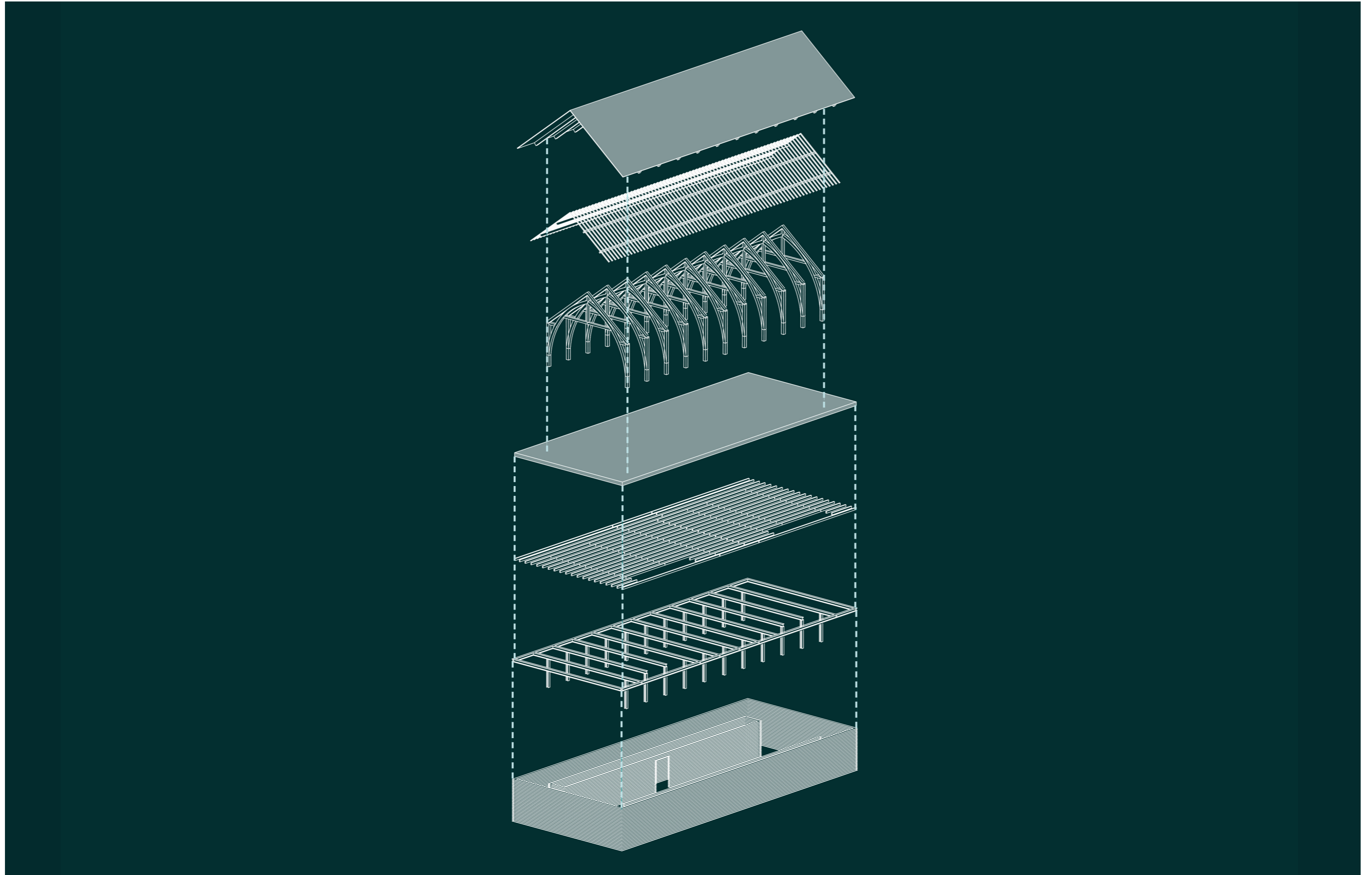


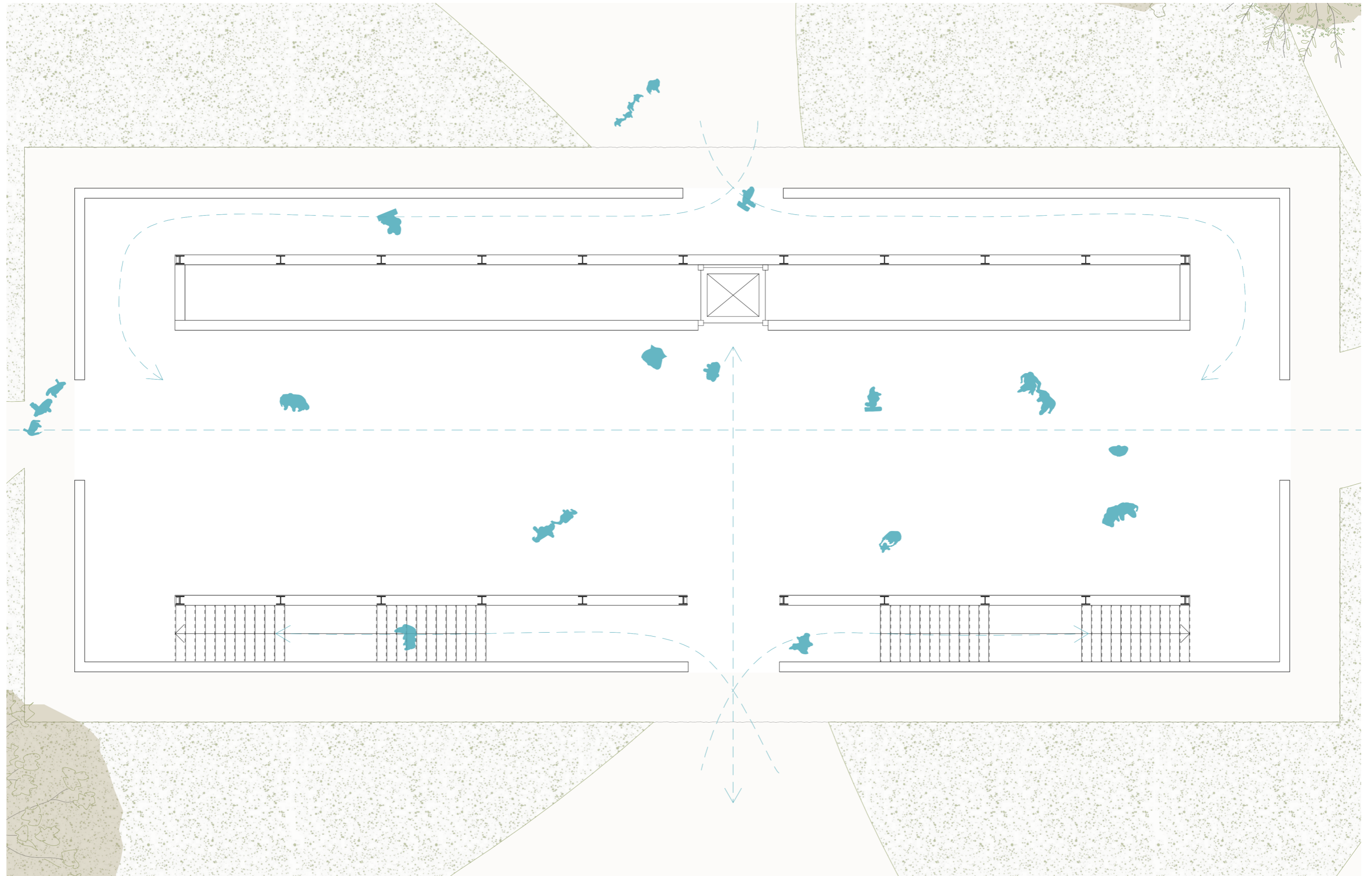




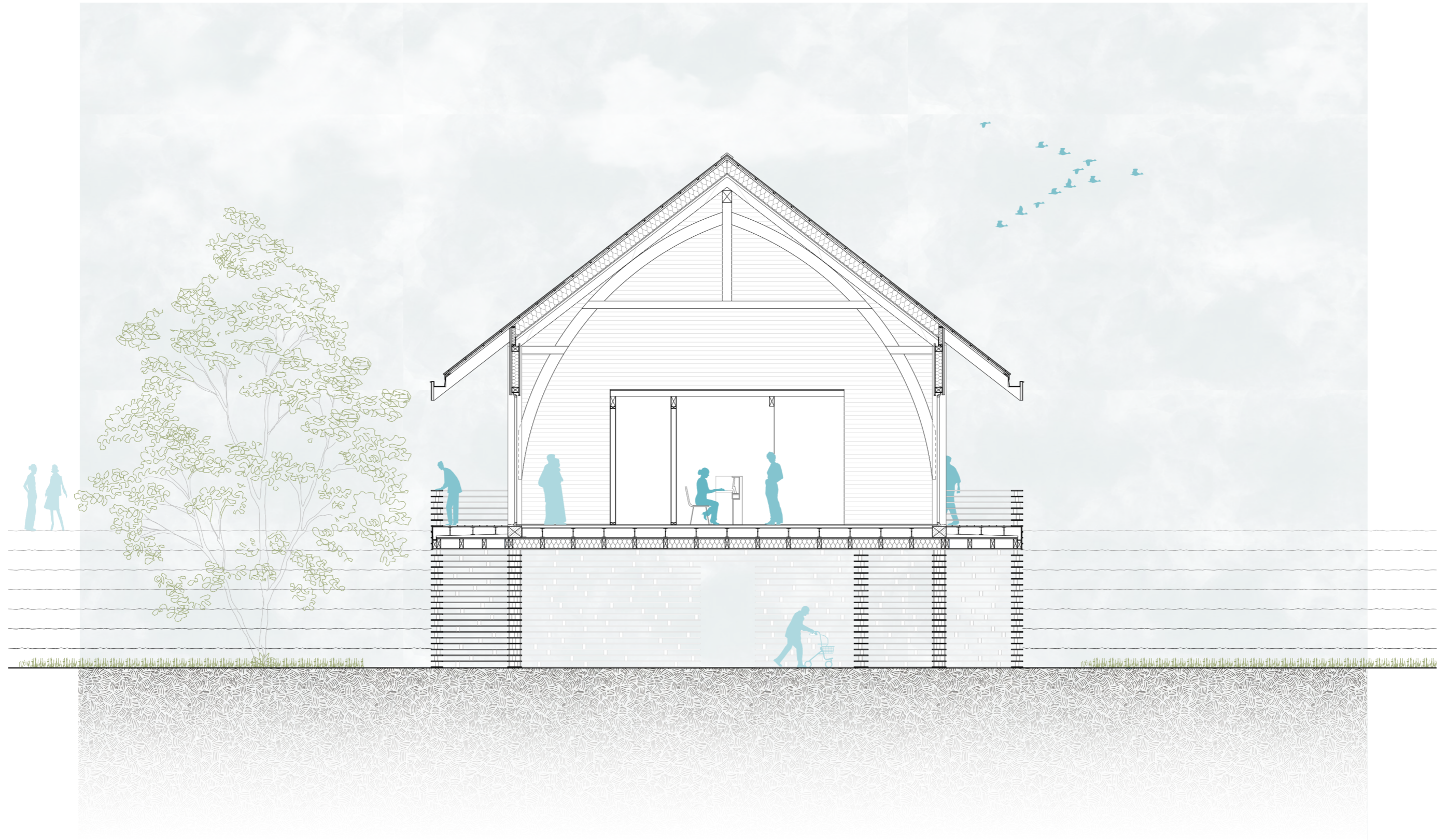


Ground floor floorplan

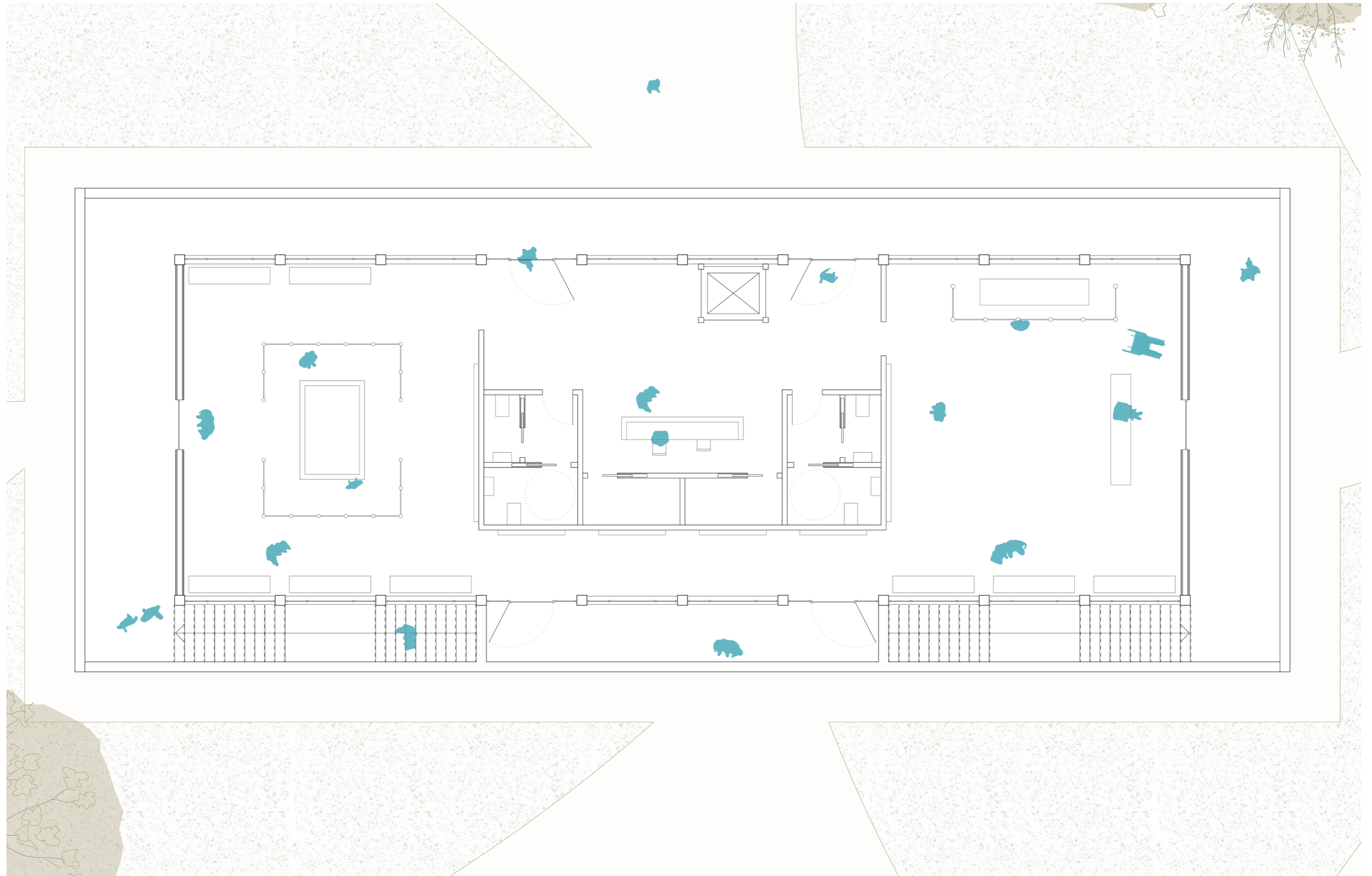




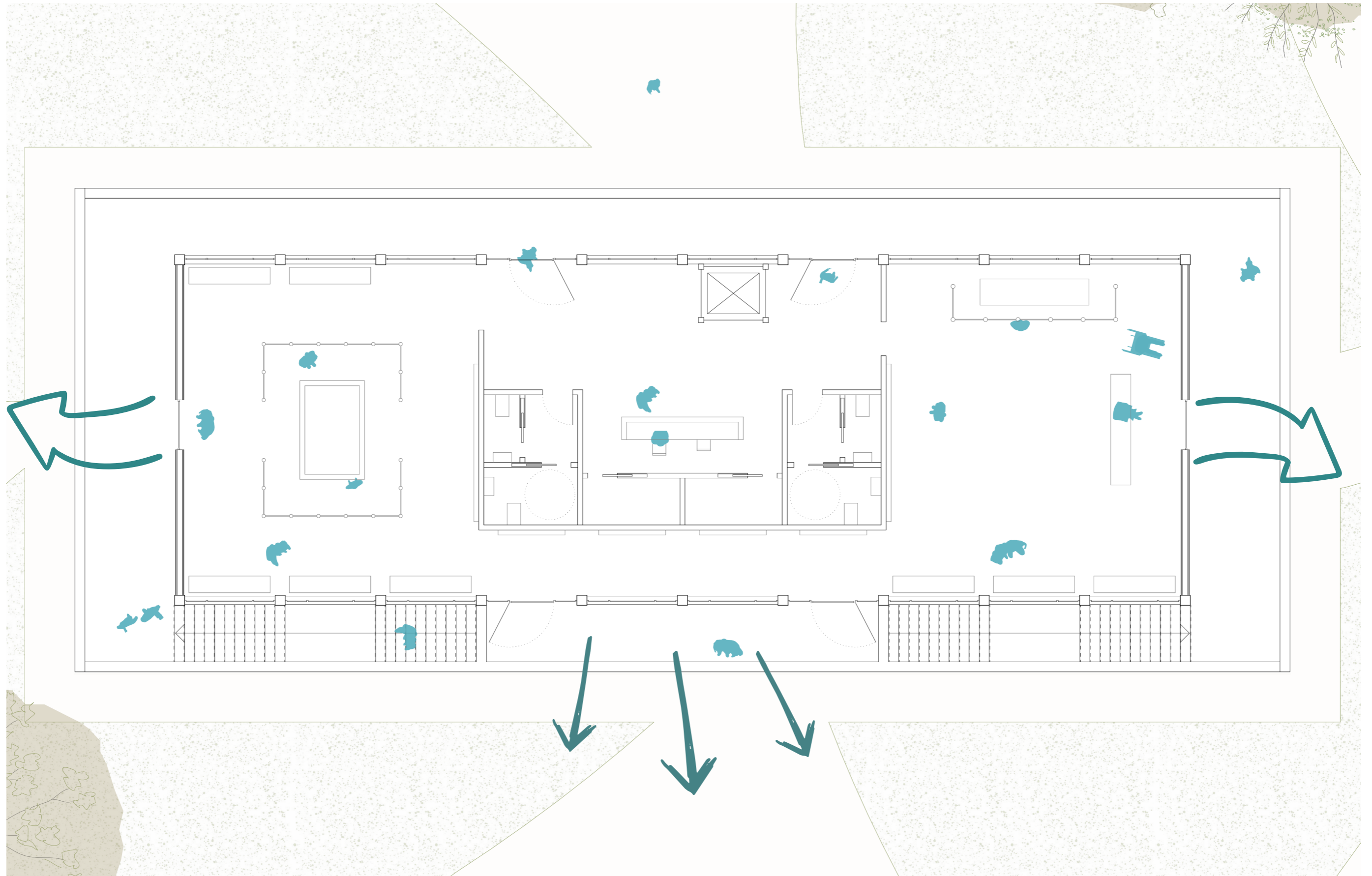
First floor floorplan



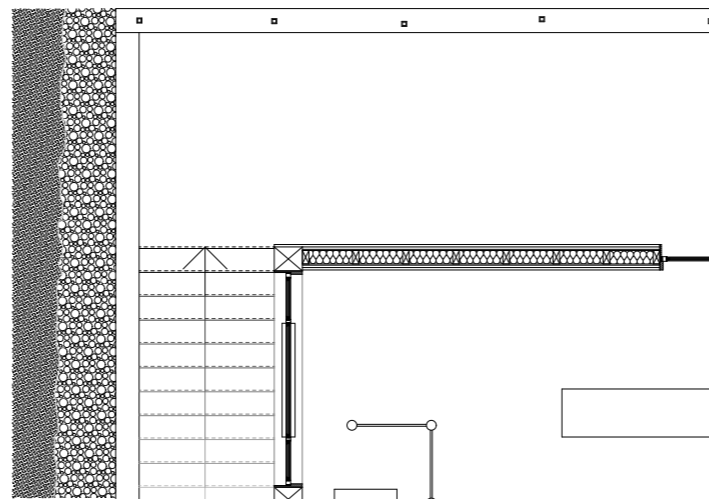
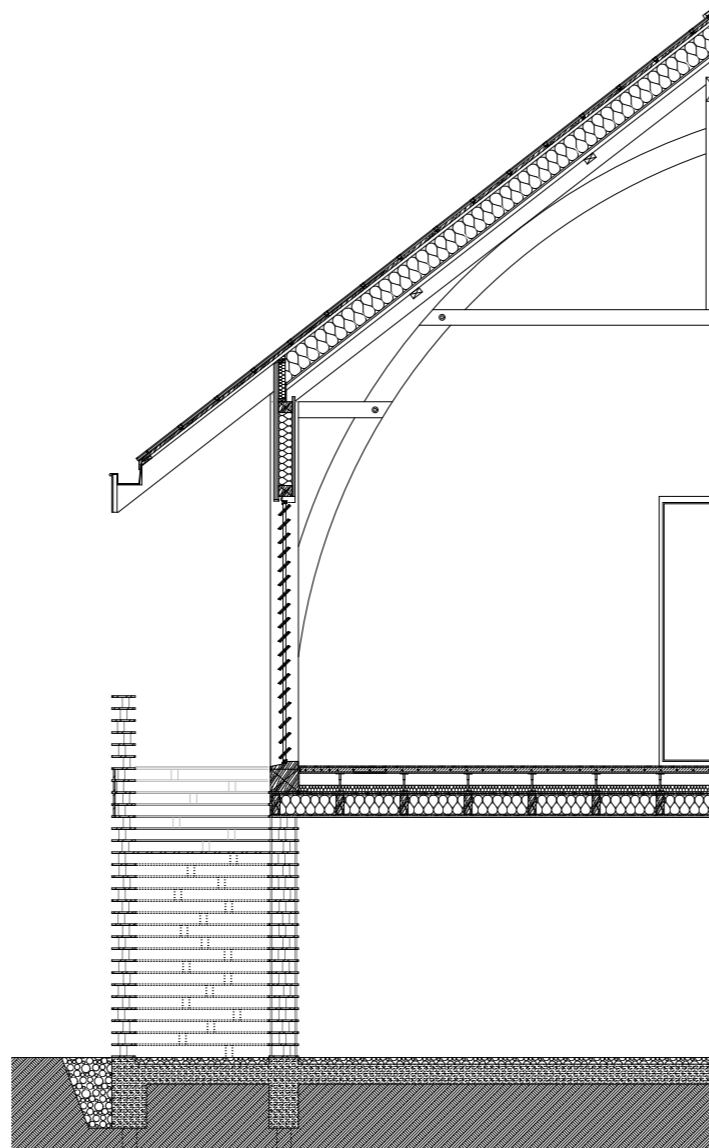
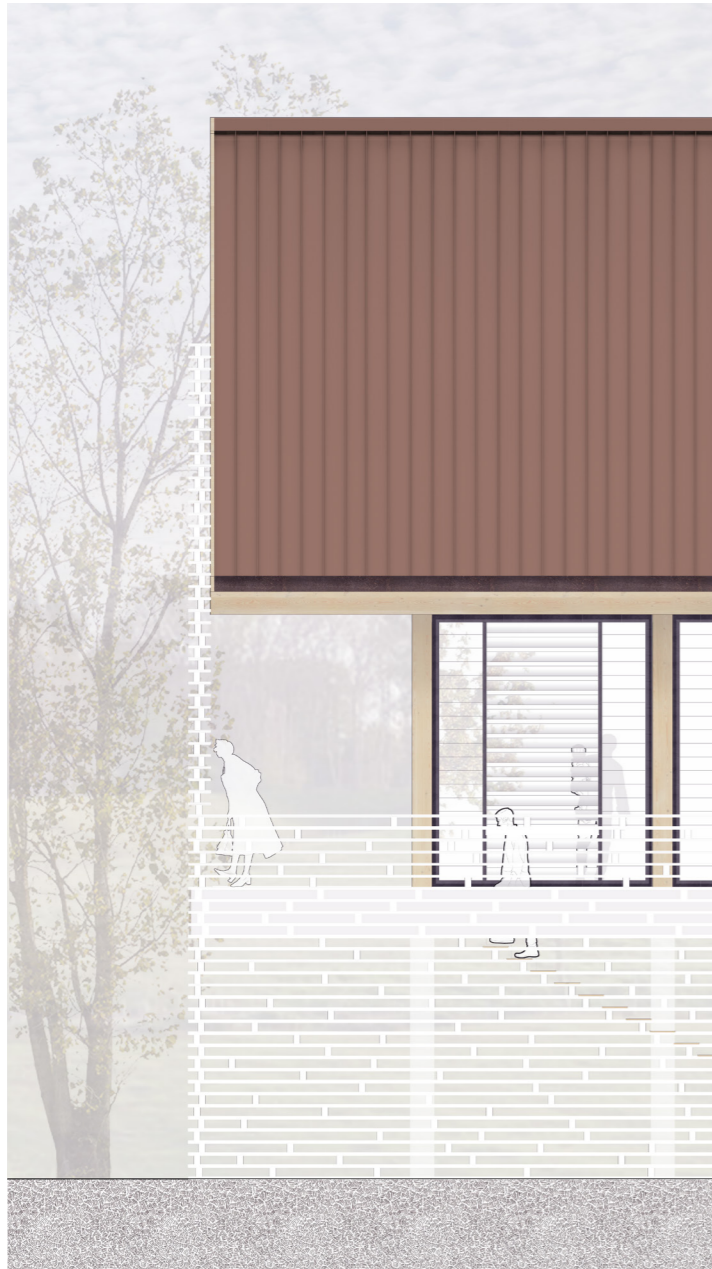


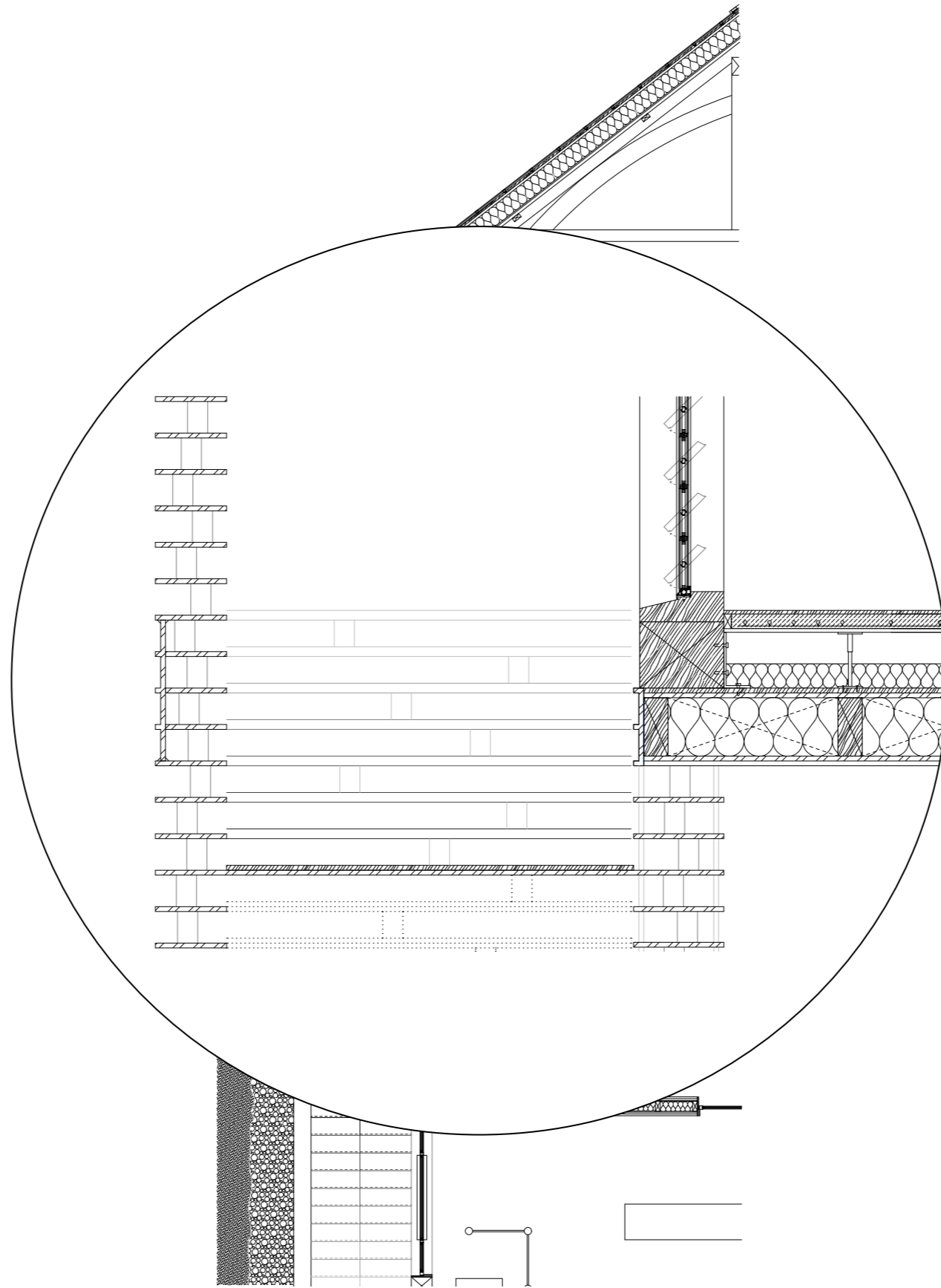
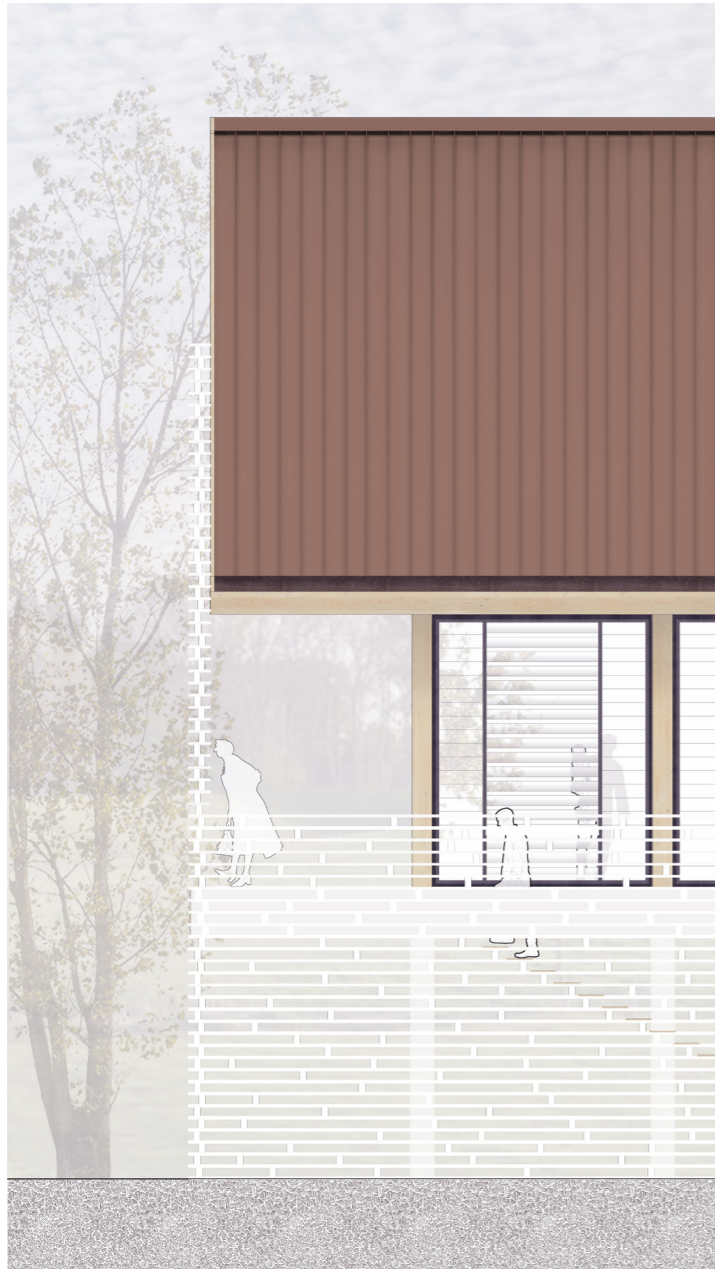


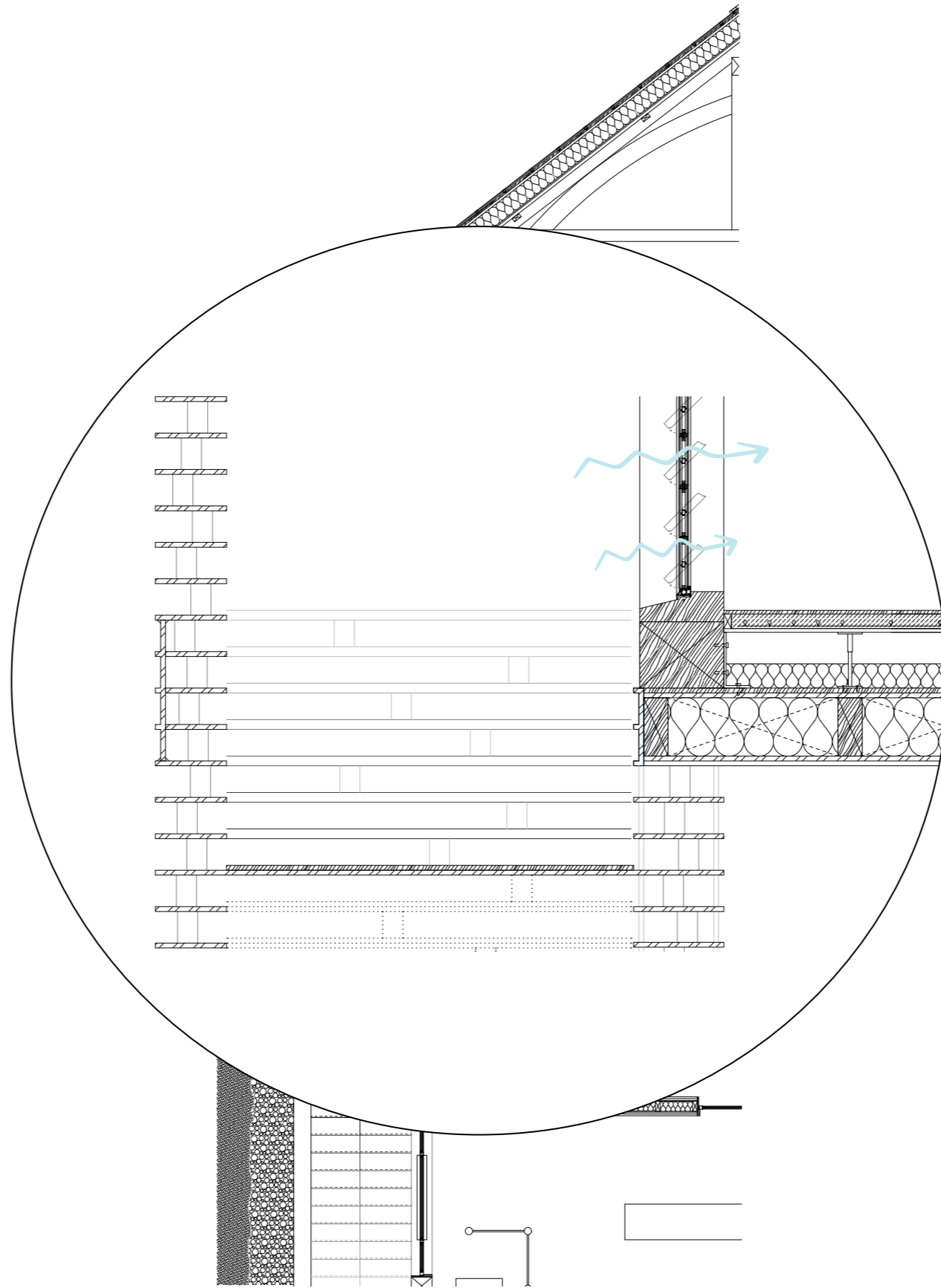
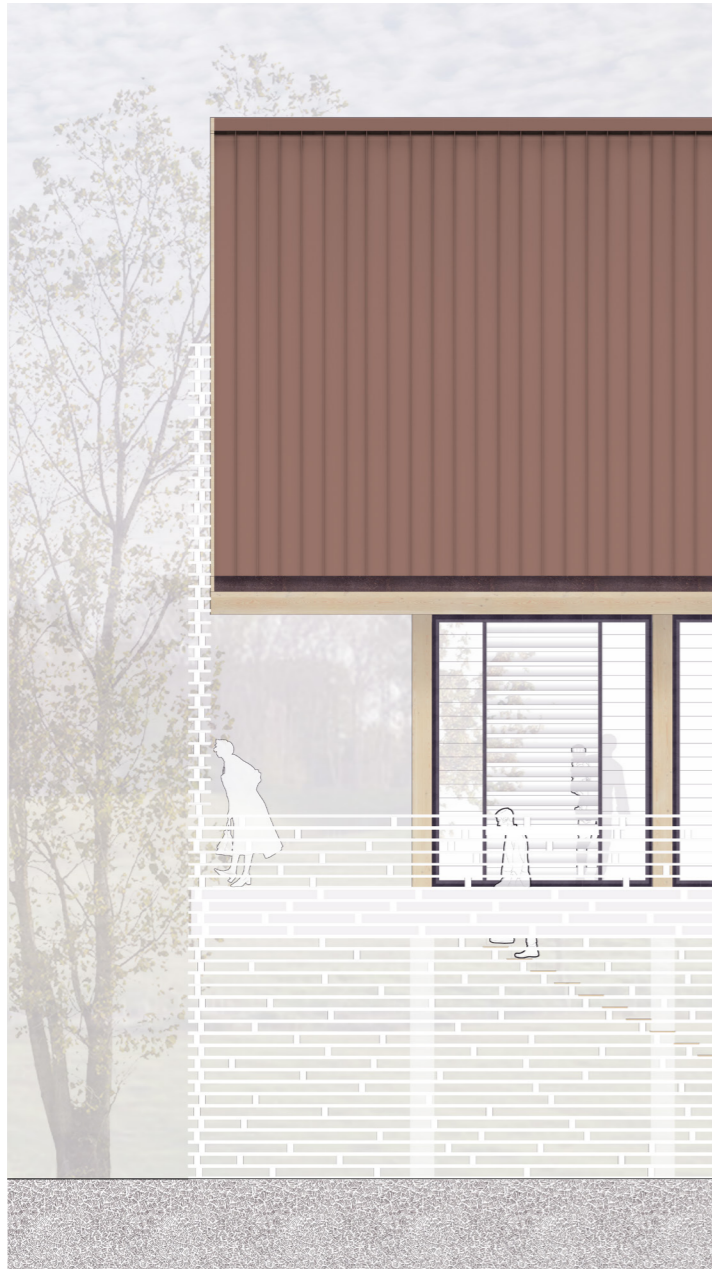
First floor floorplan

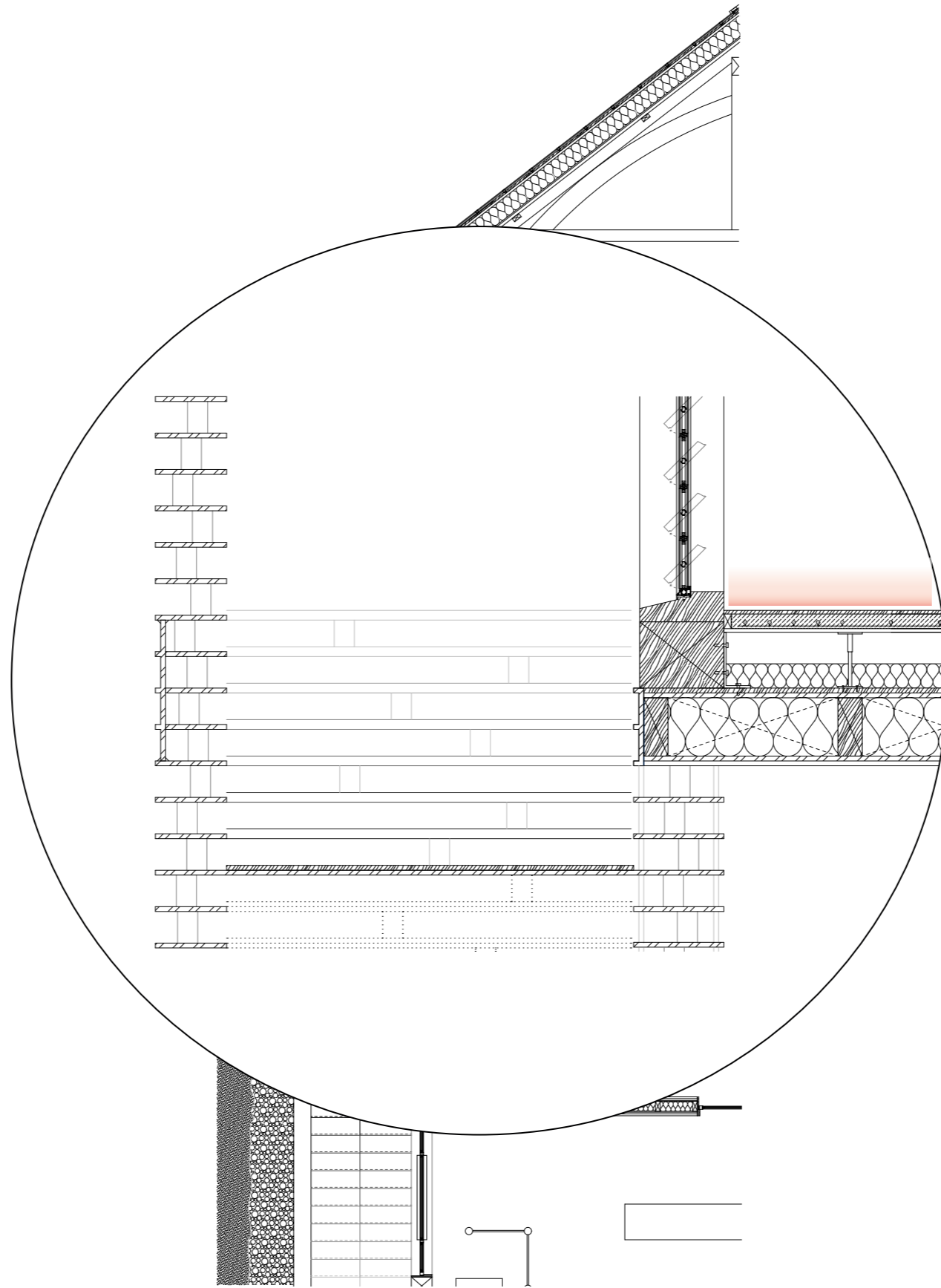
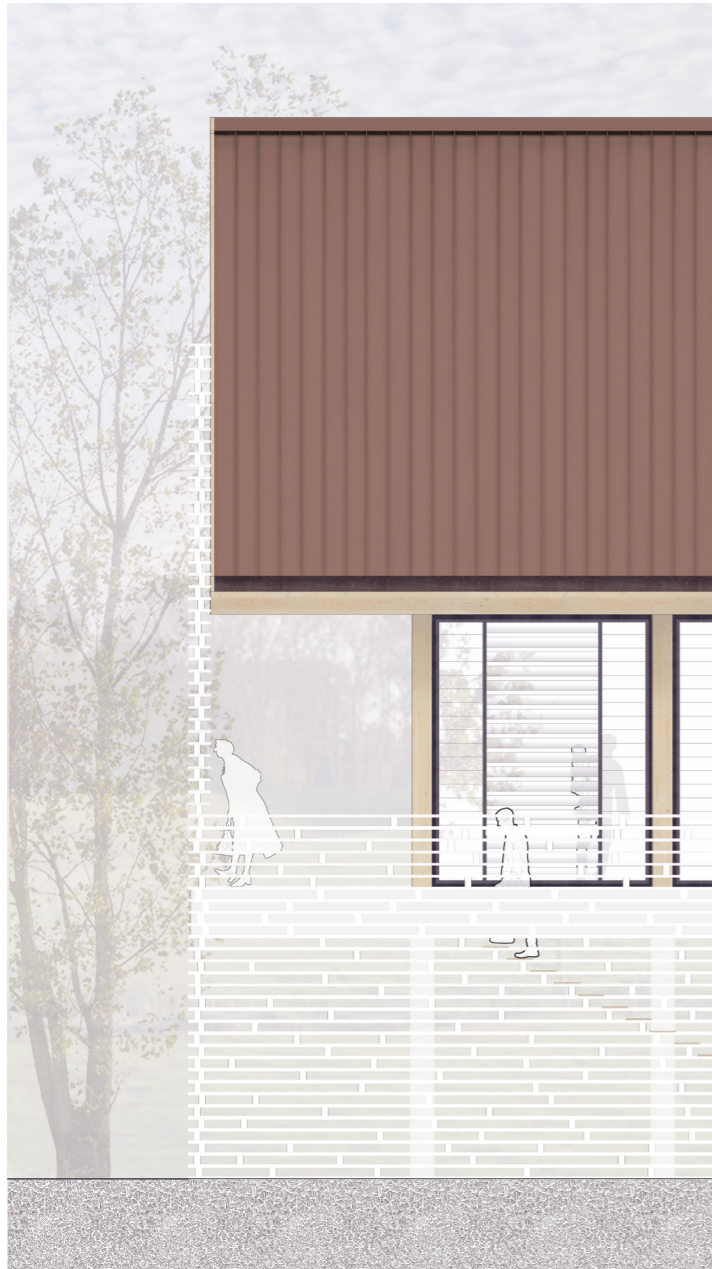


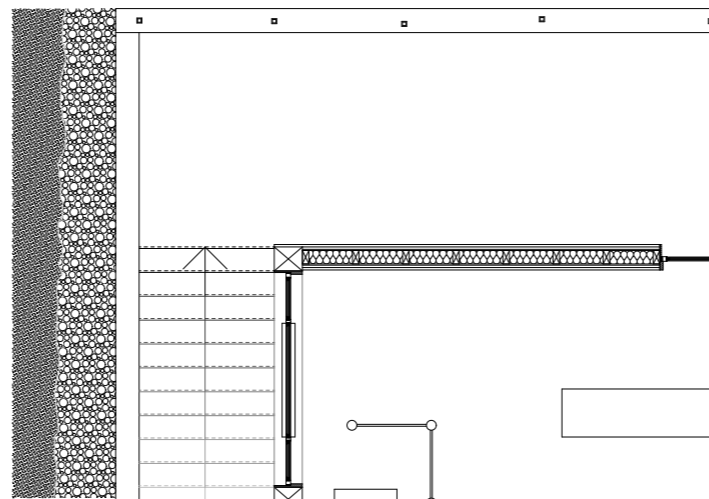
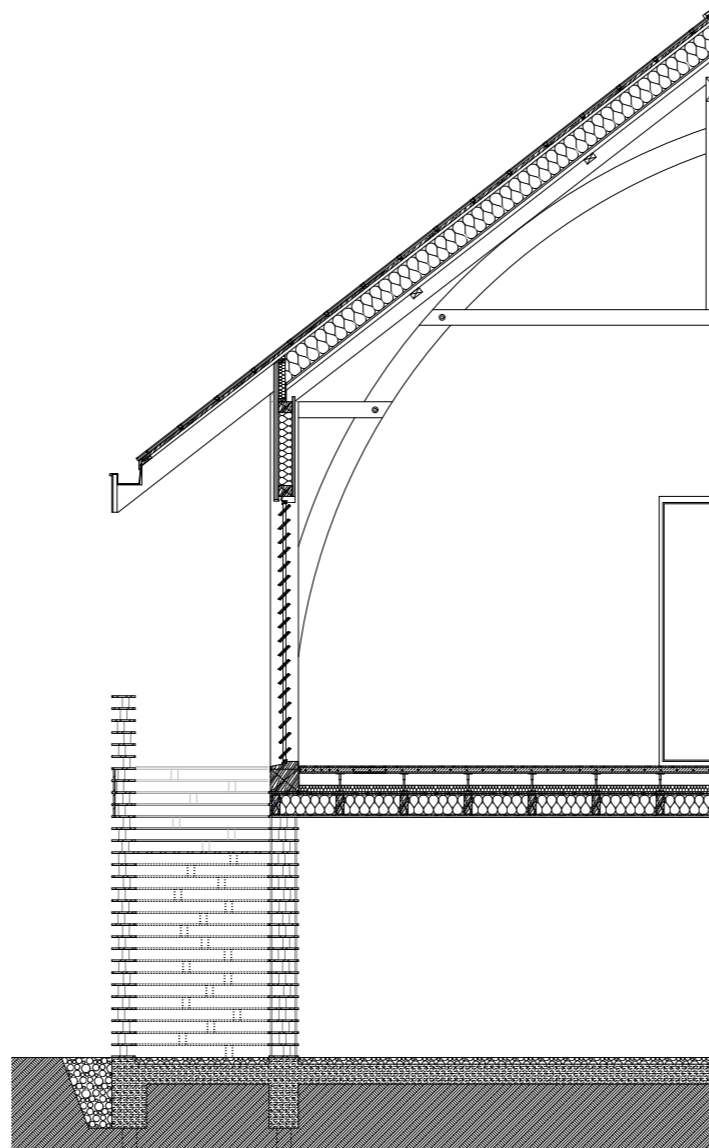
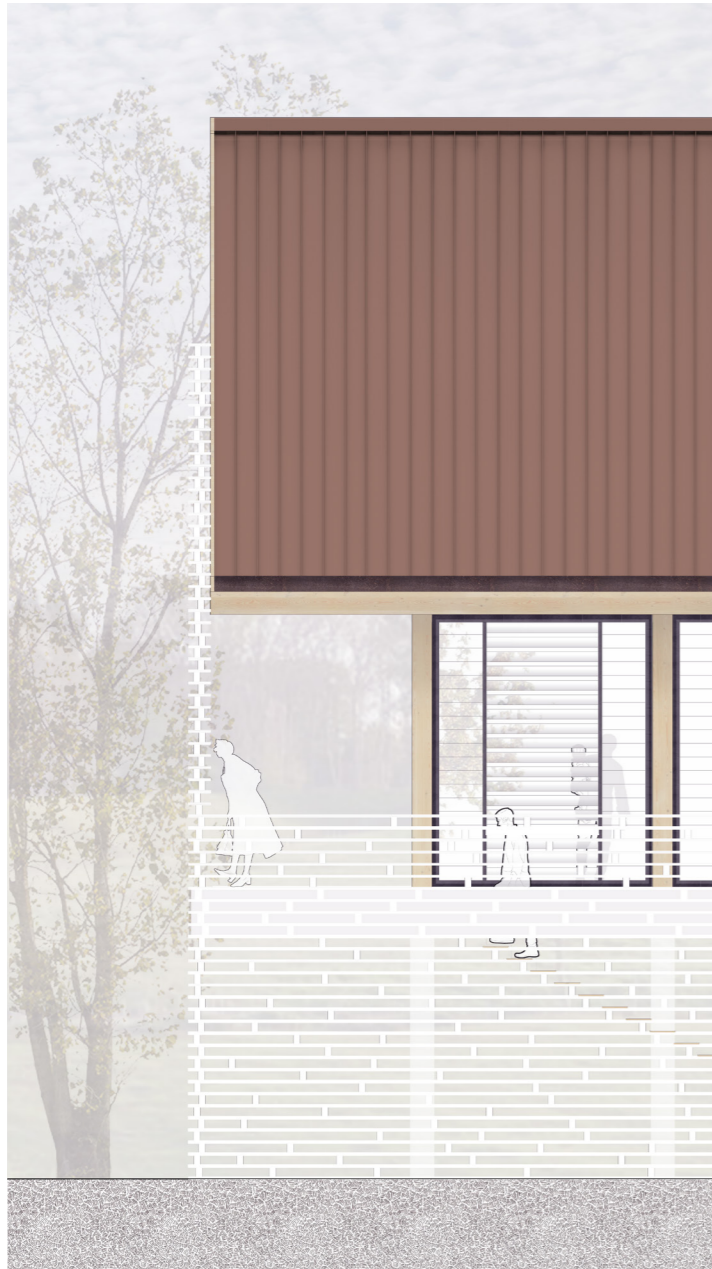
First floor floorplan

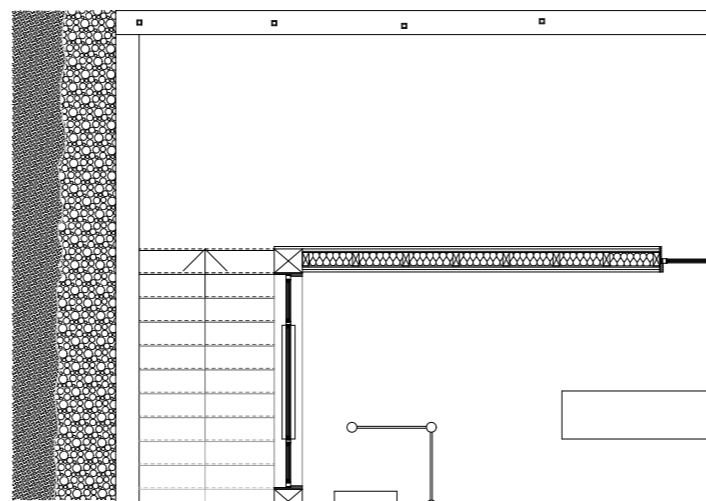
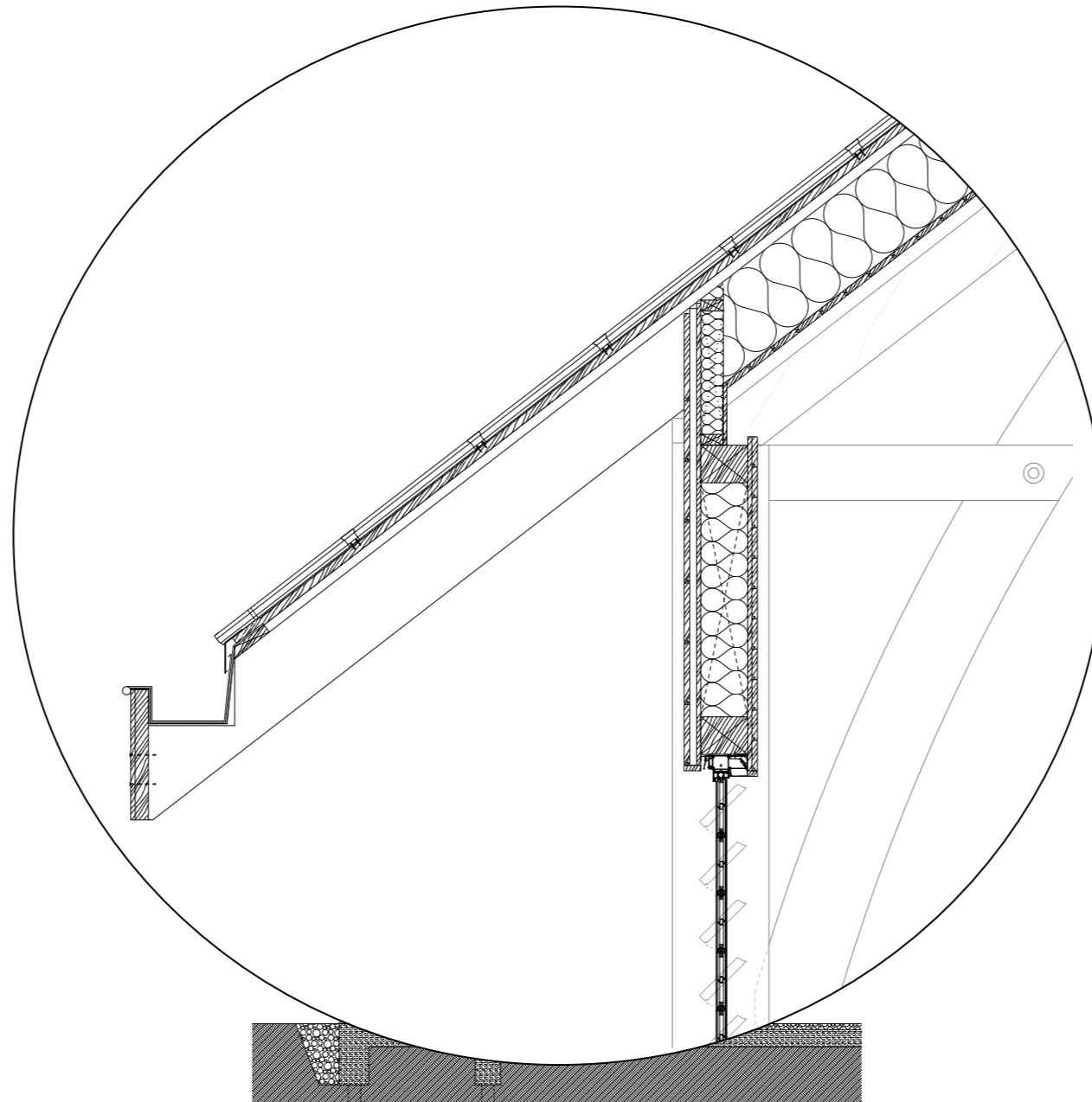
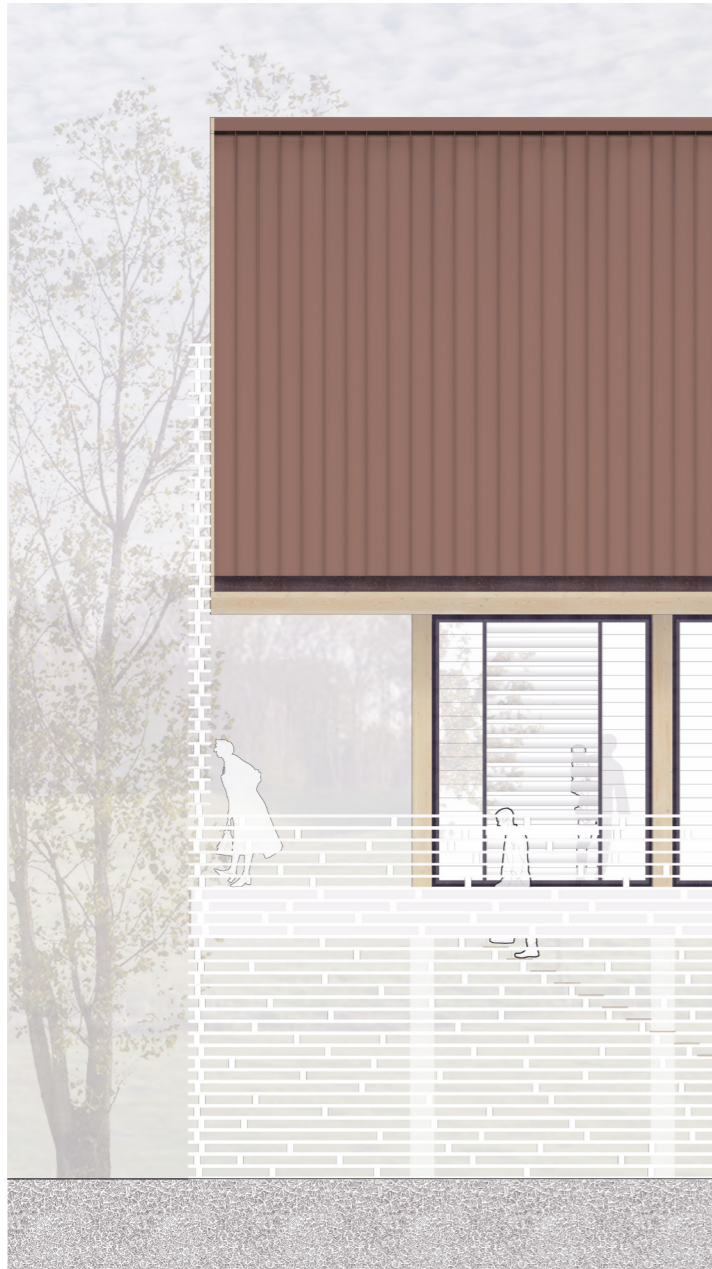


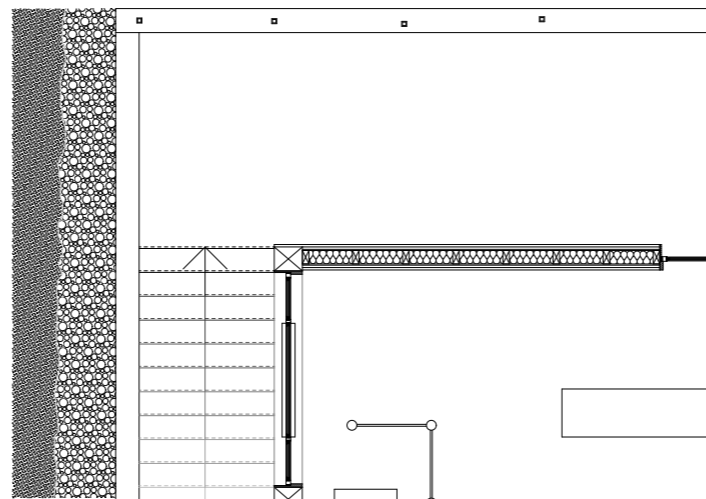
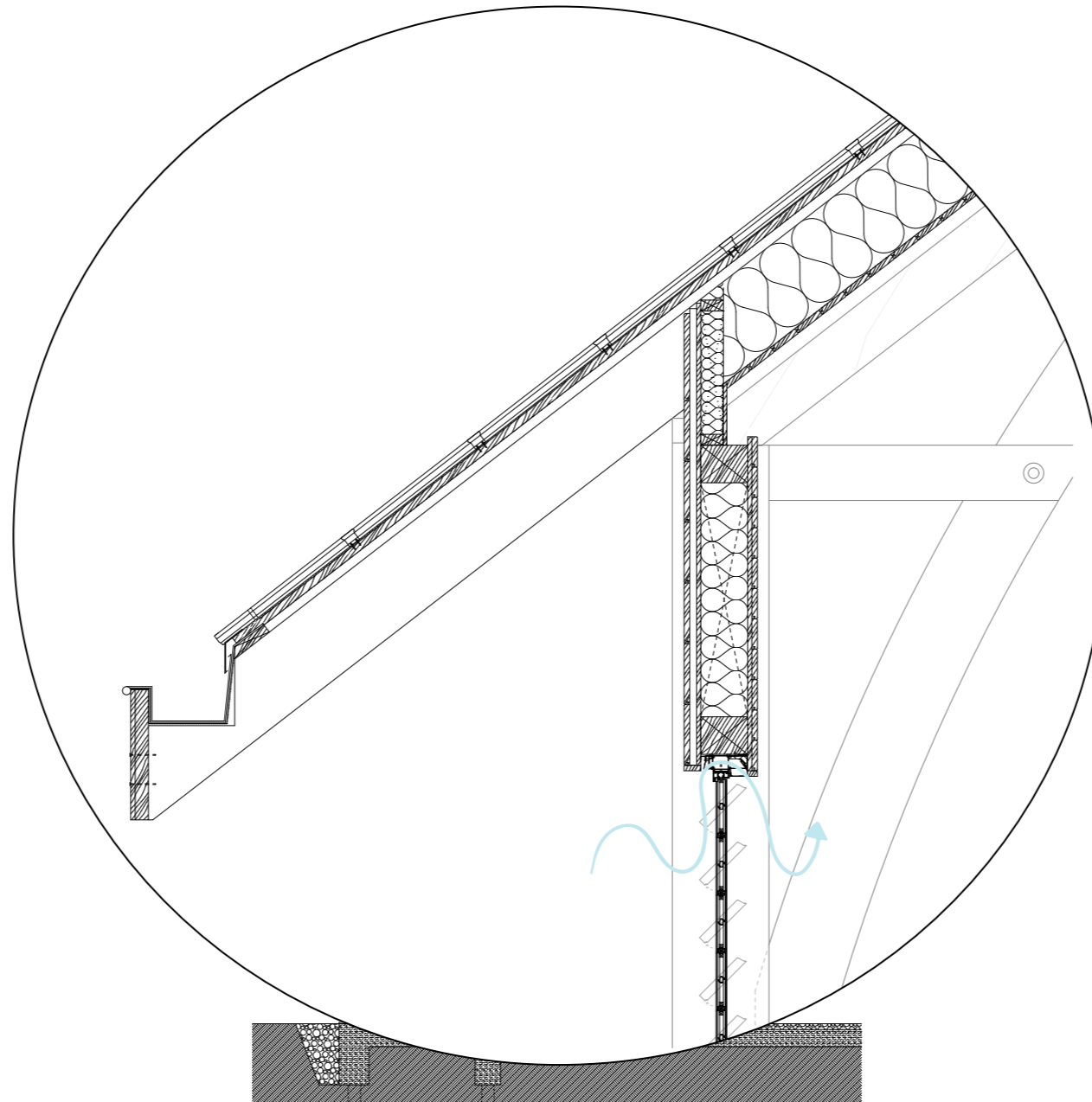
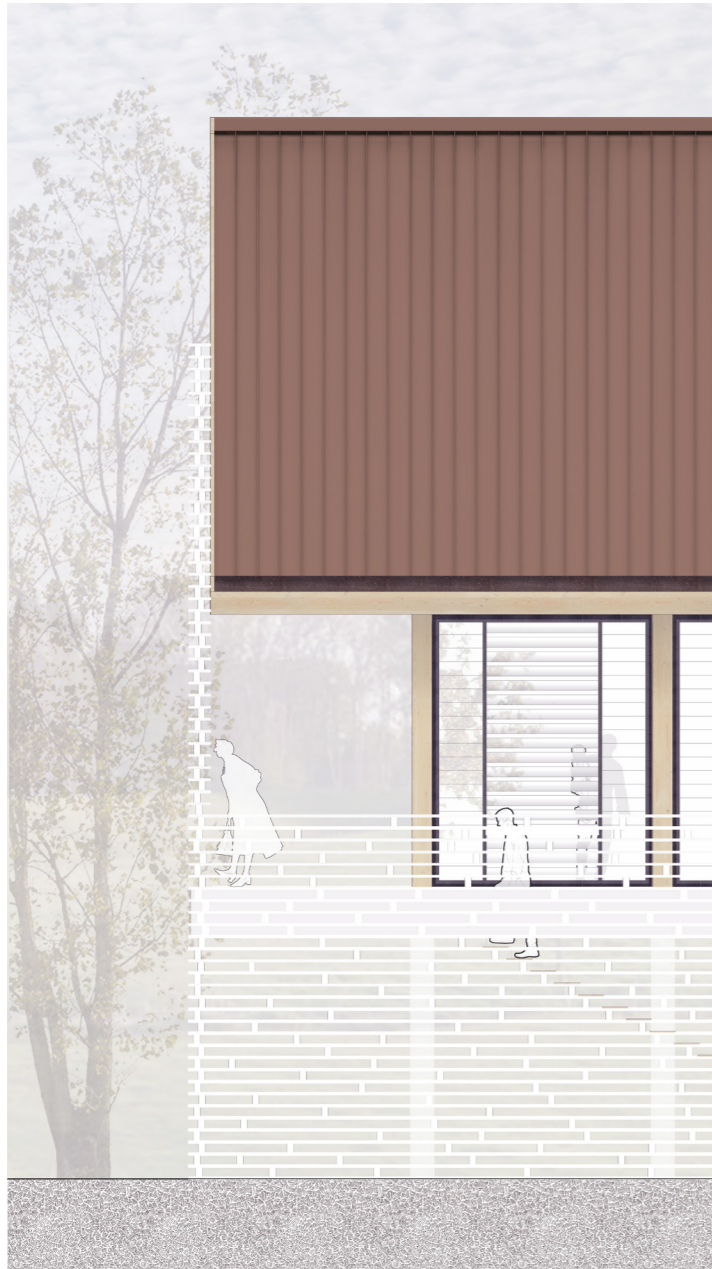


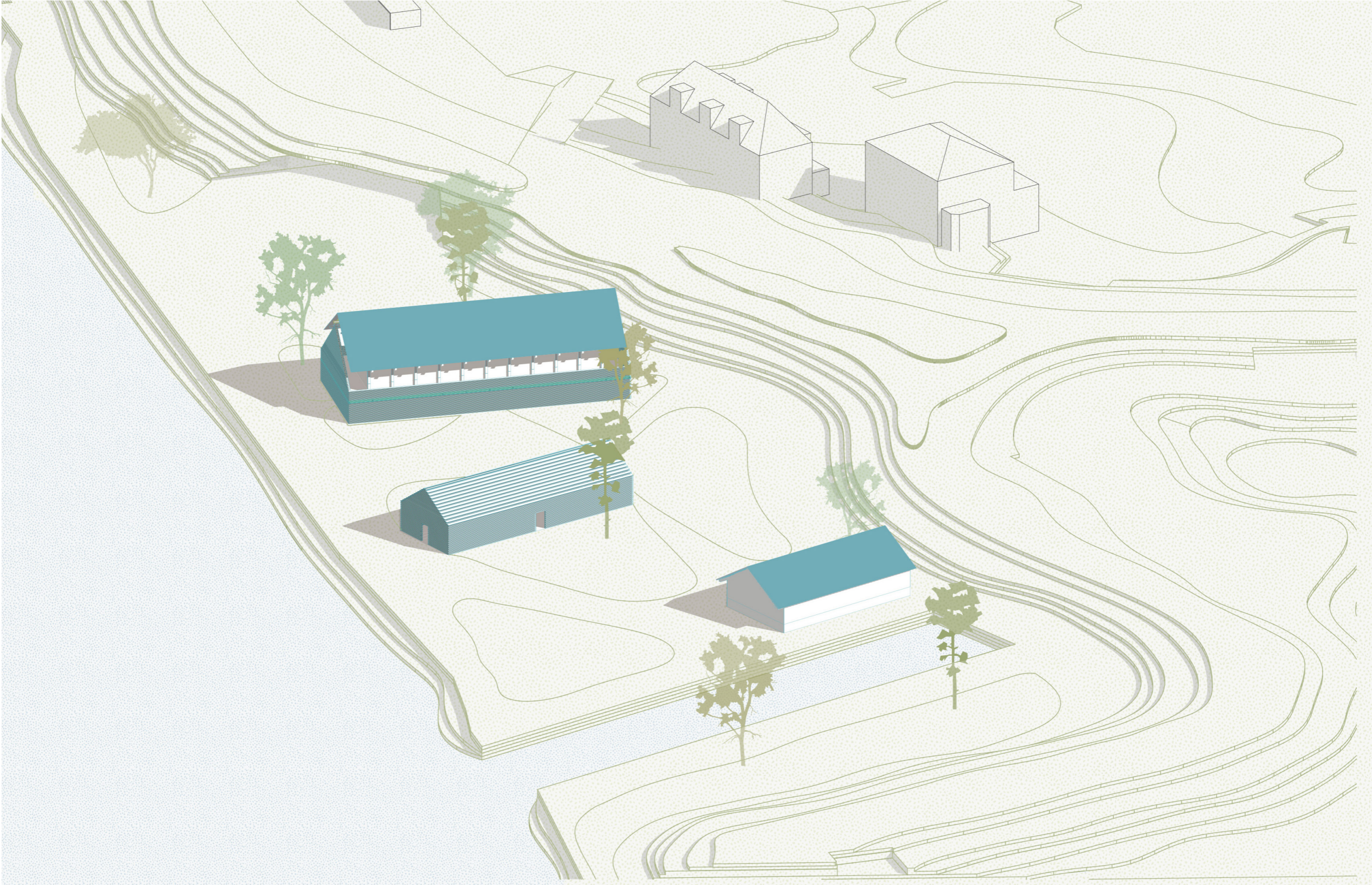




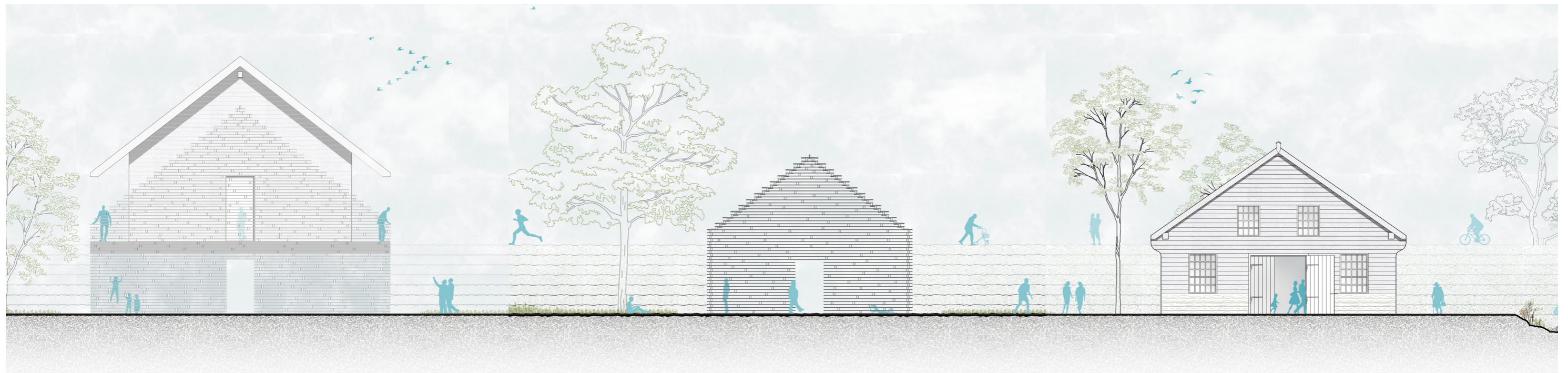
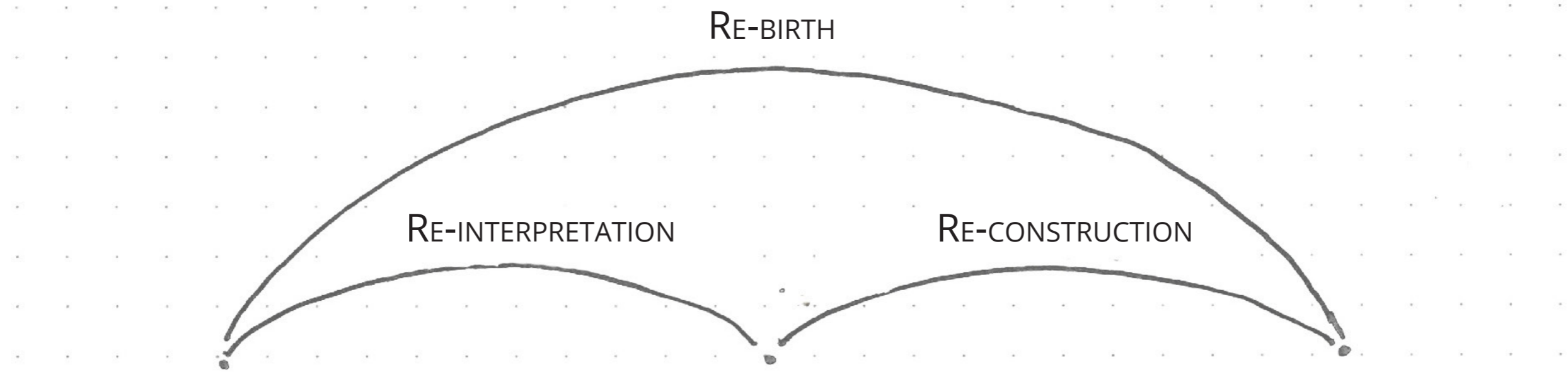












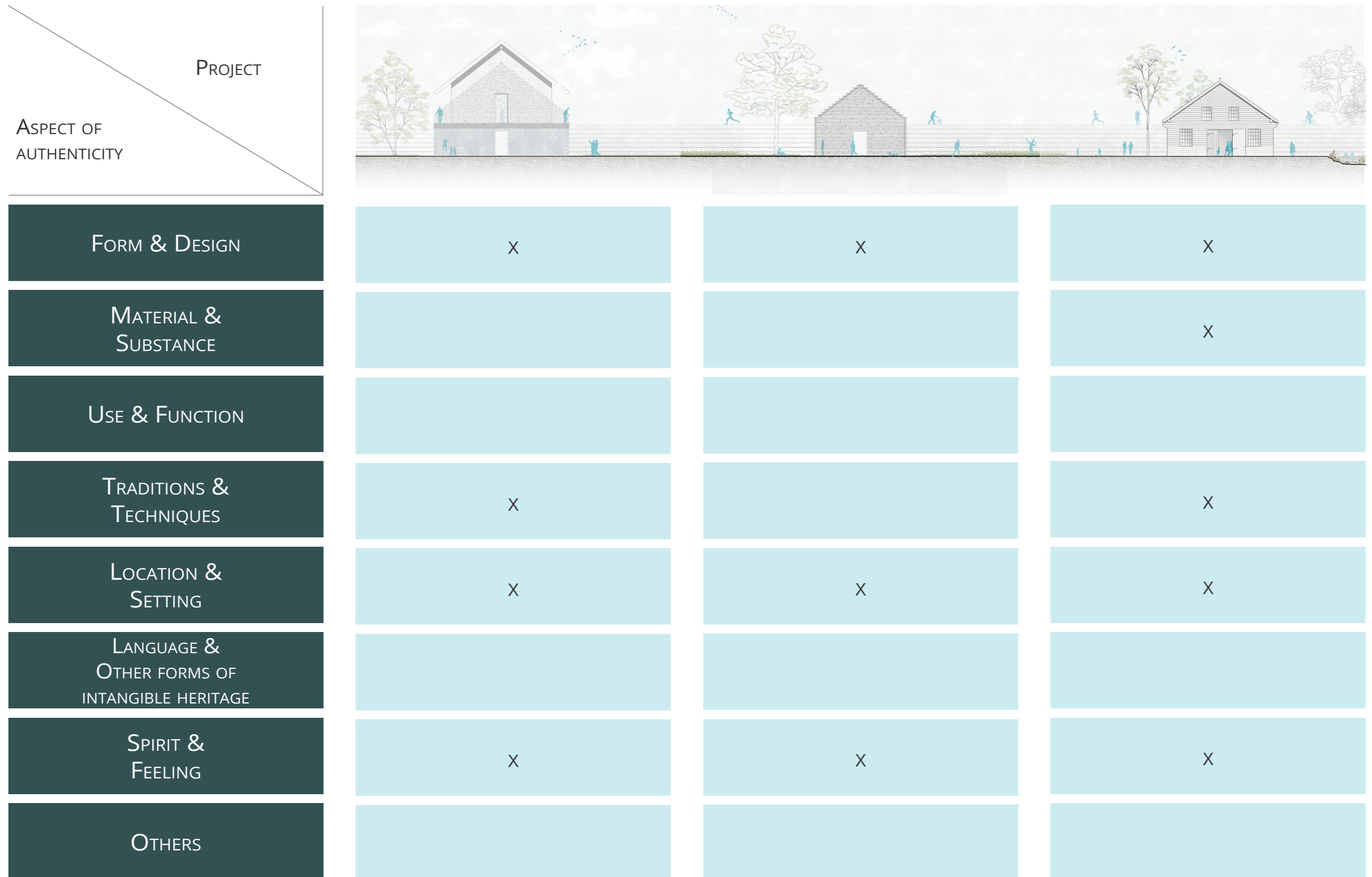


Figure 6: Matrix to identify the degree of authenticity in a reconstruction, illustrated by author Note: Aspects of authenticity have been adapted from the Operational Guidelines for the World Heritage Committee





VANISHED MATTERS

