

Timber Housing in Indonesia

'A combination of traditional and new techniques'

Presentatie:

Floris Plink

Date:

13 April 2017

Tutors:

Mo Smit

Pieter Stoutjesdijk

Maarten Meijs

P5

powered by innovation

INTECTURE 



MAKE

Indonesia

Problem Statement

INDONESIA

Java



Indonesia

Problem Statement

Population growth
Over 40 years



119.000.000



240.000.000

Indonesia

Problem Statement

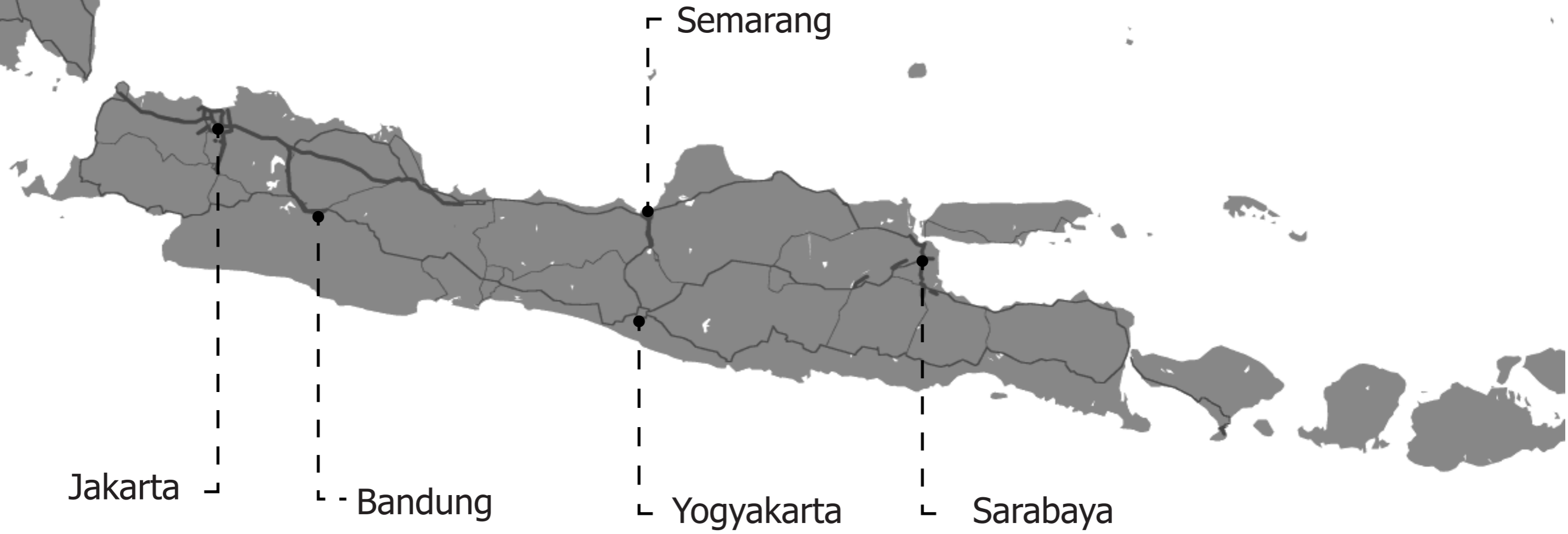

Indonesia

Problem Statement

BANDUNG



2,5 million

City Centre

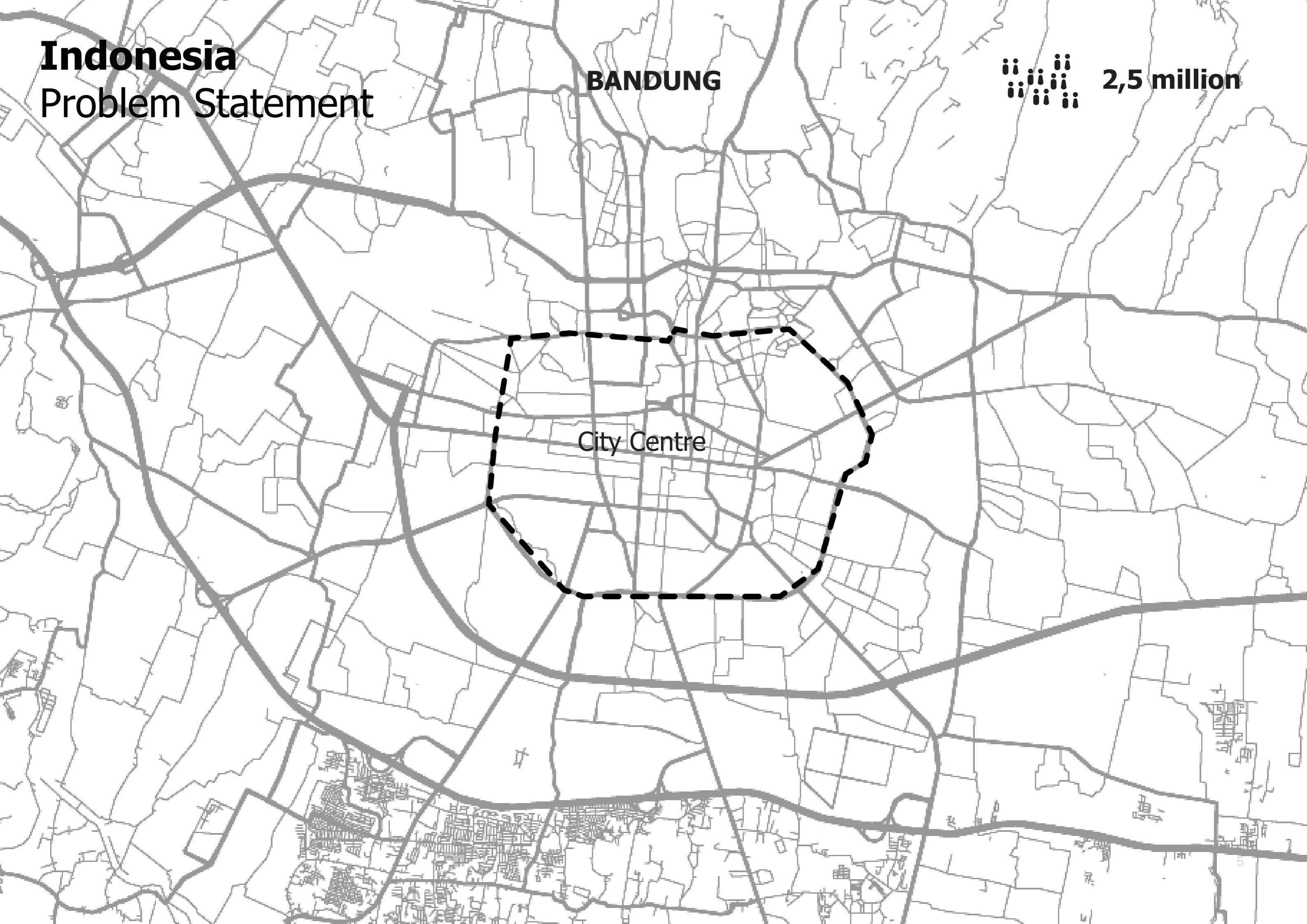

Indonesia

Problem Statement

BANDUNG

 **2,5 million**

Rural kampungs

City Centre

Rural kampungs

Rural kampungs

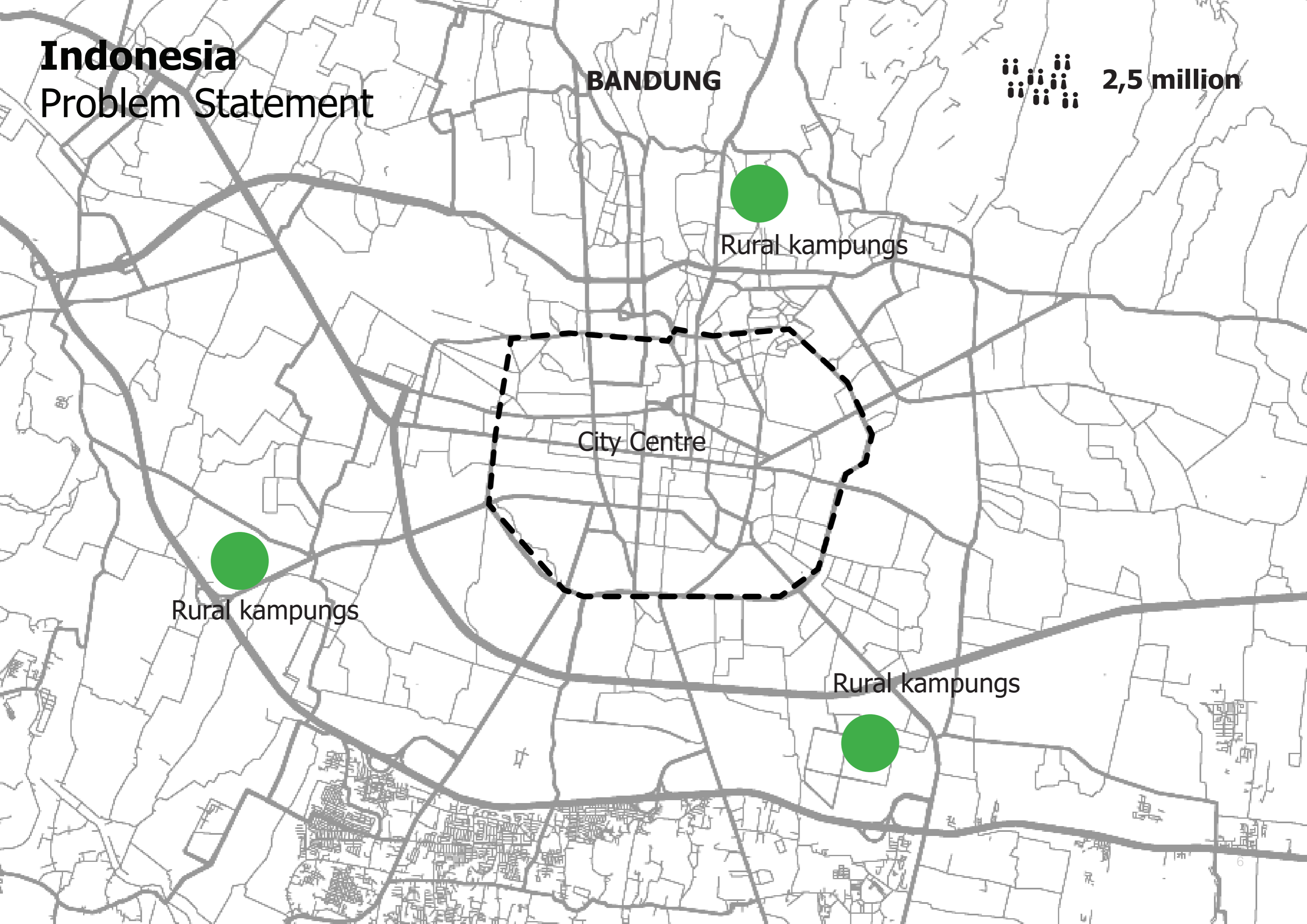

Indonesia

Problem Statement

BANDUNG

 **2,5 million**



Peri-Urban Kampung

City Centre



Peri-Urban Kampung

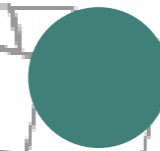

Peri-Urban Kampung

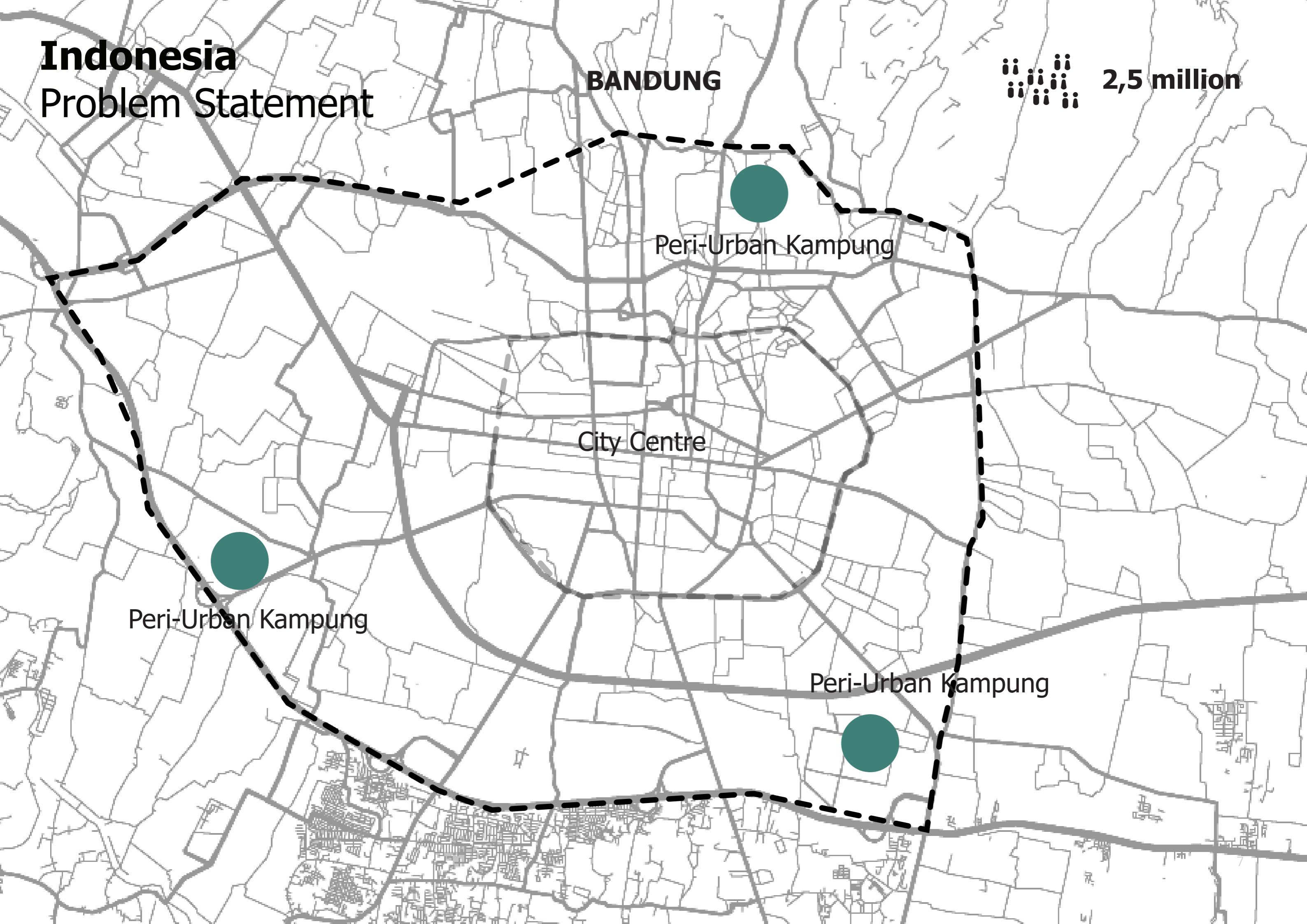

Peri-Urban Kampung - Problem Statement

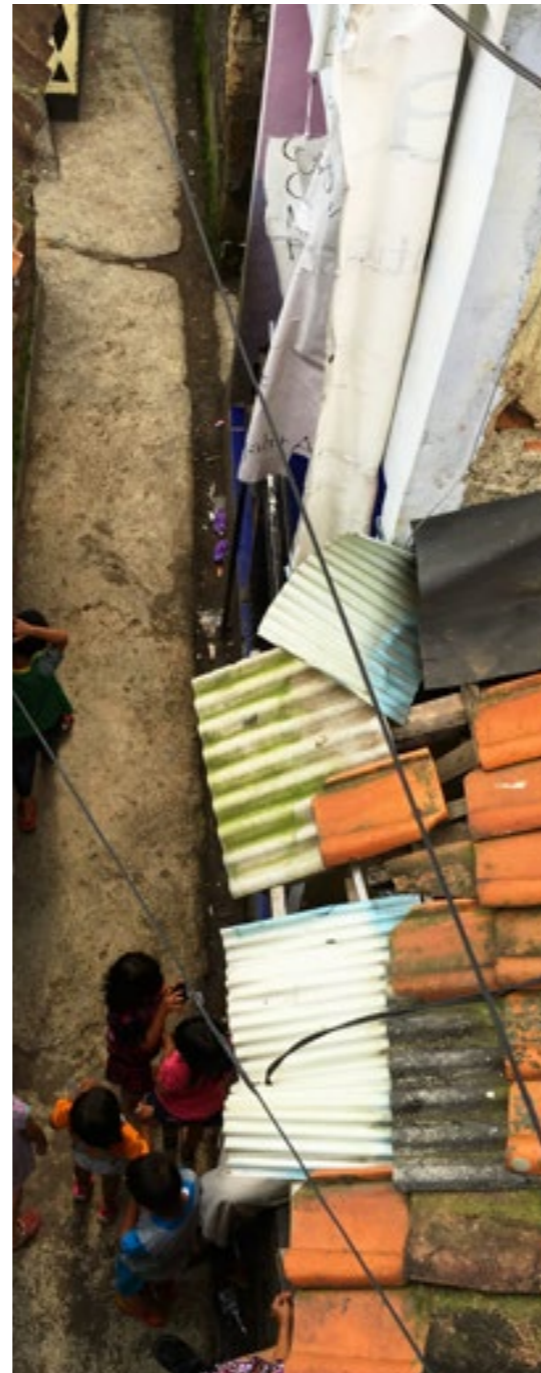

High Density
(unhealthy)

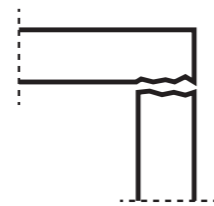

Bad quality
(unsafe)



Low income



Unsustainable
materials



Assembly
knowledge

Peri-Urban Kampung - Problem Statement

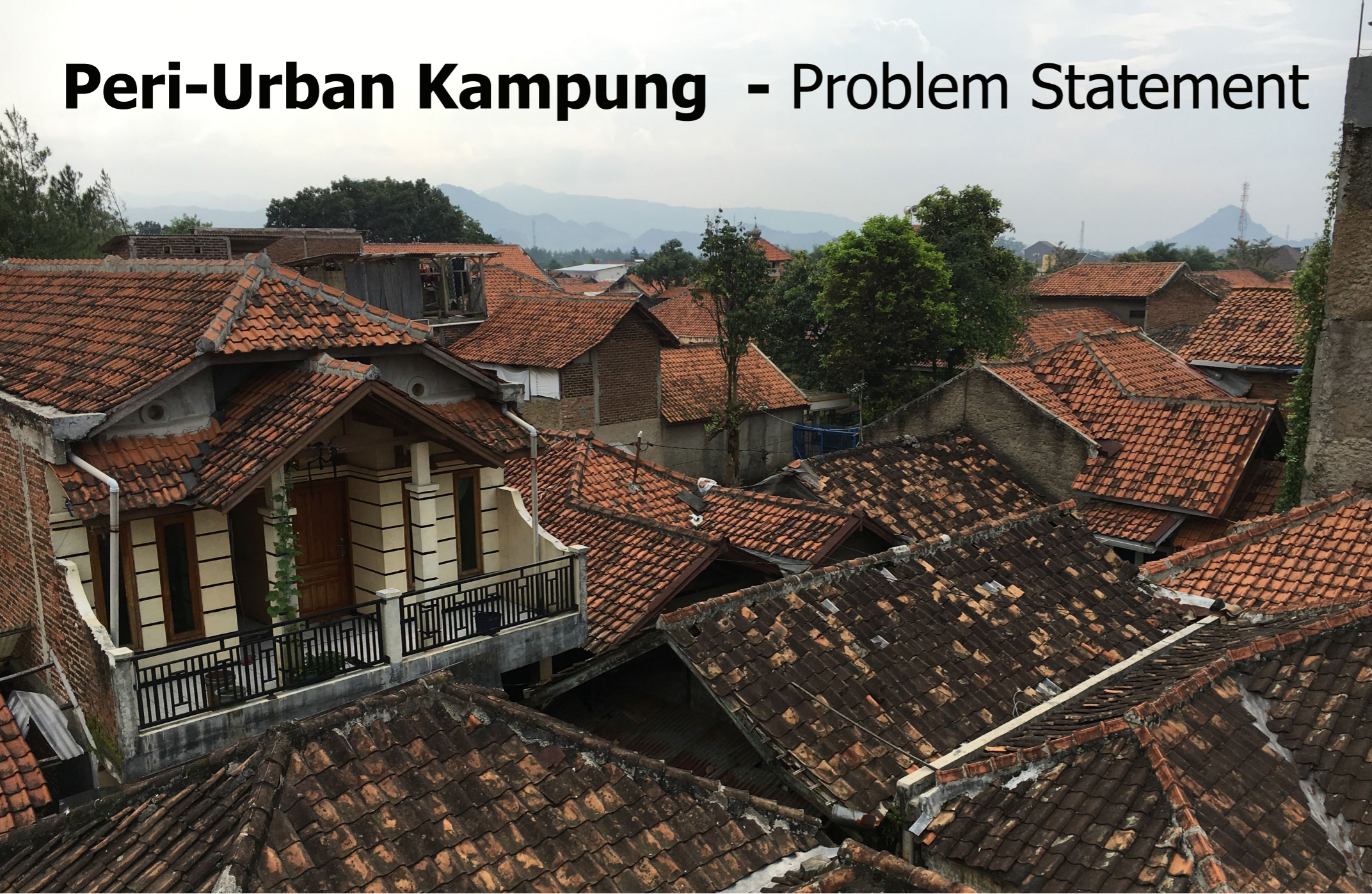

Peri-Urban Kampung - Problem Statement



Traditional Kampung - Opportunities



Low
Density

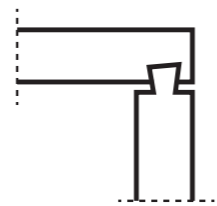

Quality
structure



re-use



Local
materials



Community
assembly

CNC Milling - Solutions

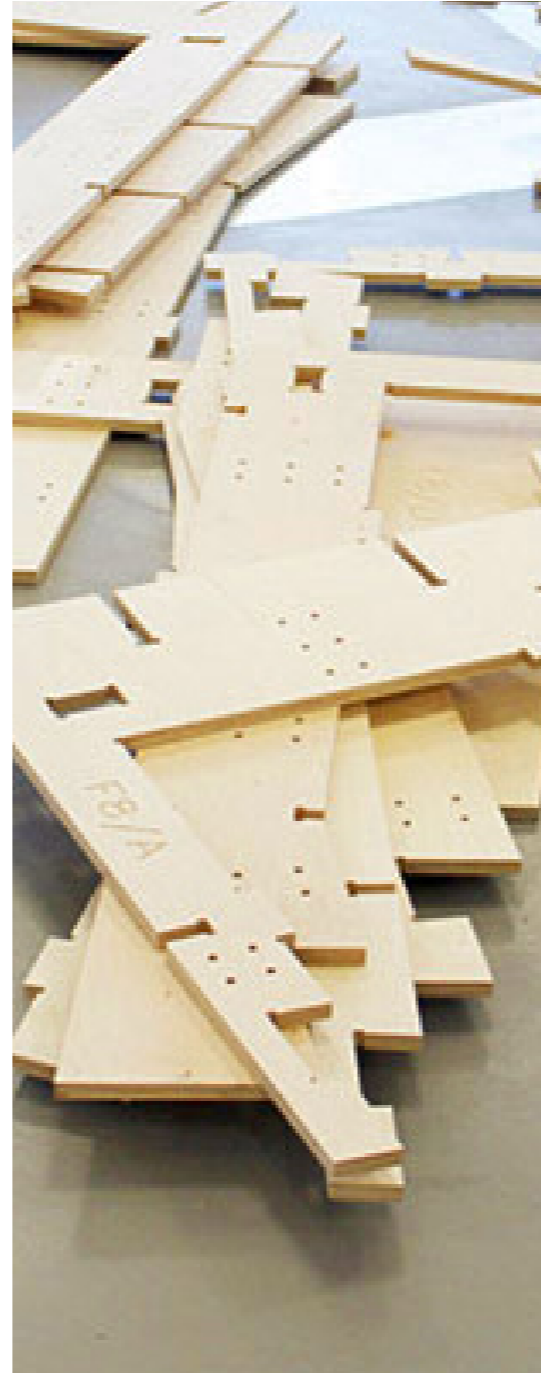

improve height

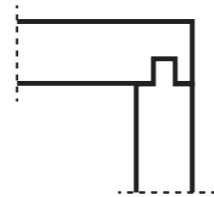

Quality
structure

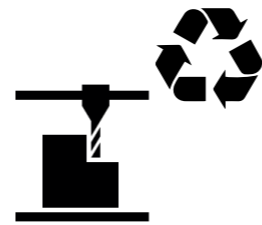

re-produce

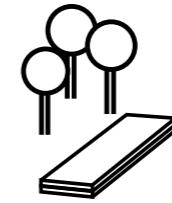

sustainable
material



Easy DIY

CNC-Milling

Computer Numerical Control

- High precision
- mass customization
- Easy and fast

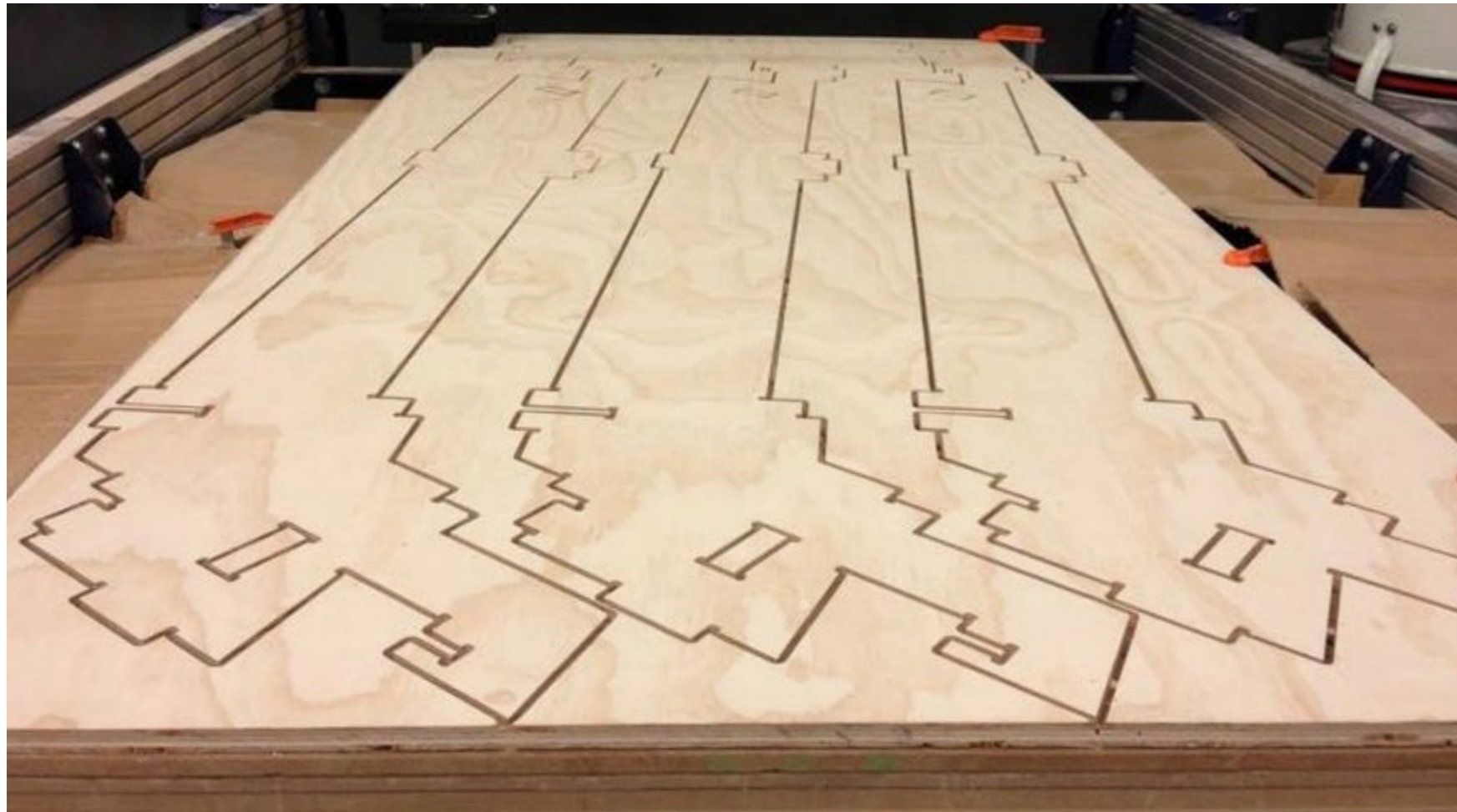
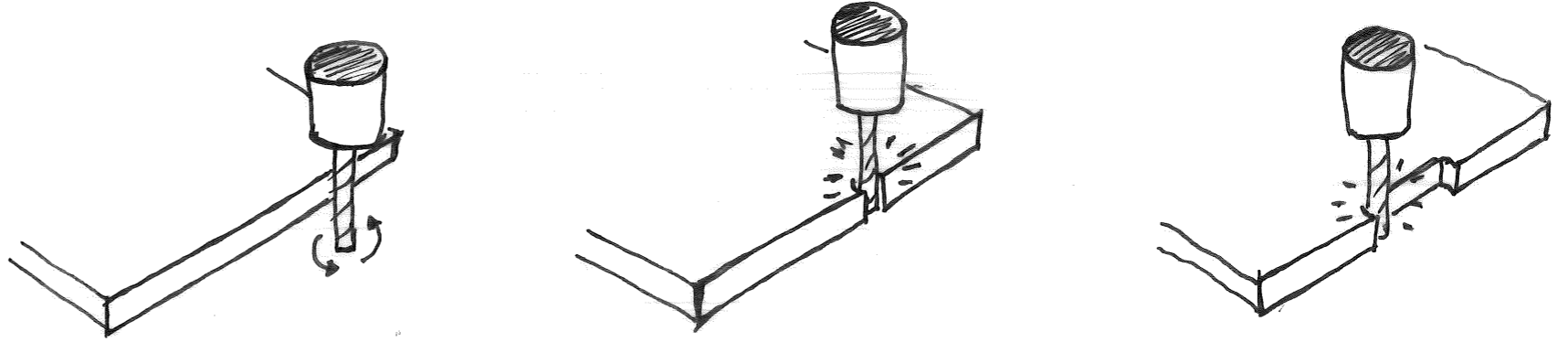

Research question

How to use Traditional and CNC-milling building methods to create sustainable affordable Do it yourself housing in the Peri-urban kampungs of Indonesia



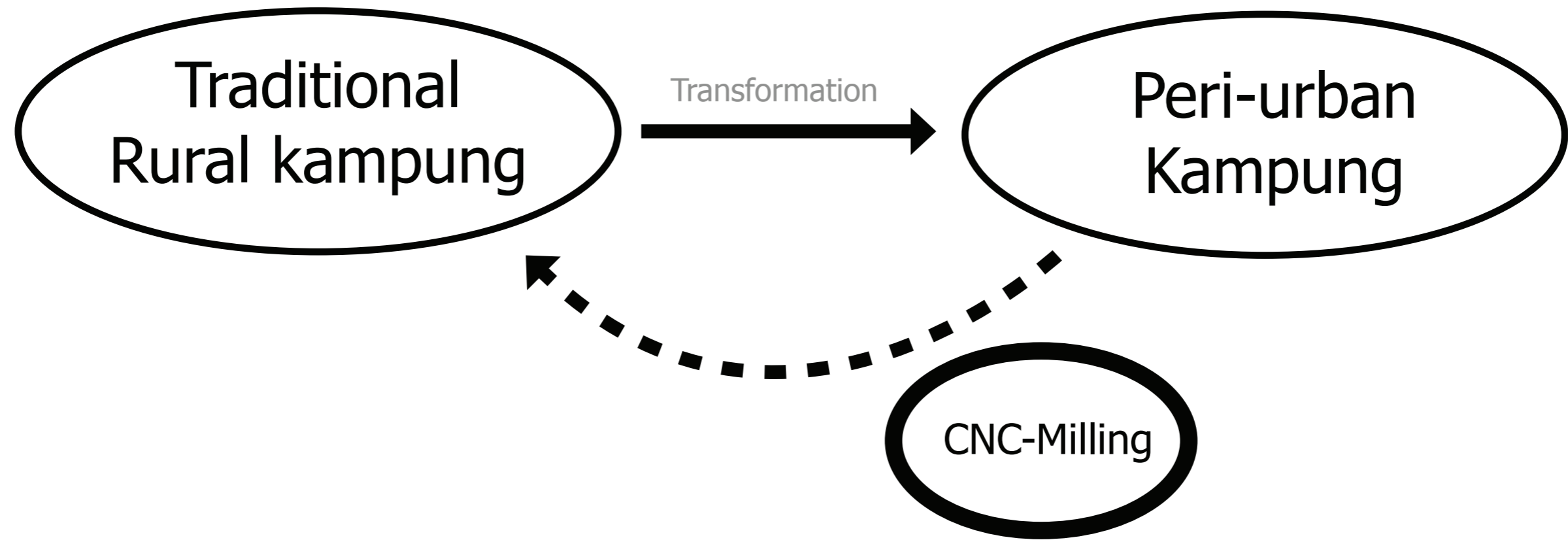

Research question

How to use **Traditional** and **CNC-milling** building methods to create sustainable affordable Do-it-yourself housing in the **Peri-urban kampungs** of Indonesia

Research question Concept



Research Methods

Case-studies	Fieldwork	Literature	Interviews	Internet
				

Research Methods

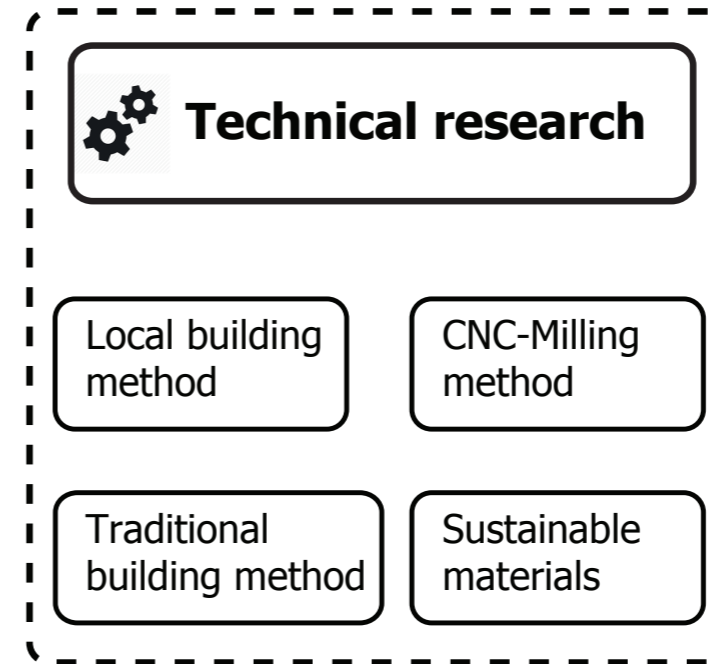
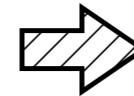
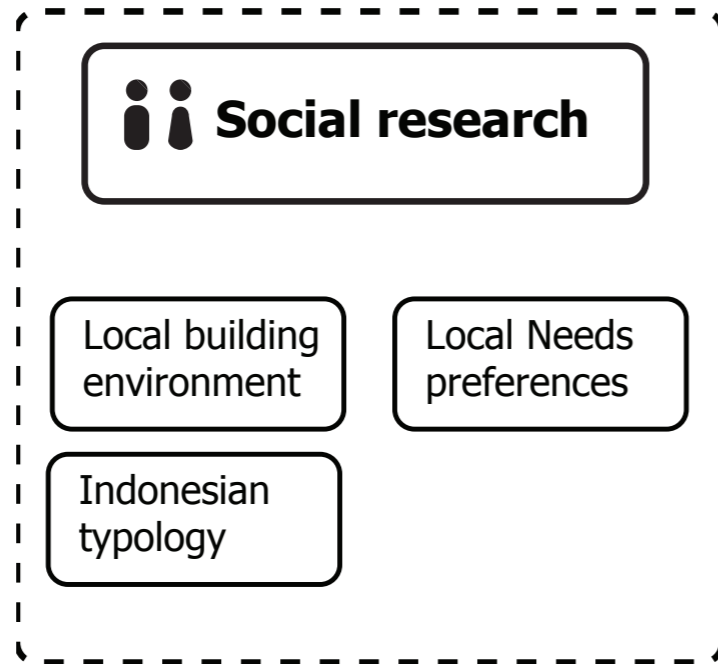
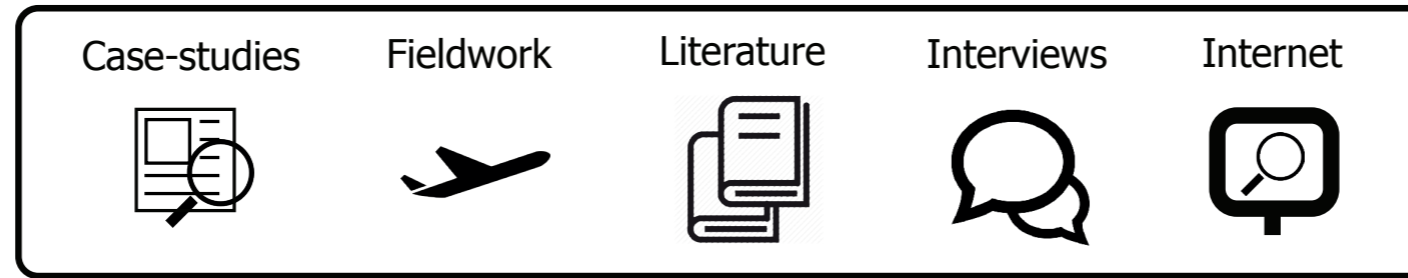

Research Methods

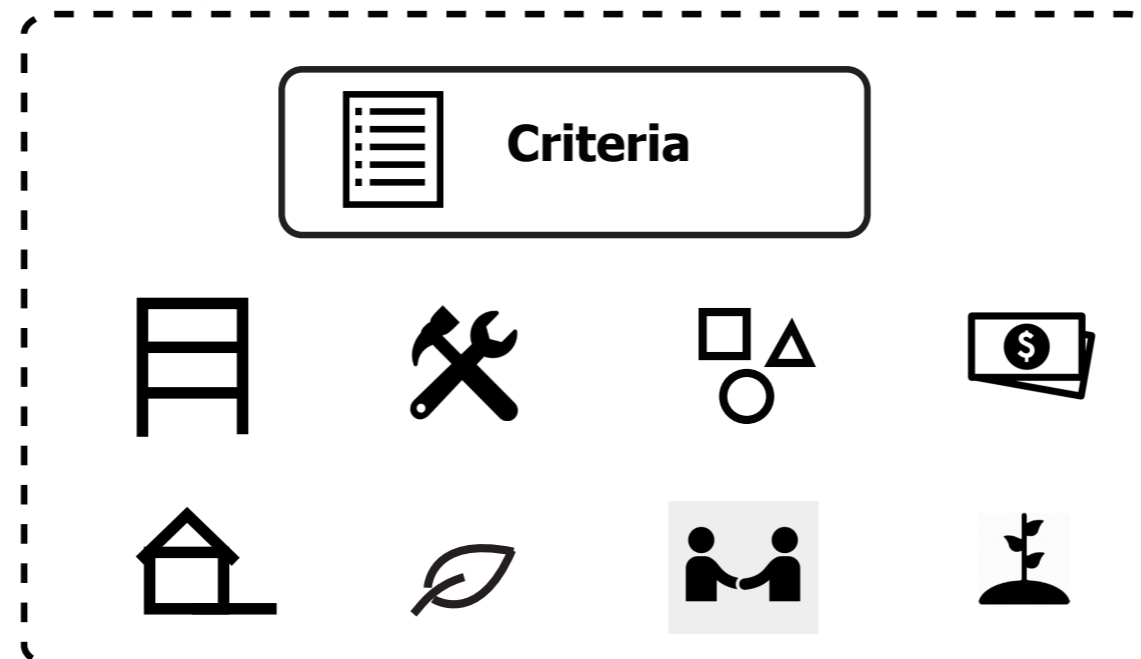
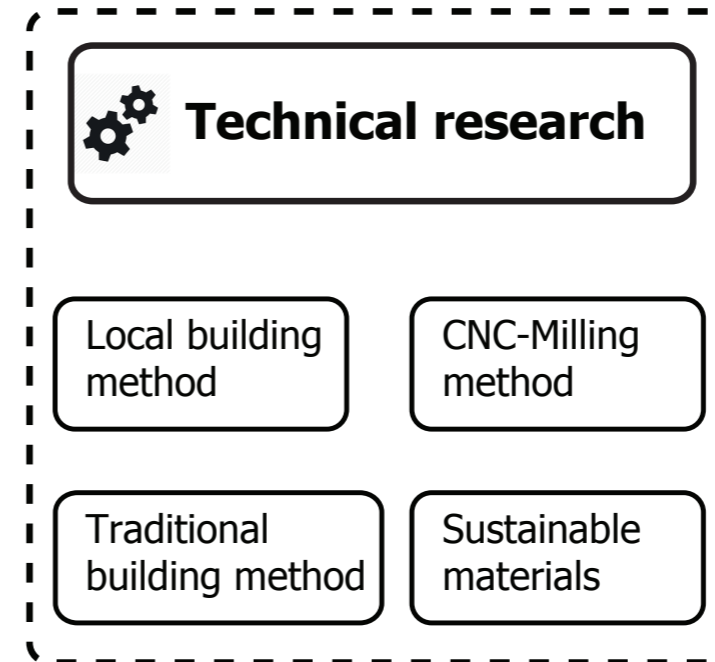
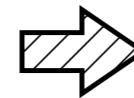
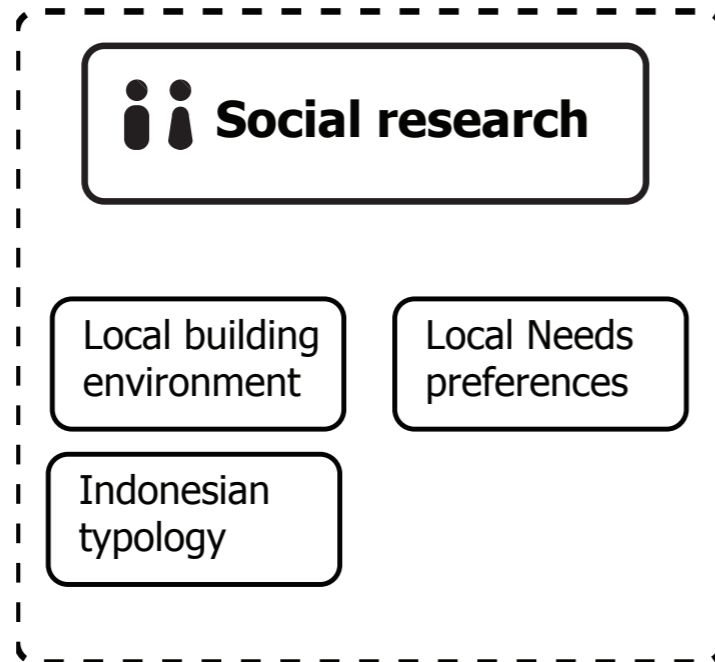
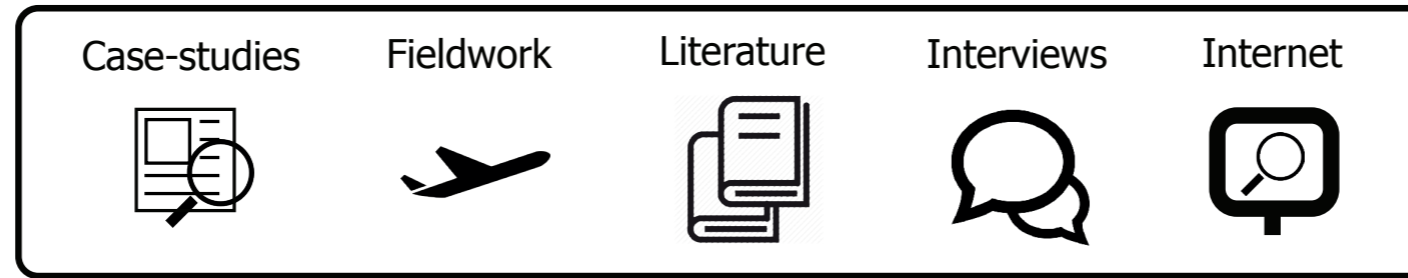

Research Method



ii Social research
living environment



Research Method



Technical research

Traditional kampung



Research Method



Technical research

CNC-Milling



Research

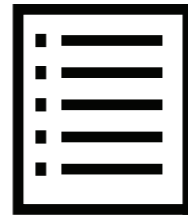

Criteria

3 storeys high

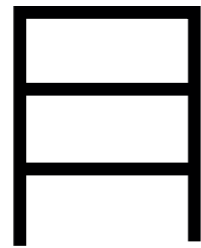

Easy DIY



Customizable

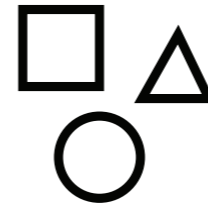

Low costs



Durable



Sustainable materials



Collective space



Plantation/green



Design Process

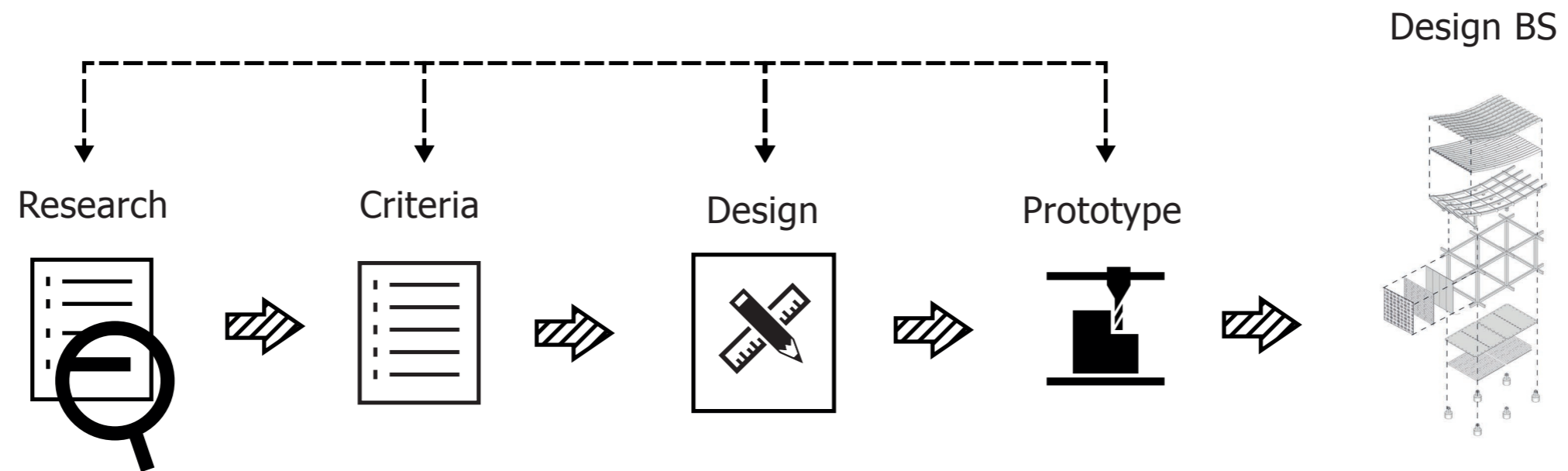

Design Process

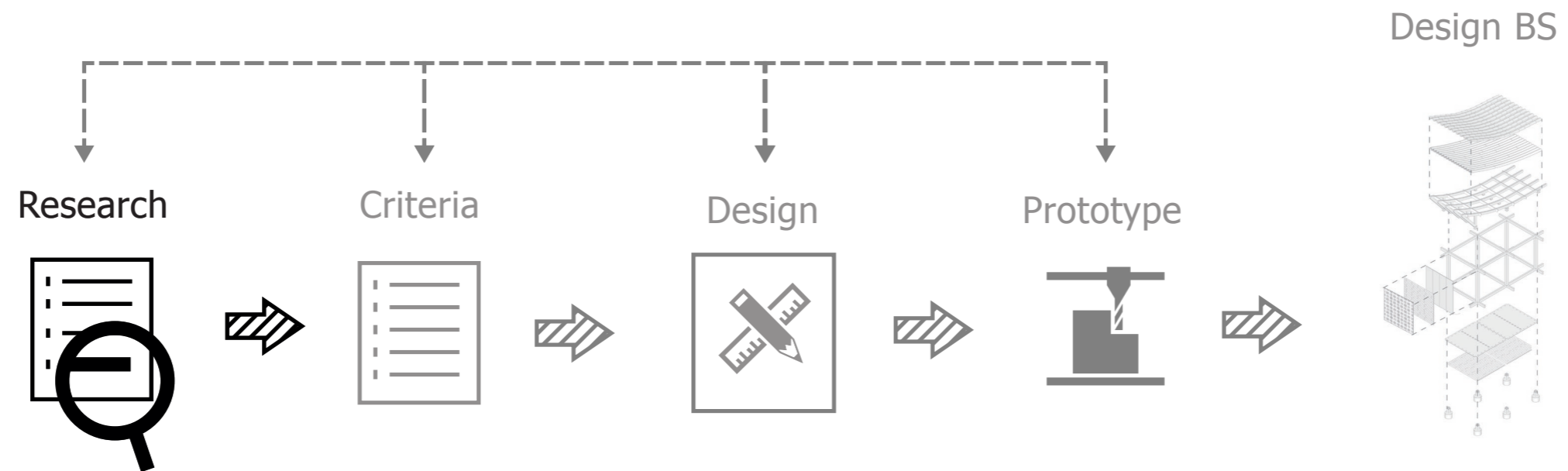

Design Process

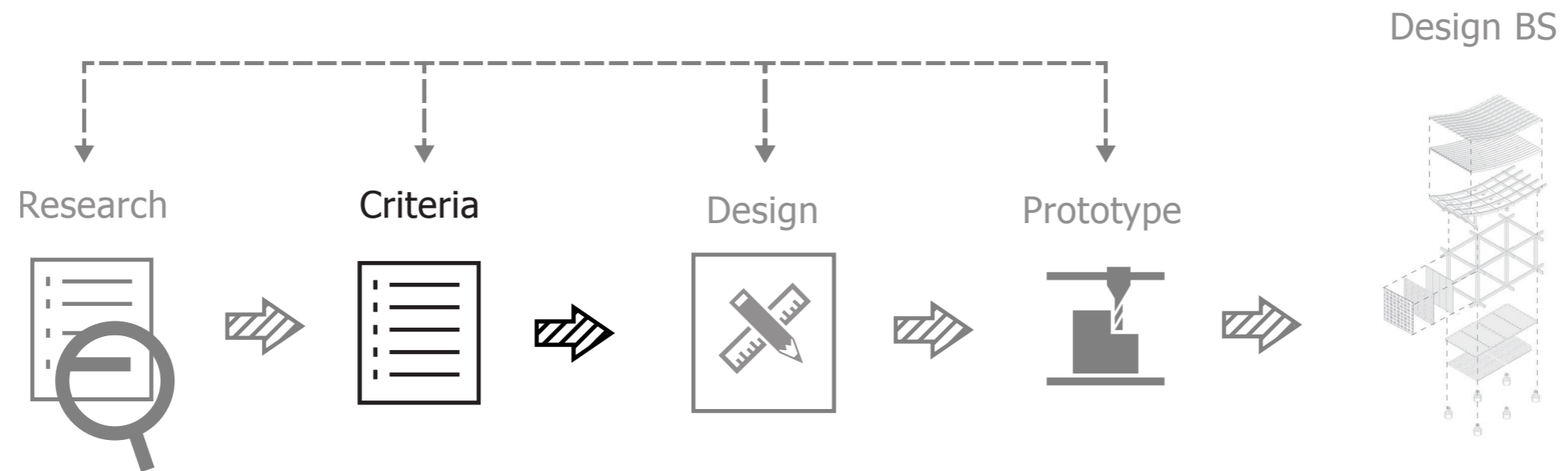

Design Process

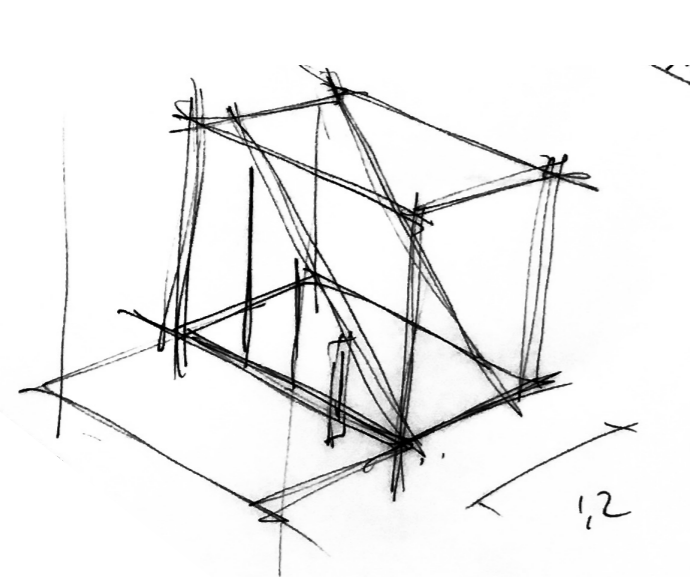
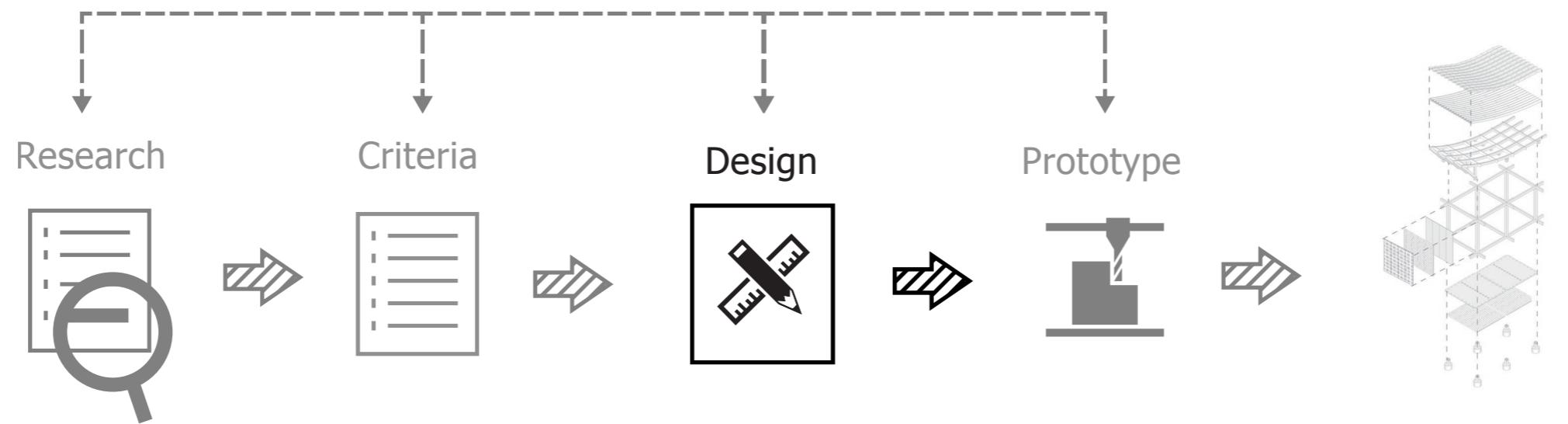
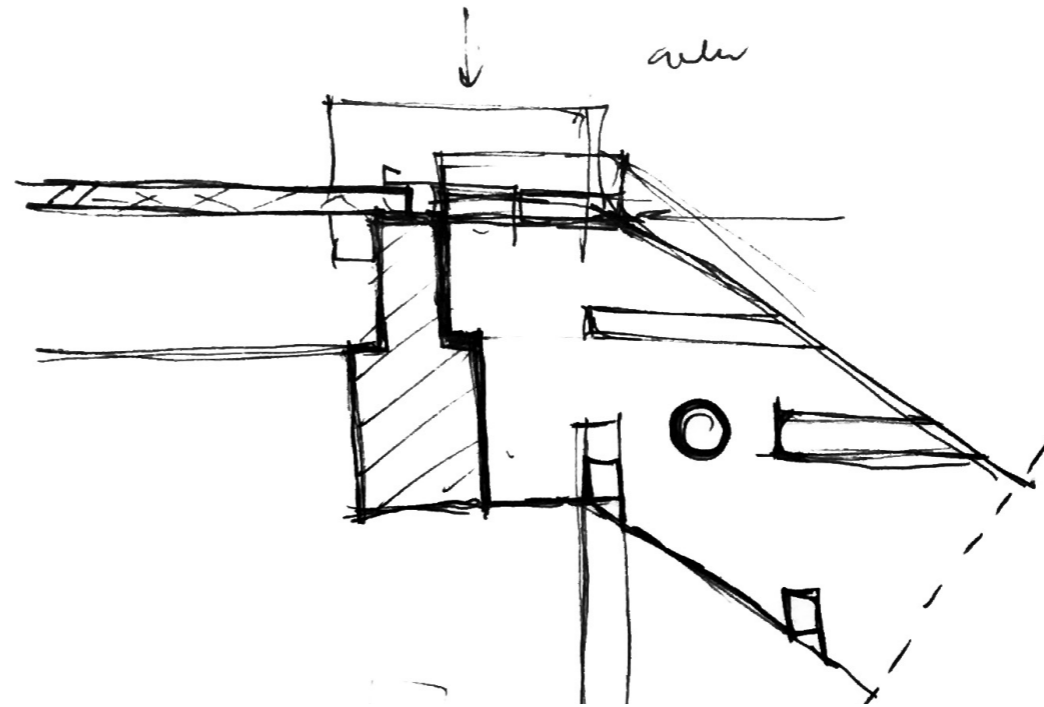
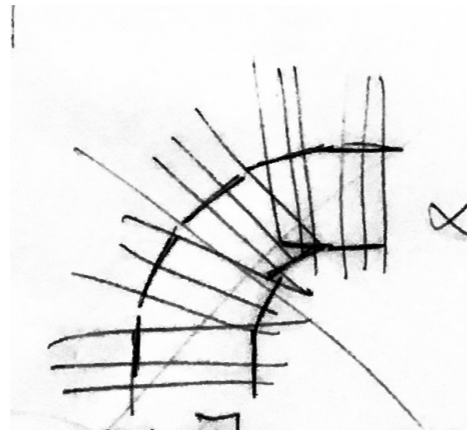



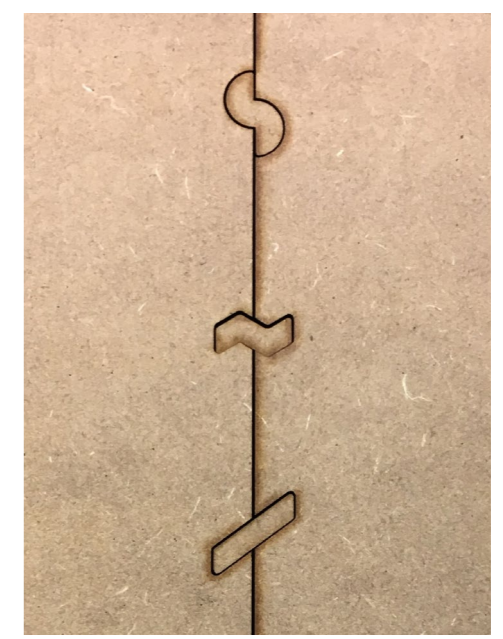
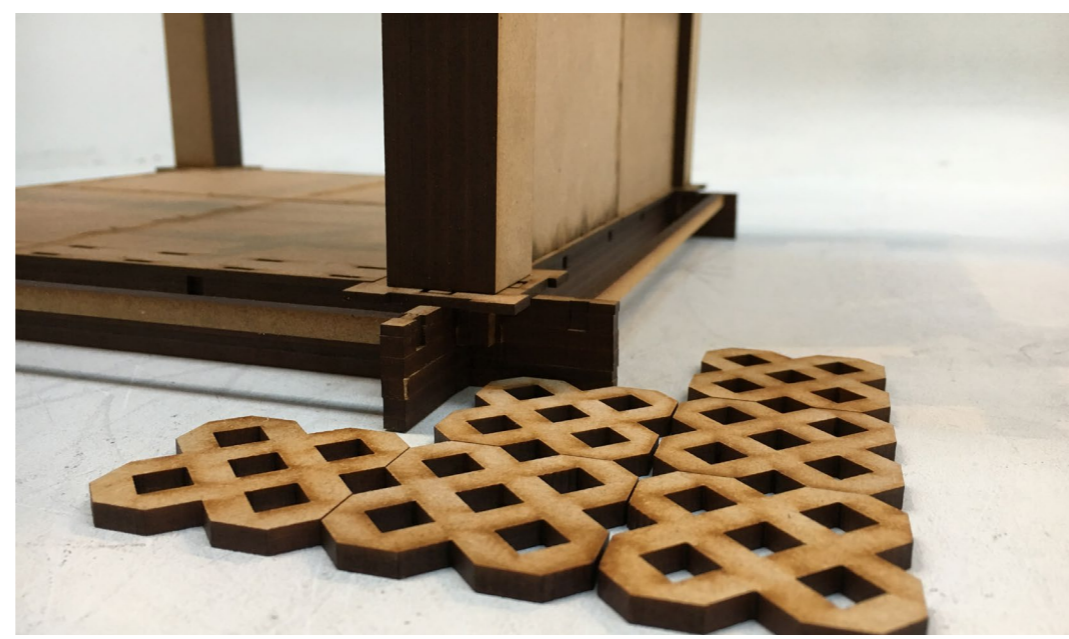
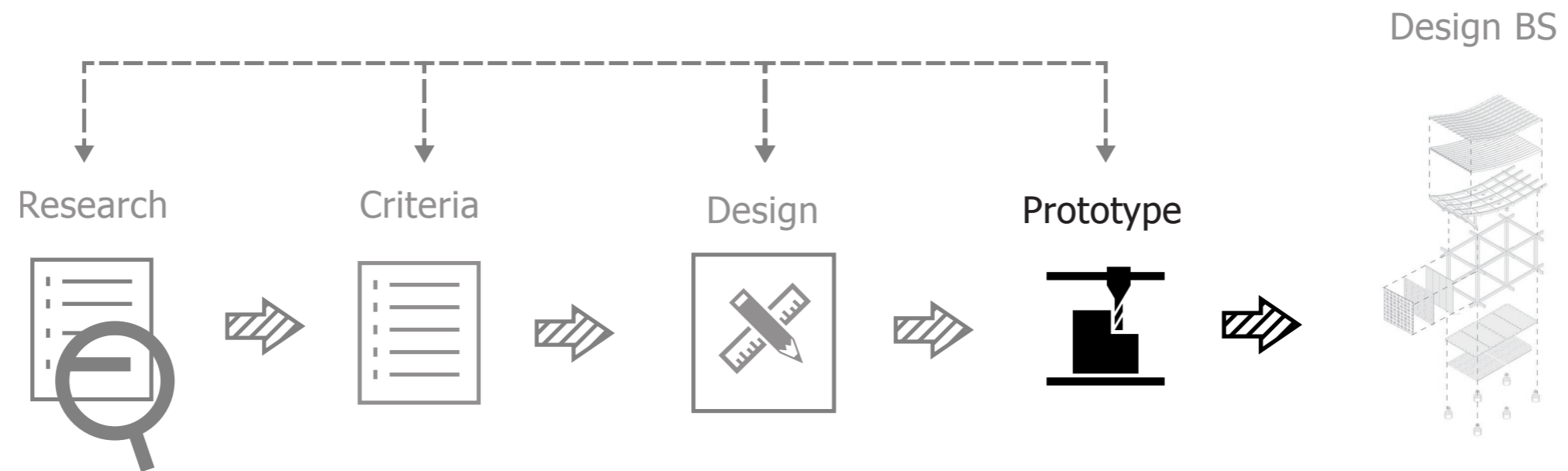
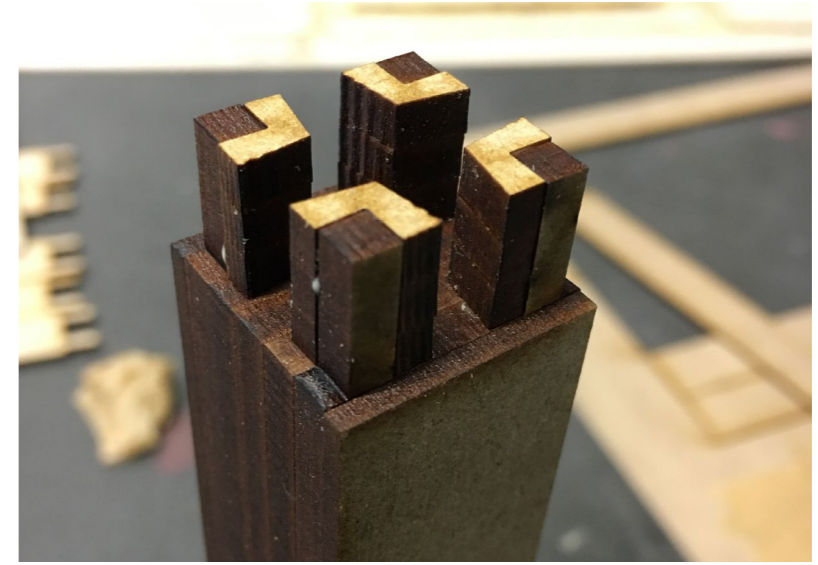
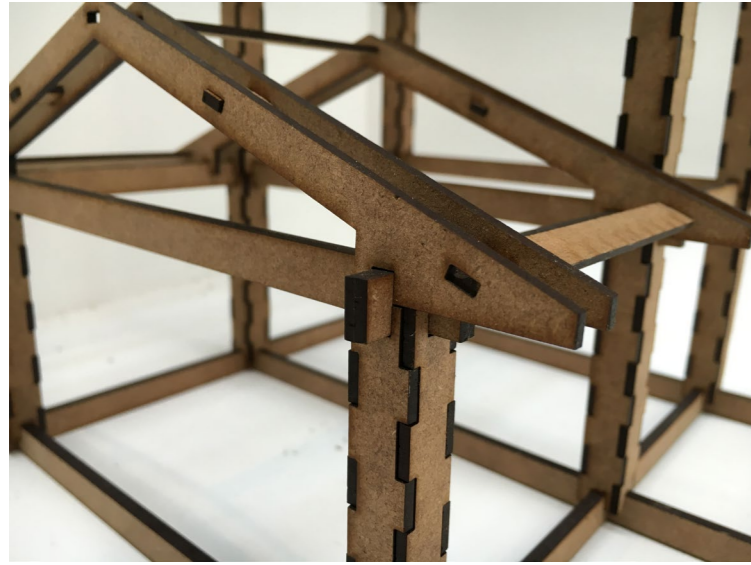

Design Process

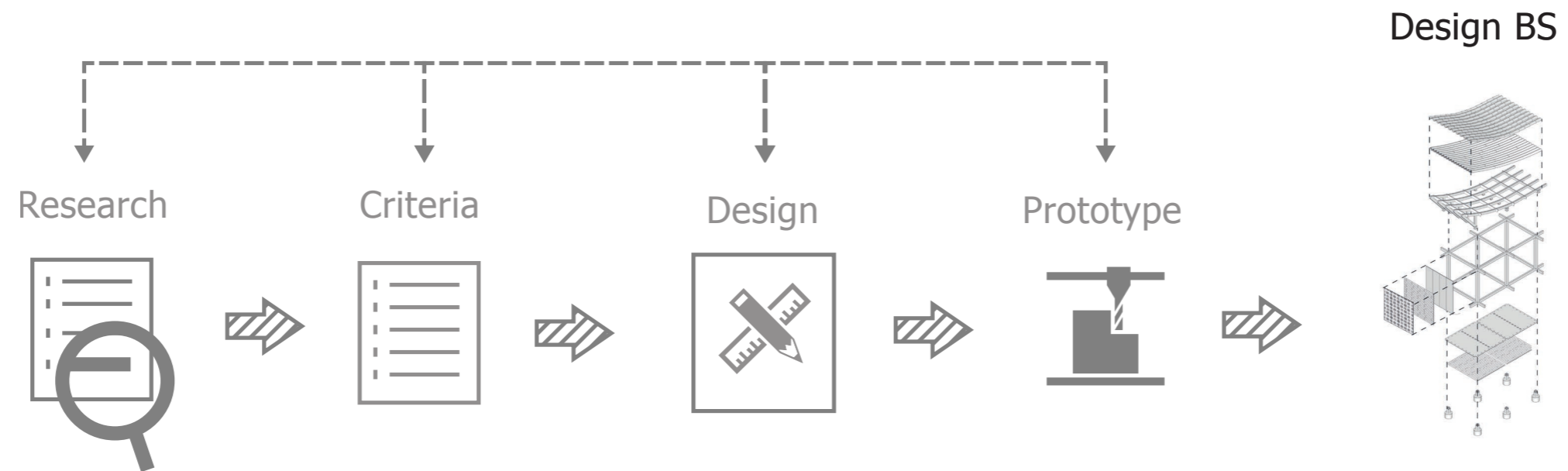

Design Process

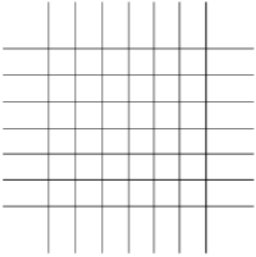
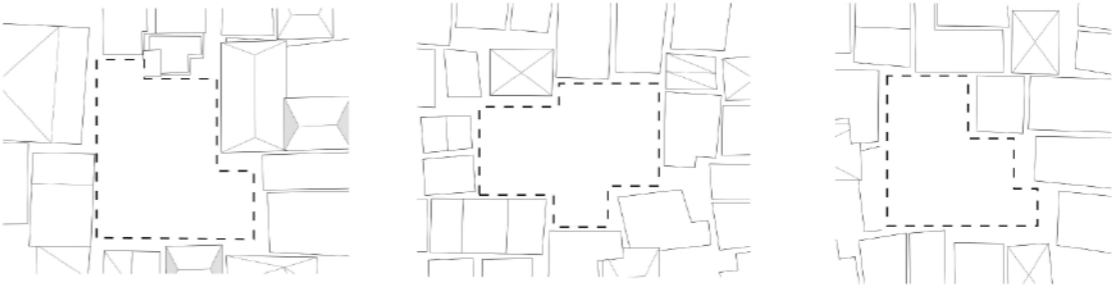
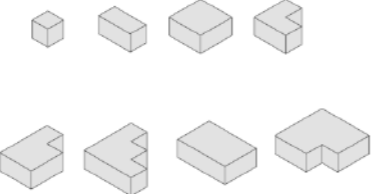
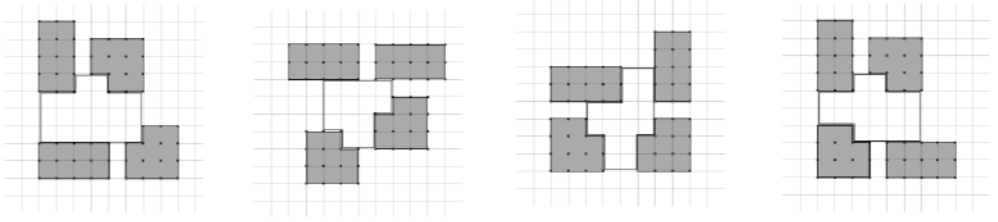
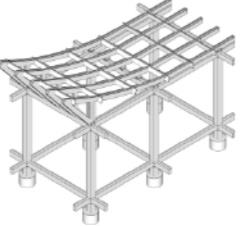

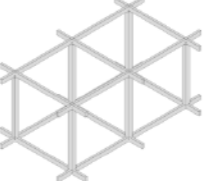
Building system

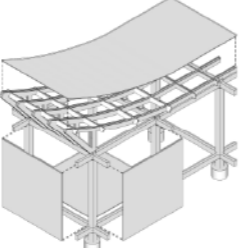
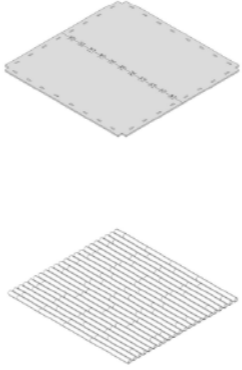
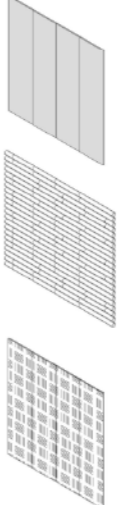
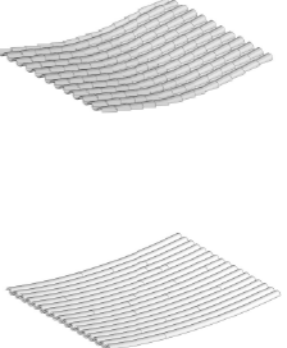
<p>Urban</p> 			
<p>Dwelling</p> 			
<p>Structure</p> 	<p>Foundation</p> 	<p>Beams/Columns</p> 	<p>Roof</p> 
<p>Envelope</p> 	<p>Flooring</p> 	<p>Facade</p> 	<p>Roof</p> 

Building system

Urban

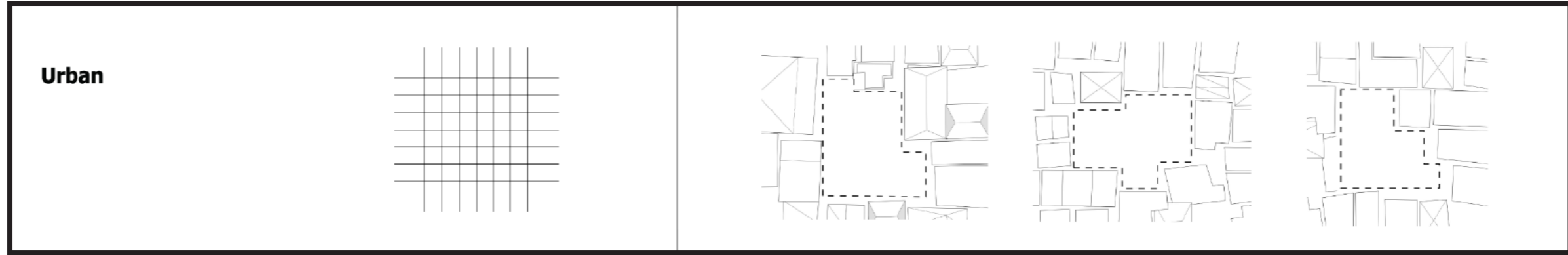

Grid based on 1200 mm

Flexible within urban tissue

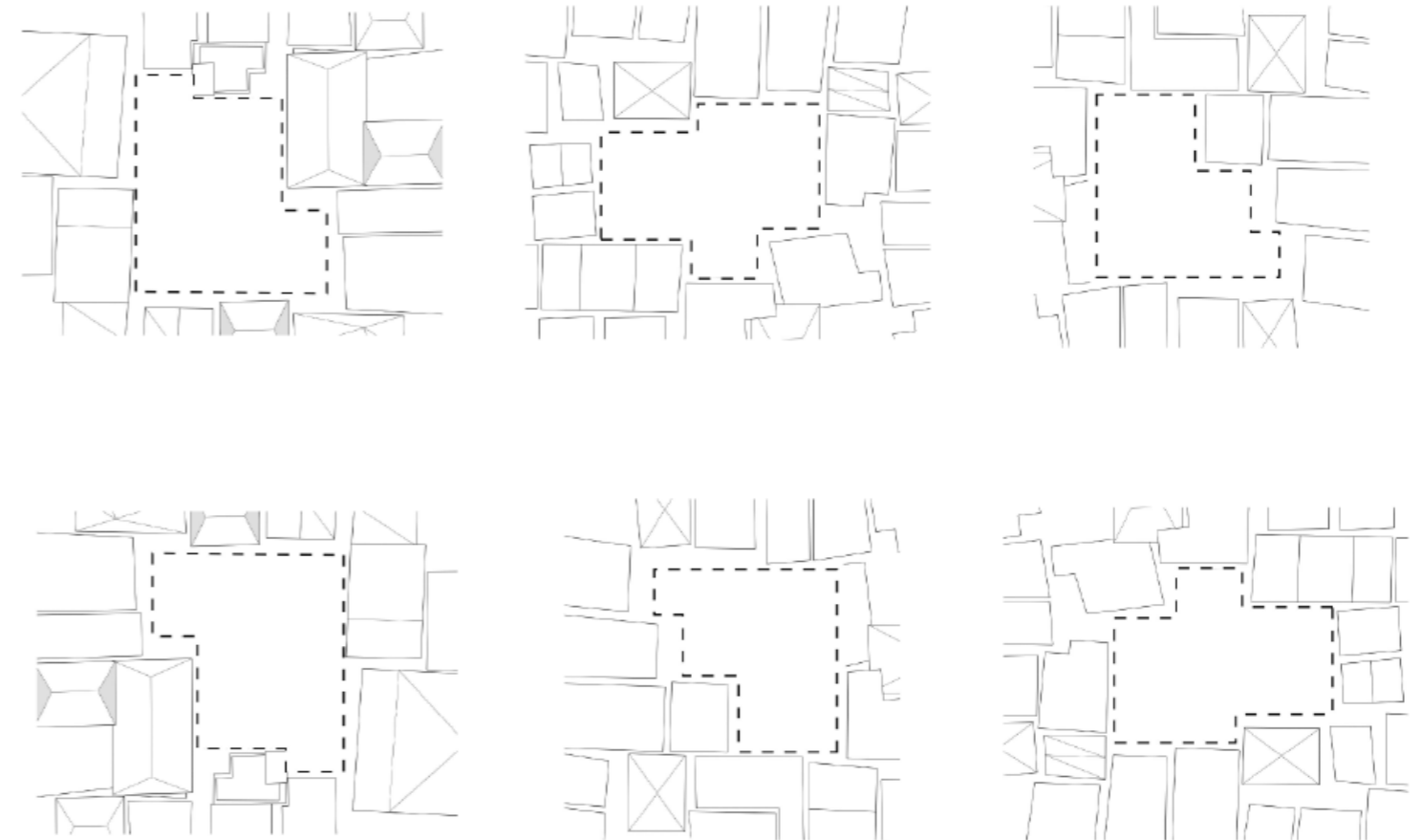
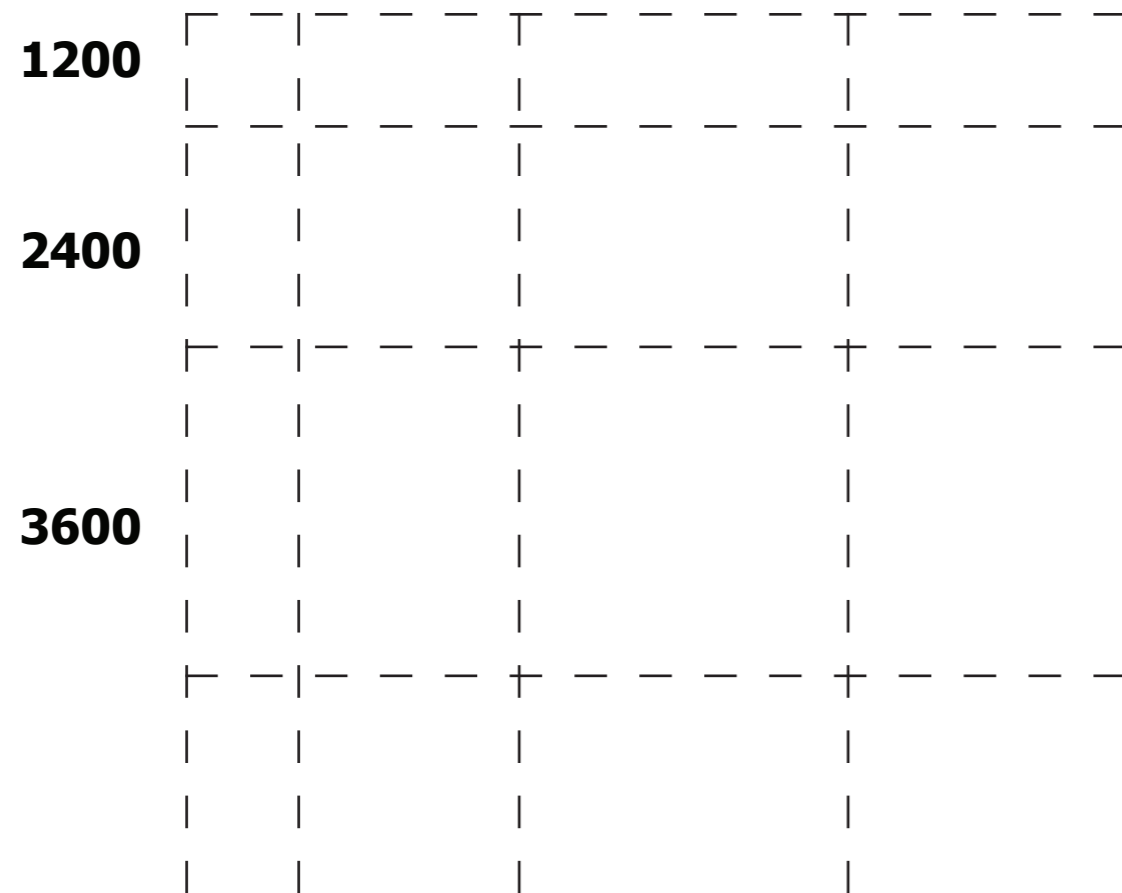

Building system



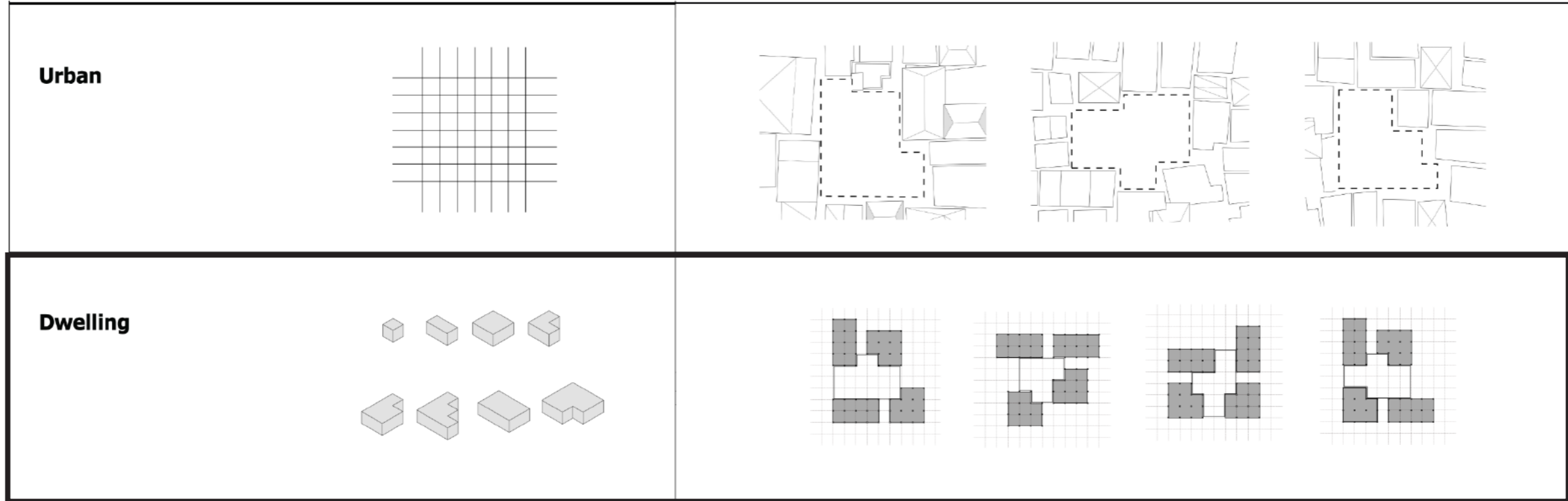



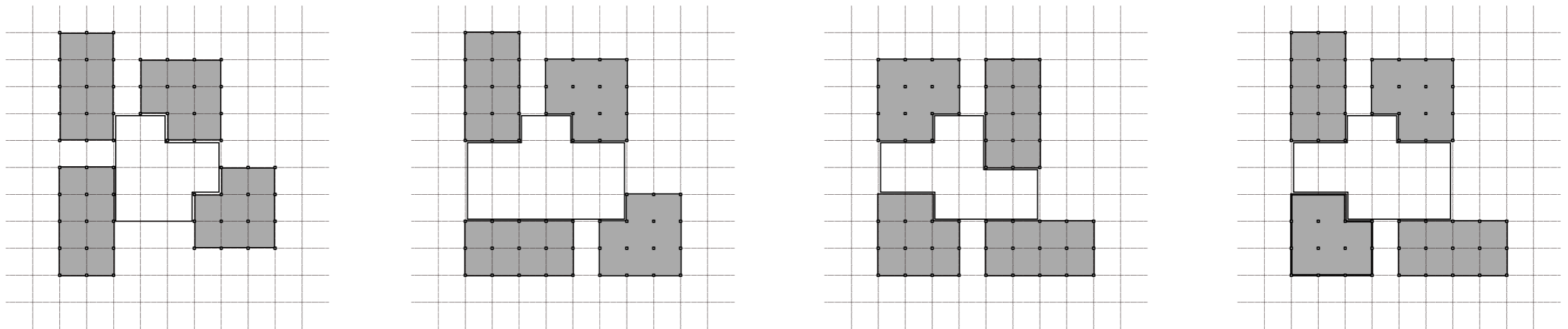

Dwelling

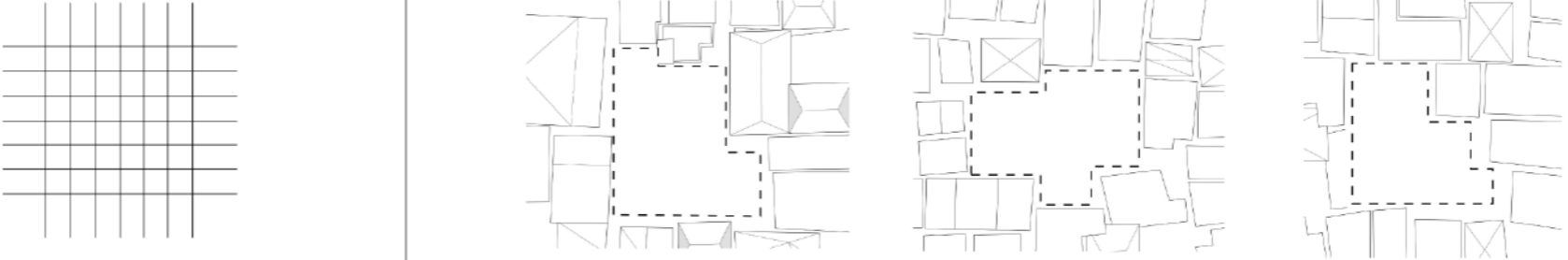
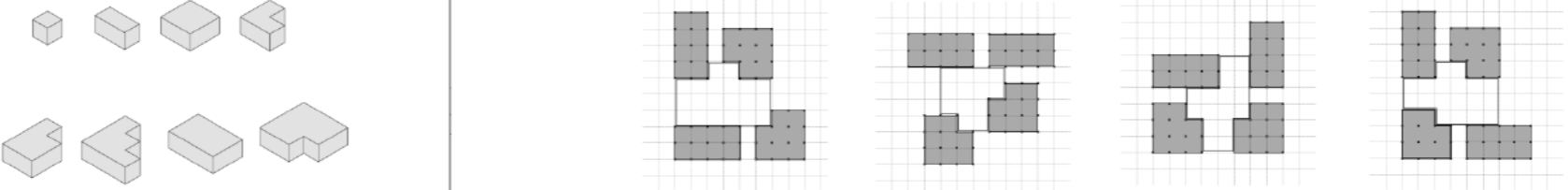

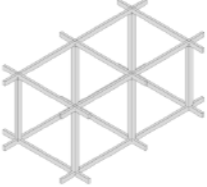
Flexible within grid

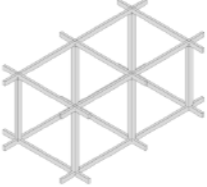

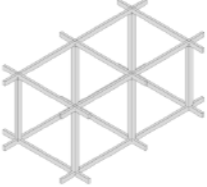
Building system

Urban	 <p>The Urban section contains three diagrams. The first is a simple grid of 10 vertical and 10 horizontal lines. The second and third are more complex line drawings showing building footprints and street layouts within a grid, with dashed lines indicating specific blocks or streets.</p>						
Dwelling	 <p>The Dwelling section contains two rows of diagrams. The top row shows four 3D rectangular blocks of varying sizes and orientations. The bottom row shows four 2D floor plans on a grid, representing different ways to arrange these blocks.</p>						
Structure	<table border="1"><thead><tr><th data-bbox="1347 980 1780 1039">Foundation</th><th data-bbox="1780 980 2226 1039">Beams/Columns</th><th data-bbox="2226 980 2614 1039">Roof</th></tr></thead><tbody><tr><td data-bbox="1347 1039 1780 1335"><p>A diagram showing six small, identical column-like structures arranged in a 2x3 grid.</p></td><td data-bbox="1780 1039 2226 1335"><p>A diagram of a hexagonal truss structure, consisting of interconnected beams forming a series of triangles.</p></td><td data-bbox="2226 1039 2614 1335"><p>A diagram of a curved roof structure, showing a series of parallel beams supported by a central column and other supports, forming a shallow arch.</p></td></tr></tbody></table>	Foundation	Beams/Columns	Roof	 <p>A diagram showing six small, identical column-like structures arranged in a 2x3 grid.</p>	 <p>A diagram of a hexagonal truss structure, consisting of interconnected beams forming a series of triangles.</p>	 <p>A diagram of a curved roof structure, showing a series of parallel beams supported by a central column and other supports, forming a shallow arch.</p>
Foundation	Beams/Columns	Roof					
 <p>A diagram showing six small, identical column-like structures arranged in a 2x3 grid.</p>	 <p>A diagram of a hexagonal truss structure, consisting of interconnected beams forming a series of triangles.</p>	 <p>A diagram of a curved roof structure, showing a series of parallel beams supported by a central column and other supports, forming a shallow arch.</p>					

Building system

Structure

Solid wood structure

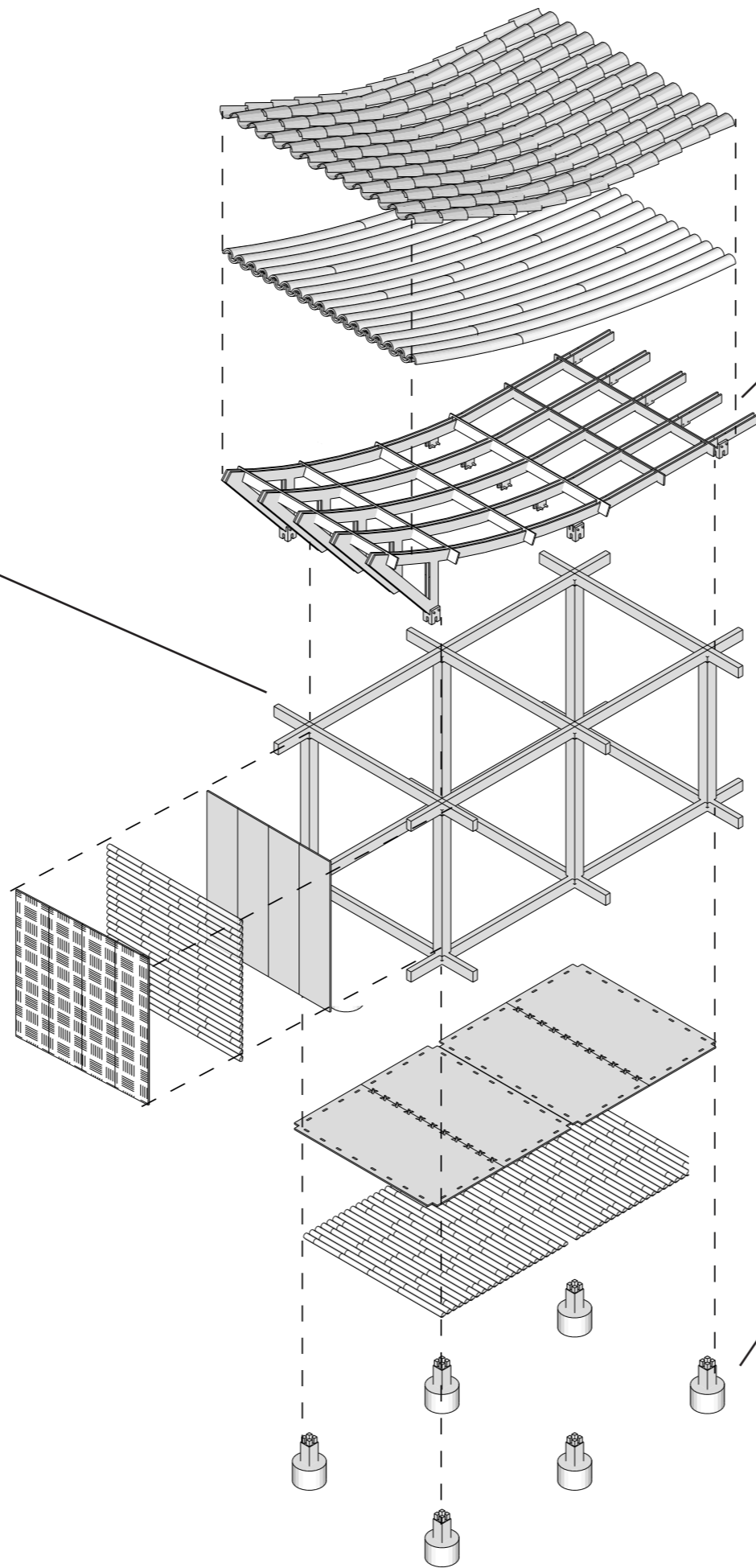
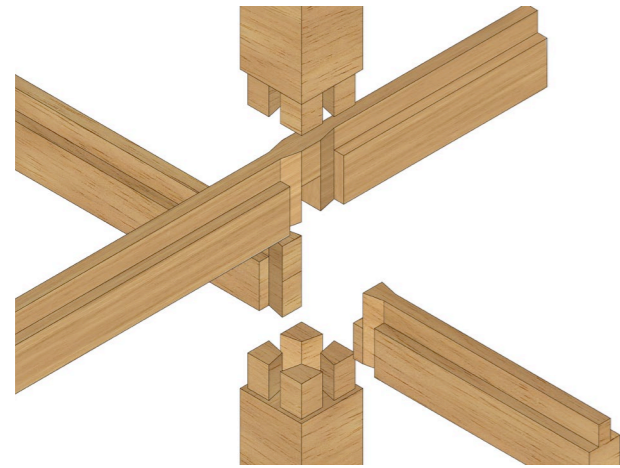

Panel wood structure

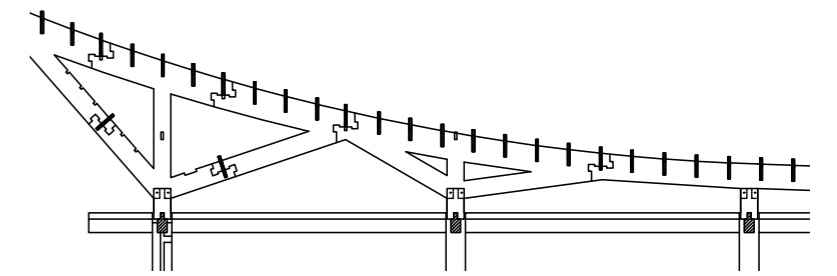



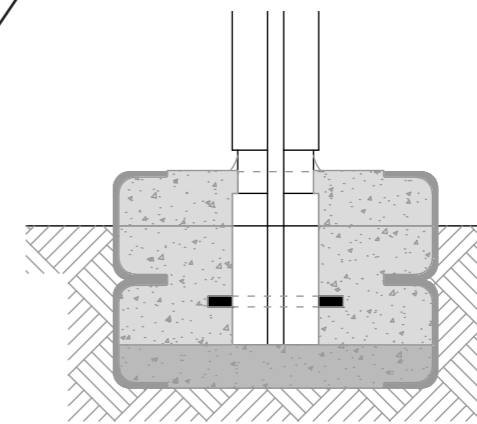

Concrete foundation



Used tyres

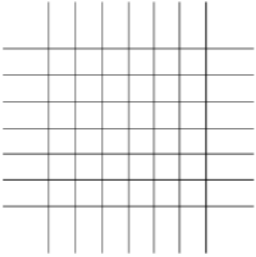
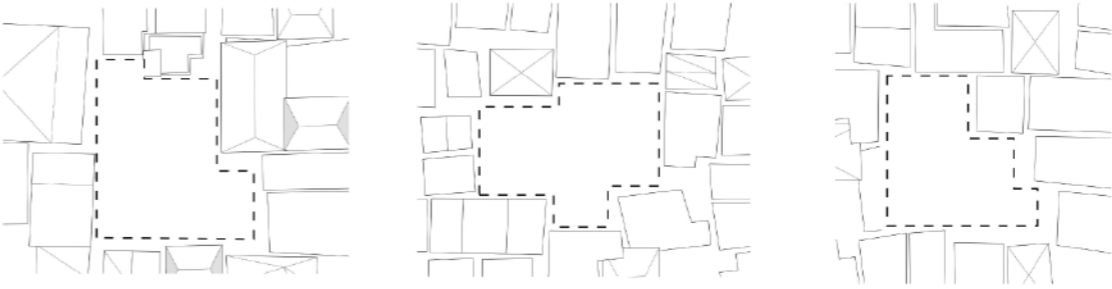
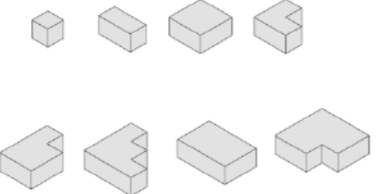
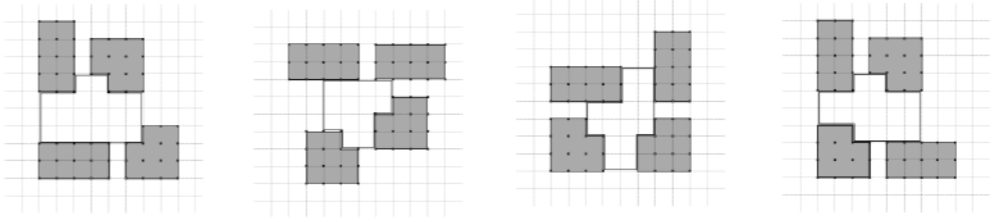
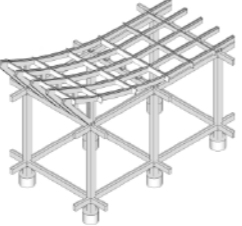

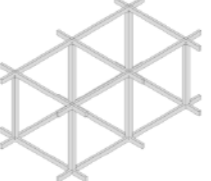
Building system

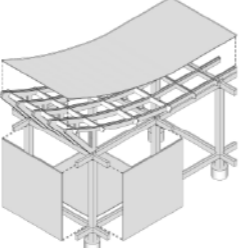
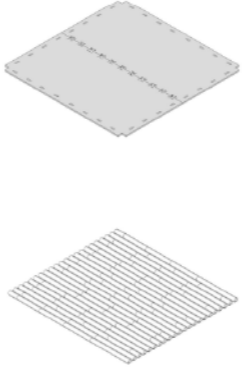
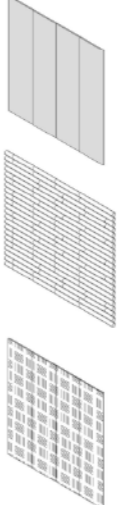
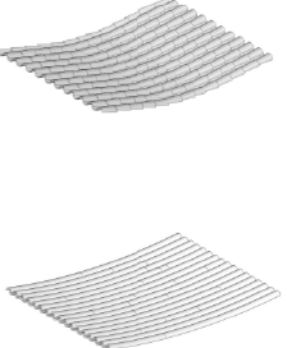
<p>Urban</p> 			
<p>Dwelling</p> 			
<p>Structure</p> 	<p>Foundation</p> 	<p>Beams/Columns</p> 	<p>Roof</p> 
<p>Envelope</p> 	<p>Flooring</p> 	<p>Facade</p> 	<p>Roof</p> 

Building system

Envelope

Facade



Board material



Bamboo

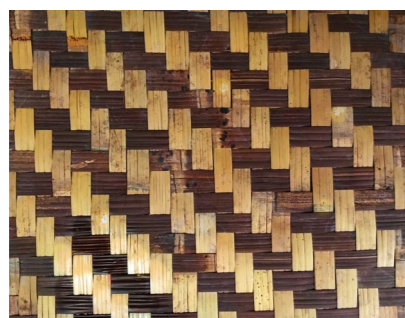

Natural panels

Roof



Roof tiles



Bamboo rods

Floor



Board material



Bamboo rods

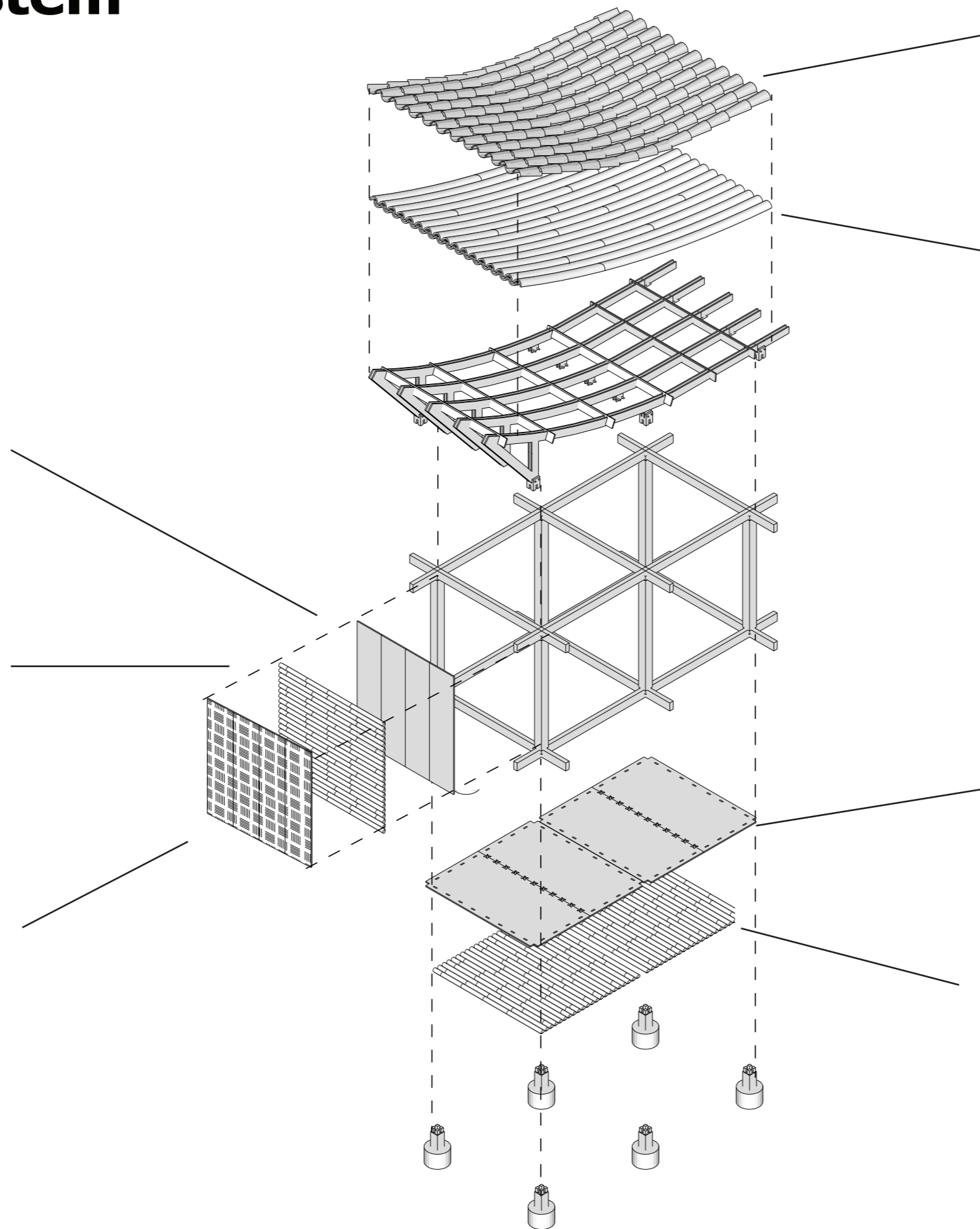

Building system

Assembly

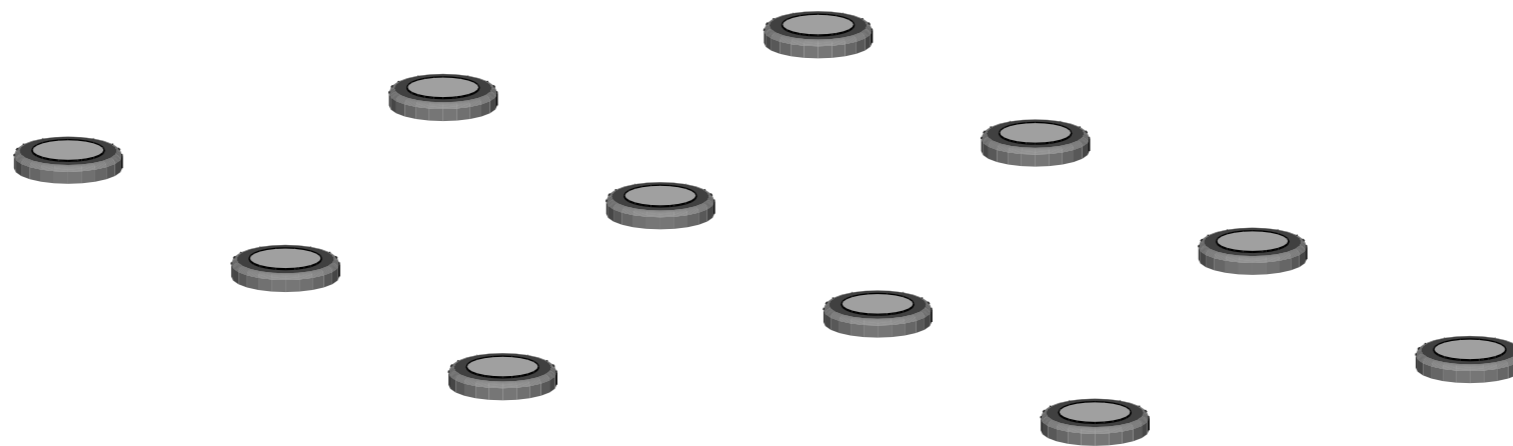

Building system

Assembly

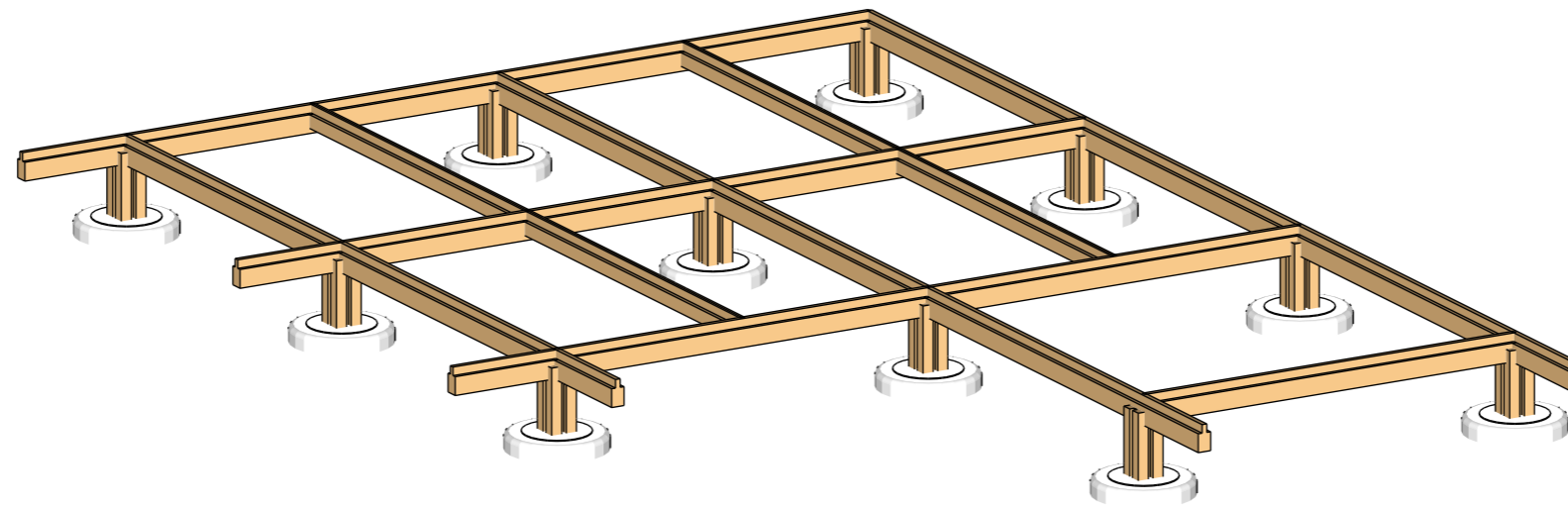

Building system

Assembly

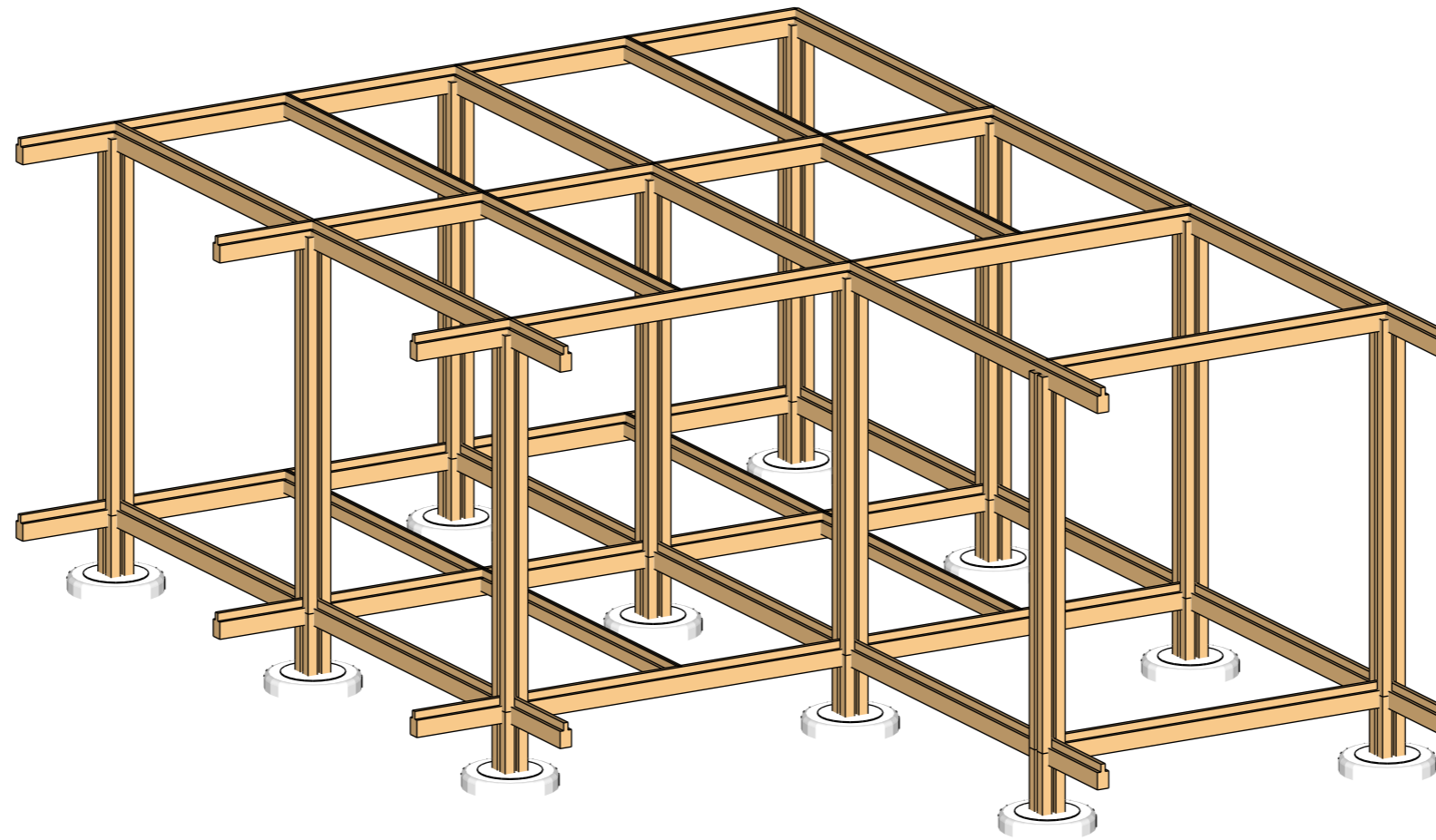

Building system

Assembly

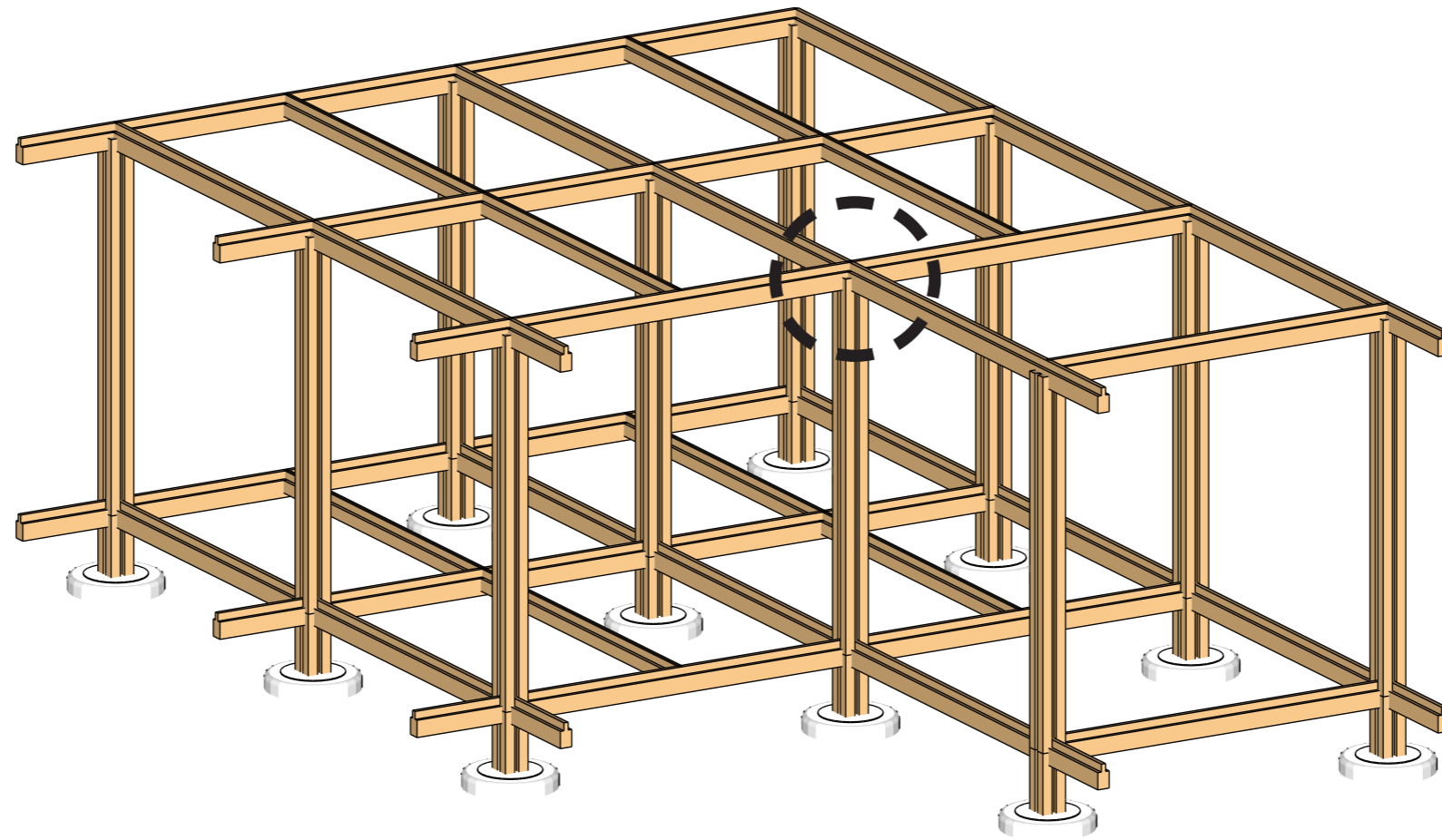
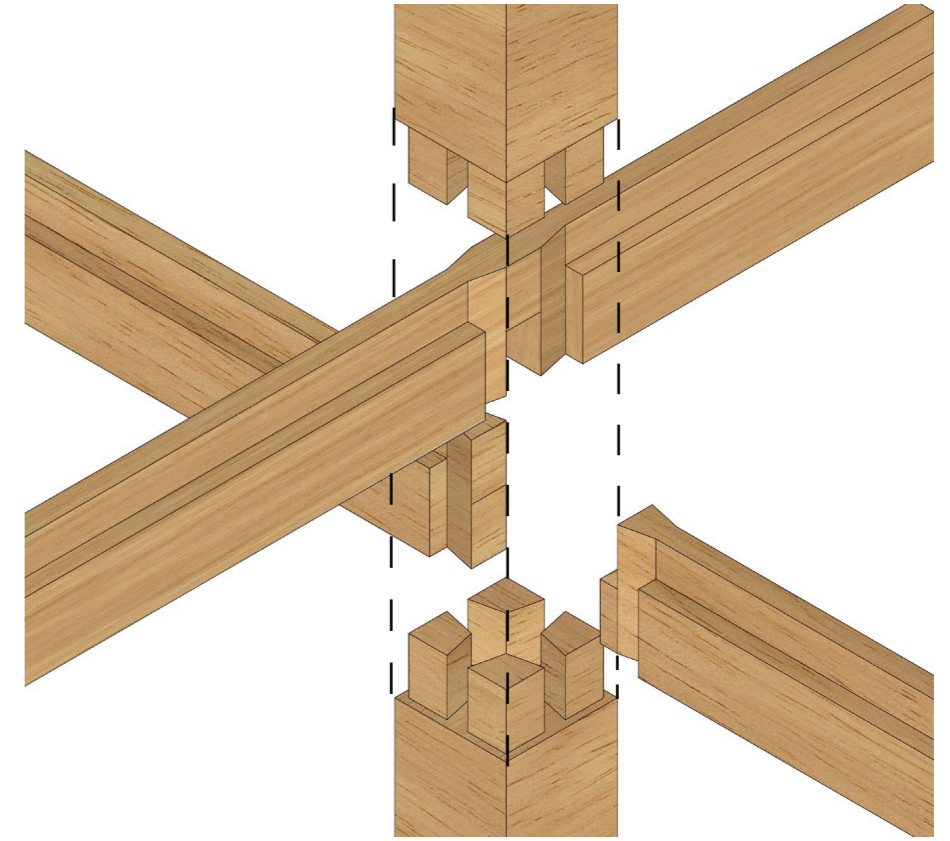

Building system

Assembly

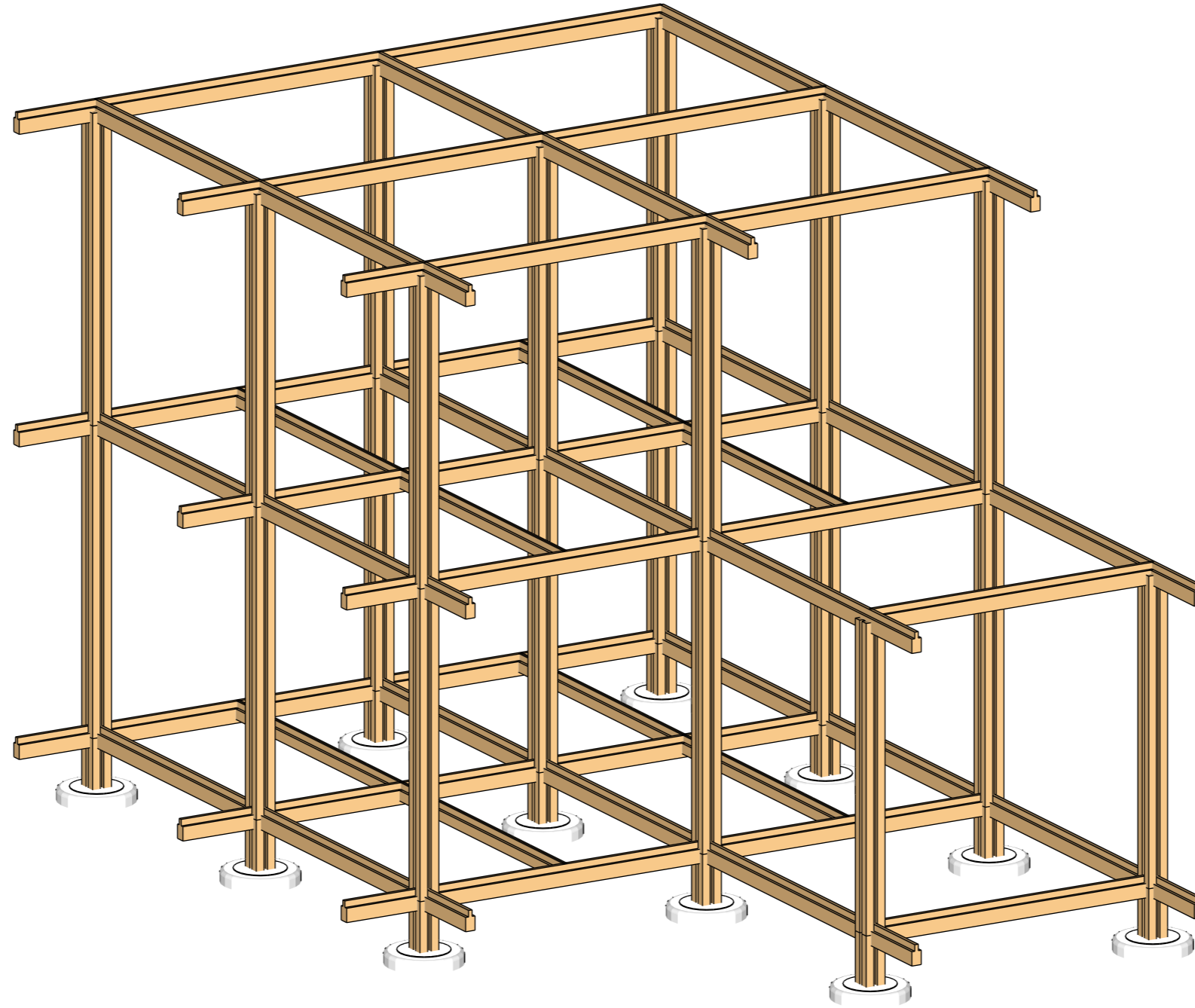

Building system

Assembly

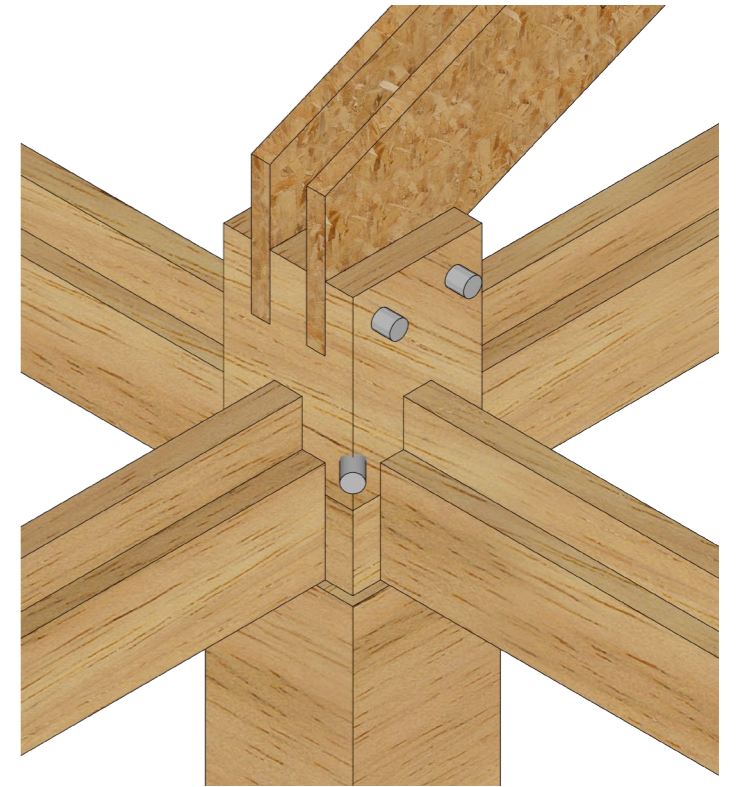
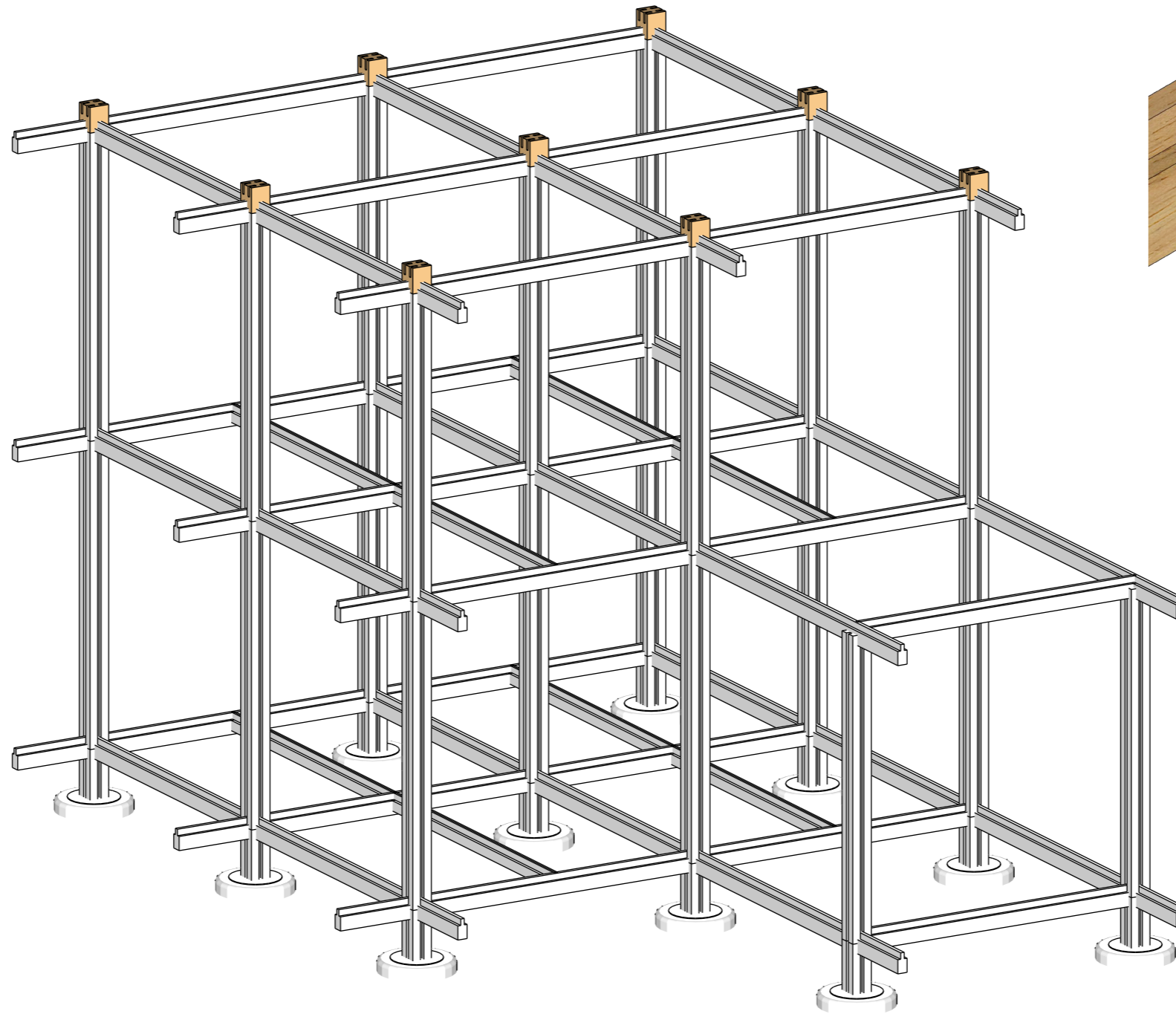

Building system

Assembly

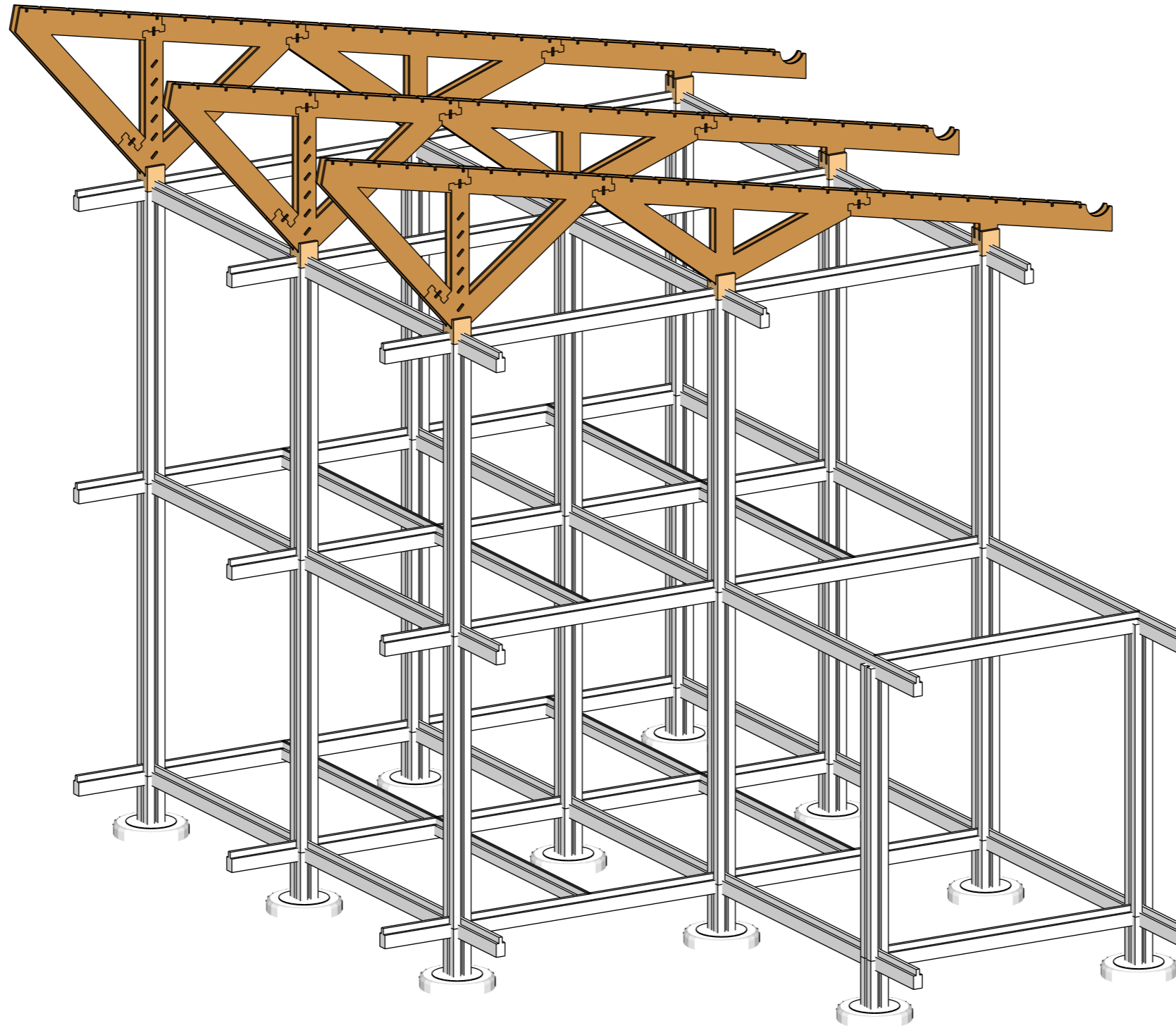

Building system

Assembly

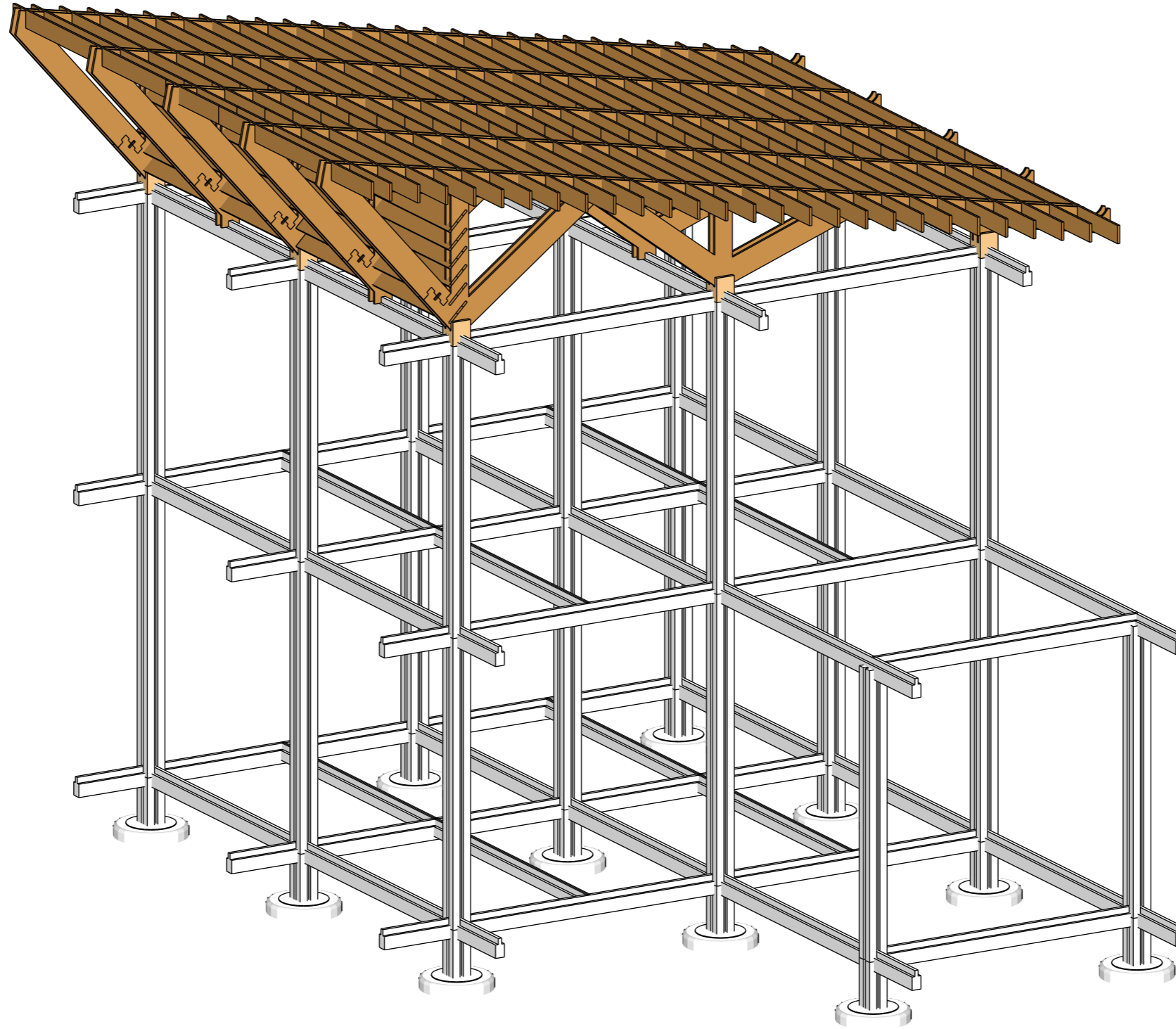

Building system

Assembly

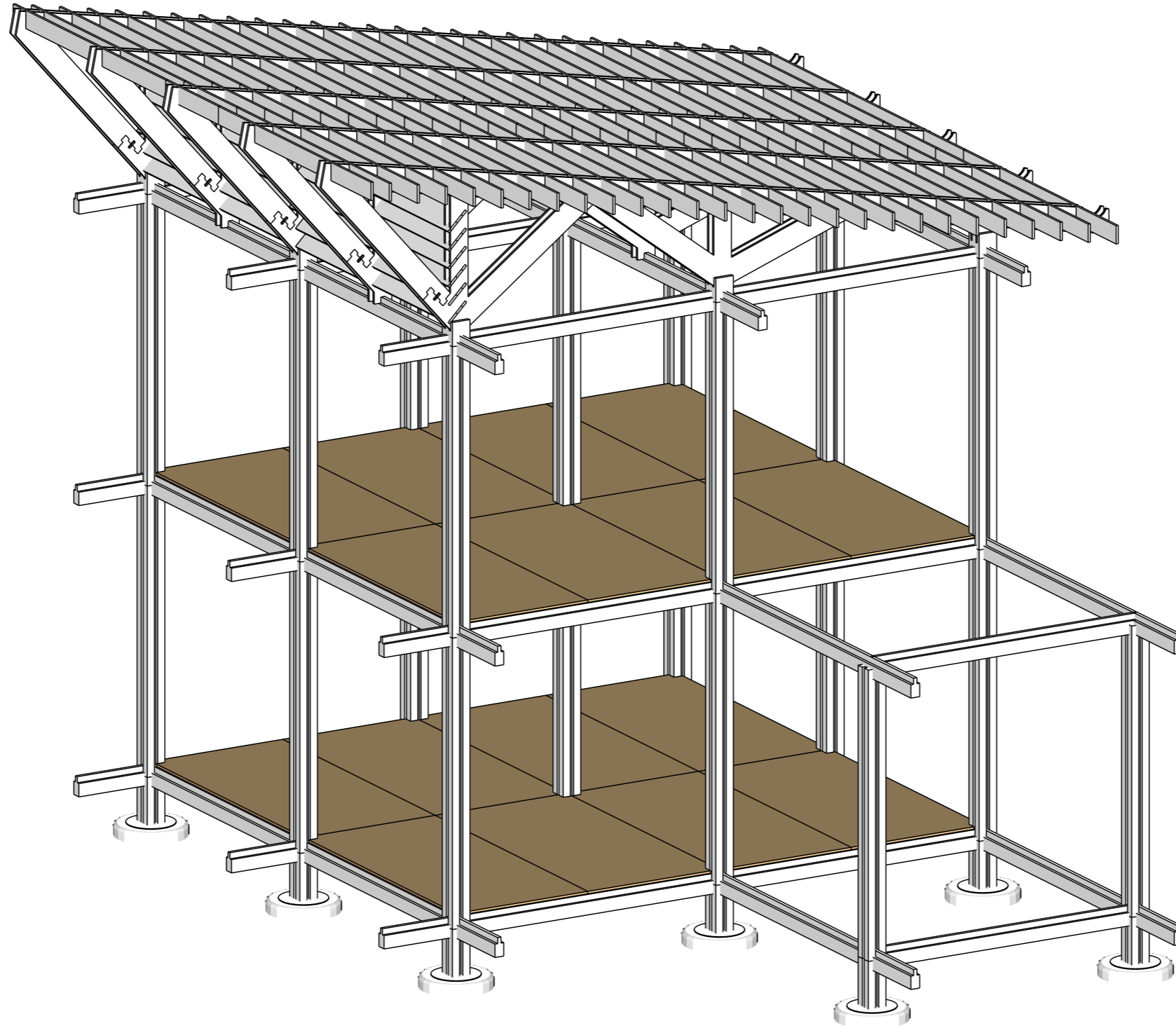

Building system

Assembly

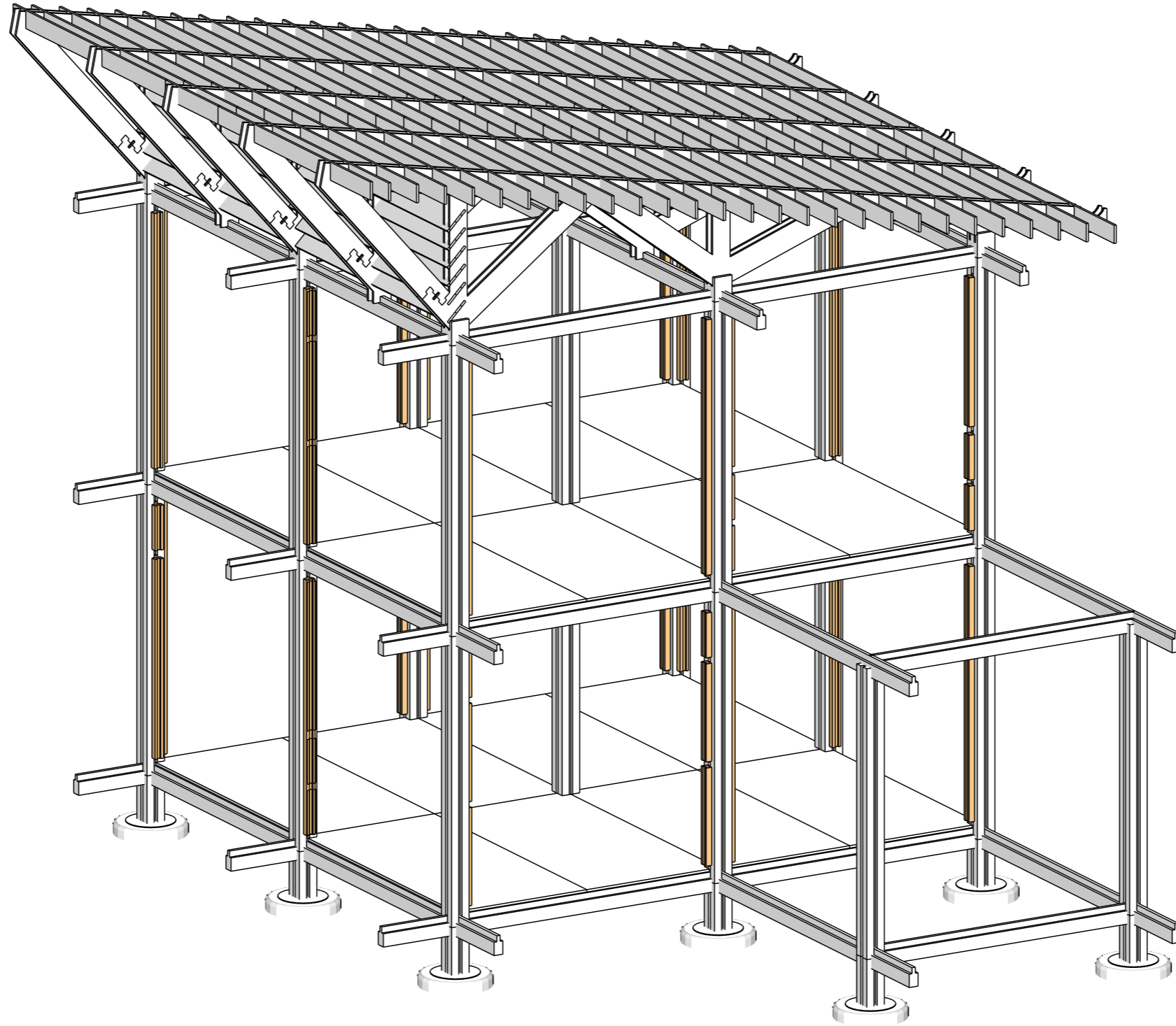

Building system

Assembly

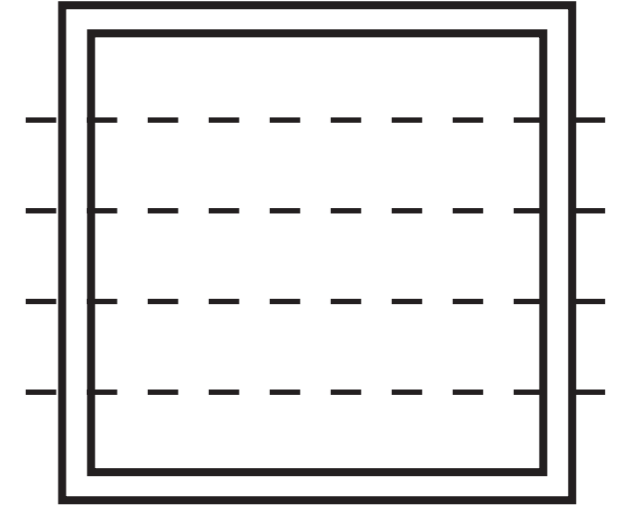
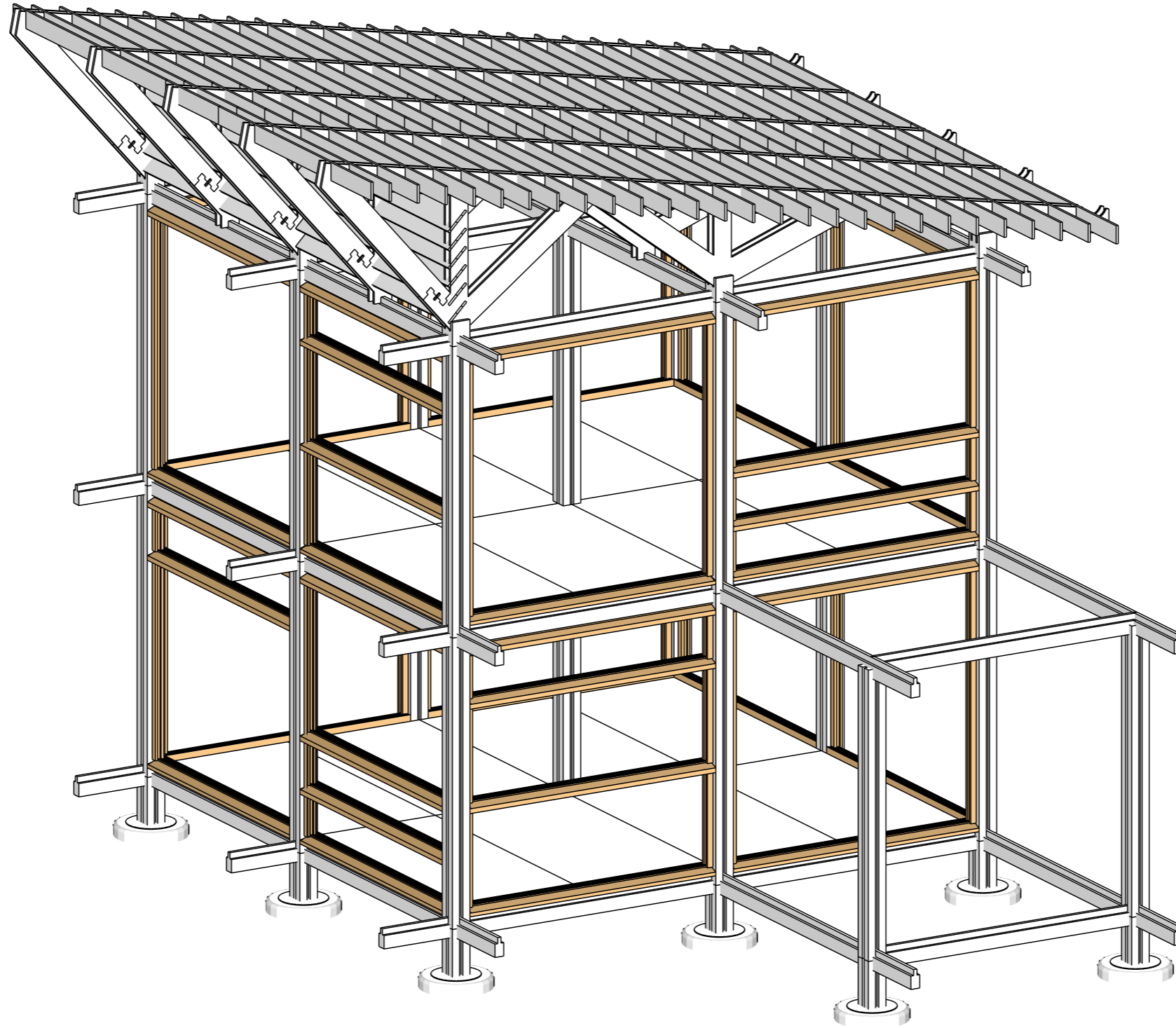

Building system

Assembly

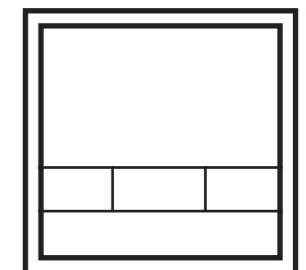
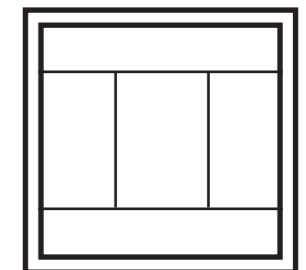
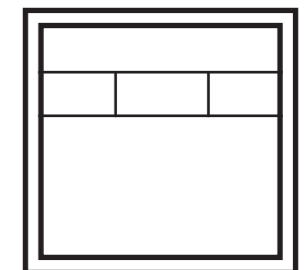
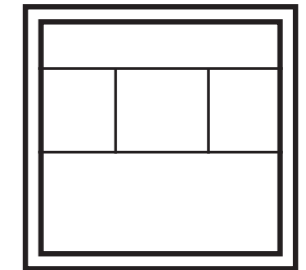
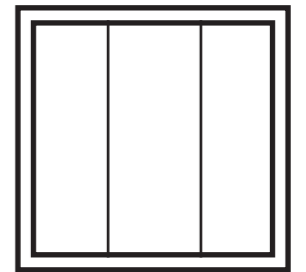
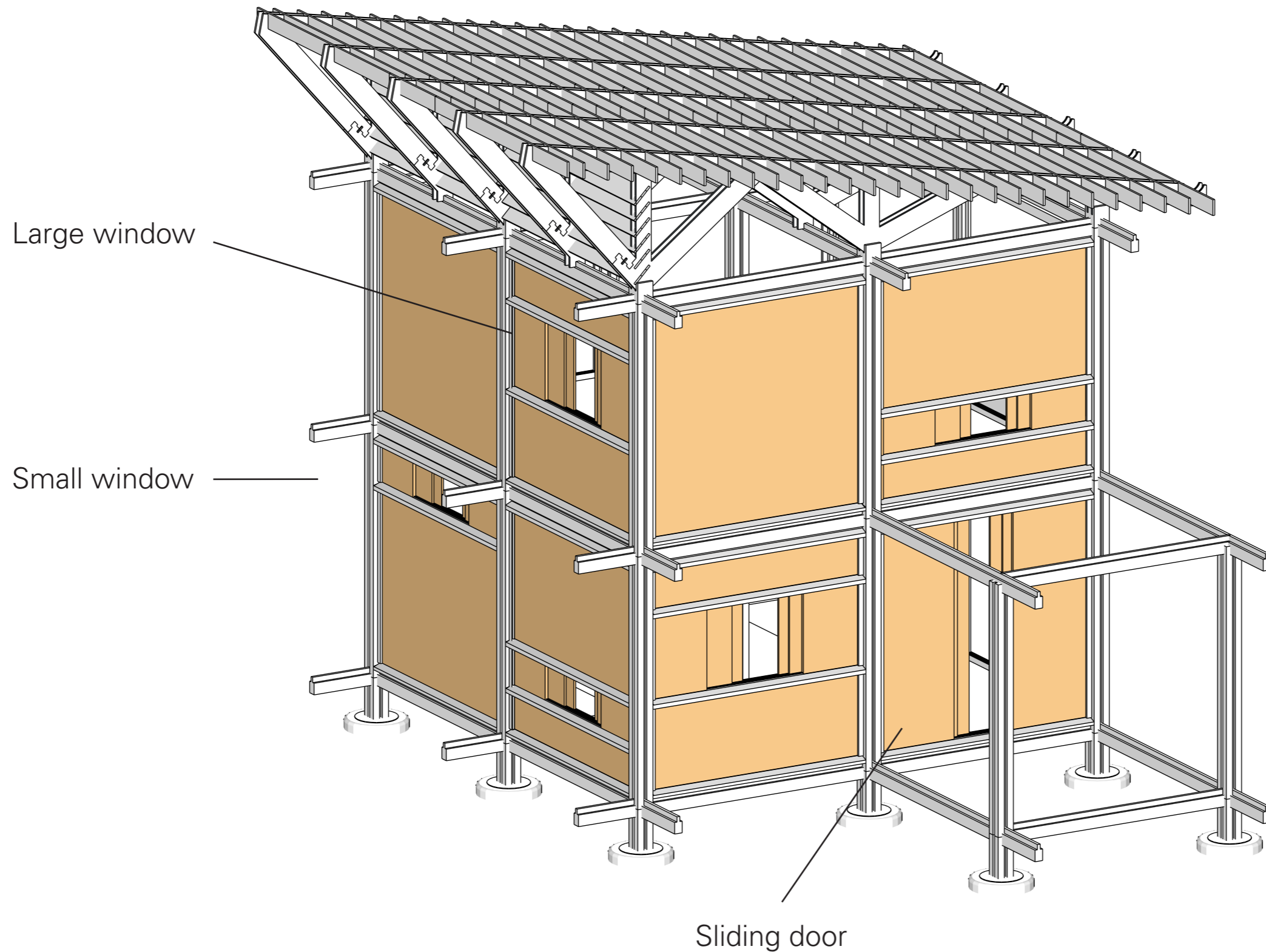

Building system

Assembly

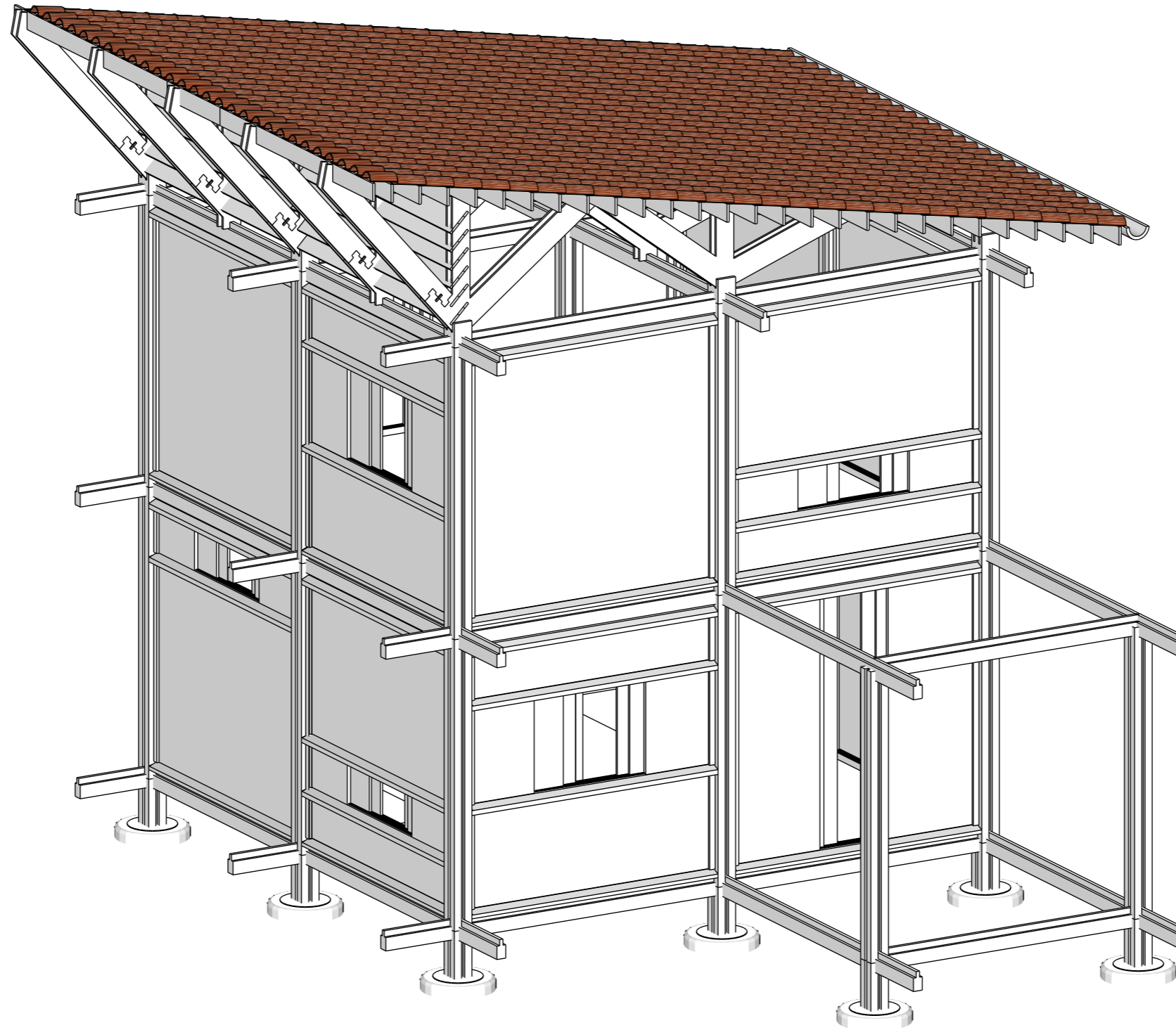

Building system

Assembly

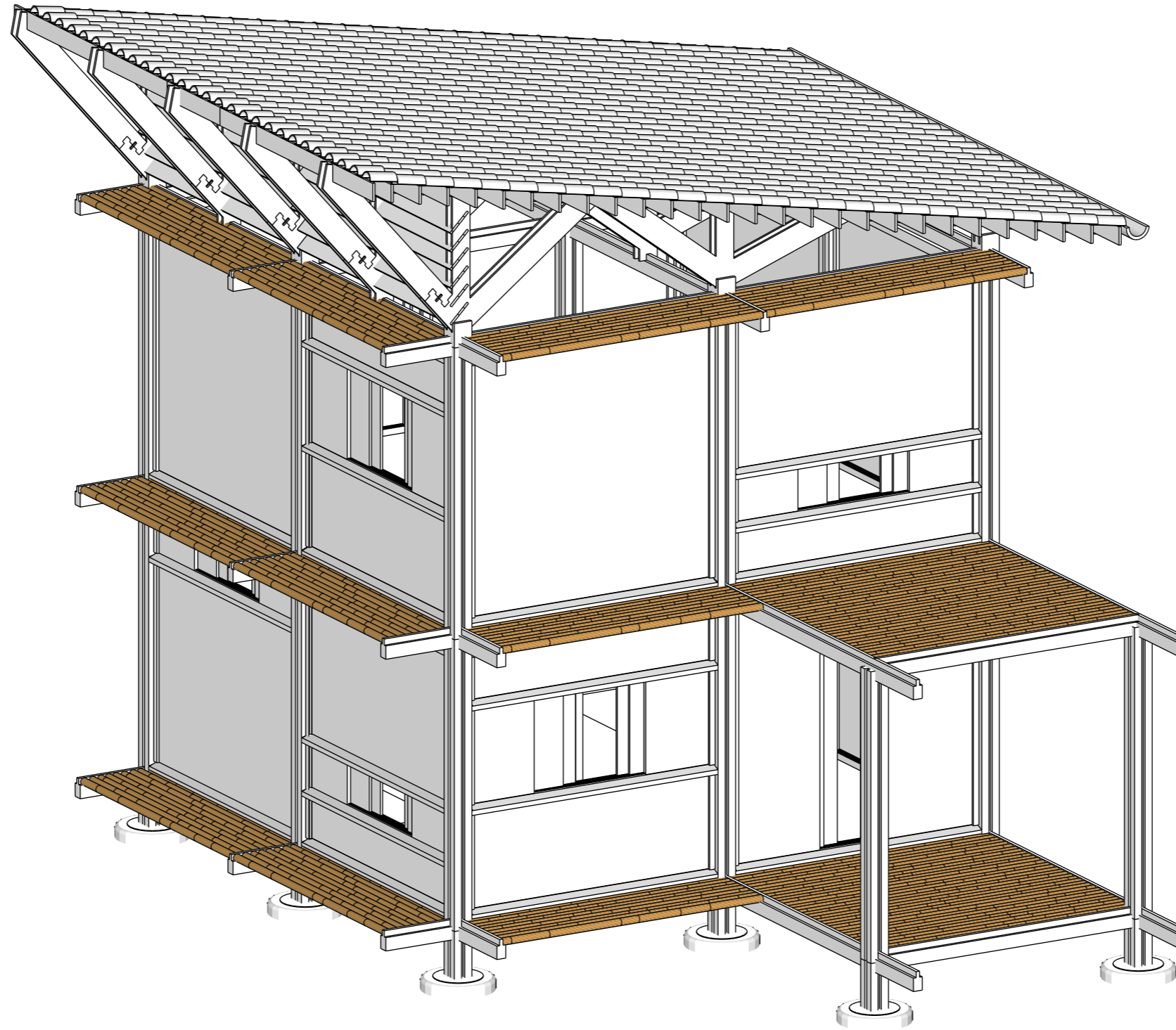





Building system

Assembly

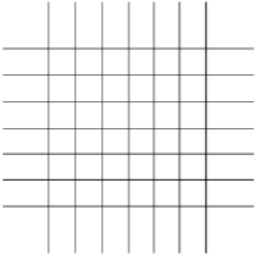
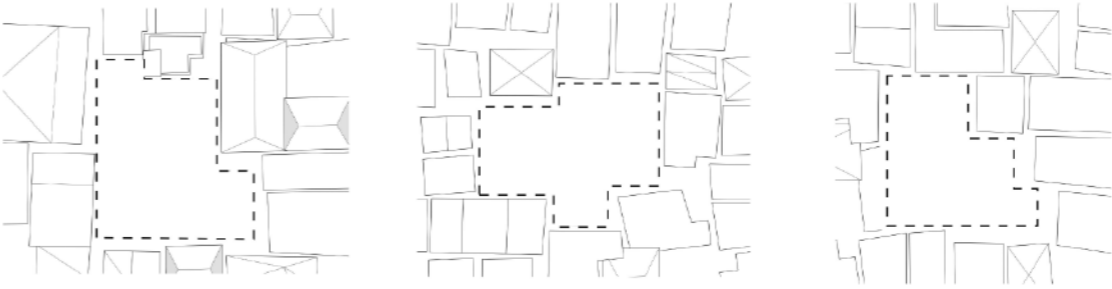
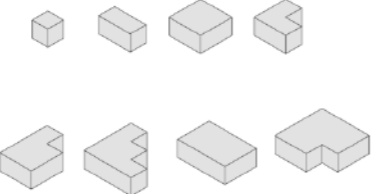
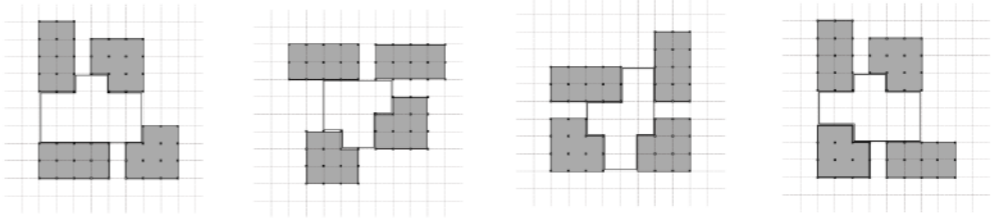
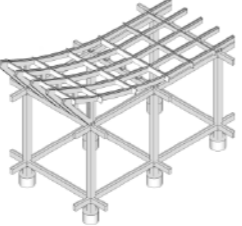

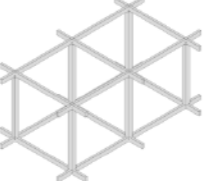
Building system

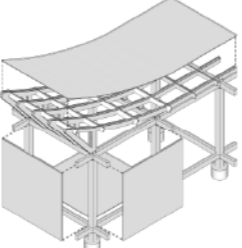
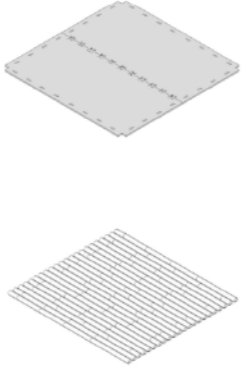
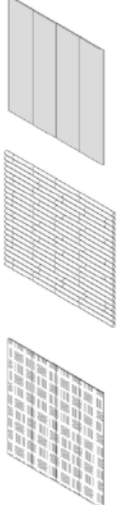
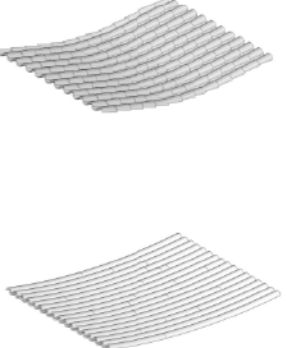
<p>Urban</p> 			
<p>Dwelling</p> 			
<p>Structure</p> 	<p>Foundation</p> 	<p>Beams/Columns</p> 	<p>Roof</p> 
<p>Envelope</p> 	<p>Flooring</p> 	<p>Facade</p> 	<p>Roof</p> 

Bandung

City Centre

Cigondewah

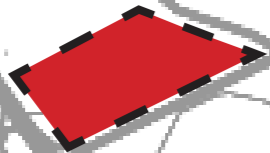

Context

Cigondewah

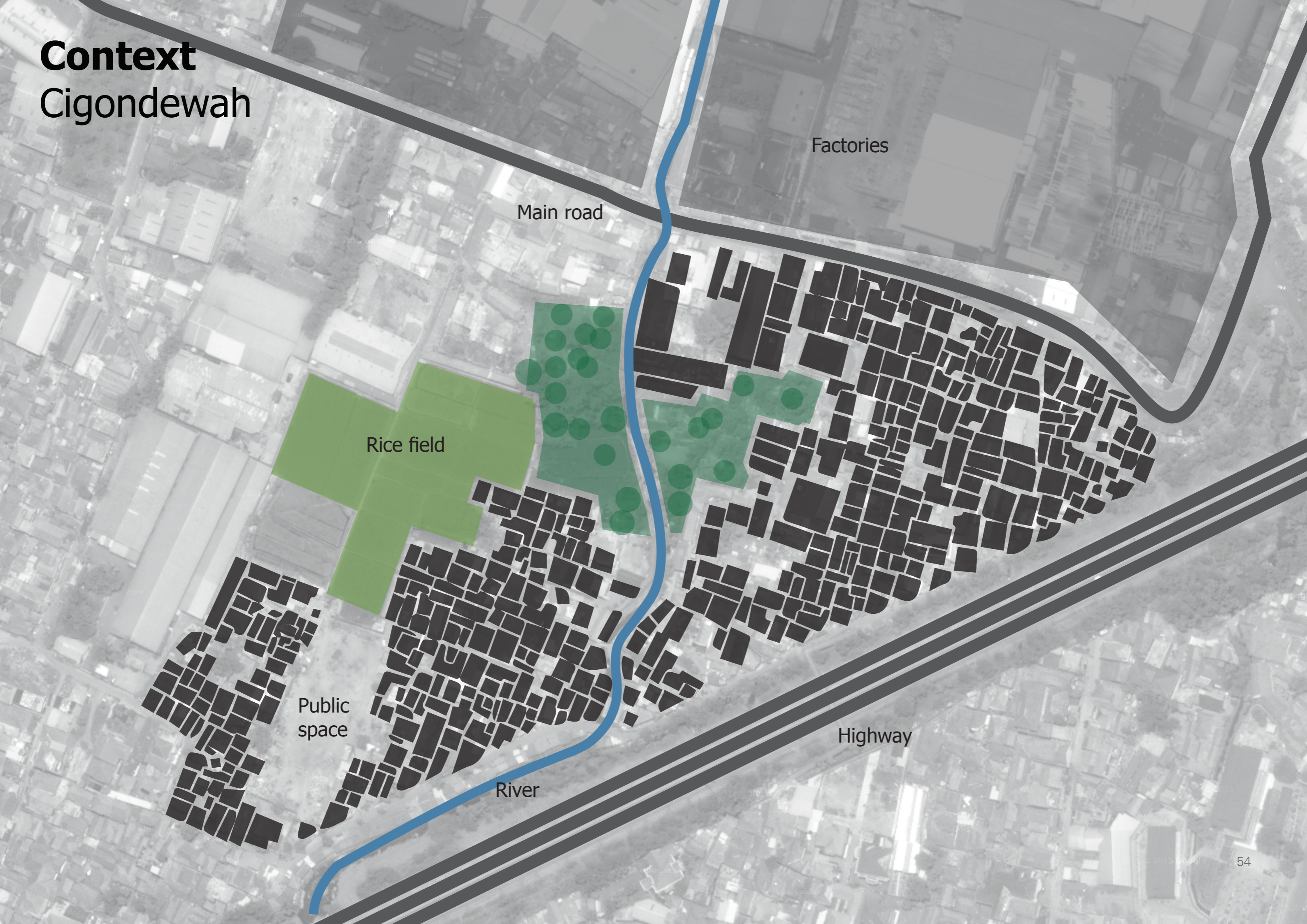

Factories

Main road

Rice field

Public space

River

Highway

Design Cigondewah

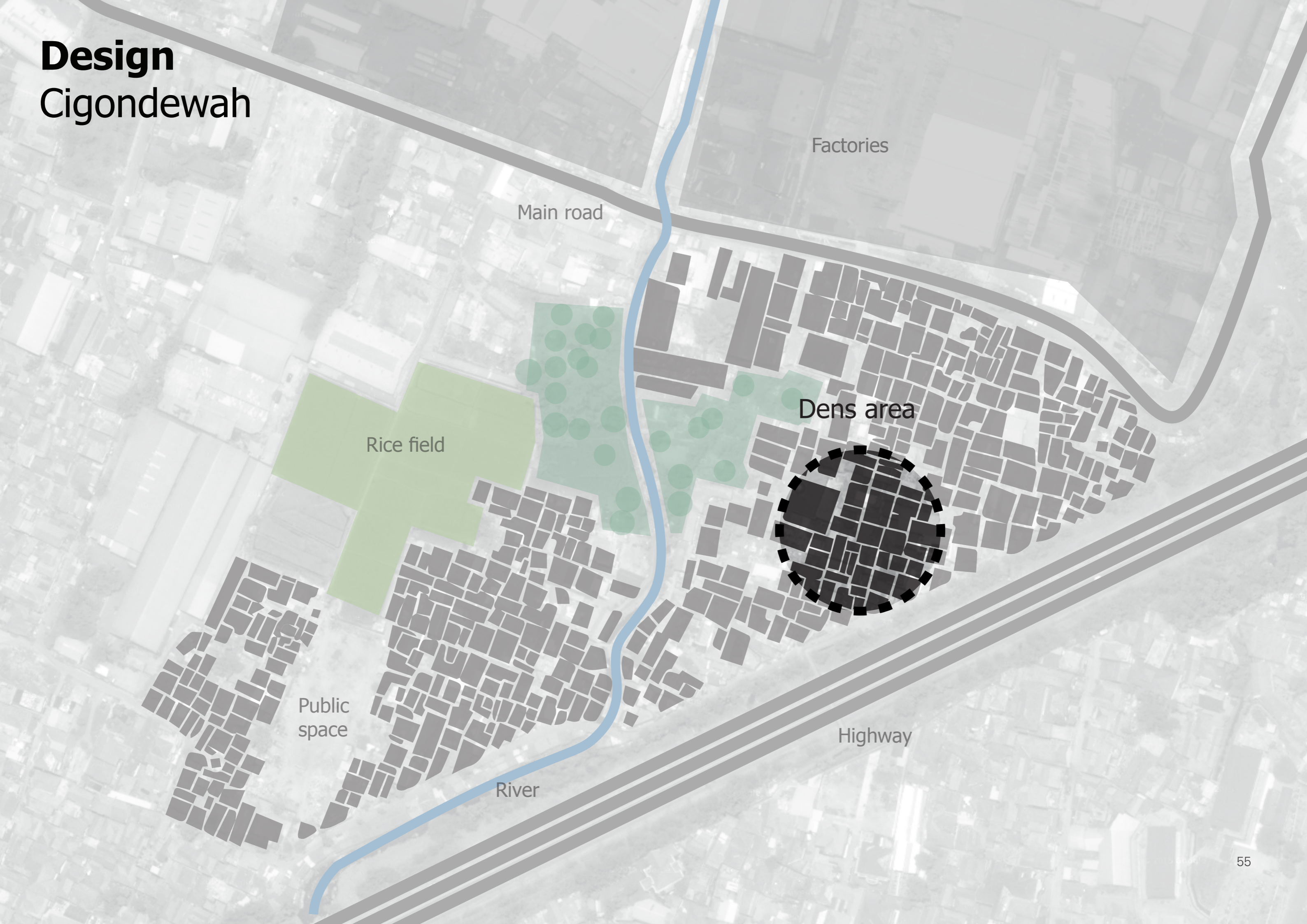

Main road

Factories

Rice field

Dens area

Public space

River

Highway

Design Urban

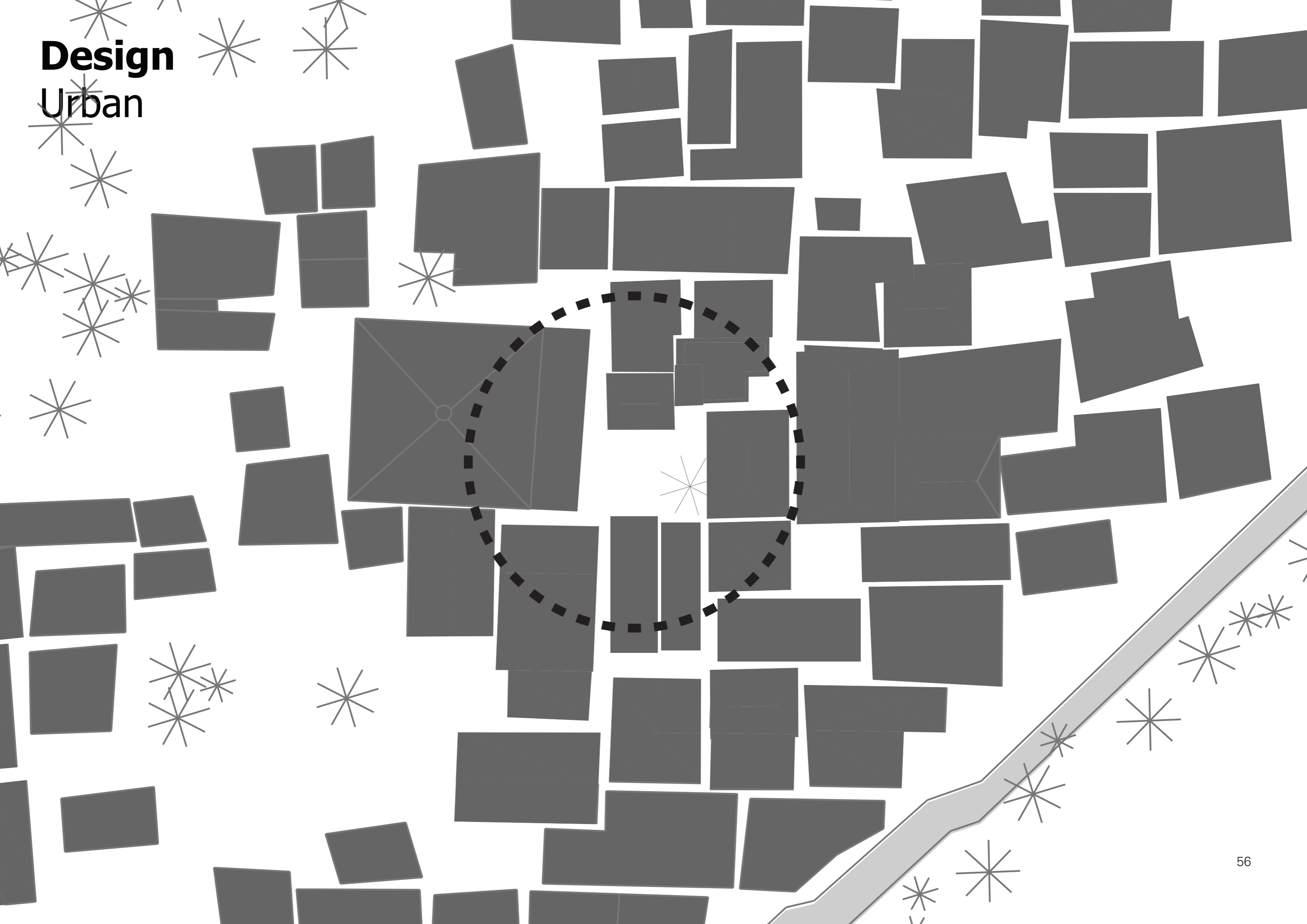

Design Urban





Design Urban

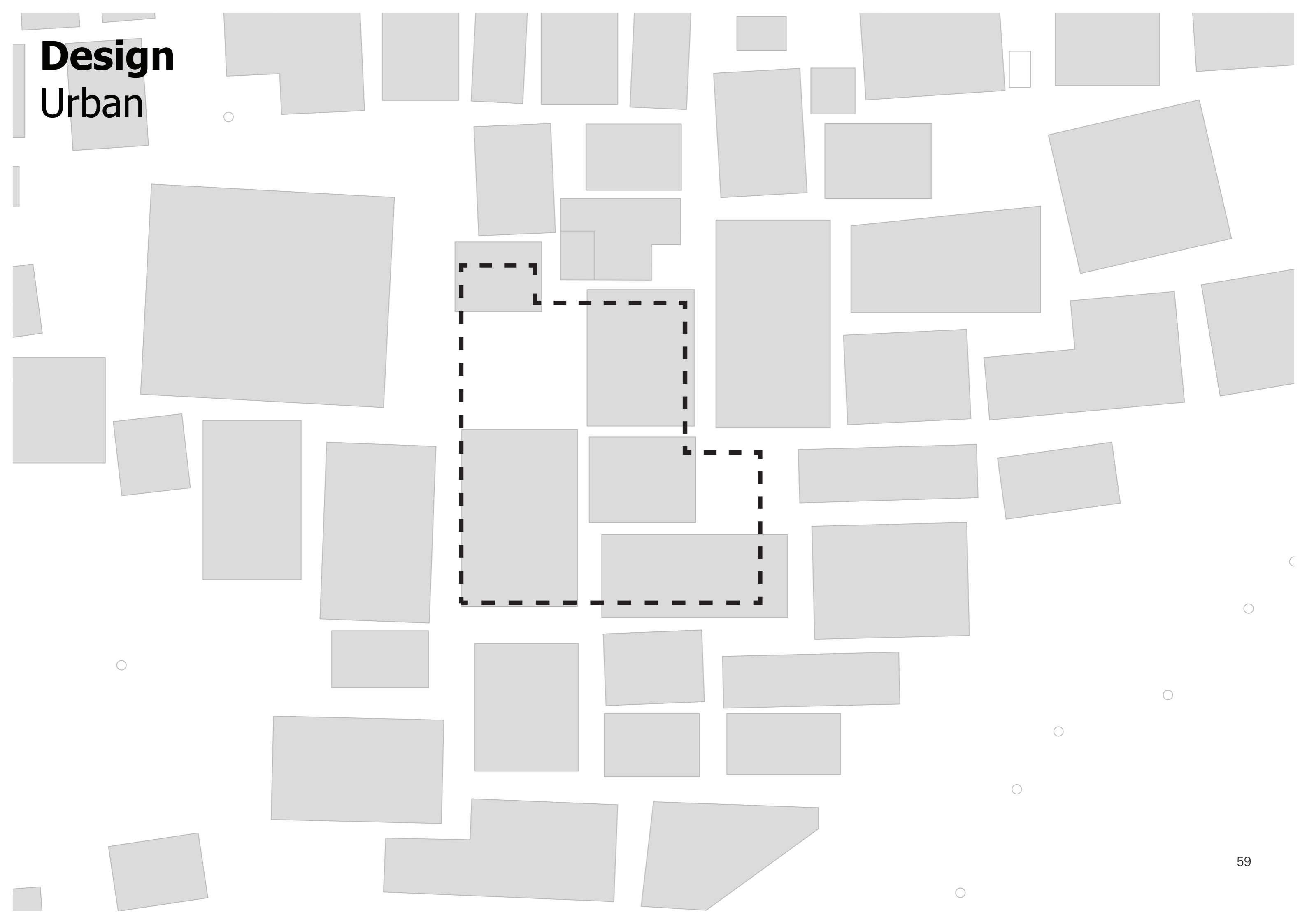

Design Urban

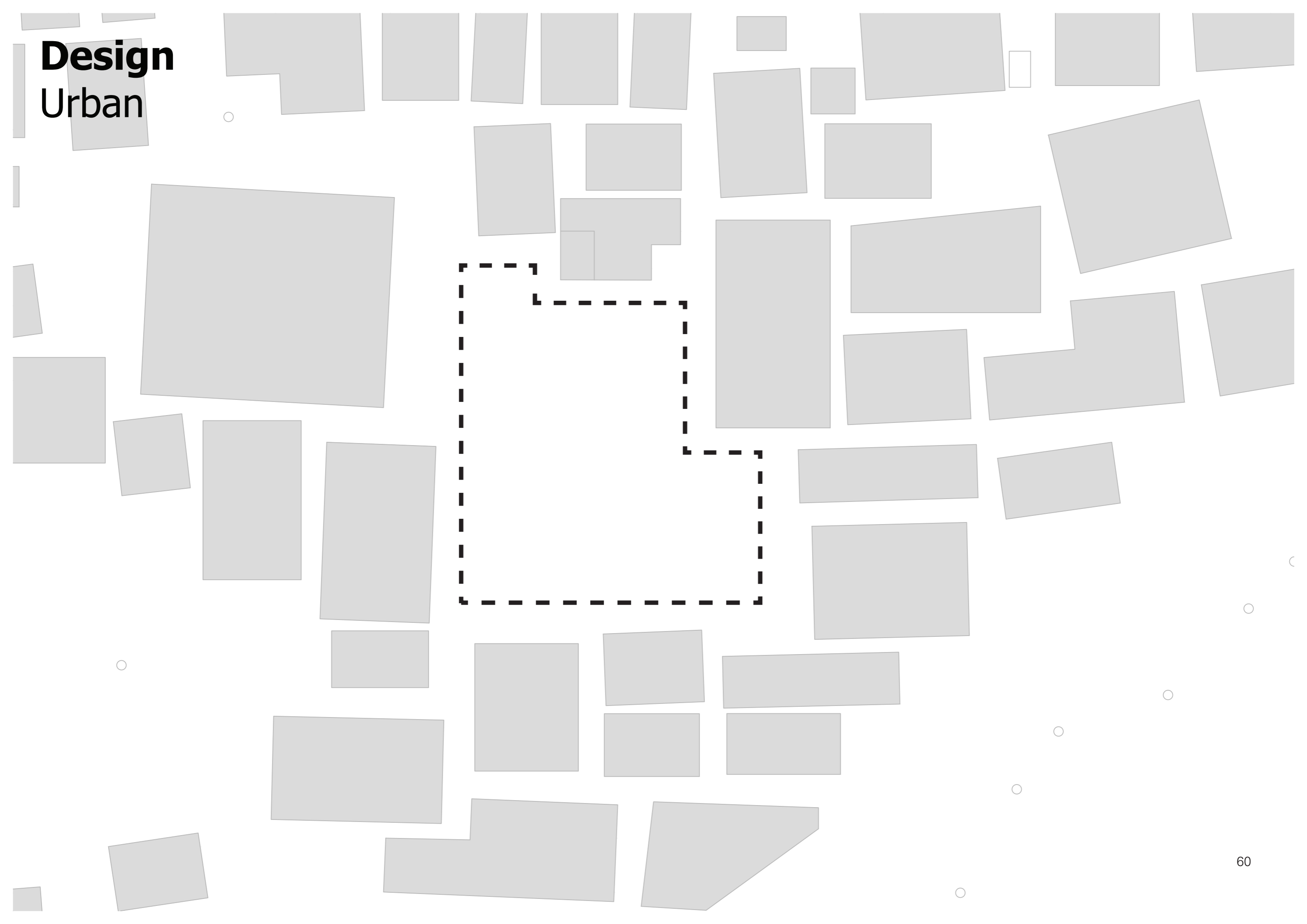

Design Urban

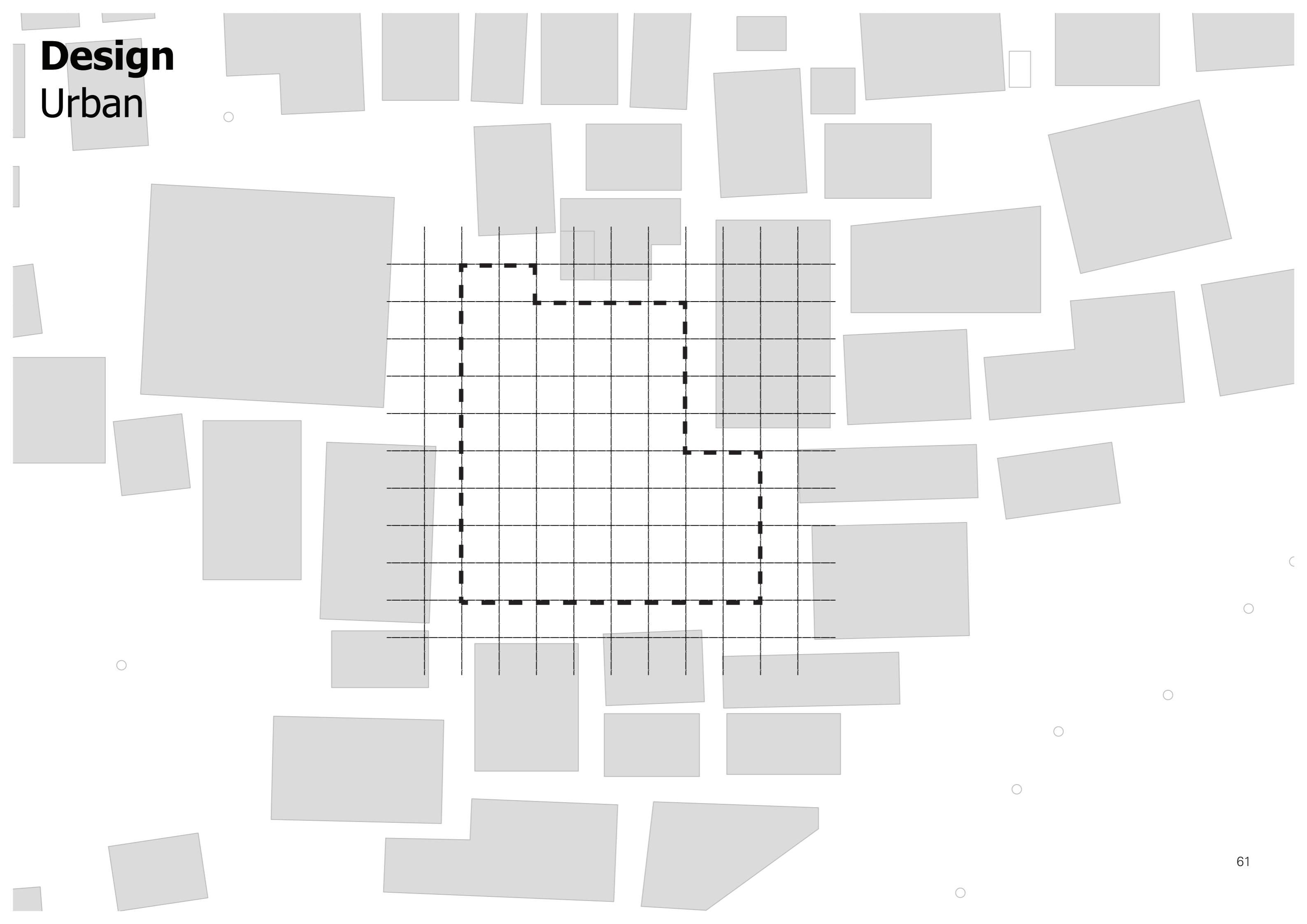

Design Urban

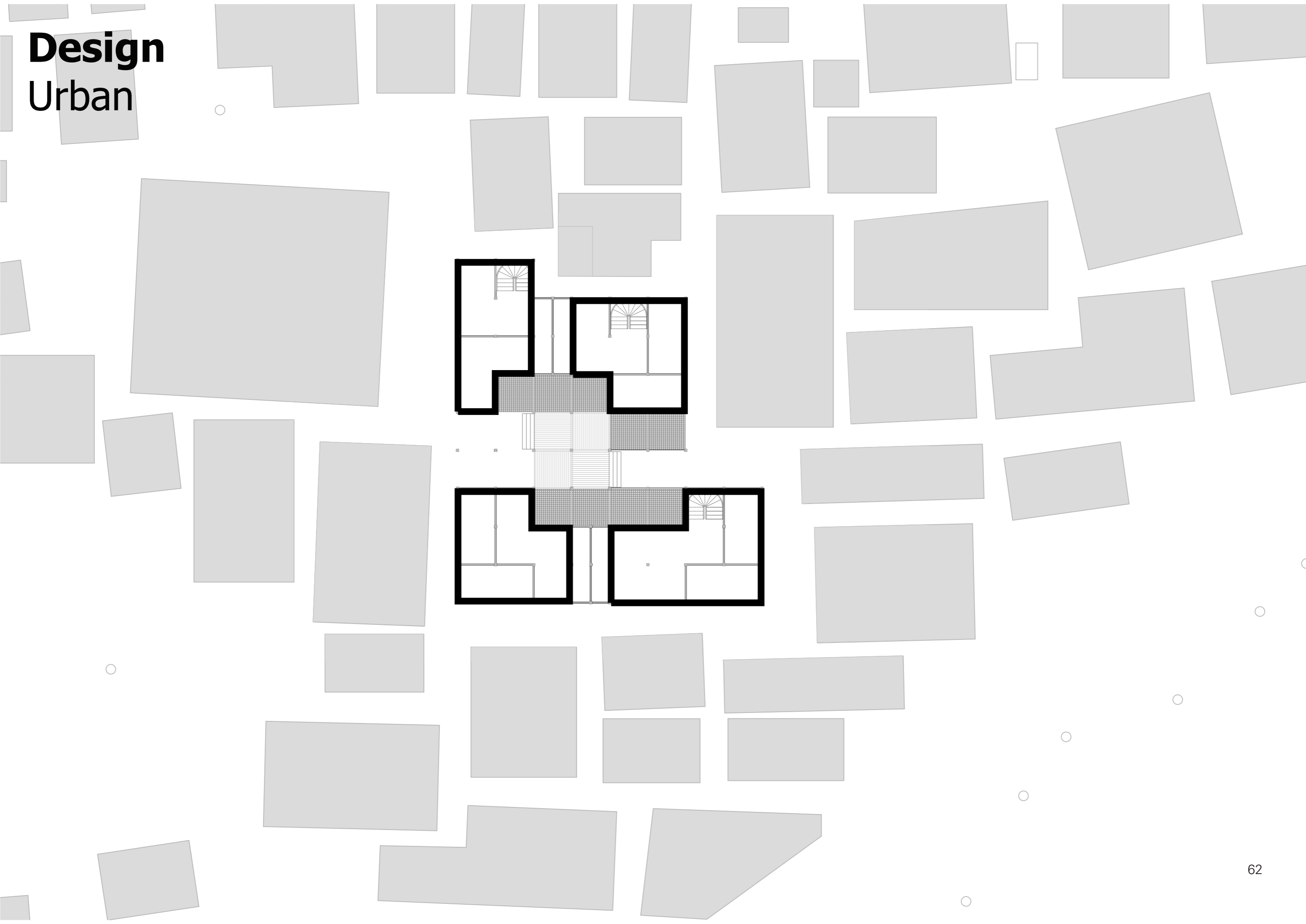

Design Urban

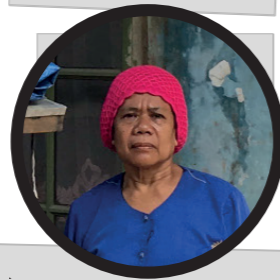
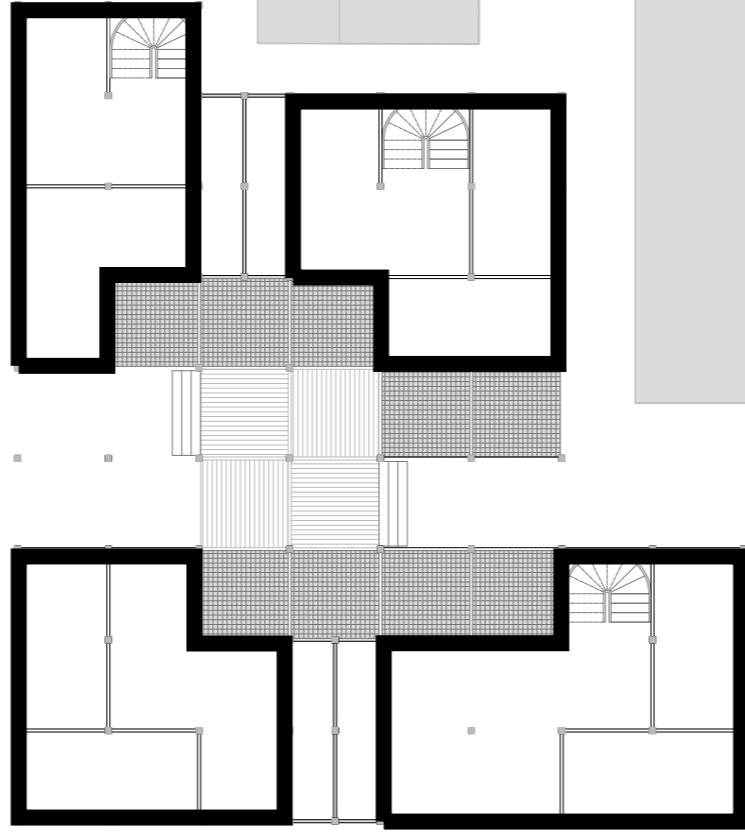

Design
Urban



Design Functions



Design Functions

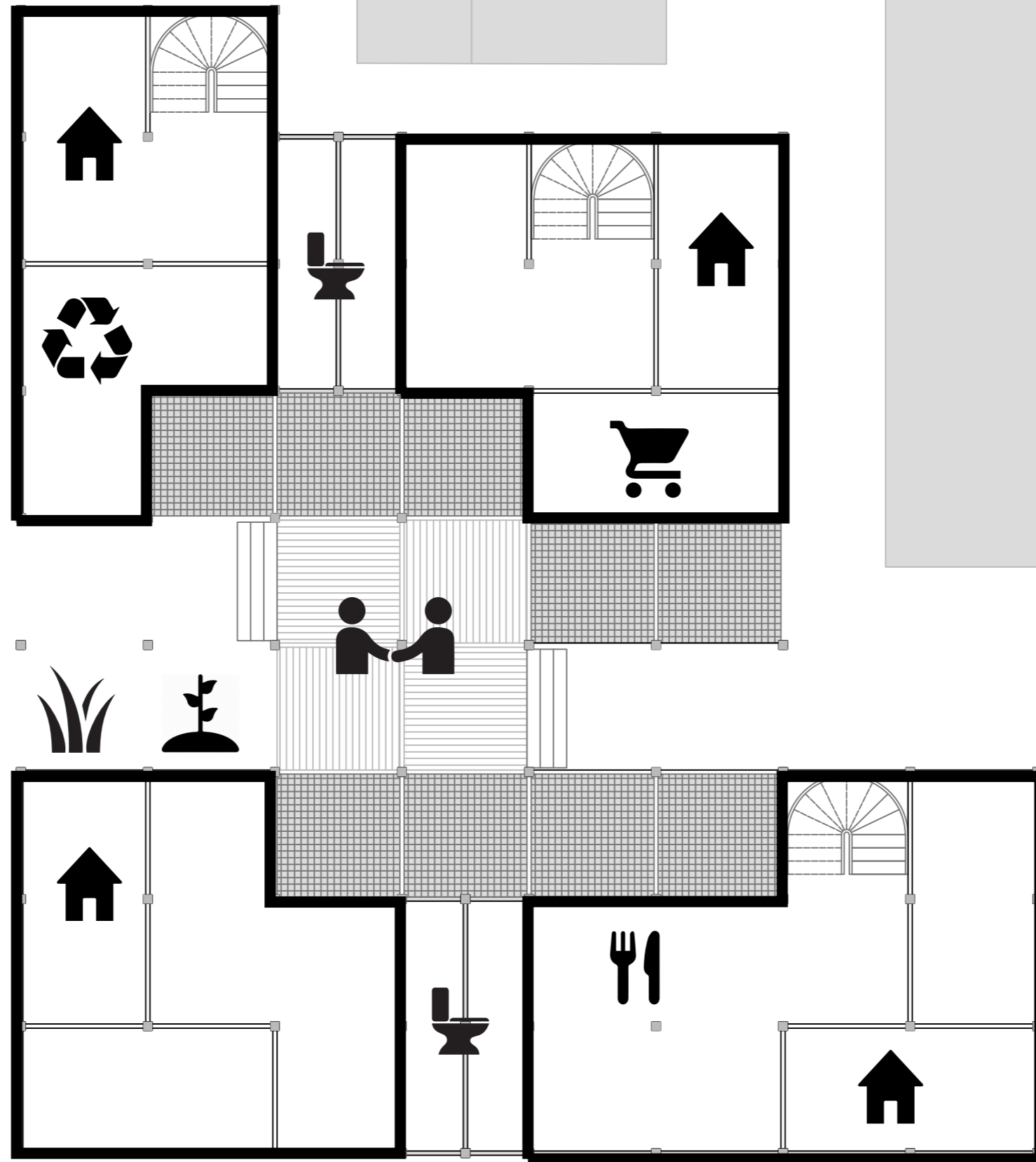

Design
Urban

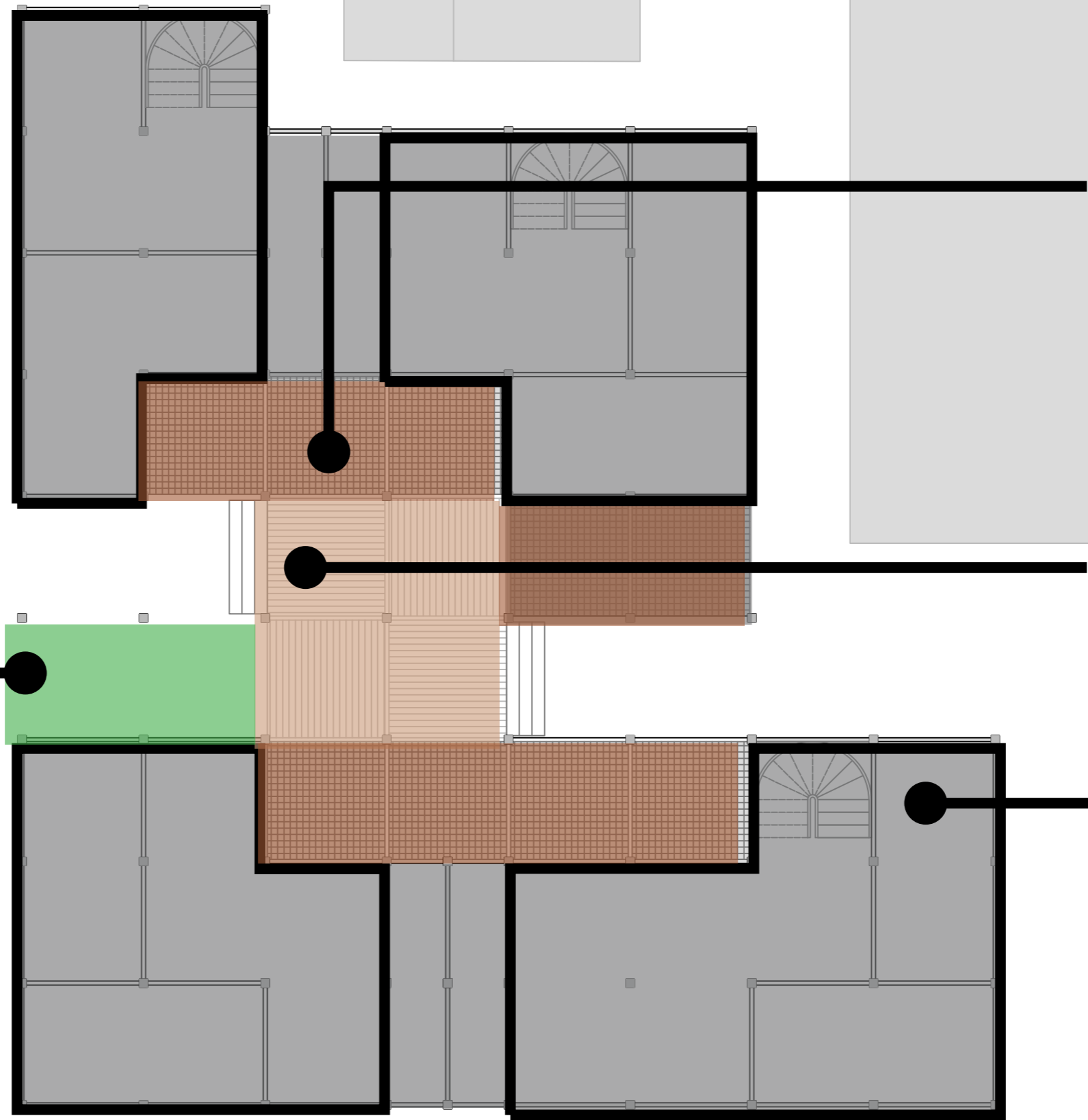

Porch

Communal
space

Green

Dwellings

Design
Urban



Design Urban



Design

Public vs Private

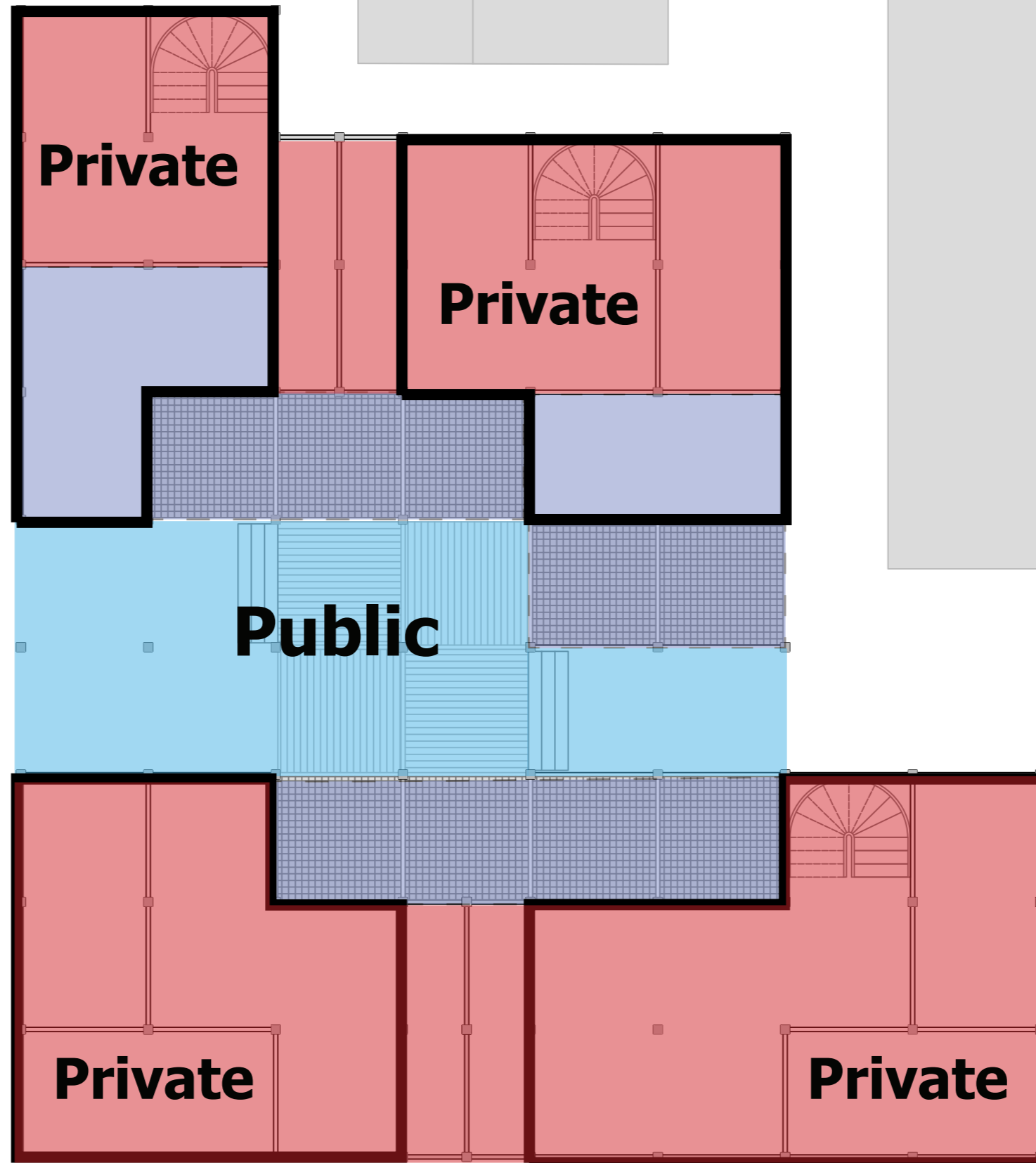

Private

Semi-public

Public

Design Routing

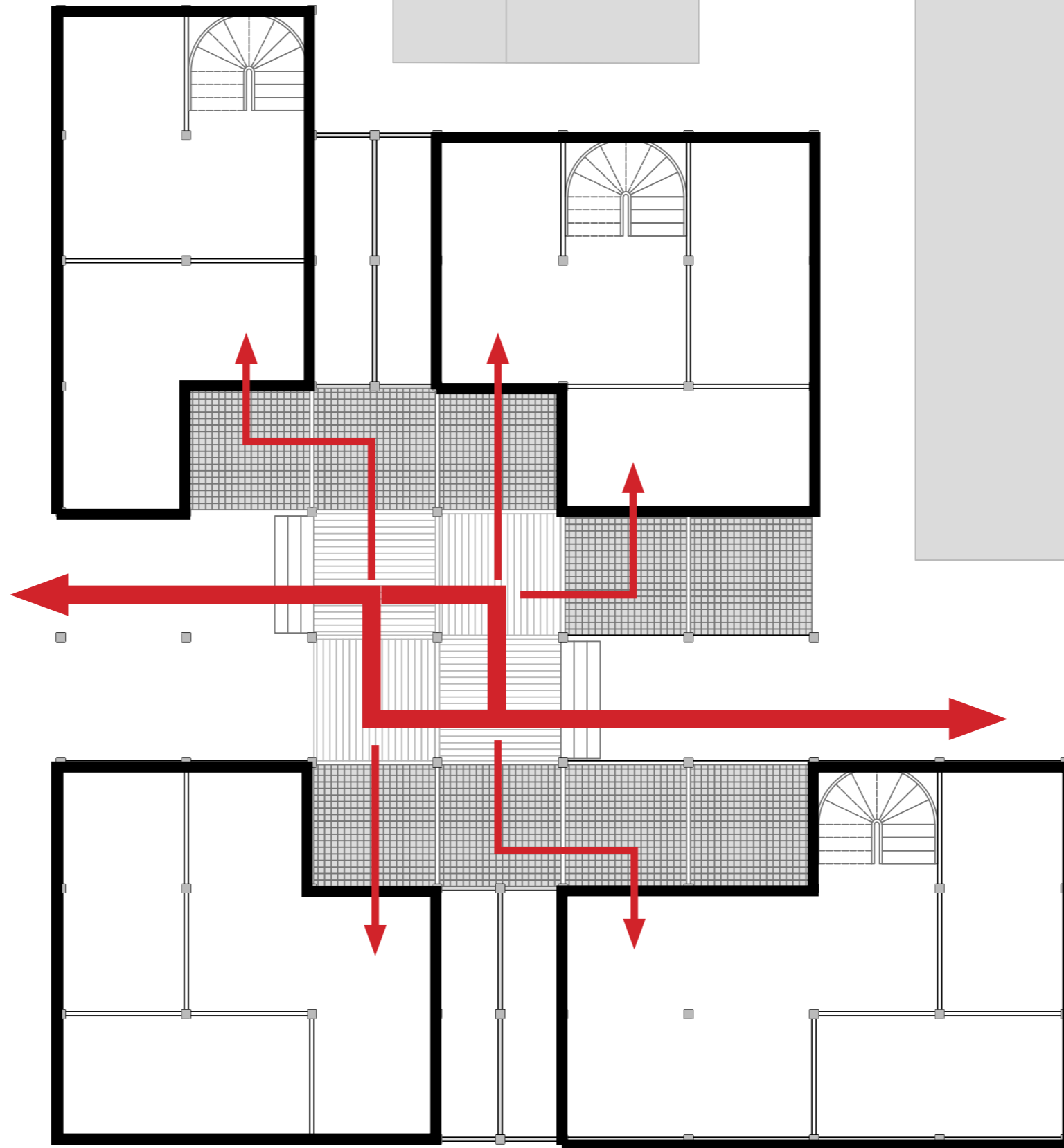

Design incrementality

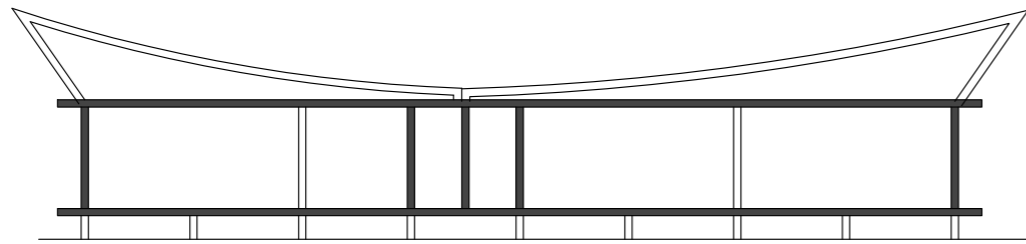

Phase 1

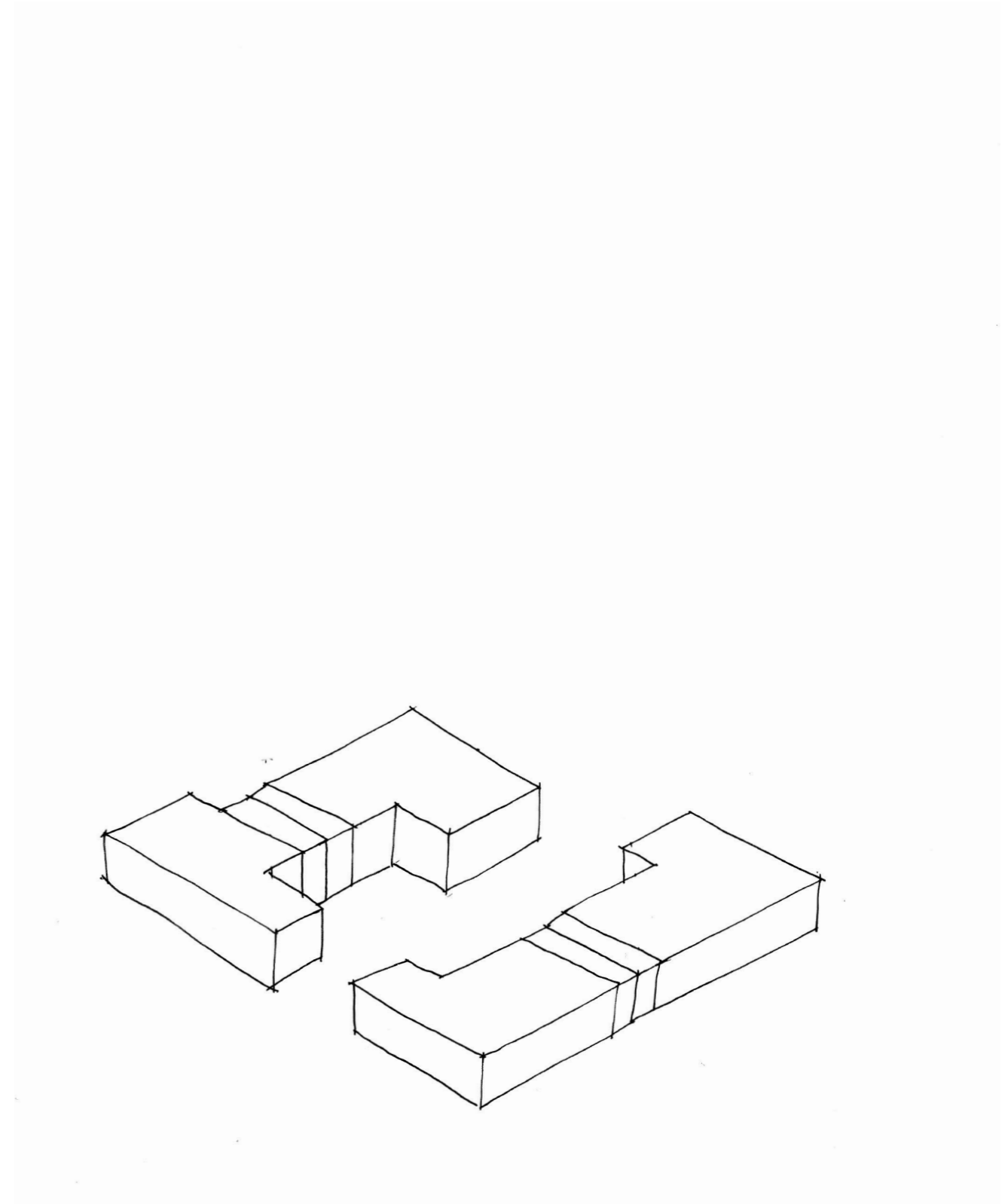

Design incrementality

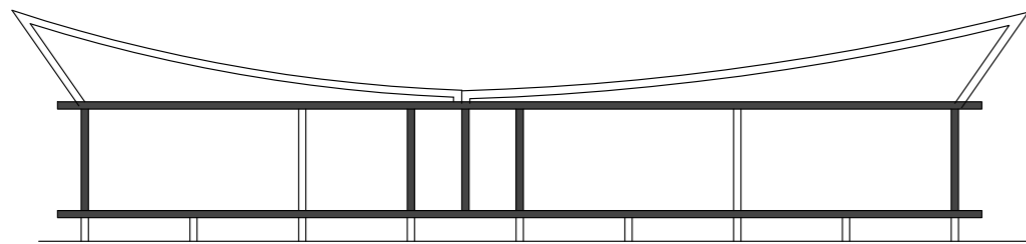

Phase 1

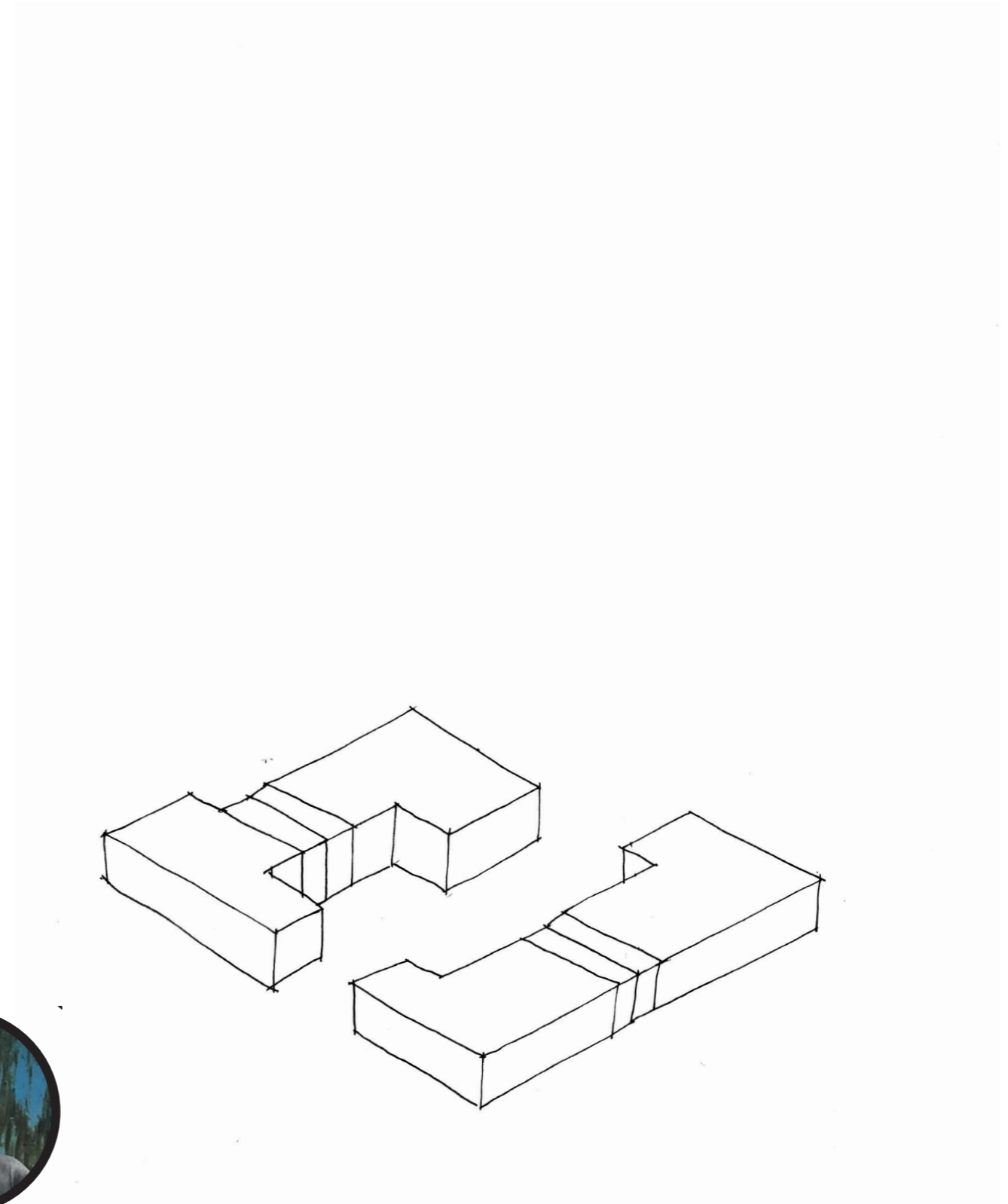

Design incrementality

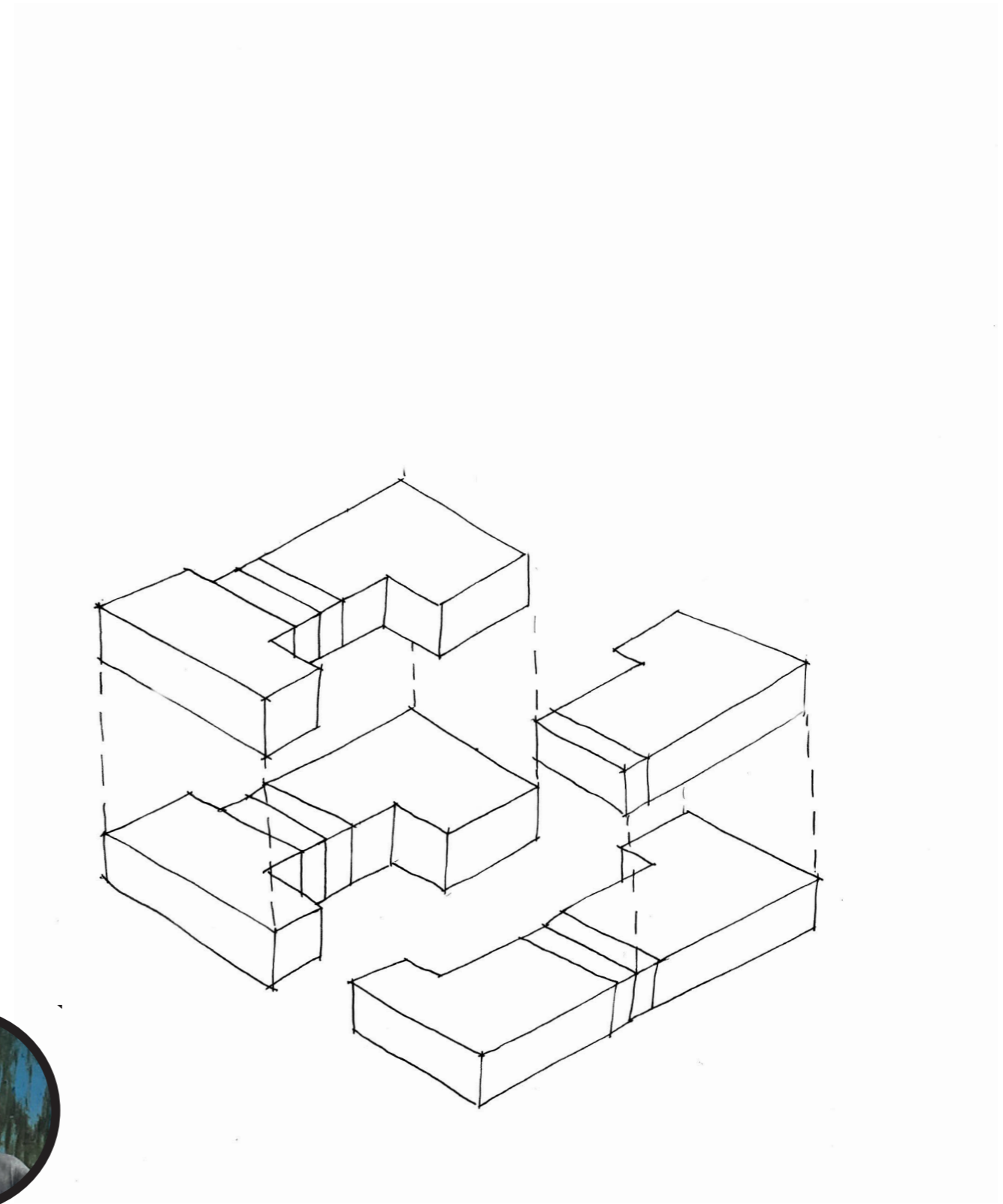
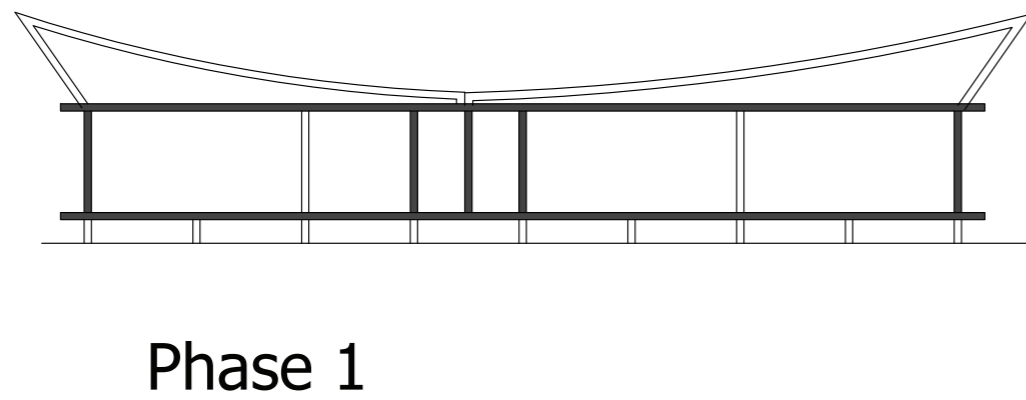
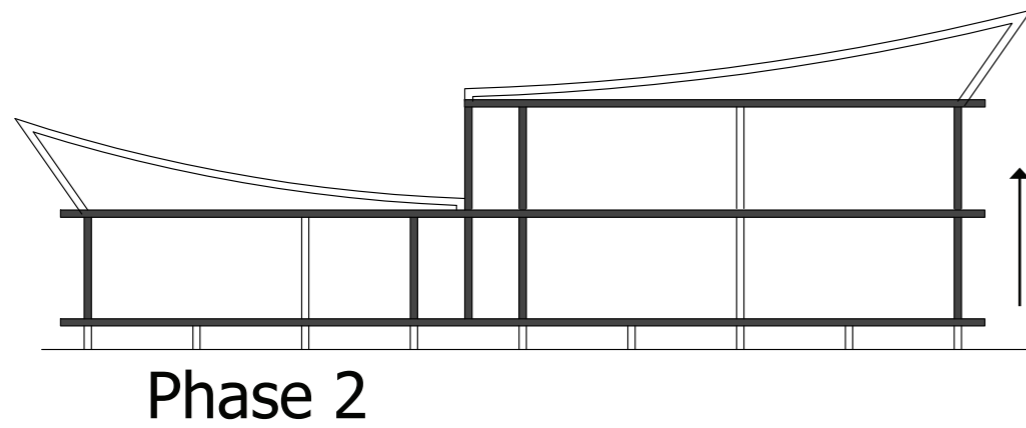

Design incrementality

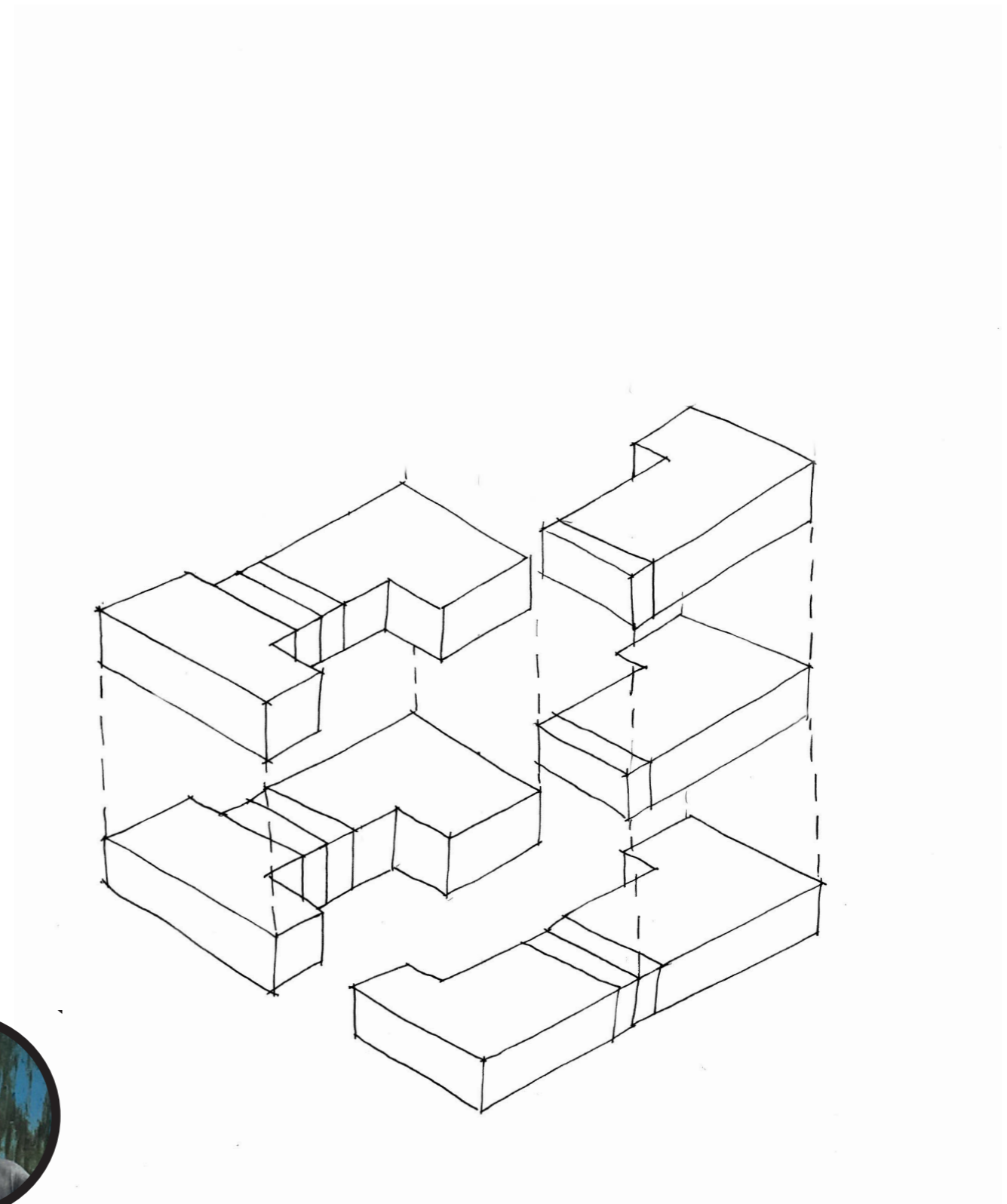
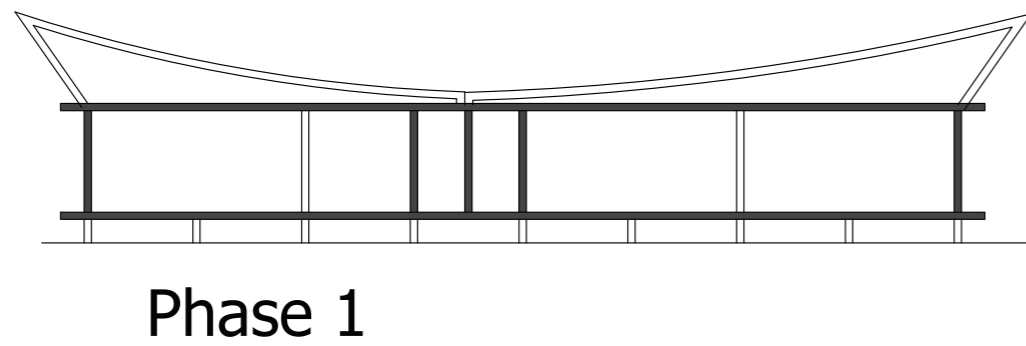
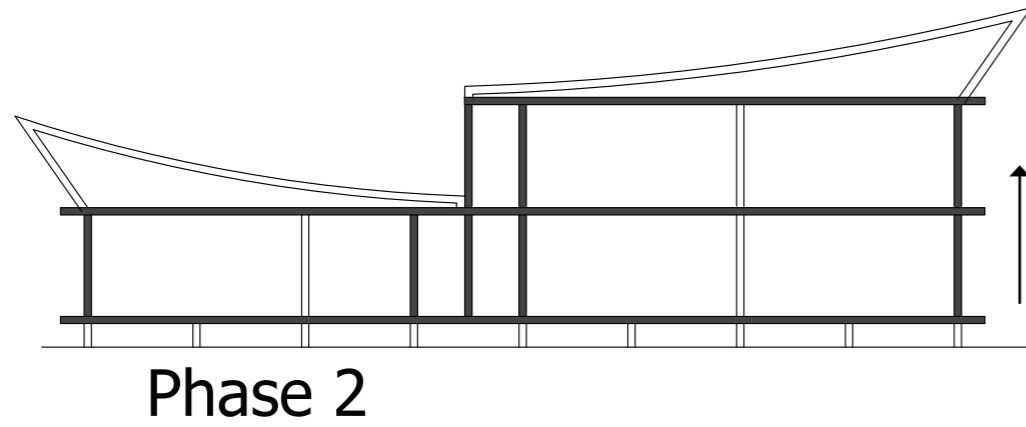
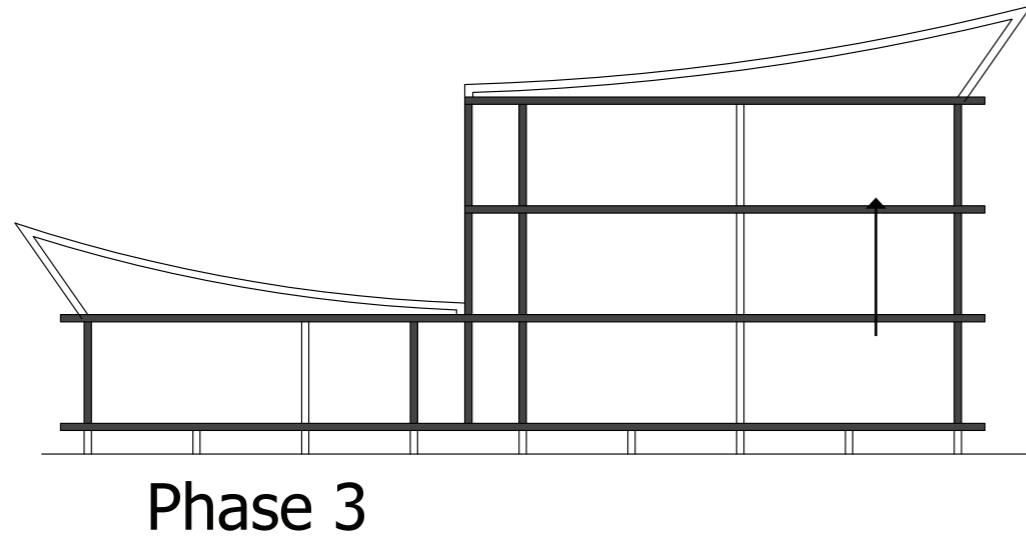

Design incrementality

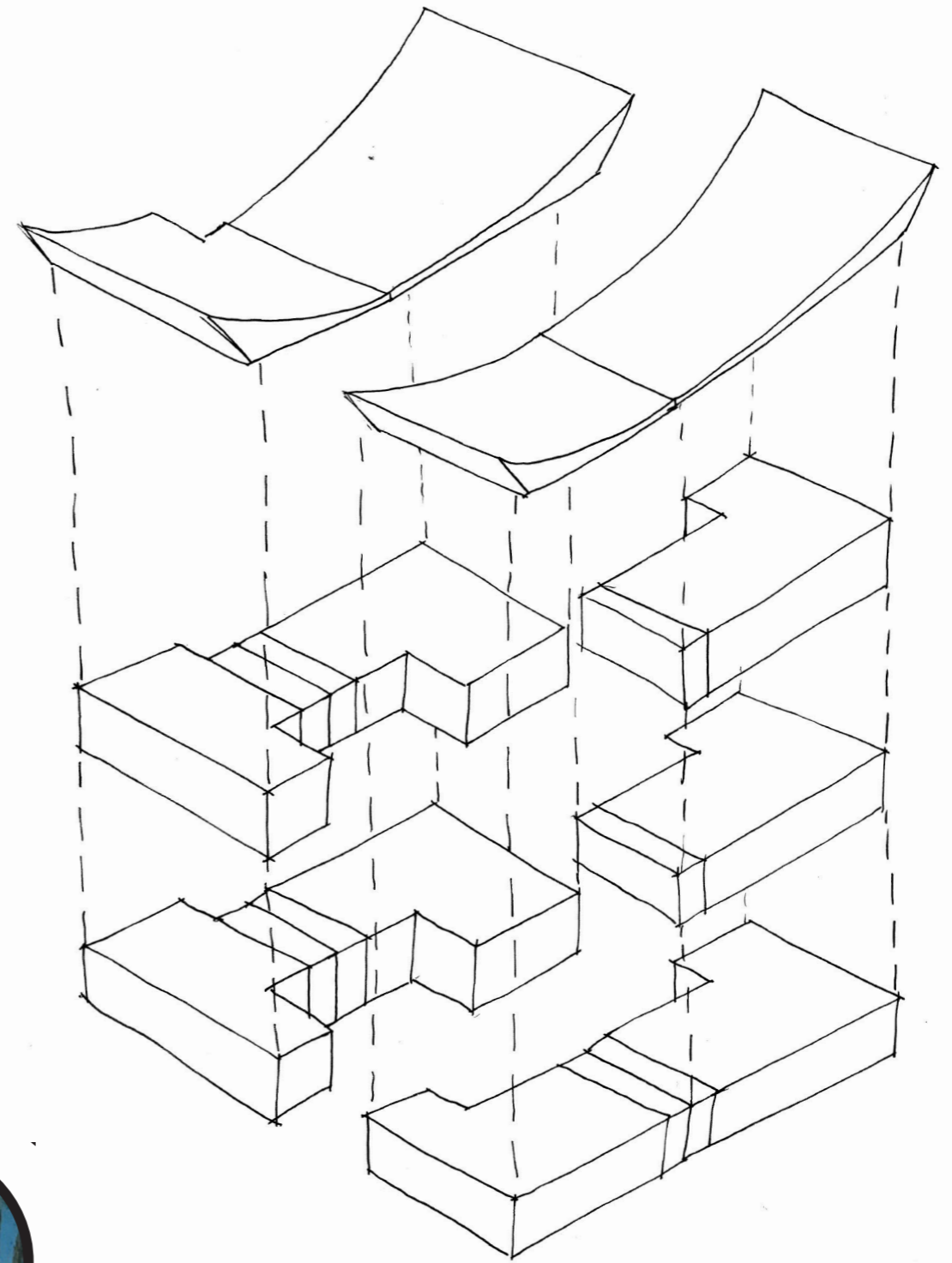
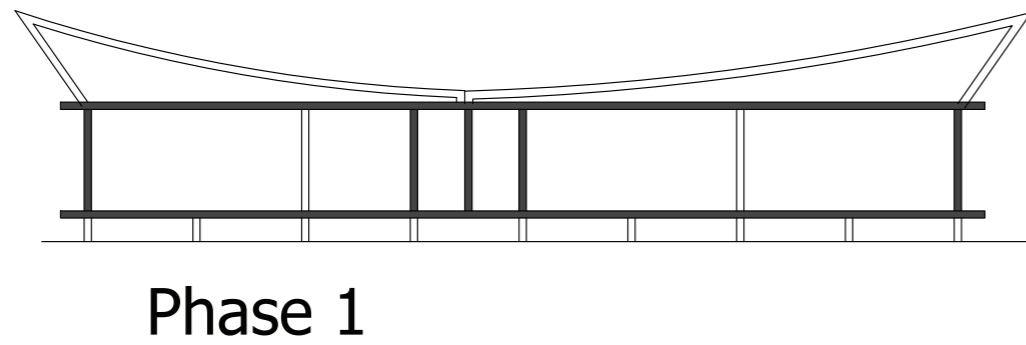
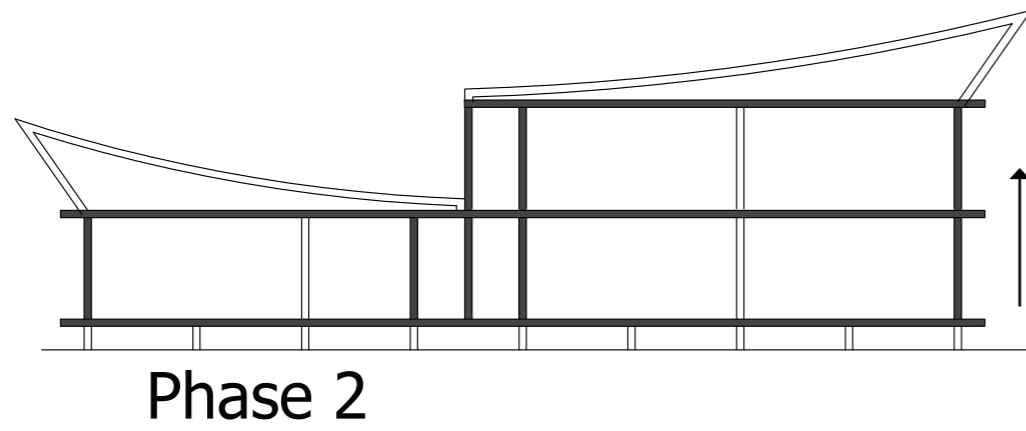
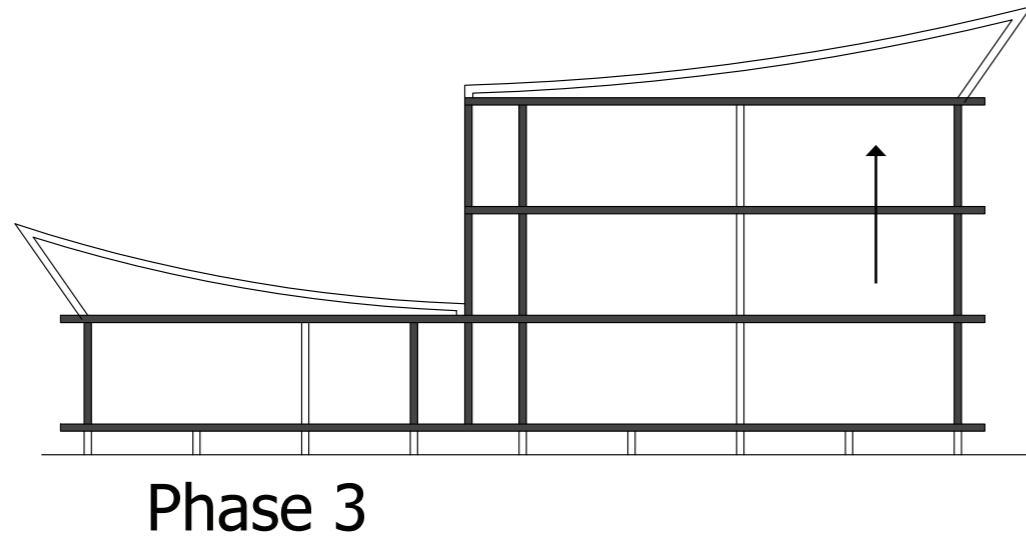

Design incrementality



Design Floorplans

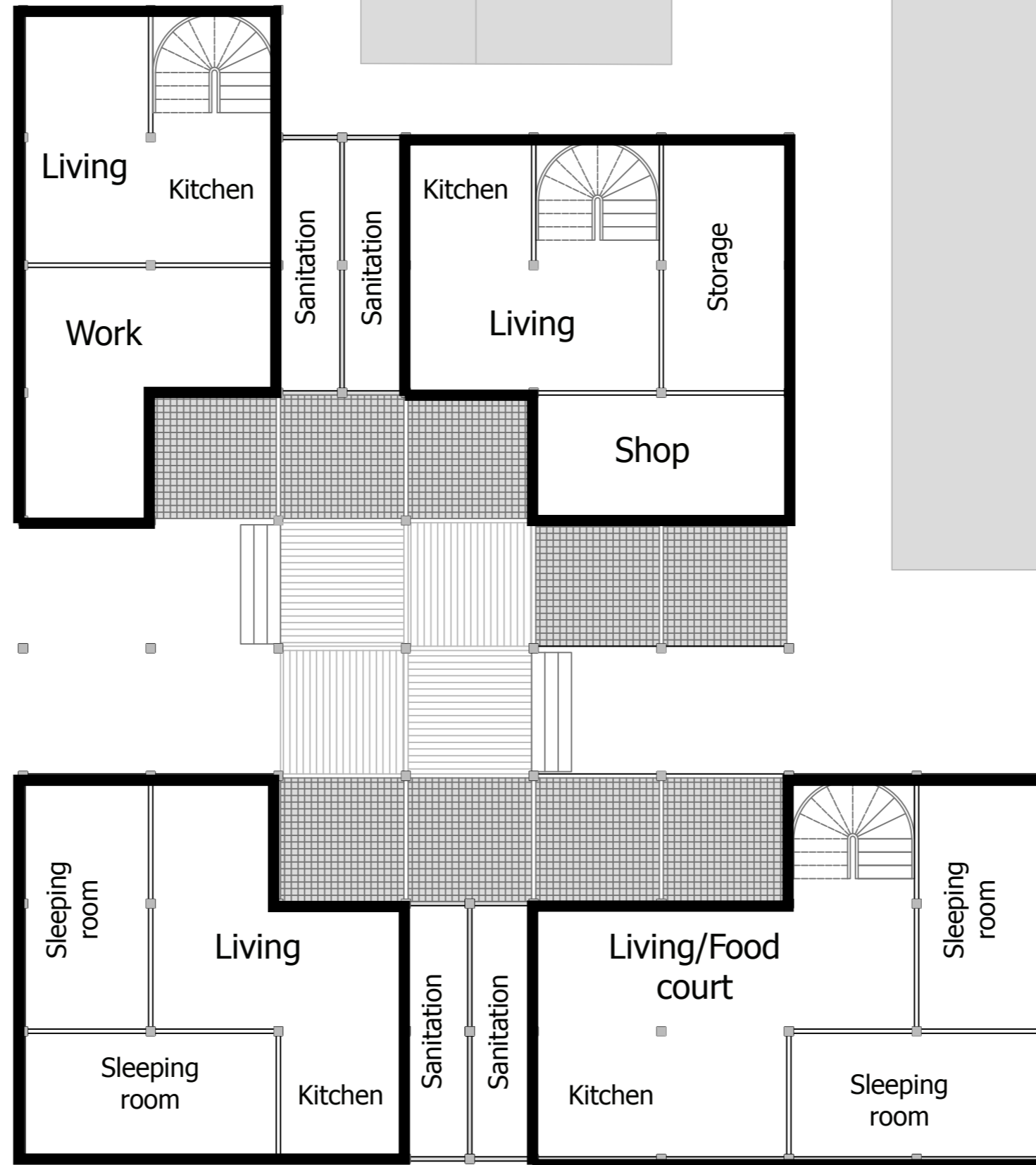

+00
Ground Floor

Design Floorplans

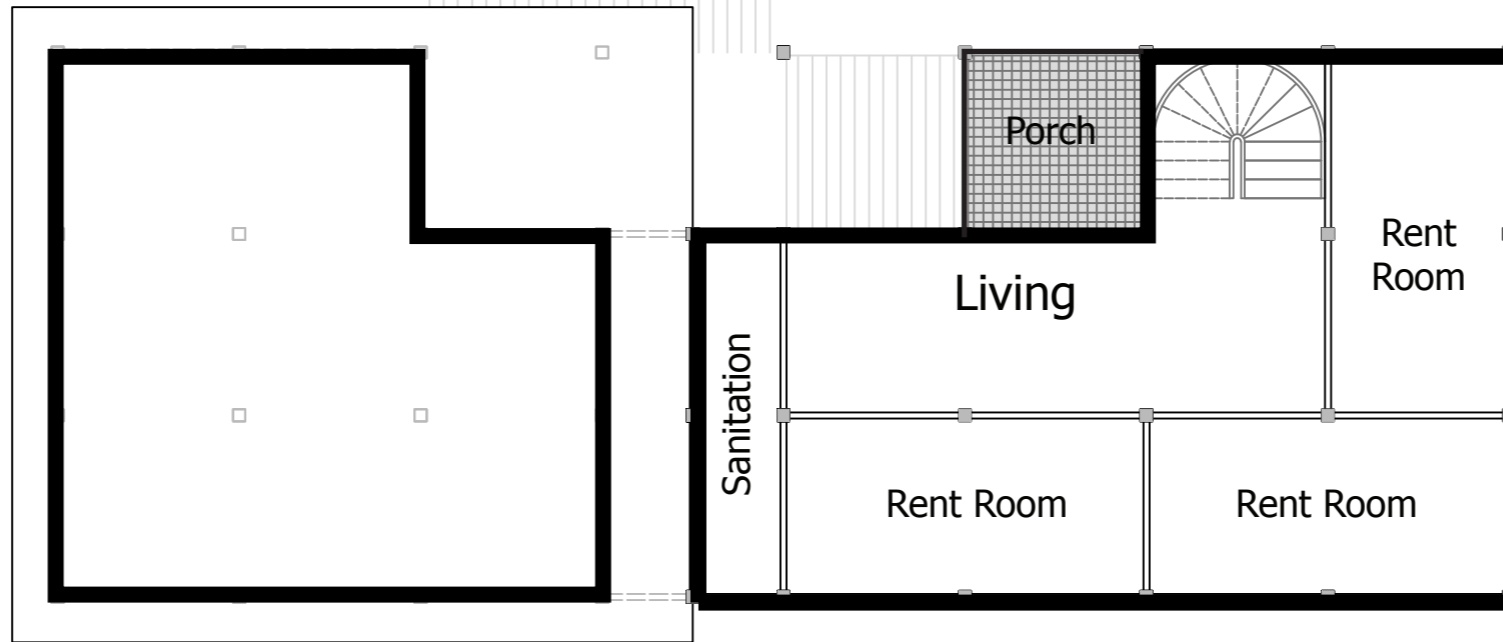
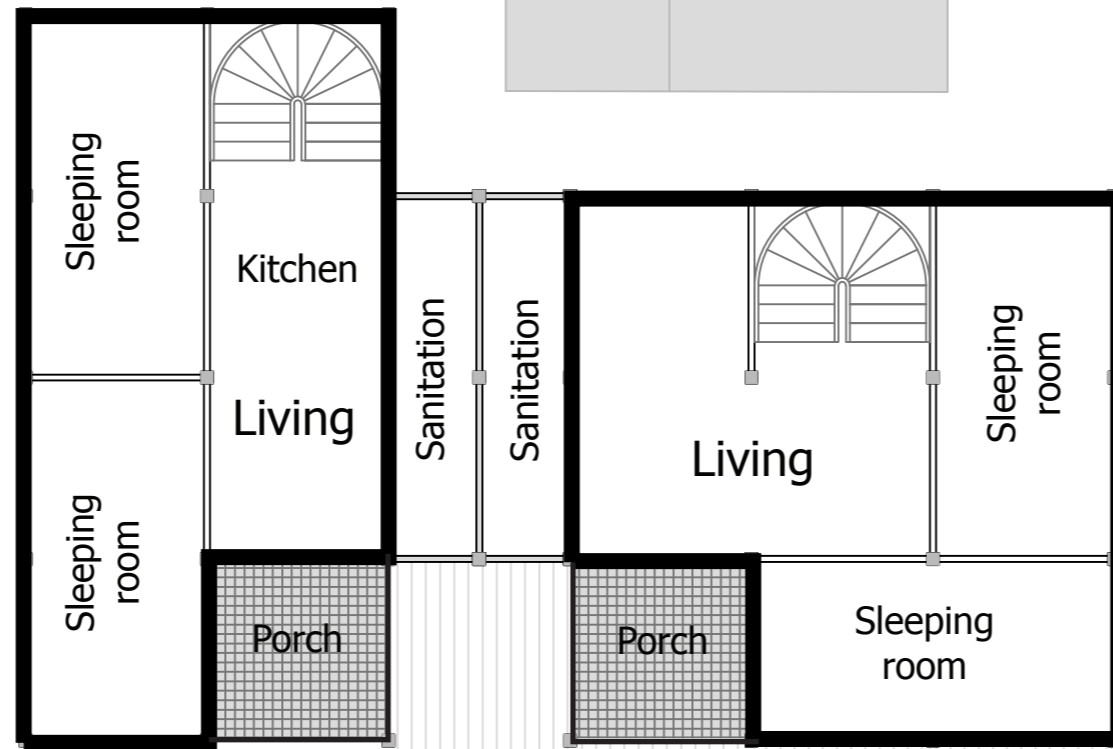

+01
1st Level

Design Floorplans

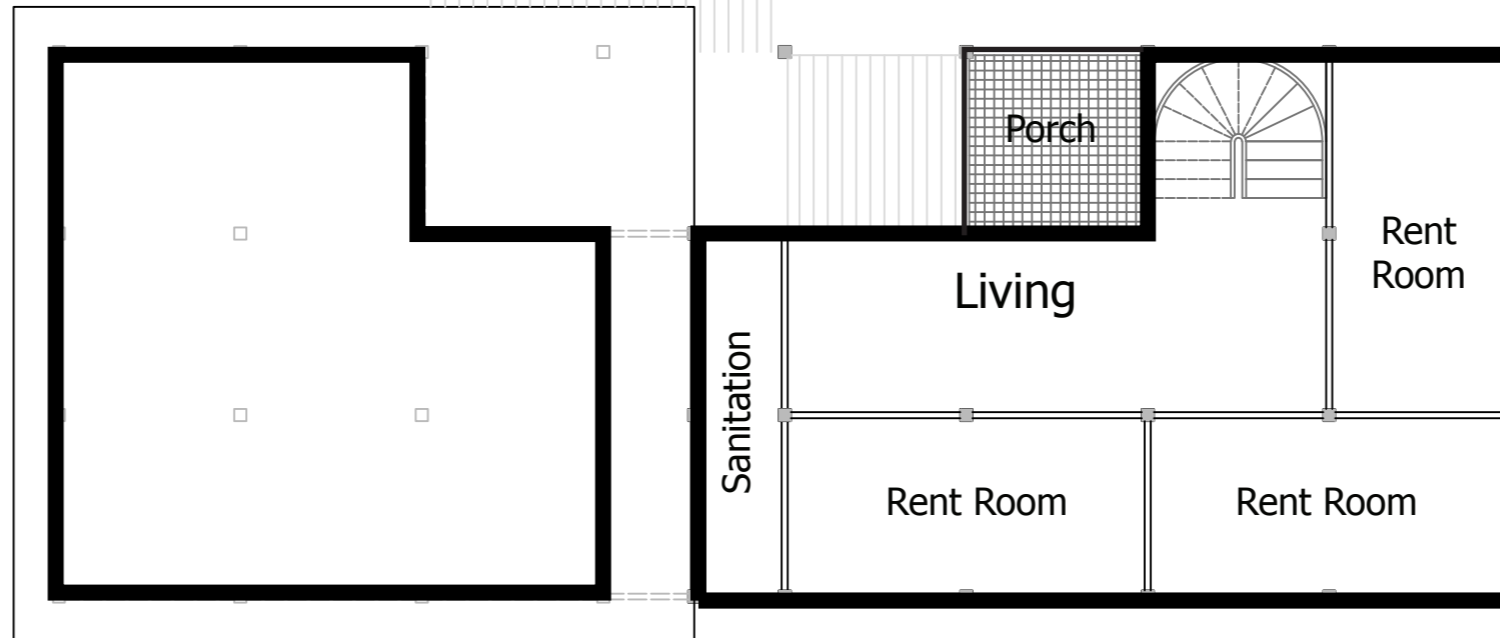
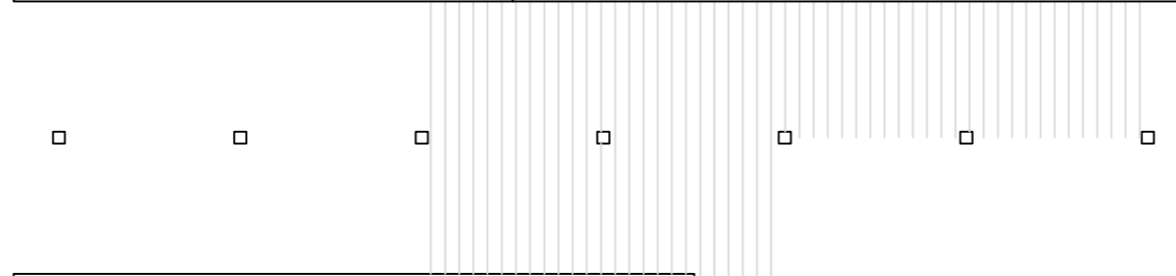
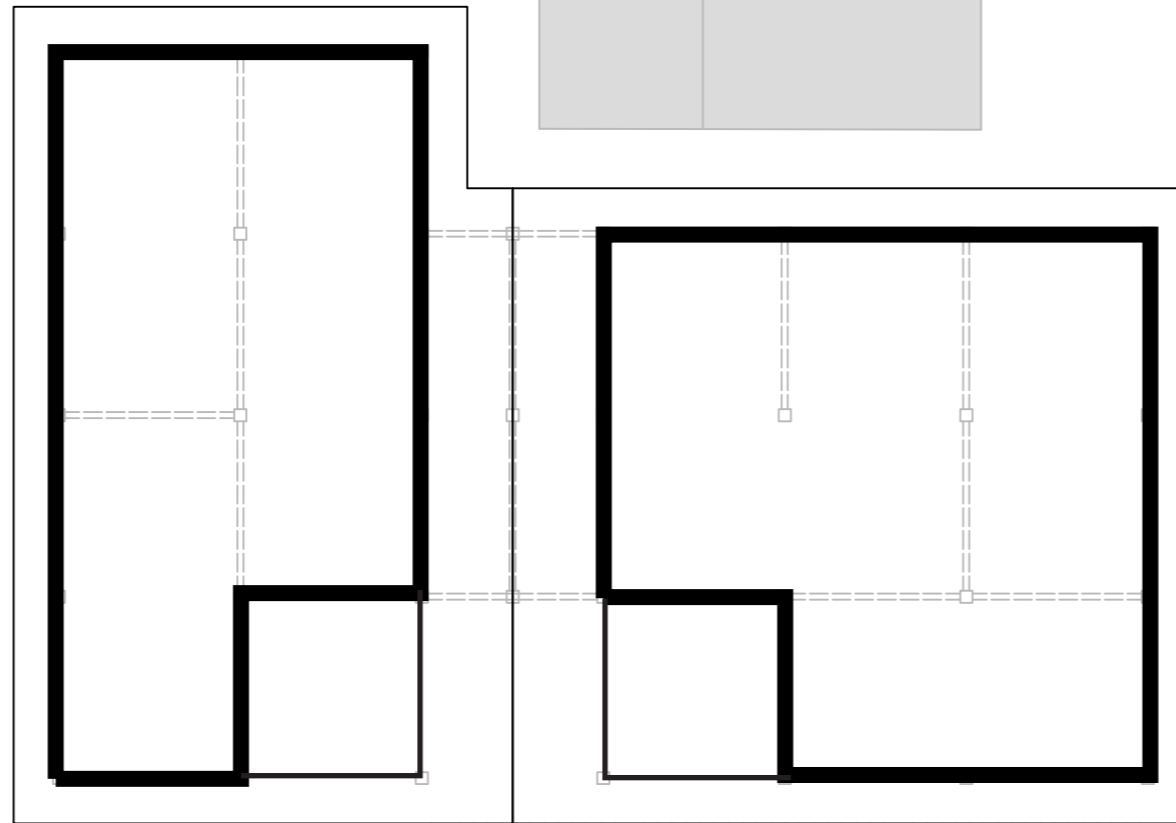

+02
2nd Level

Design Floorplans

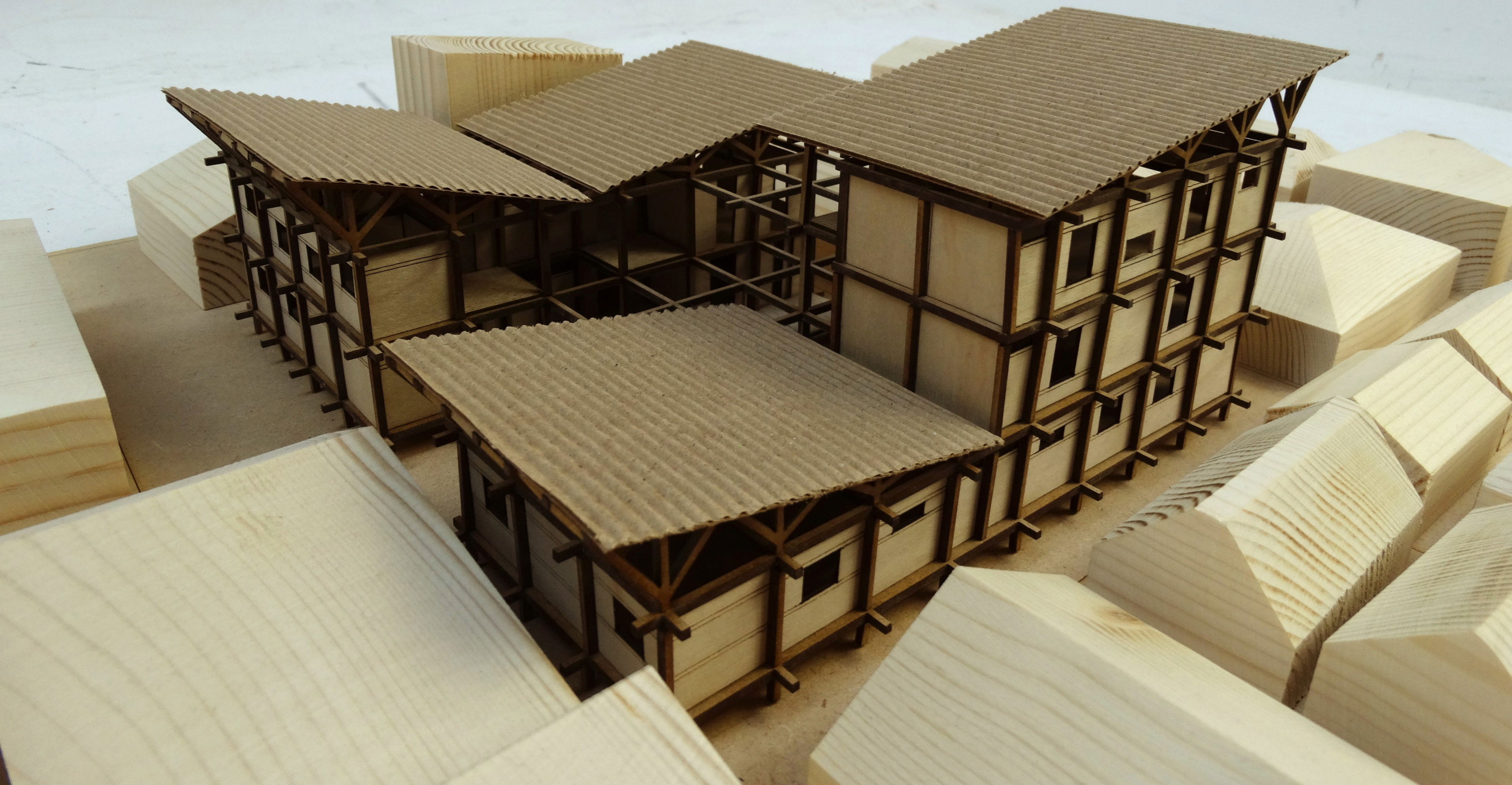

Design

Climate design

Rain water

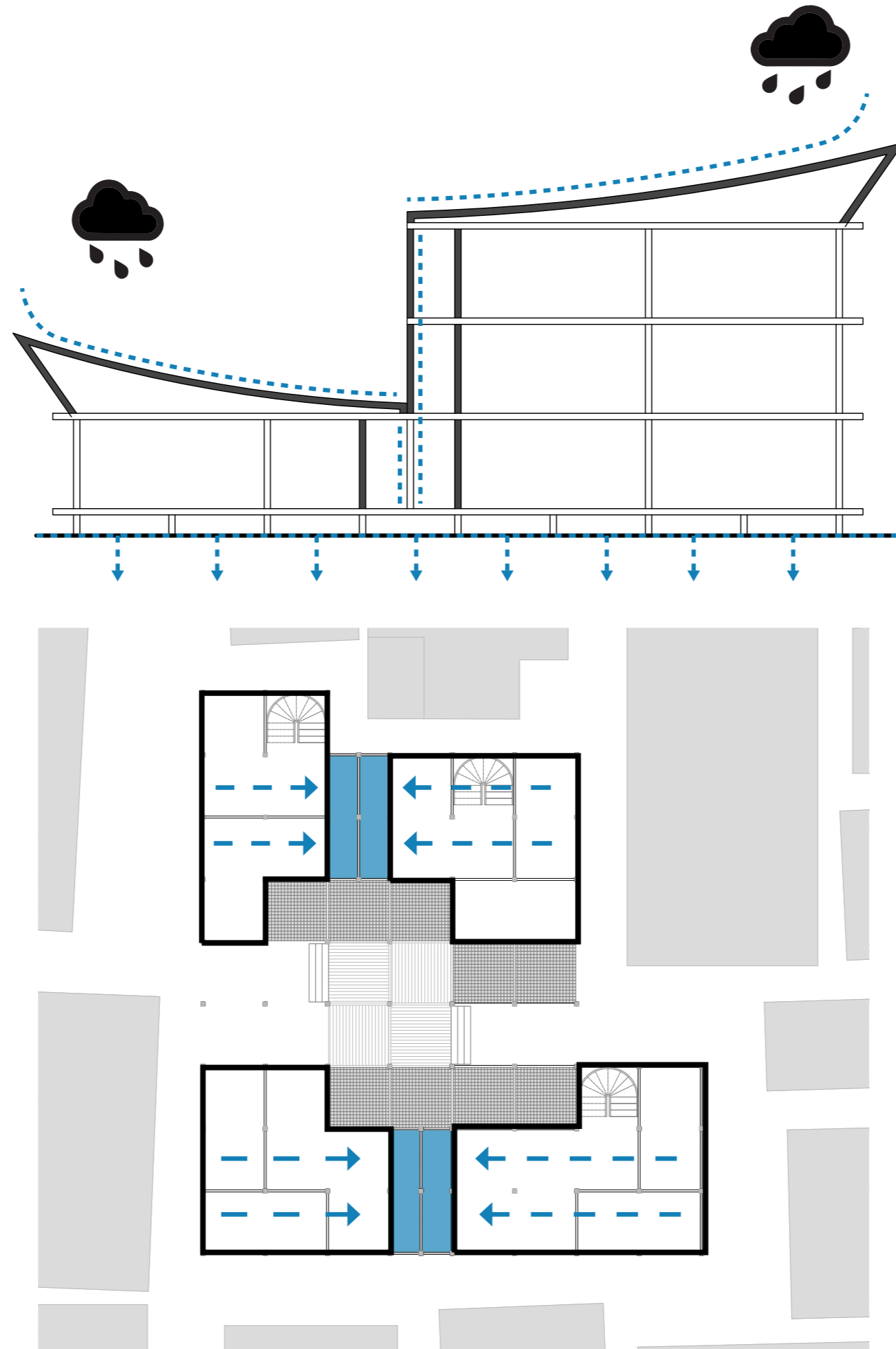

Design

Climate design

Ventilation

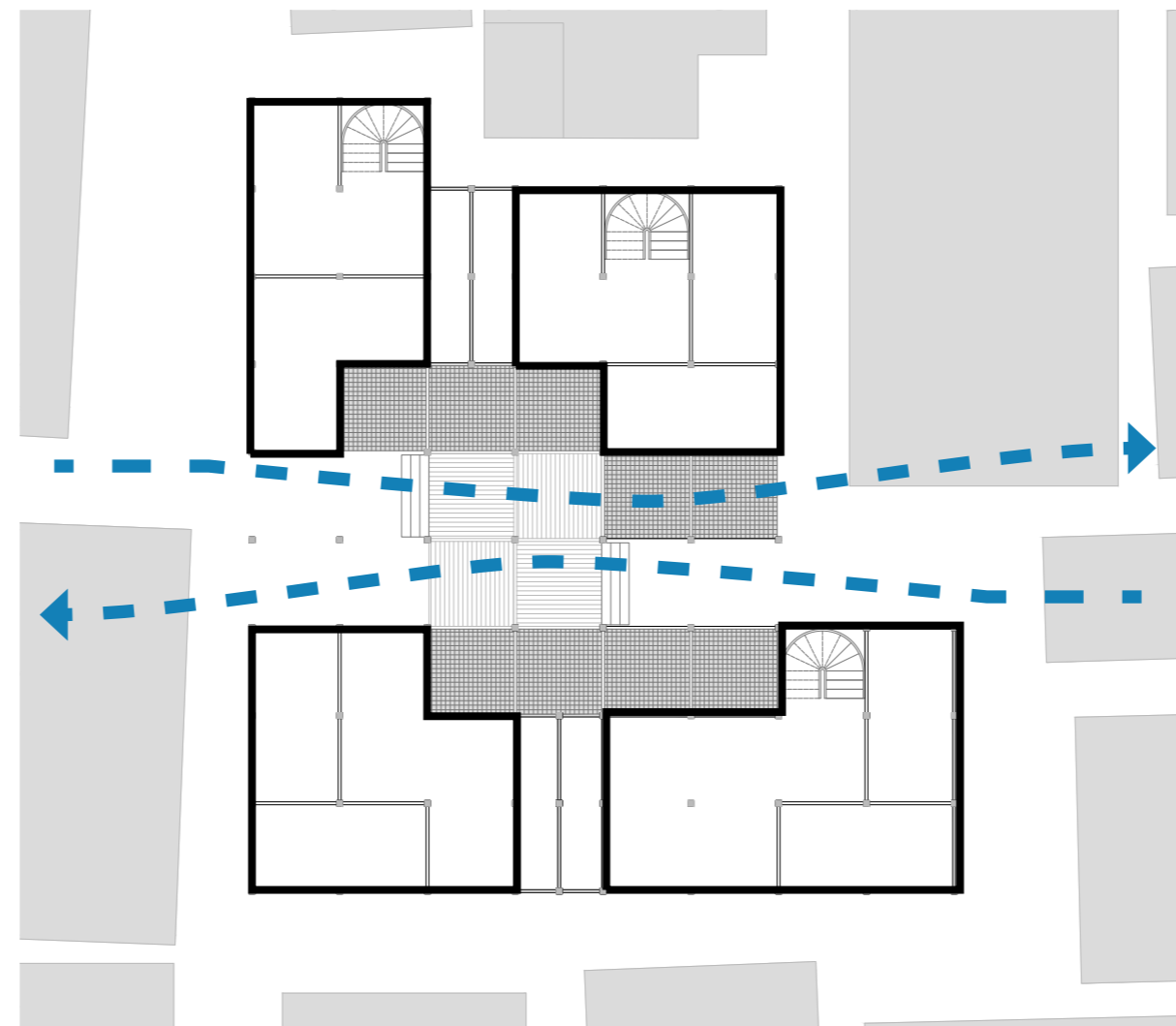
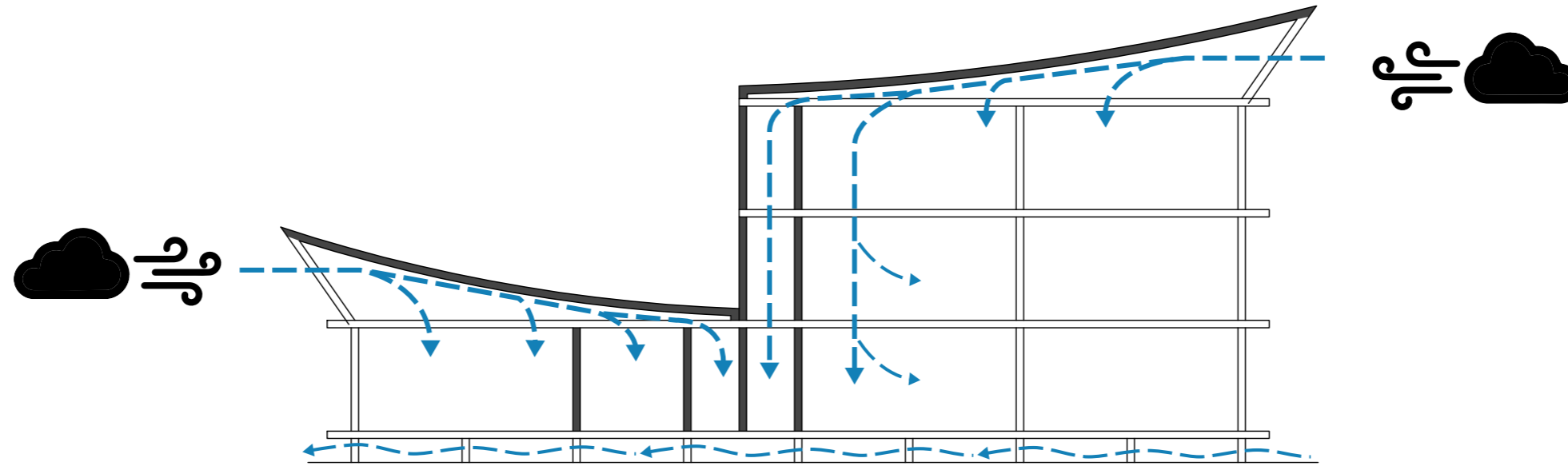

Design

Climate design

Sun Shading

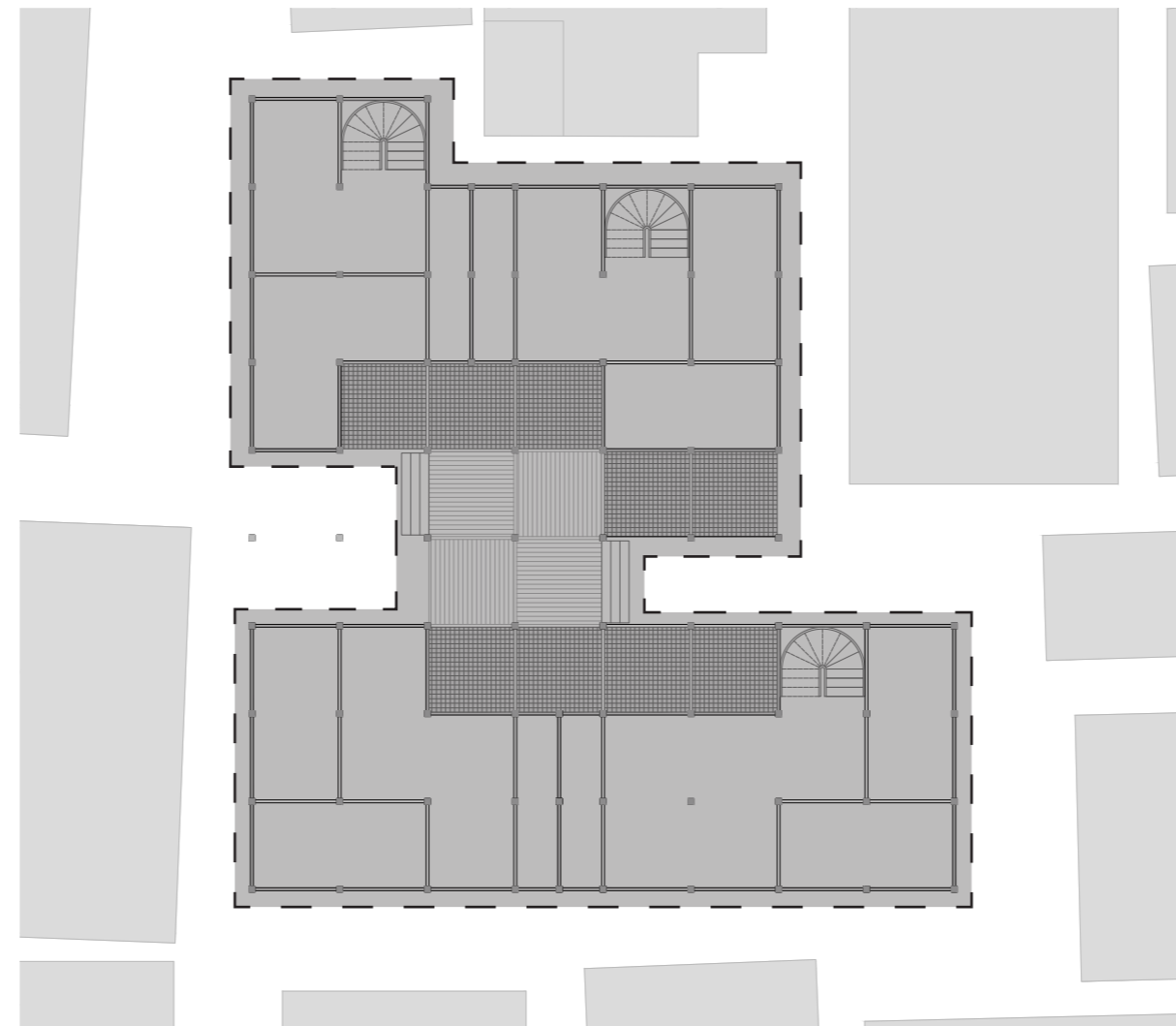
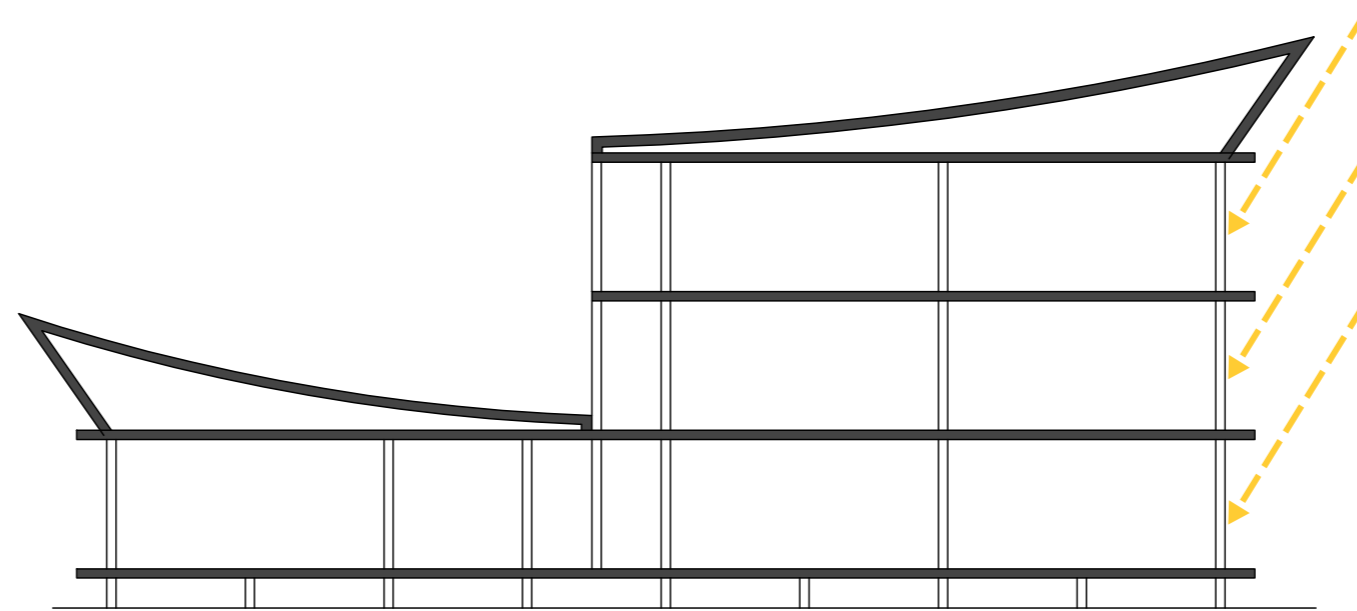

Design Facades



Design Facades



Design Facades





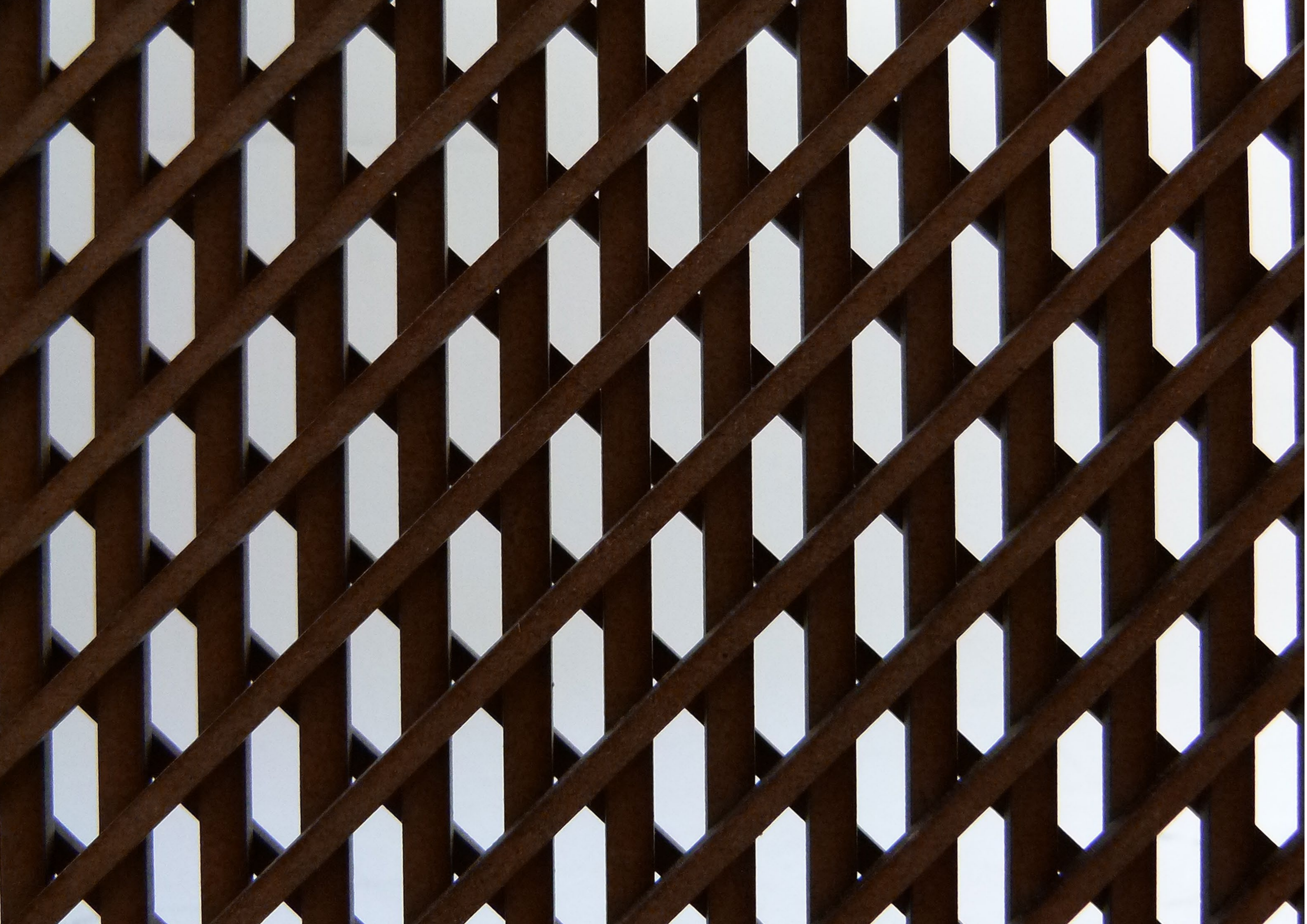

Design Facades



Design Facades



Design Facades



Design Facades

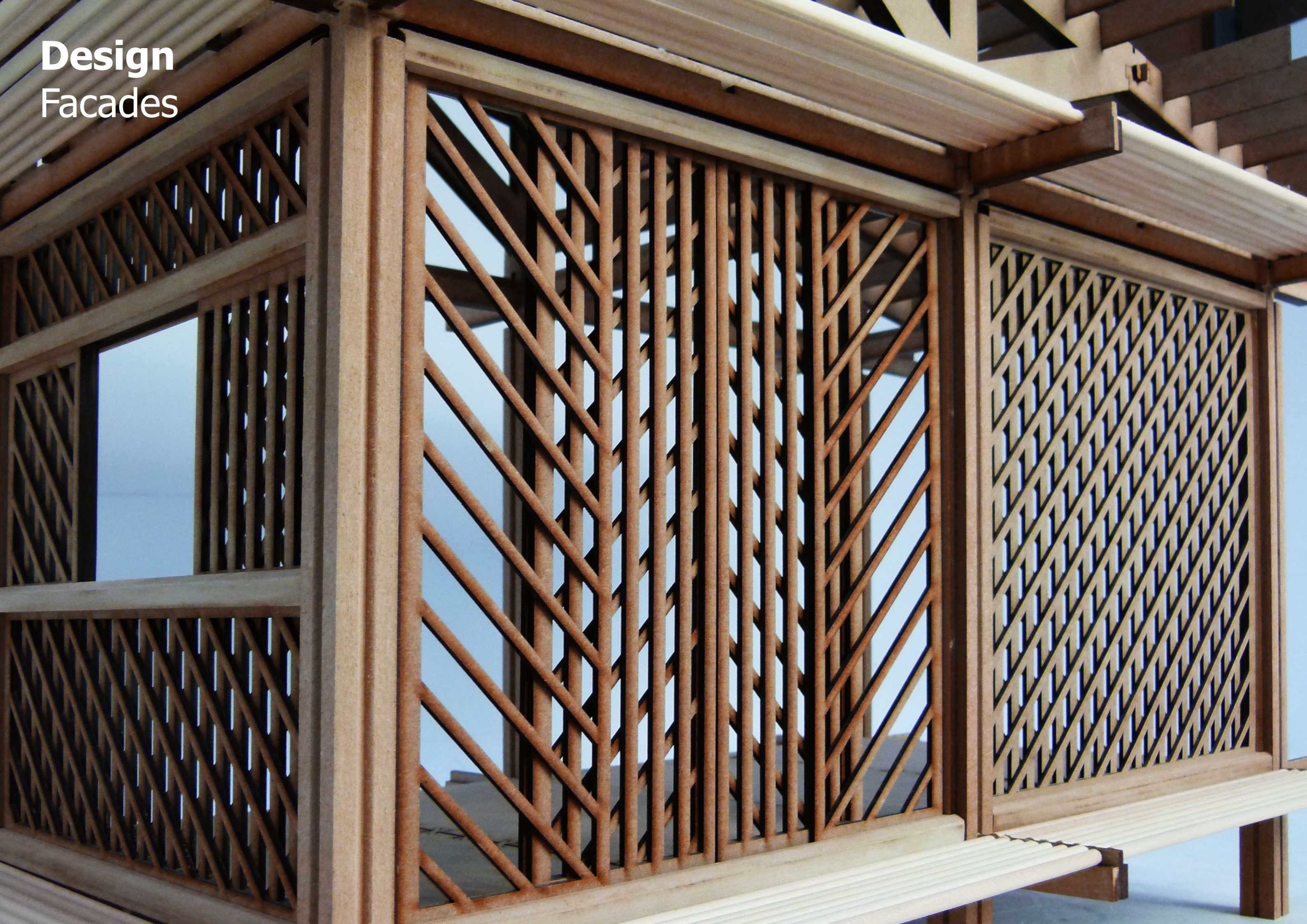







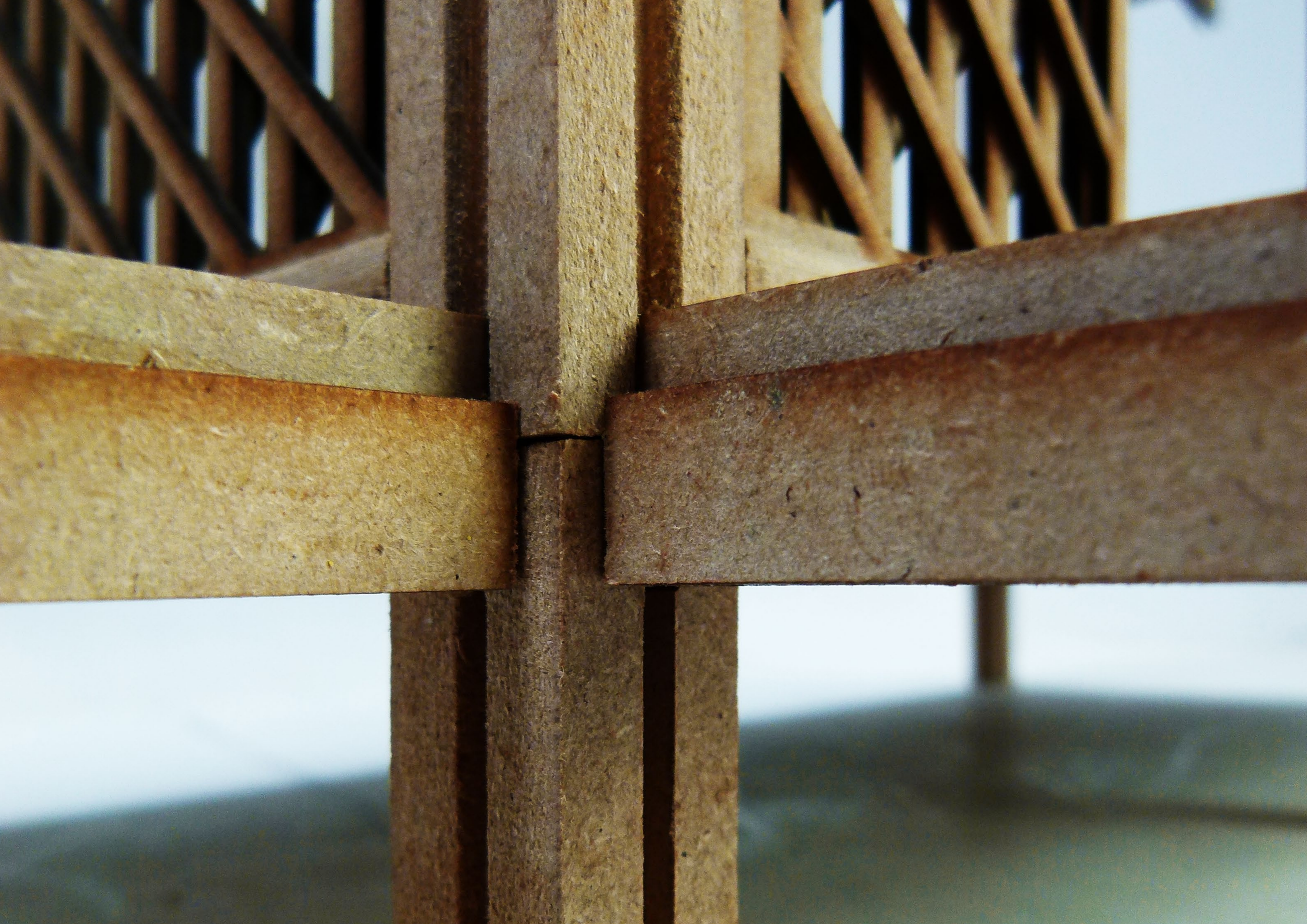







Strategic Application Community

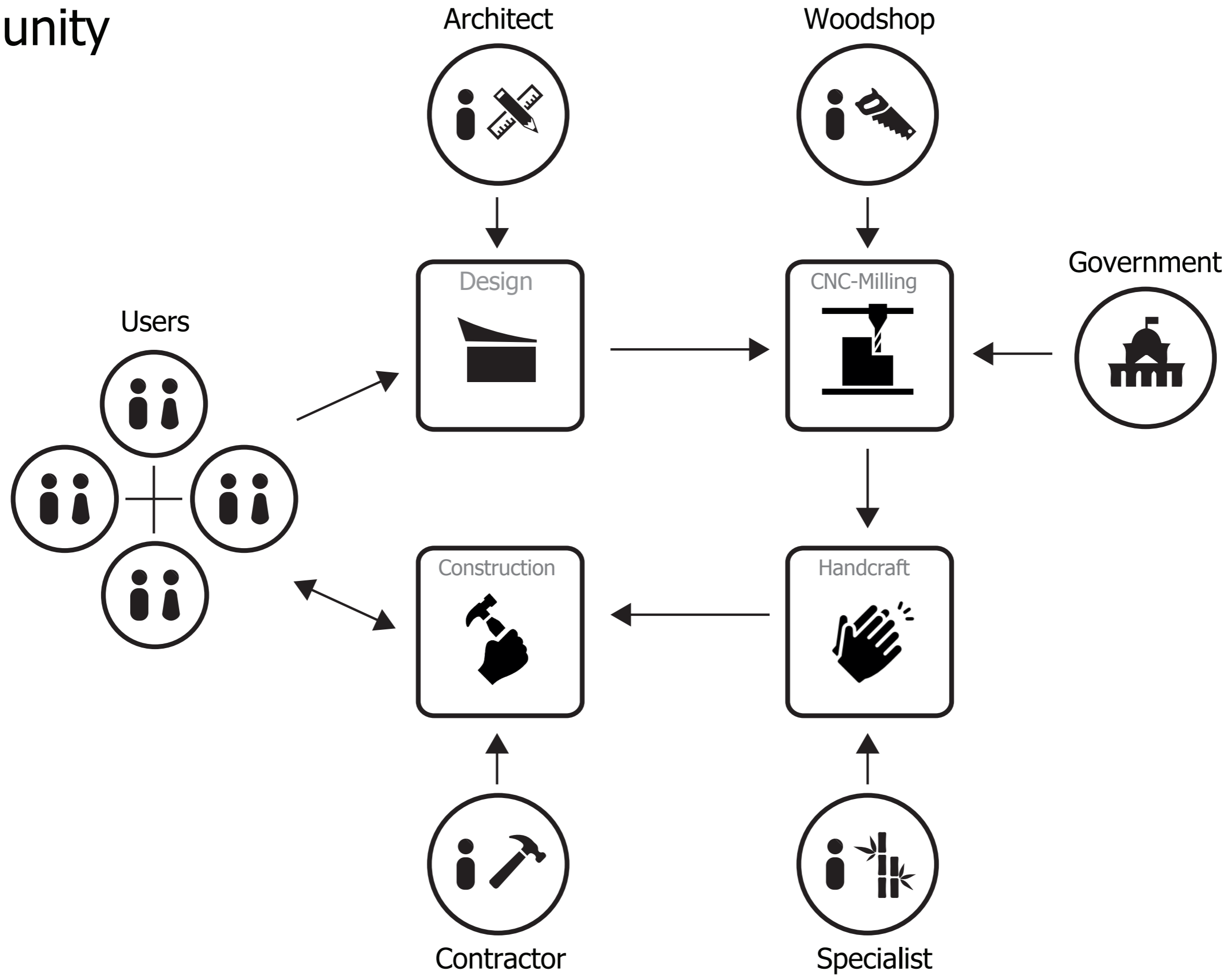

Strategic Application Community

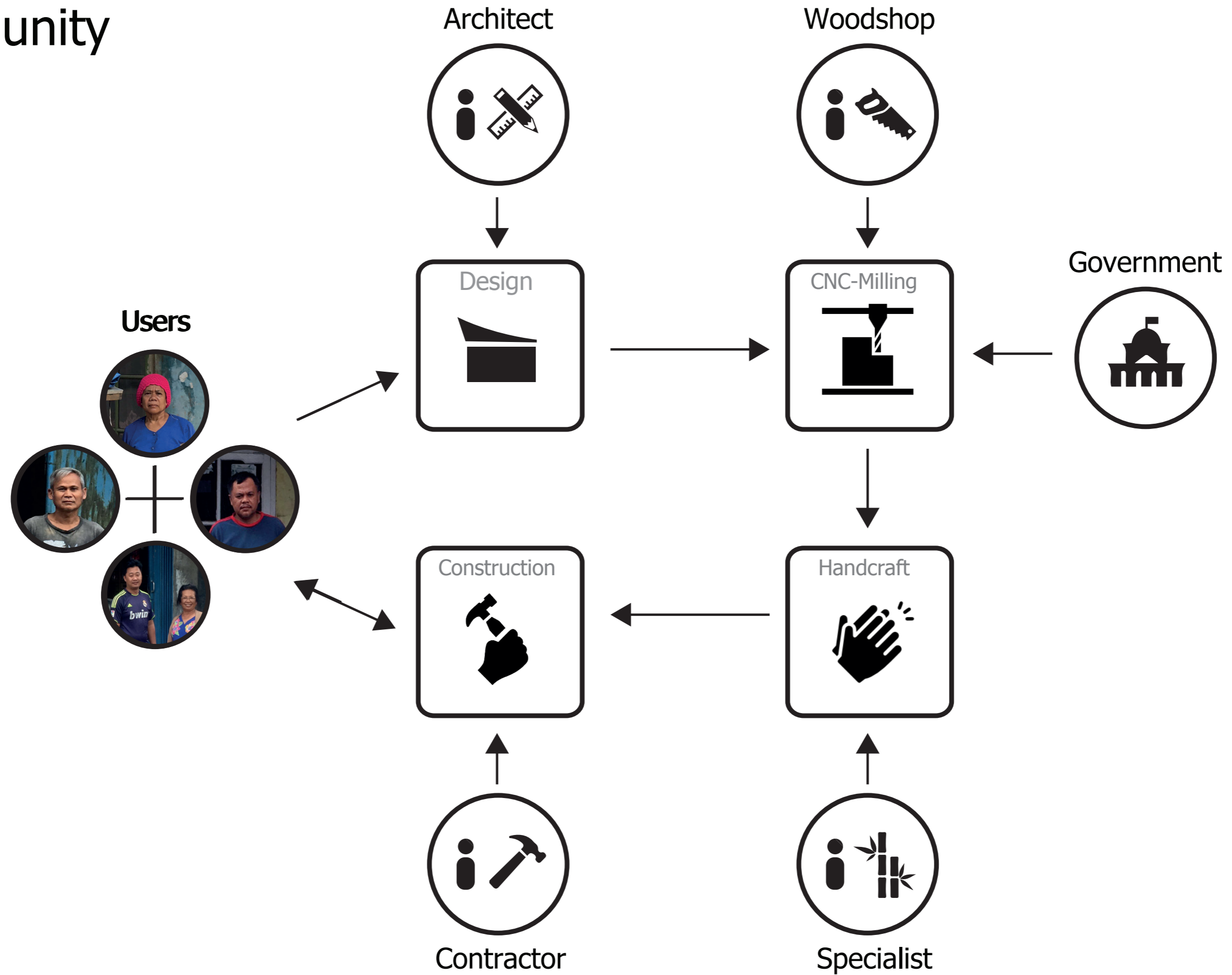

Strategic Application Community

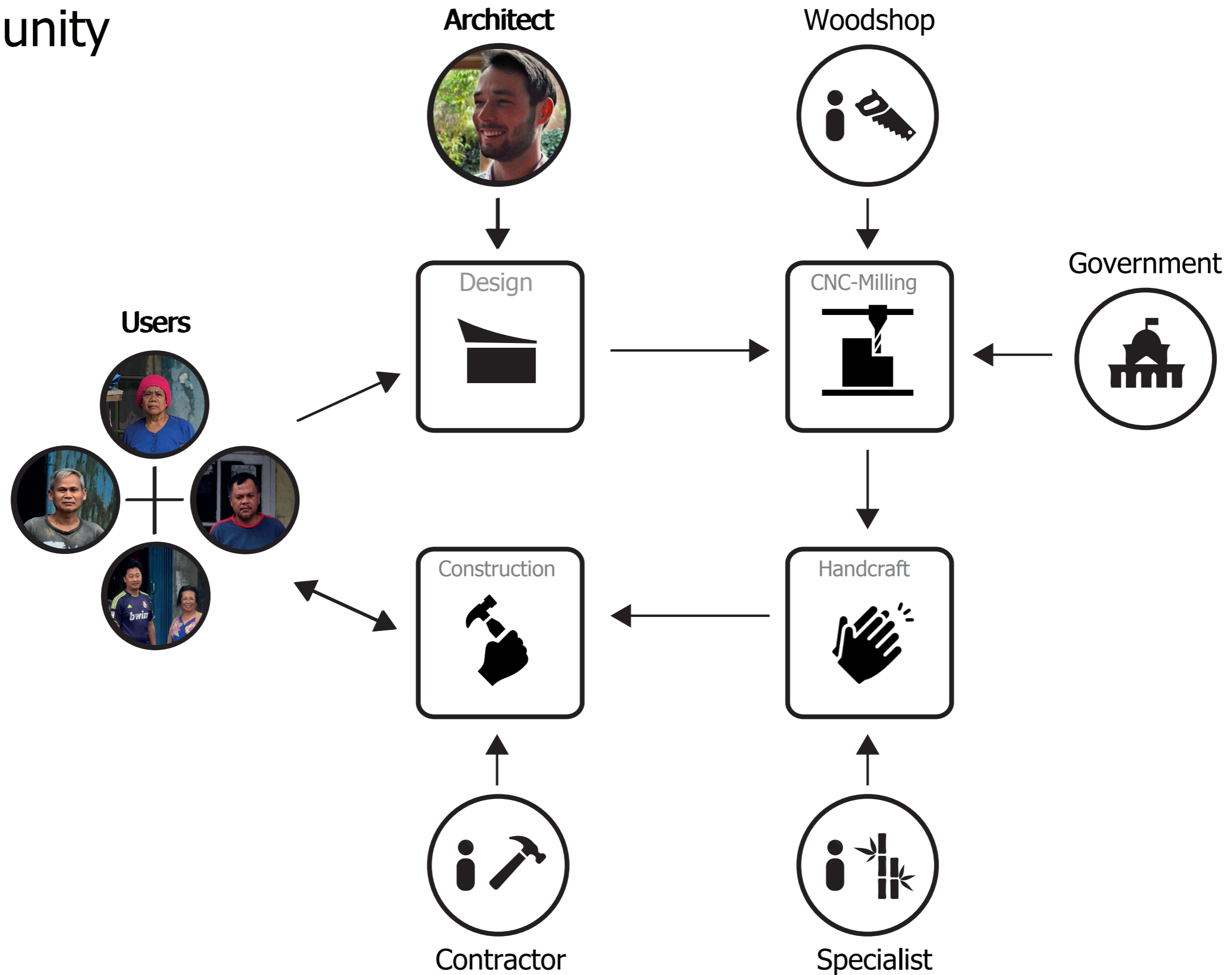

Strategic Application Community

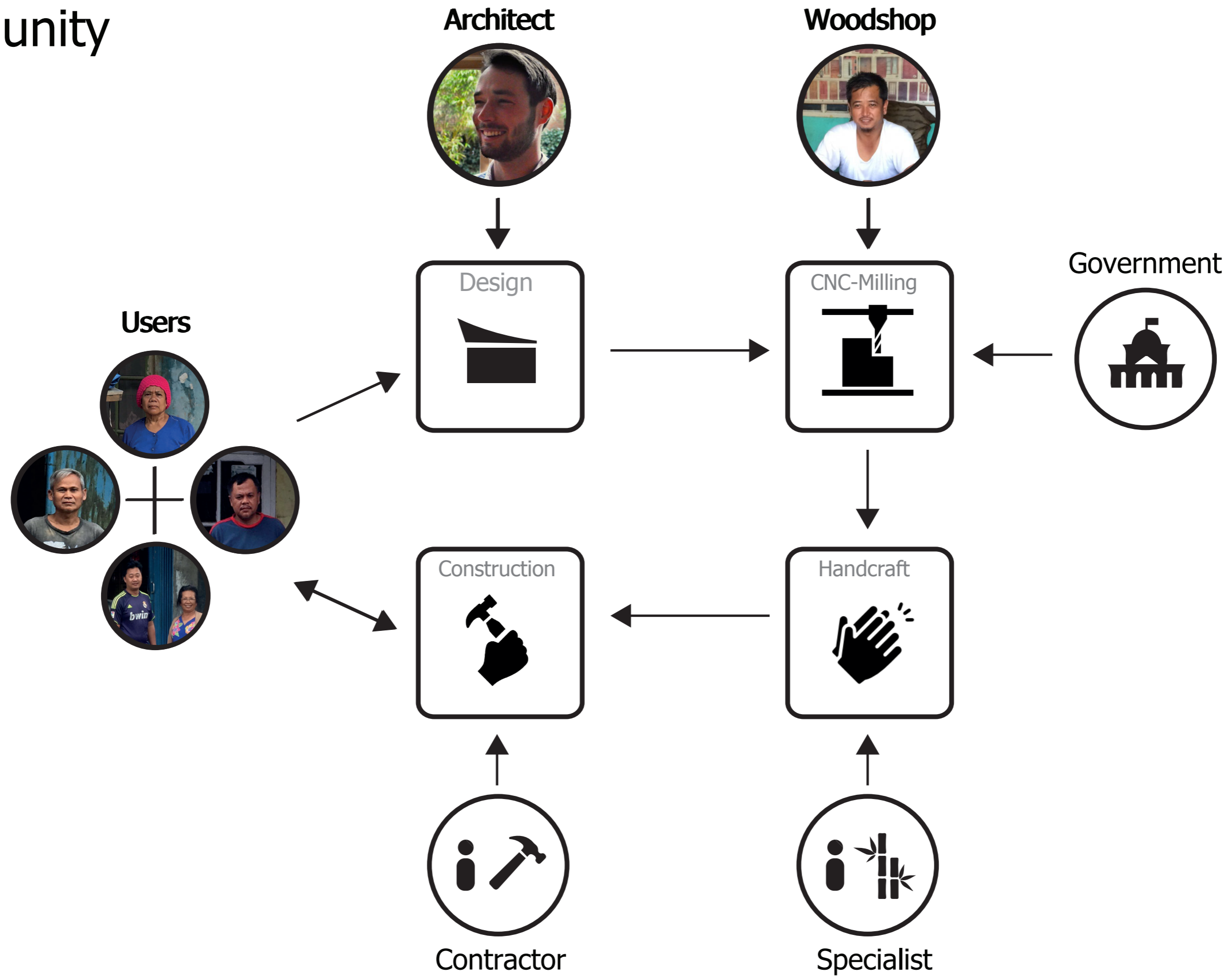

Strategic Application Community

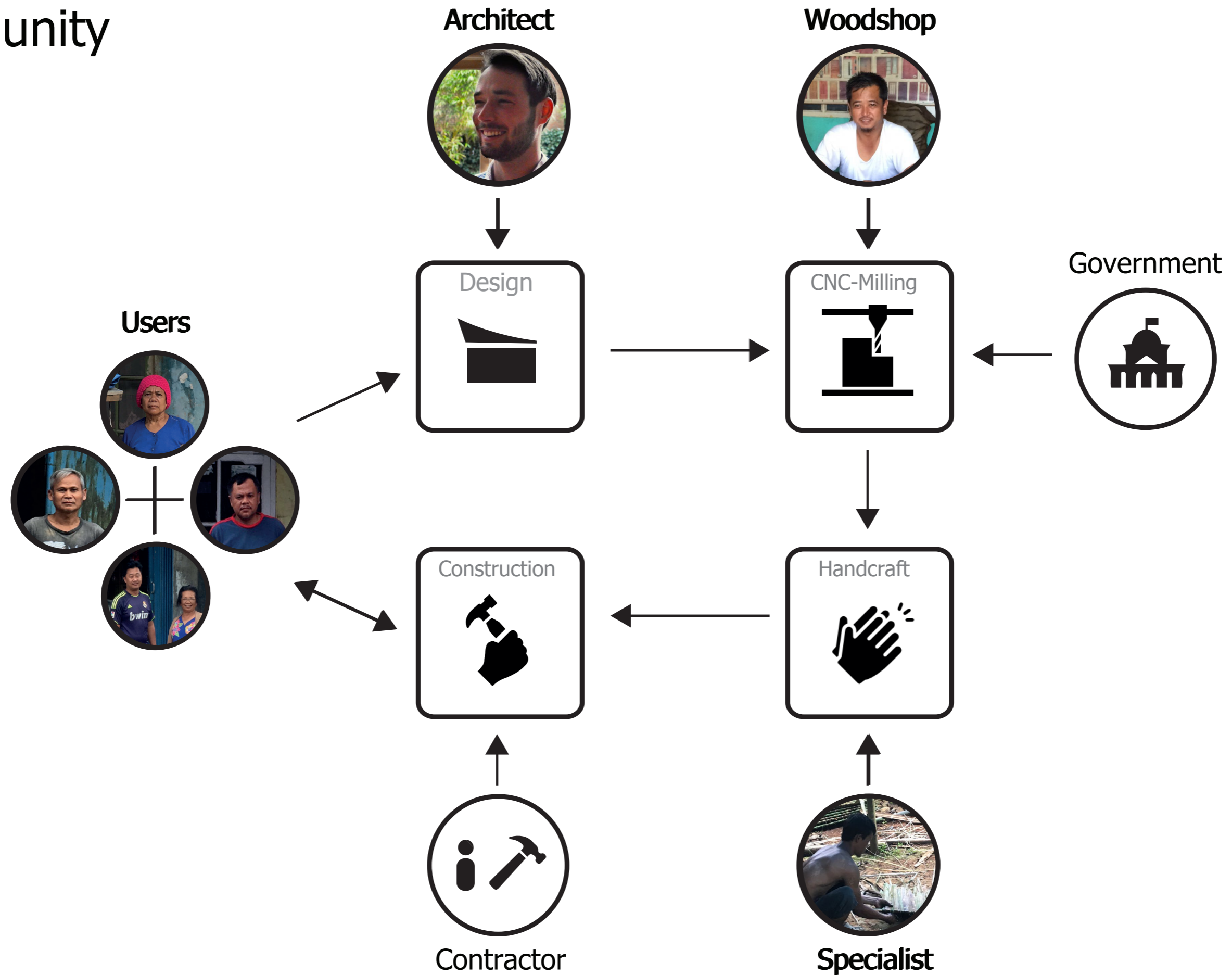

Strategic Application Community

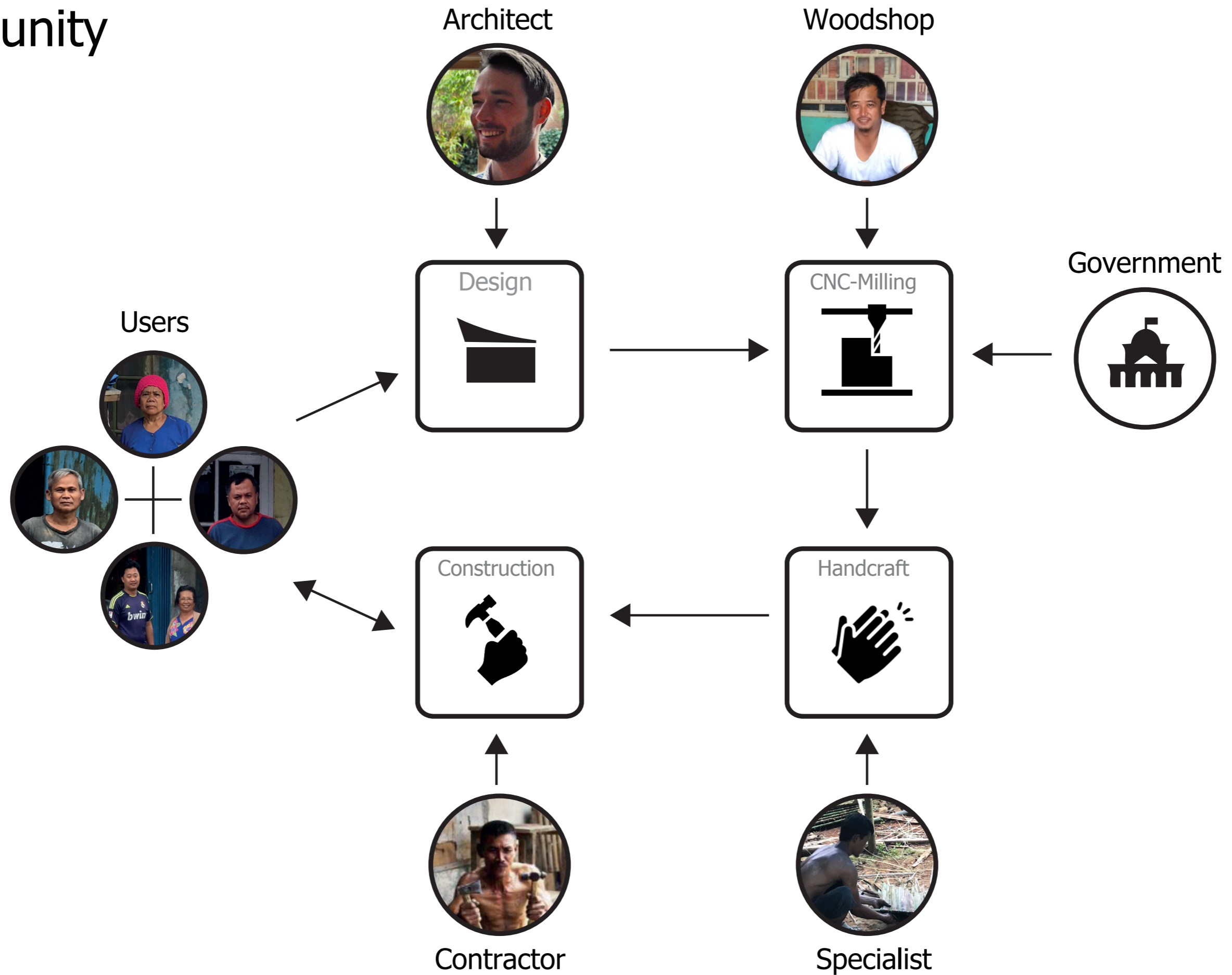

Question recap



Question

recap

How to use **Traditional** and **CNC-milling** building methods to create sustainable affordable Do-it-yourself housing in the **Peri-urban kampungs** of Indonesia

Questions?



Building system

Foundation

Criteria

- Re-use
- Durable
- Water resistance
- Easy assembly (DIY)

Materials

- Tyres (used)
- Rubberwood
or
- Mahogany wood
- Steel reinforcement

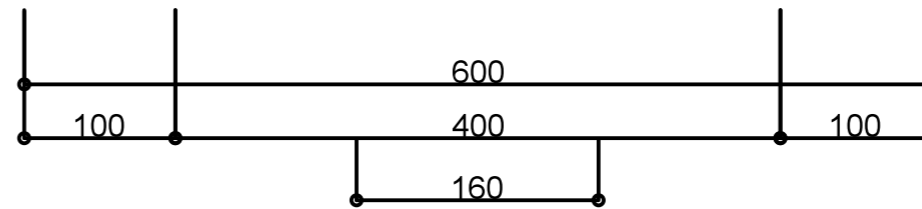
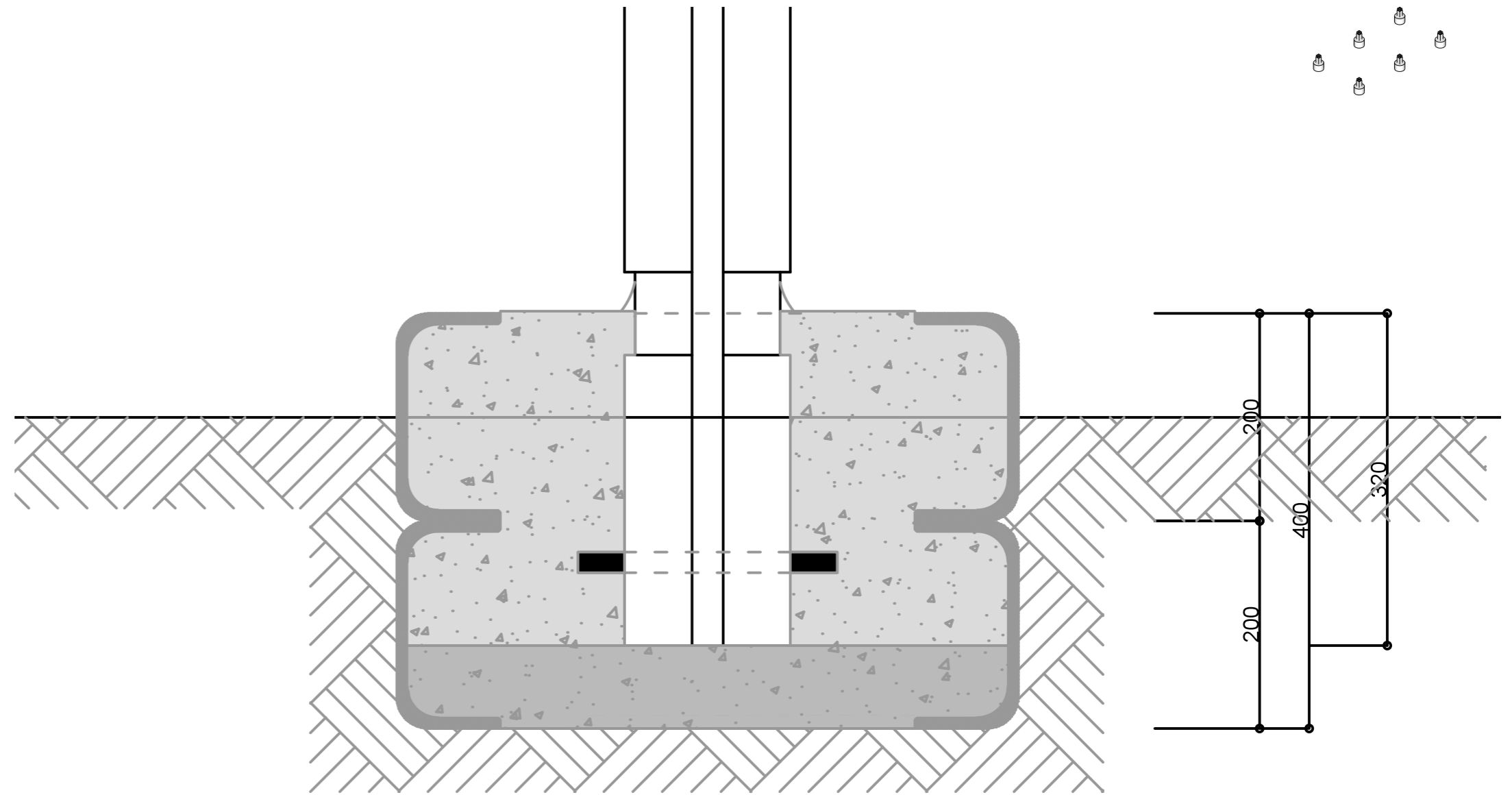

Building system

Beams and Columns

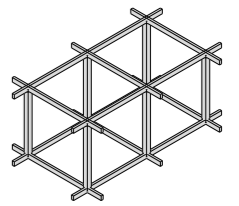

Criteria

- Easy assembly (DIY)
- Incremental
- Durable
- Water resistance

Materials

- Rubberwood
or
- Mahogany wood
- Steel pins

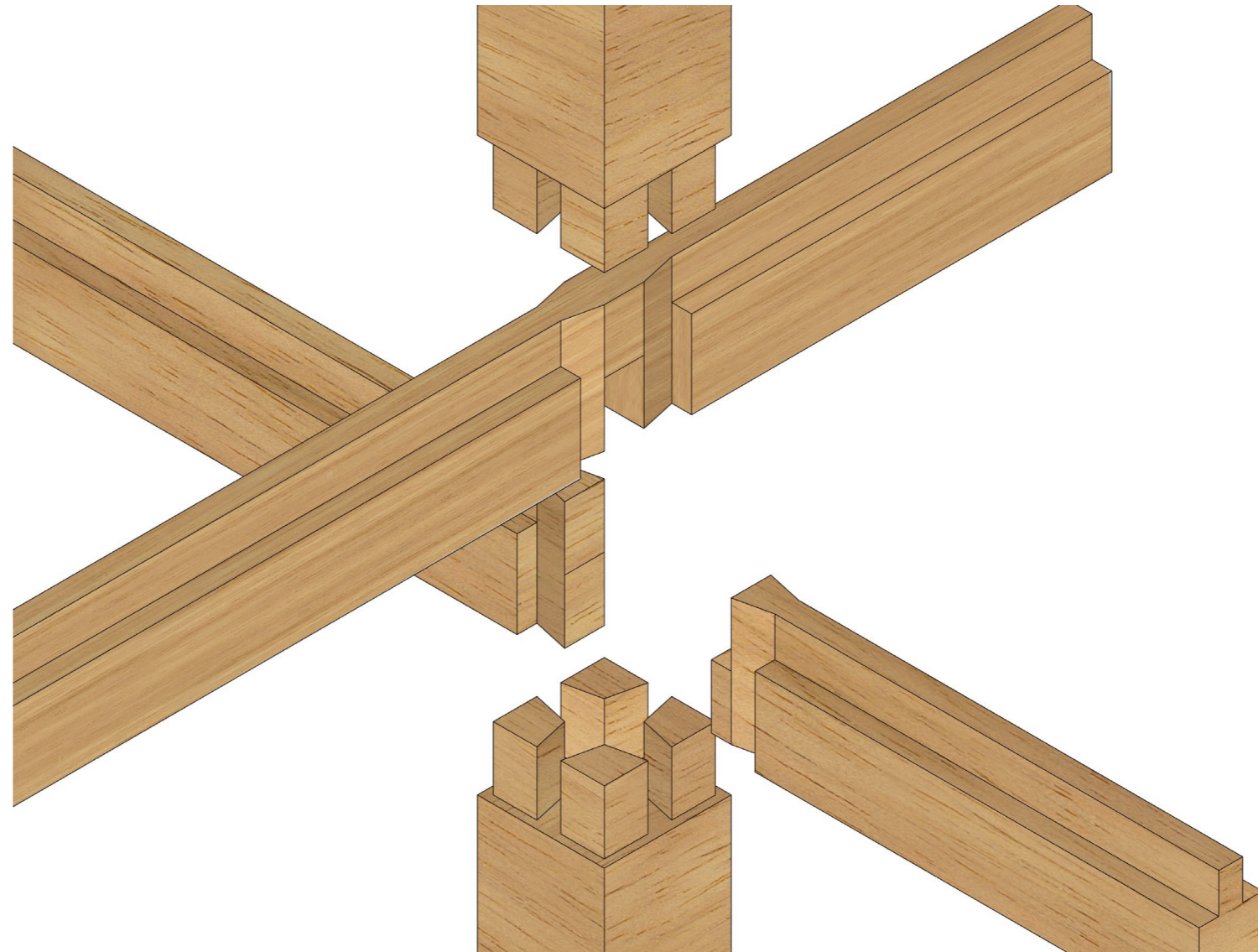

Building system

Roof structure

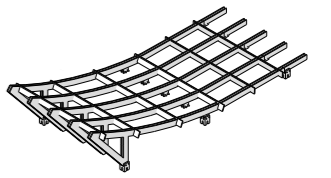

Criteria

- Easy assembly (DIY)
- Light weight
- Dismountable
- Flexible

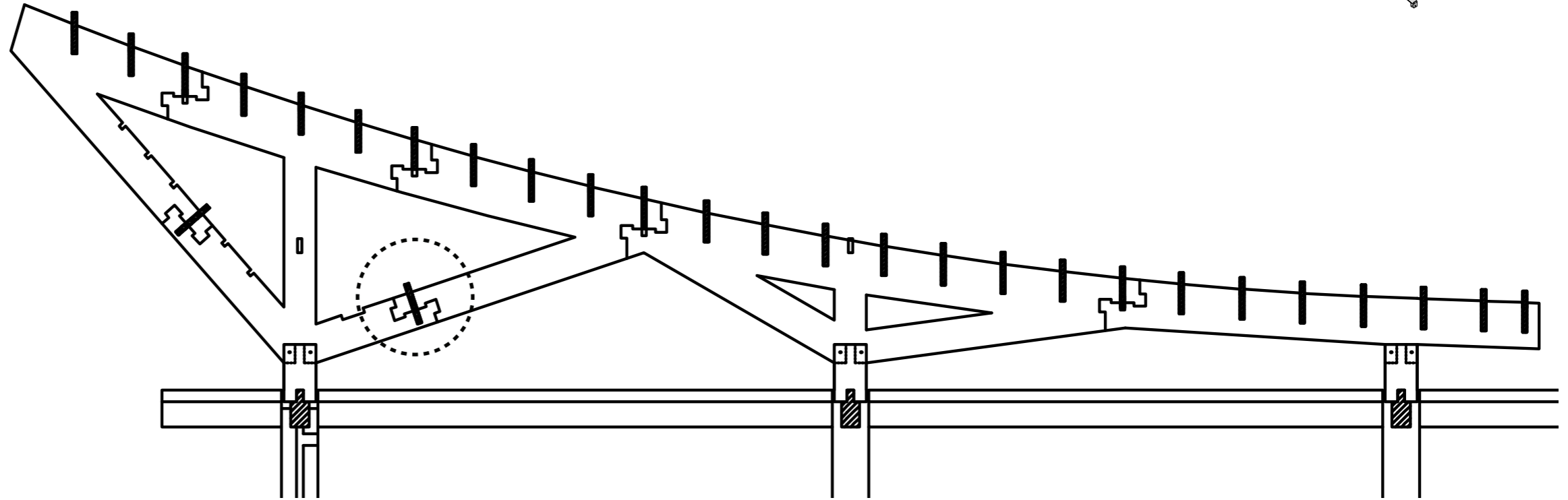

Materials

- Sengon plywood
or
- OSB (bamboe particles)
- Steel pins

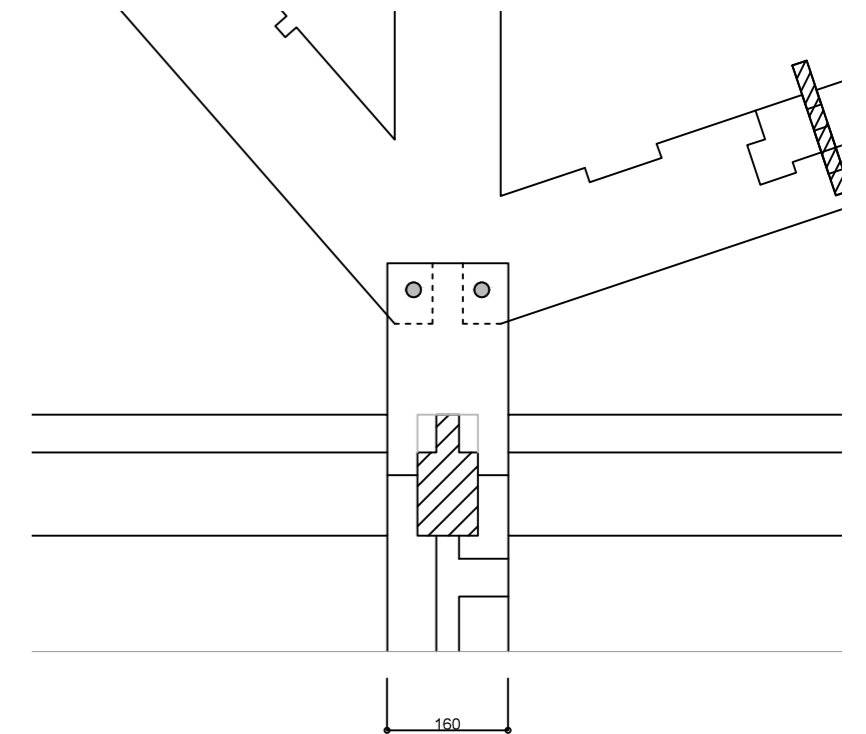
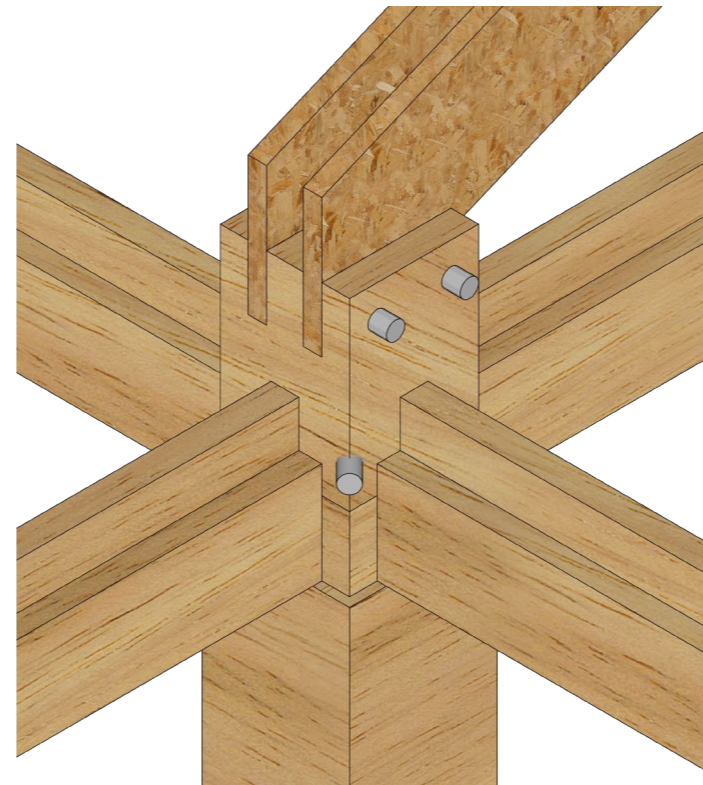
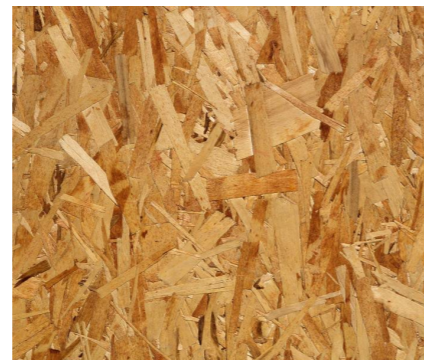

Building system

Flooring

Criteria

- Easy assembly (DIY)
- Structural properties
- Low costs
- Customizable
- Sustainable

Materials

- Bamboo rods
or
- Bamboo OSB (cheap)
or
- Bamboo Ply (expensive)
- WPC board (sanitation)

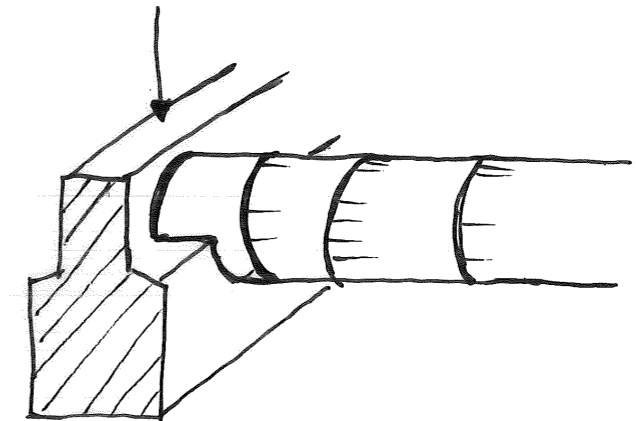
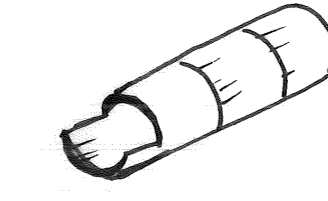
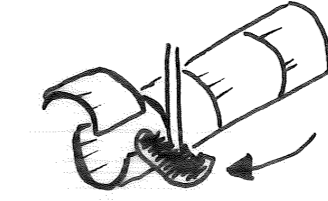
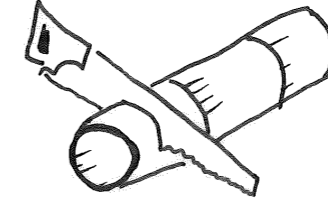
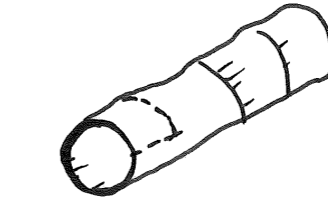
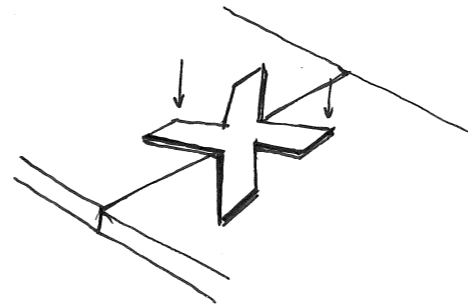
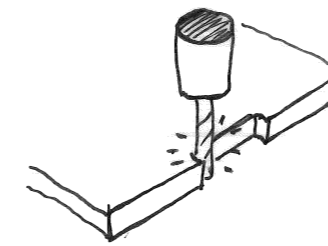
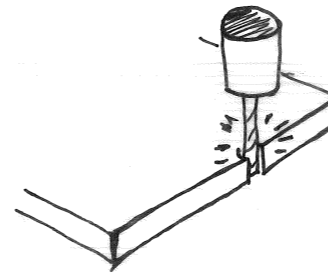
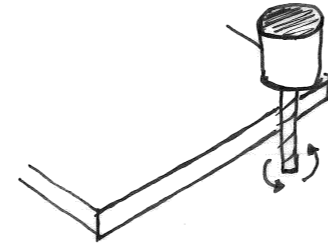
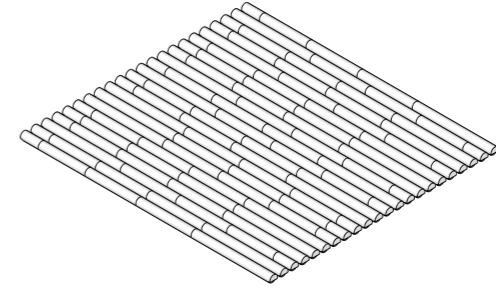
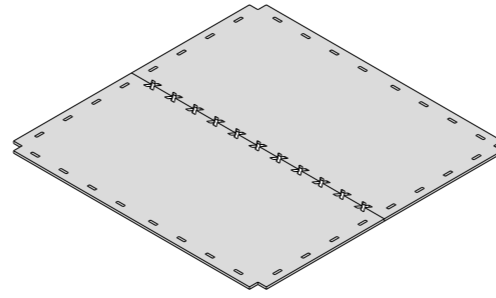

Building system

Flooring

Criteria

- Easy assembly (DIY)
- Structural properties
- Low costs
- Customizable
- Sustainable

Materials

- Bamboo rods
or
- Bamboo OSB (cheap)
or
- Bamboo Ply (expensive)
- WPC board (sanitation)

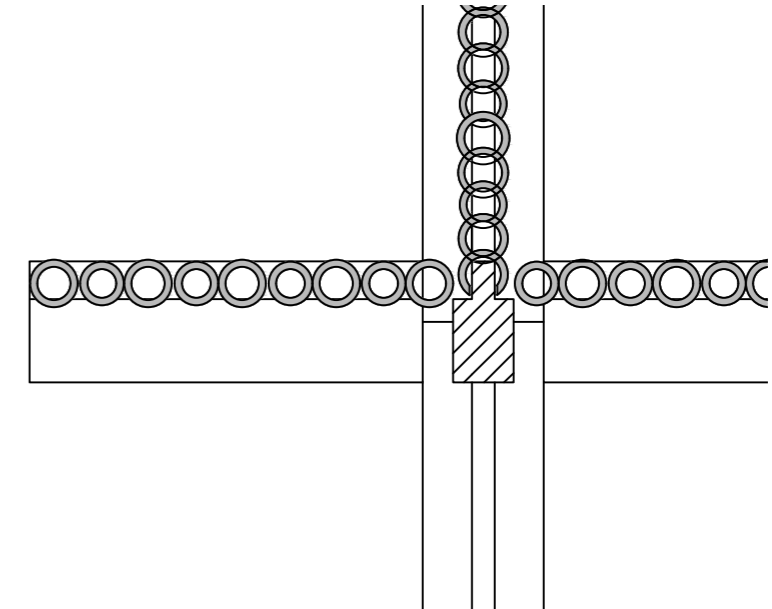
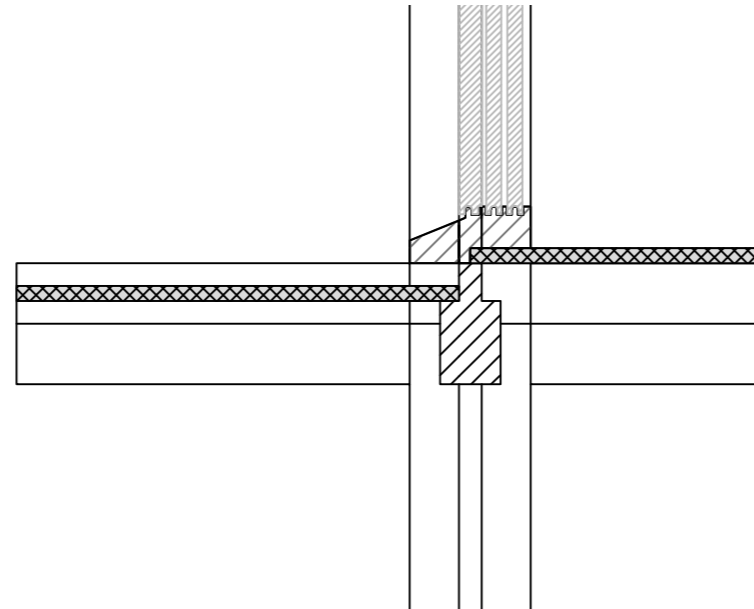
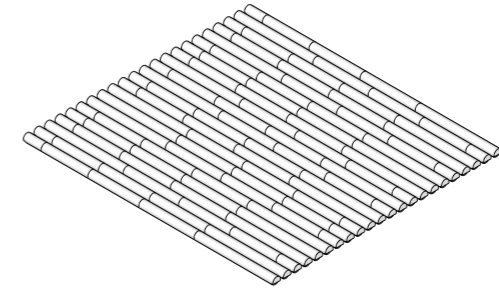
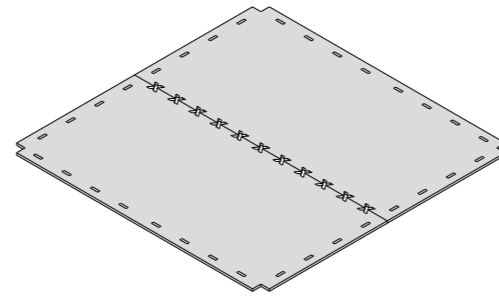

OSB

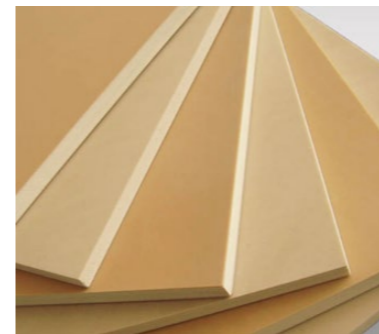

WPC



Bamboo plywood

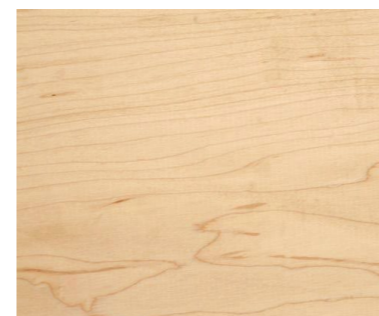

Sengon plywood



Bamboo rods

Building system

Facade

Criteria

- Easy assembly (DIY)
- Water resistance
- Low costs
- Customizable
- Sustainable
- Flexible

Materials

- Bamboo rods
or
- Bamboo OSB (cheap)
or
- Bamboo Ply (expensive)
- WPC board (sanitation)

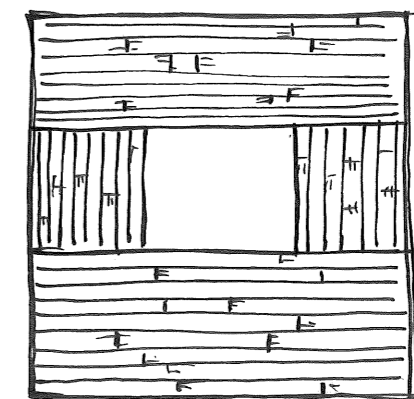
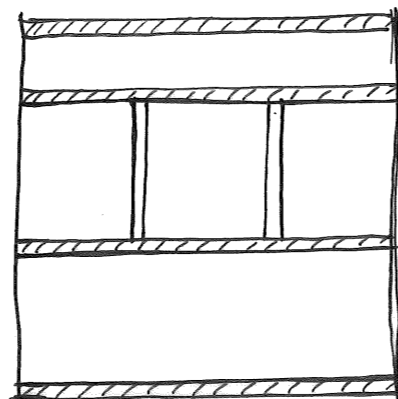
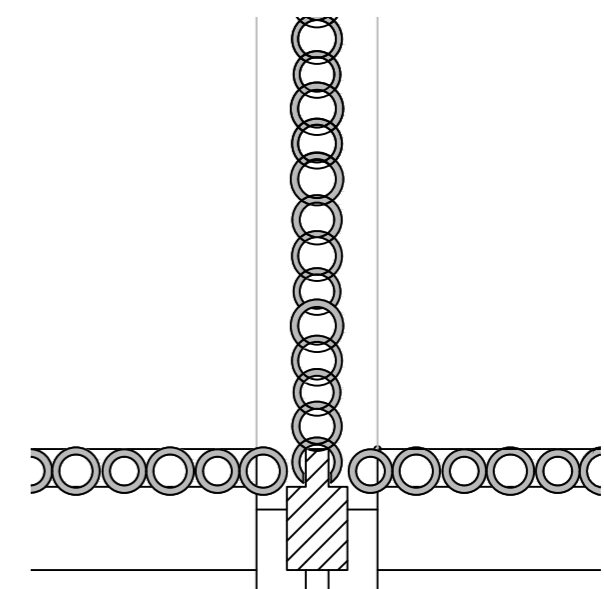
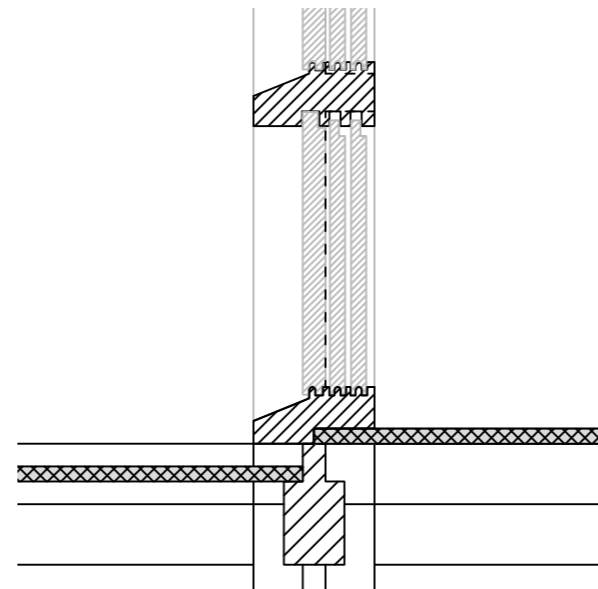
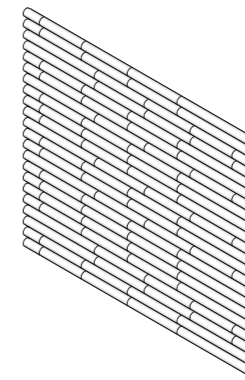
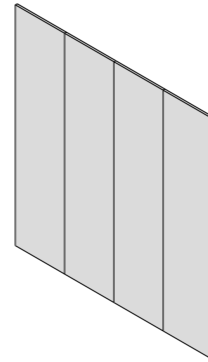

Building system

Facade

Criteria

- Easy assembly (DIY)
- Water resistance
- Low costs
- Customizable
- Sustainable
- Flexible

Materials

- Bamboo rods
or
- Bamboo OSB (cheap)
or
- Bamboo Ply (expensive)
- WPC board (sanitation)

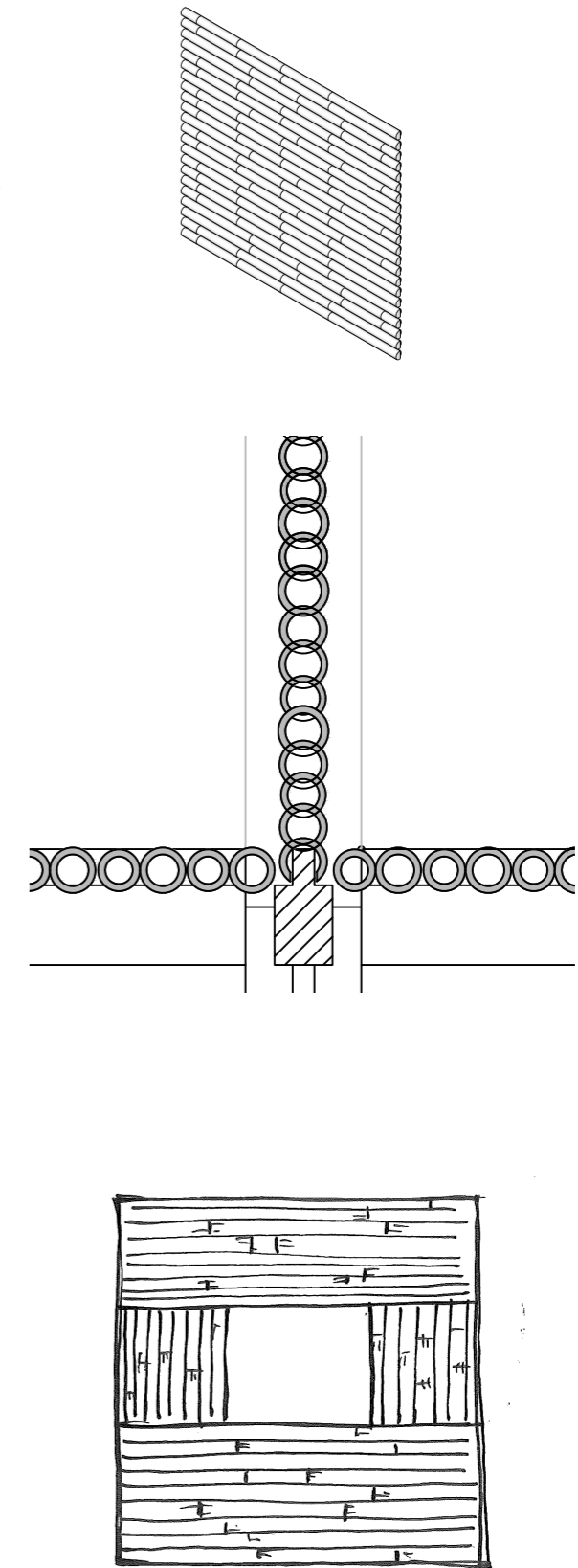
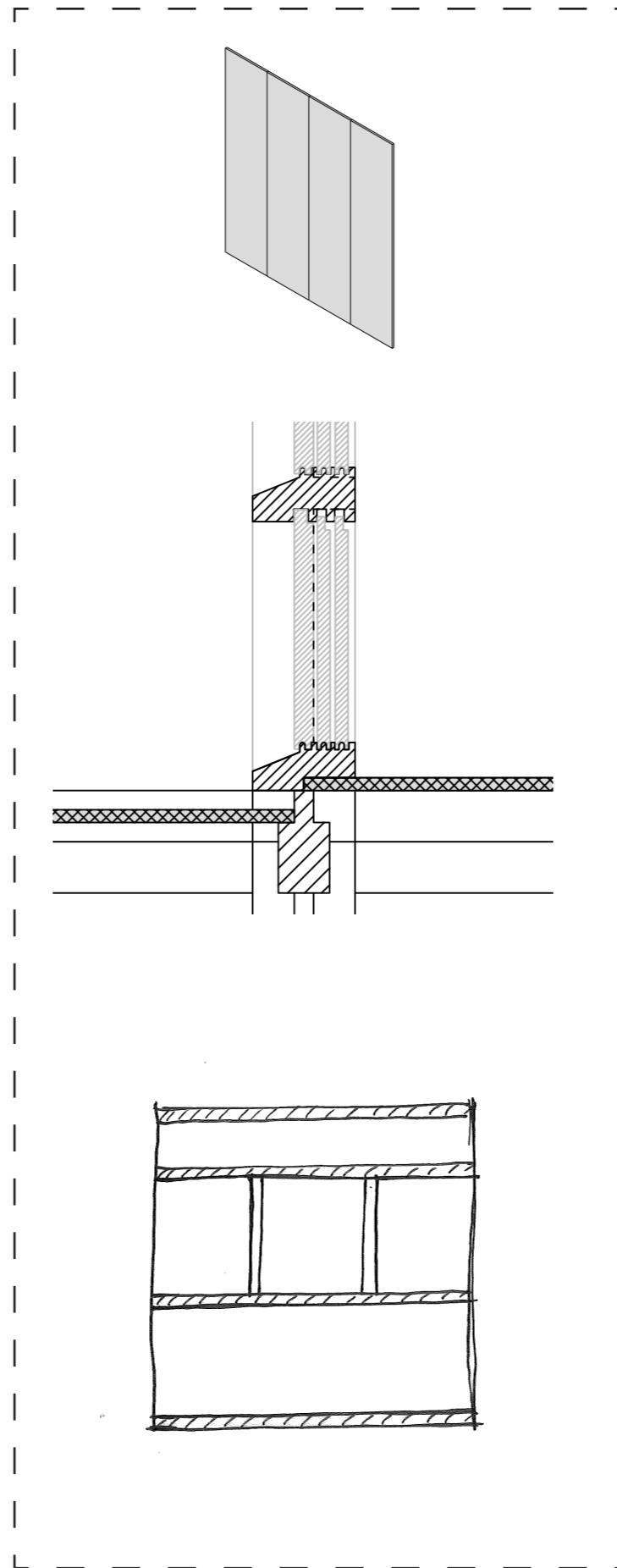

Building system

Facade

Criteria

- Easy assembly (DIY)
- Water resistance
- Low costs
- Customizable
- Sustainable
- Flexible

Materials

- Bamboo rods
or
- Bamboo OSB (cheap)
or
- Bamboo Ply (expensive)
- WPC board (sanitation)

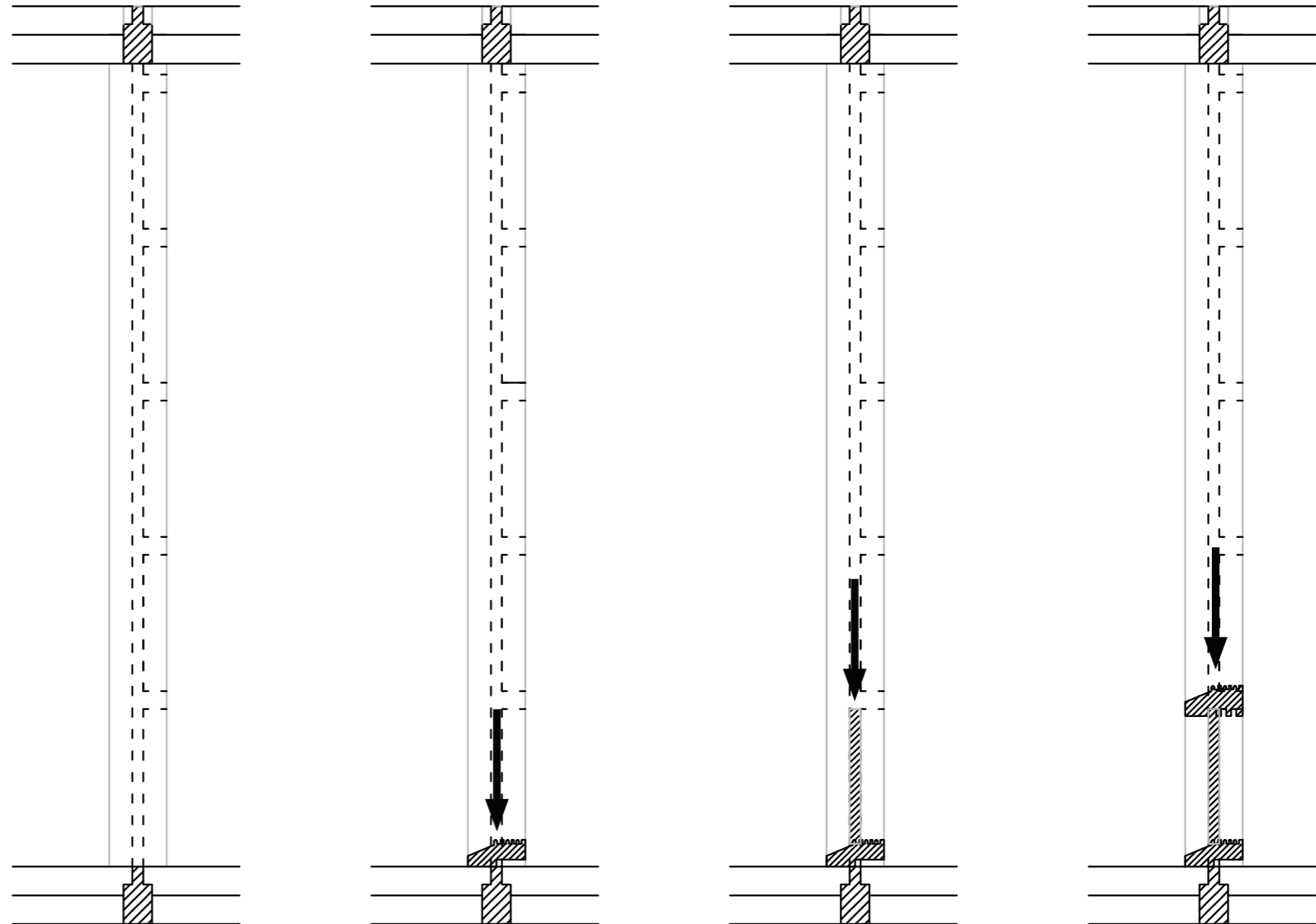

Building system

Facade

Criteria

- Easy assembly (DIY)
- Water resistance
- Low costs
- Customizable
- Sustainable
- Flexible

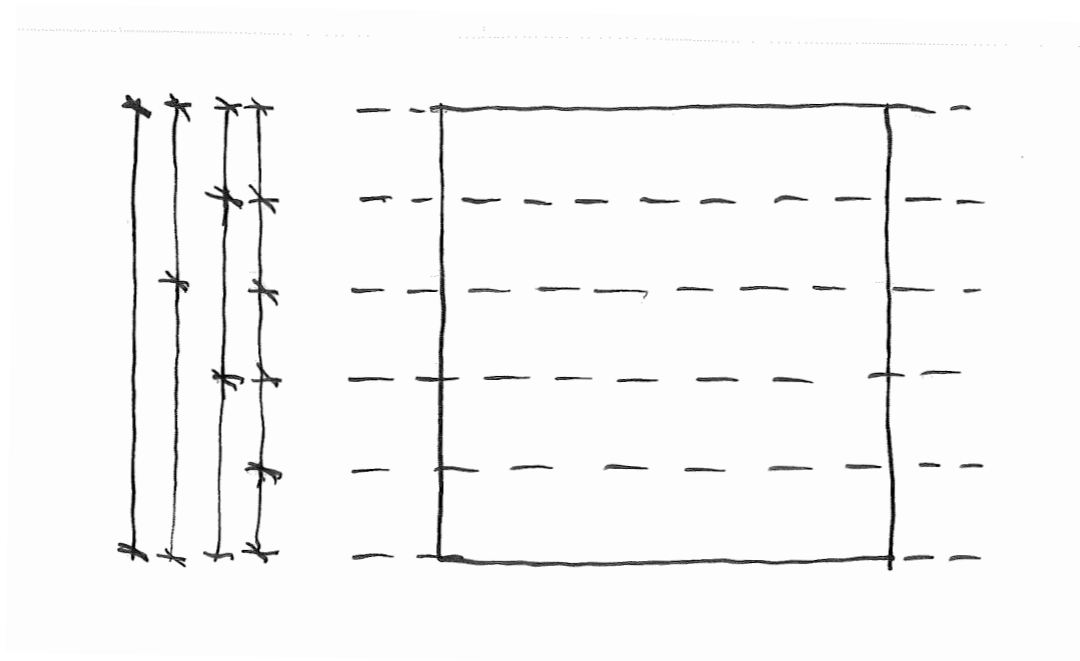

Materials

- Bamboo rods
or
- Bamboo OSB (cheap)
or
- Bamboo Ply (expensive)
- WPC board (sanitation)

Sliding door

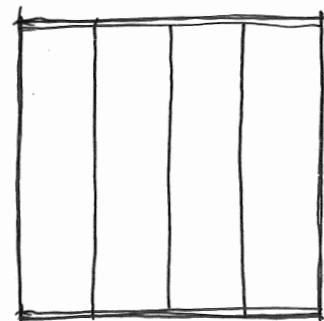

Window

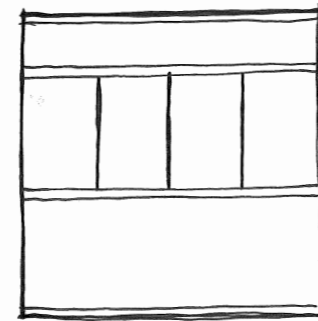

Window large

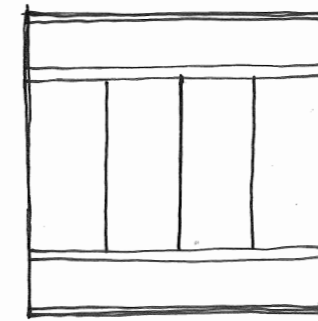

Window small

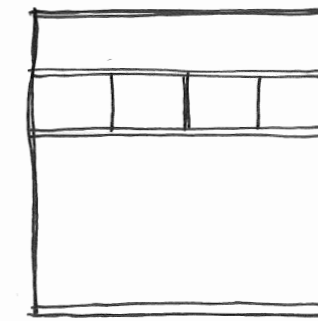

Door small

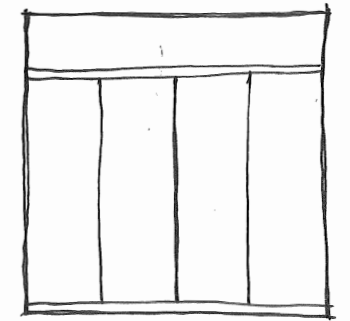

Building system

Facade

Criteria

- Easy assembly (DIY)
- Water resistance
- Low costs
- Customizable
- Sustainable
- Flexible

Materials

- Bamboo rods
or
- Bamboo OSB (cheap)
or
- Bamboo Ply (expensive)
- WPC board (sanitation)

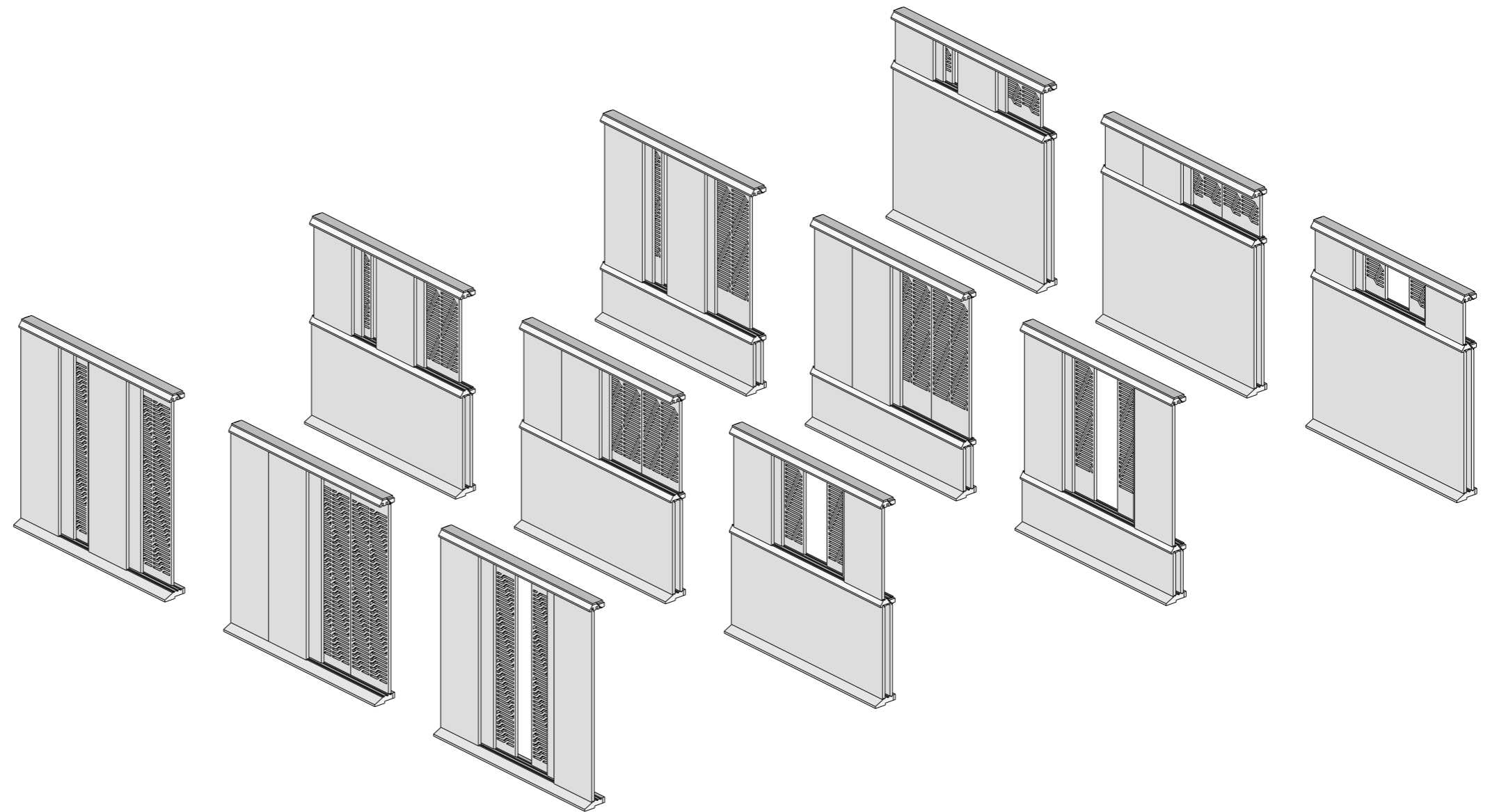

Building system

Facade

Criteria

- Easy assembly (DIY)
- Water resistance
- Low costs
- Customizable
- Sustainable
- Flexible

Materials

- Bamboo rods
or
- Bamboo OSB (cheap)
or
- Bamboo Ply (expensive)
- WPC board (sanitation)

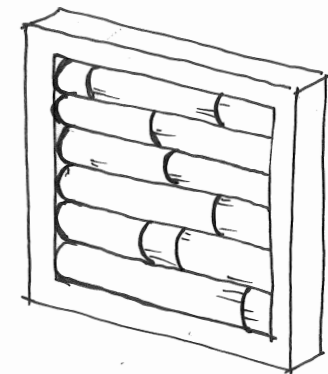
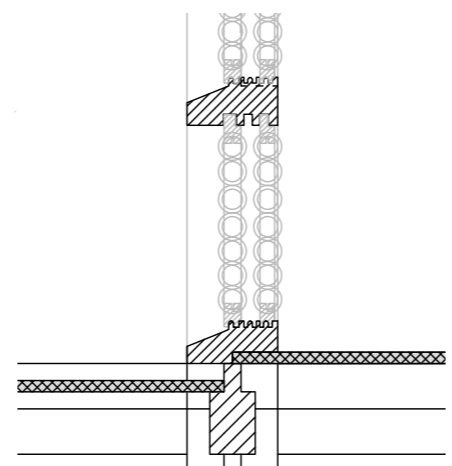
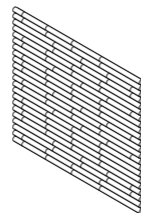
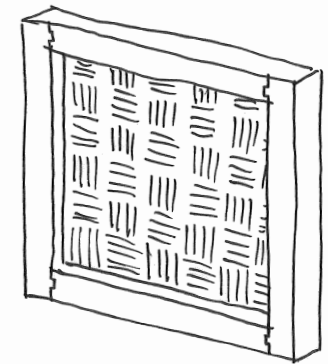
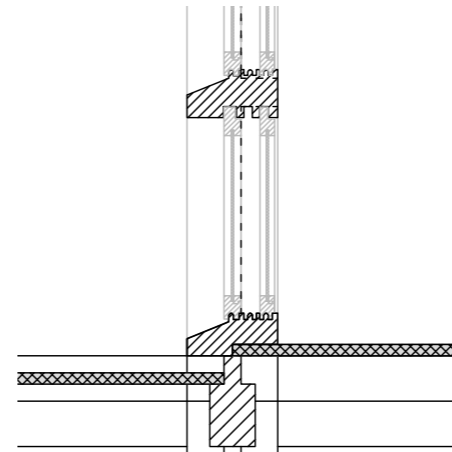
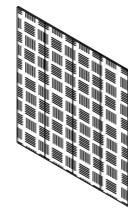
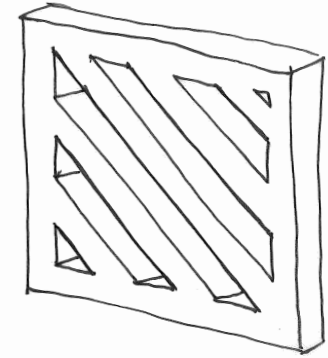
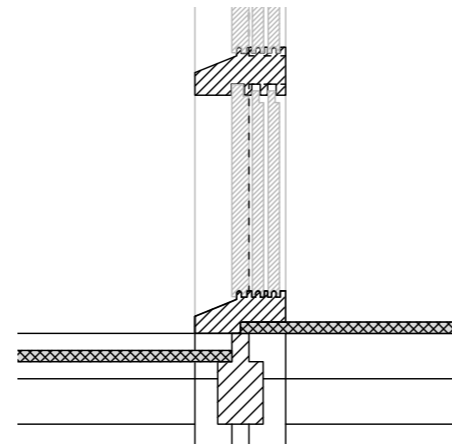
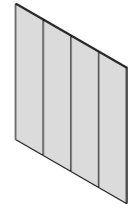

Building system

Roof

Criteria

- Easy assembly (DIY)
- Water resistance
- Low costs
- Re-use
- Sustainable
- Flexible

Materials

- Bamboo rods
or
- Roof tiles

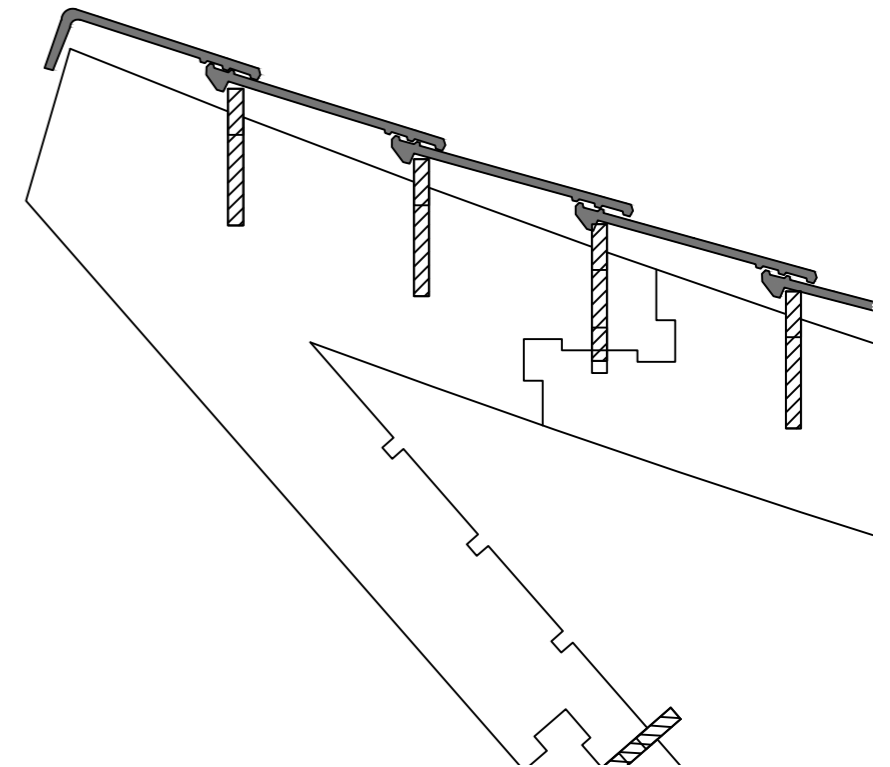
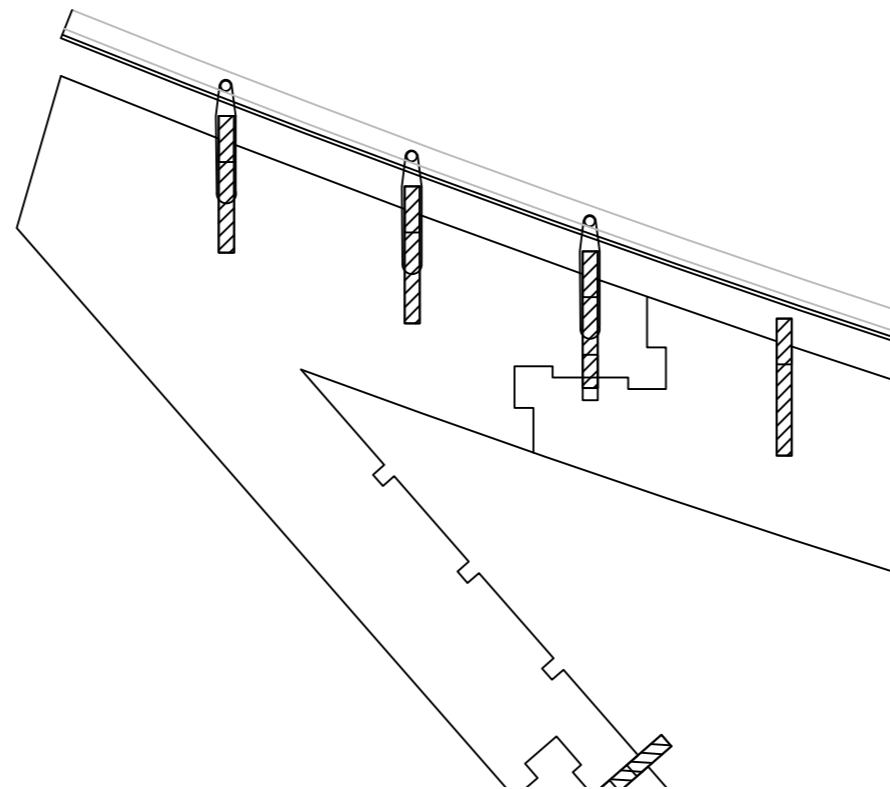
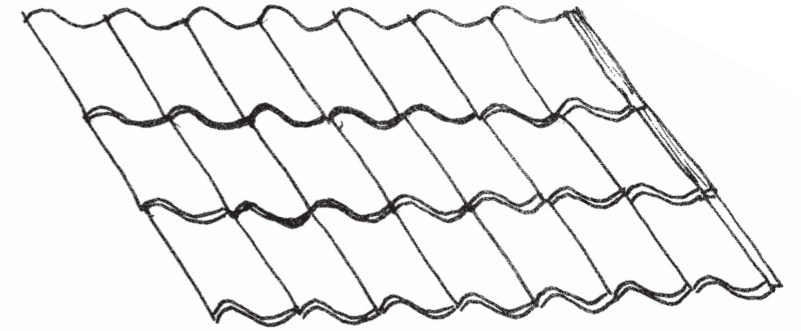
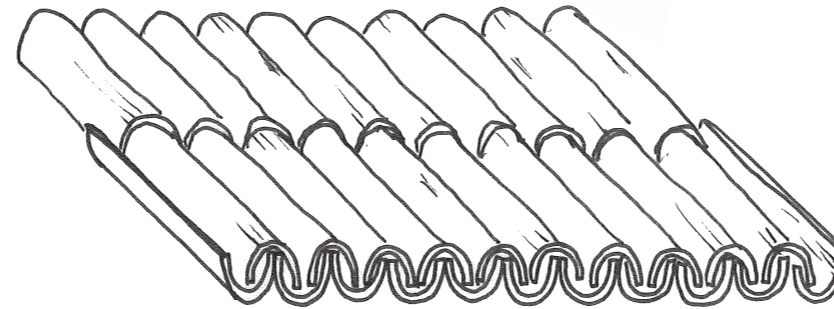
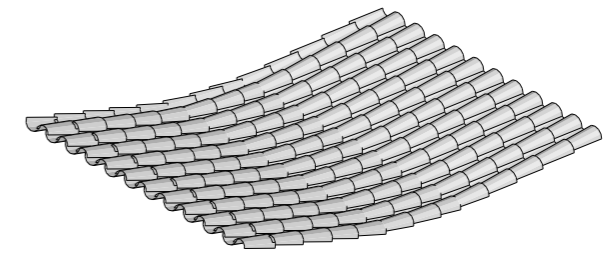
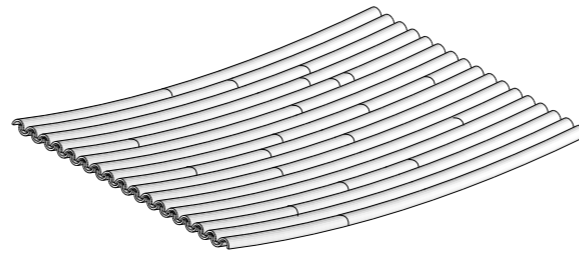

Design Facades

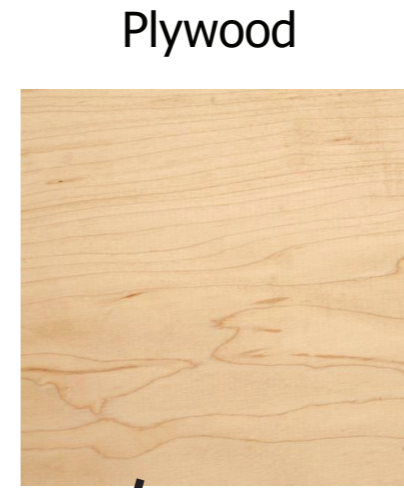











Design Facades

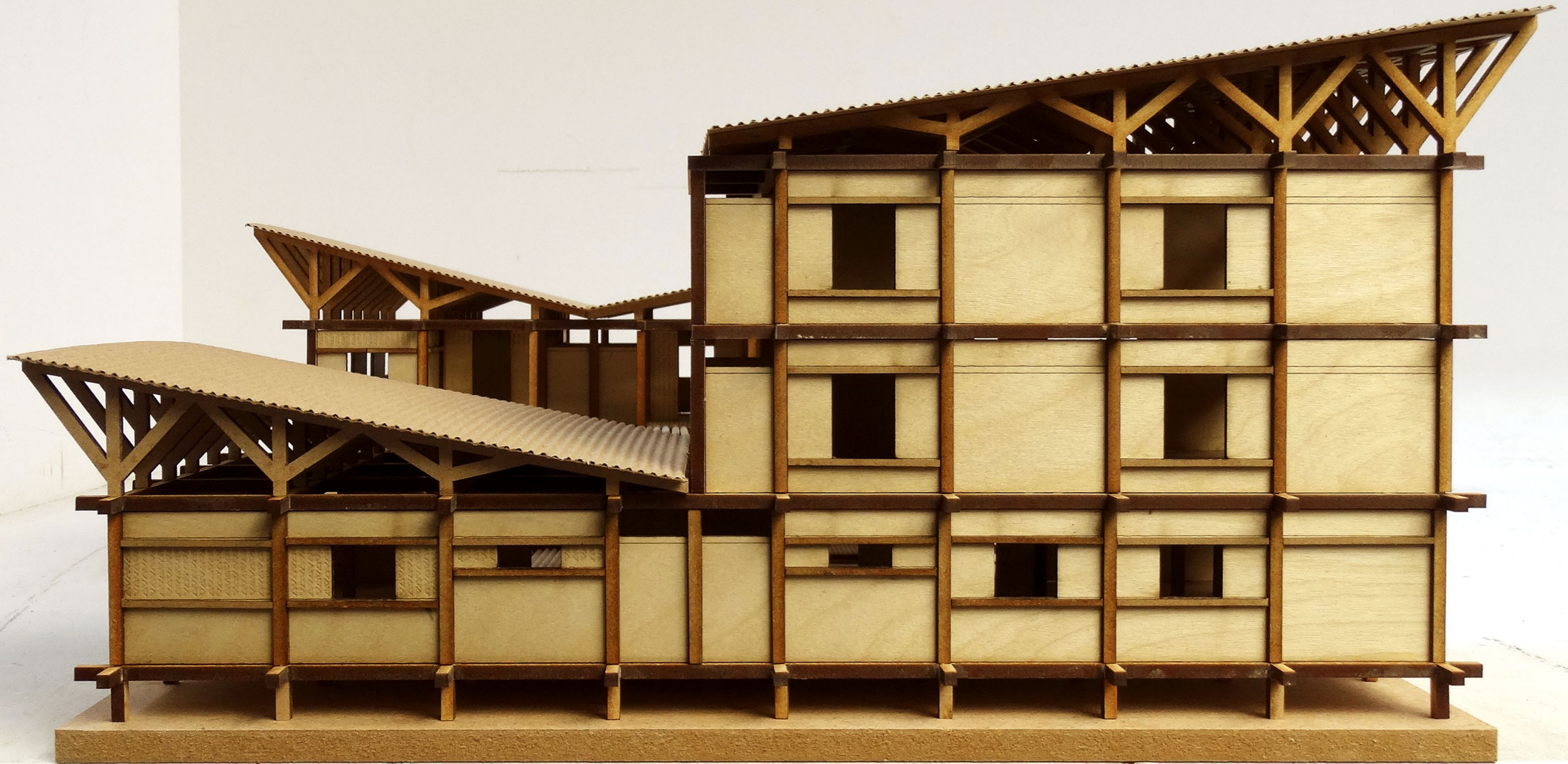

Design Facades



