

Public Building Graduation Studio 2025-26 (AR4API20)
Leisure and revitalization of post-gas Groningen Re-Start the North (NY BEGUN)

WHERE WATER CONNECTS
Architecture as a Catalyst for Year-Round Activation

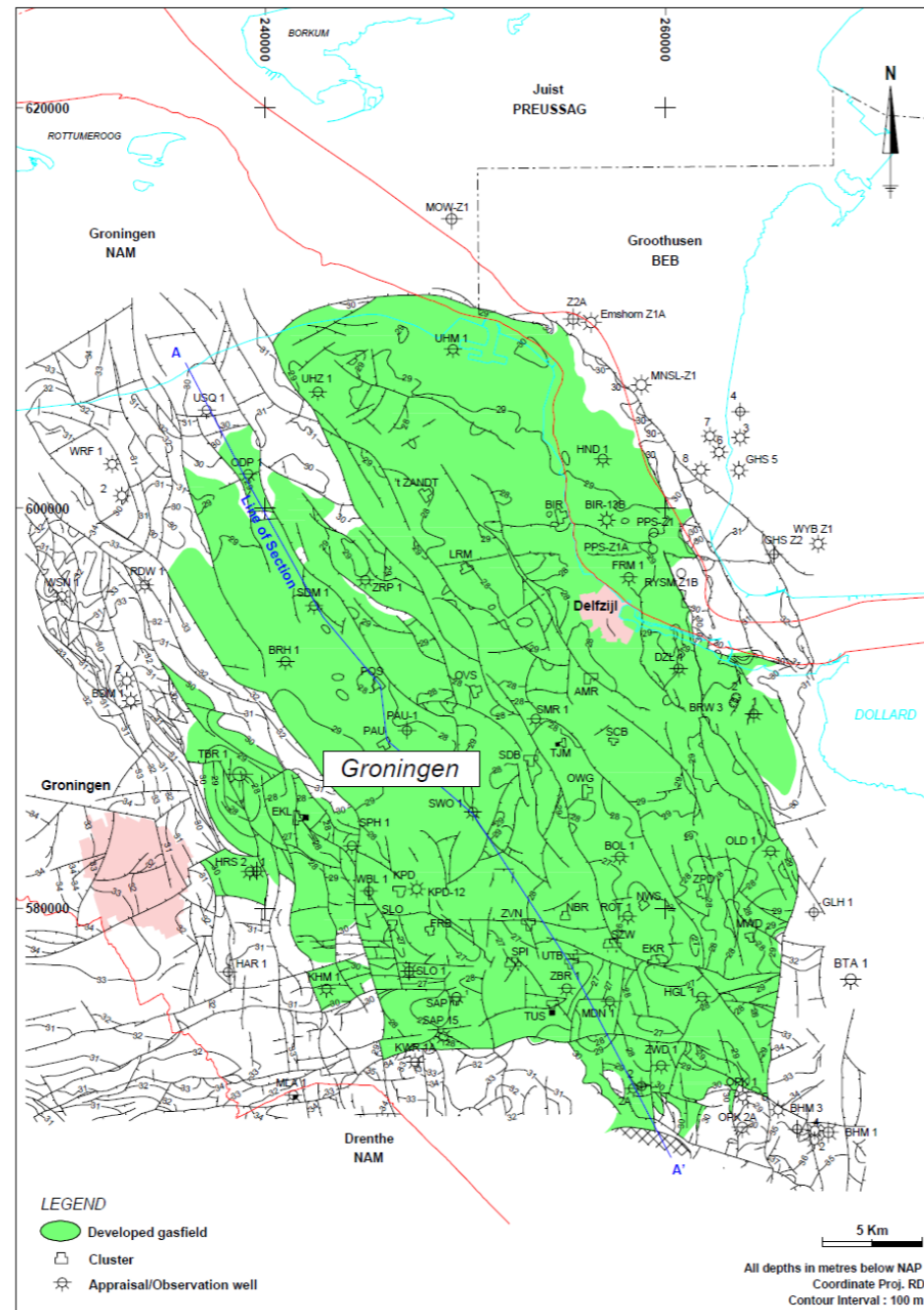

Tam Sze Ching, Ariel (6220436)
ir: Henk Bultstra (main mentor)
ir: Sien van Dam (second mentor)
Nathalie de Vries (research-by-design mentor)



**Depth Contour Map
 Groningen - Top Slochters (ROSL)**
 Scale 1 : 250 000
 NEDERLANDSE AARDOLIE MIJ. B.V | Project: ARPR | Author: ELG-DVC | Date: Jan. 2003 | Drw.Nr: 0316628001

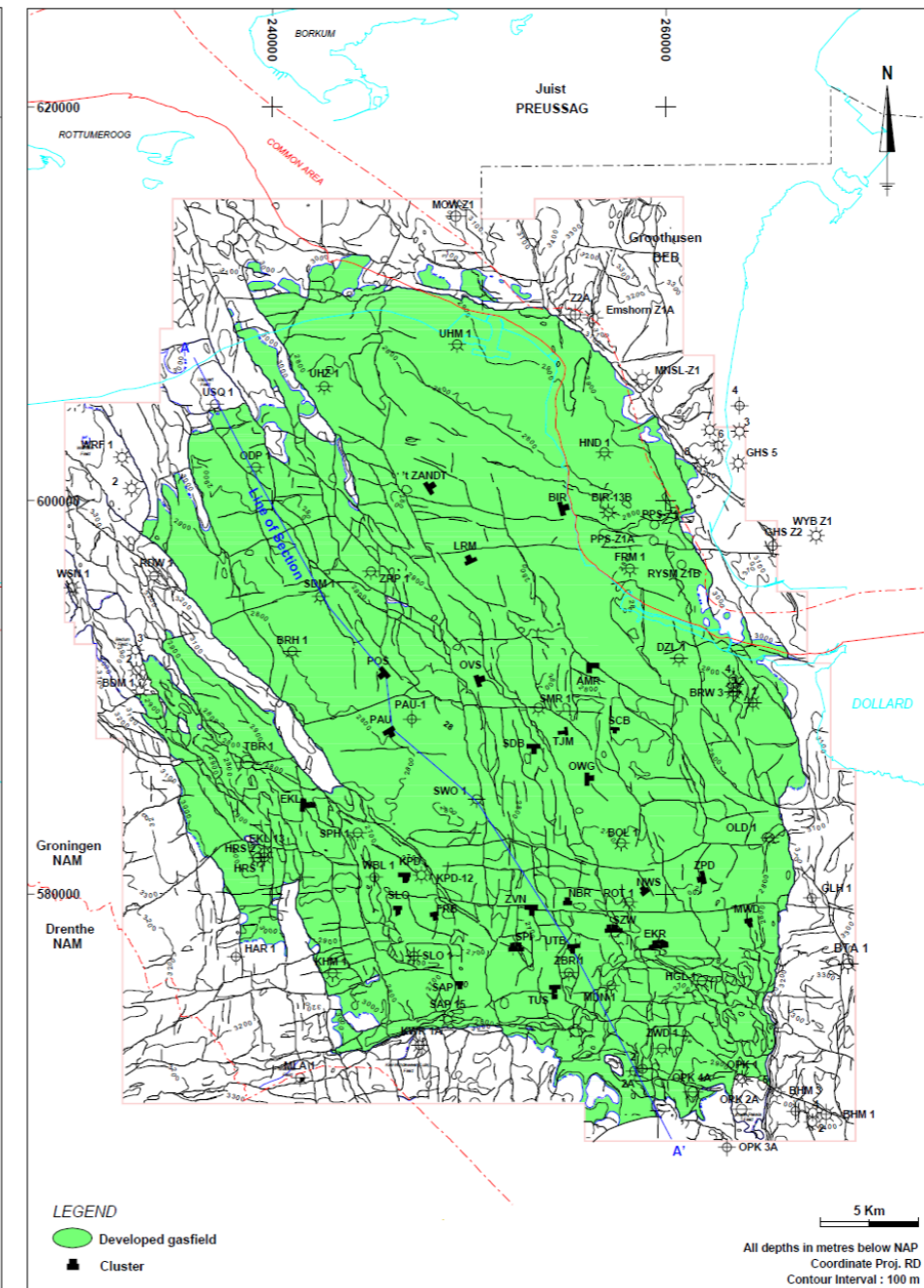

**Top Rotliegend Depth Contour Map
 Groningen**
 Scale 1 : 250 000
 NEDERLANDSE AARDOLIE MIJ. B.V | Project: ARPR | Author: ELG-DVC | Date: Mar. 2006 | Drw.Nr: 0317608002

(Structure map of Groningen gas field, NLOG Dutch Subsurface Portal)
 The Groningen field was discovered in 1959 and at that time turned out to be the largest natural gas field in the world.

Nearly 600 damage reports filed after Groningen earthquake

November 15, 2025



A village flag hanging next to Zeerijp's church. Photo: ANP / Hollandse Hoogte / Huisman Media

Almost 600 people have now reported damage to their property following Friday's earthquake in Groningen, according to the institute which monitors quake-related events. The total now stands at 593, up from 246 on Friday.

Groningen residents still feel powerless regarding earthquake measures

UG researchers: those who have been hit hardest are losing faith

08 November 2018

Gas extraction activity causes damage to the land and people. The Dutch government decided to permanently cease production in 2024

Groningen hit by second strongest earthquake in the province

November 14, 2025



A damaged cafe in Zeerijp. F

Parts of Groningen province in the early hours of natural gas.

Netherlands passes law to permanently shut Groningen gas field

The closure of the Groningen gas field is effective from 1 October 2024.

April 17, 2024

Share <



Normal gas production at the Groningen field ceased in October 2023. Credit: LiteHeavy/ Shutterstock.com.



ONS NIJ BEGUN MAKEN WE SAMEN

The Dutch government implemented a 30-year plan to build a better future for the regions of Groningen and North Drenthe. €150 million are invested in education, €180 million for commercial activities; and € 200 million for touristic and leisure activities.

Spending by tourists rose to over €111 billion in 2024

03/09/2025 06:30



© Hollandse Hoogte / Paulien van de Loo



the province of Groningen recorded the highest increase in overnight visitors in NL (2024)



ambition to increase visitor annually



increase needed to meet the goal

Holiday guests in the Netherlands, 2024*

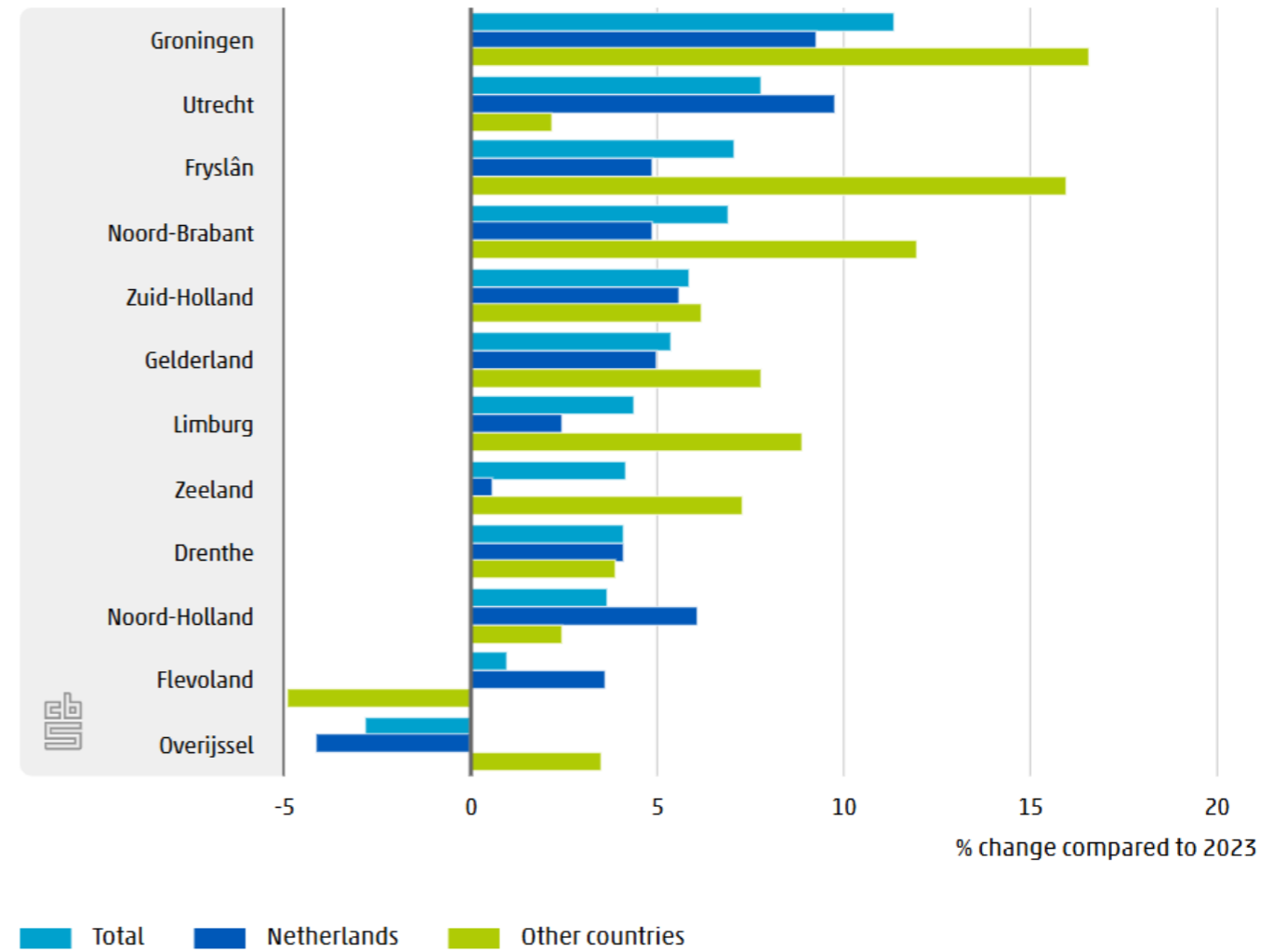

Tourism is a major driver of the Dutch economy, accounted for 4.0% of the national GDP. To fulfill the goal of the Nij Begun Agenda, the number of stays has to be doubled.



00_INTRODUCTION
01_CONTEXT
02_METHOD
03_RESULT

HOW ARCHITECTURE CAN CONTRIBUTE TO THE REGENERATION OF ECONOMICALLY AND SOCIALLY MARGINALISED AREAS?



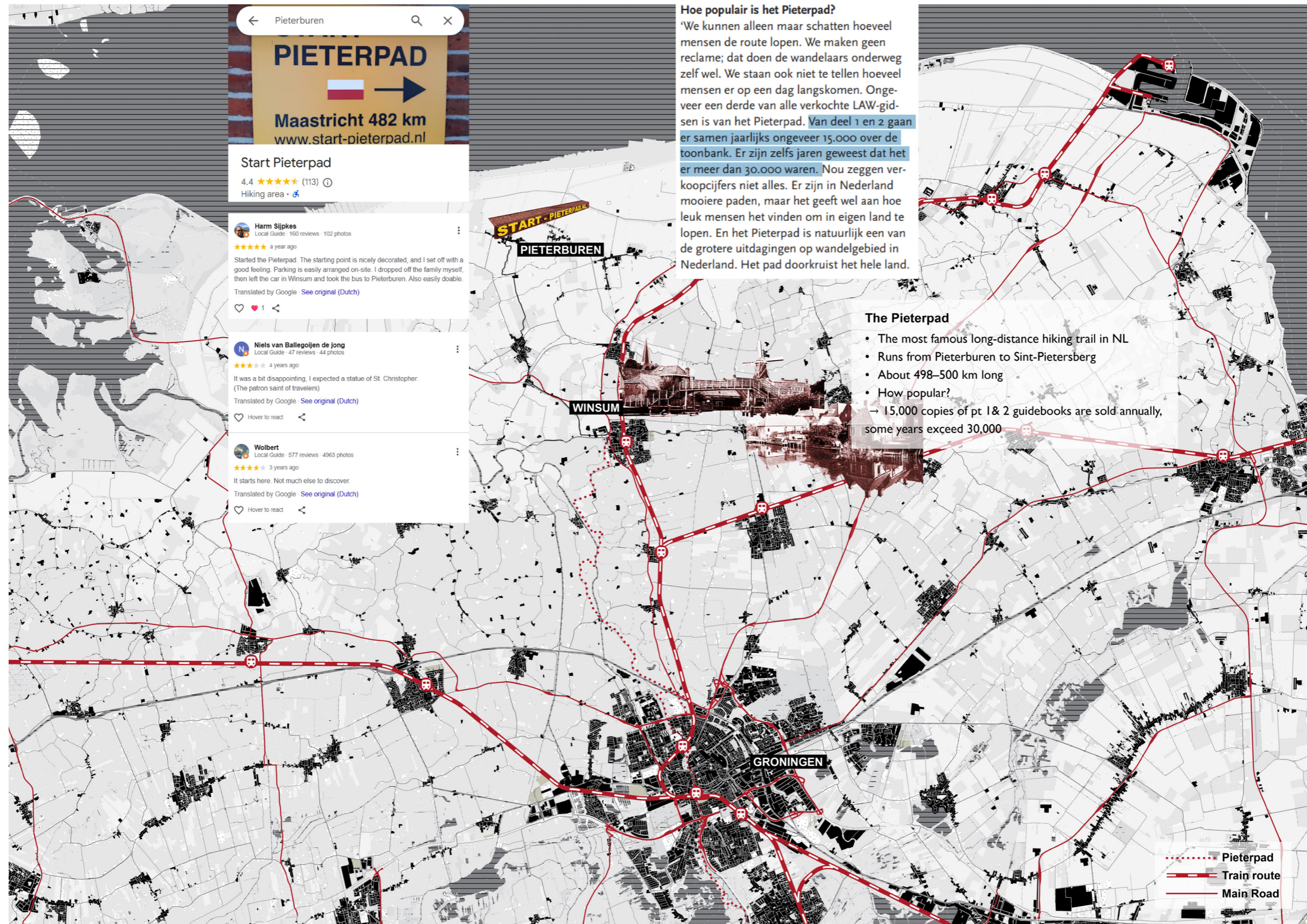

ABOUT WINSUM

SOCIAL IDENTITY

Most Beautiful Village in the Netherlands (ANWB)



Nature and Serenity



CULTURAL IDENTITY

Dominican Monastery History



Ship Building History along Winsumerdiep



SPATIAL IDENTITY

Winsum Bricks



Mighty Mills



WINSUM'S IDENTITY SHOULD BE PRESERVED AND ENHANCED

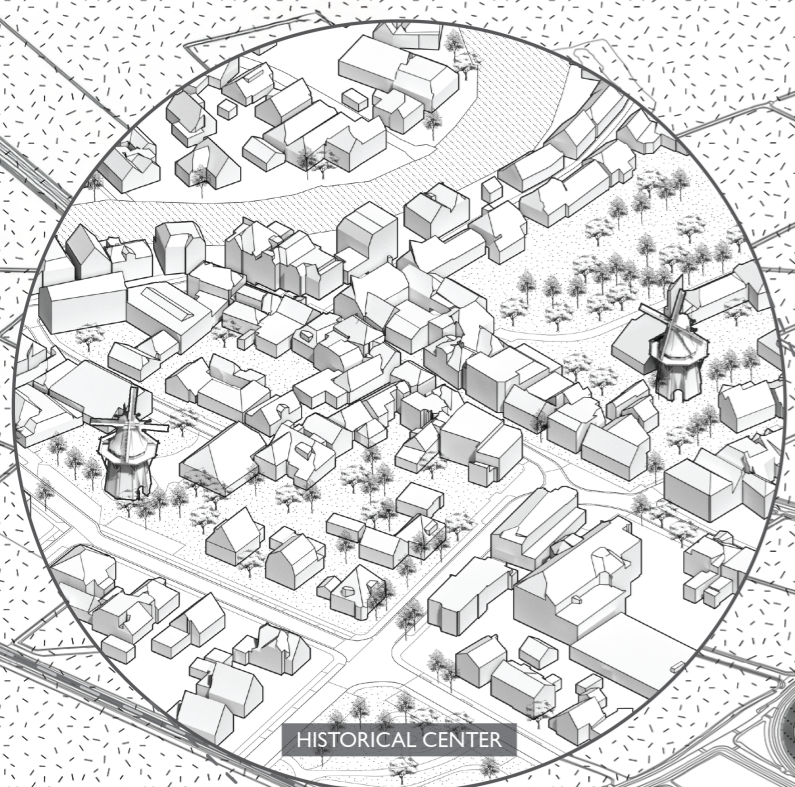

HISTORICAL CENTER



NEW DEVELOPMENT AREA

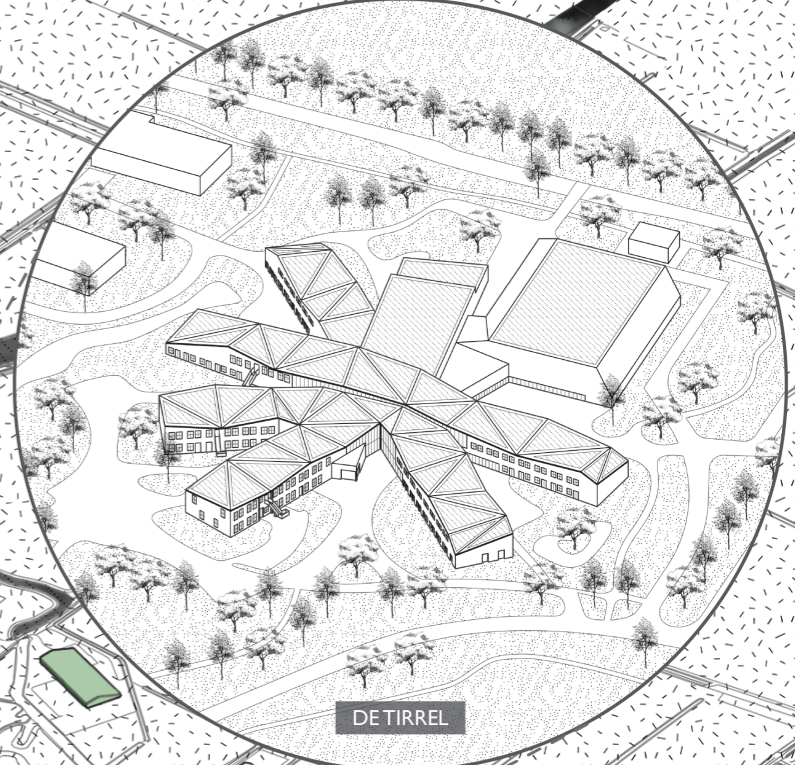

DE TIRREL

The center lies around the old village cores of Winsum and Obergum, which were originally two separate settlements. It is characterized by historic churches, traditional Groningen houses, canals, and old streets such as Kerkstraat and Hoofdstraat.

De Tirrel is a multifunctional community centre. It houses two primary schools, childcare, elderly care housing, sports hall, theatre, library spaces, and meeting areas, and is designed to encourage interaction between generations and strengthen community life in Winsum.



LEGEND

URBAN DEVELOPMENT

| | | | |
|------------|------------------|---------|------------------|
| 1836 | 1970 | 1995 | PRESENT |
| COMMERCIAL | SPORTS & LEISURE | SCHOOLS | HISTORICAL SITES |
| INDUSTRIAL | | | |



MARENLAND

Marenland offers hotel rooms, camping and camper pitches, group accommodations, and leisure facilities. It's known for hosting tourists, school camps, sports groups, and events in a green, waterside setting near the village.

- Marenland
- A Reception
 - B Winaumerdiep
 - C Kiosk
 - D Storage
 - E Playground
 - F Canoe Shed/ Meeting Room
 - G Restaurant
 - H Toilet
 - I Launderette
 - J Portable Toilet
 - K Water Station
 - L Tent
 - M Bicycle Shed
 - N Boat and Canal Rental

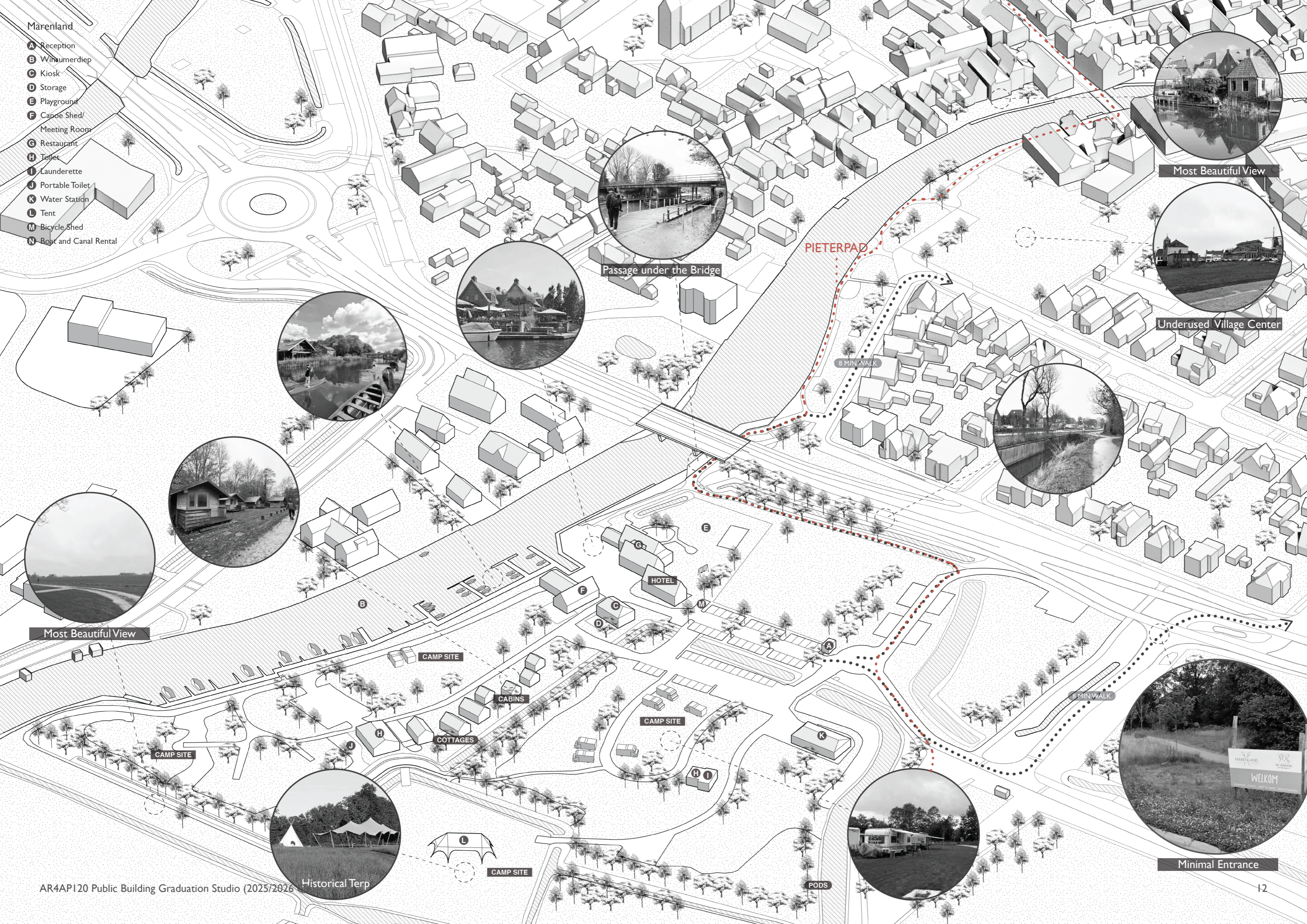

Passage under the Bridge



Most Beautiful View



Underused Village Center



Most Beautiful View



Minimal Entrance



Historical Terp



PODS

Marenland

- A 00 INTRODUCTION
- B 01 CONTEXT
- C Kiosks WHERE
- D Storage HOW
- E Playground WHO
- F Campsite Shed/ Meeting Room 02 METHOD
- G 03 RESULT
- H Toilet
- I
- J
- K
- L
- M
- N

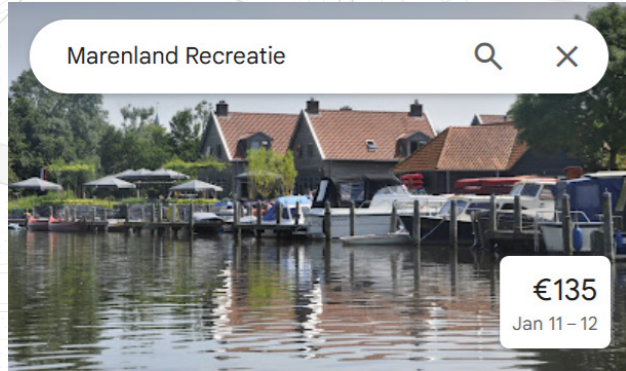

Marenland Recreatie

4.4 ★★★★★ (571) · Campground · 📍

Overview Prices Reviews About

4/5 5 months ago on Google
 Beautiful campsite, situated on the water. The pitches aren't particularly spacious, but perfectly manageable. The sanitary facilities are kept spotlessly clean. You're asked to park your car in the parking lot, so the fields are car-free, which creates a pleasant atmosphere. Friendly staff. Close to Winsum, a charming village where the friendliness is particularly noticeable for people from the Randstad, like us. Thanks to the cycling network that practically passes the campsite, we can enjoy countless cycling trips in the beautiful surroundings.

We paid extra for a waterfront pitch, but upon arrival, this turned out to mean a pitch right on the water. The downside is that there's a wall of campers between you and the water.

4/5 8 months ago on Google
 Beautiful, spacious campsite. Located at the Winsum marina. The camper pitches are not very spacious, but the view of the water more than makes up for it. I wouldn't like places less close to the water. Little shade. The dog is welcome.
 What I found special is that many people walk past who I don't think are at the campsite but, for example, have rented a canoe or eaten in the nearby restaurant.

4/5 2 years ago on Google
 Beautiful location on the Winsumerdiep canal. Good restaurant on the campsite with a lovely terrace by the water. Very friendly staff.
 When all the pitches on the campsite are occupied, some are quite close together. We also found the path quite narrow in some places, making it difficult to drive the caravan to the pitch without damage. This isn't a problem in the newer part of the campsite.
 We find it a shame that, across the entire length of the site, there are only campervan pitches at the front of the harbor. This means that caravans and tents are never pitched by the water, but always behind a row of campervans.



00_INTRODUCTION

01_CONTEXT

 _WHERE

 _HOW

 _WHO

02_METHOD

03_RESULT

HOW DO WE REVITALISE WINSUM?

TOURISM

RISK OF OVERTOURISM

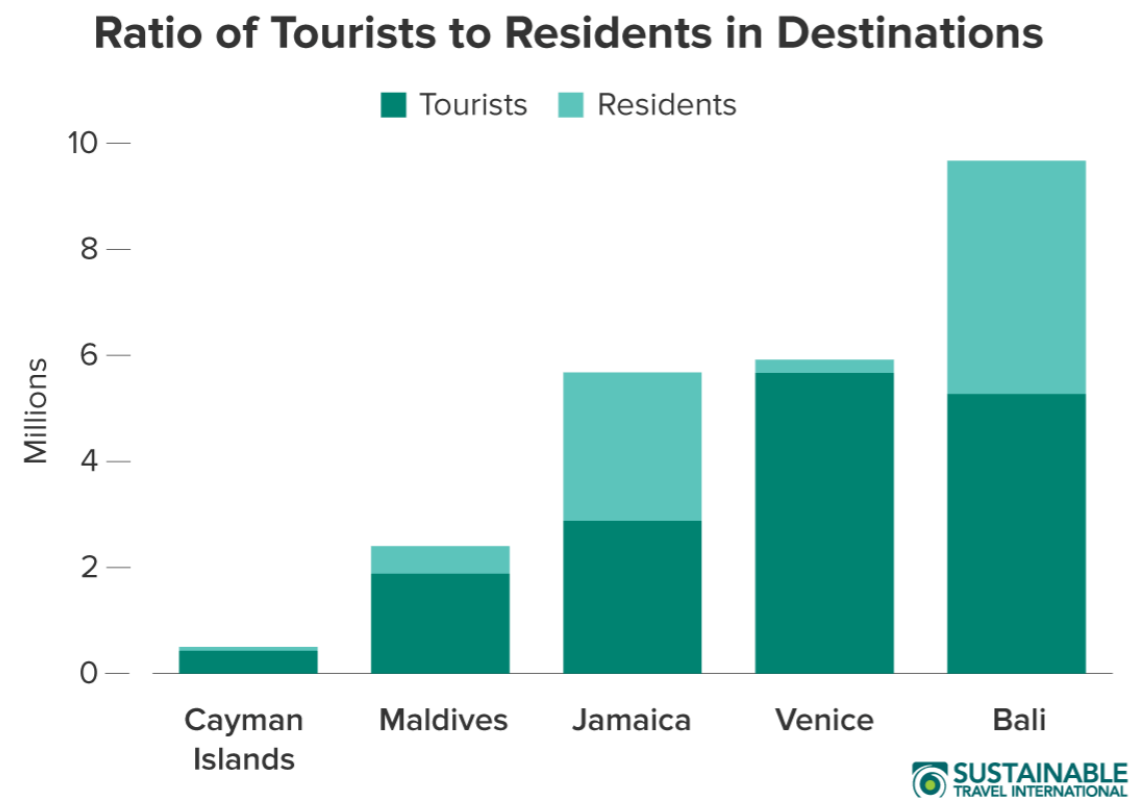

In many tourist hotspots, tourists far outnumber residents, making residents feel marginalized and as though their community is losing its identity and being transformed into a tourist attraction rather than a place to live.



Millions of tourists visit Venice annually, placing it at the forefront of overtourism headlines.

RISK OF OVERTOURISM

INTERVIEW WITH A WINSUMMER - OWNER OF MARENLAND



It is the only campsite and “hotel” in Winsum

- » Average amount of stay: 1.8 days
- » Visitors: Pieterpad walkers, elderlies
- » Tourists activities: Watersports, Camping,
Winsum a base for explorations in the surroundings
- » Peak Period: Summer and Weekends
- » Campsite only operates in Summer and Spring
(April 1st to October 1st)

Tourism in Winsum peaked during covid

- » insufficient capacity for large amount of tourists
- » Winsumers were frustrated with the overtourism

00_INTRODUCTION
01_CONTEXT
 _WHERE
 _HOW
 _WHO
02_METHOD
03_RESULT

PARADOX: MORE TOURISM BUT NOT TOO MUCH

00_INTRODUCTION

01_CONTEXT

 _WHERE

 _HOW

 _WHO

02_METHOD

03_RESULT

HOW DO WE REVITALISE WINSUM?

TOURISM

00_INTRODUCTION

01_CONTEXT

—WHERE

—HOW

—WHO

02_METHOD

03_RESULT

HOW DO WE REVITALISE WINSUM?

—TOURISM—

CURATED TOURISM

DESIGN AMBITIONS

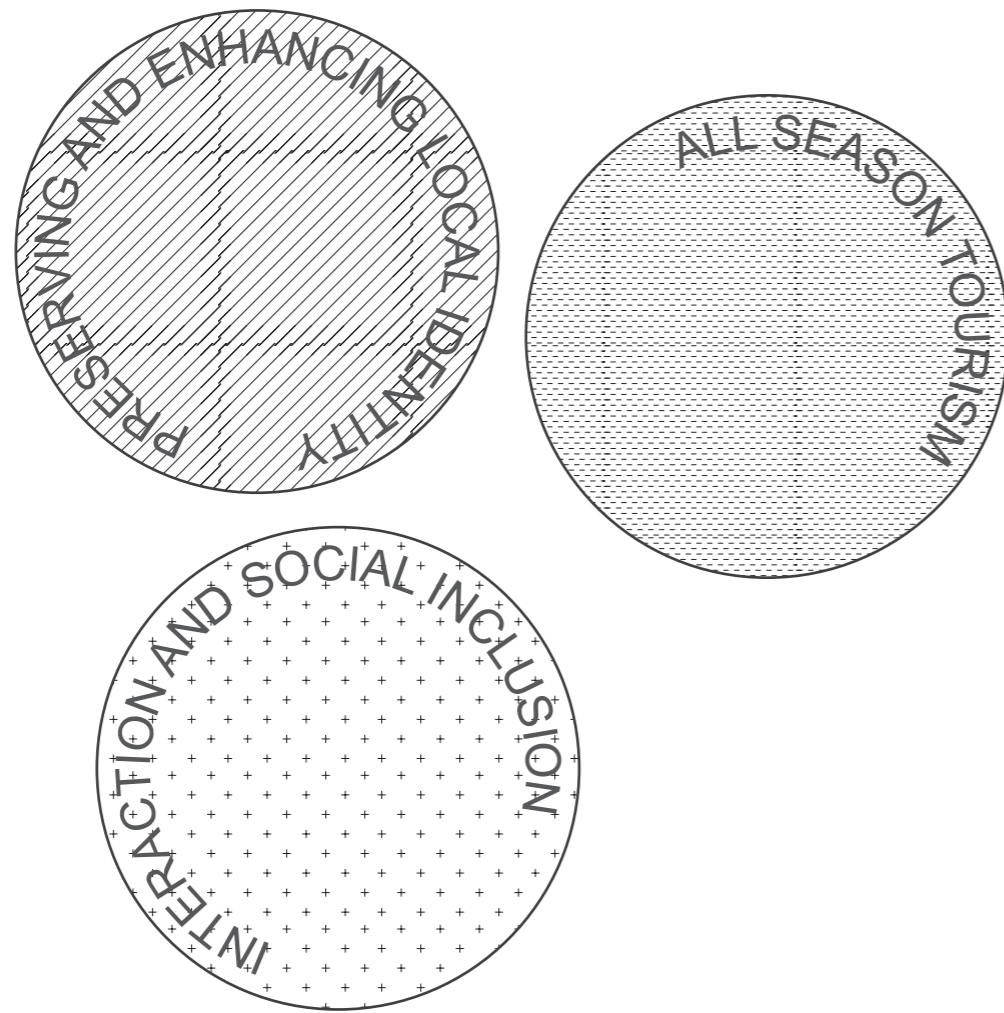

Doubling visits by distributing tourism across all seasons

DESIGN AMBITIONS

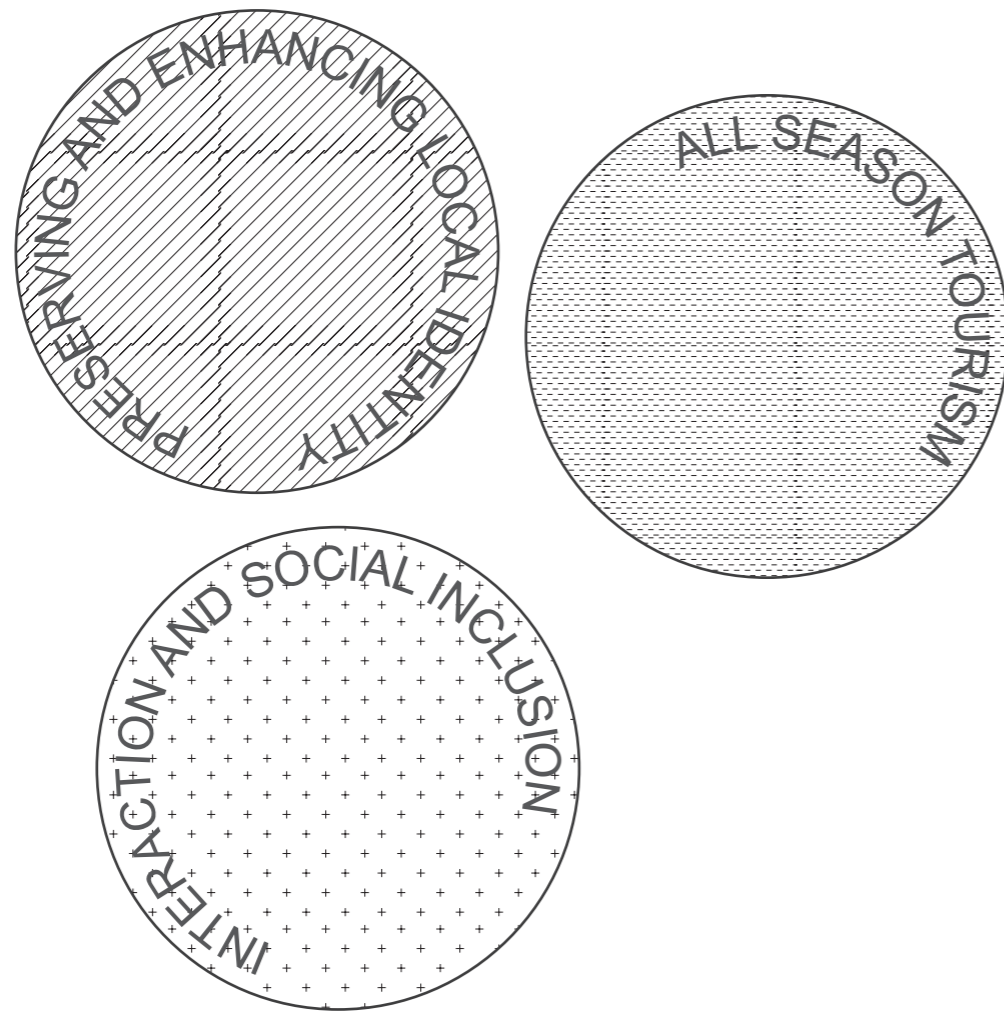

WINTERWOODS POP-UP CAMPING

OVERDAG ONTDEK JE DE BOSSEN VAN DRENTHE EN IN DE AVOND GENIET JE VAN HET KAMPVUUR OF STOOK JE DE HOUTKACHEL OP IN JE EIGEN TRADITIONELE YURT.

Vanaf €195 p.p. 16 oktober 2026 t/m 21 maart 2027

INCLUSIEF

- Je eigen traditionele yurt
- Met kachel & knusse inrichting
- Forest sauna & hottub
- Activiteiten in de natuur
- Panorama en stretchtent met gezellige opwarming

Preregistreer voor 2026/2027



Winterwoods Drenthe



Doubling visits by distributing tourism across all seasons

DESIGN AMBITIONS

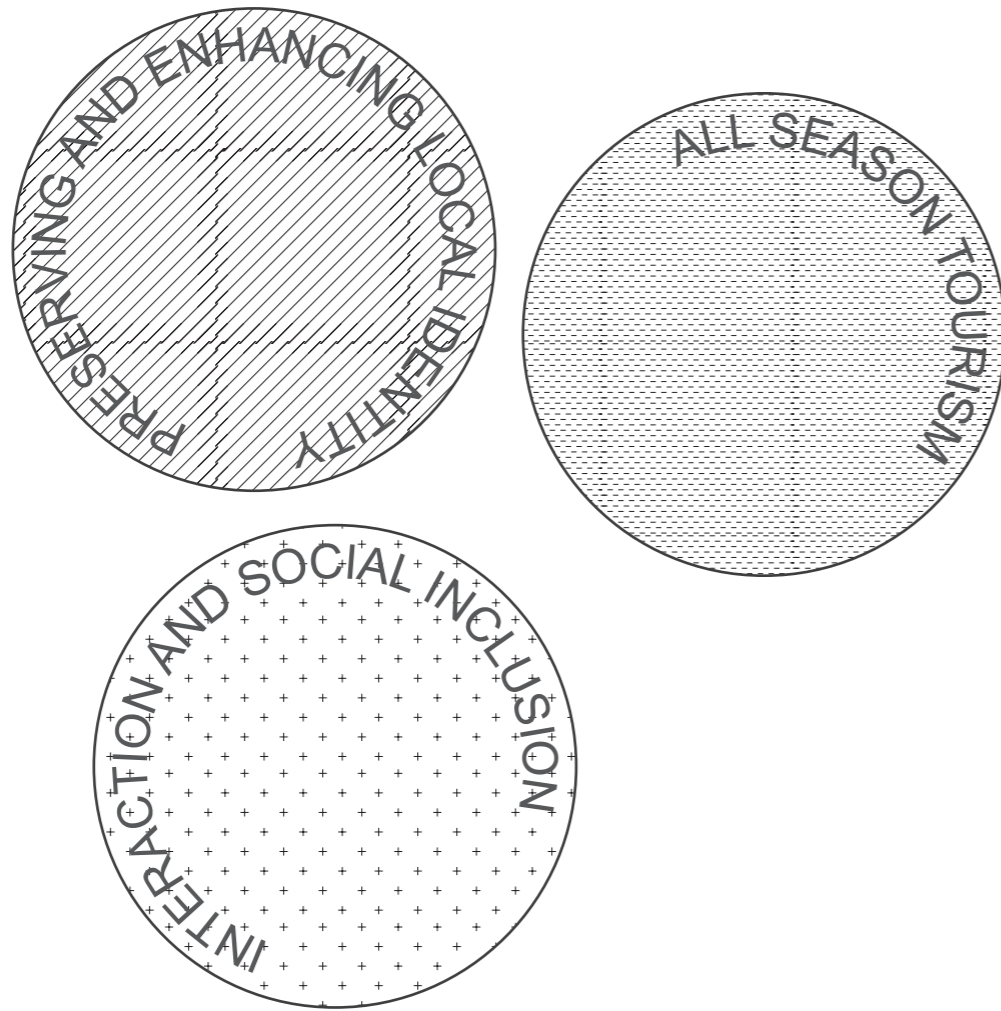

| | | |
|--|--|---|
| | <p>3/4 person hotel room ★ 9.4 • Fantastic (162 reviews)</p> <p>Large modern room with two box beds, with a comfortable dining and seating area. The sofa bed can be used for an extra guest.</p> <p>🛏 4 📏 +/- 28 m² 🚿</p> | <p>from €127.75 ✓ Incl. surcharges 📅 31-05-2026 → 01-06-2026</p> <p>Book now</p> |
| | <p>Campsite ★ 9.2 • Fantastic (365 reviews)</p> <p>Spacious pitches for caravans, tents, or folding trailers with electricity, close to the sanitary building, sunny or shady pitches.</p> <p>🛏 6 📏</p> | |
| | <p>Camper pitch ★ 9.2 • Fantastic (510 reviews)</p> <p>Spacious, paved camper pitches, with the possibility of a view of the water or the beautiful Groningen landscape. Exclusively for campers and cars with a roof tent.</p> <p>🛏 6 📏 +/- 54 m² 📏</p> | |
| | <p>Trekking tent ★ 9.2 • Fantastic (72 reviews)</p> <p>Camping with a trekking tent on our hiker's field.</p> <p>🛏 2 📏</p> | |
| | <p>Scandinavian Cottage ★ 9.2 • Fantastic (36 reviews)</p> <p>Tastefully furnished cozy cottage for four people. With 4 sleeping places spread over 2 bedrooms, and a kitchen, bathroom, and living room, it is a pleasant place to stay in...</p> <p>🛏 4 📏 +/- 35 m² 🚿</p> | <p>from €480.25 ✓ Incl. surcharges 📅 29-05-2026 → 01-06-2026</p> <p>Book now</p> |
| | <p>Scandinavian Chalet ★ 9.6 • Fantastic (9 reviews)</p> <p>A beautiful chalet that is fully equipped and has a lovely (private) terrace.</p> <p>🛏 4 📏</p> | <p>from €480.25 ✓ Incl. surcharges 📅 05-06-2026 → 08-06-2026</p> <p>Book now</p> |
| | <p>Hiker's cabin ★ 9.2 • Fantastic (122 reviews)</p> <p>A cozy, simple cabin with two bunk beds on our green campsite. This way, you can wake up in the morning right by the water.</p> <p>🛏 4 📏 +/- 9 m² 📏</p> | <p>from €104.25 ✓ Incl. surcharges 📅 29-05-2026 → 30-05-2026</p> <p>Book now</p> |
| | <p>Retro camping ★ 8.6 • Excellent (2 reviews)</p> <p>Romantic camping Don't own a camper or caravan, but still want to go camping? This is your chance!</p> <p>🛏 2 📏</p> | <p>from €104.25 ✓ Incl. surcharges 📅 29-05-2026 → 30-05-2026</p> <p>Book now</p> |

Doubling visits by distributing tourism across all seasons

DESIGN AMBITIONS

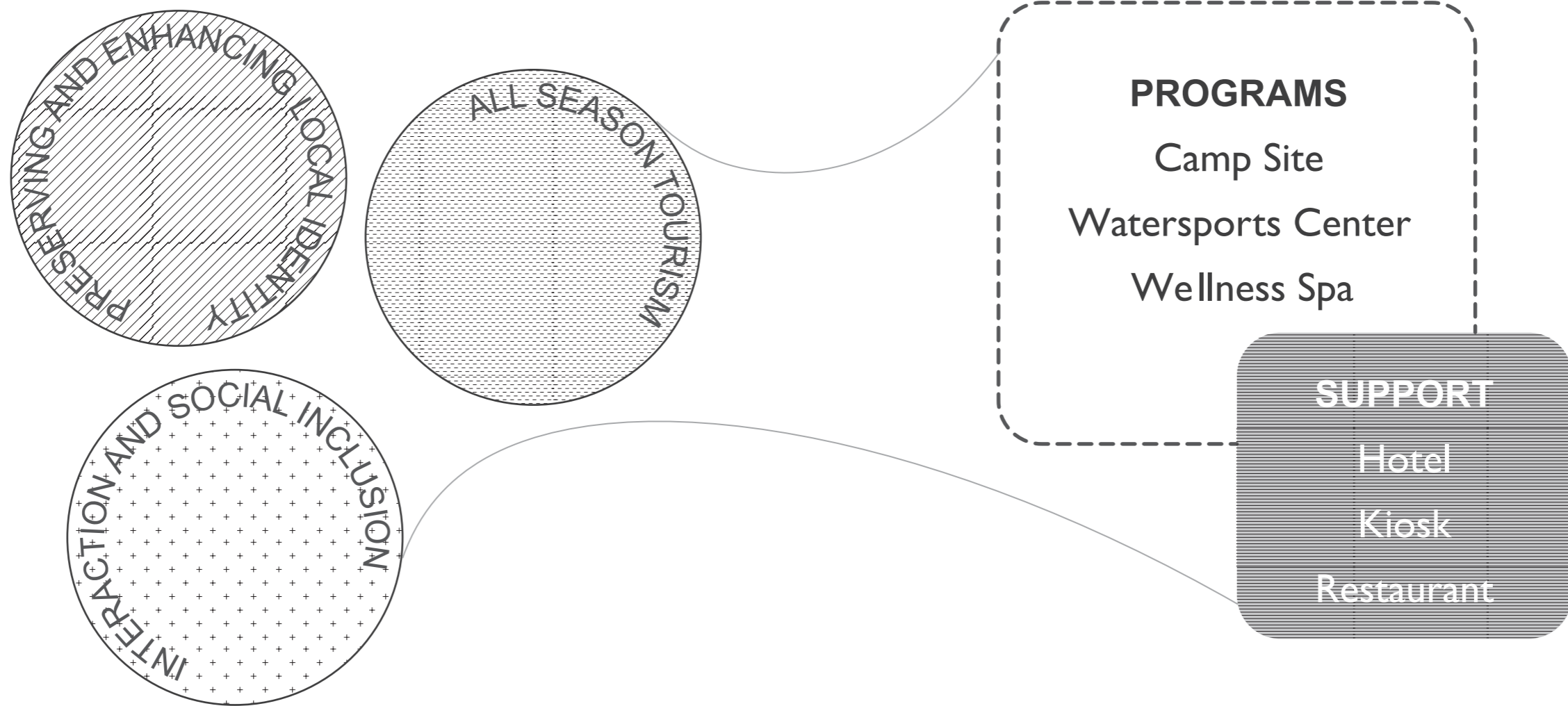

Doubling visits by distributing tourism across all seasons

00_INTRODUCTION
01_CONTEXT
 _WHERE
 _HOW
 _WHO
02_METHOD
03_RESULT

How can architecture act as a medium to DISSOLVE BOUNDARIES
between Tourists and Locals, Public and Private functions, and the Natural and Built Environment?

EXISTING CAMPING GROUP

- nature outdoor activities
- social atmosphere
- more children and crowd

CAMPERS

outdoor enthusiasts &
campervan travelers



HIKERS/ CYCLISTS

active outdoor enthusiasts
pieterpad walkers



FAMILIES

parents with children



FRIEND GROUPS

social & fun getaways

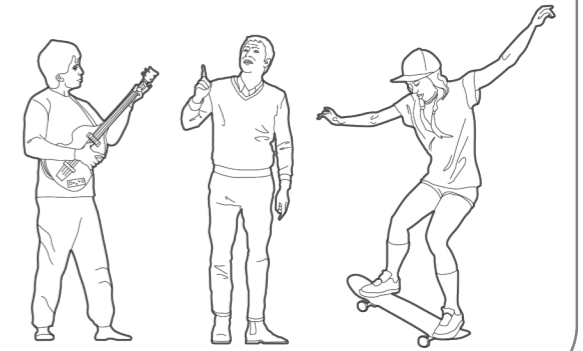

EXISTING CAMPING GROUP

- nature outdoor activities
- social atmosphere
- more children and crowd

CAMPERS

outdoor enthusiasts &
campervan travelers



HIKERS/ CYCLISTS

active outdoor enthusiasts
pieterpad walkers



FAMILIES

parents with children



FRIEND GROUPS

social & fun getaways

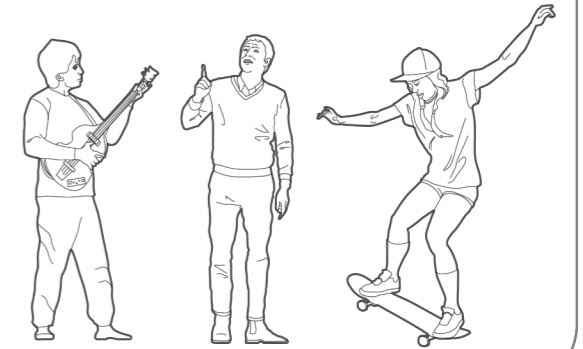

URBAN PROFESSIONALS

remote workers &
city escapers



COUPLES

romantic
getaways



WELLNESS TRAVELERS

wellness &
relaxation seekers



NEW CAMPING GROUP

- cozy and comfortable atmosphere
- relies heavier on infrastructure
- curated experience

EXISTING CAMPING GROUP

- nature outdoor activities
- social atmosphere
- more children and crowd

CAMPERS

outdoor enthusiasts &
campervan travelers



HIKERS/ CYCLISTS

active outdoor enthusiasts
pieterpad walkers



FAMILIES

parents with children



FRIEND GROUPS

social & fun getaways

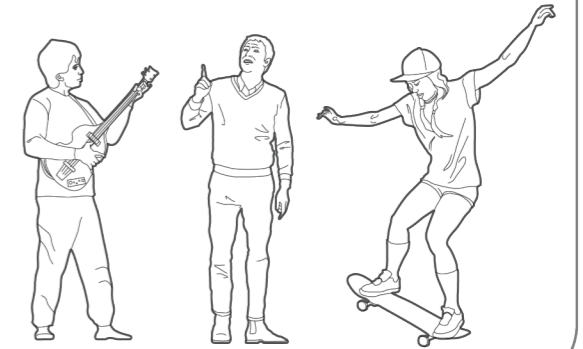

URBAN PROFESSIONALS

remote workers &
city escapers



COUPLES

romantic
getaways



WELLNESS TRAVELERS

wellness &
relaxation seekers



LOCALS

marenland turns into
a public place for all

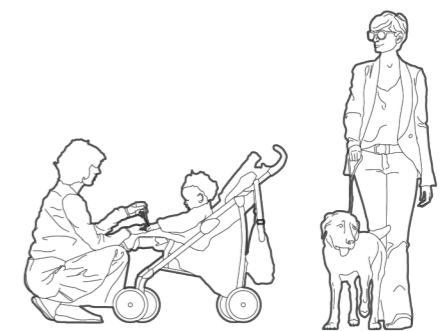

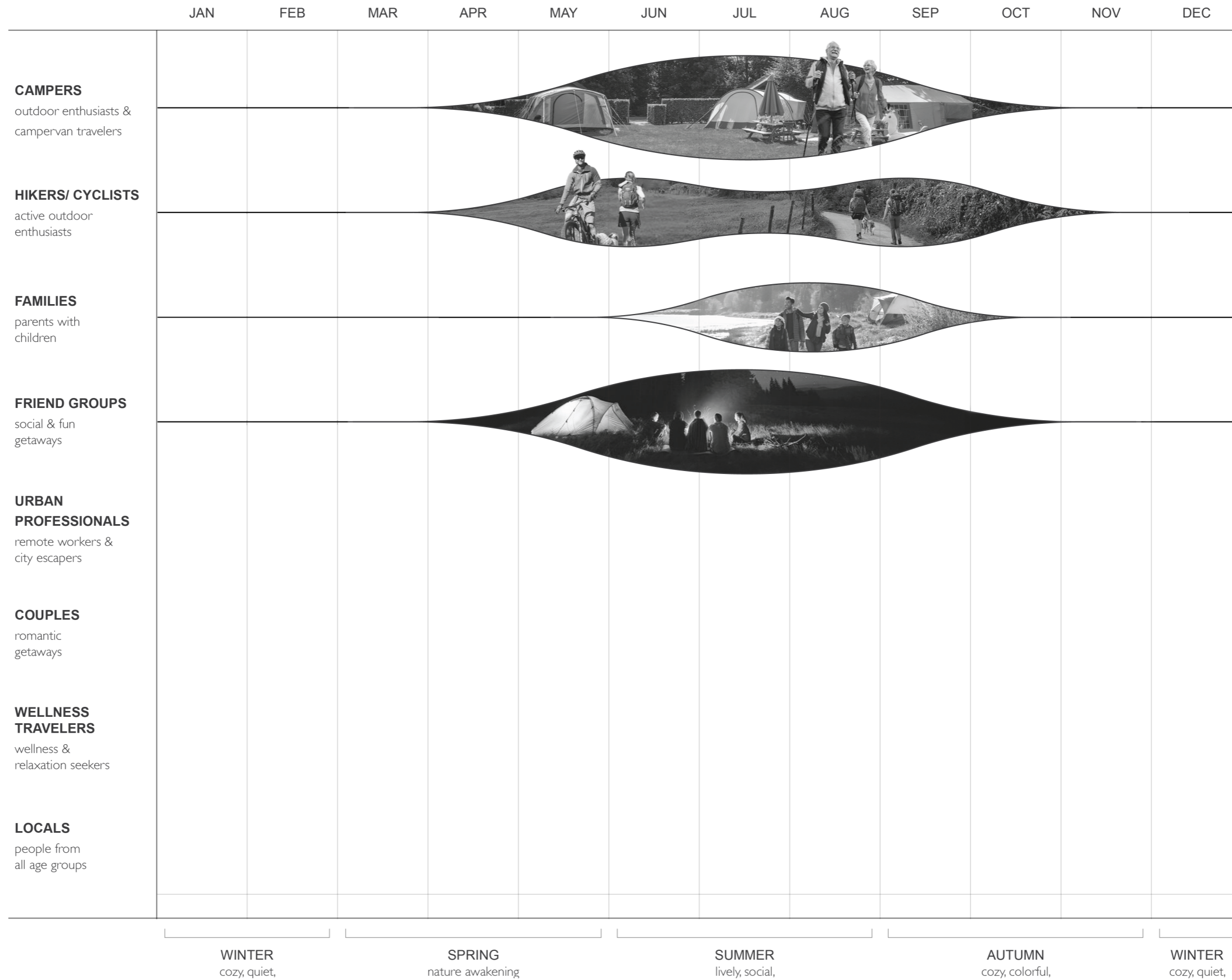



WHERE WATER CONNECTS



RIETDIEP

WHERE WATER CONNECTS



EXISTING VALUE

WHERE WATER CONNECTS



EXISTING VALUE + WINTER VALUE

CASE STUDIES



Aarhus Harbor Bath / BIG



Copenhagen Harbor Bath / BIG



Canoeing training center MOSM in Tychy / RS+ Robert Skitek

EXPERIMENTAL SKETCHES

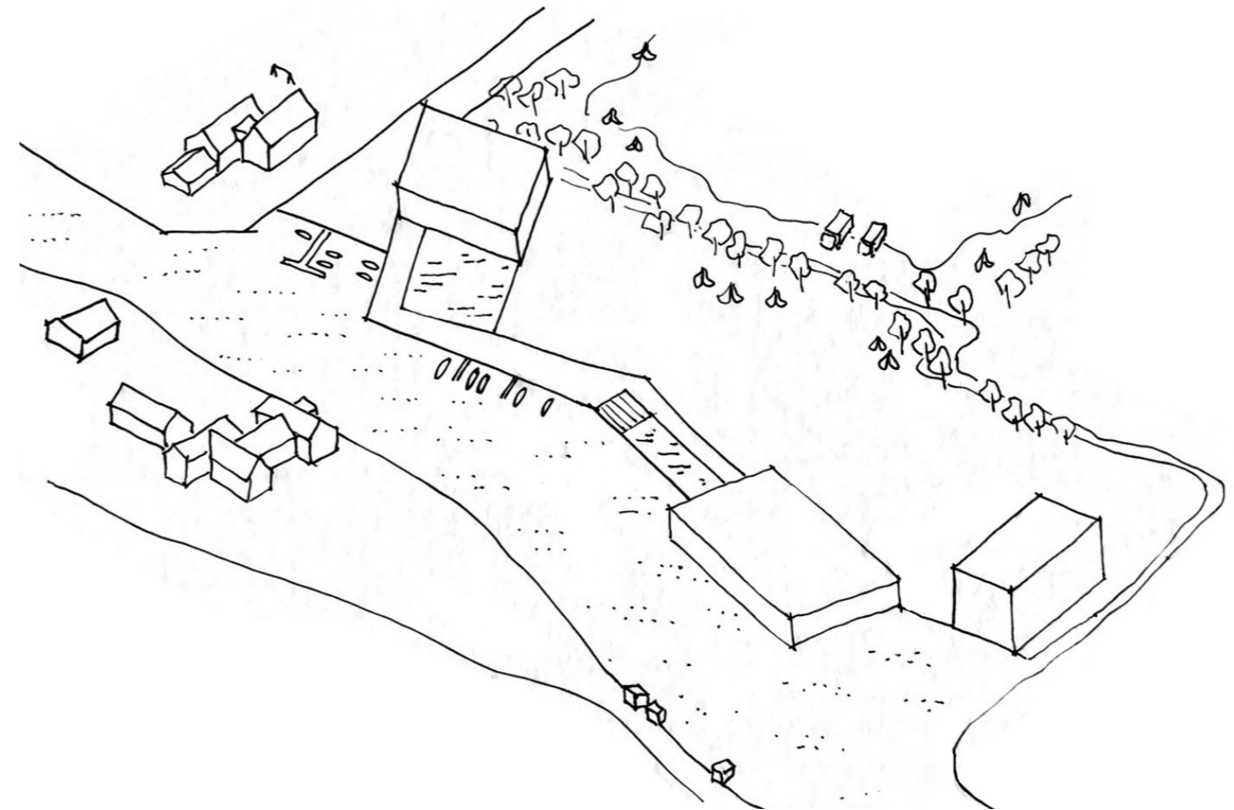
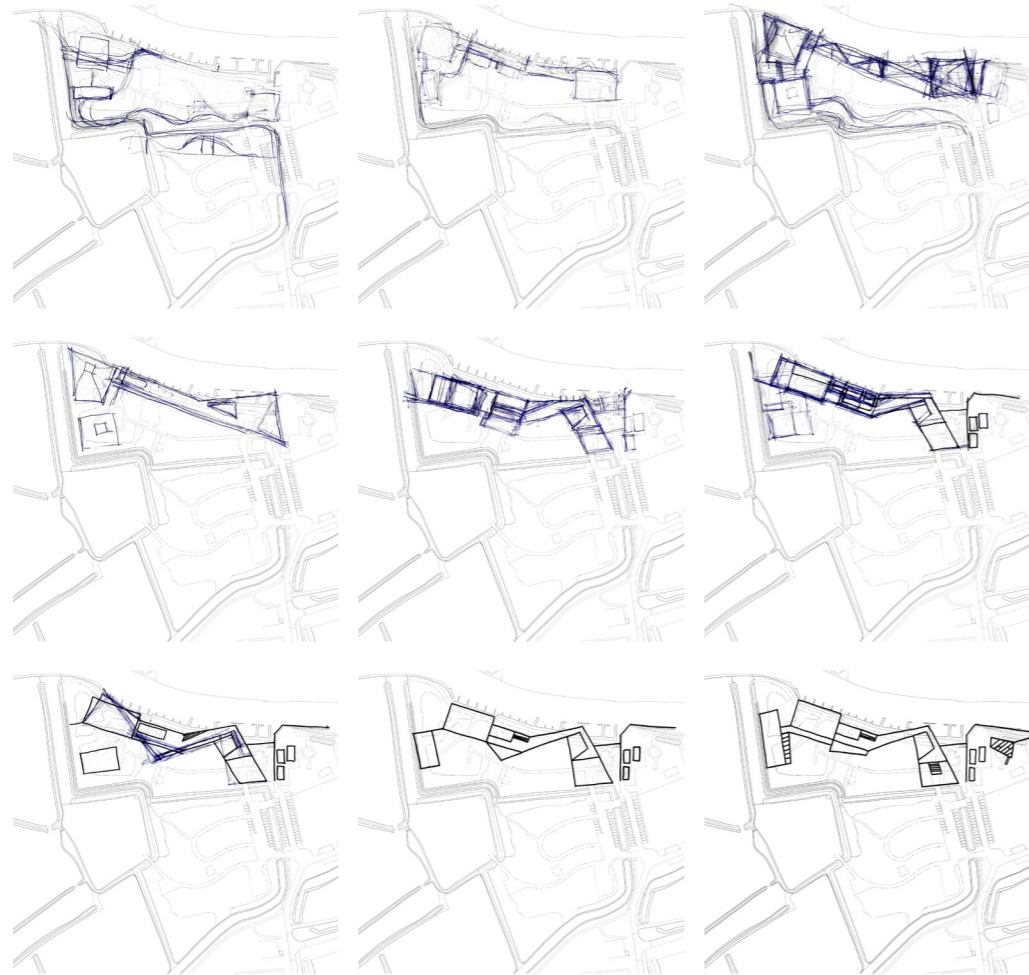

EXPERIMENTAL SKETCHES

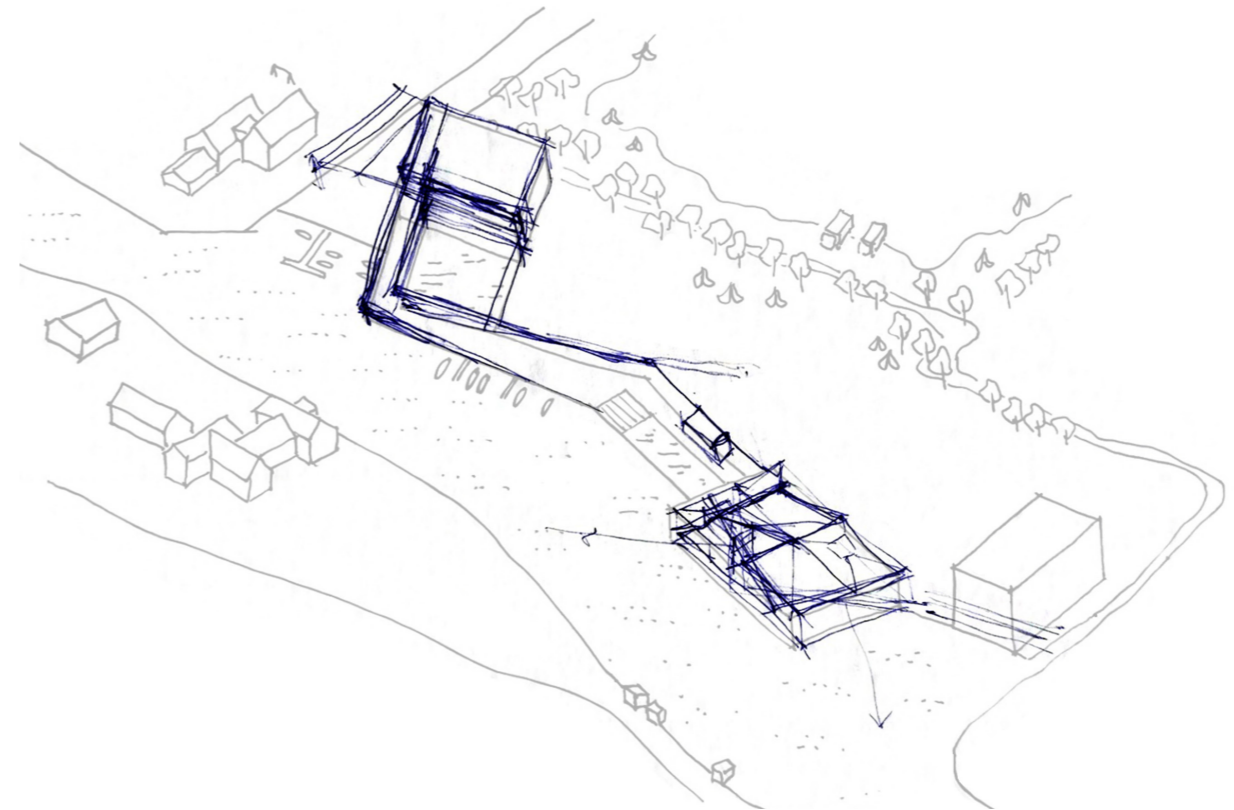
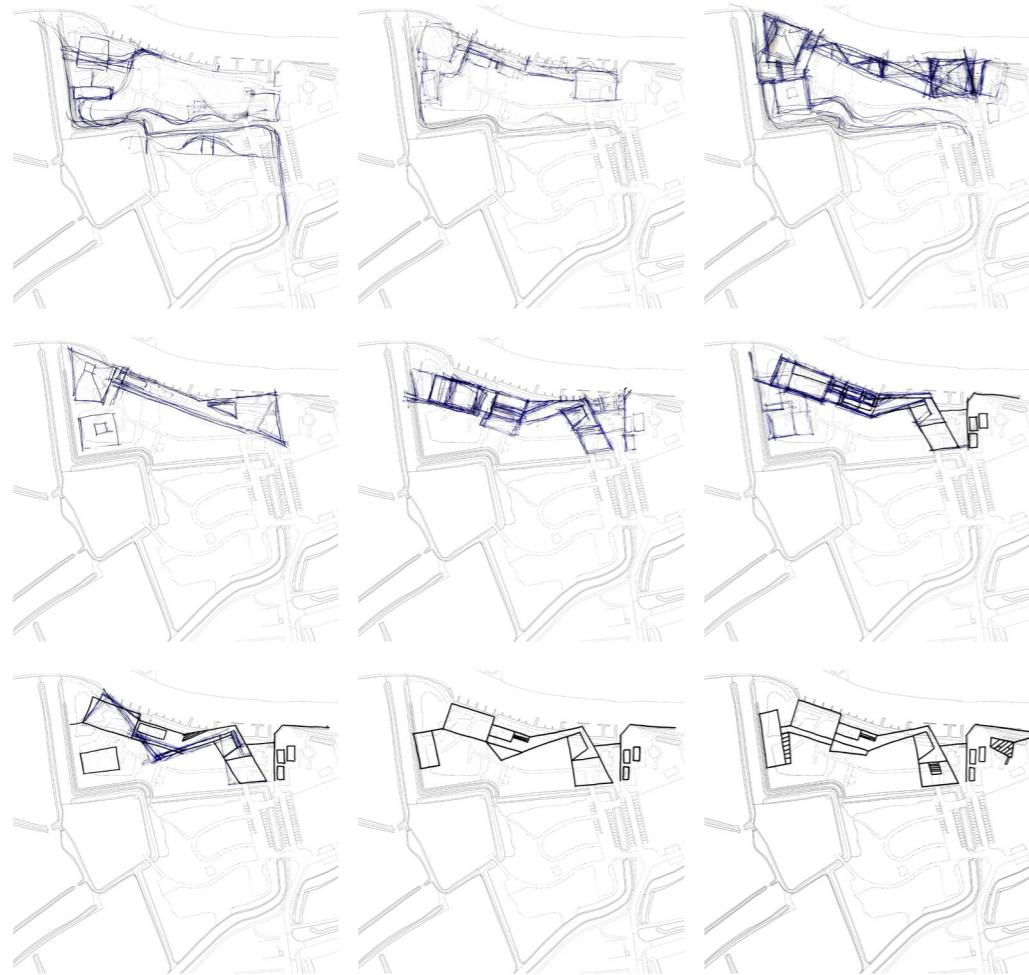

EXPERIMENTAL SKETCHES

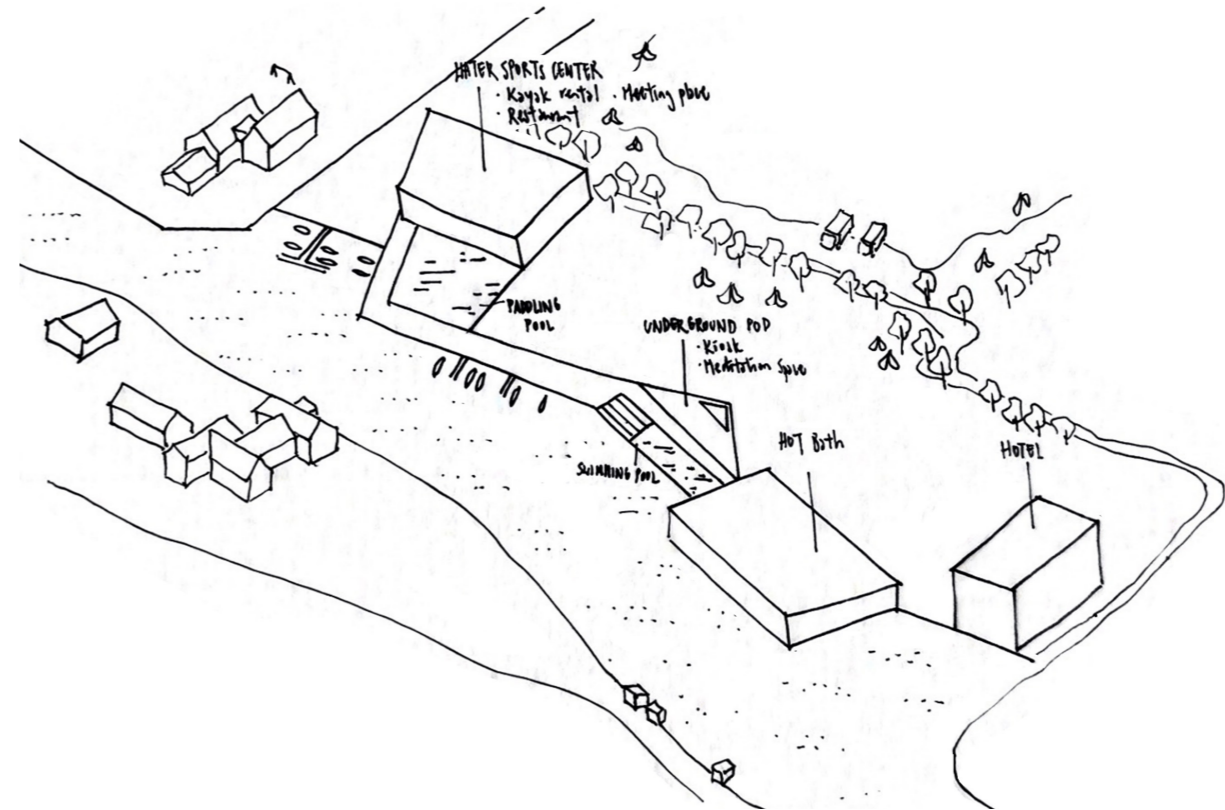
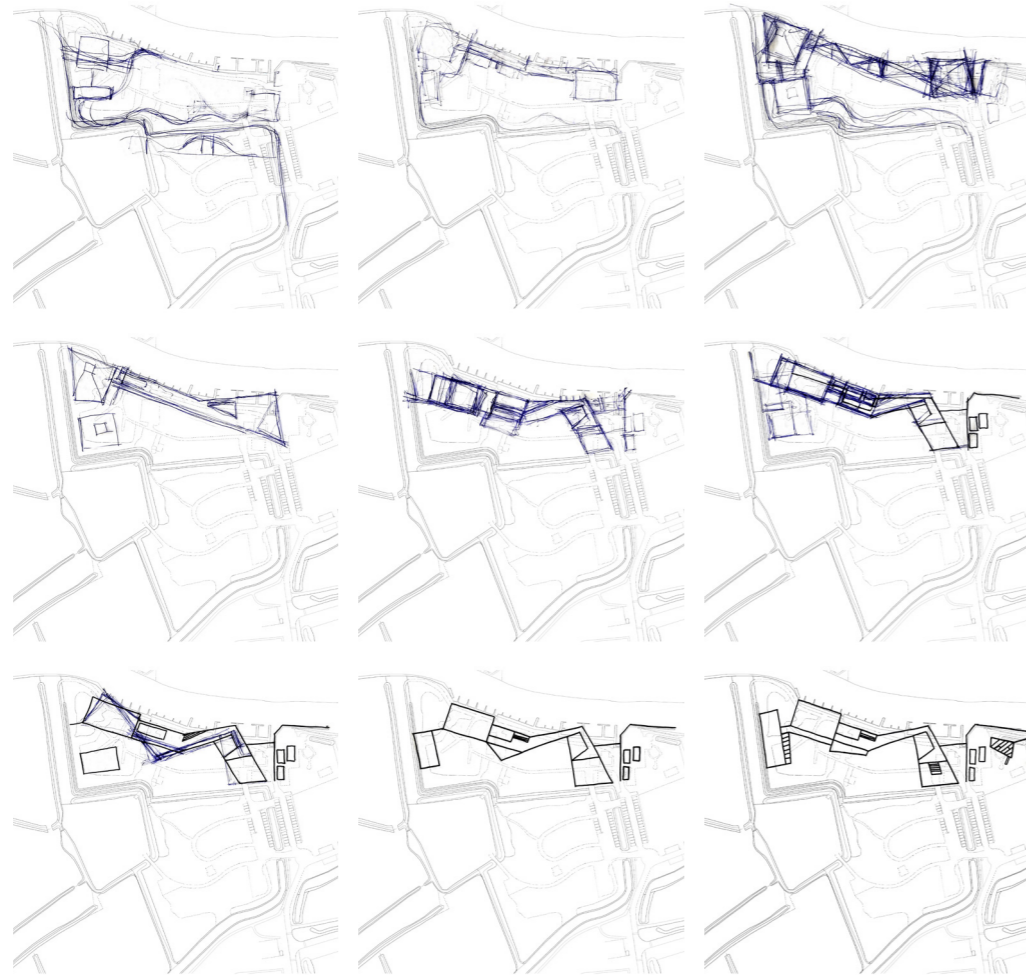

EXPERIMENTAL SKETCHES

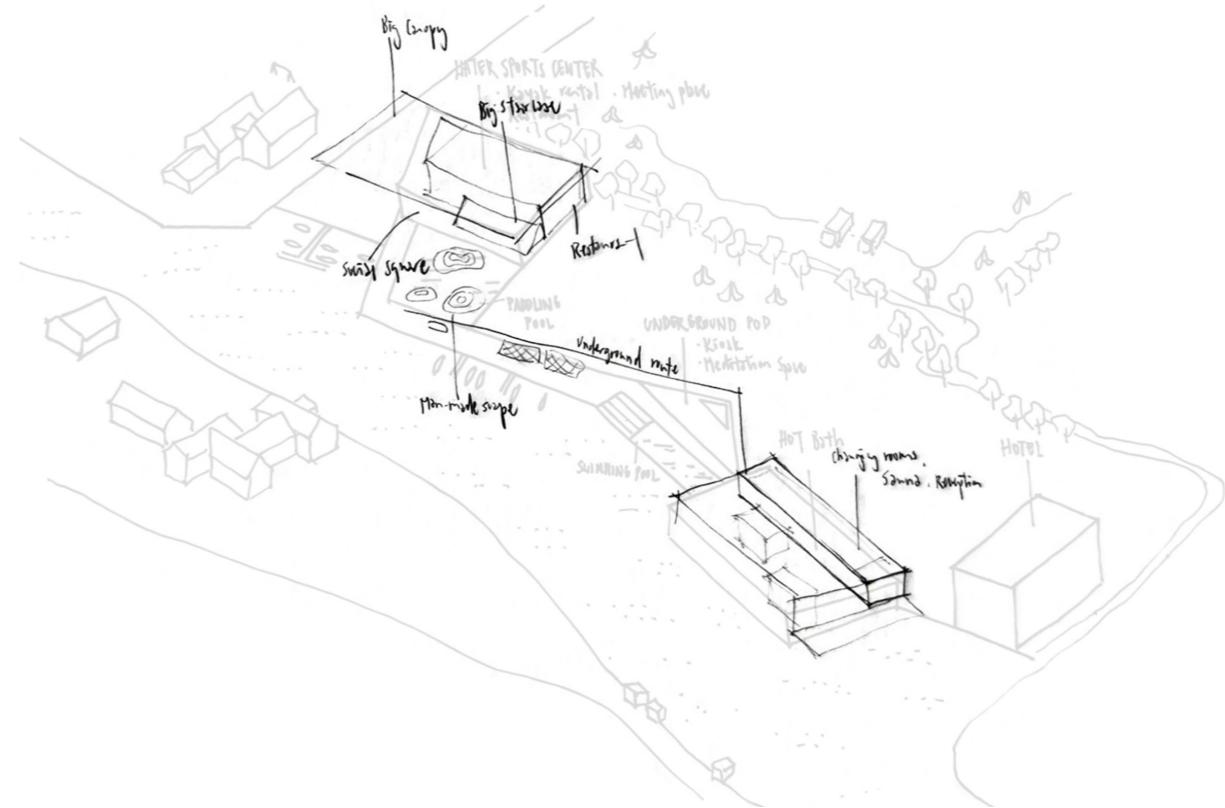
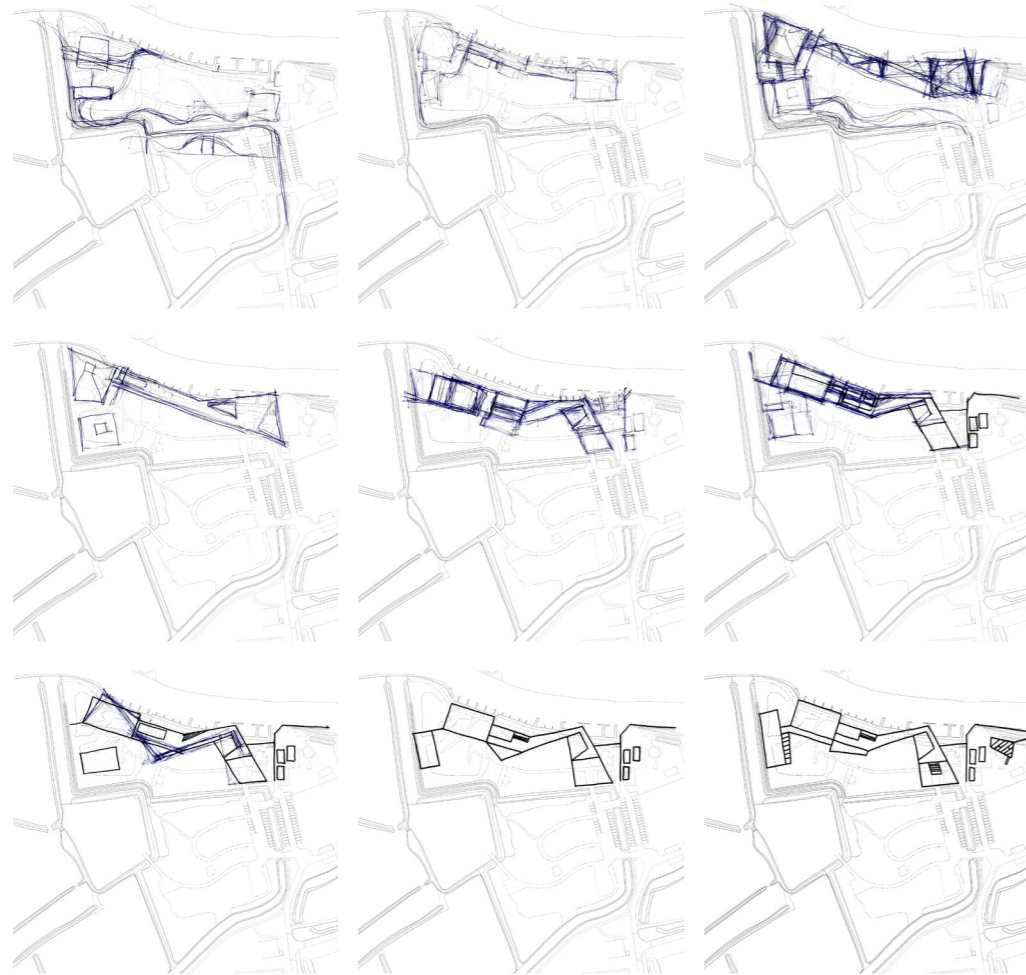

EXPERIMENTAL SKETCHES

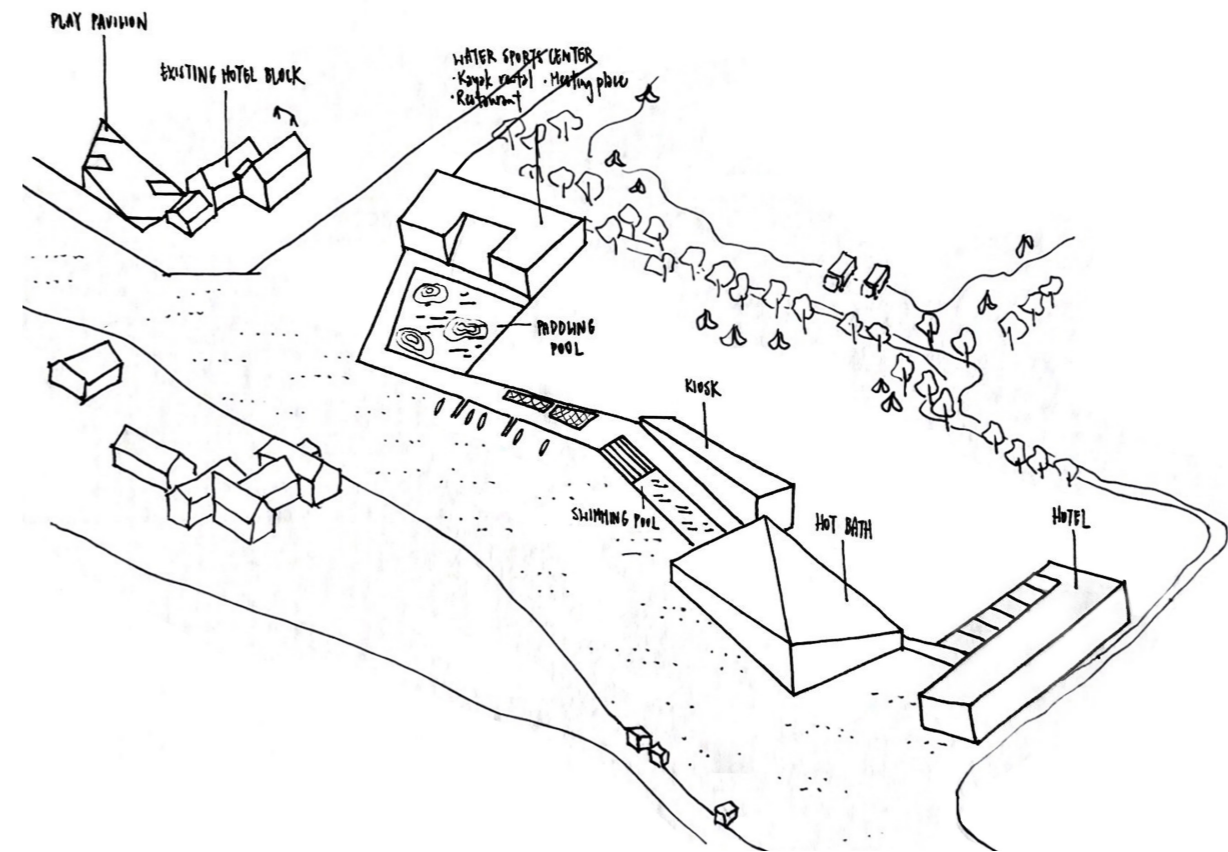
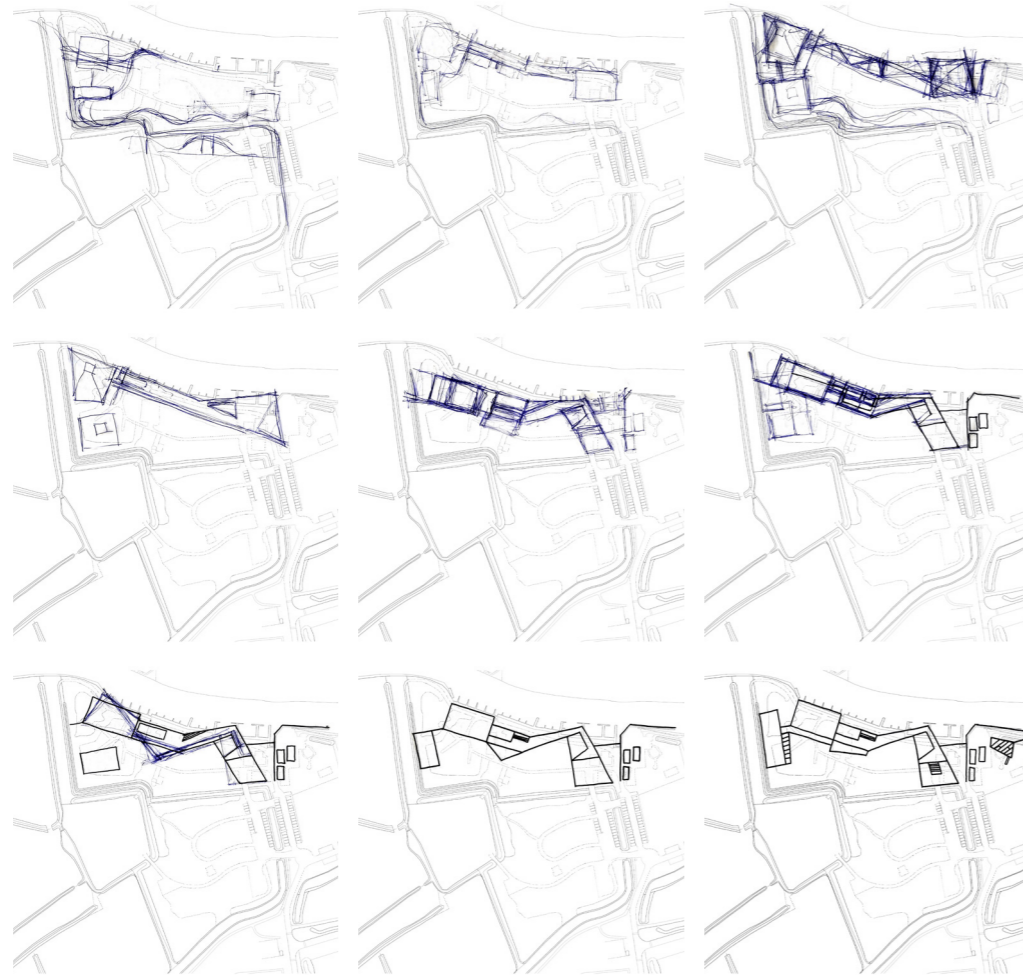

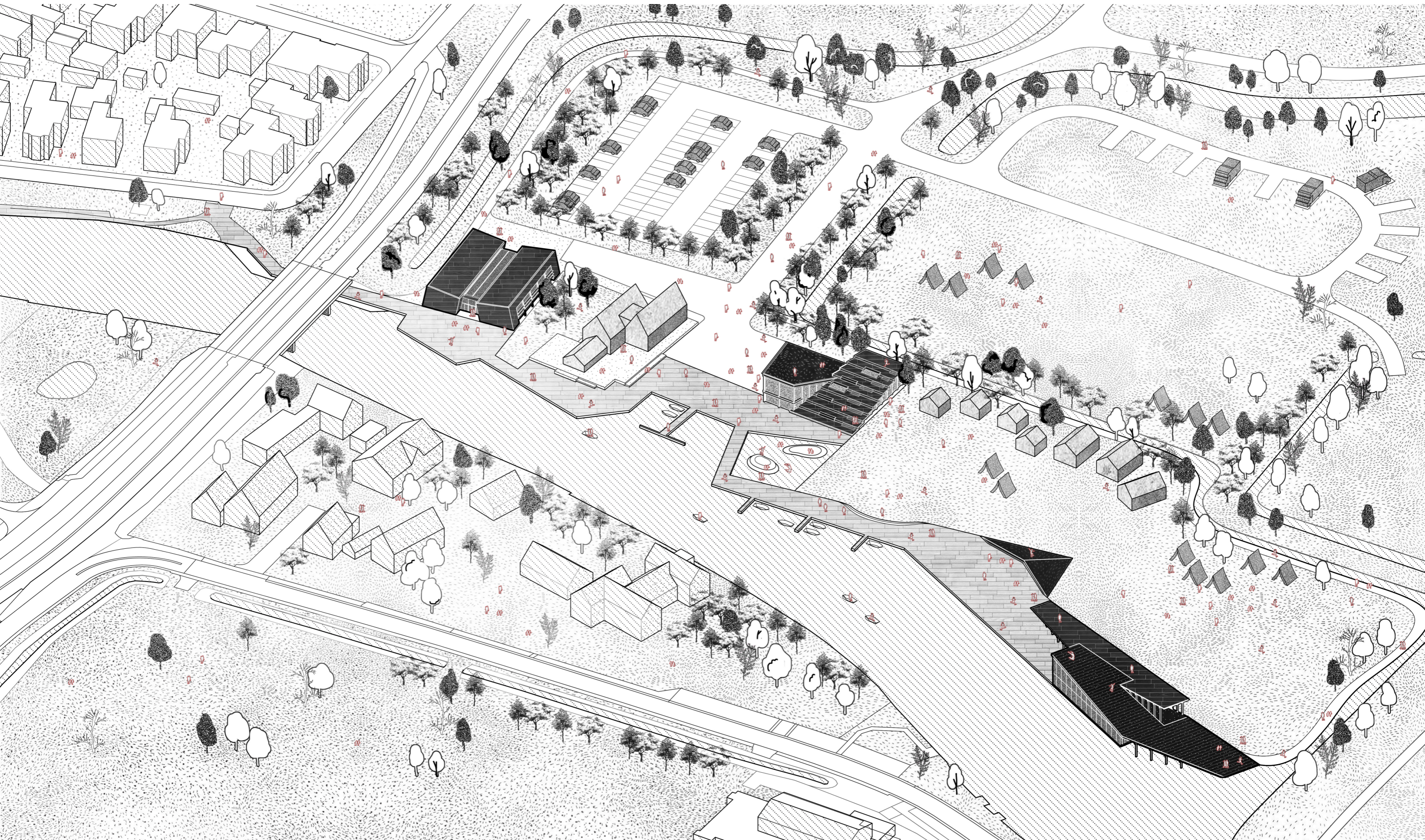

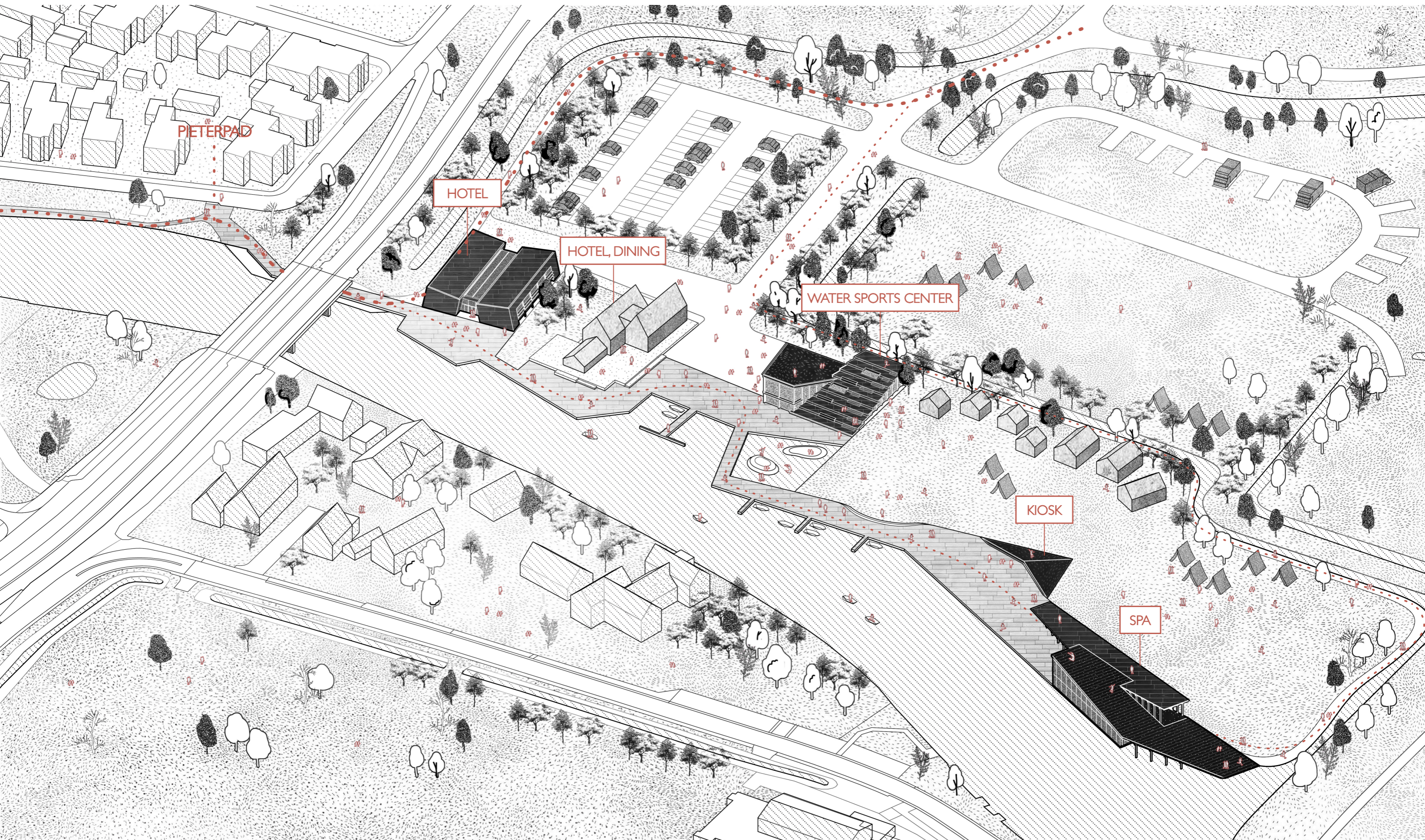

DESIGN STRATEGIES

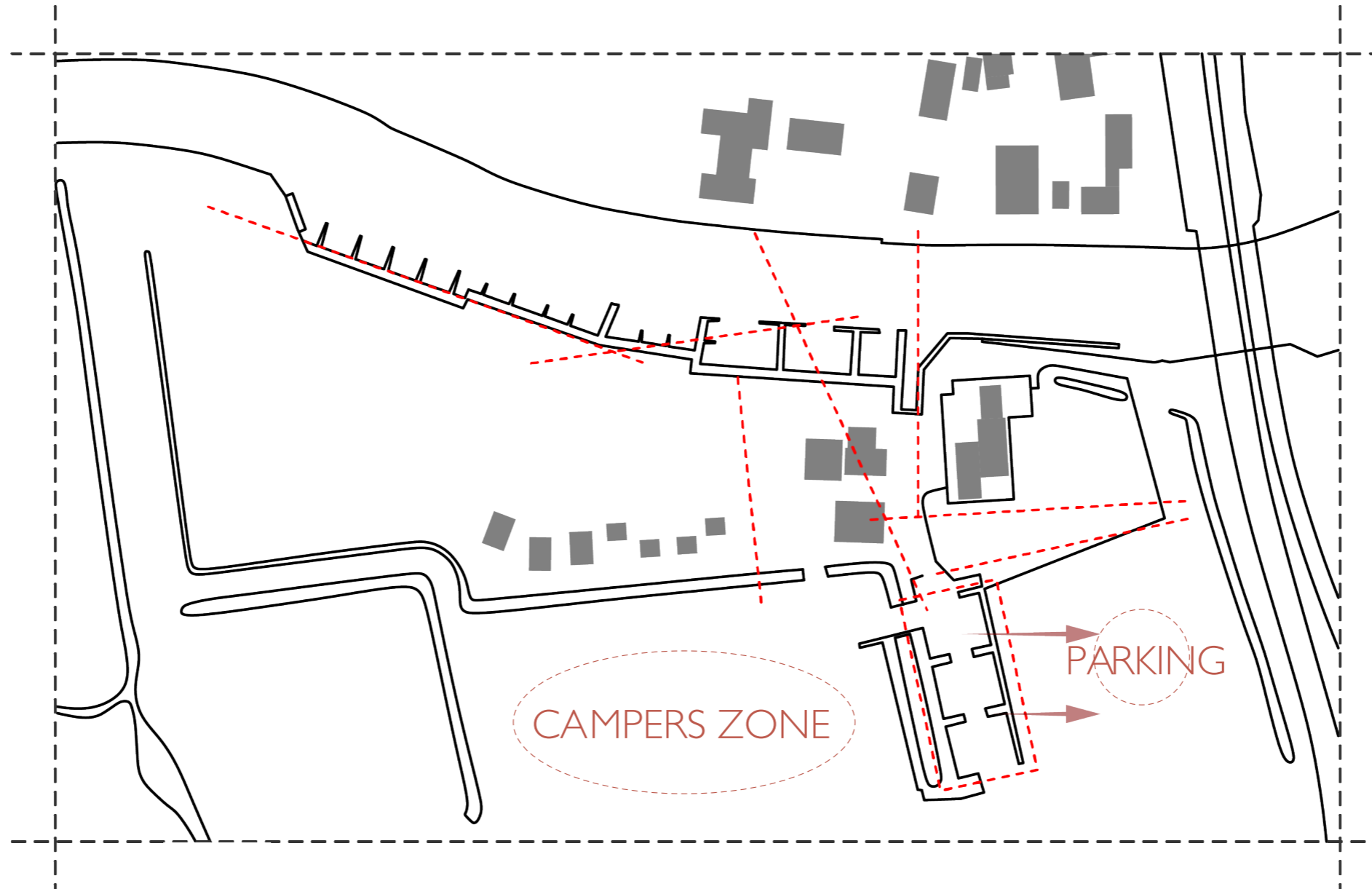

Relocating and Centralising Vehicle Zones

DESIGN STRATEGIES

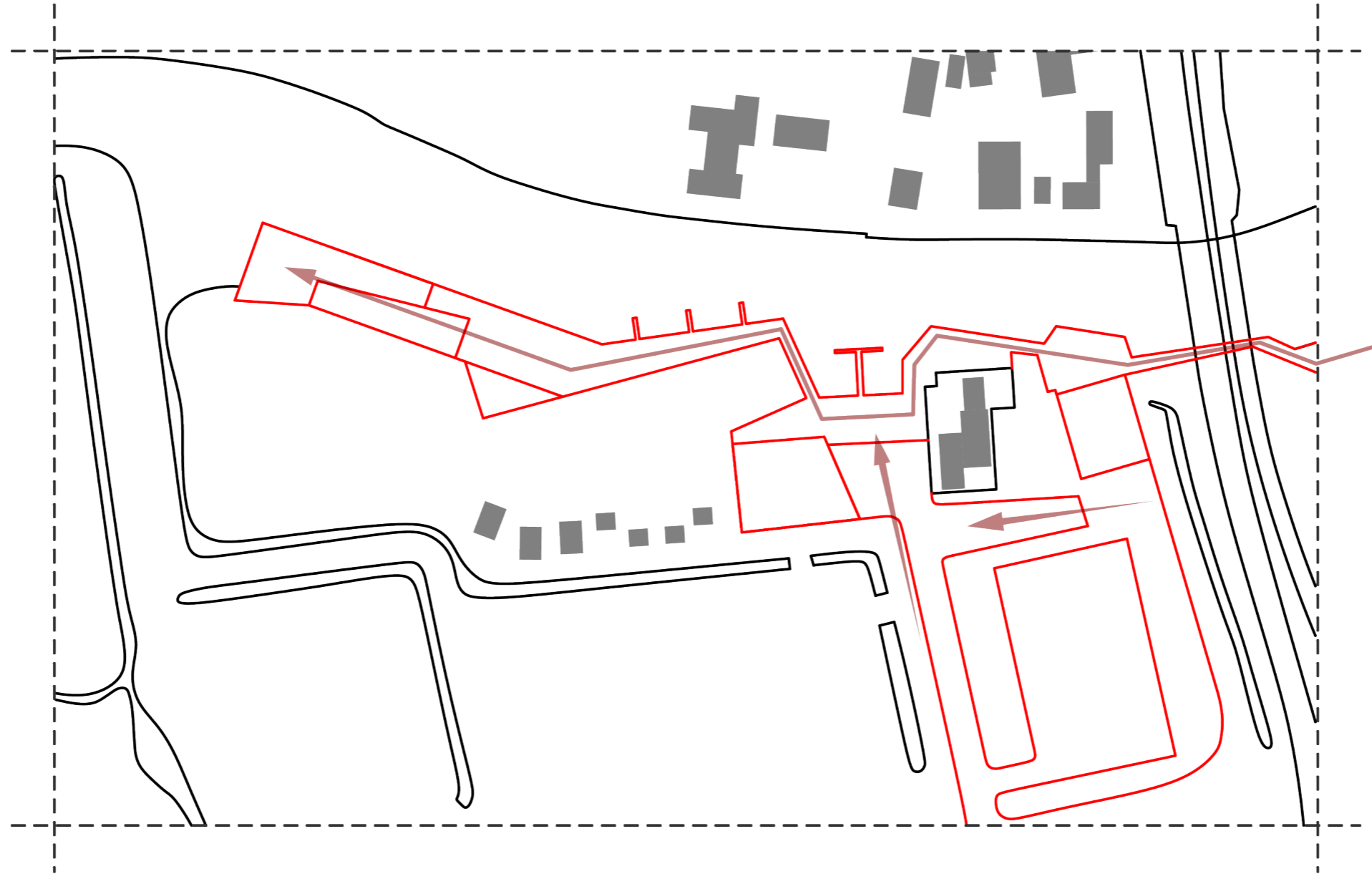

Curated Circulation

DESIGN STRATEGIES

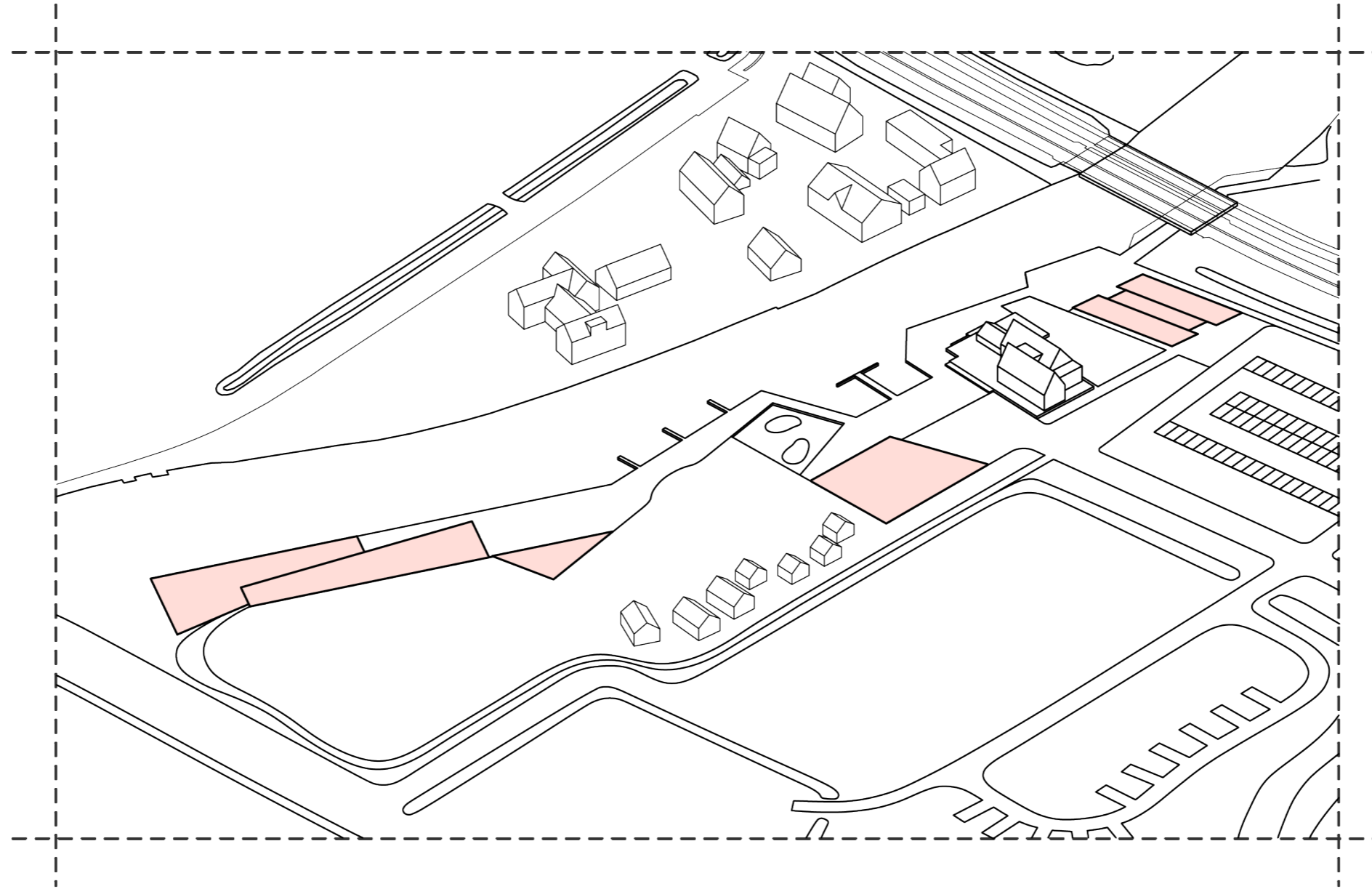

CHECK POINTS

DESIGN STRATEGIES

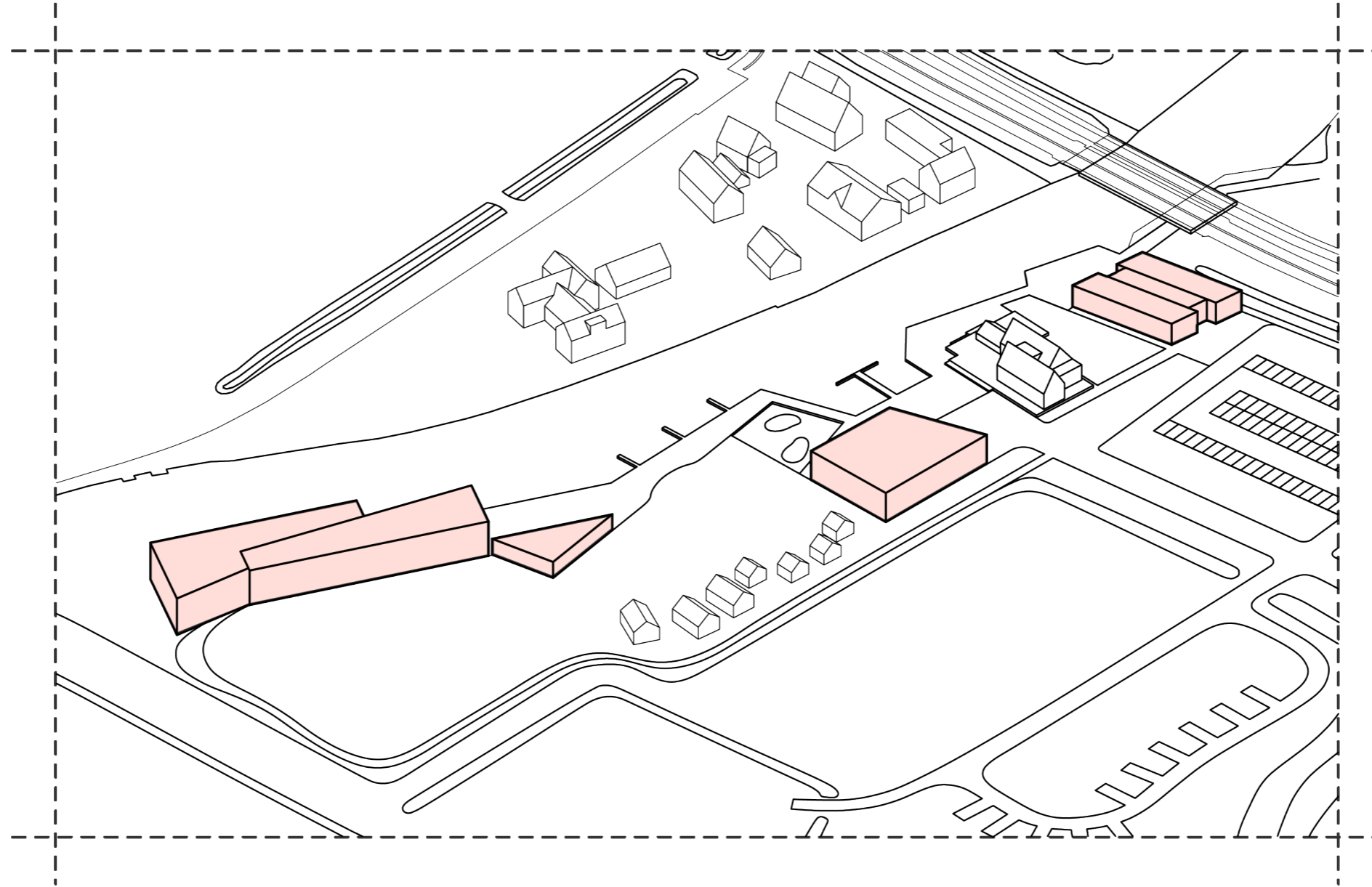

EXTRUSION

DESIGN STRATEGIES

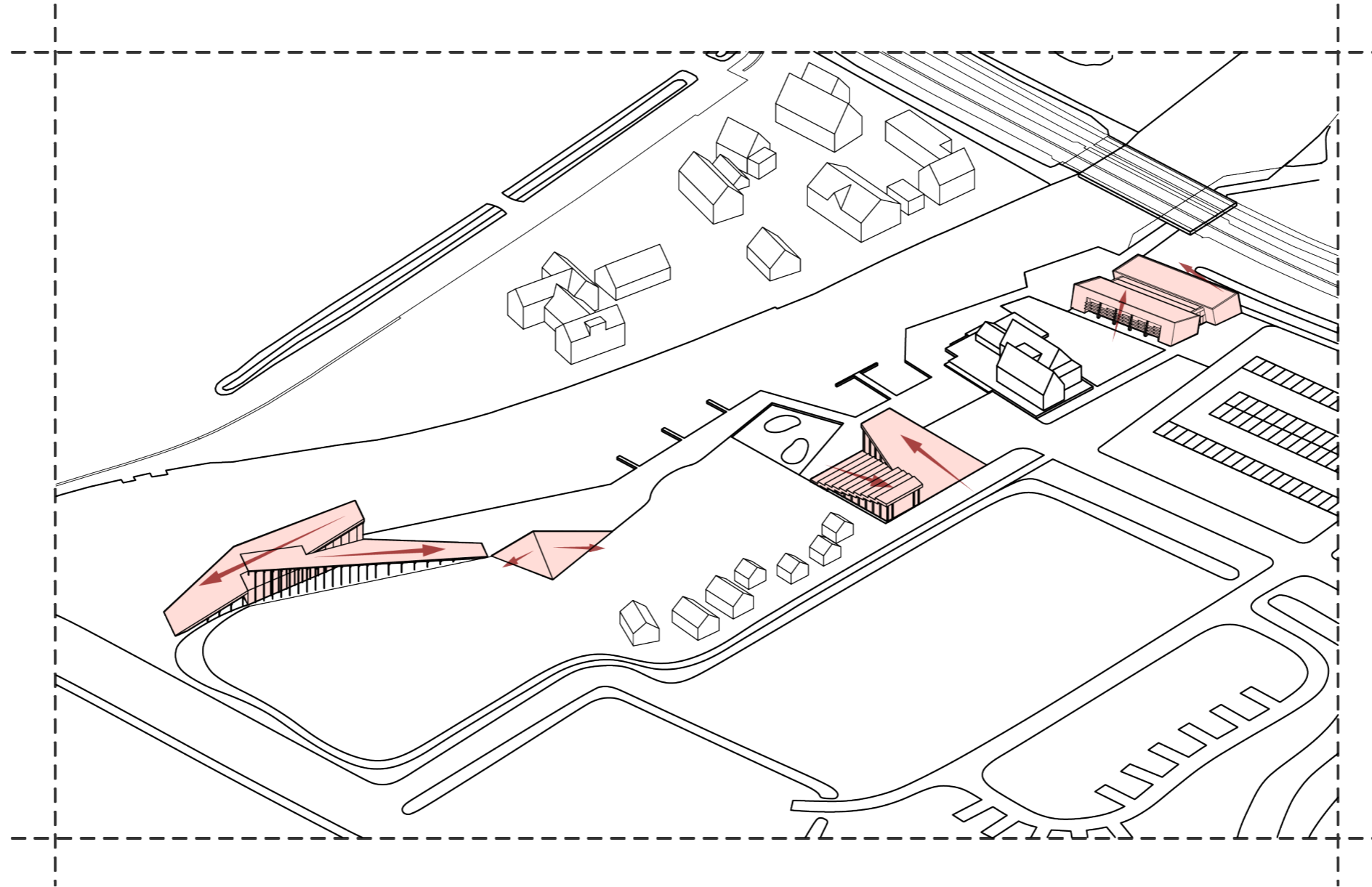

DISSOLVING VOLUMES AND BOUNDARIES



SUSTAINABLE DESIGN STRATEGIES

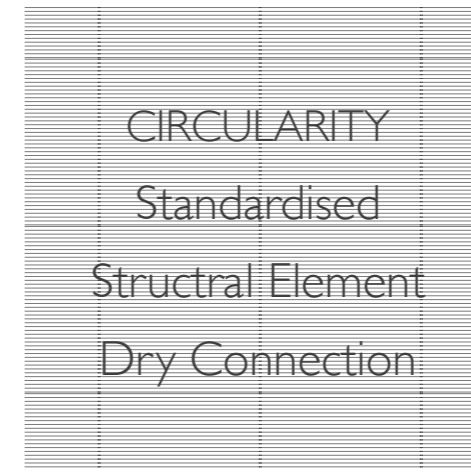

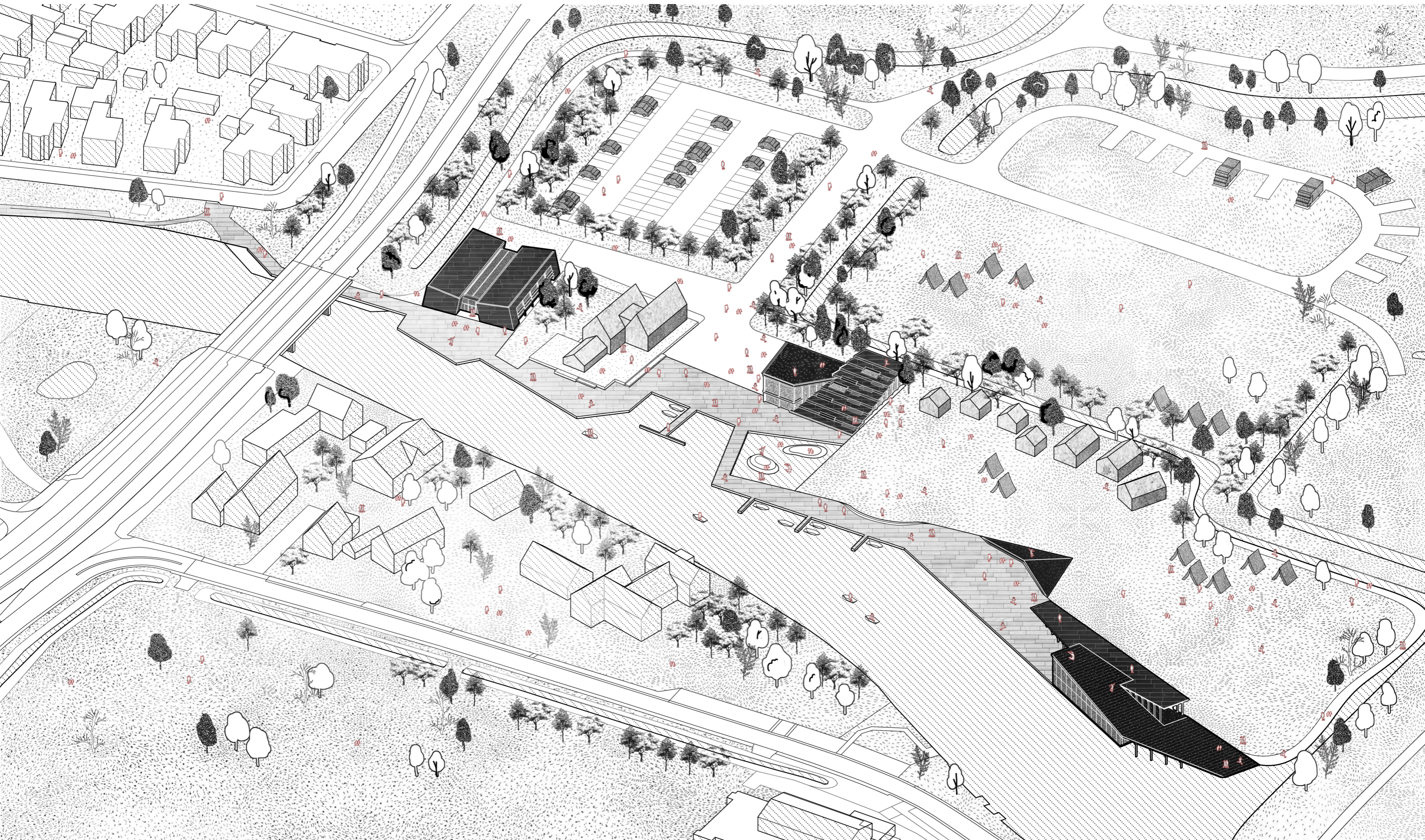

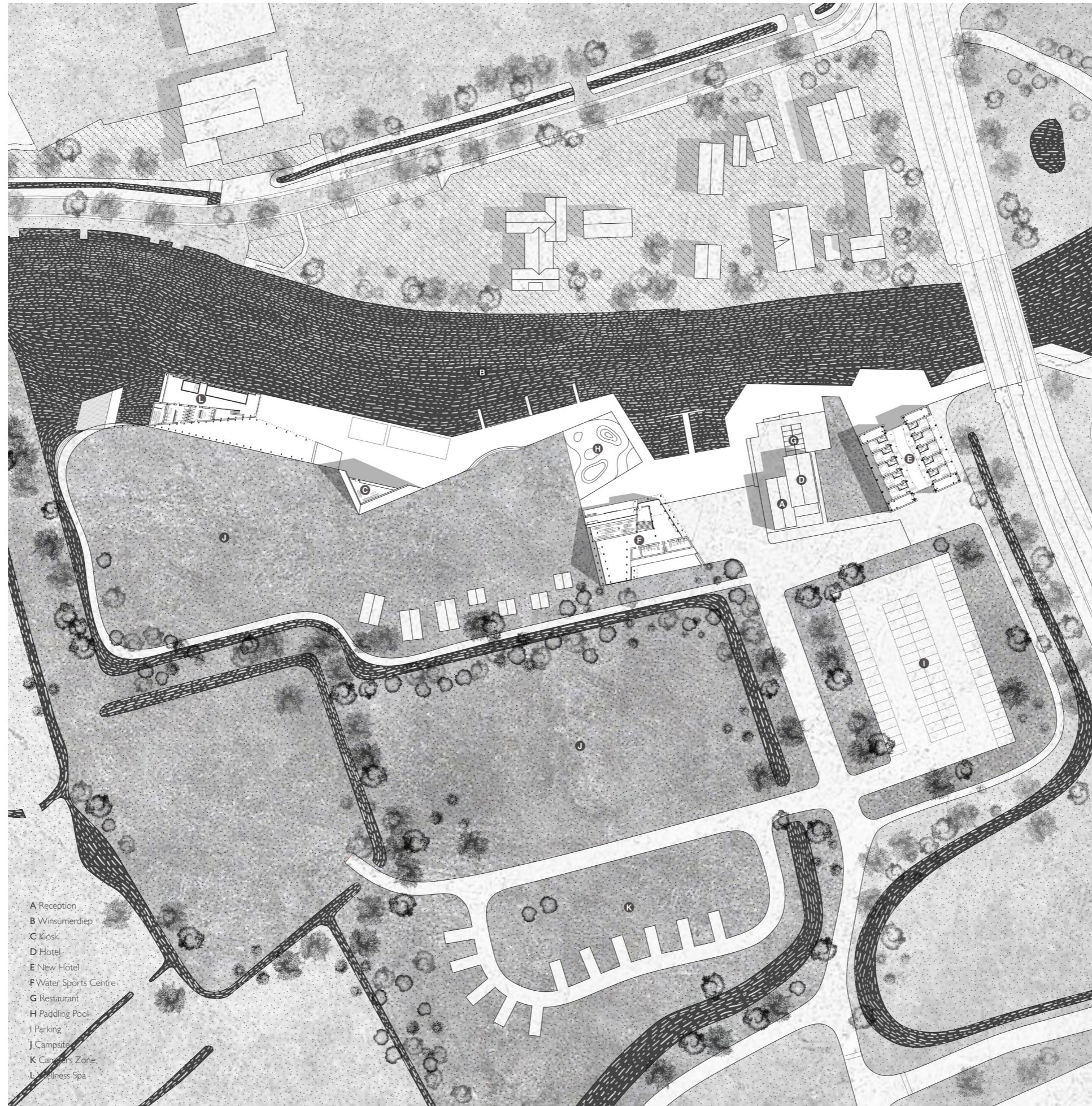



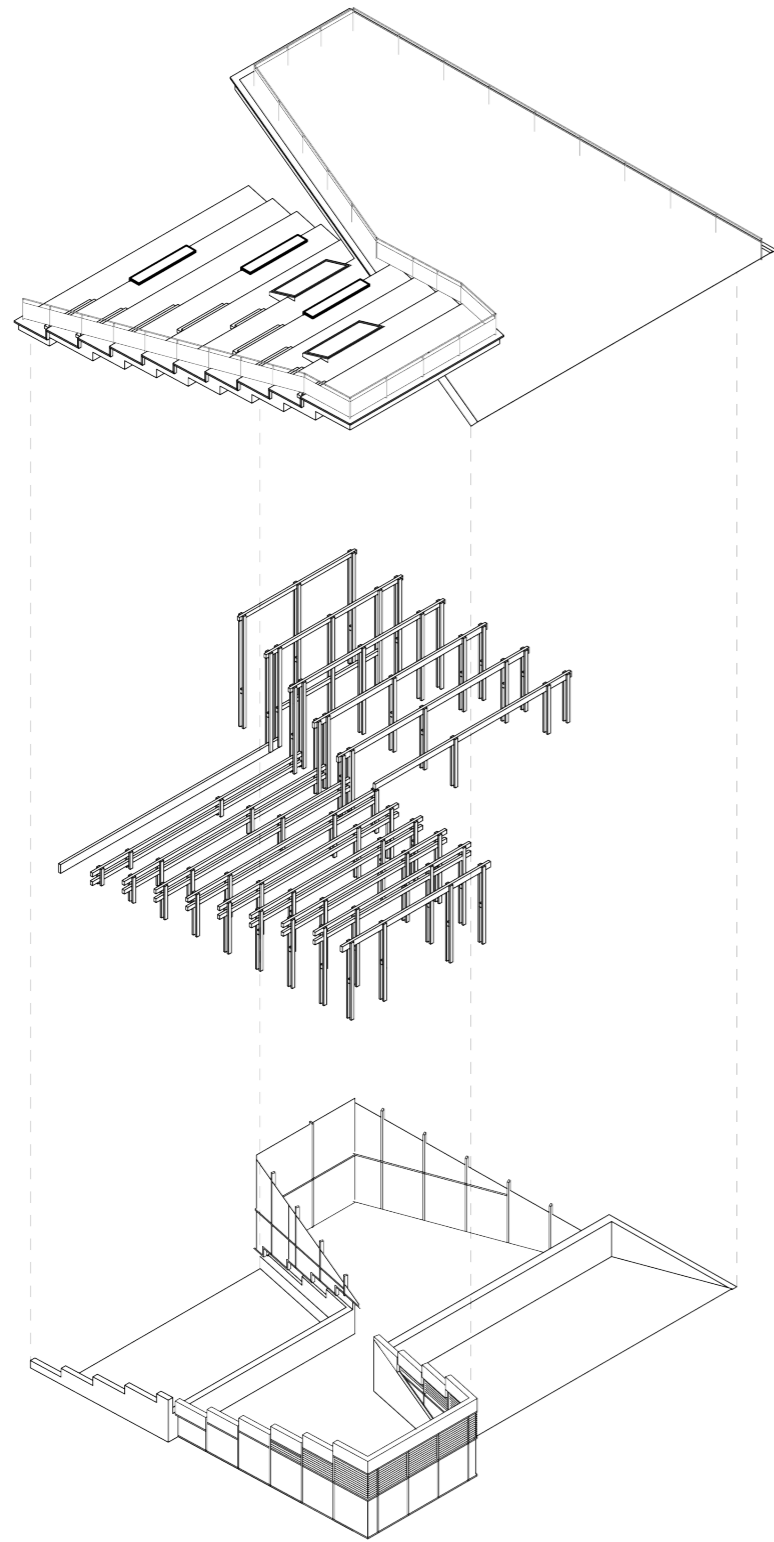

WATER SPORTS CENTER

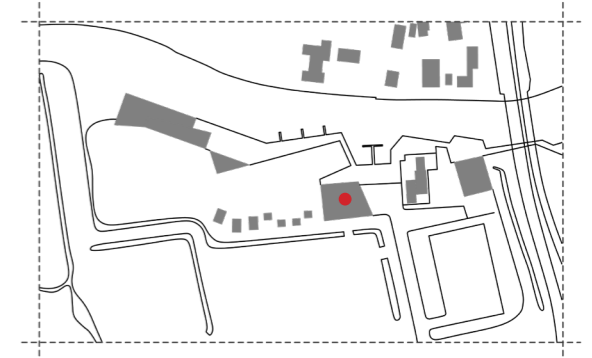

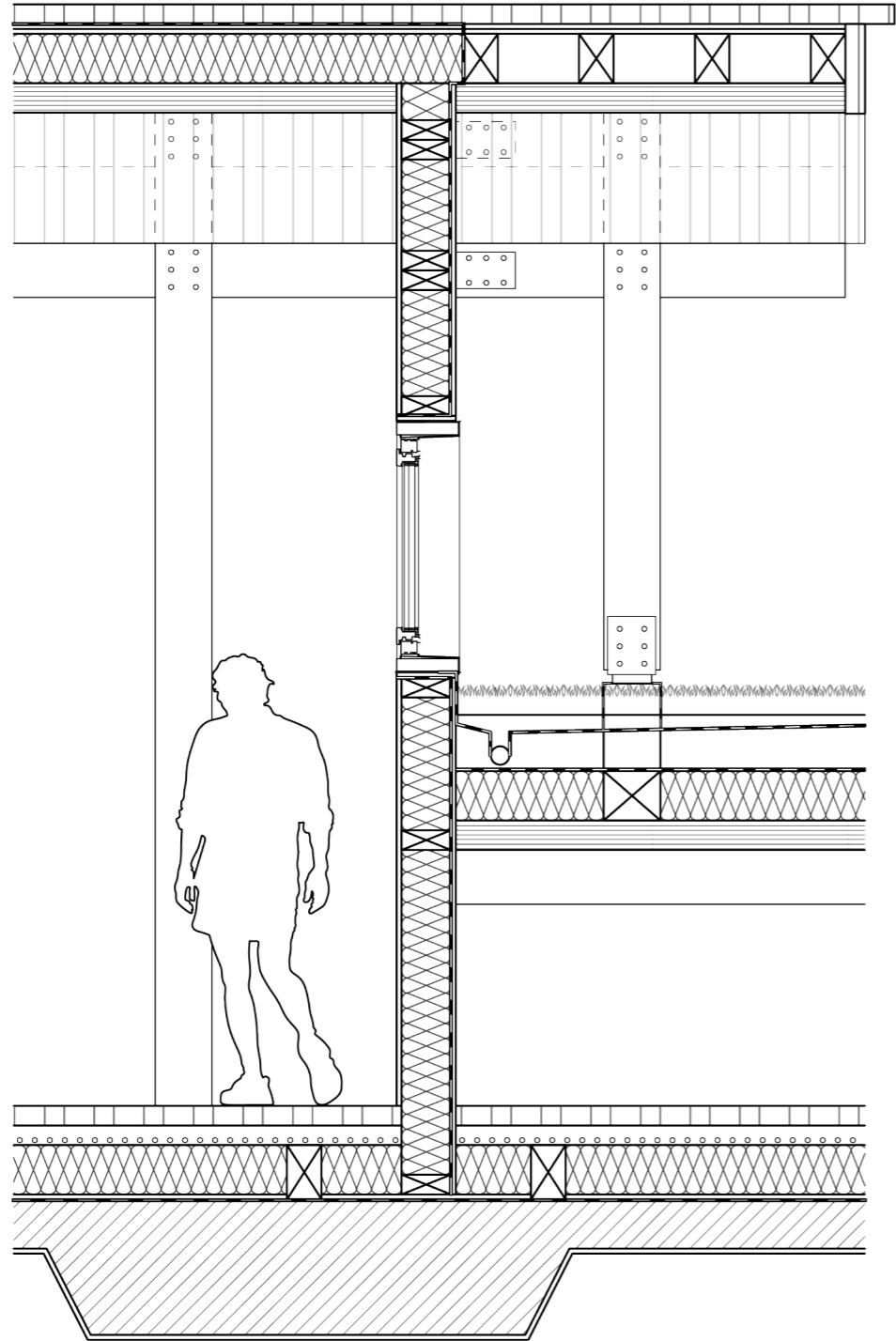

ROOF

80mm Floor boards
 20mm Structural support
 Protection and Vapour barrier
 200mm Wood fibre insulation
 120mm CLT

STRUCTURE

Timber Beam 2*140x220mm
 Timber Column 2*180x230mm
 Steel Post Base

GREEN ROOF

Vegetation Layer
 Clay
 Water Proof Membrane
 Filtration Membrane
 Gravel
 Cement Mortar

20mm structural support
 Protection and vapour barrier
 200mm wood fibre insulation
 120mm CLT

FLOOR

80mm Floor Boards
 Underfloor Heating
 200mm Wood Fibre Insulation
 140x220mm Wood Blocking
 Protection and Vapour barrier
 Reinforced Concrete

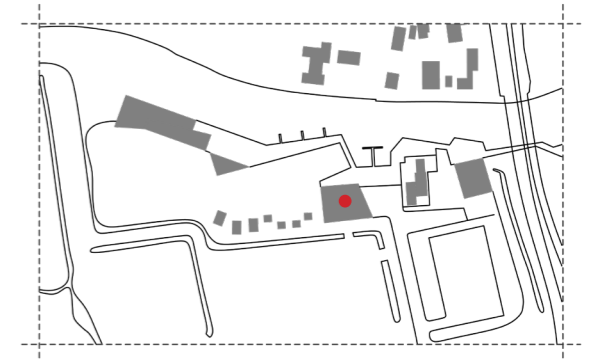

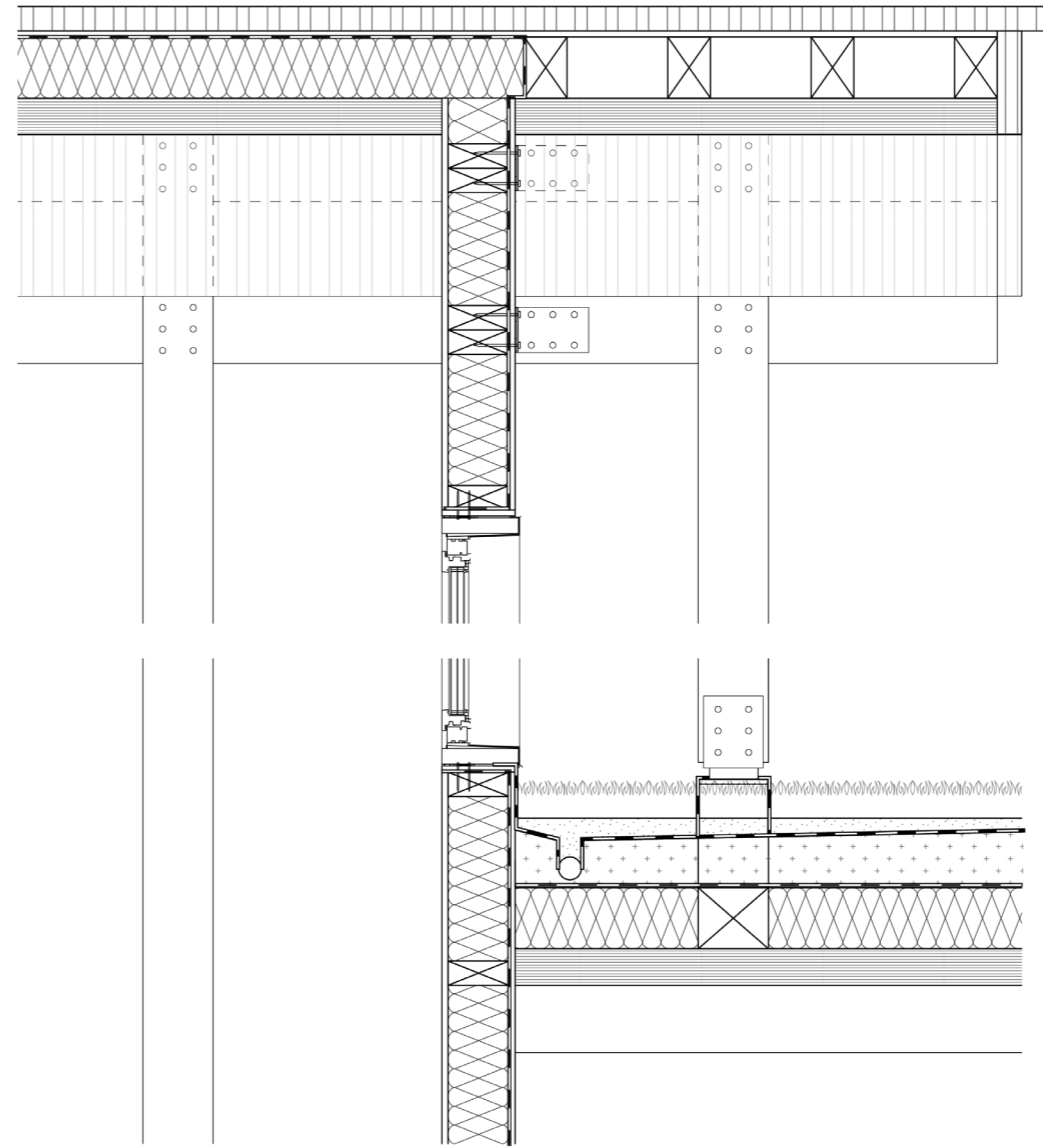
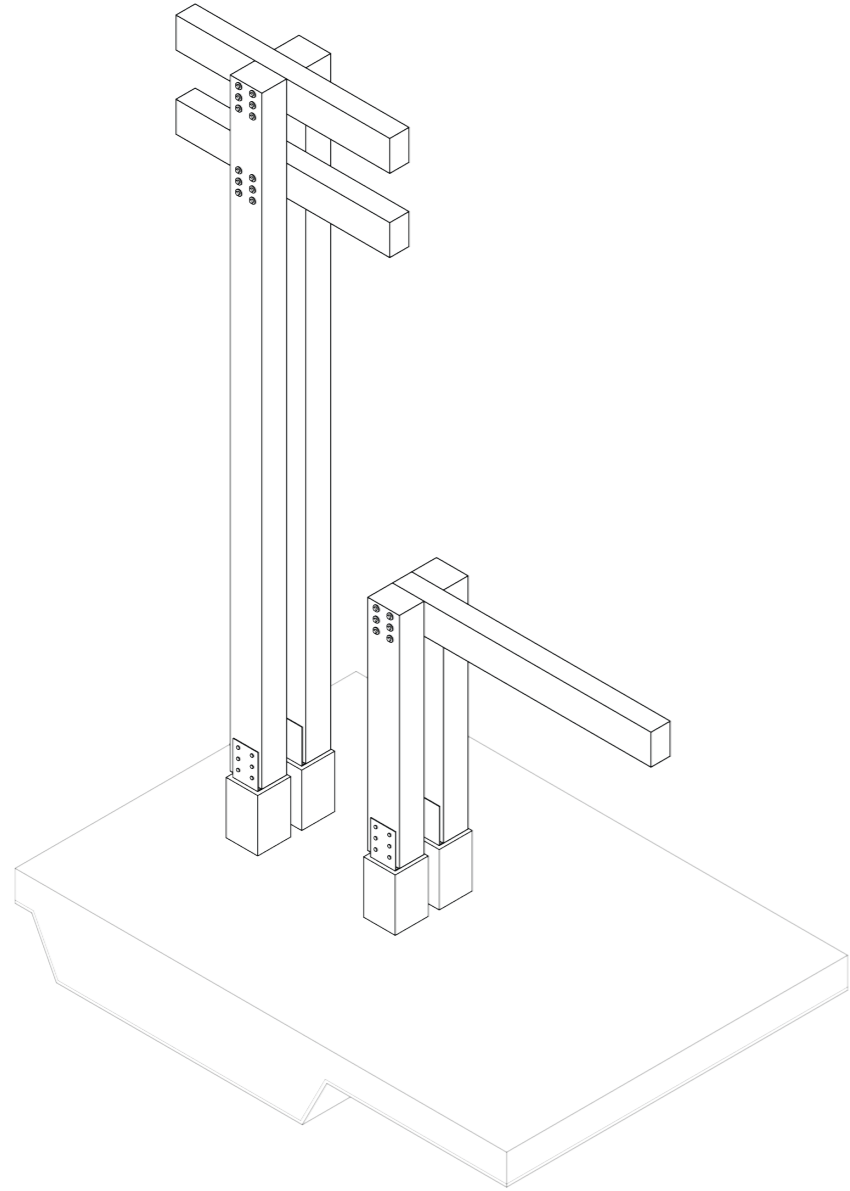

ROOF
 80mm Floor boards
 20mm Structural support
 Protection and Vapour barrier
 200mm Wood fibre insulation
 120mm CLT

STRUCTURE
 Timber Beam 2*140x220mm
 Timber Column 2*180x230mm
 Steel Post Base

GREEN ROOF
 Vegetation Layer
 Clay
 Water Proof Membrane
 Filtration Membrane
 Gravel
 Cement Mortar
 20mm structural support
 Protection and vapour barrier
 200mm wood fibre insulation
 120mm CLT

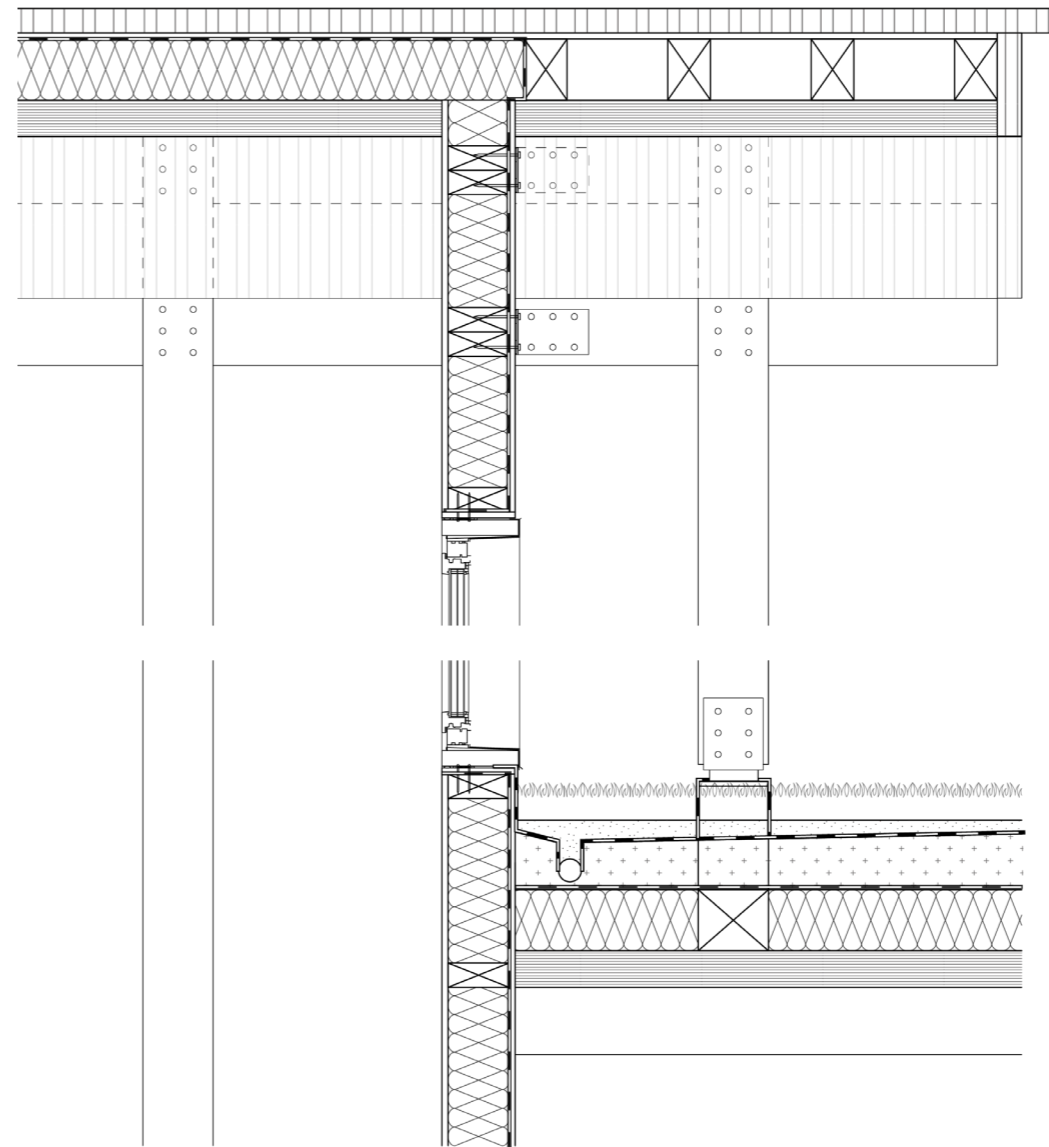
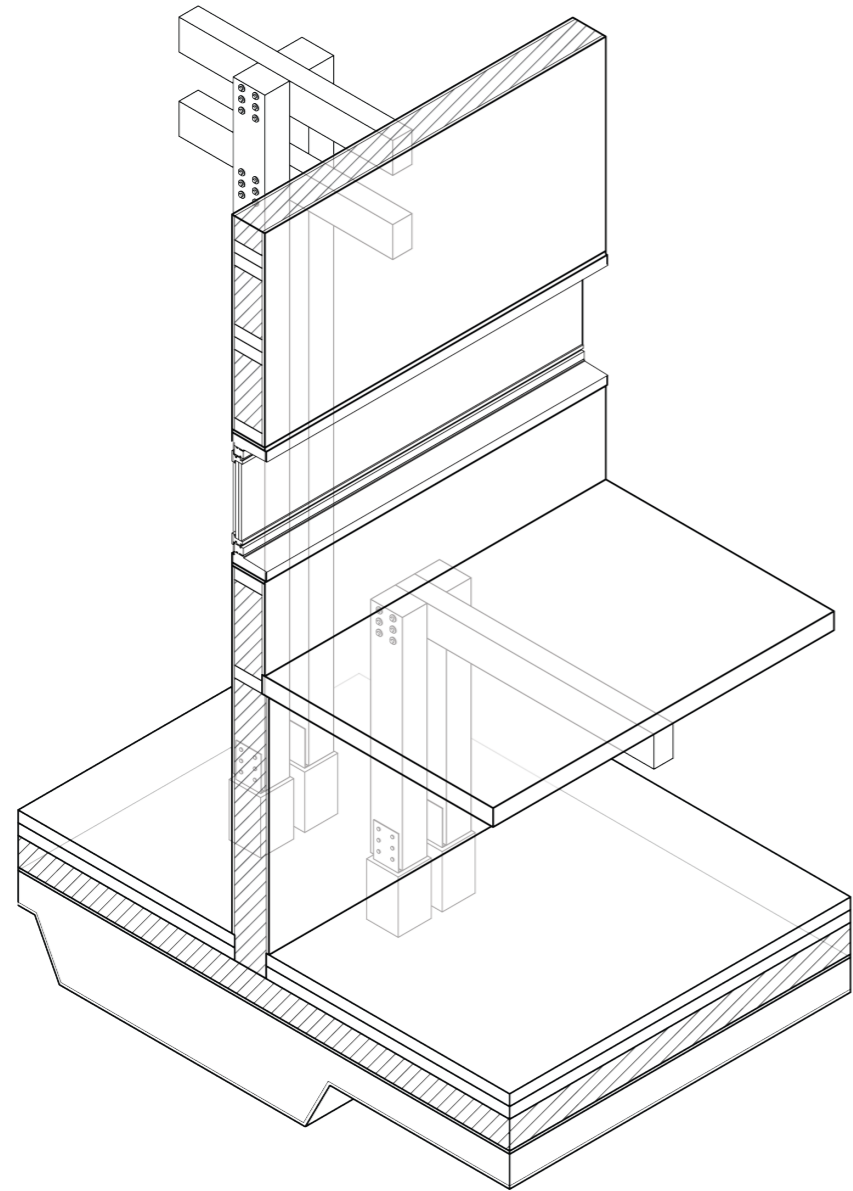

ROOF
 80mm Floor boards
 20mm Structural support
 Protection and Vapour barrier
 200mm Wood fibre insulation
 120mm CLT

STRUCTURE
 Timber Beam 2*140x220mm
 Timber Column 2*180x230mm
 Steel Post Base

GREEN ROOF
 Vegetation Layer
 Clay
 Water Proof Membrane
 Filtration Membrane
 Gravel
 Cement Mortar
 20mm structural support
 Protection and vapour barrier
 200mm wood fibre insulation
 120mm CLT

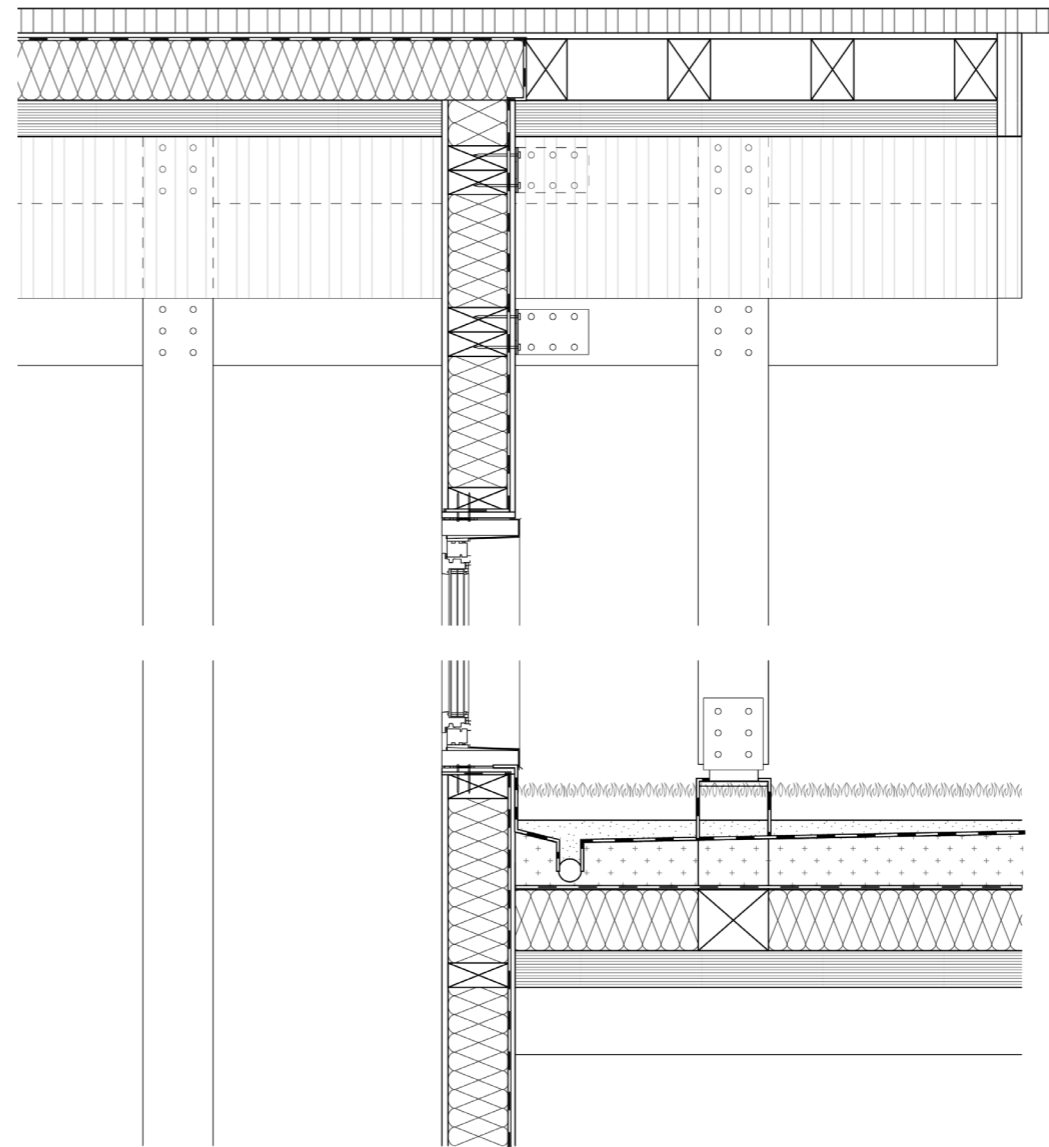
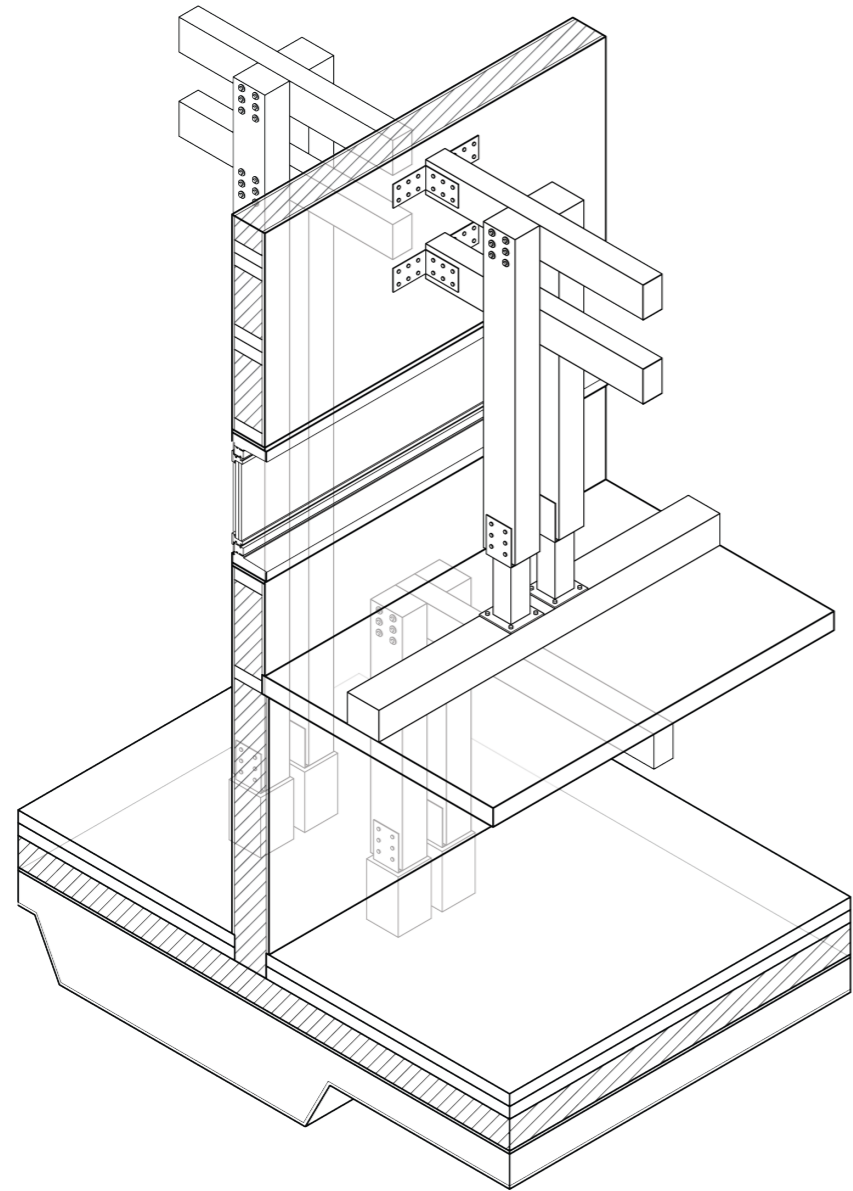

ROOF
 80mm Floor boards
 20mm Structural support
 Protection and Vapour barrier
 200mm Wood fibre insulation
 120mm CLT

STRUCTURE
 Timber Beam 2*140x220mm
 Timber Column 2*180x230mm
 Steel Post Base

GREEN ROOF
 Vegetation Layer
 Clay
 Water Proof Membrane
 Filtration Membrane
 Gravel
 Cement Mortar
 20mm structural support
 Protection and vapour barrier
 200mm wood fibre insulation
 120mm CLT

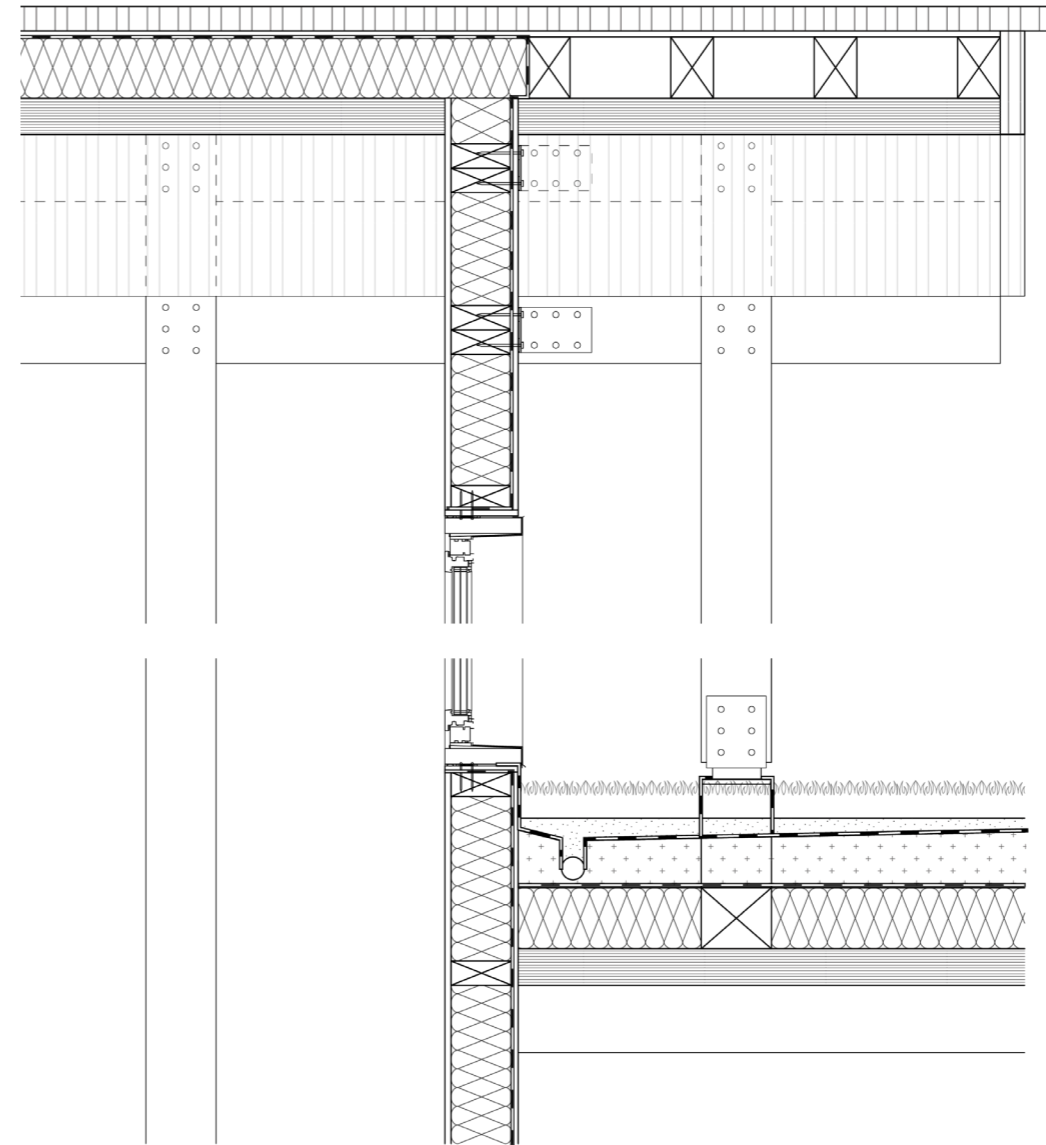
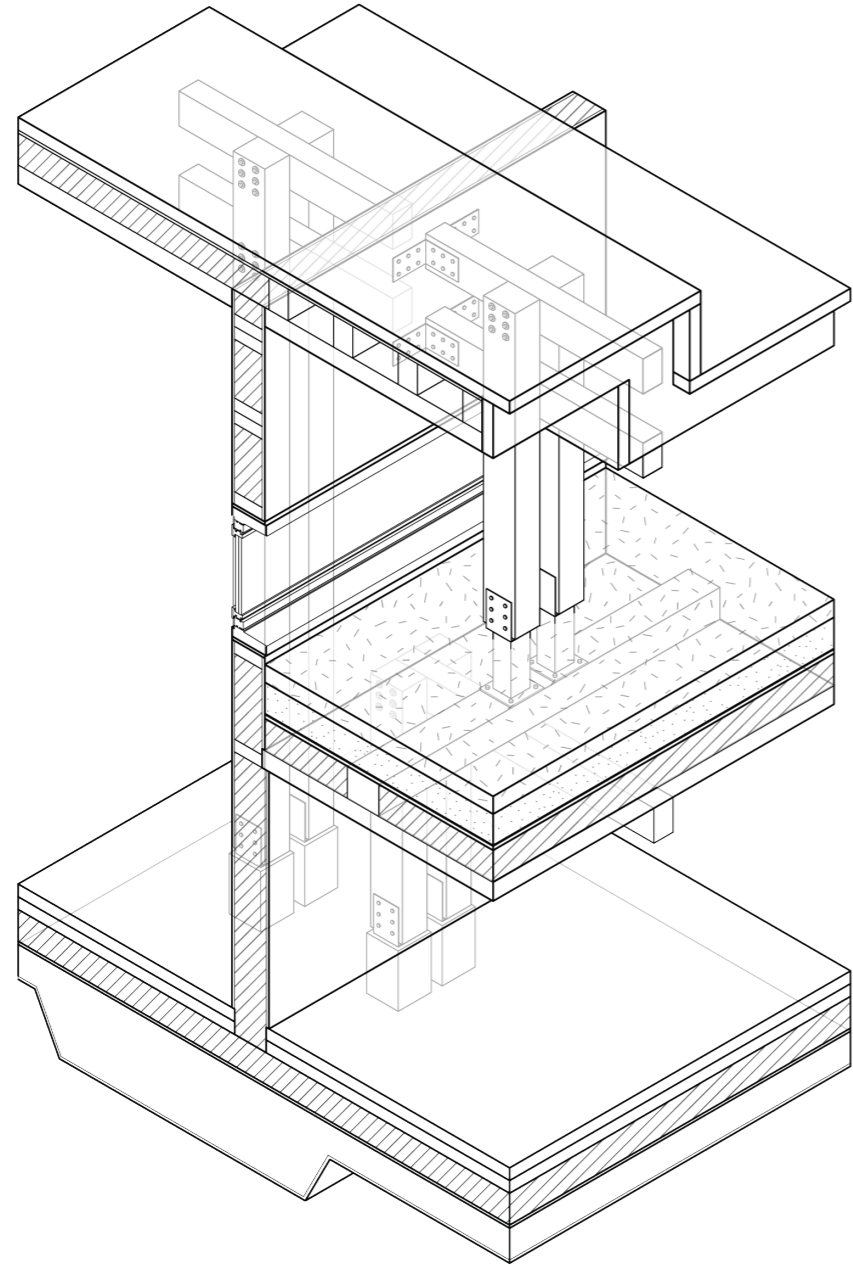

ROOF
 80mm Floor boards
 20mm Structural support
 Protection and Vapour barrier
 200mm Wood fibre insulation
 120mm CLT

STRUCTURE
 Timber Beam 2*140x220mm
 Timber Column 2*180x230mm
 Steel Post Base

GREEN ROOF
 Vegetation Layer
 Clay
 Water Proof Membrane
 Filtration Membrane
 Gravel
 Cement Mortar
 20mm structural support
 Protection and vapour barrier
 200mm wood fibre insulation
 120mm CLT

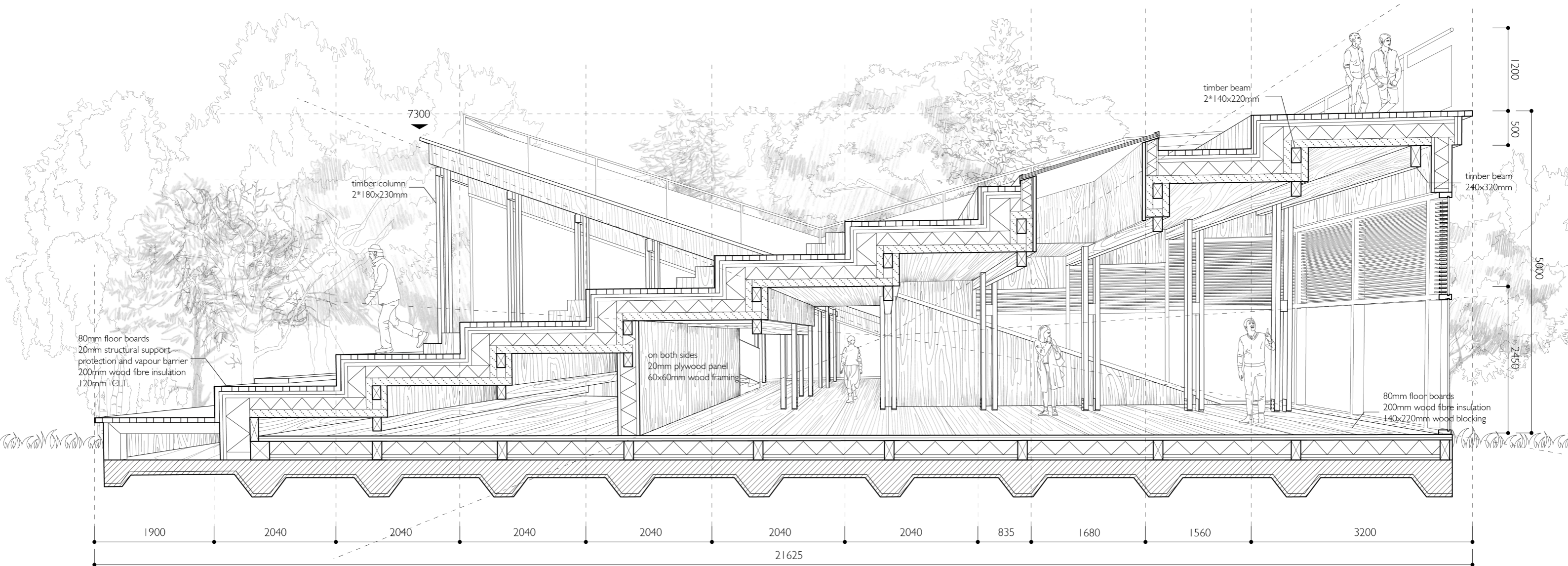

WATER SPORTS CENTER/ INTERIOR

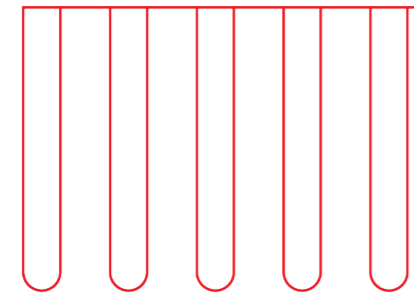
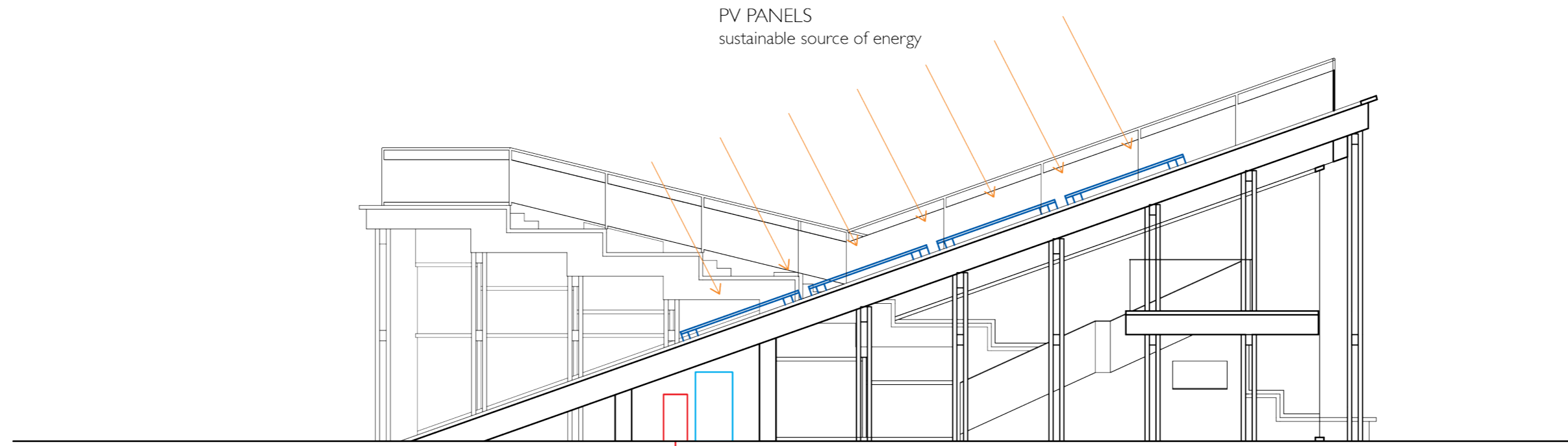

DRAIN WATER RECOVERY SYSTEM
recovers heat from used hot water and can store this heat for later use. It can reduce your water heater's energy consumption by up to 25%

GROUND SOURCE HEAT PUMP
take advantage of the constant temperature of shallow earth (40°-70°F/4.5°-21°C) to efficiently exchange temperatures, heating homes in the winter and cooling homes in the summer.

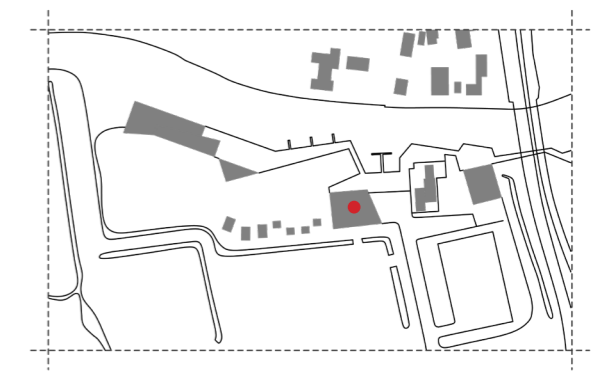

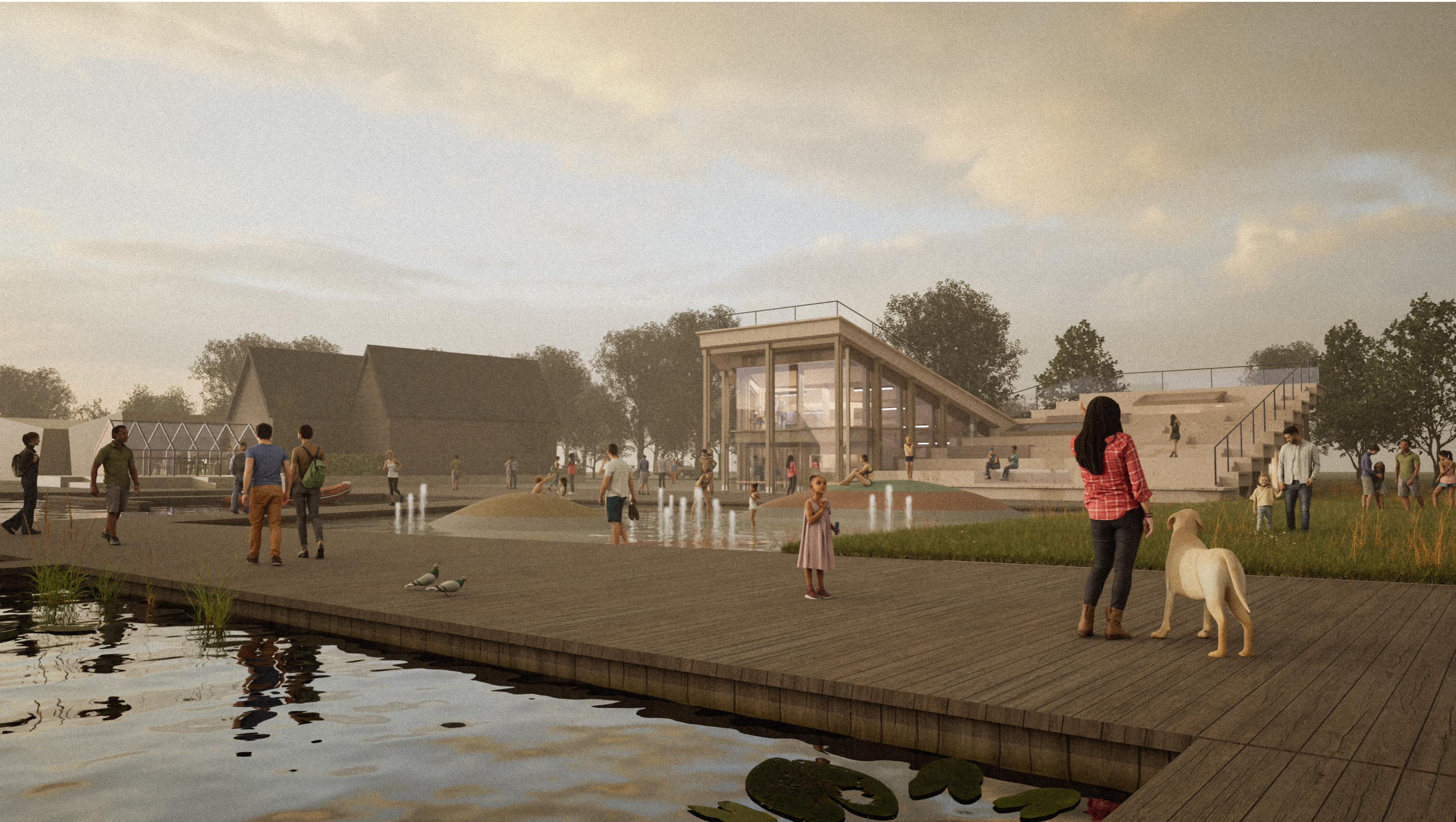



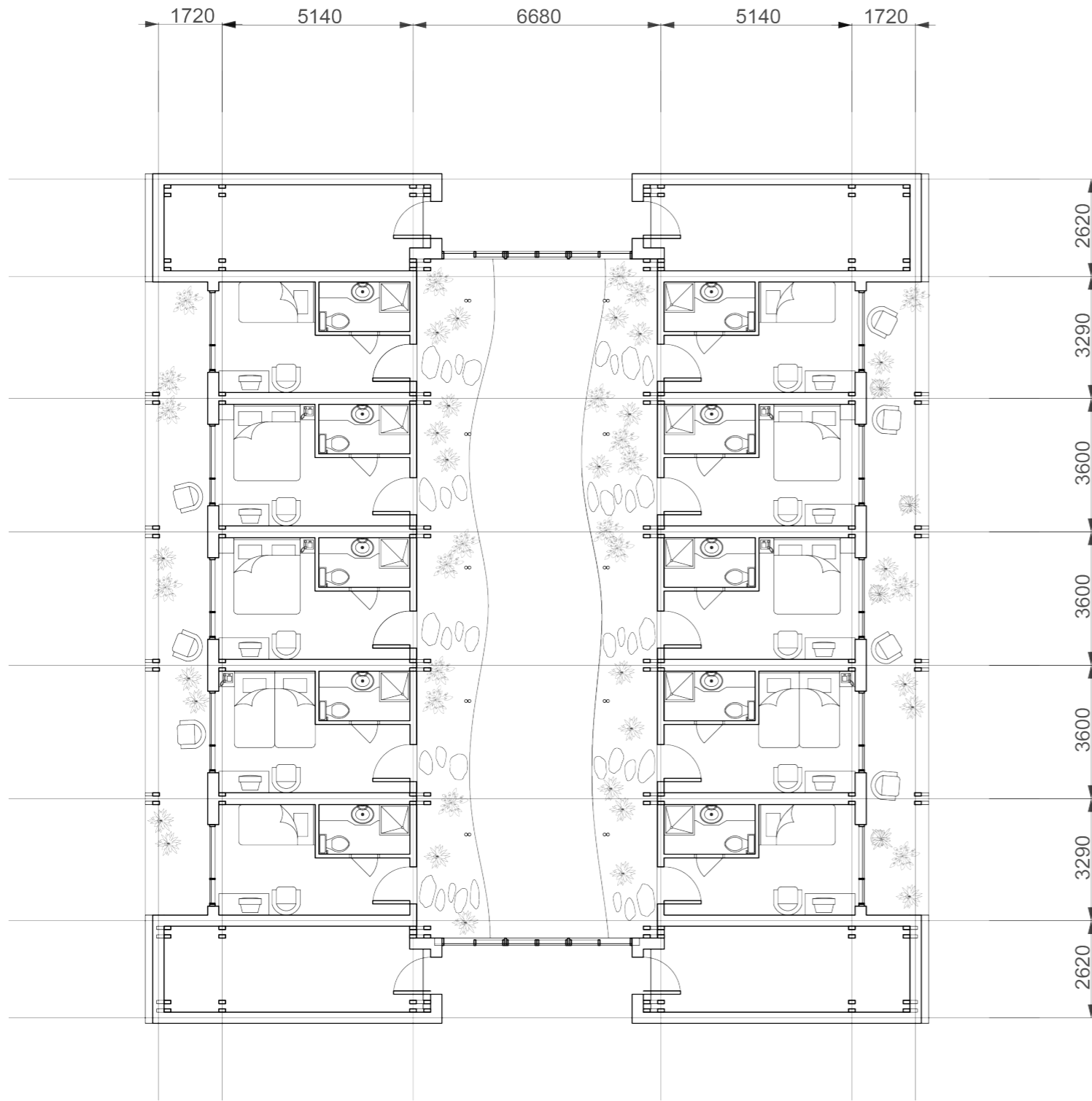

HOTEL

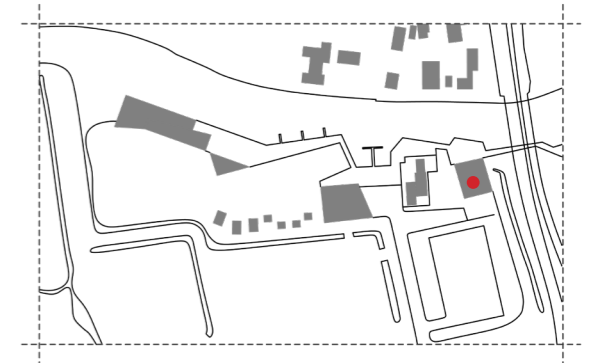

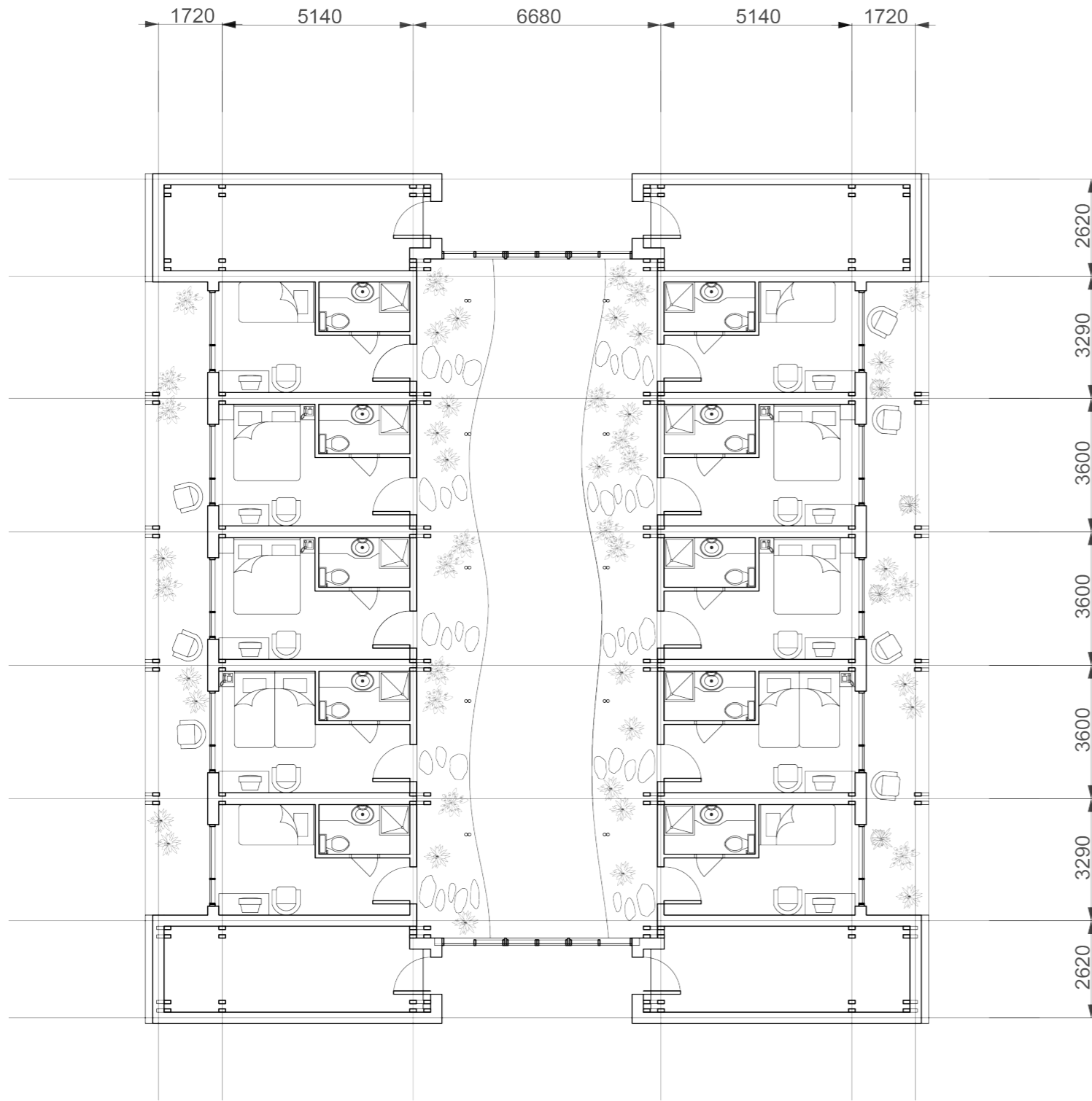

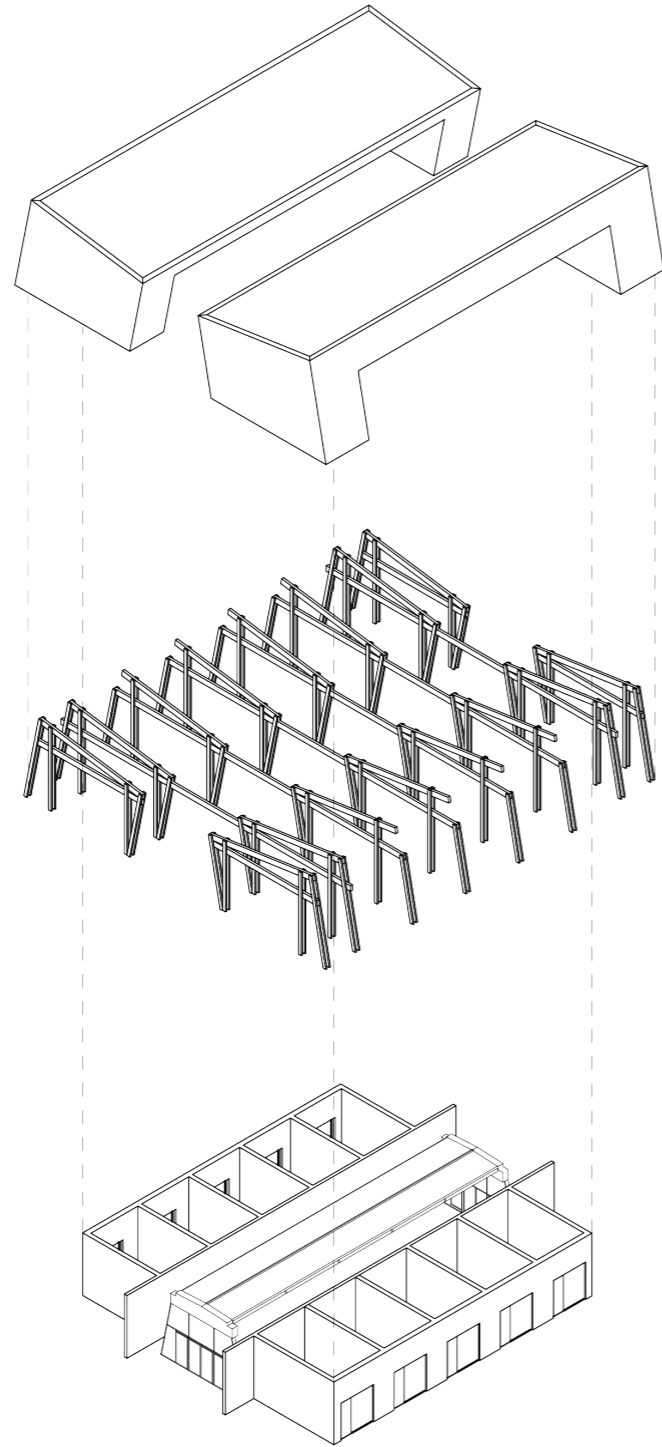

HOTEL

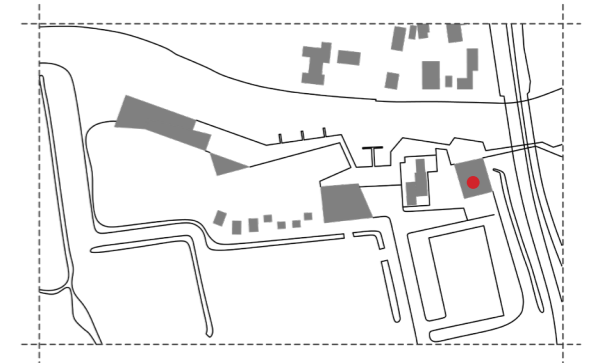

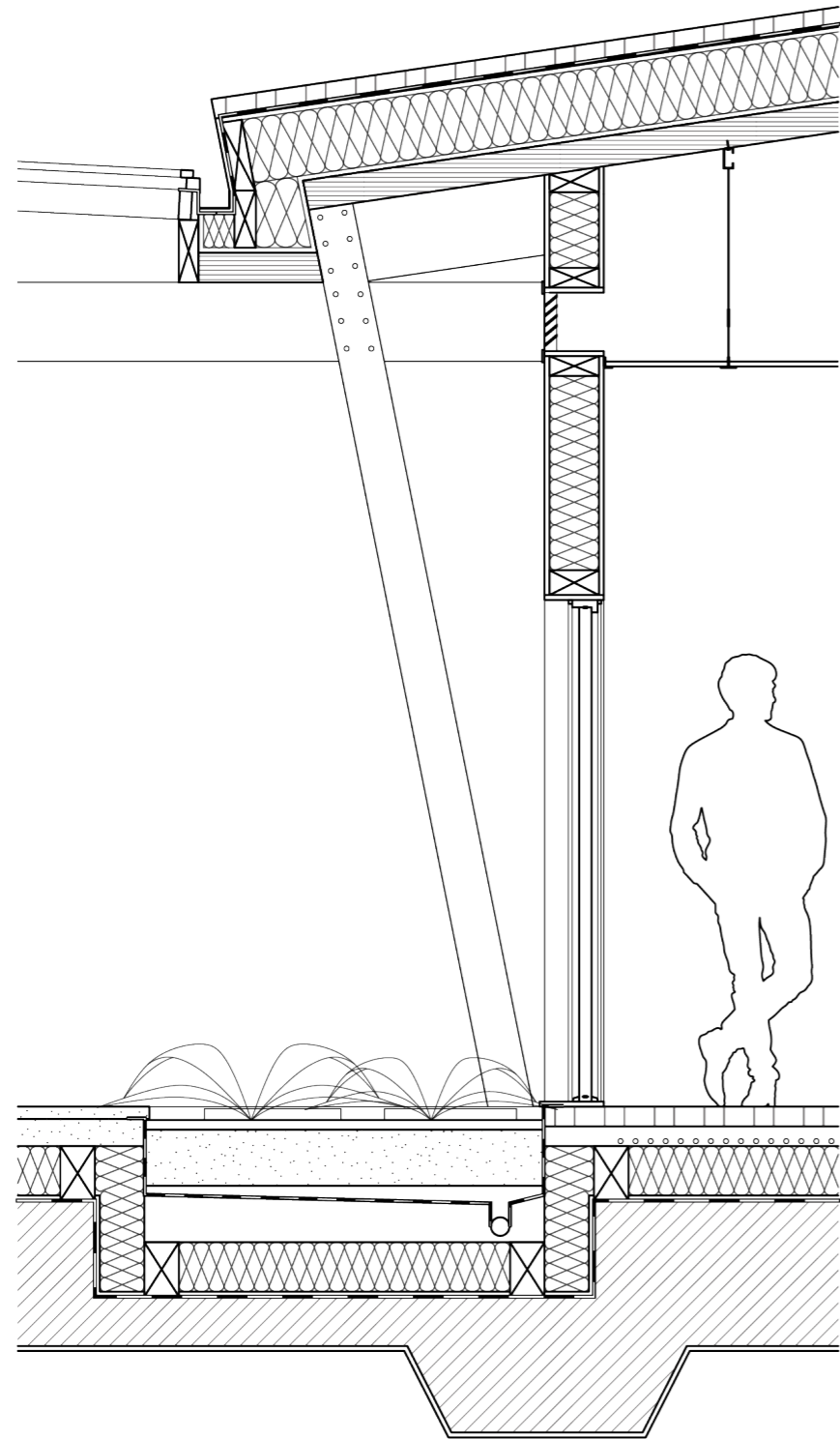

ROOF

VISS Roof Glazing
 80mm Floor boards
 20mm Structural support
 Protection and Vapour barrier
 200mm Wood fibre insulation
 120mm CLT

STRUCTURE

Timber Beam 240x320mm
 Timber Column 2*180x230mm

WALL

Ventilation Grille 200x3000mm
 Drop Ceiling

20mm Plywood Panel
 150mm Wood fibre insulation
 60x150mm Wood Blocking
 20mm Plywood Panel

PLANTER

Vegetation Layer
 Clay
 Water Proof Membrane
 Filtration Membrane
 Gravel
 Cement Mortar

20mm structural support
 Protection and vapour barrier
 200mm Wood Fibre Insulation
 140x220mm Wood Blocking
 Protection and Vapour barrier
 Reinforced Concrete



HOTEL

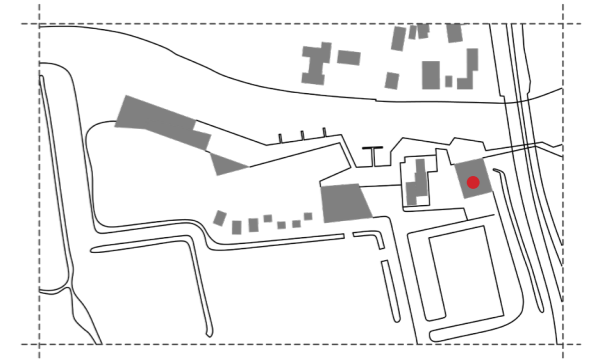

PV PANELS
 sustainable source of energy

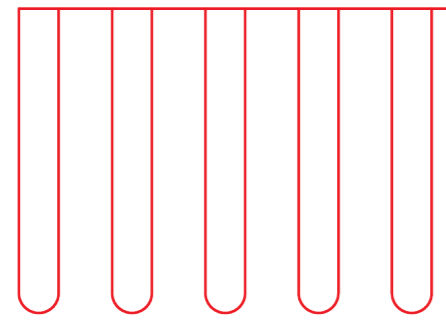
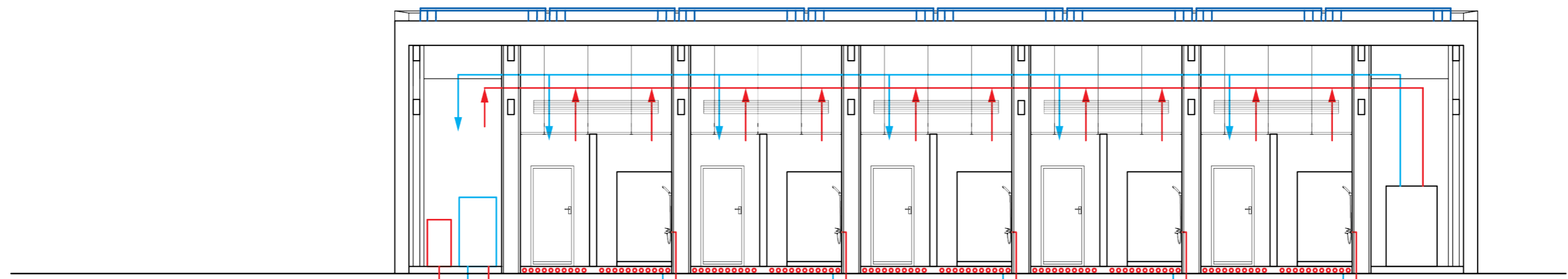

DRAIN WATER RECOVERY SYSTEM
 recovers heat from used hot water and can store this heat for later use. It can reduce your water heater's energy consumption by up to 25%

FLOOR HEATING
 floor heating within the ground level slab, acting as a thermal mass

MECHANICAL VENTILATION WITH HEAT RECOVERY
 recuperation of already heated air - minimises heat loss

GROUND SOURCE HEAT PUMP
 take advantage of the constant temperature of shallow earth (40°-70°F/4.5°-21°C) to efficiently exchange temperatures, heating homes in the winter and cooling homes in the summer.

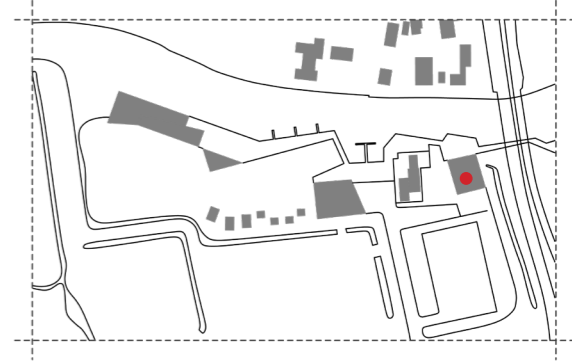





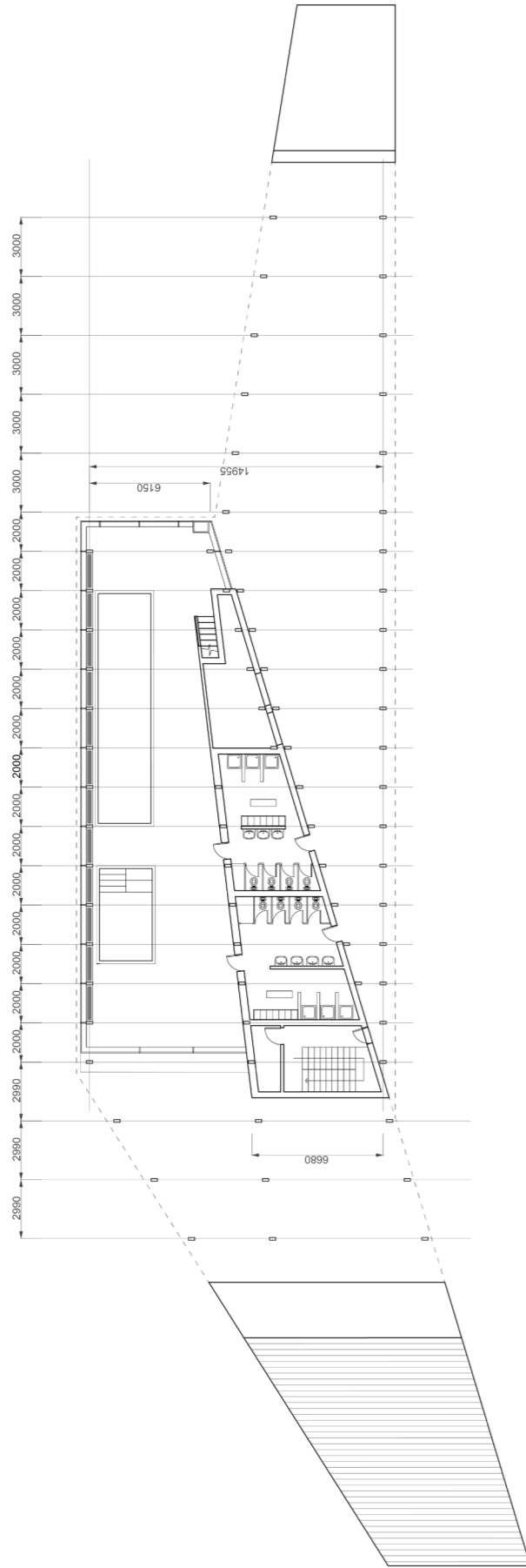

WELLNESS SPA/ INTERIOR

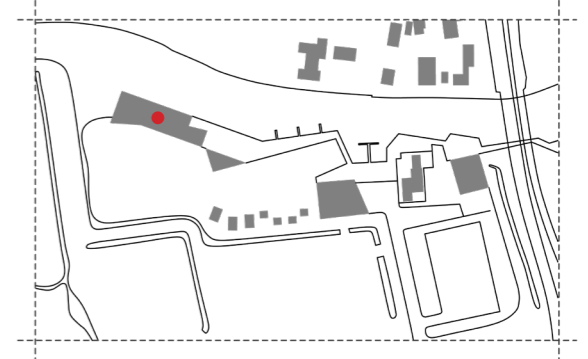

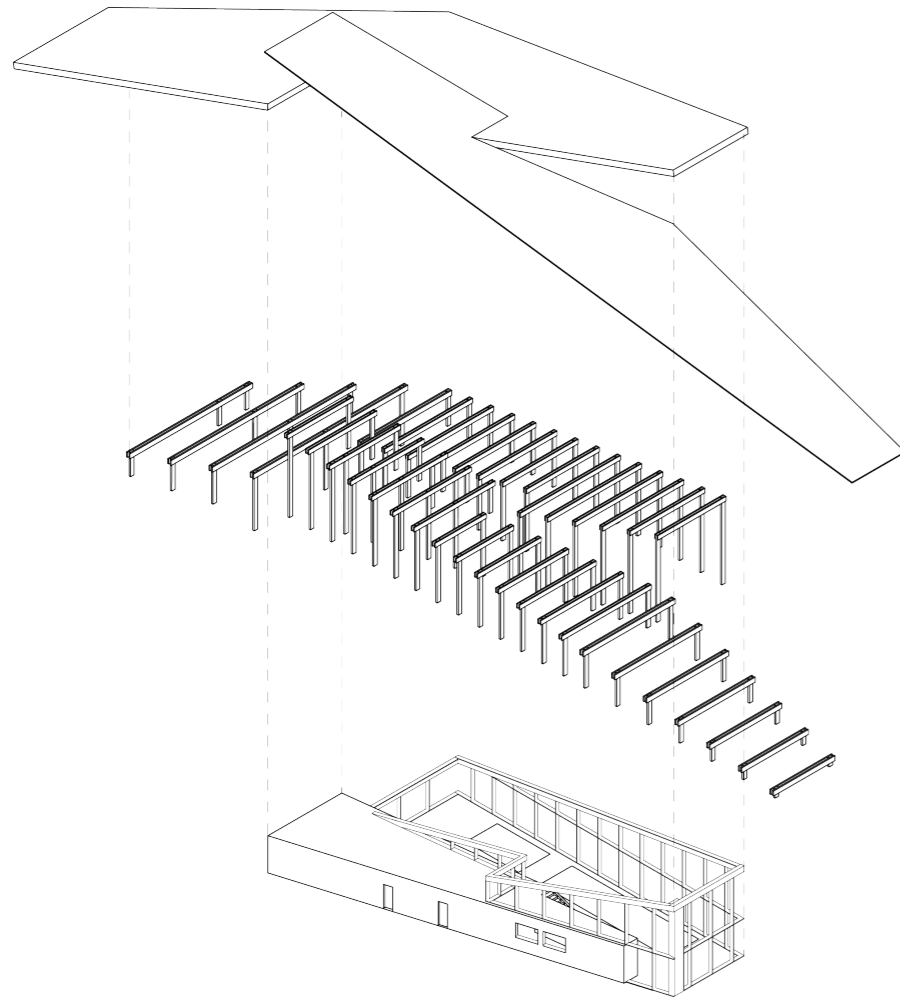

WELLNESS SPA/ INTERIOR

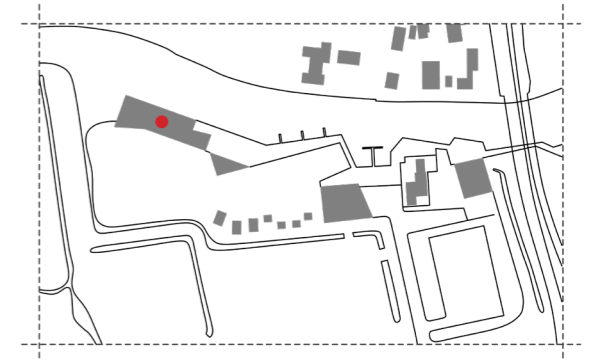

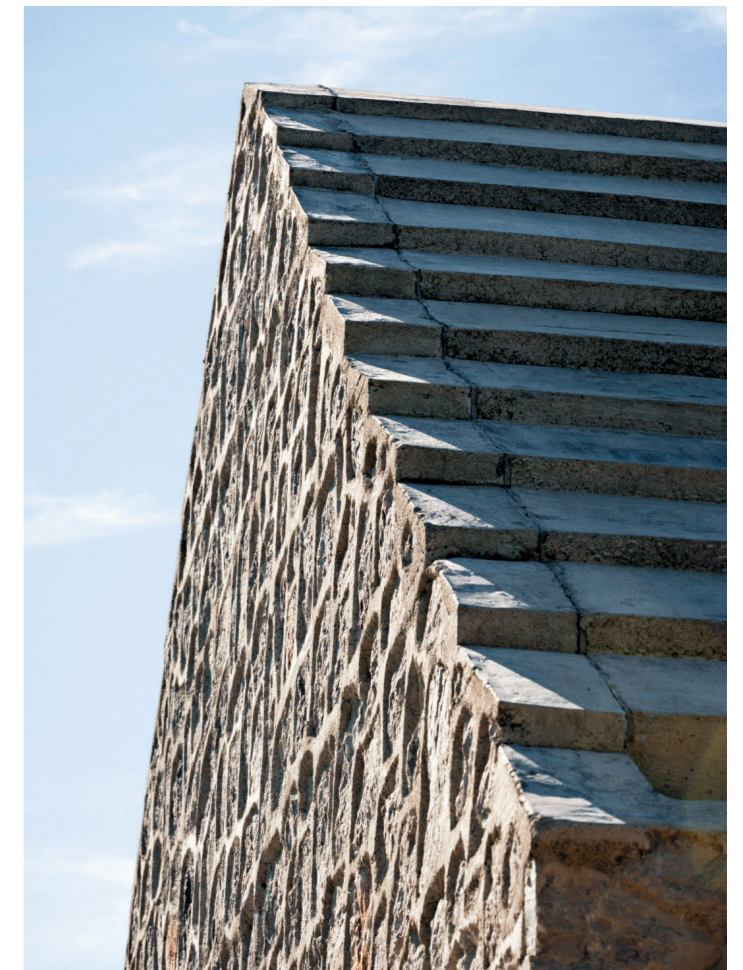
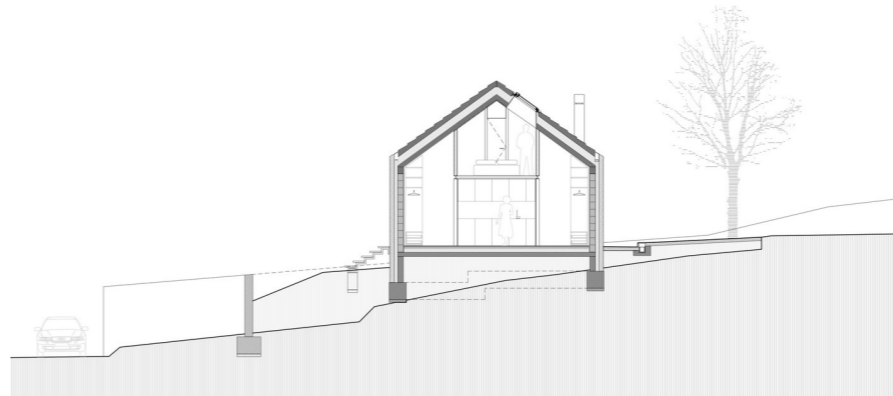
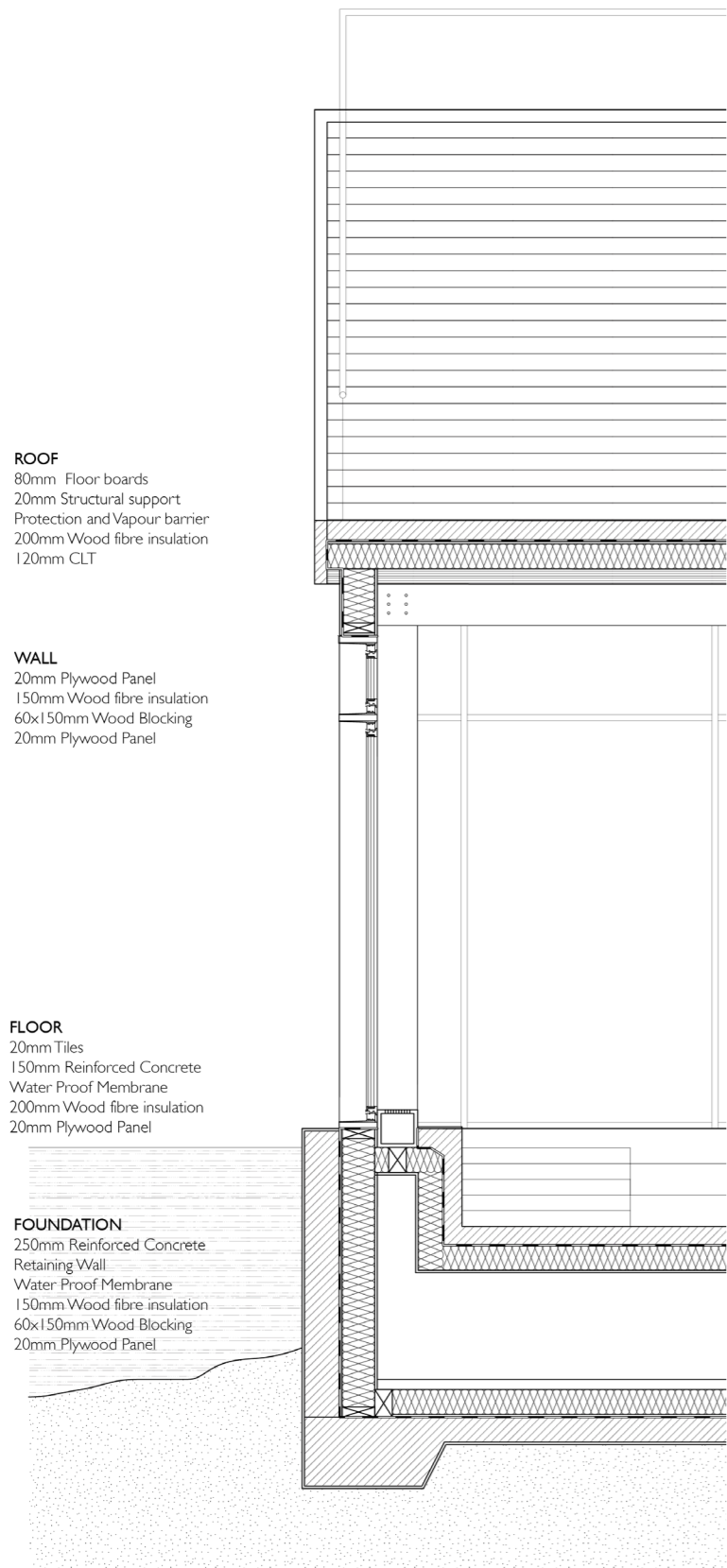

Ref: Compact Karst House / dekleva gregoric architects



WELLNESS SPA

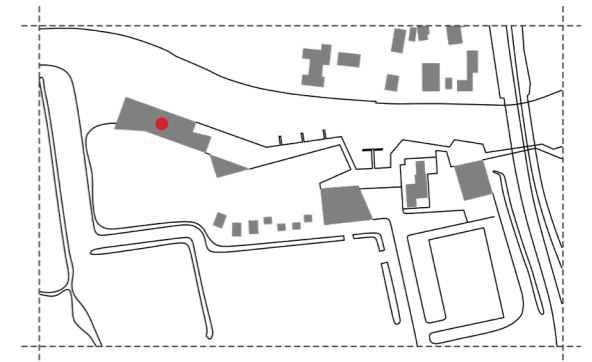

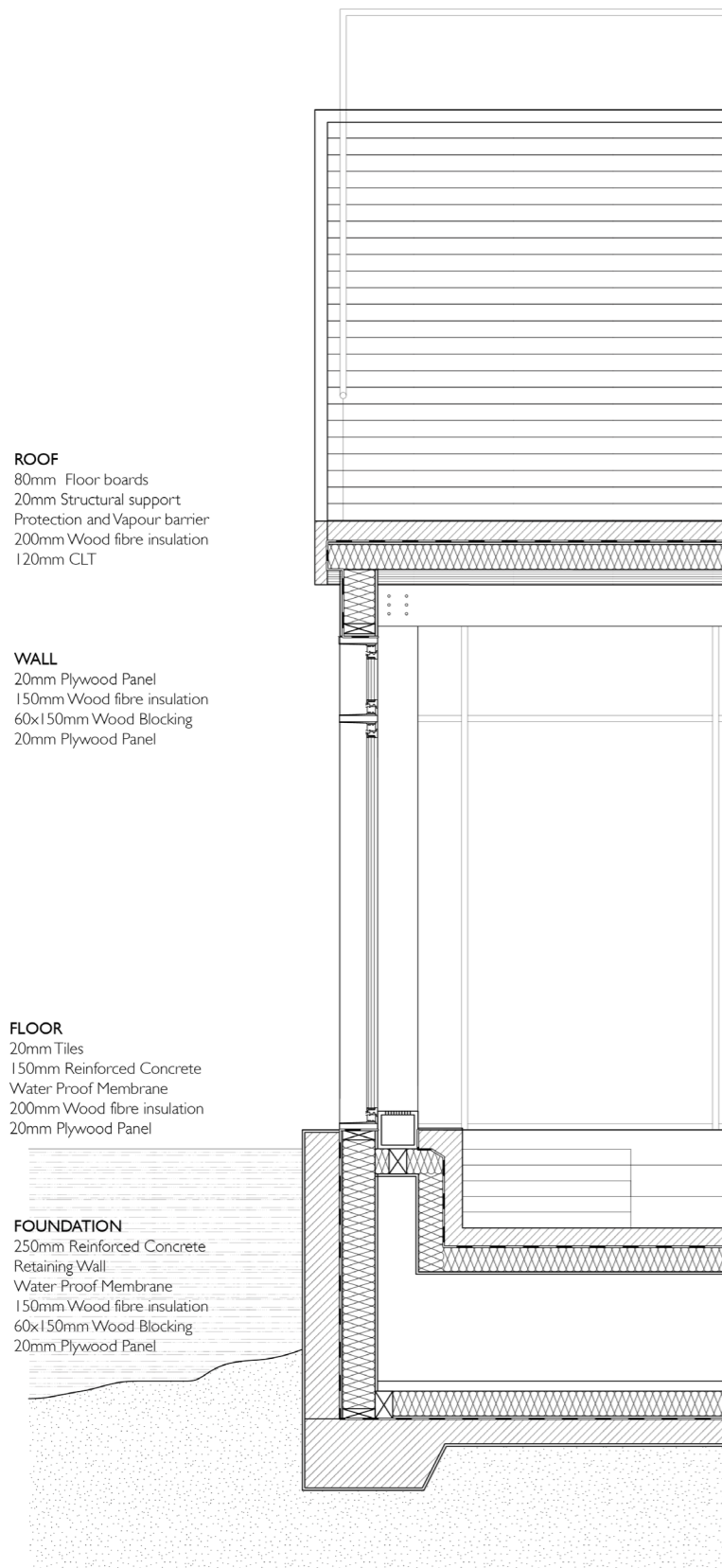

ROOF
 80mm Floor boards
 20mm Structural support
 Protection and Vapour barrier
 200mm Wood fibre insulation
 120mm CLT

WALL
 20mm Plywood Panel
 150mm Wood fibre insulation
 60x150mm Wood Blocking
 20mm Plywood Panel

FLOOR
 20mm Tiles
 150mm Reinforced Concrete
 Water Proof Membrane
 200mm Wood fibre insulation
 20mm Plywood Panel

FOUNDATION
 250mm Reinforced Concrete
 Retaining Wall
 Water Proof Membrane
 150mm Wood fibre insulation
 60x150mm Wood Blocking
 20mm Plywood Panel

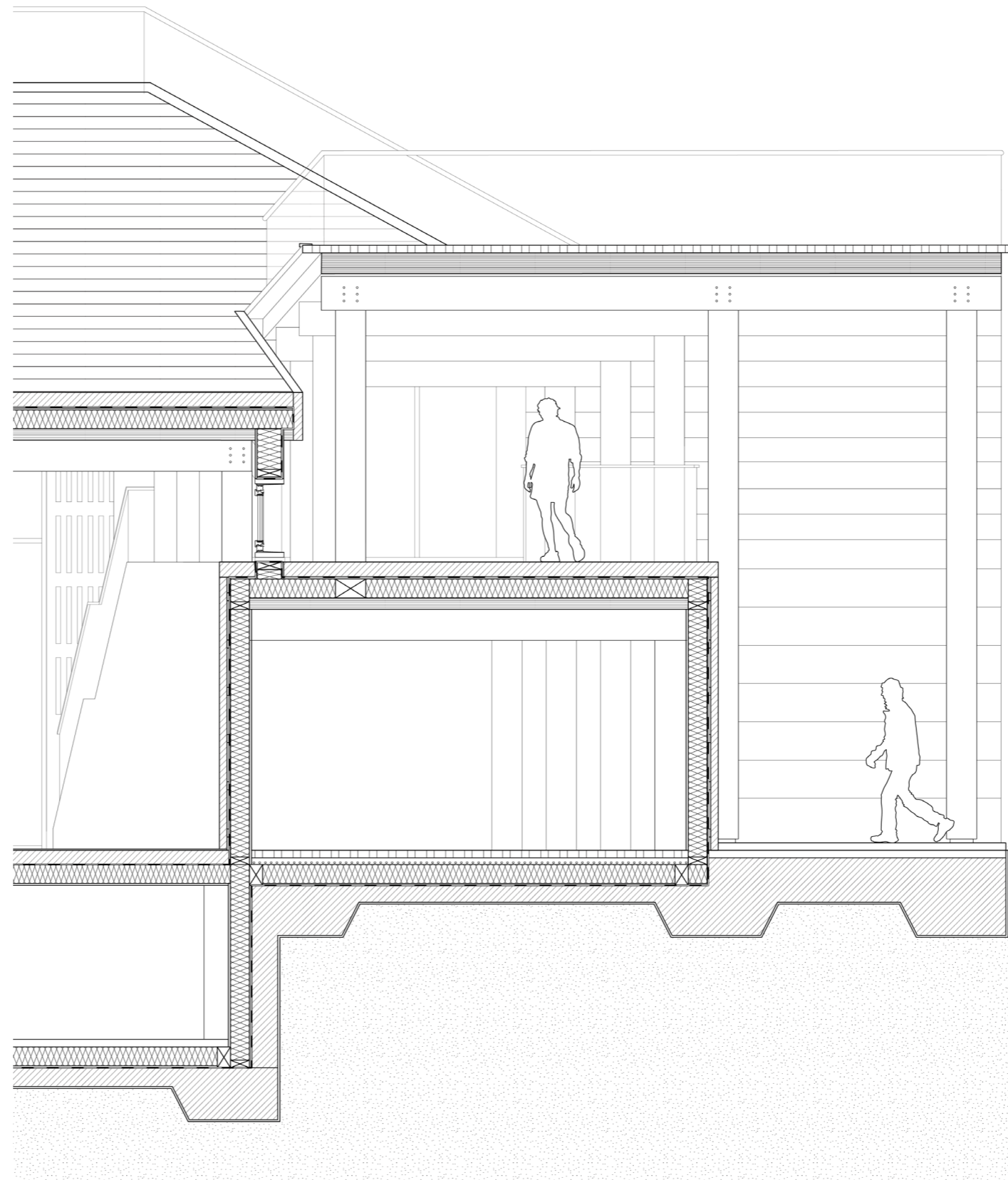

ROOF
 80mm Floor boards
 20mm Structural support
 Protection and Vapour barrier
 200mm Wood fibre insulation
 120mm CLT

STRUCTURE
 Timber Beam 140x220mm
 Timber Column 2*180x230mm

FLOOR
 150mm Cement Tiles 150mm
 20mm structural support
 Protection and vapour barrier
 200mm wood fibre insulation
 120mm CLT

FLOOR
 80mm Floor Boards
 Underfloor Heating
 200mm Wood Fibre Insulation
 140x220mm Wood Blocking
 Protection and Vapour barrier
 Reinforced Concrete

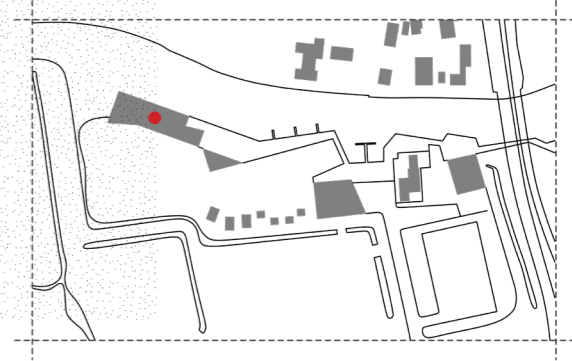

- 00_INTRODUCTION
- 01_CONTEXT
- 02_METHOD
- 03_RESULT

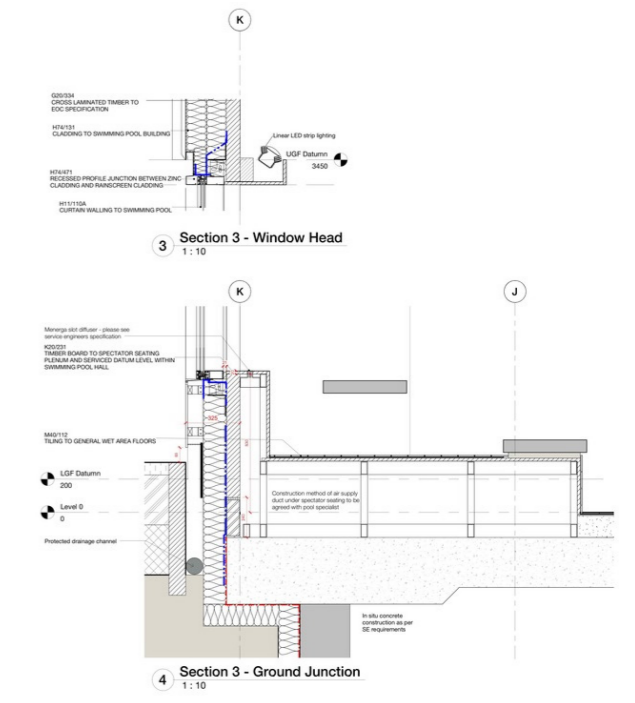

Ref: School Swimming Pool, London / Hawkins Brown

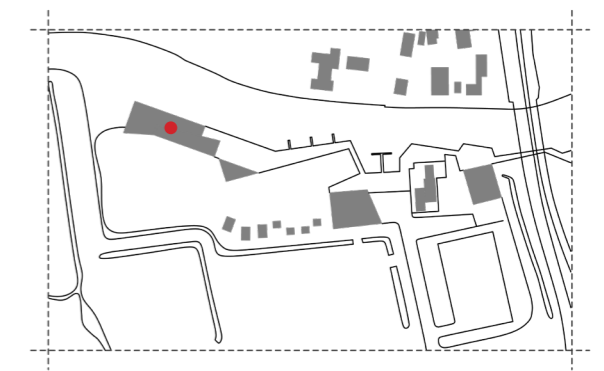
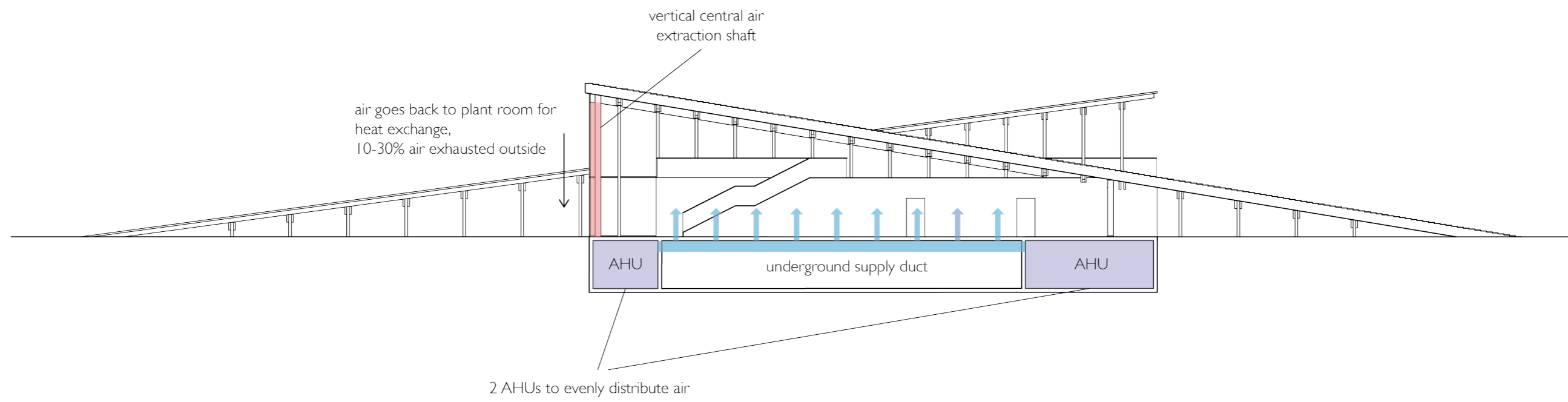



WHERE WATER CONNECTS

modules A

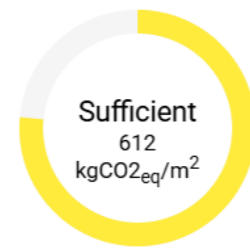

Picking all lowest impact products will lead to the **Sufficient** rating

Where is carbon emitted?

Biggest potential for reduction are in: Superstructure 8.6% Skin 5.8%

Minimum scenario

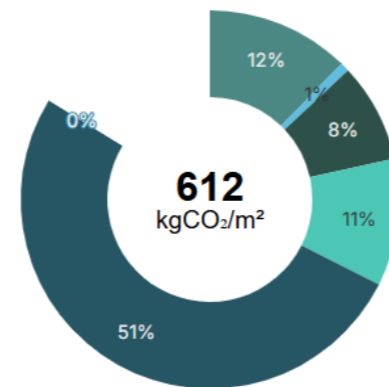

Maximum scenario

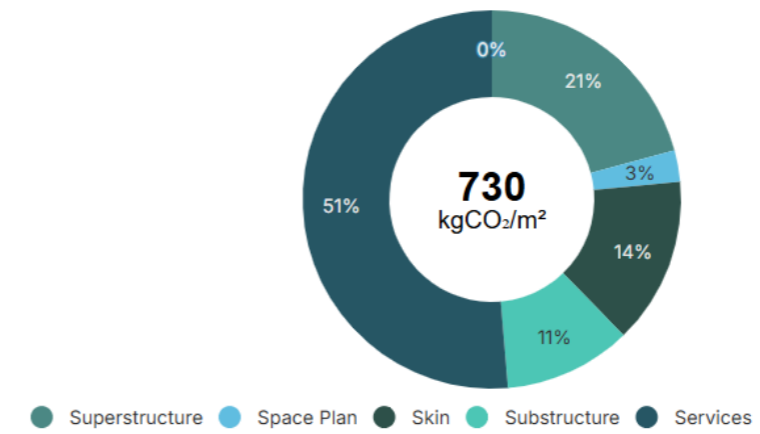

Public Building Graduation Studio 2025-26 (AR4API20)
Leisure and revitalization of post-gas Groningen Re-Start the North (NY BEGUN)

WHERE WATER CONNECTS
Architecture as a Catalyst for Year-Round Activation



Tam Sze Ching, Ariel (6220436)
ir: Henk Bultstra (main mentor)
ir: Sien van Dam (second mentor)
Nathalie de Vries (research-by-design mentor)