

A GLOBAL APPROACH TO VERNACULAR PRACTICES

P5 PRESENTATION

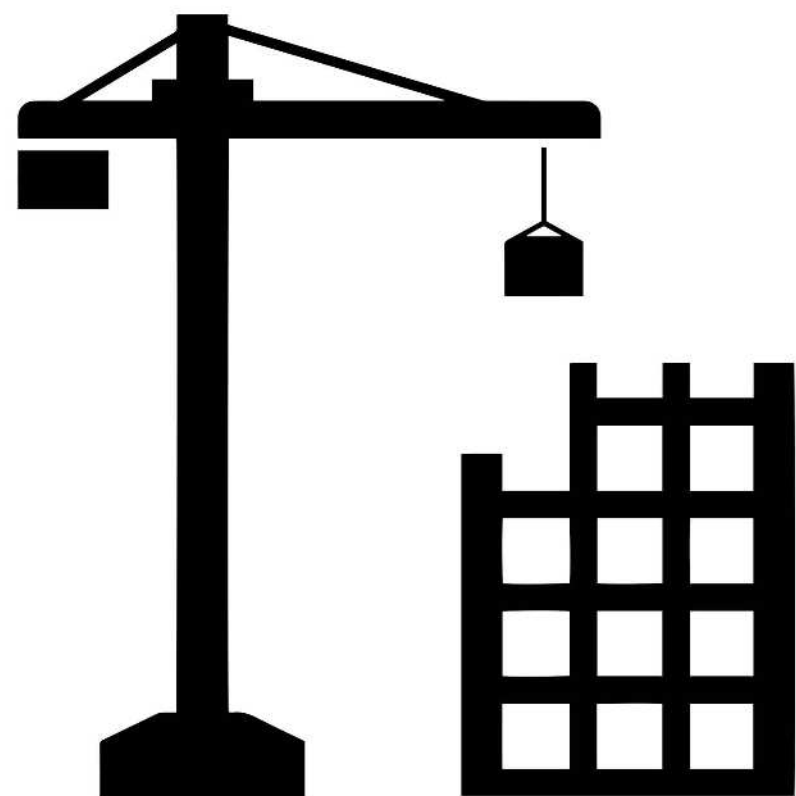

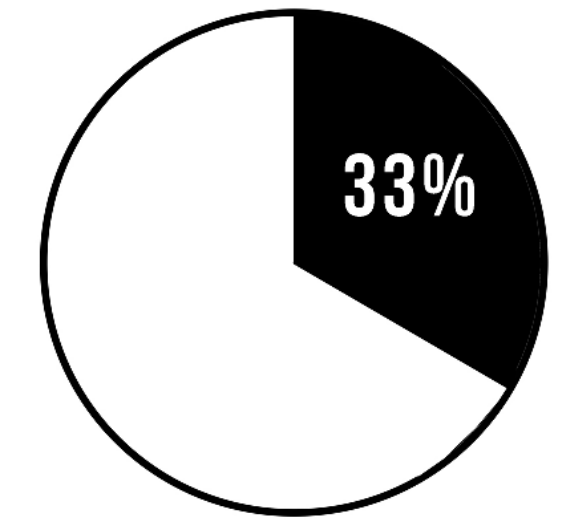
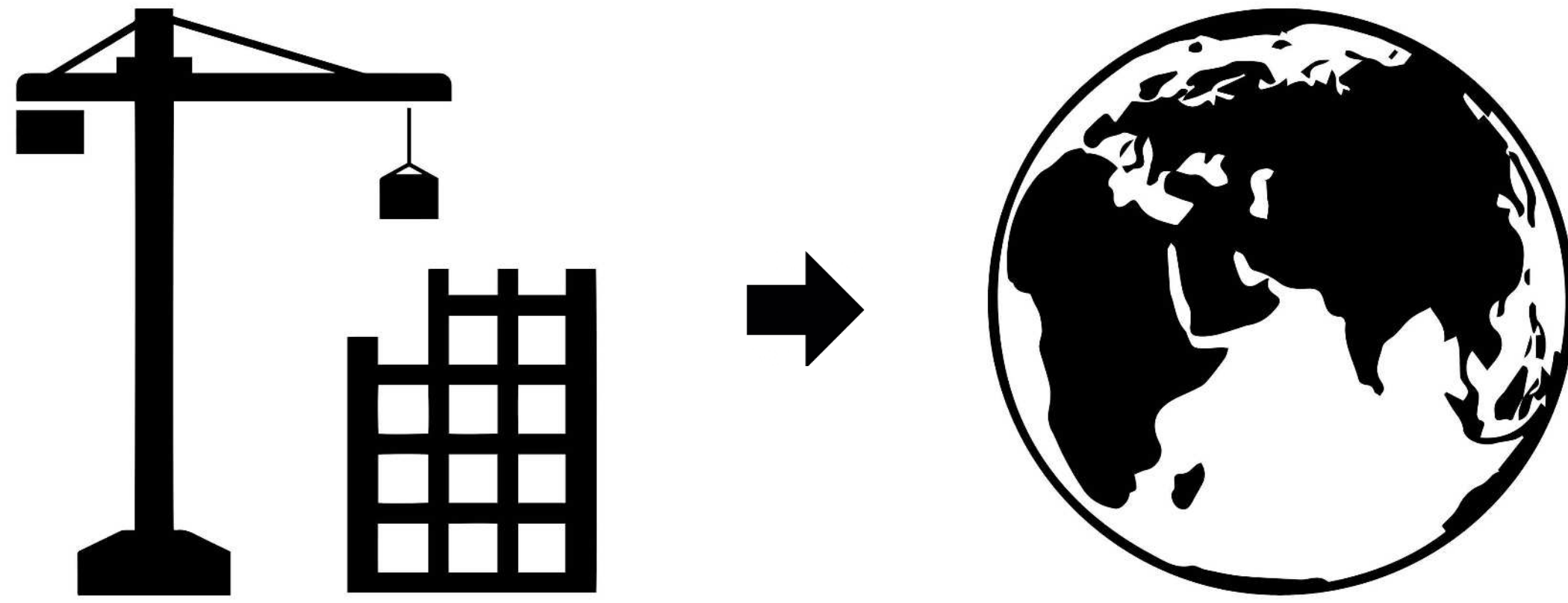

GREENHOUSE GAS EMISSIONS

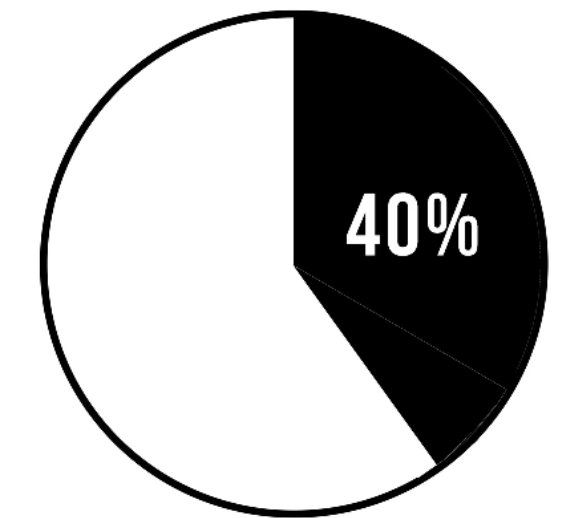

ENERGY USE



WINDSTORMS



LANDSLIDES



FLOODS



FIRES



RISING SEA LEVELS

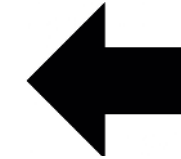
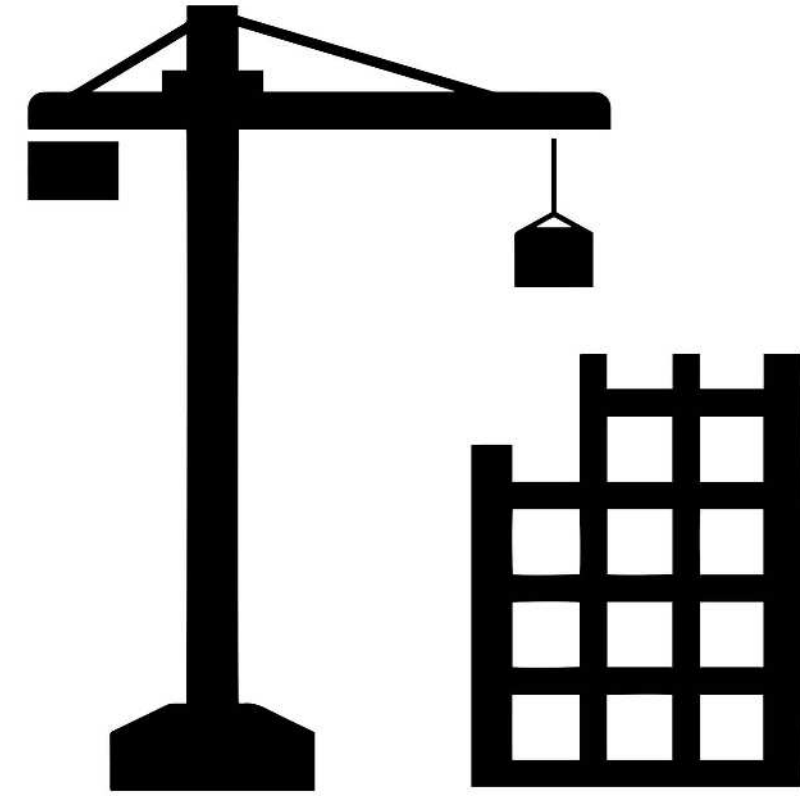



50%

**OF THE POPULATION OF SOUTH ASIA
WAS AFFECTED BY AT LEAST ONE TYPE
OF NATURAL HAZARD BETWEEN 1990
AND 2008.**

USA



CHINA



EUROPE



INDIA



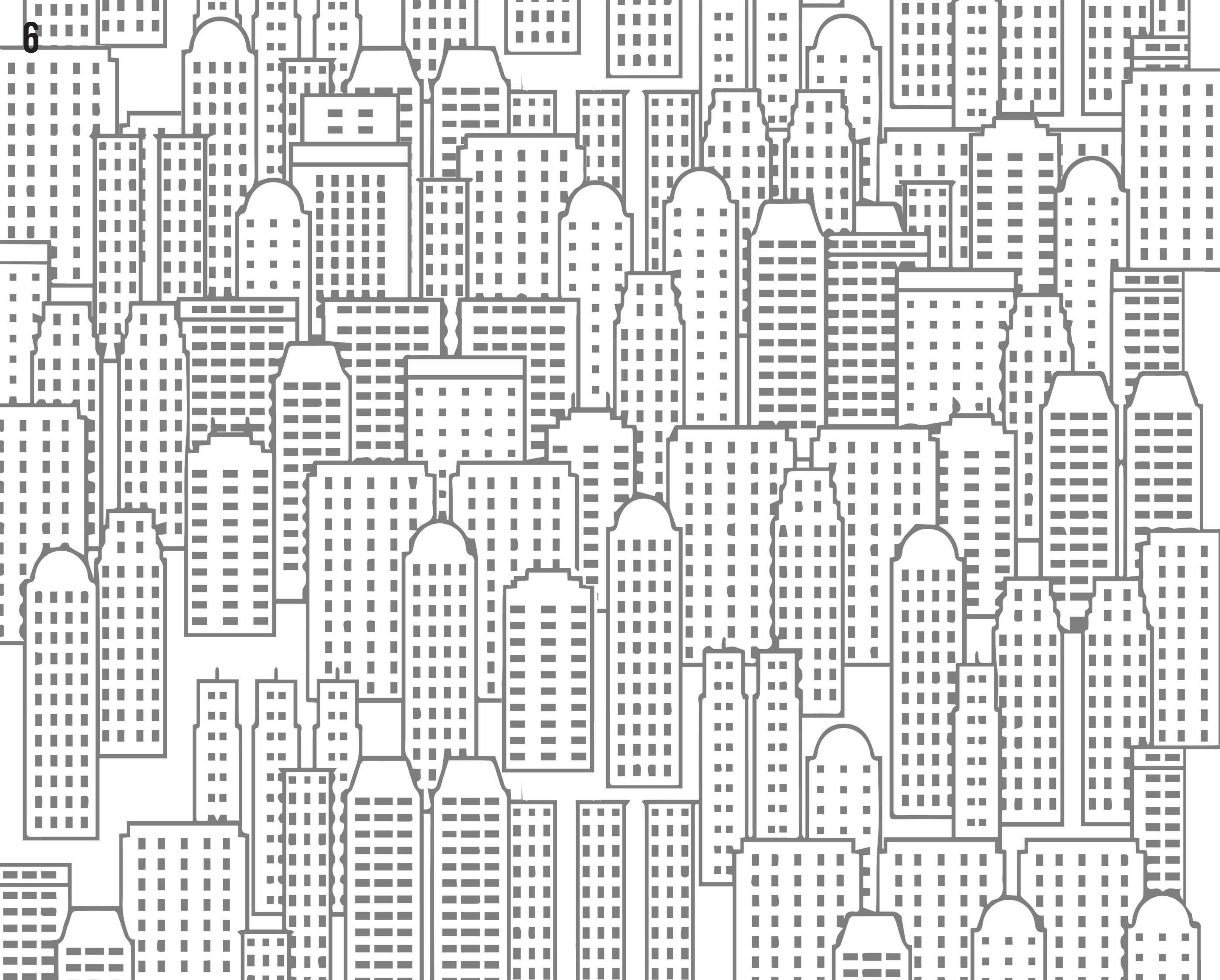

CONSTRUCTION IN INDIA

20%
NATIONAL CARBON EMISSION

80%
FOR STEEL, BRICKS, CEMENT

156%
GROWTH RATE BETWEEN 2000 - 2007

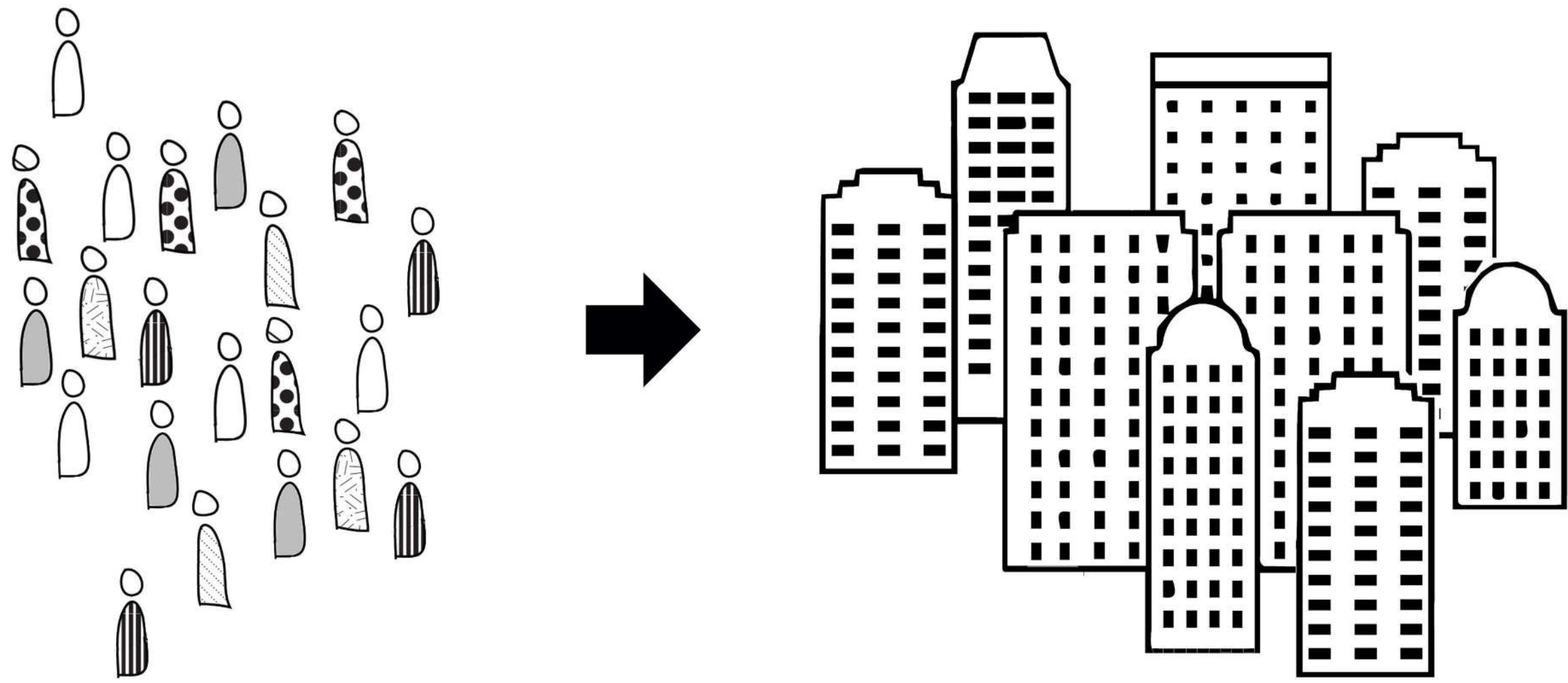

MIGRATION

URBAN POPULATION FROM 31% IN 2011 TO 42.5% IN 2025

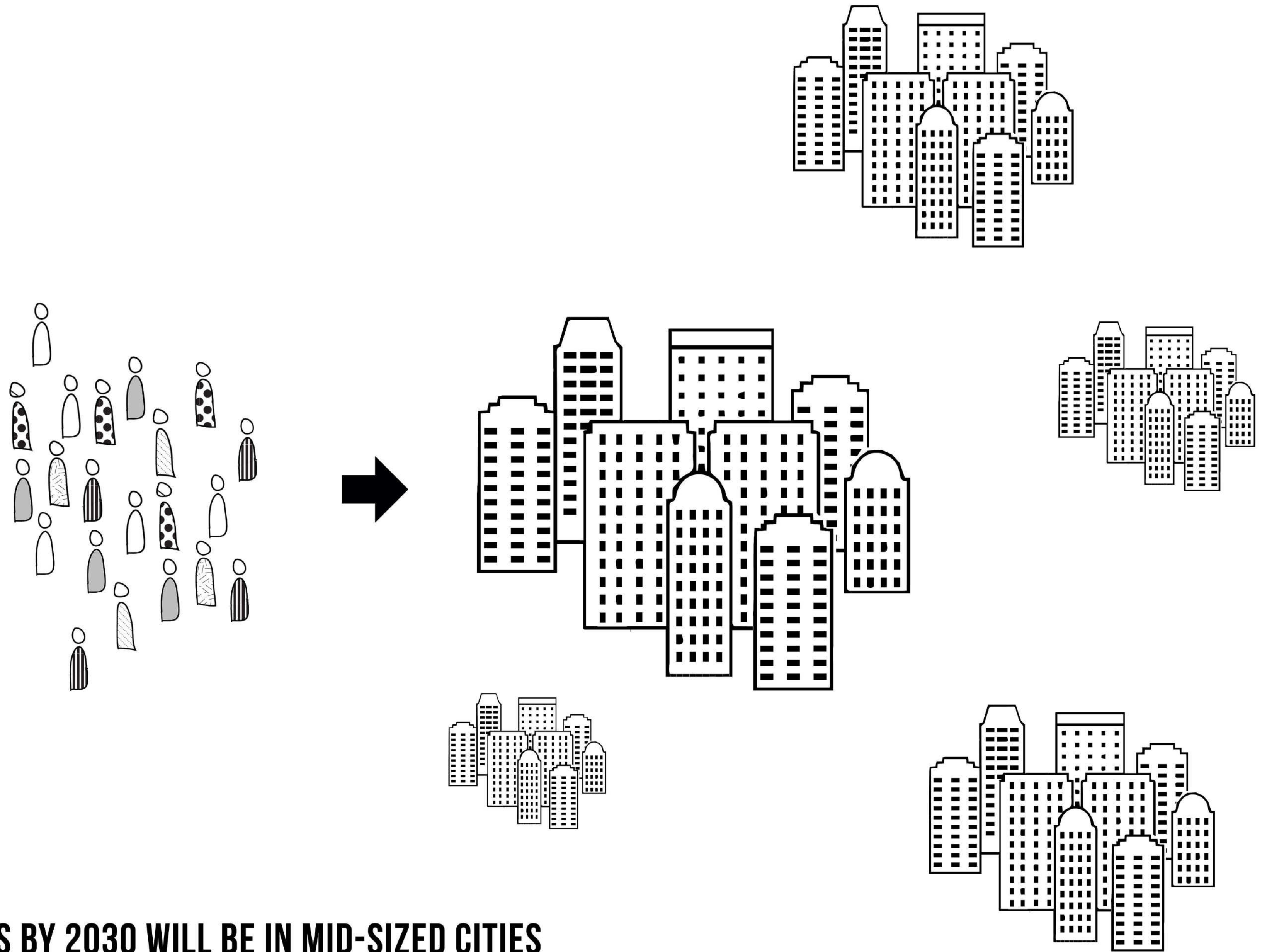

MIGRATION

50 MILLION OF NEW URBAN RESIDENTS BY 2030 WILL BE IN MID-SIZED CITIES

HIMACHAL PRADESH

AND THE FRAGILE HIMALAYAN ECOSYSTEM

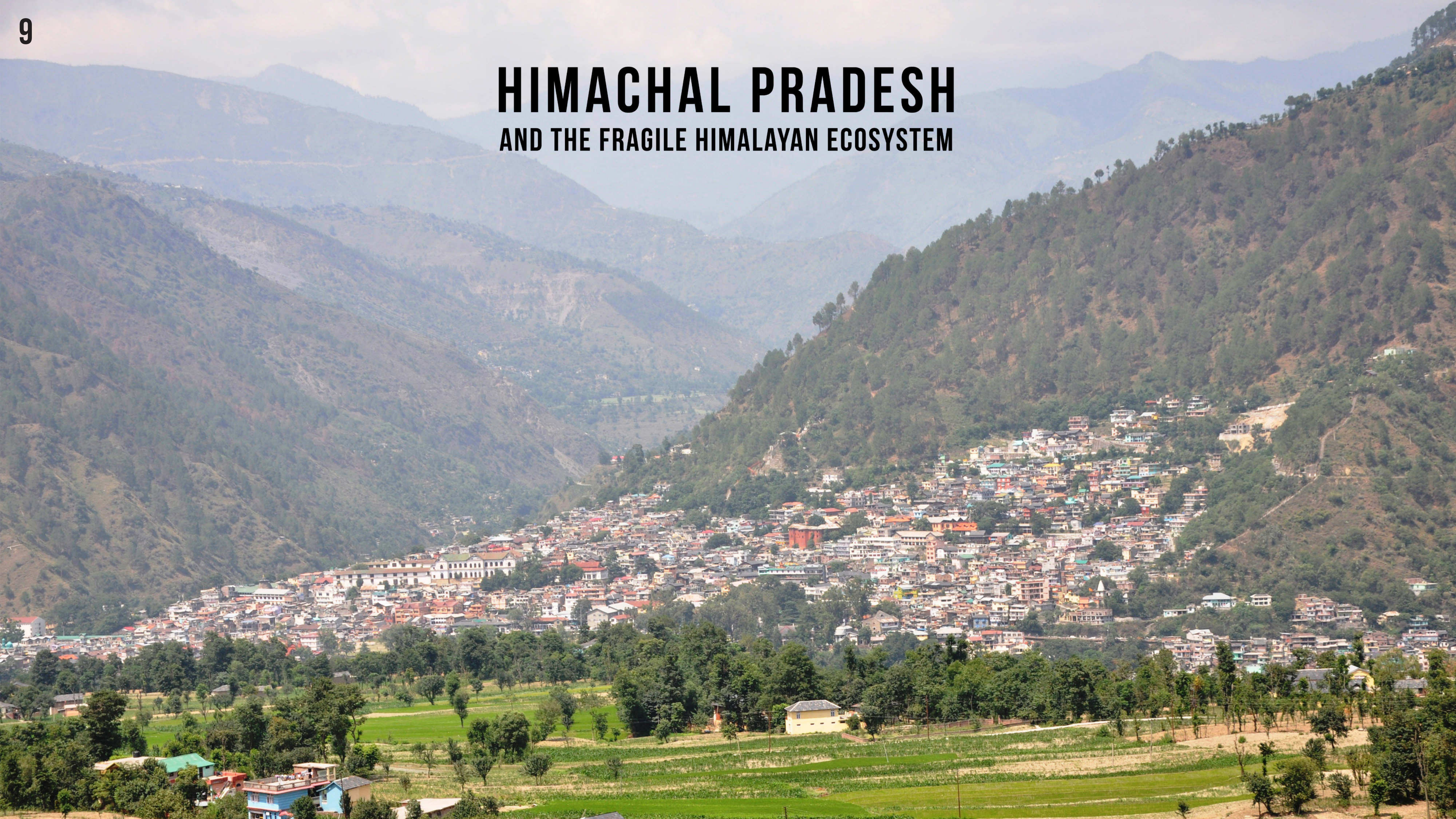

HIMACHAL PRADESH IN INDIA



**KULLU DISTRICT
IN HIMACHAL PRADESH**



KULLU DISTRICT IN HIMACHAL PRADESH

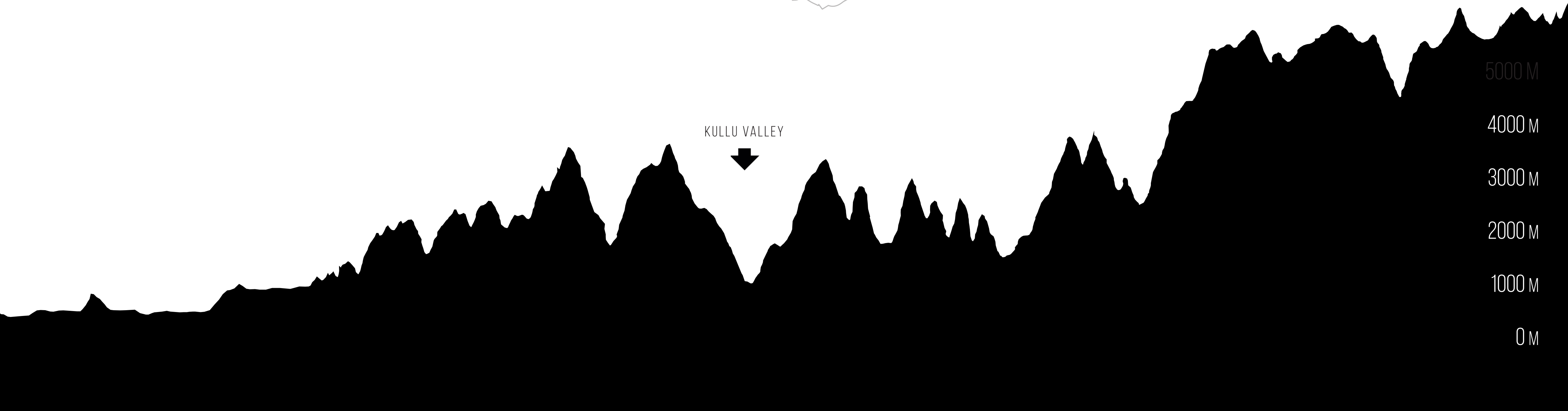
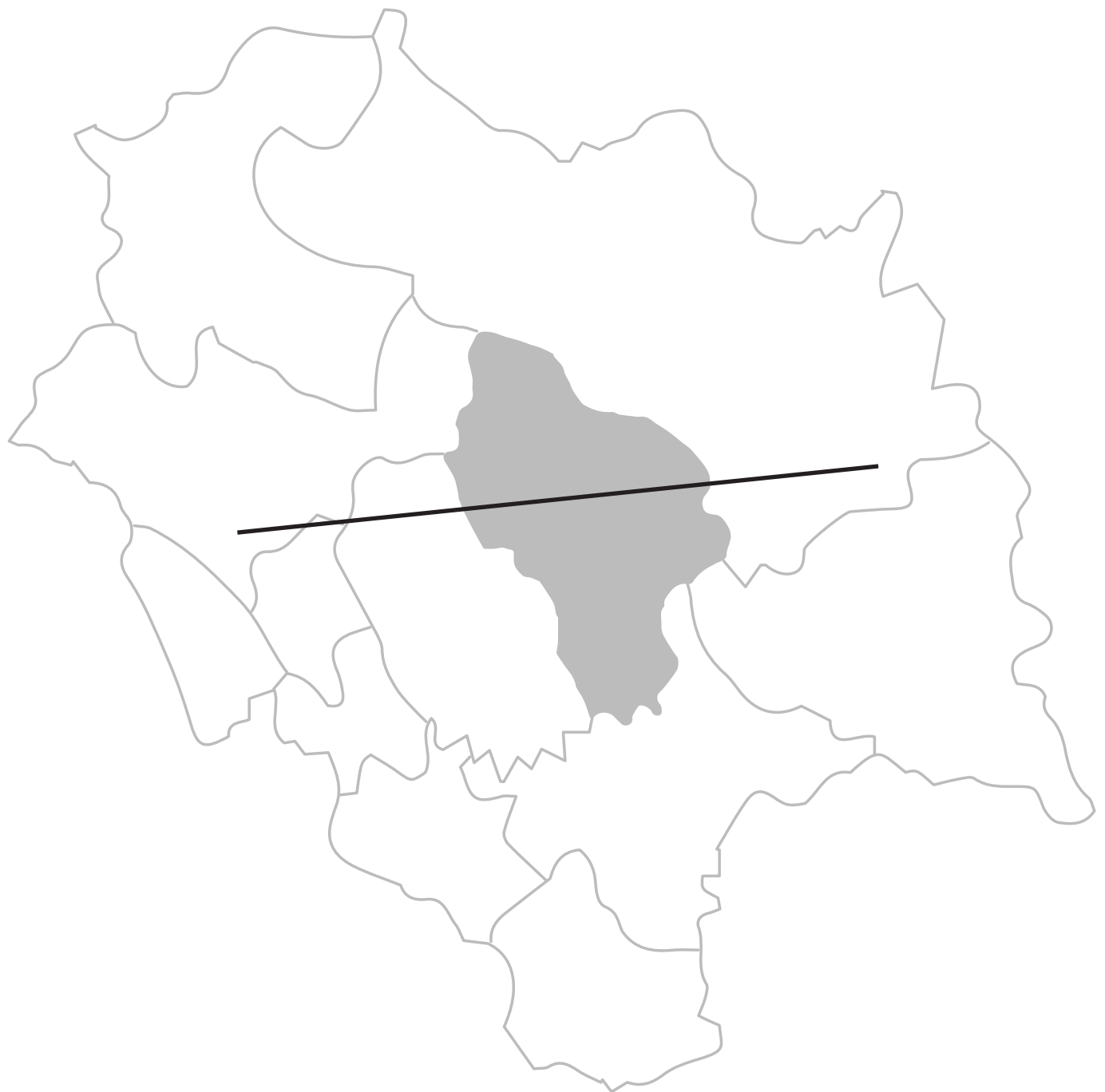



GLACIERS ARE MELTING





DEFORESTATION

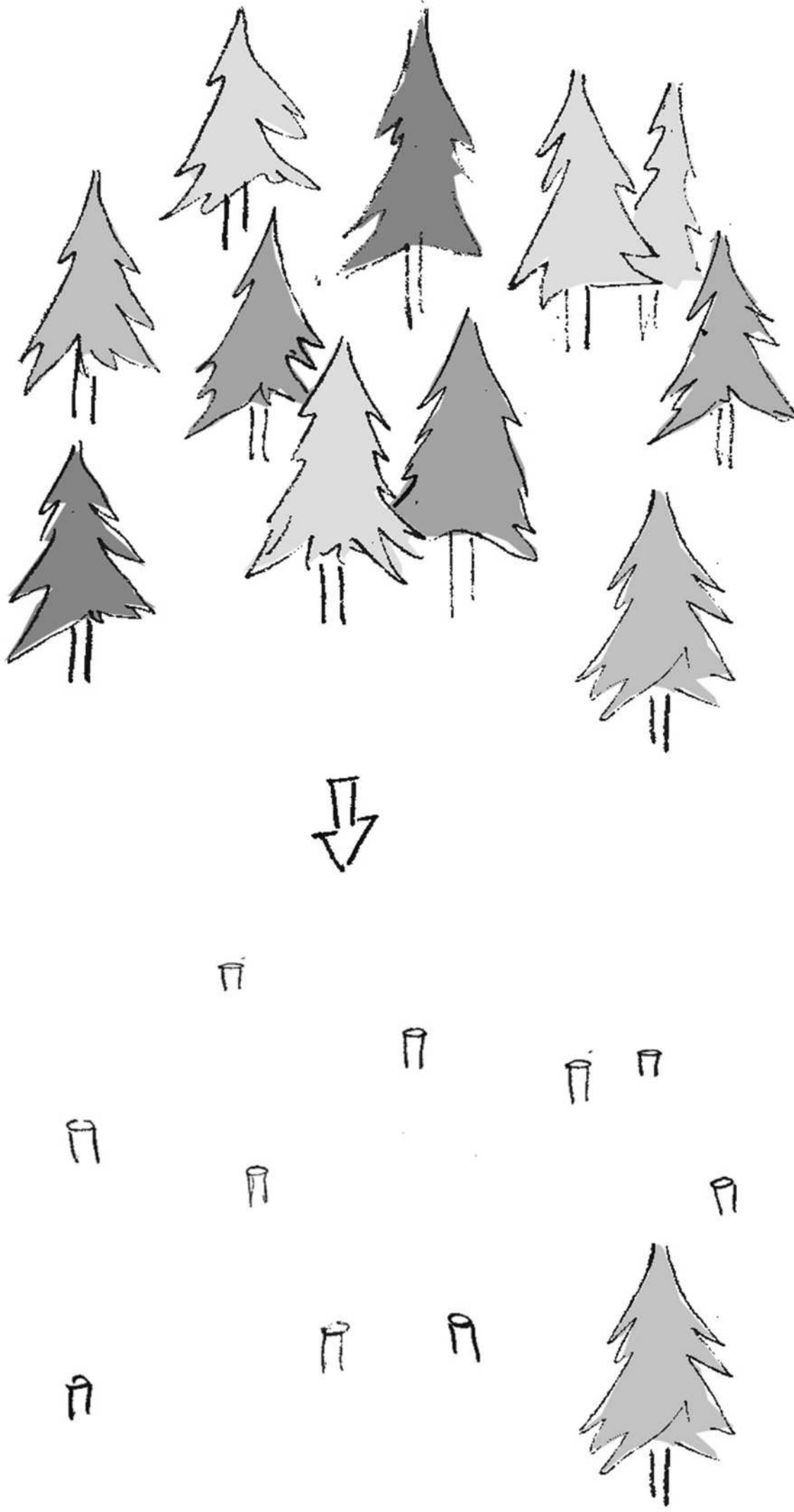



GLOBAL CIVILIZATION / CEMENTIFICATION

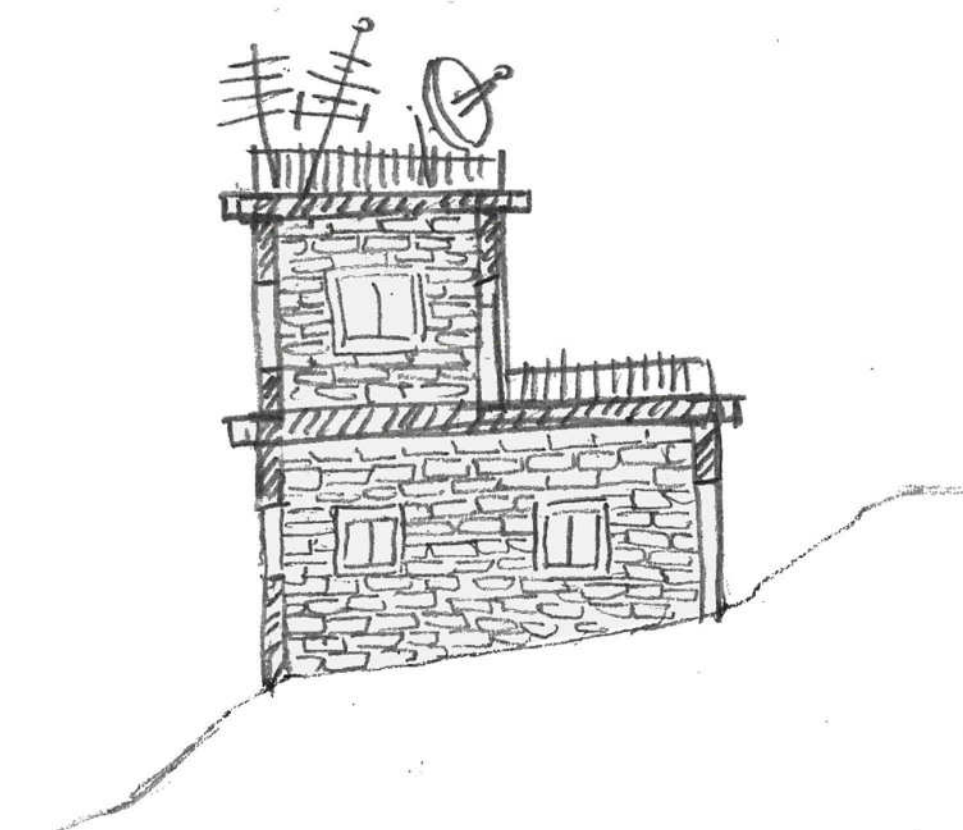

CEMENT PRODUCTION = 94% INDUSTRIAL EMISSION = 50% TOTAL CO2 OF HP



SANJAULI TOWN, SHIMLA

HOW IS THE BUILT ENVIRONMENT OF THE AREA?

VERNACULAR

THE TERM **VERNACULAR**

*derives from the Latin vernaculus, meaning “domestic, native, indigenous”;
from verna, meaning “native slave” or “home-born slave”.*

*It's the **everyday language** spoken by a people as distinguished from the literary language.*

VERNACULAR ACCORDING TO AMOS RAPOPORT

*“A satisfactory definition of vernacular is more difficult at the moment. The most successful way of describing it seems to be in **terms of process**: how it is “**designed**” and built [...]*

*The peasant **owner** is still very much a **participant in the design process**, not merely a consumer. [...]*

*The model itself is the result of the collaboration of many people, over many generations, as well as the **collaboration between makers and users of buildings** [...]*

*Since knowledge of the model is shared by all, there is **no need for drawings or designers.**”*

VERNACULAR =

“architecture without architects”



ORDINARY VERNACULAR

GRAND VERNACULAR



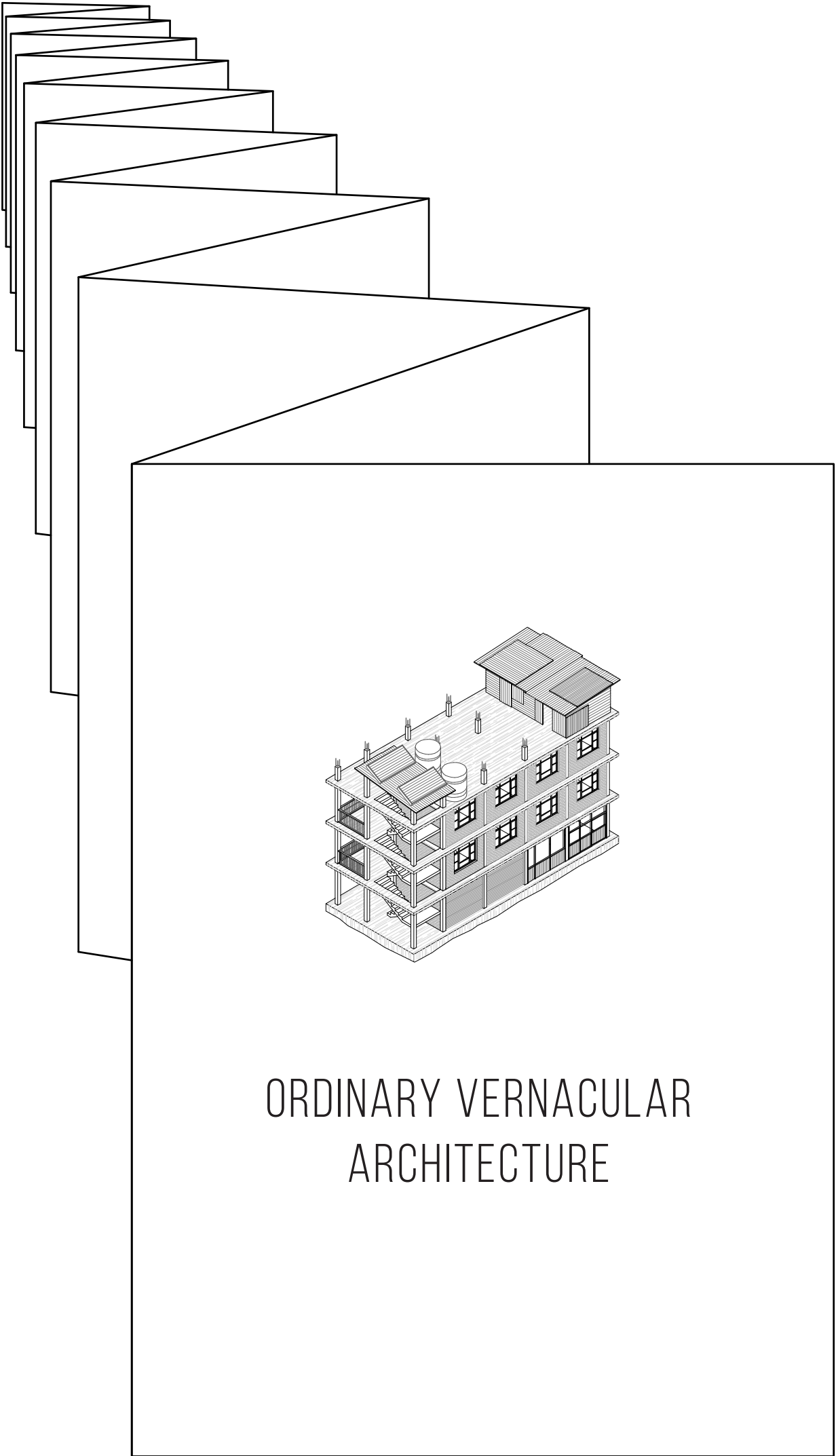
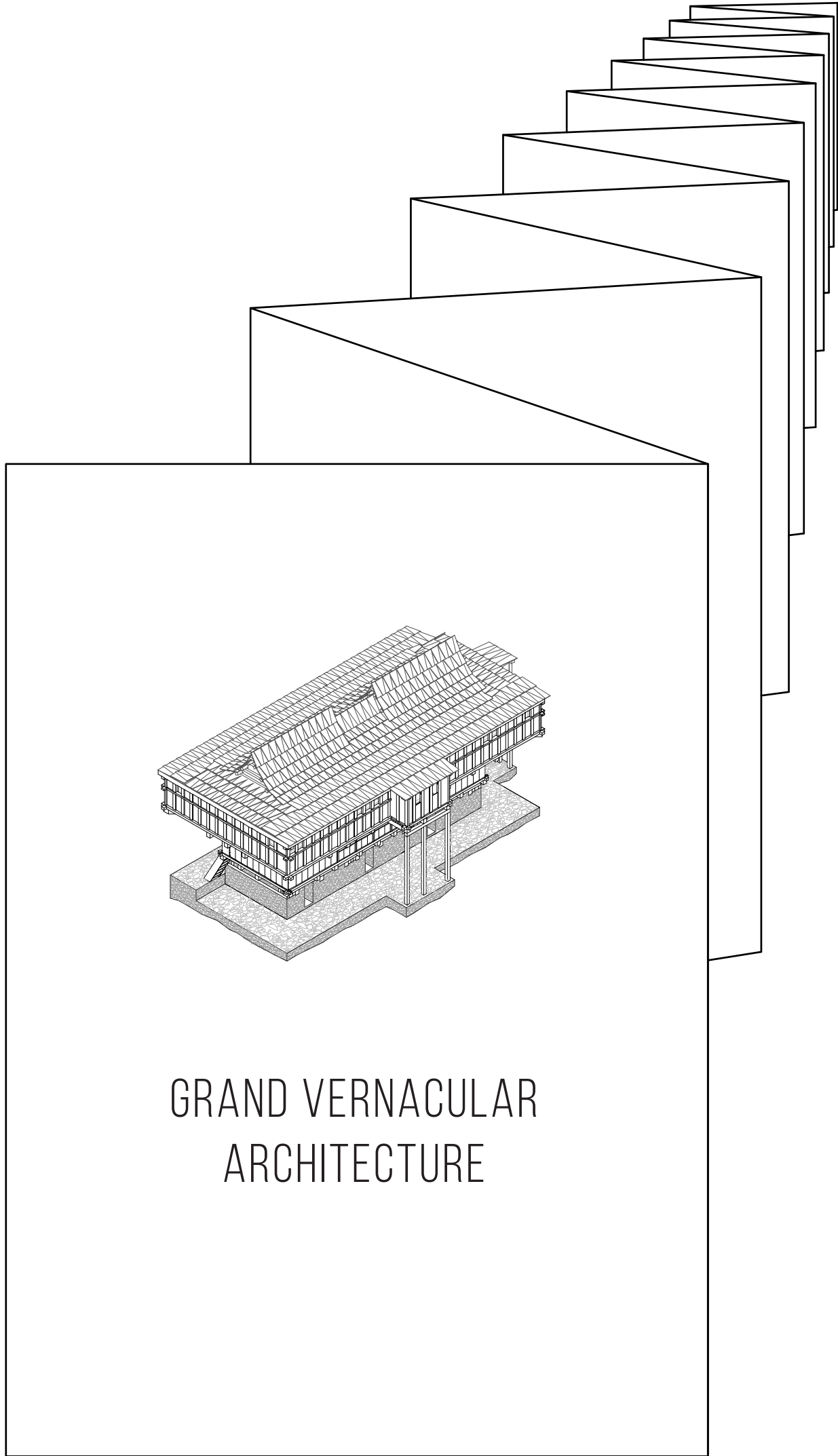

**SIDE A
CONSTRUCTION
PROCESS**

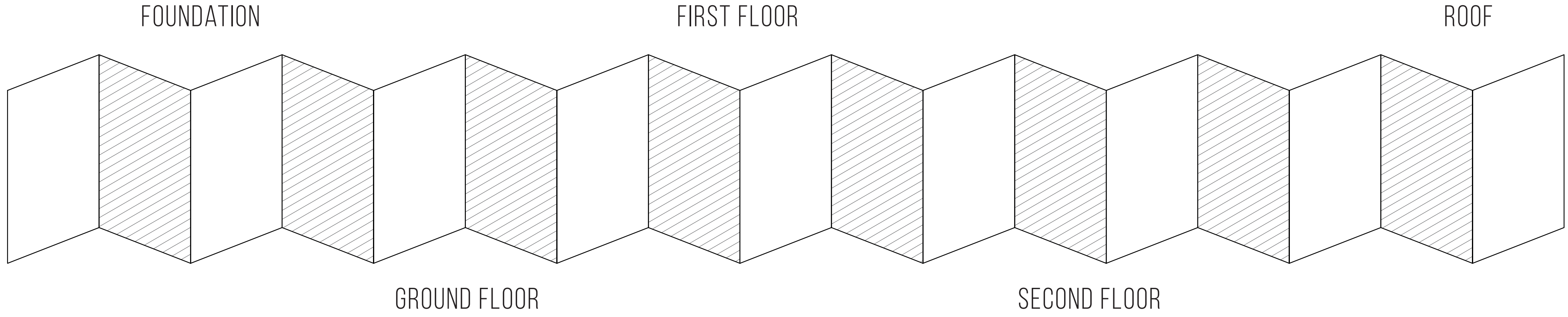

**SIDE B
BUILDING
ANALYSIS**

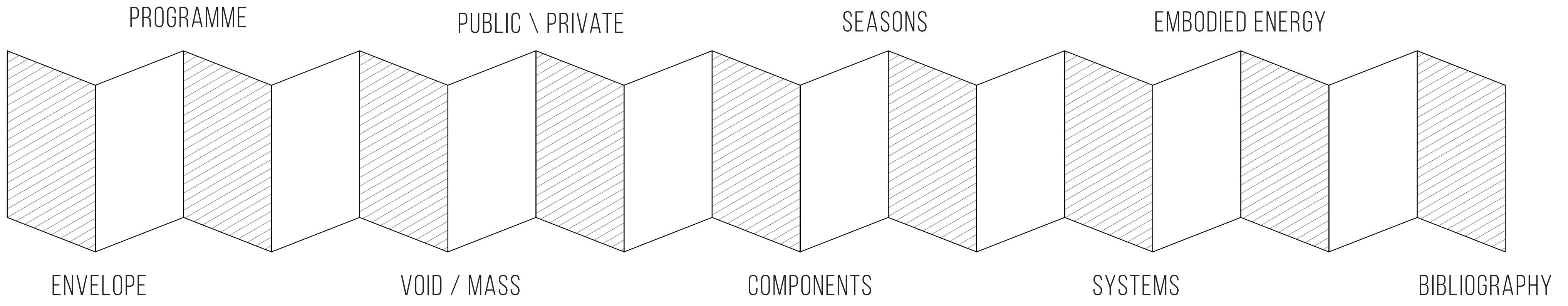

**SIDE A
CONSTRUCTION
PROCESS**

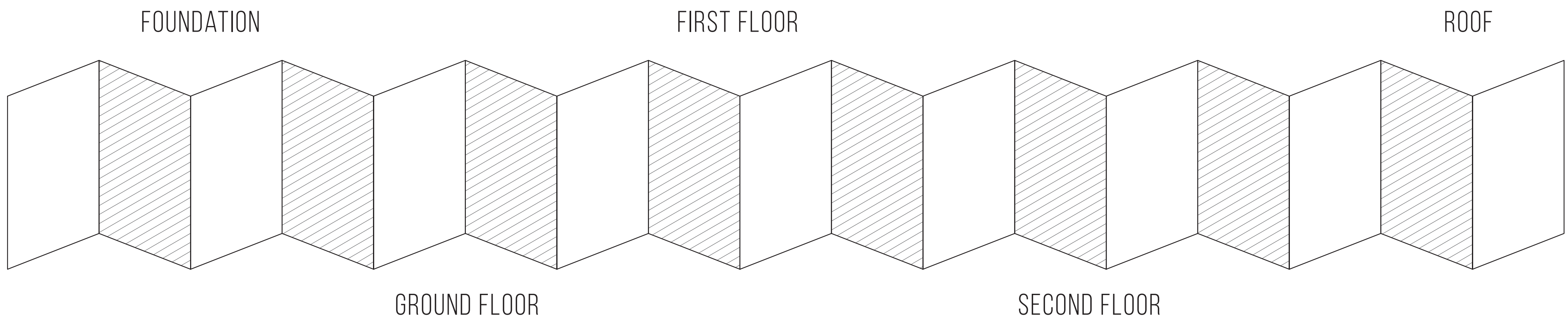

**SIDE B
BUILDING
ANALYSIS**

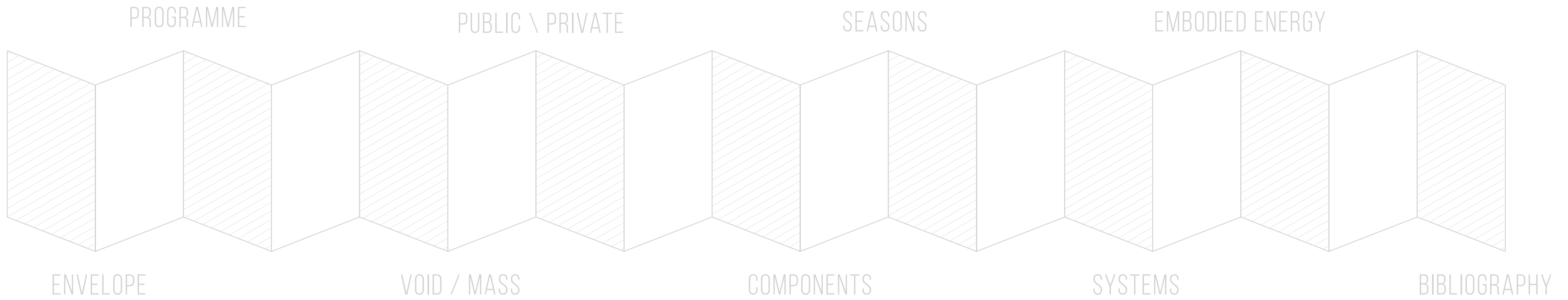

GRAND VERNACULAR
ARCHITECTURE

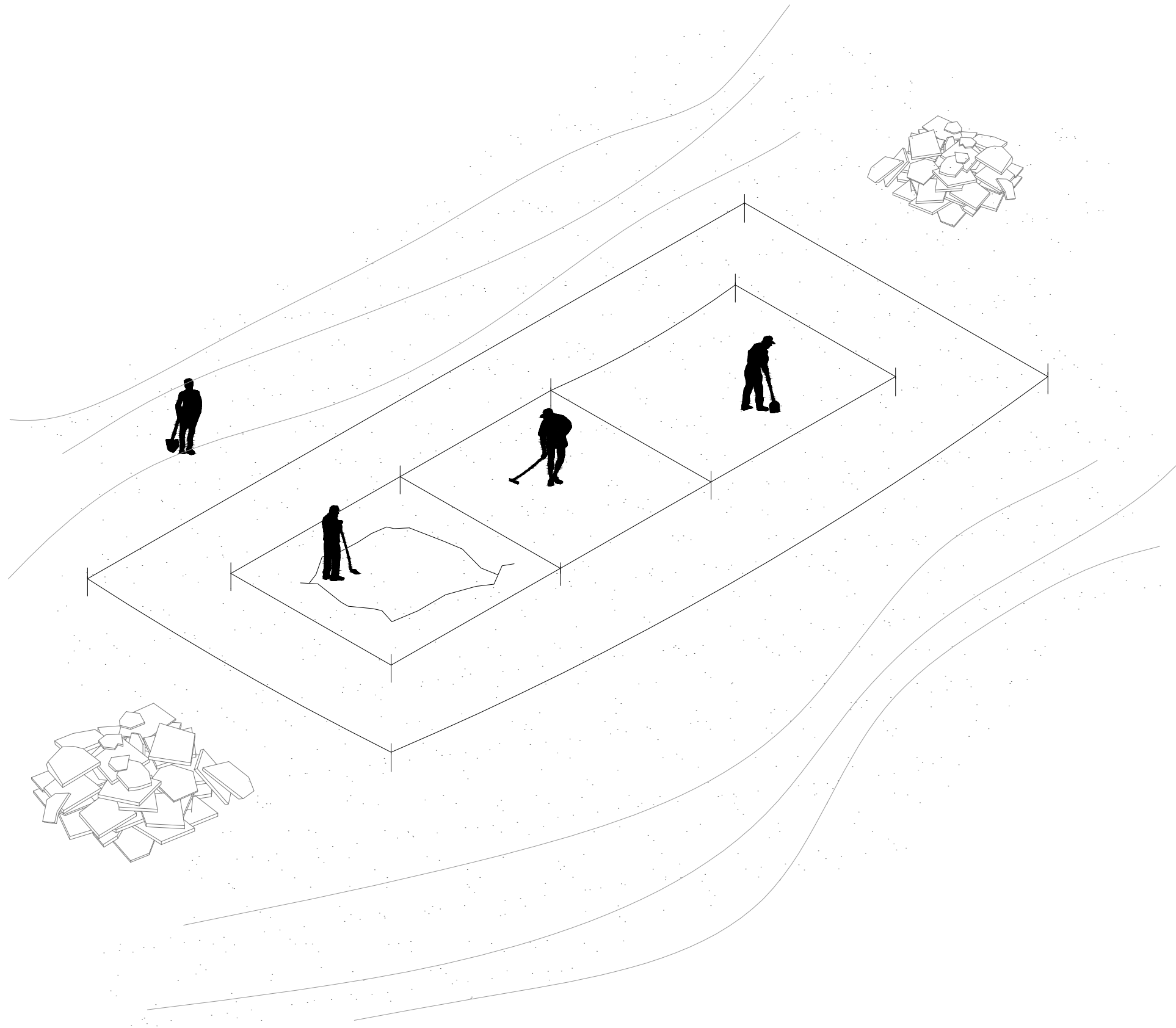

ORDINARY VERNACULAR
ARCHITECTURE

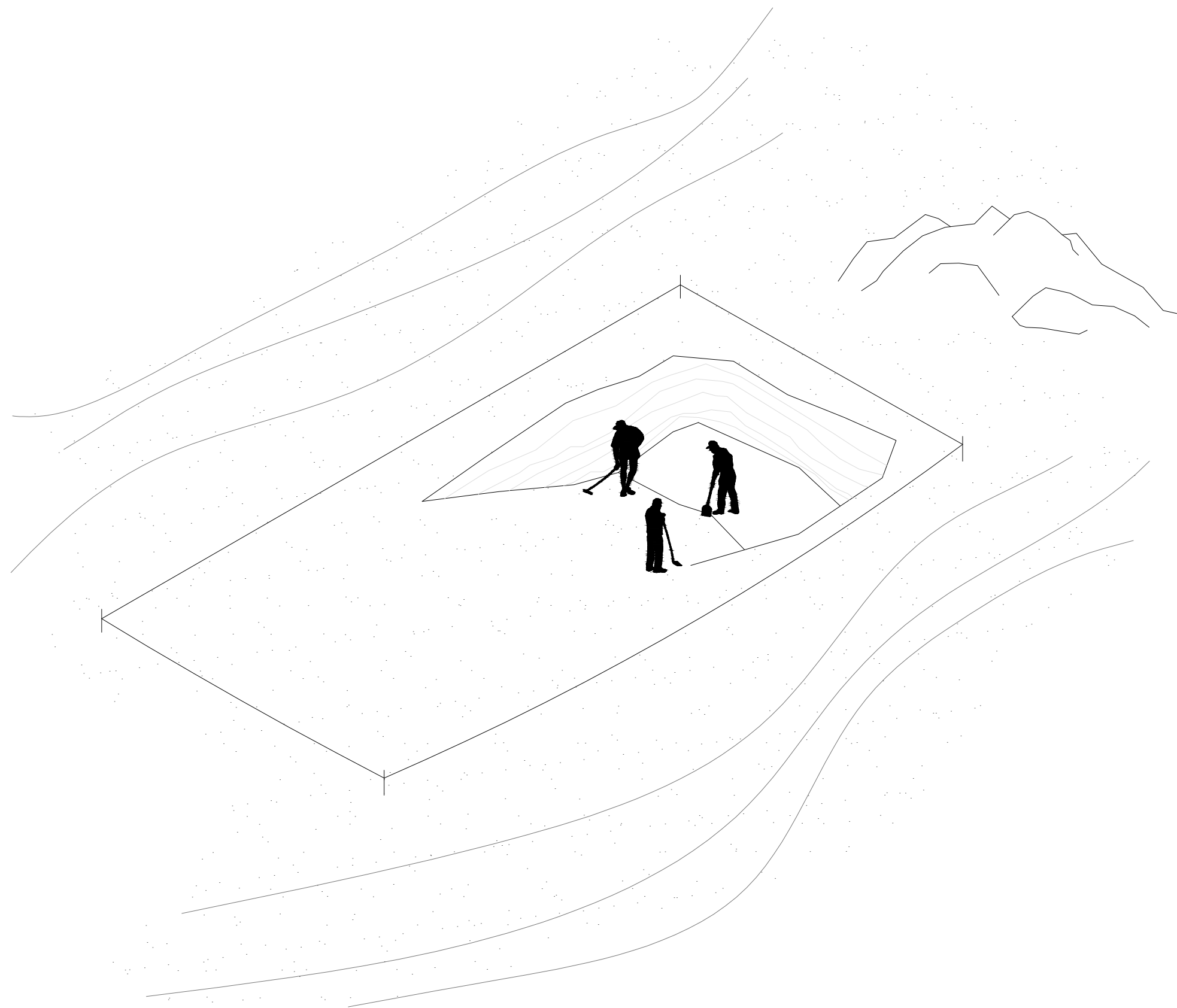

GRAND VERNACULAR
ARCHITECTURE

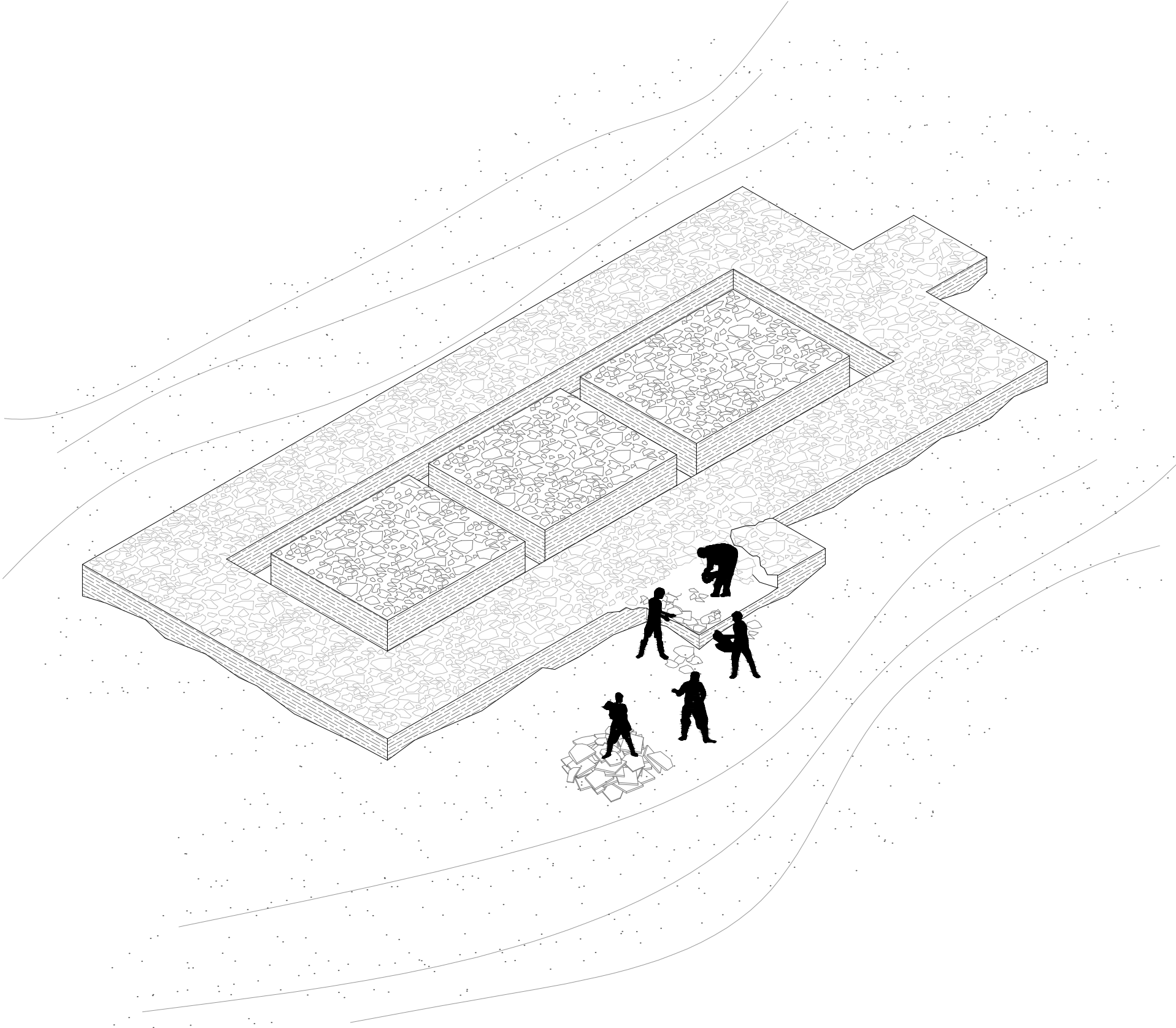

ORDINARY VERNACULAR
ARCHITECTURE

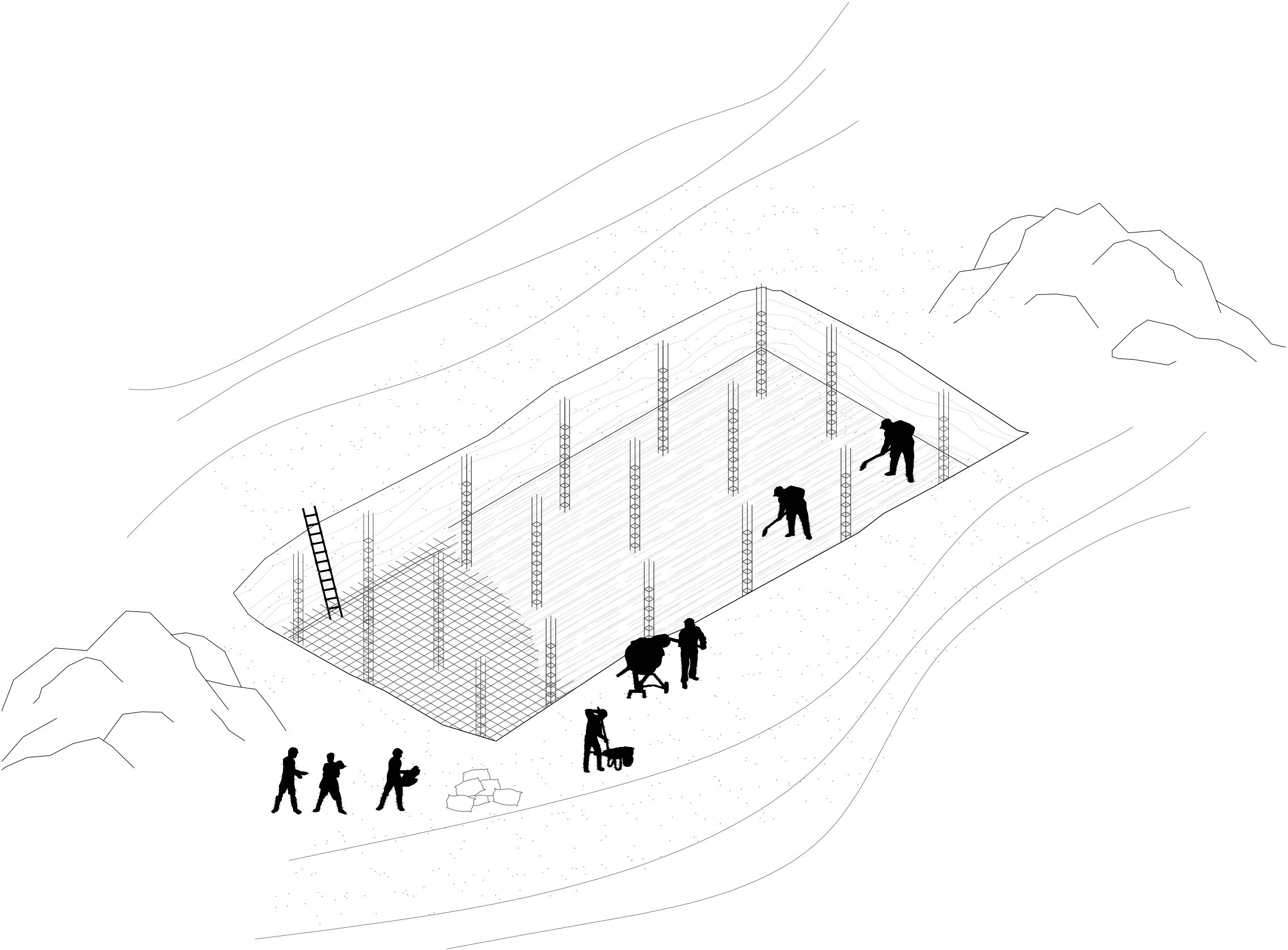

GRAND VERNACULAR
ARCHITECTURE

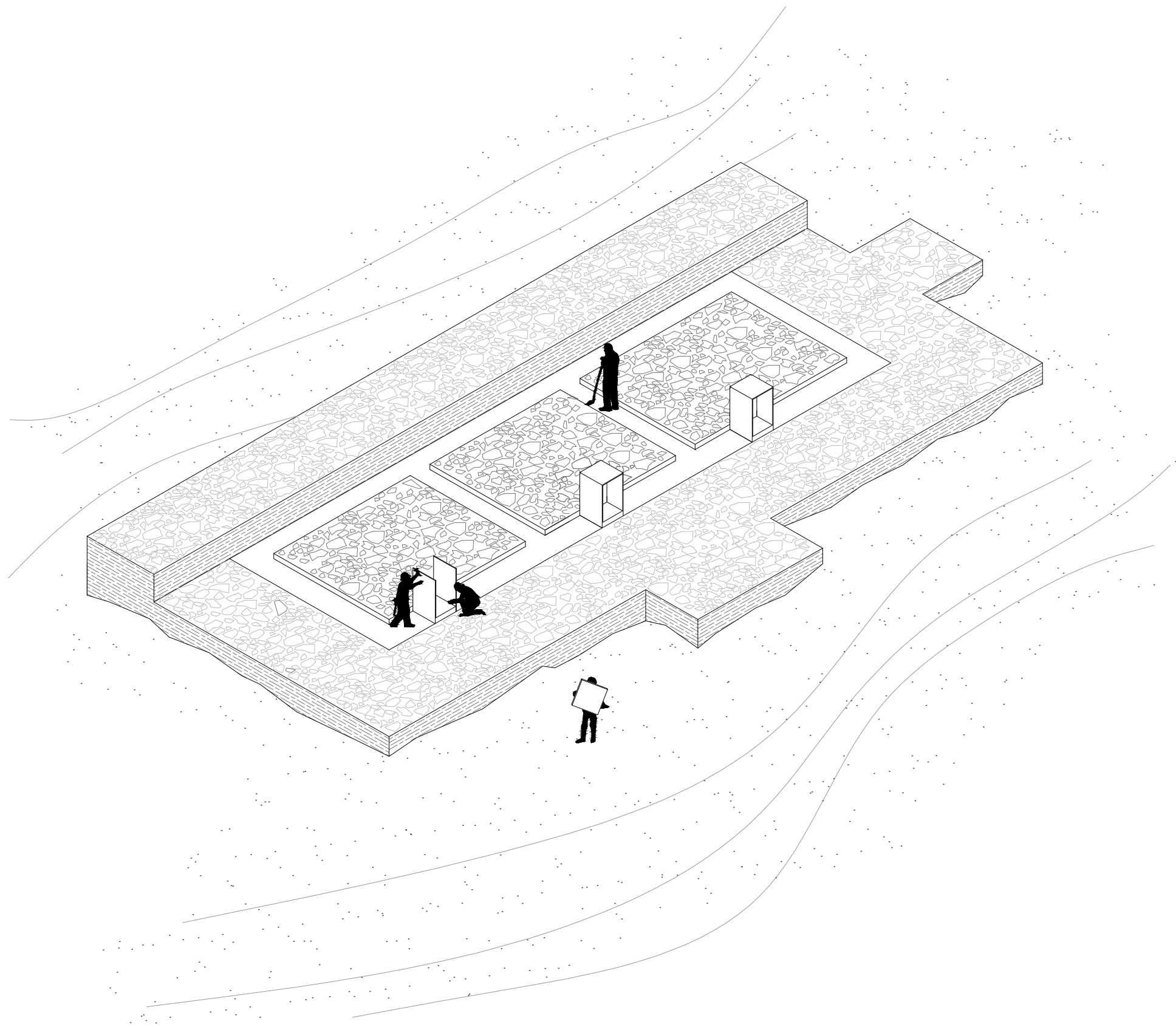

ORDINARY VERNACULAR
ARCHITECTURE

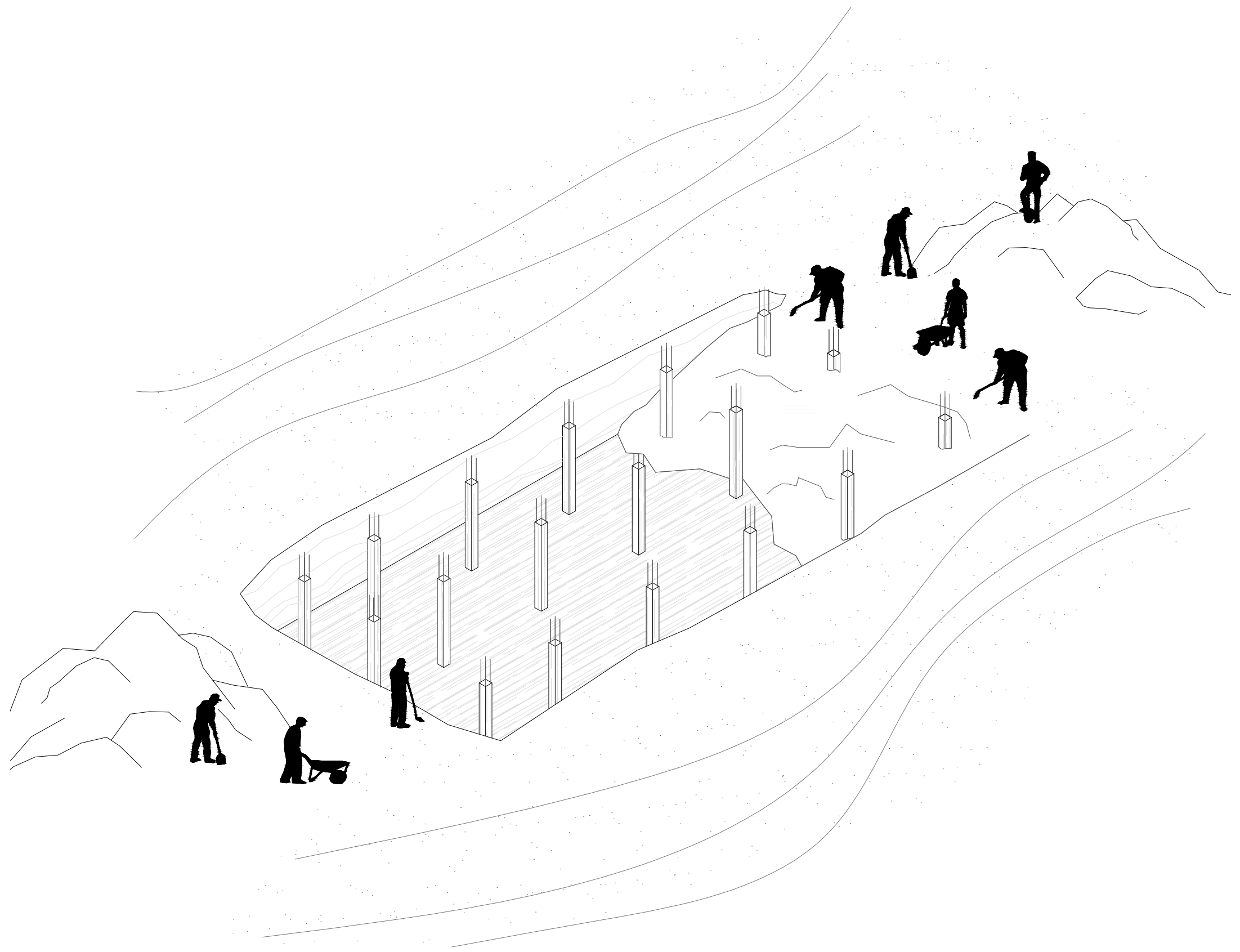

GRAND VERNACULAR
ARCHITECTURE

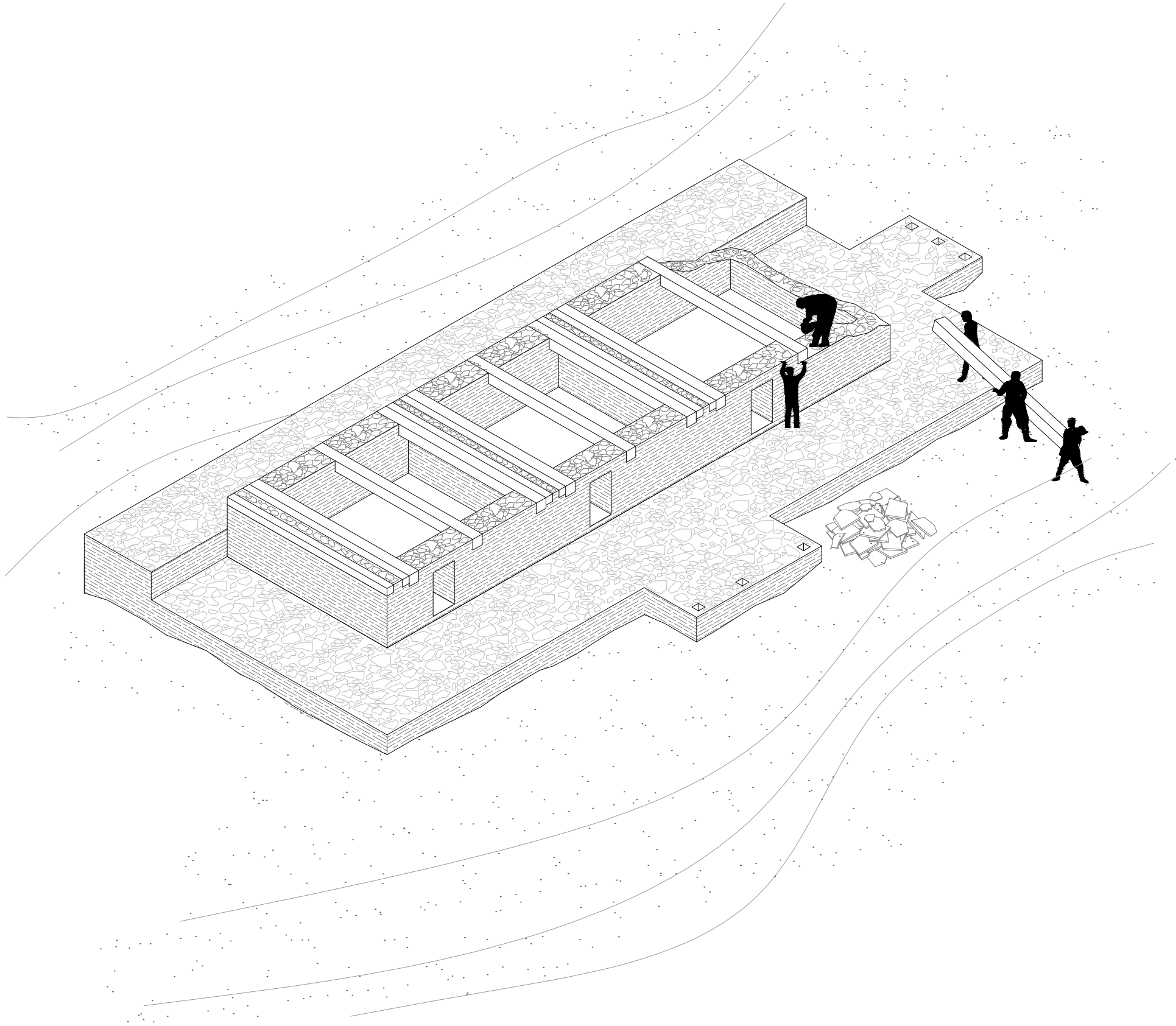

ORDINARY VERNACULAR
ARCHITECTURE

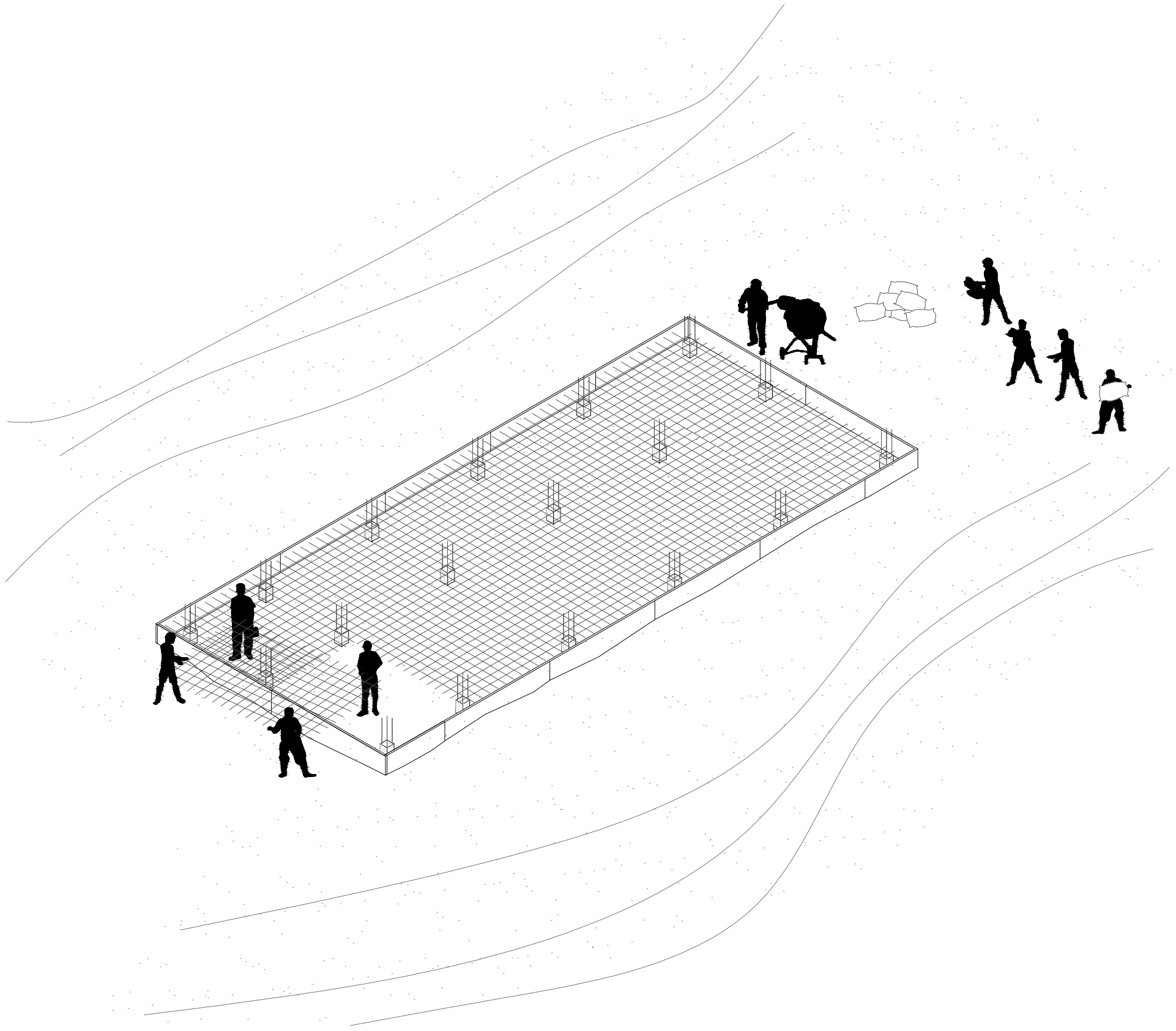

GRAND VERNACULAR
ARCHITECTURE

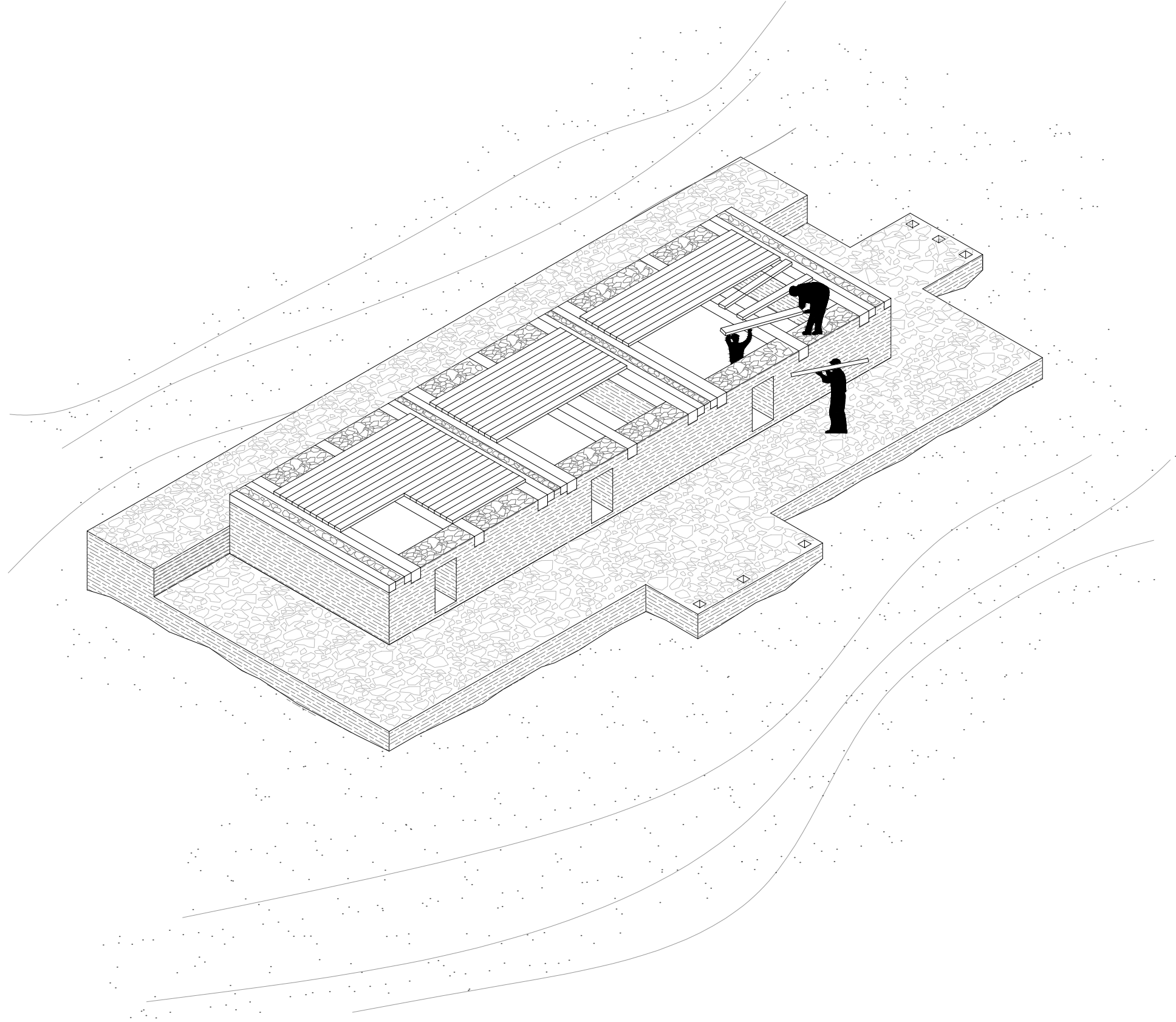

ORDINARY VERNACULAR
ARCHITECTURE

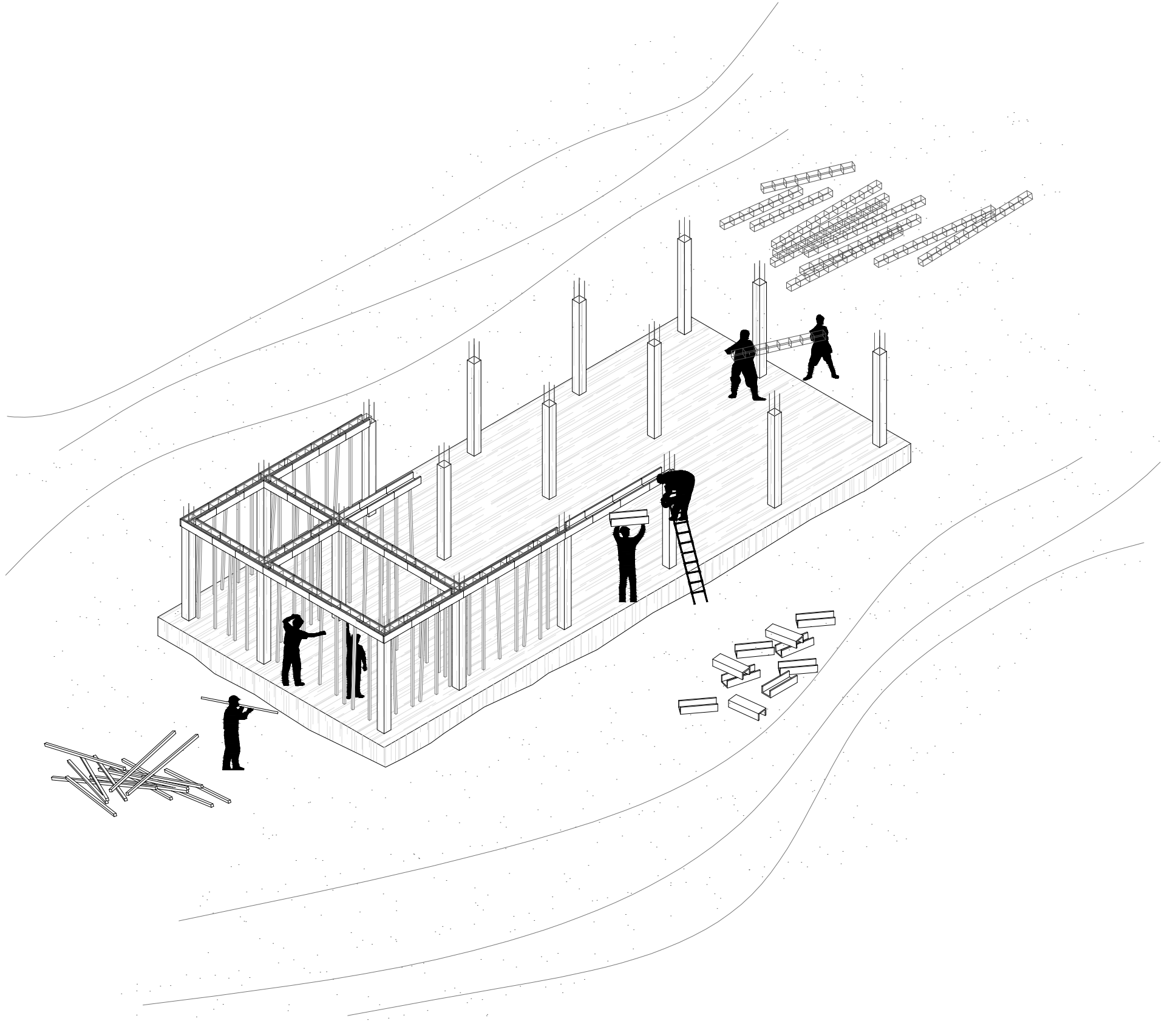

GRAND VERNACULAR
ARCHITECTURE

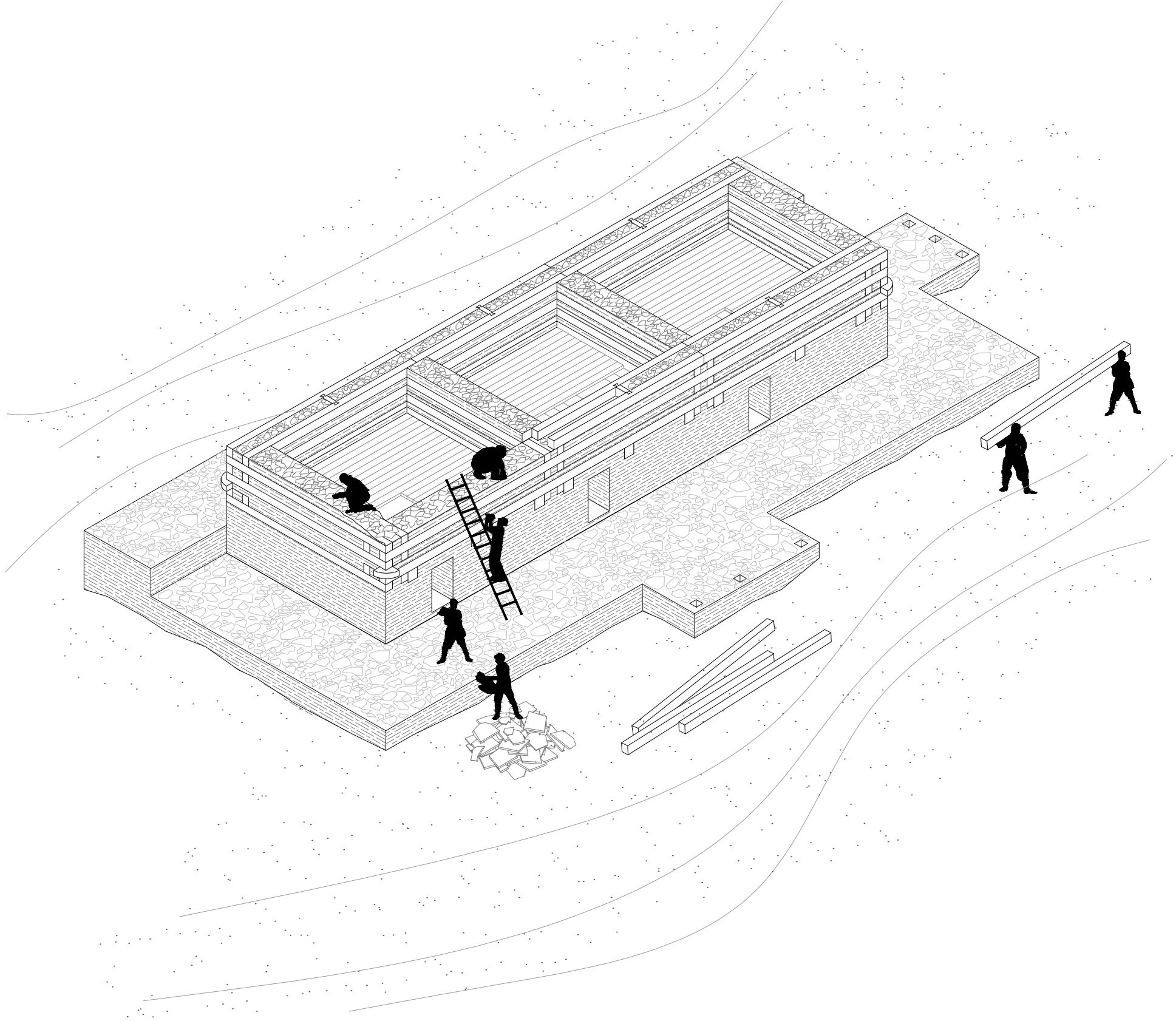

ORDINARY VERNACULAR
ARCHITECTURE

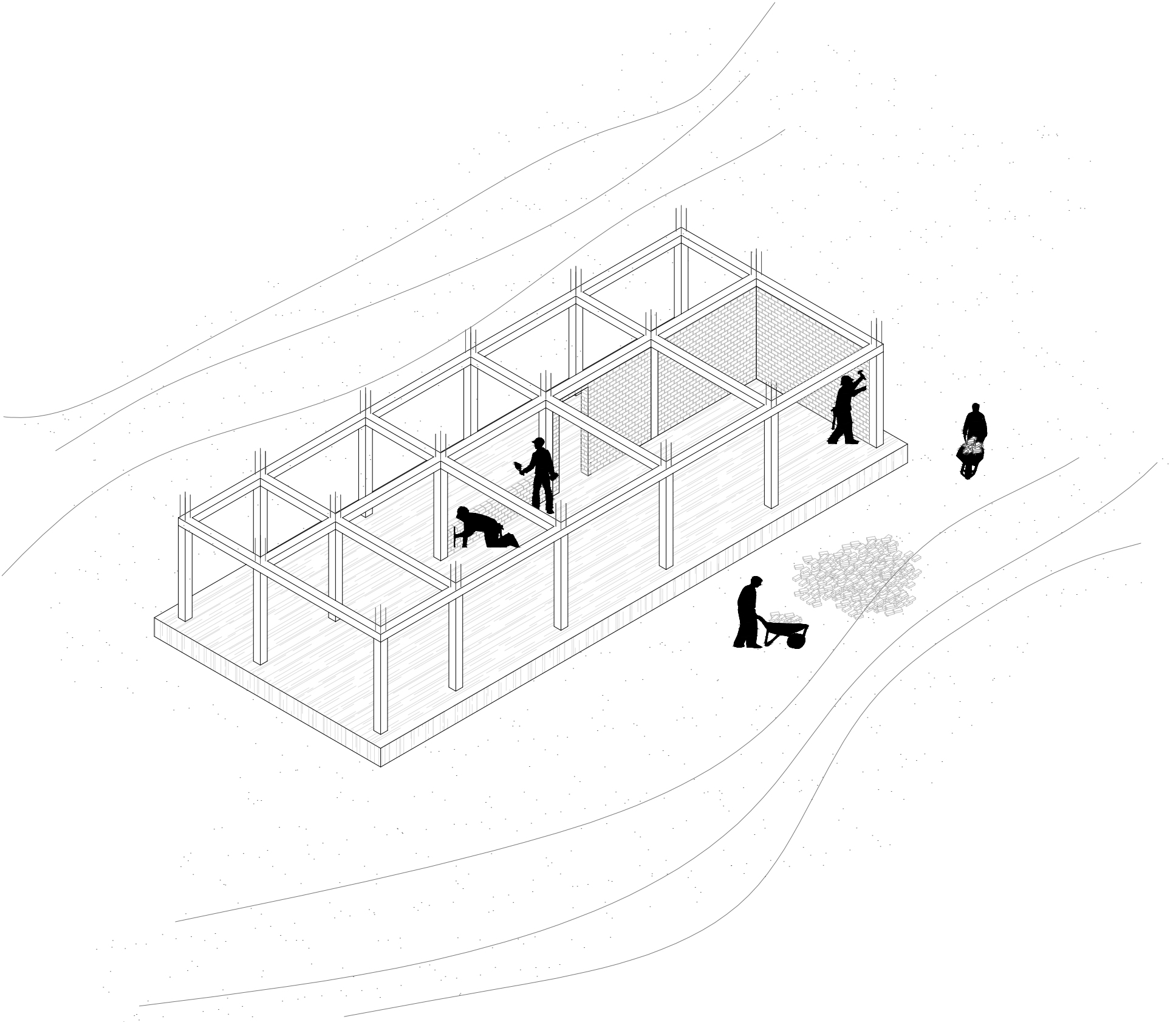

GRAND VERNACULAR
ARCHITECTURE

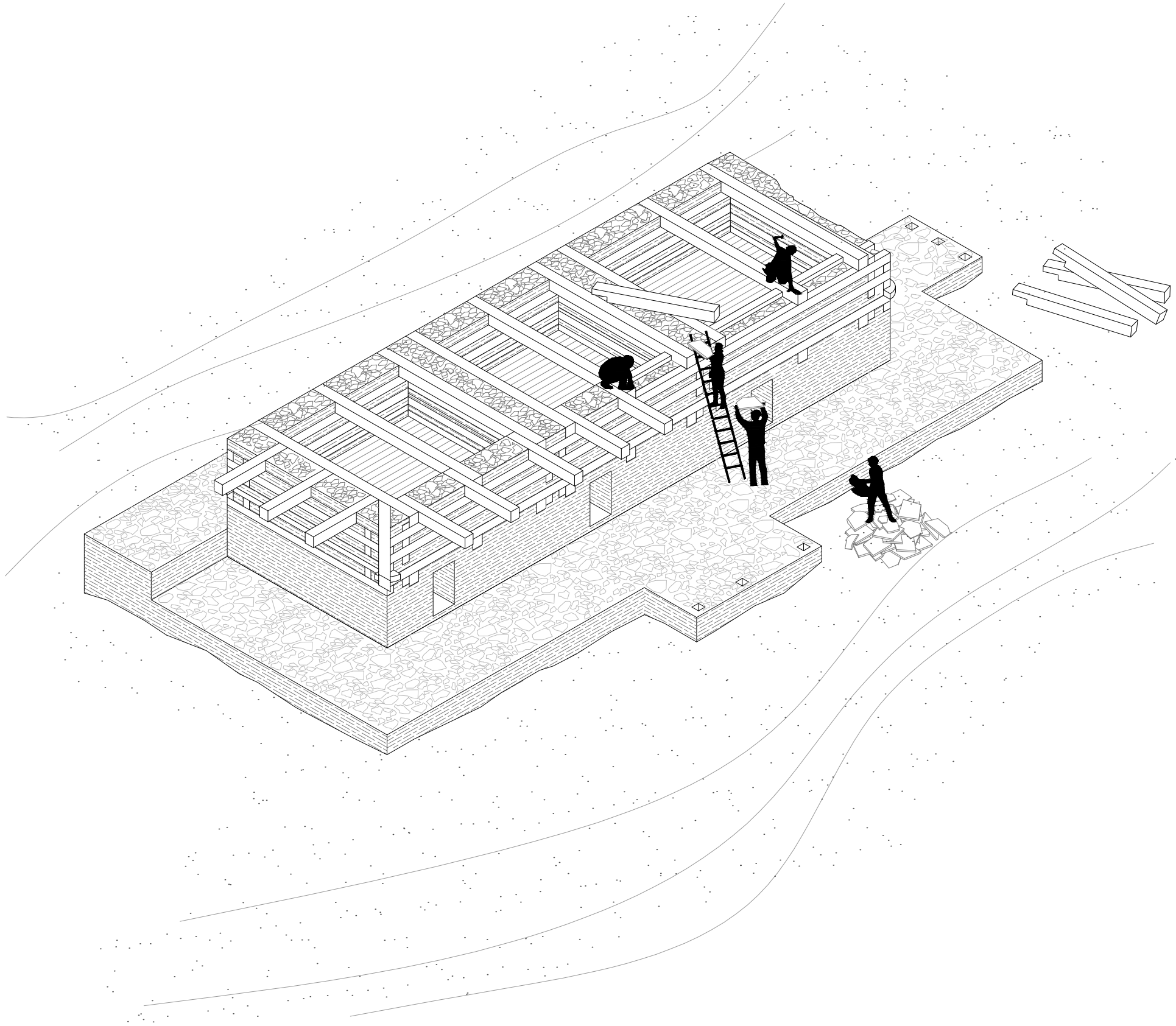

ORDINARY VERNACULAR
ARCHITECTURE

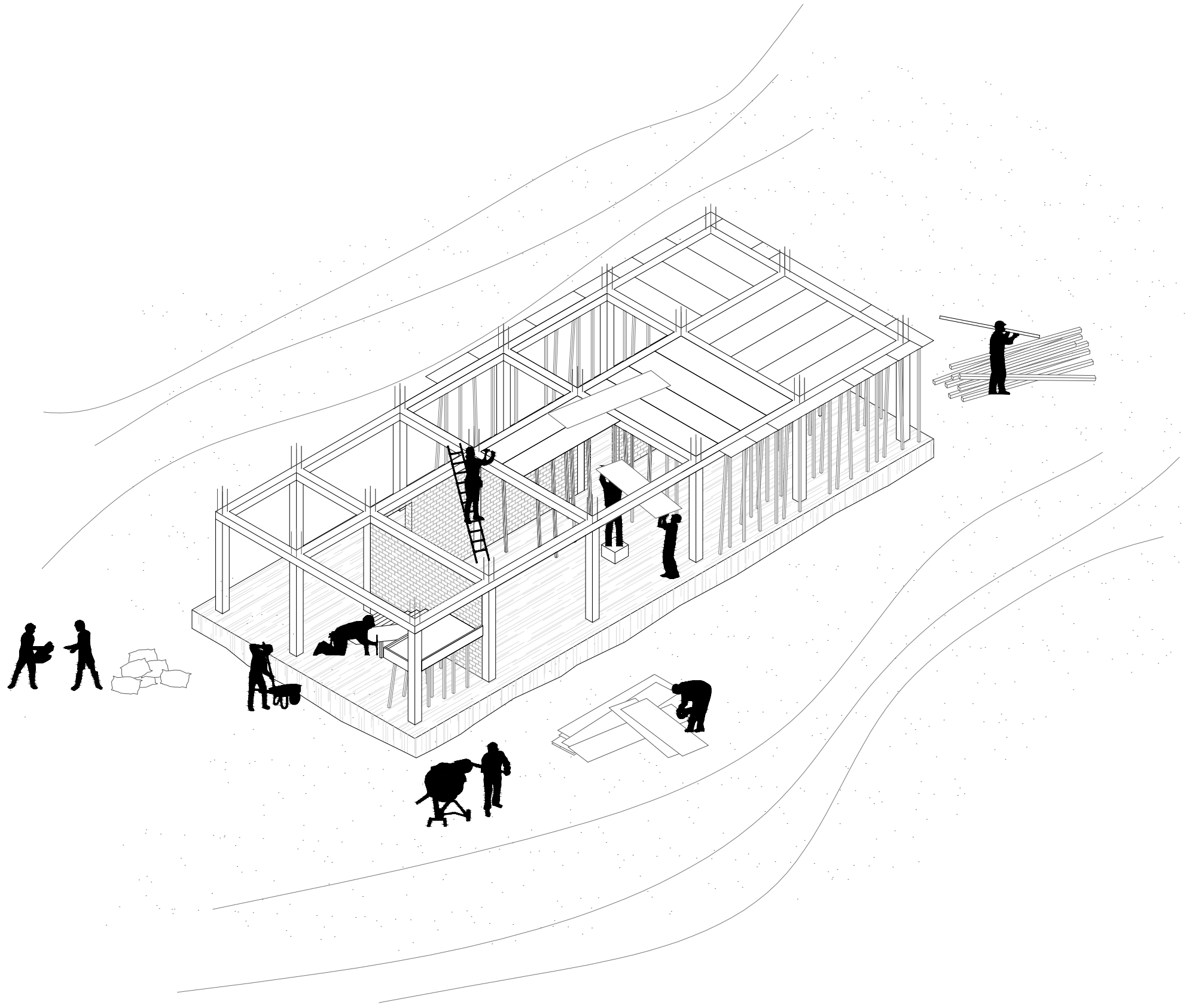

GRAND VERNACULAR
ARCHITECTURE

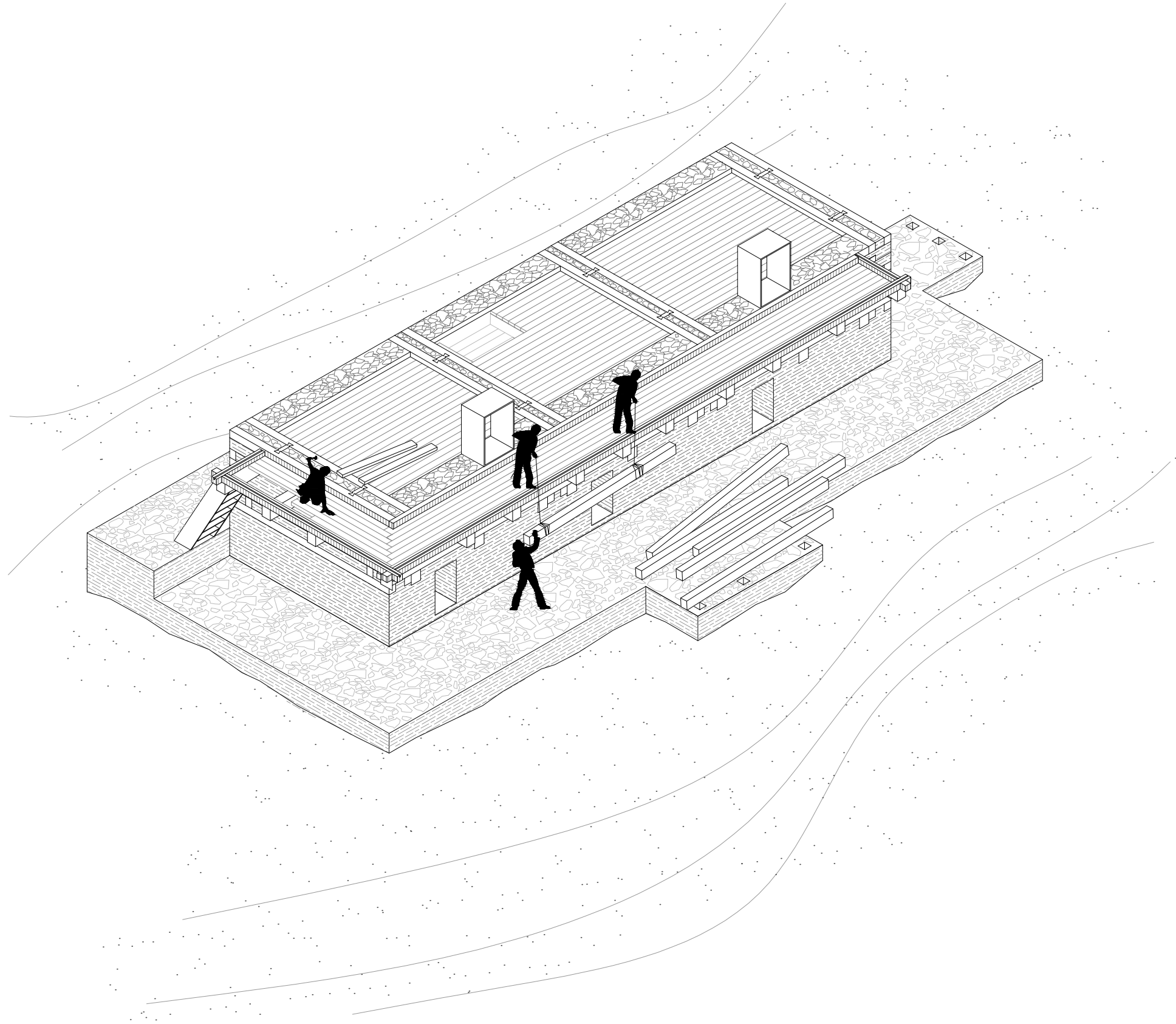

ORDINARY VERNACULAR
ARCHITECTURE

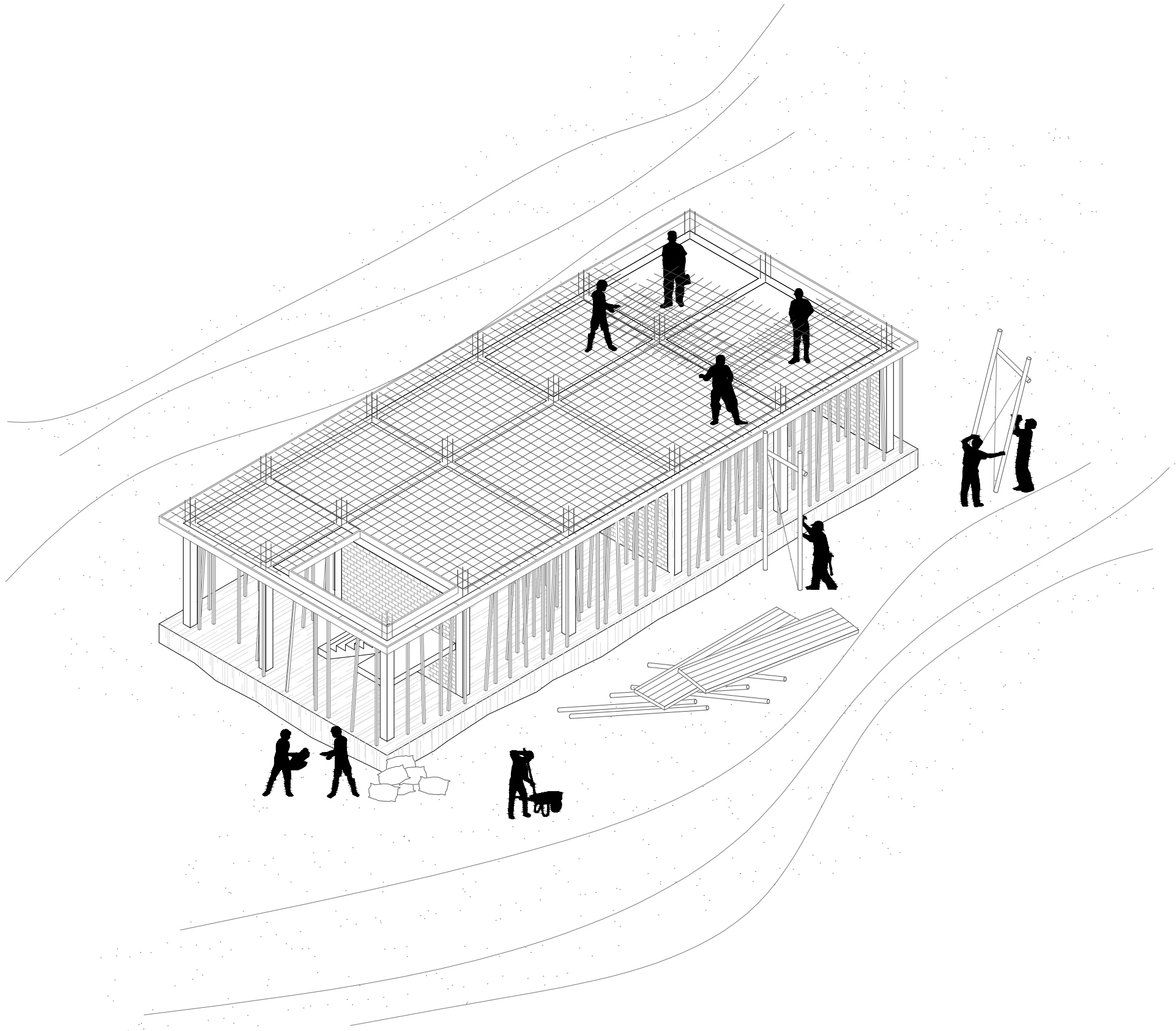

GRAND VERNACULAR
ARCHITECTURE

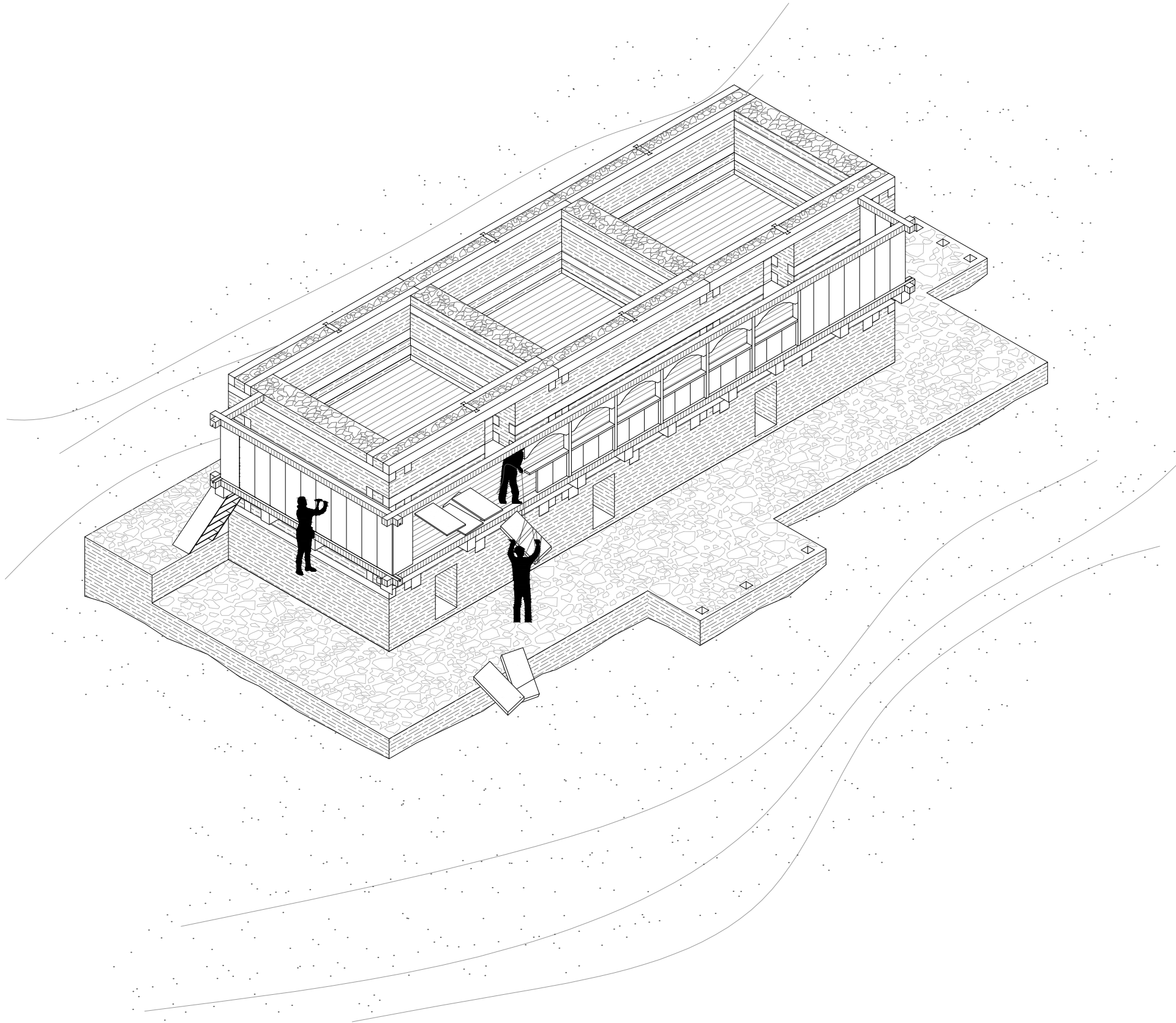

ORDINARY VERNACULAR
ARCHITECTURE

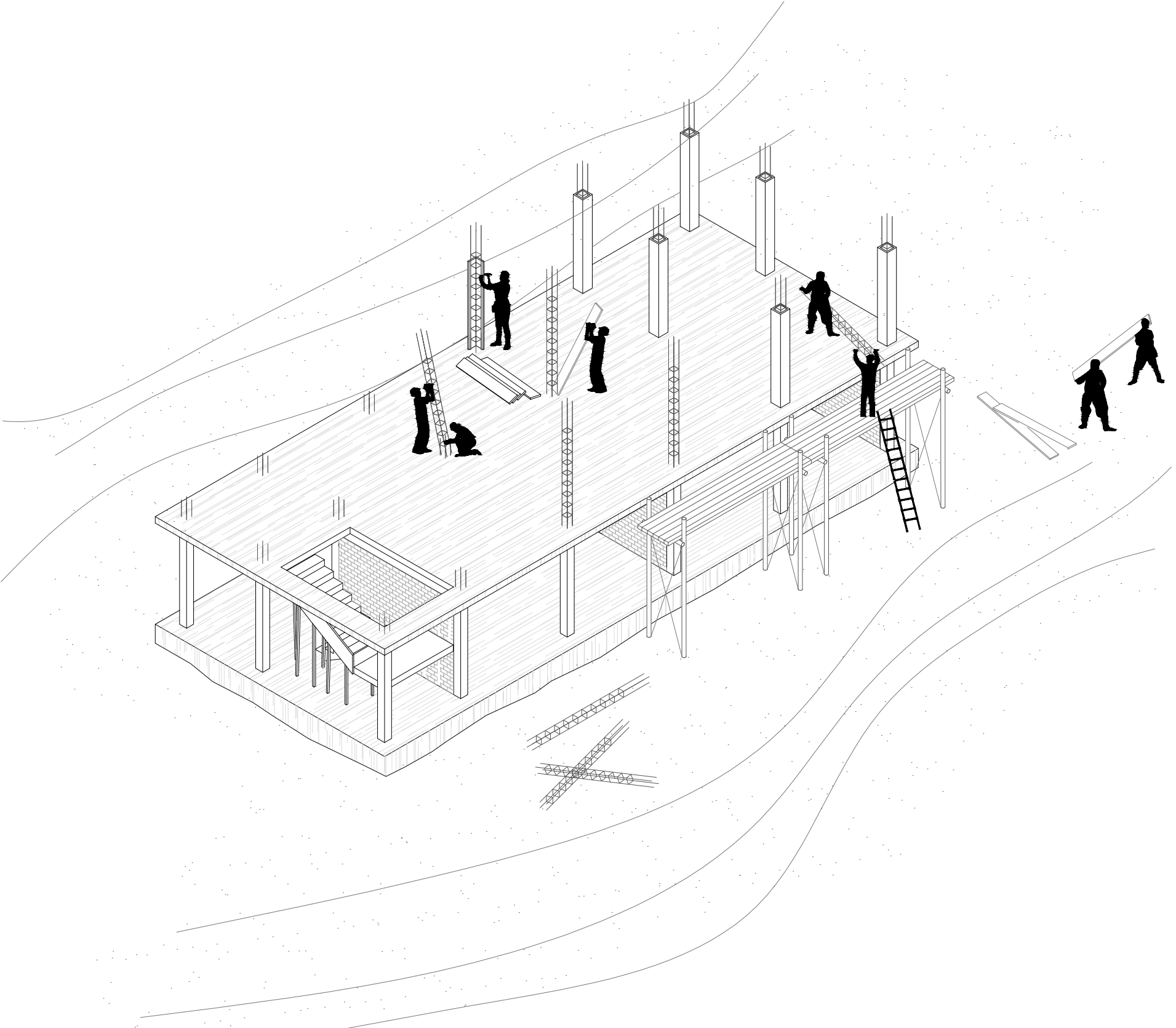

GRAND VERNACULAR
ARCHITECTURE

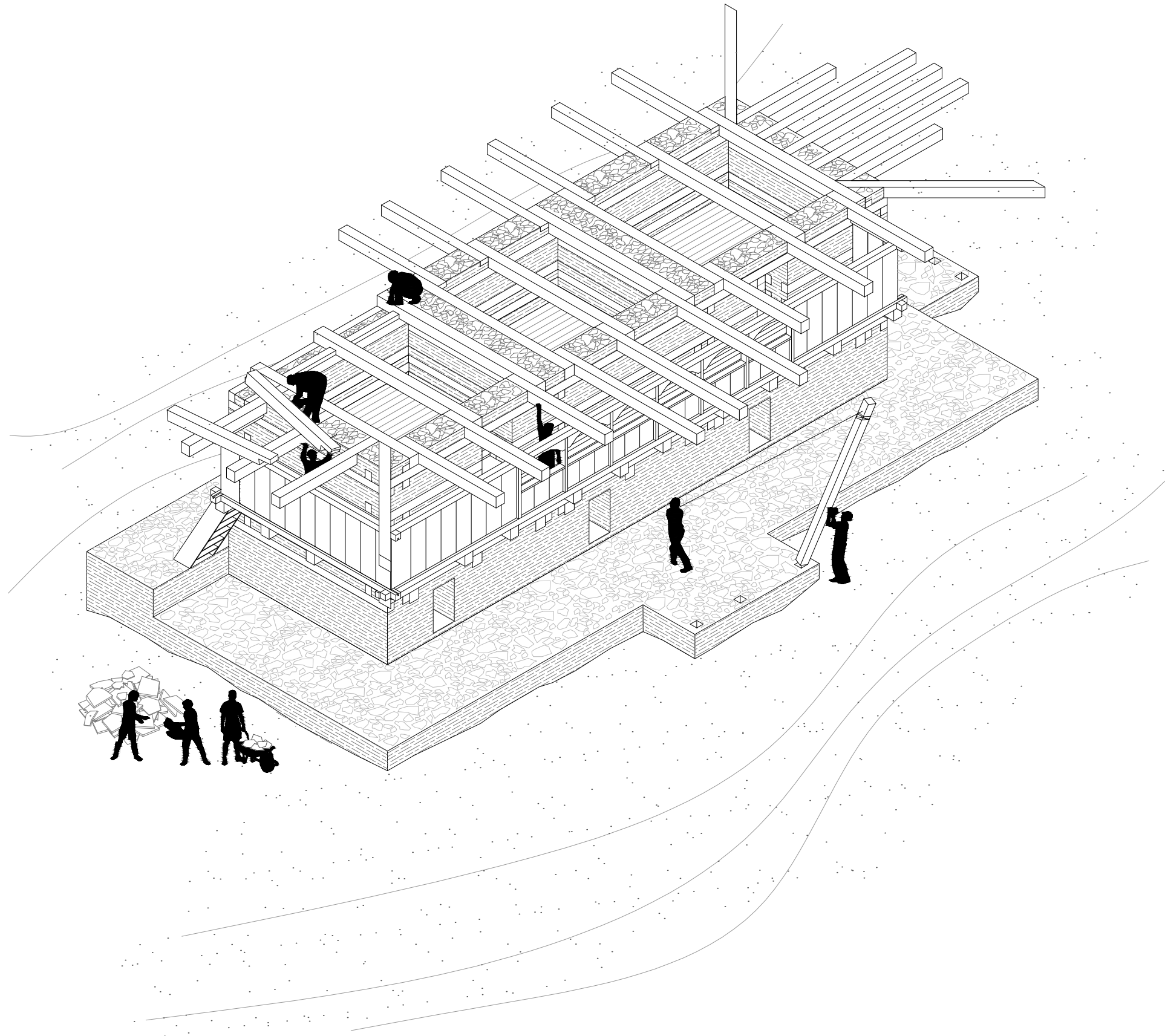

ORDINARY VERNACULAR
ARCHITECTURE

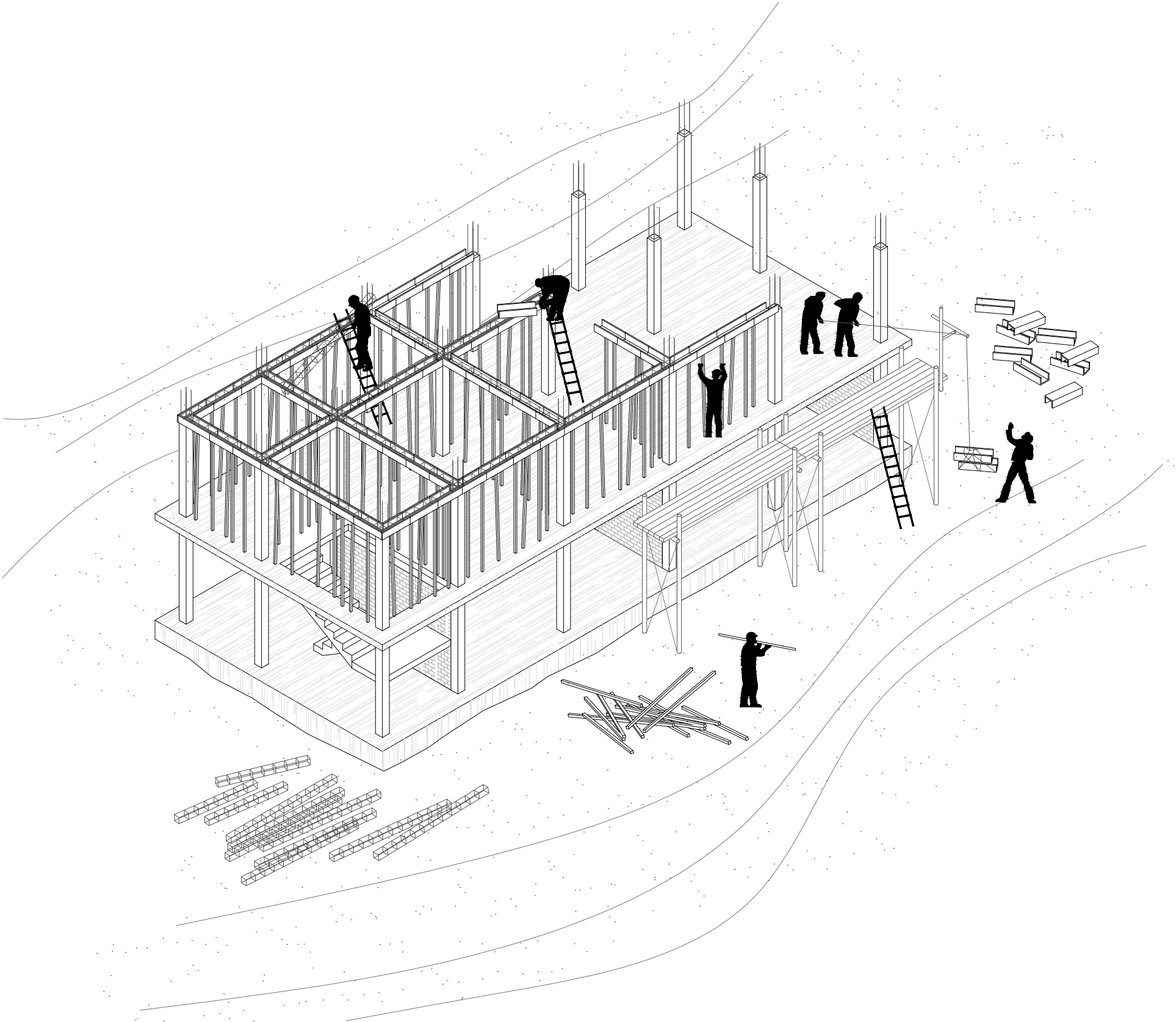

GRAND VERNACULAR
ARCHITECTURE

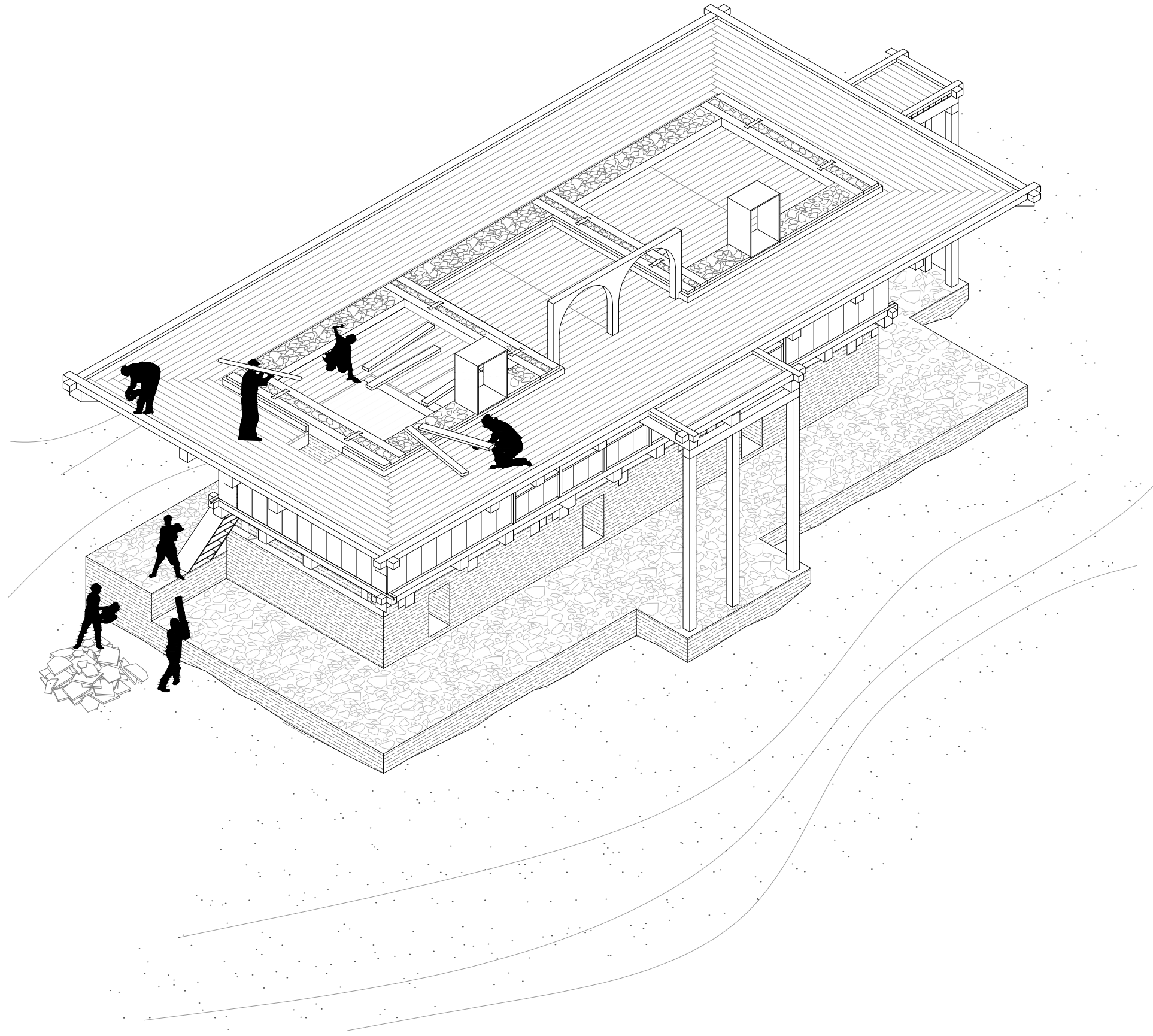

ORDINARY VERNACULAR
ARCHITECTURE

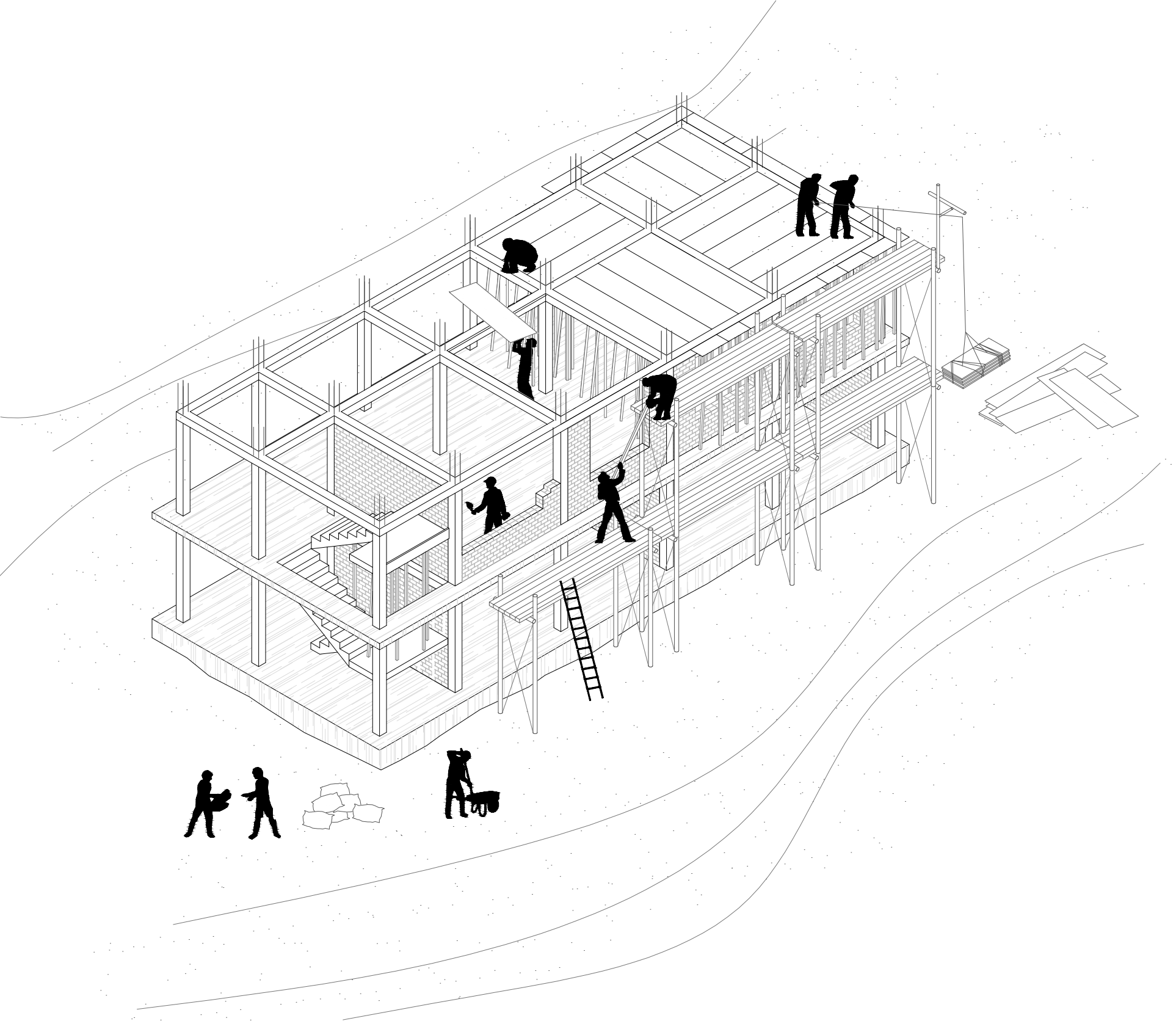

GRAND VERNACULAR
ARCHITECTURE

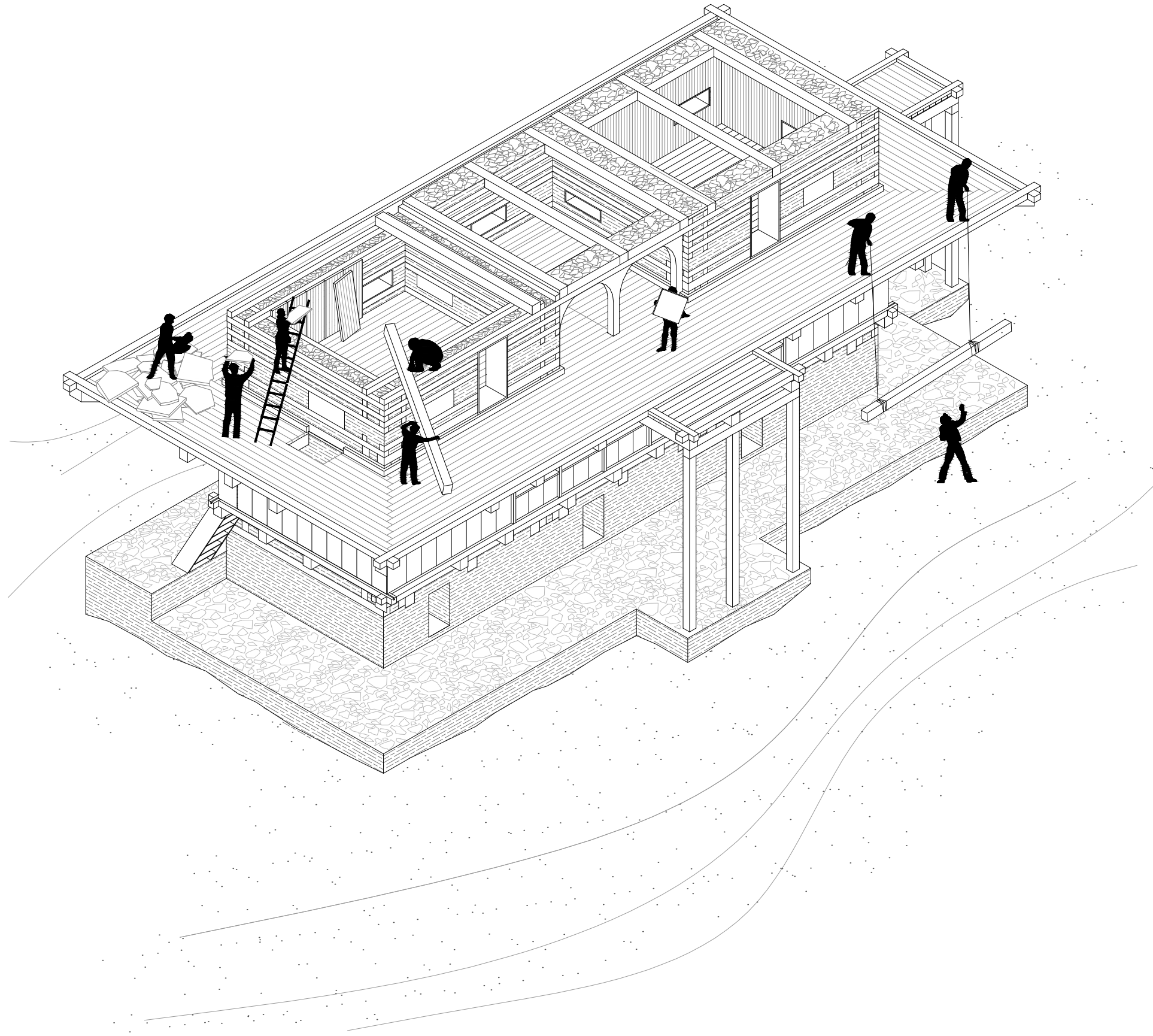

ORDINARY VERNACULAR
ARCHITECTURE

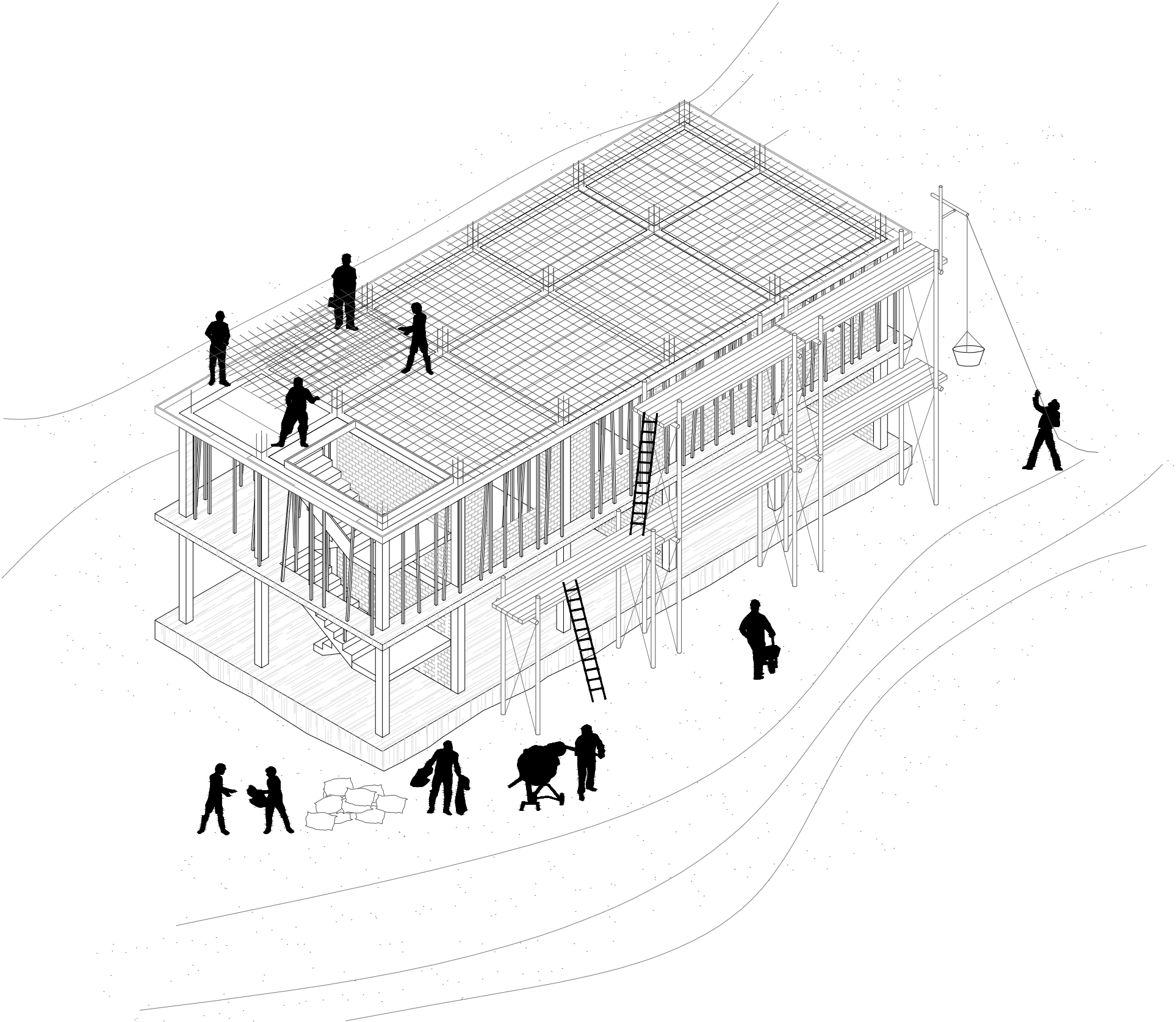

GRAND VERNACULAR
ARCHITECTURE

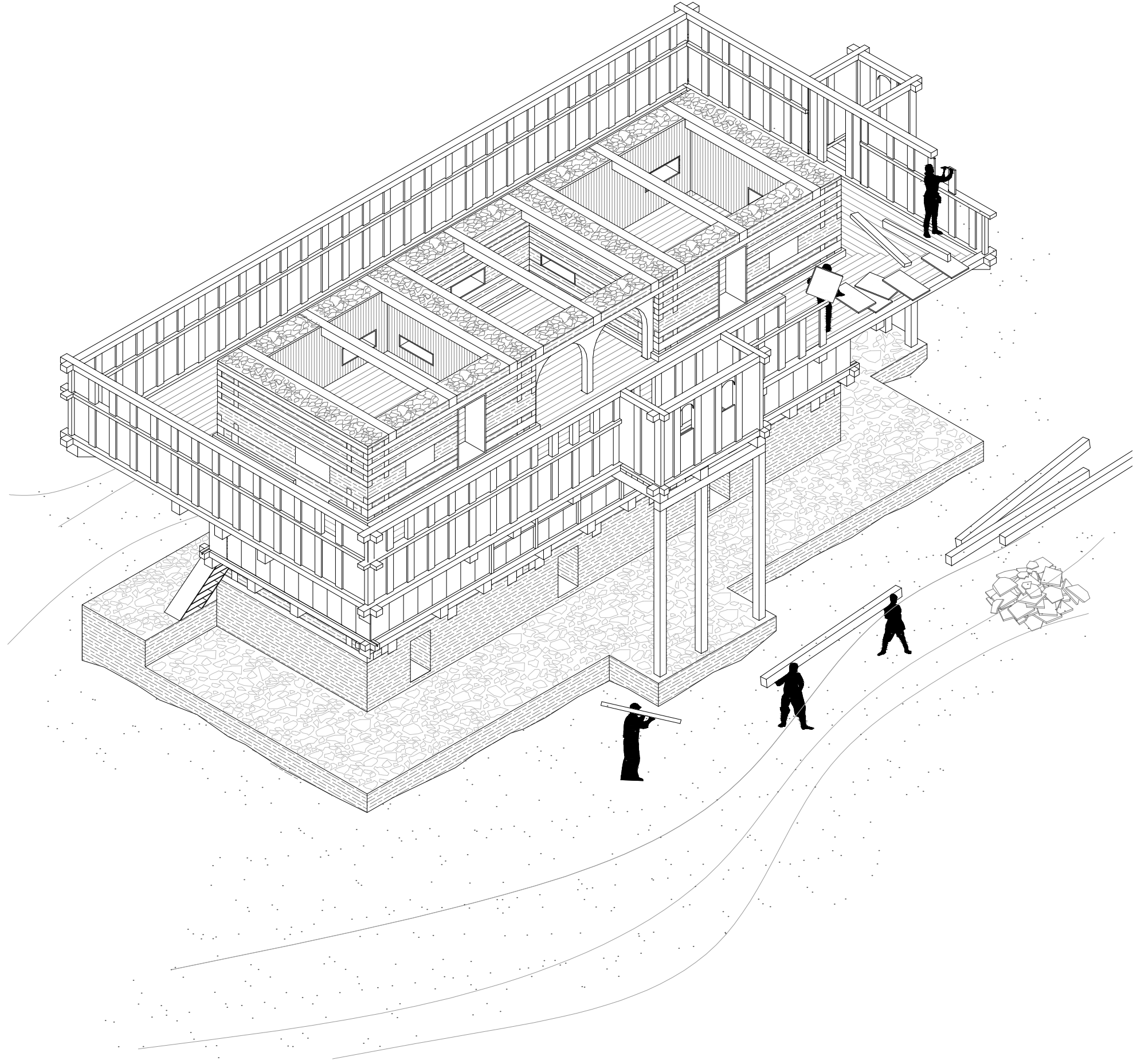

ORDINARY VERNACULAR
ARCHITECTURE

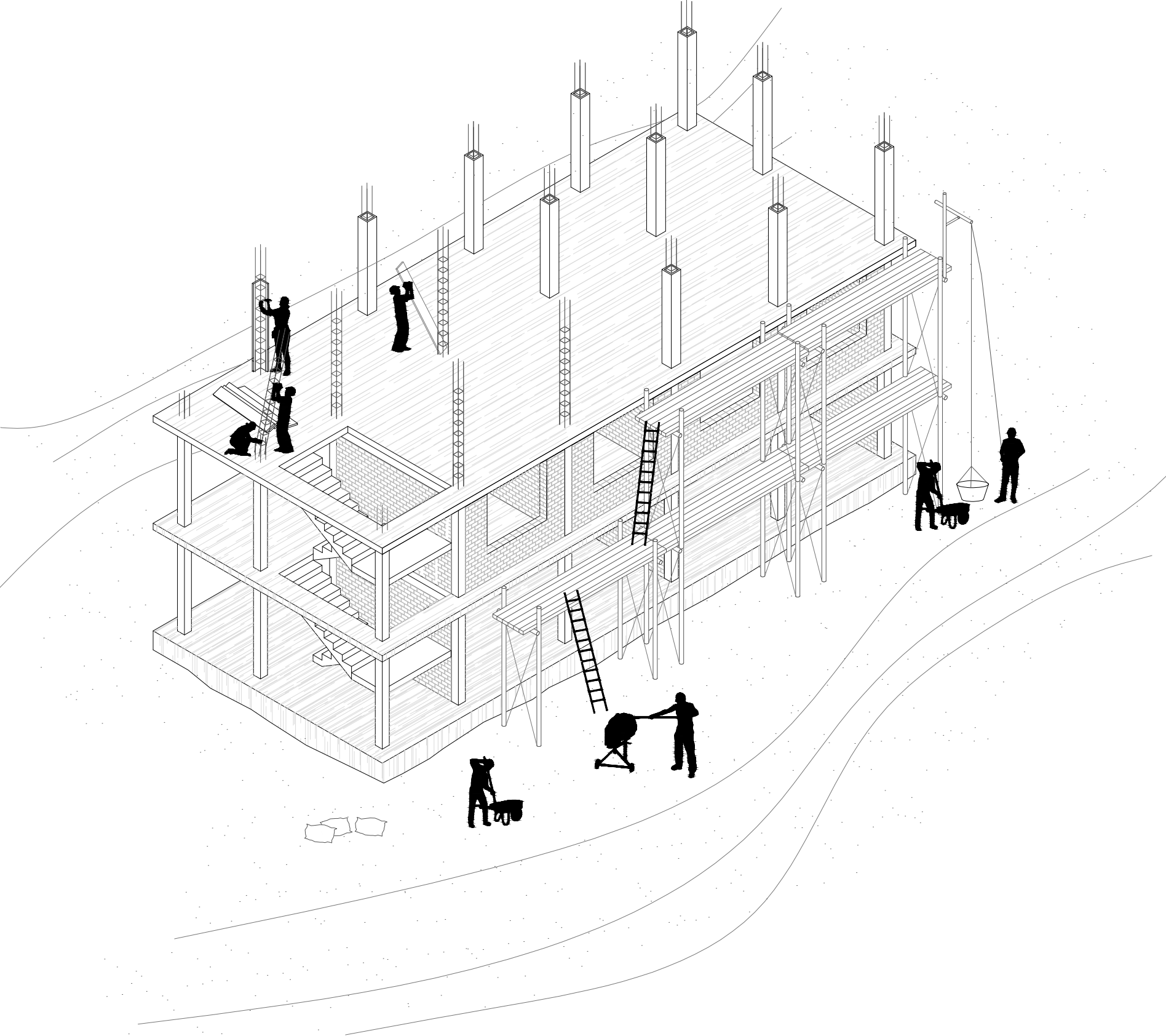

GRAND VERNACULAR
ARCHITECTURE

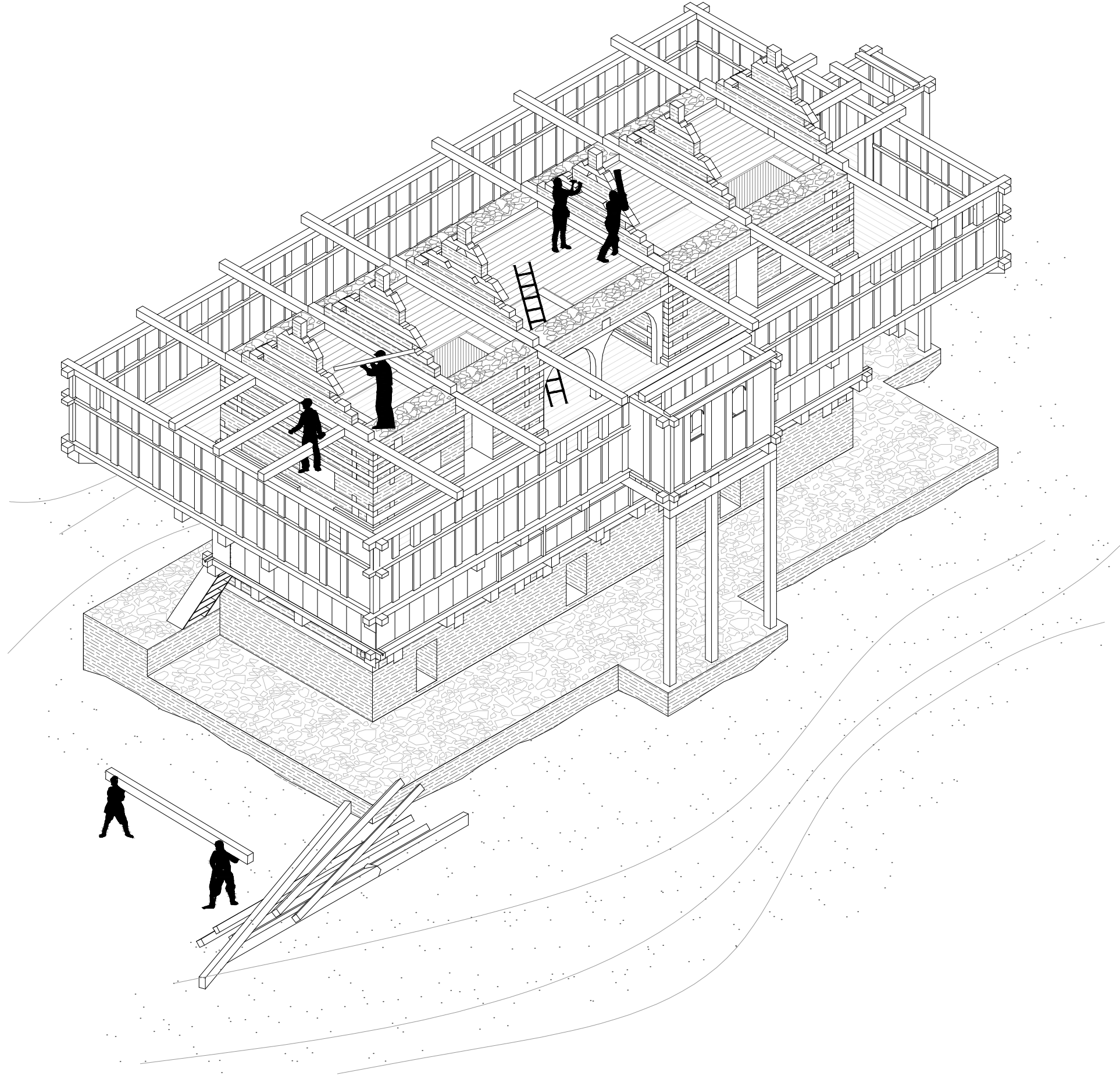

ORDINARY VERNACULAR
ARCHITECTURE

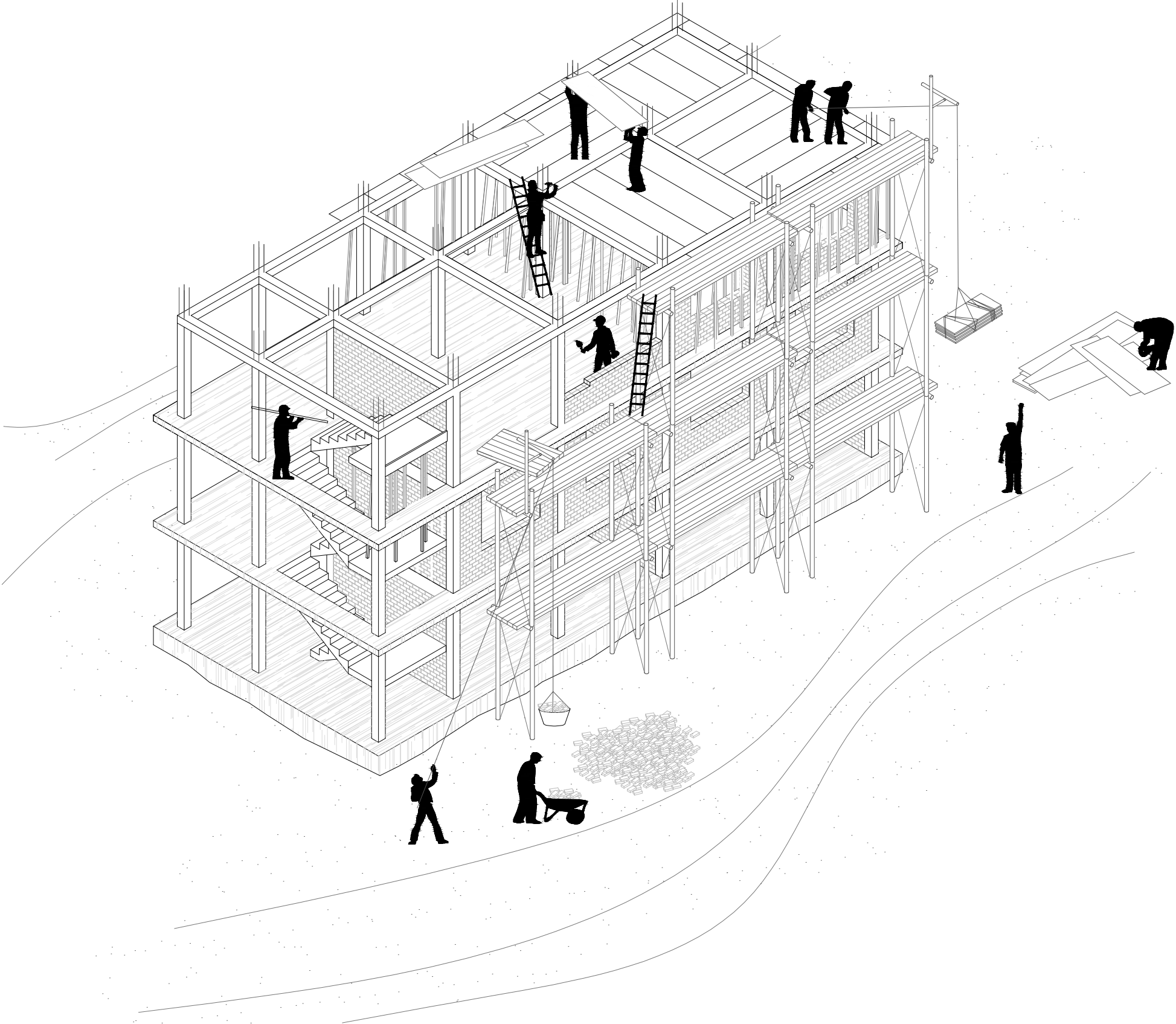

GRAND VERNACULAR
ARCHITECTURE

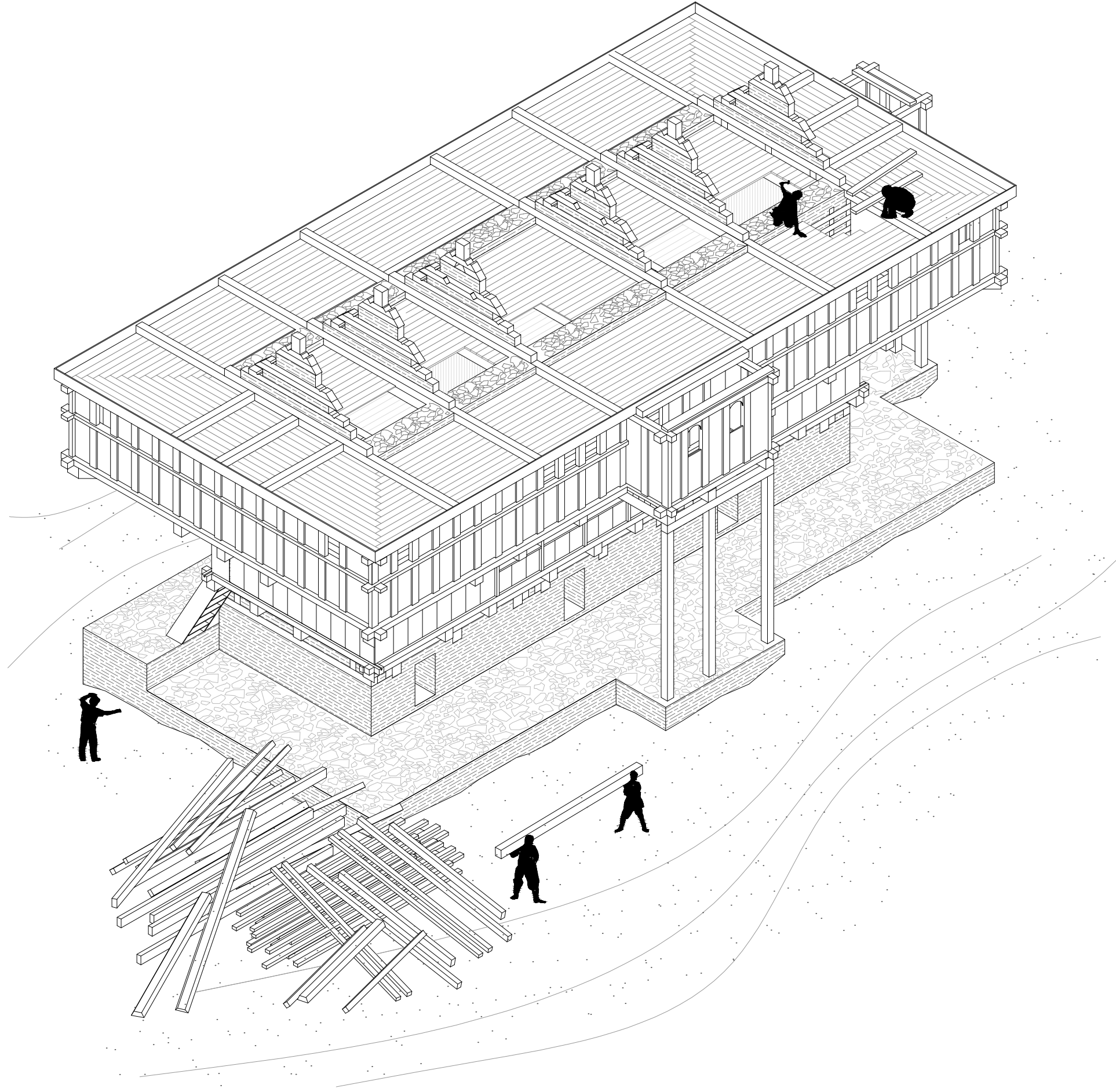

ORDINARY VERNACULAR
ARCHITECTURE

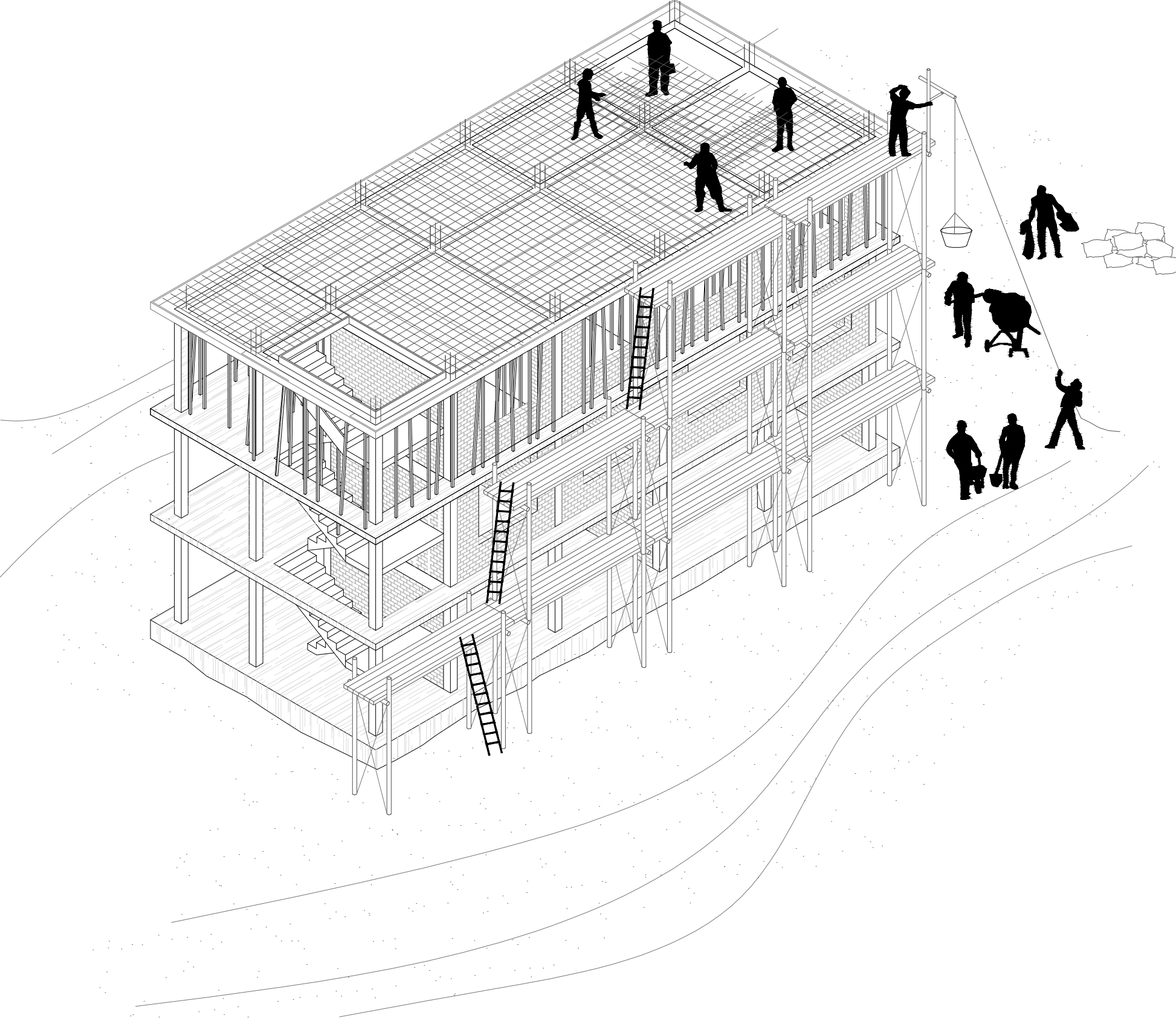

GRAND VERNACULAR
ARCHITECTURE

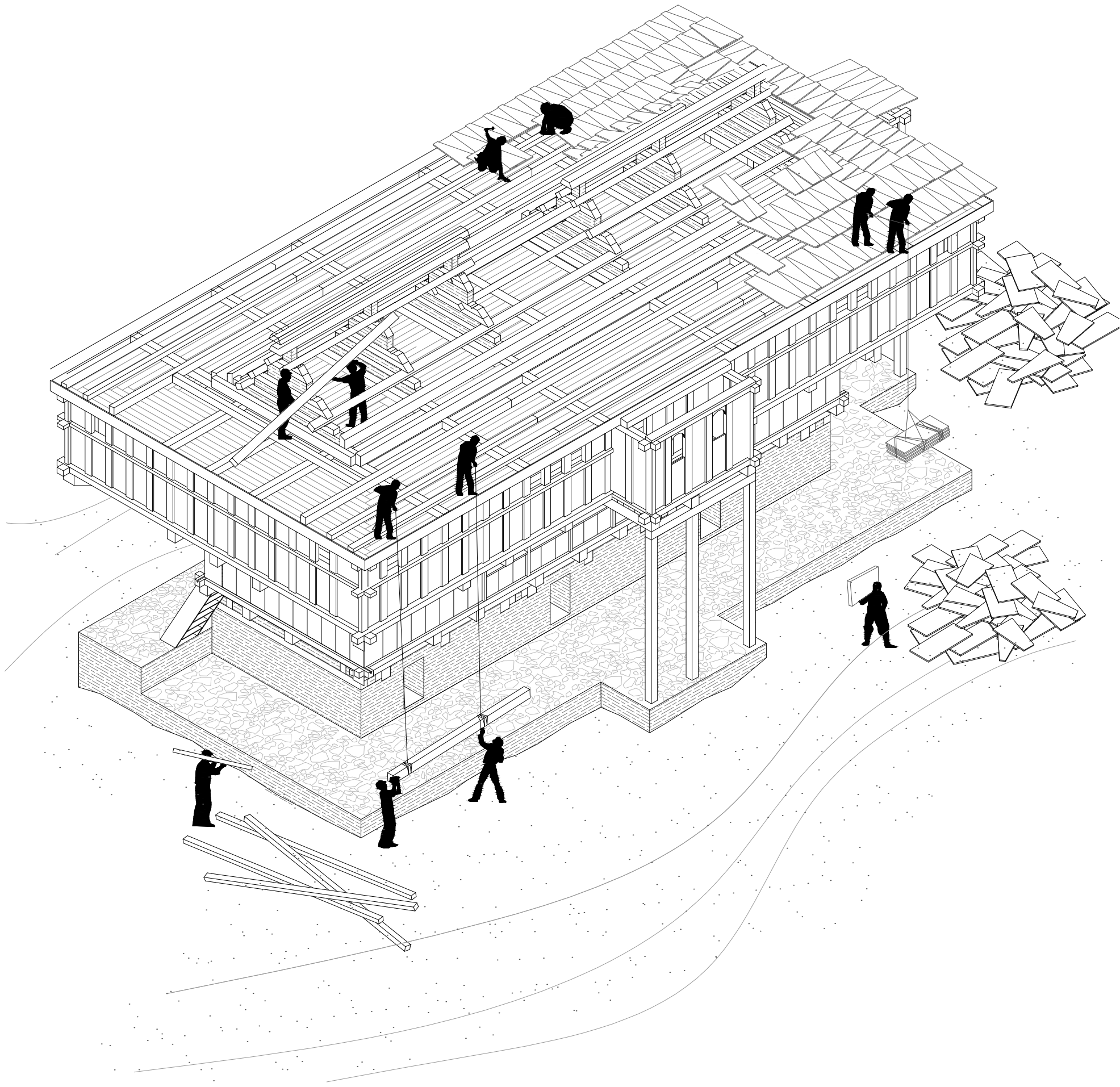

ORDINARY VERNACULAR
ARCHITECTURE

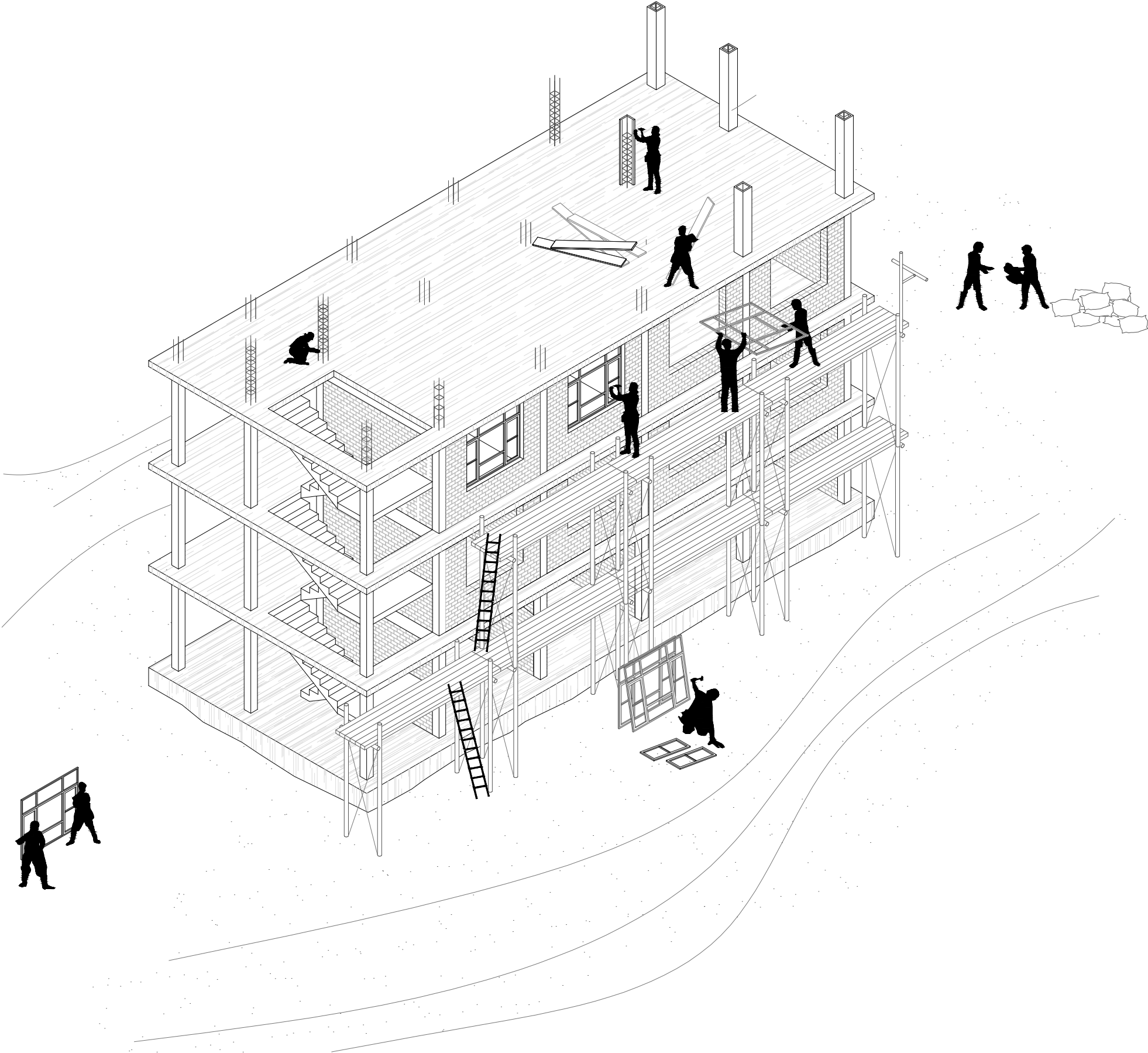

GRAND VERNACULAR
ARCHITECTURE

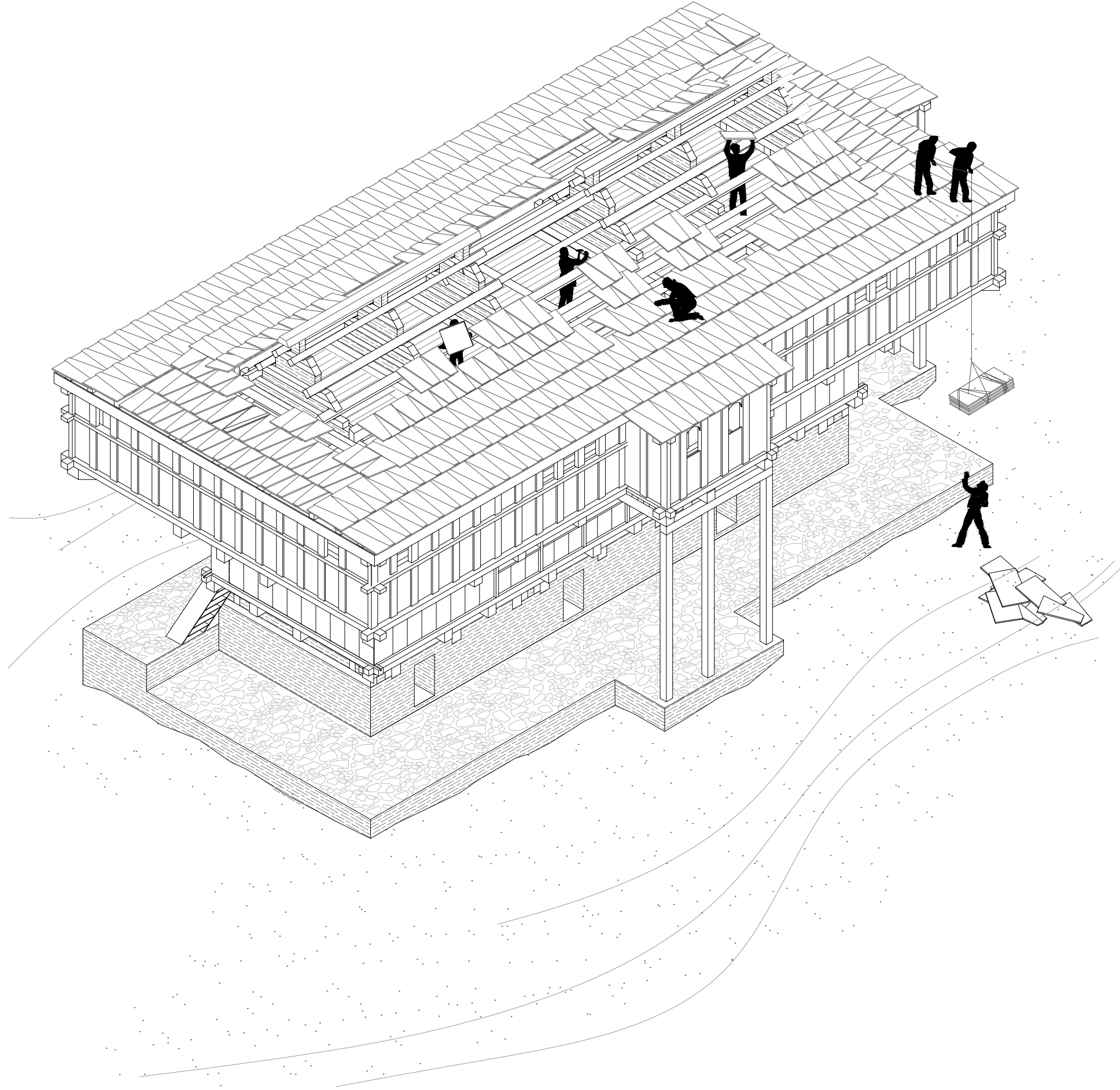

ORDINARY VERNACULAR
ARCHITECTURE

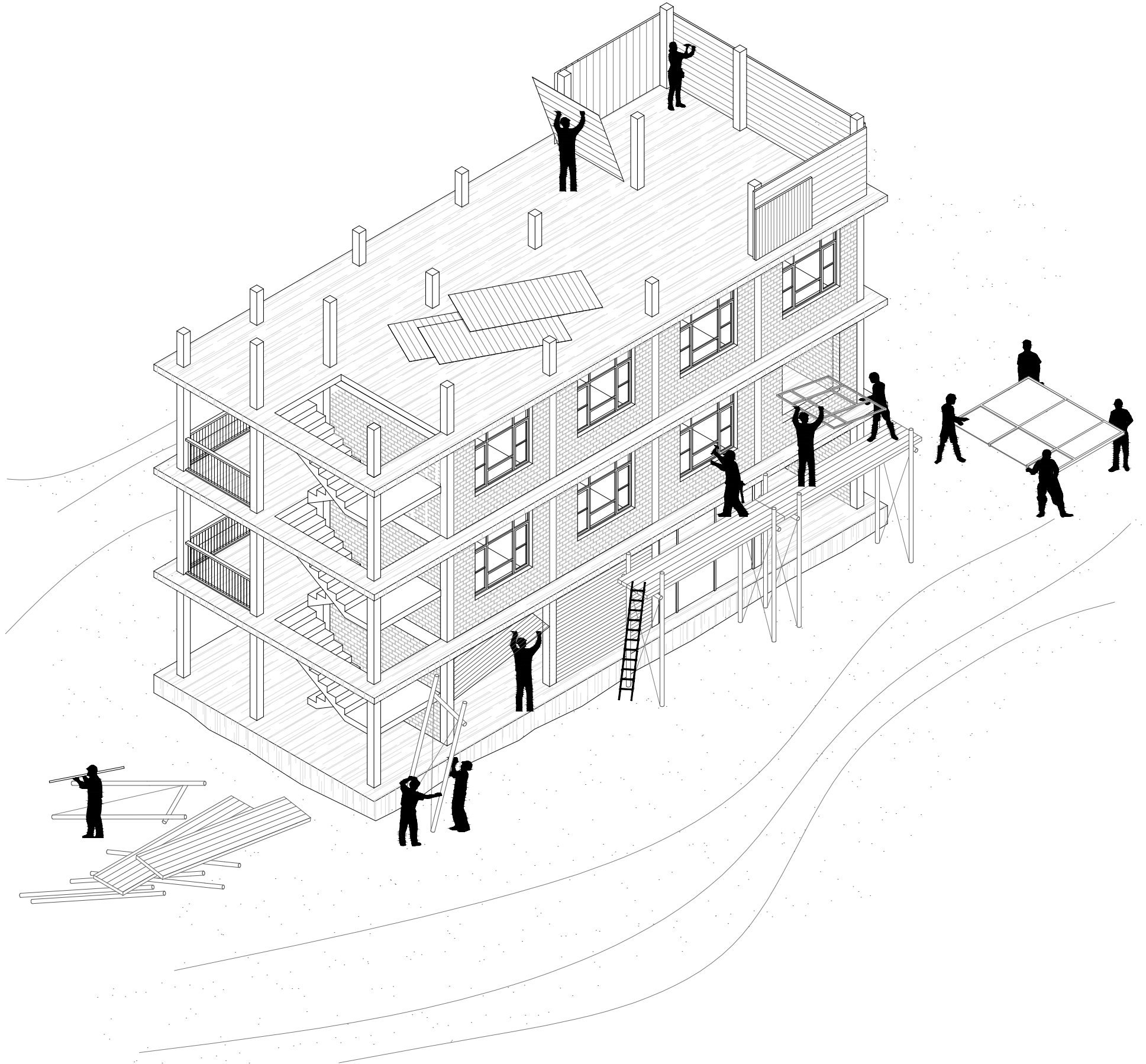

GRAND VERNACULAR
ARCHITECTURE

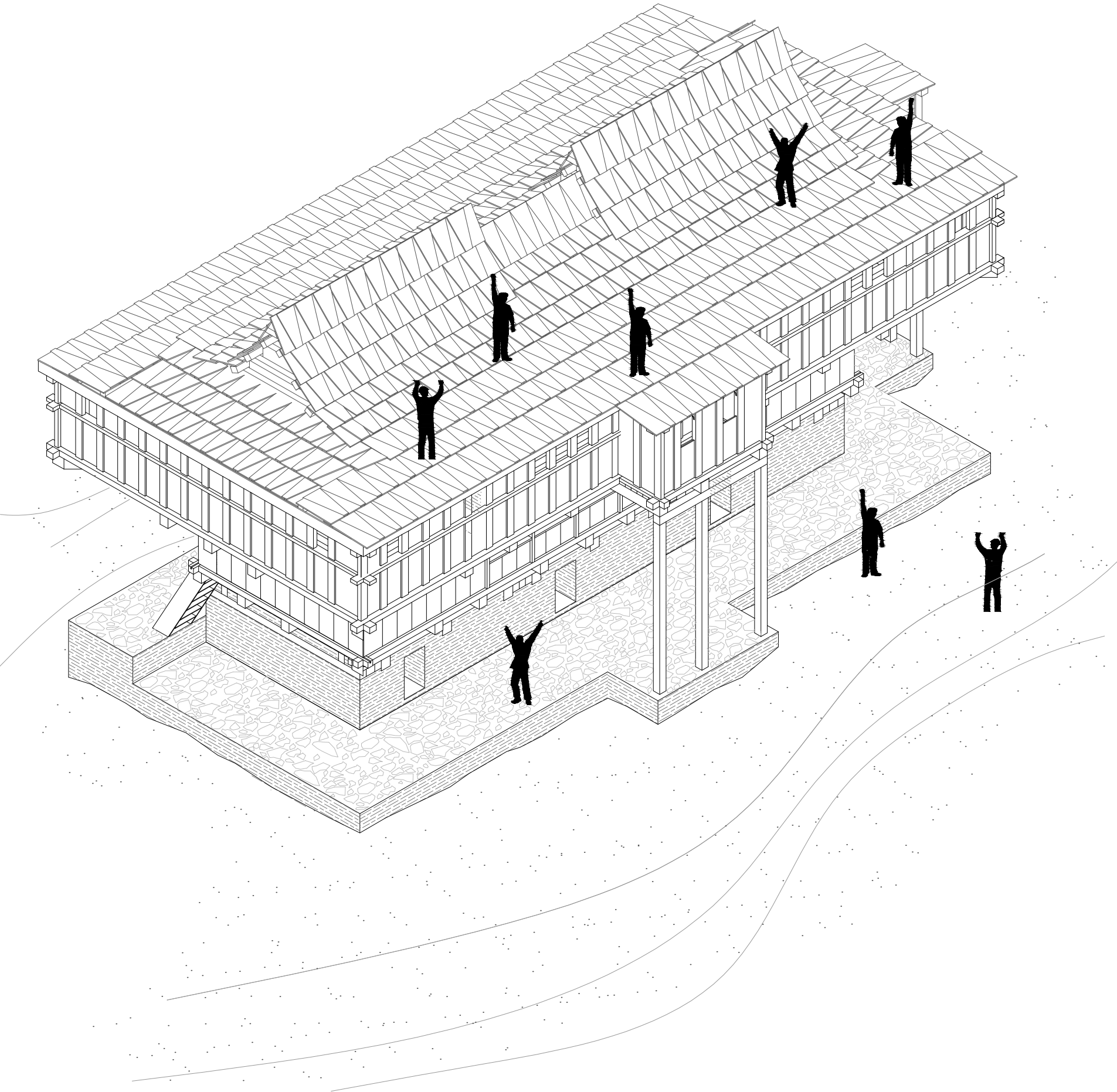

ORDINARY VERNACULAR
ARCHITECTURE

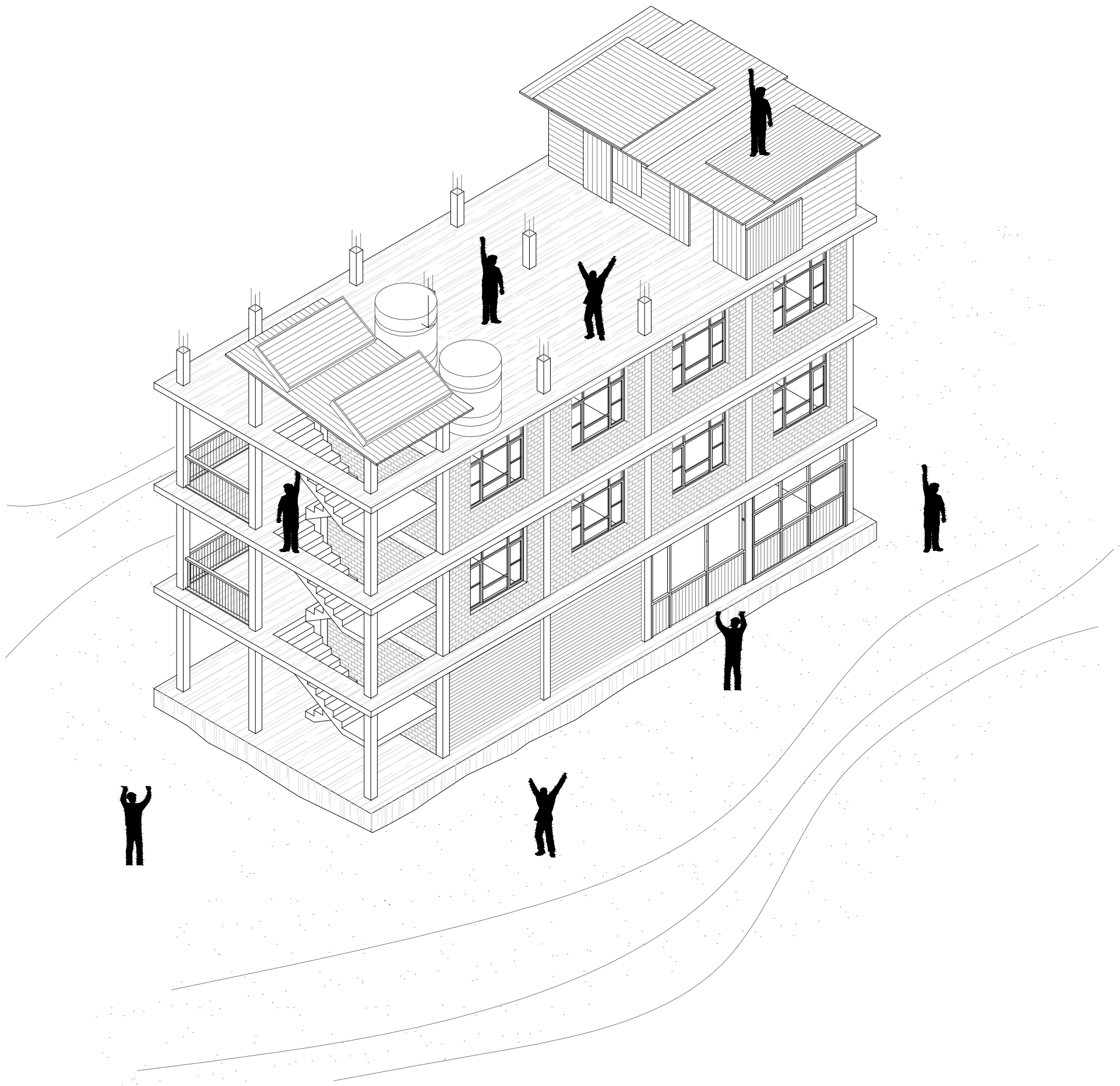

**SIDE A
CONSTRUCTION
PROCESS**

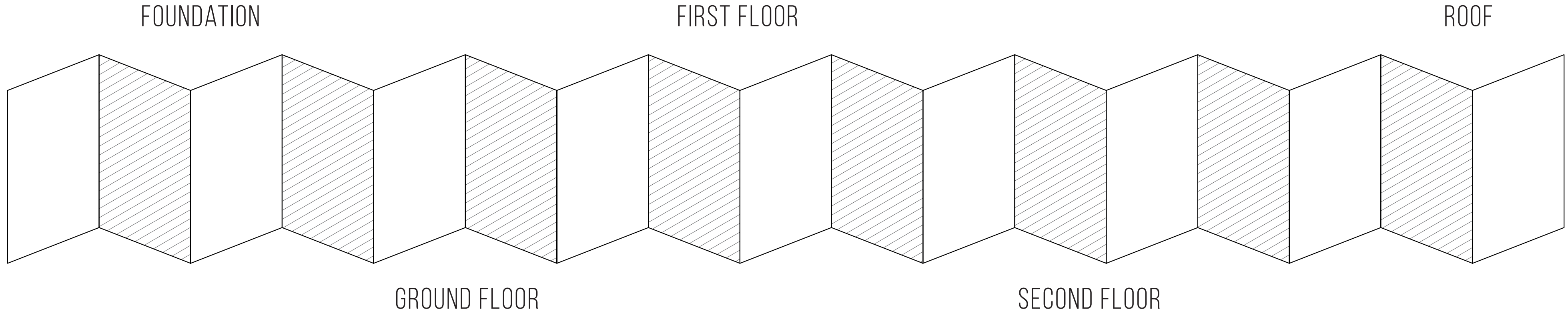

**SIDE B
BUILDING
ANALYSIS**

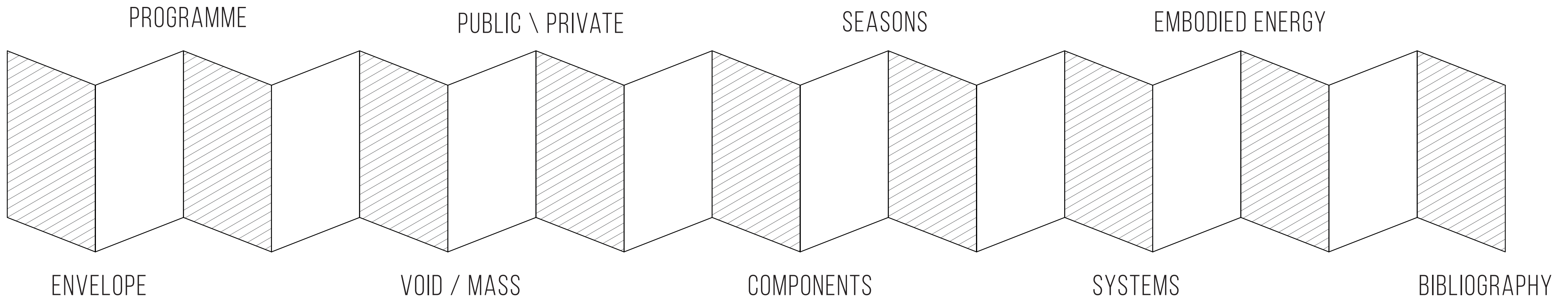

SIDE A
CONSTRUCTION
PROCESS

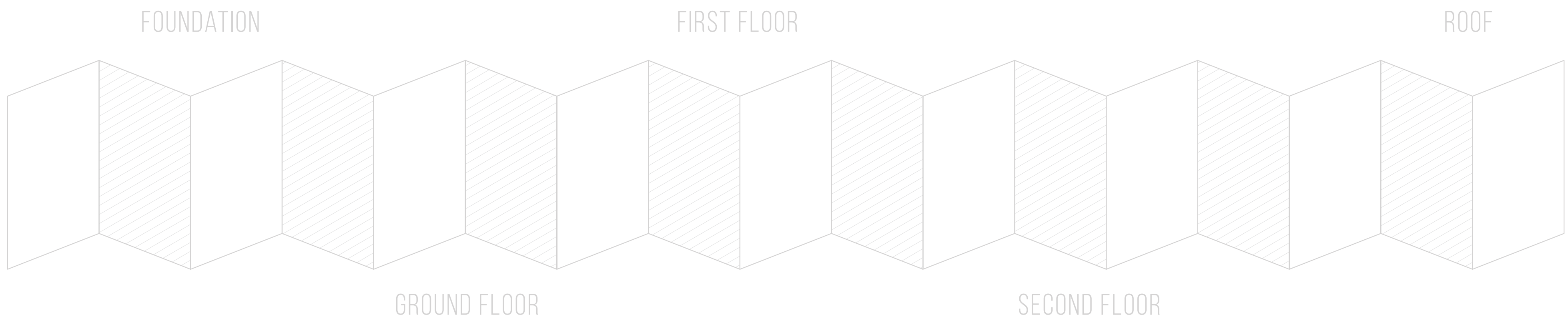

SIDE B
BUILDING
ANALYSIS

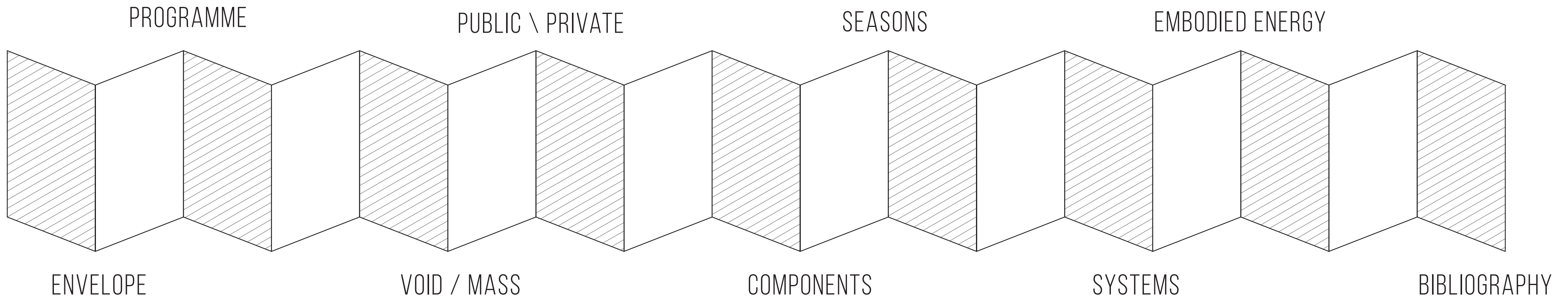



RESULTS

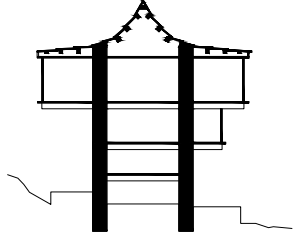

A. GRAND VERNACULAR

342 M²

(70% COVERED OUTSIDE + 30% INTERIOR)

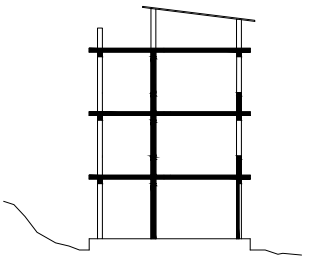

B. ORDINARY VERNACULAR

331 M²

(30% COVERED OUTSIDE + 70% INTERIOR)

A ≈ B

RESULTS



SPACES

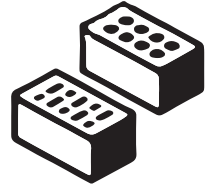

MATERIALS

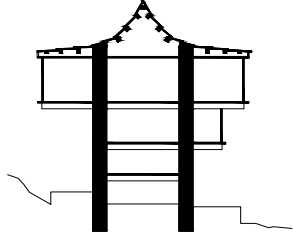

A. GRAND VERNACULAR

342 M²

(70% COVERED OUTSIDE + 30% INTERIOR)

630 M³

(144M³ WOOD + 490M³ STONE)

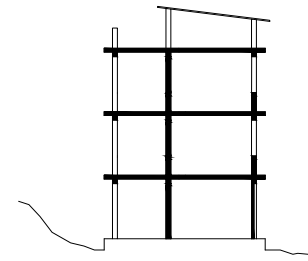

B. ORDINARY VERNACULAR

331 M²

(30% COVERED OUTSIDE + 70% INTERIOR)

290 M³

(70M³ SAND + 140M³ AGGREGATE
+ 170M³ CEMENT + 0.5M³ STEEL + 61,5M³ BRICKS)

A ≈ B

A ≈ 2B

RESULTS

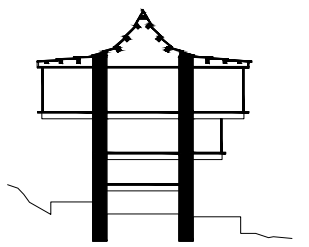

A. GRAND VERNACULAR

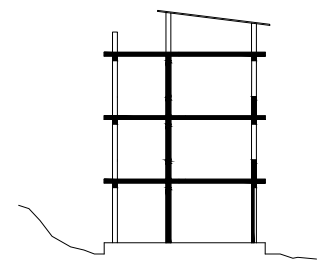

B. ORDINARY VERNACULAR



SPACES

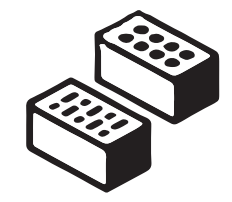

MATERIALS



EMBODIED ENERGY

342 M²

(70% COVERED OUTSIDE + 30% INTERIOR)

331 M²

(30% COVERED OUTSIDE + 70% INTERIOR)

630 M³

(144M³ WOOD + 490M³ STONE)

290 M³

(70M³ SAND + 140M³ AGGREGATE
+ 170M³ CEMENT + 0.5M³ STEEL + 61,5M³ BRICKS)

325400 MJ

631300 MJ

A ≈ B

A ≈ 2B

A ≈ 1/2 B

RESULTS

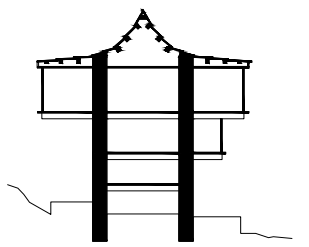

A. GRAND VERNACULAR

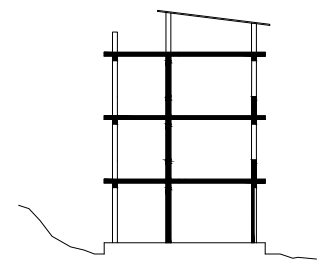

B. ORDINARY VERNACULAR



SPACES

342 M²
(70% COVERED OUTSIDE + 30% INTERIOR)

331 M²
(30% COVERED OUTSIDE + 70% INTERIOR)

A ≈ B

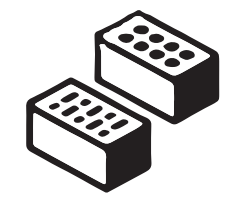

MATERIALS

630 M³
(144M³ WOOD + 490M³ STONE)

290 M³
(70M³ SAND + 140M³ AGGREGATE
+ 170M³ CEMENT + 0.5M³ STEEL + 61,5M³ BRICKS)

A ≈ 2B



EMBODIED ENERGY

325400 MJ

631300 MJ

A ≈ 1/2 B



CARBON FOOTPRINT

115000 KGco₂

80000 KGco₂

A ≈ B + 1/2 B

RESULTS

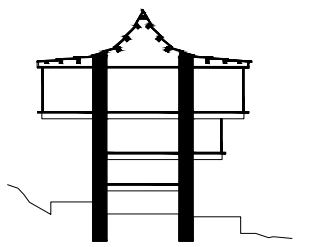

A. GRAND VERNACULAR

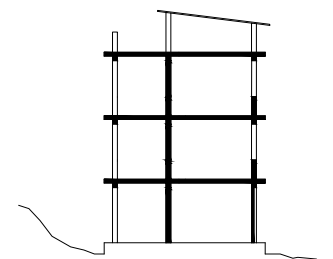

B. ORDINARY VERNACULAR



SPACES

342 M²
(70% COVERED OUTSIDE + 30% INTERIOR)

331 M²
(30% COVERED OUTSIDE + 70% INTERIOR)

A ≈ B

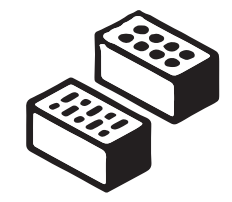

MATERIALS

630 M³
(144M³ WOOD + 490M³ STONE)

290 M³
(70M³ SAND + 140M³ AGGREGATE
+ 170M³ CEMENT + 0.5M³ STEEL + 61,5M³ BRICKS)

A ≈ 2B

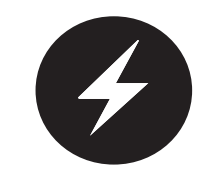

EMBODIED ENERGY

325400 MJ

631300 MJ

A ≈ 1/2 B

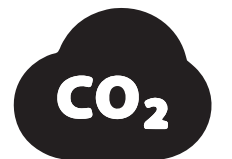

CARBON FOOTPRINT

115000 KGco₂

80000 KGco₂

A ≈ B + 1/2 B



CLIMATE

U_{HORIZ} = 0.24 W/M²K

U_{HORIZ} = 2.00 W/M²K

U_A ≈ 1/8 U_B

RESULTS

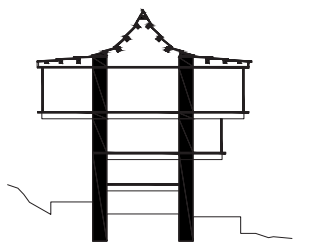

A. GRAND VERNACULAR

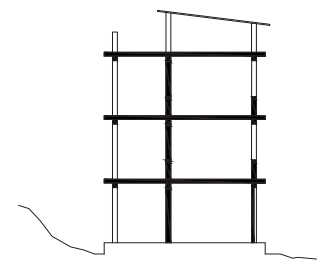

B. ORDINARY VERNACULAR



SPACES

342 M²
(70% COVERED OUTSIDE + 30% INTERIOR)

331 M²
(30% COVERED OUTSIDE + 70% INTERIOR)

A ≈ B

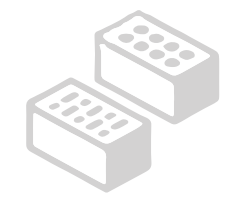

MATERIALS

630 M³
(144M³ WOOD + 490M³ STONE)

290 M³
(70M³ SAND + 140M³ AGGREGATE
+ 170M³ CEMENT + 0,5M³ STEEL + 61,5M³ BRICKS)

A ≈ 2B



EMBODIED ENERGY

325400 MJ

631300 MJ

A ≈ 1/2 B

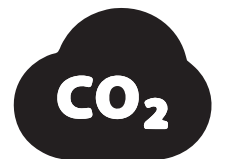

CARBON FOOTPRINT

115000 KGco₂

80000 KGco₂

A ≈ B + 1/2 B



CLIMATE

U_{HORIZ} = 0.24 W/M²K

U_{HORIZ} = 2.00 W/M²K

U_A ≈ 1/8 U_B



1 CAR X 12.500 KM

=

2.3 TON_{CO2}

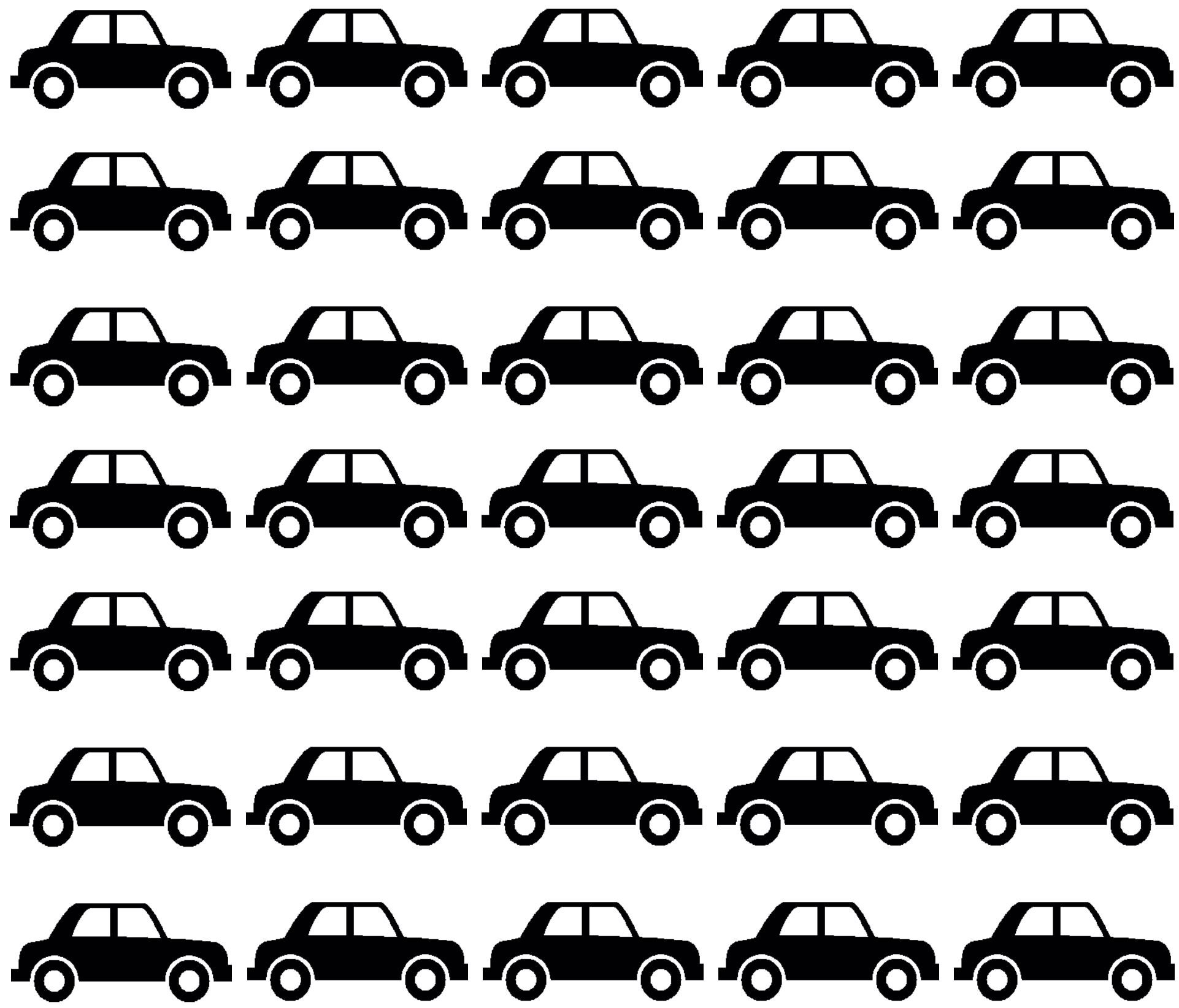

=

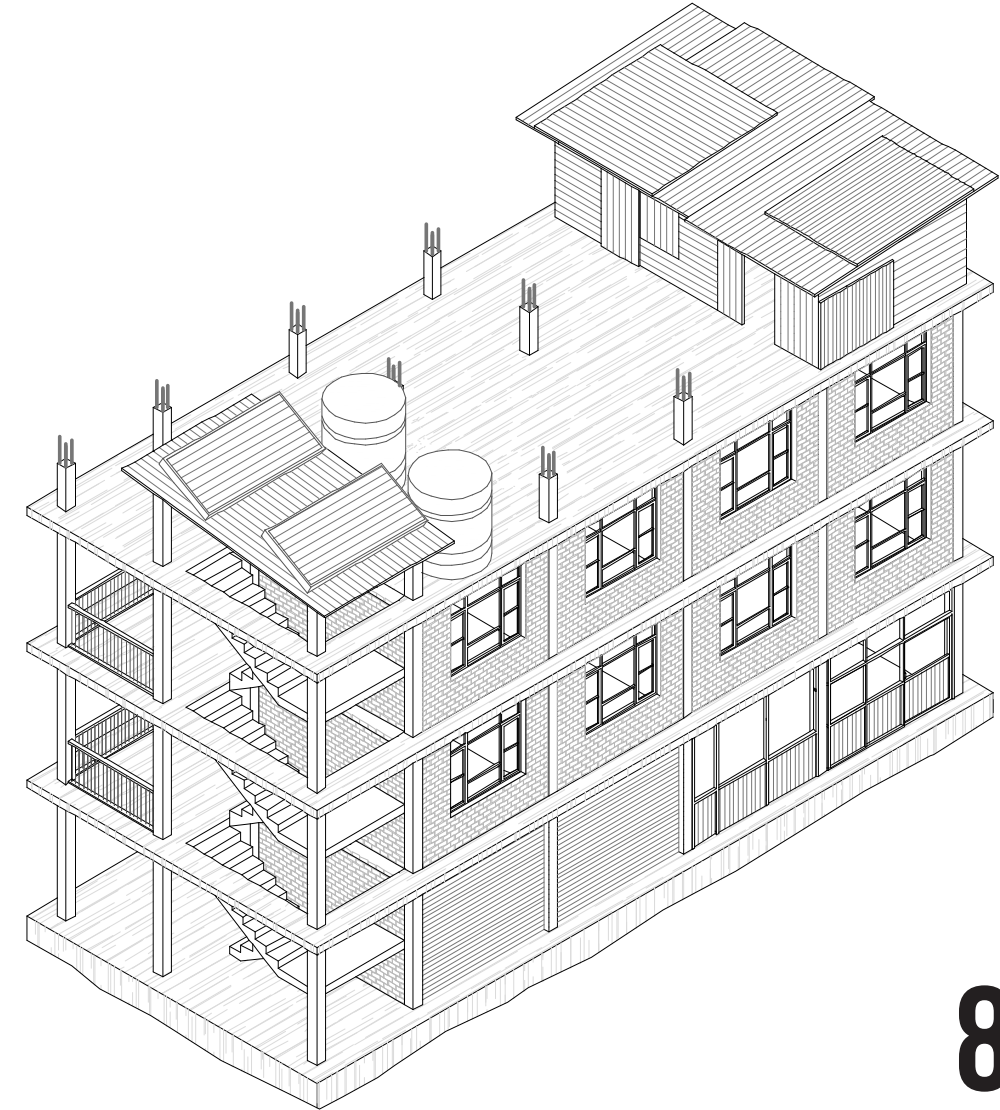

80 TON_{CO2}

35 CAR X 12.500 KM

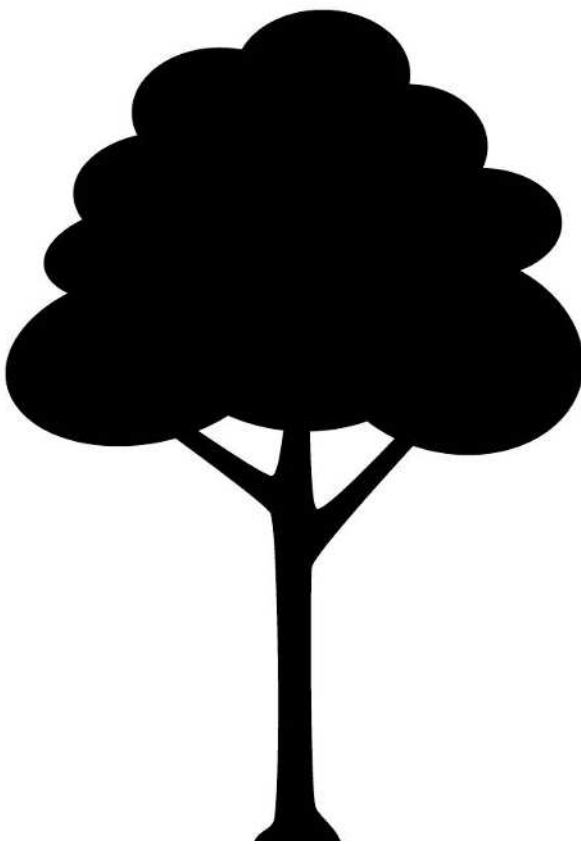

1 TREE X 50 YEARS

=

- 1 TONCO₂

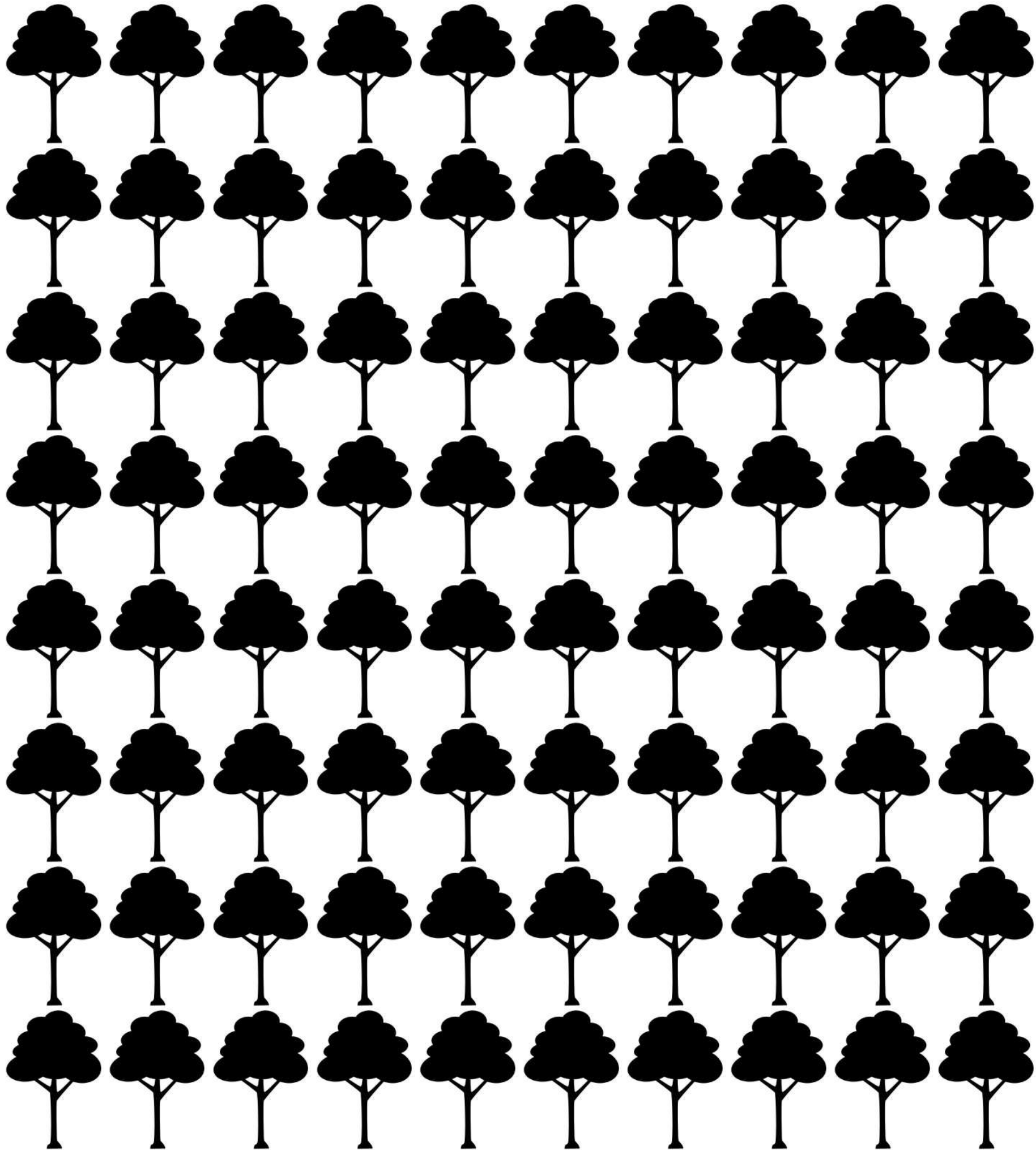

=

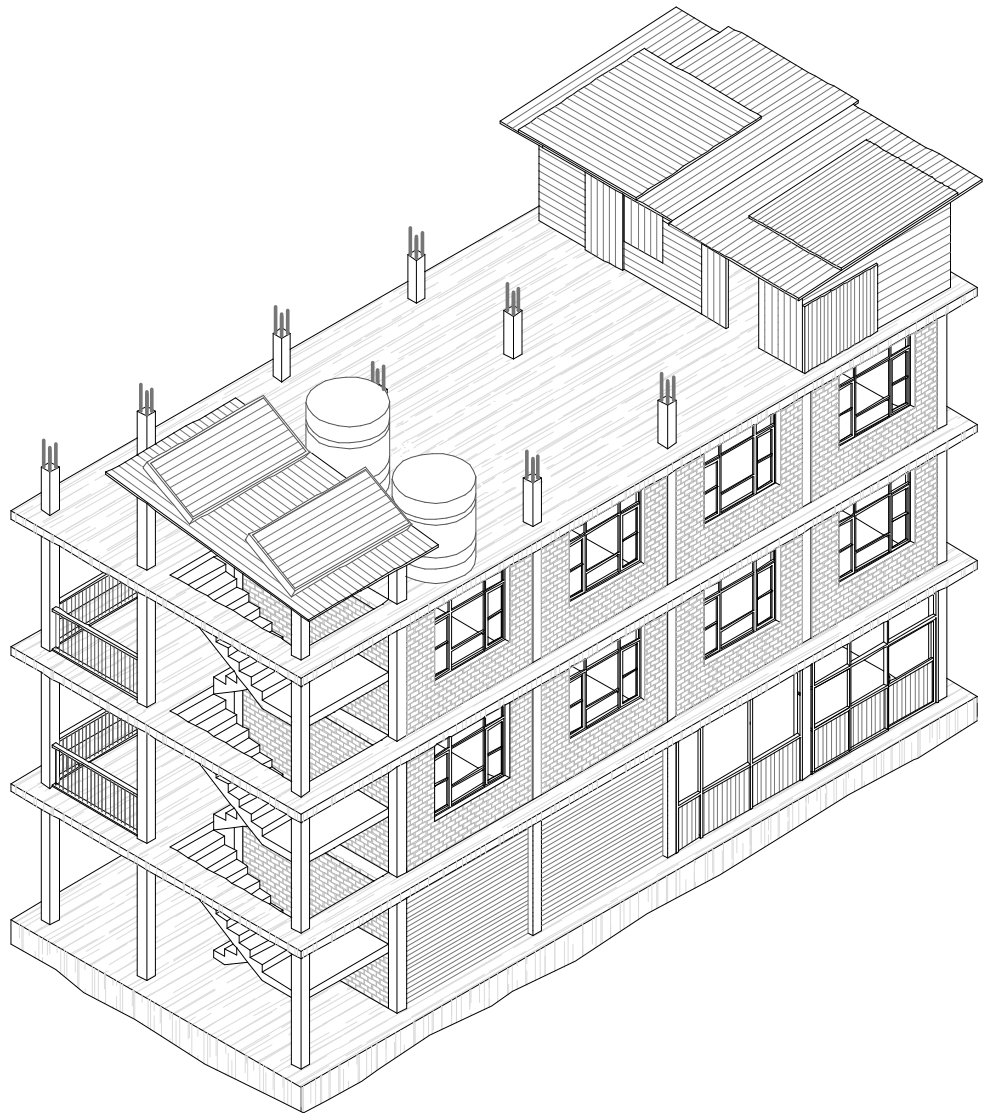

80 TREES X 50 YEARS

FROM RESEARCH TO DESIGN
TOWARDS A NEW CONTEMPORARY VERNACULAR

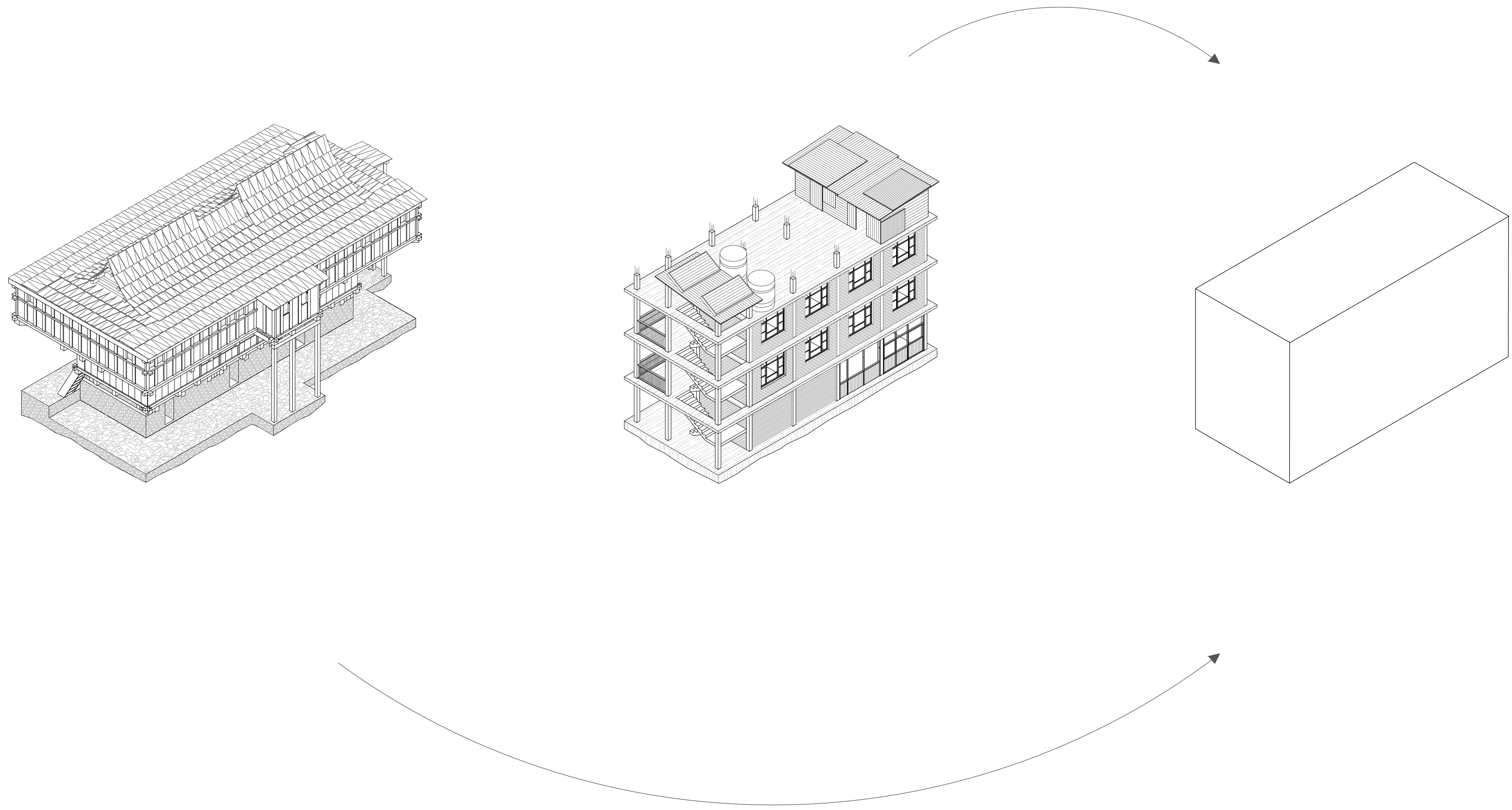

TO WHICH EXTENT THE **ARCHETYPICAL QUALITIES** OF THE HIMALAYAN **VERNACULAR ARCHITECTURE** SHOULD BE EMBODIED IN **NEW SUSTAINABLE DESIGNS**?

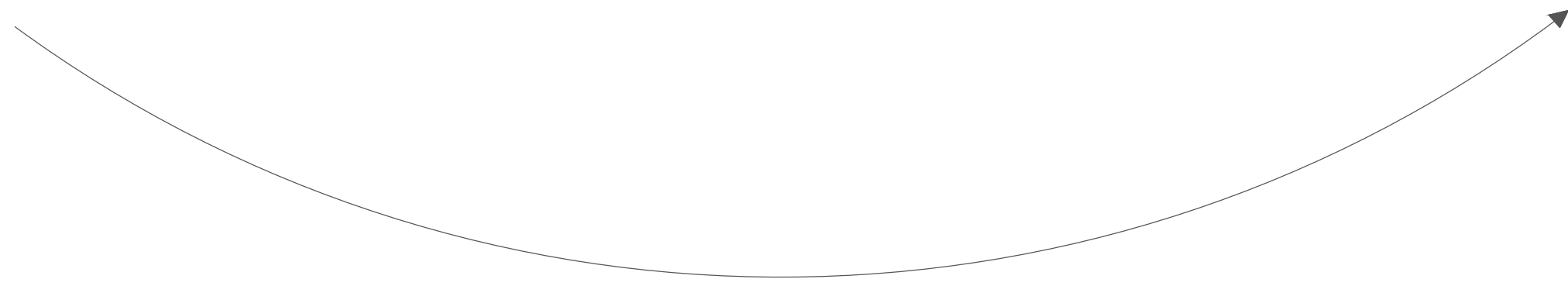
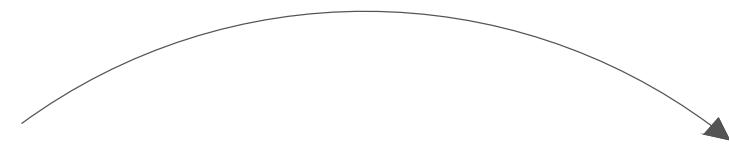
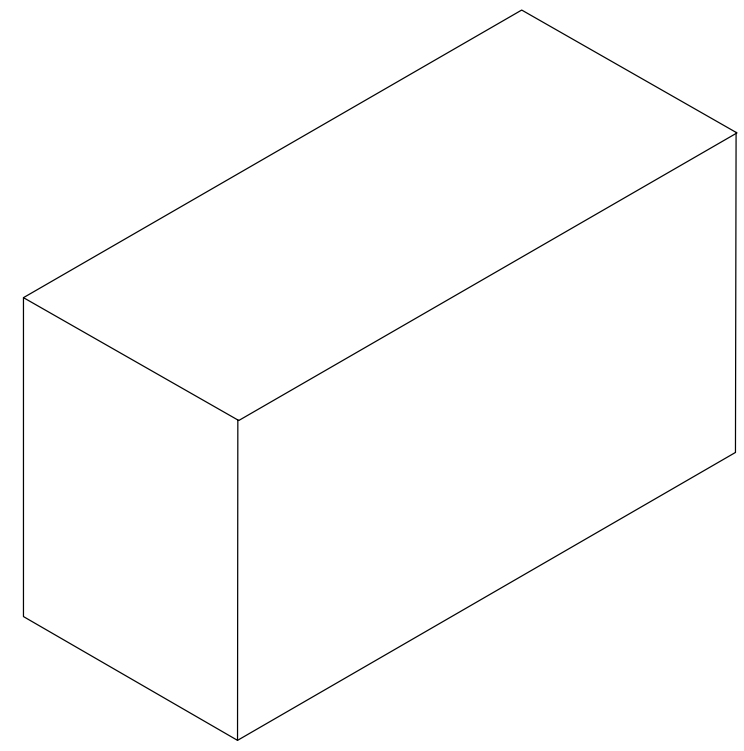
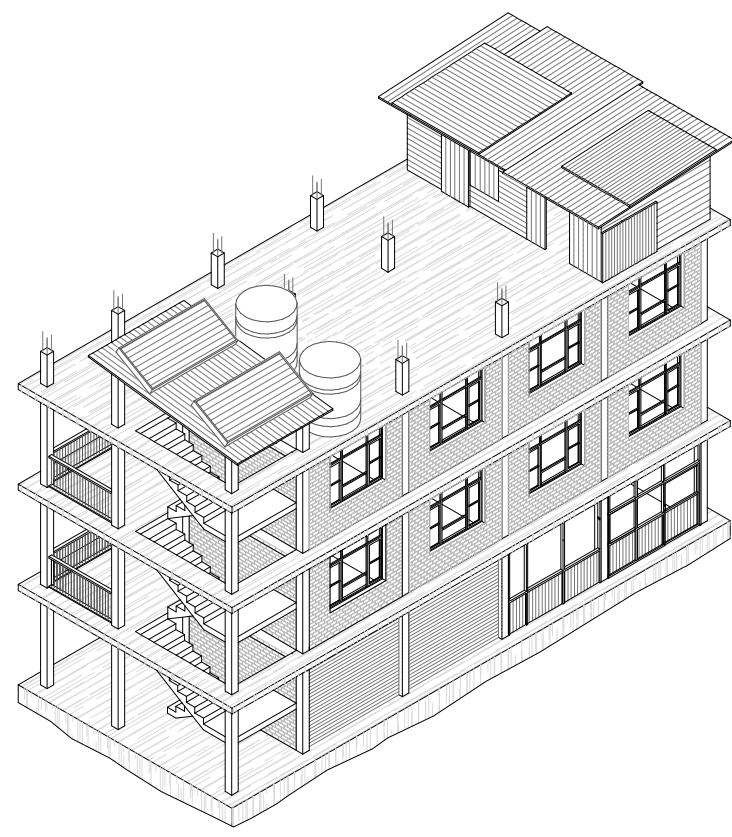
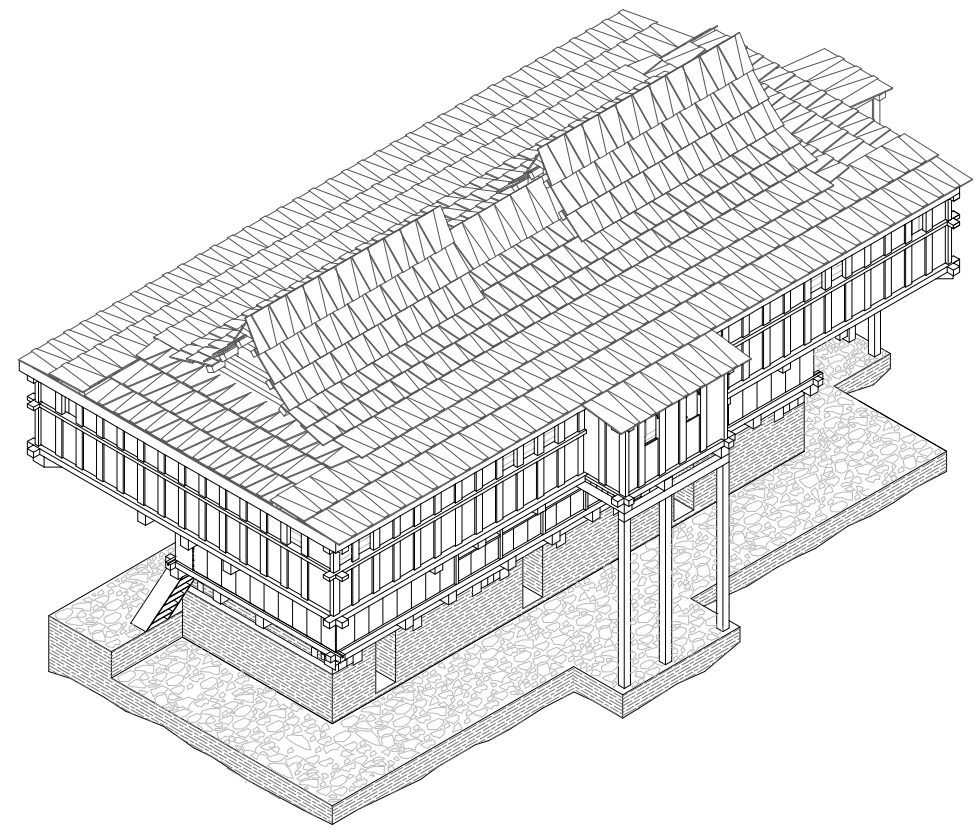

EXPLICITNESS

MODULARITY

FEASIBILITY

FLEXIBILITY

INCREMENTALITY

REPRODUCIBILITY

INSPIRED BY GRAND VERNACULAR
EXPLICITNESS
UNDERSTANDABLE CONSTRUCTION

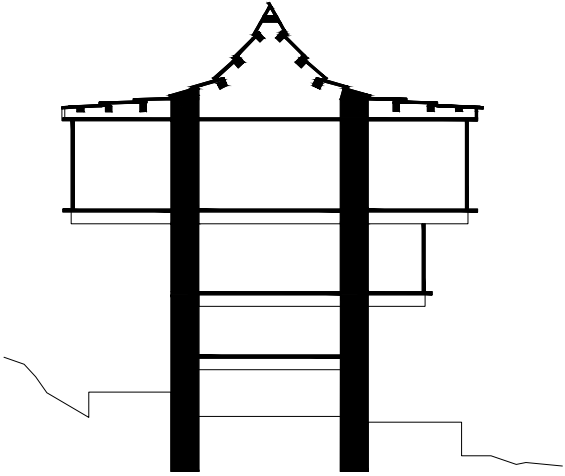
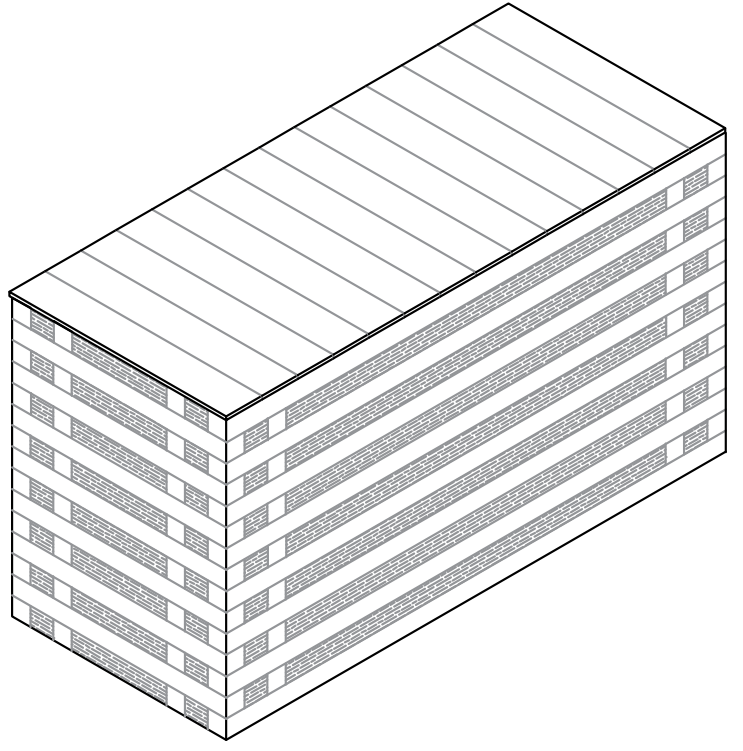

INSPIRED BY BOTH GRAND & ORDINARY VERNACULAR
FEASIBILITY
FAMILY-RUN CONSTRUCTION + SIMPLE TOOLS

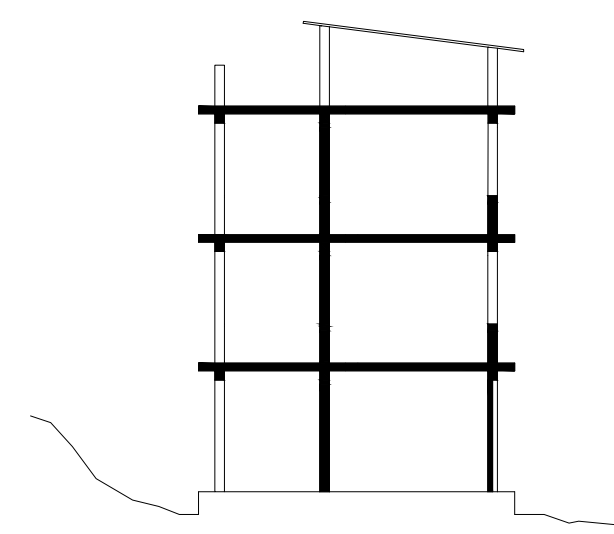
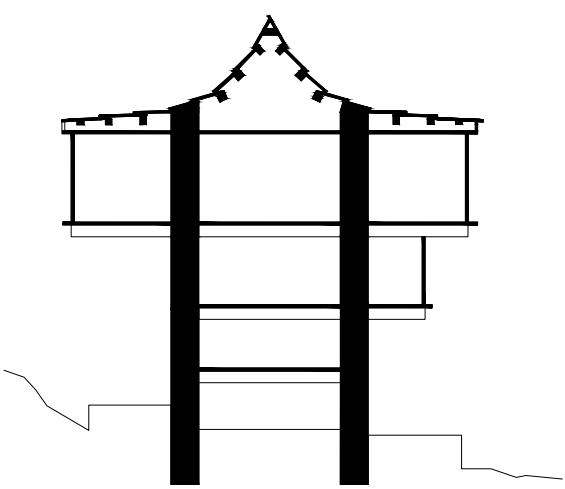
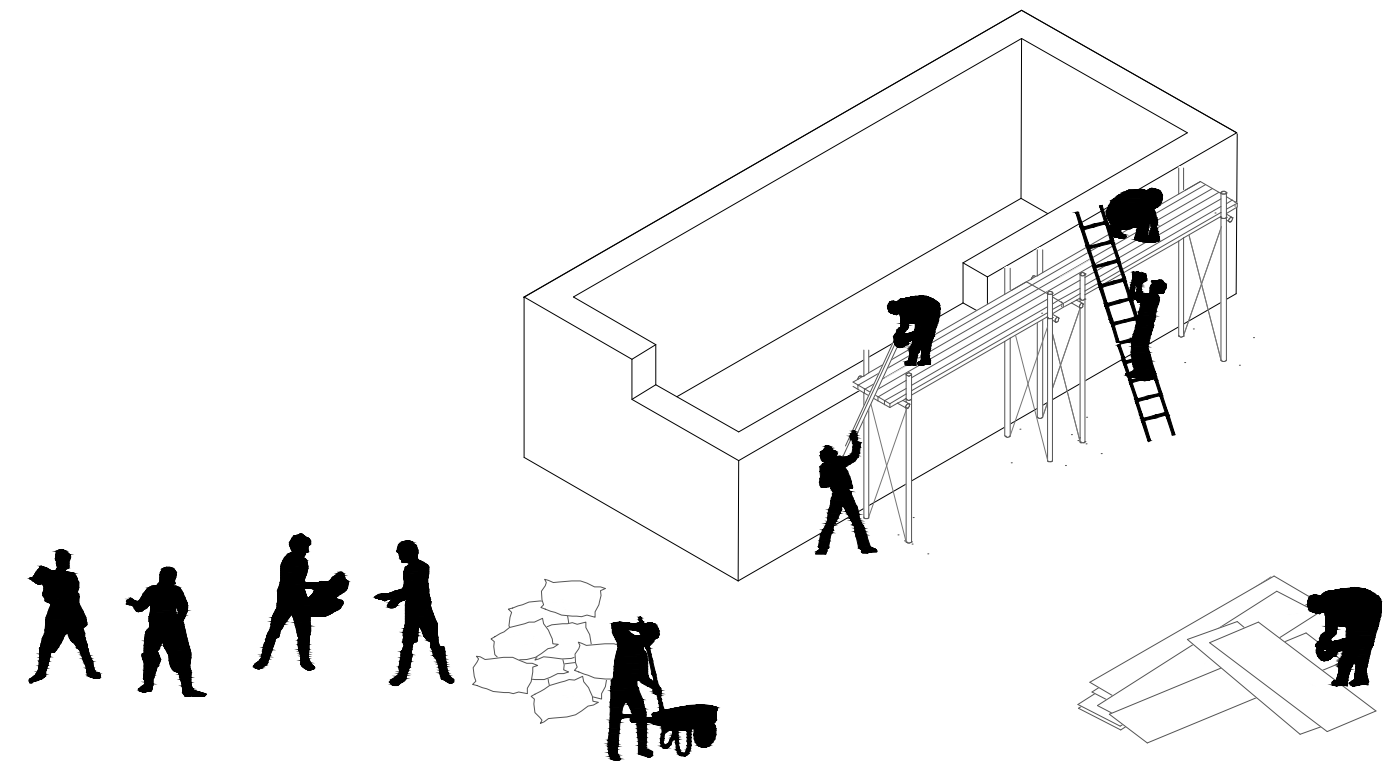

INSPIRED BY GRAND VERNACULAR
FLEXIBILITY
NON-TYPIFIED SPACES

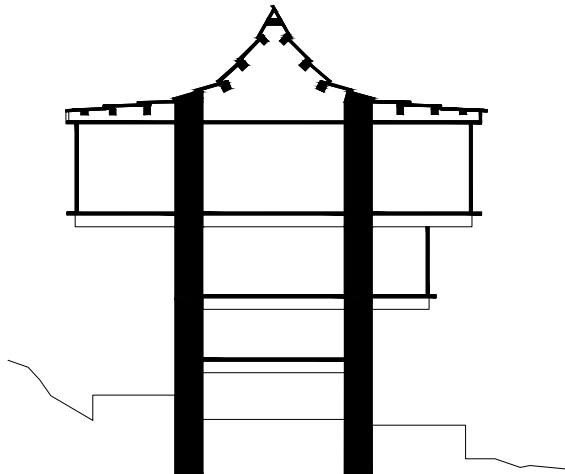
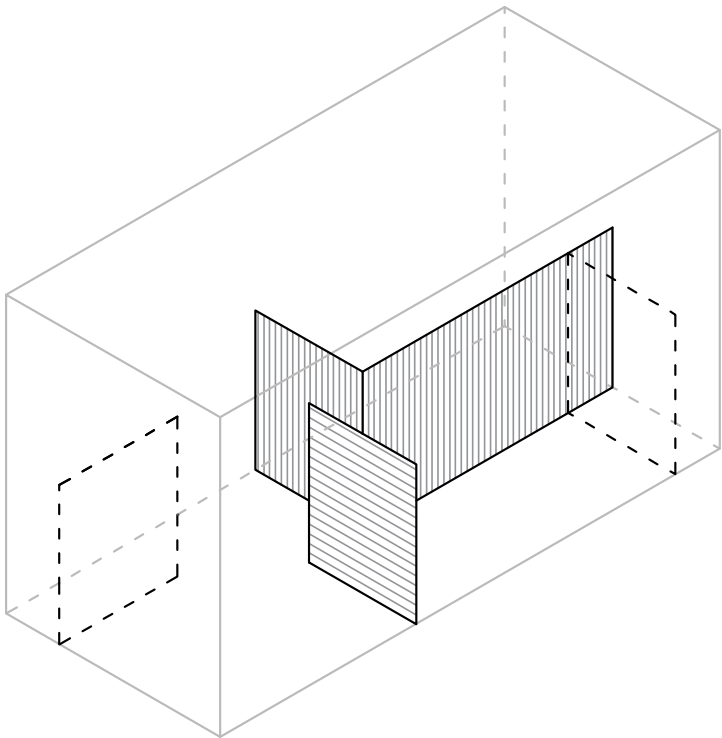

INSPIRED BY BOTH GRAND & ORDINARY VERNACULAR

MODULARITY

ONE PROJECT, ONE DETAIL

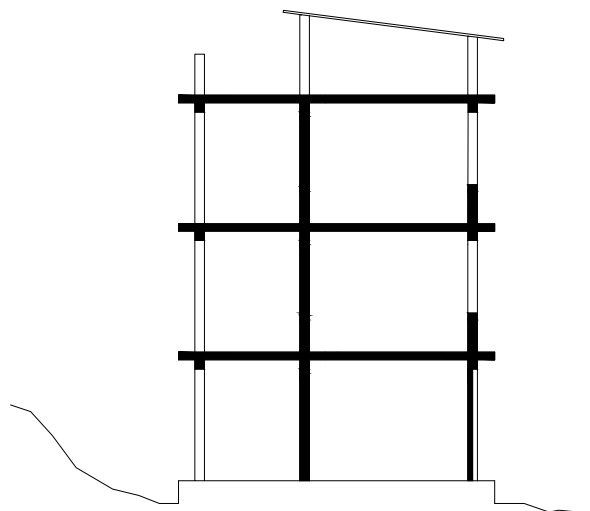
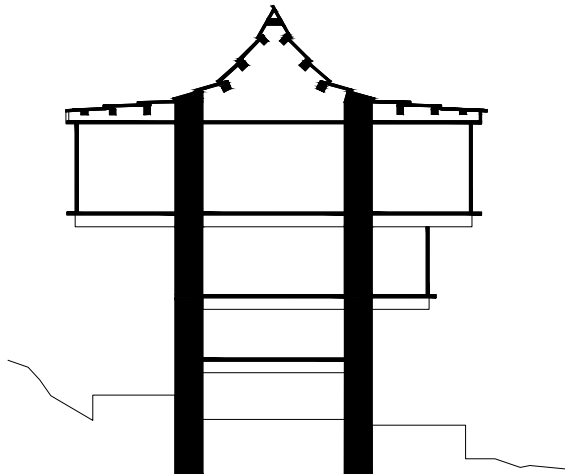
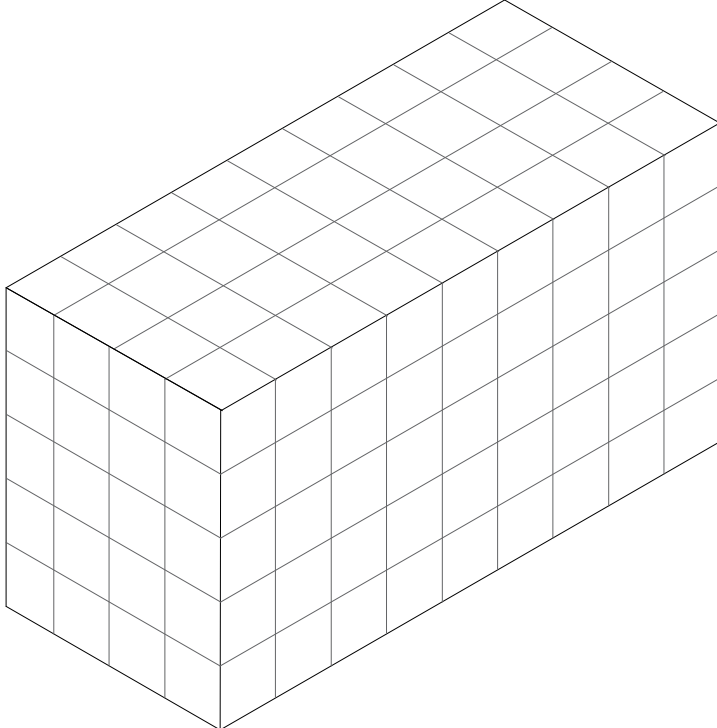

INSPIRED BY ORDINARY VERNACULAR
INCREMENTALITY
POSSIBILITY OF FUTURE EXPANSIONS

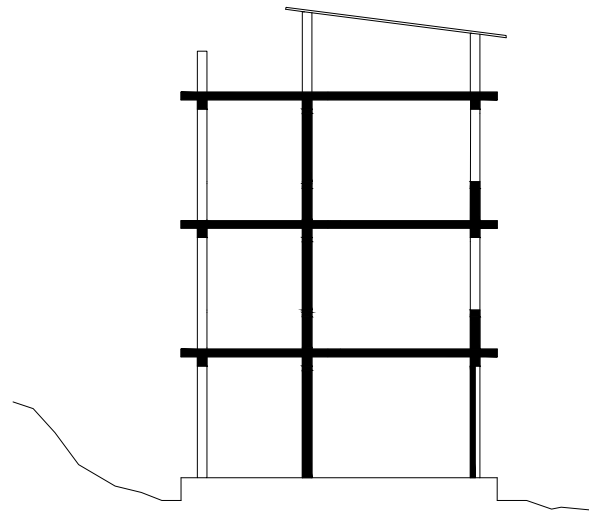
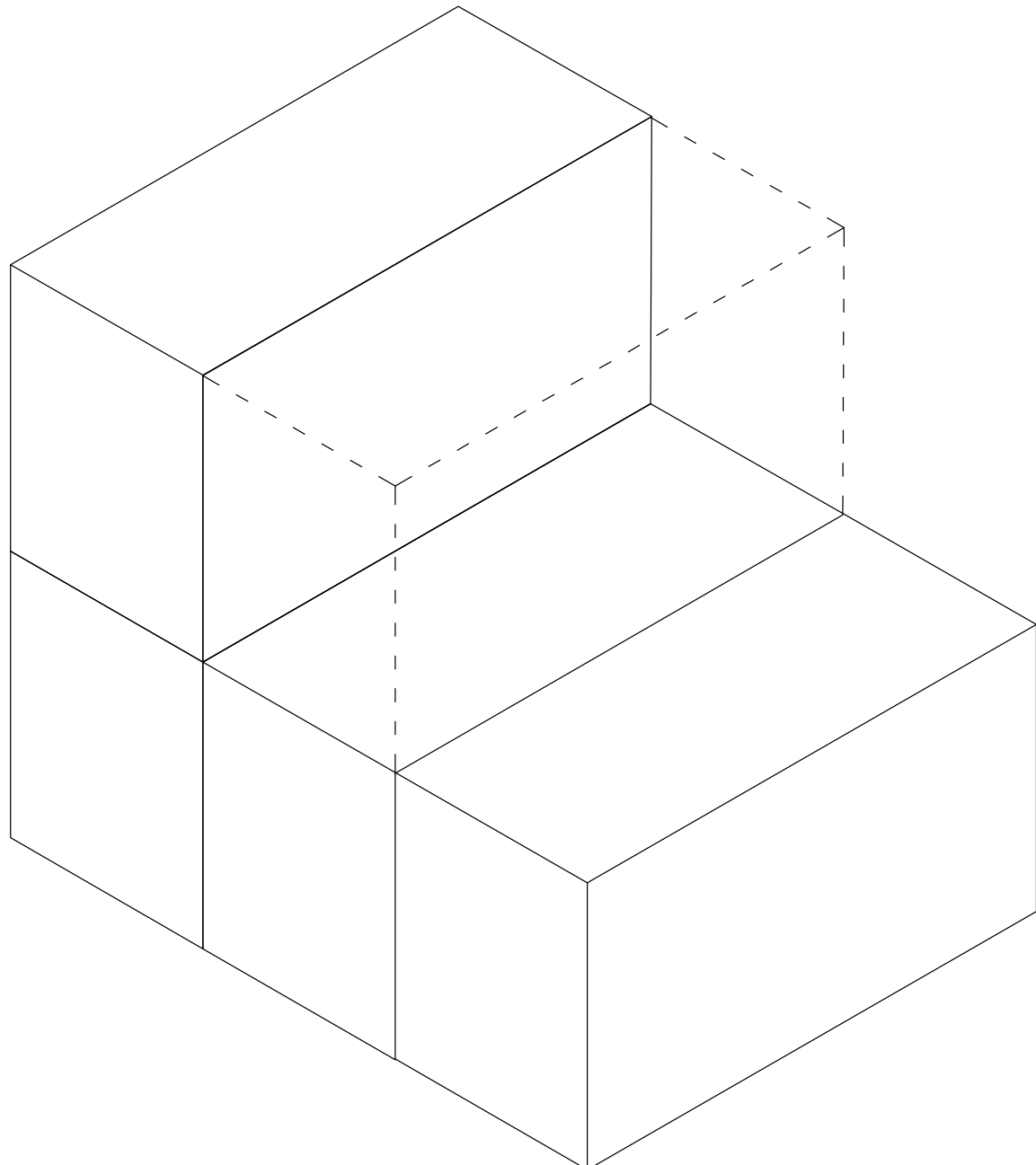

INSPIRED BY ORDINARY VERNACULAR
REPRODUCIBILITY
APPLICABILITY WITHIN A LARGER CONTEXT

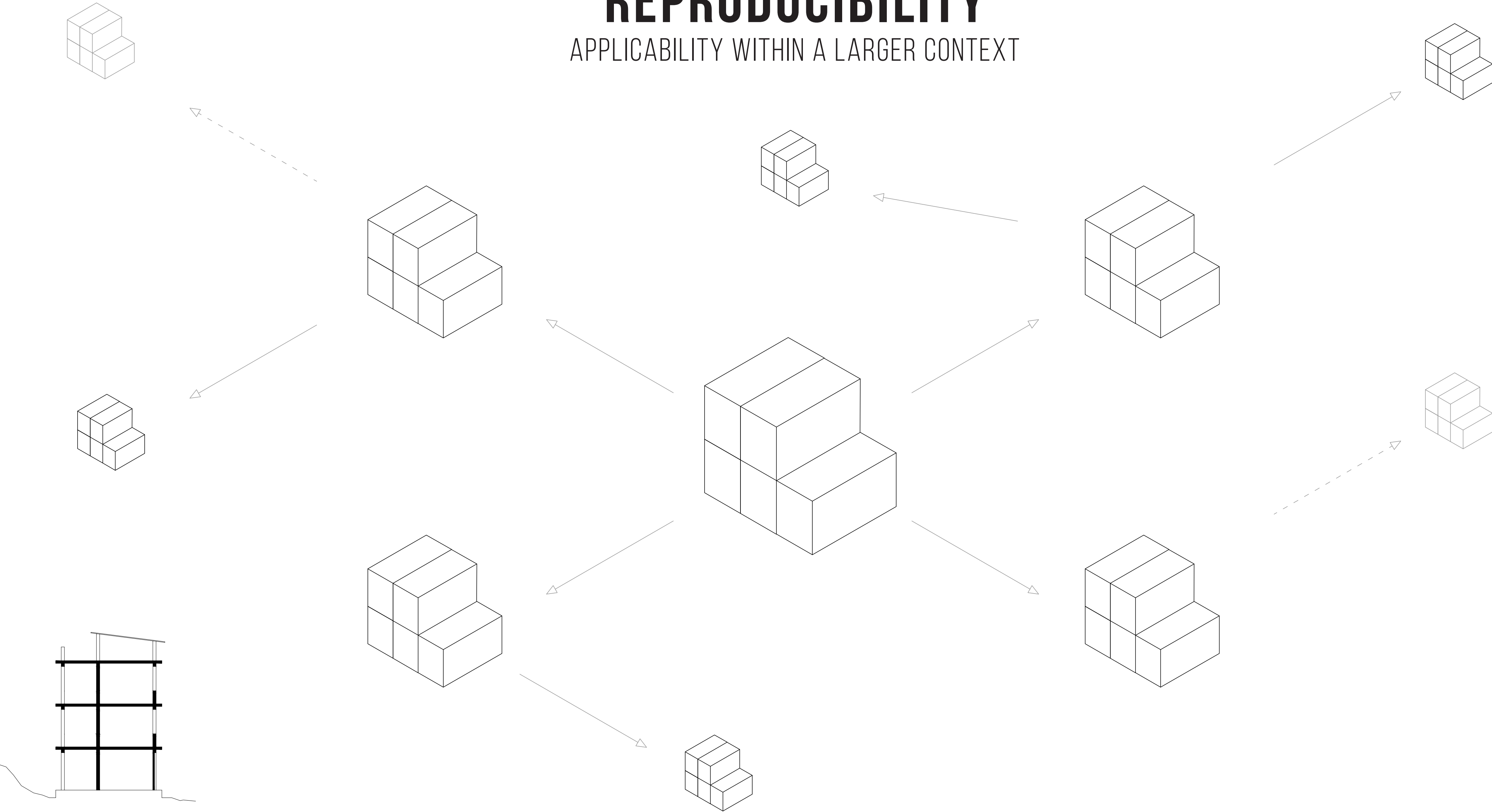

VERNACULAR
BUILT ENVIRONMENT

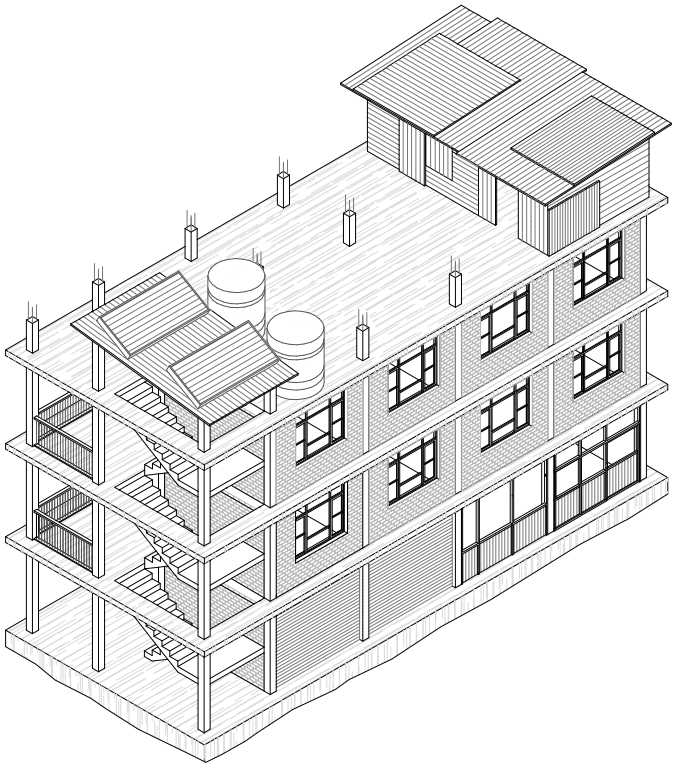
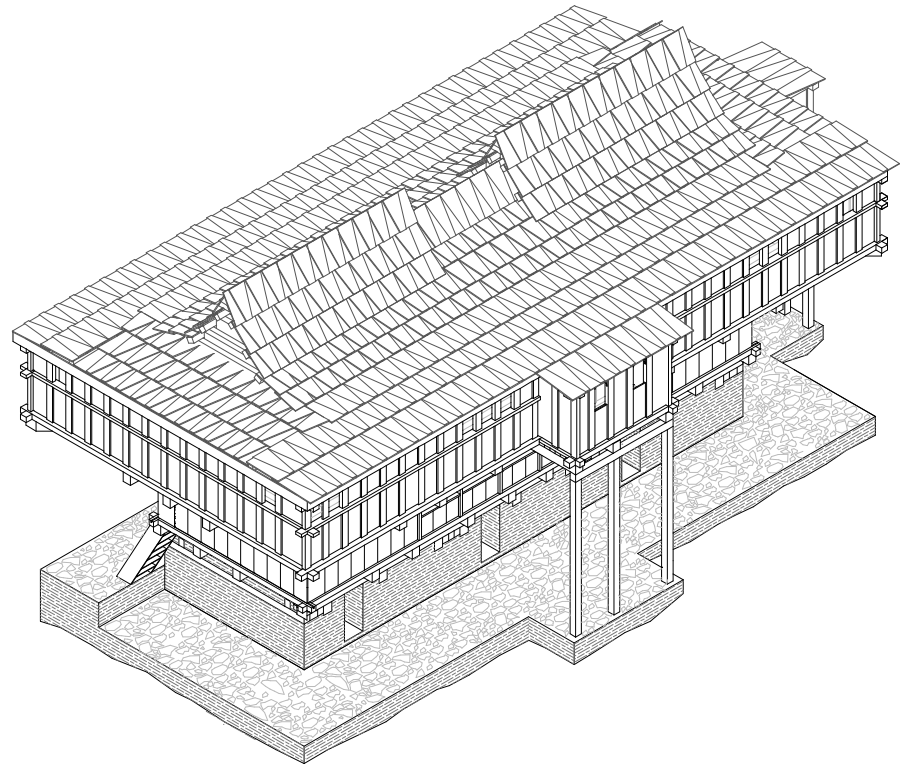

VERNACULAR
BUILT ENVIRONMENT

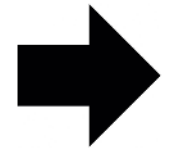
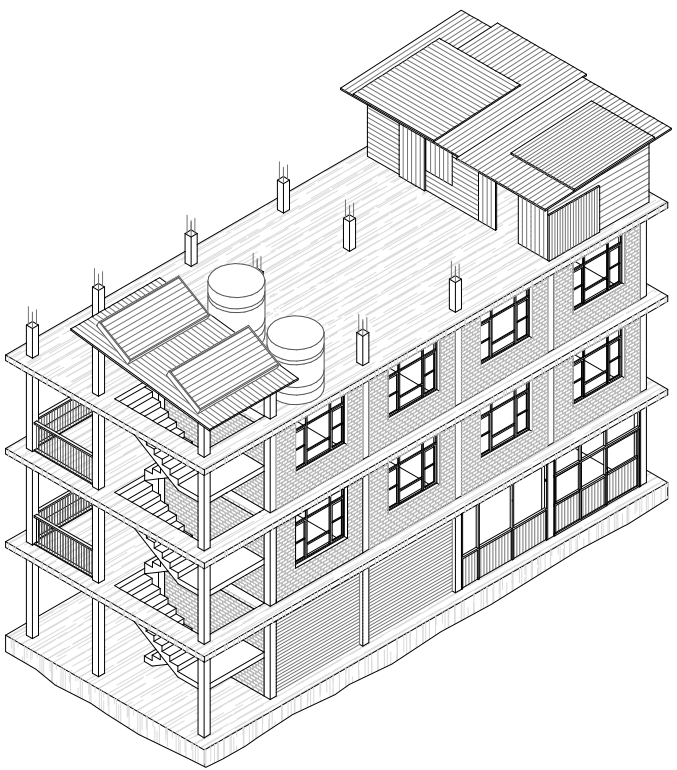
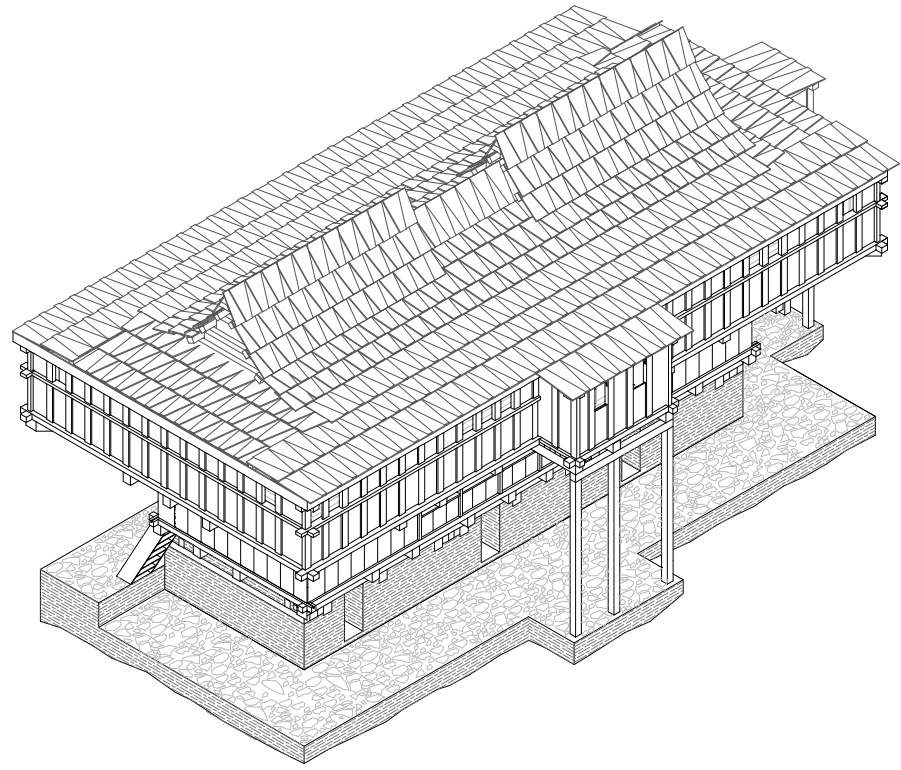

ARCHETYPICAL
QUALITIES

REPRODUCIBILITY

INCREMENTALITY

MODULARITY

FLEXIBILITY

FEASIBILITY

EXPLICITNESS

VERNACULAR
BUILT ENVIRONMENT

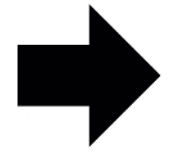
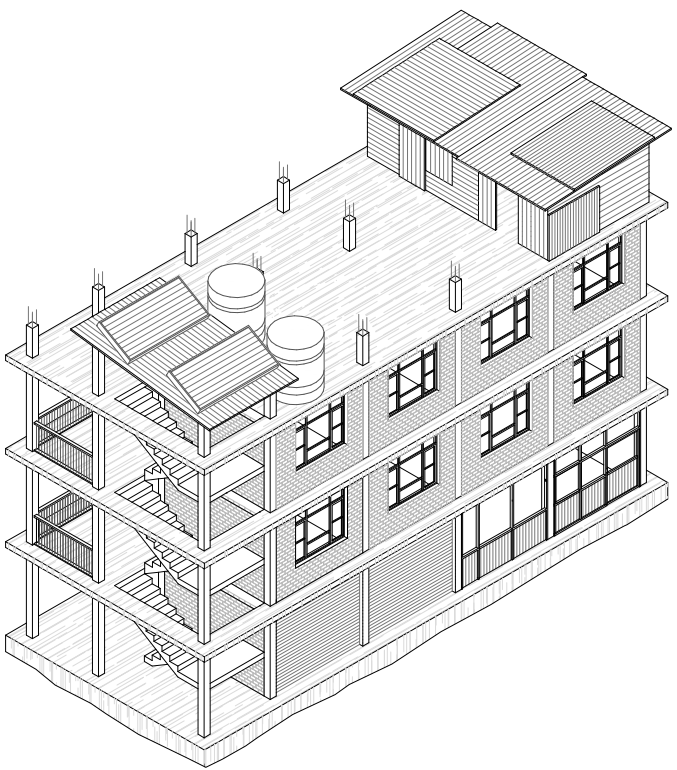
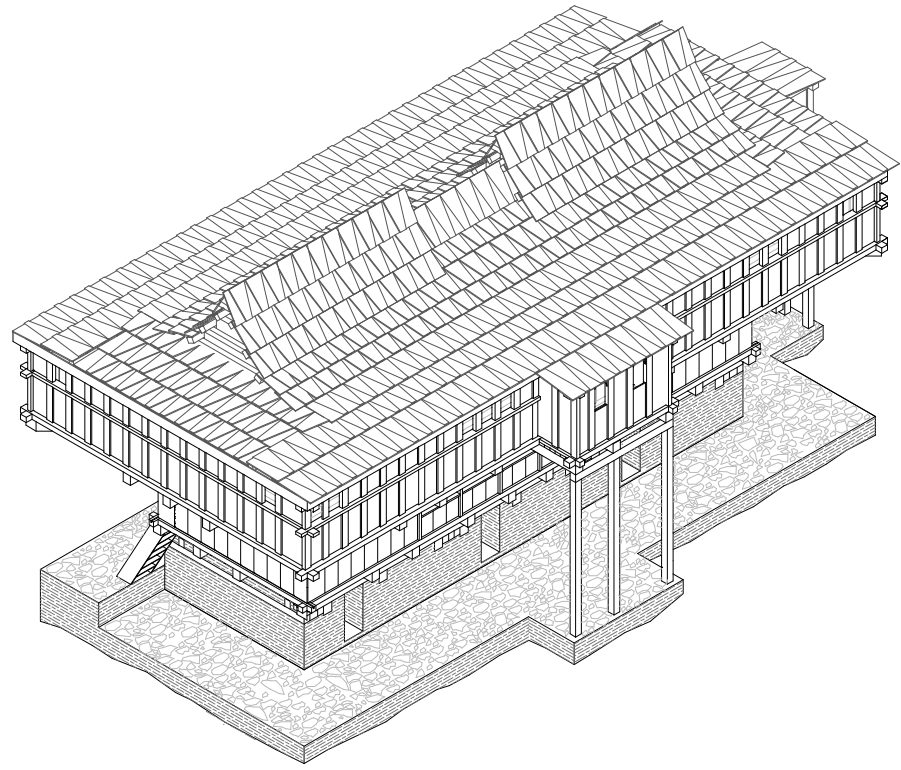

ARCHETYPICAL
QUALITIES

REPRODUCIBILITY

INCREMENTALITY

MODULARITY

FLEXIBILITY

FEASIBILITY

EXPLICITNESS

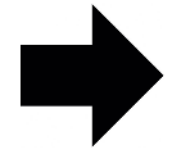

NEW
ARCHITECTURE

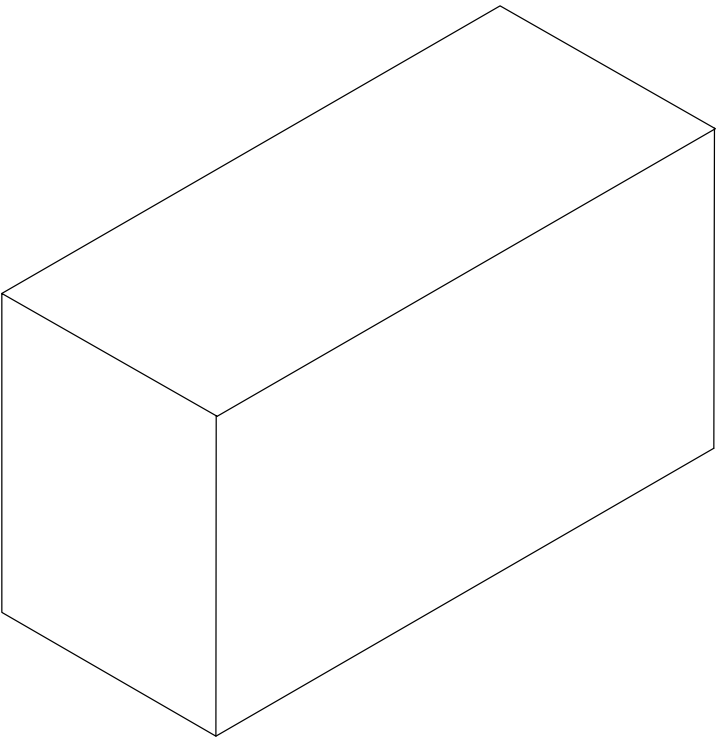

VERNACULAR
BUILT ENVIRONMENT

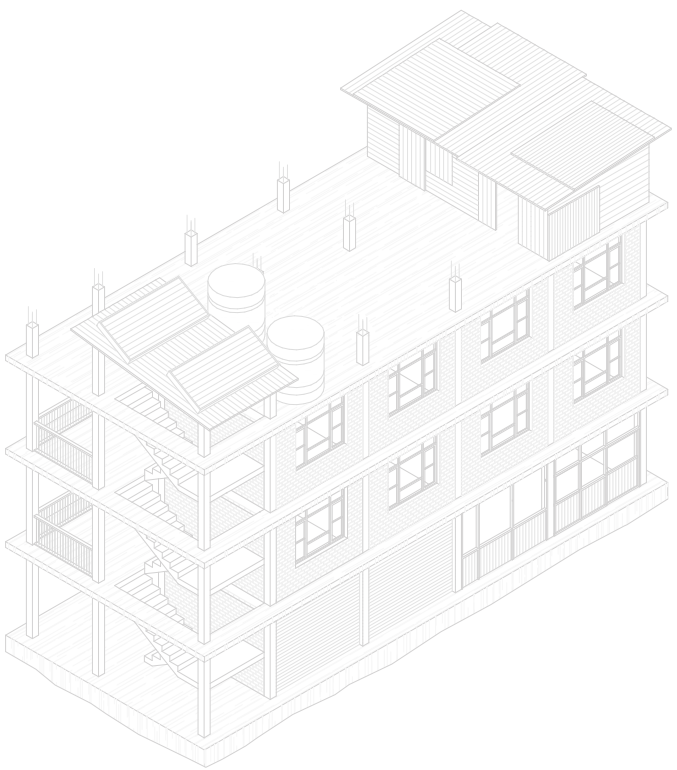
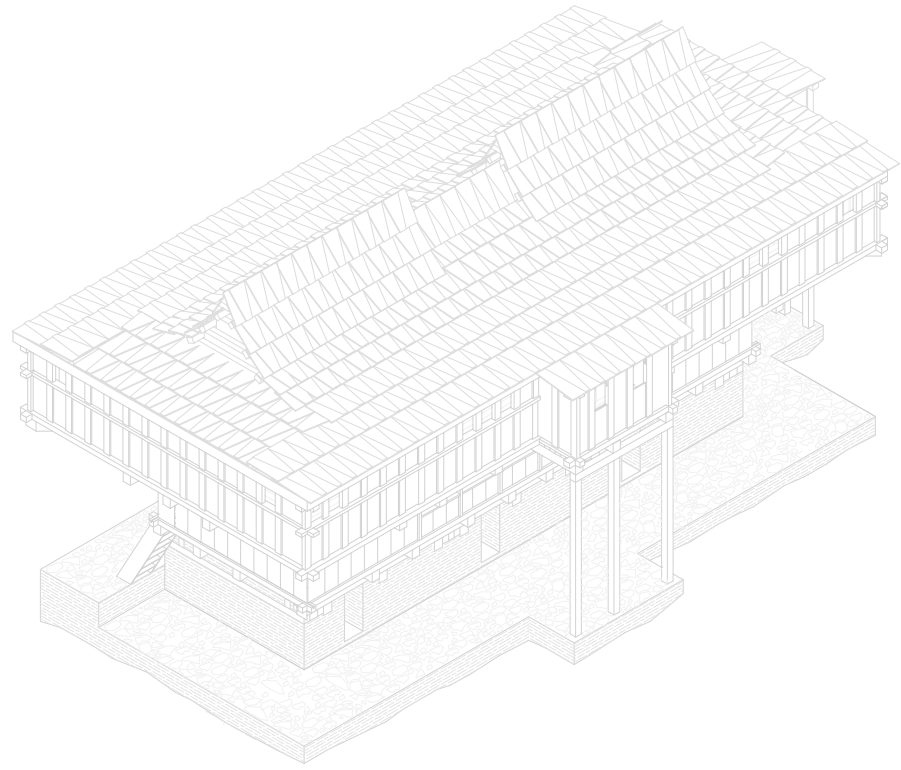

ARCHETYPICAL
QUALITIES

REPRODUCIBILITY

INCREMENTALITY

MODULARITY

FLEXIBILITY

FEASIBILITY

EXPLICITNESS



NEW
ARCHITECTURE

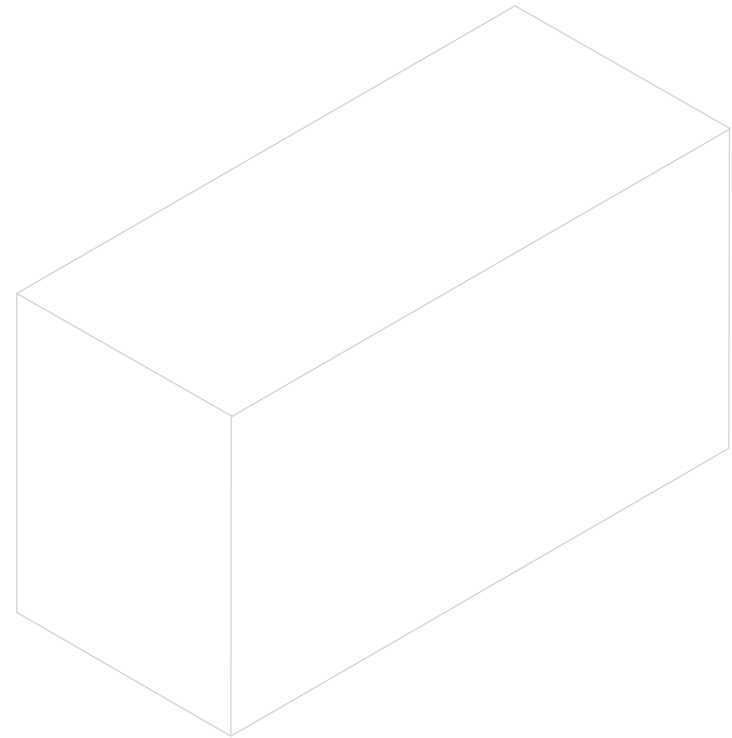

WHAT IS THE ROLE OF THE ARCHITECT?



STANDARD PRACTICE

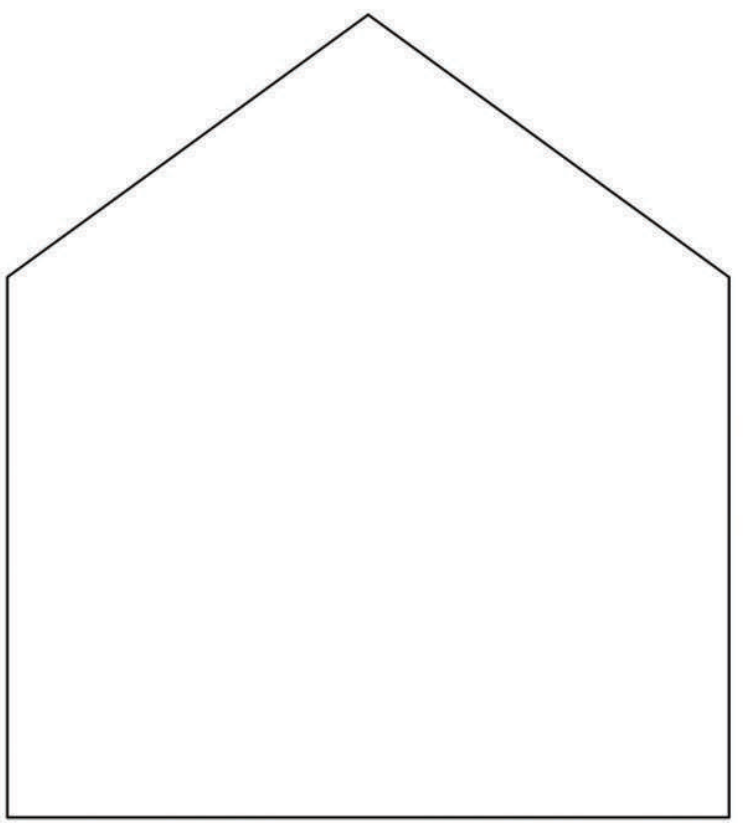
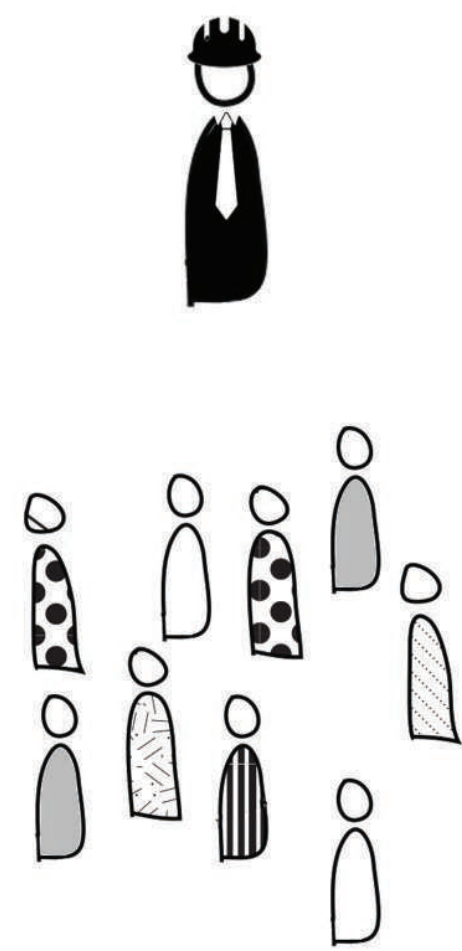

ARCHITECT DESIGN 100% OF THE BUILDING

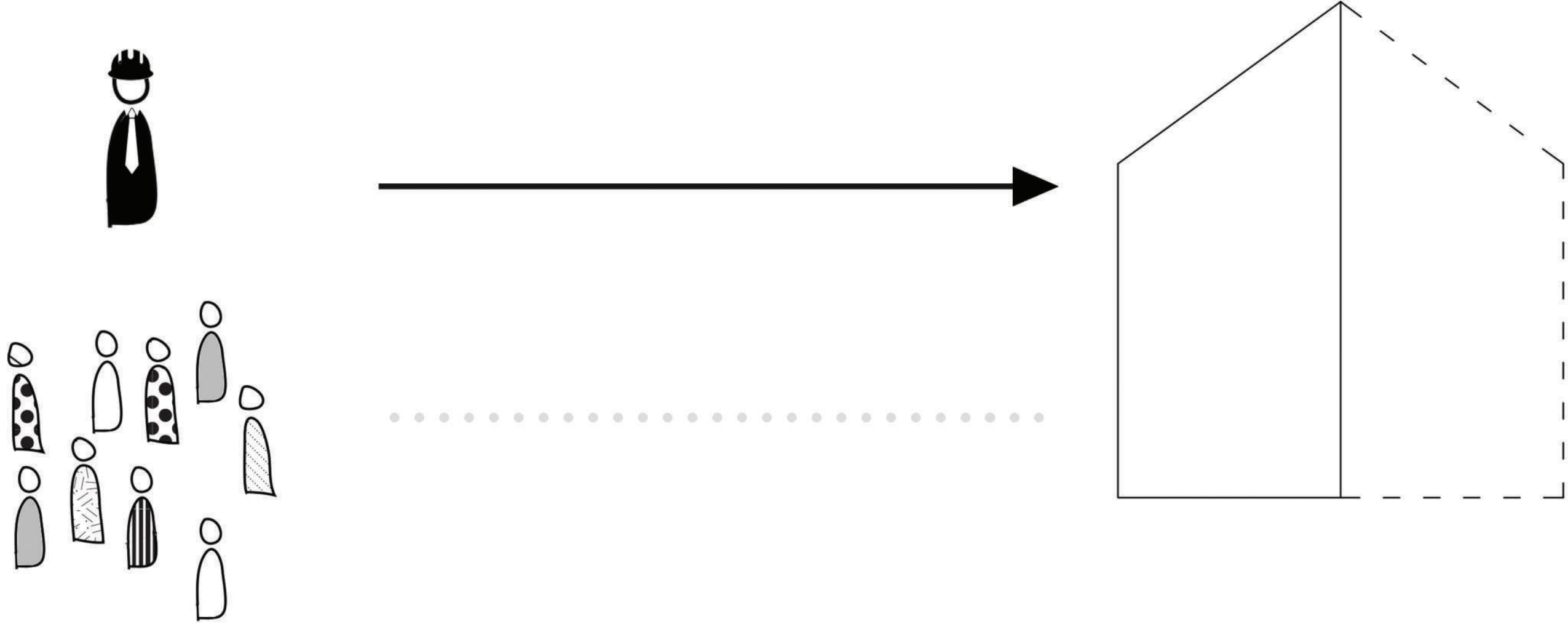

ARCHITECT BRINGS THE COMMUNITY INTO THE PROCESS

INCREMENTAL PRACTICE

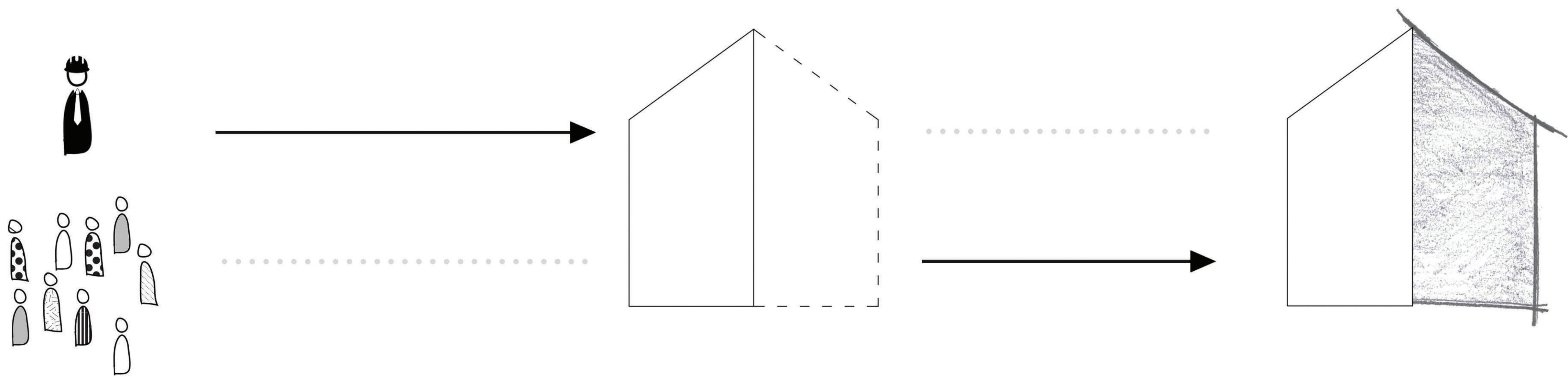

USERS COMPLETE THE DESIGN

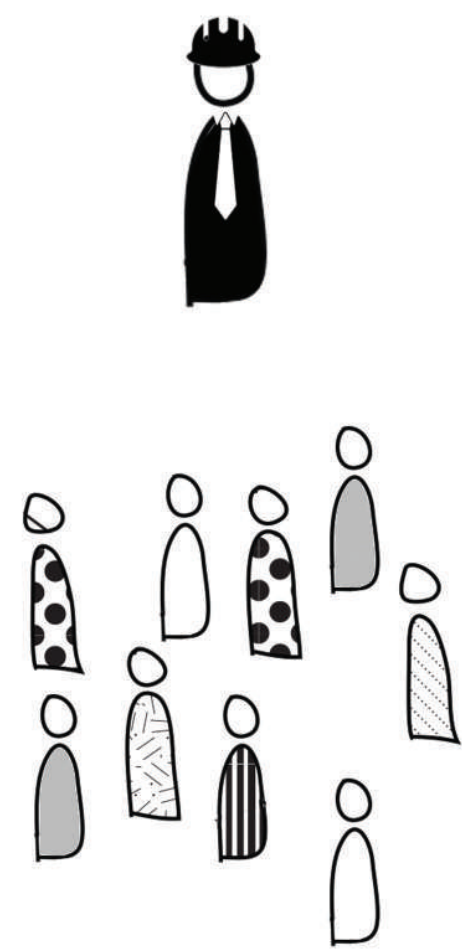

USERS DESIGN 100% OF THE BUILDING

VERNACULAR PRACTICE

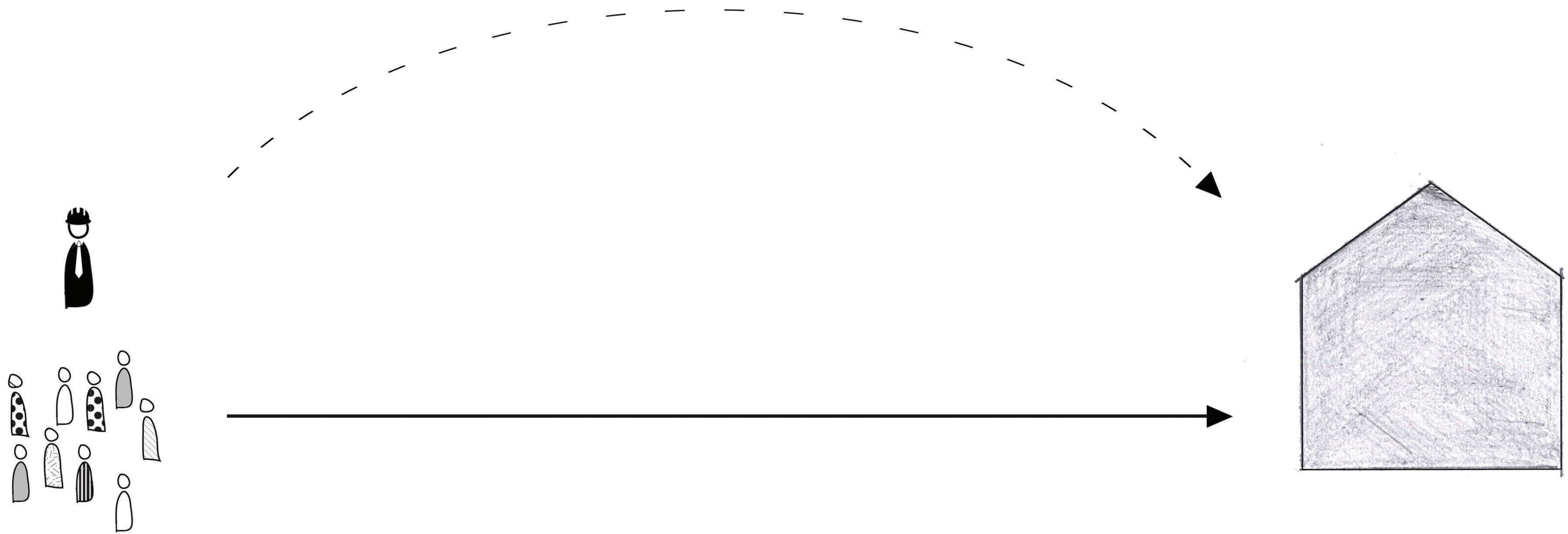

ARCHITECT CAN (INDIRECTLY) INFLUENCE THE TREND

HOW?

THREE STRATEGIES:

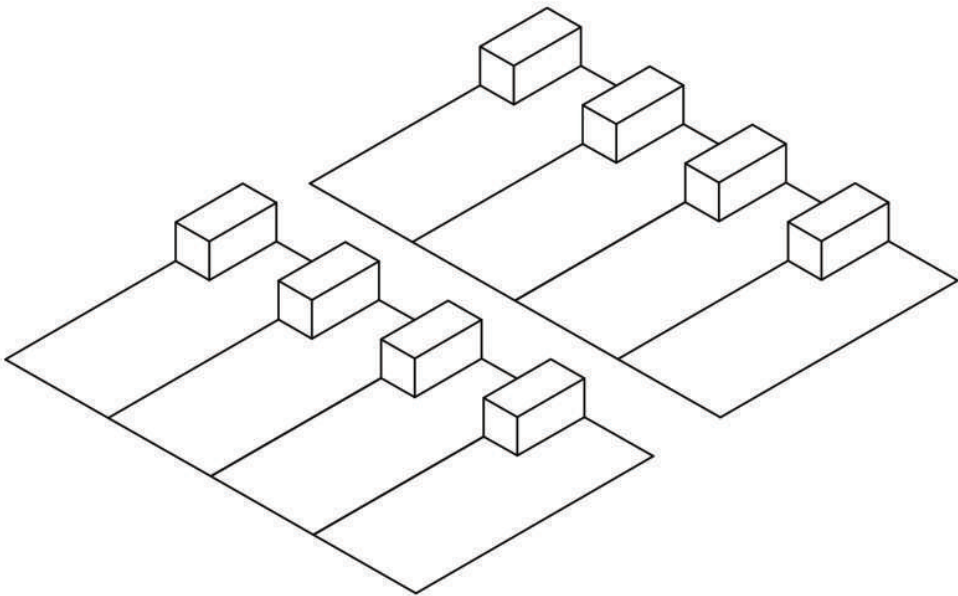

SITE AND SERVICE

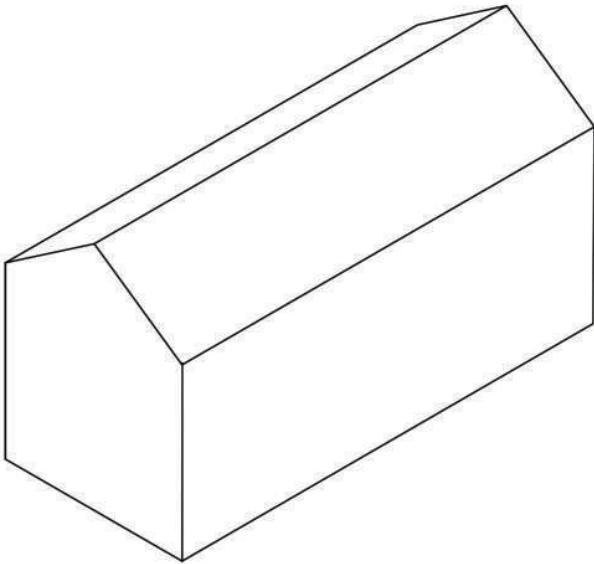

SHOWCASE

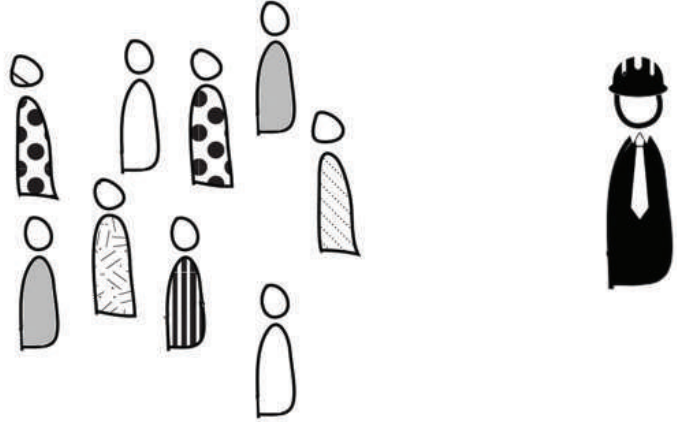

TRAINING

FOUR STRATEGIES:

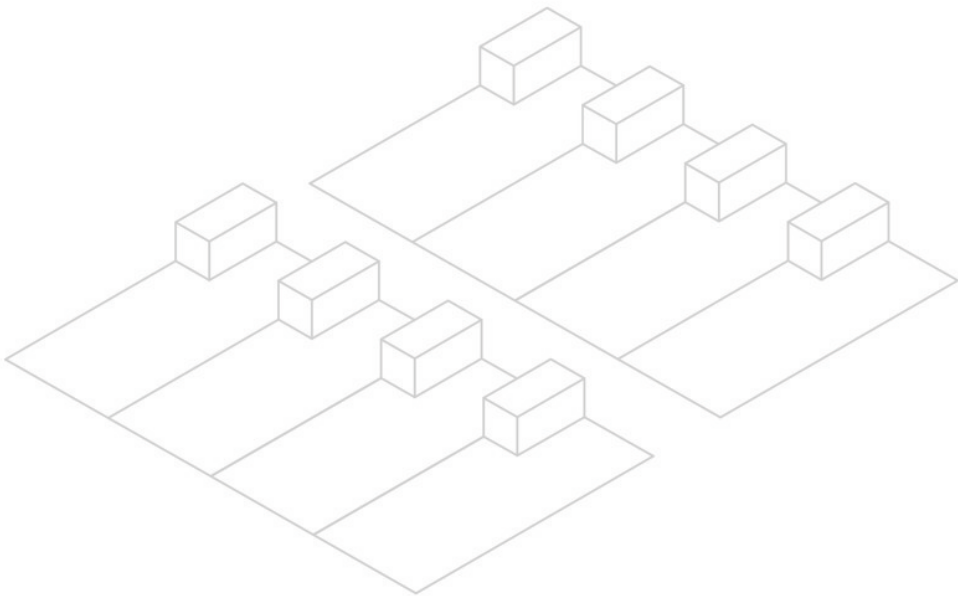

SITE AND SERVICE

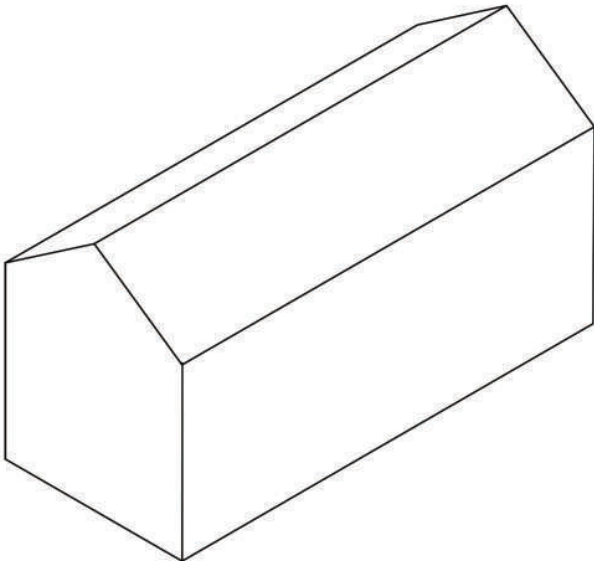

SHOWCASE

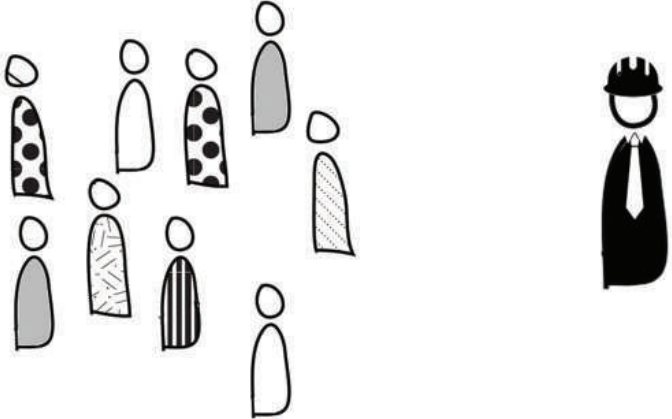

TRAINING

FOUR STRATEGIES:

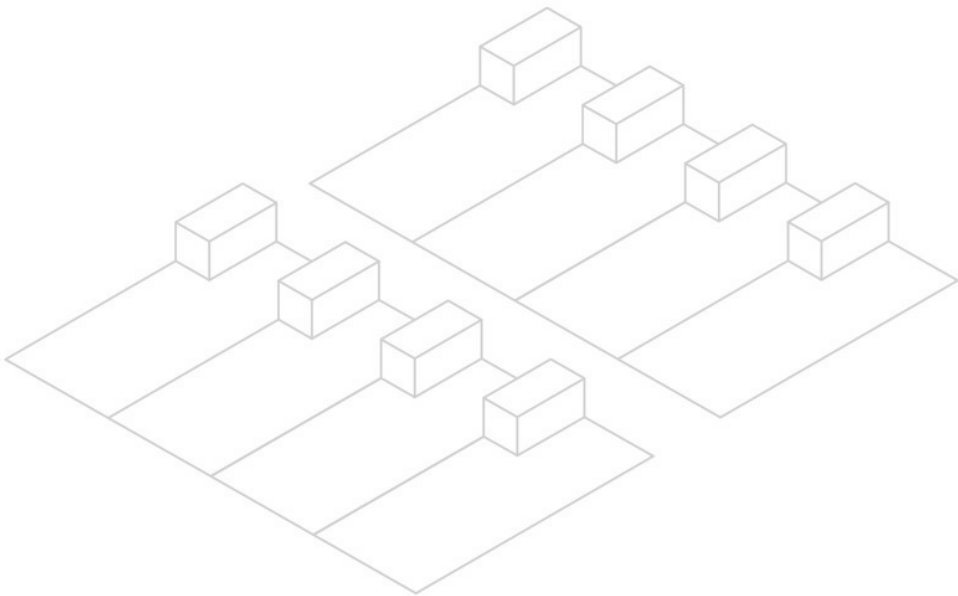

SITE AND SERVICE

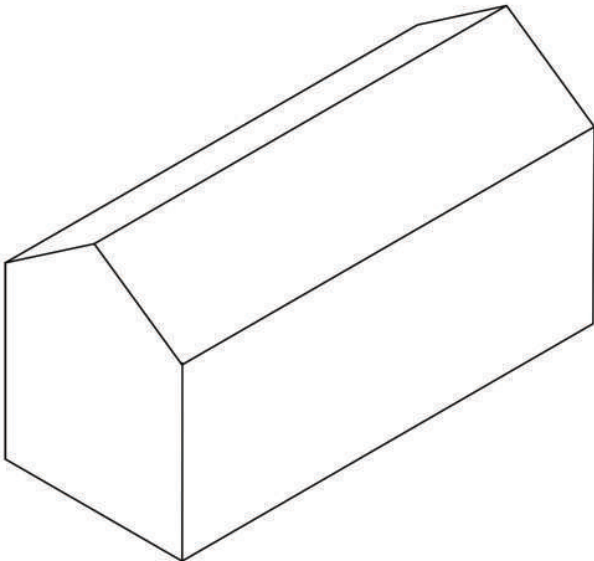

SHOWCASE



TRAINING

FOUR STRATEGIES:

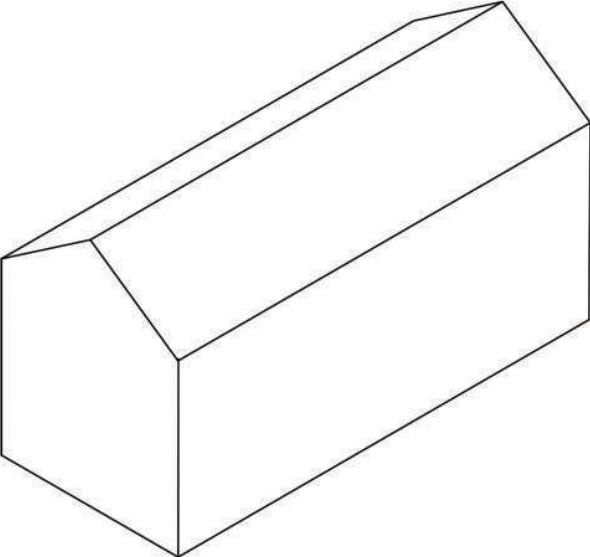

SHOWCASE

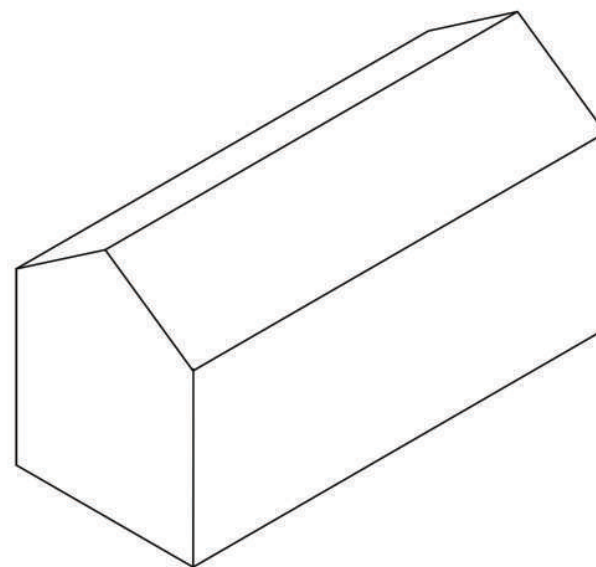

SHOWCASE

=

PILOT PROJECT WITH A PEDAGOGICAL FUNCTION

HOW TO **INTEGRATE**
ARCHETYPICAL QUALITIES INSPIRED BY VERNACULAR ARCHITECTURE
IN A SHOWCASE BUILDING?

HOW TO **COMBINE**
GENERIC ARCHETYPICAL QUALITIES INSPIRED BY VERNACULAR ARCHITECTURE
WITH **SPECIFIC REQUIREMENTS** IN A SHOWCASE BUILDING?





WHY THE DAGPO SCHOOL IS A PERFECT SHOWCASE ARCHITECTURE?

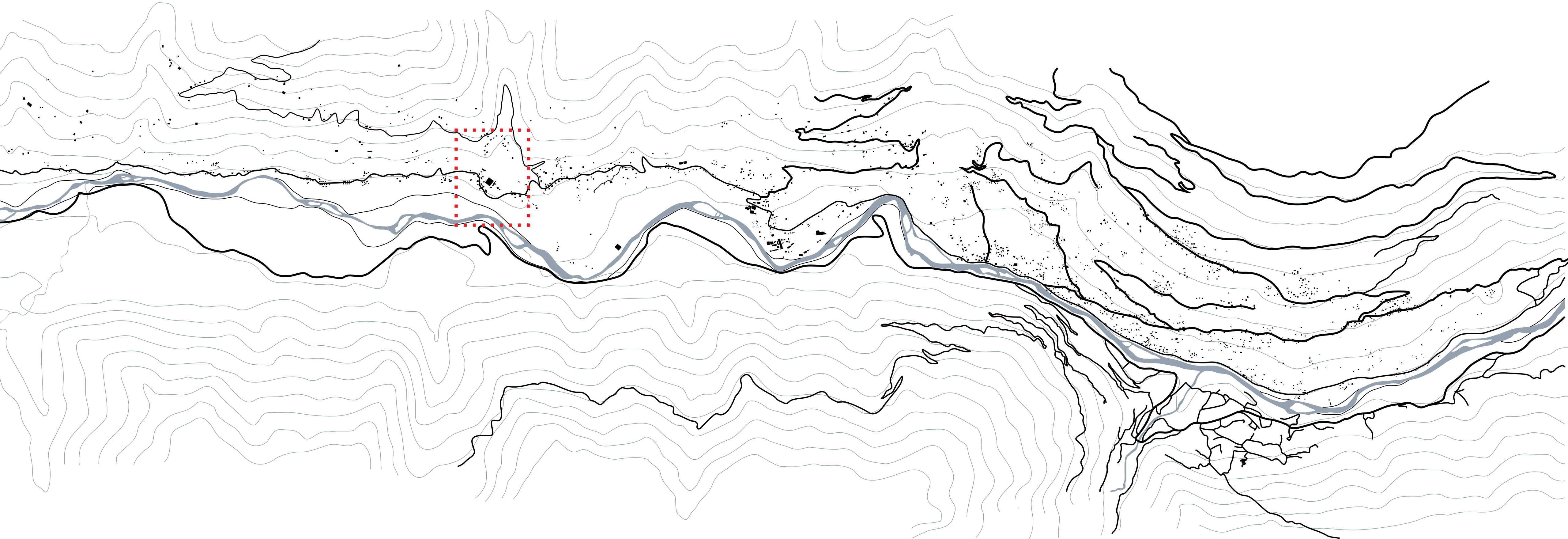

MANALI
10,000 POP



KULLU
20,000 POP



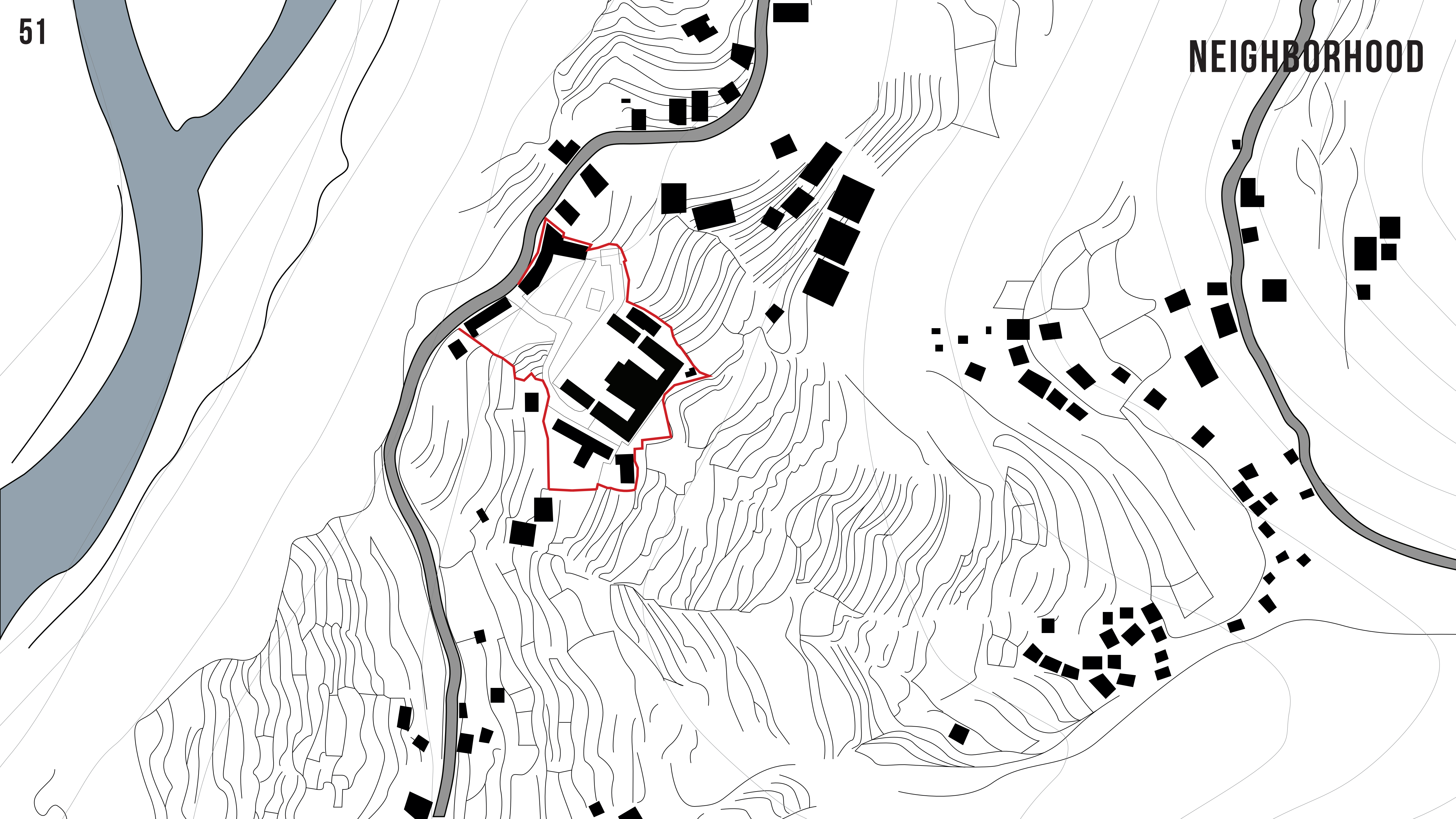

1.
LINKS A LARGE
VARIETY OF USERS

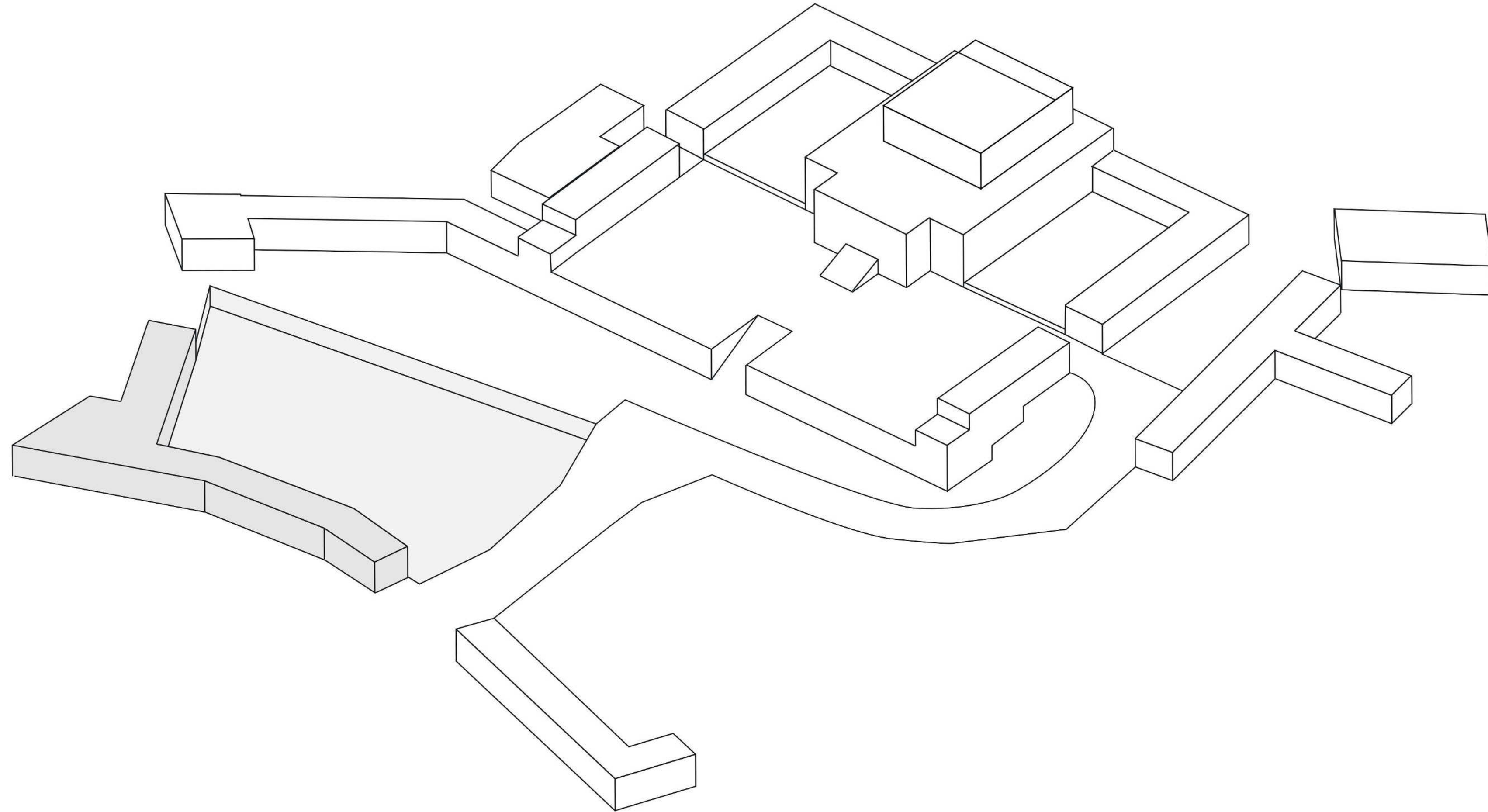

1.
LINKS A LARGE
VARIETY OF USERS

LITTLE MONKS

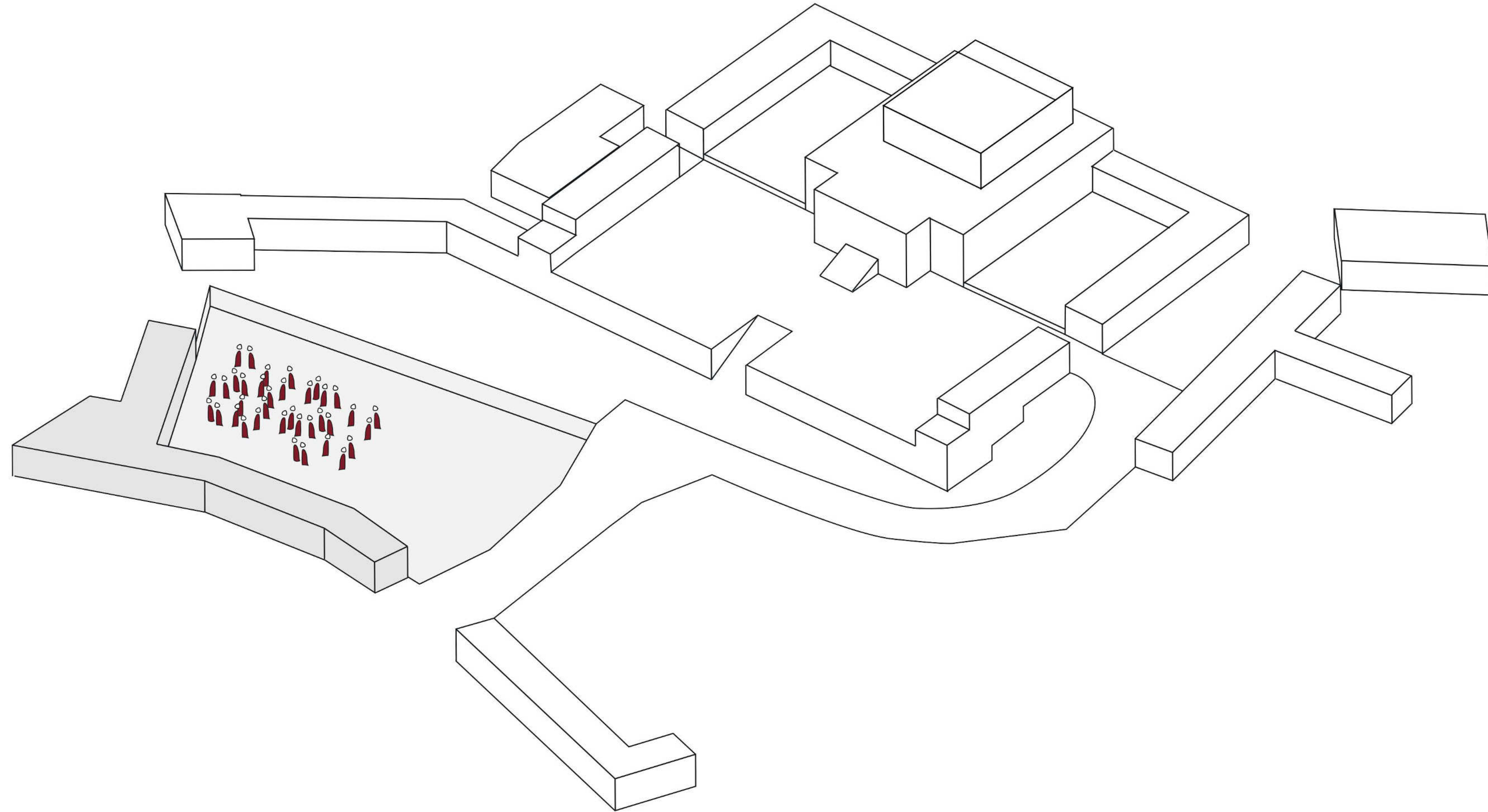

1.
LINKS A LARGE
VARIETY OF USERS

LITTLE MONKS TEACHERS

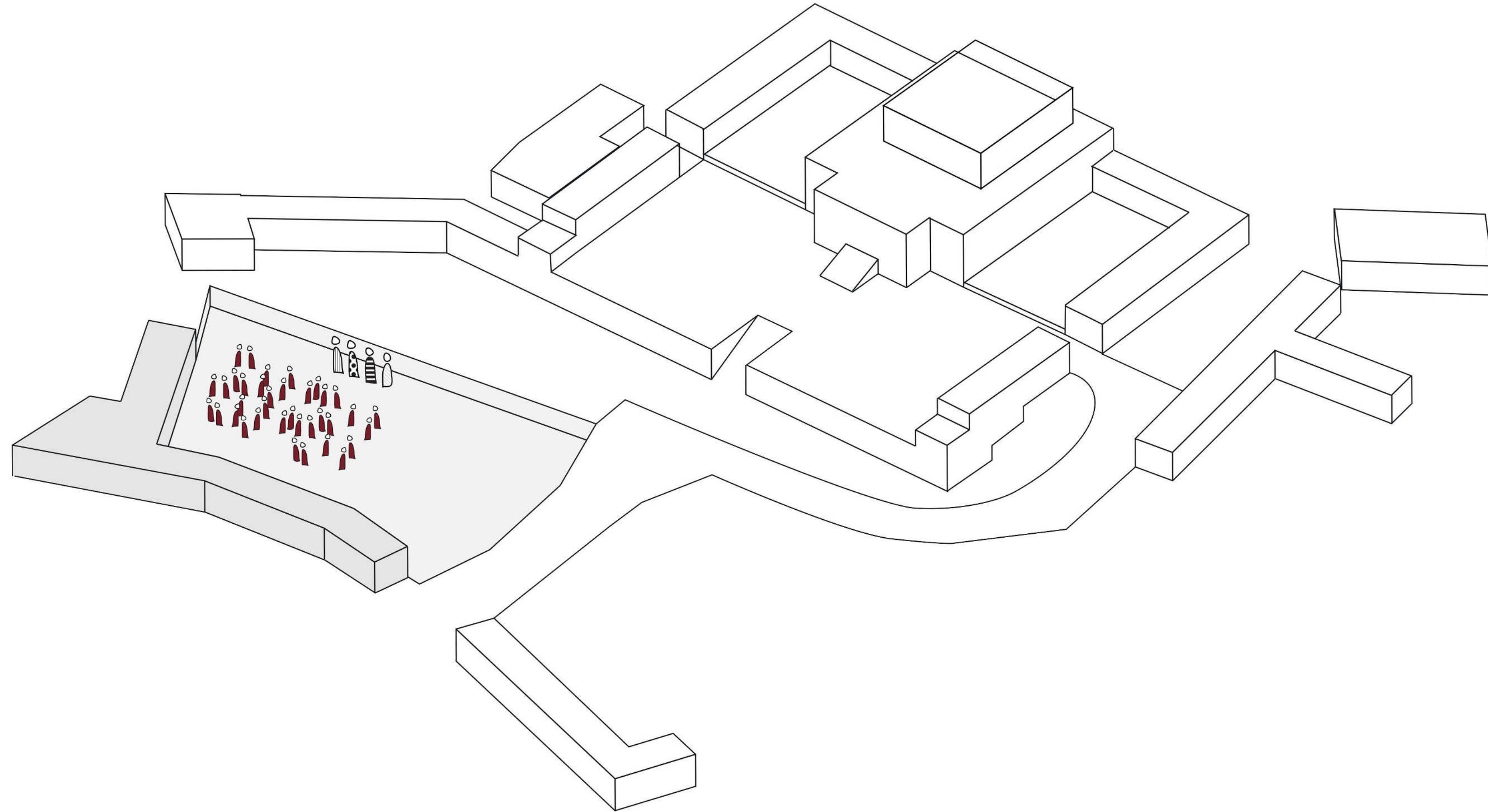

1.
LINKS A LARGE
VARIETY OF USERS

LITTLE MONKS TEACHERS MONKS

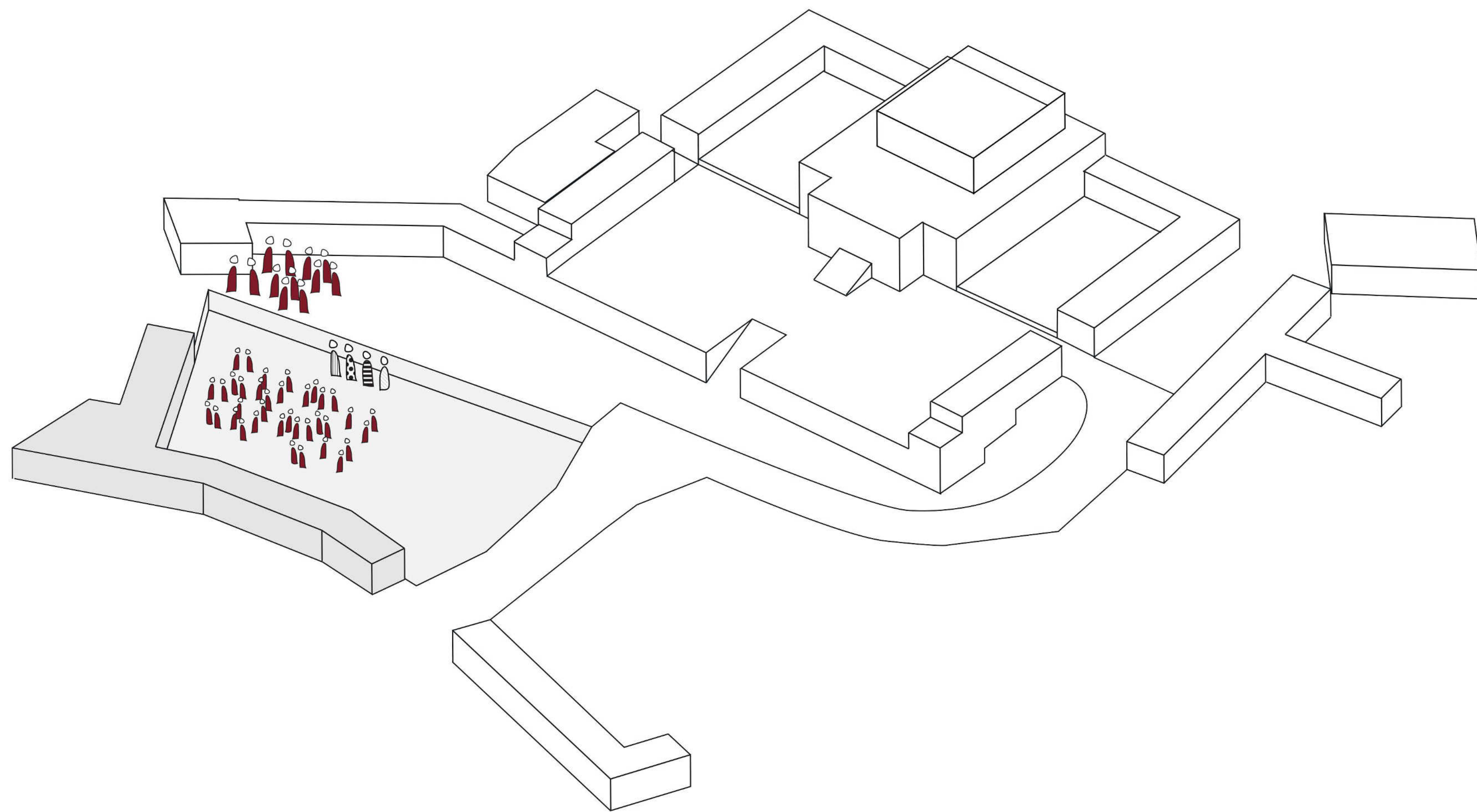

1.
LINKS A LARGE
VARIETY OF USERS

LITTLE MONKS TEACHERS MONKS CHILDREN

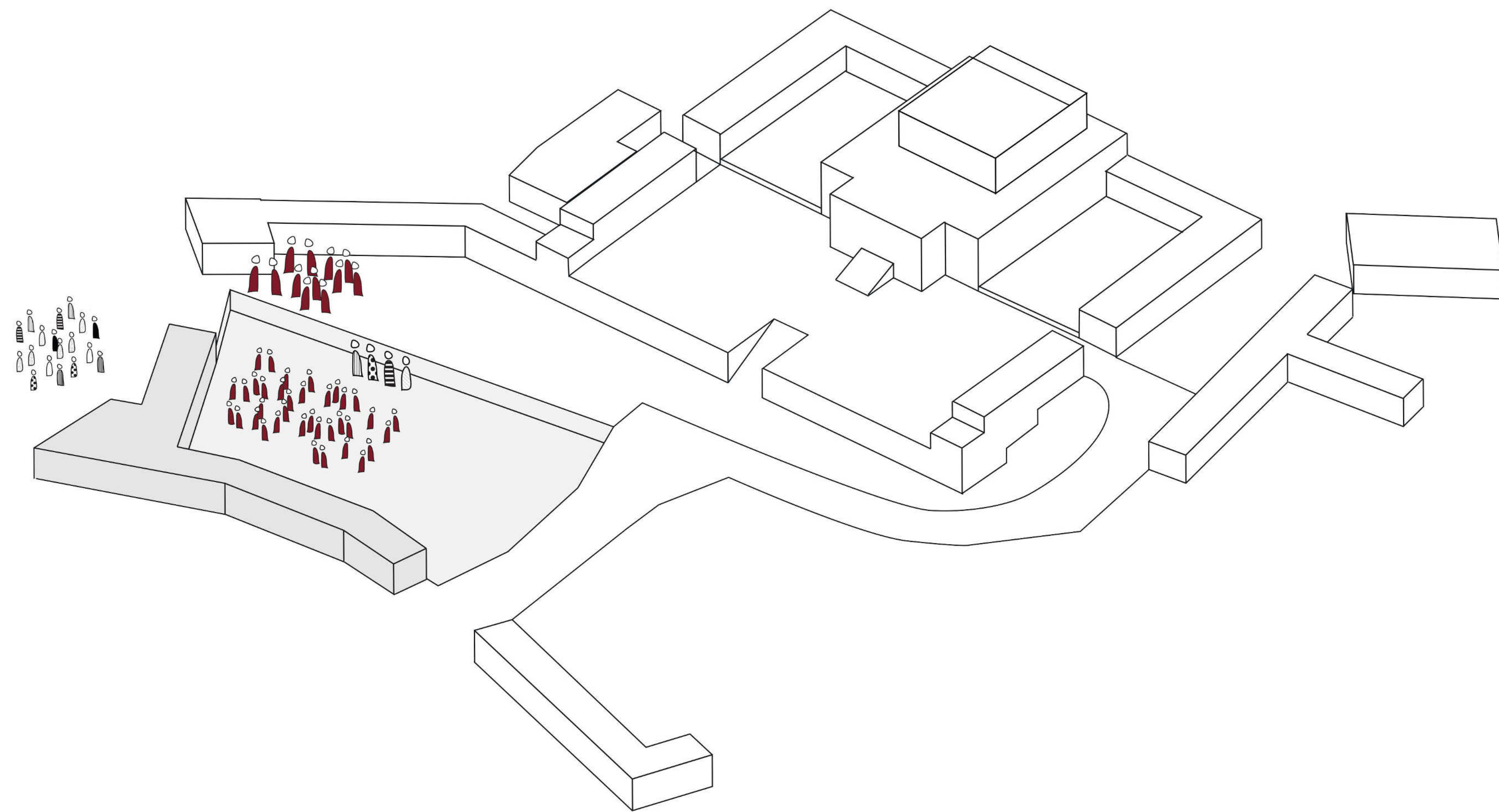

1.
LINKS A LARGE
VARIETY OF USERS

LITTLE MONKS TEACHERS MONKS CHILDREN VILLAGERS

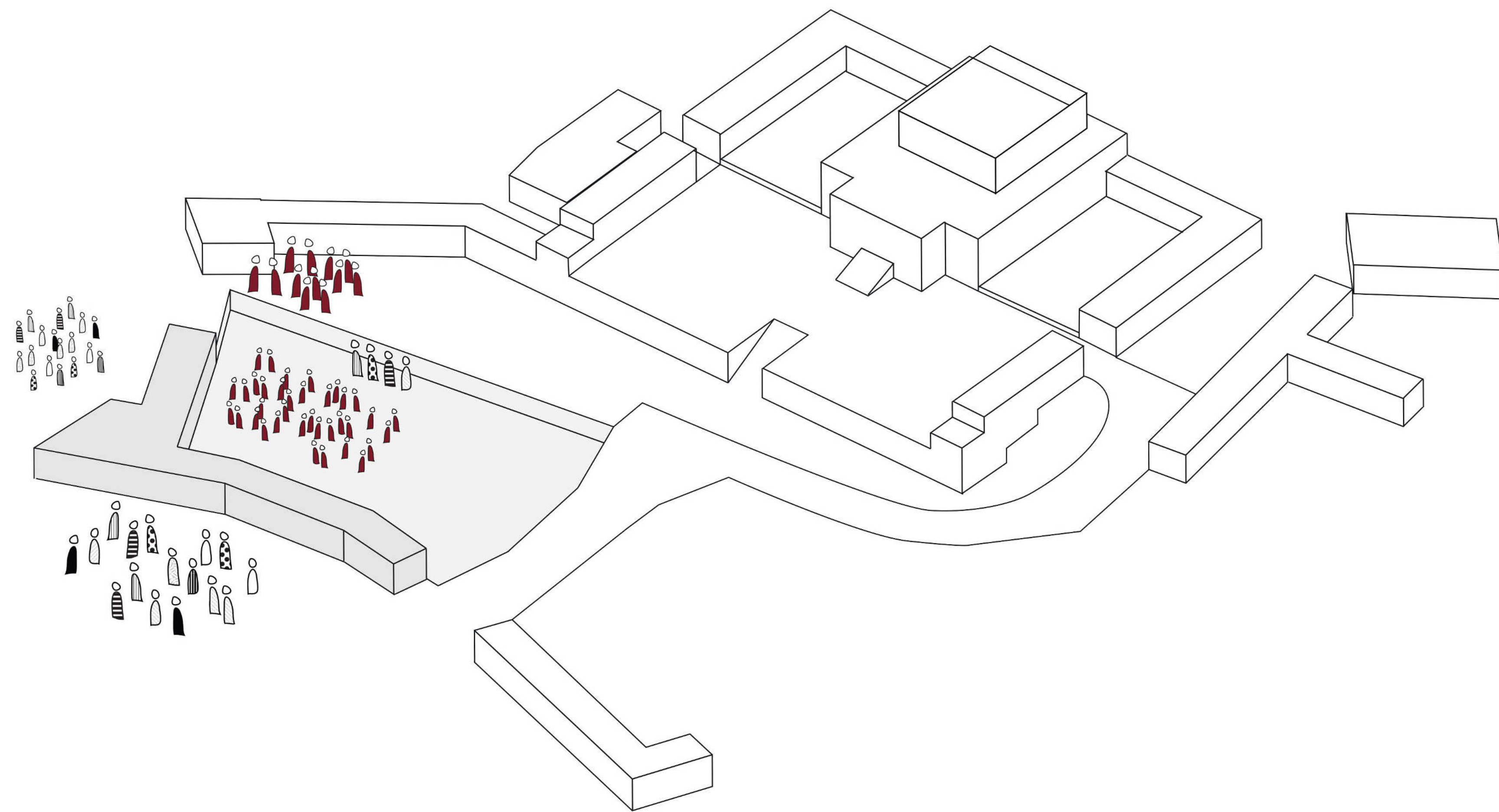

1.
LINKS A LARGE
VARIETY OF USERS

LITTLE MONKS TEACHERS MONKS CHILDREN VILLAGERS TOURISTS

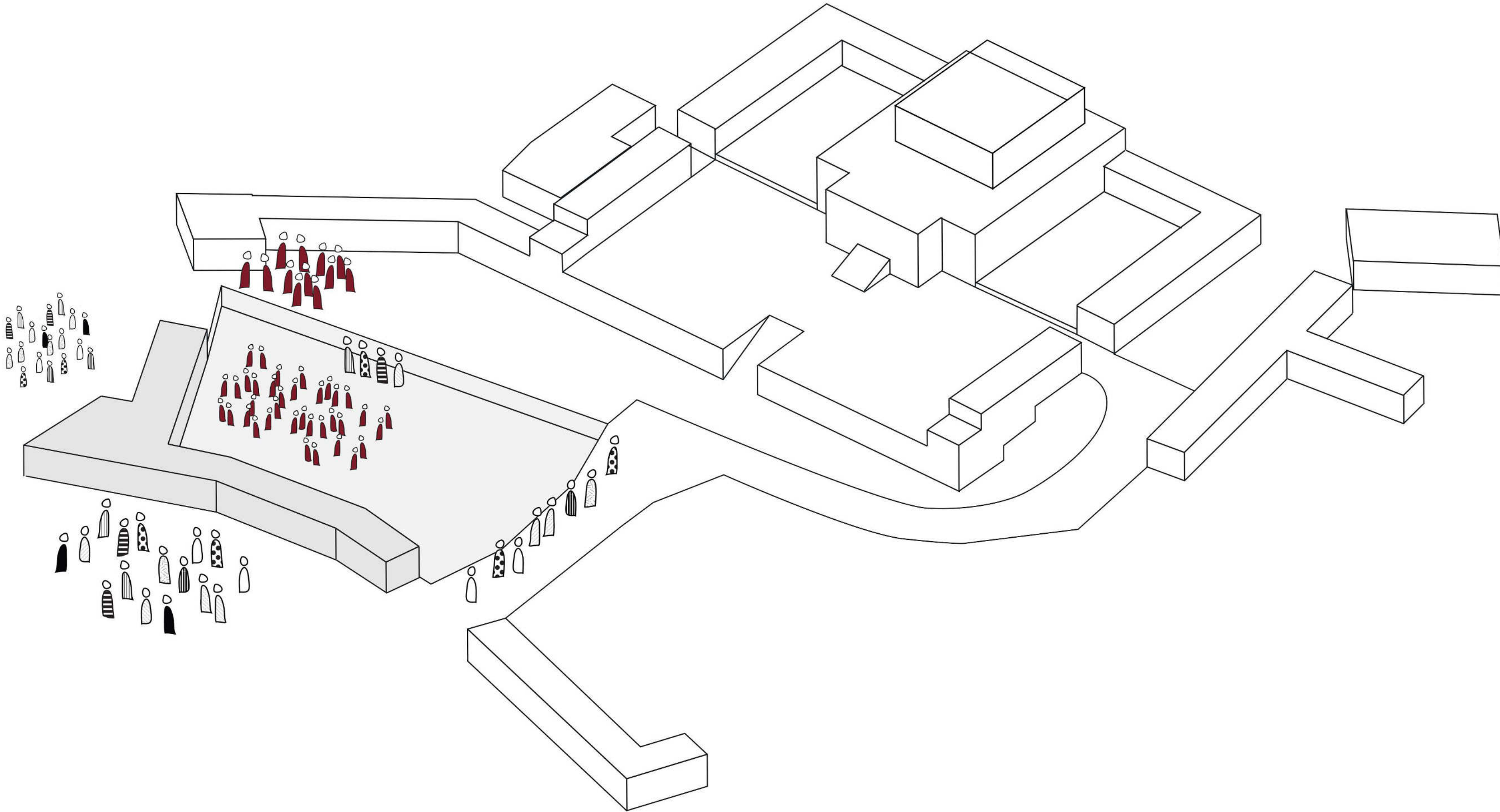

2.
IT EMBODIES THE ISSUES
OF THE LOCAL BUILT ENVIRONMENT



2.
IT EMBODIES THE ISSUES
OF THE LOCAL BUILT ENVIRONMENT



3.
IT'S A URGENT SITUATION
NO SAFETY / NO HEATING SYSTEM



3.
IT'S A URGENT SITUATION
NO SAFETY / NO HEATING SYSTEM

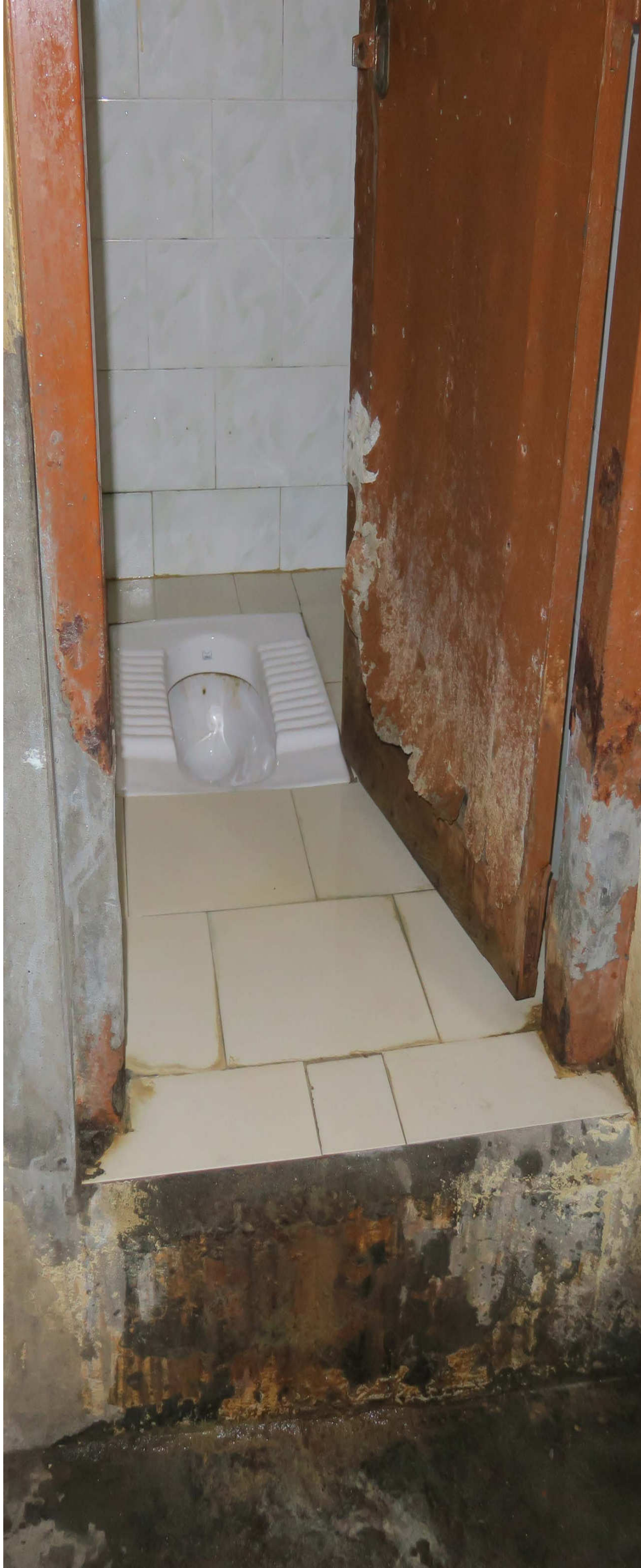

3.

IT'S A URGENT SITUATION
NO SAFETY / NO HEATING SYSTEM



STRATEGY

EXISTING STRUCTURE

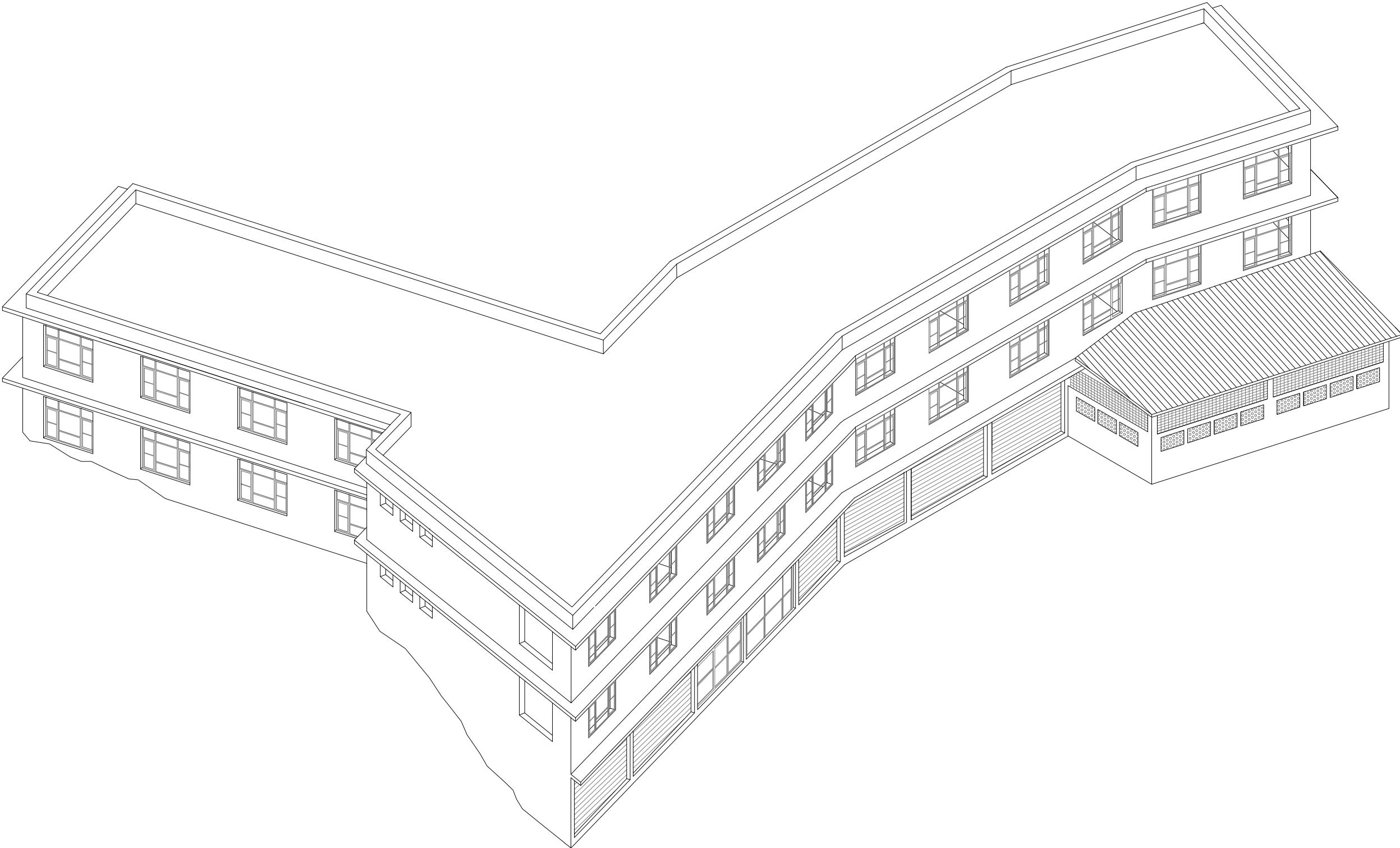

PARTIAL DEMOLITION

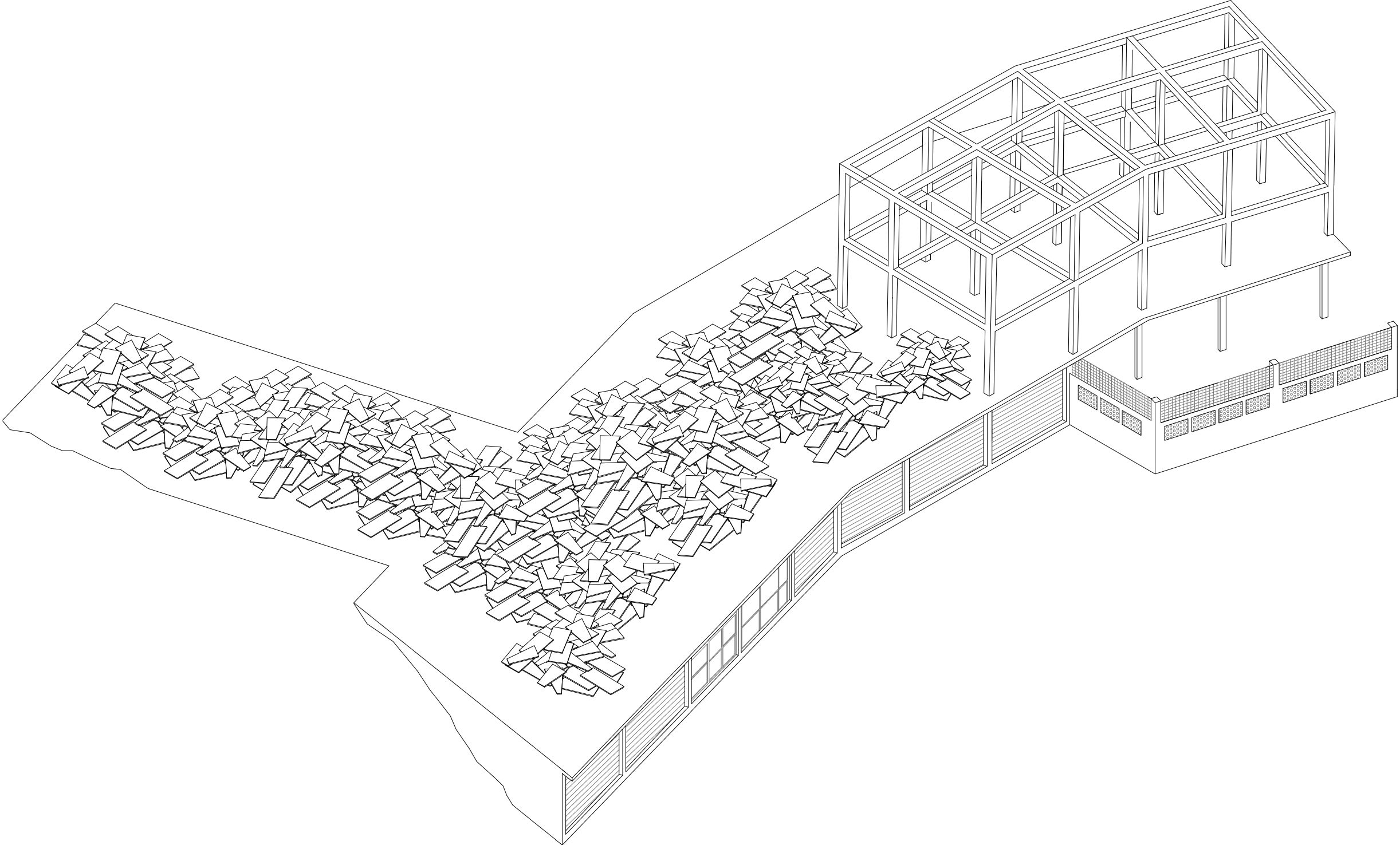

INSPIRATION BY LOCAL *GRAND VERNACULAR* ARCHITECTURE

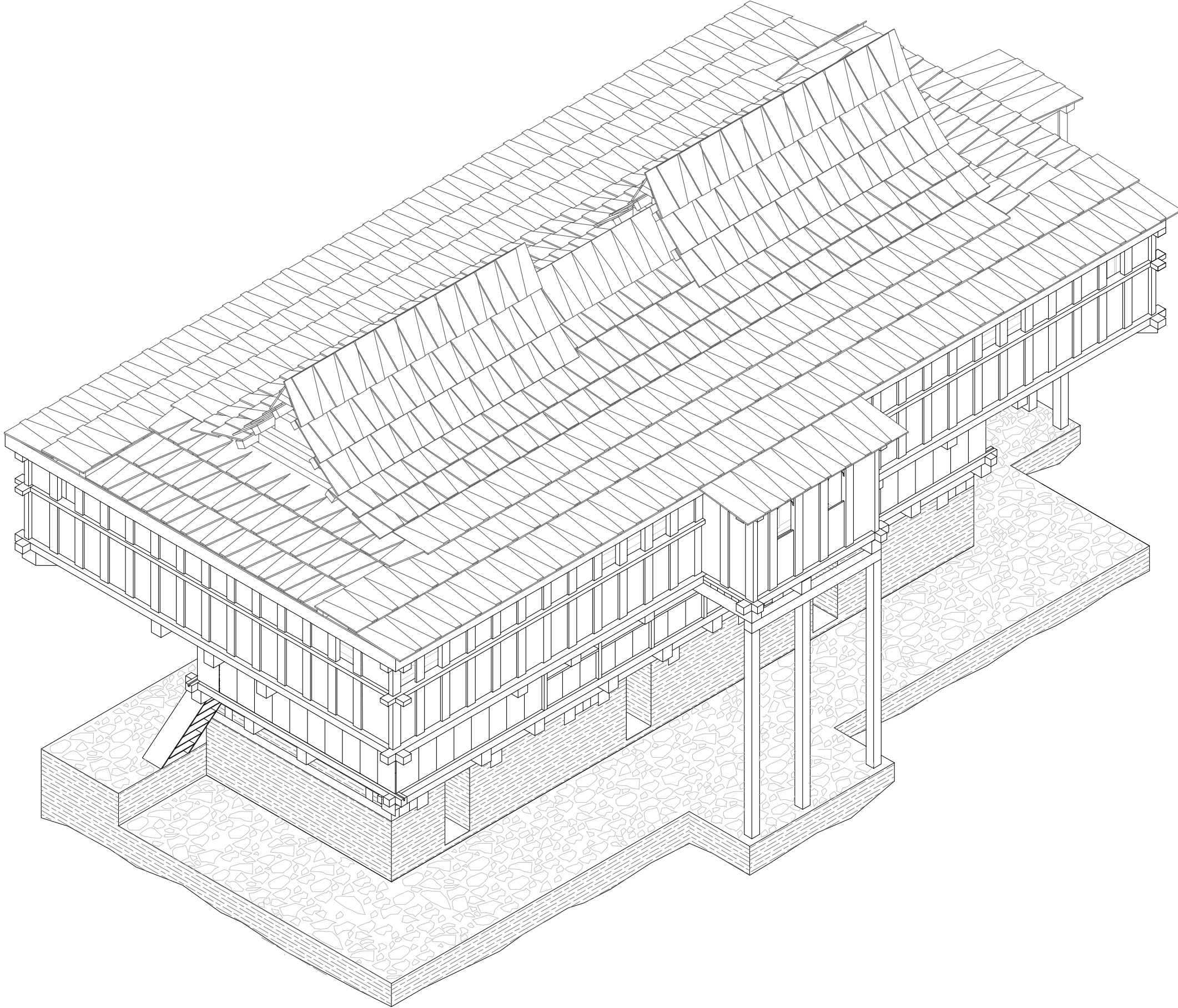

CONSTRUCTION TECHNIQUE OF THE CENTRAL CORE

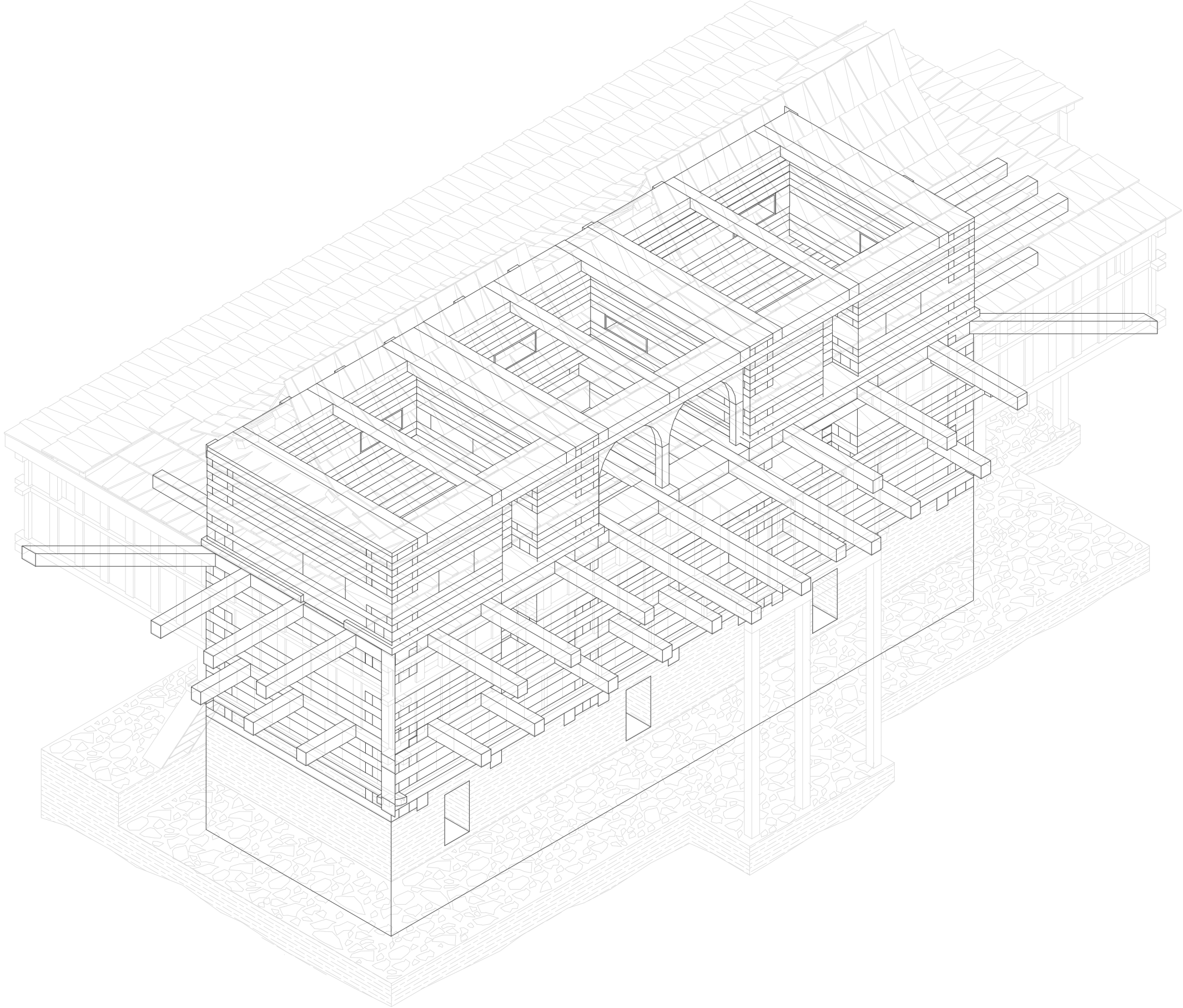

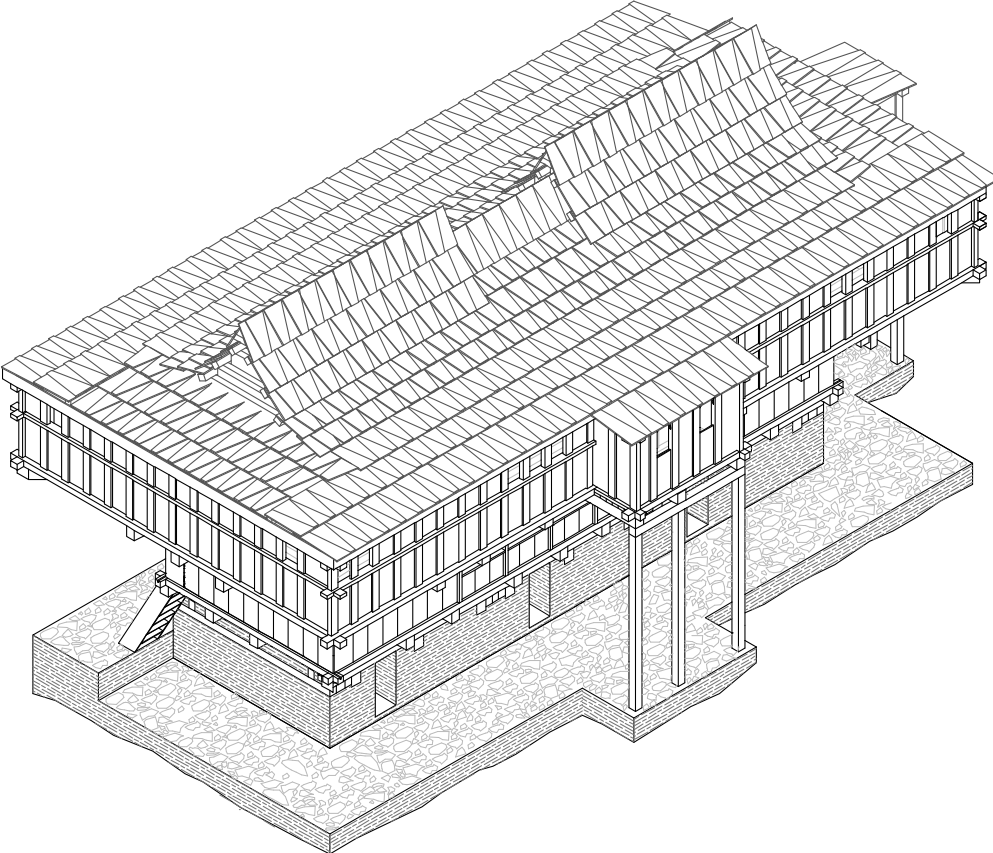

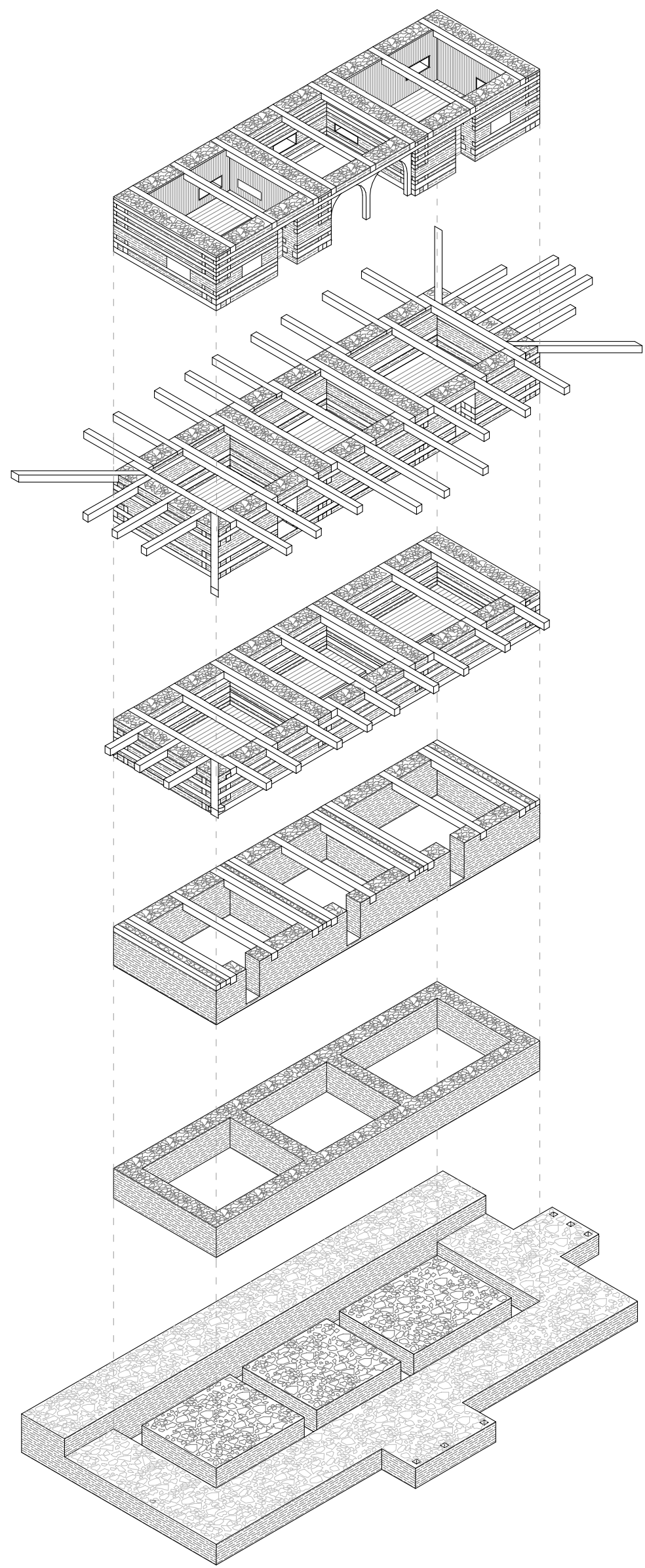

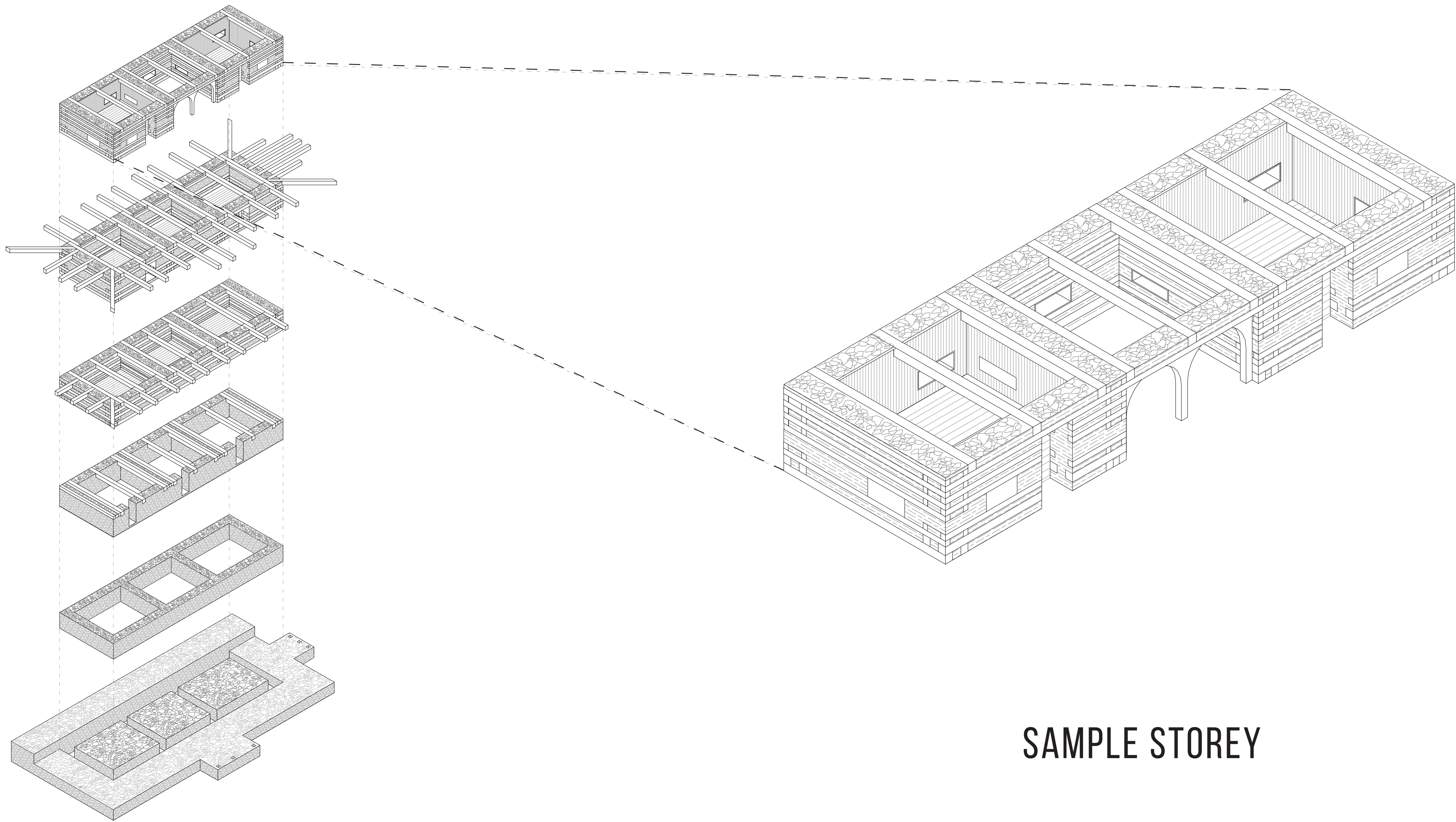

SAMPLE STOREY

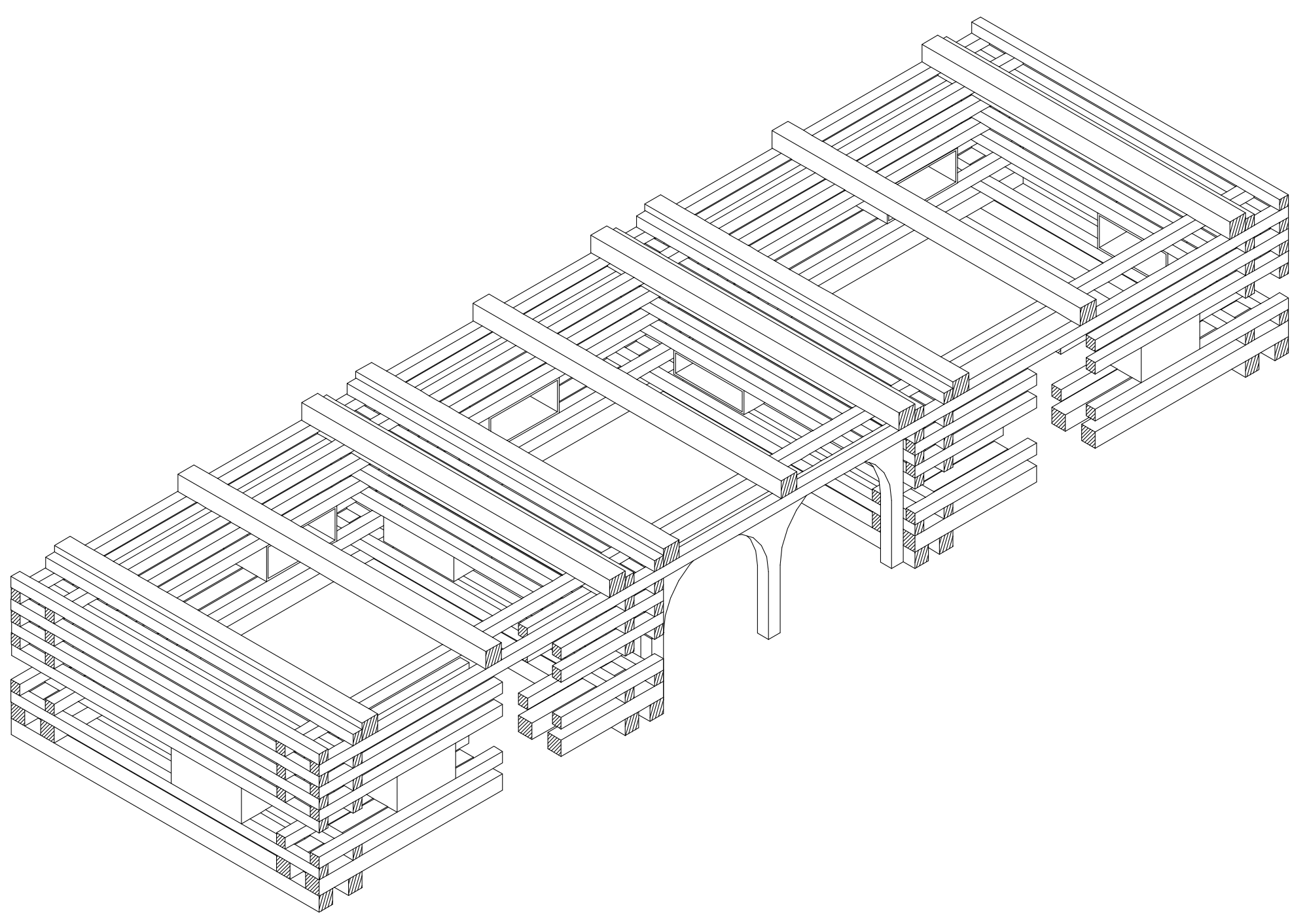
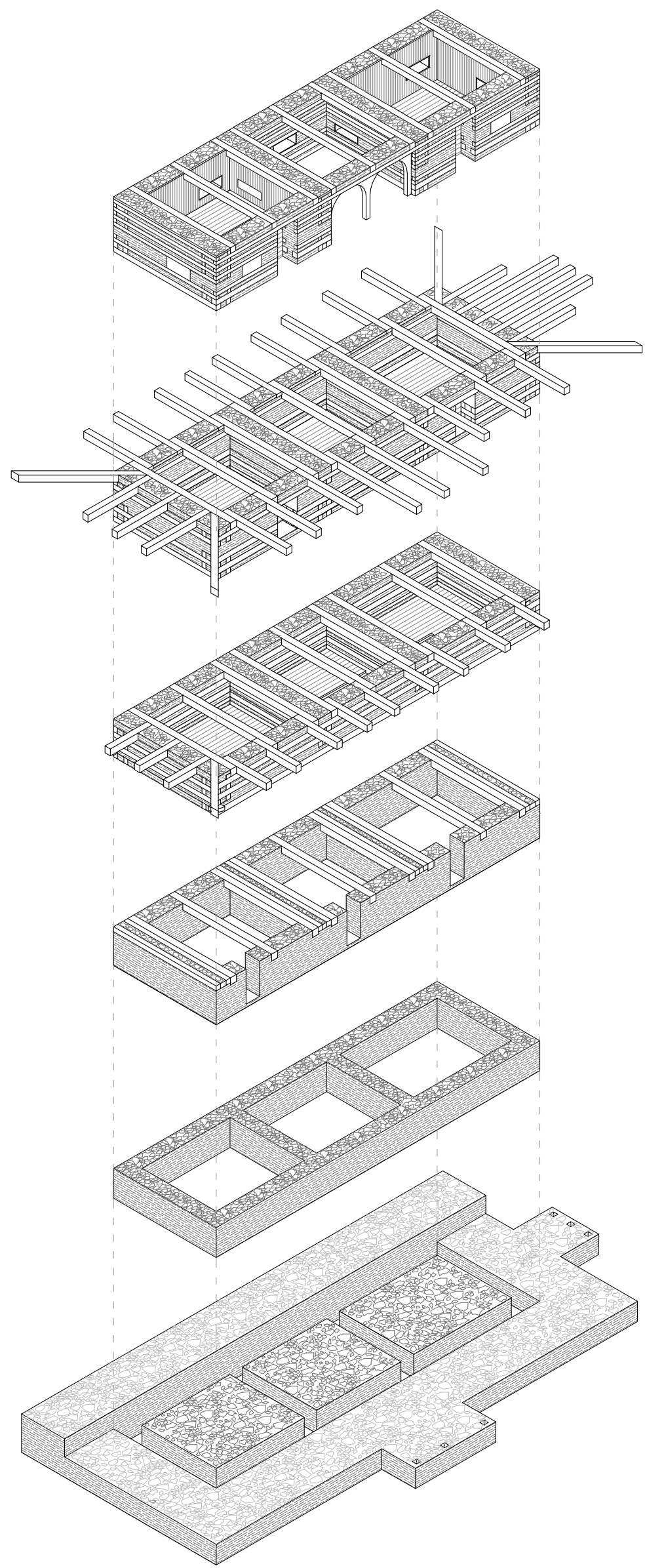

TIMBER FRAME

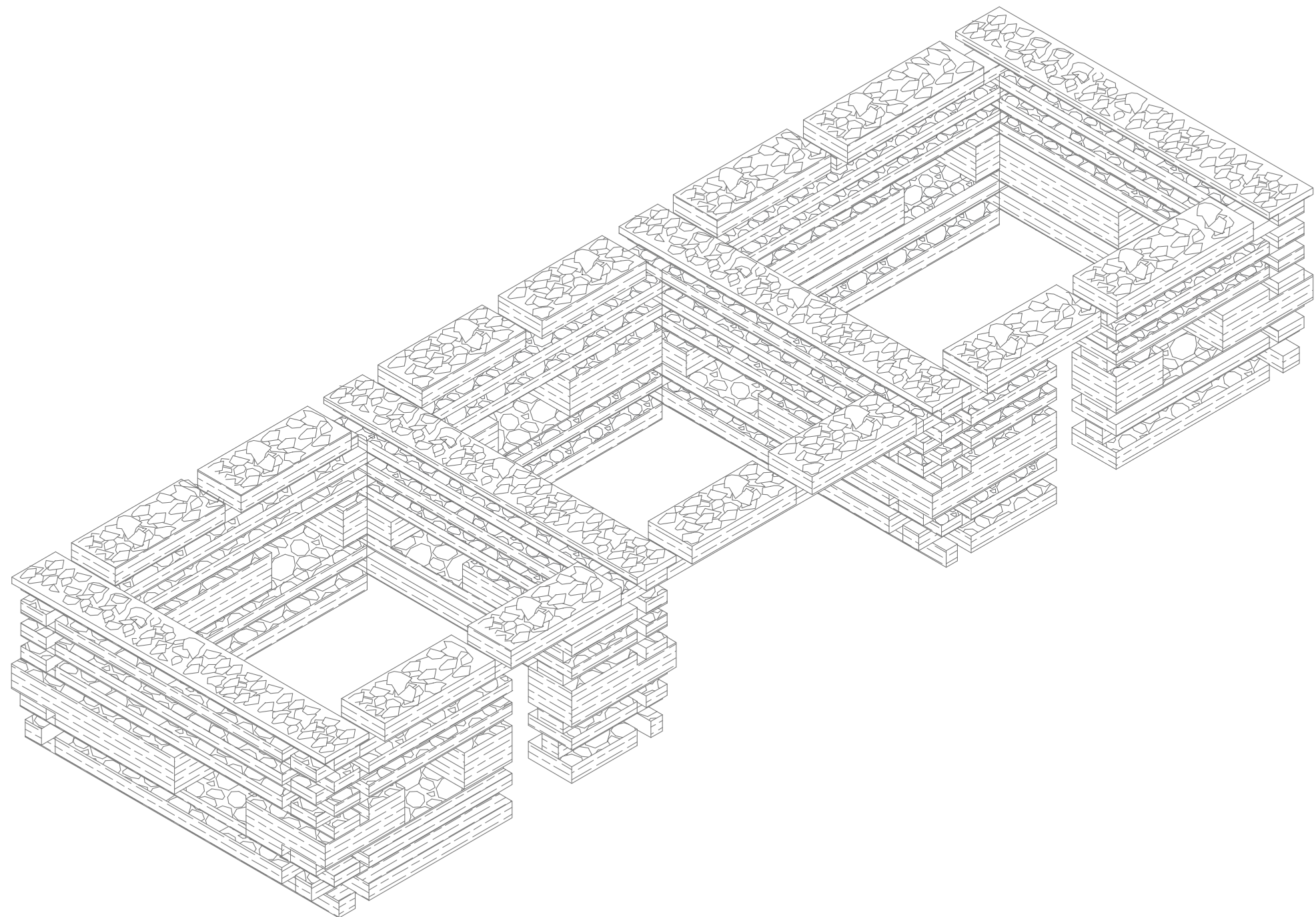
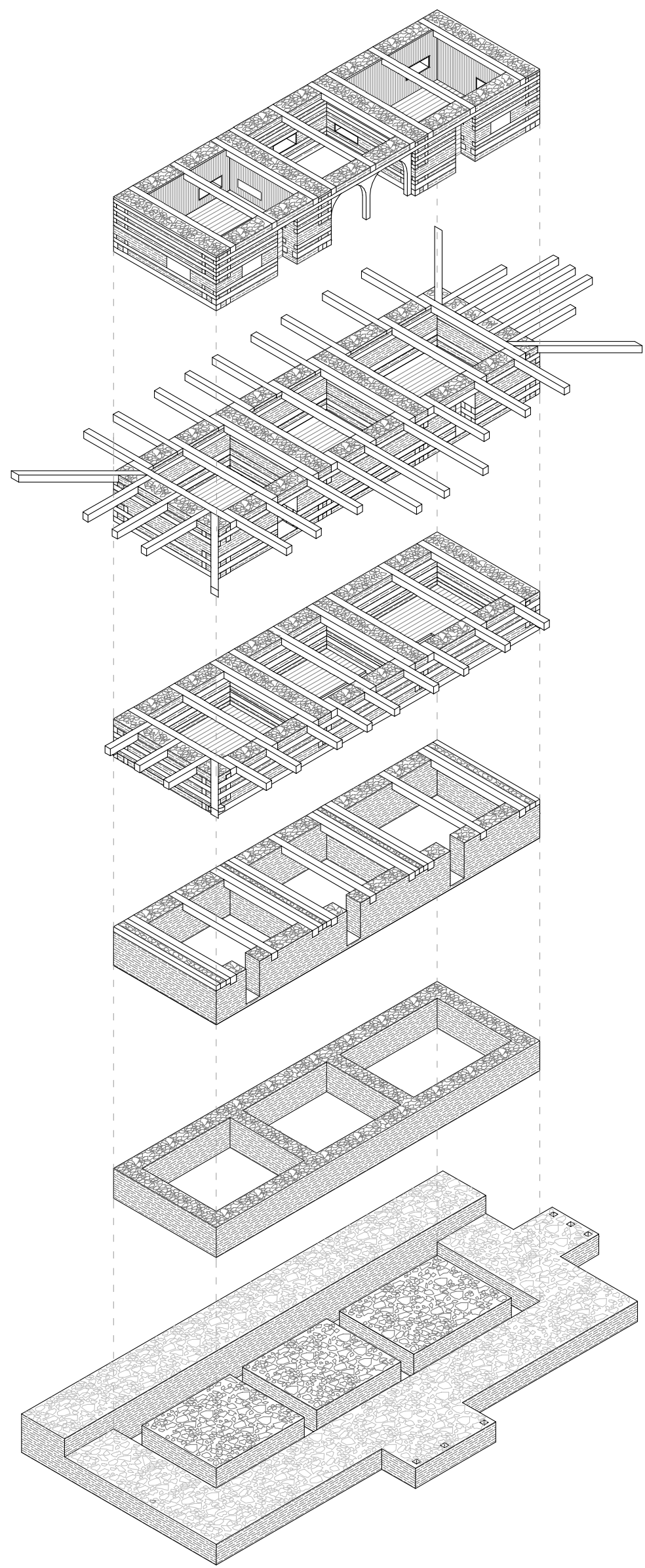

STONES INFILL

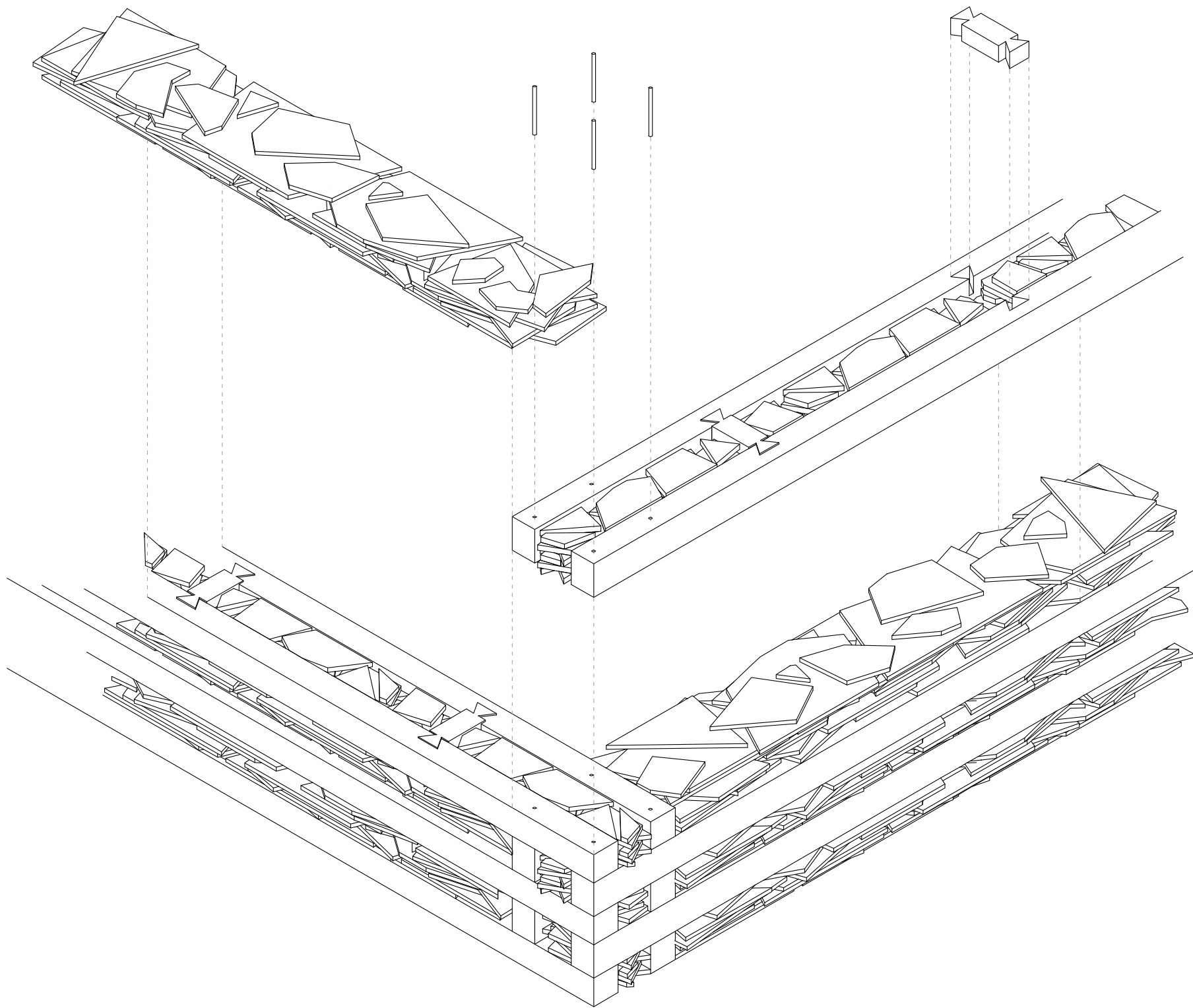

KATH-KHUNI CONSTRUCTION

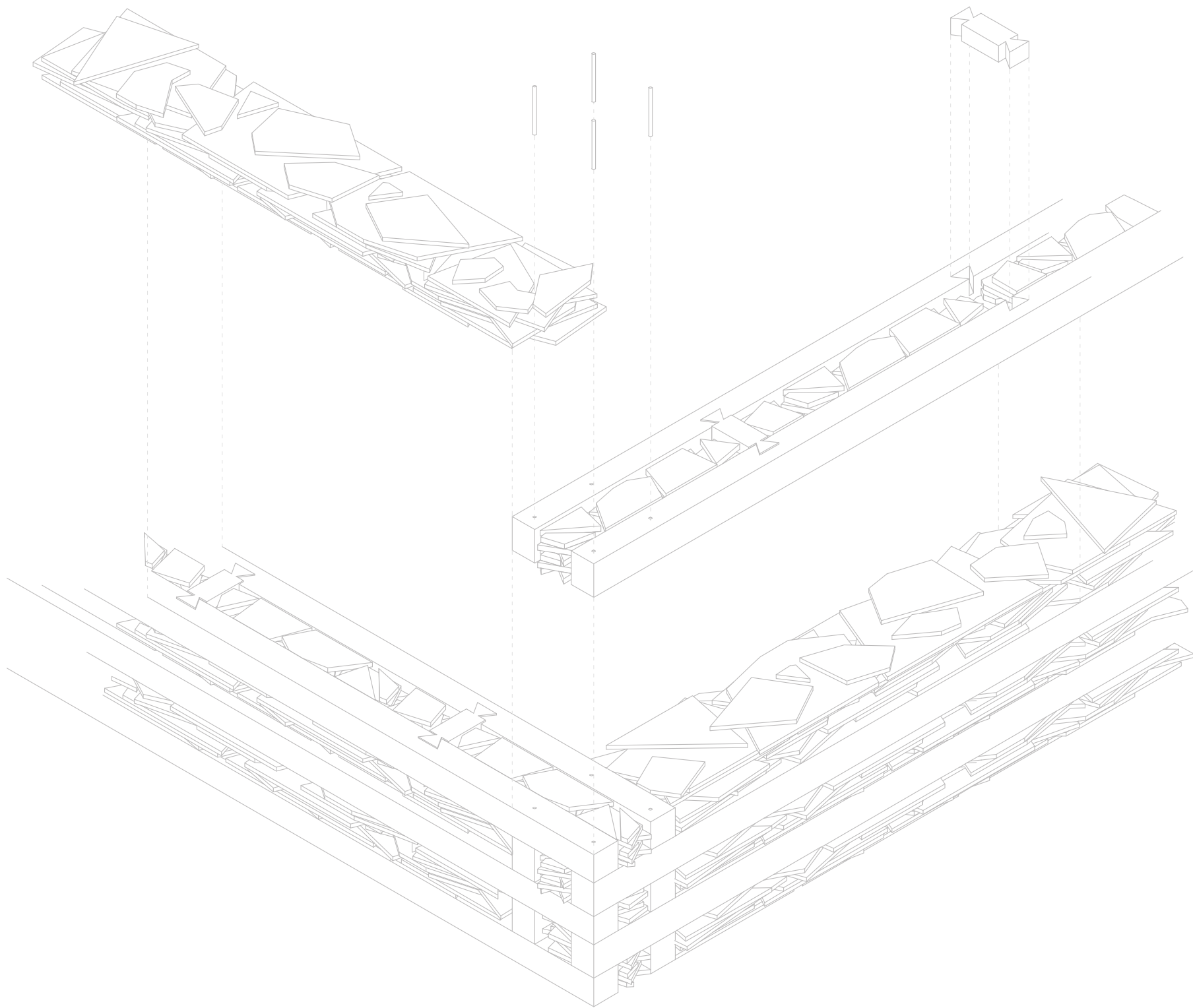
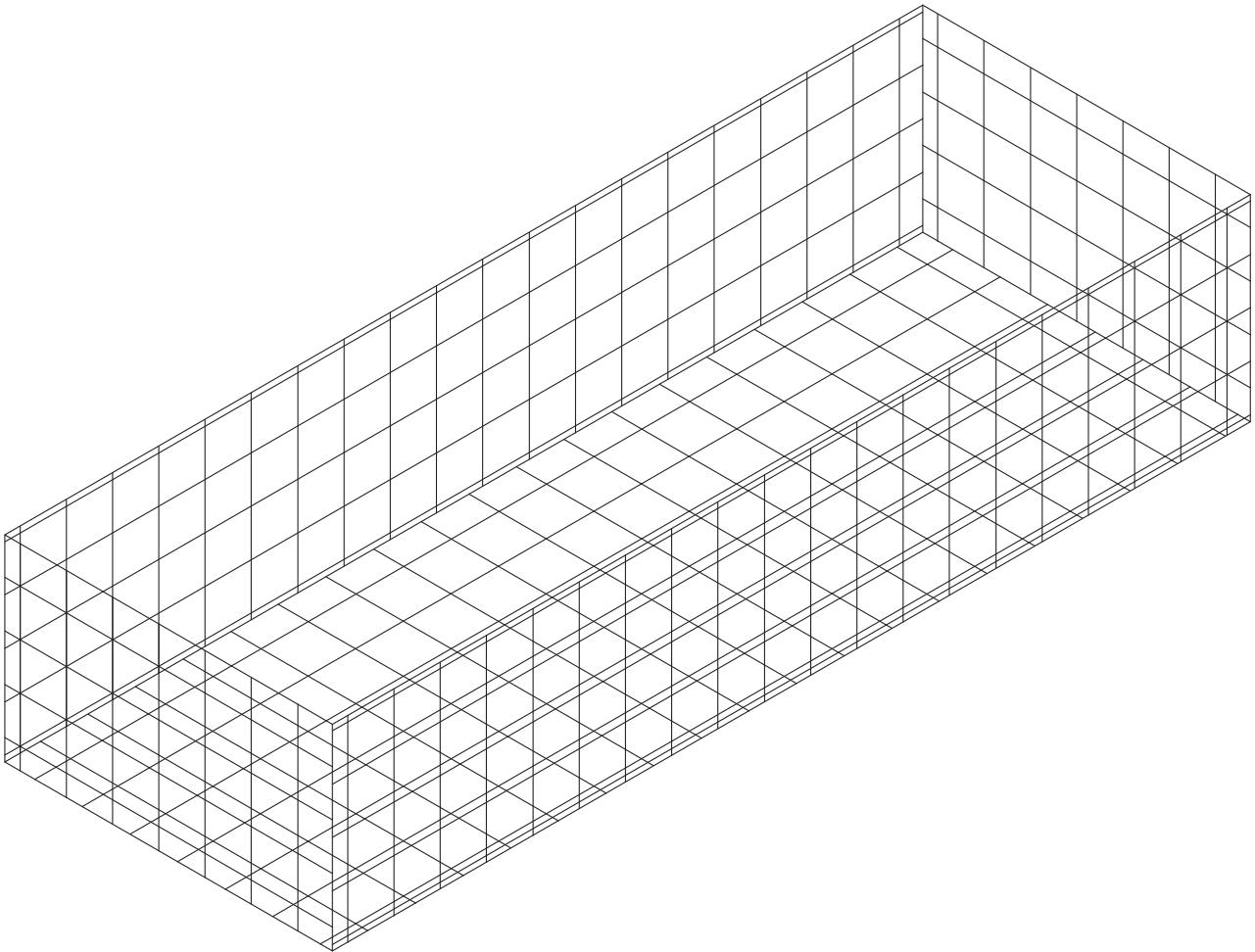

KATH-KHUNI CONSTRUCTION

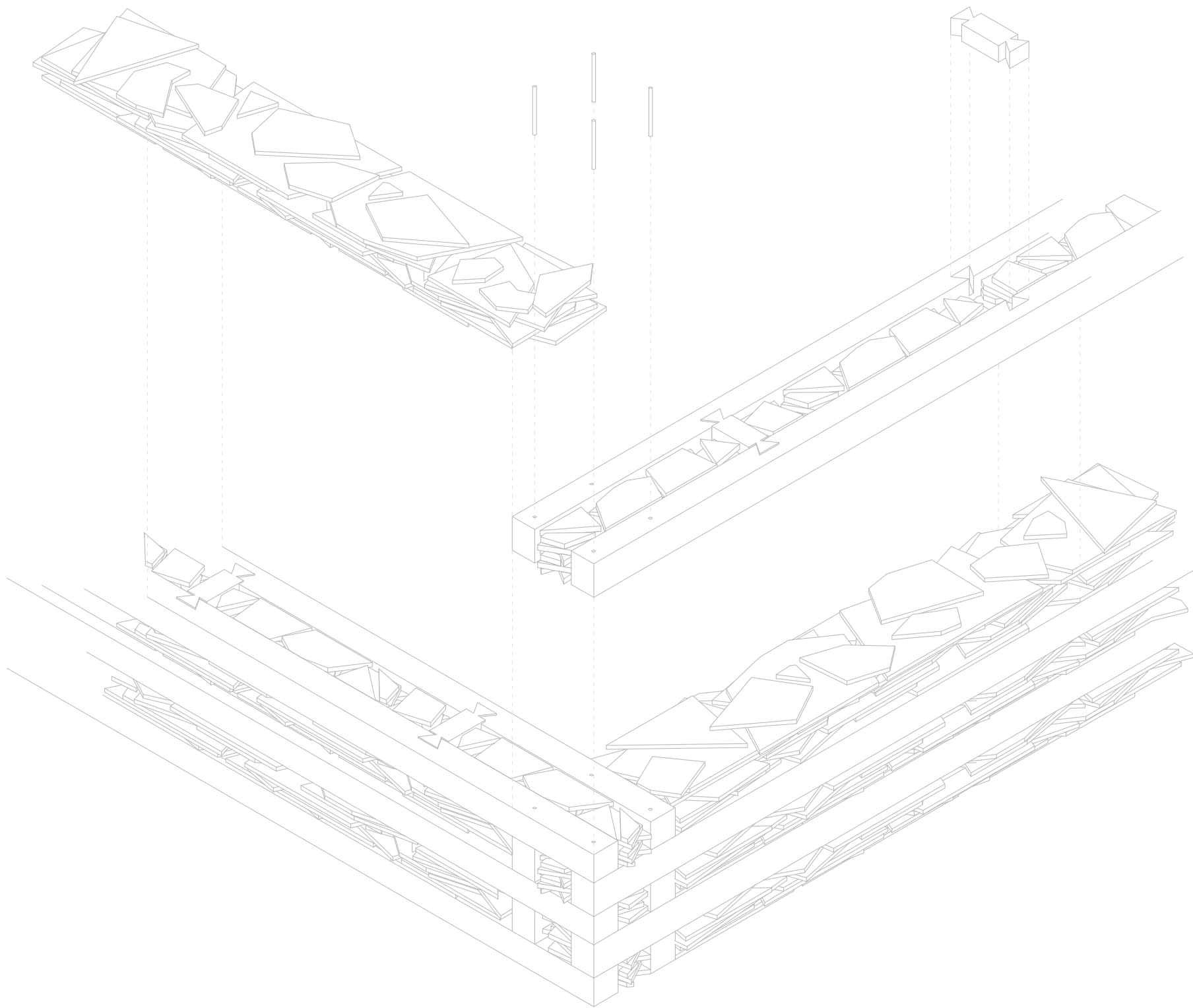
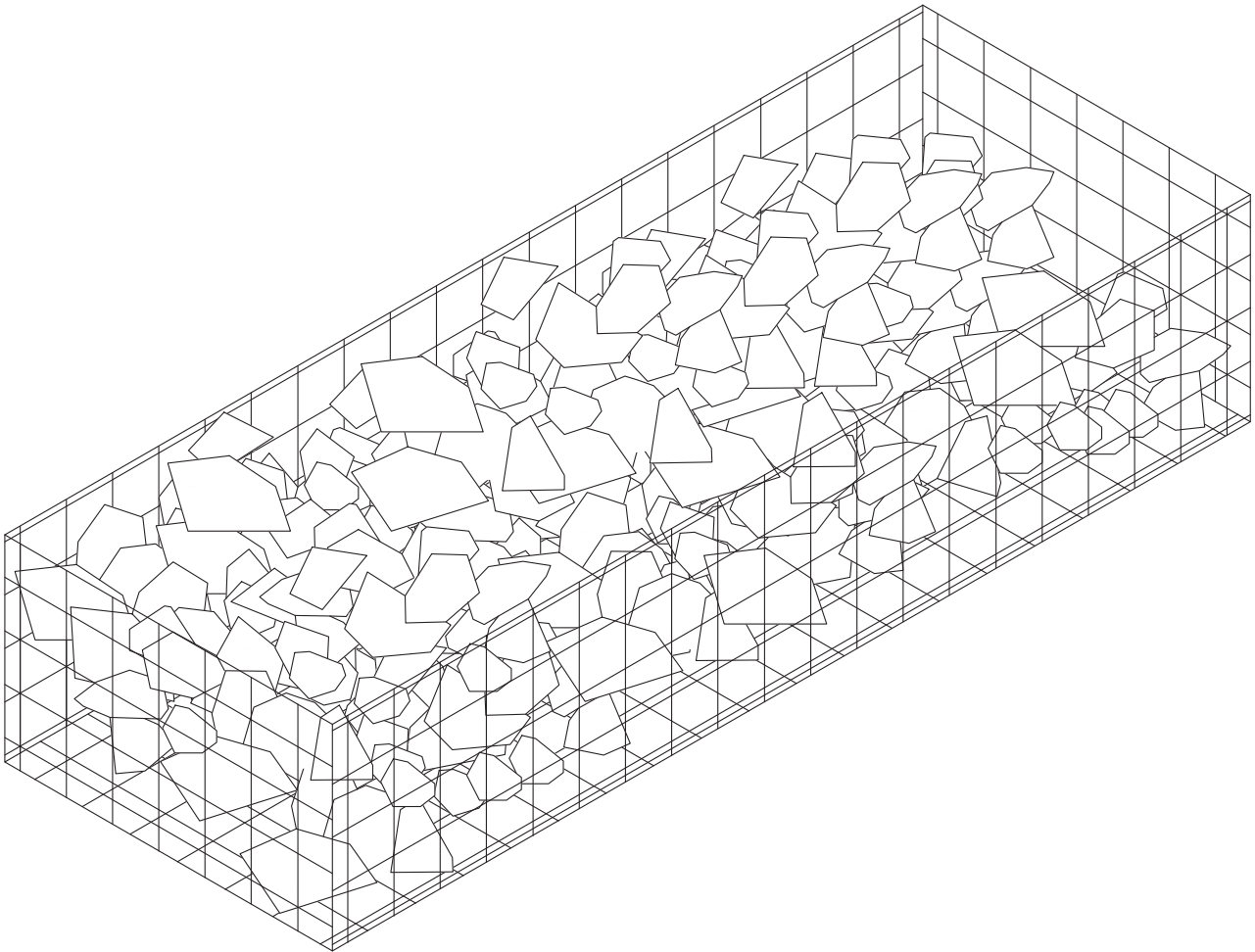

KATH-KHUNI CONSTRUCTION

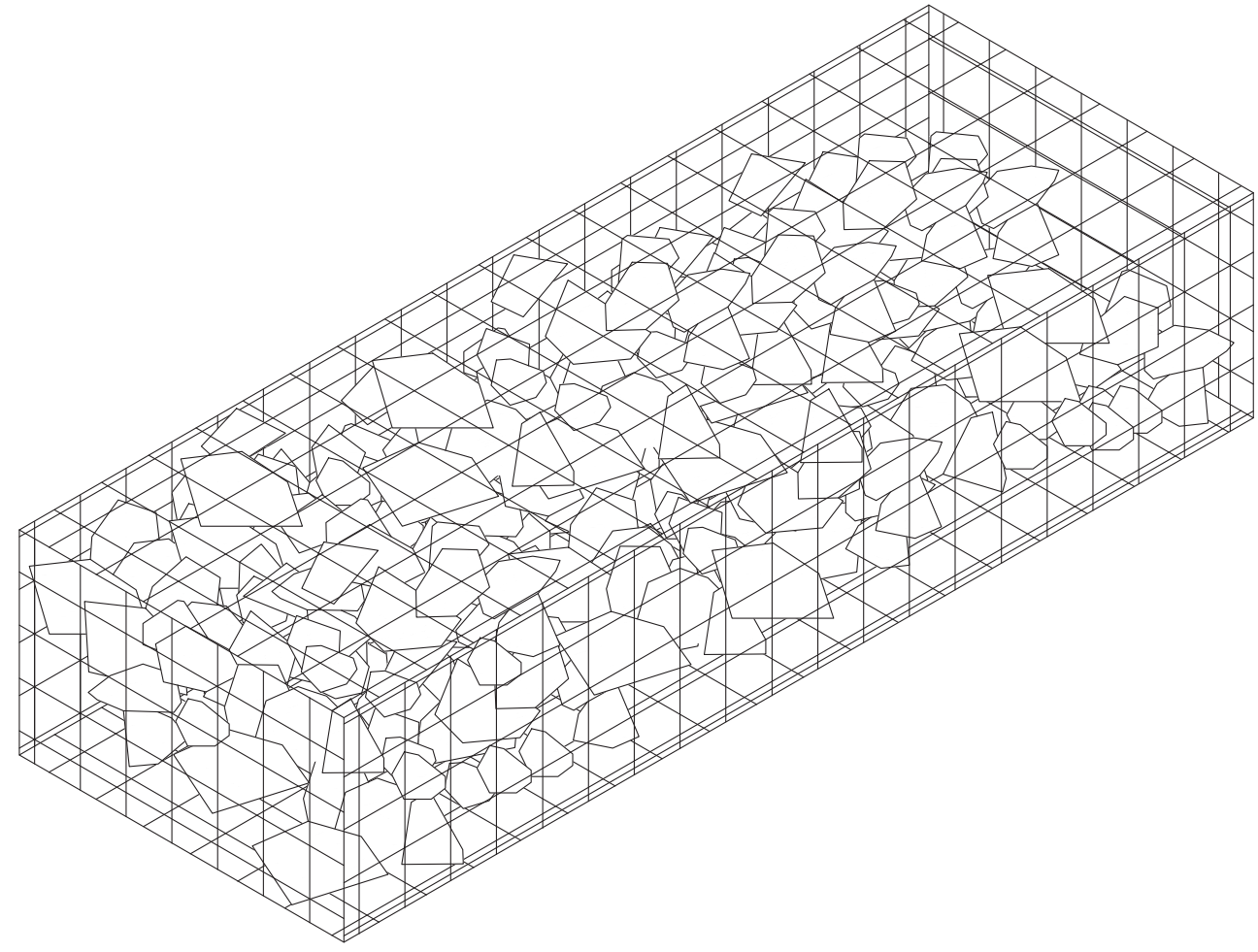

GABION BOX

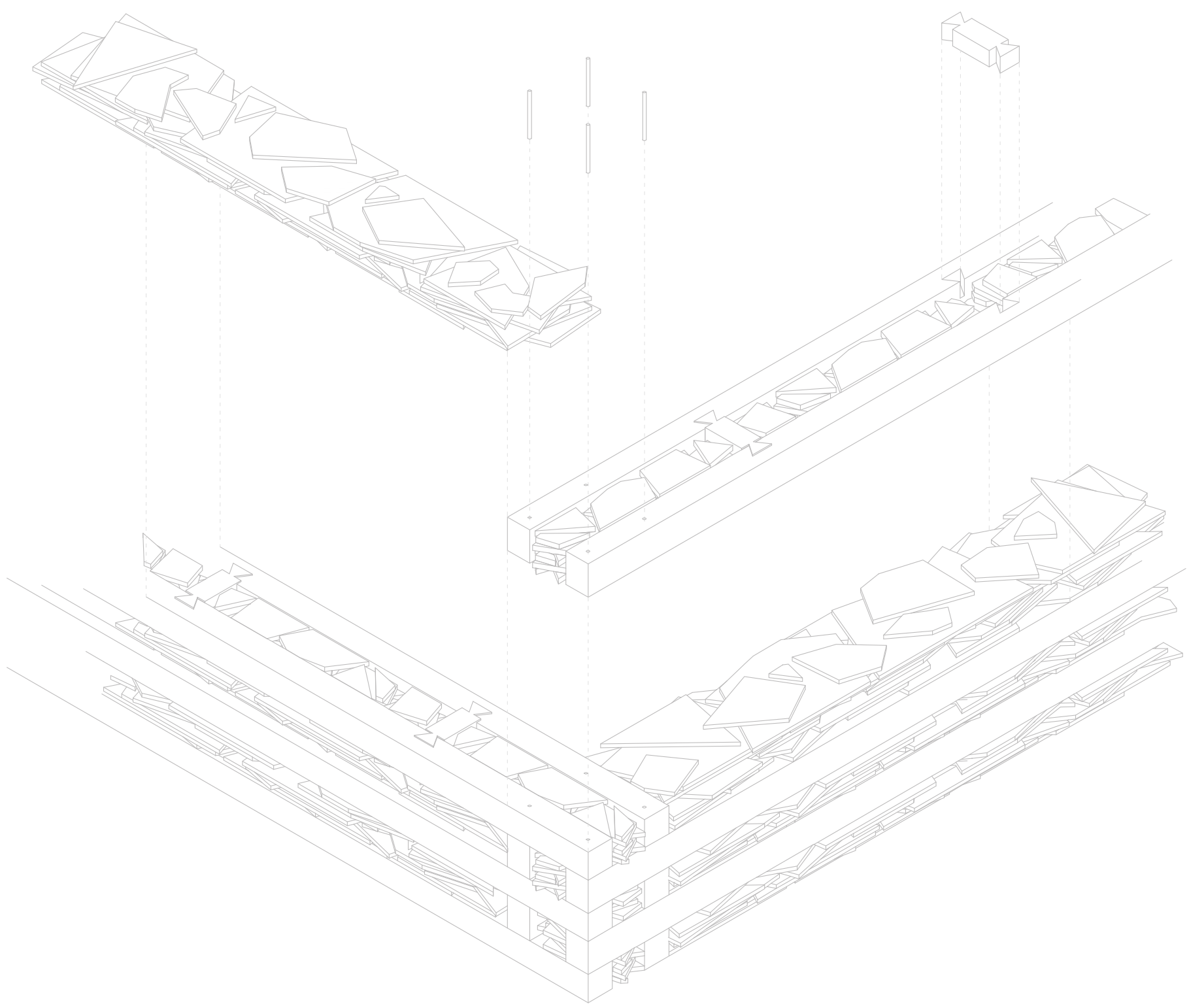

KATH-KHUNI CONSTRUCTION

GABION COMPOSITION

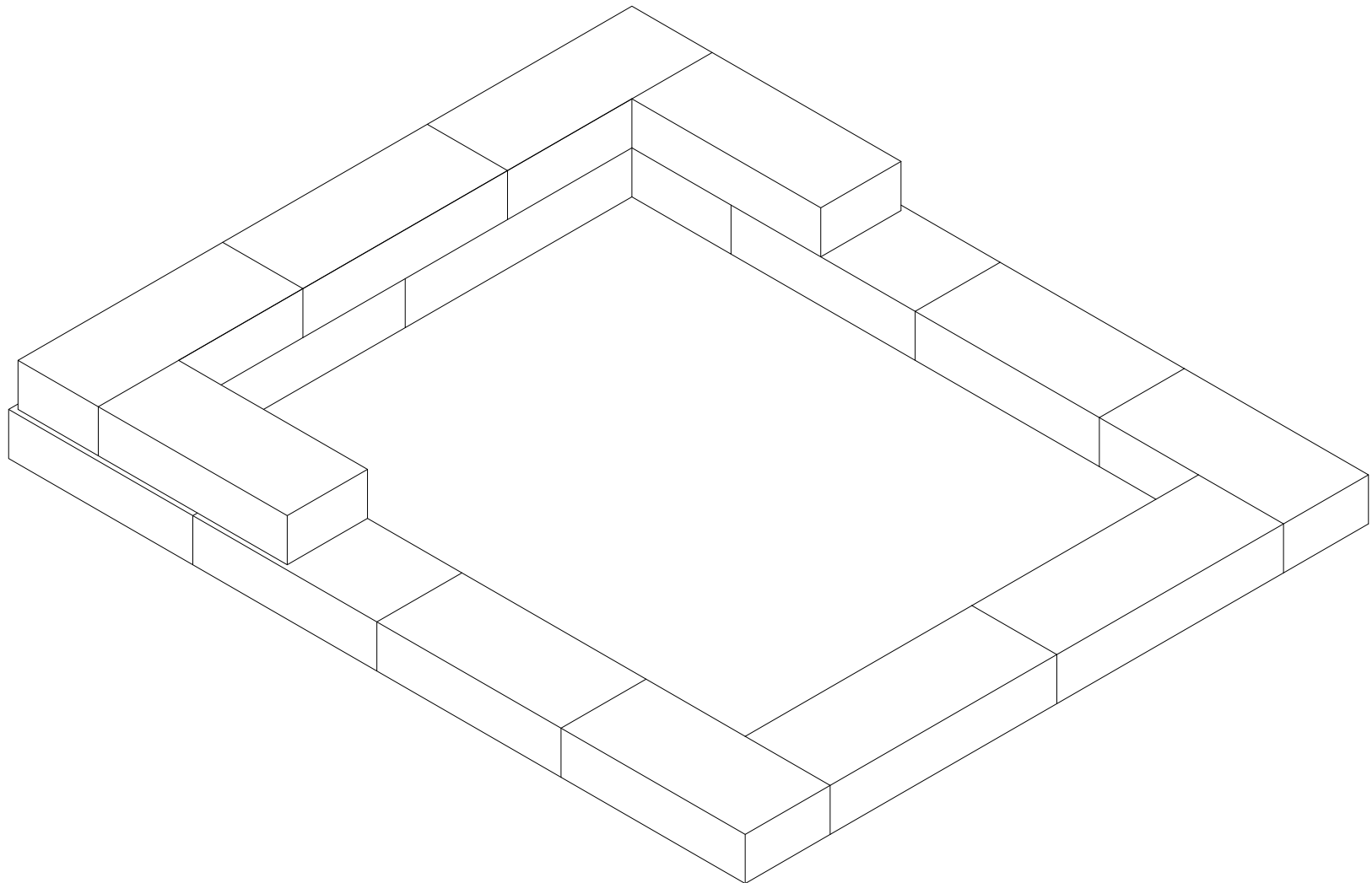

GABION COMPOSITION

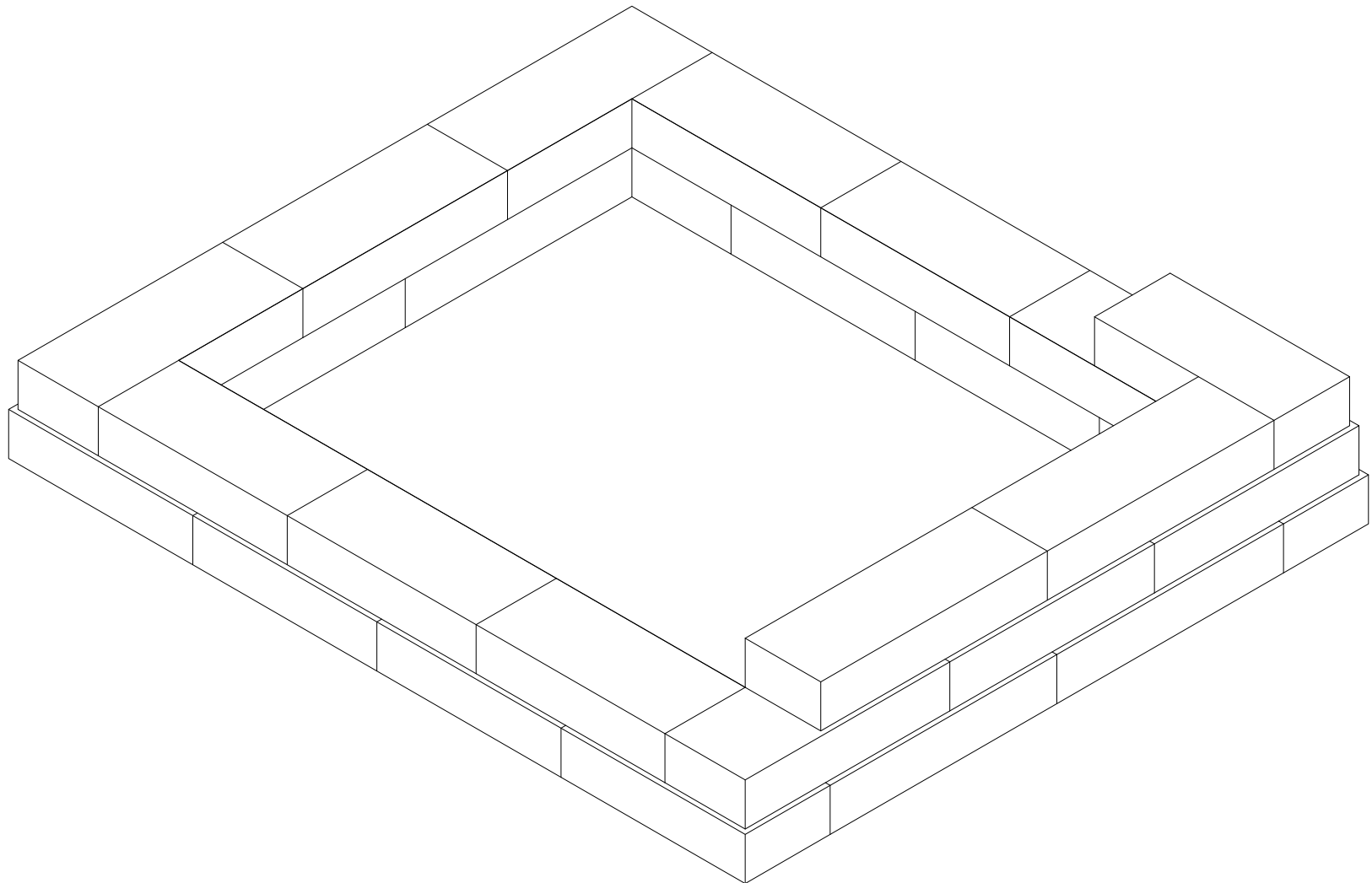

GABION COMPOSITION

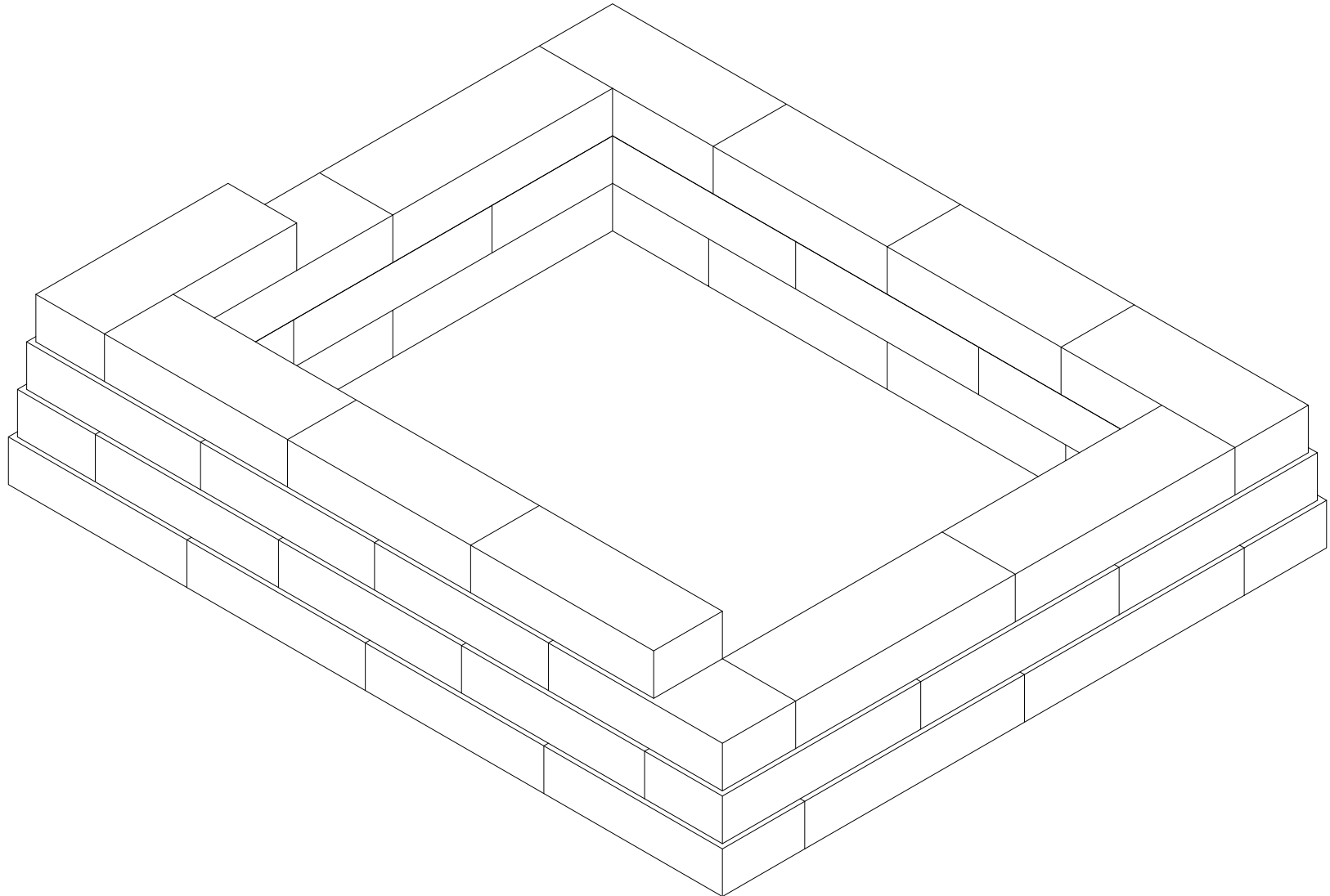

GABION COMPOSITION

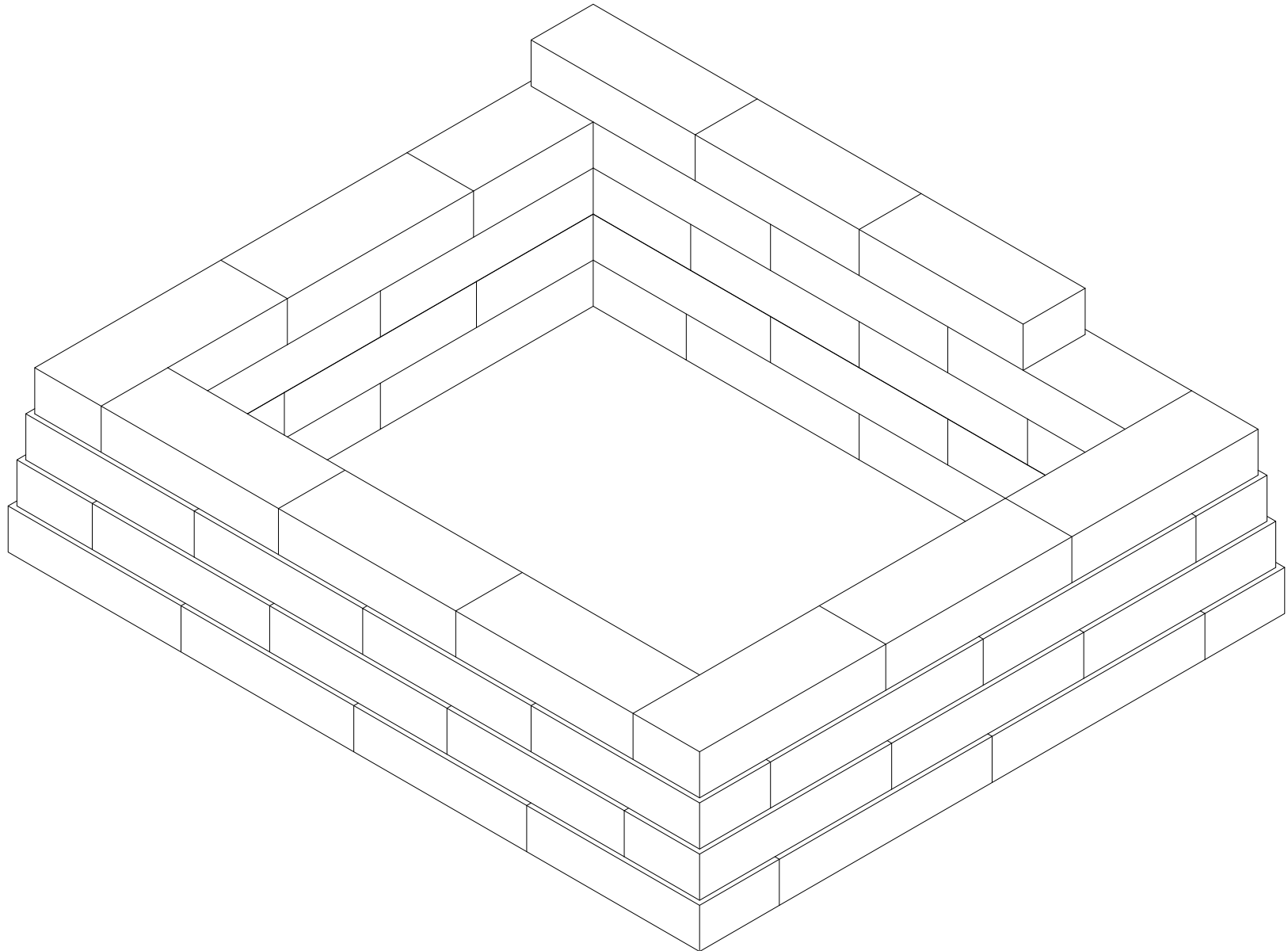

GABION COMPOSITION

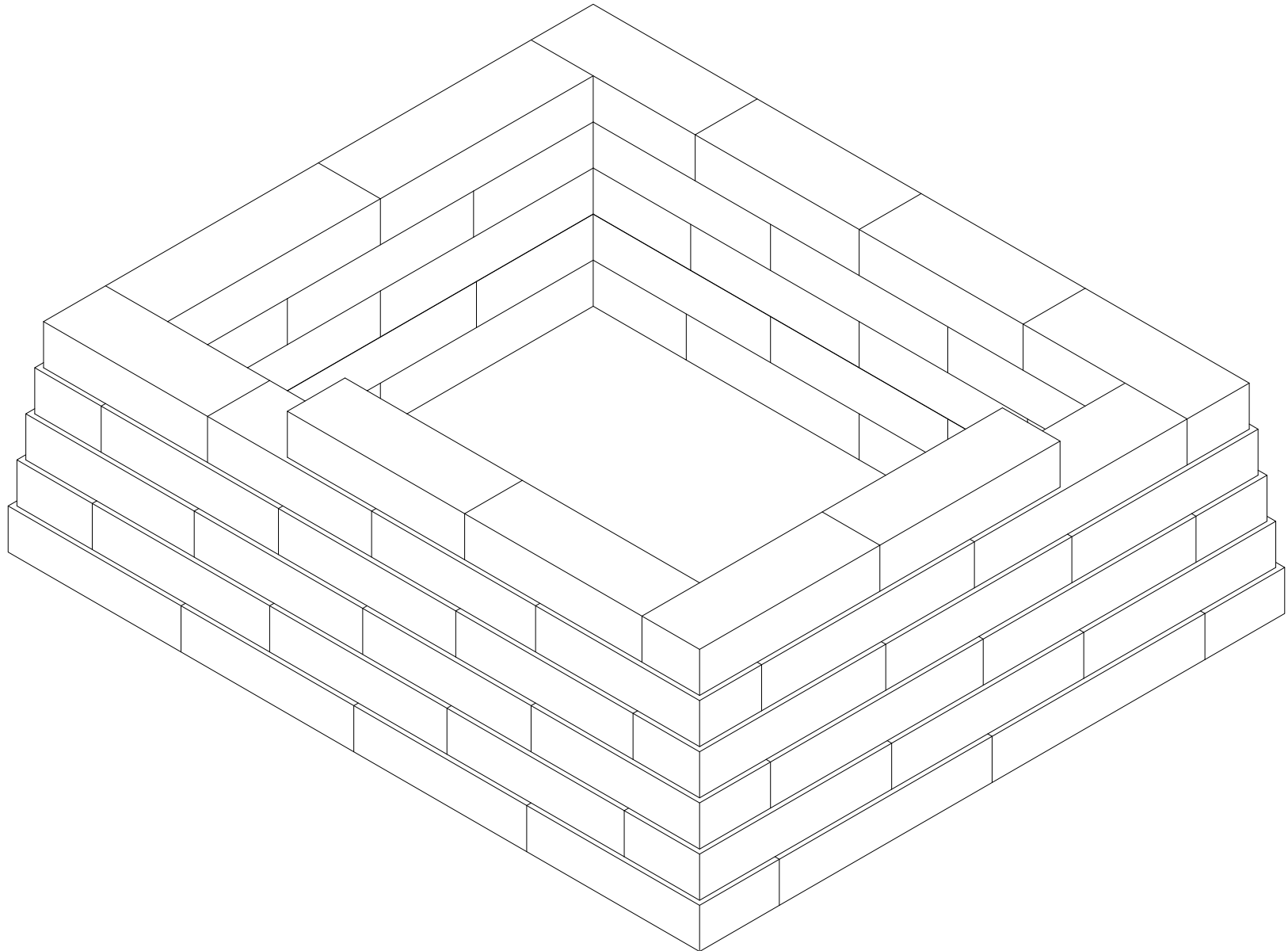

GABION COMPOSITION

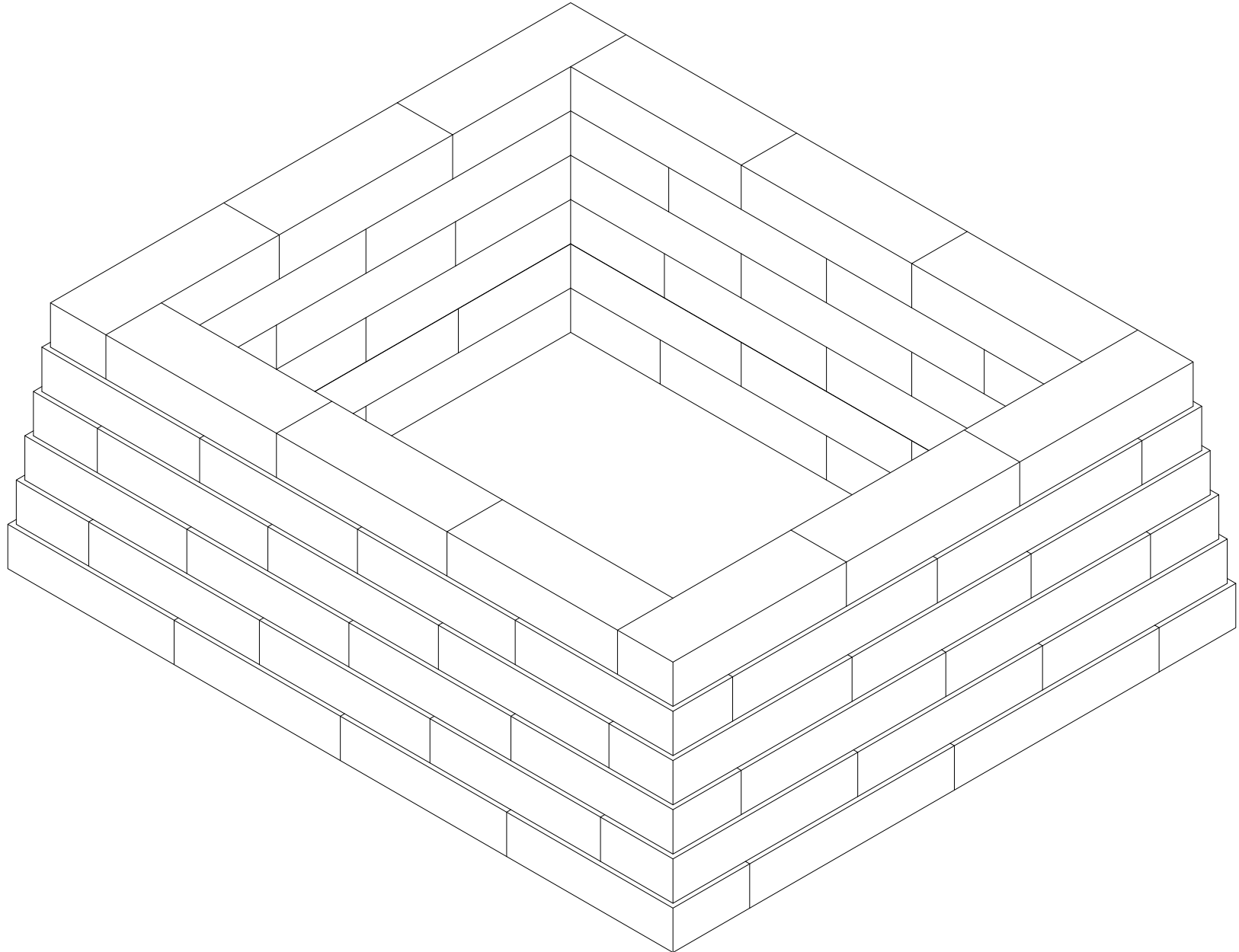

GABION COMPOSITION

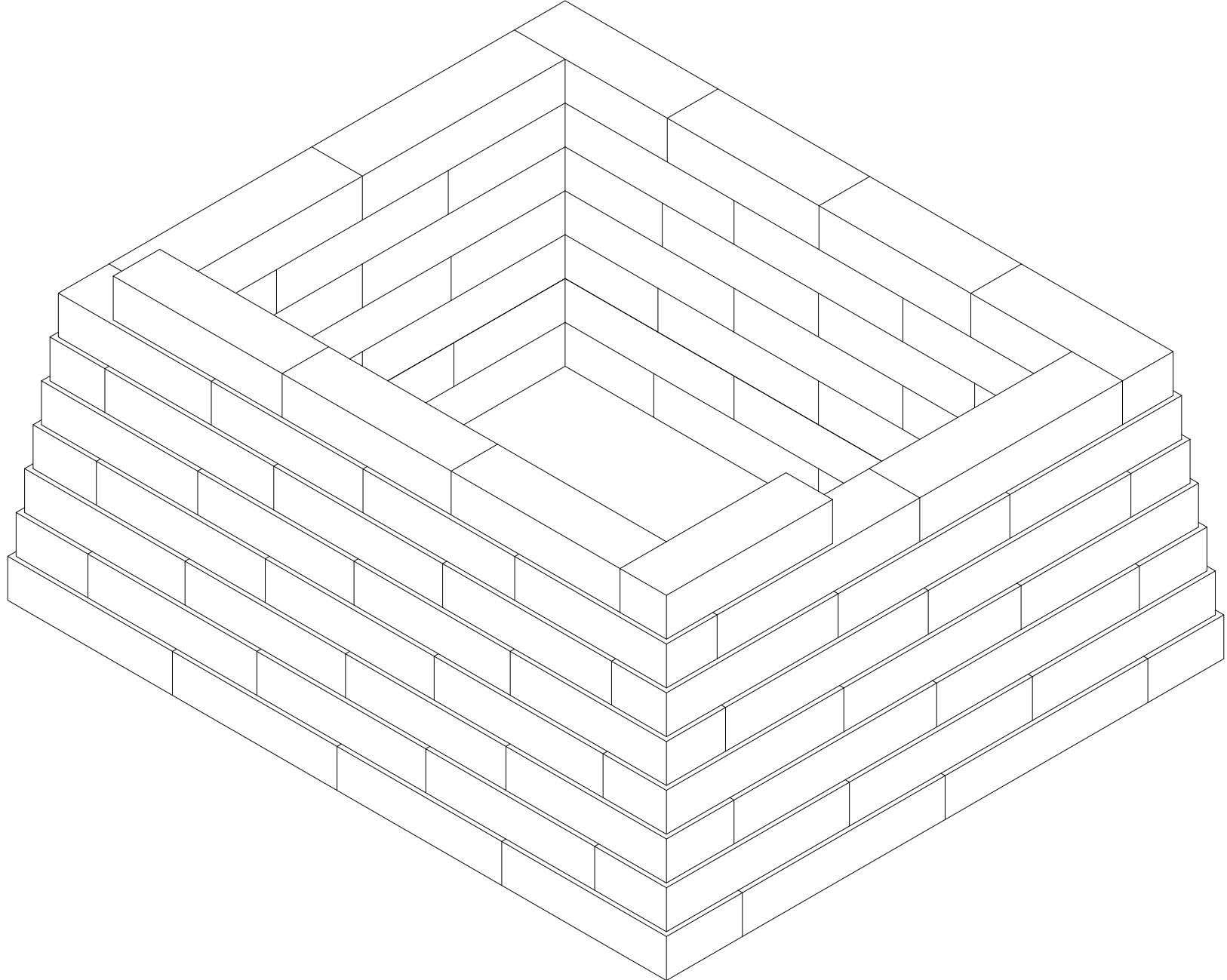

GABION COMPOSITION

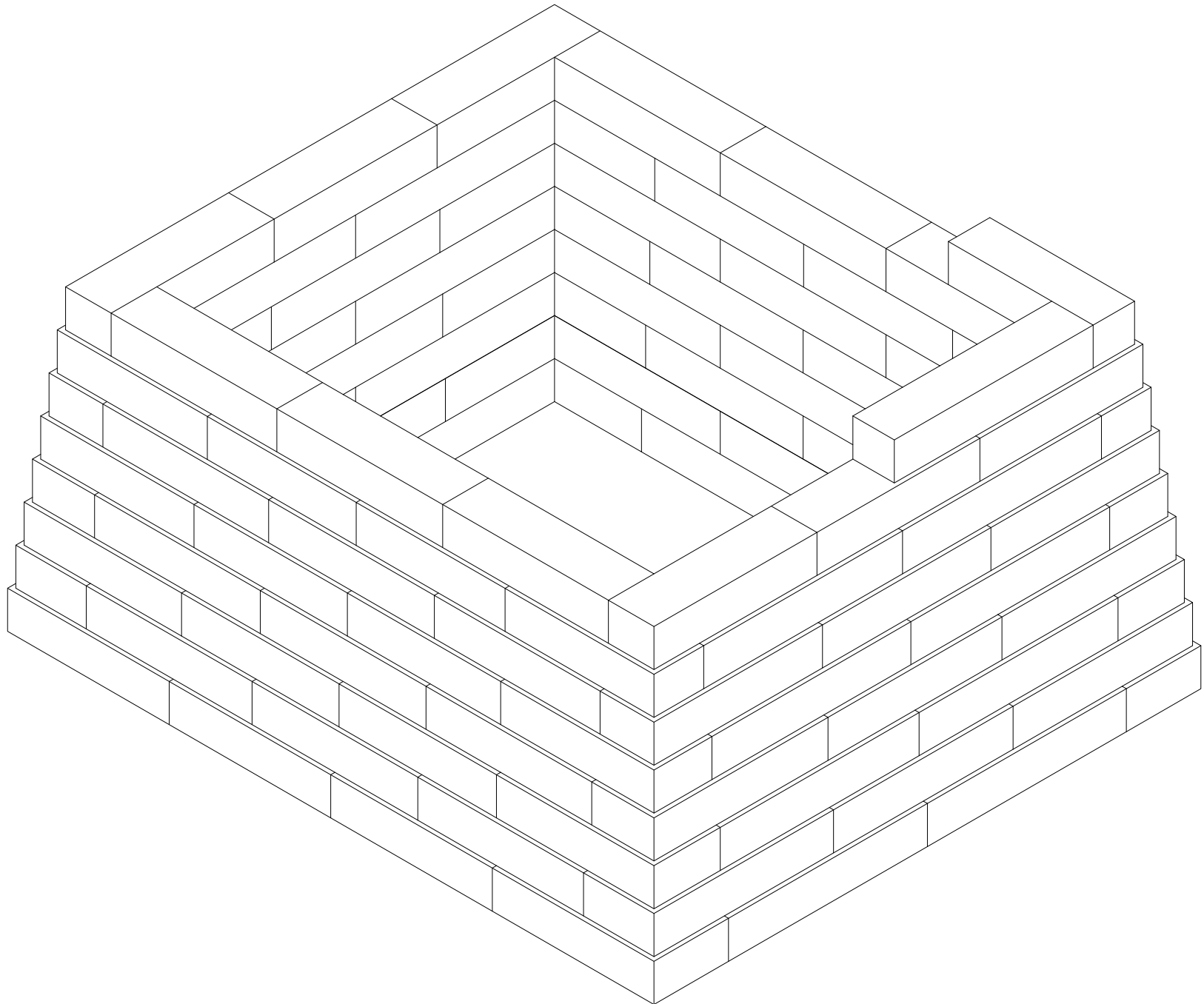

GABION COMPOSITION

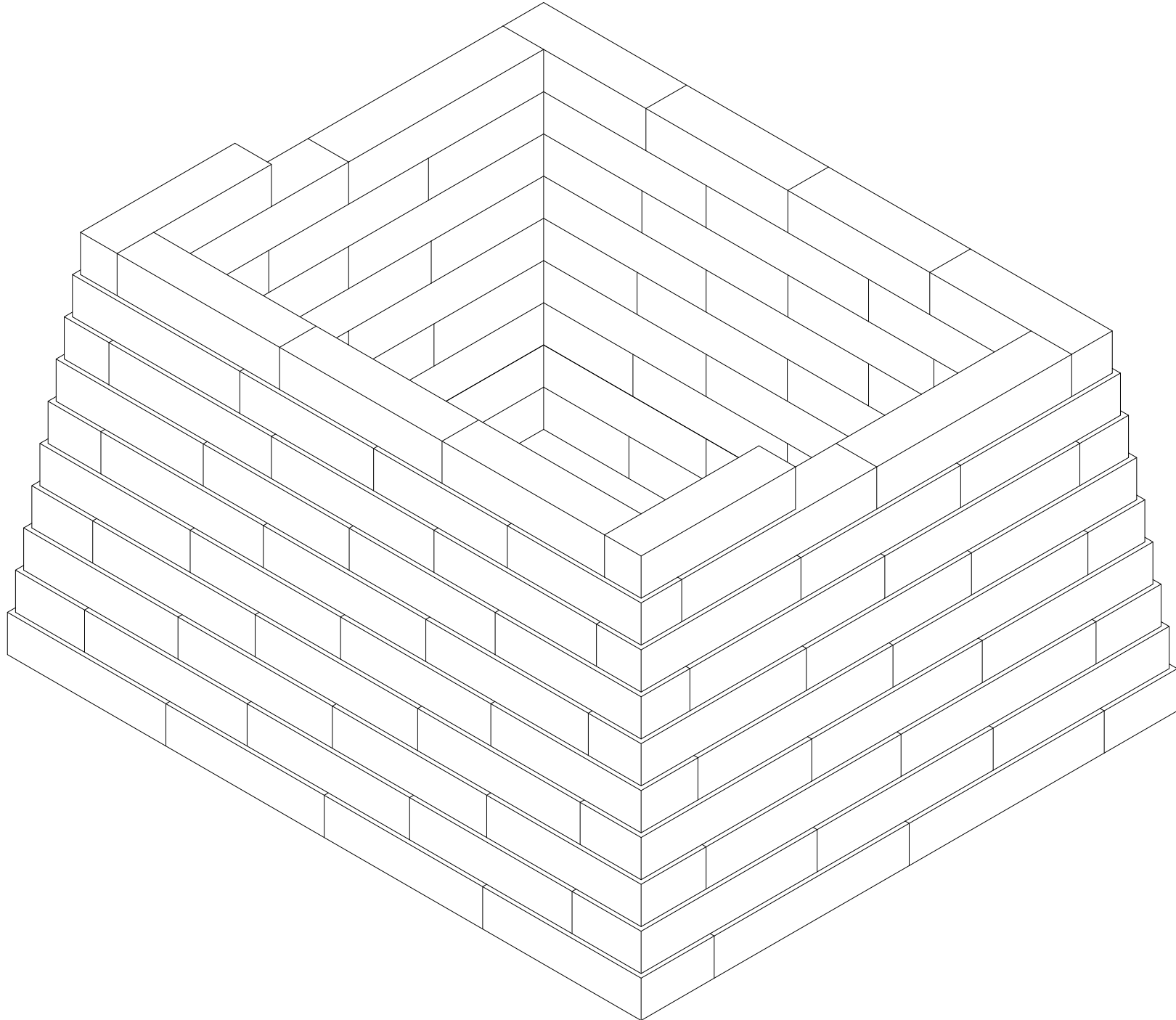

GABION COMPOSITION

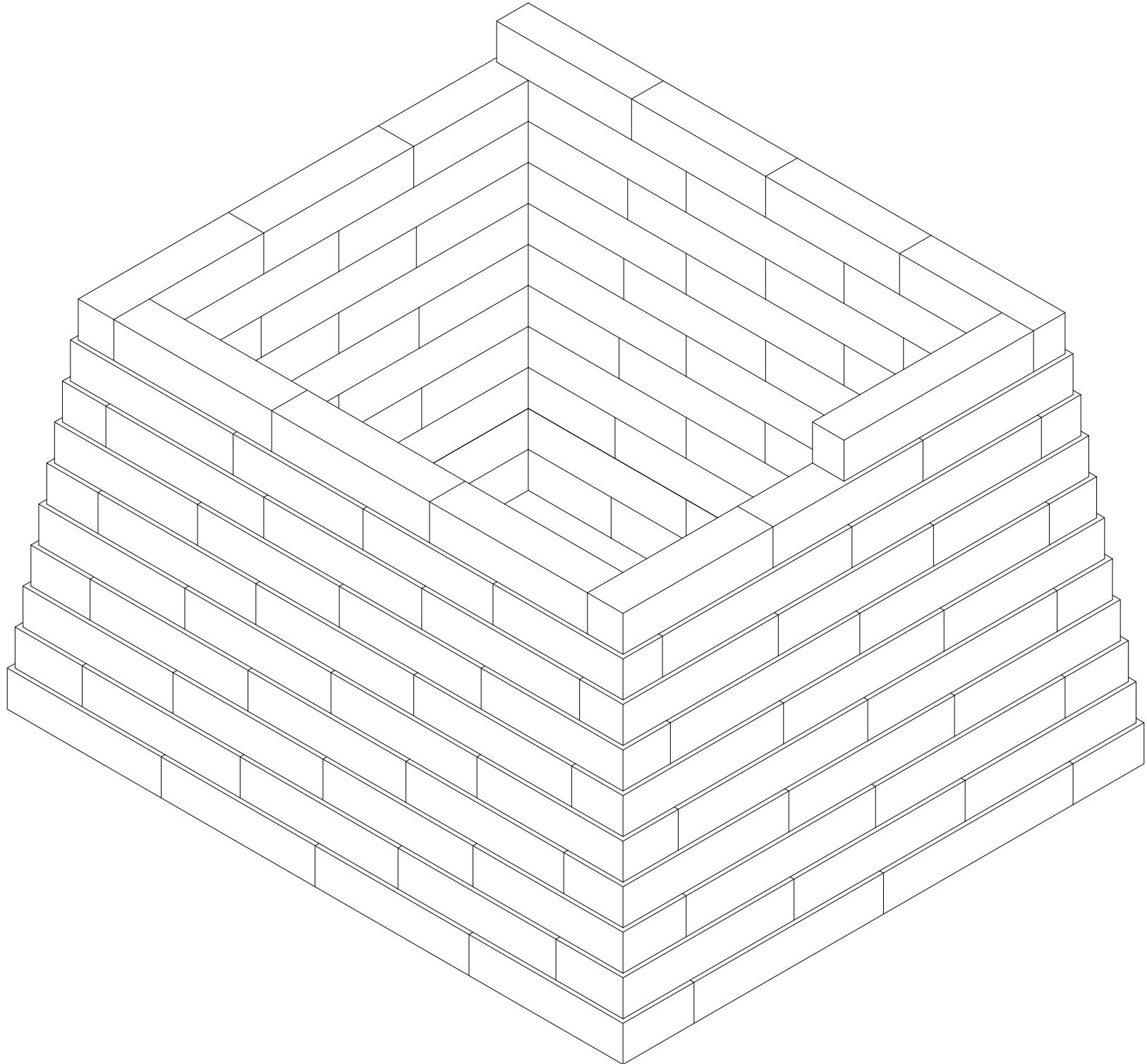

GABION COMPOSITION

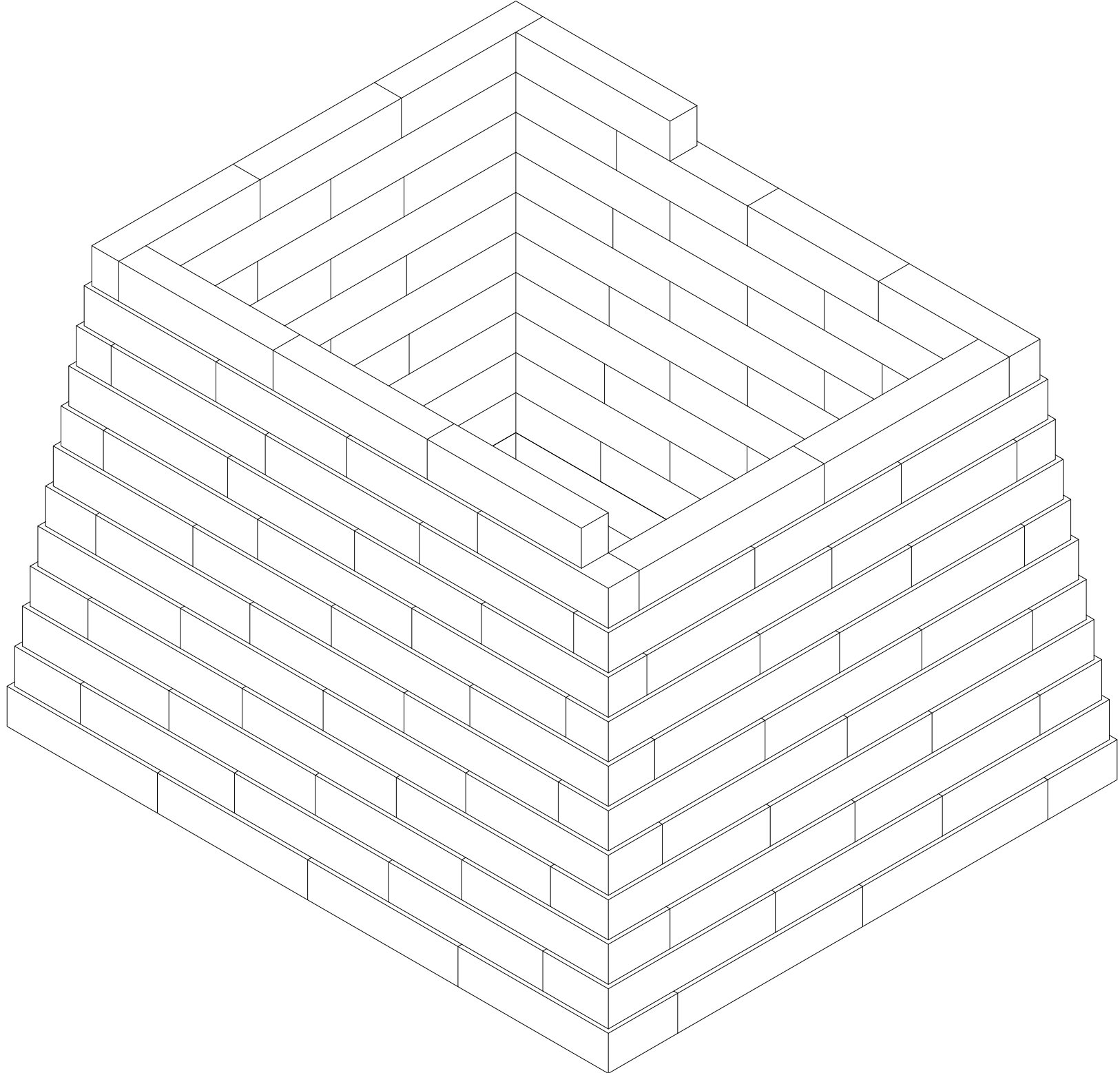

GABION COMPOSITION

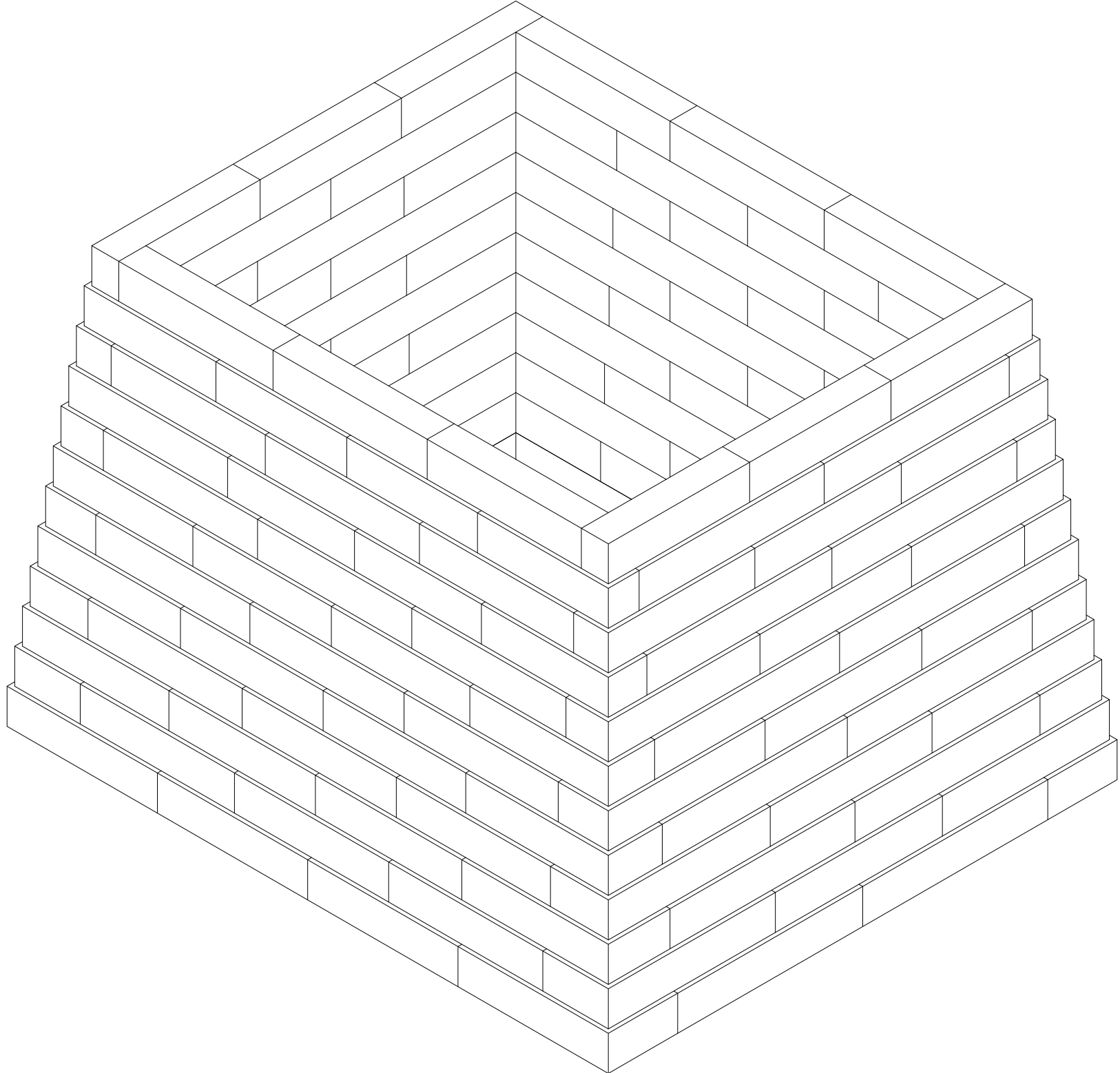

INTERNAL STRUCTURE

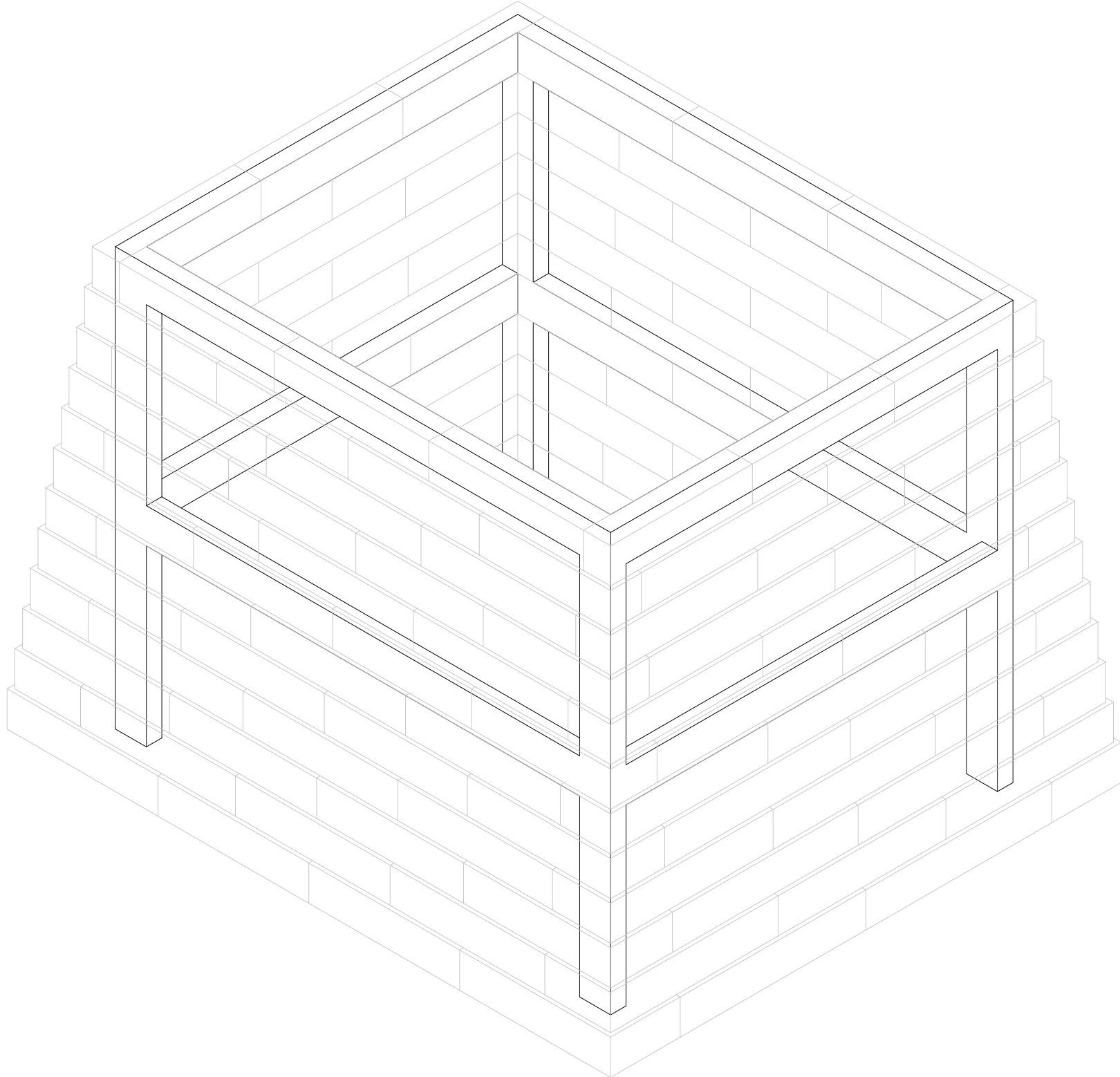



WHAT ABOUT THE THERMAL PROPERTIES OF A GABION WALL?

INSPIRATION BY LOCAL *GRAND VERNACULAR* ARCHITECTURE
ONCE AGAIN

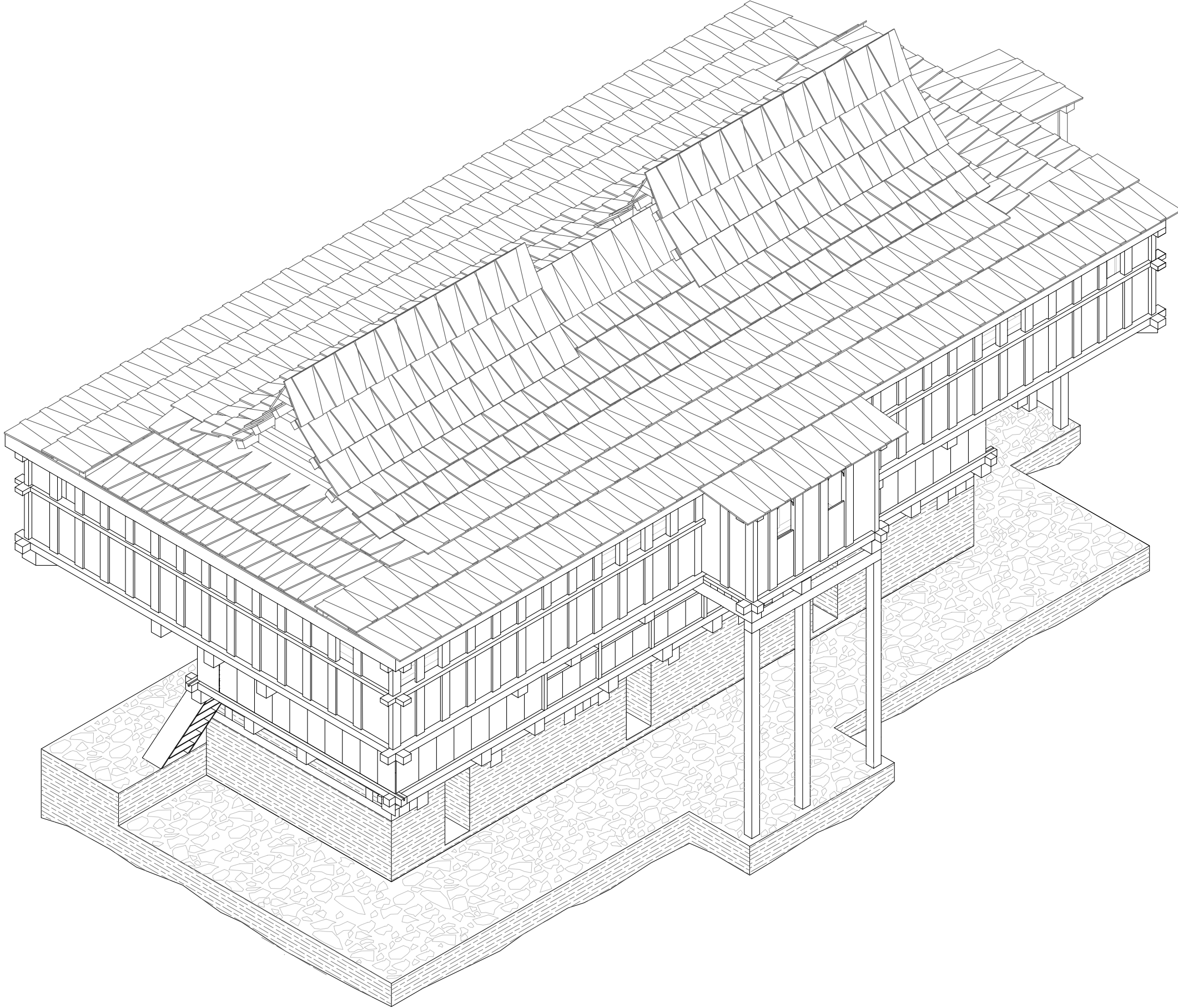

COMPOSITION OF THE VERANDAH

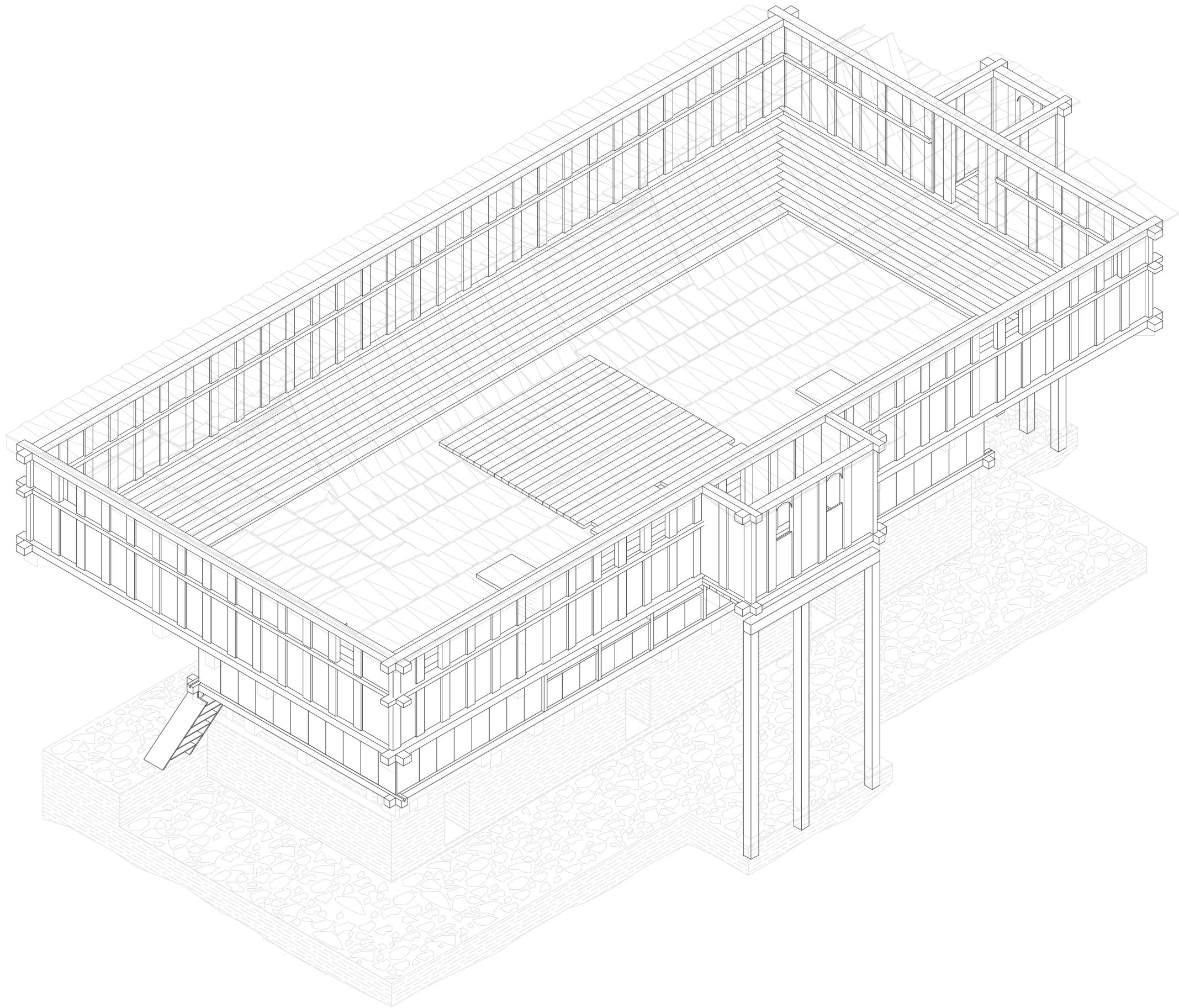

PROTECTION OF THE CENTRAL CORE / INNER SPACES

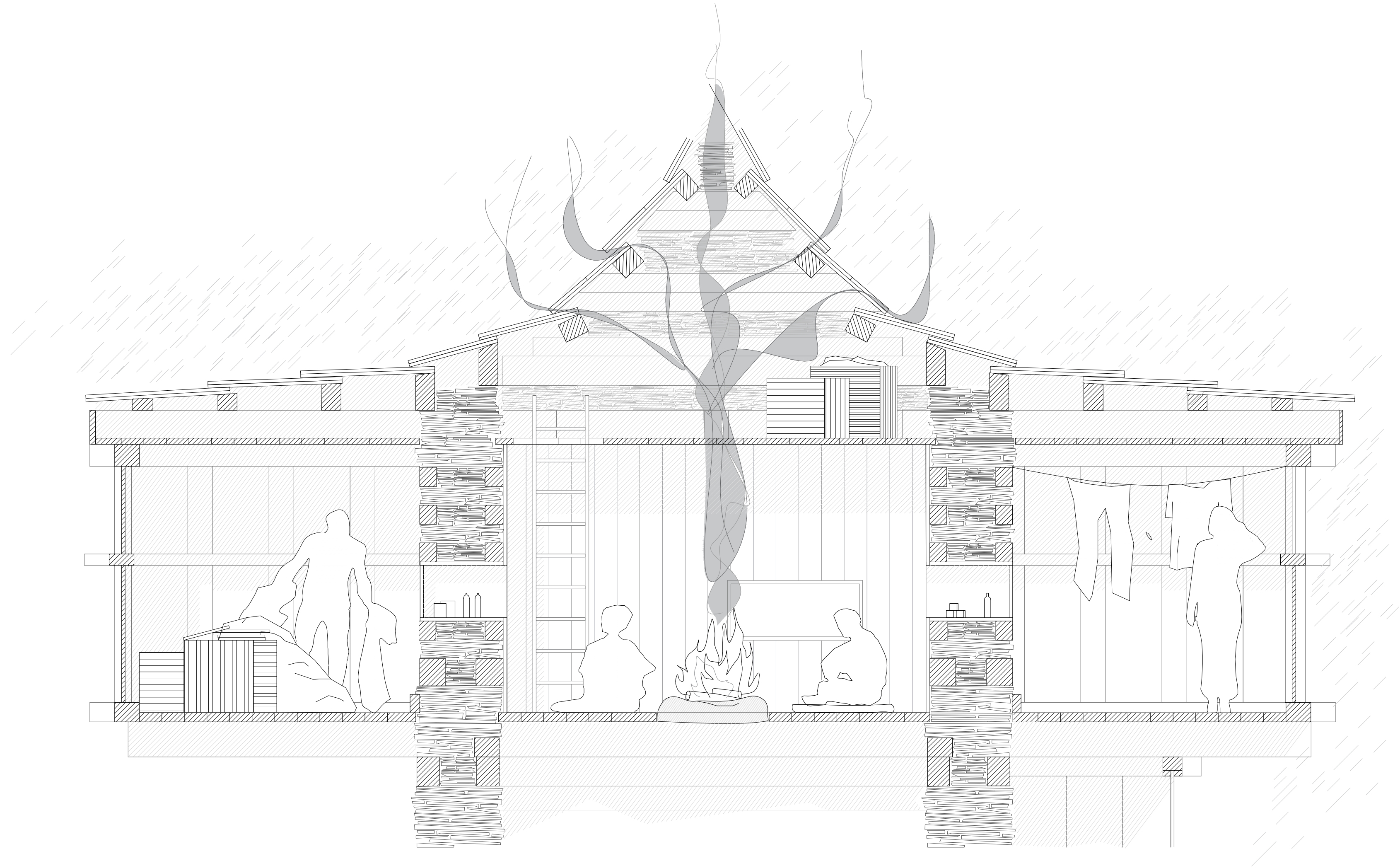

SUMMER
THE CENTRAL CORE IS SHADOWED

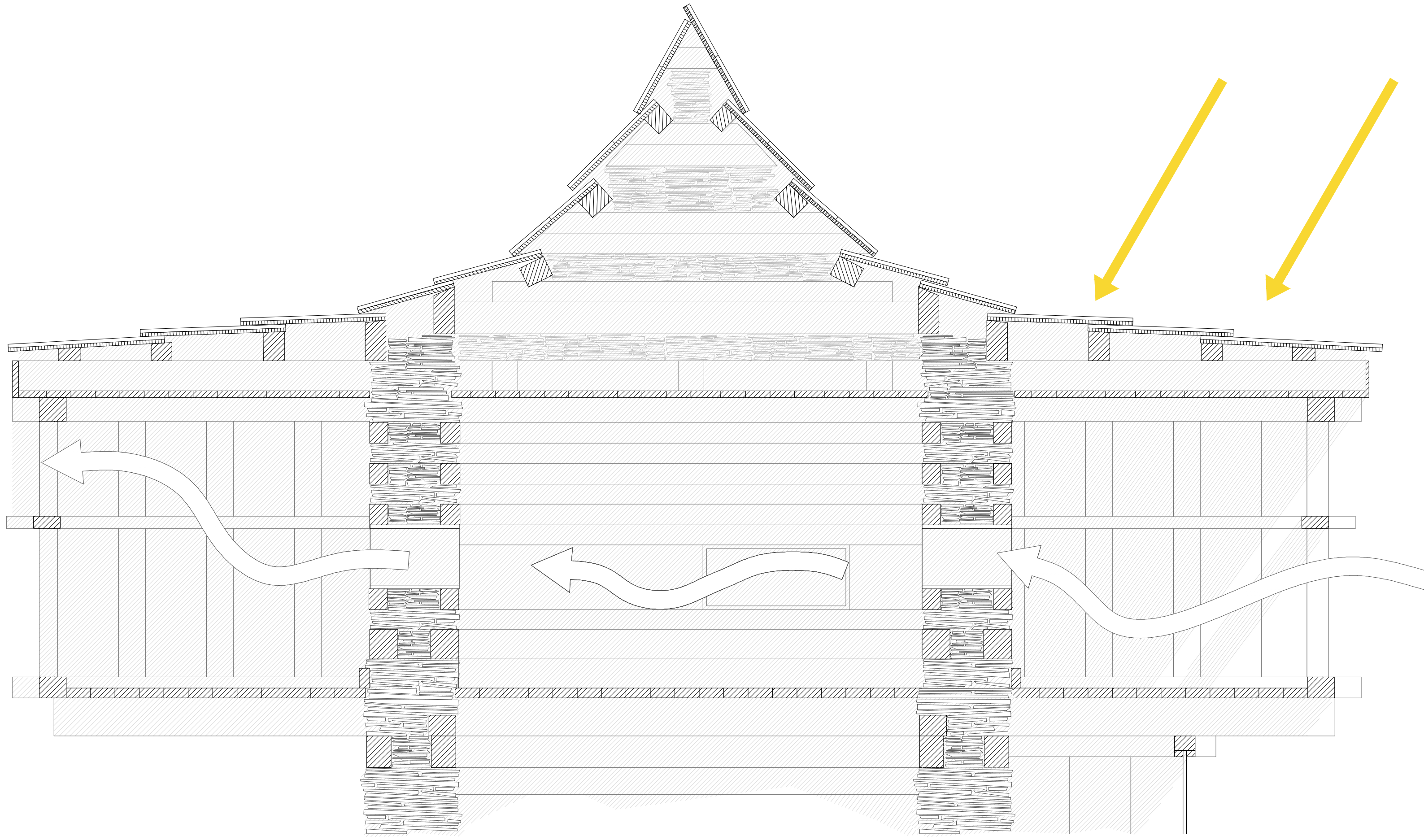

HIGH SUNRAYS
80° / 70°

WINTER
CENTRAL CORE HEATED BY THE SUN

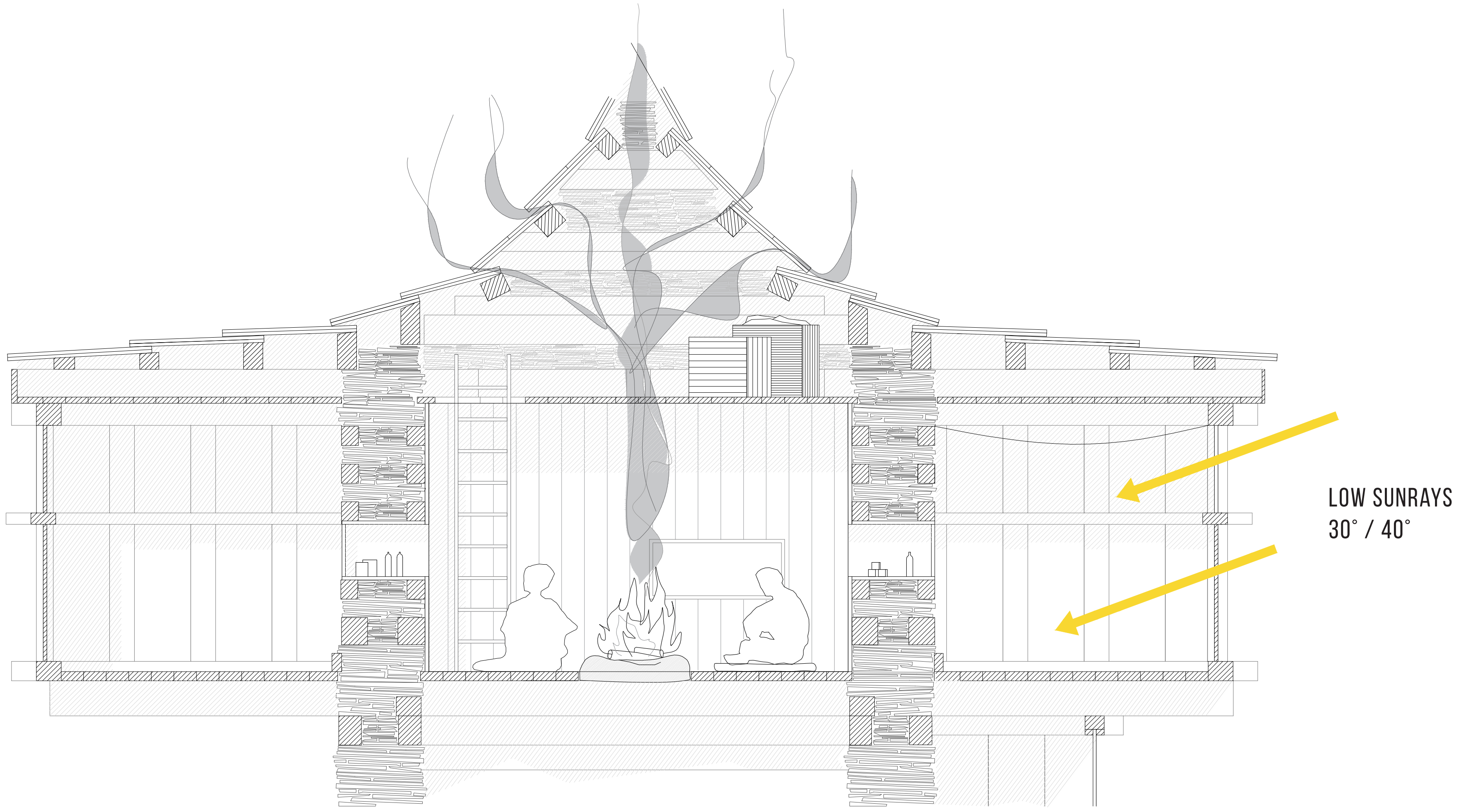

THE PRINCIPLE OF **THERMAL MASS** FOR A **SOLAR PASSIVE DESIGN**

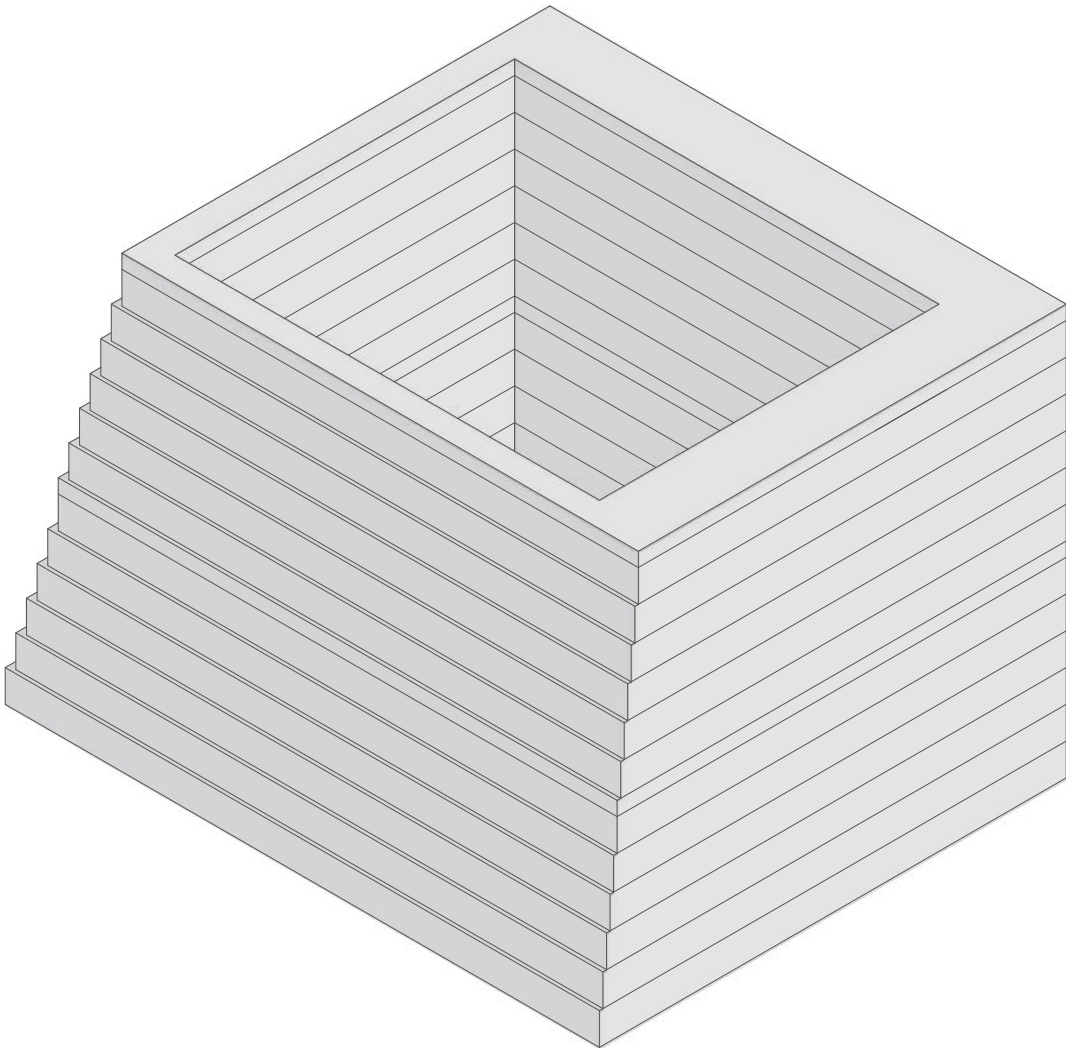

THE PRINCIPLE OF **THERMAL MASS** FOR A **SOLAR PASSIVE DESIGN**

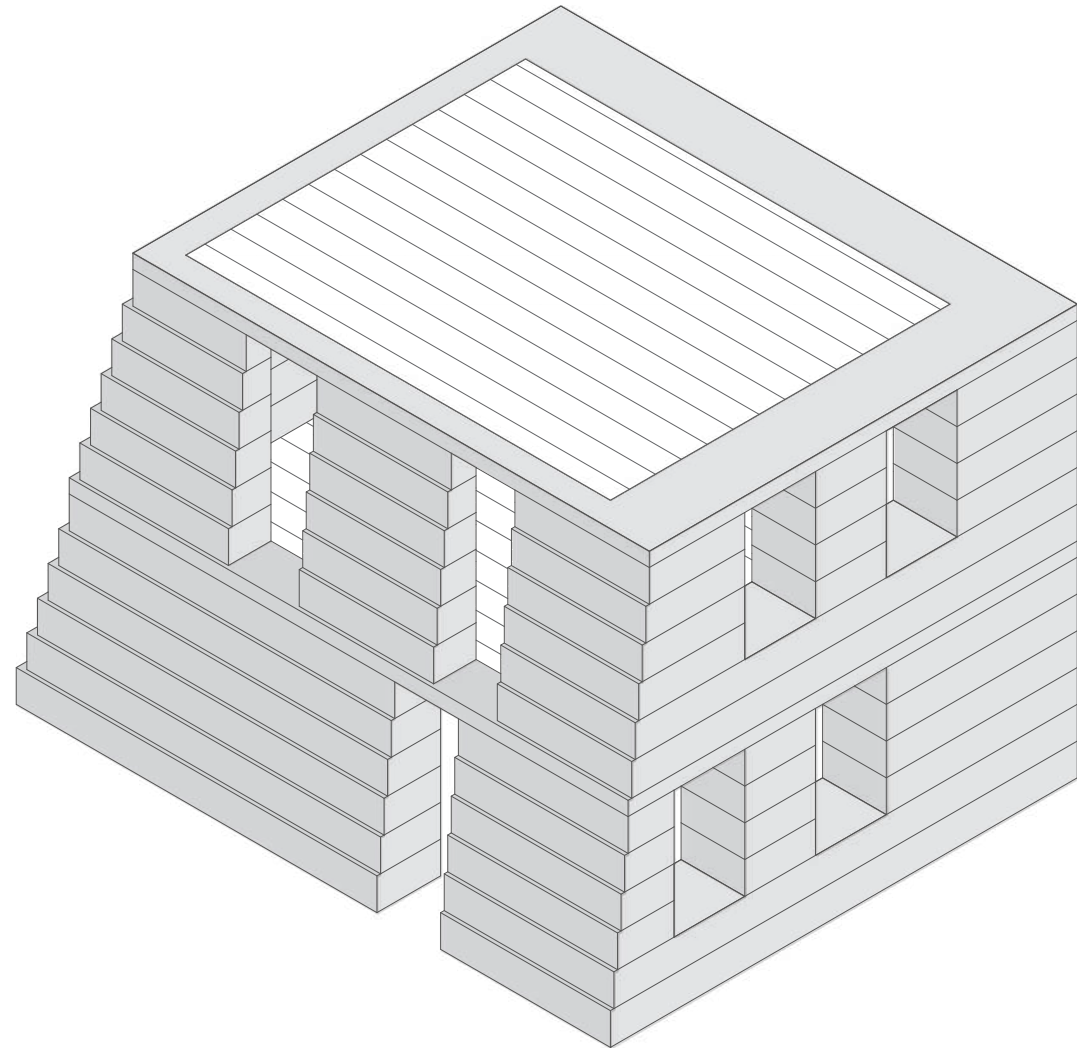

CENTRAL CORE

THE PRINCIPLE OF **THERMAL MASS** FOR A **SOLAR PASSIVE DESIGN**

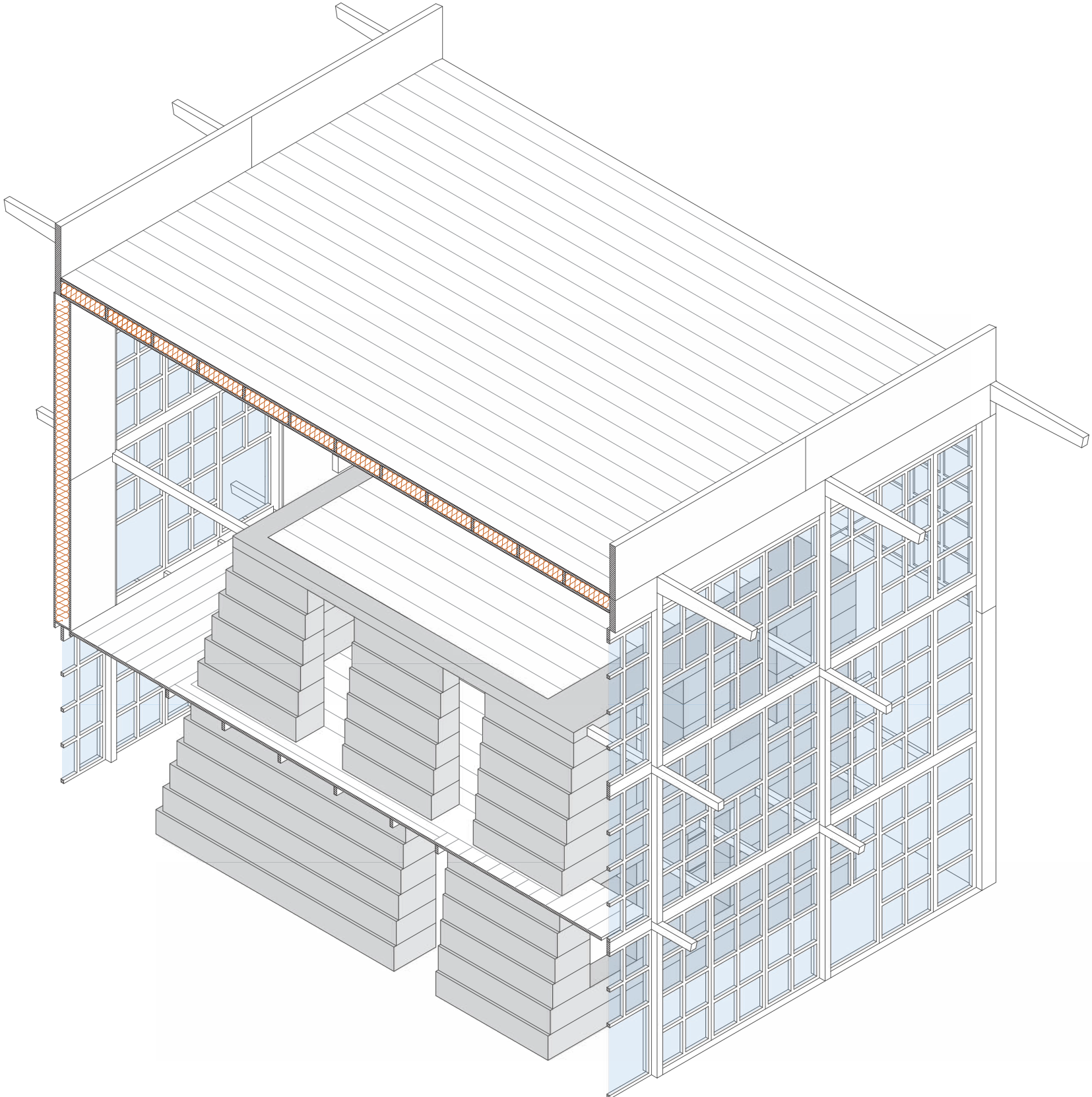

SHELL
+
CENTRAL CORE

THE PRINCIPLE OF **THERMAL MASS** FOR A **SOLAR PASSIVE DESIGN**

INSULTATED ROOF

INSULTATED NORTH FAÇADE

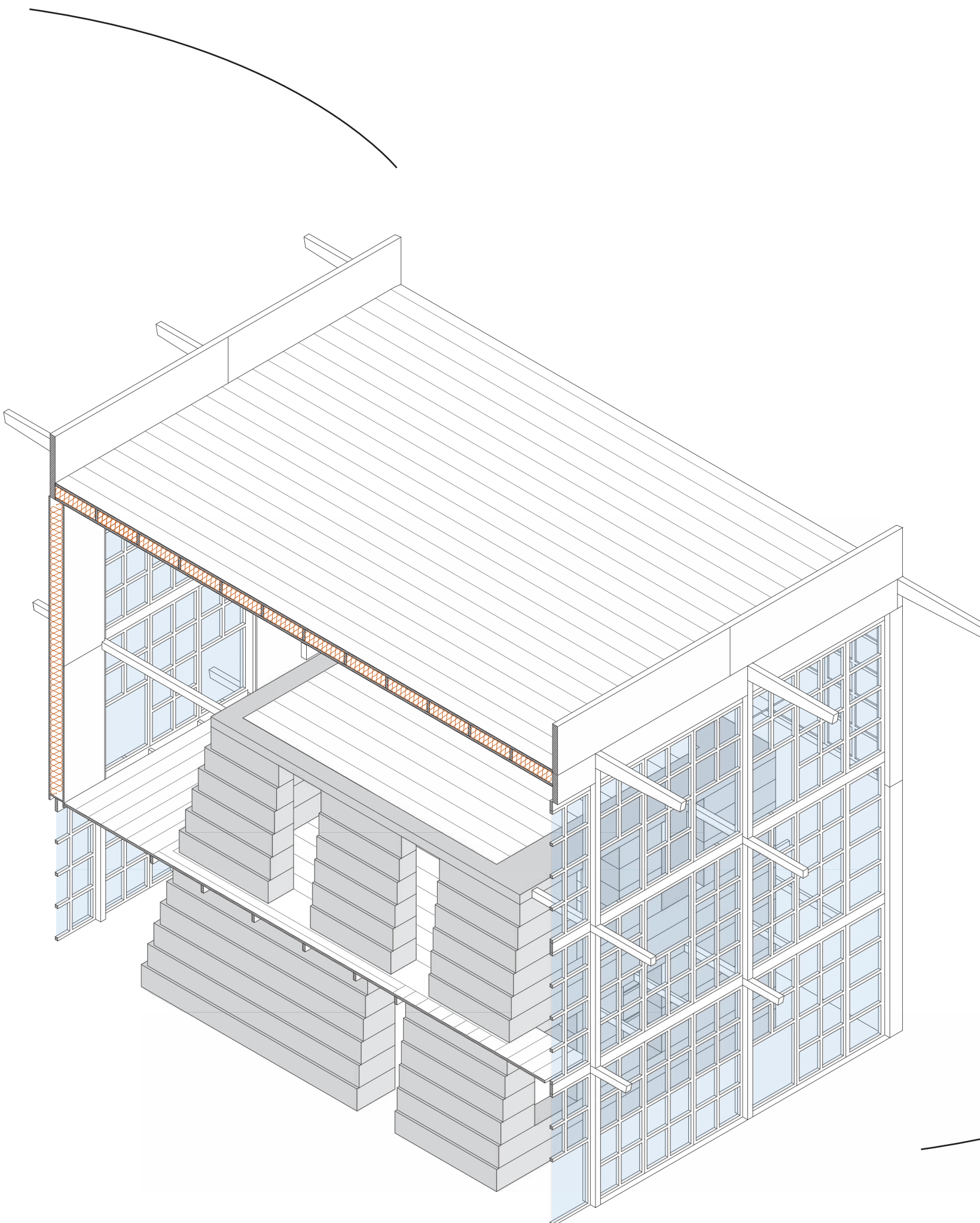

SHELL
+
CENTRAL CORE

GLAZED SOUTH FAÇADE

THE PRINCIPLE OF **THERMAL MASS** FOR A **SOLAR PASSIVE DESIGN**

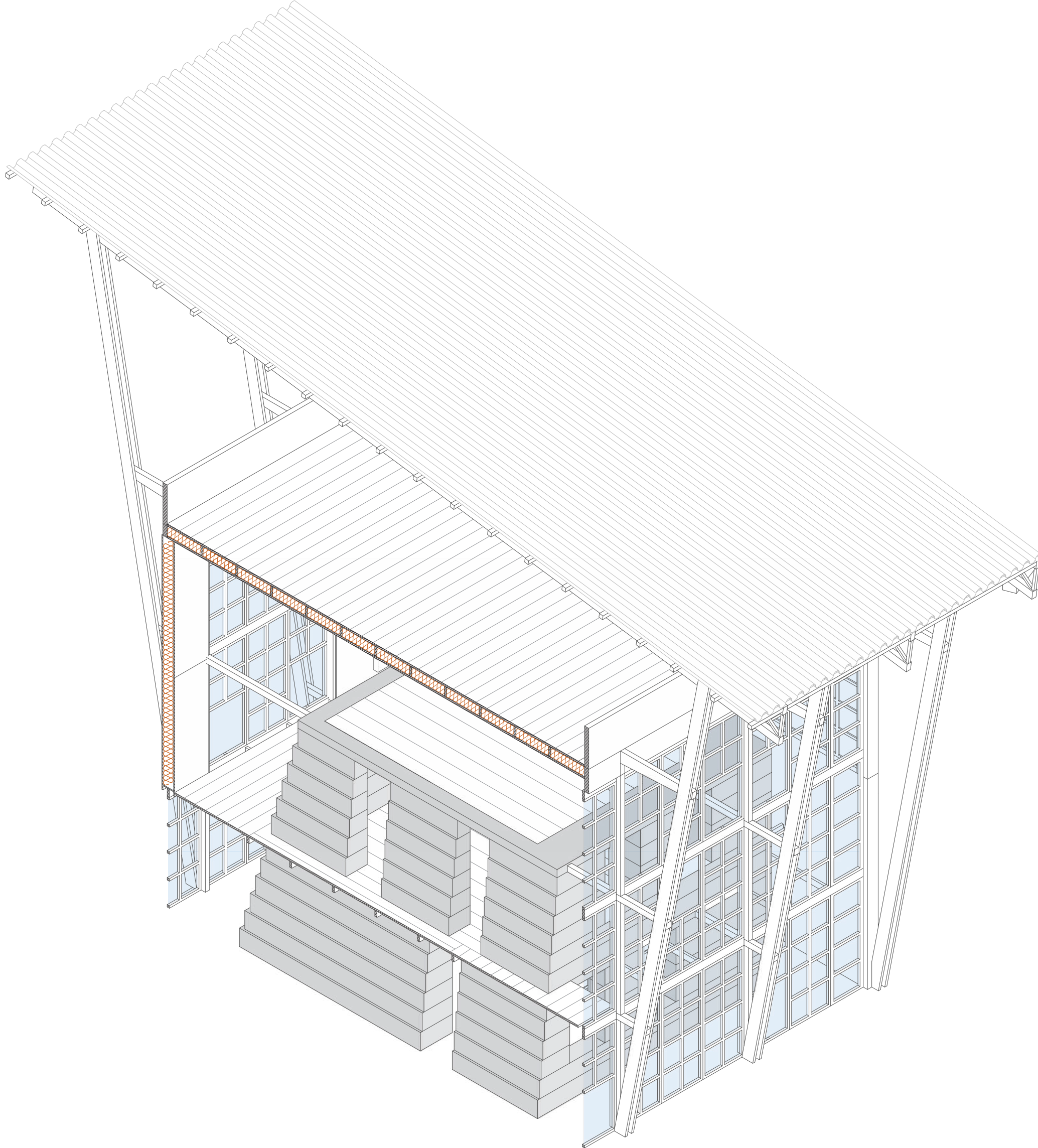

LIGHT ROOF
+
TIMBER/GLASS SHELL
+
CENTRAL CORE

TREE COMPONENTS / ONE STRUCTURE

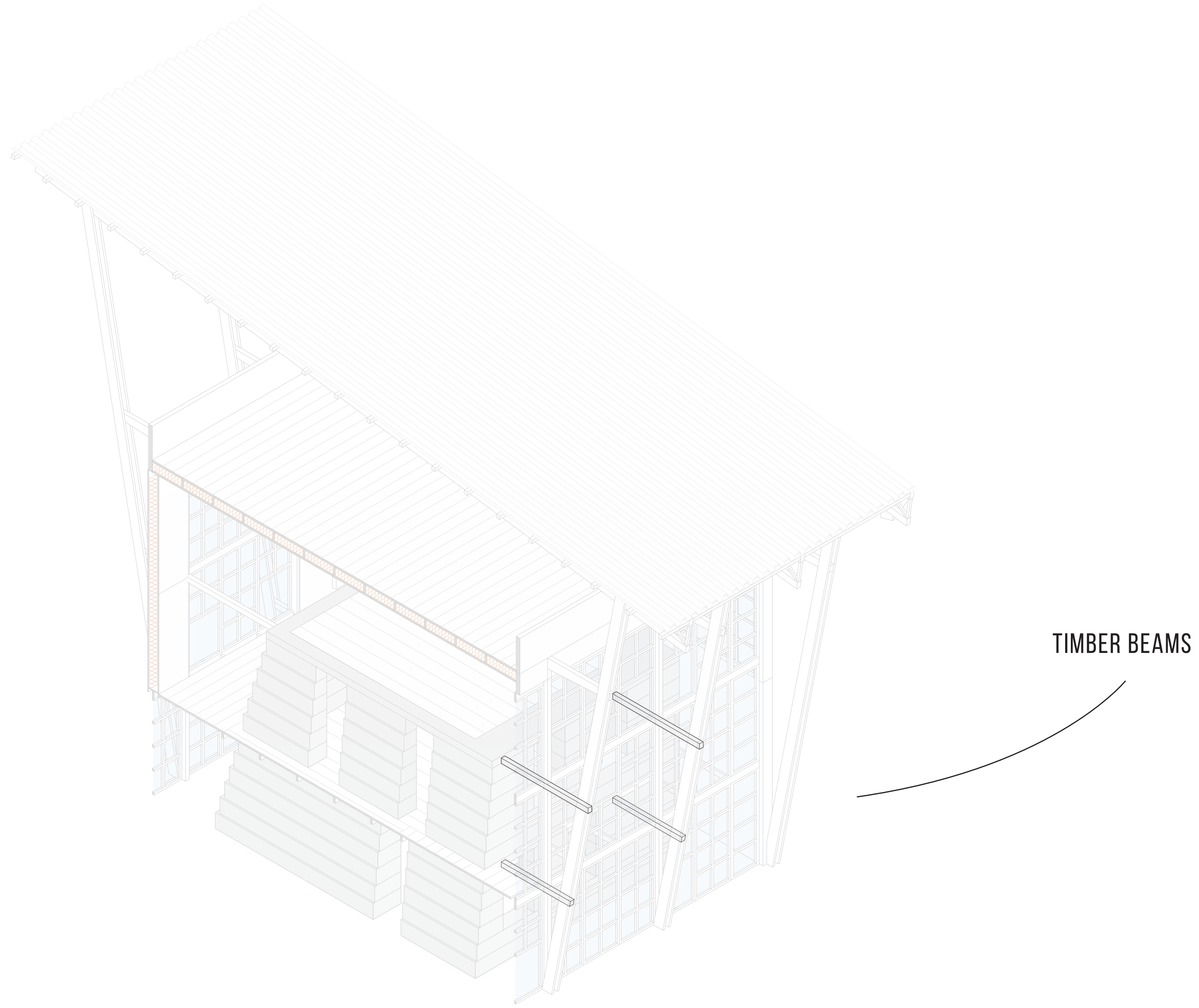

TREE COMPONENTS / ONE STRUCTURE

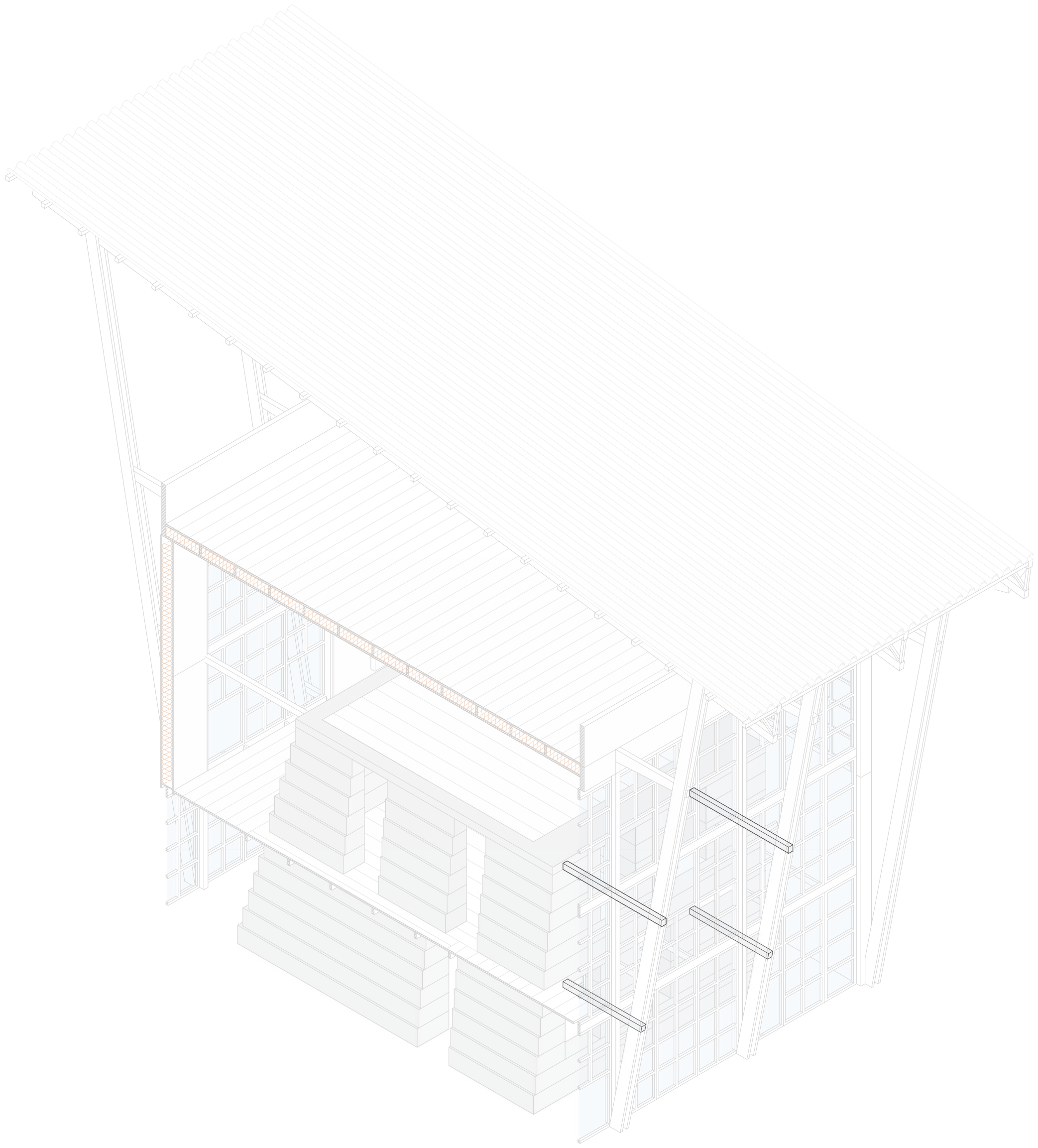

LINEAR SEQUENCE OF VOLUMES

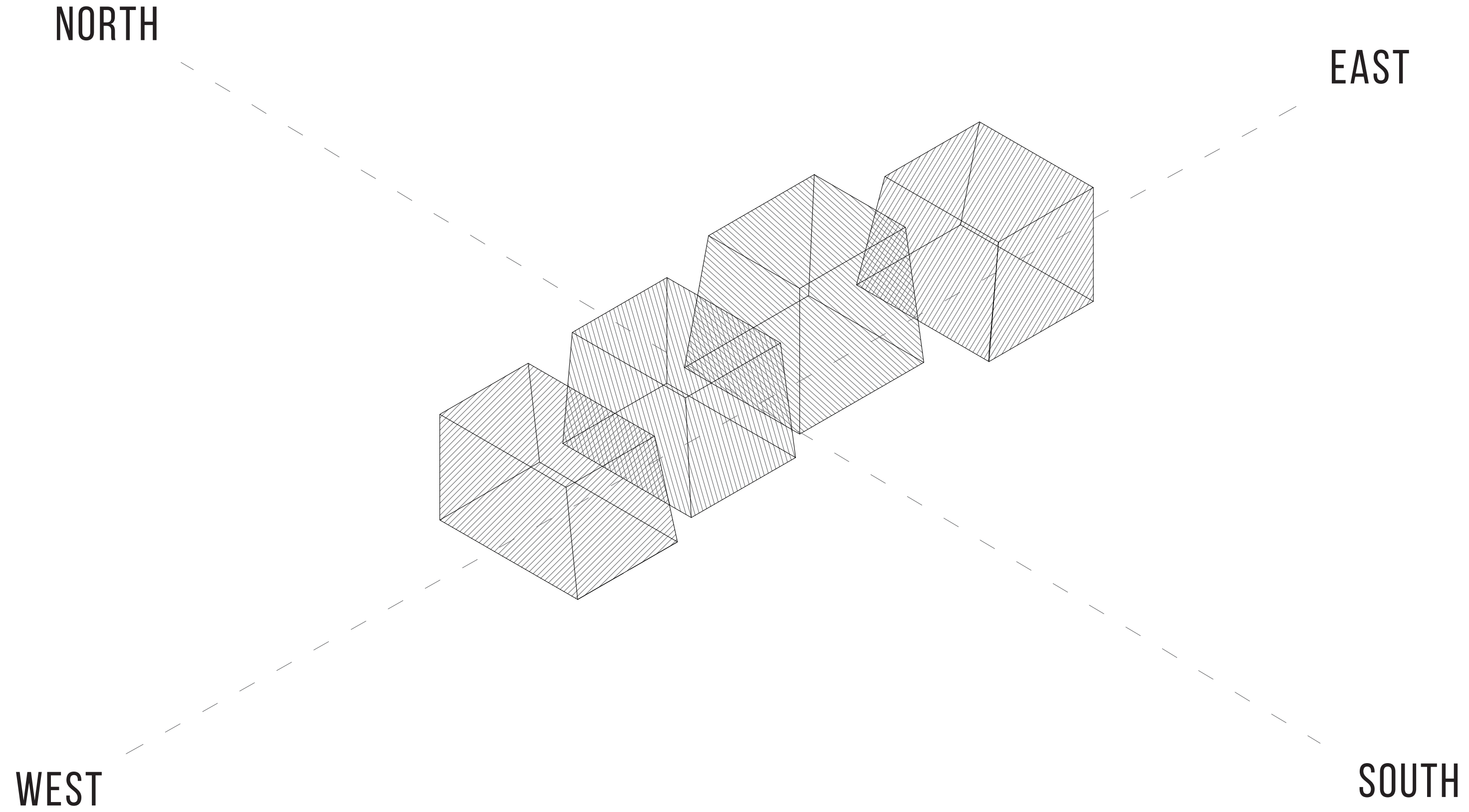

LINEAR SEQUENCE OF VOLUMES

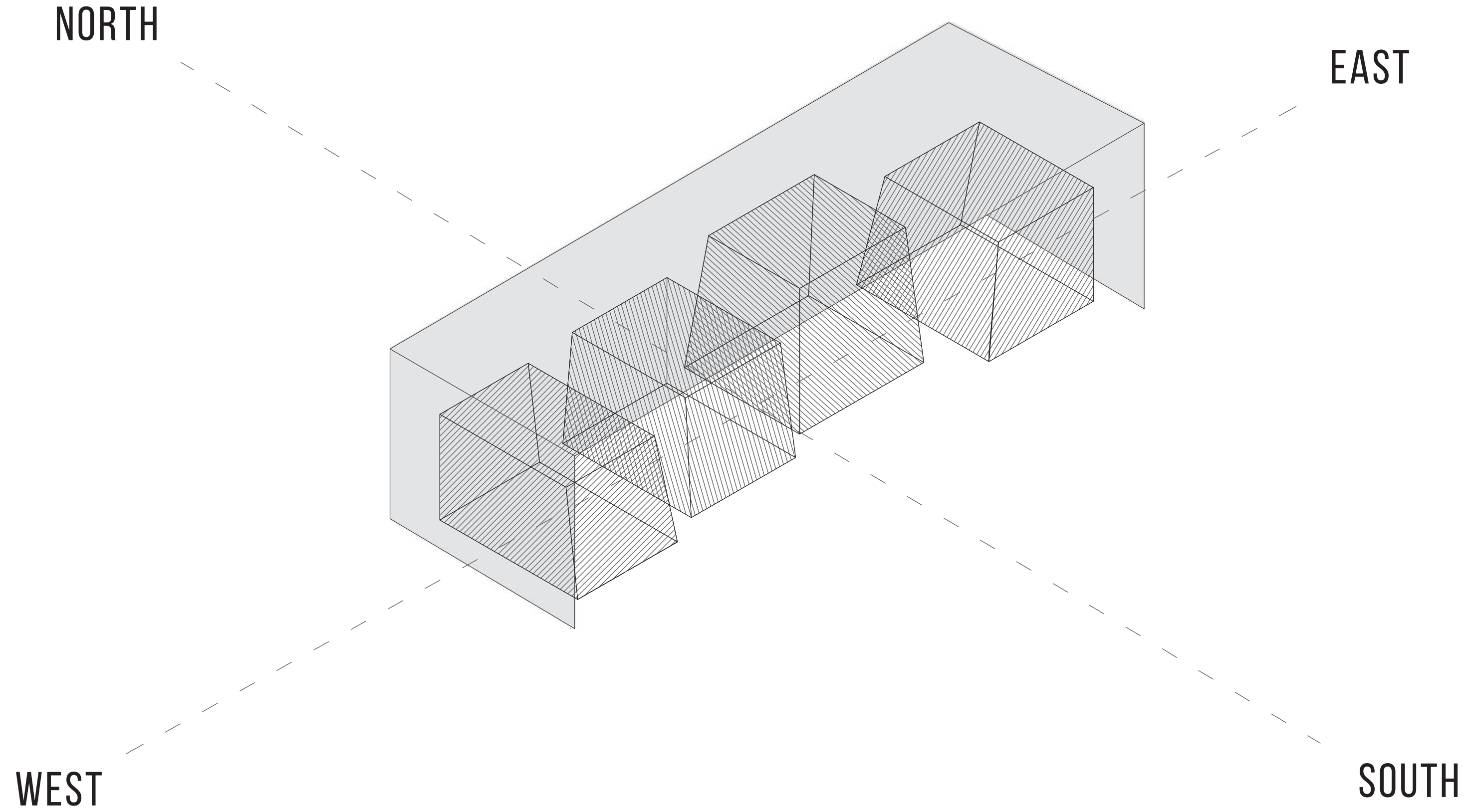

LINEAR SEQUENCE OF VOLUMES

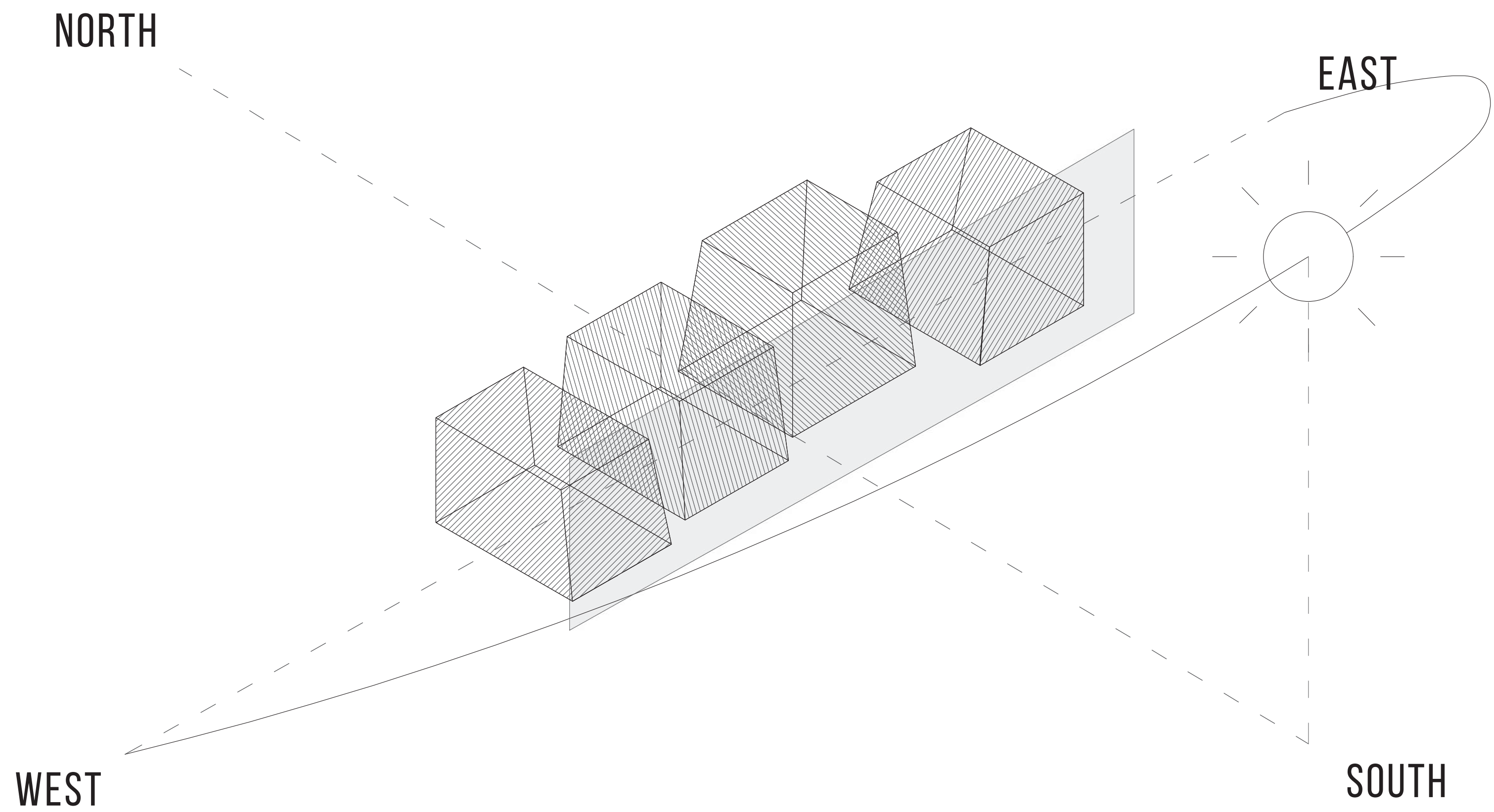

SCHOOL BUILDING

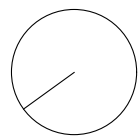
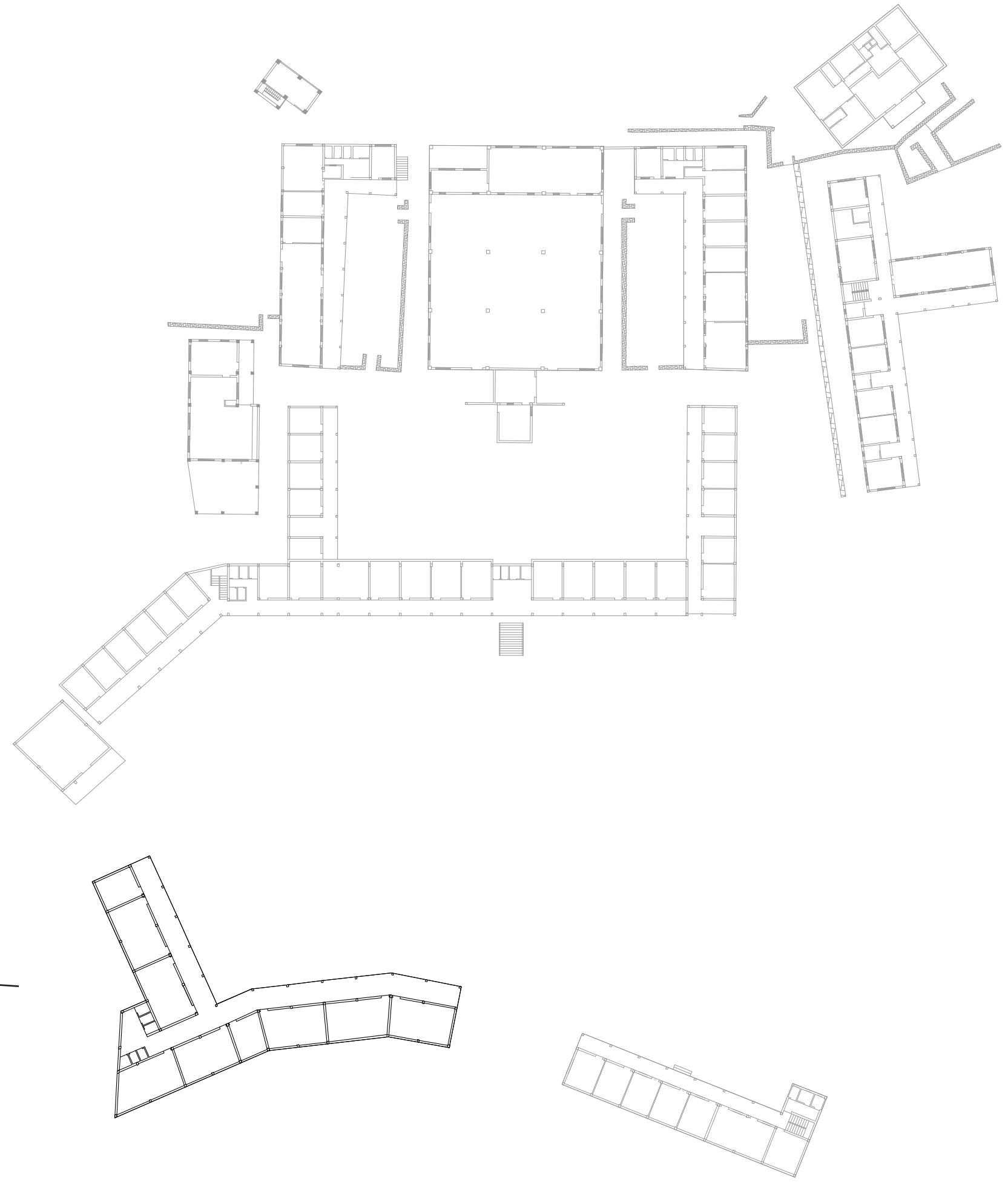

EXISTING SITUATION

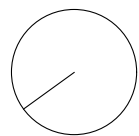
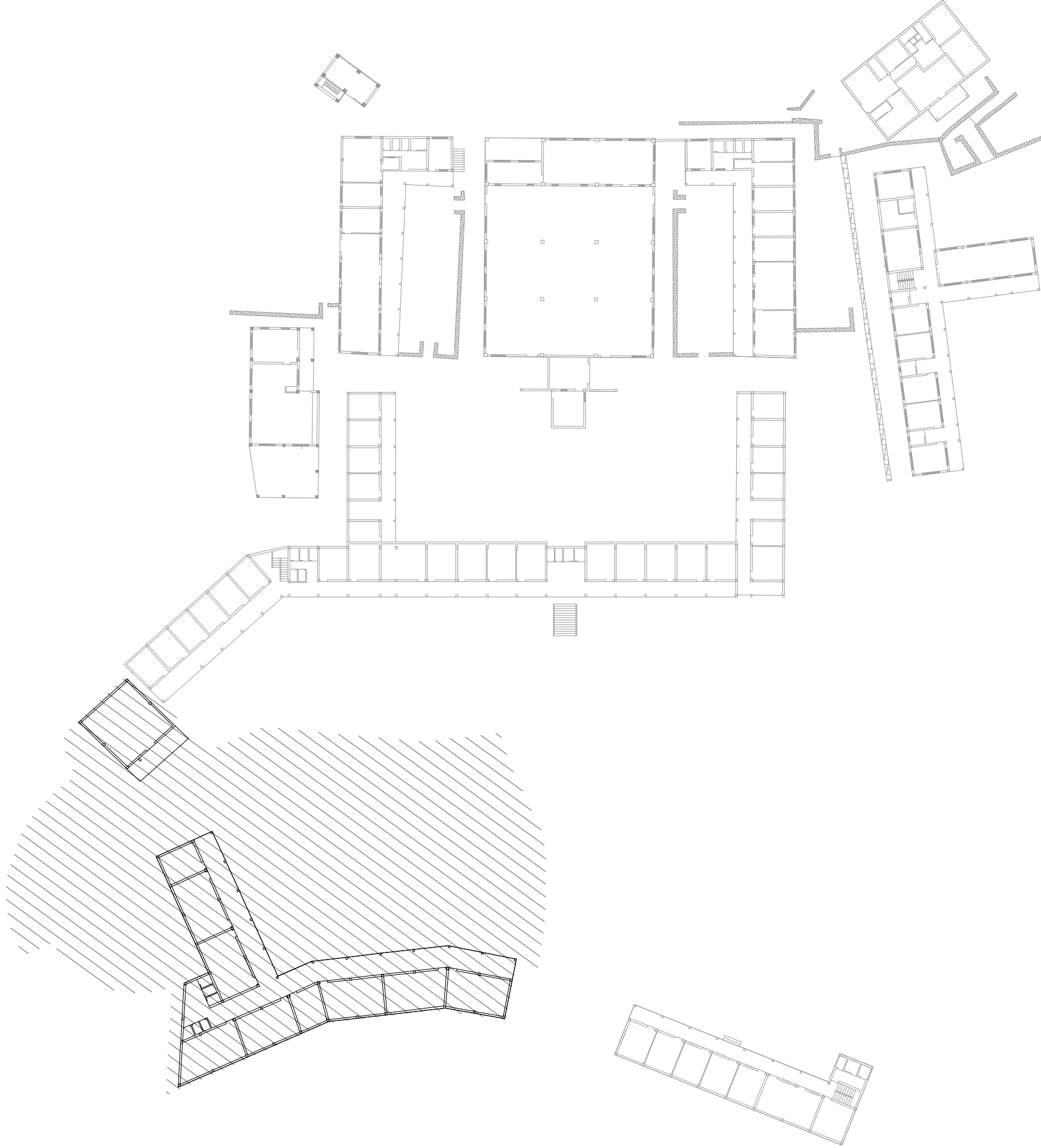

AREA OF INTERVENTION

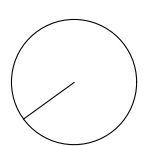
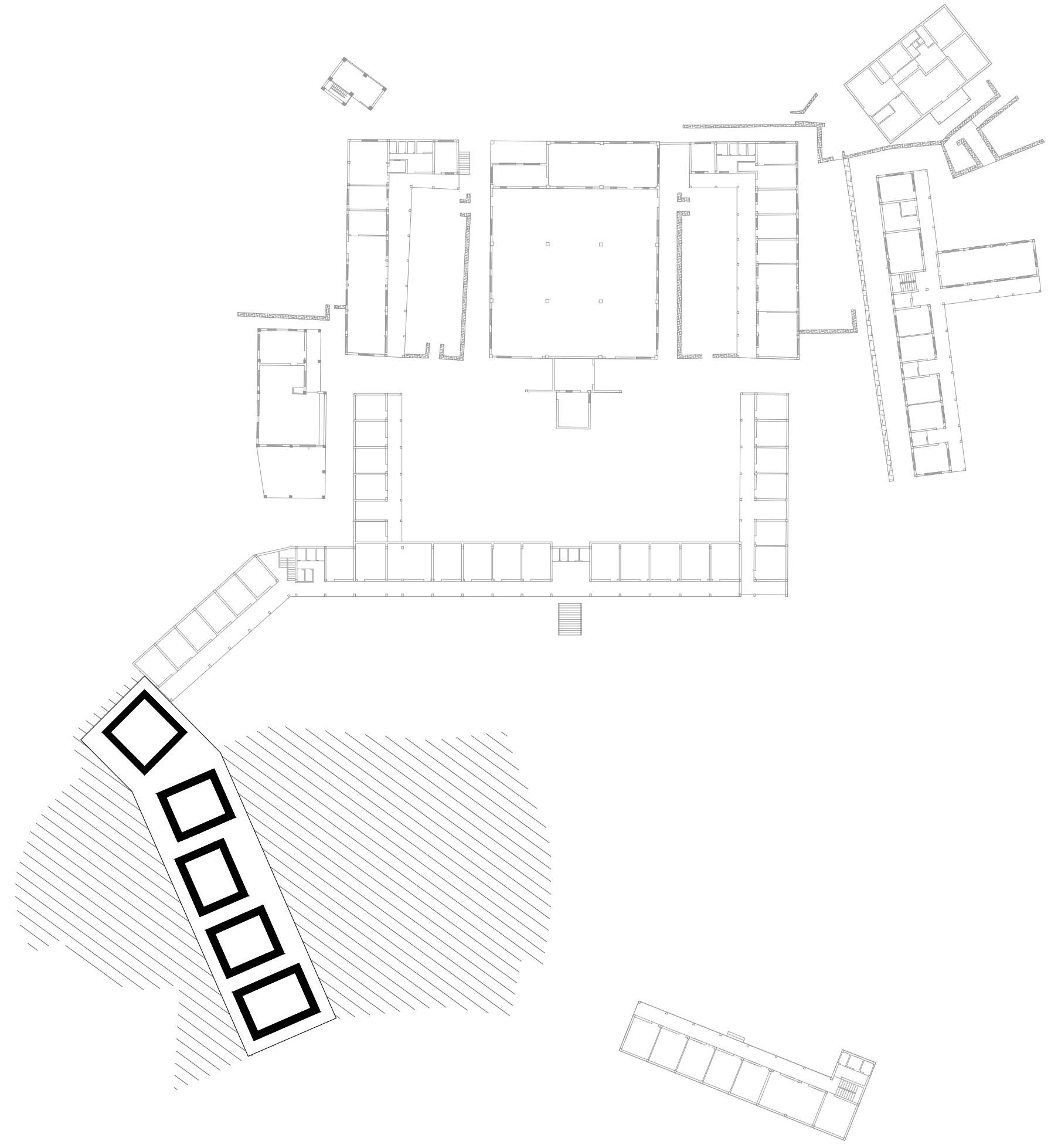

NEW ADDITION

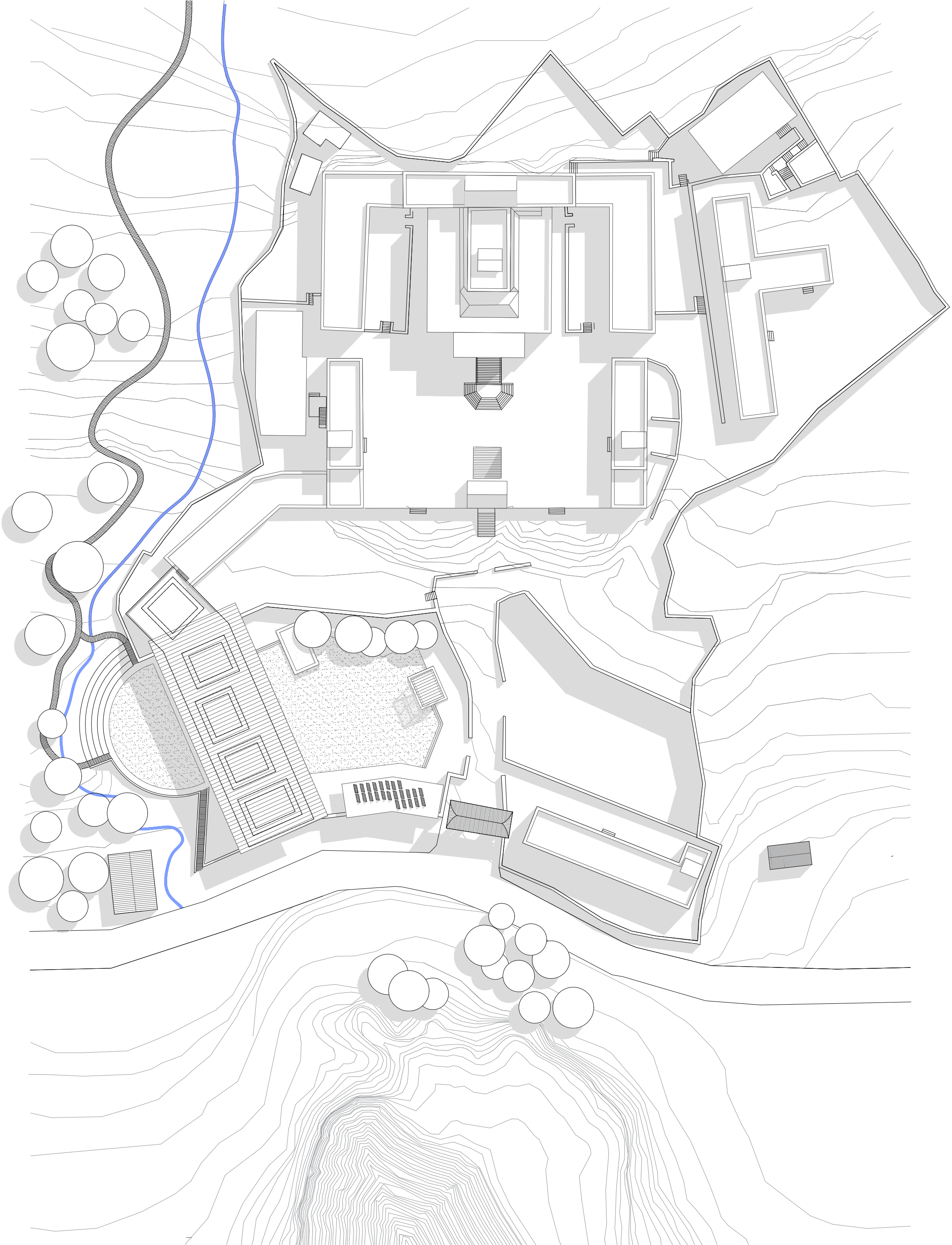

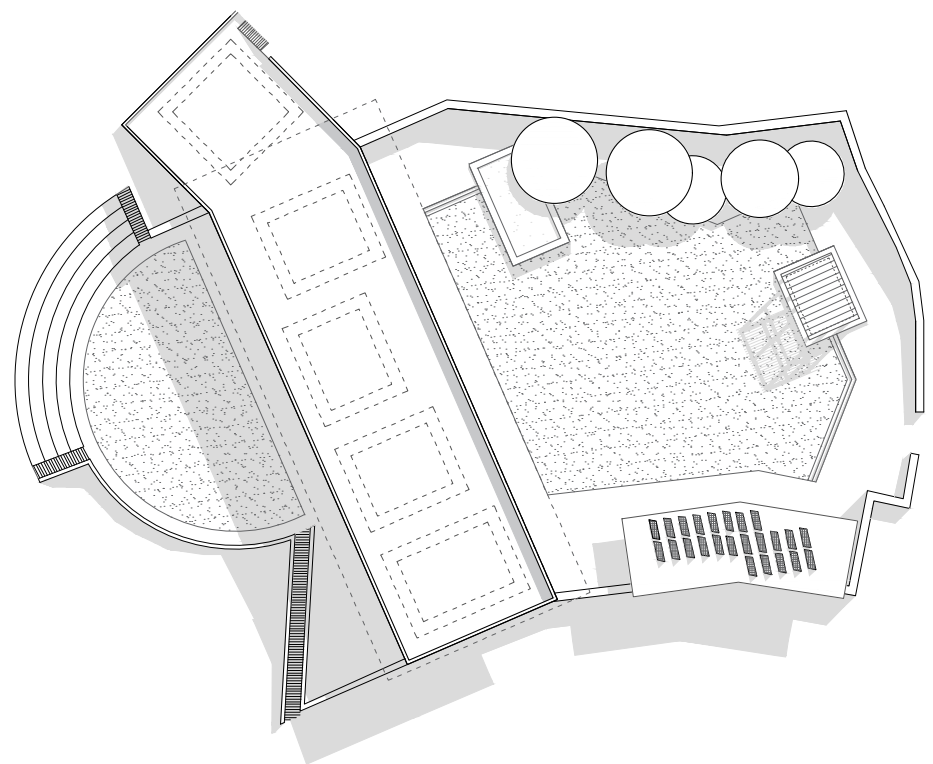

NEW CHAPEL
AS LINK TO MONASTERY

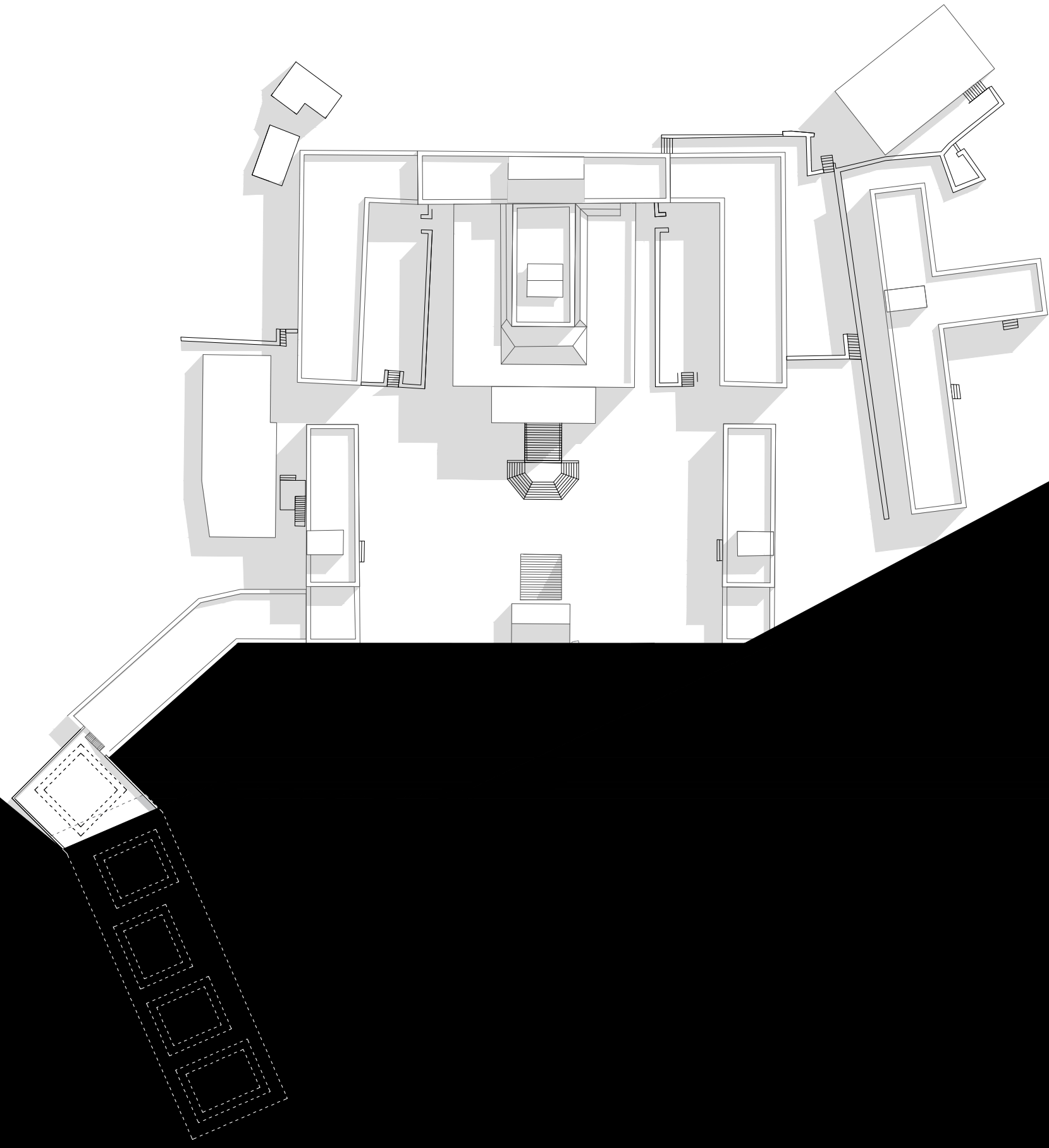

AMPHITHEATRE
AS LINK TO LOCAL COMMUNITY

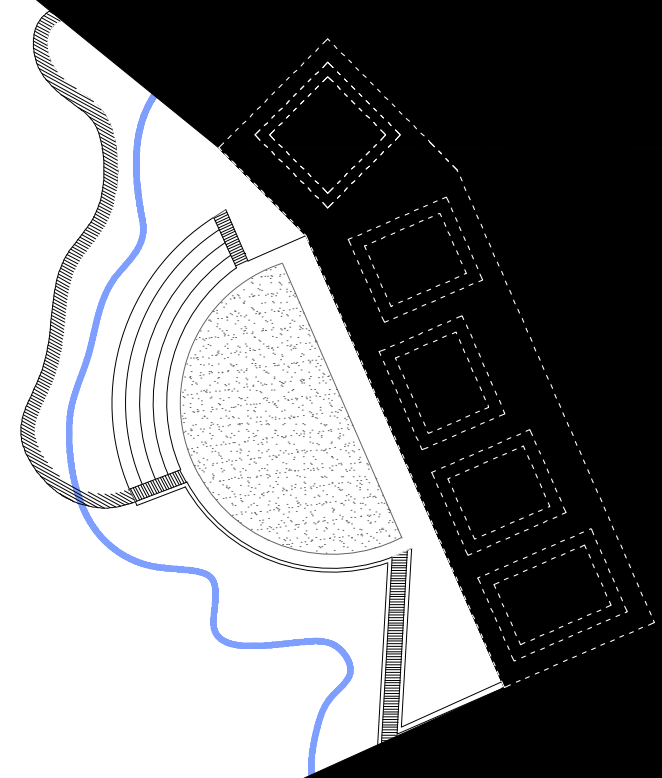

COMMUNITY CENTER
TRAINING CENTER AND MEDICAL POST

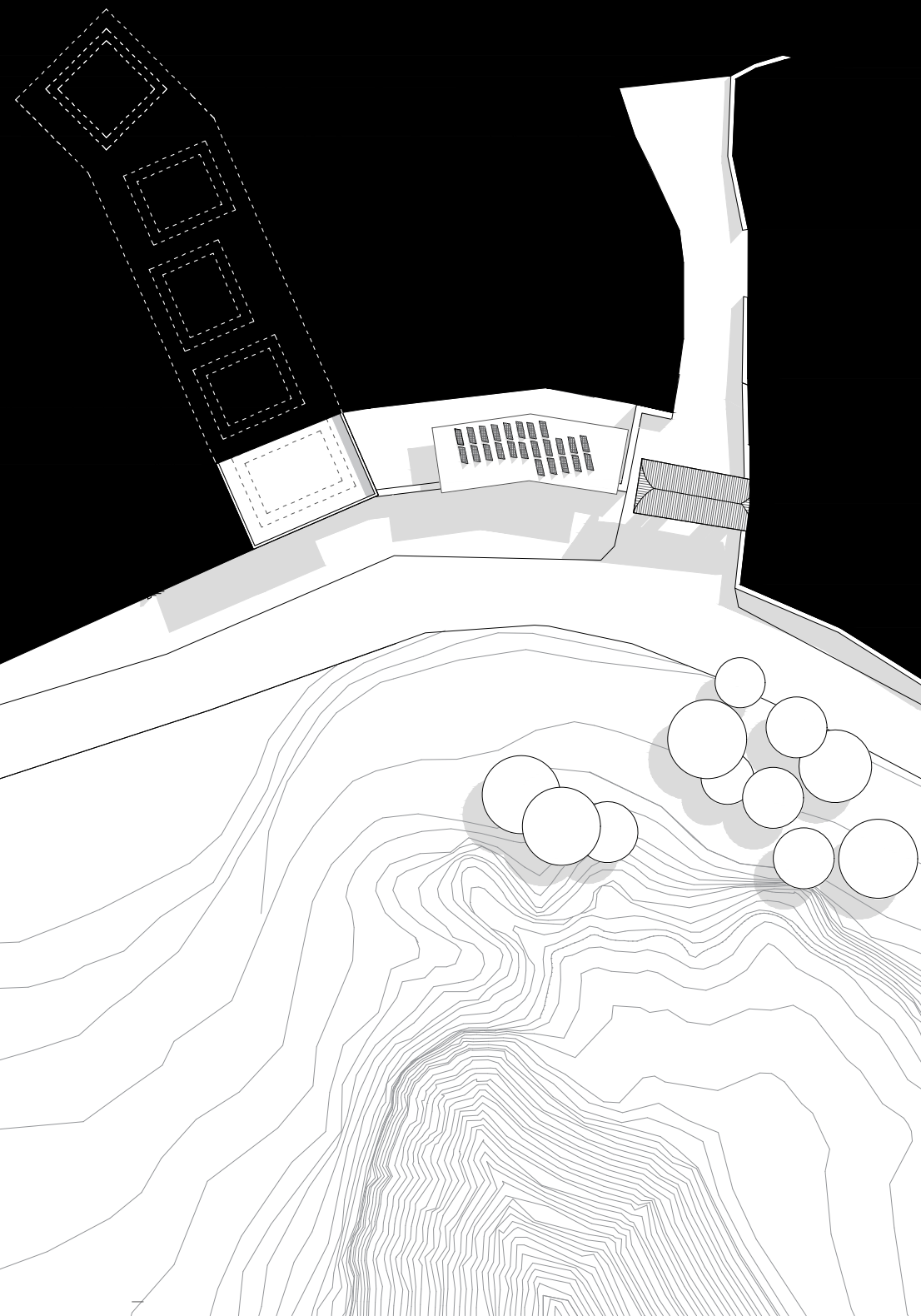

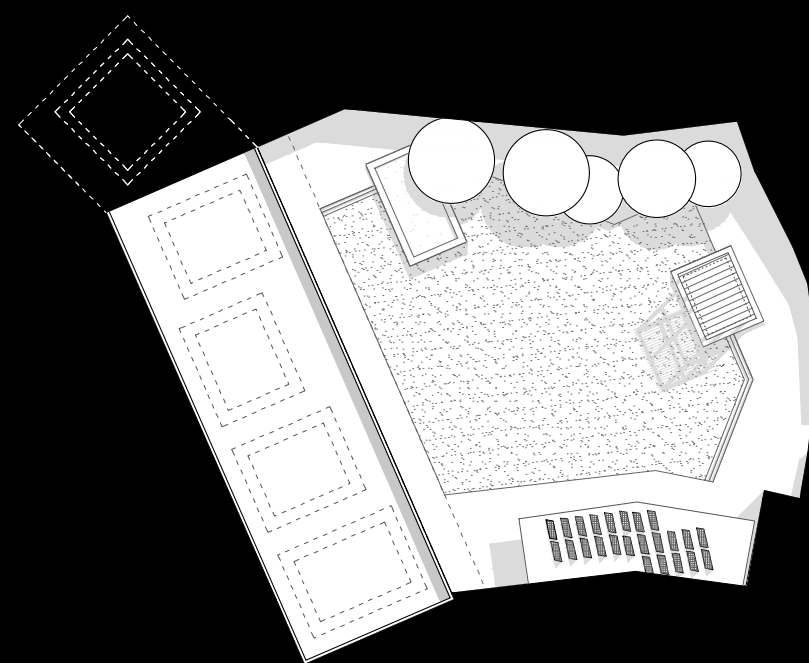

PLAYGROUND
AS SPACE FOR THE SCHOOL

THE BUILDING



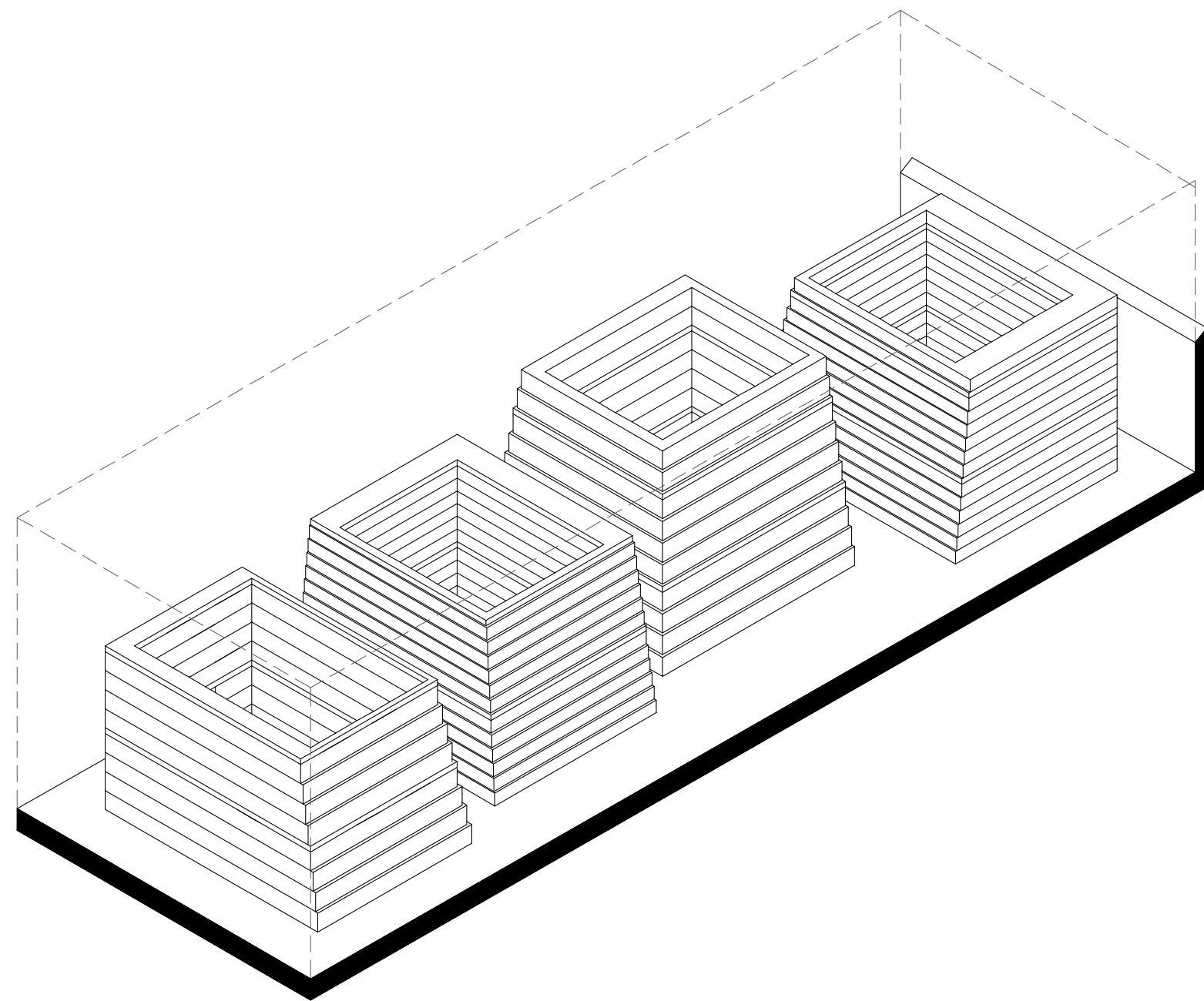

SCHOOL

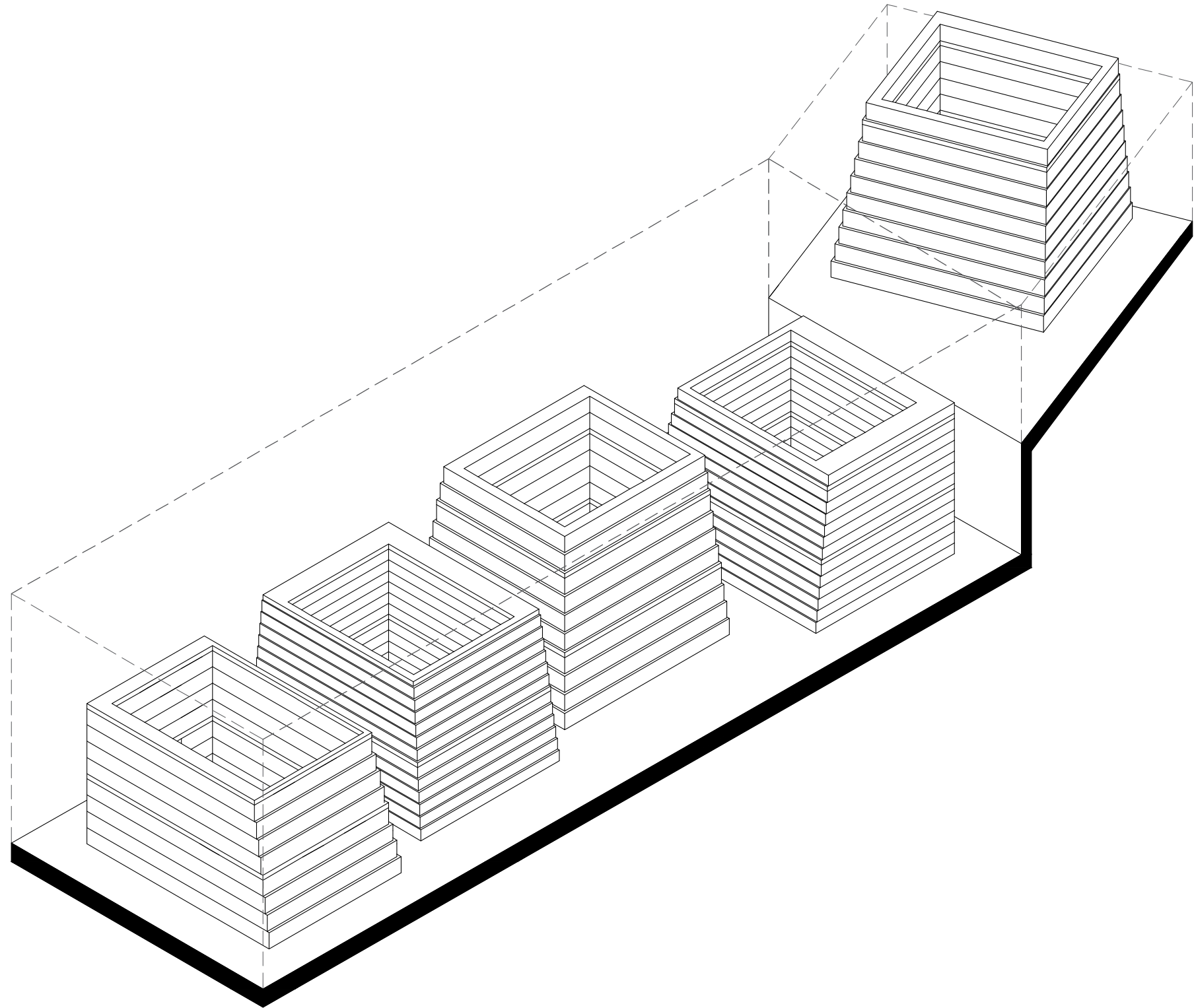

MONK'S CHAPEL

+

SCHOOL

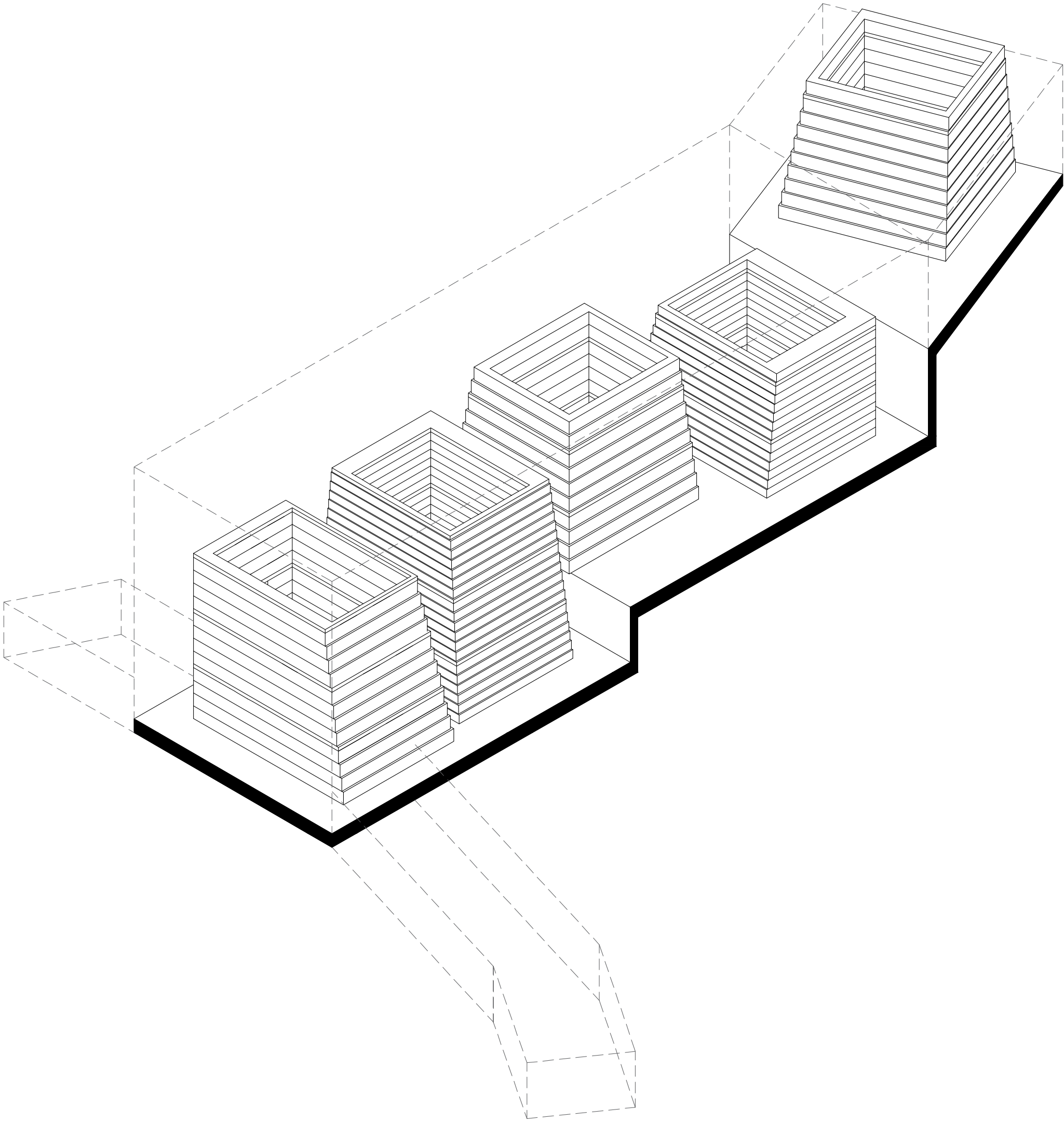

MONK'S CHAPEL
+
SCHOOL
+
COMMUNITY CENTER

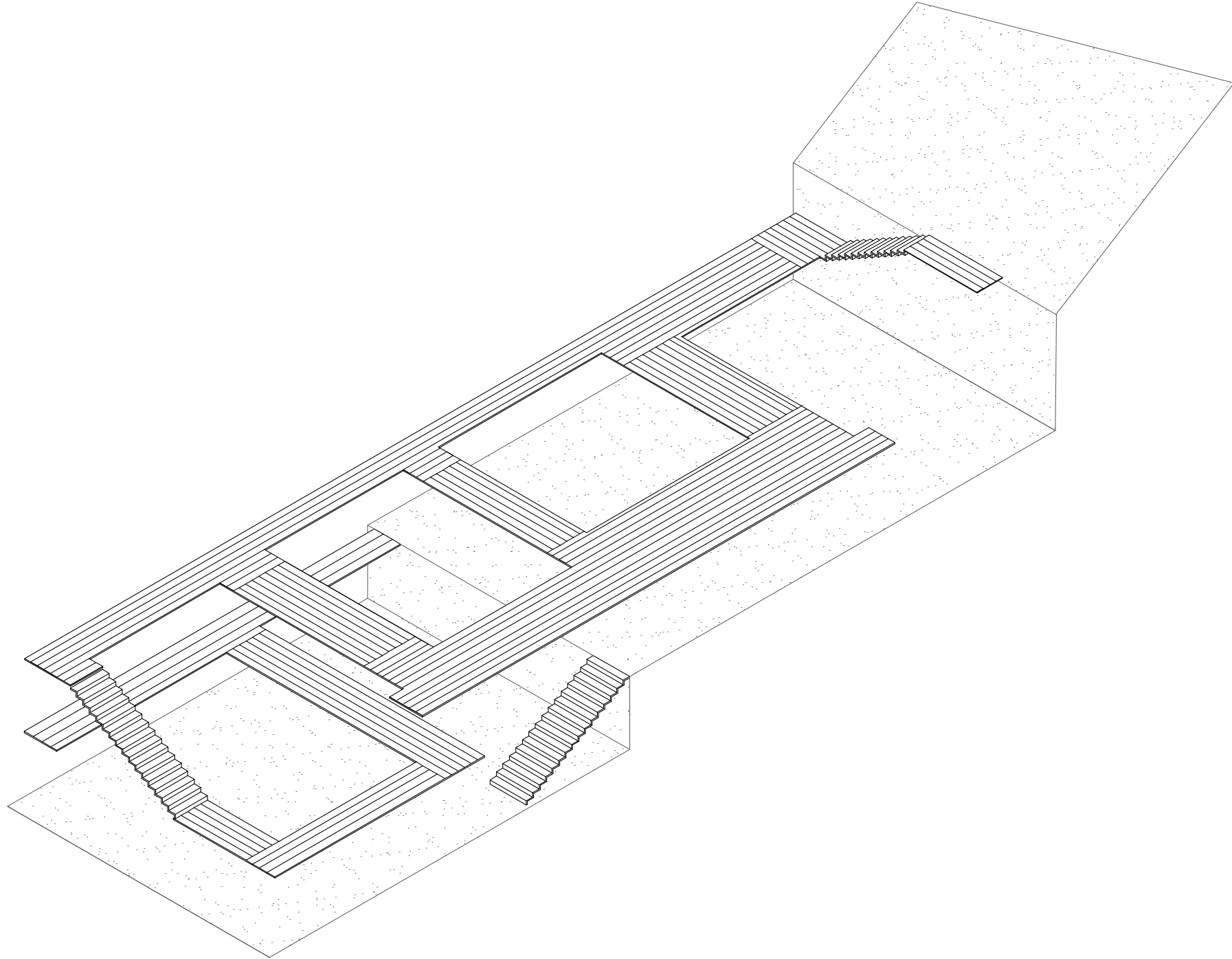

MEDIATOR

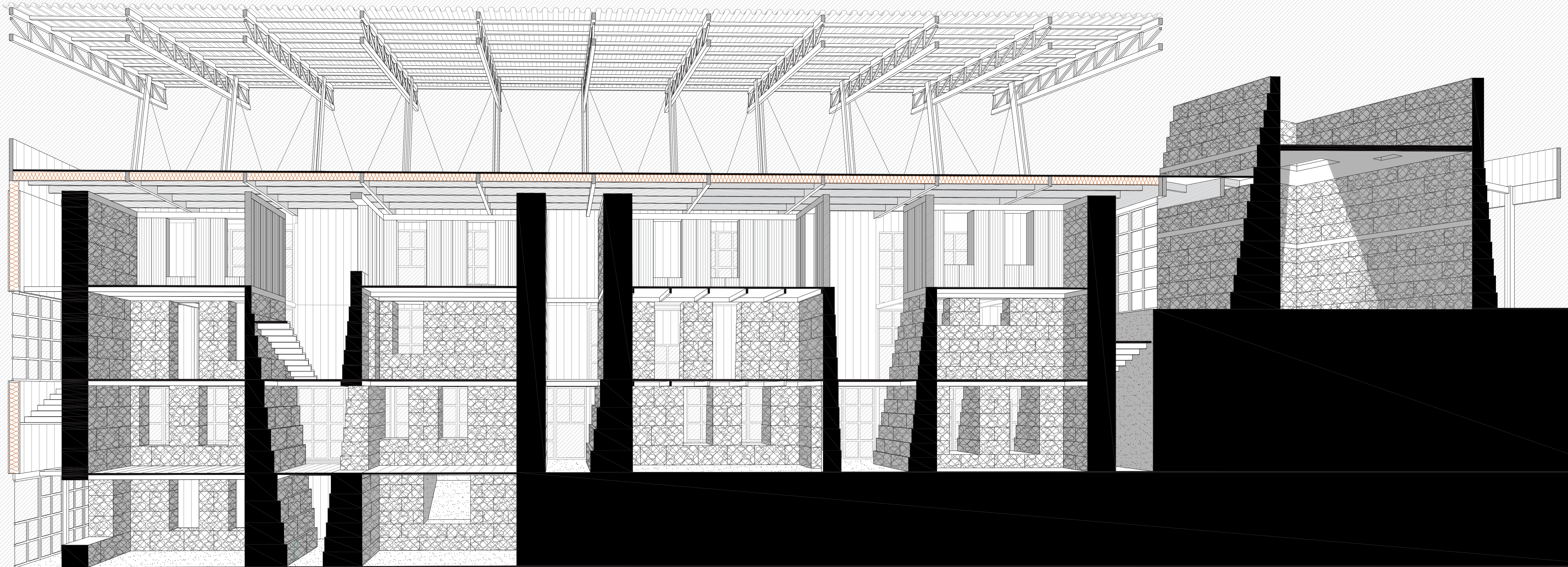

LONGITUDINAL SECTION

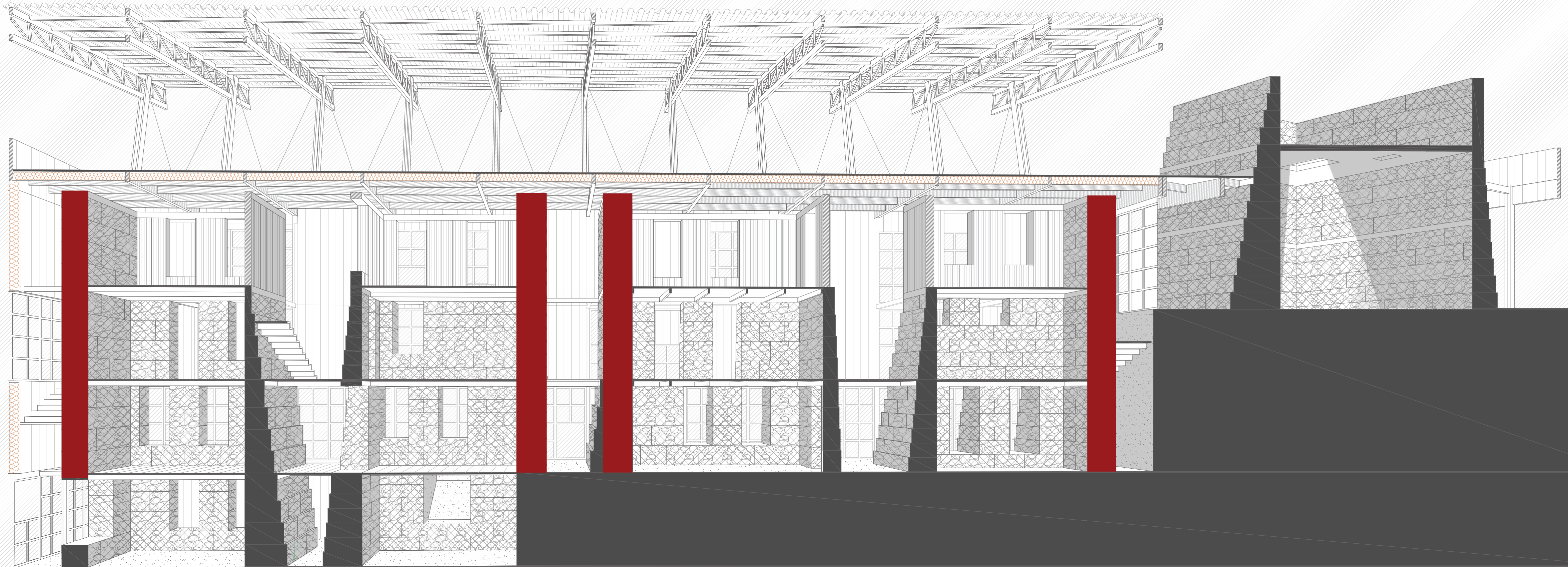

RADIANT WALLS

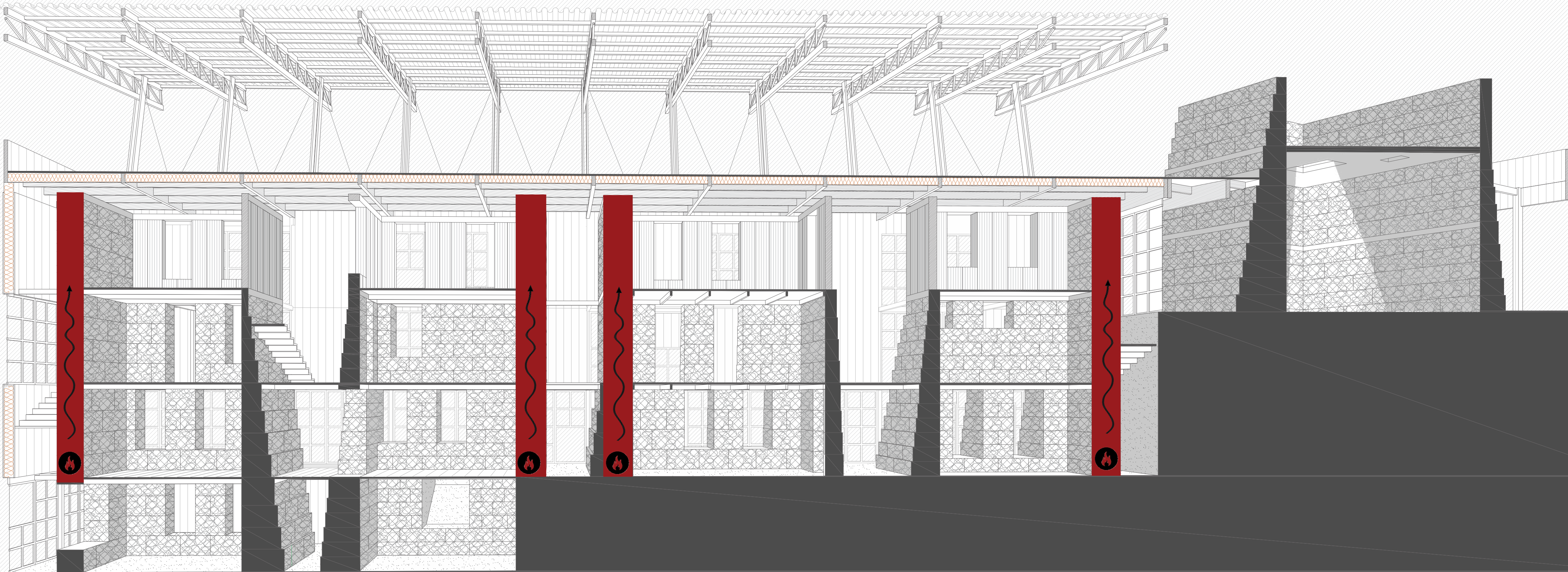

FIREPLACES AT THE GROUND FLOOR

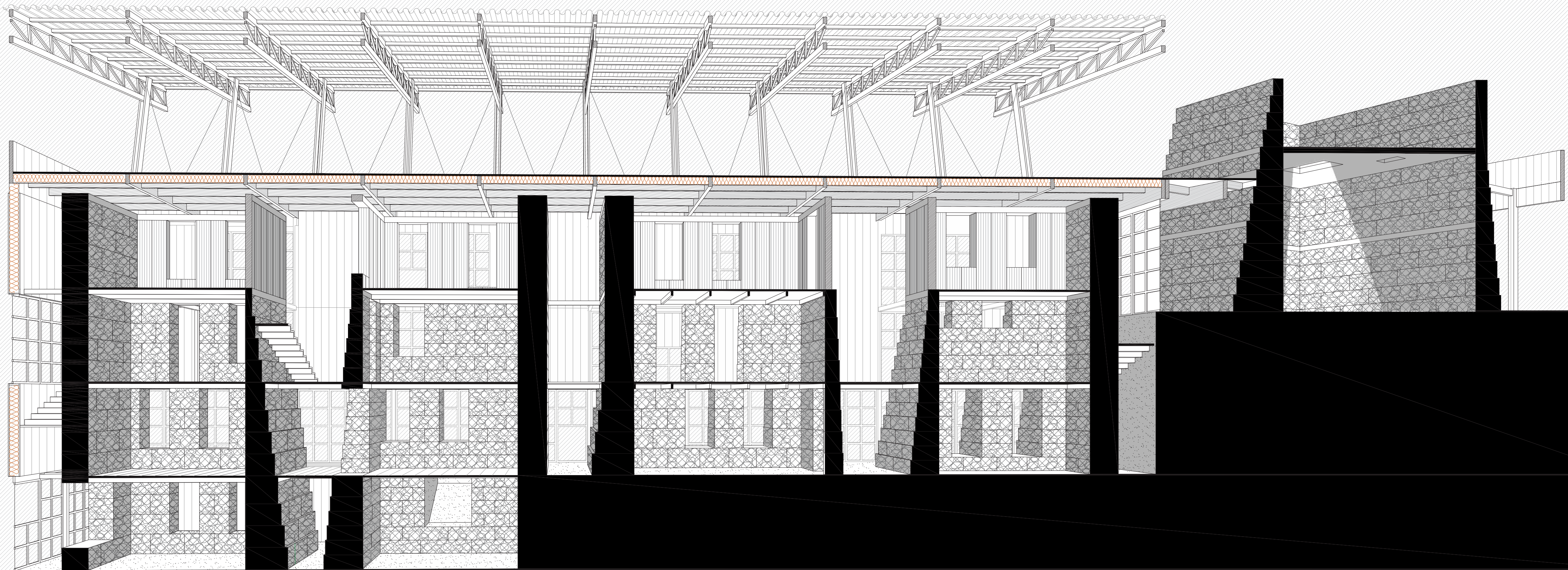

DAILY ROUTINE / HEIGHT

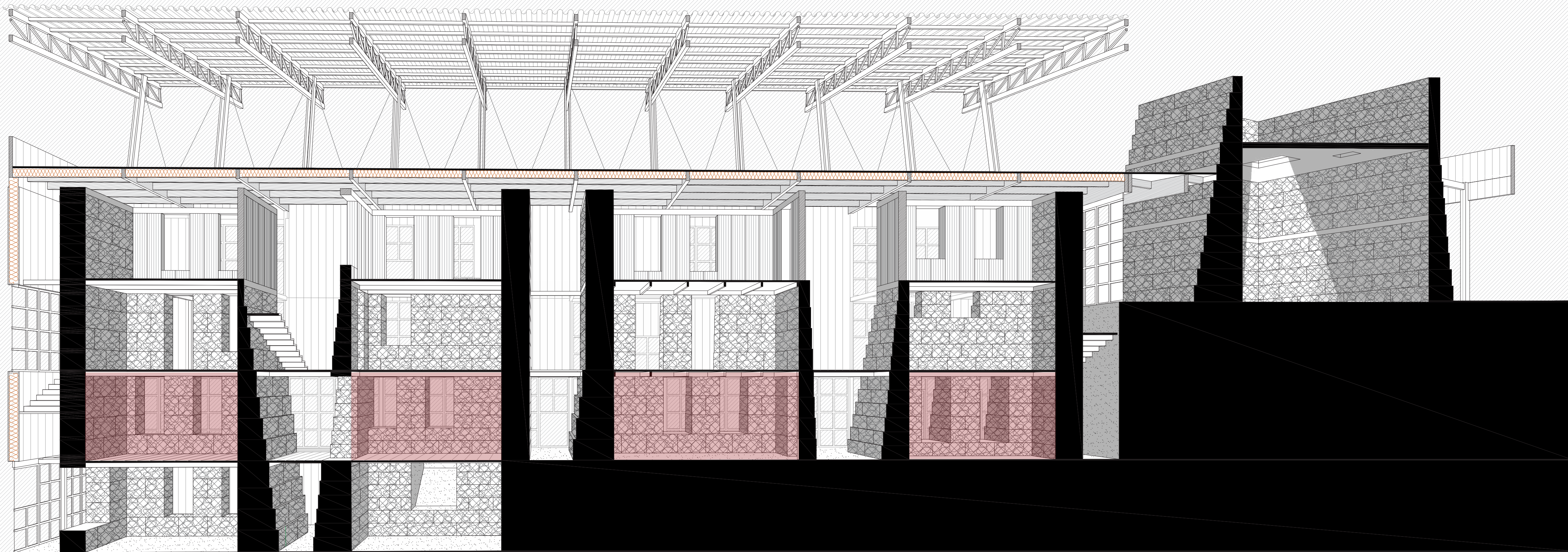

MORNING AT THE GROUND FLOOR
CLASSROOMS

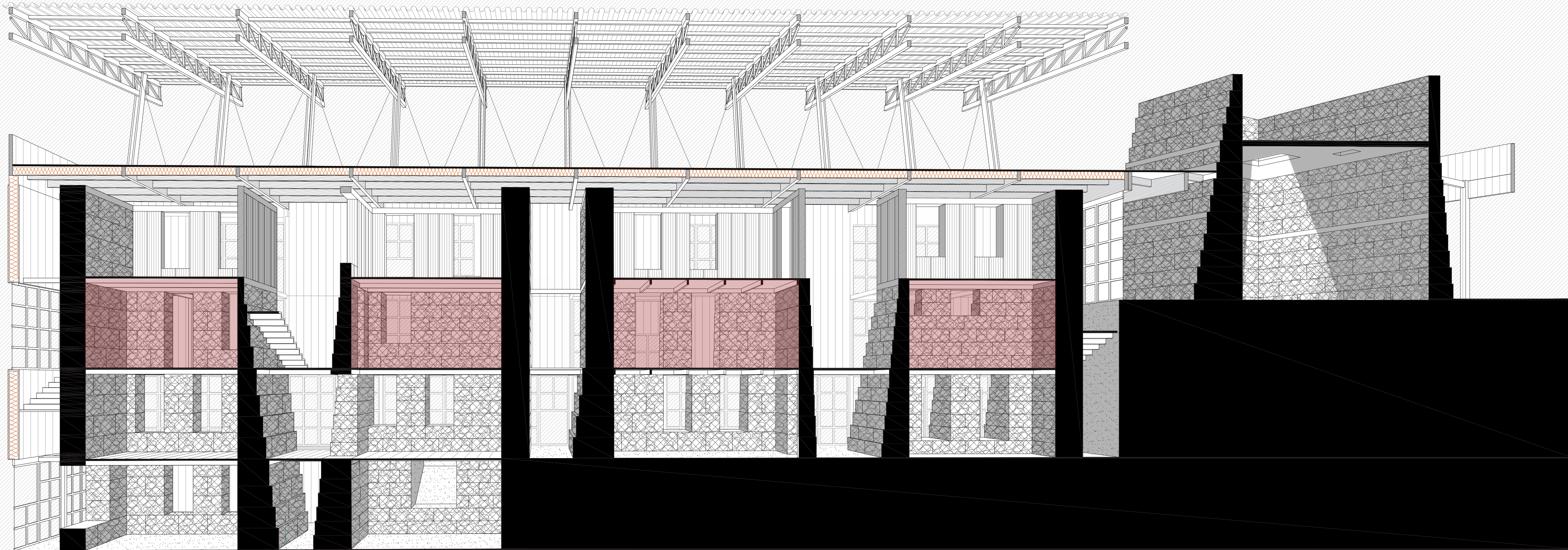

AFTERNOON AT THE FIRST FLOOR
LEISURE SPACE / LIBRARY / TEACHER'S ROOMS



NIGHT AT THE SECOND FLOOR
CHILDREN'S BEDROOMS

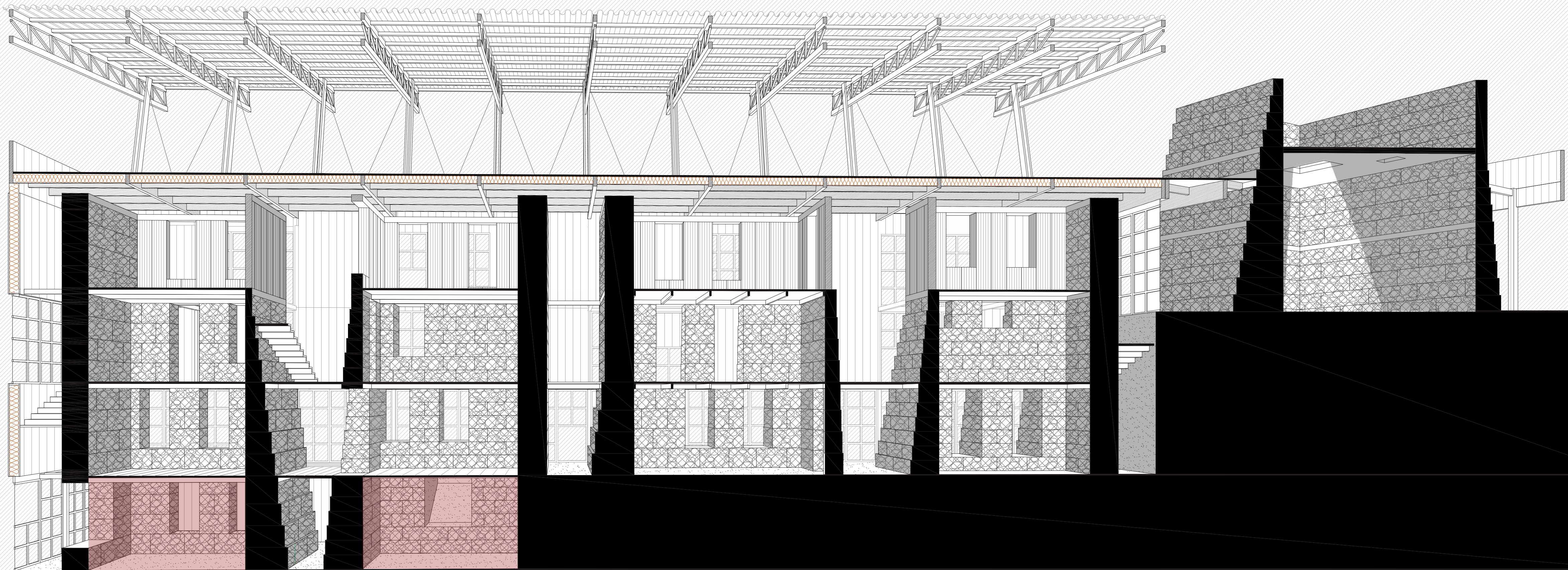

BASEMENT
CLASSROOMS FOR COMMUNITY

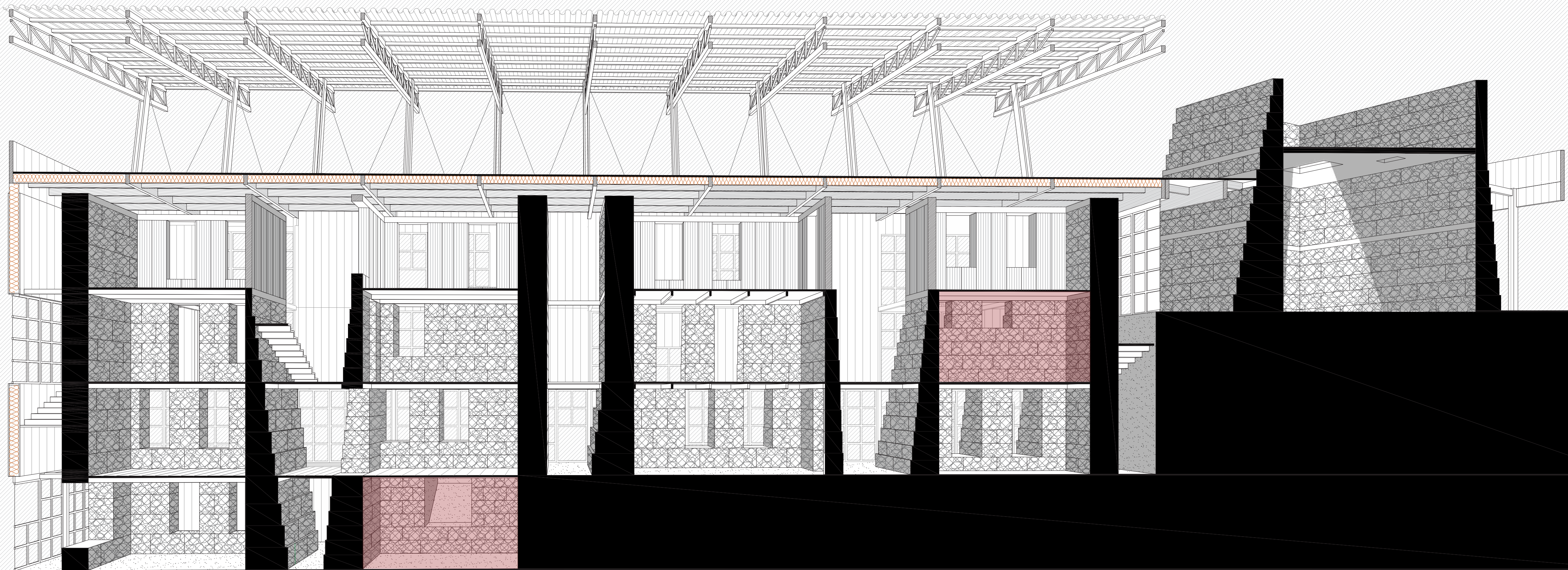

BASEMENT
TOILETS AND SHOWERS

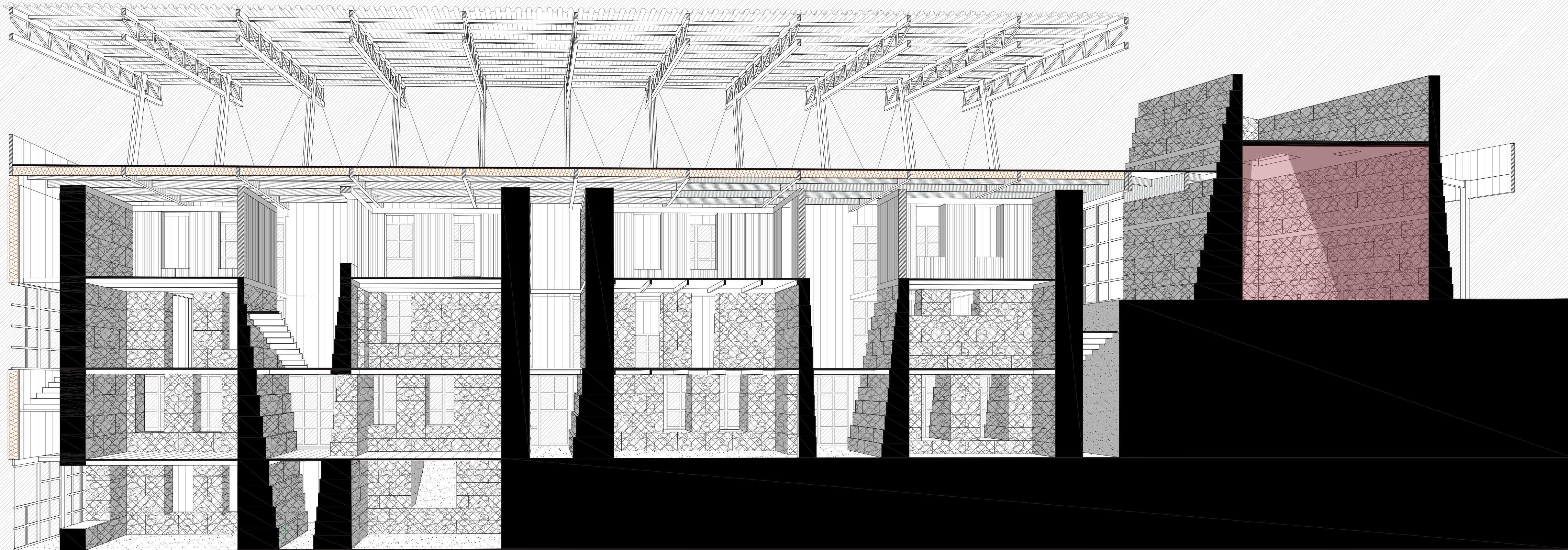

SEMI-COVERED EXTERIOR
MONK'S CHAPEL + MEDITATION SPACE

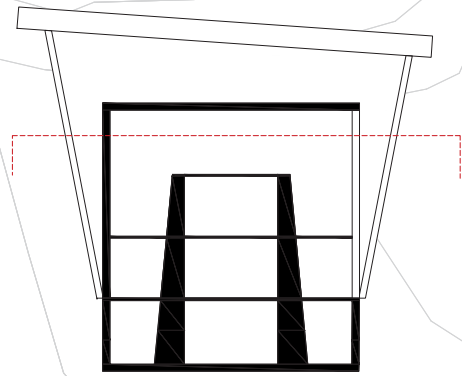
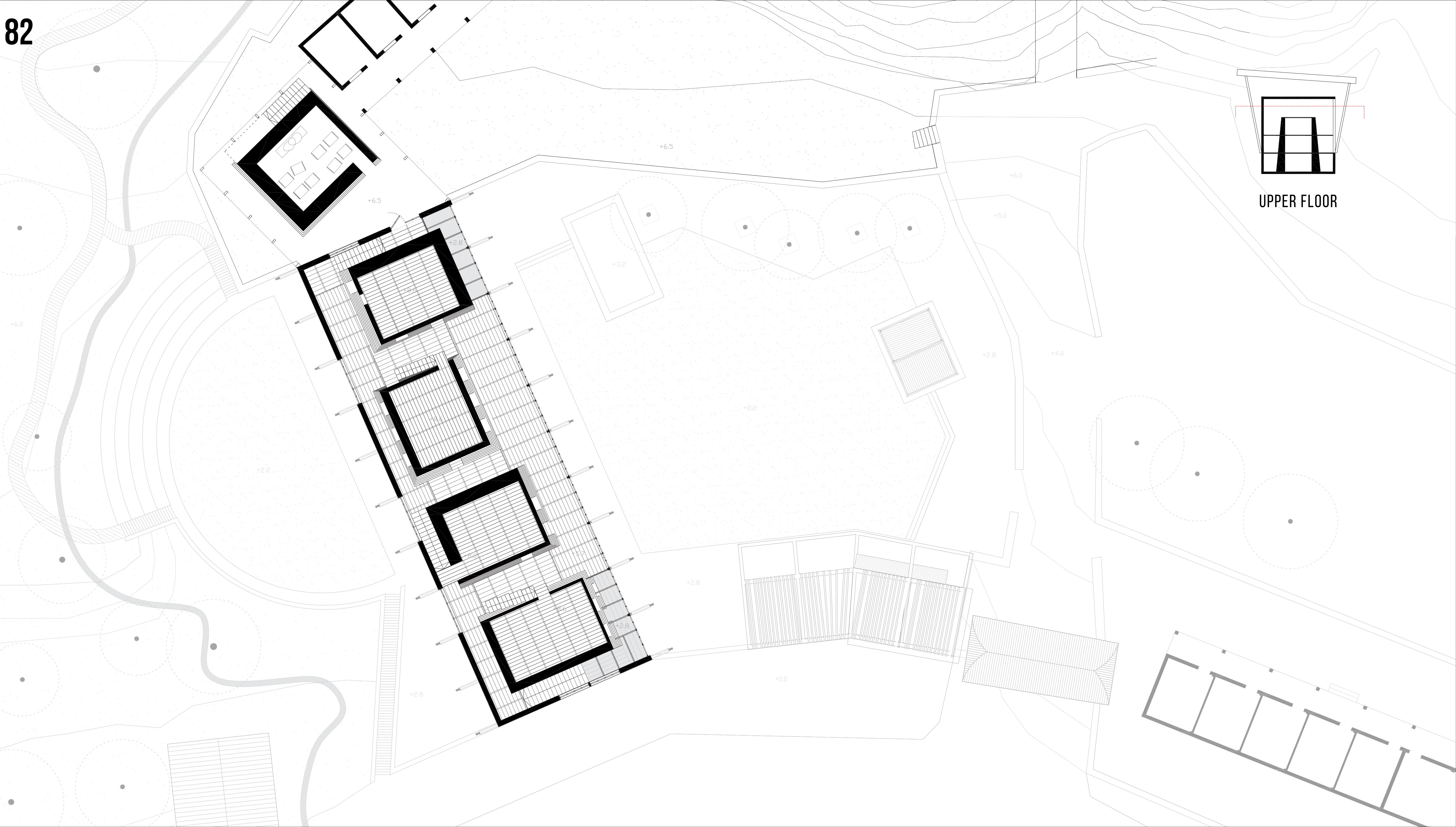

UPPER FLOOR

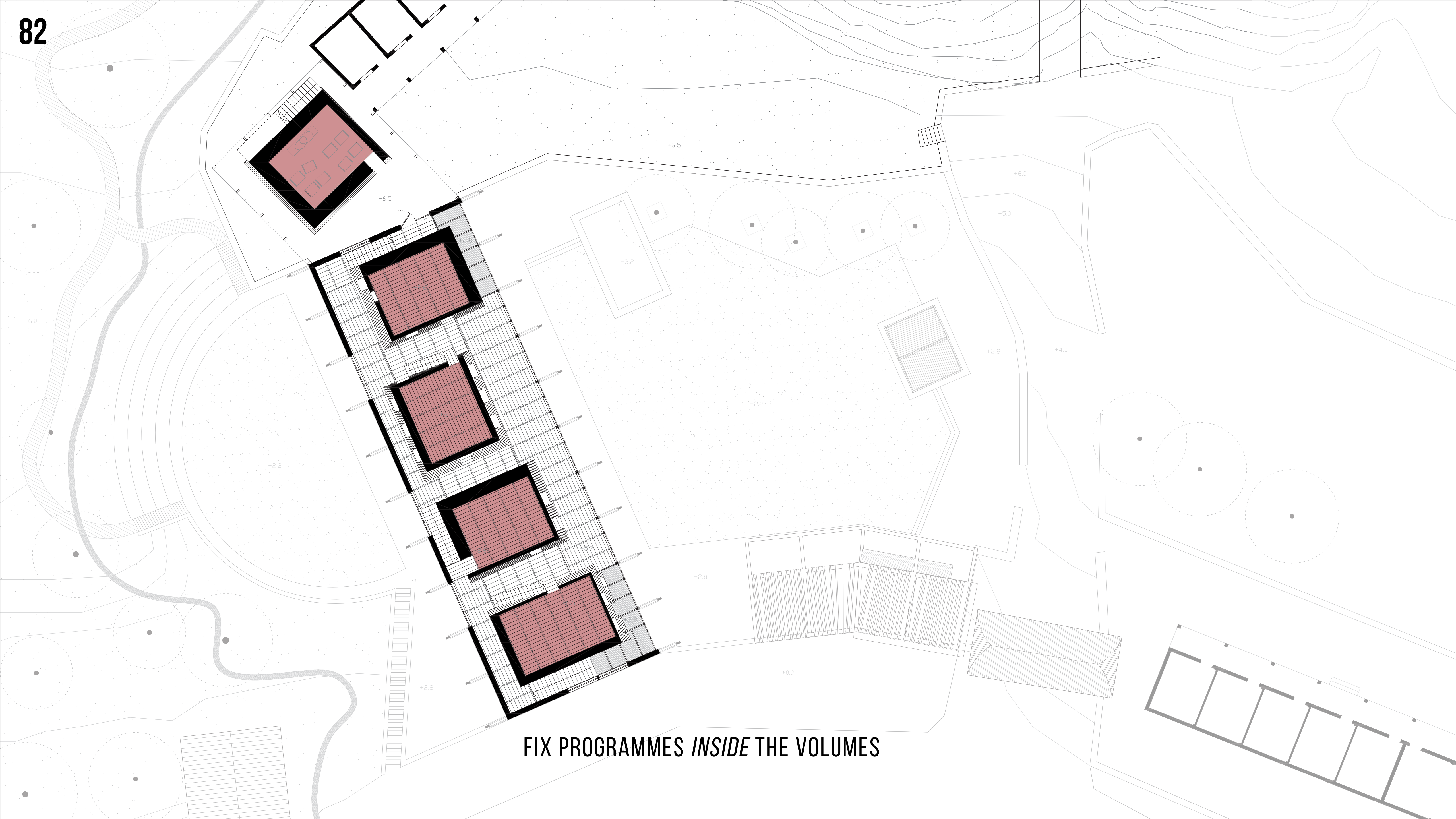

FIX PROGRAMMES *INSIDE* THE VOLUMES

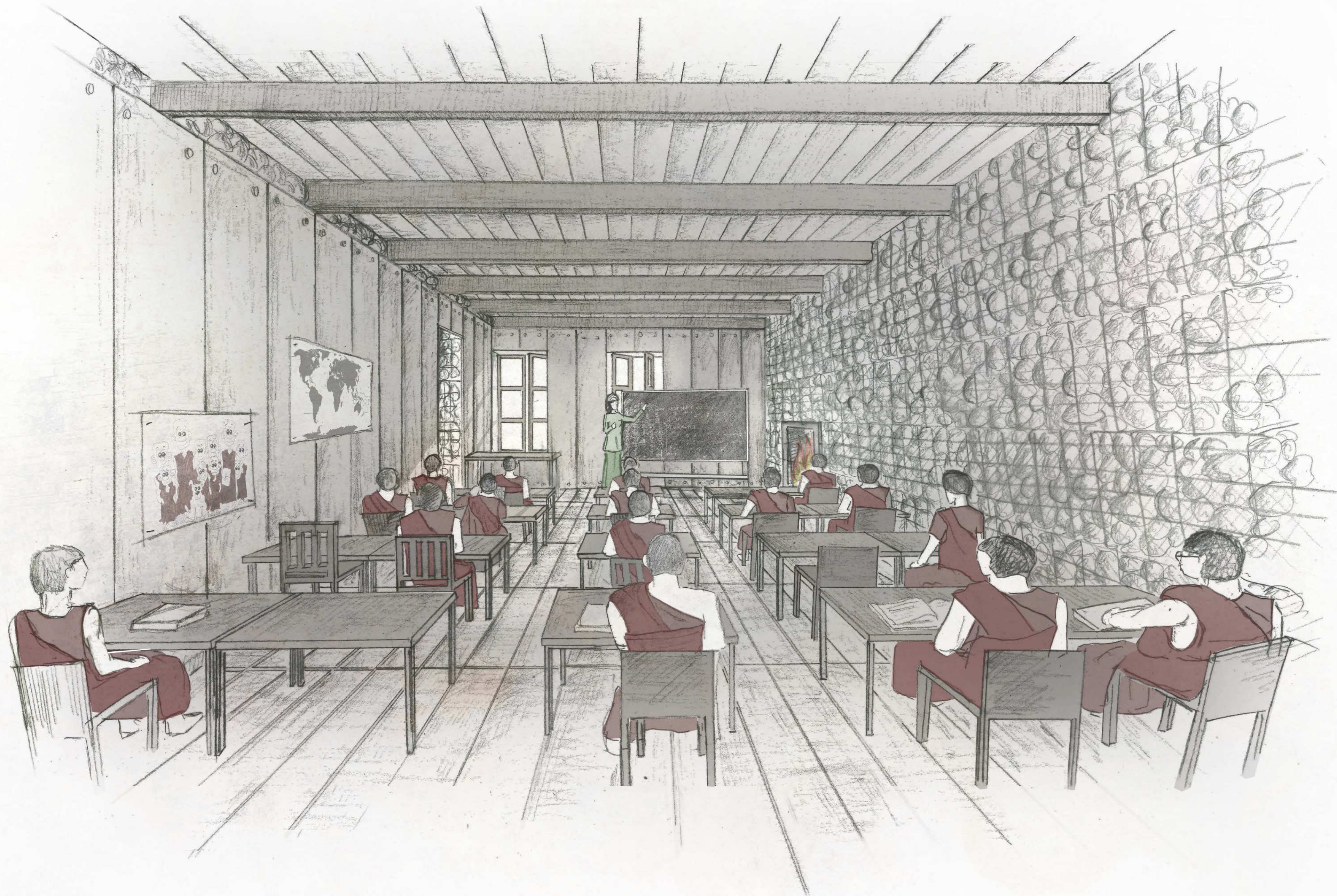

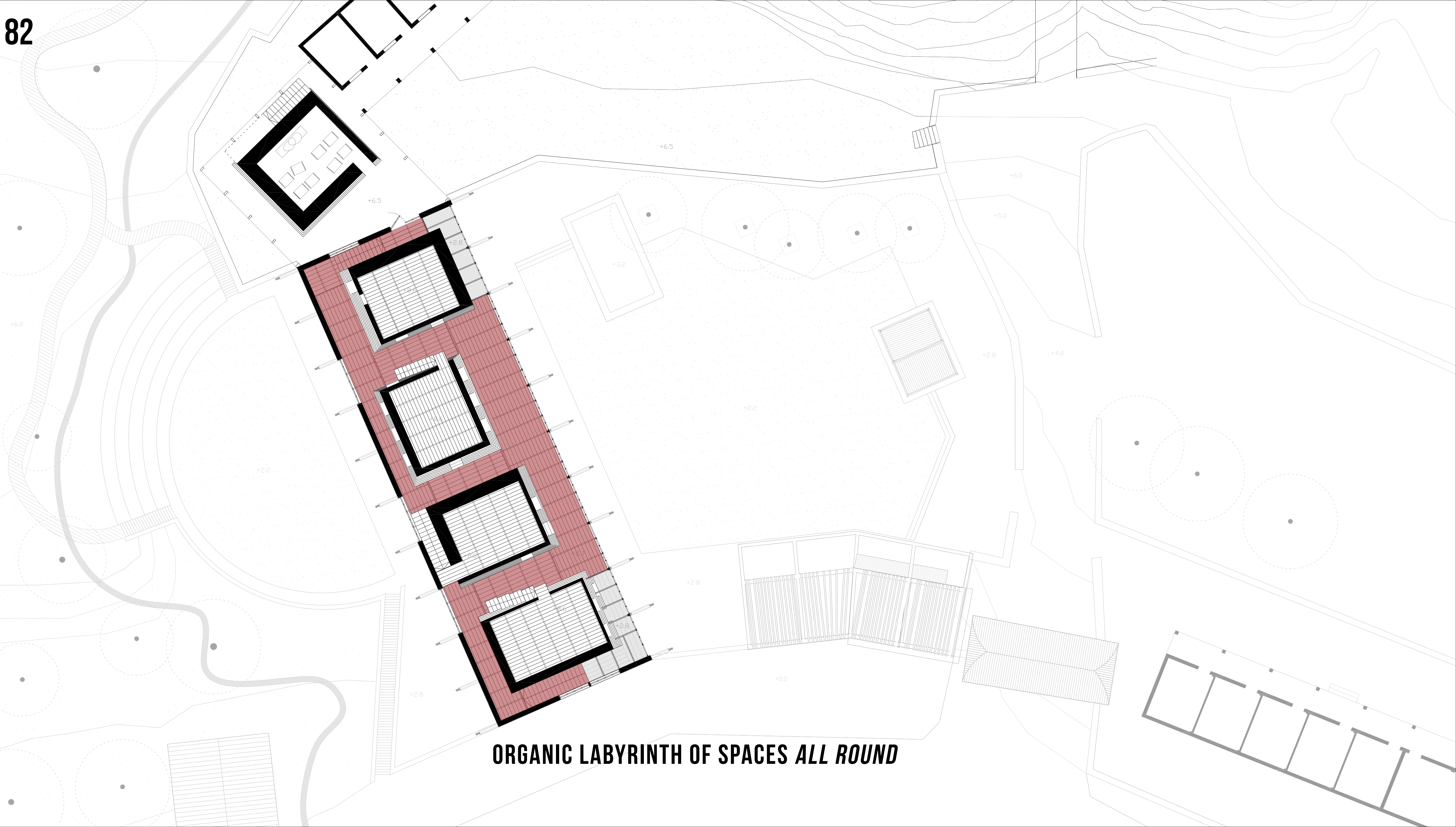

ORGANIC LABYRINTH OF SPACES *ALL ROUND*

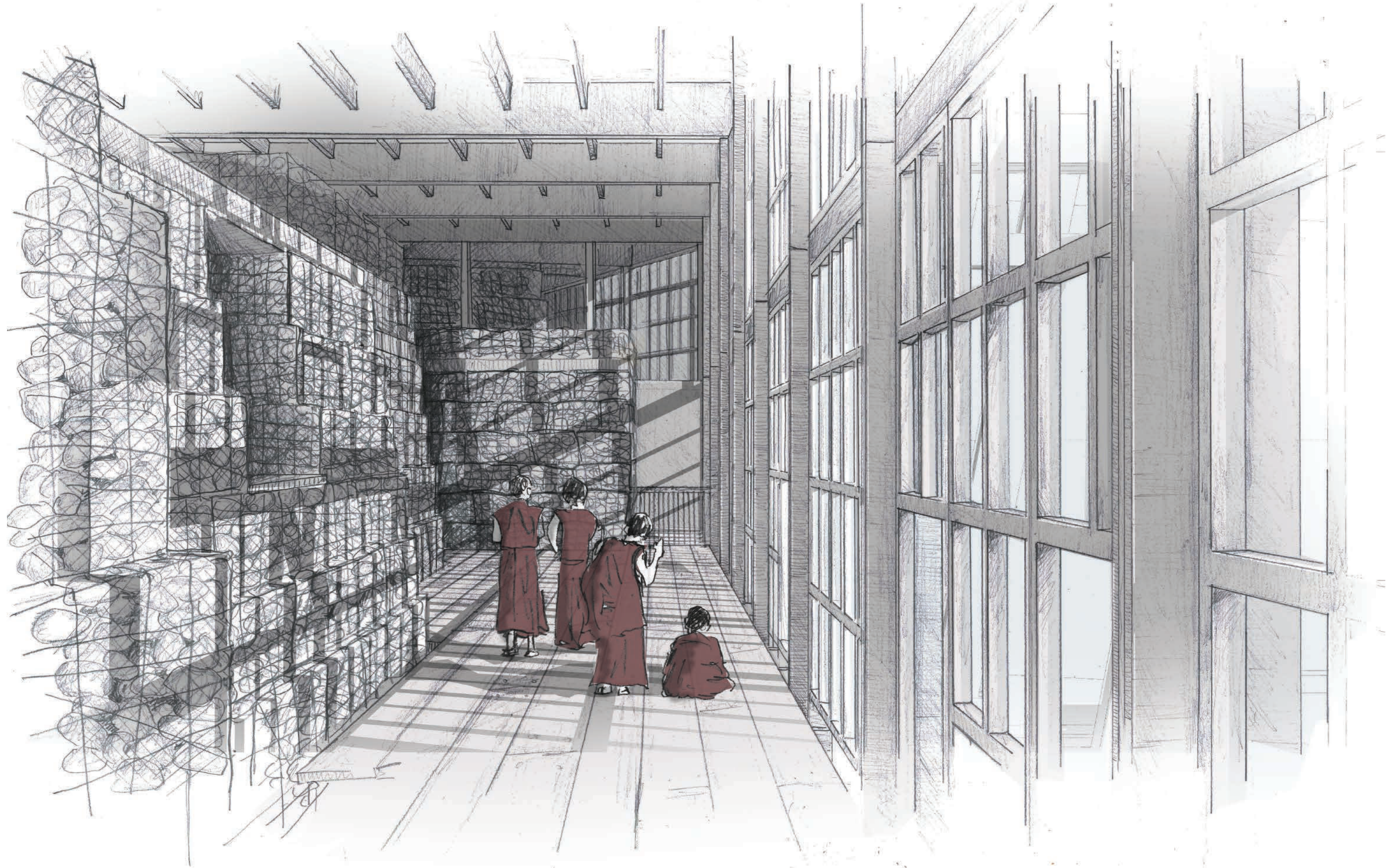

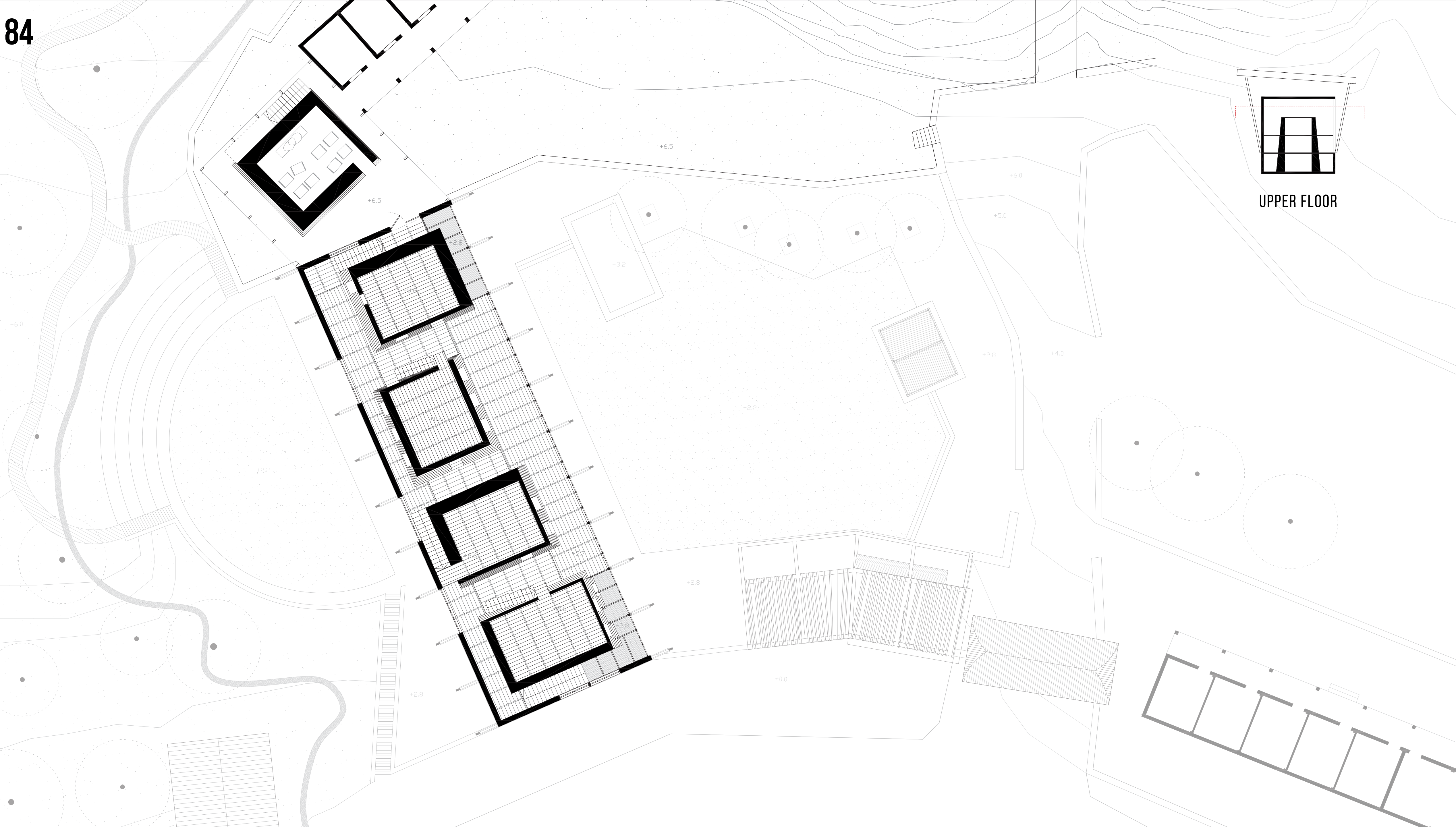

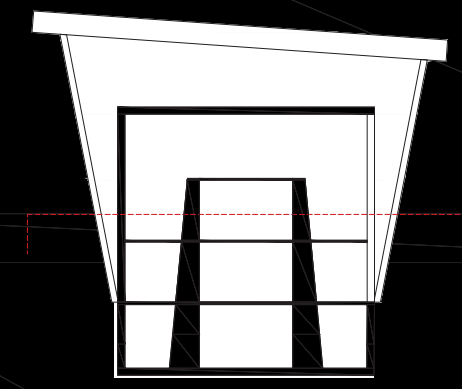

FIRST FLOOR

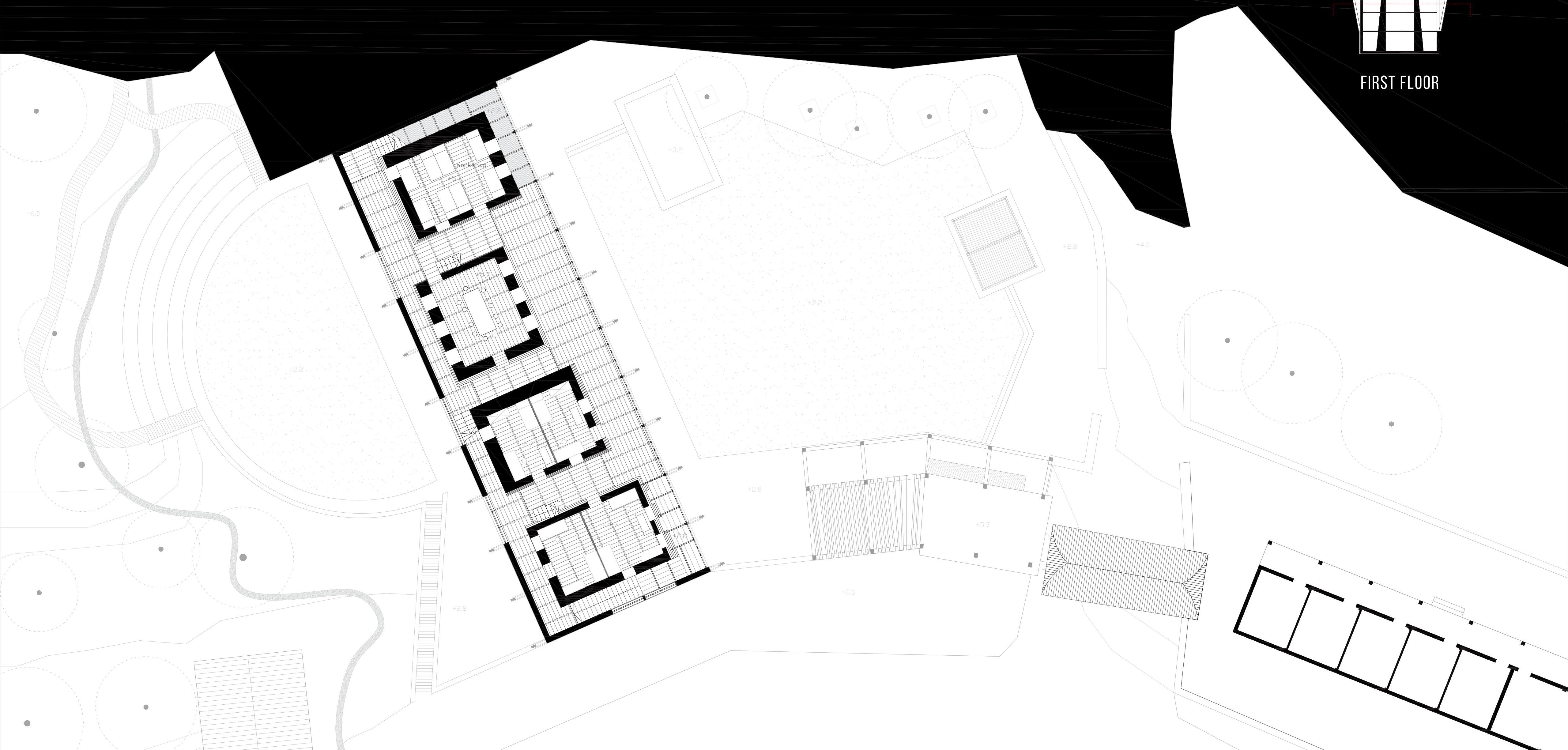

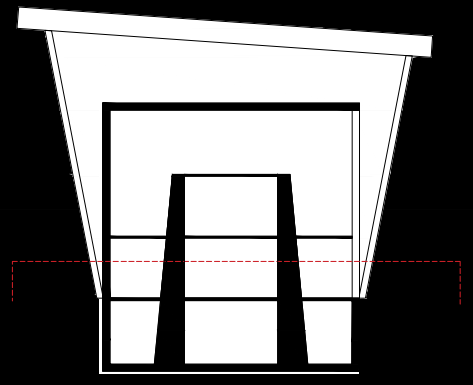

GROUND FLOOR

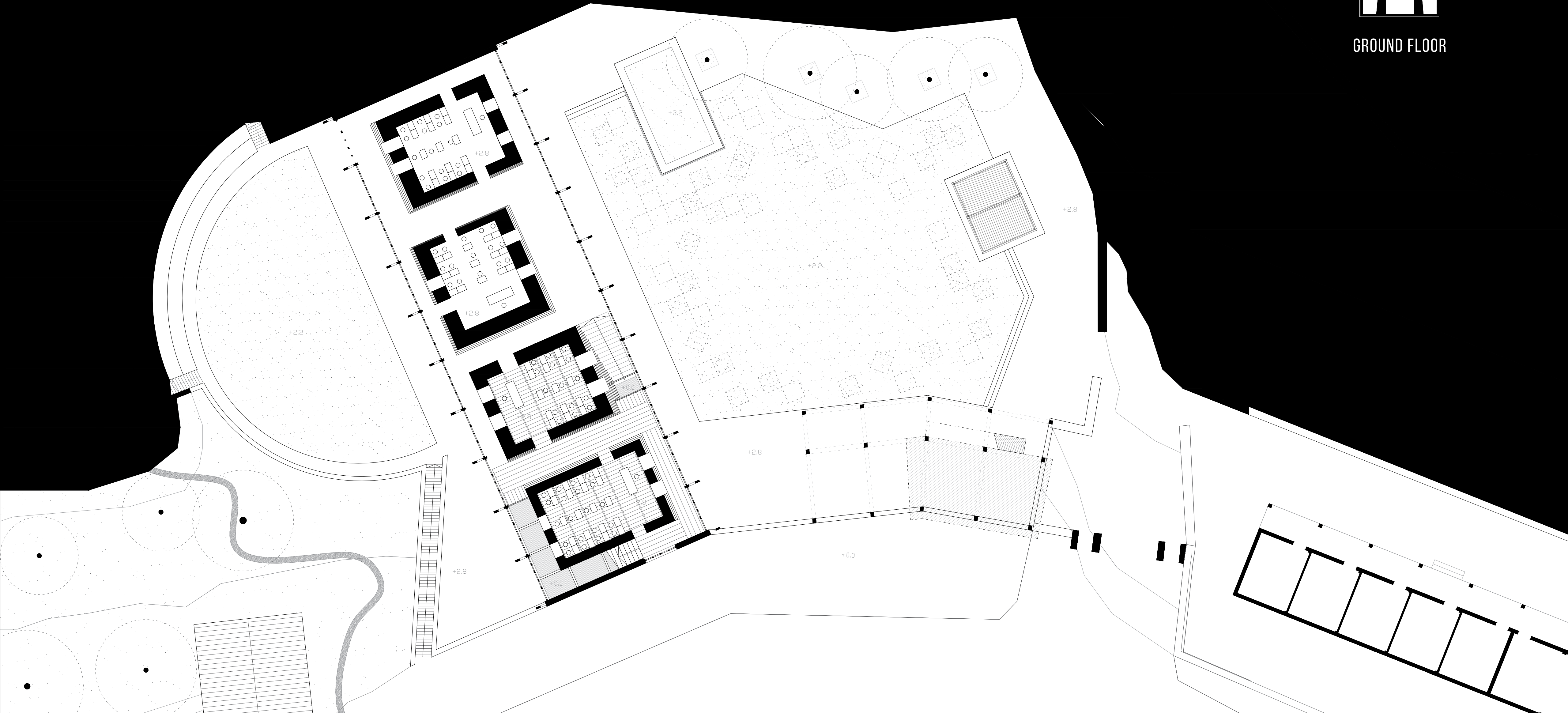

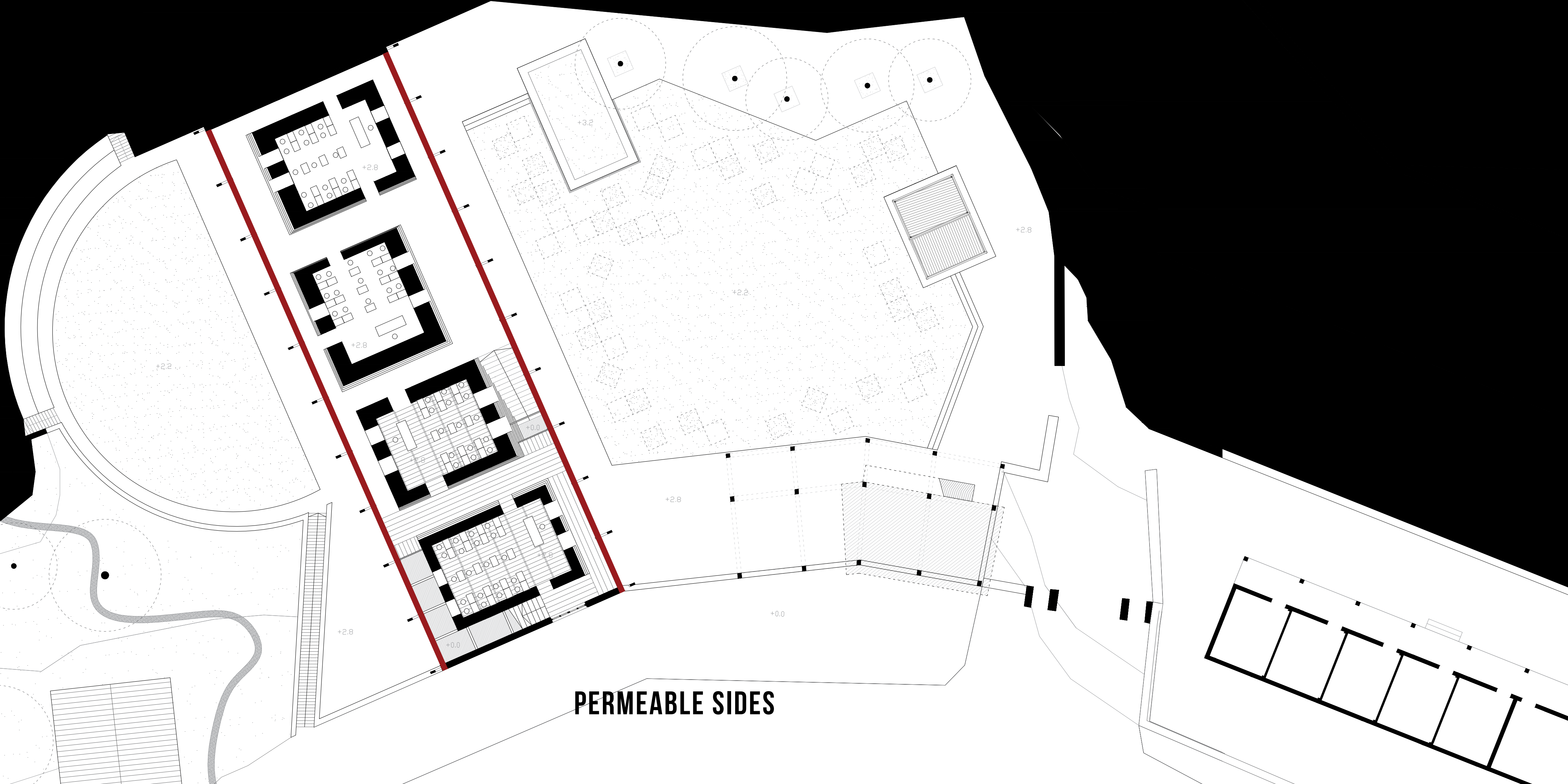

PERMEABLE SIDES

INTERIOR

EXTERIOR

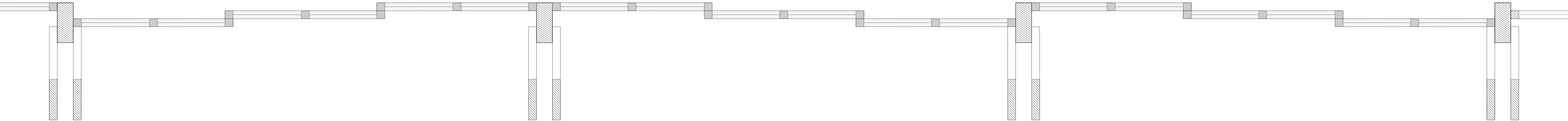

INTERIOR

EXTERIOR

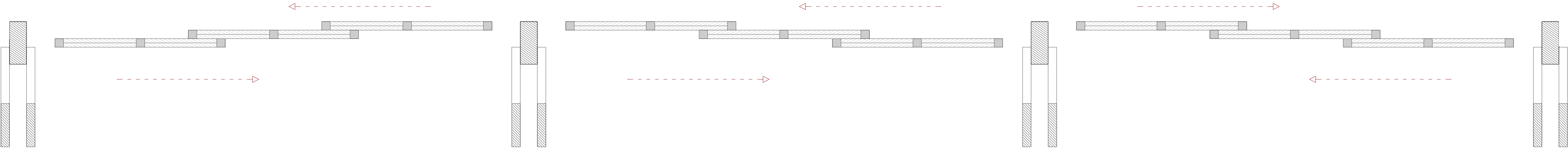

INTERIOR

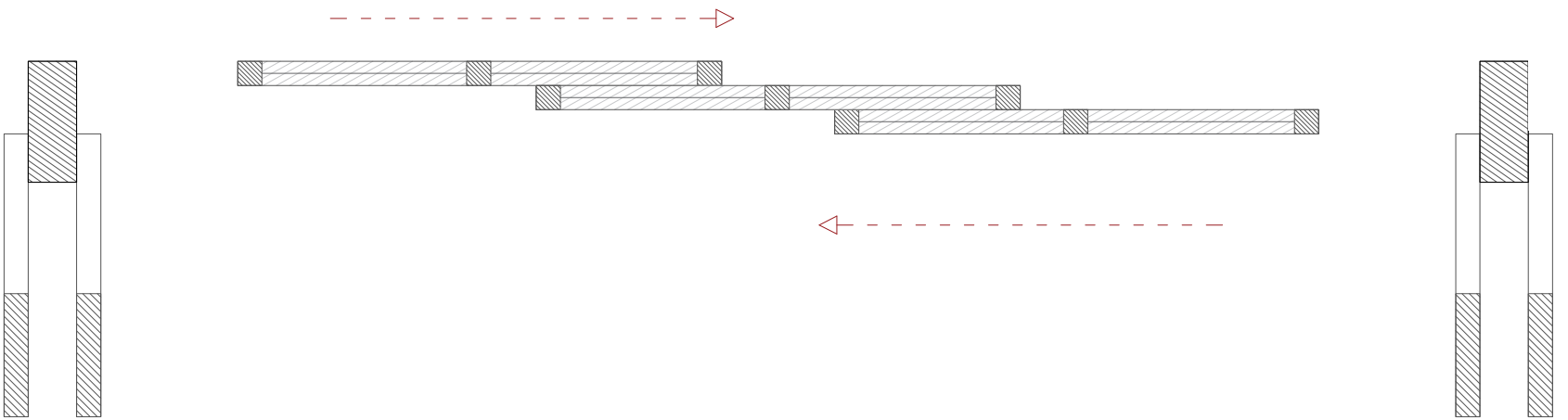
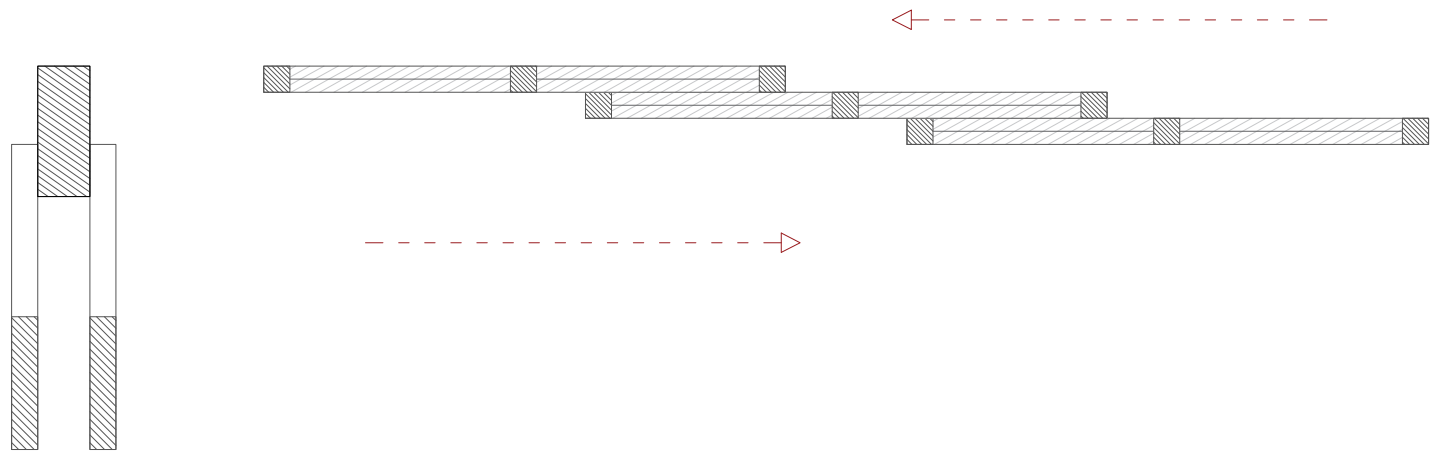
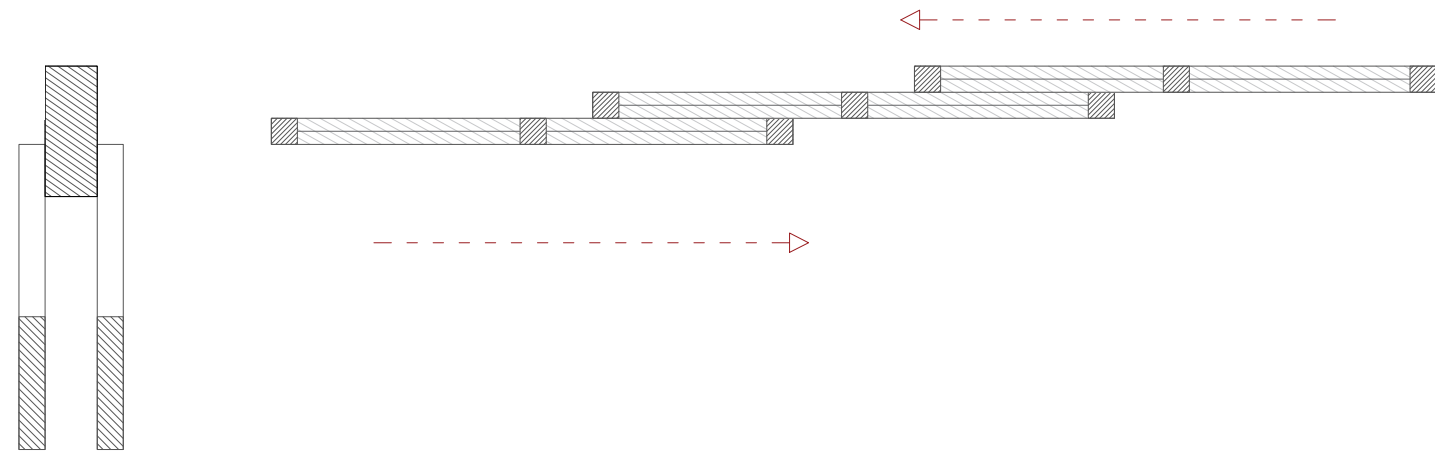

EXTERIOR

INTERIOR

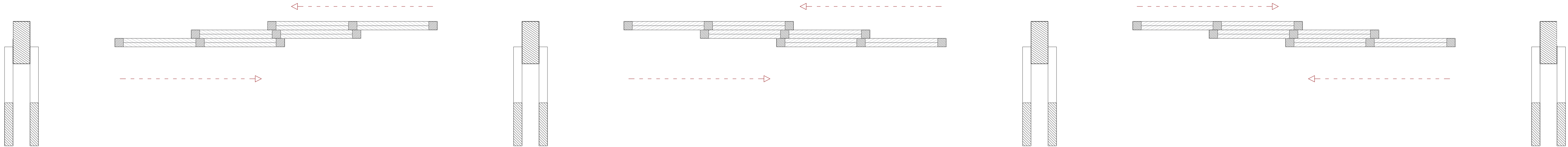

EXTERIOR

INTERIOR

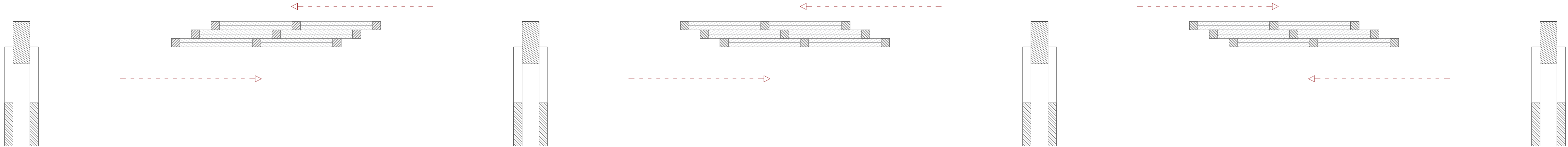

EXTERIOR

INTERIOR

EXTERIOR

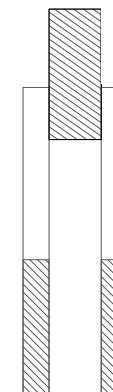
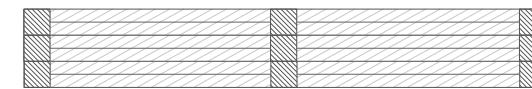
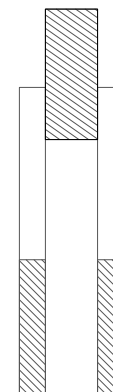
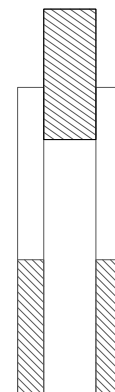
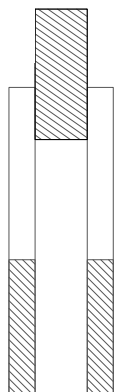

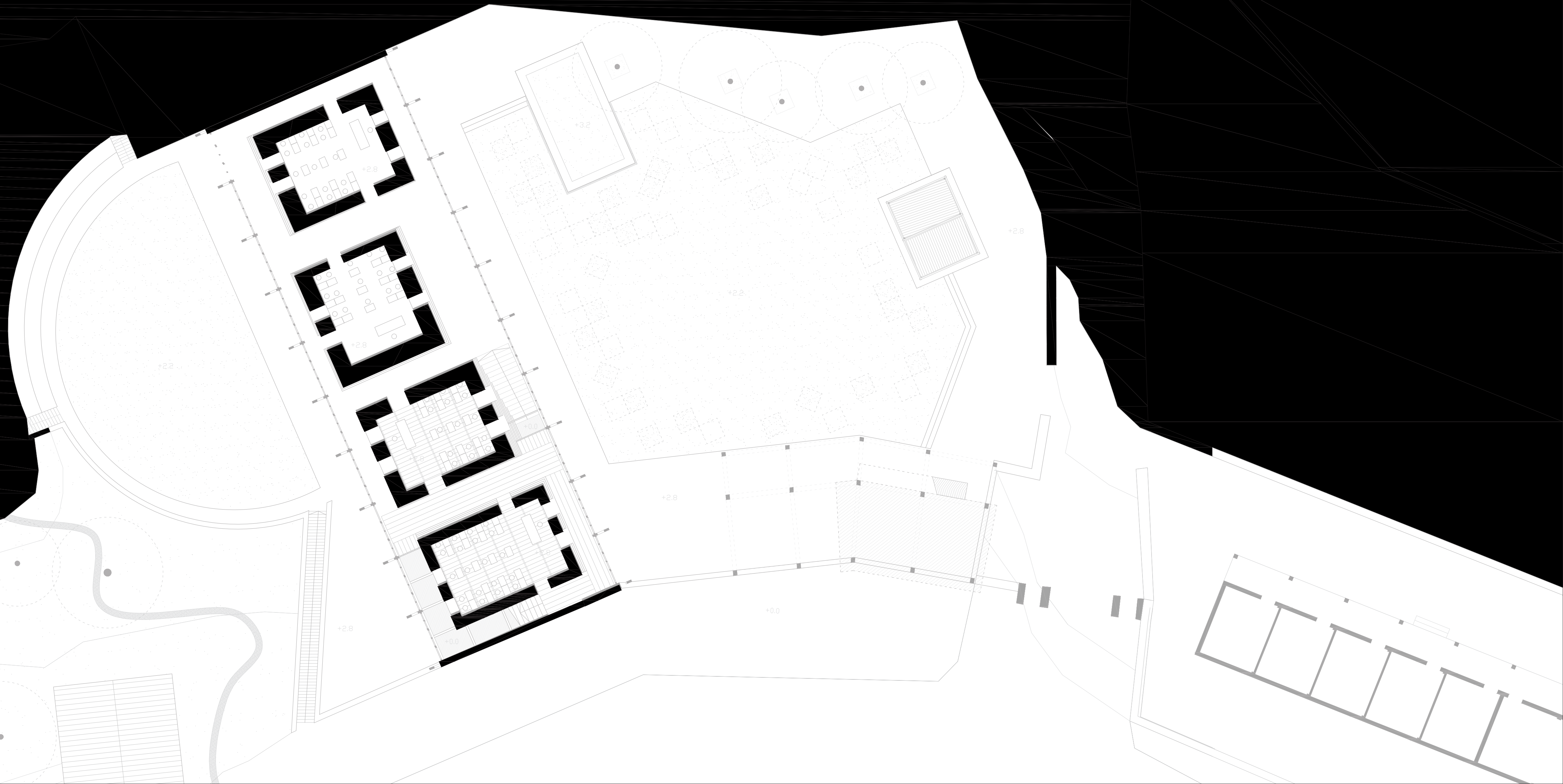

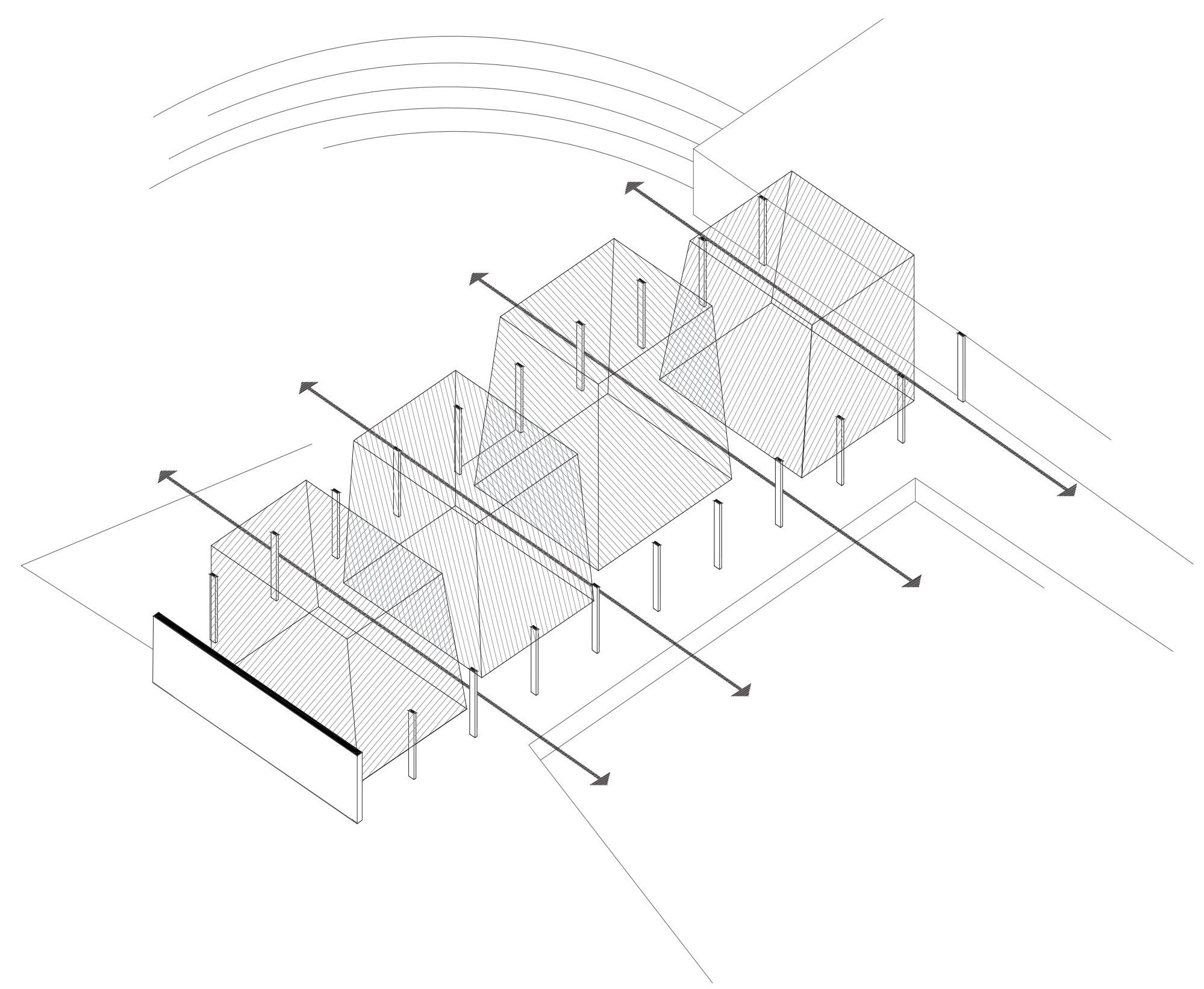
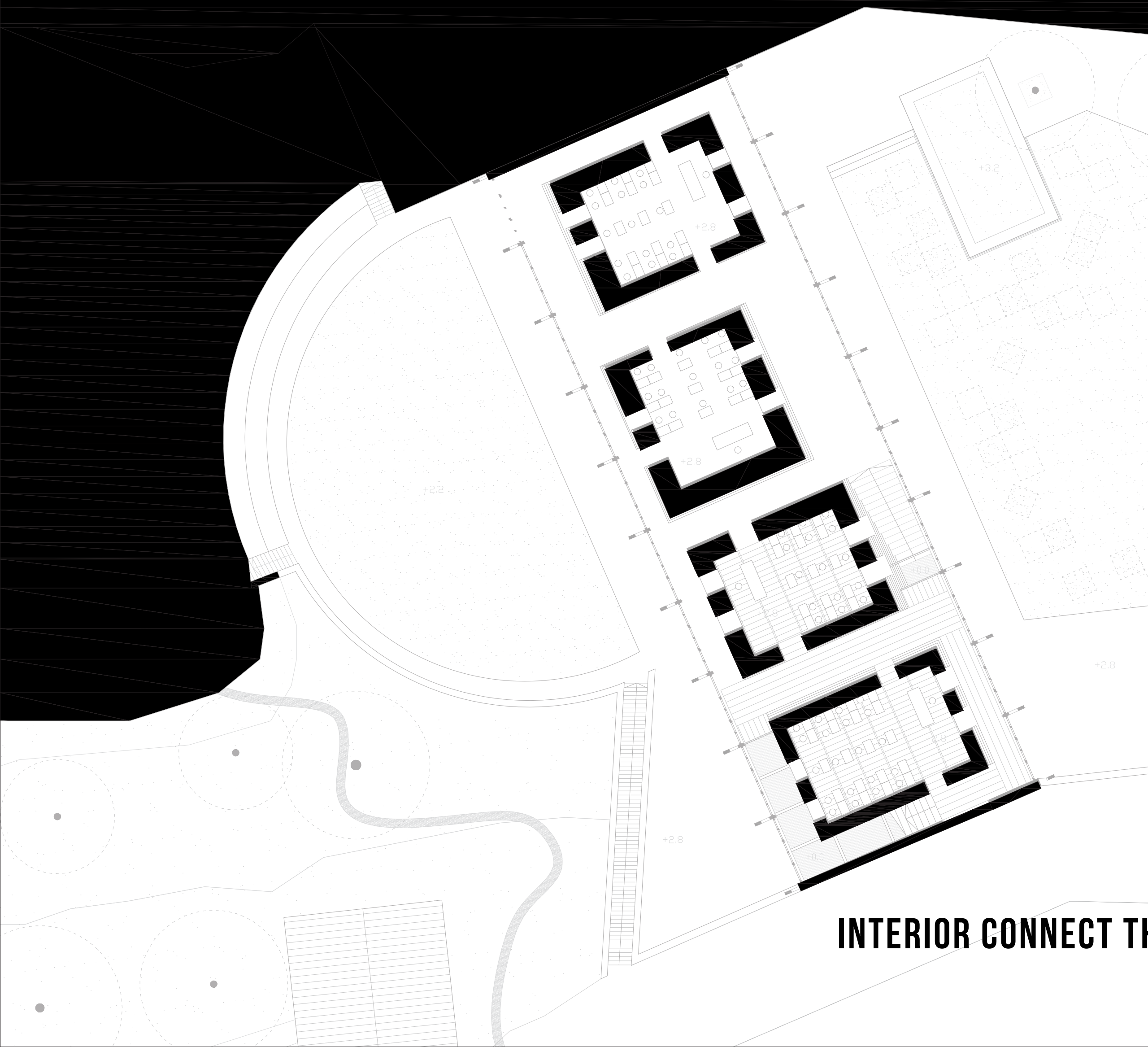

INTERIOR CONNECT THE TWO REALMS

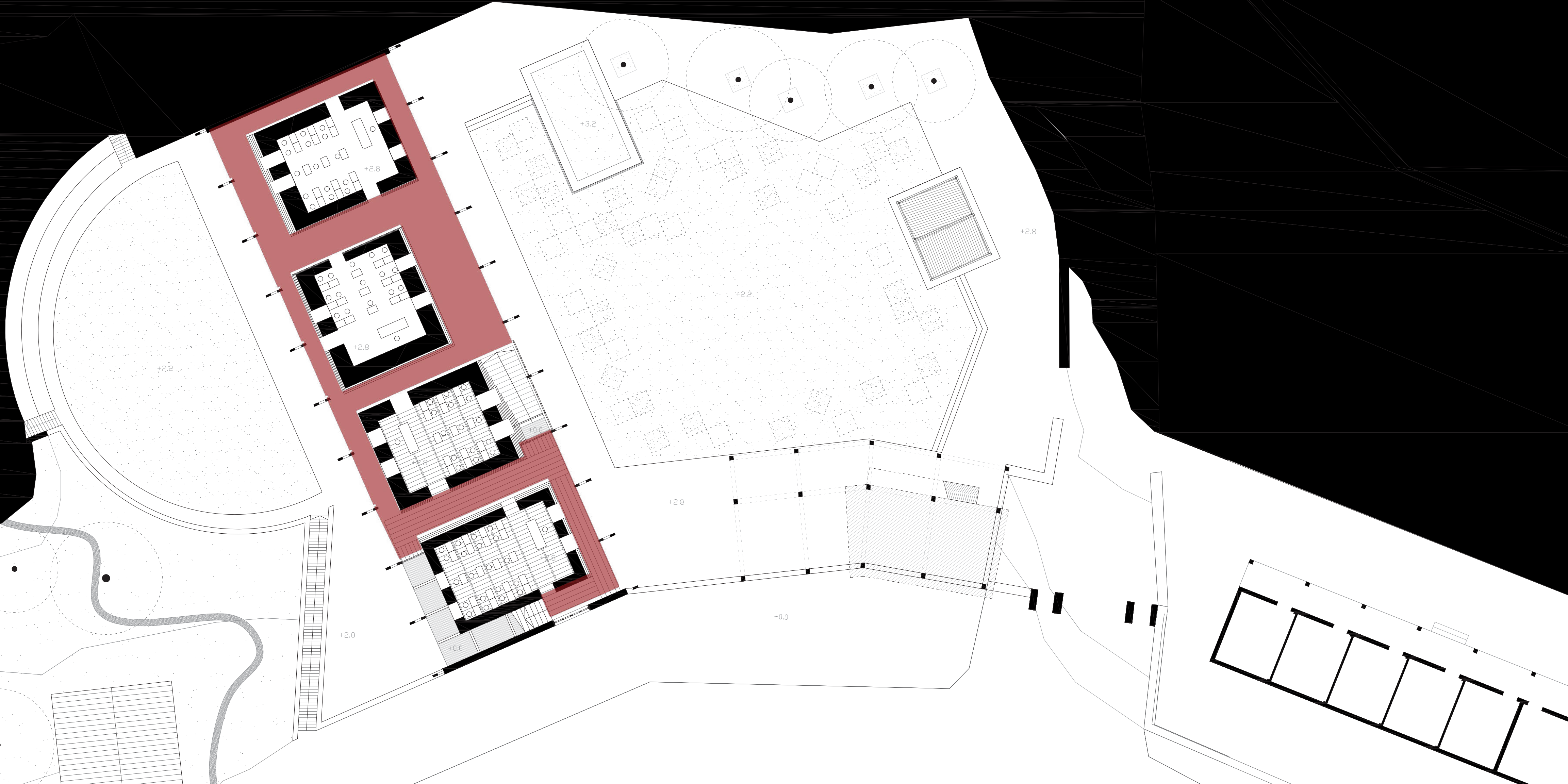

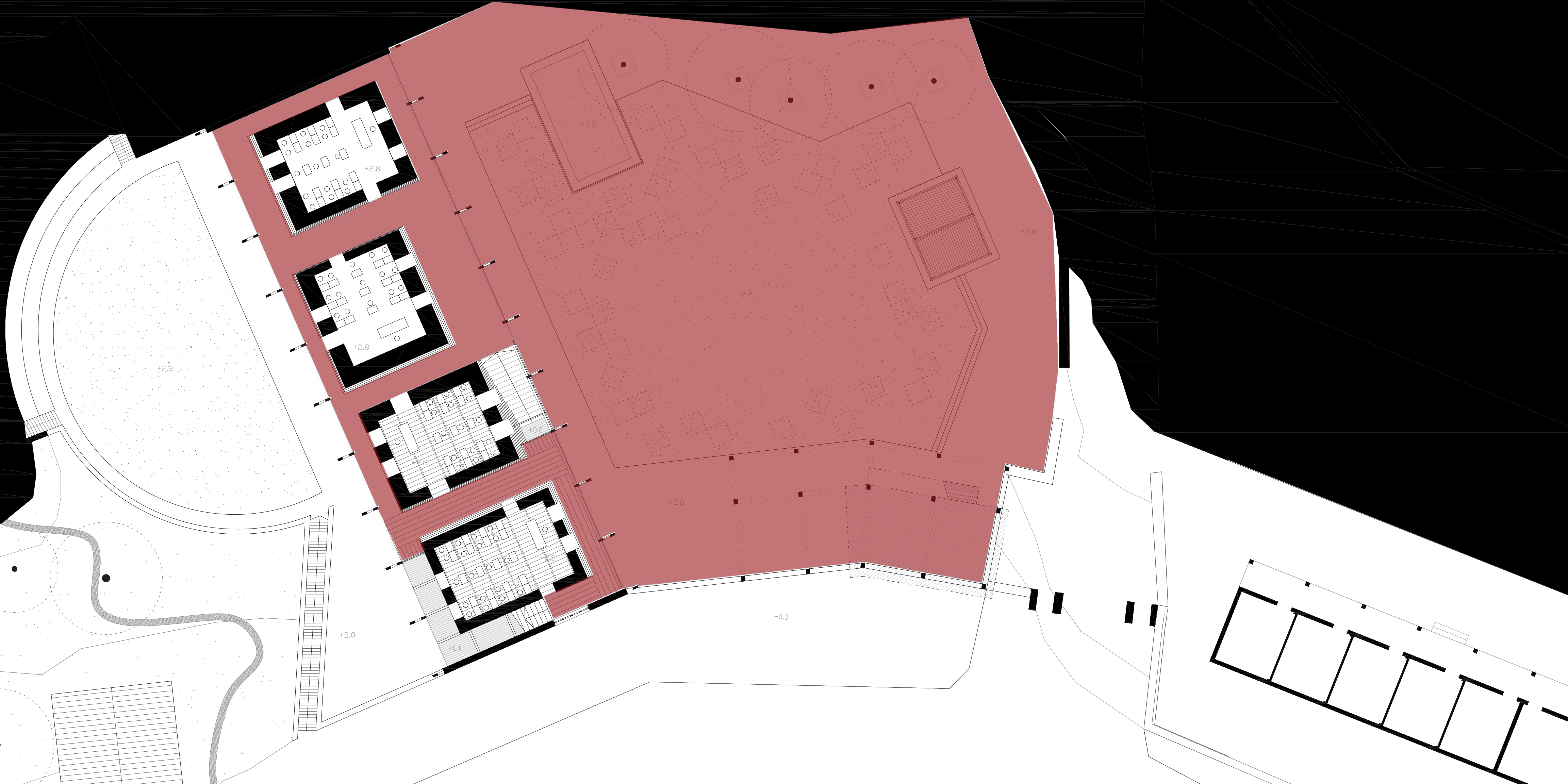

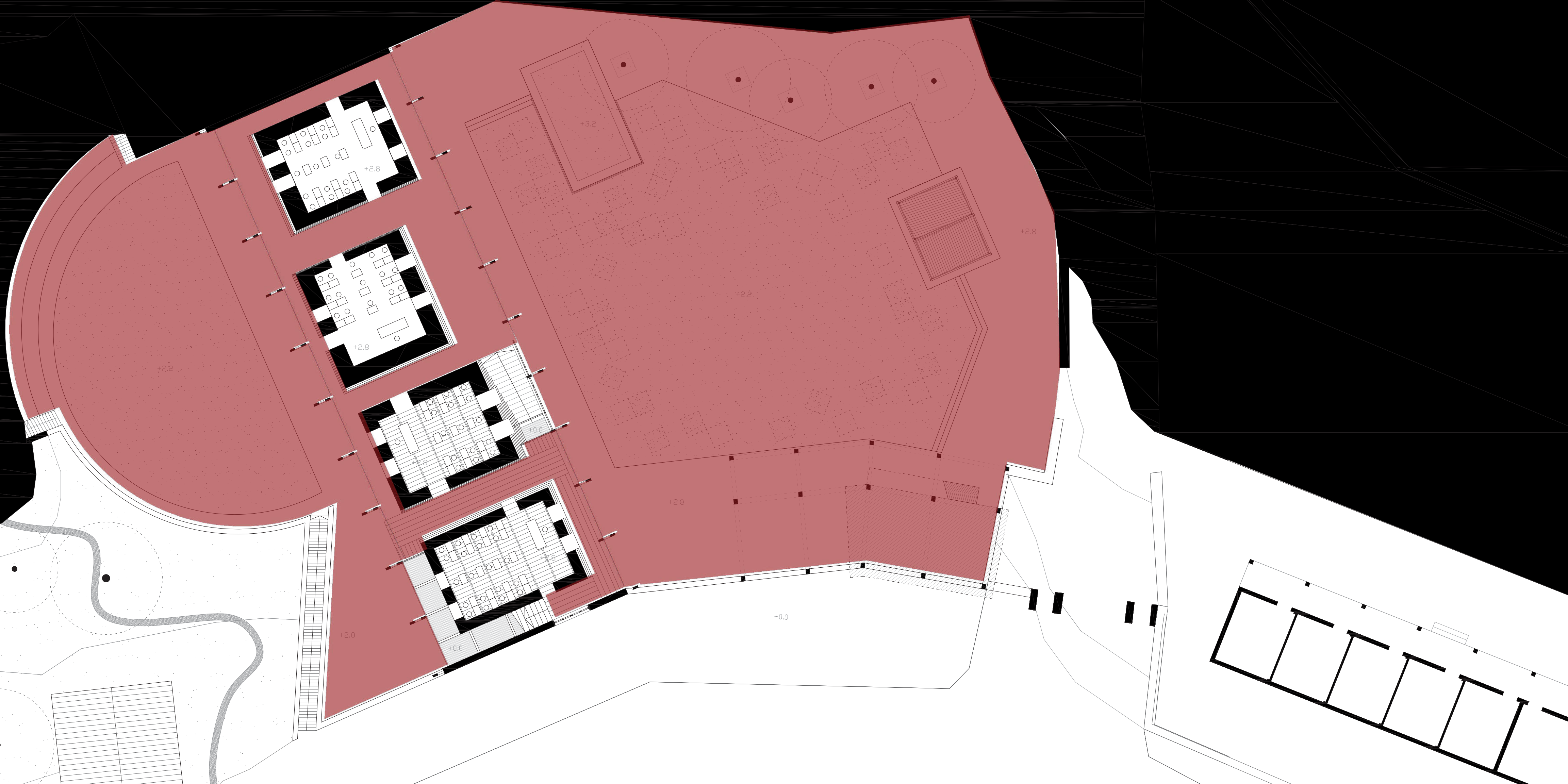



WALKABLE PATH / VERANDAH

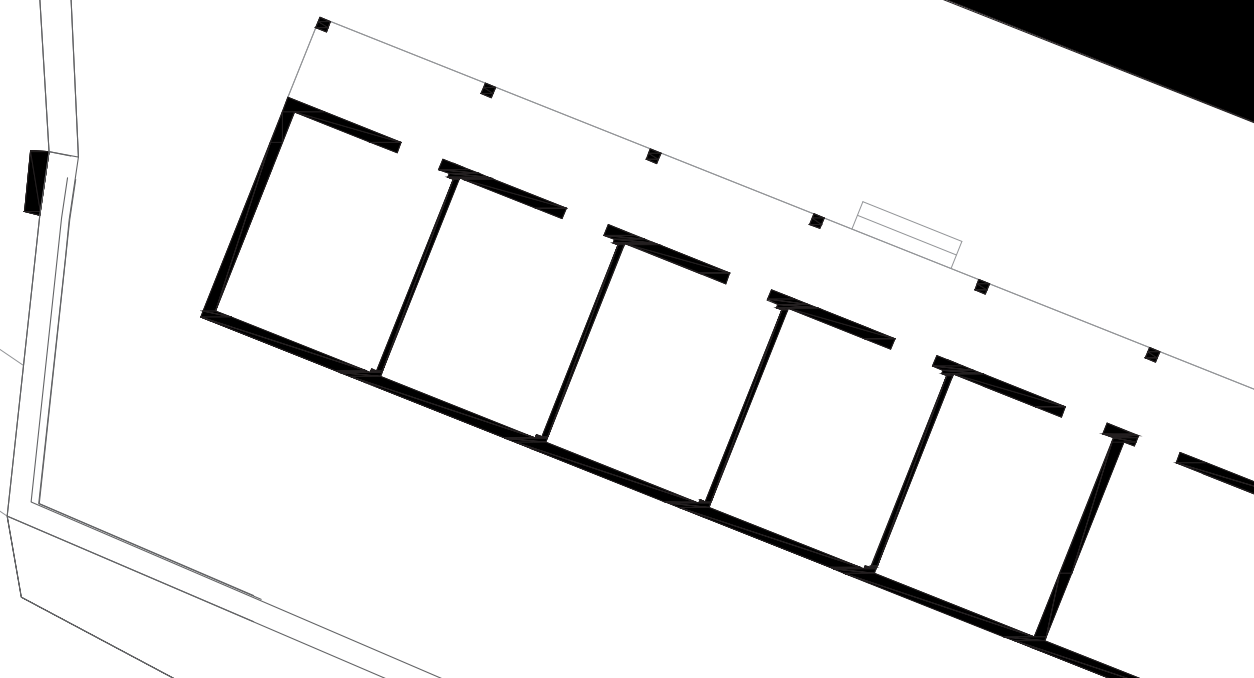

SAND

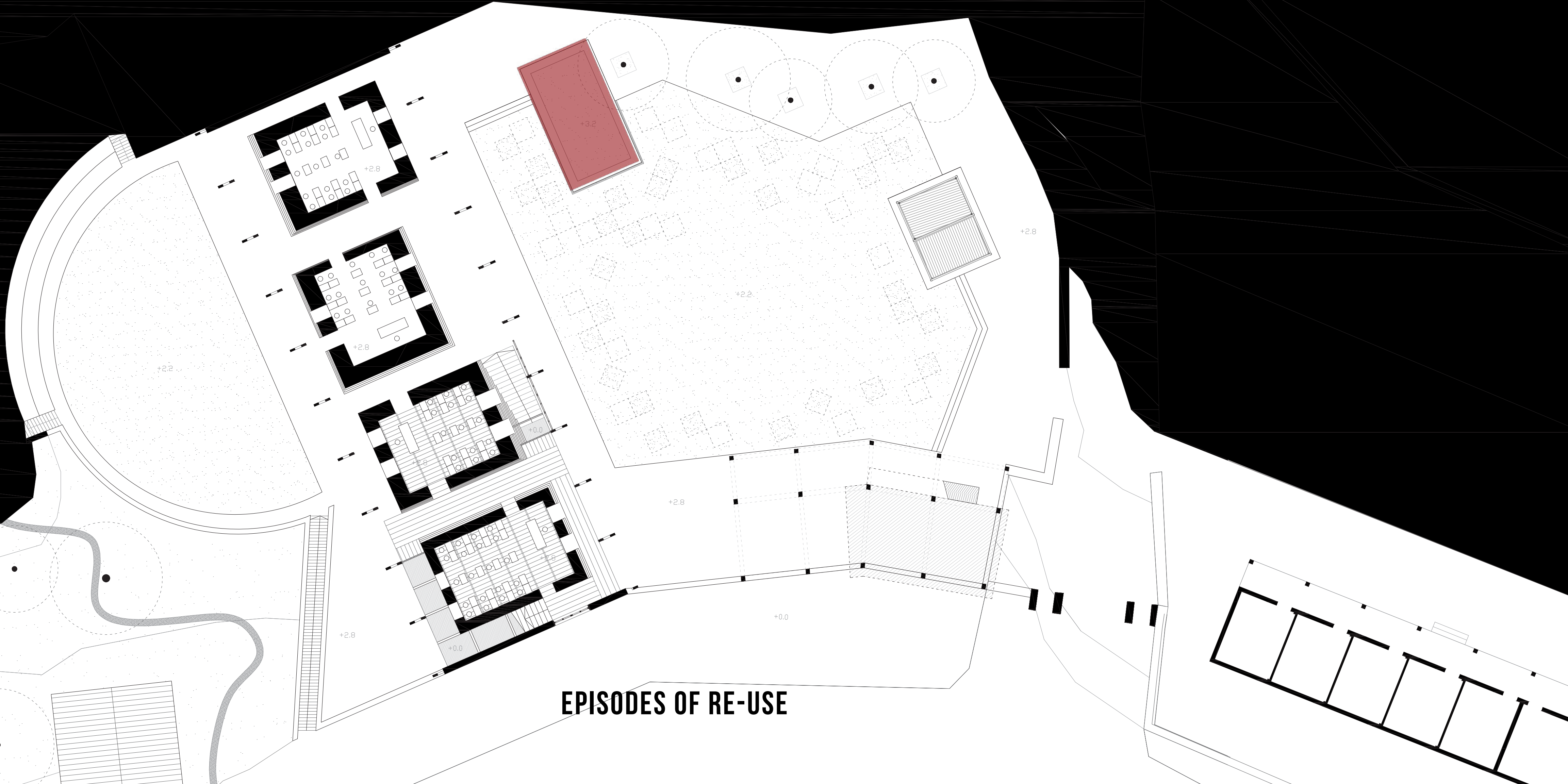
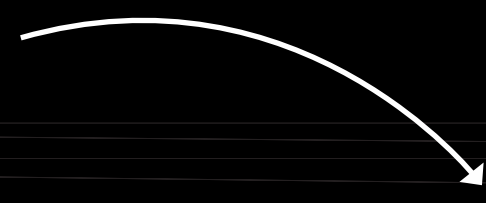

EPISODES OF RE-USE

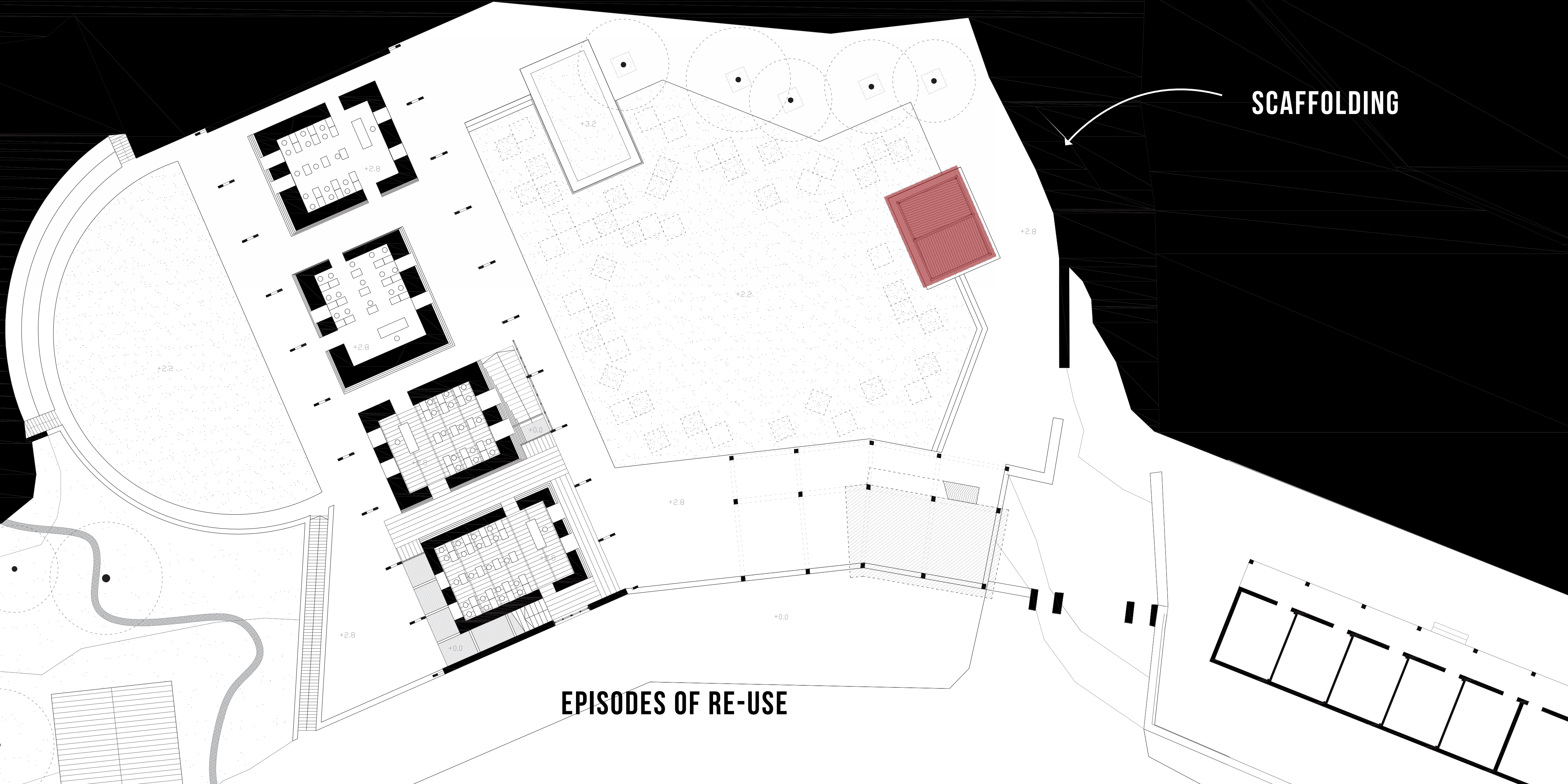

SCAFFOLDING

EPISODES OF RE-USE

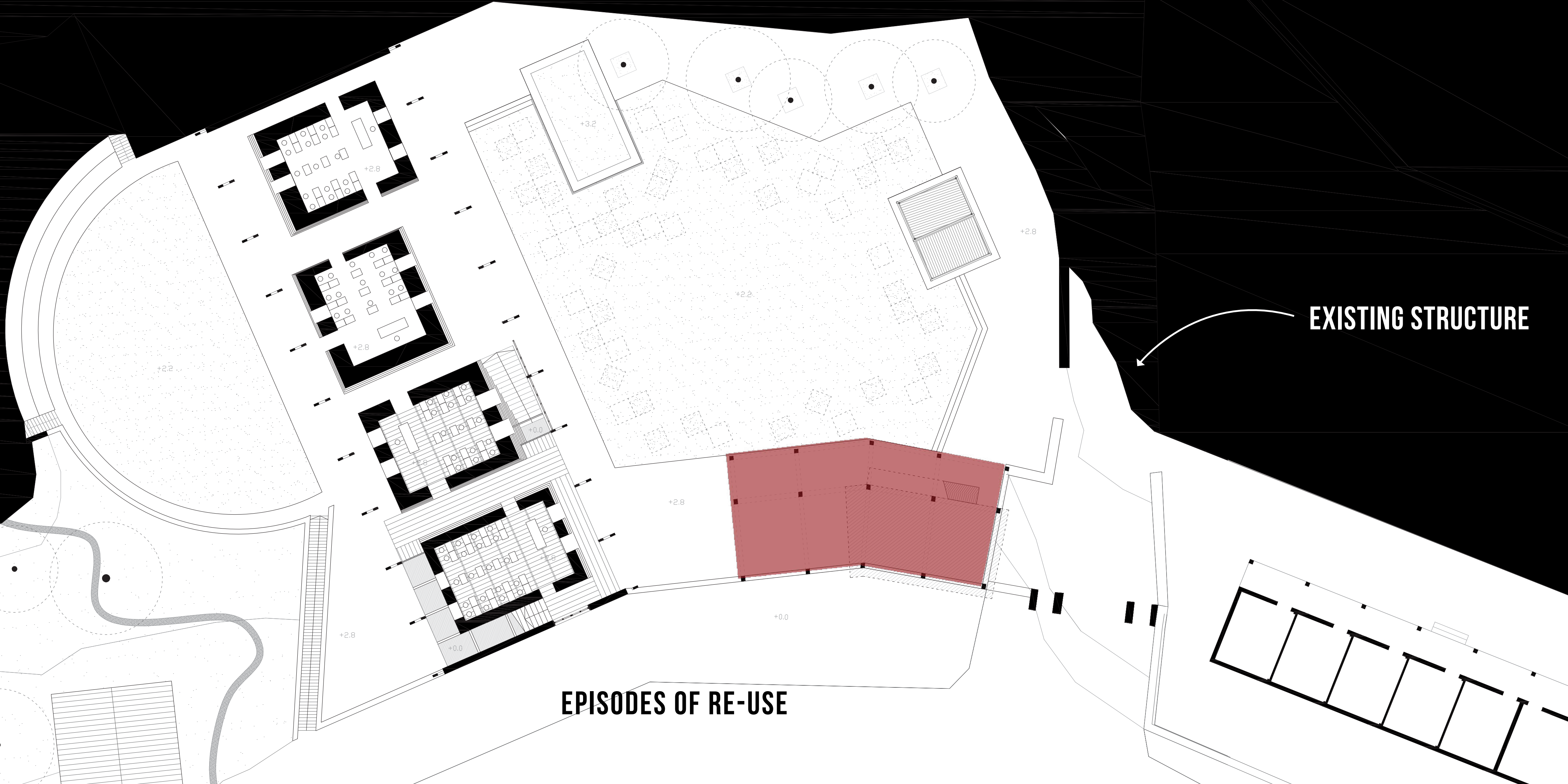

EPISODES OF RE-USE

EXISTING STRUCTURE

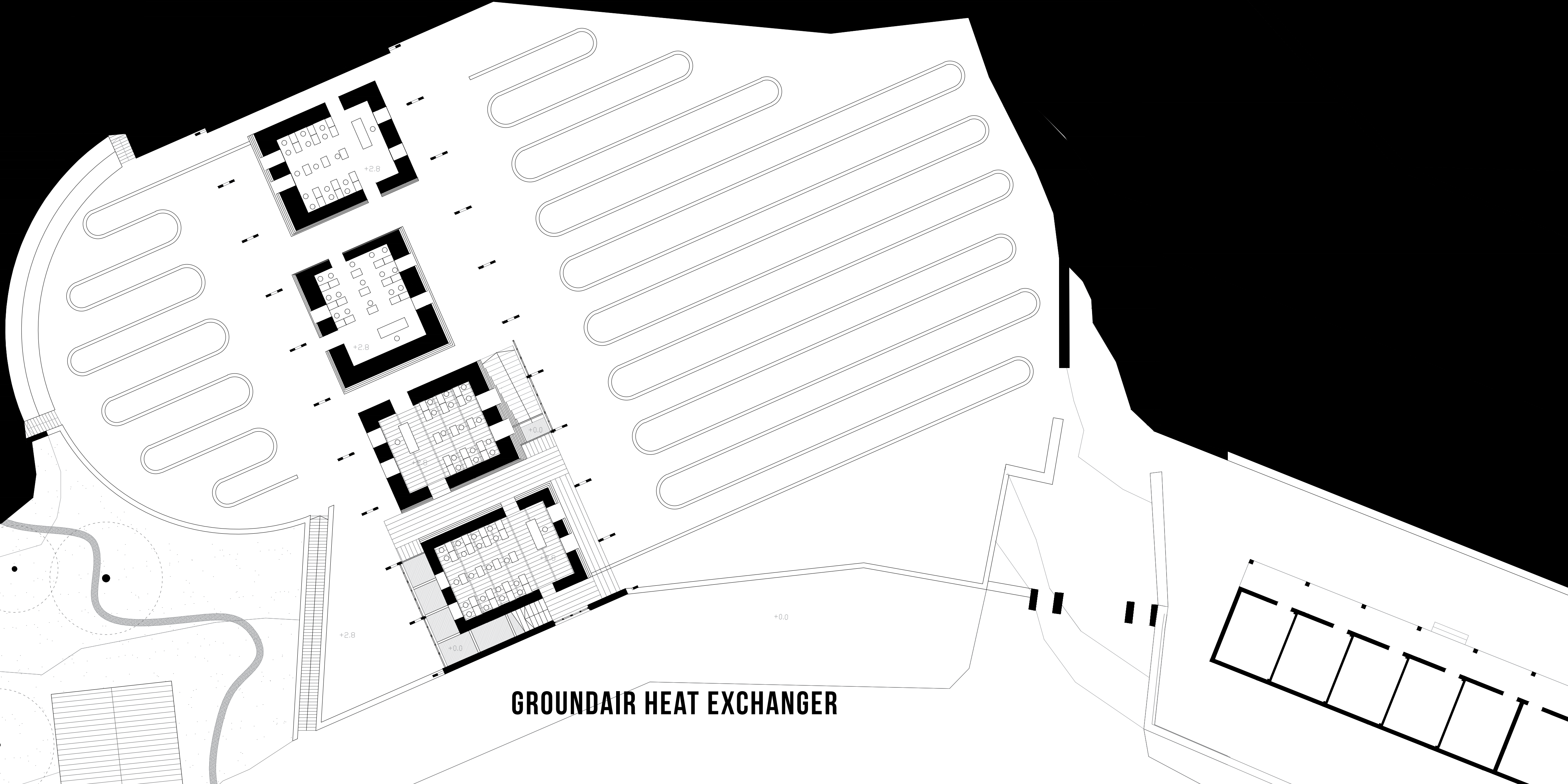

GROUND AIR HEAT EXCHANGER

CROSS SECTION

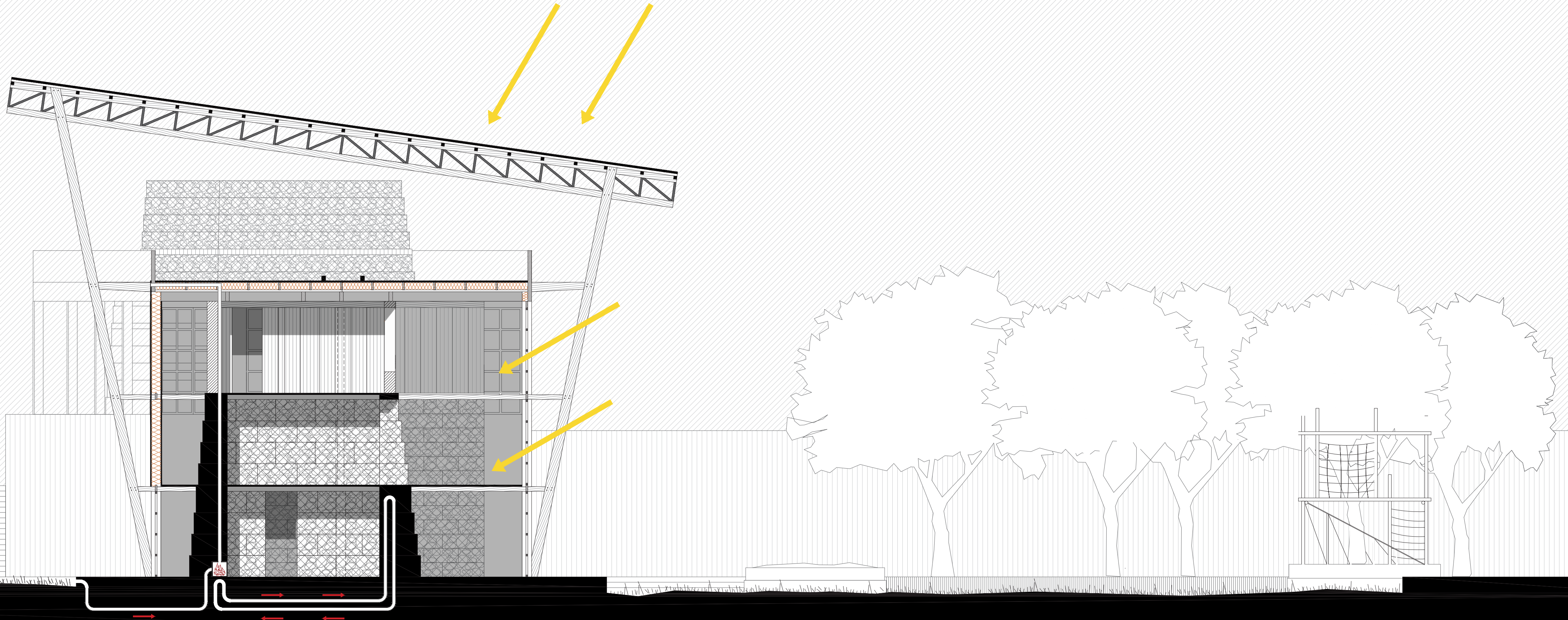

WATER MANAGEMENT

MONTH	MM OF RAIN	M3 COLLECTED
JAN	120	91
FEB	190	144
MAR	210	159
APR	140	106
MAY	110	83
JUN	140	106
JUL	290	220
AUG	250	190
SEP	130	98
OCT	40	30
NOV	30	23
DEC	70	53

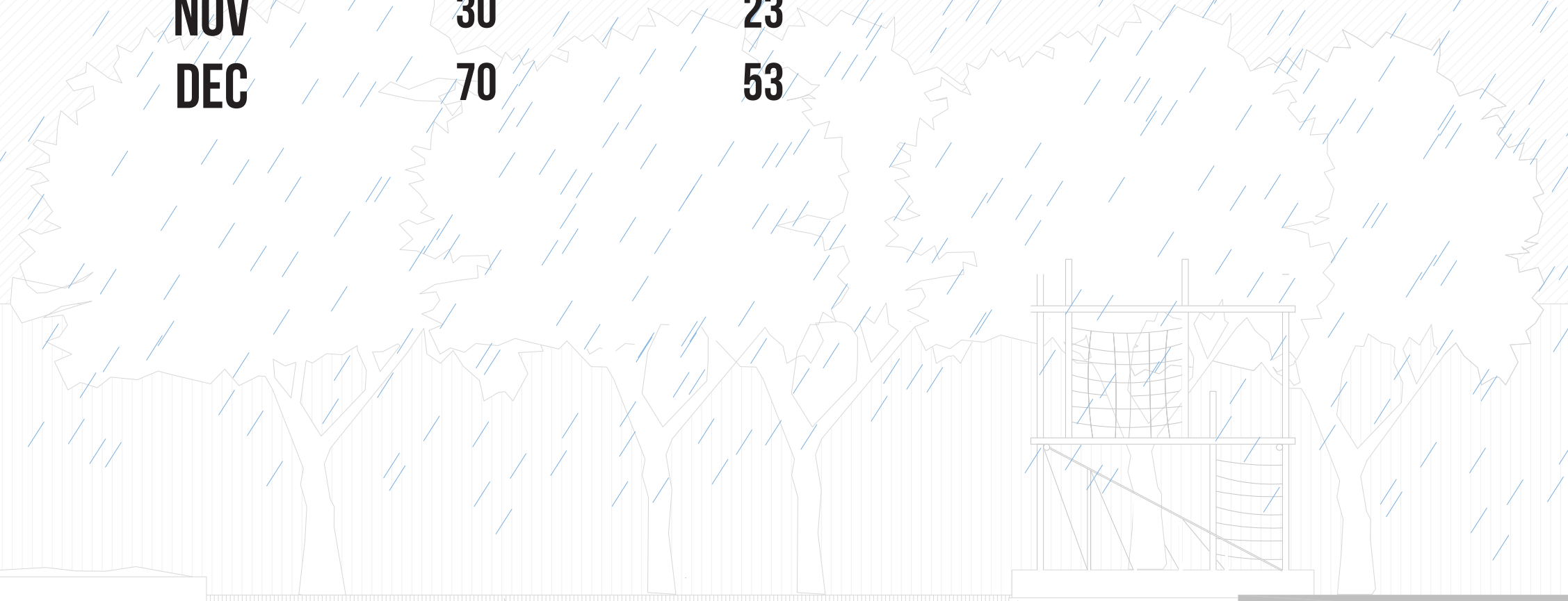
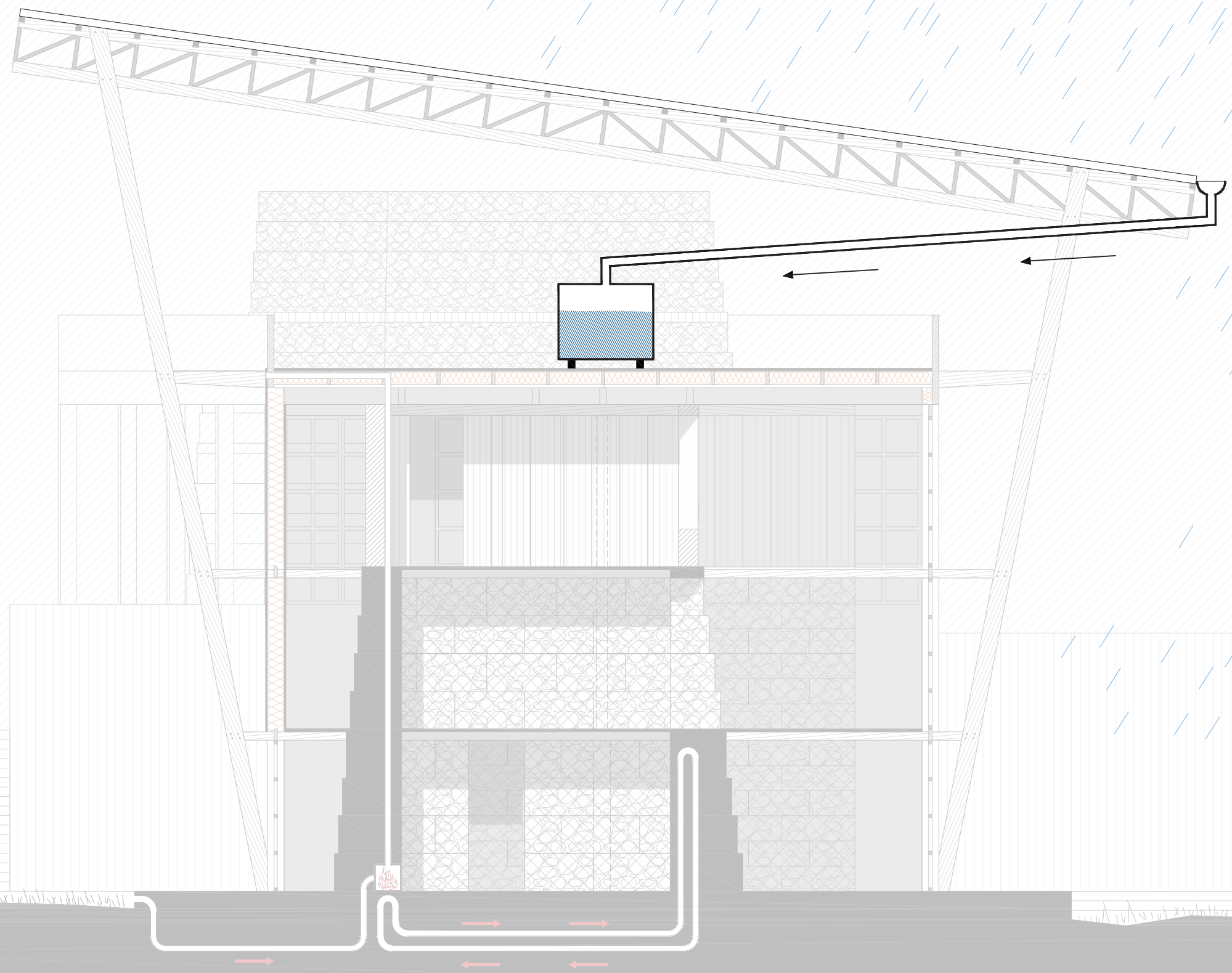

WATER MANAGEMENT

MONTH	MM OF RAIN	M3 COLLECTED	FOR TOILETS
JAN	120	91	100%
FEB	190	144	100%
MAR	210	159	100%
APR	140	106	100%
MAY	110	83	100%
JUN	140	106	100%
JUL	290	220	100%
AUG	250	190	100%
SEP	130	98	100%
OCT	40	30	52%
NOV	30	23	40%
DEC	70	53	91%

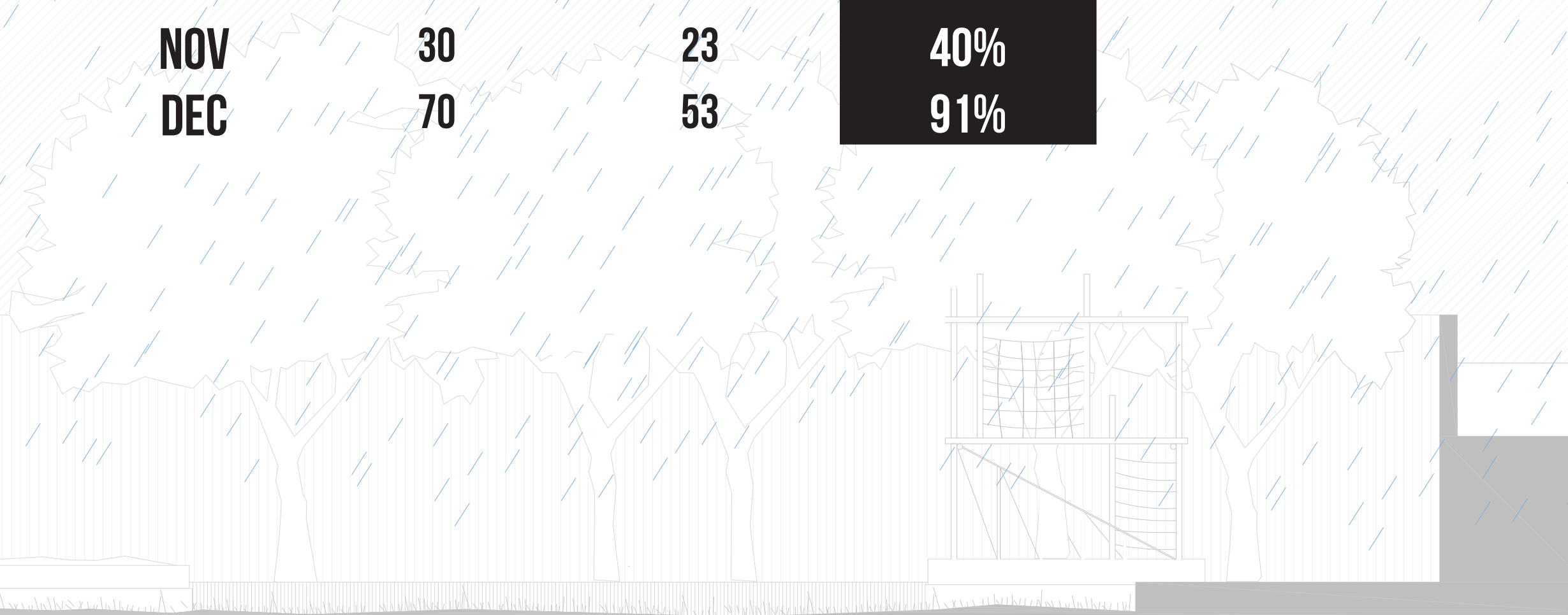
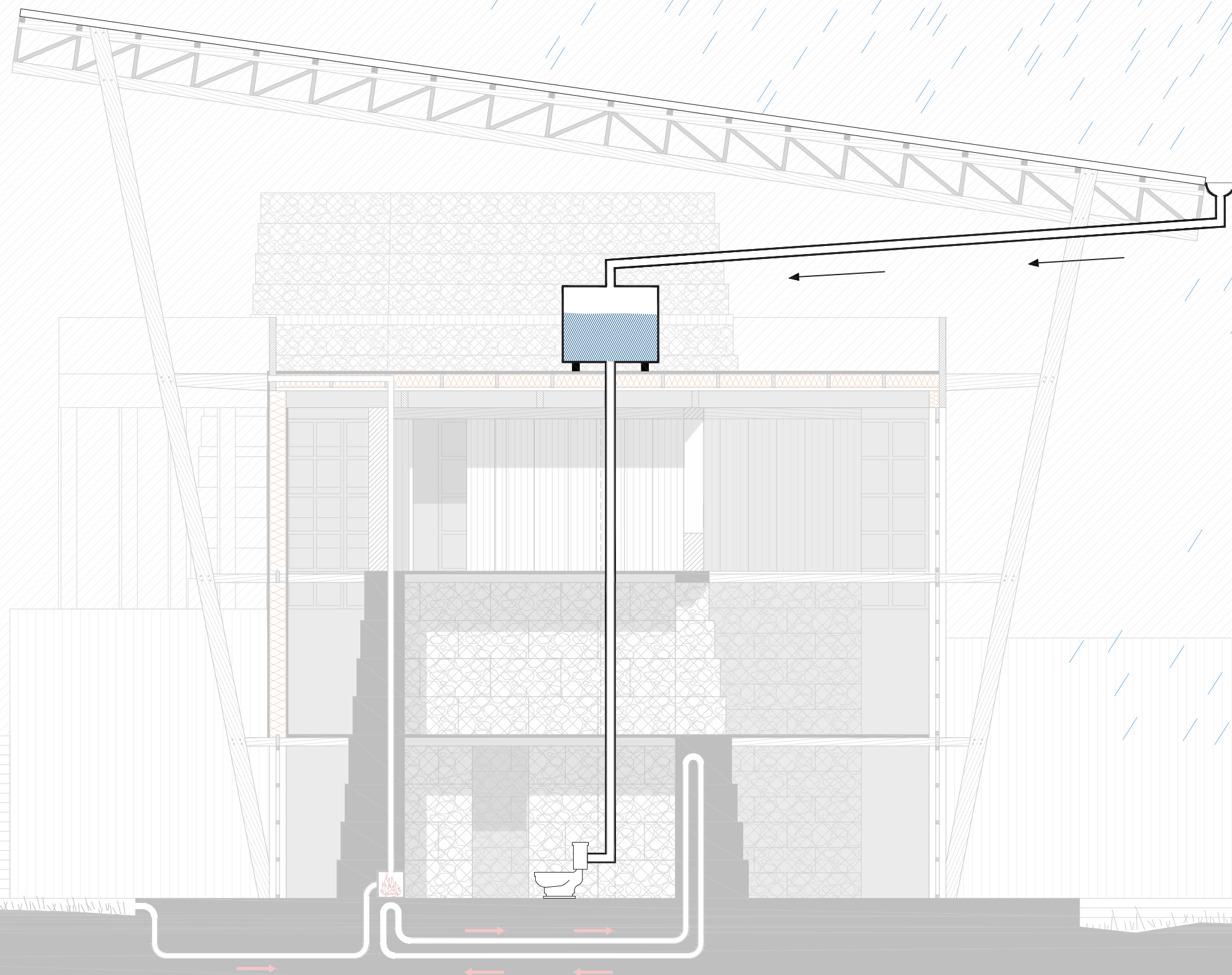

WATER MANAGEMENT

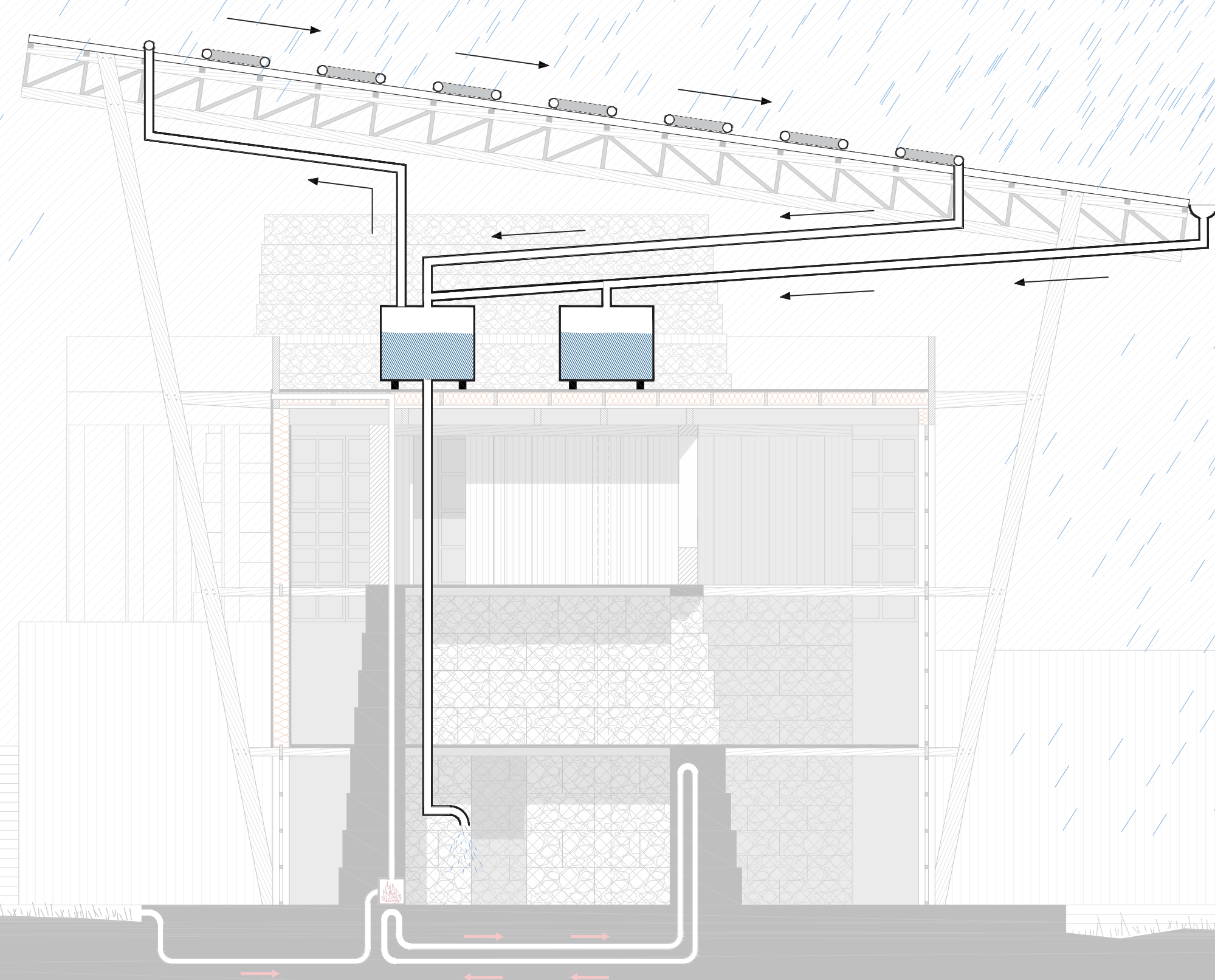

MONTH	MM OF RAIN	M3 COLLECTED	FOR TOILETS	FOR SHOWERS
JAN	120	91	100%	23%
FEB	190	144	100%	61%
MAR	210	159	100%	72%
APR	140	106	100%	34%
MAY	110	83	100%	18%
JUN	140	106	100%	34%
JUL	290	220	100%	>100%
AUG	250	190	100%	94%
SEP	130	98	100%	28%
OCT	40	30	52%	0%
NOV	30	23	40%	0%
DEC	70	53	91%	0%

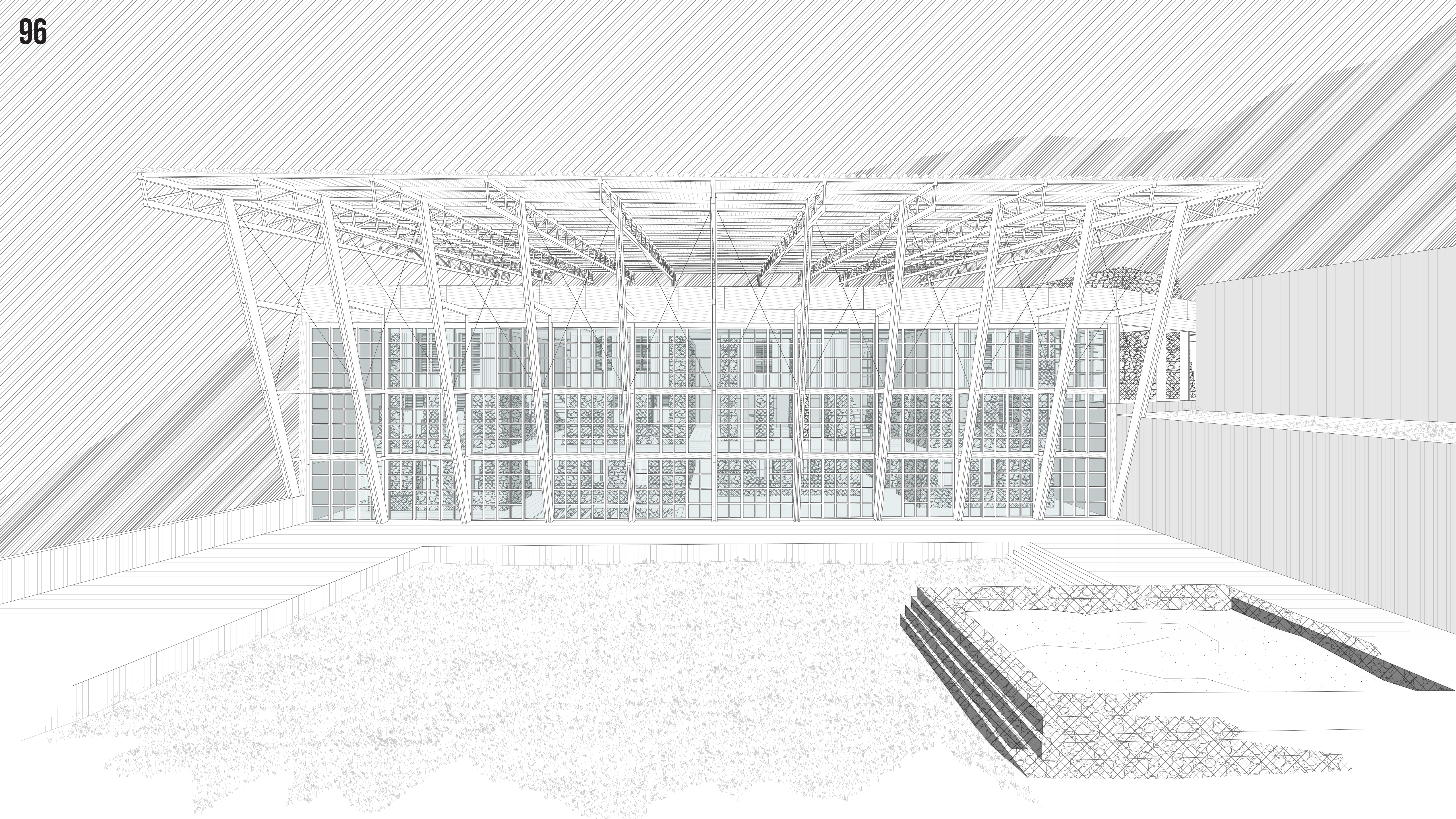

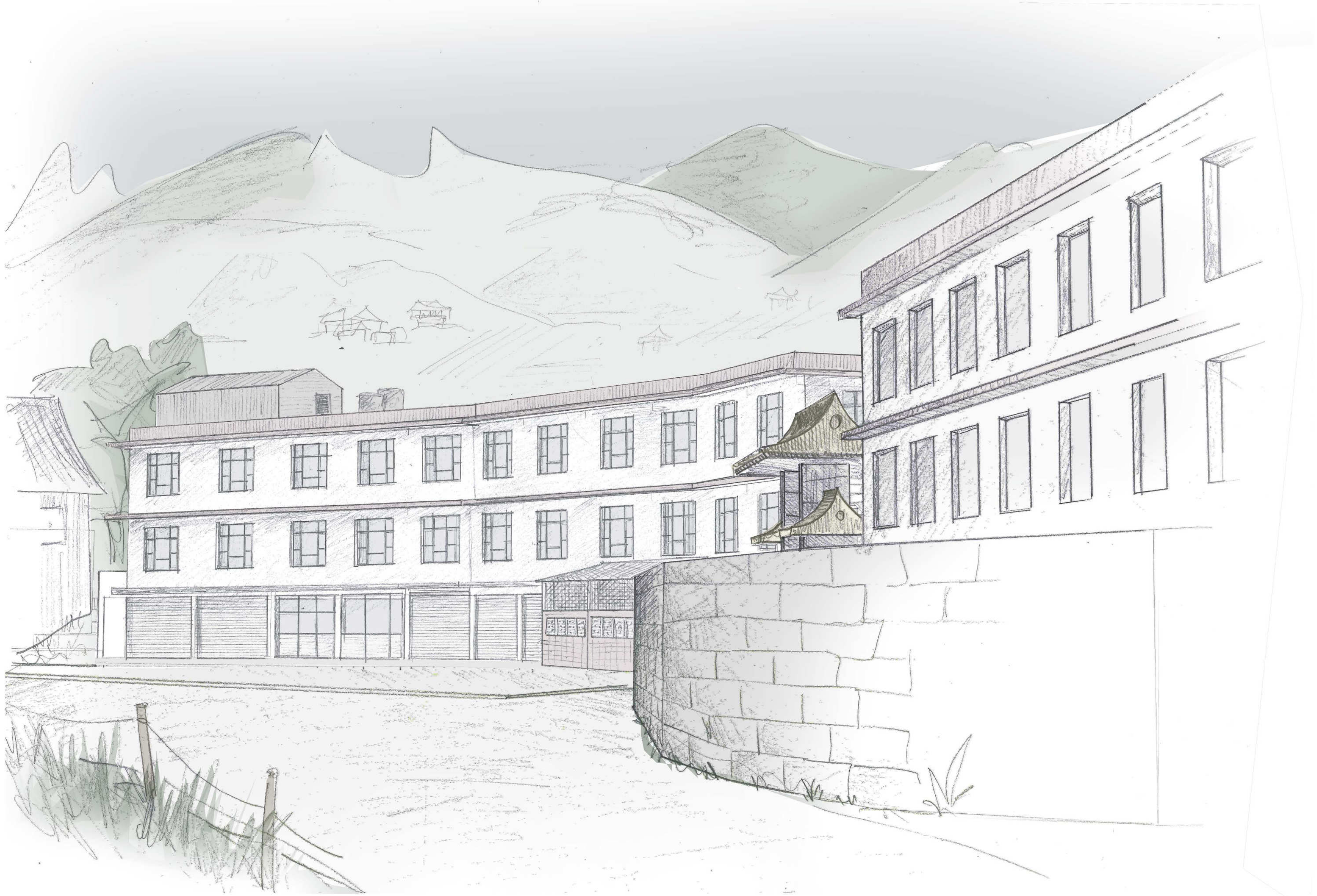



QUALITIES

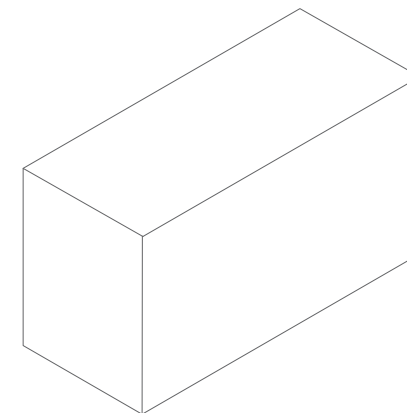
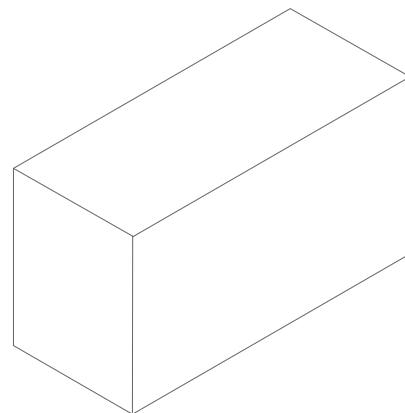
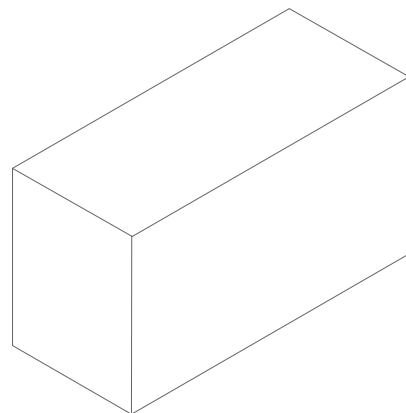
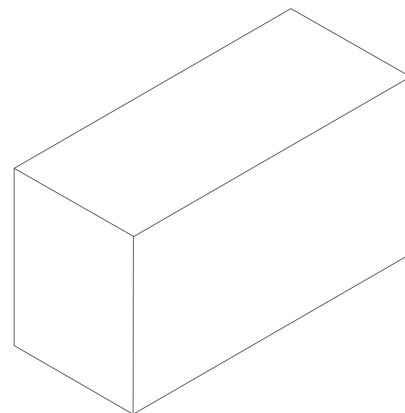
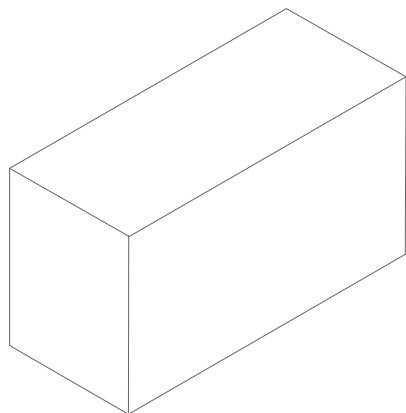

QUALITIES

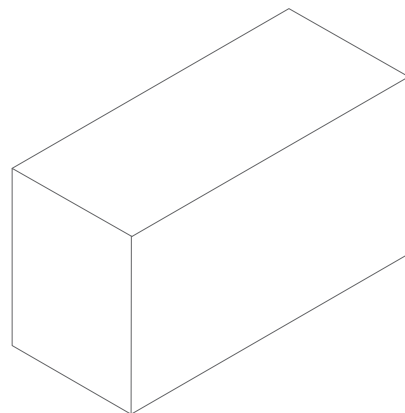
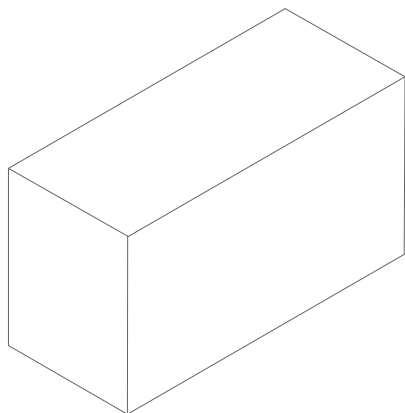
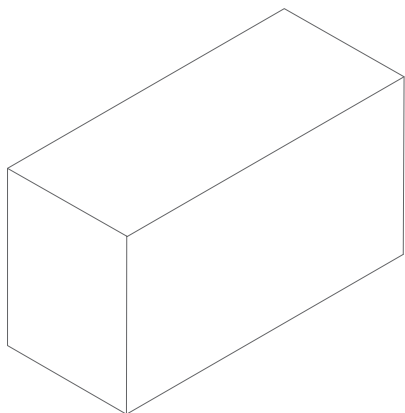
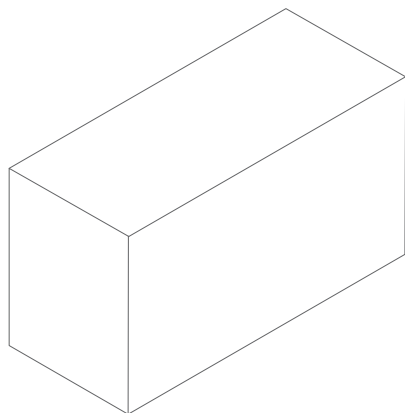
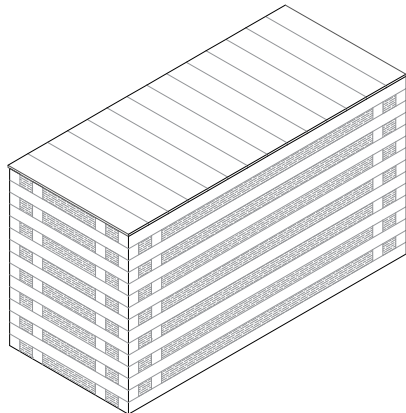

EXPLICITNESS

QUALITIES

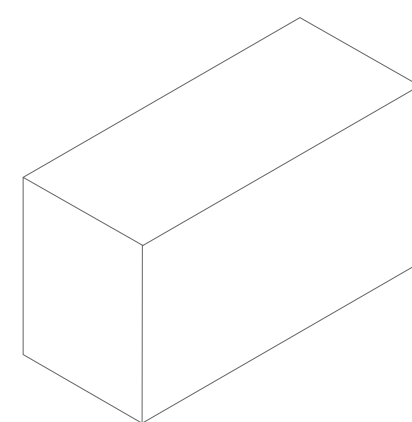
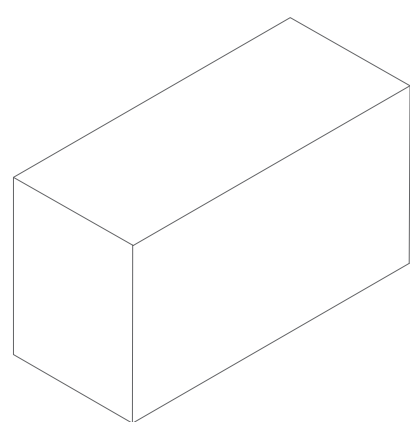
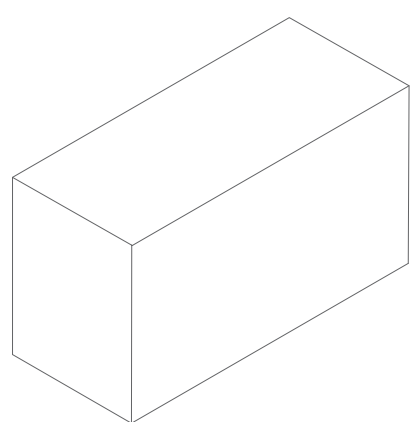
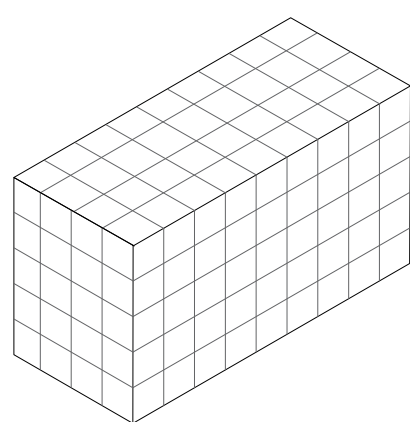
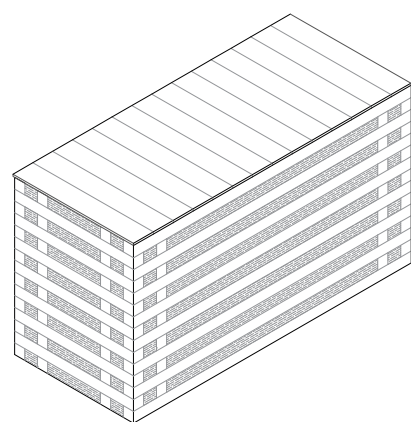

MODULARITY

QUALITIES

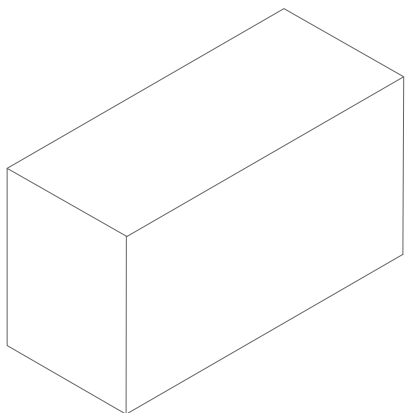
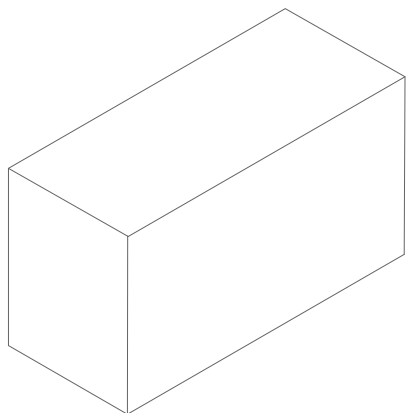
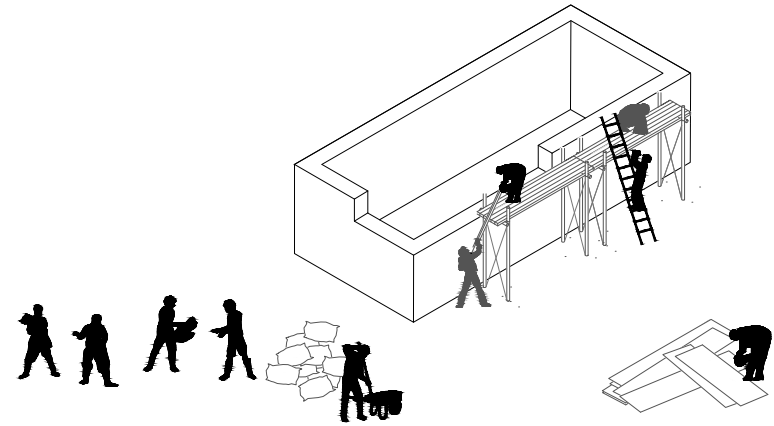
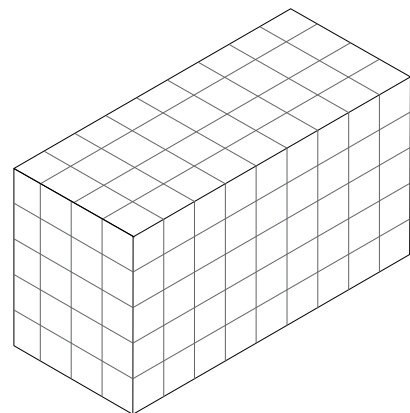
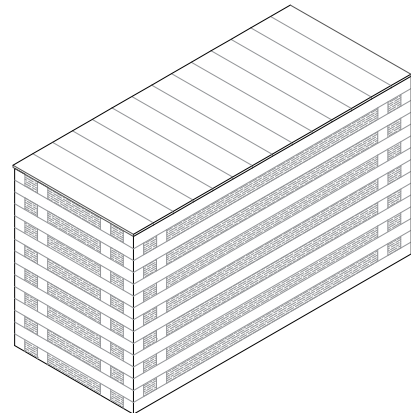

FEASIBILITY

QUALITIES

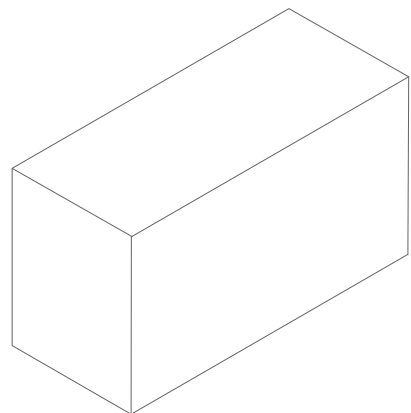
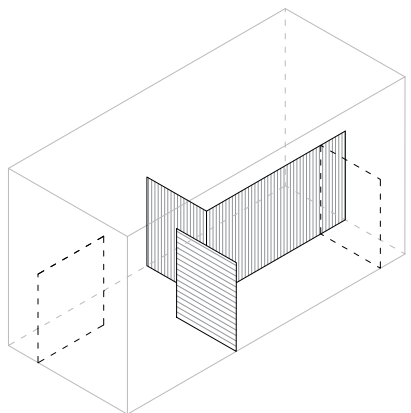
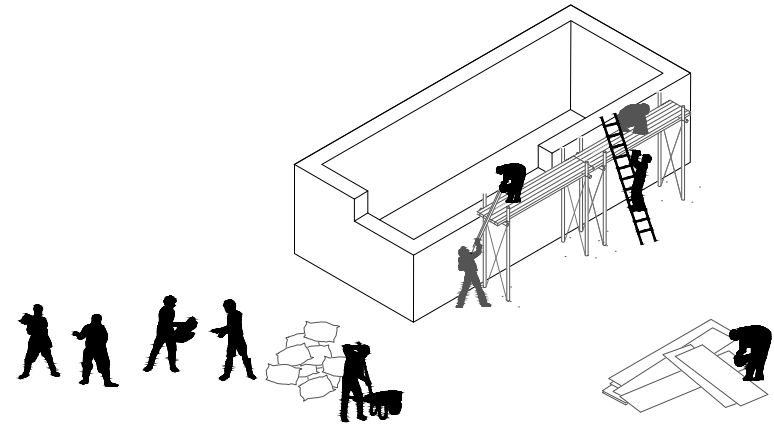
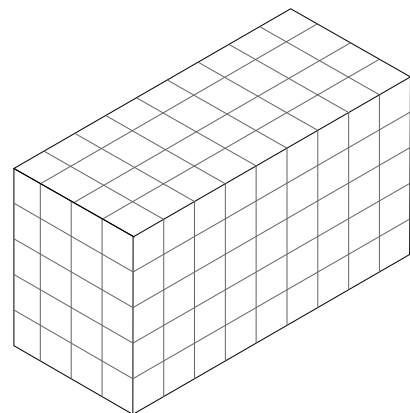
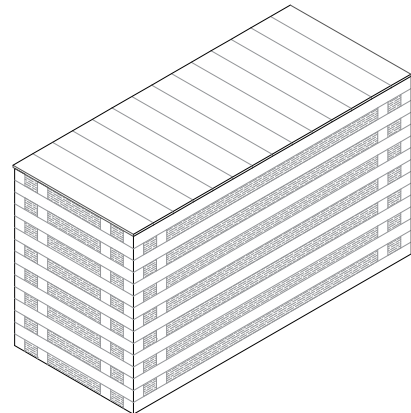

FLEXIBILITY

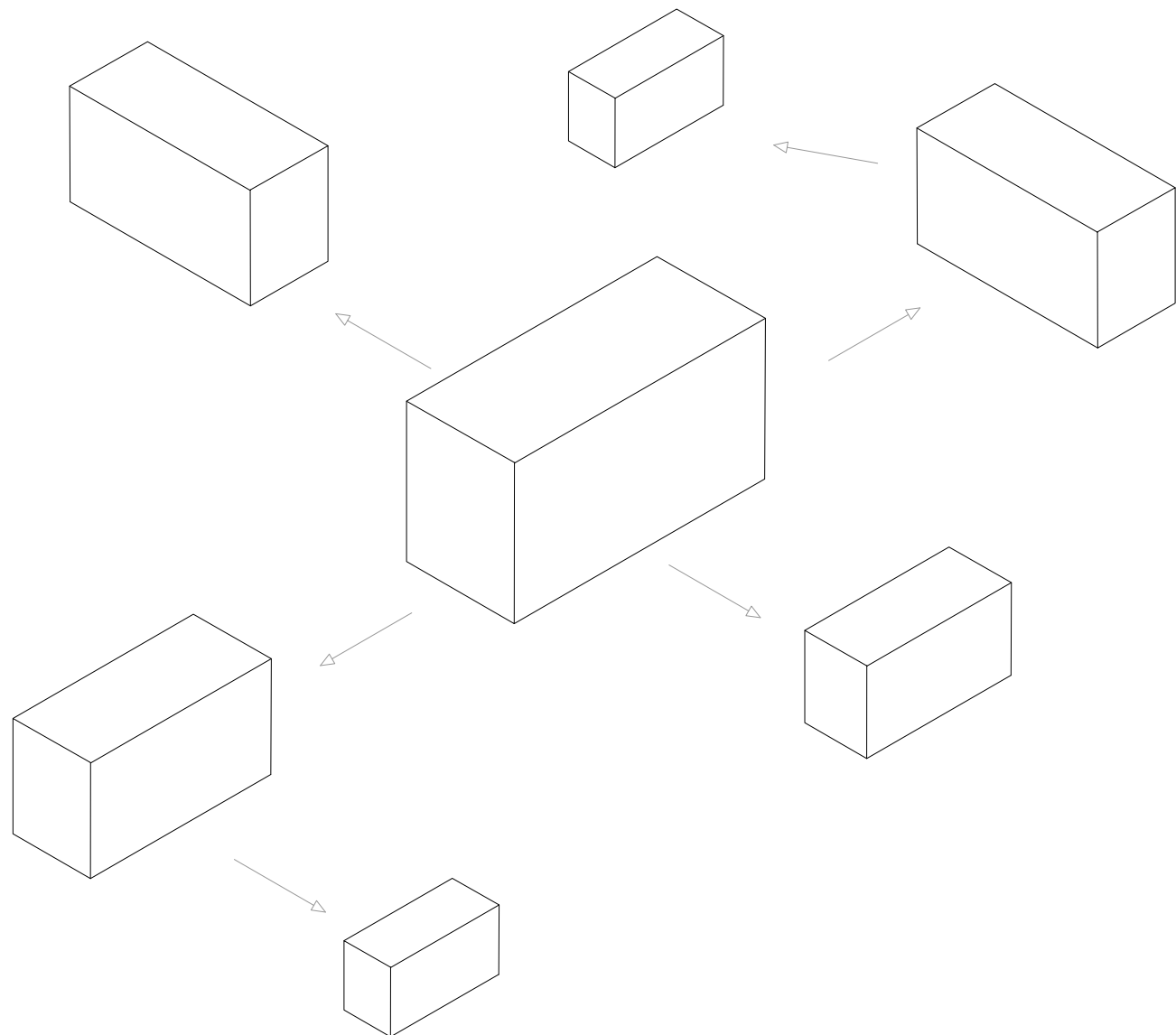
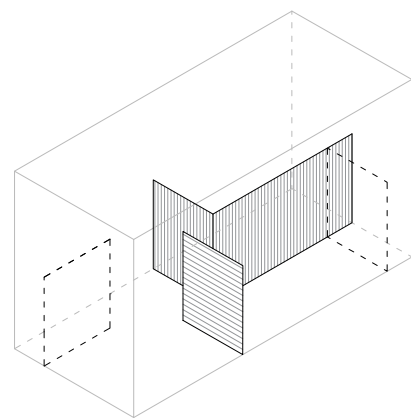
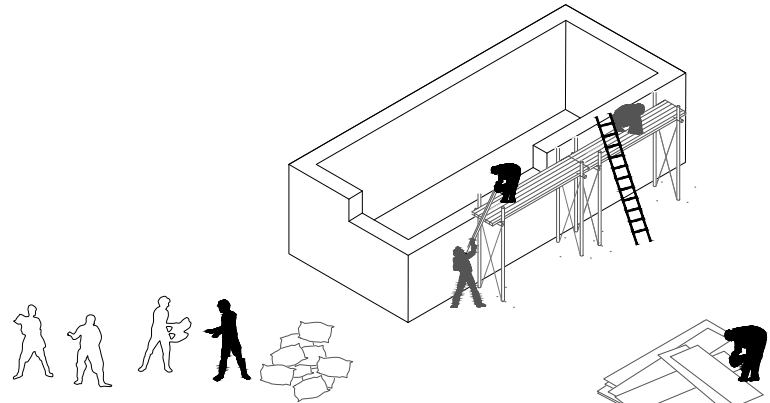
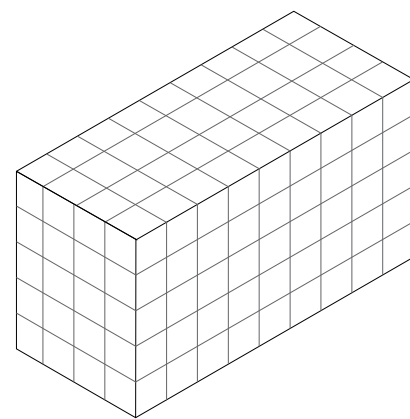
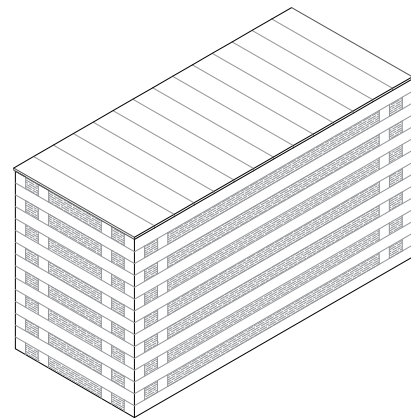

REPRODUCIBILTY

*“HOW DIFFICULT IS FOR US ARCHITECTS [...] TO ACHIEVE A RESULT AS NATURAL AS THAT OF ‘**ARCHITECTURE WITHOUT ARCHITECTS**’ THAT FARMERS AND MEN OF SEA HAVE ALWAYS BUILT WITH CONTENT UNAWARENESS.”*

GIO PONTI

THANK YOU

