

Master Graduation Thesis

The development of a microneedle applicator for facial application



 **TU Delft**

upatch™
APPLICATORS

Maan Roos Moeskops
MSc Integrated Product Design
Faculty of Industrial Design Engineering



April 17th, 2026

Delft, The Netherlands

Author

Maan Roos Moeskops

MSc Integrated Product Design

Faculty of Industrial Design Engineering

Delft University of Technology

Supervisory Team

Dr. ir. Marijke C. Dekker (chair)

Ir. Gianni Orsini (mentor)

BSc. Maarten Smit (mentor uPATCH)

Client

uPATCH B.V.

De Limes 7

2342 DH, Oegstgeest

Artificial intelligence models like Gemini, ChatGPT and Lumo have been used to paraphrase the written text for this thesis more fluently. The following prompts have been used: 'Paraphrase and make the following text flow more fluently without changing the meaning of the text'.

Acknowledgements

This thesis was a long and sometimes difficult journey. There were more than one moment that I thought I had to do something differently and was set back on a few weeks of work. But in the end, it all turned out with a product at which I am very satisfied with. I want to give special thanks to my supervisory committee. To Gianni for always offering contacts to help for my user evaluations, sparring with me and being the grammar police, which I most definitely needed. To Marijke by keeping me on the track of that I needed to do and how to make this clear to the reader. To Maarten for helping me with my design problems and coming up with creative ideas and providing me with information and feedback to conduct a successful study. And to all three of them for always reassuring me that I am doing enough sufficient work.

A special thanks to uPATCH for all their support and for offering me a healthy and fun workspace to explore a lot of possibilities for the applicator.

And lastly a special thanks to my friends, family and Oliver who supported me throughout the last months and who stood with me when I couldn't see the end of my thesis anymore.



Figure 1: Cosmetic applicator MINUS

Abstract

Microneedle patch (MNP) technology enables transdermal drug delivery (TDD) by penetrating the stratum corneum (SC) and is upcoming in the East-Asian skincare market as anti-acne microneedle patches (AAMNPs). TDD increase the absorption of active acne-fighting ingredients, which are dissolved in these microneedles. However, AAMNPs cannot penetrate the SC successfully with manual application. As manual application frequently results in inconsistent needle penetration, reduced efficacy, and needle damage during use, which has also been confirmed with this thesis. To make the microneedles (MNs) penetrate an applicator is required. At the moment there is no known cosmetic MNP applicator on the market, indicating a gap in the market. This thesis presents the design and development of MINUS, a compact AAMNP applicator for facial use. The primary objective was to create a device that ensures effective, safe, consistent, and accurate application of AAMNPs while accommodating multiple patch sizes for a broad MNP usage. The project was conducted for uPATCH, a startup primarily focused on the development for medical MNP applicator.

The research is done with a triple diamond approach with three phases: research, conceptualisation, and embodiment. Main procedures included market analysis, investigating penetration mechanics, researching AAMNP effective penetration spring force and user

evaluations. The resulting design implements an impact force delivery system, enabled by a spring that is retracted and locked by twisting the device. This spring is released by a button, pushing the inserting AAMNP forward, resulting in penetration using impact force. The design consists of nine parts that can be easily assembled under 1 minutes. The applicator accommodates AAMNPs up to 20mm in diameter and prioritizes compatibility with existing patch packaging for rapid market integration.

Findings indicate that the MINUS applicator successfully enables skin penetration of CMNPs, transforming previously ineffective topical applications into functional transdermal delivery systems. However, several limitations were identified, including testing conducted on forearm rather than facial skin, and the inability to establish direct contact with manufacturers and consumers for validation. Recommendations include exploring an adjustable impact force mechanism to accommodate for the different facial regions, investigating reparability improvements and encouraging MNP manufacturers to redesign their MNPs to be able to penetrate with a spring force of 20 N instead of 45 N.

This thesis shows that a well-designed applicator can significantly enhance the effectiveness and user experience of AAMNPs, creating value for manufacturers, clients, and end-users while addressing a clear gap in the current market.

Content

1. Introduction	13		
1.1. Background	14		
1.2. Problem definition	14		
1.3. Research questions and objectives	15		
1.3.1. Research phase	15		
1.3.2. Design phase	15		
1.4. Stakeholders	15		
1.5. Project scope	16		
1.6. Approach and methodology	16		
2. Research	18		
2.1. Microneedle patches and their use	20		
2.1.1. Working principle	20		
2.1.2. Effective penetration of microneedles	22		
2.2. Similar products and competitors	24		
2.3. Market research	28		
2.3.1. Asian beauty standard – Glass skin	28		
2.3.2. Kinds of MNPs in cosmetics	30		
2.3.3. Target audience determination: end-user	31		
2.3.4. Use of anti-acne microneedle patches	32		
Risk to touch needles	34		
2.3.5. User study 1- current use	34		
2.3.6. Effectiveness of CMNPs	38		
2.5. Facial structure	44		
2.5.1. Skin elasticity	45		
2.5.2. Facial pain threshold	45		
2.6.1. The user	46		
2.6.2. Function tree applicator	46		
2.6.3. Key focus points	47		
2.7. List of requirements	48		
		3. Conceptualisation	51
		3.1. Impact force mechanism	52
		3.2. Functions	53
		3.2.1. Function: Loading the applicator	54
		3.2.2. Function: Activating the applicator	58
		3.2.3. Function: Stretching the skin	62
		3.2.4. Function: Attaching patch to applicator	64
		3.2.5. Evaluation functions	67
		3.3. Concepts	68
		3.3.1. Concept 1: PLUS mini	68
		3.3.2. Concept 2: Shotgun	70
		3.3.3. Concept 3: Prit	72
		3.3.4. User study 2: Concept evaluation	74
		3.3.5. Concept selection	76
		4. Embodiment design	78
		4.1. Detailing	80
		4.1.1. Function: Locking rotation mechanism	82
		4.1.2. Function: Carrier	86
		4.1.3. Optimisation	86
		4.1.4. Function: Stretcher	88
		4.2. Size -Ergonomics	90
		4.3. Material Selection	92
		4.4. Assembly	94
		4.5. Appearance and form	96
		4.6. User study 3: Final product evaluation	102
		4.6.1. Attaching the patch	102
		4.6.2. Activating the applicator	103
		4.7. Lab study 3: Search for minimum spring force	106
		4.8. Final prototype	108
		4.8.1. Stiffening the elevation groove	108
		5. Final product	111
		5.1. uPATCH™ MINUS	112
		5.2. Working principle	116
		5.2.1. Carrier	118
		5.3. Use	120
		5.4. Feasibility	122
		5.4.1. BOM	122
		5.4.2. Manufacturing	122
		5.4.3. Assembly	122
		5.5. Desirability	126
		5.6. Viability	128
		5.6.1. Unit and selling price	128
		5.6.2. SWOT	129
		5.7. Recommendations	130
		5.8. Limitations	131
		5.8.1. No contact possible with the manufacturers	131
		5.8.2. Testing of MNPs	131
		6. Bibliography	132
		6.1. References	134
		6.2. References of images	139
		7. Appendix	143

Terminology

Abbreviations

AAMNP: anti acne microneedle patch

AAMNPs: anti acne microneedle patches

CMNP: cosmetic microneedle patch

MNPs: microneedle patches

MNP: microneedle patch

MNs: microneedles

MN: microneedle

TDD: transdermal drug delivery

SC: stratum corneum

SWOT: Strength, weaknesses, opportunities and threats

Glossary

(needle) Array: the region on which the microneedles are lead out.

Comedones (singular: comedo): a clogged hair follicle, commonly known as a 'black head'.

Ex vivo: used in scientific testing and revers to test to 'dead skin'.

FDM printing: 3D printing method that melts plastic filament into layers that build up a model.

High density patches: patches that have a high density in needles on the needle array.

Impact force: force by velocity.

In vivo: used in scientific testing and revers to test to 'alive skin' .

Lesion: a lesion is any abnormal change in the body, in this thesis it is used for any type of acne.

Low density patch: patches that have a low density in needles on the needle array.

Needle array: the area that the needles are structured together on a patch.

Pressing force: force by pressing.

Sebum: the oil that your skin produces in sebaceous glands.

SLS printing: Selective laser Sintering is a 3D printing method where a laser melts a powder like material into a model in layers.

Topical skin absorption: the absorption of a substance that is applied on top of the skin.

Chapter 1

Introduction



Figure 1.1 : Micro photo of CMNP

1.1. Background

Microneedle patches (MNP) are made out of tiny needles that are arranged on an array which is placed on a patch [1]. These needles can penetrate the stratum corneum, making transdermal drug delivery (TDD) possible [2], [3]. The technology for microneedles (MNs) was first described by Pistor in 1975. But the development and innovations are a bit slow.

The microneedle patches offer great opportunities in vaccines and slow drug delivery as they don't leave scarring and are not painful to administer [4], [5], [6]. Opening a world for people that e.g. are afraid of needles or have blood clotting problems. Other uses are for real time monitoring, insulin delivery, pain meds and cosmetic applications to name a few [4].

The technology is still in full development but in almost all cases needs some kind of applicator to make the patches work effectively.

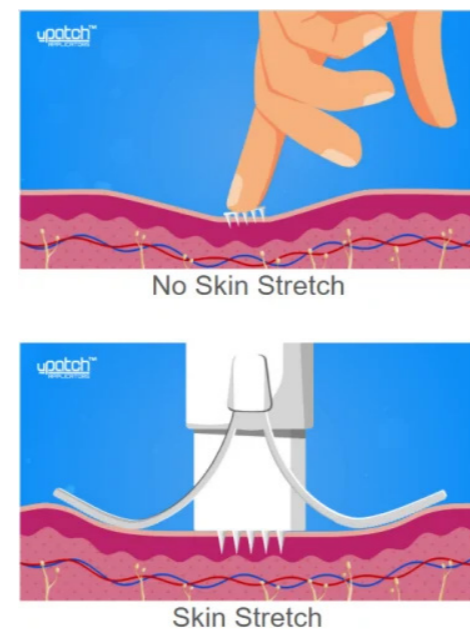

Figure 1.2 : Penetration comparison with and without stretcher [1]

1.2. Problem definition

Up until now there has been no applicator on the market to apply cosmetic microneedle patches (CMNPs), meaning there is potentially a gap in the market.

The main problem to be solved is the inconsistent and often incorrect application of CMNPs on the skin, specifically on the face. Currently, many users apply these patches by hand. This frequently leads to uneven penetration of the needles, meaning the active chemicals are not delivered effectively [7]. It can also result in the needles breaking because of poor handling, further reducing the patch's efficacy.

Another mayor point is that there is no scientific evidence that CMNPs penetrate the skin. Companies tell their customers that it works and some papers give evidence that the patches work but lack the information about the penetration success of the patches [8][9].

A CMNP can still be effective without penetrating the skin, it will work as a topical cream, fully undermining the specific value and purpose people buy the patch for.

An applicator will bring significant added value by ensuring that microneedle patches are used in a more effective, safe, consistent, and accurate manner. It will also make the patches easier to apply for the user.

For uPATCH, the start-up for which I am doing this thesis, it can expand their client base. Currently, their focus is primarily on the medical industry. By providing an innovative solution for cosmetic applications, this product can help them reach a broader market.

Designing the applicator to be modular or universal is a key part of my approach to sustainability. This means users/clients will only need one applicator to work with a wide range of patches. The full project approach can be found in Appendix A.

1.3. Research questions and objectives

Assignment: Developing a cosmetic microneedle patch applicator that can be used for multiple sized patches for a to be determined target audience.

for the applicator (impact, force, after-care)?

- Does the facial structure impact the effectiveness of penetration and stretch ability of an applicator?

1.3.1. Research phase

Research questions:

- What effects the penetration ability of a MNP?
 - o What functions does an applicator need to have?
 - o Which parameters are important?
- What are the different kind of CMNPs?
 - o What are CMNPs used for?
 - o What are the differences in geometry, form, size in CMNPs?
 - o Can CMNPs penetrate the skin in optimal circumstances?
- What does the market for (C)MNPs look like?
 - o What are the competitors for (C) MNP applicators?
 - o Which target audience would have most benefit from a CMNP applicator?
- What working principle is best suited

1.3.2. Design phase

Design questions:

- How does the user scenario of the applicator look like?
- How to design for minimal risk to touch the needles?
- How can the applicator be made so that the user wants and is able to use it?
- How can the design of the applicator help with the explanation of the use of it?
- How can the applicator be used efficiently on all areas on the face?

1.4. Stakeholders

The main stakeholders are uPATCH; the startup at which I am doing my thesis for and to be manufacturer of the applicator, the possible clients; who manufacturer and or sell CMNPs and the end-user (consumer); the person that will use the applicator. All three stakeholders have different needs and wishes. It is my purpose to balance these for all parties.

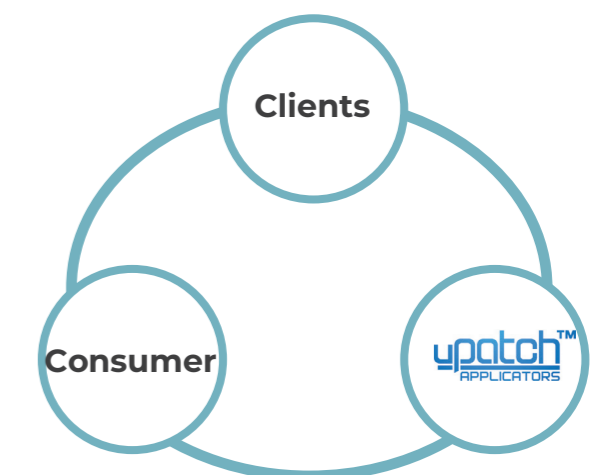

Figure 1.3 : Stakeholder visualisation

1.5. Project scope

The development of the internal components, outer casing and the feeling that the applicator will give is within the scope of this project. At the end most things need to be clear and only a few minor changes need to be made or decided to make this product ready for the market and production.

Due to time constraints a few areas will be out of scope in this project.

Designing a detailed stretcher, if this is the desired function and outcome from my research, it will not be fully embodied during this thesis. Furthermore, different sizes will also be out of scope, as well as a detailed cost price analysis and a full analysis of production. For all these areas a simple analysis will be done to give an estimation to see if the development is realistic.

1.6. Approach and methodology

The approach has a triple diamond model with a research, conceptual and embodiment phase. For the research phase the most important goals are to map out all the CMNPs, who has the most benefit with an applicator and if CMNP can penetrate. This diamond ends with a vision and reformulating of the assignment, key focus points, a function tree and a list of requirements. In the conceptualisation phase ideas will be made and worked out to three concepts and will be tested with users. This phase concludes with the concept selection to continue with in the third phase: embodiment. In this phase the concept will be detailed and developed until it is almost ready for production. Ending with a final product and recommendations for further development.

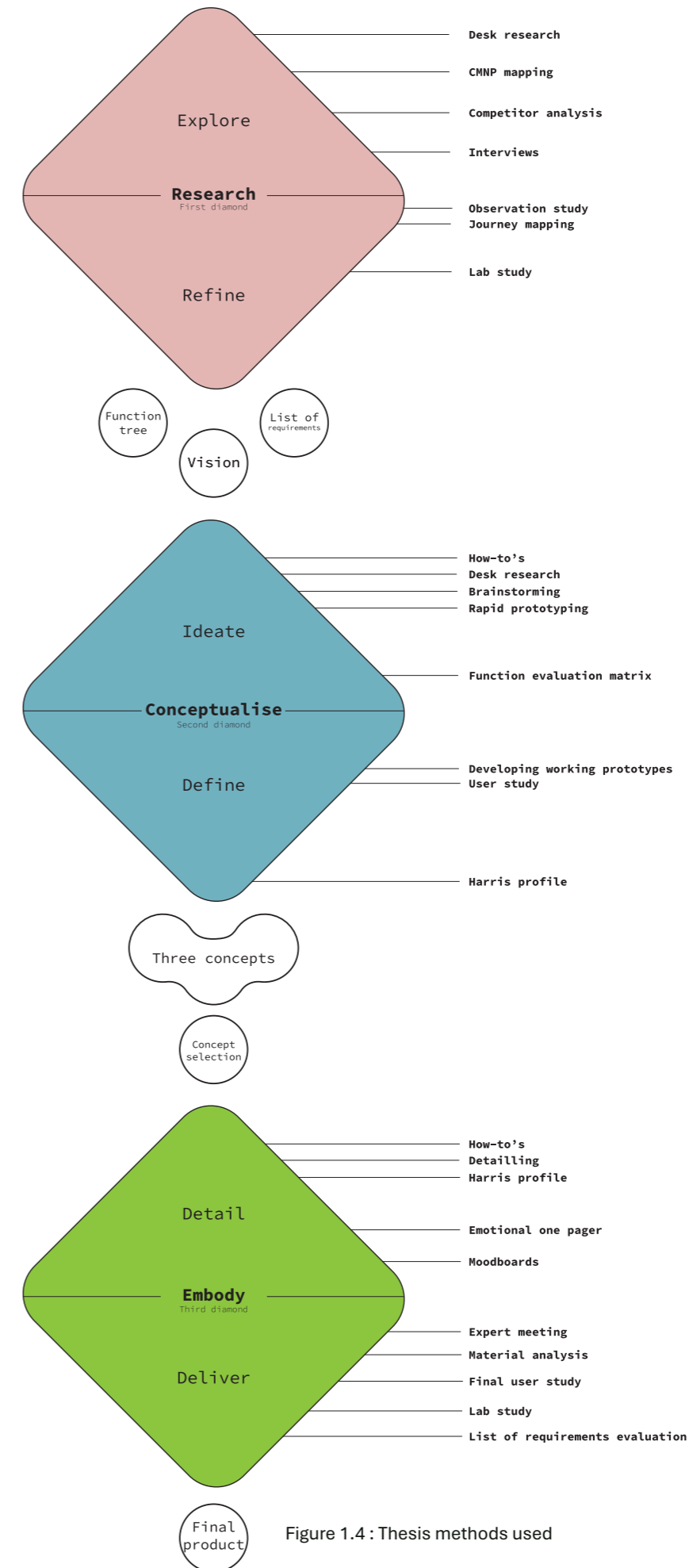

Figure 1.4 : Thesis methods used

Chapter 2

Research

2.1. Microneedle patches and their use	20
2.2. Similar products and competitors	24
2.3. Market research	28
2.5. Facial structure	44
2.7. List of requirements	48

The research phase focusses on four main research standpoints. Each will determine the project. Beginning with getting an understanding on the parameters that make MNPs penetrate and which system works best for facial application, determined which target audience has most benefit from an applicator, testing if these CMNPs can penetrate the skin and where current users pain points are with using these CMNPs.

This section will conclude with a vision on the problem statement, a defined requirements list, key challenges with the key points to focus on and a function tree.

Figure 2.1 : AAMNPs on its protection film [2]

2.1. Microneedle patches and their use

A clear understanding of microneedle patches is needed to determine what the applicator must be able to do for this an analysis of MNPs is conducted, to see what contributes to the ability of an MNP to penetrate the skin. This is done for MNPs in general and later with a focus on CMNP.

2.1.1. Working principle

To understand the use of MNPs there need to be an understanding on why and how they are used.

Some drugs cannot pass through the skin, as they are unable to penetrate the outermost layer of the skin, the stratum corneum (SC) which consists out of layers of dead skin cells [3]. To cross the SC, a drug must meet certain requirements: a molecular weight of under 500 Da, good solubility in both oil and water, a low melting point, and a high yet balanced octanol–water partition coefficient [2]. As some drugs cannot pass through the SC, TTD is required. TDD is the delivery of drugs through various layers of skin, this way the drugs can

reach the systemic circulation. The needle mostly penetrates up to the epidermis or dermis, see Figure 2.4. One of TTD main advantages opposite to injection or oral administration is the avoidance of degradation by liver metabolism and the gastrointestinal tract, while also providing a highly controlled method of delivery [2]. The needles of the MNP penetrate through the SC, making TDD possible and enables the body to absorb the drugs that can't be absorbed topically (Figure 2.4) [2].

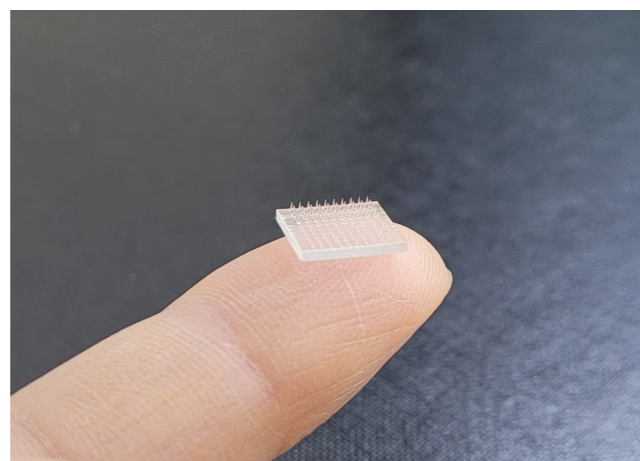

Figure 2.2 : Dissolvable MNP [4]

MNs overcome the skin barrier by creating microscopic channels through the SC. The needles are extremely small, ranging from 25 μm to 2000 μm , but are typically shorter than 1000 μm [2] [10]. MNs reach into the epidermis or upper dermis, without reaching the pain receptors which lay deeper in the skin (see Figure 2,4) [5], [6]. This means that applying an MNP should be painless.

MNs are made out of different materials, geometries and ways to deliver the drug with the needles. There are five types of MNs; solid, coated, hollow, dissolving and hydrogel MNs (Figure 2.5) [11]. The needles themselves are typically made from materials such as metal, silicon, glass, titanium, polymers, or sugar-based solutions [2], [12].

The use of MNPs is currently still in development as it is a slow innovation. But it can be used for all different kinds of drug delivery, such as for insulin or vaccine administration, monitoring and scar treatment [13], [14].

Topical cream Injection needle Microneedle patch

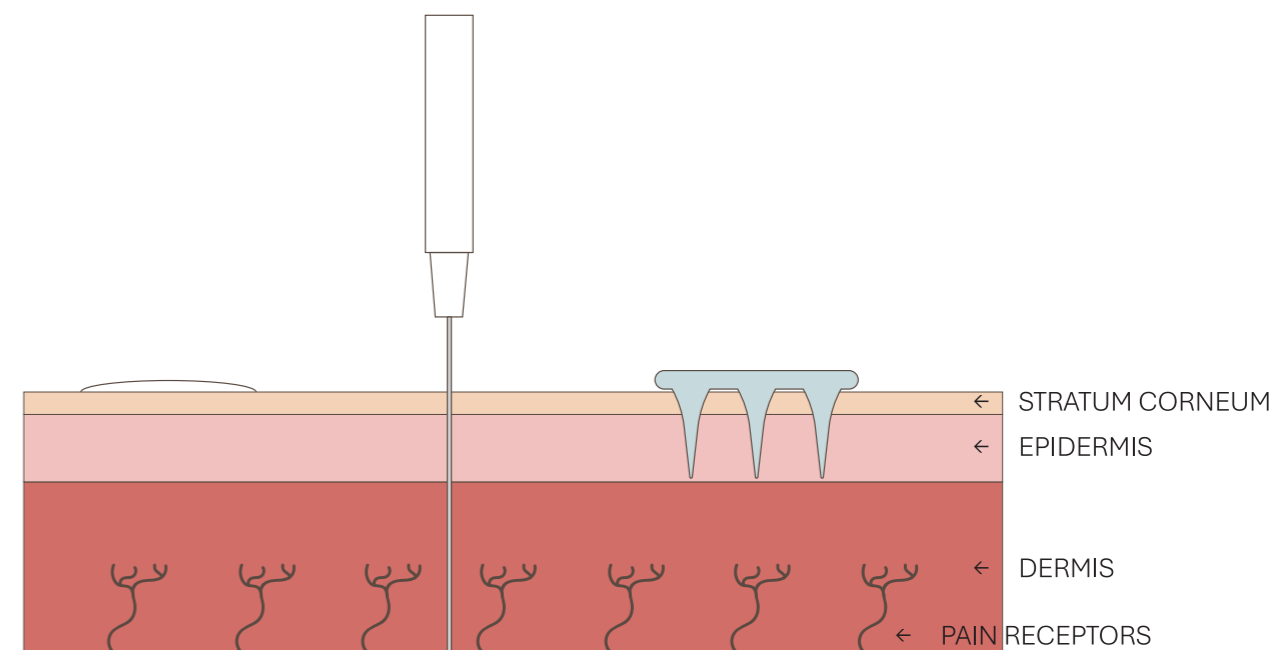

Figure 2.4 : Overview of different drug delivery systems

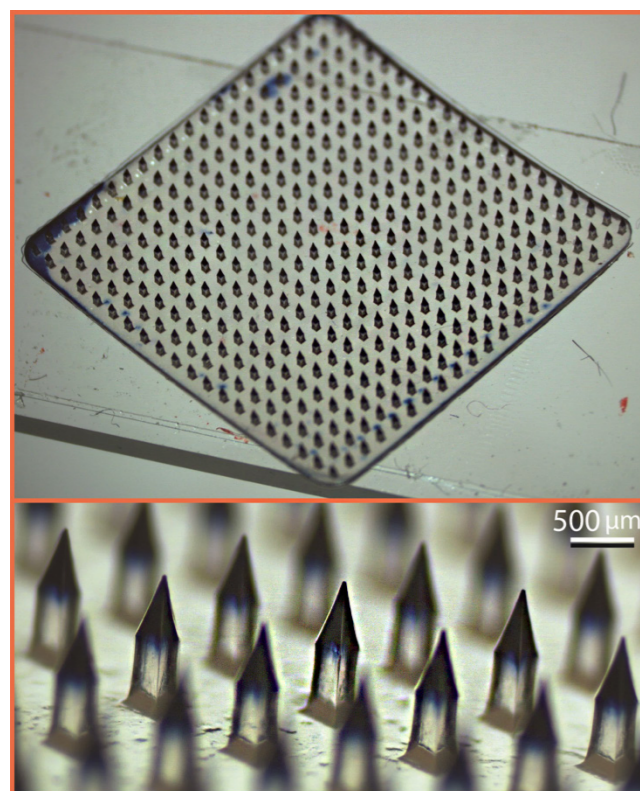

Figure 2.3 : Microscope photo of solid MNP [3]

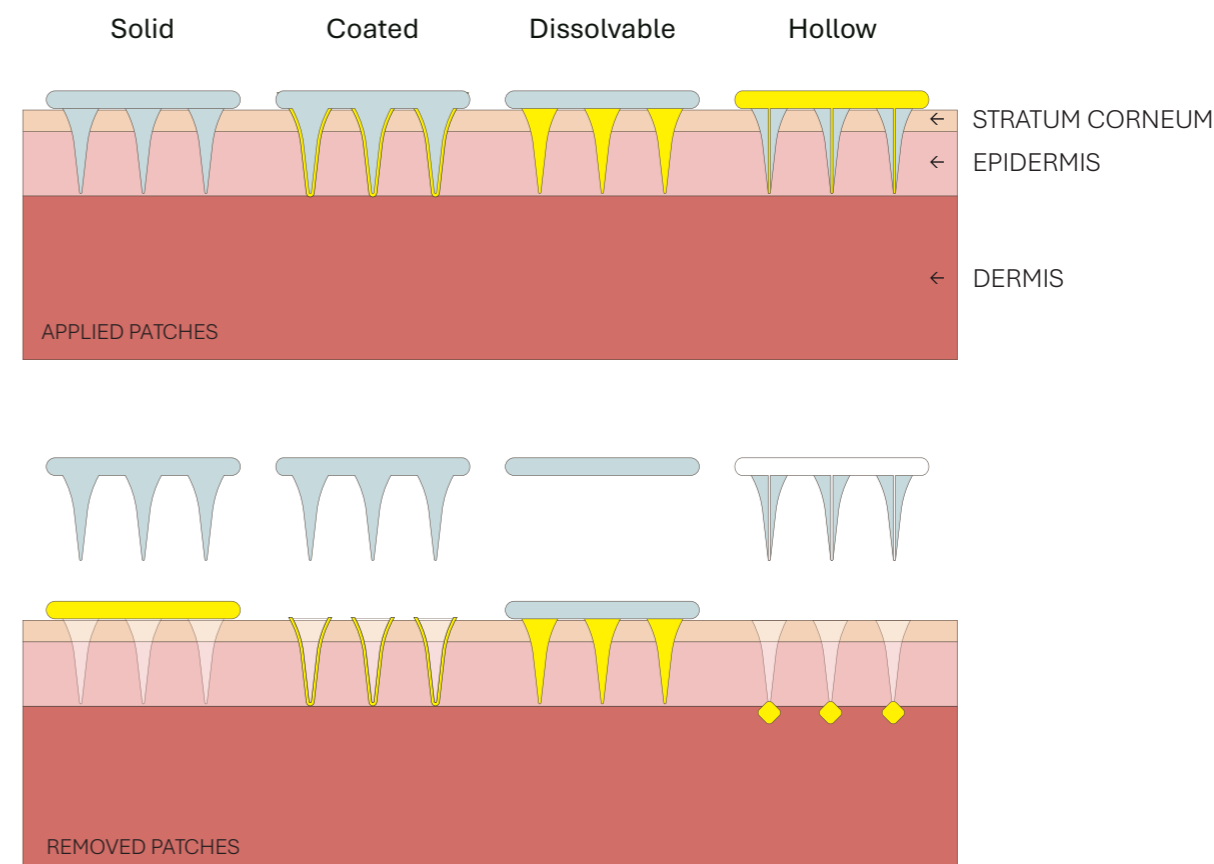

Figure 2.5 : Overview of different MNP technologies

2.1.2. Effective penetration of microneedles

Three factors contribute to the penetration of an MNP through the SC: the **architecture** of the MN and patch; the **type of force** used for application and the **skin structure**. The factors contribute to overcoming the elasticity and strength of the skin to successfully penetrate the SC[15]. Penetration could be achieved by making one factor more optimal, e.g. a higher impact force, stronger material or a sharper pointed needle. There is not a one-size-fits-all. Depending on factors and requirements, the parameters could need to be adjusted.

How - Application method

To make penetration possible the strength and elasticity of the skin needs to be overcome by the (array) of needles with a certain amount of force. There are two types of force application: velocity-driven (impact force) or force-based (pressing force) insertion[10].

Impact force is in general more effective according to research from uPATCH[10]. But it becomes less accurate when the insertion angle is not perpendicular to the skin. As not all the needles will touch the skin at the same time and the patch will lose its velocity. Pressing force applies force for a certain period time, ensuring that all needles have the same force applied. Figure 2.6 shows the difference between the two methods used in the test by uPATCH.

Generally, a higher force can be used more comfortable with impact force than for pressing force. As less discomfort is experienced as impact force is applied for only a fraction of a second and pressing force is applied from 1 second up to several hours.

What - Needle architecture

The parameters of the needle have effect on the penetrability of the patch; length, tip radius, general form and shape, wall thickness, material (mostly the structural integrity of the material)[16]. Next to the geometry of the needle and needle array has impact on penetrability. Having the needles stand too close to each other results in a

bed-of-nails effect, making penetration harder[16]. But having them far apart is also not beneficial as this results in higher elasticity that must be overcome for penetration.

Where - Application area

The thickness, elasticity of the skin and the underlying structure affect how easy the needles penetrate. High viscoelasticity of the skin makes the skin deform along with the MNs more easily. Decreasing the force of the skin against the MNs, inhibiting penetration. By increasing strain of the skin, stretching it, enables the MNs to penetrate more easily, thus with less force[16]. This can be done by stretching the skin, something that uPATCH also does in their applicators[17].

The applicator will have influence on two factors: the application area, by stretching the skin and the application method. The following step is to research which application method works best for a cosmetic applicator which is described in Chapter 2.4.

Figure 2.6 : Comparison of pressing vs impact force mechanism [10]

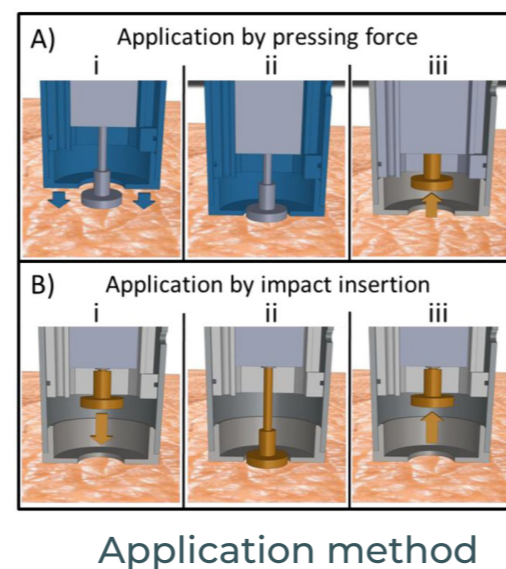

Figure 2.7 : Illustration on bed of needles effect [5]

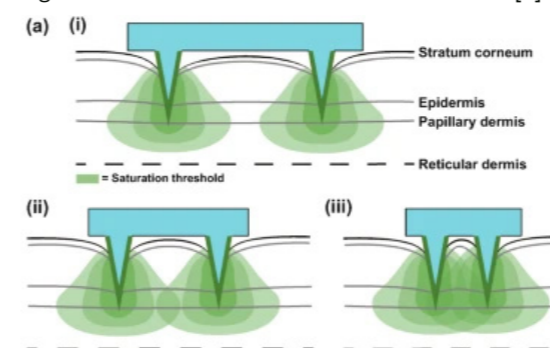
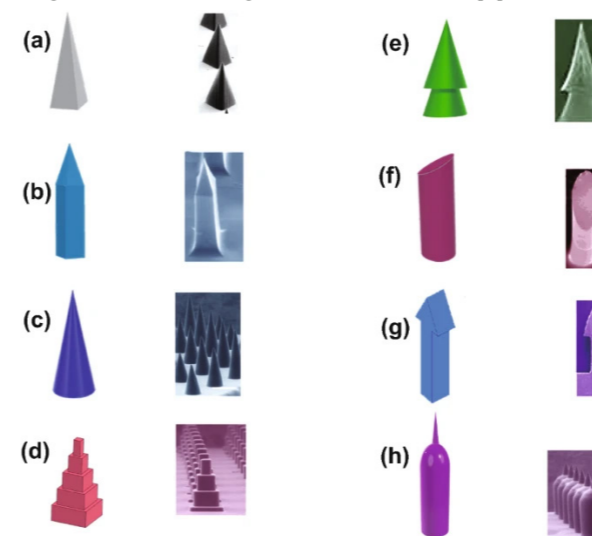

Figure 1.5 : Different geometries of needles [5]



Needle architecture

Penetration

Figure 2.8 : Effectiveness of stretching visualised [1]

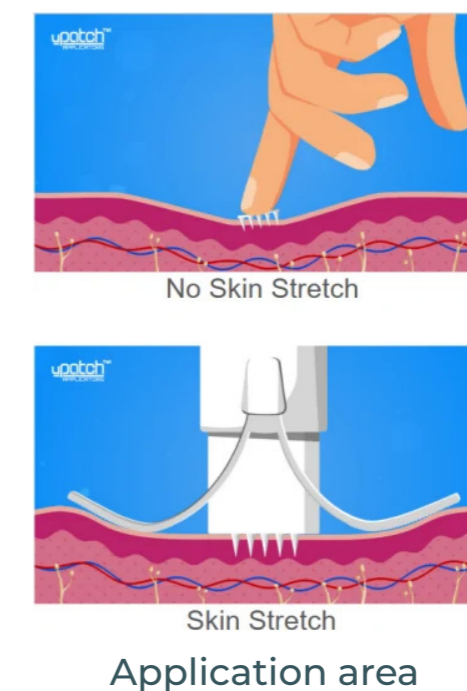

2.2. Similar products and competitors

The existing similar applicators are analysed. Which are for medical use only and are focused on application on the forearm or stomach.

The existing multiple use applicators are mostly cumbersome, tubelike form is preferred though the product. There are no cosmetic applicators on the market yest, meaning that there could be a market gap.

uPATCH PLUS— Applicator: impact force, multiple use [18]



- Impact force by spring system
- Patch is loaded with a dock
- Automated activation by pressing which released the spring
- Has stretcher

uPATCH ONE — Applicator: pressing force, single use [19]



- Pressing force by overcoming a barrier at a certain force
- Has stretcher

Kindeva — Applicator: impact force, multiple use [20]



- Hollow microneedle applicator:
- It looks like they use a kind of system that works as an epipen for activation,
- Impact force is generated with air pressure.

Kindeva — Applicator: impact force, multiple use [21]

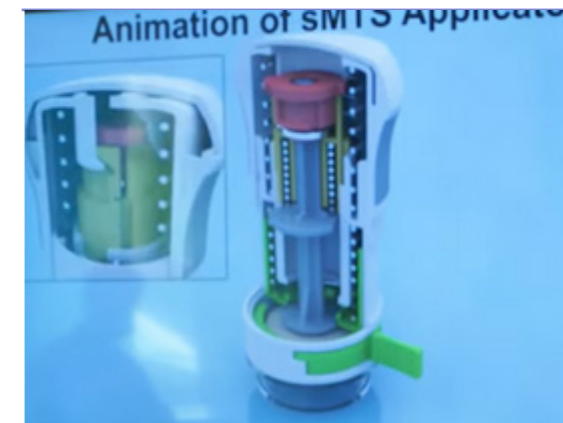

- The patch is loaded into the device with some a holder, this holder might be single use.
- The impact force is done with a spring(s).
- It is unclear how the spring it loaded and activated. It looks like it can be done with turning and then pressing to activate.



Triple ring — Applicator: impact force, multiple use [22], [23]

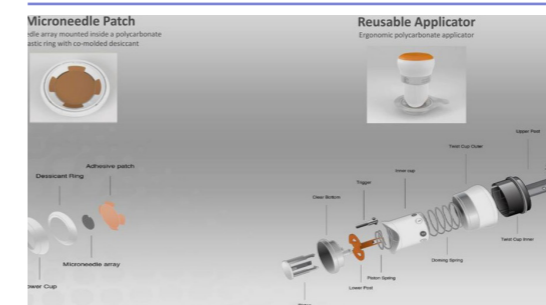

- The patch has a carrier.
- The impact force is done with a spring(s).
- It is unclear how the spring it loaded and activated. It looks like it can be done with turning and then press to activate.
- The turning motion can be for only changing the number.

Smicna — Applicator: impact force, multiple use [24], [25]



- Activated with the button on the side.
- Loaded with a dock and it needs to be twisted for the patch to be attached to the applicator.
- The tube creates tension to make penetration of the needles easier.

Corium — Conceptual applicator [26]

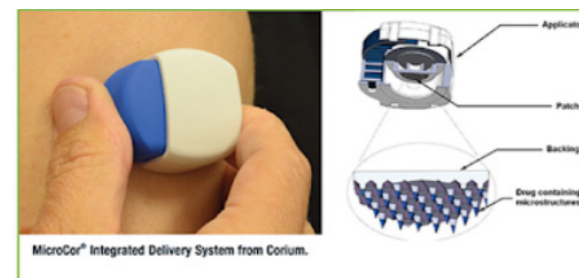

- Pinch to activate
- Most probable with pressing force but it is unclear

Micron Biomedical — Applicator : Pressing force, single use [27], [28]

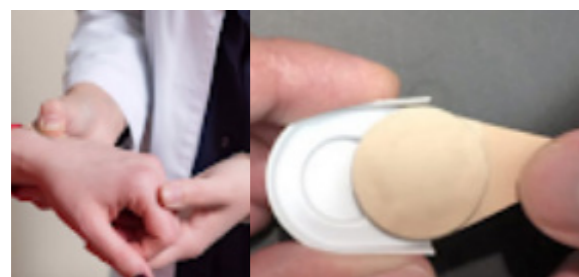

- At a certain amount of pressing force clicks inside out and pushes the microneedle array on the skin.

Pharma Latch— Applicator: sliding force, single use [29]

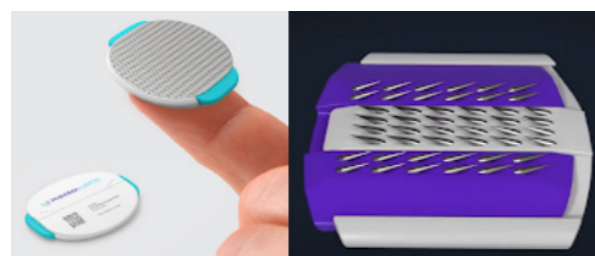

- A coated microneedle patch that latches on to the skin by use of a sliding movement

Yonsei University & JUVIC Inc.— Applicator: Pressing force, single use [30]

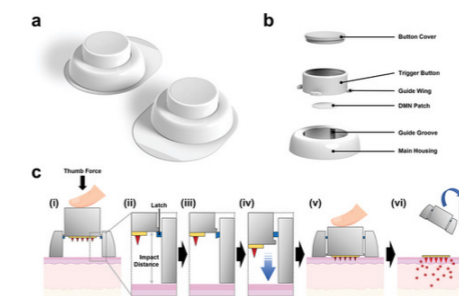

- Works by overcoming a force to break the small beams.

Research institution — Wearable integrated microneedle array [31]

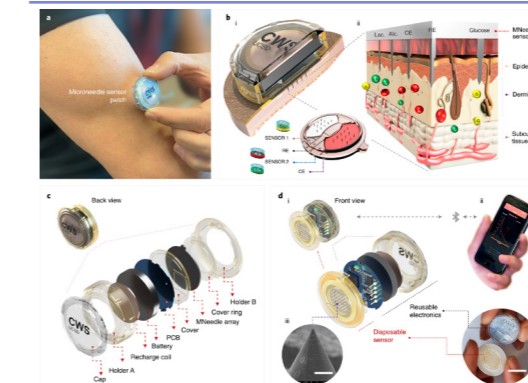

- Monitors glucose and lactate levels in the body, not clear how the patch is applied to do body.

TaikiUSA — Cosmetic applicator: pressing force, multiple use [32]



- This is a stamp that is being used to press cosmetic microneedle patches into the skin.
- This is used after the patch has been applied to the skin.

2.3. Market research

Thorough research was conducted to get a better understanding of the market that the applicator can be used in. The different kind of CMNPs are mapped and categorized, in Appendix B. Possible target audiences are analysed and compared to see which one has most need for an applicator. For uPATCH the business perspective is considered.

2.3.1. Asian beauty standard – Glass skin

In East Asia, beauty standards differ from those in Western countries. For this research, the focus is on the beauty culture in South Korea, Taiwan, Japan, and China due to its direct relevance to this project.

The East Asian ideal emphasizes skin that is clean, fair, and blemish-free, commonly referred to as “*glass skin*” or *Yuri Pibu*, see Figure 2.9 [33]. In South Korea, glass skin represents health and self-care. This trend, which originated in the early 2010s, continues to influence beauty practices today. The cultural practice to have clean, pure skin dated much further to the Joseon Dynasty. Here Confucian ideals were pale flawless skin showing women their purity and nobility among women of middle and higher social status[34][35].

The glass skin trend has since become deeply embedded in East Asian culture, particularly in South Korea, fuelled by the global spread of K-drama, K-pop, and social media [33]. History and media attention could be the reason why in Asia skincare is so important and that both consumer and companies invest and innovate in it.

Figure 2.9 : Portrait of a woman with ‘glass skin’ [6]

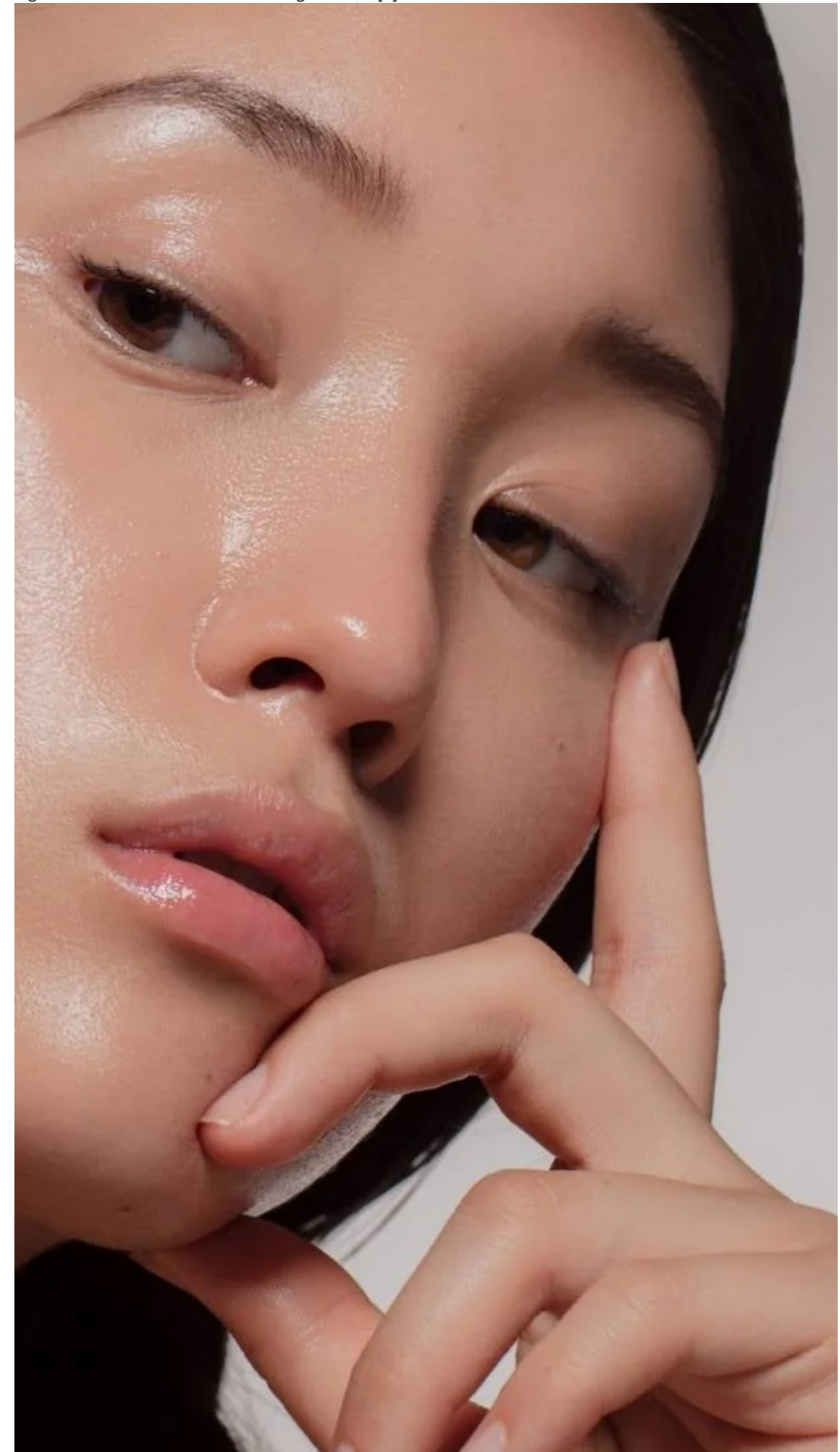

2.3.2. Kinds of MNPs in cosmetics

To identify the most suitable target audience for uPATCH to expand its market, the types of cosmetic MNPs currently available worldwide were examined. The most popular MNPs are made for skin blemishes and for treating early breakouts/acne, hereafter referred to as **anti-acne MNPs (AAMNPs)**. Also commonly known as ‘pimple’ patches. The other common MNP product is anti-aging MNPs, which target fine lines, wrinkles, and hydration, referred to from now on as **anti-aging MNPs**. Other cosmetic MNPs exist, but these are either still in early development, not widely available, or a marketing scam/placebo, thus not suited for this thesis[36].

The design and size of the kind of patches differ by use case. AAMNPs are usually small and round, while anti-aging patches come in a variety of shapes, such as bean-shaped, rectangular, teardrop-shaped, or similar to the size of a standard plaster [37], [38], [39], [40], [41], [42], [43], [44], [45], [46], [47], [48], [49].



Figure 2.10 : Anti-aging MNPs from ISBEAUSOLS [7]



Figure 2.11 : Some By Mi AAMNPs [8]

2.3.3. Target audience determination: end-user

This thesis considers two target audiences: the consumer (end user) and the client (companies purchasing the applicator). As uPATCH’s client relationships are still developing, client needs are based on informed assumptions and potential clients are mapped, Appendix C. This chapter focuses on the consumer. There are two consumer audiences for CMNPs:

- East-Asian individuals aged 11–30 with (mild) acne
- East-Asian individuals aged 44–74 concerned with skin aging[50][51].

From a market perspective, both these markets are comparable. Reported market shares vary, with anti-acne MNPs accounting for approximately 23–35% and anti-aging MNPs 28–45% [52], [53]. Although anti-aging products hold a slightly larger share, the anti-acne segment is currently the fastest growing. Most manufacturers offer both types, meaning there is no clear marketing or manufacturing driven advantage in one over the other.

Both consumer audiences can have a negative emotional and mental impact due to their acne or aging skin. Thereby both groups can benefit mentally from treating their acne or wrinkles[54].

The anti-aging group is more likely to invest in an applicator due to long-term use and higher purchasing power. The anti-acne group also presents potential, as acne is often recurring, although this group is generally more price sensitive. In the Asia-Pacific region, where skincare spending is relatively high, this concern is less significant. Given that consumers already spend €15–20 on acne patches, a similarly priced applicator is a reasonable investment.

As no clear preference emerges from market or user analysis, the decision is based on expected design challenges.

Designing for anti-aging applications introduces greater complexity, particularly in achieving consistent penetration on uneven or angled areas (see Chapter 2.5). In contrast, anti-acne patches are smaller, applied locally, and easier to control.

Considering both feasibility and future development, the anti-acne consumer audience is chosen. The required precision and compact design can later be more easily extended to other applications for uPATCH. Moreover, this focus aligns with the scope of this thesis by avoiding the most technically challenging requirements.

Selected target audience: individuals aged 11–30 in the Asia-Pacific region experiencing occasional acne.



Figure 2.12 : Woman with mild stage acne



Figure 2.13 : Woman with severe stage acne

2.3.4. Use of anti-acne microneedle patches

AAMNPs are patches that help with (deep) blemishes, early breakouts and hyperpigmentation spots on the skin. They either actively help with healing the blemish or hydrate it for better healing. The patches should not be used on active blemishes as this can irritate the skin more[55]. The most common active ingredients are niacinamide, salicylic acid, hyaluronic acid, and some other ingredients that are skin soothing and anti-inflammatory. Niacinamide calms the skin and has anti-oxidating properties[56], Hyaluronic acid hydrates the skin, makes it more flexible, helps it heal and is proven to reduce scarring [57]. Salicylic acid is the most active working ingredient against blemishes used in MNPs. It decreased inflammation, helps unclog pores and loosens dry scaly skin[58].

Some of these ingredients can already pass through the SC as they are either fatty ingredients or have a low enough Da value, such as salicylic acid and niacinamide. But the SC still does not allow for all the ingredients to fully pass through[59]. Aswell as that TDD makes the absorption of all these ingredients more effective [60]. CMNPs can be a beneficial skincare product and are used to reduce (irritated) early blemishes and hyperpigmentation.

All AAMNPs currently available use dissolvable MNs. Their size typically ranges between ~220–500 µm in length, with most averaging around 250 µm[61], [62], [63], [64], [65], [66], [67], [68]. These dissolvable needles are made from a binder, hydraulic gel. The working ingredients are absorbed into this gel and are released when the needles dissolve. The needles dissolve with the help of body enzymes, when they touch or penetrate the SC and from body heat and moisture [55].

A thorough analysis of AAMNPs has been done (Appendix B). From this analysis the following parameters are determined in Table 2.1.

Protective packaging of AAMNPs

The patches are sold in sets, typically containing 1, 2, 6, or 9 (see Figure 2.16 & 17). The packaging is made using vacuum forming. In the packaging there is an elevated rim on which the film of the patches rest, this prevents the needles from touching the bottom. The film is perforated which makes it easier to remove. Depending on the type of packaging, the rim may only be located on the outside (see Figure 2.16) or it can surround the entire patch, providing better protection (see Figure 2.17a). The packaging's with more than 2 patches can be resealed. Smaller packages come with a heat seal that needs to be ripped off.

Patches that are packaged with less than two patches are low density needles and have less risk of damaging the needles due to the packaging.



Figure 2.15 : Different AAMNPs up close [11], [12]

Parameters of anti-acne MNPs	
Form	Circular, oval, star, flower heart
Size	9-19 mm in diameter
Length needles	250 – 500 µm
Form of needle	Pointed needles or cut off on the top
Amount of needles	16 – 320
Density of needles	~30 needles/cm ² –640 needles/cm ²

Table 2.1 : parameters of AAMNPs

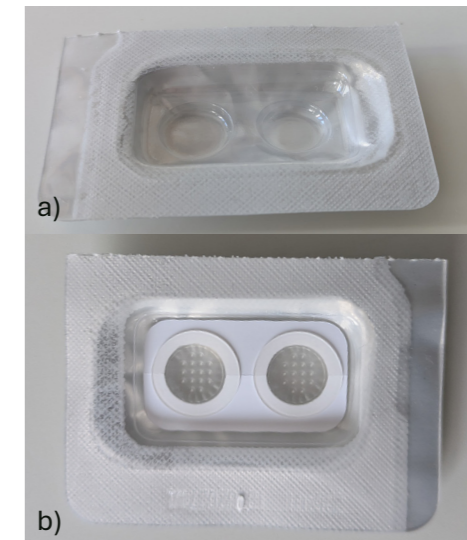

Figure 2.17 : a) Holika Holika MNP packaging for two patches b) with patches



Figure 2.16 : AAMNPs in packaging of 9 [13]

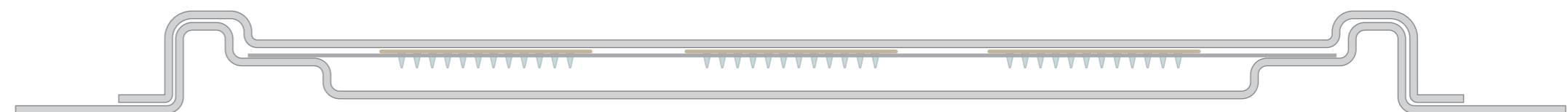
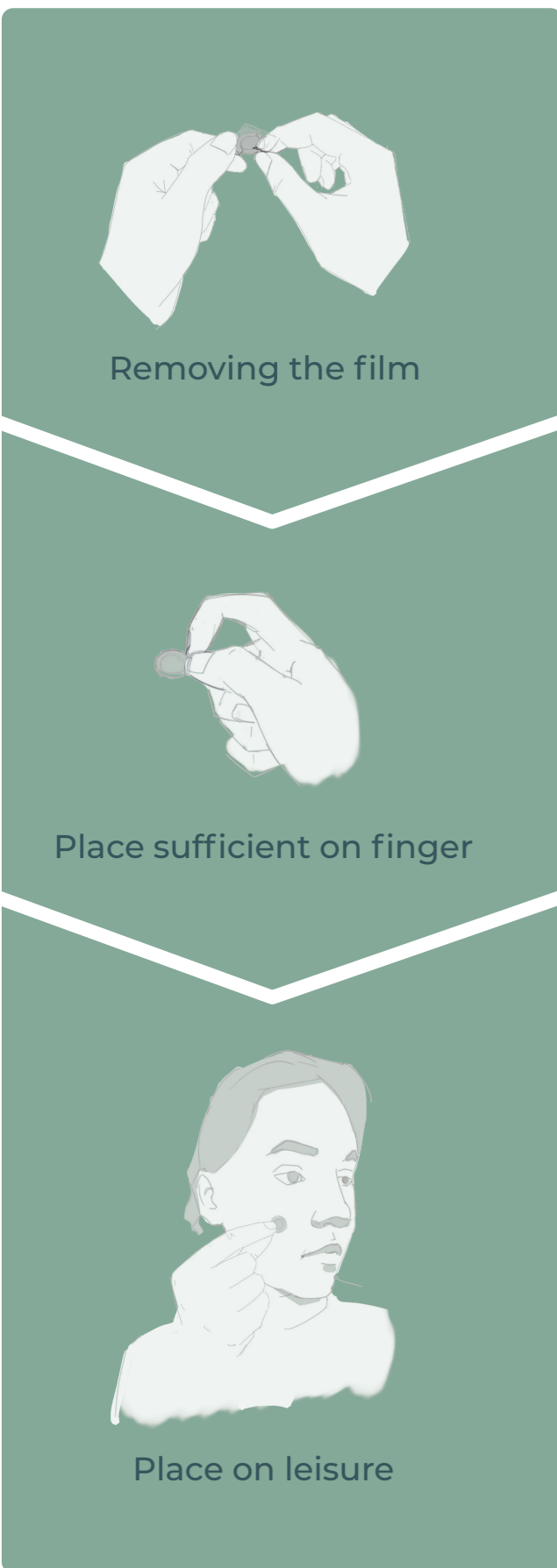

Figure 2.14 : Section view of AAMNP packaging for 9 patches

Risk to touch needles



2.3.5. User study 1- current use

The instruction for the use of AAMNPs vary slightly to one another. Varying between: press gently/ firmly for 2-20 seconds. It is curious to note that no instruction manual mentions anything about avoiding touching the needles.

To understand the situation as it currently is a user study (n=5, age 18-30, man and female) was conducted with a one-on-one semi structured interview talking about the experience of the participants. The complete study is described in Appendix D. For this study the AAMNP from Some By Mi were used. The participants were asked to apply one of the patches on their face on a pimple, if they had any.

In the study not everyone was convinced that the needles penetrated the skin, as participants didn't 'feel' it. The participants that thought that the needles penetrated, reasoned that they felt the patch prickling on their skin. This insight motivated the use of an applicator as users already are doubtful of the effectiveness of the patches.

In general the patches were hard to handle, as participants didn't want to touch the needles and their fingers and nails kept getting stuck on the sticky rim. One participants used tweezers to solve this, which gave more control.

With the current use the risk of touching the needles happens at three activity points: removing the film, place patch sufficient on finger, applying patch on the leisure. In the design of the applicator these risk points need to be eliminated as much as possible.



Figure 2.19 : P.1 doing the user test for the current use of an AAMNP

Figure 2.18 : Use steps where risk to damage needles is high

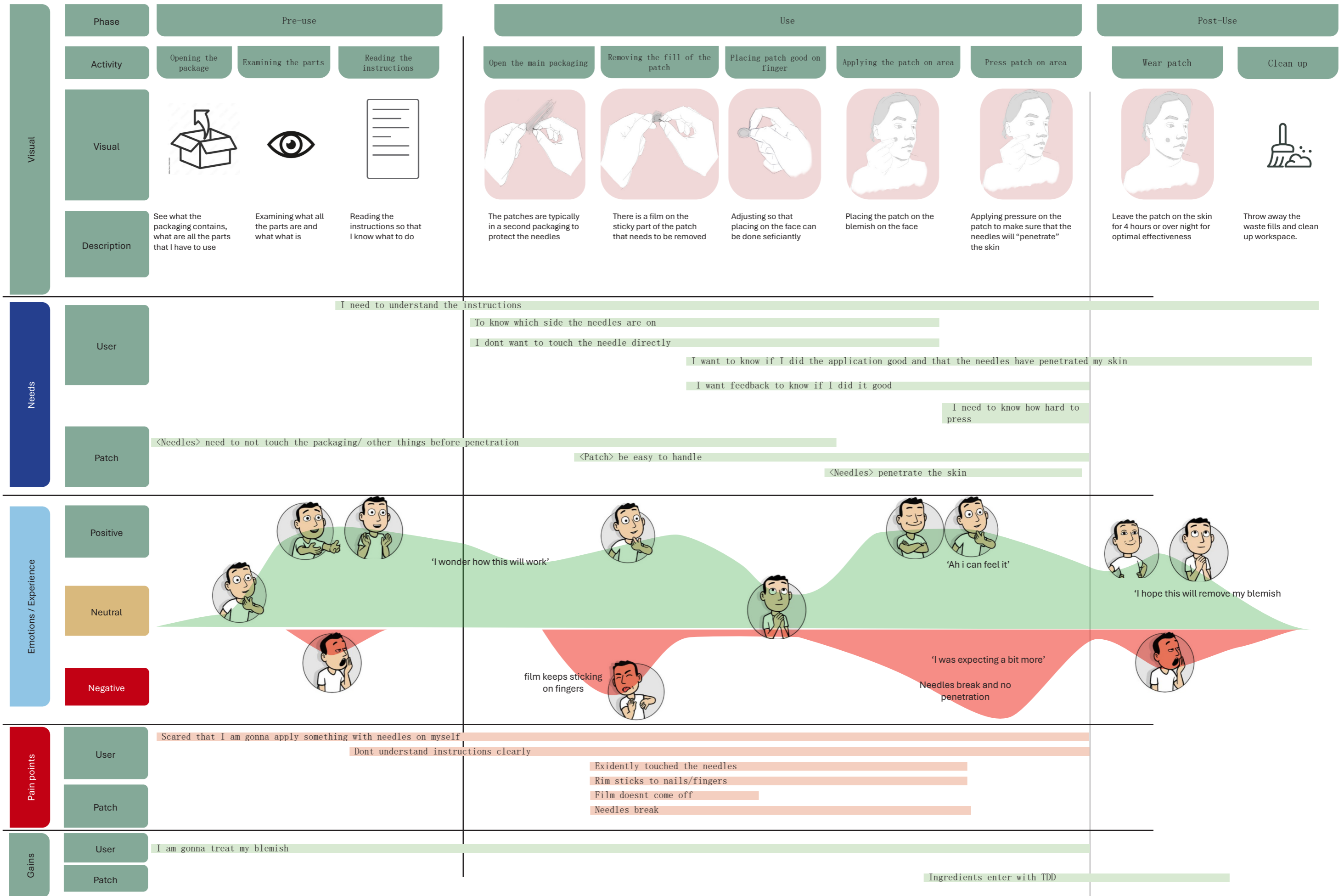

Figure 2.20 : Journey map current use

2.3.6. Effectiveness of CMNPs

Brands that sell CMNPs often claim that penetration occurs, but do not support this with (scientific) sources. This can suggest the following: the patches are not tested. They might achieve penetration or it is tested and there is no penetration.

The geometry of most cosmetic MNs are not optimal for penetration. As the length averages at 300 μm, with some being shorter, making penetration harder to achieve. Furthermore, the strength of dissolvable needles is questionable. They might break or bend more easily when attempting to penetrate the skin. As well as that some do not have a sharp point, resulting in a higher force needed to penetrate. The needles array also varies greatly with some patches already being hard to penetrate purely due to the bed of needles effect (Figure 2.21 a).

The studies that do report penetration often use testing methods that involve moderate force applied over an extended period. For example, one study applied approximately 225 g/cm² for 40 minutes [69]. Other studies do not specify the

force that was applied during testing at all [63], [64], [70]. This makes it unclear whether these findings reflect realistic use conditions.

The available research suggests that CMNPs can penetrate the SC, but under conditions that do not reflect real-world situations. This reinforces the need for an applicator to ensure penetration. For this reason, several tests were conducted that examined if penetration is possible with CMNPs in the current situation and with an extreme force to see if penetration with impact force is possible.

Lab study 1 & 2: testing penetration of AAMNPs

The first study had no significant results with no penetration in any of the tests, results can be found in Appendix E. As the conditions of this study were not realistic and somewhat questionable, a second study was done.

In the second study two different AAMNPs were used, a low-density patch seen on Figure 2.21b and a high-density patch seen on Figure 2.21a. These patches are selected to see if there is a difference for penetration effectiveness across different needle arrays.

Both types of patches were tested with two methods.

- Test method 1: current application procedure: Applying pressing force of 32N for 15 seconds with a constant pressing force device, Figure 2.22
- Test method 2: extreme velocity driven: Applying impact force of 120 N with a modified uPATCH Plus applicator, Figure 2.23

These tests were conducted **in vivo** on the inner forearm.

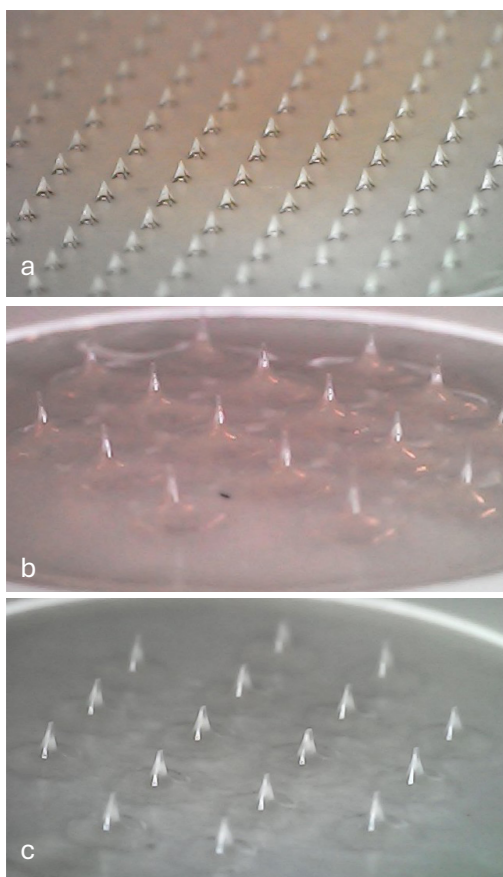

Figure 2.21 : Micro images of AAMNPs: a) by AC Balancing b) by Holika Holika c) by Raphas



Figure 2.22 : Constant pressing force device



Figure 2.23 : Modified uPATCH Plus applicator

To assess whether penetration occurred, salt water was applied to the forearm after the patches had been applied and removed. The full study is described in Appendix F.

Four observations are done to determining penetration:

- localized redness caused by the needles
- tactile irritation after applying salt of the patch location on the skin
- how far the needles are dissolved.
- the formation of visible bumps in the skin

The flow chart shown in Figure 2.24 was used to determine penetration.

Redness caused by the needles were (partly) observed in all tests, these do not necessarily indicate penetration, as microneedles can cause superficial irritation without entering the skin, but also would occur if they did penetrate. If the redness of the needles is paired with significant tactile irritation and/or bumps, penetration can be concluded.

Furthermore to check if penetration occurred, the needles are examined after application. If they did not dissolve, there is no penetration. As the needles dissolve after they make contact with moisture, heat and body enzymes, which happens when they penetrate through the SC. But also when the needles are on the skin in an enclosed space. Meaning that needle dissolution cannot be used as sole reasoning for penetration as dissolution can occur in different scenarios.

The velocity driven with low density patches, resulted in clear penetration. All four observations occurred with this test. (Figure 2.25b & d). In the pressing force test the skin did not form bumps, but all other indications that there was penetration were present. There is no penetration, as there are no bumps with the same patches with the pressing force test.

The high-density patches only had slightly dissolved needles. With the pressing force test, only the outer rim of the needle array caused redness on the skin and a lot of needles were bend (Figure 2.26a), indicating that if there was penetration only the outer rim would have penetrated. In the velocity test this redness in on the whole array but more moderate. No bumps were observed

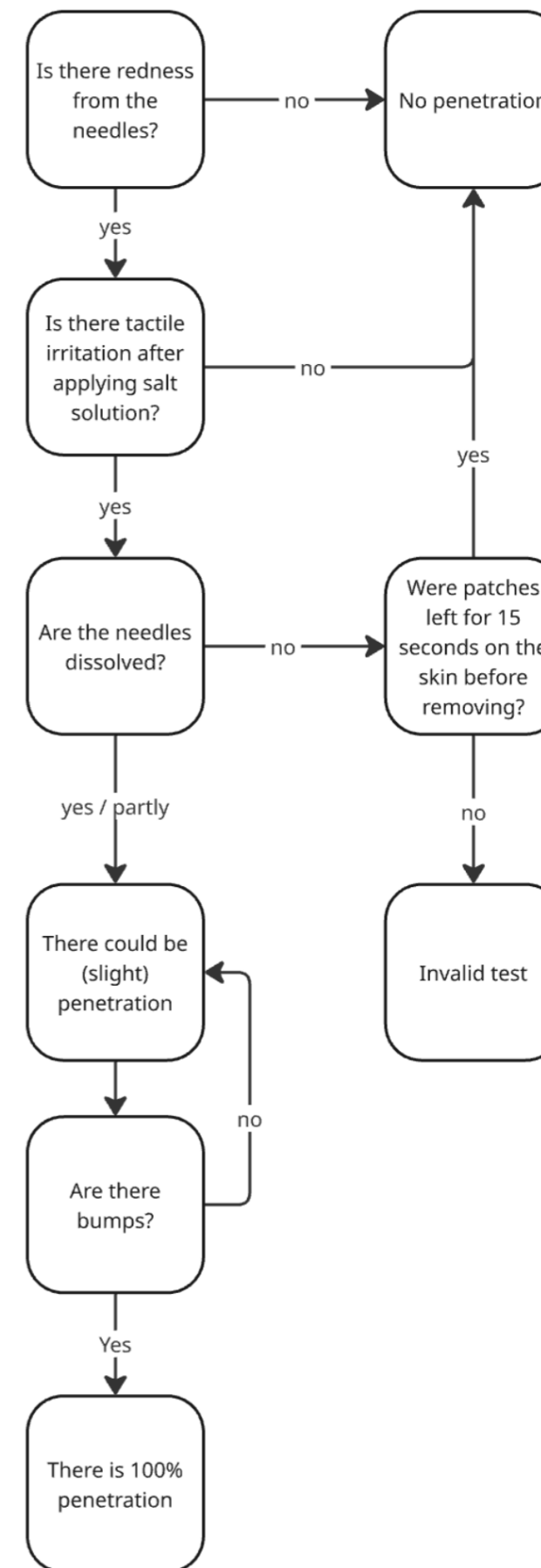

Figure 2.24 : Flow chart for determining penetration

In all tests there was tactile irritation after the application of the salt solution, but more noticeable with the low-density patches with the velocity test, reinforcing that penetration occurred here.

The tests conclude that with manual pressing force application both kind of patches do not penetrate the skin. Penetration was only seen with the low-density needles with the velocity test and is therefore the best application method to continue with. This is more comfortable to apply on sensitive and irritated skin. As the force that is applied is applied for less than a second due to do the velocity driven method. Whereas the pressing force method needs to be applied for at least a couple seconds.

An important insight has been that not all AAMNPs are suitable to become a patch that can penetrate with an applicator. Data from patch mapping analyses (Appendix B), no manufacturer has stated that consumers should be mindful with avoiding needles, this together with that high density needle arrays are unlikely to penetrate the skin and that these are the patches that are mostly packaged with 9 pieces at the time (which makes it easier to damage the needles throughout the use of the patches), makes it clear that within the AAMN market there are two groups. The AAMNP group with possible effective needles, and the group that do not and are not able to penetrate the skin even with an applicator. Thus, concluding that the second group has needles likely only for marketing advantage and not for effective use.

In a further study it will be researched what the lowest force needed for impact force to still have penetration with the low density MNPs.

Table 2.2 : Results lab test 2 for penetration probability

Test variables	Low-density, pressing	Low-density, impact	High-density, pressing	High-density, impact
penetration	Might be slight penetration	100% penetration	no penetration	no penetration

Figure 2.25 : Holika Holika, low density patches test visuals a) micro image after pressing force penetration b) micro image after impact force test. c) skin test surface after test pressing force d) skin test surface after test impact force

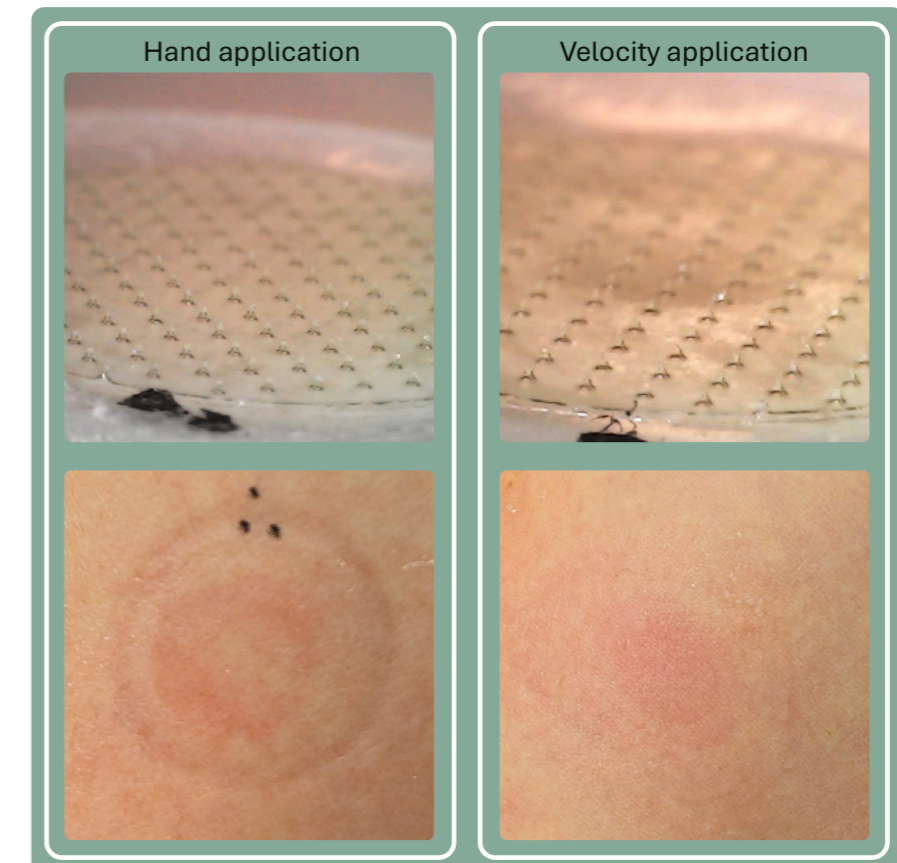
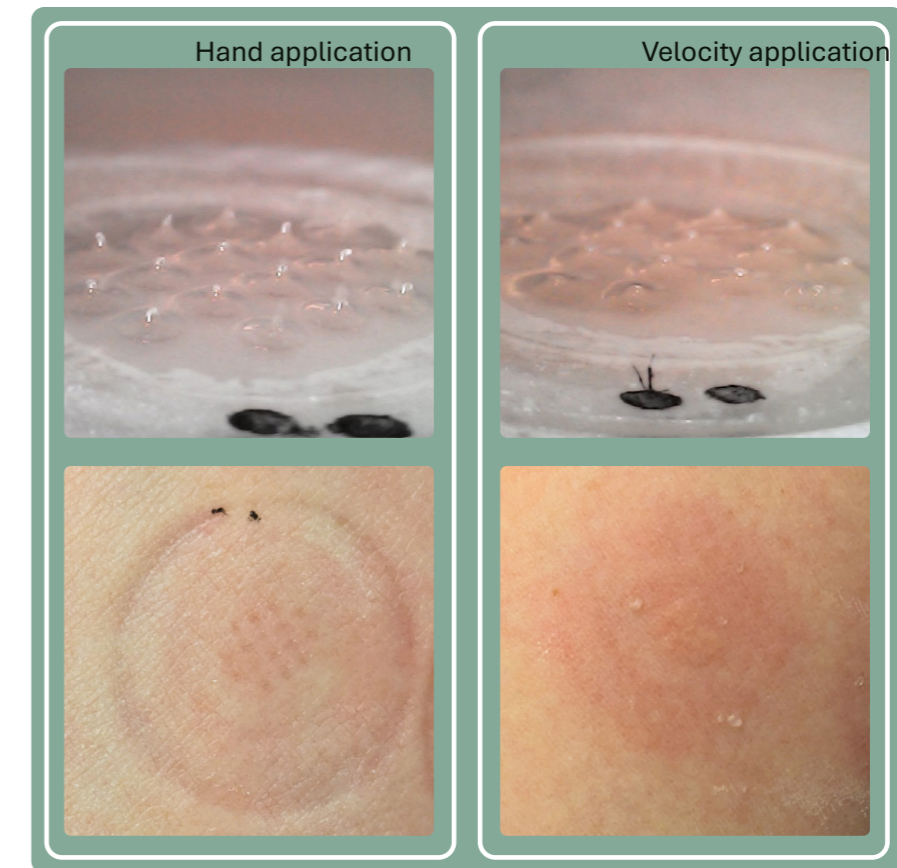

Figure 2.26 : AC Balancing, high density patches test visuals a) micro image after pressing force penetration b) micro image after impact force test. c) skin test surface after test pressing force d) skin test surface after test impact force

Acne formation

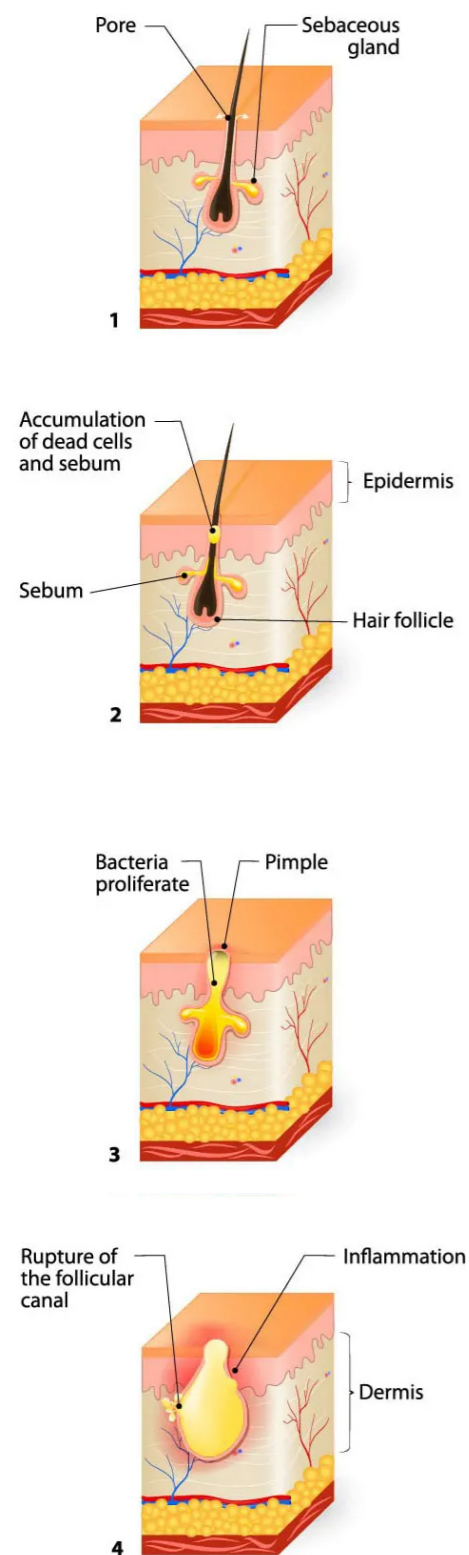

Figure 2.27 : How acne is formed in the skin [26]

2.4. The kinds of acne

To further specify the use of the applicator and AAMNPs it is important to understand the medical condition it is used for, acne, the full research on this can be found in Appendix G .

Acne, medically known as acne vulgaris, is the skin condition in which pores, hair follicles or sebaceous glands become clogged and/ or inflamed, Figure 2.27 [71], [72]. Contrary to popular belief, it is already called acne if a person has a single pimple[72]. What most people typically associate with ‘having acne’ is moderate to severe forms of the condition. Acne will mostly occur on the face, neck, chest, shoulders and back[51], [72], [73]. Acne is most common among adolescents and young adults, affecting 80-95% of individuals 11 to 30 years olds [51], [72].

There are six types of acne lesions, which are categorized in four grades, Figure 2.28. The first three grades can usually be treated with over-the-counter products, while grade four requires treatment by a dermatologist. AAMNPs are suitable for use with breakouts for grade 2, 3 and post inflammatory hyperpigmentation (PIH) spots. It is advised not to use them on matured pustules as they can cause more irritation. With more severe breakouts and more surface area where the acne occurs different treatment is better suited, like medication or topical cream. Nonetheless people could choose to still do this spot treatment as it will still work. People with all stages of acne are thereby considered as the target audience. It is expected that there will be only mild to no differences in penetration suitedness between ethnicity profiles.

Kinds of acne



Figure 2.28 : The different kinds of acne and in which grade they belong to, PIH spots do not belong to a grade since they technically aren't a kind of acne [15], [16], [17], [18], [19], [20], [21]

2.5. Facial structure

The face consists of different undergrounds of bone, muscle, skin and fat which all influence the penetrability, stretch capability and perceived pain of the face. An anatomical study (Appendix H) mapped these regions to get a better understanding for what the applicator is used on.

Based on anatomical characteristics, the facial underground can be roughly divided into five categories:

Category 1 – Flat surface, Forehead:

Flat surface with thin layer of fat and muscle followed by the skull.

Category 2 – Soft surface, temples, mouth area:

Moderate thickness of muscle and fat, with a nearly flat surface.

Category 3 – Uneven soft surface, under the eyes and jawline:

Moderate thickness of muscle and fat but uneven terrain and borders with softer surfaces.

Category 4 – Very soft surface, cheeks:

Thickest layers of muscle and fat with minimal to no direct bone support. Is highly flexible and soft.

Category 5 – Nose:

With complex angles and highly variable underlying structures.

It is anticipated that an applicator will perform best on **category 1 and 2 regions**, because the surface is relatively firm and even. In contrast, **categories 3 and 4** may present challenges due to thicker, more irregular, and softer underlying structures which will absorb the impact force more, making it less ideal for penetration.

Due to the complex shape of the nose an applicator will be unusable on here.



Figure 2.29 : Front view with categorised facial structures



Figure 2.30 : Side view with categorised facial structures

2.5.1. Skin elasticity

The viscoelasticity of the skin has effect on the penetration of the microneedle. How elastic the skin varies greatly. It is mostly affected by the dermis and proteins that are in this layer. If a person has a lot of collagens, the skin is more elastic. The skin around the mouth, eyes and forehead are most elastic as this is needed for facial expressions, this was backed up in a conversation with dermatologist Francis Wu. This means that these parts will most benefit from stretching the skin.

2.5.2. Facial pain threshold

The applicator will be 'shooting' the patch with a certain amount of force on a blemish. This force needs to be tolerable for the use. Pain is perceived worse at harder regions as the impact force can be absorbed less by the tissue[74]. This means that the impact on the forehead will feel more painful than on the cheek.

No information could be found on the amount of impact force people will find tolerable or painful. An estimation of a still tolerable force is around 20 -25 N on healthy skin (in the concept evaluation subjects found the spring force of 18N still tolerable). To incorporate for inflamed skin, the pain threshold will be divided to 66% of the maximum acceptable force: **15 N**

	Category 1
	Category 2
	Category 3
	Category 4
	Category 5

Table 2.3 : Legend of facial categories

2.6. Vision

From the research phase the assignment is reviewed and more refined, key focus points are made from this. The applicator will be developed as an over the counter product. People are more likely to be regular users of these patches, a multiple use applicator will therefore make most sense. And a multiple use applicator gives more opportunities for uPATCH. As well as that they are developing a single use applicator and are lacking a compact multiple use applicator.

2.6.1. The user

The user of the product are people that have acne, aged 11-30 years old, man and female, living in East-Asia.

The user generally would store this product in their bathroom, either in a cupboard, shelf or toiletry bag.

Tools that the user might use in combination with the applicator are sink or Table, a mirror and tweezers.

2.6.2. Function tree applicator

The function tree shows the functions that the applicator needs to have to meet main usage.

Figure 2.31 : function tree for the anti acne microneelde patch applicator

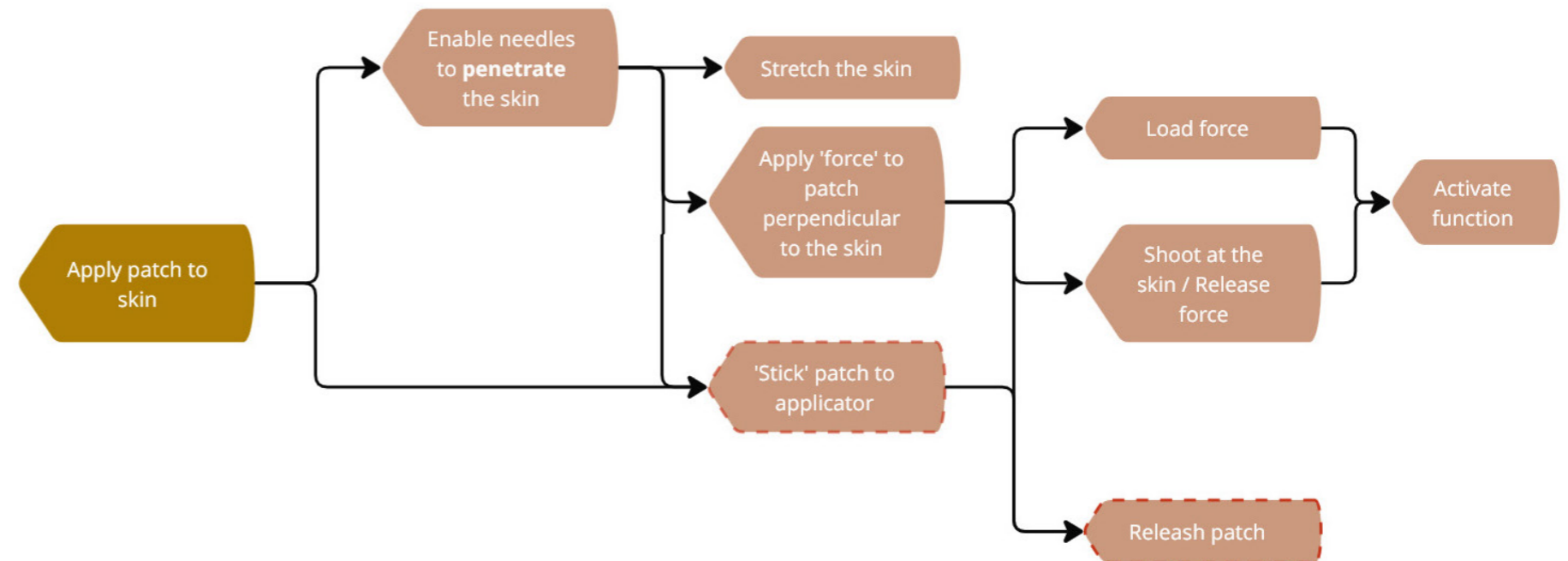

2.6.3. Key focus points

To make this product be desirable and feasible for the user and stakeholders the following aspects needs to be designed for.

- The applicator should **be comfortable and clear to use**. This is important as the applicator will shoot the patch at a certain amount of speed to a sensitive part of the face. Together with the aspect that the patch has needles, might be scary to people even though they are painless to insert. Th user might think otherwise.
- The use needs to be foolproof. **Limiting the changes for the user to accidentally touch the needles**, as these are fragile and bending them makes them unsuitable penetration.
- Researching and testing the **minimal spring force needed to penetrate the skin**.

Developing an **anti-acne microneedle patch applicator** for patches up to 20mm in diameter for people suffering from **any degree of acne** between **11-30 old based in East-Asia**

Table 2.4 : List of requirements

No.	Type	Component	Category	Description	Source	originated
1	Need	Applicator	Use	The product shall have a weight of less than 50 grams	uPATCH	
2	Need	Applicator	Use	After the needles are inserted into the skin and the user lifts the product away from the skin, the patch needs to stay adhered to the skin and be loose from the product	uPATCH	
3	Need	Applicator	Use	The product can be comfortably used by p-10 to p.90 of 11-30 year old individuals from East Asian ethnicity	MRM	
4	Need	Applicator	Use	The product can be used efficiently on face region categories 1 to 4	MRM	“2.5. Facial structure” on page 44
5	Need	Applicator	Use	The product should give feedback that the patch has penetrated the skin	MRM	“2.3.5. User study 1- current use” on page 34
6	Need	Patch	Use	It should be easy to remove the film from the patch before applying	MRM	“2.3.5. User study 1- current use” on page 34
7	Need	Applicator	Use	The user should not hear or feel the product rattle when shaken.	uPATCH	
8	Need	Applicator	Use	The product can be cleaned by the user	uPATCH	
9	Need	Applicator	Function	The patches need to accommodate at least round patches from 9-20 mm in diameter	MRM	“2.3.4. Use of anti-acne microneedle patches” on page 32
10	Need	Applicator	Function	The product shoots the patch by the velocity force	MRM	“2.3.6. Effectiveness of CMNPs” on page 38
11	Need	Applicator	Function	The product will enable the patch to penetrate the stratum corneum	MRM	
12	Need	Applicator	Function	The end velocity must be within 15% of the designated velocity.	uPATCH	
13	Need	Applicator	Design	The product's outer housing is designed so that the user knows where to hold the product	uPATCH	“3.3.4. User study 2: Concept evaluation” on page 74
14	Need	System	Design	The product's outer housing can be held comfortably by the user	uPATCH	
15	Need	System	Design	The product's outer housing radiate safety and reliability.	uPATCH	
16	Need	System	Assembly	The product can be very easily assembled within 3 minutes by hand without any complications	uPATCH	
17	Need	Applicator	Design	No chrome finishes are used in the product	uPATCH	“4.5. Appearance and form” on page 96
18	Need	Applicator	Use	The product should not be able to faulty fire	MRM	“4.1. Detailing” on page 80
19	Wish	Applicator	Use	Making the penetration action 'friendly'	MRM	
20	Wish	Applicator	Use	The use of the product involves minimal steps	MRM	“3.3. Concepts” on page 68
21	Wish	Applicator	Use	The risk for the user to accidentally touch the needles of the patch is eliminated as much as possible	MRM, uPATCH	
22	Wish	Applicator	Use	The product can be used with little to no prior explanation or instruction	MRM	
23	Wish	Applicator	Function	The product will be able to penetrate the stratum corneum with a force (15 N) that is still tolerable for the user	MRM	
25	Wish	Applicator	Function	The product can be 'loaded' without using an extra product or dock	MRM	“3.3.4. User study 2: Concept evaluation” on page 74
26	Wish	Applicator	Function	The product is able to scale up to more sizes	uPATCH	
27	Wish	System	General	It shall not be possible for the user to unintentionally trigger the product (while not on the skin)	uPATCH	
28	Wish	System	General	It shall not be possible for the user to touch the microneedles while inside the product	uPATCH	
29	Wish	System	General	No additional changes have to be made to the patch to make it usable with the product	uPATCH, MRM	
30	Wish	System	General	No changes have to be made to the packaging of the patches to make them usable with the product	uPATCH, MRM	
31	Wish	System	General	The product can be made for under five euros with a run of 10.000 pieces	MRM	
32	Wish	Applicator	Design	The form and appearance the product should radiate a medical and cosmetic product	MRM	“4.5. Appearance and form” on page 96
33	Wish	Applicator	Design	The product should give a tool like experience	MRM	“3.3.4. User study 2: Concept evaluation” on page 74

2.7. List of requirements

The list of requirements is created from the findings from the research phase, as well as the two upcoming phases, together with the requirements that already existed from uPATCH.

In the conceptualisation three concepts were developed with the help of ideation with brainstorming, rapid prototyping and how-to's, these concepts were the tested with users to see which one is more favourable and to get the applicator to feel safe and comfortable in use.



Chapter 3

Conceptualisation

3.1. Impact force mechanism	52
3.2. Functions	53
3.3. Concepts	68

Figure 3.1 : Overview of multiple prototypes of this phase

Attach patch to applicator

Load the applicator

Stretching the skin

Activate the applicator

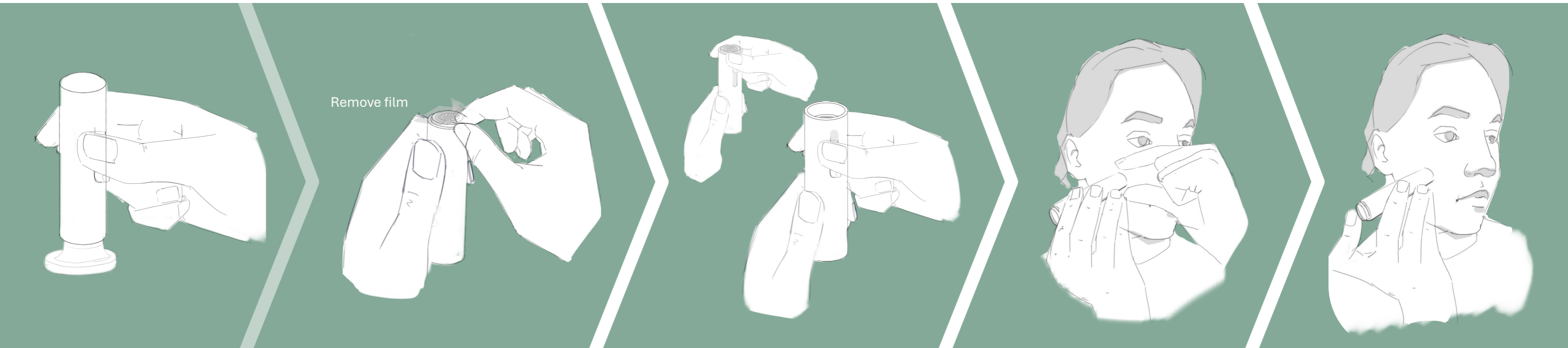

Function: action to prepare patch for application

Function: action to compress and lock the spring

Function: action to reduce force needed to penetrate

Function: action to release the spring

Figure 3.2 : Scenario of use of the applicator with functions

3.1. Impact force mechanism

The main function of the applicator is to launch a plunger onto the skin with a specific velocity and mass. Several mechanisms can be used to achieve this function. Without going into detail, this can be accomplished using e.g. a motor, a spring, magnetic force, or compressed gas.

As springs experience relatively low wear and provide significant flexibility in how the energy is stored, wound, and released. Together with the wish for the applicator to be compact, robust, simple, and relatively inexpensive, a spring-based mechanism is selected as working principle for the impact force mechanism.

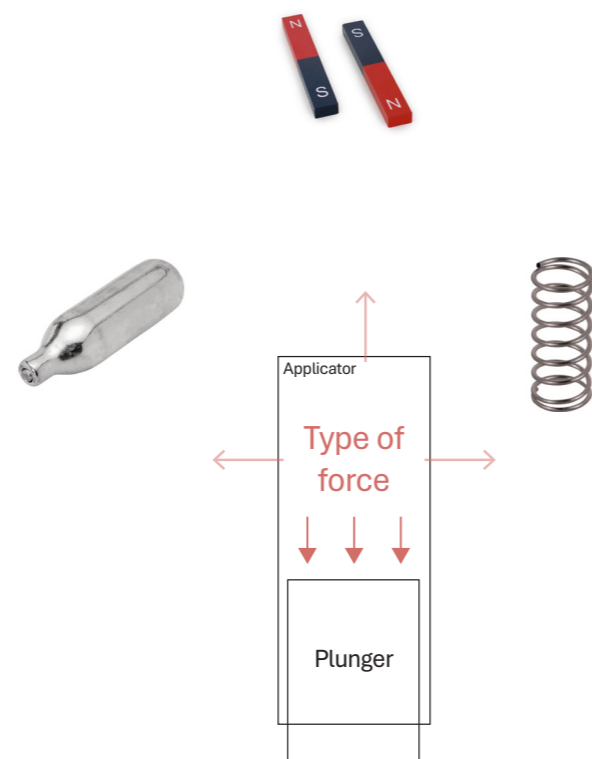

Figure 3.3 : Schematic overview possible impact force facilitators [22], [23], [24]

3.2. Functions

The function tree can be used to make a possible scenario for the use of the applicator, Figure 3.2. This scenario illustrates the different main functions the applicator should have. For ideation of each function how-to's, brainstorming and rapid prototyping are used to determine the feasibility and desirability of the possible implementation of the functions.

3.2.1. Function: Loading the applicator

To set the spring under tension which makes it really to apply the impact force. The applicator needs a way for the user to do this action.

Rotating system

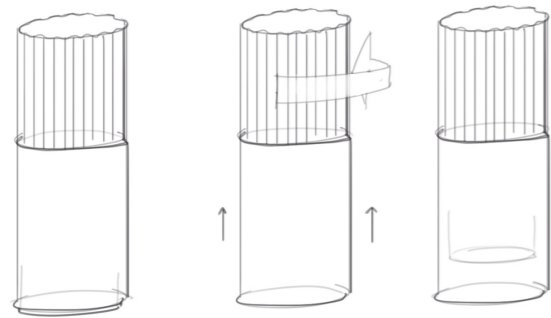

Figure 3.4 : Rotating system

- Rotate mechanism as in most lipstick, plunger (the patch is attached to this) has a pin that moves up as it rest on a screwlike groove
 - 180 degrees max to rotate, otherwise ergonomically not comfortable
- + Intuitive use
- Mechanism complicated

Mechanism

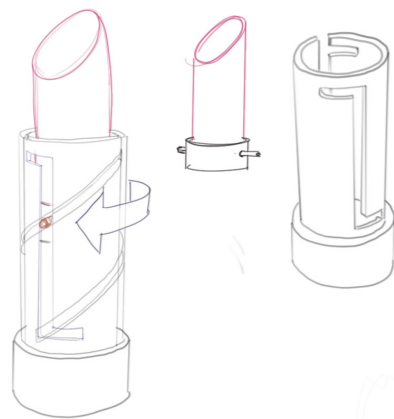

Figure 3.5 : Lipstick working principle

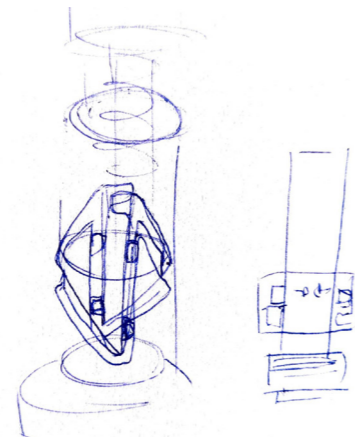

Figure 3.7 : Lipstick mechanism adjusted for applicator

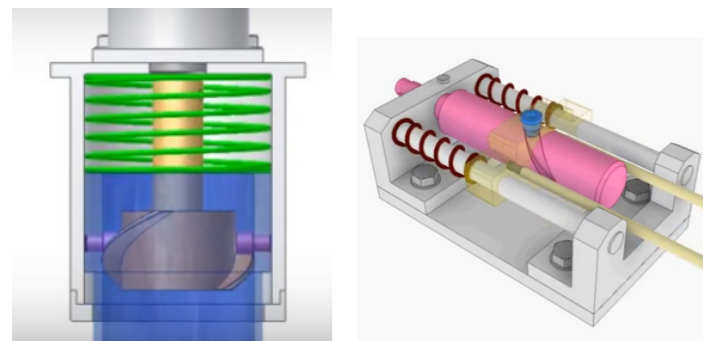

Figure 3.8 : Two different rotation axil movement systems [25], [26]

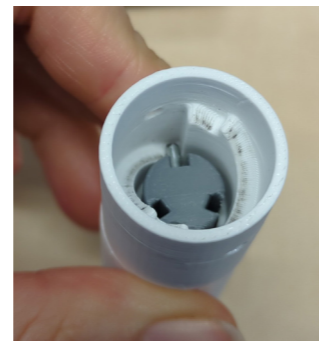

Figure 3.6 : Prototype for rotation system

Retract system

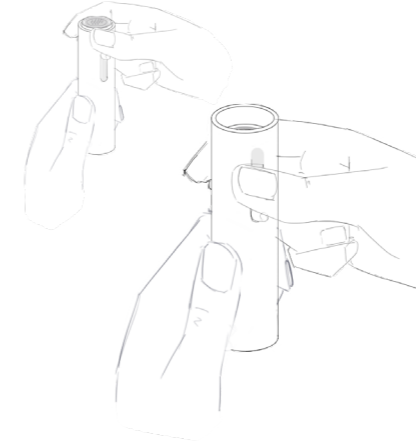

Figure 3.9 : Retract use scenario

- Retracting a sleeve upwards that takes the plunger with it to lock
 - Retracting component can be a ring or one or two points that bring the plunger up
- + Intuitive use
- Mechanism needs a fair amount of components
- Possible moving component on the outside of the model

Mechanism

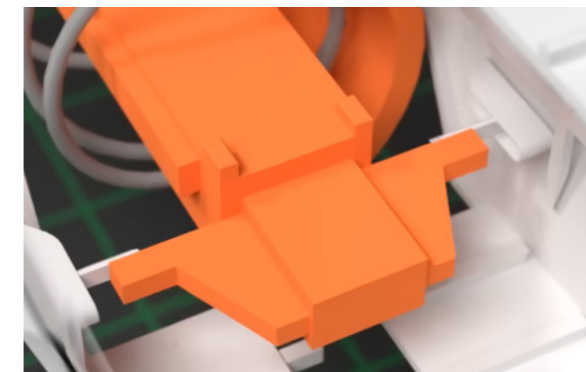

Figure 3.10 : Levers that pull back pistol of a Nerf gun [27]

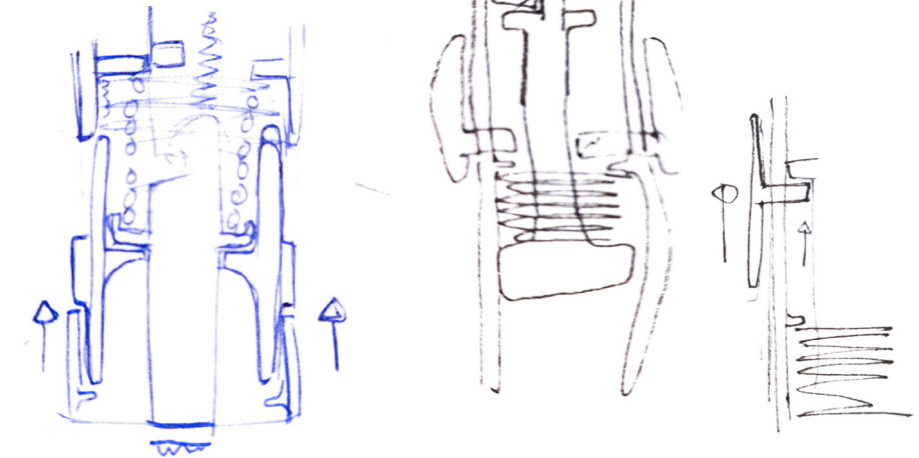

Figure 3.11 : Sketches for retract system integration in applicator

Pull handle



Figure 3.12 : Sketch of pull handle action

Mechanism



Figure 3.13 : Internal mechanism of a pull back toy gun [28]

- Works by retracting a handle, which clicks into a lock
- Needs to have a button on the side on the housing (p.XX)
- + Simple mechanism
- Moving component on the outside of the model
- Big
- Difficult in use

Dock

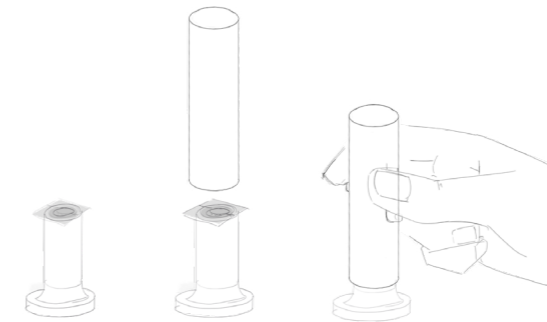

Figure 3.14 : Sketch of use scenario with a dock

- Dock will push the plunger into lock.
- + Simple mechanism
- + patch can be loaded in dock
- + Has a lot of options to lock the spring
- Extra lose component needed
- Broader housing needed

3.2.2. Function: Activating the applicator

Activating the button goes together with the mechanism the spring is kept under tension. For some activation methods several spring lock mechanisms are possible and for others only one.

Mechanisms

Top button

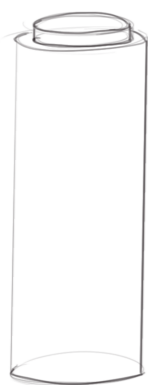

Figure 3.15 : Sketch of applicator activation button

Mechanisms

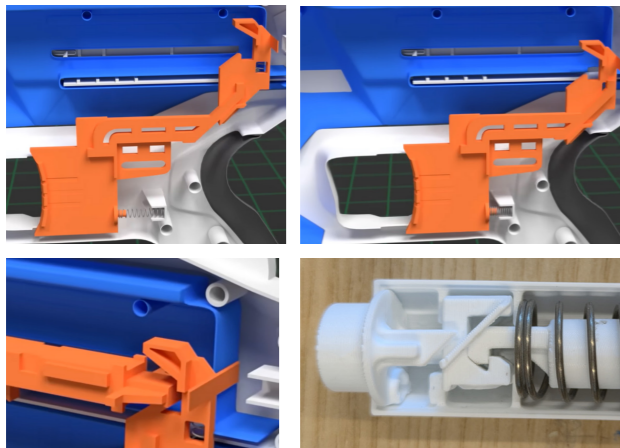

Figure 3.16 : Internal lock mechanism Nerf gun [27]

Figure 3.18 : Prototype of spring lock mechanism

Figure 3.19 : Sketch of spring lock mechanism



- Button releases the loaded spring
- Multiple mechanisms possible
- + Gives user control over activation
- Most mechanical mechanisms don't work on this scale

- Spring locks with a snapfit connection, button moves snapfit which releases the spring.
- Needs a strong small spring
- Amount of parts
- High accuracy needed, more expensive

- Button moves pivots snapfit which releases the spring.
- Difficult to do on a small size
- Amount of parts

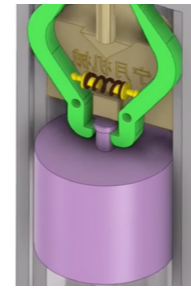

Figure 3.20 : Spring lock release mechanism [29]

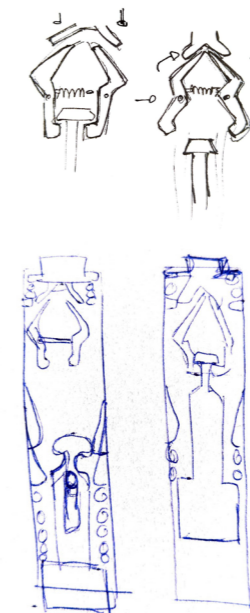

Figure 3.21 : Sketches of spring lock and release mechanism in applicator

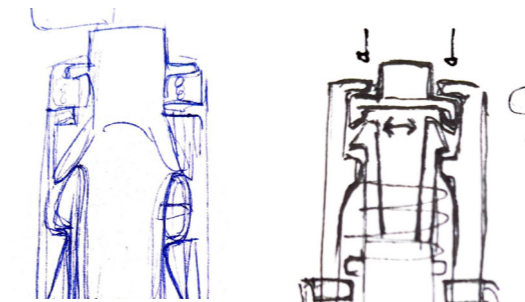

Figure 3.22 : Sketches of flexible snap fit integration to lock spring in applicator

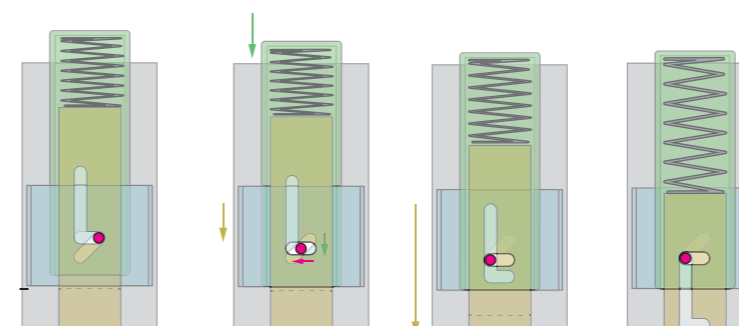

Figure 3.23 : Adapted uPATCH PLUS lock mechanism for button

- Spring is lock with a connection onto a mushroom shape, button pivots snapfit which releases the spring.
- Parts needed
- Fragile
- Plunger direction not guided well

- Spring is locked with two flexible snapfits, button pushes snapfits to the inside to release the spring
- Can be made with plastic, or metal
- Plastic could be fragile

- Spring lockes by a pin that is clamped between two sleeves, which releases again when the button is pushed.
- + Rigid
- Buttons moves up when spring is locked

Side button



Figure 3.24 : Sketch of side button applicator

Mechanism

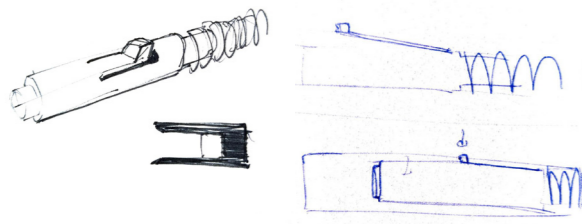

Figure 3.25 : Sketches of spring lock system of pens

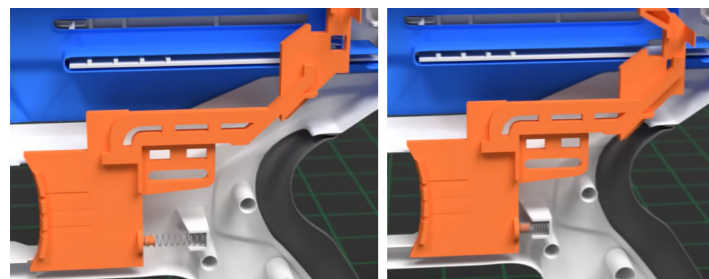

Figure 3.26 : Triggering system of two toy guns [27], [28]

- Unlocks the spring by moving a lever
- Can be made with multiple mechanisms
- + Simple mechanism
- Possible difficult activation with one hand

- Spring is locked as in ballpoint pens.
- Plastic or metal
- Side button can have a cover as 'real' button so that user does not see the inside

- Spring is locked with a snapfit, side button will release this by pivoting this snapfit
- Can not be integrated in a tube

Pinch button



Figure 3.27 : Sketch of double side button applicator

Mechanism

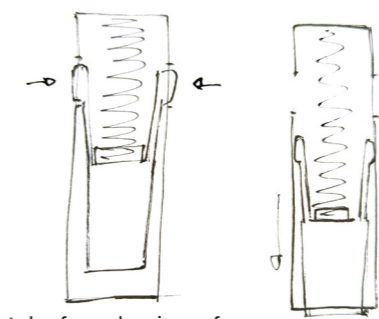

Figure 3.28 : Sketch of mechanism of side button applicator

- Similar to side button
- + Simple mechanism
- difficult activation with one hand
- Change to accidentally activate

Automatic activation



Figure 3.29 : Sketch of automatic activation applicator

Mechanism

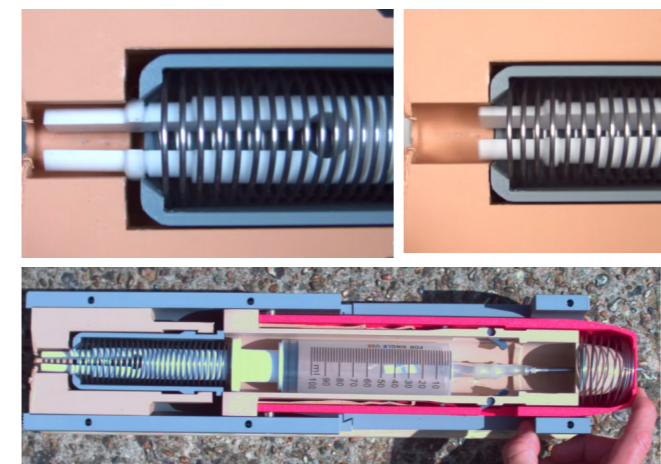

Figure 3.32 : Mechanism of an epi-pen [30]

- Releases lock spring by punching applicator on surface
- + Automatic activation
- Less control
- Broader housing needed

Figure 3.30 : Internal components of uPATCH PLUS applicator

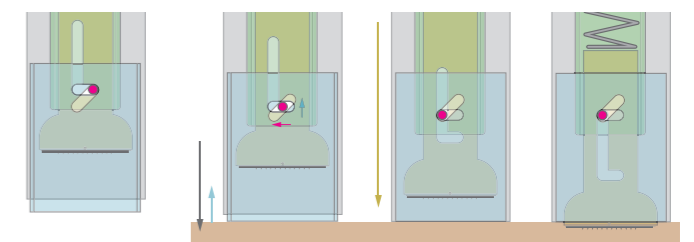

Figure 3.31 : Auto-fire mechanism

3.2.3. Function: Stretching the skin

Stretch by hand



Figure 3.33 : Sketch of hand stretching the skin

- Use fingers to stretch skin
- + Least chance to damage the skin
- + Can avoid other leisures
- + Control
- Need two hands

Stretch with stretcher - flexible or rigid



Figure 3.34 : Sketch of auto stretching applicator

Rigid

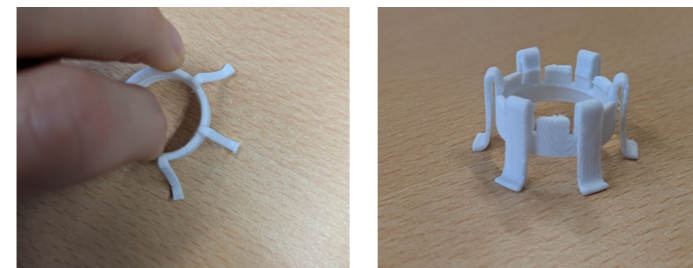

Figure 3.35 : Rigid prototype for stretcher

Flexible



Figure 3.36 : Flexible prototype for stretcher

- By pressing the applicator on the face the stretchers stretch out the skin
- Removable for difficult to reach places or damaged sensitive skin
- + Simple
- Can damage the skin
- Possible wrong application due to confusion of the use of the stretcher

- Needs a lot of space to stretch the skin
- Legs need to be long to have enough flex

- + Flexible
- + Smaller legs needed for same stretch as rigid
- + Sticks better to do skin

3.2.4. Function: Attaching patch to applicator

For optimally effective use of a CMNP the patch needs to be applied to the applicator. If the patch is first applied to the skin, the skin cannot be stretched and needles can break when they come incorrectly into contact with the skin and by flimsy handling. It is therefore essential that the patch can be easily applied to the plunger of the applicator.

Stick patch - glue, static, sticky material

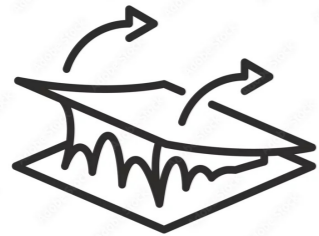

Figure 3.37 : Illustration on how an adhesive works

- Plunger has an adhesive which the patch sticks on
- Hard to pull of film without patch deattaching
- Adhesive needs to be strong enough to peel film, but weaker than adhesive patch to let go when patch is on skin
- Will get dirty
- Can loose adhesive strength

Vacuum stick



Figure 3.38 : Testing power of vacuum seal with pimple patch

- Works with negative airpressure when dock is loaded
- + Automatic activation
- Needs a dock
- Needs a cover
- Difficult to make
- Expensive

Carriers + xx

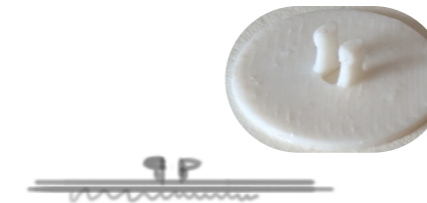

Figure 3.39 : Sketch of carrier

Carrier + cover



Figure 3.40 : Sketch of carrier with cover

Carrier + cover + grippers



Figure 3.41 : Sketch of carrier with cover



Figure 3.42 : Working principle of carrier grippers illustrated with the uPATCH PLUS

- Has a nob that clams in plunger
- The clamp is strong enough to hold while peeling of the film, but weaker than the patch adhesive connection with the skin

+ Easy to apply patch to applicator

- Client needs to change their packaging

- Same as above but has a cover
- User needs to peel of the cover after putting the patch on the applicator

+ Easy to apply patch to applicator
+ The needles are better protected

- Client needs to change their packaging drastically

- Grippers clamp the nob
- Dock removes the cover

+ Super strong connection

- Client needs to change their packaging drastically
- More parts
- Only works with a dock loading system

Possible user steps

There are multiple ways to apply the patch to the applicator, this should happen with least risk of touching the needles as possible.

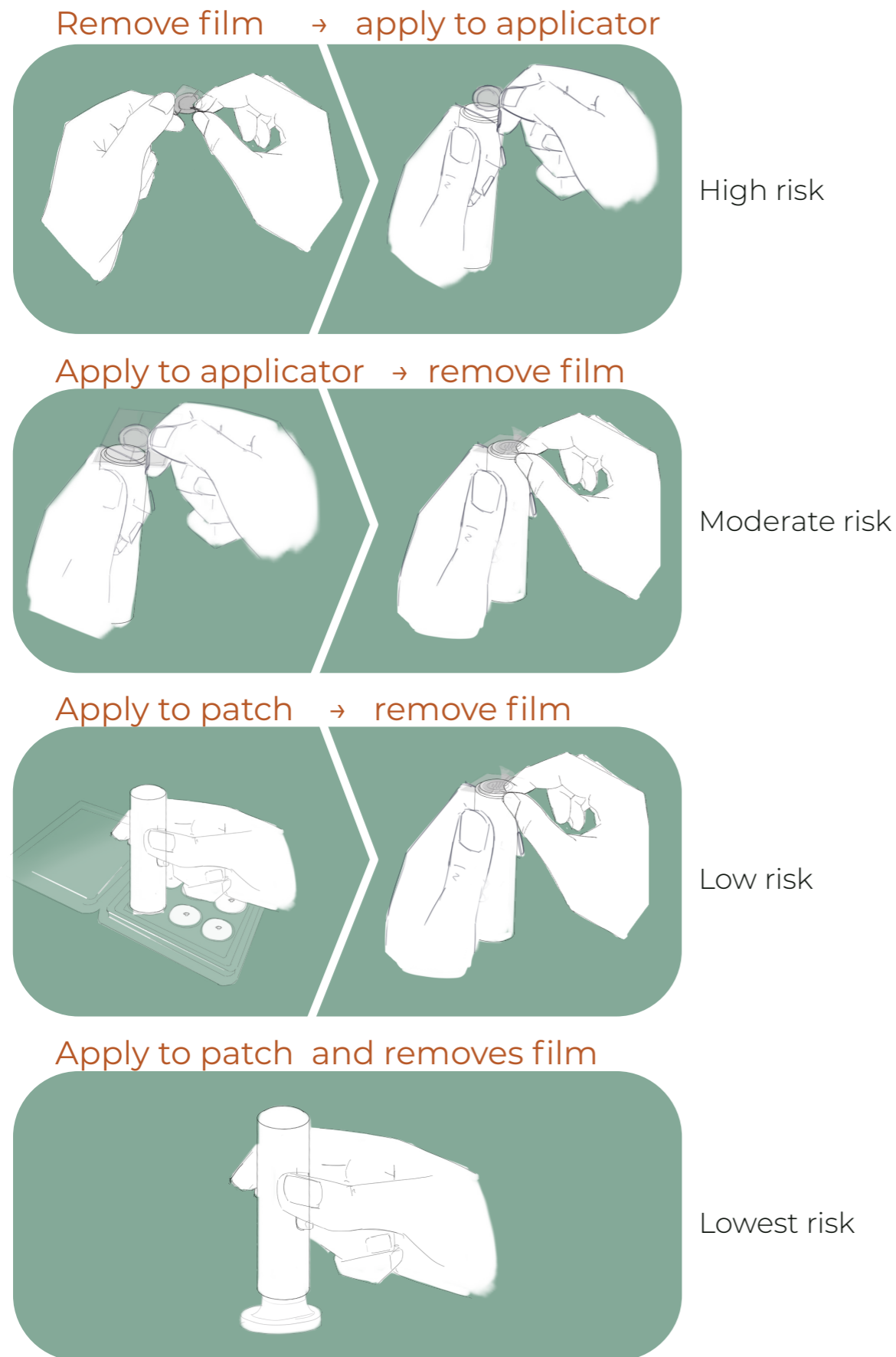

Figure 3.43 : Different use scenarios to prepare patch and remove film

Table 3.1 : Function evaluation matrix

		Feasible	Desireble	Viable	User friendliness	Robust	
	Nr.						Grade
Loading system							
Rotating		+	+	+	+	+	+
Retract		+	+	+	+	+	+
Pull		+	-	+	-	+	-
Dock		+	+	+	+	+	+
Activation system							
Top button	a	-	+	+	+	-	-
	b	-	+	+	+	-	-
	c	-	+	+	+	-	-
	d	+	+	+	+	-	+
	e	+	+	+	+	+	+
Side button	a	+	+	+	-	-	-
	b	+	-	-	-	-	-
Pinch		+	-	+	-	+	-
Automatic		+	+	+	+	+	+
Stretch system							
by hand		+	-	+	+	+	+
Rigid		+	-	+	-	-	-
Flexible		+	+	+	+	+	+
Patch pickup system							
Sticky adesive		+	-	+	-	-	-
vacuum		-	+	-	-	-	-
Carrier		+	+	+	+	-	+
Carrier + cover		+	+	-	+	-	-
Carrier with grippers + cover		+	-	-	+	+	-

3.2.5. Evaluation functions

To analyse which functions are most suitable for the applicator a selection matrix was made. In this matrix the desirability, feasibility, viability, user friendliness and robustness of the function was measured by making an educated decision on the functions to further develop into concepts.

3.3. Concepts

3.3.1. Concept 1: PLUS mini

Concept 1 is the remodelling of the uPATCH™ PLUS[18]. It has an automatic activation system and loads the spring using a dock. The dock pushes the plunger inward until it locks (Figure 3.44a:d). The automatic firing system unlocks the pin when the release tube is pushed in (Figure 3.44 e:i). This mechanical mechanism works as a moderated double-push system developed by uPATCH. All concepts use a variation of this mechanism.

The patch has a carrier with a cover to be able to be placed onto dock and plunger. The cover makes sure that the user does not accidentally touch the needles. The skin is stretched by a removable flexible stretcher. It is relatively fool proof design because of these functions.

It contains one loose component; if this component is lost, the applicator becomes unusable. The loading system is not always clear

to users, and the patches need to be modified drastically. In general, this applicator is thicker because space is required for the auto-release system. Lastly the dock is only suited for one size patch as the cover needs to be clammed onto the dock.



Figure 3.45 : Functioning prototype of concept 3

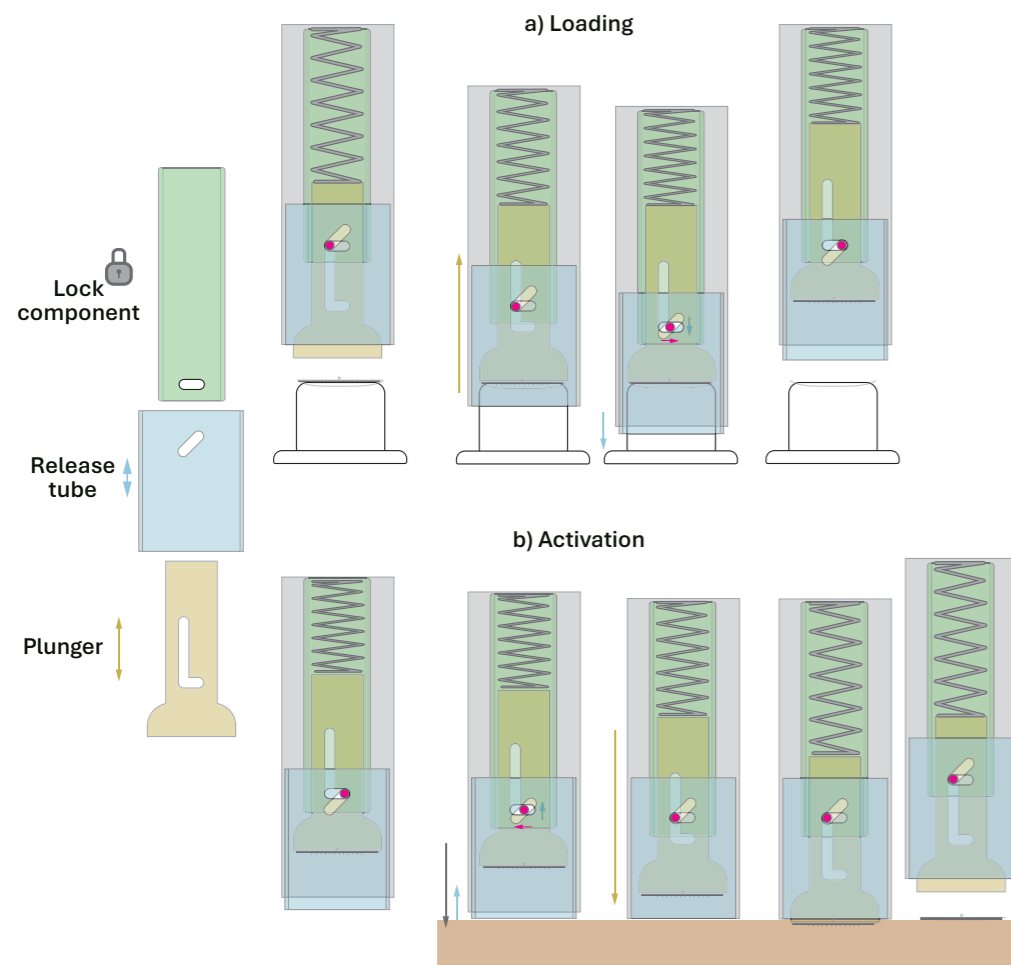

Figure 3.44 : Internal mechanism concept 1

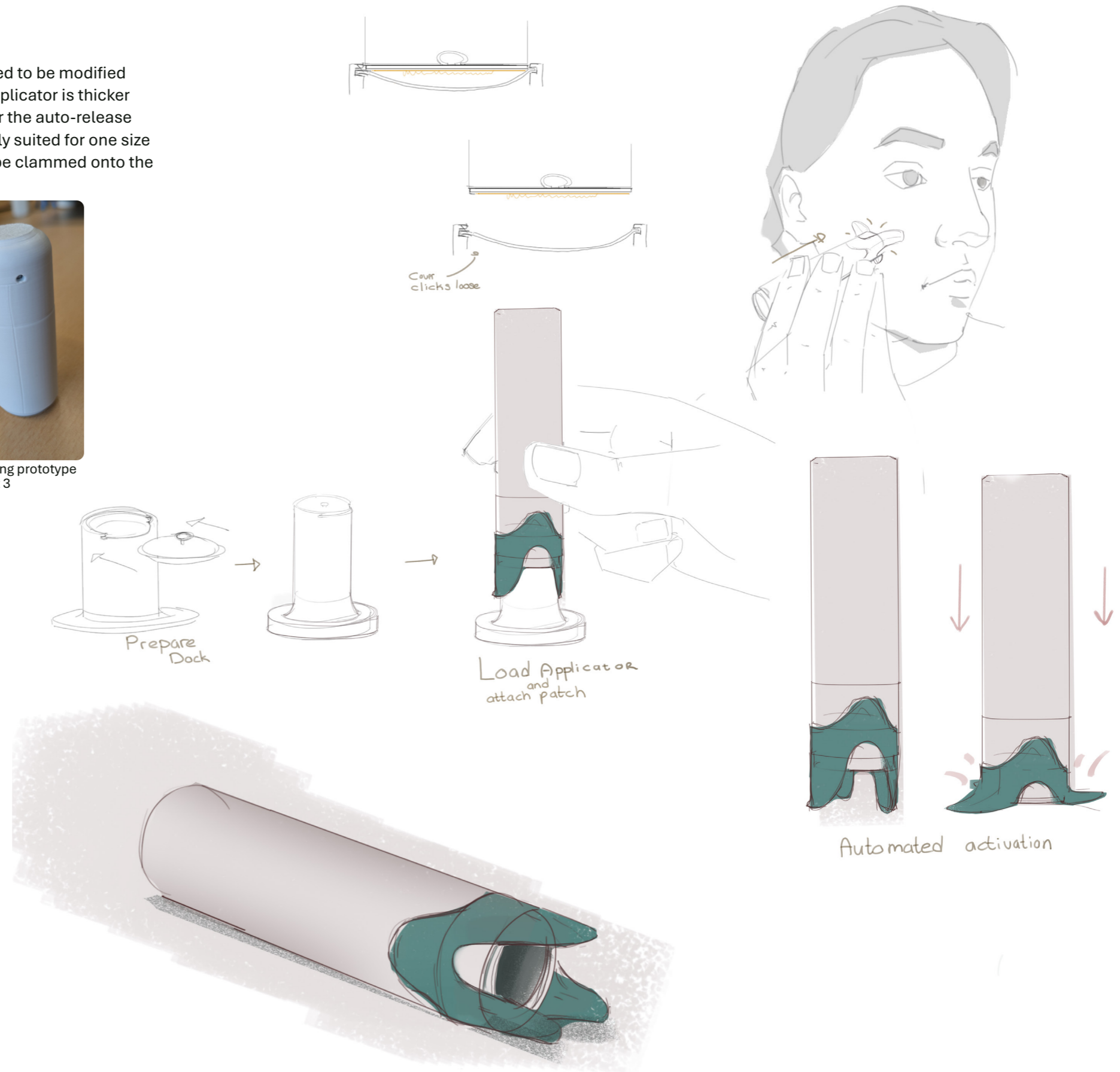

Figure 3.46 : Concept 1 one pager

3.3.2. Concept 2: Shotgun

The design uses a retract ring to retract and lock the spring. The ring moves the plunger backward until it locks into place (Figure 3.47 a). When the retractor is released, another spring moves it back down so that it does not block the plunger when the applicator is activated. It activates with a button, giving the user control over activation.

To load the patch onto the applicator, a carrier is attached to the patch. The carrier has a small flexible mushroom that clicks into a hole in the plunger. This connection is strong enough to hold while the film is removed, but weaker than the adhesive sticking strength of the patch. The carrier disconnects from the applicator when the applicator is removed from the skin.

This concept is easy to understand but has a lot of components which can make assembly more time-consuming and increase the cost price of the product.



Figure 3.48 : Functioning prototype of concept 2

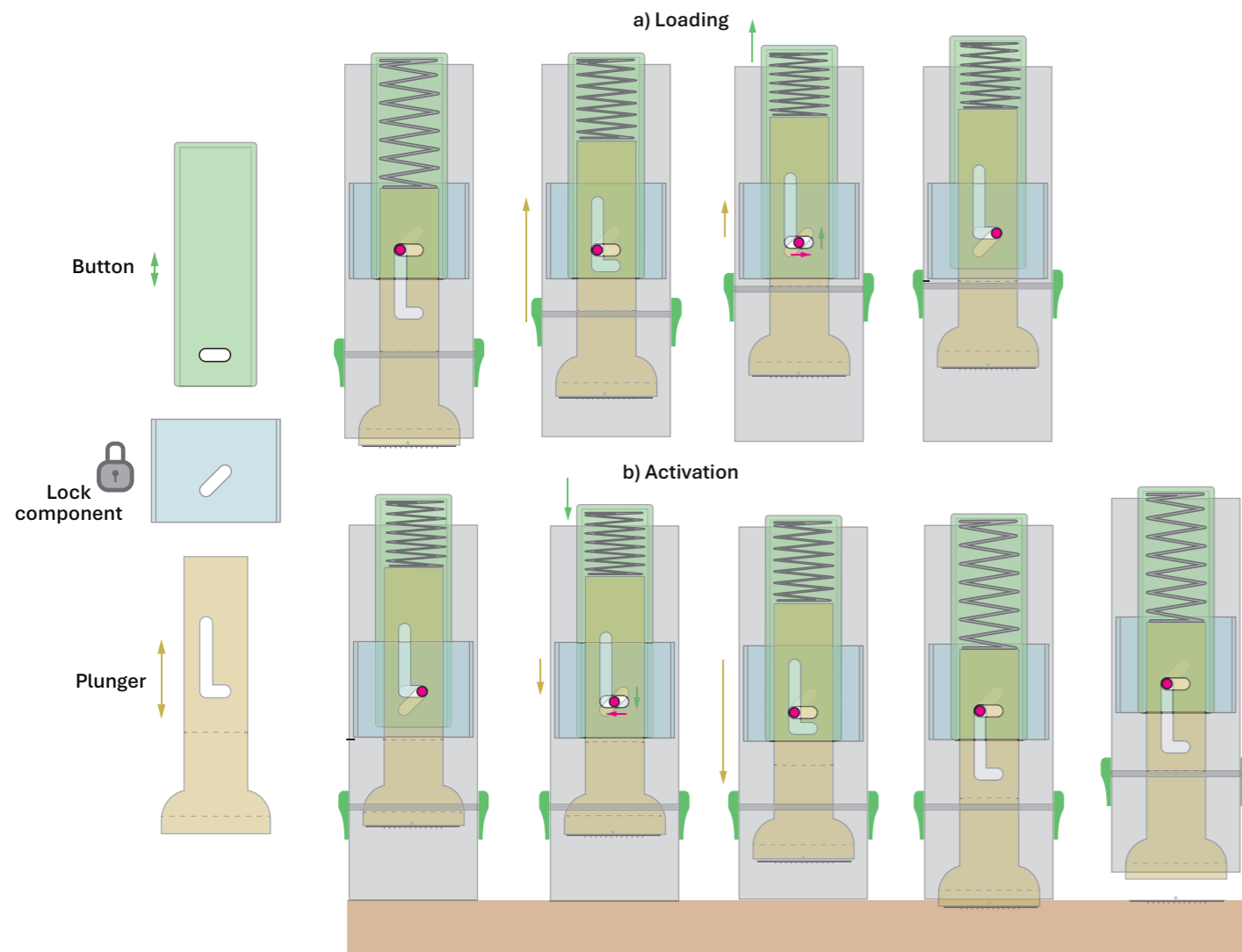

Figure 3.47 : Internal mechanism concept 2

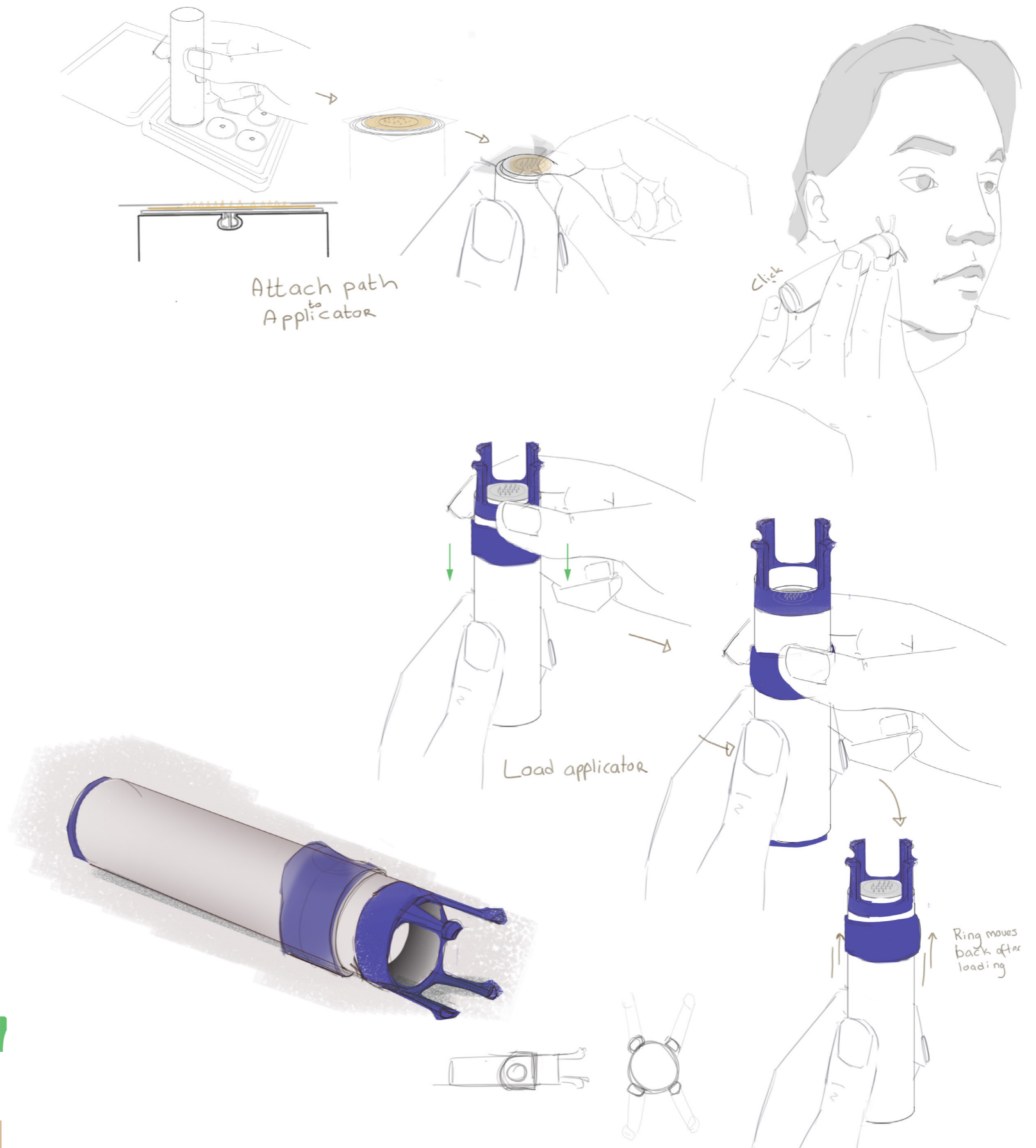

Figure 3.49 : Concept 2 one pager

3.3.3. Concept 3: Prit

Prit is loaded by twisting the applicator, activates by pushing a button and uses the same carrier system from concept 2. The skin will be stretched manually by the user.

The twisting system works with a pin through the plunger, see Figure 3.50. This pin rests in a curved groove. When the applicator is twisted, the pin moves up the groove until it locks into place.

Prit is easy to understand. However, there are some concerns regarding its feasibility. While the twisting mechanism is technically possible to manufacture, the design requires further development to ensure reliability and durability.



Figure 3.51 : Functioning prototype of concept 3

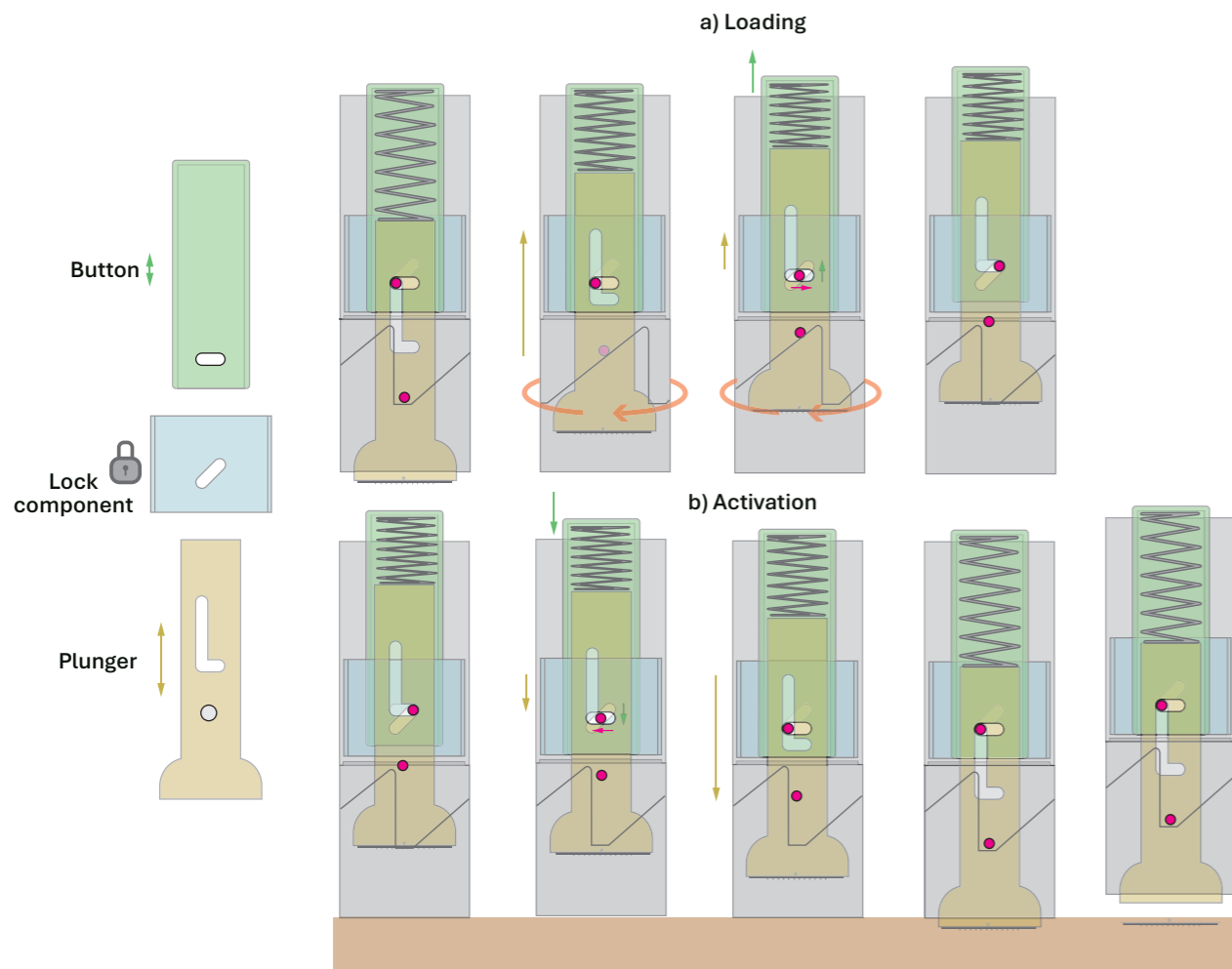

Figure 3.50 : Internal mechanism concept 3

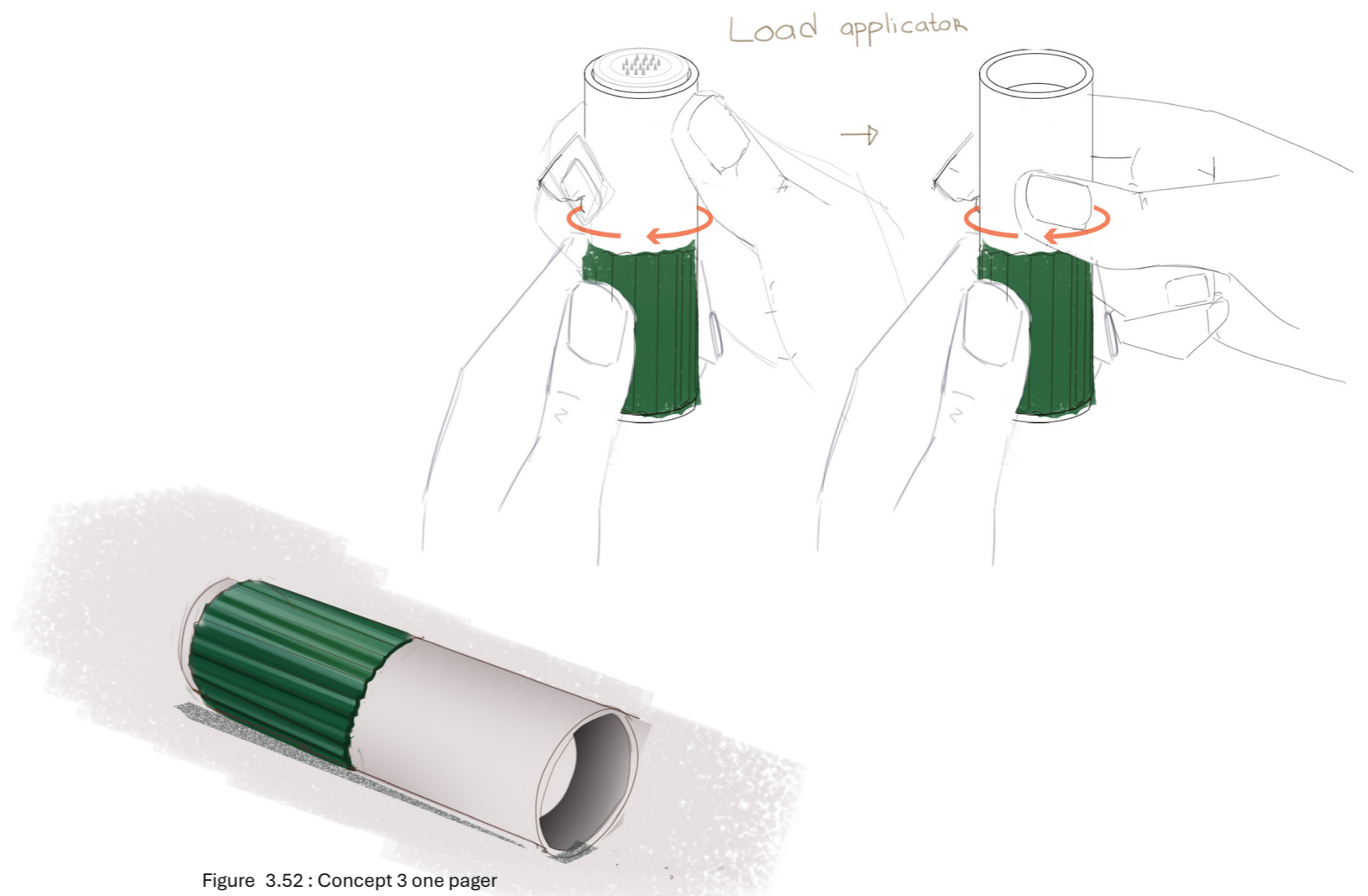

Figure 3.52 : Concept 3 one pager

3.3.4. User study 2: Concept evaluation

A user study with the three working concept prototypes was conducted to evaluate user preferences for the different loading, activation mechanisms and to identify usability issues with seven participants (N = 7; aged 20–30) with experience with acne. Participants explored and used the concepts while thinking aloud, completed a short survey based on the User Experience Questionnaire, and participated in a brief interview[75]. Observations and qualitative feedback were recorded. The full study is described in Appendix J.

“ Oh I find it very satisfying to use’
- P.2, concept 2

Overall, all concepts were received positively, and no concept clearly outperformed the other. The rotating loading mechanism of Concept 3 received the highest ratings for loading, although statistical testing (t-test, $\alpha = 0.05$) did

Graph 3.3 : Favorite amounts participants in a pie diagram

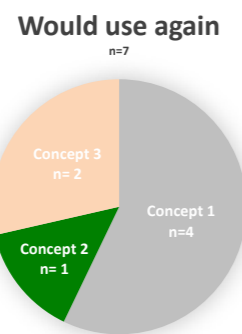

not show a significant difference compared to the other mechanisms. Some users preferred button-based activation for added control, while others were comfortable with automatic activation. The stretcher was initially misunderstood without explanation about what it is, but after the explanation all users use the stretcher correctly.

Generally users appreciated a firm effective use and feel of the concepts.

“ The impact feels and sounds most effective ‘ - P.3 , concept 1

Despite receiving lower quantitative scores, Concept 1 was most frequently selected as the preferred concept. Participants described it as feeling more practical and tool-like, with fewer operational steps. Concept 2 was considered satisfying to use but showed ergonomic issues related to the small loading ring and grip space. Concept 3 was appreciated for its rotating mechanism and grip but was perceived as too long.

These results suggest that the rotating loading mechanism is the most promising direction for further development, ideally combined with a button-based activation system, improved ergonomics and perceived effectiveness. Furthermore the applicator should give the feeling of a practical and tool like device.

Graph 3.1 : Radar graph of average scores 1-5 (with 1 being worst and 5 being best) of prototype loading function

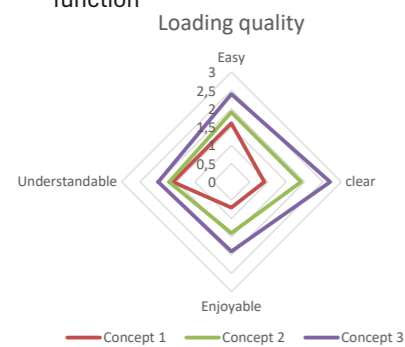

Graph 3.2 : Radar graph of average scores 1-5 (with 1 being worst and 5 being best) of prototype loading function

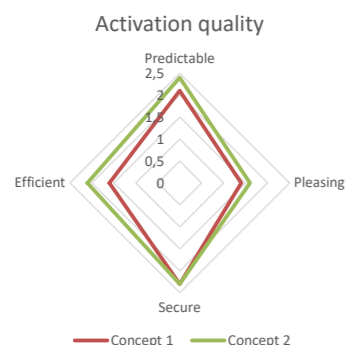

Figure 3.53 : Use by P.2

Concept 1



- Make dock attachable to applicator
- Make dock more leading in loading
- Loose component, N=6
- Hurts to shoot, N=3
- Beard got stuck in applicator while activating
- Loading confusing
- + Visually appealing
- + Can use with one hand
- + Good impact
- + Size

Concept 2



- Give it better grip for lever
- + Sounds while activating and loading is nice
- + Satisfying in use, N=2
- + Size
- + Easy in use
- + It gives me control
- Ring is too small -> no good grip, N=4
- Almost needs two hands to load
- Not enough space to hold it, N=2
- Not clear ring is a slide
- Cant pull ring when finger is on button

Concept 3



- Shorter device
- + Form, N=2
- + Grip, N=3
- + Turning motion
- + Size, N=2
- + Easy in use, N=2
- Too long, N=2
- Turning action is too long

3.3.5. Concept selection

To select the most suitable concept, a Harris Profile was used to compare the concepts against the most important wishes and requirements.

For consumers, the applicator should be affordable, easy to use and understand with as few steps as possible. In addition, the device should provide a clear sense of usefulness during application.

The client shares many of these priorities, as they aim to offer a product that satisfies their customers. However, it is also important that the applicator can be easily integrated into their existing product portfolio. From the client's perspective, a design in where the AAMNPs do not need to be modified is therefore the most desirable.

Prit is the most promising concept to development due to its intuitive loading mechanism. From the consumer perspective, Prit is easy to handle, with low risk of touching the needles, requires few steps and provides a sense of usefulness. For the client, it is easily integrated into existing product lines without modifying the AAMNPs too much, especially when compared to concept 1. Additionally a stretcher is added to the concept to accommodate to the wishes of uPATCH.

Table 3.2 : Harris profile concepts

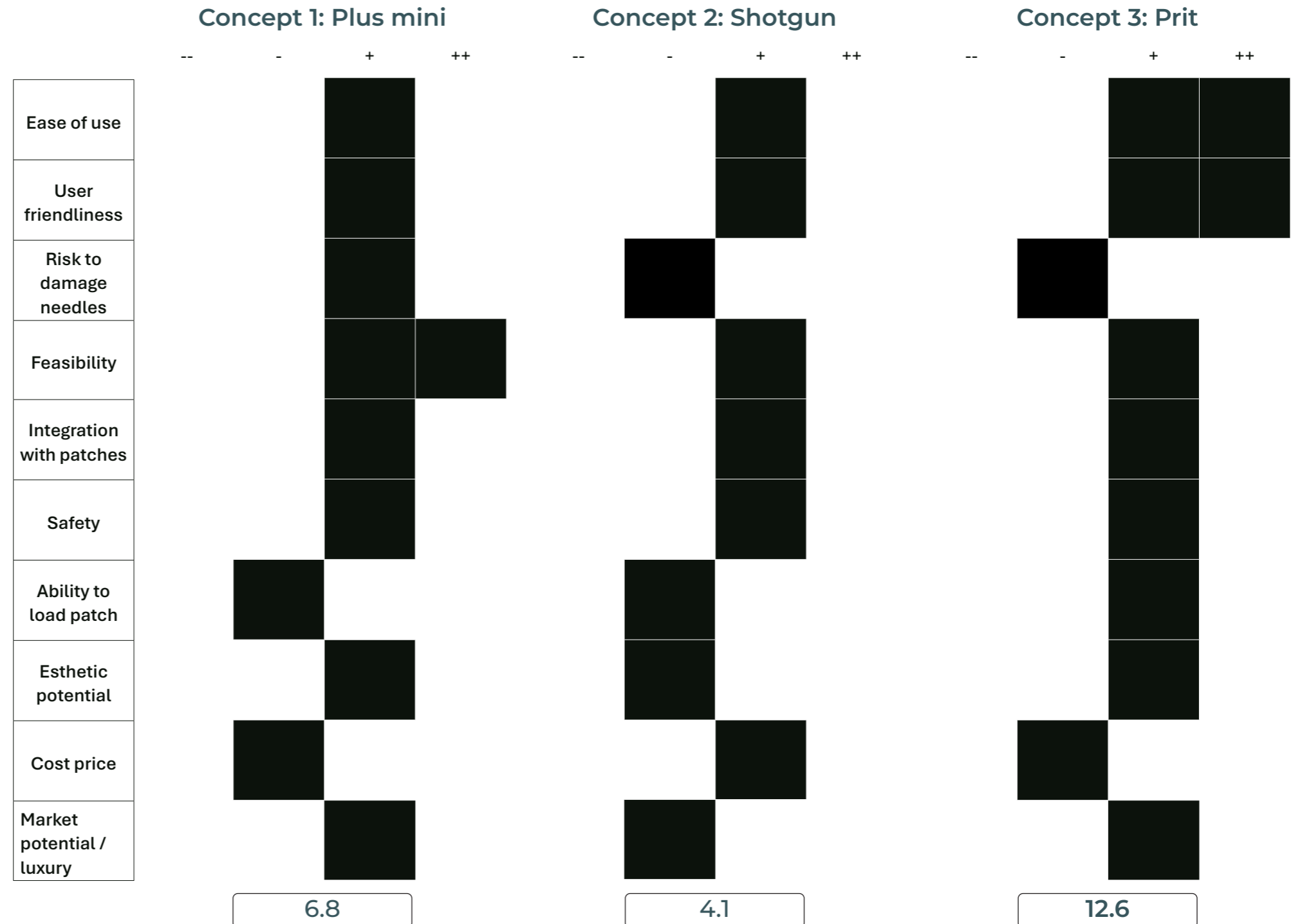

Chapter 4

Embodiment design

4.1. Detailing	80
4.2. Size -Ergonomics	90
4.3. Material Selection	92
4.4. Assembly	94
4.5. Appearance and form	96
4.6. User study 3: Final product evaluation	102
4.7. Lab study 3: Search for minimum spring force	106
4.8. Final prototype	108

The embodiment phase focuses on detailing the selected concept and developing it into a realistic product that meets all functional requirements. This chapter covers detailing, material selection, appearance and form, and related aspects. The focus lies on design for assembly and user-friendliness.

Figure 4.1 : Prototypes made during the embodiment phase

4.1. Detailing

Several issues require attention. The most critical problem occurs when the applicator is loaded: the rotation component can rotate backwards. If this happens and the applicator is fired, the plunger is obstructed as the pin hits the elevator groove (Figure 4.3c). This prevents the plunger from descending, resulting in faulty activation. Furthermore the detailing of the carrier, functionality of the stretcher and optimisation of the whole product needs to be solved.

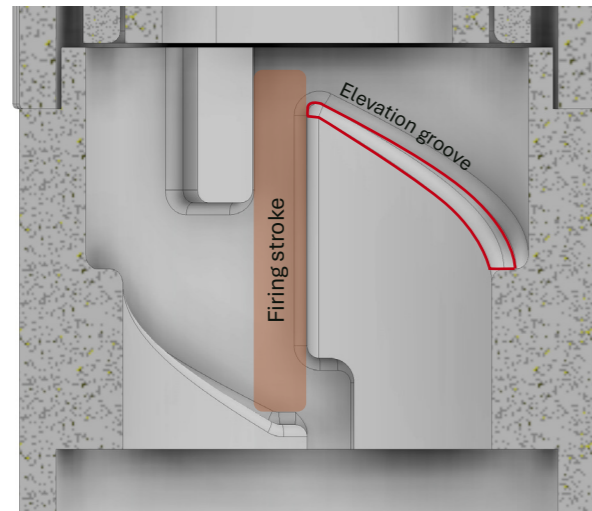

Figure 4.2 : Section view of inner rotary cylinder

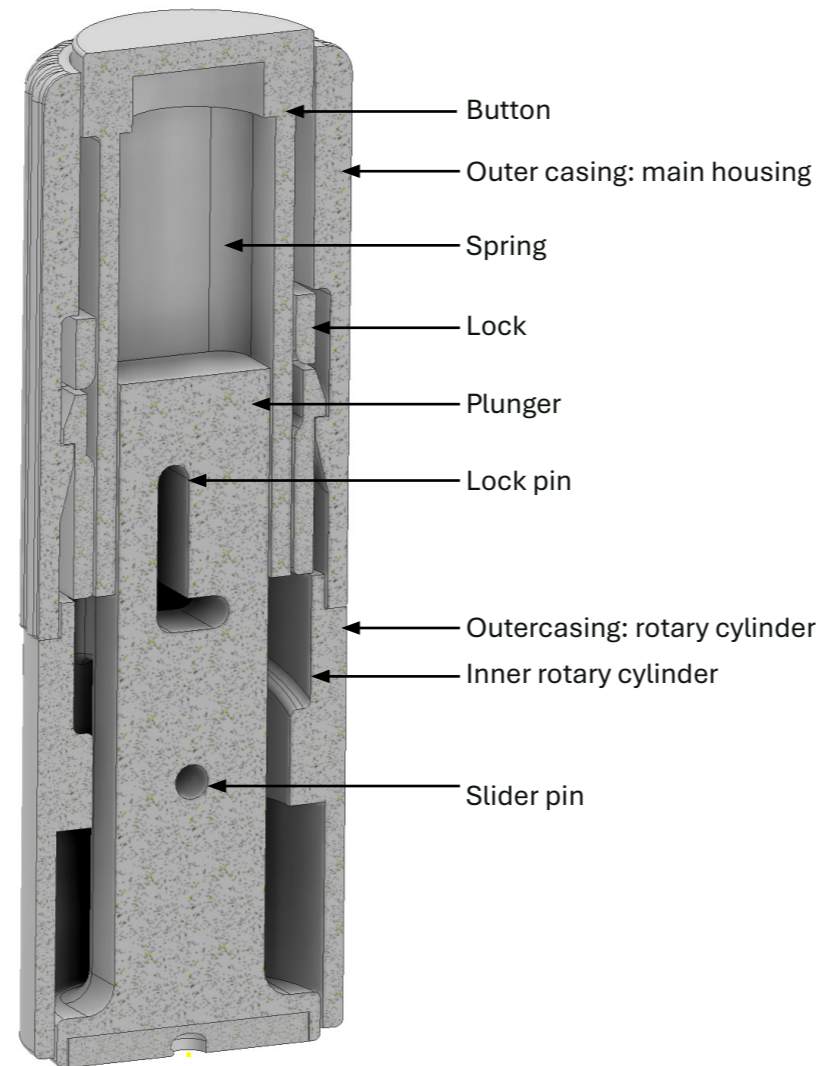

Figure 4.4 : Section view of applicator after concept selection

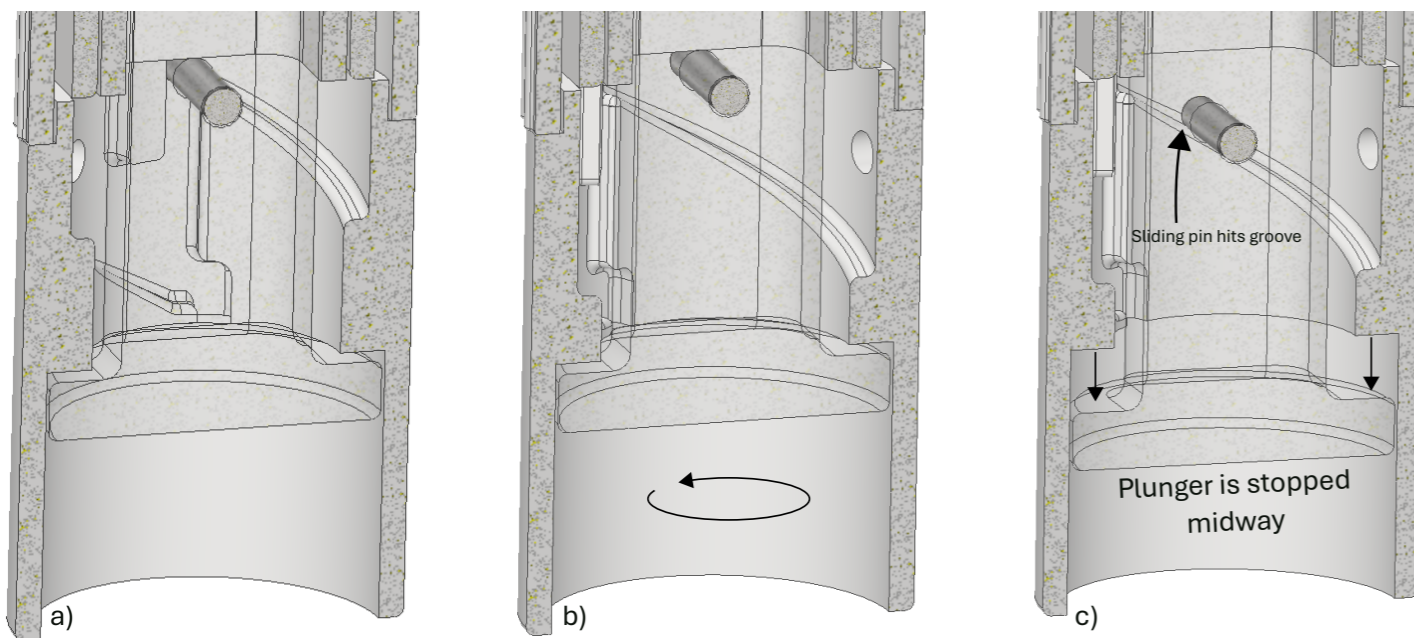

Figure 4.3 : Visualisation of the abstracted firing system a) plunger is locked b) rotation cylinder is rotated back c) applicator is fired but plunger is stopped because the sliding pin hit the groove

Model iterations combining rotation mechanism with spring lock mechanism:

1-5 : get rotation ring just right to get plunger in lock



Figure 4.5 : First working model where spring lock system and rotating system work

4.1.1. Function: Locking rotation mechanism

With assembly and low production costs in mind, five concepts were explored to prevent unwanted rotation when the applicator is loaded.

A: Interlocking pin

This solution avoids adding extra parts by guiding the pin into a groove after locking, see Figure 4.6. While functional, the system is highly sensitive; minor force can disengage the pin, making it unreliable.

Prototype iterations:

I 1-2 : get mechanism to work

	--	-	+	++
Error sensitivity	█	█		
Durability			█	█
Cost price			█	█
Assembly			█	█

Table 4.1 : Harris profile interlocking pin

B: Bottom lock

The plunger cannot move down after the spring is locked. This can be used to integrate a adapted threadlike connection on the underside of the plunger meeting the rotary cylinder.

After some iterations this mechanism worked, but the rotation mechanism can still be jammed as it can still twist a bit. Because the pin needs to move horizontally to go into the firing stroke. Making it possible to move out of the firing stroke again, Figure 4.7.

Prototype iterations:

I 1-4 : adjusting angle to fit in each other

I 5: different bottom lock

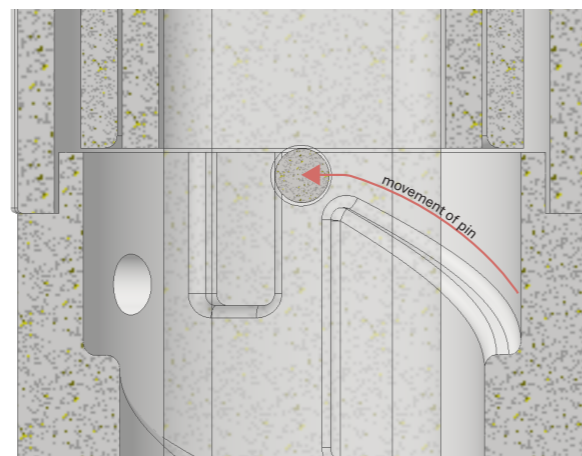

Figure 4.7 : Visualisation of the movement that the slider pin and plunger make in comparison to the rotary cylinder



Figure 4.8 : Iterations prototypes of the rotary cylinder and plunger

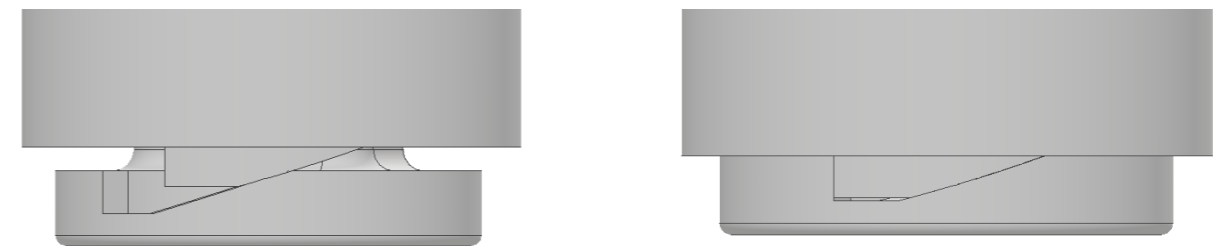

Figure 4.9 : View on the button lock threading system

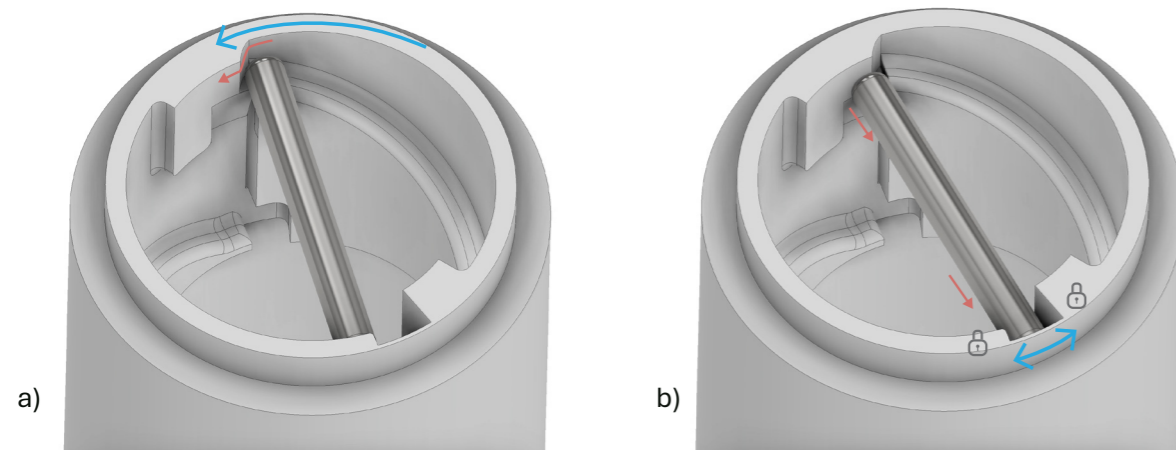

Figure 4.6 : Working principle of locking rotation mechanism a) plunger is locked but can still rotate freely b) plunger moved into the grooved and is locked for rotation

	--	-	+	++
Error sensitivity	█	█		
Durability			█	█
Cost price			█	█
Assembly			█	█

Table 4.2 : Harris profile bottom lock

C: Watch pin

After the spring is locked this pin falls into a groove in the firing stroke on both sides. The internal spring of the pin extends the pin, see Figure 4.10. Making it impossible to move out of the groove and locking further rotation. During activation the pin is retracted this can wear the pin down and increases friction, requiring a stronger main spring. Additionally, assembly requires an extra tool, Figure 4.11.

Prototype iterations:

- I 1: proof of concept
- I 2: work with better watch lock

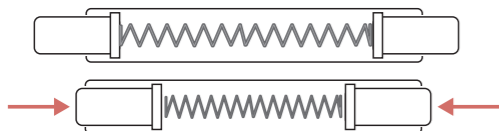

Figure 4.10 : Inside mechanism of a watch pin

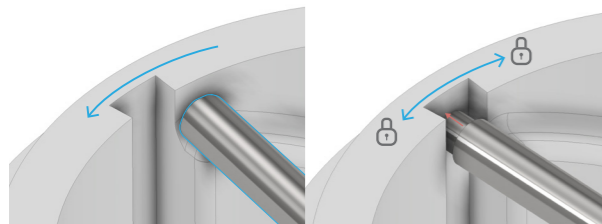

Table 3.3 : a) plunger is locked b) watch pin has extended locking plunger/rotary cylinder for rotation

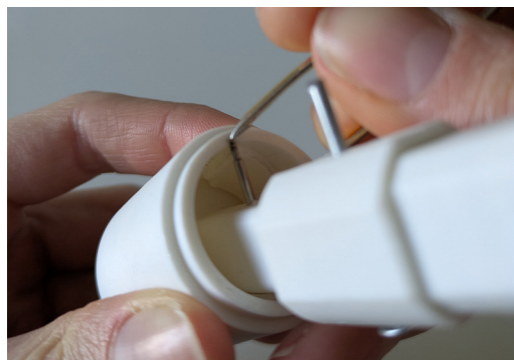

Figure 4.11 : Assembly step where tool is needed to insert the pin into the rotary cylinder

Table 4.3 : Harris profile watch pin

	--	-	+	++
Error sensitivity			■	■
Durability			■	
Cost price			■	
Assembly	■			

E: Ratchet mechanism

Like a ratchet mechanism this design works with spring-loaded teeth that lock reverse rotation every 180 degrees after locking, Figure 4.12. A rib ensures the rotation stops at the correct position, prevention further rotation, interlocking the pin. Manufacturing is challenging due to limiting thickness of the product as thicker walls will affect the flow of the material. Additionally this solution will add at least two extra parts.

Prototype iterations:

- I 1: proof of concept
- I 2: proof of concept with two teeth
- I 3: integrated in model

An iteration integrated this solution which eliminated the extra parts and production concerns, Figure 4.13.

Prototype iterations:

- I 1: proof of concept
- I 2: bigger teeth
- I 3: integrated in model

Table 4.4 : Harris profile ratchet mechanism

	--	-	+	++
Error sensitivity			■	■
Durability			■	
Cost price			■	
Assembly			■	

With the Harris profile in mind the ratchet mechanism is most suitable, due to durability and full integration and will be used in the applicator.

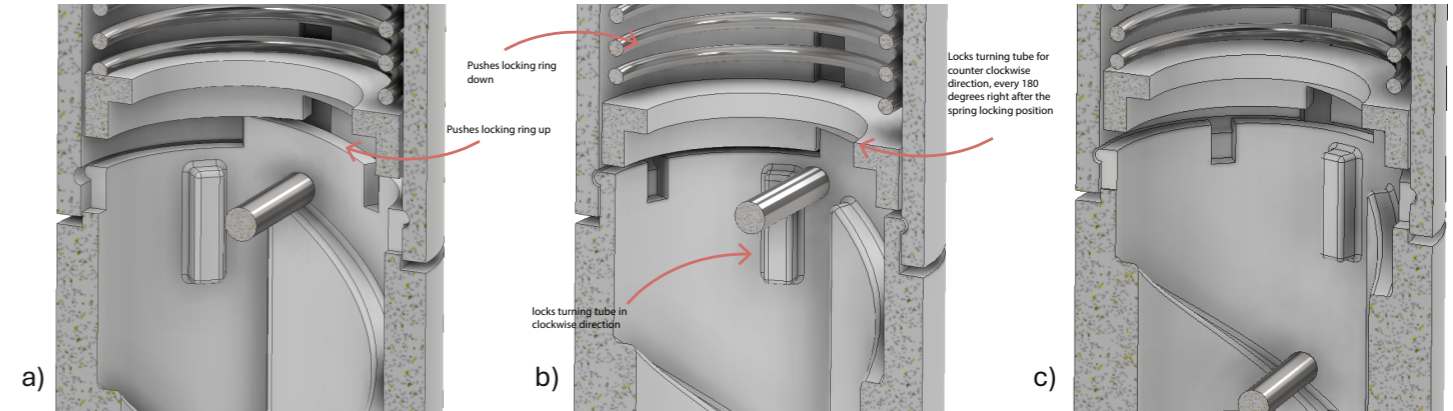

Figure 4.12 : Ratchet mechanism integrated in applicator a) just before locking plunger, rotary cylinder pushed the teeth ring up, free rotation b) plunger is in lock, teeth ring is pushed down by a spring and locked counterclockwise rotation c) applicator was fired and which makes clockwise rotation possible again

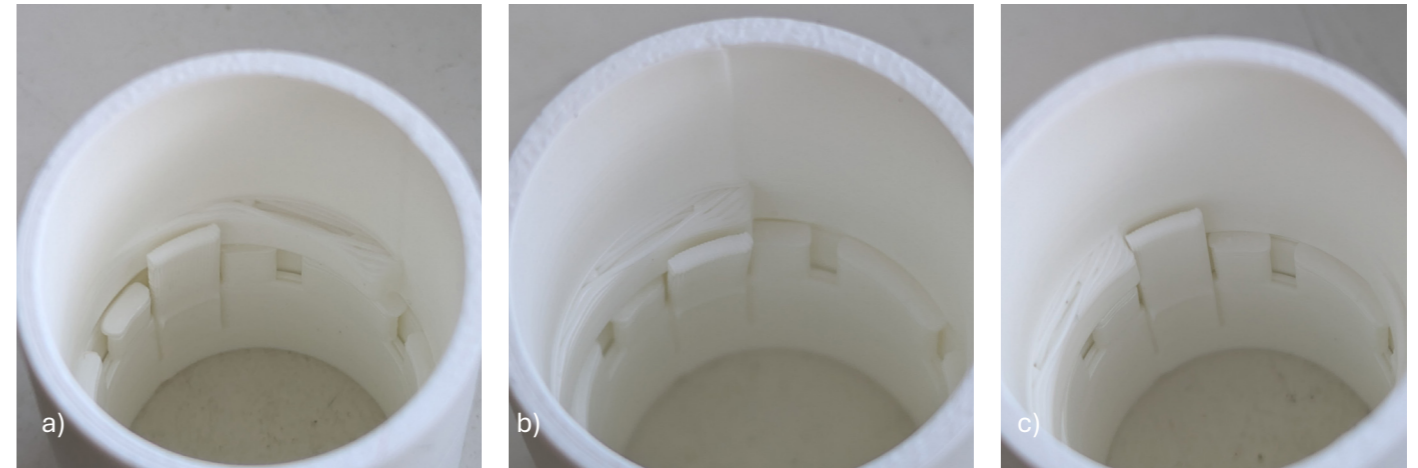

Figure 4.13 : Integrated v.2 mechanism in applicator a) free rotation b) applicator is being loaded, plunger is not in lock yet, locking bar is being pushed inwards c) plunger is in lock, counter clockwise rotation is not possible as locking strip is stopped



Figure 4.14 : Applicator with first ratchet mechanism



Figure 4.15 : Applicator with integrated ratchet mechanism

4.1.2. Function: Carrier

A centrally connected carrier is preferred, because this allows compatibility with different patch sizes without modifying the pickup system. Various designs were tested, with a flexible circular mushroom shape proving most effective as:

- A solid mushroom lacks flexibility and risks breakage.
- A rectangular mushroom offers flexibility but limits insertion orientation.



Figure 4.16 : Iterations in carrier designs

Prototype iterations:

- I 1: proof of concept, rectangle mushroom
- I 2: increase mushroom size
- I 3: change to solid round mushroom
- I 4: Make round mushroom flexible
- I 1: Adding a fifth knob to prevent sleeve interference and maintain friction with the plunger connection, Figure 4.19

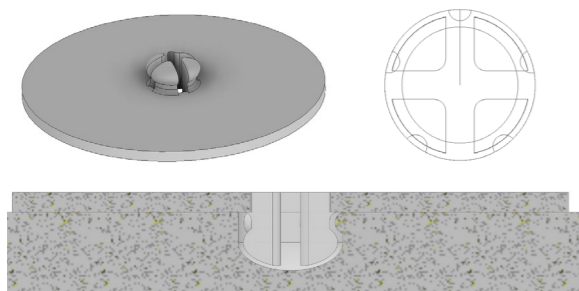

Figure 4.17 : Final carrier design

During an expert consult with Danny Sy, specialist in manufacturing and advises for medical products it appeared that the current design of the carrier holder in the plunger is not easily producible. As there are undercuts of the five knobs, see Figure 4.19. For further development this needs to be looked at. For example by removing the undercuts and making the mushroom bigger to clamp the carrier in the plunger. Due to time restrictions and the scope of this thesis this isn't dived into deeper.

4.1.3. Optimisation

To optimise the applicator the elevation that the button makes has been reduced by declining the angle of the lock component slot, Figure 4.18.

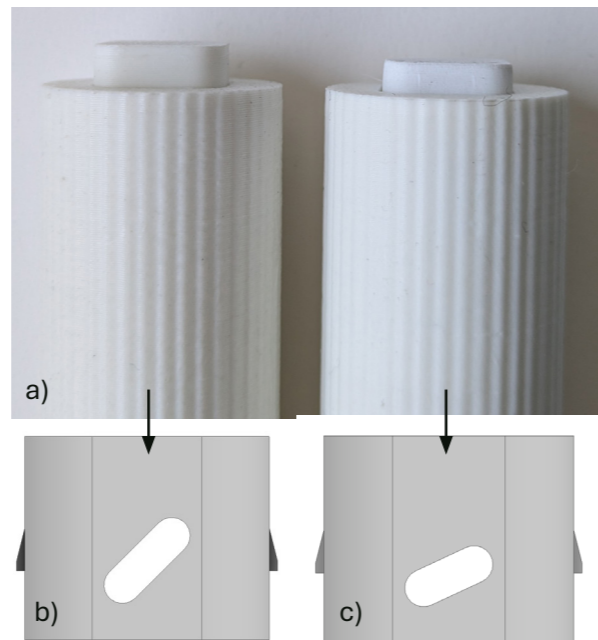

Figure 4.18 : a) old and new button height, b) old lock component, c) new lock component

The elevation groove of the rotary cylinder is sensitive to the precise height for proper working of the device. Precisely on the top of the groove the spring should lock, making the plunger unable to move up and down, Figure 4.21. If it locks before the top or after, the pin cannot move over the top or the system does not lock, Figure 4.20. For this there has been tinkered with the height of the elevation groove to make sure the device works properly.

Lastly the application has some play in rest and when the spring is locked, In the following design iteration this has been minimised. However, some play will always be present to move the pin in the activation stroke.

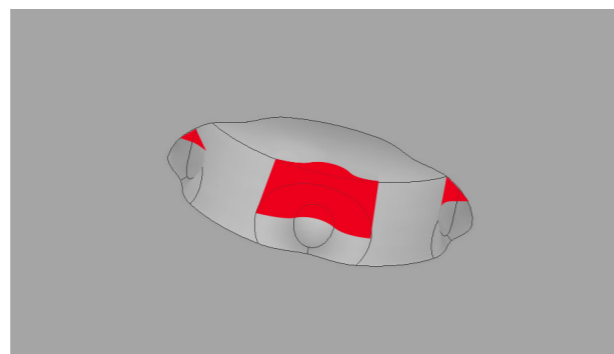
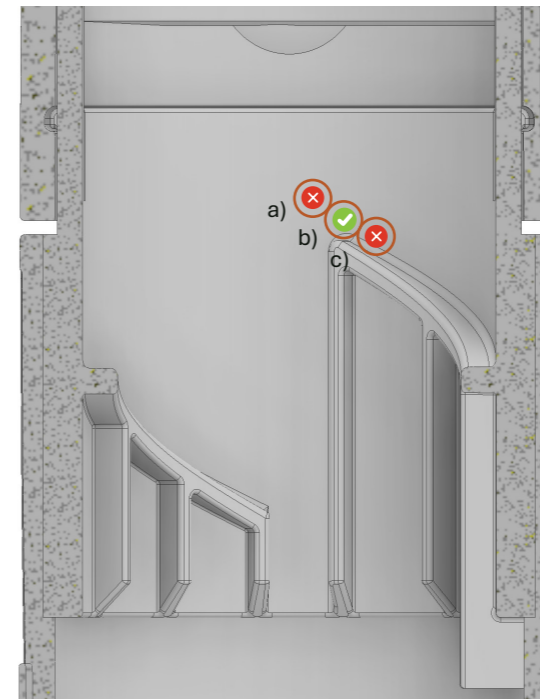

Figure 4.19 : a) undercuts of the carrier holder



○ Moment plunger is locked

Figure 4.20 : Moment where plunger is locked, a) plunger cannot move high enough as the elevation groove does not reach the right height, b) plunger is locked and can move into the firing stroke, c) plunger is locked, but the elevation groove blocked it making it unable to move to the firing stroke

Prototype iterations lock at the top of elevation groove:

- I 1-3: to get the right height

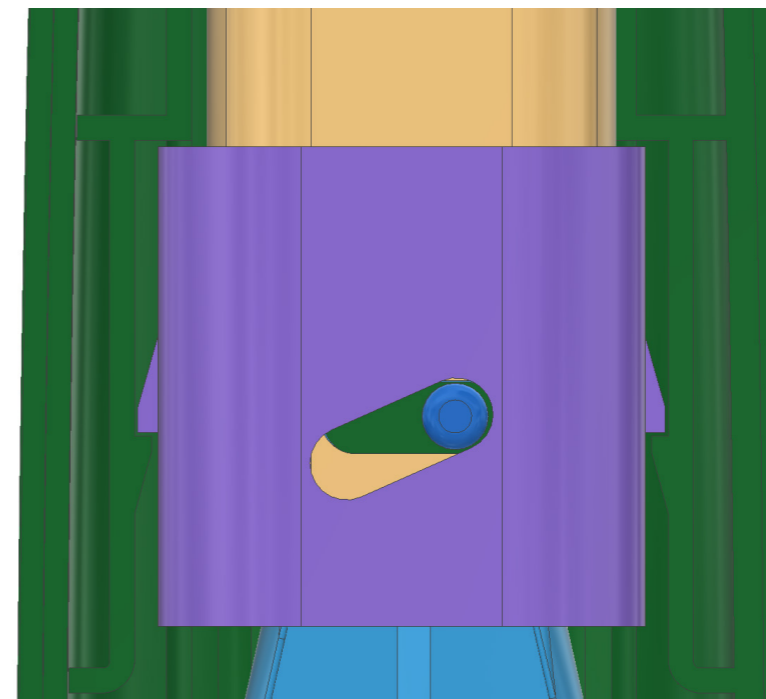

Figure 4.21 : Section view of applicator when plunger is locked

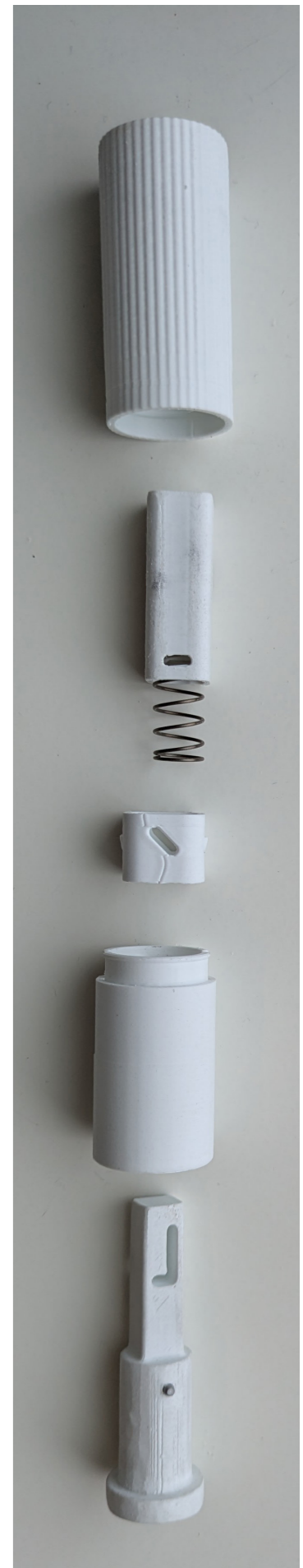

Figure 3.54 : Exploded view of prototype

4.1.4. Function: Stretcher

It was briefly tested how a flexible rubber could function to determine if this would be a valuable option to explore in later development of the applicator.

Given facial variability and usability constraints, a two-foot stretcher was selected. This allows more placement flexibility without interfering with handling and limiting touch points with possible leisure's.

Stretch ability depends strongly on grip, tissue softness and form of the stretcher. For example, skin on the forehead stretches more easily than on the cheek due to differences tissue thickness. The form of the stretcher should always have the ability to move to the outside, if the form is suited for this, or there is too much grip it will move inward, Figure 4.22 & 4.23.

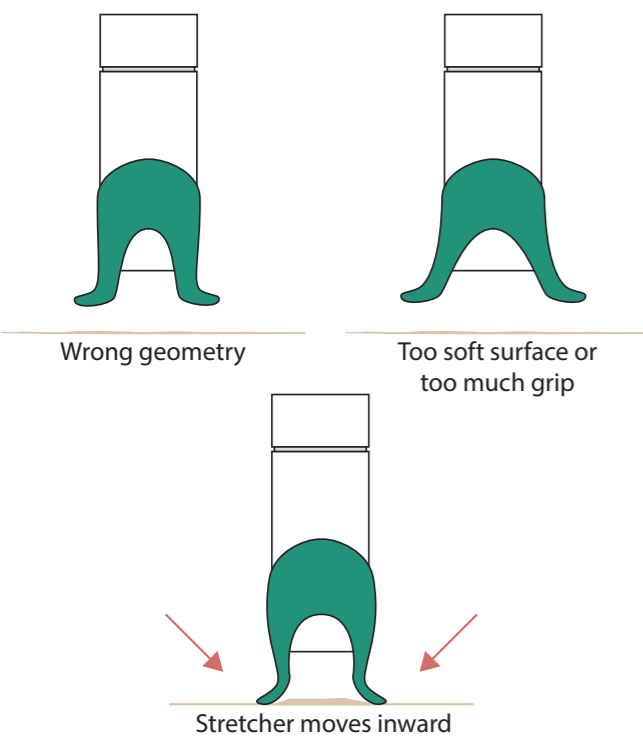

Figure 4.22 : Abstracted stretch mechanism

Prototype iterations:

- I 1: solid stretcher: lot of tension
- I 2: cut in middle to see if it works better: still tension but less
- I 3: remove inside to see if it works better : less tension but weak
- I 4: print with removed inside and differently angled on bed: good stretch but weak
- I 5: print solid again more angled to the outside, slightly thinner and differently angled on bed: good tension, good stretch

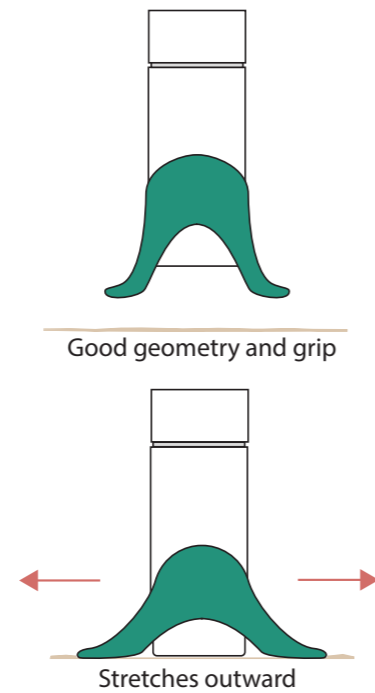

Figure 4.23 : Correct stretch geometry

A flexible stretcher works reasonable on the most facial regions. On region 4, the cheek, it doesn't have a hard underground and therefore is hard to use or doesn't work at all, Figure 4.24. On the chin the stretcher perfectly falls into the shape of the head.

As the stretcher does not work sufficiently across all facial regions a stretcher wont be added in the design as the alternative of stretching the skin with the free hand work more efficient and gives the user more control of avoided sensitive skin points.

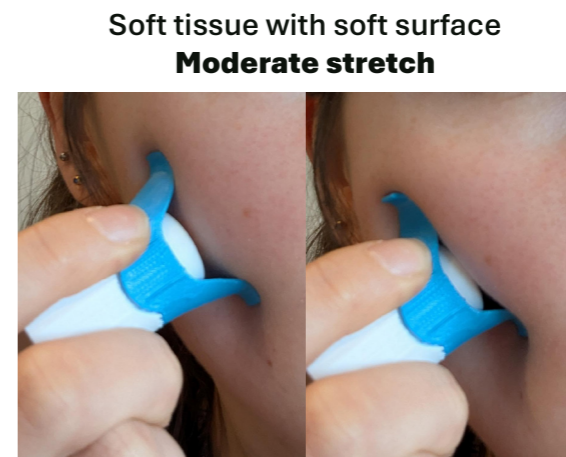
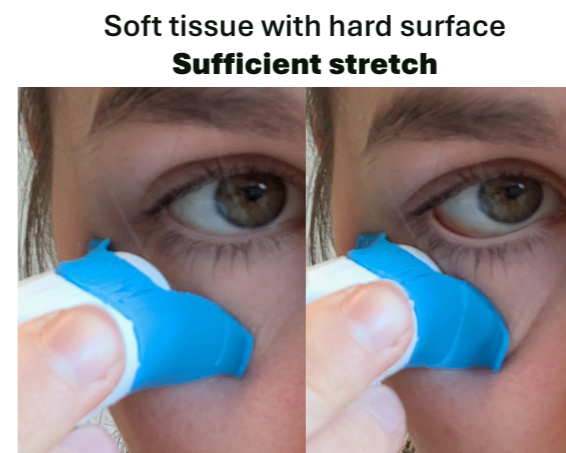

Figure 4.24 : Stretch capabilities on different face categories

4.2. Size -Ergonomics

The size is largely defined by the internal components, resulting in an outer diameter of ~ 23 mm and a button diameter of ~20 mm.

The length was determined using anthropometric data from a Korean paper [76]. Based on the 95th percentile male measurements to ensure usability for the most percentiles. Three key actions were considered:

- applying the patch
- loading
- activating

Loading as seen in Figure 4.26 requires enough length to grip and rotate both housing parts. This is the length of ~26 mm, roughly one fingertip was found to allow sufficient force to rotate.

For patch application and activation the device is held with three fingers on one side and the thumb on the other as seen in Figure 4.27. A small spacing between fingers improves comfort and stability while reducing strain.

Due to limited anthropometric data, some estimations were made. Finger contact is assumed to occur at a slight angle. A 2 mm reduction correction was done on the breath at PIP joint, since the fingertips are narrower than the base (PIP joint). Spacing between fingers is estimated at approximately 70% of finger width, Figure 4.25 and Appendix L.

These considerations result in an overall length of ~ 85 mm. Increasing the length further would reduce control and make the device feel less connected during use.

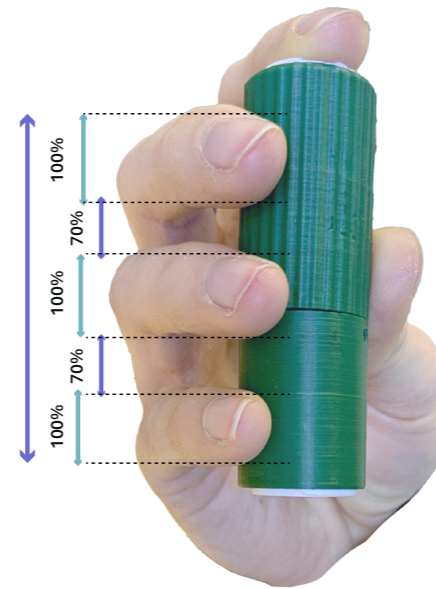

Figure 4.25 : Distribution for the length of the applicator

Intended loading hand positions

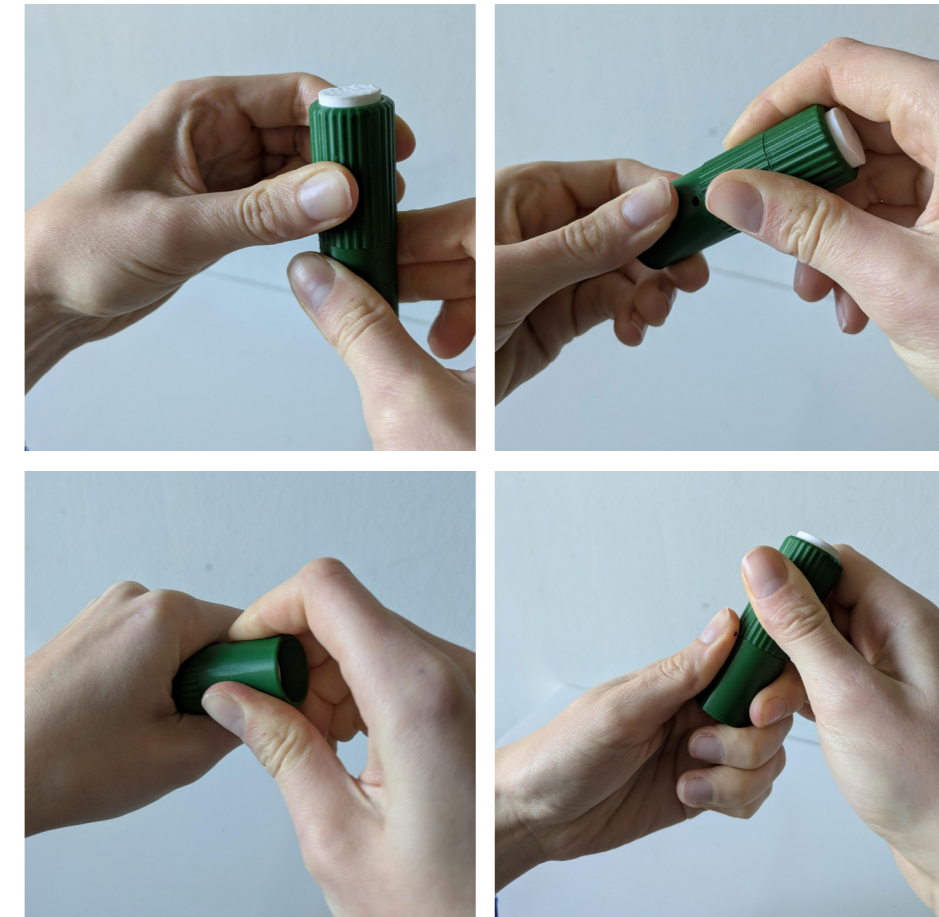

Figure 4.26 : Different ways of hand positions for the applicator during loading

Intended applying patch and activate applicator hand positions

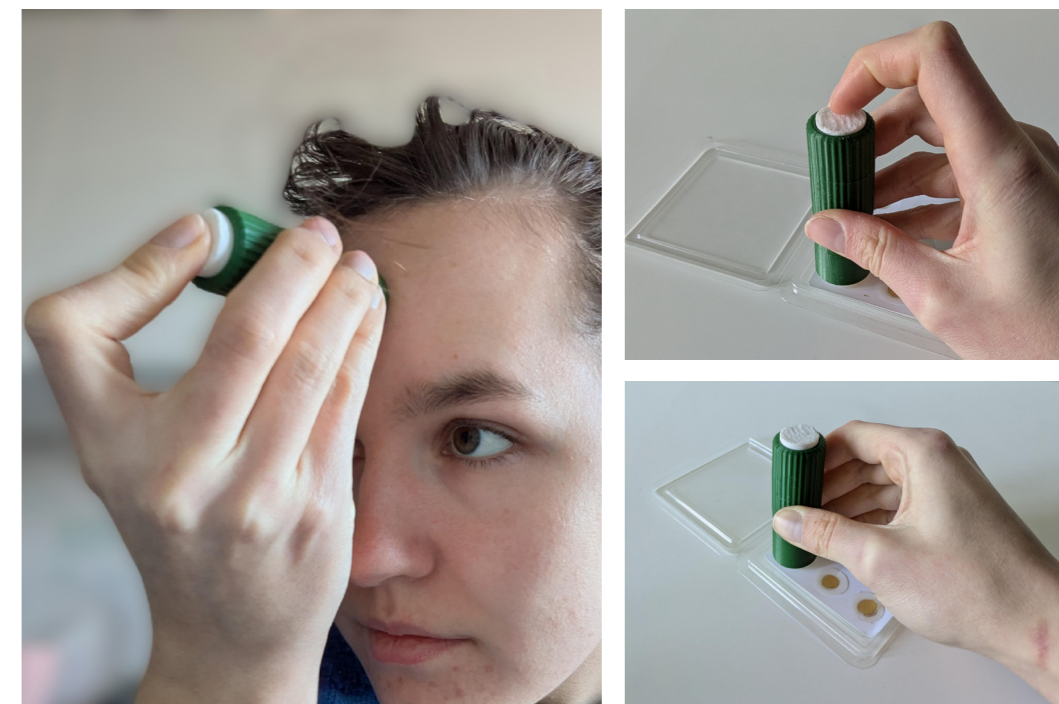

Figure 4.27 : Different ways of hand positions for the applicator during patch applying and activation

4.3. Material Selection

For the material selection the Granta Edu pack software was used to compare difficult materials in the level 2 dataset [77]. Grap 4.1 & 4.2 were used and Table 4.7 to determine the best material per component. Table 4.6 visualises the requirements per component for the mechanical properties of the material.

ABS is chosen for most components of the applicator. For the outer casing ABS is most suitable since it gives a premium feel, is of high quality and is available as medical grade. As well as that it is not brittle making it good for the snapfits which in these components and to absorb fall impact. For the basic internals the latter argument also applies for the chock impact the spring creates. ABS made sense for the inner rotary cylinder as this part is ultra sonically welded to the outer rotary cylinder from a sustainable and durability point of view. ABS also gives enough flex for the snapfits and locking strip.

PC would have also been a good option for all the above components but was discarded because of the price and minor disadvantages in toughness and a higher young's modulus.

With normal use the pins do not have a lot of strain as the impact is absorbed by the skin. However the locking pin should be able to handle repeated strain created by the springs, as when the force is not absorbed by the skin it is absorbed by this pin. By having a steel pin with 2mm Ø ensures durable use.

The rotary inner cylinder needs to have a relatively low young's modulus to accommodate for the flexibility for the snapfit and rotation lock strips. It needs a low friction coefficient with the sliding pin and a high hardness to accommodate for the wear and friction with the sliding pin. As the inter rotary cylinder will be ultra sonic welding the outer cylinder this needs to be compatible as well.

Table 4.6 : Material requirements of components

Outer casing		Basic internal components		Inner rotary cylinder	Sliding pin
Main housing	Rotary cylinder	Button - lock - plunger	Lock pin		
Premium / high quality feel		Absorb shock of spring, high fracture toughness		Low friction, High hardness, comparable highness with one another	
Moderate young's modulus			High tensile strength High yield stress	Moderate young's modulus	Moderate tensile strength
Medical grade plastic					

POM would have been a perfect option if it would be possible to weld this is any plastics. ABS is again the best options as it gives the perfect combination for the needed requirements. PC is too brittle and PS would have been too stiff.

There are three options for the pin that slides on the elevation groove, Table 4.5. The pin must have a low friction coefficient, minimize wear with the inner ring, and be sufficiently stiff and tough to withstand the static downward force applied by the spring at the outer contact points on the lock component.

Table 4.5 : Material options for sliding pin

Metal	POM	ABS
+ Low friction + strong	• needs bigger pin	• Needs bigger pin
- Larger wear	+ Lowest friction + Minimal wear	+ Fewer components - Higher friction

Comparing the options a metal or POM pin are suitable. However, the increased wear caused by the metal pin makes it less favourable. A POM pin is therefore selected. To ensure sufficient strength, the pin diameter will be increased to 3 mm and the plunger is widened to provide additional support and thereby also improved guidance. This is considered sufficient to prevent failure under the applied spring force. It is valuable to investigate in further development if the ABS groove is hard enough and won't wear over times from the POM pin.

For the patch carrier it is important that the material is transparent to make the patch more discreet. Furthermore it needs to be softer than the plunger to minimize wear from putting a carrier in multiple times. PET is the best suited material, it is cheap, transparent and relatively stiff but not brittle. PE and PP would also be good options but are considered unsuitable because of their lack of stiffness.

Graph 4.1 : Plot chart of plausible thermoplastics in Granta Edupack, dataset level 2, hardness with young's modulus

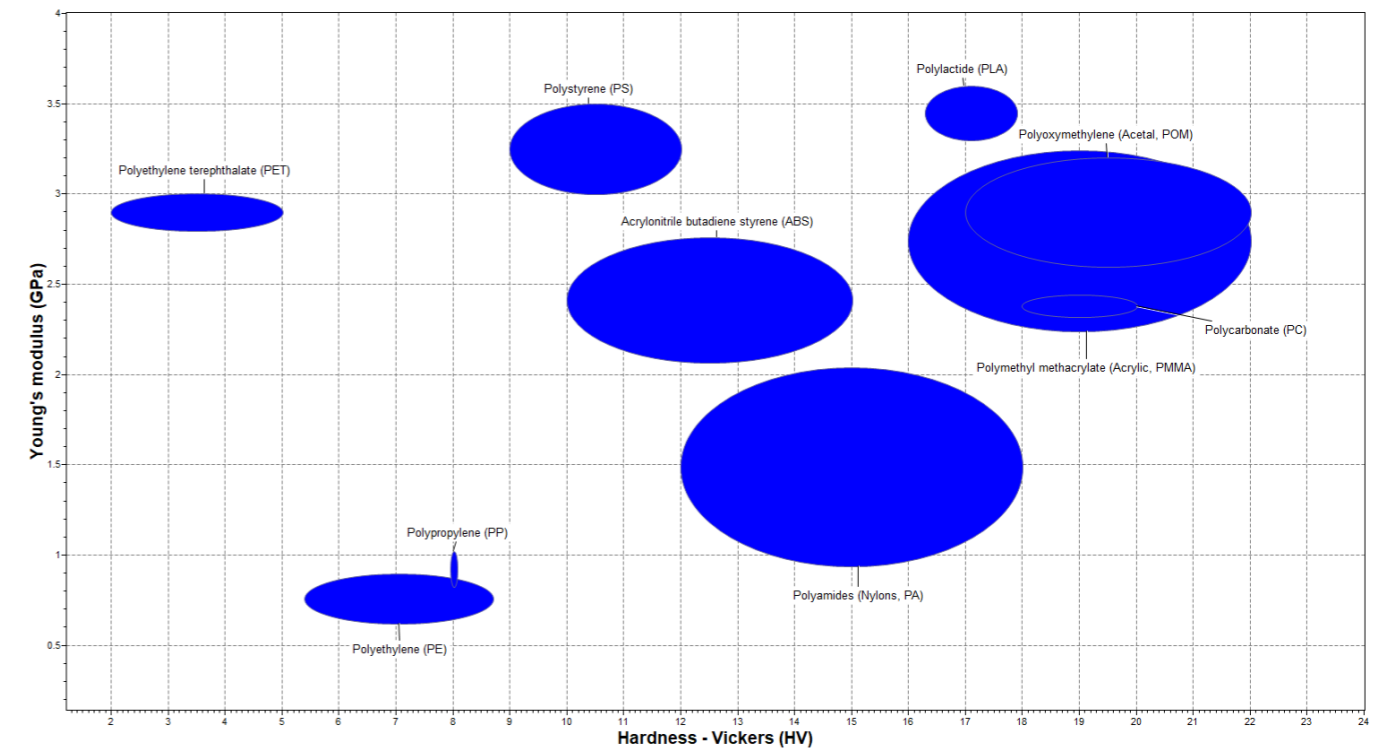

Graph 4.2 : Plot chart of plausible thermoplastics in Granta Edupack, dataset level 2, hardness with young's modulus

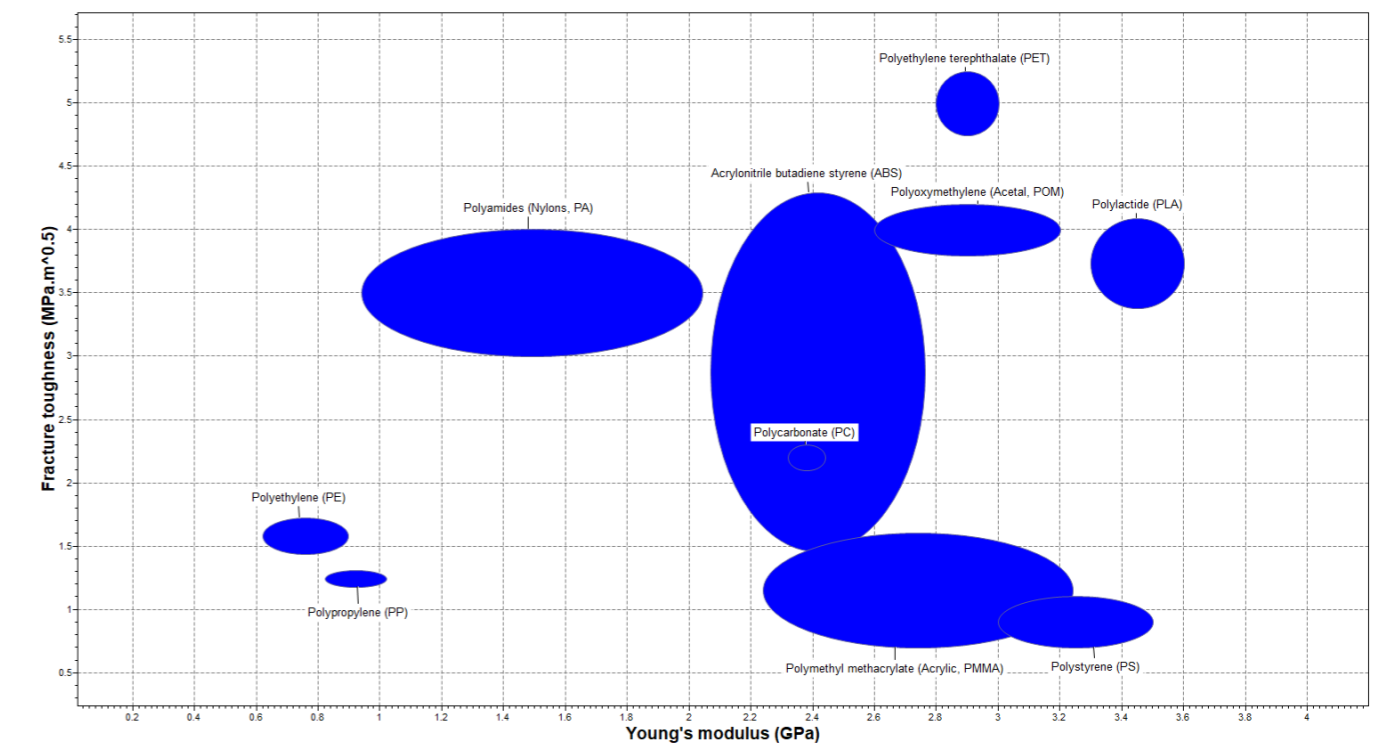

Table 4.7 : Mechanical properties of plausible thermoplastics

	ABS	PC	PE	PET	PP	POM	PS
Price EUR/kg	€2,44-€2,56	€3,11-€3,38	€1,31-€1,35	€0,74 - €1,43	€1,51-€1,73	€1,49 - €1,57	€1,96-€2,67
Young's modulus (GPa)	2.07-2.76	2.32-2.44	0.621-0.896	2.8 -3	0.824-1.02	2.6 - 3.2	3-3.5
Yield strength (MPa)	34.5-49.6	59.1-65.2	17.9-29	50 - 55	24.1-28.4	57.2 - 71.7	28.7-41.4
Tensile strength (MPa)	37.9-86.2	62.7-72.4	20.7-44.8	55 -60	26-50	71.5 - 89.6	35.9-51.7
Hardness - Vickers (HV)	10-15	18-20	5.4-8.7	2 - 5	8	17 - 22	9-12
Fracture toughness MPa m ^{0.5})	1.46-4.29	2.1-2.3	1.44-1.72	4.75 -5.25	1.18-1.31	3.8 -4.2	0.7-1.1

4.4. Assembly

Assembly has been a key consideration throughout the design process, it affects the cost price, reparability. The design resulted in a product with only seven components that can be assembled button to top with two subassemblies, Figure 4.28.

Assembly has been analysed to see if there are ways to incorrectly assemble the applicator, from this the lock component can be incorrectly placed in two ways:

1. Reversed, preventing locking due to restricted pin movement, Figure 4.29b
2. Upside down, preventing snap-fit assembly, Figure 4.29c

Implementing **poka-yoke** principles is therefore essential to ensure correct assembly.

Several solutions were considered. Most effective is adding a small rim to underside of the lock component, ensuring correct orientation during assembly. The rim has diagonal corner that is also in the plunger, ensuring correct orientation between the two, see Figure 4.29a & 4.30.

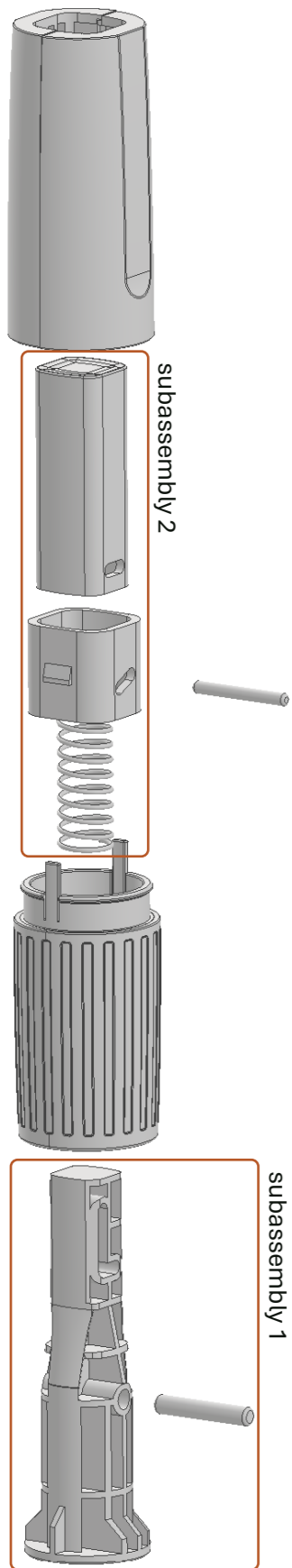

Figure 4.28 : Assembly tree of the applicator

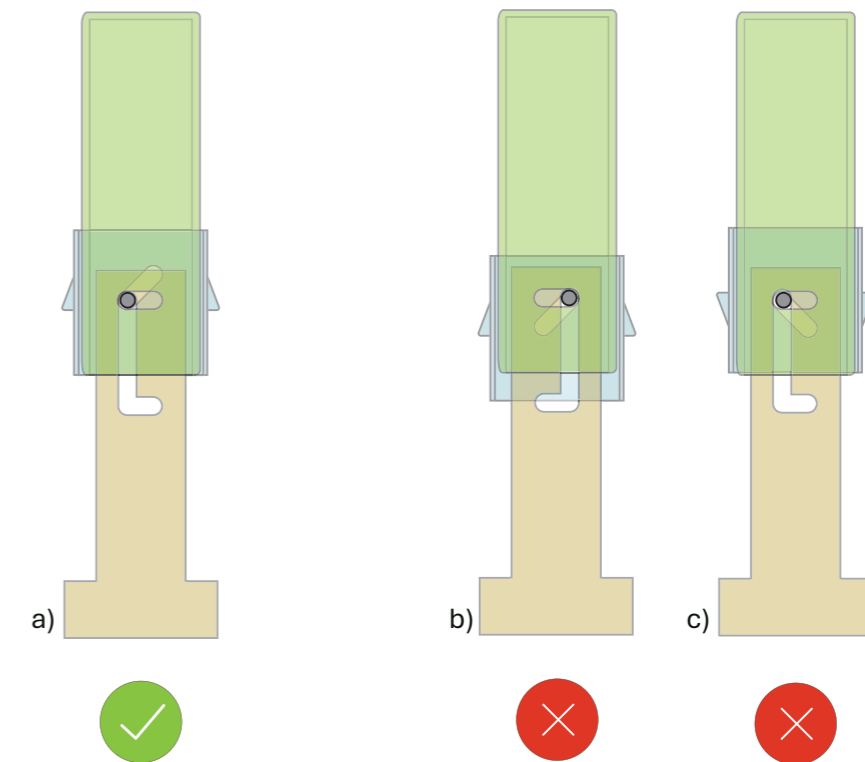

Figure 4.29 : Ways to assemble internal parts a) correct assembly b) wrong assembly, plunger is flipped c) wrong assembly, lock component is flipped

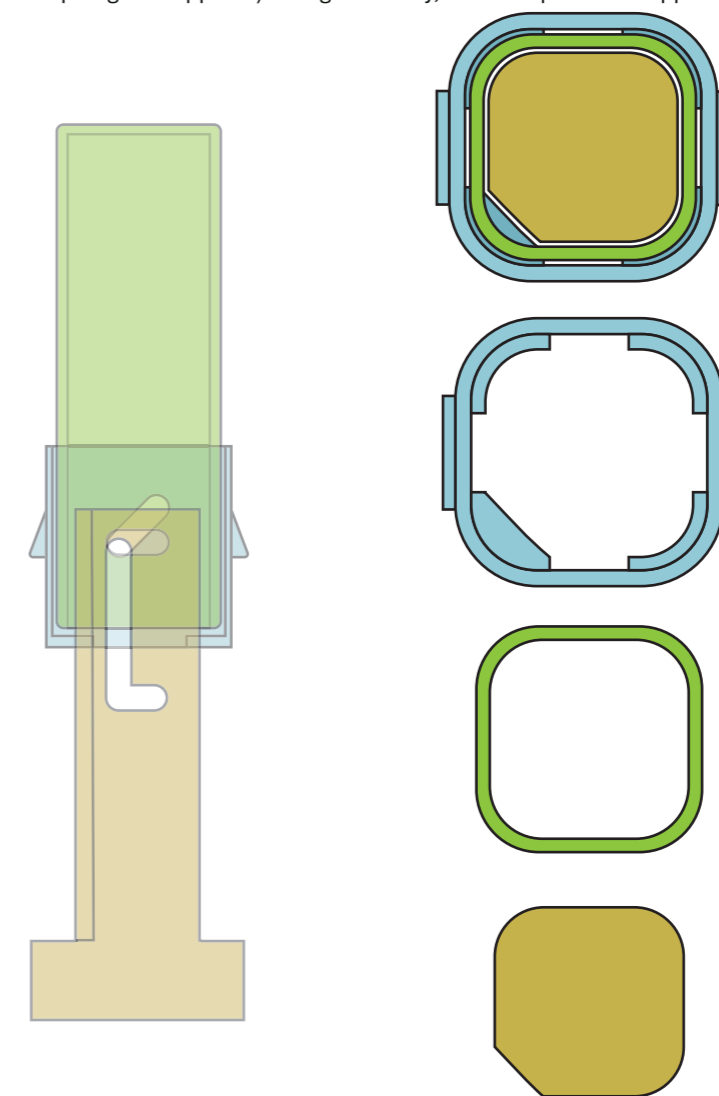

Figure 4.30 : Adjustments to internal components to make poka-yoke assembly possible a) side view assembled b) assembled and separate components top view

Gentle Precision

Safe | Gentle | Effective | Balanced | Elegant

It is **not**
a toy | a weapon | medical injection device

Clinical +-----+ Skincare



4.5. Appearance and form

User experience is a critical aspect for the applicator. The applicator has to give feedback of its use, clinking when in lock, and shooting the plunger communicate effectiveness and clearness. The appearance must therefore communicate for safety and comfort to counteract the feeling of danger.

The design should be somewhere between a medical and a personal care device. A clinical aesthetic communicates effectiveness and cleanliness, while softer elements will make it feel safer and more familiar.

Mood boards were developed to explore this balance between medical and lifestyle product characteristics, and (Korean) cosmetic design guiding the final design direction.

" it is a **skincare** product not a beauty one "



Figure 4.31 : Emotional one pager [31]



Figure 4.32 : Mood board of similar form, medical, personal hygiene, Korean skincare and cosmetic products [31]

Similar form

- Flat surfaces
- Symmetric rounding's
- One or two finished

Medical

- White and soft (blue) colours
- Rounded edges
- Slight curves
- Shiny/ matt finish
- One finish
- Minimal use of straight lines in outer casings
- Symmetric forms

Personal care

- Round edges
- Streamline
- Matt, shiny or metallic finish
- Black or soft light colours
- Symmetric forms

Korean skincare

- Pastel, deep and faded earthy colours
- Matt is a favourite finish
- Angular shapes

Beauty

- Chrome, metallic or matt finish
- Sharp edges or very rounded
- Extremes forms
- Contrasting
- Asymmetric and symmetric forms
- Patterned surfaces
- Deeper colours

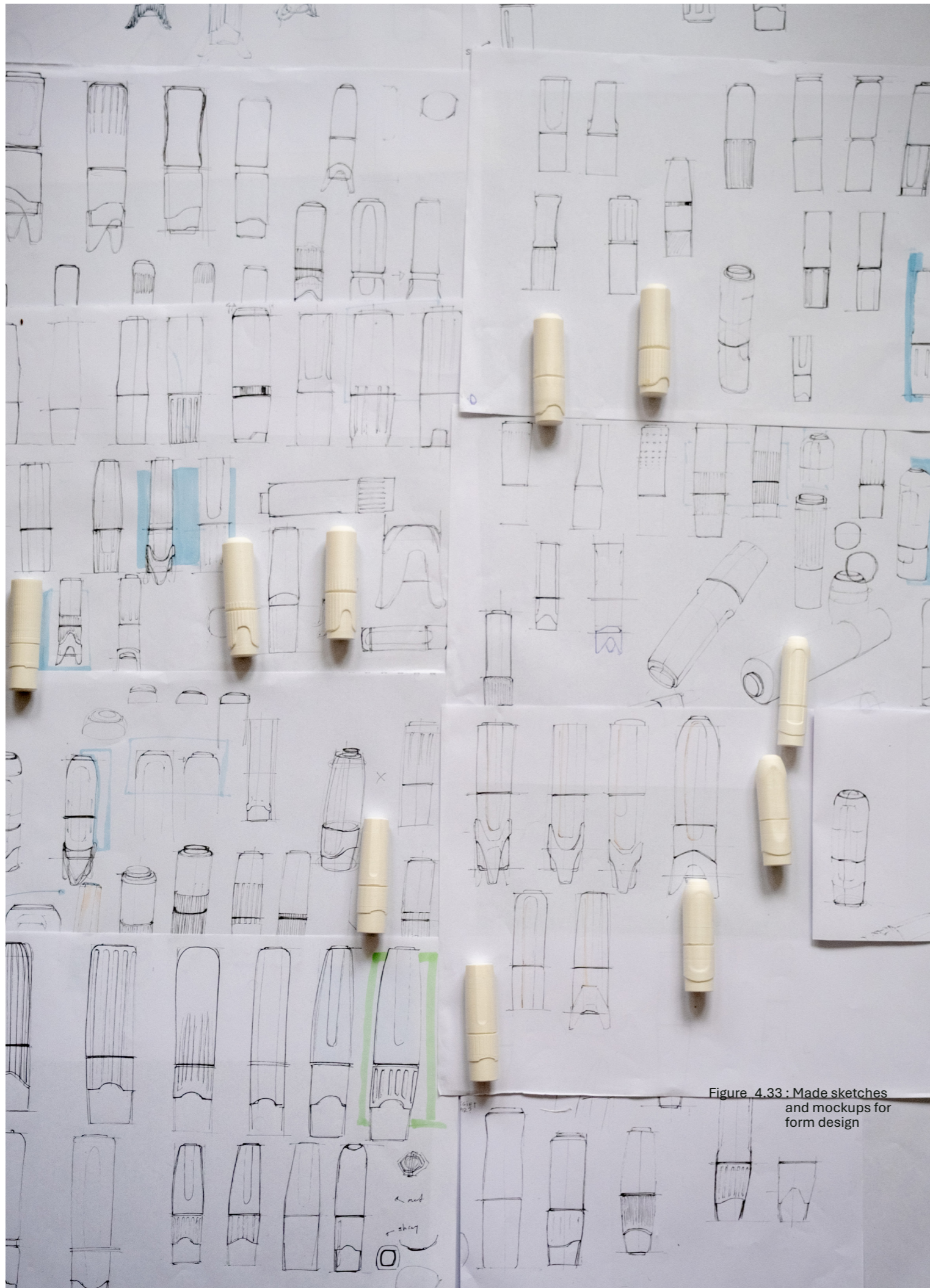

Figure 4.33 : Made sketches and mockups for form design

The first designs made didn't have the qualities I was looking for. Trying to fuse two different form worlds together resulted in designs that were not balanced, but chaotic and thrown together, the opposite of the vision. A new design strategy was applied: The form will have a medical appearance. If the form is inspired by cosmetic aspects this gives too much the appearance of a cosmetic product as can be seen in the sketches, Figure 4.33. The finish, the colour and texture, will be inspired by (Korean) cosmetic skincare products. By giving the applicator a medical form with cosmetic finish the product will stand more in the middle of the two and should balance the design more.

For the colour it must be unisex, so the stereotypical colours are not an option, e.g. pink, blue. To also get the Korean inspired elegant appearance a more muted colour was selected, together with a matt and shiny part finish.

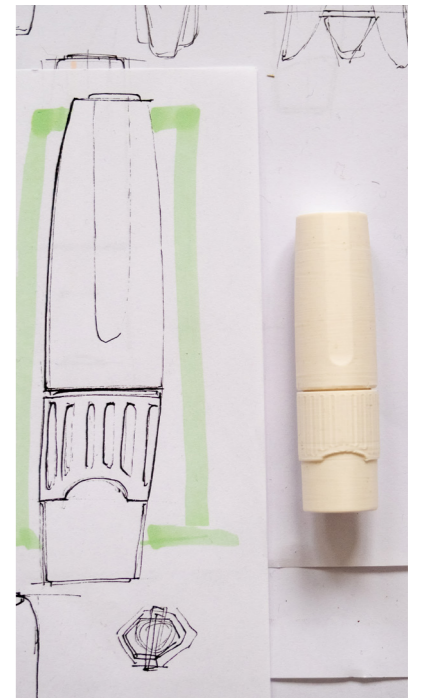

Figure 4.34 : Final mockup and form sketch

4.6. User study 3: Final product evaluation

To validate the design and use cues of the applicator a final product evaluation was conducted. The questionnaire from ISO IEC 62366-1:2015 was used to gather data for validation of the use of the product [78]. Three users who grew up in a country in East-Asia (n=3, 1=male, 2=female, 25-29 aged) were asked to test the applicator. They were given the scenario that they wanted to apply a microneedle pimple patch on their forehead with the applicator. The study is described in Appendix L. After the scenario the participant is given a questionnaire from the international standard, which is later analysed and categorised depending on if the questions had to do with the following functions:

- Preparing the applicator for loading; applying the patch to applicator
- Loading the applicator
- Activating and placing the applicator
- General; Overall opinion

Generally the product was perceived as good understandable and good in use, this can also be reflecting in the result from the questionnaire with an average score of 3.35 on 5, Graph 4.3. The score is not the highest, so there is still room for improvement.

Graph 4.3 : Radar graph of average scores 1-5 (with 1 being worst and 5 being best) of prototype

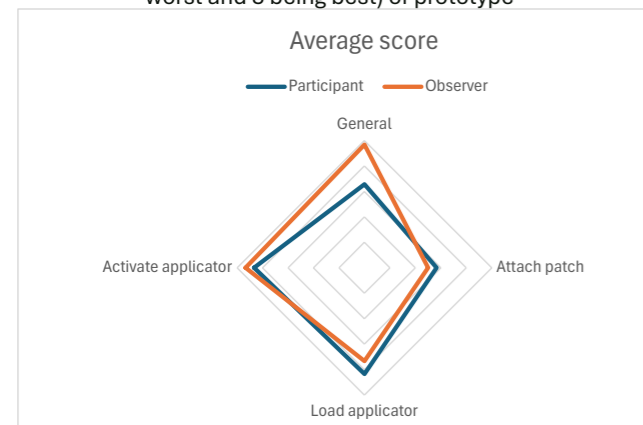

4.6.1. Attaching the patch

The biggest struggle with the applicator was with removing the film after the patch was applied to the applicator. Participant wanted to pull it straight off, but as the carrier connection with the plunger is weak this makes the carrier loose from the applicator, Figure 4.35. Participants were careful not to touch the needles in this step, but after frustration of the film not coming off one did do so in an attempt to remove the film.



Figure 4.35 : P.1 picking up the patch with the applicator and holding the film down

Loading the applicator

Loading the applicator was done sufficiently by all participants. Participants did struggle at first with how far they should twist, they expressed that it was because they knew that they were handling a prototype and didn't want to break it, and that it doesn't untwist when it is let go. The latter is caused by the 3d printed prototype, with an injection moulded product this wouldn't happen.



Figure 4.36 : P.1 loading the applicator



Figure 4.37 : P.3 and P1 activating the applicator

4.6.2. Activating the applicator

Activating the applicator was most understandable by participants. One participant used both hands for the activation, Figure 4.37.

A journey map, shown on the next page, was made to compare it with the journey map that was made for the current use without applicator, "Figure 2.20 : Journey map current use" on page 36. The journey map shows that some concerns and needs are eliminated or shortened with this applicator and the general pain points are lessened.

Due to the small sample size not a lot of definite conclusions can be drawn, regarding size and form. Therefore the take aways will be focusing on use. Concluding from the user evaluation the manual must be updated to give visuals instruction on how to remove the film. Then this needs to be tested again to confirm it is a manual issue. Next to the manual it was noted that the adhesive of the patch to the carrier was weaker than the adhesive of the film, which could also result in the film being unable to be peeled off.

Furthermore as also visualised in the journey map removing the film is still a frustration point and the chance to touch the needles is still big. To resolve this the easiest is to change package the patches per one. This removes the change to touch the needles of other patches and it also stimulates to peel the film of more, since the surface is too small to hold it down, as was done now.

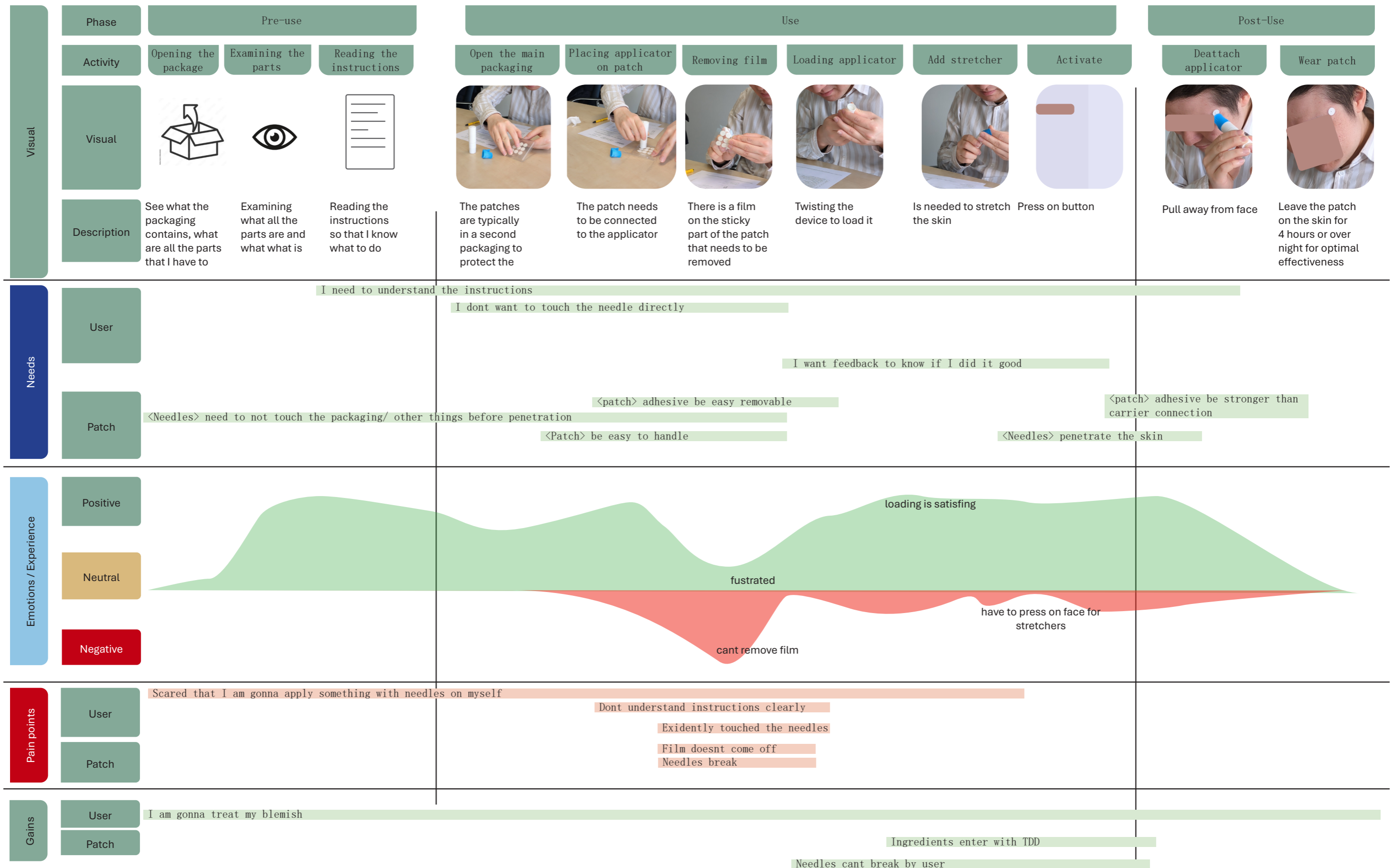

Figure 4.38 : User journey map final product evaluation

4.7. Lab study 3: Search for minimum spring force

For the applicator to work the spring force must be high enough for the AAMNPs to penetrate through the SC. In the second lab test, Appendix F, penetration was measured at 120N. This is a high force; with the following study I researched what the minimal force needed was to make AAMNPs penetrate the SC effectively with the same patches to see if this can be done with a force low enough for the user to still be tolerable. This was tested with the same protocol as lab study 2, but with a binary search to optimally search for the minimal force needed, see Figure 4.40. To make this study more accurate to using the design cosmetic applicator the modified PLUS applicator was used



Figure 4.39 : Add-on on the cover to make the application more accurate to the cosmetic

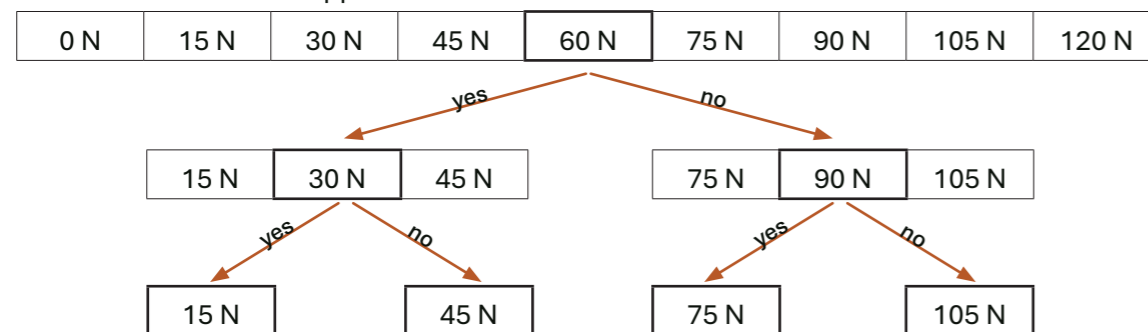

Figure 4.40 : Binary search protocol

with an add-on to replicate the surface area of the plunger of the cosmetic applicator, see Figure 4.39. For each test three patches from Holika Holika were tested.

The hypothesis was that the minimum spring force will be around 60 N. The goals of the study were to see if penetration is feasible with an applicator with a force of max 20 N and if the minimum force was higher, if that force was close enough to adjust manufacturing method of the needles. The full study is described in Appendix M.

With the study penetration was measured at 60N and 45 N but not at 30 N, Figure 4.41. This concluded that the minimum spring force is somewhere between 30-45N. More detailed tests were not conducted to make a more defined amount as this wouldn't change the conclusion or recommendation.

With the Holika Holika patches, penetration is possible from 45 N of spring force in the current testing setup.

With this minimum force it could still be possible for the manufacturers to improve their patches to make it more suitable for penetration with a lower force. With the current patches it is not possible to keep the application of the patch comfortable as the force needed is higher than the ~ 20 N set max for penetration force.

This testing setup uses a heavier plunger, this makes the impact higher than would be the cause with the same force with a lighter plunger. As impact force is velocity times mass of the plunger. This means that for the cosmetic applicator the force should be even a bit higher, as that plunger is lighter by 2.5 grams. A follow-up test could be with the cosmetic applicator with 45 N of force to see if penetration is this happening. This can also be tested on the skin of the face. Measurements of the forehead and cheek will give the most useful results as the facial undergrounds lay so far apart from each other.

Figure 4.41 : Holika Holika test visuals a) micro image after impact force of 60 N, needles dissolved b) micro image after impact force of 30 N, needles superficially dissolved, some bend c) micro image after impact force of 45 N, needles dissolved, d) skin after salt solution for test with 60N, needles penetrated, e) skin after salt solution for test with 30N, needles didn't penetrate, f) skin after salt solution for test with 45N, needles penetrated.

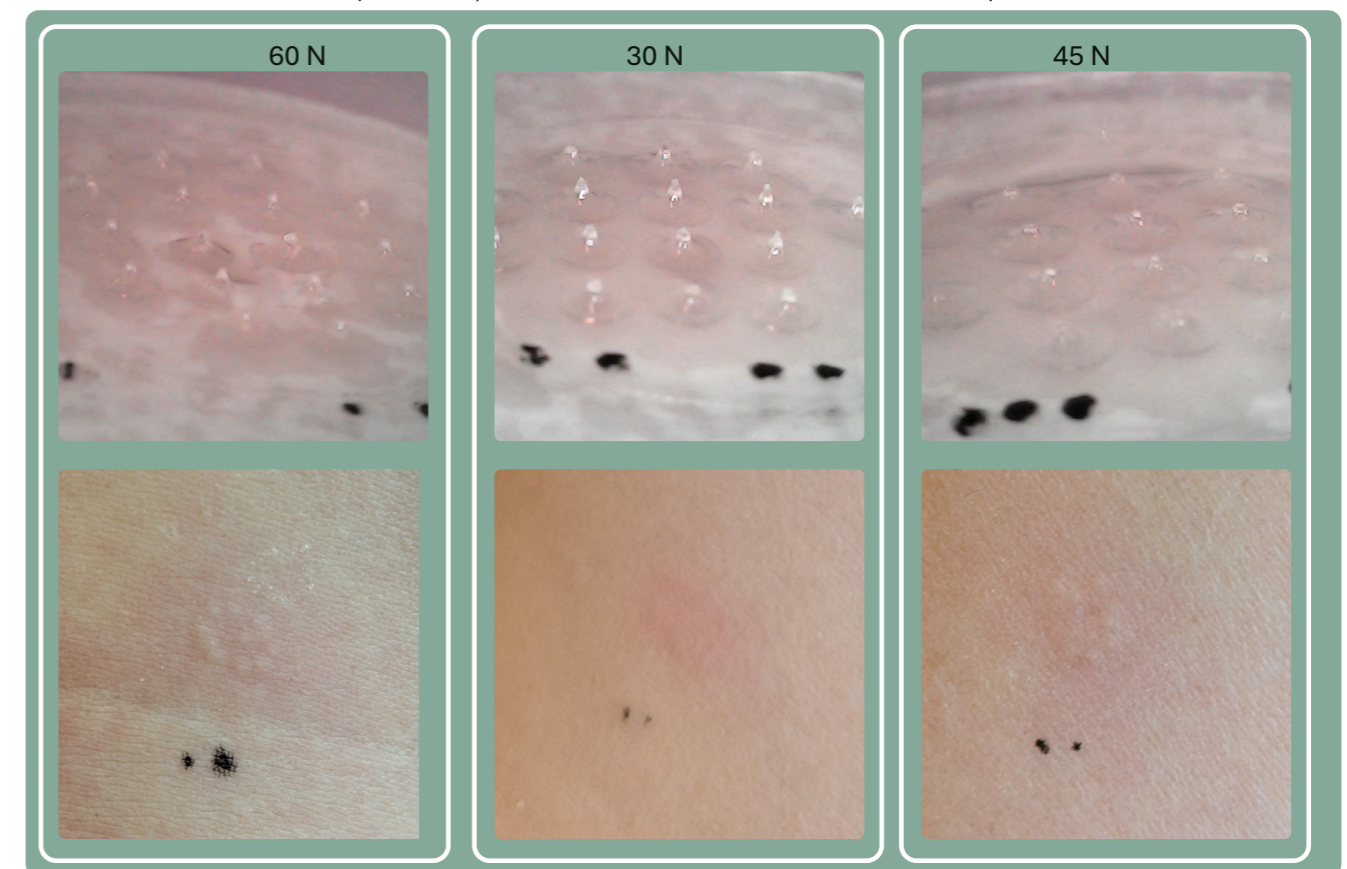

4.8. Final prototype

There are two final prototypes. The SLS print that checks if the rotation cylinder will unwind when not completely in lock and a prototype with FDM printing with the final form and finish, unfortunately this couldn't be produced in SLS since the delivery time for this ascites the timeline of the thesis.

4.8.1. Stiffening the elevation groove

A frequent problem in the prototypes is the creation of a cavity by the sliding pin in the middle of the elevation groove, Figure 4.42. Possible because of irregularities in the pin or elevation groove and the low stiffness of the PLA rotation cylinder print. This problem causes the rotation cylinder to not work anymore as the pin cannot move past the cavity.

PET-G should give more flex and more stiffness than PLA, however the flex it needs to withstand to get inserted into the main housing is too great, which resulted in snapping of the material, Figure 4.43.

For the second test PLA was used again a layer thickness of 0.08 mm. The elevation groove and sliding pin were polished to reduce friction and irregularities, which would make it harder for the sliding pin to dig into the elevation groove. This resulted in a successful prototype, Figure 4.44.



Figure 4.42 : Rotary cylinder with an damaged elevation groove



Figure 4.43 : PET G print whit broken fits



Figure 4.44 : Final working visual prototype



Figure 4.45 : SLS prototype

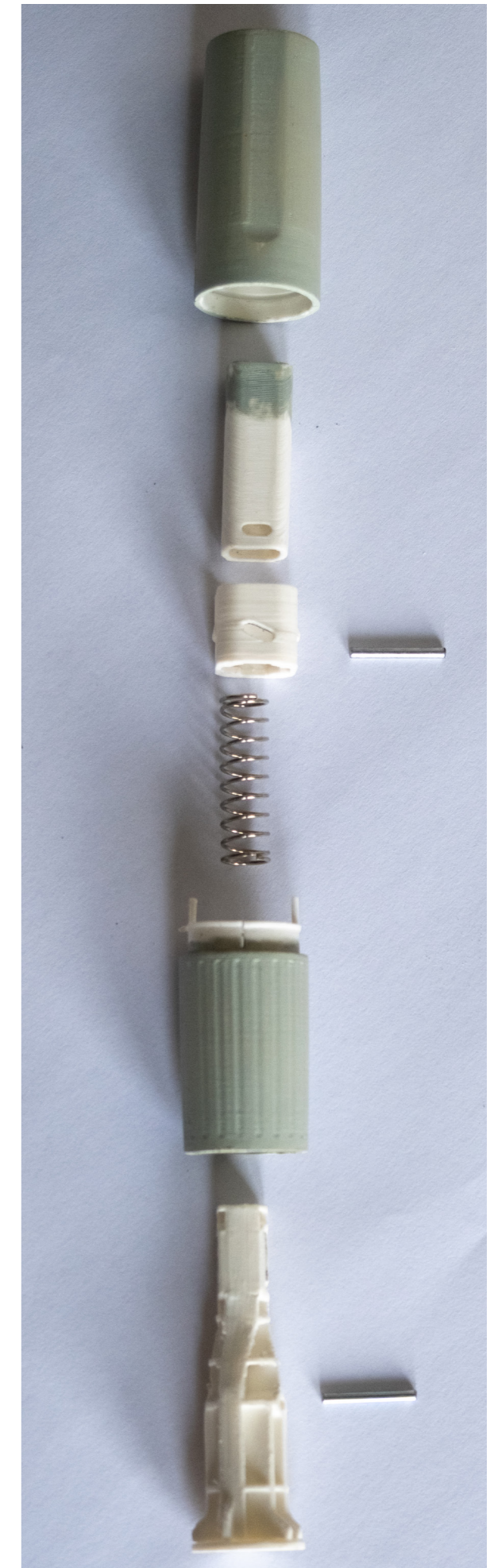

Figure 4.46 : Exploded view of visual prototype

Chapter 5

Final product

5.1. uPATCH™ MINUS	112
5.2. Working principle	116
5.3. Use	120
5.4. Feasibility	122
5.5. Desirability	126
5.6. Viability	128
5.7. Recommendations	130
5.8. Limitations	131

Figure 5.1 : Final product presentation photograph

5.1. uPATCH™ MINUS

The uPATCH MINUS is a compact applicator for facial use for effectively applying anti-acne microneedle patches. It applies the patch with an impact force powered by a spring which is loaded by twisting the bottom component, the rotary cylinder. The internal mechanism locks the spring and can be released by pressing the button on top of the MINUS. The impact force at which the plunger hits the skin enables the microneedle to go through the stratum corneum making transdermal drug delivery by dissolvment of the needles possible.

The applicator is suited for anti-acne microneedle patches up to 20mm in diameter. The use of the applicator focusses on compatibility with existing patch packaging, to support fast integration of MINUS for clients in the current market for anti-acne microneedle patches.

The MINUS gives control to the user with the button and the loading system. By loading the applicator, the bottom extrudes out of the top, indicating that the applicator is ready to use and additionally giving a premium experience. The form and appearance of the applicator are luxurious and tool like with a semi medical appearance with a cosmetic touch.

The MINUS has been validated with the list of requirements and meets all requirements except one, the validation is described in Appendix N. The one requirement that is not met: It should be easy to remove the film from the patch before applying. Although technically possible, in the user evaluation participants were struggling with don't so, thus for future development this should be a focus point.



Figure 5.2 : Render of final product

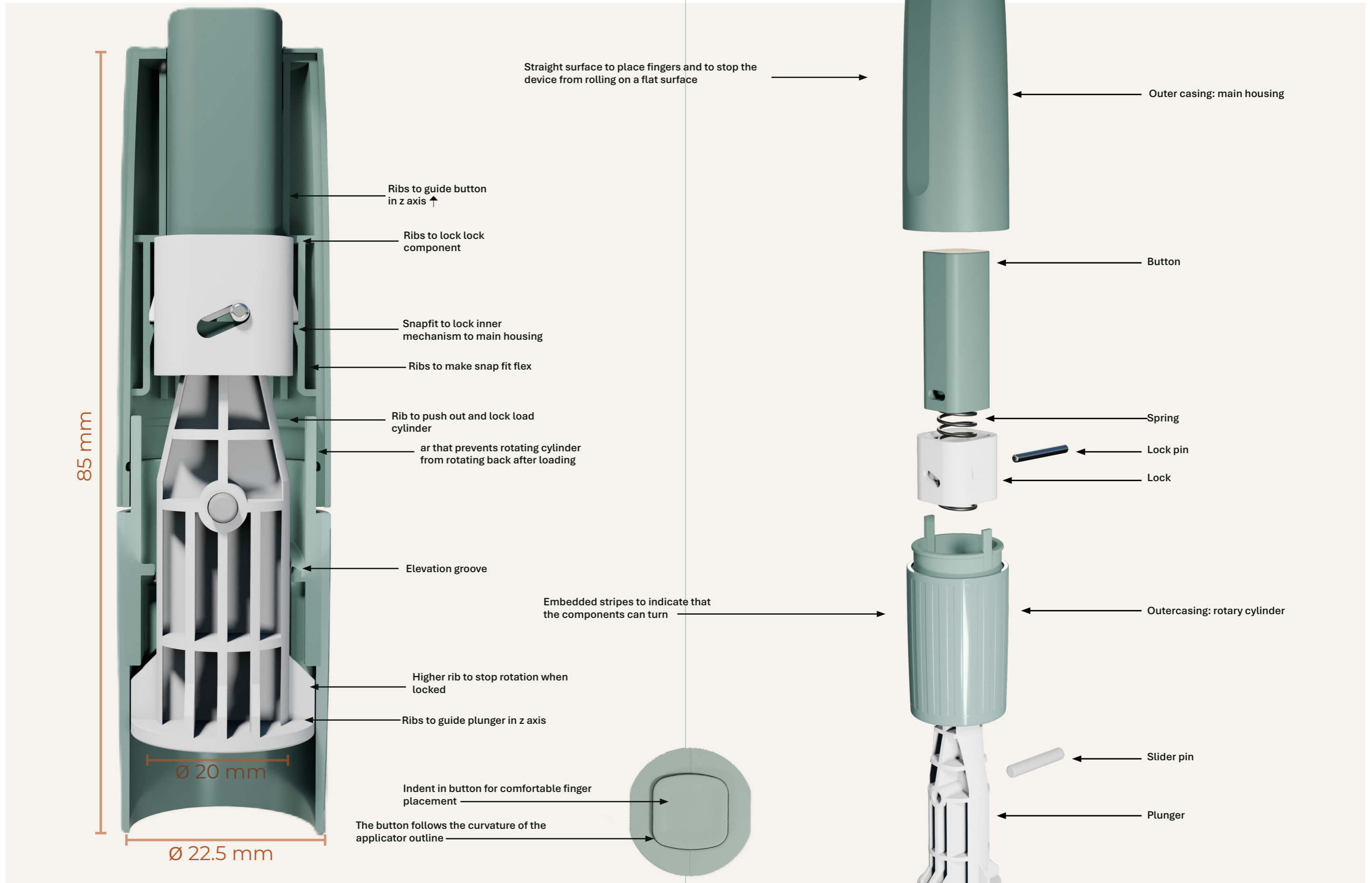

Figure 5.3 : Final design details

5.2. Working principle

Mechanical loading phases

Rest

fase 1: Mid loading

fase 2: Lock pin moving

Fase 3: Loaded

Activation

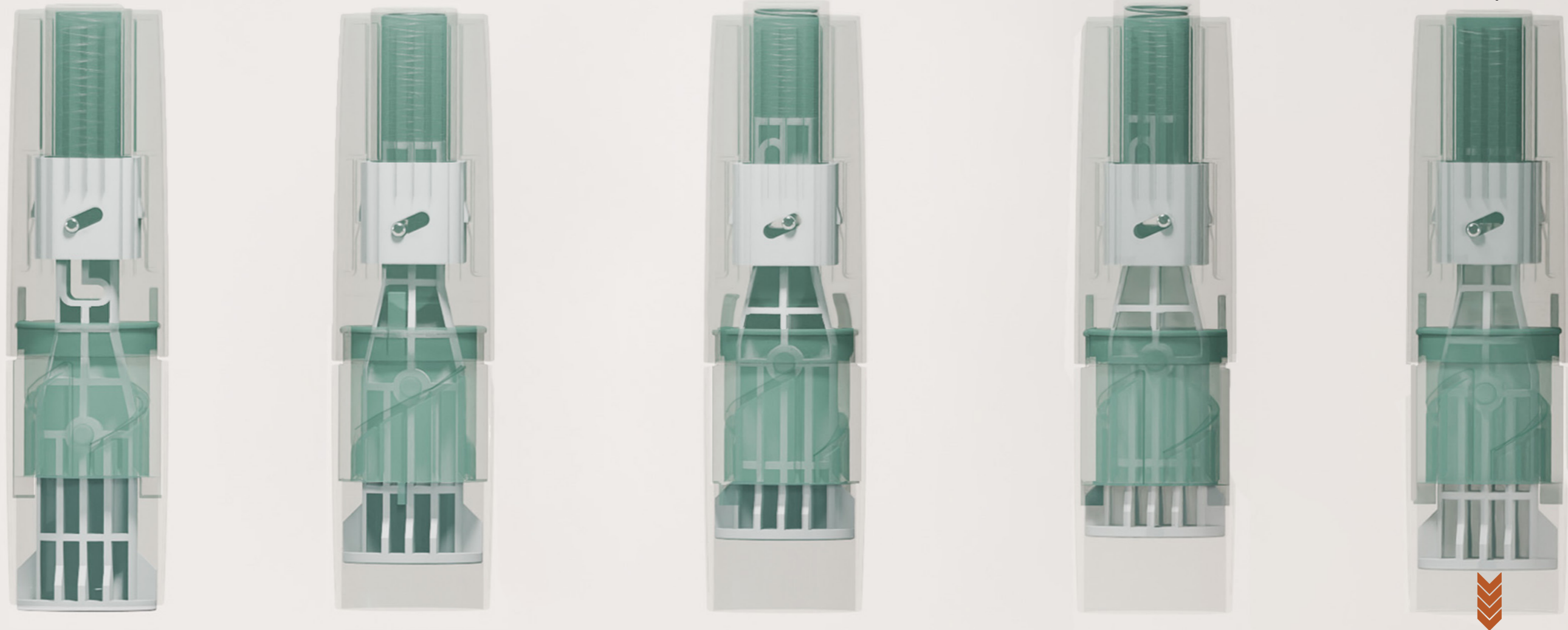

Figure 5.4 : Mechanical steps of the final product

The plunger is moved upwards by the elevation groove in the rotary cylinder while the rotary cylinder is twisted.

The diagonal slot of the lock component brings the lock pin to the right and moves the plunger and button up. The two bars on top of the rotary cylinder are being pushed inward by the main housing

The plunger is locked by the locking pin has fully moved to the right. The rotary cylinder is locking for rotation by two steps in the main housing and the plunger, Figure 5.6 and 5.7, preventing faulty fire.

By pushing the button. The button slot moves the pin to the left where the plunger's slot goes vertical enabling the spring to be release its energy and shooting the plunger down.

Figure 5.5 : Lock bar being flexed before locking

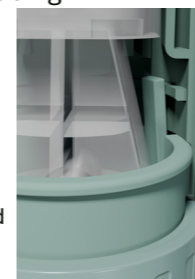

Figure 5.6 : Lock bar behind its lock

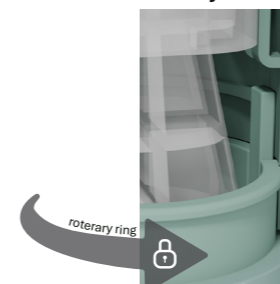

Figure 5.7 : Plunger being stopped by the inner rotary cylinder

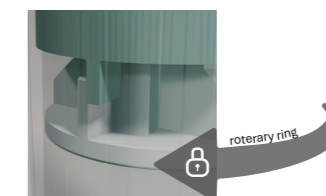
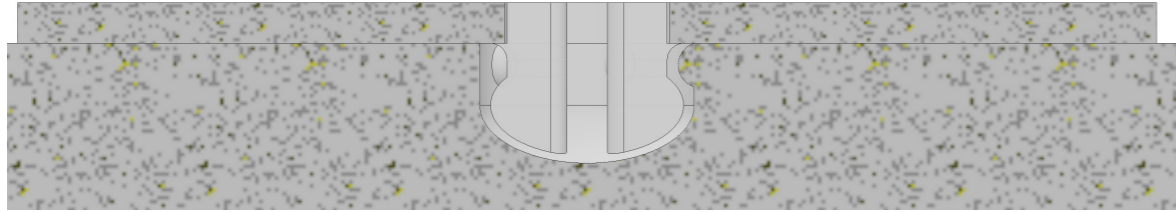

Figure 5.8 : Section view of carrier in plunger



5.2.1. Carrier

The carrier can be clicked into the plunger.

The force that is needed to free the clamping connection with the plunger is weaker than the adhesive force that sticks the patch to the skin. Allowing for the carrier to be detached from the plunger without the patch after application.

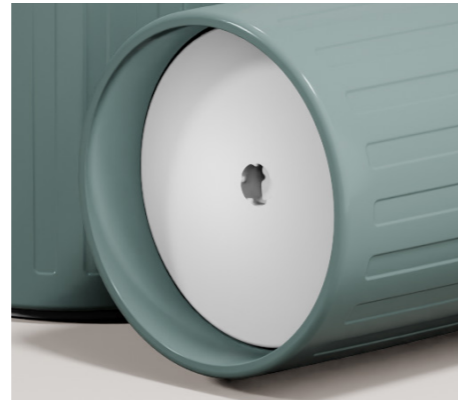

Figure 5.9 : Rendered view of the carrier holder in the plunger

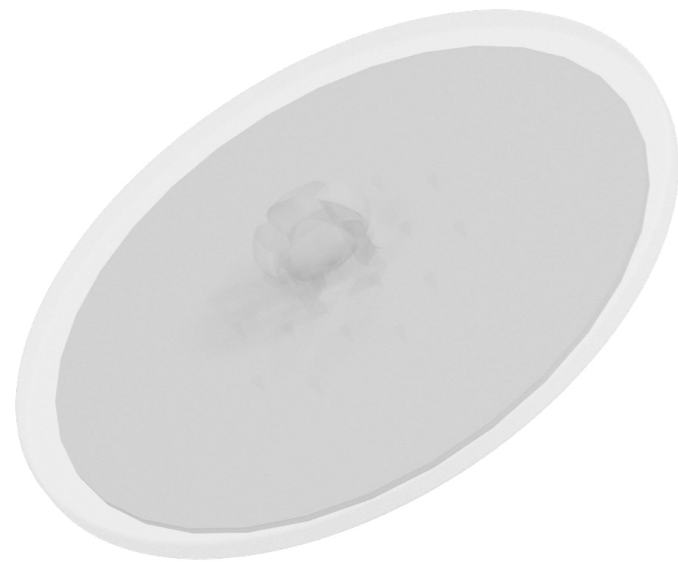

Figure 5.10 : Transtarant carrier with AAMNP



Figure 5.11 : Render of final product with AAMNP

5.3. Use

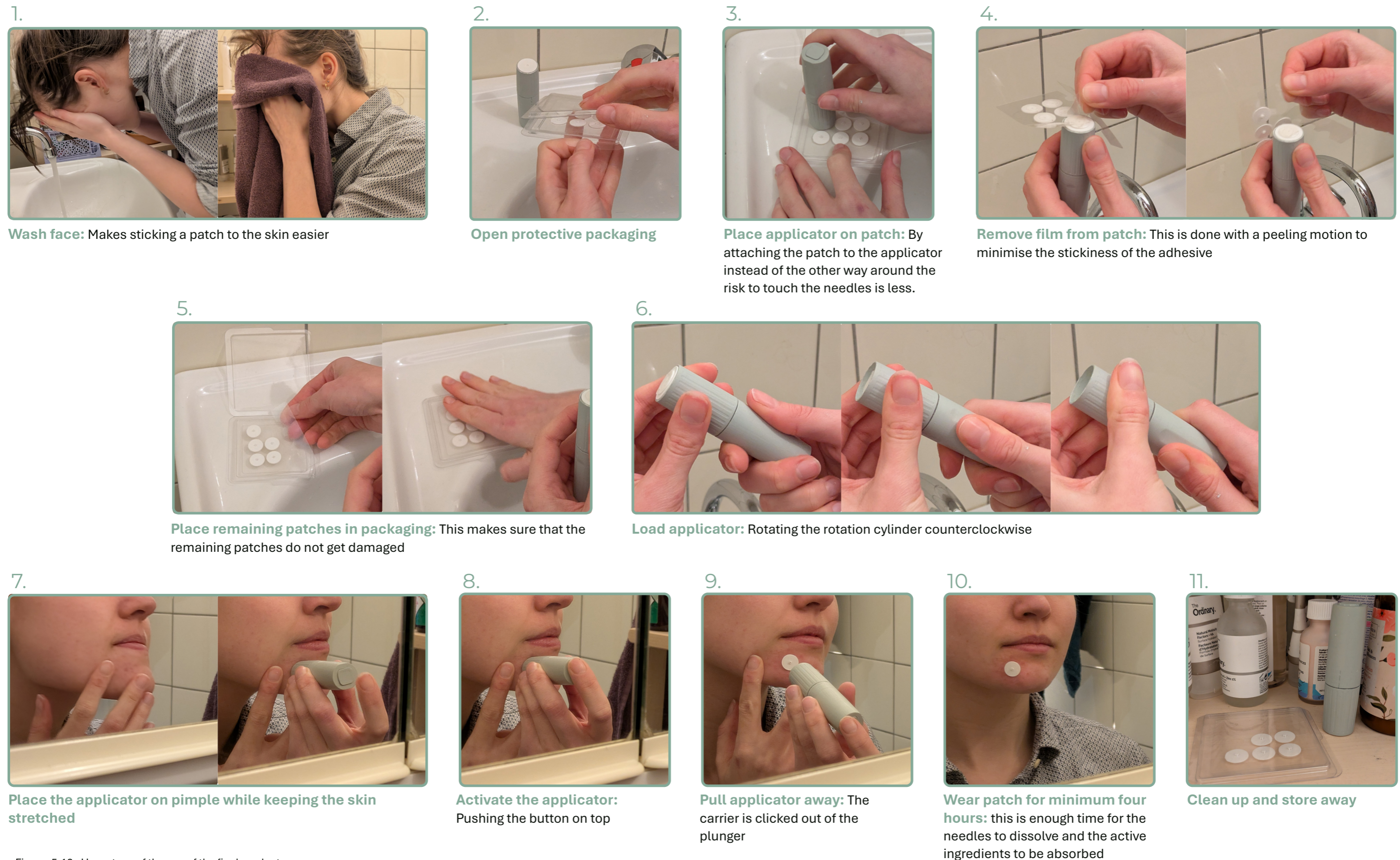

Figure 5.12 : User steps of the use of the final product

5.4. Feasibility

5.4.1. BOM

Table 5.2 : Bill of materials

Part name	Amount	Material	Manufacturing method
Main housing	1	ABS	Injection moulding, Ultrasonic welding
Button	1	ABS	Purchasing
Spring	1	Spring steel	Purchasing
Lock pin	1	Steel	Purchasing
Lock	1	ABS	Injection moulding
Rotary cylinder	1	ABS	Injection moulding, Ultrasonic welding
Sliding pin	1	POM	Purchasing
Plunger	1	ABS	Injection moulding
Carrier	1	PET	Injection moulding

5.4.2. Manufacturing

The applicator consists of seven injection-moulded parts, excluding the carrier. The housing consists of two parts that need to be connected with each other. This is done with ultrasonic welding, resulting in a nearly invisible seam compared to snap-fits.

The housing is symmetrical, allowing the same component to be used for both sides and minimising mold costs. The rotation cylinder is complex due to the need of varying wall thicknesses for its function. Therefore it is made out of two parts which are ultrasonically welded together for a strong connection.

For injection moulding thickness of the walls and the ribs for structural support have to be approximately 40-60 % of the general wall thickness. Meaning a 1.5 mm thickness generally have ribs of 1 mm to ensure that there are no sink holes, this is mostly important in the housing and plunger of the applicator. The plunger is a thick beam and must therefore have ribs internally to make it suitable for production.

A draft angle of 0.5–3 degrees is recommended for all injection moulded parts. Due to time constraints, this has not been implemented, but no major issues are expected as during the design process this has been taken into account and most components can be injected moulded with

two mold halves. However the embedded ribs on the rotation cylinder requires more than two mold halves.

The current connection for the carrier on the plunger has 5 small nobs which have undercuts, see Figure 4.19. This can technically be manufactured but will increase the cost significantly. Alternatively these nobs can be removed and the mushroom of the carrier can be redesigned so that it will clamp into the new cavity by friction.

The spring, and metal and POM pin will be either custom-made and/or purchased.

5.4.3. Assembly

Assembly can be established in under two minutes with a bottom-up approach, with two subassemblies.



Figure 5.13 : Main housing components before and after ultrasonic welding



Figure 5.14 : Rotary cylinder components before and after ultrasonic welding

Assembly tree

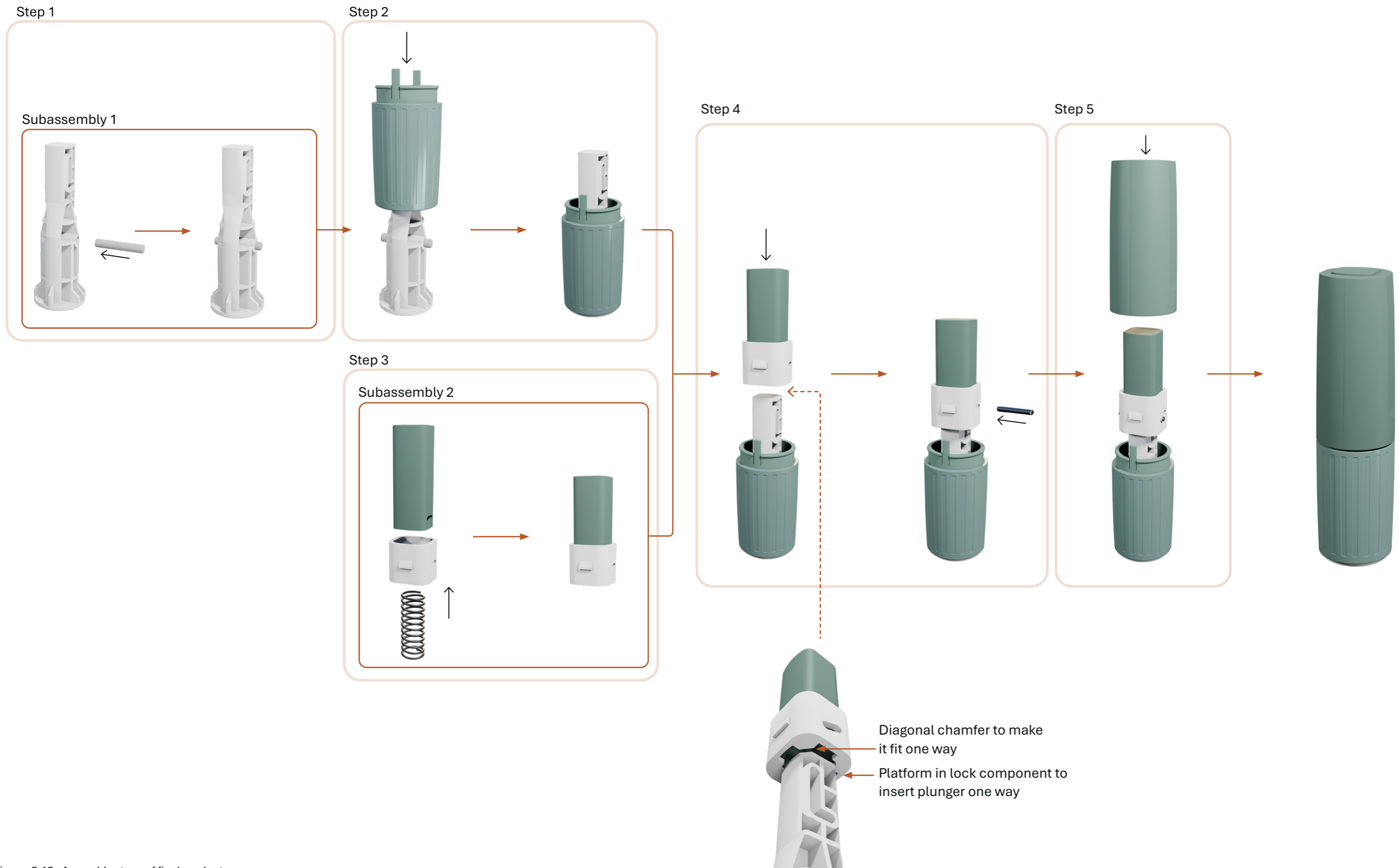

Figure 5.15 : Assembly steps of final product

5.5. Desirability

The MINUS makes AAMNPs penetrate the skin, making a path that is now a little effective, fully effective. This makes MINUS useful for the user as it makes the CMNPs useful. For potential clients this means that they can back up their MNPs with evidence that the patches penetrate.

The MINUS has been designed with quick integration in mind. This makes it easy for uPATCH to pitch it to potential clients, making it desirable for both. The MINUS can be used in existing manufacturing protocols with only minor adjustments. For the patch and packaging manufacture process this means that a carrier must be added to each path. This can be done during the assembly of the patch with the packaging. Another route could be to sell the carriers separately, meaning that the user will attach the carrier to the AAMNP that they want to use. However, the latter is not recommended as this gives a lot of more hassle for the consumer. From the client strategic strategy this is not desirable as this opens the door for consumers to use the applicator also with competitor AAMNPs.



Figure 5.16 : Existing packaging with carriers

The injected moulded outer housing of the applicator gives the opportunity to potential clients to have their own aesthetic on the applicator as in Figure 5.18 for the DERMATECH one of uPATCH's potential clients [79].

For uPATCH the option with a stretcher is still a possibility as only one component needs to be changed and the user friendliness and understanding of the stretcher has been tested with users.



Figure 5.17 : Final product prototype



Figure 5.18 : Rendered view of final product with finish for DERMATECH



Figure 5.19 : Adjusted final product with stretcher

5.6. Viability

5.6.1. Unit and selling price

The MINUS becomes viable at 20.000 pieces when production takes place in Belgian, which would be the best option when selling in Europe. However the product will first launch in East-Asie, where manufacturing in China makes most sense. The production cost are way lower in China, making the MINUS already viable at 10.000 units sold being sold at €24,75.

For the cost analysis data from the uPATCH PLUS applicator was used and conFigured to the parts in the cosmetic applicator.

Table 5.3 : Cost analysis for MINUS

	Weight in grams	Data from uPATCH Plus		Price per unit			Mold costs	
		Plus similar part cost per unit with 10.000	Weight similar part PLUS in grams	10.000	50.000	100.000	Belgian	China
Main housing	7	2,3	45,9	€ 0,55	€ 0,44	€ 0,28	€9.492	
Rotary cylinder	5	2,30	45,9	€ 0,55	€ 0,44	€ 0,28	€7.912	W
Plunger	4	0,47	6,58	€ 0,59	€ 0,47	€ 0,29	€6.544	
Button	2.3	0,48	8,61	€ 0,43	€ 0,34	€ 0,21	€7.912	
Lock	1	0,48	8,61	€ 0,36	€ 0,28	€ 0,18	€5.912	
Sliding pin	0.03	0,2		€ 0,15	€ 0,12	€ 0,08		
Lock pin	1	0,15		€ 0,15	€ 0,12	€ 0,08		
Spring	1	0,24		€ 0,18	€ 0,14	€ 0,09		
Assembly				€ 0,50	0,45	€ 0,40		
Carrier	0.02	0,4	0,31	€ 0,28	€ 0,22	€ 0,14	€6.212	
Total weight	21.5 grams		Total price	€ 3,45	€ 2,81	€ 1,88	€37.772	15.000
	Inc. mold costs	Belgian	Unit price	€ 7,23	€ 4,31	€ 2,25		
		China		€ 4,95	€ 2,81	€ 2,03		
	Minimum selling price	Belgian	€ 36,14	€ 21,55	€ 11,27			
		China	€ 24,75	€ 14,05	€ 10,13			

5.6.2. SWOT

Strengths

- **Use:** intuitively to understand.
- **Effective penetration:** MINUS makes AAMNP effectively penetrate the SC, making the patch work better.

Weaknesses

- **Repairability:** How the applicator is assembled does not make it suitable for disassembly, thus for repairability.
- **Carrier connection:** The light connection between the carrier and the plunger. It is not a foolproof function as when the user tried the pull off the film perpendicular of the applicator the carrier lets go, often resulting in a confused user.

Opportunities

- **Size:** The applicator is a small, easy to understand applicator that can be of good use in hard-to-reach places.
- **The Other markets:** It can be used for various applicator to apply a tattoo behind the ear as well as easier self-application for vaccines.

Threats

- **No trust:** A threat to the applicator is that the user does not see its added value, as the patches are now applied by hand. This could make them think that the applicator is a marketing scam for them the applicator.

5.7. Recommendations

5.7.1. Stretcher

I understand uPATCH want for a stretcher with the MINUS, as it would provide them with an advantage by making it harder for competitors to copy this applicator, due to their patent on stretching the skin with an applicator. Nonetheless a stretcher is not optimal, due to the angles and different underground of the skin. However if uPATCH decides to continue with a stretcher I recommend them to research the effectiveness across different facial regions and to put enough development time into it to ensure it reaches the effectiveness of manual finger stretching.

5.7.2. Rotary cylinder

The rotary cylinder is currently made of two separate parts that are joined using ultrasonic welding. It is recommended to revisit this design to determine whether it can be manufactured as a single part, as this would reduce production costs.

5.7.3. Carrier holder

The part of the plunger that holds the carrier has five undercuts at the moment, making it extremely expensive to manufacture. This can be fixed by redesigning the carrier to clamp into a straight cavity.

5.7.4. Adjustable impact force

The used impact force is important, but the maximum force to be used varies across facial regions. The cheek can tolerate more impact force than the forehead and the cheek is more likely to require a higher force to achieve successful penetration. Therefore, an applicator with adjustable impact force is desirable, to adjust the force needed while still being comfortable across facial regions. In the current applicator this cannot be embodied because of the internal mechanism.

5.7.5. Repairability

In its current assembly, the applicator cannot be repaired. It would be valuable for uPATCH to explore alternative assembly methods, particularly for joining the main housing halves. One of the most applicable options is to incorporate snap-fits and test whether they can withstand the turning forces while still allowing the rotary cylinder to function smoothly.

5.7.6. Study on tolerable spring force

It is most likely that the penetration of a AAMNP is high even after adjustments by manufacturers. During the thesis no information could be found on the tolerable impact force a person could experience and still find tolerable, educated assumption were made for this. However, these are still assumption and the pain threshold varies greatly between the different face regions. It is therefore valuable to do a study on the tolerable pain a person can withstand in these face regions to adjust the maximum spring force of the MINUS.

5.7.7. Potential client - Patches

For the applicator to be comfortable to use for consumers the maximum spring force must be under 20N. The current tested AAMNPs penetrate the skin at a high spring force of 45N. The manufacturers that make the MNPs should adjust their needles and needles array to be able to penetrate at this lower spring force.

5.7.8. Potential client – Patch packaging

The packaging for AAMNPs varies, but almost all are packaged on a sheet with either 2-9 patches. This gives a lot of risk to damage the needles when peeling of the film, with or without an applicator. Therefore I recommend for packaging's to be packaged per one. Furthermore by the packaging's

of 4-9 patches the elevated rim is not sufficient to keep the needles from touching the underside when the applicator is picking up the carrier. For this I recommend these companies to adjust their packaging to either package per one, or to let the rim of the patch also rest on an elevated rim as in Figure 5.24.



Figure 5.20 : Holika Holika MNP packaging

5.8. Limitations

5.8.1. No contact possible with the manufacturers

Since no contact with potential clients or manufacturers was possible, assumptions about their needs had to be made. As a result, some information may be missing, or certain assumptions may be inaccurate.

5.8.2. Testing of MNPs

The effectiveness of the CMNPs was tested on in vivo on forearm skin. While this skin shares similarities with facial skin, as discussed in Appendix XX, it still differs and does not represent all facial regions. This is a limitation of the project, as tests conducted directly on facial skin could yield different results. For this thesis, forearm testing was considered sufficient to verify penetration ability and the minimum force threshold required for the patches.

Chapter 6

Bibliography

6.1. References 134

6.2. References of images 139

6.1. References

- [1] A. Reinke, E. J. Whiteside, L. Windus, D. Desai, E. Stehr, and Z. Faraji Rad, "The advantages of microneedle patches compared to conventional needle-based drug delivery and biopsy devices in medicine," *Biomedical Engineering Advances*, vol. 8, p. 100127, Nov. 2024, doi: 10.1016/J.BEA.2024.100127.
- [2] A. L. Teo, C. Shearwood, K. C. Ng, J. Lu, and S. Moochhala, "Transdermal microneedles for drug delivery applications," *Materials Science and Engineering: B*, vol. 132, no. 1–2, pp. 151–154, Jul. 2006, doi: 10.1016/J.MSEB.2006.02.008.
- [3] A. Naik, Y. N. Kalia, and R. H. Guy, "Transdermal drug delivery: overcoming the skin's barrier function," *Pharm. Sci. Technol. Today*, vol. 3, no. 9, pp. 318–326, Sep. 2000, doi: 10.1016/S1461-5347(00)00295-9.
- [4] S. Zafar *et al.*, "Advancements in transdermal drug delivery using microneedles: technological and material perspective," *Discover Pharmaceutical Sciences 2025 1:1*, vol. 1, no. 1, pp. 5–, Apr. 2025, doi: 10.1007/S44395-025-00005-5.
- [5] T. Waghule *et al.*, "Microneedles: A smart approach and increasing potential for transdermal drug delivery system," *Biomedicine & Pharmacotherapy*, vol. 109, pp. 1249–1258, Jan. 2019, doi: 10.1016/J.BIOPHA.2018.10.078.
- [6] F. K. Aldawood, A. Andar, and S. Desai, "A Comprehensive Review of Microneedles: Types, Materials, Processes, Characterizations and Applications," *Polymers (Basel)*, vol. 13, no. 16, p. 2815, Aug. 2021, doi: 10.3390/POLYM13162815.
- [7] "THE POTENTIAL OF MICRONEEDLES," 2023, Accessed: Apr. 14, 2026. [Online]. Available: www.ondrugdelivery.com
- [8] D. H. Kim, J. H. An, H. J. Lee, and M. S. Yoon, "Anti-Wrinkle Efficacy of Cross-Linked Hyaluronic Acid-Based Microneedle Patch with Acetyl Hexapeptide-8 and Epidermal Growth Factor on Korean Skin," *Ann Dermatol*, vol. 31, no. 3, pp. 1013–9087, 2019, doi: 10.5021/ad.2019.31.3.263.
- [9] J. Y. Hong *et al.*, "Efficacy and safety of a novel, soluble microneedle patch for the improvement of facial wrinkle," *J. Cosmet. Dermatol.*, vol. 17, no. 2, pp. 235–241, Apr. 2018, doi: 10.1111/JOCD.12426.
- [10] M. Leone *et al.*, "Universal Applicator for Digitally-Controlled Pressing Force and Impact Velocity Insertion of Microneedles into Skin," *Pharmaceutics*, vol. 10, no. 4, Nov. 2018, doi: 10.3390/PHARMACEUTICS10040211.
- [11] R. Hamed *et al.*, "Recent Advances in Microneedling-Assisted Cosmetic Applications," *Cosmetics 2024, Vol. 11, Page 51*, vol. 11, no. 2, p. 51, Apr. 2024, doi: 10.3390/COSMETICS11020051.
- [12] Y. Han *et al.*, "Microneedle-Based Approaches for Skin Disease Treatment," *Nano-Micro Letters 2025 17:1*, vol. 17, no. 1, pp. 1–38, Feb. 2025, doi: 10.1007/S40820-025-01662-Y.
- [13] K. Chen, X. Sun, Y. Liu, S. Li, and D. Meng, "Advances in clinical applications of microneedle," *Front. Pharmacol.*, vol. 16, p. 1607210, 2025, doi: 10.3389/FPHAR.2025.1607210.
- [14] H. Jiang *et al.*, "Application of microneedle patch in food and medical analysis," *TrAC Trends in Analytical Chemistry*, vol. 191, p. 118351, Oct. 2025, doi: 10.1016/J.TRAC.2025.118351.
- [15] F. J. Verbaan *et al.*, "Improved piercing of microneedle arrays in dermatomed human skin by an impact insertion method," *Journal of Controlled Release*, vol. 128, no. 1, pp. 80–88, May 2008, doi: 10.1016/J.JCONREL.2008.02.009.
- [16] P. Makvandi *et al.*, "Engineering Microneedle Patches for Improved Penetration: Analysis, Skin Models and Factors Affecting Needle Insertion," *Nanomicro Lett.*, vol. 13, no. 1, p. 93, Dec. 2021, doi: 10.1007/S40820-021-00611-9.
- [17] "uPATCH Microneedle Applicators." Accessed: Apr. 13, 2026. [Online]. Available: <https://upatch.nl/applicators/>
- [18] "uPATCH™ PLUS - Microneedle Applicator for multiple-use." Accessed: Apr. 13, 2026. [Online]. Available: <https://upatch.nl/microneedle-applicator/upatch-plus/>
- [19] "uPATCH ONE™ - Single-use Microneedle Applicator." Accessed: Apr. 16, 2026. [Online]. Available: <https://upatch.nl/microneedle-applicator/upatch-one/>
- [20] "Kindeva Drug Delivery world vaccine congress presentation - Kindeva." Accessed: Feb. 20, 2026. [Online]. Available: <https://www.kindevadd.com/resources/world-vaccine-congress-presentation/>
- [21] "Microneedle Array Patches for Vaccine Delivery | PDA." Accessed: Feb. 20, 2026. [Online]. Available: <https://www.pda.org/pda-letter-portal/home/full-article/microneedle-array-patches-for-vaccine-delivery>
- [22] "Microneedle Patch Applicator - Triple Ring Technologies." Accessed: Feb. 20, 2026. [Online]. Available: <https://www.tripleringtech.com/case-studies/microneedle-patch-applicator/>
- [23] "Zosano Pharma - Trinity Capital." Accessed: Feb. 20, 2026. [Online]. Available: <https://trinitycapital.com/portfolio/zosano-pharma/>
- [24] "How to use a spring applicator - YouTube." Accessed: Feb. 20, 2026. [Online]. Available: <https://www.youtube.com/watch?v=wfQ3W-fICQI>
- [25] "Applicator System – www.smicna.com." Accessed: Feb. 20, 2026. [Online]. Available: <https://smicna.com/applicator-system/>
- [26] "SPECIAL FEATURE - Transdermal, Topical & Subcutaneous Drug Delivery: Extending Pipelines & Improving Self-Administration." Accessed: Feb. 20, 2026. [Online]. Available: <https://drug-dev.com/special-feature-transdermal-topical-subcutaneous-drug-delivery-extending-pipelines-improving-self-administration/>
- [27] "Laboratory for Drug Delivery - Microneedle Gallery." Accessed: Feb. 20, 2026. [Online]. Available: https://drugdelivery.chbe.gatech.edu/gallery_microneedles.html
- [28] "Micron Biomedical raises \$17M for needle-free drug delivery tech." Accessed: Feb. 20, 2026. [Online]. Available: <https://www.drugdeliverybusiness.com/micron-biomedical-17m-needle-free-drug-delivery/>
- [29] "AN ANGLED MICRONEEDLE PATCH FOR ENHANCED DRUG AND VACCINE DELIVERY | ONdrugDelivery." Accessed: Feb. 20, 2026. [Online]. Available: <https://www.ondrugdelivery.com/pharma-latch-angled-microneedle-patch-for-enhanced-drug-and-vaccine-delivery/>
- [30] G. Kang *et al.*, "Latch Applicator for Efficient Delivery of Dissolving Microneedles Based on Rapid Release of Elastic Strain Energy by Thumb Force," *Adv. Funct. Mater.*, vol. 33, no. 11, p. 2210805, Mar. 2023, doi: 10.1002/ADFM.202210805.
- [31] F. Tehrani *et al.*, "An integrated wearable microneedle array for the continuous monitoring of multiple biomarkers in interstitial fluid," *Nature Biomedical Engineering 2022 6:11*, vol. 6, no. 11, pp. 1214–1224, May 2022, doi: 10.1038/s41551-022-00887-1.
- [32] "Microneedle | Taikiusa." Accessed: Feb. 20, 2026. [Online]. Available: <https://taikiusa.com/private-label-masks-patches/targeted-treatments/microneedle/>
- [33] "Understanding South Korea's Beauty Standards." Accessed: Sep. 30, 2025. [Online]. Available: <https://nulook.co.id/news-articles/south-korea-beauty-standards>
- [34] "The Korean eye of Beauty < Culture < Culture < 기사본문 - The Yonsei Annals." Accessed: Sep. 30, 2025. [Online]. Available: <https://annals.yonsei.ac.kr/news/articleView.html?idxno=11113>
- [35] "Asian Beauty Standards: How They Differ from Western Beauty Norms | AB Plastic Surgery Korea."

Accessed: Sep. 30, 2025. [Online]. Available: <https://abplasticsurgerykorea.com/ab-blog/asian-beauty-standards-how-they-differ-from-western-beauty-norms>

[36]“9pcs Patches for Face : Amazon.co.uk: Health & Personal Care.” Accessed: Apr. 15, 2026. [Online]. Available: https://www.amazon.co.uk/Microdarts-Patches-Effective-Microneedle-Removal/dp/B0FLF4CF-PX?crid=2AH0SS4EU2H5Y&dib=eyJ2ljojMSJ9.TemV1h_6kR6YpCloXX4UasOg-GOZJ-NuP1qQRdA6o5sRjU43F-DOr_kNe0tcSvi5PuZ9MsaAXXqT9Wh198MZ3uVPaua-bwaf9W0wii2hh0cMIQuifSR9hvZ_749-vw3APQi0h-7GHOnMpYw_zdlheXlzwKBx1Qx2xQughSvcGjiWuphCEecl4if3GJg2GQt8Y60NCq7VMek0Wo7aLdNoqB-JRV-qfclVpisiRK29JD3GXL4VxaRX9YVa5XjyOcsZrasPkrTAOQ_E90PCBnXaFVck5rz1iSwciuZoD2PmeYJXPc.h86OYCRklkKaKo959mYN3ruNFS1epd7Kl32H7E1FX8&dib_tag=se&keywords=microneedle+patch&qid=1757508452&s=beauty&prefix=microneedle+patch%2Cbeauty%2C144&sr=1-10

[37]“AND SHINE | ALL-STAR EYE PATCH | Microneedling Patches gegen Augenringen & Co – Skincare patches with microneedling technology for acne, pimples, under eye bags and shadows and wrinkles.” Accessed: Apr. 15, 2026. [Online]. Available: <https://www.andshine.de/en/collections/all-patches/products/all-star-eye-patch>

[38]“AND SHINE | THE YOUTH PATCH® | Anti-Aging Microneedling Patches – Skincare patches with microneedling technology for acne, pimples, under eye bags and shadows and wrinkles.” Accessed: Apr. 15, 2026. [Online]. Available: <https://www.andshine.de/en/products/the-youth-patch-2-0>

[39]“Anti-Wrinkle Eye Patches | Dissolving Microneedle Beauty.” Accessed: Apr. 15, 2026. [Online]. Available: <https://youwebio.com/products/anti-wrinkle-eye-dissolving-microneedle-beauty-patches>

[40]“Microneedle Eye Patches | Dissolving Microneedle Beauty.” Accessed: Apr. 15, 2026. [Online]. Available: <https://youwebio.com/products/dark-circle-remover-dissolving-microneedle-beauty>

[41]“6PCS Dissolving Microneedle Eye Patches - Anti Wrinkle Patch - Cooling Pads - Micro Needle Patches with Hyaluronic Acid - Microneedle Patches for Dark Circles & Eye Bag : Amazon.co.uk: Beauty.” Accessed: Apr. 15, 2026. [Online]. Available: https://www.amazon.co.uk/6PCS-Dissolving-Microneedle-Eye-Patches/dp/B0FDGH9SCX?crid=2AH0SS4EU2H5Y&dib=eyJ2ljojMSJ9.TemV1h_6kR6YpCloXX4UasOg-GOZJ-NuP1qQRdA6o5sRjU43FDOr_kNe0tcSvi5PuZ9MsaAXXqT9Wh198MZ3uVPaua-bwaf9W0wii2hh0cMIQuifSR9hvZ_749-vw3APQi0h7GHOnMpYw_zdlheXlzwKBx1Qx2xQughSvcGjiWuphCEecl4if3GJg2GQt8Y60NCq7VMek0Wo7aLdNoqBJRV-qfclVpisiRK29JD3GXL4VxaRX9YVa5XjyOcsZrasPkrTAOQ_E90PCBnXaFVck5rz1iSwciuZoD2PmeYJXPc.h86OYCRklkKaKo959mYN3ruNFS1epd7Kl32H7E1FX8&dib_tag=se&keywords=microneedle+patch&qid=1757508452&s=beauty&prefix=microneedle+patch%2Cbeauty%2C144&sr=1-2-spons&sp_csd=d2lkZ2V0TmFtZT1zcF9hdGY&psc=1

[42]“PATCH PRO MICRO NEEDLE PATCH 8pcs, self-dissolving microneedle patches, facial anti-wrinkle patches, crosslinked hyaluronic acids for forehead lines, smile line, fine line, eye wrinkle, Puffy eyes : Amazon.com.au: Beauty.” Accessed: Apr. 15, 2026. [Online]. Available: https://www.amazon.com.au/PATCH-PRO-microneedle-anti-wrinkle-crosslinked/dp/B07JZ6S64M/356-0684393-7139143?pd_rd_w=jZ4vA&content-id=amzn1.sym.c3e67ad4-8c3b-4d61-8525-47091874fb48&pf_rd_p=c3e67ad4-8c3b-4d61-8525-47091874fb48&pf_rd_r=6HVMVZG0KQ5RJM7S8R005&pd_rd_wg=sqFvb&pd_rd_r=8b8a32bb-34b3-4b8e-840c-86a9b1fd11f3&pd_rd_i=B07JZ6S64M&psc=1

[43]“Mighty Patch™ for Early-Stage Blemishes | Hero Cosmetics.” Accessed: Apr. 15, 2026. [Online]. Available: <https://www.herocosmetics.us/products/mighty-patch-for-early-stage-blemishes>

[44]“Age-Defying Microneedle Patches for acne, smile lines, & wrinkles – Karuna Skin.” Accessed: Apr. 15, 2026. [Online]. Available: <https://karunaskin.com/products/age-defying-microneedle-patches>

[45]“FAQ™ Microneedling Anti-Wrinkle Patches for Forehead.” Accessed: Apr. 15, 2026. [Online]. Available: https://www.foreo.com/faqs/microneedling-patches-forehead?v=1997&utm_source=AysPbYF8vuM&utm_medium=Linkshare_cps&utm_campaign=1291442&utm_content=10&utm_cost=ccAFF&affid=RAK&ranMID=40214&ranEAID=AysPbYF8vuM&ranSiteID=AysPbYF8vuM-3QcqmV92VXoJs5XwKZ_CBw

[46]“Acnator Pimple Clearing Patch - Holika Holika.” Accessed: Apr. 15, 2026. [Online]. Available: <https://www.holikaholika.ee/en/special-care/1795-acnator-pimple-clearing-patch>

[47]“Whitening & Spot-Lightening Microneedle Patches | OEM/ODM Beauty Solut.” Accessed: Apr. 15, 2026. [Online]. Available: <https://youwebio.com/products/whitening-spot-lightening-dissolving-microneedle-beauty>

[48]“SAISZE Microdart Pimple Patch, Hydrocolloid Spot Patch for Early Stage Pimples(18 Patches) : Amazon.com.au: Beauty.” Accessed: Apr. 15, 2026. [Online]. Available: <https://www.amazon.com.au/SAISZE-Microdart-Hydrocolloid-Pimples-Patches/dp/B0DMVXGGXN>

[49]“Get Rid of Acne Dark Spots | Microcrystal Dark Spot Cover | Rael.” Accessed: Apr. 15, 2026. [Online]. Available: <https://www.getrael.com/products/microcrystal-dark-spot-cover?variant=39409665638515>

[50]“Anti-acne Dermal Patch Market Size Report, 2022-2030.” Accessed: Sep. 23, 2025. [Online]. Available: <https://www.grandviewresearch.com/industry-analysis/anti-acne-dermal-patch-market-report>

[51]“Acne - NHS.” Accessed: Sep. 26, 2025. [Online]. Available: <https://www.nhs.uk/conditions/acne/>

[52]“Cosmetics Microneedle Patches Market Size, Industry Development & Forecast.” Accessed: Sep. 23, 2025. [Online]. Available: <https://www.verifiedmarketreports.com/product/cosmetics-microneedle-patches-market/>

[53]“Soluble Microneedle Patches Market Market Size, Share & Report [2025-2034].” Accessed: Sep. 23, 2025. [Online]. Available: <https://www.globalgrowthinsights.com/market-reports/soluble-microneedle-patches-market-120275>

[54]J. Ayer and N. Burrows, “Acne: more than skin deep,” *Postgrad. Med. J.*, vol. 82, no. 970, p. 500, Aug. 2006, doi: 10.1136/PGMJ.2006.045377.

[55]“Pimple Patches for Acne – How Effective Are Acne Stickers?” Accessed: Dec. 11, 2025. [Online]. Available: <https://ensoulclinic.com/pimple-patches-for-acne-how-effective-are-acne-stickers/#3nbspMicroneedlingnbspPatch>

[56]“Niacinamide: Belangrijk Ingrediënt in CeraVe - Ontdek Nu!” Accessed: Nov. 27, 2025. [Online]. Available: https://www.cerave.nl/ingredienten-in-cerave/niacinamide?gad_source=1&gad_campaignid=17197450242&gclid=Cj0KCCQIAiqDJBhCXARIsABk2kSI0njq_OOidYuZENAYH-2BLTFICf2zAnZ45QCKLHpC8yc9kclCZIVQaAiYLEALw_wcB

[57]“Hyaluronic Acid: What It Is, Benefits, How To Use & Side Effects.” Accessed: Nov. 27, 2025. [Online]. Available: <https://my.clevelandclinic.org/health/articles/22915-hyaluronic-acid>

[58]“Salicylic Acid: Uses, Brands & Interactions.” Accessed: Nov. 27, 2025. [Online]. Available: <https://my.clevelandclinic.org/health/drugs/20341-salicylic-acid-topical-gel-cream-lotion-solution>

[59]K. Somboon, C. P. Chng, C. Huang, and S. Gupta, “Enhancing Niacinamide Skin Penetration via Other Skin Brightening Agents: A Molecular Dynamics Simulation Study,” *Int. J. Mol. Sci.*, vol. 26, no. 4, p. 1555, Feb. 2025, doi: 10.3390/IJMS26041555.

[60]S. Singh *et al.*, “Microneedles in cosmetology: A SWOT analysis,” *European Journal of Medicinal Chemistry Reports*, vol. 12, p. 100197, Dec. 2024, doi: 10.1016/J.EJMCR.2024.100197.

[61]M. Tai *et al.*, “Acne and its post-inflammatory hyperpigmentation treatment by applying anti-acne dissolving microneedle patches,” *J. Cosmet. Dermatol.*, vol. 21, no. 12, pp. 6913–6919, Dec. 2022, doi: 10.1111/JOCD.15352.

[62]J. H. Bae *et al.*, “Clinical Benefit and Safety of Microneedle Patches Composed of Magnesium: A Pilot Study in Acne Patients,” *Dermatol. Ther.*, vol. 2023, no. 1, p. 7667296, Jan. 2023, doi: 10.1155/2023/7667296.

[63]M. Kim, H. Yang, H. Kim, H. Jung, and H. Jung, “Novel cosmetic patches for wrinkle improvement: retinyl retinoate- and ascorbic acid-loaded dissolving microneedles,” *Int. J. Cosmet. Sci.*, vol. 36, no. 3, pp. 207–212, Jun. 2014, doi: 10.1111/ICS.12115.

[64]V. Zvezdin, L. Penno-Mazzarino, N. Radionov, T. Kasatkina, and I. Kasatkin, "Microneedle patch based on dissolving, detachable microneedle technology for improved skin quality – Part 1: ex vivo safety evaluation," *Int. J. Cosmet. Sci.*, vol. 42, no. 4, pp. 369–376, Aug. 2020, doi: 10.1111/ICS.12627.

[65]J. Y. Hong *et al.*, "Efficacy and safety of a novel, soluble microneedle patch for the improvement of facial wrinkle," *J. Cosmet. Dermatol.*, vol. 17, no. 2, pp. 235–241, Apr. 2018, doi: 10.1111/JOCD.12426.

[66]K. Y. Park *et al.*, "Efficacy and safety of a new microneedle patch for skin brightening: A Randomized, split-face, single-blind study," *J. Cosmet. Dermatol.*, vol. 16, no. 3, pp. 382–387, Sep. 2017, doi: 10.1111/JOCD.12354.

[67]"Microdart Pimple Patch Invisible Hydrocolloid Acne Patches for All Skin – SAISZE.COM." Accessed: Sep. 23, 2025. [Online]. Available: <https://saisze.com/products/microdart-pimple-patch-invisible-hydrocolloid-acne-patches-for-all-skin-types>

[68]"BLOOMORA Microdart Pimple Patch, Spot Patches Salicylic Acid & Hyaluronic Acid, Cystic Acne Treatment, Pimple Patches Microneedle Technology - Early Stage Acne Patch (12 Pieces) : Amazon.co.uk: Beauty." Accessed: Sep. 23, 2025. [Online]. Available: https://www.amazon.co.uk/dp/B0DZ1L9R9X/ref=sspa_dk_detail_3?pd_rd_i=B0DZ1L9R9X&pd_rd_w=5Tocv&content-id=amzn1.sym.9a64fe05-cdee-4d53-a27b-f3614d726545&pf_rd_p=9a64fe05-cdee-4d53-a27b-f3614d726545&pf_rd_r=EFDF54E5EKE5JM6G73J7&pd_rd_wg=rPlcm&pd_rd_r=5ab3b064-bb24-4e99-81cd-8f1d49f2f156&sp_csd=d2lkZ2V0TmFtZT1zcF9kZXRhaWxfdGhlbWFOaWM&th=1

[69]V. Zvezdin, L. Penno-Mazzarino, N. Radionov, T. Kasatkina, and I. Kasatkin, "Microneedle patch based on dissolving, detachable microneedle technology for improved skin quality – Part 1: ex vivo safety evaluation," *Int. J. Cosmet. Sci.*, vol. 42, no. 4, pp. 369–376, Aug. 2020, doi: 10.1111/ICS.12627.

[70]J. Y. Shin, D. H. Han, K. Y. Yoon, D. H. Jeong, and Y. Il Park, "Clinical Safety and Efficacy Evaluation of a Dissolving Microneedle Patch Having Dual Anti-Wrinkle Effects With Safe and Long-Term Activities," *Ann. Dermatol.*, vol. 36, no. 4, p. 215, 2024, doi: 10.5021/AD.23.136.

[71]"Zoek een huidaanpak (patiëntenfolders)." Accessed: Sep. 26, 2025. [Online]. Available: <https://nvdv.nl/patienten/dermatologie/zoek-een-huidaanpak/acne>

[72]"Acne: Types, Causes, Treatment & Prevention." Accessed: Sep. 26, 2025. [Online]. Available: <https://my.clevelandclinic.org/health/diseases/12233-acne>

[73]"Kids Health Info : Acne and teen skin health." Accessed: Sep. 26, 2025. [Online]. Available: https://www.rch.org.au/kidsinfo/fact_sheets/acne/

[74]M. Melia *et al.*, "Pressure pain thresholds: Subject factors and the meaning of peak pressures," *Eur. J. Pain*, vol. 23, no. 1, pp. 167–182, Sep. 2018, doi: 10.1002/EJP.1298.

[75]"User Experience Questionnaire (UEQ)." Accessed: Apr. 13, 2026. [Online]. Available: <https://ueq-online.org/>

[76]S. C. Jee and M. H. Yun, "An anthropometric survey of Korean hand and hand shape types," *Int. J. Ind. Ergon.*, vol. 53, pp. 10–18, May 2016, doi: 10.1016/J.ERGON.2015.10.004.

[77]"IEC 62366-1:2015 - Medical devices — Part 1: Application of usability engineering to medical devices." Accessed: Apr. 16, 2026. [Online]. Available: <https://www.iso.org/standard/63179.html>

[78]"DERMATECH | Skincare Patch Manufacturer - Acne, Pimple, Hydrocolloid... Made in Korea." Accessed: Apr. 14, 2026. [Online]. Available: <https://www.dermatech.life/>

6.2. References of images

[1]"uPATCH Microneedle Applicators." Accessed: Apr. 13, 2026. [Online]. Available: <https://upatch.nl/applicators/>

[2]"Microneedle patches No color Skin & out - Beauty | Printemps.com." Accessed: Feb. 20, 2026. [Online]. Available: <https://www.printemps.com/lu/en/skinout-microneedle-patches-9500376>

[3]"An alternative to the syringe - College of Engineering at Carnegie Mellon University." Accessed: Feb. 19, 2026. [Online]. Available: <https://engineering.cmu.edu/news-events/news/2020/04/07-microneedle-array.html>

[4]"Microneedle tech: 3D printing to the rescue - Medical Device Network." Accessed: Feb. 19, 2026. [Online]. Available: <https://www.medicaldevice-network.com/features/microneedle%E2%80%AFtech-3d-printing-to-the-rescue/?cf-view>

[5]P. Makvandi *et al.*, "Engineering Microneedle Patches for Improved Penetration: Analysis, Skin Models and Factors Affecting Needle Insertion," *Nanomicro Lett.*, vol. 13, no. 1, p. 93, Dec. 2021, doi: 10.1007/S40820-021-00611-9.

[6]"Glass Skin in K-Beauty – How to Achieve the Glow." Accessed: Feb. 20, 2026. [Online]. Available: <https://kbeautystudio.com/blogs/news/what-is-glass-skin>

[7]"Pack of 4 Dissolving Microneedle Eye Patches - Anti Wrinkle Patches - Micro Needle Patches with Peptides, Hyaluronic Acid - Hydrating and moisturizing eye mask : Amazon.co.uk: Health & Personal Care." Accessed: Apr. 14, 2026. [Online]. Available: <https://www.amazon.co.uk/Pack-Dissolving-Microneedle-Eye-Patches/dp/B0F28QNQGG>

[8]"Some By Mi Micro Pin Spot Patch | Korean Skincare – Korean-Skincare." Accessed: Apr. 14, 2026. [Online]. Available: <https://koreanskincare.nl/products/some-by-mi-micro-pin-spot-patch>

[9]"10 Acne Tips to Effectively Manage Acne Prone Skin - Linia Skin Clinic." Accessed: Mar. 09, 2026. [Online]. Available: <https://liniaskinclinic.com/acne-tips/>

[10]"Severe acne protocol – Skin Cosmetics London." Accessed: Mar. 09, 2026. [Online]. Available: <https://www.skincosmetics.co.uk/treatment/potenza-acne-treatment/>

[11]"Köp Niche Beauty Lab Acnemy Zitless Patches 5 st | Apohem." Accessed: Apr. 14, 2026. [Online]. Available: <https://www.apohem.se/hudvard/hudbesvar/akne/aknepatches/niche-beauty-lab-acnemy-zitless-patches-5-st>

[12]"Salicylic Acid Microneedles Acne Pimple Patches with Fast-Acting - Salicylic Acid Acne Patch and Acne Patch price." Accessed: Feb. 20, 2026. [Online]. Available: https://idercare.en.made-in-china.com/product/QwBToAcyheGt/China-Salicylic-Acid-Microneedles-Acne-Pimple-Patches-with-Fast-Acting.html?pv_id=1jhtm7n7i51f&faw_id=1jhtmb7448a&bv_id=1jhtn04kee59&pbv_id=1jhtm7krce9am

[13]"Salicylic Acid Acne Pimple Patches / Microneedle Spot Patch / Trummed Medical." Accessed: Feb. 20, 2026. [Online]. Available: <https://trummed.com/products/microneedle-salicylic-acid-acne-pimple-patches-stickers>

[14]"What Is Acne? - Piedmont HealthCare." Accessed: Dec. 09, 2025. [Online]. Available: <https://piedmonthealthcare.com/what-is-acne-2/>

[15]"Blackheads | Blackhead Treatments | Skin Treatments." Accessed: Dec. 09, 2025. [Online]. Available: <https://www.victoriahouseclinic.co.uk/blackheads/>

[16]"How to Get Rid of Whiteheads | Clinikally." Accessed: Dec. 09, 2025. [Online]. Available: <https://>

www.clinikally.com/blogs/news/how-to-get-rid-of-whiteheads?srsId=AfmBOor2uuv2BFwlu33SD1lybWcmAGQeydAbqG8AnkwLdzNscGXpVX8D

[17]“6 Steps To Heal A Stubborn Pimple | Baird, MD.” Accessed: Dec. 09, 2025. [Online]. Available: <https://farmingtonderm.com/6-steps-to-heal-a-stubborn-pimple/>

[18]“Pimples on Chin - Indicates, Reasons, How to Get Rid of Pimples on Chin – The Pink Foundry.” Accessed: Dec. 09, 2025. [Online]. Available: https://www.thepinkfoundry.com/blogs/news/how-to-get-rid-of-pimples-on-chin?srsId=AfmBOopt_PBprnmNWvmgar0UZxzwnQE85NCMGPAGueav3cTvQjgUuMjp

[19]“How to Treat Cystic Acne | Dr. Dennis Gross.” Accessed: Dec. 09, 2025. [Online]. Available: <https://www.drdenniscross.com/how-to-treat-cystic-acne.html?srsId=AfmBOoq1Ed0fSGUGSi8FcPJ6TWtz89EwWvZ1cAtHONHyxsovMdp2Eblf>

[20]“Facial acne nodule - Stock Image - M108/0808 - Science Photo Library.” Accessed: Dec. 09, 2025. [Online]. Available: <https://www.sciencephoto.com/media/250468/view/facial-acne-nodule>

[21]“Your Guide to Treat Post Inflammatory Hyperpigmentation – GLO Skin Body.” Accessed: Dec. 09, 2025. [Online]. Available: <https://gloskinbody.com.au/blogs/the-skincare-blog/what-is-acne-post-inflammatory-hyperpigmentation>

[22]“North & South Identified Bar Magnets |.” Accessed: Apr. 14, 2026. [Online]. Available: <https://e-magnetsuk.com/product/north-south-identified-bar-magnets/>

[23]“Prime-Line Compression Spring, 3/4 in. x 3/8 in. (6-pack) SP 9702 | Zoro.” Accessed: Apr. 14, 2026. [Online]. Available: <https://www.zoro.com/prime-line-compression-spring-34-in-x-38-in-6-pack-sp-9702/i/G600921306/>

[24]“HENDI Slagroompatronen – 10 stuks – Duurzaam en Betrouwbaar – Lang houdbaar | bol.” Accessed: Apr. 14, 2026. [Online]. Available: <https://www.bol.com/nl/nl/p/hendi-slagroompatronen-10-stuks-duurzaam-en-betrouwbaar-lang-houdbaar/9200000065493577/>

[25]“Barrel cam mechanism of snap motion - YouTube.” Accessed: Mar. 10, 2026. [Online]. Available: <https://www.youtube.com/watch?v=v9Rg59cUB8k&t=24s>

[26]“Spring barrel cam - YouTube.” Accessed: Mar. 10, 2026. [Online]. Available: https://www.youtube.com/watch?v=Z-_lp4Rno8

[27]“Hoe werkt een Nerf-pistool? - YouTube.” Accessed: Mar. 10, 2026. [Online]. Available: <https://www.youtube.com/watch?v=N8JpePwvuHw>

[28]“Whats Inside a toy gun? - YouTube.” Accessed: Mar. 10, 2026. [Online]. Available: <https://www.youtube.com/watch?v=KCIXJ5JQO24>

[29]“Snap Motion - mechamechanisms.com.” Accessed: Apr. 14, 2026. [Online]. Available: <https://mechamechanisms.com/snap-motion-11>

[30]“The EpiPen Chain Reaction - YouTube.” Accessed: Mar. 10, 2026. [Online]. Available: <https://www.youtube.com/watch?v=CfhsW1kaa2Q&t=7s>

[31]“Pin op uPATCH.” Accessed: Apr. 14, 2026. [Online]. Available: <https://za.pinterest.com/pin/832532681159208374/>

Chapter 6

Appendix

Appendix A: Project brief	144
Appendix B: Cosmetic Microneedle Patch mapping	148
Appendix C: Potential clients database	152
Appendix D: User test 1: Current use	153
Appendix E: Lab test 1: Anti acne microneedle test on ex vivo skin	155
Appendix F: Lab test 2: AAMNP penetration test on in vivo skin	159
Appendix G: Acne research	164
Appendix H: Anatomical study : Facial tissue structure	166
Appendix I: Expert conversations dermatologists	168
Appendix J: User test 2: Concept evaluation	169
Appendix K: Korean Anthropometrical data	179
Appendix L: User test 3: Final product evaluation	182
Appendix M: Lab test 3: Cosmetic microneedle patches minimal force test	190
Appendix N: List of requirements validation	196
6.3. References of Appendixes	200

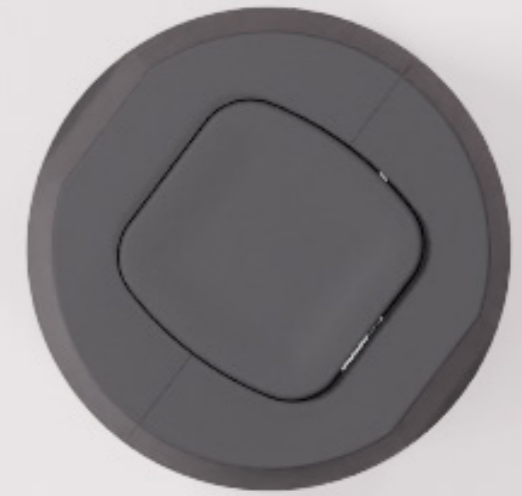

Appendix A: Project brief





Personal Project Brief – IDE Master Graduation Project

Name student Maan Roos Moeskops Student number 5,886,511

PROJECT TITLE, INTRODUCTION, PROBLEM DEFINITION and ASSIGNMENT
 Complete all fields, keep information clear, specific and concise

Project title Developing a diverse cosmetic microneedle patch applicator

Please state the title of your graduation project (above). Keep the title compact and simple. Do not use abbreviations. The remainder of this document allows you to define and clarify your graduation project.

Introduction

Describe the context of your project here; What is the domain in which your project takes place? Who are the main stakeholders and what interests are at stake? Describe the opportunities (and limitations) in this domain to better serve the stakeholder interests. (max 250 words)

Upatch is a start-up that is developing and making applicators for microneedle patches for medical use. (see their current applicator in figures 1 & 2).

A microneedle applicator is crucial for accurate use and high efficacy of microneedle patches. These patches contain small needles that enable the delivery of medication or other substances through penetration of the skin. They are used by healthcare professionals as well as consumers.

The main goal is to develop a universal applicator for cosmetic microneedle patches, such as those for retinol, acne, and blemishes, that individuals can use independently at home. The applicator needs to be adaptable, either by accommodating different patch sizes directly or by being modular to adjust for different dimensions. This adaptability is key to making the applicator truly universal.

The key stakeholders for this project will be Upatch, their potential cosmetic industry clients, and the consumers of cosmetic microneedle patches. Dermatologists may also be considered stakeholders, but this will be explored further at the beginning of the project.

A significant opportunity in this project lies in making microneedle patches more effective. Many cosmetic microneedle patches are used without an applicator, which often leads to uneven or insufficient penetration of the skin by the needles, limiting their efficacy. The applicator will ensure proper and consistent skin penetration, thereby maximising the patch's effectiveness. An applicator also enhances the user experience of applying a cosmetic microneedle patch.

One of the main challenges I anticipate is that the product might not be compatible with all microneedle patches due to the wide variation in patch sizes. I may need to develop different applicators for the specific groups of patch dimensions, small, medium, bi. The size of the patch depends on the specific use of the patch (e.g. pimple or scar patch) and on the area and placements on the skin that need to be treated. Overcoming this will be a central part of the project's development.

→ space available for images / figures on next page

introduction (continued): space for images



image / figure 1 Use of the multiple use patch applicator from uPATCH

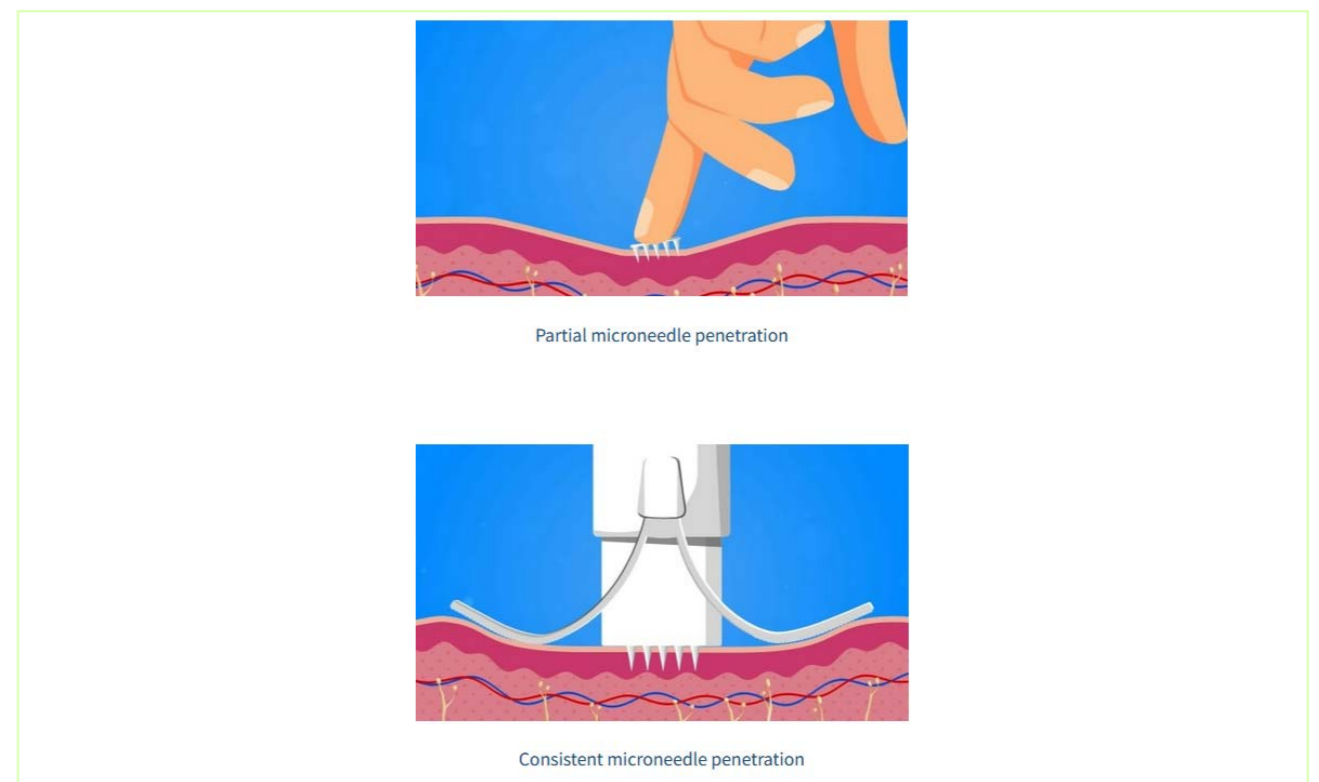
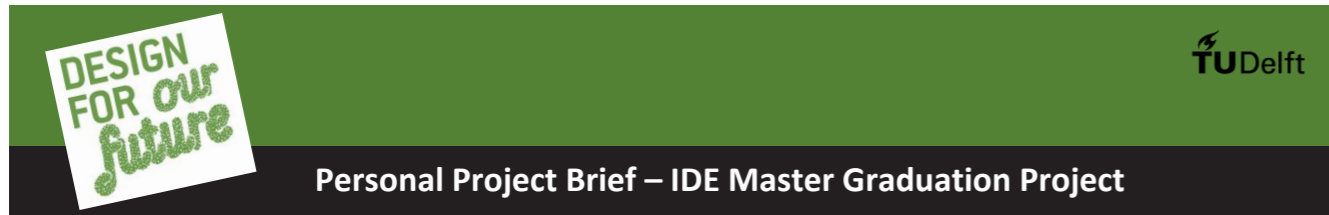

image / figure 2 Working principle of the applicator from uPATCH



Problem Definition

What problem do you want to solve in the context described in the introduction, and within the available time frame of 100 working days? (= Master Graduation Project of 30 EC). What opportunities do you see to create added value for the described stakeholders? Substantiate your choice. (max 200 words)

In this project, the main problem to be solved is the inconsistent and often incorrect application of cosmetic microneedle patches into the skin. Currently, many users apply these patches by hand. This frequently leads to uneven penetration of the needles, meaning the active chemicals aren't delivered effectively. It can also result in the needles breaking due to poor handling during application, further reducing the patch's efficacy. The applicator will bring significant added value by ensuring that microneedle patches are used in a more effective, safe, consistent, and accurate manner. It will also make the patches easier to apply for the user. For Upatch, it can expand their client base. Currently, their focus is primarily on the medical industry. By providing an innovative solution for cosmetic applications, this product can help them reach a broader market. Designing the applicator to be modular or universal is a key part of my approach to sustainability. This means users/clients will only need one applicator to work with a wide range of patches (one applicator for small-, one for medium- and one for big patches), reducing the need for multiple (single-use) applicators.

Assignment

This is the most important part of the project brief because it will give a clear direction of what you are heading for. Formulate an assignment to yourself regarding what you expect to deliver as result at the end of your project. (1 sentence) As you graduate as an industrial design engineer, your assignment will start with a verb (Design/Investigate/Validate/Create), and you may use the green text format:

Development of a cosmetic microneedle patch applicator that can be used for multiple sized patches for a specific target group (to be specified... e.g., teenagers with acne or people with rheumatism or arthritis that need help applying patches, etc).

Then explain your project approach to carrying out your graduation project and what research and design methods you plan to use to generate your design solution (max 150 words)

The double diamond method will be used for the research and design phase. As it is not clear yet for what exact cosmetic patches this applicator will be used for, this will be one of the first things that need to be explored. It will consist of categorizing patches (for what use, size, where on the body etc..) and seeing for which one an applicator would be best suited and useful. This stage is combined with further research of what is already on the market, similar products etc... This is the first diamond and will conclude with a list of requirements and the more narrowed down design question and target group.

The second diamond is the ideation and concept phase. Where I will orient in possible solutions, do a lot of prototyping and testing (on users, pig/artificial skin, myself). At the end of this stage there will be 3 concepts, where 1 will be worked out in the final diamond.

The third diamond will consist of the embodiment, detailing the product with keeping in mind that it can be produced in the future with only slight modifications.

Project planning and key moments

To make visible how you plan to spend your time, you must make a planning for the full project. You are advised to use a Gantt chart format to show the different phases of your project, deliverables you have in mind, meetings and in-between deadlines. Keep in mind that all activities should fit within the given run time of 100 working days. Your planning should include a **kick-off meeting, mid-term evaluation meeting, green light meeting and graduation ceremony**. Please indicate periods of part-time activities and/or periods of not spending time on your graduation project, if any (for instance because of holidays or parallel course activities).

Make sure to attach the full plan to this project brief. The four key moment dates must be filled in below

Kick off meeting 9 Sep 2025

Mid-term evaluation 13 Nov 2025

Green light meeting 29 Jan 2026

Graduation ceremony 10 Mar 2026

In exceptional cases (part of) the Graduation Project may need to be scheduled part-time. Indicate here if such applies to your project

Part of project scheduled part-time	<input checked="" type="checkbox"/>
For how many project weeks	25
Number of project days per week	4,0

Comments:
I will spend 4 days a week on my thesis and have some time free around christmas

Motivation and personal ambitions

Explain why you wish to start this project, what competencies you want to prove or develop (e.g. competencies acquired in your MSc programme, electives, extra-curricular activities or other).

Optionally, describe whether you have some personal learning ambitions which you explicitly want to address in this project, on top of the learning objectives of the Graduation Project itself. You might think of e.g. acquiring in depth knowledge on a specific subject, broadening your competencies or experimenting with a specific tool or methodology. Personal learning ambitions are limited to a maximum number of five. (200 words max)

As a designer I want to have a good impact on the environment and societal influence. This project has good societal value as it makes the use of microneedle patches easier and more effective. What motivates me is that this product will make people's lives easier and will help them treat their possible illnesses (acne, scars, dark spots etc.).











A challenge I see in this project is the negative emotional effect that inserting the patch could have, if not designed well e.g. using a 'shooting' device on your face does spark a bit of fear. The design question here is how to make the product comfortable and feel safe for the end-user.







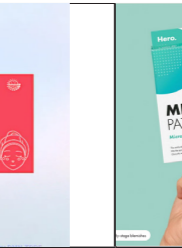

Personal learning ambitions:

- Learn to conduct scientific testing, with support from Upatch. Such as testing for the effectiveness of the product on (artificial or animal) skin.
- Carry out proper user testing during this project.
- Change my approach to leadership: I often frame actions as questions when reporting to a boss (e.g., "I wanted to do X is that okay?"). Instead, I want to present them as statements, and only ask when I truly need confirmation.
- Strengthen my academic writing skills and how I formulate good and understandable sentences.
- Become a better listener. I tend to speak or ask questions too quickly, sometimes interrupting others. I find this rude and unhelpful, and I want to change it.

Appendix B: Cosmetic Microneedle Patch mapping

Table A.1 : Analysis of CMNPs on the market

											
Name	Microdart pimple patches	Patch Promicroneedle patch	Miracle patch microcrystal spot cover	Miracle patch vitamin c dark spot cover	Microdart pimple patch	Naterido Microdart	Breakout patch classic dart	Micro pin spot patch	Whitening & Spot-Lightening Microneedle Patches	Micropoint for Blemishes	Acneclear pimple clearing patch
brand	BLOOMORA	PATCH PRO	Real	Rael	Saisze	Naterido	Skin choice	SOME BY MI	youwebio	Hero cosmetics	Holika Holika
source	[1]	[2]	[3]	[4]	[5]	[6]	[7]	[8]	[9]	[10]	[11]
application	for early and deep breakouts	blemishes	early breakouts, deep blemishes	post blemish	deep and early breakouts	deep and early blemishes	early stage acne treatment	early state spots	spot treatment, to make skin even toned	early breakouts	breakouts, hyperpigmentation, inflammation
underlying use	unclogging pores, hydrate, anti inflammation	unclogging pores, hydrate, suck out puss	hydrate	exfoliate	unclog pores, hydrate	hydrate, anti inflammatory		unclogging pores, hydrate	hydrate	unclogging pores, hydration, add moisture	hydration, anti-inflammation
key ingredients	hyaluronic acid, paris polyphylla yunnanensis, salicylic acid	opper tripeptide-1, EGF, epilobium angustifolium flower extract, hydrocolloid, madecassoside, salicylic acid, and olive oil	Hydrolyzed Hyaluronic Acid, Glycerin	Hippophae Rhamnoides Fruit Extract, Niacinamide, Madecassoside,	centella asiatica extract, hyaluronic acid, salicylic acid	hyaluronic acid, centella asiatica, tea tree oil		hyaluronic acid, salicylic acid, truecica	Hyaluronic acid	salicylic acid, niacinamide, willow bark, sodium hyaluronate	hyaluronic acid, niacinamide, centella asiatica
size										medium	medium
dimensions	16 mm diameter	15 mm diameter	14mm diameter	14mm?	16mm diameter	19mm diameter	18 mm diameter			unknown	
form	circle	oval	circle	circle	circle	circle	circle (with flower)	circle		circle	circle
length of needles	290 nm		unknown		400 µm			micro pin 200EA		unknown	unknown
Amount of needles	160		a lot	240	a lot	a lot		320	a lot		16 needles
Duration of applying	6 + hours	4 + hours	4-8hours	6 + hours	6 - 8 hours	6 + hours	4 + hours	4 hours	1.5 + hours		2 hours
use	press gently for 30 seconds	Press gently for 5 seconds	Press gently for 3 seconds	Press gently for 10 seconds	Press down for 20 seconds	Press for 30 seconds	press for 15 seconds	press firmly 2-3 times in a vertical direction without rubbing	press 3-5 seconds several times until there are no bubbles	press gently for 20 seconds	press firmly

									
Name	PATCH PRO Micro Needle Patch for Anti-Wrinkle	Dissolving Microneedle Eye Patches	dissolving microneedle eye patches	Dark circle remover microneedle eye patches	Anti-Wrinkle Eye Microneedle Patches	The youth patch	All star eye patch	Age Rewind Microneedle Patches	FAQ™ Microneedling Patches for Forehead
brand	PATCH PRO	IZBEAUVO	ISBEAUSOLS	Youwebio	Youwebio	And shine	And shine	Karuna	FAQ tm
source	[12]	[13]	[14]	[15]	[16]	[17]	[18]	[19]	[20]
application	minimize fine lines and wrinkles	Wrinkle smoothing	dark circles & puffy eyes	dark circles and puffy eyes	dark circles and puffy eyes	Hydrates, plumps and reduces expression lines	rejuvenate, depugg,	target fine line, wrinkles and uneven texture	anti wrinkling
size	big	big	big	big	big	medium	medium	medium	medium
dimentions						5.5 x 1.7 cm	5.4 cm X 2.2 cm		
form	bean	bean	bean	bean and/or recgtagle patch	bean and/or recgtagle patch	rechtangle bean	water drop	rectangle	parasuit
length of needles	25 nm	27nm							
duration of applying	?	10-20 minutes	1-2 hours	1.5 hours +	1.5 hours +	4 + hours	4 + hours	leave overnight	
use	?		press gently	press 3-5 seconds several times	press 3-5 seconds several times	press softly for 2-3 minutes	press softly for 2-3 minutes	lighty press for 30-60 sevonds	gently press 5-10 seconds

	
Name	Microneedle BOT NIC
source	{21}
application	wrat removal support for healing
size	
dimentions	
form	circle
kind of needles	
brand	ShengQiu
Duration of applying	
use	gently press for 5 seconds

Appendix C: Potential clients database

Table A.2 : Potential client for the cosmetic applicator database

Potential client	Source
Nissha	[22]
TaikiUSA	[23]
DERMATECH	[24]
cosMED pharmaceutical	[25]
daewoong	[26]
wcc biomedical	[27]
Raphas	[28]
endoderma	[29]

Appendix D: User test 1: Current use

Goal: Understand what the user feels and thinks about the current use of AAMNPs, how they use the patches and what the current struggles are.

Methods and materials.

This study was conducted in a semi realistic environment. In a quiet room with a table, a chair, a hand mirror and decent lighting. The study was a semi-controlled observation. Observer gave an introduction and instruction. Participants were given the scenario that they have a beginning pimple coming up, and that they want to treat it with a MNP that they just bought at Douglas. They have been told that I will be asking to question/ have a small interview after the application process. Participants were asked to sign a consent form beforehand, see next heading.

Observer was taking notes throughout the user test and when the user consents to audio recording this was later analysed and visualised in the journey map. The journey map is the method used to analyse the and show the results of the study. Premo emotion measurement instrument was used to help participants with explaining there emotion throughout the use [30]

Materials

- Hand mirror
- Some by Mi AAMNPS

Interview questions:

- What do you normally do when you have an upcoming pimple?
- Can you describe this experience, you can look at the emotion map Premo and this step-by-step visualisation
- Can you go through all the steps you did and make additional remarks one how you felt doing that, I have a map here with emotions that can help you identify the emotions that you had, Premo.
- Do you think you used the product as intended
- What would for you be a reason to use such a patch?
- Now that you have used this patch, would you use it in the future?

Demographics users

This observation study was conducted with four participants with the Dutch ethnicity (n=4, male and female 50/50, 24-30 years old). N=2 had experience with pimple patches and n=2 did not. For this user test the difference in demographics from the target group is deemed acceptable.

Consent form

Participant ID:

Observation study of the use of a microneedle pimple patch

This research is conducted as part of the MSc study Industrial Design Engineering at TU Delft.

Student: Maan Roos Moeskops

Contact person: Maan Roos Moeskops, maanroos.moeskops@upatch.nl, + 31 6 21431529

Informed consent participant

I participate in this research voluntarily.

I acknowledge that I received sufficient information and explanation about the research and that all my questions have been answered satisfactorily. I was given sufficient time to consent my participation. I can ask questions for further clarification at any moment during the research.

I am aware that this research consists of the following activities:

1. Apply a microneedle patch on self chosen part of my face
2. The possibility that I will be asked questions during the application of the microneedle patch
3. A brief debrief interview

I am aware that data will be collected during the research, such as notes, photos, video and/or audio recordings. I give permission for collecting this data and for making photos, audio and/or video recordings during the research. Data will be processed and analysed anonymously (without your name or other identifiable information). The data will only be accessible to the research team and their TU Delft supervisors.

The photos, video and/or audio recordings will be used to support analysis of the collected data. The video recordings and photos can also be used to illustrate research findings in publications and presentations about the project.

I give permission for using photos and/or video recordings of my participation:

(select what applies for you)

- in which I am recognisable in publications and presentations about the project.
- in which I am not recognisable in publications and presentations about the project.
- for data analysis only and not for publications and presentations about the project.

I give permission to store the data for a maximum of 5 years after completion of this research and using it for educational and research purposes.

I acknowledge that no financial compensation will be provided for my participation in this research.

With my signature I acknowledge that I have read the provided information about the research and understand the nature of my participation. I understand that I am free to withdraw and stop participation in the research at any given time. I understand that I am not obliged to answer questions which I prefer not to answer and I can indicate this to the research team.

Last name

First name

___ / ___ / 2025

Date (dd/mm/yyyy)

Signature

Results and discussion

Results and discussion are covered in the main report

Appendix E: Lab test 1: Anti acne microneedle test on ex vivo skin

Goal: Is to test the efficiency of AAMNPs. This was tested with a brand of pimple patches from Raphas. This test was to conclude if manual application had effective penetration and to see if application with impact force gave effective penetration.

Materials and methods

To ensure that the experimental conditions closely mimic realworld use, the testing protocol was designed to replicate the way the AAMNP would be applied cosmetically. In practice, the patch is lightly pressed onto the skin, each press lasting approximately 3 seconds. Because the applied force varies with each press, the procedure is inherently difficult to reproduce precisely. Based on preliminary measurements, the average pressure exerted during these presses is estimated to be about 25 N, which remains comfortably tolerable for facial application. This was done with three patches

A second set of tests examined the effectiveness of impact application. In this case, three patches were shot onto the skin at a velocity of roughly 3.8 m s^{-1} .

For each experimental condition, three identical patches were tested. Each patch (Figure 2.21a) incorporates a matrix of 16 microneedles distributed over an 8 mm diameter circular area with a nominal needle length of $\sim 300 \mu\text{m}$.

The tests were done on ex vivo skin of the abdomen, which is stretched to represent the tension of in-vivo skin. Abdomen skin has similar upper-skin-layers as the forearm and some parts of the face and is therefore be used for testing, see Appendix H for details. The ex vivo skin rests on a silicon pad to simulate the softness under the skin.

To examine the penetration of the SC trypan blue was put on the spots where the patches were applied (Figure A.4) for approx. 60 minutes. After the pigment was wiped with a paper towel and alcohol, then the SC in was stripped with painters tape, until no visual dead skin cells are seen on the tape, or after ~ 20 strips. Then the skin was examined, when little dots are visual there is penetration.

Materials

- uPATCH Check velocity (Figure A.3)
- Six Raphas microneedle patches
- Exvivo skin specimens
- Skinstretch apparatus (tensile testing machine)
- Microscope camera
- Isopropyl alcohol (for surface cleaning)
- Disposable rubber gloves
- Laboratory coat
- Blue pigment (for visual tracking)
- Absorbent paper towels
- Painters tape



Figure A.3 : Check velocity applicator

Procedure

1. Clean the ex vivo skin with alcohol and dry
2. Mark the test sites to indicate which treatment will be applied where
3. Apply three patches with each method:
 1. *Impact*: with CHECK velocity with speed of 3.8 m s^{-1}
 2. *Force*: pressing with the finger for 15 s
4. Keep the patch in place 5 minutes
5. Remove the patches carefully
6. Place rings around each test
7. Apply trypan blue in each ring
8. Wait for 60 minutes, meanwhile examine the patches under microscope camera
8. Remove the trypan blue and rings
9. Wiped the area clean with alcohol wipes
10. Strip the area with painters tape
11. Examine the ex vivo skin

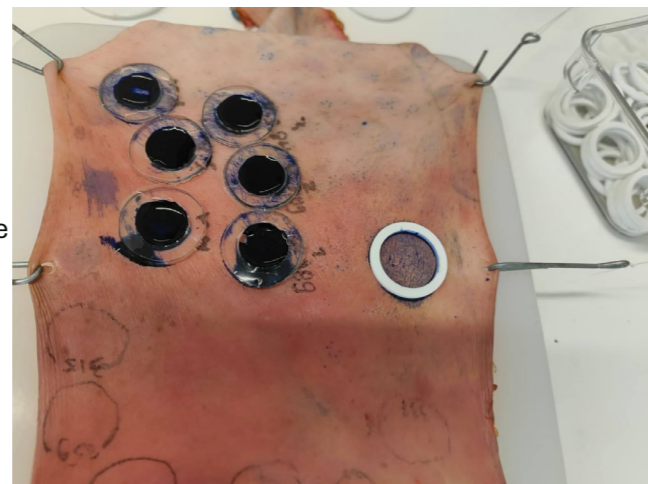

Figure A.4 : ex vivo skin after application of trypan blue pigment

Results

No penetration was observed in any of the tests (Figure A.5). After the penetration attempts, the needles themselves were inspected; some had dissolved completely while others were partially bent.

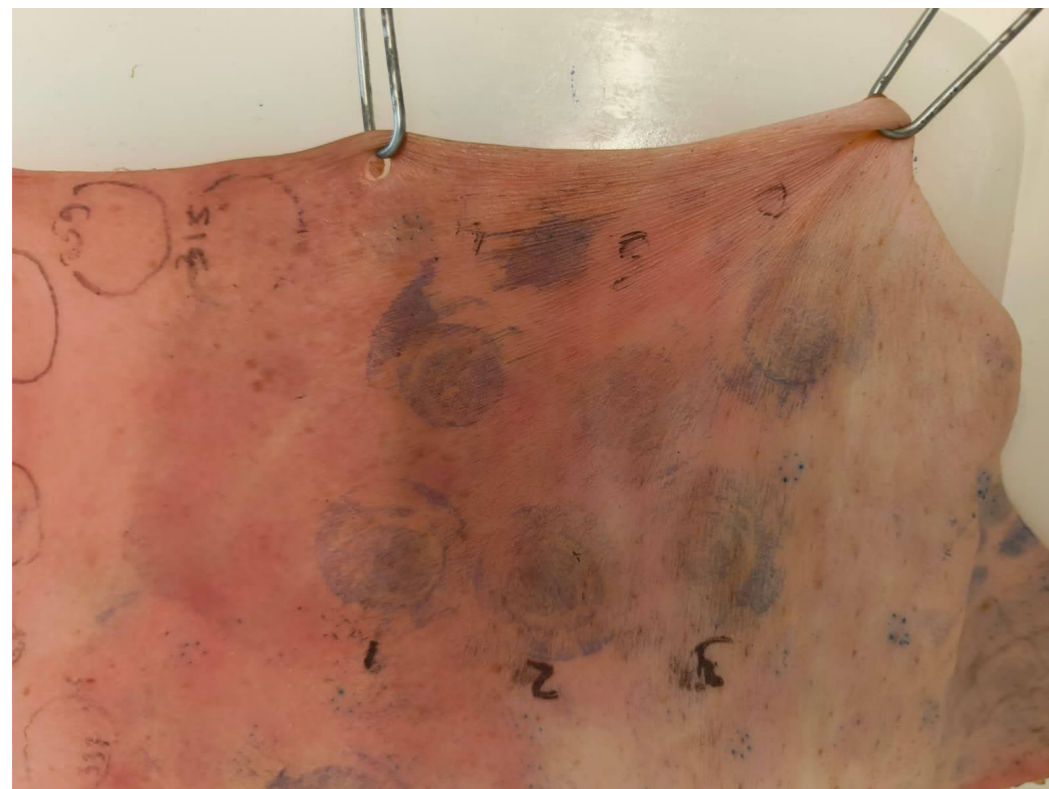

Figure A.5 : Ex vivo skin after cleaning with alcohol and tripping the SC

Table A.6 : Results of the tests

Test number	Velocity	Penetration	Condition needle after application	Picture post penetration
v.1	3.89 m/s	None	Dissolved	
v.2	3.89 m/s	None	Bend	
v.3	3.84 m/s	None	Partially bent	lost
v.4	Manual ~ 20N	None	Dissolved	
v.5	Manual ~ 20N	None	Slightly dissolved	
v.6	Manual ~ 20N	None	Bend	

Discussion

No penetration was seen in all the tests. These findings should be interpreted cautiously because the test parameters do not fully replicate realworld conditions. In practice the patches are applied to the face, where the layered structure of skin, subcutaneous fat, muscle, and bone provides a much firmer substrate than the soft exvivo model used here. Moreover, the skin in the experiment felt looser than in vivo tissue and the underlying material was deliberately soft, which likely reduced the chance of penetration. Furthermore, other regions of the same ex vivo skin sample had already been used and the skin has already been defrosted a few times. These conditions can also explain the lack of penetration.

The current setup most closely resembles the anatomy of the cheek. It is reasonable to expect that harder facial regions, such as the neck, forehead, temples, undereye area, chin, and cheekbones, would require less force to achieve penetration because of their greater rigidity.

Because the underlying material was intentionally very soft, the experimental conditions represented a worstcase scenario for penetration, lowering the likelihood of successful penetration. But if penetration is possible in this condition, there can be assumed that penetration on the other regions of the face is also possible.

Several factors could explain the lack of penetration:

- The microneedles may be too soft or blunt.
- Insufficient force was applied.
- Needle bending prevented effective insertion.
- The skin's elasticity or softness hindered penetration.
- The viscoelastic properties of the test substrate were unrealistically high.

Conclusion

Given the limited sample size and the many uncontrolled variables, a definitive conclusion cannot be drawn. The data suggests that the patches did not penetrate under the tested conditions. Improved testing using invivo skin, a thinner silicone backing, greater skin tension, or fresher exvivo samples, could yield different outcomes.

Recommendation

Conduct additional studies to evaluate the penetration capability of these dissolvable microneedles under more realistic conditions.

Compare these patches with other microneedle patches known to penetrate when applied with an applicator, then assess whether manual application can achieve comparable results. Such comparative work would clarify whether the limitation lies with the microneedle design itself, suggesting that manufacturers may need to produce sturdier needles.

Since uPATCH has limited access to exvivo skin and the current test environment does not fully represent clinical use, explore the feasibility of invivo testing to obtain more representative data.

Appendix F: Lab test 2: AAMNP penetration test on in vivo skin

Introduction

The previous penetration study showed no penetration. A new experiment was therefore performed using two types of cosmetic microneedle patches: one with high density array of needles, the AC balancing patches, and a low-density array of needles patches, the Holika Holika Acnenator patches.

Goal: Determine if AAMNP can penetrate the body.

Material and Methods

All tests were carried out on **invivo** forearm skin. This was safe as the products are already begin sold on the market and the subject gave consent (the researcher) gave consent. To determine whether a patch penetrates the skin, the patch is removed after application and the test site was wiped with a cloth with a strong salt solution. If the SC has been breached, the salt solution gives this region a tactile irritation with possible bumps. The flowchart in Figure 2.24 is used to determine penetration. The tests were done with two application methods, with three patches each:

- **Method 1: Pressing force** (controlled pressure held for 15 s with pressing force device, Figure A.7)
- **Method 2: Velocitydriven** (impact force with 120 N spring force with modified uPATCH PLUS applicator, Figure A.8)

To verify the reliability of this irritation check, control tests were performed in parallel without any patch for each application method. Should the controls exhibit irritation, the test would be deemed unreliable.

As an additional validation step, a dermomicroneedle pen, known to reliably breach the SC was used to create a positive control. Successful irritation with the pen confirms that the saltsolution test can detect true penetration of the SC.

For each patch type, I applied **extreme forces** to achieve penetration. Because the microneedles are fragile and prone to bending, the patches were handled with extreme care. The first tests of the study aimed to replicate the current use scenario how many brands instruct users to apply these patches: gently pressing the patch onto the blemish for approximately 5–20 seconds. To make this method repeatable, a controlled setup was used in which a force of 32 N was applied to the patch for 15 seconds using a device that ensured a consistent applied force. As the previous study gave no penetration a higher force is used to make the scenario and the patches more likely to achieve penetration.

After application, the patches remained on the skin for 15 seconds before removal.

Photographs of each microneedle patch were taken from the top and side views before and after application.



Figure A.7 : Constant pressing force device



Figure A.8 : Modified uPATCH Plus applicator

Materials

- Isopropyl alcohol
- Disposable wipes
- Strong salt solution (irritant probe)
- 6 Holika Holika patches
- 6 AC balancing patches
- UPATCH plus of 130 N force (velocity driven device)
- Pressing force device (set on 32 N)
- Skinstretch apparatus (tensile testing machine)
- Microscope camera
- Derma pen needle set (positive control)

Procedure

1. Clean the forearm with soap and water and dry.
2. Mark the test sites to indicate which treatment will be applied where.
3. Apply the patches with each method according to the schedule below:
 - a. Apply the three patches with each method
 - b. Keep the patch in place for 15 seconds.
 - c. Remove the patch carefully.
 - d. Swipe the test area with the salt solution.
 - e. Record visual irritation and the condition of the needles after removal.
 - f. Examine patches under microscope camera.
4. Do the same procedure with each method without patch (the control runs)
5. Do the same procedure with for the positivecontrol with a derma pen



Figure A.9 : Study setup

Results

Table A.10 : Results of tests with low-density patches (Holika Holika)

Test no.	Appli-cation method	Force (N)	Penetration	Condition needle after application	Tactile irritation	Patch after application	Visual irritation
A.1	Pressure	32N	Possible	Top of needles dissolved	Yes skin is red (needle points visual)		
A.2	Pressure	32N	Possible	Top of needles, some bend	Yes skin is red (needle points visual)		
A.3	Pressure	32N	Possible	Top of needles, some bend	Yes skin is red (needle points visual)		
A.4	Impact	130N	Most likely	Dissolved	Yes, skin is bumpy and red (needle points)		
A.5	Impact	130 N	Most likely	Dissolved	Yes, skin is bumpy and red (needle points)		
A.6	Impact	130 N	Most likely	Dissolved	Yes, skin is bumpy and red (needle points)		

Table A.11 : Results of tests with high-density patches (AC Balancing)

Test no.	Appli-cation method	Force (N)	Penetration	Condition needle after	Tactile irritation	Patch after application	Visual irritation
AC.1	Pressure	32N	Possible	Some tops of needles dissolved, most bend	Partly, only outer rim of the needles the is applied		











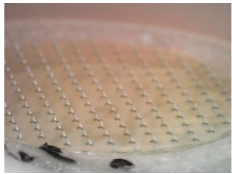

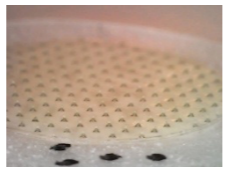
AC.2	Pressure	32N	Possible	Top of needles dissolved, some bend	Partly, only outer rim of the needles the is applied		
AC.3	Pressure	32N	Possible	Top of needles dissolved, some bend	Partly, only outer rim of the needles the is applied		
AC.4	Impact	130N	Possible	Top of needles dissolved, some bend	Yes skin is red		
AC.5	Impact	130 N	Possible	Top of needles dissolved	Yes skin is red		
AC.6	Impact	130 N	Possible	Top of needles dissolved, some bend	Yes skin is red		

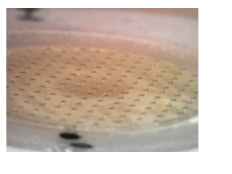
Table A.12 : Results of tests control tests

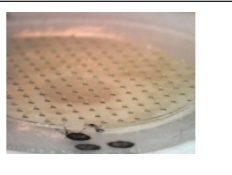
Dermapen after salt application	Prickling sensation after salt application	
Pressing force test after salt application	No tactile irritation	
Velocity force test after salt application	No tactile irritation	

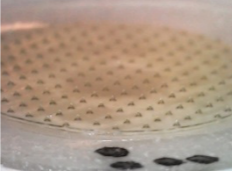
One hour after application, only the velocitydriven tests still displayed noticeable redness. All MNPs tests produced some degree of irritation, whereas the control runs without a patch showed only transient redness that faded within ten minutes and no significant reaction to the salt solution. Controls using the derma pen exhibited clear redness and irritation at the needle entry points, confirming that the saltsolution assay reliably detects true SC penetration.

Discussion

Negative control experiments (no patch) generated only mild redness, likely due to the mechanical force applied, but no substantive tactile irritation, indicating that tactile irritation only occurs when penetration has happened.

The derma pen positive control produced distinct redness and a tingling irritation at needle sites, validating that the saltsolution test can validate penetration.

In the derma pen control test, both redness and more noticeable tactile irritation were present. However, no visible bumps developed in the skin. The bumps only occurred with the velocity driven test with low density patches. These bumps can be a reaction of the in-vivo skin for a mild allergic reaction. As these bumps didn't appear in the pressing force test with the same patches. It can be concluded that this reaction only occurs with penetration through the SC and not with superficial contact with the SC and that there is probably no penetration with the low-density with the pressing force test.

The low-density patches achieved the highest penetration rates, probably because their needles are longer and fewer per square centimetre, reducing the bed of needles effect.

With the high-density patches ("AC Balancing"), pressing force application only saw redness cause by the needles on the outermost ring of needles array, likely due to a "bedofnails" effect. In contrast, impact application produced uniform redness due to needles across the entire needle array area, presumably because the high speed overcomes the interneedle interference. However no needlepoints here visible and tactile irritation was minimal, which means that there was likely no penetration with both methods.

In general the velocitydriven (impact) applications caused stronger irritation than staticforce applications, possible because of the higher force used contributing to deeper needle insertion. Future work will therefore focus on refining the minimum velocity required for consistent penetration.

The results of the pressing force test and velocity test can not be fairly compared to each other, as the force used is significantly different with each other. Nevertheless the impact force test is most likely to be able to apply more force to the skin as this is only felt for a fraction of a second. Meaning that that application is more comfortable than with the same force with pressing force application.

Therefore it makes most sense to continue with impact force as working principle for the applicator, as there is penetration with this method and the

Conclusion

Comparing the two designs, the low-density ("Holika Holika") patch is superior for achieving reliable skin penetration. Among the application techniques tested, velocity impact has the greatest probability for penetration, whereas pressing force is less effective, especially for tightly spaced needle arrays. Also considering that the use for these patches is applied on pimple, which can already be very painful, pressing something on it for an extended period of time will not be comfortable.

Further steps

Systematically vary impact velocities to identify the lowest speed/force that still ensures penetration for the patches.

Appendix G: Acne research

There are six types of acne lesions, which are categorized in four grades. The first three grades can usually be treated with over-the-counter products, while grade four requires treatment by a dermatologist.

Grade 1: Blackheads and Whiteheads

Blackheads and whiteheads are comedies clogged with dead cells and oil. A closed comedo is a whitehead, while an open comedo is a blackhead. In blackheads, the exposed sebum dries and turns dark [31]. These lesions are non-inflammatory and can be recognized by a small white or black spot on the skin.

Grade 2: Papules (pimple)

Papules are inflamed comedones that do not contain pus or sebum. They appear as a small pink/red bump, typically less than 5 mm in diameter[32].

Grade 3: Pustules (pimple)

Pustules are fully inflamed lesions with a pus-filled centre, they are typically known as pimples [32]. Pustules are filled with dead skin cells and excess oil, appearing as red bumps with a white or yellow head in the centre [33].

Grade 4: Nodules and cysts

Nodules are inflamed pores that are clogged with dead skin cells, excess oil and bacteria[32]. They are deep under the skin and affect the surrounding area. They are often firm to the touch and painful [31]. Nodules range from 5-10 mm in diameter and appear as a red lump to the skin[32].

Cysts are like nodules but are also filled with pus and can appear as red/white big lumps[32], [34]. As grade four lesions can cause scarring and over the counter products are often not very effective, they should be treated by a dermatologist[31].

Post acne

After acne has healed, or after any skin trauma, PIH can occur[35]. This is the body's response to the lesion, which causes the production of extra melanin in the affected spot[36]. PIH is also known as red or dark spots on the skin. Dark spots are temporary but may last for a few weeks up to a year. Several cosmetic products or procedures can help heal dark spots, such as glycolic or azelaic acid or chemical peels.

Severity levels: mild, moderate, severe

Mild acne: Primarily grade 1 lesions, with occasional papules or pustules. Usually fewer than 30 lesions in total [31] [37]. Most people will have some form of mild acne in their lives.

Moderate acne: Multiple papules and pustules, ranging up to 125 total lesions [[31], [37].

Severe acne: Numerous papules and pustules that cause scarring or the presence of nodules and cysts[37], [38].

Acne on the face

Since this project focuses on acne on the face, it is important to identify where it occurs most frequently. Acne can appear on any facial area, but it is most common on the cheeks, followed by the chin and forehead. The nose and jawline are also moderately affected.

Asian ethnicity skin

Asian skin contains more melanin and a higher number of melanin-producing cells compared to Caucasian skin [35]. This makes it more prone to hyperpigmentation, which increases the likelihood of PIH after acne lesions have healed [39].

In general, Asian skin also has a thinner SC, making it more sensitive, but better suited for MN penetration [40][41]. Asian skin also has more collagen and elastin making it more flexible, which is not beneficial for penetration of the needles.

While acne treatment is the same across all ethnic groups, Asians tend to have higher sebum production, which increases the likelihood of developing grade 2 and 3 lesions [39], [40].

It is expected that there will be only mild to no differences in penetration suitedness between ethnicity profiles.

Appendix H: Anatomical study : Facial tissue structure

The face consists of five primary layers:

- **skin,**
- **superficial fat**
- the **superficial musculoaponeurotic system (SMAS)** and facial muscles
- **deep fat**
- Bone (the skull)[42].

The thickness of each layer and precise anatomy varies depending on the facial area, age, genetics and body fat percentage.

All layers are present throughout the face, though their proportions differ [43], [44]. For instance, the cheeks and perioral region have an average skin thickness of 1.8 mm and a superficial fat layer of about 5.0mm, making them one of the softest facial regions[45].

The SMAS consists of the muscles responsible for fine facial expressions. Some of the deep fat layers intertwine with these muscles [46]. The thickness of the muscles varies widely, for example, jaw muscles average around 17 mm at rest in one study and that of the forehead muscles at 2 mm [47].

Desk research revealed some conflicting findings regarding the distribution of deep fat across the face [43], [44]. In general, deep fat pads are present in most areas, though most studies focus on the deep facial pads in the cheeks [46]. This might imply that these are the thickest deep fat regions. It remains unclear whether the thickness of these deep fat layers significantly differs across facial regions, as no research could be found of this.

The skull structure is complex, with some areas of bone lying directly beneath the surface (e.g., forehead), while others are covered by thick layers of muscle and fat.

The cheekbone sticks outward, creating a hard and angled underlying surface. In most facial regions, the muscles and fat are closely connected to the bone underneath. The cheeks are an exception, they are not directly connected to the skull as they allow for the movement of the jaw, resulting in a much softer and more flexible area.

Thickness of the stratum corneum

Understanding the thickness of the SC at different body sites is important for predicting penetration efficiency and to see if results of tests on one body site can be used for the other. Testing will most likely be carried out on *ex vivo* abdominal skin as well as *in vivo* skin of the forearm. Knowing the differences in SC thickness allows for better hypotheses regarding the effectiveness of the designed applicator across various sites.

In general, the SC is between 10-20 μm thick[48]. Table A.13 summarises the different and relevant SC thicknesses across the body. Notably, the SC of the abdomen, volar forearm, forehead, and cheeks show similar SC thickness values.

Table A.13 : Data on skin layers on the body

Body site	Thickness SC in μm	Number of cell layers [49]
Abdomen	14.52 \pm 1.44 [50]	14 \pm 4
Volar Forearm	19.5 \pm 2.8 [51] 12.98 \pm 1.89 [50]	16 \pm 4
Face		
Forehead	14.36 \pm 2.06 [50]	9 \pm 1
Eye area		8 \pm 2
cheeks	12.8 \pm 1.5 [51] 15.37 \pm 1.57 [50]	10 \pm 3
nose		10
chin		

Appendix I: Expert conversations dermatologists

For my research I wanted to talk to dermatologists to see what their view is on cosmetic microneedle pimple patches. I talked to two of them, Dr. Michiel Uffen and Dr. Francis Wu. Dr. Michiel Uffen was not familiar with MNPs and couldn't therefore answer my questions.

The following questions were asked :

Questions concerning MNPS

Heeft het drukken van een pimple patch op een papel of pustel negatieve effecten op de puist doordat hier dan druk op wordt uitgeoefend?

No giving pressure on a pimple doesnt make it worse or more irritated as long as you do not disrupt the surface

Welke werkzame stoffen zou u het liefst zien in een microneedle pimplepatch om de effectiviteit (het voorkomen van de puist) te maximaliseren?

Ingredients as salicylic acid, glycol acid, I wouldnt want tea tree oil in it as people could become allergic to this if it is absorbed atopically.

Voor welk specifiek type en ernst van acne (bijv. papels, pustels) schat u dat deze microneedle patches de meeste meerwaarde zouden kunnen bieden?

Afhankelijk of u ervaring en bekend met met microneedle pimple patches

Zou u microneedle pimple patches aanraden als aanvulling voor patienten of voor mensen met lichte acne als over the counter product.

Vragen over de anatomie/huidstructuur van het gezicht

Hoe verschilt de huidstructuur en elasticiteit in het gezicht?

The skin that has to move a lot is the most elastic, these are the mouth corners, area around the eyebrows, chin, cheeks

Welke delen in het gezicht zijn het meest gevoelig/ kwetstbaar voor het aanbrengen van patches.

The area around the eyes, eyebrows and temples.

Appendix J: User test 2: Concept evaluation

Introduction

The objective of this user study is to establish which variant of execution of the loading function and activation function the intended user prefers. Next to that, the user test is used for establishing which (negative) emotions occur during application.

Research questions that this user study will answer:

- Is there any difference in desirability between the different variants of a function?
- Do the emotions felt during the procedure of applying the patch to the face differ between the concepts?

Method

Participants

Around 8 people will be asked for this user study. It is important that the users are somewhat similar to the intended users of the product:

The users should be between 12-30 years old, male or female, preferable suffering from some kind of acne somewhere in their life (doesn't have to be at the moment). They can be a novice user (never have used any kind of pimple patch), or expert user (have used (microneedle) pimple patches).

Stimuli

- The three to be tested concept prototypes (see Figure A.15)
- Microneedle pimple patches
- Survey (see end of file)
- Stretcher

Figure A.14 : User evaluation set up

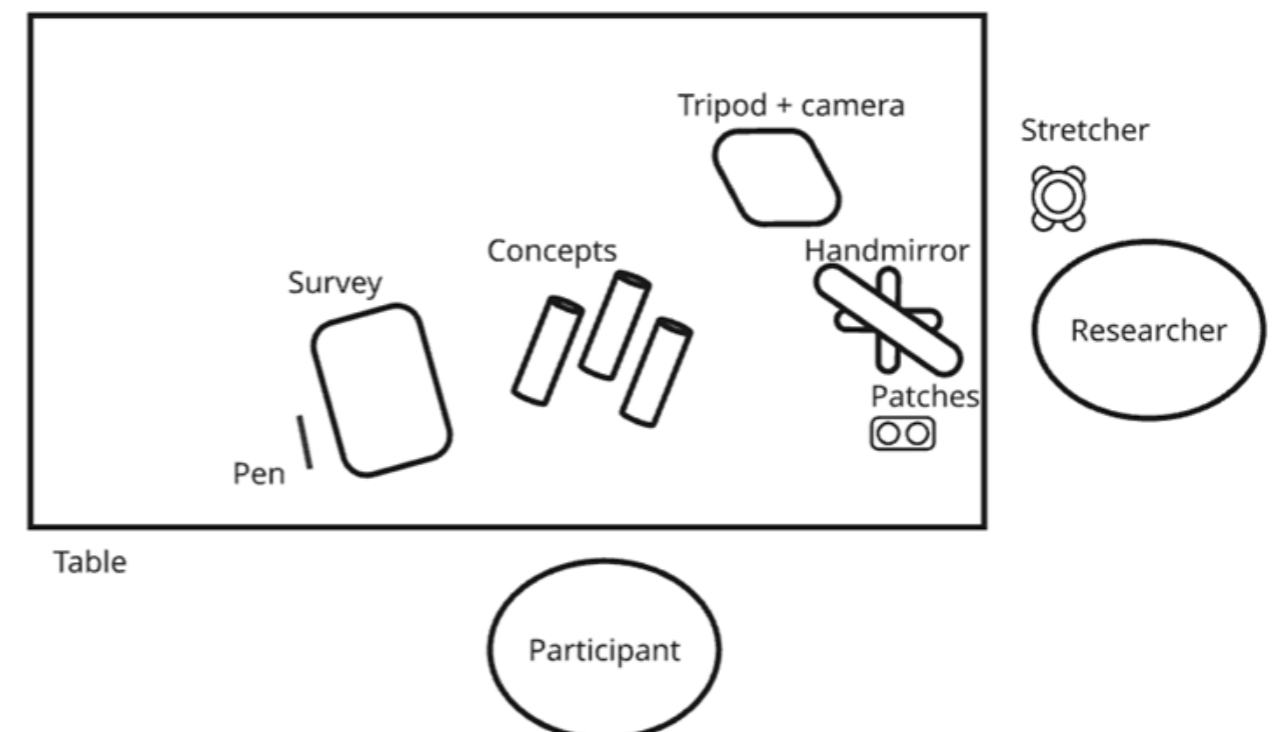
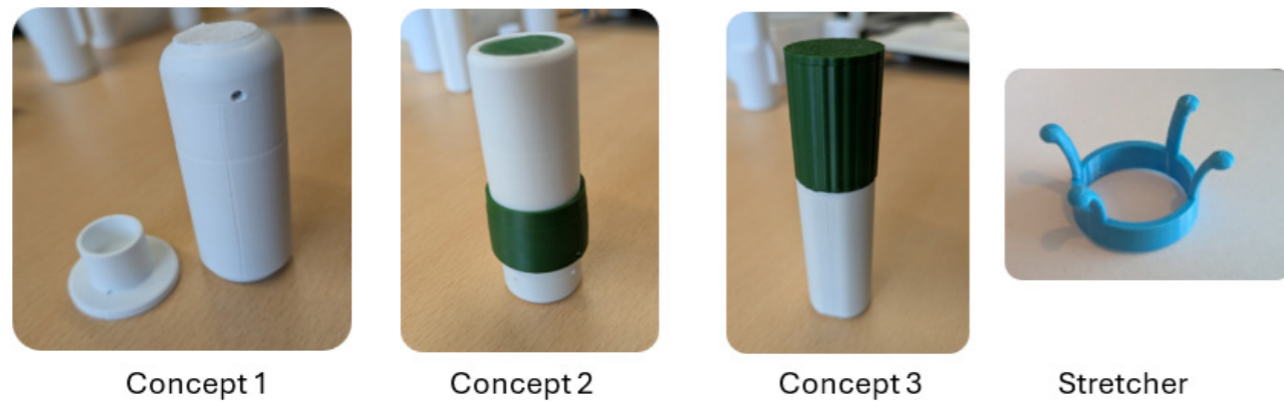

Figure A.15 : The concepts



Apparatus

- Tripod with phone for video recording the use of the products and recording the interview at the end.
- Consent form
- Pen
- Hand mirror

Procedure

The user study will take place at the university in a reserved room for privacy. The researcher is present as an observer and only asked questions afterwards each activity or at the end.

Steps of the procedure:

Researcher gave introduction about the project, what the user will be testing, consent form is given, researcher asked participant if it is okay if they record
 Users were asked to explore the products and think out loud. Explain what they thought about the product and how it has to be used. The participant was told before the exploration started that they were not allowed to activate the concepts on their face and that the screws that are visible on two concepts should stay in the concepts
 After the researcher gave additional instruction of how each concept works, if this wasn't clear yet (**ring** for concept 2 should be down, as this is how it is intended, concept 3 is supposed to have the **same button** as concept 2, concept 1 dock isn't to apply patch)
 User was asked to follow instructions on the survey and fill out the survey
 Concept 2 is given again with the add-on of a stretcher, participant is asked to perform the activation again.
 Researcher will ask following questions

- o What do you think this add-on is?
- o How did the application feel?
- o How can you feel that the applicator is on your skin with the stretcher?
- o Where would you store this device
- o Would you purchase this device
 - If yes, how much money would you think you would want to spend on it

When done, researcher and participant went through the survey together
 Researcher thanked the participant for participating

Measures

The variables that are being measured are the difficulties the participant experiences while handling the prototypes, either by observation (by videorecording) and with the participant thinking out loud. This was addressed with the interview at the end. This is all supported with the survey they filled out about each feature of the concepts. The survey questions are a selection of the User Experience questionnaire[52].

User survey

You are asked to perform two actions with each prototype. After doing each action you are asked to fill a few questions about the use and experience that the action and product gave you, this will be repeated for the three prototypes. Afterwards you will go through the survey with the researcher, and she will ask you some additional questions.

It is important to note that you as the participant cannot do anything wrong, that there are no fault answers.

The scenario in which you are performing the actions: you have a pimple and want to apply a microneedle pimple patch on it (note* the pimple patch is already on the prototypes, you do not have to do this).

Concept 1 : Plus



Perform the action: Loading the applicator (* do not fire it yet)

Please assess the use of this action by ticking one circle per line:

complicated	<input type="radio"/> <input type="radio"/> <input type="radio"/> <input type="radio"/> <input type="radio"/> <input type="radio"/> <input type="radio"/> <input type="radio"/>	easy
confusing	<input type="radio"/> <input type="radio"/> <input type="radio"/> <input type="radio"/> <input type="radio"/> <input type="radio"/> <input type="radio"/> <input type="radio"/>	clear
annoying	<input type="radio"/> <input type="radio"/> <input type="radio"/> <input type="radio"/> <input type="radio"/> <input type="radio"/> <input type="radio"/> <input type="radio"/>	enjoyable
not understandable	<input type="radio"/> <input type="radio"/> <input type="radio"/> <input type="radio"/> <input type="radio"/> <input type="radio"/> <input type="radio"/> <input type="radio"/>	understandable

Perform the action: Activate the applicator (on your face)

Please assess the use of this action by ticking one circle per line:

unpredictable	<input type="radio"/> <input type="radio"/> <input type="radio"/> <input type="radio"/> <input type="radio"/> <input type="radio"/> <input type="radio"/> <input type="radio"/>	predictable
unlikable	<input type="radio"/> <input type="radio"/> <input type="radio"/> <input type="radio"/> <input type="radio"/> <input type="radio"/> <input type="radio"/> <input type="radio"/>	pleasing
secure	<input type="radio"/> <input type="radio"/> <input type="radio"/> <input type="radio"/> <input type="radio"/> <input type="radio"/> <input type="radio"/> <input type="radio"/>	not secure
inefficient	<input type="radio"/> <input type="radio"/> <input type="radio"/> <input type="radio"/> <input type="radio"/> <input type="radio"/> <input type="radio"/> <input type="radio"/>	efficient

Answer the following open questions:

What would you change about this concept?

What did you like about this concept?

What didn't you like about this concept?

Concept 2 : Ring



Perform the action: Loading the applicator (* do not fire it yet)

Please assess the use of this action by ticking one circle per line:

- complicated o o o o o o o easy
- confusing o o o o o o o clear
- annoying o o o o o o o enjoyable
- not understandable o o o o o o o understandable

Perform the action: Activate the applicator (on your face)

Please assess the use of this action by ticking one circle per line:

- unpredictable o o o o o o o predictable
- unlikable o o o o o o o pleasing
- secure o o o o o o o not secure
- inefficient o o o o o o o efficient

Answer the following open questions:

What would you change about this concept?

What did you like about this concept?

What didn't you like about this concept?

Concept 3: Prit



Perform the action: Loading the applicator (* do not fire it yet)

Please assess the use of this action by ticking one circle per line:

- | | | | | | | | | |
|--------------------|-----------------------|-----------------------|-----------------------|-----------------------|-----------------------|-----------------------|-----------------------|----------------|
| complicated | <input type="radio"/> | <input type="radio"/> | <input type="radio"/> | <input type="radio"/> | <input type="radio"/> | <input type="radio"/> | <input type="radio"/> | easy |
| confusing | <input type="radio"/> | <input type="radio"/> | <input type="radio"/> | <input type="radio"/> | <input type="radio"/> | <input type="radio"/> | <input type="radio"/> | clear |
| annoying | <input type="radio"/> | <input type="radio"/> | <input type="radio"/> | <input type="radio"/> | <input type="radio"/> | <input type="radio"/> | <input type="radio"/> | enjoyable |
| not understandable | <input type="radio"/> | <input type="radio"/> | <input type="radio"/> | <input type="radio"/> | <input type="radio"/> | <input type="radio"/> | <input type="radio"/> | understandable |

(for this concept we only test the loading of the applicator :))

Answer the following open questions:

What would you change about this concept?

What did you like about this concept?

What didn't you like about this concept?

Look at all concepts again and answer the following questions:

Which concept would you use again and why?

Order the concepts in the following order (with 1 being most and 3 being least):

This concept gives me the most sense of control:

This concept felt most safe to use :

This product was most enjoyable:

Does any of the above answers change if the force of which the plunger comes on your skin increases?
Discuss this with the researcher.

Results

The study was conducted with 7 participants (N=7, 3 are female, 4 are male, all in 20-30 age group and had/have acne at some point in their life).

Table A.16 : Feedback on the concepts

	Concept 1	Concept 2	Concept 3
Negative	<ul style="list-style-type: none"> - Loose component, N=6 - Hurts to shoot, N=3 - Beard got stuck in applicator while activating - Loading confusing 	<ul style="list-style-type: none"> - Ring is to small -> no good grip, N=4 - Almost needs two hands to load - Not enough space to hold it, N=2 - Not clear ring is a slide - Can't pull ring when finger is on button 	<ul style="list-style-type: none"> - too long, N=2 - Turning action is too long
Positive	<ul style="list-style-type: none"> - Visually appealing - Can use with one hand - Good impact - Size 	<ul style="list-style-type: none"> - Sounds while activating and loading is nice - Satisfying in use, N=2 - Size - Easy in use - It gives me control 	<ul style="list-style-type: none"> - Form, N=2 - Grip, N=3 - Turning motion - Size, N=2 - Easy in use, N=2
Change	<ul style="list-style-type: none"> - Make dock attachable to applicator - Make dock more leading in loading 	<ul style="list-style-type: none"> - grip 	<ul style="list-style-type: none"> - Shorter device - Make turning shorter

Discussion

The user test did not reveal a clearly superior concept; all three received overall positive ratings. When the loading mechanism was examined, Concept 3's rotating system earned the highest scores, but a ttest ($\alpha = 0.05$) showed no significant advantage over Concepts 1 and 2. While the activation function, whether automatic or manual, was similarly wellreceived for all concepts. Both loading and activation functions were rated positively across the participants, with Concept 3 showing the clearest benefit for loading.

Interestingly, despite receiving the lowest quantitative grades, Concept 1 was the most frequently chosen for future use. The reasoning from the participants suggested partly that ergonomics, more a tool than a toy, less steps in activation and overall "feel" was the reasoning for this decision.

The loading system for concept 1 was confusing for most people with no prior explanation. Everyone figured it out after some trial and error. No one was a fan of having a lose component.

The hypothesis that a button will feel more secure and comfortable to use is partly felt by users. The users that preferred concept 2 or 3 had this as part of their reasoning. The users that preferred concept 1 didn't mind the automatic activation over the extra control that a button gives.

Multiple people liked the 'fidgety' aspects on the concepts but wouldn't always like it in this kind of product.

With no explanation the stretcher is confusing and most users think it is a damper for the force and activate is ~5 mm before the skin. With explanation, people do push it hard on their skin. Indicating that when people know that the function of it is to stretch the skin the applicator is used correctly.

The following limitations could have influences the outcomes of this study:

- Small sample size (N=7)
- Not the exact same impact force on all concepts
- Size and appearance on the concept not the same
- Lack of proper use cue for the ring on concept 2, for the other concepts this was more developed
- Participants had to imagine that concept 3 had a button,

Conclusion for concept choosing

The user study didn't have a clear superior concept, but did have a superior loading system, the rotation system of concept 3. As part of the users did experience more control with an activation button and the other group didn't find this significantly better, it is then logical to add a button to accommodate more for the users that do find it more comfortable in use. Even though the effect of feeling more in control was smaller than first was anticipated, it was still present. For the further development of the applicator, it is important to spend more time on the ergonomics of the device. As some people didn't find it clear how to hold it and had to adjust their hand to activate the button. Multiple people found the fidgety aspects of concept 2-3 enjoyable but some didn't necessarily want it in a product like this. For further development of the concept this must be designed for. An extra wish is added for this to the list of requirements.

Stretchers

- With no instructions super unclear, not touching skin
- With instructions people really push it in skin, plungers hits harder, not always clear when you need to push, hence the harder pushing.

Graph A.2 : Score of loading

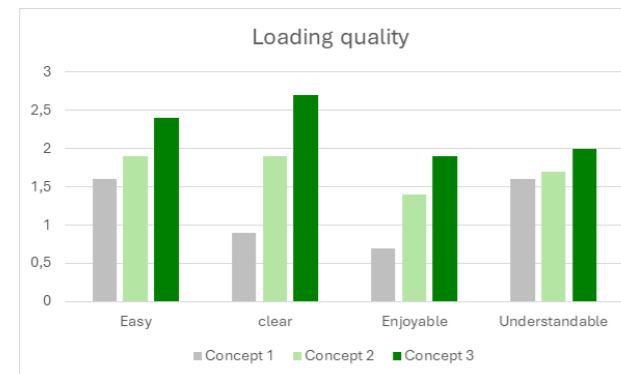

Graph A.3 : Score of activating

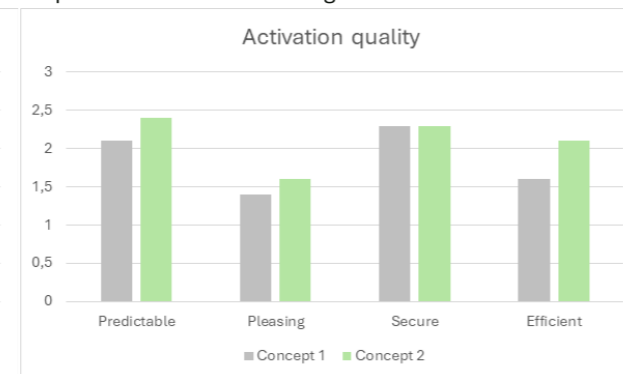

Graph A.4 : Overall score

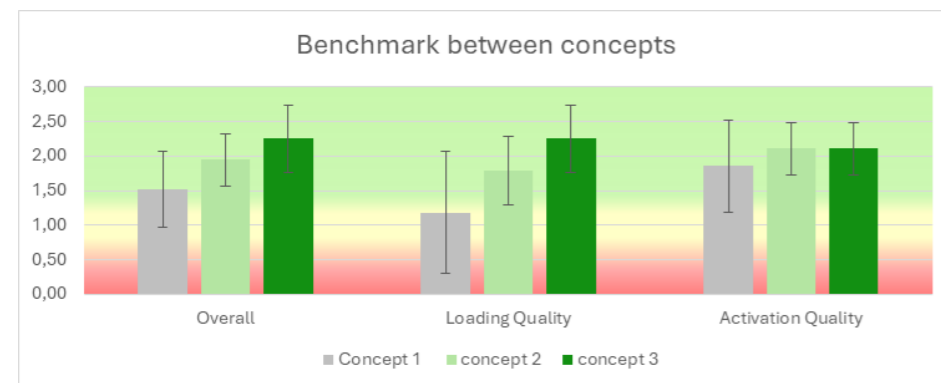

Graph A.5 : Favorites of participant

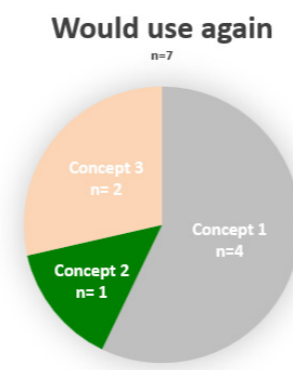

Consent form

Participant ID:

User concept evaluation study of microneedle patch applicator

This research is conducted as part of the MSc study Industrial Design Engineering at TU Delft.

Student: Maan Roos Moeskops

Contact person: Maan Roos Moeskops, m.r.moeskops@student.tudelft.nl, +31 6 21431529

Informed consent participant

I participate in this research voluntarily.

I acknowledge that I received sufficient information and explanation about the research and that all my questions have been answered satisfactorily. I was given sufficient time to consent my participation. I can ask questions for further clarification at any moment during the research.

I am aware that this research consists of the following activities:

1. Observation: Evaluation three concepts
 - a. Exploring concepts
 - b. Conducting tasks: loading applicator, activating device on the face
2. Filling in a questionnaire
3. Post evaluation interview

I am aware that data will be collected during the research, such as notes, photos, video and/or audio recordings. I give permission for collecting this data and for making photos, audio and/or video recordings during the research. Data will be processed and analysed anonymously (without your name or other identifiable information). The data will only be accessible to the research team and their TU Delft supervisors.

The photos, video and/or audio recordings will be used to support analysis of the collected data. The video recordings and photos can also be used to illustrate research findings in publications and presentations about the project.

I give permission for using photos and/or video recordings of my participation:
(select what applies for you)

- in which I am not recognisable in publications and presentations about the project.
- for data analysis only and not for publications and presentations about the project.

I give permission to store the data for a maximum of 5 years after completion of this research and using it for educational and research purposes.

I acknowledge that no financial compensation will be provided for my participation in this research.

With my signature I acknowledge that I have read the provided information about the research and understand the nature of my participation. I understand that I am free to withdraw and stop participation in the research at any given time. I understand that I am not obliged to answer questions which I prefer not to answer and I can indicate this to the research team.

The researchers take the applicable COVID-19 measures into account. I confirm to respect the COVID-19 measures taken and will follow instruction about these provided by the researchers.

I will receive a copy of this consent form.

Last name

First name

Appendix K: Korean Anthropometrical data

The paper by Soo-chan Jee and Myung Hwan Yun, an anthropometric survey of Korean hand and hand shape types, was used to gather anthropometric data of the end-user target audience to make an estimation about the length of the applicator [53].

Table A.17 : Descriptive statistics of Korean males and females (in mm) [53]

Hand dimensions	Male		Female			
	50th	95th	5th	50th	95th	
5th						
Fingertip to root digit 1	53.4	61.5	67.6	50.5	56.2	61.6
Fingertip to root digit 2	63.6	70.5	78.5	58.5	66.0	73.6
Fingertip to root digit 3	71.3	78.6	86.6	66.7	73.5	81.4
Fingertip to root digit 4	66.7	74.3	82.2	62.6	69.1	76.2
Fingertip to root digit 5	51.1	59.6	65.8	45.4	54.7	61.6
Center of wrist crease to root digit 1	71.3	79.5	87.9	65.3	72.8	79.9
Center of wrist crease to root digit 2	103.2	113.4	121.8	95.8	104.7	113.7
Center of wrist crease to root digit 3	102.8	112.6	121.9	97.0	104.1	114.6
Center of wrist crease to root digit 4	98.0	108.4	117.5	92.9	99.4	109.4
Center of wrist crease to root digit 5	89.3	99.8	109.0	84.7	91.2	100.7
Hand length	168.3	183.2	197.6	159.6	169.4	184.5
Palm length	96.7	105.1	113.2	89.7	97.1	105.1
Breadth at PIP joint of digit 1	19.8	22.5	25.2	17.3	19.4	22.3
Breadth at PIP joint of digit 2	18.8	20.4	22.5	16.5	18.3	20.5
Breadth at PIP joint of digit 3	18.8	20.7	22.7	16.4	18.4	20.4
Breadth at PIP joint of digit 4	18.0	19.5	21.5	15.3	17.1	19.4
Breadth at PIP joint of digit 5	15.6	17.5	19.1	13.2	15.3	17.3
Hand breadth at metacarpals	78.7	85.9	92.3	71.6	77.6	86.1
Wrist breadth	55.7	61.6	66.0	50.1	55.5	62.1
Circumference at PIP joint of digit 1	61.4	68.0	76.0	54.0	61.0	70.0
Circumference at PIP joint of digit 2	60.0	64.0	71.6	52.0	58.0	65.0
Circumference at PIP joint of digit 3	60.0	67.0	73.0	54.0	59.0	68.0
Circumference at PIP joint of digit 4	56.0	62.0	68.0	49.7	55.0	63.0
Circumference at PIP joint of digit 5	49.0	55.0	60.0	42.0	49.0	55.2
Wrist circumference	159.8	175.0	192.8	143.7	155.5	174.5
Hand depth	42.2	49.0	55.4	36.9	41.8	48.1

Table A.18 : Definition of hand dimensions [53]

	Hand dimensions	Definition
1	Fingertip to root digit 1	The distance from proximal flexion crease of the finger to the tip of the thumb
2	Fingertip to root digit 2	The distance from proximal flexion crease of the finger to the tip of the index finger
3	Fingertip to root digit 3 (3DL)	The distance from proximal flexion crease of the finger to the tip of the middle finger
4	Fingertip to root digit 4	The distance from proximal flexion crease of the finger to the tip of the ring finger
5	Fingertip to root digit 5	The distance from proximal flexion crease of the finger to the tip of the little finger
6	Center of wrist crease to root digit 1	The distance from center of wrist crease to the proximal flexion crease of the thumb
7	Center of wrist crease to root digit 2	The distance from center of wrist crease to the proximal flexion crease of the index finger
8	Center of wrist crease to root digit 3	The distance from center of wrist crease to the proximal flexion crease of the middle finger
9	Center of wrist crease to root digit 4	The distance from center of wrist crease to the proximal flexion crease of the ring finger
10	Center of wrist crease to root digit 5	The distance from center of wrist crease to the proximal flexion crease of the little finger
11	Hand length (HL)	The distance from the middle of inter stylium to the tip of middle finger
12	Palm length	The distance from the middle of inter stylium to the proximal flexion crease of the middle finger
13	Breadth at PIP joint of digit 1	The distance from the most lateral point on thumb proximal joint to the most medial point
14	Breadth at PIP joint of digit 2	The distance from the most lateral point on index finger proximal joint to the most medial point
15	Breadth at PIP joint of digit 3	The distance from the most lateral point on middle finger proximal joint to the most medial point
16	Breadth at PIP joint of digit 4	The distance from the most lateral point on ring finger proximal joint to the most medial point
17	Breadth at PIP joint of digit 5	The distance from the most lateral point on little finger proximal joint to the most medial point
18	Hand breadth at metacarpals (HB)	The distance from the most lateral point on the index finger metacarpal to the most medial point on the little finger metacarpal
19	Wrist breadth	The distance from the most lateral point on the wrist to the most medial point of wrist
20	Circumference at PIP joint of digit 1	The superficial distance around the edge of proximal joint in thumb
21	Circumference at PIP joint of digit 2	The superficial distance around the edge of proximal joint in index finger
22	Circumference at PIP joint of digit 3	The superficial distance around the edge of proximal joint in middle finger
23	Circumference at PIP joint of digit 4	The superficial distance around the edge of proximal joint in ring finger
24	Circumference at PIP joint of digit 5	The superficial distance around the edge of proximal joint in little finger
25	Circumference at metacarpal	The superficial distance around the edge of metacarpal
26	Wrist circumference	The superficial distance around the edge of the wrist
27	Hand depth	The distance from the lowest part of the thumb interphalangeal joint to the upper most part of the back of hand

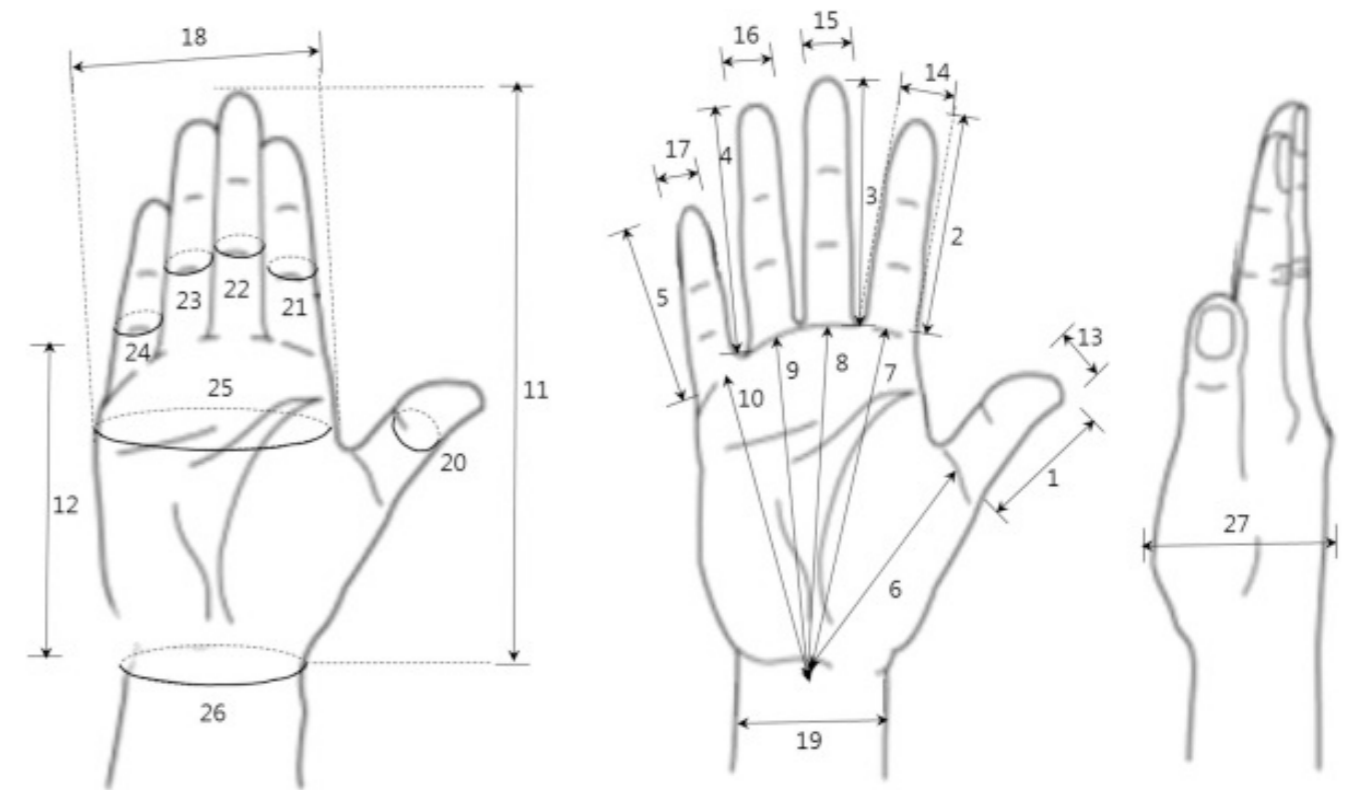

Figure A.19 : Hand dimensions [53]

Appendix L: User test 3: Final product evaluation

Introduction

The objective of this user study is to evaluate the final design of the applicator. This is done by using a standardised questionnaire of international standard, IEC 62366-1:2015 Medical devices Part 1: Application of usability engineering to medical devices [54].

Method

Participants

Three participants that come from East-Asia conducted the user evaluation (n=3, female and male 2/1, 24-29 years old. All participants had experience with pimples, but only one participant had used MNPs before.

Stimuli (Figure A.21)

- The final prototype
- Microneedle pimple patches, modified with carriers
- Survey (see end of chapter)
- Stretcher
- Product manual (figure A.20)

Figure A.20 : Product manual final product evaluation

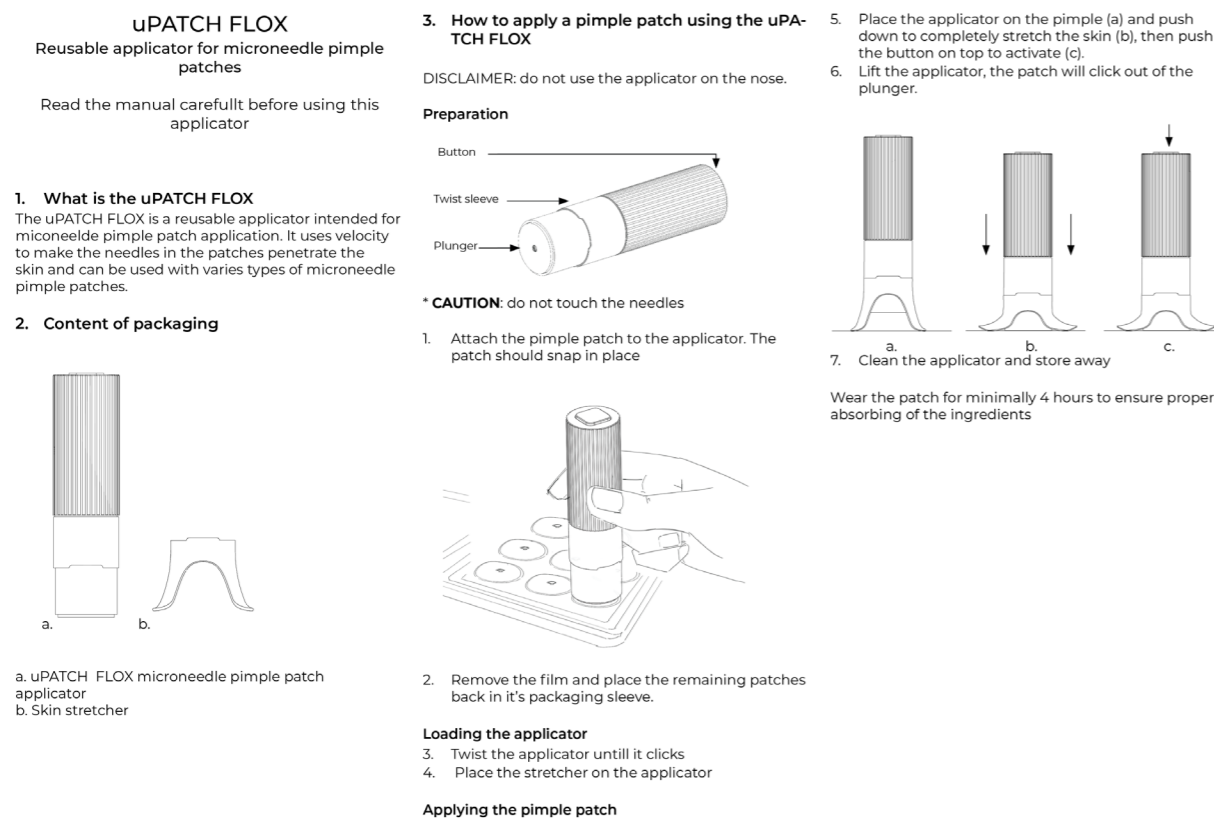
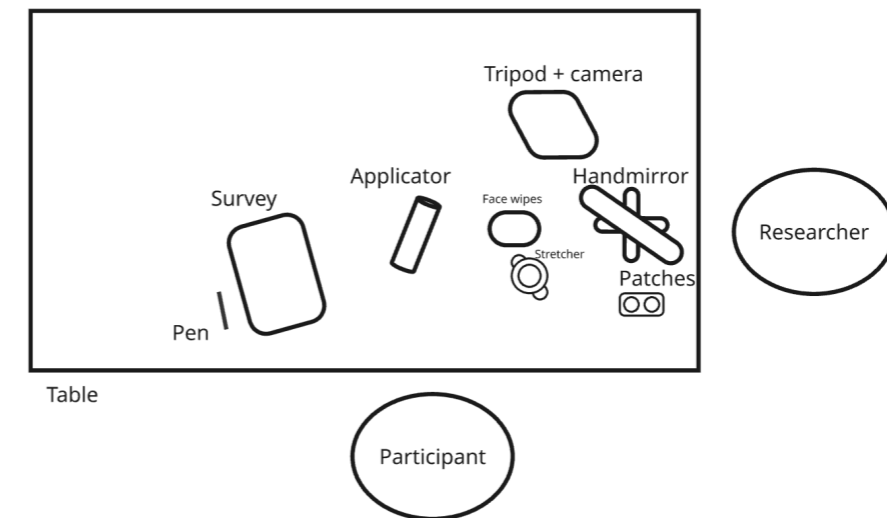

Figure A.21 : User evaluation set up



Apparatus

- Tripod with phone for video recording the use of the products and recording the interview at the end.
- Consent form
- Pen
- Hand mirror

Procedure

The user study was taking place at the university in a reserved room or at the observers house for privacy. The researcher was present as an observer and only asked questions afterwards each activity or at the end.

Steps of the procedure:

1. Researcher gave introduction about the project, what the user will be testing, consent form is given, researcher asked participant if it is okay if they record
2. The researcher gave a scenario the participant was to follow: use the applicator to apply a MNP on the upcoming pimple you 'have' on your forehead with help of the manual and to fill in the survey at the end of the experiment.
3. When done, researcher and participant went through the survey together
4. Researcher thanked the participant for participating

Measures

The variables that are being measured are the difficulties the participant experiences while handling the prototypes, either by observation (by videorecording) and with the participant thinking out loud. This will also be addressed with the interview at the end. This is all supported with the survey they fill in about the product. The survey is the IEC 62366-1:2015 Medical devices Part 1: Application of usability engineering to medical devices [54]

Survey

uPATCH™ Cosmetic applicator Usability Questions

Participant nr.	.../....	Date	
Age		Test environment	
Sex		Company representative	
Location		Function/experience	

General questions (User)

Have you even used microneedle pimple patches before?: yes / no

Have you even used normal pimple patches before?: yes / no

Nr.	1= Strongly Disagree, 5= Strongly Agree	1	2	3	4	5
1	Would you be willing to use this device again if needed?					
2	I found the device unnecessarily complex					
3	I thought the device was easy to use					
4	I think that I would need the support of a technical person to be able to use this device.					
5	I found the various functions in this system were well integrated.					
6	I thought there was too much inconsistency in this system					
7	I would imagine that most people would learn to use this system very quickly.					
8	I found the system very cumbersome to use.					
9	I felt very confident using the system.					
10	I needed to learn a lot of things before I could get going with this system					

Product specific questions (User):

5	4			Questions 1= Strongly Disagree, 5= Strongly Agree	Nr.	DTM-ID
				It was easy to load the applicator	1	6.1.2+ 10.13
				It was easy to apply a patch on the skin using the applicator	2	6.1.3
				Overall, was easy to understand and use the applicator	3	6.2.2
				It was easy to remove the film when the patch was attached to the applicator	4	5.4.1.5
				Clicking sounds clearly indicated when the device was in the loading state and when it was activated	5	5.3.4
				The design of the applicator makes it clear where and how to hold it	6	5.4.1.2
				The aesthetics of the applicator give me a sense of safety and reliability.	7	5.4.1.3
				The applicator is easy to carry and feels portable.	8	6.1.5
				The weight of the applicator feels comfortable to hold.	9	5.3.1
				The user manual was easy to understand	10	U15
				I did not experience pain on bruising during the application	11	U3
				It was easy to clean the PLUS applicator	12	5.5.1

Your comments to the design of the device or labelling are much appreciated:

Observational questions (uPATCH representative)

URS ID	Nr.	Observations 1= Strongly Disagree, 5= Strongly Agree	1	2	3	4	5
5.6.1.1 + 10.18	13	The user shall be able to apply patches onto the applicator without touching the Microneedle array					
	14	The user shall be able to remove the film without touching the microneedle arrays					
	15	The user shall be able to load the applicator by twisting the device					
6.1.1	16	The user shall be able to apply patches to the skin by pressing the button					

RMM ID	Nr.	Observations 1= Strongly Disagree, 5= Strongly Agree	1	2	3	4	5
U4	17	User knows how to position stretcher on the applicator					
U6	18	User does not touch microneedles while applicator is loaded					
U8	19	Patch does land perpendicular enough on the skin.					
U10	20	User looks not into the loaded PLUS and triggers the device					
U12	21	User places the applicator in a way so that the legs do stretch the skin					
U13	22	The applicator lets go of the patch after activation					

Results

Table A.22 : Cosmetic applicator, SUS score - Raw results

SUS Question	User	1	2	3	4	5	6	7	8	9	10
1	Lay person	4	1	4	1	4	1	5	2	4	1
2	Lay person	3	4	2	4	3	2	3	2	2	3
3	Lay person	4	1	4	1	4	1	5	4	3	2

Table A.26 : Legenda

General	
Attach patch	
Load applicator	
Activate applicator	

Table A.23 : Final SUS score cosmetic applicator

SUS Question	User	1	2	3	4	5	6	7	8	9	10	Total	SU
1	Lay person	3	4	3	4	3	4	4	3	3	4	35	87,5
2	Lay person	2	1	1	1	2	3	2	3	1	2	18	45
3	Lay person	3	4	3	4	3	4	4	1	2	3	31	77,5
												Mean	28
	average	2,7	3,0	2,3	3,0	2,7	3,7	3,3	2,3	2,0	3,0		70

Table A.24 : Cosmetic applicator, Product specific questions

SUS Question	User	1	2	3	4	5	6	7	8	9	10	11	12
1	Lay person	5	5	4	1	5	5	4	5	5	4	4	4
2	Lay person	3	2	2	2	3	4	4	4	4	3	5	4
3	Lay person	4	4	5	5	5	4	4	3	3	2	3	4
	Average	4,0	3,7	3,7	2,7	4,3	4,3	4,0	4,0	4,0	3,0	4,0	4,3

Table A.25 : Observations specific questions

SUS Question	User	1	2	3	4	5	6	7	8	9	10
1	Lay person	2	4	5	4	5	5	5	5	5	5
2	Lay person	1	1	1	4	5	5	3	4	5	5
3	Lay person	4	3	5	4	5	5	5	5	5	5
	Average	2,3	2,7	3,7	4,0	5,0	5,0	4,3	4,7	5,0	5,0

Graph 4.4 : Radar graph of average scores 1-5 (with 1 being worst and 5 being best) of prototype

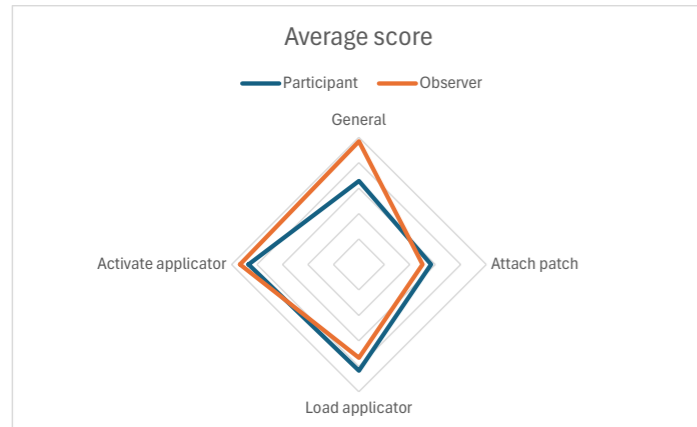

Discussion

See main report Chapter 4.6.

Consent form

Participant ID:

User final product evaluation study of microneedle patch applicator

This research is conducted as part of the MSc study Industrial Design Engineering at TU Delft.

Student: Maan Roos Moeskops

Contact person: Maan Roos Moeskops,

Informed consent participant

I participate in this research voluntarily.

I acknowledge that I received sufficient information and explanation about the research and that all my questions have been answered satisfactorily. I was given sufficient time to consent my participation. I can ask questions for further clarification at any moment during the research.

- I am aware that this research consists of the following activities:
1. Activity: Evaluation facial microneedle patch applicator
 - a. Scenario: applying a (microneedle) pimple patch on a 'pimple' on the forehead
 - b. Conducting the following tasks: applying patch to applicator, loading applicator, activating applicator on the face with a (microneedle) pimple patch
 2. Filling in a questionnaire
 3. Post evaluation interview

I am aware that data will be collected during the research, such as notes, photos, video and/or audio recordings. I give permission for collecting this data and for making photos, audio and/or video recordings during the research. Data will be processed and analysed anonymously (without your name or other identifiable information). The data will only be accessible to the research team and their TU Delft supervisors.

The photos, video and/or audio recordings will be used to support analysis of the collected data. The video recordings and photos can also be used to illustrate research findings in publications and presentations about the project.

I give permission for using photos and/or video recordings of my participation:
(select what applies for you)

- in which I am not recognisable in publications and presentations about the project.
- for data analysis only and not for publications and presentations about the project.

I give permission to store the data for a maximum of 5 years after completion of this research and using it for educational and research purposes.

I acknowledge that no financial compensation will be provided for my participation in this research.

With my signature I acknowledge that I have read the provided information about the research and understand the nature of my participation. I understand that I am free to withdraw and stop participation in the research at any given time. I understand that I am not obliged to answer questions which I prefer not to answer and I can indicate this to the research team.

The researchers take the applicable COVID-19 measures into account. I confirm to respect the COVID-19 measures taken and will follow instruction about these provided by the researchers.

I will receive a copy of this consent form.

Last name

First name

___ / 04 / 2026
Date (dd/mm/yyyy)

Signature

Appendix M: Lab test 3: Cosmetic microneedle patches minimal force test

Introduction

For the applicator to work the spring force must be high enough for the AAMNPs to penetrate through the SC. In the second lab test, appendix XX, penetration was measured at 120N. This is a high force, with the following study I researched what the minimal force needed was to make AAMNPs penetrate the SC effectively with the same patches to see if this can be done with a force low enough for the user to still be tolerable.

Goal: Determine the minimum spring force needed to make AAMNP penetrate the SC.

The hypothesis was that the minimum spring force will be around 60 N. The goals of the study were to see if penetration is feasible with an applicator with a force of max 20 N and if the minimum force was higher, if that force was close enough to adjust manufacturing method of the needles.

Methods and materials

This was tested with the same protocol as lab study 2, but with a binary search to optimally search for the minimal force needed, see figure 4.40. To make this study more accurate to using the design cosmetic applicator the modified PLUS applicator was used with an add-on to replicate the surface area of the plunger of the cosmetic applicator. For each test three patches from Holika Holika were tested.

Materials

- Disposable wipes
- Strong salt solution (irritant probe)
- 16 Holika Holika patches
- Modified uPATCH plus applicator with suitable spring for 30N, 45N, 60N, 75N, 90N, 105N
- Force measuring device (to select springs for the modified uPATCH PLUS)
- Microscope camera

Procedure













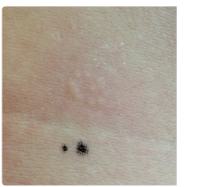
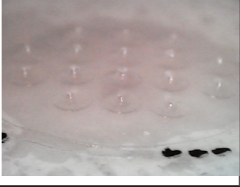

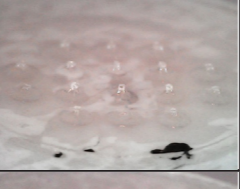

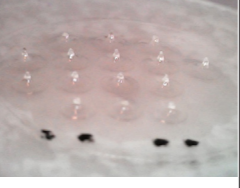
1. Procedure for each tested force (example with 60N):
 1. Wash forearm with soap and water and dry the arm
 2. Stretch area of the skin where the patch will be applied
 3. Apply three patches with 60 N with the modified PLUS applicator.
 4. Remove the patches after 15 seconds
 5. Apply salt solution
 6. Document irritation
 7. Photograph patches
 8. Determine if penetration happened.
 9. Make decision for next force to test e.g. penetration with 60 N → test 30N next.
 10. Repeat procedure with the next force to test.

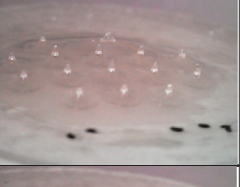

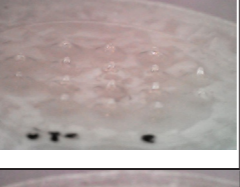
Figure A.27 : Add-on on the cover to make the application more accurate to the cosmetic applicator

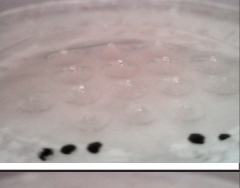
Results

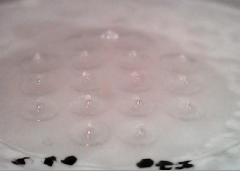
Table A.28 : Results of tests with low-density patches (Holika Holika)

Test number	Force (N)	Penetration? (yes/no)	Redness from needles after application?	Redness form needles after salt	Appearance of bumps	Tactile irritation after application	Tactile irritation after salt solution	Needles dissolved	Condition needle after application	Picture of MNP after application	Picture of skin after salt solution
V1.1	60 N	yes	yes	yes	yes	yes	yes	yes	all dissolved		
V1.2	60N	yes	yes	yes	yes	yes	yes	yes	all dissolved		
V1.3	60N	yes	yes	yes	yes	yes	yes	yes	all dissolved		
V2.1	30 N	no	yes	yes	no	very subtle	yes subtle	no	3 bend		
V2.2	30 N	no	yes	yes	no	very subtle	yes subtle	yes	slightly dissolved		
V2.3	30 N	no	partly	yes	very light at the bottom	niet	yes lighty	no	4 bend		
V3.1	45 N	yes	yes	yes	yes	yes	nog steeds	yes	all dissolved		
V3.2	45 N	yes	yes	yes	yes	yes	nog steeds	yes	all dissolved		
V3.3	45 N	yes	yes	yes	yes	yes	nog steeds	yes	all dissolved		

Discussion

With the study penetration was measured at 60N and 45 N but not at 30 N. This concluded that the minimum spring force is somewhere between 30-45N. More detailed tests were not conducted to make a more defined amount as this wouldn't change the conclusion or recommendation.

With the Holika Holika patches, penetration is possible from 45 N of spring force in the current testing setup.

With this minimum force it could still be possible for the manufacturers to improve their patches to make it more suitable for penetration with a lower force. With the current patches it is not possible to keep the application of the patch comfortable as the force needed is higher than the ~ 20 N set max for penetration force.

This testing setup uses a heavier plunger, this makes the impact higher than would be the cause with the same force with a lighter plunger. As impact force is velocity x mass of the plunger. This means that for the cosmetic applicator the force should be even higher, as that plunger is lighter. A following test could be with the cosmetic applicator with 45 N of force to see if penetration is this happening. This can also be tested on the skin of the face. Measurements of the forehead and cheek will give the most useful results as the facial undergrounds lay so far apart from each other.

Recommendations

The next step is to test this with the cosmetic applicator with a force of 45 N with applying the same binary search to further specify the minimum force and to see if this test is accurate.

Appendix N: List of requirements validation

No.	Type	Component	Category	Description	Source	originated	Validated	Reason
1	Need	Applicator	Use	The product shall have a weight of less than 50 grams	uPATCH			It weighs 20 grams, chapter "Table 5.3 : Cost analysis for MINUS" on page 128
2	Need	Applicator	Use	After the needles are inserted into the skin and the user lifts the product away from the skin, the patch needs to stay adhered to the skin and be loose from the product	uPATCH			The connections of the carrier with the plunger is weaker than the adhesive power of the patch with the skin
3	Need	Applicator	Use	The product can be comfortably used by p-10 to p.90 of 11-30 year old individuals from East Asian ethnicity	MRM			"4.2. Size -Ergonomics" on page 90
4	Need	Applicator	Use	The product can be used efficiently on face region categories 1 to 4	MRM	"2.5. Facial structure" on page 44		Applicator does work structurally on facial regions 1-4
5	Need	Applicator	Use	The product should give feedback that the patch has penetrated the skin	MRM	"2.3.5. User study 1-current use" on page 34		The shooting of the plunger indicates this, together with the prickling sensation that the needles give after penetration
6	Need	Patch	Use	It should be easy to remove the film from the patch before applying	MRM	"2.3.5. User study 1-current use" on page 34		In the final user test this was still an issue, possible due to insufficient instruction
7	Need	Applicator	Use	The user should not hear or feel the product rattle when shaken.	uPATCH			Tested with final prototype
8	Need	Applicator	Use	The product can be cleaned by the user	uPATCH			-
9	Need	Applicator	Function	The patches need to accommodate at least round patches from 9-20 mm in diameter	MRM	"2.3.4. Use of anti-acne microneedle patches" on page 32		Patches up to 20mm can be used"5.2. Working principle" on page 116
10	Need	Applicator	Function	The product shoots the patch by the velocity force	MRM	"2.3.6. Effectiveness of CMNPs" on page 38		This is done with a spring"5.2. Working principle" on page 116
11	Need	Applicator	Function	The product will enable the patch to penetrate the stratum corneum	MRM			It technically can, however the force needed to do so is to great to be applied on the face
12	Need	Applicator	Function	The end velocity must be within 15% of the designated velocity.	uPATCH			No equipment available to test this
13	Need	Applicator	Design	The product's outer housing is designed so that the user knows where to hold the product	uPATCH	"3.3.4. User study 2: Concept evaluation" on page 74		"3.3.4. User study 2: Concept evaluation" on page 74
14	Need	System	Design	The product's outer housing can be held comfortably by the user	uPATCH			"4.2. Size -Ergonomics" on page 90
15	Need	System	Design	The product's outer housing radiate safety and reliability.	uPATCH			"4.5. Appearance and form" on page 96
16	Need	System	Assembly	The product can be very easily assembled within 3 minutes by hand without any complications	uPATCH			Is tested with the final prototype, assembly is under a minute
17	Need	Applicator	Design	No chrome finishes are used in the product	uPATCH	"4.5. Appearance and form" on page 96		"4.5. Appearance and form" on page 96
18	Need	Applicator	Use	The product should not be able to faulty fire	MRM			"5.2. Working principle" on page 116
19	Wish	Applicator	Use	Making the penetration action 'friendly'	MRM			By making the action a button and making the appearance of the applicator elegant and soft with makes the action as friendly as it can be
20	Wish	Applicator	Use	The use of the product involves minimal steps	MRM	"3.3. Concepts" on page 68		"5.3. Use" on page 120
21	Wish	Applicator	Use	The risk for the user to accidentally touch the needles of the patch is eliminated as much as possible	MRM, uPATCH			"3.3. Concepts" on page 68, "5.3. Use" on page 120

No.	Type	Component	Category	Description	Source	originated	Validated	Reason
22	Wish	Applicator	Use	The product can be used with little to no prior explanation or instruction	MRM			The loading and activation steps are self explanatory, Applying the patch and removing the film however requires explanation
23	Wish	Applicator	Function	The product will be able to penetrate the stratum corneum with a force (15 N) that is still tolerable for the user	MRM			It is around 45N
25	Wish	Applicator	Function	The product can be 'loaded' without using an extra product or dock	MRM	"3.3.4. User study 2: Concept evaluation" on page 74		It is loading by twisting the two component of the product
26	Wish	Applicator	Function	The product is able to scale up to more sizes	uPATCH			The internal mechanism makes this possible
27	Wish	System	General	It shall not be possible for the user to unintentionally trigger the product (while not on the skin)	uPATCH			This is possible
28	Wish	System	General	It shall not be possible for the user to touch the microneedles while inside the product	uPATCH			Users can technically do this, but there has been no scenario where this is seen during any of the user evaluations
29	Wish	System	General	No additional changes have to be made to the patch to make it usable with the product	uPATCH, MRM			No changes to the patch, however a carrier needs to be added on top of the patch
30	Wish	System	General	No changes have to be made to the packaging of the patches to make them usable with the product	uPATCH, MRM			Minor changes are wished to be made, but not necessary need to be made, depending on manufacturer
31	Wish	System	General	The product can be made for under five euros with a run of 10.000 pieces	MRM			If it is produced in China the unit price is 4,95
32	Wish	Applicator	Design	The form and appearance the product should radiate a medical and cosmetic product	MRM	"4.5. Appearance and form" on page 96		"4.5. Appearance and form" on page 96
33	Wish	Applicator	Design	The product should give a tool like experience	MRM	"3.3.4. User study 2: Concept evaluation" on page 74		"4.5. Appearance and form" on page 96
34	Need	Applicator	Use	The product should not be able to faulty fire	MRM	"4.1. Detailing" on page 80		"5.2. Working principle" on page 116

6.3. References of Appendixes

- [1]“BLOOMORA Microdart Pimple Patch, Spot Patches Salicylic Acid & Hyaluronic Acid, Cystic Acne Treatment, Pimple Patches Microneedle Technology - Early Stage Acne Patch (12 Pieces) : Amazon.co.uk: Beauty.” Accessed: Apr. 15, 2026. [Online]. Available: https://www.amazon.co.uk/dp/B0DZ1L9R9X?pd_rd_i=B0DZ1L9R9X&pd_rd_w=5Tocv&content-id=amzn1.sym.9a64fe05-cdee-4d53-a27b-f3614d726545&pf_rd_p=9a64fe05-cdee-4d53-a27b-f3614d726545&pf_rd_r=EFDF54ESEKE5JM6G73J7&pd_rd_wg=rPlcm&pd_rd_r=5ab3b064-bb24-4e99-81cd-8f1d49f2f156&sp_csd=d2lkZ2V0TmFtZT1zcF9kZXRhaWxfidGhlfWF0aWM&th=1
- [2]“PATCH PRO MICRO NEEDLE PATCH Trouble Dr. 9 pcs., microdart acne pimple patch, absorbing hydrocolloid with microneedle for pimple dots, acne treatment, invisible acne spot patches, all skin types : Amazon.com.au: Beauty.” Accessed: Apr. 15, 2026. [Online]. Available: <https://www.amazon.com.au/PATCH-PRO-invisible-hydrocolloid-madecassoside/dp/B085TKF162?th=1>
- [3]“Microcrystal Spot Cover | Microneedle Pimple Patches | Rael.” Accessed: Apr. 15, 2026. [Online]. Available: <https://www.getrael.com/products/microneedle-technology-acne-healing-patch?variant=18489298714739>
- [4]“Get Rid of Acne Dark Spots | Microcrystal Dark Spot Cover | Rael.” Accessed: Apr. 15, 2026. [Online]. Available: <https://www.getrael.com/products/microcrystal-dark-spot-cover?variant=39409665638515>
- [5]“SAISZE Microdart Pimple Patch, Hydrocolloid Spot Patch for Early Stage Pimples(18 Patches) : Amazon.com.au: Beauty.” Accessed: Apr. 15, 2026. [Online]. Available: <https://www.amazon.com.au/SAISZE-Microdart-Hydrocolloid-Pimples-Patches/dp/B0DMVXGGXN>
- [6]“Amazon.com: Naterido Microdart Hydrocolloid Acne Patch 24 Counts,Pimple Patch Hyaluronate Acid & Salicylic Acid Pimples Overnight for Deep, Early and Hidden Blemishes : Beauty & Personal Care.” Accessed: Apr. 15, 2026. [Online]. Available: <https://www.amazon.com/Naterido-Hydrocolloid-Treatment-Remover-Stickers/dp/B0DQYJCYPD?th=1>
- [7]“MicroDarts Pimple Patches with Salicylic Acid | Skin Choice.” Accessed: Apr. 15, 2026. [Online]. Available: <https://www.skinchoice.co.uk/nl/products/microdart-pimple-patches>
- [8]“Some By Mi Micro Pin Spot Patch I Korean Skincare – Korean-Skincare.” Accessed: Apr. 14, 2026. [Online]. Available: <https://koreanskincare.nl/products/some-by-mi-micro-pin-spot-patch>
- [9]“Whitening & Spot-Lightening Microneedle Patches | OEM/ODM Beauty Solut.” Accessed: Apr. 15, 2026. [Online]. Available: <https://youwebio.com/products/whitening-spot-lightening-dissolving-microneedle-beauty>
- [10]“Mighty PatchTM for Early-Stage Blemishes | Hero Cosmetics.” Accessed: Apr. 15, 2026. [Online]. Available: <https://www.herocosmetics.us/products/mighty-patch-for-early-stage-blemishes>
- [11]“Acnenator Pimple Clearing Patch - Holika Holika.” Accessed: Apr. 15, 2026. [Online]. Available: <https://www.holikaholika.ee/en/special-care/1795-acnenator-pimple-clearing-patch>
- [12]“PATCH PRO MICRO NEEDLE PATCH 8pcs, self-dissolving microneedle patches, facial anti-wrinkle patches, crosslinked hyaluronic acids for forehead lines, smile line, fine line, eye wrinkle, Puffy eyes : Amazon.com.au: Beauty.” Accessed: Apr. 15, 2026. [Online]. Available: https://www.amazon.com.au/PATCH-PRO-microneedle-anti-wrinkle-crosslinked/dp/B07JZ6S64M/356-0684393-7139143?pd_rd_w=jZ4vA&content-id=amzn1.sym.c3e67ad4-8c3b-4d61-8525-47091874fb48&pf_rd_p=c3e67ad4-8c3b-4d61-8525-47091874fb48&pf_rd_r=6HVMZG0KQ5RJM7S8R005&pd_rd_wg=sqFvb&pd_rd_r=8b8a32bb-34b3-4b8e-840c-86a9b1fd11f3&pd_rd_i=B07JZ6S64M&psc=1
- [13]“6PCS Dissolving Microneedle Eye Patches - Anti Wrinkle Patch - Cooling Pads - Micro Needle Patches with Hyaluronic Acid - Microneedle Patches for Dark Circles & Eye Bag : Amazon.

co.uk: Beauty.” Accessed: Apr. 15, 2026. [Online]. Available: https://www.amazon.co.uk/6PCS-Dissolving-Microneedle-Eye-Patches/dp/B0FDGH9SCX?crd=2AH0SS4EU2H5Y&dib=eyJ2ljojMSJ9.TemV1h_6kR6YpCloXX4UasOg-G0ZJ-NuP1qQRdA6o5sRjU43FDOr_kNe0tcSvi5PuZ9MsaAXXqT9Wh198MZ3uVPaua-bwaf9W0wii2hh0cMIQuifSR9hvZ_749-vw3APQi0h7GHOnMpYw_zdlheXlzwKBx1Qx2xQughSvcGjiWuphCEecl4if3GJg2GQt8Y60NCq7VMek0Wo7aLdNoqBJRV-qfclVpisIRK29JD3GXL4VxaRX9YVa5XjyOcsZrasPkrTAOQ_E90PCBnXaFVck5rz1iSwciuZoD2PmeYJXPc.h86OYCRklkKaKo959mYN3ruNFS1epd7KI32H7E1FX8&dib_tag=se&keywords=microneedle+patch&qid=1757508452&s=beauty&sprefix=microneedle+patch%2Cbeauty%2C144&sr=1-2-spons&sp_csd=d2lkZ2V0TmFtZT1zcF9hdGY&psc=1

[14]“Pack of 4 Dissolving Microneedle Eye Patches - Anti Wrinkle Patches - Micro Needle Patches with Peptides,Hyaluronic Acid - Hydrating and moisturizing eye mask : Amazon.co.uk: Health & Personal Care.” Accessed: Apr. 14, 2026. [Online]. Available: <https://www.amazon.co.uk/Pack-Dissolving-Microneedle-Eye-Patches/dp/B0F28QNQGG>

[15]“Microneedle Eye Patches | Dissolving Microneedle Beauty.” Accessed: Apr. 15, 2026. [Online]. Available: <https://youwebio.com/products/dark-circle-remover-dissolving-microneedle-beauty>

[16]“Anti-Wrinkle Eye Patches | Dissolving Microneedle Beauty.” Accessed: Apr. 15, 2026. [Online]. Available: <https://youwebio.com/products/anti-wrinkle-eye-dissolving-microneedle-beauty-patches>

[17]“AND SHINE | THE YOUTH PATCH® | Anti-Aging Microneedling Patches – Skincare patches with microneedling technology for acne, pimples, under eye bags and shadows and wrinkles.” Accessed: Apr. 15, 2026. [Online]. Available: <https://www.andshine.de/en/products/the-youth-patch-2-0>

[18]“AND SHINE | ALL-STAR EYE PATCH | Microneedling Patches gegen Augenringen & Co – Skincare patches with microneedling technology for acne, pimples, under eye bags and shadows and wrinkles.” Accessed: Apr. 15, 2026. [Online]. Available: <https://www.andshine.de/en/collections/all-patches/products/all-star-eye-patch>

[19]“Age-Defying Microneedle Patches for acne, smile lines, & wrinkles – Karuna Skin.” Accessed: Apr. 15, 2026. [Online]. Available: <https://karunaskin.com/products/age-defying-microneedle-patches>

[20]“FAQTM Microneedling Anti-Wrinkle Patches for Forehead.” Accessed: Apr. 15, 2026. [Online]. Available: https://www.foreo.com/faqswiss/microneedling-patches-forehead?v=1997&utm_source=AysPbYF8vuM&utm_medium=Linkshare_cps&utm_campaign=1291442&utm_content=10&utm_cost=ccAFF&affnid=RAK&ranMID=40214&ranEAID=AysPbYF8vuM&ranSiteID=AysPbYF8vuM-3QcqmV92VXoJs5XwKZ_CBw

[21]“9pcs Patches for Face : Amazon.co.uk: Health & Personal Care.” Accessed: Apr. 15, 2026. [Online]. Available: https://www.amazon.co.uk/Microdarts-Patches-Effec-tive-Microneedle-Removal/dp/B0FLF4CFPX?crd=2AH0SS4EU2H5Y&dib=eyJ2ljojMSJ9.TemV1h_6kR6YpCloXX4UasOg-G0ZJ-NuP1qQRdA6o5sRjU43FDOr_kNe0tcSvi5PuZ9MsaAXXqT9Wh198MZ3uVPaua-bwaf9W0wii2hh0cMIQuifSR9hvZ_749-vw3APQi0h7GHOnMpYw_zdlheXlzwKBx1Qx2xQughSvcGjiWuphCEecl4if3GJg2GQt8Y60NCq7VMek0Wo7aLdNoqBJRV-qfclVpi-siRK29JD3GXL4VxaRX9YVa5XjyOcsZrasPkrTAOQ_E90PCBnXaFVck5rz1iSwciuZoD2PmeYJXPc.h86OYCRklkKaKo959mYN3ruNFS1epd7KI32H7E1FX8&dib_tag=se&keywords=microneedle+patch&qid=1757508452&s=beauty&sprefix=microneedle+patch%2Cbeauty%2C144&sr=1-10

[22]“Nissha Co., Ltd. | Dissolving Microneedle Patch for Cosmetics.” Accessed: Apr. 14, 2026. [Online]. Available: <https://www.nissha.com/english/products/allproducts/dds.html>

[23]“Microneedle | Taikiusa.” Accessed: Apr. 14, 2026. [Online]. Available: <https://taikibeauty.com/private-label-masks-patches/targeted-treatments/microneedle/>

[24]“DERMATECH | Skincare Patch Manufacturer - Acne, Pimple, Hydrocolloid... Made in Korea.” Accessed: Apr. 14, 2026. [Online]. Available: <https://www.dermatech.life/>

- [25]“Transdermal Patches | CosMED Pharmaceutical Co., Ltd.” Accessed: Apr. 14, 2026. [Online]. Available: <https://cosmed-pharm.com/rd/patch/>
- [26]“[?]” Accessed: Apr. 14, 2026. [Online]. Available: https://en.daewoongrx.co.kr/RND_microneedle
- [27]“Cosmetics Microarray Patch - WCC Biomedical.” Accessed: Apr. 14, 2026. [Online]. Available: <https://wccbiomedical.com/en/products/cosmetics-microarray-patch/>
- [28]“Cosmetic Area | RAPHAS.” Accessed: Apr. 14, 2026. [Online]. Available: <https://www.raphas.com/en/business/cosmetic?ckattempt=1>
- [29]“ENDODERMA.” Accessed: Apr. 14, 2026. [Online]. Available: https://endoderma-en.batns.co.kr/sac_series
- [30]P. M. A. Desmet, “PrEmo card set: Male version.” pp. 1–2, 2019, Accessed: Apr. 15, 2026. [Online]. Available: <https://diopd.org/premo/>
- [31]“Pictures: Different Types of Acne & How to Treat Them.” Accessed: Sep. 26, 2025. [Online]. Available: <https://www.webmd.com/skin-problems-and-treatments/acne/ss/slideshow-acne-dictionary>
- [32]M. Vasam, S. Korutla, and R. A. Bohara, “Acne vulgaris: A review of the pathophysiology, treatment, and recent nanotechnology based advances,” *Biochem. Biophys. Rep.*, vol. 36, p. 101578, Dec. 2023, doi: 10.1016/J.BBREP.2023.101578.
- [33]“Acne: Types, Causes, Treatment & Prevention.” Accessed: Sep. 26, 2025. [Online]. Available: <https://my.clevelandclinic.org/health/diseases/12233-acne>
- [34]“Acne - NHS.” Accessed: Sep. 26, 2025. [Online]. Available: <https://www.nhs.uk/conditions/acne/>
- [35]“Asian Skin Care - Golden State Dermatology.” Accessed: Sep. 30, 2025. [Online]. Available: <https://www.goldenstatedermatology.com/blog/asian-skin-care/>
- [36]S. M. Bulengo-Ransby et al., “Topical Tretinoin (Retinoic Acid) Therapy for Hyperpigmented Lesions Caused by Inflammation of the Skin in Black Patients,” *New England Journal of Medicine*, vol. 328, no. 20, pp. 1438–1443, May 1993, doi: 10.1056/NEJM199305203282002.
- [37]“Overview: Acne,” Dec. 2022, Accessed: Sep. 26, 2025. [Online]. Available: <https://www.ncbi.nlm.nih.gov/books/NBK279211/>
- [38]A. H. Sutaria, S. Masood, H. M. Saleh, and J. Schlessinger, “Acne Vulgaris,” Aug. 2023, Accessed: Sep. 26, 2025. [Online]. Available: <https://www.ncbi.nlm.nih.gov/books/NBK459173/>
- [39]“Asian Skin and Acne - Acne.org.” Accessed: Sep. 30, 2025. [Online]. Available: <https://www.acne.org/ethnic-asian-skin>
- [40]“Why is Asian skin different from other Skin types? | London Clinic.” Accessed: Sep. 30, 2025. [Online]. Available: <https://skinnv.co.uk/blog/why-is-asian-skin-different-from-other-skin-types>
- [41]C. L. Goh et al., “Meeting the Challenges of Acne Treatment in Asian Patients: A Review of the Role of Dermocosmetics as Adjunctive Therapy,” *J. Cutan. Aesthet. Surg.*, vol. 9, no. 2, p. 85, Apr. 2016, doi: 10.4103/0974-2077.184043.
- [42]Z. B. Whitney, M. Jain, and P. M. Zito, “Anatomy, Skin, Superficial Musculoaponeurotic System (SMAS) Fascia,” *StatPearls*, Jan. 2024, Accessed: Oct. 06, 2025. [Online]. Available: <https://www.ncbi.nlm.nih.gov/books/NBK519014/>
- [43]S. R. Cohen and H. Womack, “Injectable Tissue Replacement and Regeneration: Anatomic Fat Grafting to Restore Decayed Facial Tissues,” *Plast. Reconstr. Surg. Glob. Open*, vol. 7, no. 8, 2019, doi: 10.1097/GOX.0000000000002293.
- [44]“Fat pad anatomy: Deep fat pads | Dr Tim Pearce.” Accessed: Oct. 06, 2025. [Online]. Available: <https://drtimpearce.com/2022/12/15/fat-pad-anatomy-the-upper-middle-lower-face-deep-fat-pads/>
- [45]Y. S. Kim et al., “Regional thickness of facial skin and superficial fat: Application to the minimally invasive procedures,” *Clinical Anatomy*, vol. 32, no. 8, pp. 1008–1018, Nov. 2019, doi: 10.1002/CA.23331.
- [46]“Fat pad anatomy: Deep fat pads | Dr Tim Pearce.” Accessed: Oct. 06, 2025. [Online]. Available: <https://drtimpearce.com/2022/12/15/fat-pad-anatomy-the-upper-middle-lower-face-deep-fat-pads/>
- [47]T. Abe et al., “Assessments of facial muscle thickness by ultrasound in younger adults: Absolute and relative reliability,” *Cosmetics*, vol. 6, no. 4, Dec. 2019, doi: 10.3390/COSMETICS6040065.
- [48]D. Mohammed, P. J. Matts, J. Hadgraft, and M. E. Lane, “Variation of stratum corneum biophysical and molecular properties with anatomic site,” *AAPS Journal*, vol. 14, no. 4, pp. 806–812, Dec. 2012, doi: 10.1208/S12248-012-9400-3/FigureS/7.
- [49]Z. Ya-Xian, T. Suetake, and H. Tagami, “Number of cell layers of the stratum corneum in normal skin relationship to the anatomical location on the body, age, sex and physical parameters,” *Arch. Dermatol. Res.*, vol. 291, no. 10, pp. 555–559, 1999, doi: 10.1007/S004030050453/METRICS.
- [50]T. Tsugita, T. Nishijima, T. Kitahara, and Y. Takema, “Positional differences and aging changes in Japanese woman epidermal thickness and corneous thickness determined by OCT (optical coherence tomography),” *Skin Research and Technology*, vol. 19, no. 3, pp. 242–250, Aug. 2013, doi: 10.1111/SRT.12021.
- [51]A. Böhling, S. Bielfeldt, A. Himmelmann, M. Keskin, and K. P. Wilhelm, “Comparison of the stratum corneum thickness measured in vivo with confocal Raman spectroscopy and confocal reflectance microscopy,” *Skin Research and Technology*, vol. 20, no. 1, pp. 50–57, Feb. 2014, doi: 10.1111/SRT.12082.
- [52]“User Experience Questionnaire (UEQ).” Accessed: Apr. 15, 2026. [Online]. Available: <https://www.ueq-online.org/>
- [53]“IEC 62366-1:2015 - Medical devices — Part 1: Application of usability engineering to medical devices.” Accessed: Apr. 16, 2026. [Online]. Available: <https://www.iso.org/standard/63179.html>

