

Report

Erosion Processes on Dike Slopes

(Draft from July 2006)



edited by:

Dipl.-Ing. Lars Vavrina

(University of Duisburg-Essen^{*2}, E-Mail: Lars.Vavrina@uni-due.de)

Guidance:

Ir. H. J. Verhagen
Prof. Dr.-Ing. W. Richwien
Dipl.-Ing. C. Pohl

TU Delft^{*1}
University of Duisburg-Essen^{*2}
University of Duisburg-Essen^{*2}

University of
Duisburg - Essen
Campus Essen
Institute for Foundation
Engineering and Soil
Mechanics

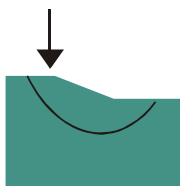

^{*2} Institute for Foundation Engineering and Soil Mechanics
University of Duisburg-Essen,
Universitätsstr. 15, 45117 Essen,
Tel.: +49/(0)201-183-2857,
E-Mail: werner.richwien@uni-due.de

^{*1} Section of Hydraulic Engineering,
Coastal Engineering, TU Delft
Stevinweg 1, 2628 CN DELFT
Tel.: +39/(0)152785067,
E-Mail: H.J.Verhagen@tudelft.nl

Technische Universiteit Delft

Contents

| | | |
|-----------|---|-----------|
| 1. | Introduction | 3 |
| 2. | What is a grass cover | 5 |
| 2.1 | Structure of the grass cover | 6 |
| 2.2 | Function of a grass cover | 8 |
| 3. | Loads causing erosion | 10 |
| 3.1 | Water running up, wave overtopping and water running down | 10 |
| 3.2 | Wave impact | 14 |
| 3.3 | Infiltration | 15 |
| 4. | Erosion and forms of appearance | 19 |
| 4.1 | Detachment process | 19 |
| 4.2 | Transport process | 23 |
| 4.3 | Erosion velocity | 25 |
| 5. | Biological structure of a grass layer | 29 |
| 5.1 | Aggregates and particle diameter | 29 |
| 5.2 | Tensile and Shear strength of roots | 30 |
| 5.3 | Root depth and density | 34 |
| 5.4 | Canopy cover | 36 |
| 5.5 | Grassland management | 37 |
| 6. | Models to describe erosion processes | 39 |
| 6.1 | CIRIA | 40 |
| 6.1.1 | Loads | 41 |
| 6.1.2 | Strength | 42 |
| 6.1.3 | Conclusions | 44 |

| | | |
|-----------|---|-----------|
| 6.2 | VTV (2004) | 44 |
| 6.2.1 | Loads | 45 |
| 6.2.2 | Strength | 47 |
| 6.2.3 | Conclusions | 49 |
| 6.3 | EPM (Bos, 2006) | 49 |
| 6.3.1 | Loads | 52 |
| 6.3.2 | Strength | 53 |
| 6.3.3 | Conclusions | 54 |
| 6.4 | Computer - aided approach and future perspectives | 55 |
| 6.5 | Comparison of models | 58 |
| 7. | Approach to a design concept | 60 |
| 7.1 | Evaluation of strength | 61 |
| 7.1.1 | Erosion of loose material at surface | 61 |
| 7.1.2 | Erosion of root embedded aggregates | 63 |
| 7.1.3 | Failure of roots | 64 |
| 7.2 | Evaluation of load | 65 |
| 7.3 | Approach to design concept | 70 |
| 8. | Summary and conclusions | 73 |

1. Introduction

In 1953 and 1962 stormfloods flooded a wide area of the Netherlands and Germany, where many people lost their lives. Gained experience of these events has formed present construction methods of dikes.

Studies about damages on dike slopes have shown different mechanisms of failure. One mechanism is the so called parallel sliding which is described by Edelman (1953), but now flatter inclinations are applied for slopes and this causes a higher erosion risk. Erosion should be avoided with the help of the cover, which consists of clay and sometimes vegetation. Many kinds of material to protect soil are possible. Some dikes show asphalt as cover and others have concrete or stone settings to protect the sandy core against erosion, but most dikes show grass as cover. Every kind of cover has advantages and disadvantages, so it could be discussed which possibility to protect dike slopes against erosion is the best. Nevertheless this report is dealing with grass as cover.

Grass is a living organism, so it grows differently and due to growing habits, grass structure distincts from plant to plant, as well as at surface and in underground. But it is important to fulfill the main function of protection against erosion, responded by loads of water.

The first load which appears on a dike is the wave impact on outer slope. The content of hitting water runs up the slope and at temporally intervals down again. In similar cases wave overtopping happens, so a content of water runs over the crest of a dike and runs down at land side slope, which responses erosion processes.

Erosion processes are divided in two parts, whereas first process is detachment process and second process is transport of detached soil. The main function of grass cover is to avoid detachment. Therefore certain strength is necessary to execute this assignment.

Resistance of grass covers are affected by several parameters. The influencing parameters are density of canopy cover, root depth as well as tensile and shear strength of roots. Also the mentioned parameters are influenced by grassland

management which has no engineering background, but management changes growing habit and determines strength of turf.

In the present, models to evaluate strength as well as loads are concerned with the effecting parameters. Models of CIRIA (Construction Industry Research and Information Association) deal with general slopes in landscapes and loads caused by rainfall and running down of rainwater. Another model which is directly concerned with dikes is VTV 2004 (Voorschrift Toetsen op Veiligheid). VTV 2004 has disposed concepts to evaluate strength of grass covers and loads caused by waves. The most current model is EPM (Erosiegevoelige Plekken Model), which is a graduation report. This report is custom-built at the TU Delft and deals with spots susceptible to erosion on dike slopes. EPM describes those spots with help of scouring models. All those models evaluate strength and load separate.

This report results from cooperation of TU Delft and University of Duisburg-Essen with the aim to summarize knowledge of erosion processes on dike slopes of both countries.

Due to this assignment, attributes and properties of vegetation are detected. In addition it is checked, how canopy cover effects velocity of flow and determines magnitude of load. By the way, signification of root density is analyzed and a first model to describe the effect on roots on erosion resistance has been developed. and interaction of clay and vegetation is described with the aid of an example calculation. Finally this paper shows the lack of knowledge and gives a perspective for subsequently research.

2. What is a grass cover

A lot of sides along the coast of the northern sea show dikes and most of them offer grass as a cover. This kind of revetment is a significant part of a dike surface, so since mid eighties specified experiments and tests were taken to analyze grass layers and function of it.

Vegetation grows in many different species. There are trees, bushes, grass and many more. Inherently grass must be divided into different kinds and attributes.

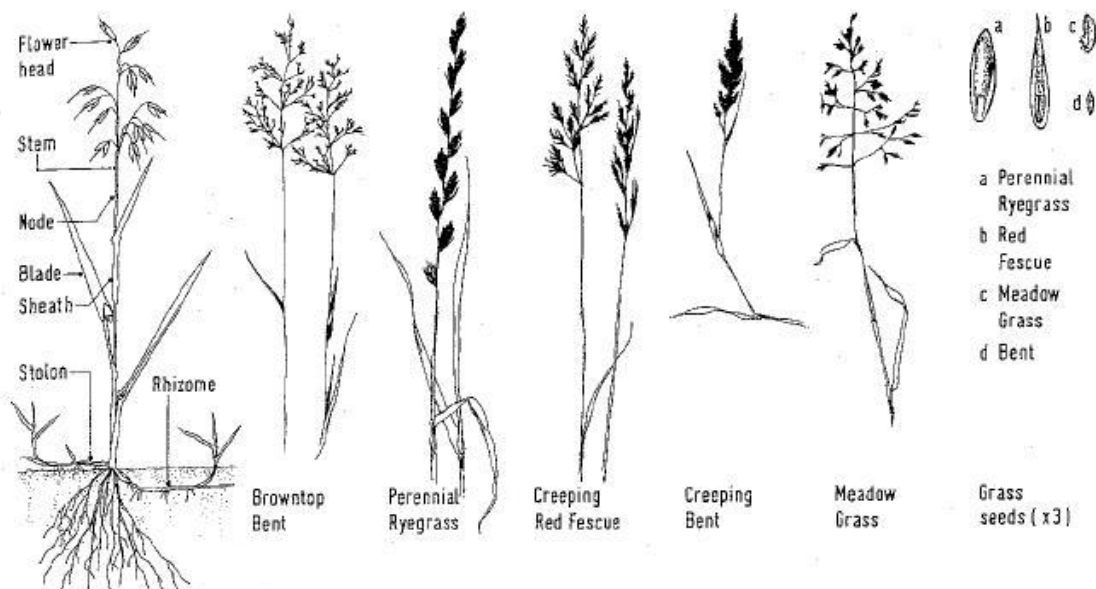

Figure 2.1: Examples of vegetation (Hewlett et al., 1987)

Range above soil has different attributes as range in soil. Range above soil is called sward and it generally consists of a flower head, a stem and blades. Appearance of sward is different from plant to plant. Figure 2.1 shows examples of typical vegetation on dike slopes. Range of turf underground shows differences in each root system. Some kinds have deep and dense root growth which is influenced by content of nutrient and also pasturing the sward.

Also, figure 2.1 presents seeds of vegetation and it is well known, that a plant is a living organism. This means, that vegetation needs time to develop from seed to a complete plant which is called establishment period. First this is the time between

sowing of seeds and stage of coming out of ground. Second part of establishment period is the period of a young plant which has no complete developed function and quality. Both periods create problems in case of flood and seasonal changing like rain or wind, so plants have to be protected in establishment period by using other materials of cover.

After vegetation is fully developed, plants have the wanted structure and can develop their function. The combination of soil and vegetation is the so called grass cover or sometimes called turf.

2.1 Structure of the grass cover

Thickness of grass cover varies from dike to dike, because every administrator of a dike treads it different in case of clay thickness, management and clay composition, which depends on individual as well natural development of soils. Nevertheless, a commonness of every grass layer is the classification into top soil and lower soil called subsoil (Figure 2.2). Top soil often consists of sandier and more humus soil to benefit better plant growth which causes a more porous and moister layer that is elastic.

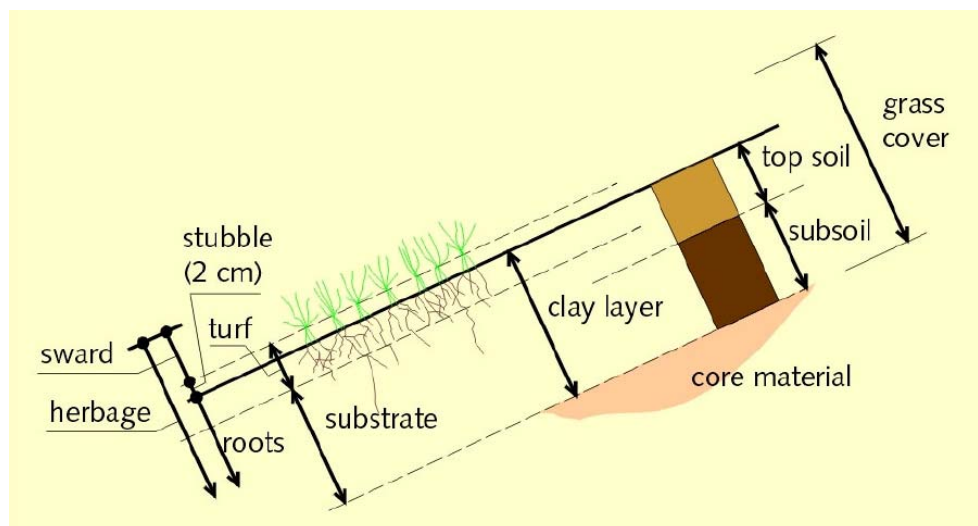

Figure 2.2: Structure of a grass covers (TAW, 1999)

The subsoil is composed of heavier clay which is stiff as well as plastic. Root density in subsoil is less which causes a less porous soil and a less therefore permeability.

In contrast to subsoil the top soil is affected by climate (shrink and swell), root growth and activity of soil fauna. Activity of soil fauna means that animals like moles and voles dig in soil layers and leave holes or channels.

These effects lead to a changing structure of top soil. This report is mainly concerned with root growth and its influence on changing soil structure. Roots are growing in vertical and horizontal direction. Vertical growth can reach into subsoil and protects the layer against sliding. Horizontal roots especially in top soil, the so called Rhizomes, support formation of aggregates and clods which creates an elastic layer. So, structure of soil shows different sized aggregates with cracks and pores in-between (Figure 2.3).

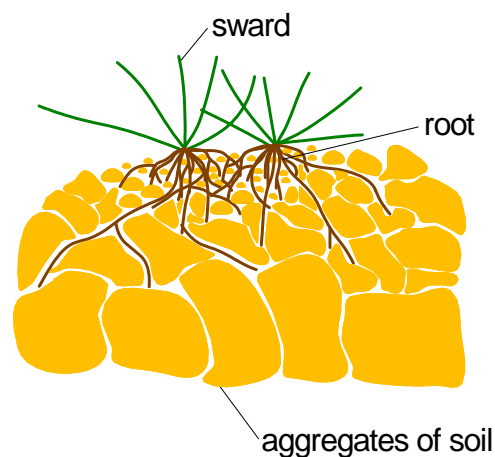

Figure 2.3: Interaction of root density and soil aggregates

Another influence is climate condition which causes shrinkage and swell. Extraction of moisture by plant roots causes cracks of shrinkage. Crack and finer aggregates increases permeability and that also enhance infiltration. Depth of cracks can be greater than 125mm and sometimes increase with depth below the heavily rooted topsoil.

In contrast to the fact of deep cracks the single aggregates are bounded together by system of roots. Sparsely vegetated slopes with a lot of open spots show extensive and deep cracks (Coppin/Richards, 1990), so permeability and infiltration cause a meaningful load to cause inner erosion.

But at least it is important to tell that roots reinforce the sod and give the dike cover a certain erosion resistance.

2.2 Function of a grass cover

Literature describes covers with reinforcement types like for example concrete stone layer, asphalt layer or geo grids and many more. Many kinds of reinforcement of soil layer on dike slopes are possible, but this report especially is concerned with grass cover.

Grass cover has different assignments and properties. The main function of the turf is to raise resistance against erosion caused by rainfall, waves and flow. Properties of a grass layer which are important for resistance are a dense and regular growth (Hewlett et al., 1987, Coppin/Richards, 1990; Sprangers, 1999). It is important to get no open spots in the layer, so seeds have to be protected against washing out and a seed mixture for plants with a high growing velocity has to be applied to get a complete sward. The assignment of the sward is to protect soil layer of drying out and to control the draining by evapotranspiration (Hewlett et al., 1987, Coppin/Richards, 1990; Sprangers, 1999), while mechanical properties of roots like tensile or shear strength are influenced by a dense deep and regular root growth. A dense root growth connects soil particles to bigger aggregates and clods, so local stability increases by the connection of the single aggregates.

Different kinds of vegetation are applied to raise the erosion resistance on dike slopes, so one part of a dike uses several mixtures of seeds, because of the miscellaneous attributes of vegetation. EAK 2002 gives examples of vegetation types which are seeded on German dike slopes (Table 2.1).

Quality of vegetation depends on attributes like for example persistence, fast growing as well as a high degree of canopy cover (EAK, 2002). Vegetation applied on German dikes like Kentucky Blue-Grass has deep and wide system of roots that are good to shape a connection between soil and vegetation as well as other vegetation. Perennial Rye-Grass (*Lolium perenne*) signalizes a fast growing and high degree of canopy cover. Both sorts of grass are first-class pasture, so pasturing by sheep is possible. Red fescue shows a good growth of roots, so deep areas of soil in layers are connected by roots and this causes a good protection against erosion. The problem of Red fescue compared to the other two kinds of grass is that young plants are growing very slowly.

Table 2.1 lists typical types of vegetation with attributes of grass which are suggested by EAK 2002.

| Type of vegetation (EAK 2002) | Mixture of seeds | Attributes |
|---|---------------------|--|
| Perennial Rye-Grass (<i>Lolium perenne</i>) | 30 | Persistent; first-class pasture; dense turf; resident against tread; fast growing; high tensile strength of roots |
| Kentucky-Bluegrass (<i>Poa pratensis</i>) | 30 | Persistent; first-class pasture; poor of blades; deep and wide system of roots; with a lot of rhizome; needs fertilization; low tolerance of salt |
| Red fescue with short tillers (<i>Festuca rubra</i> . <i>trichophylla</i>) | 25 | Persistent; thick leaves; dense turf with good protection of erosion; good resistance against salt; younger plants are growing slowly |
| Red fescue with long tillers (<i>Festuca rubra</i> ssp. <i>Rubra</i>) | 15 | Persistent; large rhizome; thick leaves; dense turf with good protection of erosion; good resistance against salt; younger plants are growing slowly |

Table 2.1: Typical applied mixture of seeds on german sea dikes (EAK, 2002, modified)

These are just a few kinds of plants which appear on dike slopes, but as shown before, the attributes are important. Which vegetation will be used depends on kind of dike, location of dike as well as climatic conditions, but these are only a few examples of dependency.

Appendix A shows a list of used vegetation with scientific names and translations in Dutch and English.

3. Loads causing erosion

Erosion processes can be released by different loads. Those loads are water running up and down, wave overtopping, flow forces as well as breaking waves. Those loads never appear at the same time or at the same slope. Figure 3.1 shows the different zones where a load appears at the dike slope.

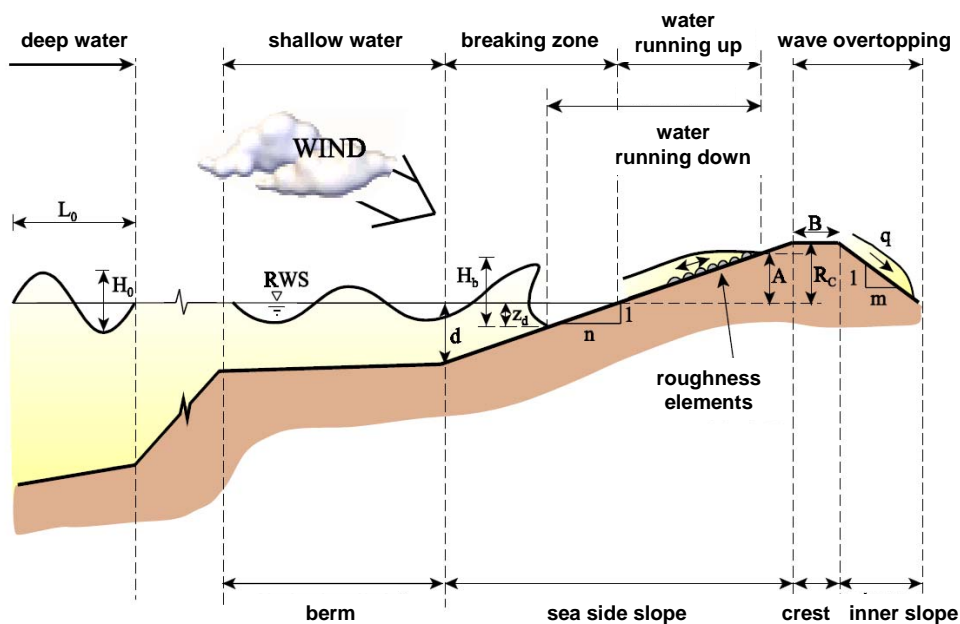

Figure 3.1: Description of loading zones (EAK, 2002, modified)

The figure clearly indicates that loads like water running up and down as well as a directly wave impact of a breaking wave just appear at outer slopes. Wave overtopping affects dike crests and water running down influences inner slopes. These loads are well known in literature and are defined as followed.

3.1 Water running up, wave overtopping and water running down

Simply said, dikes are loaded by water and this exactly means that a wave hits the outer dike slope and splits into an amount of water which runs down the slope again as well as a contingent that directly runs up to the dike crest. This content of

water is described by height of water running up z_{98} in [m], which is the height that is exceeded by 2% of every wave running up.

EAK (2002) defines the height of water running up on a slope as followed.

$$z_{98} = 2,02 \cdot \sqrt{H_s} \cdot T_p \cdot \tan \alpha \leq 3,2 \cdot H_s \quad 3.1$$

Where

H_s is the significant height of a wave at feed of a dike in [m]

T_p is the period of waves in [s]

α is the angle of an outer dike slope

The amount of water running up is a kinetic energy which EAK (2002) describes as a velocity $v_{0,98}$ and gives following definition.

$$v_{0,98} = 1,1 \cdot \sqrt{2 \cdot g \cdot z_{98}} \quad 3.2$$

The plenty of water that runs down the outer slope has a velocity $v_{0,min}$ in [m/s] and is defined as

$$v_{0,min} = 0,82 \cdot \sqrt{2 \cdot g \cdot z_{98}} \quad 3.3$$

Figure 3.2 and 3.3 show an evaluation of velocities on outer dike slopes which applies a range of peak period from 3s up to 7s and is calculated with the before mentioned definitions for a slope of 1:6.

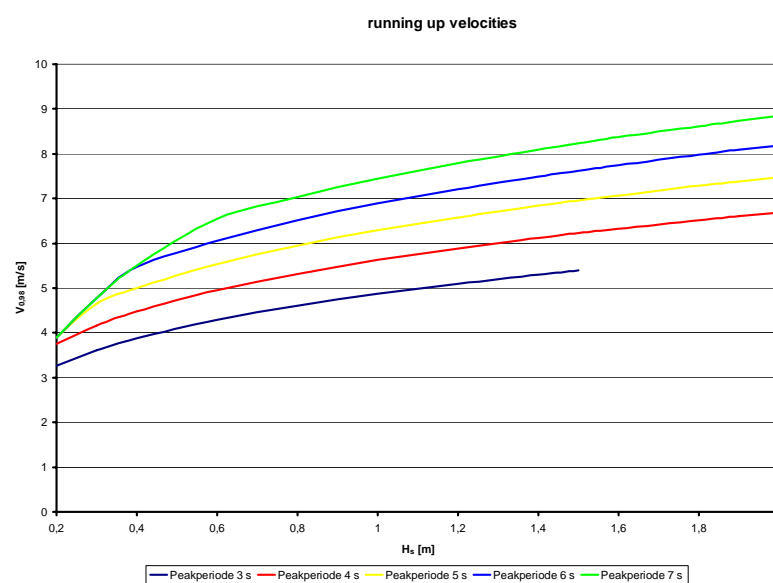

Figure 3.2: Velocity of water running up depending on periods of peak

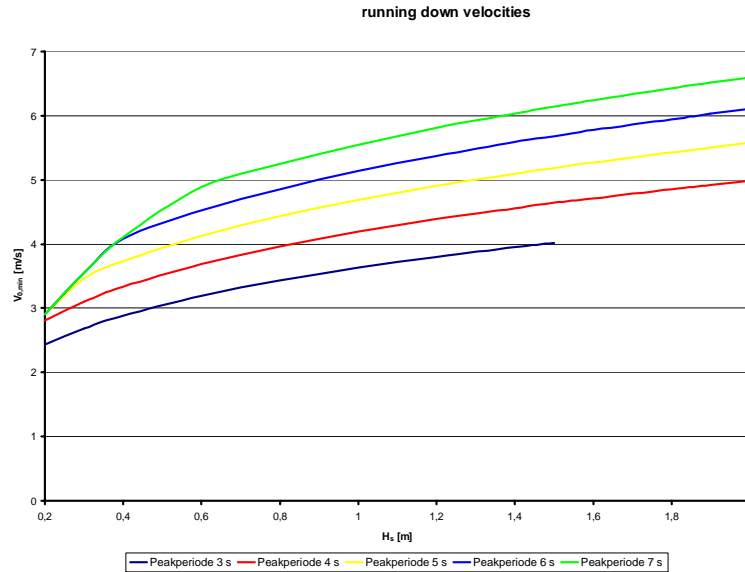

Figure 3.3: Velocity of water running down depending on periods of peak

These evaluations present that velocities of water running up are higher than the velocities of water running down.

By the time water reaches the dike crest, overtopping happens. This overtopping is defined by Schüttrumpf (2001) as overtopping rate q in [$\text{m}^3/(\text{s}\cdot\text{m})$] and can be calculated as followed.

$$q = Q_0 \cdot \exp\left(-5,5 \cdot \frac{R_c}{z_{98}}\right) \cdot \sqrt{2 \cdot g \cdot H_s^3} \quad 3.4$$

Q_0 is a dimensionless overtopping parameter and depends on the coefficient of breaking water ξ_d which configures the type of wave.

$$Q_0 = 0,038 \xi_d, \text{ for } \xi_d < 2,0 \quad 3.5$$

$$Q_0 = \left(0,096 - \frac{0,160}{\xi_d^3}\right) \text{ for } \xi_d \geq 2,0 \quad 3.6$$

As well as the coefficient of a breaking wave ξ_d is defined as following:

$$\xi_d = \frac{\tan \alpha}{\sqrt{\frac{H_s}{L_0}}}, \quad 3.7$$

in which L_0 in [m] is the length of the wave in deep water and α is the angle of sea side slope.

An example (Schüttrumpf, 2001) with a 1:6 outer dike slope as well as wave parameters $H_S = 2,0\text{m}$ and $T_S = 7,0\text{s}$ results a velocity of water running up $v_{0,98} = 4,68\text{m/s}$ and connected to this velocity an overtopping rate $q = 100\text{l}/(\text{sm})$.

Generalplan Küstenschutz Schleswig-Holstein (2001) allows an overtopping rate of $2\text{ l}/(\text{sm})$, because former considerations are concerned with higher dikes, but future plans will be to develop inner dike slopes which can take the load of water and so higher overtopping rates are permitted.

Additionally Schüttrumpf (2001) divides between velocities on dike crests v_K and velocities on inner slopes v_B . Figure 3.4 shows zones of loads with definitions of each symbol.

Velocity at dike crests is give as

$$v_K(x_K) = \exp\left(-\frac{x_K \cdot f}{2 \cdot h_K}\right) \cdot v_K(0) \quad 3.8$$

Whereat f is a roughness coefficient and $v_K(0)$ is the velocity at the beginning of the dike crest. Parameter x_K defines a point, where velocity on the crest can be calculated, because the velocity of flow is not constant on dike crests and even not constant on inner slopes. Height of water decreases, so in combination with this potential energy decreases, but to fulfill the conservation of energy kinetic energy increases and this simply means that velocity of flow must become higher.

Velocity at land side slopes is

$$v_B = \frac{v_B(0) + \frac{k_1 \cdot h_B}{f} \cdot \tanh\left(\frac{k_1 t}{2}\right)}{1 + \frac{f v_B(0)}{h_B k_1} \cdot \tanh\left(\frac{k_1 t}{2}\right)}, \quad 3.9$$

in which $v_B(0) = v_K(x_K = B)$

and

$$t \approx -\frac{v_B(0)}{g \sin \beta} + \sqrt{\frac{v_B^3(0)}{g^2 \sin^2 \beta} + \frac{2s_B}{g \sin \beta}} \quad 3.10$$

$$k_1 = \sqrt{\frac{2fg \sin \beta}{h_B}} \quad 3.11$$

are the time t when water reaches the location x_K and k_1 is a coefficient for velocity.

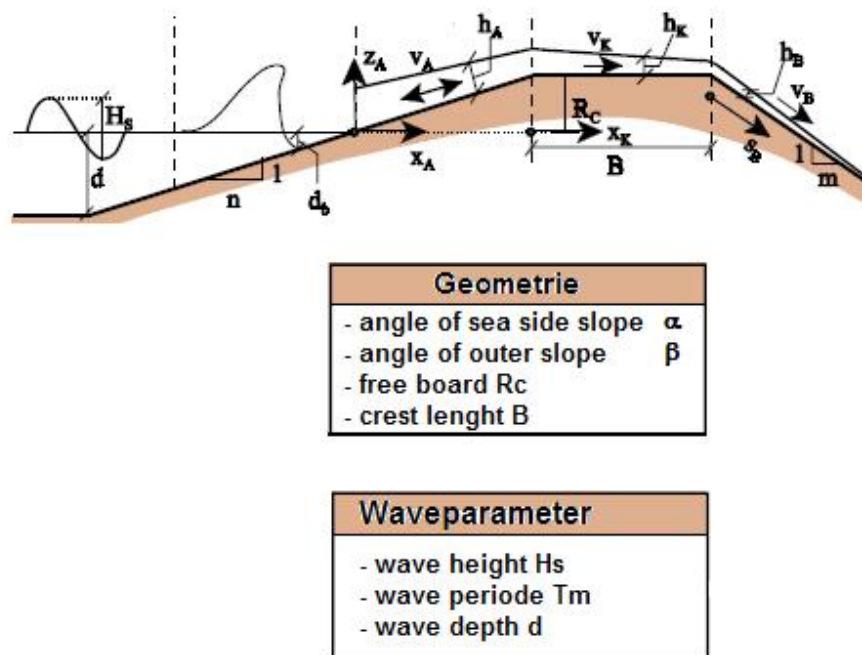

Figure 3.4: Definition of symbols (Schüttrumpf, 2001, modified)

3.2 Wave impact

Wave impact happens on outer slopes and it is responded by a plunging breaker. The energy which is created by the wave lasts just 1/100 seconds and loads the pressure a few decimeters on the dike slope. Impact of wave is probabilistic and the responded load is a lot higher than hydrostatic loads.

Führböter (1966) presents a linear dependency between maximum of wave impact p_{\max} in $[\text{kN}/\text{m}^2]$ and height of wave H_s in $[\text{m}]$:

$$p_{\max} = C(i) \cdot \rho_w \cdot g \cdot H_s \quad 3.12$$

Where ρ_w in $[\text{g}/\text{cm}^3]$ is the density of water and g in $[\text{m}/\text{s}^2]$ is acceleration of gravity. $C(i)$ is a dimensionless coefficient. Following to Sparboom (1991), $C(i)$ is equal to 5 for irregular waves on a slope with an inclination of 1:6. Just one of 1000 waves should exceed this value. Due to the pressure at slope surface pore water pressure will increase. Depending on permeability of soil overburn pressure

will decrease in the soil. This is compared to a load which presses from the inner side of the dike against the cover and lifts it up.

3.3 Infiltration

Penetration of water into the soil layer of slopes is called infiltration. Pores and cracks of soil are filled with water which affects that content of water increases as well as moisture of soil. Damming up of water depends duration. As long as infiltration lasts, the soil will be saturated with an enhancing depth (Weißmann, 2003). The saturated water has the velocity of flow which is characterized by law of Darcy:

$$\vec{v} = -K(\theta) \cdot \vec{i} = -K(\theta) \cdot \text{grad}\psi \quad 3.13$$

In which $K(\theta)$ is the tensor of pervious ness and ψ is the Potential.

$$\Psi = \psi_z \cdot \psi_m \cdot \psi_p \quad 3.14$$

With sub potential:

ψ_z = potential of gravity

ψ_m = potential of matrix

ψ_p = potential of pressure

Potential of gravity increases with depth of infiltration z_s . Potential of pressure is the medial highness of damming up. Potential of matrix depends on the content of water at the beginning and reduces in the zone of moisture caused by tension of vacuum as shown in Figure 3.5 (Weißmann, 2003).

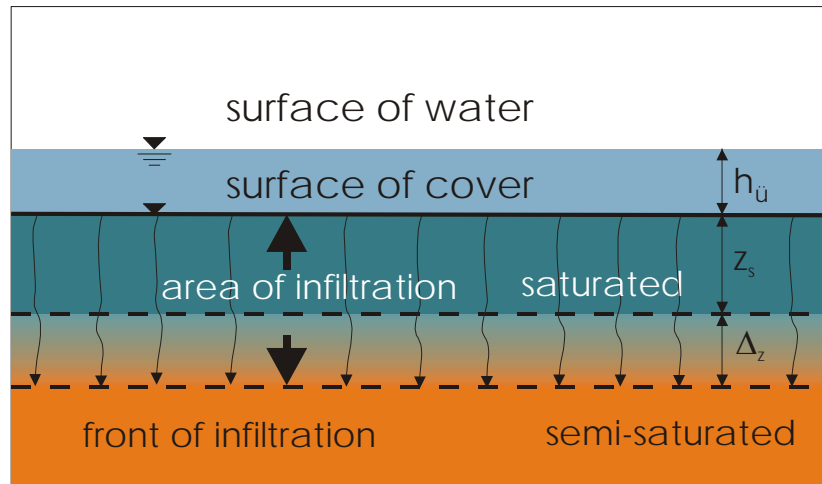

Figure 3.5: Infiltration (Weißmann, 2003, modified)

Vertical velocity of infiltration in a soil containing a permeability of k_f is:

$$v_{\text{inf}} = k_f \cdot \frac{f \cdot \Delta\psi_m + h_u z_s}{z_s} \quad 3.15$$

With function of potential of matrix, highness of damming up h_u and depth of infiltration the velocity of infiltration spreads at the beginning v_a like:

$$v_a = \frac{v_{\text{inf}}}{\theta_s - \theta_a} = \frac{k_f}{\theta_s - \theta_a} \cdot \frac{f \cdot \Delta\psi + h_u + z_s}{z_s} \quad 3.16$$

In which θ_s is the content of volumetric saturation and θ_a is content at the beginning. The volumetric content is connected to the general content of water w which is defined as followed:

$$w = \frac{\rho_w}{\rho_d} \cdot \theta \quad 3.17$$

where ρ_w and ρ_d are the density of water and the density of dry soil.

Duration of infiltration is defined as:

$$t = \frac{\theta_s - \theta_a}{k_f} \cdot \left(z_s + (\Delta\psi'_m + h_u) \cdot \ln \left(\frac{\Delta\psi'_m + h_u}{\Delta\psi'_m + h_u + z_s} \right) \right) \quad 3.18$$

The above deduced definitions are valid for a discontinuous damming up of the slope and have been verified by Weißmann (2003).

If flow of infiltration reaches the sand-core than the water will run down without any influence of pressure, because sand core is more permeable as the cover of clay. In fact of being dammed up till limit of soil cover than the cover layer can be lifted up and fails. Normally, amount of water caused by infiltration is not as high to create problems of lifting the canopy cover, but if pores between the aggregates gets bigger and cracks appear by influence of shrinking or living soil fauna, than the content of water increases and a failure of lifting is possible again.

Changing of moisture is influencing strength of soil layer, because strength of soil depends on the content of water. Strength is high when soil is dry and gets lower as moisture enhances (Weißmann, 2003). From this it follows that strength do not depends directly on content of water, but rather on state of shape and consistency and is defined as a actual content of water referenced to the limit of state.

$$I_c = \frac{w_L - w}{w_L - w_p} \quad 3.19$$

As w is the actual content of water and w_L and w_p are the amounts of water which appear at the defined states of soil shape. So w_L is crossing from fluid to muddy as well as w_p is crossing from stiff to semi-solid state.

Shear strength of soil is defined concerned with the content of water as followed.

$$c_u(w) = c_u(w_p)^{I_c} \quad 3.20$$

Shear strength $c_u(w_p)$ has a range from 10kN/m^2 to 100kN/m^2 and figure 3.6 shows width of shear strength of a soil which is saturated.

Figure 3.6 shows range of $c_u(w_p)$ for saturated soils.

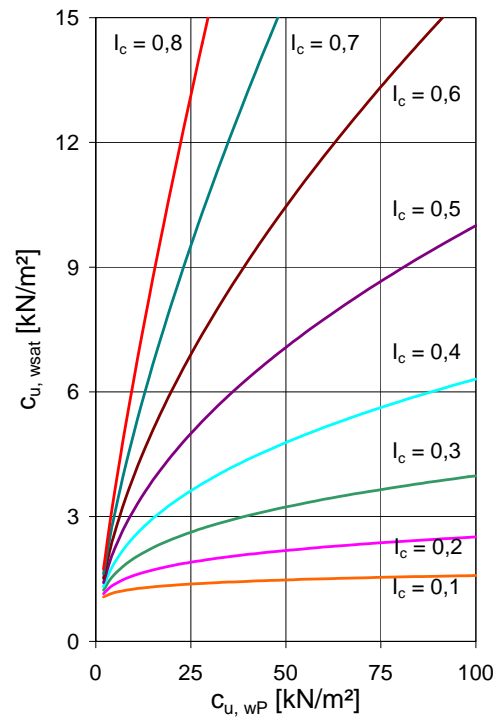

Figure 3.6: Shear strength (Weißmann, 2003)

4. Erosion and forms of appearance

Erosion shows several forms of appearance. Forms of erosion like cascade or channel erosion appear where some local failure happened before or open spots exist. Local failure and open spots yield a benefiting point of attack to flow forces and this response erosion (Figure 4.1)



Figure 4.1: Forms of erosion (Weißmann, 2003)

Internal erosion is another form of erosion. Flow carries sediments in a cover layer and this invisible process can response a slope failure suddenly.

Nevertheless, erosion processes generally are divided in two parts. First part is detachment process and second is transport process.

4.1 Detachment process

In the past many considerations have been made to describe the detachment of particles. Results of this consideration show several models and descriptions.

Different numerical models and programs have been developed to describe detachment processes for agricultural areas (Klisch, A, 2003), e.g. EROSION 2D/3D, which deals of theoretical thoughts by Schmith (1996). Effect of erosion is described by power pulse current caused by rainfall or water running down a slope ($\rho_{r,\alpha}$ and ρ_d). Resistance of this power pulse current is the shear strength which is expressed by a critical power pulse current ρ_{crit} . These values are defining a dimensionless erosion rate E.

$$E = \frac{\varphi_{r,\alpha} + \varphi_q}{\varphi_{crit}} \quad 4.1$$

Where at ρ is the power pulse current in [N/m²]

In case of $E > 1$, sediments are detached, because detaching power pulse current is higher as resistance power pulse current. On the other hand case $E < 1$ describes an erosion free condition.

The power pulse current $\rho_{r,\alpha}$ caused by rainfall is defined as:

$$\rho_{r,\alpha} = r \cdot \cos \alpha \cdot \Delta x \cdot \Delta y \cdot \rho_r \cdot v_r \cdot \sin \alpha \cdot (1 - C_L) \quad 4.2$$

With: r is the rainfall intensity in [m/s]

α is angle of slope in [°]

ρ_r is density of rainfall in [kg/m³]

v_r is the medial velocity of flow of rain drops in [m/s]

C_L is the canopy cover of vegetation in [-]

Δy is the width of an element in [m]

The power pulse current ρ_q by water running down a slope is defined as:

$$\rho_q = \frac{q \cdot \rho_d \cdot v_q}{\Delta x} \quad 4.3$$

With: q is volume of flow by water running down a slope in [m³/(ms)]

ρ_d is the density of fluid in kg/m³

v_q is medial velocity of flow in [m/s]

Δx is length of an element in [m]

The critical power pulse current ρ_{crit} is defined as:

$$\rho_{crit} = \frac{q_{crit} \cdot \rho_d \cdot v_q}{\Delta x} \quad 4.4$$

With: q_{crit} is the critical flow in [m³/(ms)] which is verified by tests (Schmidt, 1996)

Richwien/ Wang / Weißmann (2000) have published another possibility to describe detachment processes exemplary for „Borghauser Hauptdeich“.

The detachment process is described as followed:

$$DF = 0,276\eta(\tau - \tau_s) \quad 4.5$$

DF is the rate of soil particle detachment by flow in [kg/m²]

η is the efficiency of bed load transport, for sand it is about 0,13

The shear stress of flow τ is defined as:

$$\tau = \rho_w g S Q \quad 4.6$$

In which

ρ_w is the density of water

g is the acceleration of gravity

The velocity of flow u in [m/s] and the overtopping rate Q in [m³/(sm)] are given as followed:

$$u = R^{0,667} \cdot \frac{S^{0,5}}{n} \quad 4.7$$

$$Q = R^{1,667} \cdot \frac{S^{0,5}}{n} \quad 4.8$$

In which:

u is the velocity of flow in [m/s]

R is the hydraulic radius in [m]

S is the slope energy line in [m/m]

n is Manning`s roughness coefficient for slope surface

This Manning`s n is influenced by length of grass layer and it has a different range.

Hewlett et. al (1987) have analyzed influence of vegetation on roughness coefficient n (compare Figure 4.2 and Table 4.1). For example, a grass with a retardance C and a flow parameter of 0,02m²/s shows a roughness n=0,2 while a retardance E displays a roughness around n=0,05-0,06.

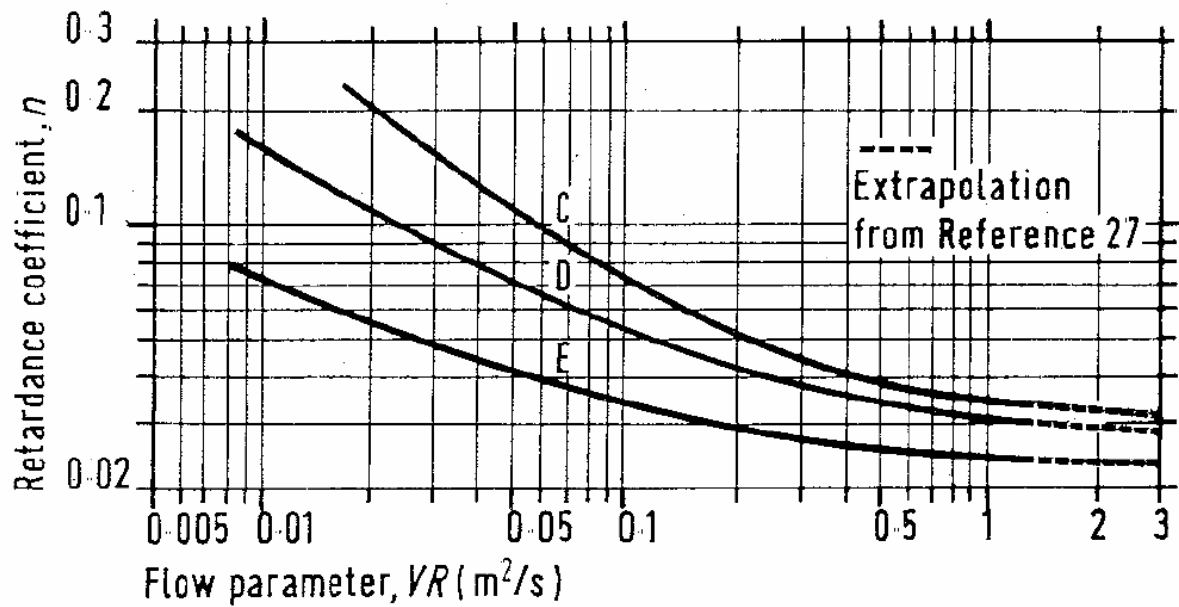

Figure 4.2: Evaluation of roughness (Hewlett et. Al, 1987)

| Average of grass length | Retardance |
|-------------------------|------------|
| 150 to 250 mm | C |
| 50 to 150 mm | D |
| Less than 50 mm | E |

Table 4.1: Average grass length to evaluate roughness (Hewlett et. al, 1987)

If this different grass covers will be compared to management category with range good till poor than figure 4.3 will reveal that a good cover will resist a velocity of about 4m/s for a short time and a poor one will resist just a velocity of 3m/s. This clearly indicates that velocity of water running down depends on grass cover.

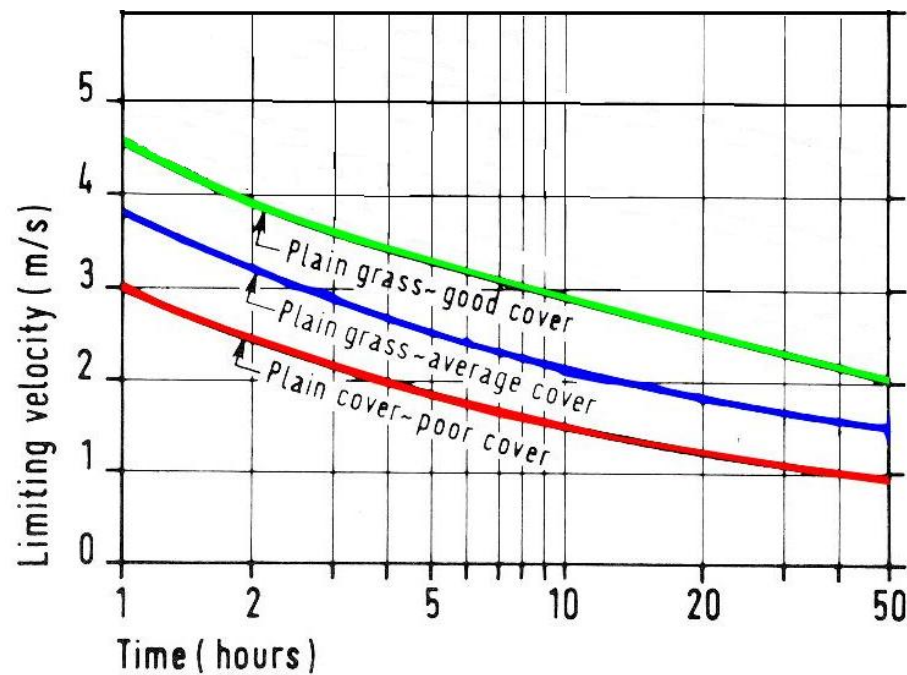

Figure 4.3: Dependency of roughness (Hewlett et. al, 1987, modified)

The range of velocities which are presented in figure 4.3 seem to be in contrast to velocities of running up as well as running down (figure 3.2, and 3.3), but it has to be noticed that figure 3.2 and 3.3 deal with a load which remains a short while and figure 4.3 deals with hours.

4.2 Transport process

Wang (2000) describes transport capacity with subject to the diameter of soil particles and the roughness of slope surface. The detached soil particles which are transported by flow can be estimated by:

$$Q_s = 0,0061Q^{1,8}S^{1,13}n^{-0,15}d_{35}^{-1} \quad 4.9$$

Where:

Q_s is the transport capacity in [$m^3/(sm)$]

d_{35} is the diameter at which 35% of the soil particles are finer in [mm]

These equations are valid for particles of non cohesive soils.

Hoffmans explains transport processes of soil particles by considering shear stresses in similar ways and he has analysed numerical considerations of two dimensional scouring (Hoffmans, 1992). Main objective of scour process studies

has been computation of scour for non-cohesive material mathematically. A model called DUCT-SUSTRA came to application. DUCT-SUSTRA is a combination of a flow-(DUCT) and morphological part (SUSTRA) which also considers eddy viscosity. Unknown parameters and calibration of parameters are obtained by $k - \varepsilon$ model and flume experiments.

Generally movement of particles is caused by longitudinal velocity of flow whereat a turbulent flow disrupts soil layer, sediment particles are detached and finally are transported by flow.

Sediment transport is influenced by shear stress and the instantaneous shear stress as well as density of soil material, diameter of particles and porosity of soil as shown with power pulse current in EROSION2D/3D. Concentration, depth-average suspend load are simulated by integration of concentration fields and velocity fields as well as the mass balance equation. Also instantaneous shear stress is computed on a stochastic approach with respect to van Rijn in 1986. The applied parameters are calibrated and verified in several sensitivity analyses.

Hoffmans (1998) describes the critical shear stress and refers to Shields who has defined critical shear stress in 1936.

$$\tau_c = \rho u_{*,c}^2 \quad 4.10$$

In which ρ in $[\text{kg}/\text{m}^3]$ is density of flow and $u_{*,c}$ in $[\text{m}/\text{s}]$ is critical bed shear velocity.

For uniform flow and a hydraulically rough bed the critical mean velocity U_c is:

$$U_c = \frac{u_{*,c}^2 \cdot C}{\sqrt{g}} \quad 4.11$$

C is the Chezy coefficient, which is a smoothness coefficient.

$$C = \frac{\sqrt{g}}{\kappa} \cdot \ln\left(\frac{12R}{k_s}\right) \quad 4.12$$

In which R is the hydraulic radius in $[\text{m}]$, k_s is the equivalent roughness of Nikuradse and $\kappa = 0.4$ constant of von Kármán.

Literature treats theories for particles of non cohesive soil exhaustively. By seasonal conditions soil layer is marked by aggregates which are refined by temporally developing of roots, thus forms smaller aggregates. Still those small aggregates are bigger than soil particles, so the point is whether soil particles theories can be applied directly to aggregated soils.

4.3 Erosion velocity

Grass covers have been analysed in several experiments to find information of a good quality. Previous experiments like field observations in Flevoland or the two laboratory studies Scheldebak (1994) and Deltagroot (1992) teaches a lot about erosion (TAW, 1999). In Scheldebak tests lower waves are used as load, so typical conditions were wave height of 0.3m with an interval of 2,5s and the duration of loading up to 60 hours. Grass layer has been in spring condition which is not fertilized and has a sandy soil. Figure 4.4 presents the test conditions.



Figure 4.4: Test conditions of Scheldebak test (TAW,1999)

Results of Scheldebak test have been that after many hours of loading a few centimetres have been eroded of a good grass cover. A moderately grass cover show spots which are more than 0,1m deep and a poor quality shows holes deeper than 0,2m.

In the Deltagoot tests the grass cover is loaded by waves of 0.75 to 1.35m, with intervals of 3.4 and 4.7s and the duration of more than one day. Figure 4.5 presents that the applied loads leave deep holes in the moderately fertilized and dense rooted turf.



Figure 4.5: Test conditions of Deltagoot tests (TAW, 1999)

Results of both tests build an empirical comparison between wave attack H_S in [m] and erosion velocity E in [mm/h] (Figure 4.6).

$$E = c_E \cdot H_S^2 \quad 4.13$$

By means of grass erosion coefficient c_E a description of quality can be made (Seijffert/ Verheij, 1998).

Grass erosion coefficient is classified by the quality of grass layer. The quality is divided in three parts. These three parts, a good, an average and a poor quality, are published by TAW and built the basis for VTV 2004 later.

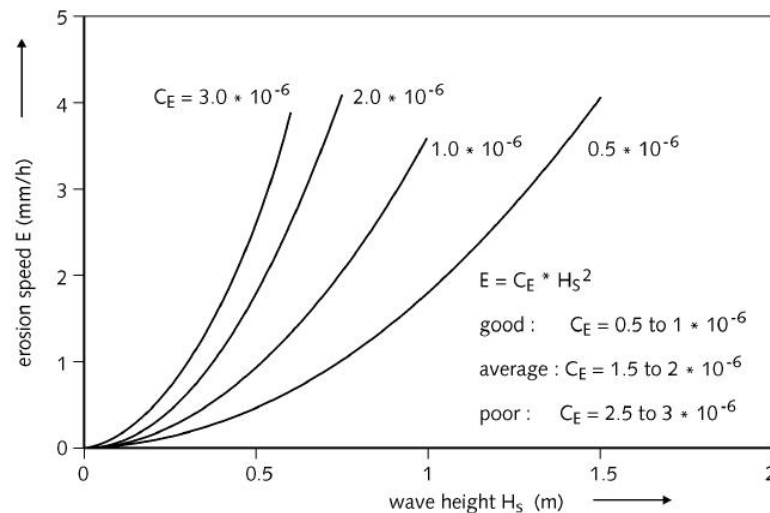

Figure 4.6: Grass erosion coefficient (Seiffert/Verheij, 1998)

Table 4.2 shows the different values of the grass erosion coefficient. This coefficient should be based on parameters like percentage of coverage by vegetation, root length and amount of fines, but Seiffert & Verheij (1998) are giving no further information about the engineering parameters which were relevant for a description of behavior of grass layers.

| Quality of grass cover | $c_E [m^{-1}s^{-1}]$ |
|------------------------|--|
| Good | $0.5 \cdot 10^{-6}$ to $1.5 \cdot 10^{-6}$ |
| Average | $1.5 \cdot 10^{-6}$ to $2.5 \cdot 10^{-6}$ |
| Poor | $2.5 \cdot 10^{-6}$ to $3.5 \cdot 10^{-6}$ |

Table 4.2: Values of c_E (Seiffert/Verheij, 1998, modified)

Seiffert/Verheij (1998) assessed that waves with a height less than 0.5m do not damage vegetation on slopes with a grad of 1:4. A good quality of the turf can carry waves with a height from 0.5m till 1.5m without damaging the turf during 6 hours.

Also Seiffert and Verheij have shown that acceptable loads depend on the duration of attack (Figure 4.7).

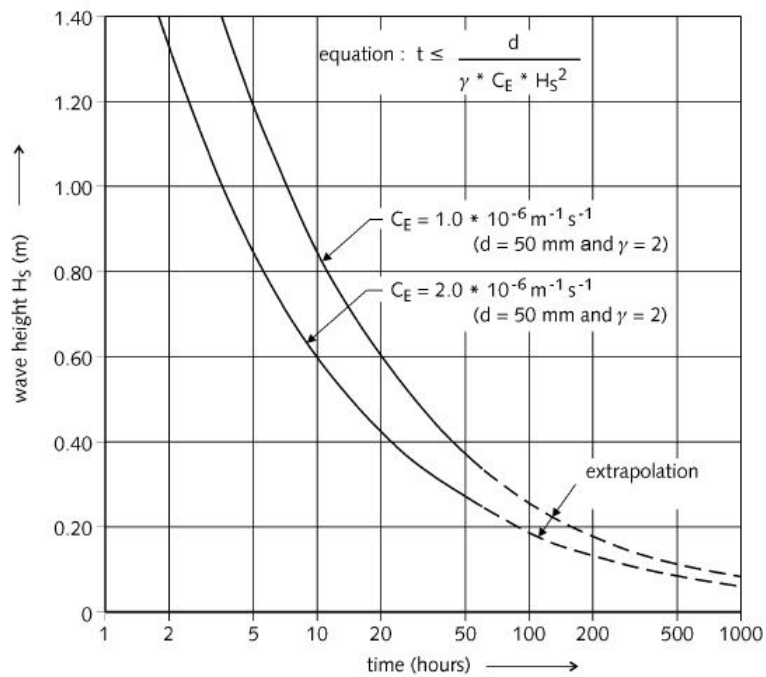

Figure 4.7: Permissible duration of wave attack (Seiffert/Verheij, 1998)

Use of the mentioned grass erosion coefficient c_E builds the basis for categorisation of grass layers (TAW, 1999).

5. Biological structure of a grass layer

It can be mentioned that quality of grass cover depends on grassland management and age of sod (Hewlett et al, 1987; TAW, 1999; Jittler, 2001), additionally expansion of roots as well as growth of sward are influenced by seasonal changing.

Literature gives some details about biological structure of the turf in sense of engineering parameters. Biological structure as parameters and their determination are further explained.

5.1 Aggregates and particle diameter

Structure of soil is described in detail as arrangement of different soil particles. This structure can be divided into a micro and a macro structure. Macro structures can be evaluated by soil mechanical properties while configuration of micro structures depends on chemical observations which are not important in this report.

Macro structures can be classified into a single particle,- coherent- and an aggregated structure (Richwien, 2004).

The single particle structures are mineral or organic particles without any connection to each other. Shape and dimension of particles, and angle of inner friction as well as the load influences the behavior of the single particles.

The coherent structure is a soil mass which is fixed together by cohesion forces. This structure appears to cohesive soils like clay which have not been influenced by weathering already.

The third group of structure is the aggregated structure. Drying out or biological processes leave cracks that separate the soil in clods and aggregates.

That is the way the big group of aggregated soils is developed. The aggregates depend on content of water and degree of weathering. They can be divided into sub steps (Richwien, 2004).

In the first step the soil layer gets divided by cracks into bigger aggregates (diameter > 5cm). By the following steps horizontal and vertical cracks appear which divide the soil layer and the bigger aggregates into smaller parts (diameter < 5cm) (Richwien, 2004).

Aggregated structures have an important influence on mechanical properties and especially on the strength, because they create an elastic grass-soil layer structure.

5.2 Tensile and Shear strength of roots

Hähne (1991) and Tobias (1991) separately have been concerned with mechanical strength of root and refer to the interaction of living organism and building material. Both describe the effect of roots in analogy to a reinforced soil. Furthermore they have done field shear observations which have shown that shear strength of soil with roots increases. This higher shear strength is called root cohesion c_w , because it rises without increasing of vertical stresses.

Hähne (1991) has done several field observations and developed a shear frame with the measures of 500*500mm to qualify the root cohesion.

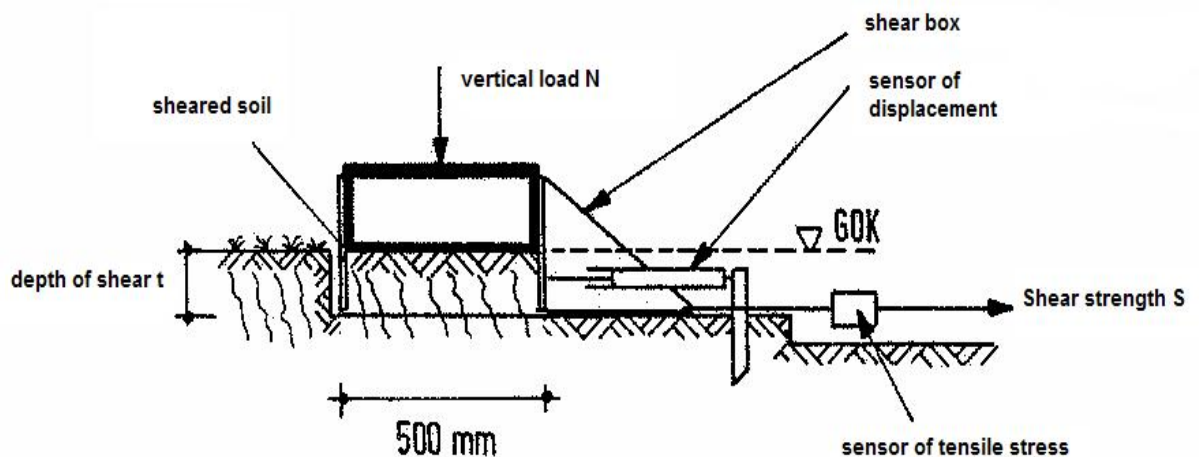

Figure 5.1: Shear box (Hähne, 1991, modified)

Shear box is divided into an inner box and an outer box with a height of 30 cm respectively 60cm (Figure 2.1). Both boxes have been pushed into rooted soil and additionally loaded with vertical stresses in form of soil dead load, while the frame is pulled with a velocity of shear to 2,3mm/min.

The results of Hähne and Tobias confirm that a well rooted soil has higher shear strength as the same non rooted soil. Furthermore it should be mentioned that the material behavior is changing. After the maximum of shear strength arrives in the shear gap the roots absorb the rest of shear strength. The rooted soil acts like a reinforcement.

Hähne established the term of cohesion to describe strength of roots and he put the behavior of a rooted soil in to comparison with a non rooted soil which can be described with Mohr Coulomb shear formula. The shear strength increases with cohesion of roots and not with increasing of vertical stresses (Figure 5.2).

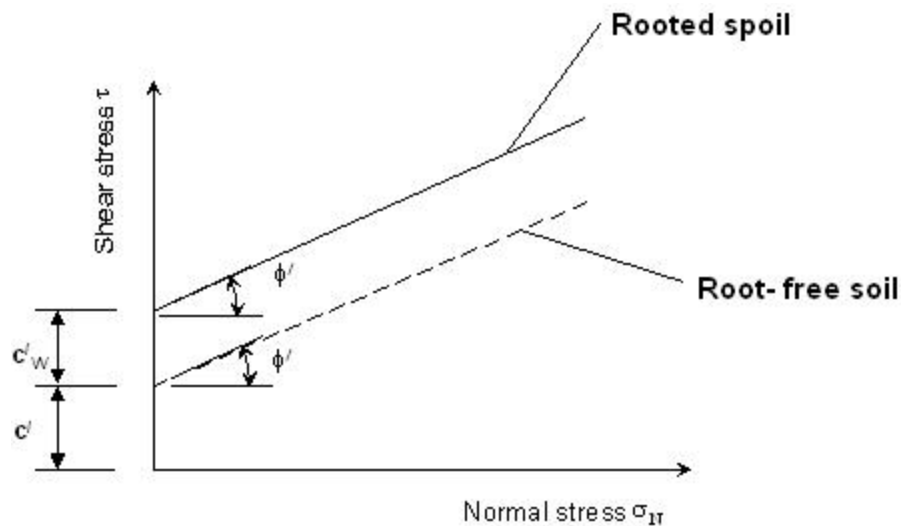

Figure 5.2: Cohesion of roots

According to Mohr-Coulombs shear formula and to the results of authors the shear strength can be described as followed:

$$\tau_f = c' + \sigma' \cdot \tan \varphi' + c_w \quad 5.1$$

whereat:

τ_f = shear stress in shear gap in [kN/m²]

c' = cohesion of soil in [kN/m²]

σ' = vertical stresses in [kN/m²]

φ' = angle of inner friction

Hähne and Tobias have shown separately that roots are increasing shear strength of a soil layer. The gain in shear strength ranges from 5 kN/m^2 to 15 kN/m^2 , but the influence depends of density of roots and therefore on depth of the shear gap.

Figure 5.3 illustrates two results of the observations of Hähne (1991). In spite of an increasing vertical load shear strength is lower in a higher depth which proves the dependency of roots. Also the rest shear strength is increasing.

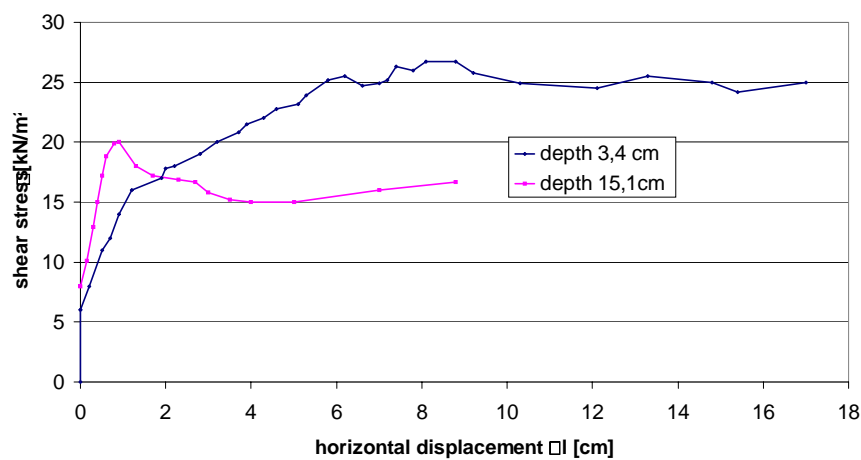

Figure 5.3: Shear strength diagram (Hähne, 1991)

In addition Hähne has shown that the angle of inner friction and also vertical stresses are not influencing shear strength of rooted soil.

Both authors idealize a straight root with tensile strength t_w . After deformation the root has moved with an angle of Θ in the shear zone (Figure 5.4).

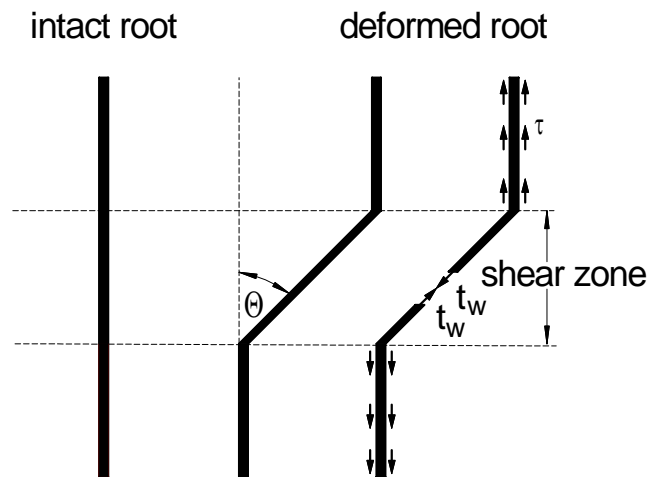

Figure 5.4: Idealization of roots (Coppin/Richards, 1990, modified)

Where c_w is:

$$\tau_w = t_w \cdot (\cos \Theta \cdot \tan \varphi' + \sin \Theta) \quad 5.2$$

Also tensile strength of roots is described by Hähne. First the outer covering coat fails by expansion. With more strain the outer covering coat lasts on the central cylinder that reforms till it gets back in the starting position (Figure 5.5).

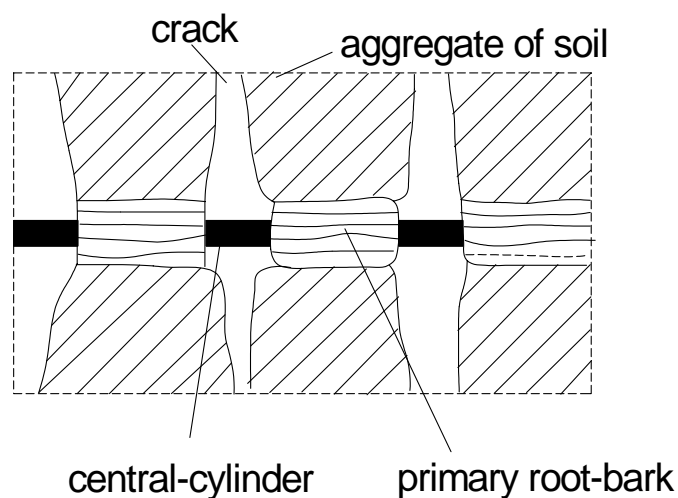

Figure 5.5: Scheme of a rooted soil (Hähne, 1991, modified)

Central cylinder has an ideal elastic behaviour. At small strains the root can slide in the central cylinder with no contact to the aggregated soil. This supports the elastic behaviour of rooted soil. Tensile strength can be calculated as:

$$t_w = \tau_w * (\sum A_w / A) \quad 5.3$$

Hähne has determined strength of around 5kN/m² by a “Horstrot- und Schafschwingel” on water saturated soil.

Also MSD (1998) applies the results of Hähne and claims that in case of a dense grass cover the local stability can be proved with cohesion of roots c_w in a depth to 0.2m.

Additionally Tobias (1991) describes strength against pulling out reinforcement and gives a possibility to calculate it.

$$f^* = \frac{\tau}{\gamma^* h}, \quad 5.4$$

With:

f^* = coefficient of friction

τ = tensile strength

γ = Weight of soil

h = height of soil above the reinforcement

But this formula is valid for reinforcement like soil nails.

Tobias (1991) informs about a special fact that shear strength of a dry soil after evapotranspiration is higher as the root strength. So a wet soil has higher shear strength.

5.3 Root depth and density

Another conclusion which was claimed by Hähne concerns about the depth of roots. Shear tests analyzed several shear gaps in different depth. In lower depth a bigger shear stress was measured and that shows the effects of roots.

So Hähne defined a limit of root growth t_G , where properties of roots mainly effect the system of soil and root as a reinforcement. The limit of root growth t_G is for an intensive cultivated soil a value of 12,8cm coherent to a minimum of shear strength with a value 10,1 kN/m².

But the limit of root growth depends on the way of cultivation, too. An extensive cultivated soil has a deeper root growth as an intensive cultivated soil. It comes up to biological expectations that a plant has to build the roots as deep as they need to get some nutrients. So the system of roots grows deeper with an extensive cultivation which means a lower content of nutrient.

Additionally Hähne has analyzed density of roots, but the results he got depends on the used sward, location and composition of soil, so no further information could be excepted. Coppin/Richards (1990) claimed that biomass of root is around 60 – 80 % in upper 5cm of top layer. Also Hähne has shown this for the example of “Horstschwingel” as modified shown in Figure 5.5.

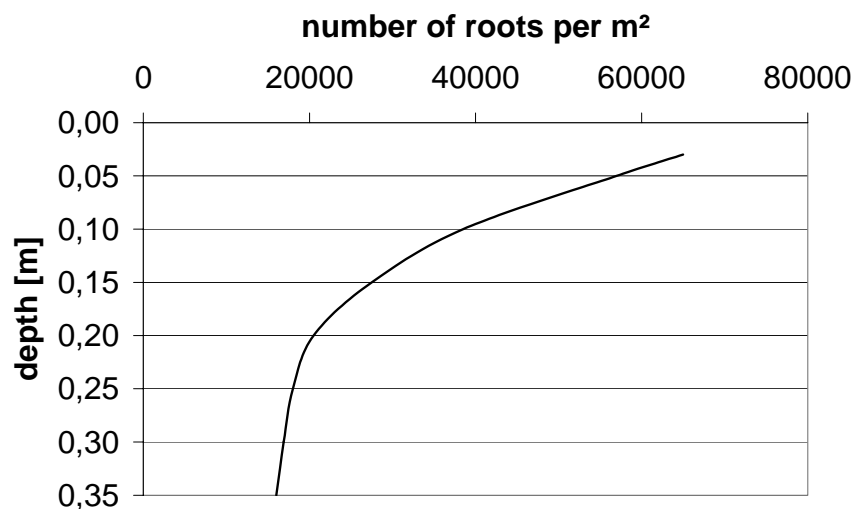

Figure 5.6: Density of roots (Hähne, 1991, modified)

Figure 5.7 demonstrates how the influence of the depth of growth t_G on the turf as well as the hyperbolic process of shear and direct stress shows that the main strength is in the near of the point of growth.

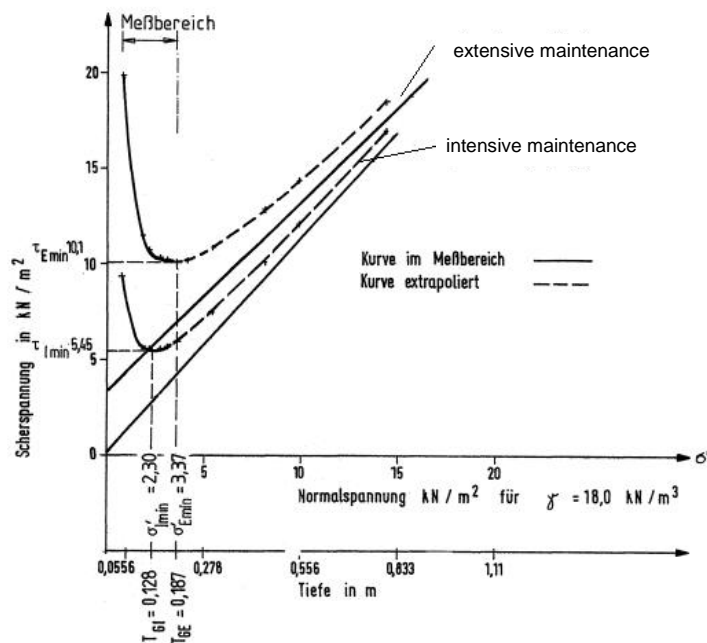

Figure 5.7: Density of roots (Hähne, 1991)

Experiments have shown that an extensive cultivation is important, because it leads to a better and deeper growth of roots.

5.4 Canopy cover

Canopy cover is another important parameter treated by literature. (Coppin/ Richards, 1990). Canopy cover means the degree of vegetation on a dike slope.

Resistance against erosion depends on dense of grass cover, Figure 5.9 reveals connection between canopy cover and erosion. These results are taken from water run off tests by CIRIA (Coppin/ Richards, 1990). Where degree of cover is zero there will appear full rate of erosion. The other way around, a high percentage of cover has a lower erosion rate.

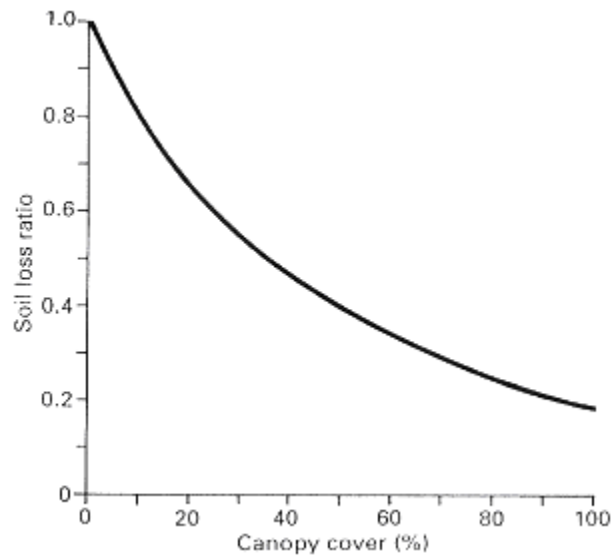

Figure 5.8: Canopy cover vs erosion (Coppin/Richards, 1990)

A cover with a low percentage shows a lot of open spots which are caused by growing habit, local failure and living organisms.

5.5 Grassland management

Management means the control of vegetation to achieve a required growth habit or to manipulate the plant community (Hewlett, et. al, 1987). Due to the fact that vegetation is a living process, considerations of management are important.

Literature review shows an important dependency of management related to strength of the turf. Jittler (2001) has analyzed vegetation and was concerned with the strength of grass covers. She has done penetration tests on several areas of dikes. Penetration tests have shown that resistance of penetration depends on content of moisture. By means of resistance of penetration Jittler (2001) has claimed categories of strength. Categories of strength last from “smooth” (0 – 1000 kN/m²) to “solid” (1000 – 2000 kN/m²). These different values of penetration are influenced by management.

Also Dutch literature knows about consequences of management on quality of grass cover. Technical Advisory Committee for Flood Defense in the Netherlands (Technische Adviescommissie voor de Waterkeringen, TAW) has realized the influence of management on quality of grass layers at an early stage.

TAW is a guide to flood defense based on the background of Rijkswaterstaat (RWS) which publishes information concerned with stability of dikes. Just for the record, TAW is a guide, but no rule at all. The use of this information should be treated with respect to the users own risk (TAW, 1999).

Investigations and experiences have shown that a good management leaves a good strength of the turf. Laboratory tests prove that the amount of sand in clay is important, because according to the substance of sand the content of nutrients can be controlled. A lower content amount of nutrients causes a good grass cover.

It needs time to get a good quality of a turf, which is in balance with vegetation process and grassland management, so seedlings and younger plants must be protected about 4 years. After 4 years the sward can be categorized into 4 categories and that builds the basis of VTV (2004). These 4 categories are a satisfying way to find the quality of a turf. The conclusions of Jittler and TAW are similar but both give no further information about hydro or soil mechanical parameters.

6. Models to describe erosion processes

Most investigations to vegetation and their strength against erosion were made since the last twenty years, but erosion resistance depends on several factors. Literature deals dissimilar with these factors, so different models were developed in the last years to describe the function and at least the strength of grass covers.

Former literature and considerations unite in Technical Note 71 (Whitehead, et al: 1976) and are summarized in CIRIA (Hewlett et. al.; 1987) later. Technical Note 71 bases on several reports and guidelines which have been presented in earlier years (Figure 6.1).

SCS (1954) analysed flow velocity and acceptable duration of flow with several kinds of grass on a very shallow channel (1:20). Also report 93 (Cornish, et al; 1967) has analysed a channel with a gradient 1:4.5 and a grass sod in age of 5-30 weeks. By now the age of sods is important for density and depth of roots, but at this time no information can be given about the dependency of age on the roots. Report 95 (Yong, Stone; 1967) is concerned with the flow velocity in an open channel and tested erosion resistance of grass sods with slope gradients from 1:10 to 1:2.6. Results of these tests cannot be used for a better understanding of the vegetation, because the content of sand was too high, so damage was caused by removal of sand particles. Roughness and Manning's n firstly were mentioned and analysed in Bulletin 16 (Eastgate, 1969). These four reports are basis of Technical Note 71 and this report builds basis for CIRIA report 116 (Hewlett et al.;1987).

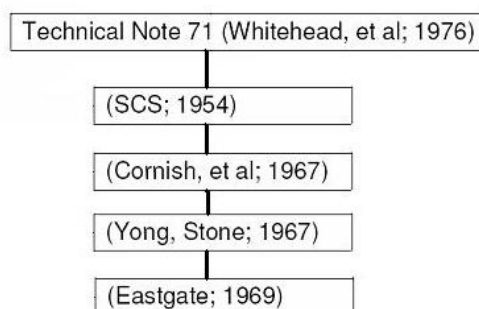

Figure 6.1: Development of TN 71 (v.d. Bos, 2006, modified)

CIRIA is concerned with degree of vegetation cover. In contrast VTV (2004) deals with roots.

VTV (2004) bases on considerations of TAW. TAW deals with several categories to qualify a sod. These four categories depend on management and build an evaluation concept of strength in VTV (2004).

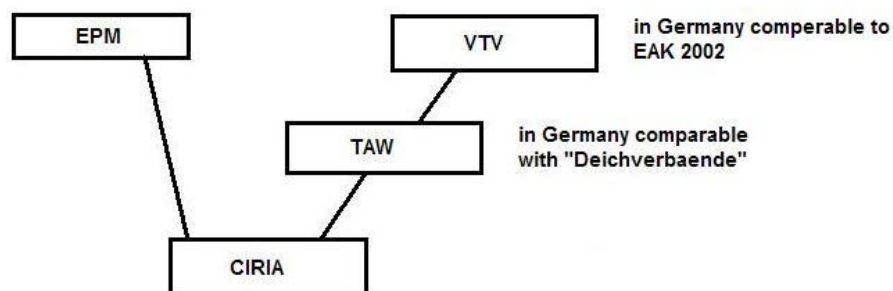

Figure 6.2: State of the art in Netherlands and Germany

Figures 6.2 shows how actual models can be compared with each other as well as it shows that after CIRIA two directions of development have taken place. Second direction is a Dutch graduation report to evaluate erosion on dike slopes and is based on scouring models.

It is important to tell that Dutch guidelines from TAW and German guidelines are summarized as recommendations. In Dutch it is VTV 2004 which is comparable to EAK 2002 in Germany.

6.1 CIRIA

CIRIA, the Construction Industry Research and Information Association, is a non-profit distributed body which is concerned with water engineering and environmental research and managing.

Similar to TAW in Dutch, members of CIRIA publish reports that give new information and function as a technical guide to practice engineering. In contrast to TAW, CIRIA is specialized on slopes in landscapes and not on dike slopes. This difference will not lead to differences in strength, because CIRIA is concerned with vegetation and canopy cover of vegetation on slopes. Strength of grass on

landscape slopes is comparable to behavior on dike slopes, but loads on landscapes slope are different. There appears no wave impact and no wave overtopping, but rather CIRIA analyses loads like rainfall, water running off a slope and infiltration.

By the way, CIRIA gives a lot of useful information about vegetation and about function to stabilize slopes as well as to protect slopes against erosion.

6.1.1 Loads

Loads of CIRIA distinguishes from loads on dike slopes, because CIRIA is more concerned with slopes at road or agriculture ways. So loads are rainfall, run off volume and run off velocity as well as infiltration.

Vegetation can intercept rainfall. This interception ranges from 100% of light rainfall to only 25% in high intensity storms. Table 6.1 presents degree of interception by different vegetation types (Coppin/ Richards, 1990).

| Forms of vegetation | Interception [%] |
|---------------------------------|------------------|
| Northern hardwood (Forest) | 10-15 |
| Temperate broad-leaved (Forest) | 15-25 |
| Temperate coniferous (Forest) | 25-35 |
| Tropical (Forest) | 25-30 |
| Grass | 25-40 |
| Maize | 25 |
| Cereals (wheat, oats, barley) | 20-25 |

Table 6.1: Interception of rainfall (Coppin/Richards, 1990)

Also table 6.1 shows that grass has the highest value of interception, because grass layer is dense and uniform, so blades and stems store rain drops.

Water which is not intercepted is running off the slope or is infiltrated.

Vegetation reposes a higher rate of infiltration by root growth and pipes or holes where roots have decayed (figure 6.3).

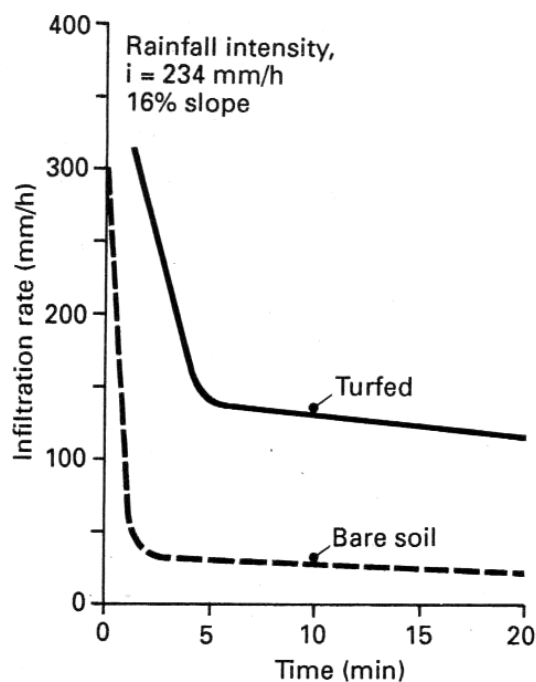

Figure 6.3: Infiltration in bare and rooted soil (Coppin/ Richards (1990))

So water runoff volume which typically is 10-20% of rainfall and rises to 30-40% under cultivation. A higher runoff volume reposes a higher runoff velocity.

Runoff velocity is influenced by volume of water as well as roughness, but the roughness of grass has to be divided in three parts. Firstly, blades and stems stand straight and rigid which causes a high roughness that slows down runoff velocity. Secondly, if the runoff volume and flow forces are increasing than grass blades begin to oscillate. Due to turbulences which absorb kinetic energy, oscillating blades have a higher roughness. At least blades and stems will be pulled down by flow, so roughness reduces and gets similar to a bare soil (Coppin/Richards, 1990).

6.1.2 Strength

First load to cause erosion is rain impact. Grass cover needs a good strength to reduce potentially erosion. Leaves and blades store raindrops. This decreases content of erosion by limiting rainfall. Interception changes shape and size of a raindrop, e.g. reducing volume of water, which is connected to kinetic energy of a

falling drop. A drop with a high energy can detach soil more easily than a drop with low energy.

| Cover expected | Channel-Gradient (%) 0.5 | Channel-Gradient (%) 5-10 | Channel-Gradient (%) >10 |
|---|-----------------------------|------------------------------|-----------------------------|
| Easily eroded soils(sands, sandy loams, silt loams, silts, loamy sands) | | | |
| Very good cover | 1.8 | 1.5 | 1.2 |
| Good cover | 1.5 | 1.2 | 0.9 |
| Moderate cover | 0.8 | - | - |
| Erosion resistant soils(clay loams, clays) | | | |
| Very good cover | 2.4 | 2.1 | 1.8 |
| Good cover | 2.1 | 1.8 | 1.5 |
| Moderate cover | 1.1 | - | - |

Table 6.2 Maximum allowable velocities of flow (Coppin/Richards, 1990)

Secondly, vegetation protects soil layer by limiting runoff velocity, but when roughness increases than velocity of flow is decreasing responded by Manning's n . On the other hand laid down blades are protecting the soil in another kind. Blades lay on layer and build a cover upon soil which gives water no point to attack and to detach particles from ground (Coppin/ Richards, 1990).

So canopy cover and also gradient of slope influences velocity of flow, but after all velocity is limited. It does not matter if blades and stems protect soil layer, because after a certain velocity soil ratio happens without any influence of roughness. Table 6.2 shows the allowable velocity of run off.

The last load which creates erosion is infiltration of water into the layer. Infiltration can be influenced so easily like the velocity, but evapotranspiration removes moisture of soil.

6.1.3 Conclusions

Both reports by CIRIA (Hewlett et al., 1987; Coppin/ Richards, 1990) teach a lot about vegetation and the use of plants as revetment.

CIRIA is concerned with different loads which appear at road and landscape slopes. This is rainfall which can be neglected, compared to overtopping rate or water running off volume on dikes. Due to rainfall, a certain volume of water runs down a slope and this volume is influenced by interception. CIRIA gives also information about degree of infiltration and how roots influence infiltration.

Another important fact is that CIRIA has made tests about roughness and has demonstrated that Manning`s n has a remarkable influence on velocity of flow.

CIRIA gives a lot of information about strength of a grass cover. The influences of canopy cover are described and it is shown that a dense cover will reduce erosion. Coppin/ Richards (1990) give information about root. The tensile and the shear strength are analyzed, but CIRIA gives no values for tensile or shear stresses.

6.2 VTV (2004)

Dikes are divided in several sections which are inspected and qualified as each section for it's own by several surveyors. In the past, surveyors have published criteria and experiences to evaluate dikes in several reports.

Comparable to EAK 2002, Directoraat – General Rijkswaterstaat have made an approach to put all reports, preferences and technical guides in one rule. This rule, VTV 2004 (Voorschrift Toetsen op Veiligheid), contains all considerations about dikes, slope stability, load and much more. One chapter of VTV 2004 is the „grasmat“, where some ways are shown to describe quality of a grass layer. First strength of a grass cover can be judged by the kind of management and as second by counting the numbers of roots, but separated models leading to the categories of management.

6.2.1 Loads

Velocity of flow and duration of load characterize reasons of erosion. In VTV 2004 value of velocity of crest and of inner slope are the same values of sea side slope.

Duration of load t_{sr} will be calculated with the wave run off at the sea side which is measured at point of prove. The distance between water level and point of prove will be measured and is a fictive distance between level of prove and a point where the overtopping level is $q=0,1\text{l/m/s}$ (Figure 6.4).

VTV 2004 suggests that duration of load is calculated as:

$$t_{sr} = \left(1 - \frac{z}{z_q}\right) t_s \quad 6.1$$

z = niveau of water at outer slopes

z_q = fictive height of crest

But loads are not only describable by duration of load, so velocity of flow on landside slopes is:

$$v_r = 700 * H_S / T_p * (0,085 - H_S / L_{\ddot{U}P}) * (1 - z / z_q)^{0,5} * \tan \alpha_0 \quad 6.2$$

With: $\tan \alpha$ = average height of landside slopes

H_S = height of wave

L_0 = length of a wave at period of peak

T_p = period of peak

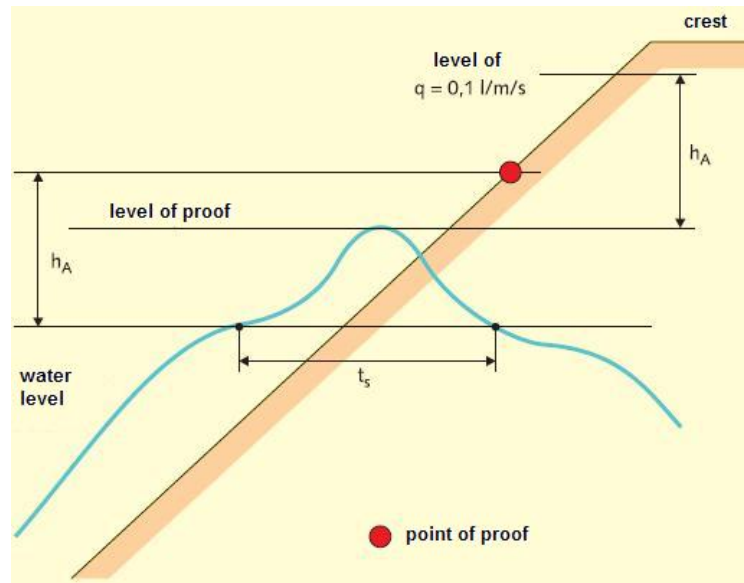

Figure 6.4: Evaluation of duration by loads (VTV2004, modified)

After velocity and duration of load are calculated, figure 6.5 shows how to evaluate quality of grass cover. Figure 6.5 contains three qualities. Qualities from good till poor are available. The calculated velocity and duration will lead to the necessary quality.

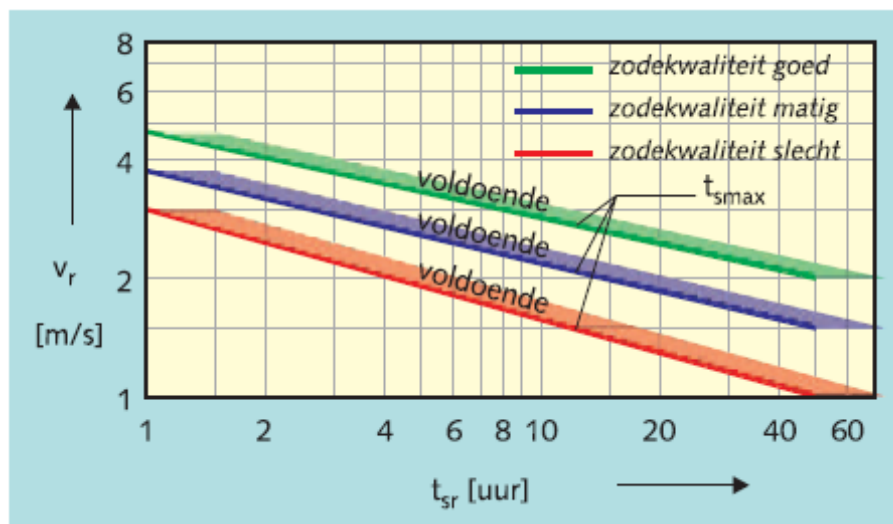

Figure 6.5: Diagram of erosion resistance (VTV 2004, modified)

6.2.2 Strength

VTV (2004) presents two principles to evaluate grass covers. First criteria are objective criteria, because quality of a grass layer depends on grassland management (figure 6.7) and will be judged by optical features.

| Management | Canopy cover | Root penetration | Quality of sod |
|---|---------------------|--|-----------------------|
| Haying No fertilization (A) | >70% | Many thick and thin roots in layer 0-0.15m | Good |
| Pasturing Fertilisation < 70kgN/ha oder 7-8 times pasturing without fertilization (B) | >85% | Many thin roots in layer 0-0.18m | Average |
| Pasturing and fertilization >70kgN/ha; Herbicide (C) | >85% | Few thin roots in layer 0-0.05m | Poor |
| Haying; Fertilization without removal (D) | <60% | Particular thick roots in layer 0-0.15m | Poor |

Figure 6.6: Evaluation of strength by management (VTV, 2004, modified)

Figure 6.7 shows that quality is judged by management features like fertilization haying or pasturing which are divided in classes from A to D. The other characteristics are canopy cover with an approximate percentage from 85 to less than 60 and thickness and length of roots, but VTV 2004 gives no practical values to evaluate quality of grass cover.

The second one depends on root density. At a rectangular place of 5-5m 4 spots, which are placed individually, are penetrated and cut out. Diameter of spots is 3cm and upper part is divided into parts of 2,5cm (figure 6.8, left side). The whole length of this penetration is 20cm. After penetration roots are counted, but just these with a length of 1cm or more. The roots which are shorter are not important for this evaluation. Figure 6.7 shows categories linked to number of roots, so dike surveyors can choose a category depending on root density (Figure 6.7).

| Category | Root density |
|-----------------|---------------------|
| 0 | No roots |
| 1 | 1-5 roots |
| 2 | 6-10 roots |
| 3 | 11-20 roots |
| 4 | 21-40 roots |
| 5 | > 40 roots |

Figure 6.7: Density of roots and Categories (VTV, 2004, modified)

Also length of roots is important to find a categorization, because as told before, penetration is divided into 2.5cm deep parts, so you can divide number of counted roots could be divided to each depth in soil. Number of roots will be registered in a table shown in figure 6.8 at the left side and will be transferred to a diagram. This diagram is divided into parts from very poor (purple field) till good (green field).

As example VTV 2004 has chosen an average grass cover.

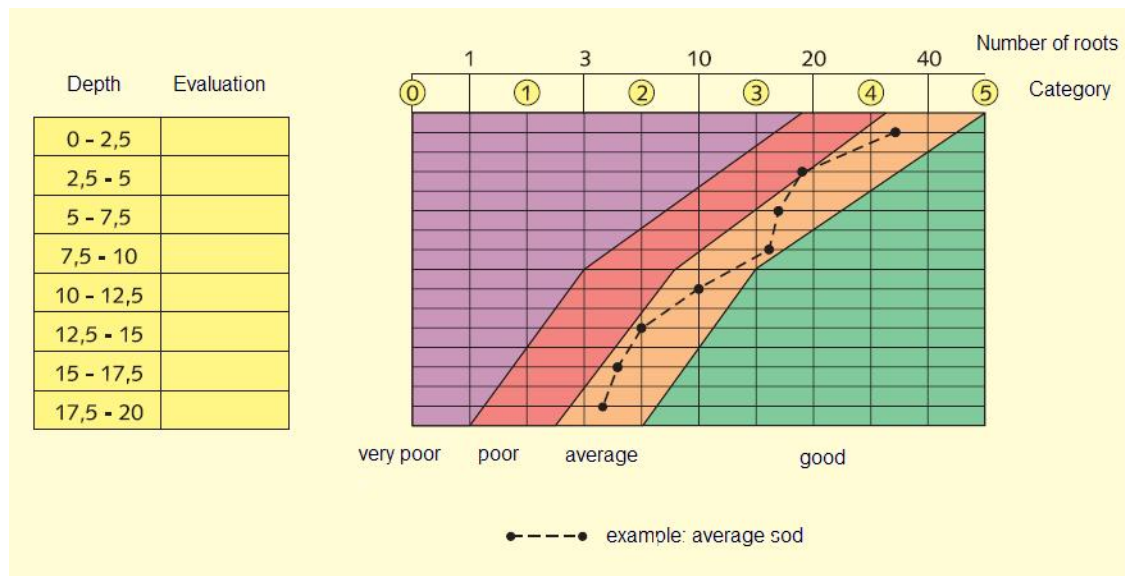

Figure 6.8: Evaluation of strength by roots (VTV, 2004, modified)

6.2.3 Conclusions

VTV 2004 recommendations about quality of grass cover and evaluating are divided into two parts. First required quality will be calculated by using duration of wave load and water run up velocity on sea side slopes, but makes simplifications by using same water velocity on sea side slope as on inner slope.

As second part, the present quality of grass cover is evaluated, but VTV 2004 gives no exact information about the evaluation procedure. It shows tables about thin or thick roots, but gives no details about diameter, but divides it in categories. At this moment the categories and evaluation of categories is in discussion, because the engineering background is missing.

6.3 EPM (Bos, 2006)

In reality the turf of a dike is never in full intact or has a complete dense cover. There are local failures caused by soil fauna or open spots. Failures and open spots support erosion by giving a point of attack to the flow forces.

Van den Bos (2006) developed a model which is concerned with spots without a grass layer, the so called "spots susceptible to erosion" („Erosiegevoelige Plekken Model“). Indeed the slope offers no grass at an open spot, so van den Bos (2006) idealized soil layer with a hole (Figure 6.9).



Figure 6.9: Spot susceptible to erosion (Bos v. d. 2006)

He based his model on the theory of Breusers (1966) who divided the scouring process of a hole or a spot susceptible to erosion into 4 phases (Figure 6.10) as followed in the initial, development, stabilization and equilibrium phase.

Formula of Breusers taken from Hoffmans (1998) is valid for the development phase. This means that the time at the first measurement of scouring depth t is lower as the characteristic time at the moment of the second measurement t_1 .

So, the important phase is the developing phase and Breusers gives a formula for scouring as followed:

$$\frac{y_m}{\lambda} = \left(\frac{t}{t_1} \right)^\gamma \quad 6.3$$

y_m = depth of erosion

λ_m = characteristic length

t = time

γ = coefficient (0,4 – 0,8)

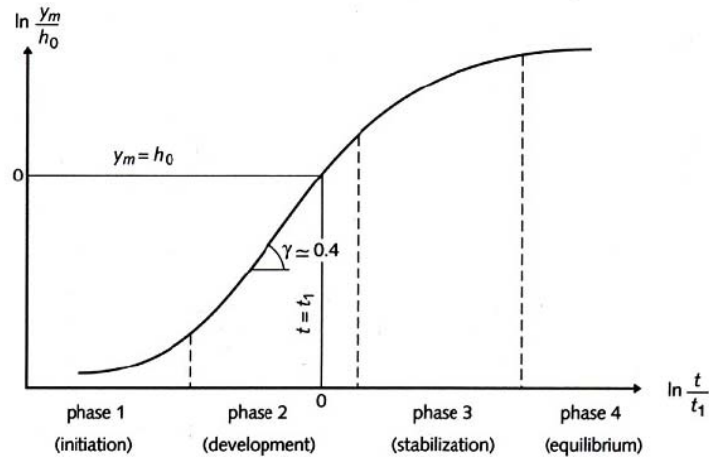

Figure 6.10: Four phases of scouring (Bos, v. d. ,2006)

Breusers has defined the characteristic time t_1 as:

$$t_1 = \frac{\text{Volume of scouring}}{\text{sediment transport}} = \frac{V}{s} \quad 6.4$$

By calibration of Breusers formula and defining all parameters, the central equation of EPM results to:

$$\frac{y_m}{\lambda_m} = \left(\frac{(\alpha U_0 - U_c)^2}{C \Delta^{1.7}} \right) t \quad 6.5$$

C is constant

α is coefficient of turbulence

U_0 is average velocity of flow

U_c is average critical velocity of flow

Δ is relative density

On basis of this calibration, the characteristic time will be:

$$t_1 = \frac{K \lambda_m^2 \Delta^{1.1}}{(\alpha U_0 - U_c)^{4.3}} \quad 6.6$$

EPM makes possible to describe the depth of an open spot according to the time. So, this is a good way to quantify spots which are in real danger of being eroded.

6.3.1 Loads

Loads causing erosion on a slope especially are shear stresses. Shear stresses are related to velocity of flow. Slope beds tolerate a characteristic flow velocity which describes the velocity that is necessary to cause scouring. In an overtopping test, velocities on the inner slope are measured and described with a cosines function (Figure 6.11):

$$U(t) = U_{\max,0} \cos\left(\frac{2\pi}{A}t\right) \quad \text{for} \quad 0 \leq \frac{2\pi}{A}t \leq \frac{1}{2}\pi \quad 6.7$$

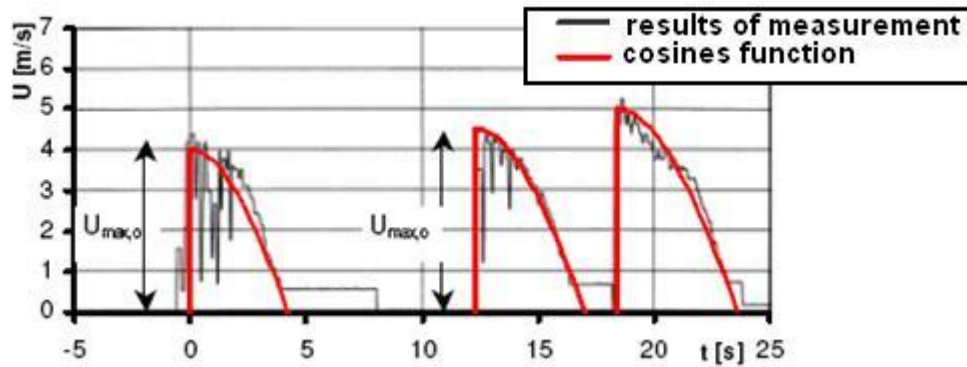

Figure 6.11: Characteristic velocities of flow (Bos, 2006)

The characteristic velocity is calculated as:

$$U_K = \frac{1}{\alpha} \left(\sqrt{\frac{\int (\alpha U(t) - U_c)^2 dt}{t}} + U_c \right) \quad 6.8$$

Both equations combined lead to:

$$U_K = \frac{1}{\alpha} \left(\sqrt{\left(\frac{1}{\sqrt{2}} \alpha U_{\max,0} - U_c\right)^2 + \left(\sqrt{2} - \frac{4}{\pi}\right) \alpha U_{\max,0} U_c} + U_c \right) \quad 6.9$$

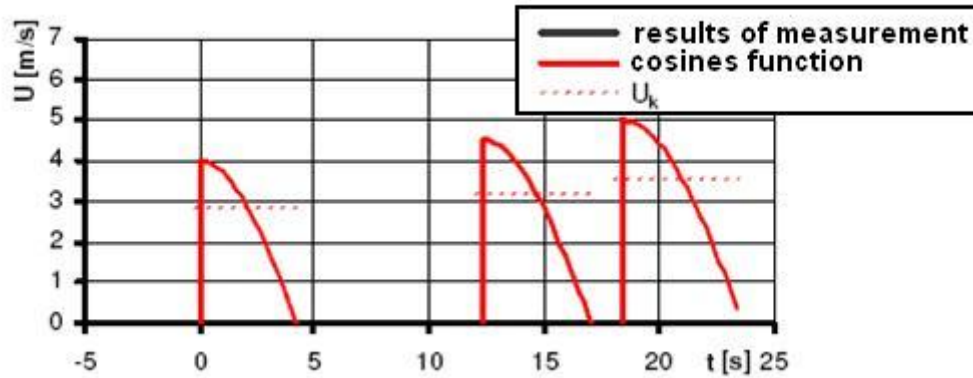

Figure 6.12: Presentation of characteristic velocity of flow (v.d.Bos, 2006)

A simplification is made for the case of $U_{\max} > U_c$, so characteristic velocities are calculated as followed:

$$U_K = \frac{1}{\sqrt{2}} U_{\max} \quad 6.10$$

Characteristic velocity is equivalent to approximated values (Figure 6.12).

The velocity U_0 will be calculated with formulas of Schüttrumpf (2001). EPM uses the velocity on an inner slope, which is calculated with half of the velocity of the sea side slope.

6.3.2 Strength

EPM was calibrated and validated by the results of several tests like in Flevoland (Jong, 1970). For a range of velocity, the scouring depth of an open spot was measured and results are shown in Figure 6.13.

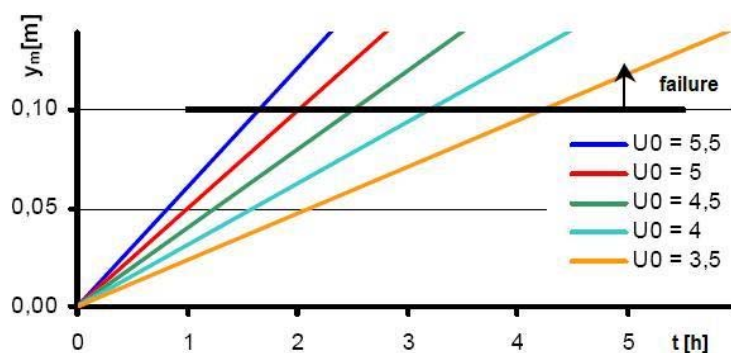

Figure 6.13: Influence of flow velocity and moment of failure (Bos, v. d. ,2006)

Taking into account that the turf is only from 10 to 20 cm thick, a maximum of scouring depth $y_m=10\text{cm}$ is the failure condition of EPM.

Figure 6.14 shows the acceptable velocity in relation to duration of loading.

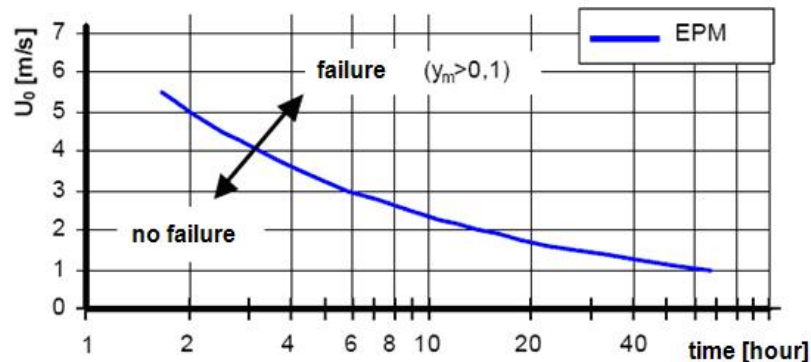

Figure 6.14: Moment of failure by EPM (Bos, v. d. ,2006)

6.3.3 Conclusions

In contrast to VTV 2004, EPM (2006) is concerned with the load on the landside slope. Velocity of flow U_0 is calculated according to considerations of Schuettrumpf. Velocity on inner slopes must be bigger than the critical velocity U_C , because this interrelationship describes the transport of sediments in the development phase.

As resistance offer EPM the scouring of an open spot. An open spot can be scoured till a depth of 10 cm. After a depth of 10 cm a spot completely is eroded, because a grass layer is just a few centimeters deeper, so the cohesive layer would be without any protection against wave impact.

Summarizing, EPM physically is based and describes erosion, caused by over topping realistically. As first step the behavior of grass blades and of roots, like published in CIRIA reports and VTV, have been neglected. Unfortunately, EPM gives no information about number of open spots nor size.

6.4 Computer - aided approach and future perspectives

Additionally to numerical scour modeling, new numerical approaches have been made according to loads and covers. These numerical approaches are commissioned by Rijkswaterstaat.

There are programs in VTV (2004) mentioned as for example:

- ANAMOS: to design stone settings (by Delft Hydraulics)
- STEENTOETS: to prove stone settings (by Rijkswaterstaat, 2002)
- GOLFKLAP: to design asphalt covers concerning to wave impact (by Rijkswaterstaat, 2004)
- GRASTOETS: to prove grass covers (by Rijkswaterstaat, 2004)

All this programs work on background and considerations of VTV 2004. First three mentioned programs are concerned with other kind of revetments. ANAMOS is a program to design stone setting, but it has no implementation to prove this setting, so a second program have to be used for this verification (STEENTOETS). GOLFKLAP is a program to design asphalt covers which are loaded by wave impact.

VTV 2004 contains a program which especially is concerned with the grass layer. This program is called GRASTOETS and is based on Microsoft EXCEL. Background of GRASTOETS is the load, the counting of roots and the management categorization which was introduced by VTV 2004, so this program just transforms theories of VTV (2004).

Actually some projects concerned with dike stability and erosion are made by communities like for example ComCoast (COMBined functions in COASTal defense zones). ComCoast is an international project which is concerned with new innovative solutions to protect coast against storm floods with participation in Netherlands, Great Britain, Germany, Belgium as well as Denmark. Structure of ComCoast projects is realized in cooperation of Rijkswaterstaat as project manager.

Former projects have been a concrete flume field experiment where some overtopping test have made based on considerations by van den Meer (2005).

However these former tests have been concerned with influence of loads by overtopping, so new tests will be made in near future to observe new methods of grass reinforcement, called smart grass reinforcement. Those tests apply reinforced grass with rolled grass layers. Concept of rolling up a grass layer can be compared to a sports field turf. Layer on a dike slope near Groningen will be rolled off, smart grass reinforcement (Geogrid) is putted in between and rolled down again. Figure 6.15 presents how this principle should work.

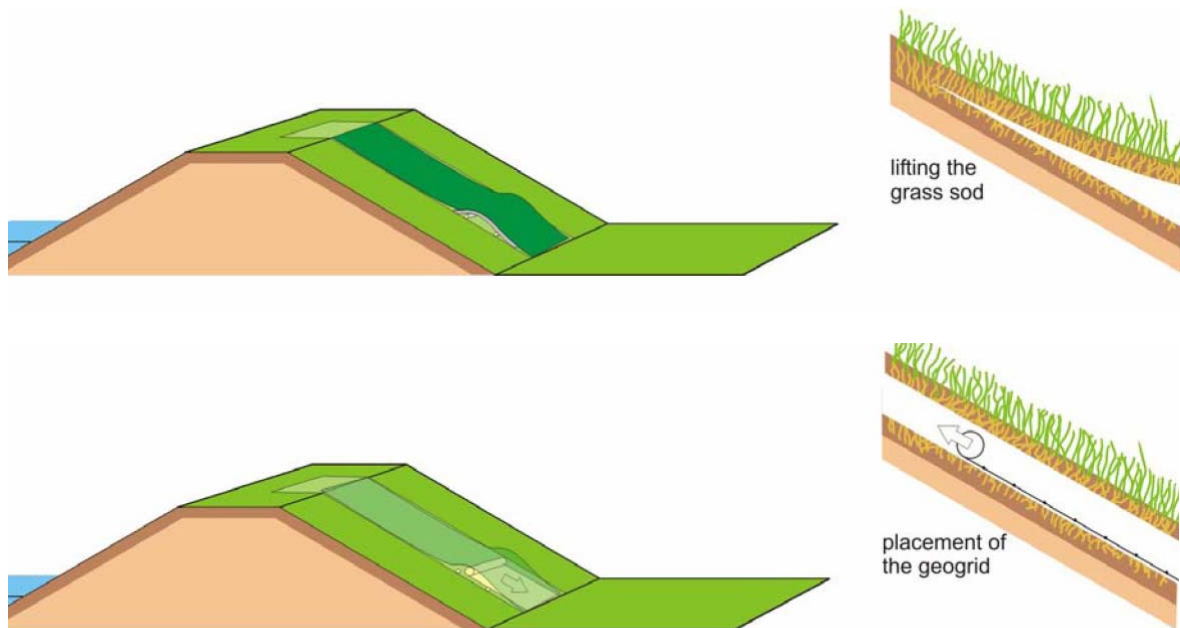

Figure 6.15: Principle of constructing reinforcement with geogrid (ComCoast, 2005)

Another principle is to press Geocells in the turf. Figure 6.16 gives an impression of both geosystems.



Figure 6.16: Geogrids and Geocells (CoamCoast, 2005)

So ComCoast make use of the overtopping machine which will be tested in autumn 2006 and real tests will occur in spring 2007 and should give more information about behavior of interaction between smart reinforcement and the turf.

ComCoast has many more new and innovative ideas. One idea is to put a drainage system at the dike crest which should take the contingent of overtopping water. Another idea is to realize a thick sand cover on dike slopes which will be eroded in case of flood, but the higher thickness will lead to the fact that there is no risk for damage, because first the sand layer has to be taken away and works as sacrification layer.

Nevertheless, final aim of these ideas should be to allow a higher overtopping rate without being scared about damaging the inner slope.

6.5 Comparison of models

Table 6.3 shows a summarized comparison between the models which were discussed in this report.

| | CIRIA (1987) | VTV (2004) | EPM (2006) |
|------------|---------------------------------|--|--|
| Age of sod | Age of sod is 2 years | Age of sod 3-5 years | Age of sod 4 years |
| Load | | Loads on inner side slope are assumed as on sea side slope | Loads are calculated for inner slopes on basis of Schüttrumpf (2001) |
| Spots | No spots susceptible to erosion | No spots susceptible to erosion | Spots susceptible to erosion |
| Background | Depends on canopy cover | Depends on quality of sod | Depends on resistance of erosion |
| Failure | | Failure is unknown | Failure expressed in a recess of the spot |

Table 6.3: Comparison of models

At first it is obvious that every model is concerned with different ages of sod. CIRIA claims the youngest age of sod, so after two years a sod can develop strength and VTV 2004 claims the oldest one. EPM specifies an age in the middle of both, but in reality age of sod is not important to EPM, because it is concerned with open spots and this means that there actually is no grass at the cover.

Adhere to statement that EPM uses no grass cover it can be said that resistance of this open spot is depending on processes of scouring. EPM is based on a scouring model and describes strength of a hole with help of the characteristic velocity of flow as well as open spots expand in the developing phase of scouring. The other ones are concerned with canopy cover and quality of grass. CIRIA

published a relationship between canopy cover and soil loss ratio. Soil loss ratio describes detachment of particles as a dimensionless value.

In contrast, VTV gives no information about roughness and canopy cover and makes evaluation by management, content of nutrient and optical criteria. Only parameter linked to management categories is velocity of erosion by Verheij (TAW, 1999), who divided categories of management with help of a erosion coefficient c_E , but in VTV (2004) any information about this coefficient is given.

Description of failure is another difference of models. Just EPM gives a failure criterion and claims a scouring depth of $y_m = 10\text{cm}$, but at least van den Bos has developed this value fictional by determining depth of the grass layer to 20 cm, so a value of depth about 50% of it would be absolute limit of scouring. Unfortunately CIRIA and VTV give no value of failure.

Finally application of loads must be compared. CIRIA is not concerned with dike slopes, so several other loads appear and other are not mentioned. On land side slopes loads like water running off are caused by rainfall and not by overtopping. Due to this fact loads are completely different, but infiltration and influence of roughness in combination with water running off are explained in detail. VTV 2004 calculates loads on sea side slope and transferred to inner slopes without considering a changing in velocity or flow by overtopping at dike crests. EPM is concerned with whole load spectra. It calculates velocity and water depth with formula of Schüttrumpf separately for every slope and for crests.

7. Approach to a design concept

Former considerations deal with load and strength as two separated factors which influence and response erosion. In an engineering consideration, it would make more sense to evaluate both together, the strength and the load.

Figure 7.1 shows how influence of both will be combined and reveals, if strength (A) is reduced, than a slope could just be loaded with lower forces (B). So the other way round, if loads (B) decrease than logically a slope do not need such a high revetment (A) as before. After considering both sides together, it can be simply said, that if A is equal to B than no erosion occurs.

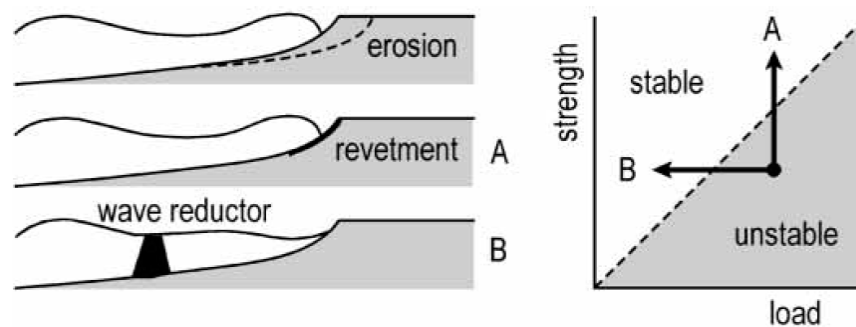

Figure 7.1 : Interaction of load and strength (Schierreck, 2001)

Both, A and B, are influenced by vegetation. Sward and blades of sward can be compared to a wave- or flow reductor, because roughness of vegetation reduces velocity and will cause a lower load. Additionally roots form a revetment with certain strength of roots and strength of roots is depending on cohesion of roots. So a higher cohesion of roots will cause an increasing strength.

If A and B would be combined than a concept to judge erosion stability can be given as followed:

$$\tau_A = \tau_B \quad \text{or} \quad \frac{\tau_B}{\tau_A} \leq 1 \quad 7.1$$

τ_A and τ_B are resisting and acting shear stresses.

7.1 Evaluation of strength

Erosion mechanisms of vegetated soil could be divided into three parts which occur with a temporally dependency (Figure 7.2). First mechanism of erosion happens near surface at the borderline between water running down a slope and the top soil of grass layer. Loose sediments and particles are scoured out of the grass cover and leave a point of attack to response degradation. This appearing damage can be easily described with scouring models, because in this moment roots of grass layer are not yet active. Second mechanism could be that aggregates are washed out of the top layer. In the beginning small aggregates are carried out and in progress are bigger clods taken away. At this time roots activate their strength. Roots of grass cover resist the load of water by their friction and their tensile strength. At last the roots will fail by being pullout or tearing up and a description of strength could be made by friction of roots again.

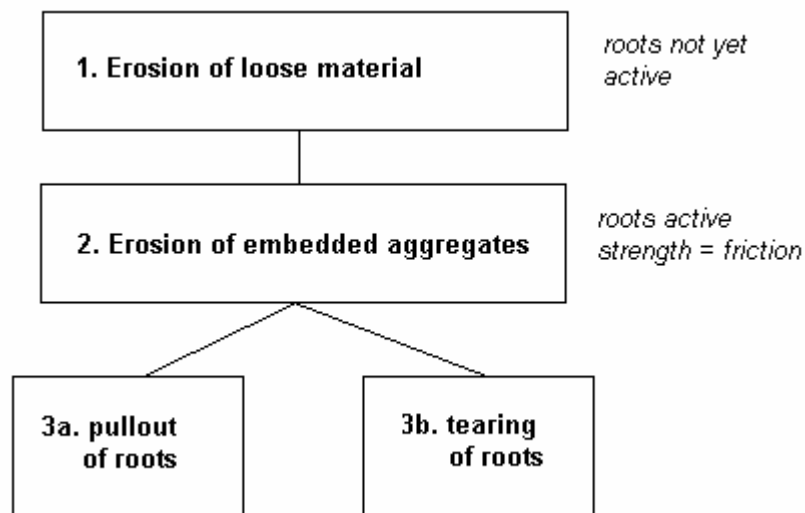

Figure 7.2: Scheme of strength

7.1.1 Erosion of loose material at surface

After loose sediments and particles are carried out than clods and aggregates near surface are laying blank. It can be said that these aggregates are not yet embedded in the system of roots responded to their position close to surface and the fact that roots are not fully developed at the borderline.

Considering figure 7.3, it can be concluded in this case the resistance τ can be described by soil cohesion c' . Force of flow S and weight of soil G can be neglected, because direction of influence is positive to erosion.

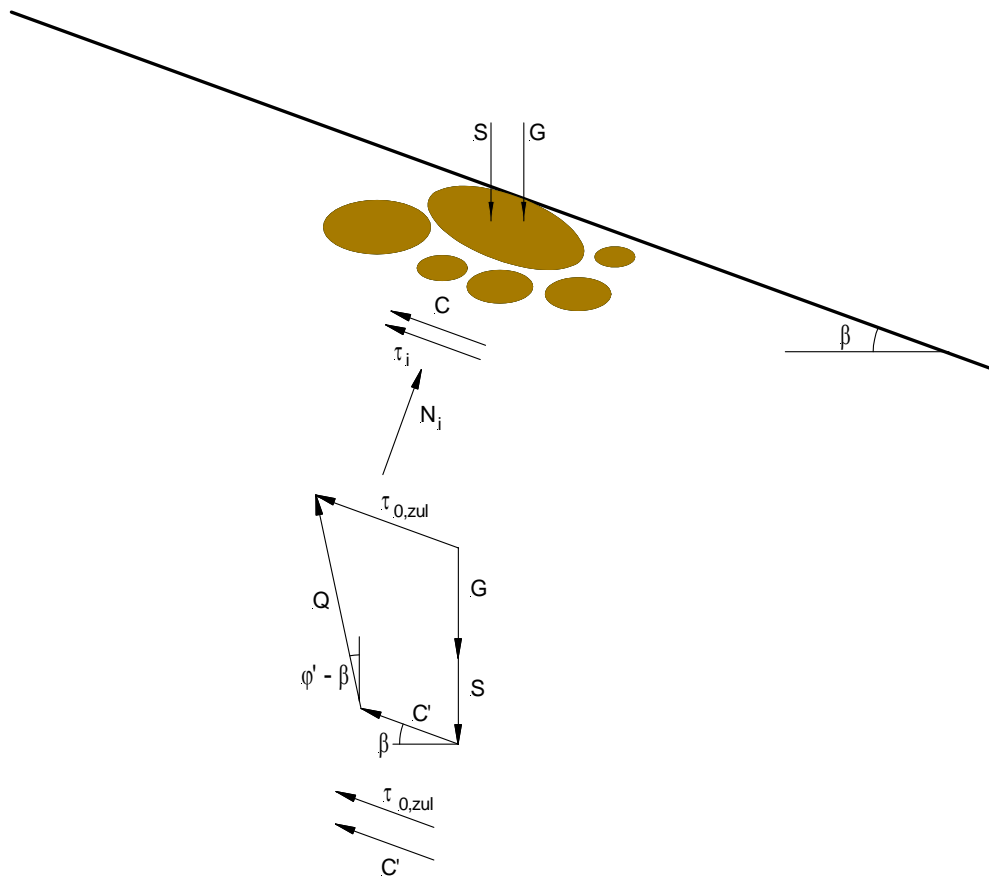

Figure 7.3: Scheme of first detachment

Polygon of forces reduces to soil cohesion c' and this c' is the resistance of soil τ .

So, in this first step, strength against erosion can be simplified defined as followed:

$$\tau_A = c' \quad 7.2$$

7.1.2 Erosion of root embedded aggregates

In this second case of erosion, aggregates must separate from the root-soil-system. Acting like the principle of erosion at surface, erosion of root embedded aggregates is described by a mechanical model in figure 7.4.

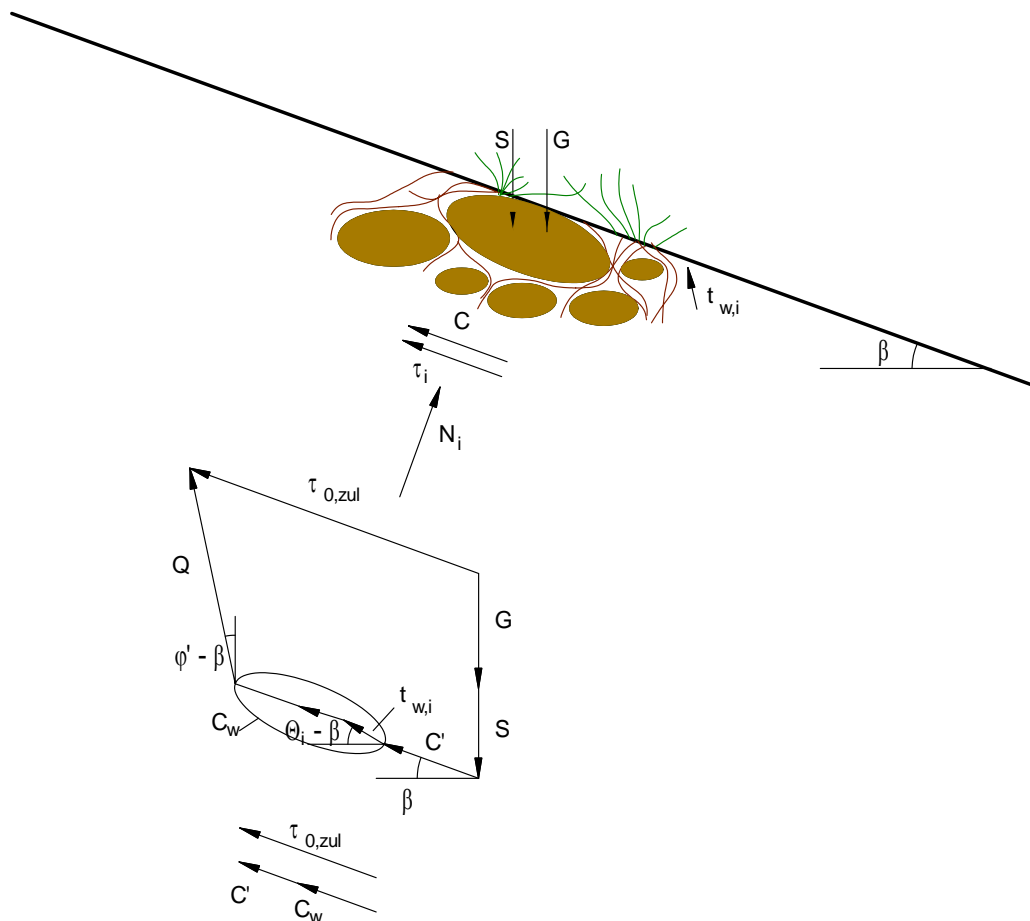

Figure 7.4: Erosion of root embedded aggregates

In difference to erosion of loose material, slope parallel strength of root cohesion c_w is added in sum of all surrounded roots to cohesion of soil. If forces of flow as well as weight of soil are neglected again than the simplification for the polygon of forces can be given as:

$$\tau_A = C' + C_w$$

The sum of strength of every single root in the shear gap corresponds to the cohesion of roots which is treated in analogy to soil cohesion as slope parallel. Nevertheless, application of root cohesion must be taken with care as far as tensile strength of a root is activated by high displacements, because a root has a high elasticity. Due to the high displacements, the risk is given that aggregates slide out of the root soil system without any influence of the root cohesion, so it is safer to deal with a reduced cohesion of root c_w^* .

Due to this reduction, strength of roots are described as:

$$\tau_A = c' + c_w^* \quad 7.3$$

7.1.3 Failure of roots

The last case of erosion can be seen as failure of roots at the time when soil is eroded and roots are pulled out or teared.

Some mechanical considerations lead to a description of this state of erosion. Figure 7.5 shows a mechanical consideration about friction and how it can be modeled. A force F which wants to pullout an aggregate is in balance to a reaction force F^* . This force F^* describes the strength that a root has against being pulled out and can be calculated with the mechanical friction law $F^* = \mu \cdot N$ with N as a force rectangular to F^* and μ as a friction coefficient. The force N is evaluated with a mean stress in depth direction and leads to $N = \frac{1}{2} \gamma \cdot b \cdot L^2$. So, if F is $4 \cdot F^*$ is valid than the tensile force F that an aggregate can take, will be calculated as:

$$F = \mu \cdot \frac{1}{2} \cdot \gamma \cdot b \cdot L^2 \quad 7.4$$

If this force exceeds than roots will be carried out.

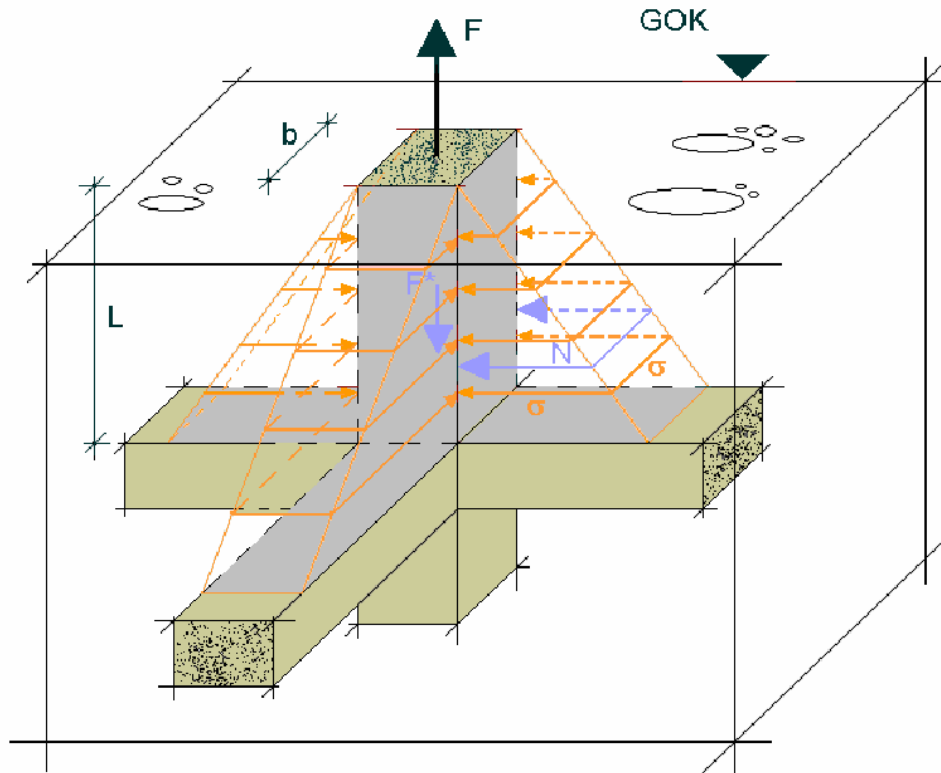

Figure 7.5: Pullout of roots

Roots will not only fail by being pulled out, but as well by tearing, so strength of roots can be described with help of tensile strength of roots $t_{w,i}$ per area, so strength is defined as:

$$\tau_A = \sum t_{w,i} \cdot \frac{A_i}{A_{tot}} \quad 7.5$$

Where at A_i is the rooted area and A_{tot} the whole regarded area.

7.2 Evaluation of load

Calculating a load caused by flowing water is difficult, especially at the slope surface, because water shows in bed area a non uniform behavior. Flow of water shows turbulences as well as eddies which influence the energy line and

connected to this, it is hard to describe velocity of flow, so some simplifications are necessary to calculate bed shear stress.

First mechanical formulation is a static approximation. The weight of a single water particle presses on bed with ρgh as vertical component to slope bed. Second component will exist parallel to the slope bed and is ρghS , where S is the gradient of slope which is calculated as the sine of slope angle.

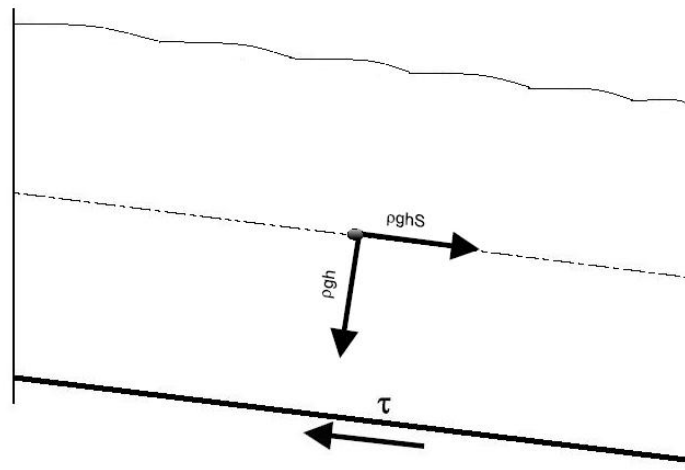

Figure 7.6: Definition of shear stress caused by flow

Figure 7.6 shows a definition of shear stress caused by flow and critical bed shear stress can be calculated as followed:

$$\tau = \rho ghS \quad 7.6$$

With help of equation 7.6 and some fictional depth of water from 0,05 to 5m the shear stresses on slope surface will be calculated. Table 7.1 shows the results of shear stress which are quite low. For example a depth of water $h=10\text{cm}$ creates a shear stress $\tau_B = 0,1702 \text{ kN/m}^2$ and such a little shear stress will never response erosion on a dike slope. So, this approach does not lead to a usable shear stress. Nevertheless the critical shear stress can be evaluated with help of velocity of flow, because shear stress mainly depends on velocity of flow.

But another problem will be that flow velocity is not constant with depth of water h so the velocity at bed is approximate zero, what is a simplification, because at a bed exists turbulences and eddies which makes a realistic mechanical description

complicated. Due to this fact another simplification is that a uniform flow is postulated.

| depth [m] | shear stress [kN/m ²] |
|-----------|-----------------------------------|
| 0,05 | 0,085087607 |
| 0,1 | 0,170175214 |
| 0,15 | 0,255262821 |
| 0,2 | 0,340350428 |
| 0,5 | 0,850876071 |

Table 7.1.: Results of shear stress depending of depth

The simplification to define S as $\sin \alpha$ is just valid for an ideal smooth underground, but a rough slope has a high loss of energy, so concerning this the before mentioned formulation is transferred to:

$$\tau_B = \rho g l \quad 7.7$$

Where at l is slope of energy and is defined by Manning-Strickler as followed:

$$l = \frac{v^2}{\left(\frac{1}{n}\right)^2 r_{hy}^{4/3}} \quad 7.8$$

Concerning the slope of energy, the shear stress of water can be given as:

$$\tau_B = \rho g h \frac{v^2}{\left(\frac{1}{n}\right)^2 r_{hy}^{4/3}}, \text{ where } r_{hy} \text{ is the hydraulic radius is defined as followed:}$$

$$r_{hy} = \frac{A}{U} = \frac{bh}{b+2h} = \frac{h}{1+2\frac{h}{b}} \quad 7.9$$

Additionally a wide of slope, b will be infinite, so it can be simply said that $r_{hy}=h$.

Due to the simplification of the hydraulic radius and some mathematical changing's than the shear stress can be calculated as:

$$\tau = \rho v^2 \frac{n^2 g}{h^{1/3}} \quad 7.10$$

Dealing with roughness n of grass cover than Chezy coefficient C and roughness f have to be compared as followed:

$$C = \frac{1}{n} R^{1/6} \quad 7.11$$

$$f = \frac{g}{C^2} \quad 7.12$$

respectively the relation of n and f follows to:

$$f = \frac{n^2 g}{h^{1/3}} \quad 7.13$$

Compared to the equation of roughness than the shear stress can be formulated by Shields (Hoffmans, 1998):

$$\tau = \rho v^2 f \quad 7.14$$

With help of equation 7.13, roughness f can be transformed into Manning's n and Table 7.2 gives some examples for a depth of water $h=0,2\text{m}$.

Due to equation 7.14 shear stresses are calculated for different n and several running off velocities. Results of these calculations are presented in figure 7.7 and 7.8.

The relation of Manning's n and shear stress seems to be obvious. A high roughness slows down the flow of water, but it delivers high values of shear stresses. So, a dense grass with a coefficient $n=0,25$ presents with a velocity $v=4 \text{ m/s}$ as well as a water depth $h=0,1\text{m}$ a shear stress of around 21 kN/m^2 .

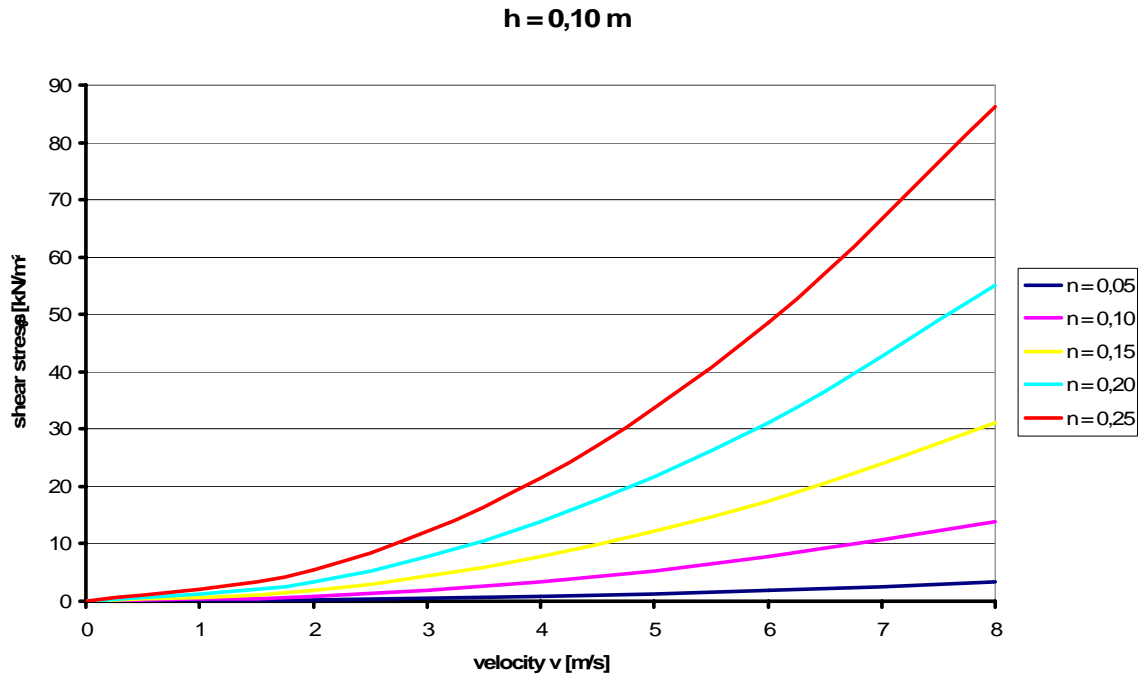

Figure 7.7: Shear stresses with $h=0,1\text{m}$ for several velocities and Manning's n

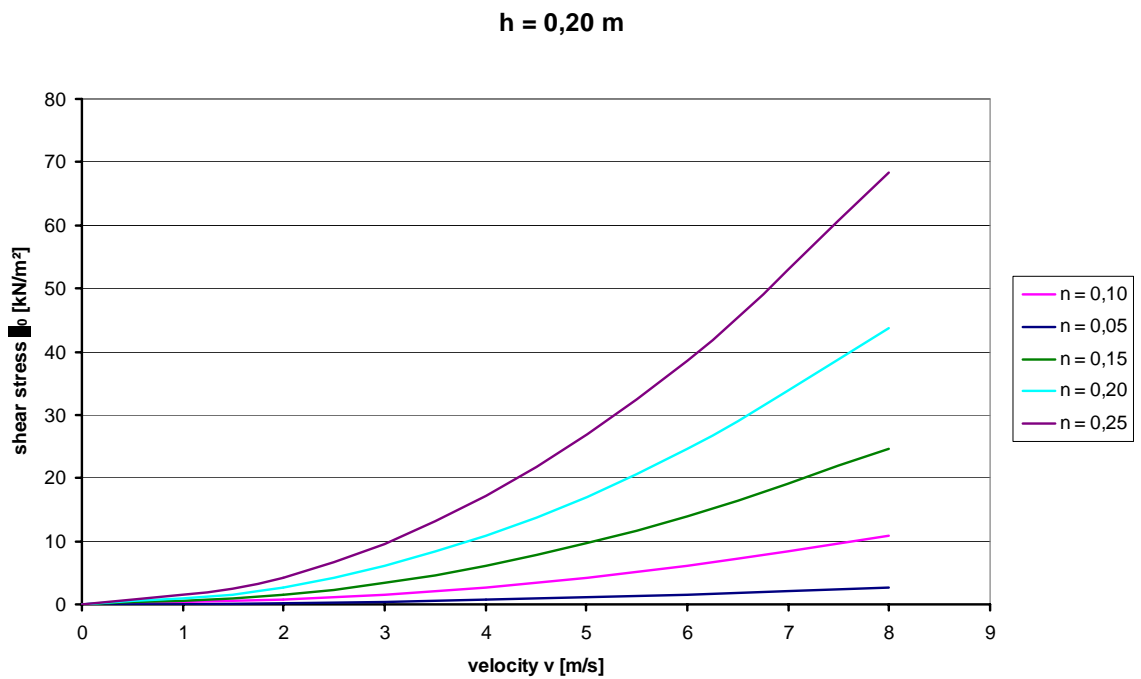

Figure 7.8: Shear stresses with $h=0,20\text{m}$ for several velocities and Manning's n

| | n | f |
|----------------|------|--------|
| Bare clay loam | 0,02 | 0,0067 |
| Short grass | 0,15 | 0,38 |
| Dense grass | 0,24 | 0,97 |

Table 7.2: Transformation of n into f with a depth of water $h=0,2m$

7.3 Approach to design concept

In contemplation of van Rijn (1993) a stochastic approach to define initiation of motion has been made. A standard distributed stress τ_B describes bed shear stress caused by flow. On the other hand, τ_A is shear stress of the turf which can be, according to a bed shear stress, although denifined as standard deviation.

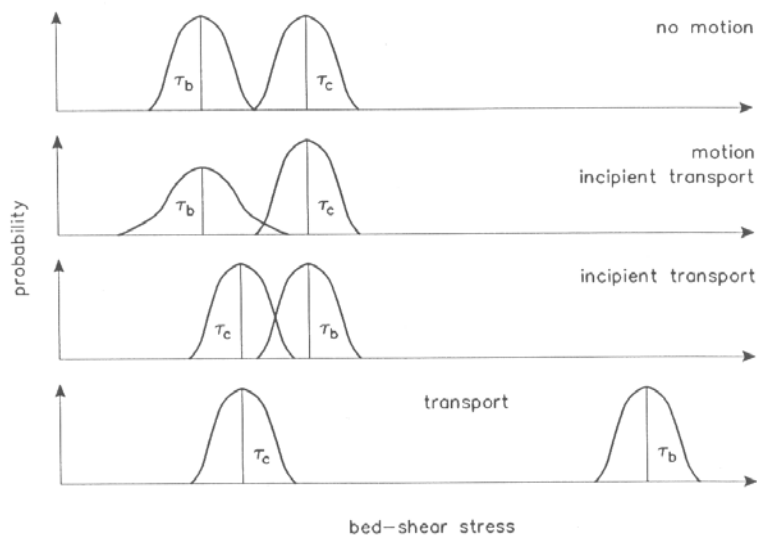

Figure 7.9: Stochastic approach to a design concept (van Rijn, 1993)

Considering Figure 7.1 and connection of τ_A and τ_B as called general A and B before, Figure 7.9 describes the same thesis on basis of a stochastic approach.

If τ_B is less than τ_A will occur no motion of particle. At the time as both overlap than motion of particle appears and associated to increasing τ_B also erosion increases.

Contemplation of this stochastic approach can be concerned that shear stresses of water as well as strength of the grass cover are not constant on a slope. Considering that a grass cover consists of mixed seed and has several growing attributes this will lead to a grass cover which is different at every part of a dike. So it makes sense to look at this approach in stochastic ways.

To evaluate this concept an example is calculated, but the standard deviation is not yet attached.

Figure 7.10 presents how the concept should work. First the shear stresses of flow will be calculated.

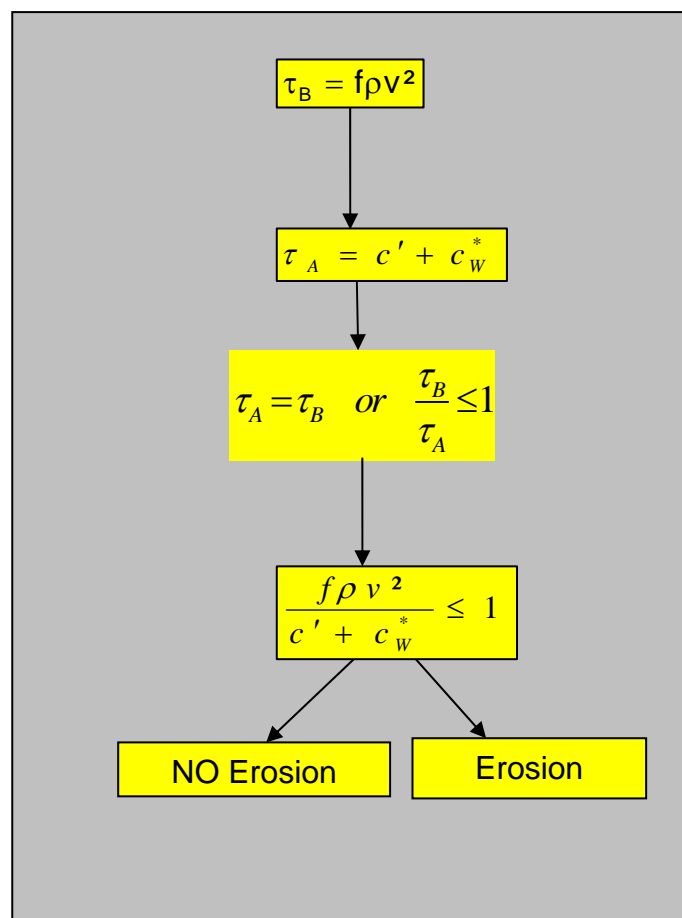

Figure 7.10: scheme of erosion

As shown before the shear stress is effected by Manning's n , so in this application a roughness of a dense grass ($n=0,24$) till a short grass ($n=0,15$) is used. Figure 7.11 shows the results of shear stress in dependency of roughness as well as velocity which is the running down and has a variety from 1 to 4 m/s. In the second

step the reduced cohesion of roots c_w^* is given with a range from 2 to 5kN/m². Strength of soil has been neglected for this example.

In the third step the cohesion of roots is compared with the calculated loads and finally can be chosen if erosion or no erosion occurs.

Also, figure 7.11 presents the results of three grass layers with several roughness coefficients. The layer with $n=0,24$ can take a velocity around 1 to 1,3 m/s with support of a root cohesion and in this case no erosion occurs. Higher velocities lead to higher shear stresses, so an increasing cohesion is needed.

The turf with $n=0,15$ can take higher velocities, but in dependency of roughness the shear stresses are lower. So at an inner slope and with velocities around 2 m/s it can be said that cohesion of roots with 2kN/m² can resist erosion. Nevertheless increasing velocities lead to higher shear stresses.

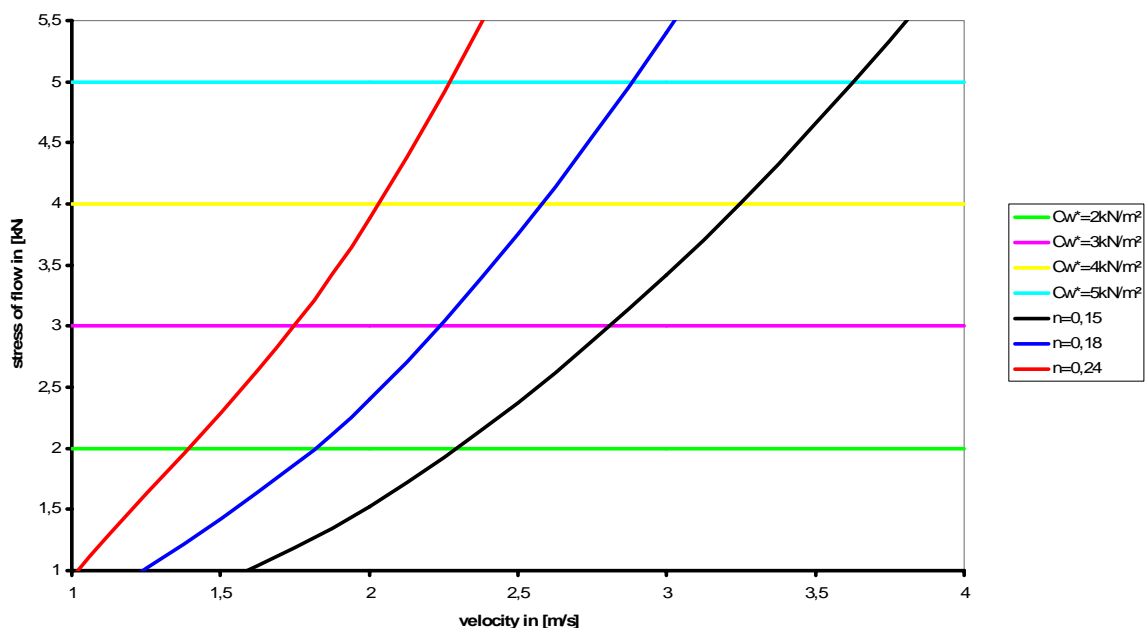

Figure 7.11: results of the scheme of erosion ($h=0,2m$)

The before mentioned probabilistic approach is not installed in this simplified concept to evaluate erosion. Advanced efforts must be to attach a standard deviation into this concept.

8. Summary and conclusions

Studies concerned with erosion on dike slopes and function of grass cover as resistance against erosion have shown some technical expertise.

Grass cover can be divided in two zones. First zone is underground which consists of the topsoil and subsoil. Topsoil exists of clay with a content of sand and humus where the main part of roots grows. Subsoil has, in contrast to the elastic topsoil, heavy and plastic clay with a lower density of roots. Nevertheless roots of both soil layers connect aggregates and construct reinforcement. Second zone of grass cover is the sward at surface. Grass at surface has a significant influence on water running down velocity, because length of grass has an effect on roughness of the turf on a large scale.

Water running up and running down velocity has been described with present models of EAK 2002 and is quantified with example calculations. Calculations present a higher overtopping rate as supposed before, and this is important to keep in mind, because overtopping water releases erosion processes.

It is well known that erosion processes can be divided in two parts. Transport processes are well described in literature and well known, but about detachment process in combination with roots still exists a lack of information. Certainly tests about erosion in combination with roots have been made, but no experience about interaction of roots and soil in an engineering sense could be made.

On the other hand observations concerned with shear strength of grass cover have been made, which results, that cohesion of roots can be concluded from tensile strength of roots. Supported by cohesion of roots strength of grass cover could be calculated.

Nevertheless diverse models to describe erosion on dike slopes have been created, but most of them show weak spots. CIRIA is occupied with slopes on landscapes, so loads on landscape slopes are caused by rainfall and can not be compared with loads responded by waves. Model of VTV 2004 is concerned with dike slopes, but loads on inner slopes will be equated with loads on the sea side slope and this leads to an inexact magnitude of load. Also EPM is concerned with

dike slopes and describes loads exactly by application of present models, but in EPM the grass cover is neglected. So no model exists which is concerned with all parameters.

In this report a new model is developed which characterizes detachment processes on a large scale. Detachment of loose material can be evaluated by present scouring models, but application of soil cohesion is an alternative which is suggested by this new concept. Evaluation supported by cohesion of soil makes sense, because cohesion of roots can be added and strength of roots is included in this way. Additionally pulling out or tearing into pieces of roots can be quantified with considerations of technical mechanics. At the moment this new model specifies interaction of soil and roots simplified and must be extended by probabilistic considerations due to the irregular growing habit of grass cover. So this model is just a first step and must be enhanced.

Advantages of this model are that consequences of grass on the load can be evaluated as well as loads and grass can be combined. Due to climatic changing and the rising water level as a result of this changing climate, it must be higher overtopping rates allowed. So it becomes important to develop a concept which can describe grass cover exactly and realistic. The concept that has been developed in this report gives a good basis for subsequent considerations, but it must be verified in tests and a concept of safety must be included.

Finally it has to be gratefully mentioned that without help and support of the TU Delft it would never been possible to gain in such a short period of time so many experience on such a large scale about grass cover and loads.

| Dutch name | Scientific name | English name |
|---------------------|--------------------------------|---------------------------|
| Akkerdistel | <i>Cirsium arvense</i> | Creeping Thistle |
| Akkerhoornbloem | <i>Cerastium arvense</i> | Field Mouse-ear Chickweed |
| Beemdlangetbloem | <i>Festuca pratensis</i> | Meadow Fescue |
| Brunel | <i>Prunella vulgaris</i> | Self-heal |
| Echte kruisdistel | <i>Eryngium campestre</i> | Field Eryngo |
| Engels raai gras | <i>Lolium perenne</i> | Perennial Rye-grass |
| Fluitenkruid | <i>Anthriscus sylvestris</i> | Cow Parsley |
| Geel walstro | <i>Galium verum</i> | Yellow Bedstraw |
| Gewone berenklauw | <i>Heracleum sphondylium</i> | Cow Parsnip |
| Gewone zandmuur | <i>Arenaria serpyllifolia</i> | Thymeleaf Sandwort |
| Gewoon herderstasje | <i>Capsella bursa-pastoris</i> | Shepherd's Purse |
| Gewoon reukgras | <i>Anthoxanthum odoratum</i> | Sweet Vernal Grass |
| Glad walstro | <i>Galium mollugo</i> | Hedge Bedstraw |
| Grote brandnetel | <i>Urtica dioica</i> | Stinging Nettle |
| Grote streepzaad | <i>Crepis biennis</i> | Rough Hawk's-beard |
| Grote tijm | <i>Thymus pulegioides</i> | Broad-leaved Thyme |
| Grote vossenstaart | <i>Alopecurus pratensis</i> | Meadow Foxtail |
| Heggewikke | <i>Vicia sepium</i> | Bush Vetch |
| Heksenmelk | <i>Euphorbia esula</i> | Leafy Spurge |
| Hondsdrif | <i>Glechoma hederacea</i> | Ground-ivy |
| Jakobskruiskruid | <i>Senecio jacobaea</i> | Ragwort |
| Kamgras | <i>Cynosurus cristatus</i> | Crested Dog's-tail |
| Kleefkruid | <i>Galium aparine</i> | Goosegrass |
| Kleine bevernel | <i>Pimpinella saxifraga</i> | Burnet Saxifrage |
| Kleine leeuwentand | <i>Leontodon saxatilis</i> | Lesser Hawkbit |
| Knolboterbloem | <i>Ranunculus bulbosus</i> | Bulbous Buttercup |
| Kruisbladwalstro | <i>Cruciata laevipes</i> | Crosswort |
| Madeliefje | <i>Bellis perennis</i> | Daisy |
| Muizenoor | <i>Hieracium pilosella</i> | Mouse-ear hawkweed |
| Rapunzelklokje | <i>Campanula rapunculus</i> | Rampion |
| Ridderzuring | <i>Rumex obtusifolius</i> | Round-leaved Dock |
| Rood zwenkgras | <i>Festuca rubra</i> | Red Fescue |
| Scherpe boterbloem | <i>Ranunculus acris</i> | Meadow buttercup |
| Slikkelklaver | <i>Medicago falcata</i> | Sickle Medick |
| Straatgras | <i>Poa annua</i> | Annual Meadow-grass |
| Timotee gras | <i>Phleum pratensis</i> | Timothy |
| Tril gras | <i>Briza media</i> | Quaking-grass |
| Veldsalie | <i>Salvia pratensis</i> | Meadow clary |
| Vijfvingerkruid | <i>Potentilla reptans</i> | Cinquefoil |
| Viltig kruiskruid | <i>Senecio erucifolius</i> | Hoary groundsel |
| Vogelmuur | <i>Stellaria media</i> | Chickweed |
| Wilde marjolein | <i>Origanum vulgare</i> | Wild Marjoram |
| Zachte haver | <i>Avenula pubescens</i> | Hairy Oat-grass |
| Zachte ooievaarsbek | <i>Geranium molle</i> | Dove's-foot Crane's-bill |

Appendix A: This table shows translations of Dutch names into scientific meanings and the English names

| Type of vegetation | Management | canopy cover | density of roots | Quality of sod |
|--|------------|----------------------------|------------------|----------------|
| P: Pioniervegetatie (< 4 jaar) Soortenarme pioniergemeenschap op pas ingezaaide dijken. <u>Kenmerkende soorten:</u> Kweek, Engels raaigras, Straatgras, Herderstasje, Akkerdistel, Echte Kamille, Krulzuring, Vogelmuur, Witte klaver, Klein kruiskruid | D | average-poor | poor | poor |
| Weiland | | | | |
| W1: Beemdgras-raaigrasweide Soortenarm productieweiland, bemest en intensief beweid, gebruik van herbiciden <u>Kenmerkende soorten:</u> Engels raaigras, Kropaar, Kweek, Fioringras, Kruiptie, Rietzwenkgras, Zachte dravik, Paardebloem, Gewone hoornbloem, Vogelmuur, Herderstasje | D/C | good | poor | poor |
| W2: Soortenarme kamgrasweide Relatief soortenarm, onbemest tot licht bemest, periodiek weiden met schapen, incl. bloten. Ook gazonbeheer. <u>Kenmerkende soorten:</u> Engels raaigras, Rood zwenkgras, Fioringras, Kamgras, Zachte dravik, Gewoon duizendblad, Madeliefje, Zachte ooievaarsbek, Gewone hoornbloem, Kleine klaver, Witte klaver | B | good | average | average |
| W3: Soortenrijke kamgrasweide Relatief soortenrijk, onbemest, periodiek weiden met schapen, incl. bloten <u>Kenmerkende soorten:</u> Rood zwenkgras, Fioringras, Kamgras, Engels raaigras, Gewoon straaigras, Zachte dravik, Goudhaver, Gewoon duizendblad, Madeliefje, Kleine leeuwetand, Hopklaver, Smalle weegbree, Kleine klaver, Witte klaver, Knolboterbloem, en vele andere kruiden | A | regular | good | good |
| Hooiland | | | | |
| R: Ruig hooiland Verruigd, soortenarm glanshaver-hooiland, geklepelmaaid <u>Kenmerkende soorten:</u> (Groot aandeel ruigtelkruiden) Kweek, Kropaar, Glanshaver, soms Grote Veenstaart, Akkerdistel, Bereklauw, Hondsdraf, Veenwortel, Grote brandnetel | D | very poor, many open spots | poor-heterogen | poor |
| H1: Soortenarm hooiland Bemest hooiland <u>Kenmerkende soorten:</u> Kweek, Glanshaver, Rietzwenkgras, Kropaar, Engels raaigras, Ruw beemdgras, Madeliefje, Kruiptie boterbloem, Paardebloem, Witte klaver | D | poor | poor | poor |
| H2: Minder soortenarm hooiland Minder soortenarm, minder ruig, onbemest. Onregelmatig gehooid hooiland, of regelmatig gehooid (herstelbeheer) <u>Kenmerkende soorten:</u> Glanshaver, Kropaar, Ruw beemdgras, Rietzwenkgras, Kweek, Rood zwenkgras, Gestreepte witbol, Fluïtkruid, Akkerdistel, Peen, Gevlekte rupsklaver, Smalle wikke, Witte klaver, Scherpe boterbloem, Smalle weegbree, Duizendblad | B | average | average | average |
| H3: Soortenrijk hooiland Langdurig onbemest hooien <u>Kenmerkende soorten:</u> Gevarieerd grassenbestand, veel kruiden: Glanshaver, Rood zwenkgras, Veldbeemdgras, Fioringras, Gestreepte witbol, Reukgras, Goudhaver, Kamgras, Veldgerst, Duizendblad, Peen, Knoopkruid, Echte kruisdistel, Gevlekte rupsklaver, Vijffingerkruid, Knolboterbloem, Viltig kruiskruid, Rode klaver, Smalle wikke, Margriet, Echt walstro (e.a.) | A | regular | good | good |

Appendix B: Evaluation of grass covers by VTV 2004 (VTV, 2004)

References:

- Bos, v. d., W. (2006): Erosiebestendigheid van grasbekleding tijdens golfoverslag, Afterstudeeronderzoek, Technische Universiteit Delft
- ComCoast (2005): Work package 3: Smart grass reinforcement, Development of alternative overtopping-resistant sea defences, Phase 2:Elaboration of smart grass reinforcement concept, Royal Haskoning
- Coppin; Richards (1990): Use of vegetation in civil engineering, CIRIA, Construction Industry Research and Information Association, London
- EAK (2002): Empfehlungen für Küstenschutzwerke, Fachausschuss für Küstenschutzwerke der DGGT und der HTG, Die Küste, Heft 65, Westholsteinische Verlagsgesellschaft Boyens &Co, Heide in Holstein
- Edelmann, T. (1953): Die Aufgabe der Kommission „Grasnarbe auf Deichen“ auf Grund der Erfahrung bei der Sturmflutkatastrophe vom 1. Februar 1953, Übersetzung Hdt, Büsum, den 21. Januar 1955
- Hähne, K. (1991): Der Einfluß von Gräser- und Gehölzwurzeln auf die Scherfestigkeit von Böden und damit auf die Scherfestigkeit von Hängen und Böschungen, Institut für Landschaftsbau, Fachbereich Landschaftsentwicklung der TU-Berlin, Dissertation
- Hewlett et. al. (1987): Design of reinforced grass waterways, CIRIA report 166, Construction Industry Research and Information Association, London
- Hofmans , G.J.C.M. (1998): Incipient motion and scouring of loose materials, In: Pilarzcyk, K.W. (Hrsg.), Dikes and revetments, Design, Maintenance and safety Assessment, Balkema, Rotterdam/ Brookfield, pp. 125-144
- Jittler, M. (2001): Struktur und Standortanalysen der Vegetation von Landschutzdeichen im Elbästuar, eine Analyse vor dem Hintergrund der Deichsicherheit, Verlag Dr. Kovac, Hamburg
- MSD (2005): Merkblatt Standsicherheit von Dämmen an Bundeswasserstraßen, Bundes Anstalt für Wasserbau, Karlsruhe

- Richwien W.(2004): Bemessung der Kleiabdeckung von Deichaußenböschungen für die geplante Deicherhöhung und –verstärkung von Schweiburg bis Dangast, Abschlussbericht zum Forschungsvorhaben im Auftrage des II. Oldenburgischen Deichbands
- Rijn, v.L.C. (1993): Principals of sediment transport in Rivers, Estuaries and coastal seas, Amsterdam: Aqua Publicatios
- Schiereck, G.J.(2001): Indtroduction to bed, bank and shore protection, Delft University Press, Vereniging voor Studie- en Studentenbelangen te Delft (VSSD)
- Schiels A. (1936): Anwendung der Ähnlichkeitsmechanik und der auf die Geschiebebewegung, Erschienen im Eigenverlage der Preußischen Versuchsanstalt für Wasserbau und Schiffbau, Berlin NW 87
- Schuettrumpt, H.F.R. (2001): Wellenüberlaufströmungen bei Seedeichen Fachbereich für Bauingenieurwesen der Technischen Universität Carolo-Wilhelmina zu Braunschweig
- Seijffert, J. W., Verheij, H. (1998), Grass covers and reinforcement measures, In: Pilarczyk, K. W. (Hrsg.), Dikes and revetments, Design, Maintenance and safety Assessment, Balkema, Rotterdam/ Brookfield, pp. 289-302
- Sparboom U. (1991): Full-scale investigations on wave loading of sea dyke structures, Preprint: Proc. 3rd International conference on coastal and port engineering in developing countries (COPEDEC III), Mombasa, Kenya
- Sprangers H.(1999): Vegetation dynamics and erosion resistance of sea dyke grassland, van de Landbouwniversiteit Wageningen
- TAW (1999): Technical report erosion resistance of grassland as dike covering, Technical Advisory Commitee for Flood Defence in The Netherlands, Delft
- Tobias, S. (1991): Bautechnisch nutzbare Verbundfestigkeit von Boden und Wurzel, Dissertation 9483 Eidgenössische Technische Hochschule Zürich
-

- VTV (2004): De veiligheid van de primaire waterkeringen in Nederland, Voorschrift Toetsen op Veiligheid voor de tweede toetsronde 2001-2006, Ministrie van Verkeer en waterstaat
- Wang, Z., Weißmann, R. (2000): Assesment of erosion on the inner slope of Borghorster dyke, Projekt: Borghorster Hauptdeich, Anhang D (unveröffentlicht)
- Weißmann, R. (2003): Die Widerstandsfähigkeit von Seedeichbinnenböschungen gegenüber ablaufendem Wasser, Dissertation, Universität Essen, Mitteilungen aus dem Fachgebiet für Grundbau und Bodenmechanik, Herausgeber Prof. Dr.-Ing. W. Richwien, Heft 30, Glückauf Verlag, Essen
