

Mediating Religious Elements

Collective memory of religious spaces to incentivise the transformation of decommissioned churches

P5 Presentation

AR3AH115 Revitalizing Heritage: Zero Waste Church

Mentors: Catherine Visser, Wido Quist, Mo Smit

Tanishka Sarma
5484804

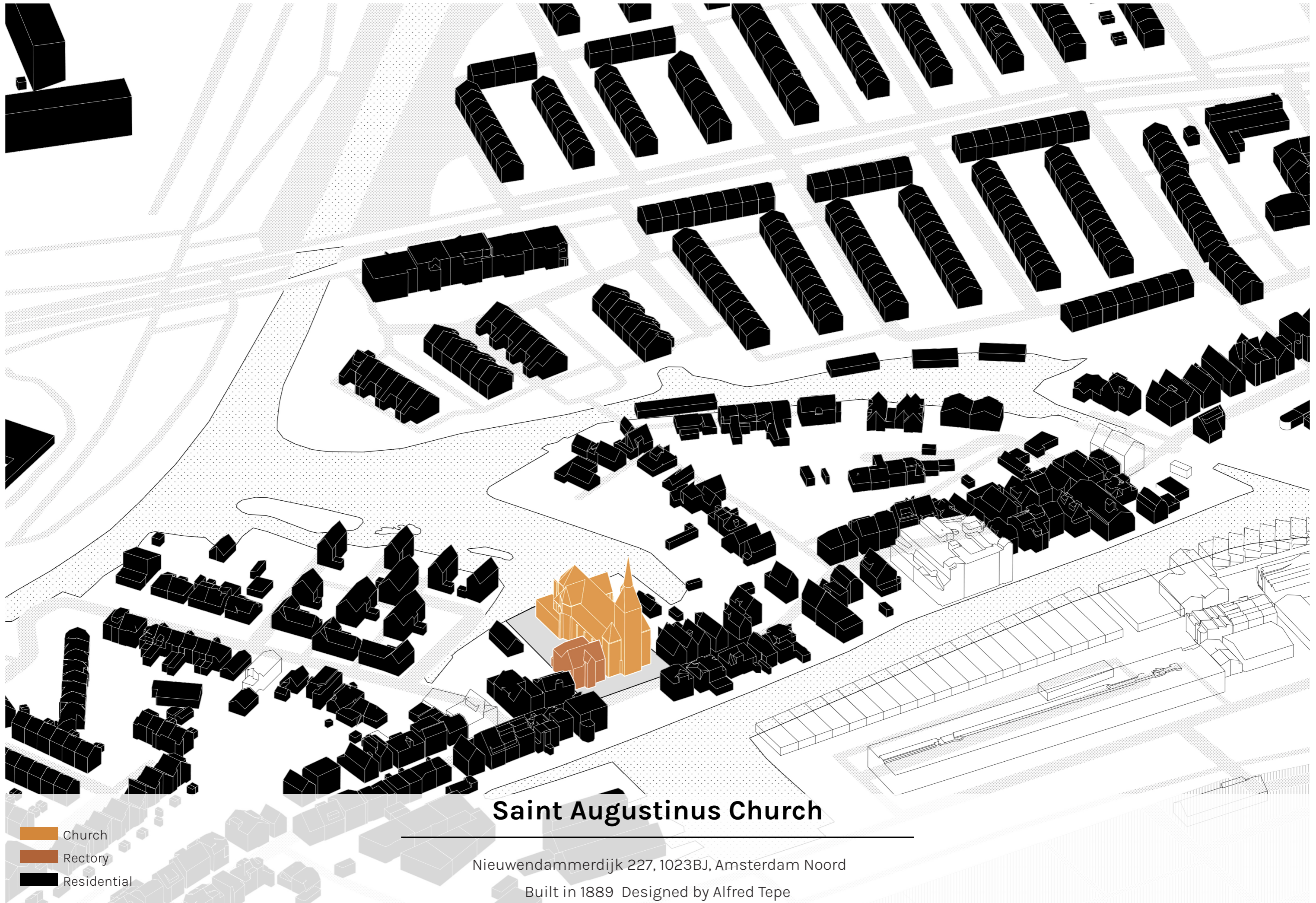

Saint Augustinus Church

Nieuwendammerdijk 227, 1023BJ, Amsterdam Noord

Built in 1889 Designed by Alfred Tepe

- Church
- Rectory
- Residential

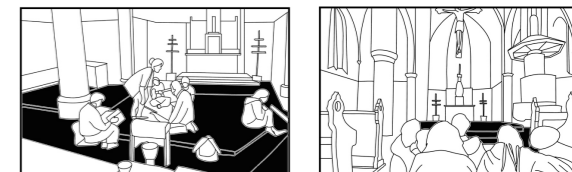

The squatters took over the church

“In mid-February, a group of squatters moved into the church, who had already spent about was vacant for four years. The new residents heralded by way of greeting to the near the church bells. They also had four years dust cleaned.”

The squatters host function for the community

“We are turning the church into a cultural community center. We leave it up to the neighborhood to organize what they want. Think of music performances, poetry, meditation or yoga evenings. But the church could also be used again for services. The pastor has stopped by and was thrilled.”

Local residents of the church draw up a petition advocating for the extension of temporary residence. In April the squatters are evicted

“That way the building is managed. And that’s good, because vacancy is not good for the building or for the neighborhood,’ the website states.”

The church is rented out for events and meditation sessions are held for financial benefit



The Neighborhood: A Community

The people of Nieuwendammerdijk has come together multiple times since its decommissioning to save the church

Collective Memory

Collective groups of people hold memories that would constitute their collective identities which could contribute a sense of togetherness. The experience of place is, within the realm of architecture, in a sense made of memories of previous visits and expectations of what it could be.¹ For a church, such a process of building of emotions has already happened and brought to a standstill as the church shuts down.

¹ Juhani Pallasma and Marc Treib, "Space, Place, Memory and Imagination: The Temporal Dimension of Existential Space," in *Spatial Recall: Memory in Architecture and Landscape* (New York, NY: Routledge, 2009), 17.

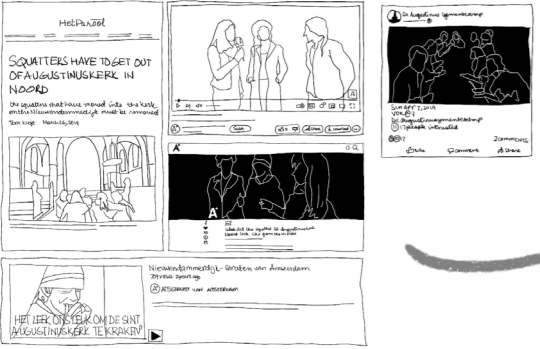
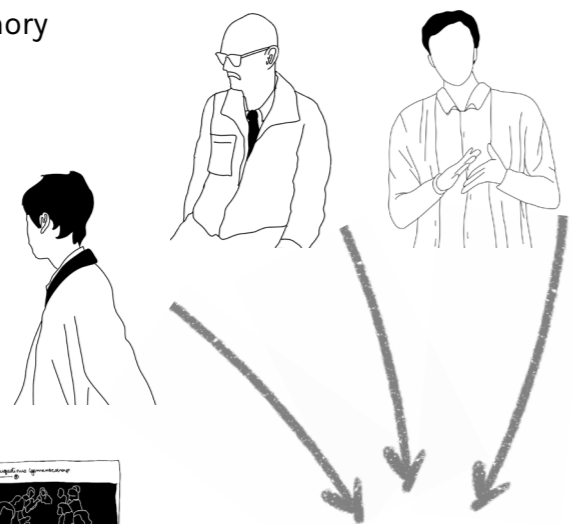

Narratives

Collective Memory

The study of the collective memory of the church and its elements could lead to a more socially sustainable space intertwined with the lives of the neighborhood.

Sense of belonging

Incentivise transformation

Create a sense of engagement

Participation

Through the introduction of social capital¹

For the people to get invested in the future of the church

Citizen Control/Power

Participatory design approach

The study of the collective memory of the church and its elements could lead to a more socially sustainable space intertwined with the lives of the neighborhood.

¹ Giles Mohan and John Mohan, "Placing Social Capital," Progress in Human Geography 26, no. 2 (2002): 191-210, <https://doi.org/10.1191/0309132502ph364ra>, 193.

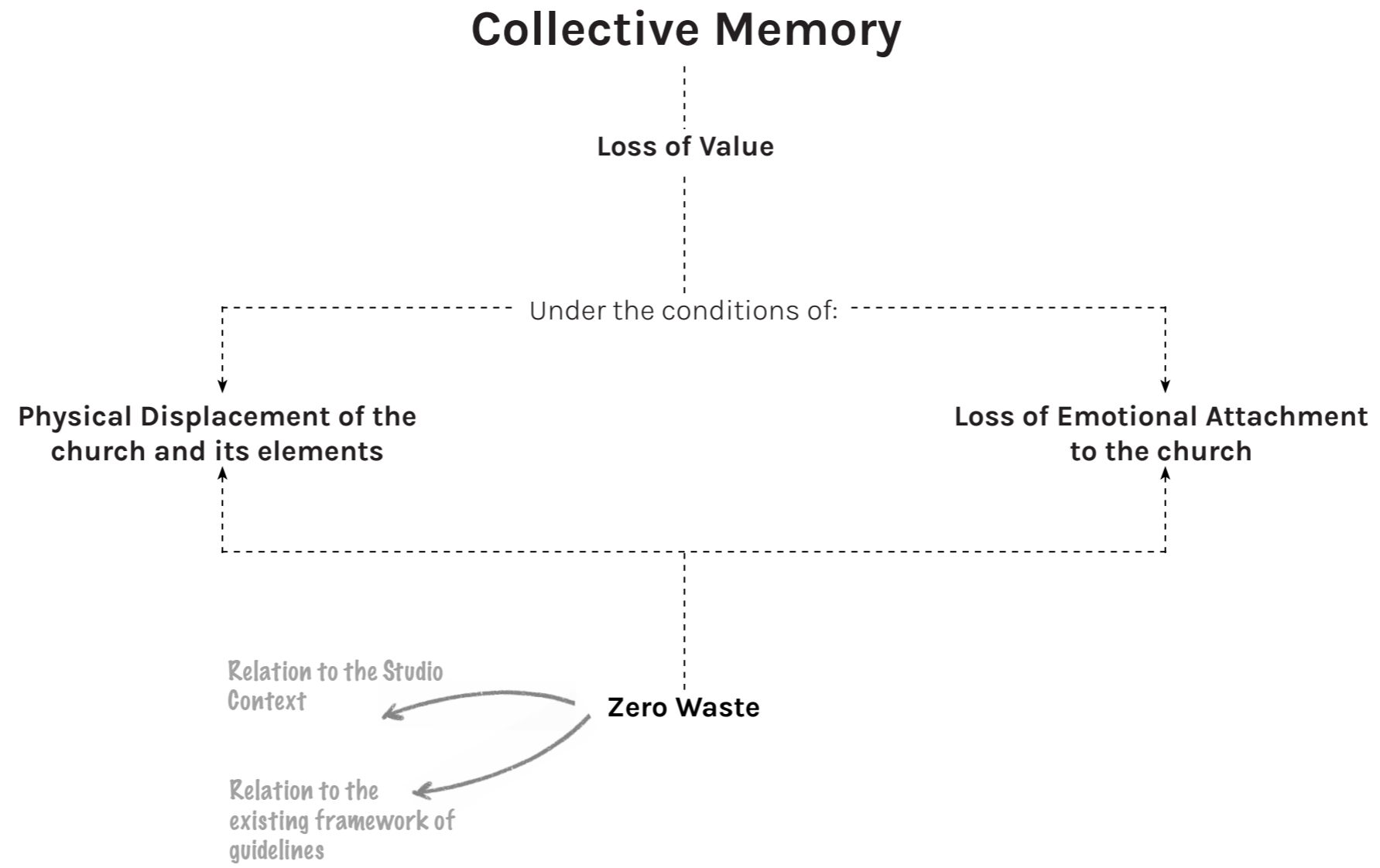



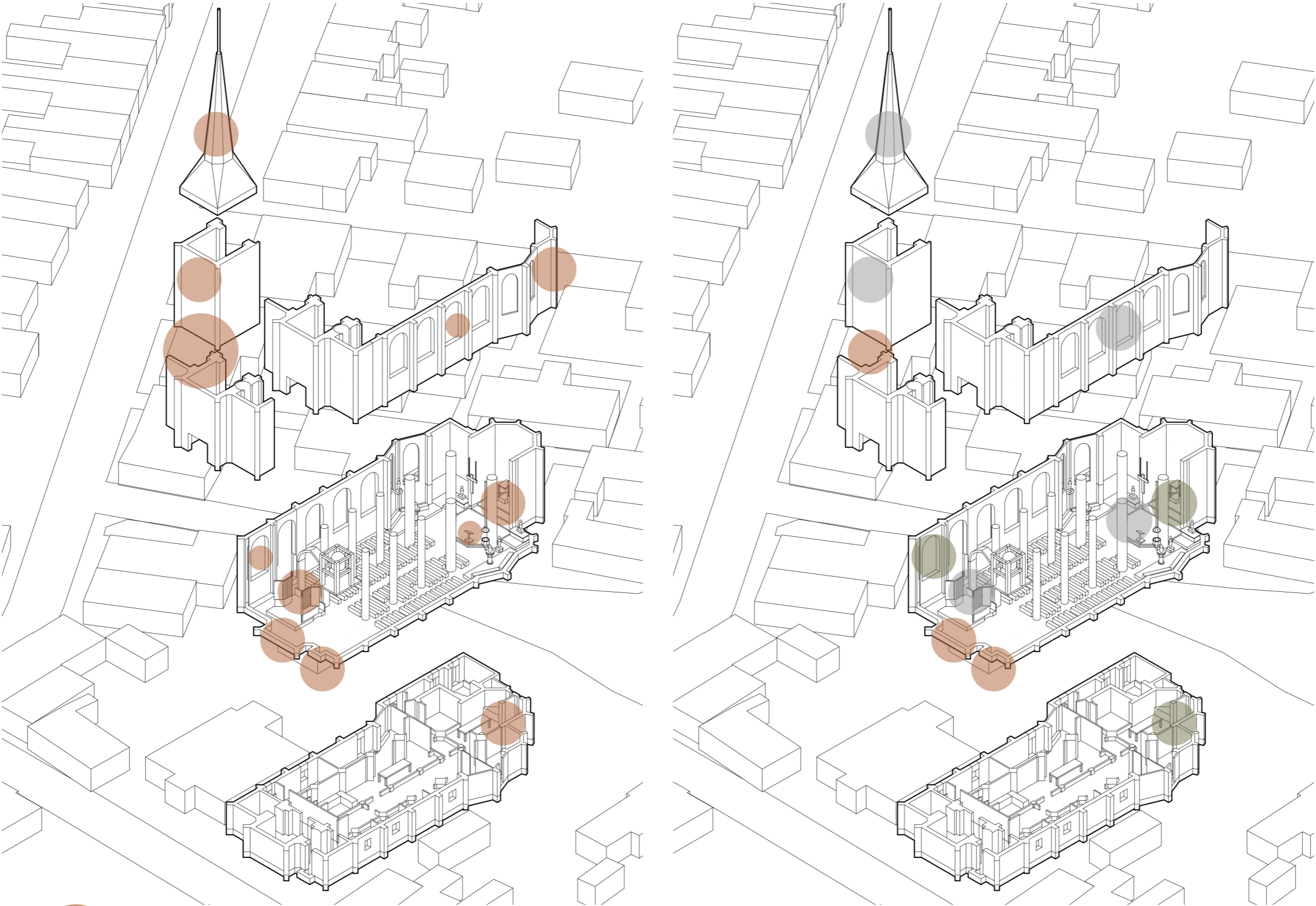

Value Assessment

A study was done with respect to the church its perception. Here, the responses are compared to the documents available

Collective Memory

Treated as a
value assessment tool

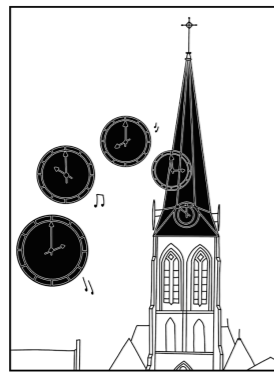

The church and its environment

“One night I half woke up and unconsciously lay counting the number of strokes of the clock. When I got to 30 it dawned on me that something wasn't right. **The clock had run out.** It took more than half an hour for someone to turn it off.”



“The next door neighbor, who is now deceased, was the sexton. **The church bell was often broken, so I suggested starting a fundraiser for repairs.** I still miss the striking of the hours now. He didn't do anything about it, unfortunately.”

The elements inside the church

“When **the bell** to call everyone to the church as a neighborhood, it brought all of us together. We went over for tea and looked at the church after our years”



“The church is very intriguing. It smelled like **frankincense** when we first opened the church after it was closed for so long.”

“When we come here on Sundays, it really feels like the old days when the church had **the pub** before it closed.”

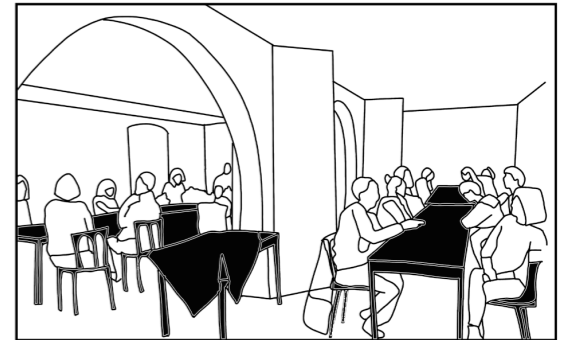



Collective Memory

Elemental Analysis ←

Spatial Analysis ←

Linearity and Procession ←

The focus on the altar and its objective value for religious aspects

Hierarchy ←

Social and spatial stratification in the church structure

Isolation ←

The Church as an isolated object in the neighborhood

Accessibility ←

Multiple parts of the church not accessible to the general public or to woman

Silence ←

Festivals, Church bells and Music (and their absence)

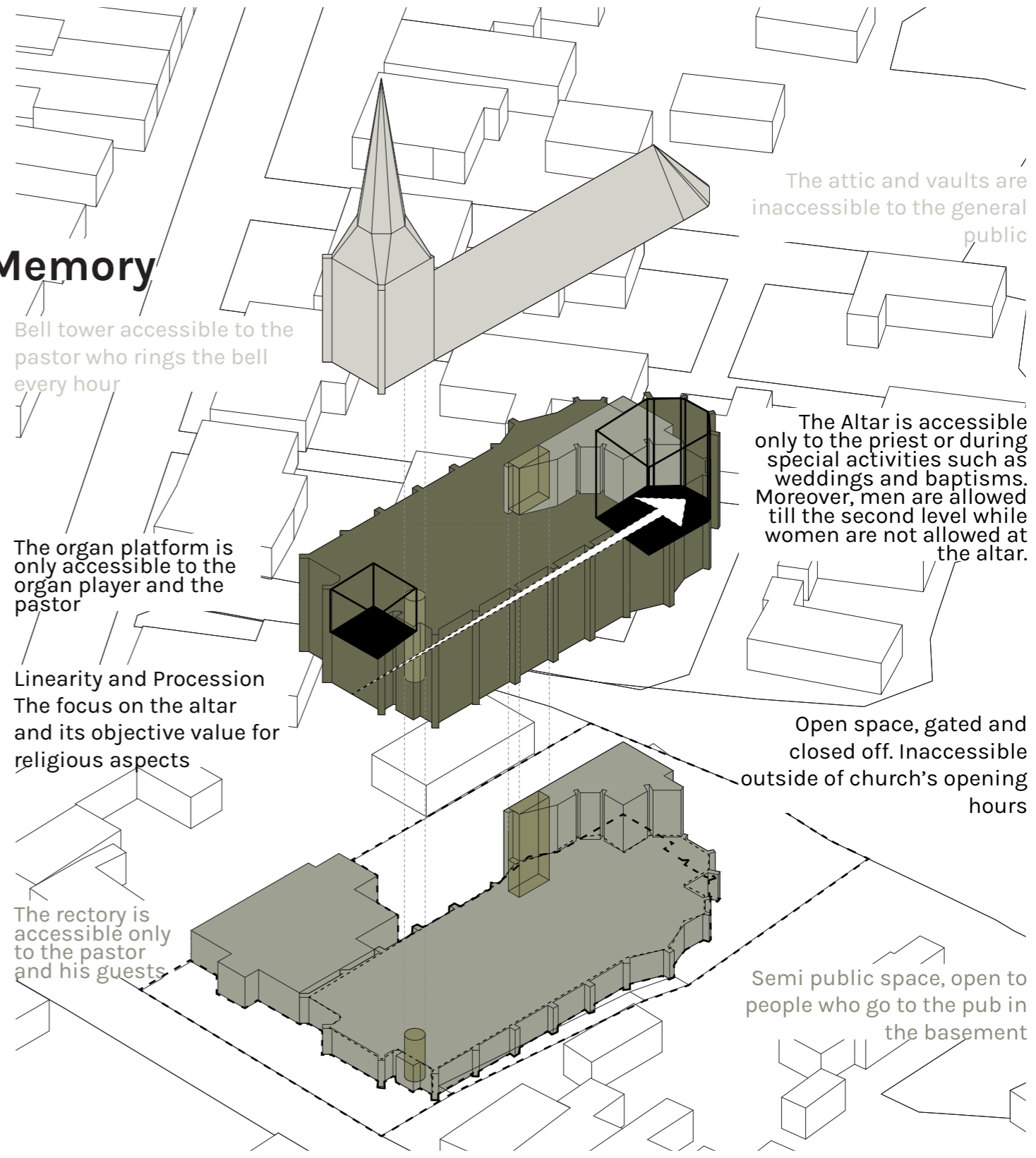

Pastor General Public

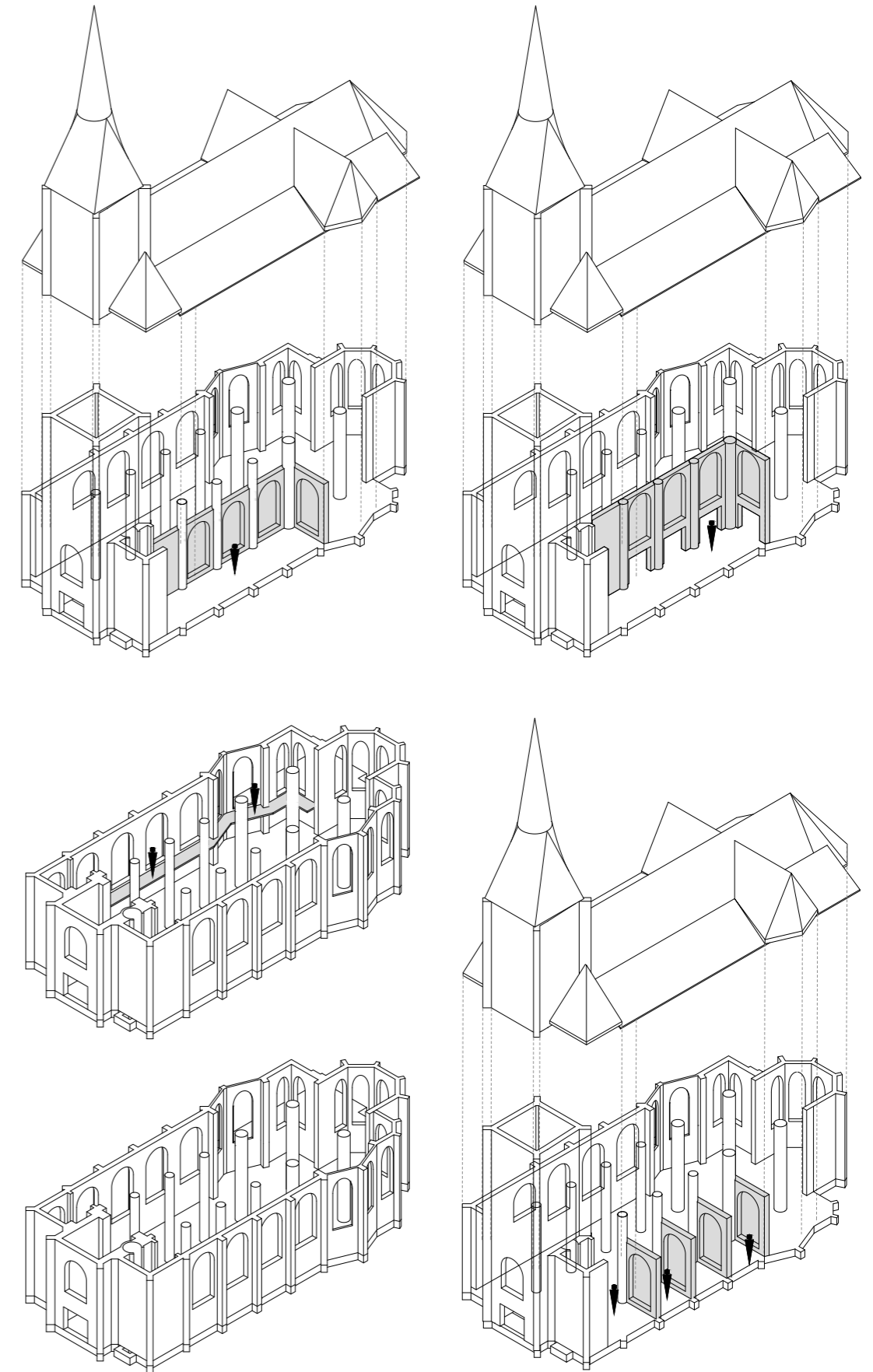
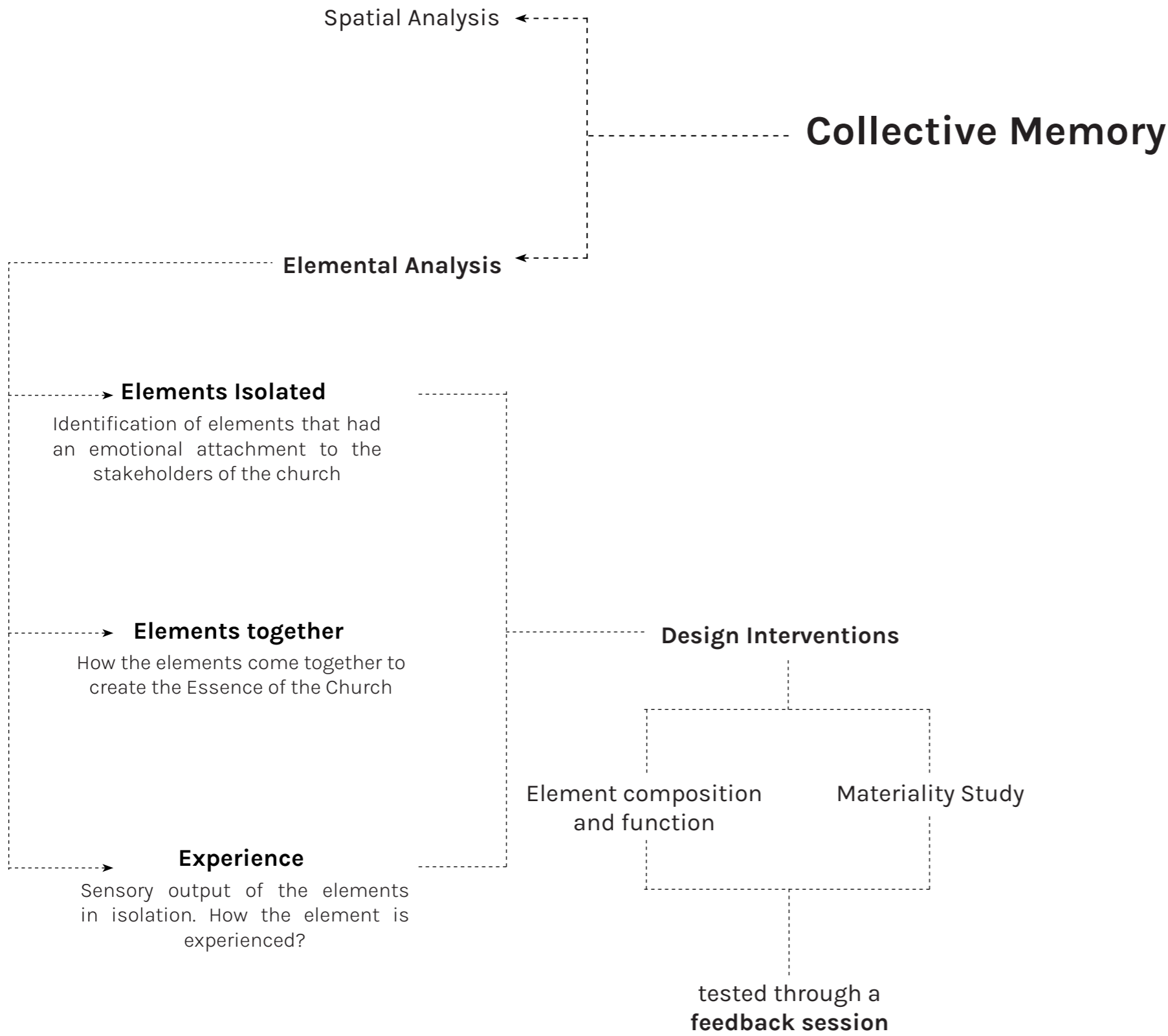

Spatial Analysis ←
Collective Memory

Elemental Analysis ←

**Craftsmanship and artisanal
attributes of religious
elements in a church**

Music and
performance

Stained glass
Work

Intricate wooden
Furniture

Sculpture

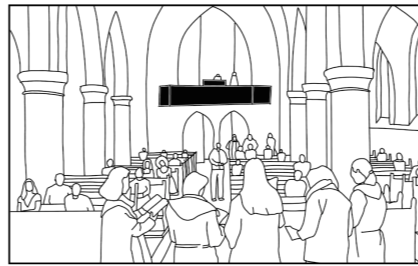
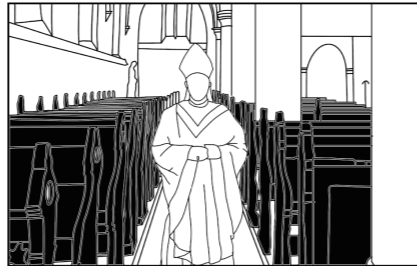

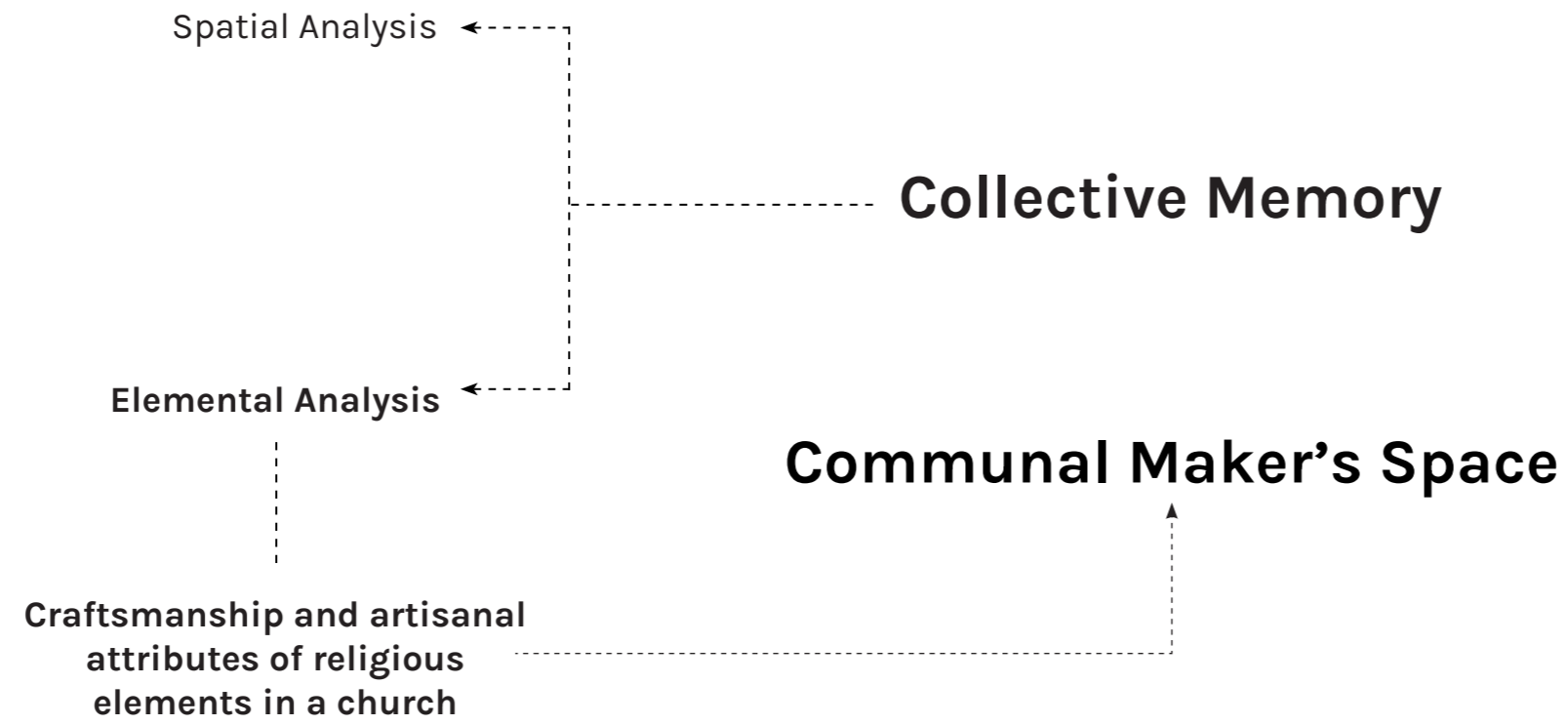

Collective Memory

Communal Maker's Space

The design output would be something that lends a sense of belonging to the people in the neighborhood and employs the stories of the community towards a more socially resilient structure

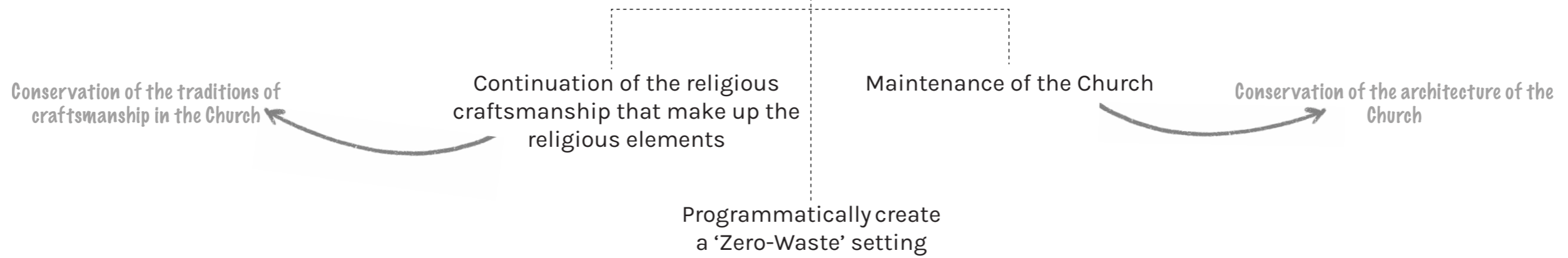

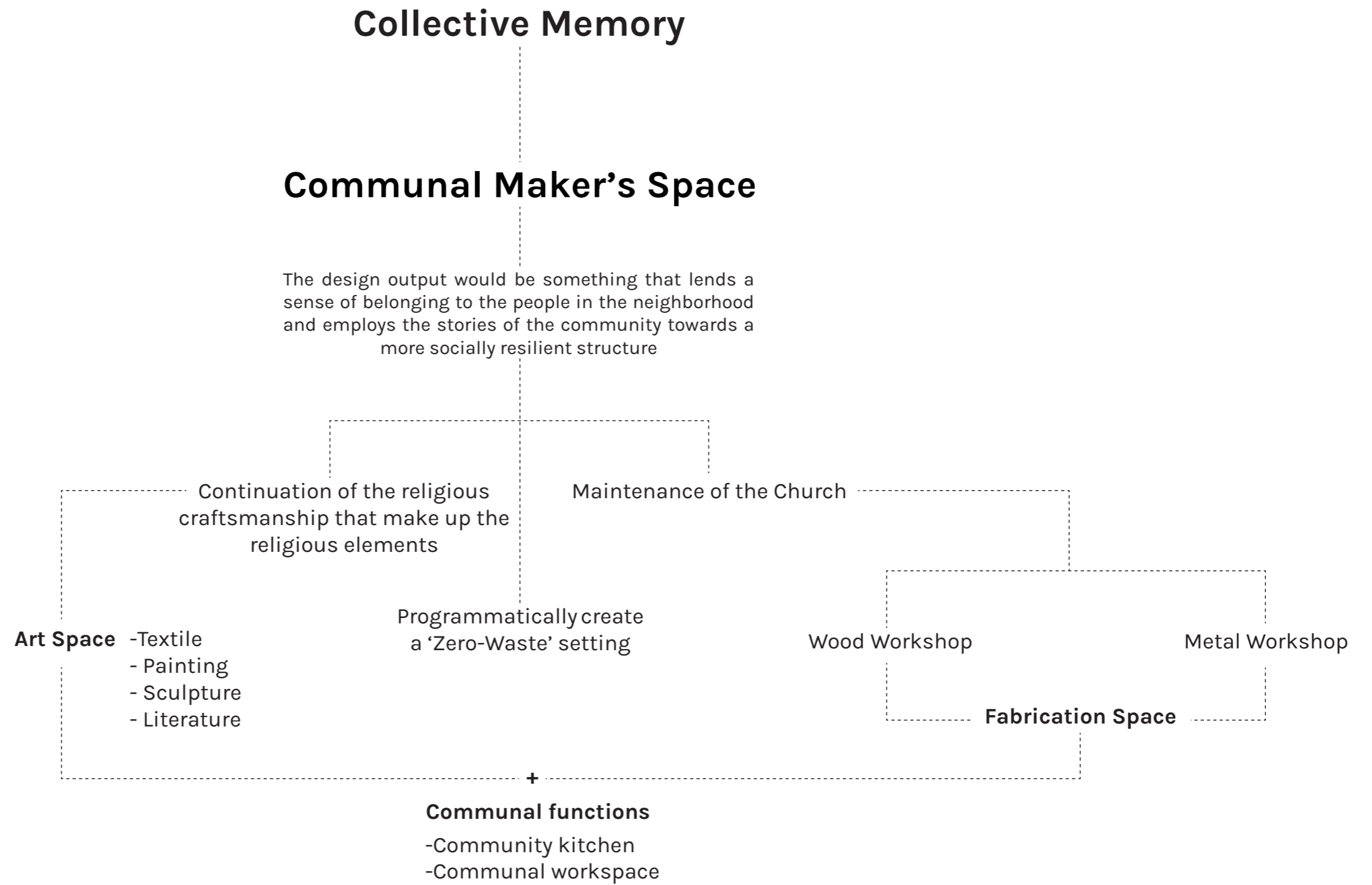

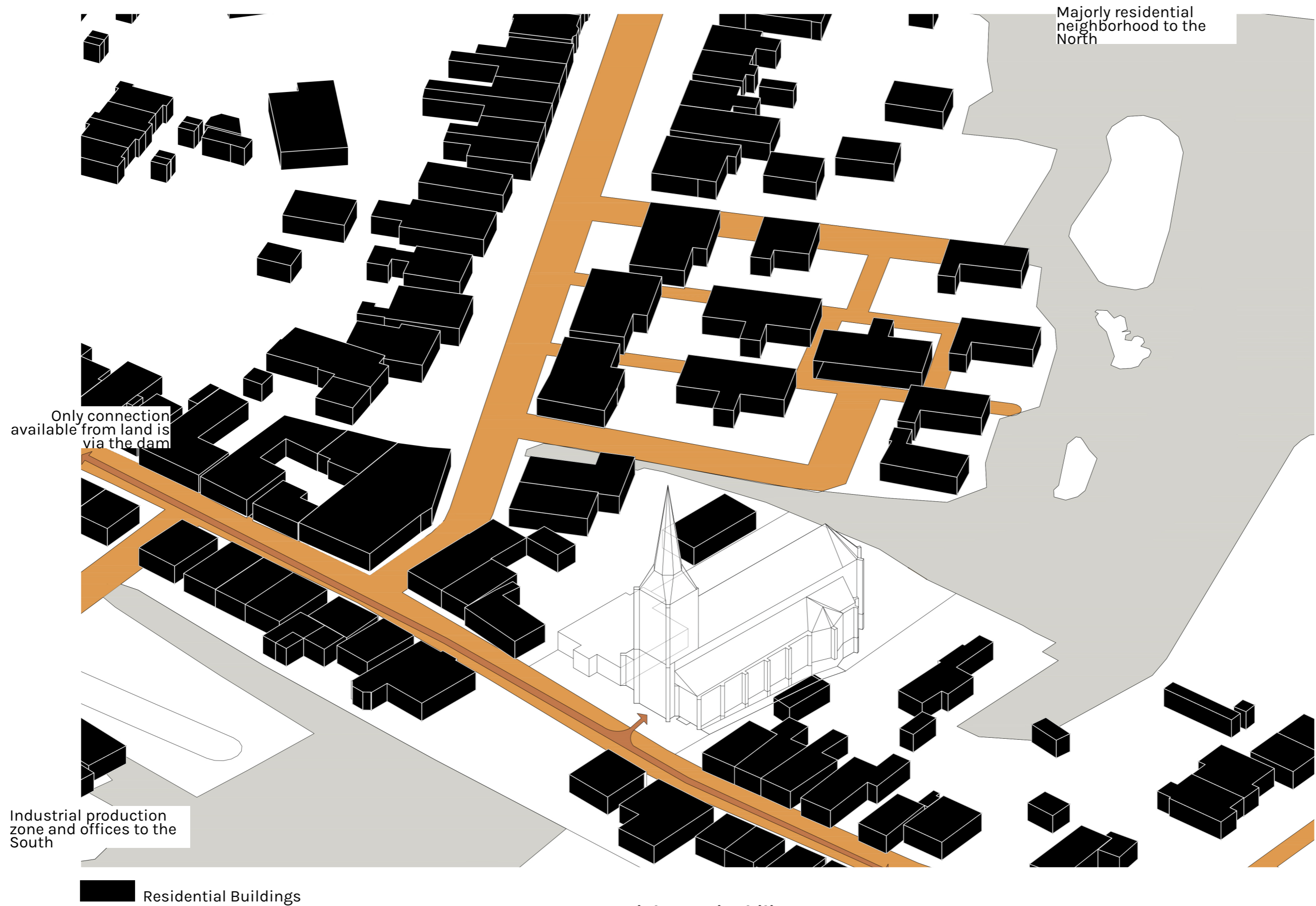

Social Sustainability

The church sits between two programmatically opposing zones, the industrial marina and the residential areas to the North and on the Nieuwendammerdijk

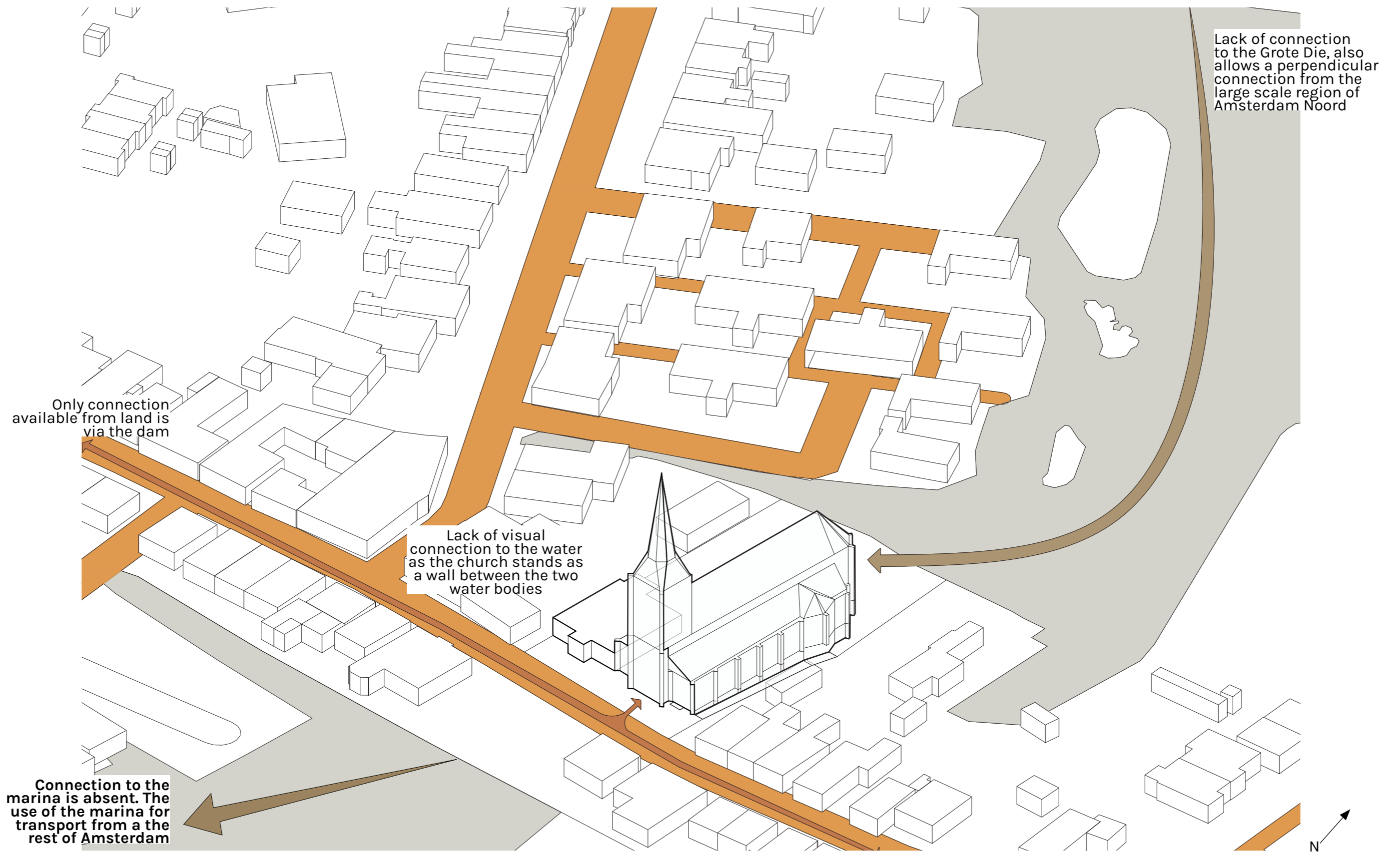

Social Sustainability

The church is very visually accessible from the walk on the dam. This thus could be an opportunity to connect the two bodies of water, one more commercial and one more residential.



Social Sustainability

Ability to bring together the people of the surrounding areas from artists, craftsmen, photographers and more.

○ Artists

Social Sustainability

Flnding ways to introduce people into the church to prevent it from going into disuse.

Neo-Gothic Religious Church and their Introduction

People came together to build the church and raise funds for its construction and maintenance

Creating Community Engagement

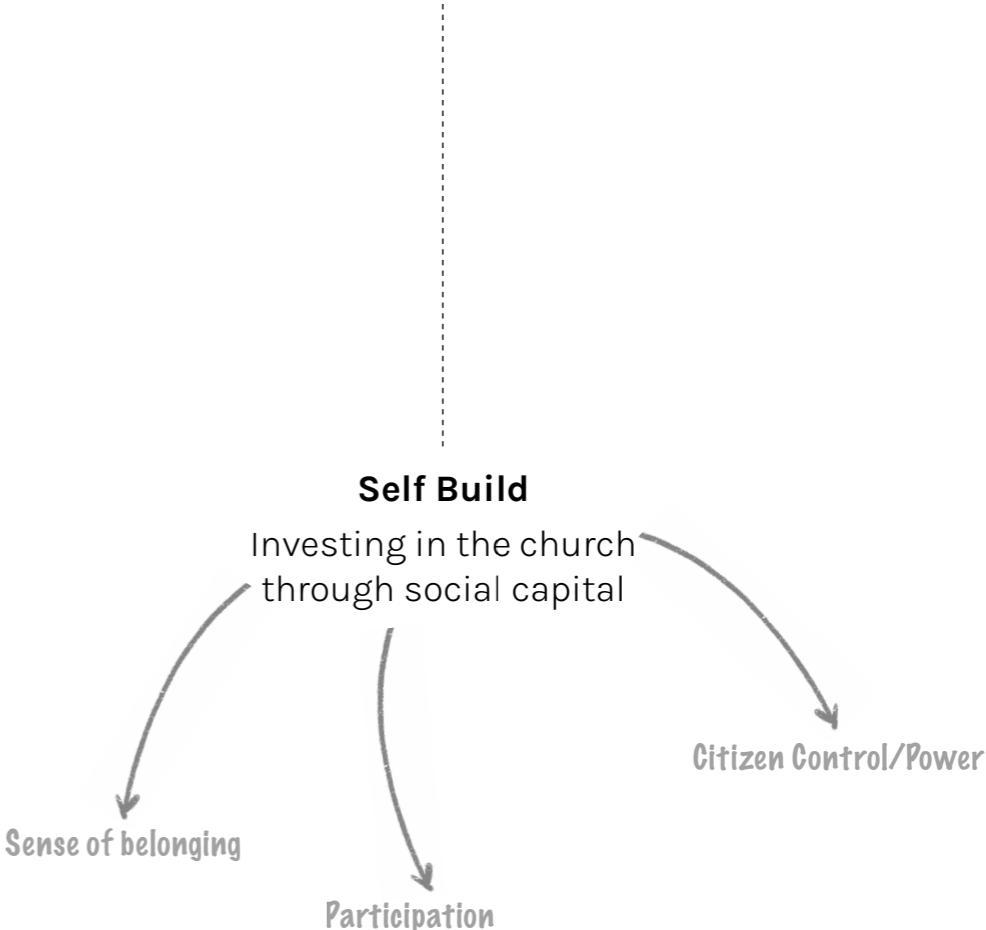

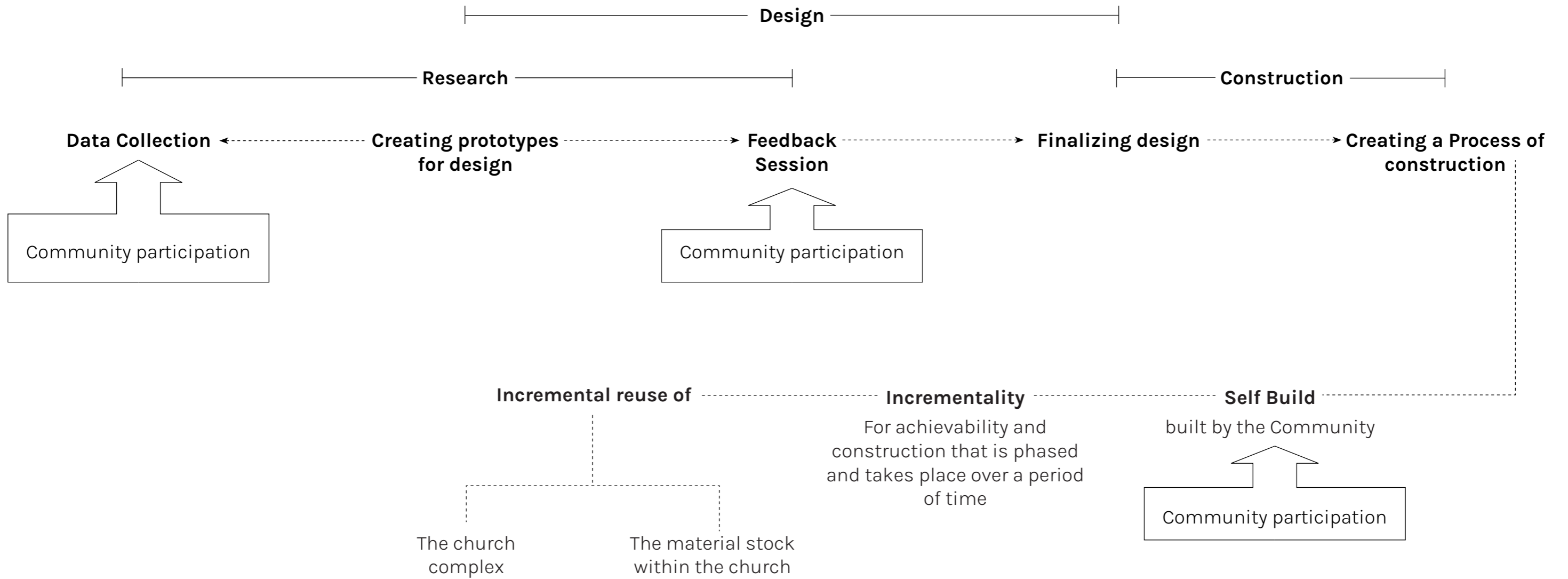

Phased Construction process

Demolition and Preparation
of site

Insulation of the skin

Assembly of units

Utilisation of Spaces

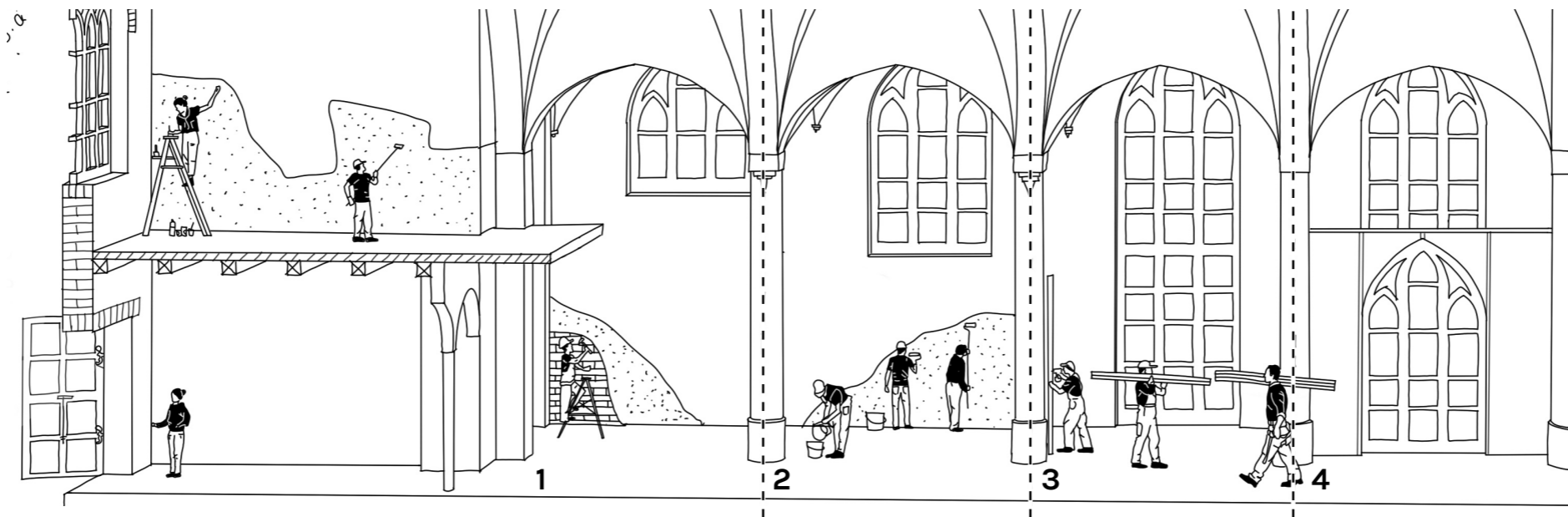

Phased Construction process

Role of the Architect

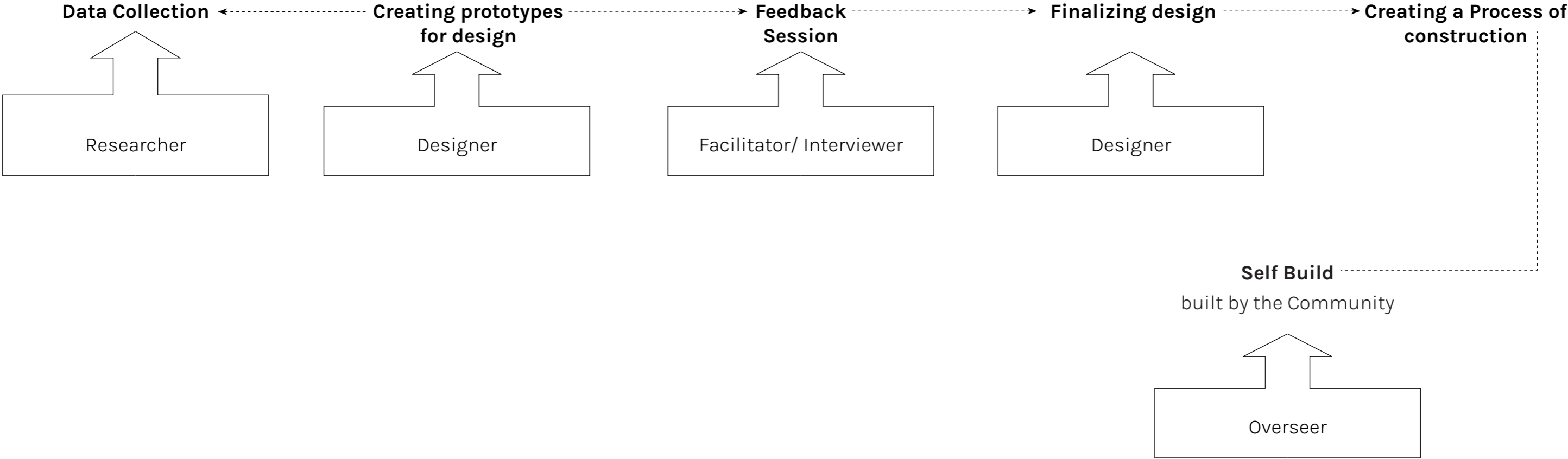

Phased Construction process

Types of Community Participation



Managerial crew:

This group will be made of people who will maintain and update construction timelines, material storage and keep and account of all volunteers. This is overseen by the architect.

Construction Crew:

The group focused on construction will be made of volunteers who have a prior knowledge of construction techniques and means of demolition and harvesting. They will help from stage 1 to 3.

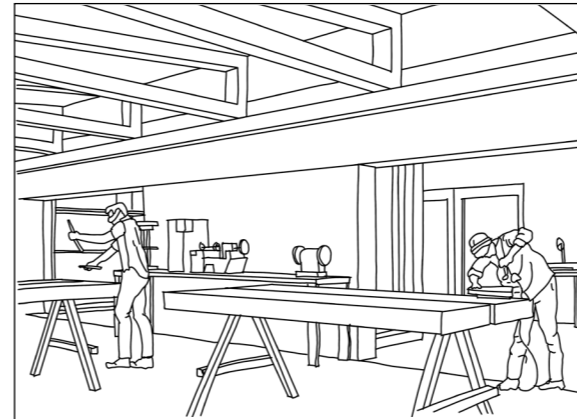
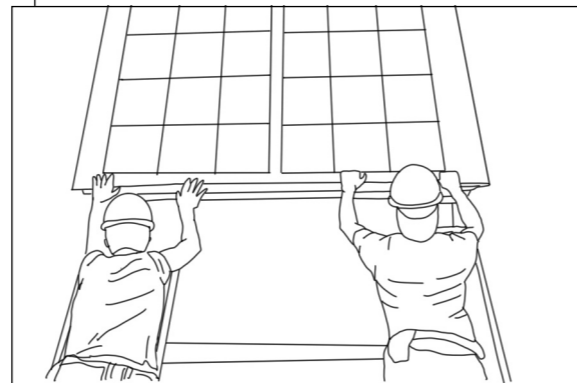

Fabrication Crew:

This group will work in the fabrication lab in the rectory and work with metal and timber elements harvested from the church. They will be formed of people who have knowledge of equipment in wood and metal workshops who will then teach the other volunteers how to use the equipment. They will together create the various design elements in the church.

Assembly Crew:

This group will be brought in at stage 5 to assemble and put together the element created by the fabrication crew. Their work will be concentrated in the church and focus mainly on connecting the elements to form the whole usable space.

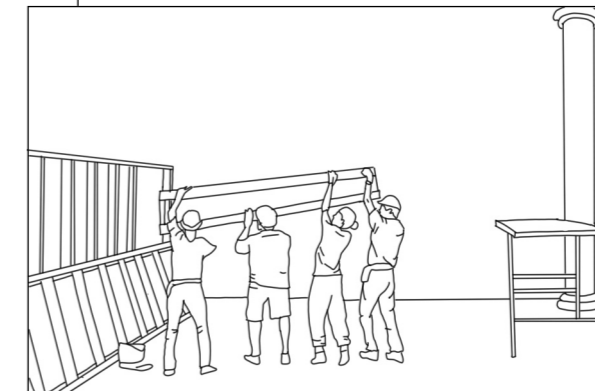

Phased Construction process

The Building Manual

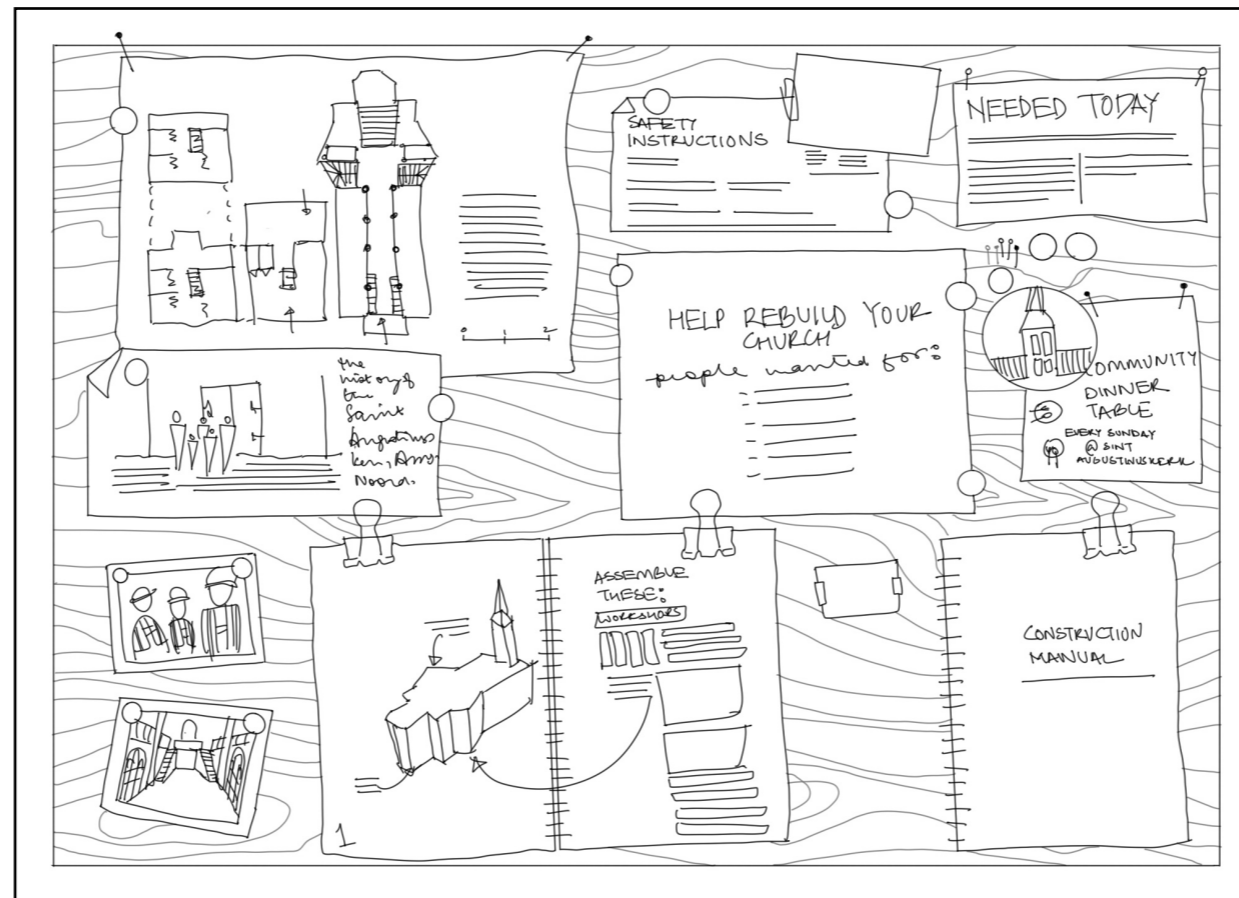

Phased Construction process

**Demolition and Preparation
of site**

Insulation of the skin

Assembly of units

Utilisation of Spaces

Phased Construction process

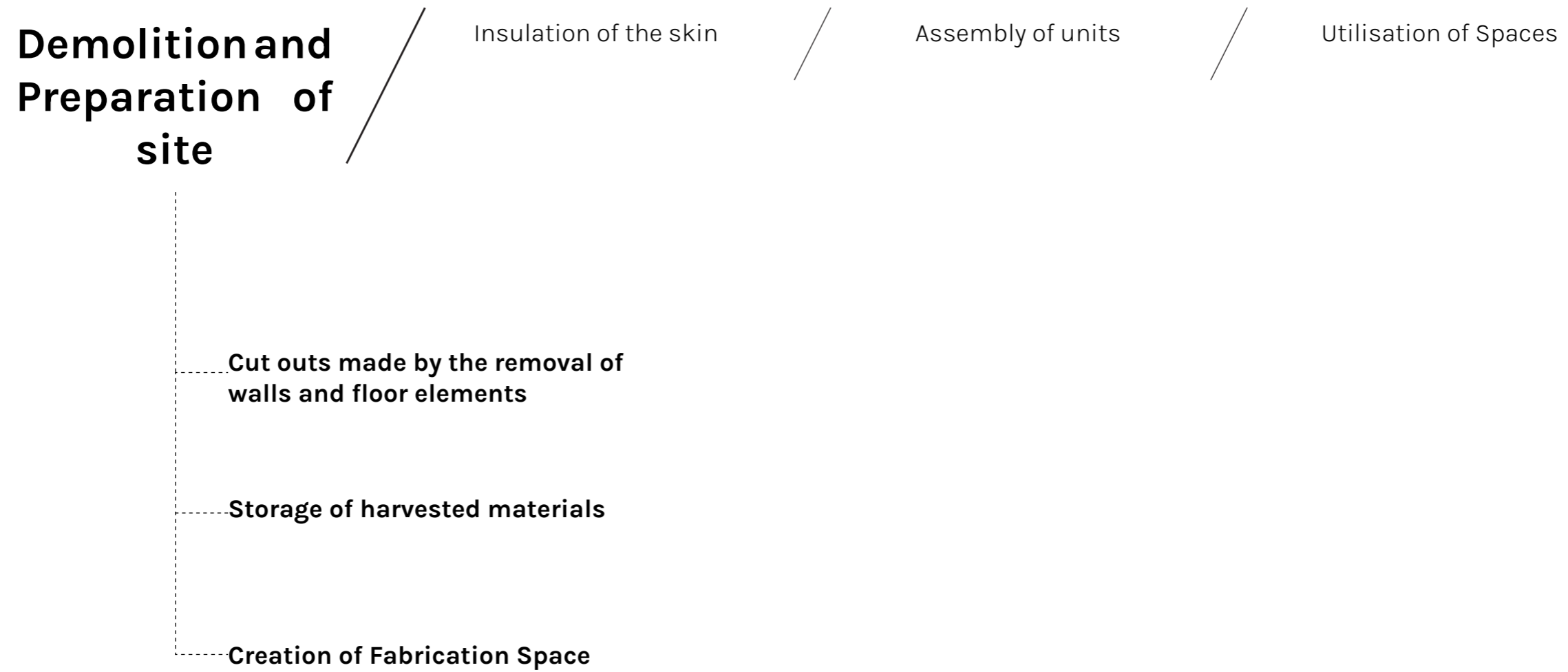

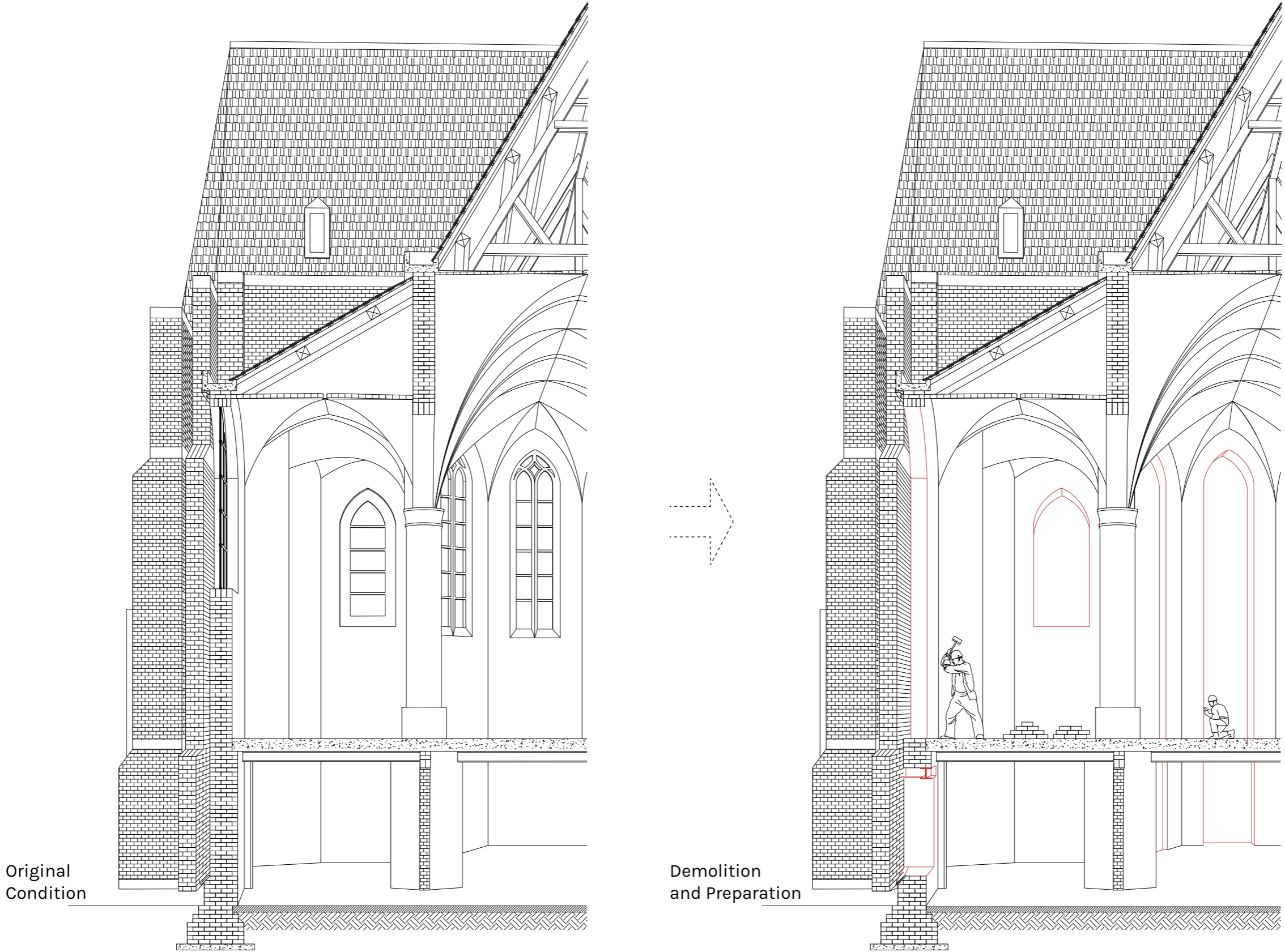

Removal of windows and inserting reinforcements
 The stained glass windows are sent for restoration. H-Beams harvested from the floor are reused in the support for the new openings

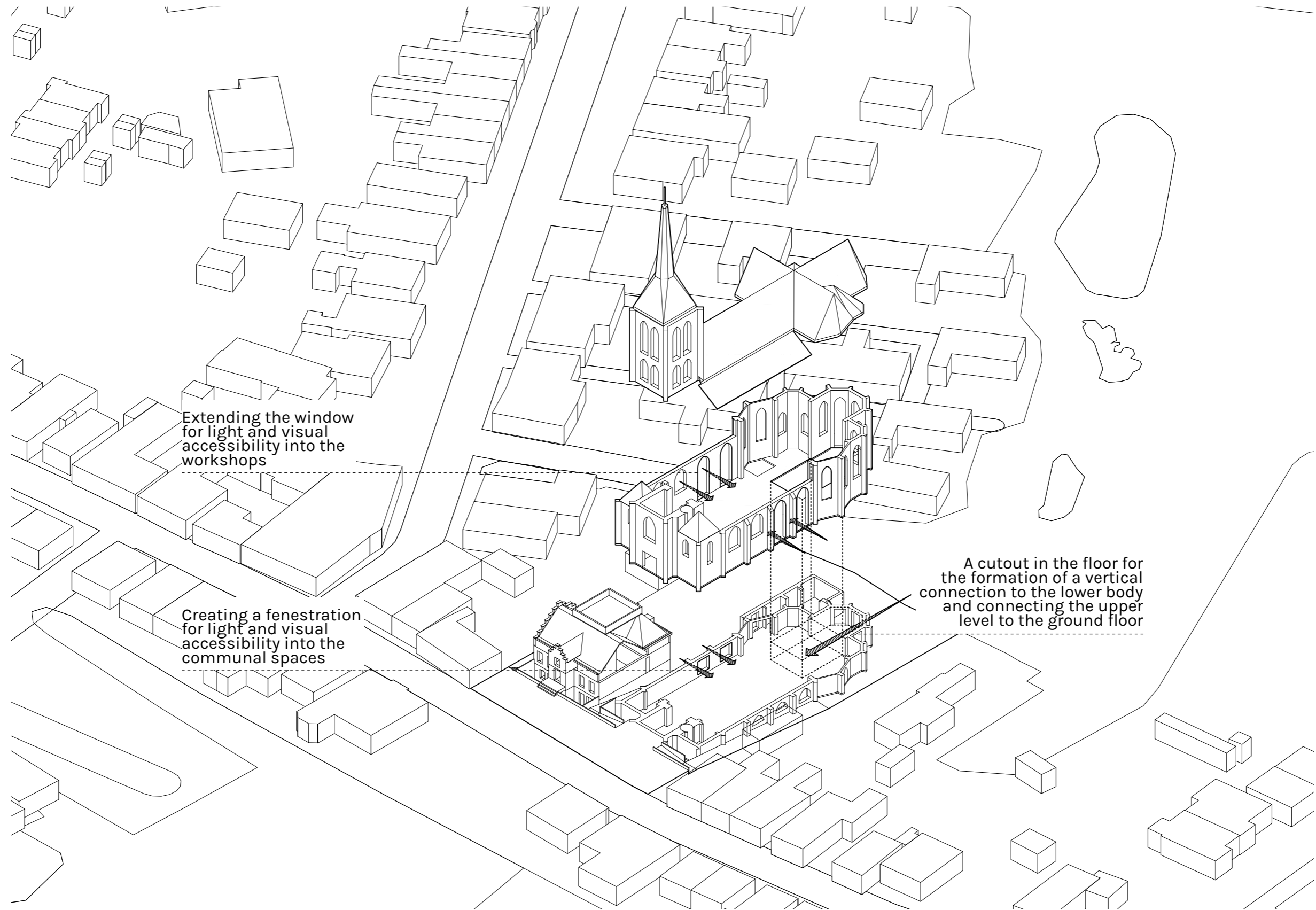

Cut-outs made by the removal of walls and floor elements
Connection to the outside and penetration of light is prioritized in this stage and wall and floor segments are removed.

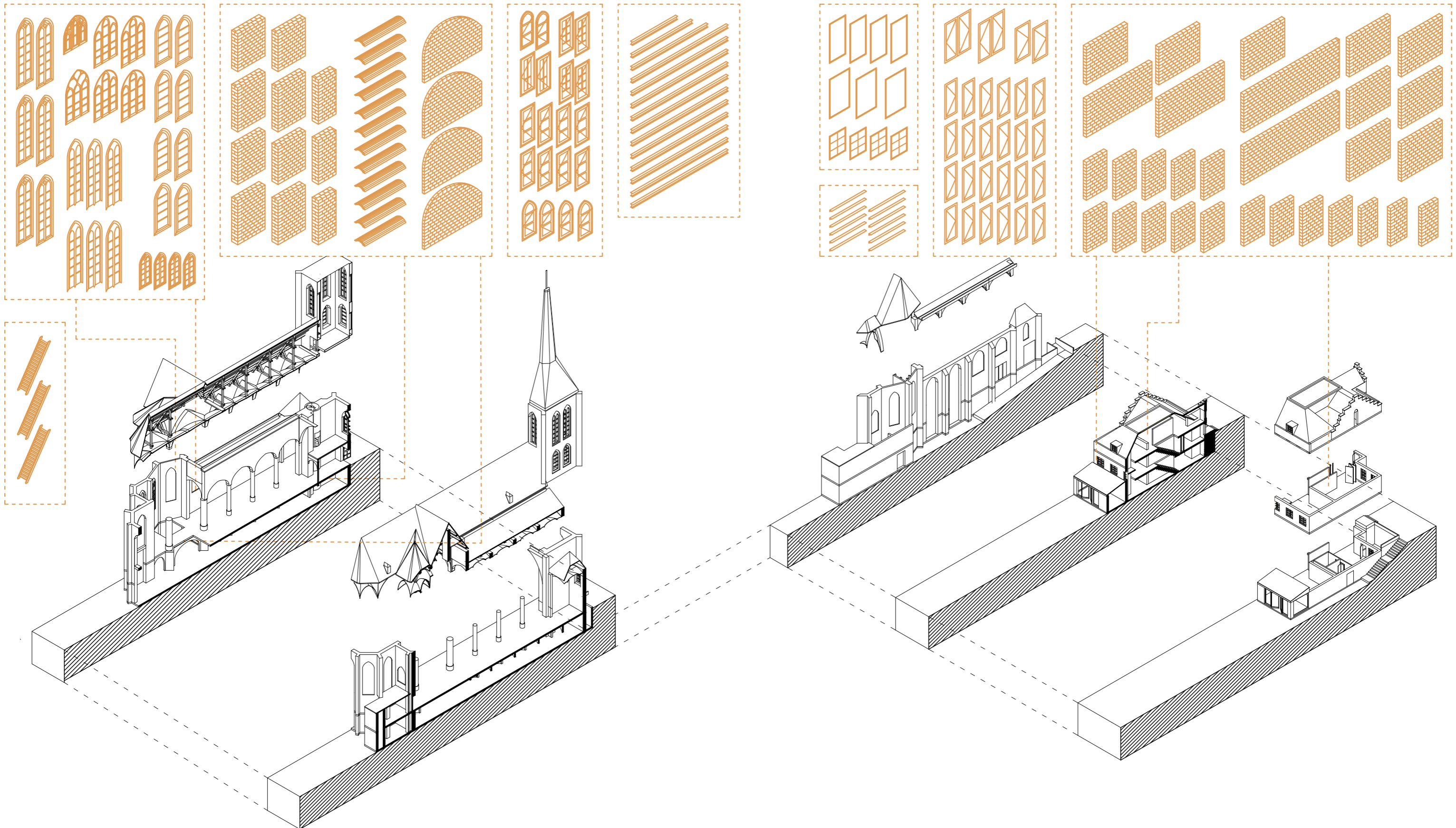

Materials Harvested

Materials are removed from the building and stored in the rectory. This will either be used in the construction or for future use.

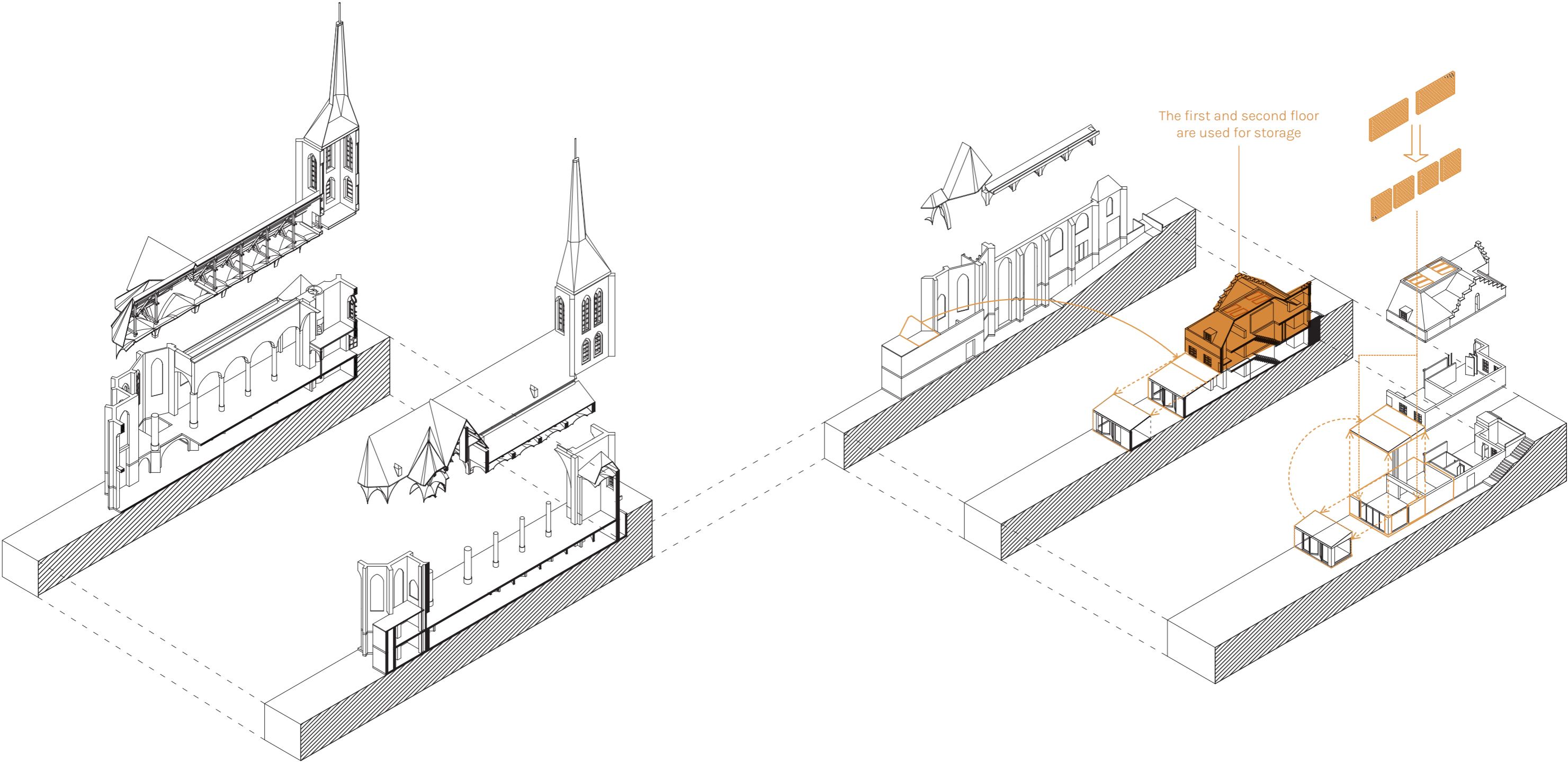

Use of the Rectory

The rectory is converted into a fabrication space on the ground floor. This is then used for the construction of all units for the design.

Phased Construction process

Demolition and Preparation
of site

**Insulation of
the skin**

Assembly of units

Utilisation of Spaces

Climatisation and zoning of
the interiors

Treating the stained glass
windows

Introduction of new double
glazed windows

Repairs to the slate roof and
Roof Insulation

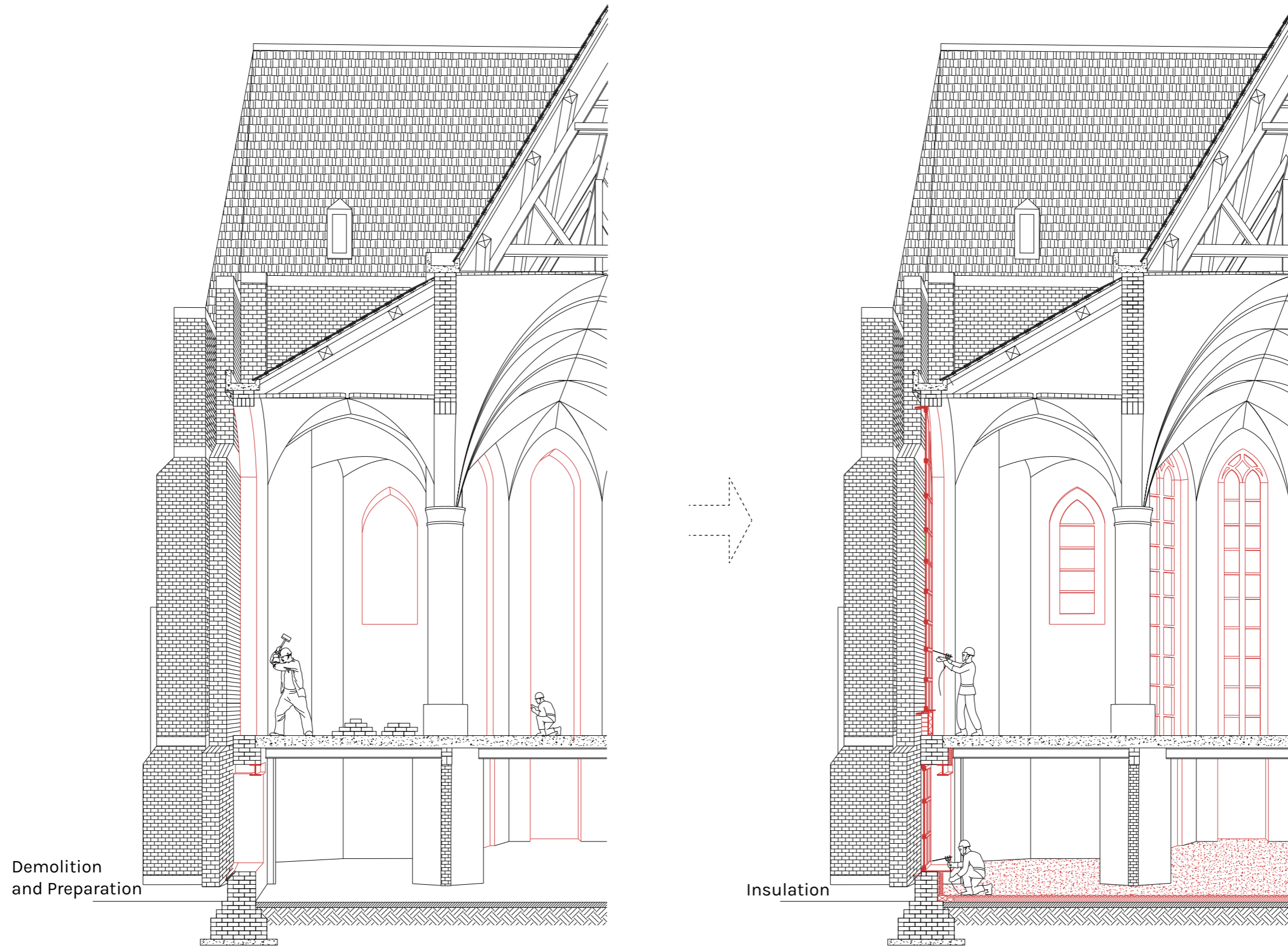

Removal of windows and replacement on skin

This step involves the insertion of the new double glazed windows with a wooden frame and damp open floor with drainage

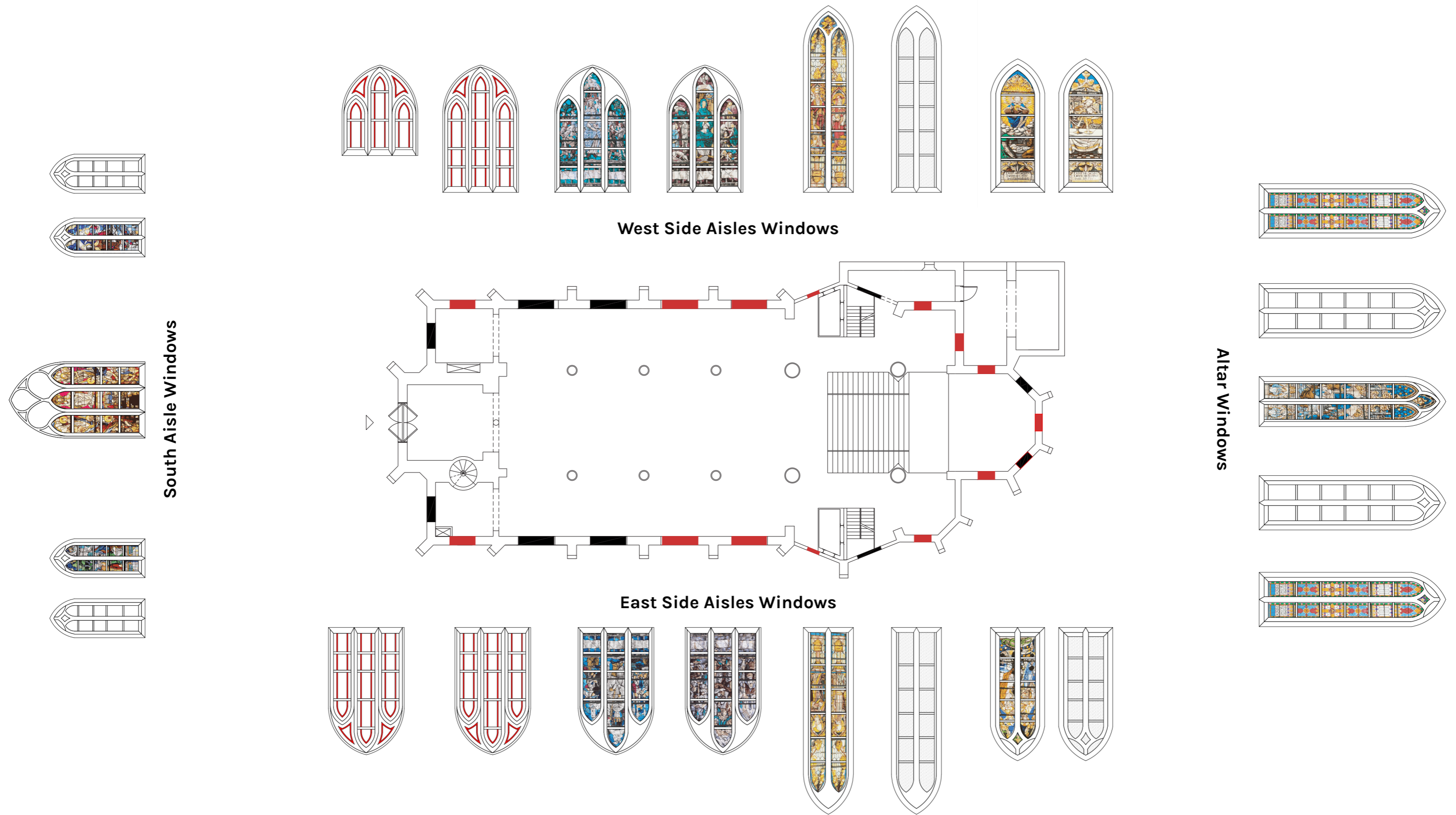

West Side Aisles Windows

South Aisle Windows

East Side Aisles Windows

Altar Windows

- Stained Glass Windows (16 nos)
- Frosted Glass Windows (17 nos)

Removal of windows

The reasons for removal of windows are based on the existing condition of the window and its impact on the interiors

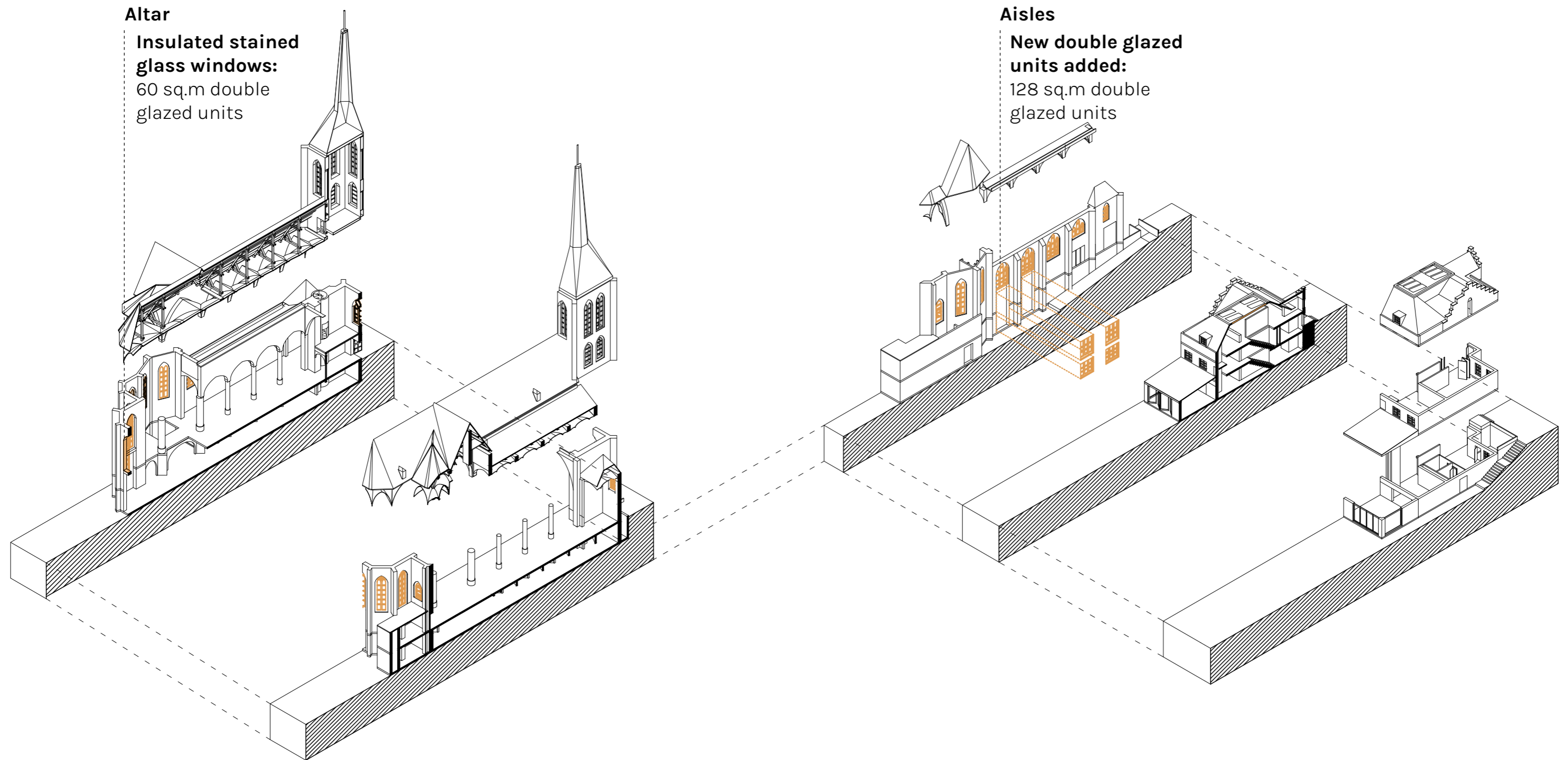

Material Concept and New glass usage

Most of the stained glass windows are warping after years of neglect. They also are single paned and do not provide enough insulation.

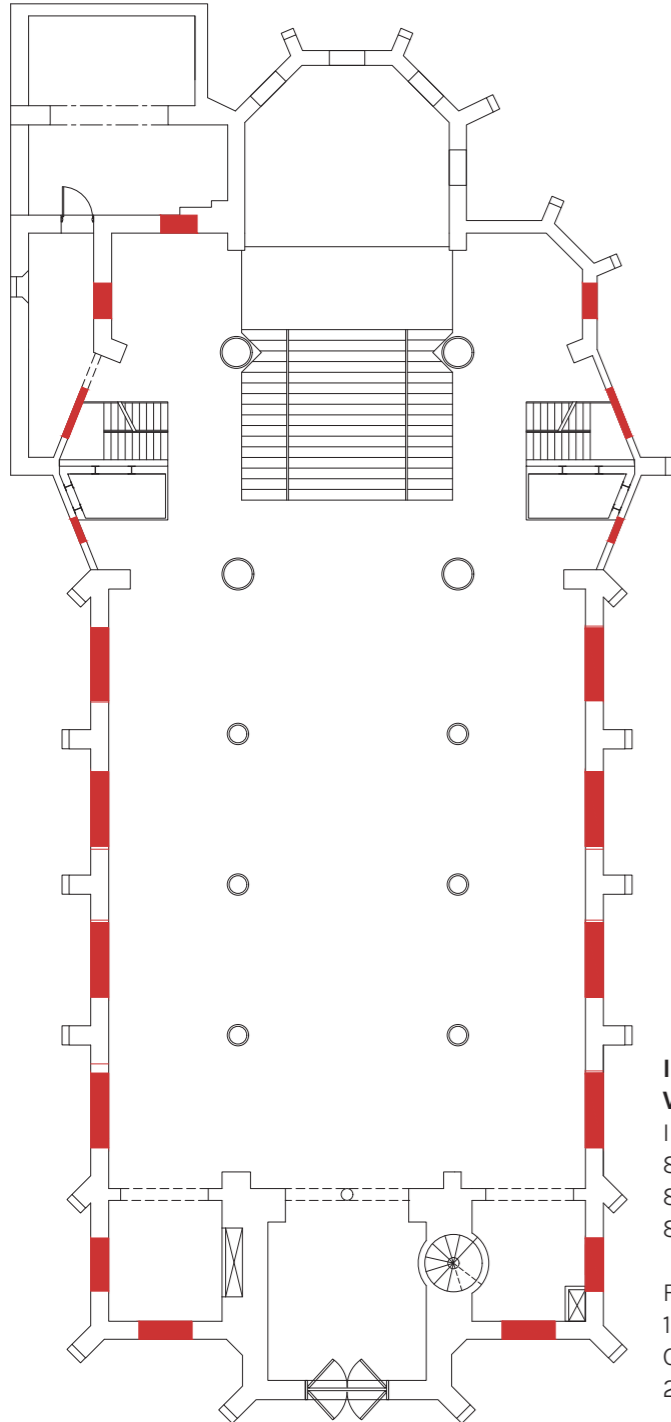

Insulated Double Glazed Window:
 Inside to Outside
 8 Clear Glass Pane
 8 Sealent
 8 Clear Glass Pane

Frame Components:
 114x68 glulam wooden
 CnC routed Frame
 25x114 wooden sill

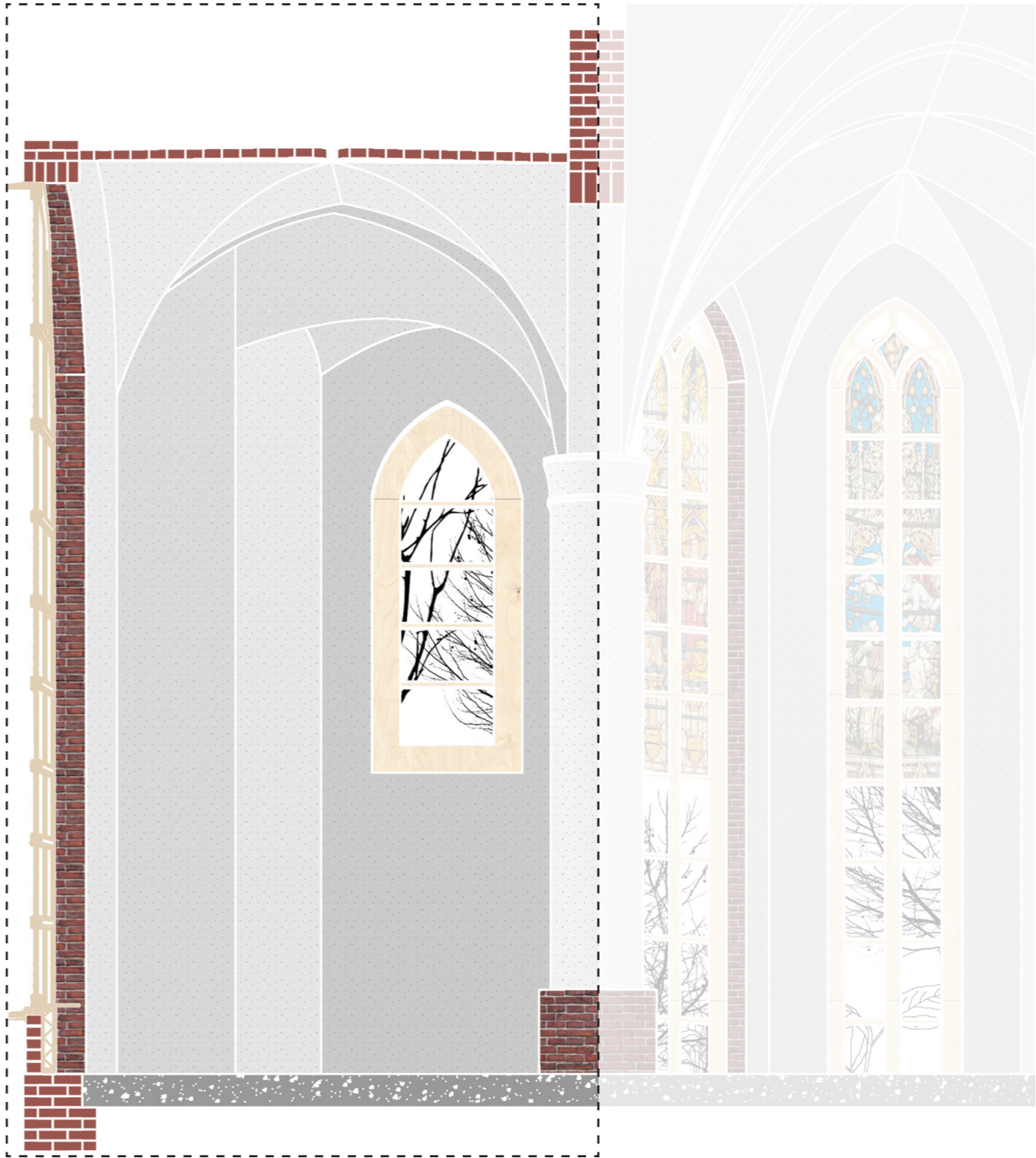
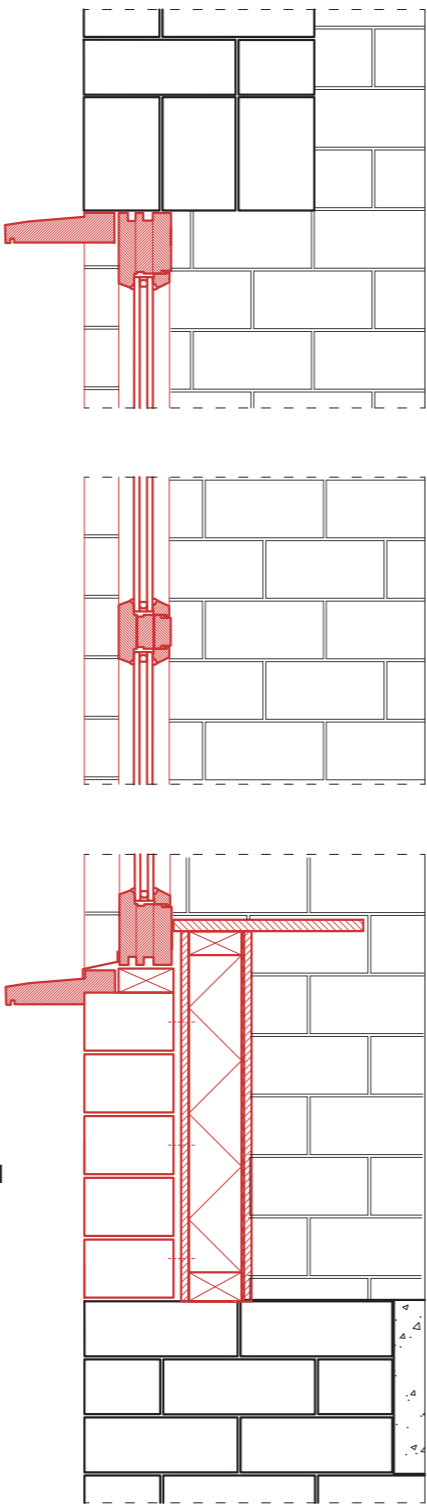

Insulated Stained Glass windows and New glass windows
 Most of the stained glass windows are warping after years of neglect.
 They also are single paned and do not provide enough insulation.

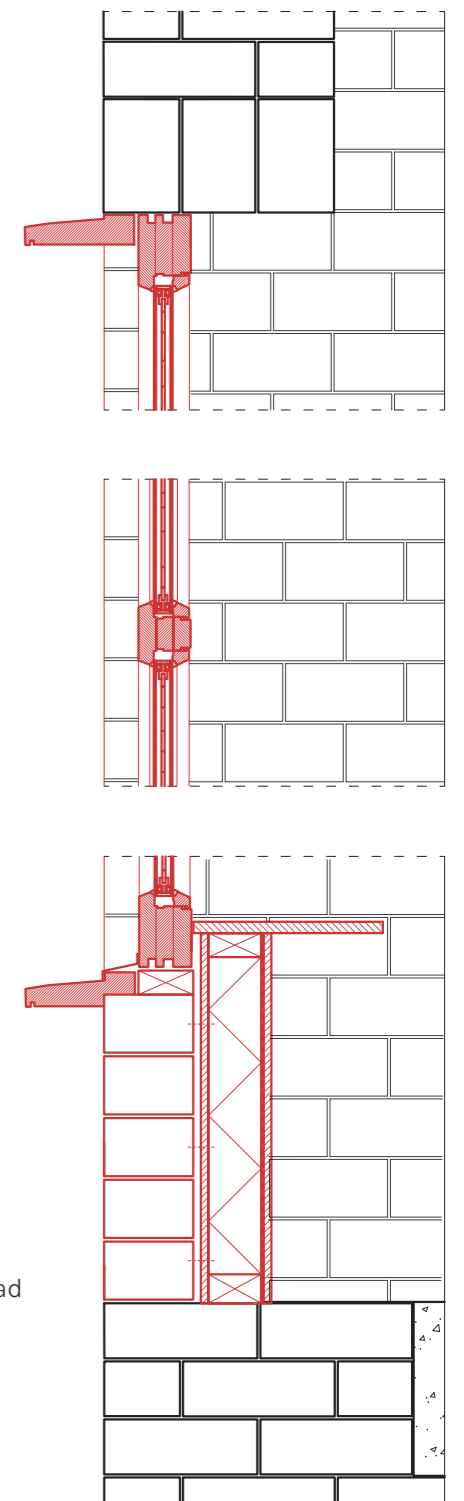
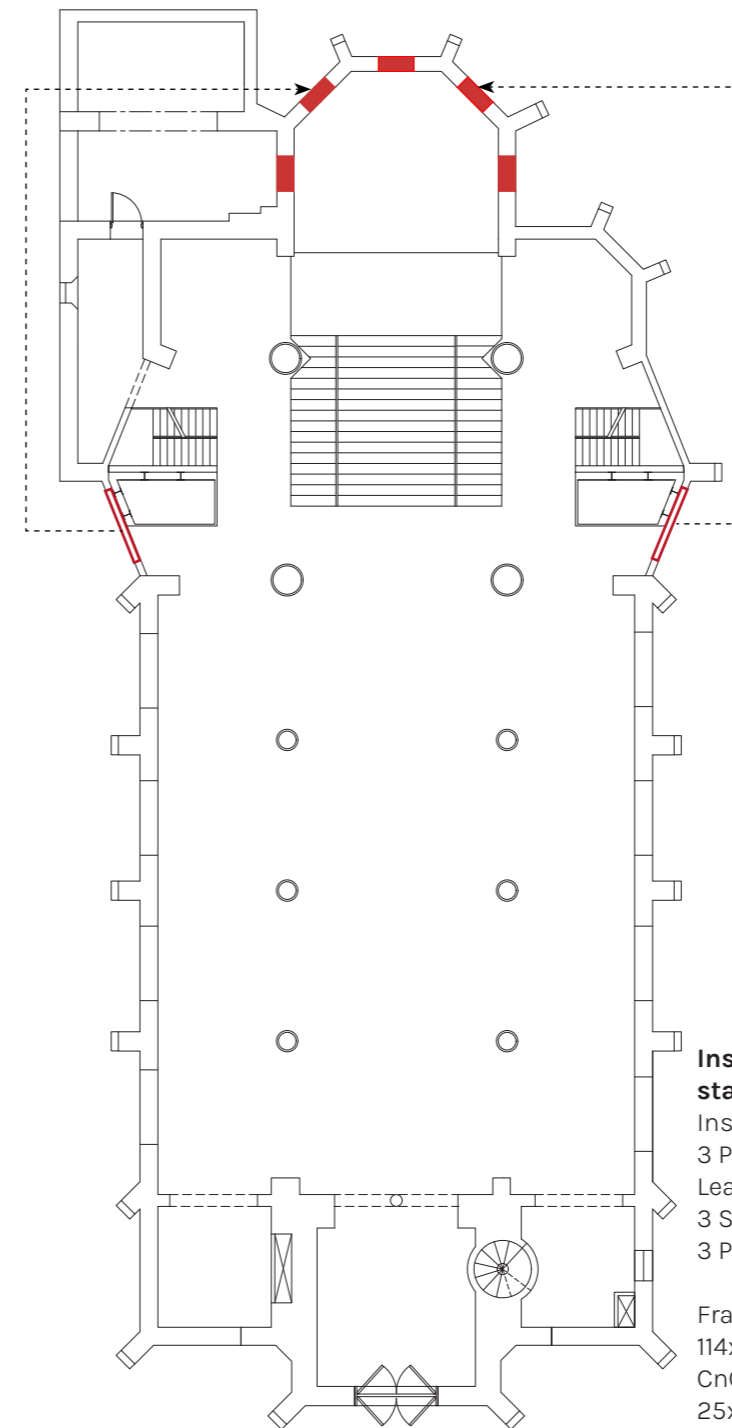

Insulated Triple Glazed stained Glass Window:
Inside to Outside
3 Plane Glass panel
Leaded glass pane with Y-Lead
3 Sealant
3 Plane Glass panel

Frame Components:
114x68 glulam wooden
CnC routed Frame
25x114 wooden sill

Insulated Stained Glass windows and New glass windows
Most of the stained glass windows are warping after years of neglect.
They also are single paned and do not provide enough insulation.

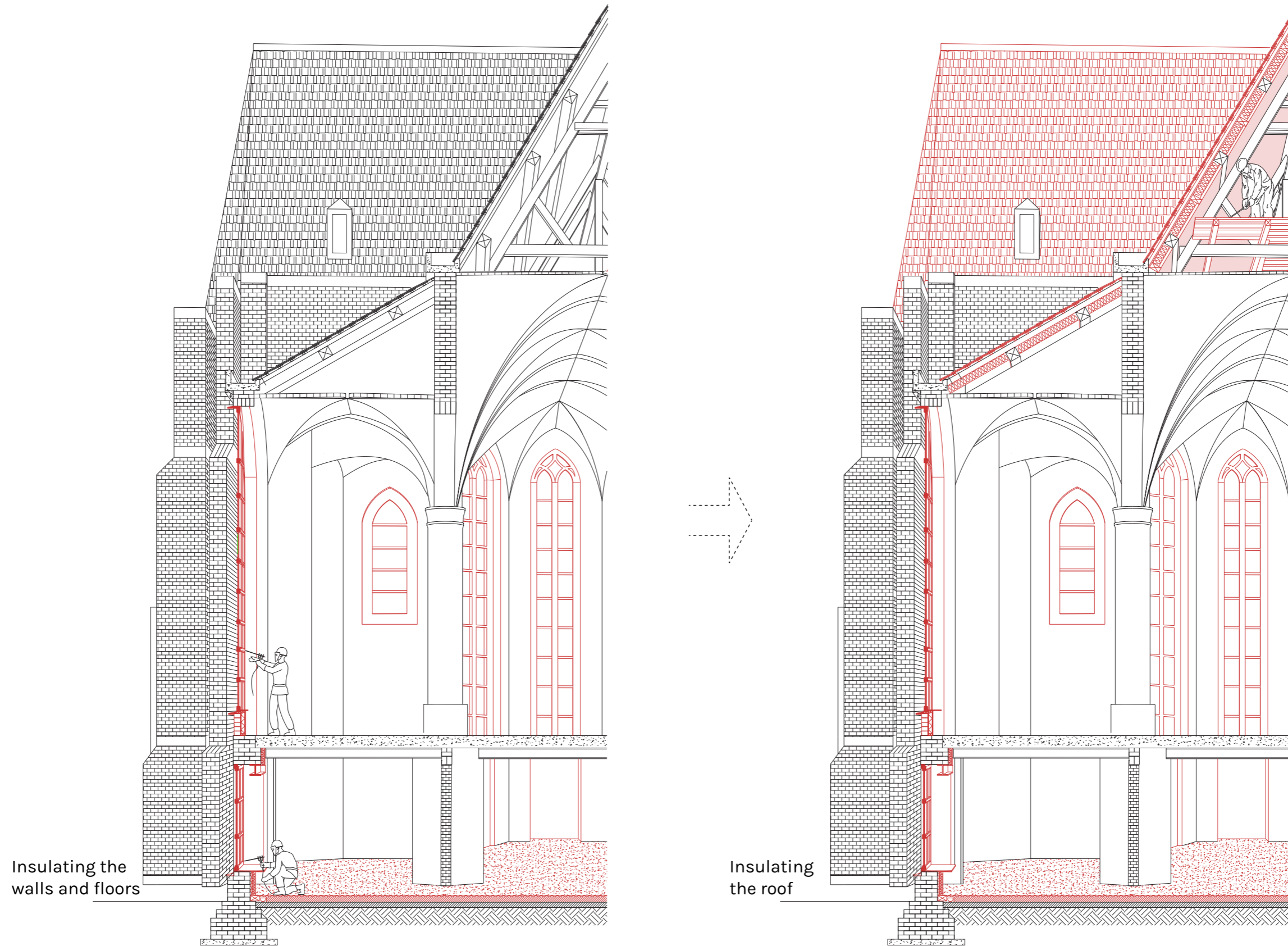

Insulating the Roof

The slate roof is repaired and isolated with friction fit hempwool insulation with wooden batons in a damp open form

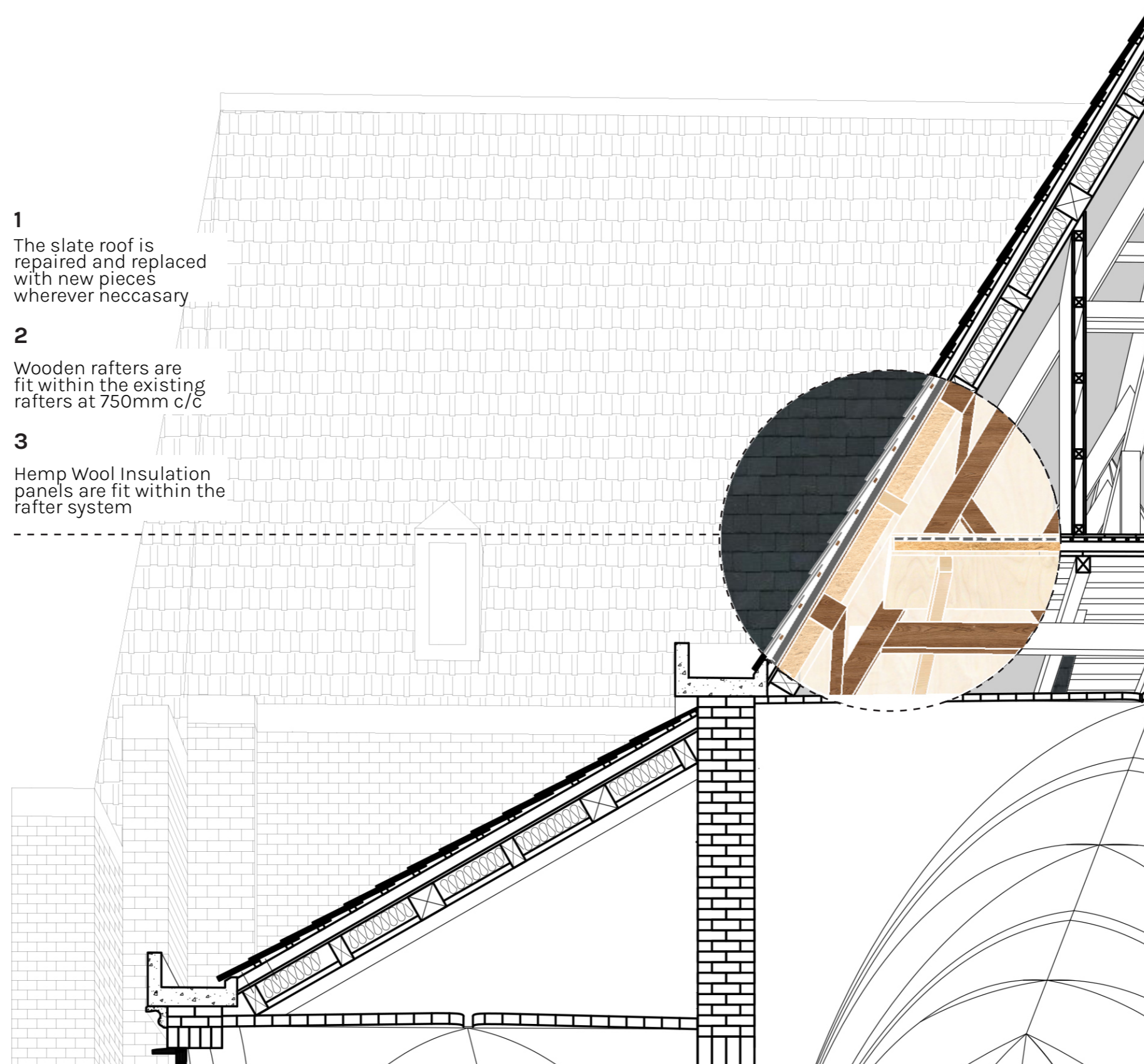

Insulating the Roof

The slate roof is repaired and isolated with friction fit hempwool insulation with wooden batons in a damp open form

Phased Construction process

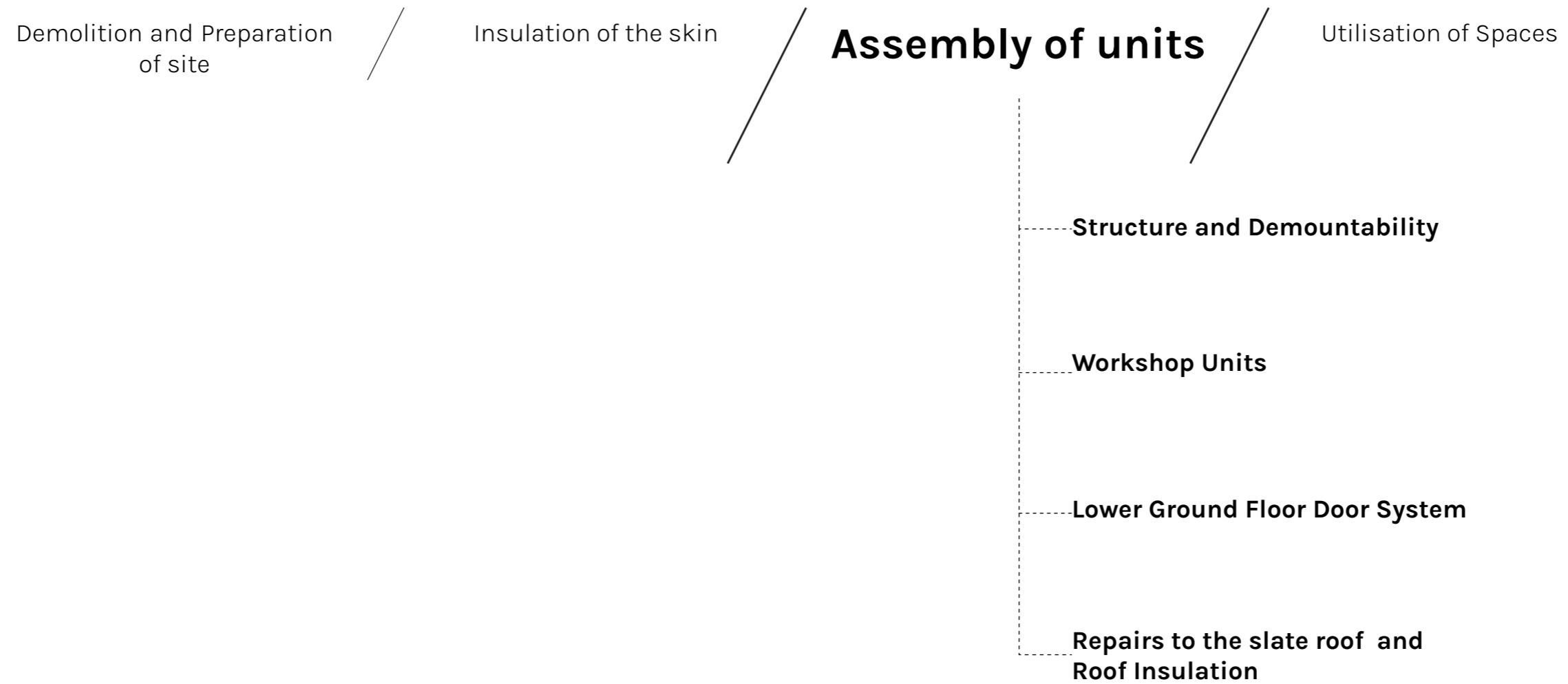

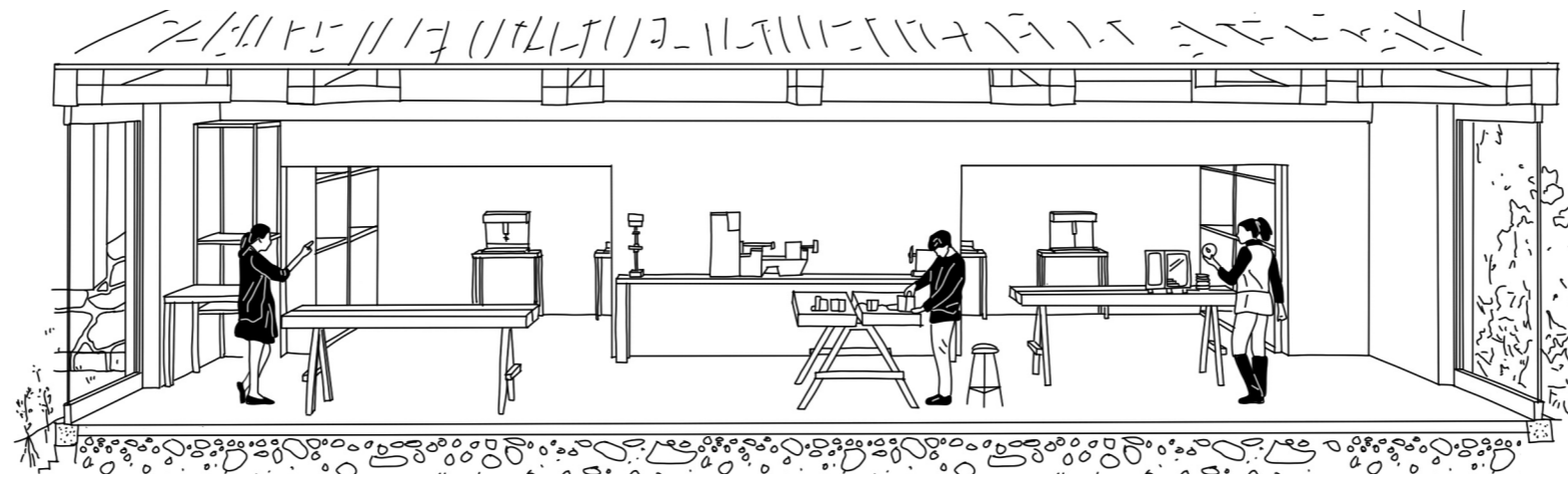

The Fabrication Lab

The ground floor of the rectory is used for the creation of all design interventions. These are then moved into the church for assembly and installation. The furniture is also restored here and then reused in the transformed church.

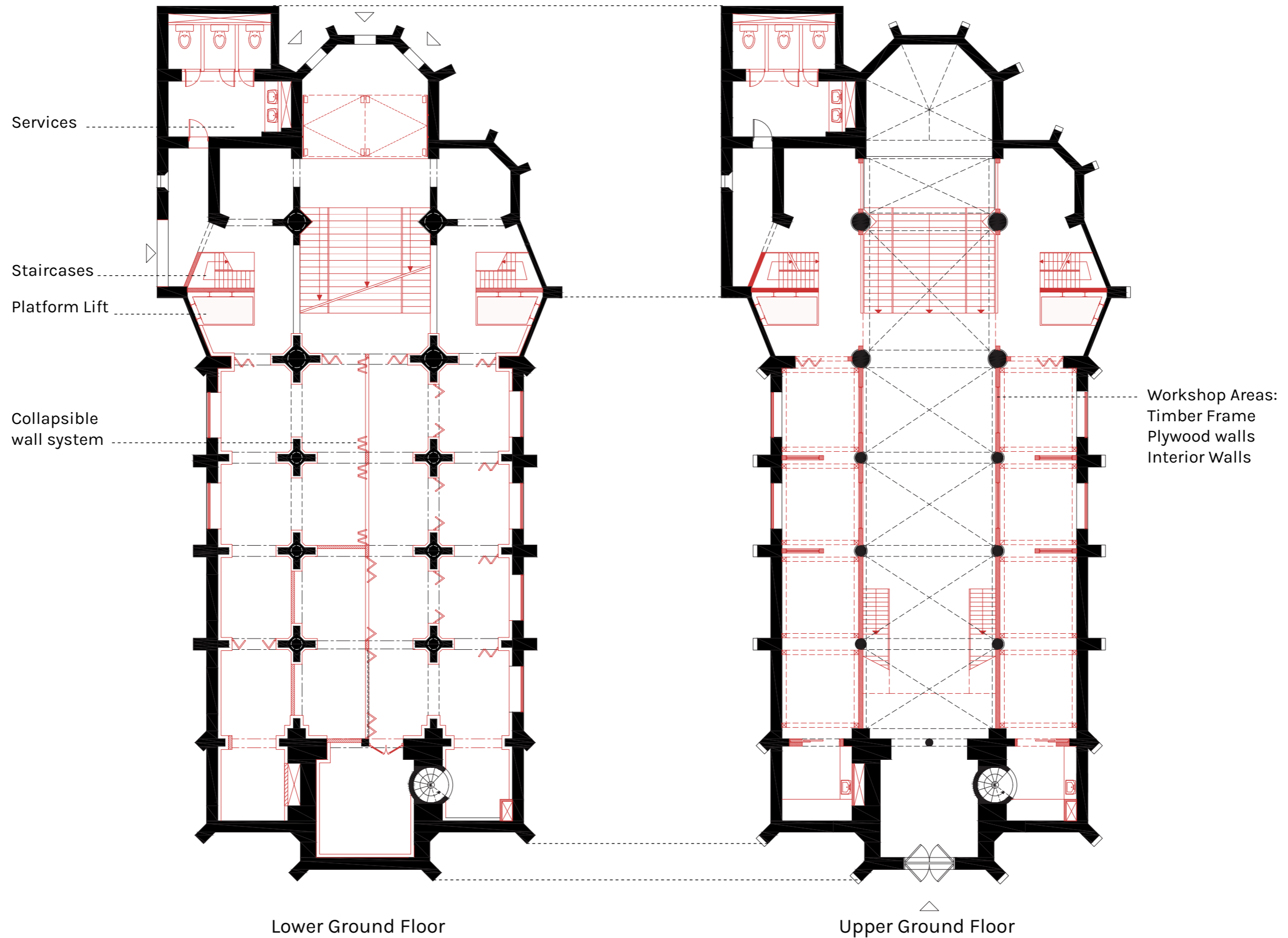

Types of Assembled Units

Each unit is made independent of the existing structure for ease of assembly, demountability and disassembly

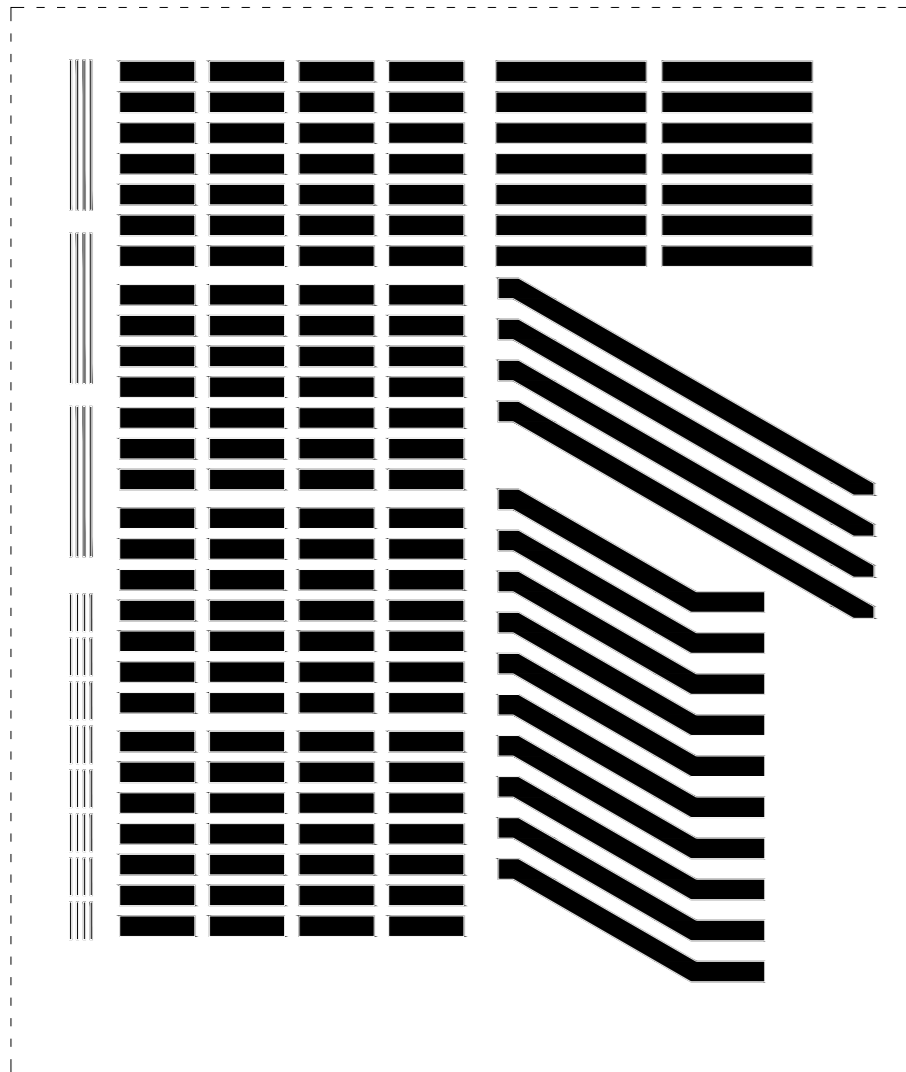

Staircases

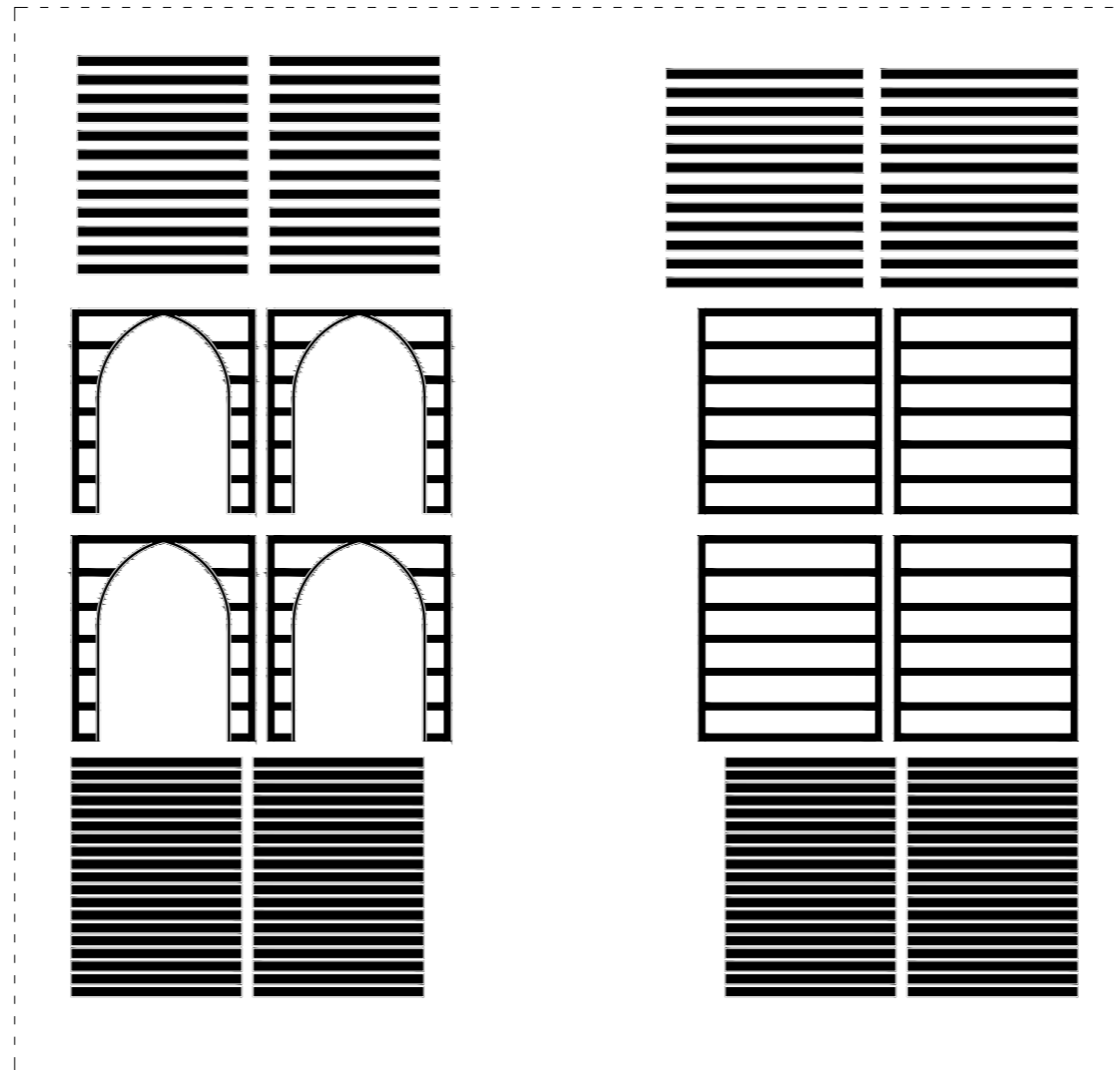

Workshop Areas:
Timber Frame
Plywood walls
Interior Walls

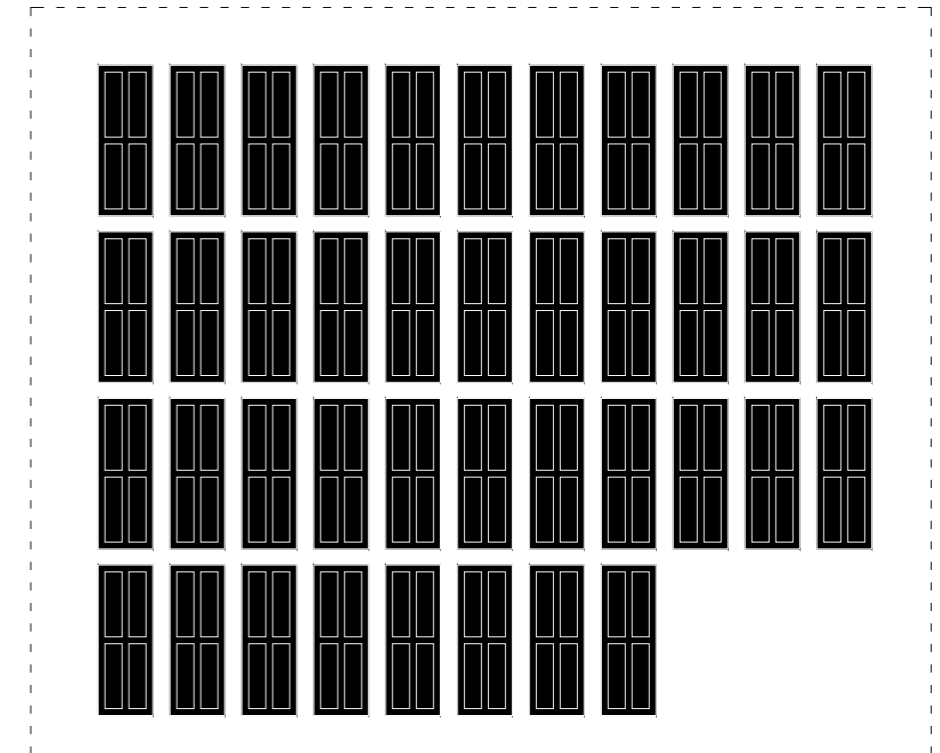

Collapsible wall system

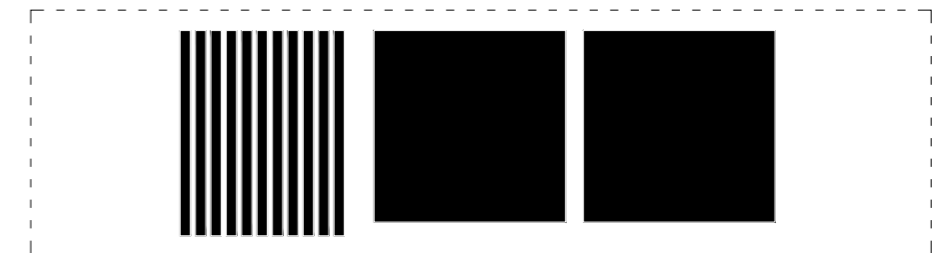

Platform Lift

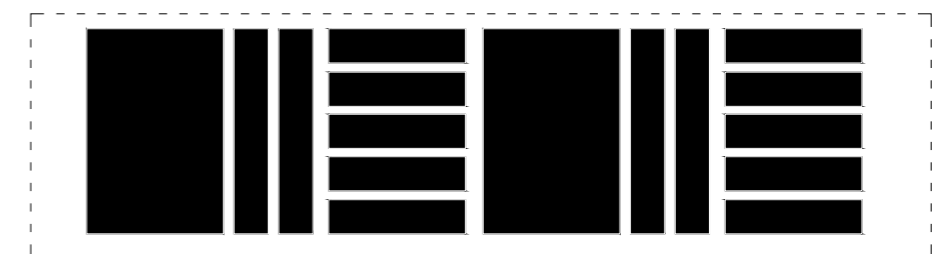

Storage

Assembled Units

Each unit is made independent of the existing structure for ease of assembly, demountability and disassembly

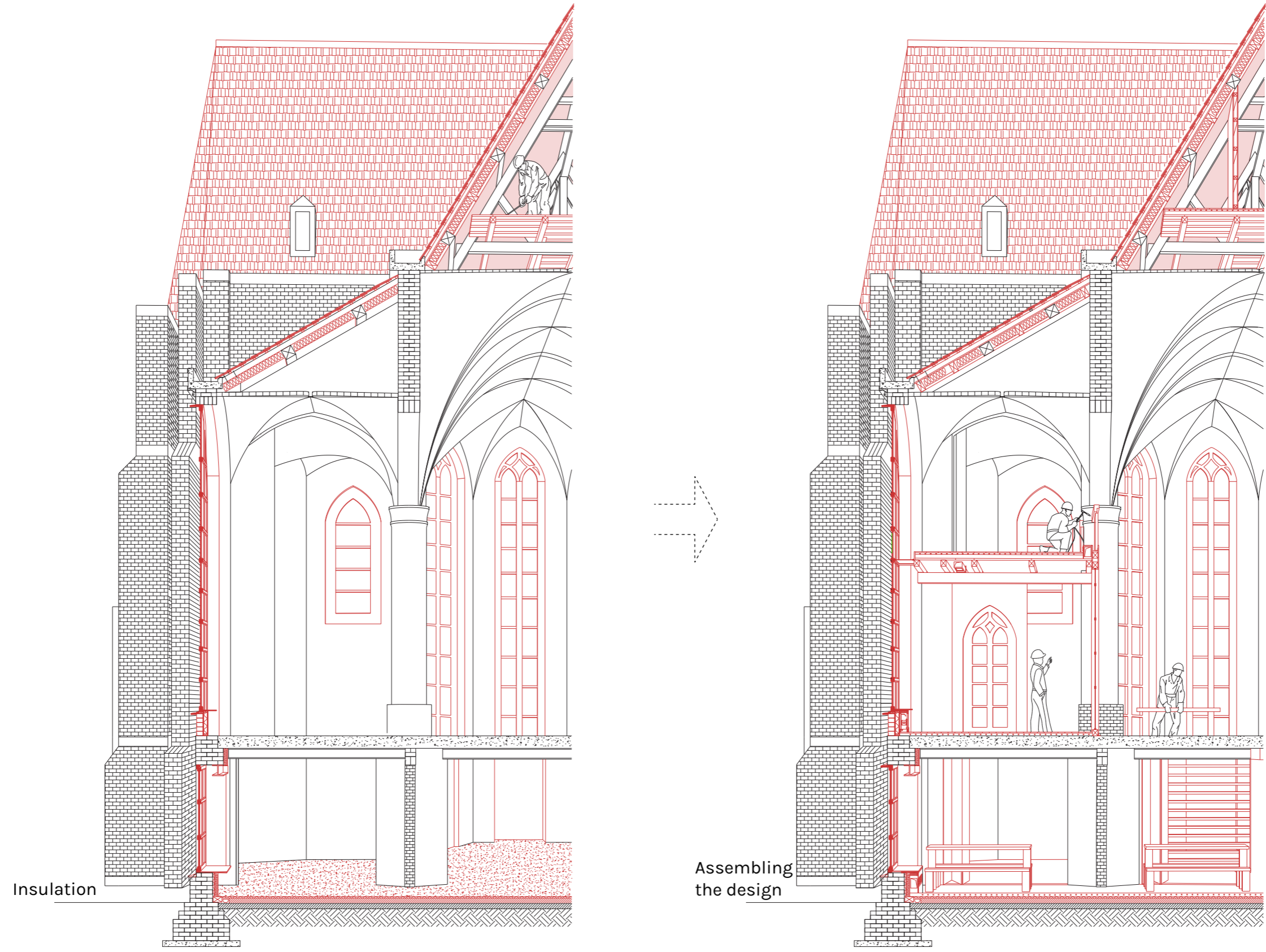

Assembled Units

Each unit is made independent of the existing structure for ease of assembly, demountability and disassembly

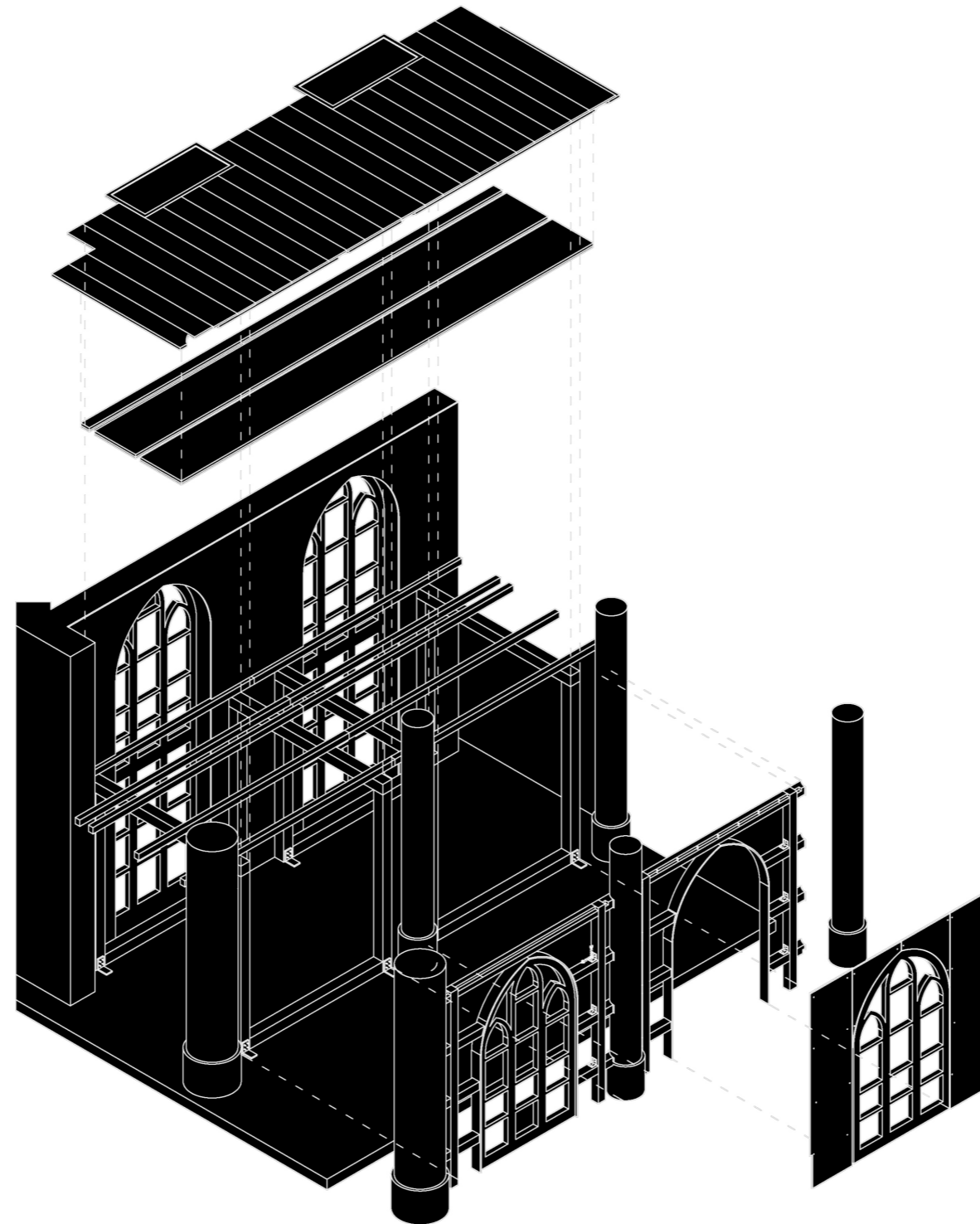

The Workshops

A Timber frame structure with timber walls and floors are fabricated in the fabrication room and then transported to church floor for assembly.



Preparation of the Site:

The church is prepared for the introduction of new elements. Furniture is removed and wooden flooring is stripped.

Timber structure:

The timber structure made of reclaimed wood is built in such a way that it stands separate from the old structure.

Creating a Floor:

The skin is placed on the structure with flooring and heating connected to the heat pump.

Extension and vertical circulation:

Baseboard heating and balustrades are created and then enclosed in plywood pieces.

Infill Walls:

The workshop spaces are enclosed in a series of timber frame walls. This divided the workshop from the performance spine.

Demountability

All units created in the fabrication space will be made and assembled in the church by the community

Floor Configuration 1:

- 20 reclaimed timber plank flooring
- 75 Floor heating with pipe 100mm cc
- 150 Hempcrete insulation
- 20 Plywood
- 110x155 Rafter

750x2100 Tempered Horizontal Window

Insulated Double Glazed Window:

- | | |
|--------------------|----------------------|
| Inside to Outside | Frame Components: |
| 8 Clear Glass Pane | 114x68 glulam wooden |
| 8 Sealant | CnC routed Frame |
| 8 Clear Glass Pane | 25x114 wooden sill |

75x75 Angle Cleat

110x155 Harvested Spruce Beam

300x300 Steel Plate

110x155 Harvested Spruce Column

180x120 mechanical ventilation shaft

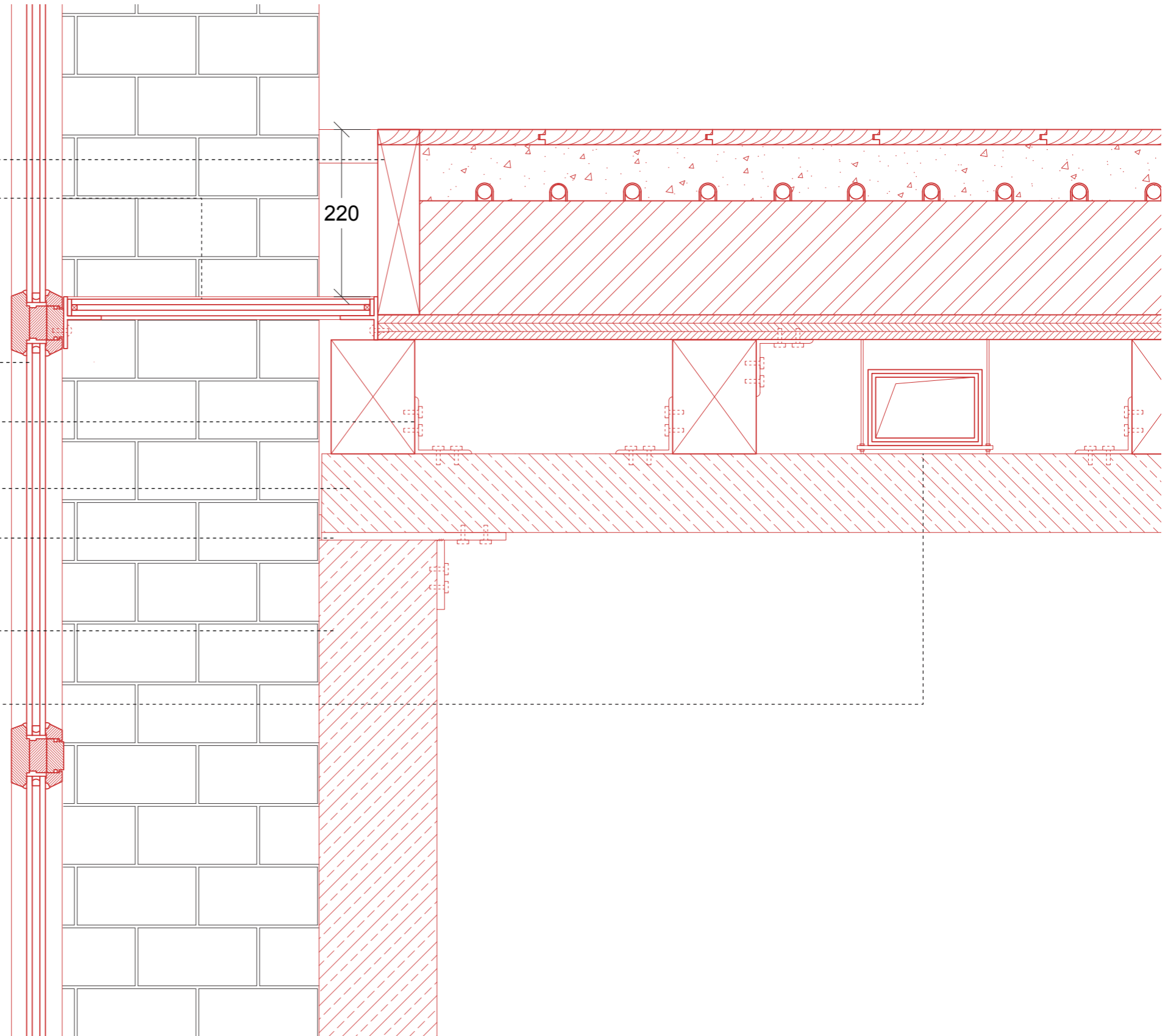

Demountability

For disassembly and reuse of elements in the future case of disuse,
each element is joined with minimal intervention

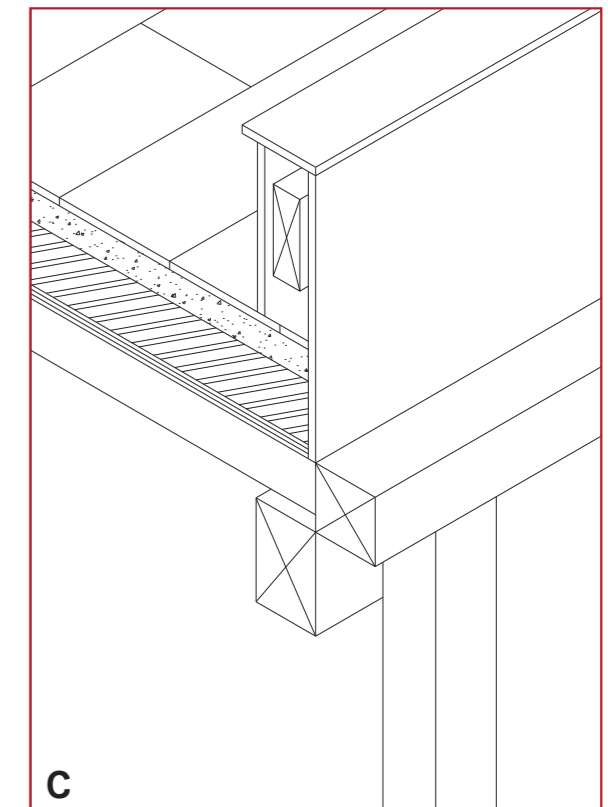
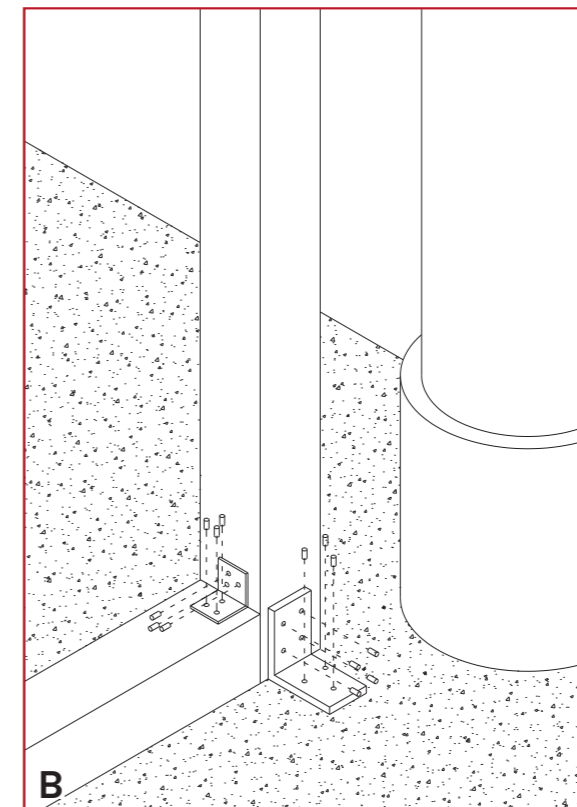
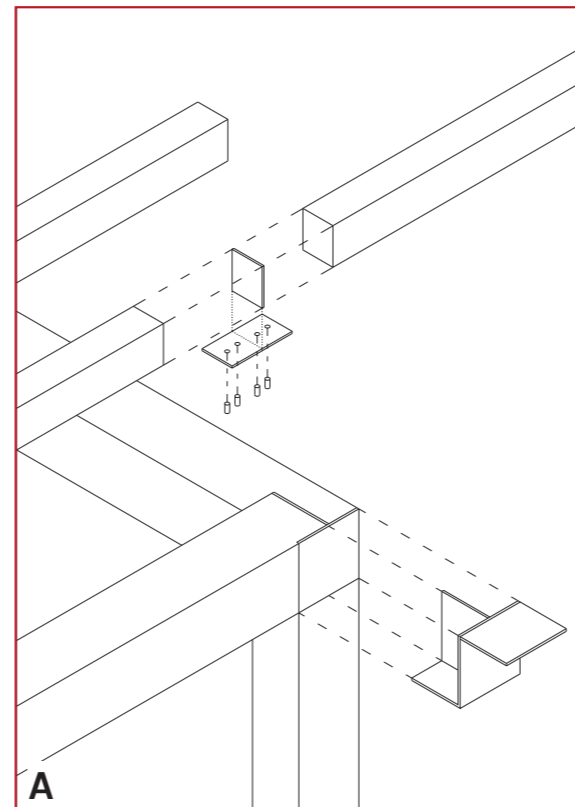
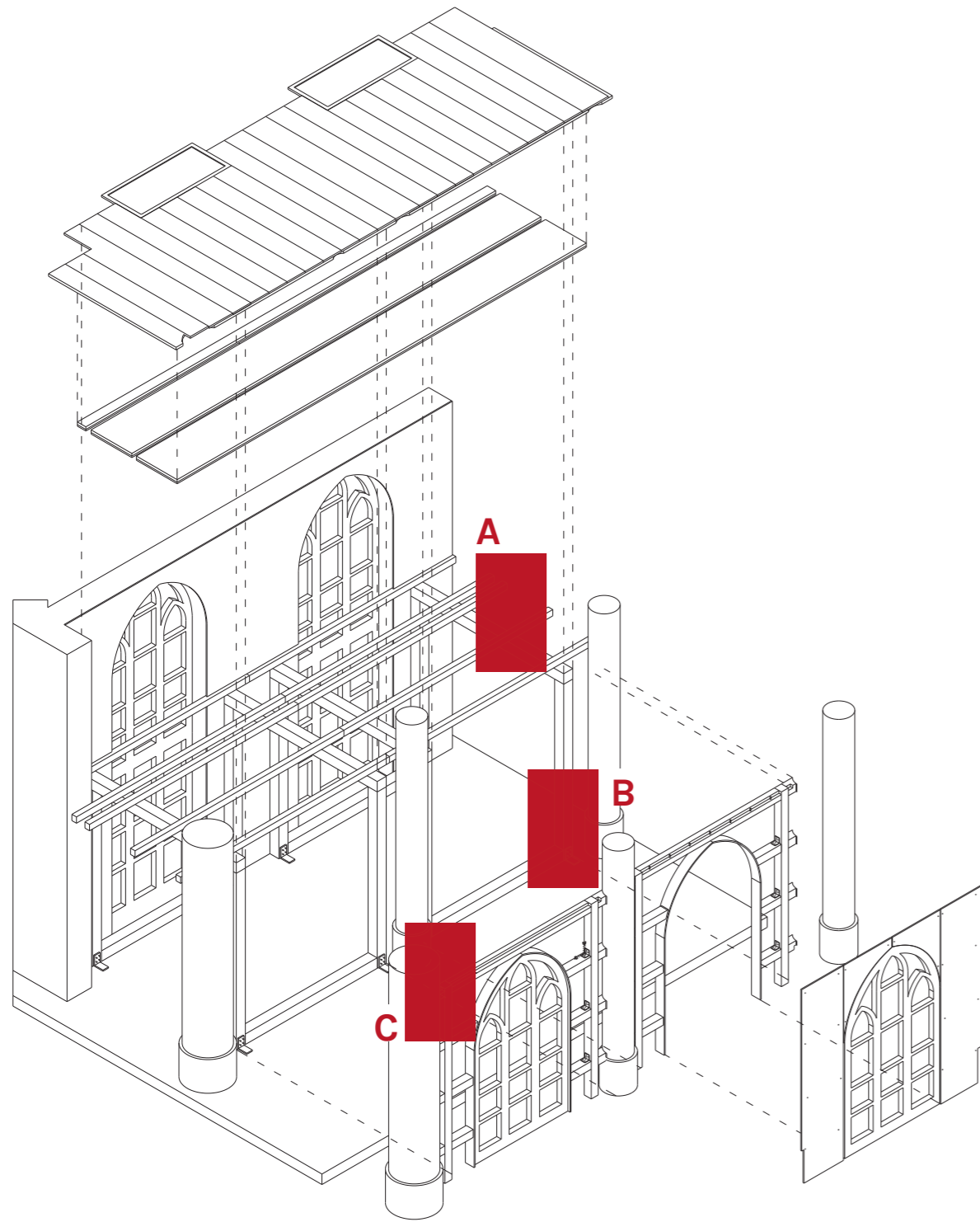

Demountability

For disassembly and reuse of elements in the future case of disuse,
each element is joined with minimal intervention

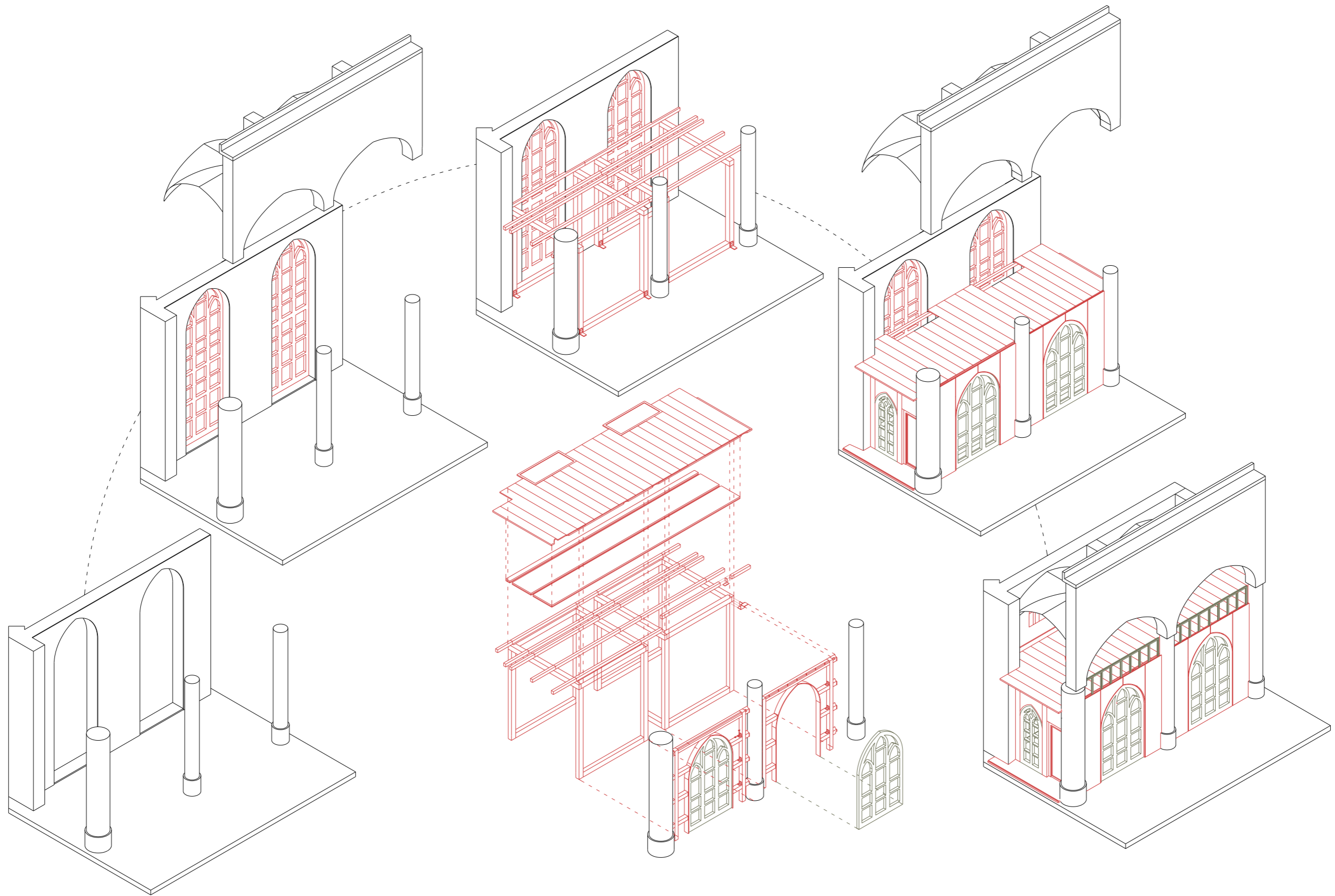

Harvested Material Type:

— from Church

— from around Amsterdam

Demountability

All units created in the fabrication space will be made and assembled in the church by the community



Amsterdam
 Reclaimed:
 1) 20x1210x2440 Plywood
 2) 55x155x4500 Spruce Beam Rough
 3) 25x120x4500 Spruce Beam Rough
 4) 110x155x4500 Spruce Beam Rough



Amsterdam
 Organ 1: by Sybrand Adema
 Organ 2: by Jan Wisse
 Clocks: J.H. Addicks and Zn.



Den Haag
 Side Aisle, stained glass window: by Gisèle Waterschoot van de Gracht

Valstreek
 Brick: factories for 25 percent of the bricks



Geshert
 Bell: by Petit and Gebr. Edelbrock in Geshert

Millingen en Gendt
 Brick: factories for 75 percent of the bricks

Utrecht
 Apse stained glass window: by Van vven Willemse

Material Strategy

Any new material is sourced from Amsterdam with respect to the circularity strategy. Materials are hemp or timber based.

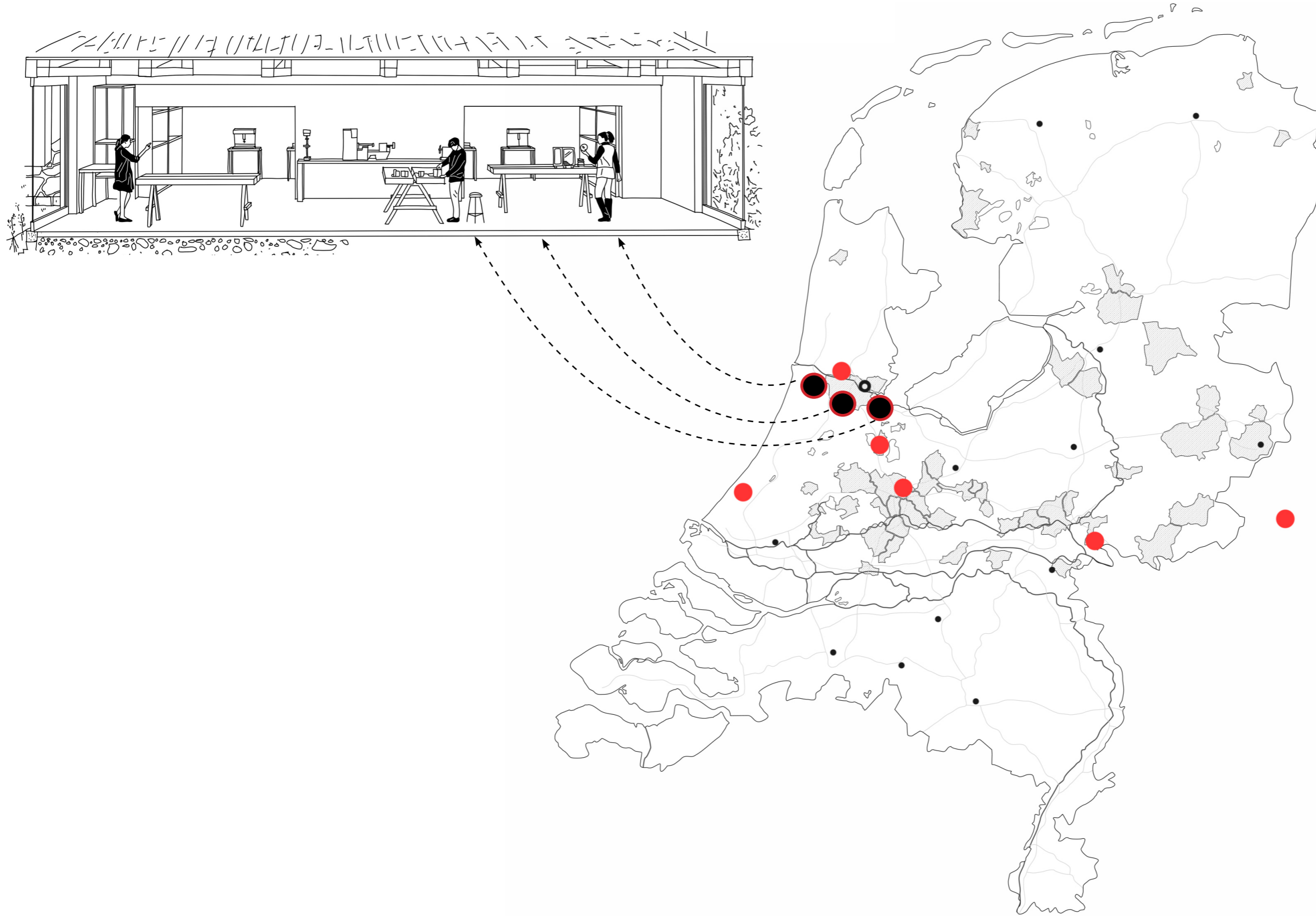

Material Strategy

Any new material is sourced from Amsterdam with respect to the circularity strategy. Materials are hemp or timber based.

		Structure	Noise	Access
Fine Arts Zone	Textile Photography Printmaking Literature	LOW	HIGH	INDIV.
Fine Arts Zone	Painting Sculpture	LOW	LOW	INDIV.
Fabrication Zone	Metal Workshop Wood Workshop	HIGH	HIGH	INDIV.
Culinary arts	Community Kitchen Eating Zone	LOW	HIGH	PUBLIC
Performance arts	Music Hall Stage	HIGH	HIGH	PUBLIC

Scale:

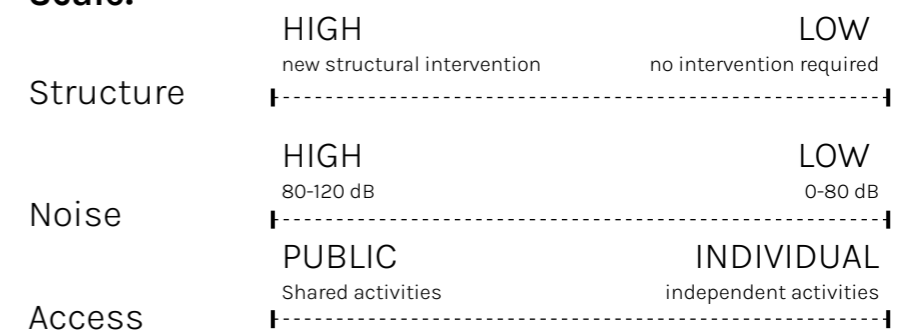

Functional Zoning

Every form of art and craft is matricised based on the amount of structural intervention, amount of noise created and public access

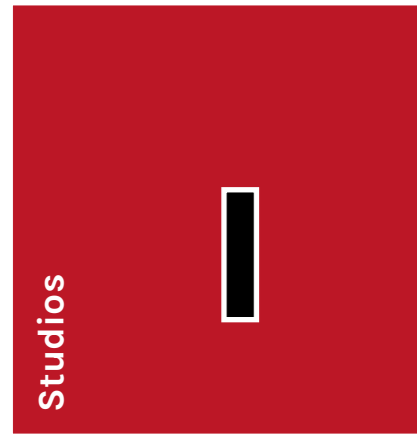

First Floor Plan
Plan 1:200

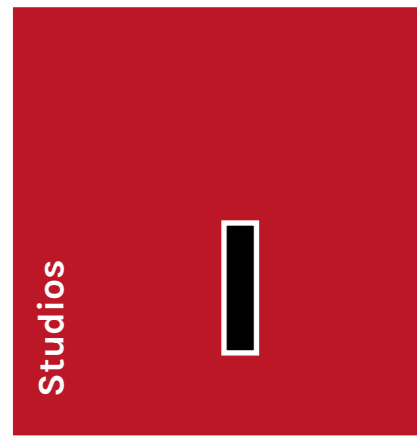

Upper Ground Floor Plan
Plan 1:200



Lower Ground Floor Plan
Plan 1:200

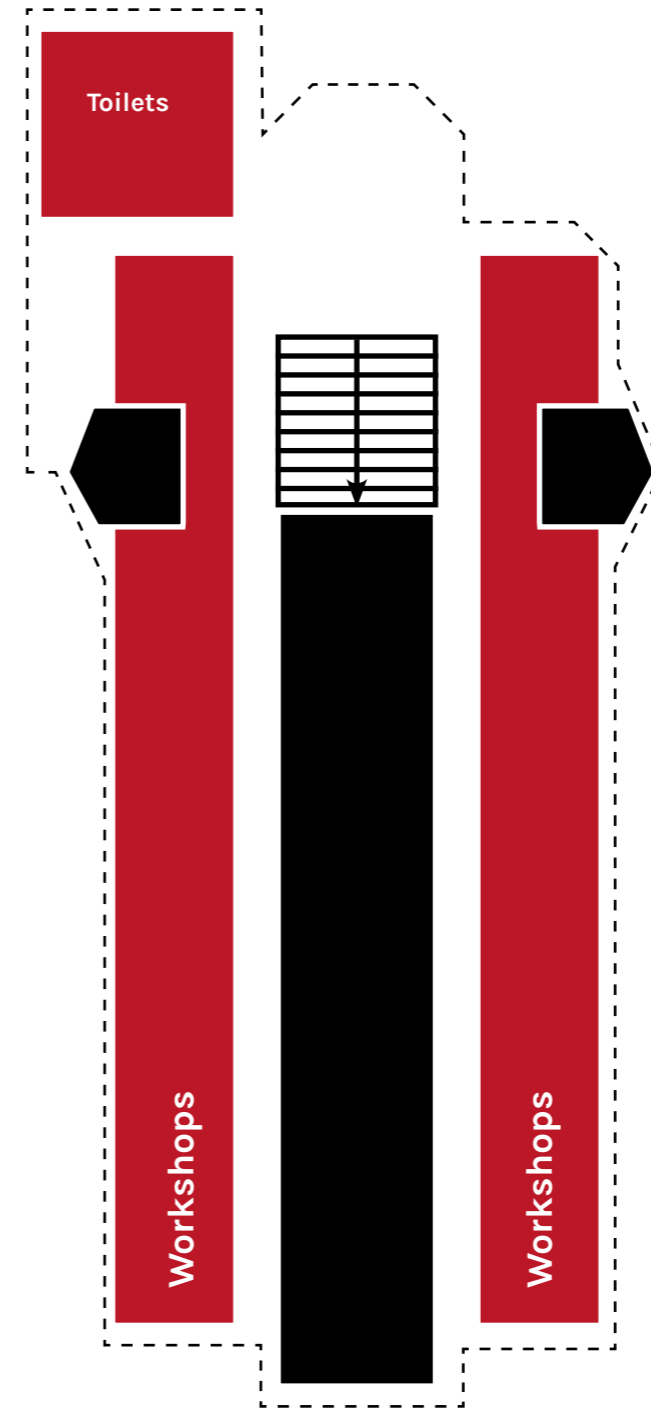
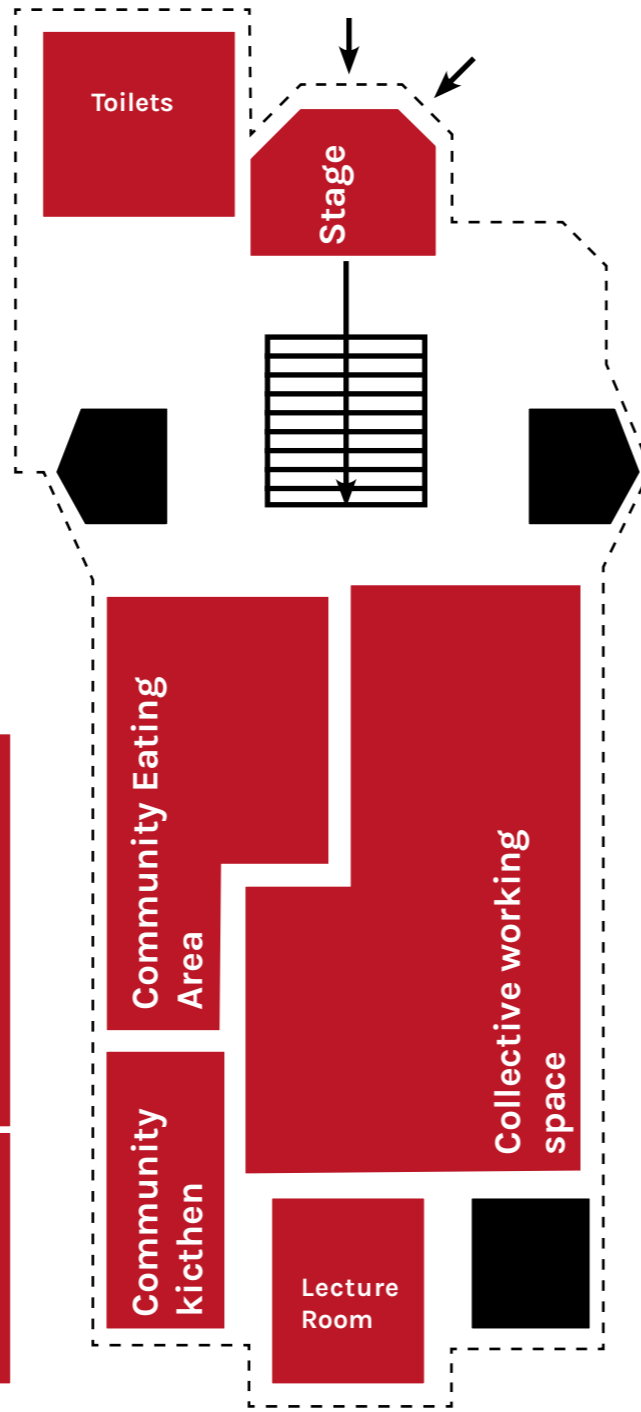

Upper Ground Floor Plan
Plan 1:200

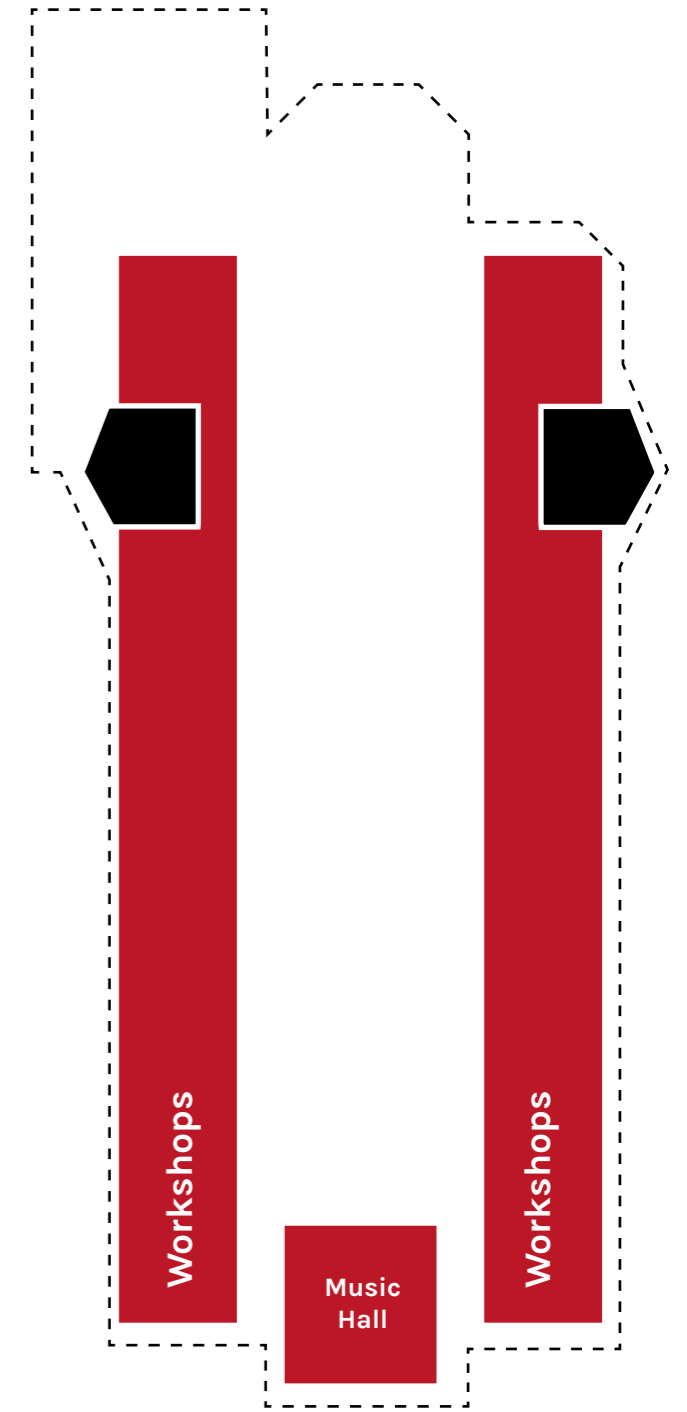

Mezzanine Level Plan
Plan 1:200

Functional Space
Circulation

Functional Zoning

Each workshop and communal space is defined with respect to the closed and open areas

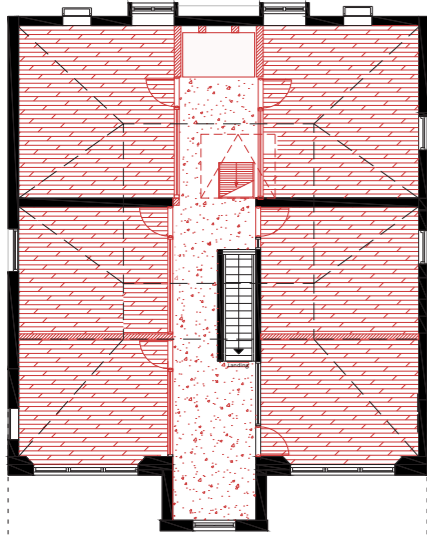

First Floor Plan
Plan 1:200

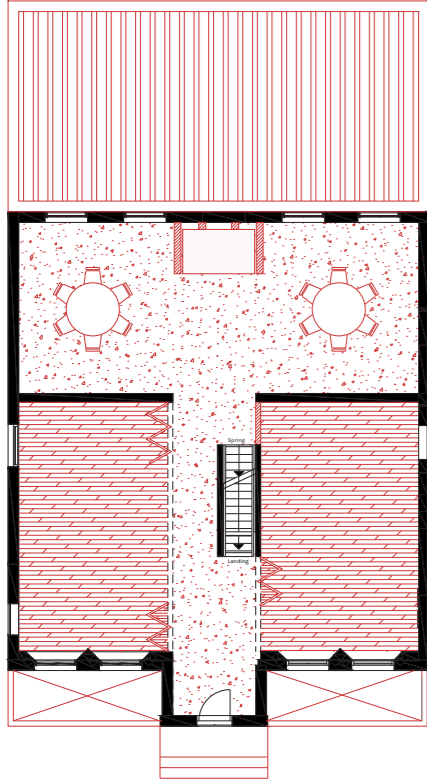

Upper Ground Floor Plan
Plan 1:200

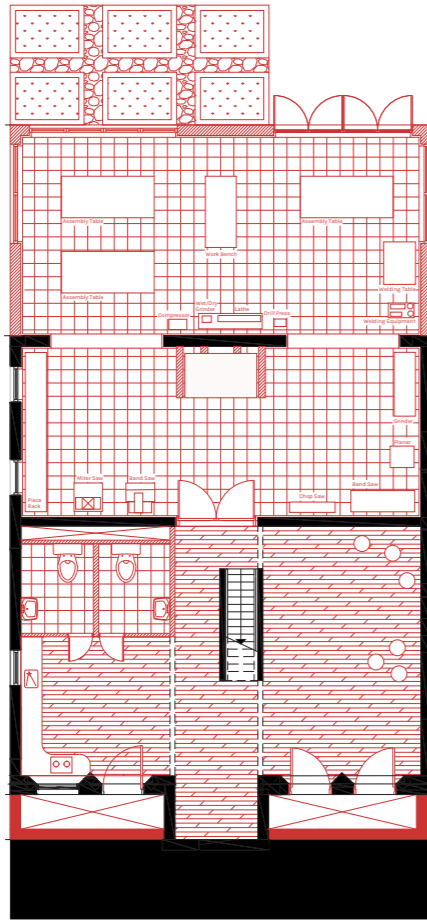

Lower Ground Floor Plan
Plan 1:200

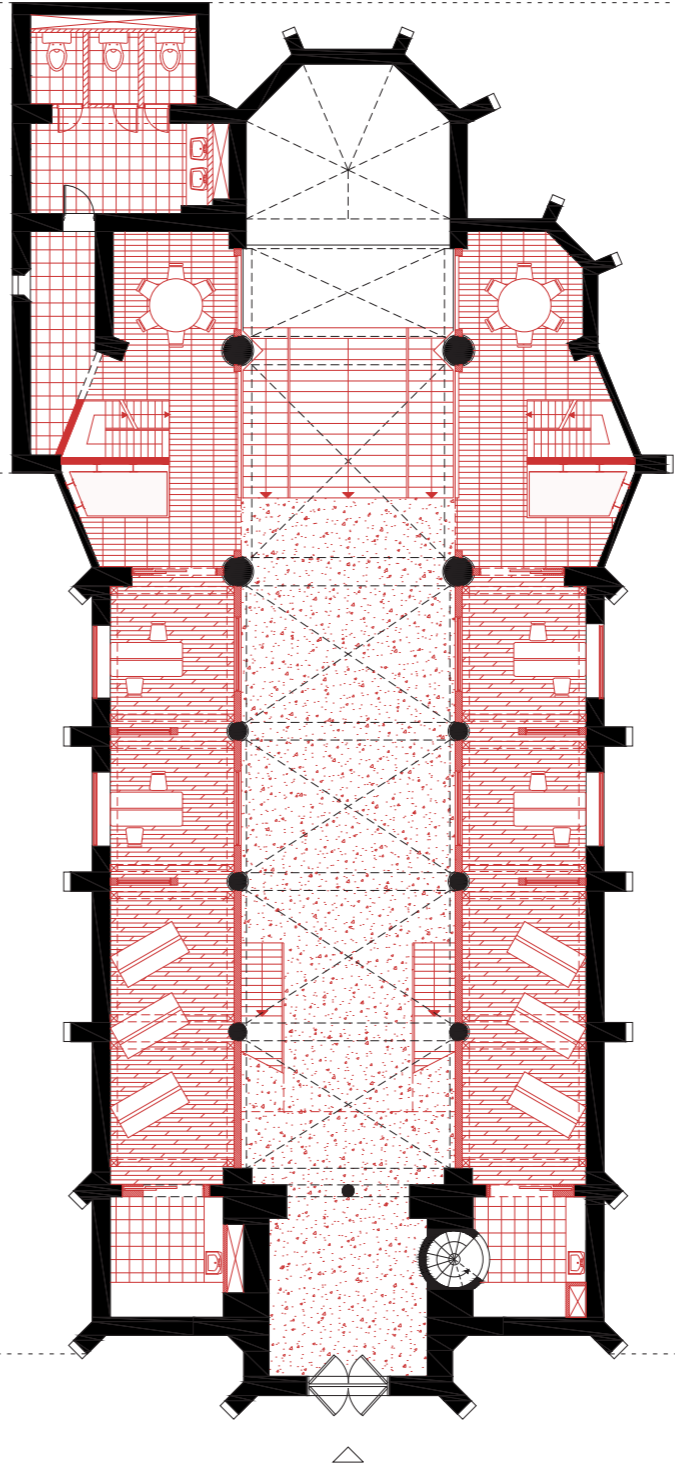
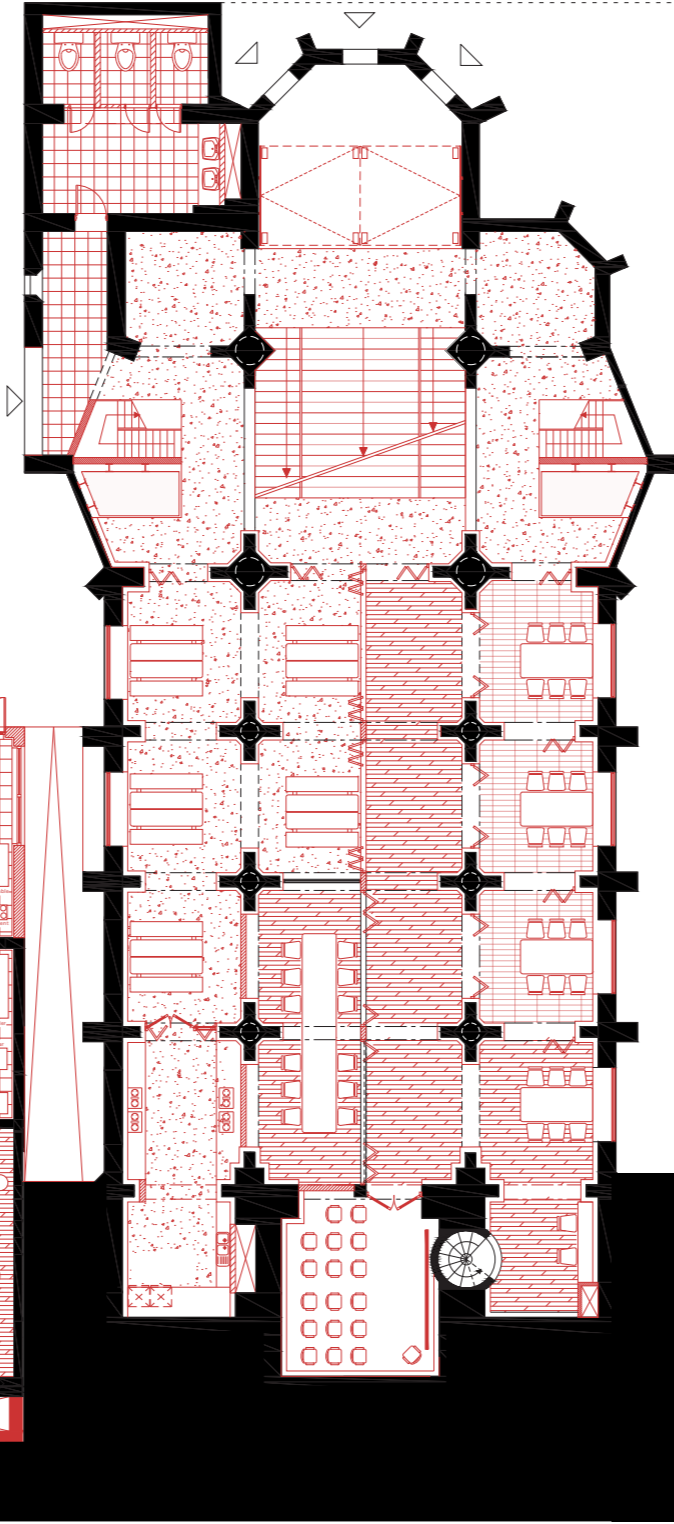

Upper Ground Floor Plan
Plan 1:200

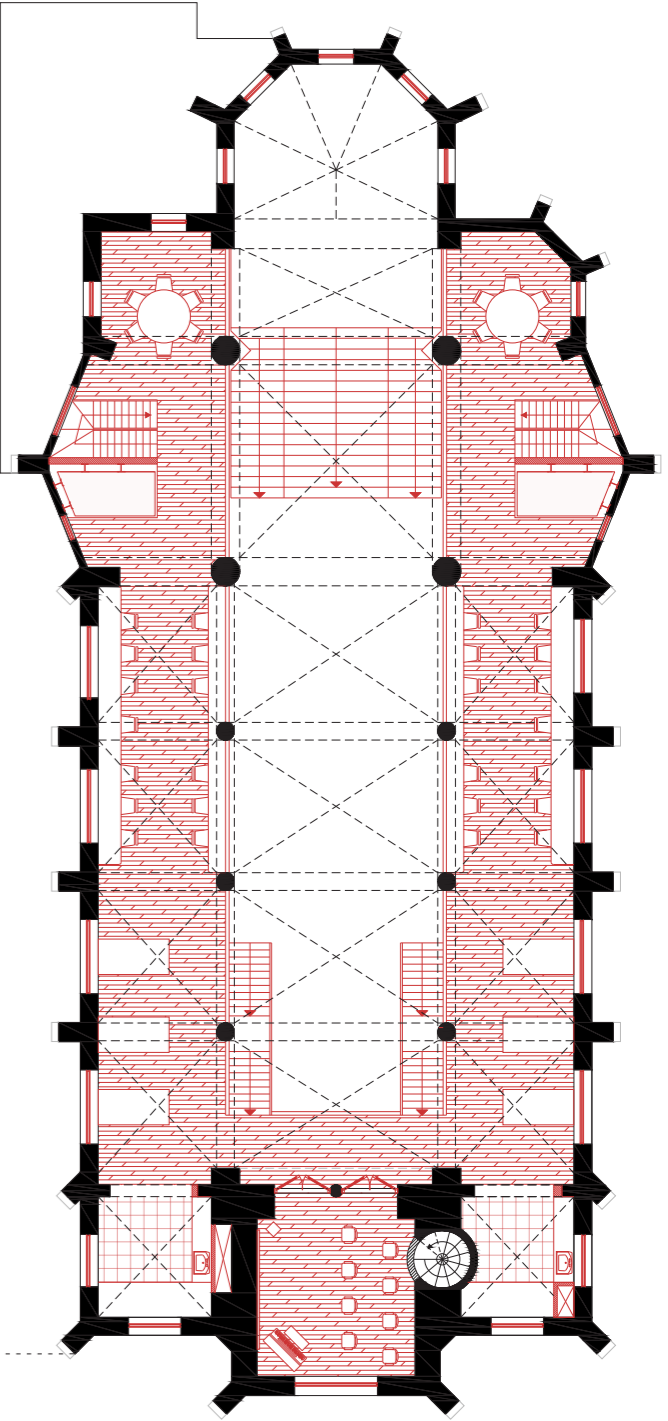

Mezzanine Level Plan
Plan 1:200

Functional Zoning

Each workshop and communal space is defined with respect to the closed and open areas

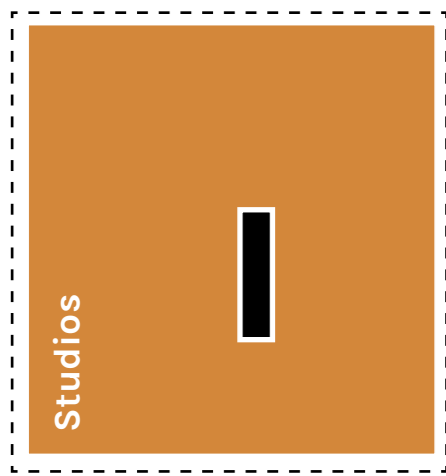

First Floor Plan
Plan 1:200

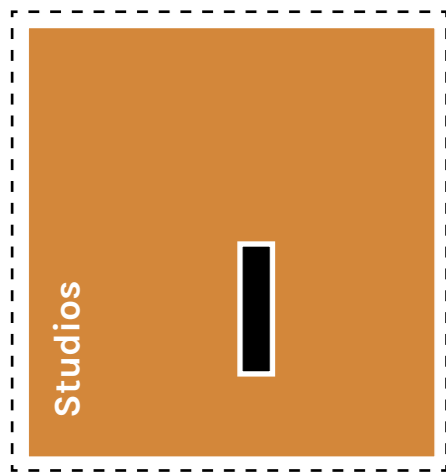

Upper Ground Floor Plan
Plan 1:200

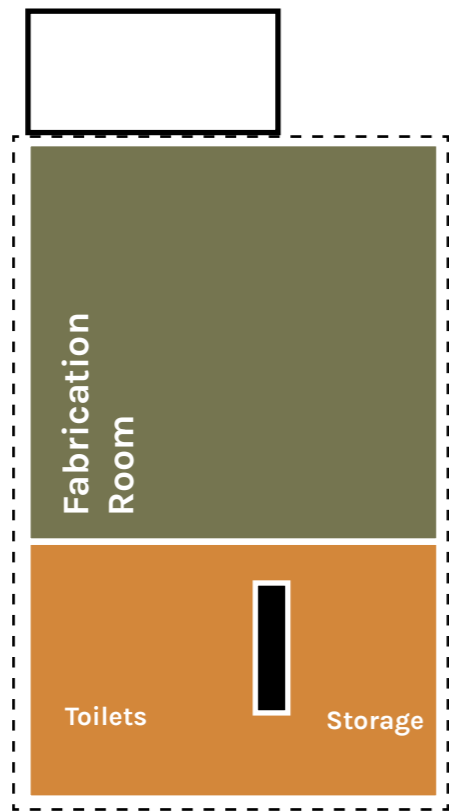

Lower Ground Floor Plan
Plan 1:200

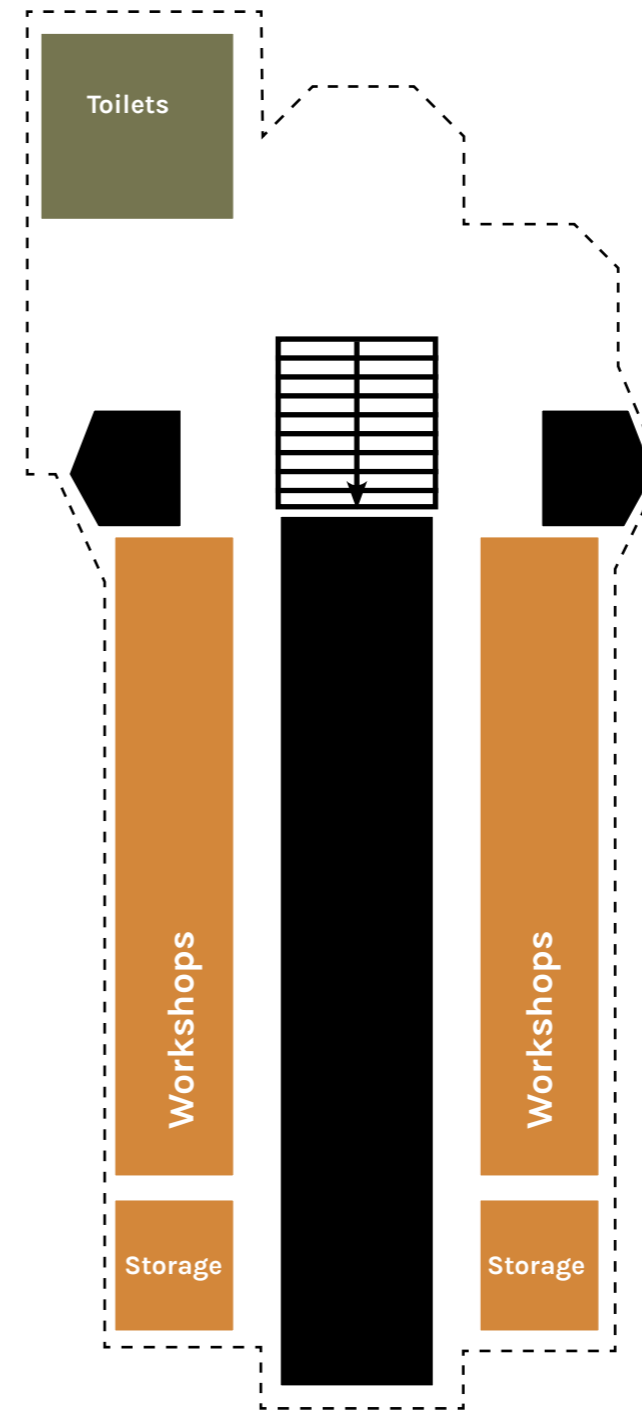
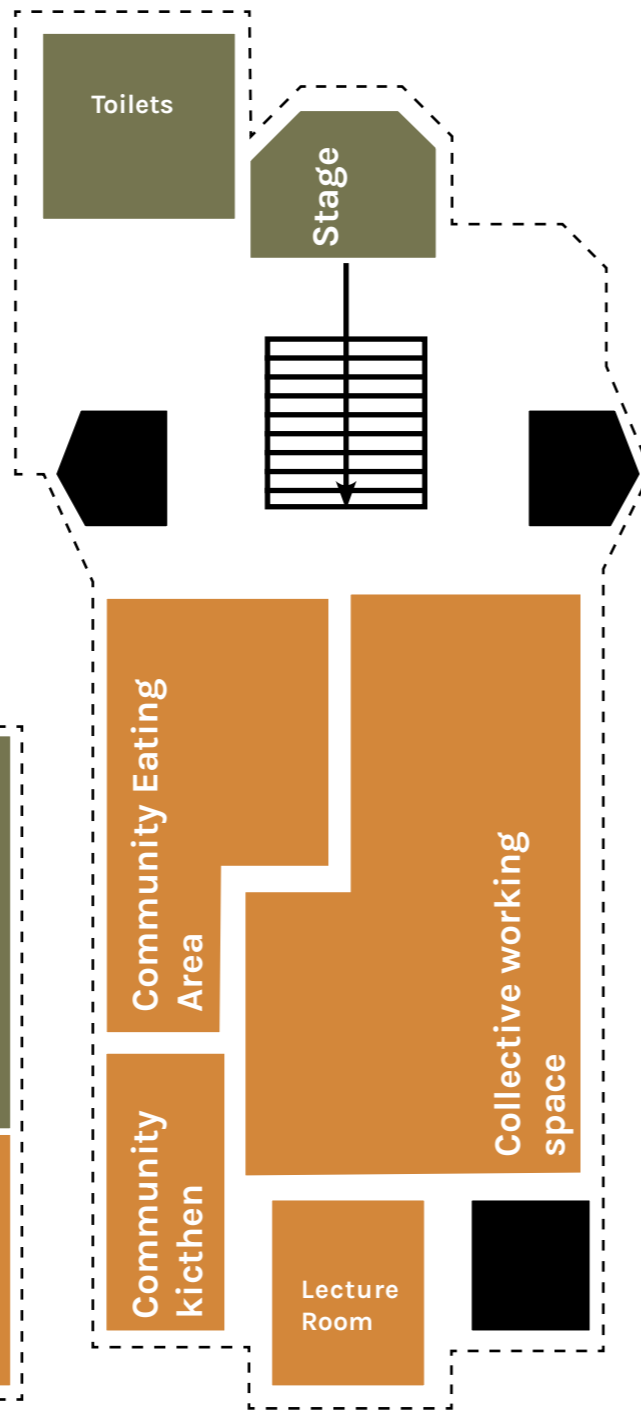

Upper Ground Floor Plan
Plan 1:200

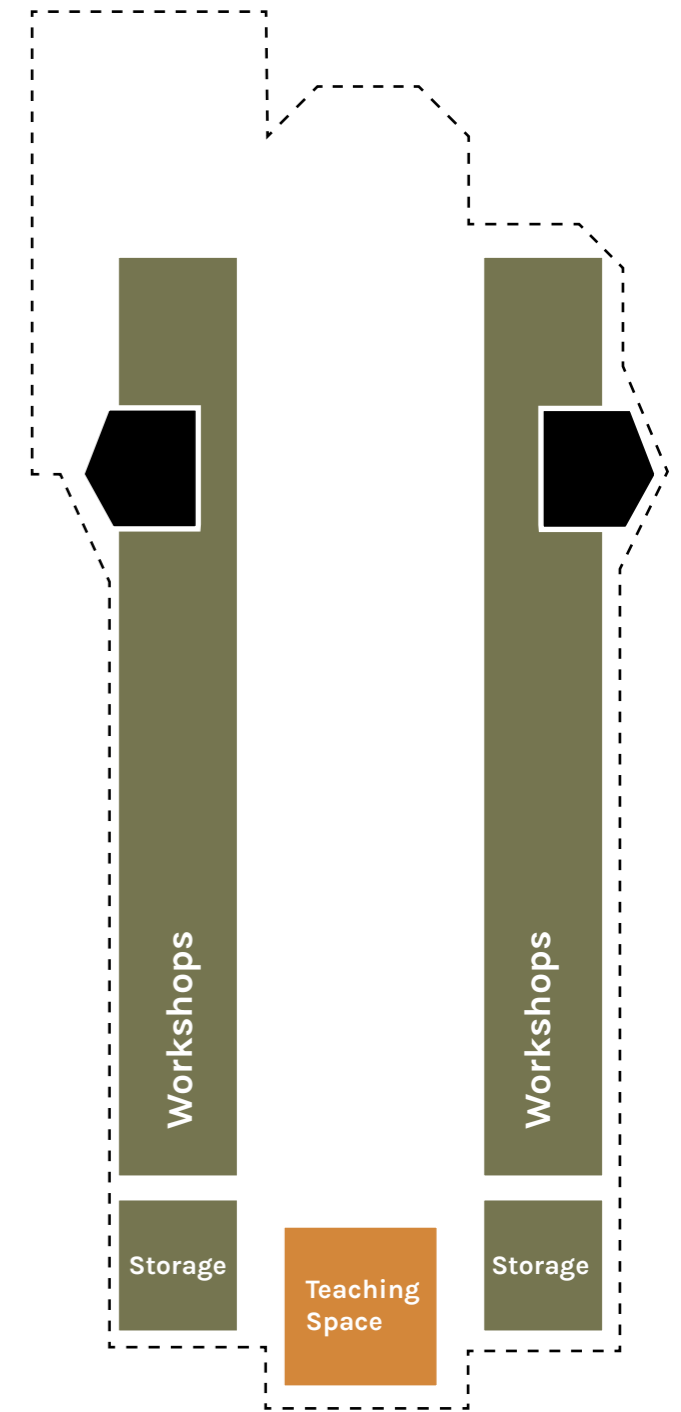

Mezzanine Level Plan
Plan 1:200

- Insulation boundary
- Heated Closed Area
- Unheated Open Area

Climate Strategy

The church is completely insulated. The floor heating creates a stable temperature while the church has closed and unheated areas.

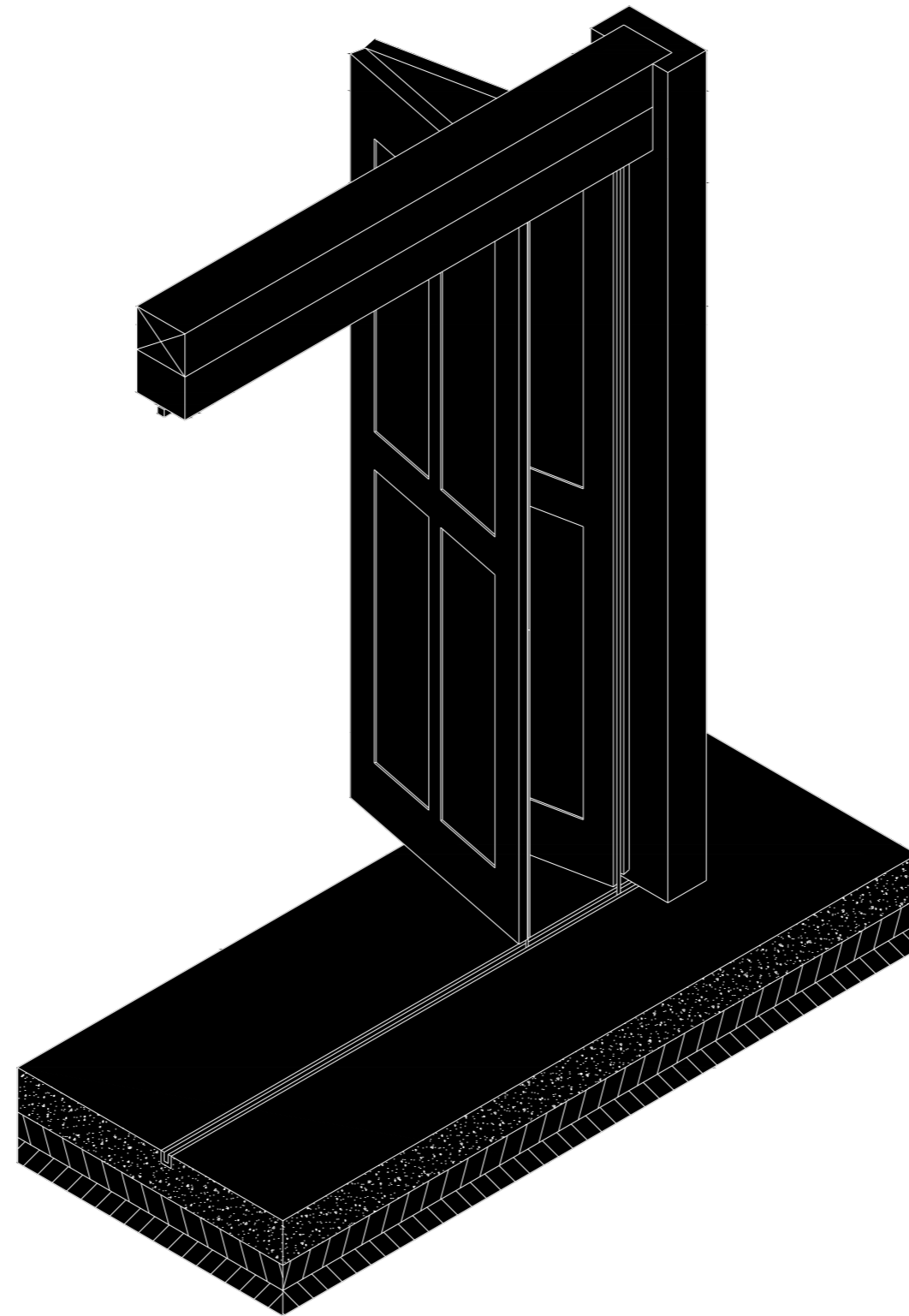

Collapsible Wall System

A series of doors joined together with new joinery and placed on channels form the basis of the walls system on the basement level

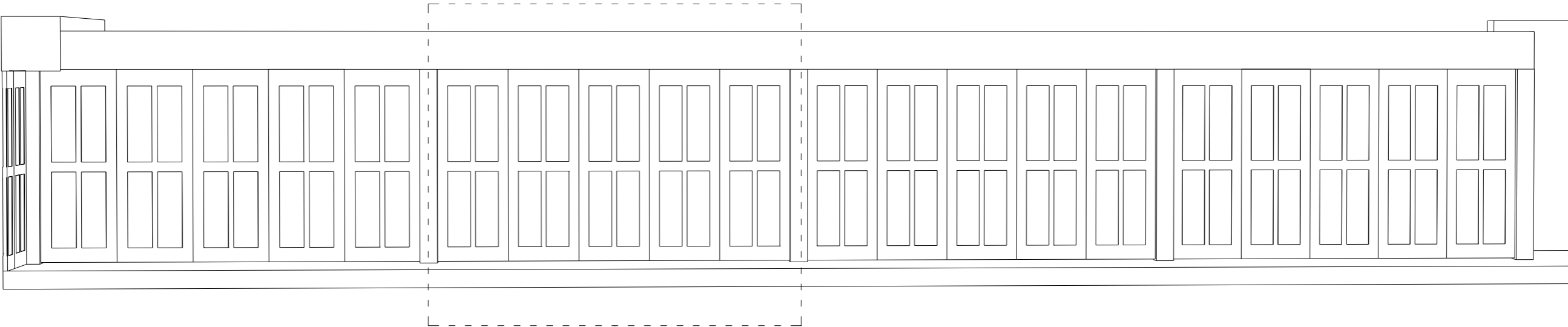

Collapsible Wall system

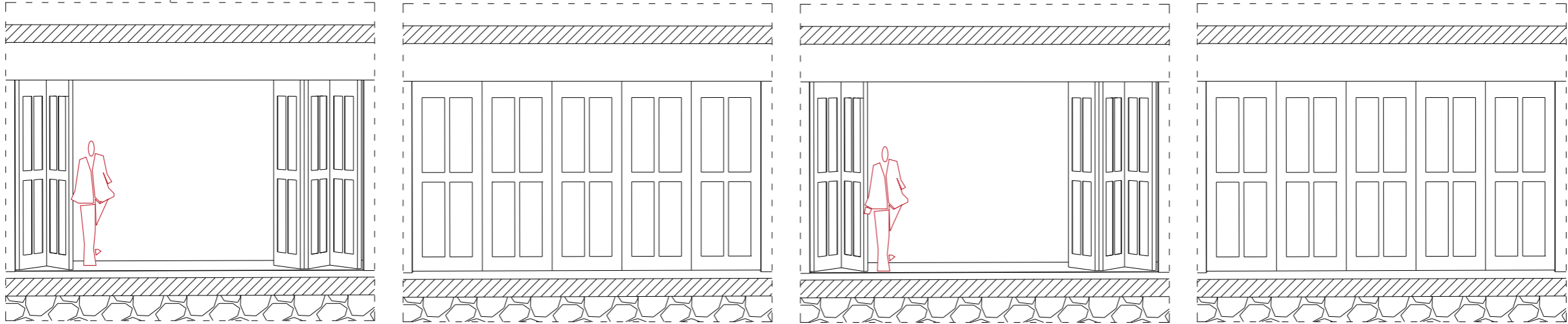

Open

Closed

Open

Closed

Collapsible Wall System

A series of doors joined together with new joinery and placed on channels form the basis of the walls system on the basement level

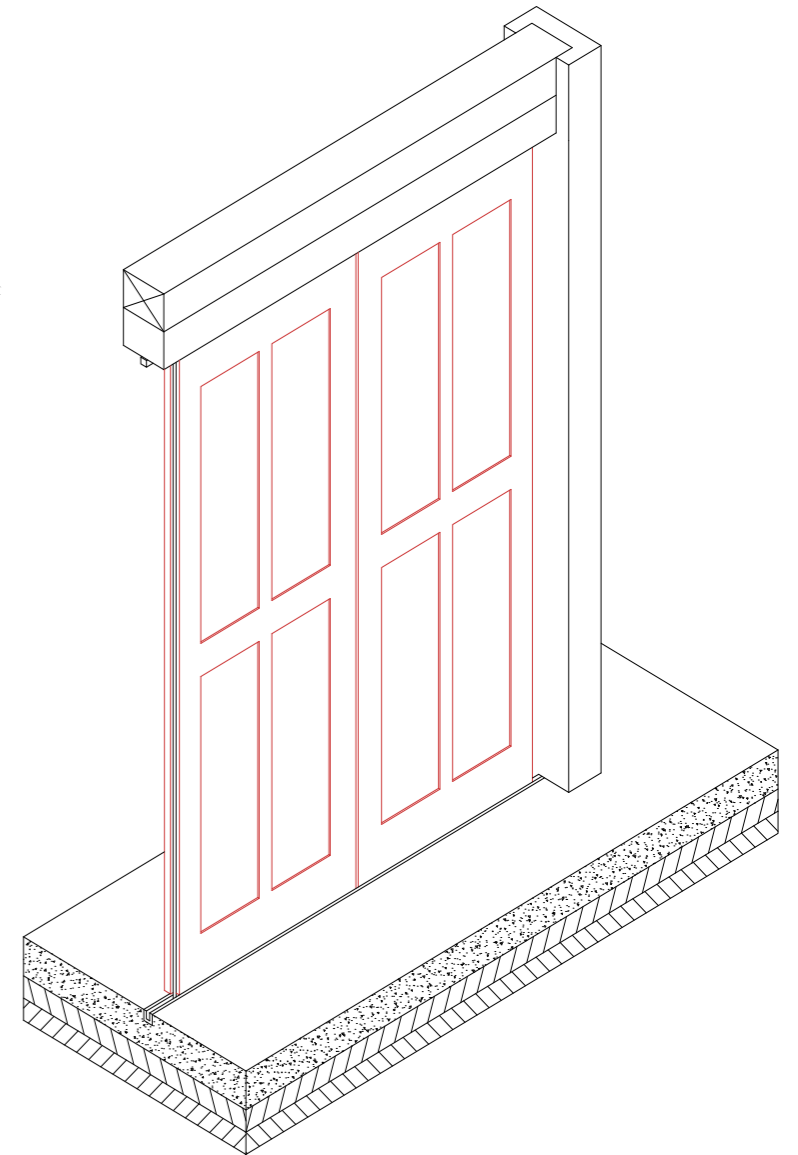
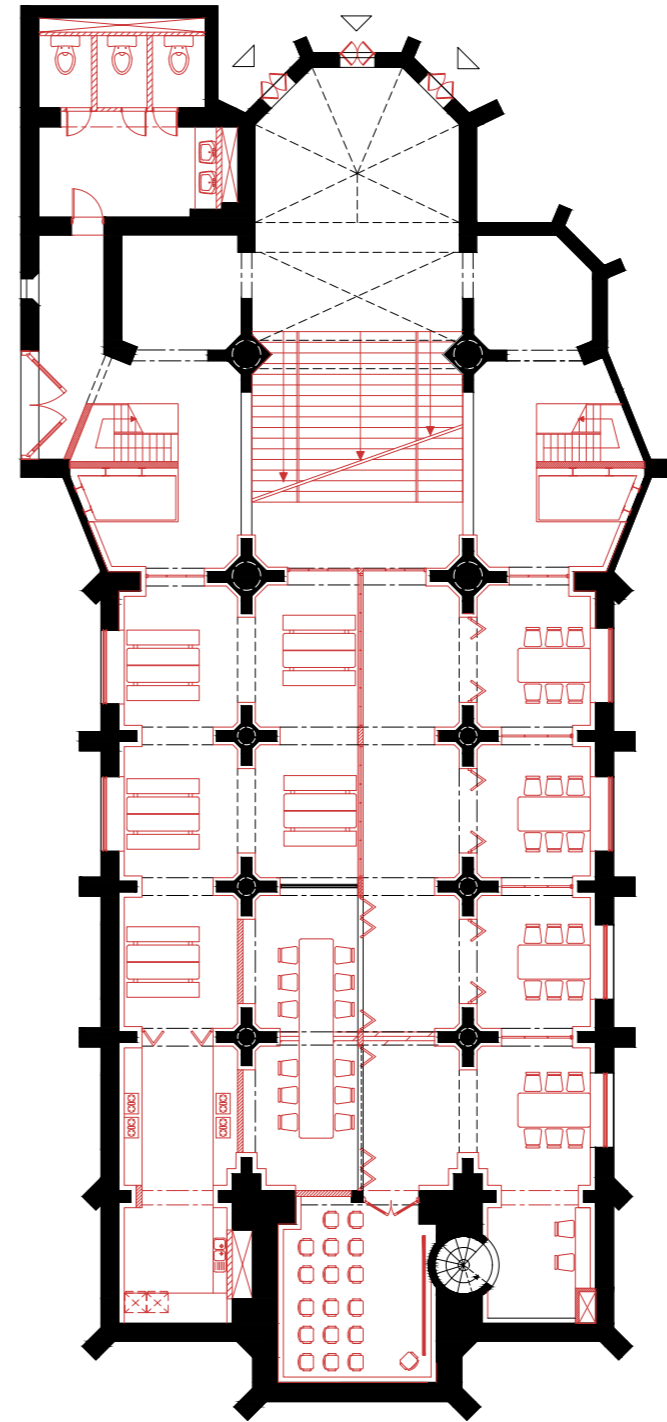
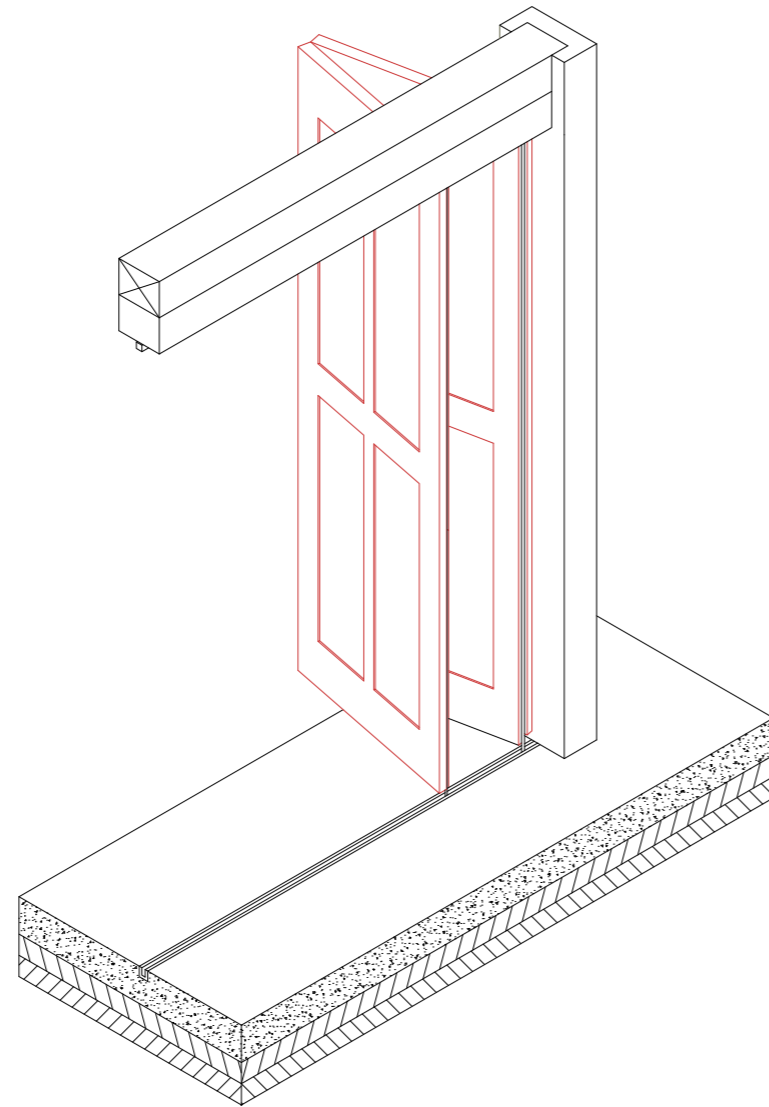
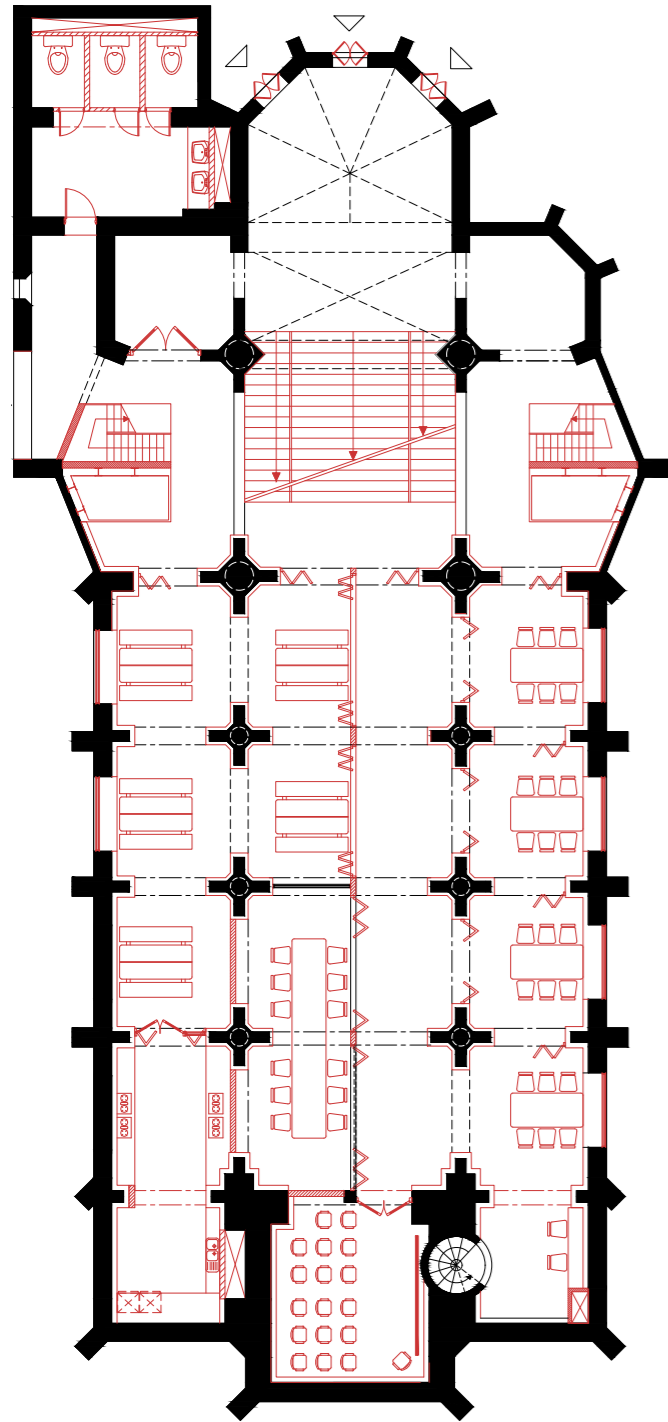

Collapsible Wall System

A series of doors joined together with new joinery and placed on channels form the basis of the walls system on the basement level

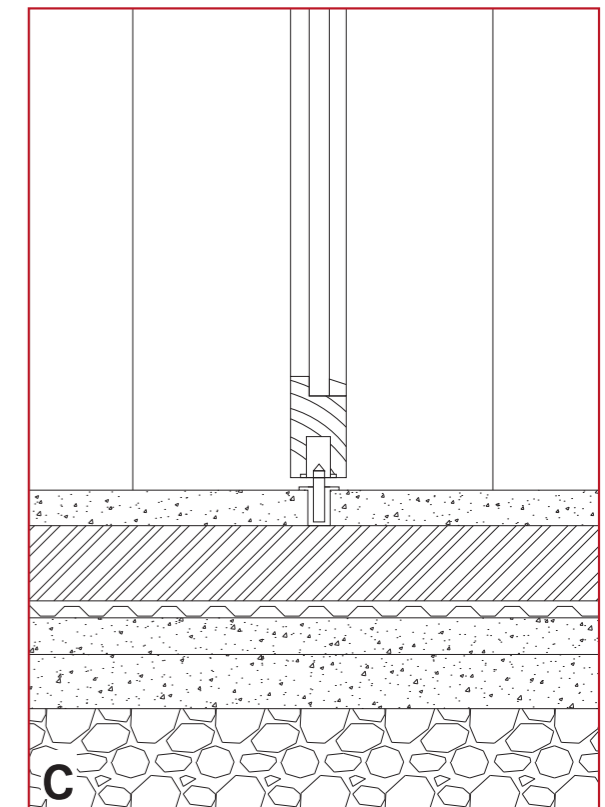
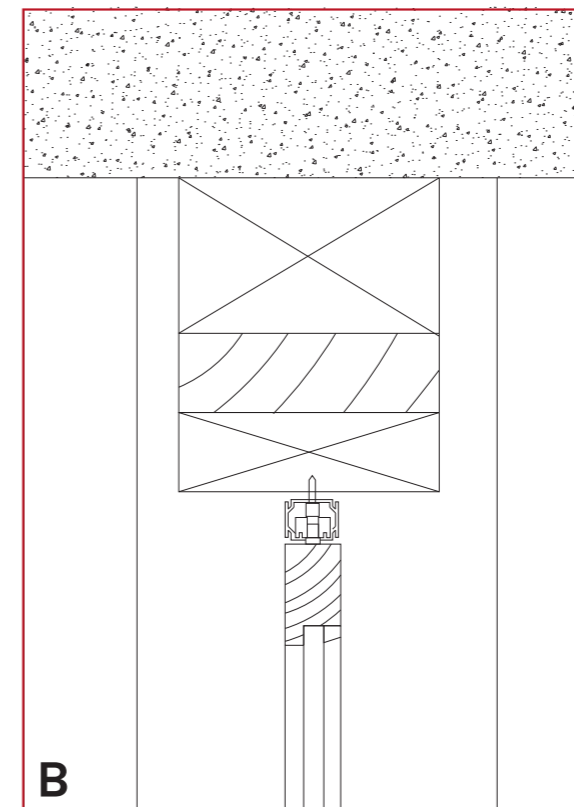
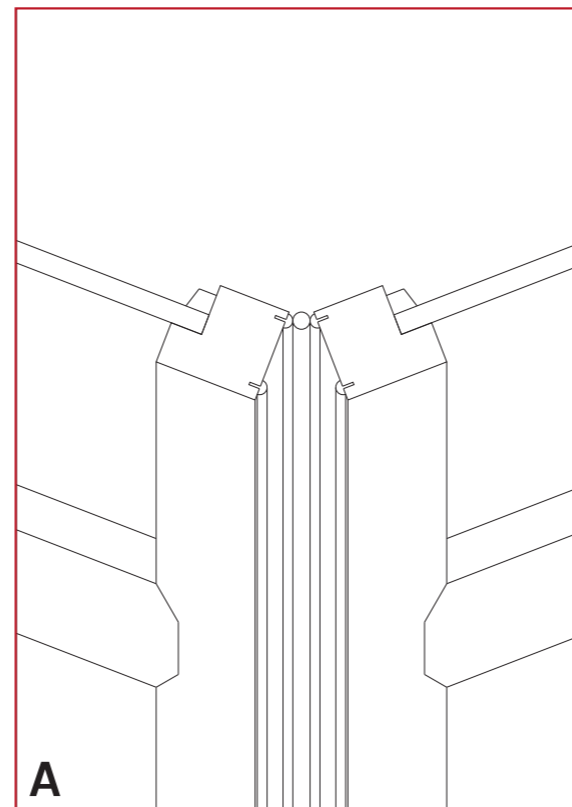
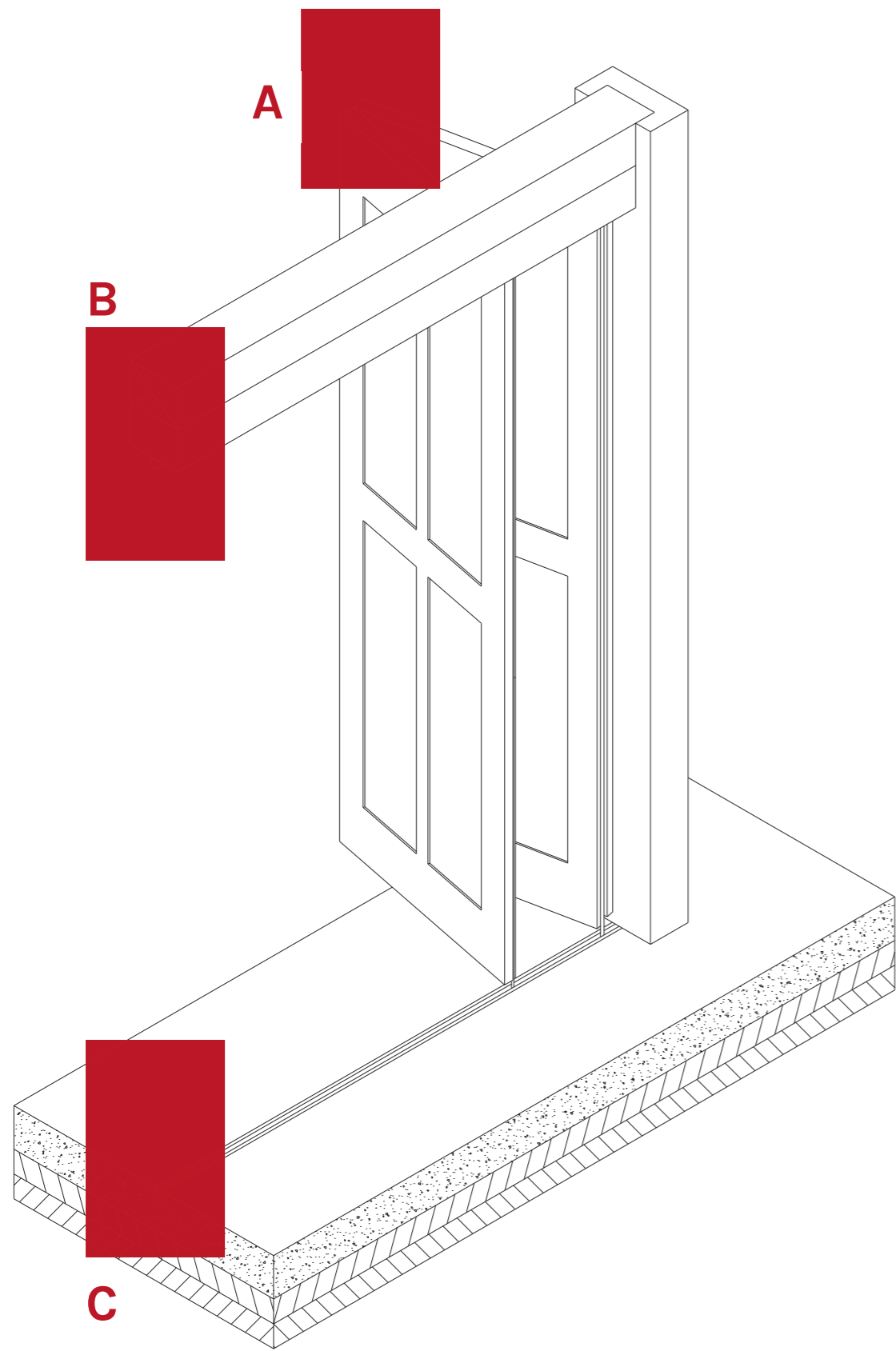

Collapsible Wall System



A series of doors joined together with new joinery and placed on channels form the basis of the walls system on the basement level

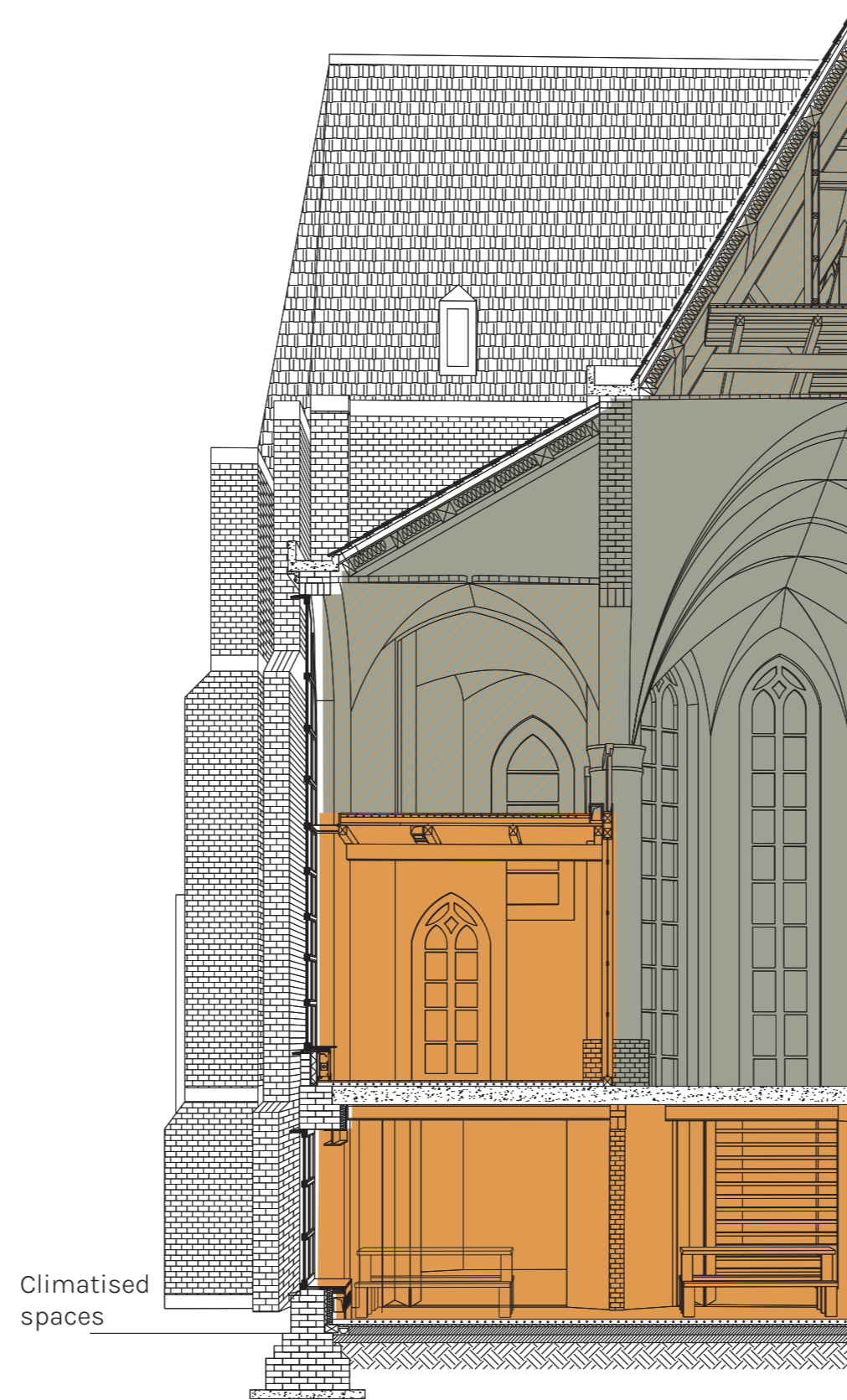

Collapsible Wall System

These walls are made of a mosaic of different doors collected from the rectory and as such create a collage of doors of different colours, textures, heights and widths



-  Heated Closed Area
-  Unheated Open Area
-  Heated Open Area

Climate Strategy

The church is completely insulated. The floor heating creates a stable temperature while the church has closed and unheated areas.

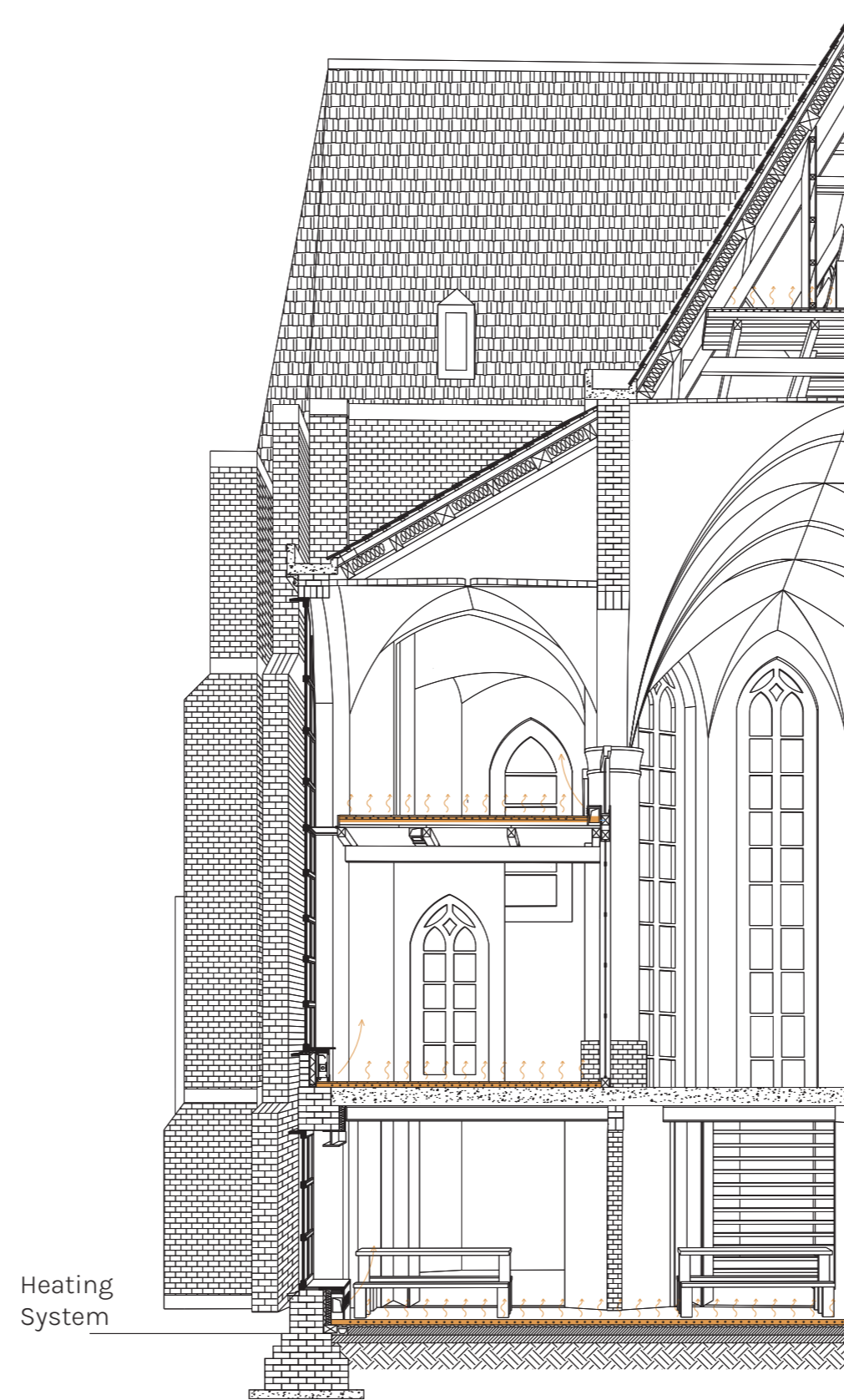

Heating
System

Climate Strategy

The church is completely insulated. The floor heating creates a stable temperature while the church has closed and unheated areas.

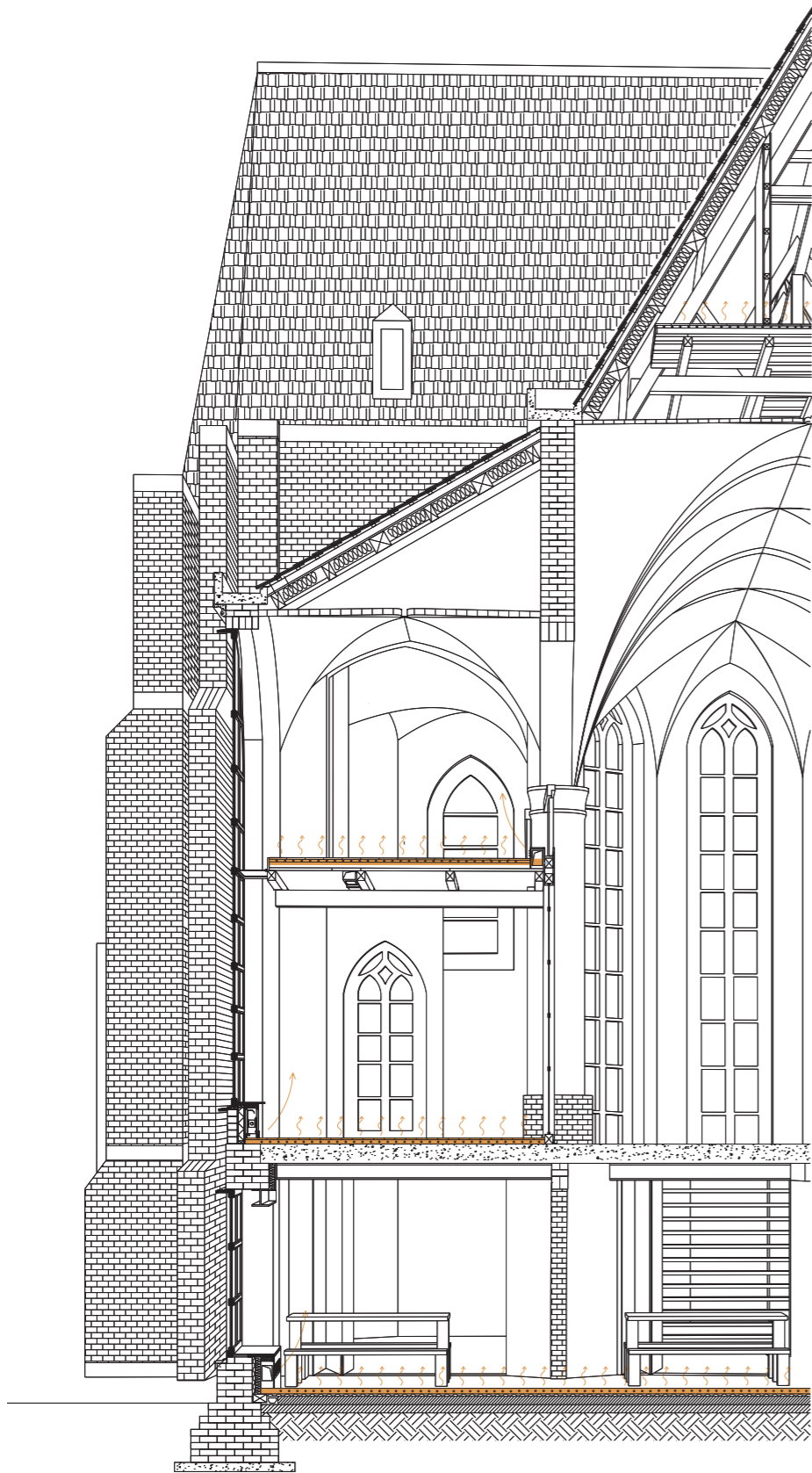

Insulated Double Glazed Window:

Inside to Outside	Frame Components:
8 Clear Glass Pane	114x68 glulam wooden
8 Sealant	CnC routed Frame
8 Clear Glass Pane	25x114 wooden sill

Exterior Bund Wall Configuration 1:

Inside to Outside
 120x150 baseboard heating unit
 20 plywood
 vapour protection
 75 Hempcrete Insulation
 Waterproofing
 20 plywood
 20mm air gap
 75 reused brick

Floor Configuration 1:

20 timber plank flooring
 75 Floor heating with pipe 100mm cc

Existing Floor

Existing brick vault

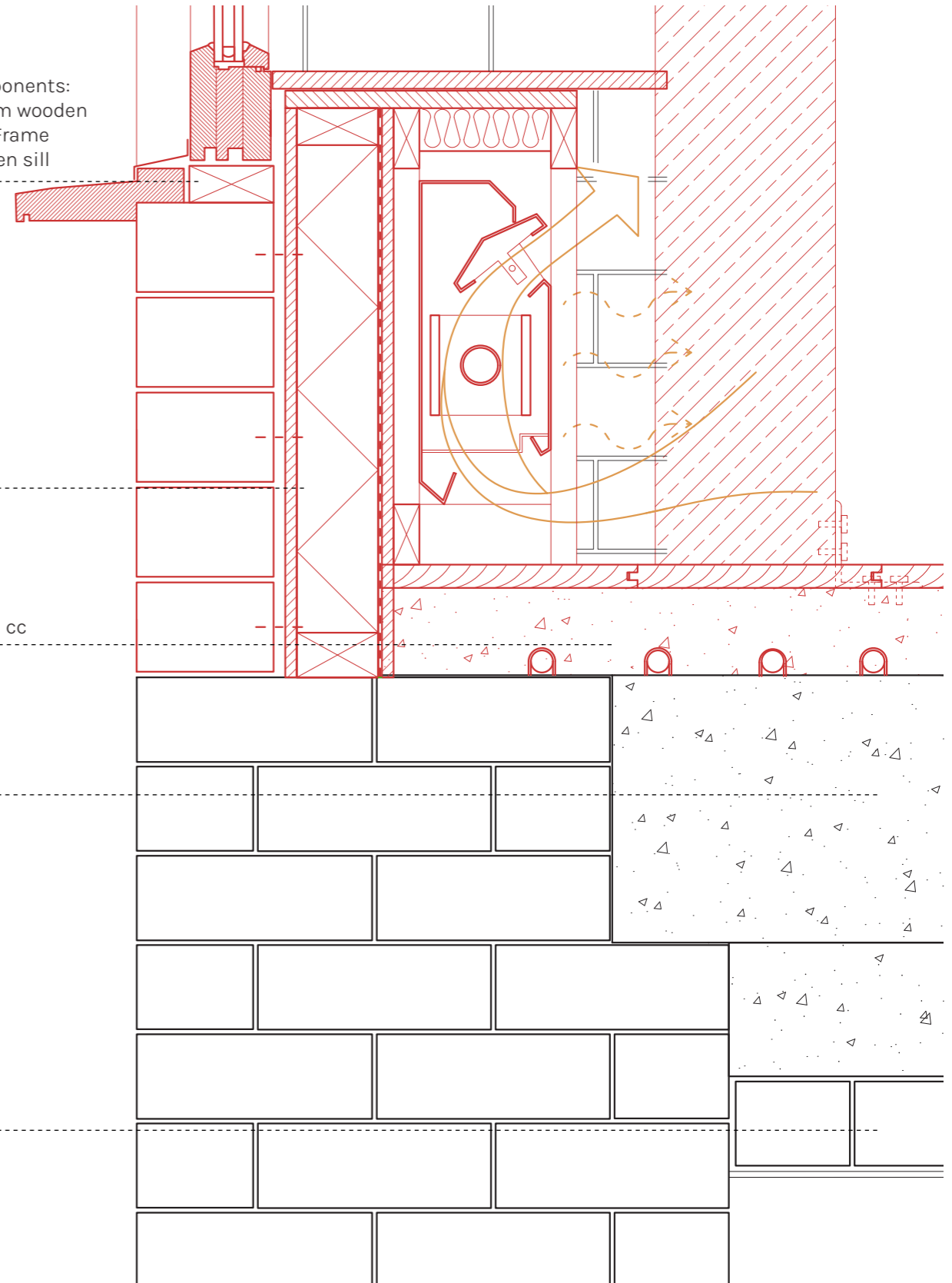

Climate Strategy

Floor heating creates a stable temperature of 18 degree celcius and baseboard heating units can be switched on when required.

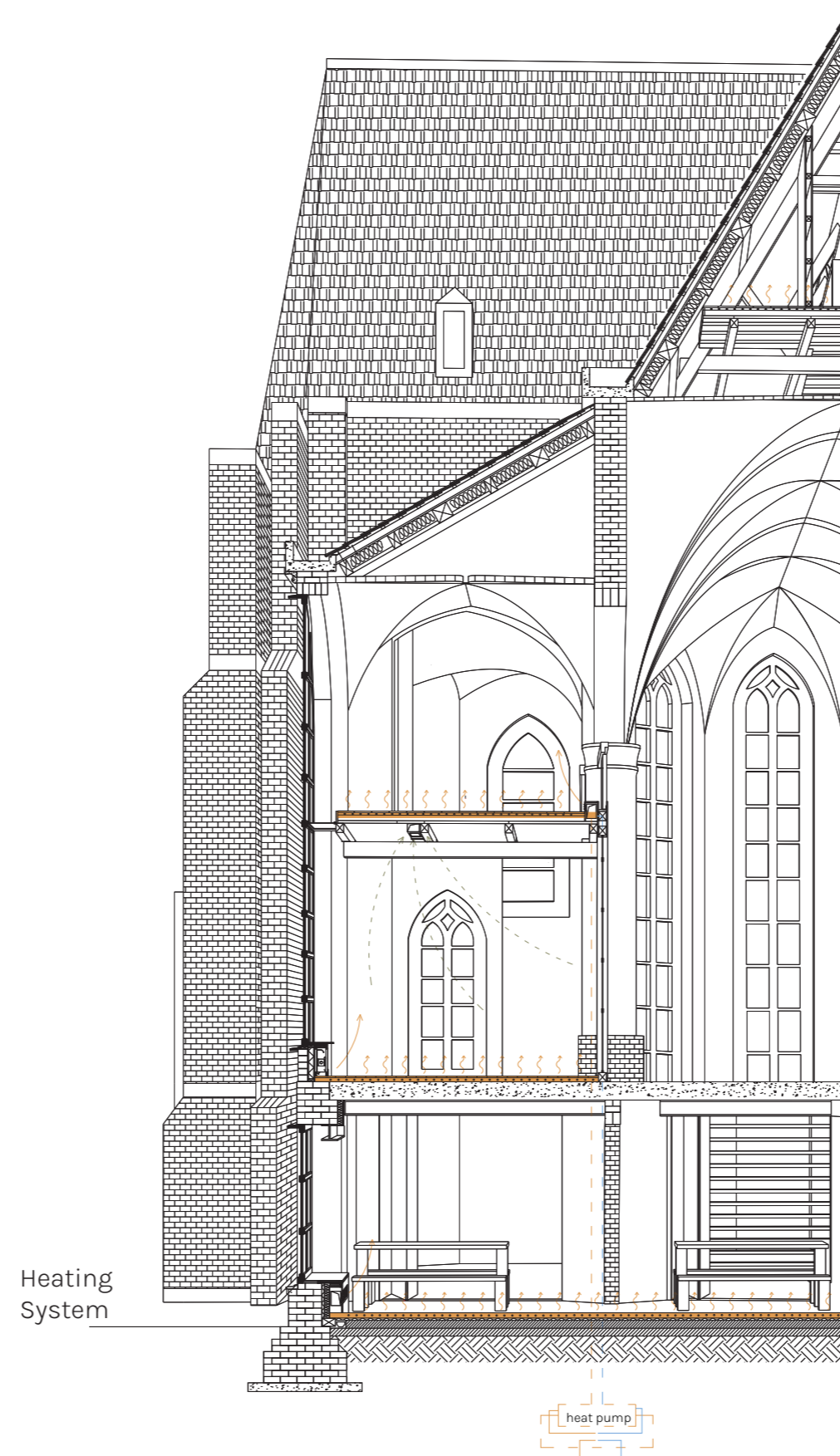

Climate Strategy

Heat Pump is used for the floor heating system which also uses the rainwater harvested, stored and treated within the church

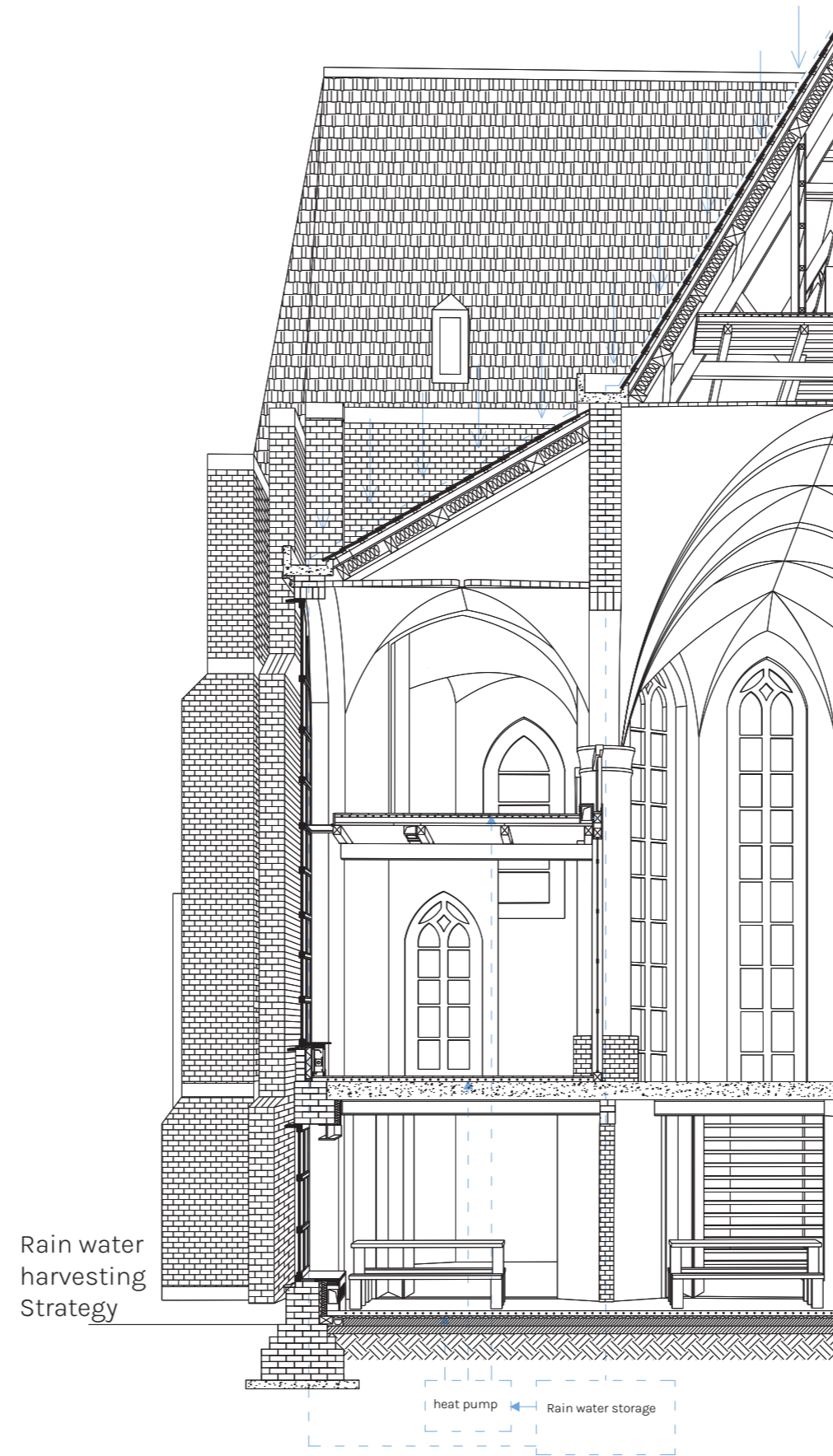

Climate Strategy
Heat Pump is used for the floor heating system which also uses the rainwater harvested, stored and treated within the church

Phased Construction process

Demolition and Preparation
of site

Insulation of the skin

Assembly of units

Utilisation of Spaces

Fixed and Flexible Areas

Adaptable Zones

The Performance Area

Everyday life of the building

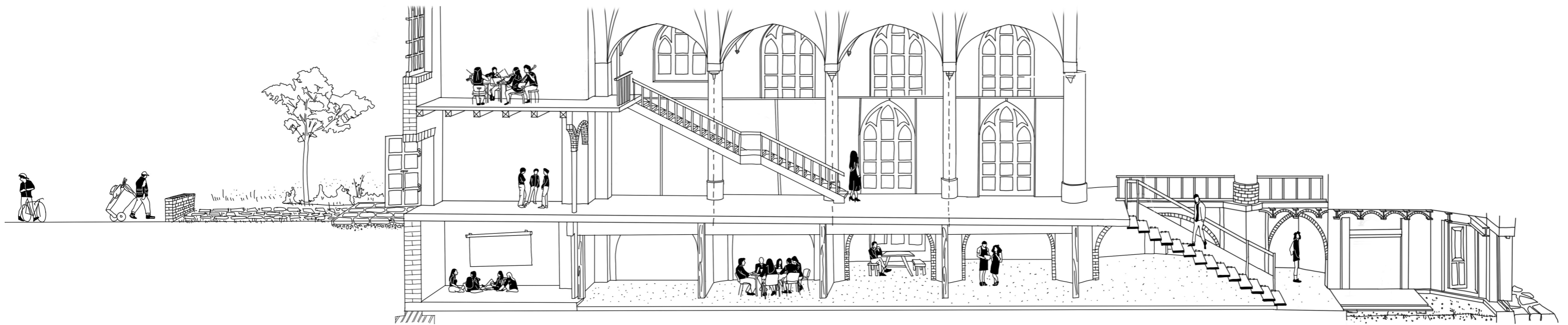

Functional Zoning

The church holds functions based on different forms of art and creates a series of spaces where people of different walks of life come together to create

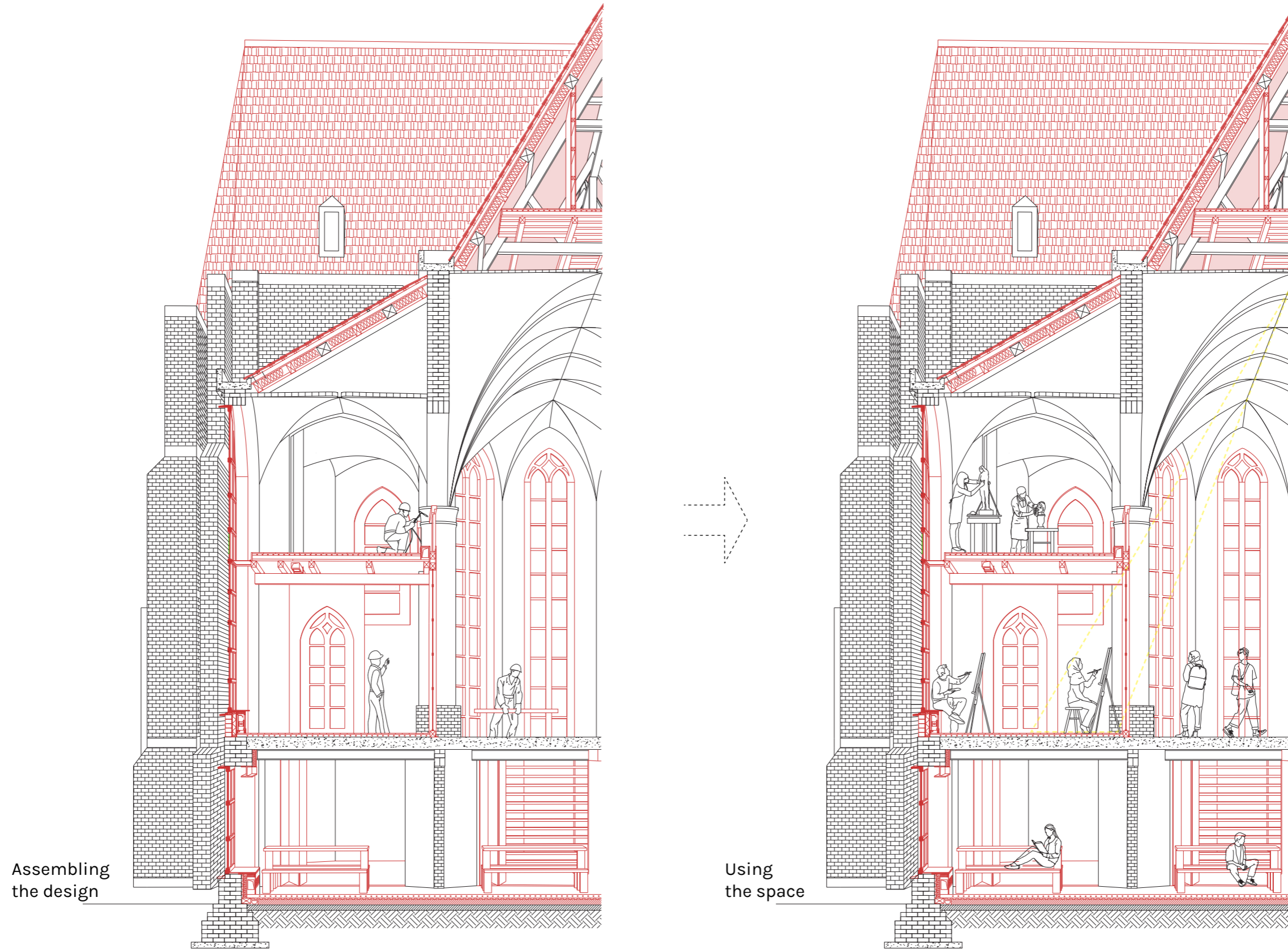

Assembling the design

Using the space

Functional Zoning

The workshops are divided into fixed and flexible spaces where programme does not create a conforming boundary for the design

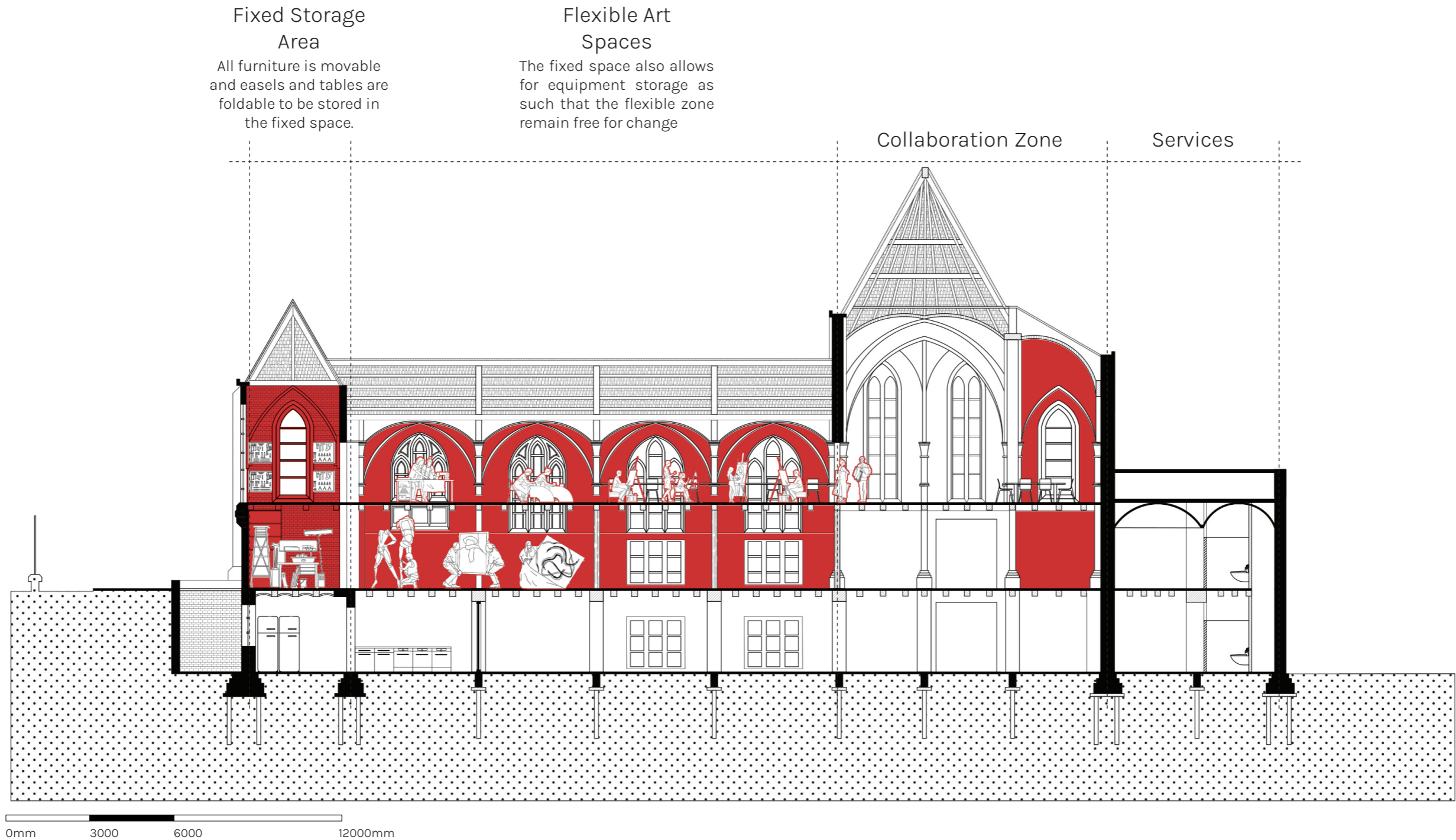

Functional Zoning

The workshops are divided into fixed and flexible spaces where programme does not create a conforming boundary for the design

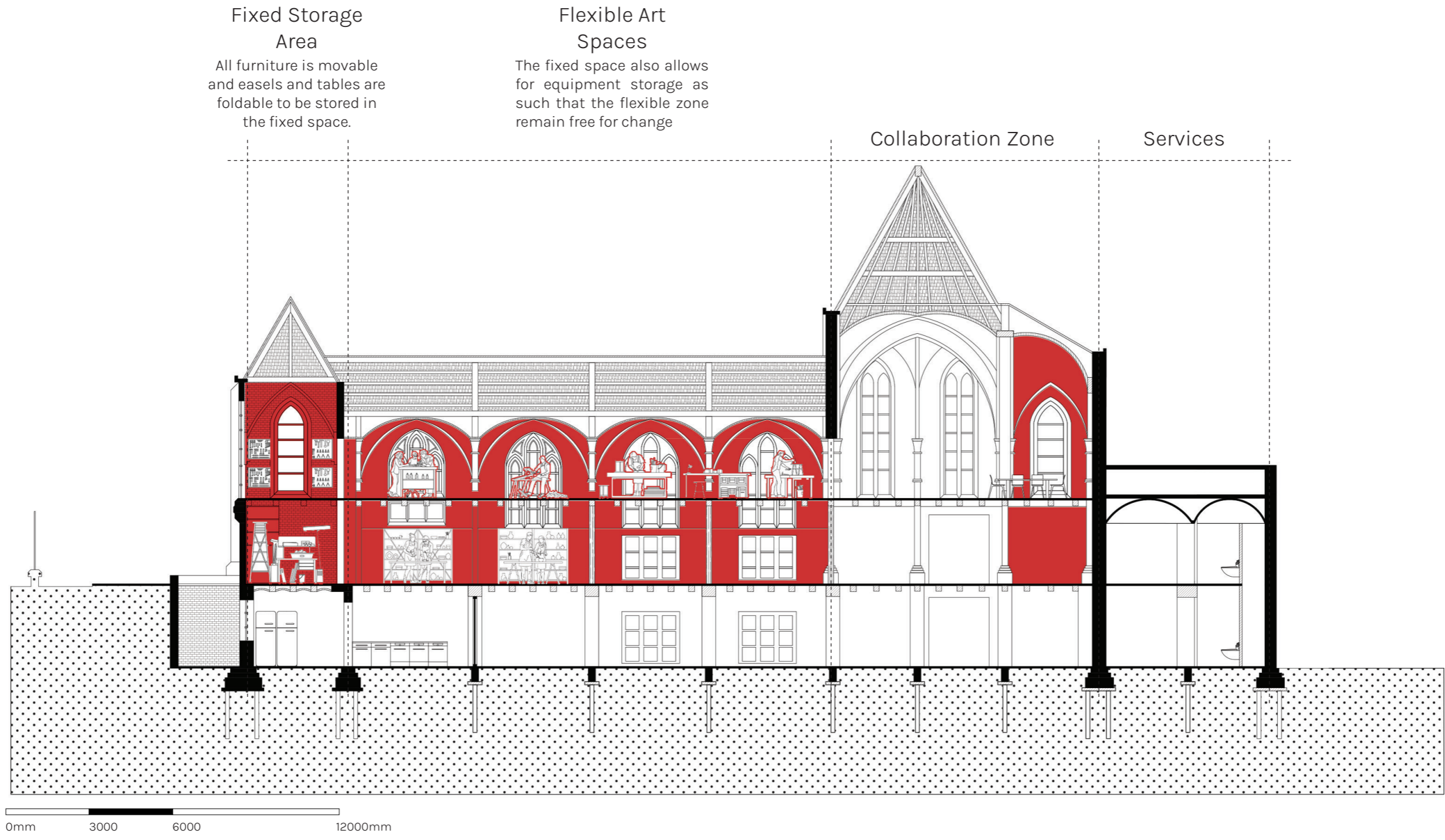

Functional Zoning

The workshops are divided into fixed and flexible spaces where programme does not create a conforming boundary for the design

Fixed Storage Area
All furniture is movable and easels and tables are foldable to be stored in the fixed space.

Flexible Art Spaces
The fixed space also allows for equipment storage as such that the flexible zone remain free for change

Collaboration Zone

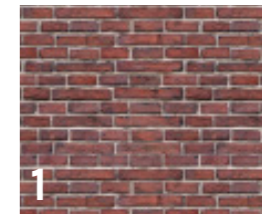
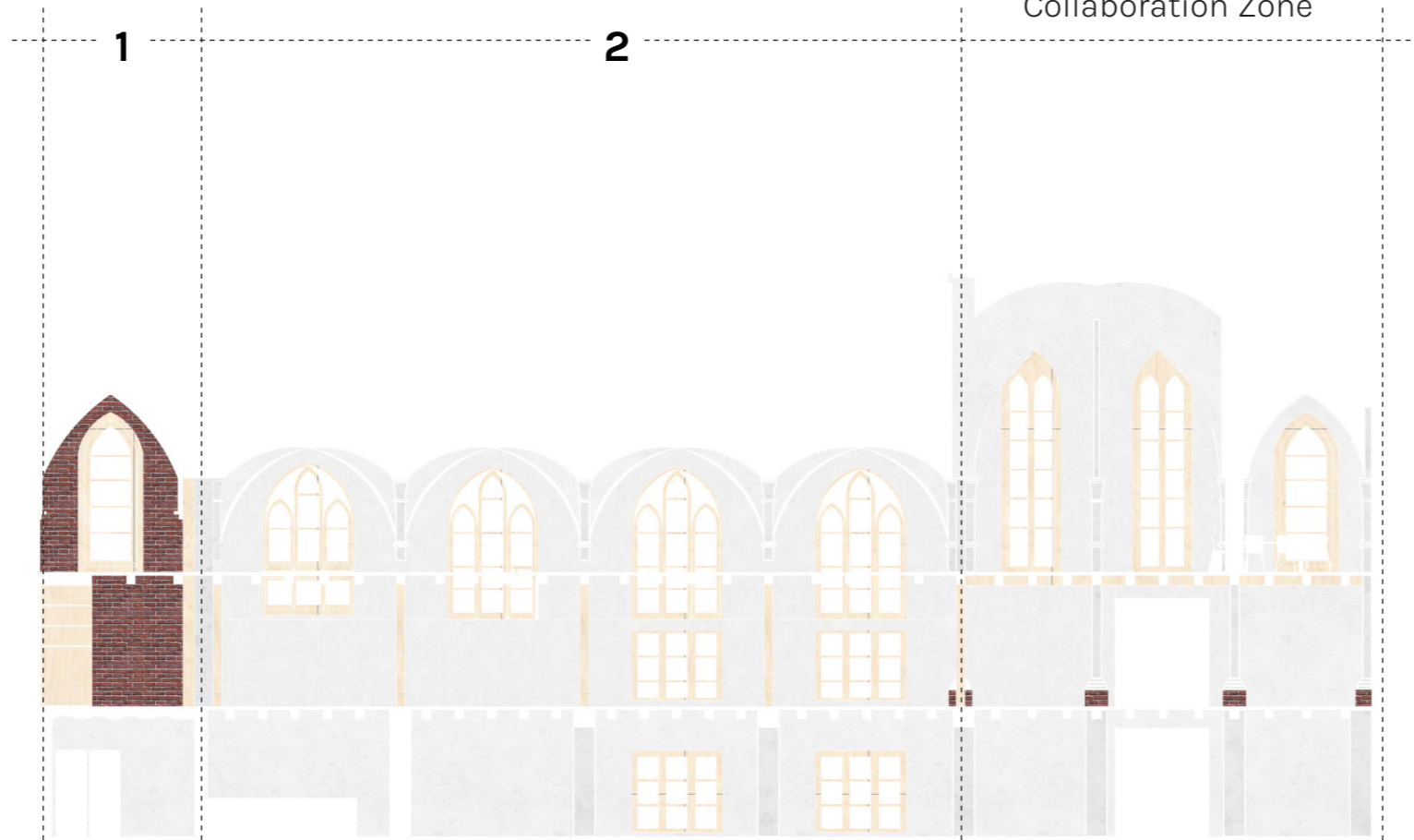

Existing Brick Walls

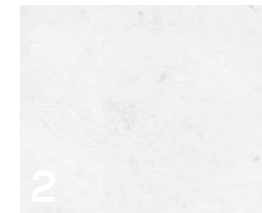

Plastered Walls

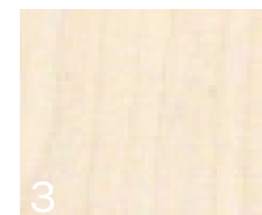

CnC routed Window Frames

Functional Zoning

The workshops can be read as dark and light spaces based on the function held within it.

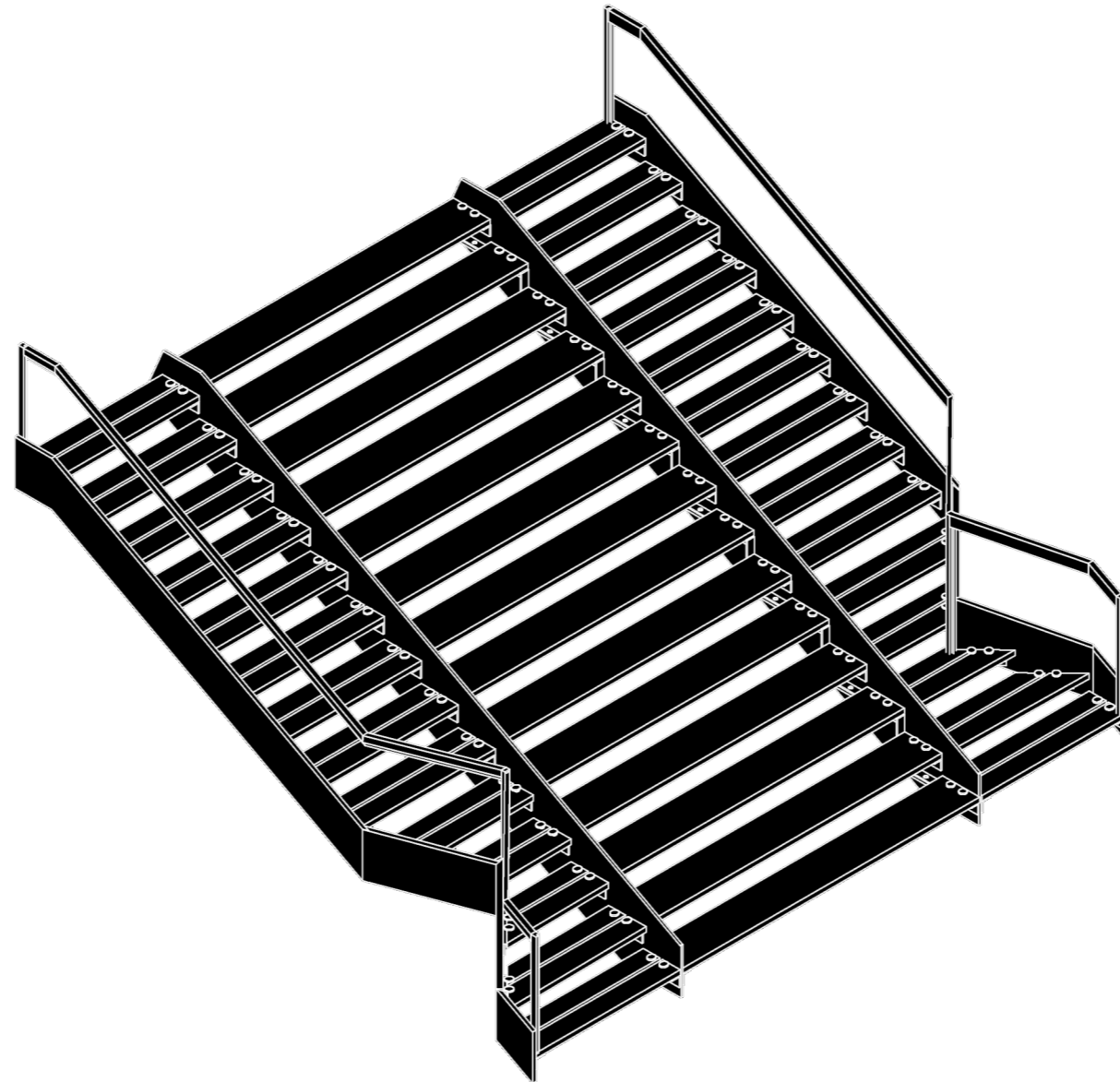

The Staircase

Concepts of flexibility are extended to the performance spine through a plethora of adaptable areas such as the stage and stairs

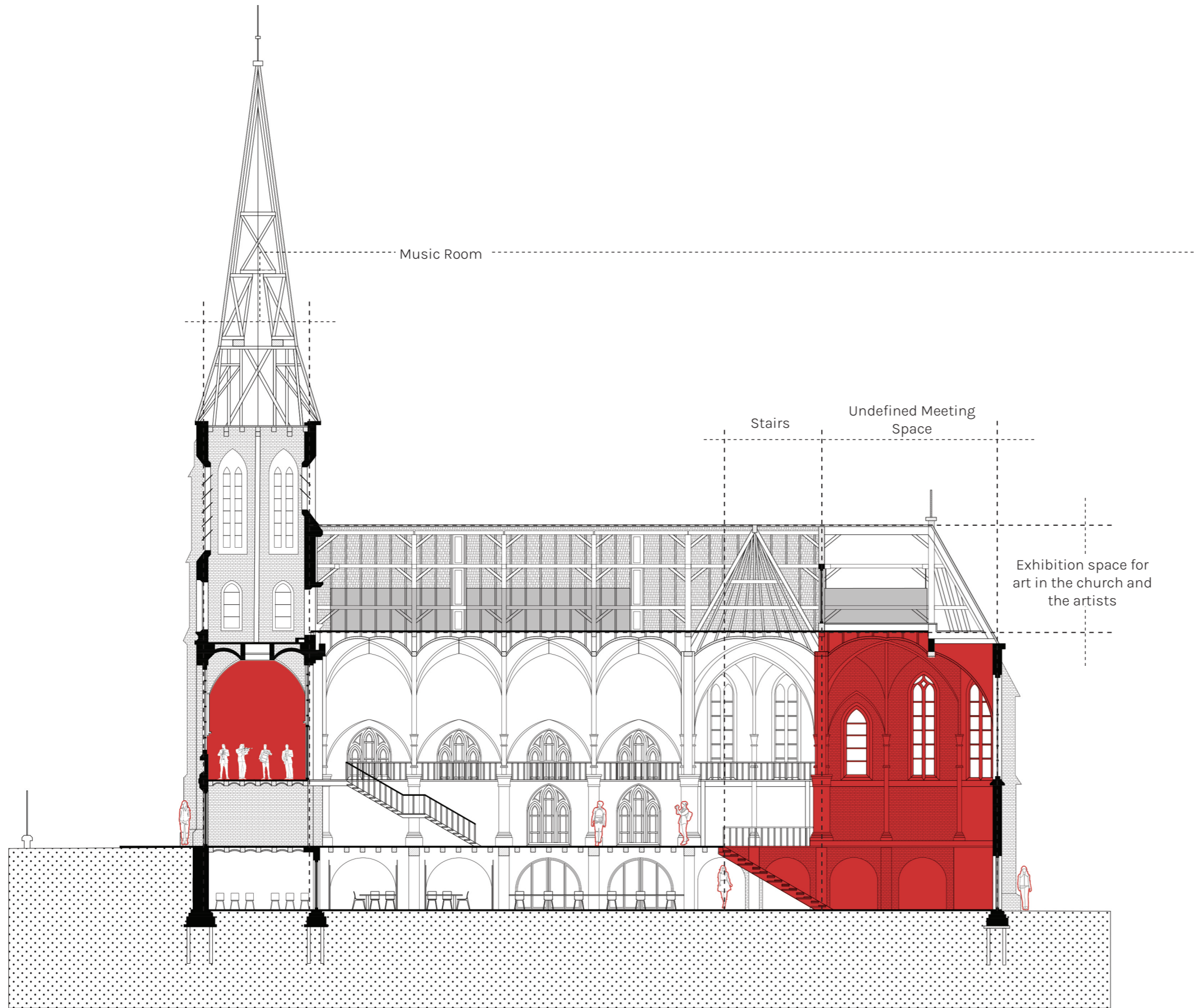

The Performance Spine is divided into two zones, the music room in the above the entrance where the organ used to be is a fixed zone while the stairs and the stage are flexible.

These stairs remain a normal stairs on an every day basis but during performances the stairs would be changeable for audiences during performances

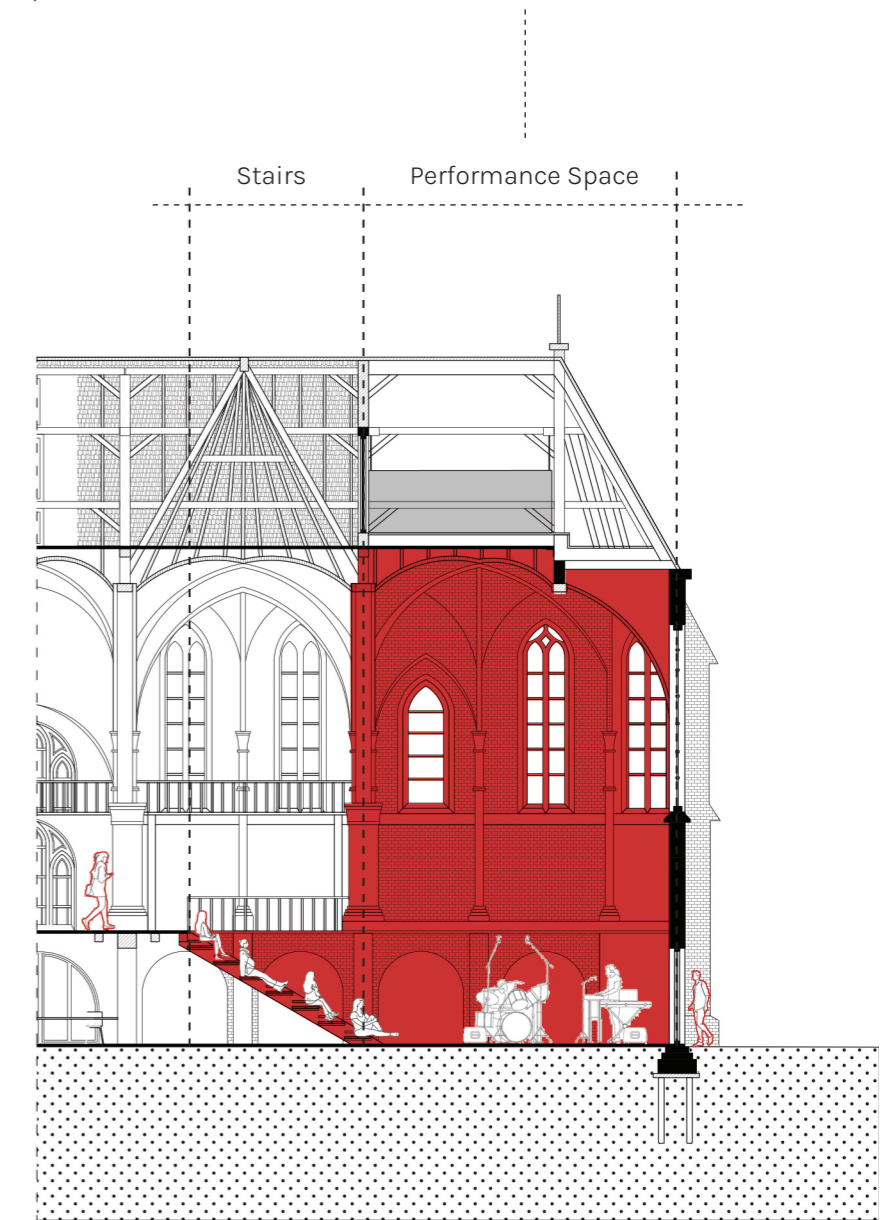

Functional Zoning

Concepts of flexibility are extended to the performance spine through a plethora of adaptable areas such as the stage and stairs



Staircase as a Space for movement



Staircase as a Space for viewing performances

Adaptability: Stairs

The stair changes from a place for movement to a seating area for lectures, performances and recitals

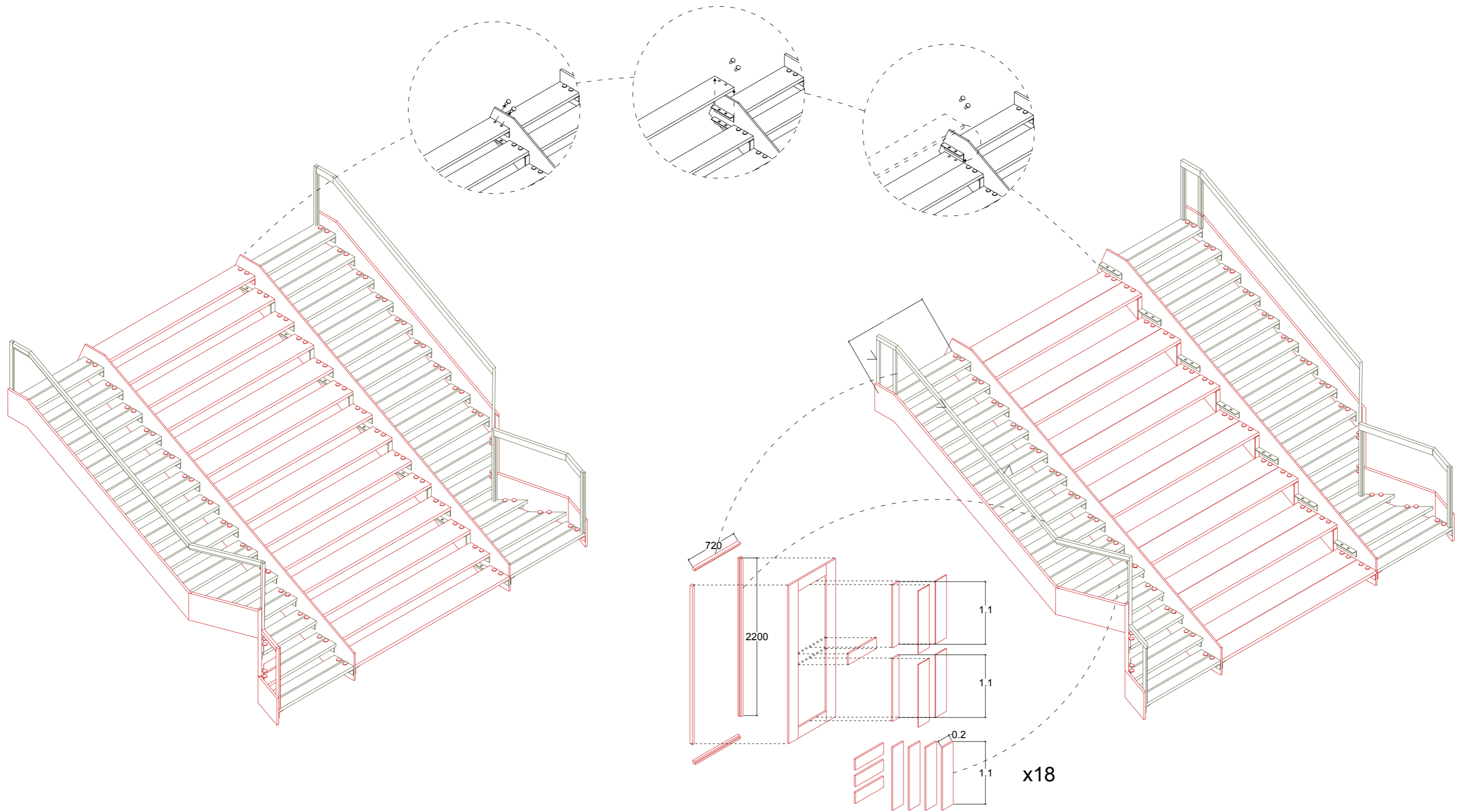

Adaptability: Stairs

The stairs are divided into three segments. The side segment is the repeatable standard for all staircases. It is made of reclaimed plywood and harvested timber panel doors from the rectory

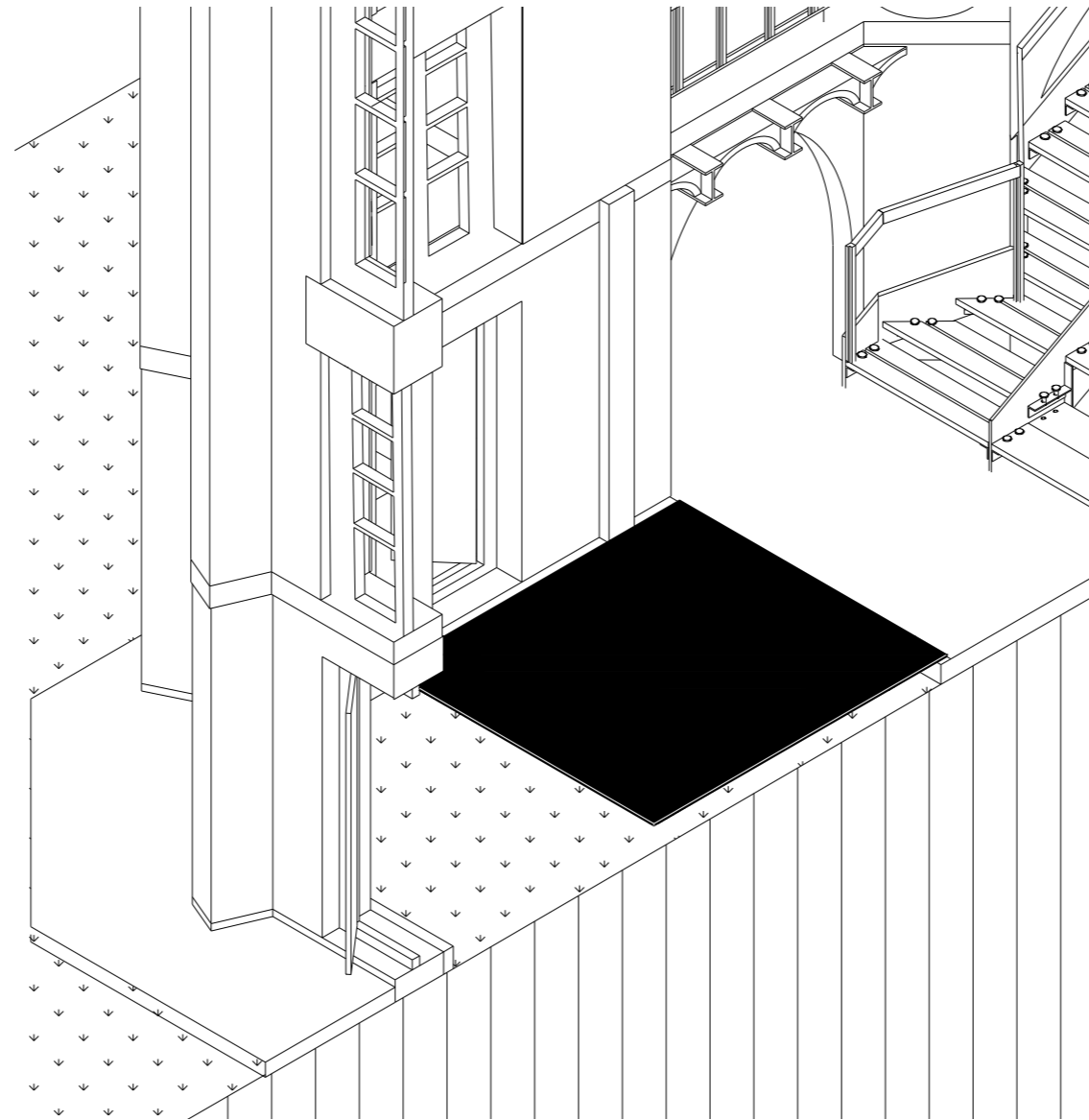

The Stage

Concepts of flexibility are extended to the performance spine through a plethora of adaptable areas such as the stage and stairs

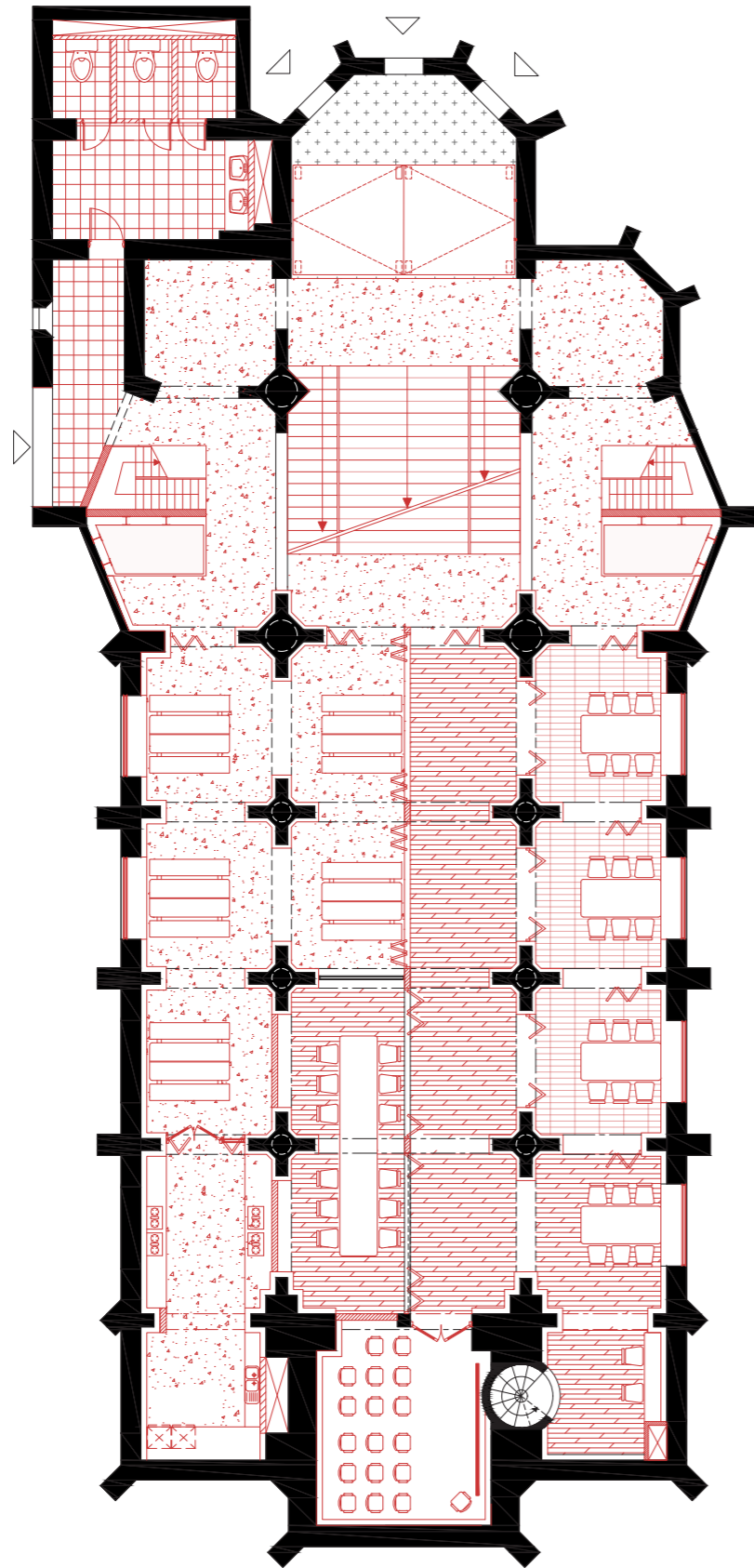

Adaptability: Stage

The stage is a flexible space that accommodates theatrical expression when it is in the open position with anchors, platforms and steps

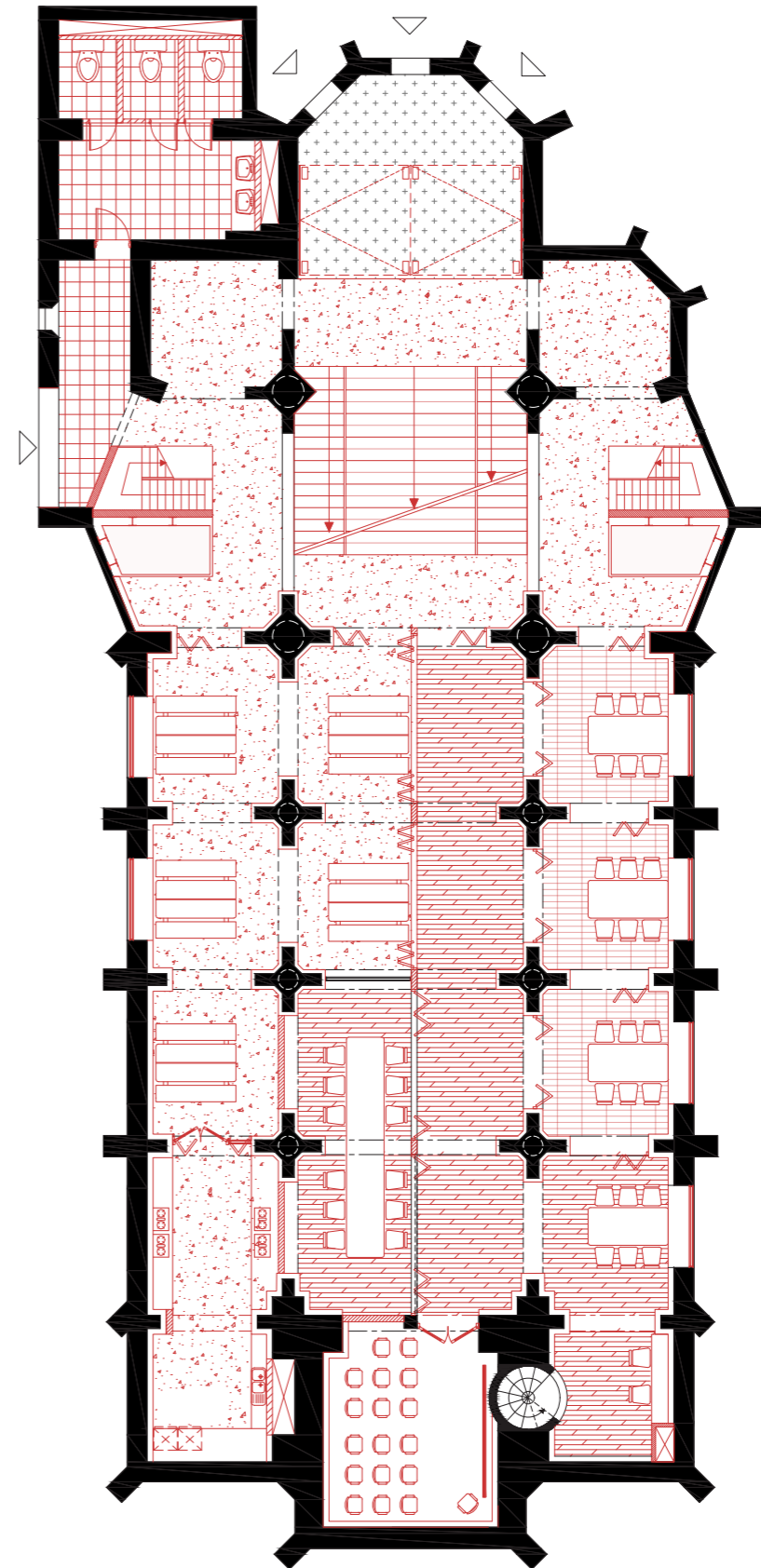

Adaptability: Stage

The stage becomes a gathering space, when it is in a closed position. It becomes a connector between the outside and inside and a space for movement

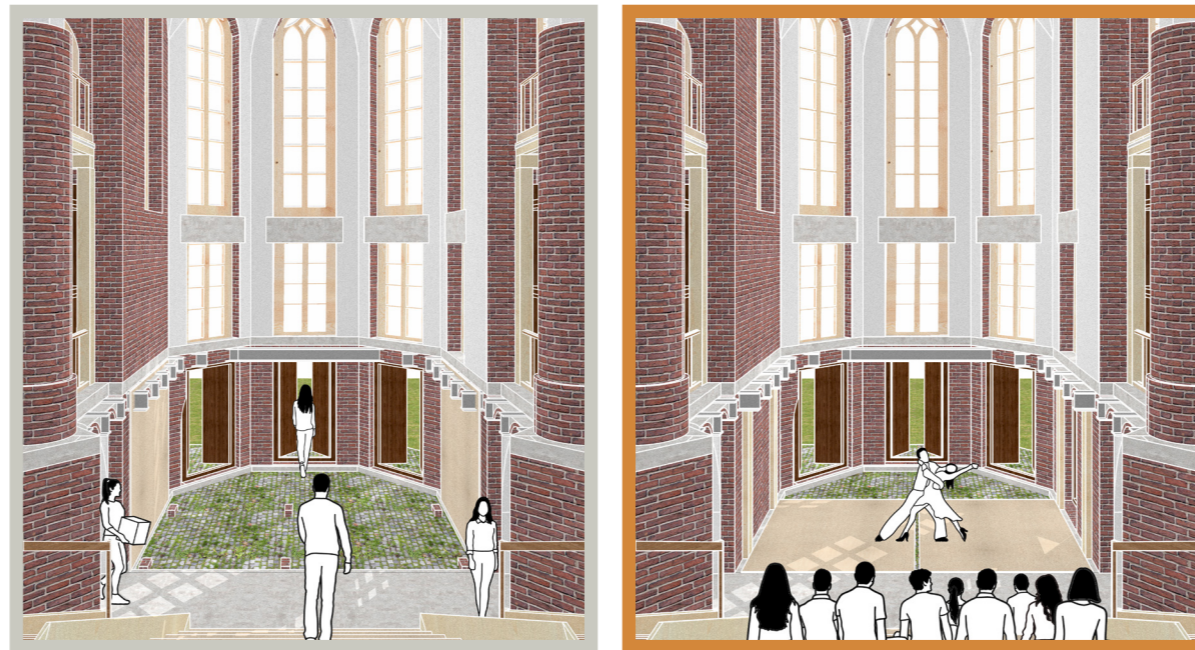

Adaptability: Stage

The stage is a flexible space that allows for democratic artforms which can create a series of connections for composite scene creation

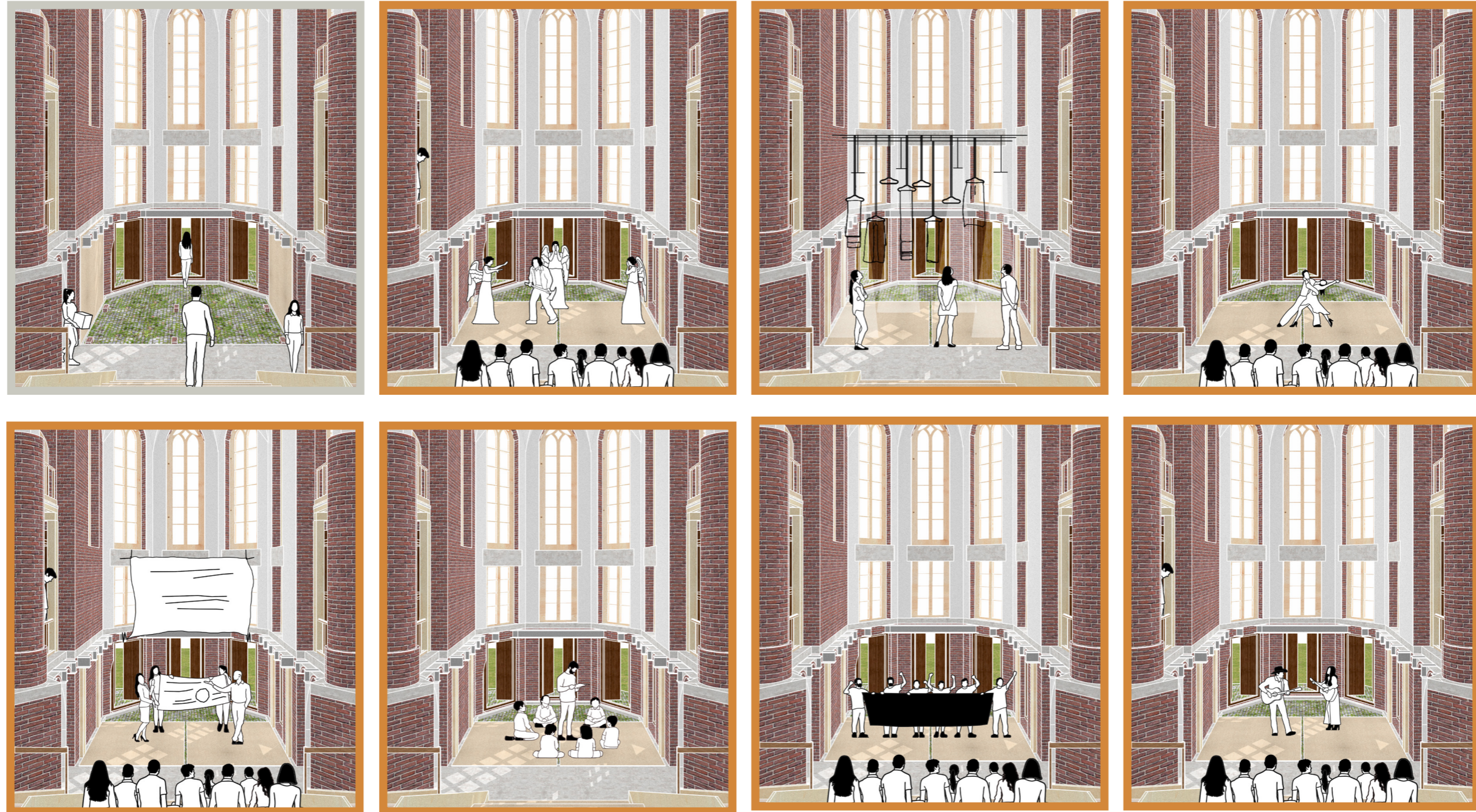

Adaptability: Stage

The stage is a flexible space that allows for democracy in artforms which can be created through a series of connections for composite scene creation



Good Morning! How are you today? Is this a church? Can you tell me what has happened to the old church?

Hello! I am a furniture restorer. The church is now an artisan and craftsman centre. I came to the church to see the transformation and got really invested in the process.

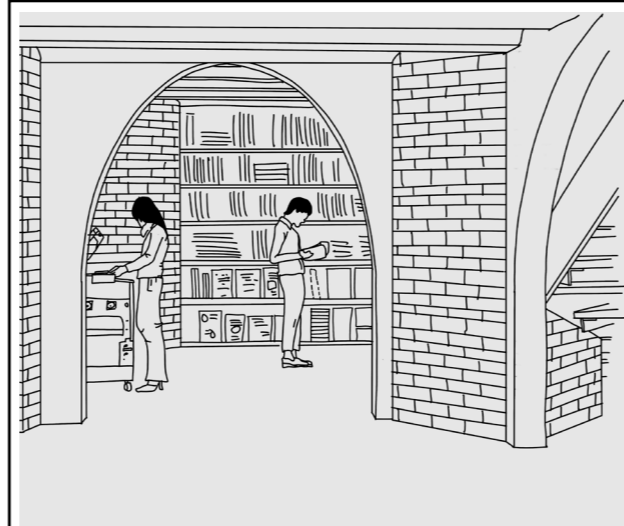

I went to the information center which had books and other resources on transformation of heritage buildings.



When I first came to the church, they were building the insides of the church in the wood workshop. It was so interactive, I decided to see if I can join and help

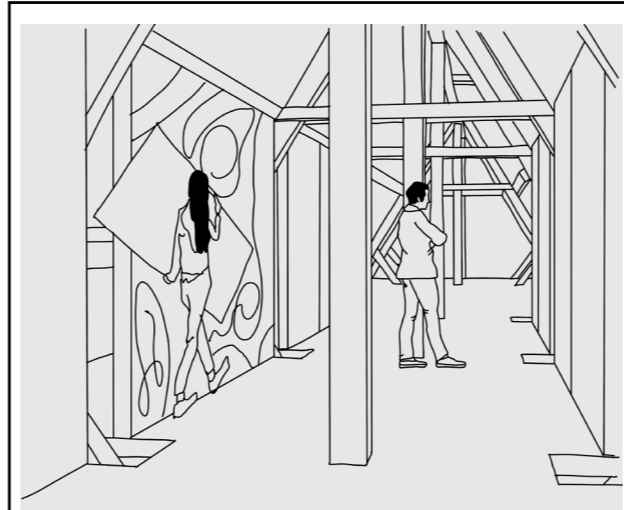

Any of the work we create in the studio classes, we display in the exhibition space. It attracts a lot of people around the neighborhood.



Once the church was completed, I decided to take over a studio where I teach classes on restoration and conservation.

Information Centre

The programme within the church requires a degree of flexibility as it becomes a teaching centre for the artisanal and craftsmanship based trades

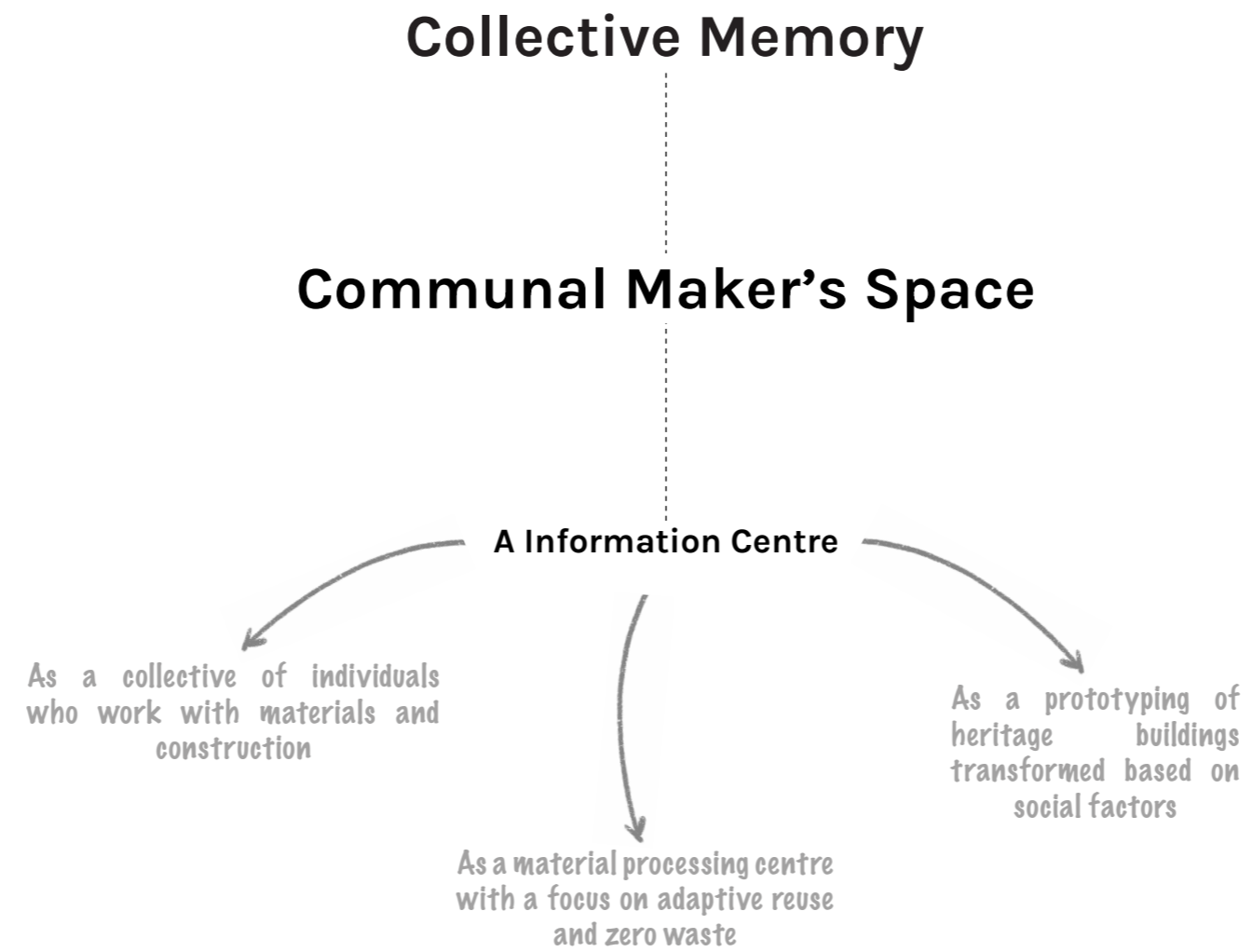



Mediating Religious Elements

Collective memory of religious spaces to incentivise the transformation of decommissioned churches

Apendix



Workshop Spaces

The Isolation of the church as an object is broken through the creation of visual transparency from within the church structure to the outside

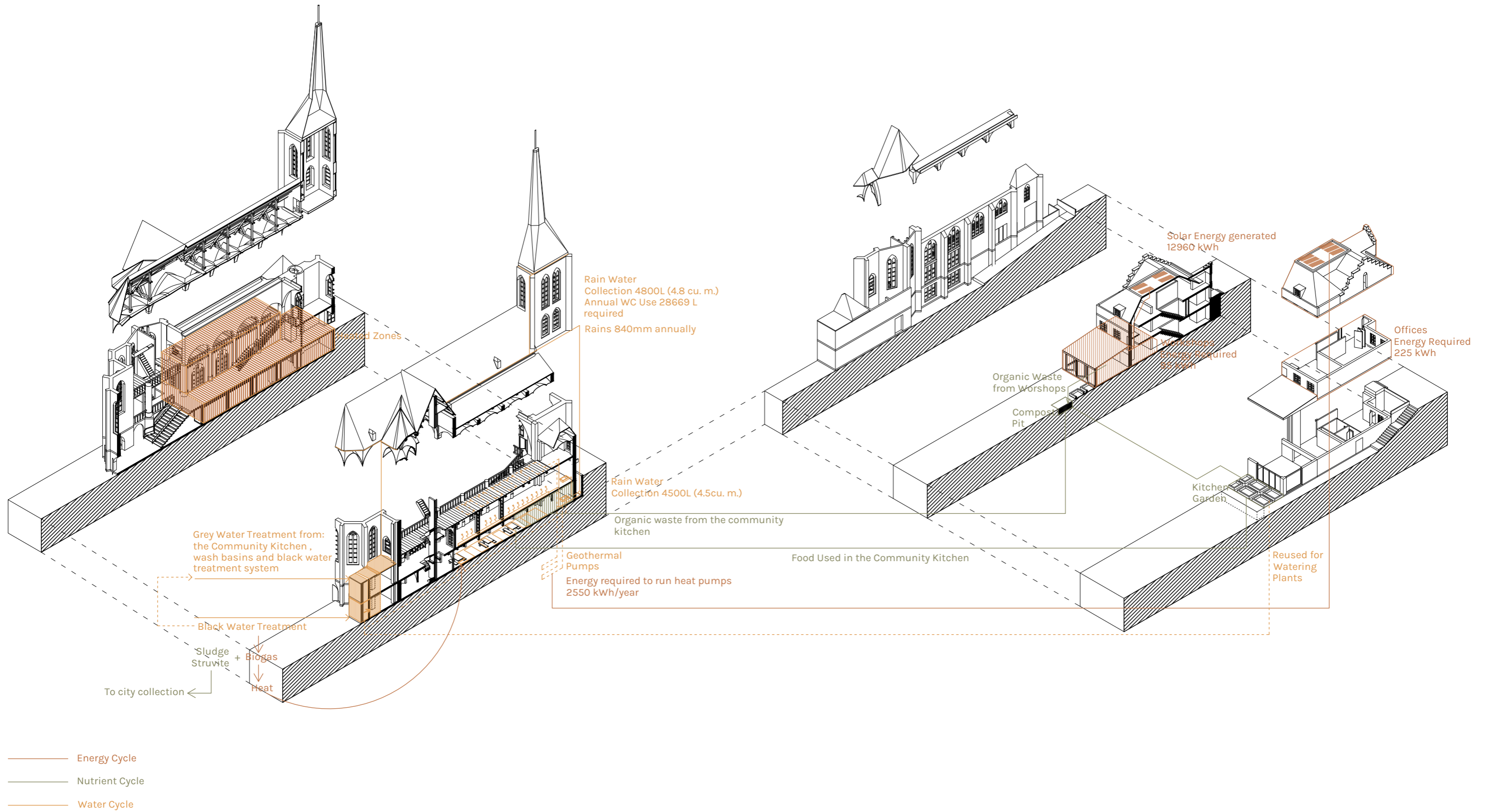

Circularity Strategy
From a site level, every energy, nutrients and water cycles are treated from a stand point of self sufficiency

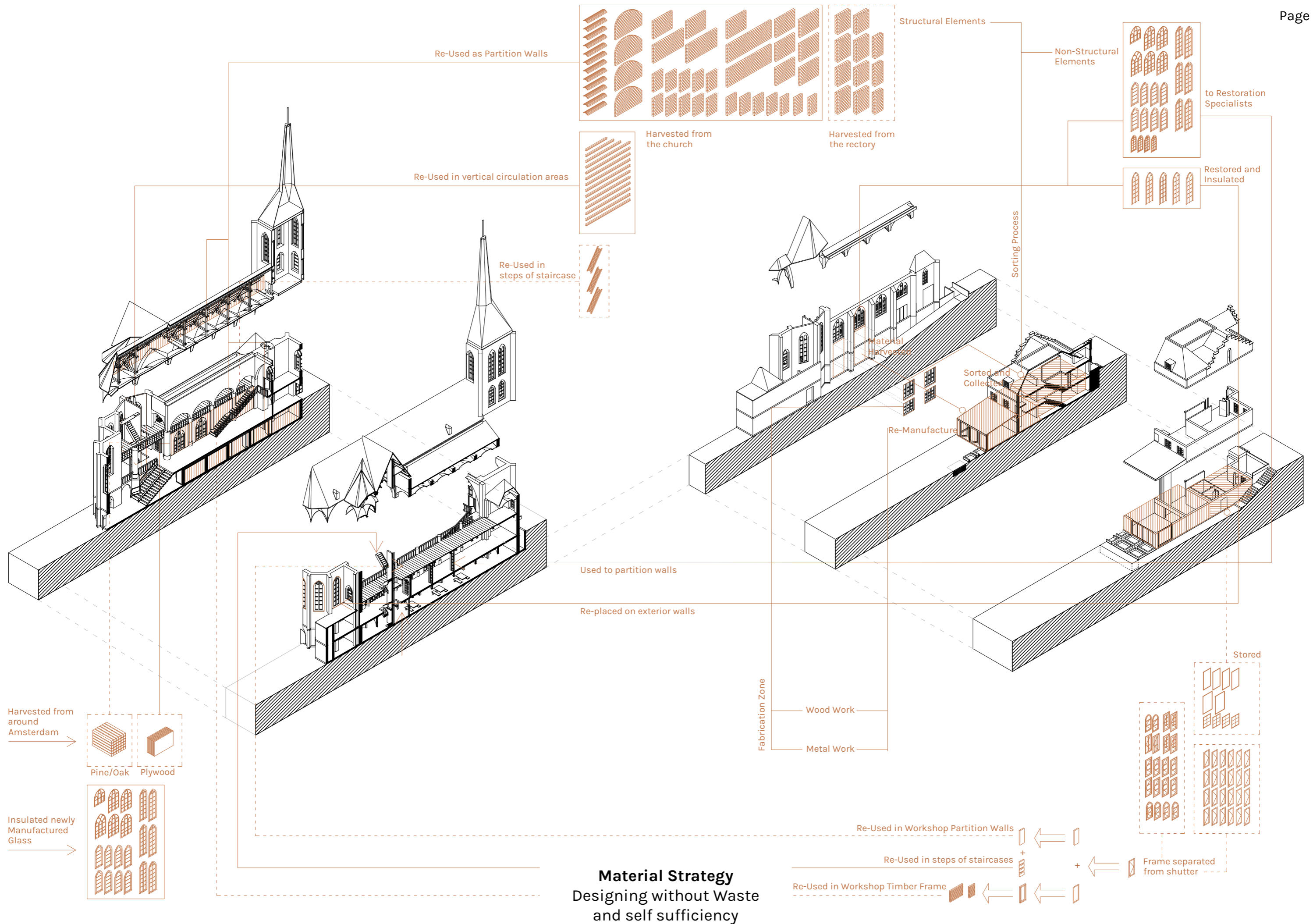

Material Strategy
 Designing without Waste
 and self sufficiency

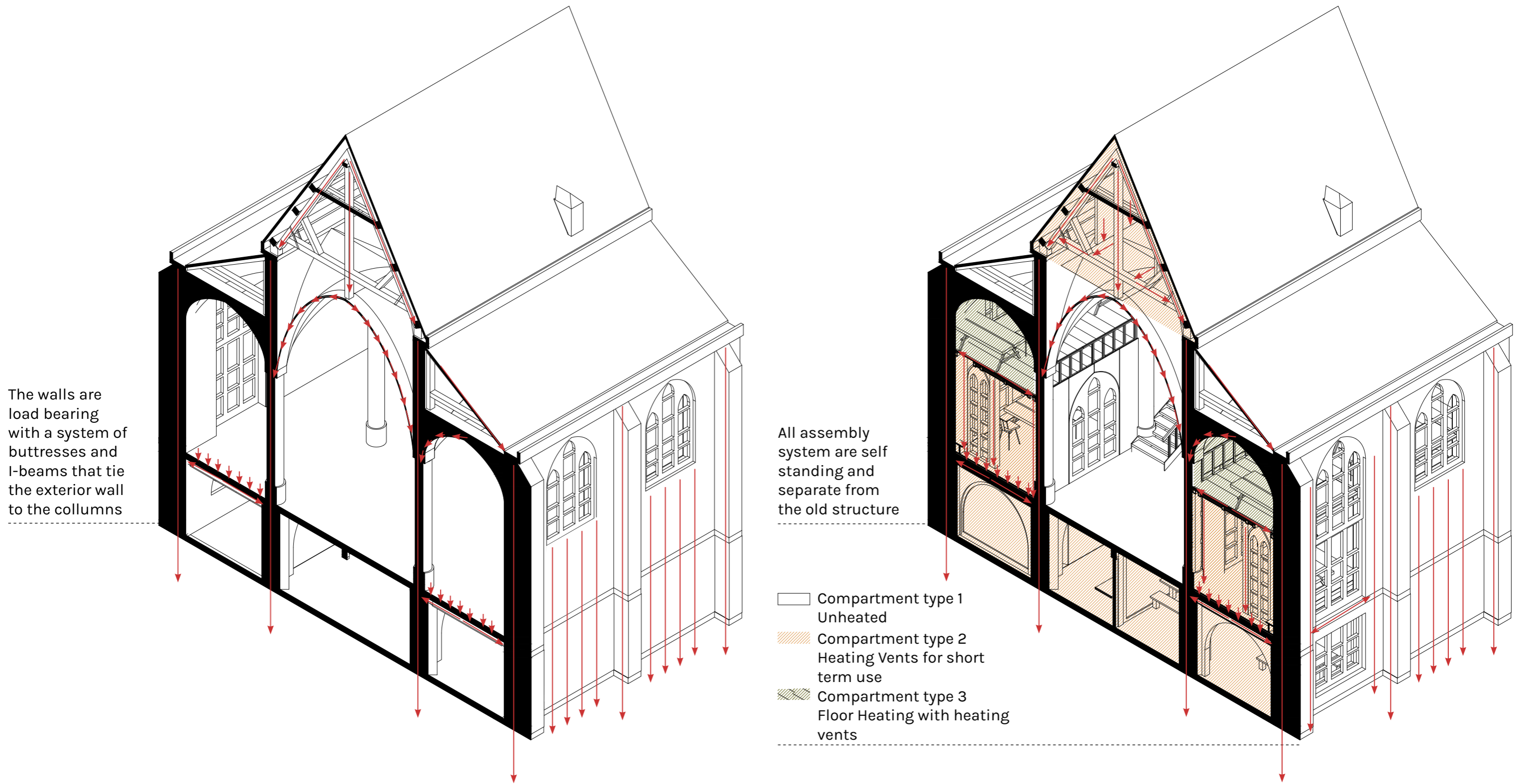

Zoning division, Structure and compartments
1:100 section showing the closed, semi-open versus open depicting degrees of control

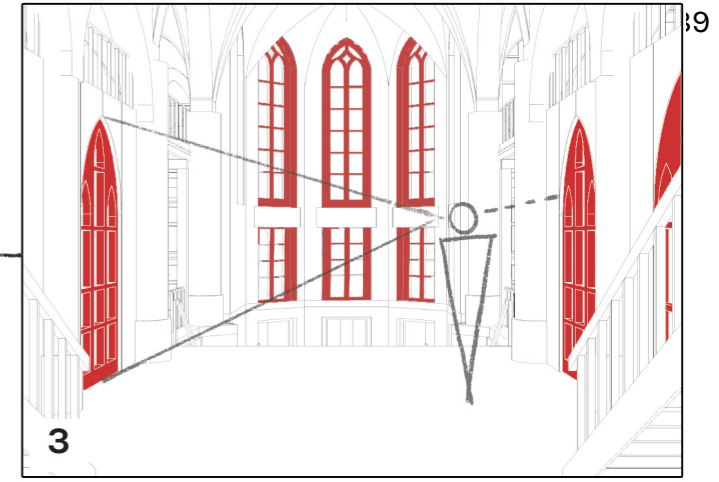
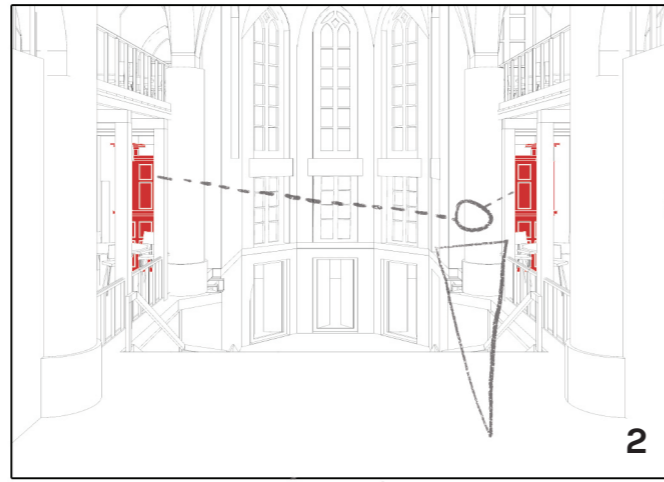
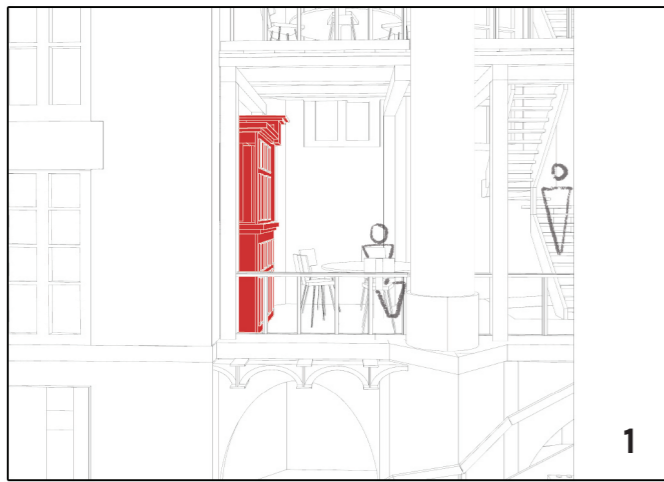

Organ_Meeting Zone

Organ_Nave

Stained Glass_Nave

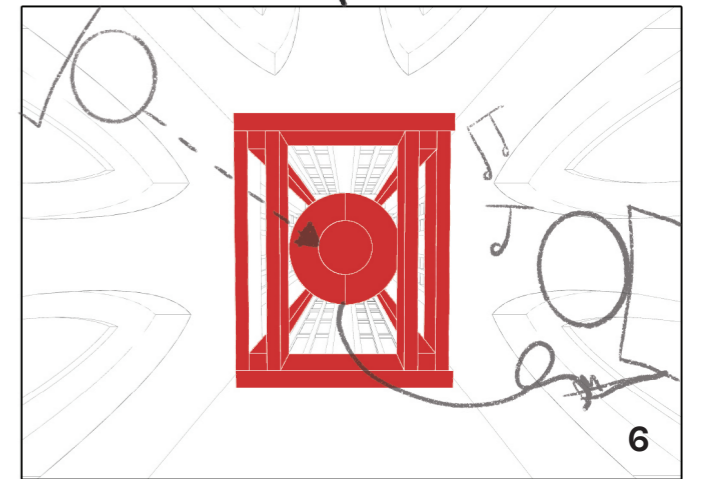
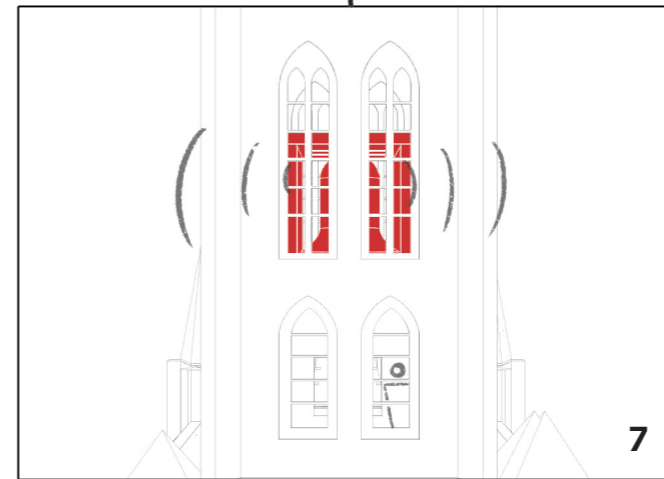
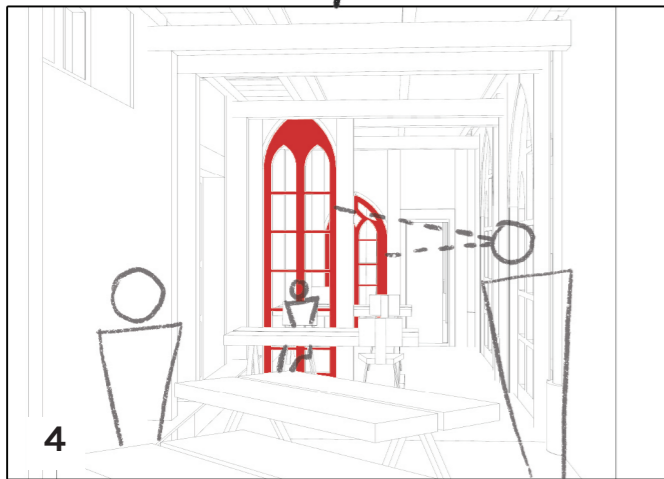
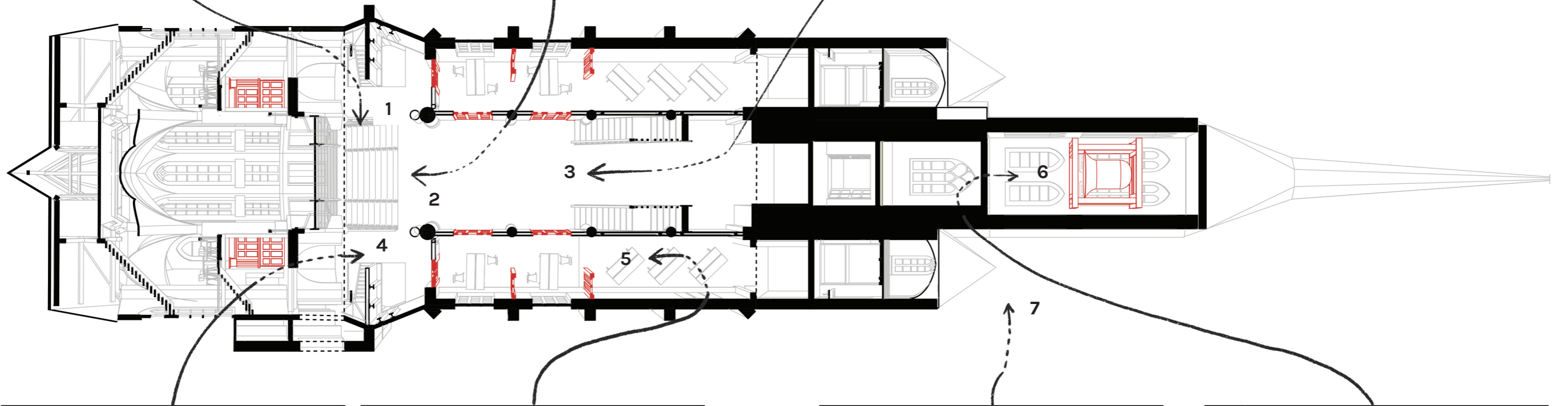

Stained Glass_Workshops

Stained Glass_Meeting Zones

Tower and Bell_external view

Tower and Bell_interior view

Experience Map

The experience of the religious elements are based on the workshop and how people perceived them

/



View of the vertical circulation and nave



View of the Art Workshops