

## Industrial symbiosis in emerging Economies

### A system approach to study industrial symbiosis in industrial clusters

Noori, S.

**DOI**

[10.4233/uuid:d33a5a8a-8423-4854-833c-403f8ed214e2](https://doi.org/10.4233/uuid:d33a5a8a-8423-4854-833c-403f8ed214e2)

**Publication date**

2022

**Document Version**

Final published version

**Citation (APA)**

Noori, S. (2022). *Industrial symbiosis in emerging Economies: A system approach to study industrial symbiosis in industrial clusters*. [Dissertation (TU Delft), Delft University of Technology]. <https://doi.org/10.4233/uuid:d33a5a8a-8423-4854-833c-403f8ed214e2>

**Important note**

To cite this publication, please use the final published version (if applicable). Please check the document version above.

**Copyright**

Other than for strictly personal use, it is not permitted to download, forward or distribute the text or part of it, without the consent of the author(s) and/or copyright holder(s), unless the work is under an open content license such as Creative Commons.

**Takedown policy**

Please contact us and provide details if you believe this document breaches copyrights. We will remove access to the work immediately and investigate your claim.

# **INDUSTRIAL SYMBIOSIS IN EMERGING ECONOMIES**

**A system approach to study industrial symbiosis in  
industrial clusters**

**Shiva NOORI**

Printed by: Ridderprint | [www.ridderprint.nl](http://www.ridderprint.nl)  
Design and layout: Ridderprint | [www.ridderprint.nl](http://www.ridderprint.nl)

Copyright © 2022 by S. Noori  
ISBN: 978-94-6458-412-7

An electronic version of this dissertation is available at <http://repository.tudelft.nl/>

# **INDUSTRIAL SYMBIOSIS IN EMERGING ECONOMIES**

**A system approach to study industrial symbiosis in  
industrial clusters**

## **Dissertation**

for the purpose of obtaining the degree of doctor  
at Delft University of Technology  
by the authority of the Rector Magnificus, Prof.dr.ir. T.H.J.J. van der Hagen,  
chair of the Board for Doctorates  
to be defended publicly on  
Wednesday 7 September 2022 at 12:30 o'clock

by

**Shiva NOORI**

Master of Science in Energy systems engineering  
Sharif University of Technology, Iran  
born in Qazvin, Iran

This dissertation has been approved by the promotors.

Composition of the doctoral committee:

Rector Magnificus,	chairperson
Prof.dr.ir. A. Ramírez Ramírez	Delft University of Technology, promotor
Dr.ir. G. Korevaar	Delft University of Technology, copromotor

Independent members:

Prof. dr. F.A. Boons	Maastricht University
Prof.dr. E. van der Voet	Leiden University
Prof.dr. A.R. Balkenende	Delft University of Technology
Prof.dr. E. Worrell	Utrecht University
Prof.dr. M.E. Warnier	Delft University of Technology, reserve member

We are alive of being unsettled,  
We are waves, our stagnation is our death!

*Saeb Tabrizi*

To **Reza**  
*My turbulence and adventure companion*

# Table of Contents

<b>Summary</b> .....	<b>9</b>
<b>Samenvatting</b> .....	<b>13</b>
<b>Acronyms and Symbols</b> .....	<b>19</b>
<b>1 Introduction</b> .....	<b>23</b>
1.1 Research background .....	23
1.2 Exploring the complexity of IS emergence .....	25
1.3 Knowledge gap .....	28
1.4 Research goal and research questions .....	28
1.5 Scope and methods.....	29
1.6 The case study.....	31
1.7 Research outline.....	33
<b>2 Assessing Industrial Symbiosis Potential in Emerging Industrial clusters</b> .....	<b>37</b>
2.1 Introduction.....	38
2.2 The case study.....	40
2.3 Materials and methods.....	42
2.4 Results .....	48
2.5 Conclusions.....	58
<b>3 Institutional Lens upon Industrial Symbiosis Dynamics</b> .....	<b>61</b>
3.1 Introduction.....	62
3.2 Theoretical Background .....	64
3.3 The Case Study .....	66
3.4 Methods .....	67
3.5 Results .....	73
3.6 Conclusion.....	80
<b>4 Exploring the emergence of waste recovery and exchange in industrial clusters</b> .....	<b>83</b>
4.1 Introduction.....	84
4.2 Methods .....	86
4.3 The case study.....	91
4.4 Results .....	96
4.5 Discussion.....	102

<b>5 The interplay between industrial symbiosis and other industrial decarbonization strategies .....</b>	<b>107</b>
5.1 Introduction.....	108
5.2 Methods.....	110
5.3 Results .....	119
5.4 Discussion and conclusion.....	124
<b>6 Conclusion .....</b>	<b>127</b>
6.1 Overview .....	127
6.2 Exploring the complexity of industrial symbiosis formation.....	128
6.3 Reflections and limitations .....	132
6.4 Contributions .....	136
6.5 Recommendations for further research .....	139
<b>References.....</b>	<b>143</b>
<b>Appendixes.....</b>	<b>161</b>
Appendix A. Location and Schematic Map of the PGSEZ.....	161
Appendix B. Waste heat Recovery Technology Ranking.....	162
Appendix C: Input-Output block diagram and Plant-Level Block Diagram of Steelmaking and Direct Reduction Plants .....	163
Appendix D: Annual Input/ Output Flowrates in 2018 based on the field data.....	165
Appendix E: The Questionnaire: Survey Regarding Collaboration Efforts among Companies in PGSEZ.....	175
Appendix F: ADICO coding sample translated to English .....	180
Appendix G: Linny-R and industrial symbiosis modeling .....	181
Appendix H: PGSEZ model material and energy data .....	182
Appendix I: Model economic input data (Chapter 4) .....	185
Appendix J: Annualized cost calculations (Chapter 5).....	187
Appendix K: Electronic published research data.....	189
<b>Acknowledgment .....</b>	<b>191</b>
<b>List of Publications.....</b>	<b>193</b>
<b>Curriculum Vitae .....</b>	<b>194</b>



## Summary

Rapid industrial development after World War II has not only created countless business opportunities but also caused many challenges, such as resource scarcity and climate change (Zhe et al., 2016). Nevertheless, more and more low to middle-income developing and transition countries are attempting to accelerate their economic growth through industrialization. These emerging economies produce 70-90% of the world's steel, cement, and chemicals (IEA, 2021), which are essential for development. However, performance indicators such as carbon intensity and energy use per GDP reveal that industrial development trends in emerging economies are not sustainable.

The ideal of industrial development that sustains and improves environmental and social structures has resulted in several scientific disciplines, one of which is *industrial ecology*. Industrial ecology implies that industrial systems must perform as an embedded part of natural and social systems (Roland Clift and Druckman, 2015; Graedel, 1996). In this context, the analogy between industrial and biological ecosystems has inspired the concept of *industrial symbiosis (IS)*. Nowadays, clustering is a dominant industrialization pattern worldwide and in emerging economies. Imitating natural ecosystems, IS aims to benefit from geographic proximity in industrial clusters for waste recovery and exchange between traditionally separate industries. IS results in economic and environmental benefits that cannot be achieved separately (Chertow and Park, 2016a).

The formation of IS results in a more sustainable production system by improving the material and energy efficiency of the whole cluster. However, industrial clusters are complex socio-technical systems in which several internal and external factors influence the emergence of symbiotic collaborations. The first requirement for IS emergence is the existence of technical and collaborative potential due to geographic proximity. In this dissertation, technical potential for IS is defined as an overlooked match between available waste flows (sources) and demanded inflows (sinks), possibly after a waste recovery process. However, a literature review revealed inconsistency in the identification of sinks and sources that can influence the assessment of technical potential. Moreover, this technical potential will not become operational unless the actors collaborate. When IS collaborations are not fully shaped, pre-emergence interactions among the actors are the key to gaining insight into the structure and dynamics of probable IS collaborations in the cluster.

Besides technical and collaborative potentials, external factors also influence actors' behaviors in the cluster and, consequently, IS formation. Rules and regulations, on the one hand, and economic conditions, on the other hand, steer actors' decisions toward IS implementation. Many emerging economies cannot afford the high investment required to implement novel sustainable industrialization strategies. Moreover, legislation has not evolved in many emerging economies to

### *Summary*

support sustainable industrialization. In the absence of effective environmental regulations, many polluting industries are migrating to emerging economies (Fan and Friedmann, 2021).

Here, there is a need for a systematic approach that acknowledges the socio-technical complexity of clusters for IS implementation. This Ph.D. dissertation aimed to understand how industrial symbiosis (IS) shapes within the complex socio-technical structure of industrial clusters to improve their environmental and economic performance in the long term. This research is original because of its interdisciplinary approach combining engineering, social science, and economic assessment methods to study IS emergence as a part of a (larger) system. It addresses key issues entwined with IS formation in industrial clusters in emerging economies.

To this end, a stepwise approach was taken, starting with assessing the technical potential for IS in an emerging industrial cluster (Chapter 2). We then studied the structure of previous collaborations in the cluster by analyzing regional and national institutions governing actors' behavior (Chapter 3). After assessing IS emergence's technical, collaborative, and institutional aspects, these aspects were incorporated with financial requirements in a MILP optimization model to study system behavior as a whole (Chapter 4). We investigated the formation of IS collaboration under different external conditions and evaluated the contribution of formed IS collaborations to cluster performance improvement. The research further examined the interplay between IS and carbon capture and storage toward a more sustainable cluster development (Chapter 5).

To examine the feasibility and functionality of the proposed methods, we used the “Persian Gulf mines and metals special economic zone” (PGSEZ), an iron and steel-based cluster in Iran, as a real case study. Iran stands in the 10<sup>th</sup> place in world crude steel production, producing 29 million tonnes crude steel annually (WSA, 2021), with plans to reach 55 million tonnes capacity. The steel industry is critical for economic modernization and one of the most energy-intensive and polluting industries. 23% of final energy demand and 28% of direct CO<sub>2</sub> emissions in the industrial sector belong to iron and steel production (IEAGHG, 2018).

An assessment of IS technical potential in the case study showed that higher quality or quantity of waste heat might be available for symbiotic exchanges if waste flows are traced back inside plant boundaries. It also demonstrated that a recovered flow could find new usages if sink exploration extends to nearby urban areas or future cluster development possibilities, for instance, utilizing steel plants' waste material in construction and ceramic industries.

We gained insight into actors' previous collaborations and their motives to engage in an IS collaboration by conducting a survey. The survey revealed that pre-emergence collaborations in the

case study were mainly self-organized and provided a proper ground for IS emergence. It also demonstrated that the most influential IS drivers for the actors were infrastructure readiness, financial support, and resource scarcity. Our institutional analysis, conducted using the ADICO grammar of institutions, uncovered the perspective of Iranian rules and regulations to promote self-organized IS. However, sanctions and penalties for breaking the laws were not proportionate to environmental damages.

Optimization models are normative, creating a vision of how the system works if specific constraints are applied. The modeling focused on waste heat recovery and exchange. The model in Chapter 4 resulted in the production level of different industrial plants and investment decisions made by actors on waste recovery under varying energy prices and limited electricity supply. The results demonstrated the dependence of waste recovery operation on the whole cluster's techno-economic conditions. It also showed that not all technically possible waste heat recovery possibilities result in symbiotic exchanges, and not all symbiotic exchanges improve cluster economic and energy performance. Moreover, techno-economically favorable symbiotic exchanges do not necessarily belong to previously collaborating actors.

The more complex model of Chapter 5 analyzed techno-economic challenges and potentials of IS and CCS implementation in the cluster. It showed that different decarbonisation strategies might suit the cluster under different external conditions. In our case study, low carbon taxes did not stimulate CCS, and low energy prices did not result in waste heat recovery. Moreover, the carbon mitigation capability of IS was limited compared to CCS and IS-CCS configurations. However, lower carbon emissions were caused not only by CCS operation but also because of the decline in the production level of industrial plants. Our models in Chapters 4 and 5 also revealed that waste heat recovery and exchange might be techno-economically feasible for one actor while CCS is not and vice versa.

This dissertation extends our understanding of the formation of IS as an integrated component of industrial clusters through several conceptual and methodological contributions. In first place, this work aimed to clarify IS definition by examining different entity and system boundaries in IS potential assessment. This resulted in a plant design approach, in which the scope of waste management is not limited to the plant boundaries but considers neighbor industrial or urban entities. Adapting ADICO grammar of institutions to IS dynamics in Chapter 3 provided a basis for the systematic investigation of national and international rules and regulations with IS lens, which has not been done before. The designed questionnaire could be adjusted to uncover the dynamics of pre-emergence collaborations in other industrial clusters.

### *Summary*

In the novel conceptualization introduced in Chapter 4, IS is not enforced on the system but is one of the different possible options specified with different techno-economic, environmental, and social constraints. The models dealt explicitly with actors' investment in waste recovery while ensuring that none of the actors would face economic loss by engaging in IS. The extended model in Chapter 5 dug into the challenges and potential of IS and CCS integration in climate change mitigation. Despite their simplicity, essential aspects of IS formation in industrial clusters are reflected in the models. The model demonstrated its functionality in representing the complex structure of industrial clusters, and can be easily adapted to answer multiple questions about the effects of internal and external factors on IS formation in the long term. The applied case study contributes to filling the gap of regional IS studies in developing oil-rich countries, where governing institutional and economic conditions are different from developed economies.

## Samenvatting

De snelle industriële ontwikkeling na de Tweede Wereldoorlog heeft niet alleen talloze zakelijke kansen gecreëerd, maar ook veel uitdagingen veroorzaakt, zoals schaarste aan hulpbronnen en klimaatverandering (Zhe et al., 2016). Toch proberen steeds meer ontwikkelings- en transitielanden met een laag tot gemiddeld inkomen hun economische groei te versnellen door middel van industrialisatie. Deze opkomende economieën produceren 70-90% van 's werelds staal, cement en chemicaliën (IEA, 2021), die essentieel zijn voor ontwikkeling. Uit prestatie-indicatoren zoals koolstofintensiteit en energieverbruik per BBP blijkt echter dat industriële ontwikkelingstrends in opkomende economieën niet duurzaam zijn.

Het ideaal van industriële ontwikkeling die ecologische en sociale structuren in stand houdt en verbetert, heeft geleid tot verschillende wetenschappelijke disciplines, waaronder *industriële ecologie*. Industriële ecologie houdt in dat industriële systemen moeten functioneren als geïntegreerd onderdeel van natuurlijke en sociale systemen (Roland Clift en Druckman, 2015; Graedel, 1996). In deze context heeft de analogie tussen industriële en biologische ecosystemen het concept van industriële symbiose (IS) geïnspireerd. Tegenwoordig is clustering een dominant industrialisatiepatroon wereldwijd en in opkomende economieën. IS bootst natuurlijke ecosystemen na en wil profiteren van geografische nabijheid in industriële clusters voor afvalbeheer en uitwisseling tussen traditioneel gescheiden industrieën. IS resulteert in economische en ecologische voordelen die niet afzonderlijk kunnen worden behaald (Chertow en Park, 2016a).

De vorming van IS resulteert in een duurzamer productiesysteem door de materiaal- en energie-efficiëntie van het hele cluster te verbeteren. Industriële clusters zijn echter complexe socio-technische systemen waarin verschillende interne en externe factoren het ontstaan van symbiotische samenwerkingen beïnvloeden. De eerste vereiste voor de opkomst van IS is het bestaan van technisch en samenwerkingspotentieel vanwege de geografische nabijheid. In dit proefschrift wordt technisch potentieel voor IS gedefinieerd als een over het hoofd gezien match tussen beschikbare afvalstromen (bronnen) en vereiste instromen (sinks), mogelijk na een afvalverwerkingsproces. Een literatuuronderzoek bracht echter inconsistentie aan het licht in de identificatie van putten en bronnen die de beoordeling van technisch potentieel kunnen beïnvloeden. Bovendien wordt dit technische potentieel pas operationeel als de verschillende partijen samenwerken. Wanneer IS-samenwerkingen niet volledig zijn vormgegeven, zijn pre-emergence interacties tussen de partijen de sleutel om inzicht te krijgen in de structuur en dynamiek van mogelijke IS-samenwerkingen in het cluster.

## *Samenvatting*

Naast technische en collaboratieve mogelijkheden, beïnvloeden ook externe factoren het gedrag van de betrokken partijen in het cluster en, bijgevolg, IS-vorming. Regels en voorschriften enerzijds en economische actoromstandigheden anderzijds sturen de beslissingen van betrokkenen in de richting van implementatie van IS. Veel opkomende economieën kunnen de hoge investeringen die nodig zijn om nieuwe duurzame industrialisatiestrategieën te implementeren niet betalen. Bovendien is de wetgeving in veel opkomende economieën niet geëvolueerd om duurzame industrialisatie te ondersteunen. Bij gebrek aan effectieve milieuregelgeving migreren veel vervuilende industrieën naar opkomende economieën (Fan en Friedmann, 2021).

Hier is de behoefte aan een systematische aanpak die de socio-technische complexiteit van clusters voor IS-implementatie erkent. Dit proefschrift gericht op het begrijpen van hoe industriële symbiose (IS) vorm krijgt binnen de complexe sociaal-technische structuur van industriële clusters om hun ecologische en economische prestaties op de lange termijn te verbeteren. Dit onderzoek is uniek vanwege de interdisciplinaire benadering die technische, sociale wetenschappen en economische beoordelingsmethoden combineert om de opkomst van IS te bestuderen als onderdeel van een (groter) systeem. Het behandelt belangrijke kwesties die verweven zijn met IS-vorming in industriële clusters in opkomende economieën.

Hiertoe is een stapsgewijze aanpak gevolgd, om te beginnen met het beoordelen van het technische potentieel voor IS in een opkomend industrieel cluster (hoofdstuk 2). Vervolgens hebben we de structuur van eerdere samenwerkingen in het cluster bestudeerd door regionale en nationale instellingen te analyseren die het gedrag van de betrokken partijen bepalen (hoofdstuk 3). Na beoordeling van de technische, collaboratieve en institutionele aspecten van IS emergentie, werden deze aspecten samen met de financiële vereisten opgenomen in een MILP-optimalisatiemodel om het systeemgedrag als geheel te bestuderen (hoofdstuk 4). We onderzochten de vorming van IS-samenwerking onder verschillende externe omstandigheden en evalueerden de bijdrage van gevormde IS-samenwerkingen aan het verbeteren van clusterprestaties. Binnen het onderzoek werd er verder naar de wisselwerking tussen IS en koolstofafvang en -opslag in de richting van een meer duurzame clusterontwikkeling bekeken (hoofdstuk 5).

Om de haalbaarheid en functionaliteit van de voorgestelde methoden te onderzoeken, hebben we de "Persian Gulf mines and metal special economic zone" (PGSEZ), een op ijzer en staal gebaseerd cluster in Iran, als een echte case studie gebruikt. Iran staat op de 10<sup>e</sup> plaats in de wereldproductie van ruw staal en produceert jaarlijks 29 miljoen ton ruw staal (WSA, 2021), met plannen om de capaciteit van 55 miljoen ton te bereiken. De staalindustrie is van cruciaal

belang voor economische modernisering en een van de meest energie-intensieve en vervuilende industrieën. 23% van de finale energievraag en 28% van de directe CO<sub>2</sub> emissies in de industriële sector behoren tot de ijzer en staal productie (IEAGHG, 2018).

Een beoordeling van het technische potentieel van IS in de casestudy toonde aan dat een hogere kwaliteit of kwantiteit van afvalwarmte beschikbaar zou kunnen zijn voor symbiotische uitwisselingen als afvalstromen worden getraceerd binnen de fabrieksgrenzen. Het toonde ook aan dat een teruggewonnen stroom nieuwe toepassingen kan vinden als de exploratie van putten zich uitbreidt tot nabijgelegen stedelijke gebieden of toekomstige mogelijkheden voor clusterontwikkeling, bijvoorbeeld door gebruik te maken van afvalmateriaal van staalfabrieken in de bouw- en keramische industrie.

Door middel van een enquête hebben we inzicht gekregen in eerdere samenwerkingen van de betrokken partijen en hun motieven om een IS-samenwerking aan te gaan. Uit het onderzoek bleek dat de samenwerkingen vóór opkomst in de case studie voornamelijk zelfgeorganiseerd waren en een goede basis vormden voor de opkomst van IS. Het toonde ook aan dat de meest invloedrijke IS-drijfveren voor de infrastructuurgereedheid van de betrokken partijen, financiële steun en schaarste aan middelen waren. Onze institutionele analyse, uitgevoerd met behulp van de ADICO-grammatica van instellingen, onthulde het perspectief van Iraanse regels en voorschriften om zelfgeorganiseerde IS te promoten. Sancties en straffen voor het overtreden van de wetten stonden echter niet in verhouding tot milieuschade.

Optimalisatiemodellen zijn normatief en creëren een visie op hoe het systeem werkt als er specifieke beperkingen worden toegepast. De modellering was gericht op terugwinning en uitwisseling van restwarmte. Het model in Hoofdstuk 4 resulteerde in het productieniveau van verschillende industriële installaties en investeringsbeslissingen van de betrokken partijen over afvalbeheer bij variërende energieprijzen en een beperkte elektriciteitsvoorziening. De resultaten toonden de afhankelijkheid van afvalbeheer van de technisch-economische omstandigheden van het hele cluster aan. Het toonde ook aan dat niet alle technisch mogelijke mogelijkheden voor terugwinning van restwarmte resulteren in symbiotische uitwisselingen, en niet alle symbiotische uitwisselingen verbeteren de economische en energieprestaties van het cluster. Bovendien behoren techno-economisch gunstige symbiotische uitwisselingen niet noodzakelijk toe aan eerder samenwerkende partijen.

Het meer complexe model van Hoofdstuk 5 analyseerde de techno-economische uitdagingen en mogelijkheden van IS- en CCS-implementatie in het cluster. Het toonde aan dat verschillende decarbonisatiestrategieën geschikt kunnen zijn voor het cluster onder

## *Samenvatting*

verschillende externe omstandigheden. In onze case studie stimuleerden lage CO<sub>2</sub>-belastingen CCS niet en leidden lage energieprijzen niet tot terugwinning van restwarmte. Bovendien was het CO<sub>2</sub>-reductievermogen van IS beperkt in vergelijking met CCS- en IS-CCS-configuraties. Lagere koolstofemissies werden echter niet alleen veroorzaakt door de CCS-operatie, maar ook door de daling van het productieniveau van industriële installaties. Onze modellen in hoofdstuk 4 en 5 lieten ook zien dat terugwinning en uitwisseling van restwarmte technisch-economisch haalbaar kan zijn voor één partij, terwijl CCS dat niet is en vice versa.

Dit proefschrift breidt ons begrip van de vorming van IS als een geïntegreerd onderdeel van industriële clusters uit door middel van verschillende conceptuele en methodologische bijdragen. In de eerste plaats was dit werk bedoeld om de IS-definitie te verduidelijken door verschillende entiteits- en systeemgrenzen te onderzoeken bij de beoordeling van IS-potentieel. Dit resulteerde in een fabrieksontworpbenadering, waarbij de reikwijdte van afvalbeheer niet beperkt is tot de fabrieksgrenzen, maar rekening houdt met naburige industriële of stedelijke entiteiten. Het aanpassen van de ADICO-grammatica van instellingen aan IS-dynamiek in hoofdstuk 3 verschaftte een basis voor het systematisch onderzoeken van nationale en internationale wet- en regelgeving met IS-lens, wat nog niet eerder is gedaan. De ontworpen vragenlijst zou kunnen worden aangepast om de dynamiek van pre-emergence samenwerkingen in andere industriële clusters bloot te leggen.

In de nieuwe conceptualisering die in hoofdstuk 4 is geïntroduceerd, wordt IS niet opgelegd aan het systeem, maar is het een van de verschillende mogelijke opties die gespecificeerd zijn met verschillende technisch-economische, ecologische en sociale beperkingen. De modellen hadden expliciet betrekking op de investeringen van de partijen in afvalbeheer en zorgden ervoor dat geen van dezen economisch verlies zou lijden door zich met IS bezig te houden. Het uitgebreide model in hoofdstuk 5 ging dieper in op de uitdagingen en het potentieel van IS- en CCS-integratie bij het tegengaan van klimaatverandering. Ondanks hun eenvoud worden essentiële aspecten van IS vorming in industriële clusters weerspiegeld in de modellen. Het model heeft zijn functionaliteit bewezen door de complexe structuur van industriële clusters weer te geven, en kan eenvoudig worden aangepast om meerdere vragen te beantwoorden over de effecten van interne en externe factoren op IS-vorming op de lange termijn. De toegepaste case study draagt bij aan het opvullen van de leemte van regionale IS-studies in olierijke ontwikkelingslanden, waar de institutionele en economische omstandigheden anders zijn dan die in ontwikkelde economieën.

Samenvattend, de systematische stappen in hoofdstuk 2 om het technische potentieel voor IS te beoordelen, de georganiseerde aanpak in hoofdstuk 3 om de structuur van eerdere

samenwerkingen en instellingen bloot te leggen, en de uitgebreide maar handige modelleringsaanpak in de hoofdstukken 4 en 5, alles bij elkaar vergroten ze de huidige kennis over IS-opkomst in industriële clusters, waardoor toekomstige wetenschappelijke ontwikkelingen op dit gebied worden vergemakkelijkt. Ik hoop dat dit proefschrift zal dienen als een waardevolle opstap naar meer duurzame industrialisatie in opkomende economieën en mijn land, Iran.



## Acronyms and Symbols

Absorption Chiller	ABC
Agent-Based Modelling	ABM
Anode Baking Plant	ABP
Almahdi aluminum complex	AAC
Annualized cost	AC
Aluminum Refining Plant	ARP
Blast furnace	BF
Basic oxygen furnace	BOF
Capital expenditures	CAPEX
Cold Briquetting Plant	CBP
Cooling	CL
Coefficient of Performance	COP
Capital recovery factor	CRF
Carbon capture and storage	CCS
Carbon capture and utilization	CCU
Department of environment	DOE
Direct reduced iron	DRI
Direct reduction plant	DRP
Electric arc furnace	EAF
Electricity	EL
Enhanced oil recovery	EOR
Greenhouse gases	GHG
Gas turbine power plant	GPP
Heat recovery steam generator	HRSG
Hormozgan steel complex	HOS
Hormoz power plant	HPP
Iranian Mines & Mining Industries Development & Renovation	IMIDRO
Industrial Symbiosis	IS
Location factor	LF
Monoethanolamine	MEA
Mixed-integer linear programming	MILP

Natural gas	NG
Natural gas fired steam boiler	NSB
Operating expenses	OPEX
Organic Rankine Cycle	ORC
Persian Gulf mines and metals special economic zone	PGSEZ
Peta joule	PJ
Production level	PL
Reference cost	RC
Persian Gulf Saba Steel Company	SAB
Scaled cost	SC
Steam methane reforming	SMR
Simplified retrofit factor	SRF
South Kaveh steel complex	SKS
Steam turbine	ST
Steelmaking plant	SMP
Tonne	t
Total capital requirement	TCR
Total plant cost	TPC
Tera joule	TJ
Waste disposal	WD
Waste recovery	WR
Waste recovery steam generator	WRSG
Year	yr





# 1 Introduction

## 1.1 Research background

### 1.1.1 Sustainable development and Industrial symbiosis

The term *Sustainable development* was first introduced in 1987 to respond to environmental problems caused by rapid industrialization after World War II. Rapid industrial development has resulted in business and employment opportunities while causing many challenges such as resource scarcity, environmental pollution, and climate change (Zhe et al., 2016). Today, the United Nation's Sustainable Development Goals (SDGs) cover a range of social, economic, and environmental issues such as gender equality, no poverty, and clean energy (UN DESA, 2016). The idea of a new economic growth era, in which technology and social structures can be managed and improved together, has resulted in several paradigms such as net-zero economy, industrial ecology, and inclusive circular economy.

Industrial ecology is the study of industrial systems embedded in natural ecosystems (Graedel, 1996). This field deals with industry- society- biosphere as an integrated system (R Clift and Druckman, 2015) to understand its emergent behavior (Allenby, 2006). Moreover, the analogy between industrial and natural ecosystems inspires the design of more sustainable industrial systems (R Clift and Druckman, 2015). One of those analogies has emerged in the concept of *industrial symbiosis* (IS). IS seeks waste material and energy exchange between traditionally separate neighboring industries to achieve economic and environmental benefits that cannot be achieved separately (Chertow and Park, 2016b).

“The keys to industrial symbiosis are collaboration and the synergistic possibilities offered by geographic proximity (M. R. Chertow, 2000, P: 313).” Geographic concentrations of industries and inputs, services, and infrastructure providers in a particular location are

called clusters (Porter, 1998). Clustering is one of the dominant industrial development patterns in today's economy. Industrial clusters are also promising contexts for IS implementation as a sustainable transformation strategy (Taddeo et al., 2017). Technical, economic, regional, social, and institutional conditions result in different IS development pathways in industrial clusters (Boons et al., 2016).

Several academic studies have investigated established symbiotic exchanges in industrial clusters and their contribution to cluster sustainability (Chertow et al., 2019; Jacobsen, 2006; Taddeo, 2016; Wen and Meng, 2015). However, in clusters where IS has not been shaped yet, the first consideration is to investigate IS formation process. In recent years, researchers have paid attention to the emergence of IS in industrial clusters as a sustainable development strategy. Studying IS emergence as a sustainable development strategy requires an interdisciplinary approach that acknowledges the socio-technical complexity of industrial clusters.

### **1.1.2 Industrialization in emerging economies**

Nowadays, more and more low to middle-income developing and transition countries are integrating into the global financial system. The United Nations Industrial Development Organization (UNIDO) defines emerging industrial economies as countries with a share higher than 0.5% in the world manufacturing value added (MVA) or with a MVA between 1000 to 2500 \$ per capita (UNIDO, 2019a). These countries, called in short emerging economies in this dissertation, are eager to improve their economic conditions and bring welfare to their growing population. Emerging economies share 70-90% of the global production of steel, cement, and chemicals (IEA, 2021), which are essential, almost irreplaceable, for development in today's world. However, nearly 70% of the industry sector's CO<sub>2</sub> emissions and 60% of its energy consumption belong to these industries (IEA, 2021). Consequently, manufacturing CO<sub>2</sub> emissions and energy use per unit of MVA in emerging economies are much higher than in industrialized economies (UNIDO, 2019b), emphasizing the need to steer industrial development in order to lower environmental damages while maintaining economic growth.

As stated in the previous section, IS provides opportunities to improve industrial clusters' material and energy efficiency and gain simultaneous economic and environmental benefits. IS has been studied for many contexts and countries with different levels of economic development. The highest number of IS publications belong to China, followed by advanced economies such as the US, Australia, Denmark, the United Kingdom, Finland, South Korea, Sweden, and the Netherlands (Chertow and Park, 2016a), while the number of IS studies is

relatively limited in emerging economies (e.g., India and Brazil). Cases in the Middle East and oil-rich countries have rarely been investigated. Research has already indicated that IS studies should be adapted to suit each country's conditions (Chiu and Yong, 2004). Insights from developed economies are not easily transferable to emerging economies because of significant differences in geographical, political, and economic conditions.

The formation of IS in industrial clusters in emerging economies is not straightforward. Providing the investments required for novel sustainable solutions is a challenge in emerging economies. Moreover, legislation has not evolved in many emerging economies to support sustainable industrialization. For instance, a recent report evaluated government targets and climate change actions in most emerging economies as critically or highly insufficient (CAT, 2021). Therefore, it is crucial to understand whether aggregated energy-intensive industries in emerging economies can continue operation or survive under future increased energy prices and carbon taxes. Based on context-related technical, institutional, and social research, policies could be recommended (C. Yu et al., 2015).

## 1.2 Exploring the complexity of IS emergence

As discussed in section 1.1.1, IS contributes to cluster sustainability. The first requirement for IS emergence is its technical possibility. Symbiotic exchange is technically feasible when there is a match in the cluster between available waste flows (sources) and demanded inflows (sinks), possibly after a waste recovery process. Overlooked technically possible IS opportunities are referred here as technical potential. IS literature has set different boundaries for sinks and sources to assess technical potential. While many studies have searched plant outputs for waste flow exploration (e.g., (Chertow and Park, 2016a), (Kastner et al., 2015), and (Dong et al., 2013)), some recent works have looked inside industrial plants seeking available waste flows (e.g., (Kuznetsova et al., 2016), (Pan et al., 2016) and (Wu et al., 2016)). The latter approach shows overlap with total site integration studies in energy networks (e.g., (Hackl and Harvey, 2014, 2013) and (Mian et al., 2016a, 2016b)).

Evaluation approaches on the demand side are not consistent either. For instance, some studies consider urban areas as potential receivers of recovered waste (Chertow et al., 2019; Liu et al., 2018), while others focus on demand inside the cluster. Moreover, in emerging industrial clusters, there is a possibility of adding new industries to the cluster in the near future. The possibility of utilizing waste flows from existing industries as input to future industries influences cluster boundaries in IS assessment. Thus far, previously published IS studies are not consistent in dealing with system boundary setting and its effect on technical assessment.

Coming to the social aspects of IS emergence, we have to differentiate between two categories of studies: the studies that explore social forces that influence IS collaborations and those that aim to incorporate such factors in IS modeling. Extensive research has been conducted in the first category to capture influential social aspects of IS, such as structural, cultural, and cognitive embeddedness (Ashton and Bain, 2012), organizational and social proximity (Velenturf and Jensen, 2016), shared behavioral norms, and actors' common understanding (Chertow and Ehrenfeld, 2012), and cooperation and coordination among firms (Rui and Heijungs, 2010). Mortensen & Kørnøv (2019) define IS emergence as a social process of raising awareness, exploring potential connections, and organizing new connections. However, they acknowledge the role of overlooked technical and institutional conditions in IS emergence.

In modeling works, for instance, Ghali, Frayret, & Ahabchane (2017) formulated social factors such as trust, knowledge sharing, and willingness to commit, and built an agent-based model that simulates such factors effect on the formation of IS collaborations. The model emphasizes social structure and dynamics and has a simplified approach to techno-economic and institutional aspects of IS emergence. Simboli, Taddeo, Raggi, & Morgante (2020) have aimed to gain insight into potential IS development by investigating the structure and organization of existing networks in Italian industrial clusters. However, although network analysis is a hopeful method to investigate social ties, the method is rather qualitative and incapable of incorporating techno-economic and institutional aspects of IS. Although these studies confirm the role of social factors in IS formation, our knowledge in this field is far from proposing a causal relationship between social factors and IS emergence.

Technically possible symbiotic exchanges between two companies will not become operational unless the two actors are willing to collaborate. Pre-emergence interactions within the community of actors develop collaborative capacity, and opportunities for future IS interaction (Spekkink and Boons, 2016). IS emerges and evolves in a cluster through different pathways characterized by initial actors and their motivation, sequence of actions, and outcomes (Boons et al., 2016). The question is whether the pathways are recognizable in pre-emergence collaboration when symbiotic exchanges have not been shaped yet.

Cluster internal conditions are not, however, the only parameters that influence IS. Institutions can also promote or prohibit IS emergence. In the absence of effective environmental regulations, many polluting industries are migrating to emerging economies (Fan and Friedmann, 2021). The role of legislative drivers and political support is considerable in the IS field as well (Liu et al., 2018). As an example, a case study of existing industrial clusters in Brazil found legal support and government and public agency incentives as pivotal in IS

development (Bechara et al., 2008). In a recent study, Lybæk, Christensen, & Thomsen (2021) have probed into the role of policies in IS development. They have investigated policy recommendations from the literature and existing policies and frameworks set by international organizations to recommend policies to support IS. However, they highlight only the main emphasis of the policy frameworks, not the operational details. Given the importance of rules and legislations, a systematic approach is needed to investigate regional and national policies and legislations regarding IS implementation.

Besides legislation, an influential external force on IS emergence is economic conditions. Roberts (2004) stated that although IS is defined based on an environmental and social agenda, the primary driver for the actors to participate in industrial symbiosis is economic benefit (Roberts, 2004). Chertow also argued that economic benefit is the key to stable symbiotic exchanges either motivated by economic, social, environmental, or regulatory forces (Chertow, 2007). A case study in China showed that economic benefits resulting from material substitution, stricter environmental standards, taxes, and financial subsidies were the main drivers of symbiotic exchanges (F. Yu et al., 2015). Several agent-based models have defined fitness goals only as a function of economic benefit (e.g., (Albino et al., 2016), (Fraccascia et al., 2017b) and (Fraccascia and Yazan, 2018)). Nevertheless, the high investment required for energy and water symbiosis makes it hard to establish (F. Yu et al., 2015).

So far, we have discussed different aspects of IS emergence in industrial clusters. However, IS is not the only sustainable industrialization strategy in emerging economies. Several strategies must be implemented simultaneously to achieve sustainability goals, especially in energy and carbon-intensive industries. Among industrial decarbonisation strategies, carbon capture and storage (CCS) is one of the most studied in power generation (IEAGHG, 2020), hydrogen (IEAGHG, 2017), cement (Gardarsdottir et al., 2019), and steel (IEAGHG, 2018) industries. However, the downside of CCS technologies is their high energy consumption. IS could facilitate CCS by utilizing available waste flows at the cluster level.

However, any technological change that influences the supply or demand side of symbiotic exchanges will affect IS formation. For instance, energy or material efficiency improvements can decrease the amount of generated waste flow. CCS also changes the cluster's energy demand profile; influencing IS potential. Furthermore, implementing IS and CCS together makes investment decisions for actors more complex. The interplay between IS and other mitigation levels at the cluster level has not been investigated in the literature. In brief, actors'

decision on waste recovery and exchange is influenced by technical opportunities, social intentions, relevant rules and regulations, and economic conditions. Emergence of IS collaborations as a system component to improve economic and environmental performance of the whole cluster requires a system approach to assess and analyse different aspects of IS emergence together.

### 1.3 Knowledge gap

The argumentation in section 1.2 elaborates that IS emergence is affected by technical, social, institutional, and economic circumstances. The system becomes more complex when IS is integrated with other strategies. This points out the need for a system approach to explore IS emergence and its role in improving clusters economic and environmental performance under different internal and external conditions in long term. The literature review showed several elements of a knowledge gap in this regard. In this research, the following knowledge gaps are addressed:

- Lack of clarity in system boundary settings in IS technical potential definition and assessment;
- Insufficient insight into the influence of previous collaborations and institutional conditions on IS development pathways;
- Lack of a systematic approach in studying the emergence of IS in industrial clusters under different technical and institutional conditions;
- Insufficient insight into the interplay between IS and CCS, and their impact, individually and together, on improving the economic and environmental performance of industrial clusters.

### 1.4 Research goal and research questions

In emerging economies, energy intensity and CO<sub>2</sub> emission per unit of value-added are higher than in industrialized economies. These two indicators must be improved to achieve SDGs in emerging economies. IS can improve industrial clusters' material and energy efficiency while gaining economic benefit. However, IS implementation requires a comprehensive approach to include a cluster's technical, social, institutional, and economic conditions as a system. This thesis aims to understand *how industrial symbiosis emerges within the complex socio-technical structure of industrial clusters in emerging economies to improve their economic and environmental performance in the long term*. In line with the knowledge gaps presented before, we have formulated four research questions to achieve this goal:

**RQ1:** How do system boundary settings influence the assessment of the technical potential for waste recovery and exchange in emerging industrial clusters? (*Chapter 2*)

**RQ2:** What insights can pre-emergence collaborations and institutional conditions provide regarding probable future IS dynamics in emerging industrial clusters? (*Chapter 3*)

**RQ3:** How can the emergence of industrial symbiosis in industrial clusters be modeled under different technical and institutional conditions in the long term? (*Chapter 4*)

**RQ4:** How to assess the interplay between industrial symbiosis and carbon capture and storage in industrial clusters, and their impact, individually or together, on an industrial cluster's economic and environmental performance? (*Chapter 5*)

## 1.5 Scope and methods

The research questions presented in section 1.4 address different aspects of IS emergence, so they were answered through different methods. We assessed technical, collaborative, institutional, and economic conditions influencing IS and integrated them into a model to study IS formation in the cluster and its influence on cluster performance in the long term. Scope and methods implemented in this research are briefly introduced in this section.

### 1.5.1 Technical potential assessment

We proposed a systematic approach to uncover the technical potential for IS by implementing the concept of sources and sinks. Sources were explored by tracing waste flows inside and outside the plant boundaries, and sinks inside and outside current cluster boundaries were examined. We then matched sources and sinks, considering possible waste recovery technologies, and investigated the effect of different boundary settings on technically possible material and energy exchanges.

### 1.5.2 Collaboration assessment

The studies emphasize the role of actors' motivations and their pre-emergence collaborations on IS emergence in an emerging industrial cluster. A survey was designed to gain insight into probable IS development pathways by investigating pre-emergence collaborations in the cluster. The survey aimed to map the network of previous collaborations that could lead to future symbiotic exchanges and investigate the structure of successful ones. Moreover, respondents ranked IS drivers, obtained from the literature, to uncover the most dominant

drivers in the cluster. The number and type of pre-emergence collaborations among different actors provided insight into the possibility of their future collaboration, and investigating involved stakeholders and their roles in collaborations revealed the dominant dynamic of successful collaborations.

### **1.5.3 ADICO institutional analysis**

To systematically explore the relevance of rules and regulations to IS emergence, we implemented the ADIOC grammar of institutions. Five components of each institutional statement in ADICO analysis are attributes (A), deontic (D), aim (I), condition (C), and or else (O) (Crawford and Ostrom, 1995). We correlated these components to the structure of IS development pathways introduced by Boons et al. (2016). For this purpose, industrial development, environmental protection, and energy efficiency regulations were identified, all IS-related statements were separated, and five components were distinguished for each statement to match them with IS development dynamics. The statements were also categorized based on their type. Rules incorporate all five components, norms do not declare penalties or sanctions, and shared strategies are composed of an attribute, aim, and condition only.

### **1.5.4 Modeling approach**

An industrial cluster could be modeled as a system. External factors, either in the form of exogenous parameters or policy measures, influence the system. System structure and relationships operate as a function that transforms external factors into outcomes (Kwakkel, 2017). There are different approaches to model such systems. Optimization models are normative, creating a vision of how the system works if specific constraints are applied. In this dissertation, we implemented Linny-R, a diagram-based mixed-integer linear programming (MILP) modeling tool for techno-economic analysis and optimization of industrial systems. The building blocks of a Linny-R model are products and processes, either physical or non-physical.

To study IS emergence, the existing structure of the cluster was built in Linny-R first using a case study. The focus of the modeling phase was on energy recovery. Designated waste recovery or CCS plants and their incorporated investment and operation costs were later added to the cluster to investigate which collaborations could shape under different external factor scenarios. Our conceptualization was based on decomposing industrial interactions into a set of physical and non-physical activities, applying system constraints to processes and products, and giving actors the opportunities to select among different routes. The Linny-R model resulted in the production level of different processes and investment decisions made by actors under

various external conditions. Consequently, material and energy consumptions, symbiotic exchanges, actors' cash flow, and carbon emissions were obtained.

## 1.6 The case study

In this dissertation, the methods introduced in section 1.5 were examined on an iron and steel-based industrial cluster in Iran to verify the methods' functionality and reflect IS contribution to cluster sustainability in a real case study.

### 1.6.1 Iron and steel industry in emerging economy

The steel industry is a key player not only in economic modernization but also in environmental pollution. Countries count on steel for their security and economic development (Fan and Friedmann, 2021). However, steel consumption is not the same in all countries. Developed economies are saturated from the in-use stock of steel, while many developing countries, even China and India, are far below the saturation point (IEA, 2020a). Therefore, crude steel demand is expected to grow in the coming decades (IETS, 2020). Global iron and steel production nearly tripled over the last three decades, mostly due to a steep increase in emerging economies (WSA, 2021). As it could be expected, crude steel production of industrialized countries has remained almost the same. Meanwhile, the production of Turkey, Brazil, India, and Iran as typical emerging economies has increased over this period. The highest growth belongs to China, where around ninety percent of production is consumed internally (WSA, 2021).

As the International Energy Agency's Greenhouse Gas R&D program (IEAGHG) reported, 23% of final energy demand and 28% of direct CO<sub>2</sub> emissions in the industrial sector belong to the iron and steel industry (IEAGHG, 2018). Steel production processes also generate a wide range of emissions to soil, air and water in the form of sludge, slag and air pollutants (SEAI, 2008). This has caused international efforts to develop innovative sustainable steel production technologies (IETS, 2020). However, steel production plants have high investment costs and long capital lifetimes (Fan and Friedmann, 2021), and therefore already established plants will continue operation for the coming decades before more sustainable novel technologies are commercialized. Therefore, solutions for sustainable steel production for existing plants in the short and mid-term are needed.

### 1.6.2 The Persian Gulf Mining and Metal Industries Special Economic Zone

Iran is the leading country in natural gas based Direct Reduced Iron (DRI) production (MIDREX, 2017). With 29 million tonnes yearly production, the country stands in 10<sup>th</sup> place in

world crude steel production (WSA, 2021), with plans to reach 55 million tonnes capacity to overcome increasing internal demand and import to neighbour least developed countries (SEASI, 2017). However, industrial development in Iran suffers from water scarcity (Madani, 2014; Madani et al., 2016), high carbon emissions (Global Carbon Project, 2016), low energy and material productivity, and insufficient electricity grid capacity (FIECO, 2016).

The Persian Gulf Mining and Metal Industries Special Economic Zone (PGSEZ) is located in the south of Iran. PGSEZ benefits from proximity to the South Pars natural gas fields for establishing energy-intensive metal processing industries. As listed in Table 1.1, active industries in PGSEZ are three steel production, one aluminum production, and one gas turbine power plant. PGSEZ has several development plans in either existing industries or establishing new ones. This cluster has a semi-governmental management body responsible for coordinating activities and providing shared infrastructure for industries. This Ph.D. research uses the case study of PGSEZ to address the challenge of IS formation to improve the environmental and economic performance of industrial clusters in emerging economies.

*Table 1.1 Industries established in PGSEZ*

<b>Company</b>	<b>Plant</b>	<b>Type (*)</b>	<b>Capacity</b>
Kish South Kaveh Steel Company	P1	DRP	1,850,000 t/year
	P2	SMP	1,200,000 t/year
Hormozgan Steel Complex	P3	DRP	1,650,000 t/year
	P4	SMP	1,500,000 t/year
	P5	CBP	75,000 t/year
Hormoz Power Plant	P6	GPP	160 MW
Persian Gulf Saba Steel Company	P7	DRP	1,000,000 t/year
Almahdi Aluminium Complex	P8	ABP	93,000 t/year
	P9	ARP	172,000 t/year
(*):	CBP: Cold Briquetting Plant		
DRP: Midrex Direct Reduction Plant	GPP: Gas turbine power plant		
SMP: Electric Arc Furnace Steelmaking Plant	ARP: Hall-Héroult Aluminium Refining Plant		
	ABP: Anode Baking Plant		

## 1.7 Research outline

Figure 1.1 shows the structure of the dissertation. The socio-technical structure of the cluster is investigated in Chapters 2 and 3, continued by modeling work in Chapters 4 and 5. Chapter 2 elaborates on the technical assessment of IS, and Chapter 3 presents collaboration and institutional studies. In Chapter 4, IS emergence under energy price and resource scarcity scenarios is modeled. In Chapter 5, the model is extended to cover CCS implementation under a broader range of scenarios. In chapter 6, the outcomes of Chapters 2 to 5 are discussed to conclude how taken steps in this research resulted in answering the main research question and how this answer contributes to the scientific field of IS. The dissertation provides methodological and contextual contributions to IS emergence studies as a sustainable industrial development strategy, especially in emerging economies.

This work is original because of its interdisciplinary approach investigating technical, collaborative, institutional, and economic aspects of IS. For this purpose, it combines engineering, social science, and economic assessment methods. As a result, it provides valuable insights into IS emergence, not as standalone phenomena but as a part of a complex socio-technical system. This research also analyses techno-economic challenges and potentials of IS implementation along with CCS that has not been examined before. Applied case study fills the gap of regional IS studies in developing oil-rich countries, where governing institutional and economic conditions are different from developed economies.

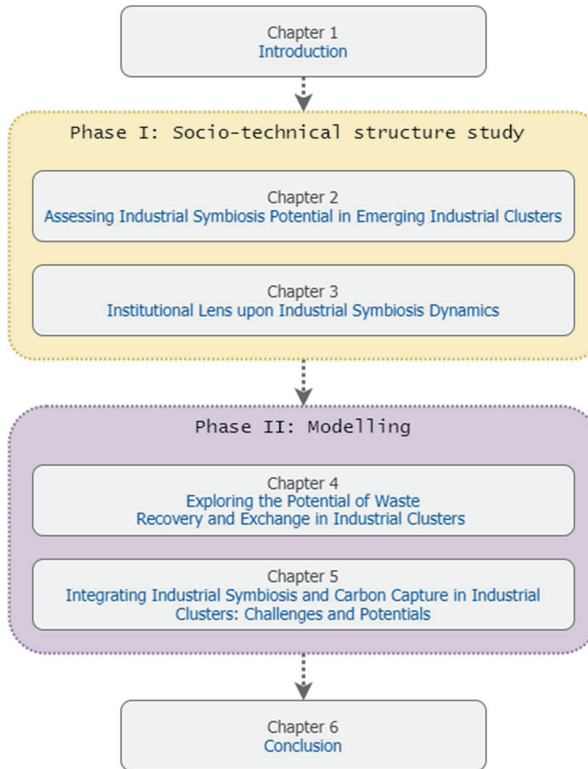

Figure 1.1 Thesis structure





# 2 Assessing Industrial Symbiosis Potential in Emerging Industrial clusters<sup>1</sup>

## ABSTRACT

Industrial Symbiosis (IS) is a means for sustainable cluster development. The first consideration for implementing IS in a cluster is to identify technical opportunities for exchanging waste material and or energy. However, the definition and methods for assessing the technical potential of IS are not elaborated in the literature. This research proposes a method to evaluate IS potential that considers different system boundaries. The method allows for explicitly reflecting current and expected developments at plant and cluster level. The suggested method was applied to the Persian Gulf Mining and Metals Special Economic Zone (PGSEZ) in Iran. The case study shows that expanding the system boundaries to include the waste flows inside steelmaking and direct reduction plants could result in an 8% increase in available waste heat. Heat recovery possibilities outside the cluster boundaries offered 118 MW cooling plus 368 MW heating potential compared to 158 MW demand for electricity in the cluster. Furthermore, less than 20% of generated by-products could currently be reused in the cluster, while theoretically all by-products could be utilized today in other industries such as cement and ceramic. These findings support the use of IS as a way to open new perspectives for EIC development policies.

---

<sup>1</sup> This chapter has been published as Noori, S., Korevaar, G., & Ramirez, A. R. (2021). Assessing industrial symbiosis potential in Emerging Industrial Clusters: The case of Persian Gulf Mining and metal industries special economic zone. *Journal of Cleaner Production*, 280. <https://doi.org/10.1016/j.jclepro.2020.124765>

## 2.1 Introduction

Clustering is one of the main industrialization patterns in today's economies (Porter, 1998). Industrial clusters are complex socio-technical systems composed of several actors. Actors benefit from clustering in the form of supply chain, utility and service sharing, and by-product and waste exchange (UNIDO, 2017). The concept of Industrial Symbiosis (IS) takes into account the complexity of the industry- society- environment system in industrial clusters. IS has been defined as a collaborative relationship between nearby industrial plants to exchange waste material or energy and achieve economic and environmental benefits that cannot be gained individually (Chertow, 2007). Emerging Industrial Clusters (EICs) are clusters in their first stages of evolution with unrealized possibilities for rapid growth (Teräs, 2011). EICs are expected to play an influential role in the industrialization of emerging economies. Although IS is acknowledged as a way toward sustainable industrial development (van Berkel, 2010), the first consideration to implement IS in EICs is to establish if any potential for waste material and energy exchange does indeed exist (Kastner et al., 2015).

Industrial clusters can be examined at different levels: a cluster can be composed of different companies where each company can include one or more industrial plants, working mostly in the same industrial supply chain (Kastner et al., 2015). An industrial plant, in turn, is a set of unit operations to produce the desired product from raw materials (Douglas, 1988). Material and energy exchanges take place between unit operations, plants, and companies. Nevertheless, it is not clear in the literature which levels are considered when assessing potentials of IS. Most studies have focused on exchanges between plants (Chertow and Park, 2016a; Kastner et al., 2015; Notarnicola et al., 2016) or companies (Dong et al., 2013), although some recent IS studies have moved toward examining flows inside the plants (Kuznetsova et al., 2016; Pan et al., 2016; Wu et al., 2016).

While there has been a trend in IS towards including data at plant and unit operation level, process integration studies are extending their scope to include data at the cluster level. For instance, Total Site Analysis (TSA) method has extended pinch methodology to involve several processes and centralized utility systems for energy exchange (Bagajewicz and Rodera, 2002, 2000; Becker and Maréchal, 2012; Hackl and Harvey, 2014, 2013; Mian et al., 2016b, 2016a). Similarities between TSA and IS are not limited to energy networks. Examples are already available on TSA studies focusing on the material (El-Halwagi, 2013) and water integration (Savulescu and Alva-Argaez, 2013). Considering plant-level details in IS assessment, there are indications of overlap between IS and process integration methods. Common elements in definitions and system boundaries have resulted in different understandings of IS potential.

The term potential has been used along with IS in the literature, but not with a unique interpretation. Bailey and Gadd (2015) aimed to quantify the potential of IS in the low-carbon industrial manufacturing parks (LOCIMAP) project. Although the findings of the research are notable, no clear definition of commercial and physical potential and its calculation method is presented. Notarnicola et al. (2016) have inventoried potential of available wastes and potential of produced new materials, without distinguishing which one is anticipated as IS potential. Holgado et al. (2018) also proposed a method which only identifies the potential receivers and donors for IS. The only explicit definition of industrial symbiosis potential is given by Chertow et al. (2019, p.1) as "the sum of the wastes and by-products from all of the industrial facilities in a defined area that could reasonably serve as resource inputs to other processes." Remembering that IS is an exchange among suppliers and consumers, this definition ignores the importance of the consumer side in the interaction. Herein the need for a potential definition and conceptualization emerges.

Here is also a question of how to assess IS potential in EICs while IS is not shaped yet. Chertow et al. (2019) have proposed an algorithm to determine IS potential in a city. The overall storyline of the algorithm is remarkable and is partly followed in this research. However, as they have obtained flow data from available databases, it is not clear how someone can investigate industrial units from scratch to determine IS potential. The possibility of development is not foreseen in the algorithm as well. UNIDO (2017) has also recommended guidelines for EIP implementation from managerial, social, and technical aspects, which is more theoretic rather than practical. On the other hand, as stated above, it is crucial to look into the difference between IS and process integration approaches while determining such potential. Therefore, there is a need for an adapted solution to assess IS potential in EICs by analysing flows at different levels.

Lack of knowledge in the definition and assessment method of IS potential prompted this study. Departing from the guidelines provided by UNIDO (2017) and Chertow et al. (2019) for IS assessment, this paper systematically explores the importance of system boundaries in IS potential. In this study, IS potential refers to the overlooked technically possible recovery and reuse of wastes from one plant as a resource to a neighbouring one in the EIC. The paper assesses the impact of plant-level details and cluster development approach on IS potential in EICs. The method is applied in the context of Iron and steel industry on the case of Persian Gulf Mining and Metals Special Economic Zone, Iran. The paper is structured as follows. Section 2.2 introduces the case study, section 2.3 describes the methods, and section 2.4 presents the results for each step of the research. Finally, Section 2.5 states the contribution of this research to the IS field and provides recommendations for future studies.

## 2.2 The case study

One of the growing industries in emerging economies is iron and steel, which is also among the most energy-intensive ones. This industry accounts for approximately 10% and 17% of industrial energy use in OECD and non-OECD countries, respectively (Conti et al., 2016). Steel production also results in a wide range of air pollutants, contaminated wastewater and solid wastes (SEAIISI, 2008; Villar et al., 2012). World crude steel production has increased by a factor of two over the last thirty years, driven by a steep increase in steel production in emerging economies and China (WSA, 2019). Economic pressure and the carbon tax on energy-intensive sectors in Europe has driven iron and steel industries to immigrate to less strictly regulated countries (Bailey and Gadd, 2015).

IS has been examined before in the steel industry dominated clusters. For instance, Ang et al. (2013) compared the total annual symbiotic material exchange and gained economic benefit from those exchanges in three iron and steel clusters in China and Japan. Yu et al. (2015) mapped an integrated steel mill from raw material to finished product. They analysed which IS connections can contribute to CO<sub>2</sub> emission reduction more effectively. Wu et al. (2016) investigated IS evolution in an iron and steel cluster in China from 1958 to 2012 and confirmed the contribution of symbiotic energy exchange to CO<sub>2</sub> emission mitigation. Pinto et al. (2019) revealed how collaboration between the steel plants and cities could contribute to sustainable urbanization. These studies have confirmed the economic and environmental benefits of IS in the steel industry.

With 24.5 million tonnes of crude steel production, Iran ranks 11<sup>th</sup> in world crude steel production (WSA, 2019). Moreover, there are plans to increase this capacity up to 55 million tonnes in the near future (SEAIISI, 2017) despite the current sanctions, water scarcity (Madani, 2014; Madani et al., 2016) and high CO<sub>2</sub> emissions in the country (Global Carbon Project, 2016). Literature has barely studied IS cases in Iran. We looked for academic papers that included Industrial Symbiosis and Iran in the title, abstract, or keywords resulted in only one article in which Vahidi et al. (2018) listed available solid wastes for exchange in Alborz industrial state through field study. No evidence was found for implementing the findings of that research. Publicly available governmental reports, as well as websites of Iran Small Industries and Industrial Parks Organization (ISIPO) and the Ministry of Industry, Mine, and Trade, were also checked and no institution was observed governing IS concept.

Here, PGSEZ was used as a case study to illustrate IS potential in EICs. PGSEZ was founded in 1998 to facilitate domestic and foreign investment in energy-intensive industries and turn

into a hub of steel, aluminium, mineral and oil products (PGSEZ, 2020) because of proximity to the South Pars, which is one of the largest natural gas reservoirs in the world (EIA, 2018). PGSEZ is one of the few clusters in Iran, in which several big metal processing industries are located. Besides, the researchers could gather original filed data from this cluster. The cluster has a governmental management team, which is under direct administration of the Iranian Mines and Mining Industries Development and Renovation Organization (IMIDRO). PGSEZ is located in the south of Iran, 14 kilometres west of Bandar Abbas. The area is approximately 5,000 hectares, 2,000 hectares of which are operational and another 3,000 hectares are under preparation for future development. For the location of the cluster and companies, refer to Appendix A. Currently, the cluster includes one aluminium production company (AAC), three steel production companies (HOS, SAB, and SKS), and a gas turbine power plant, recently commissioned. (PGSEZ, 2020). An under-construction pelletizing plant was not included in the existing structure of the cluster but taken into account as part of the development plan. Besides, two small zinc production and scrap melting companies, with the capacity of almost one-tenth of other companies, are also located in the cluster. Two companies, which operate independently and have no technical or managerial interaction with the other companies or cluster manager, are not included in this study.

MIDREX is a gas-based direct reduction technology to convert iron oxide into Direct Reduced Iron (DRI). Iran produces the highest amount of DRI through natural gas based MIDREX process worldwide (MIDREX, 2017). In a Steel Making Plant (SMP), DRI from Direct Reduction Plant (DRP) is melted with scrap in an Electric Arc Furnace (EAF), and then it is shaped in a continuous casting machine. 90% of Iran's crude steel is produced through this route (WSA, 2019), in HOS and SKS as well. SKS has another SMP under construction. SAB has one DRP, recently commissioned and planned to reach the design capacity by the end of 2020. AAC produces aluminium ingots in the Hall–Héroult process, which is the dominant industrial process for smelting aluminium. An anode baking plant provides the required anode for the smelting process. **Table 2.1** gives an overview of the companies, plants and their current capacities.

**Table 2.1** Companies and plants in the PGSEZ cluster and their operating capacities in 2018

Company	Plant	Operating Capacity
Kish South Kaveh Steel Company (SKS)	Direct Reduction Plant (DRP)	1,850,000 t/yr (skesco.ir/)
	Steelmaking Plant (SMP)	1,200,000 t/yr

Hormozgan Steel Complex (HOS)	Direct Reduction Plant (DRP)	1,650,000 t/yr (hosco.ir/)
	Steelmaking Plant (SMP)	1,500,000 t/yr
	Cold Briquetting Plant (CBP)	57,600 t/yr
Persian Gulf Saba Steel Company (SAB)	Direct Reduction Plant (DRP)	1,000,000 t/yr (sabasteel.co)
Almahdi Aluminium Complex (AAC)	Aluminium Refining Plant (ARP)	172,000 t/yr (almahdi.ir/)
	Anode Baking Plant (ABP)	93,000 t/yr
Hormoz Power Plant (HPP)	Gas turbine power plant (GPP)	160 MW (pgsez.ir/)

## 2.3 Materials and methods

A bottom-up approach was taken in this study. The method of the study is summarized in **Figure 2.1**. First, building blocks of the cluster were identified (Section 2.3.1), inputs and outputs in each block were specified and combined in a comprehensive cluster block diagram (Section 2.3.2), material and energy input-output diagram of the whole cluster was generated, and available sources and sinks were determined (Section 2.3.3). Then, in order to find higher quality or quantity of sources, waste streams were traced back at plant-level for processes such as cooling, separation, and mixing before disposal (Section 2.3.4). Finally, IS potential was estimated matching between sinks and sources (Section 2.3.5).

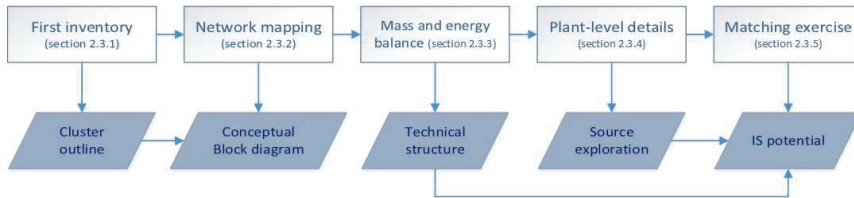
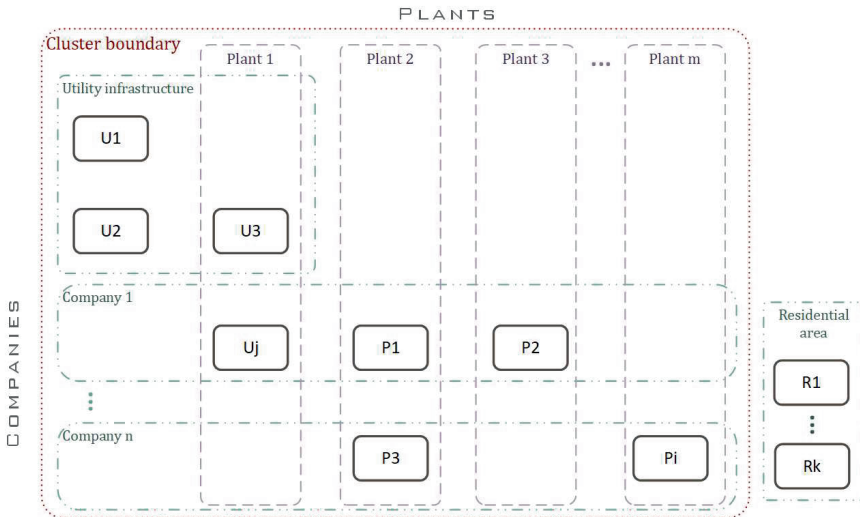

**Figure 2.1** Method of the study and outcomes of each step

The research was carried out in 2018 in Iran and the Netherlands. Field data was gathered through semi-structured interviews. Interviews were conducted in Farsi with the development and planning manager of the cluster and with operation managers of the plants. AAC management did not allow technical data gathering in the field, therefore only general characteristics were collected via interviews with the operation manager and energy manager of the plants. The electricity supply structure of the cluster was mapped according to the data collected during interviews and complemented with information from a study of the electricity network of the PGSEZ (Monenco group, 2017).

### 2.3.1 First Inventory

As stated in section 2.1, a cluster includes companies, which might have one or several production and utility plants. We considered production plants (P) and utility plants (U) as building blocks of the cluster. The list of active companies, production plants, and their operating capacities was obtained from the cluster and company websites, national reports, google maps, and catalogues. When daily capacity was available, the annual capacity was calculated based on the actual plant working days per year considering regular maintenance and unforeseen interruptions. Since energy supply to residential areas is also one of the proven successful forms of IS (e.g., Bechara et al., 2008; Jacobsen, 2006; Korhonen and Snäkin, 2005), the population of neighboring residential areas (R) were also gathered from official reports. This information was verified, and complemented through site visits and semi-structured interviews (spring and summer 2018). Then, we mapped all building blocks together to create the cluster outline as schematically illustrated in **Figure 2.2**. Cluster, company, and utility infrastructure boundaries are shown in this outline. Production and utility plants inside each company are displayed as boxed named  $P_i$  or  $U_j$ . To make the outline more structured, similar plants in different companies are shown below each other. Residential areas are outside the cluster boundaries.



**Figure 2.2** Schematic diagram for a cluster outline showing cluster boundaries, companies, plants, and residential areas

### 2.3.2 Network Mapping

Once the building blocks of the cluster were identified, material and energy flows to and from each block were investigated to generate plant input-output diagrams. Flows were grouped into three main categories: material, energy, and water (Kastner et al., 2015). When a stream mattered both in mass and energy balance, its energy, and material content were considered as two separate flows. Electricity (EL), fossil fuels (FF), and waste heat (WH) were assumed as energy flows while non-energy-carrier streams were regarded as material flows (Kuznetsova et al., 2016). Waste heat was defined as unintended rejected heat from the plant (Brückner et al., 2015; Oluleye et al., 2016) and classified to three temperature levels: low-grade heat (less than 100 °C), medium-grade heat (100-400 °C) and high-grade heat (more than 400 °C). As heat recovery from solid materials is not technically easy, only waste heat from liquid and gas streams was taken into account in this paper.

Besides the main product, a plant can generate co-products (with an economic value close to the main product), by-products (lower economic value), and waste (little or zero economic value) (Horne and Matthews, 2004). The definition of co-product, by-product, and waste is based on their value for the plant, which might vary in different organizations or countries (Kuznetsova et al., 2016). Therefore, we have included them all under the category of by-products to refer to the material outflows, which are not the primary aim of the production plant. Thus, feedstock, main product, and by-product shaped three categories of material flow in this study.

Materials with a flow rate lower than 1% (compared to the main product) were ignored unless literature or field investigation indicated the presence of hazardous or valuable components in it. In the case study, water is used only as a cooling fluid, not as feedstock to the processes. Based on the water specification, we identified three categories of water: seawater (SW) taken from the Gulf to the RO plants, industrial water (IW) used in the cooling systems, and concentrated water (CW) discharged from RO or production plants to the Gulf.

Finally, an input-output diagram for each building block of the cluster was generated and flows between the blocks were mapped. The resulting diagram is referred to as the conceptual block diagram of the cluster. Material, energy, and water flows were depicted with different colours and named as M-i, E-j and W-k respectively where i, j, and k starts from 1. Code, description, network, category, temperature range (for waste heat), origin, and destination of each flow were recorded as well. In this case, the origin or destination of each flow was identified as market,

sea, air, waste disposal or other plants in the cluster. A data set of all flows' characteristics was generated for further analysis.

## 2.3.3 Material and energy balance

### 2.3.3.1 Data gathering

One of the prominent difficulties in data gathering for IS is that flow rates of waste energy and materials are not usually measured or recorded as they are not essential for the plant. **Figure 2.3** shows the data gathering and verification procedure of this research. To gather actual operating data of the plants, interviews with the management of different plants were conducted. The block diagrams of each plant were given to the interviewees to provide flow data based on the operational condition of each plant. In parallel, available official reports, plant design data, operation data of plants with similar technology, and academic literature were also reviewed. If the required data was not obtainable from these sources, it was calculated or estimated based on available information. Wherever possible, gathered data from different sources were compared for verification purposes.

### 2.3.3.2 Calculation

In this step, the annual rate of all listed flows was calculated based on gathered field data. When needed, the thermodynamic properties of the substances were used (Green and Perry, 2008). If only a range for temperature or flowrate was available, the mean was assumed. If gathered field data was not sufficient to calculate the energy content of a flow, it was estimated based on literature or average world data for similar plants. Field data tables in Appendix D give more details on each flow.

All energy flows were calculated in MW. Waste stream temperature in each plant was obtained from field data and compared with literature for verification. Theoretically, available heat of waste streams, regardless of technical limitations, was calculated using the average temperature and flow rate. When such data was not available, waste heat was estimated based on plant efficiency or literature. Once all energy flows were estimated, all supplied electricity and fossil fuel from the market to the cluster were summed up to obtain the total energy input. The energy outputs from the cluster to the market or the environment were in the form of either electricity or waste heat. Total theoretical waste heat in each temperature level was calculated separately.

The annual material flow rates were calculated in tonnes. The ratio of feedstock or by-product to the main product was obtained from the field data. When actual field data was not available, the ratios were estimated based on literature. By multiplying the ratios with the yearly

production rates, the annual tonnages were estimated for each material flow in the data set. Overall material balance calculations were conducted to check the inputs and outputs of each plant. Calculated annual flow rates were listed in the data set as well. Materials with similar properties were added together. Material inputs were defined as the flows originating outside the cluster. The outputs not supplied to the market were considered as available sources for material exchange.

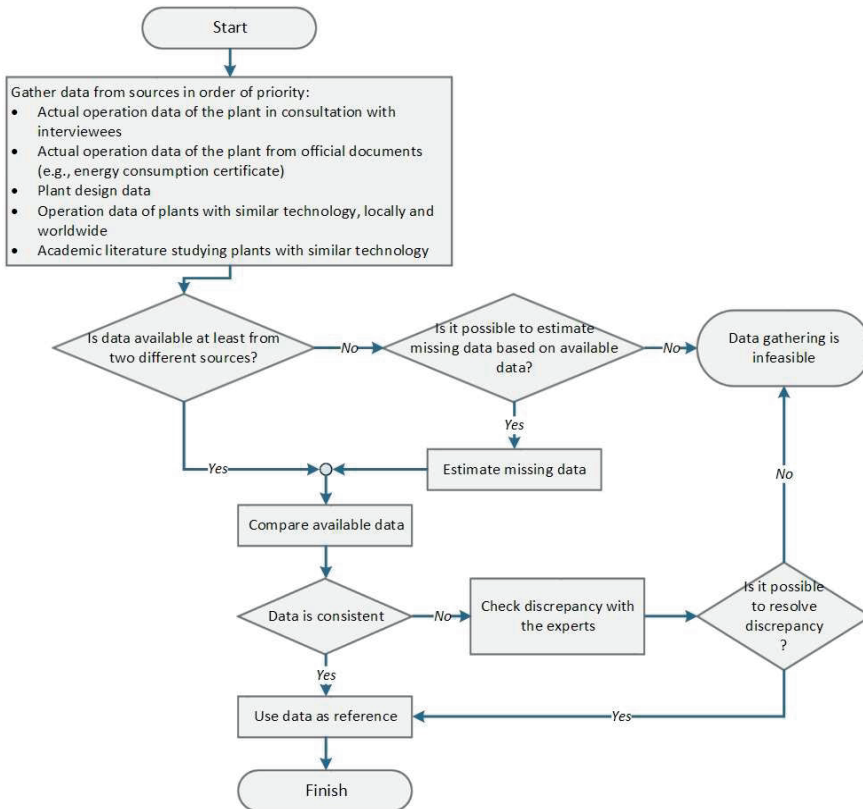

**Figure 2.3** Flow data gathering and verification procedure of the research

### 2.3.4 Plant level assessment

In preceding steps, a cluster technical structure has been generated to identify waste material and energy flows that were not utilized inside the cluster. Those streams were the sources for IS. Any processing on the waste flows before disposal was investigated to understand whether

considering plant-level details affects the IS potential. For instance, if flue gases were cooled down before exhaust because of environmental limitations. If so, we calculated the energy content of the waste flow before processing to check if a higher source for exchange is available. For this purpose, plant-level block diagrams, including unit operations, were generated. Waste material and energy flows were traced back among unit operations, particularly for processes such as mixing, splitting and cooling taking place before releasing the flow into the environment. When field data was not available, temperatures and flow rates were estimated based on the literature. Then, available IS sources were estimated and compared with those obtained in section 2.3.3 to understand how moving the system boundaries affects the IS potential.

### 2.3.5 Matching exercise

Waste recovery matters only if there is a consumer for it (Bailey and Gadd, 2015). As explained at the beginning of section 2.3.2.3, the potential consumer is referred to as a sink in this paper. In this stage, we looked for the sinks in the literature, regardless of whether the consumer already exists in the EIC. Afterward, a matching exercise between sources and sinks, inside and outside the cluster boundaries, was conducted. Like the other sections, energy and material flows were studied separately for simplicity purposes.

#### 2.3.5.1 Energy exchange

Energy exchange potential is part of theoretically available waste heat, which is recoverable according to technology and demand limitations (Brückner et al., 2015). A wide range of technologies is offered in literature to recover waste heat in the form of power, heating, or cooling (Huang et al., 2017; Jouhara et al., 2018; Oluleye et al., 2016, 2015; Reddy, 2013). The real performance of Waste Heat Recovery (WHR) technology is the ratio of useful output to input waste heat and work (Brückner et al., 2015), which depends on the source and sink temperature. Oluleye et al. (2017) evaluated the deviation of real performance from the ideal performance for six common industrial WHR technologies and developed a selection framework based on waste heat temperature for temperatures lower than 265 °C. Other studies suggest heat recovery via a heat exchanger or power generation from high-grade waste heat (Huang et al., 2017; Jouhara et al., 2018; Reddy, 2013). In this paper, the framework by Oluleye et al. (2017) was adopted to select the most suitable technology. Accordingly, technologies in each temperature range are ranked by numbers in Appendix B. More technologies are available to recover energy from medium-grade waste heat.

To identify suitable types of technologies, we looked first at whether current energy flows could be replaced with recovered energy from waste heat. Then using the quantity and temperature of available waste heat, a suitable technology was selected from Appendix B considering the source temperature and demand type. The energy exchange potential was estimated by multiplying the performance of technology (from literature) with the amount of available waste heat. Then, we estimated the energy exchange potential of each waste flow through first ranked technology to examine how cluster demand affects IS potential.

### **2.3.5.2 Material exchange**

Material exchange potential is defined here as the part of available by-products which can be recovered to be used as feedstock for other plants. Once the list of unused by-products was generated, literature was reviewed to find potential applications for each by-product. Possibilities for material use were not as broad as energy. We listed the plants that can utilize by-products as feedstock and categorized them into existing and new plants. Material exchange potential among existing plants in the cluster and with other probable plants was estimated and compared.

## **2.4 Results**

### **2.4.1 Cluster outline**

During the first inventory, production plants in each company; water, and electricity supply plants; operation capacity of the plants; and neighbouring residential areas were identified. Water is supplied to the cluster through three water intake units alongside the sea that are utilized by PGM, HOS, and SKS. Seawater is then treated in RO desalination plants. Natural Gas (NG) and electricity are the current main energy sources in the cluster. NG is supplied to PGSEZ via pipeline from the South Pars field. The only power plant within the cluster boundaries is a 160 MW gas turbine power plant. The cluster purchases excess electricity demand from the grid. A 400/230 kV sub-station connects HOS, SKS, and SAB to the grid. Electricity to AAC is supplied from the Hormozgan power plant directly. The residential areas just outside the cluster boundaries have 1,350 households. Furthermore, 177,000 households are in Bandar Abbas (within a 14-kilometer distance from the cluster).

### **2.4.2 Conceptual block diagram**

The cluster block diagram with all input and output flows is presented in **Figure 2.4**. This block diagram reveals the existing connections within and between the plants as well as unutilized material, energy, and water streams. Three steel companies collaborate with the cluster

management for water and energy supply. AAC did not collaborate with the cluster management or the other companies. There was only one by-product exchange between HOS and SKS, and one water exchange connection between SKS and SAB, both intermittent. Site investigation identified an extra capacity of around 5,000 tonnes per year for HOS CBP. SKS has used this capacity to convert part of its produced DRI dust to cold briquette iron. There is also a pipeline connecting SAB to the SKS desalination plant to supply water from SKS in case of emergency. Inside the companies, two by-product recycling were identified. In HOS, produced dust in DRP was reused as feedstock to CBP. In AAC, unused anode butt was sent back to ABP for reuse. Furthermore, there was no connection between the cluster and residential areas. Regarding emissions, stack gases from different plants were emitted to the air, concentrated water from desalination and production plants were sent back to the sea, and solid by-products were dumped in open areas inside the cluster.

### 2.4.3 Technical structure

Annual flow rates of all feedstock, main products, and by-products of the cluster are presented in **Figure 2.5 (a)**. From the total material input going into the cluster, 50% was converted to main products, 33% was wasted in the form of gaseous products and 17% as solid by-products. The main material inputs to the cluster were iron oxide pellet, natural gas, alumina, lime, and ferroalloys. Billet, slab, hot briquette iron and aluminium ingot were the main products of the cluster. Gaseous by-products were generated mainly because of reduction processes. Roughly, 1.35 Mt of solid by-products were generated in the cluster, half of which was EAF slag. The other solid by-products were iron oxide dust (16%), CCM scale (14%), DRI dust (10%), EAF dust (2%), CCM losses (4%), and SPL (less than 1%).

Energy inputs to the cluster were electricity, natural gas, and coke. Waste energy flows were categorized according to their temperature level. **Figure 2.5 (b)** depicts the energy input-output of the cluster. From almost 1,410 MW energy input to the cluster in the form of electricity or natural gas, 578 MW was wasted in the flue gases. The recently commissioned gas turbine power plant lost 330 MW as high-grade waste heat. Exhaust gases from MIDREX, anode baking, and Hall-Heroult processes contained about 208 MW medium-grade waste heat. Steelmaking flue gas carried only 40 MW low-grade waste heat because hot gases generated in the melting unit were cooled down and mixed with low-temperature gases before being emitted into the atmosphere. The remaining 832 MW of input energy was consumed for plant energy demand or unknown wastes.

As stated in section 2.3.2, in PGSEZ, water was used only for cooling and scrubbing in the plant, not as reactant or feedstock. Therefore, the water network was investigated only for utility sharing opportunities. As illustrated in **Figure 2.5** (c), the cluster consumed about 7.8 million m<sup>3</sup> of IW per year as make-up water to compensate evaporation losses in cooling towers, blow-down, and other losses in the water circulation systems from which 1.7 Mm<sup>3</sup> was supplied to SAB directly from the regional water company. To produce remained IW, RO plants required 21.9 Mm<sup>3</sup> SW from the Gulf yearly. The RO plants recover only around 30 to 35 % of intake SW. 14.9 Mm<sup>3</sup> CW from RO plants plus 3.3 Mm<sup>3</sup> CW from water circulating systems was discharged back to the Gulf. Note that neither the cluster management nor the individual plants had installed industrial water treatment systems to recover and reuse it. SKS has installed a wastewater treatment plant project, which is currently in its last stage of construction. A comparison of the installed capacity with the demand showed that SKS and HOS had extra desalination capacity. The total installed capacity of the RO units was 14.4 million m<sup>3</sup> of IW per year. It means that in full capacity these units can release more than 30 million m<sup>3</sup> of CW to the Gulf each year. CW contains chemicals added to the water during the treatment process, but there was no monitoring of the quality of water disposed to the sea.

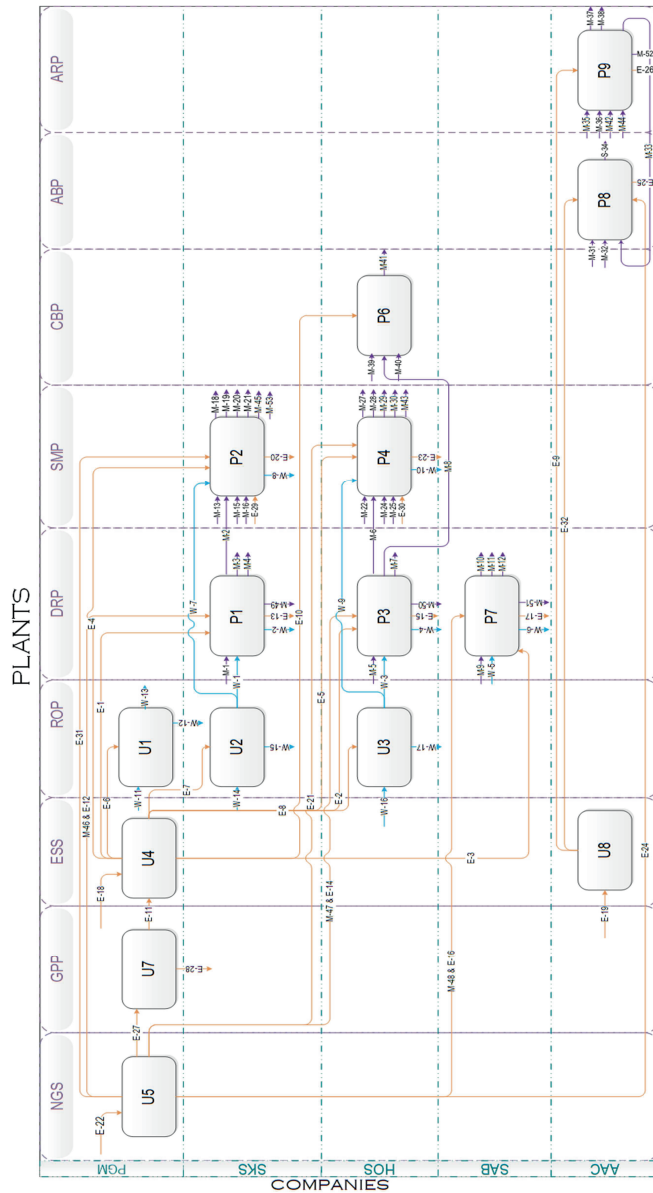

Figure 2.4 PGSEZ block diagram including companies, plants, and material, energy, and water flows to and from each plant

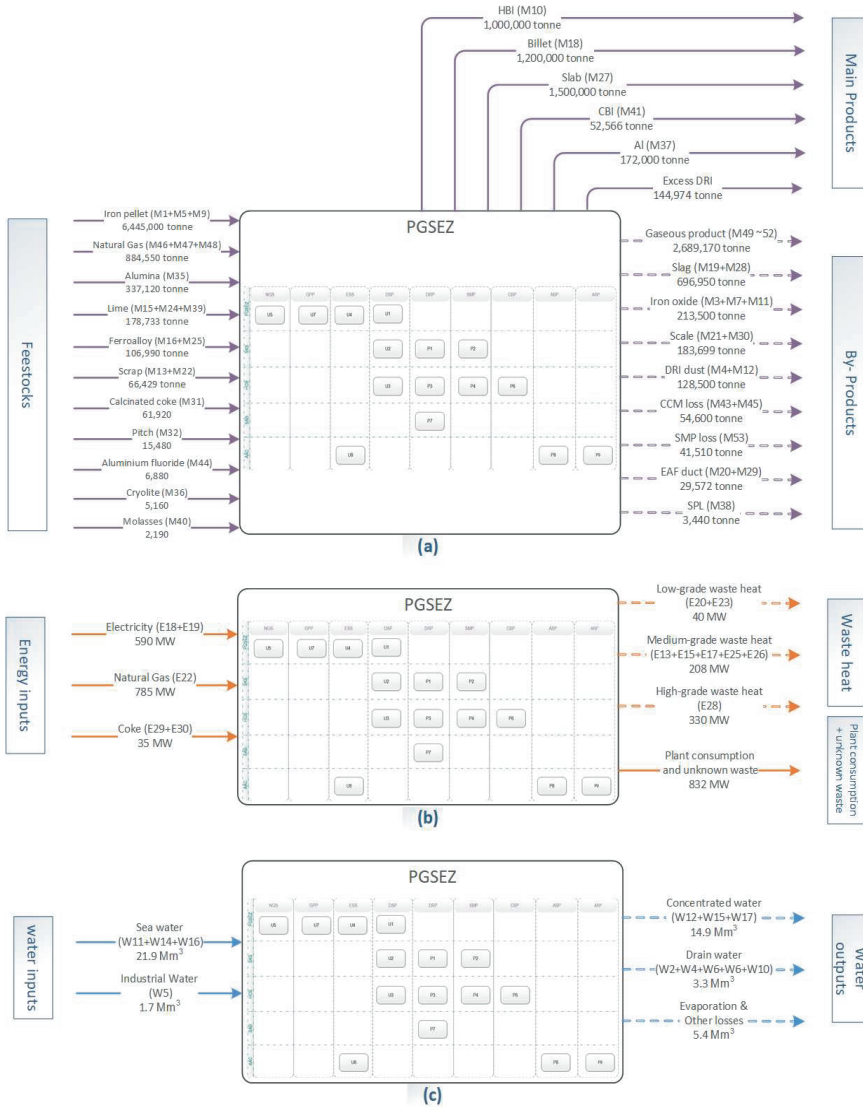

Figure 2.5 (a) Material input-output, (b) Energy input-output and, (c) Water input-output of the PGSEZ cluster

## 2.4.4 Source exploration

For simplicity purposes, we performed this step only for SMP and DRP to investigate the influence of considering plant-level details to estimate the IS potential.

### 2.4.4.1 Steelmaking plant

A plant-level block diagram of SMP (P2 and P4), including unit operations and material, energy, and water flows between them is presented in Appendix C. Flue gas from the melting unit goes through a gas treatment unit before it is emitted from the stack. In the gas treatment unit, the EAF flue gas, with an average temperature around 1100 °C (Kirschen et al., 2001; Pfeifer et al., 2005), is cooled down, mixed with collected dusty air from melting hall, and then filtered to remove dust. Literature indicates that, depending on the operating condition, 15 to 35 % of the energy input to an EAF is lost in the flue gas (Barati, 2010; Kirschen et al., 2011a; H. Wang et al., 2016). This would mean that flue gas from P2 & P4 carries 85 MW high-grade energy before the gas treatment unit while 40 MW low-grade waste heat was estimated in this paper at plant outputs (when the plant is assessed as a black box). In modern steelmaking processes, hot flue gas stream preheats the scrap before charging to EAF (Toulouevski and Zinurov, 2017; Villar et al., 2012). This energy can also be utilized for other purposes such as input in waste heat boilers (Steinparzer et al., 2012). The plant-level block diagram showed no mixing, splitting, purifying, or other operations on the by-products before disposal; therefore, in this case, the sources of IS for material exchange did not change by the plant-level investigation.

### 2.4.4.2 Direct reduction plant

A plant-level block diagram of the DRP was generated based on literature (Atsushi et al., 2010; Sarkar et al., 2018) and interviews to track waste energy and by-product flow inside the plant (

Appendix C). This diagram revealed that combustion flue gas is currently mixed with ambient air before going to the stack. Therefore, heat could in fact be recovered from the flue gas at a higher temperature before mixing. This temperature was around 450 °C according to the field data. Utilizing the waste heat flow for IS before mixing offers 130 MW high-grade waste heat from P1, P3, and P7 instead of 130 MW medium-grade waste heat which was observed in section 2.4.3. No change in available by-products from DRP was recorded by investigating plant-level block diagram. **Figure 2.6** compares the theoretically available waste heat for symbiotic exchange obtained from two approaches: the traditional input-output approach and studying plant-level details. Including plant-level details results in an increase of both the quality and quantity of available energy for exchange.

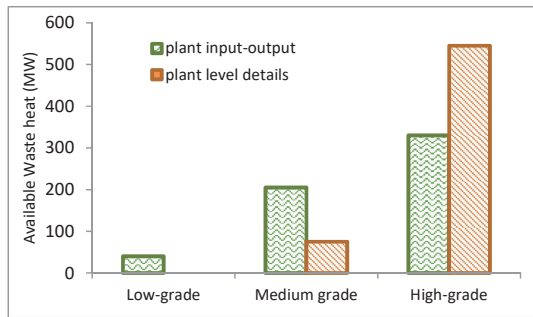

**Figure 2.6** Comparison of total available waste heat with different approaches to flows in SMP and DRP

## 2.4.5 IS Potential

### 2.4.5.1 Energy exchange

Waste energy can be recovered in the form of power, heating, or cooling. Energy exchange potential depends on the demanded energy form by the consumers and the efficiency of used WHR technology. For instance, Organic Rankine Cycle (ORC) is a choice for electricity recovery for heat source temperature up to 340 °C with efficiencies of around 10% at 90°C, 17% at 150 °C, and 27% at 300°C (Oluleye et al., 2016).

Energy exchange potential of each waste flow was estimated first, considering current cluster demands then, based on the first ranked technology from Appendix B. The results are compared in **Table 2.2**. No domestic heating or cooling was anticipated in the existing structure of the cluster. Therefore, for cluster demand, we assumed energy recovery in the form of electricity,

resulting in 157 MW power from plant output waste flows or 187 MW power considering plant-level details.

As per Appendix B, regardless of cluster demand limitations, the first ranked WHR technology for waste heats from 70 to 180 °C is the absorption chiller. Energy recovery in the form of cooling was not suggested for waste heat at higher than 180 °C due to working fluid limitations (Oluleye et al., 2017). A wide range of heat exchangers such as Heat Recovery Steam Generator (HRSG), economizer, plate heat exchanger, and boiler are available for energy recovery in the form of heating (Huang et al., 2017; Jouhara et al., 2018; Reddy, 2013). We assumed an average efficiency of 80% for heat exchangers (Jouhara et al., 2018). As per calculations in **Table 2.2**, the first ranked technologies could recover 118 MW cooling plus 368 MW heating from plant output waste flows or 90 MW cooling plus 436 MW heating taking into account plant-level details. These estimations, although rough, give an overview of energy exchange potential without requiring detailed engineering calculations. For instance, the average household electricity consumption in Iran is about 3,000 kWh per year (Enerdata, 2014), 30% of which is used for cooling (Moradi et al., 2013). Bandar Abbas with 177,000 households (Statistical Centre of Iran, 2018) has around 17.7 MW cooling demand which could be obtained from low-grade waste heat from PGSEZ.

**Table 2.2** Comparison of energy recovery potential of waste heat streams considering cluster demand and first ranked technology

	Available waste heat (MW)	Temperature (°C)	Energy exchange potential (MW)			
			Cluster demand		1 <sup>st</sup> ranked technology	
			Amount	Form	Amount	Form
Plant input-output	40	90	4 <sup>(1)</sup>	electricity	28 <sup>(2)</sup>	cooling
	75	150	13 <sup>(3)</sup>	electricity	90 <sup>(4)</sup>	cooling
	130	300	35 <sup>(5)</sup>	electricity	104 <sup>(7)</sup>	heating
	330	500	106 <sup>(6)</sup>	electricity	264 <sup>(7)</sup>	heating
Plant-level details	75	150	13 <sup>(3)</sup>	electricity	90 <sup>(4)</sup>	cooling
	130	450	42 <sup>(6)</sup>	electricity	104 <sup>(7)</sup>	heating
	330	500	106 <sup>(6)</sup>	electricity	264 <sup>(7)</sup>	heating
	85	1100	27 <sup>(6)</sup>	electricity	68 <sup>(7)</sup>	heating
<ol style="list-style-type: none"> <li>ORC efficiency for low-temperature input heat was assumed 10% (Oluleye et al., 2016)</li> <li>Single-stage absorption chiller COP was assumed 0.7 (Reddy, 2013)</li> <li>ORC efficiency was assumed 17% (Oluleye et al., 2016)</li> </ol>						

4. Double stage absorption chiller COP was assumed 1.2 (Reddy, 2013)
5. ORC efficiency was assumed 27% (Oluleye et al., 2016)
6. The efficiency of the HRSG plus steam turbine is assumed 32% (Ahmed et al., 2018).
7. The average efficiency of heat recovery heat exchangers was considered 80% (Jouhara et al., 2018)

#### 2.4.5.2 Material exchange

Recovery potentials of each by-product are summarized in **Table 2.3**. Possible applications in the current structure of the cluster are indicated in a separate column. The results show limited potential for material recovery inside the cluster. Recycling CCM losses in EAF does not fall in IS exchange as it occurs within the same plant. Processing DRI dust in existing cold briquetting is limited since HOS has only ten percent extra capacity. Therefore, the only material exchange potential among existing plants is to recover iron oxide sludge as feedstock to the pelletizing plant, which is under construction now.

The last column in **Table 2.3** shows other type of industrial plants that theoretically could use by-products generated in the cluster. EAF slag is composed of FeOx, Al<sub>2</sub>O<sub>3</sub>, CaO, SiO<sub>2</sub>, and MgO. It may also contain phosphorus, chromium, and zinc oxides. Depending on the composition, EAF slag could be used in the asphalt mix (Skaf et al., 2017), or construction material (Márkus and Grega, 2007). EAF dust contains Fe, Zn, Mg, Mn, Si, and Pb (Yu et al., 2011). Dust with high zinc content is categorized in hazardous wastes (De Araújo and Schalch, 2014) and requires zinc removal before reuse (Lobato et al., 2015). Various treatment methods have been examined for this purpose (Hui-gang Wang et al., 2016; Yu et al., 2011). Literature shows the use of low zinc content dust in red ceramic (Vieira et al., 2013), glass-ceramic (Nazari et al., 2018), and cement mixture (Alsheyab and Khedaywi, 2013). CCM scale is generated as a result of oxidation of steel surface during continues casting (Lobato et al., 2015). These oxides could be reduced by carbon (Martín et al., 2009) or hydrogen (Azad, 2006). SPL (Spent Pot Lining) is generated through the replacement of aluminium smelting cell cathodes (Birry et al., 2016). SPL contains leachable fluoride and cyanide compounds, thus categorized as hazardous waste (Breault et al., 2011).

**Table 2.3** Material recovery potential inside and outside PGSEZ boundaries

Type	Approx. production (t/year)	SINKS	
		Inside cluster boundaries	Outside cluster boundaries
EAF slag	697,000	----	Asphalt (Skaf et al., 2017) Construction (Márkus and Grega, 2007)
EAF dust	30,000	----	Zinc recovery (Hui-gang Wang et al., 2016; Yu et al., 2011) Glass-ceramic (Lobato et al., 2015; Nazari et al., 2018), Red ceramic (Vieira et al., 2013)
CCM scale	80,000	----	Reduction by hydrogen (Azad, 2006) reduction by carbon (Martín et al., 2009)
CCM losses	200,000	Recycle in EAF	----
SPL	3,440	Steelmaking (Meirelles et al., 2014; Parhi, 2014)	Cement (Parhi, 2014; Personnet, 2013) Red brick (Mikša et al., 2003)
Iron oxide sludge	213,000	Pelletizing	----
DRI dust	128,000	----	Cold briquetting

This approach can improve IS opportunities in the future development of the cluster through diversity. The role of diversity in IS collaboration has been acknowledged in the literature as well. Van Berkel (2006) recognized diversity, not only in input and output flows but also in actors and their interdependencies, as a cornerstone to apply natural ecosystem principals into industrial ecosystems. Bailey and Gadd (2015) argued that stable and effective IS shapes among diverse industries. This study showed in a real case that restricting IS studies to the demand inside the cluster diminishes the IS potential while having a development approach to the cluster results in larger potentials.

An important challenge in IS research is data availability as IS looks for unutilized by-products and waste energy in the cluster while these flows are generally not monitored or even measured in many plants as they are considered of less importance for plant operation. This study shows the importance of monitoring waste flows within the plant boundaries as this results in larger IS potentials. The IS potential gives an overview of type and quantity of generated by-products and their possible application in other plants. Detailed engineering and economic analysis can

then be used to select the proper recovery method. This shows a strong need for collaboration between IS researchers and plant designers.

It should, however, be noted that collaboration between industries for symbiotic exchange is entwined with social interactions. The successful emergence of IS in a cluster needs both opportunities for material and energy exchange as well as opportunities for collaboration. Technically possible symbiotic exchanges will in fact be sustained by institutional capacity (Tudor et al., 2007), economic drivers (Roberts, 2004) and social connections between the entities (Yu et al., 2014b). Understanding the social structure of EICs is needed to reveal economic and institutional drivers and barriers for IS implementation. As this study focused on the technical potential in IS, those aspects were not considered in this analysis. Further research is, therefore, needed to investigate the social potential of IS. Assessing technical and social aspects together will lead to a better understanding of IS contribution to sustainable industrial development.

## 2.5 Conclusions

This paper assessed IS potential in EICs. It presented a systematic method to identify IS potential by developing the conceptual block diagram and analyzing the flows at different levels. Then, examined it in a case study: The Persian Gulf mining and metal industries special economic zone, Iran. Implementation of the method in the case study verifies its applicability. Moreover, as literature has rarely investigated IS cases in the Middle East, this study provides insight for future regional comparative studies. The paper adds value to the fields of process integration and IS by addressing the overlap between them and presenting the benefits of combining two approaches. Method transparency makes the research reproducible in other cases.

The key knowledge gap leading this research was the current ambiguity in IS potential and the way it is assessed in the literature. This paper showed that considering the plant as a black box and only studying its input-output flows results in an underestimation of energy exchange sources and a lower IS potential. By investigating the flows between unit operations inside steelmaking and direct reduction plants, IS could make use of the energy content of the flue gases before cooling due to environmental regulations, which could result in not only an 8% increase in the amount of available waste heat but also shifting its quality toward high-grade waste heat. Contrary to energy flows, the plant-level assessment did not change the amount and quality of available material flows for exchange in this case study.

Examining waste recovery possibilities outside the cluster boundaries offered a higher IS potential. Although all available waste heat could be recovered to meet part of electricity demand inside the cluster, this is not the most efficient way of energy recovery. For instance, low-grade waste heat from industry could be utilized for residential cooling in hot regions. In the case study, waste heat could be used to satisfy 118 MW cooling plus 368 MW heating. A similar conclusion applies to available waste heat from the plant-level assessment.

In the clusters dominated by a particular industry, IS potential is restricted due to limited types of inflow and outflow. In this cluster, less than 20% of generated by-products are recoverable in existing plants. When examining possibilities outside the cluster, additional opportunities for material recovery were found. For example, by-products of this steel-dominated cluster could be used in cement, brick, and ceramic plants. These results show that IS approach provides new insights for EIC development policies by introducing new plants, which can utilize waste flows generated in the existing plant.



# 3 Institutional Lens upon Industrial Symbiosis Dynamics<sup>2</sup>

## ABSTRACT

Industrial Symbiosis (IS) is a collaboration between nearby industrial plants to exchange waste material and energy and achieve economic and environmental benefits that cannot be obtained individually. IS emergence in a cluster requires both technical potentials for material and energy exchange and social readiness for collaboration. In this paper, to gain insight into IS dynamics in emerging industrial clusters; we investigate shared concepts governing actors' behavior in the form of rules and regulations, and social norms and practices. We implemented the IS dynamics framework to reveal which dynamics are supported either by the legislation or actors' preferences. The Persian Gulf Mining and Metal Industries Special Economic Zone in Iran is used as a case study. The case study revealed that previous successful collaborations in the cluster were often self-organized, but stakeholders preferred to initiate new IS collaborations if financial incentives and infrastructure are provided. Meanwhile, the institutional analysis showed that institutional arrangements (e.g., pricing and penalties) are not in favor of IS emergence. Even though stakeholders might engage in self-organized IS because of inherent problems such as resource scarcity, the lack of clear and effective institutions could hinder IS. This understanding can help both the government and stakeholders in their strategies for future collaborations under different economic and environmental policies.

---

<sup>2</sup> This chapter has been published as Noori, S.; Korevaar, G.; Ramirez Ramirez, A. Institutional Lens upon Industrial Symbiosis Dynamics: The case of Persian Gulf Mining and Metal Industries Special Economic Zone. *Sustainability* 2020, 12, 6192. <https://doi.org/10.3390/su12156192>

### 3.1 Introduction

Industrial systems are not only embedded in natural ecosystems (Graedel, 1996), but are also entwined with human society, shaping social construction (Cohen-Rosenthal, 2000). In Industrial Symbiosis (IS), this becomes more notable as stakeholders' behavior is affected by other stakeholders in the network, as well as social norms and practices (Ashton and Bain, 2012). Industrial Symbiosis is a collaborative relationship in which two or more nearby industrial plants exchange co-products, by-products, waste material, or waste energy to achieve economic and environmental benefits that cannot be obtained individually (Kokoulina et al., 2019). IS emergence is a phase of IS evolution in which stakeholders become aware of IS opportunities, explore new connections, and look for potential partners to build symbiotic relationships (Mortensen and Kørnøv, 2019). The successful IS emergence in a cluster needs both opportunities for material and energy exchange as well as opportunities for collaboration.

All IS practices have not emerged through the same evolution pathways. In this study, we call these evolution pathways dynamics. In general, IS dynamics could be categorized into self-organized, facilitated, and planned. Self-organized IS is initiated by involved stakeholders themselves, while planned IS is regulated by governmental or regional development policies. Facilitated IS is coordinated and administered by a third party (Kokoulina et al., 2019). Boons et al. developed a more detailed approach to IS evolution pathways and recognized seven IS dynamics worldwide, characterized by initial stakeholders, their motivations, and events leading to IS contact. In this framework, IS initiated by industrial stakeholders could lead to self-organization or organizational boundary change dynamics. Facilitated IS passes through brokerage, collective learning, or pilot facilitation and dissemination dynamics. Finally, planned IS is classified into government planning and eco-cluster development dynamics (Boons et al., 2016). Later, Sun et al. (Sun et al., 2017) defined anchoring activities to refer to the effort of local stakeholders creating favorable technical and institutional conditions for IS emergence. In this study, we considered anchoring as an eighth dynamics mainly to address physical and social facilitation in the cluster.

An Emerging Industrial Cluster (EIC) is a cluster in the first stages of development, while expected to expand rapidly (Teräs, 2011). EICs play a significant role in the industrialization of developing countries. Existence of technical potential for symbiotic exchange in an EIC does not result in a unique IS dynamic, since institutional and geographical conditions play an influential role in IS emergence (Mortensen and Kørnøv, 2019). Institutions are “shared concepts used by humans in repetitive situations” (Crawford and Ostrom, 1995, p.23). Laws and regulations are very important to promote or hinder industrial symbiosis emergence

(Kokoulina et al., 2019). Recent studies have aimed to examine the role of institutions in IS emergence. In extensive research, to investigate the development of IS networks in seven existing IS examples, Mileva-Boshkoska et al. (Mileva-Boshkoska et al., 2018) have studied institutions within a multi-attribute decision-making model, along with non-social aspects. Fraccascia et al. have confirmed that policy measures such as economic subsidy and landfill tax support the emergence of self-organized IS. Some other researchers focused on the role of national institutional arrangements in IS development. For instance, the weakness or geographic variation of financial incentives, and legislative problems are also recognized as essential IS development barriers in Europe (Domenech et al., 2019). In the Finnish legislation system, there is a need for an innovative by-product assessment procedure (Pajunen et al., 2013) while the National Industrial Symbiosis Program (NISP) in the UK promotes IS through institutional capacity building (Abreu and Ceglia, 2018). However, as various interpretations of IS in different countries exist as a result of diversity in economic and legal systems (Boons et al., 2016), there is a need for a systematic institutional analysis in the IS field to understand how institutions could lead to different IS dynamics.

IS emerges in a cluster as a consequence of particular interactions at the network level such as orientation, feasible study, planning, and implementation (Boons et al., 2014). These pre-emergence interactions create common ground among stakeholders (Spekkink and Boons, 2016) and improve relational, knowledge, and mobilization capacity of the cluster (Boons et al., 2014). As the interaction proceeds, trust and shared vision are created between the organizations (Doménech and Davies, 2011). In a supplier–buyer relationship, interactions such as joint efforts and dedicated investments tighten the relationship between the stakeholders (Nyaga et al., 2010). Intentional pre-emergence network development provides a platform for IS emergence (Paquin and Howard-Grenville, 2012). Frequent interaction, tacit knowledge exchange, and shared culture among the organizations provide favorable conditions for IS emergence. (Doménech and Davies, 2011) These studies emphasize the role of pre-emergence collaborations in IS, but it is not clear if such collaborations could promote a particular IS dynamics in the future development of EICs.

According to Beckert's social field theory, social networks, institutions, and cognitive frames are three social forces that shape socially embedded markets (Beckert, 2009). While many previous studies investigated existing IS networks, this research focuses on emerging industrial clusters (EICs) in which IS is not shaped yet. We adopt the IS dynamics framework by Boons et al. to investigate social forces shaping IS relationships in the form of pre-emergence collaborations, institutions guiding those collaborations, and capture stakeholders' motivation to engage in IS. Assuming that the technical potential for symbiotic exchange already exists in

an EIC (Chapter 2), we aim to understand which IS dynamic could be expected to emerge. For this purpose, previous collaborations in an EIC and the structure of successful ones are studied through a questionnaire to all stakeholders. Then, the same group of stakeholders are asked under which conditions they will engage in IS collaboration. In parallel, regional and national regulations governing industrial activities are investigated by systematically analyzing a selection of laws and regulations (e.g., environmental regulations and energy prices). Finally, we examine which IS dynamic is more likely to emerge by comparing the outcomes of the previous three steps in the IS dynamics framework. We employ the Persian Gulf Mining and Metals Special Economic Zone, Iran as a case study of an emerging industrial cluster. The paper holds six sections. Section 3.2 explains the theoretical background, section 3.3 briefly introduces the case study, section 3.4 describes the methods, and section 3.5 presents the results. Section 3.6 states the contribution of this work to IS social studies.

## 3.2 Theoretical Background

### 3.2.1 IS drivers

Even though the availability of matching waste sources and sinks is the starting point for symbiotic exchanges, different drivers can promote IS in various regulatory and institutional contexts (Yap and Devlin, 2017). To study IS, it is crucial to understand which motives and mechanisms influence IS emergence (Boons et al., 2014; Yu et al., 2014a). IS drivers have been studied extensively in the literature. (e.g., (Bacudio et al., 2016; Golev et al., 2015; Mathews and Tan, 2011; Yu et al., 2014a; F. Yu et al., 2015)). IS dynamics framework (Boons et al., 2016) also considers actors' motivation determinant in IS dynamics as indicated in the second column of **Table 3.1**. To implement the IS dynamics framework in practice, we made an inventory of IS drivers from the literature and checked each driver matches which dynamic's motive. For instance, information about IS opportunities and potential synergy partners (Yu et al., 2014a) matched market transparency and workshops, conferences, seminars, and forums (Bacudio et al., 2016) suited knowledge development. **Table 3.1** shows how IS driver literature is linked to the IS dynamics framework.

**Table 3.1** *Industrial Symbiosis (IS) drivers linked to IS dynamics - author generated*

<b>IS Dynamics</b>	<b>Motive</b>	<b>Drivers from literature</b>
<b>(Boons et al., 2016; Sun et al., 2017)</b>	<b>(Boons et al., 2016; Sun et al., 2017)</b>	<b>(Bacudío et al., 2016; Golev et al., 2015; Mathews and Tan, 2011; Yap and Devlin, 2017; Yu et al., 2014a; F. Yu et al., 2015)</b>
Self-organization	Economic/ environmental benefit	Energy and utility supply costs/Waste disposal cost Redundancy in energy, water, and material supply Resource scarcity Increasing eco-efficiency of the company
Organizational boundary change	Business integration/ separation	New business opportunities
Facilitation—brokerage	Market transparency	Feasible studies Information about IS opportunities and potential synergy partners
Facilitation—collective learning	Knowledge development	Community awareness about environmental and economic impacts of the companies Workshops, conferences, seminars and forums
Pilot facilitation and dissemination	Best practice development by piloting	Other successful IS experiences in the cluster Learning from non-local IS experiences
Government planning	Governmental control and command	Governmental plans for IS implementation Stimulation policies/incentives/subsidies by the government Monitoring and environmental assessment by governmental organizations
Eco-cluster development	Regional economic development	Regional policies to transform the cluster into EIP Innovative solutions for cluster development
Anchoring	Physical and social anchoring	Infrastructure readiness Managerial support Social interactions

### 3.2.2 ADICO; the Grammar of Institutions

A socio-technical system is a dynamic entity composed of stakeholders and technical artifacts interacting in interdependent physical and social networks (Hu et al., 2010; van Dam et al., 2013). Stakeholders' perceptions and interactions in a socio-technical system are guided by institutions (Geels, 2004). Institutions are expressed in the form of rules, norms, and strategic

visions in human behavior patterns. These linguistic expressions are called Institutional statements. “Institutional statement refers to shared linguistic constraint or opportunity that prescribes, permits or advises actions or outcomes for stakeholders” (Basurto et al., 2010, P.30).

Crawford and Ostrom (Crawford and Ostrom, 1995) introduced a grammatical syntax to analyze institutional statements called ADICO. ADICO refers to five components of institutional statements, which are attribute (A), deontic (D), aim (I), condition (C), and or else (O). Different combinations of ADICO syntax shape three types of institutional statements: Rules include all components (ADICO); norms consist of the attribute, deontic, aim, and condition (ADIC); and shared strategies only have the attribute, aim, and condition (AIC) (Crawford and Ostrom, 1995). In the IS dynamics framework, each dynamic is characterized by its initial stakeholder and overall storyline (Boons et al., 2016). ADICO grammar provides a lens to study institutional statements in terms of attribute and aim and link them to the stakeholder and storyline in the dynamics. Using ADICO, legal enforcement for IS implementation could be examined by studying deontic and sanctions. Often, institutions are not expressed in separate institutional statements but nested within other institutions. Basurto et al. (Basurto et al., 2010) set practical guidelines explaining how to identify institutional statements in legislation systematically, code and classify institutional statements using ADICO grammar, and analyze the coded data independently and nested. We implemented their method to discover and analyze institutional statements that form the basis for IS and reveal which dynamics are supported by the institutions.

### 3.3 The Case Study

The Persian Gulf Mining and Metal Industries Special Economic Zone (PGSEZ) is located in the southern part of Iran, 14 kilometers west of Bandar Abbas, at the Persian Gulf. The cabinet approved cluster establishment in this area in 1998. PGSEZ is a subsidiary of the Iranian Mines and Mining Industries Development and Renovation Organization (IMIDRO), which is a state-owned corporation itself. The cluster management provides common infrastructures, coordinates relationships, and supervises development plans of the established companies. PGSEZ is planned to be a hub of energy-intensive industries in the Middle East because of proximity to the South Pars, which is one of the largest natural gas reservoirs in the world (EIA, 2018). Key established industries in the cluster, their main product, capacity, commissioning year, and principal shareholder are listed in **Table 3.2**. Main shareholders of PGSEZ management (PGS), South Kaveh Steel Company (SKS), Persian Gulf Saba (SAB), and Hormoz Power Plant (HPP) are state-owned organizations themselves. This composition of semi-governmental and private energy-intensive and polluting industries makes this EIC a

suitable case for IS implementation as a strategy for sustainable development. Almost all companies have expansion projects in construction or feasibility study phase. Furthermore, new companies are also planned to be established in this cluster. However, industrial development in Iran struggles with US sanctions on metal industries, water scarcity (Madani, 2014; Madani et al., 2016), and high CO<sub>2</sub> emissions (Global Carbon Project, 2016).

**Table 3.2** Located organizations in the Persian Gulf Mining and Metal Industries Special Economic Zone (PGSEZ), their capacity, ownership, and establishment year (<http://www.pgsez.ir>)

Organization	Main product	Capacity	Start Year	Main Shareholder
PGSEZ Management (PGS)	---	---	1998	IMIDRO
Hormozgan Steel Complex (HOS)	Steel slab	1,500,000 t/yr	2009	Mobarakeh Steel Company
South Kaveh Steel Company (SKS)	Steel billet	1,200,000 t/yr	2012	Mostazafan Foundation of Islamic Revolution
Persian Gulf Saba Steel Company (SAB)	Direct reduced iron	1,000,000 t/yr	2017	Civil Pension Fund Investment Company
Maad Koosh Pelletizing Plant (MKP)	Iron pellet	2,500,000 t/yr	2018	Arzesh Holding
Almahdi Aluminum and Hormozal Complex (AAC)	Aluminum ingot	172,000 t/yr	1990	Mapna group
Hormoz Power Plant (HPP)	Electricity	160 MW	2018	Ghadir Investment Company

### 3.4 Methods

In socio-technical analysis, stakeholders could be individuals or organizations (Kokoulina et al., 2019). In this work, we studied organizational stakeholders. To get insight into the IS emergence dynamic in the cluster, we investigated previous collaborations between stakeholders, their motivations to start new IS collaboration, and institutions governing their activities. This study was conducted in two phases. In the introductory study, we obtained a general overview of the current structure of the cluster and its environmental problems via site visits and open interviews. Then, data for the in-depth study were gathered via questionnaire and desk research. Through the questionnaire, we aimed to understand the dynamics of previous collaborations in the cluster. IS drivers were also studied to figure out the preferred dynamics for future IS, based on **Table 3.1**. In desk research, we investigated the institutional context of the cluster in the form of industrial energy and water prices, national regulations governing energy, and environmental-related issues in the industry. We analyzed the institutions using

ADICO grammar to understand which IS dynamic is supported by official regulations. Finally, the field observations, survey, and desk research outcomes were compared and criticized from the viewpoint of the dynamics to get insight into IS dynamics in the cluster. We investigated mismatches to reveal IS emergence barriers. A detailed description of the methods is given in section 3.4.13.4.1 to 3.4.3.

### **3.4.1 Introductory Study**

During the introductory study carried out in summer 2018 in Iran, we interviewed experts from industries, cluster management, consultation companies, and representatives from governmental policy-making organizations at the industrial site of PGSEZ. To maintain flexibility, we conducted open personal interviews to understand how current collaborations among stakeholders have been shaped and reveal drivers and limitations for sustainable development of the cluster. Each interview took around 45 to 60 min. The interviews were conducted in Persian. While gathering technical data about gaseous, liquid, and solid wastes, we also looked into the monitoring, treatment, and disposal of such pollutants in the field. Notes taken during interviews and site visits were summarized and translated to English in field observation report (Appendix K). This introductory study helped us to get insight into the structure, power hierarchy, collaborations, and barriers to sustainable development in the cluster. It also revealed some shared strategies especially about the role of cluster management and province-level governmental organizations in cluster development.

### **3.4.2 Focused Survey**

#### **3.4.2.1 Survey Design**

To study previous collaborations and IS drivers, a questionnaire was designed (See Appendix E). The questionnaire covered four sections: General information, collaboration matrix, successful collaborations, and drivers of Industrial Symbiosis. Under general information, we asked about the respondent's organization, occupation, and experience related to the current job to assure they have sufficient knowledge and expertise to participate in the survey. In collaboration, two or more stakeholders share tangible (e.g., money, physical asset) or intangible resources (e.g., insights, knowledge, and authority) to solve problem or attain benefits greater than working isolated (Nyaga et al., 2010). Based on Boons et al. (2014) and Nyaga et al. (2010), we defined three categories of collaboration in the questionnaire: (a) Knowledge sharing (including technical advice, supervision and project management), (b) trade, (including main and by-product trade), and (c) dedicated investment (covering utility supply, and joint investment). The collaboration matrix aimed to capture different types of

collaboration between every two organizations in the cluster during the last five years. In the third part, we asked the respondents to consider one of the most successful collaborations their organization has in this period and indicate the contract type, involved organizations, initiator, facilitator, and communication method of that collaboration. The quality of such collaboration was also reviewed in terms of its influence on shared strategic vision, long-term relationships, and information exchange among organizations. Finally, based on **Table 3.1**, the respondents were asked to indicate which parameter would encourage their organization to start new Industrial Symbiosis collaborations with existing or future companies in the PGSEZ. This part was designed in a five-point Likert scale. The questionnaire was translated to Persian. For clarity, the concepts of collaboration and IS were defined at the beginning of the questionnaire.

### **3.4.2.2 Sampling and Data Collection**

We collected the research data from surveys distributed among managers of the business and non-business organizations in the cluster in November and December 2019. Before sending the questionnaire to the main respondents, we tested it by distributing among a sample group in academia, which was familiar with the IS concept. The potential respondents were selected among the company, plant operation, energy, infrastructure, and technical managers in each organization to ensure all types of collaborations were reported. The managers each had more than three years of experience in the cluster. First, an invitation email, explaining the purpose of the survey, was sent to the suggested respondents to ask if they participate in the survey. In the case of negative or no response, we looked for other potential respondents. After ensuring at least three managers from three different departments of the organization were willing to fill the questionnaire, the link to the online survey was sent to them.

### **3.4.2.3 Data Analysis**

The collected data were analyzed qualitatively and quantitatively. After collecting the filled questionnaires, we checked the occupation and experience of the respondents in their current occupation, which ensured us they have enough knowledge and expertise about previous collaborations in the cluster. Based on the collaboration matrix, we mapped the collaborations network as a graph. For collaborations between two organizations, we combined reported collaborations by the respondents from both organizations. This representation enabled us to examine which stakeholders have mostly collaborated, and which types of collaborations were prevalent in the cluster. Stakeholders who have historically bridging roles are also more likely to start new collaborations (Spekkink and Boons, 2016). We checked whether such stakeholders exist in the cluster, especially looked at the cluster management. We also examined if the

structure of the graph was more homogenous or preferential. In planned IS, network growth is mostly homogenous while it is preferential in self-organized IS (Zhu and Ruth, 2014).

Analyzing the third part of the questionnaire, we especially aimed to trace the role of cluster management and the government in initiating, facilitating, and monitoring previous successful collaborations. We also investigated the formality of the collaborations in its contract and information exchange method. This part helped us to understand whether previous collaborations were often facilitated, planned, or self-organized. We also evaluated if shared vision, long-term relationships, and communication among the organizations have improved or damaged as a result of the collaboration. As Stated in section 3.13.1, improvement in those aspects provides a platform for IS emergence in the cluster. The last part of the questionnaire was designed to reveal under which circumstances the organizations would engage in IS collaboration. In Likert scale, "very" and "completely" were considered to highly motivate IS, while "not at all" and "slightly" supposed to have a low impact on IS emergence. According to **Table 3.1**, we matched the driver with IS dynamics to see which dynamics are more preferred by the organizations. Comparing results of part three and four, we checked if the governing dynamics of previous collaborations matched with stakeholders' preferences for future IS relationship or not.

### 3.4.3 Desk Research

Complementary desk research was conducted to gain insight into institutions governing industrial activities and cluster development. For examining environmental institutions, we checked the collection of environmental laws and regulations. The collection has two parts: National laws and international conventions and treaties. In this paper, we focused on national laws. This part covered hunting, farming, tourism, trade, urbanization, and industrial activities. We limited the scope to the regulations related to the industry sector and ignored those related to a specific province. Finally, we ended in 10 documents. In the energy sector, we reviewed the "energy consumption pattern reform law". The scope of this law is management and optimization of all produced, imported, or consumed energies in the country to improve efficiencies, avoid losses, protect the environment, and support sustainable development. We also studied the executive procedure of clause 26 of this law, which defines penalties for disobedient industries. To industrial development, we investigated the rules and regulations for the establishment of production, industrial, and mining units. The list of 13 documents was sent to a few experts in the cluster to ensure all laws and procedures are currently active.

For ADICO coding, all clauses, paragraphs, and notes were copied to an excel sheet indicating the title of legislation, its issue or approval date, clause number, and note number. The list was generated in Farsi, and ADICO components were extracted from Farsi statements. Since headings, introductions, and definitions do not form institutional statements, we ignored them while tracing the legislations. In case a statement had several parts, we decomposed it to a few statements (Basurto et al., 2010). Then, we checked if the institutional statement is relevant to IS or not. Our criteria was relevance to the industry section, industrial clusters, waste management, and energy consumption and recovery in the industry. In total, 183 IS-related statement were recognized. Then, attribute, deontic, aim, condition, and sanction of those statements were identified. Many statements were passive. We decided about the attribute according to the other sentences in the legislation. In the case of ambiguity, all possible attributes were listed. We also indicated whether the statement is a rule, norm, or strategic vision. Within a broad legal system, which allows sanctions for disobeying, all written legislation might be regarded as rules. In this paper, however, we studied institutional statements as nested elements that operate at one level as a whole system and at a different level as part of another complex system (van Dam et al., 2013). To identify norms from strategies, we accepted implicit deontic. Thus, when deontic was not explicit in the statement but linked to previously stated deontic in the legislation, we considered the latter one as a norm. For instance, the first clause of the “Air pollution prevention law” and “Waste management law” obliges all organizations and individuals to follow regulations and policies described in these laws. Thus, we considered this obligation for all clauses in the law. When the aim of the statement was "subjected to" or "dependent on" another activity, this was assumed as an obligation, therefore categorized as a norm. The terms “in charge of” and “responsible” were also assumed as obligation for the stakeholders. We divided norms into obligation, permission, and prohibition. Then, we checked when and where the institutional statement is applicable. Finally, the penalties and sanctions in case the institutional statement is not followed were checked.

**Table 3.3** shows how ADICO-coded institutional statements were analyzed in line with IS dynamics framework. In attribute, we checked if a statement refers to the industries, cluster management, or the government and governmental organizations. As the aims of the institutional statements were too diverse, we categorized them in a few topics (Basurto et al., 2010) and linked them to IS dynamics. These topics were pricing (e.g., pricing of energy, material, waste disposal), eco-efficiency improvement (e.g., technical improvement, environmental protection, and energy efficiency), infrastructure provision, market brokerage, knowledge development and awareness (e.g., training, information sharing), economic

stimulation (e.g., tax cut and loan), industrial and cluster development (e.g., distance from cities, industry classification), regulatory and legislation (e.g., defining new standards and execution procedures), and environmental monitoring and assessment (e.g., effluent measurement and self-declaration). Institutional statements aimed at pricing and eco-efficiency improvement were regarded to support the self-organized dynamics. Statements with economic stimulation, legislation, and environmental monitoring and assessment topics were considered to promote government planning dynamics. Market brokerage, knowledge development, industrial and cluster development, and infrastructure provision topics were related to facilitation-brokerage, facilitation-collective learning, eco-cluster development, and anchoring dynamics respectively.

**Table 3.3** ADICO grammar linked to IS dynamics—author generated

Attribute	Deontic	Topic	Condition	Or else
Government/ Governmental organizations	Obligation	Pricing	When	Penalties
	Permission	Eco-efficiency improvement	Where	Sanctions
	Prohibition	Infrastructure provision	If	
Cluster management		Market brokerage	Unless	
Industries		Knowledge development and awareness		
		Economic stimulation		
		Industrial and Cluster development		
		Regulatory and legislation		
		Environmental monitoring and assessment		

After this classification, we analyzed the legislations in terms of attribute and their topic to examine whether each statement supports any IS dynamics. We looked especially for the role of governmental organizations and cluster management to facilitate or enforce material and energy exchange between the industries. The penalties and sanctions in case the rules are not followed were also investigated in depth separately. When it was nested in another institution, that institution was also checked to clarify the sanctioning. Discretionary imprisonments were converted to equivalent fines, and the fines calculated in Euro. Since many sanctions were determined as a percentage of prices, we considered prices also as institutions and gathered industrial energy and water prices during the last five years (2015–2019). Any ambiguities in the statements and conflicts in the in the sanctions were also investigated.

### 3.5 Results

The questionnaire was distributed among 21 managers in the cluster and received 13 filled questionnaires back from six out of seven active organizations. No one from AAC filled the questionnaire. The majority of the respondents were from management, and development and planning departments. There were also respondents from operation, energy and utility, engineering, and environmental protection departments. They had, on average, around six years of experience in their position. The position and experience of the respondents ensured us that they have sufficient knowledge about the topic of the questionnaire.

#### 3.5.1 Previous Collaborations

Previous collaborations in the cluster are visualized in **Figure 3.1** as a multigraph. Three categories of collaboration, knowledge sharing, trade, and dedicated investment, are indicated by letters from a to c respectively. For AAC, we used the reported collaborations from the other companies to map the graph. Almost all types of collaborations have taken place in the cluster during the last five years. Collaborations were mainly shaped between the cluster management and three steel industries: HOS, SKS, and SAB. The three other organizations (HPP, AAC, and MKP) have rarely collaborated with other organizations in the cluster. This shows that the network structure was preferential rather than homogenous, which resembles a self-organized dynamic.

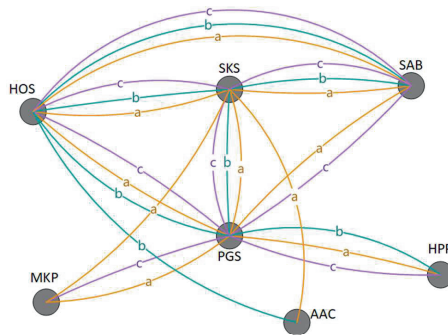

**Figure 3.1** Previous collaborations network in PGSEZ (a: Knowledge sharing; b: Trade; c: Dedicated investment).

AAC is the first company established in the area, before the area was transformed officially into an industrial cluster, but it has had only two collaborations with HOS and SKS during the last five years. Hormoz Power Plant (HPP) had the largest technical potential for energy exchange (Chapter 2), but it has been reported to have no collaboration with the other industries in the cluster during the last five years of construction and operation. On the other hand, SAB

is almost new in the cluster but has significantly collaborated with two other steel industries. The number and diversity of collaborations for HOS and SKS showed that these stakeholders are likely to engage in further collaborations.

Several technical advice and consultation interactions in the cluster represent capability for knowledge transfer, which is essential for IS emergence. By-product trade has not occurred frequently between the companies, which could be because of limited technical potential for it (Chapter 2). All stakeholders, unless ACC, had an investment collaboration with the cluster management since it is responsible for utility supply to the industries. However, this category of collaborations was not limited to cluster management. SKS, SAB, and HOS collaborated in the form of utility supply or joint investment, which shows their tendency to tangible resource sharing.

**Figure 3.2** presents the structure of previous successful collaborations in terms of other involved organizations, initiator, and infrastructure provider. Province-level governmental organizations were involved in successful collaborations more than the other listed organizations. Despite **Figure 3.2** showing cluster management collaborated with the other organizations, it was reported to be involved only in around 30% of successful collaborations. The organizations themselves started these collaborations and provided the required infrastructure for it. It could be said that previous collaborations were more likely to be self-organized. We also observed formality of previous collaborations in terms of contract type and communication method. Formal agreements were routine in successful collaborations. The preferred way of communication was formal meetings over other means (e.g., email, phone call, and social media). The most successful collaborations in the cluster were long-term with an average length of six years, mostly still ongoing. The respondents collectively answered that these collaborations have created or developed shared strategic vision, long-term relationship, and information exchange base between the organizations which have proven positive influence on IS emergence. Diversity of previous collaborations, duration of successful ones, and relational improvement because of such collaborations show that a basis for IS emergence has been created in the cluster.

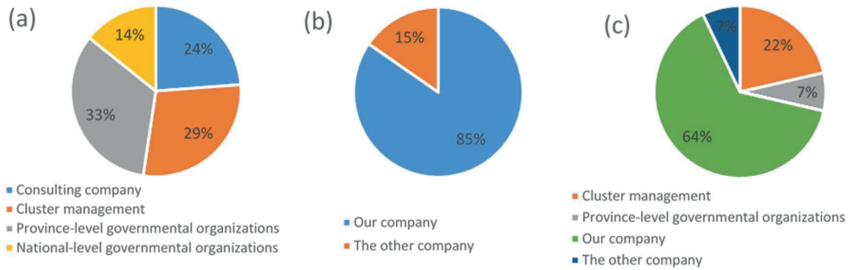

**Figure 3.2** Previous successful collaborations in the cluster: (a) The other involved organizations; (b) initiator; (c) infrastructure provider

### 3.5.2 Drivers of Industrial Symbiosis

In the questionnaire, increasing material productivity or energy efficiency and decreasing Greenhouse Gas (GHG) emissions were regarded as environmental benefit drivers, which were found to moderately drive stakeholders to initiate IS collaboration. An increase in resource costs or waste disposal costs was not also a strong driver for IS collaborations. Among self-organized IS drivers, only resource scarcity was considered very likely to motivate the organizations. This was compatible with field observation, which showed resource scarcity played an influential role in current collaborations in the cluster. For instance, land shortage near the sea for desalination units has caused water trade between the industries.

Most managers pointed out that infrastructure readiness and governmental financial stimulation policies (e.g., subsidies or tax cuts) were very likely to promote IS in their organization. Thus, anchoring and government planning dynamics were the most preferred dynamics by the stakeholders for future IS collaborations in the cluster. The next influential drivers were information about available waste heat and material in the cluster for exchange, information about other successful industrial symbiosis projects, and cluster development plans organized by the cluster management. It shows that IS might also emerge in the cluster as a result of market transparency, pilot facilitation, or eco-cluster development plans. Monitoring and environmental assessment by governmental organizations and short or long-term business opportunities were almost a moderate motivation for organizations to participate in new IS connections. Surprisingly, an increase in resource prices or waste disposal cost was not among the dominant drivers of IS emergence. To understand the reason, we investigated these two parameters in more detail in institutional analysis. Collective learning was the least favored dynamic by the stakeholders. Therefore, the most preferred dynamics by the stakeholders are the ones that are supported by the government. However, the cluster management can also

facilitate IS through market brokerage, sustainable development plans, and introducing successful IS experiences to the cluster.

Coming to each company, the drivers were slightly different. For instance, supportive policies by the government and cluster management were found less important for HOS, but new business opportunities were more significant for this company. SKS managers paid higher attention to economic benefit than other respondents. This shows that HOS and SKS are more interested in industry-initiated dynamics. The number and diversity of collaborations of these two companies during the last five years also reflected this approach. The cluster management had a minor concern about economic benefit but showed a high interest in eco-efficiency improvement. They mentioned that environmental monitoring by the government considerably motivates IS. The other companies followed more or less similar motives of the whole cluster.

### 3.5.3 Institutional Analysis

In **Table 3.4**, we have listed investigated laws and regulations, indicating the clauses governing industrial activities, the total number of IS-related statements, and number of rules, norms, and strategies. A sample of ADICO coded statements translated to English is available in Appendix F. With assumptions in section 3.4.3, 19 out of 183 statements were identified as rules, 137 as norms without clear sanctioning in case of disobedience, and 27 as strategies. From 137 norms, 114 were obligatory, 15 permissive, and 8 prohibitive.

The institutions were also classified by attribute and topic and consequently linked to dynamics as visualized in **Figure 3.3**. Coming to the attribute, 92 statements referred to the government or governmental organizations, 82 belonged to the industries, and only 5 addressed the cluster management directly. Four statements were also recognized to apply to all actors. Among governmental organizations, the DOE (Department of Environment) and ministries, especially the ministries of energy and petroleum, were the focal attributes.

**Table 3.4** List of investigated regulations and number of IS-related rules, norms, and strategies (Noori, 2020a)

Legislation	Issue/ approval year	Applicable to the industries	IS-related statements	Rules	Norms	Strategies
1 Fifth country development plan	2011	Clause 192	6	1	5	0

	Legislation	Issue/ approval year	Applicable to the industries	IS-related statements	Rules	Norms	Strategies
2	Sixth country development plan	2017	Clause 35 to 50	19	0	18	1
3	Air pollution prevention law	1995	Chapter 3	24	1	23	0
4	The executive procedure of air pollution prevention	2000	All	0	0	0	0
5	The executive procedure of environmental impact assessment of large manufacturing, service, and development plans and projects	2011	All	6	2	4	0
6	The executive procedure of water pollution prevention	1994	All	19	1	12	6
7	Waste management law	2004	All	13	4	9	0
8	The executive procedure of waste management	2005	Clause 12, 28, 30, 31, 32	10	2	6	2
9	Value Added Tax (VAT) law	2008	Clause 38	3	1	1	1
10	Soil Protection law	2019	Clause 13	12	4	7	1
11	Energy consumption pattern reform law	2011	All	33	1	25	7
12	Executive procedure of clause 26 of energy consumption pattern reform	2014	All	10	1	7	2
13	Rules and regulations for the establishment of production, industrial and mining units	2018	All	28	1	20	7
<b>Total number</b>				183	19	137	27

IS was not addressed in the legislation directly. We considered environmental monitoring and assessment, economic stimulation, and regulatory and legislation to support governmental planning dynamic. Regarding the total number of statements, this dynamic was supported by

institutions. Even though as per written institutions, monitoring air, water, and soil effluents, and notifying lawbreaker industries is DOE's responsibility, we realized in the field observation that the provincial environmental department does not monitor water and air effluents adequately. In such a condition, the questionnaire also revealed that the organizations do not seem to consider environmental monitoring a powerful driver for IS. Technical improvement in the form of energy efficiency improvement and material productivity improvement had been obliged to both the industries and the government. The institutional study showed that even though the country has joined the Paris Agreement, there is not effective regulation about industrial GHG emissions in legislation. That might explain why, as per the questionnaire outcomes, decreasing GHG emission is not currently a driver for material and energy exchange among industries. Furthermore, collective learning dynamic was rarely addressed in the legislation. Stakeholders were not interested in this dynamic for future IS collaborations. We did not find any institutional statements governing pilot facilitation and dissemination, and organizational boundary change dynamics.

In market brokerage topic, only few regulations were found aiming electricity trade between the industries and the ministry of energy. This IS drivers study showed market transparency and information about available waste energy and material for recovery, which can encourage industries to initiate IS. Anchoring via infrastructure provision was the favored dynamic for future IS in the cluster, but this dynamic was not supported strongly in the official institutions. Infrastructure provision in the form of desalination units, wastewater treatment units, and electricity for the industries was in the scope of government and ministry of energy, but previous successful collaborations showed that cluster management or governmental organizations did not afford infrastructures. Even though eco-efficiency improvement was seen to be highly supported by the institutions, the stakeholders appeared not interested in it as a driver for IS collaboration (section 3.5.2). Lack of legal enforcement on environmental regulations found out in the field observation, low energy prices, and negligible penalties for environmental effluents can describe the insignificant concern about eco-efficiency improvement.

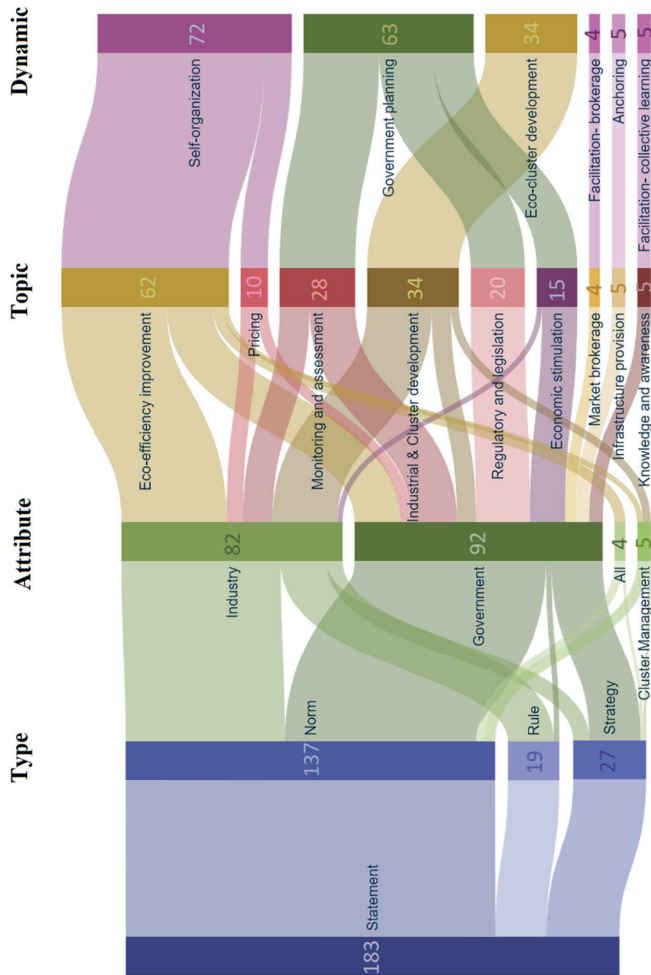

**Figure 3.3** Distribution of institutional statements by type, attribute, and dynamics

As discussed in section 3.5.2, the respondent managers indicated that financial stimulation policies by the government (e.g., subsidies or tax cuts) significantly promote their organizations toward IS. However, we found only 15 statements aiming at economic stimulation in the institutions. More investigation showed that incentives are often vague and undetermined in the legislation. Although the government, Ministry of Energy, Ministry of Petroleum, and the Energy Council have to provide economic incentives for the industries to improve their energy efficiency and install energy recovery systems, such incentives are not clearly defined. Industrial development in the form of clustering was highly recommended in the regulations.

The technical study (Chapter 2) showed that cluster management could improve the technical potential for IS by introducing new industries to the cluster. As stakeholders also admitted cluster development plans by cluster management, eco-cluster development was recognized as a probable IS emergence dynamic in this cluster, supported technically as well as by institutions and stakeholders.

Then, the sanctions were investigated in more detail. Despite the high inflation rate in Iran (Statistica, 2019), most fines remained fixed in the legislation. For instance, the maximum fine for air pollution was only around 35 €, soil contamination 70 €, and waste disposal 690 €. According to VAT law, industries that do not follow environmental protection standards and regulations have to pay one percent of their sales price as pollution tax too. The penalty of energy consumption exceeding national standards was a percentage of energy prices. We checked industrial electricity, natural gas, and water prices in Hormozgan province in 2015 to 2019 (Noori, 2020b). Euro to Rial exchange rate had a steep increase during the last two years, but energy prices have not increased proportionally. Thus, we recognized a decreasing trend in the prices. Furthermore, energy costs were significantly lower than in developed economies. (e.g., the electricity price was one-tenth of the Netherlands (Eurostat, 2018a) and natural gas price one-fifteenth (Eurostat, 2018b)). As stated in section 5.2, the rise in energy supply or waste disposal cost was not supposed by the stakeholders to boost IS in the cluster. This can explain why an increase in such costs cannot encourage industries to exchange waste energy and material.

### 3.6 Conclusion

This paper aimed to gain insight into IS emergence in EICs through IS dynamics framework. It investigated previous collaborations in the cluster, stakeholders' motivations to initiate new collaborations, and institutions governing industrial activities in the case of Persian Gulf Mining and Metal Industries Special Economic Zone in Iran.

Pre-emergence conditions are acknowledged in the literature to affect IS emergence. The need for an integrated approach in studying pre-emergence conditions in EICs, where symbiotic exchanges have not shaped yet, led to this research. Study of previous collaborations in the case study revealed that existence of cluster management as coordination body in the cluster, does not guarantee facilitated collaboration between the companies. The stakeholder initiated successful collaborations and provided their required infrastructures by themselves. Long-term ongoing collaborations are considerable signs for future long-term relationships in the cluster,

especially mentioning the point that such collaborations created or improved shared strategic vision and information exchange platform between the organizations.

A comparison of stakeholders' drivers and institutional analysis results showed a discrepancy between stakeholders' preferred dynamic for future IS collaboration and the supported dynamics by the regulations. Financial stimulation and infrastructure provision highly motivate stakeholders for IS, but institutional statements are unclear and ineffective in this regard. The institutions do not support market brokerage for symbiotic exchange properly. However, sustainable industrial development through clustering is highly recommended in the institutions and supported by the stakeholders. It could be said that although inherent challenges such as resource scarcity can promote self-organized IS in the cluster, in the absence of adequate economic and environmental institutions, stakeholders will not engage in IS collaboration. For sustainable industrialization, environmental rules and regulations must be improved continuously ahead of industrial growth.

However, this framework has also limitations. Looking for global IS evolution patterns, the framework focuses on network and institution level motivations and does not consider stakeholder level drivers such as short mental distance (Ashton and Bain, 2012), willingness to collaborate (Bacudio et al., 2016), and trust (Batten, 2009; Ghali et al., 2017; Golev et al., 2015). Data gathering for social studies was much more challenging than gathering technical data. Technical data might be available mid-level managers and engineering and operation staff, but collaboration data should be gathered from top managers of the organizations, which also had limited time and accessibility. As EICs are in the first stages of development, one apparent restriction in EIC research is the limited number of surveyed organizations and stakeholders. Recognizing the importance of empirical data in this work, we carefully selected the interviewees and respondents from involved stakeholders in previous and future collaborations.



# 4 Exploring the emergence of waste recovery and exchange in industrial clusters<sup>3</sup>

## ABSTRACT

Self-organized industrial symbiosis (IS) starts with one actor's decision to invest in a waste recovery plant and the other actors' decision to buy the recovered flow. Technical and institutional conditions of the cluster influence actors' decisions. This paper explores the emergence of IS collaborations in industrial clusters under different techno-economic conditions in the long term. We propose a mixed-integer linear programming model that incorporates costs and constraints associated with waste recovery and exchange to study actors' investment decisions and investigate shaped symbiotic exchanges under rising energy prices and limited electricity supply. The approach is implemented in Iran's Persian Gulf Mining and Metals Special Economic Zone (PGSEZ) as a case study. The results revealed that changes in internal or external conditions simultaneously influence the industrial and waste recovery plants. For instance, increasing energy prices without rising product prices significantly declined the production level of industrial plants and consequently heat recovery potential. Furthermore, the contribution of the waste heat recovery plants to improve the cluster's economic and environmental performance was not the same. Electricity recovery from a power plant's waste heat can result in 55 PJ grid electricity intake reduction and 720 M€ cluster cash flow increment. Recovered cooling or electricity from the steelmaking plant waste heat was consumed internally rather than shaping IS. These model outcomes show its capability to study

---

<sup>3</sup> This chapter is has been submitted for publication as Noori, S., Korevaar, G., Stikkelman, R., & Ramirez, A. (2022). Exploring the emergence of waste recovery and exchange in industrial clusters.

IS within the socio-technical structure of the cluster, not a standalone phenomenon. Implemented conceptualization offers a novel system-level approach, which could be adjusted to assess other industrial development strategies.

## 4.1 Introduction

Industrial clusters are complex systems of actors that benefit from clustering in many ways, including the waste material and energy exchange, known as Industrial Symbiosis (IS). IS implementation in industrial clusters requires a dynamic interdisciplinary approach to understanding how various internal and external conditions influence the emergence of symbiotic collaborations (Boons et al., 2014; Yu et al., 2014a). Generally, waste flows need treatment, referred to as waste recovery, before exchange between two actors (Fraccascia et al., 2017a). Several waste recovery options with different techno-economic specifications might be technically possible in a cluster. Actors decide on waste recovery based on the economic benefit, motives, previous collaborations, and institutions governing those collaborations (Albino et al., 2016; Fraccascia et al., 2017b; Noori et al., 2020; Spekkink and Boons, 2016). Governments can also foster IS through pricing, regulatory enforcement, and infrastructure provision (Fraccascia et al., 2017b; Sun et al., 2017; C. Yu et al., 2015). All these circumstances turn decision-making for IS into a complex multi-objective challenge.

Interestingly, while IS usually imposes additional investment and operation costs to the system, only a few models have included those costs in their formulation. The government, industries, or a facilitating body can make the required capital investments at the system level. Taskhiri et al., (2015) developed a formulation to maximize the satisfaction level of actors based on the investment payback period in a waste-to-energy network. While their model considered the investment cost and its allocation among the actors, it ignored the time value of money in the investment decision. Teo et al., (2017) developed a hybrid optimization model to integrate a sustainable central utility system into an eco-industrial park. They evaluated the system's economic performance based on net present value but overlooked the role of social drivers in decision-making. We argue that it is crucial to correctly incorporate operation and investment costs in the model to investigate actors' decisions.

Modeling is a standard method for the structured investigation of complex systems (Greiner et al., 2014). Different modeling approaches have been used to study IS formation depending on the problem formulation and the modeling question. One approach is agent-based modeling (ABM), where the actors' status and interactions are simulated in a descriptive bottom-up approach to gain insight into the emergent behavior of a system (Ghali et al., 2017). A drawback

of ABM is its incapability to optimize the economic benefit of actors (Davis et al., 2009), which plays an undeniable role in IS formation. Another widely used modeling approach is linear programming and optimization. Montemanni and Jamal (2018), for instance, presented a model to maximize the cash flow of a whole industrial cluster. Although they defined cluster prices for each by-product, the model did not include waste recovery costs.

Most optimization models have targeted economic benefits, but increasingly multi-objective models include environmental or social aspects of IS in the optimization process. For instance, Afshari et al. (2018) incorporated environmental impact in their objective function to optimize a heat exchanger network in eco-industrial parks, while Brondi et al. (2018) coupled life cycle sustainability assessment in a symbiotic network optimization under different scenarios. An interval chance-constraint fuzzy program including environmental limitations (Rao et al., 2019) and a pricing model for waste recovery (He et al., 2020) are other recent efforts to develop more inclusive optimization models for assessing IS.

Investments in waste recovery are a long-term decision for industrial actors. Nevertheless, industrial clusters are not static systems and change over time due to internal and external conditions variations. Regulations and policies such as waste transportation cost (Domenech et al., 2019), taxes (Fraccascia et al., 2017b), environmental limitations (C. Yu et al., 2015), governmental stimulation plans (Behera et al., 2012), and infrastructure readiness (Sun et al., 2017) are external parameters that influence actor's decision-making. Moreover, previous successful collaborations (Spekkink and Boons, 2016) and actors' motivation to engage in IS also impact the system internally. Internal and external parameters influence multi-criteria decisions for waste recovery and exchange. A way of understanding the impact of uncertainties in future developments is scenario analysis (Enserink et al., 2010). Scenario analysis explores a range of plausible future outcomes of a system and investigates development paths resulting in such futures.

Based upon and related to the points discussed above, this paper explores which IS collaborations could emerge in industrial clusters in the long term under different technical and institutional arrangements. We built a socio-technical cluster model using a case study of the Persian Gulf Mining and Metal Industries Special Economic Zone (PGSEZ) in Iran. This model examines different waste recovery options under increasing energy price and limited energy supply scenarios, although the proposed conceptualization is not limited to these external factors. The model is built in Linny-R, a graphical user interphase for Mixed Integer Linear Programming (MILP) problems developed at the Delft University of Technology (Bots, 2021). It uses Gurobi mathematical optimization solver (Gurobi Optimization, 2021). A brief

introduction to Linny-R and its implication in IS modeling is given in Appendix G. Linny-R provides the possibility to include physical and non-physical processes and flows in one model and to find the cheapest way of meeting the demands regarding technical and non-technical constraints.

This paper is divided into five sections. Section 4.2 explains Linny-R's methodological background, IS conceptualization, and modeling. In section 4.3, the model is applied to a case study. The results are presented in section 4.4. Finally, discussions and contribution of this work to IS modeling studies is stated in section 4.5.

## 4.2 Methods

### 4.2.1 Conceptualizing waste recovery and exchange

An industrial cluster comprises several companies; each includes one or more production plants. We modeled waste recovery and exchange in an industrial cluster using Linny-R software. In Linny-R, each plant is a process that transforms some physical or non-physical products into outgoing products, physical or non-physical (Bots, 2021). A brief description of Linny-R functionalities for cluster modeling is given in Appendix G. **Figure 4.1** shows how waste recovery and exchange between two actors is conceptualized in Linny-R.

IS emerges in a cluster when the actors select waste recovery and exchange over waste disposal. In **Figure 4.1**, actor  $k$  consumes resource  $R$  to produce the main product  $M$  and waste flow  $W$ . The actor seeks the cheapest way to handle  $W$ , considering system conditions. It can decide to either send  $W$  to waste disposal (WD) or, if technically possible, to the waste recovery (WR). The recovered flow ( $R'_{\text{recovered}}$ ) could either be utilized internally (in P2) or traded inside the cluster, if actor  $h$  decides to replace its existing resource supply from the market ( $R'_{\text{market}}$ ) with  $R'_{\text{recovered}}$ , partially or entirely. In these conditions, IS shapes between the two actors. Several costs and limitations are associated with processes and products shown in **Figure 4.1** that influence IS formation.

**Table 4.1** summarises how such variables and constraints were implemented in Linny-R, followed by a more extensive description in the rest of this section.

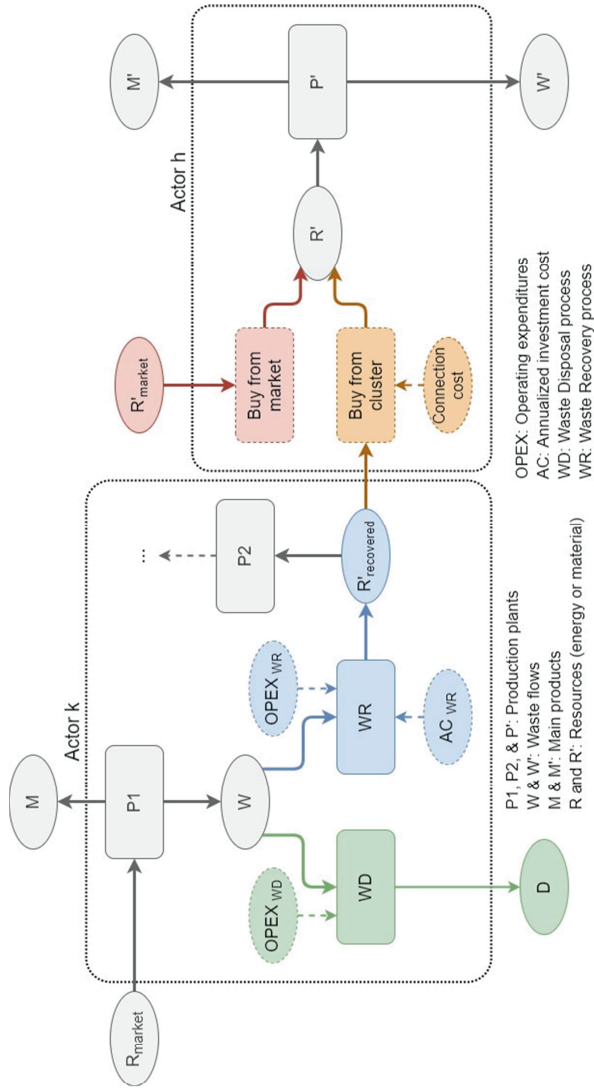

**Figure 4.1** Conceptualizing waste recovery and exchange between two actors in Linn-R

**Table 4.1** Description of influential parameters in the conceptual model of IS formation

Parameter	Implementation in the Model
The capacity (size) of the P1, P2, and P'	Upper/ lower bound of the process
Resource consumption and waste generation rate of the processes	Inflow and outflow rates
The market prices of the products	The price assigned to M and M'
Availability of the resources ( $R_{\text{market}}$ and $R'_{\text{market}}$ )	See Section 4.2.1.1
Maximum/ minimum demand the products	Upper/ lower bound of the M and M'
Waste Disposal (WD):	
Waste disposal tax	Price of D (negative) (see Section 4.2.1.3)
Operating expenditures (e.g., transportation)	OPEX <sub>WD</sub> (see Section 4.2.1.3)
Waste Recovery (WR):	
Efficiency	The ratio of $R'_{\text{recovered}}$ to W
The cost price of recovered resources	Price of $R'_{\text{recovered}}$
Operating expenditures	OPEX <sub>WR</sub> (see Section 4.2.1.2)
Required capital investment	AC <sub>WR</sub> (see Section 4.2.1.2)
Connection cost	see Section 4.2.1.3
Actors' willingness to sell/buy from the other actors	Upper bound of the process "Buy from the cluster" (see Section 4.2.1.5)

More complex waste recovery systems can be modeled similarly as a collection of waste treatment or transfer processes, each with techno-economic specifications. Suppose several recovery options are technically possible for a particular waste flow. In that case, each option can be added to the cluster separately, then the system operation under different configurations can be compared.

#### 4.2.1.1 Resource scarcity

The market's lack of available raw material or energy has been identified as a dominant IS driver in industrial clusters (Mortensen and Kørnøv, 2019; van Beers et al., 2007). In Linny-R, a product could be a source or sink type. A negative lower bound on a source reflects the maximum extractable amount of the source. Scarcity on an incoming flow was implemented by setting a negative lower bound equal to the maximum available amount of raw material or energy. When an input product is available from two sources with different prices and or availabilities (e.g., from the market or as a recovered flow within the cluster), Linny-R allows the actor to get the amount it requires as a mix from various sources to maximize its cash flow.

#### 4.2.1.2 Operation and investment costs

Each process holds capital expenditures (CAPEX) and operating expenses (OPEX). OPEX has variable and fixed components. Variable OPEX is proportionate to the production level of the process, but fixed costs (CAPEX and  $OPEX_{fixed}$ ) do not change with production level. Fixed costs were calculated and implemented in the model as annualized cost (AC) (Equation 4.1). In **Figure 4.1**, AC is deducted from the actor's cash flow annually when WR starts up. .

$$CRF = \frac{R}{1 - (1 + R)^{-n}} \quad \text{Equation 4.1}$$

$$AC = (CAPEX \times LF_{cap} \times CRF) + (OPEX_{fixed} \times LF_{op}) \quad \text{Equation 4.2}$$

Where:

$R$ : interest rate

$n$ : the repayment period

$OPEX_{fixed}$ : fixed operation expenses

$LF_{cap}$ : CAPEX location factor (material cost factor  $\times$  contingency factor)

$LF_{op}$ : labor cost location factor (labor productivity factor  $\times$  labor cost factor)

#### 4.2.1.3 Costs and constraints associated with waste disposal

Price-based emission control policies such as a carbon tax could be implemented in Linny-R by assigning a negative price to disposed waste. To apply quantity-based emission control, the upper bound of the WD process was set equal to the maximum allowable amount of emitted waste. Waste disposal costs such as transportation costs could be implemented as operating expenditures of WD ( $OPEX_{WD}$ ).

#### 4.2.1.4 Connection costs

Investment and operation costs represent the costs associated with waste recovery. However, exchanging a recovered flow between two actors also entails the costs of contracting or establishing a new connection. In the model, to represent the costs associated with starting an exchange connection, the cost was assigned to each buying process in the form of a start-up cost. This cost is deducted from the buyer's cash flow as soon as the exchange occurs.

#### 4.2.1.5 Willingness to collaborate

In **Figure 4.1**, IS emerges when actor  $h$  decides to buy  $R'_{recovered}$  from actor  $k$  instead of the market. Besides the economic benefit, the decision might be influenced by actors' willingness to collaborate. The literature shows that actors engaged in pre-emergence collaborations and

open to new businesses are more likely to start symbiotic exchanges (Ashton and Bain, 2012; Spekkink and Boons, 2016). The upper bound of the “Buy from cluster” process reflects the maximum amount that actor  $h$  is willing to buy from actor  $k$ . If actor  $h$  is unwilling to buy from actor  $k$ , the upper bound is zero. However, it should be noted that willingness to collaborate is an exogenous parameter to the model, and must be assessed through separate field studies.

### 4.2.2 Model formulation

In an industrial cluster, each actor might hold several processes. The cash flow of actor  $k$ ,  $U_k$ , is the sum of the  $A_k$ 's profits from all processes owned by  $A_k$ :

$$U_k = \sum_i CF_i \quad \text{Equation 4.3}$$

Where,  $CF_i$  is cash flow of process  $i$  owned by actor  $k$ . Process cash flow equals income from outgoing products minus its expenditures. The expenditures are the total cost of input products, plus the operation and investment costs. Therefore, the cash flow of a representative process  $i$  can be formulated at each time step as:

$$CF_i = PL_i \cdot \sum_m Pr_m \cdot O_{i,m} - PL_i \cdot \sum_n Pr_n \cdot R_{i,n} - PL_i \cdot VC_i - AC_i \quad \text{Equation 4.4}$$

Where,

$PL_i$ : Production level process  $i$

$Pr_m$ : Price of product  $m$

$O_{i,m}$ : Generation rate of output  $m$  of the process  $i$  to produce one unit of the main product

$R_{i,n}$ : Consumption rate of resource  $n$  to produce one unit of the main product

$VC_i$ : Variable Cost process  $i$  for a unit of main product

$AC_i$ : Annualized Cost process  $i$

The formulation applies to each process owned by an actor. If an actor decides to start a process under specific circumstances, the variable in the formula is multiplied by a binary variable to express such a decision. Therefore, the optimization model is defined by Equation 4.5, in which the decision variables are production levels and process on/off integer variables.

$$\text{Optimize } \sum U_k \quad \text{Equation 4.5}$$

Subject to the constraints elaborated in section 4.2.1

### 4.3 The case study

A case study was used to explore how energy availability and price changes can influence IS formation in an emerging industrial cluster. The Persian Gulf Mining and Metal Industries Special Economic Zone (PGSEZ) in Iran was selected. PGSEZ was established near South Pars natural gas fields to exploit the comparative advantage of extensive energy resources in developing energy-intensive industries. A previous survey showed that successful pre-emergence collaborations in this cluster were self-organized mostly (Chapter 3). Moreover, IS is not referred to directly in Iranian rules and regulations. Rules and regulations primarily define obligations for industrial actors to improve their energy and environmental performance. Responsibilities of the government or cluster management, e.g., in facilitating or financing such improvements, are vague and limited. A detailed institutional study showed that rules and regulations in Iran also support self-organized IS (Chapter 3). Figure 4.2 shows the companies and plants included in the case study. Currently, one aluminum production company (AAC), three steel production companies (SKS, HOS, and SAB), and one gas turbine power plant (HPP) are active in PGSEZ. There is a pelletizing plant under construction, which was not included in the model. For modeling purposes, the maximum capacity of the plants was considered equal to the design capacity. Industrial water was assumed as an input into the processes to decrease complexity.

As shown in **Figure 4.2**, Each company was modeled as a sub-cluster that includes all related processes and products. Waste streams were considered to have no economic value for the actors. Each time step in the model was considered a year, and the system was then simulated for 20 years.

Increasing electricity demand by conventional air conditioners in the household sector has caused electricity shortages in Iran (Azadi et al., 2017). Thus, the possibility of supplying recovered electricity to Bandar Abbas city (BAC), at a 14-kilometer distance from PGSEZ, was added to the model. Electricity demand for cooling was assumed to be one-third of household electricity consumption (Pourazarm and Cooray, 2013) and increased at the same rate as urban population growth. To take into account the differences in prices, urban and industrial electricity were modeled separately.

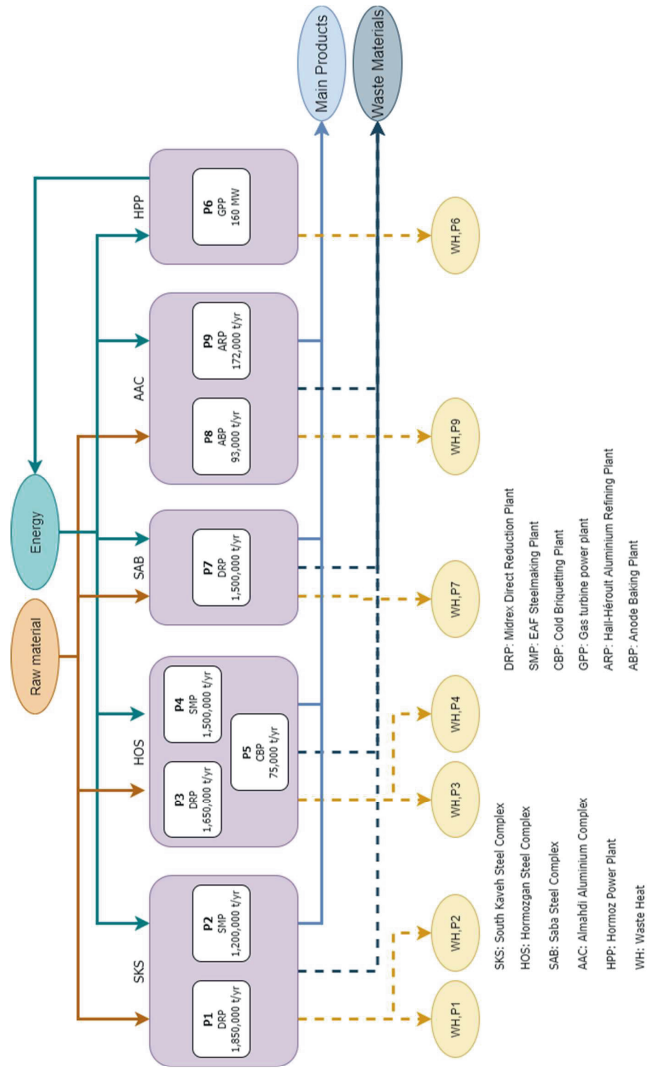

Figure 4.2 Companies and plants in PGSEZ

### 4.3.1 Input data

As described in section 4.2.1 and Appendix G, all incoming and outgoing flows of different industrial plants are required to model the cluster for IS examination. However, Linny-R does not conduct process mass and energy balances itself. All incoming and outgoing flow rates to plants listed in **Figure 4.2** were obtained from Chapter 2, as given in the Appendix H. Energy

flows are presented in TJ, and material flows in thousand tonnes per unit of main product. Process capacities were expressed in thousands of tonnes per year.

All flows were priced based on the literature or publicly available data. See Appendix I for costs and prices used in this study. Because Iran's economy has been highly affected by sanctions and the US withdrawal from the Joint Comprehensive Plan of Action in 2018, the model was therefore built based on economic data for the year 2016 to exclude distortion in prices. Household and industrial electricity prices were obtained from Iran's power generation and distribution company databases (Appendix K). A previous institutional study showed no explicit penalties or limitations for waste disposal applied in PGSEZ (Chapter 3). Therefore waste disposal cost was set equal to zero in the model.

A previous collaboration study revealed that three steel production companies (SKS, HOS, and SAB) had experienced more collaborations with each other, so they were more willing to collaborate. In contrast, the power plant (HPP) and aluminum reduction company (AAC) had rarely collaborated with the others (Chapter 3). Although the actor's willingness to collaborate can be incorporated in the model as explained in section 4.2.1.5, we explored all technoeconomically feasible IS connections without implementing such a limitation. Then, the results were interpreted considering involved actors' previous collaborations.

### **4.3.2 Model verification**

As the model explores future development under different configurations and scenarios, it was not possible to compare the outcomes with actual data. However, model functionality can be examined by looking at the current cluster structure and model outcomes under extreme boundary conditions. First, it was checked whether the model could replicate the present exchanges in the cluster. When adding the possible connections between these two actors, the model results showed 195,000 tones/year surplus sponge iron and 21,000 tones/year of dust oxide flow from SKS to HOS. A further look into actor cash flows showed that these trades increased HOS and SKS cash flows by 6% and 15%, respectively. The economic viability of these options is in agreement with the current existing collaboration in PGSEZ, as was observed in a previous field study (Appendix K). The model was also run for extreme boundary conditions. For instance, as expected, the industrial plants stopped operation because of increasing raw material prices or decreasing market prices. Furthermore, the model was checked at every development step for any unreasonable outcome, such as negative cash flows or sharp fluctuations in flow rates. Although these tests do not constitute a complete verification of the model, they provide confidence in the robustness of the results.

### 4.3.3 Experimental design

#### 4.3.3.1 Configurations

A previous technical potential study in this cluster revealed several unutilized IS possibilities for energy and material waste flows (Chapter 2), four of which were examined in this paper, focusing on energy flows, as explained in **Table 4.2**. In each configuration, the researcher added the intended WR plant to the model and connected the recovered energy flow to all possible consumers, inside or outside the cluster. WR efficiency was obtained from the literature. In the case study, we assumed that existing production plants had been paid off completely. Thus, CAPEX was applied only to WR. CAPEX and OPEX were obtained from the literature and adjusted to the case study conditions using location factors. An interest rate of 10% and a repayment period of 20 years were considered for the CRF calculation (Equation 4.1). AC was calculated as explained in section 4.2.1.2, and the cost price of recovered flow was obtained by dividing AC by WR capacity and adding variable cost to it. Technical specifications were considered stable during the simulation. Assumptions on other economic parameters used in the model are summarized in Appendix I.

The Linny-R models of the four configurations are presented in Appendix K. In configuration A, no waste recovery and exchange were added to PGSEZ. In Configuration B, a steam turbine power plant (P14) was added to HPP. Recovered electricity could be consumed by SKS, HOS, SAB, or AAC or sent to the urban area (BAC). It was also possible to sell excess recovered electricity to the grid.

As SKS has previously had several successful collaborations with other actors in the cluster (Chapter 3), configurations C and D explored its potential for IS collaborations. Steelmaking plant (SMP) exhaust gas in SKS has a temperature of 90 °C. An absorption chiller (ABC) is a proper waste heat recovery technology at this temperature (Oluleye et al., 2017). We inspected industrial cooling demands in more detail to identify ABC-generated cold-water utilization possibilities. In direct reduction plants, the cooling circuit was open, and ABC cold-water utilization needed an extra heat exchanger installation. Therefore, this option was not considered in our study. In SMPs (HOS and SKS), evaporative cooling towers generated cooling water for water-cooled heat exchangers, and seawater reverse osmosis plants produced makeup water for the cooling towers. It was possible to replace this system with ABC. Cooling demand in SKS was estimated based on field data (water flow rate and temperature rise). As such data were not available for HOS, cooling demand was assumed 50% of energy input to SMP (Barati, 2010; Kirschen et al., 2011b). Electricity consumption and operating cost of the existing system were obtained from field data or literature. ABC's coefficient of

performance (COP) was calculated to be 0.72, assuming that the generator and evaporator temperatures equal the waste heat and demanded cooling water temperatures, respectively.

In configuration D, energy recovery from SMP off-gas before internal cooling was examined. Studies show that 15 to 35 percent of energy input to electric arc furnaces (EAF) was lost through off-gas (Barati, 2010; Kirschen et al., 2011b; Steinparzer et al., 2014). Here, 25 percent was considered in the calculation. Several studies have investigated energy recovery possibilities from this flow type, though only a few have been implemented at an industrial scale. In this study, an evaporative cooling system plus waste heat steam generator was considered to recover around 70% of off-gas heat (Pili et al., 2020). Then, an ORC with an efficiency of 20% converted this heat into electricity (Bause et al., 2015; Pili et al., 2020). Recovered electricity can be used internally, exchanged with HOS, SAB, AAC, or BAC, or sent to the grid.

**Table 4.2** Configurations of waste recovery and exchange considered in this study

Configuration	WR	Possible exchanges
(a)	No waste recovery unit added	No symbiotic exchange
(b)	P14 (Electricity recovery from waste heat of P6)	Electricity exchange HPP with SKS, HOS, SAB, AAC, or BAC; Electricity supply to the grid
(c)	P14, plus P16 (cooling recovery from waste heat of P2)	As (b), plus cooling exchange SKS with HOS, internal use of recovered cooling in SKS
(d)	P14, plus P18 (electricity recovery from waste heat of P2 before cooling)	As (b), plus electricity exchange SKS with HOS, SAB, AAC, or BAC and internal use of recovered electricity in SKS

#### 4.3.3.2 Scenarios

In this step, we investigated how variation over time in external factors influences the formation of IS in PGSEZ. More specifically, we examined the role of energy prices and resource availability. The current energy sources of PGSEZ are natural gas and electricity. In Iran, electricity and natural gas prices are not set through a market mechanism but are determined by governmental legislation annually. Current energy prices in Iran are significantly lower than EU average prices and have not increased dramatically during the last years (Appendix K). Energy prices were changed under three scenarios to study the impact of institutional conditions on IS emergence. In the EN0 scenario, energy prices remained fixed during the next 20 years. In the moderate rise scheme (EN+), prices increased yearly by 10%. In a drastic rise scenario (EN\*), the prices were first doubled and then increased by 10% annually.

In a previous field study in PGSEZ, actors pointed out limited electricity supply from the grid as a prominent driver for IS (Appendix K). We designed another set of scenarios to examine the effect of this limitation on IS. RA0 presented unlimited electricity availability, while in RA-; the maximum electricity supply from the grid was equal to 50% of cluster electricity consumption in the current condition. Combining external factor variations resulted in a total of six scenarios in this study namely, EN0RA0, EN+RA0, EN\*RA0, EN0RA-, EN+RA- and EN\*RA-.

## 4.4 Results

Only selected model outputs are presented in this section. The detailed excel sheets of model results in different configurations and scenarios are provided in Appendix K.

### 4.4.1 Operation of production and waste recovery plants

Before exploring symbiotic exchanges, we investigated the operation of production plants and waste recovery plants. Investigating production levels of industrial plants in configuration A showed that energy price and resource scarcity did not affect all plants in the same way. The grid's limited electricity supply forced the aluminum processing plants (P8 and P9) to stop, but the production level of other plants did not change in RA- scenarios compared to RA0.

The power plant (P6) operated at maximum capacity in all scenarios. Other plants also operated at full capacity in EN0RA0 but shut down one by one at a moderate annual rise in energy prices (**Figure 4.3 (a)**). P9 and P8, the most energy-intensive plants in the cluster, stopped operation in the 9<sup>th</sup> year when electricity and natural gas prices reached 9.5 and 1.8 €/GJ, respectively. P3 and P4 (DRP and SMP of HOS) stopped production afterward. However, P5 (CBP of HOS) stayed in operation until the year 14, receiving iron dust from SKS. P1 and P2 (DRP and SMP of SKS) operated until energy prices were almost 3.5 times higher than current prices. P7, the less energy-intensive company in the cluster, operated until year 17. A similar shutdown sequence was observed in EN\* at the same energy prices, which happened sooner in this scenario.

Except HPP, actors' cash flow dropped by EN+ scenario and even more in EN\*. The highest drop happened for HOS. Under constant energy prices, HOS and SKS had higher cumulative cash flows, but the cash flow of SAB surpassed HOS and SKS in EN+ and EN\* scenarios. Note that the cash flow of the urban area (BAC) was negative, as it is only a consumer. As RA- influenced the production level of AAC, only its cash flow dropped in RA- scenarios.

Then we investigated production level of waste recovery plants. In configuration B, P14 operated at maximum capacity in all scenarios recovered 54.8 PJ electricity over 20 years. P14 remained in operation at full capacity in configurations C and D as well, but P16 and P18 did not (**Figure 4.3 (b)**). As described above, the production level of P2, and consequently the amount of generated waste heat, dropped under a moderate and drastic rise in energy prices; but it was not influenced by resource scarcity. The same pattern was observed in the production level of P16 and P18. Under fixed energy prices, P16 and P18 could recover 8.2 PJ cooling or 2.7 PJ electricity over 20 years. In the EN+ scenario, the amount of recovered energy in P16 and P18 dropped over time and ended at zero in year 19. In EN\* scenario, P16 and P18 stopped operation after the upstream industrial plant (P2) stopped operating in the 12<sup>th</sup> year at electricity price of 25.4 €/TJ. These results clearly show the dependency of energy recovery on industrial plants' operations.

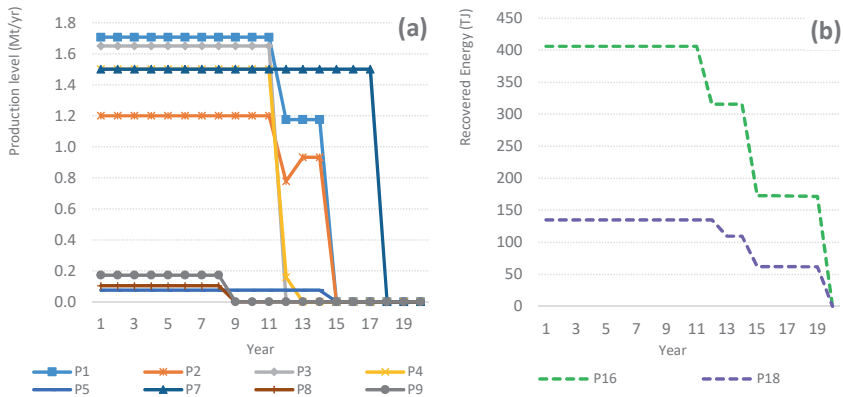

**Figure 4.3** Production levels in EN+RA0 scenario; (a): industrial plants; (b): waste recovery plants

#### 4.4.2 Symbiotic and non-symbiotic exchanges

**Figure 4.4** shows the utilization of recovered energy inside and outside PGSEZ over 20 years. In configuration B, 54.8 PJ recovered electricity in P14 ( $EL_{r-HPP}$ ) was consumed by different actors under different scenarios. As the household electricity price was much higher than  $EL_{r-HPP}$ , the urban area (BAC) received 5.6 PJ of  $EL_{r-HPP}$  over 20 years in all scenarios. In the EN0 scenarios, HOS used the remaining 49.2 PJ  $EL_{r-HPP}$ . Under the EN+ scenario,  $EL_{r-HPP}$  found new destinations, and symbiotic exchanges formed with SKS, SAB, and AAC. Electricity intake by SKS was higher than SAB because of the demand for steelmaking (P2). AAC also received 2.4 PJ in the last year. When grid electricity prices increased drastically, symbiotic exchanges

helped AAC to start production again from year 13, consuming annually around 2.4 PJ  $EL_{T-HPP}$ . Thus, the share of AAC from recovered electricity increased to 19.6 PJ in EN\* scenarios.

In configuration C, two waste recovery plants operated in PGSEZ simultaneously: P14 and P16. Recovered cooling in P16 ( $CL_{T-SKS}$ ) was used internally and did not result in IS collaboration. However,  $CL_{T-SKS}$  did not meet process demands completely, and the existing cooling system remained in operation. This change influenced the distribution of  $EL_{T-HPP}$ . Again, BAC received all its electricity requirements from  $EL_{T-HPP}$ . In EN0 scenarios, AAC received the remaining  $EL_{T-HPP}$ . In EN+RA0, the share of SKS from  $EL_{T-HPP}$  increased compared to the same scenario in configuration B. In the other three scenarios,  $EL_{T-HPP}$  was used the same way as configuration B. We replaced P16 with an electricity recovery unit (P18) in configuration D. Although P18 came into operation in all scenarios, partially or entirely, all recovered electricity was consumed internally in SKS and did not result in IS.  $EL_{T-HPP}$  utilization pattern remained almost similar to configuration C.

In all these configurations, energy recovery in HPP played a significant role in the prospected IS collaboration. However, a previous study showed that HPP had no substantial collaborations with the other companies in PGSEZ (Chapter 3). The same survey showed that SKS has collaborated with other companies in the industrial cluster and expressed openness to engage in new collaborations. Nonetheless, the model showed that adding waste recovery units to SKS in configurations C and D did not result in symbiotic exchanges, although it improved the energy efficiency of SKS. These results reveal that technically feasible collaborations do not necessarily correlate with actors' historical collaborations. Historical collaboration is an important parameter but does not necessarily result in IS emergence.

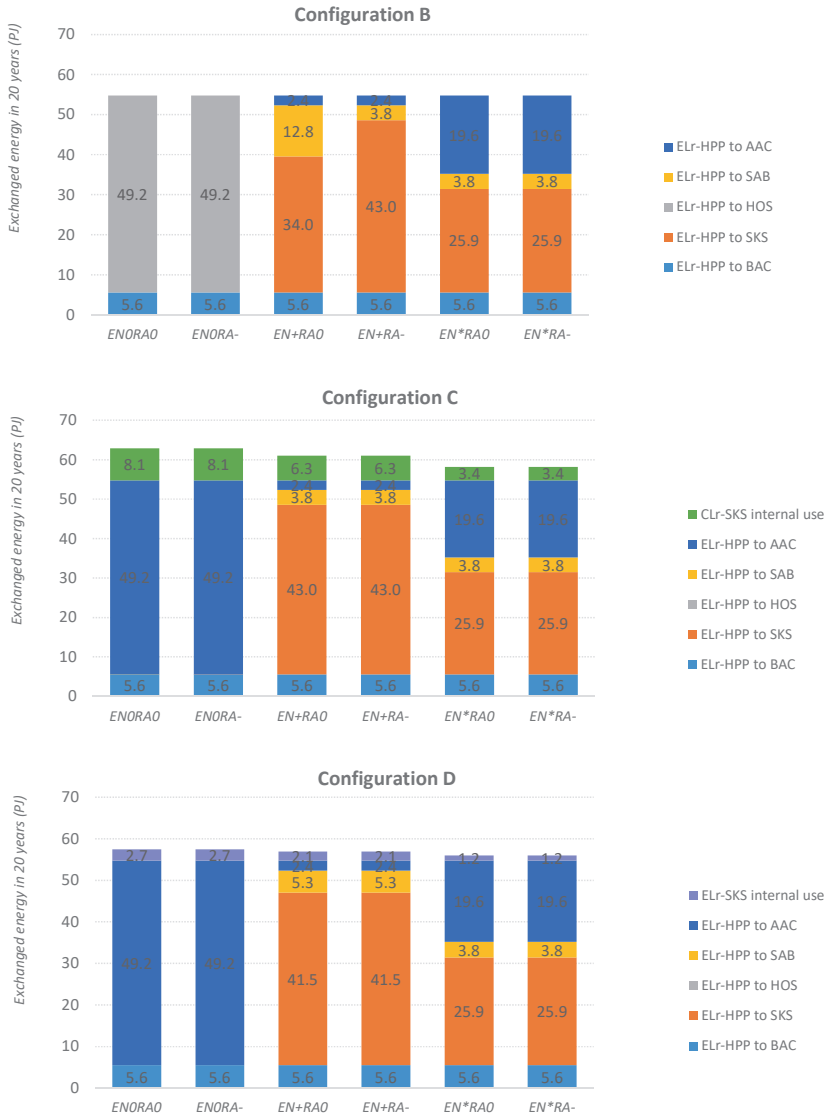
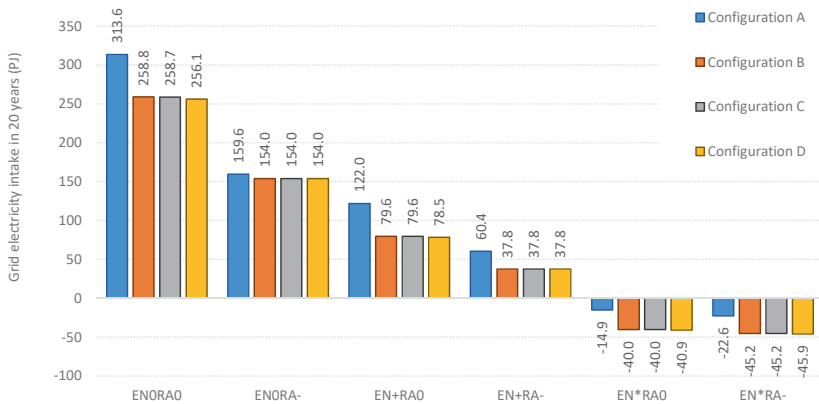

Figure 4.4 Exchanged energy among actors in 20 years in Configurations B, C and D

### 4.4.3 IS contribution to cluster performance improvement

#### 4.4.3.1 Grid electricity consumption

Net grid electricity consumption is the sum of PGSEZ and BAC’s electricity intake minus excess electricity supply from PGSEZ to the grid. Negative values in **Figure 4.5** represent net supply to the grid over 20 years. With a decline in industrial plants’ production level in EN+ scenarios, electricity intake from the grid also dropped. In the EN\* scenario, cluster electricity generation was larger than its demand, and thus the net intake became negative. All implemented waste recovery and exchange configurations decreased grid electricity intake compared to configuration A. The highest reduction was caused by P14, which had the highest capacity among the waste recovery plants and remained in operation under all examined conditions. In the EN0RA0 scenario, electricity recovery in P14 reduced electricity intake from the grid by 17.5% compared to configuration A. The amount of recovered energy in P16 and P18 was lower than the total electricity requirement of the cluster. Therefore, grid electricity intake barely dropped in configurations C and D, compared to B. Nevertheless, the energy recovery plants could not compensate for the restricted electricity supply from the grid in RA-scenarios. Therefore, the total cluster electricity intake dropped under RA- scenarios compared to RA0.

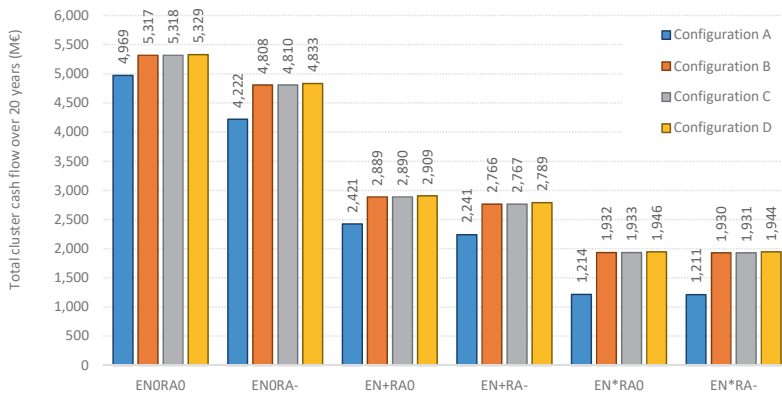

**Figure 4.5** Electricity intake from the grid in 20 years under different configurations and scenarios

#### 4.4.3.2 Cluster cash flow

**Figure 4.6** shows the 20-year cash flow of the system. In all configurations, cash flow dropped by increasing energy prices. Unless under fixed energy prices, restricted electricity supply from the grid did not influence overall cash flow significantly. **Figure 4.6** also shows that overall

cash flow increased in configurations B, C, and D investment and operation costs of waste recovery plants. However, the increase was minor in configurations C and D compared to B. Under current energy prices, investment in P14 in configuration B resulted in overall cash flow improvement by 348 M€. Under moderate and drastic rise in energy prices, cash flow improvement due to recovered energy utilization increased and reached 719 M€ in EN\*RA-scenario.



**Figure 4.6** Overall cash flow over 20 years in different configurations and scenarios

#### 4.4.4 Sensitivity analysis to product prices

As discussed in section /4.4.1, an increase in input energy prices decreased actors' cash flow and resulted in a reduction in the production level of industrial plants (**Figure 4.3**). Consequently, the amount of recovered waste heat declined, and the energy exchange pattern among actors changed (**Figure 4.4**). In those scenarios, we kept the market price of the final products fixed. Therefore, cash flow decreased by rising input energy prices. In this section, we provide results of the sensitivity of the results to increases in product prices. We increased the product prices annually by 1% to 6% annually in the six scenarios.

First, we investigated under which increased market prices the industrial plants maintained production at maximum capacity despite rising energy prices. The results were different for EN+ and EN\* scenarios. In the absence of waste recovery and exchange, SKS and HOS continued production at maximum capacity with a 2% and 3% annual rise in market prices under EN+ and EN\* scenarios, respectively. For SAB, the required increase rate in market price to prevent a drop in production level was 1% in the EN+ scenario and 2% in EN\* scenario. The rates were 3% and 6% for AAC, respectively. Configuration B improved HOS's operation,

where the required product price increment to remain operational at full capacity under the EN+ scenario was 1%. In configurations C and D, the same behavior was observed for SKS.

As stated in section 4.4.1, the production level of P14 was not changed by rising energy prices. Nevertheless, P16 (in Configuration C) and P18 (in Configuration D) stopped operation after a few years, followed by the same trend in the production level of P2. A 1% and 3% increase in product prices under EN+ and EN\* scenarios prevented the drop in the production level of P2. Consequently, P16 and P18 did not stop operation. However, again, all recovered energy was consumed by SKS internally.

The annual rise in product prices increased the cash flow of all actors. Symbiotic exchanges among actors were influenced widely by this change. For instance, in Configuration B, a 1% and 2% rise in product prices turned HOS into the primary receiver of  $EL_{T-HPP}$ . Under 3% and more product price rise, AAC started to receive the majority of  $EL_{T-HPP}$ . These observations matched with changes in production level observed in the above section. In configuration C, the primary receivers of  $EL_{T-HPP}$  were HOS, SKS, and AAC under 1%, 2%, and 3% rise in product prices, respectively. Only recovered energy supply to BAC remained untouched in all configurations. BAC received all its 5.6 PJ electricity requirements from HPP despite all changes.

## 4.5 Discussion

This paper investigated the emergence of IS collaborations in industrial clusters under varying external conditions. It proposed a system-level approach for techno-economic analysis and exploring waste recovery and exchange configurations. The approach's novelties were decomposing symbiotic exchange into a set of physical and non-physical processes and flows, applying cluster's technical, economic, and institutional requirements as model constraints, and giving actors the opportunities to select among different waste management options. This paper's conceptualization and modeling approach does not have a complicated formulation but an easy-to-understand visual interface. As argued in the introduction, many previous IS studies have not dealt with waste recovery's investment and operation costs and the present value of this investment in actors' decisions. This paper dealt explicitly with actors' investment decisions in waste recovery in the long-term while external factors change over time.

The case study showed that a steep rise in energy prices does not necessarily result in further waste recovery and exchange. As observed in configuration A, the production level of energy-intensive steel and aluminum plants dropped because of a steep rise in electricity and natural gas prices. A drop in the production level of industrial plants reduces both the amount of

generated waste heat and the demand for recovered energy. It also decreases actors' cash flows and influences their investment decision on waste recovery plants. Variations in energy prices also affected the utilization of recovered energy by the other actors. In our case study, although recovering the power plant's waste heat was techno-economically feasible under all examined scenarios, the primary receiver of recovered electricity changed with increasing energy prices. Thus, pointing out the need to study IS formation in conjunction with the whole system operation.

Investigating improvements in cluster cash flow and electricity consumption revealed that all technically possible waste heat recovery options do not necessarily improve cluster performance. Investment and operation costs of different waste heat recovery technologies should be considered along with their technical specifications in system analysis.

Comparing shaped symbiotic exchanges with previous field studies revealed that techno-economically feasible collaborations do not necessarily correlate with the network of previous collaborations. For instance, despite SKS being perceived as one of the most willing actors to engage in new collaboration in the industrial cluster, adding waste heat recovery plants to SKS did not result in IS connections. On the other hand, HPP showed substantial energy exchanges while not experiencing many previous collaborations in the cluster. However, it should be noted that although our conceptualization allows the modeler to incorporate social parameters in actors' decisions, social characteristics are exogenous parameters for economic optimization in Linny-R. If properly assessed and quantified outside the model, social factors could be added above economic benefit as an influential factor in waste recovery and exchange.

A sensitivity analysis showed that a 2% rise in the product price enabled steel industries to operate at maximum capacity despite increasing energy prices. Consequently, related waste recovery plants worked at full capacity. The amount of recovered electricity by the power plant was not sensitive to changes in steel prices, but its utilization by other actors was. This indicates how actors' cash flow increment influences their production levels and affects optimal cluster energy supply patterns.

Every model is embedded in a system of assumptions. In this paper, a key assumption was that the waste recovery process was owned by the actor who generated the waste. Other business models are indeed possible, which calls for further research. Moreover, other actors, such as facilitators, governmental organizations, or cluster management, could be introduced to model different IS dynamics. Depending on their role, the actors can contribute to waste recovery and

exchange costs. If the actor is a non-profit organization, Linny-R settings could exclude it from the economic optimization procedure.

We applied a fixed connection cost to the receiving actor in the case study. However, every two actors might have different contracting and supervision costs (Fraccascia et al., 2017b) or investments required for the exchange (e.g., piping). These costs could be implemented by defining two separate sell and buy processes for two actors. In addition, it should be noted that a more detailed techno-economic study is necessary before implementing this system-level assessment. Incorporating non-physical and physical entities in Linny-R provides a novel opportunity for system-level analysis of industrial clusters. This approach can be easily adjusted for any industrial cluster, while its application is not limited to IS. It provides a basis to study different industrial development strategies under various external conditions.





# 5 The interplay between industrial symbiosis and other industrial decarbonization strategies

## ABSTRACT

So far, no unique decarbonization strategy can fully decarbonize hard-to-abate industrial sectors. In the complex structure of industrial clusters, different decarbonization strategies affect each other technically and economically, and external factors influence these strategies in different ways. This chapter aimed to assess the interplay between industrial symbiosis and carbon capture and storage (CCS) in industrial clusters, and their impact, individually or together, on the cluster's carbon intensity and cash flow. For this purpose, we extended the conceptual framework introduced in Chapter 4 and added different CCS and IS options to the cluster, along with costs and constraints associated with each option. The Persian Gulf Mining and Metals Special Economic Zone (PGSEZ) in Iran was used as a case study to compare cluster cash flow and carbon emission in four configurations: the current structure, IS-only, CCS-only, and IS plus CCS implementation. In the case study, CCS plants operated only under high or exponentially increasing carbon taxes, rising steel prices, and fixed or moderately rising energy prices. Cluster performance improved more in CCS-IS compared to CCS-only configuration. Under a low carbon tax, the IS-only configuration resulted in better performance because CCS plants did not come into operation. However, this performance improvement was much lower than the CCS-IS configuration. The model shows that intertwined production, waste recovery, and carbon capture plants must be studied as a system. In this system, the success of different strategies in cluster performance improvement depends on external factors.

## 5.1 Introduction

In Chapters 2 and 3 of this dissertation, we investigated the socio-technical structure of an emerging industrial cluster. In Chapter 4, a MILP model of the cluster was built to explore the emergence of IS in an industrial cluster under different scenarios and IS contribution to energy efficiency and cash flow improvement of the whole system. IS was chosen as a way to promote sustainable development in industrial clusters through recovering and utilizing available waste flows. Flue gases containing carbon dioxide have caught much attention in recent decades because of CO<sub>2</sub> role in global climate change and no surprises there is a wealth of literature dedicated to explore pathways to mitigate CO<sub>2</sub>. There has been, however, significantly less attention to the decarbonisation capability of IS, alone or in combination with other decarbonization strategies.

Nowadays, many countries share the impressive ambition of significantly reducing carbon emissions to limit long-term global temperature rise to 1.5 °C (IEA, 2021). Almost 30% of global greenhouse gas is emitted by the industry sector (Ritchie and Roser, 2020), calling for immediate action. Almost 70% of carbon emissions and 60% of energy consumption of the industry sector belong to the iron and steel, cement, and chemical industries (Paltsev et al., 2021). The carbon dioxide emissions of these industries are both energy-related and process-related. Low-carbon energy input cannot eliminate process emissions, while other technical options to reduce such emissions are limited, making these industries hard-to-abate (Paltsev et al., 2021). Moreover, these industries are expected to grow primarily in emerging industrial economies because steel and cement are essential, almost irreplaceable, for development in today's world. Emerging economies want to ensure reliable energy supply and economic growth through the transition to net-zero carbon emission.

To date, no unique carbon emission reduction strategy exists for the hard-to-abate sector. Energy recovery and exchange among neighboring industries, known as industrial symbiosis (IS), can contribute indirectly to carbon mitigation by decreasing industrial clusters' energy intake (B. Yu et al., 2015). However, this may not be enough to achieve a deep reduction in carbon emissions. Carbon capture, transport and storage (CCS) is one of the most studied strategies to reduce industrial CO<sub>2</sub> emissions in hard to abate sectors (IEAGHG, 2020, 2018, 2017; Roussanaly et al., 2017). One of the challenges of CCS deployment is its high energy requirement. In power plants, this energy is extracted from the turbine itself. Other industries will need additional energy supply systems for CCS (e.g., combined heat and power, gas-fired steam boilers, or devices for electrification), which might generate CO<sub>2</sub>, depending on the energy source.

CCS energy demand can decrease by technological improvements in capture processes. Moreover, Innovative energy sources could be utilized to meet this demand (Carapellucci et al., 2015). Heat integration within the carbon-emitting plant or a nearby plant is a promising solution (Roussanaly et al., 2021a). There is also an opportunity for symbiotic energy supply to CCS from cluster-level available waste heat. Simultaneous implementation of IS and CCS in industrial clusters might result in higher carbon abatement. However, IS influences CCS operation through its energy supply, and CCS influences the IS network by changing the energy demand pattern of the cluster. As discussed in Chapter 2, changes in demand influence IS potential. If utilized for CCS, waste heats will not be available for other recovery and exchange possibilities. On the other hand, utilizing captured CO<sub>2</sub> from one plant as raw material to another plant in the cluster will result in a material-based symbiotic exchange.

Besides technical interconnections, IS and CCS can interact through economic flows. Both strategies require significant investments while industrial actors' economic resources are limited. Previous studies have showed that CCS increases the production cost per unit of the final product (e.g., Roussanaly et al., 2021b). The increase depends on plant-specific conditions and external factors such as energy prices and carbon tax (Roussanaly et al., 2021a). However, most CCS cost data are available for Western Europe or North American contexts. In emerging economies, operation costs might be lower because of smaller labor factors and lower energy prices. But, higher investment costs are expected due to higher project contingency and location factors for large-scale energy projects in these countries (Roussanaly et al., 2021b). Moreover, while IS could reduce the operating cost of CCS, it might impose higher investment costs to waste heat generating actors than other CCS energy supply options.

As stated above, IS and CCS interact technically and economically in industrial clusters. Material and energy networks in the cluster change by adding CCS, affecting the technical potential for IS, as discussed in Chapter 2. Besides, when CCS is on the agenda, external factors such as carbon emission control policies will influence actors' decisions and cluster performance. In Chapter 4, we proposed a conceptual framework based on Linny-R functionalities to model the techno-economic structure of the cluster from its building blocks: processes and products. Products are flow-type entities, either physical (e.g., material and energy) or non-physical (e.g., money and information). The process is an activity owned by an actor that transforms some products into others (Bots, 2021). A process could also be physical (e.g., an industrial plant) or non-physical (e.g., decision-making, contracting). Processes and products are defined by their upper and lower bounds and connected through links and constraints. Defining non-physical entities enables the modeler to implement economic, environmental, and institutional costs and limitations to the system. Linny-R solver maximizes

the cash flow of the whole system, subject to its restrictions. These functionalities have made Linny-R a proper tool for industrial system analysis.

This chapter extends the conceptual framework introduced in Chapter 4 to assess the suitability of the model to provide robust insights into more complex conditions. Here, we mapped carbon intensity on industrial plants, then added various IS and CCS options, separately and together, to examine their interplay and its effect on cluster carbon emission and cash flow. The modeling approach was implemented on PGSEZ to explore its functionality in a case study. Section 5.2 presents the conceptualization and modeling method, and its implementation in the case study. Results of the model are presented and discussed in section 5.3. Section 5.4 discusses the results and reflects the contribution of these modeling works to the broader field of IS modeling.

## 5.2 Methods

### 5.2.1 Conceptualizing IS and CCS integrating into cluster structure

IS and CCS integration in the techno-economic structure of the cluster is illustrated schematically in **Figure 5.1**. Three representative actors in this figure have several options. Actor 1, for instance, can dispose of its waste heat or recover it as electricity (Waste recovery option 1) or steam (Waste recovery option 2). Recovered electricity can be used internally, sold to the grid, or exchanged with Actor 3. If Actor 1 decides for electricity recovery, and Actor 3 buys electricity from Actor 1 instead of the grid, IS shapes between the two actors. Simultaneously, Actor 2 can emit its generated CO<sub>2</sub> to the environment or capture it via CCS. If CCS is selected, its steam requirement for the capture process can be supplied from an auxiliary steam boiler or from Actor 1 (waste recovery option 2). The latter results in IS collaboration between Actors 1 and 2 instead of previously expected IS between Actors 1 and 3.

Actors go through different CO<sub>2</sub> mitigation routes based on the costs and constraints associated with each choice to maximize their cash flow. As shown in **Figure 5.1**, the commencement of new plants (e.g., waste recovery, CCS, or auxiliary steam boiler) imposes investment and operation costs to actors. One actor's decisions affect other actors' choices and accordingly IS and CCS establishment in the complex structure of industrial clusters. An increase in the number of actors or plants held by each actor results in more waste recovery or CCS

opportunities in the system. The next section explains how these options are modeled in Linny-R, considering their costs and constraints.

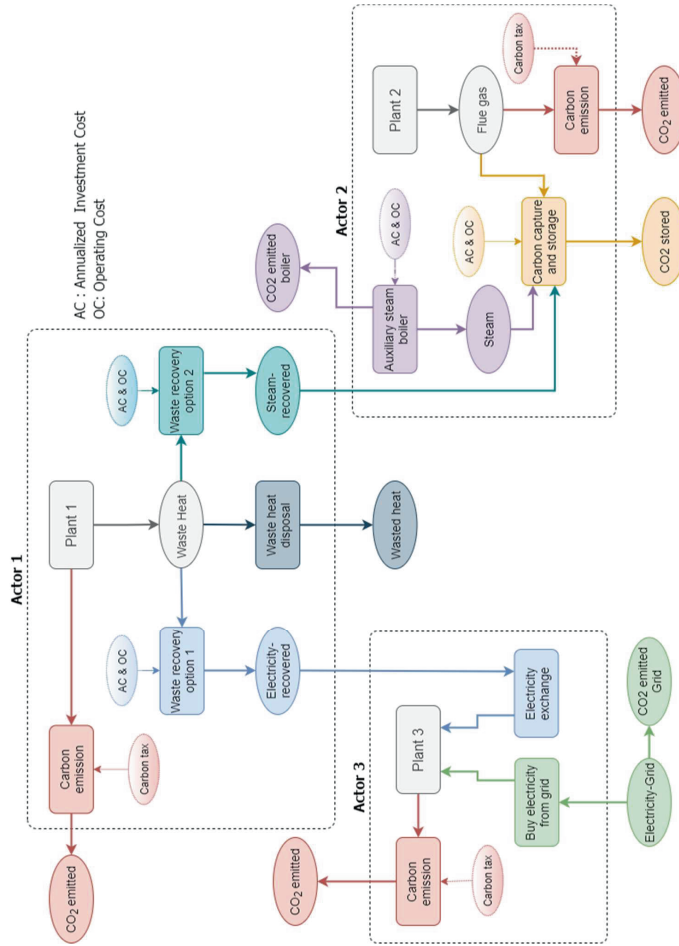

Figure 5.1 Schematic integration of IS and CCS and interplay between them in an industrial cluster

### 5.2.2 Industrial cluster modeling in Linny-R

Based on the conceptualization of Chapter 4, to model the industrial cluster, we considered each industrial plant a process and its incoming and outgoing flows, including carbon intensities, as

products. It should be noted that our model optimizes the system, not individual units. Technical and cost specifications of production, waste recovery, and CCS plants are exogenous input data, obtained from actual field data or literature. The model optimizes the system using a bottom-up approach. All incoming and outgoing flows were priced, if applicable. Non-physical activities and flows were also added to the cluster as data-type entities. In our model, continuous variables of the optimization function were production levels of processes, and integer variables were the start-ups of new plants or connections. The following sections elaborate on how different routes presented in **Figure 5.1** were integrated into the cluster model.

### 5.2.2.1 Implementing costs and constraints associated with environmental emissions

The disposal of generated waste flows in industrial plants to the environment might be associated with disposal costs (e.g., crushing and transportation). The unit disposal cost was applied to the waste disposal process as a data-type entity (**Figure 5.2** (a)). Moreover, as waste disposal might be ruled by environmental regulations, two leading emission control policies, for either carbon or other environmental effluents, are included. Price-based policies (**Figure 5.2** (a)) such as carbon tax (IEAGHG, 2020) or landfill tax (Fraccascia et al., 2017b) were implemented in the model in the same way as unit waste disposal costs. Quantity-based policies (**Figure 5.2** (b)) such as cap and trade policy for CO<sub>2</sub> emission were modeled by adding emission trade cycle. The upper bound of the waste disposal process in **Figure 5.2** (b) was set to the allowable emission limit. Waste flow could be emitted at no cost up to the maximum allowable emission. Deviations from this limit can be sold or bought in the emission trade market, where traded waste has a negative price.

### 5.2.2.2 Establishment of a new plant in the cluster

After defining waste disposal options as explained in section 5.2.2.1, intended waste recovery or CCS options were added to the model in parallel to the waste disposal route. Material and energy consumption and technical specifications of new processes were obtained from the literature. Captured CO<sub>2</sub> was sent to storage. Recovered energy was connected to either CCS or other prospected demands through non-physical *selling* and *buying* processes. Costs associated with these processes (e.g., contracting and supervision) were implemented as data-type flows.

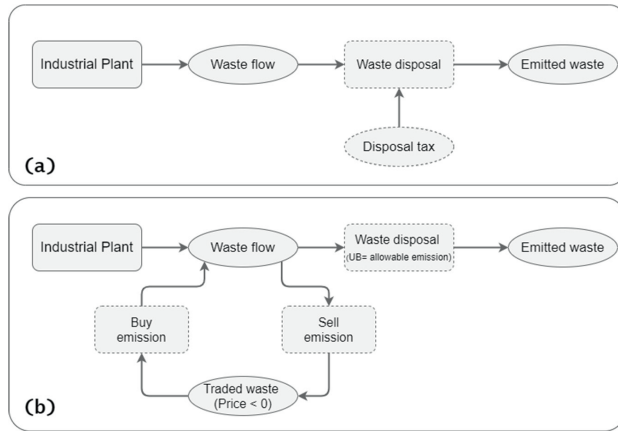

**Figure 5.2** Implementing waste disposal costs and limitations in Linny-R; (a): price-based; (b): quantity-based

The establishment and operation of a new plant have their own costs as well. Cost estimation is essential for system analysis, especially when investment decisions are made. Three types of costs are associated with the operation of every production plant: capital expenditures (CAPEX), fixed operating expenses (OPEX<sub>fixed</sub>), and variable operating expenses (OPEX<sub>var</sub>). In this work, we assumed that the existing plants had been fully paid off completely. Therefore, CAPEX was considered only for the capture and compression, waste recovery, and auxiliary energy supply plants.

Following IEAGHG guidelines for carbon capture from fossil fuel power plants and Steam-Methane Reforming (SMR) hydrogen plants, Total Capital Requirement (TCR) was used in CAPEX estimations (IEAGHG, 2020, 2017). The cost was adjusted to account for economy of scale, retrofit, location, and contingency factors. For the purpose of this analysis, a simplified retrofit factor (SRF) equal to 1.09 for brownfield projects was used (NETL, 2013a). When equipment cost was available for a different size, it was scaled using scaling factors obtained from cost scaling guidelines for energy system studies (NETL, 2013b). OPEX<sub>fixed</sub> was estimated as a percentage of total plant cost (TPC) when not directly available in the literature (Feron et al., 2020; NPC, 2019). CAPEX and OPEX<sub>fixed</sub> values were also multiplied with location factors (Roussanaly et al., 2021b). Finally, CAPEX and OPEX<sub>fixed</sub> were reflected in the model as annualized cost (AC). Using the start-up functionality of Linny-R, when an actor decided to invest in a new installation, AC was deducted from its cash flow annually regardless of the production level of the new plant. OPEX<sub>var</sub> was implemented in the model directly as inflow and subtracted from cash flow proportionate to the production level of the plant.

### 5.2.2.3 Reflecting social factors on actors' decisions

Actors' decision to invest in a new plant or start a new collaboration is not only influenced by economic benefits. Such decisions are influenced by social factors such as actors' social embeddedness (Ashton and Bain, 2012), their organizational and cultural proximity (Velenturf and Jensen, 2016), or information-sharing platforms (Fraccascia and Yazan, 2018). We did not replicate social processes in the model but proposed a way to incorporate actors' social willingness to collaborate in the emergence of new connections and processes based on results of Chapter 2. The social willingness of different actors was introduced in the model as exogenous parameters. The upper bound of decision-based processes (e.g., sell and buy) was set to zero if the actor's willingness was lower than a defined threshold. Otherwise, the upper bound was equal to its maximum technically possible amount.

## 5.2.3 Case study implementation

### 5.2.3.1 The Persian Gulf mines and metals special economic zone

The iron and steel industry causes 7% of global CO<sub>2</sub> emissions (IEA, 2020b). Two main primary steel production routes are Blast furnace-basic oxygen furnace (BF-BOF) and Direct reduced iron to electric arc furnace (DRI-EAF) (Fan and Friedmann, 2021). Carbon intensities of 1,600-2,224 kg CO<sub>2</sub>/ t<sub>steel</sub> and 500-1,395 kg CO<sub>2</sub>/ t<sub>steel</sub> are reported for these two routes (Fan and Friedmann, 2021; IETS, 2020; Kappes and Both, 2021). Although there are several studies of technologies, at different readiness levels, to reduce the carbon intensity of the BF-BOF process, publicly available studies on DRI-EAF are limited.

The Persian Gulf mines and metals special economic zone (PGSEZ) in the south of Iran comprises two DRI-EAFs, one DRI, one aluminum reduction, and one power generation plant. The DRI plants are all gas-based using MIDREX technology (Atsushi et al., 2010). The modeling approach elaborated in section 5.2.2 was implemented to assess the interplay between IS and CCS in PGSEZ and their impact on the cluster's carbon emission and cash flow in the long term. To map the carbon intensity of the cluster, we considered direct emissions of production plants and indirect emissions due to grid electricity consumption. **Table 5.1** summarizes the carbon intensities used in this study. We gathered data on the CO<sub>2</sub> intensity of industrial processes per unit of final product from the literature. The carbon intensity of grid electricity was calculated based on the average efficiency of power plants in Iran, obtained from national statistics. Note that the amounts do not cover CO<sub>2</sub> emission from raw material extraction, processing, and transport to and from cluster boundaries.

**Table 5.1** Carbon intensity of industrial plants and grid electricity used in this study

Carbon source	Unit emission
MIDREX direct reduction	0.52 t CO <sub>2</sub> /t DRI <sup>1</sup>
EAf steelmaking	0.08 t CO <sub>2</sub> /t steel <sup>2</sup>
Hall-Heroult aluminum reduction	1.80 t CO <sub>2</sub> /t Al <sup>3</sup>
Natural gas-fired power plant	0.154 t CO <sub>2</sub> /TJ electricity <sup>4</sup>
Grid electricity	0.114 t CO <sub>2</sub> /TJ electricity <sup>5</sup>

1. Based on MIDREX data (Kappes and Both, 2021) and (Fan and Friedmann, 2021)
2. The average amount of 0.06 ~ 0.10 t CO<sub>2</sub>/t steel from (Demus et al., 2012).
3. Based on (Jilvero et al., 2014)
4. It is calculated based on CO<sub>2</sub> emissions from natural gas combustion (EIA, 2021) and plant efficiency.
5. Electricity CO<sub>2</sub> intensity is calculated based on CO<sub>2</sub> emissions from natural gas combustion (EIA, 2021) and the average efficiency of thermal power plants in Iran (tehrantimes, 2019)

### 5.2.3.2 Adding CCS plants to PGSEZ

To explore the carbon capture possibility for point sources inside the cluster, we looked into both CO<sub>2</sub> concentration in the flue gas and modifications in the existing design to add CCS to the plant. Considering the production capacity and carbon intensity of MIDREX DRI plants (Table 5.1), three MIDREX plants are the biggest carbon emitters in PGSEZ. CO<sub>2</sub> concentration in MIDREX DRI flue gas is around 15%, one-third of which is process-related due to using natural gas as feedstock, and two-thirds is energy-related. Although several reliable international studies have been conducted to implement CCS in the BF-BOF steelmaking route (IEAGHG, 2018; Roussanaly et al., 2021b), no techno-economic assessments data were (publicly) available for MIDREX DRI plants. The only commercialized CCS from a DRI plant is the Al-Reyadah project in UAE, which implemented MEA post-combustion capture technology (Fan and Friedmann, 2021; IETS, 2020). Unfortunately, the technical specifications of the project were not publicly available.

However, the MIDREX reformer process is similar to the Steam-Methane Reforming (SMR) hydrogen generation process. Its flue gas composition also matches SMR flue gas (Fan and Friedmann, 2021; IEAGHG, 2017). MIDREX reformer cracks NG into H<sub>2</sub> and CO to be used as reduction gas in the furnace. The furnace reaction product is circulated back to the reformer. Part of it is used as fuel with NG to provide the required energy for cracking reactions. The IEAGHG has published an extensive techno-economic assessment of carbon capture in SMR hydrogen generation plants (IEAGHG, 2017). We used techno-economic data from Case 3 of

the IEAGHG report as a proxy of CCS in MIDREX plants. A 90% capture rate and 11 MPa pressure at pipeline take-over point were assumed for all CCS plants. Reference cost (RC) for MIDREX CCS plants was also taken from the same reference, including dehydration and compression costs.

For the gas turbine power plant (P6), an amine-based post-combustion carbon capture, the most mature and commercialized technology, was considered according to benchmark studies by IEAGHG (2020). Performance parameters and energy and solvent requirements of selected capture and compression plants are summarized in **Table 5.2**. The researchers used RC for the power plant capture unit from Feron et al.(2020). The reference did not include compression costs. Therefore, compressor investment cost was calculated based on Knoope et al. (2014). Detailed cost calculations are presented in Appendix J.

**Table 5.2** Performance parameters of capture and compression plant used in this study

Parameter	Power plant	MIDREX plants
	(From (Feron et al., 2020) unless otherwise noted)	(From (IEAGHG, 2017) unless otherwise noted)
Capture type	MEA-based PCC	MEA-based PCC
CO <sub>2</sub> removal efficiency	90%	90%
Capacity factor	95%	95%
Heating demand	3.0 TJ/ kt CO <sub>2</sub>	2.7 TJ/ kt CO <sub>2</sub>
Electricity (pumps, blower)	0.17 TJ/ kt CO <sub>2</sub>	0.149 TJ/ kt CO <sub>2</sub>
Electricity (compressor)	0.384 TJ/ kt CO <sub>2</sub> <sup>(1)</sup>	0.384 TJ/ kt CO <sub>2</sub> <sup>(1)</sup>

1. It is calculated according to (Farajzadeh et al., 2020), considering efficiencies of 90% and 70% for drive and compressor.

CO<sub>2</sub> concentration in aluminum smelter flue gas is lower than one volumetric percent because of dilution with cell cooling airflow (Jilvero et al., 2014). Carbon capture at this low concentration is considered too expensive. For instance, each cell must be modified to increase outlet CO<sub>2</sub> concentration to 4%. Considering 290 smelting cells installed in AAC (Almahdi, 2022), this would mean extensive changes. Moreover, the flue gas also contains oxygen, which is harmful to conventional solvents (Broek and Save, 2013). Therefore, we did not consider CCS for AAC in this study. In an electric arc furnace (EAF) steelmaking, CO<sub>2</sub> is generated from carbon and oxygen injection for foamy slag generation and reactions in the metal and slag phases (Echterhof, 2021). However, the average CO<sub>2</sub> emission from EAF steelmaking is very low (**Table 5.1**), while its concentration changes during each charge. EAF off-gas is then mixed

with other flue gases, resulting in an even lower concentration (Nardin et al., 2018). We have therefore not included CCS in EAF plants in the study.

## 5.2.4 Experimental design

### 5.2.4.1 IS and CCS configurations

In PGSEZ, several waste heat flows are available for recovery (see Chapter 2 of this thesis). As the focus of this chapter is to understand whether the modeling approach developed in Chapter 4 can be used to assess how different measures interact with each other, we decided to simplify the system and focus on power plant waste heat in this chapter. A configuration is defined here as different arrangements of carbon capture and waste recovery in the cluster. Four configurations were examined in this study (see

Table 5.3) to gain insights into the interplay between IS and CCS in PGSEZ, and their impact on cluster carbon emission and cash flow. Configuration A corresponds to the existing structure of the cluster without CCS or IS.

Four CCS plants with specifications given in Table 5.2 were added to the cluster in CCS-only configuration. In this configuration, electricity was supplied to the CCS plants from the grid, and low-pressure steam for heating was generated in NG-fired steam boilers (NSB) with an efficiency of 90%. The amount of emitted CO<sub>2</sub> from a NSB was assumed as 0.057 kt CO<sub>2</sub>/TJ<sub>Steam</sub> (Roussanaly et al., 2021a). A cost function introduced by Carapellucci et al. (2015) was used to calculate NSB investment cost.

In the IS-only configuration waste heat from the gas turbine power plant was used for electricity generation by adding a heat recovery steam generator (HRSG) and a steam turbine (ST), converting the gas turbine power plant to a combined cycle. Generated electricity was supplied to the other industries or to nearby urban areas to meet a part of their electricity demand. The investment cost for electricity recovery from power plant waste heat was calculated based on IEAGHG (2020), Manzolini et al. (2015), and Kuramochi et al. (2010).

As pointed out in the introduction, IS potential might change by adding CCS to the cluster. In the CCS-IS configuration, actors received the steam required for their CCS plants through IS instead of conventional energy supply methods (NSB in this case). Because of the need for steam, gas turbine waste heat was used for steam generation instead of electricity generation, transforming the power plant to a simple cycle CHP (combined heat and power). Generated

steam was connected to all four CCS plants. We used the cost suggested by Kuramochi et al. (2013) for steam recovery. Electricity required for CCS was supplied from the grid.

**Table 5.3** Configurations considered in this study

	CCS	WR	Energy supply to CCS
<b>A</b>	---	---	---
<b>CCS-only</b>	Capture and compression plants with specifications given in Table 5.2 were added to P6, P1, P3, and P7 (respectively called CCS1, CCS2, CCS3, and CCS4)	---	Electricity from the grid Heating from NSB
<b>CCS-IS</b>	Same as CCS-only	P15 (simple cycle CHP): Steam recovery from HPP waste heat	Electricity from the grid Heating from P15
<b>IS-only</b>	---	P14 as in Chapter 4 (HRGS + ST): Electricity recovery from HPP waste heat	---

#### 5.2.4.2 External factor scenarios

CO<sub>2</sub> emissions are subject to environmental taxes and limitations in many countries and this is soon expected to be the case in more regions and countries. Middle East countries, including Iran, have not implemented a carbon emission control policy yet. We examined the impact of future changes in carbon tax on CCS and IS deployment in PGSEZ in four scenarios (Table 5.4). CTf, CTl, and CTh represent constant zero, low, and high carbon tax implementation in the next 20 years. CTe represents an increasing carbon tax starting from 20 €/t, CO<sub>2</sub> and increases with an annual rate of 10%.

The marginal revenue is not enough to cover CCS costs in many industries. Therefore, imposing a carbon tax alone may not be enough to promote carbon capture (NPC, 2019). In SP scenarios, we examined the role of increased final product prices. In the SPf scenario, steel prices remained unchanged during the whole simulation time. In the SPi scenario, steel prices increased annually to reach the forecasted steel prices for the DRI-EAF route in the case of carbon tax implementation, according to IEA (2020b).

Electricity and natural gas prices in Iran are set by the government, not by the market, and prices are significantly lower than average European prices (Appendix K). Energy price scenarios

look at the role of future energy prices on production, waste recovery, and the capture plants. Three energy price scenarios were investigated in this study: no change (EPf), moderate rise (EPm), and drastic rise (EPd). In the EPm scenario, energy prices increased with an annual rate of 10%, and in the EPd scenario, energy prices first doubled and then rose 10% annually.

In each configuration, 24 scenarios were examined. Each scenario was named using the format CTx.SPy.EPz, where CTx, SPy, and EPz represent conditions summarized in Table 5.4. All scenarios were designed for 20 years. Model configurations with applied scenarios are presented in the Appendix K.

Table 5.4 Scenarios examined in this study

Carbon tax (€/t CO <sub>2</sub> )		Steel price (€/t)		Energy price (€/TJ)	
CTf	0	SPf	2016 steel prices	EPf	2016 energy prices
CTI	50	SPi	SPf x 1.02 <sup>(t-1)</sup>	EPm	EPf x 1.10 <sup>(t-1)</sup>
CTh	100			EPd	EPf x 2 x 1.10 <sup>(t-1)</sup>
CTe	20 x 1.10 <sup>(t-1)</sup>				

## 5.3 Results

### 5.3.1 Operation of carbon capture and waste recovery plants

*The results of four configurations revealed that CCS and WR plants came into operation under different external conditions (Table 5.5). CCS plants, consequently steam recovery plant from HPP waste heat for CCS consumption (P15 as defined in*

**Table 5.3**), operated only in four scenarios: CTh.SPi.EPf, CTh.SPi.EPm, CTe.SPi.EPf, and CTe.SPi.EPm. In the IS-only configuration, P14 (electricity recovery from HPP waste heat) came into operation in a broader range of scenarios. In the absence of a carbon tax, P14 came into operation at all energy and product prices, as it was observed in Chapter 4 as well. By introducing a carbon tax into the system, P14 operated only under rising energy prices (Em and EP scenarios). In two scenarios (CTe.SPi.EPm and CTh.SPi.EPm), three suggested CCS and IS technical arrangements (CCS-only, CCS-IS, IS-only) were feasible. This shows the dependence of techno-economic feasibility of different decarbonization strategies to external conditions. Low carbon tax, fixed product price, or drastically rising energy prices could not result in carbon capture in the cluster. On the other hand, applying a carbon tax and not increasing electricity prices prevents electricity recovery by HPP. In the following sections,

cluster carbon emission and cash flow are further analyzed to understand the impact of CCS and IS on cluster performance.

**Table 5.5** Feasibility of different configurations under different scenarios

	CT0		CTI		CTh		CTe	
	SPf	SPi	SPf	SPi	SPf	SPi	SPf	SPi
<b>EPf</b>	IS-only	IS-only	---	---	---	CCS-only CCS-IS	---	CCS-only CCS-IS
<b>EPm</b>	IS-only	IS-only	IS-only	IS-only	IS-only	CCS-only CCS-IS IS-only	IS-only	CCS-only CCS-IS IS-only
<b>EPd</b>	IS-only	IS-only	IS-only	IS-only	IS-only	IS-only	IS-only	IS-only

## 5.3.2 Cluster performance with carbon capture

### 5.3.2.1 Carbon emission

As stated in the previous section, carbon capture happened in the cluster only in four scenarios. While working at maximum capacity, the industrial plants emit a total of 73.8 Mt CO<sub>2</sub> during 20 years. The total capacity of CCS plants added to the cluster was equal to 57.0 Mt carbon capture if operated at maximum capacity for 20 years. However, CCS1 (capture and compression plant added to HPP) did not run in any designed scenario. CCS2, CCS3, and CCS4 started operation in the above-listed scenarios.

**Figure 5.3** compares direct carbon emission, indirect carbon emission, and captured CO<sub>2</sub> in these four scenarios. Direct carbon emission (CO<sub>2,dr</sub>) refers to total CO<sub>2</sub> emitted directly from industrial plants and NSBs over 20 years, and indirect carbon emission (CO<sub>2,grid</sub>) reflects CO<sub>2</sub> emission due to grid electricity consumption. As shown in **Figure 5.3**, CTh scenarios resulted in more CO<sub>2,captured</sub> than CTe. The highest CO<sub>2,captured</sub> was 42.5 Mt, in CTh.SP<sub>i</sub>.EP<sub>f</sub>. In this scenario, three CCS plants operated at almost maximum capacity. Both CCS-only and CCS-IS configurations lowered the total emitted CO<sub>2</sub> (CO<sub>2,dr</sub> plus CO<sub>2,grid</sub>), although total generated CO<sub>2</sub> (CO<sub>2,dr</sub> plus CO<sub>2,grid</sub> plus CO<sub>2,captured</sub>) was higher in these configurations. The total emitted CO<sub>2</sub> was the lowest in CCS-IS, although the amount of captured CO<sub>2</sub> was not consistently higher than in the CCS-only scenario. The highest reduction in total CO<sub>2</sub> emission was 31.0 Mt in the CTh.SP<sub>i</sub>.EP<sub>f</sub> scenario. Another interesting result is the significant share of CO<sub>2,grid</sub> in the total emitted CO<sub>2</sub>. CCS plants capture generated CO<sub>2</sub> directly from industrial plants' operations. CO<sub>2,grid</sub> remains high because of the high electricity intensity of steelmaking and aluminum

reduction plants. Similar to Chapter 4, an investigation of the production level of industrial plants is required to interpret changes in emitted and captured CO<sub>2</sub>.

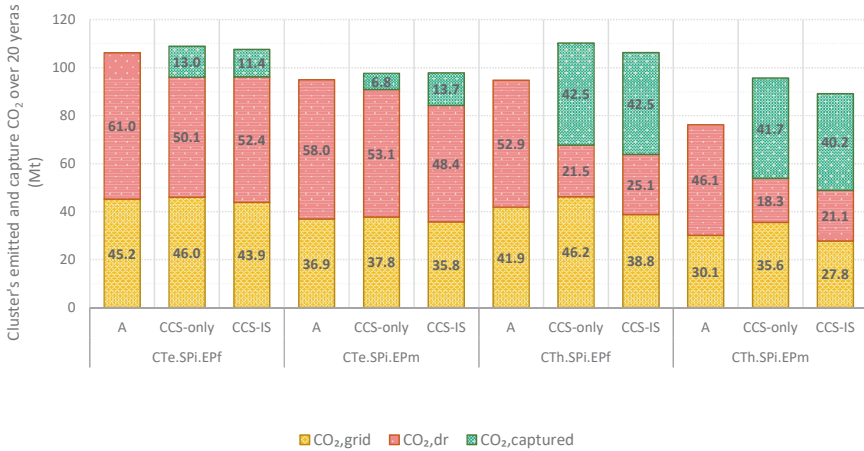

**Figure 5.3** Comparison of directly emitted, indirectly emitted, and captured CO<sub>2</sub> in configurations A, CCS-only and CCS-IS

### 5.3.2.2 Cash flow

As expected, in all configurations, the cash flow of the whole cluster (CF<sub>PGM</sub>) dropped with the rise in the carbon tax and energy prices. In all four scenarios, CCS-only and CCS-IS improved CF<sub>PGM</sub>. However, the improvement was not significant because of the high investments required for CCS and WR. CCS-IS showed slightly better economic performance under increasing energy prices (EPm scenarios). The increase in cash flow and decrease in emitted CO<sub>2</sub> indicates that CCS improves cluster operation, individually or in combination with IS. The amount of emitted CO<sub>2</sub> per generated cash flow is illustrated in **Figure 5.4**. As the figure shows, CCS-IS resulted in lower specific carbon emissions. The lowest amount was in the CTh.SPi.EPf scenario (9.3 kt of CO<sub>2</sub> per M€ of cash flow). The highest drop was observed in the CTh.SPi.EPm scenario, in which carbon emission dropped by 26.3 kt of CO<sub>2</sub> per M€ of cash flow.

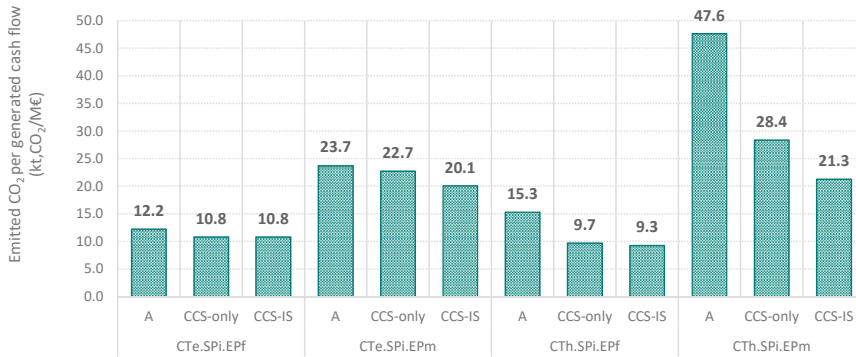

**Figure 5.4** Comparison of total emitted CO<sub>2</sub> per generated cash flow over 20 years in configurations A, CCS-only and CCS-IS

### 5.3.3 Cluster performance in IS-only configuration

#### 5.3.3.1 Carbon emission

As displayed in **Table 5.5**, in the absence of CCS, electricity recovery from power plant waste heat and its exchange with the other industries was feasible under 18 scenarios. Surprisingly, IS formation did not necessarily lower the total carbon emission compared to Configuration A, although the amount of indirect emissions (CO<sub>2,grid</sub>) dropped. Utilizing recovered waste heat helped industrial plants increase their production levels, thereby boosting CO<sub>2,dr</sub>. Consequently, total emitted CO<sub>2</sub> increased in 11 scenarios and decreased in seven scenarios, in three of which the decrease was limited (less than 1 Mt over 20 years). In four scenarios, namely CT0.SPi.EPm, CT0.SPi.EPd, CT1.SPi.EPm, and CTe.SPi.EPm, IS contribution to total CO<sub>2</sub> emission reduction was considerable (**Figure 5.5**). However, the highest reduction obtained was only 5.4 Mt (CT0.SPi.EPm scenario). As observed in section 5.3.2, the reduction reached 31.0 Mt when CCS was added to the cluster.

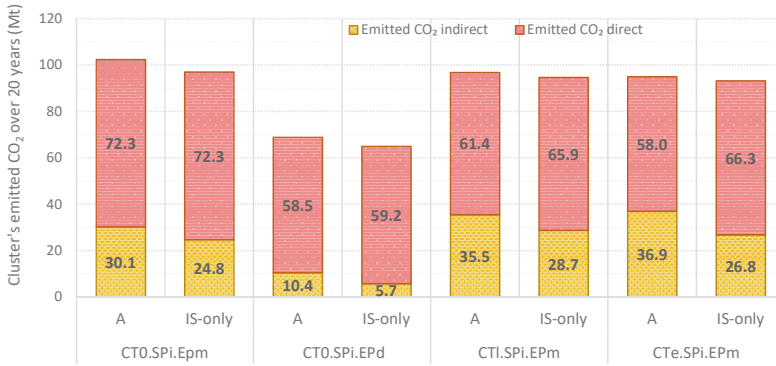

Figure 5.5 Comparison of directly and indirectly emitted CO<sub>2</sub> in configuration A and IS-only

### 5.3.3.2 Cash flow

In all 18 scenarios, overall cash flow (CF<sub>PGM</sub>) improved under waste recovery and exchange operation; otherwise, the WR plant would not come into operation. Similar to the previous section, we compared emitted CO<sub>2</sub> per generated cash flow (Figure 5.6). It could be seen that although CO<sub>2</sub> mitigation was not significant (Figure 5.5), IS lowered carbon emission per cash flow generation by improving overall cluster cash flow. The lowest amount of specific carbon emission was 11.8 kt of CO<sub>2</sub> per M€ of cash flow. However, this amount could not be compared with 9.3 in Figure 5.4 because each happened under different external conditions.

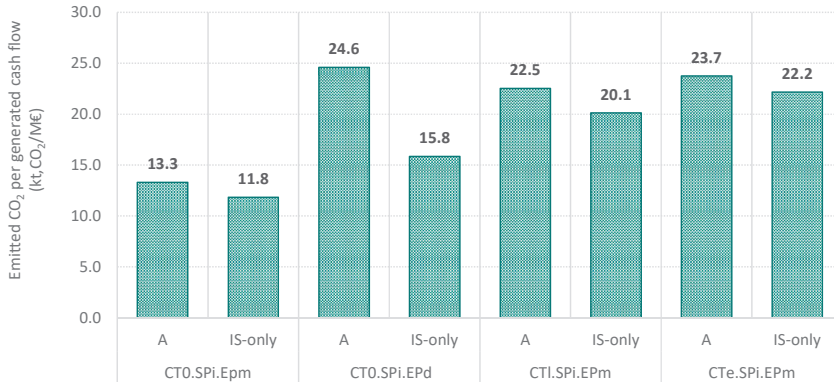

Figure 5.6 Comparison of total emitted CO<sub>2</sub> per generated cash flow over 20 years in configurations A and IS-only

## 5.4 Discussion and conclusion

This chapter extended the conceptual framework introduced in Chapter 4 to model IS in interaction with other sustainable industrial development strategies. This study elaborates on the techno-economic complexity of industrial clusters for carbon mitigation. We examined the functionality of our modeling framework in a more complex situation. IS and CCS were implemented on the industrial cluster as two techno-economically intertwined decarbonization strategies, while several external factors (carbon tax, product price, and energy price) changed over time. We explored the interplay between IS and CCS in improving cluster carbon emission and cash flow.

Similar to Chapter 4, it was not possible to interpret model outcomes without investigating the production level of the industrial plants. Lower carbon emission could happen not only because of CCS operation but also because of the decline in the production level of industrial plants. In the same energy price and carbon tax schemes, an increase in steel prices results in higher production levels of industrial plants and, therefore, more direct and indirect carbon emissions unless CCS plants come into operation. Under the same steel price and carbon tax schemes, an increase in energy prices resulted in lower production levels of industrial plants and, therefore, less direct and indirect carbon emissions.

As observed in section 5.3.1, waste recovery and carbon capture plants came into operation under different external conditions. Neither a low carbon tax could promote CCS, nor a low energy price result in waste heat recovery. Besides, IS and CCS resulted in different levels of carbon emission mitigation. The net reduction in total emitted CO<sub>2</sub> under CCS operation was around 31.0 Mt over 20 years (CTh.SPi.EPf scenario). The carbon mitigation capability of IS was limited to 5.4 Mt over 20 years in CT0.SPi.EPm scenario.

Our models also revealed distinctions in the techno-economic feasibility of decarbonization strategies for different actors. In the form of either electricity or steam, waste heat recovery and exchange was a promising strategy for HPP, but the proposed CCS plant for HPP did not come into operation under given economic assumptions and examined external factor scenarios. On the other hand, in Chapter 4, SKS did not engage in IS collaborations by recovering its available waste heat, as either electricity or cooling. In contrast, in Chapter 5, CCS was a techno-economically possible solution for SKS under given conditions. Although the present work used rough technical and economic assumptions from IEA benchmark studies for SMR plants, it revealed the opportunity for CCS in MIDREX under specific energy prices, carbon tax, and

steel price schemes. It should be noticed that prospected CCS investment costs are high in the Middle East due to higher interest rates, location, and contingency factors.

Comparing direct and indirect carbon emissions revealed that indirect carbon emissions were even higher than direct emissions in some scenarios due to the high electricity intensity of EAF and aluminum reduction plants. The carbon intensity of metal processing industries relates to fossil fuel burning, process-related emissions, and electricity consumption. Adding CCS plants capture directly emitted CO<sub>2</sub>, not indirect CO<sub>2</sub>. Zero-carbon grid electricity (e.g., from renewable sources) could significantly reduce the total carbon emission of aluminum and DRI-EAF industries.

As stated in the introduction, utilizing innovative energy sources to meet CCS heating demand has been one of the promising solutions for CCS deployment. This study revealed the techno-economic feasibility of utilizing waste heat from neighboring industries for CCS energy supply and showed its economic and environmental advantage over NSB. Moreover, as mentioned in Chapter 4, the weakness of many previous IS studies is their inability to incorporate the investment and operation costs of waste recovery and the present value of this investment in actors' decisions. This chapter explored actors' decisions with several investment options on CCS, waste recovery, or auxiliary energy supply systems.

However, limited configurations and scenarios were examined in the case study. For instance, auxiliary steam supply units other than NSB might need different investment costs and produce different carbon emissions. Finally, it should be noted that these models were built based on literature data waste recovery and carbon capture plants for proxy plants. Although these estimations are sufficient for system-level analysis, a more precise techno-economic assessment must be carried out for future implementation.



# 6 Conclusion

## 6.1 Overview

In recent decades industrial symbiosis has been acknowledged as a way to improve the economic competitiveness and resource efficiency of industrial clusters. However, within the socio-technical structure of industrial clusters, several internal and external factors influence the formation of symbiotic collaborations. As our knowledge about different aspects of IS improves, the complexity of its implementation becomes more apparent. This consideration led to the main research question of this dissertation:

**How does industrial symbiosis shape within the complex socio-technical structure of industrial clusters to improve their environmental and economic performance in the long term?**

This research question was subdivided into four sub-questions:

**RQ1:** How do system boundary settings influence the assessment of the technical potential for waste recovery and exchange in emerging industrial clusters? (*Chapter 2*)

**RQ2:** What insights can pre-emergence collaborations and institutional conditions provide regarding probable future IS dynamics in emerging industrial clusters? (*Chapter 3*)

**RQ3:** How can the emergence of industrial symbiosis in industrial clusters be modeled under different technical and institutional conditions in the long term? (*Chapter 4*)

**RQ4:** How to assess the interplay between industrial symbiosis and carbon capture and storage in industrial clusters, and their impact, individually or together, on the cluster's carbon footprint and cash flow? (*Chapter 5*)

The key outcomes of each sub-question are presented and discussed in section 6.2 to understand how they have collectively answered the main research question. Then, a reflection on the limitations of this work is presented in section 6.3.6.3 and content-related, case-related contributions are elaborated on in section 6.4. This chapter ends with recommendations for future research in section 6.5.

## **6.2 Exploring the complexity of industrial symbiosis formation**

This section reviews the key outcomes of each step of this dissertation to picture the research roadmap and our step-by-step approach to meet the research goal. We explored the complexity of IS emergence in a comprehensive study. Different assessment methods were implemented to assess IS emergence's technical, collaborative, and institutional aspects in Chapters 2 and 3. In Chapters 4 and 5, these aspects were integrated in a model to investigate IS formation in the cluster and unveil its contribution to cluster performance improvement under a range of future external factor scenarios.

### **6.2.1 Multi-level assessment of Industrial symbiosis technical potential**

Chapter 2 introduced a methodological approach to uncover overlooked technically possible waste material and energy exchanges in industrial clusters. This approach also investigated the effect of boundary settings on IS potential. We assessed technical potential through mapping available waste flows (sources) and inflows (sinks) and matching them based on specifications of recovery technologies. After mapping inflows and outflows of the existing plants, we studied a level inside the plant boundaries for source exploration and outside cluster boundaries for sink exploration. This multi-level approach was implemented in a case study (The Persian Gulf Mining and Metal Industries Special Economic Zone in Iran).

The assessment results proved its usefulness in revealing unutilized material and energy exchanges between the plants, and showed that higher quality or quantity of waste flow might be available for symbiotic exchanges if waste flows inside plant boundaries are further examined. For instance, 85 MW of high-grade waste heat was estimated inside steelmaking plants compared to 40 MW of low-grade heat available at plant boundaries. This suggests a waste flow management approach in plant design, which considers utilization possibilities outside plant boundaries.

A recovered flow could find new destinations if sink exploration covers nearby urban areas or future cluster development possibilities. Specifically, material exchange potential demonstrated the possibilities of utilizing steelmaking plants' waste material in construction and ceramic industries. Such industries could be considered in cluster development strategies to move toward a minimal-waste cluster. Implementing IS perspective can improve the material and energy efficiency of the cluster in its existing format and bring about novel opportunities for sustainable future development.

### **6.2.2 The collaborative and institutional structure of the cluster**

After unveiling technically possible symbiotic exchanges, in Chapter 3, we aimed to understand whether the institutional and social structure of the cluster promotes different IS development pathways in the case study. We gained insight into actors' shared strategies, previous collaborations, and their position in the cluster through a survey. A questionnaire was designed based on academic literature on IS emergence and its drivers and barriers. Investigating pre-emergence collaborations and their structure in the case study revealed that they were often self-organized despite the presence of a centralized management body in the cluster. The three steel industries in the case study also had the most collaborations in the last five years. The most influential IS drivers appeared to be infrastructure readiness, financial support, and resource scarcity. On the other hand, carbon emission mitigation and waste disposal costs were less prominent for the respondents, although they are known as prevailing sustainable industrialization drivers in developed countries. Perhaps the absence of effective prohibitive regulations has made respondents less sensitive to waste disposal and carbon emissions, but this will require further research.

In this research, the ADICO grammar of institutions was implemented in the IS field for the first time. Industrial symbiosis was not named in legislation directly. Therefore, we matched ADICO grammatical syntax with eight IS dynamics identified by (Boons et al., 2016) and Sun et al. (2017) to study legislation with an IS lens. Our analysis showed that although regulations encourage energy efficiency improvement and environmental monitoring, explicit penalties and sanctions in case of violations were not specified. Among 183 institutional statements, only 19 were identified as rules, whilst the penalties were not proportionate with damages. This result could explain current weak environmental monitoring and assessment of industrial activities in the case study. It highlights that rules and regulations must evolve in parallel to industrial development for sustainable industrialization to happen.

In addition, the role of cluster management was not elaborated in the legislation, as we found only five statements with cluster management as an attribute. A few statements pointed to infrastructure provision, knowledge development, and market brokerage. It could be said that legislation in Iran does not support either facilitated IS or eco-clustering. Self-organization and governmental planning were the most supported dynamics in investigated regulations. This finding aligned with the field study outcomes, which showed that the most successful previous collaborations had been initiated and facilitated by industrial actors, not the cluster management.

### **6.2.3 The emergence of industrial symbiosis**

After assessing technical, collaborative, and institutional aspects of IS emergence in an industrial cluster, these aspects were integrated into a MILP model. This normative model aimed to explore the emergence of IS collaborations in the long term under a range of external factor variations and technical possibilities. The model outcomes shed light on the fact that IS cannot be investigated as a standalone phenomenon but as a system component in the industrial cluster. For instance, despite initially a drastic rise in energy prices expected to promote IS, such a rise caused energy-intensive metal processing industries to shut down. Consequently, their connected waste heat recovery plants stopped operation. The results showed that a rise in final product prices could compensate for increasing energy prices and let the plants continue operating at maximum capacity.

Considering the amount of available waste heat, the efficiency of waste recovery technology, and capital and operation costs, not all technically possible waste recovery options improved cluster energy efficiency and cash flow. The results also revealed that techno-economically favorable IS collaborations are not necessarily held by the actors who are more likely to collaborate. Significant symbiotic exchanges might not shape in the cluster without encouraging previously isolated actors to collaborate. This outcome provides more realistic insights into socio-technically favorable collaborations and actors' investment decisions.

Although the model focused on energy recovery and exchange, the proposed system-level approach for techno-economic analysis and comparison can also be applied to material networks. The concept of proposing several possible options to the model, decomposing each option into a set of physical and non-physical processes and flows, and assigning costs and constraints for each option could be implemented as a guideline for future cluster modelling works. However, it should be noted that the conclusions are valid for conceptual design and system-level analysis. The establishment of suggested collaborations calls for more specific

technical and economic considerations such as detailed technical and cost assessment of waste recovery plants.

#### **6.2.4 The interplay between industrial symbiosis and carbon capture and storage**

Chapter 1 pointed out that hard to abate industries such as steel and cement are growing in emerging economies. Part of the carbon emission of these industries is process-related, which cannot be mitigated through waste heat recovery and exchange. Carbon capture, transport and storage (CCS) is an option to reduce this type of carbon emissions. However, IS and CCS interact in the cluster both technically and economically. In the extended model in Chapter 5, we studied the techno-economic complexity of industrial clusters for carbon mitigation. We aimed to understand the interactions between IS and CCS and whether the model approach in Chapter 4 could be used to study their influence on cluster cash flow and carbon intensity under different carbon tax, steel price, and energy price scenarios.

The results showed that higher interest rates, contingency, and retrofit factors can result in higher CCS investment costs in emerging economies. In the case study, CCS came into operation, with or without IS, only in four scenarios: high or exponential rising carbon tax, fixed or moderate increasing energy prices, and rising product prices. In these scenarios, CCS-IS integration resulted in more carbon mitigation than CCS alone, the maximum reduction of around 31.0 Mt over 20 years in the CTh.SP<sub>i</sub>.EP<sub>f</sub> (high carbon tax, increasing steel price, and fixed energy price) scenario. In an scenario with zero or low carbon taxes CT0.SP<sub>i</sub>.EP<sub>m</sub> (zero carbon tax, increasing steel price, and moderately rising energy price), where CCS plants did not operate, IS-only could improve cluster economic and environmental performance, but the maximum CO<sub>2</sub> emission reduction was 5.4 Mt of CO<sub>2</sub> over 20 years. This indicates that although IS and CCS integration makes actors' decision-making more complex, they result in a better overall economic and environmental performance under specific external conditions.

Finally, this dissertation implements engineering, social science, and economic assessment methods to understand IS formation in industrial clusters, not as standalone phenomena but as a part of a complex socio-technical system. It provides valuable insights into different aspects of IS emergence and its contribution to improving industrial clusters' economic and environmental performance. The case study contributes to filling the gap of regional IS studies in emerging economies, where institutional and economic conditions are different from developed economies.

## 6.3 Reflections and limitations

So far, we have presented the key research outcomes. However, without discussing the limitations and assumptions behind these results, it would not be possible to justify the contributions of this work to the broader context of IS studies. This section reflects on the assumptions and boundary settings in different research steps to identify the limitations and possible extensions, with some limitations arising from scope settings and some from selected methods.

### 6.3.1 Reflections on socio-technical structure studies

Chapter 2 assessed the technical potential for IS under different system boundary settings. Gathering the quality and quantity of waste flows is crucial for this assessment. However, waste flows are less important for industrial actors, and therefore actual data was unavailable for all waste flows in the case study. When field data was unavailable, the required information was estimated based on the literature, which might influence assessment results. More accurate waste flow data could result in a different technical potential.

In Chapter 3, we aimed to explore actors' willingness to engage in IS based on the current social structure of the cluster. For this purpose, we focused on pre-emergence collaborations that could pave the road for IS and the importance of various IS drivers for the actors. In Chapters 4 and 5, we proposed a method to incorporate such willingness in actors' decision-making in a linear optimization model. However, looking back to Chapters 3 to 5, not all social and institutional aspects of IS were sufficiently assessed and considered in this research.

First, in recent years, extensive research has been conducted to capture influential social aspects of IS, such as structural, cultural, and cognitive embeddedness (Ashton and Bain, 2012), organizational and social proximity (Velenturf and Jensen, 2016), shared behavioral norms, and actors' common understanding (Chertow and Ehrenfeld, 2012), and cooperation and coordination among firms (Rui and Heijungs, 2010). As stated above, in this dissertation, we focused on pre-emergence collaborations and actors' motivations. However, this may have been too limited. Other social factors, such as trust (Yap and Devlin, 2017) and short mental distance (Ashton and Bain, 2012), could be incorporated in evaluating actors' willingness to collaborate if appropriately assessed in field studies.

Moreover, in Chapter 3, it was not possible to perform statistical analysis on survey results because of the limited number of respondents. A broader range of respondents, for instance, in more extended industrial clusters, would make it possible to perform statistical analysis with

quantified results instead of descriptive outcomes. Implementing quantified data in the model would be more straightforward. As stated in Chapter 2, new industries could be added to the cluster to utilize generated waste flows from existing industries. However, our assessment about collaboration with new industries was limited to *openness to new collaborations* in the questionnaire, which might not be detailed enough to reflect social readiness for collaboration with new industries.

From a social point of view, industrial development is sustainable when it is inclusive and just (UNIDO, 2013). This dissertation assessed IS sustainability based on its economic and environmental impacts, and did not include societal aspects such as inclusiveness and justice. However, societal impacts could be modeled as non-physical outcomes of the waste recovery and exchange process. For this purpose, societal impacts must be quantified through proper KPIs first. Similar to environmental impacts, translating such intangible effects into a quantified model input is the challenging part of the work.

In ADICO analysis, we focused on rules and regulations. Institutions, in a broader context, include norms and shared strategies (Crawford and Ostrom, 1995). Analyzing norms and shared strategies along with rules and regulations provides a more realistic insight into the institutional arrangement of the cluster. Such analysis requires extensive field studies to explore unwritten norms governing actors' behavior and shared visions which was not conducted in this research.

Deployment of novel technologies and products depends on their social acceptance (Gough and Mander, 2019), which applies to CCS and CO<sub>2</sub>-driven products. Three key dimensions of policy and technology innovations are socio-political, market, and community acceptance (Jones et al., 2017). Social acceptance arises from public support and awareness in different geographical contexts (Whitmarsh et al., 2019). However, Chapter 5 of this study aimed to model the techno-economic interaction of CCS and IS inside the industrial cluster, not its acceptance in broader society. Investigating social acceptance of carbon capture and utilization technologies requires specific attention in emerging economies.

Finally, it should be noted that although our conceptualization allows the modeler to incorporate social parameters in actors' decisions, it cannot replicate social processes such as knowledge sharing and negotiation in the model. Social characteristics of a cluster are exogenous parameters for economic optimization in the Linny-R model. If appropriately assessed and quantified outside the model, social factors could be added above economic benefit as an influential parameter on actors' decisions.

### 6.3.2 Reflections on modeling phase

In Chapters 4 and 5, we presented modeling works aiming to study IS emergence as a part of a broader system, in interaction with industrial plants and other sustainable industrial development strategies. In an industrial system, actors make different decisions to fulfill their objectives. In the models, we defined parallel different possible routes for actors to explore the emergent behavior of the system. Each prospected route was decomposed into a set of processes and products. A process receives a set of physical (e.g., material, energy, water, land) and non-physical (e.g., information, money) resources, generates some physical (e.g., material, energy) and non-physical (e.g., environmental and societal) outcomes. This framework deals with non-physical processes and flows in the same way as physical ones. Depending on assigned prices and bounds to each process and product, the actors select different routes to maximize the cash flow of selected actors.

Every model has some limitations and is embedded in its assumptions. Our models are also valid within entailed limitations and assumptions. The limitations might arise from model input data, the decisions made while translating the real world into model components, or software and its functionalities. First, our model explored possible futures under uncertain conditions. The number of examined internal configurations and external scenarios in Chapters 4 and 5 was limited, although they provided valuable insight into cluster behavior under different conditions.

Available technical and economic specifications for novel technologies are not precise. Based on the literature, we estimated techno-economic characteristics of waste recovery and carbon capture technologies, acknowledging uncertainties in such evaluations. When the input data become more precise, the results will be more reliable. Furthermore, as discussed in section 6.3.1, our assessment of actors' willingness to collaborate was limited to their previous collaborations. Incorporating other social factors will make the assessment more realistic. Furthermore, the model time step in this work was a year, so monthly or daily fluctuations in model parameters were not considered. If such variations are essential in the studied system, model time step and all flows and production levels must be expressed as hourly, daily, or monthly rates in input datasets. However, the running time will be much longer.

We defined separate waste recovery or carbon capture plants for each actor. However, the actors could make a shared investment in some facilities, for instance, centralized CCS for the whole cluster or the shared CO<sub>2</sub> transportation pipeline, as mentioned in Chapter 5. A centralized facility might be less expensive due to economies of scale but needs special considerations for

joint or independent investment and operation. A way to share the investment costs between the two actors is to define two separate pay annualized cost processes owned by two actors and divide the annualized cost among them. Similarly, different contract types are imaginable between two actors, either for IS or CCS, which could be modeled using non-physical entities. Moreover, the selling price of recovered flow was assumed to equal the cost price to cover all its recovery expenses. However, the selling price of a recovered flow can vary from cost price to market price. Linny-R cannot calculate the optimal selling price itself, but it is possible to perform sensitivity analysis in a set of experiments. The model also accepts different selling prices to different actors. Therefore, our assumption on dedicated investment or selling price does not limit the future application of the modeling approach.

The models simplified the connection cost between two actors as a fixed cost applied to the receiving actor. However, every two actors might have different transaction costs due to negotiation, contracting, and supervision (Fraccascia et al., 2017b). Defining two separate sell and buy processes for two parties makes it possible to impose the costs on both of them. Transaction costs could be calculated and assigned as start-up costs of sell and buy processes. In many cases, the exchange of recovered flow between two actors needs extra investment depending on the maximum amount of exchanged flow and distance (e.g., piping and cabling). This cost could not be covered by simple connection cost, as explained in Chapter 4. As the rate of exchanged flow is unknown to the modeler from the beginning, a rough calculation could be done based on the geographic allocation of plants for each prospected exchange and assigned as investment cost to the affiliated sell or buy process, depending on who will pay for it.

We only applied a carbon tax to flue gases as a limitation on a waste disposal route in the case study. Other external factors, such as landfill tax (Fraccascia et al., 2017b), might also affect the disposal route. Still, quantity-based or priced-based environmental policies could be implemented in the model as presented in Chapter 5. Other waste handling costs such as transport costs could be assigned to different waste disposal processes.

Another underlying assumption in our conceptualization was that IS is self-organized, in which IS is not forced into the system but introduced as an option that becomes functional if it is economically favorable. However, new actors, such as facilitators, governmental organizations, or cluster management, could be introduced to shape other IS dynamics. The actors can contribute to waste recovery and exchange costs depending on their role. If the actor is a non-profit organization, it could be excluded in Linny-R settings from the economic optimization procedure.

Chapter 5 focused on carbon emission as an indicator for environmental sustainability. Nevertheless, IS contributes to sustainable industrialization in a broader scope by reducing resource intake and the environmental footprint of industrial activities. As long as required resources (e.g., land, water, labor) or generated process outcomes (e.g., soil and water pollutants) could be quantified and priced, we can define them as an influential entity in the model. However, quantifying and pricing such physical and non-physical entities is not always straightforward.

### **6.3.3 Reflections on the case study**

The methods developed in this research were illustrated on a case study from an emerging economy, and scenarios were designed to reflect conditions in Iran. Here the question arises to what extent and under which considerations the research outcomes apply to other developing economies. Although the case-specific results could not be generalized, the methods developed for potential assessment, institutional analysis, and modeling apply to other contexts. However, specific contextual considerations might affect the methods. Particularly, there are differences in institutions between emerging and developed economies. Specific contextual considerations need to be taken into account. For instance, in the Iranian context, the government defines the electricity price annually. So, we applied yearly changes in electricity prices in the case study. Nevertheless, electricity price is set in the market mechanism in many economies.

In Chapters 2 to 5, we used PGSEZ as an illustrative case study for implementing proposed methods. Although the numeric results of a single case study cannot be generalized, it provides insight into the rarely investigated context of an oil-rich Middle East country. Of course, the specific context of Iran has faced specific deep uncertainties due to international sanctions and unstable political and economic conditions. By performing our analysis based on economic data from 2016, before US withdrawal from The Joint Comprehensive Plan of Action (JCPOA), we attempted to escape deep uncertainties and focus on cluster structure investigation and modeling.

## **6.4 Contributions**

### **6.4.1 Content-related and methodological contributions**

Although many previous studies have focused on already shaped IS collaborations, this research extends our understanding of the emergence of new IS collaborations as a system component. This was possible due to several methodological contributions. Looking back to the overall storyline of this dissertation, we first decomposed technical, collaborative, and institutional

aspects of IS, proposing systematic methods to assess each aspect. Then, we integrated them in a model to study system behavior as a whole.

In Chapter 2, we proposed a systematic method to uncover overlooked technical possibilities for IS. This work contributed to IS definition clarification by rethinking entity and system in assessment of IS potential. We showed that IS studies should not have a rigid approach to setting industrial plant and cluster boundaries. Industrial plants are not black-box entities in IS assessment, but waste management inside the plant boundaries also matters. For instance, waste heat that has no use inside an industrial plant is sometimes diluted or cooled down before disposal. As happened in our case study, waste heat might have some users in neighboring plants if not processed before disposal. This might offer a more tailored plant design, not as a standalone plant but as a part of a cluster.

Chapter 3 adapted the ADICO grammar of institutions with IS dynamics as a basis for the systematic investigation of rules and regulations, which has not been done before. The designed questionnaire in this chapter could be adjusted in future IS studies to gain insight into the dynamics of collaborations and actors' willingness to collaborate through the number, type, structure, and effectiveness of pre-emergence interactions.

The novel conceptualization introduced in Chapter 4 for system integration does not include a complicated formulation but an easy-to-understand visual interface. In the model, IS is not enforced on the system, but actors can choose from different routes while each route is specified by its techno-economic, environmental, and social constraints. As argued in Chapter 4, the weakness of many previous IS studies is their inability to incorporate the investment and operation costs of waste recovery and the present value of this investment in actors' decisions. Our models dealt explicitly with actors' investment in waste recovery, while ensured that none of the actors would lose by engaging in IS. The waste-generating actor sells the recovered flow at the price that covers all its recovery costs, and the receiver buys it at a price lower than the market. While even several agent-based models have defined fitness goals only as a function of economic benefit (e.g., (Albino et al., 2016), (Fraccascia et al., 2017b) and (Fraccascia and Yazan, 2018)), our conceptualization proposed a way to reflect non-economic parameters in actors' decisions. However, as noticed in section 6.3.1, its ability to reflect social interactions in the model is limited.

Our extended model in Chapter 5 contributed to both IS emergence and system-level CCS studies by digging into the challenges and potential of IS and CCS integration in climate change mitigation. The model resulted in both economic and environmental benefits of such integration

to provide more realistic insights into possible future developments under different scenarios. Based on the previous state-of-the-art IS literature, these conceptual and methodological contributions have extended our knowledge about IS emergence in industrial clusters, facilitating future scientific developments in the field.

Nevertheless, systematic steps in Chapter 2 to assess the technical potential for IS, organized approach in Chapter 3 to uncover the structure of previous collaborations and institutions, and comprehensive yet handy modeling procedure in Chapters 4 and 5 all together have contributed to IS emergence studies in industrial clusters. Although we have illustrated the functionality of each step in a specific case study, the methods are applicable to the broader scope of IS modeling in other contexts. Our model demonstrated its functionality in representing the complex structure of industrial clusters (Chapters 4 and 5) and holds room for significant improvements, as discussed above. The conceptual framework and modeling approach introduced in this study provide a reliable foundation for more complex future IS studies.

#### **6.4.2 Case-specific contributions**

PGSEZ is steel industry-oriented. The similarity of different plants' inflows resulted in limited material exchange potential inside the cluster. More source and sink matches might be found between diverse industries. IS approach advises including diverse industries in the future cluster, regional or provincial development plans to utilize generated waste material from the steel industry. Urban cooling is one of the major electricity consumers in the south of Iran, which causes electricity supply shortages in hot seasons. Regional and provincial urban development planners could consider centralized cooling systems based on industrial waste heat recovery.

Besides opportunities for economic and environmental performance improvement in PGSEZ, our study also revealed weaknesses and shortcomings for sustainable industrial development. This study was one of the first academic investigations on Iranian rules and regulations regarding sustainable industrialization. ADICO analysis demonstrated the inadequacy and inefficiency of legislation, especially in environmental protection. Proper legislation for novel sustainable industrialization strategies such as IS is needed. Existing regulations must also be updated, especially in terms of sanctions and penalties. The field study exposed the power hierarchy in the cluster and the weak position of cluster management in monitoring or supporting industrial activities. It also revealed weak supervision of industrial waste disposal to land, water, and air, even in the presence of regulations. Strict supervision by the cluster management or provincial organizations could prevent environmental disasters in the region.

In the sustainability transition of industrial systems, models can facilitate dialogue between the modeler and involved stakeholders (Cuppen et al., 2021). Our model could increase awareness about PGSEZ behavior under uncertain future conditions. Despite examining a limited set of scenarios, the outcomes were remarkable. The model outcomes revealed the vulnerability of the industries to increasing energy prices or carbon taxes, which provides long-term insight for industrial actors and cluster development decision-makers. From a practical point of view, the model developed in Chapters 4 and 5 could provide long-term insights into possible future developments for industries and policy-makers.

The outcomes of Chapter 5 highlight the large amount of electricity-related carbon emission of the cluster, simply because EAF and Hall–Hérout processes are very electricity-intensive. Solar based electricity could be a solution to decrease emissions from power generation, mainly because the southern part of Iran has a very high solar energy potential (SOLARGIS, 2021). This however imposes other challenges such as dealing with the intermittency of solar based power for industries that demand a continuous demand of electricity. Cluster management or national-level decision-makers could extend our model to study such a possibility. Moreover, some Iranian oil fields now use natural gas for Enhanced Oil Recovery (EOR). Captured CO<sub>2</sub> from industrial sources could be used instead. However, the sustainability of CO<sub>2</sub> EOR for its whole life cycle is doubted (Farajzadeh et al., 2020).

## 6.5 Recommendations for further research

Having discussed the key outcomes of this dissertation and its contributions, the final section of this chapter addresses ways of extending this research line in future academic studies.

Participatory Modeling (PM) is a "purposeful learning process for action that engages stakeholders' implicit and explicit knowledge to create formalized and shared representations of reality (Voinov et al., 2018, p.233)." PM could happen in different modeling stages, from data gathering to interpreting the model outcomes. In the IS field, which is highly case-dependent, technically and socially, PM is a promising approach to building a more realistic cluster model. In this thesis, even though we obtained and verified a considerable part of technical and social information about the case study through surveys (Refer to Chapters 2 and 3), it was not practically possible to engage stakeholders in the modeling phase due to restraints imposed by the sanctions as well as the lockdowns due to the Covid pandemic. PM is recommended for future IS modeling works if such participation is possible.

No single model can capture industrial socio-technical systems' complexity adequately; neither does our model. An approach to capturing all relevant dimensions of complex socio-technical

systems could be to have a set of interacting models reflecting different aspects of reality (Cuppen et al., 2021). This multi-modeling approach could be used in the IS field as well. In this perspective, our MILP model could be interconnected to social behavior modeling approaches such as ABM to provide a more realistic representation of the system. Alternatively, future Linny-R cluster modeling works could link to process modeling software like ASPEN to provide more precise techno-economic data for novel technologies. PM, as discussed above, could be implemented in multi-modeling as well.

As stated in section 6.3.2, a limitation in interpreting model outcomes arose from the limited number of examined scenarios and configurations. Exploratory Modeling and Analysis (EMA) aims to provide decision support for complex, uncertain systems through computational modeling (Kwakkel and Pruyt, 2013). Recently, Linny-R has developed significantly in sensitivity analysis and experimental design functionalities (Bots, 2021). Besides, an EMA workbench has been developed in TU Delft to generate and execute a range of experiments on a modeling function (Kwakkel, 2017). The workbench is implemented in Python. So, it can be linked to Linny-R as a multi-modeling strategy in future modelling works under deep uncertainty.

As mentioned in section 6.3.2, we limited our environmental sustainability assessment to the carbon footprint. From the researcher's point of view, water shortage and water pollution were among the most severe problems in industrial development in Iran. However, preliminary site visits and field studies made it clear that no reliable data was available for water networks based on which a model could be developed. Challenges remain present to assess and understand the contribution of IS to water network improvement in the emerging economies. We also did not investigate industries' sensitivity to water price, as they consume seawater for industrial purposes and discharge wastewater to the sea at no cost. Thus, a recommendation is to include water network assessment in future IS studies in emerging economies, where data that are more reliable are available.

Several sustainable industrialization strategies could be implemented in a cluster simultaneously. As elaborated in Chapter 5, IS potential changes by introducing new plants or technical changes in existing plants. An example of this was provided in that chapter to investigate the interplay between IS and CCS. However, more technological changes are expected in future, such as hydrogen-based DRI, which would influence the available waste heat and CO<sub>2</sub> concentration in the flue gas; consequently, both IS and CCS. This implied the need to consider this strategy in future sustainable steel cluster studies. Because of coal availability, the BF-BOF steelmaking route has been developed worldwide. In contrast, gas-

based DRI, which is much less carbon-intensive, has mainly been limited to Iran and India. Hydrogen-based DRI is not dependent on natural gas and could be extended worldwide when hydrogen is available reasonably priced on an industrial scale.

In its basics, carbon capture and utilization (CCU) is a form of material-based IS itself. Adding novel carbon utilization plants to the model required extensive technical and economic data gathering, which was out of the focus of this research. It could be interesting to extend the discussion and examine CCU as a form of IS in future studies. Existing IS literature, could provide dedicated guidelines for CCU assessment at the system level.

Although implemented methods are not perfect and more academic studies are feasible to improve the proposed approach, this thesis has significantly contributed to IS emergence studies from concept examination, system analysis, and comprehensive modeling perspectives.



## References

- Abreu, M.C.S. de, Ceglia, D., 2018. On the implementation of a circular economy: The role of institutional capacity-building through industrial symbiosis. *Resour. Conserv. Recycl.* 138, 99–109. <https://doi.org/10.1016/j.resconrec.2018.07.001>
- Afshari, H., Farel, R., Peng, Q., 2018. Challenges of value creation in Eco-Industrial Parks (EIPs): A stakeholder perspective for optimizing energy exchanges. *Resour. Conserv. Recycl.* 139, 315–325. <https://doi.org/10.1016/j.resconrec.2018.09.002>
- Ahmed, A., Esmacil, K.K., Irfan, M.A., Al-Mufadi, F.A., 2018. Design methodology of heat recovery steam generator in electric utility for waste heat recovery. *Int. J. Low-Carbon Technol.* 13, 369–379. <https://doi.org/10.1093/ijlct/cty045>
- Albino, V., Fraccascia, L., Giannoccaro, I., 2016. Exploring the role of contracts to support the emergence of self-organized industrial symbiosis networks: An agent-based simulation study. *J. Clean. Prod.* 112, 4353–4366. <https://doi.org/10.1016/j.jclepro.2015.06.070>
- Allenby, B., 2006. The ontologies of industrial ecology? *Prog. Ind. Ecol.* 3, 28–40. <https://doi.org/10.1504/pie.2006.010039>
- Almahdi, 2022. Almahdi Aluminium Co. – The most advanced manufacturer of pure aluminium ingots in Iran [WWW Document]. URL <https://en.almahdi.ir/> (accessed 1.31.22).
- Alsheyab, M.A.T., Khedaywi, T.S., 2013. Effect of electric arc furnace dust (EAFD) on properties of asphalt cement mixture. *Resources, Conserv. Recycl.* 70, 38–43. <https://doi.org/10.1016/j.resconrec.2012.10.003>
- Ashton, W.S., Bain, A.C., 2012. Assessing the “Short Mental Distance” in Eco-Industrial Networks. *J. Ind. Ecol.* 16, 70–82. <https://doi.org/10.1111/j.1530-9290.2011.00453.x>
- Atsushi, M., Uemura, H., Sakaguchi, T., 2010. Midrex processes. *KOBELCO Technol. Rev.* 29, 8.
- Azad, M., 2006. Enviro-Friendly Hydrogen Generation From Steel Mill-Scale via Metal-Steam Reforming. *Bull. Sci. Technol. Soc.* 26, 305–313. <https://doi.org/10.1177/0270467606290710>
- Azadi, P., Mahmoudzadeh, A., Shirvani, T., 2017. The Outlook for Natural Gas, Electricity, and Renewable Energy in Iran About the Stanford Iran 2040 Project Stanford Iran 2040 Project Citation and Correspondence.
- Bacudio, L.R., Benjamin, M.F.D., Eusebio, R.C.P., Holaysan, S.A.K., Promentilla, M.A.B., Yu, K.D.S., Aviso, K.B., 2016. Analyzing barriers to implementing industrial symbiosis networks using DEMATEL. *Sustain. Prod. Consum.* 7, 57–65. <https://doi.org/10.1016/j.spc.2016.03.001>
- Bagajewicz, M., Rodera, H., 2002. Multiple plant heat integration in a total site. *AIChE J.* 48,

2255–2270. <https://doi.org/10.1002/aic.690481016>

- Bagajewicz, M., Rodera, H., 2000. Energy savings in the total site heat integration across many plants. *Comput. Chem. Eng.* 24, 1237–1242. [https://doi.org/10.1016/S0098-1354\(00\)00318-5](https://doi.org/10.1016/S0098-1354(00)00318-5)
- Bailey, M., Gadd, A., 2015. Quantifying the Potential of Industrial Symbiosis: The LOCIMAP Project, with Applications in the Humber Region, in: *Taking Stock of Industrial Ecology*. pp. 343–357. <https://doi.org/10.1007/978-3-319-20571-7>
- Balomenos, E., Pantias, D., Paspaliaris, I., 2011. Energy and exergy analysis of the primary aluminum production processes: A review on current and future sustainability. *Miner. Process. Extr. Metall. Rev.* 32, 69–89. <https://doi.org/10.1080/08827508.2010.530721>
- Barati, M., 2010. Energy intensity and greenhouse gases footprint of metallurgical processes: A continuous steelmaking case study. *Energy* 35, 3731–3737. <https://doi.org/10.1016/j.energy.2010.05.022>
- Basurto, X., Kingsley, G., McQueen, K., Smith, M., Weible, C.M., 2010. A systematic approach to institutional analysis: Applying Crawford and Ostrom’s grammar. *Polit. Res. Q.* 63, 523–537. <https://doi.org/10.1177/1065912909334430>
- Batten, D.F., 2009. Fostering industrial symbiosis with agent-based simulation and participatory modeling. *J. Ind. Ecol.* 13, 197–213. <https://doi.org/10.1111/j.1530-9290.2009.00115.x>
- Bause, T., Campana, F., Filippini, L., Foresti, A., Monti, N., Pelz, T., 2015. Cogeneration with ORC at Elbe-Stahlwerke Feralpi EAF shop. *Iron Steel Technol.* 12, 290–299.
- Bechara, L., Veiga, E., Magrini, A., 2008. Eco-industrial park development in Rio de Janeiro, Brazil: a tool for sustainable development. <https://doi.org/10.1016/j.jclepro.2008.11.009>
- Becker, H., Maréchal, F., 2012. Energy integration of industrial sites with heat exchange restrictions. *Comput. Chem. Eng.* 37, 104–118. <https://doi.org/10.1016/J.COMPCHEMENG.2011.09.014>
- Beckert, J., 2009. The social order of markets. *Theory Soc.* 38, 245–269. <https://doi.org/10.1007/s11186-008-9082-0>
- Beglery, M., Ameri Siahooei, M., Baharvand, B., 2018. Investigating the effect of coke aggregate on gas consumption in anode plant, in: *Iran International Aluminium Conference (IIAC2018)*. Tehran, p. 6.
- Behera, S.K., Kim, J.H., Lee, S.Y., Suh, S., Park, H.S., 2012. Evolution of “designed” industrial symbiosis networks in the Ulsan Eco-industrial Park: “Research and development into business” as the enabling framework. *J. Clean. Prod.* 29–30, 103–112. <https://doi.org/10.1016/j.jclepro.2012.02.009>
- Bhattacharyya, A., Biswas, C., Rajib, D., 2019. Cold briquetting of iron ore fines for DRI production : challenges , possibilities and solutions, in: *Iron Ore Conference*. Perth, pp.

- Birry, L., Leclerc, S., Poirier, S., 2016. The LCL&L Process: A Sustainable Solution for the Treatment and Recycling of Spent Potlining. *Light Met.* 2016 467–471. <https://doi.org/10.1002/9781119274780.ch77>
- Boons, F., Chertow, M., Park, J., Spekkink, W., Shi, H., 2016. Industrial Symbiosis Dynamics and the Problem of Equivalence: Proposal for a Comparative Framework. *J. Ind. Ecol.* <https://doi.org/10.1111/jiec.12468>
- Boons, F., Spekkink, W., Jiao, W., 2014. A Process Perspective on Industrial Symbiosis: Theory, Methodology, and Application. *J. Ind. Ecol.* 18, 341–355. <https://doi.org/10.1111/jiec.12116>
- Bots, P., 2021. Linny-R [WWW Document]. URL <https://mod-est.tbm.tudelft.nl/linny-r.html> (accessed 11.5.20).
- Bréault, B.R., Poirier, S., Hamel, G., Pucci, A., 2011. A ‘ green ’ way to deal with spent pot lining 22–25.
- Broek, S., Save, S., 2013. The Applicability of Carbon Capture and Sequestration in Primary Aluminium Smelters. *Essent. Readings Light Met.* 2, 993–998. <https://doi.org/10.1002/9781118647851.ch147>
- Brondi, C., Cornago, S., Ballarino, A., Avai, A., Pietrarola, D., Dellepiane, U., Niero, M., 2018. Sustainability-based Optimization Criteria for Industrial Symbiosis: The Symbioptima Case, in: *Procedia CIRP*. pp. 855–860. <https://doi.org/10.1016/j.procir.2017.11.026>
- Brückner, S., Liu, S., Miró, L., Radspieler, M., Cabeza, L.F., Lävemann, E., 2015. Industrial waste heat recovery technologies: An economic analysis of heat transformation technologies. *Appl. Energy* 151, 157–167. <https://doi.org/10.1016/j.apenergy.2015.01.147>
- Carapellucci, R., Giordano, L., Vaccarelli, M., 2015. Studying heat integration options for steam-gas power plants retrofitted with CO<sub>2</sub> post-combustion capture. *Energy* 85, 594–608. <https://doi.org/10.1016/j.energy.2015.03.071>
- CAT, 2021. Global Update - Climate target updates slow as science ramps up need for action - Sept 2021.
- Chertow, M., Ehrenfeld, J., 2012. Organizing Self-Organizing Systems: Toward a Theory of Industrial Symbiosis. *J. Ind. Ecol.* 16, 13–27. <https://doi.org/10.1111/j.1530-9290.2011.00450.x>
- Chertow, M., Gordon, M., Hirsch, P., Ramaswami, A., 2019. Industrial symbiosis potential and urban infrastructure capacity in Mysuru, India. *Environ. Res. Lett.* 14, 75003. <https://doi.org/10.1088/1748-9326/ab20ed>
- Chertow, M., Park, J., 2016a. Scholarship and Practice in Industrial Symbiosis: 1989–2014, in: *Taking Stock of Industrial Ecology*. Springer International Publishing, Cham, pp. 87–116. [https://doi.org/10.1007/978-3-319-20571-7\\_5](https://doi.org/10.1007/978-3-319-20571-7_5)

- Chertow, M., Park, J., 2016b. Scholarship and Practice in Industrial Symbiosis: 1989--2014, in: Clift, R., Druckman, A. (Eds.), *Taking Stock of Industrial Ecology*. Springer International Publishing, Cham, pp. 87–116. [https://doi.org/10.1007/978-3-319-20571-7\\_5](https://doi.org/10.1007/978-3-319-20571-7_5)
- Chertow, M.R., 2007. “Uncovering” Industrial Symbiosis. *J. Ind. Ecol.* 11, 11–30.
- Chertow, M.R., 2000. Industrial Symbiosis: Literature and Taxonomy. *Ind. symbiosis* 25, pp 313-337.
- Chiu, A.S.F., Yong, G., 2004. On the industrial ecology potential in Asian developing countries. *J. Clean. Prod.* 12, 1037–1045. <https://doi.org/10.1016/j.jclepro.2004.02.013>
- Clift, Roland, Druckman, A., 2015. Taking stock of industrial ecology. *Tak. Stock Ind. Ecol.* 1–362. <https://doi.org/10.1007/978-3-319-20571-7>
- Clift, R., Druckman, A., 2015. *Taking Stock of Industrial Ecology*, Springer International Publishing. <https://doi.org/10.1007/978-3-319-20571-7>
- Cohen-Rosenthal, E., 2000. A Walk on the Human Side of Industrial Ecology. *Am. Behav. Sci.* 44, 245–264. <https://doi.org/10.1177/0002764200044002007>
- Conti, J., Holtberg, P., Diefenderfer, J., Angelina, L., Turnure, J.T., Westfall, L., 2016. *International Energy Outlook 2016 With Projections to 2040*. <https://doi.org/10.2172/1296780>
- Crawford, S.E.S., Ostrom, E., 1995. A Grammar of Institutions. *Am. Polit. Sci. Rev.* 89, 582–600.
- Cuppen, E., Nikolic, I., Kwakkel, J., Quist, J., 2021. Participatory multi-modelling as the creation of a boundary object ecology: the case of future energy infrastructures in the Rotterdam Port Industrial Cluster. *Sustain. Sci.* 16, 901–918. <https://doi.org/10.1007/s11625-020-00873-z>
- Davis, C., Nikolić, I., Dijkema, G.P.J., 2009. Integration of life cycle assessment into agent-based modeling toward informed decisions on evolving infrastructure systems. *J. Ind. Ecol.* 13, 306–325. <https://doi.org/10.1111/j.1530-9290.2009.00122.x>
- De Araújo, J.A., Schalch, V., 2014. Recycling of electric arc furnace (EAF) dust for use in steel making process. *J. Mater. Res. Technol.* 3, 274–279. <https://doi.org/10.1016/j.jmrt.2014.06.003>
- Demus, T., Echterhof, T., Pfeifer, H., Schulten, M., Quicker, P., 2012. Investigations on the use of biogenic residues as a substitute for fossil coal in the eaf steelmaking process., in: *10 Th European Electric Steelmaking Conference*. Graz.
- Domenech, T., Bleischwitz, R., Doranova, A., Panayotopoulos, D., Roman, L., 2019. Mapping Industrial Symbiosis Development in Europe\_ typologies of networks, characteristics, performance and contribution to the Circular Economy. *Resour. Conserv. Recycl.* 141, 76–98. <https://doi.org/10.1016/j.resconrec.2018.09.016>

- Doménech, T., Davies, M., 2011. The role of Embeddedness in Industrial Symbiosis Networks: Phases in the Evolution of Industrial Symbiosis Networks. *Bus. Strateg. Environ.* 20, 281–296. <https://doi.org/10.1002/bse.695>
- Dong, L., Zhang, H., Fujita, T., Ohnishi, S., Li, H., Fujii, M., Dong, H., 2013. Environmental and economic gains of industrial symbiosis for Chinese iron/steel industry: Kawasaki's experience and practice in Liuzhou and Jinan. *J. Clean. Prod.* 59, 226–238. <https://doi.org/10.1016/j.jclepro.2013.06.048>
- Douglas, J.M., 1988. Conceptual design of chemical processes, McGraw-Hill chemical engineering series. TA - TT -. McGraw-Hill, New York SE - XVIII, 601 p. : illustrations ; 22 cm.
- Echterhof, T., 2021. Review on the use of alternative carbon sources in EAF steelmaking. *Metals (Basel)*. 11, 1–16. <https://doi.org/10.3390/met11020222>
- EIA, 2021. How much carbon dioxide is produced when different fuels are burned? [WWW Document]. U.S. Energy Inf. Adm. URL <https://www.eia.gov/tools/faqs/faq.php?id=73&t=11> (accessed 6.10.21).
- EIA, 2018. Country Analysis Brief: Iran. <https://doi.org/false>
- El-Halwagi, M.M., 2013. Conserving Material Resources through Process Integration: Material Conservation Networks, Handbook of Process Integration (PI): Minimisation of Energy and Water Use, Waste and Emissions. Woodhead Publishing Limited. <https://doi.org/10.1533/9780857097255.3.422>
- Enerdata, 2014. Electricity use per household | Iran [WWW Document]. World Energy Council. URL <https://wec-indicators.enerdata.net/household-electricity-use.html> (accessed 6.24.19).
- Enserink, B., Hermans, L., Kwakkel, J., Thissen, W., Koppenjan, J., Bots, P., 2010. Policy Analysis of Multi-Actor-Systems. LEMMA, The Hague.
- Eurostat, 2018a. Electricity price statistics - Statistics Explained [WWW Document]. Eur. Comm. URL [https://ec.europa.eu/eurostat/statistics-explained/index.php/Electricity\\_price\\_statistics#Electricity\\_prices\\_for\\_non-household\\_consumers](https://ec.europa.eu/eurostat/statistics-explained/index.php/Electricity_price_statistics#Electricity_prices_for_non-household_consumers) (accessed 2.26.20).
- Eurostat, 2018b. Natural gas price statistics - Statistics Explained [WWW Document]. Eur. Comm. URL [https://ec.europa.eu/eurostat/statistics-explained/index.php/Natural\\_gas\\_price\\_statistics#Natural\\_gas\\_prices\\_for\\_non-household\\_consumers](https://ec.europa.eu/eurostat/statistics-explained/index.php/Natural_gas_price_statistics#Natural_gas_prices_for_non-household_consumers) (accessed 2.26.20).
- Fan, Z., Friedmann, S.J., 2021. Low-carbon production of iron and steel: Technology options, economic assessment, and policy. *Joule* 5, 829–862. <https://doi.org/10.1016/j.joule.2021.02.018>
- Farajzadeh, R., Eftekhari, A.A., Dafnomilis, G., Lake, L.W., Bruining, J., 2020. On the sustainability of CO<sub>2</sub> storage through CO<sub>2</sub> – Enhanced oil recovery. *Appl. Energy* 261,

114467. <https://doi.org/10.1016/j.apenergy.2019.114467>

- Feron, P.H.M., Cousins, A., Jiang, K., Zhai, R., Garcia, M., 2020. An update of the benchmark post-combustion CO<sub>2</sub>-capture technology. *Fuel* 273, 117776. <https://doi.org/10.1016/j.fuel.2020.117776>
- FIECO, 2016. Iran 2025 Steel Vision. Esfahan.
- Forni, D., Campana, F., Di Santo, D., 2014. Innovative system for electricity generation from waste heat recovery. *Eceee Ind. Summer Study Proc.* 2, 393–403.
- Fraccascia, L., Albino, V., Garavelli, C.A., 2017a. Technical efficiency measures of industrial symbiosis networks using enterprise input-output analysis. *Int. J. Prod. Econ.* 183, 273–286. <https://doi.org/10.1016/j.ijpe.2016.11.003>
- Fraccascia, L., Giannoccaro, I., Albino, V., 2017b. Efficacy of landfill tax and subsidy policies for the emergence of industrial symbiosis networks: An agent-based simulation study. *Sustain.* 9. <https://doi.org/10.3390/su9040521>
- Fraccascia, L., Yazan, D.M., 2018. The role of online information-sharing platforms on the performance of industrial symbiosis networks. *Resour. Conserv. Recycl.* 136, 473–485. <https://doi.org/10.1016/j.resconrec.2018.03.009>
- Gardarsdottir, S.O., De Lena, E., Romano, M., Roussanaly, S., Voldsund, M., Pérez-Calvo, J.F., Berstad, D., Fu, C., Anantharaman, R., Sutter, D., Gazzani, M., Mazzotti, M., Cinti, G., 2019. Comparison of technologies for CO<sub>2</sub> capture from cement production—Part 2: Cost analysis. *Energies* 12. <https://doi.org/10.3390/en12030542>
- Geels, F.W., 2004. From sectoral systems of innovation to socio-technical systems: Insights about dynamics and change from sociology and institutional theory. *Res. Policy* 33, 897–920. <https://doi.org/10.1016/j.respol.2004.01.015>
- Ghali, M.R., Frayret, J.M., Ahabchane, C., 2017. Agent-based model of self-organized industrial symbiosis. *J. Clean. Prod.* 161, 452–465. <https://doi.org/10.1016/j.jclepro.2017.05.128>
- Global Carbon Project, 2016. CO<sub>2</sub> Emissions | Global Carbon Atlas [WWW Document]. URL <http://www.globalcarbonatlas.org/en/CO2-emissions> (accessed 1.14.19).
- Golev, A., Corder, G.D., Giurco, D.P., 2015. Barriers to Industrial Symbiosis: Insights from the Use of a Maturity Grid. *J. Ind. Ecol.* 19, 141–153. <https://doi.org/10.1111/jiec.12159>
- Gough, C., Mander, S., 2019. Beyond Social Acceptability: Applying Lessons from CCS Social Science to Support Deployment of BECCS. *Curr. Sustain. Energy Reports* 6, 116–123. <https://doi.org/10.1007/s40518-019-00137-0>
- Graedel, T.E., 1996. On the concept of industrial ecology. *Annu. Rev. Energy Environ.* 21, 69–98. <https://doi.org/10.1146/annurev.energy.21.1.69>
- Green, D.W., Perry, R.H., 2008. *Perry's Chemical Engineers' Handbook*. McGraw-Hill

Companies, Inc.

- Greiner, R., Puig, J., Huchery, C., Collier, N., Garnett, S.T., 2014. Scenario modelling to support industry strategic planning and decision making. *Environ. Model. Softw.* 55, 120–131. <https://doi.org/10.1016/j.envsoft.2014.01.011>
- Gurobi Optimization, 2021. Gurobi: The fastest Solver [WWW Document]. URL <https://www.gurobi.com/> (accessed 8.31.21).
- Hackl, R., Harvey, S., 2014. From heat integration targets toward implementation - A TSA (total site analysis)-based design approach for heat recovery systems in industrial clusters. *Energy* 90, 163–172. <https://doi.org/10.1016/j.energy.2015.05.135>
- Hackl, R., Harvey, S., 2013. Applying exergy and total site analysis for targeting refrigeration shaft power in industrial clusters. *Energy* 55, 5–14. <https://doi.org/10.1016/j.energy.2013.03.029>
- He, M., Jin, Y., Zeng, H., Cao, J., 2020. Pricing decisions about waste recycling from the perspective of industrial symbiosis in an industrial park: A game model and its application. *J. Clean. Prod.* 251, 119417. <https://doi.org/10.1016/j.jclepro.2019.119417>
- Holgado, M., Benedetti, M., Evans, S., Baptista, A.J., Lourenço, E.J., 2018. Industrial symbiosis implementation by leveraging on process efficiency methodologies. *Procedia CIRP* 69, 872–877. <https://doi.org/10.1016/j.procir.2017.11.078>
- Horne, R.E., Matthews, R., 2004. BIOMITRE Technical Manual, Renewable Energy.
- Hu, F., Mostashari, A., Xie, J., 2010. *Socio-Technical Networks: Science and Engineering Design*. CRC Press.
- Huang, F., Zheng, J., Baleynaud, J.M., Lu, J., 2017. Heat recovery potentials and technologies in industrial zones. *J. Energy Inst.* 90, 951–961. <https://doi.org/10.1016/j.joei.2016.07.012>
- IEA, 2021. Net Zero by 2050: Aroadmap for the Global Energy Sector, International Energy Agency. OECD, Paris. <https://doi.org/10.1787/c8328405-en>
- IEA, 2020a. Tracking Iron and Steel 2020 – Analysis - IEA. Paris.
- IEA, 2020b. Energy Technology Perspectives 2020, International Energy Agency. <https://doi.org/10.1787/ab43a9a5-en>
- IEA, 2020c. Iron and Steel Technology Roadmap Towards more sustainable steelmaking. <https://doi.org/10.1787/3dcc2a1b-en>
- IEAGHG, 2020. IEAGHG - Techno-Economic Benchmarks for Fossil Fuel-Fired Power Plants with CO2 Capture.pdf.
- IEAGHG, 2018. Cost of CO2 capture in the Industrial Sector: Cement and Iron and Steel Industries.

- IEAGHG, 2017. Techno - Economic Evaluation of SMR Based Standalone (Merchant) Hydrogen Plant with CCS. Tech. Rev. 2017-02 286.
- IEAGHG, 2013. Iron and Steel CCS Study (Techno-Economics Integrated Steel Mill).
- IETS, 2020. Survey of current projects and novel technologies in the steel industry.
- International Aluminium Institute, 2018. Prebaked Anodes for Aluminium Electrolysis.
- Jacobsen, N.B., 2006. Industrial symbiosis in Kalundborg, Denmark. *J. Ind. Ecol.* 10, 239–255. <https://doi.org/10.1162/108819806775545411>
- Jilvero, H., Mathisen, A., Eldrup, N.H., Normann, F., Johnsson, F., Müller, G.I., Melaaen, M.C., 2014. Techno-economic analysis of carbon capture at an aluminum production plant - Comparison of post-combustion capture using MEA and Ammonia. *Energy Procedia* 63, 6590–6601. <https://doi.org/10.1016/j.egypro.2014.11.695>
- Jones, C.R., Olfe-Krätlein, B., Naims, H., Armstrong, K., 2017. The social acceptance of carbon dioxide utilisation: A review and research Agenda. *Front. Energy Res.* 5, 1–13. <https://doi.org/10.3389/fenrg.2017.00011>
- Jouhara, H., Khordehghah, N., Almahmoud, S., Delpech, B., Chauhan, A., Tassou, S.A., 2018. Waste heat recovery technologies and applications. *Therm. Sci. Eng. Prog.* 6, 268–289. <https://doi.org/10.1016/j.tsep.2018.04.017>
- Kappes, H., Both, I., 2021. Energy Transition in the European Steel Industry - Reality Not Exception - Midrex Technologies, Inc. [WWW Document]. Midrex Technol. Inc. URL <https://www.midrex.com/tech-article/energy-transition-in-the-european-steel-industry-reality-not-exception/> (accessed 5.28.21).
- Kastner, C.A., Lau, R., Kraft, M., 2015. Quantitative tools for cultivating symbiosis in industrial parks; a literature review. *Appl. Energy* 155, 599–612. <https://doi.org/10.1016/j.apenergy.2015.05.037>
- Keller, F., Sulger, P. O., Meier, M.W., Severo, D.S., Gusberti, V., 2010. SPECIFIC ENERGY CONSUMPTION IN ANODE BAKE FURNACES. *Light Met.* 408–413. <https://doi.org/10.1007/978-3-319-48179-1>
- Khawaji, A.D., Kutubkhanah, I.K., Wie, J.-M., 2008. Advances in seawater desalination technologies. *Desalination* 221, 47–69. <https://doi.org/10.1016/j.desal.2007.01.067>
- Kirschen, M., Badr, K., Pfeifer, H., 2011a. Influence of direct reduced iron on the energy balance of the electric arc furnace in steel industry. *Energy* 36, 6146–6155. <https://doi.org/10.1016/j.energy.2011.07.050>
- Kirschen, M., Badr, K., Pfeifer, H., 2011b. Influence of direct reduced iron on the energy balance of the electric arc furnace in steel industry. *Energy* 36, 6146–6155. <https://doi.org/10.1016/j.energy.2011.07.050>
- Kirschen, M., Pfeifer, H., Wahlers, F.-J., Mess, H., 2001. Off-gas measurements for mass and

- energy balances of stainless steel EAF ., in: 59th Electric Furnace Conference. Iron and Steel Society, Phoenix, Arizona, pp. 737–748.
- Knoope, M.M.J., Guijt, W., Ramírez, A., Faaij, A.P.C., 2014. Improved cost models for optimizing CO<sub>2</sub> pipeline configuration for point-to-point pipelines and simple networks. *Int. J. Greenh. Gas Control* 22, 25–46. <https://doi.org/10.1016/j.ijggc.2013.12.016>
- Kokoulina, L., Ermolaeva, L., Patala, S., Ritala, P., 2019. Championing processes and the emergence of industrial symbiosis. *Reg. Stud.* 53, 528–539. <https://doi.org/10.1080/00343404.2018.1473568>
- Korhonen, J., Snäkin, J.P., 2005. Analysing the evolution of industrial ecosystems: Concepts and application. *Ecol. Econ.* 52, 169–186. <https://doi.org/10.1016/j.ecolecon.2004.07.016>
- Kuramochi, T., Faaij, A., Ramírez, A., Turkenburg, W., 2010. Prospects for cost-effective post-combustion CO<sub>2</sub> capture from industrial CHPs. *Int. J. Greenh. Gas Control* 4, 511–524. <https://doi.org/10.1016/j.ijggc.2009.12.008>
- Kuznetsova, E., Zio, E., Farel, R., 2016. A methodological framework for Eco-Industrial Park design and optimization. *J. Clean. Prod.* 126, 308–324. <https://doi.org/10.1016/j.jclepro.2016.03.025>
- Kwakkel, J.H., 2017. The Exploratory Modeling Workbench: An open source toolkit for exploratory modeling, scenario discovery, and (multi-objective) robust decision making. *Environ. Model. Softw.* 96, 239–250. <https://doi.org/10.1016/j.envsoft.2017.06.054>
- Kwakkel, J.H., Pruyt, E., 2013. Exploratory Modeling and Analysis, an approach for model-based foresight under deep uncertainty. *Technol. Forecast. Soc. Change* 80, 419–431. <https://doi.org/10.1016/j.techfore.2012.10.005>
- Liu, Z., Adams, M., Cote, R.P., Geng, Y., Li, Y., 2018. Comparative study on the pathways of industrial parks towards sustainable development between China and Canada. *Resour. Conserv. Recycl.* 128, 417–425. <https://doi.org/10.1016/j.resconrec.2016.06.012>
- LME, 2016. London Metal Exchange: Historical data for cash settled futures [WWW Document]. URL <https://www.lme.com/en-GB/Market-Data/Reports-and-data/Historical-data-for-cash-settled-futures> (accessed 9.2.20).
- Lobato, N.C.C., Villegas, E.A., Mansur, M.B., 2015. Management of solid wastes from steelmaking and galvanizing processes: A brief review. *Resour. Conserv. Recycl.* 102, 49–57. <https://doi.org/10.1016/j.resconrec.2015.05.025>
- Lybæk, R., Christensen, T.B., Thomsen, T.P., 2021. Enhancing policies for deployment of Industrial symbiosis – What are the obstacles, drivers and future way forward? *J. Clean. Prod.* 280, 124351. <https://doi.org/10.1016/j.jclepro.2020.124351>
- Madani, K., 2014. Water management in Iran: what is causing the looming crisis? *J. Environ. Stud. Sci.* 4, 315–328. <https://doi.org/10.1007/s13412-014-0182-z>
- Madani, K., AghaKouchak, A., Mirchi, A., 2016. Iran’s Socio-economic Drought: Challenges

- of a Water-Bankrupt Nation. *Iran. Stud.* 49, 997–1016. <https://doi.org/10.1080/00210862.2016.1259286>
- Manzolini, G., Sanchez Fernandez, E., Rezvani, S., Macchi, E., Goetheer, E.L.V., Vlugt, T.J.H., 2015. Economic assessment of novel amine based CO<sub>2</sub> capture technologies integrated in power plants based on European Benchmarking Task Force methodology. *Appl. Energy* 138, 546–558. <https://doi.org/10.1016/j.apenergy.2014.04.066>
- Márkus, R., Grega, O., 2007. The EAF Slag as Construction Material. *Mater. Sci. Forum* 537–538, 671–678. <https://doi.org/10.4028/www.scientific.net/MSF.537-538.671>
- Martín, M.I., López, F.A., Rabanal, M.E., Torralba, J.M., 2009. Obtainment of Sponge Iron By Reduction of a Steelmaking By-Product. 1st Spanish Natl. Conf. Adv. Mater. Recycl. Eco – Energy 107–110.
- Mathews, J.A., Tan, H., 2011. Progress toward a circular economy in China: The drivers (and inhibitors) of eco-industrial initiative. *J. Ind. Ecol.* 15, 435–457. <https://doi.org/10.1111/j.1530-9290.2011.00332.x>
- Meirelles, B., Santos, H., Metallurgy, S., 2014. Economic and Environmental Alternative for Destination of Spent 565–570.
- Mian, A., Martelli, E., Maréchal, F., 2016a. Multi-period Sequential Synthesis of Heat Exchanger Networks and Utility Systems including storages. pp. 967–972. <https://doi.org/10.1016/B978-0-444-63428-3.50166-1>
- Mian, A., Martelli, E., Maréchal, F., 2016b. Framework for the Multiperiod Sequential Synthesis of Heat Exchanger Networks with Selection, Design, and Scheduling of Multiple Utilities. *Ind. Eng. Chem. Res.* 55, 168–186. <https://doi.org/10.1021/acs.iecr.5b02104>
- MIDREX, 2017. World direct reduction statistics, Midrex Technologies, Inc. <https://doi.org/10.1016/j.mechatronics.2012.09.007>
- Mikša, D., Homšak, M., Samec, N., 2003. Spent potlining utilisation possibilities. *Waste Manag. Res.* 21, 467–473. <https://doi.org/10.1177/0734242X0302100509>
- Mileva-Boshkoska, B., Rončević, B., Uršič, E.D., 2018. Modeling and evaluation of the possibilities of forming a regional industrial symbiosis networks. *Soc. Sci.* 7. <https://doi.org/10.3390/socsci7010013>
- Monenco group, 2017. comprehensive study of electricity supply system in PGSEZ [WWW Document]. URL <https://monencogroup.com/FullStory.aspx?nid=16>
- Montemanni, R., Jamal, J., 2018. Industrial cluster optimization based on linear programming. 2018 5th Int. Conf. Ind. Eng. Appl. ICIEA 2018 241–246. <https://doi.org/10.1109/IEA.2018.8387104>
- Moradi, M.A., Shakouri G, H., Aboutaleb, A.M., 2013. Developing the Electricity Demand Model for Iran's Residential Sector Based on LEAP, in: *بیست و هشتمین کنفرانس بین المللی برق*.

- Tehran, pp. 1–5. <https://doi.org/10.13140/2.1.2218.7205>
- Mortensen, L., Kørnøv, L., 2019. Critical factors for industrial symbiosis emergence process. *J. Clean. Prod.* 212, 56–69. <https://doi.org/10.1016/j.jclepro.2018.11.222>
- Moya, J.A., Boulamanti, A., 2016. Production costs from energy-intensive industries in the EU and third countries. <https://doi.org/0.2790/056120>
- Nardin, G., Ciotti, G., Dal Magro, F., Meneghetti, A., Simeoni, P., 2018. Waste heat recovery in the steel industry: Better internal use or external integration? *Proc. Summer Sch. Fr. Turco 2018-Sept.*
- Nazari, A., Shafyeyi, A., Saidi, A., 2018. Recycling of electric arc furnace dust into glass-ceramic. *Mater. Chem. Phys.* 205, 436–441. <https://doi.org/10.1016/j.matchemphys.2017.11.045>
- Nazari, R., Maleki, G., 2008. Chemical and Combustion Analysis of IRAN Natural Gas with Emission Level, in: 2nd National Conference of Combustion. Mashhad.
- NETL, 2013a. Cost and Performance of Retrofitting Existing NGCC Units for Carbon Capture.
- NETL, 2013b. Quality Guidelines for Energy System Studies Capital Cost Scaling Methodology.
- Noori, S. (Shiva), 2020a. ADICO coding of Energy and Environment Regulations in Iran (1994-2018). <https://doi.org/https://doi.org/10.4121/uuid:accf9f0a-cadb-4935-a880-bd018fe93f7a>
- Noori, S. (Shiva), 2020b. Industrial Electricity, Natural Gas, and Water Prices in Iran (2015-2019). <https://doi.org/https://doi.org/10.4121/uuid:9a5fe5fd-77a6-4e38-9527-1c08dc32b9d7>
- Noori, S., Korevaar, G., Ramirez Ramirez, A., 2020. Institutional Lens upon Industrial Symbiosis Dynamics: The case of Persian Gulf Mining and Metal Industries Special Economic Zone. *Sustainability* 12, 6192. <https://doi.org/10.3390/su12156192>
- Notarnicola, B., Tassielli, G., Renzulli, P.A., 2016. Industrial symbiosis in the Taranto industrial district: Current level, constraints and potential new synergies. *J. Clean. Prod.* 122, 133–143. <https://doi.org/10.1016/j.jclepro.2016.02.056>
- NPC, 2019. CCUS SUPPLY CHAINS AND ECONOMICS, in: Meeting the Dual Challenge: A Roadmap to at-Scale Deployment of Carbon Capture, Use, and Storage. pp. 2-1 2-25.
- Nyaga, G.N., Whipple, J.M., Lynch, D.F., 2010. Examining supply chain relationships: Do buyer and supplier perspectives on collaborative relationships differ? *J. Oper. Manag.* 28, 101–114. <https://doi.org/10.1016/j.jom.2009.07.005>
- Oluleye, G., Jiang, N., Smith, R., Jobson, M., 2017. A novel screening framework for waste heat utilization technologies. *Energy* 125, 367–381. <https://doi.org/10.1016/j.energy.2017.02.119>

- Oluleye, G., Jobson, M., Smith, R., 2015. A hierarchical approach for evaluating and selecting waste heat utilization opportunities. *Energy* 90, 5–23. <https://doi.org/10.1016/j.energy.2015.05.086>
- Oluleye, G., Jobson, M., Smith, R., Perry, S.J., 2016. Evaluating the potential of process sites for waste heat recovery. *Appl. Energy* 161, 627–646. <https://doi.org/10.1016/j.apenergy.2015.07.011>
- Pajunen, N., Watkins, G., Husgafvel, R., Heiskanen, K., Dahl, O., 2013. The challenge to overcome institutional barriers in the development of industrial residue based novel symbiosis products - Experiences from Finnish process industry. *Miner. Eng.* 46–47, 144–156. <https://doi.org/10.1016/j.mineng.2013.03.008>
- Paltsev, S., Morris, J., Kheshgi, H., Herzog, H., 2021. Hard-to-Abate Sectors: The role of industrial carbon capture and storage (CCS) in emission mitigation. *Appl. Energy* 300, 117322. <https://doi.org/10.1016/j.apenergy.2021.117322>
- Pan, M., Sikorski, J., Akroyd, J., Mosbach, S., Lau, R., Kraft, M., 2016. Design technologies for eco-industrial parks: From unit operations to processes, plants and industrial networks. *Appl. Energy* 175, 305–323. <https://doi.org/10.1016/j.apenergy.2016.05.019>
- Paquin, R.L., Howard-Grenville, J., 2012. The Evolution of Facilitated Industrial Symbiosis. *J. Ind. Ecol.* 16, 83–93. <https://doi.org/10.1111/j.1530-9290.2011.00437.x>
- Parhi, S.S., 2014. Gainful utilization of spent pot lining - A Hazardous Waste from aluminum industry. National Institute of Technology Rourkela.
- Personnet, P.B., 2013. Treatment and Reuse of Spent Pot Lining, an Industrial Application in a Cement Kiln, in: *Essential Readings in Light Metals: Electrode Technology for Aluminum Production*. pp. 1049–1056. <https://doi.org/10.1002/9781118647745.ch141>
- Pfeifer, H., Kirschen, M., Simoes, J.P., 2005. Thermodynamic analysis of EAF electrical energy demand, in: *8th European Electric Steelmaking Conference*. IOM Communications, Birmingham, pp. 211–232.
- PGSEZ, 2020. Introduction to Persian Gulf Mining and Metal Industries Special Economic Zone [WWW Document]. URL <http://www.pgsez.ir/Modules/CMS/CMSPages/showpage.aspx?MItemID=IRRIIRRI> (accessed 5.1.20).
- Pili, R., García Martínez, L., Wieland, C., Spliethoff, H., 2020. Techno-economic potential of waste heat recovery from German energy-intensive industry with Organic Rankine Cycle technology. *Renew. Sustain. Energy Rev.* 134, 110324. <https://doi.org/10.1016/j.rser.2020.110324>
- Pinto, J.T.M., Morales, M.E., Fedoruk, M., Kovaleva, M., Diemer, A., 2019. Servitization in support of sustainable cities: What are steel's contributions and challenges? *Sustain.* 11. <https://doi.org/10.3390/su11030855>
- Porter, M.E., 1998. Clusters and the New Economics of Competition. *Harv. Bus. Rev.* 77–90.

<https://doi.org/10.1042/BJ20111451>

- Pourazarm, E., Cooray, A., 2013. Estimating and forecasting residential electricity demand in Iran. *Econ. Model.* 35, 546–558. <https://doi.org/10.1016/j.econmod.2013.08.006>
- Rao, Y., Zhou, M., Cao, C., Tan, S., Song, Y., Zhang, Z., Dai, D., Ou, G., Zhang, L., Nie, X., Deng, A., Cairen, Z., 2019. Exploring the quantitative relationship between economic benefit and environmental constraint using an inexact chance-constrained fuzzy programming based industrial structure optimization model. *Qual. Quant.* 53, 2199–2220. <https://doi.org/10.1007/s11135-019-00865-x>
- Reddy, C.C.. and N.S.V., 2013. *Waste Heat Recovery Methods And Technologies - Chemical Engineering.*
- Ritchie, H., Roser, M., 2020. Emissions by sector - Our World in Data [WWW Document]. Univ. Oxford. URL <https://ourworldindata.org/emissions-by-sector> (accessed 11.12.21).
- Roberts, B.H., 2004. The application of industrial ecology principles and planning guidelines for the development of eco-industrial parks: An Australian case study. *J. Clean. Prod.* 12, 997–1010. <https://doi.org/10.1016/j.jclepro.2004.02.037>
- Rosenberg, E., 2012. *Energy Technology Systems Analysis Programme: Aluminium Production.*
- Roussanaly, S., Berghout, N., Fout, T., Garcia, M., Gardarsdottir, S., Nazir, S.M., Ramirez, A., Rubin, E.S., 2021a. Towards improved cost evaluation of Carbon Capture and Storage from industry. *Int. J. Greenh. Gas Control* 106, 103263. <https://doi.org/10.1016/j.ijggc.2021.103263>
- Roussanaly, S., Berghout, N., Fout, T., Garcia, M., Gardarsdottir, S., Nazir, S.M., Ramirez, A., Rubin, E.S., 2021b. Towards improved guidelines for cost evaluation of carbon capture and storage, *International Journal of Greenhouse Gas Control.* <https://doi.org/10.1016/j.ijggc.2021.103263>
- Roussanaly, S., Fu, C., Voldsund, M., Anantharaman, R., Spinelli, M., Romano, M., 2017. Techno-economic Analysis of MEA CO<sub>2</sub> Capture from a Cement Kiln - Impact of Steam Supply Scenario. *Energy Procedia* 114, 6229–6239. <https://doi.org/10.1016/j.egypro.2017.03.1761>
- Rui, J., Heijungs, R., 2010. Industrial ecosystems as a social network, in: *The 14th European Roundtable on Sustainable Production and Consumption (ERSCP) and The 6th Environmental Management for Sustainable Universities (EMSU)*, pp. 1–11.
- Sarkar, S., Bhattacharya, R., Roy, G.G., Sen, P.K., 2018. Modeling MIDREX Based Process Configurations for Energy and Emission Analysis. *Steel Res. Int.* 89, 1–9. <https://doi.org/10.1002/srin.201700248>
- Savulescu, L.E., Alva-Argaez, A., 2013. *Process Integration Concepts for Combined Energy and Water Integration, Handbook of Process Integration (PI): Minimisation of Energy and Water Use, Waste and Emissions.* Woodhead Publishing Limited.

<https://doi.org/10.1533/9780857097255.4.461>

- SEAIISI, 2017. Iran 2025 Steel Vision Reviewed [WWW Document]. South East Asia Iron Steel Inst. URL <http://www.seaisi.org/News/6463/Iran+2025+Steel+Vision+Reviewed> (accessed 11.8.17).
- SEAIISI, 2008. Dealing with Environmental Pollution in the Iron and Steel Industry: The China Case Study [WWW Document]. South East Asia Iron Steel Inst. URL <http://www.seaisi.org/News/662/Dealing+with+Environmental+Pollution+in+the+Iron+and+Steel+Industry:+The+China+Case+Study> (accessed 2.9.18).
- Simboli, A., Taddeo, R., Raggi, A., Morgante, A., 2020. Structure and Relationships of Existing Networks in View of the Potential Industrial Symbiosis Development 57–71. [https://doi.org/10.1007/978-3-030-36660-5\\_4](https://doi.org/10.1007/978-3-030-36660-5_4)
- Skaf, M., Manso, J.M., Aragón, Á., Fuente-Alonso, J.A., Ortega-López, V., 2017. EAF slag in asphalt mixes: A brief review of its possible re-use. *Resour. Conserv. Recycl.* 120, 176–185. <https://doi.org/10.1016/j.resconrec.2016.12.009>
- SOLARGIS, 2021. Global Solar Atlas - About [WWW Document]. URL <https://globalsolaratlas.info/map?c=-22.429567,45.508226,2> (accessed 1.4.22).
- Spekkink, W.A.H., Boons, F.A.A., 2016. The Emergence of Collaborations. *J. Public Adm. Res. Theory* 26, 613–630. <https://doi.org/10.1093/jopart/muv030>
- Springer, C., Hasanbeigi, A., 2016. Emerging Energy Efficiency and Carbon Dioxide Emissions- Reduction Technologies for Industrial Production of Aluminum.
- Statistica, 2019. Iran Inflation Rate [WWW Document]. Statistica. URL <https://www.statista.com/statistics/294320/iran-inflation-rate/> (accessed 2.25.20).
- Statistical Centre of Iran, 2018. Selected Findings of the 2016 National Population and Housing Census. Tehran.
- Steel Price (Europe) | Historical Charts, Forecasts, & News [WWW Document], n.d. URL <https://www.focus-economics.com/commodities/base-metals/steel-europe> (accessed 9.2.20).
- Steelonthenet, 2020a. DRI prices: India, direct reduced iron dollars per tonne [WWW Document]. URL <https://www.steelonthenet.com/files/dri.html> (accessed 9.2.20).
- Steelonthenet, 2020b. Electric arc furnace steelmaking costs 2020 [WWW Document]. URL <https://www.steelonthenet.com/cost-eaf.html> (accessed 9.2.20).
- Steinparzer, T., Haider, M., Fleischanderl, A., Hampel, A., Enickl, G., Zauner, F., 2012. Heat exchangers and thermal energy storage concepts for the off-gas heat of steelmaking devices, in: *Journal of Physics: Conference Series*. <https://doi.org/10.1088/1742-6596/395/1/012158>
- Steinparzer, T., Haider, M., Zauner, F., Enickl, G., Michele-Naussed, M., Horn, A.C., 2014.

- Electric arc furnace off-gas heat recovery and experience with a testing plant. *Steel Res. Int.* 85, 519–526. <https://doi.org/10.1002/srin.201300228>
- Sun, L., Spekink, W., Cuppen, E., Korevaar, G., 2017. Coordination of industrial symbiosis through anchoring. *Sustain.* 9. <https://doi.org/10.3390/su9040549>
- Taddeo, R., 2016. Local industrial systems towards the eco-industrial parks: the model of the ecologically equipped industrial areas. *J. Clean. Prod.* 131, 189–197. <https://doi.org/10.1016/j.jclepro.2016.05.051>
- Taddeo, R., Simboli, A., Morgante, A., Erkman, S., 2017. The Development of Industrial Symbiosis in Existing Contexts. Experiences From Three Italian Clusters. *Ecol. Econ.* 139, 55–67. <https://doi.org/10.1016/j.ecolecon.2017.04.006>
- Taskhiri, M.S., Behera, S.K., Tan, R.R., Park, H.S., 2015. Fuzzy optimization of a waste-to-energy network system in an eco-industrial park. *J. Mater. Cycles Waste Manag.* 17, 476–489. <https://doi.org/10.1007/s10163-014-0259-5>
- tehrantimes, 2019. Efficiency of Iran’s power plants to reach 38% [WWW Document]. *tehrantimes*. URL <https://www.tehrantimes.com/news/437835/Efficiency-of-Iran-s-power-plants-to-reach-38> (accessed 6.10.21).
- Tenova, 2009. Tenova Reference Sheet Georgsmarienhütte gmbh [WWW Document]. URL <https://www.tenova.com/product/ecs-whb-solutions/>
- Teo, K.Y., Ng, T.Y., Wau, C.M., Liew, J.T.S., Andiappan, V., Ng, D.K.S., 2017. Hybrid Optimisation Model for the Synthesis of Centralised Utility System in Eco-Industrial Park. *Process Integr. Optim. Sustain.* 1, 33–57. <https://doi.org/10.1007/s41660-017-0003-4>
- Teräs, J., 2011. Emerging Clusters: Theoretical, Empirical and Political Perspectives on the Initial Stage of Cluster Evolution - Edited by Dirk Fornahl, Sebastian Henn, and Max-Peter Menzel. *Reg. Stud.* 45, 1290–1292. <https://doi.org/10.1080/00343404.2011.608258>
- Toulouevski, Y.N., Zinurov, I.Y., 2017. Fuel Arc Furnace (FAF) for Effective Scrap Melting. Springer. <https://doi.org/10.1007/978-981-10-5885-1>
- Tudor, T., Adam, E., Bates, M., 2007. Drivers and limitations for the successful development and functioning of EIPs (eco-industrial parks): A literature review. *Ecol. Econ.* 61, 199–207. <https://doi.org/10.1016/j.ecolecon.2006.10.010>
- UN DESA, 2016. THE 17 GOALS | Sustainable Development [WWW Document]. *Sustain. Dev.* URL <https://sdgs.un.org/goals> (accessed 1.10.22).
- UNIDO, 2019a. Industrial Development Report 2020: Industrializing in the digital age., United Nations Industrial Development Organization. Vienna.
- UNIDO, 2019b. Statistical Indicators of Inclusive and Sustainable Industrialization. Vienna.
- UNIDO, 2017. Implementation handbook for eco-industrial parks. United Nations Industrial Development organization.

- UNIDO, 2013. Inclusive and Sustainable Industrial Development [WWW Document]. United Nations Ind. URL <https://www.unido.org/inclusive-and-sustainable-industrial-development> (accessed 2.7.22).
- Vahidi, H., Hoveidi, H., Kazemzadeh, J., 2018. Analyzing material flow in Alborz industrial estate , Ghazvin , Iran. *J. Mater. Cycles Waste Manag.* 20, 450–460. <https://doi.org/10.1007/s10163-017-0601-9>
- van Beers, D., Corder, G., Bossilkov, A., Berke, R. van, 2007. Industrial Symbiosis in the Australian Minerals Industry The Cases of Kwinana and Gladstone. *J. Ind. Ecol.* 11, 18.
- van Berkel, R., 2010. Quantifying sustainability benefits of industrial symbioses. *J. Ind. Ecol.* 14, 371–373. <https://doi.org/10.1111/j.1530-9290.2010.00252.x>
- van Dam, K., Nikolic, I., Lukszo, Z., 2013. Agent-based modelling of socio-technical systems, Springer. <https://doi.org/10.1007/978-94-007-4933-7>
- Velenturf, A.P.M., Jensen, P.D., 2016. Promoting Industrial Symbiosis: Using the Concept of Proximity to Explore Social Network Development. *J. Ind. Ecol.* 20, 700–709. <https://doi.org/10.1111/jiec.12315>
- Vieira, C.M.F., Sanchez, R., Monteiro, S.N., Lalla, N., Quaranta, N., 2013. Recycling of electric arc furnace dust into red ceramic. *J. Mater. Res. Technol.* 2, 88–92. <https://doi.org/10.1016/j.jmrt.2012.09.001>
- Villar, A., Arribas, J.J., Parrondo, J., 2012. Waste-to-energy technologies in continuous process industries. *Clean Technol. Environ. Policy* 14, 29–39. <https://doi.org/10.1007/s10098-011-0385-x>
- Vogl, V., Åhman, M., Nilsson, L.J., 2018. Assessment of hydrogen direct reduction for fossil-free steelmaking, *Journal of Cleaner Production.* Elsevier Ltd. <https://doi.org/10.1016/j.jclepro.2018.08.279>
- Voinov, A., Jenni, K., Gray, S., Kolagani, N., Glynn, P.D., Bommel, P., Prell, C., Zellner, M., Paolisso, M., Jordan, R., Sterling, E., Schmitt Olabisi, L., Giabbanelli, P.J., Sun, Z., Le Page, C., Elsawah, S., BenDor, T.K., Hubacek, K., Laursen, B.K., Jetter, A., Basco-Carrera, L., Singer, A., Young, L., Brunacini, J., Smajgl, A., 2018. Tools and methods in participatory modeling: Selecting the right tool for the job. *Environ. Model. Softw.* 109, 232–255. <https://doi.org/10.1016/j.envsoft.2018.08.028>
- Wang, Hui-gang, Gao, J., Liu, W., Zhang, M., Guo, M., 2016. Recovery of metal-doped zinc ferrite from zinc-containing electric arc furnace dust: Process development and examination of elemental migration. *Hydrometallurgy* 166, 1–8. <https://doi.org/10.1016/j.hydromet.2016.08.004>
- Wang, H., Yu, H., Teng, L., Seetharaman, S., 2016. Evaluation on material and heat balance of eaf processes with introduction of CO<sub>2</sub>. *J. Min. Metall. Sect. B Metall.* 52, 1–8. <https://doi.org/10.2298/JMMB150627002W>
- Weather atlas, 2019. Bandar Abbas, Iran - Detailed climate information and monthly weather

forecast | Weather Atlas [WWW Document]. URL <https://www.weather-atlas.com/en/iran/bandar-abbas-climate> (accessed 1.28.19).

- Wen, Z., Meng, X., 2015. Quantitative assessment of industrial symbiosis for the promotion of circular economy: A case study of the printed circuit boards industry in China's Suzhou New District. *J. Clean. Prod.* 90, 211–219. <https://doi.org/10.1016/j.jclepro.2014.03.041>
- Whitmarsh, L., Xenias, D., Jones, C.R., 2019. Framing effects on public support for carbon capture and storage. *Palgrave Commun.* 5. <https://doi.org/10.1057/s41599-019-0217-x>
- Worrell, E., Price, L., Neelis, M., Galitsky, C., Nan, Z., 2007. World Best Practice Energy Intensity Values for Selected Industrial Sectors. Lawrence Berkeley Natl. Lab. 51.
- WSA, 2021. World Steel in Figures 2021, World Steel Association. Brussels.
- WSA, 2019. World Steel in Figures 2019, World Steel Association.
- Wu, J., Qi, H., Wang, R., 2016. Insight into industrial symbiosis and carbon metabolism from the evolution of iron and steel industrial network. *J. Clean. Prod.* 135, 251–262. <https://doi.org/10.1016/j.jclepro.2016.06.103>
- Yap, N.T., Devlin, J.F., 2017. Explaining Industrial Symbiosis Emergence, Development, and Disruption: A Multilevel Analytical Framework. *J. Ind. Ecol.* 21, 6–15. <https://doi.org/10.1111/jiec.12398>
- Yu, B., Li, X., Shi, L., Qian, Y., 2015. Quantifying CO<sub>2</sub> emission reduction from industrial symbiosis in integrated steel mills in China. *J. Clean. Prod.* 103, 801–810. <https://doi.org/10.1016/j.jclepro.2014.08.015>
- Yu, B.S., Wang, Y.R., Chang, T.C., 2011. Hydrothermal treatment of electric arc furnace dust. *J. Hazard. Mater.* 190, 397–402. <https://doi.org/10.1016/j.jhazmat.2011.03.056>
- Yu, C., Davis, C., Dijkema, G.P.J., 2014a. Understanding the evolution of industrial symbiosis research: A bibliometric and network analysis (1997-2012). *J. Ind. Ecol.* 18, 280–293. <https://doi.org/10.1111/jiec.12073>
- Yu, C., De Jong, M., Dijkema, G.P.J., 2014b. Process analysis of eco-industrial park development - The case of Tianjin, China. *J. Clean. Prod.* 64, 464–477. <https://doi.org/10.1016/j.jclepro.2013.09.002>
- Yu, C., Dijkema, G.P.J., de Jong, M., 2015. What Makes Eco-Transformation of Industrial Parks Take Off in China? *J. Ind. Ecol.* 19, 441–456. <https://doi.org/10.1111/jiec.12185>
- Yu, F., Han, F., Cui, Z., 2015. Evolution of industrial symbiosis in an eco-industrial park in China. *J. Clean. Prod.* 87, 339–347. <https://doi.org/10.1016/j.jclepro.2014.10.058>
- Zhe, L., Yong, G., Hung-Suck, P., Huijuan, D., Liang, D., Tsuyoshi, F., 2016. An emergy-based hybrid method for assessing industrial symbiosis of an industrial park. *J. Clean. Prod.* 114, 132–140. <https://doi.org/10.1016/j.jclepro.2015.04.132>

Zhu, J., Ruth, M., 2014. The development of regional collaboration for resource efficiency: A network perspective on industrial symbiosis. *Comput. Environ. Urban Syst.* 44, 37–46. <https://doi.org/10.1016/j.compenvurbsys.2013.11.001>

## Appendixes

### Appendix A. Location and Schematic Map of the PGSEZ

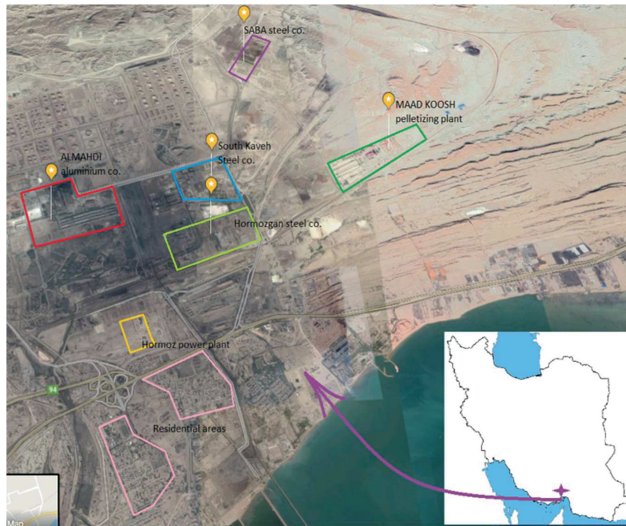

**Figure A1** Location and schematic map of the PGSEZ

Source: <https://www.google.nl/maps>

## Appendix B. Waste heat Recovery Technology Ranking

**Table B1** Ranking of Waste Heat Recovery technologies in different temperatures (In each row, number 1 is the most efficient technology in that temperature range) (Huang et al., 2017; Jouhara et al., 2018; Oluleye et al., 2017)

		SINK								
			Chilling		Heating			Power		
			ABC	AHP	AHT	HEX	MHP	ORC	PGC	
SOURCE	Low grade	< 70 °C				1	2			
		70 °C ~ 100 °C	1		4	3		2		
	Medium grade	100 °C ~ 140 °C	1	2			4	3		
		140 °C ~ 180 °C	1			2	3	4		
		180 °C ~ 200 °C				1		2		
		200 °C ~ 265 °C				1		2		
		265 °C ~ 400 °C				1			1	
	High grade	> 400 °C				1			1	
	Technologies: ABC: Absorption Chiller; AHP: Absorption Heat Pump; AHT: Absorption Heat Transfer; HEX: Heat Exchanger; MHP: Mechanical Heat Pump; ORC: Organic Rankine Cycle; PGC: other Power Generation Cycle									

## Appendix C: Input-Output block diagram and Plant-Level Block Diagram of Steelmaking and Direct Reduction Plants

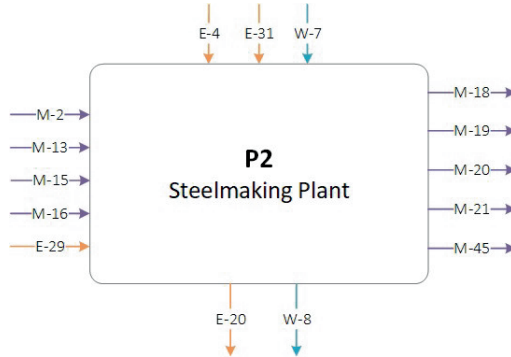

Figure C1 Input-Output diagram of Steelmaking Plant

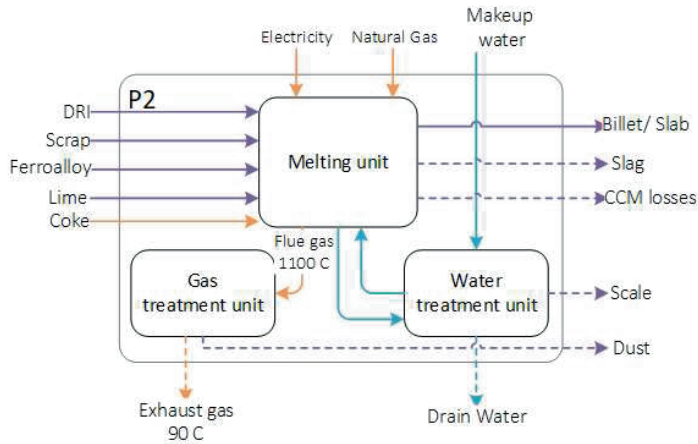
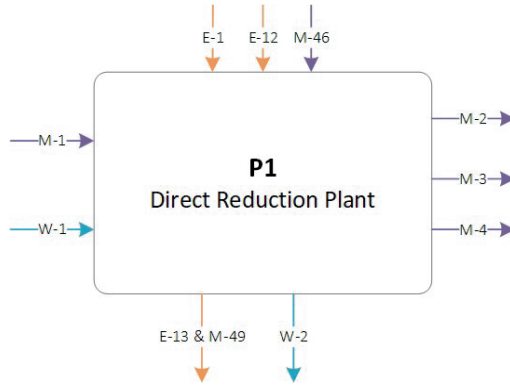
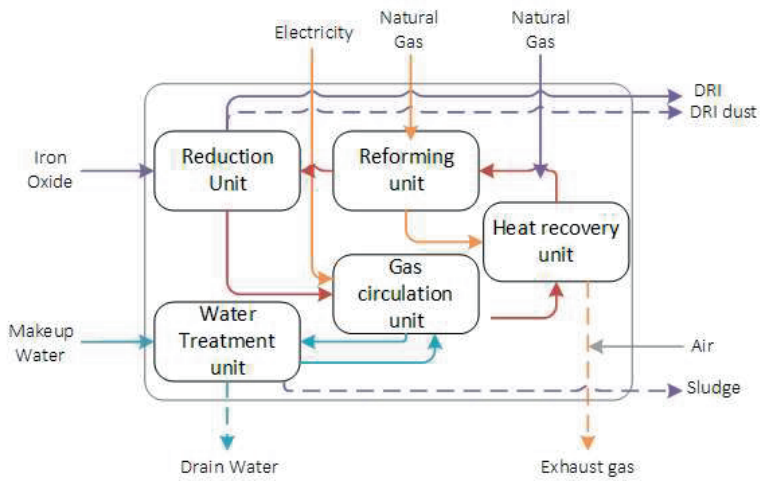

Figure C2 Plant-level block diagram of Steelmaking Plant

A



**Figure C4** Input-Output diagram of Direct Reduction Plant



**Figure C3** Plant-level block diagram of Direct Reduction Plant

## Appendix D: Annual Input/ Output Flowrates in 2018 based on the field data

*Table D1* Calculated annual material flows in the PGSEZ in 2018

Company	Plant	Code	Description	Type	From	To	Annual rate (t)	Field data	Calculation notes
SKS	DRP	M-1	Iron pellet	FS	MT	P1	2,682,500	1.45 t/ t product	In agreement with literature (1.45 t/ t product (Sarkar et al., 2018))
SKS	DRP	M-2	DRI	MP	P1	P2	1,850,000	1,850,000 t/year	
SKS	DRP	M-3	Sludge DRI	BP	P1	WD	92,500	5% of final product	
SKS	DRP	M-4	Dust DRI	BP	P1	WD	111,000	6% of final product	
SKS	DRP	M-49	Gaseous products	BP	P1	AR	995,744		Calculated from plant material balance
SKS	DRP	M-46	Natural Gas	FS	U5	P1	366,744	290 ~ 300 Nm <sup>3</sup> /t product	84% of input NG used as process gas (Sarkar et al., 2018)
HOS	DRP	M-5	Iron pellet	FS	MT	P3	2,392,500	1.45 t/ t product	In agreement with literature (1.45 t/ t product (Sarkar et al., 2018))
HOS	DRP	M-6	DRI	MP	P3	P4	1,650,000	1,650,000 t/year	
HOS	DRP	M-7	Sludge DRI	BP	P3	WD	99,000	6% of final product	
HOS	DRP	M-8	Dust DRI	BP	P3	P6	49,500	3% of final product	
HOS	DRP	M-50	Gaseous products	BP	P3	AR	924,990		Calculated from plant material balance

Company	Plant	Code	Description	Type	From	To	Annual rate (t)	Field data	Calculation notes
HOS	DRP	M-47	Natural Gas	FS	U5	P3	330,990	295 Nm <sup>3</sup> /t product	84% of input NG used as process gas (Sarkar et al., 2018)
SAB	DRP	M-9	Iron pellet	FS	MT	P7	1,370,000	1.37 t/t product	In agreement with literature (1.45 t/ t product (Sarkar et al., 2018))
SAB	DRP	M-10	HBI	MP	P7	MT	1,000,000	1,000,000 t/year	Plant production capacity at 2019
SAB	DRP	M-11	Sludge DRI	BP	P7	WD	22,000	2.2% of final product	
SAB	DRP	M-12	Dust DRI	BP	P7	WD	17,500	1.75% of final product	
SAB	DRP	M-51	Gaseous products	BP	P7	AR	517,316		Calculated from plant material balance
SAB	DRP	M-48	Natural Gas	FS	U5	P7	186,816	277.9 Nm <sup>3</sup> /t product	84% of input NG used as process gas (Sarkar et al., 2018)
SKS	SMP	M-13	Scrap	FS	MT	P2	22,041	18 kg/t product	
SKS	SMP	M-14	DRI	FS	P1	P2	1,506,122	1.23 t/t product	
SKS	SMP	M-15	Lime	FS	MT	P2	84,490	69 kg/t product	
SKS	SMP	M-16	Ferroalloys	FS	MT	P2	30,000	25 kg/t product	
SKS	SMP	M-18	Billet	MP	P2	MT	1,200,000	1,200,000 t/year	
SKS	SMP	M-19	Slag	BP	P2	WD	306,122	250 kg/t product	
SKS	SMP	M-20	Dust SMP	BP	P2	WD	11,020	9 kg/t product	

Company	Plant	Code	Description	Type	From	To	Annual rate (t)	Field data	Calculation notes
SKS	SMP	M-21	Sludge SMP	BP	P2	WD	60,000	0.05 t/ t product	
SKS	SMP	M-45	CCM Losses	BP	P2	WD	24,000	2% of product	
SKS	SMP	M-53	Other SMP losses	BP	P2	WD	41,510		Calculated from plant material balance
HOS	SMP	M-22	Scrap	FS	MT	P4	44,388	30 kg/t product	
HOS	SMP	M-23	DRI	FS	P3	P4	1,848,980	1.23 t/ t product	
HOS	SMP	M-24	Lime	FS	MT	P4	93,367	62 kg/t product	
HOS	SMP	M-25	Ferroalloys	FS	MT	P4	76,990	51 kg/t product	
HOS	SMP	M-27	Slab	MP	P4	MT	1,500,000	1,500,000 t/year	
HOS	SMP	M-28	Slag	BP	P4	WD	390,828	261 kg/t product	
HOS	SMP	M-29	Dust SMP	BP	P4	WD	18,552	12 kg/t product	
HOS	SMP	M-30	Sludge SMP	BP	P4	WD	123,669	0.08 t/t product	
HOS	SMP	M-43	CCM Losses	BP	P4	WD	30,600	2% of product	
AAC	ABP	M-31	Calcined Coke	FS	MT	P8	61,920		Estimated based on literature (0.60 t/t product (Beglery et al., 2018))
AAC	ABP	M-32	Pitch	FS	MT	P8	15,480		Estimated based on literature (0.15 t/t product (Beglery et al., 2018))

Company	Plant	Code	Description	Type	From	To	Annual rate (t)	Field data	Calculation notes
AAC	ABP	M-33	Spent Anode	FS	P9	P8	25,800		Estimated based on literature (0.25 t/t product (Beglery et al., 2018))
AAC	ABP	M-34	Baked Anode	MP	P8	P9	103,200		0.25 return anode (International Aluminium Institute, 2018)
AAC	ARP	M-35	Alumina	FS	MT	P9	337,120	1.96 t/t product	
AAC	ARP	M-36	Cryolite	FS	MT	P9	5,160		Estimated based on literature (30 kg/t product (Balomenos et al., 2011))
AAC	ARP	M-44	Aluminium fluoride	FS	MT	P9	6,880		Estimated based on literature (40 kg/t product (Balomenos et al., 2011))
AAC	ARP	M-42	Anode	FS	P8	P9	77,400		Estimated based on literature (0.45 net t/t product (Balomenos et al., 2011))
AAC	ARP	M-37	Aluminium ingot	MP	P9	MT	172,000	172,000 t/year	
AAC	ARP	M-38	SPL (Spent Pot Lines)	BP	P9	WD	3,440		Estimated based on literature (0.02 kg/kg product (Balomenos et al., 2011))

Company	Plant	Code	Description	Type	From	To	Annual rate (t)	Field data	Calculation notes
AAC	ARP	M-52	Gaseous products	BP	P9	AR	244,240		Estimated based on literature (1.53 kg/kg product (Balomenos et al., 2011))
HOS	CBP	M-39	Lime	FS	MT	P6	876	0.2 t/hr	
HOS	CBP	M-40	Molasses	FS	MT	P6	2,190	0.5 t/hr	
HOS	CBP	M-41	CBI	MP	P6	MT	52,566	12 t/hr	
PGM	NGS	M-17	Natural Gas	FS	MT	U5	884,550		Calculated based on cluster material balance

**Table D2** Calculated energy flows in the PGSEZ in 2018

Company	Plant	Code	Description	Type	From	To	Energy (MW)	Field data	Calculation notes
SKS	DRP	E-1	Electricity	EL	U4	P1	33.4	120 ~ 130 kWh/t product	In agreement with literature (Worrell et al., 2007)
SKS	DRP	E-12	Natural Gas	FF	U5	P1	112.5	290 ~ 300 Nm <sup>3</sup> /t product	Matches with literature. 16% of input NG used as fuel gas (Sarkar et al., 2018) Heating value NG= 33.4 MJ/Nm <sup>3</sup> (Nazari and Maleki, 2008)
SKS	DRP	E-13	Exhaust Gas-M	WH	P1	AR	52.2	500,000 m <sup>3</sup> /hr per module Temperature= 300 °C	Ambient temperature = 27 °C (Weather atlas, 2019)

Company	Plant	Code	Description	Type	From	To	Energy (MW)	Field data	Calculation notes
HOS	DRP	E-2	Electricity	EL	U4	P3	27.0	118 kWh/t product	In agreement with literature (Worrell et al., 2007)
HOS	DRP	E-14	Natural Gas	FF	U5	P3	100.4	295 Nm3/t product	Matches with literature. 16% of input NG used as fuel gas (Sarkar et al., 2018) Heating value NG= 33.4 MJ/Nm3 (Nazari and Maleki, 2008)
HOS	DRP	E-15	Exhaust gas	WH	P3	AR	49.1	483,000 m3/hr per module Temperature= 300 °C	Ambient temperature = 27 °C (Weather atlas, 2019)
SAB	DRP	E-3	Electricity	EL	U4	P7	19.4	139.8 kWh/ t product	In agreement with literature (Worrell et al., 2007)
SAB	DRP	E-16	Natural Gas	FF	U5	P7	57.3	278 Nm3/t product	In agreement with literature. 16% of input NG used as fuel gas (Sarkar et al., 2018) Heating value NG= 33.4 MJ/Nm3 (Nazari and Maleki, 2008)
SAB	DRP	E-17	Exhaust gas	WH	P7	AR	28.5		Data was not available. 4,200 m3/t product assumed such as other DRPs.

Company	Plant	Code	Description	Type	From	To	Energy (MW)	Field data	Calculation notes
SKS	SMP	E-29	Coke	FF	MT	P2	22.8	15 kg/t product	Heating value C= 32.8 MJ/kg (Green and Perry, 2008)
SKS	SMP	E-4	Electricity	EL	U4	P2	125.0	750 kWh/t product	In agreement with literature (Kirschen et al., 2011a; Pfeifer et al., 2005)
SKS	SMP	E-31	Natural Gas	FF	U5	P2	8.5	5,5 Nm3/t product	Heating value NG= 33.4 MJ/Nm3 (Nazari and Maleki, 2008)
SKS	SMP	E-20	Exhaust gas	WH	P2	AR	21.3	2,000,000 Nm3/hr Temperature = 90 °C	Ambient temperature = 27 °C (Weather atlas, 2019)
HOS	SMP	E-30	Coke	FF	MT	P4	11.6	6 kg/t product	Heating value C= 32.8 MJ/kg (Green and Perry, 2008)
HOS	SMP	E-5	Electricity	EL	U4	P4	159.6	766 kWh/t product	In agreement with literature (Kirschen et al., 2011a; Pfeifer et al., 2005)
HOS	SMP	E-21	Natural Gas	FF	U5	P4	6.4	3.3 Nm3/t product	Heating value NG= 33.4 MJ/Nm3 (Nazari and Maleki, 2008)
HOS	SMP	E-23	Exhaust gas	WH	P4	AR	19.0	1,683,520 Nm3/hr Temperature = 90 °C	Ambient temperature = 27 °C (Weather atlas, 2019)

Company	Plant	Code	Description	Type	From	To	Energy (MW)	Field data	Calculation notes
PGZ	ROP	E-6	Electricity	EL	U4	U1	0.6		Estimated based on literature (4.5 kWh/m <sup>3</sup> (Khawaji et al., 2008))
SKS	ROP	E-7	Electricity	EL	U4	U2	2.3	3.7 kWh/ m <sup>3</sup> product	In agreement with literature (2~5 kWh/m <sup>3</sup> (Khawaji et al., 2008))
HOS	ROP	E-8	Electricity	EL	U4	U3	3.3	2.7 kWh/m <sup>3</sup> product	In agreement with literature (2~5 kWh/m <sup>3</sup> (Khawaji et al., 2008))
AAC	ABP	E-24	Natural Gas	FF	U5	P8	9.8		Estimated based on literature (2.45 GJ/t product (Springer and Hasanbeigi, 2016))
AAC	ABP	E-32	Electricity	EL	U8	P8	2.0		Estimated based on literature (140 kWh/t product (Springer and Hasanbeigi, 2016))
AAC	ABP	E-25	Exhaust gas	WH	P8	AR	2.2		Estimated based on the literature (Keller et al., 2010): 4,000 Nm <sup>3</sup> /t anode; Temperature = 250 °C
AAC	ARP	E-9	Electricity	EL	U8	P9	377,4	15,800 kWh/t product	

Company	Plant	Code	Description	Type	From	To	Energy (MW)	Field data	Calculation notes
AAC	ARP	E-26	Exhaust gas	WH	P9	AR	75.5		20% of energy input is considered as flue gas losses (Balomenos et al., 2011)
HOS	CBP	E-10	Electricity	EL	U4	P6	0.1	16.7 kWh/t product	
PGM	GPP	E-27	Natural Gas	FF	U5	U7	490.0	33% thermal efficiency	NG consumption calculated based on efficiency
PGM	GPP	E-28	Exhaust gas	WH	U7	AR	330	33% thermal efficiency Temperature= 500 °C	Waste heat calculated based on efficiency
PGM	GPP	E-11	Electricity	EL	U7	U4	160.0	160 MW power plant	
PGM	ESS	E-18	Electricity	EL	MT	U4	210.6	Total electricity input to HOS, SKS, SAB.	In agreement with consultant reports (Monenco group, 2017)
AAC	ESS	E-19	Electricity	EL	MT	U8	377.4	Total electricity input to AAC.	In agreement with consultant reports (Monenco group, 2017)
PGM	NGS	E-22	Natural Gas	FF	MT	U5	781.5	Total NG input to the cluster.	

**Table D3** Calculated annual water flows in the PGSEZ in 2018

Company	Plant	Code	Description	Type	From	To	Annual rate (Nm <sup>3</sup> )	Field data	Calculation notes
SKS	DRP	W-1	Makeup water	IW	U2	P1	1,850,000	1.0 m <sup>3</sup> /t product	
SKS	DRP	W-2	Drain Water	WW	P1	SE	740,000		assumed same as HOS DRP

Company	Plant	Code	Description	Type	From	To	Annual rate (Nm <sup>3</sup> )	Field data	Calculation notes
HOS	DRP	W-3	Makeup water	IW	U3	P3	1,485,000	1.0 m3/t product	
HOS	DRP	W-4	Drain Water	WW	P3	SE	495,000	0.3 m3/t product	
SAB	DRP	W-5	Makeup water	IW	U6	P7	1,720,000	1.72 Nm3/ t product	
SAB	DRP	W-6	Drain Water	WW	P7	SE	688,000		ratio to makeup assumed same as HOS
SKS	SMP	W-7	Makeup water	IW	U2	P2	1,346,939	1.1 Nm3/ t product	
SKS	SMP	W-8	Drain Water	WW	P2	SE	630,000		assumed same as HOS SMP
HOS	SMP	W-9	Makeup water	IW	U3	P4	1,395,804	0.93 Nm3/ t product	
HOS	SMP	W-10	Drain Water	WW	P4	SE	787,500	0.53 Nm3/ t product	
PGM	ROP	W-11	Sea Water	SW	SE	U1	3,000,000		Calculated based on 30% recovery
PGM	ROP	W-12	Concentrated Water	WW	U1	SE	2,100,000		Calculated based on 30% recovery
PGM	ROP	W-13	Industrial Water	IW	U1		900,000		Calculated considering 3,000 Nm3/day and 300 working days per year
SKS	ROP	W-14	Sea Water	SW	SE	U2	10,656,463	30% recovery & process consumption	Calculated based on 30% recovery
SKS	ROP	W-15	Concentrated Water	WW	U2	SE	7,459,524	70% concentration	Calculated based on 30% recovery
SKS	ROP	W-19	total treated water	IW	U2	P1 & P2	3,196,939		Total makeup needed for SMP & DRP
HOS	ROP	W-16	Sea Water	SW	SE	U3	8,230,869		Calculated based on 35% recovery

Company	Plant	Code	Description	Type	From	To	Annual rate (Nm <sup>3</sup> )	Field data	Calculation notes
HOS	ROP	W-17	Concentrated Water	WW	U3	SE	5,350,065		Calculated based on 35% recovery
HOS	ROP	W-18	total treated water	IW	U3	P4 & P3	2,880,804	Make up for SMP & DRP	Total make up needed for SMP & DRP

## Appendix E: The Questionnaire: Survey Regarding Collaboration Efforts among Companies in PGSEZ<sup>4</sup>

*Introduction:* Industrial Symbiosis (IS) is defined as collaborative relationship in which two or more nearby industrial plants exchange co-products, by-products, waste material or waste energy to achieve economic or environmental benefits that cannot be obtained individually. It can increase material productivity and energy efficiency and improve the corporate image of the whole cluster.

An Emerging Industrial Cluster (EIC) is an industrial cluster in its first stages of evolution which has unrealized possibilities for rapid growth. EICs play an influential role in the industrialization of emerging economies. This questionnaire is part of the Ph.D. research of Shiva Noori at Delft University of Technology, The Netherlands, on the evaluation of Industrial Symbiosis in emerging industrial clusters. The Persian Gulf Mines and Metals Special Economic Zone (PGSEZ) cluster has been selected as the case study in this research. Successful Industrial Symbiosis needs technical potential for material and energy exchange as well as social readiness for collaboration. In the first part of this PhD project, the technical potential for Industrial Symbiosis was investigated. In this part, we aim to assess cluster readiness for IS emergence. In this questionnaire, previous collaborations in the cluster and the enablers of successful ones will be studied first. Then, we would like to identify under which conditions actors will engage in IS collaboration. In parallel to this survey, we are investigating regional and national regulations governing industrial activities (e.g., environmental regulations and energy prices). The combination of the survey outcomes with desk research (literature review) will help us to understand the cluster readiness for IS emergence. This knowledge will help

<sup>4</sup> The distributed questioner was in Persian, and this is a translation.

both companies and cluster management in their strategies for future collaborations in the cluster under different economic and environmental policies.

The survey results will be anonymized and all names and positions will remain confidential according to EU General Data Protection Regulation (GDPR). Data gathered through this survey will be analyzed together with institutional statements, and the results will be published in an academic journal. If you are interested, a summary of the results will be sent to you. For any complementary data or clarification, you can contact me via contact information provided at the end of the questionnaire. Completing the survey will take about 15 minutes. It would be appreciated to receive filled questionnaire within a week.

Your name .....

*Table E.1 General information*

1 Please specify the company for which you work:

- The cluster management (PGS)                      Hormozgan Steel Complex (HOS)
- South Kaveh Steel Complex (SKS)                      Persian Gulf Saba Steel (SAB)
- Almahdi Aluminum company (AAC)                      Maad Koosh iron ore pelletizing company (MKP)
- Hormoz Power Plant (HPP)

2 Please specify the division in which you work:

- Management              Engineering              Energy & Utility              Development Planning
- HSE                      Operation              Others, please specify .....

3 How long have you worked in this company? .....

*Table E.2 Collaboration matrix*

*Collaboration* refers to the joint effort of two actors to share resources such as experience, knowledge, money, or physical assets to solve a problem or gain an advantage collectively. In this survey, we focus on intra-organizational collaborations. We have listed six collaboration types in the table below. For each of the other companies in the PGSEZ cluster, please indicate in which way(s), if at all, your company has collaborated with them within the last 5 years.

## 4 Collaboration matrix

Collaboration with Company	Technical advice & consultation	Supervision & project management	Product trade	By-product trade	Utility supply (electricity, water, or natural gas)	Joint investment	Other
PGS	<input type="checkbox"/>	<input type="checkbox"/>	<input type="checkbox"/>	<input type="checkbox"/>	<input type="checkbox"/>	<input type="checkbox"/>	<input type="checkbox"/>
HOS	<input type="checkbox"/>	<input type="checkbox"/>	<input type="checkbox"/>	<input type="checkbox"/>	<input type="checkbox"/>	<input type="checkbox"/>	<input type="checkbox"/>
SKS	<input type="checkbox"/>	<input type="checkbox"/>	<input type="checkbox"/>	<input type="checkbox"/>	<input type="checkbox"/>	<input type="checkbox"/>	<input type="checkbox"/>
SAB	<input type="checkbox"/>	<input type="checkbox"/>	<input type="checkbox"/>	<input type="checkbox"/>	<input type="checkbox"/>	<input type="checkbox"/>	<input type="checkbox"/>
AAC	<input type="checkbox"/>	<input type="checkbox"/>	<input type="checkbox"/>	<input type="checkbox"/>	<input type="checkbox"/>	<input type="checkbox"/>	<input type="checkbox"/>
MKP	<input type="checkbox"/>	<input type="checkbox"/>	<input type="checkbox"/>	<input type="checkbox"/>	<input type="checkbox"/>	<input type="checkbox"/>	<input type="checkbox"/>
HPP	<input type="checkbox"/>	<input type="checkbox"/>	<input type="checkbox"/>	<input type="checkbox"/>	<input type="checkbox"/>	<input type="checkbox"/>	<input type="checkbox"/>

Table E.3 Successful Collaborations

Here we would like you to select what in your opinion is the most successful collaboration your company has had in the PGSEZ within the last 5 years and answer questions 5 to 16 accordingly.

- 5 How long did the collaboration last? .....
- 6 Is the collaboration still ongoing?  
 Yes  No
- 7 Which organizations were involved in the collaboration? (Multiple answers possible)  
 Consulting company  Cluster management  
 Province-level governmental organizations  National-level governmental organizations  
 No other organization was involved  Others, please specify .....
- 8 Who decided to start the collaboration?  
 Your company  The other company  
 Consulting company  Cluster management  
 Governmental organizations  Others, please specify .....  
 I do not know
- 9 What was the manner of agreement for the collaboration?



- Not at all       Slightly       Moderately       Very       Completely
- 18 Increase in waste disposal costs (e.g. landfill tax or carbon tax)
- Not at all       Slightly       Moderately       Very       Completely
- 19 Resource scarcity (land, water, energy...)
- Not at all       Slightly       Moderately       Very       Completely
- 20 New short or long term business opportunities for your company
- Not at all       Slightly       Moderately       Very       Completely
- 21 Increasing energy efficiency or material productivity of your company
- Not at all       Slightly       Moderately       Very       Completely
- 22 Information about available waste heat and material in the cluster for exchange
- Not at all       Slightly       Moderately       Very       Completely
- 23 Decreasing Greenhouse Gas (GHG) emissions of the company
- Not at all       Slightly       Moderately       Very       Completely
- 24 Readiness of required infrastructures (e.g. road transport road , pipeline) to carry out the exchanges
- Not at all       Slightly       Moderately       Very       Completely
- 25 Information about other successful industrial symbiosis projects (national or worldwide)
- Not at all       Slightly       Moderately       Very       Completely
- 26 Financial stimulation policies by the government (e.g., subsidies or tax cuts)
- Not at all       Slightly       Moderately       Very       Completely
- 27 Monitoring and environmental assessment by governmental organizations (e.g. stack gas monitoring, waste water quality monitoring)
- Not at all       Slightly       Moderately       Very       Completely
- 28 Cluster development plans organized by the cluster management
- Not at all       Slightly       Moderately       Very       Completely
- 29 Workshops, conferences, seminars in the cluster to enhance networking and awareness of IS
- Not at all       Slightly       Moderately       Very       Completely

Please mention below any additional issues related to implementation of Industrial Symbiosis in this cluster that you think are important and were not included in this questionnaire.

## Appendix F: ADICO coding sample translated to English

Regulation	Clause	Code	Description
Sixth country development plan	38	A	The government
		D	must
		I	Completion and implementation of wastewater and sewage collection, treatment, recycling, and management facilities in cities, industrial parks, service areas, and other units which generate swage with pollution level higher than national standards limit through contracting for sale or pre-sale of sewage discharge from existing facilities or future development plans.
		C	---
		O	---
		Type	N
The executive procedure of waste management	12	A	Production units, using recycled raw material
		D	---
		I	will be exempt from payment of determined charges.
		C	for the use of such materials
		O	---
		Type	S
Soil Protection law (Act)	13	A	Managers of Free Trade Zones, Industrial and Special Economic Zones, and Industrial parks
		D	must
		I	eliminate pollution and destruction within the scope of this Act and submit a report of actions to the DOE or ministry as appropriate.
		C	In cases of pollution or destruction of soil is reported by DOE or the ministry
		O	---
		Type	N
Energy consumption pattern reform law	69	A	The ministry of energy in collaboration with the ministry of industry, mine, and trade
		D	must

Regulation	Clause	Code	Description
		I	plan and conduct practical training courses in general energy management and specific heat and electricity management for energy managers of industrial units in the national training center of energy management in industry, and grant a certificate to the trainees.
		C	---
		O	---
		Type	N
Rules and regulations for the establishment of production, industrial and mining units	12	A	All Executive Organizations
		D	---
		I	promote industrial plants to settlement in industrial areas and prevent the dispersal of these plants.
		C	---
		O	---
		Type	S

## Appendix G: Linny-R and industrial symbiosis modeling

The challenge of required technical and economic details for system-level analysis of industrial plants led to the development of Linny-R software. Process modeling tools cannot take into account the non-technical variables in actors' decision-making, and Agent-based models are incapable of finding an optimal operating condition of the system. Linny-R is a diagram-based modeling tool for analyzing and optimizing the performance of systems composed of multiple processes and their input/output products, developed by Pieter Bots at Delft University of Technology (Bots, 2021) to solve MILP problems that incorporate physical and non-physical variables. In Linny-R, physical (e.g., material and energy) and data (e.g., information and monetary) flows are modeled as products. Any activity with inflows and outflows is modeled as a process. Activities such as selling, buying, and contracting, which are crucial in IS collaborations, are regarded as processes. In the model, an activity receives input (physical and data flow) to generate outputs. Note that operating and investment costs associated with each activity are implemented in the model as data flows.

Linny-R visualizes all processes and products in network format. A company can then be modeled as a cluster of processes owned by the same actor. The whole system is referred to as

the industrial cluster to avoid confusion. Linny-R maximizes profit or minimizes the cost of the entire industrial cluster subject to system constraints. Linny-R assumes actors' behavior is rational, not random. Actors make a decision based on their economic benefit considering the system constraints. The constraints (e.g., prices, taxes, and environmental pollution limits) can be defined as the lower bounds, upper bounds, production and consumption rates, and prices. It is possible to apply temporal changes in input data in the form of time series, data sets, or functions of other model parameters, then investigate the output variations over time. However, optimizing the industrial cluster's operation in Linny-R has limitations. Linny-R does not check the material and energy balance. The predecessor to cluster modeling in Linny-R is the technical and institutional study of the cluster. Decision variables in the optimization procedure are the production levels of processes in each time step. Prices, capacities, and production and consumption rates are exogenous variables. Thus, their values and temporal changes have to be determined outside the model, and the solver does not calculate such parameters in each time step by itself.

## Appendix H: PGSEZ model material and energy data

**Table H.1** Material and energy consumption and generation rates in different processes in PGSEZ

Actor	Plant	Product	flow rate	Unit
SKS	P1	Pellet	1.45	tone/ tone product
		DRI	1.00	tone/ tone product
		Sludge <sub>DRI</sub>	0.05	tone/ tone product
		Dust <sub>DRI</sub>	0.06	tone/ tone product
		EL <sub>input</sub>	0.47	GJ/tone product
		Natural Gas Feedstock	0.20	tone/ tone product
		Natural Gas	1.58	GJ/tone product
		Waste Heat <sub>P1</sub>	0.71	GJ/tone product
		Industrial Water	1.00	Nm <sup>3</sup> /tone product
		Waste Water	0.40	Nm <sup>3</sup> /tone product
HOS	P3	Pellet	1.45	tone/ tone product
		DRI	1.00	tone/ tone product
		Sludge <sub>DRI</sub>	0.06	tone/ tone product
		Dust <sub>DRI</sub>	0.03	tone/ tone product
		EL <sub>input</sub>	0.42	GJ/tone product
		Natural Gas Feedstock	0.20	tone/ tone product

Actor	Plant	Product	flow rate	Unit
		Natural Gas	1.58	GJ/tonne product
		Waste Heat <sub>P3</sub>	0.75	GJ/tonne product
		Industrial Water	1.02	Nm <sup>3</sup> /tonne product
		Waste Water	0.30	Nm <sup>3</sup> /tonne product
		Pellet	1.37	tonne/ tonne product
		HBI	1.00	tonne/ tonne product
		Sludge <sub>DRI</sub>	0.02	tonne/ tonne product
		Dust <sub>DRI</sub>	0.02	tonne/ tonne product
SAB	P7	EL <sub>input</sub>	0.50	GJ/tonne product
		Natural Gas Feedstock	0.19	tonne/ tonne product
		Natural Gas	1.49	GJ/tonne product
		Waste Heat <sub>P7</sub>	0.72	GJ/tonne product
		Industrial Water	1.72	Nm <sup>3</sup> /tonne product
		Waste Water	0.69	Nm <sup>3</sup> /tonne product
		Scrap	0.02	tonne/ tonne product
		DRI	1.26	tonne/ tonne product
		Lime	0.07	tonne/ tonne product
		Ferrous alloys	0.03	tonne/ tonne product
		Coke	0.49	GJ/tonne product
		Billet	1.00	tonne/ tonne product
		Slag	0.26	tonne/ tonne product
SKS	P2	Dust <sub>SMP</sub>	0.01	tonne/ tonne product
		Sludge <sub>SMP</sub>	0.05	tonne/ tonne product
		CCM Loss	0.02	tonne/ tonne product
		EL <sub>input</sub>	2.70	GJ/tonne product
		Natural Gas	0.18	GJ /tonne product
		Waste Heat <sub>P2</sub>	0.47	GJ/tonne product
		Industrial Water	1.12	Nm <sup>3</sup> /tonne product
		Waste Water	0.53	Nm <sup>3</sup> /tonne product
		Scrap	0.03	tonne/ tonne product
HOS	P4	DRI	1.23	tonne/ tonne product
		Lime	0.06	tonne/ tonne product

Actor	Plant	Product	flow rate	Unit
		Ferroalloys	0.05	tone/ tone product
		Coke	0.20	GJ /tone product
		Slab	1.00	tone/ tone product
		Slag	0.26	tone/ tone product
		Dust <sub>SMP</sub>	0.01	tone/ tone product
		Sludge <sub>SMP</sub>	0.08	tone/ tone product
		CCM Loss	0.02	tone/ tone product
		EL <sub>input</sub>	2.76	GJ /tone product
		Natural Gas	0.11	GJ /tone product
		Waste Heat <sub>P4</sub>	0.34	GJ /tone product
		Industrial Water	0.93	Nm <sup>3</sup> /tone product
		Waste Water	0.53	Nm <sup>3</sup> /tone product
		Calcined Coke (CPC)	0.60	tone/ tone product
		Pitch (CTC)	0.15	tone/ tone product
		Spent Anode	0.25	tone/ tone product
AAC	P8	Anode	1.00	tone/ tone product
		Natural Gas	2.45	GJ /tone product
		EL <sub>input</sub>	0.50	GJ /tone product
		Waste Heat <sub>P8</sub>	0.56	GJ /tone product
		Alumina	1.96	tone/ tone product
		Cryolite	0.03	tone/ tone product
		Aluminum fluoride	0.04	tone/ tone product
		Anode	0.45	tone/ tone product
AAC	P9	Aluminum ingot	1.00	tone/ tone product
		SPL	0.02	tone/ tone product
		EL <sub>input</sub>	56.88	GJ /tone product
		Waste Heat <sub>P9</sub>	11.38	GJ /tone product
		Lime	0.02	tone/ tone product
		Molasses	0.04	tone/ tone product
HOS	P5	CBI	1.00	tone/ tone product
		EL <sub>input</sub>	0.06	GJ /tone product
HPP	P6	Natural Gas	3.06	GJ/GJ product

Actor	Plant	Product	flow rate	Unit
		Waste Heat <sub>P6</sub>	2.06	GJ/GJ product
		EL-HPP	1.00	GJ/GJ product

## Appendix I: Model economic input data (Chapter 4)

**Table I.1** CAPEX and OPEX of different waste recovery technologies

Specification	Amount	Reference
<b>P14 (heat recovery steam generator + steam turbine (HRSG+ST))</b>		
efficiency	0.32	
Capacity (GT + ST) (TJ)	6887	
Capacity (GT + ST) (kW)	229,879	
total capital requirement (TCR) (€/kW)	800	(IEAGHG, 2020)
Cost ratio GT/ (HRSG+ST)	1.16	(Manzolini et al., 2015)
TCR, total (€)	183,903,457	
TCR, P14 (k€)	85,140	
AC, capital (k€/yr)	9,961	
OPEX, fixed	398	(Kuramochi, Faaij, Ramírez, & Turkenburg, 2010)
AC, P14	10,360	
OPEX, var (k€/TJ)	0.16	(Manzolini et al., 2015)
Cost price generated electricity	3.94	
<b>P16 (absorption chiller (ABC))</b>		
efficiency	0.72	calculated (Oluleye, Jiang, Smith, & Jobson, 2017)
Capacity (TJ/yr)	406.1	
Capacity (kW)	13,554.4	
total capital requirement (TCR) (€/kW)	500	(U.S. Department of Energy, 2016)
Investment cost (k€)	6,777	
AC, capital (k€/yr)	793	
OPEX, fixed (k€/yr)	29	(U.S. Department of Energy, 2016)
AC, P14	822	

Specification	Amount	Reference
OPEX, var (k€/TJ)	0.07	(U.S. Department of Energy, 2016)
Cost price generated cooling	2.1	
P18 (waste heat steam generator + Organic Rankine Cycle (WRS+ORC))		
type		
efficiency	0.14	Nardin et al., 2018; Pili et al., 2020; Bause et al., 2015
Capacity (TJ/yr)	134.4	
Capacity (kW)	4,486	
total capital requirement (TCR) (€/kW)	1.82	(Tenova, 2009); (Nardin et al., 2018)
Investment cost (k€)	8,165	
AC, capital (k€/yr)	955	
OPEX, fixed (k€/yr)	120	(Forni et al., 2014)
AC, P14	1,075	
OPEX, var (k€/TJ)	0	
Cost price generated cooling	8.0	

**Table I.2** Input prices and costs to the model

Resources	Value	unit	reference
Electricity at ENO	4.45	€/GJ	(Noori et al., 2020)
Natural Gas at ENO	0.83	€/GJ	(Noori et al., 2020)
Industrial Water	0.14	€/Nm <sup>3</sup>	(Noori et al., 2020)
Pellet	100.0	€/tone	(Vogl et al., 2018)
DRI	215.0	€/tone	(Steelonthenet, 2020a)
Lime	120.0	€/tone	(Steelonthenet, 2020b)
Molasses	100.0	€/tone	
Coke	231.0	€/tone	(Moya and Boulamanti, 2016)
scrap	225.0	€/tone	(LME, 2016)
Ferroalloys	920.0	€/tone	(Moya and Boulamanti, 2016)
Alumina	279.5	€/tone	
Aluminum Fluoride	1025	€/tone	
Cryolite	900	€/tone	
Calcined coke	200	€/tone	

Pitch	200	€/tone	
slab	410	€/tone	("Steel Price (Europe)   Historical Charts, Forecasts, & News," n.d.)
Aluminum	1440	€/tone	
CBI	280	€/tone	(Bhattacharyya et al., 2019)
SMP variable cost	66.5	€/tone	(Vogl et al., 2018)
DRP variable cost	27.5	€/tone	(IEAGHG, 2013; Vogl et al., 2018)
ARP variable cost	200	€/tone	(Rosenberg, 2012)

## Appendix J: Annualized cost calculations (Chapter 5)

Annualized costs were calculated according to the below formulations:

$$AC = CAPEX * CRF + OPEX_{fixed} \quad \text{Equation 1}$$

$$CRF = \frac{R}{1 - (1 + R)^{-n}} \quad \text{Equation 2}$$

$$CAPEX = SC_{cap} * LF_{cap} * SRF \quad \text{Equation 3}$$

$CRF$  is the capital recovery factor,  $SC_{cap}$  is the scaled capital cost,  $SRF$  is a simplified retrofit factor, and  $LF_{cap}$  is location factors related to material costs and contingency. At this level of design, an  $SRF$  equal to 1.09 for brownfield projects was multiplied in the calculated total plant cost (NETL, 2013a).

**Table J.1** Annualized cost calculation for natural gas steam boilers in configuration CCS-only

	NSB1	NSB2	NSB3	NSB4
CCS Capacity (kt/yr)	576	800	773	703
Heating demand (TJ/yr)	1,728	2,160	2,087	1,898
Heating demand (MW)	57.68	72.10	69.66	63.36
Investment cost (€) <sup>(1)</sup>	16,958,510	20,047,960	19,538,325	18,195,718
Annualized Cost (M€/yr)	2.61	3.08	3.00	2.80

Cost function obtained from (Carapellucci et al., 2015)

**Table J.2** Annualized cost calculation for MIDREX CCS plants

	Exponent <sup>(1)</sup>	Reference Plant <sup>(2)</sup>	CCS2	CCS3	CCS4
Capture unit investment cost (€)	0.61	95,162,000	106,350,674	104,172,945	98,289,110
Compression & dehydration unit investment cost (€)	0.77	28,036,000	32,259,340	31,427,756	29,203,910
Cooling and BOP unit investment cost (€)	0.71	16,696,000	19,002,176	18,550,048	17,336,292
Total Plant Cost (TPC) (€)		139,894,000	157,612,189	154,150,748	144,829,312
Total Capital Requirement (TCR) (€)		181,862,200	204,895,845	200,395,972	188,278,106
Annualized capital cost (€/yr)			31,479,622	30,788,274	28,926,519
labour cost (€/yr)		300,000	132,480	132,480	132,480
maintenance cost (€/yr) <sup>(3)</sup>		2,098,410	2,364,183	2,312,261	2,172,440
other costs (€/yr) <sup>(4)</sup>		1,398,940	1,576,122	1,541,507	1,448,293
OPEX, fixed		3,797,350	4,072,785	3,986,249	3,753,213
AC, total (M€/yr)			35.55	34.78	32.68

1) Obtained from (NETL, 2013b)  
2) Obtained from (IEAGHG, 2017)  
3) 1.5% TPC  
4) 1.0% TPC

**Table J.3** Annualized cost calculation for waste heat recovery from steelmaking plants

	Reference Plant	SKS	HOS
Steelmaking plant capacity (t, steel/hr)	140	170	220
Available waste heat (MWh/yr) <sup>(1)</sup>	102,000	195,833	223,055
Investment cost (M€) <sup>(2)</sup>	4.50	5.26	6.46
Operation cost (M€/yr) <sup>(1)</sup>	0.1	0.17	0.19
AC (M€/yr)		0.82	0.99

- 
- 1) Obtained from (Tenova, 2009)
  - 2) Obtained from (Forni et al., 2014)
- 

## Appendix K: Electronic published research data

This appendix presents model files and other supporting documents to different chapters published online in 4TU research data repository.

Supporting documents for Chapter 3:

- Noori, Shiva (2020): Field observations in The Persian Gulf Mining and Metal Industries Special Economic Zone (PGSEZ)- Institutions and collaborations. 4TU.ResearchData. Dataset. <https://doi.org/10.4121/uuid:1af39107-ee71-4cd1-9289-ea6a5ca21fb8>
- Noori, Shiva (2020): Industrial Electricity, Natural Gas, and Water Prices in Iran (2015-2019). 4TU.ResearchData. Dataset. <https://doi.org/10.4121/uuid:9a5fe5fd-77a6-4e38-9527-1c08dc32b9d7>
- Noori, Shiva (2020): ADICO coding of Energy and Environment Regulations in Iran (1994-2018). 4TU.ResearchData. Dataset. <https://doi.org/10.4121/uuid:accf9f0a-cadb-4935-a880-bd018fe93f7a>

Supporting documents for Chapter 4:

- Noori, Shiva (2022): Industrial cluster modeling in Linn-R; supporting the publication: Exploring the emergence of waste recovery and exchange in industrial clusters. 4TU.ResearchData. Dataset. <https://doi.org/10.4121/17886707.v1>

Supporting documents for Chapter 5:

- Noori, Shiva (2022): PGSEZ models in Linn-R- Supporting information for Chapter 5 of the dissertation (The interplay between industrial symbiosis and other industrial decarbonization strategies). 4TU.ResearchData. Dataset. <https://doi.org/10.4121/19494038.v1>



# Acknowledgment

Doing a Ph.D. at TU Delft has been my most challenging experience so far, and who knows? Life might have more challenges for me ahead. This journey was not only about obtaining a degree but a transformation into a more capable person (hopefully!). I am proud to push my boundaries in different directions and open doors to new horizons.

Dear Andrea and Gijsbert! Thank you thousand times for steering my ship in the stormy ocean of research. Without your guidelines, I would have been lost. As I have told you several times, I admire your patience and foresight in supervising my work. You gave me the bravery to dive into unknown fields and find confidence in making impossibles possible.

And, of course, one of the most unbelievable parts of this new life was coming across wonderful friends. When I left my old buddies in Iran behind, I thought I could never find close friends at this age again. First, let me thank my dear family and friends in Iran. Thanks for understanding, believing, and encouraging us to stay faithful to our destiny. Mom! Thanks for being here on the special day of my defense. Dear Hossein and Lili! Love you so much! We have constantly received your spiritual support despite thousands of kilometers between us.

Dear Zofia! I was so lucky to spend most of my Ph.D. life during your management. Wonderful Andrea's research group, E&I community, ESS department, and all other TPM friends! I cannot name one by one how many amazing people were around me and guided and supported me with no expectations. I have learned a lot from you all. I hope to return this favor to other souls somewhere on the earth.

Extraordinary secretaries of the E&I, Priscilla and Diones! You are the Wonderwomen of the section with magical capabilities and skills.

Outstanding cooking club chefs! I had beautiful moments with you during Covid times and afterward. Now I am leaving, but promise me to covert ESS to an international restaurant soon.

My roommates, Kailan and Ashis! Your companion made TPM such a pleasant place to come to every day. My Iranian E&I friends, Sina, Molood, and Javanshir! Thanks for all your empathy and backing. My thoughtful and kind Maya! You were around me any moment I needed a hand.

In the past four years, the Iranian community of Delft has supported us like blood brothers and sisters. We never felt lonely and isolated in such a warm and welcoming community. Dear Naghmeh, Shila, and Hanieh! I wish I had found you and your lovely families earlier in my life.

I am pleased that my beloved family remained resilient despite all difficulties of these years. Looking back, I see our relations deeper and more tightened. My beloved Reza! No one knows how much I owe you for finishing this Ph.D. It needs another dissertation to describe your self-devotion and support in this journey and a whole life to compensate for it. My wonderful Alborz! You are the wisest kid one could ever have. My decision to do a Ph.D. affected your life the most; I was impressed by your adaptability and stability in facing this significant change. Four years ago, we stepped on an unknown road together through which we came across several unpredicted troubles. Without you two, I would have collapsed. Love you more than you can even imagine!

## List of Publications

- Noori, S., Korevaar, G., Ramirez, A.R., 2021. Assessing industrial symbiosis potential in Emerging Industrial Clusters: The case of Persian Gulf Mining and metal industries special economic zone. *J. Clean. Prod.* 280.  
<https://doi.org/10.1016/j.jclepro.2020.124765>
- Noori, S., Korevaar, G., Ramirez Ramirez, A., 2020. Institutional Lens upon Industrial Symbiosis Dynamics: The case of Persian Gulf Mining and Metal Industries Special Economic Zone. *Sustainability* 12, 6192. <https://doi.org/10.3390/su12156192>
- Noori, S., Korevaar, G., Ramirez Ramirez, A., 2021. Development of a Sustainable Steel Cluster in Iran through Industrial Symbiosis, in: Schnitzer, H., Braunegg, S. (Eds.), 20th European Roundtable on Sustainable Consumption and Production. Graz. <https://doi.org/10.3217/978-3-85125-842-4-13>
- Noori, S., Korevaar, G., Ramirez Ramirez, A., Exploring the emergence of waste recovery and exchange in industrial clusters, *Journal of Industrial Ecology*, Under review

## Curriculum Vitae

Shiva Noori was born in Qazvin, Iran, on September 14, 1980. She graduated from Farzanegan high school (administered under the National Organization for Development of Exceptional Talents) in 1998 and started her B.Sc. in mechanical engineering at Sharif University of Technology (SUT), continued by M.Sc. in energy systems engineering at the same university.

After graduation in 2005, she started working in Iran's iron and steel development projects, from proposal to commissioning, for over ten years. Zooming out and investigating the projects at the system level, she realized that the engineering approach alone is insufficient for sustainable industrial development. Being interested in industrialization's environmental, social, economic, and institutional aspects, Shiva started a Ph.D. in industrial symbiosis in emerging economies. During her Ph.D., she aimed to understand and model the socio-technical structure of industrial clusters by integrating engineering knowledge (e.g., multi-criteria decision-making, process economics, and sustainability assessment) with social science practices (e.g., stakeholder assessment and institutional analysis).



