



The Different Stages of To Be

Cathy Floris

- Methods of Analysis and Imagination

To understand

*To know why or how
something happens or works*

- Cambridge Dictionary





Helsinki

TALLINN

Ferry
TERMINAL

Medieval
city centre

REALLY
Big ROAD

Newer Soviet
DEVELOPMENTS

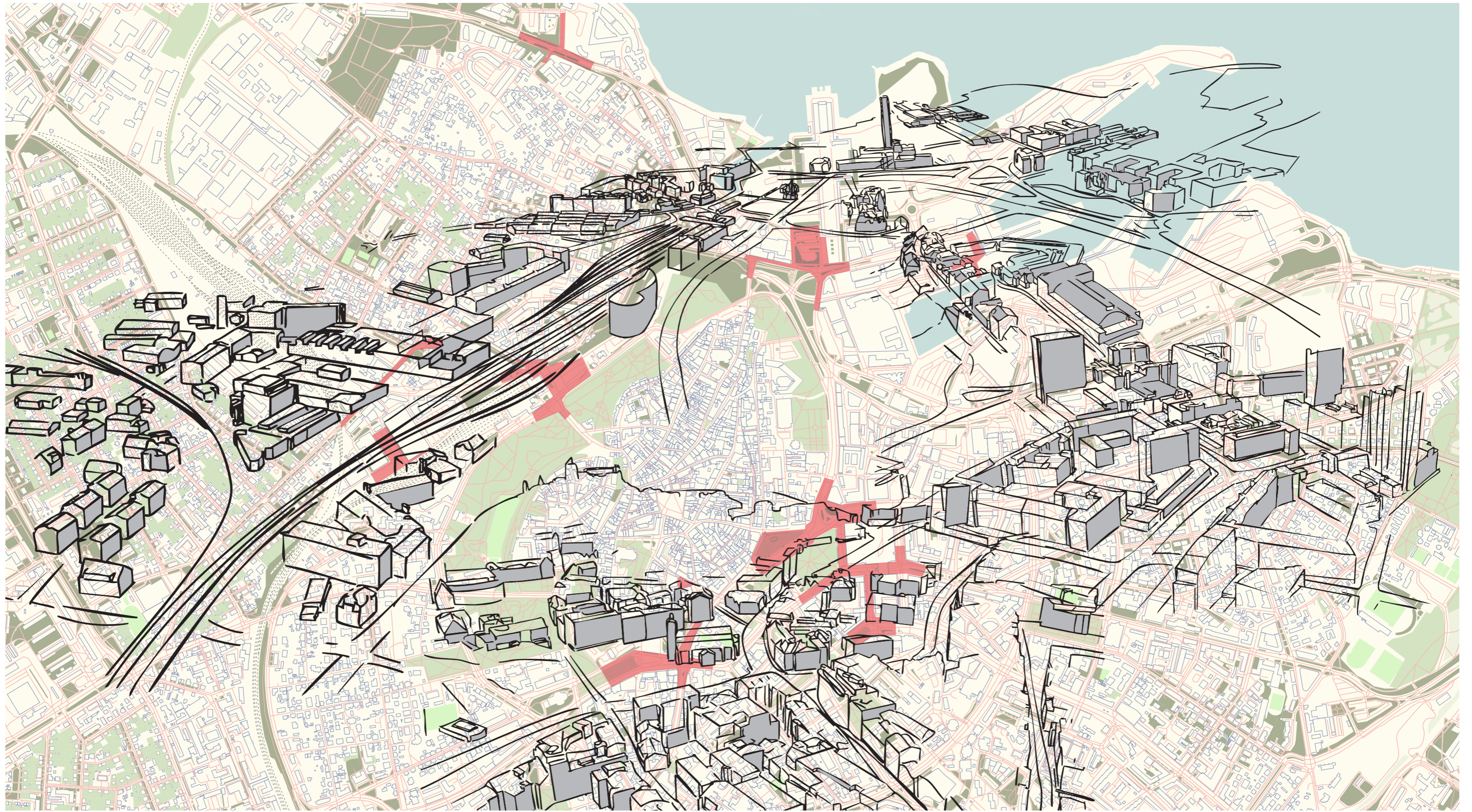

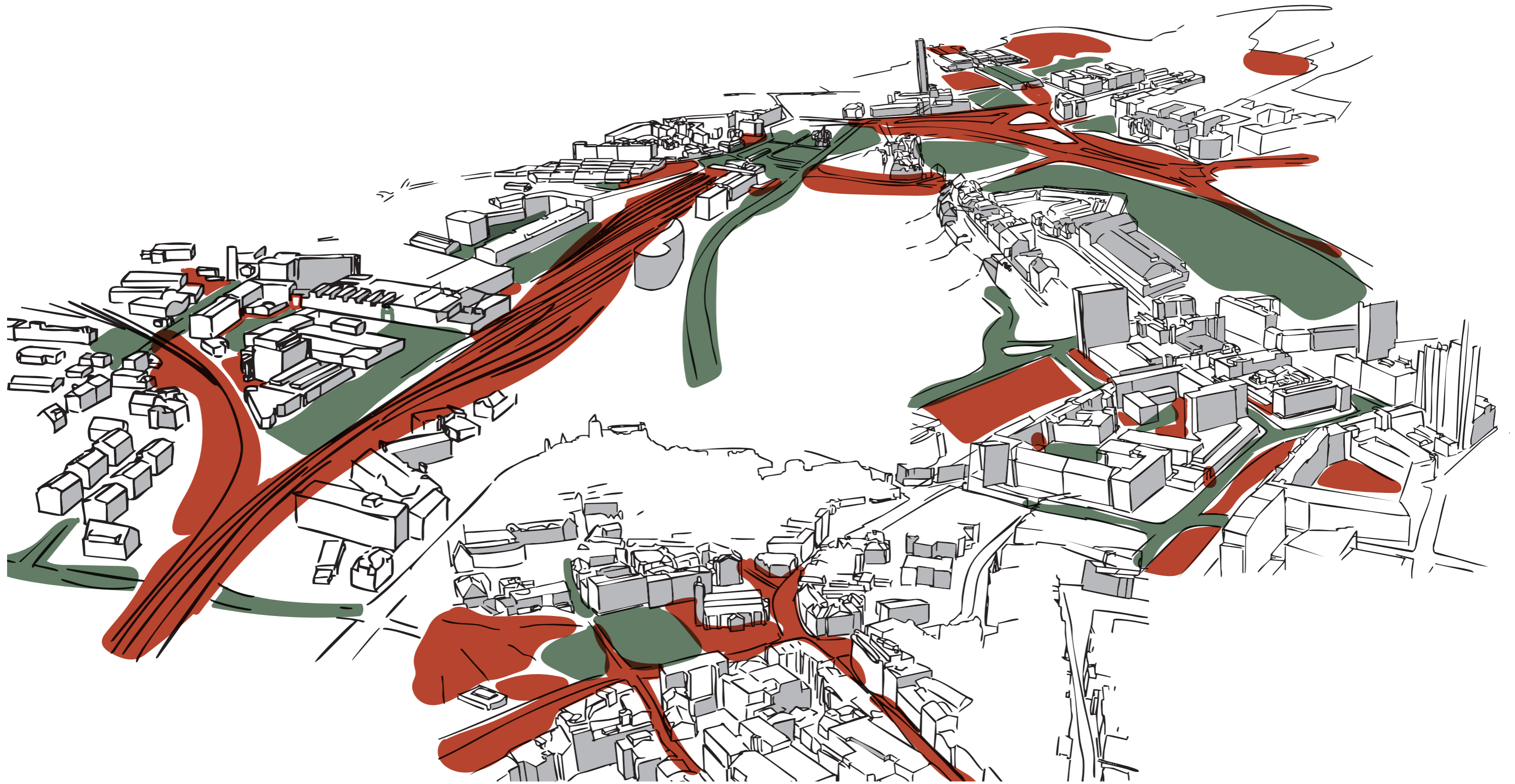

Public
Private

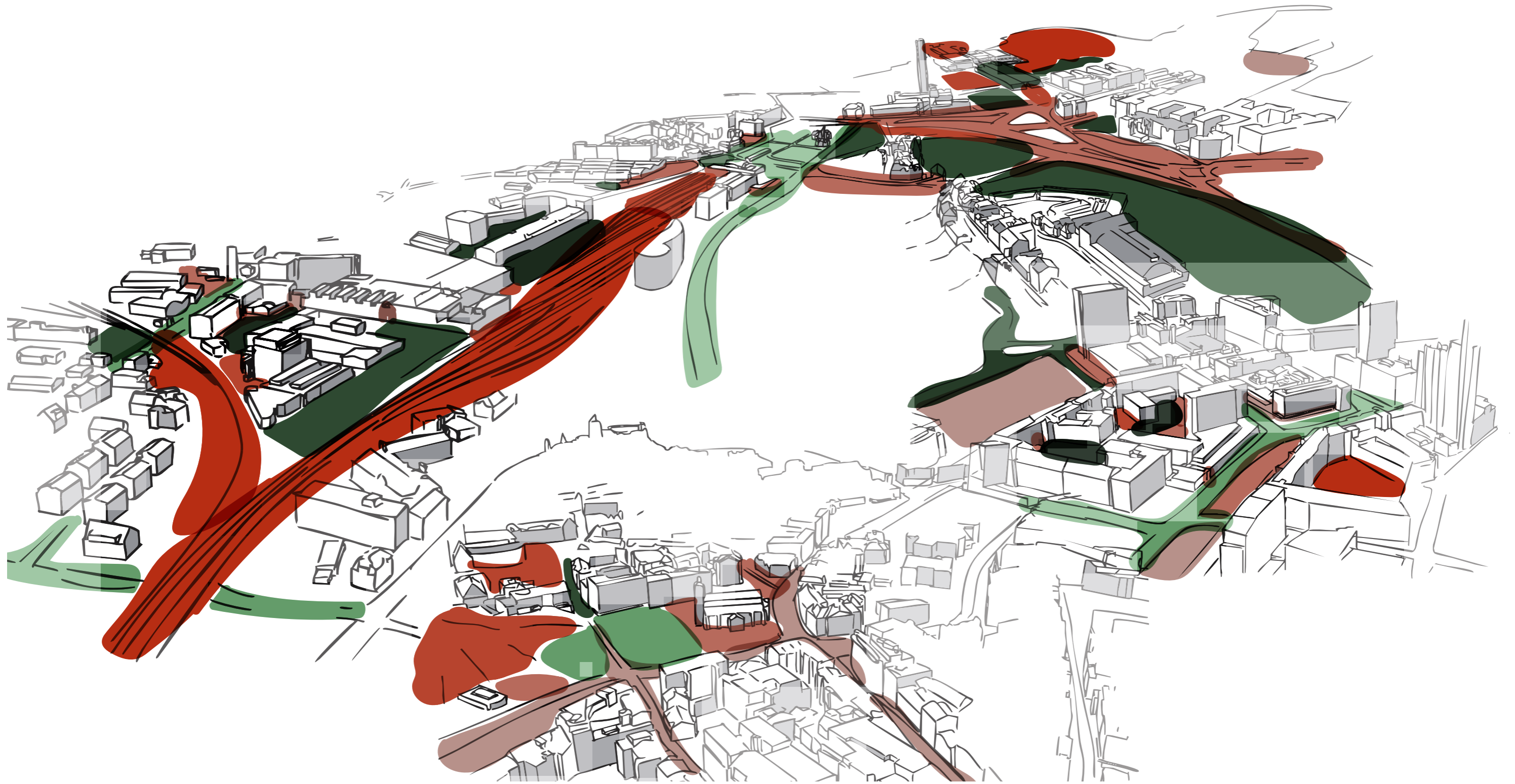

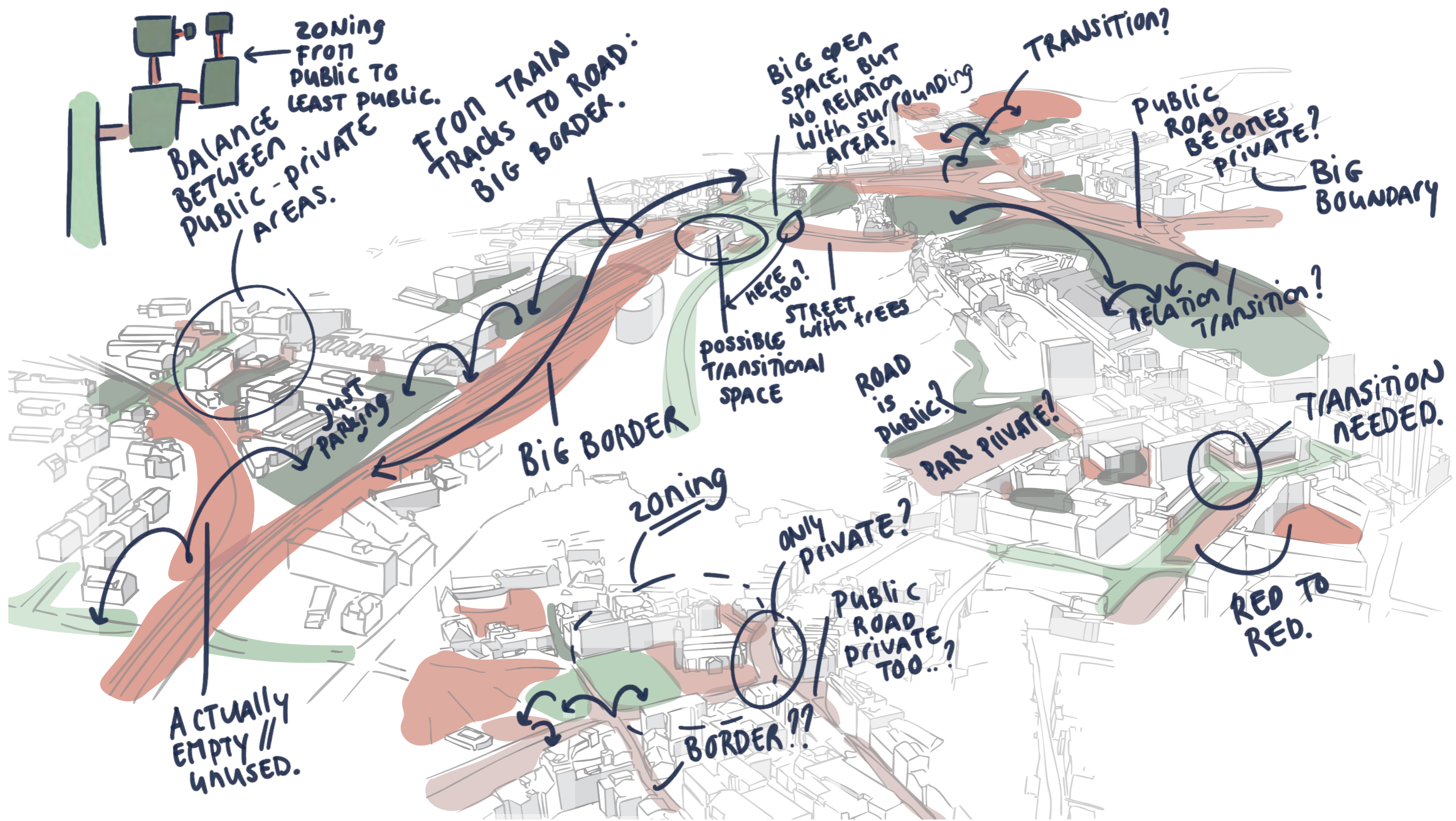

ZONING FROM PUBLIC TO LEAST PUBLIC.
 BALANCE BETWEEN PUBLIC-PRIVATE AREAS.

FROM TRAIN TRACKS TO ROAD: BIG BORDER.

BIG OPEN SPACE, BUT NO RELATION WITH SURROUNDING AREAS.

TRANSITION?

PUBLIC ROAD BECOMES PRIVATE?

BIG BOUNDARY

HERE TOO!
 STREET WITH TREES
 POSSIBLE TRANSITIONAL SPACE

RELATION / TRANSITION?

ROAD IS PUBLIC?

PARK PRIVATE?

TRANSITION NEEDED.

RED TO RED.

ONLY PRIVATE?

PUBLIC ROAD PRIVATE TOO..?

ZONING

BIG BORDER

BORDER??

ACTUALLY EMPTY // UNUSED.

JUST PARKING



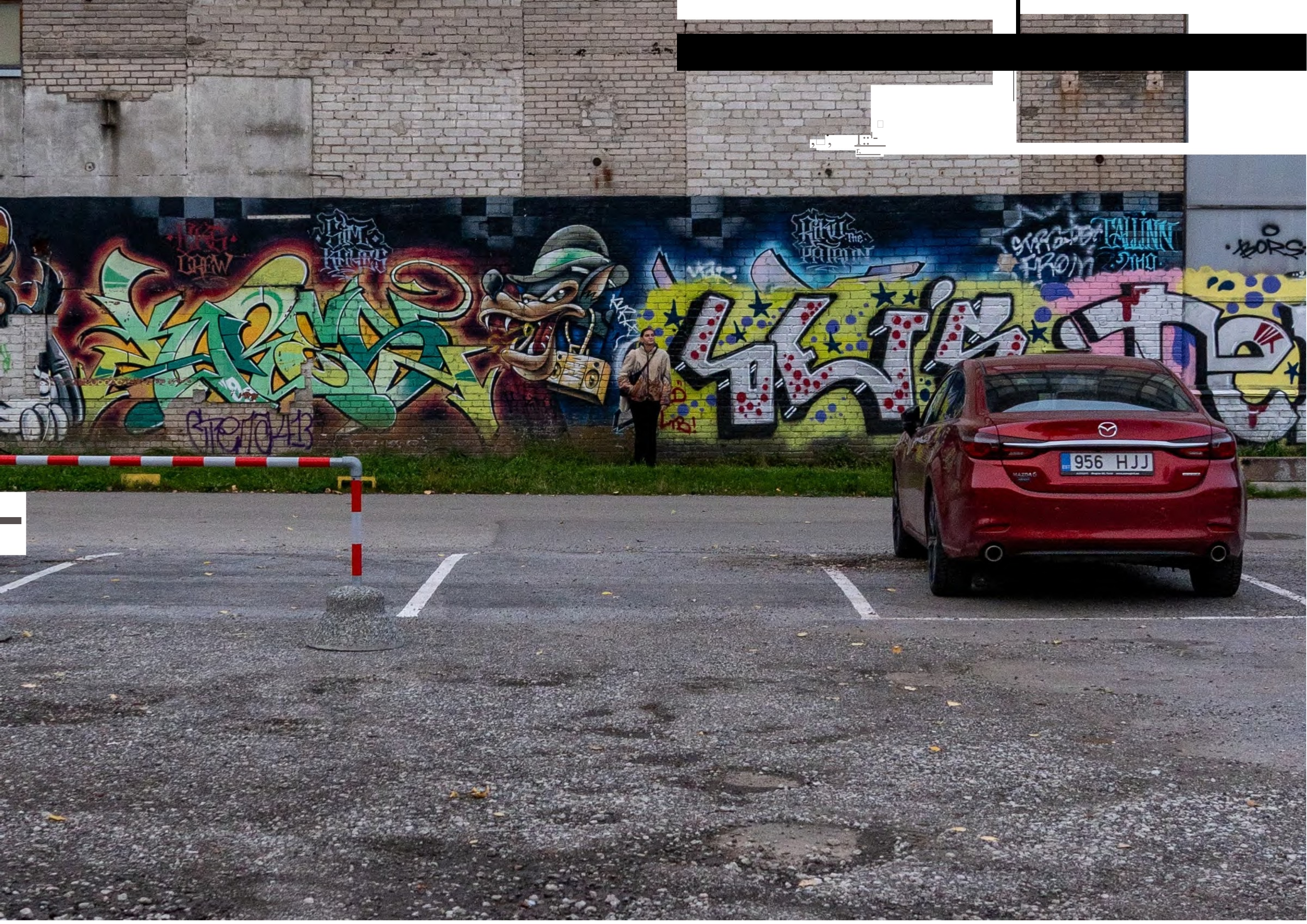



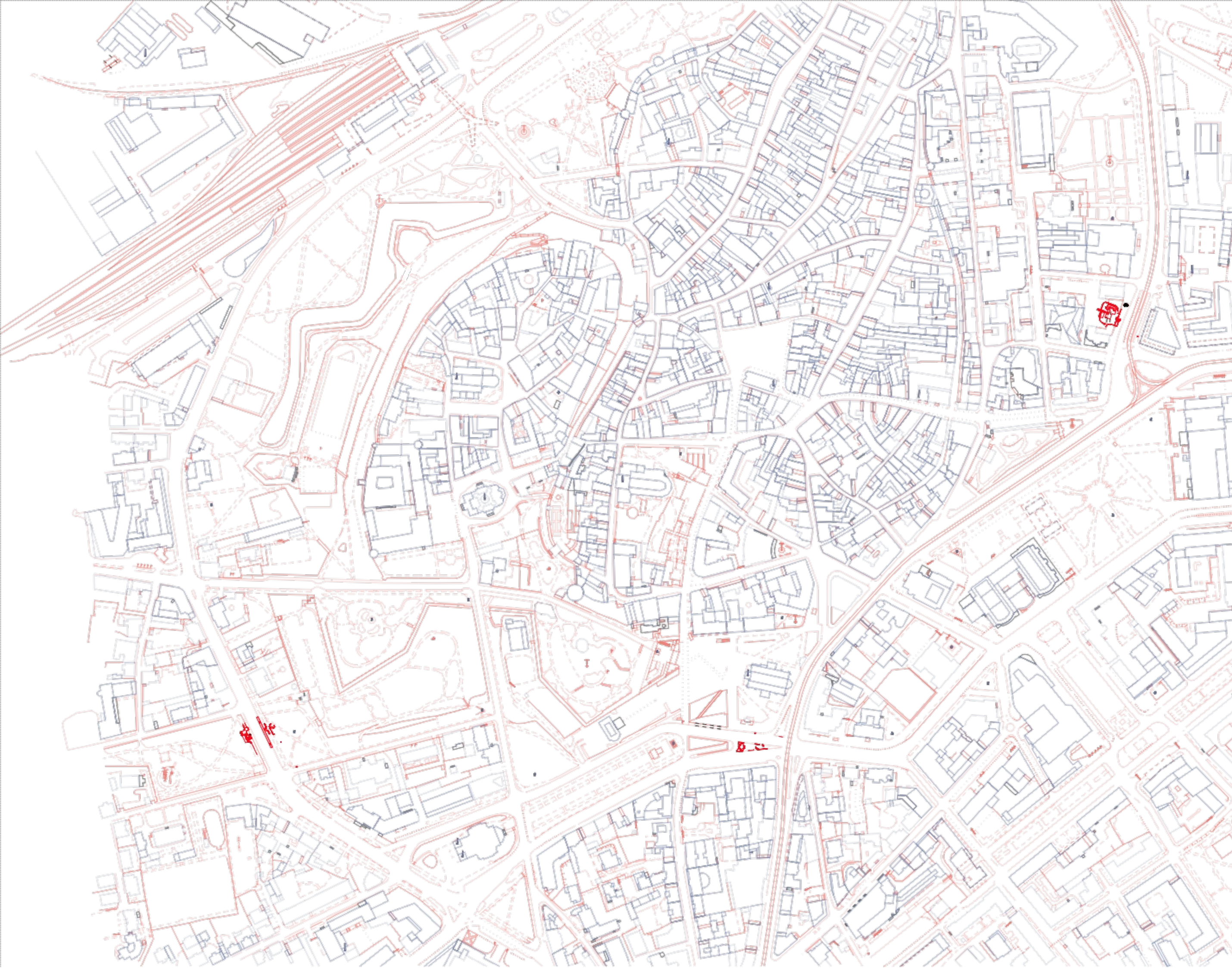

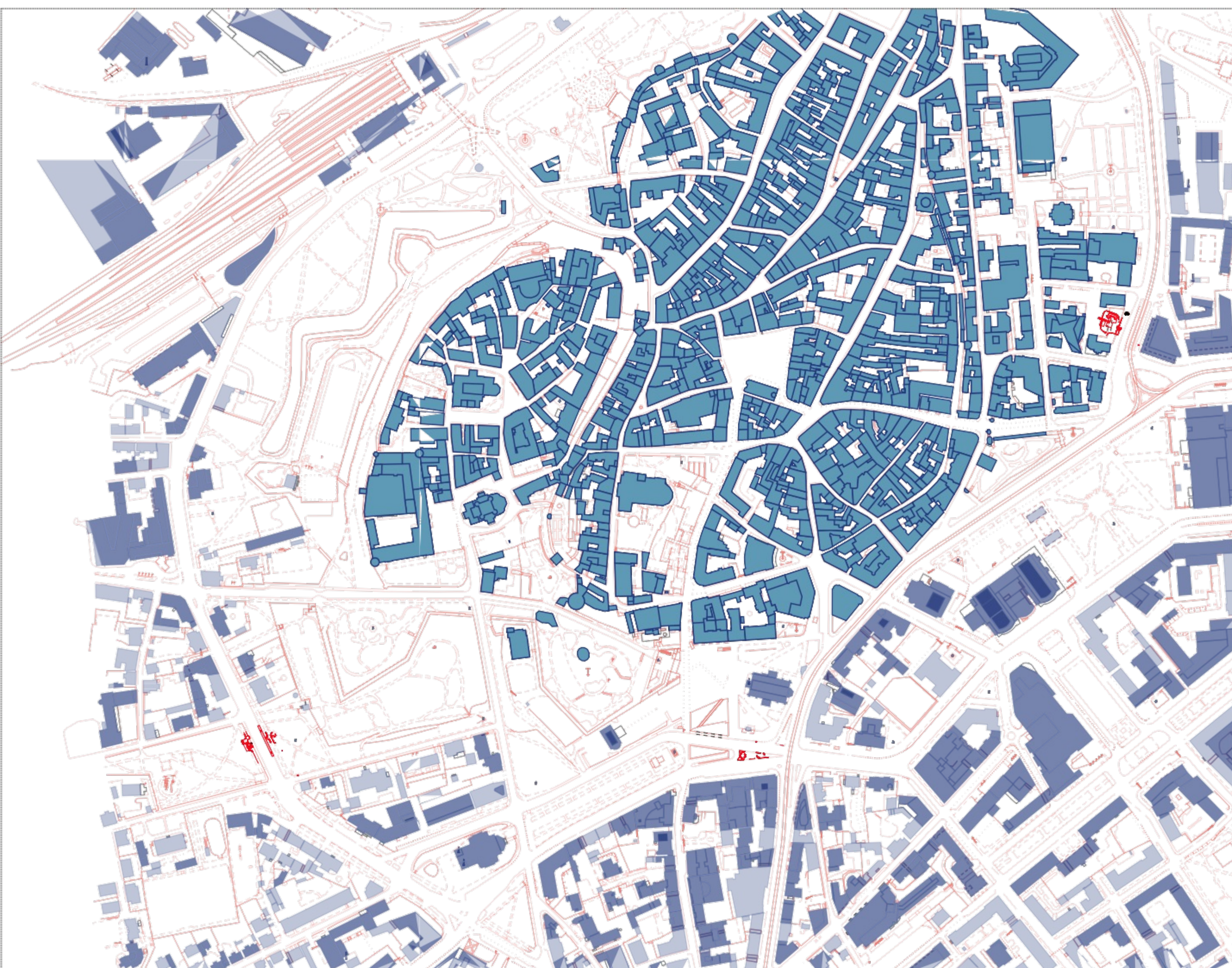

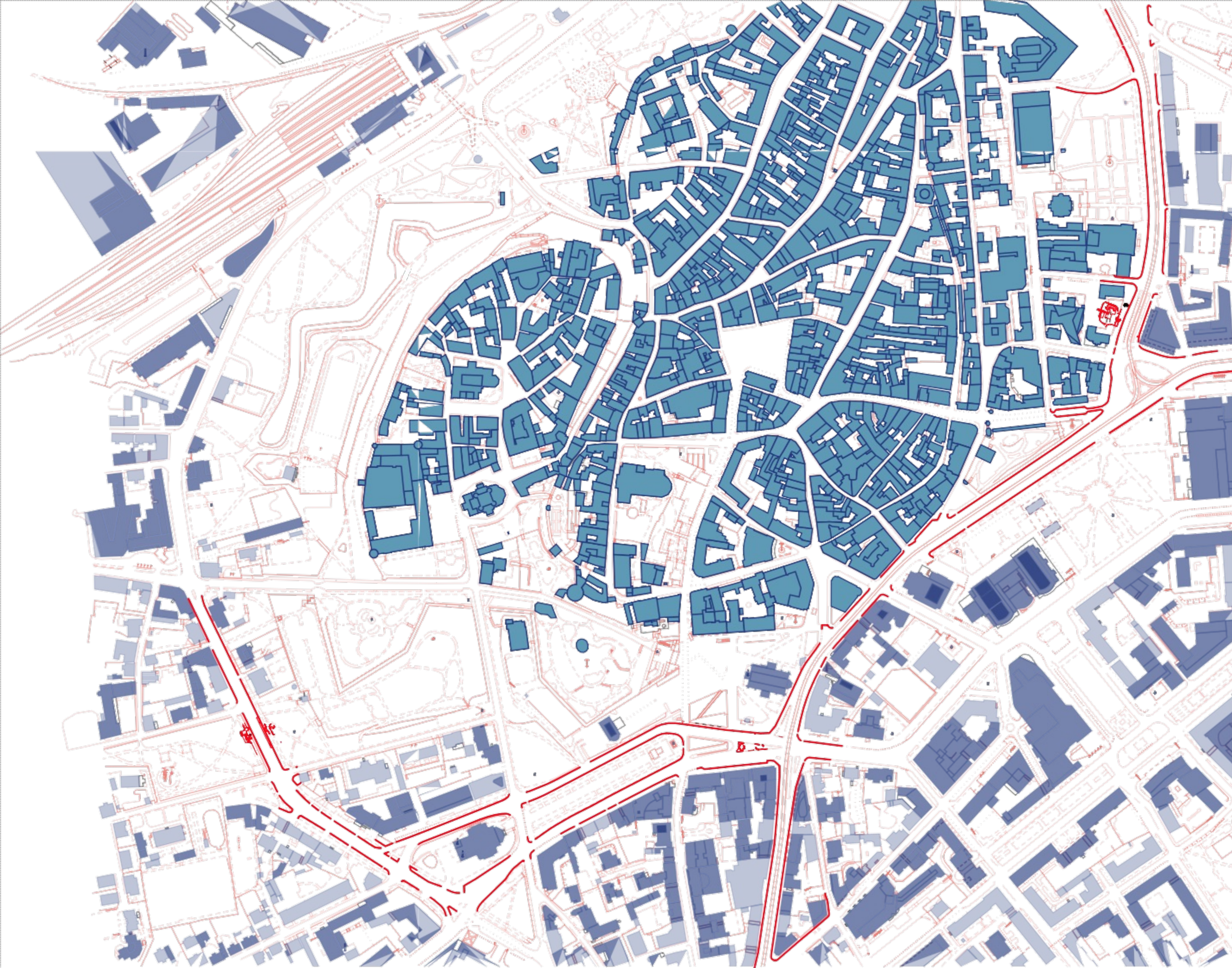

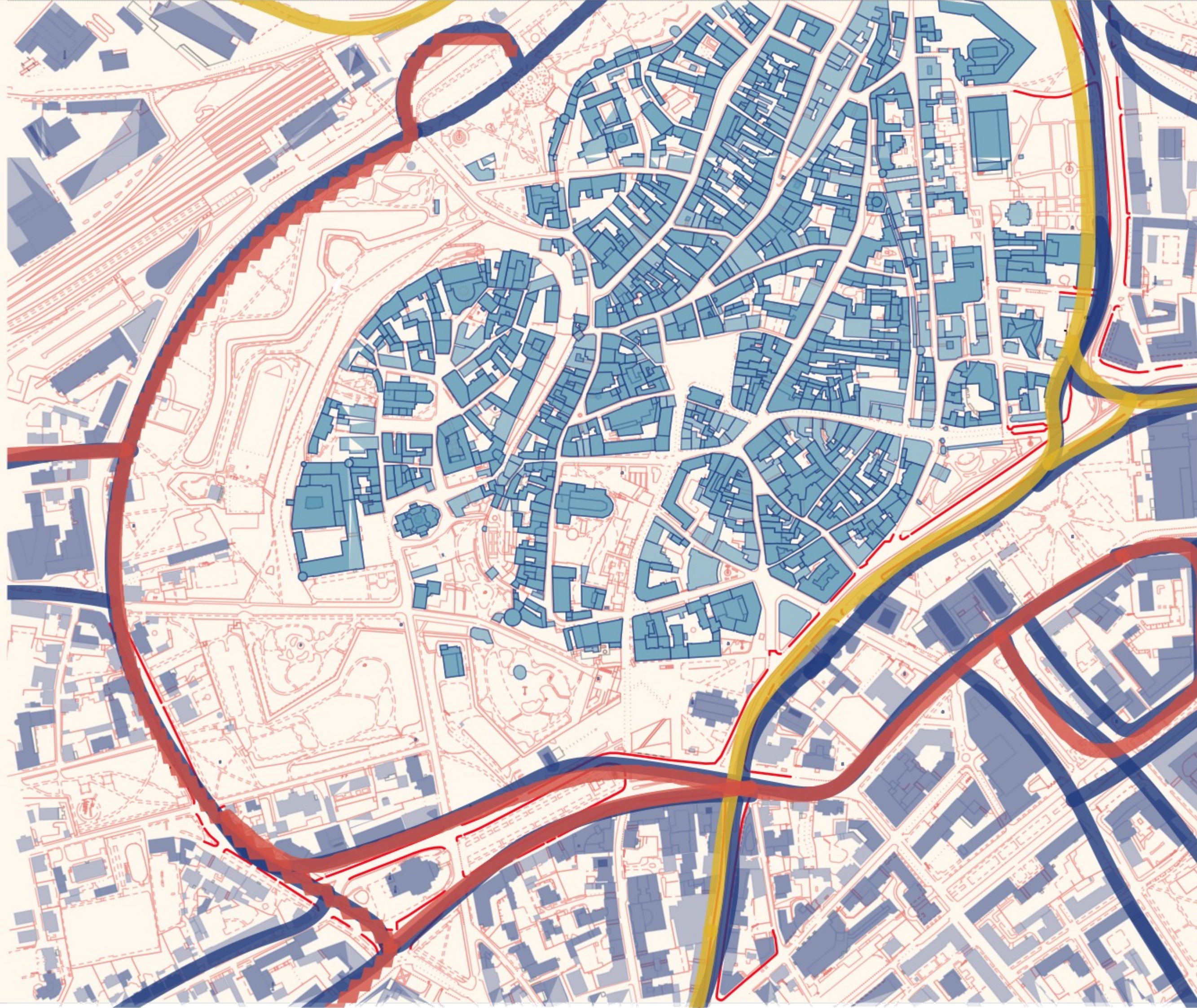

- Trolleylines
- Tramlines
- Buslines
- 1-5000

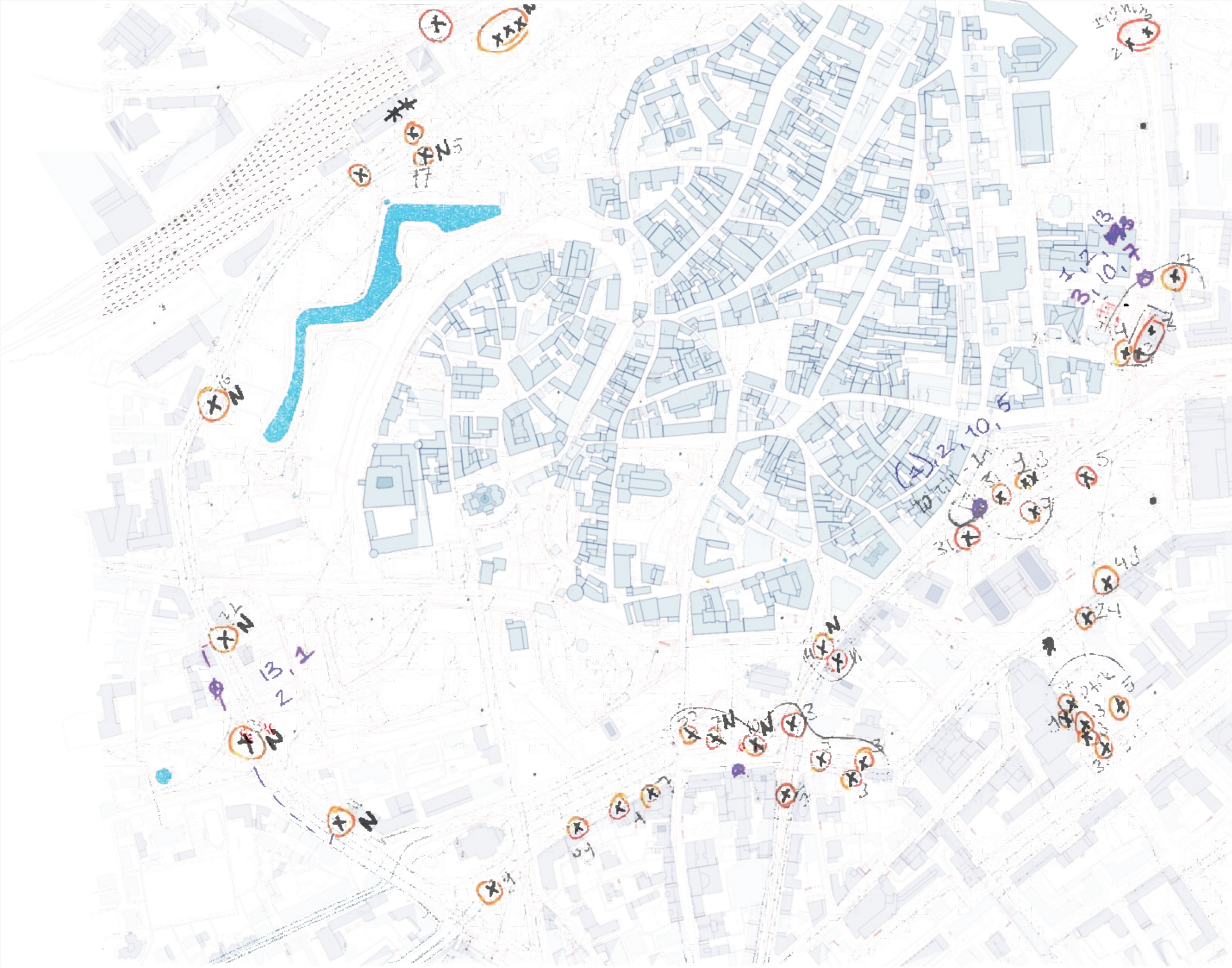

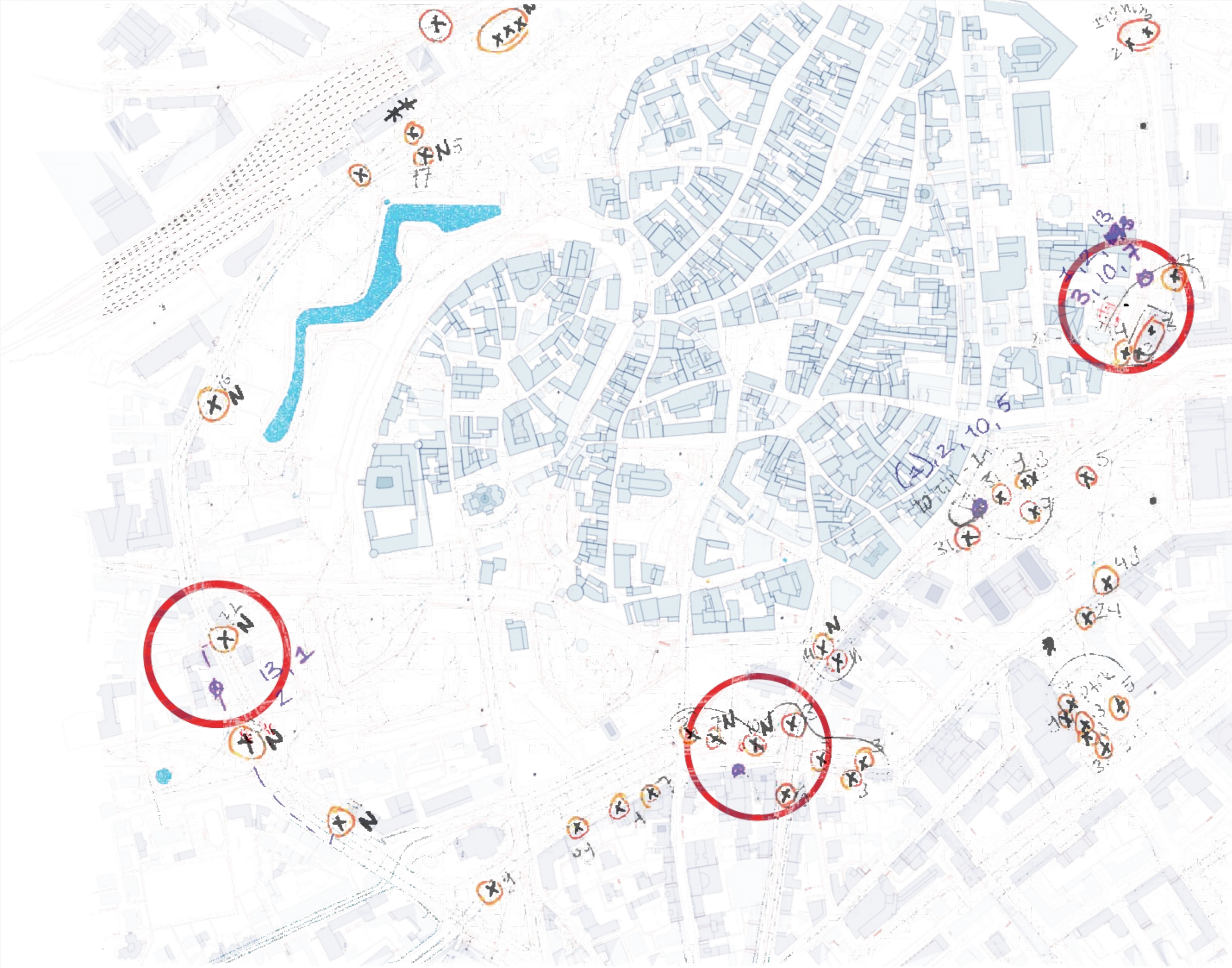



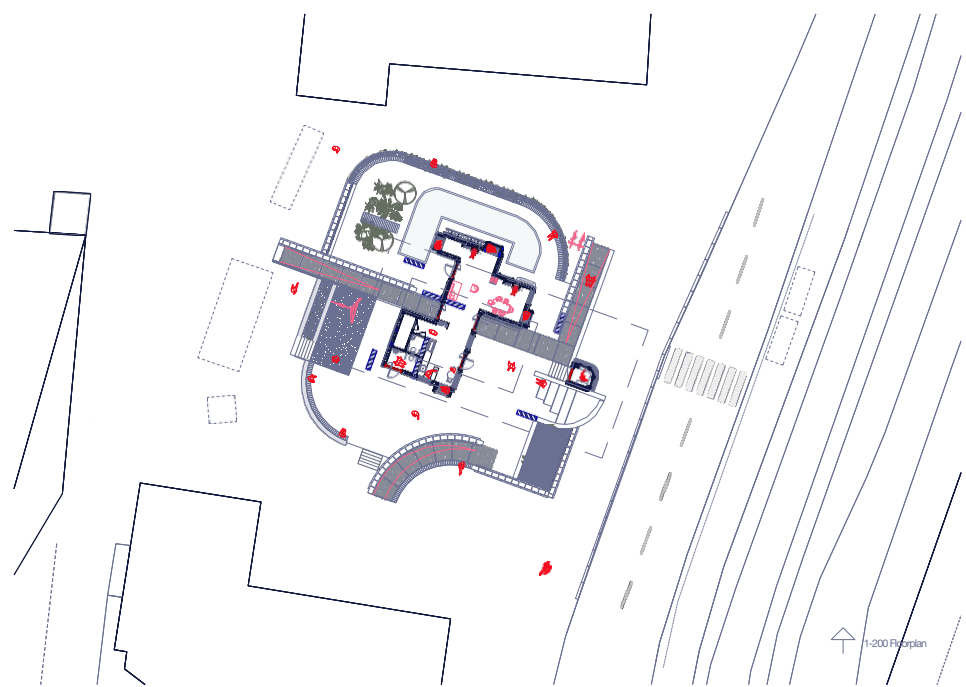

Viru - Main Location

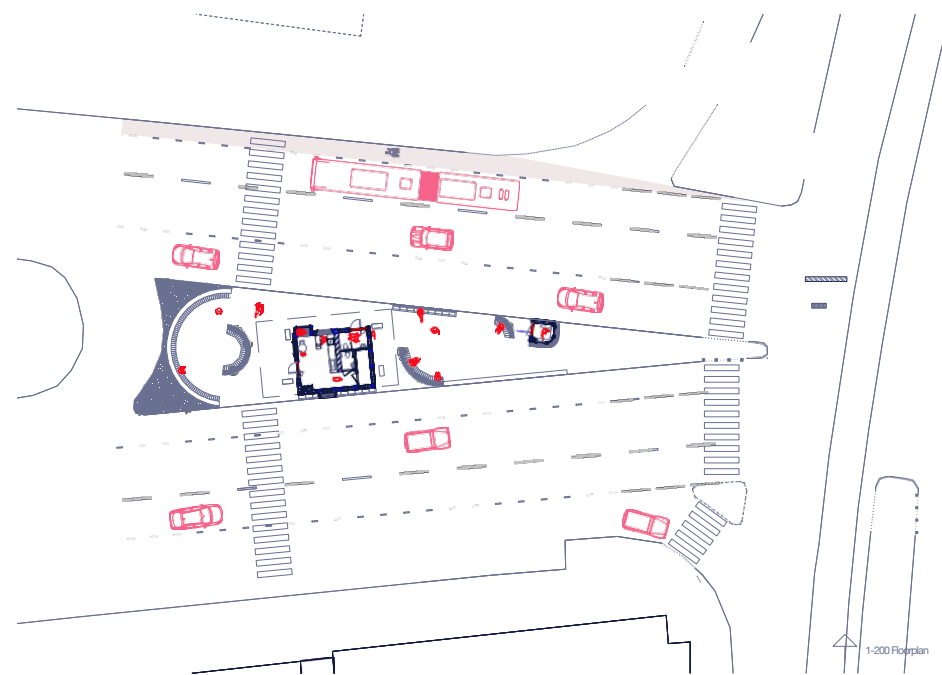

Freedom Square

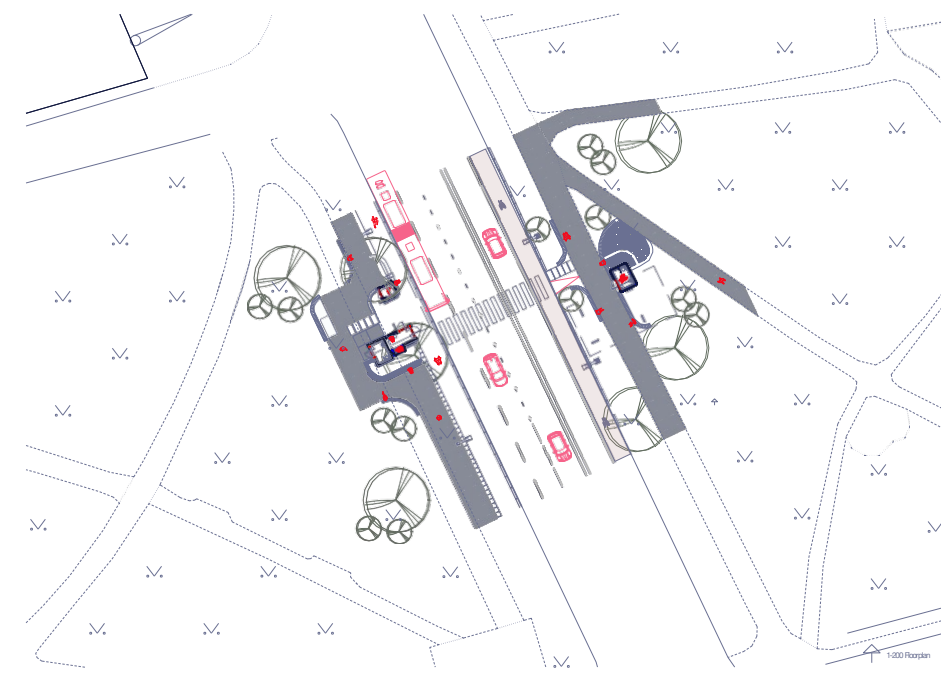

Night Bus

To create

To make something new, or invent something

- Cambridge Dictionary

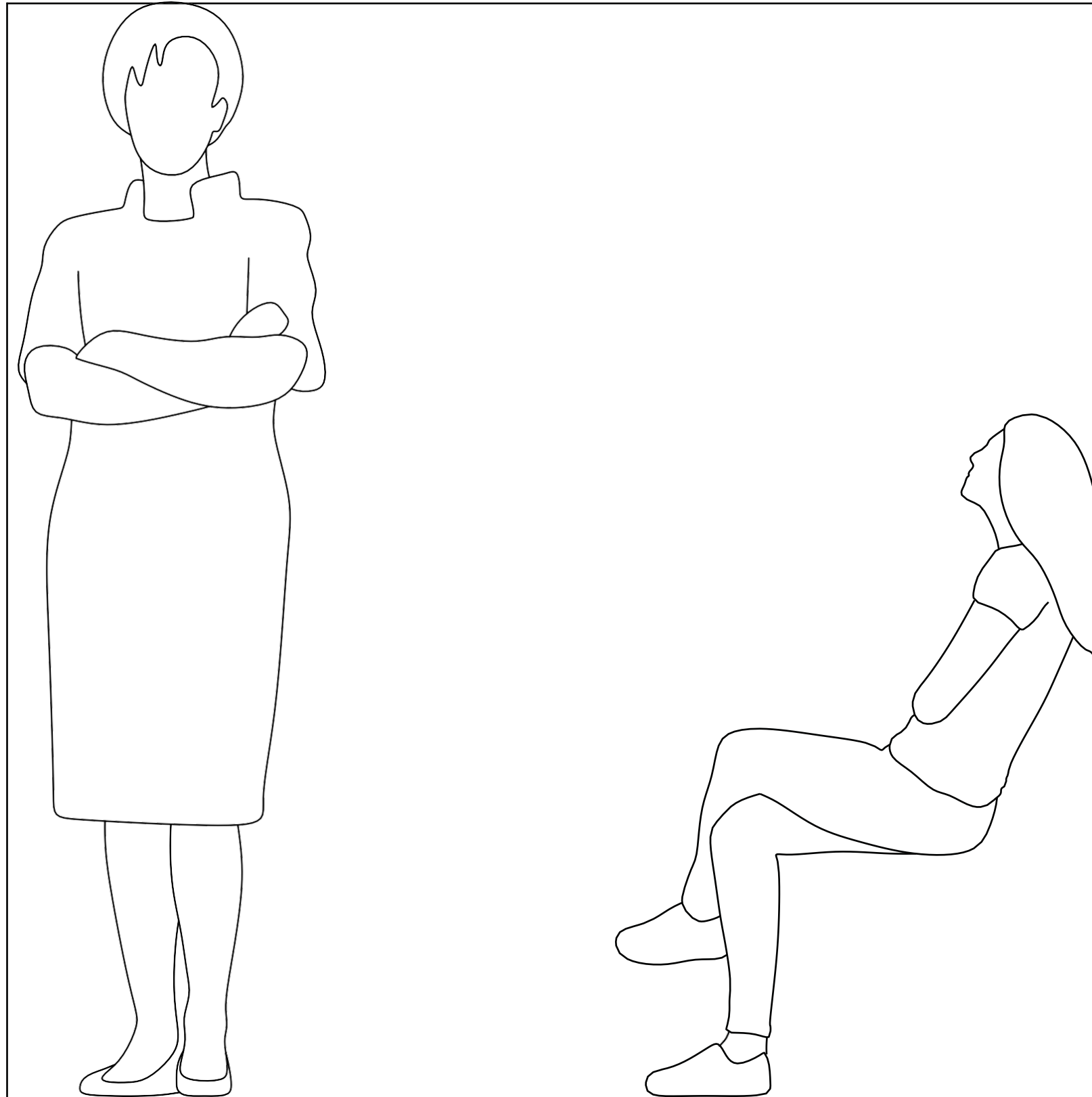

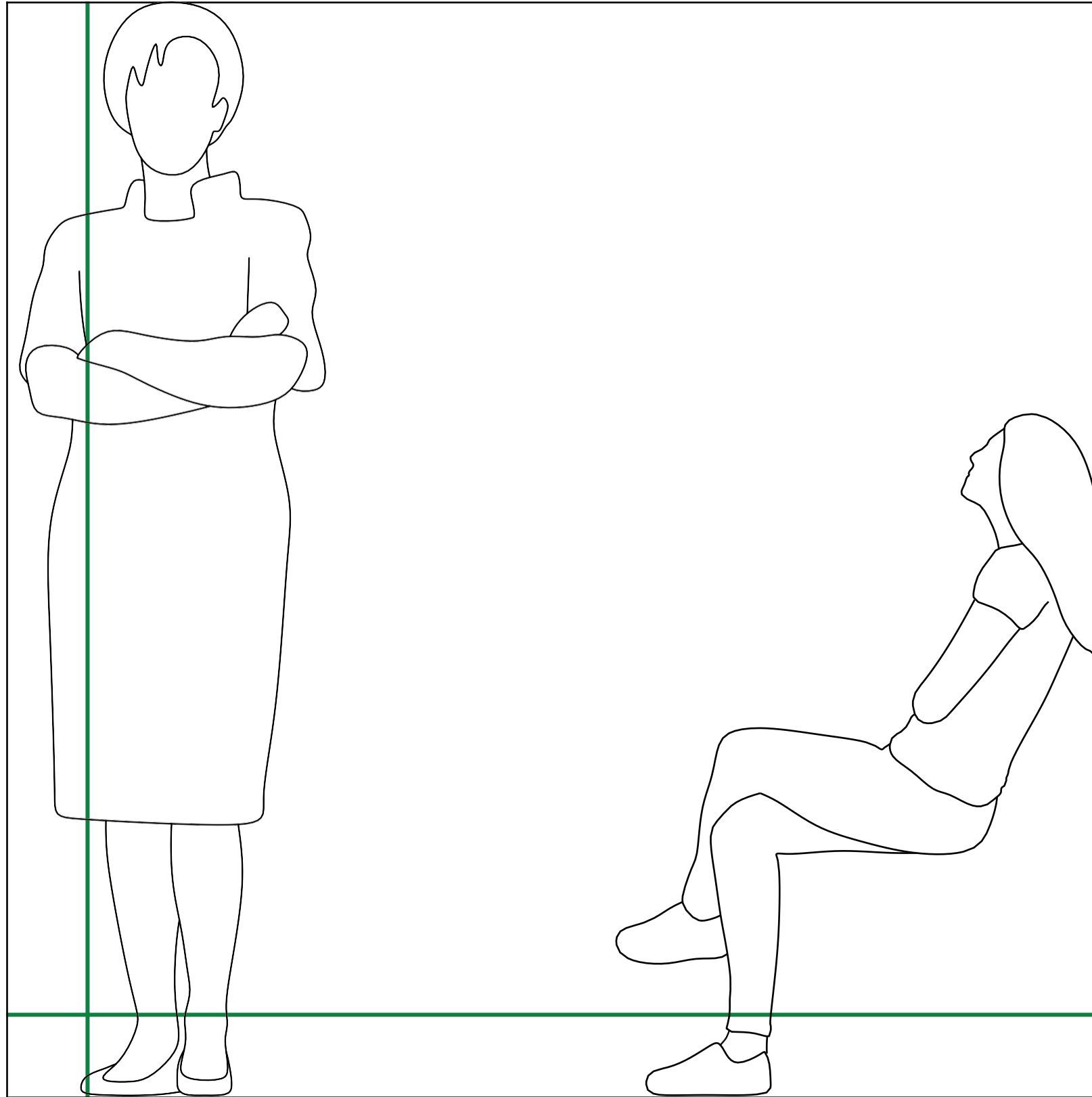

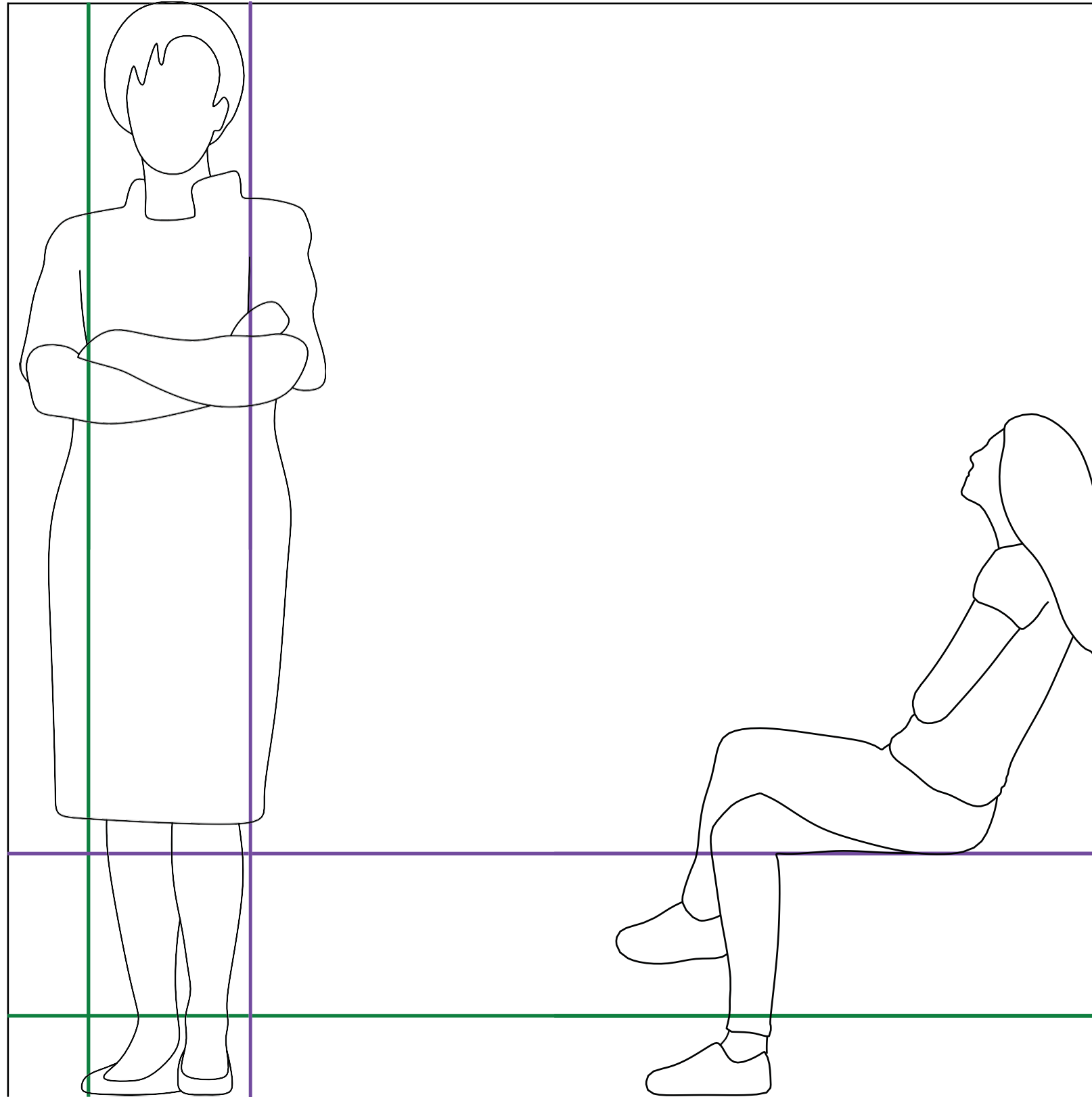

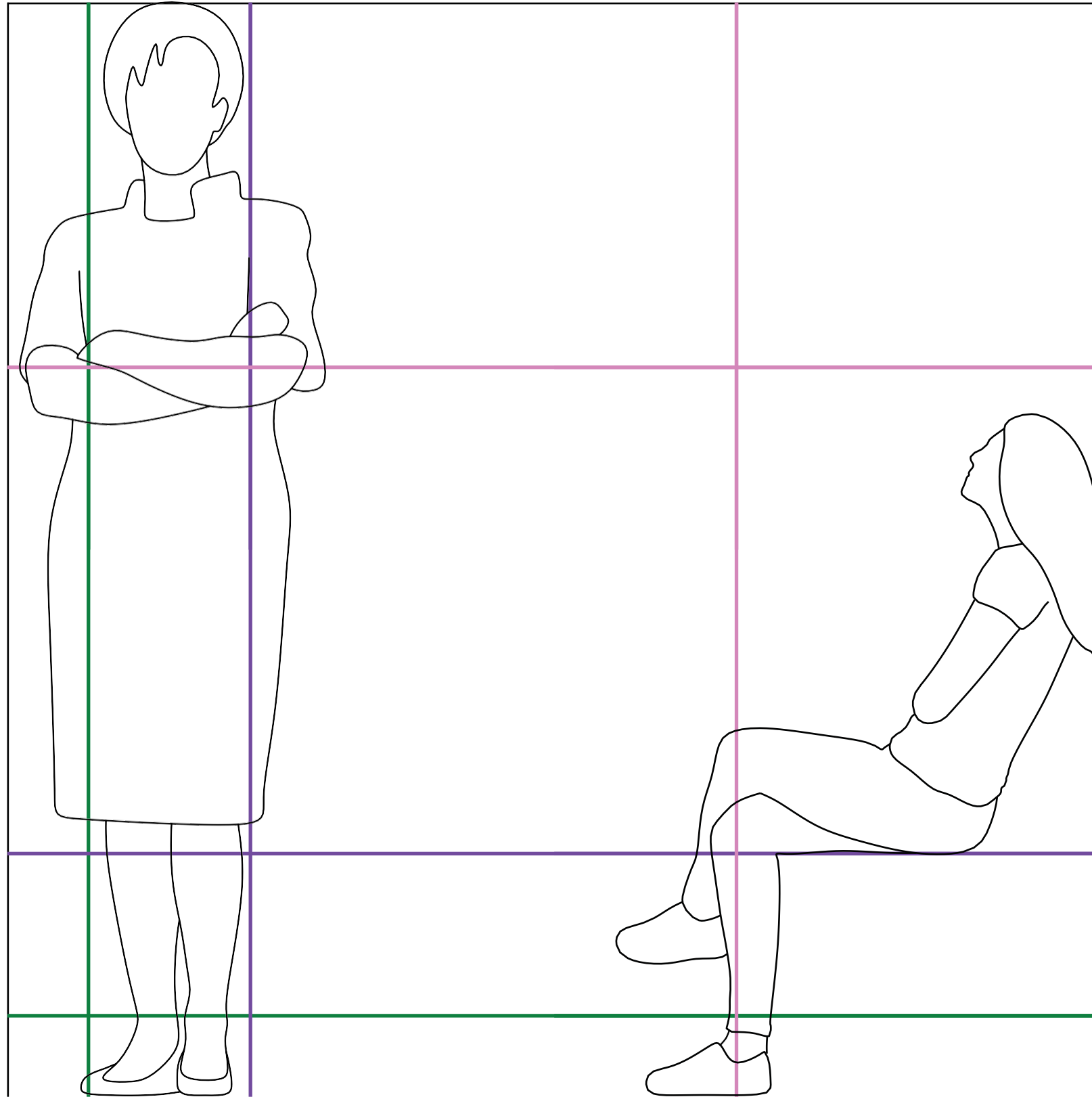

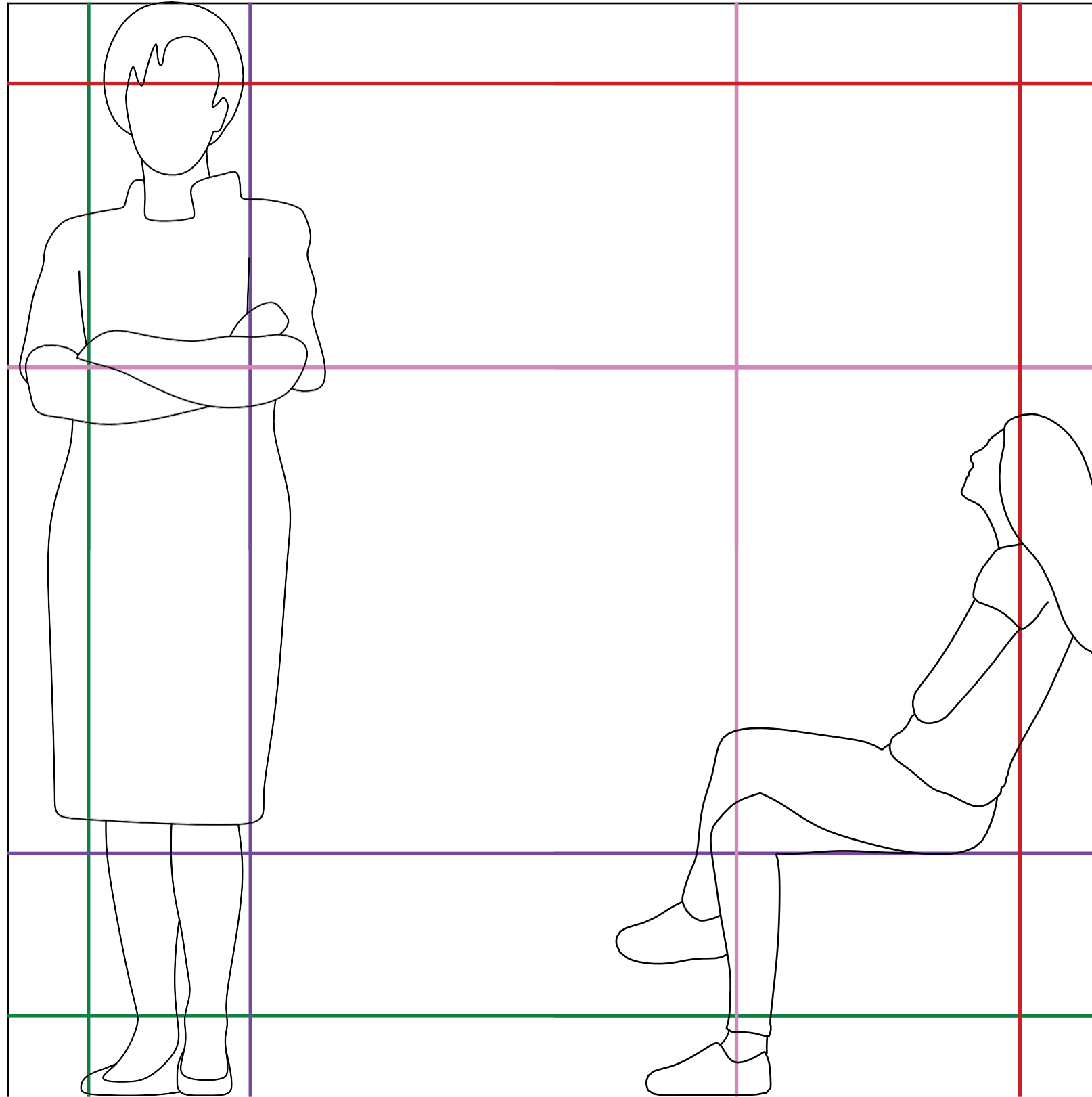

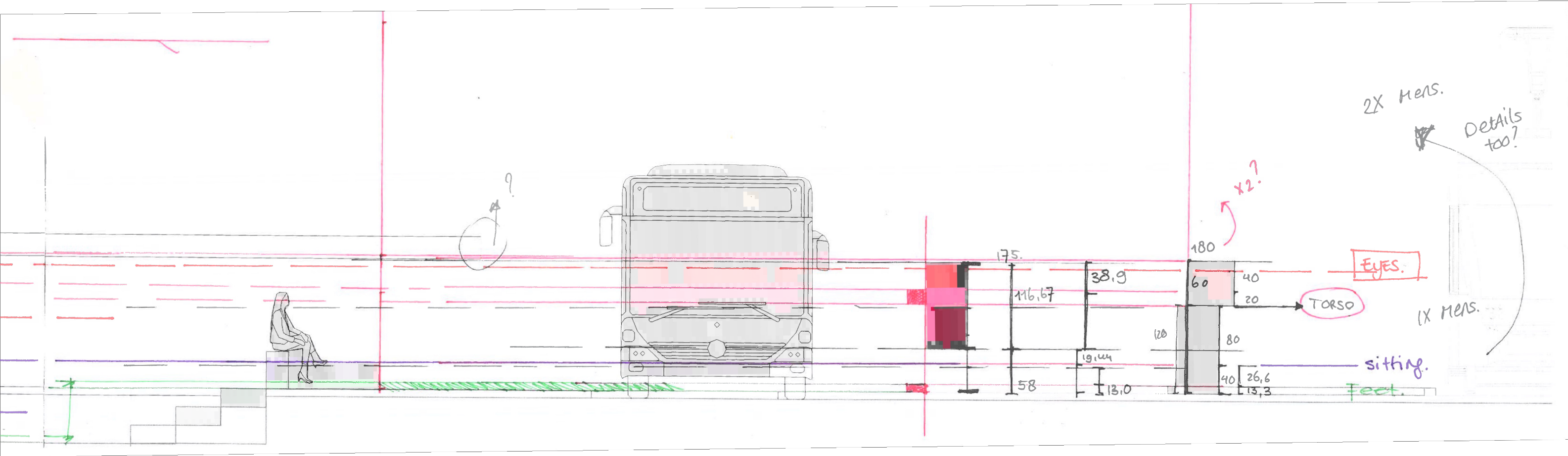



Maria, 32

Mom with two kids, lives in Pöhja. Works mostly from home as a graphic designer and uses public transport mostly to head to the various shopping malls for errands and shopping.

Avoids peak hours and preferences the bus due to easier access with buggy.



Erik, 9

Lives in Pirita and uses public transport mainly to go to school in the city centre.

Uses a combination of tram and bus.



Aino, 72

Lives in Lasnamaë with her husband and uses public transport to head to church, the local market and to visit her grandchildren.

Uses bus and tram mostly.

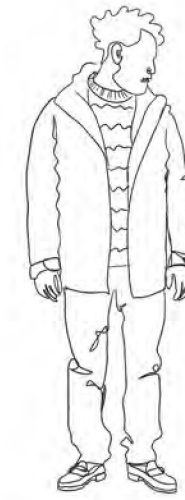

Toomas, 28

Lives in Mustamaë and works in Rotermanni Quarter. Uses public transport to commute to work and during the weekends to go to a bar in Telliskivi to meet with friends.

Uses the bus mostly.



Antti & Maarit, 42, 44

Visiting from Helsinki for some shopping and sightseeing. Visits Old Town and the shopping centres.

Combination of bus and walking.



Maria, 32



Erik, 9



Aino, 72

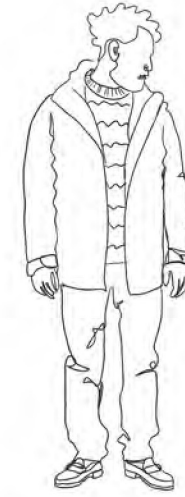

Toomas, 28



Antti & Maarit, 42, 44

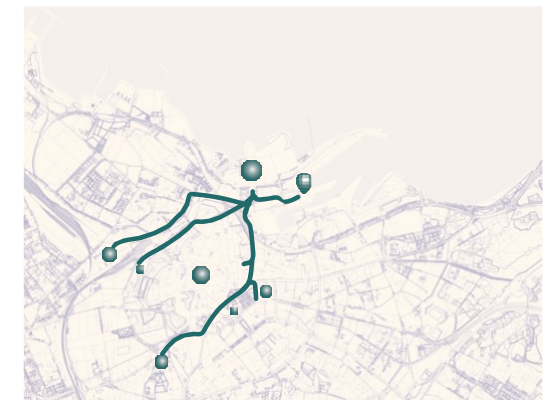
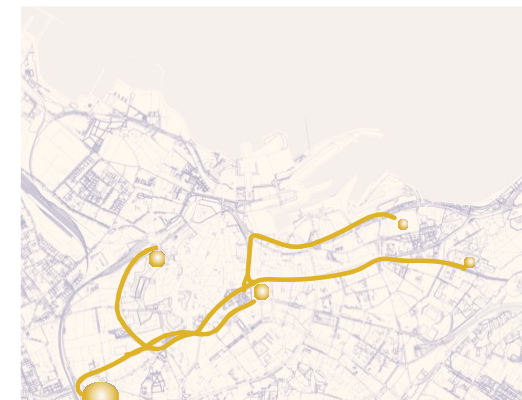
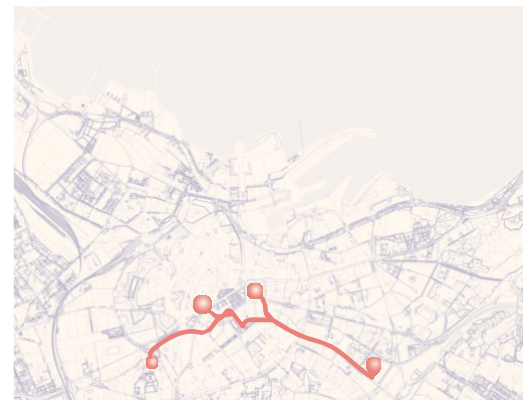
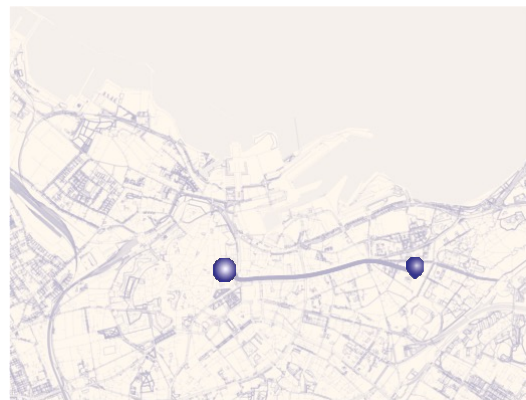
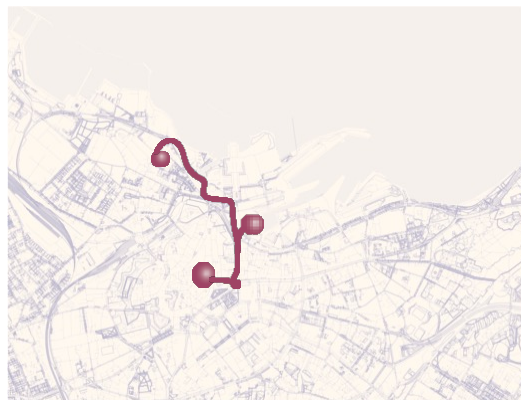



Maria, 32



Erik, 9



Aino, 72

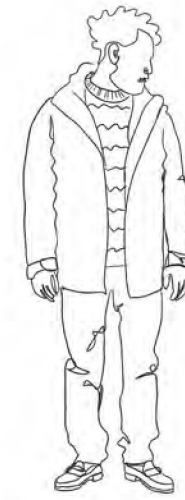

Toomas, 28



Antti & Maarit, 42, 44

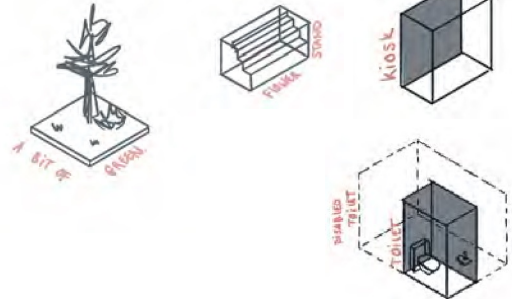
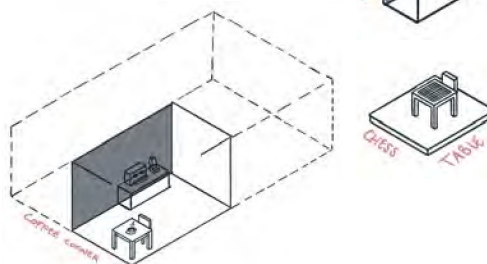
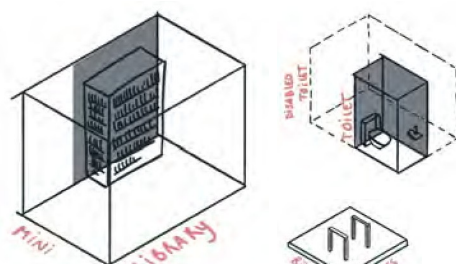
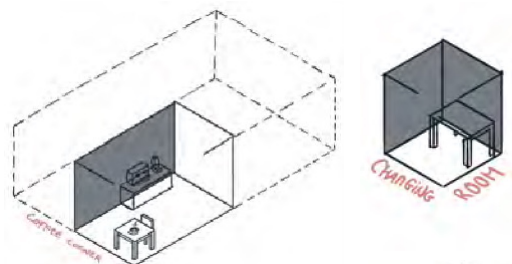
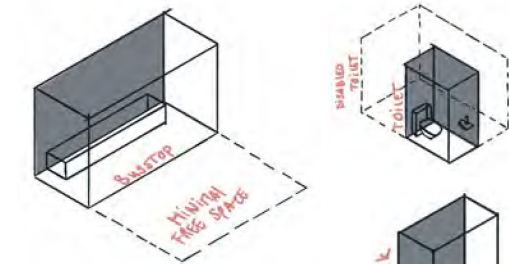
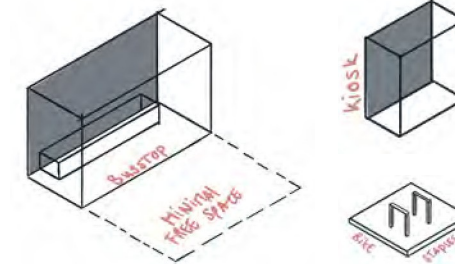
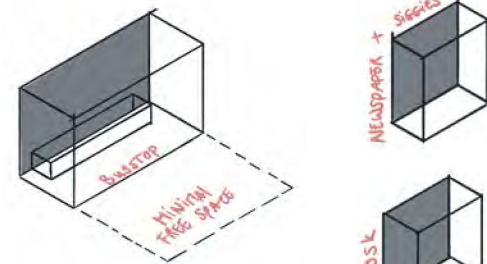
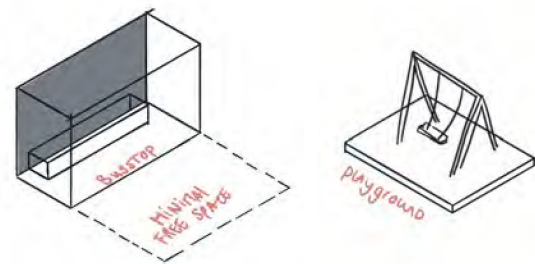
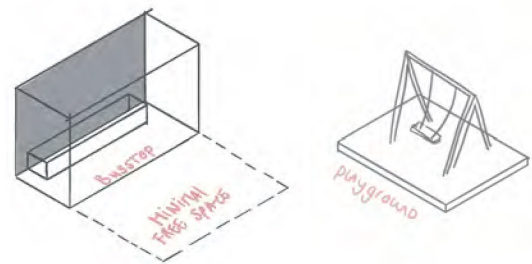



Maria, 32



Erik, 9



Aino, 72

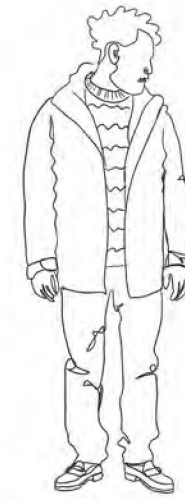

Toomas, 28



Antti & Maarit, 42, 44

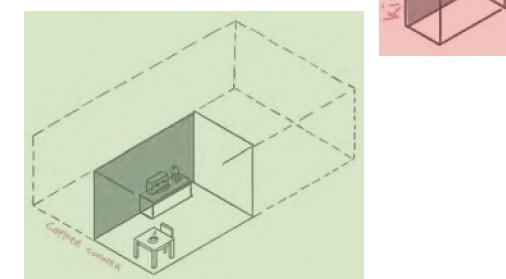
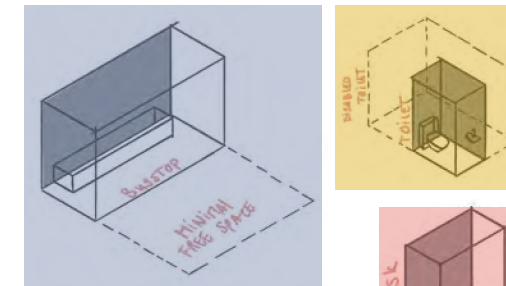
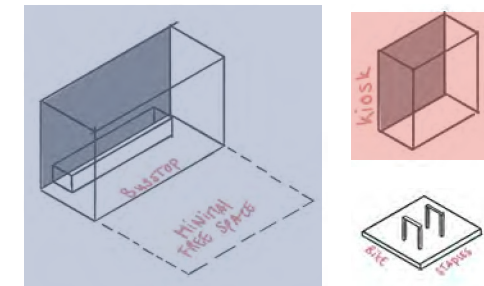
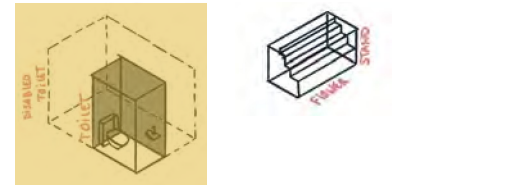
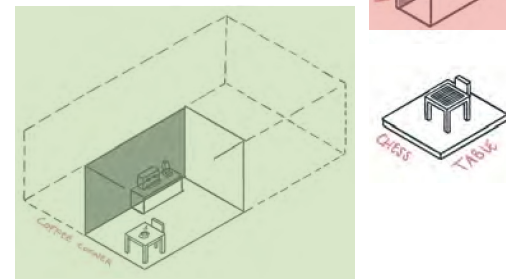
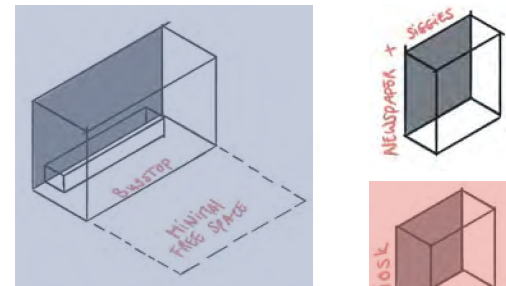
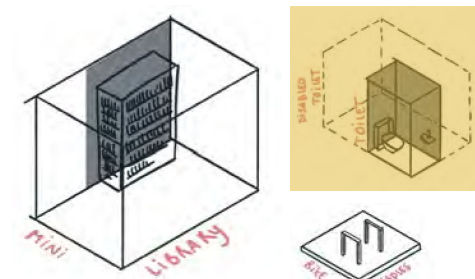
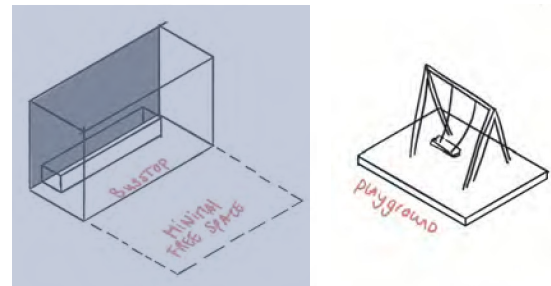
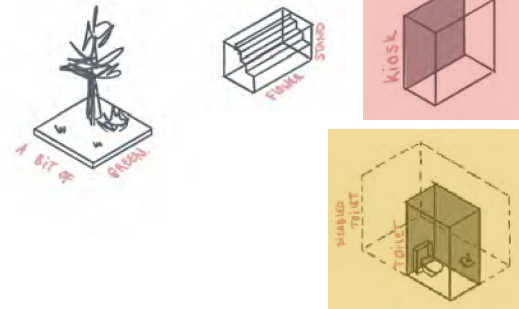
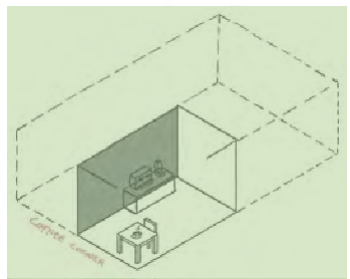
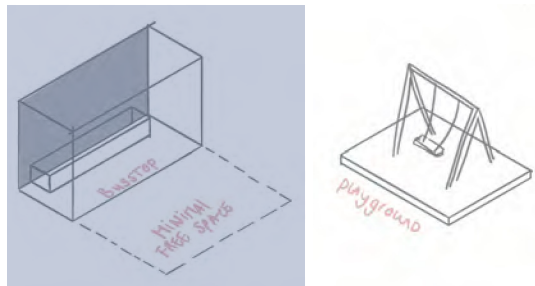

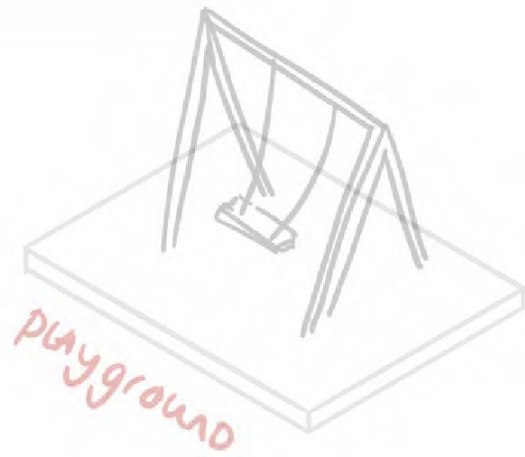
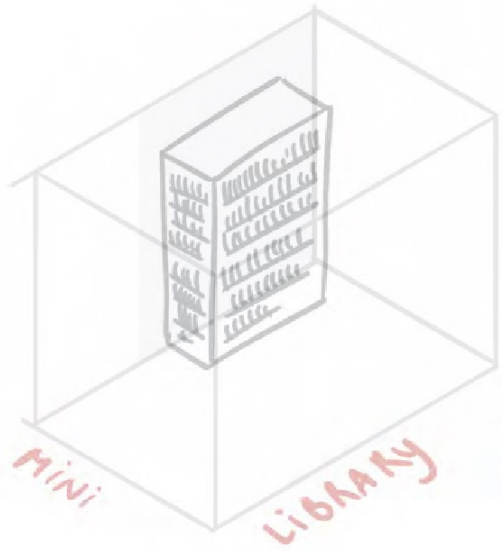
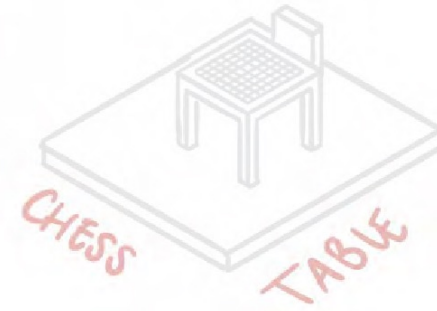
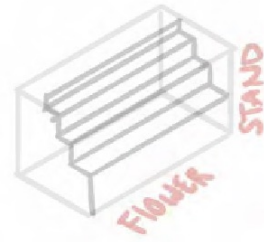
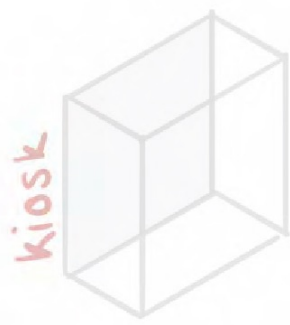
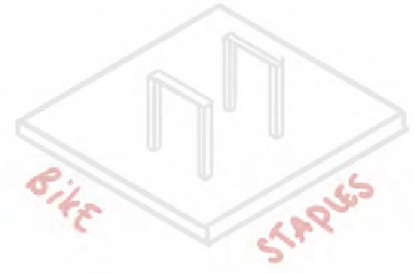
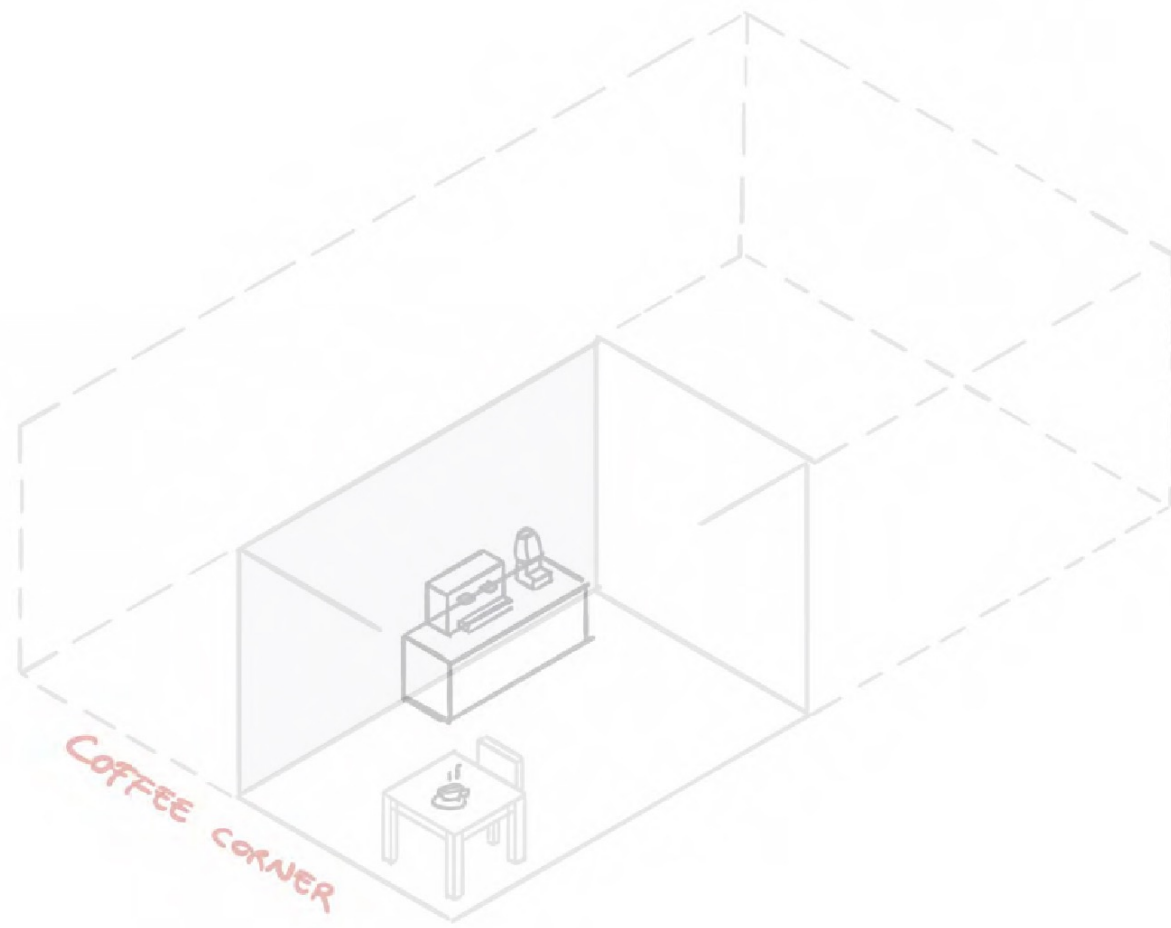
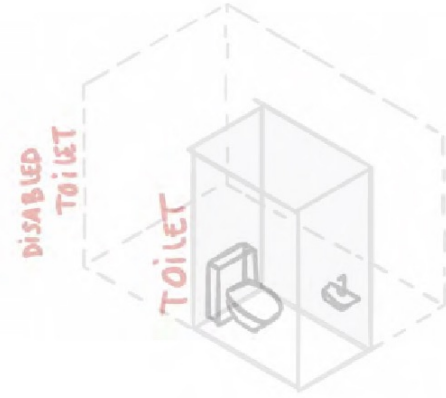
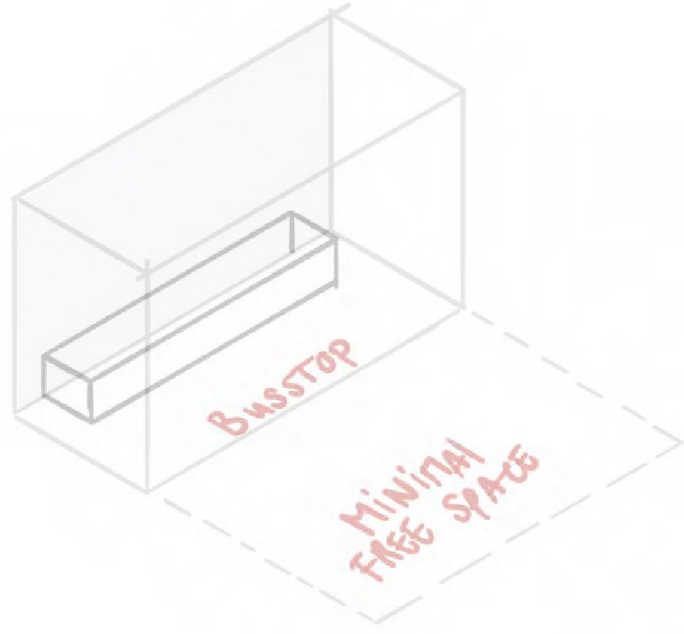

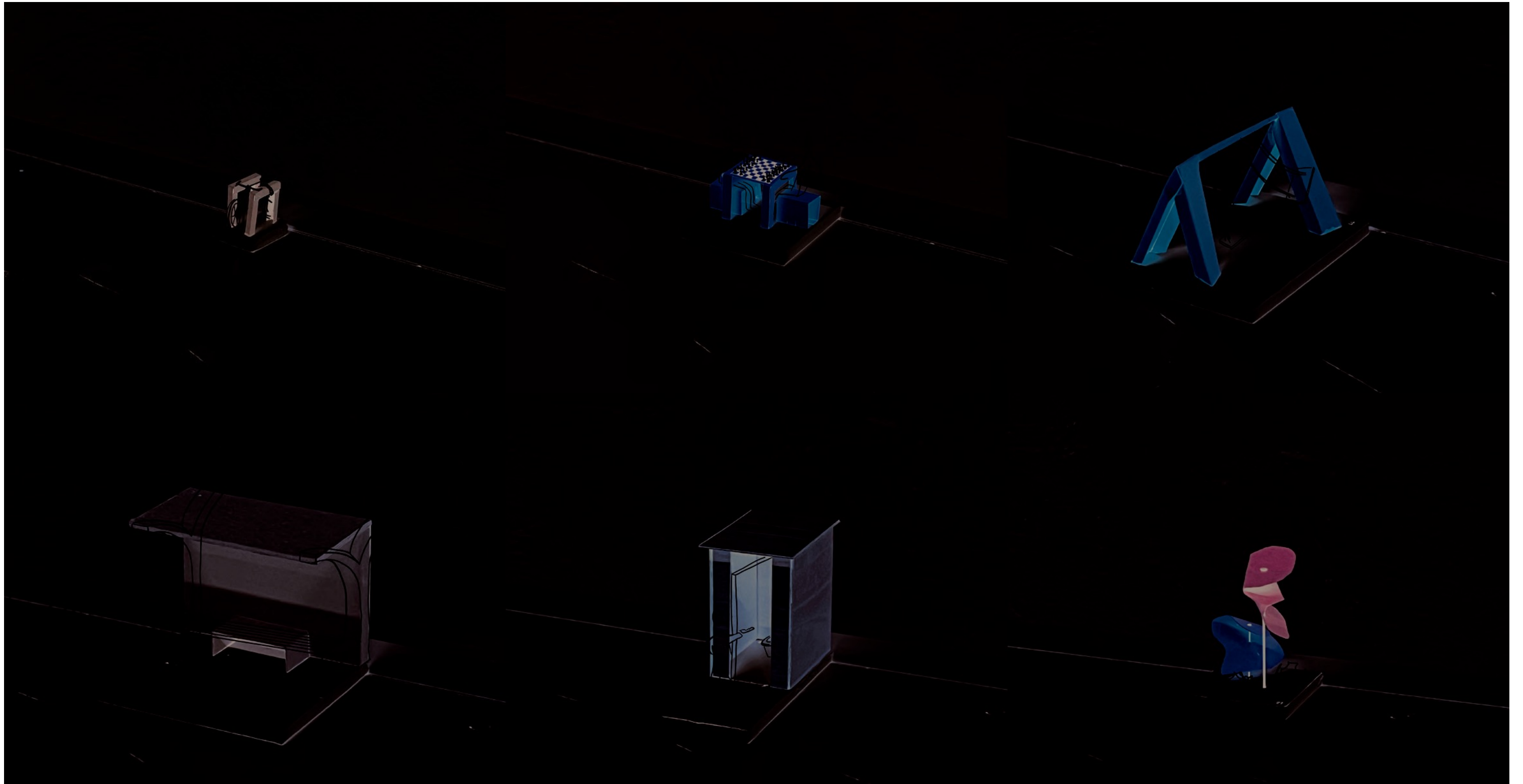

To do

*To perform (an action, the precise
nature of which is often unspecified)*

To achieve or complete

- Oxford Languages

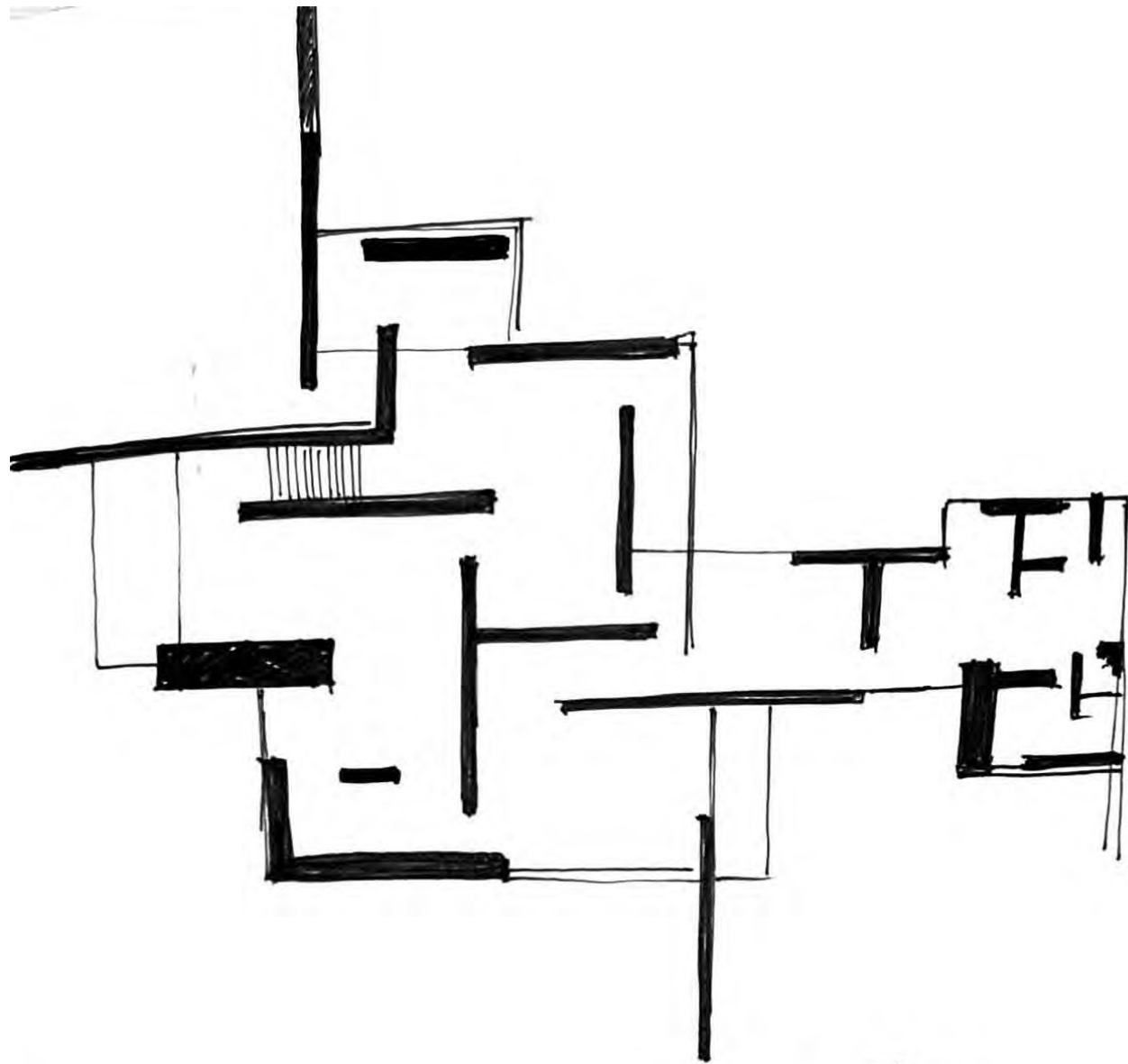

Mies van der Rohe

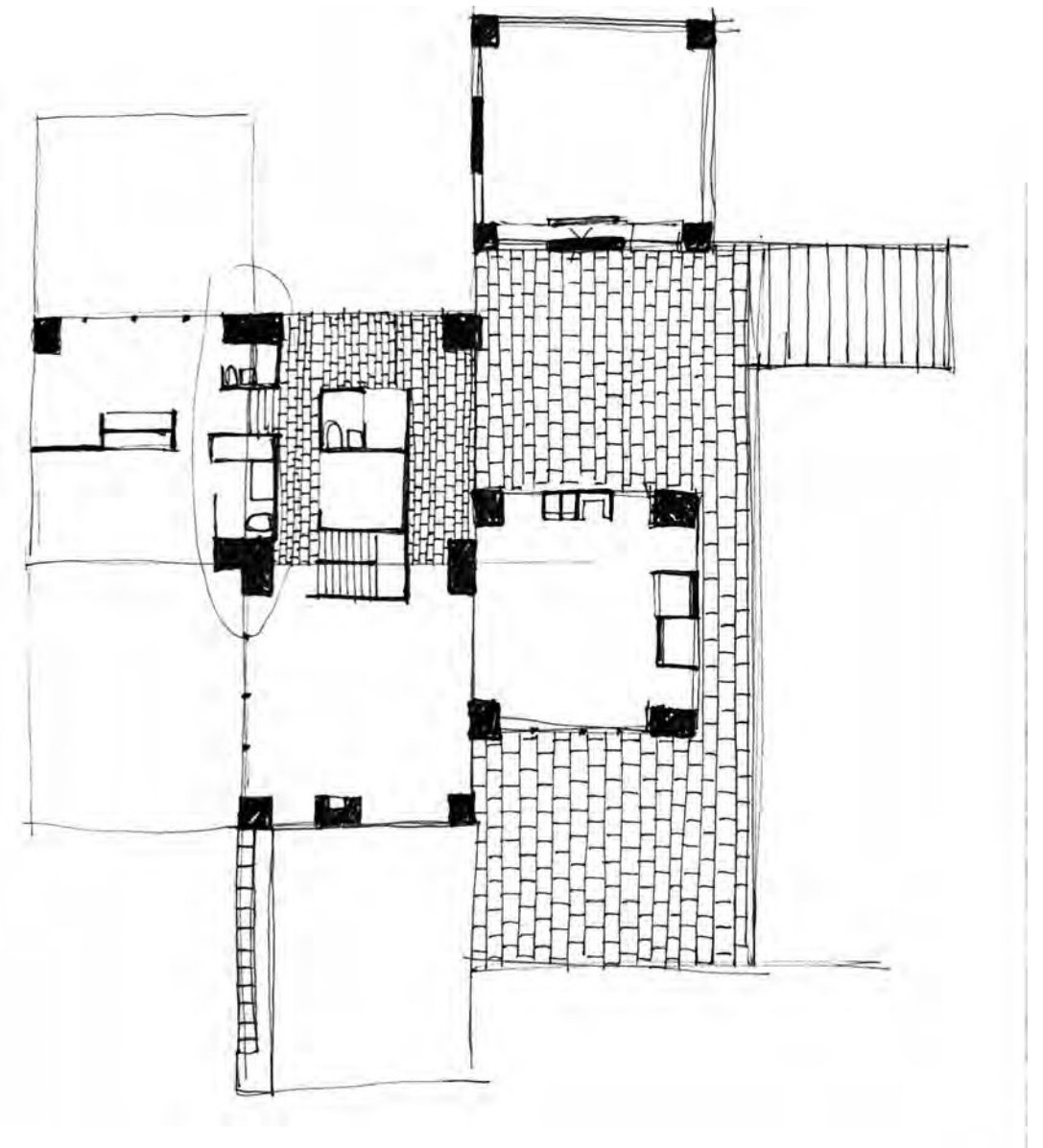

Luis Kahn

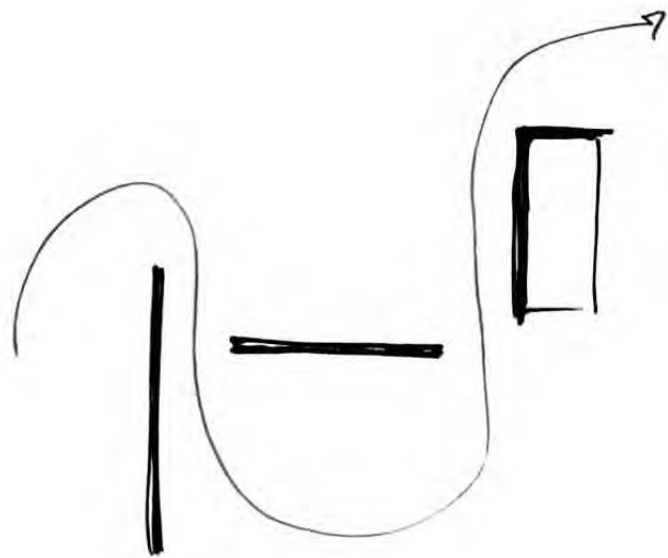
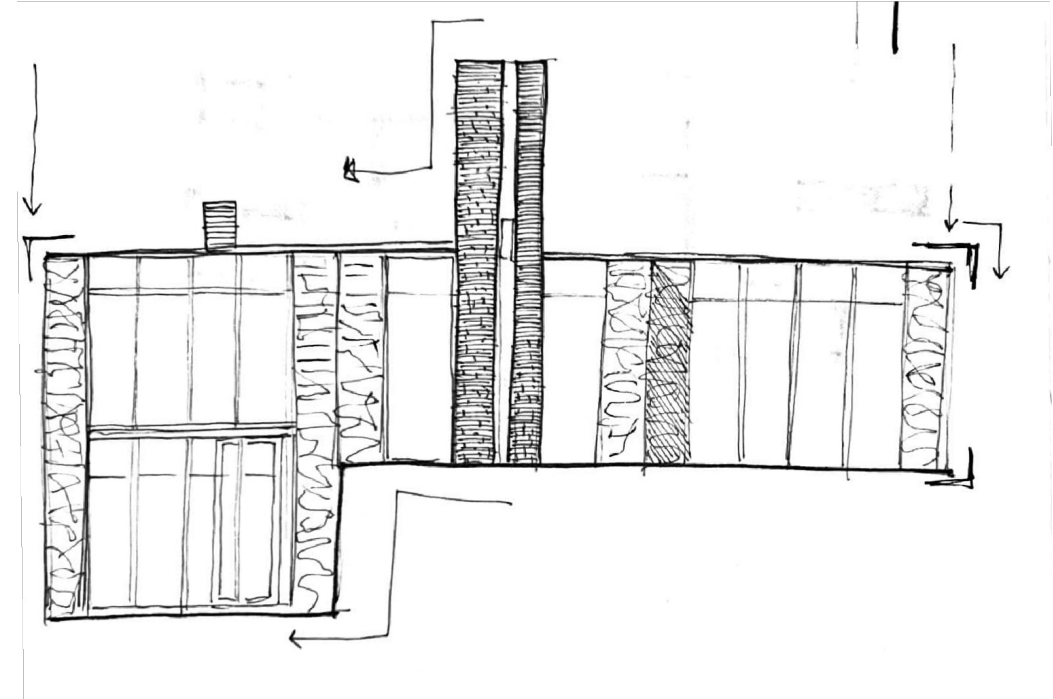
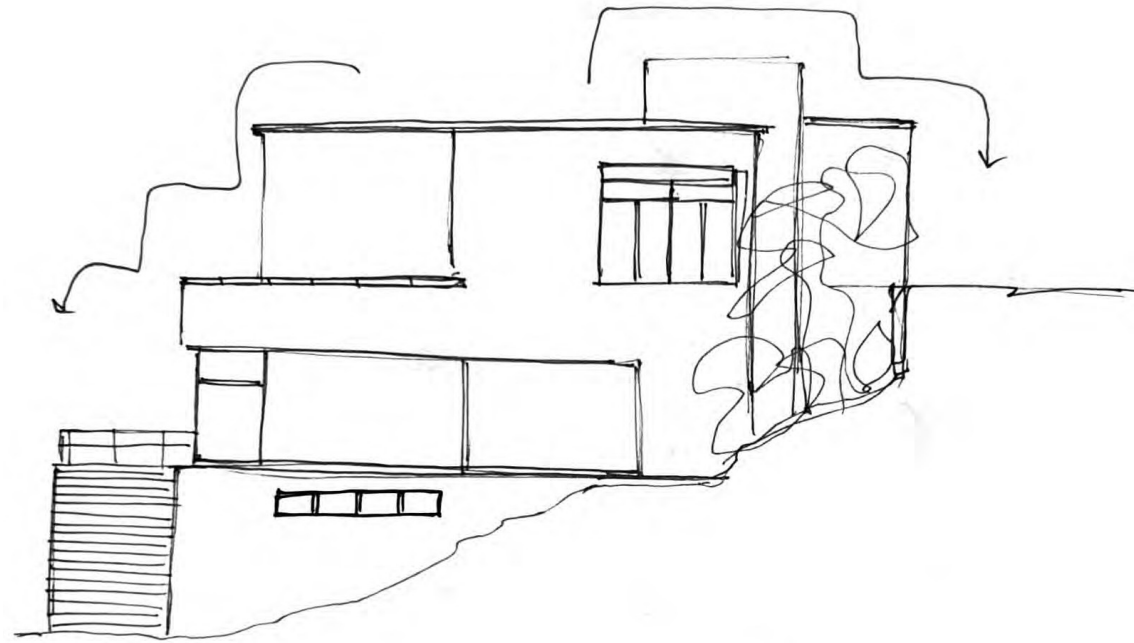

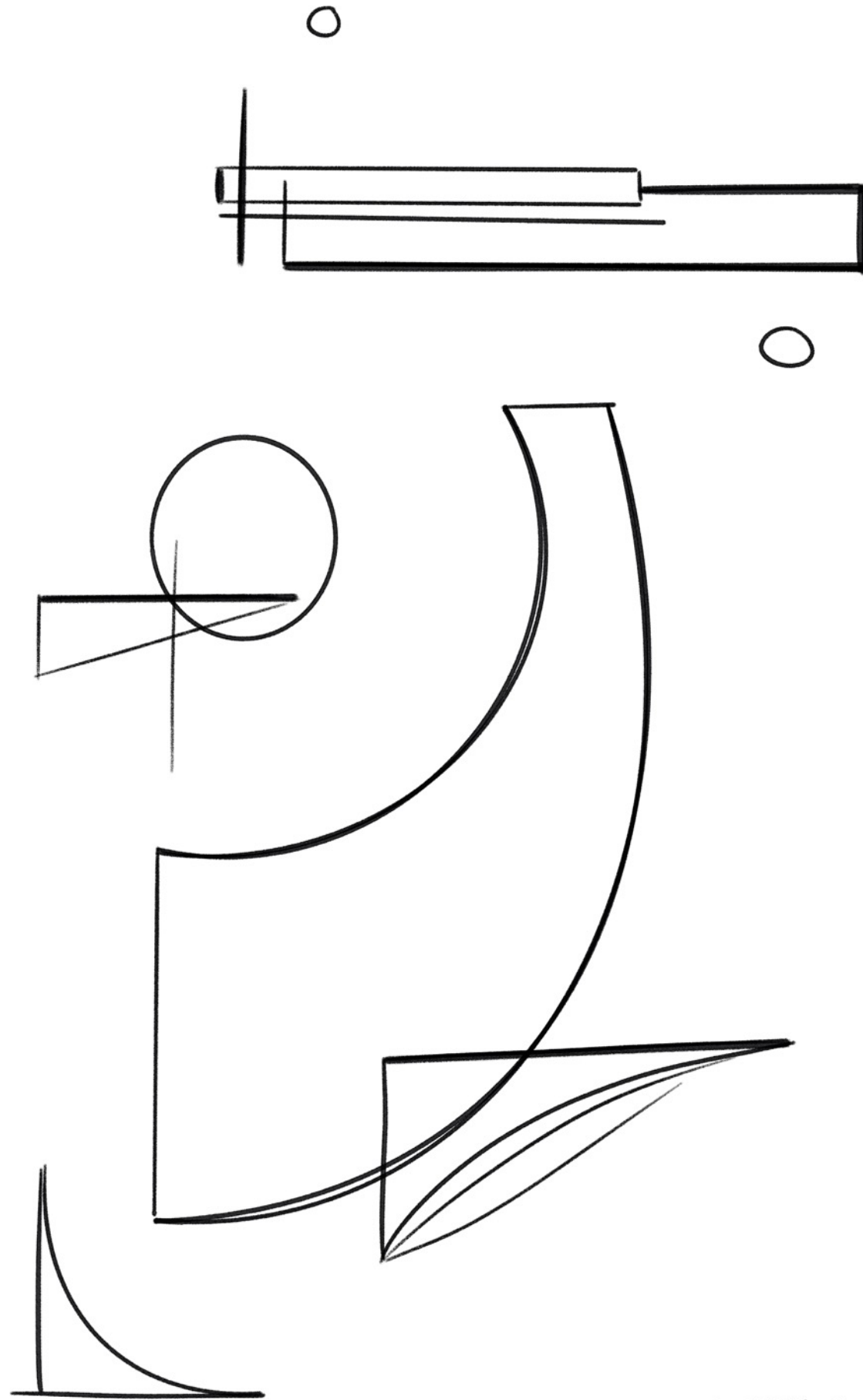

IS THERE SUCH A
thing AS BALANCE?
10-09-22

1.200
rule of thirds.

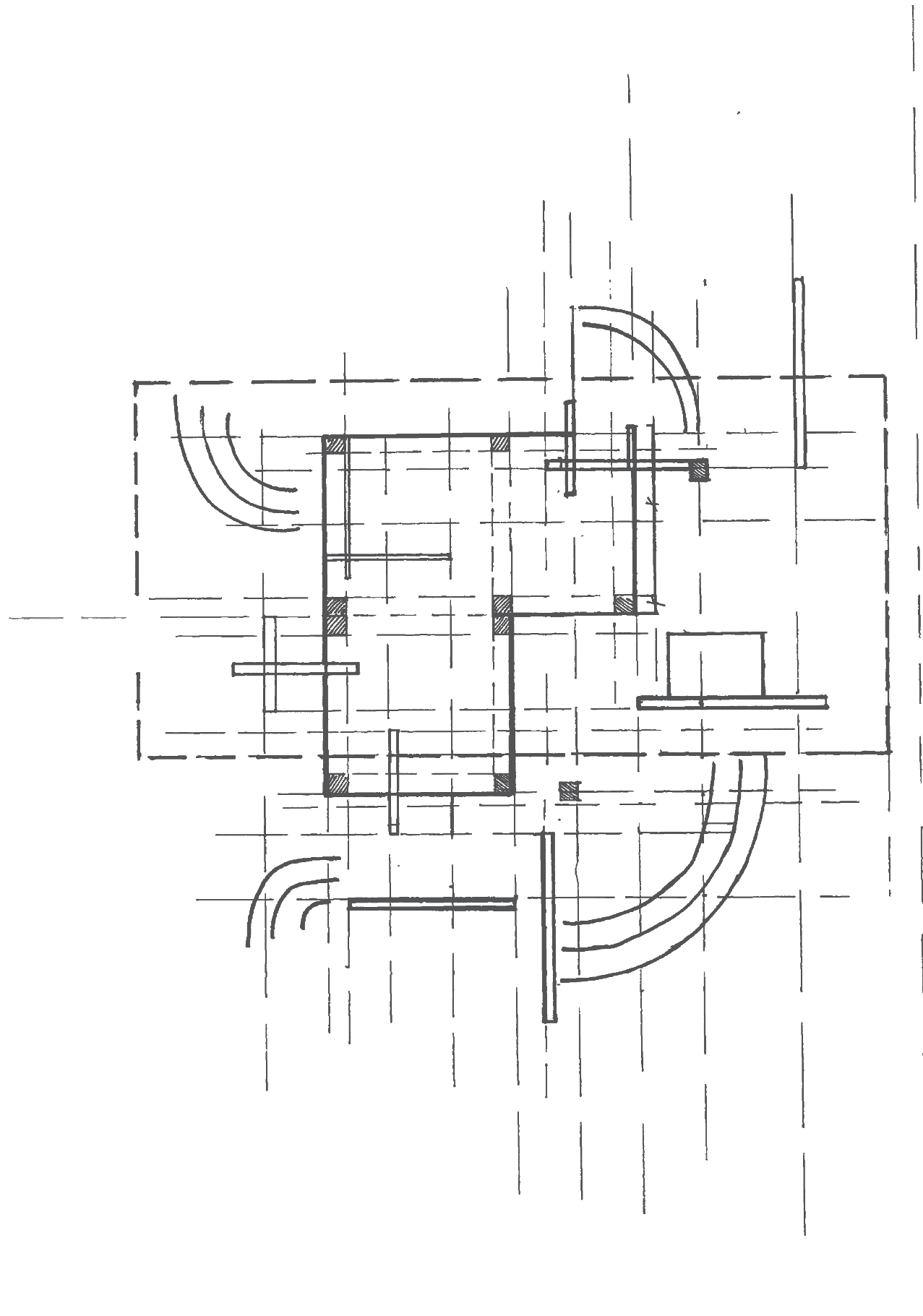

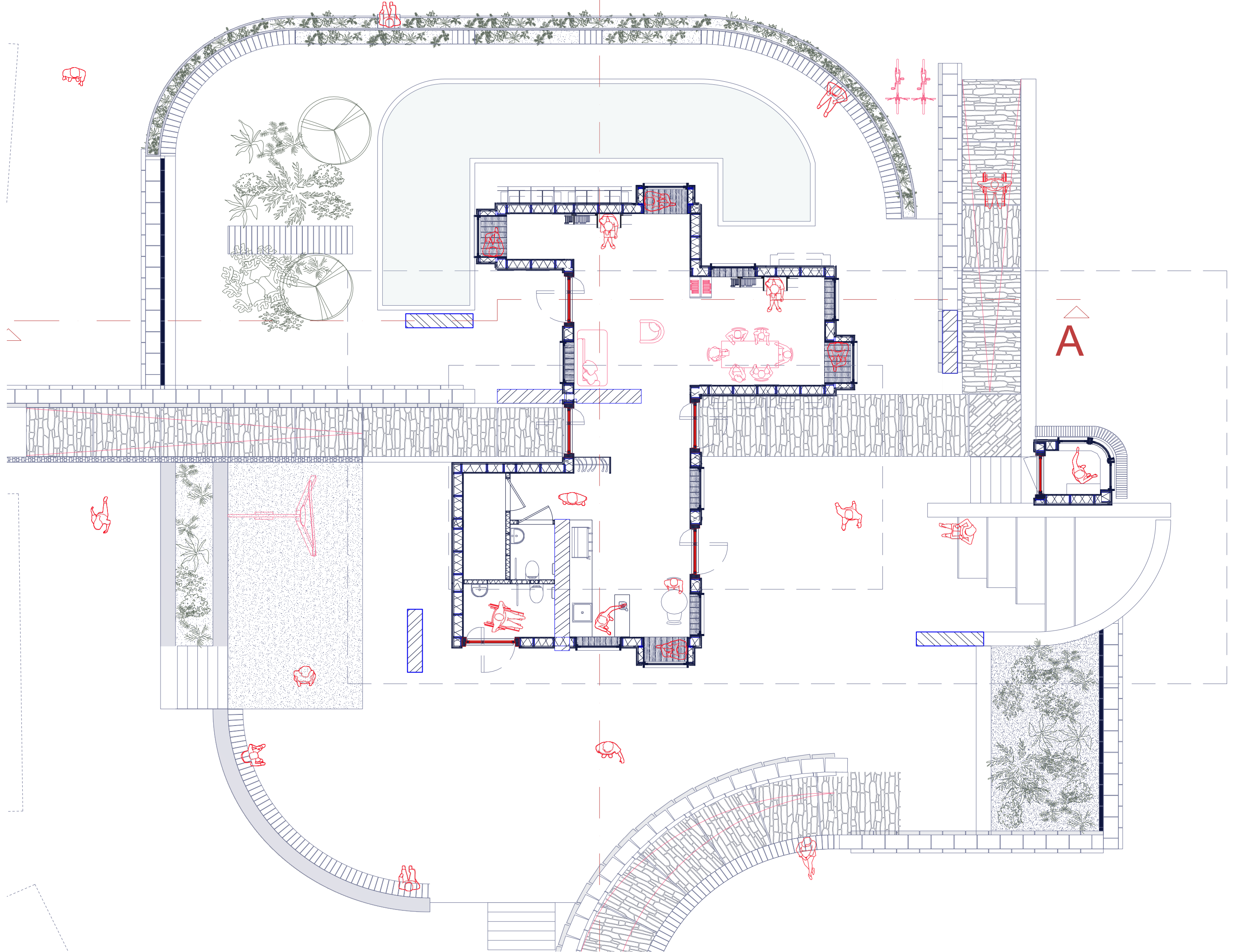

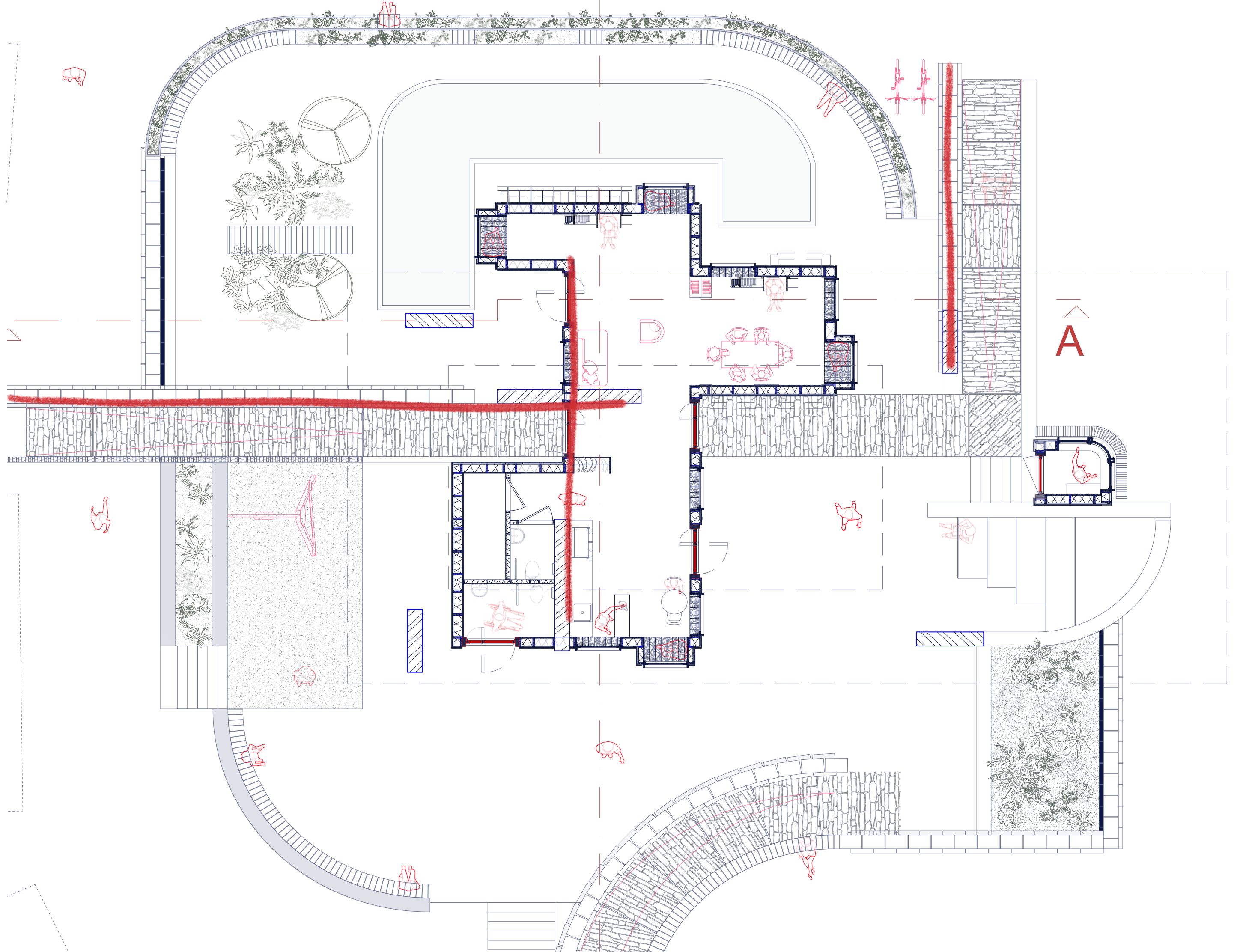

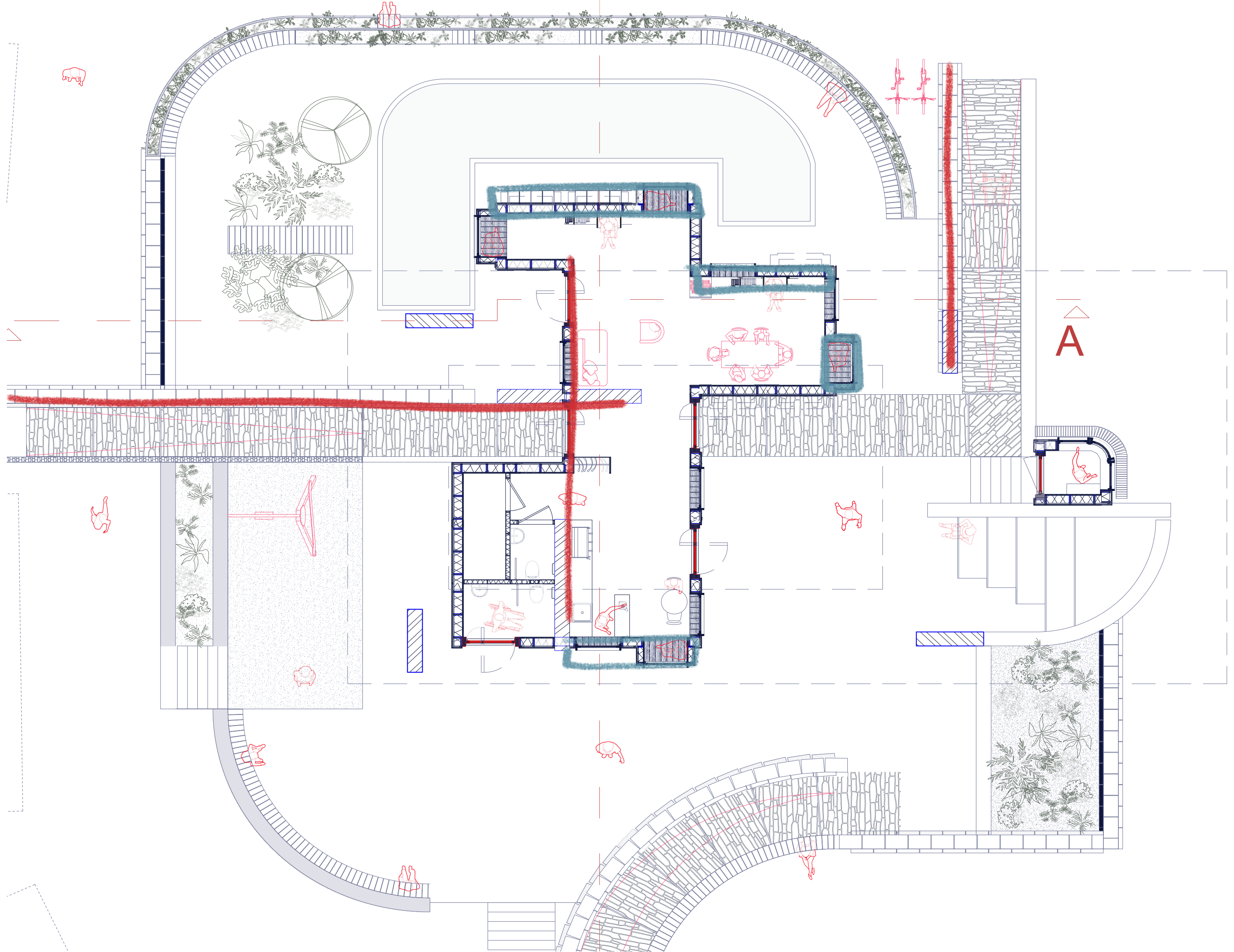

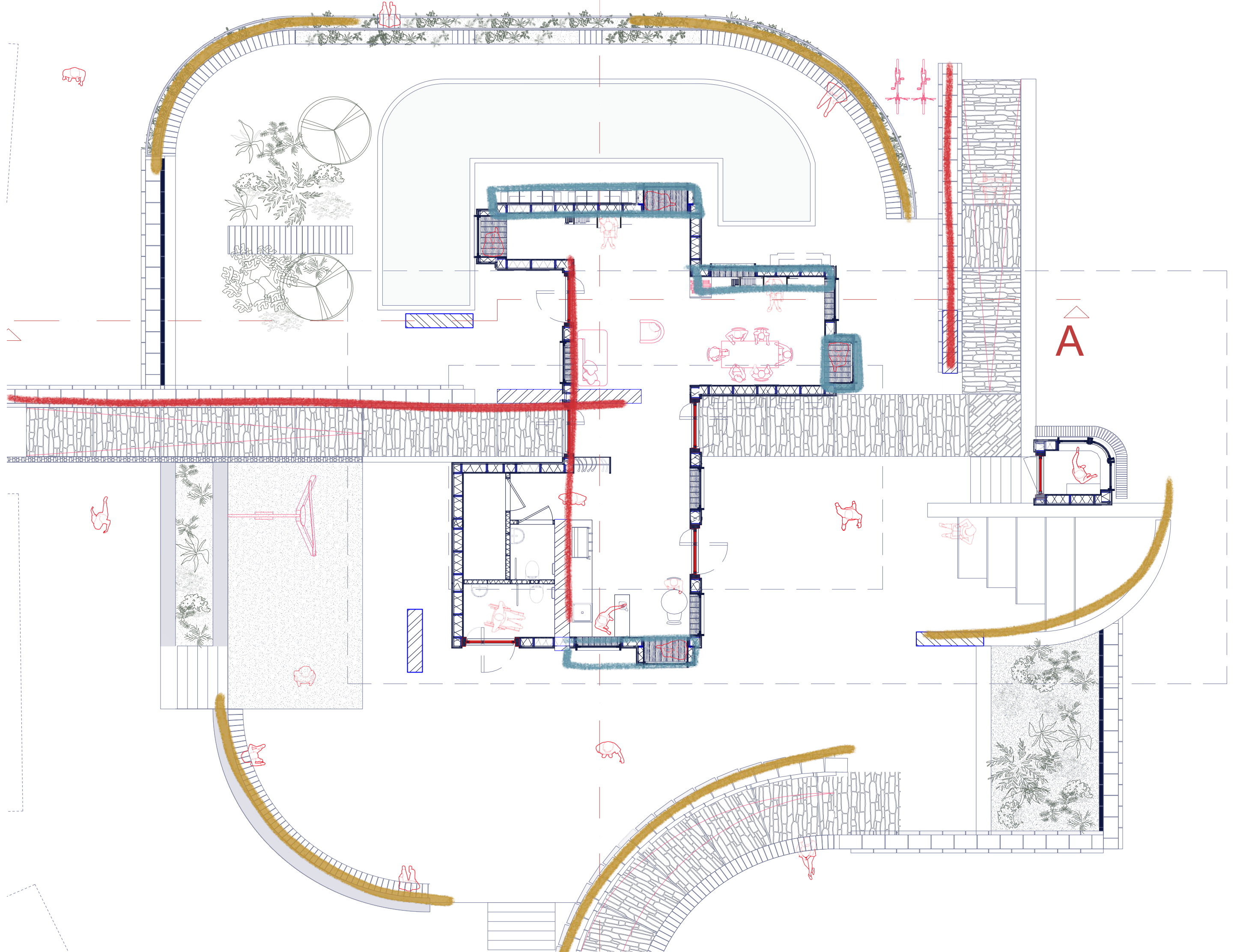















The Window

The Door

The Box

The High Window

The Closed Wall



The Window

The Door

The Box

The High Window

The Closed Wall

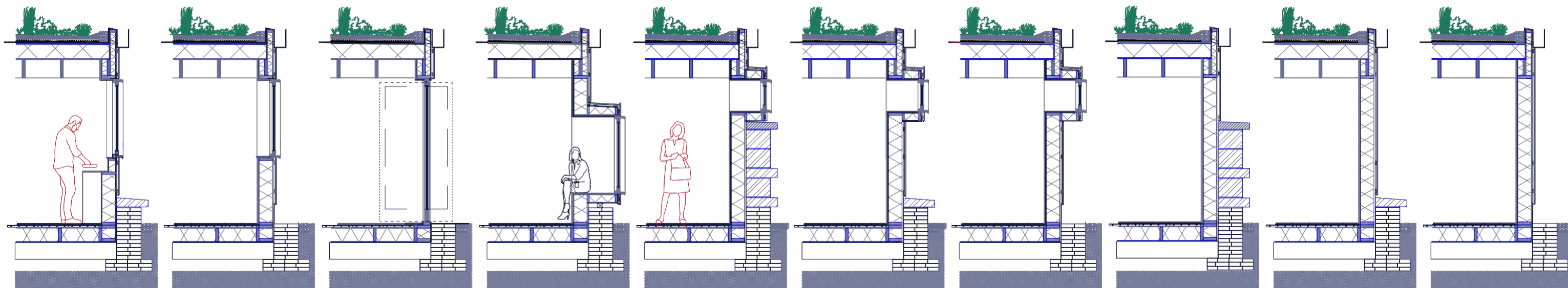



To be

To exist

To occur, take place

- Oxford Languages

Viru - Main Location



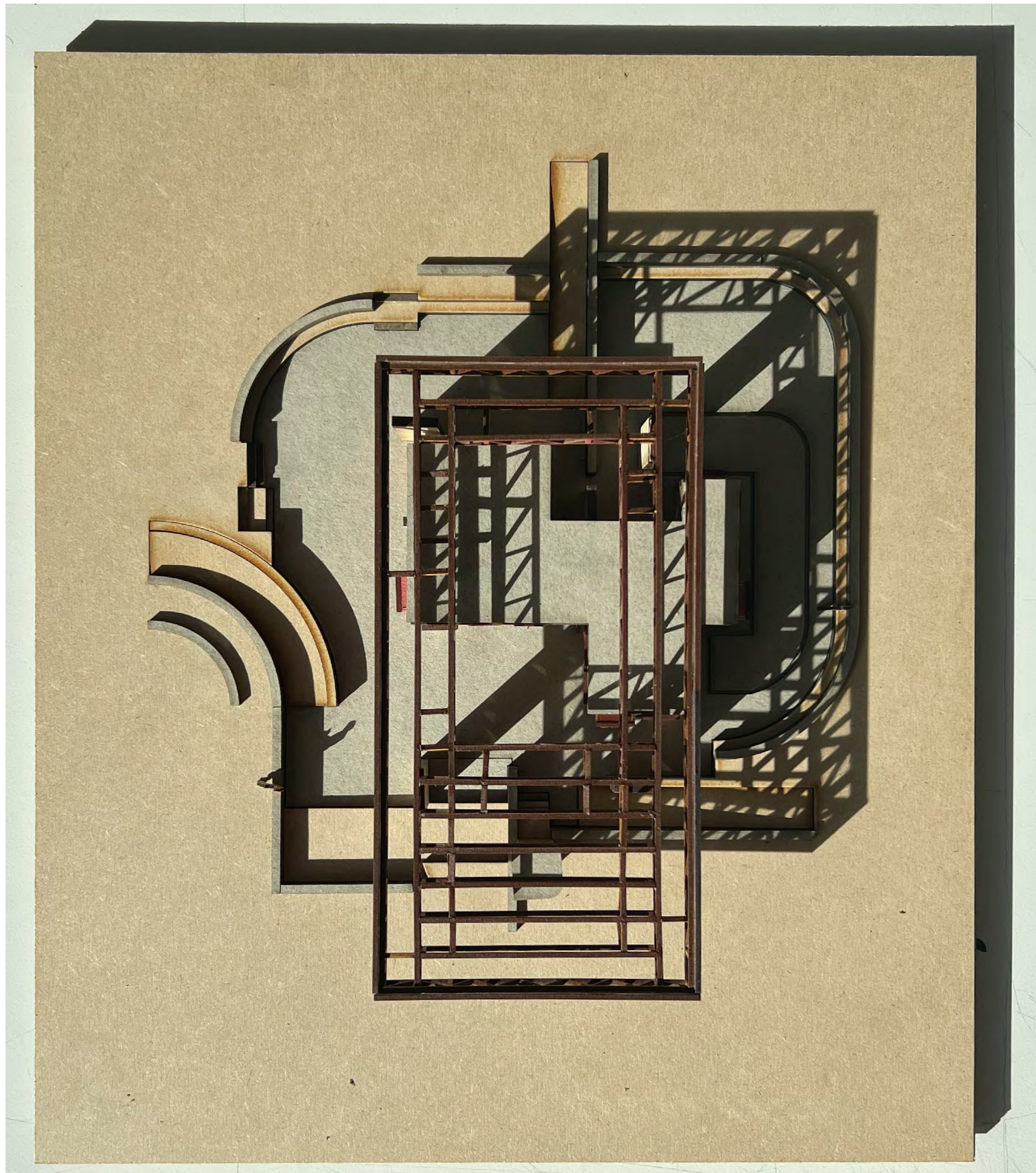

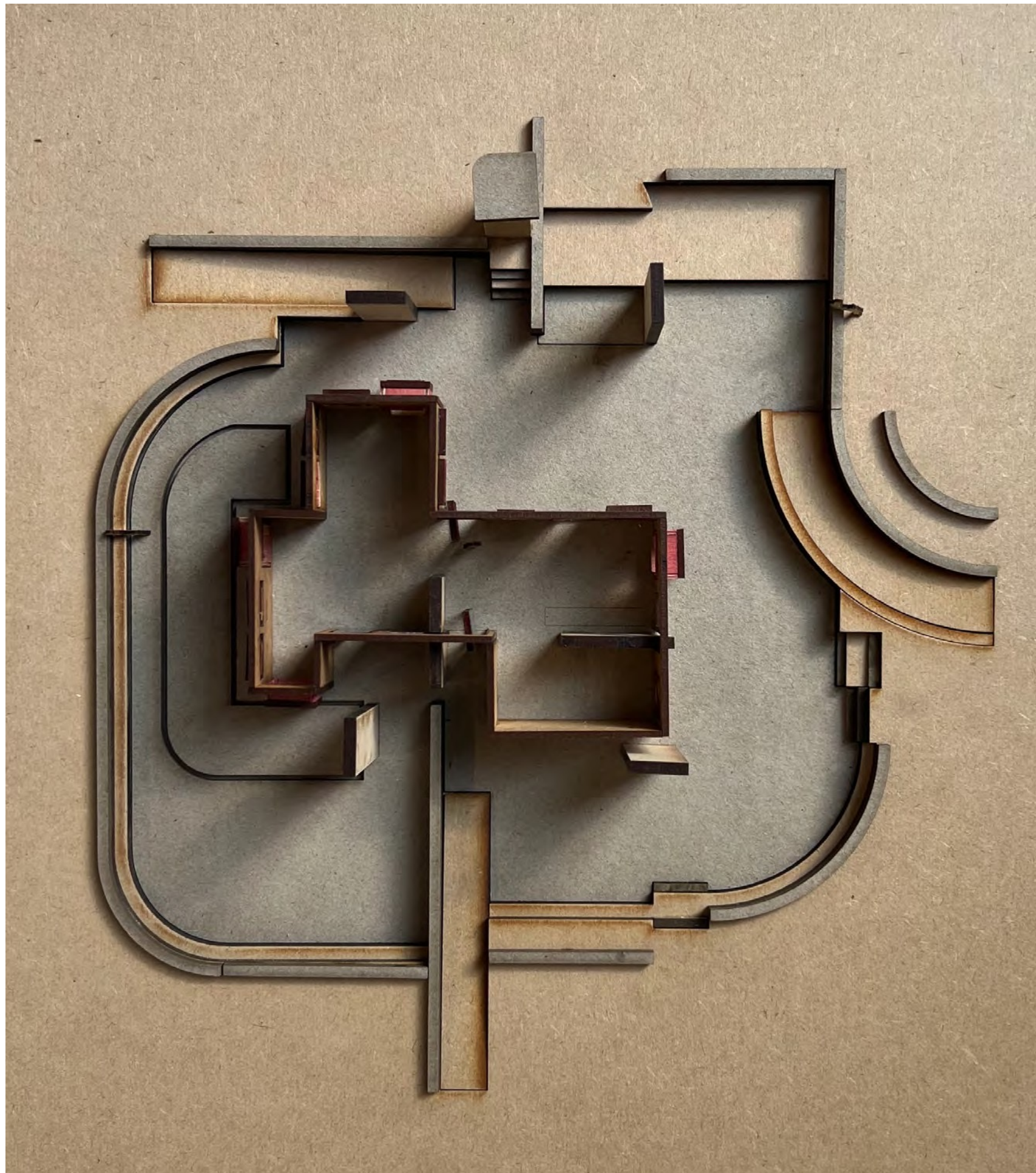

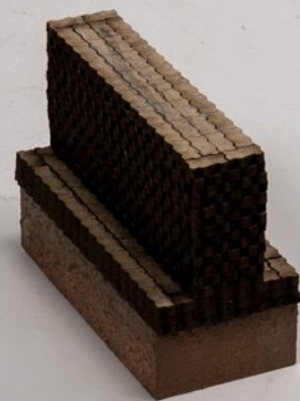

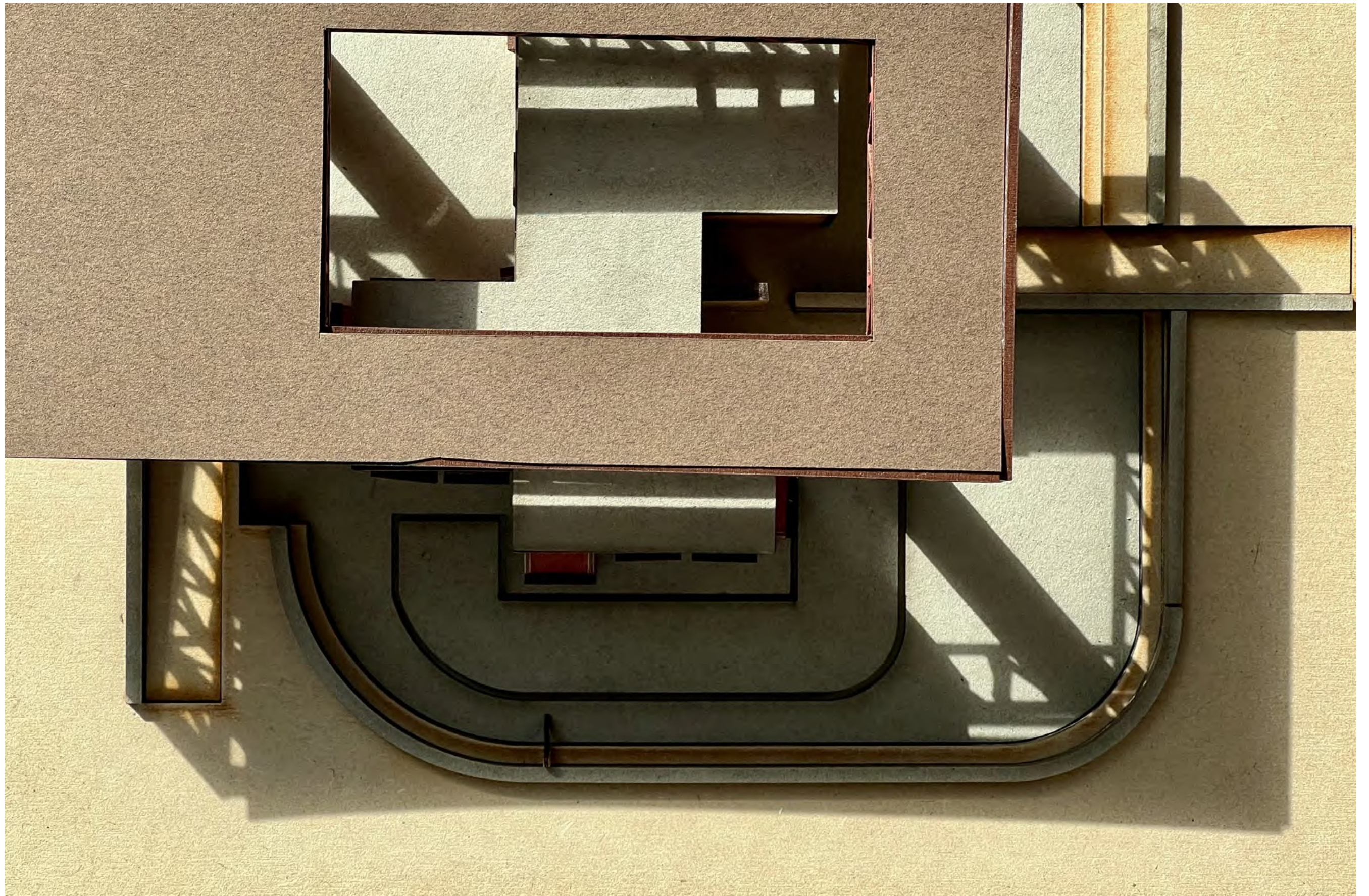













To see

To perceive with the eyes; discern visually

-Cambridge Dictionary



Freedom Square



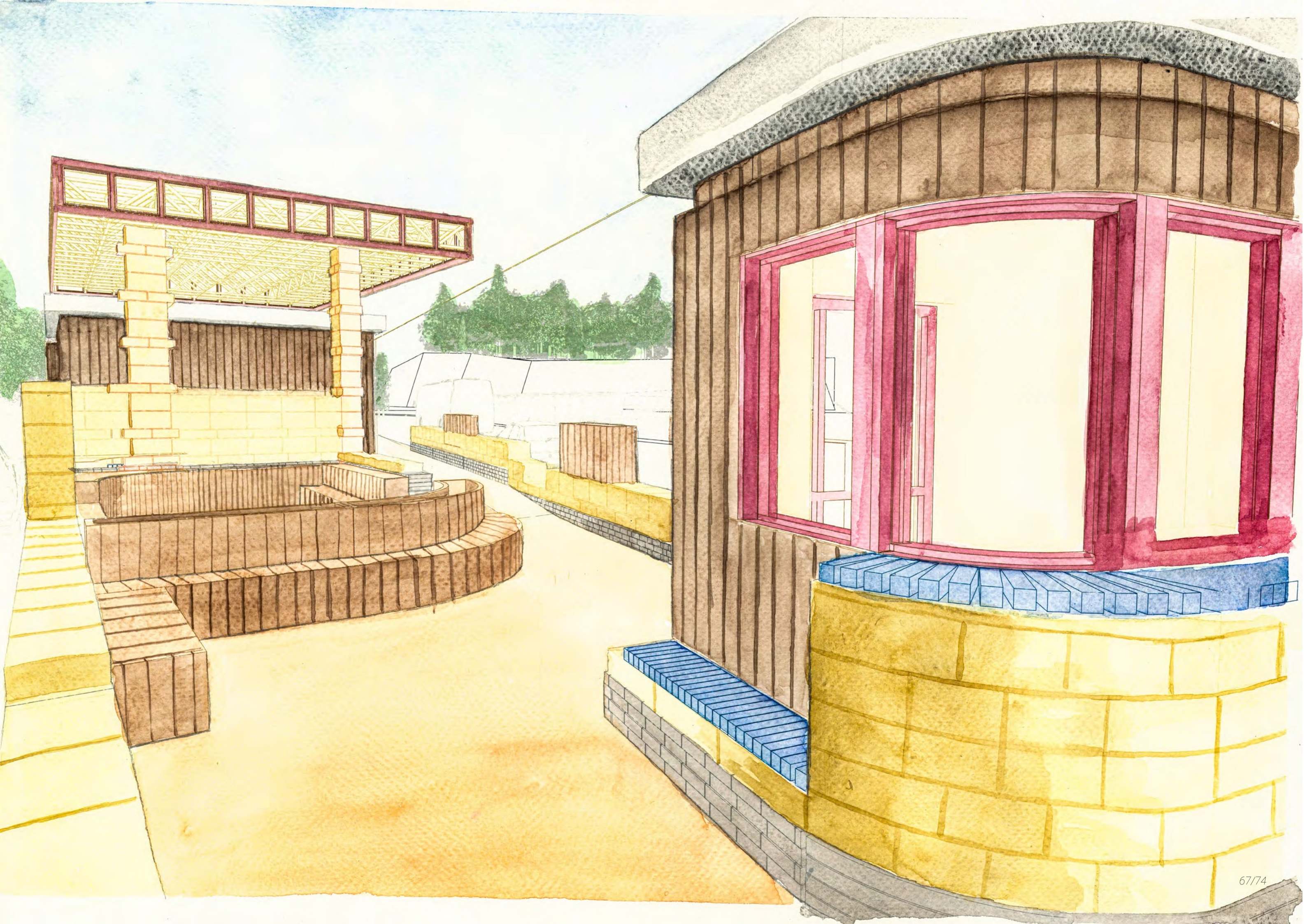

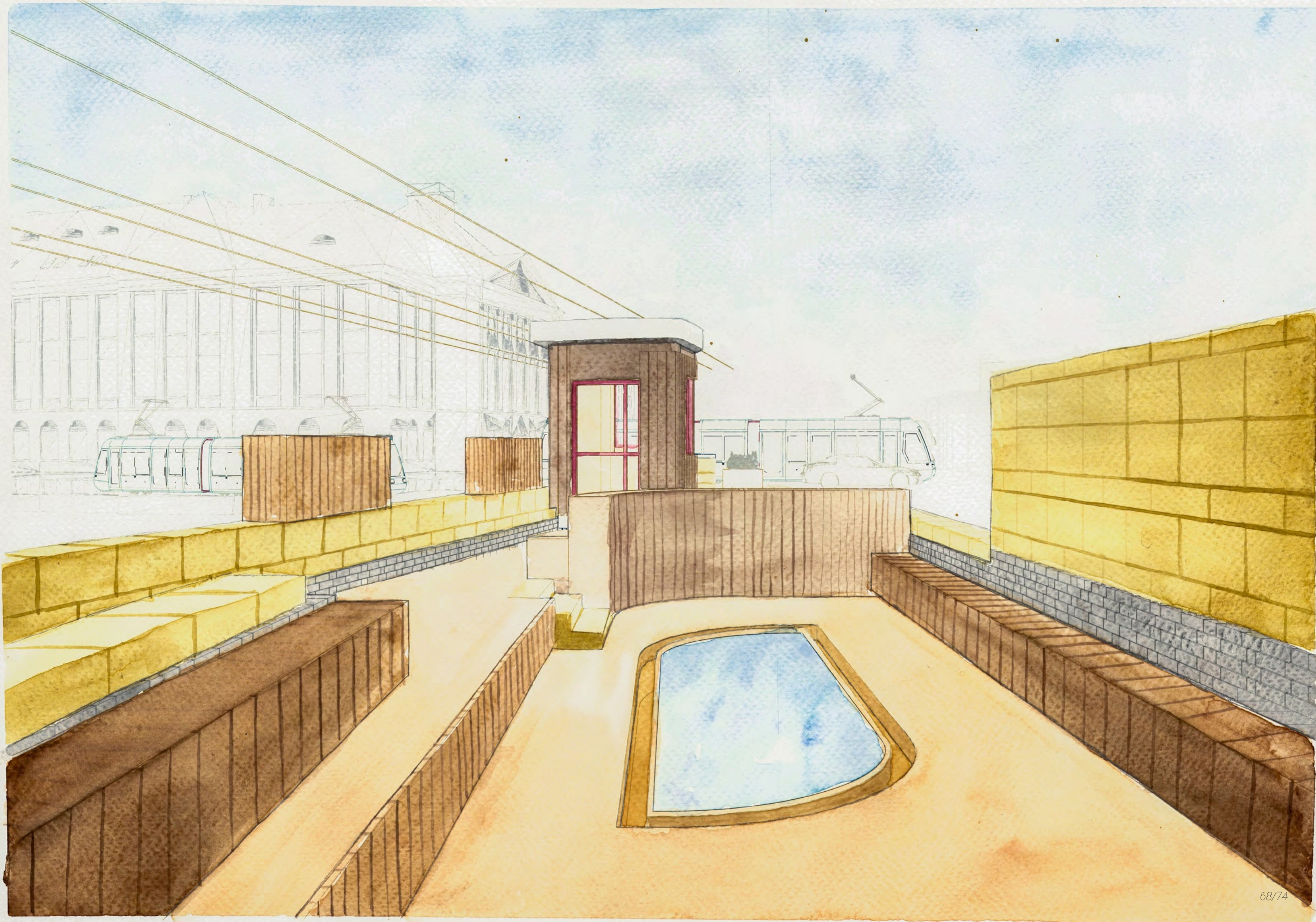

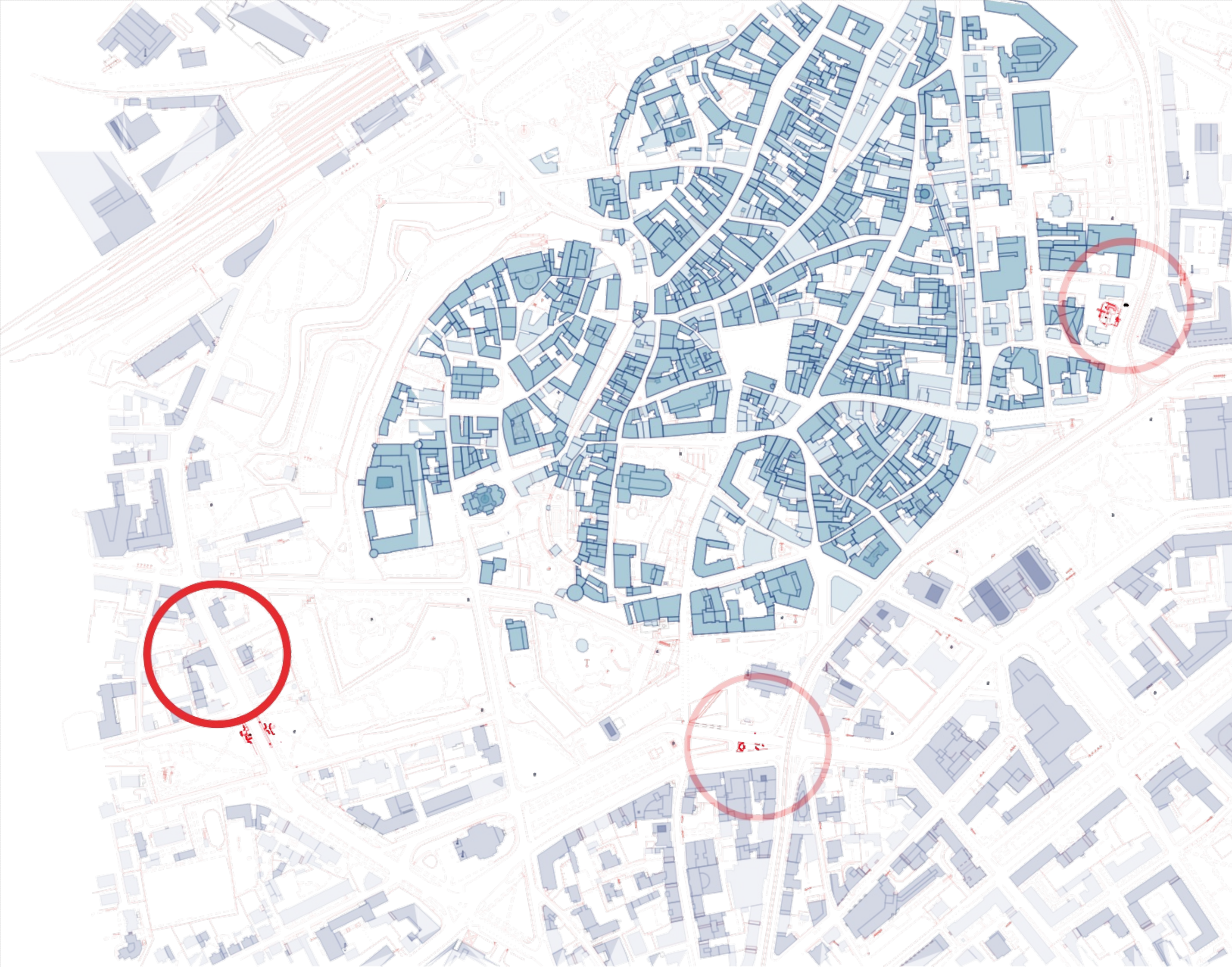

Night Bus



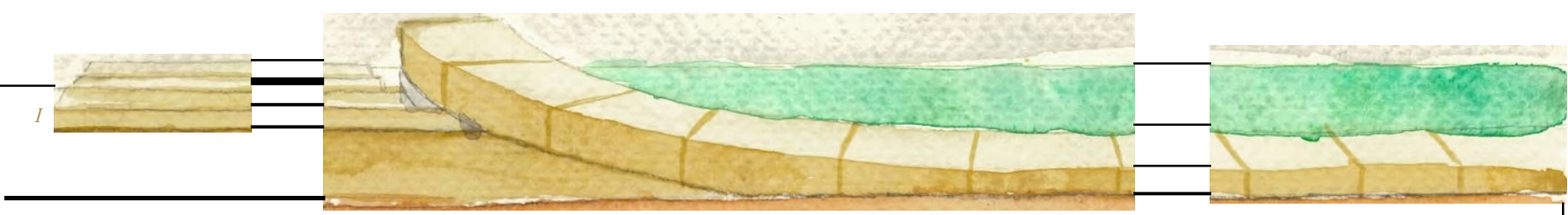
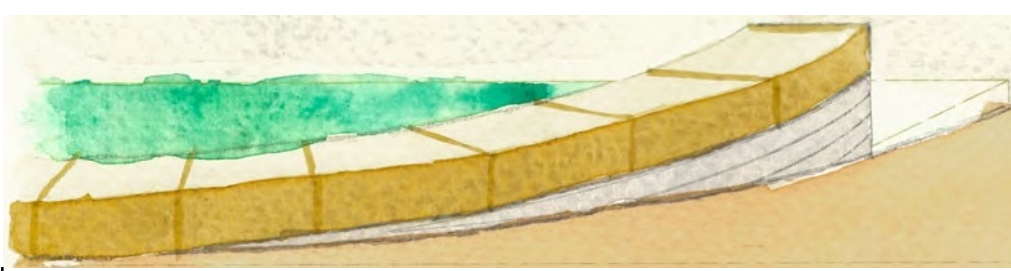

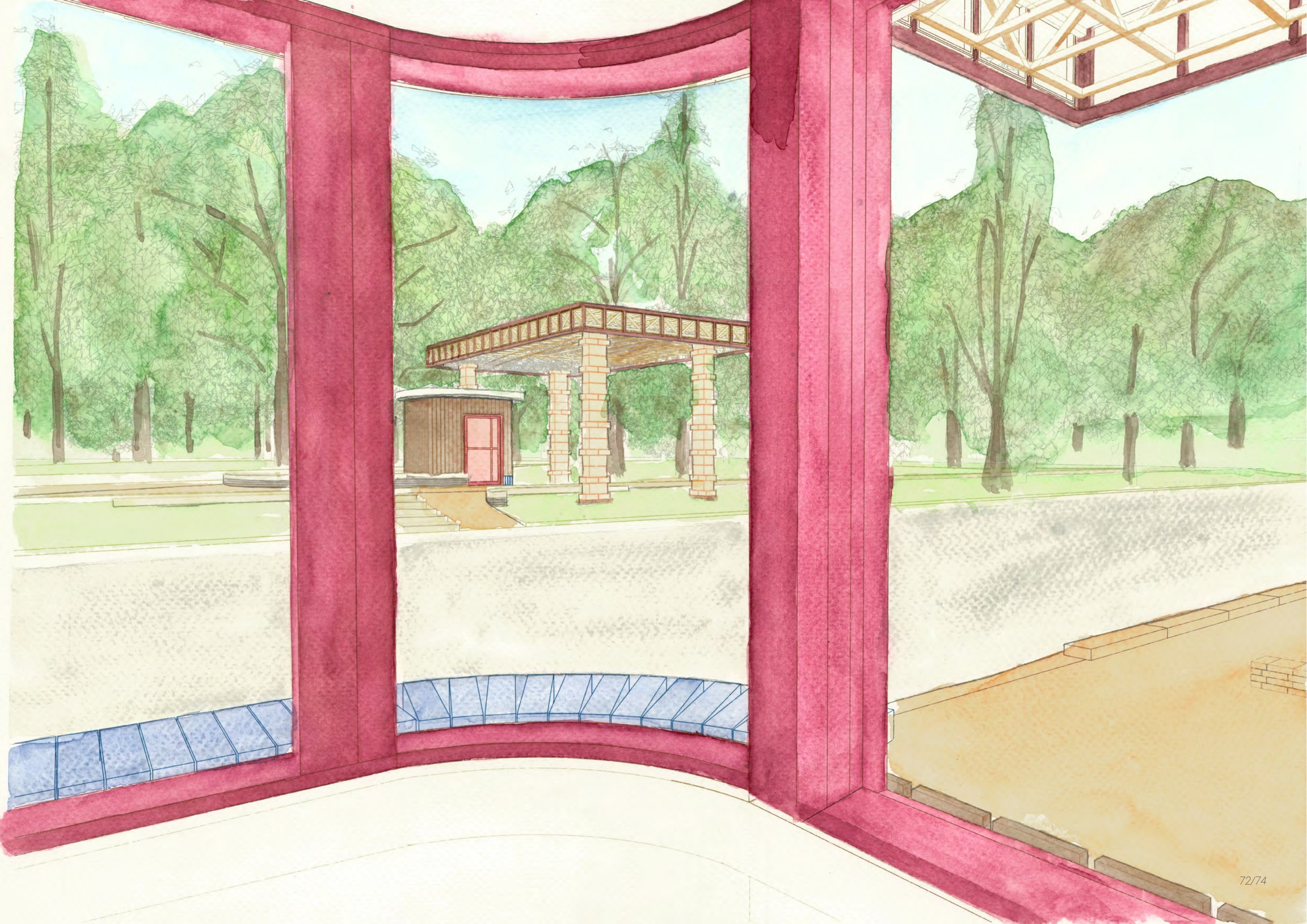

To end

A final part of something, especially a period of time, an activity, or a story.

come or bring to a final point; finish

- Cambridge Dictionary

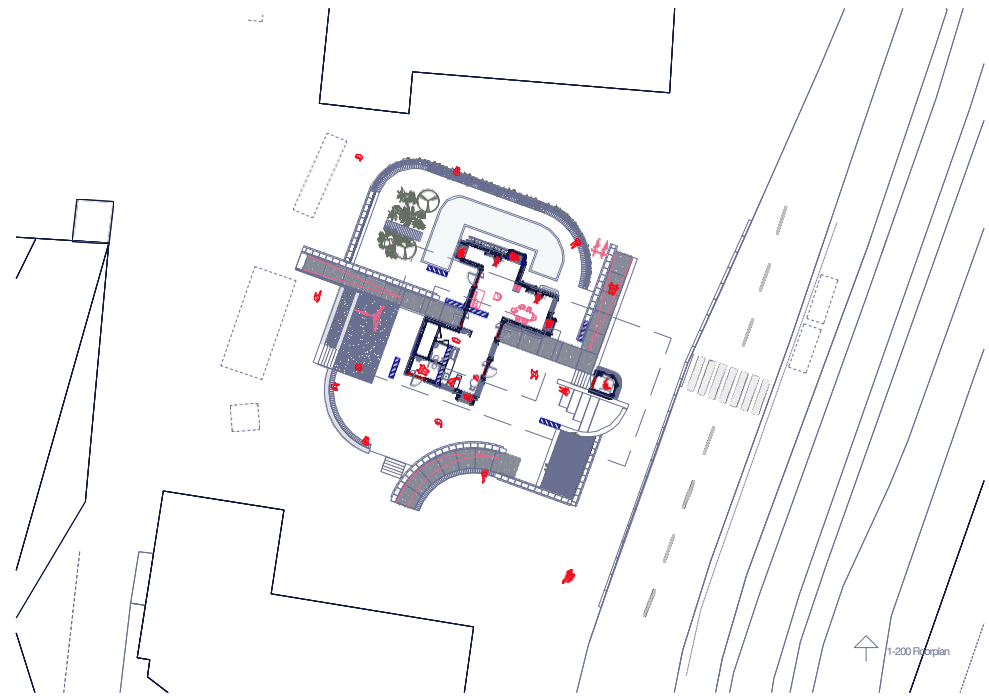

Viru - Main Location

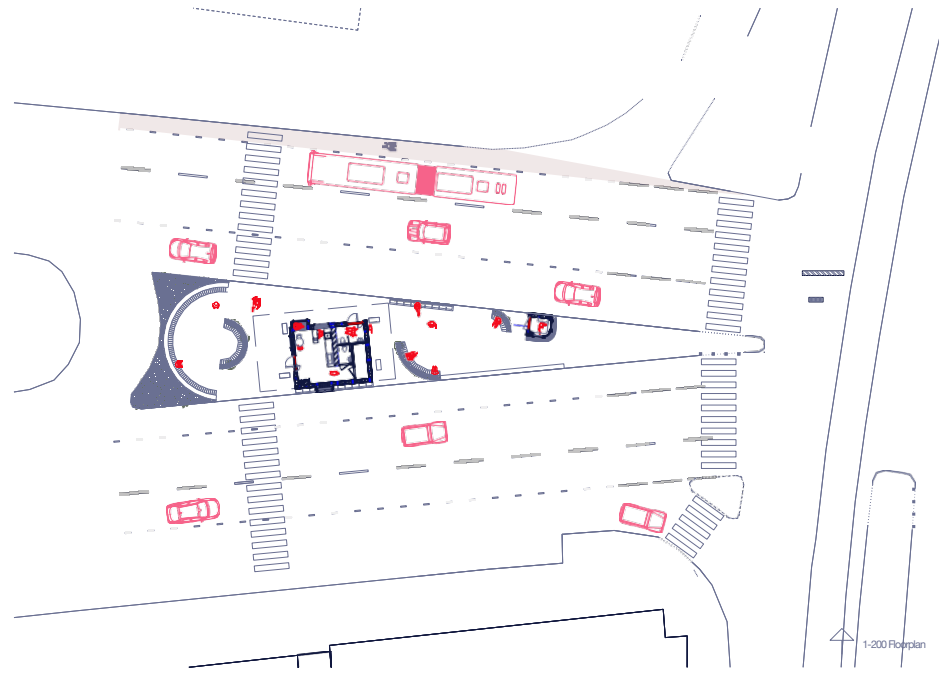

Freedom Square

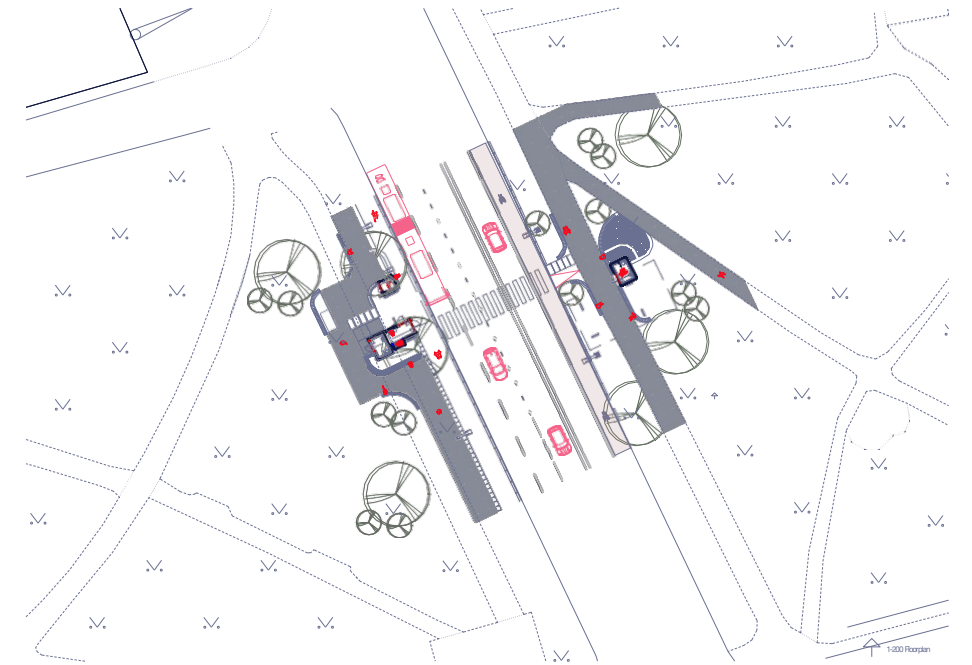

Night Bus

