

Sustainable embodiment of a digital microscope to be produced in Africa

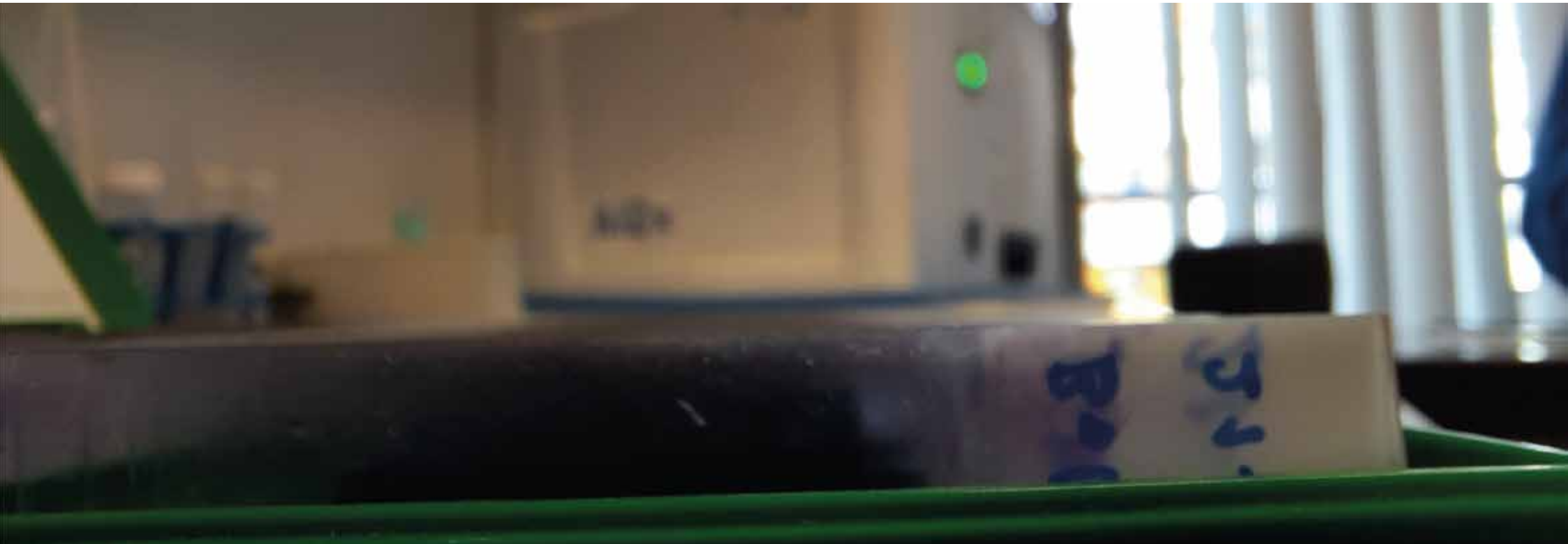

GRADUATION REPORT

IVAN EIKELENBOOM

ACKNOWLEDGEMENTS

This thesis is written by me, but I could never have done it without all the support I got from the people around me.

First I would like to thank my supervisors J.C. Diehl and Stefan Persaud for keeping my expectations of what I could complete during my graduation realistic. Sometimes I was too ambitious and they brought me back on the ground. Also special thanks to Stefan Persaud for pushing me when I was stuck in the process and helping me understand 'how to design an aesthetically pleasing device'!

Next to that I would like to thank my company mentor Temitope Agbana for giving me his time to ask hundreds of questions about the context and introducing me to several important stakeholders.

I also want to thank Satyajith for helping me to work out the electronics.

Next to these individuals I would like to thank the employees of Applied Labs, PMB and my family for supporting me in the process and giving me advice when needed.

Marinus Jan Eikelenboom

August 26th, 2022

Master thesis
Master Integrad Product Design
Faculty of Industrial Design Engineering

Graduation Committee
Chair: Dr ir. J.C. Diehl
Mentor: MSc. S.M. Persaud
Company mentor: Dr. Ir. Temitope Agbana

Delft University of Technology
Faculty of Industrial Design Engineering
Landbergstraat 15, 2628 CE Delft, The Netherlands

Company
AiDx Medical

Executive summary

Neglected Tropical Diseases (NTDs) are a group of highly infectious diseases which are mostly present in poor, remote areas in Sub-Saharan Africa.

People infected with one of the NTDs are suffering from a lot of health problems. These problems can become chronic or even lethal when not treated.

The current treatment method is done based on manual diagnosis by microscopy through skilled medical personnel. Standard microscopes require people to perform the diagnosis in unergonomical postures. Next to that, the staff is prone to fatigue and mistakes after several hours of analysing. Thus this is a time-inefficient, expensive and labor unfriendly process.

Therefore AiDx Medical is developing an Automated Diagnostic device based on microscopy. Through Artificial intelligence, the device is able to scan glass slides and identify infected areas in on the glass slide. For the current prototype to work, the device has to be connected to the net power, monitor, mouse and keyboard. Next to that the housing of the device did not convey it to be a medical device.

As NTD's are present in remote areas, a more portable device had to be developed. Next to that the device had to have a medical appearance.

By means of talking with several stakeholders and analysing their preferences I created, the initial device of AiDx Medical was redesigned.

With this iteration, the device was made portable by means of including a battery and a touchscreen. The medical appearance was developed by means of multiple sketch iterations, foam models and interviews with the stakeholders. The result of this ideation phase was prototyped during my graduation in order to test if the redesign could be produced.

A first low-fi prototype was brought to Nigeria and tested by local experts in order to validate the configuration.

The focus of this graduation was on making a robust, aesthetically pleasing, portable new version of the current device. Therefore a substantial amount of time was put in the process of creating the prototype

During this prototyping 3D printing was used as less as possible, as it should be made ready for series production by using 'Thermoforming', 'Vacuum molding' and milling in order to produce it. These techniques were chosen because the starting costs are low and the production technique is also locally available in Nigeria.



Figure 1: Existing prototype at the start of my graduation

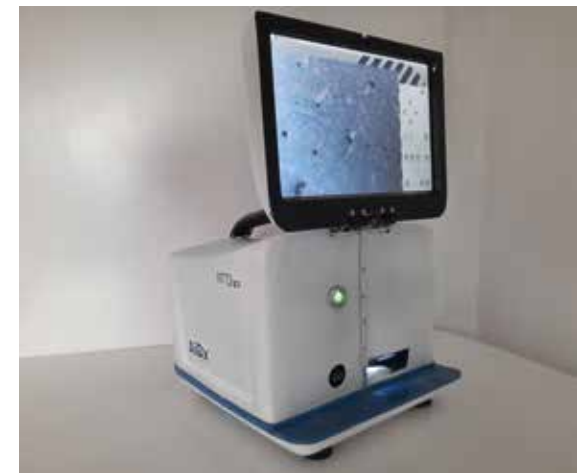

Figure 2: End result

ABBREVIATIONS AND DEFINITIONS

AiDx	Artificial intelligence Diagnostics (AiDx Medical is my graduation company)
CHW	Community Healthcare Workers
CMD	Chief Medical Directors
IDE	Industrial Design Engineering (faculty)
INSPIRED	Research group within the TU Delft focusing on making INclusive diagnoStics for Poverty RElated parasitic Diseases
IPD	Integrated Product Design (Master)
NGO	Non-Governmental Organisation
NTD	Neglected Tropical Disease
TRL	Technological Readiness Level
WHO	World Health Organisation.

Table of content

Introduction	5	8. Appearance	33	Discussion	68
1. Project scope	6	8.1 Shape	33	15. Conclusion	70
1.1 Introduction	6	8.2 Styling	35	16. Recommendations	71
1.2 Design brief	8	9. Concept	37	17. Reflection	73
2. Project approach	9	9.1 Concept selection	37	18. Sources	74
2.1 Design vision	9	9.2 Final concept	39		
2.2 Structure	10			Appendix	75
		Deliver	42		
Discover	12	10. Housing	43		
3. Environment	13	10.1 Production technique	43		
3.1 Context	13	10.2 Assembly options	44		
3.2 Journey map	14	10.3 Prototyping	45		
3.3 Stakeholders	15	11. Other parts	52		
4. Current design	17	11.1 Overview	52		
4.1 Explanation	18	11.2 Working principle	55		
4.2 Benchmarking	19	11.3 Servo plate change	56		
		12. Electronics	58		
Define	20	12.1 Requirement	58		
5. Design goals	21	12.2 Electronics explained	59		
5.1 Envisioned TRL	21	12.3 Prototyping	60		
5.2 Nine times Appearance	22	12.4 Cooling	61		
5.3 Interaction Flowchart	25	13. Tests	62		
6. List of requirements	26	13.1 Aesthetics	62		
		13.2 Interaction	63		
Develop	27	13.3 Waterproof (story)	64		
7. Orientation	28	13.4 Robustness	65		
7.1 Cardboard prototyping	28	13.5 Battery life span	66		
7.2 Ideation & selection	30	14. Cost	67		
7.3 Validation	32				



INTRODUCTION

- 1. Project scope
- 2. Project approach

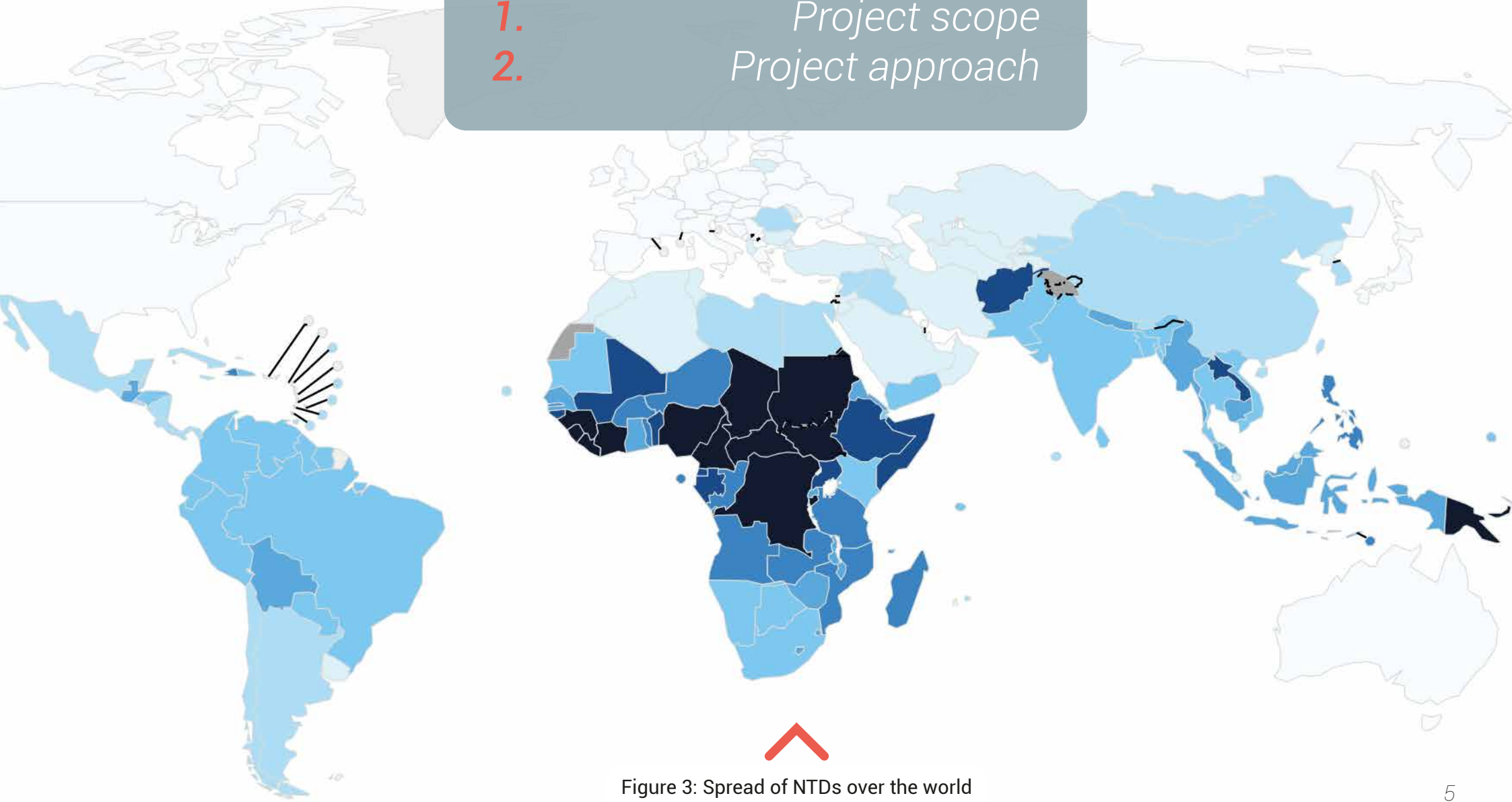

Figure 3: Spread of NTDs over the world
Source: weforum, 2020

1.1 INTRODUCTION

Neglected Tropical Diseases (NTDs) is a designation of a group of 20 different diseases. These diseases are mainly prevalent in tropical areas like Nigeria and Gabon, affecting poor remote communities and individuals mainly.

Problem

NTDs are mainly vector-borne, have animal reservoirs or are associated with complex life cycles (WHO). This group of diseases consists out of viruses, bacteria, parasites, fungi and toxins amongst others. This means that the diseases can be spread via various ways like water, blood and insects. Examples of NTDs are schistosomiasis and lymphatic filariasis.

When someone is infected with an NTD, it will not be clear immediately. People suspect that they just have a cough or a fever. However after a few years without treatment the symptoms and health risks are increased enormously. Also the needed treatment will be more severe (CDC). Therefore treatments of NTDs should be done as early as possible.

Impact

1.7 billion people every year suffer from at least one of these NTDs every year. This group should be addressed by means of prevention and treatment. Through NTDs around 200.000 deaths and 19 million DALYs are lost each year according to the WHO.

Treatment is available, but as stated before, NTDs are mostly prevalent in remote areas. Therefore it is not easy to diagnose and treat local people regularly. Additionally, when an infected person feels sick and has clear symptoms, the barrier to travel for days to a hospital is very high. This results in long and persistent presence of an NTD in an individual, increasing the spreading of the NTD throughout a community.

Current diagnosis practices

In order to diagnose and treat the population in remote settings, governments of countries with a presence of NTDs have established national programs to eradicate these diseases. Also NGO's have established such programs. At the moment there are two practices to fight these NTDs.

Firstly, through the vast network of Community Healthcare Workers (CHW) a local outbreak or presence of an NTD can be reported. The Community Healthcare Worker is gathering samples and bringing it to a laboratory where a Medical Lab Scientist is assessing the samples by means of microscopy and prescribing treatment which is brought back to the village by the Community Healthcare Worker.

Secondly, 'missions' are carried out on behalf of the government or NGO's. Such a party is heavily subsidized and expensive, therefore these missions are seldom carried out. A mission is a party of

Chapter 1

PROJECT SCOPE

In this chapter the broad context, the assignment and the project structure is explained

health workers and experts that goes to a village or high risk area in order to diagnose and treat. The best way to diagnose is by means of manual microscopy whereas microscopy is the only reliable method to scan for multiple NTDs at the same time. For this, high skilled microscopists are needed. These microscopist can scan only a limited amount of samples per day and are prone to human errors due to fatigue. Also ,the logistics around setting up a local lab is a vast operation. Therefore, currently rapid tests are performed upon which treatment is given. Rapid tests however are not reliable and can not detect multiple NTDs at the same time. (Oyibo, 2022)

Both current diagnostic practices are not sustainable. The first practice carried out by the Community Healthcare Worker takes much time and effort and only works if a Healthcare Worker is in close contact with the infected. The second practice is very cost-inefficient and therefore difficult to scale which is needed to eradicate multiple NTDs.

Fighting individual NTDs one at a time is costly and inefficient, therefore microscopy is the golden standard as this method can be used to diagnose for multiple NTDs. However manual microscopy is not cost-effective as well. WHO recognizes this problem and calls for a cross-cutting approach to eradicate NTDs. For such a cross-cutting approach, no effective cost-efficient solution to diagnose a large amount of people in remote areas is developed yet.

Current diagnostic developments

In order to answer the call of the WHO, knowledge institutions, research teams and companies are researching and developing diagnostic tools to detect NTDs.

TU Delft & INSPIRED

Over the last few years the TU Delft and especially the Faculty of Industrial Design Engineering (IDE) has been involved in numerous projects around developing affordable diagnostics by using the technique of microscopy. They do this in close collaboration with the INSPIRED project, researchers and Nigerian universities and stakeholders.

During this INSPIRED project the focus was mainly on the diagnosis and development of diagnostics for Schistosomiasis (one of the NTDs) in an affordable cost-effective manner. The joint research between IDE and the INSPIRED researchers have resulted in multiple versions of the Schistoscope. The Schistoscope is an automated diagnostic microscope in order to diagnose if a subject is contaminated with Schistosomiasis only.

AiDx Medical

As discussed before the group of NTDs is a quite diverse group. Most of these NTDs can and are diagnosed by means of microscopy. As the WHO called for an cross-cutting efficient approach to eradicate NTDs, there appears a need for a tool that can help in the fight for multiple NTDs at the same time.

In order to answer this call, AiDx Medical is founded. AiDx medical aims to develop a portable, high quality, cost-effective automated diagnostic microscope that is able to scan and diagnose for multiple NTDs with only one scan; the NTDx. The NTDx is also very scaleable as one person can operate multiple devices at the same time, resulting in a higher throughput of samples than possible with manual microscopy. The company is targeting Nigeria as their beachhead market as the prevalence of NTDs is high in this country (Hotez 2012). To be more specific, they want to make a drastic change in the way diagnosis and treatment of NTDs is being carried out in Nigeria.

They envision that a trained community healthcare worker would be able to do the work of a microscopist with the NTDx. This means that diagnostic care can be offered in remote areas, without the need of traveling to a hospital or starting a 'mission' in order to bring a whole lab consisting out of multiple high qualified staffmembers. So this device is saving a huge amount of time and money.

AiDx Medical has been through multiple design cycles and iterations in order to bring such a device to the market. Currently they have developed a working prototype which is tested in the relevant environment. The developed device works by means of combining digital microscopy and Artificial Intelligence in order to recognize NTDs in

1.2 DESIGN BRIEF

This graduation finds place at the crossroad of most of the involved stakeholders. The project is carried out by me, an Integrated Product Design (IPD) master student. This project is assigned to me by AiDx Medical and supervised by the department of Sustainable Design Engineering at the TU Delft. The supervisory team structure can be found in **figure 5**

Origin of project

Before this graduation project started, AiDx medical was developing their automated diagnostic microscope already for a few years. They optimized and improved the mechanical parts and placed it in a container that fitted the design. Next to that the software has also been developed and improved. At the start of my graduation the team was working on training the AI to be able to scan a second NTD.

As a result of using a random box of the right size, the current design of the container does not fit the envisioned context for the use of the device. The device was meant as a portable, robust, automated microscope that could be brought on missions to remote areas. But at the start of my graduation it did not meet these requirements: The content of the device was not optimized for compactness; It was not easy to walk around with the device; the robustness was not to the aimed level; and the appearance did not meet the expectations of the users as they were expecting a medical device.

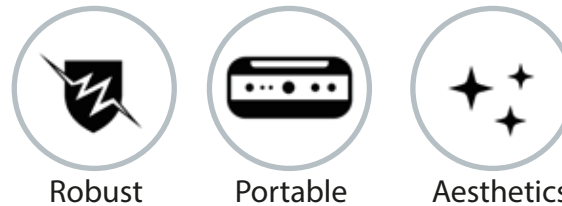

Figure 4: Project goals

Project description

During my graduation I am going to focus on the development of the housing mostly. Broadly my project consists out of three pillars: increasing the portability, aesthetics and robustness. After optimizing my design with regard to these topics, I will make sure that the design can be mass produced.

I will increase the portability of the device by integrating all the necessary components in one device. At the moment the existing NTDx works by means of connecting a monitor to the device and using net power (**figure 13**). To increase the portability, the NTDx should have an inbuilt touchscreen and accu. While making the device more portable, I will also make sure that the components in the device are placed as compact as possible which will reduce the size and increase the portability of the device.

Secondly, I will make sure that the device will be robust enough to withstand the environmental factors present in tropical circumstances when the device is being brought to remote areas. e.g. Impact resistant, humidity, high temperatures

Lastly I will make the housing of the NTDx aesthetically pleasing to such an extent that the appearance of the device will fit in the category of medical devices according to the future users.

Summary

So in short, the goal of my graduation project is to develop a robust, portable and aesthetically pleasing appearance of the NTDx and make sure that this design can be produced.



Ivan Eikelenboom
IPD Graduate



Jan Carel Diehl (Chair)
Design for the
Base of the Pyramid



Stefan Persaud (Mentor)
Sustainable Design
Engineering



Temitope Agbana
CEO AiDx Medical

Figure 5: Supervisory team composition

2.1 DESIGN VISION

Chapter 2 PROJECT APPROACH

Summary of chapter

I believe that a designer should stimulate others to come up with ideas and solutions rather than creating the ideas and solutions himself. Combining insights of relevant stakeholders and experts is the most valuable thing you can do as a designer to boost the quality of your design.

The creativity a designer really needs to wield has to do with questions like 'How do I know whose suggestions I should pursue' and 'How to combine all these wishes and requirements of these experts to create the best product?' Especially during this graduation I became more and more aware of the importance of how you answer these questions.

I think that the answers to these questions can best be answered by the future users themselves. I have done this by listening closely and asking questions endlessly. For me designing is asking questions. That is what I have done constantly during my thesis on my quest to the best embodiment of the NTDx. It may sound as if I have mastered this skill, but during my graduation, I became well aware that I have to push myself again and again to do this. I am still learning!

Therefore, during my thesis I have been in close contact with numerous stakeholders and users, keeping them updated about the progress of the project. As a result I have executed regular questionnaires, interviews, follow up interviews and chat conversations about their opinions on the designs I combined from their input. The list of interviewed people can be found on the right.

Chairman Medical Laboratory Scientists OYO state

Function	Amount	What	Appendix
Medical lab Scientist & directors	10	Questionnaire, Filmed interaction	
Medical lab Scientist	1	Regular update and interviews	
Field microscopist	1	Regular update and interviews	
PhD'er LMUC; Diagnostics of NTD Expert	1	Regular update and interviews	
Community Health worker	6	Creative session, Questionnaires	
Nigerian recycler and manufacturer	1	Interview	
Medical device regulations expert	1	Interview	

Figure 6: *Interviewed experts during Graduation*

2.2 STRUCTURE

Project structure

Structure in a big project like this is important. Therefore I structured my design work according to the double diamond model (**figure 9**). More details about the used methods in each phase additional to the displayed methods can be found in my planning (**Appendix 1**).

As the focus in my project will be mostly on the embodiment phase of designing, more time is spent on the Develop and Deliver phase of the double diamond model. However to establish a solid base, the first two phases had to be addressed first.

This model however looks linear, but it is not used that way. It illustrates the broad structure of the design process. During this process I have gone back and forth to the different phases when necessary.

An example of this non-linear development is the development of low-fi prototypes as a probe to stimulate the imagination of the interviewees. The interviews are categorized in the discovery phase, while the prototyping belongs in the development phase.

Thesis structure

This thesis is structured according to the double diamond process as well.

In the discovery phase, the context and the stakeholders are mapped. Also the current design is benchmarked by using the TRL method.

This TRL method is used in the Define stage again where I explain specific goals regarding the improvement of the NTDx. In this section the List of requirements is introduced as well. Throughout my thesis this list of requirements will be updated continuously. The final list of requirements can be found in **Appendix 2**.

After this, the development phase starts. In this phase, iterations regarding portability, robustness and appearance are discussed. This section will end with a preliminary 'final' design.

In section four, iterations on this preliminary design are shown in order to make the design producible. The final result is a working prototype. In this section the production techniques, the prototyping and the electronics are discussed.

Lastly the design is discussed and the process is reflected on.



Figure 7: Working on the ideation phase

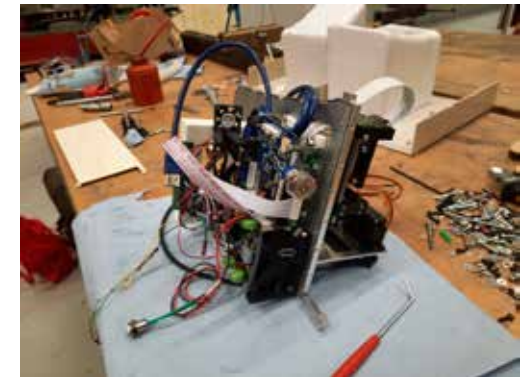
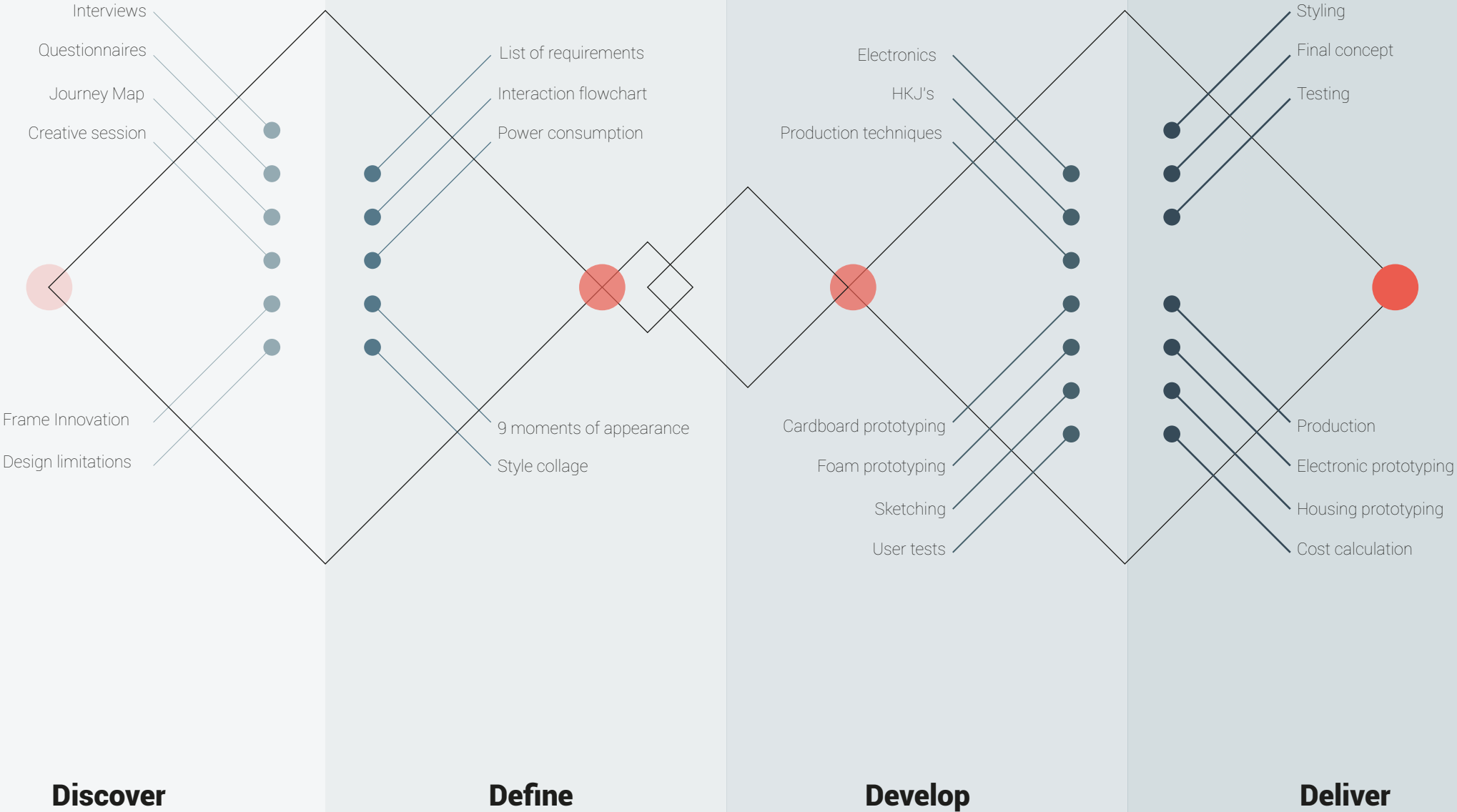

Figure 8: Working on the embodiment phase

Figure 9: Double diamond structure of my process



DISCOVER

3.

Environment

4.

Current design



Figure 10: Community healthcare worker
Source: Gatesfoundation, 2021

3.1 Context

As stated in the introduction, NTDs are present in tropical regions, especially in the more remote areas. The country this thesis project focusses on is Nigeria. In this country currently expensive missions are carried out on behalf of NGOs and the government in which diagnosis is done most often by means of rapid tests.

These missions can be distinguished into two categories. One-day missions and Multiple-day missions.

One-day missions

The One-day missions are missions that are lasting for one day. These missions are executed in easy accessible areas where the party can reach the village or area by car, sometimes in addition of a few hours walk. When they arrive at a village they first are meeting up with the Community Health Worker after which they are setting up their equipment, preferably outdoors on a tabel that is provided by the villagers. After this, they start gathering samples and diagnosing and treating the villagers. The Health Worker instills trust for the team in the locals, because he is known to them. If proper preparation of the side of the Health Worker is not carried out, the locals may have trust issues regarding the team: 'they are going to experiment with my DNA'. These trust issues can also be resolved by showing that the team belongs to an renounced organisation they they already know by

looking proffessional. At the end of the day they go back to their car and drive to their hotel to go to another village the next day.

Multiple-day missions

The Multiple-day missions are carried out in really remote areas where no road is present. These missions are not carried out that often currently, because the available equipment is not suitable for multiple day trips. However if the NTDx is available with a rechargeable accu, this will be one of the use cases of the device.

In this use case, the approach will be the same as with the One-day missions until the end of the day. At the end of the day, the party will not go back to their car and hotel, but will sleep in the village and continue traveling to the next village the next morning.

A more detailed timeline of the activities of such a party can be found in **figure 11**. This figure shows both the envisioned timeline of the One-day and Multiple-day missions and the timeline of current mission practices. In this timeline, the experiences thoughts and worries of a field microscopist are added where possible. This timeline is developed in collaboration with 2 Nigerian Field microscopists and 6 Community Health Workers by means of interviews and a creative session. The process of developing this timeline can be found in **Appendix 3**.

Chapter 3

Environ- ment

In this chapter the close context is analysed and summarized in a stakeholder overview.

3.2 JOURNEY MAP

Figure 11: Current and envisioned Journey maps of One-day and Multiple day 'missions'

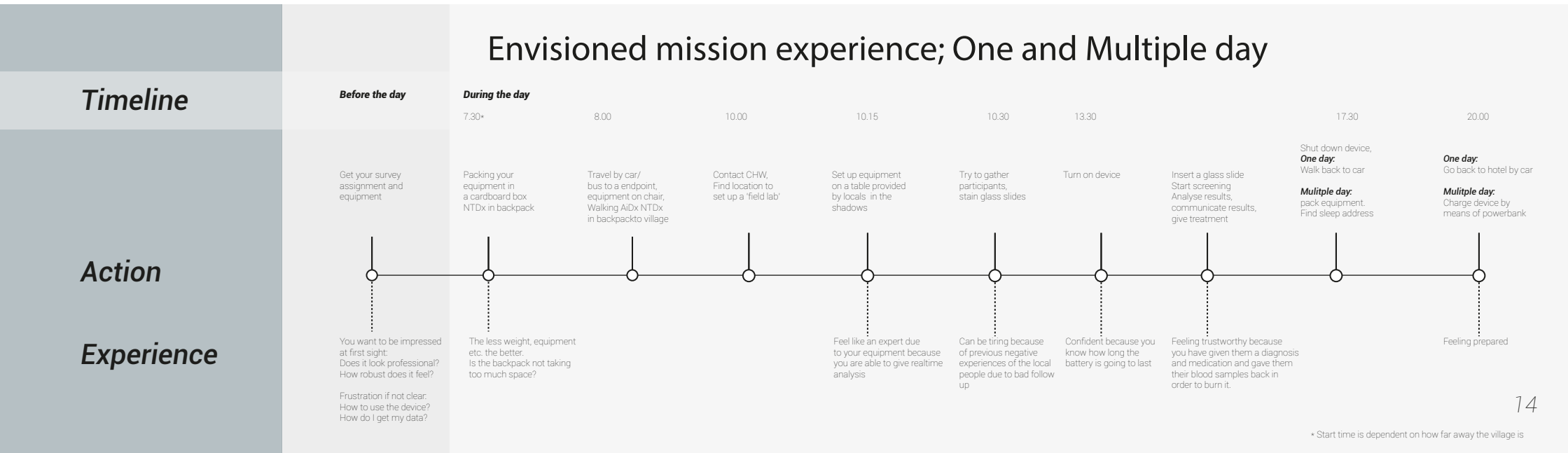
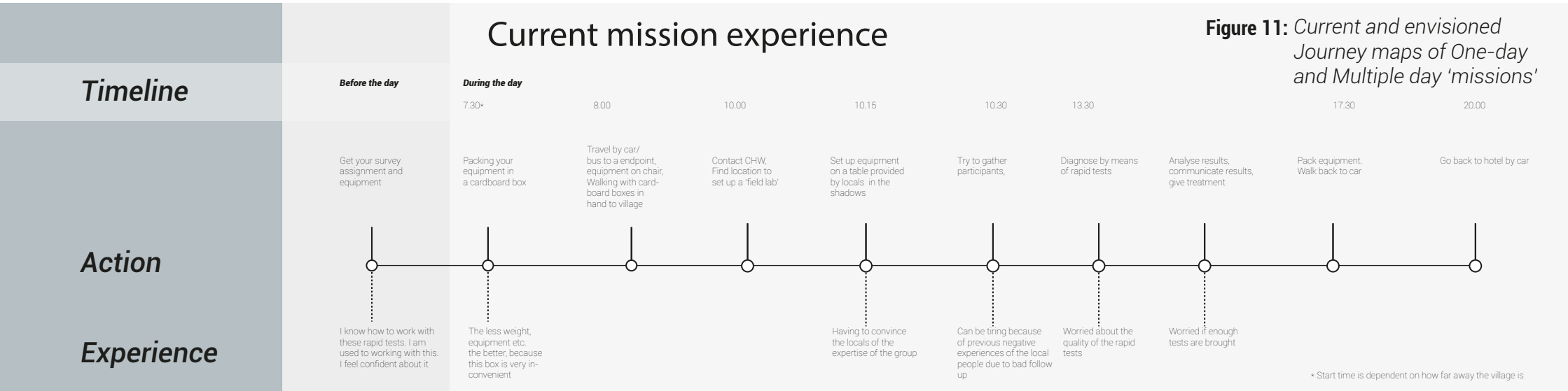

3.3 STAKEHOLDERS

To deepen my insight in the context I started to analyse the gathered information by using the method 'Frame Innovation'. In this analysis all the information I got from my interviews, questionnaires and research came together. In this section I will show the involved stakeholders and explain the role of the key stakeholders. The entire Frame Innovation process can be found in **Appendix 4**. A visual representative of the stakeholders can be found in **figure 12**.

In the future, microscopists or Community Health Workers will be the end user of the AiDx NTDx. However I chose the 'local with an NTD' as the central stakeholder because treating that person is the goal of creating the device in the first place.

Stakeholder discussion

Resource providing NGO's provides money for NGO's that are executing the diagnostic tasks on ground. The last mentioned NGO's have specific program managers per country and/or NTD who will contract State microscopists for the duration of a treatment/diagnostic mission of a few months. So, NGO's do not have permanent microscopists employed. NGO's are trying to hire the same microscopists every time they are carrying out a mission, but this is not always possible. Therefore these NGO's work with different microscopists every time. This means that the AiDx NTDx is going to be used by different people

each time a new mission is carried out. For the product, this means that the device has to be as simple as possible, without a lot of additional functions, whereas the future user will not have previous experience with the device or time to get used to it.

The State microscopists are employed by a state mission manager normally. These state mission managers are executing a treatment/diagnostic mission or program on behalf of a state NTD center. The Abuja NTD center is the 'head' of all these centers. These centers are financed by the Ministry of health of Nigeria.

These missions are only executed if a Community Healthcare Worker has prepared the local population in such a way that they support the treatment. These community healthcare workers are known and trusted by the locals. That way the missions can be executed safely.

Next to this, people sometimes find help for their diseases themselves. Most of the time they end up by public hospitals. In these hospitals the CMD determines the available diagnostic instruments. In the hospital medical laboratory the diagnostic tests are performed by the hospital microscopists. Sometimes people with an NTD ends up in a private hospital, but that only occurs in rare cases where a private hospital is founded by churches or

retired healthcare workers and located in a remote area; NTD's are diseases for the poor.

Another location that contaminated people search for help are the pharmacies. There they can buy rapid tests and treatment for their disease.

NTD-researchers are distant stakeholders in this scenario, because they are involved in providing 'heat maps' of the presence of NTD's but not treating the population. These heat maps are helping the state and NGOs to direct their operations to certain areas.

Conclusion

After analysing all the stakeholders and information by using the technique Frame Innovation, I came to the same conclusion as AiDx Medical; the best way to diagnose and treat people with an NTD in remote areas is by giving more responsibility to the Community Health Workers. They are trusted by the locals, they are the first to know if someone might have an NTD and they already have basic medical knowledge. The only thing they miss right now is a device that can help them diagnose without them having to become experts in field of microscopy. By providing them with the AiDx NTDx and little training, they will be able to diagnose and treat the contaminated people in remote areas. Eliminating the need for expensive missions by the government or NGO's.

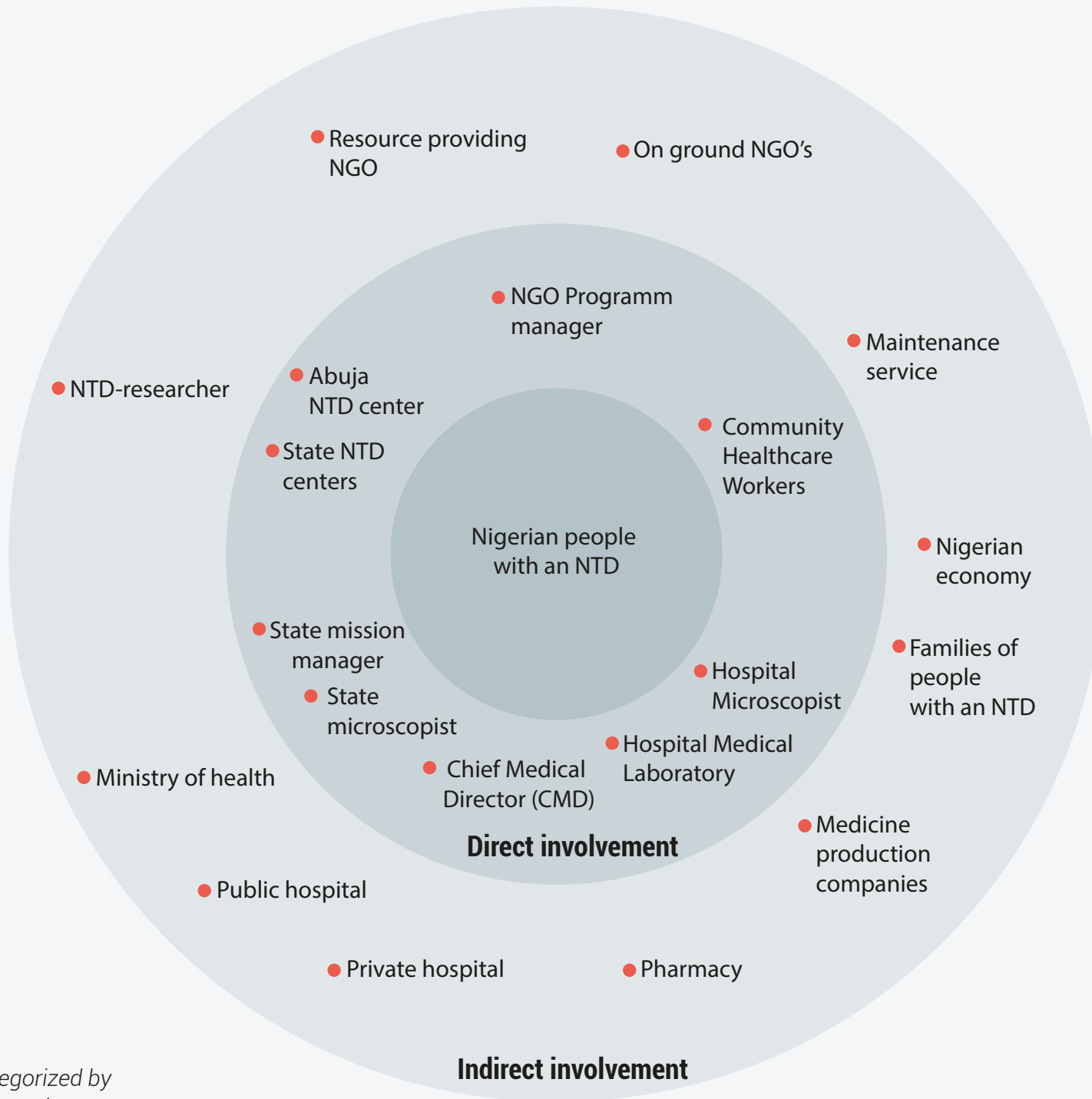



Figure 12: Stakeholders categorized by means of involvement



Figure 13: Current AiDx NTDx embodiment

4.1 EXPLANATION

The AiDx NTDx is a diagnostic device that is able to scan stained glass slides. It works according to the following steps:

- 1 First a glass slide has to be stained with a sample. After this, the slide can be inserted in the AiDx NTDx.
- 2 Then, the user has to select for which NTD the slide has to be examined.
- 3 When this is done, the user has to start the scan.
- 4 What follows is the machine scanning the glass slide by capturing digital images of the whole slide. These images are stored on the onboard SD-card. At the same time, the onboard AI is scanning the images with regard to the selected NTD.
- 5 When the scan is finished, the device is selecting areas on these images where it suspects an NTD and shows it to the user on the screen of the NTDx.
- 6 After this, the user still has to determine if the selected areas are showing an NTD. Lastly, when the user has made his decision, he can prescribe treatment.

This way the device eliminates the need of a trained and skilled microscopist, while the clients still gets the right treatment in a cost-effective manner. This diagnosis and treatment will be executed by a Community Health Worker.

Chapter 4

CURRENT DESIGN

In this chapter the working principle of the current prototype of AiDx Medical is explained. Also that prototype is analysed using the TRL system.

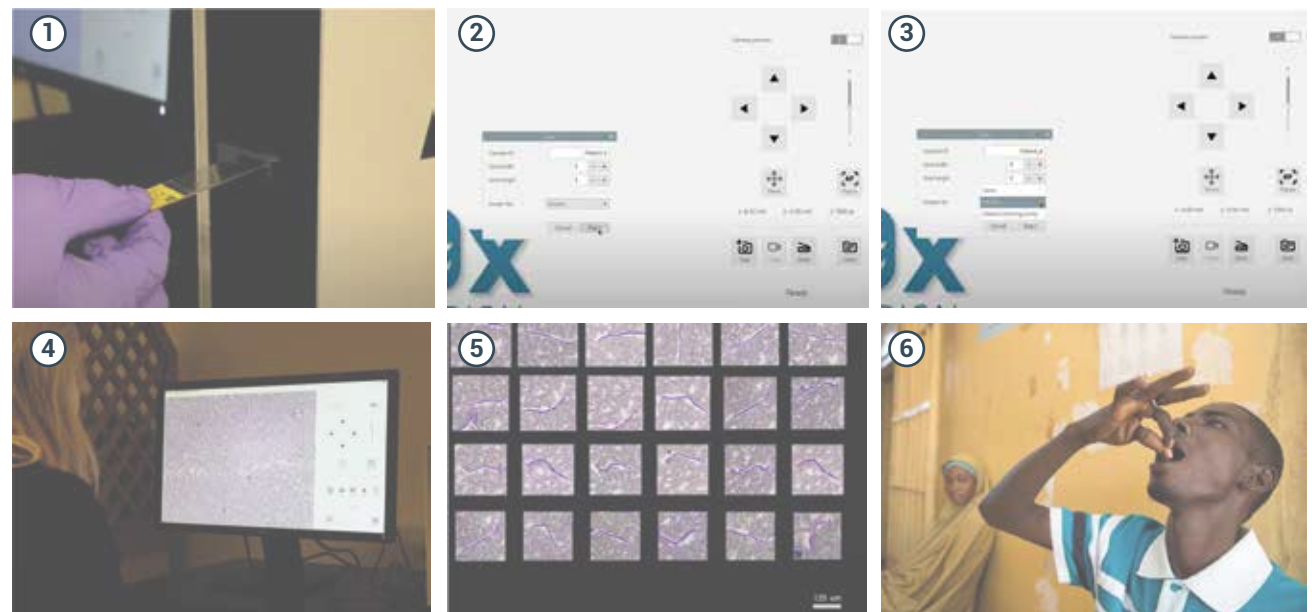

Figure 14: Step by step overview of the operation with the AiDx NTDx. Source Picture 6: Afro, 2018

4.2 BENCHMARKING

The embodiment of the device can be split into five categories. The housing, software, electronics, optical system and mechanical system.

With building the first few version of the NTDx, focus has been on the technical functionalities mainly. This means that the mechanical and optical system and the software has been developed quite far. To make the whole device work, the electronics needed to be developed to a certain extend. The whole technical system also has been demonstrated in a relevant context before some microscopists in Nigeria.

During these field demonstrations it appeared that the robustness of the internal mechanical system was not good enough; screws came loose and last minute repairs had to be made.

For these demonstrations the previous mentioned parts of the device needed to be protected. Therefore the whole system was put in a box in which everything fitted. Almost no thought has been given to the appearance of the box and little to the interaction with the user.

These developments have resulted in a device that works, but does not look like an automated microscope. So, the current looks do not instill trust and confidence by the future users because the design does not align with their aesthtical

expectations of such a device. This has to change in the next version of the device.

Next to this, the current NTDx works in combination with a monitor, mouse and keyboard in order to interact with the user. All these things together make the device not suitable for remote areas, because the user has to bring a lot of assesories with him in order to make the NTDx work. Therefore in the housing, a touchscreen should be incorporated.

Due to these reasons, most of the sub-categories of the category 'housing' have a very low TRL level.

Next to this, the current device currently is only able to run on nett power. This is often not available in remote areas. Therefore an accu should be included to provide power when nett power is not available.

The TRL levels of the mentioned categories at the start of my graduation are presented in **figure 15**.

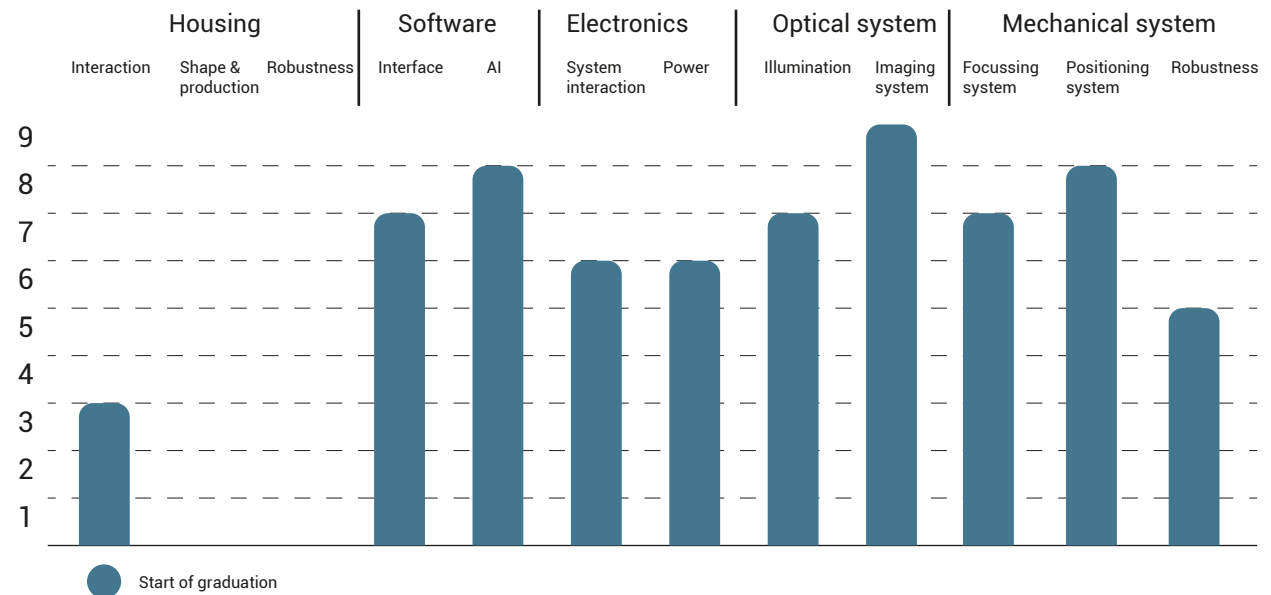

Figure 15: Overview of status of the current design of the NTDx, categorized by using the TRL system

DEFINE

- 5. *Design goals*
- 6. *List of requirements*



Figure 16: Rendered appearance of the current NTDx (ASSIST)

5.1 ENVISIONED TRL

During my graduation I will mainly focus on developing the housing and little on the electronics.

I will redesign the housing in such a way that the device will get an aesthetically pleasing medical appearance. Next to this I will incorporate a touchscreen in the device. By doing this I will take into account the robustness and portability of the device. Lastly, with regard to the housing, I will incorporate usecases that will make the interaction with the NTDx intuitive.

The design of the housing has to be suitable for local production in Nigeria. Therefore the design has to be made in such a way that it can be produced with 'simple' production techniques.

Lastly, I am going to focus on including an accu in the device which makes sure that the device can be used in remote areas without net power.

The way I am going to improve the AiDx NTDx in terms of TRL levels can be found in **figure 17**.

Chapter 5

DESIGN GOALS

In this chapter I explain what my goals were for the new iteration of the prototype for AiDx medical. I go a bit more in depth with the goals regarding the aesthetics and interaction.

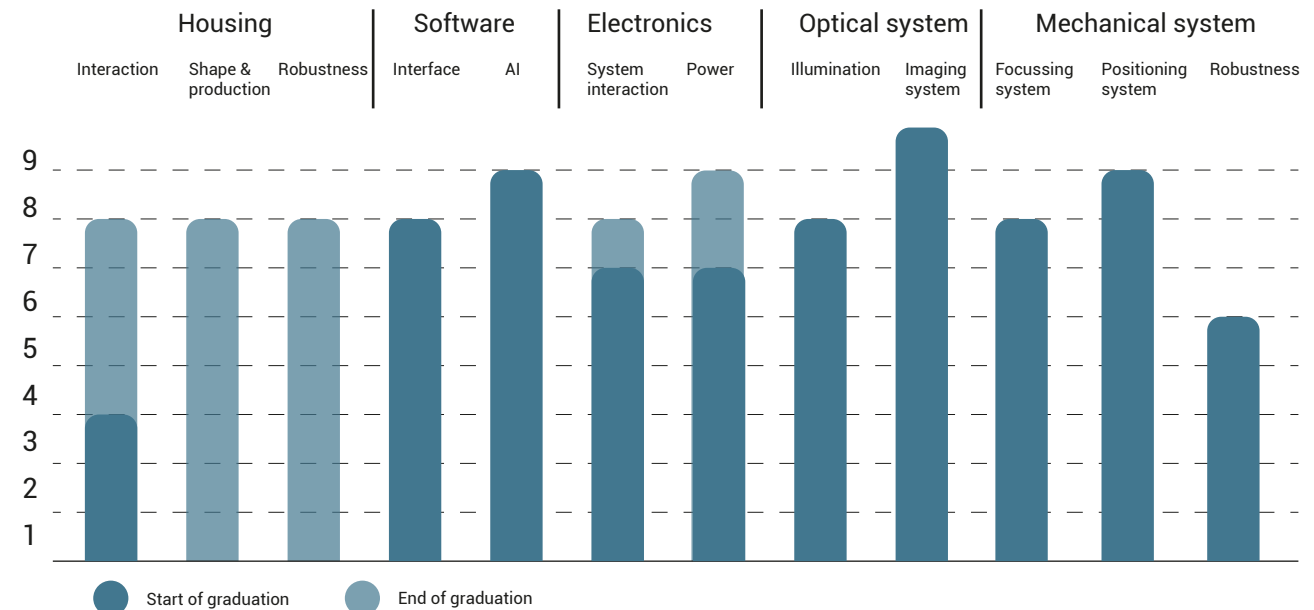

Figure 17: Overview of status of the current design of the NTDx, categorized by using the TRL system

5.2 NINE TIMES APPEARANCE

One of the main challenges at the start of the project was finding the right design language; how to style the embodiment of the housing of the microscope in such a way that it appeals to the future users? The appearance should meet their expectations of how a automated diagnostic microscope should look like.

One of the first steps in this process was looking at other medical devices and automated diagnostic microscopes and analyse what aspects, design features and colors made these designs look medical. The devices are chosen by looking at what the target users are currently using.

In order to approach this methodologically, I used the framework '9 moments of appearance'. With this method I first analysed the strength and weaknesses of the current appearance of the NTDx with the designs of other automatic microscopes. The following aspects are analysed: Aesthetics, Meaning and Emotion.

Based on this analysis a matrix is made in which the envisioned appearance of the NTDx is given and explained by means of an example (**Figure 18**). The full analysis can be read in **Appendix 5**.

Focus

In the coming design process I decided to focus on Micro-Aesthetics, Micro-Meaning and Meta-Emotion. These are colored dark blue.

Micro-Aesthetics

On the level of detail (micro), the current NTDx does not have much intriguing factors. The whole embodiment is made out of one material, has one shape and one structure. This results in a boring device which is not pleasing to see.

The NTDx that has to be designed should rather be intriguing to look at. So variety should be included in material, shape and colors. It should invite to take a closer look to the device.

Micro-Meaning

At the start of my graduation, the NTDx was looking robust to a certain extend. It had a robust structure and the whole shape looks quite dense. On the other hand, this aspect could still be improved because the mentioned robust features are not emphasizing that the device is made robust.

Therefore in the robust appearance in the next design of the NTDx can be improved by adding robust angles and a rough texture.

Meta-Emotion

The current appearance of the NTDx will embarrass the future users of the device through its unprofessionalism: The device does not look like a medical device currently. It only is a simple rectangle shape whereas most medical devices are designed more 'rounded'.

The appearance of the next NTDx should make the future user proud. It should make the user able to stand between other medical devices with his device and be recognized as an expert.

Collage

Based on the insights from the method '9 moments of appearance', input from multiple experienced microscopists and the creative session with the Community Health Workers (**appendix 7**), I drafted a first collage. This collage represented the style and colors that the future appearance of the NTDx should have. I discussed this draft version with a few Nigerian microscopists and developed the collage in **figure 19**. The process of developing this collage can be read in more detail in **appendix 17**.

According to this collage, the future NTDx should be mainly white, with blue accents whereas blue is the color of health and hospital according to my interviewees. However if certain surfaces are going to be touched frequently, it should be made grey, because dirt is more difficult to see on a grey surface.

Also style language of the device should be rounded and have symmetry according to this analysis.

More detail about this comparison and how I used the '9 moments' can be found in **appendix 5**.

ENVISIONED MATRIX









	Micro	Macro	Meta
Aesthetics	 <p>Intriguing</p> <p>Variety in materials, shape and colors 'you want to touch it, feel it, just to explore'</p>	 <p>Dedicated</p> <p>On the device, the necessary functions should be obvious and stressed</p>	 <p>Professional</p> <p>Add remarkable detail to increase autonomy; white monitor vs dark environment</p>
Meaning	 <p>Robust feeling</p> <p>Obtuse angles, consistent over a longer surface/area of the product, texture</p>	 <p>Portable feeling</p> <p>The whole system should be designed with eye to intuitive portability</p>	 <p>Modern feeling</p> <p>A 'clean electronic look' should be integrated in order to be experienced as 'new'</p>
Emotion	 <p>Trust</p> <p>Thick rubber black edges say: I am designed for accidents</p>	 <p>Impenetratable</p> <p>The looks of being made of one piece</p>	 <p>Confident feeling</p> <p>'I am made for this'. The product should stand in its environment and 'belong'</p>

Figure 18: Envisioned experience matrix of the NTDx as a result from using the method 'Nine moment of appearance'

APPEARANCE COLLAGE



Figure 19: Envisioned appearance collage

5.3 INTERACTION FLOWCHART

The interaction between the user and the device can be splitted into two routes. The manual operation and the automated operation.

With the manual operation, the user is moving the field of view of the microscope by himself by interacting live with the buttons on the screen. This is most often used if the user wants to revisit a specific field of view on a stained glass slide. The manual operation will not be used very often.

The automated operation option is going to be used more often, Here, the user is letting the device scan a glass slide on a selected NTD automatically.

The interaction with the device will most often happen via the screen, whereas this part of the device is located in eyesight of the user.

The device is going to operate without being connected to nett power often. Therefore additional flash lights and sounds should not be added to spare the battery. However an indication light showing the user that the device is powered is appreciated **appendix 7**.

The current sound the device is producing by means of its servo's when scanning gives the users a clear indication that the device is working and when a scan is finished. This way of commu

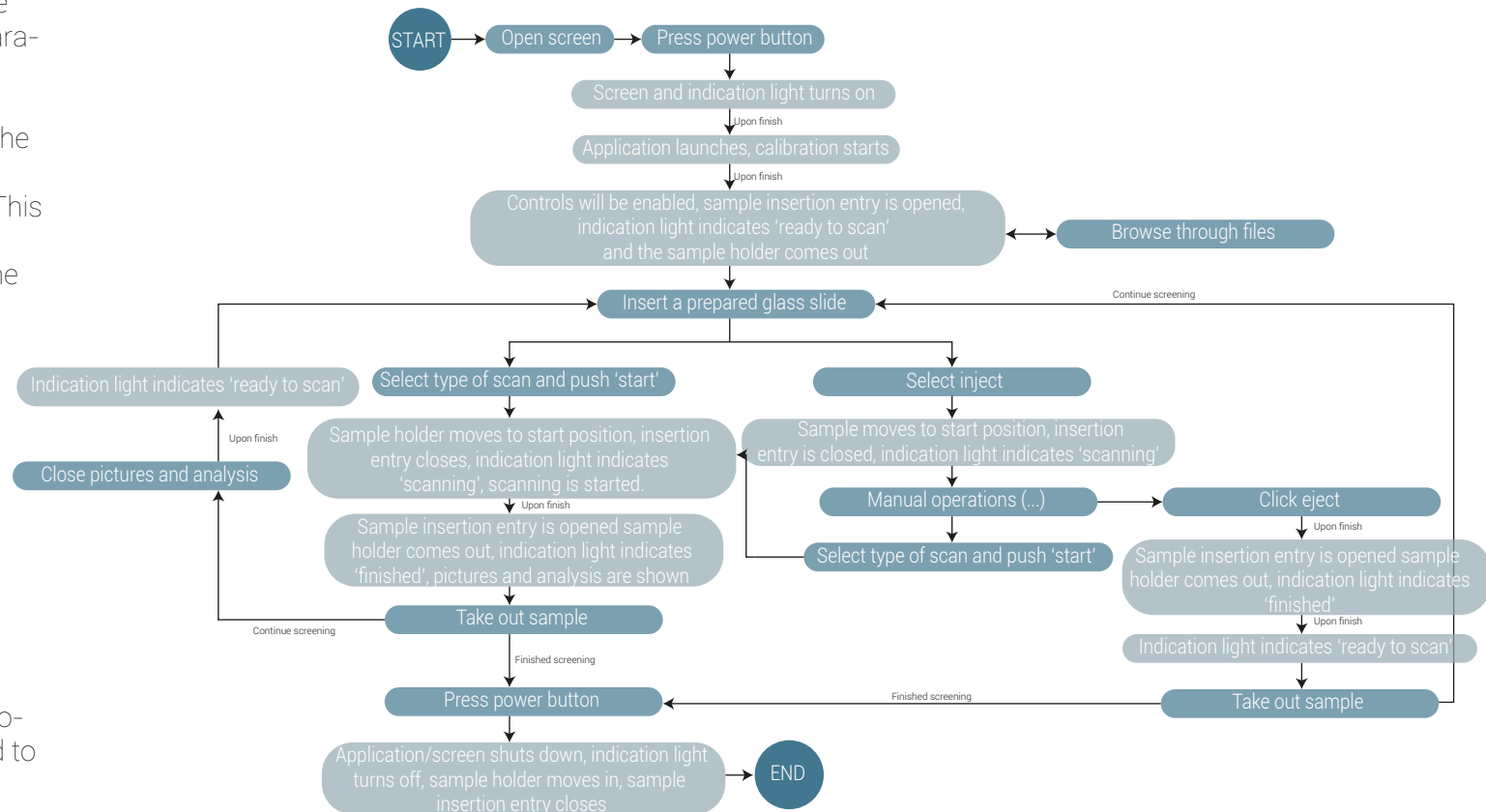

Figure 20: Envisioned flowchart for interaction with the NTDx

nicating the status of the scanning was experienced positively by the community health workers **appendix 7**. Additionally it should be visible from a

distance if the scan is ready whereas the user will do other things when the machine is scanning

Through all this research, interviews and tests, I have been gathering a lot of requirements. The requirements that I have touched upon in the past chapters will be displayed here. I will only name the most important requirements in this chapter. All the details and sources about the requirements can be found in **Appendix 2**.

In the next chapters new requirements will appear. These will be added to the list in this chapter by marking the text in red in which the requirement is explained like is done to the right of this text.



Chapter 6

LIST OF REQUIREMENTS

Requirements

1. The embodiment should be robust enough to withstand transportation by car over unpaved roads
2. The material of the housing should have excellent UV-resistance
3. The embodiment should be dust/sand resistant
4. The embodiment should be reasonable waterproof
5. The embodiment should be able to withstand humidity
6. The color of the housing should be white mainly
7. Details should be blue
8. The device should look intriguing
9. The device should feel robust
10. The device should feel portable
11. The design of the NTDx should make the user feel confident between other professionals
12. The design of the device should be 'fluent'
13. The main communication should be done by via the screen, not additional lights
14. The on/off button should be positioned in eyesight
15. It should be obvious where to put in the sample on sight
16. The embodiment should have an integrated screen
17. The screen should be powered from the accu directly
18. The accu must be rechargeable
19. The embodiment should fit in a backpack
20. The embodiment should be compact
21. The embodiment should have a handle

DEVELOP

7. Orientation
8. Appearance
9. Concept

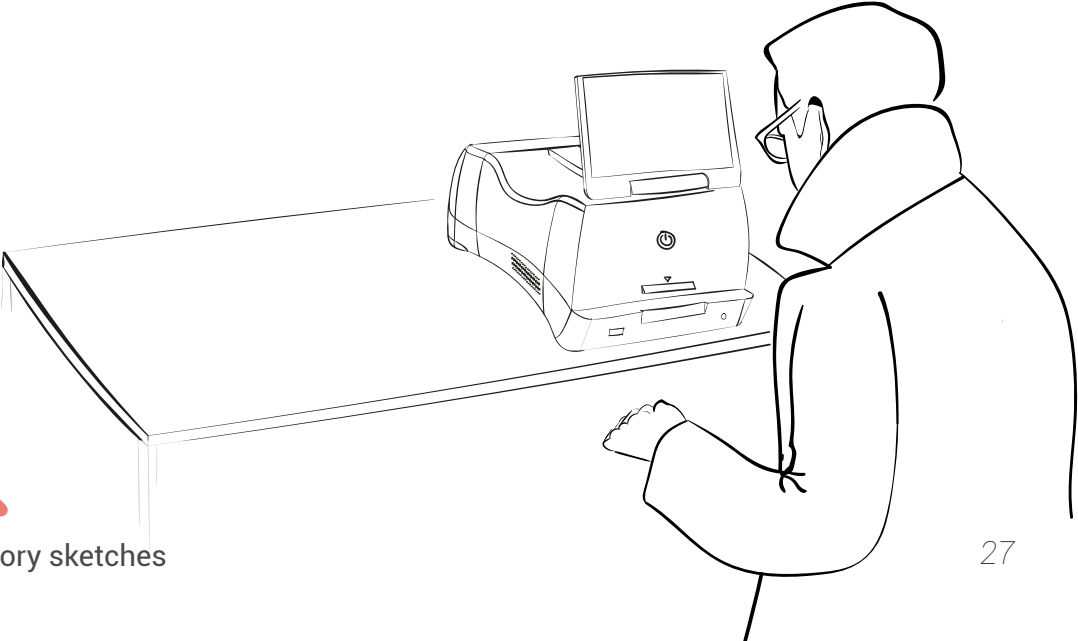
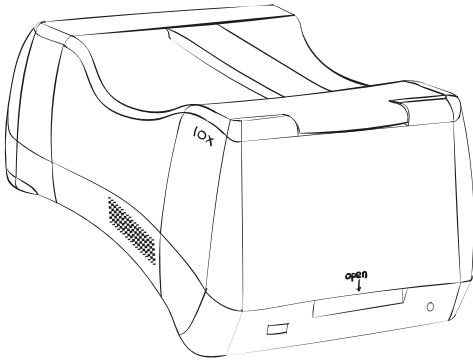
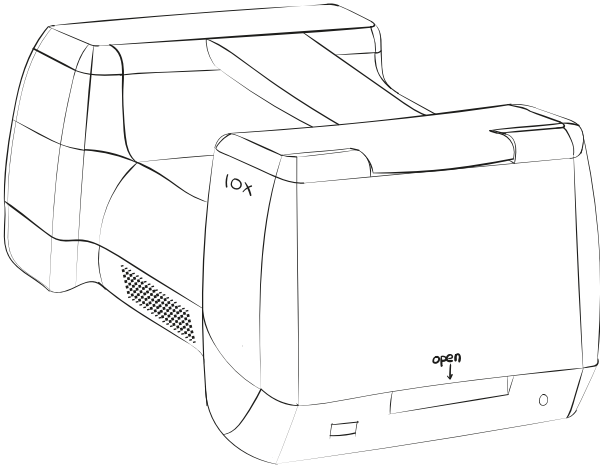
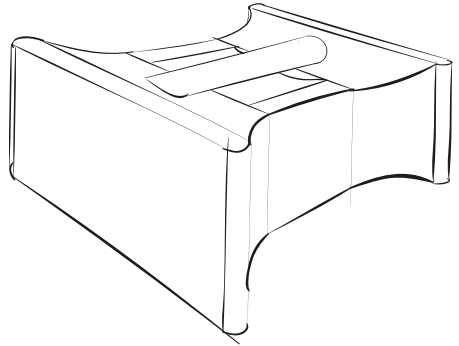
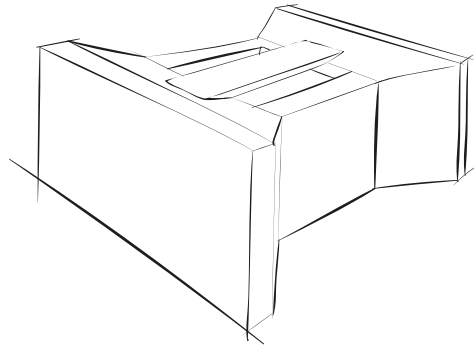
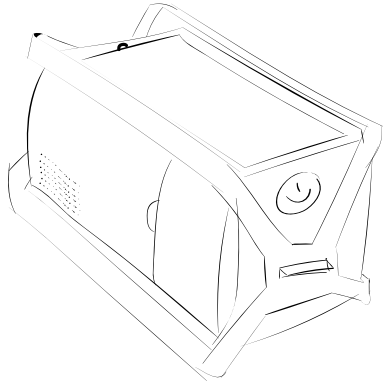
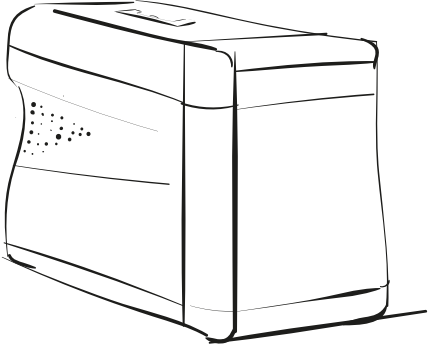
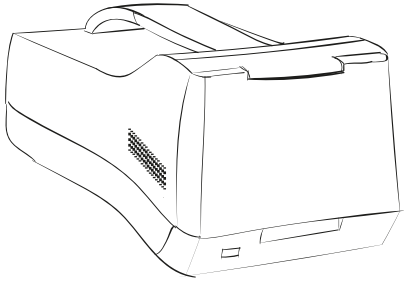
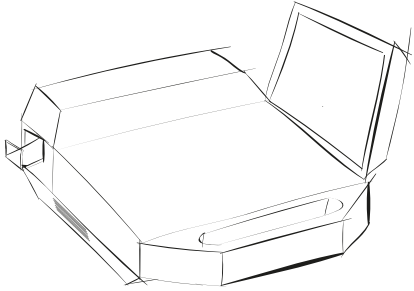

Figure 21: Exploratory sketches

7.1 CARDBOARD

The starting point of the redesign of the NTDx is the spacial orientation of the design. Especially the placing of the screen with regard to the shape.

The inner components, like the mechanisms were developed quite far already and I had decided to not work on these aspects in this project. The size and orientation of the inner components limited me with regard to the design possibilities **Appendix 6**. Due to these limitations, the length of the device had to be bigger than the width whereby the insertion of the sample should be on the smaller side of the device **figure 22**.

When taking a closer look at the inner components, I found that I could reduce the size of these parts for a little, but that the general orientation of these parts could not be changed.

On this device, a screen has to be mounted. Through my interviews, I discovered that the orientation of this screen should be in landscape mode **Appendix 7**. To discover the possible screen possibilities, I created a cardboard box as big as the future device could be, together with cardboard 'screens' which sizes ranged from 7 to 10 inch. On these screens, a field of view with parasites was displayed as large as possible.

I performed two tests with this prototype. First I discovered that the screen should be as big as possible according to Moroccan field microscopists, but 10 inch was good enough. **Appendix 9**

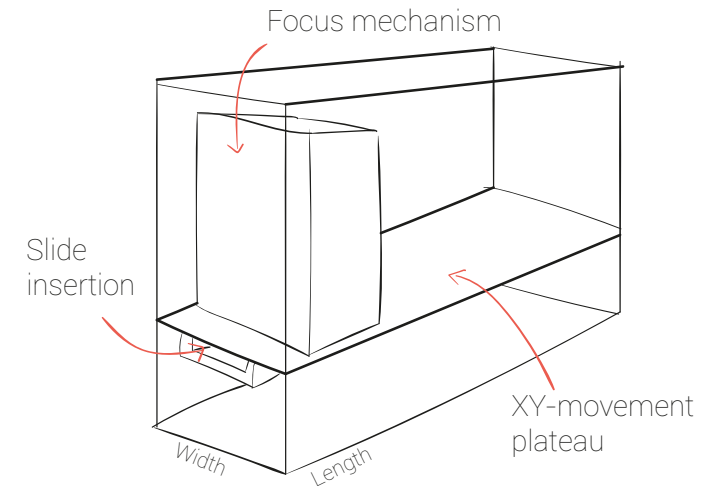

Figure 22: Rough inner component configuration



Figure 23: Render of inner component configuration

Chapter 7

Orientation

The orientation possibilities of the new AiDx device are limited through the orientation of the mechanism parts that should be put in the device.

Figure 24: A few examples of my cardboard prototype session

Secondly, I researched the possible placements of the screens on the device. Previously, screens were transported to Nigeria and they broke down by rough handling during transportation. In the future the device will also endure rough handling. Therefore I decided that the screen should be protected by the housing and that the screen could be opened like a laptop screen.



Also I discovered that the users want the interaction, the slide insertion, to be on the same side of the device as the screen interface would be. This resulted in a tradeoff.



The tradeoff I had to make was compactness versus screen size. The bigger the screen, the bigger the device. This while the device had to be as compact as possible because it has to be travelled with.

The conclusion of this research was that if the size of the screen had to be 10 inch as requested, two placement options were left. First, it is possible to place the screen on the side of the device, whereby the screen could open up. Secondly the screen can be placed on the front of the device and rotating it in such a way that the screen could be viewed from the front **Appendix 8**.

With this information I started to develop ideas and prototype these ideas by means of foam prototyping.



Figure 25: Temitope Agbana executing the 'screen size test' in Morocco

7.2 IDEATION & SELECTION

I started the ideation with HKJs. I did not have enough information or creativity yet in how to answer the HKJs. So for each HKJ, I searched for inspiration and I made for a collage for each HKJ in order to be able to 'answer' these HKJs. **Appendix 10**

Based on these HKJs, I developed a Morphological chart and developed 10 initial ideas. I judged these ideas mainly on compactness versus the screen size and secondly on robustness. **Appendix 11**

After this, I developed three more detailed concepts including the interaction (**Appendix 12**). Then I decided to prototype these embodiments and mechanisms in foam, to really understand the shape and dimensions I was proposing. These designs and foam models are presented in **figure 26**. When I prototyped these concepts I understood more the complexity of the mechanisms I was proposing and I concluded that most of these mechanisms were too fragile, too expensive to produce for a low quantity and too difficult to understand without having to use a manual.

When I presented these concepts to the three experienced Nigerian microscopists who advised me through the whole project, I learned that the placing of the interaction of the 'Coverup' was the most pleased interaction, because all of the interaction happens at the same side of the device. Also the 'use position' of the screen was more preferred than the other options.

This made me decide to place the screen on the front of the device. With the Coverup I used a complex mechanism to get the screen from portrait mode on the front of the device into landscape mode to get to the 'use position'. This was because my thoughts and creativity were limited to the initial shape of the NTDx. My supervisors inspired me to think broader and not stick to the shape of the current design.

That made me realize that I could increase the width of the NTDx and place the screen initially in landscape mode on the front and open the screen by means of one simple hinge.

The second concept, The Toolbox, gives the users much freedom in the way they set up their equipment. In this concept is the screen attached to the device by means of wires and can the screen be placed where the user wants it to be. But while prototyping, I encountered technical problems with the concept 'toolbox'. If the screen has to slide out the device, the wires connecting the screen to the device should have a 'slot'. Otherwise the wires could break. Next to this, connectors to a screen are on the side of a screen always. To make sure that these connectors will not damage, there should be an addition made to the screen. This increases the size of the device and the need for a custom screen.

Not connecting the screen to the device, sounds like a solution. But through interviews, I discovered

that the screen will be stolen or get lost that way. So that was not a solution either. Through these interviews, I got to know that it is important to close the glass slide opening all the time; it should only open when a glass slide is inserted in the device. This to prevent dust from coming in the device.

I also learned that working with the device can be done while sitting, but often also standing. This means that the angle of the screen should be adjustable to the preferences of the user.

The third concept, the Camscreen required a complex hinge system, just like the Coverup. An additional disadvantage was that the interaction with the screen of the Camscreen would not be at the same place as the glass slide injection. This decreased the ease of use of the Camscreen.

Through these thoughts, interviews with users and a Harris profile, I decided to implement the orientation of the screen and interaction of Coverup in my final design. More details about this choice can be found in **Appendix 12**.

In this chapter I have determined the best orientation of the NTDx with regard to the screen and interaction. In the next chapter I will go more in detail about the development of the styling of the NTDx. Concluding on this chapter: the screen should be on the front on the same side as the sample insertion opening.



Coverup



Toolbox



Camscreen



Figure 26: Sketched Concepts made from foam

7.3 VALIDATION

In order to verify if the future users indeed love this orientation and interaction with the device, I developed a working prototype. This prototype was brought to Nigeria and tested with ten high profile Nigerian microscopists **figure 28**. They used the NTDx with the touchscreen. By means of filmed interaction while they used the device and a questionnaire, I could validate that they liked the current orientation of the screen and device. The questionnaire and results can be found in **Appendix 13**.



Figure 27: Prototype test setup; Left: opened screen. Right: closed screen



Figure 28: Prototype test in Nigeria with 10 experienced microscopists

8.1 SHAPE

In order to discover the desired shape of the NTDx I have analysed devices the users are already using, created collages and discussed the shape of the 'orientation' prototypes with the future users.

This is conform the analysis of other medical devices I did in **Appendix 5**.

These early shapes and sketches are not styled sufficient enough to proceed with; it does not have the wanted medical appearance yet. Therefore styling research and development is executed.

The following parts should be present in the embodiment of the device:

- A handle
- A screen
- A power button
- A USB port
- Nett power inlet
- Ventilation openings
- Glasslide insertion opening

A first attempt to catch the wanted appearance of the future users was made by presenting the sketches displayed in **figure 29**. These sketches were made based on the findings from earlier interviews and research. **Appendix 17**

From their feedback, it appeared that symmetry was a very important factor for them. Especially because the device should be portable. If symmetry would not be present in the device, the device seemed difficult to transport to them immediately.

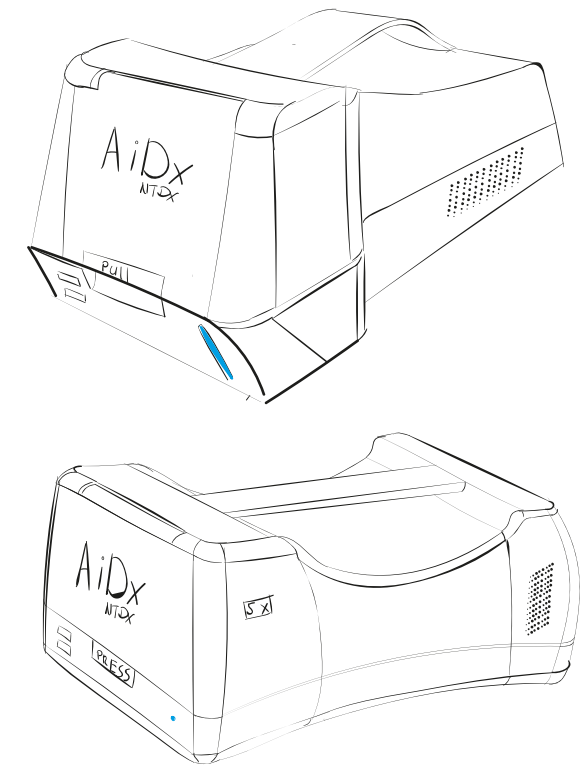

Figure 29: First appearance sketches

Chapter 8

APPEAR- ANCE

In this chapter the developemnt of the appearance is explained.



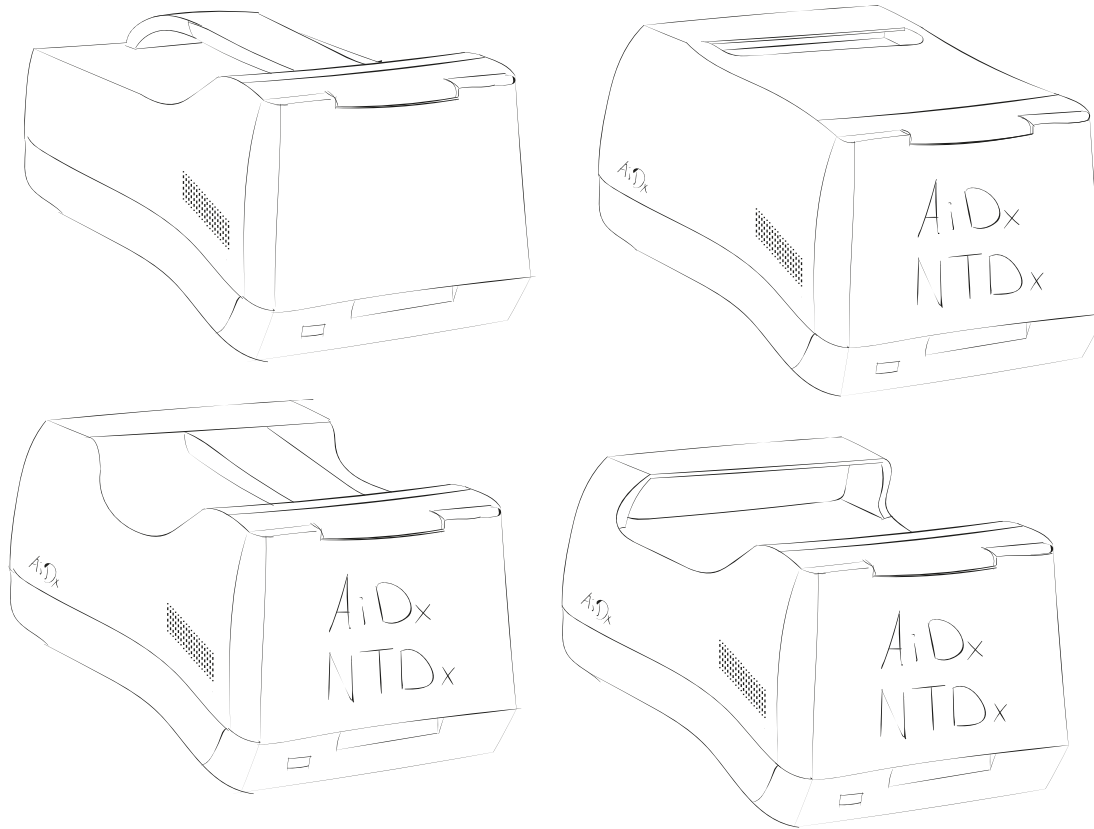

Figure 30: Different handle considerations

Next to that, I researched what type of handle the device should have. In order to test this I sketched different handles on the same design **figure 30, Appendix 14**. I got inspiration from handles of current devices and implemented these type of handles in my own design. It appeared that a handle in the middle on top of the device was preferred. This handle should be incorporated in the fluent shape of the rest of the design and preferably without hinges whereas that seemed not robust.



When discussing the current device with the PhD expert, we came to the conclusion that the current device is too big for its weight and that the distribution of the weight was at the bottom of the device. That makes the device feel fragile. For the redesign, the device should look and feel more dense.



Lastly, the preferences regarding the size of the device and ease of interaction were discovered. As my contacts were presented with three configurations **Appendix 12**, they chose a configuration which meant that the device would not be as small as possible, but the interaction would be as easy as possible. Based on this, I conclude that the advantage of an easy interaction with the device is more important than the disadvantage of a slightly decreased portability.



8.2 STYLING

So the overall shape should be symmetric and compact whereby the handle and the screen should be integrated. Ne next question is: how should this look like? How to include all these things in the design that it looks attractive?

To answer these questions the right form language has to be found. In this case I devised the form language in the following categories edges & planes, colors and material.

Edges & planes

Out of the collage I made and discussion I had with future users, it appeared that users liked the edges and planes to be rounded over square edges. But to which extend? Therefore I sketched two designs with rounded edges and planes, wherby the one design was build out of 'blocks' with rounded edges and the other design just a fluent rounded whole. **Figure 31.** After consulting three field experts I concluded that the fluent rounded design was more favourable. The reason for this was that they liked a coherent design more than one that was build out of separate 'blocks'. This did not gave answer to the initial question, but it gave me another guideline for designing the final appearance.

Because my interviewees went for the fluent rounded design, I chose to proceed with long-bended and rounded edges with the notion that I had to revisit this choice lateron.

Colors

From earlier analysis I knew that the users like the device to be mainly white, with blue and grey accents. Now I need to know how much blue and grey was preferred and where to position it.

At this point I still did not know what the device was going to look like; my sketches were still only showing partly designs instead of holistic designs. This made the designs untill now look 'unfinished' and 'boring'. One reason of this was that I did not include colors in previous designs.

Combining these two things, I sketched four different holistic designs. For each design I picked an existing device out of my collage of which I 'took' some design characteristics in order to create one of these four designs (**figure 32, Appendix 15**). In these designs I played around with the amount and placing of the colors blue and grey.

After discussing these designs with three experts, I came to the conclusion that the handle should be colored either blue or preferably grey, in order to make the device look clean as long as possible when it is operated with dirty hands.

When asking them to rate the designs on attractiveness with regard to each other. They rated design three as most attractive **Figure 33**. Lastly they learned me that the amount of blue should be more than the amount of grey. The more blue the better.

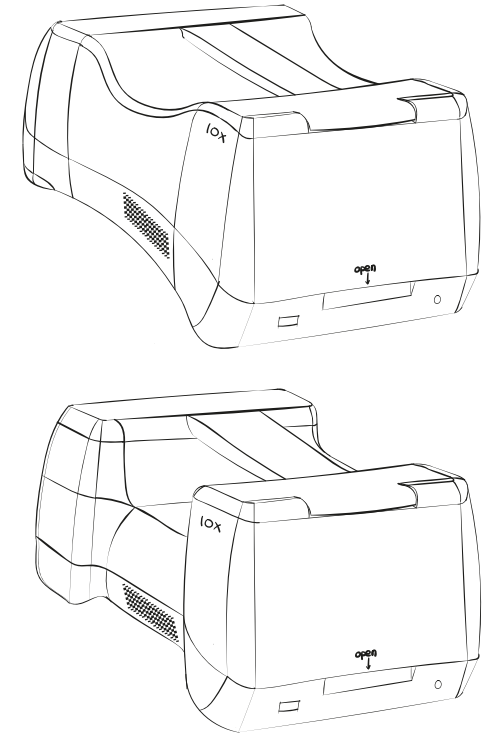

Figure 31: Roundness experiment sketches

Material

At this stage the type of material was not determined yet through sketches. When consulting my contacts about this, they said that they did not want a very shiny product, but that it did not matter that much for them. The most important thing for them was that it should be robust.

Design 1



Design 2

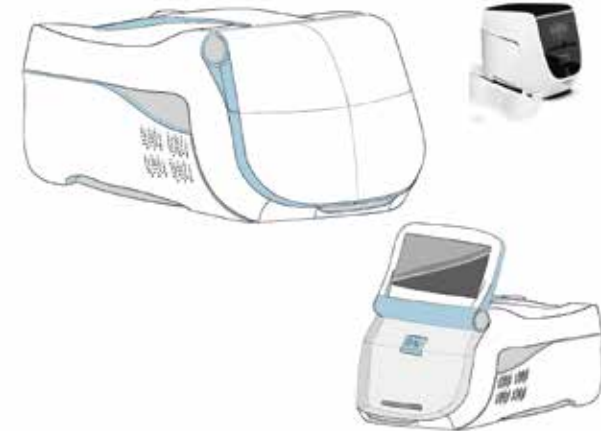

Design 3

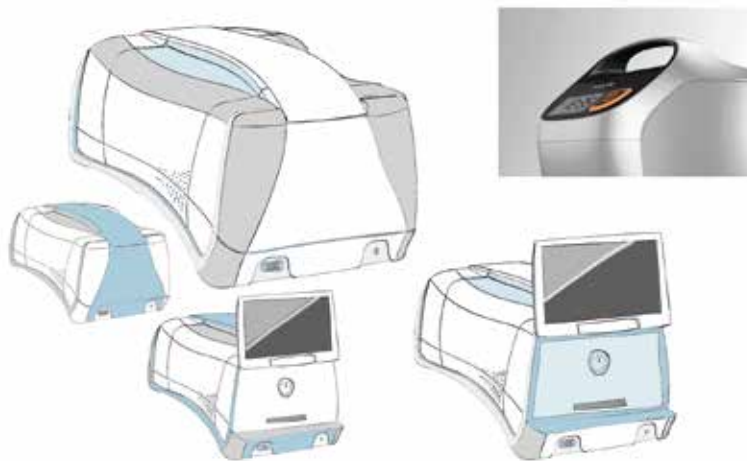

Design 4

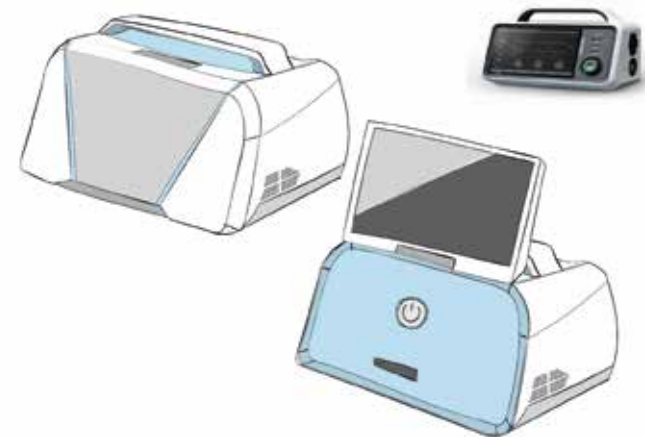

Figure 32: Holistic design style sketches

So we concluded that design three was the most attractive design. The 'smaller drawn' version of design three with more blue was preferred over more grey. However the blue should be placed elsewhere because they were worried that the blue on the handle would get dirty too fast. Instead of blue, the handle should be grey.

'The more blue it is the more attractive. But it's position on the device has to be strategic.'

'I like this (design 3) most because it looks robust to me'

- Microscopist expert

	Design 1	Design 2	Design 3	Design 4
Rating	3	2	4	1

Figure 33: Evaluation of the four designs by three microscopist experts. Design 3 was chosen as the most attractive design.

9.1 SELECTION

Chapter 9

CONCEPT

In this chapter the concept choice is explained. After that the concept is elaborated further on.

At last a final concept selection has to be made. I sketched two different versions of version 3. One of these is going to become the the final concept-**figure 34, 35.**

These two concepts are developed with regard to appearance, inner component placement, interaction, placing in context and size.

In Chapter 8.2 I wanted to test to which extend the design should be rounded. I did not find the answer to that question there. As it turned out that design three was the most favourable design, I had to revisit that question now before the final concept was developed. Therefore the two designs I sketched in **figure 34, 35** are the refined designs out of Chapter 8.2. These designs are displayed in more detail in **Appendix 16.** At this point I knew already that I was going for the 'Fluent bend' design. With these last sketches I was only focus-
ing on which roundness I should pursue.

As my sketching skills were limited and my interviewees did not have a clear opinion on the matter of how rounded the device should be, I decided to compare my design with current medical devices. Not by means of drawing but physically. For this I created the rounded preferred design out of Chapter 8.2 out of foam (**figure 37**).

Having a physical design like that in my hands made it possible to evaluate the roundness it should have. After discussing the design with my supervisors and the AiDx Medical, I came to the conclu-

sion that the foam models overall shape and size was very good. However it was too round. This made the device look a bit childish. All the faces and edges of the device were double curved. That gave the design a cute and toyish vibe. When thinking about this, literature also suggests that rounded shapes are affiliated with childish and cute design.

When comparing this finding with designs of other medical devices, I discovered something I did not realize before: Yes, designs of medical devices are rounded, but they consist also out of big slightly bended planes. So there should be no double bended edges on every plane. Only the edges are curved. The sides are mostly flat and only sometimes a little curved.

The U-shape design in **figure 35** has these design characteristics. The housing is not rounded wherever possible, but only on some planes.

Therefore the final concept will have the shape of the the 'fluent bend' design and the non- or slightly-curved faces of the U-shape design.



FLUENT BEND

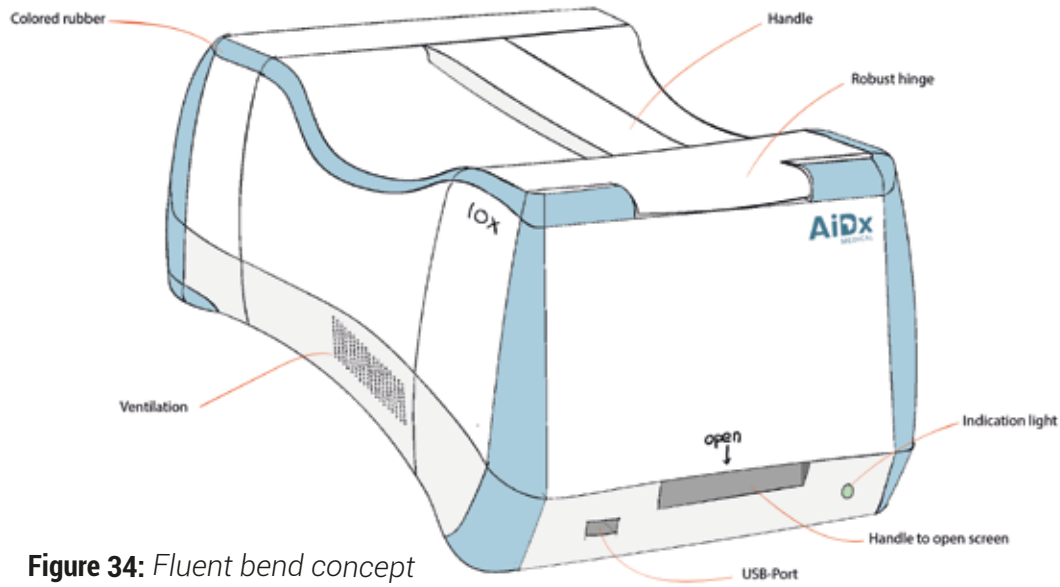

Figure 34: *Fluent bend concept*



Figure 36: *Process of making the foam model*

U-Shape

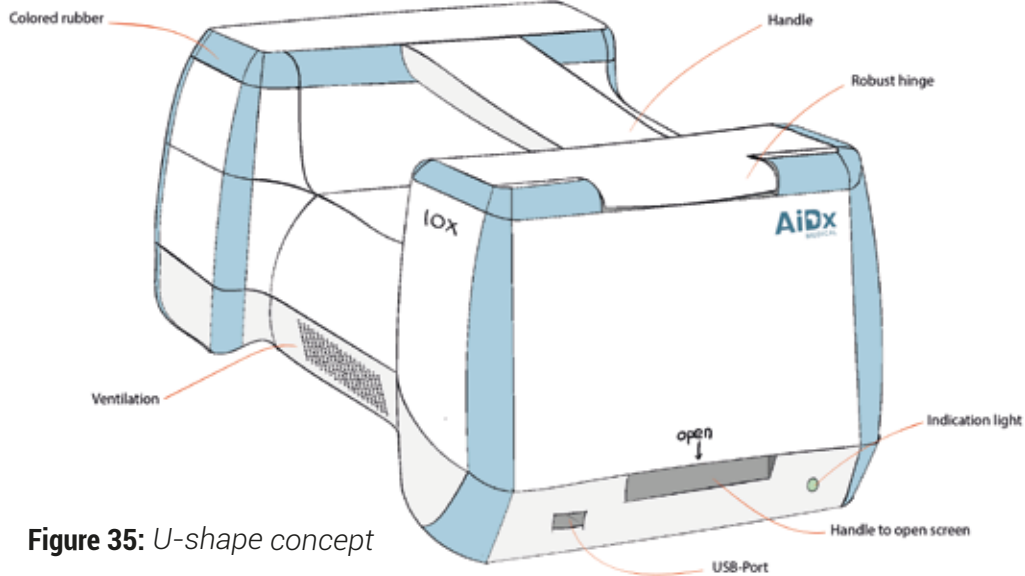

Figure 35: *U-shape concept*



Figure 37: *End result of foam model*

9.2 FINAL CONCEPT

The redesign of the NTDx should be robust, portable, intuitive and aesthetically pleasing. The research I did until now, resulted in the final concept explained in this chapter.

Aesthetics

A lot has been said about the appearance. In short, the device should be symmetric; mainly white with blue and grey accents; rounded edges with noticeable radius and flat planes. In order to get the last two requirements right in the design, I had to put in most effort.

Even in the last iteration from the 'fluent bend' design to the final concept of the NTDx I was still playing with the exact shape. In order to get a more detailed design, I made side-view drawings of the design **figure 38**. The first drawing I made was still too rounded, cute and playful for a medical device. So I iterated it a second time and ended up with the final concept **figure 39**.

After the side view was in the correct style, I imitated this style for the front and top view. As can be seen in **figure 42**, the corners are rounded and the rest is quite rectangle. The appearance model of this first design can be found in **figure 43**.

Now the appearance is 'ready', I could focus on the second important thing: The interaction.

Interaction

In Chapter 5.3, I touched the subject interaction. Now it's time to make that interaction feel more real **figure 40**.

First of all the transportation of the device is made easy by including a handle. When the device is used, it is placed on a table and the screen is folded open.

Beneath the screen, the power button and the glassslide insertion opening are placed. So all the interaction with the device finds place at one side: the front.

Normally the insertion opening is closed to prevent dust from coming in. When a glassslide should be inserted it opens.

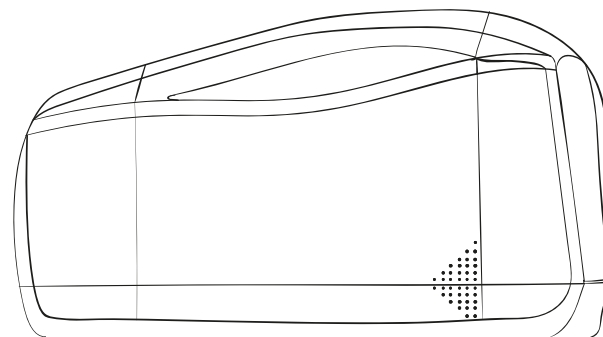

Figure 38: *Too rounded side view*

When the device is scanning, it will be visible on the screen. Next to that an indication light will blink to indicate that the NTDx is scanning. When finished, the blinking will stop and shine continuously.

The device can be used on net power and on an onboard battery. The indication light will do the described interaction in green when the battery is more than 50 percent, orange between 50 and 10 percent and red by 10 percent.

When finished working with the device, the power button has to be pushed again which makes the device to power down. After that the screen should be closed, and you are ready to go.

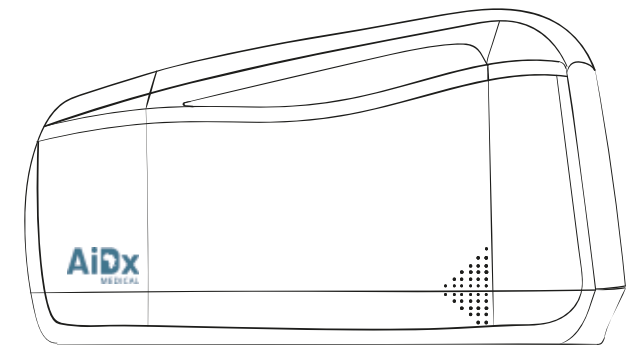

Figure 39: *Final concept side view*

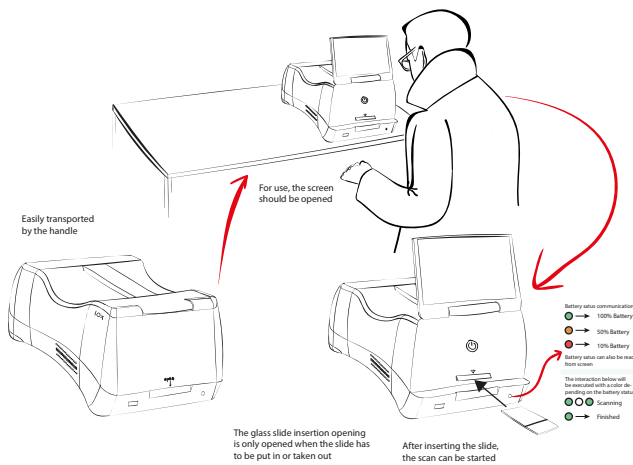

Figure 40: Envisioned interaction with the NTDx

Inner components

As the redesign of the device is wider than the previous version, components can be placed next to each other. This means that the device can be made shorter and less high **figure 41**.

Most of the inner components are attached to the plate that holds the camera and XYZ-system. This is placed in the middle.

I chose to place the electronics like the Jetson Nano and the power deviation circuit next to the device because these do not weigh much.

This is important because the device should be in balance because it is a portable device. Therefore the accu is placed on the centerline of the device.

By means prototyping I will learn where the 'heavy' components should be placed to keep the device in balance.



If the housing appears not to be robust enough, and cracks, it will be enforced by means of covering the edges by rubber.

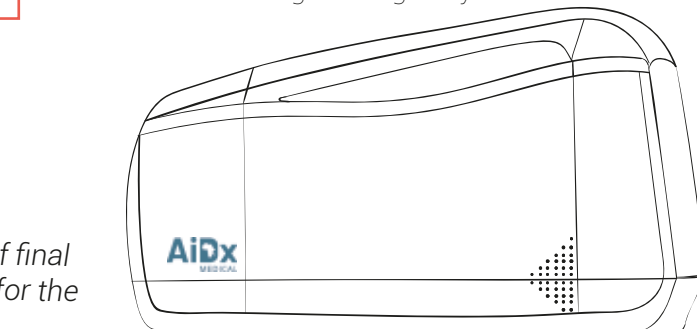

Figure 42: views of final design for the NTDx

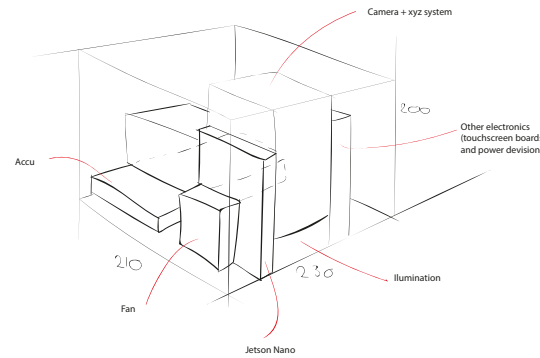

Figure 41: Inner components placement

Robustness

As mentioned, the plate in the middle holds almost all components. Especially the vulnerable components. This plate is made from aluminium and serves as the base of the housing as well as the housing will be connected to this plate.

The housing will be the shell that makes sure that no dirt and water comes in. The aluminium plate will ensure that the shape stays intact.

Production

The shell parts of the housing will be produced by means of thermoforming and made of 2mm thick HDPE as this material is very robust and has an excellent UV resistance.

The aluminium plate will be made by means of milling. Aluminium is chosen because it is very stiff, high fracture toughness and light as it has to be portable.

The part that is holding the screen at the front of the device will be made by means of vacuum casting of PC

For the material considerations in more detail see **Appendix 26**

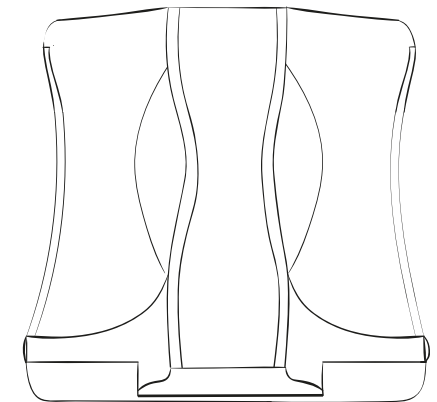



Figure 43: Chosen concept envisioned in local context

DELIVER

- 10.
- 11.
- 12.
- 13.

Housing
Other parts
Electronics
Test

Figure 44: First version of prototyping the housing

10.1 TECHNIQUE

Chapter 10 HOUSING

The housing consists out of several parts. Each of them needs a dedicated production technique in order to produce.

The production techniques I can use are limited through the following requirements. First the production techniques should be available, so not complicated, in low resource settings like Nigeria. Secondly the production technique should be cost effective for a low badge size of 100 pieces. In accordance with AiDx medical we determined that number, because the NTDx is going to be one of the first devices of AiDx that is going to be sold.

Techniques that fit these requirements are Thermoforming, Vacuum casting, 3d printing for plastics and Milling for metal. Look at **Appendix 19** for more details of the analysis of techniques.

After this initial selection of possible production techniques, the production technique of each part has to be chosen according to its geometries.

The following production techniques are chosen for each of the parts as displayed in **figure 45**.

Side housing - Thermoforming
Bottom housing - Thermoforming
Front housing - Thermoforming
Inside housing - Vacuum casting
Baseplate - Milling
Mounting plate - Milling

In the following paragraphs the development of each part is explained, for more detail and the assembly process look at **Appendix 20**. These developments can mean slight changes or even combining different parts.

Here the housing parts are shown and the prototyping of these parts is explained.

Figure 45:
Exploded view of housing parts

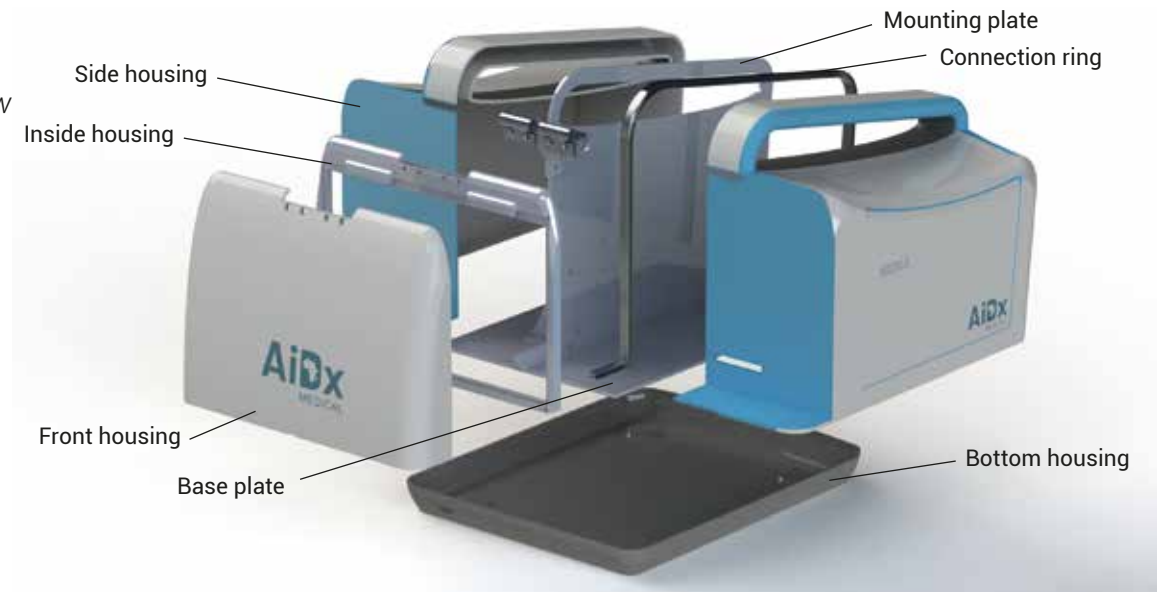

10.2 ASSEMBLY OPTIONS

Before going in detail about the different parts, we need to discuss the assembly options. I have considered a few different options which I will discuss here. The last assembly option is the one I chose to continue with, even though it is a different configuration than the image in Chapter 10.1.

My first idea was to split the housing in two parts. A bottom and a top housing **Figure 46**. That way I could do with only three molds, which makes the assembly easy and cheap. The idea was to frase a opening in the top housing for the bottom of the handle which could be inserted from the bottom.

After discussing this with my supervisors, I came to the conclusion that this would become very difficult as it requires tight tolerances which are difficult to get with thermoforming.

This made me come up with the second option. I would create a left and a right part which would be

connected to each other by means of a connection ring. This ring would also support the robustness of the whole device as it would be made of aluminium **Figure 47**.

When explaining this in PMB we came to the conclusion that it is a good direction, but that the little protrusion at the front would not be easy to thermoform. Next to that the connection ring would be too fragile to mill. So they suggested to make the mounting plate as thick as the connection ring and make it out of one 6mm thick plate instead of two parts.

That made me create the third option. We still have the left and right parts, but now we have a third part: the bottom part. This way all the parts could be easy to thermoform **Figure 48**.

This third assembly option was tested. It appeared that the hole of the handle was too deep to thermo

form **figure 50**. This made me create a fourth part: the handle. The handle will be screwed on the housing after the housing will be thermoformed. **figure 49**



Figure 50: First thermoformed housing part

The handle will also be made using another production technique. The advantage this brings is that the color and material of the handle can be different than the color and material of the rest of the housing. The housing had to be white, while the handle should be darker in order to be better resistant to dirt. The final design can be found in **figure 51**

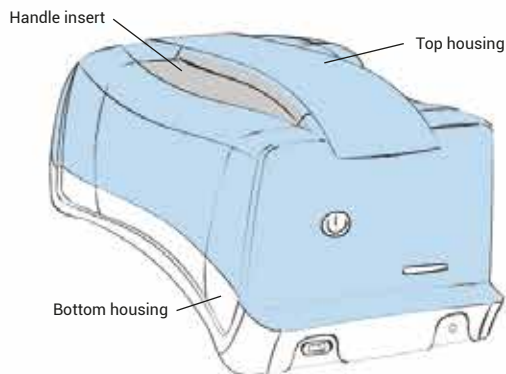

Figure 46: Top-bottom assembly option

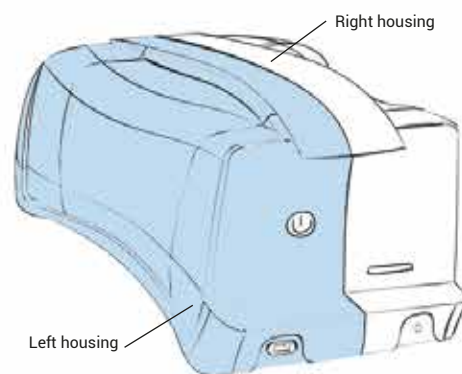

Figure 47: Left-right side assembly option

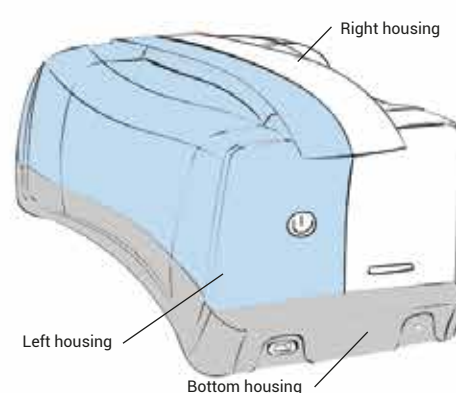

Figure 48: Three parts assembly option

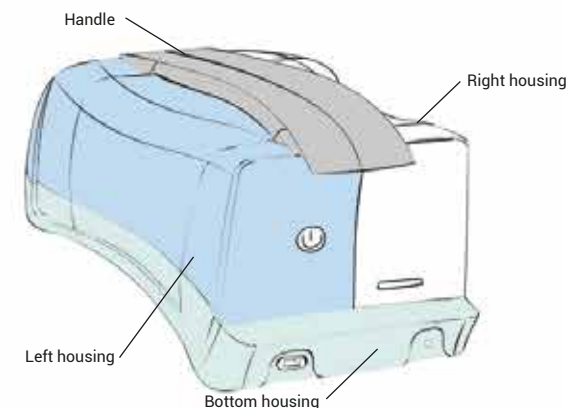

Figure 49: Four parts assembly option

10.3 PROTOTYPING RESULT



Figure 51: Final housing parts including production technique

10.3.1 SIDE HOUSING

After the first iteration (Chapter 10.2) I was able to make the first total version of the side housing. Still two things could be improved.

First of all the thermoformed sheet needs to go somewhere at the corners of the mold. Then, the excess material forms a protrusion **figure 52**.

Secondly, the cutout at the top of the side housing is not as neat as I want. This time I only used two big holes to suck the air out of this cutout during thermoforming. For the next iteration I will drill more and smaller holes along the edge.



Figure 52: Top: unclear cutout
Bottom: excess material

For the second iteration I used more holes along the edge of the cutout **figure 53**. This resulted in a cutout with sharp edges.

This time I also tried to get rid of the excess material at the corners of the molded part. I made the bottom 20 mm of the mold gradually bigger than needed **figure 53**. This would 'catch' the excess material. This bigger part was cut off after the molding was done.

This technique worked partly as the amount of excess material was a little less, enabling me to use this second iteration of the side housing for my final prototype.



Figure 53: Top: holes in the thermoform mold
Bottom: Tapered mold

After the part was molded, the excess material was cut off, making the part exactly the right size. In order to get the right size, several tries had to be done.

After that, holes were cut out to fit the power button, USB ports, HDMI port and power inlet.

The last step was painting the parts as the thermoform material at PMB (Vikureen) is prone to scratches. Therefore other material is chosen if the device was to be produced in series **Appendix 26**.

I painted the material white, over which I sprayed a clear protection coat. Then the part was ready to be assembled.



Figure 54: Assembled end product

10.3.2 BOTTOM HOUSING



Figure 55: Unclear cutout for the 'feet'

The shape and size of the bottom housing was very good after the first time thermoforming. **figure 55.**

For the next version the recesses at the bottom of this part should be more neat. There were supposed to be four of these recesses, only one is visible and in bad shape. The recesses are meant for the 'rubber legs' to keep the device stable.

For the next version of this part, I will make more and smaller holes around the edge of the recess. Currently I have made only one in the middle of a recess, which apparently does not work good enough; the air can not be sucked away in all the edges.



Figure 56: Iterated mold

The iterated mold with regard to the recess can be seen in **figure 56**. The result of this iteration is shown in **figure 57**. This second iteration turned out to be good enough to use in the final prototype. The same post processing steps were made as with the 'Side Housing' part.

Four holes are drilled in the four recesses of the bottom part in order to fit the four 'legs' which will give the device a stable stand.



Figure 57: Final result



Figure 58: Assembled bottom housing

10.3.3 FRONT HOUSING

The first version of the front housing was thermoformed perfectly. **figure 59.**

When taking a closer look at this part, it appears as quite a boring part. In the design there are some stickers pasted on the front and also it should be seen in the whole context of the device.

The function of this part is to protect the screen and the electronics connected to it from dust and dirt. The structural stiffness of the screen comes from an aluminum plate.

After assembling all the parts of the device, I discovered that the screen can not open entirely because the 'front housing' part is pushing against the handle. In this version of the device it

is dealt by reducing the size of the handle at the front'. It is made in such a way that the screen can rest on the handle when fully opened in order to contribute to the robustness.

Next to that I discovered that the front part was a few millimeter too big to be able to close entirely. Moving the whole front a few millimeters to the top would result in a misalignment of the front and the rest of the housing. So I decided to make the front housing again, the second version, but this time a little smaller by shaving off some material from the mold.

For a next iteration, the curvature of the front housing and the placement of the handle should be looked into to make the range bigger.



Figure 62 Attachment method



Figure 59: First iteration front part



Figure 60: Earlier screen assembly



Figure 61: Screen can fully open

10.3.4 INSIDE HOUSING



Figure 63: *Too small 'inside housing'*

In order to vacuum cast the inside housing, a master model has to be made. This is done by means of 3d printing.

The first 3d printed part did not fit on multiple places. The recess for the screen was too small and the wires of the screen were blocked by the protrusion that holds the screen in its place **figure 63**.

Looking at the first version, I saw that the edge of the front housing is not that beautiful. So in the second version of the inside housing, I covered this edge by making a slot for the edge of the front housing **figure 64**.

When evaluating the screen placement in the third iteration, I discovered that the screen was not placed robust; when touching the screen, the screen moved backwards. This had to do with the distant placement of the 3D printed 'screen holders'.

When discussing this with my supervisors, they stressed the importance of this part. The whole experience of working with the device is determined by the robustness of the screen.

So, for the fourth iteration I mounted an aluminum plate on the back of the screen. This aluminum plate is connected directly to the hinges and the Aluminium baseplate. **figure 65**.



Figure 64: *'Inside housing' covering the edges of the 'front housing'*

This made sure that the interaction with the screen feels robust. The aluminium plate takes care of the structural stiffness. The 3D printed 'inside housing' closes the enclosure.

After assembling the whole device, I learned that the dimensions of this part were a few millimeters too big. This made me remake this part a fifth time, this time a little smaller.

This part had to be vacuum cast in silicon by using the 3d print as the male mold. Due to time limitations, I was not able to do that. The part used in the prototype is a painted 3d print.



Figure 65: *Final part, including aluminum plate*

10.3.5 CONNECTION RING

The connection ring connects the bottom and side housings together. This part had to be made by means of vacuum casting.

First a male model was made by means of 3d printing in order to make sure that the dimensions were right **figure 66**. Several iteration were made as the edge of the vacuum formed parts (side and bottom housing) are difficult to predict exactly, but they had to fit in the groove exactly.

This part had to be printed in two separate parts as it was too big for even the Ultimaker 5S. With that came the issue of connecting these two parts without bulking this part..



Figure 66: Result of the first iterations

After the right dimensions were found, the part needed to be made stronger as this part is going to get a lot of impact during use of the device.

The cross-section of the ring was therefore doubled. Next to that, eight aluminum brackets were used to attach the connection plate with the baseplate. The brackets result into increased robustness and it holds the part on its place. Additionally the part is attached to the mounting plate **figure 67**.

The right size and the right strength was found. Now the part had to be made from the right material and production technique.

For the first try, I 3D-printed the negative mold of



Figure 67: Connection ring attachment technique

the connection ring. In this mold I poured PU with a Hardness of D40 (stiff) **figure 68**. Of course I could not get the part out of the mold; one of the parts, the mold or the part, should be able to stretch for that.

So, I made a second mold using silicon. First I poured half of the silicon in a cardboard container, then I pushed the positive mold in the liquid silicon. After it was cured, I poured the remaining silicon on top of it. After everything was cured, I removed the male model and poured the PU in it. The shape was very good and I had to do little post-processing **figure 68**, however it still had some aesthetic flaws.

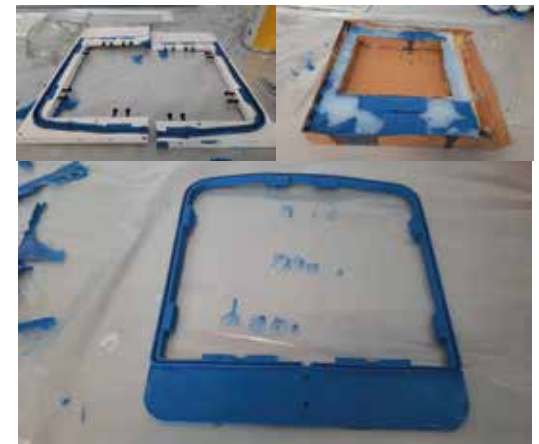

Figure 68: Top: Two tried molding techniques
Bottom: End result

10.3.7 MOUNTING PLATE



Figure 69: connection ring & mounting plate separated parts



Figure 70: Mounting plate design



Figure 71: Mounting plate result

At first I was planning on making a connection ring as discussed in the previous paragraph in order to hold the two side housings together. The side housing parts would be attached to this ring by putting the edge of the thermoformed parts in the groove which was present at both sides, after which a bolt was screwed through the ring, through the side housing to clamp the latter from inside out **figure 69**.

The ring was connected to the mounting plate by means of brackets. This mounting plate had to be made from aluminium to give it extra stiffness and robustness.

When discussing this with the crew at PMB we came to the conclusion that this ring was difficult to make because it is a long thin part with a deep cutout. After this I decided that the mounting plate and the connection ring could be made from one part. It is attached to the baseplate by means of two brackets. This part would form the strong basis of the whole device.

This part was milled at PMB out of a 6mm thick aluminum plate. The processing of this part took approximately 1.5 month due to unclear reasons, which limited me in proceeding as fast as I wanted.

All the components of the device are mounted to the mounting plate. The mounting plate is positioned in the middle of the device. On one side the microscope parts are mounted and on the other side all the electronics are positioned. This makes sure that the user will not have to see the electronics through the glassslide insertion opening.

In the mounting plate, some big holes are made in order to get the cables for the servo's and camera from one side to the other.

11.1 OVERVIEW

Chapter 11

OTHER PARTS

In order to make the device work and the parts fit together some small changes has been made to existing parts and some small new parts has been added. The following parts are added and will be discussed in this chapter:

Hinge-system
Brackets
Rubber 'feet'
Handle
Baseplate
Battery holder
Button plate

In **figure 79** an exploded view of the inside of the NTDx is displayed. In this exploded view the placement of all the other parts are showed. Another change I made with regard to the previous version of the NTDx is that I made the servo plate smaller, this is discussed in Chapter 11.3. In order to understand this, the working principle is discussed in Chapter 11.2. The working principle is not

discussed earlier in this report, because I am focussing on the housing mainly and not much on improving the inside components and mechanism.

Hinge-system (Figure 72)

The hinge system consists out of four components. Two brackets connecting the hinges to the Mounting plate and two hinges which resistance can be changed. Through this, the screen can be positioned in steadily in different angles.

Brackets (Figure 73)

Four brackets are used in the design. Two which are connecting the baseplate with the mounting plate. And two which are connecting the servo plate with the mounting plate. These brackets have the same design.

Rubber 'feet' (Figure 74)

Lastly there are four rubber feet which make sure that the device stays stable and has grip on a lot of surfaces. These rubber feet also connect the bottom of the housing to the baseplate.

The other smaller parts are discussed shortly and the servo plate change is explained.



Figure 72: Hinge system



Figure 73: Brackets



Figure 74: Rubber feet

Handle (Figure 75)

The handle should be made by means of vacuum casting, but due to time limitations, the handle was made by means of 3d printing after which it was painted. The diameter of the handle is made 35 mm as that is the optimal diameter of a handle according to Kong (2005) and Rossi (2012). Also the diameter is made elliptic for optimal comfort and ease of use (Seo, 2011).

Baseplate (Figure 76)

The baseplate is the stable base of the mounting plate. This baseplate is hold firmly by four 'legs'. This baseplate also makes sure that the connection ring stays in its position by means of the aluminum brackets.

The baseplate will be milled, were the device to be produced in series. However for prototyping purposes the baseplate is made by hand.



Figure 75: Handle

Battery holder (Figure 78)

After feeling the ballance of the device, I decided to place the battery on the electronics side in the back. That way the device was balanced the best. The battery is placed vertical due to spacial limitations.

As the output cables of the battery are placed in the middle a cutout is made. The battery holder holds the battery by means of friction. The holder is designed in such a way that it clamps the battery slightly in all dimensions.

Button plate (Figure 77)

Pushing the power button or interacting with the usb port on the front with too much force, can damage the housing easily. This is likely to happen. In order to prevent damage, a aluminum button plate was placed just behind the housing. On this plate the usb port and the power button are attached.

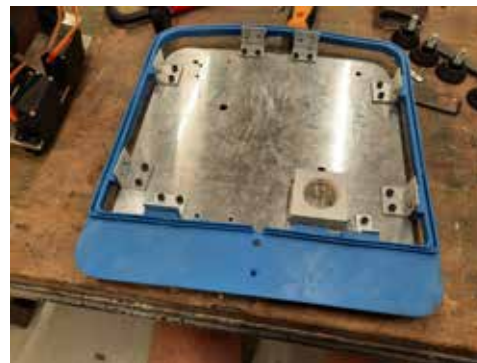

Figure 76: Baseplate



Figure 78: Battery holder



Figure 77: Button plate

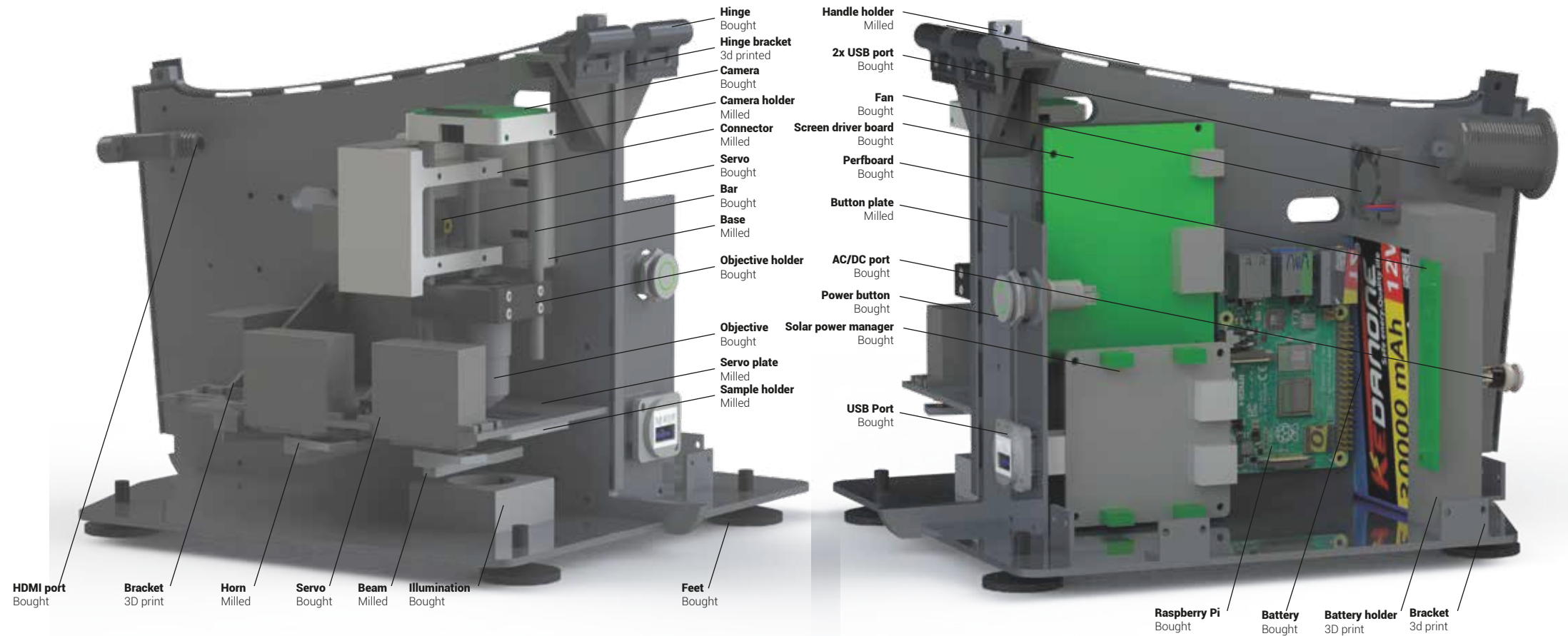

Figure 79: Left and right side showing the inner components of the NTDx

11.2 WORKING PRINCIPLE

The mechanical parts that make the microscope work can be divided in two separate parts. The xy-mechanism **Figure 80** and the focussing mechanism **Figure 81**.

The xy-mechanism is able to move the glassslide holder (1) in the x- and y-direction. It does this by means of three servo's (2) which are connected to the glassslide holder by means of crank mechanisms (3). The servo's are able to rotate 180 degree, making sure that the glassslide holder can move twice as far as the length between the centre of the servo and the attachment of the beam (4) to the horn (5).

When the user gives an input via the interface of the screen, the connected Jetson Nano computes how much degrees each servo has to move and

gives that command to the servo's.

The sample holder is attached to the servo plate (6) by means of magnets, making sure that the sample holder always moves in the xy-plane.

The focussing mechanism consists out of two parts. The objective (7) connected to the camera (8) and the connector (9) is the moving part. The movement is made possible by the two flat springs (10)

The cam (11) connected to the servo (12) which is connected to the base (13) is the stable part.

When the device starts to focus, the servo and so the cam starts to rotate. The diameter of the cam changes from 12.4 to 10.7 mm making sure that

the moving part is able to move 1.7 mm back and forth.

Because the flat springs press the moving part against the cam, the position of the objective with regard to the glassslide (14) changes smoothly.

When the cam rotates 180 degrees, the Jetson Nano captures images continuously. After the rotation is done, it determines based on captured images which image is the sharpest and moves the servo back to that position. Now the image is sharp and displayed on the screen.

This whole process happens in a few seconds.

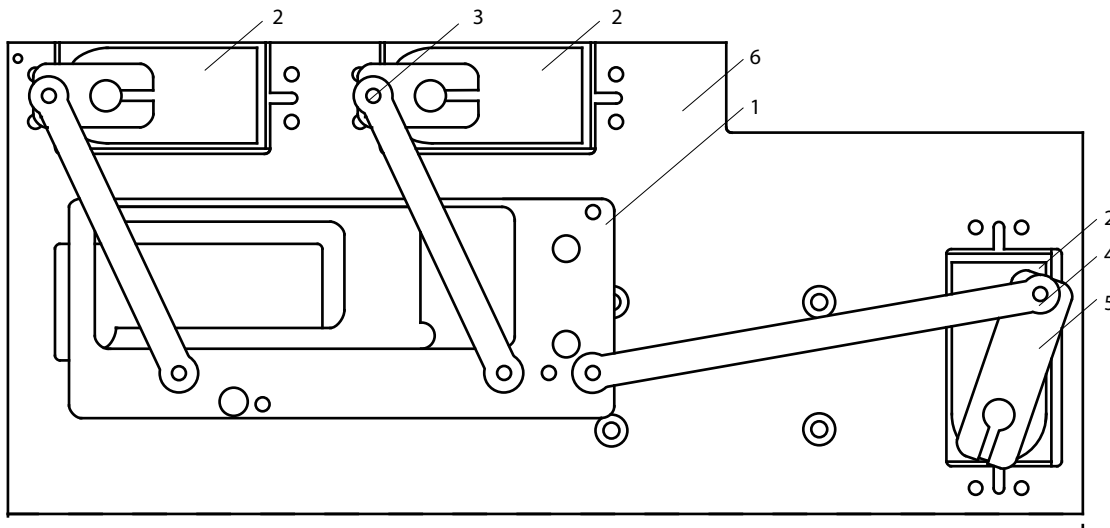

Figure 80: xy-movement system

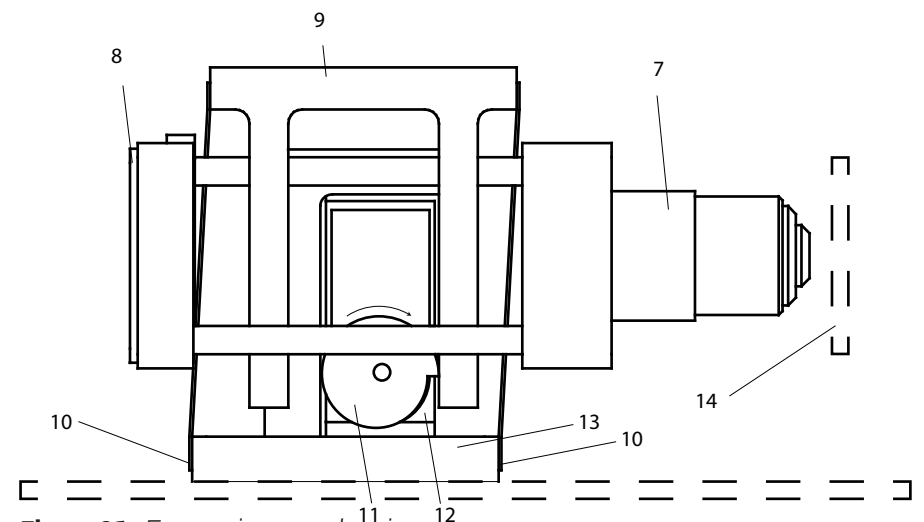

Figure 81: Focussing mechanism

11.3 SERVO PLATE CHANGE

In the previous chapters the servo plate has been discussed. This is the plate over which the glasslide moves in the xy-direction.

The crank mechanism makes sure that the device can move in these directions. The bigger the horns of each of the three crank mechanisms, the bigger the distance that the glasslide holder can move. The length of the horns are chosen based on the size of a glasslide. The xy-mechanism should have a reach in such a way that a whole glasslide could be covered and that the glasslide holder can be ejected.

Therefore the size of the smaller horns are 11 mm and the size of the big horn is 24 mm.

The beams just support this movement. The only requirement the beams have that they should be at least twice as long as the horn.

In the initial version (**figure 82**) the length of the big beam is 86.5mm. Some of this length is needed, but it is not needed to be this long.

I wanted to make the new version as small as possible, so I reduced the length of this beam to xxmm **figure 83** as this whole length was not needed.

For prototyping purposes I reshaped the size of an existing servo plate. This plate was made in China previously from high carbon steel. This made it really difficult to process it. After hours of trying, I succeeded in creating the wanted dimensions.

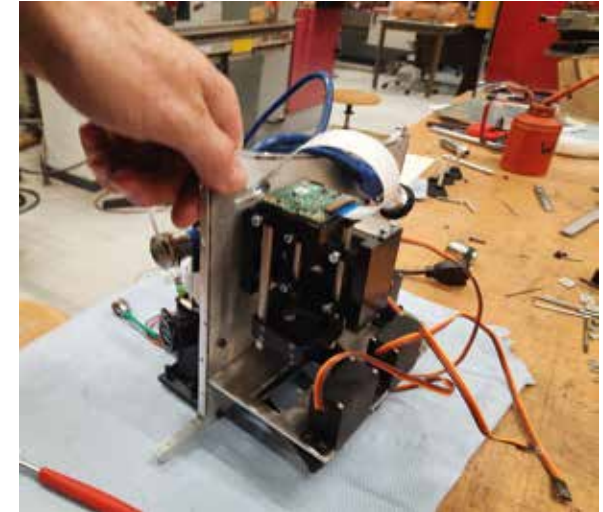

Figure 84: Servo plate attached to prototype

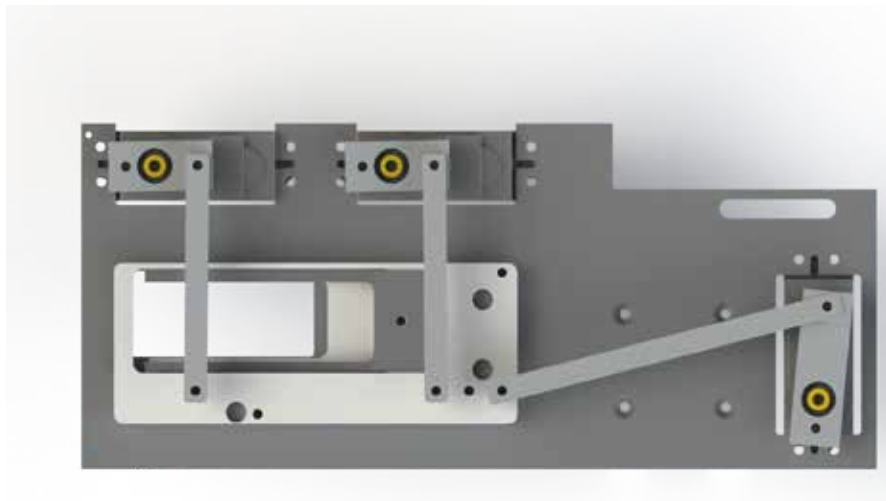

Figure 82: Old bigger version of the servo plate

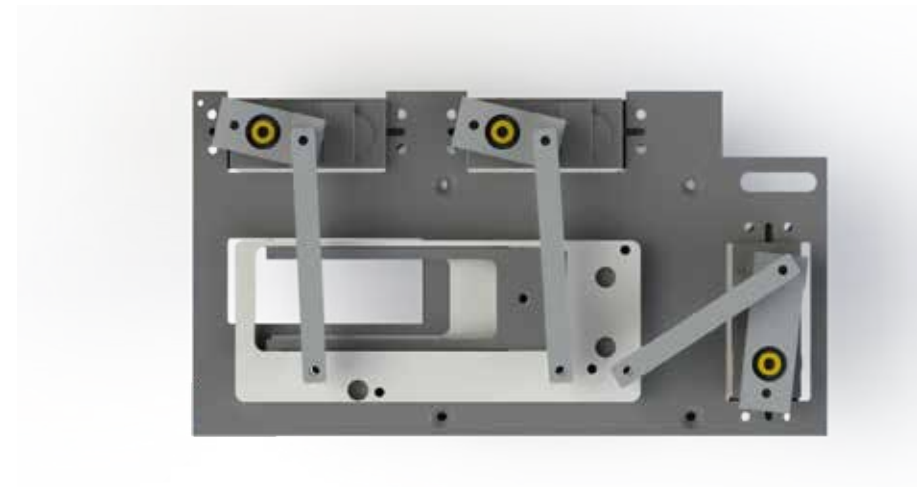

Figure 83: New smaller version of the servo plate

11.3 PROTOTYPE DISCUSSION

● The height of the front part is too high, therefore the hinge mounts are clearly visible. Next iteration: Decrease the front height

● The cables of the screen are vulnerable
Next version: Shrinking tube around the cables.

● The front is can only be closed when pressed on the screen due to too less space. Next version: More space between two sides of the hinges.



● The aluminum is bended when the screws are tightened. Next iteration: thicker sides

● The side housing parts are not identical. Next version: less sanding for the molds

● The paint is too fragile
Next version: no paint, tougher material in the right color. (after this picture I repainted the prototype)

Chapter 12

ELEC- TRONICS

The battery duration requirement is calculated and a circuit is developed. After that the prototyping of the electronics is explained

12.1 REQUIREMENT

The device should be operated in remote areas, off grid. Therefore the device should have an accu.

After a discussion with AiDx Medical and feedback of my advisory team of field experts we decided to design the accu duration in such a way that it could last 6 hours minimum on one charge, with the notion that 'the longer, the better'. See **Appendix 21** for the calculation.

The 6 hours is chosen as the scanning day only begins at one pm. Before that time, microscopists are traveling to the remote location and collecting and staining samples. The day is finished around 18 pm, which comes down to five hours needed uptime. The 6 hours is enough for a full working day including a spare hour of uptime.

This accu can be charged by means of multiple powerbanks during use to extend that range.

It is chosen to make the accu rechargeable without it to be replaceable because spare accus will get lost. If this accu is specific designed for this application, it will not be easy replaceable when it gets lost.

I have also looked into other standard accu's like accu's for tools, laptops or electric bikes (**Appendix 21**) which could be easily replaceable. But most of these accus did not meet the power requirements of the device as that power requirement is high.

The accu that met the power requirements were too big or too heavy to be implemented in the device in an ergonomic way.

Another option was to not include an accu in the device, but rather give a separate accu with the device. When explaining this option to the experts in Nigeria, they appeared to be strongly against this approach. This way you had to carry more separate things with you when you go surveying; everything should be included in one thing, it should be a self-sufficient device.

Based on these findings, I chose to include an accu that is not replaceable in the device.

The other electrical parts are explained more in detail in **Appendix 22** and can be found in the schematic overview of the circuit in Chapter 12.2.

Battery size calculation

6 hours, total of 12,4 Watt at 5V

$$12,4 \times 6/5 = 14,88 \text{ Ah}$$

6 hours, total of 7,6 Watt at 12V

$$7,6 \times 6/12 = 3,8 \text{ Ah}$$

Including Efficiency accu & power manager:

$$14,88 \times 1,1 \times 1,1 \times 5 = 90 \text{ Wh}$$

$$3,8 \times 1,1 \times 1,1 \times 12 = 55 \text{ Wh}$$

Total power requirement = 145 Wh

The accu I use has 360 Wh (best option)

Figure 86: Power requirement calculation
See Appendix 21 for more detail

12.2 ELECTRONICS EXPLAINED

So in order to make the device suitable for remote operation, a screen and a battery should be included. These additions make the electronics complicated, as there should be a chip monitoring if the device is connected to net power or the accu in order to decide from where to draw power for the device.

Also the chosen screen runs on 12V, which is normal. At the same time, the rest of the device runs on 5V. This means that I could not use a commonly used 'powerbank module'. That is also not possible because the current on these ports are limited to 2.5A/3A while I needed a current of 4A. There are multiple options to overcome this. These options are explained in **Appendix 21**.

In the end I found a Solar Power manager which has all the mentioned functions.

Earlier in the process I described that a Jetson Nano will be included in the prototype. However the software for this board was not finished yet. Therefore I chose to implement a Raspberry Pi for the prototype.

The power button is a DPDT switch. It can switch on/off two circuits. In total there are three circuits. So I chose to connect the switch to the Raspberry Pi and the servo circuit and leave the screen in sleep mode, because it draws almost no power in sleep mode.

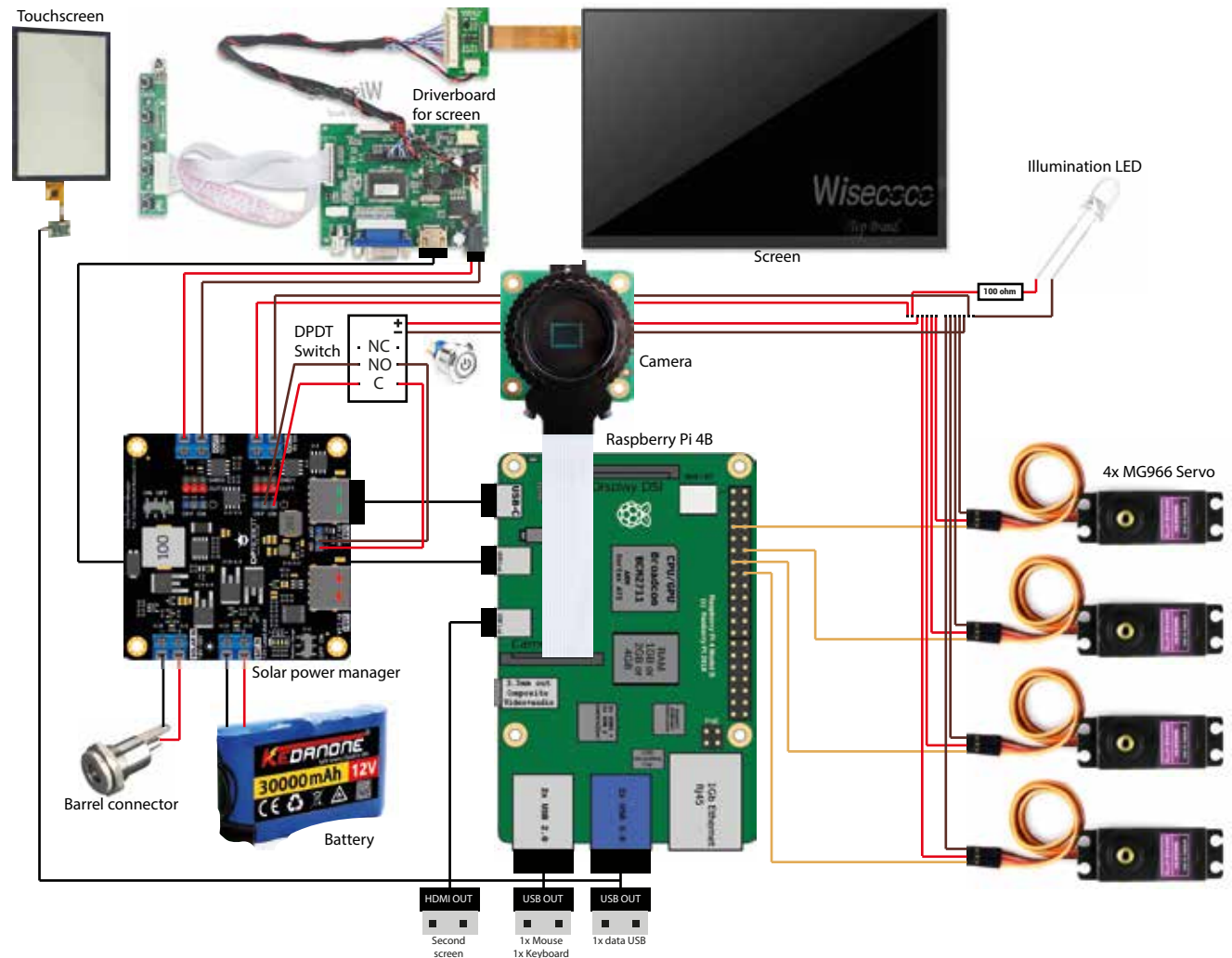

Figure 87: Electronic circuit of the device

12.3 PROTOTYPING

The first prototyping step was making the screen work in combination with the Raspberry Pi. The screen came with multiple modules and the touchscreen had to be pasted manually on the accompanying screen.

Without further modifications, I could test the screen **figure 88**. It appeared that the size of the interface should be adapted to the size of the screen; it does not automatically change size when connected to another screen. This was handled together with the software engineer from AiDx Medical.

After this, I proceeded to check how to connect all the wires to make the device as a whole work together by means of using a breadboard **figure 89**

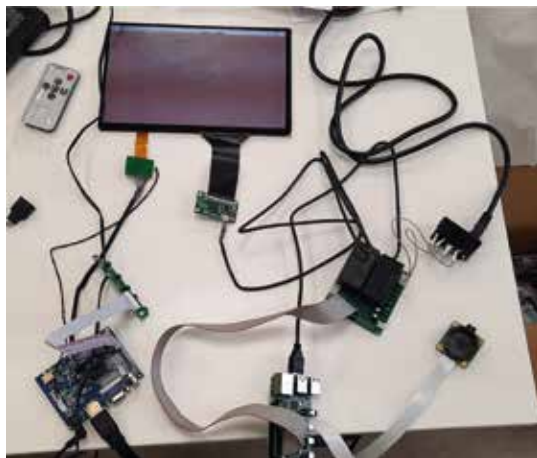

Figure 88: Screen test

The Solar power manager has on-board battery level indicators **figure 90**. That is one of the reasons I chose this board. I supposed that I should be able to solder wires from this indicator to LED-indicators in the housing of the device. This however was not possible because the indicators were really small and difficult to reach.

To overcome this for the prototype, another chip should be placed between the battery and the Solar power manager on which indication LEDs can be placed. However it should be looked into that his chip can handle charging current and load current as the current goes in both directions through the wire.

Another problem with regard to the Solar Power manager is shutting down the Raspberry Pi.

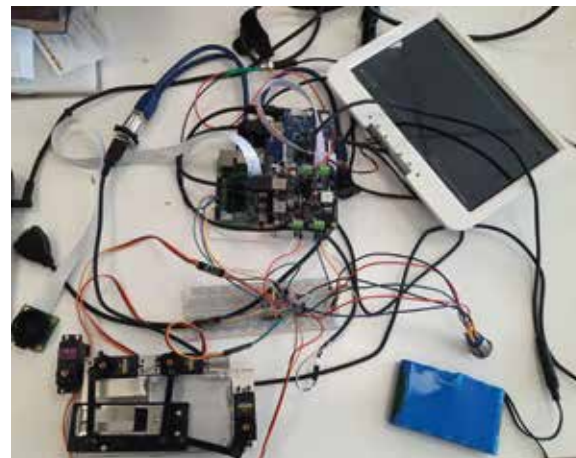

Figure 89: Breadboard prototype

The DPDT switch is connected to the Servo and the Raspberry Pi circuit. This is chosen because the Pi is using most of the power in idle state (4W). Additionally the Servo's will draw current as long as they are connected to current eventhough they do not have to move. Therefore this circuit should be shut down as well. As said earlier the screen will be powered on all the time and goes in sleep mode when the Pi is shut down.

Unfortunately the Pi and the screen are connected by means of an HDMI Cable. This cable gives the Pi constant power eventhough the power circuit of the Pi is shut off. The whole system still works, but the power consumption is not optimal.

All these problems lead to the conclusion that there should be developed a customized board.

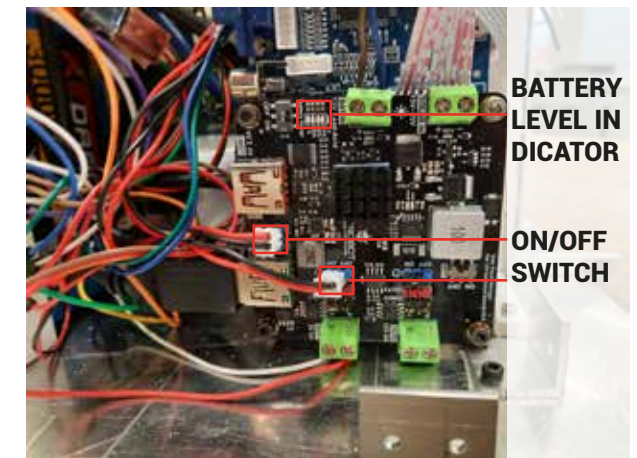

Figure 90: Solar power manager

12.4 COOLING

The NTDx5 will be used in remote area's. Sometimes even outside. This means that the device will be exposed to sunlight and warmth. Afterwards, when the device is placed out of the sun, the device will cool down which could lead to condensation in the device.

Condensation in the device can lead to malfunction of the electronics in the device. Thus the electronics should be protected from condensation.

An constant air flow through the device makes sure that the temperature inside the device does not fluctuate fast. That way less condensation will be present in the device.

In order to obtain that constant air flow, a fan was placed in the device which stimulates the air to circulate. Warm air will go up. Therefore the fan was placed and ventilation openings are made at the top back of the device. Additionally ventilation openings are made at the side of the device to get 'fresh' cold air. **Figure 91.**

Another option next to the option that I pursued is to shield off the top of the electronics from water drops by means of a cover.

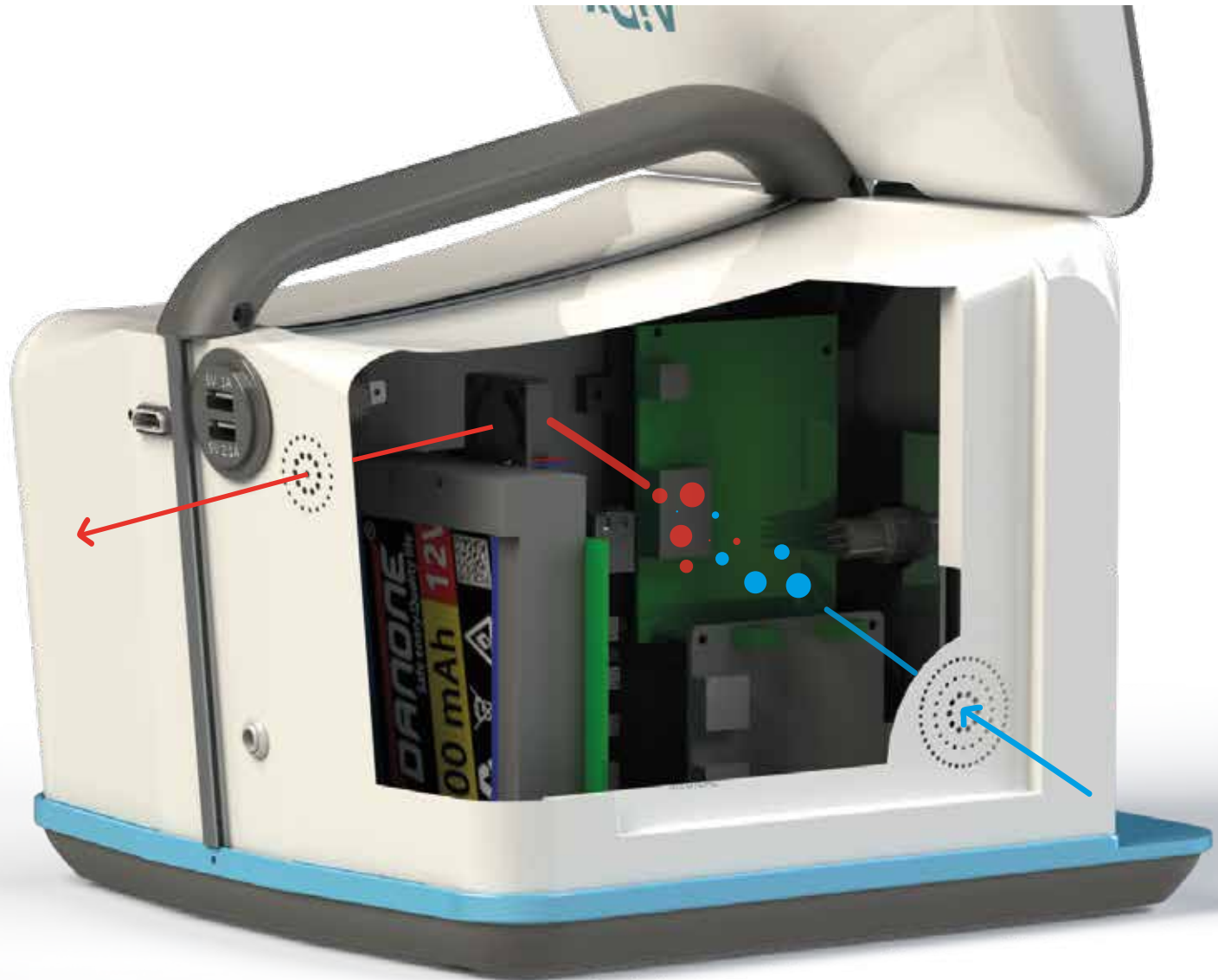

Figure 91: Cooling system

13.1 AESTHETICS

Chapter 13 TESTS

In chapter 5.2, I explained the goals I had with regard to improving the aesthetics of the previous device. These goals were mostly focussing on the Micro level as a lot could be won in this category. The goals I envisioned were the following:

- Intriguing (Micro)
- Robust feeling (Micro)
- Confident feeling (Meta)

The overall goal of my project was to make the device more robust, which is captured in the first two mentioned goals. Next to that the device should be more aesthetically pleasing as a medical device; That is captured in the third goal.

In order to test if the design has improved with regard to these aspects, I executed a test. I asked 10 participants to fill out a online questionnaire. 40 percent of the participant were medical trained

First I asked them to analyse four different devices to which extend the devices look medical or beautiful to them on a scale of five.

After that, I asked to do the same for the previous and the developed Aidx NTDx. In this section I also asked them to rate the AiDx NTDx on:

- If they feel like they want to interact with it
- If the design gives them a robust feeling
- If the design makes them feel confident between other medical devices

The first questions were asked to introduce the participants to medical devices and let them think about how a medical device should look like. After that the real questions were asked.

The results are summarized in **Figure 92**. below . The numbers are averages of the reactions of the ten participants. The raw results of this test can be found in **Appendix 28**.

Interesting about the results is that all the aspects are improved except for the robustness. Especially the Medical and the Intriguing factors are increased. The medical schooled people rated the device on average higher on all aspects than the average

With these results it should be taken into account that most of the people know that I put in effort in the 'new design' and therefore rate that design better.

	Previous NTDx	Current NTDx
Intriguing	3,3	4,3
Robust feel	3,4	3,4
Confident	3,8	4,2
Medical	3,6	4,6
Beautiful	3,6	3,8

Figure 92: Average scores given to the two prototypes. Highest score is 5.

Several tests are executed in order to test if the device is suitable to be used in the envisioned context

13.2 INTERACTION

Another important part was to increase the ease of use of the device. On that terrain, I tested if the users understand the prototyped interaction.

In Chapter 5.3 I explained the envisioned interaction with the prototype by means of a model. The prototype that was realized in the end has all the functions that modelled. Except that the screen turns on and off when pressed on the power button. The screen will turn off after a while without use and it will power on again when the screen is touched twice.

It is important to the future users that it is immediately clear how to operate the device. Therefore I tested this with five industrial design student participants. Also, I tested it with one microscopist.

The test was shaped in such a way that the participants had to execute a few little assignments:

- Pick the device up
- Open the screen
- Turn it on
- insert a glasslide
- shut it down
- bring it back to the original place

On purpose it was chosen not to let the users interact with the interface because this was not part of the improvement of the design. When they asked to proceed and check a sample, they were allowed to continue.

The previously described steps were taken by all the participants. Each participant did spend approximately an equal amount of time per step.

The interaction was straight forward and it took about one minute to go through all the steps. Thus making the device ready for scanning a sample.

Only the last step, the glass slide insertion was quite difficult. The participants did not understand in which orientation and how far the slide should be inserted. Interestingly the microscopist who performed the test did not have difficulties with this step. Probably, he got used to inserting slides in other machines and the insertion method is the same for this machine. But this requires further research.

Next to the time measurements I also asked the participants to think out loud. The most important insights from this are:

- The device as heavy as expected by its looks
- The opening method of the screen is not obvious as there is no space under front housing in order to open the screen.
- The USB port on the front is not notable enough; Half of the participants did not recognize it as a USB port

The raw results of this test can be found in **Appendix 27**.

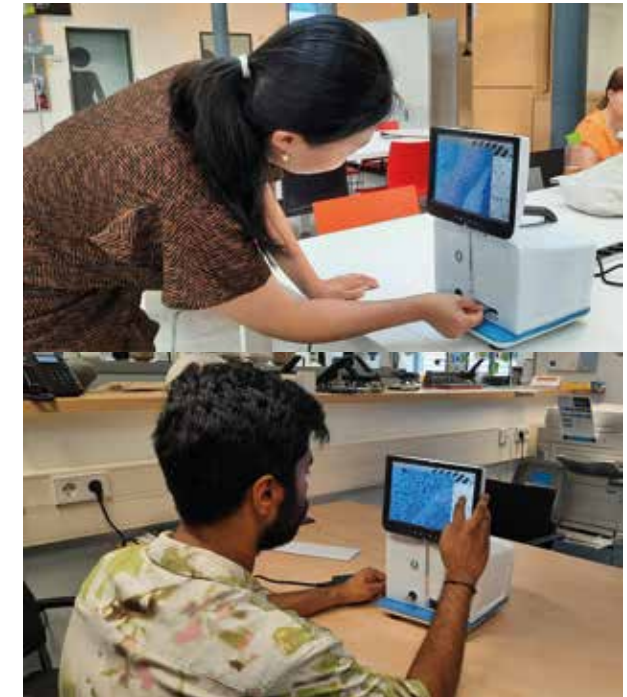

Figure 93: Test participants participating in the research



Figure 94: Test participant interacting with the device

13.3 WATERPROOF (STORY)

As the device will be brought to remote areas, people will walk with the device to for a few hours. In those hours it can start raining and soak everything. Therefore the device should have a IP rating of IP45. Still with this rating, the device should be carried around in a waterproof bag that is easy to wear on your back.

During the prototype process I discovered on accident that the device in its current form can handle some water. However it should be looked into more thoroughly.

I was testing the prototype on robustness on my scooter, see Chapter 14.4 for more details. When I was riding the last kilometer, it started to pour rain **figure 97**. It soaked everything, also the bag in which I was carrying the prototype. There was even a layer of water in the bag **figure 98**. So I can say that the prototype has seen some water.

As I was scared that it would not withstand the water, I was a bit stressed out and handled the device quite rough. Maybe that was one of the reasons that the screen did not display the software afterwards. I was scared that the water had shorted one of the circuits. After pushing the button by which I can determine the 'source' of the screen, it was started up and was functioning perfectly.

I still do not know how it came to pass that the input 'source' of the screen was changed, but I think it was the rough handling.

This is just a story about how the prototype withstood some water accidentally, but this story also proves that the prototype has the potential to survive harsh circumstances. It only has to be improved on several points still. For that see the recommendation chapter.

I suggest to perform a waterproofing test with this prototype without the electronics in it in order to test if this design meets IP45 after the mentions recommendations are implemented. Due to time issues, I did not have the chance to test it myself. I did not prioritize this as the device can be protected from water by just using a waterproof bag. The robustness was a more important issue.



Figure 97: *The weather that moment*



Figure 98: *Bag in which the prototype was carried*



Figure 99: *Wet prototype*

13.4 ROBUSTNESS

For robustness tests it is always difficult to define what is 'robust enough'. I did not have the time to do much iterations with regard to the robustness of the device, if the device would break down during the tests. e.g. droptests. This was because I could not make the whole assembly because I missed the mounting plate.

I decided to test if the device is robust enough to be used in the circumstances that it is developed for. If the device is not strong enough for these circumstances, the robustness criteria for the device were not met.

In the normal circumstances, the device will be brought to a remote village via the roads. First it will be taken by car or motor to a certain area, after which the users will take it further by foot.

To simulate these circumstances, I took the device with me and biked 5 kilometers holding it in my hand by the handle (**figure 100**). As I do not have a car and the impact will be bigger when it is transported on a motor than by car, I put the device in a sportsbag without padding, put it on my back and drove 15 kilometers with it on a scooter (**figure 101**). The maximum speed I got was 55 kilometers per hour.

After the first test, everything was working fine. Nothing was damaged. After some time the device felt quite heavy to hold in your hand due to all the aluminum parts in it. That's also the reason why I put the device in a sportsbag for the second test.

After the second test, the device was also still working fine, however the paint on the device was damaged multiple places (**figure 102**). Some of these damages already happened during the assembling process, but this second test increased the amount of damages by a lot. Therefore I repainted the whole prototype after this test.

More robustness tests should be done to be sure if the structure is strong enough to hold for a longer period of time and also in harsher circumstances. A good test is to let it be handled by the luggage handlers at the airport, as the device will be taken to Nigeria that way. Some of the previous devices did not survive that process.

Concluding, for normal circumstances, the structure of the device is strong enough. The choice of paint should be revisited and maybe even another material can be chosen for the thermoforming. That way the parts do not have to be painted at all, which makes it more robust.



Figure 100 : Bike test



Figure 101: Scooter test



Figure 102: Damages

13.5 Battery life span

As discussed in Chapter 12.1, the stakeholders agreed that a 6 hour battery span was good enough. Next to that, the battery can be charged with an additional power bank.

In order to test if the battery could last 6 hours or even longer, as calculated, I used a code that makes the NTDx scan continuesly. Through this code, the NTDx moves the glasslide holder to random locations. Next to that the scanning mechanism is focussing each time the glasslide holder is moving to a different position. This way it is possible to test how long the battery lasts once its charched fully.

The battery was charged for a whole night to simulate the use scenario of the device: the first day it is used for a few hours after which the device is charged in the hotel room. The second day the device is used again.

For the first test, when taking off the device from the nett power, I noticed that only two lights were blinking on the Solar Power Manager. That means that the battery is only charged for 25 to 50 percent. The device lasted 2 hours and 45 minutes before it shut down. After this result, I decided to try again.

This time the same setup was used, but I opened the device to check what was going on inside the device.

When charging the device, the battery level indicators turned on one by one untill the blue one was turned on **Figure 103**. When disconnecting the charging wire, the battery indication lights immediately went back to 25 to 50 percent charged **Figure 104**. Even after charging it longer, the behaviour was not different.

After this conclusion I performed the test with the battery level between 25 and 50 percent. After 3 hours the device turned off. So in the current configuration, the battery life span is 3 hours.

Another option would be that the battery is not able to transfer all the stored energy. There can be looked into different batteries to extend the life span.

The battery is not charged fully by means of this circuit, probably because of its voltage limitations. Again this is a call to develop a customized PCB.

If the battery would be charged to 100 percent, I assume that the life span would bee 6 hours.

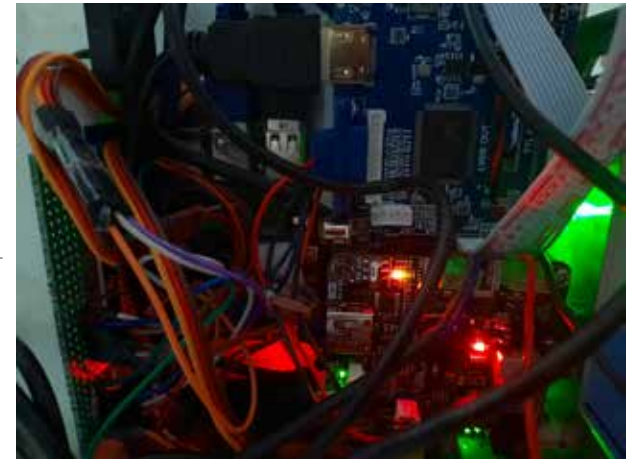

Figure 103: First test: battery level 35-50 percent. Only the red and orange LED are on.



Figure 104: Second test: Battery level 100 percent. All LED's are on.

14 COSTSPRICE

Chapter 14 COSTS

This individual parts of this new iteration of the NTDx will cost all together €1.217,85. This amount can be deviced over different groups as shown below. In order to compare the prices, I splitted the costs for the previous version of the NTDx in the same categories. See **Appendix 23** for more detail.

	Previous version	New version
Electronics	381,76	489,67
Housing	61,14	35,19
Milling	377,60	544,10
3D prints	4,58	1,26
Other	125,85	147,63
Total	950,94	1217,85

So seperate parts of the portable NTDx are in total approximately 250 euro more expensive than the fixed NTDx. The most contributing groups for this increase are 100 euro of the electronics and 150 euro for milling aluminum parts.

The additional 100 euro's by the electronics are mostly because off:

Solar Power manager	25
Battery	25
Touchscreen (upgrade from monitor)	50

The additional 150 euro's of the milled parts are because of the estimated costs of producing aluminum parts in order to attach the screen to the housing in a robust way. Next to that an extra

plate (base plate) was needed.

The 1217,85 euro's are the costprice of the different parts only. To this number assembling costst and a margin of one third should be added in order to come to the minimal viable sales price.

I estimate that it is possible to assemble one device in one day if all the parts are produced properly. Unfortunately I ran out of time before I could test this. Assumed that assembling hourly rate would be 20 euro's per hour, this would cost 160 euro, which results in total costs of 1377,85 per device.

A margin of one third should be added to this price to cover the development and organisational costs.

Therefore the minimal price at which this portable device should be sold should be 1832.54

Salesprice: 1835,- Euro

The costprice is calculated and the differences between the costprice of the previous prototype are explained.

DISCUSSION

- 15. Conclusion
- 16. Recommendations
- 17. Reflection



Figure 105: Details of prototype



Touchscreen

Handle

On the back:

- AC/DC port
- HDMI port
- Double USB port

Power button

Single USB port
Slide insertion

Figure 106: Final prototype

15 CONCLUSION

At the start of my graduation the biggest challenge was to create a new embodiment of the NTDx that was portable and looked like a medical device.

At that moment, the device had to be connected to the net power and monitor, keyboard and mouse in order to work. Also the device was put in a regular box in order to make a working prototype. This meant that I had to design and develop the whole housing and appearance. Next to that I had to develop a system that worked disconnected from the net power in a portable way.

Regarding the latter, I estimated that it would not be much work and valued the TRL level of the 'system interaction' at a 6 and I had to bring it to a 7. It turned out that a lot of effort had to put in that part as well as it was not simple to attach all the electronics together. For that part I actually needed to develop the proof of concept still (marked in red). (Figure 107)

With the given time, I have delivered a working prototype as the plan was. The prototype has all the functionalities as planned with a few side notes.

The 'interaction' and 'system intercation' category is not developed as far as I initially wanted. This is due to two reasons.

First, the battery charging status is not easily visible from the outside. It is possible to drill a hole in the housing to see the battery status on the Solar Power Manager. But it is not a solid solution.

Secondly, the power button is not able to shut down all the circuits when pressed. This results in a shorter battery span, because the battery is drained slightly even if the device is turned off.

In conclusion, the device is portable, it looks like a medical product and the target users are happy with it! It has a few flaws still, but it is a big step forward to improving treatment options for people with an NTD in remote areas in sub-saharan Africa.

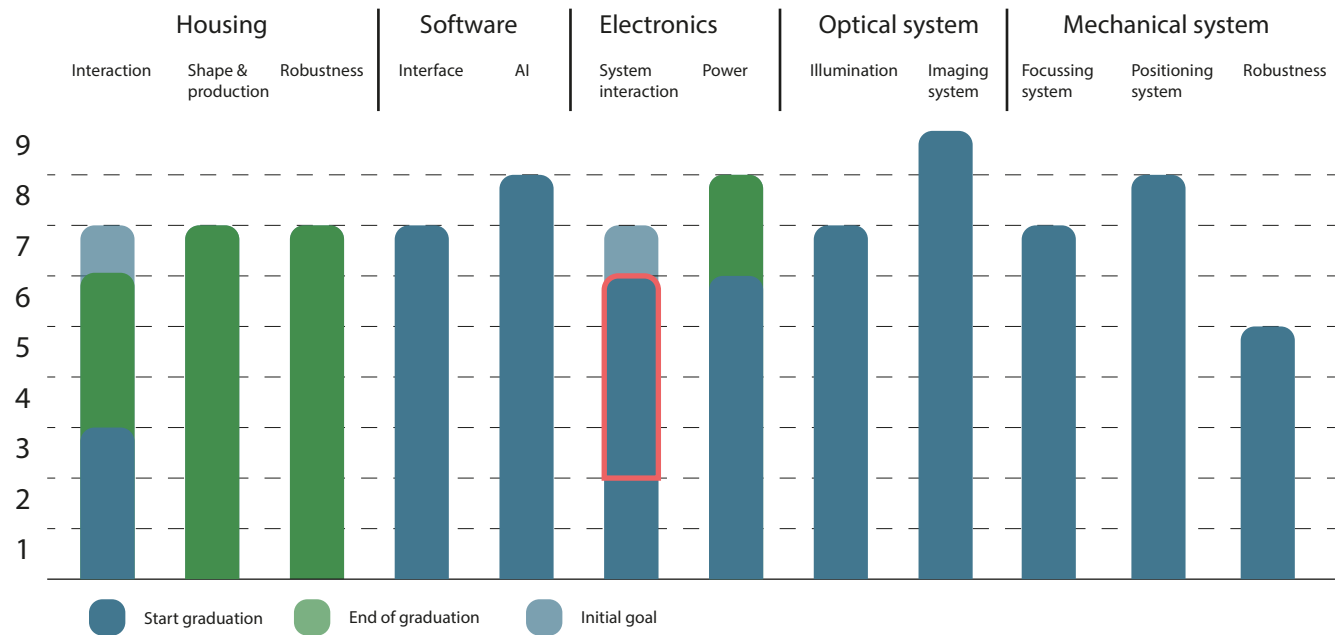

Figure 107: Overview of the TRL level goals and what I have achieved at the end of my graduation

16 RECOMMENDATIONS

In this last part of my report, except for my reflection on my work, I will describe the recommendations that I have for the device I made. I divided the recommendations I have over the subjects: Housing, Electronics and Interaction.

Housing

The first recommendation is to change the material of which the thermoformed parts are made to HDPE. Currently the plastic housing parts are made from Vikureen which damages easily.

Combined with that, the chosen material should have the wanted color and appearance directly. This will make sure that it is not needed to paint the parts which will be more time efficient.

Secondly, The current color of the housing parts is 'high gloss white'. Before I applied this color, I painted the parts with a Primer which had a light grey matt color. That color suited the device very good and is easier to keep clean than the current white color. I painted the parts white as I wanted to see how it would look like in the initial designed color.

Third, the handle should be placed more to the back to allow the screen to be opened with a bigger angle. This makes the device easier to use while standing.

Also, I did not test to which extend the housing is waterproof in a controlled manner, but you can see the gaps between the mounting plate and the side housing. It can be considered to place a bit of rubber in between the groove in the mounting plate. Another option would be to reduce the width of the groove.

The same is true for the top part of the front housing. There should be added a part that closes of the top part of the device.

Front of the housing is too big for the current configuration of the rest of the housing. This made me cut off a part of the housing, making it not waterproof at all. For the next version the height of the front housing should be reduced .

That is if the current design should be pursued. An alternative design is to remove the function of the mounting plate of holding the two thermoformed parts together. After that, the left and the right side of the housing can be combined into one part. That eliminates an opening in the middle through which water can flow to the inside. Also it makes it easier to assemble, less expensive and less vulnerable. Although a little design changes should be made to achieve this 'big' top mold.

Regarding the front housing part, I suggested to add a part that closes off the current gap at the top of this part. Another option would be to attach the hinge on top of both housings; the front and the main housings. Of course with a stable structural part beneath those points in the housings. That way it is not needed to make a big hole in the housing to attach the hinges.

Lastly I recommend the housing to be tested more thoroughly with regard to waterproofness, robustness and climate-proofness.

Electronics

In order to cool down the electronics, a fan is placed in the housing. Warm air will go up in the device. Therefore the opening for ventilation is placed in the top back of the device. However the openings are a little too much on the top of the device, through which water, were it be spilled on the device, can enter through these holes by means of gravity. For the next version it can be considered to place the ventilation holes lower on the back under the slight overhang.

The 3d printed electronics holder which hold all the boards on the side of the mounting plate can be omitted in future versions. The holes in this electronics holder can be made in the mounting plate on which the electronics will be attached. That

way, it is easy for the electronics to radiate their warmth through the metal connectors to the mounting plate which will give its warmth to the outside of the device.

Next to that, I suggest to design a customised PCB that has the same functions as the Solar Power Manager. The additional functions of this PCB should be that it should be easy to connect a battery indicator light from the PCB to the housing of the device. Currently it is not possible to see what charging status the battery is in. Next to that it should be possible to shut down all the circuits with one button.

Also think about cable management. The cables should be more ordered to increase lifespan.

Interaction

People on the field suggested that the lens should be easily reached in order to clean it. Currently it is not possible to reach out to the lens in order to clean it in an easy way. There can be thought about increasing the glasslide insertion opening and making a 'door' in order to open and close this opening.

This, because the same people suggested that the glasslide insertion opening should be closed all the time except when the glasslide is inserted

Overall

Also the overall ease of assembling should be looked into. I had several problems with assembling everything which can be solved easily by redesigning the parts.

Additionally, the camera and the objective are connected with each other by means of rods. This makes it easy for dust to soil the camera and the lenses. Therefore I suggest to make a closed system that connects these parts together.

The prototype has several openings through which water can enter the electronics. So I recommend to transport the current design of the device in a waterproof bag, when it is traveled with.

My final remark is that in this prototype version the 'handle' and the 'inside front housing' are 3D printed. If this version is going to be produced in series, I suggest to vacuum mold these as well.

17 REFLECTION

Looking back on the whole project, I can see that it has been a big project in which I have learned a lot! In this Chapter I will reflect on the this process. First by reflecting on the learning goals I formulated in the design brief, after that I will go on with a general reflection on several points.

Learninggoal 1&2 - Working with local recycled plastic & manufacturers

At the start of my graduation I explored what kind of plastics I could use for producing the device and what would be locally available by talking to a Nigerian plastic recycler. Also I researched what manufacturing techniques were available locally. I discovered that almost every 'common' material and production technique was available. However I decided not to stress recycled plastic in my graduation after all, as there were other more important aspects to focus on like making the device portable. This experience really learned me to set priorities and that it is not wrong to differ from the original plan.

Learninggoal 3 - Developing aesthetical device

In the first few months I have been working to create the appearance of the next version of the NTDx. This was one of the personal learning goals I pursued during for my graduation. Looking back on the process, I have learned much. I learned the basics of how to desing aesthetically pleasing products by looking to other designs and talking with the future users of the device.

However I have been stuck for too long in the sketching phase. Yes, I wanted to learn how to

sketch beautiful designs, but I learned that that is not really my thing. So, I discovered that my style of working is to shape a product aesthetically pleasing by working in the 3D world: foam models & prototyping.

As that is my style of working I am good in having little 'accidents' while prototyping that are not easily undone. I learned from myself that it is not easy for me to give a prototype that final touch that it looks perfect. In this case it is the damaged paint for example. I am more the guy that makes it work instead of making it beautiful.

General reflection

Next to that, I learned how to deal with multiple stakeholders who say opposite things. I enjoyed interviewing different stakeholders in the project and deciding which direction I should design. By means of analysing from which perspective, which function and background the interviewee is talking, it is possible to decide whom to listen to in different occasions. An example of this the question: How long should the battery last on one charge?

Additionally, It was great to work together in a team, eventhough I was graduating on my own. I learned a lot about electronics, the context and also the from previous prototypes by means of talking with teammembers at AiDx. From this I learend that it is important to analyse what has been done before, before creating a new 'improved' design. I have spend hours talking with AiDx during my graduation, but also during my internship before I started my graduation.

At the same time this was difficult as well. Because I did my internship at AiDx, I had iterated the previous version of the NTDx already. During my graduation it had to be produced several times. It was difficult to keep my attention on my graduati-on this whole time as the pressure to produce a few devices was quite high. But I managed to do this by distancing myself physically to the university for a few days per week.

When looking back at the prototyping phase, I should have put more pressure on milling the mounting plate. I had plenty of work to do before the mounting plate was finished, therefore I did not push for it at PMB. But through that it was only possible for me to make 'one' mounting plate thorough the whole prototyping process. whereas this plate could be improved a lot still.

During the whole desing process, I proved to myself that I am able to work independent on my own and finish the work that has to be done. Sometimes it was hard to keep focus. Expecially when I got stuck in the middle of the process where my drawings could not produce aesthetical designs. However, discussing the designs with other people, teammembers at AiDx and my supervisors helped me to get through this. I learned that is really helpfull to have other people around you that support you when you need it.

18 SOURCES

Bilharzia affects 240 million people. Let's get rid of it. (2020, 3 december). World Economic Forum. Consulted 24 juni 2022, from <https://www.weforum.org/agenda/2020/12/bilharzia-affects-240-million-people-we-can-eliminate-it/>

CDC - Schistosomiasis - Disease. (2020). CDC. Consulted 24 juni 2022, from <https://www.cdc.gov/parasites/schistosomiasis/disease.html>

Celebrating the Second Annual World NTD Day: A Q&A with Katey Owen. (2021, 28 januari). Bill & Melinda Gates Foundation. Consulted 24 juni 2022, van <https://www.gatesfoundation.org/ideas/articles/world-ntd-day-katey-owen>

Hotez PJ, Asojo OA, Adesina AM (2012) Nigeria: "Ground Zero" for the High Prevalence Neglected Tropical Diseases. PLoS Negl Trop Dis 6(7): e1600. <https://doi.org/10.1371/journal.pntd.0001600>

Kong, Y. K., & Lowe, B. D. (2005). Optimal cylindrical handle diameter for grip force tasks. *International Journal of Industrial Ergonomics*, 35(6), 495-507.

Marcus, A., & Ma, X. (2016, July). Cuteness Design in the UX: An Initial Analysis. In *International Conference of Design, User Experience, and Usability* (pp. 46-56). Springer, Cham.

Neglected tropical diseases -- GLOBAL. (2021, 27 juli). WHO. Consulted 24 juni 2022, from https://www.who.int/health-topics/neglected-tropical-diseases#tab=tab_1

Oyibo, P., Jujjavarapu, S., Meulah, B., Agbana, T., Braakman, I., van Diepen, A., ... & Diehl, J. C. (2022). Schistoscope: An Automated Microscope with Artificial Intelligence for Detection of *Schistosoma haematobium* Eggs in Resource-Limited Settings. *Micromachines*, 13(5), 643.

Seo, N. J., & Armstrong, T. J. (2011). Effect of elliptic handle shape on grasping strategies, grip force distribution, and twisting ability. *Ergonomics*, 54(10), 961-970.

Rossi, J., Berton, E., Grélot, L., Barla, C., & Vigouroux, L. (2012). Characterisation of forces exerted by the entire hand during the power grip: effect of the handle diameter. *Ergonomics*, 55(6), 682-692.

WHO redoubles efforts to leave no one behind in treatment of Neglected Tropical Diseases. (2022, 18 juni). WHO | Regional Office for Africa. Consulted 24 juni 2022, from <https://www.afro.who.int/news/who-redoubles-efforts-leave-no-one-behind-treatment-neglected-tropical-diseases>

World Health Organization. (2020). Ending the neglect to attain the Sustainable Development Goals: a road map for neglected tropical diseases 2021–2030.

APPENDIX

1. Planning
2. Requirements
3. Journey map report
4. Frame innovation
5. 9 moments of appearance
6. Design limitation due to component size
7. Interviews
8. Cardboard prototyping
9. Screen size test
10. HKJ's
11. 10 idea sketches
12. Three ideas
13. Touch screen field experiment
14. Handle options
15. pre-concepts
16. Final concepts
18. Size exploration
19. Production technique consideration
20. Prototyping documentation
21. Electronics evaluation
22. Power circuit
23. Cost calculation
24. Assembling documentation
25. Material consideration
26. Interaction research
27. Aesthetics research
28. Graduation project brief