

---

# Progressive Collapse Indicator

*A tool to indicate a structure's collapse resistance*



*Final Report Master's Thesis*

November, 2009

Simon Bolle



---

---

---

# Progressive Collapse Indicator

*A tool to indicate a structure's collapse resistance*

*Final Report Master's Thesis*

**Status: Final**

November 13<sup>th</sup>, 2009

**Simon Bolle**

student number: 1142682

email: S.J.Bolle@gmail.com

Delft University of Technology  
Faculty of Civil Engineering and Geosciences  
Department of Structural and Building Engineering  
Structural Design Lab

*Graduation Committee:*

Prof.dr.ir. J.G. Rots

Ir. J.L. Coenders

Ir. J.W. Welleman

Ir. K.C. Terwel

 **TU Delft**

Delft  
University of  
Technology



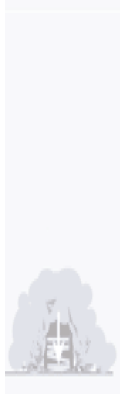
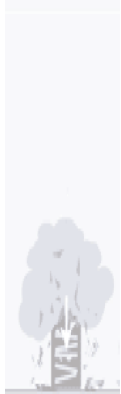

This document is the final report of my Master's thesis on progressive collapse. The thesis has been conducted under the Structural Design Lab (SDL), an educational and research body which deals with subjects of innovation in structures and the related conceptual and structural design process and technologies. On the educational side, the Structural Design Lab concentrates its activities on students who want to explore and gain insight in the structural design of special structures, design tools and the accompanying aspects of the design process. The SDL is part of the Structural and Building Engineering Department of Delft University of Technology, faculty of Civil Engineering and Geosciences.

The research has been conducted at the faculty of Civil Engineering and Geosciences at which I could work and get support. This final report combines all previous preliminary reports and replaces these reports. The subject of the Master's thesis is progressive collapse of buildings. Focus is on the development of a tool that can calculate the sensitivity of a building concerning its collapse resistance.

I would like to thank ir. Jeroen Coenders at the Structural Design Lab for coming up with this subject and for his support. I would also like to express my gratitude to prof. dr. ir. J.G.Rots, Ir. J.W. Welleman and Ir. K.C. Terwel for their support. Finally, I would like to thank the entire committee for supervising and assessing my graduation project.

Delft, November 2009

Simon Bolle



# Abstract



Progressive collapse is a collapse where a local failure leads to a disproportionate collapse. Different terms like initial failure, propagation of failures and disproportionate damage are important aspects of such collapses. In current design practice, a method to measure a structures' progressive collapse sensitivity in its early design phase and taking into account all aspects of a structures collapse resistance does not exist. The objective of this research is to develop a tool that takes into account all aspects of a progressive collapse and can aid the engineer in assessing a design, in its early design stage, on progressive collapse.

At first, the initial failure is elaborated. Different events can cause the failure of elements. The probability an initiating event occurs at a certain element is different for each element. Mitigating measures can limit the chance of occurring for certain events. The initial events are applied on the model in 2 steps. First the location (or: element) of the event is chosen by a random selection method and a distribution of failure chances on the model. Second, the size of the damage is determined by applying a Gaussian curve over the model, both in x- and z-direction. This determines if adjacent elements, related to the removed element in step 1, are removed.

Second, the design should be generated by the tool. Different two-dimensional preset structural systems can be generated by the tool. The number of columns, floors and the cross sectional properties can be specified in the tool. Loads and load combinations are also applied by the tool. If elements have failed, debris will fall on the remaining building. Static impact loads are applied on the model to account for this, by using an amplification factor.

The model is calculated by FEA-software. Only linear and first order calculations are considered. These limitations lead to inaccuracies of the results compared with reality. A stability analysis has been performed to determine the buckling lengths of columns with more accuracy. Catenary action is one of the main modelling methods in designing against progressive collapse. This method is implemented into the tool. Iteratively, the forces and deformations are calculated which develop during the occurrence of catenary action.

The evaluator of the tool determines whether or not a progressive collapse can be assumed based on four failure criteria. The first criterion is the occurrence of a local mechanism. If this occurs a progressive collapse is counted. Local mechanisms are reduced by applying rotational and translational springs in structural systems with pinned connections. The second condition is a strength criterion. For all elements, unity checks are calculated. If a unity check exceeds 1, the element will be removed from the model and the model is reanalysed and evaluated. The third criterion is a deformation condition. If the displacement of an element exceeds a limit it is assumed the element has failed, but will not be removed from the model. Finally, a progressive collapse is based on the amount of total damage. If the damage is disproportionate, the collapse is called a progressive collapse. If none of the above happens, no progressive collapse occurred.

A progressive collapse indicator (PCI) is calculated. One design is analyzed a certain number of iterations, resulting in an amount of progressive collapses. Then, the PCI is the number of progressive collapses, divided by the number of iterations performed. It gives an indication about the sensitivity of a design to progressive collapse.

There are different methods in the order of evaluating elements, which have influence on the resulting PCI. A fixed order of element removal will result in irregular failure patterns. The method that is used in the tool, is the removal of one element which exceeds the unity check the most. It showed, that for some cases reasonable failure patterns are retrieved. Though, for some other cases the failure pattern will be irregular.

The accuracy of the resulting PCI can be represented by the variance and standard deviation. When performing more iterations, the result will become more accurate. A linear relation between the amount of iterations performed and the time needed to complete the calculations is present. A minimum amount of iterations is needed to make sure enough initial failure combinations are included in the calculations. The PCI can be used to validate a design on progressive collapse. The PCI of a design needs to be compared with the PCI of a preset structural system. If the PCI of the design is larger than the PCI of the preset structure, the design is more sensitive to a progressive collapse and adjustments are needed. An upper bound for the PCI will also aid the validation of a design.

It is concluded that a tool is developed that includes all aspects of a progressive collapse, but that it can not be used in daily practice. Yet, the resulting propagating failure of elements sometimes leads to irregular results and thus needs refinement. Also, since input of a user's design is not possible, implementations are needed to achieve that.



# Table of contents

Preface	v
Abstract	vi
Table of contents	viii
Ch1.Introduction	10
1.1 Background	10
1.2 Problem analysis	11
1.2.1 Current situation in design practice	11
1.2.2 Proposal for progressive collapse tool	11
1.2.3 Problem definition	13
1.2.4 Master's project aim	13
1.2.5 Most important starting points	13
1.3 Thesis structure overview	14
Ch2.Definitions	16
2.1 Progressive collapse	16
2.2 Initiating event	16
2.3 Damage	17
2.4 Progressive collapse (probability approach)	17
Ch3.Types of progressive collapse	20
3.1 Pancake type collapse	20
3.2 Zipper type collapse	21
3.3 Domino type collapse	22
3.4 Instability type collapse	23
3.5 Mixed type collapse	24
3.6 Classes	25
<b>PART I. Initial failure</b>	<b>27</b>
Ch4.Initiating events and measures	28
Ch5.Initiating events applied in tool	32
5.1 Step 1: Location	32
5.2 Step 2: Adjacent chance of failures	34
<b>PART II. Structural mechanics</b>	<b>37</b>
Ch6.PCI tool	38
6.1 Generator	38
6.1.1 Nodes	38
6.1.2 Elements	38
6.1.3 Properties	40
6.1.4 Structural systems	41
6.2 Loads	48
6.3 Evaluator	51
6.3.1 FEA	51
6.3.2 Failure criteria	52
6.4 Iterations and simulations	58
Ch7.Iterative calculation	60
7.1 Quantifying disproportionate damage	60
7.2 Failure criteria	61
7.3 Iterative calculation	62



Ch8.Increased loading	64
8.1 Debris loading	64
8.2 Impact loading	65
8.2.1 Floor impact	65
8.2.2 Column failure	66
Ch9.Improvements	68
9.1 Stability analysis	68
9.1.1 Buckling	68
9.1.2 Non-linear calculation	71
9.1.3 Validation	75
9.1.4 Global stability	75
9.2 Catenary action	76
9.2.1 Calculations	76
9.2.2 Validation	80
<b>PART III. Validation</b>	<b>81</b>
Ch10.Evaluation order	82
Ch11.Sensitivity analysis	86
11.1 Variance and standard deviation	86
11.2 Average PCI	87
11.3 Optimum amount of iterations	88
Ch12.Verification	90
12.1 General	90
12.2 Situation 1	91
12.3 Situation 2	94
12.4 Situation 3	98
12.5 Comparing PCI's	99
<b>PART IV. Usability and discussion</b>	<b>101</b>
Ch13.Usability of PCI	102
13.1 Specific comparison	102
13.2 General comparison	103
Ch14.Discussion	104
Conclusions	108
Recommendations	110
<b>Appendices</b>	<b>CXIII</b>
A.List of tables and figures	CXIV
B.List of formulas and symbols	CXVI
C.Linear calculation	CXXIV
D.Unity checks for steel and concrete	CXXVI
E.Codes	CXXXVI
F.Average lengths	CXLII
G.Buckling analysis	CXLIV
H.Catenary action	CLVI
I.GUI PCI-tool	CLX
J.Sensitivity analysis	CLXII
K.Failure order	CLXVI
L.Bibliography	CLXXX



# Ch1.Introduction

## 1.1 Background

On May 16<sup>th</sup>, 1968, the 22-story Ronan Point apartment building in London (partially) collapsed. On the 18<sup>th</sup> floor, a gas explosion knocked out the load-bearing precast concrete panels near the corner of the building. This resulted in the loss of support for the upper floors and caused them to collapse. The impact of these collapsing floors set off a chain reaction of collapses all the way to the ground. The corner bay of the building completely collapsed from top to bottom, resulting in the death of 4 people (Shankar Nair, 2004).



*Figure.1.1 Collapse of Ronan Point*

*[Source: <http://www.911review.com> (left), <http://www.bdonline.co.uk> (right)]*

The previously described collapse was labeled with the term "Progressive Collapse". Although there exist different definitions of progressive collapse, they look very similar. In general, progressive collapse is referred to as an event where the initial local loss or failure of load bearing capacity, results in the local failure of the structural frame, which causes a further loss of support and, ultimately, the failure of a large part of, if not the entire structure.

In other words, progressive collapse is characterized by a pronounced disproportion between the magnitude of a triggering local event and the resulting widespread collapse of large parts or the entire structure (Starossek, 2008). "Chain reaction" and "disproportionate" are important terms in this context.

## 1.2 Problem analysis

The probability of a progressive collapse  $P(F)$  as a result of an abnormal event can be represented as a chain of partial probabilities (Ellingwood&Dusenberry, 2005):

$$P(F) = P(F | DH) \cdot P(D | H) \cdot P(H) \quad \text{with,} \quad (\text{formula.1.1})$$

$P(H)$	the probability of a hazard for the structure [-],
$P(D H)$	the probability of local damage D as a result of the event H and [-],
$P(F DH)$	the probability of failure F of the structure as a result of local damage D by H [-]
$P(F)$	the probability of a progressive collapse [-]

In this description, a distinction is made between robustness and collapse resistance. According to Starossek (Starossek, 2008), robustness is defined as the insensitivity of a structure to local failure depending on its structural properties, while collapse resistance is a property that is influenced by both structural features as well as possible causes of initial failure.

### 1.2.1 Current situation in design practice

In the design practice of structural engineering, progressive collapse is mainly considered in a late stage of the design. However, in the past few years a growing concern for progressive collapse can be noticed. Because of the Ronan Point disaster, more attention to progressive collapse was introduced in the building codes and standards. The Dutch NEN 6700-series stated the following:

*'Building structures should be designed in such a manner that failure of a part of the structure does not lead to disproportionate damage.'*(NNI, 2005)

There can be much discussion about how to interpret the term progressive collapse and the standards correctly. For instance, what exactly can be understood with local? And when is damage disproportionate?

Next to this, hardly any quick analysis tools exist for progressive collapse. Therefore, ir. Coenders proposed a progressive collapse tool and a progressive collapse indicator (PCI). A progressive collapse indicator is a proposal to assess the aspect of progressive collapse and initial failure in the early stage of the design (Coenders & Wagemans, 2005). It can be a method for quantifying a design for the potential of progressive collapse. This progressive collapse indicator is the inspiration for this Master's thesis.

### 1.2.2 Proposal for progressive collapse tool

In chapter 1.1 the terms "robustness" and "collapse resistance" have been introduced, which play an important role in designing against progressive collapse. Traditionally, engineers and design tools merely focus on the robustness of the structure. This can limit the design possibilities. If a lower level of robustness is accepted, still a high level of collapse resistance can be achieved, by means of measures like standoff distance, collision preventing obstacles or by providing local resistance.

In order to provide in the need of a design tool that analyses the total collapse resistance, a quick building assessment tool for progressive collapse was proposed by ir. Coenders (Coenders & Wagemans, 2005).



# Ch1.Introduction

That analytical tool uses a probabilistic approach to the initial failure of elements of a structure and is able to give a rough indication about the sensitivity of the design to progressive collapse. The basic computational method of the tool is schematically depicted in figure.1.2. The tool consists of three elements; a generator, a finite element analysis application and an evaluator. The generator uses the initial geometry of the structure to randomly create a 'damaged' structural geometry in which certain elements are missing, based on their chances of failure and failure distribution. The generator uses a random simulation technique. It is possible that multiple elements are missing in the damaged structural geometry. This randomly created geometry is analysed by the finite element application with geometric- and physical- linear calculations. The evaluator checks whether failure or non-failure should be assumed.

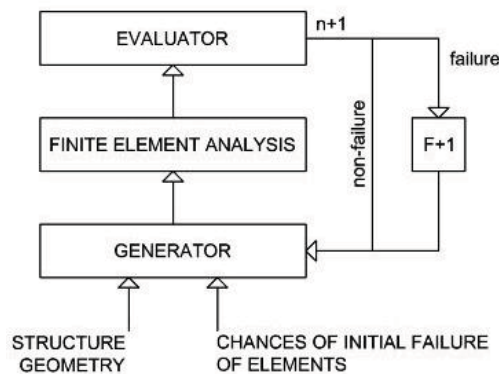

Figure.1.2 Proposed progressive collapse indicator tool

Four situations are defined;

1. A mechanism occurs and can not be calculated. It is assumed that the structure then fails.
2. Stresses in elements become too high, which results to failure of these elements leading to a second collapse.
3. Deformations are too much, for instance when a deformation is larger than the space between the floors, or that linear calculation assumptions do not apply anymore. It is assumed that the structure then fails.
4. None of the above happens, so no progressive collapse occurs.

One type of structure is generated n number of times and the amount of failures F is counted. This gives the progressive collapse indicator (PCI);

$$PCI = \frac{F}{n} \cdot 100\% \quad (\text{Coenders \& Wagemans, 2005}) \quad \text{with,} \quad (\text{formula.1.2})$$

PCI            the Progressive collapse indicator [%]  
 F                the number of failures [-]  
 n                the number of calculations [-]

The proposed prototype is a very crude tool because the failure conditions do not describe a progressive collapse, since the failure of only one element, will not necessarily result in a chain reaction of failures. Therefore, improvements have to be made, like for instance, iterative calculation with element removal if an element fails, increased loading from debris and refinement of the chances of initial failure of elements. E.g. the chance of failure, concerning traffic impact, is higher for elements at ground level than at the second floor.

The PCI gives a value for the sensitivity of a design to progressive collapse, but what information exactly does this provide? The value itself is meaningless, as it does not tell us whether for instance a PCI of 10% is good or bad. A proper judgment can only be made, when comparing the calculated value to a certain reference value. In other words, the PCI for a designed structure has to be compared with the PCI of several other structures in order to properly indicate the sensitivity to progressive collapse for the designed structure. Note that the PCI is not an indication of the chance of failure of a building, but provides its sensitivity.

With the PCI, an indication can be given for a designed structure on its collapse resistance. This can be used to complement the codes with respect to progressive collapse in the early design stage. For instance, when a PCI of a building is lower than a reference value, the building is not sensitive to progressive collapse and the design process can be continued. When the PCI is larger than the reference value, adjustments have to be made on the design before further designing the building. This can mean improvements on the structure itself as well as reducing the occurrence of an event (event control).

### 1.2.3 Problem definition

In current design practice a method to measure a structures' progressive collapse sensitivity in its early design phase and taking into account all aspects of a structures collapse resistance does not exist. A proposal for such a method is provided by ir. Coenders' tool. Though, this prototype is very crude and refinement is needed.

### 1.2.4 Master's project aim

The objective is a refined design tool of ir. Coenders' prototype for quick assessment of a building on the sensitivity to progressive collapse, in which aspects like chain reaction of failures, debris loading and distribution of chances of initiating events are taken into account.

### 1.2.5 Most important starting points

- ir. Coenders' proposed progressive collapse tool will be used as the basis for the development of the tool.
- Geometric and physical linear calculations are considered.
- 2D calculations are considered.



## 1.3 Thesis structure overview

The report is divided into 4 main parts. Each part corresponds to a specific subject of the PCI tool. A structural mechanics part, a statistical part, a validation part and a usability part are distinguished. First a description is given of the terms and definitions mostly used concerning progressive collapse. Then, the possible failure modes exhibiting in a progressive collapse will be discussed. Several types and classes will be discussed. Then the different parts, above mentioned, will be discussed.

### **PART I:**

In the statistical part, at first a description is given about what initiating events can occur on a building. Also, the measures that can be taken to mitigate the chance of occurring for several events are discussed. In the second chapter of this part, it is discussed how the events and their chances are applied on the model.

### **PART II:**

In the structural mechanics part, at first, a description is given about how the PCI-tool works. The basic features of the generator and evaluator are discussed as well as the applied loads. In the next chapter, a refinement on the basic tool is given in expanding the evaluator with an iterative calculation. The next chapter continues the refinement of the tool, by taking into account increased loads from debris and impact loading. The last chapter of this part describes other improvements made on the tool, like stability analysis and calculation with catenary action.

### **PART III:**

In this part of the report, the tool is being validated. First, the evaluation order of the elements, used in the calculation, is discussed. Different methods can be used, which produce more or less reliable results. The second chapter of this part describes how many iterations are needed to come up with a reliable PCI value. In the last chapter, multiple runs are performed with which it is verified if the tool produces results that can be expected in advance.

### **PART IV:**

This part of the report focuses on how the tool can be used in daily practice. First, the meaning of the PCI value is discussed and what consequences this value has on the design. Second, a chapter is added in which it is discussed what imperfections the tool still has got and what can be done to improve the reliability of the results.

The PCI tool has been developed using the following software;

Programming software: Microsoft Visual Studio 2005

Programming language: Visual Basic 2005.NET

FEA: Oasys GSA Analysis 8.3.1.21



## 2.1 Progressive collapse

In literature, many definitions of progressive collapse exist. Two of the most relevant definitions will be presented here. Article 5.3.3 of the Dutch NEN6700:2005-series states;

*'Building structures should be designed in such a manner that failure of a part of the structure does not lead to disproportionate damage.'*(NNI, 2005)

While professor B.R.Ellingwood, researcher at the School of Civil and Environmental Engineering at Georgia Tech, has a more elaborate definition;

*'A progressive collapse of a building is a catastrophic partial or total failure that ensues from an initiating event that causes local damage that can not be absorbed by the inherent continuity and ductility of the building structural system. Following this local damage or failure, a chain reaction of failures propagates vertically or horizontally and develops into an extensive partial or total collapse, where the resulting damage is disproportionate to the local damage caused by the initiating event.'*(Ellingwood, 2002)

This last definition will be retained since it clearly shows the relation between the associated terms concerning a progressive collapse, namely initiating event, local and global damage and disproportional damage. These terms will be discussed next.

## 2.2 Initiating event

The initiating event triggers the sequence in which a progressive collapse can develop. Several initiating events can be thought of, like a truck colliding with a column near a road, a gas explosion (as was the case with the Ronan Point disaster) or a terrorist attack. The events can be categorized in six categories:

- 1 Misuse
- 2 Fire
- 3 Accidental impact
- 4 Error(s) in construction or design
- 5 Foundation failure
- 6 Blast loading

The common feature of the events is that they result in abnormal loading and/or deformation and have a small probability of occurrence. The probability of an initiating event, occurring at a certain element, is different for each element. A car collision for instance, is more likely to occur at columns at ground level than on the second floor. Also, the function of a building is of importance in determining the chance that an event takes place. Terrorists will most likely strike governmental buildings, or buildings with many occupants, instead of industrial buildings. A broader discussion about initiating events and relating chances is given in PART I of this report.



## 2.3 Damage

### *Local damage*

The initiating event causes one (or more) element(s) of the building structure to fail, or at least partially fail, with which the load bearing capacity of that element reduces. The partial failure of elements is beyond the scope of the Master's thesis and it is assumed that, if an initiating event occurs, elements interfering with the event will completely fail.

### *Global damage*

The reduction of the load bearing capacity of an element can cause adjacent elements to fail. This, in its turn, can lead to another failure, triggering a chain reaction of failures. When the chain reaction of collapses stops, the total damage to the structure is attained. This damage is called global damage.

### *Disproportionate damage*

The term disproportionate damage is susceptible to a lot of discussion. Damage is disproportionate if it is out of proportion to the initial failure, but still the question remains when this is the case. The indistinctiveness to what extent damage is disproportionate can also be seen in various codes and standards. The codes and standards all describe an admissible damage, but differ into what extent this damage should be allowed. This illustrates the difficulty in determining a definition for the term disproportionate damage. What can be said about disproportionate damage, and where the various codes do agree upon, is that it is a damage which exceeds an allowable damage. The quantity of this damage can be attained from the standard generally applicable for the considered region. An elaborate discussion about the quantification of disproportionate damage in various codes is provided in chapter seven.

## 2.4 Progressive collapse (probability approach)

When considering the probability of a progressive collapse as a combination of partial probabilities, as discussed in the introduction, more terms concerning progressive collapse can be distinguished. Figure.2.1 clearly illustrates this.

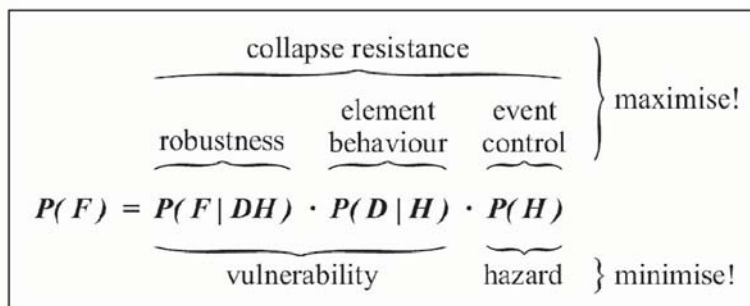

- $P(H)$             *the probability of a hazard for the structure [-]*
- $P(D|H)$         *the probability of local damage D as a result of the event H and [-]*
- $P(F|DH)$        *the probability of failure F of the structure as a result of local damage D by H*  
*[-]*
- $P(F)$             *the probability of a progressive collapse [-]*

Figure.2.1 Terms in context of progressive collapse [Source: (Starossek&Haberland, 2008)]

## Ch2.Definitions

### *Robustness*

Robustness is defined as *'the insensitivity of a structure to local failure. [...] It is a property of the structure alone and independent of the possible causes and probabilities of the initial local failure.'* (Starossek, 2006) The properties of the elements define the robustness since these determine the strength capacities of the material. E.g. thicker elements are more robust than thin elements of the same material and with the same shape.

### *Collapse resistance*

Collapse resistance is defined as the *'insensitivity of a structure to accidental circumstances, which comprise unforeseeable or low-probability events. [...] It is a property that is influenced by both structural features as well as possible causes of the initial failure.'* (Starossek, 2006) The combination of the structural features as well as causes of the initial failure are not taken into account in 'traditional' engineering. The PCI-tool does incorporate both of the features and thus will be a preferable method in predicting the collapse resistance of a building.

### *Continuity*

*'Continuity refers to the continuous connection of components as well as the continuous reinforcement of concrete components. Integrity, redundancy and/or local resistance can be improved and special load-carrying mechanisms enabled by continuity.'* (Starossek, 2006) The connections between the elements will define the continuity since these will have effect on the load distribution of the structure. E.g. the bending moments for a multi-span floor slab are different compared with a single-span floor slab.

### *Ductility*

*'Ductility is the ability of a component or structural system to withstand large plastic deformations. Ductility has a large influence on progressive collapse and is often listed as a factor which increases the robustness of a structure.'* (Starossek&Haberland, 2008) Ductile behavior is completely material dependant and is defined by its stress-strain curve. Under increased tensile stress the material will deform and at some point will fracture. Opposite to ductile behavior some material show brittle failure wherein under increased loading, it hardly will deform and at some point will suddenly fracture.

### *Integrity*

*'Integrity refers to the condition of a structural system and implies that the structure and its components remain intact over the intended lifetime of the structure.'* (Starossek&Haberland, 2008) During a structure's lifetime the environment will affect the structure. Under the influence of sunlight and rain the material its strength capacities will decrease as well as the integrity of the structure.

### *Redundancy*

*'Structural redundancy refers to the multiple availability of load-carrying components or multiple load paths which can bear additional loads in the event of a failure. If one or more components fail, the remaining structure is able to redistribute the loads and thus prevent a failure of the entire structure. Redundancy depends on the geometry of the structure and the properties of the individual load carrying elements. Redundancy is not synonymous with static indeterminacy.'* (Starossek&Haberland, 2008) When designing against progressive collapse, redundancy is used to increase the structure's robustness. This method is referred to as the alternate load path method.



# Ch3.Types of progressive collapse

When investigating several historical cases where structures collapsed progressively, different types of failure modes can be distinguished. Five different types of progressive collapse can be determined in this way<sup>(1)</sup>. When comparing the specific features of the progressive collapse types, another subdivision into four classes can be established. The following discussed types and cases are derived from publications by U. Starossek (Starossek, 2007). He is a professor of structural engineering at Hamburg University of Technology and has published several papers concerning progressive collapse.

## 3.1 Pancake type collapse

The collapse of the World Trade Centre (WTC) towers in New York on 11 September 2001 is a typical example of a pancake type collapse. Because of the impact of the airplanes and the resulting fires, the load bearing capacity of the columns on the related floors reduced. Although this was limited to a few floors, it affected the load bearing capacity of the columns over the entire horizontal cross section. This reduction in strength resulted in a downward motion of the upper floors. On impact with the lower floors, which were still intact, extra forces in the columns were introduced. These forces exceeded the load bearing capacity and caused the columns to fail over the entire floor area. This led to the same preceding failure mode resulting in a total collapse.



Figure.3.1 Pancake type collapse [Source: <http://www.911review.com>]

This failure type shows the following characteristics:

- One of the main features of this kind of collapse is the initial failure of vertical load bearing elements. This is the triggering event whereby a chain reaction of failures is initiated. Without this initial failure no progressive collapse develops.
- A second main feature is the vertical rigid body motion. If vertical load bearing elements fail, the upper elements will lose their vertical restraints.
- A third important feature is the transformation of potential energy into kinetic energy. Prior to an initial failure, the structure above the failing elements has a certain mass and height

<sup>1</sup> N.B.: In his paper (Starossek, 2007) Starossek also defines a sixth type of progressive collapse; a section type collapse. This type of collapse is not discussed here because it basically is not a progressive collapse but a fast fracture. It concerns single element failure and therefore does not describe how the progression of failures propagates but only can be a cause of initial failure.

and due to gravity it consist potential energy. This energy is restraint by the vertical load bearing elements, hence the structure is in equilibrium. When elements fail, the structure above these elements start to move vertically due to gravity. This motion, combined with the mass, results in the release of potential energy into kinetic energy.

- A next feature is the impact of the upper structure on the remaining lower structure. When the upper structure starts to move, its velocity will increase as well as the kinetic energy. On impact on the lower structure, the kinetic energy is released resulting in impact loading.
- A last feature is the failure of other vertical load bearing elements, due to the impact loading. The kinetic energy that is released on impact, have to be restraint by the remaining vertical load bearing elements. If the reserve capacity of the elements is exceeded by the impact load, the elements will fail. The impact forces tend to concentrate in the immediately impacted elements due to the dynamic nature of impact.

### 3.2 Zipper type collapse

The zipper type collapse can best be illustrated by the Tacoma Narrows Bridge collapse in 1940. The bridge was a single span cable-stayed bridge, with a length of approximately 850 meters. A wind, blowing perpendicular to the bridge span direction, induced the bridge to vibrate. This 'flutter' introduced high tensile forces in the hangers at which the girders are connected. These forces exceeded the tensile capacities of the hangers. Consequently, the hangers snapped and the entire girder peeled of and fell.



*Figure.3.2 Zipper type collapse; Tacoma Narrows Bridge [Source: <http://www.jalopnik.com>]*

This failure type shows the following characteristics:

- A specific feature for this type of collapse is a redistribution of forces, that will be carried by the remaining structure. Provided that one or more elements fail, due to whatever reason, the forces have to be transmitted through the remaining structure. Therefore a redistribution of these forces takes place.
- Another feature is the impulsive loading of the structure. Specifically the initial failure occurs suddenly, as can be seen for the Tacoma Narrows Bridge. Because of this sudden failure, a sudden redistribution of forces takes place. A sudden application of forces results in impulsive loading. Although impulsive loading can also be caused by impact loading, that type of impulsive loading does not occur for this type of collapse.

## Ch3.Types of progressive collapse

- The impulsive loading causes the remaining structure to respond dynamically. This dynamic response generates extra internal forces.
- The combined forces, induced by the load redistribution and dynamic response, cause a force concentration in elements adjacent to, or in the vicinity of, the initially failing elements. The affected elements have similar function and type. When the force concentration exceeds the force capacity of the elements, they will fail, proceeding in a series of similar failures.
- The last, and perhaps most characteristic feature of this failure type, is the progression of the collapse in a direction transverse to the principal forces in the failing elements. The parallel load transfer of the structure causes it to fail, corresponding to the motion of a zipper.

Besides the Tacoma Narrows Bridge collapse, other examples of this type of collapse can be distinguished. A continuous girder supported by slender columns can fail in this type of collapse when a column buckles, resulting in the overloading and failure of adjacent columns. Also a local damage to a membrane or cable net structure can induce this type of collapse.

### 3.3 Domino type collapse

As the name already suggests, this type of collapse is characterized by a chain reaction of falling blocks onto another.



*Figure.3.3 Domino type collapse; Overturning office building in Manila impacting adjacent apartment building [Source: <http://www.archidose.org>]*

It exhibits the following characteristic features:

- The initial overturning of an element. This can be seen as the consequence of an initial event. For instance, the failure of the anchorage of a temporary scaffolding tower can result in instability of the tower leading to overturning of it.
- When a slender and unbraced element becomes unstable, it will start to fall. This fall is accompanied by an angular rigid body motion around a bottom edge. This means, that on each point on the element a vertical and a horizontal motion is noticeable.
- Similar as with the pancake type collapse, during the fall of an element potential energy is transformed into kinetic energy. When an element is rotated around its bottom edge, the distance between the upper part of the element and the bottom edge increases. Because of the dead weight (or: potential energy) of the element, the velocity as well as the kinetic energy increases.
- At a certain moment, the falling element will hit an adjacent element. The upper edge of the element impacts the side face of a neighbouring element. Due to the impact, a horizontal force is transmitted to the still unharmed element. This horizontal force consists of a static part when the element leans on the adjacent element and a dynamic part because of the horizontal movement of the falling element.
- When the extra horizontal force exceeds the reserve capacity of the adjacent element, this element will start to overturn as well, leading to the same failure mode as described before. The collapses will progress in the direction of the overturning elements.

Similarities can be seen between this type of collapse and a pancake type collapse. For both types of collapses the impact forces is important for the progression of the collapse. Also the zipper type collapse shows similarities, as in both cases the principal forces in the falling structures are orthogonal to the failure propagation. Therefore, a separate type of collapse is distinguished apart from the pancake and zipper type collapse.

An example of this type of failure is the collapse of several overhead transmission line towers. In addition to the earlier discussed features, some extra characteristics have to be distinguished. First, the impact between elements can also be indirect. In this case, the power lines are mediator between the different towers. Due to this extra feature, it is not necessary for the motion of failure propagation, to be parallel to the direction of overturning. If a tower falls orthogonal to the direction of the power lines, the power lines will pull the other towers towards the initially falling tower. It thus follows, that the propagating action can also be a pulling force instead of an impact force.

### 3.4 Instability type collapse

Instability is the sensitivity of a structure to show large deformations due to small imperfections or transverse loading. Normally, structures are designed by considering that instability may not occur. If however, a bracing element fails, the structure can become unstable and collapse. It is important to consider the following condition. Take for instance a continuous girder with stabilizing compression chords. If one of these chords fails, a span of the girder will fail as well. Consequently, other chords can fail. Although initially this failure mode seems to fit the instability type collapse, it is not the same. The successively failure of chords is caused by a redistribution of forces and thus fits the zipper type collapse. Therefore, in an instability type collapse, the propagating action is a destabilization rather than a force.



## Ch3.Types of progressive collapse

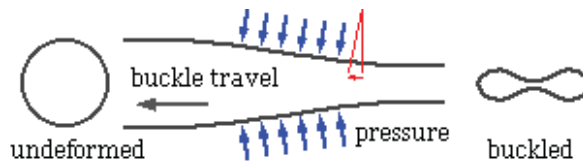

Figure.3.4 Instability type collapse; Buckling of a pipe line [Source: <http://www.mech.uwa.edu.au>]



Figure.3.5 Instability type collapse; Buckling of a pipe line [Source: <http://www.mie.uth.gr>]

It has the following characteristics:

- The initial event affects stabilizing load carrying elements in compression, leading to failure of these elements.
- When the initial stabilizing elements fail, parts of, or the entire structure becomes unstable. Despite this instability, the structure will not collapse (yet).
- When small perturbations, like small deformations or transverse loads, are applied on the destabilized elements, they will suddenly fail.
- A repetition of the previously described features results in a progressive collapse.

An example of this type of collapse is a truss tower in which a leg has failed. Immediately after the failure the tower will collapse. Although in this example there is no progressive failure it is still characterized an instability type collapse, as there is a strong disproportion between cause and effect.

Another, perhaps more convenient, example is the buckling of deep-water pipelines. A small initial instability can propagate into a large part of the pipe because the shell of the pipe has a load bearing function as well as a stabilizing function.

### 3.5 Mixed type collapse

The previously described types of progressive collapse were rather easy to distinguish. There are also some cases where this division is not so clear and several types of collapse interact.

The collapse of the Murrah Federal Building in Oklahoma City in 1995, for instance showed features of more than one type of collapse. First, a pancake type collapse was visible, where a bomb destroyed one column and severely damaged several other columns, resulting in the collapse of a part of the building over the full height of the building. Also a domino type collapse could be distinguished. Horizontal forces were introduced, by falling elements that were still connected to the adjacent structure through continuous reinforcing bars.



Other cases of interacting types of collapse can be seen in bridge design. With cable stay bridges, the cables not only support the girders, but also provide stability for the towers. The loss of one or more cables, can thus result in failure of the girder, but can also lead to instability. In such cases, the zipper type collapse and instability type collapse interact.

In building structures it even seems possible that more than two types interact. A pancake type collapse and a domino type collapse have been described for the Murrah Federal Building, but it is also thinkable that a zipper type collapse or instability type collapse contributed to the progressive collapse. As earlier described, a continuous girder supported by slender columns can fail in a zipper type collapse when a column buckles resulting in the overloading and failure of adjacent columns. This can also be the case for a continuous frame structure commonly used in building structures. When a collapse propagates through a building an increasingly amount of elements will fail. This will strongly affect stiffness and bracing of the structure resulting in destabilization of the building. Thus, an instability type collapse also can be involved.

### 3.6 Classes



Figure.3.6 Murrah Federal Building after the bombing in 1995 [Source: <http://www.911review.com>]

Further generalization and classification of progressive collapses is possible, when the previously described progressive collapse types and their specific features are examined. The different classes can be used to effectively model the collapse, when developing the PCI-tool. They can also proof useful when deciding what countermeasures have to be taken, to account for a progressive collapse. Four progressive collapse classes are specified:

#### *Redistribution class*

This class characterizes itself by a redistribution of forces, carried by the remaining structure during a collapse, as can be seen with a zipper type collapse. The propagating action features overloading of the structure, as the result of a redistribution of forces.

## Ch3.Types of progressive collapse



### *Impact class*

The impact class is a combination of the pancake type collapse and the domino type collapse. During both types of collapse, potential energy is transformed into kinetic energy. This kinetic energy is released at the impact of the failing element on the remaining structure. The propagating action features overloading of the structure, as the result of impact forces.



### *Instability class*

This class is formed by the instability type collapse and is characterized by a destabilization of load carrying elements in compression. The propagating action features overloading of the structure, as the result of destabilization.



### *Mixed class*

The mixed type collapse is fully applicable to this class. A combination and interaction of the previous classes is reasonably possible during the collapse of a structure. The propagating action features overloading of the structure, as the result of a combination of redistribution of forces, impact forces and destabilization.

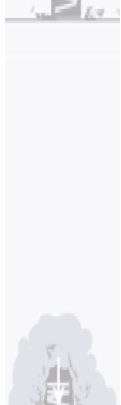
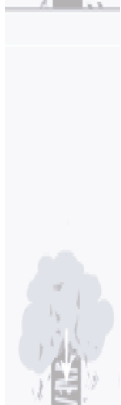

## PART I. Initial failure



## Ch4. Initiating events and measures



Before a progressive collapse can occur, an initiating event should trigger the sequence of failures. There are different events with different chances of occurring. Each event in its turn, also has got different chances of occurring at different elements throughout the building. The occurrence of several events can be prevented by applying certain countermeasures. These will reduce the failure chance of elements. In this part of the report, attention is given to the initiating events, mitigating measures and their application into the tool.



The initiating event triggers the sequence in which a progressive collapse can develop. There can occur a lot of initiating events, like a gas explosion (as was the case with the Ronan point disaster), a terrorist attack, or a car colliding with a column.

The events all have in common that they have a small probability of occurrence and that they will result in abnormal loading or deformation. For each element, different events can occur and can have different chances. For instance, an accidental impact due to road traffic will not occur at columns on the 4th floor.

Also, the function of a building determines the distribution of the failure chances of elements. Gas explosions of course do not occur, if no gas lines are available in the building. Hence, it will reduce the failure chance of the elements in that building.

The events can be categorized in six categories:

1. Misuse
2. Fire
3. Accidental impact
4. Error(s) in construction or design
5. Foundation failure
6. Blast loading

### *Misuse*

This hazard falls in the same category as design/construction error. Human involvement can cause the building to be loaded too much. It is not used what it was designed for. This can result in the failure of one or more elements. All elements can be affected by this event. Some building owners regularly inspect their building to make sure it is not misused. However, this event is hard to prevent due to the human nature of this event.

### *Fire*

A fire can decrease an element's load bearing capacity and can even cause it to fail. The strength and stiffness of structural material is dependant on the temperature. With high temperatures during fires, the elements can thus lose their structural function. All elements can be affected by fire. Some mitigating measures can be taken to decrease the chance that an element will fail due to fire. For instance, fire protecting coatings can be used that will limit the ignition of a fire. Also, compartmentalization can be used to make sure the fire can not spread through the entire building. A lot more measures can be taken which will all influence the fire resistance of the elements. The fire resistance is expressed in minutes. The higher the fire resistance, the lower the chance an element fails due to fire. Hence, a mitigating measure for this event is a large fire resistance, which is composed out of several individual measures. As a reference value, 90 minutes fire resistance is used. In other words, this means that the fire resistance for the element is significantly high.

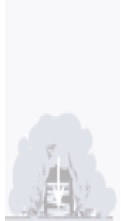
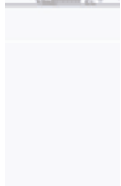

## *Accidental impact*

The accidental impact can be divided into two basic causes, impact by aircraft or impact by road traffic. The chance of impact by aircraft will be higher if buildings are built near airports. If aircrafts crash and they impact a building, they will most probably hit at upper floors. Though, this type of accidental impact is not incorporated within the initiating events, since the damage caused by it will be significantly high and a lot of elements should be removed initially. The disproportionateness of the collapse will then be questionable. However, on further development concerning this subject this can be investigated.

Most buildings are built close to roads, making them vulnerable to an impact by traffic. If there are no obstacles between the road and the building, the cars or trucks will be stopped by the building in case of an accident. The force of impact depends on the distance from the road to the building, as well as the speed, direction and weight of the vehicle (see also figure.4.1).

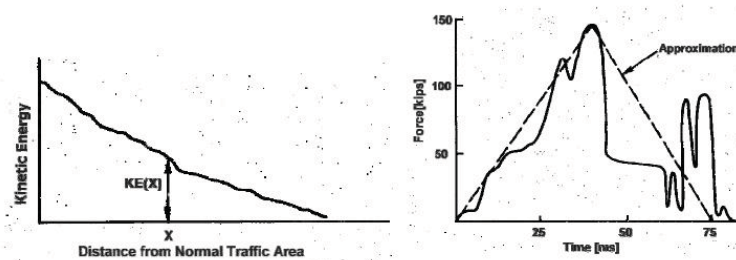

Figure.4.1 Vehicular impact (Source: NIST,2007)

The vehicle will impact at the columns at the lower level and the exterior columns. Avoiding this event can be simply done by applying traffic barriers that stop the vehicle before it can impact the building. Other possible measures all attempt to avoid interference of traffic with the building.

## *Error(s) in construction or design*

This initiating event is the result of human involvement. As a result of errors in planning, design, construction and the use of stochastic variability in resistance and load, elements can fail. These unforeseen circumstances occur, even when qualified personnel is involved. Hence, this event is very unpredictable. All elements can be affected by this event. This event can only be dealt with by proper management and control.

## *Foundation failure*

The foundation of a building is one of the most important aspects of a building, since all the loads are transferred to it. The foundation is built in soil which does not have homogeneous properties. The properties differ from place to place and layer to layer. Weather influences may even change the soil properties. These aspects can cause the foundation, or a part of it, to fail. Hence, other elements can fail as well. Most probably, the elements connected to the foundation will fail. Proper soil inspection before erecting the structure may limit the chance of foundation failure, but real mitigating measures can not be taken.

## *Blast loading*

This event is characterized by the failure of elements due to an explosion. Due to this explosion a pressure wave travels away from the centre of the explosion. This pressure exhibits a force on the elements and can cause them to fail. The strength of the force depends on the distance from the blast and the time after the blast (see also figure.4.2).



# Ch4. Initiating events and measures

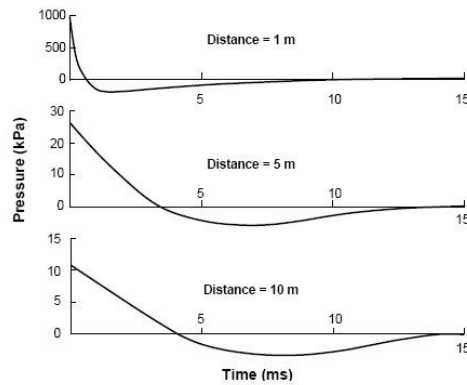

Figure.4.2 Blast loading (Source: NIST,2007)

The explosion can be caused by several things. It can be caused intentionally, by a bomb explosion in a terrorist attack, or by an accidental ignition of a liquid or gas. Both events can be prevented in different ways. Terrorists most likely strike at governmental buildings, or buildings with many occupants to increase the social impact of the attack. Non-governmental buildings thus have much lower probability of bomb explosions. Although changing the function of a building can not be a solution in mitigating the risk of the event, being a non-governmental building does decrease the risk, and thus is labeled a mitigating measure. Another measure can be the improvement of security checks. Accidental explosions by ignition of a gas of course will only happen if that gas is available. Most residential buildings provide gas to the residences for cooking purposes and thus can be vulnerable to such explosions. Prohibiting the use of gas for cooking and not providing gas lines can mitigate the chance of occurring for gas explosions.

Table.4.1 gives a summary of the initiating events and its mitigating measures.

Nr.	Event	Affected elements		Mitigating measure
1	misuse	all		-
2	fire	all		improve fire resistance
3	accidental impact	exterior	interior	traffic barriers
		level 0	facade level 0	
4	error(s) in construction or design	all		-
5	foundation failure	level 0		-
6	blast loading			
6a	bomb	level 0		non-governmental building
6b	gas	all		no gas in building

Table.4.1 Initiating events and mitigating measures

# PART I. Initial failure



# Ch5. Initiating events applied in tool

Previous described initiating events and measures also have to be applied in the tool. A method is developed to apply the chances of initial failure and to determine which element(s) fail. It consists of two steps which will be discussed next.

## 5.1 Step 1: Location

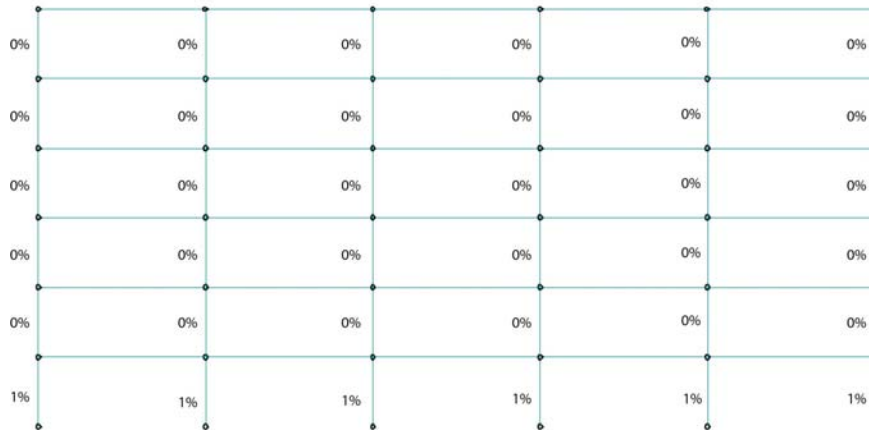

Figure.5.1 Initiating event applied on the model for accidental impact ( $p_i=1\%$ )

The first step of the procedure to apply the chances of initial failure, is the determination of the location of an initiating event (or: which element will fail). For each location of an element, different chances exist for different events. If an event can take place at an element, the relative chance of occurring for that element and event is assumed to be  $p$ . For each element, several events can take place (not at the same time). The total relative chance of occurring is thus the sum of all  $p$ 's for the different events:

$$p_n = \sum_{i=1}^7 p_i \quad \text{with,} \quad (\text{formula.5.1})$$

$p_i$  the chance of occurring for element n of event i [%]

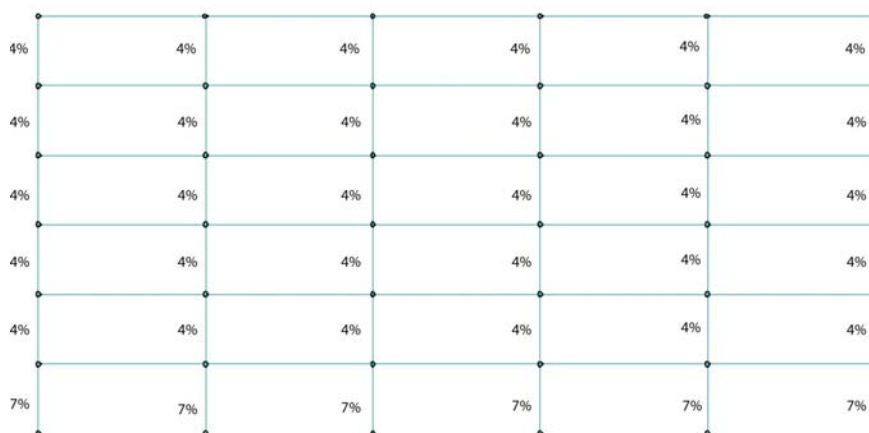

Figure.5.2 Sum of initiating events applied on the model ( $p_i=1\%$ )



# PART I. Initial failure

Mitigating measures will minimize the occurrence of an event. In the tool, this is modelled by assuming the measure will completely eliminate the chance of occurrence for the event. This is of course not completely true, since each measure will only limit the chance of occurring and will not completely prevent it.

$$p_n = \sum_{i=1}^7 (p_i - p_{i, \text{mitigating measure}}) \quad \text{with,} \quad (\text{formula.5.2})$$

$p_i$  the chance of occurring for element n of event i [%]

$p_{i, \text{mitigating measure}}$  the mitigating measure for element n of event i [%]



Figure.5.3 Initiating events applied on the model with mitigating measure: traffic barrier

For instance, for the columns at level 0:

$$\begin{aligned} p_n &= (p_{\text{misuse}} - p_{\text{mitigating measure, misuse}}) + (p_{\text{fire}} - p_{\text{mitigating measure, fire}}) + (p_{\text{acc. impact}} - p_{\text{mitigating measure, acc. impact}}) \\ &\quad + (p_{\text{errors}} - p_{\text{mitigating measure, errors}}) + (p_{\text{foundation}} - p_{\text{mitigating measure, foundation}}) \\ &\quad + (p_{\text{bomb}} - p_{\text{mitigating measure, bomb}}) + (p_{\text{gas}} - p_{\text{mitigating measure, gas}}) \\ &= (1-0) + (1-0) + (1-1) + (1-0) + (1-0) + (1-0) + (1-0) = 6\% \end{aligned}$$

For each element, a total chance of failure for all events can be calculated. Since at least one element should fail<sup>(1)</sup>, the total chance of failure for all elements should be 100%. Hence  $p_n$  is rewritten in:

$$p_n = \frac{\sum_{i=1}^7 p_i}{\sum p_n} \cdot 100\% \quad (\text{formula.5.3})$$

(1) Undamaged structures are not of interest, since these will not result in a progressive collapse and will only cause an increase in calculation time for the tool.

# Ch5. Initiating events applied in tool

It is very difficult to come up with reliable values, as there is not enough statistics available for most events. For instance, statistics on error in construction are hard to predict since otherwise it could be prevented more easily. Hence, the failure chance of each event should not be seen as an absolute value, but as a ratio with respect to the other chances. Therefore, for now it is assumed that  $p_i=1\%$  for all events<sup>(2)</sup>.

Figure.5.4 gives a graphical representation of the initiating events, applied on the model for  $p_i=1\%$  and no mitigating measures.

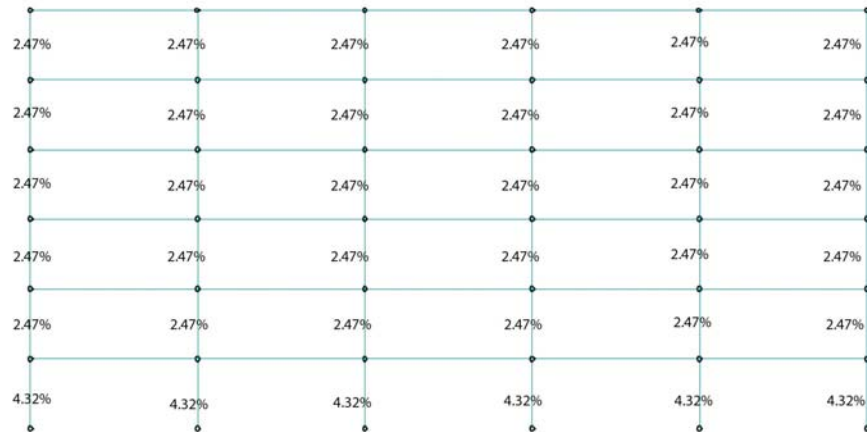

$$\sum p_n = 162 \qquad p_n = \frac{7}{162} \cdot 100\% = 4.32\% \qquad p_n = \frac{4}{162} \cdot 100\% = 2.47\%$$

Figure.5.4 Initiating events applied on the model for  $p_i=1\%$

## 5.2 Step 2: Adjacent chance of failures

Step one determines which element will fail. In step 2 it is determined which adjacent elements will fail as well. If, for instance a gas-explosion causes failure of one element, the adjacent elements also have a high chance of failure. For most events the chances of failure for adjacent elements will decrease with increasing distance to the centre of the event.

A Gaussian curve is used to determine the chances of failure of the adjacent elements:

$$p(x) = \frac{1}{\sigma\sqrt{2\pi}} e^{\left(-\frac{x^2}{2\sigma^2}\right)} \qquad \text{with,} \qquad \text{(formula.5.4)}$$

$\sigma$  a factor which determines the shape of the curve

Since the element has failed (from step 1), at  $x=0$  the chance of failure is  $p(0) = \frac{1}{\sigma\sqrt{2\pi}}$ . The relative chance of failure for an adjacent element then becomes:

$$p_{rel}(x) = \frac{p(x)}{p(0)} = e^{\left(-\frac{x^2}{2\sigma^2}\right)} \qquad \text{with,} \qquad \text{(formula.5.5)}$$

$x$  the distance from the initial event to the adjacent element [m]

(2) In future research more investigation on these chances is advised.

# PART I. Initial failure

For both x- and z-direction the relative chance of adjacent failure can be calculated with the Gaussian formula. The factor  $\sigma$  should be determined on basis of experience and knowledge. As a first indication, for  $\sigma$  in x-direction 3.5 is used and for z-direction 1.5. With these values the adjacent columns have a failure chance of approximately 10%, if the distance between the columns is 7.2m and in z-direction 3m.

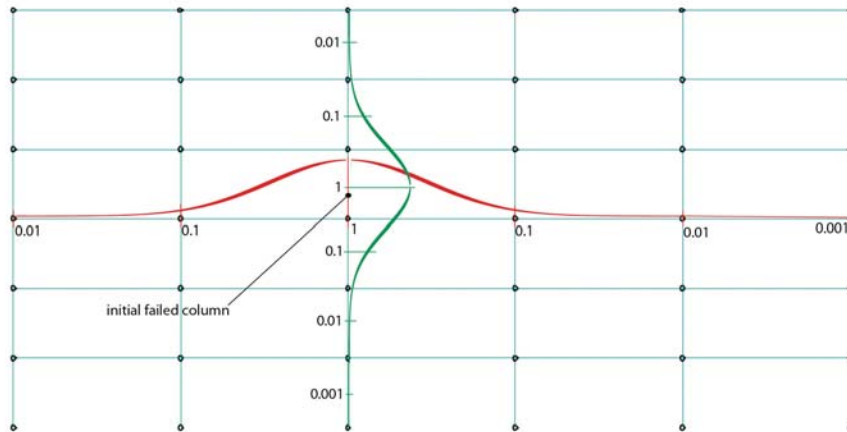
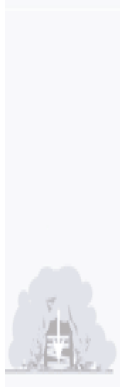
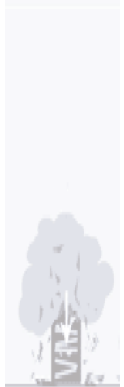
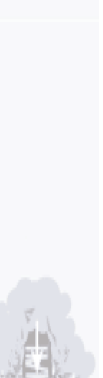
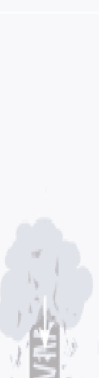

Figure.5.5 Gaussian curve applied on the model





## PART II. Structural mechanics



# Ch6.PCI tool

The PCI tool consists of three main components; a generator, finite element analysis (FEA) and an evaluator, like already introduced in chapter 1.2.2. The generator and evaluator will be explained in this chapter. The FEA is performed by existing software (Oasys GSA Analysis 8.3.1.21) and therefore will only be discussed briefly.

In the development stage of the tool, the redistribution class of a progressive collapse (see chapter 3) was considered in modeling the collapse. This means that the impact class, instability class, and mixed class do not occur. In order to avoid an instability class collapse to occur (in the development stage), the initial failure of elements will not take place at bracing or stabilizing elements. Though, if instability is taken into account (see chapter 9), the initiating events will affect bracing and stabilizing elements. The impact class collapse is considered in chapter eight, where an increased load due to falling debris is applied. In appendix I. the graphical user interface of the tool is presented.

## 6.1 Generator

### 6.1.1 Nodes

The generator is the first part of the tool. It 'draws' a model of the structure. The first step is to generate the nodes. Nodes have a node number and x-, y-, and z-coordinates. Because only 2D modeling is considered, the y-coordinate is neglected.

### 6.1.2 Elements

The second step of the generator, is to create the elements of the model. This can be done using the earlier created nodes. Elements have an element number, a property and a topology. The topology of an element describes the begin- and end- node of that element. The topology provides a linear relation between nodes and elements. In this context, linear means that only straight, or non-curved, elements can be modeled. When combining the node coordinates and element topology in a clever way, it is

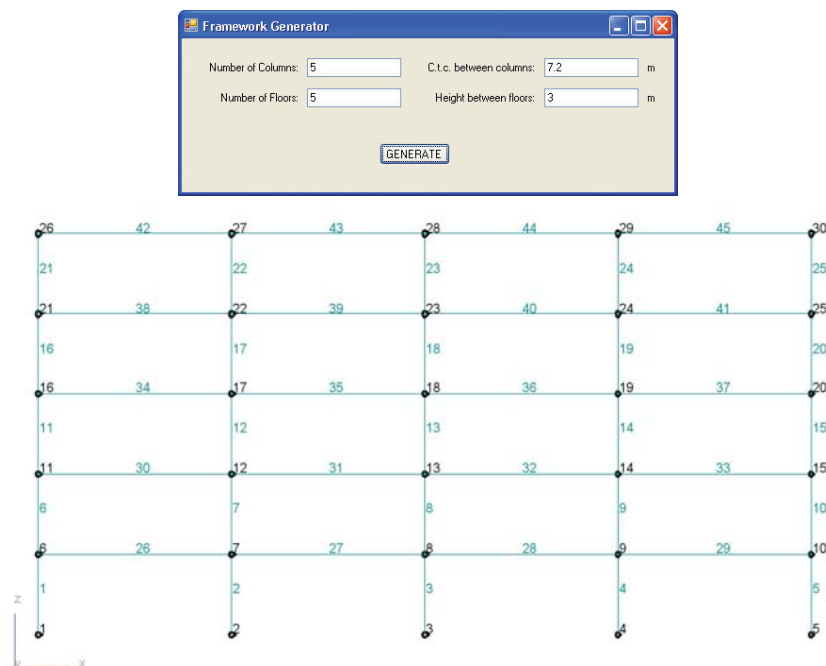

Figure.6.1 Simplified generator (top) and resulting generated model (bottom)

possible to generate a model of a building structure. Figure.6.1 shows a simplification of the generator and the resulting generated model.

As a consequence of 2D modeling, forces, stiffness, deformations etcetera, in y-direction are not taken into account. When the main structure's load bearing elements consist of beams, columns and walls this restriction still seems to approach reality, as these element's main directions and reactions are in x- and z-direction. In y-direction a building has several repetitive bays. The generated model can thus be seen as one of these bays. Normally, these bays are connected to each other and if a vertical cross section over the bays is made, it will produce a similar view as the bay itself. Consequently, the load distribution of the floors will be divided non-linearly over the x- and y-direction, as can be seen in plate and slab analysis (Lowe, 2005). In order to execute 2D calculations and limit complexity, it is assumed that the regarded bays' stiffness is higher in its main direction and thus will attract most forces. Therefore, the influence of the interconnecting elements between the bays is neglected and a linear load distribution on the main bays is regarded. This also means, that imposed rotations due to deformations in y-direction are not taken into account. Another restriction of the fact that only 2D considerations are taken into account is that failure in y-direction is disregarded. This can be accounted, for when analyzing the model both in x- and y-direction. An elaborate discussion about what load distribution is applied on the model, is given in paragraph 6.2.

When calculating the PCI of a certain bay, a distinction has to be made between two types of bays, an interior bay and an exterior bay. The characteristics of these bays are the same, but the applied loads differ. On the exterior bay half of the applied load for the interior bay is applied. Extending the generator with these features, results in the new generator presented in figure.6.2.



Figure.6.2 New generator

### Initial event

The generator takes into account initiating events. An elaborate discussion about initiating events was given in part I of this report. The event has a certain chance of occurring and can affect more than one column at the same time. It does not affect floors. However, floors can fail if 2 columns above each other have failed. The adjacent floors between the columns are removed in that case, if systems with pinned connections are considered. Before creating a column, the generator randomly picks numbers between 1 and 100, including 1 and 100. If for instance,  $p=1\%$  and the picked number equals 1 the column will not be generated. In other words, the initial event has a chance of 1% of occurring for every column and if it occurs will completely destroy the column.

This random method in generating a damaged structure, is in a way similar to the 'traditional' calculation method, wherein each element is removed at least once and the resulting structure is analyzed. Though, the random method is used. If the traditional method is used, a lot of calculations are needed to analyse all possible combinations. Especially when multiple elements can be affected simultaneously and large structures are considered large computational capacities are needed which will result in long calculation time. The random method does not calculate all possible combinations, which will improve calculation speed considerably. However, a certain minimum amount of iterations will be needed to retrieve accurate and reliable results. This will be investigated in part III of this report.

Another advantage of the random method, is the ability to adjust the chances of occurrence of the initial event for each element. In this way, the total collapse resistance is considered since the robustness as well as the initiating events are incorporated in the method.

## 6.1.3 Properties

When generating a model of the structure, it is important to specify the properties of the elements. The material and cross sectional properties have to be specified. Steel and concrete, and in less extent, wood are mainly used in building structures. Therefore, steel and concrete can be selected in the generator.

As only linear elastic behavior is considered in the calculations of the PCI, for steel the following properties are used:

Yield stress:	235 N/mm <sup>2</sup>
Young's modulus:	2.05*10 <sup>11</sup> Pa
Poisson's ratio:	0.3
Density:	7850 kg/m <sup>3</sup>

Several steel profiles can be selected; HE140A, HE200A, HE300A and HE400A.

For concrete (C35/45) the following properties are used:

Compressive yield stress:	27 N/mm <sup>2</sup>
Young's modulus <sup>(1)</sup> :	2.8*10 <sup>10</sup> Pa (for uncracked concrete) 1.4*10 <sup>10</sup> Pa (for cracked concrete)
Poisson's ratio:	0.2
Density:	2400 kg/m <sup>3</sup>

There are two different values for the Young's modulus, one for cracked concrete and another for uncracked concrete. Since a structure in damaged state is considered, the Young's modulus for cracked concrete will be used. If a structural system with a core (see also chapter 6.1.4) is used, for the concrete core elements, the uncracked concrete Young's modulus will be used.

The width and height of a rectangular cross section can be indicated. Since concrete is only able to transfer compressive forces and very little tensile forces reinforcing bars are applied. A percentage of 3% of the cross section is assumed for the cross section area of reinforcement for columns. For the beams a percentage of 1.5% is assumed. This assumptions only gives a very rough estimation of the amount of reinforcement for the elements and is only used to give a first indication. Hence, it is advised to calculate the amount of reinforcement more precisely and use those values.

For the reinforcing bars the following properties are used:

Yield stress:	435 N/mm <sup>2</sup>
Young's modulus:	2.05*10 <sup>11</sup> Pa

(1) *These values are the default values from the FEA program. Hence it is advised to adjust these values according to building regulations. From the Dutch TGB1990 it follows that for C35/45 this will hold;  $E=22250+250*45=33500$  N/mm<sup>2</sup> for short term loading and  $E=27/1.75*10^{-3}=15400$  N/mm<sup>2</sup> for long term loading. It can be seen that the default values are conservative.*



## 6.1.4 Structural systems

In the introduction, it is discussed that the PCI for a designed structure can be compared with the PCI of several other structures, in order to properly indicate the sensitivity to progressive collapse for the designed structure. For instance, when a PCI of a building is lower than a reference value, the building is less sensitive to progressive collapse.

Several structural systems exist in building structures. In order to properly indicate the PCI and to compare them, different systems can be generated by the generator. Each system will have its specific PCI, to which the designed structure can be compared with. The designed structure can then be assigned to a specific category, dependant on its PCI.

The main differences between the structural systems consist of geometry, adjustment in restraints, supports or element releases. The following systems can be generated by the tool:

### *Moment resistant framework*

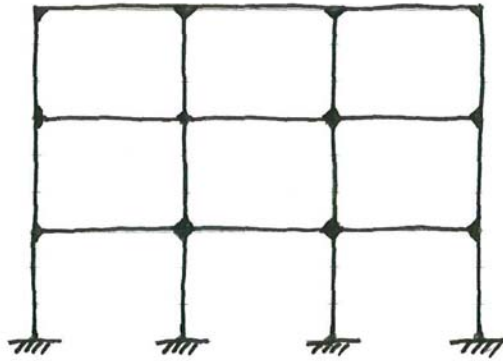

Figure.6.3 Moment resistant framework

This is the basic framework from which each different system can be modeled. In this system, all elements are fully fixed to the nodes. The nodes can displace in x- and y-direction and can rotate around the y-axis. The x- and z- displacements, as well as the yy-rotations are restraint for the supports.

### *Moment resistant framework with stability bracing*

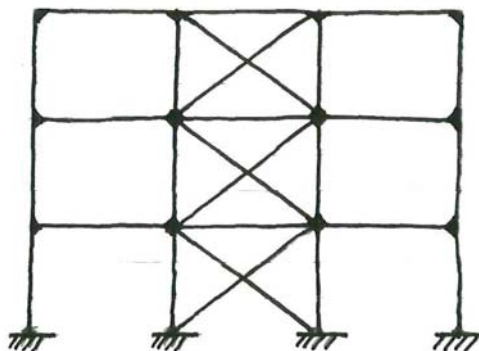
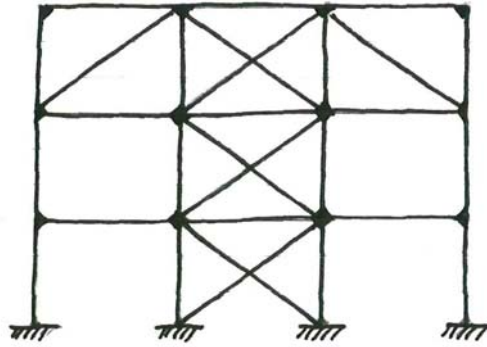

Figure.6.4 Moment resistant framework with stability bracing

## Ch6.PCI tool

This is the continuation of the basic framework, with additional bracing. In this system, all elements are fully fixed to the nodes. The nodes can displace in x- and y-direction and can rotate around the y-axis. The x- and z- displacements, as well as the yy-rotations are restraint for the supports. The additional bracing is applied at the centre of the bay. This system will hardly occur in daily practice, but is only used to compare different systems and validate the results of the tool.

### *Moment resistant framework with stability bracing and outrigger*



*Figure.6.5 Moment resistant framework with stability bracing and outrigger*

This is the continuation of the basic framework and stability bracing, with an outrigger. In this system, all elements are fully fixed to the nodes. The nodes can displace in x- and y-direction and rotate around the y-axis. The x- and z- displacements as well as the yy-rotations are restraint for the supports. The additional bracing is applied at the centre of the bay and the outrigger is applied at the top of the building.

### *Pinned framework with stability bracing*

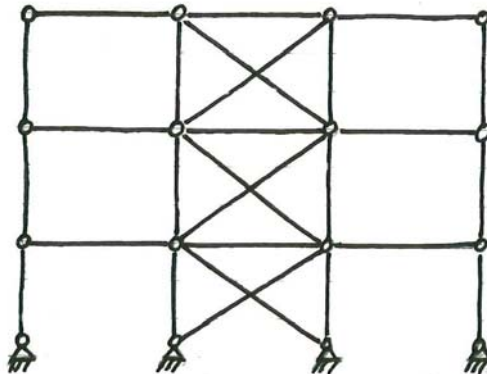

*Figure.6.6 Pinned framework with stability bracing*

This framework is similar to the moment resistant framework with stability bracing except for the element's connections. In this system, all elements can rotate around the nodes. The nodes can displace in x- and y-direction. The supports are restraint in x- and y-direction. In addition to the regular beam elements, that are used in generating previous models, the frameworks with pinned connections also uses spring elements. This is a necessity in order to deal with matrix singularities, resulting from the analysis of the model. If, for instance, a column is removed from the model, it is clear that the elements above this column will displace due to the pinned connections and unrestrained nodes. A local mechanism occurs.

## PART II. Structural mechanics

When trying to analyse this type of models, matrix singularities will result and the analysis will fail. In order to prevent this type of calculation error, it is necessary to restrain the remaining structure. This is done by applying translational springs and rotational springs. Two different phases are distinguished, phase 1 and phase 2.

### *Phase 1 (rotational spring)*

Phase 1 is the situation of the structure directly after the failure of the column at  $t=0$ . The floors above the failed column have not (or: hardly) deformed yet. The vertical loads are redistributed and will be transferred to the columns (see figure.6.7).

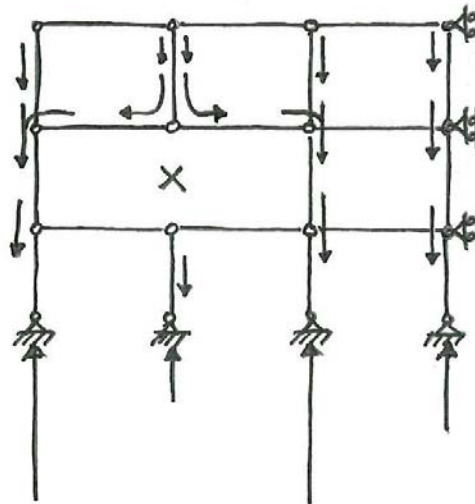

*Figure.6.7 Phase 1: load distribution directly after the initial failure*

At this phase, rotational springs will be used. These springs can resist a certain bending moment, if it is rotated. It is governed by the following relation:

$$M_s = r\theta \quad \text{with,} \quad \text{(formula.6.1)}$$

- $M_s$             the bending moment on the spring [Nmm]
- $r$                 the spring stiffness [Nmm/rad]
- $\theta$               the rotation of the spring [rad]

A rotational spring is applied at each node at the ends of the floor above the failed column (see figure.6.8).

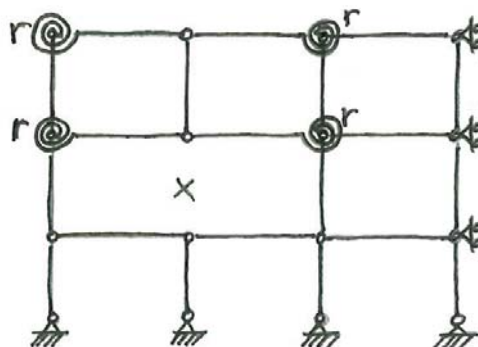

*Figure.6.8 Phase 1: rotational springs*



The model is analyzed by the FEA-program. From these results it can be seen that (if  $\theta$  is chosen large enough), the springs will attract bending moments. Though, the original model only had pinned connections, which can not attract bending moments. Hence, the results should not be used to check the elements. Only the normal forces should be used in this phase. Directly after the failure of a column, the adjacent columns will redistribute the vertical load. By applying a rotational spring, this redistribution is simulated. The system has become a two span beam without the middle support and rotational springs at the ends. The vertical support reactions of this system, loaded with a uniform distributed load  $q$ , is simply  $0.5ql$ . Thus, the vertical load is redistributed to the adjacent columns. Hence, at phase 1 only the columns are checked, solely for the normal force. If no column fails, due to the redistribution of vertical forces, the system will step into phase 2. However, each time a column is removed, the structure moves to phase 1, since for every time a column is removed, it should be checked whether the adjacent columns can bear the extra vertical forces.

A first indication for the spring stiffness should be given. Since the original model only consists of pinned connections, the stiffness should be zero. But, if the spring stiffness is zero, the connection behaves as a pinned connection and a local mechanism can occur. Since the springs are applied to avoid these local mechanisms, a small stiffness is applied. If the stiffness is chosen too small, numerical calculation errors can occur in the FEA-program. Hence, the stiffness should not be chosen too small. A random stiffness of  $r=10.000 \text{ Nm/rad}$  is used. Since the rotational springs are only used to calculate the axial forces in the columns, which are independent from the spring stiffness, the value has got minor significance and an arbitrary value can be chosen.

### *Phase 2 Translational spring*

After a short period of time after the failure of a column, the floors above the failed column will be deformed. At this phase catenary action can develop in the floors. This will be discussed in chapter 9. If catenary action is not taken into account, or if it does not occur, the floors will exhibit large deformations. The model of the FEA will even show infinite deformation, since only geometric linear calculations are used. However, the deformations of the real structure will be restraint by physical boundaries like the earth or the structure itself. At some moment in time, the deformation of the floors is that much, that it will touch the lower floor. In phase 2, this deformed state of the structure is considered (see figure.6.7).

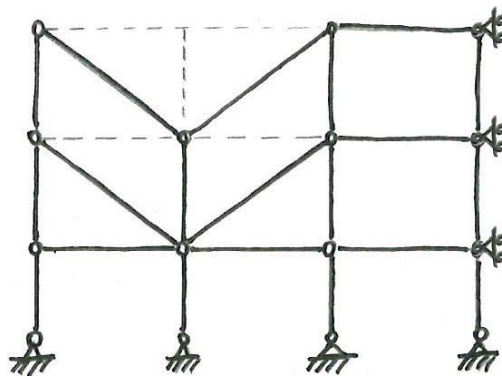

*Figure.6.7 Phase 2: deformed shape of the structure (without catenary action)*

Now, the vertical forces are both carried by the adjacent columns, as well as the column below the failed column. A physical support develops that can only bear vertical forces. A translational spring is used to simulate this behavior. The failed column is substituted by the spring and creates a physical connection between the upper and lower floors. The spring can be thought of a column with very little stiffness.

# PART II. Structural mechanics

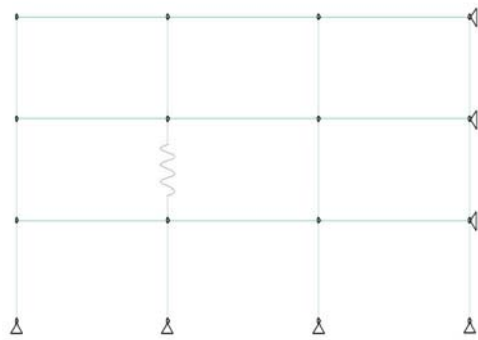

Figure.6.8 Phase 2: translational spring applied on the model

A translational spring, is an element that can only withstand normal forces if subjected to a certain displacement, hence it is very suitable in this model. Only vertical forces should be transferred, under an imposed deformation. A translational spring possesses such properties and is governed by the following simple relation:

$$F_s = k \cdot u \quad \text{with,} \quad (\text{formula.6.2})$$

- $F_s$  the normal force on the spring [N]
- $k$  the spring stiffness [N/mm]
- $u$  the displacement of the spring [mm]

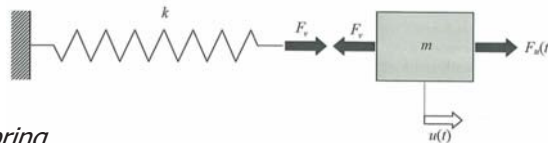

Figure.6.9 A translational spring

The spring formula consist of three yet unknown parameters. At first, it should be determined what displacement should be allowed. When considering the actual displacement of the structure above a failed column, it is restricted by the structure below the failed column. Therefore, the maximum displacement is equal to the height between the floors (or: the column height  $h$ ). At this displacement, the upper structure impacts the lower structure. The force that the spring is subjected to, has to be defined. In this part of the tool's development, no increased loading due to impact or debris is considered and a static contemplation can be used.

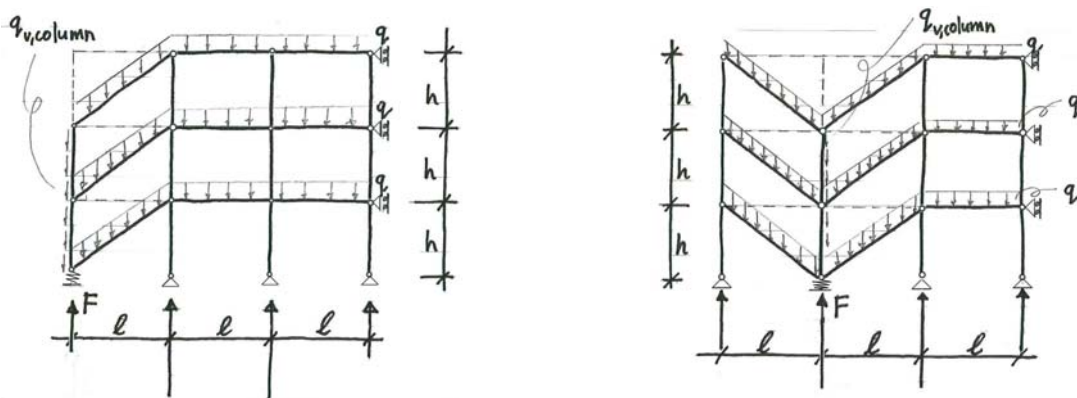

Figure.6.10 Force subjected to translational spring in phase 2 (without catenary action): failure of exterior column (left), failure of interior column (right)

# Ch6.PCI tool

In determining the force two situations can occur. A column can fail at the side of the building or somewhere in the middle of the building. The force consist of a part originating from the distributive load from the floors above the spring and a part originating from the vertical loads of the columns above the spring, see also figure.6.10.

The following relation of the force is valid for an exterior column failure:

$$F = (0.5 \cdot q \cdot l \cdot n) + (q_{v,column} \cdot h \cdot (n - 1)) \quad (\text{formula.6.3})$$

The following relation of the force is valid for an interior column failure:

$$F = (q \cdot l \cdot n) + (q_{v,column} \cdot h \cdot (n - 1)) \quad \text{with,} \quad (\text{formula.6.4})$$

$F$	the support reaction at the failed column [N]
$q$	the distributive load from the girder [N/mm]
$l$	the length of the girder [mm]
$q_{v,column}$	the vertical load from the column [N/mm]
$h$	the height of the columns [mm]
$n$	the number of floors above the failed column [-]

When rewriting the spring relation in  $k = F_s / u$  and setting  $F_s = F$ , the spring stiffness can be determined:

$$k = \frac{(0.5 \cdot q \cdot l \cdot n) + (q_{v,column} \cdot h \cdot (n - 1))}{h} \quad \text{for exterior springs} \quad (\text{formula.6.5})$$

$$k = \frac{(q \cdot l \cdot n) + (q_{v,column} \cdot h \cdot (n - 1))}{h} \quad \text{for interior springs} \quad \text{with,} \quad (\text{formula.6.6})$$

$k$  the spring stiffness [N/mm]

The system has become a single span beam, with a pinned support at one side and a spring at the other side. All forces and deformations resulting from the FEA can now be used to check the elements. If a column is removed in phase 2 the structure will move to phase 1 and the calculation process is repeated as shown in the flowchart in figure.6.11.

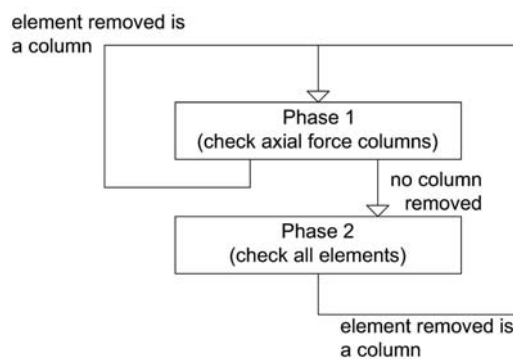

Figure.6.11 Flowchart of calculation process with 2 phases

### *Pinned framework with stability bracing and outrigger*

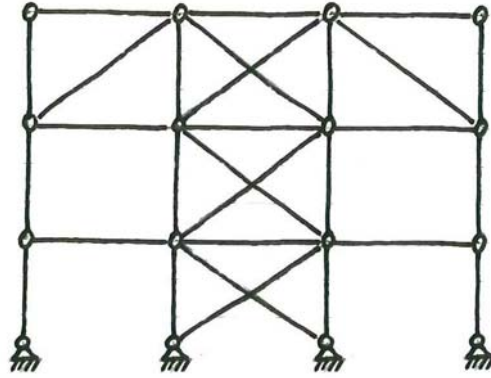

Figure.6.12 Pinned framework with stability bracing and outrigger

This framework is similar to the previous framework, except that an outrigger is added. In this system, all elements can rotate around the nodes. The nodes can displace in x- and y-direction. The supports are restraint in x- and y-direction. Springs have to be applied, if two or more columns in one vertical line fail. If, in this system only one column fails, the remaining structure above the failed column is suspended by the outrigger. Tensile forces will develop in the columns and will guide the loads to the outrigger and subsequently to the supports. The structure below the failed column is restraint by the remaining structure as ordinarily, so no spring has to be applied. Yet, if another column in the same line fails, the structure above the highest failed column will be suspended by the outrigger as described before. The structure below the lowest failed column will be supported ordinarily, but the structure between the failed columns will become unrestraint. Thus, this part of the structure has to be restraint by a spring.

### *Pinned framework with stabilizing core*

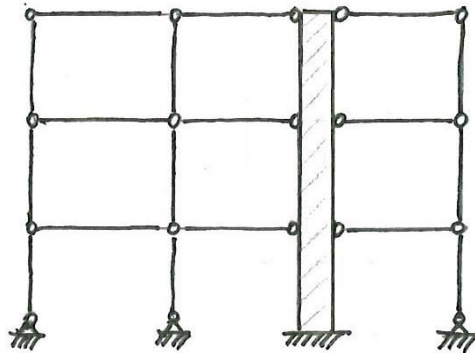
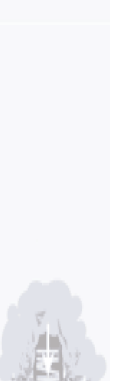
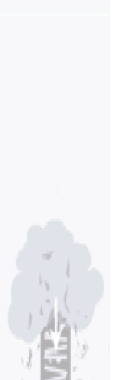

Figure.6.13 Pinned framework with stabilizing core

This framework is similar to the pinned framework with stability bracing, but instead of bracing with crosses, a stabilizing core is used. The core is modeled as a simple bending beam of reinforced concrete. It has a rectangular hollow cross section, with width  $b$  and depth  $h$  and wall thickness  $t$ .

The supports for this system are restraint in x- and z-direction. Springs have to be applied if columns fail. The support for the core is restraint in x- and z-direction and in y-rotation.



*Pinned framework with stabilizing core and floors fixed to core*

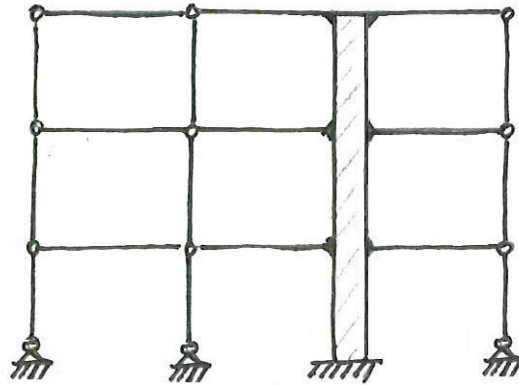

*Figure.6.14 Pinned framework with stabilizing core and floors fixed to core*

This framework is similar to the previous system, but instead of floors that are pinned connected to the core they are fixed to the core. The rotational freedom of the floors is restricted at the connection with the core. The supports are restraint in x- and z-direction. The support for the core is restraint in x- and z-direction and in y-rotation. Springs have to be applied if columns fail, only for columns supporting floors not directly connected to the core.

*Pinned framework with stabilizing core and outrigger*

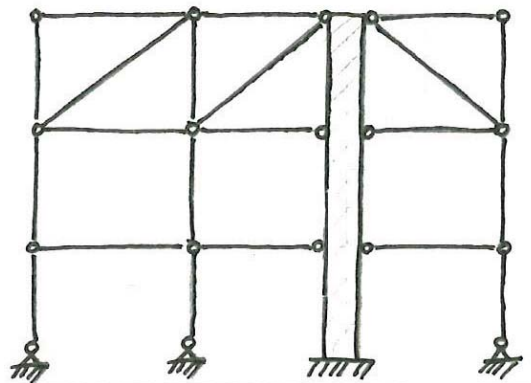

*Figure.6.15 Pinned framework with stabilizing core and outrigger*

This system is completely similar to the pinned framework with stabilizing core, but in addition, an outrigger is applied. The supports are restraint in x- and z-direction. Springs have to be applied if two or more columns in one line below the outrigger fail. The support for the core is restraint in x- and z-direction and in y-rotation.

## 6.2 Loads

Until now, the model itself is generated, but can not be calculated yet. The loads acting on the structure have to be applied. In retrieving an indication for these loads, the NEN6702:2007 (NNI, 2007) has been used. See also appendix B for the used codes and tables. The loads can be categorized in permanent loads and variable loads. The permanent load is the dead weight of the structure. For the floors, hollow core slabs are used, which are supported by the beams. Different types of slabs can be used, dependant on



## PART II. Structural mechanics

the loads and span. For the tool a typical slab is used with a dead weight of  $300^{(2)}\text{kg/m}^2$ . The variable load can be divided in floor and roof loads, snow load, wind load and temperature load. Progressive collapse is considered an extreme design and analysis situation, and therefore has different combination and safety factors, compared with normal situation calculations. Later, it will be discussed that if these factors are applied, only floor loads and wind loads have to be examined. Hence, snow loads and temperature loads will not be discussed.

### Floor loads

Table C.3 of NEN6702:2007 (NNI, 2007, pp.139-141) contains the values for floor and roof loads, that have to be applied for buildings, dependant on their function. Buildings susceptible to progressive collapse, mostly are office buildings since these are occupied by many people, commonly house governmental organizations and are multi-story buildings. Therefore the office type function is used for determining the load;  $P_{\text{rep}} = 2.5 \text{ kN/m}^2$

An introduction of the discussion about the consequences of 2D modeling, is given in paragraph 6.1. It was mentioned that it is assumed that the regarded bay's stiffness is higher in its main direction and thus will attract all forces and therefore the influence of the interconnecting elements between the bays is neglected and a linear load distribution on the main bays is regarded. Consequently, the beams in the considered direction will transmit all forces from the floor load. For the beams this consideration will be rather conservative. A reduction of the load distribution is possible when taking into account some plate and slab analysis (Lowe, 2005).

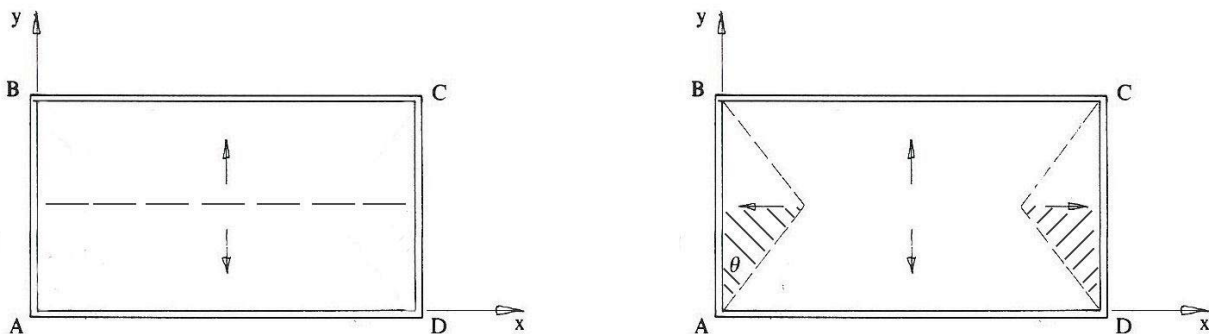

Figure.6.16 Load distribution of floors:  
a. Conservative (left),

b. Hillerborg's strip method (right).

Around 1960, A. Hillerborg proposed the 'strip method', by assuming that the slab does not support any twisting moment in the x- and y-directions<sup>(3)</sup>. The slab is thought of as a grid of beams, which in some manner interact with one another to carry the load. The method assumes the full load is dispersed to the slab supports, by beam strips in both x- and y-direction (figure.6.16.b). The dotted lines divide the slab into zones. The whole load within the zone is then assumed to be carried by strips in the direction of the arrow. A decision should be made what angle  $\theta$  to use. When considering a homogenous square slab with equidistant sides, the loads will be equally transferred in x- and y-directions resulting in an angle  $\theta=45^\circ$ . Although concrete slabs are not homogenous and the support conditions and reinforcement lay-out will influence the division, this value is used. When an extremely deviating lay-out is used, the angle should be adjusted.

- (2) This is the dead load of a hollow core slab with a height of 200mm which can span approximately 8m. It is advised to adjust the appropriate dead weight for the used slab by the user  
(3) This method is also used in the NEN6720:1995 for the load distribution of floor slabs

As a consequence of this reduced load distribution for the beams, too small loads are regarded for the columns. Consider the floor and load distribution from figure.6.16.b. This floor is supported by columns at the corners A, B, C and D. Now, consider the bay of the structure in x-direction. This is a portal frame consisting of column A, beam AD and column D. Beam AD has a trapezoid load distribution (see distributed load of figure.6.17). If only this load is applied on the beam, the vertical support reaction for column A and B will be too small since also the load from beams AB and CD has to be supported by column A and D respectively (hatched surface). Therefore, a vertical force has to be applied on the columns, to take into account the reduced load on the beams (see point loads from figure.6.17).

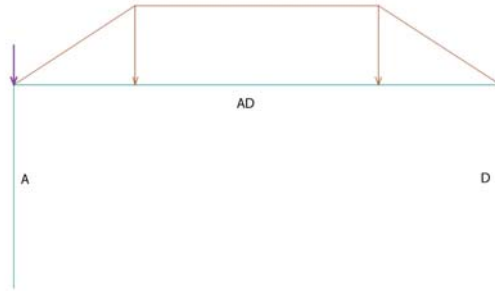

Figure.6.17 Loads on beam

### Wind loads

Wind loads can be extracted from annex A of NEN6702:2007 (NNI, 2007). For each building, different wind loads have to be applied. Influencing factors in determining the wind load are, the geography of the building, geometry and shape of the building and the considered part of the building. If all these factors have to be accounted for, calculations will become far too complicated. Therefore only an indicative equally distributed wind load of  $p_w=1.0 \text{ kN/m}^2$  will be used.

To maintain a load distribution as close as possible to the real situation, the ratio of the provided shape factors are used (disregarding under- and over-pressure). For buildings with a rectangular cross section, the factors for the facades are 0.8 and 0.4, resulting in a ratio of 0.5. The factors from the code are then equivalent to a factor of 1.0 and 0.5 respectively. For the factor for the roof, from the code a value of 0.4 and 0.7 can be retrieved. Since the upward wind load on the roof will have a positive effect on withstanding a progressive collapse, the lowest value is used, resulting in a factor of 0.5 for the entire roof.

Two configurations can be considered for the wind load, one in positive x-direction and another in negative x-direction. In both cases the wind load on the roof will be an upward wind load.

### Load combinations

When applying the loads different situations can be defined. They can be applied individually, as well as combined. Four individual loads are defined:

$G_{\text{rep}}$  = dead load

$Q_{1,\text{rep}}$  = floor load

$Q_{2,\text{rep}}$  = wind in positive x-direction

$Q_{3,\text{rep}}$  = wind in negative x-direction

These are the representative values and have to be multiplied by the safety factor to retrieve the design value. Since an extreme design situation is considered, the code provides  $\gamma=1.0$  for all individual loads, and the formula for the fundamental combinations becomes (considering the building has a design lifetime of  $t=50$  years):

$$F_{f,d} = G_{rep} + Q_{i,rep} + \sum \psi_i Q_{i,rep} \quad \text{with,} \quad (\text{formula.6.7})$$

$F_{f,d}$  the fundamental load combination  
 $G_{rep}$  and  $Q_{i,rep}$  the individual loads  
 $\psi_i$  the combination factor

The combination factors can be derived from NEN-EN 1990:2002/NB:2007 (NEN, 2007-2). From table A1.3 and A1.1 (see also appendix B.3) it follows that:

$\psi_1 = 0.3$  for floor loads  
 $\psi_2 = 0.2$  for wind loads  
 $\psi = 0$  for snow and temperature loads

This will result in the following load combinations:

$$F_{1,d} = G_{rep} + Q_{1,rep} \quad (\text{formula.6.8a})$$

$$F_{2,d} = G_{rep} + Q_{1,rep} + 0.2Q_{2,rep} \quad (\text{formula.6.8b})$$

$$F_{3,d} = G_{rep} + Q_{1,rep} + 0.2Q_{3,rep} \quad (\text{formula.6.8c})$$

## 6.3 Evaluator

The evaluator is the part of the tool that extracts data from the finite element analysis (FEA) in order to determine whether the structure has failed, taking into account certain criteria.

### 6.3.1 FEA

In order to calculate the occurring forces and deformations of the generated structure, FEA-software is used. Different calculation methods exist, like linear or non-linear calculation and first or second order calculation.

#### *Linear calculation*

For the development of the tool only linear calculations are considered. This means that the underlying rules of physics and geometry for the material and model are applied linearly. See appendix A for an elaborate discussion about linear calculations.

Because of linear consideration, plastic behavior and increased load capacity is not taken into account. Another disadvantage of linear calculations is that catenary action is not taken into account. This is one of the main modeling methods in designing against progressive collapse. It describes the development of tensile forces in the floor slab, due to deformations as a consequence of the loss of one support, for a two span floor slab. Significant rotation capacity of the connections, as well as large elongation capacity is required. If a geometric linear relation is applied, an elongation of the element is incorporated in the model and tensile forces will not develop, since the horizontal deformation is neglected. Further discussion about catenary action can be found in chapter 9.

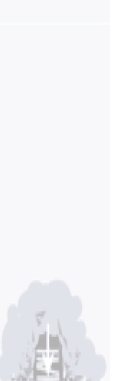
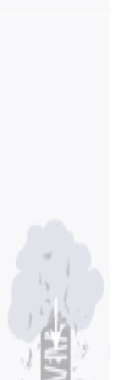

An important aspect to consider with geometric linear calculation, is that only small rotations are allowed (see also appendix A). In reality, the appearing rotations of a progressive collapse calculation will be rather large. Therefore, the retrieved results will deviate from the actual results. Hence, they should only be used as an approximation of the real values. For instance, consider a beam with span  $l=7.2\text{m}$ , which is displaced at one edge with  $u=3.0\text{m}$  (the situation that the floor touches the lower floor). If a geometric calculation is considered, this will result in:  $\theta = u/l = 0.4167$ . For a non-geometric calculation this will result in  $\theta = \tan^{-1}(u/l) = 0.3948$ . This gives an error of 5%.

### *First order calculation*

A first order calculation is performed by the FEA-software. This means, that deformations and internal forces are retrieved when applying the loads on the undeformed structure. In reality, a deformation due to the initial load, will result in a change in load configuration. A second calculation is needed, in which the loads are applied on the deformed structure. This is a so called second order calculation. This calculation predicts the deformations of the structure with more accuracy, with respect to a first order calculation, and thus would be the preferred method. However, a first order calculation is performed, because a second order calculation will need to perform many calculations, hence affecting the total calculation time considerably. While calculation speed of the PCI-tool is important, since it will be used in the early design stage and fast results are required.

### 6.3.2 Failure criteria

Before extracting data from the FEA, it is important to determine what data is needed. The four situations of the proposed tool, described in the introduction, in which failure or non-failure is assumed, are considered:

1. A mechanism occurs and can not be calculated. It is assumed that the structure then fails.
2. Stresses in elements become too high which leads to failure of these elements, leading to a second collapse.
3. Deformations are too much, for instance a deformation larger than the space between the floors, or that linear calculation assumptions do not apply anymore. It is assumed that the structure then fails.
4. None of the above happens, so no progressive collapse occurs.

### *Criterion 1; Calculation error*

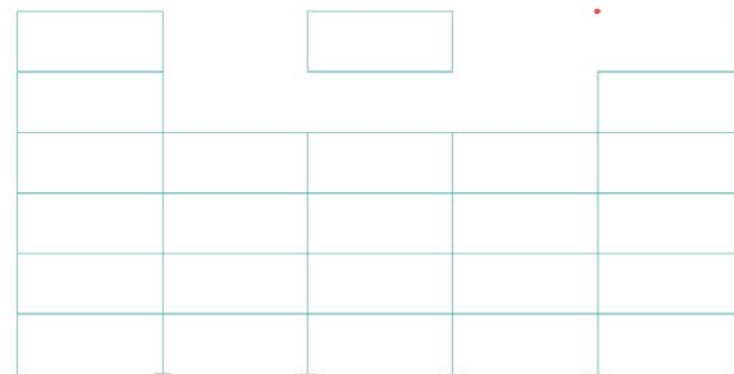

Figure.6.18 Occuring of a calculation error if two separate structures are generated

## PART II. Structural mechanics

The occurrence of a local mechanism in the model will result in a calculation failure and must be prevented. By applying springs at locations where columns have failed, this can be dealt with for certain systems. Though, in some situations a calculation error can still occur, resulting in wrong results. In that case a calculation error message will emerge and failure of the building is assumed. Hence, this criterion can also be labeled a calculation error.

### *Pre-analysis algorithm*

An example of the occurrence of a calculation error is, when multiple elements are removed from a structure with multiple iterative calculation cycles (see chapter 7.3). When removing many elements, occasionally separate structures can be generated. Usually at least one of these structures is unrestrained (or: floating) which will lead to a local mechanism. The FEA will not always recognize multiple structures, causing wrong calculation results. Therefore, a pre-analysis algorithm<sup>(4)</sup> will track for multiple structures and will remove the floating elements.

Elements will also be removed if they are unconnected and unsupported at one side and simply supported at the other side. These elements will rotate around its connection, and thus result in a local mechanism. If these elements are analyzed in the FEA, they can cause wrong results. Hence, removing them from the model can avoid that.

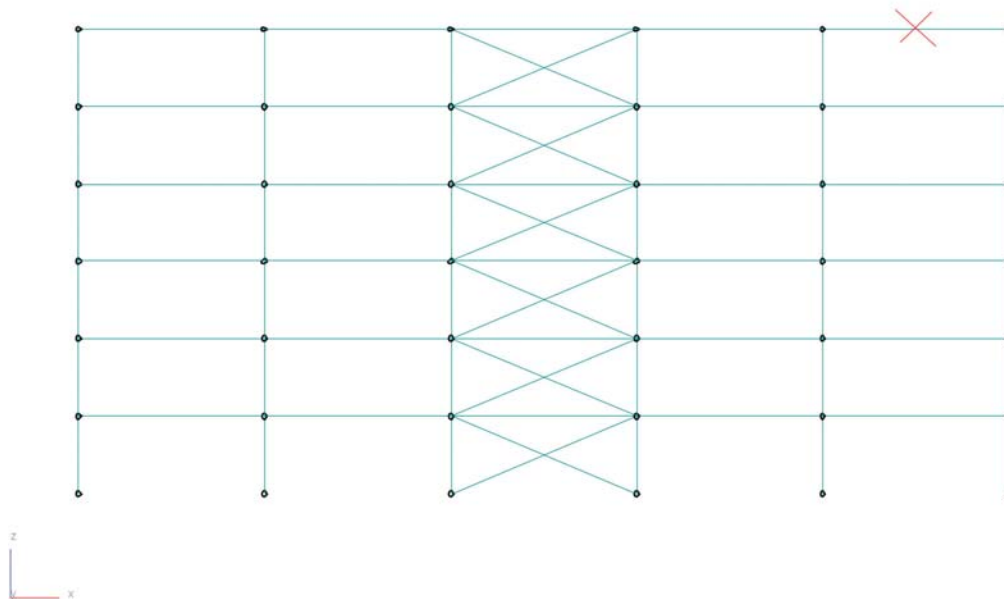

*Figure.6.19 Avoiding a local mechanism by removing an unsupported element at one side and simply supported at the other side*

A local mechanism can also occur, when all columns of one floor are removed. The upper structure no longer is supported and thus will be unrestrained. Therefore, the algorithm also tracks the amount of columns on each floor. If all columns of a floor are removed, failure is assumed.

<sup>(4)</sup> NB: The multiple structures algorithm is only able to recognize separate vertical or separate horizontal elements and will not recognize a separate structure consisting of a combination of a floor and a column

Another local mechanism can occur, if systems with pinned connections are considered. The horizontal load transfer is governed by the stabilizing elements (e.g. core or cross-bracing). The loads are transferred from the facade, through the floors to the stabilizing elements. If an interior floor is removed from the model, the elements on the same level and one lower level, on the facade side of the building, will be unrestrained, since the horizontal load can not be transferred through the floors anymore. The elements will rotate around its connections, resulting in a local mechanism. If such a configuration occurs, the unrestrained elements will be removed from the model. See also figure 6.20.

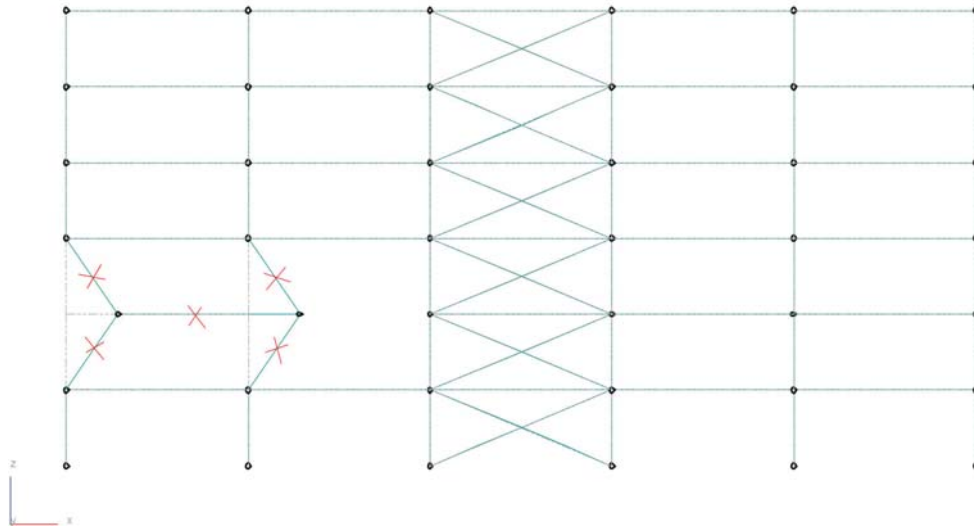

Figure.6.20 Occuring local mechanism if a floor is removed under horizontal loading

### Criterion 2; Strength<sup>(5)(6)</sup>

For the second failure criterion, the occurring forces for each element have to be extracted from the FEA. These forces have to be compared with the capacities of the elements. For steel and concrete different calculation methods exist. The complete calculations can be found in appendix D.

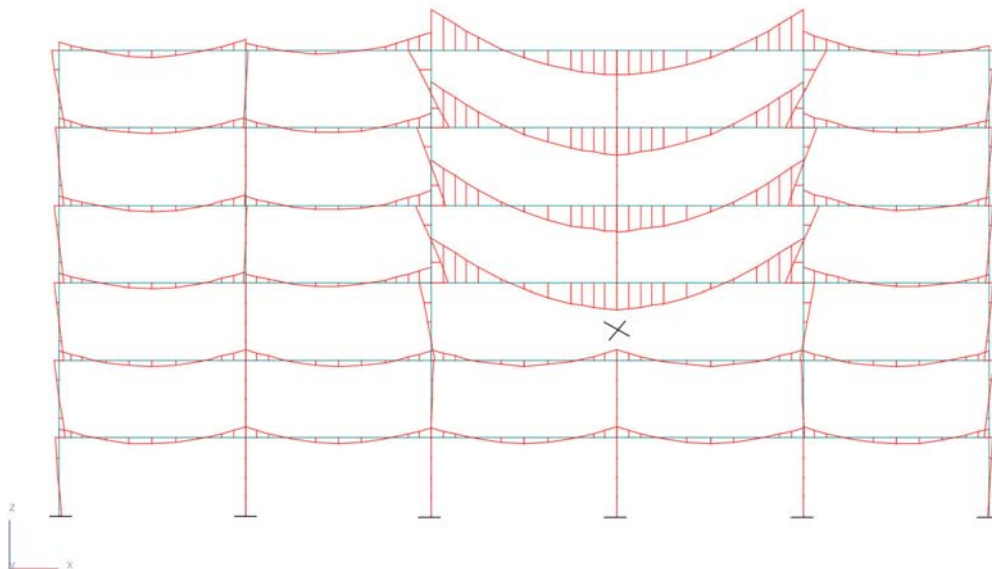

Figure.6.21 Occuring bending moments if one column fails for a system with fixed connections

(5) Here, only calculations for strength are presented. Stability calculations are discussed in chapter 7

(6) Note that the calculations are not entirely according to current building standards

## Steel

For steel the strength capacity check yields:

$$\text{Unity check} = \frac{N_d}{N_u} + \frac{M_d}{M_u} \leq 1 \quad \text{and,} \quad (\text{formula.6.9a})$$

$$\text{Unity check} = \frac{N_d}{N_u} - \frac{M_d}{M_u} \leq 1 \quad \text{with,} \quad (\text{formula.6.9b})$$

$N_d$	the axial load on the element [N]
$M_d$	the bending moment on the element [Nmm]
$N_u$	the normal force capacity of the element [N]
$M_u$	the bending moment capacity of the element [Nmm]

Since the bending moment and axial forces can be both positive and negative, the absolute values are used.

## Concrete

The calculations for concrete are in a way similar to that for steel. The bending moment capacity is calculated, which should be higher than the bending moment the element is subjected to. In order to be able to compare the results, for different elements and between steel and concrete, the strength capacity check is written as a unity check:

$$\text{Unity check} = \frac{M_d}{M_u} \leq 1 \quad \text{with,} \quad (\text{formula.6.10})$$

$M_d$	the bending moment on the element [Nmm]
$M_u$	the bending moment capacity of the element [Nmm]

The bending moment capacity for concrete is not a fixed value, like for steel, but depends on the combination of the axial force and bending moment on the element. With calculating the bending moment capacity, the axial force is used, hence the axial force is incorporated in the bending moment capacity and therefore is not directly part of the unity check. A couple of situations are distinguished;

### Compressive force and bending moment

For this situation, first the compressive zone  $x_u$  is calculated, which follows from the equilibrium of internal and external axial forces  $\Sigma N=0$ . If  $x_u$  is known the internal forces can be calculated. Now, all forces are known and the bending moment capacity can be calculated from equilibrium around the centre of gravity  $\Sigma M=0$ . The unity check can then be calculated. In order to take into account building imperfections, a minimum bending moment is used for elements under compression:

$$M_d > 0.1hN'_d \quad \text{with,} \quad (\text{formula.6.11})$$

$h$	the height of the cross section of the element [mm]
$N'_d$	the compressive axial force on the element [N]

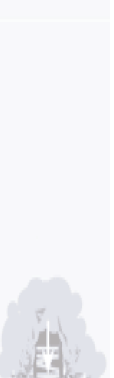
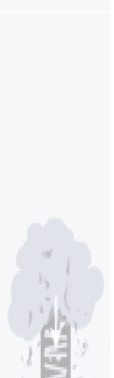
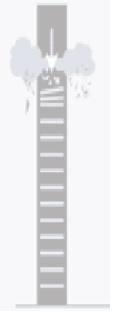

## Tensile force and bending moment

A combination of tensile force and bending moment is also possible. The ratio of axial force and bending moment determines the calculation method. An artificial bending moment  $M_d^*$  is introduced:

$$M_d^* = M_d - N_d e \quad \text{with,} \quad (\text{formula.6.12})$$

e the distance between centre of gravity and centre of the reinforcing bars [mm]

$$M_d^* < 0$$

If  $M_d^* < 0$  there will be no compressive zone in the cross section. Since concrete is not able to resist any tensile force, the reinforcing bars provide the strength of the element. If the element is not loaded with a bending moment, the unity check is transformed to a unity check of axial forces only:

$$\text{Unity check} = \frac{N_d}{N_u} \leq 1 \quad \text{with,} \quad (\text{formula.6.13})$$

$$N_u = A f_s \quad \text{the axial force capacity of the reinforcing bars [N]}$$

A the cross section area of the reinforcing bars [mm<sup>2</sup>]  
 $f_s$  the yield stress of the reinforcing bars [N/mm<sup>2</sup>]

If the element is loaded with a bending moment, the reinforcing bars provide the bending moment capacity. The bending moment capacity is compared with the artificial bending moment, instead of the external bending moment. The unity check then yields:

$$\text{Unity check} = \frac{M_d^*}{M_u} \leq 1 \quad (\text{formula.6.14})$$

$$M_d^* > 0$$

If  $M_d^* > 0$  a compressive zone will develop in the cross section. The calculation procedure is similar to that of an element loaded in compression. Unfortunately, the values for the axial forces are not known, since the strain in the concrete is unknown. Only the strain of the reinforcing bar under tension is known, as it is advised that the reinforcing bar should yield before failure of the element. Thus, the strain of that bars is  $\varepsilon_s = 2.175\text{‰}$ . In order to calculate the internal forces, use has been made of interaction diagrams from GTB-tables 11 (Betonvereniging, 2006) and their underlying formulas. The bending moment capacity is compared with the artificial bending moment, instead of the external bending moment. The unity check then yields:

$$\text{Unity check} = \frac{M_d^*}{M_u} \leq 1 \quad (\text{formula.6.15})$$

## Calculation of core

For the calculations of the core, the same considerations hold as for the calculation of regular elements. However, the calculation of the axial force in the concrete is different. Since the core has got a hollow rectangular cross section it differs from a normal rectangular cross section. If the compressive zone is larger than the wall thickness of the core, the force can not be retrieved from  $N_c' = \alpha b x_u \sigma_c'$  since the concrete area is smaller ( $b(x_u > t) = 2t \neq b$ ). The stress diagram for concrete should be split into smaller pieces from which, from the individual parts, the axial force can be calculated.



## PART II. Structural mechanics

In formula the strength criterion for all elements yields;

*If unity check > 1 then --> element failed* (formula.6.16)

This condition is valid if only strength considerations are applied, though also stability conditions have to be considered. These will be discussed in chapter 9.

### Criterion 3; Deformation

For the third failure criterion the resulting deformations of the nodes are of interest and have to be extracted from the FEA. In formula the criterion yields;

*If  $w > w_{ultimate}$  then --> element failed* with, (formula.6.17)

$w$  the deformation of the element in z-direction [mm]

$w_{ultimate}$  the ultimate allowable deformation of the element in z-direction [mm]

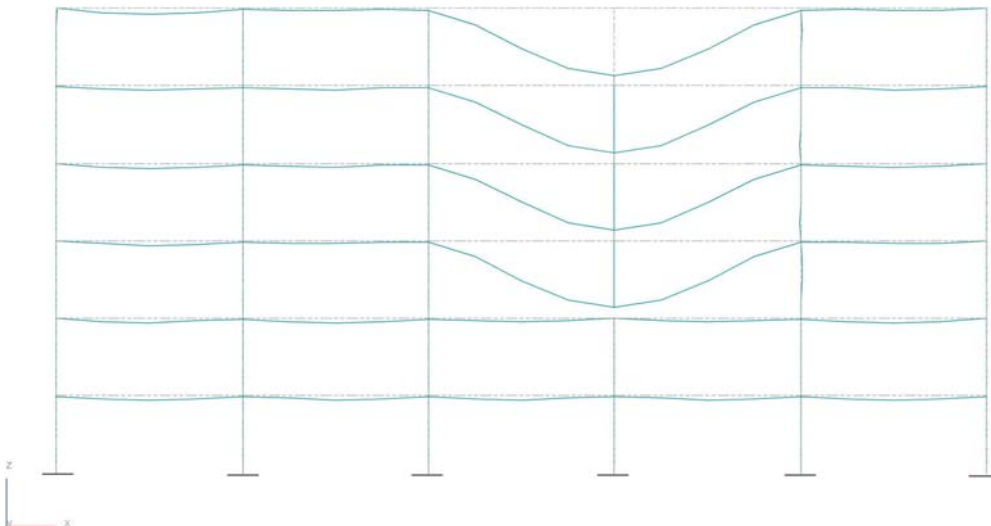

Figure.6.22 Occuring deformations if one column fails for a system with fixed connections

The element's deformations are not considered, since it is assumed that these will be small if the structure is unharmed. Extracting these deformations is thus useless. Instead, the node's deformations are considered, since when a column fails, the maximum deformation will occur directly above the failed column. Thus, the deformations will be maximum for that node.

The value of  $w_{ultimate}$  is not known yet and can be derived in several ways. A way to retrieve a value for  $w_{ultimate}$  is to assume failure only occurs when the upper floor deforms in such a way that no room between the floors remains, e.g. the upper floor touches the lower floor. Then,  $w_{ultimate}$  equals the floor depth. This situation is not very likely, because building materials are not that flexible and will fail for the strength criterion before the ultimate deformation occurs.

When looking at recent codes and standards, a fixed quantity for the ultimate deformation can not be given, but it is said that in case of an incidental action, a safe evacuation of the occupants of the building should be guaranteed (NNI, 2006). Therefore, it is reasonable to assume that the amount of free space

between the floors should not be less than the maximum average length of the occupants of the building. The Dutch central bureau of statistics (CBS) has estimated an average length of 1.81m of the Dutch man in 2006 (CBS, 2008). See also appendix E. This is an average length, therefore some extra height should be added to guarantee a safe evacuation of longer people. An estimate for the maximum length of people can be obtained when taking the 1% exceedance probability for the length distribution. This is approximately 2.0m, thus  $w$  should not exceed the free space between the floors minus 2.0m.

Another way of retrieving a value for  $w_{ultimate}$  is to use the same conditions for deformations as in the serviceability limit state. From NEN6702 (NNI,2007), it follows that the allowable vertical deformation is equal to  $L/500$ . For the progressive collapse tool this method is not very suitable, because the limit is determined under normal loading conditions, which is not the case for a progressive collapse. Hence, eventually the second method is used to determine  $w_{ultimate}$ :

$$w_{ultimate} = \text{floor depth} - 2.0m \quad (\text{formula.6.18})$$

## 6.4 Iterations and simulations

As described in the introduction the PCI is calculated by dividing the number of failures by the number of iterations;

$$PCI_s = \frac{F}{n} \cdot 100\% \quad \text{with,} \quad (\text{formula.6.19})$$

- $PCI_s$  the Progressive Collapse Indicator for simulation  $s$  [%]
- $F$  the number of failures [-]
- $n$  the number of iterations [-]

For each simulation a number of structures is generated, equal to the number of iterations. Each iteration represents a generated structure. For each iteration, failure or non-failure is registered. For every simulation a PCI is calculated. If  $s$  simulations are performed,  $s$  PCI's are calculated. The average PCI is then represented by:

$$PCI = \frac{\sum_s PCI_s}{s} \cdot 100\% \quad (\text{for } s \geq 1) \quad \text{with,} \quad (\text{formula.6.20})$$

- $PCI$  the average PCI [%]
- $PCI_s$  the PCI of simulation  $s$  [%]
- $s$  the number of simulations [-]

In figure.6.23 the calculation with iterations and simulations is schematically depicted.

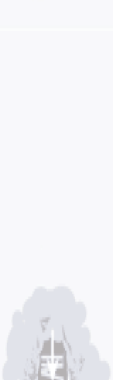
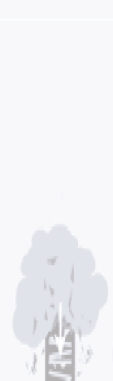
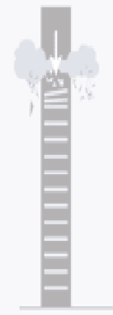

# PART II. Structural mechanics

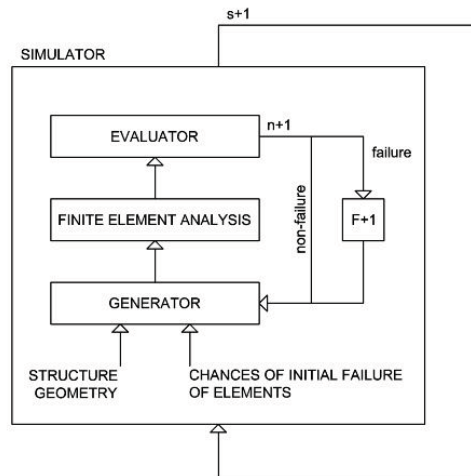

Figure.6.23 Schematic representation of the tool with iterations and simulations

# Ch7. Iterative calculation

In chapter 6.3.2 some criteria are given to determine whether a structure collapses progressively. With these conditions, it was assumed that failure occurred if the strength or deformation at some point of the structure exceeded a maximum value. This of course does not determine if the collapse is progressive. In the definition of progressive collapse, it is stated that the damage should be disproportionate to the initiating event, in order to call a collapse progressive. Therefore, a quantification of disproportionate damage is needed.

## 7.1 Quantifying disproportionate damage

The indistinctiveness to what extent damage is disproportionate can be seen in various codes and standards. The Eurocode (NNI, 2006) for example, recommends an allowable boundary for local damage. The indicative boundary for building structures is the smallest value of 100m<sup>2</sup> or 15% of the floor area of 2 adjacent floors caused by the removal of an arbitrary load bearing column or wall. This will probably give the structure the necessary robustness, irrespective if an abnormal load is taken into account. The UK building regulations (HMSO, 1991), similarly to the Eurocode, limit the admissible damage to 70m<sup>2</sup>.

The American Unified Facilities Criteria issued by the Department of Defense, make a distinction between the removal of an external or internal column or load bearing wall;

*'For the removal of a wall or column on the external envelope of a building, the damage limits require that the collapsed area of the floor directly above the removed element must be less than the smaller of 70 m<sup>2</sup> or 15% of the total area of that floor and the floor directly beneath the removed element should not fail. In addition, any collapse must not extend beyond the structure tributary to the removed element. For the removal of an internal wall or column of a building, the damage limits require that the collapsed area of the floor directly above the removed element must be less than the smaller of 140 m<sup>2</sup> or 30% of the total area of that floor, and the floor directly beneath the removed element should not fail. In addition, any collapse must not extend beyond the bays immediately adjacent to the removed element.'* (DoD, 2005)

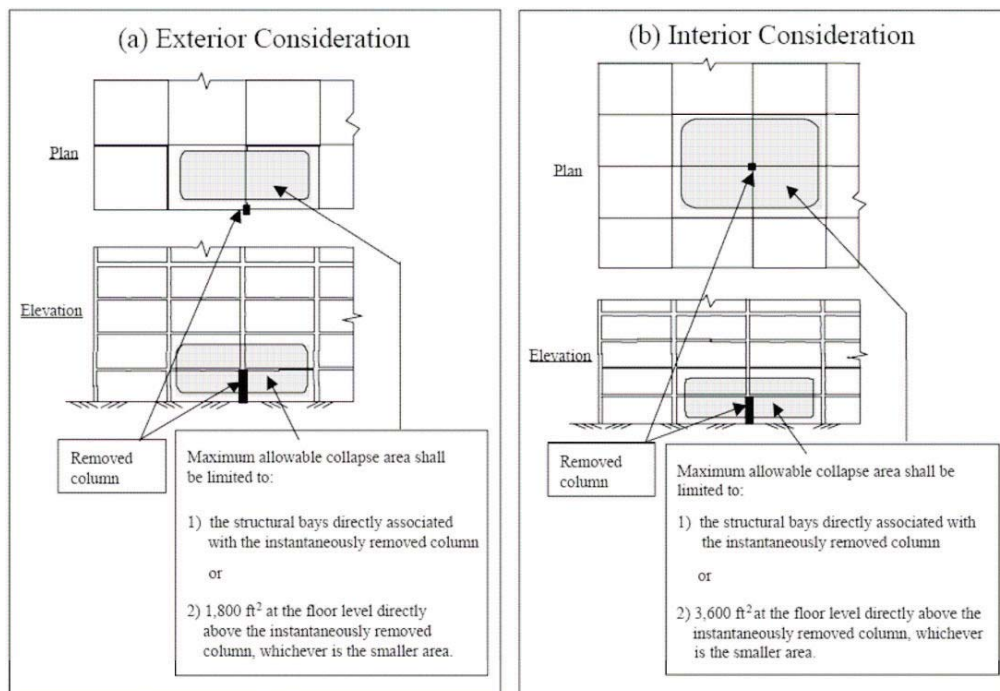

Figure.7.1 Maximum allowable collapse area provided by GSA guidelines. [source: (GSA,2003)]

# PART II. Structural mechanics

The U.S. General Services Administration guidelines (GSA, 2003), have a similar approach as the DoD, only the damage is limited to the structural bays directly associated with the instantaneously removed vertical member in the floor directly above the removed vertical member, with a maximum of 170 and 330 m<sup>2</sup> for a perimeter vertical member, respectively an internal vertical member, see figure.7.1.

Table.7.1 gives a summary of the discussed allowable damages in the various building codes. The codes and standards all describe an admissible damage, but differ into what extent this damage should be allowed.

	Floor area		Maximum	
	Exterior	Interior	Exterior	Interior
Eurocode	15%	15%	100 m <sup>2</sup>	100 m <sup>2</sup>
UK Regulations	15%	15%	70 m <sup>2</sup>	70 m <sup>2</sup>
U.S. D.o.D.	15%	30%	70 m <sup>2</sup>	140 m <sup>2</sup>
U.S. GSA	adjacent bays	adjacent bays	170 m <sup>2</sup>	330 m <sup>2</sup>

Table.7.1 Quantification of disproportionate damage in various standards

## 7.2 Failure criteria

The values in table.7.1 give a lower bound for the damage during a collapse in order to call the damage disproportionate. When the criterion that damage is disproportionate is met, it can be stated that a progressive collapse has occurred. The criterion that a chain reaction of failures occurs in a progressive collapse is neglected. Though, when considering that if a column has failed and consequently only the adjacent floors above the column fail, the total damaged floor area most probably will not exceed the disproportionate damage. If subsequently another column would fail the damaged floor area will increase and at some point will exceed the lower bound for disproportionate damage. Thus, in most cases, a chain reaction of failures must have occurred in order to exceed the disproportionate damage criterion. Also, the damage of a floor, as a result of the failure of a column, exhibits a chain reaction of failures. Hence, the criterion will always be met, if the disproportionate damage criterion is met. The quantities given by the American GSA-guidelines are used, resulting in the following criteria:

$$\begin{aligned}
 & \text{If } A_{\text{floor}} > A_{\text{adjacent}} \quad \text{or} \quad (formula.7.1) \\
 & A_{\text{tot}} > A_{\text{adjacent,tot}} \\
 & \text{then --> progressive collapse} \quad \text{with,}
 \end{aligned}$$

- $A_{\text{floor}}$  the damaged floor area per floor [mm<sup>2</sup>]
- $A_{\text{adjacent}}$  the adjacent floor area per initial damaged column per floor [mm<sup>2</sup>]
- $A_{\text{tot}}$  the total damaged floor area for the entire structure [mm<sup>2</sup>]
- $A_{\text{adjacent,tot}}$  the total adjacent floor area for all initial damaged columns for the entire structure [mm<sup>2</sup>]

If one of these criteria is met a progressive collapse has occurred and a failure is counted for the PCI of the structure.



# Ch7. Iterative calculation

## 7.3 Iterative calculation

To be able to accurately predict the damaged floor area of a structure susceptible to progressive collapse, multiple iterative calculations are needed. The basic PCI-tool only represents the situation directly after an initiating event. When determining the damaged floor area, the situation directly after the initiating event is not of interest, but the situation after the progressive collapse. Iterative calculations are performed to retrieve this final state.

During each calculation the criteria for failure of elements are considered. If a floor element exceeds the displacement criterion, it is assumed that the complete floor element has failed, resulting in a damaged floor area equal to that floor element. The floor is not removed from the model, since it did not fail for the strength criterion. If the strength criterion is exceeded, the element has failed and is removed from the model. For each iterative calculation only one element can be removed. Subsequently, a new calculation is performed, in which the new model is re-analysed, resulting in different forces and deformations. These are evaluated again, possibly leading to the removal of another element and a new calculation. Calculations are performed until all remaining elements comply with the failure conditions. Now, the progressive nature of a progressive collapse is also taken into account. If a floor element is removed from the model, the damaged floor area is equal to the area of the removed element.

Figure.7.2 shows the schematic representation of the tool including the iterative calculations. In that figure,  $n$  represents the amount of iterations and  $s$  represents the amount of simulations, see also chapter 6.4.

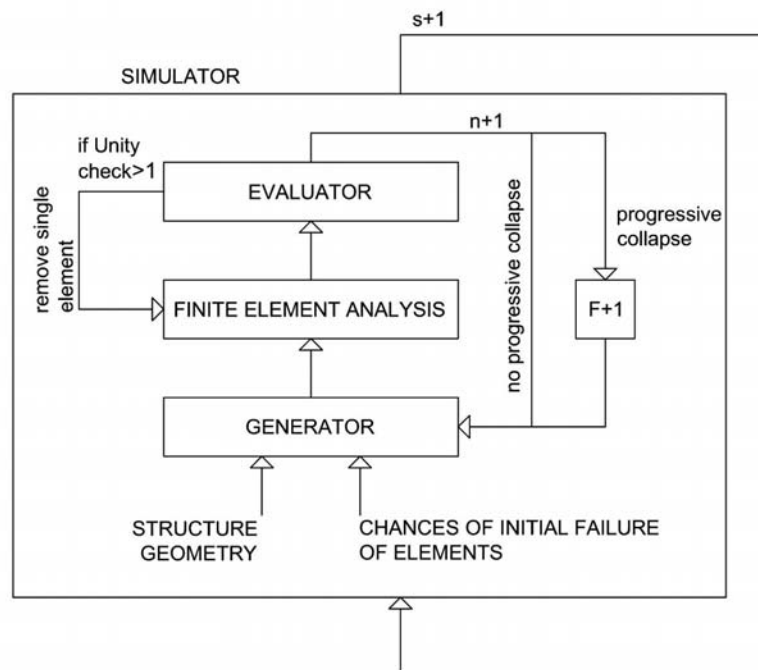
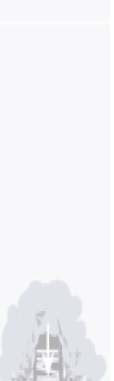
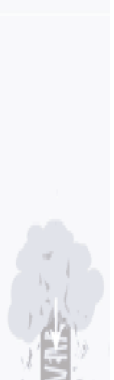

Figure.7.2 Schematic representation of the tool including iterative calculations

# PART II. Structural mechanics

---



# Ch8. Increased loading

In chapters 6 and 7 it is discussed that, if the unity check of an element is  $>1$ , it will fail and is removed from the model. Removing an element from the model, will also result in the loss of the load acting on that element. These loads can not disappear and have to be reapplied on the model. Failure of an element can also lead to falling of other elements, which will impact the lower structure. These loads also have to be applied on the model.

## 8.1 Debris loading

If, in a real situation a column is damaged, due to a certain event, a part of, or the whole column will fail. Parts of the column will fall and disperse over the underlying structure. These pieces introduce extra loads on the lower structure. Falling debris will cause dynamic forces on impact with the lower structure. After impact, the dispersed debris is laying on the lower structure, causing static loads. These loads also have to be applied in the model. In order to apply these loads, some simplifications are needed.

First, because the column will collapse into multiple smaller pieces, the impact force will also represent smaller individual forces. The impact force will thus be smaller than the load of the entire column and therefore will be neglected. Second, the debris of the column will scatter and it is hard to predict where it will land, especially when a blast is the cause of the initiating event. However, it can be said that the debris most certainly will appear near the damaged column itself. Last, the entire column is removed from the model and not a part of it. Thus, a load equal to the entire column has to be applied. Therefore, a static load is applied as a point load on the lowest node of the failed column (see figure.8.1).

If floors fail, it will also result in debris. This will not be discussed here, since it is incorporated in impact loading (see chapter 8.2). In this context debris load is only a static load and considered only for columns, whereas if floors are considered, debris is applied as impact load. Since this load is a static load and only contains the dead weight of the column it is added to load case  $G_{rep}$ .

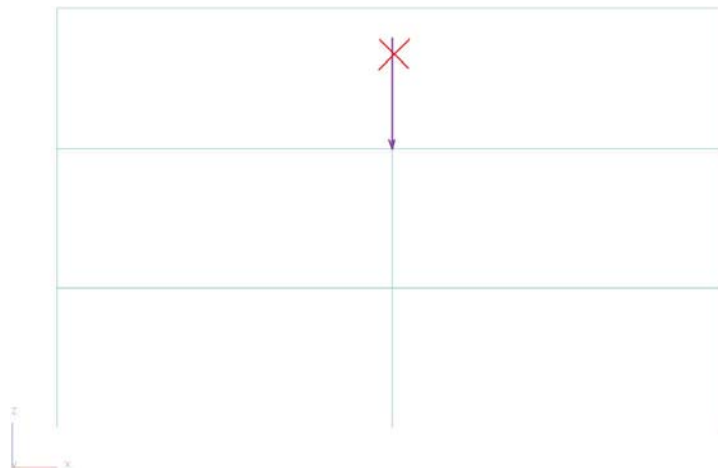

Figure.8.1 Debris loading



## 8.2 Impact loading

There are two different cases in which impact loads can occur. It can be caused by failing floors impacting the lower structure, or due to failing columns causing the upper structure to deform and impacting the lower structure. These two cases will be discussed.

### 8.2.1 Floor impact

If the load capacity of a floor is exceeded, it will fail. Parts of, or the entire floor will start to fall on the lower floor. On impact with the lower floor, it will exhibit dynamic forces. These forces have to be applied on the structure. If the lower structure is in equilibrium, the dynamic forces are damped out and the failed floor is only exhibiting a static load on the structure, equal to the dead weight of that floor. These forces should also be applied. Though, they will be neglected, since first the impact load will be applied, which is much larger than the static load.

Because dynamic loads are considered, a dynamic analysis would be an obvious analysis method. A disadvantage of such analysis is the time-consuming process. Therefore it will not be used. A static analysis is performed, that takes into account the dynamic load. The static load is transformed to an estimated dynamic load by an amplification factor. From the American Unified Facilities Criteria, issued by the Department of Defense (chapter3-2.4.2), an amplification factor of 2.0 is retrieved (DOD,2005).

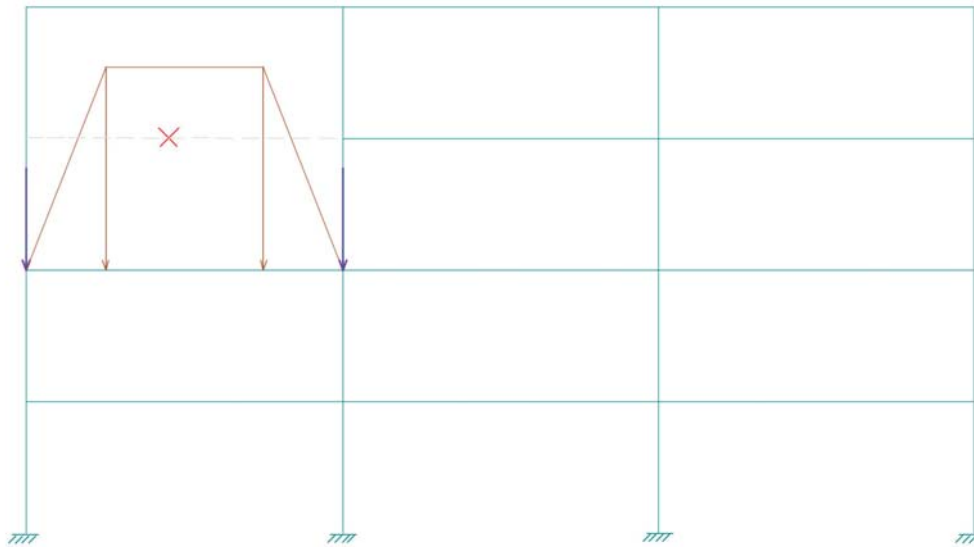

Figure.8.2 Floor impact load

If a floor is removed from the model, the loads from that floor are doubled and applied on the element directly below the failed element. If that element has failed as well, the loads from both floors are added and doubled and applied on the element below the failed floors.



# Ch8. Increased loading

## Loadcase

An additional load case is added to the load cases from chapter 6.2;  $Q_{4,rep}$  = impact load. Also, an additional combination case is added;  $F_{1,d} = G_{rep} + Q_{4,rep} + 0.3Q_{1,rep}$ . The impact load case is only combined with the dead load of the structure, since it is very unlikely that the short during impact load takes place with another load case at the same time. This will result in the following load cases and combination cases:

Load cases:

$G_{rep}$  = dead load

$Q_{1,rep}$  = floor load

$Q_{2,rep}$  = wind in positive x-direction

$Q_{3,rep}$  = wind in negative x-direction

$Q_{4,rep}$  = impact load

Combination cases:

$$F_{1,d} = G_{rep} + Q_{4,rep} + 0.3Q_{1,rep} \quad (\text{formula.8.1a})$$

$$F_{2,d} = G_{rep} + Q_{1,rep} \quad (\text{formula.8.1b})$$

$$F_{3,d} = G_{rep} + Q_{1,rep} + 0.2Q_{2,rep} \quad (\text{formula.8.1c})$$

$$F_{4,d} = G_{rep} + Q_{1,rep} + 0.2Q_{3,rep} \quad (\text{formula.8.1d})$$

## 8.2.2 Column failure

If a column has failed, the upper structure will start to deform. When a system with moment resistant connections is considered, this deformation will be restraint by these connections. If, on the other hand, a system with pinned connections is considered and catenary action is not taken into account, these deformations can not be restraint by the connections and the structure will fall down. Since only geometric linear calculations (see appendix A) are considered and catenary action (see chapter 9.2) is not taken into account, the structure above the failed column will impact the structure below the failed column. The upper node of the failed column will impact at the lower node of that column, therefore a point load that represents the dynamic load is added at that point. Analogous with the dynamic floor load, the static load is transformed to an estimated dynamic load by an amplification factor of 2.0.

If a system with pinned connections is considered and a column is removed from the system the axial force in the failed column (if it would still be there) due to dead load and floor load is doubled and added to the model as a vertical point load on the lowest node of the failed column, see figure.8.3. The load is added as load case  $Q_{4,rep}$  = impact load and combination case  $F_{1,d} = G_{rep} + Q_{4,rep} + 0.3Q_{1,rep}$  is also valid.

Since multiple columns can fail, this can result in multiple impact forces. Though, these forces will only last for a short time and depend on the order of column failure. Therefore, a pattern on applying the impact forces needs to be developed. When analyzing a structure for progressive collapse, the highest forces are of interest which will cause elements to fail. Therefore, if multiple columns in one vertical line have failed, only the impact forces due to the lowest failed column will be applied, since this will result in the highest forces. Applying the impact forces of higher failed columns will be useless since the floors below that failed column already have failed.

Another aspect of impact forces is that they will only last for a short period of time. Therefore, the impact load must only be applied directly after a column has failed. If another column fails, the impact force due to the first failed column will be damped out and must not be applied on the model. If this rule is

## PART II. Structural mechanics

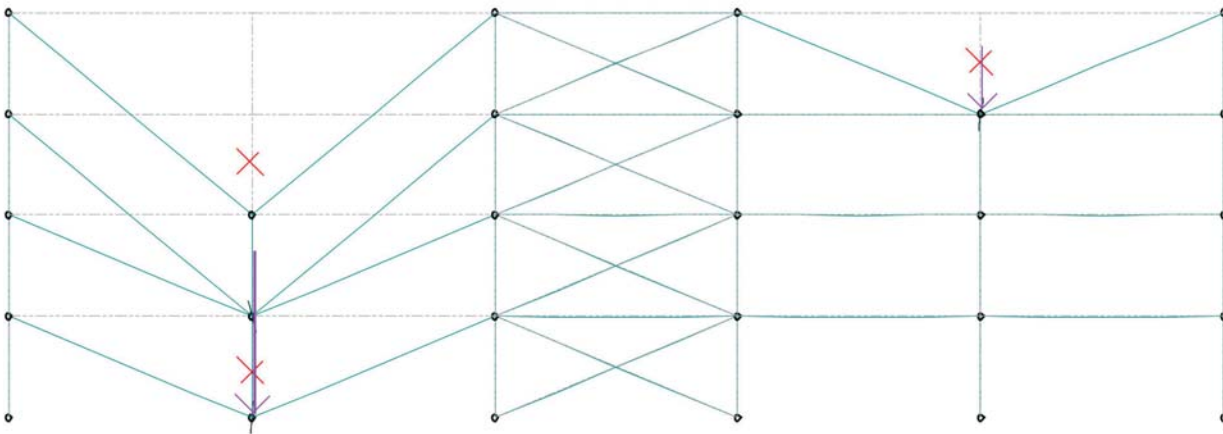

Figure.8.3 Example of impact loads on deformed structure with pinned connections after multiple columns have failed

applied for the model, it will cause wrong results. The elements of the structure can be evaluated in a certain pattern, e.g. from left to right and bottom to top (see also Part III). When the force capacity in an element is exceeded, it will be removed from the model and the structure is re-analysed. If, only the impact force, due to the last removed column is applied, it can happen that a column, right of the removed column, is checked for a too low force, if an impact force was applied above the considered column, before the last removed column failed. Therefore, the impact force on a certain vertical line of columns must only be removed, if the lowest column in that line has passed the analysis checks for the impact case and combination case including the impact case.

Concluding, the impact force is always applied on the lowest node of the lowest failed column, for each vertical line of columns. Each vertical line of columns thus has maximum one impact force applied.

Dependant on the evaluation method, the impact force due to column removal is applied, or is not applied. If, for instance elements are evaluated in a fixed order (e.g. from left to right and bottom to top), the following method is applicable: after all forces for the impact load combination case have been checked and the lowest column in a line passes these checks, the impact force will be removed for the considered line of columns only.

If, on the other hand the evaluation method does not have a fixed pattern (e.g. removal of elements with highest unity check exceedence), it is not clear which elements have already been checked. Hence, the impact force is always applied on the lowest removed column, for each vertical line of columns, in that case. The possible evaluation methods will be discussed in chapter 10.

By adding the impact load case to the model, besides the redistribution class collapse, also an approximation of the impact class collapse can be described as discussed in chapter 3.6. Since both classes are combined in the model, also the mixed class is almost applicable. Only the stability class should still be implemented. This will be discussed in the next chapter.

Note that the domino type collapse is not modeled. The overturning of elements (e.g. if floors are partially damaged and still attached to the surrounding structure at one side) is not taken into account. Since it is assumed the complete floor is damaged, this situation can not occur. Though, it is advised to incorporate this behavior in further developments, since the horizontal forces resulting from this impact can have an influence on the structure's behavior and thus on its progressive collapse.

# Ch9.Improvements

The previously described tool is far from complete. A lot of functionalities still have to be applied, in order to become suitable for daily practice. However, the basic ideas and principles concerning structural aspects behind the tool have been introduced. In order to produce more reliable results, some improvements will be implemented into the tool. A stability analysis and catenary action analysis will be discussed. In both cases the results will be validated, or retrieved via a non-linear analysis using GSA.

## 9.1 Stability analysis

When analyzing a structure, three basic aspects have to be checked; strength, stiffness and stability. So far, only strength and stiffness have been considered. Therefore, a stability analysis will be implemented into the tool. Different types of stability can be regarded, for instance on elementary level buckling or lateral-torsional buckling, and on a global level stability of the entire building. Only buckling of the columns and global stability will be regarded. Buckling of the girders is disregarded, since this probably will not influence the model as much as column buckling. Though, on further development of the tool this should be investigated.

### 9.1.1 Buckling

If a column is loaded with an axial force  $F$ , the Euler buckling load, the load at which the column will buckle, is provided by:

$$F_c = \frac{\pi^2 EI}{l_c^2} \quad \text{with,} \quad \text{(formula.9.1)}$$

$F_c$  Euler buckling load (N)  
 $EI$  bending stiffness (Nmm<sup>2</sup>)  
 $l_c$  buckling length (mm)

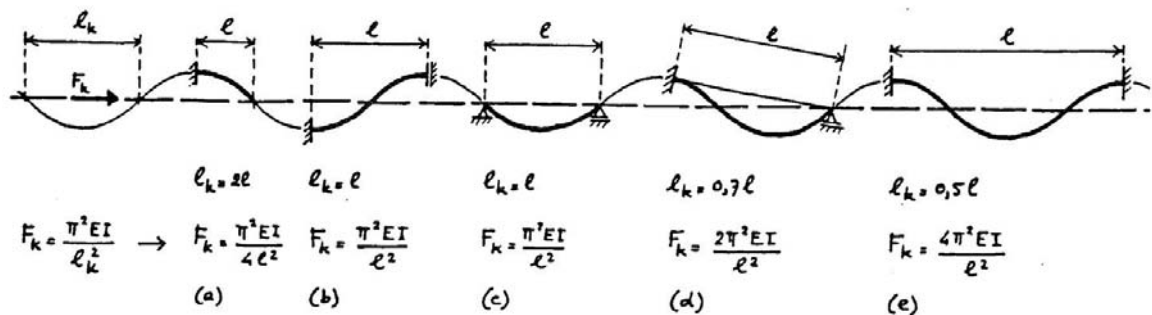

Figure.9.1 Some basic buckling modes (Hartsuijker, 2000)

In figure.9.1 different buckling modes are provided for some basic element configurations. For each mode, or element configuration, a specific buckling length can be retrieved. With formula.9.1 this buckling length, combined with the elements specific bending stiffness, provides the buckling load. The formula for the Euler buckling load can be rewritten in:

$$\sigma_c = \frac{\pi^2 EI}{l_c^2 A} \quad \text{with,} \quad \text{(formula.9.2)}$$

$\sigma_c$  Euler buckling stress (N/mm<sup>2</sup>)  
 $l_c$  buckling length (mm)  
 $A$  cross section area (mm<sup>2</sup>)

The Euler buckling stress is the maximum stress the element can withstand, before it will buckle and fail. Only compressive stresses are considered here, since tensile stresses will not cause an element to buckle. The buckling length for a single element is governed by the system length of the element and the connection properties at both sides of the element (see figure.9.1). These properties can change, if elements are removed from the structure. If, for instance the floors at both sides of a column are removed, the system length of the column is doubled. If, from that doubled column one column is removed, one side of the column is free and thus the connection property has changed. An algorithm tracks the system length and connection properties for each column. The determination of the buckling length from figure.9.1 is only valid for single elements. If a structure with multiple elements is considered, other aspects will influence the buckling length of a single column (e.g. braced or unbraced structures). Simply retrieving the buckling lengths from that figure will result in under- or over estimating the Euler buckling capacity. Hence, some non-linear calculations have been performed for different geometric configurations. This will be discussed in chapter 9.1.2.

The unity checks can be applied for the stability case. Again, different methods are used for steel and concrete:<sup>(1)</sup>

### Steel

For steel elements, the following unity check is used to determine if the element will fail:

$$\text{Unity check} = 1.1 \frac{N'_d}{\frac{\sigma_c}{f_y} N_u} + 1.1 \frac{M_d}{1.0 M_u} < 1 \quad \text{with,}^{(2)} \quad (\text{formula.9.3})$$

$\sigma_c$  the Euler buckling stress of the element [N/mm<sup>2</sup>]  
 $N'_d$  the compressive axial force on the element [N]

### Concrete

The calculation of stability for concrete elements is governed by a first or second order calculation. First, it should be determined if a second order calculation is needed. This can be done by calculating  $\alpha_n$  and  $\lambda_h$ .

$\alpha_n$  follows from:

$$\alpha_n = \frac{N'_d}{N'_u} = \frac{N'_d}{A_c f'_c + A_s f_s} \quad (\text{formula.9.4})$$

$\lambda_h$  follows from:

$$\lambda_h = \frac{l_c}{h} \quad (\text{formula.9.5})$$

No second order calculation is needed if:

$$\lambda_h \leq 5 / \sqrt{\alpha_n} \quad \text{with} \quad \alpha_n \leq 0.25 \quad (\text{formula.9.6a})$$

$$\lambda_h \leq 10 \quad \text{with} \quad 0.25 < \alpha_n \leq 0.5 \quad (\text{formula.9.6b})$$

$$\lambda_h \leq 15 - 10\alpha_n \quad \text{with} \quad \alpha_n > 0.5 \quad (\text{formula.9.6c})$$

(1) Note that the calculations are not entirely according to current building standards

(2) Note that for torsional buckling a factor of 1.0 is used and that torsional stability thus is not taken into account. Hence the capacity of the element will be overestimated.



# Ch9.Improvements

If a second order calculation is not needed, no further calculations have to be made to check the element. Though, if a second order calculation is needed, an extra bending moment should be applied on the element by adding a certain eccentricity  $e_t$ :

$$e_t = (e_0 + e_c)\xi \geq e_0 \quad \text{with,} \quad (\text{formula.9.7})$$

$e_t$	the total eccentricity [mm]
$e_0$	the initial eccentricity [mm]
$e_c$	the additional eccentricity [mm]
$\xi$	a factor ( $\xi = 1$ ) <sup>(3)</sup>

The extra bending moment on the element due to the total eccentricity is:

$$M_{d,buc} = e_t N_d' \quad \text{with,} \quad (\text{formula.9.8})$$

$M_{d,buc}$  the extra bending moment due to second order [Nmm]

This should be added to the original bending moment:

$$M_{d,tot} = M_d + M_{d,buc} \quad \text{with,} \quad (\text{formula.9.9})$$

$M_{d,tot}$  the total bending moment on the element.

The unity check now yields:

$$\text{Unity check} = \frac{M_{d,tot}}{M_u} \leq 1 \quad (\text{formula.9.10})$$

## Core

The calculation of the stability of the core is similar to that of regular elements. It should be checked whether a first or second order calculation is needed. No second order calculation is needed if:

$$l_c \leq \sqrt{\frac{(EI)_d}{G}} \quad \text{with,} \quad (\text{formula.9.11})$$

$(EI)_d$	the design value for EI [Nmm <sup>2</sup> ]
G	the weight of the building supported by the core [N]

The design value for EI is composed of the moment of inertia I and the effective modulus of elasticity for the core  $E_{ef}$ . This is dependant of  $\alpha_n$  (see formula.9.4):

$$E_{ef} = 2200 + 4400\omega + (24000 - 2200\omega\alpha_n) > 5000 \quad \text{If } \alpha_n \leq 0.5 \quad (\text{formula.9.12a})$$

$$E_{ef} = 21300 + 4950\omega(1 - \frac{2}{3}\alpha_n) \quad \text{If } \alpha_n > 0.5 \quad \text{with,} \quad (\text{formula.9.12b})$$

$\omega$  the reinforcement percentage ( $A_s/A_c$ ) [-]

(3) This factor is dependant on the eccentricities at the top and at the middle of the element and will result from the deformation of the element. Since in advance the deformed shape of the element is unknown the eccentricities are unknown and  $\xi$  is unknown. Hence  $\xi = 1$  is used.

If a second order calculation is needed, the following calculations of the eccentricity have to be made:

$$e_t = (e_0 + e_c)\xi \geq e_0 \quad \text{with,} \quad (\text{formula.9.13})$$

$e_t$	the total eccentricity [mm]
$e_0$	the initial eccentricity [mm]
$e_c$	the additional eccentricity [mm]
$\xi$	a factor dependant on the spring stiffness of the foundation of the core ( $C=\infty \rightarrow \xi = 1$ )

If the total eccentricity is known, the extra bending moment due to second order can be calculated and the unity check can be calculated.

Apart from the total stability, also partial instability should be investigated with core calculations. It should be checked if a wall of the core will buckle by calculating it as an individual element. It is assumed that the wall element is completely in compression and the bending moment capacity is provided by  $M_u = N_s z$ . For the buckling length, it is assumed that the floors will restrain the wall element, thus  $l_c = l$ , with  $l$  the length of the wall element between the floors. Further calculations are similar to that of a normal element.

In buckling analyses, also second order calculations are needed to accurately predict the occurring internal forces. Since only first order calculations are considered<sup>(4)</sup>, the attained results will deviate from the actual values. Further research with second order calculation therefore is recommended.

## 9.1.2 Non-linear calculation

In order to estimate the buckling length of columns more accurately, some buckling analysis have been performed with the FEA software. The results of that analysis are discussed here. In appendix G all results of the analysis are given.

The analysis has been performed with different configuration types that will influence the buckling behavior of the elements. First of all, two different systems are considered. The system with moment resistant connections and the system with pinned connections are distinguished. Next, different geometric configurations of the systems are investigated. The surrounding structure of a specific element, from which the buckling length is investigated, determines how the structure will deform. It thus has great influence on the buckling mode of the specific element. Hence, the numbers of floors, the number of columns, the distance between the columns versus the distance between the floors, the bending stiffness of the floors versus the bending stiffness of the columns, or the stiffness of the stabilizing structure, are a few examples of parameters that will result in different buckling lengths.

The analysis has been performed by applying a point load  $F = 1000 \text{ N}$  on top of one line of columns (see figure.9.2) and adjusting only one of the previously described parameters. The load is applied, either on the façade line, or on a line of columns between the facades. Both cases will result in different buckling lengths, since to an exterior column less elements are attached, compared with an interior column. For each case and specific mode, a load factor  $\alpha$  can be retrieved from the analysis.

<sup>(4)</sup> The second order calculations performed with the unity check of the stability are basically first order calculations amplified with a factor.



# Ch9.Improvements

This load factor gives the ratio for the applied load and the buckling load:

$$F_c = \alpha \cdot F \quad \text{with,} \quad (\text{formula.9.14})$$

$F_c$  the buckling load [N]  
 $\alpha$  load factor [-]  
 $F$  the applied force of 1000 N [N]

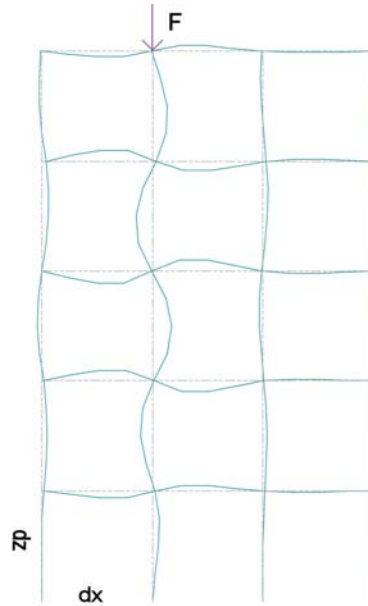

Figure.9.2 Buckling length analysis

With the Euler buckling load formula (formula.9.1), the buckling length of a single column underneath the applied load can be calculated:

$$l_c = \sqrt{\frac{\pi^2 EI}{F_c}} \quad \text{with,} \quad (\text{formula.9.15})$$

$l_c$  buckling length [mm]  
 $EI$  the bending stiffness [Nmm<sup>2</sup>]  
 $F_c$  the buckling load [N]

When investigating the gained results, changing the amount of columns and the ratio of the distance between the columns versus the distance between the floors, will show the biggest change in buckling length. Hence, only these two parameters are presented and will be used for the determination of the buckling lengths.

## Pinned connections

First, the system with pinned connections and stability bracing is considered. Figure.9.3 shows the results when changing the ratio  $dx/dz$  (an arbitrary constant system length of 7.0m is used). This is the ratio of the distance between the columns versus the distance between the floors. It can be seen, that for



## PART II. Structural mechanics

exterior considerations, a constant buckling length of  $l_c = 6.34\text{m}$  is retrieved (the system length is  $7.0\text{m}$ ). If, on the other hand, interior columns are considered, a non-linear relation can be seen which, if  $dx/dz$  approaches infinity, the buckling length will become approximately  $l_c = 6.34\text{m}$ . This non-linear behavior can be explained by the fact that the diagonal bracing also will attract some of the applied vertical force. The retrieved load factor therefore should not be multiplied by the total applied load, but only by the part that the vertical column attracts. If the ratio of  $dx/dz$  is very small, the diagonal member will bear a significant amount of vertical load and the calculated  $l_c$  will become smaller. If the ratio of  $dx/dz$  becomes larger, the vertical load the diagonal member can bear will become smaller and the calculated  $l_c$  will be more reliable. Since for most building structures a  $dx/dz$ -ratio of approximately 3.0 is valid and considering previous described evaluations, for the buckling length in structures with pinned connections  $l_c = 6.34\text{m}$  will be used.

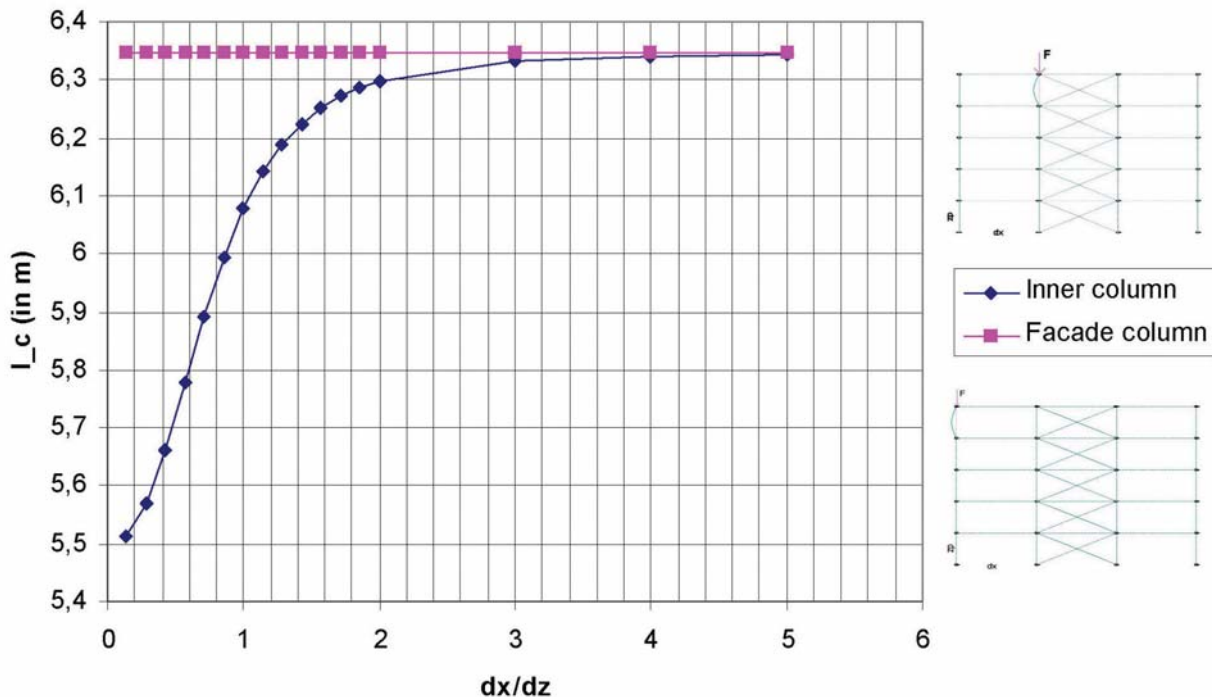

Figure.9.3 Buckling length versus ratio of width between column and height between floors for a structure with pinned connections (system length =  $7.0\text{m}$ )

Combining the system length with the buckling lengths, provides the following relation;

$$l_c = 0,9 \cdot l_{\text{sys}} \quad \text{with,} \quad (\text{formula.9.16})$$

$l_c$                       buckling length [mm]  
 $l_{\text{sys}}$                     system length [mm]

### Fixed connections

For systems with fixed connections, also a relation between the buckling length and  $dx/dz$ -ratio can be found. Unlike for systems with pinned connections, where a significant difference between interior and exterior columns can be seen, the system with fixed connections only shows a marginal difference. Therefore, it is assumed they are the same and only interior columns will be treated further. Though, the

# Ch9.Improvements

number of columns combined with the dx/dz-ratio does have an influence on the buckling length (see appendix G). Although the determination of the buckling lengths seems to be accurate, it is not. A lot of inaccuracies are still neglected. As discussed earlier, the buckling length of an element is influenced by various configurations, which have not been investigated here. Hence, the different buckling length lines are merged into one approximated line from which the buckling lengths can be derived (see figure.9.4).

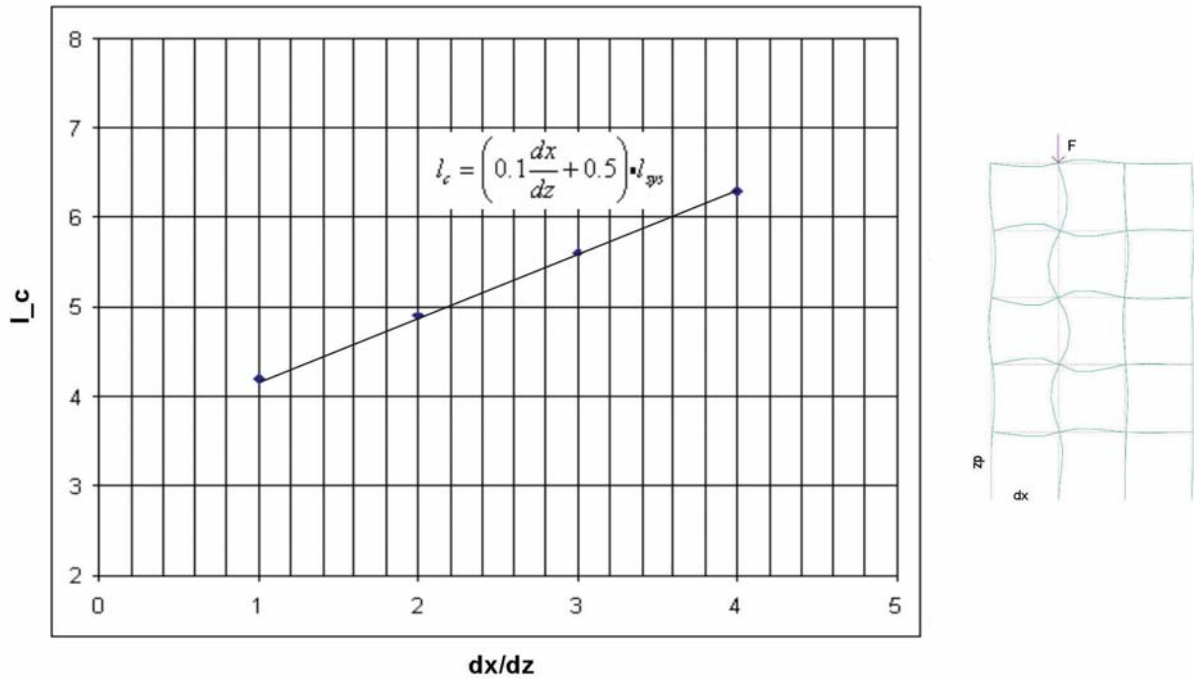

Figure.9.4 Buckling length versus ratio of width between column and height between floors for a structure with fixed connections (number of floors =5, system length =7.0m)

If the dx/dz-ratio increases, the buckling length will increase. As discussed before, the buckling length of an element is greatly influenced by its connection properties and consequently by its rotation capacities. The stiffer the elements attached to the connection behave, the less the connection will rotate and the lower the buckling length will be. If the dx/dz-ratio is increased, or in other words, the length of the floor elements is increased, the floor elements will deform more and consequently rotate at their connections, resulting in a larger buckling length. It can also be said, that on increase of length of the floor elements, the connections will become less stiff, resulting in a behavior approximating pinned connections.

From formula.9.17 the buckling length can be derived for different dx/dz-ratio and system length.

$$l_c = \left( 0.1 \frac{dx}{dz} + 0.5 \right) \cdot l_{sys} \quad \text{with,} \quad (\text{formula.9.17})$$

- $l_c$             buckling length [mm]
- $l_{sys}$          system length [mm]
- $dx$             distance between columns [mm]
- $dz$             distance between floors [mm]

## 9.1.3 Validation

The previously derived formulas can be used to determine the buckling length of vertical elements. It is important to keep in mind, that these formulas only give approximations of the buckling lengths, instead of precise numbers. Here, only two different structural systems are investigated. The results though are applied for all structural systems and can therefore deviate from the precise results. Hence, further research is recommended.

The derived formulas for the buckling length can be compared with the basic buckling modes from figure.9.1. First, the system with pinned connections at both sides is considered. From the figure (image c), it may be assumed that the buckling length is equal to the system length. From the buckling analysis it follows, that the buckling length is 0.9 times the system length, which is near the assumed value. A reduction of 10% is gained.

When considering the system with fixed connections at both sides from the figure (image b and e), a buckling length between 0.5 to 1.0 times the system length may be assumed. When filling in the derived formulas for different  $dx/dz$ -ratio, buckling lengths between 0.53 and 1.08 times the system length are retrieved. This seems to fit the preliminary assumed values.

## 9.1.4 Global stability

Previously, the stability of single elements was considered. Another type of stability is the global stability of a building. If a building is subjected to horizontal loading, e.g. wind, it will deform horizontally. If no, or insufficient, stabilizing elements are applied, these deformations will become very large and can cause the building to collapse. In order to prevent this from happening, stabilizing elements or structures are applied, which can divert the horizontal load into the foundation of the building. Such stabilizing elements or structures are portal frames, diagonal bracing, or cores. To check global stability the following conditions are applied for the maximum horizontal displacement:

$$u_{\max} = \frac{h}{500} \quad \text{for the entire height of the building} \quad (\text{formula.9.18a})$$

$$u_{\max} = \frac{h}{300} \quad \text{for each floor} \quad (\text{formula.9.18b})$$

If these conditions are exceeded, global instability is assumed.



# Ch9.Improvements

## 9.2 Catenary action

An important modeling method in designing against progressive collapse, is catenary action. It describes the development of tensile forces in the floor slab due to deformations, as a consequence of the loss of one support for a two span floor slab. Significant rotation capacity of the connections, as well as large elongation capacity is required. Hence, only systems with pinned connections are considered.

### 9.2.1 Calculations

Consider a two span beam with pinned connections and an equally distributed load  $q$  (see figure.9.5). If the middle support is removed (a column is removed from the model), the beams will deform under the applied load  $R$ , which represents the load originally supported by the middle support. A displacement  $w$  is noticeable. Due to this displacement, the elements must elongate with  $\Delta L$ . Since the elements will restrain the elongation, an axial force  $F$  will develop in the elements. Due to the displacement  $w$ , the orientation of the element has rotated with  $\theta$ . Therefore, also the force  $F$  has rotated with  $\theta$ . Hence, it can be split into a horizontal ( $H$ ) and a vertical ( $V$ ) component. The horizontal component is known as the membrane force.

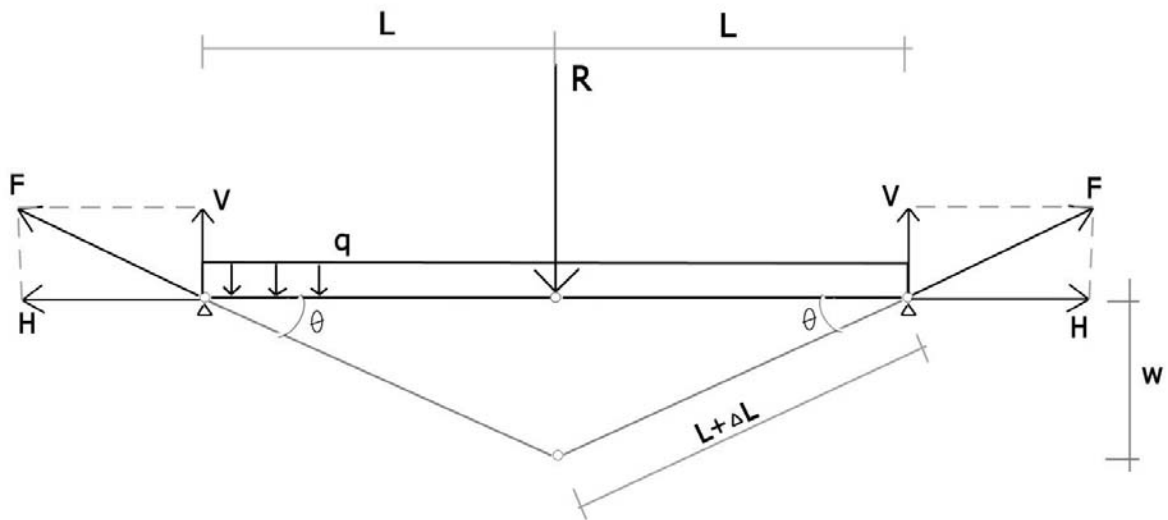

Figure.9.5 2D catenary action

The two vertical components  $V$  must equal with the load  $R$ , for the system to become in equilibrium. This final state is of interest, since then the loads can be restrained by the structure itself. To retrieve this final state, some iterative calculations needs to be performed:

1. Start with  $\theta = 0$
2. Apply a small rotation with small increment:  
 $\theta_1 = \theta_i + \Delta\theta$
3. Calculate the elongation of elements  $\Delta L$ :

(formula.9.19.2)

$$\Delta L = \frac{L}{\cos \theta_1} - L \quad (\text{formula.9.19.3})$$

4. Calculate the force  $F$  in the element due to the elongation:

$$F = EA \frac{\Delta L}{L} \quad (\text{formula.9.19.4})$$

5. Calculate the displacement  $w$ :

$$w = L \tan \theta_1 \quad (\text{formula.9.19.5})$$

6. Calculate the horizontal component  $H$ :

$$H = F \cos \theta_1 \quad (\text{formula.9.19.6})$$

7. Calculate the vertical component  $V$ :

$$V_1 = F \sin \theta_1 \quad (\text{formula.9.19.7})$$

8. Check if the system is in equilibrium:

$$2V_1 \geq R \quad (\text{formula.9.19.8})$$

If the last formula (9.19.8) is not valid, steps 2 till 8 must be repeated. If the last formula is valid, the final state is reached and the occurring displacements and forces have been obtained.

In previous considerations, no attention was given to whether or not the load capacity of the elements was exceeded. When considering only the linear-elastic part of the material, the element will fail if the maximum force it can withstand, is exceeded. Catenary action will not occur in that case. Though, when considering also the non-linear part of the material, an increase in strain is possible with constant load capacity (see figure.9.6). This is favourable, since an increase in strain will result in larger deformations and consequently smaller tensile forces. This consideration is applied in the iterative calculation. At step 4, the force  $F$  in the element is calculated. If this force exceeds 80% (STUFIB, 2006) of the tensile capacity of the element, it is assumed that the force is constant. In further iterations step 4 is omitted. There is also a limit to which the element can extend. From stress-strain curves a limit of approximately 25% is used for steel material. If this limit is exceeded, it is assumed that catenary action does not occur.

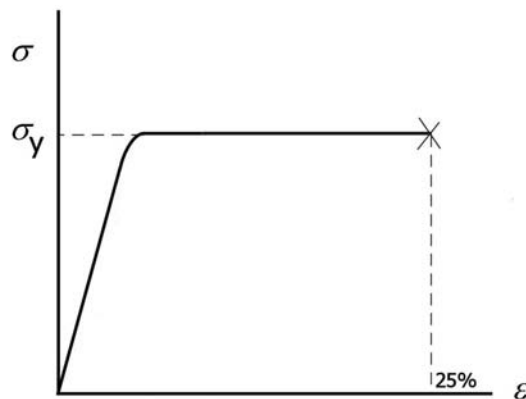

*Figure.9.6 Used stress-strain curve for catenary action*

Previous theoretic considerations have to be applied in the model. First, the occurring forces and deformations are calculated from which it can be determined whether catenary action has occurred. An extra condition is applied for the deformation. Since the free space between the floors must not be smaller than 2.0 meters, in order to provide a safe evacuation of the occupants of the building (see chapter 6.3.2), this condition also holds for catenary action considerations. If catenary action does occur, forces associated with it must be applied on the structure (see figure.9.7). Tensile forces in the element will pull at the attached structure, hence two horizontal forces  $H$  are applied. The floors where catenary action develops will be restraint by rotational springs at both ends of the floor. The stiffness of

## Ch9.Improvements

the rotational spring can be calculated from formula.6.1, since the occurring displacement is known as well as the occurring bending moment. However, the calculated displacement from the catenary action calculation will slightly deviate from displacement from the FEA. This is caused by the difference in the bending moment. In the tool the bending moment is calculated under the assumption that the floor is totally fixed, whereas in the FEA the floor is fixed with a rotational spring. This will result in a bending moment which is slightly smaller than the bending moment if it were totally fixed. Hence the rotational spring stiffness will be a bit larger and consequently the displacement from the FEA will be smaller than the displacement calculated with the catenary action calculation. The resulting displacement of the FEA of the floors where catenary action develops, can thus only be used as an estimation of the actual displacements. The unity checks for the floors where catenary action develops are not performed, since it is already checked whether the floor can withstand the occurring forces. This is incorporated in the calculation of the catenary action. Since also the maximum displacement of the floor is incorporated in the catenary action calculation, the displacement condition of the floors is checked correctly.

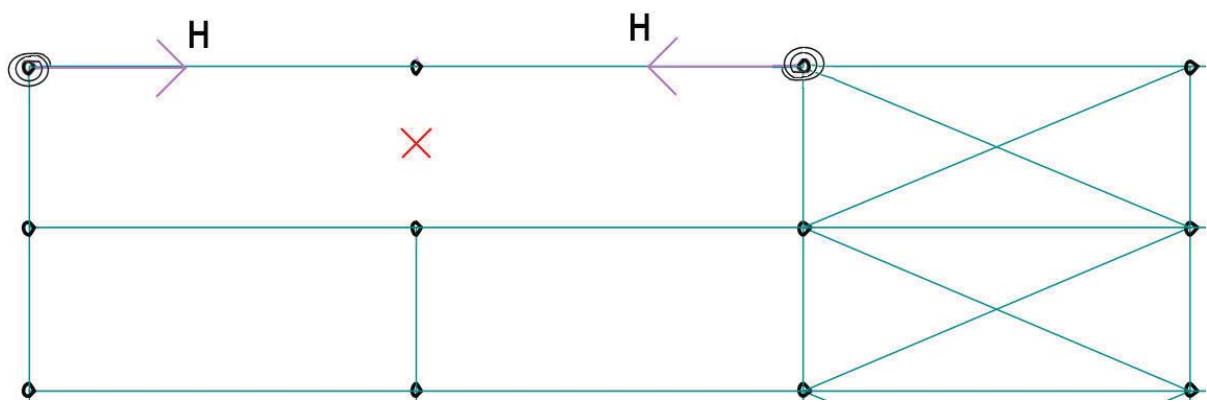

Figure.9.7 Catenary action applied on model

If two or more adjacent columns fail, the floor will deform different than for the case with one column failure. The middle floor will displace vertically. Since the tensile force is the same for all floor elements, the middle floor will also elongate. Thus, the middle nodes will displace in horizontal direction. Consequently, the force in the exterior floors will change. Hence changing the other forces and displacements as well. Since this will result in an elaborate calculation, the deformation of the floor is simplified. It is assumed that the middle floor only displaces vertically and will not elongate, since the displacement in z-direction is much larger than in x-direction<sup>(5)</sup>. The middle nodes are merged into one node and the catenary action is calculated similar as for one column failure (but with a higher load).

### 3D

With previous described determination of catenary action, only a two-dimensional configuration was considered. In fact also a three-dimensional configuration needs to be considered. This is almost similar to the 2D case (see figure.9.5). Now, a two span beam with lengths  $s$  is attached to the floor, in perpendicular direction. The rotation in direction 1 ( $\theta_1$ ) can be related to the rotation in direction 2 ( $\theta_2$ ) with:

$$\theta_2 = \tan^{-1}\left(\frac{L}{s} \tan \theta_1\right) \quad (\text{formula.9.20.2})$$

(5) From non-linear calculation the elongation of a middle element is in the order of 200 times smaller compared with the vertical displacement.

## PART II. Structural mechanics

Steps 3 till 7 can now be calculated in the same way as with the 2D case. This will result in two vertical forces  $V_1$  and two vertical forces  $V_2$ . Step 8 can now be rewritten as:

$$2V_1 + 2V_2 = R \quad (\text{formula.9.20.8})$$

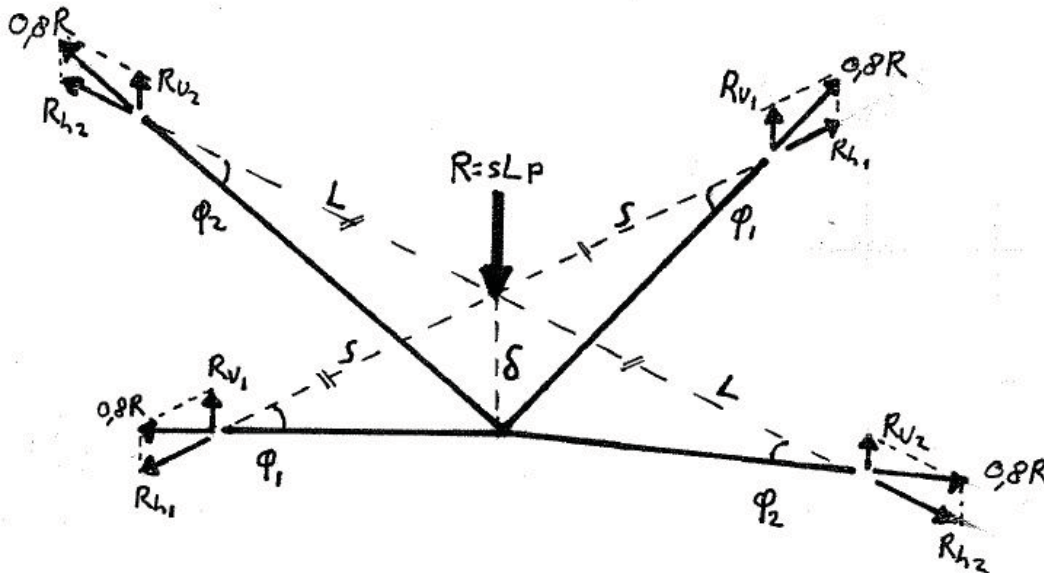

Figure.9.8 3D Catenary action

The 3-dimensional case can only be used, if interior supports are removed with interior bay consideration. In other cases, the 2-dimensional calculations must be used, except if corner columns are removed. In that case, catenary action can not develop.

If steel elements are used, the elements itself can provide the tensile capacity to withstand the catenary action. If, on the other hand, concrete elements are used, the tensile capacity is very low and catenary action must be restraint by the reinforcing bars. In concrete building design, additional steel strips are added to provide for the need of extra tensile capacity, to be able to develop catenary action. Hence, it is recommended to add the possibility to add extra steel strips in the PCI-tool, if concrete elements are considered.

In previous considerations, no attention is given to the fact that the tensile forces should be transmitted through the adjacent structure. The forces should be restraint by the stabilizing elements. If figure.9.7 is considered, the structure is only stabilized at one side of the building and the tensile force at the left side can not be restraint by the surrounding structure. Hence, catenary action can not develop. Though, the tensile forces can be restraint by the surrounding structure in a different way. The floor slabs surrounding the deformed floor can transmit the forces to the stabilizing elements at the right side as well. To determine whether they can bear the load, 3-dimensional considerations are needed. For now, only 2-dimensional considerations are used and it is assumed the floor slabs can transmit the forces. However, it is advised to check if this assumption is valid.

# Ch9.Improvements

## 9.2.2 Validation

The previously described calculation method in determining the forces and deformations if catenary action occurs, have been validated using a non-linear analysis with the FEA software (see appendix H). For each different steel profile, the displacement  $w$  is calculated for different load  $R$ . This has been done, both with the FEA-software as with the described calculation method. The results of both methods give exactly the same values and thus it may be assumed that the calculation method is correct. Though, deviating results may be obtained, if the rotation increment is chosen incorrect. With the validations, a rotation increment of 0.0001 has been used, which is rather small. To decrease the calculation time, larger increments can be used. Hence, for different rotation increments, the displacements are calculated for a 3D case with HE200A beams with lengths of 4m and increasing loads. These results are graphically represented in figure.9.9.

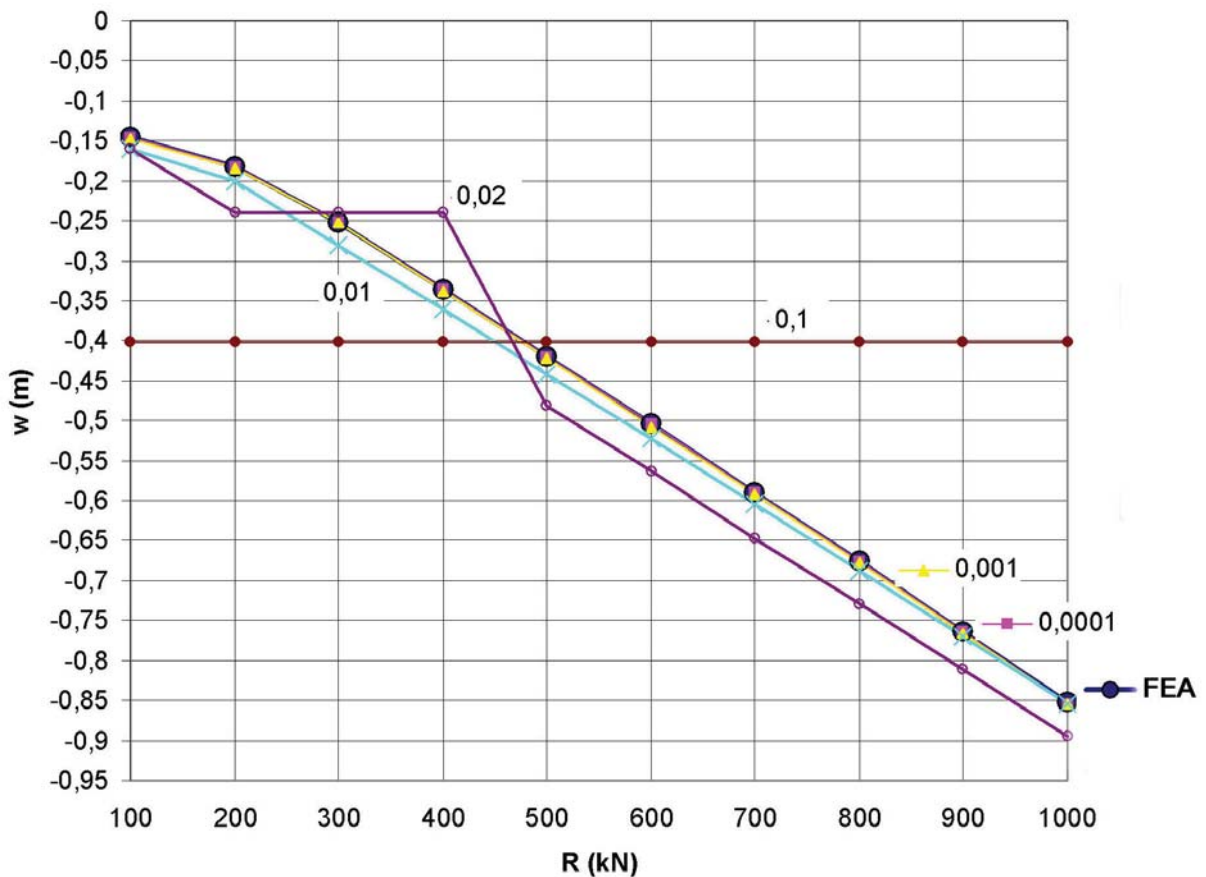

Figure.9.9 3D Catenary action displacements with different rotation increments

One of the lines represent the results of the FEA analysis. The calculated results should approach this line as close as possible. When the rotation increment  $\Delta\theta$  is 0.1, a constant displacement is found for changing loads. Using this rotation increment will result in large errors. When  $\Delta\theta=0.01$ , the retrieved displacements seem to fit the FEA results. Though, they still deviate. If  $\Delta\theta=0.001$ , the displacement can be calculated with an accuracy of a few millimeters. If  $\Delta\theta=0.0001$ , the results are accurate within a millimeter. It is recommended to use a rotation increment of at least  $\Delta\theta=0.001$ , since also the internal forces are sensitive to the rotation increments. For instance if  $R=100\text{kN}$ ,  $L=4\text{m}$ ,  $s=4\text{m}$ , profile=HE200A, for  $\Delta\theta=0.0001$  is found;  $V_1=25.0\text{kN}$ . Whilst for  $\Delta\theta=0.001$ ;  $V_1=26.5\text{kN}$  is found. Using  $\Delta\theta=0.001$  will result in an error of 6%. Hence,  $\Delta\theta=0.0001$  is used in the PCI-tool.



PART III. Validation



# Ch10.Evaluation order

In the previous parts of this report, the tool is discussed. The calculation procedures and its principles are distinguished, with which the PCI can be calculated. In this part of the report, it is discussed whether the calculated PCI is reliable and how many iterations are needed. First, the evaluation order is discussed.

The order of element evaluation and consequently element removal, influences the behavior of the model. If an element is removed from the model, the forces will have to be redistributed to the other elements. For different evaluation methods, different elements can be removed. Hence, it has got great influence on the reliability of the model. Several methods can be thought of. The general methods will be discussed here. Probably, even more methods can be thought of but they will be similar to the ones discussed here.

### *Fixed order*

The elements can be evaluated in a fixed order. For each iteration, the same order of evaluation is used. A lot of different methods exist, for instance, the floors can be evaluated first and the columns second, or vice versa. It is also possible to start at the bottom left column and finish at the most top right column, or vice versa. It is even possible to change the order of evaluation for the load cases for one element. An element can pass the unity check for one load case, but will fail at another. It is clear that a lot of combinations are possible. An advantage of these methods is the fast calculation, since not all elements have to be checked if an element fails. Though, a disadvantage of these methods is, that the failure of elements has not got a strong relation to the initiating event and the progressive collapse will show an unpredictable progression. Hence, this method seems to produce rather unreliable results. Only if the evaluation starts at the initial failed element and progresses to the boundaries of the building, a stronger relation between the initial event and propagating failures can be expected.

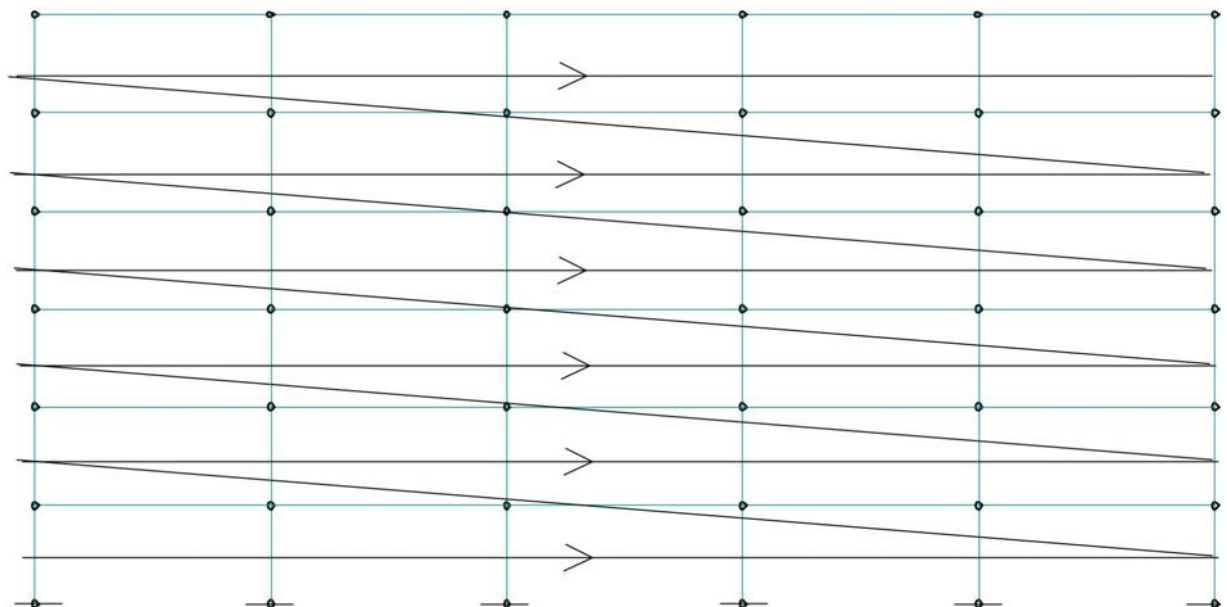

Figure.10.1 Evaluation of elements in a fixed order

## *Highest unity check exceedance*

Another evaluation order depends on the exceedance of the stress (or: unity check). The element with the highest exceedance is removed. In order to properly compare the results for the different elements, it is important that all unity checks are written in the same way. Otherwise, the results are not comparable. This method shows an arbitrary order, since in advance it is not known which element will fail. An advantage of this method is that the relation between initial event and progressive failure of elements is clear, since the elements near the initial failed element will be loaded most severe. Another advantage (compared with multiple element removal), is that the results are rather insightful and can be easily checked, since each time only one element is removed. A disadvantage is the speed of calculation. Before it can be determined whether an element fails, all elements have to be checked. Especially when large structures with a lot of elements are concerned, the calculation time will be considerably larger compared with the fixed order method. However, this method produces far more reliable results.

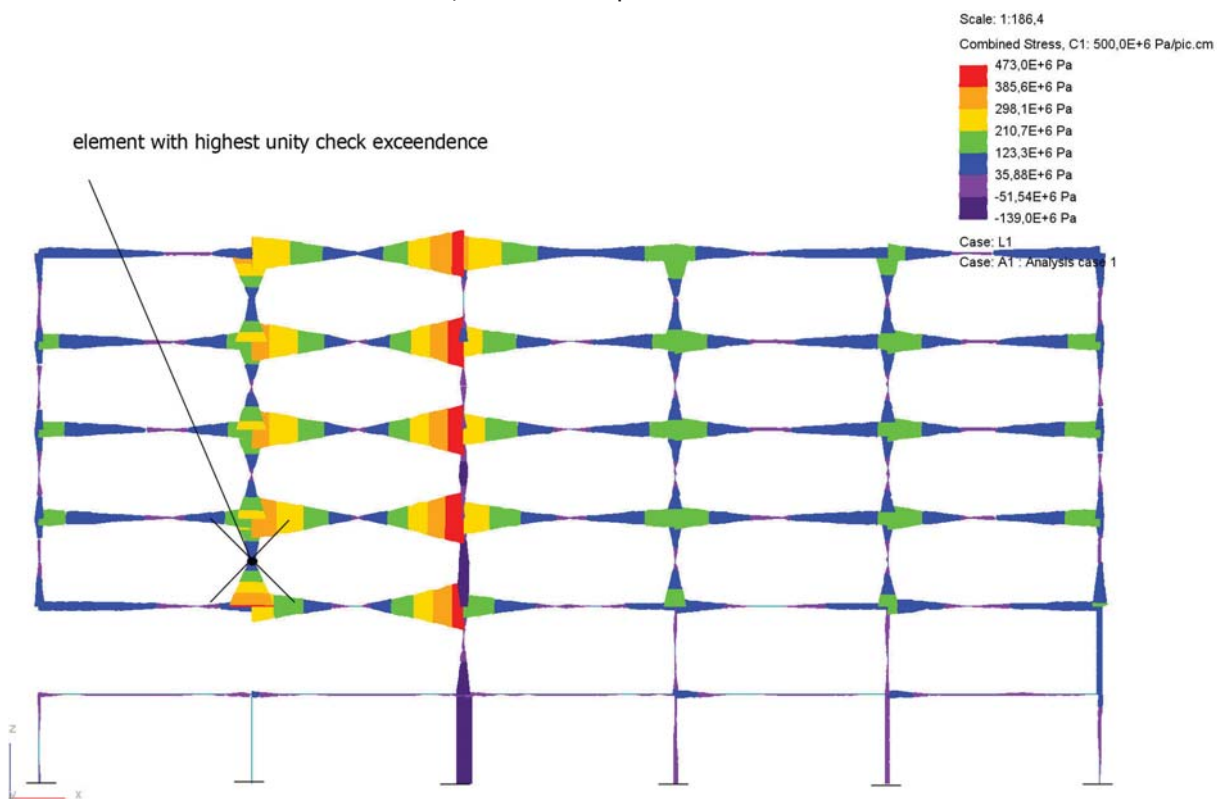

Figure.10.2 Evaluation of elements with highest unity check exceedance

# Ch10.Evaluation order

## *Multiple element removal*

A third possible evaluation order, is the removal of all elements which exceed the unity check limit. This method also shows an arbitrary order, since in advance it is not known which element will fail. An advantage of this method is, that it will remove all elements that are expected to fail. This method is faster than the second method, since for an entire calculation fewer steps are needed, as multiple elements are removed per step. Though, this method also has got disadvantages. For instance, the progression of the collapse will be harder to follow since multiple elements can be removed per step. Consequently, the results are harder to verify, which reduces the reliability of the model.

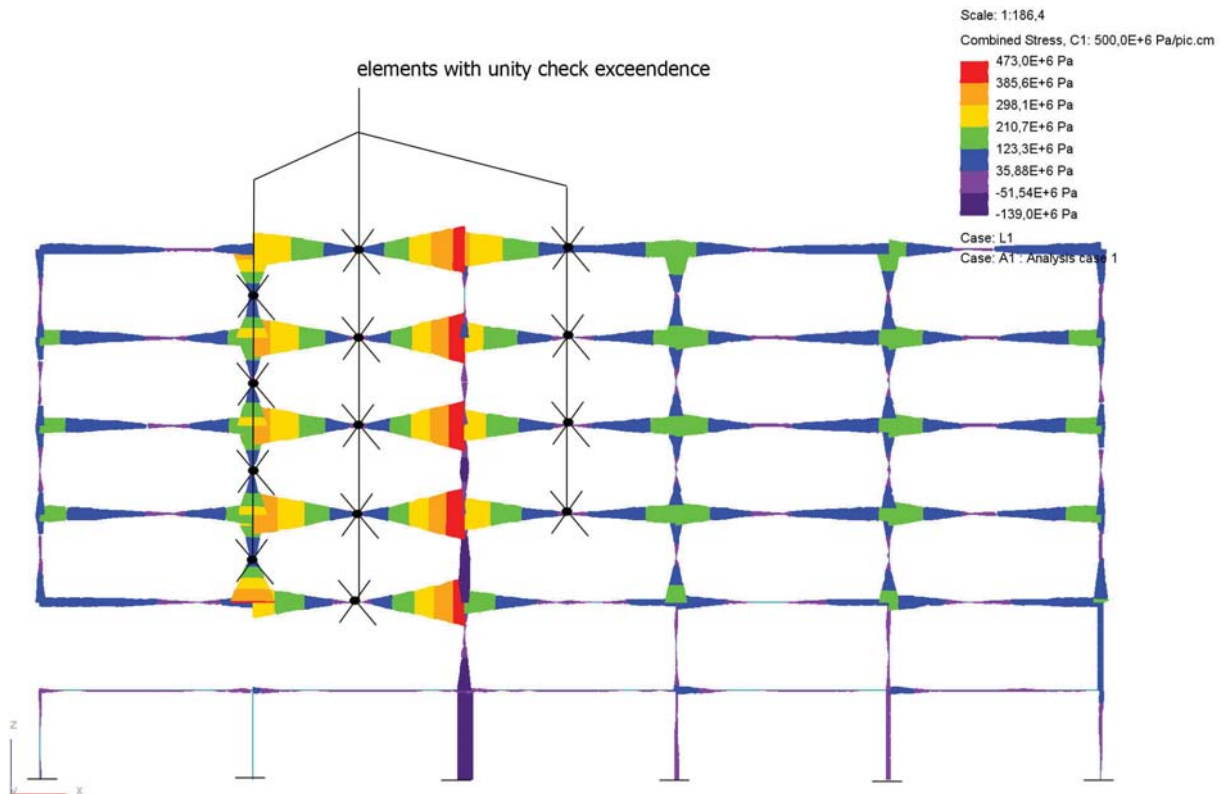

Figure.10.3 Evaluation of elements with multiple element removal

## *Gradually increasing load*

A fourth possible method focuses on how the load is applied on the model. With previous methods, the load is fully applied on the model and afterwards the elements are evaluated. This method gradually increases the load which is applied on the model. Simultaneously, the unity checks of all elements are evaluated. The load is increased until the total load is applied, or one element reaches its ultimate capacity. That element is removed from the model and again the load is gradually applied until another element reaches its ultimate capacity. If the total load is applied on the model and no element is removed, the system is in equilibrium. In figure.10.4 this method is schematically depicted. In that figure the load is set against the deformation of the structure. The load is increased, resulting in the deformation of the structure. At some point the ultimate load capacity of an element is exceeded, leading to the failure of that element. That element is removed and the load again is gradually increased until a second element fails. After some cycles, the structure is in equilibrium. The advantage of this method will be that the progression of the collapse will be clear. However, a disadvantage of this method will be the low calculation speed.

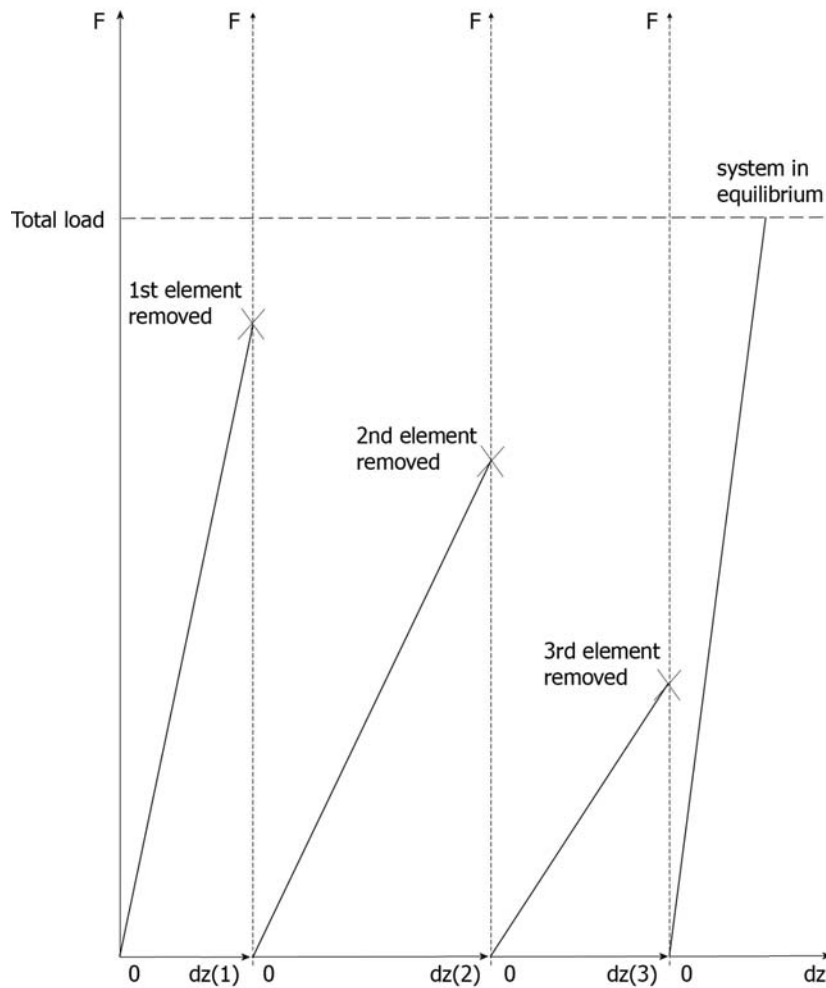

Figure.10.4 Evaluation of elements with gradually increasing load

From the four methods, the method with the highest unity check exceedence is used in the tool. The main reason is, that it will most probably produce reliable results and that it will clearly show the progression of the collapse. The method with multiple element removal or gradually increasing the load can also be used. On further development of the tool it can be investigated which of the methods is more reliable and faster. It is not advised to use the method with a fixed order, since the reliability of that method is unpredictable.



# Ch11.Sensitivity analysis

With the tool, a PCI-value can be calculated. This value depends on the number of progressive collapses and the number of iterations (see formula.6.19). Hence, these parameters have got great influence on the outcome of it. Especially the number of iterations determines the result of the calculated PCI. If, for instance, only one iteration is performed, the resulting PCI can only be 0% or 100%, since a progressive collapse can occur or it can not occur. If, on the other hand two iterations are performed, the PCI can also be 50% (one progressive collapse and one no progressive collapse). Hence, increasing the amount of iterations will increase the amount of possible values for the PCI.

By increasing the amount of iterations, an increase in accuracy is reached for the calculated PCI. Though, also an increase in calculation time will result. Hence, performing infinite iterations is practically impossible. An optimum should be searched. Therefore, a sensitivity analysis has been performed which will be discussed next.

## 11.1 Variance and standard deviation

The analysis has been performed by repetitively running the tool. During each run, a different amount of iterations is chosen, namely 10, 100 and 1000 iterations. In order to investigate the spread in possible PCI's, each run is repeated 10 times, so the number of simulations is 10. This will result in 10 different PCI's. From these PCI's, an average PCI can be calculated (see formula.6.20). The spread of the PCI's can be indicated by the variance and the standard deviation;

$$Var(PCI) = \frac{\sum (PCI_{gem} - PCI_s)^2}{s} \quad (formula.11.1)$$

$$SD = \sqrt{VAR(PCI)} \quad with, \quad (formula.11.2)$$

Var(PCI)	the variance of PCI [-]
$PCI_{gem}$	the average PCI [%]
$PCI_s$	the PCI of simulation s [%]
s	the amount of simulations [-]
SD	the standard deviation [-]

The variance and standard deviation give an indication about how much the PCI's deviate from each other. Hence, a large standard deviation indicates that the PCI values differ a lot and that the calculated average PCI will not be accurate.

The analysis has been performed for each structural system. In each run, this resulted in 10 PCI's, an average PCI, a variance, a standard deviation and a calculation time. Some of the results will be discussed next. For all results see appendix J.

## 11.2 Average PCI

In figure.11.1 and 11.2 the results for the moment resistant framework and for the pinned framework with stability bracing are presented.

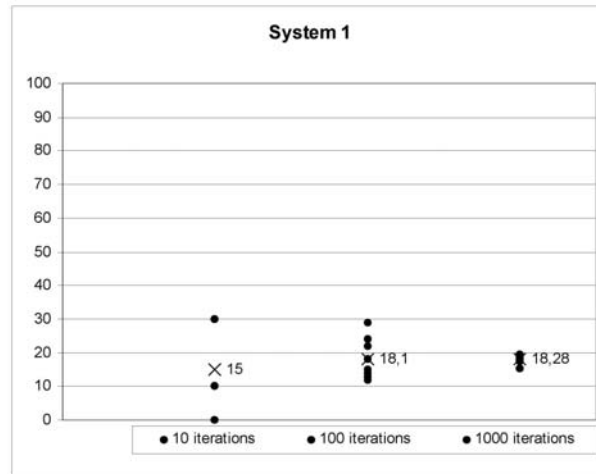

Figure.11.1 PCI's of moment resistant framework with different amount of iterations including the average PCI

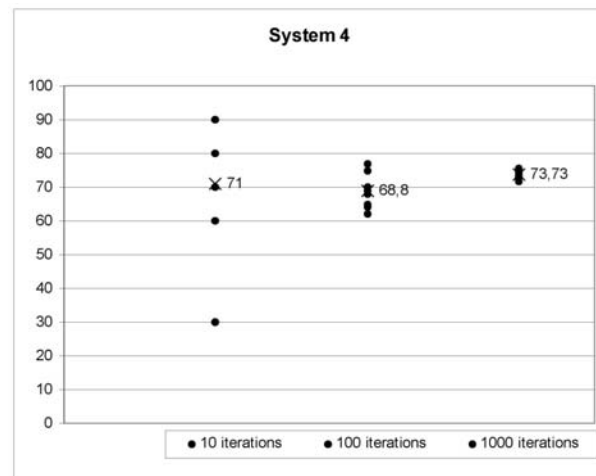

Figure.11.2 PCI's of pinned framework with stability bracing with different amount of iterations including the average PCI

As expected, it can be seen that the range of calculated PCI-values decreases with increasing iterations<sup>(1)</sup>. The more iterations, the more accurate the calculated average PCI will be. The average PCI converges to a certain value.

(1) Note that for the results of 10 iterations not all PCI-values are visible, since some PCI-values are equal. See also figure.J.4 in appendix J

# Ch11.Sensitivity analysis

As discussed before, an increase in iterations will result in an increase in calculation time. Figure.11.3 illustrates this.

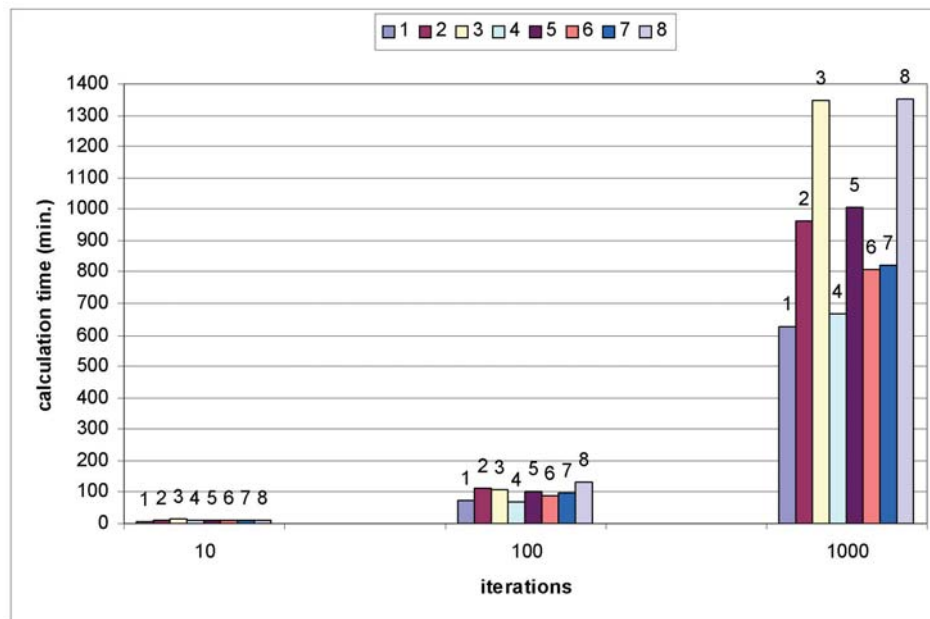

Figure.11.3 Calculation time versus number of iterations for the different structural systems

There is a linear relation between the number of iterations and the time needed to perform all calculations. An increase of  $x$  times the amount of iterations, will take  $x$  times longer to finish. The calculation time is not only dependant on the number of iterations. Other important aspects influencing the speed of the calculations of the tool are for instance, the calculation speed of the computer or, the number of elements removed during an iteration before a progressive collapse is counted, or the amount of elements of the model. Hence, the calculation time showed here is only an indication of the actual calculation time.

## 11.3 Optimum amount of iterations

An optimum amount of iterations can be determined, when comparing the resulting PCI with the time needed to perform the calculations. The optimum can then be found when considering that the tool will be used in the early design stage, in which fast results are required. Hence, a calculation time of 1000 minutes will not be favourable. Thus, using 1000 iterations will not be practical. On the other hand, using only a few iterations will not be favourable as well, since the resulting PCI then will be inaccurate. Hence, using only 10 iterations is also not advised. Using this consideration, the optimum lays between 10 and 1000 iterations.

Though, since the user determines the criteria with which the calculations should be performed, the optimal amount of iterations should be determined by the user. He or she should decide between fast, but inaccurate calculations, or slow and accurate calculations. In both cases it is important to know how accurate or inaccurate the results are. Useful parameters for the assessment of the accuracy are the variance and the standard deviation. Since these parameters give the dispersion of the PCI's, they thus provide information about the accuracy. For instance, if the average PCI is 50% and the calculations give a standard deviation of 10, it may be expected that the PCI could also be 60% or 40%. Hence, with a decreasing standard deviation, an increase in accuracy can be governed. In other words, the



## PART III. Validation

standard deviation gives a value that determines the range of inaccuracy for the PCI. The user should decide how much inaccuracy or standard deviation is admissible. This can then be used to determine the number of iterations. Beforehand, the resulting standard deviation is unknown. Therefore, the amount of iterations should be chosen by determining the target standard deviation, and then selecting the amount of iterations by using the results from the runs. The resulting standard deviation should then be smaller than the target standard deviation. If this is not the case, new calculations should be performed with a larger number of iterations.

Another important aspect in determining the optimum amount of iterations which is not covered yet, involves the initial damage of the structure. For each iteration one damaged structure is generated. Thus, if only one iteration is performed, only one possible initial damage is taken into account, resulting in a PCI that is meaningless. Since the sensitivity of a progressive collapse for the entire structure is investigated, at least each element should be removed once. Hence, the amount of elements determines the minimum amount of iterations that need to be performed. Performing more iterations will consequently result in a more accurate PCI.

Concluding, an optimum for the amount of iterations can not be given. The optimum should be determined by the user, who decides what criteria are important. Though, the user is assisted by providing the standard deviation of the PCI with which the accuracy of the result can be expressed. Also a lower bound for the number of iterations, determined by the amount of elements, can aid the user by choosing the number of iterations.



# Ch12.Verification

Before the tool can be used in daily practice, a verification of the tool is needed. If it will produce unpredictable and impossible failure modes, the tool is not suitable for daily practice, since the results will be unreliable. Hence the tool is tested by executing test runs. Since similar tools do not exist (besides the prototype tool of ir. Coenders), it is hard to say if the tool and its results are correct, since hardly any comparable data is available. Though, a verification can be performed on whether or not the failure order of the elements is logic. Hence, the results of the tests are validated by looking at the failure order of the collapse and if it coincides with what should be expected in advance. In this chapter, only the results for the moment resistant framework are discussed, since these provide an irregular failure order. The failure order of some other structural systems is presented in appendix K. In chapter 12.5, a short comparison between the tests performed on ir. Coenders' prototype tool and the current tool will be discussed.

During the development of the tool also checks have been executed to see if the calculations (e.g. strength or catenary action) performed are correct. The results from the tool were compared with manual calculations. Since the calculations already are discussed in this report, a verification of those calculations is not given here.

## 12.1 General

In general, for all structural systems, the global stability of the model has got a lot of influence on the resulting final stage of the model. In order to reduce calculation time, during each step an element is removed, the global stability is checked. If the model does not pass this check, the calculation is terminated before the final stage of the collapse can be reached. Hence, the test runs are performed with and without the global stability check.

Also, the occurring of local mechanisms (or: calculation error) can have serious influence on the resulting final stage of the model, for all structural systems. If a calculation error occurs, the calculations are terminated before the final stage of the collapse can be reached. In most cases, calculation errors only appear after some elements have been removed. Hence, it may be assumed that a progressive collapse will occur. Thus it will not influence the calculated PCI. Though, if one is interested in the final damage of the model, the occurring calculation error does restrict.

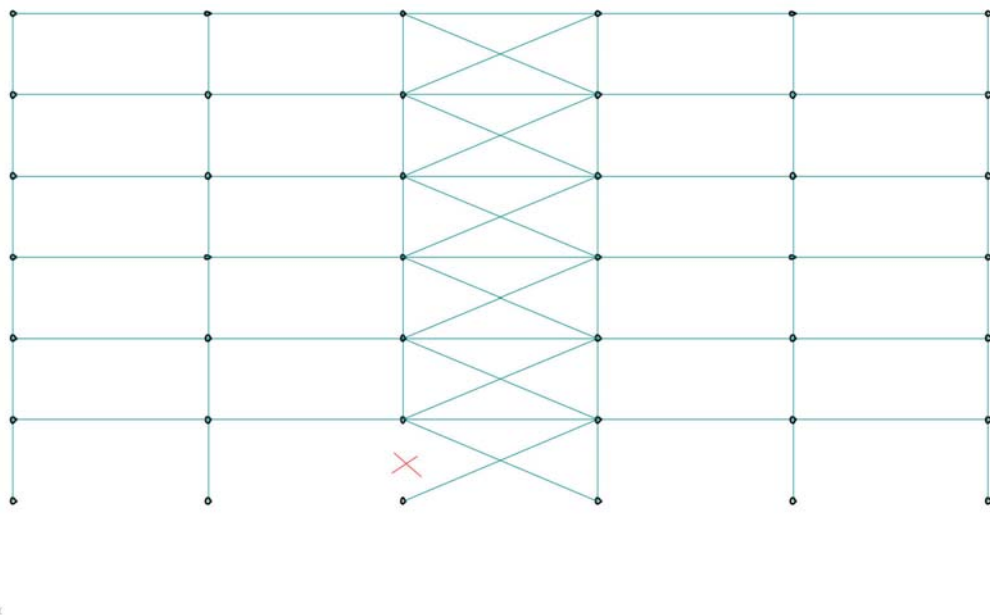

Figure.12.1 Configuration of a system with stability bracing at which a calculation error occurs

If a system with cross-bracing is considered, a calculation error occurs if a chord of the bracing at ground level is removed (see figure.12.1). The calculation is terminated and a progressive collapse is assumed. If this configuration is generated initially, a progressive collapse is assumed even before more elements have been removed. The structure actually did not collapse, since no element is removed and an incorrect PCI is obtained. Though, the obtained PCI can be correct, if one considers the fact that if such configuration is generated and a certain amount of floors is taken into account, the structure will be unstable. Hence, the model would not pass the global stability check if it could have been calculated. It thus will result in a correct PCI.

When validating the results of the runs for the moment resistant framework, several failure modes, or order of element removal can be seen. Three different situations will be discussed. The first two situations show an irregular pattern in element removal. The third situation shows a failure order of elements that can be expected in advance. All runs are performed with steel HE300A columns and steel HE400A floors.

## 12.2 Situation 1

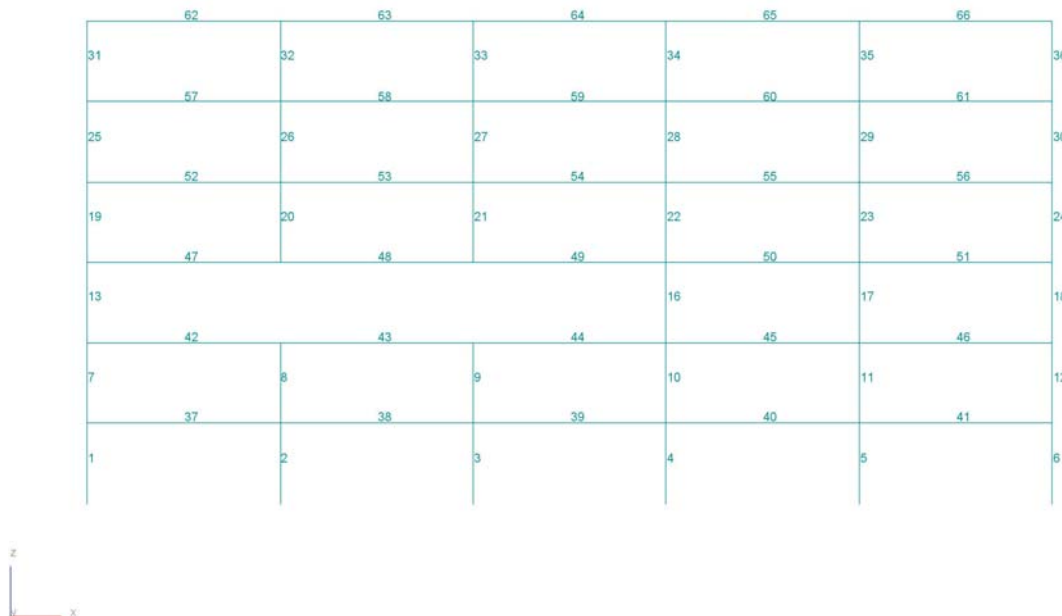

Figure.12.2 Situation 1: Initial generated damaged model with moment resistant framework

Let's first consider the damaged structure from figure.12.2. Beforehand, one may expect that, due to vertical loading, elements 13 and 16 will be removed due to high axial forces and a combination of some bending moment, or that elements 47, 49, 52, 54, 57, 59, 62 or 64 will be removed due to high bending moments. Though, the tool will remove element 31. At first sight, it seems as if an error occurs in the tool. In order to check if that is the case, at first the unity checks are validated by manual calculations.

The internal forces are extracted from the FEA and the unity checks are calculated (see appendix K.4). From this calculation, it also follows that element 31 is loaded most severe and thus should be removed from the model first. This can be a coincidence, hence the resulting unity checks, carried out by the tool, are compared with the results from the manual unity checks. In both cases, the results coincide. Apparently, numerically the tool works correct.

# Ch12.Verification

Another reason for the unexpected element removal can be that the calculated forces are incorrect. Hence, these have to be validated as well. A first check has been carried out by viewing the sum of the total loads and reactions. These should be 0, which is the case. Then, the occurring forces and deformations (see figure.12.3) are investigated.

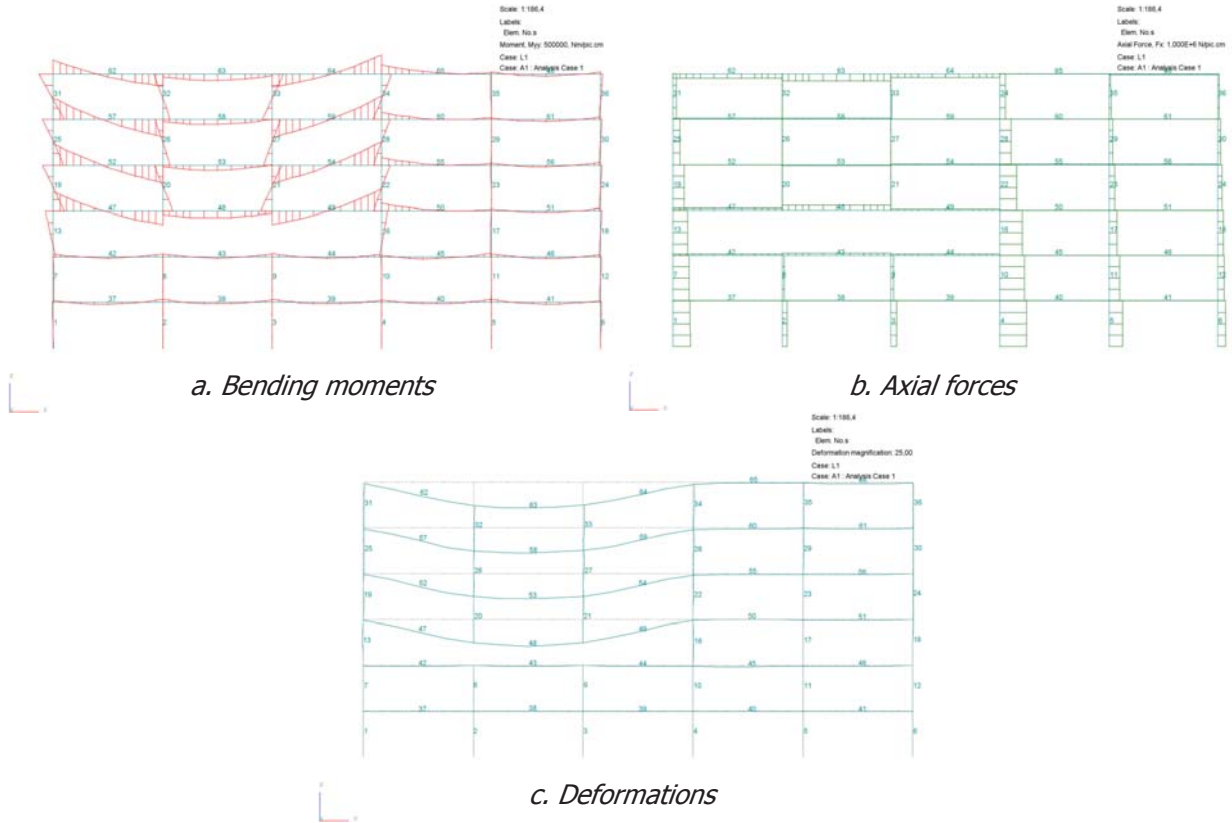

Figure.12.3 Situation 1: Occuring forces and deformations for the damaged model calculated by GSA

Especially the forces and deformations in the top left corner of the model are of interest. Due to the removal of two elements, in that top left corner, in fact a very high beam is generated which can be modeled as shown in figure.12.4. Comparing the resulting forces and deformations, they roughly coincide.

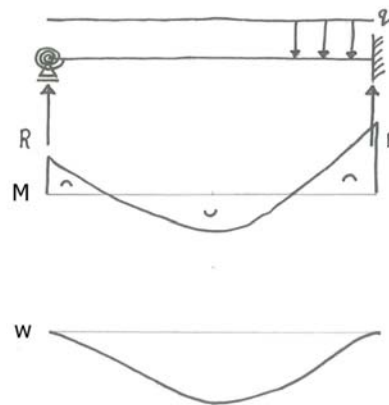

Figure.12.4 Situation 1: Simplification of the damaged model

Though, using this simplification neglects the occurring of shear behavior in very high beams. Hence, a final validation is performed by modeling the structure as shown in figure.12.5 and calculate it with another FEA-program<sup>(1)</sup>.

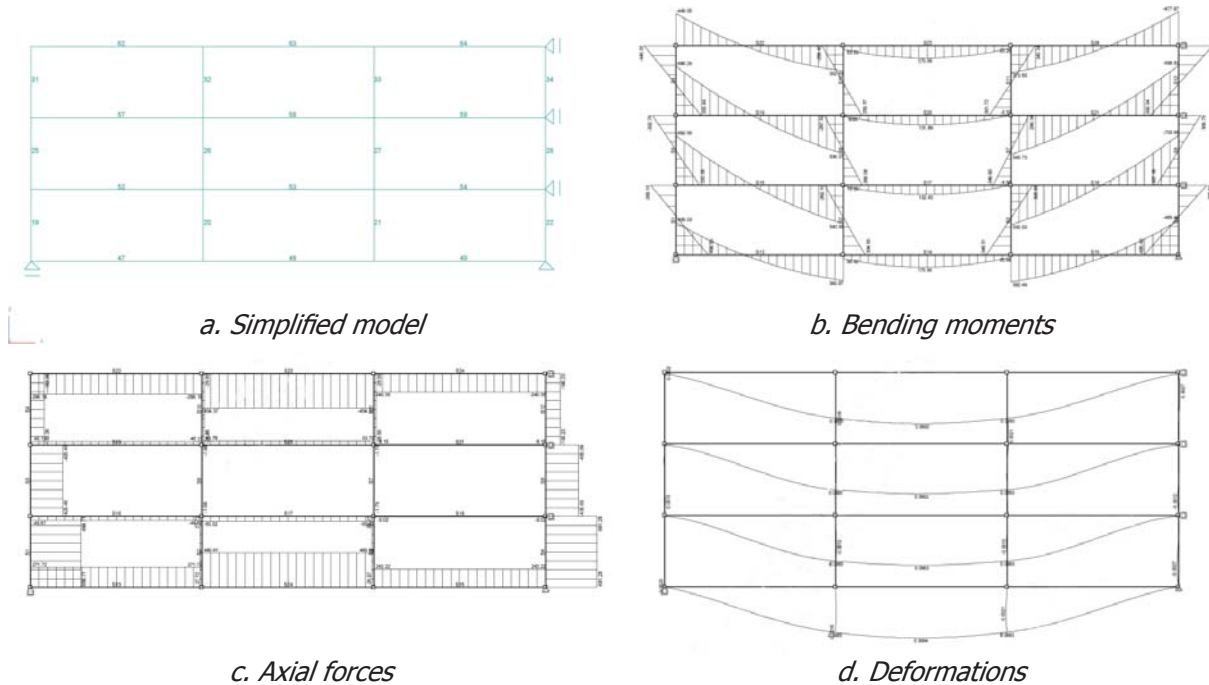

Figure.12.5 Situation 1: Occuring forces and deformations for the damaged model calculated by MatrixFrame

Comparing the results from the calculations of GSA, with the results from the calculations with Matrixframe, shows that the shapes of the bending moment lines, axial force lines and deformation lines are the same. Hence, it may be expected that the calculated forces and deformations by GSA will be correct.

Apparently, the tool and the FEA both work correct, but still it is unclear why element 31 is removed from the model. The unity checks provide more insight into that question. The unity checks consist of a combination of an axial check and a bending moment check. Looking at both components separately, the failure of the elements mostly depends on the bending moment part of the check. The elements consist large axial force capacity, but low resistance considering the bending moment. Evaluating the unity checks for the undamaged structure will show that the bending moment part will be largest for the facade columns at the top floor. Hence, if elements are removed from the model, the bending moments will increase, causing the components for the bending moment to increase as well. Since, these are governing in removing an element from the model, the facade elements at the top floor are most sensitive to be removed first. Thus, avoiding these elements to fail, can be done by increasing the bending moment capacity for those elements.

Although at first sight the removed element seems incorrect, the tool removes the correct element from the model. Numerically the tool thus works correct. Though, the propagation of the failures still is discussable. The resulting failure order of the elements, in this situation, is not very logic (see figure.12.6).

(1) MatrixFrame4.0.1 studentenversie

# Ch12.Verification

As can be seen, after some elements have been removed, the failure of elements suddenly propagates to the other side of the building, which is unexpected, since the left part of the building already is severely damaged. It thus results in an irregular propagation of failures. Thus, although the removal of elements is numerically correct, in practical sense it is not.

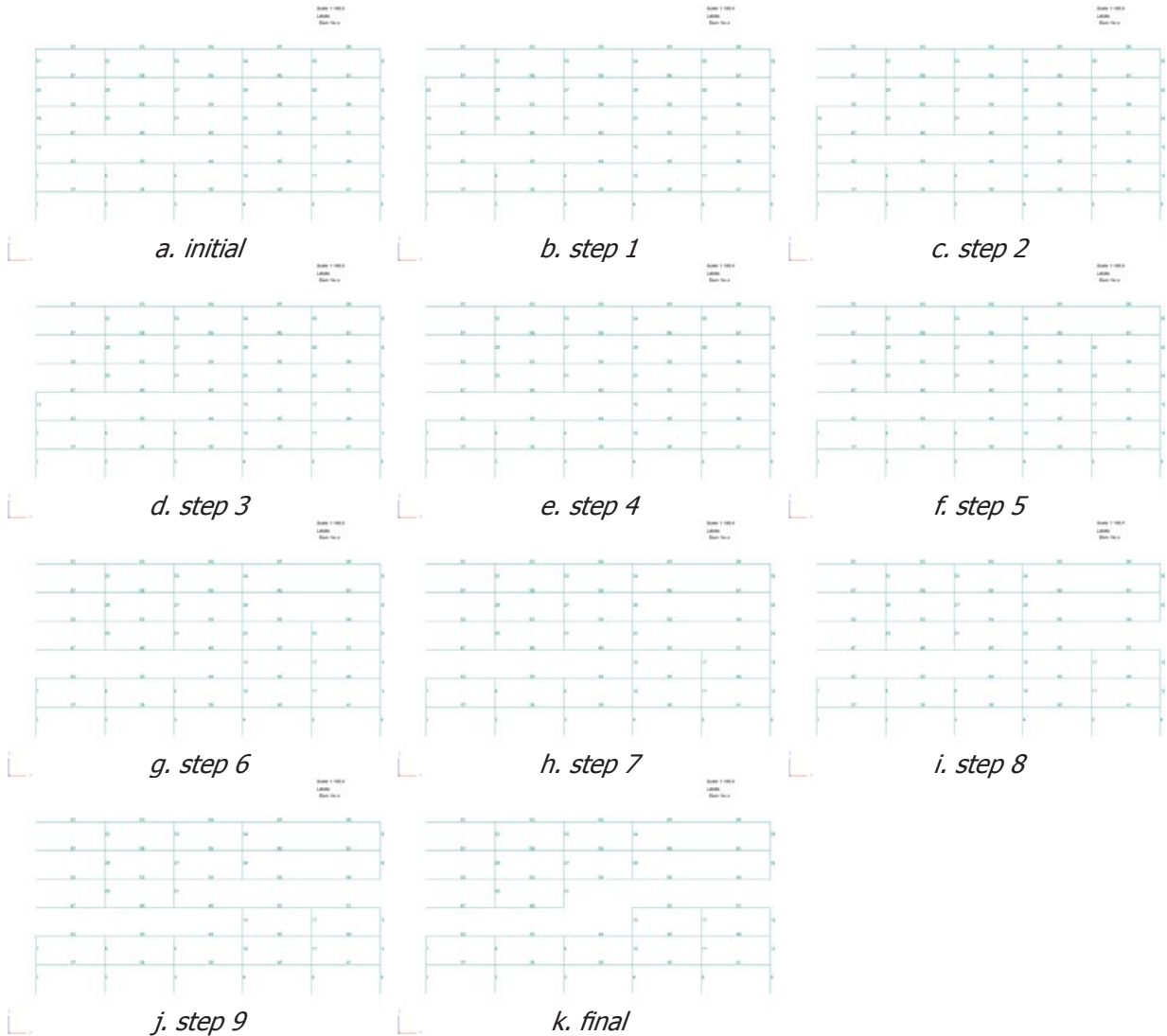

Figure.12.6 Situation 1: Failure order of elements with moment resistant framework

Fortunately, the method of element removal only has minor influence on the resulting PCI, since if one element is removed, most probably more elements will be removed and a progressive collapse is counted. This is especially the case for this type of initial situations. Though, if also information about how the building will collapse is needed, the current propagation of element removal will not be suitable. Hence, the method in element removal should be reviewed in further development of the tool.

## 12.3 Situation 2

In the second situation, the initial damaged model from figure.12.7 is generated. Beforehand, it may be expected that, due to vertical loading, element 10 will be removed due to a combination of high axial loading and bending moment, or that element 45, 50, 55, 60 or 65 will be removed due to high bending

# PART III. Validation

moments. Though, element 17 will be removed. Again, it seems as if an error occurs in the tool. In order to validate this, the same checks as in situation 1 are performed. First, the unity checks are calculated manually (see appendix K.4), then the resulting forces and deformations are validated by checking the sum of the total loads and reactions. In both cases no deviating results are gained. Therefore, the model is simplified and calculated and compared with other FEA-software.

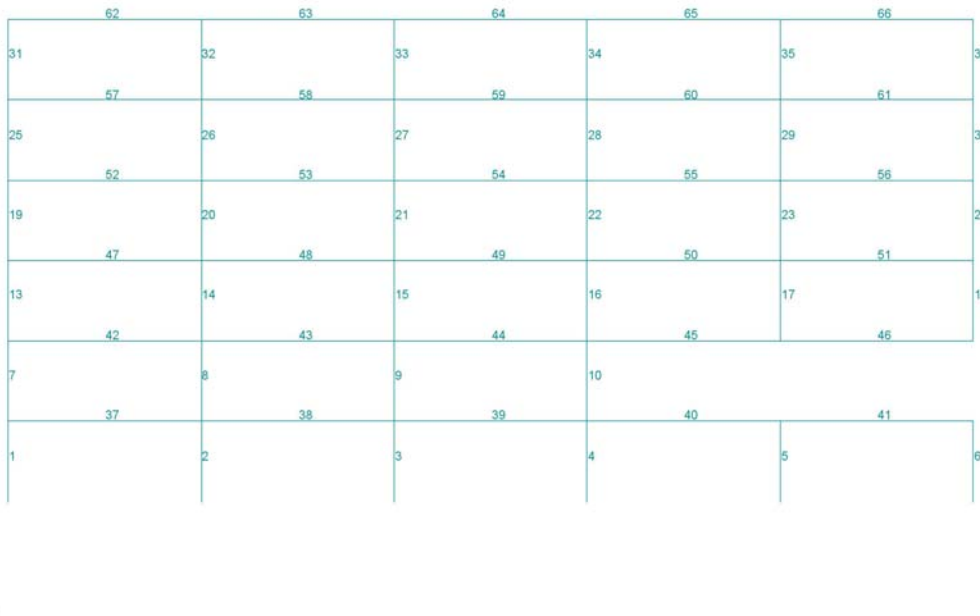

Figure.12.7 Situation 2: Initial generated damaged model with moment resistant framework

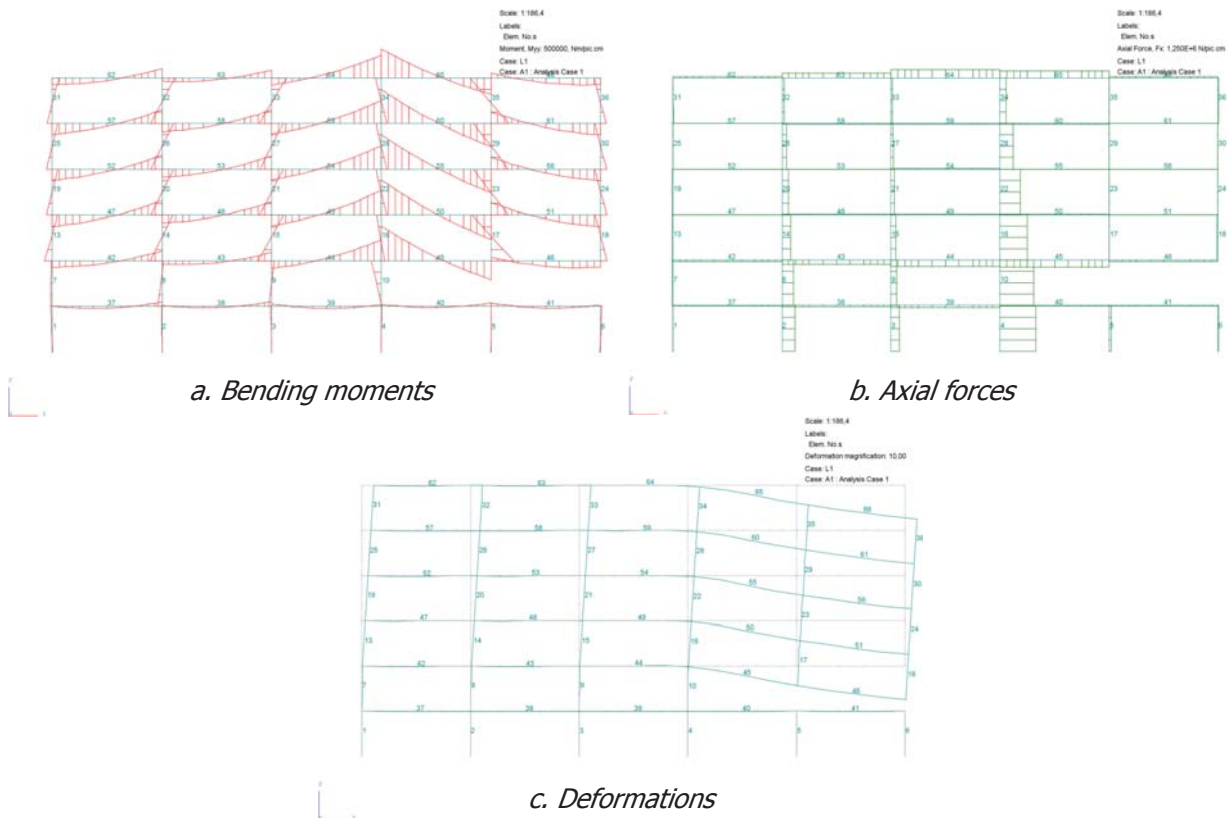

Figure.12.8 Situation 2: Occuring forces and deformations for the damaged model calculated by GSA

# Ch12.Verification

Especially the forces and deformations in the top right corner of the model are of interest. Due to the removal of two elements, in that top right corner in fact a very high cantilever beam is generated, which can be modeled as shown in figure.12.9. This model is analyzed with other FEA-software and the resulting forces and deformations are compared.

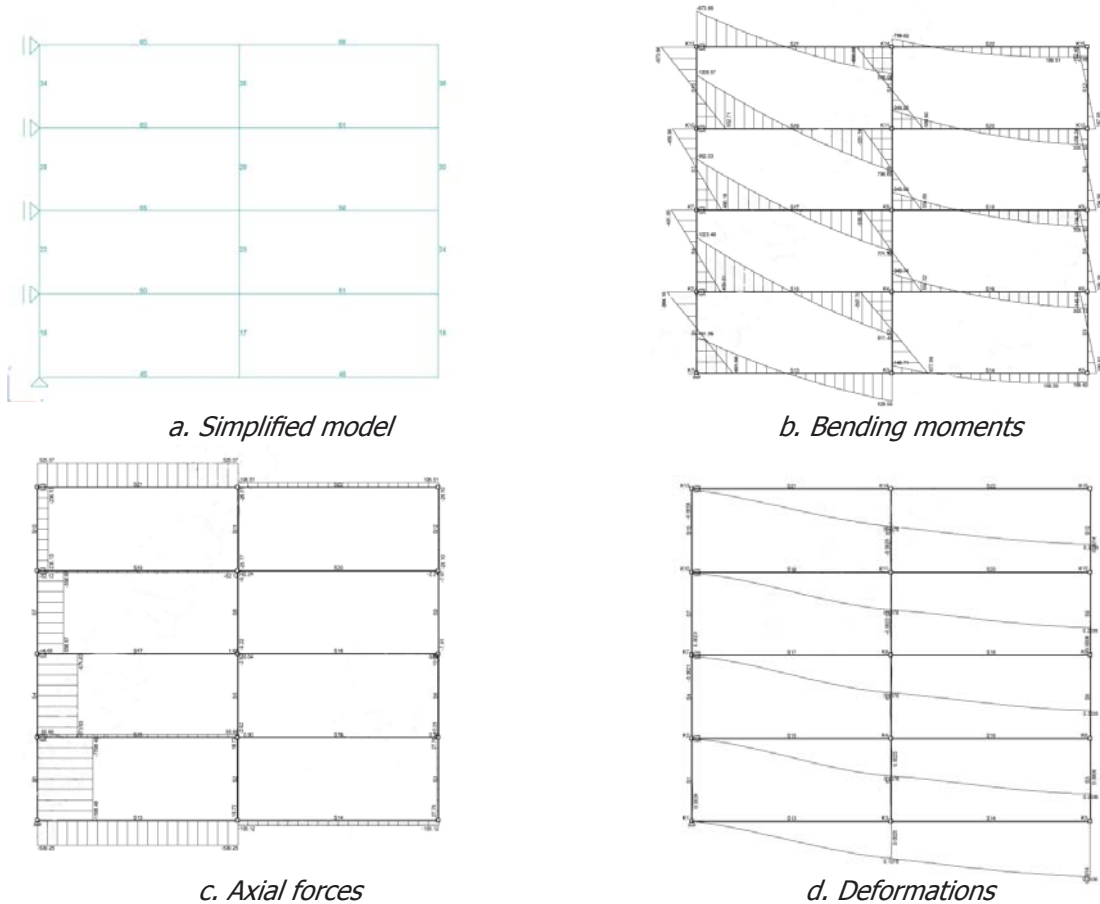

Figure.12.9 Situation 2: Ocurring forces and deformations for the damaged model calculated by MatrixFrame

Comparing the results from the calculations of GSA, with the results from the calculations with Matrixframe shows that the shapes of the bending moment lines, axial force lines and deformation lines are the same. Hence, it may be expected that the calculated forces and deformations by GSA will be correct.

Apparently, the tool and the FEA both work correct for this situation as well, but still it is unclear why element 17 is removed from the model. Investigation into the separate components of the unity checks can provide more information. Looking at the components for element 17 in the undamaged model, shows that the axial force component is governing. Though, when considering the damaged model, the bending moment component will be governing. Due to the loss of vertical supports, the vertical loads are no longer carried by axial forces, but by bending and shear. Especially due to the shear deformation and the moment resistant connections of the elements, the columns will mostly be loaded with bending moments. Since the columns consist large axial force capacity, but low resistance considering bending moment, they will be vulnerable to large bending moments.



For this situation, again, at first sight the removed element seems incorrect, though the tool removes the correct element from the model. Numerically the tool thus works correct. The propagation of the failures still is discussable. The resulting failure order of the elements in this situation, although more logic than in previous situation, it still is not very logic (see figure.12.10).

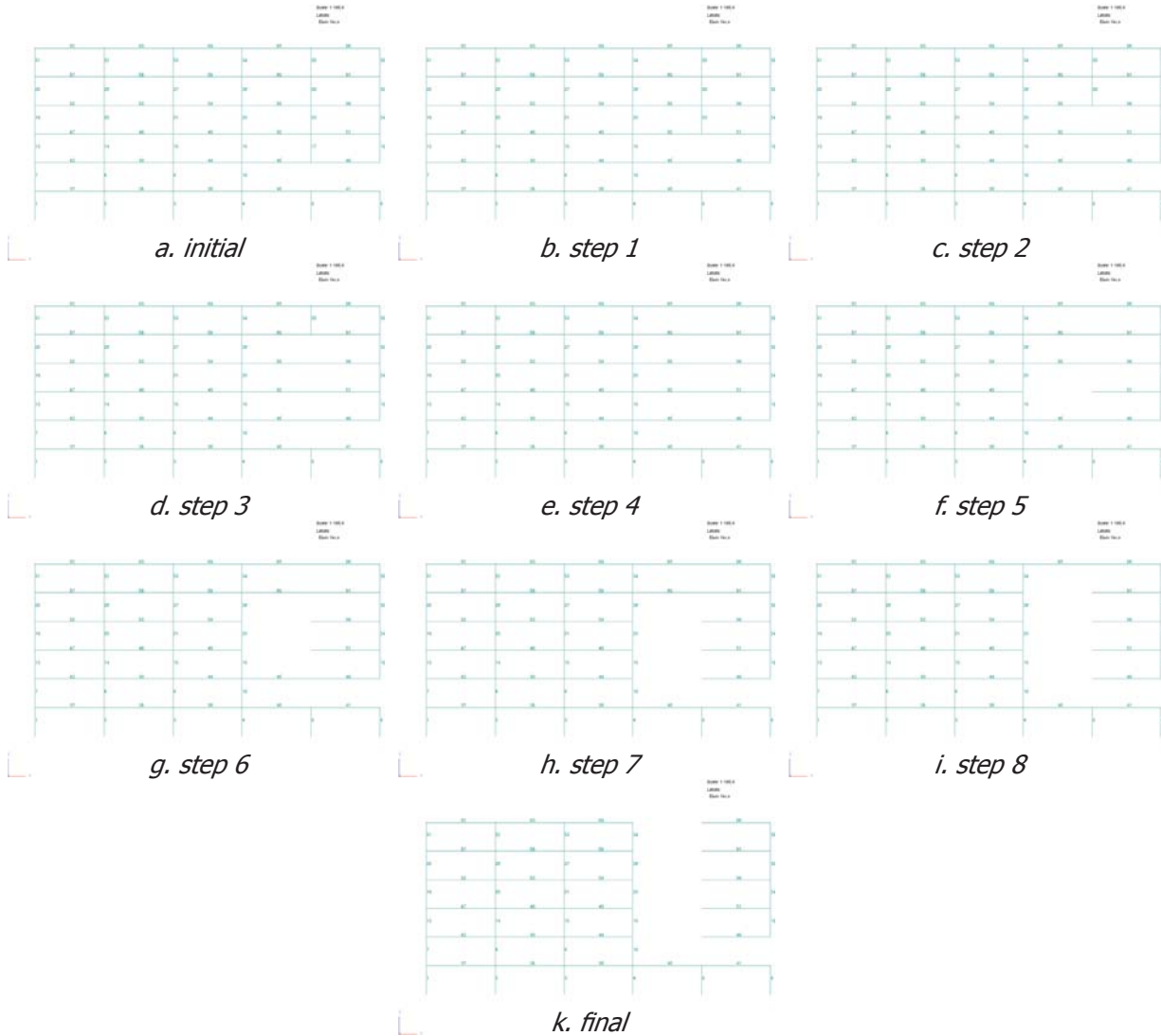

Figure.12.10 Situation 2: Failure order of elements with moment resistant framework

As can be seen, the propagation of failures moves upward instead of downward, which is unexpected. Thus, also for this situation, although the removal of elements is numerically correct, in practical sense it is not.



## 12.4 Situation 3

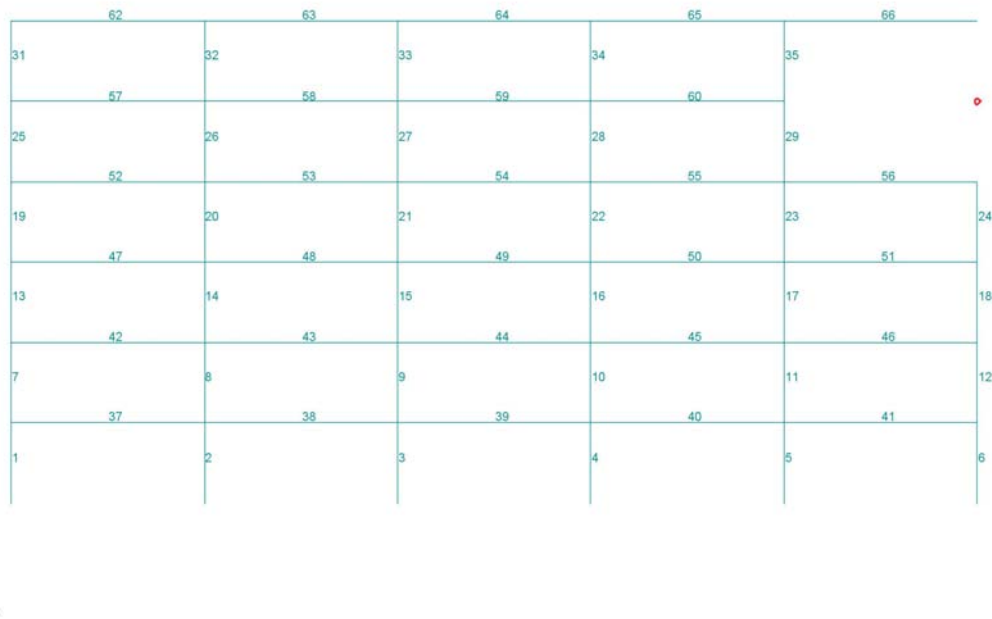

Figure.12.11 Situation 3: Initial generated damaged model with moment resistant framework

For this particular situation, in advance, one can expect that element 66 will fail first due to large bending moments. After element 66 has been removed from the model, most probably element 56 or 24 will fail. Since two upper floors have failed, extra load is applied on element 56. Hence, element 56 has to bear an additional bending moment and element 24 has to bear an additional axial force. Due to previous experience, element 24 will also be loaded with an additional bending moment, due to the moment resistant connection between the floor and the column. Therefore, it can be expected that element 24 will be the second element that fails. After element 24 is removed, it can be expected that element 56 will fail. This cycle of failures will continue, until the last element from the left bay is removed. Figure.12.12 shows the order of element removal calculated by the tool. As can be seen, the expected propagation of failures coincides with the calculated propagation of failures.

Although this situation shows a logic failure order, even in this situation it can be discussed if it is the right failure order. After some floors have been removed, the impact load on the floors will be very high. The axial forces in the columns, at both sides of the floors, will then also be significantly higher than in the undamaged state of the model. This means that, at some point during the collapse, also the columns at the left side of the bay will be loaded far above their capacities. Hence, these elements will also fail in a real situation. Thus, for all results of the propagation of failures, one has to take in mind that the results are only an indication about how a building can collapse, but can not show the actual collapse as it would occur in reality.

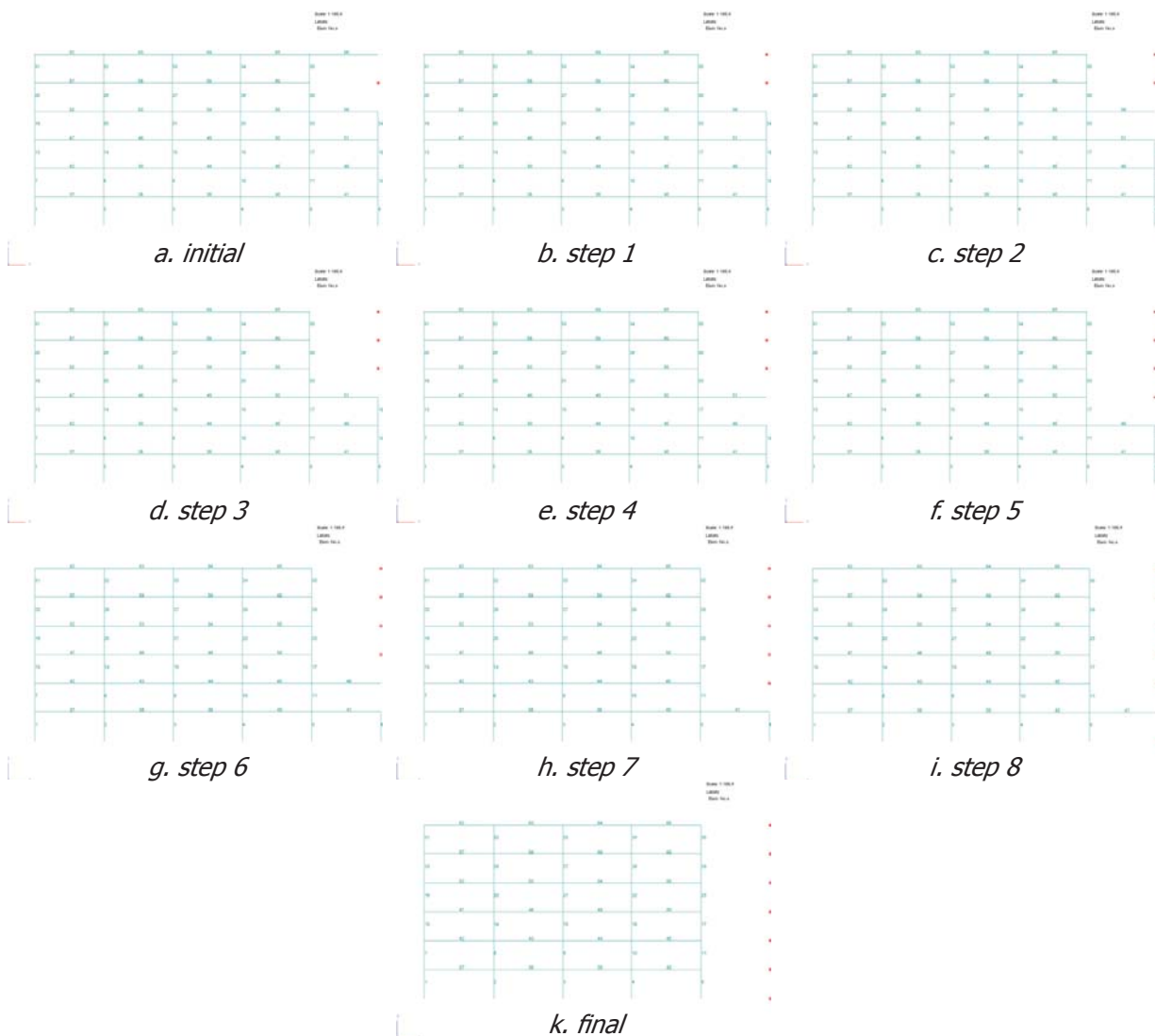

Figure.12.12 Situation 3: Failure order of elements with moment resistant framework

## 12.5 Comparing PCI's

A last check that can be performed in validating the results of the tool, is comparing the PCI's of the different structural systems. For each case, in advance, it can be estimated if a system is more sensitive or less sensitive to a progressive collapse. For instance, the moment resistant framework with stability bracing, will be less sensitive than the moment resistant framework. This will also be the case for the moment resistant framework with stability bracing and outrigger, and the moment resistant framework with stability bracing. In advance, the following ranking can be estimated for the PCI for the moment resistant connections (from highest PCI to lowest PCI);

1. Moment resistant framework (system 1)
2. Moment resistant framework with stability bracing (system 2)
3. Moment resistant framework with stability bracing and outrigger (system 3)

In advance, the following ranking can be estimated for the PCI for the pinned connections (from highest PCI to lowest PCI);

1. Pinned framework with stability bracing (system 4)
2. Pinned framework with stability bracing and outrigger (system 5)

# Ch12.Verification

In advance, the following ranking can be estimated for the PCI for the systems with a stabilizing core (from highest PCI to lowest PCI);

1. Pinned framework with stabilizing core (system 6)
2. Pinned framework with stabilizing core and floors fixed to core (system 7)
3. Pinned framework with stabilizing core and outrigger (system 8)

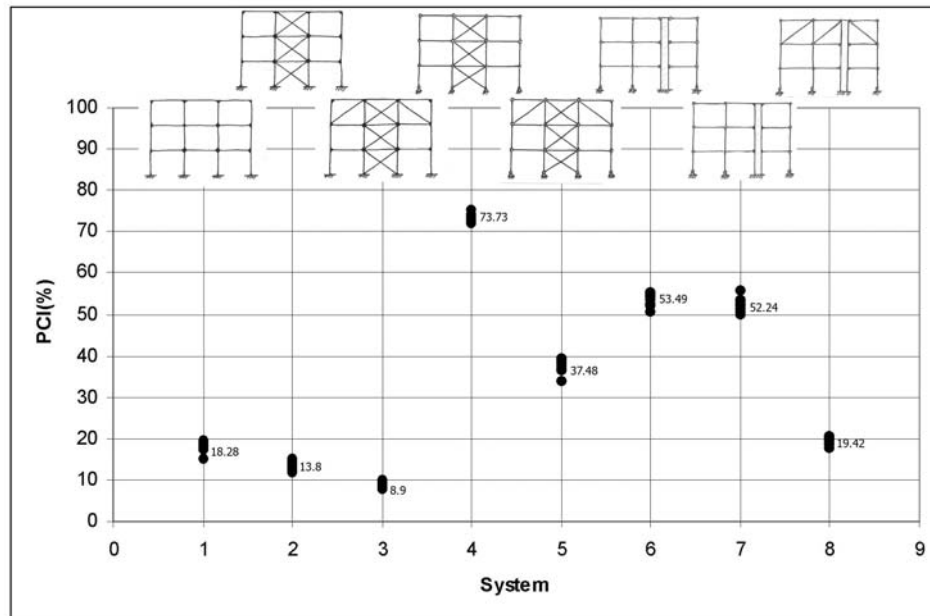

Figure.12.13 Average PCI's for the different structural systems  
(1000 iterations and 10 simulations, 6 columns: HE300A, 6 floors: HE400A)

In figure.12.13 the calculated PCI's for the different systems are shown. What can be seen, is that when comparing the estimated ranking of the PCI's and the calculated PCI's, they match. The only thing that can be concluded from this, is that globally the tool generates correct results. Whether or not the values are correct, can not be said since enough comparable data is not available.

The only comparable data can be retrieved from tests on ir. Coenders' prototype tool (Coenders & Wagemans, 2005). The test was performed with 1000 iterations and 100 simulations for system 1 and 3 (but with 4 columns and 5 floors). For system 1 the PCI was 9.73% and for system 3 the PCI was 2.10%. Comparing this data with the current tool shows that the results of the current tool are slightly higher (18.28% and 8.9% resp.). This can be explained by the fact that the amount of columns and floors is not the same for both cases and the sectional properties are different. Hence, the absolute values will differ. Comparing the relative values of both tests shows that in both cases system 3 will be significantly less sensitive to a progressive collapse. From this, again it can be concluded that in general the results are correct.

The systems with moment resistant connections (systems 1, 2 and 3) behave better considering a progressive collapse, compared with the other structural systems. Especially the pinned framework with stability bracing (system 4) is very vulnerable to a progressive collapse. Applying an outrigger (system 5) shows very effective for that system, since it reduces the sensitivity with a factor 2. Though, compared with the systems with moment resistant connections, it will still be twice as sensitive to a progressive collapse. Also for the other systems, applying an outrigger (system 3 and 8) is very effective and will reduce the sensitivity of a progressive collapse approximately by a factor 2.

**PART IV. Usability and discussion**





In previous parts of this report, it is discussed how the tool works and how the PCI is calculated. So far, no attention is given what should be done with this PCI. The PCI is a value that provides the sensitivity of a structure concerning progressive collapse, instead of the chance of failure of a building, but how can that be used? As already discussed in the introduction, the value itself is meaningless as it does not tell us whether for instance a PCI of 10% is good or bad. When verifying a design, the engineer wants to know if the design is safe or unsafe. The PCI can aid in this verification when comparing the PCI for a designed structure with other structures.<sup>(1)</sup> There can be thought of different methods in using the PCI. This will be discussed in this chapter.

## 13.1 Specific comparison

The PCI of a designed building can be compared with a specific construction system. This is a specific comparison. The PCI of a designed building, is then compared with the PCI of a structural system. After this comparison, it can be determined if the design is satisfying or if it should be adjusted. There are two possible approaches.

### *PCI --> Construction system*

With this method, at first the PCI of a designed structure is calculated. For each structural system different PCI's can be calculated in advance. The PCI of the designed building then can be compared with the PCI's of the different systems. The system which PCI is closest to the PCI of the design, can then be selected. Now, it is known which specific system matches the design best. For each specific design the weaknesses and strengths can be known to prevent a progressive collapse. Hence, the weaknesses and strengths for the designed building can be known and the appropriate measures can be taken. Although this method seems rather simple, it will not be good applicable. First of all, the comparison will be uncorrelated, since a lot of parameters will influence the result of the PCI, like the spans, element lengths, profiles etc. This can be overcome by making a lot of calculations for different parameters in advance. These can be presented in tables, from which the right PCI's can be read. A second, and perhaps bigger, disadvantage is the relation between the weaknesses and strengths of the design and specific system. If a PCI of a designed building matches a PCI of a specific system, it does not automatically tell what elements should be adjusted or where the weak spots are. A lot of the decisions will still depend on the judgment of the user. The PCI does not provide the user a lot of extra information, since he or she could also match its designed building to a specific system by looking at the static indeterminacy of the systems. Hence another approach seems to be more effective.

### *Construction system --> PCI*

With this method, the designed building will be matched to a specific system by looking at the static indeterminacy. Then, the PCI of the designed building is compared with the PCI of that specific system. Hence, two calculations are needed, one for the design and one for the specific system. The different parameters should be similar in both calculations. If both PCI's are known, they can be compared. If the PCI of the design is larger than the PCI of the specific system, it can be said that the design is more sensitive to a progressive collapse and that adjustments are needed. If, on the other hand, the PCI of the design is lower than the PCI of the specific system, the sensitivity to progressive collapse is lower and no further adjustments are needed. This approach seems better applicable in daily practice, since it clearly states whether the design is safe or unsafe. Though, the disadvantage of this method is that the result

---

(1) *Note that the tool is a completion on the current verification methods of a design and is not the only method to verify the design on structural safety*

only shows that the design is more, or less sensitive to progressive collapse, compared with another system. But the design could still be very sensitive to progressive collapse, if the specific system to which it is compared is also very sensitive. Hence, an upper bound for the PCI is needed.

### 13.2 General comparison

Another method to value the PCI, next to the specific comparison, is the general comparison. This method does not make any distinction between the different structural systems. An upper bound for the PCI is determined, to which the PCI of a design is compared. If the PCI of the designed building is higher than this upper bound, the design should be adjusted. If it is lower, no adjustments are needed. The disadvantage of this approach is that an upper bound for the PCI is hard to give since, as discussed before, the value is not the chance of a progressive collapse, but provides the sensitivity to progressive collapse.

When looking at the calculation of the PCI (formula.6.20), it is determined from the amount of progressive collapses and the amount of calculations. Considering article 5.3.3 of the Dutch NEN6700: *'Building structures should be designed in such a manner that failure of a part of the structure does not lead to disproportionate damage.'* (NNI, 2005) it is clear that a progressive collapse may not occur for any building. In recent design practice, this statement is checked by removing single elements from the design and subsequently calculate if the building fails. In each calculation, a different element is removed until all elements have been removed once. If, at one of the calculations, the building fails, adjustments are needed. Translating this to the tool, the PCI should always be 0, since it is the ratio of the amount of progressive collapses and the amount of calculations. Though, there is a difference between the traditional method and the method of the tool. In the traditional method, single elements are removed, wherein in the tool, multiple elements can be removed at once. Hence, fixing the upper boundary for the PCI on 0 will be too strict.

A proper judgment on the upper bound for the PCI can only be given by applying the tool to a lot of case studies. These cases should consist of buildings which failed progressively, as well as undamaged buildings. This will result in a value for the PCI at which it is safe to say the design will not fail. If the upper bound is known, it can be used in combination with the specific comparison: *Construction system-->PCI*. Then, a proper judgment can be made whether a design should be adjusted or not.



# Ch14.Discussion



In previous chapters, the progressive collapse indicator has been discussed and the applied improvements have been explained. The final tool is less crude than the original prototype and it does describe a progressive collapse. Though, there can be some comments on the methods, failure criteria and assumptions used. These will be discussed here. Also, some other improvements to make the tool even more usable and accurate will be discussed. Several assumptions had to be made to make quick and relative simple calculations possible. Though, as a consequence of each assumption the accuracy of the tool is decreased. Some of these assumptions are presented here<sup>(1)</sup>:

## *Young's modulus concrete*

The Young's modulus depends on the age and loading of the concrete. The Young's modulus for C35/45 is 2 times bigger for uncracked concrete compared with cracked concrete. Hence, choosing the wrong value can lead to significant inaccuracies. For the tool, the default values are used which differ 16% with the actual values. Hence, user specified values should be used.

## *Initial failure chance for elements*

These values are assumed to be equal for each event. However, the chance of failure due to a car impact is different from that of a bomb explosion. Therefore, the ratio between the chances of the events will be different. This will cause some elements to fail more often than they would in reality. Extensive investigation is needed to come up with reasonable values for the chances of the events.

## *Amplification factor for impact loading*

The amplification factor to transform the static load into an impact load is assumed to be 2.0. This value is gained from American building regulations, but how they have come up with that specific value could not be retrieved. There are a lot of influencing parameters that may change this value like, the height of the falling load and the area of impact. These are not taken into account. Hence, the dynamic load will be rather inaccurate. Extensive investigation is needed on this topic.

## *Maximum strain for steel elements considering catenary action*

The maximum strain for steel is assumed to be 25%. This is a rather high value, but since the second criterion for catenary action is that the displacement should be smaller than the maximum allowable displacement, this value will not be reached. Most importantly, the connection should be able to resist the elongation and rotation of the floor. By applying this high strain, it is assumed the connection can withstand the deformations. Though, it should be calculated if this is true.

## *Complete failure of elements*

Partial failure, or a reduction of the load capacity of elements, is not incorporated in the model. In reality, elements will not fail in an orderly fashion, but they will fail only partially or will lose some strength. Hence, the modeled failure will only be a theoretic representation. It is also assumed that if an element has failed, the entire load will remain inside the building, whereas in reality also some parts will fall outside the building.

---

(1) *Note that even more assumptions/simplifications have been made, but only the most important ones are discussed here.*



# PART IV. Usability and discussion

## *Calculation procedure with 2 phases*

In order to avoid local mechanisms, a calculation procedure with springs and 2 phases is developed. This procedure is rather cumbersome. Extra calculations are needed and some of the results can not be used. The procedure can be sensitive to errors. It is preferable not to change the original system but to calculate the forces directly. Hence, another method should be developed.

## *Schematic representation of structural systems*

The schematic representation of structural systems is a simplification of the real situation. The connections between elements can never be completely pinned or completely fixed. Hence, the gained results will deviate from the real situation. The connections between the elements would better be represented by rotational springs.

## *Evaluation order of elements*

The evaluation order determines how the progression of failures will develop in the structure. Single element removal is used, but in reality multiple elements may fail at once. It should be investigated if better results are gained, if in stead of a single element removal method, a multiple element removal method, or a gradually load increasing method is used.

## *Determination buckling length*

For the determination of the buckling length of columns, some simplifications had to be made. For instance, the surrounding elements will have an effect on the buckling length of a single element. Some research has been done on this subject to gain more accurate results for the buckling lengths. Although, this is an improvement on the basic buckling modes, it still has got some uncertainties, like the stiffness of the surrounding structure. Hence, further investigation should be performed to increase accuracy. Another simplification influencing the results, is that only lateral buckling of columns is accounted for. However, also torsional buckling of the beams should be calculated. Adding that calculation, will improve the reliability of the results.

## *Catenary action calculation*

With the catenary action calculation, several assumptions have been made. Only the axial forces are considered. Intermediate failure of the floor due to shear forces and bending moment is disregarded. Directly after the failure of a column, the forces in the floors will be redistributed. Since the catenary action has not fully developed yet, the forces will not only be redistributed by axial forces but also by shear forces and bending moments. The combination of these forces can overload the floor and can cause it to fail before the catenary action has fully developed. In a real situation this of course can occur and thus this should be implemented in further developments of the tool.

## *Unity checks*

The calculations of the capacities and consequently the unity checks of the elements are not entirely complete. For all elements, only the axial forces, bending moments and/ or a combination of both are checked. These forces have the biggest influence on the failure of the elements. Though, also the shear forces should be considered. For instance, in concrete beam elements, shear reinforcement is needed, especially near the supports. If insufficient reinforcement is applied, the beam will fail near the support, hence causing the entire element to fail. Therefore, also shear forces should be considered in the unity checks.



# Ch14.Discussion

## *2D-calculation*

One of the starting points for the development of the tool, was that only 2-dimensional calculations were considered. This limits the accuracy of the results of the tool. The load bearing capacities of real buildings are not limited to 2 dimensions, but will be reliant on the 3-dimensional configuration. Hence, the results will deviate from that of a real situation if only 2 dimensions are considered. Due to 2D considerations, also some assumptions have to be made. For instance, with the calculation of catenary action in the floors, it had to be assumed that the tensile forces, resulting from the catenary action can be restraint by the adjacent floors. In a 3-dimensional calculation this can be checked, hence leading to more reliable results.

## *Linear calculation*

Another starting point for the development of the tool was that only geometric linear calculations and linear-elastic calculations were considered. These calculations will be less accurate, compared with non-linear calculations. Geometric linear calculations can only be applied if small rotations are considered. But, since large rotations will develop in a progressive collapse, this condition will not apply anymore, resulting in slightly deviating results. Also linear-elastic calculations limit the abilities of the tool. If also non-linear material behavior is considered, it will describe the real behavior of the material better. Also an increased load capacity is possible with increasing strains for steel. This is in a way incorporated in the calculations for catenary action, but it could also be used for the strength calculations of all the elements.

The previously given comments on the reliability of the tool, all depend on how accurate a certain method or assumption is. Some structural behavior had to be modeled, to be able to calculate the PCI of a structure. For each aspect, the model will deviate from the real situation, making the tool less accurate. Though, it has to be considered that the tool should be used for designs in the early design stage. In that stage, not all aspects are known yet, giving the design a certain inaccuracy. Hence, it is not incorrect if the tool also has got some inaccuracy of the same order. Though, if the tool should also be used for final designs, the inaccuracies and uncertainties should be limited.

Besides improvements that can make the tool more accurate, also an important improvement to make the tool more usable can be made. Since the tool should be used to validate the users own design, he or she should be able to insert that design into the tool. For now, only the basic structural systems, described in this report, can be calculated. The tool should thus be adjusted to import external files and calculate these.



# PART IV. Usability and discussion

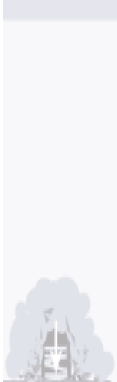

# Conclusions

In the introduction, the Master's project aim has been given. Refinement of ir. Coenders' prototype tool is pursued. Some of this refinement has been mentioned explicitly, namely a chain reaction of failures, debris loading and distribution of chances of initiating events.

- The first implementation on the prototype, was the distribution of chances of initiating events. This can be seen as an improvement on the prototype, since a realistic initial damaged can be generated. Especially when comparing it with the traditional calculation method (remove every element once), this is an improvement, because an initial damage is not limited to only one column.
- Since the possible causes of the initiating events are taken into account, the total collapse resistance of the building is calculated, instead of only the robustness. This makes the tool very usable in the early design stage. Hence, it can be concluded that this implementation increases the quality of the tool.
- The second implementation was the chain reaction of failures. This is an important aspect in a progressive collapse. Hence, it is clear that due to this implementation, a progressive collapse is described more accurate compared with the prototype.
- The method which determines what element is removed from the model, has got great influence on the progression of the failures and thus on the resulting progressive collapse. Methods which uses a fixed order of element evaluation (e.g. from left bottom to right top) are not suitable. Evaluation methods which verify all elements before making a decision what element to remove need to be used.
- The single element removal with the highest unity check is used and gives good results for most cases. Though, since the propagation of element removal not always leads to logic results, they should be used with care. For all results of the propagation of failures, one has to take in mind that the results are only an indication about how a building can collapse. A lot more possible failure modes are possible depending on building imperfections. The tool thus can not show the actual collapse as it would occur in reality.
- If the actual propagating collapse is of interest, other methods should be used. For instance the removal of multiple elements at once, or by gradually reducing the strength and stiffness of elements (element softening), are such methods that can be investigated on further research.
- Although the propagation of failure of elements not always is logic, the resulting PCI will still be reliable, since the PCI is almost independent from the order of element removal.
- The third implementation was the debris loading. An amplification factor is used to transform the static load into a dynamic load. This works correct with systems with moment resistant connections, where the impact loads are applied on the floors. Though, if systems with pinned connections are concerned, the impact loads are applied as point loads on the columns. During the verification of the tool, no column under the impact load was removed. Apparently, the impact load, and thus the amplification factor, was chosen too small.

- Another implementation, that also has been made, was the calculation of catenary action. This is a significant improvement on the prototype. Catenary action is an important method in designing against progressive collapse. This clearly results when running the tool, with and without, taking catenary action into account. The resulting PCI with catenary action then will be significantly lower, compared with the PCI without catenary action. Though, some assumptions can cause the calculation to differ from reality. Hence, these assumptions should be further developed.
- The occurring of local mechanisms during the calculation process has been tried to minimize. Since these cause the counting of a progressive collapse, every avoided local mechanism is an improvement on the tool. Some unforeseeable local mechanisms can occur. Eliminating those mechanisms on further development will therefore increase the accuracy of the calculated PCI.
- The current tool can not be used in daily practice yet, since the user can not insert his or her design into the tool. This is one of the most important future improvements before the tool is practically usable. At this point PCI's for 8 different structural systems can be calculated and compared.
- Although the PCI is represented as a percentage, it does not provide the chance of a progressive collapse for the building and it must thus not be used as such. The PCI gives an indication of the sensitivity of a building concerning progressive collapse and it should be used to compare different designs.
- Finally, it can be concluded that the developed tool is improved compared with the prototype. It describes a progressive collapse, in which all aspects of the collapse resistance are considered; initial failure or initial damage, progression or chain reaction of failures, and disproportionate final damage. Still, more implementations are recommended. If these are implemented into the tool, it will be a useful complementation for the structural engineer concerning progressive collapse.



# Recommendations

The discussed tool in this report, is an improvement on the initial proposed prototype. Although the tool covers a lot of aspects from a progressive collapse, the tool is not completely finished and can not be used in daily practice yet. Improvements are needed to accomplish that. Some of these improvements are based on the assumptions that have been made. Other improvements are related to expanding the features of the tool. Most of the improvements are explained in chapter 14 of this report and it is recommended to implement those into the tool to improve it. Other improvements and recommendations consider the following aspects;

- The most important improvement to make the tool suitable for daily practice is the implementation of the feature to input a user's design. Without this feature, one can only compare preset structures. Hence, this should be the first step towards a better usability of the tool. To achieve this, instead of considering specific cases separately, the source code of the tool should be programmed as general as possible, to be able to calculate all possible configurations.
- As a second improvement to make the tool more reliable and accurate, it is recommended to thoroughly investigate the methods in element evaluation and removal. As discussed, the methods influence the propagation of the element removal and thus the progressive collapse. The methods with single element removal have been investigated, but it is also advised to consider other possible methods, like for instance, the removal of multiple elements or, gradually decreasing the strength and stiffness of elements, or gradually increasing the load.
- Before the tool actually can be used in daily practice, the utility of the PCI value needs to be clearly distinguished. It is discussed that the PCI's of different systems or designs can be compared, in order to know if a design is more sensitive to progressive collapse or not, but it is not known if that design is safe. Hence, it is recommended to investigate when a design meets the progressive collapse requirements, based on the PCI value. An upper bound for the PCI should be found. This can be achieved by using the tool with some case studies, in which a progressive collapse occurred and where no progressive collapse occurred. Comparing that data can provide more information about the usability of the PCI.
- Since the tool can identify if a progressive collapse occurs, with a certain initial damage, the tool can also be used the other way around. If a progressive collapse is assumed, the initial failure of elements that will cause this progressive collapse, can be found. In other words, the tool can then indicate what elements should be removed initially, to cause a progressive collapse. This 'terrorist' or 'demolition' approach can be used when designing against progressive collapse, since it will indicate what elements (key elements) need to be adjusted, to avoid a progressive collapse. Hence, it is recommended to implement this feature into the tool, since it can aid the user in designing against progressive collapse.
- In the report, a lot of improvements on the methods, failure criteria and assumptions used, that can be made on the tool, are discussed. Although individually they all will improve the tool, it is not recommended to implement them all. It is important to consider, that the purpose of the tool is to aid the engineer in the early design stage, in which not every aspect of the design is fully developed. Some uncertainties are still present, making it less accurate. Hence, making the tool very accurate will be useless. Also, increasing the amount of features of the tool, can cause a decrease in calculation speed making the tool less usable. Hence, for every implementation or improvement on the tool, it is recommended to consider, if and how, it will improve the tool and how much it will aid the user.

- Finally, since a lot of calculations are performed during a run of the tool, which are not directly accessible for the user, it is important to clearly report all information about these calculations. To avoid the tool becoming a 'black-box', it is recommended to maintain a manual in which the calculations are discussed and in which future improvements are explained. This report can be the first version of the manual. It is also recommended to validate the results after each run since bugs can occur. Saving the GSA-files, for every iteration, can provide useful information. Checking the order of element removal can also be an effective method in validating the results, but currently can be an elaborate task. Hence, it is recommended to implement the ability to create a graphical view about the propagation of the collapse.



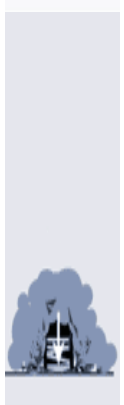
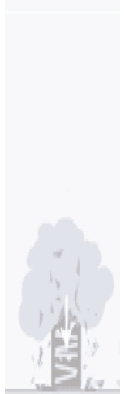



# APPENDICES



# A. List of tables and figures

Figure.1.1 Collapse of Ronan Point

[Source: <http://www.911review.com> (left), <http://www.bdonline.co.uk> (right)]

Figure.1.2 Proposed progressive collapse indicator tool

Figure.2.1 Terms in context of progressive collapse [Source: (Starossek&Haberland, 2008)]

Figure.3.1 Pancake type collapse [Source: <http://www.911review.com>]

Figure.3.2 Zipper type collapse; Tacoma Narrows Bridge [Source: <http://www.jalopnik.com>]

Figure.3.3 Domino type collapse; Overturning office building in Manila impacting adjacent apartment building [Source: <http://www.archidose.org>]

Figure.3.4 Instability type collapse; Buckling of a pipe line [Source: <http://www.mech.uwa.edu.au>]

Figure.3.5 Instability type collapse; Buckling of a pipe line [Source: <http://www.mie.uth.gr>]

Figure.3.6 Murrah Federal Building after the bombing in 1995 [Source: <http://www.911review.com>]

Figure.4.1 Vehicular impact (Source: NIST,2007)

Figure.4.2 Blast loading (Source: NIST,2007)

Table.4.1 Initiating events and mitigating measures

Figure.5.1 Initiating event applied on the model for accidental impact ( $p_i=1\%$ )

Figure.5.3 Initiating events applied on the model with mitigating measure: traffic barrier

Figure.5.4 Initiating events applied on the model for  $p_i=1\%$

Figure.5.5 Gaussian curve applied on the model

Figure.6.1 Simplified generator (top) and resulting generated model (bottom)

Figure.6.2 New generator

Figure.6.3 Moment resistant framework

Figure.6.4 Moment resistant framework with stability bracing

Figure.6.5 Moment resistant framework with stability bracing and outrigger

Figure.6.6 Pinned framework with stability bracing

Figure.6.7 Phase 1: load distribution directly after the initial failure

Figure.6.8 Phase 1: rotational springs

Figure.6.7 Phase 2: deformed shape of the structure (without catenary action)

Figure.6.8 Phase 2: translational spring applied on the model

Figure.6.9 A translational spring

Figure.6.10 Force subjected to translational spring in phase 2 (without catenary action):  
failure of exterior column (left), failure of interior column (right)

Figure.6.11 Flowchart of calculation process with 2 phases

Figure.6.12 Pinned framework with stability bracing and outrigger

Figure.6.13 Pinned framework with stabilizing core

Figure.6.14 Pinned framework with stabilizing core and floors fixed to core

Figure.6.15 Pinned framework with stabilizing core and outrigger

Figure.6.16 Load distribution of floors:

a. Conservative (left),

b. Hillerborg's strip method (right).

Figure.6.17 Loads on beam

Figure.6.18 Occuring of a calculation error if two separate structures are generated

Figure.6.19 Avoiding a local mechanism by removing an unsupported element at one side and simply supported at the other side

Figure.6.20 Occuring local mechanism if a floor is removed under horizontal loading

Figure.6.21 Occuring bending moments if one column fails for a system with fixed connections

Figure.6.22 Occuring deformations if one column fails for a system with fixed connections

Figure.6.23 Schematic representation of the tool with iterations and simulations

Figure.7.1 Maximum allowable collapse area provided by GSA guidelines. [source: (GSA,2003)]

- Table.7.1 Quantification of disproportionate damage in various standards*
- Figure.7.2 Schematic representation of the tool including iterative calculations*
- Figure.8.1 Debris loading*
- Figure.8.2 Floor impact load*
- Figure.8.3 Example of impact loads on deformed structure with pinned connections after multiple columns have failed*
- Figure.9.1 Some basic buckling modes (Hartsuijker, 2000)*
- Figure.9.2 Buckling length analysis*
- Figure.9.3 Buckling length versus ratio of width between column and height between floors for a structure with pinned connections (system length =7.0m)*
- Figure.9.4 Buckling length versus ratio of width between column and height between floors for a structure with fixed connections (number of floors =5, system length =7.0m)*
- Figure.9.5 2D catenary action*
- Figure.9.6 Used stress-strain curve for catenary action*
- Figure.9.7 Catenary action applied on model*
- Figure.9.8 3D Catenary action*
- Figure.9.9 3D Catenary action displacements with different rotation increments*
- Figure.10.1 Evaluation of elements in a fixed order*
- Figure.10.2 Evaluation of elements with highest unity check exceedence*
- Figure.10.3 Evaluation of elements with multiple element removal*
- Figure.10.4 Evaluation of elements with gradually increasing load*
- Figure.11.1 PCI's of moment resistant framework with different amount of iterations including the average PCI*
- Figure.11.2 PCI's of pinned framework with stability bracing with different amount of iterations including the average PCI*
- Figure.11.3 Calculation time versus number of iterations for the different structural systems*
- Figure.12.1 Configuration of a system with stability bracing at which a calculation error occurs*
- Figure.12.2 Situation 1: Initial generated damaged model with moment resistant framework*
- Figure.12.3 Situation 1: Occuring forces and deformations for the damaged model calculated by GSA*
- Figure.12.5 Situation 1: Occuring forces and deformations for the damaged model calculated by MatrixFrame*
- Figure.12.6 Situation 1: Failure order of elements with moment resistant framework*
- Figure.12.7 Situation 2: Initial generated damaged model with moment resistant framework*
- Figure.12.8 Situation 2: Occuring forces and deformations for the damaged model calculated by GSA*
- Figure.12.9 Situation 2: Occuring forces and deformations for the damaged model calculated by MatrixFrame*
- Figure.12.10 Situation 2: Failure order of elements with moment resistant framework*
- Figure.12.11 Situation 3: Initial generated damaged model with moment resistant framework*
- Figure.12.12 Situation 3: Failure order of elements with moment resistant framework*
- Figure.12.13 Average PCI's for the different structural systems  
(1000 iterations and 10 simulations, columns HE300A, floors HE400A)*

## B. List of formulas and symbols

$$P(F) = P(F | DH) \cdot P(D | H) \cdot P(H) \quad \text{with,} \quad (\text{formula.1.1})$$

P(H) the probability of a hazard for the structure [-],  
 P(D|H) the probability of local damage D as a result of the event H and [-],  
 P(F|DH) the probability of failure F of the structure as a result of local damage D by H [-]  
 P(F) the probability of a progressive collapse [-]

$$PCI = \frac{F}{n} \cdot 100\% \quad (\text{Coenders \& Wagemans, 2005}) \quad \text{with,} \quad (\text{formula.1.2})$$

PCI the Progressive collapse indicator [%],  
 F the number of failures [-] and,  
 n the number of calculations [-]

$$p_n = \sum_{i=1}^7 p_i \quad \text{with,} \quad (\text{formula.5.1})$$

$p_i$  the chance of occurring for element n of event i [%]

$$p_n = \sum_{i=1}^7 (p_i - p_{i, \text{mitigating measure}}) \quad \text{with,} \quad (\text{formula.5.2})$$

$p_{i, \text{mitigating measure}}$  the mitigating measure for element n of event i [%]

$$p_n = \frac{\sum_{i=1}^7 p_i}{\sum p_n} \cdot 100\% \quad (\text{formula.5.3})$$

$$p(x) = \frac{1}{\sigma \sqrt{2\pi}} e^{-\frac{x^2}{2\sigma^2}} \quad \text{with,} \quad (\text{formula.5.4})$$

$\sigma$  a factor which determines the shape of the curve

$$p_{rel}(x) = \frac{p(x)}{p(0)} = e^{-\frac{x^2}{2\sigma^2}} \quad \text{with,} \quad (\text{formula.5.5})$$

$x$  the distance from the initial event to the adjacent element [m]

$$M_s = r\theta \quad \text{with,} \quad (\text{formula.6.1})$$

$M_s$  the bending moment on the spring [Nmm]  
 $r$  the spring stiffness [Nmm/rad]  
 $\theta$  the rotation of the spring [rad]

$$F_s = k \cdot u \quad \text{with,} \quad (\text{formula.6.2})$$

$F_s$  the normal force on the spring [N]  
 $k$  the spring stiffness [N/mm]  
 $u$  the displacement of the spring [mm]

$$F = (0.5 \cdot q \cdot l \cdot n) + (q_{v, \text{column}} \cdot h \cdot (n - 1)) \quad (\text{formula.6.3})$$

$$F = (q \cdot l \cdot n) + (q_{v, \text{column}} \cdot h \cdot (n - 1)) \quad \text{with,} \quad (\text{formula.6.4})$$

$F$  the support reaction at the failed column [N]  
 $q$  the distributive load from the girder [N/mm]  
 $l$  the length of the girder [mm]  
 $q_{v, \text{column}}$  the vertical load from the column [N/mm]  
 $h$  the height of the columns [mm]  
 $n$  the number of floors above the failed column [-]

$$k = \frac{(0.5 \cdot q \cdot l \cdot n) + (q_{v, \text{column}} \cdot h \cdot (n - 1))}{h} \quad \text{for exterior springs} \quad (\text{formula.6.5})$$

$$k = \frac{(q \cdot l \cdot n) + (q_{v, \text{column}} \cdot h \cdot (n - 1))}{h} \quad \text{for interior springs} \quad \text{with,} \quad (\text{formula.6.6})$$

$k$  the spring stiffness [N/mm]

$$F_{f,d} = G_{\text{rep}} + Q_{i,\text{rep}} + \sum \psi_i Q_{i,\text{rep}} \quad \text{with,} \quad (\text{formula.6.7})$$

$F_{f,d}$  the fundamental load combination  
 $G_{\text{rep}}$  and  $Q_{i,\text{rep}}$  the individual loads  
 $\psi_i$  the combination factor

$$F_{1,d} = G_{\text{rep}} + Q_{1,\text{rep}} \quad (\text{formula.6.8a})$$

$$F_{2,d} = G_{\text{rep}} + Q_{1,\text{rep}} + 0.2Q_{2,\text{rep}} \quad (\text{formula.6.8b})$$

$$F_{3,d} = G_{\text{rep}} + Q_{1,\text{rep}} + 0.2Q_{3,\text{rep}} \quad (\text{formula.6.8c})$$

$$\text{Unity check} = \frac{N_d}{N_u} + \frac{M_d}{M_u} \leq 1 \quad \text{and,} \quad (\text{formula.6.9a})$$

$$\text{Unity check} = \frac{N_d}{N_u} - \frac{M_d}{M_u} \leq 1 \quad \text{with,} \quad (\text{formula.6.9b})$$

$N_d$  the axial load on the element [N]  
 $M_d$  the bending moment on the element [Nmm]  
 $N_u$  the normal force capacity of the element [N]  
 $M_u$  the bending moment capacity of the element [Nmm]



## B. List of formulas and symbols

$$\text{Unity check} = \frac{M_d}{M_u} \leq 1 \quad (\text{formula.6.10})$$

$$M_d > 0.1hN_d' \quad \text{with,} \quad (\text{formula.6.11})$$

$h$  the height of the cross section of the element [mm]

$N_d'$  the compressive axial force on the element [N]

$$M_d^* = M_d - N_d'e \quad \text{with,} \quad (\text{formula.6.12})$$

$e$  the distance between centre of gravity and centre of the reinforcing bars [mm]

$$\text{Unity check} = \frac{N_d}{N_u} \leq 1 \quad \text{with,} \quad (\text{formula.6.13})$$

$N_u = Af_s$  the axial force capacity of the reinforcing bars [N]

$A$  the cross section area of the reinforcing bars [mm<sup>2</sup>]

$f_s$  the yield stress of the reinforcing bars [N/mm<sup>2</sup>]

$$\text{Unity check} = \frac{M_d^*}{M_u} \leq 1 \quad (\text{formula.6.14})$$

$$\text{Unity check} = \frac{M_d^*}{M_u} \leq 1 \quad (\text{formula.6.15})$$

If unity check > 1 then --> element failed (formula.6.16)

If  $w > w_{ultimate}$  then --> element failed (formula.6.17)

$w$  the deformation of the element in z-direction [mm]

$w_{ultimate}$  the ultimate allowable deformation of the element in z-direction [mm]

$$w_{ultimate} = \text{floor depth} - 2.0m \quad (\text{formula.6.18})$$

$$PCI_s = \frac{F}{n} \cdot 100\% \quad \text{with,} \quad (\text{formula.6.19})$$

$PCI_s$  the Progressive collapse indicator for simulation s [%]

$$PCI = \frac{\sum_s PCI_s}{s} \cdot 100\% \quad (\text{for } s \geq 1) \quad \text{with,} \quad (\text{formula.6.20})$$

$PCI$  the average PCI [%]

$PCI_s$  the PCI of simulation s [%]

$s$  the number of simulations [-]

If  $A_{floor} > A_{adjacent}$  or  $A_{tot} > A_{adjacent,tot}$  (formula.7.1)

then --> progressive collapse with,

$A_{floor}$  the damaged floor area per floor [mm<sup>2</sup>]  
 $A_{adjacent}$  the adjacent floor area per initial damaged column per floor [mm<sup>2</sup>]  
 $A_{tot}$  the total damaged floor area for the entire structure [mm<sup>2</sup>]  
 $A_{adjacent,tot}$  the total adjacent floor area for all initial damaged columns for the entire structure [mm<sup>2</sup>]

$$F_{1,d} = G_{rep} + Q_{4,rep} + 0.3Q_{1,rep} \quad (formula.8.1a)$$

$$F_{2,d} = G_{rep} + Q_{1,rep} \quad (formula.8.1b)$$

$$F_{3,d} = G_{rep} + Q_{1,rep} + 0.2Q_{2,rep} \quad (formula.8.1c)$$

$$F_{4,d} = G_{rep} + Q_{1,rep} + 0.2Q_{3,rep} \quad (formula.8.1d)$$

$$F_c = \frac{\pi^2 EI}{l_c^2} \quad \text{with,} \quad (formula.9.1)$$

$F_c$  Euler buckling load (N)  
 $EI$  bending stiffness (Nmm<sup>2</sup>)  
 $l_c$  buckling length (mm)

$$\sigma_c = \frac{\pi^2 EI}{l_c^2 A} \quad \text{with,} \quad (formula.9.2)$$

$\sigma_c$  Euler buckling stress (N/mm<sup>2</sup>)  
 $A$  cross section area (mm<sup>2</sup>)

$$\text{Unity check} = 1.1 \frac{N'_d}{\frac{\sigma_c}{f_y} N_u} + 1.1 \frac{M_d}{1.0 M_u} < 1 \quad \text{with,} \quad (formula.9.3)$$

$\sigma_c$  the Euler buckling stress of the element [N/mm<sup>2</sup>]  
 $N'_d$  the compressive axial force on the element [N]

$$\alpha_n = \frac{N'_d}{N_u} = \frac{N'_d}{A_c f'_c + A_s f_s} \quad (formula.9.4)$$

$$\lambda_h = \frac{l_c}{h} \quad (formula.9.5)$$

$$\lambda_h \leq 5 / \sqrt{\alpha_n} \quad \text{with} \quad \alpha_n \leq 0.25 \quad (formula.9.6a)$$

$$\lambda_h \leq 10 \quad \text{with} \quad 0.25 < \alpha_n \leq 0.5 \quad (formula.9.6b)$$

$$\lambda_h \leq 15 - 10\alpha_n \quad \text{with} \quad \alpha_n > 0.5 \quad (formula.9.6c)$$



## B. List of formulas and symbols

$$e_t = (e_0 + e_c)\xi \geq e_0 \quad \text{with,} \quad (\text{formula.9.7})$$

$e_t$  the total eccentricity [mm]  
 $e_0$  the initial eccentricity [mm]  
 $e_c$  the additional eccentricity [mm]  
 $\xi$  a factor ( $\xi = 1$ )

$$M_{d,buc} = e_t N'_d \quad \text{with,} \quad (\text{formula.9.8})$$

$M_{d,buc}$  the extra bending moment due to second order [Nmm]

$$M_{d,tot} = M_d + M_{d,buc} \quad \text{with,} \quad (\text{formula.9.9})$$

$M_{d,tot}$  the total bending moment on the element.

$$\text{Unity check} = \frac{M_{d,tot}}{M_u} \leq 1 \quad (\text{formula.9.10})$$

$$l_c \leq \sqrt{\frac{(EI)_d}{G}} \quad \text{with,} \quad (\text{formula.9.11})$$

$(EI)_d$  the design value for EI [Nmm<sup>2</sup>]  
 $G$  the weight of the building supported by the core [N]

$$E_{ef} = 2200 + 4400\omega + (24000 - 2200\omega\alpha_n) > 5000 \quad \text{If } \alpha_n \leq 0.5 \quad (\text{formula.9.12a})$$

$$E_{ef} = 21300 + 4950\omega(1 - \frac{2}{3}\alpha_n) \quad \text{If } \alpha_n > 0.5 \text{ with,} \quad (\text{formula.9.12b})$$

$\omega$  the reinforcement percentage ( $A_s/A_c$ ) [-]

$$e_t = (e_0 + e_c)\xi \geq e_0 \quad \text{with,} \quad (\text{formula.9.13})$$

$\xi$  a factor dependant on the spring stiffness of the foundation of the core  
 ( $C = \infty \rightarrow \xi = 1$ )

$$F_c = \alpha \cdot F \quad \text{with,} \quad (\text{formula.9.14})$$

$F_c$  the buckling load [N]  
 $\alpha$  load factor [-]  
 $F$  the applied force of 1000 N [N]



$$l_c = \sqrt{\frac{\pi^2 EI}{F_c}} \quad \text{with,} \quad (\text{formula.9.15})$$

$l_c$  buckling length [mm]  
 $EI$  the bending stiffness [Nmm<sup>2</sup>]  
 $F_c$  the buckling load [N]

$$l_c = 0,9 \cdot l_{sys} \quad \text{with,} \quad (\text{formula.9.16})$$

$l_c$  buckling length [mm]  
 $l_{sys}$  system length [mm]

$$l_c = \left(0,1 \frac{dx}{dz} + 0,5\right) \cdot l_{sys} \quad \text{with,} \quad (\text{formula.9.17})$$

$l_c$  buckling length [mm]  
 $l_{sys}$  system length [mm]  
 $dx$  distance between columns [mm]  
 $dz$  distance between floors [mm]

$$u_{\max} = \frac{h}{500} \quad \text{for the entire height of the building} \quad (\text{formula.9.18a})$$

$$u_{\max} = \frac{h}{300} \quad \text{for each floor} \quad (\text{formula.9.18b})$$

$$\theta_1 = \theta_i + \Delta\theta \quad (\text{formula.9.19.2})$$

$$\Delta L = \frac{L}{\cos \theta_1} - L \quad (\text{formula.9.19.3})$$

$$F = EA \frac{\Delta L}{L} \quad (\text{formula.9.19.4})$$

$$w = L \tan \theta_1 \quad (\text{formula.9.19.5})$$

$$H = F \cos \theta_1 \quad (\text{formula.9.19.6})$$

$$V_1 = F \sin \theta_1 \quad (\text{formula.9.19.7})$$

$$2V_1 \geq R \quad (\text{formula.9.19.8})$$

$$\theta_2 = \tan^{-1}\left(\frac{L}{s} \tan \theta_1\right) \quad (\text{formula.9.20.2})$$

$$2V_1 + 2V_2 = R \quad (\text{formula.9.20.8})$$

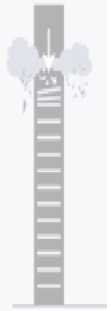

## B.List of formulas and symbols

$$Var(PCI) = \frac{\sum (PCI_{gem} - PCI_s)^2}{s} \quad (formula.11.1)$$

---

$$SD = \sqrt{VAR(PCI)} \quad with, \quad (formula.11.2)$$

---

Var(PCI)	the variance of PCI [-]
$PCI_{gem}$	the average PCI [%]
$PCI_s$	the PCI of simulation s [%]
s	the amount of simulations [-]
SD	the standard deviation [-]



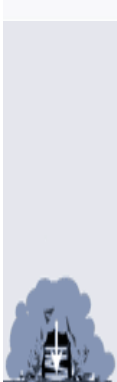
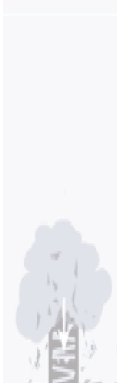

# C.Linear calculation

## C.1 Physic linear calculations

When considering a typical stress strain curve, a linear elastic relation (Hook's law) is found for the modulus of elasticity, for the first part of the curve until the yield point. This part of the curve is considered in the model of the PCI-tool. When following the curve from the yield point to the right, rapture will occur. This is the plastic region of the material. As can be seen from the curve, an increase of deformation can occur until some point, leading to an increase in load capacity.

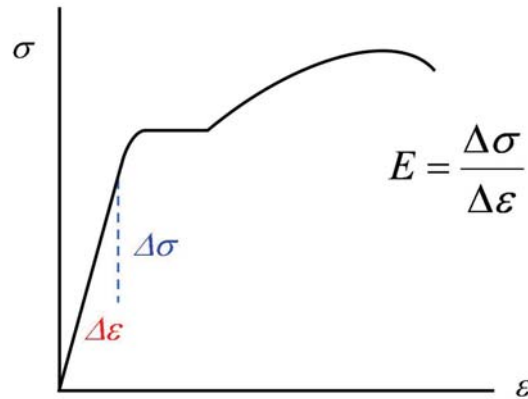

Figure.C.1 Stress-strain curve

The following stress-strain curves are used for the calculation of the bending moment capacity for concrete elements.

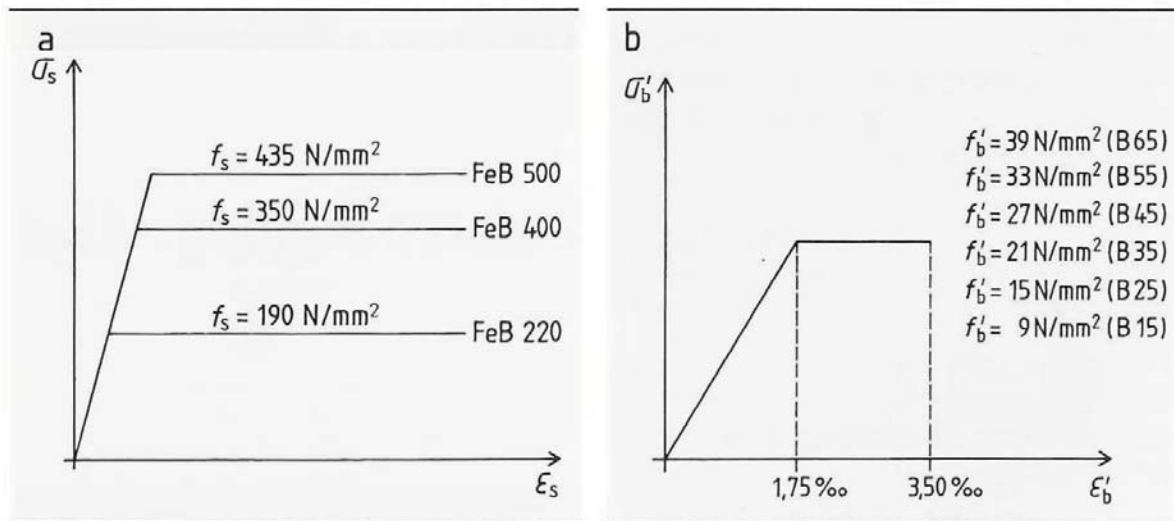

Figure.C.2 Stress-strain curve for steel (left) and concrete (right)

The fiber-model (Hartsuijker, 2001), can be used in describing the physical linear behavior of the material. The following assumptions are used in this model:

- A bar is assumed to be build of a large amount of fibers parallel to the length. The area of a fiber approaches zero if the number of fibers approaches infinity.
- The fibers are kept together by a large number of stiff surfaces perpendicular to the fibers. The number of surfaces is that large that  $\Delta x$  approaches zero.
- After deformation of the bar, surfaces remain perpendicular to the fibers. This is also known as Bernoulli's theory.
- It is assumed that the cross section of the material is homogeneous.

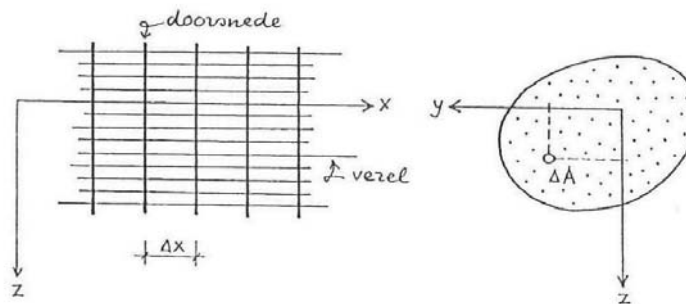

Figure.C.3 Fiber-model [Source: (Hartsuijker,2001)]

## C.2 Geometric linear calculations

Geometric linear calculation means, that a linear relation between deformation, length and rotation is valid;

$$dz = l \cdot \theta \quad \text{with,} \quad (\text{formula.C.1})$$

$dz$       the deformation [mm]  
 $l$         the length of the element [mm]  
 $\theta$         the rotation of the element [rad]

This can only be valid for small rotations as  $\tan(\theta) \approx \theta$  for small rotations.

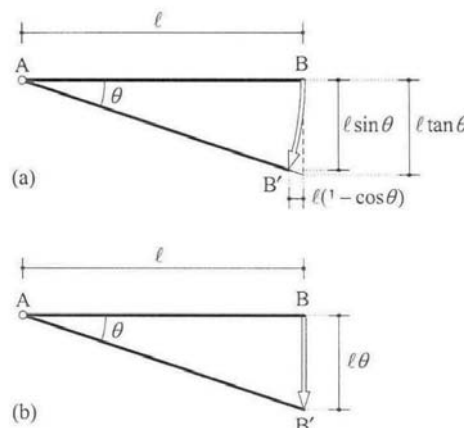

Figure.C.4 Geometric linear relation [Source: (Hartsuijker,2001)]

# D.Unity checks for steel and concrete<sup>(1)</sup>

## D.1 Strength

### Steel

For steel the strength capacity check yields:

$$\text{Unity check} = \frac{N_d}{N_u} + \frac{M_d}{M_u} \leq 1 \quad \text{and,} \quad (\text{formula.D.1a})$$

$$\text{Unity check} = \frac{N_d}{N_u} - \frac{M_d}{M_u} \leq 1 \quad \text{with,} \quad (\text{formula.D.1b})$$

$N_d$	the axial load on the element [N]
$M_d$	the bending moment on the element [Nmm]
$N_u$	the normal force capacity of the element [N]
$M_u$	the bending moment capacity of the element [Nmm]

The capacities of the element are calculated with:

$$N_u = f_y A \quad (\text{formula.D.2a})$$

$$M_u = f_y W \quad \text{with,} \quad (\text{formula.D.2b})$$

$f_y$	the yield stress of steel [N/mm <sup>2</sup> ]
A	the cross section area of the element [mm <sup>2</sup> ]
W	the section modulus [mm <sup>3</sup> ]

Since the bending moment and axial forces can be both positive and negative, the absolute values are used.

### Concrete

The calculations for concrete are in a way similar to that for steel. A bending moment capacity is calculated, which should be higher than the bending moment the element is subjected to. In order to be able to compare the results, for different elements and between steel and concrete, the strength capacity check is written as a unity check:

$$\text{Unity check} = \frac{M_d}{M_u} \leq 1 \quad \text{with,} \quad (\text{formula.D.3})$$

$M_d$	the bending moment on the element [Nmm]
$M_u$	the bending moment capacity of the element [Nmm]

The bending moment capacity for concrete is not a fixed value like for steel, but depends on the combination of the axial force and bending moment on the element. With calculating the bending moment capacity, the axial force is used, hence the axial force is incorporated in the bending moment capacity and therefore is not directly part of the unity check. A couple of situations are distinguished. For each situation the following conditions are used for the determination of the bending moment capacity:

- Concrete is not able to withstand tensile forces
- The strains of concrete and reinforcement are linear dependant with respect to the distance from the neutral axis.
- The stress-strain curves from appendix C are used.
- If  $M_d=0$  or  $M_u=0$  a value of 1 is used in order to avoid the unity check to become infinitely large or infinitely small. Otherwise a comparison of the unity checks between different elements is not possible.

<sup>(1)</sup> Note that the calculations are not entirely according to current building standards

## Compressive force and bending moment

The cross section and stress and strain diagrams from figure.D.1 are used for the determination of the bending moment capacity.

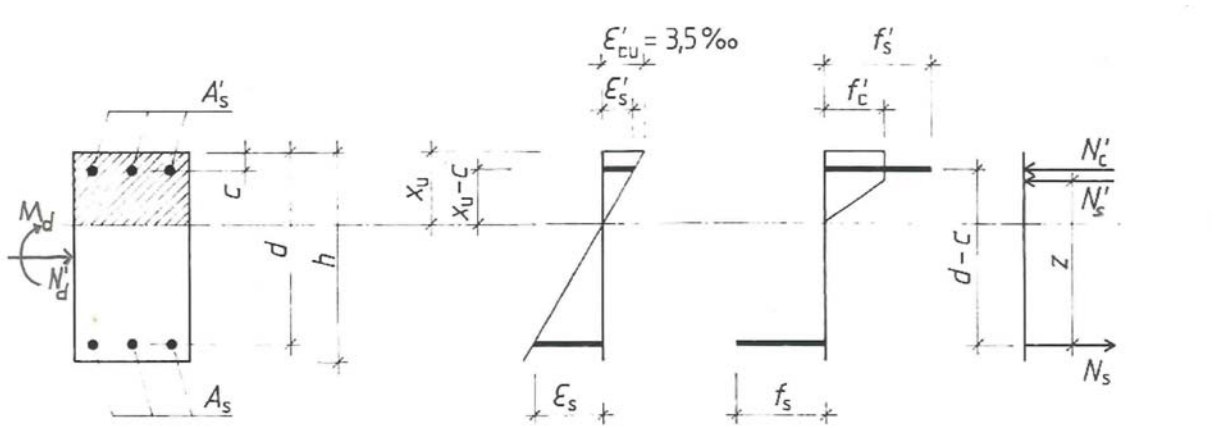

Figure.D.1 Concrete calculation with compressive force and bending moment

First the compressive zone  $x_u$  is calculated, which follows from the equilibrium of internal and external axial forces  $\sum N = 0$ :

$$N'_c + N'_s - N_s = N_d \quad (\text{formula.D.4})$$

Under the assumption that  $A_s = A'_s$  and that both the upper and lower reinforcement yields, it can be said that;

$$N_s = N'_s = A_s f_s \quad \text{and} \\ N'_c = \alpha b x_u f'_c$$

Since  $N'_s = N_s$  it follows that  $N'_c = N_d$ . Now, the compressive zone  $x_u$  can be calculated;

$$x_u = \frac{N_d}{\alpha b f'_c} \quad \text{with,} \quad (\text{formula.D.5})$$

- $x_u$  the compressive zone [mm]
- $\alpha$  a 'volheidsfactor', for rectangular cross section  $\alpha = 0.75$  [-]
- $b$  the width of the cross section [mm]
- $f'_c$  the compressive stress for concrete [N/mm<sup>2</sup>]

Now that the compressive zone is known, the strains for the reinforcing bars can be calculated at both sides of the element;

$$\epsilon'_s = \frac{x_u - c}{x_u} \epsilon'_c \quad \text{with,} \quad (\text{formula.D.6})$$

- $\epsilon'_s$  the strain in the reinforcing bars under compression [-]
- $\epsilon_s$  the strain in the reinforcing bars under tension [-]
- $\epsilon'_c$  the strain in the concrete at the edge of the cross section  $\epsilon'_c = 3.5\text{‰}$  [-]
- $h$  the height of the cross section [mm]
- $c$  the distance from the edge of the cross section to the middle of the reinforcing bars [mm]

## D.Unity checks for steel and concrete

With these strains, the forces in the cross section can be calculated. These depend on the strain. If it is larger than the strain at yielding ( $\epsilon_s = 2.175\text{‰}$ ), the forces are calculated with formula.D.4. If the strains are smaller, they are calculated with:

$$N_s = \epsilon_s EA_s \quad \text{with,} \quad (\text{formula.D.7})$$

E the Young's modulus for steel [N/mm<sup>2</sup>]  
 A<sub>s</sub> the cross section area of reinforcement [mm<sup>2</sup>]

Now, all forces are known and the bending moment capacity can be calculated from equilibrium around the centre of gravity  $\sum M = 0$ :

$$M_u = N'_c(0.5h - \beta x_u) + N'_s(0.5h - c) + N_s(0.5h - c) \quad \text{with,} \quad (\text{formula.D.8})$$

$\beta$  a 'afstandsfactor', for rectangular cross section  $\beta = 0.389$  [-]

The unity check can now be calculated. In order to take into account building imperfections, a minimum bending moment is used for elements under compression:

$$M_d > 0.1hN'_d$$

### Tensile force and bending moment

A combination of tensile force and bending moment is also possible. The ratio of axial force and bending moment, determines the calculation method. An artificial bending moment  $M_d^*$  is introduced:

$$M_d^* = M_d - N_d e \quad \text{with,} \quad (\text{formula.D.9})$$

e the distance between centre of gravity and centre of the reinforcing bars [mm]

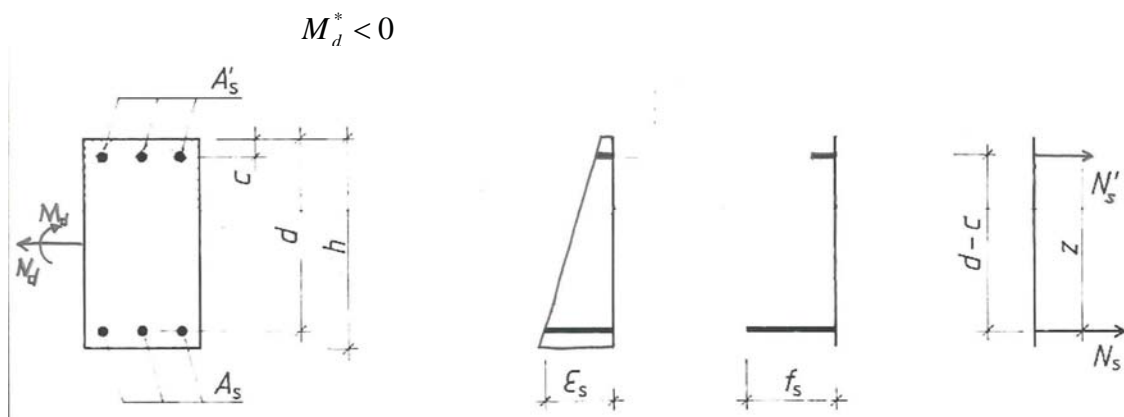

Figure.D.2 Concrete calculation with tensile force and bending moment  $M_d^* < 0$

If  $M_d^* < 0$  there will be no compressive zone in the cross section. Since concrete is not able to resist any tensile force, the reinforcing bars provide the strength of the element. If the element is not loaded with a bending moment, the unity check is transformed to a check of axial forces only:



$$\text{Unity check} = \frac{N_d}{N_u} \leq 1 \quad \text{with,} \quad (\text{formula.D.10})$$

$N_u = Af_s$  the axial force capacity of the reinforcing bars [N]  
 $A$  the cross section area of the reinforcing bars [mm<sup>2</sup>]  
 $f_s$  the yield stress of the reinforcing bars [mm<sup>2</sup>]

If the element is loaded with a bending moment, the reinforcing bars provide the bending moment capacity. For the tensile force, a capacity of  $0.5N_d$  is needed. The remaining capacity is  $N_u = Af_s - 0.5N_d$ . Thus, for the bending moment capacity yields:

$$M_u = (Af_s - 0.5N_d)z \quad \text{with,} \quad (\text{formula.D.11})$$

$z$  the distance between the reinforcing bars from centre to centre over the height of the cross-section [mm]

The bending moment capacity is compared with the artificial bending moment instead of the external bending moment. The unity check then yields:

$$\text{Unity check} = \frac{M_d^*}{M_u} \leq 1 \quad (\text{formula.D.12})$$

$$M_d^* > 0$$

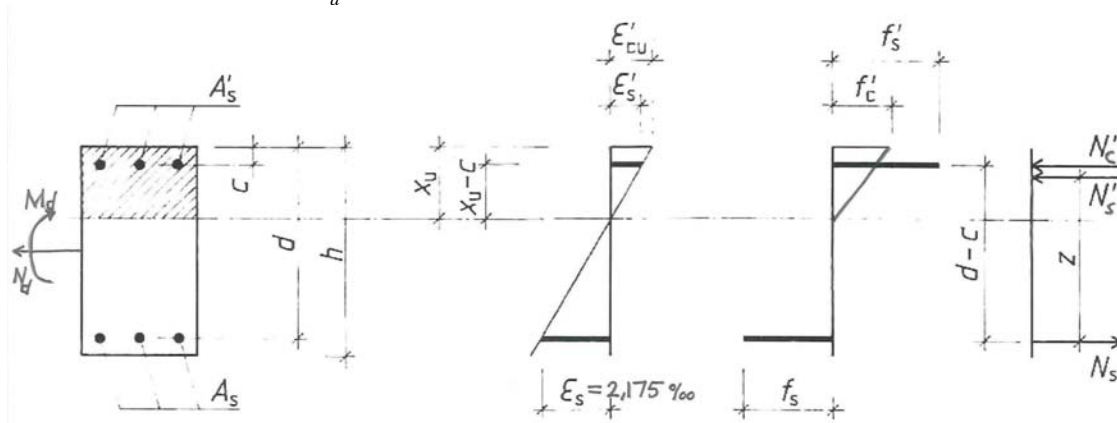

Figure.D.3 Concrete calculation with tensile force and bending moment  $M_d^* > 0$

If  $M_d^* > 0$  a compressive zone will develop in the cross section. The calculation procedure is similar to that of an element loaded in compression. Unfortunately, the values for the axial forces are not known, since the strain in the concrete is unknown. Only the strain of the reinforcing bar under tension is known, as it is advised that the reinforcing bar should yield before failure of the element. Thus, the strain of that bars is  $\epsilon_s = 2.175\text{‰}$ .

## D.Unity checks for steel and concrete

In order to calculate the internal forces, use has been made of interaction diagrams from GTB-tables 11 (Betonvereniging, 2006) and their underlying formulas.

A relative axial force is introduced:

$$n_d = \frac{N_d}{bhf'_c} \quad (\text{formula.D.13})$$

From vertical equilibrium it follows that:

$$N_d = N'_s + N'_c - N_s \quad \text{with,} \quad (\text{formula.D.14})$$

$$N'_s = A'_s \sigma'_s$$

$$N'_c = \alpha b x_u \sigma'_c$$

$$N_s = A_s \sigma_s$$

Combining formula D.13 with D.14 results in:

$$n_d = \frac{N_d}{bhf'_c} = \frac{A'_s \sigma'_s + \alpha b x_u \sigma'_c - A_s \sigma_s}{bhf'_c}$$

Rewriting this gives:

$$n_d = \frac{N_d}{bhf'_c} = \psi' \frac{\sigma'_s}{f'_c} + \alpha k_x \left(1 - \frac{c}{h}\right) \frac{\sigma'_c}{f'_c} - \psi \frac{\sigma_s}{f'_c} \quad \text{with,} \quad (\text{formula.D.15})$$

$$\psi' = \frac{\omega' f'_s}{f'_c}$$

$$\psi = \frac{\omega f'_s}{f'_c}$$

$$\omega' = \frac{A'}{bh}$$

$$\omega = \frac{A}{bh}$$

$$k_x = \frac{\varepsilon'_c}{\varepsilon'_c + \varepsilon_s}$$

$$\varepsilon_s = 0.002175$$

$$\varepsilon'_c = \varepsilon_s \frac{x_u}{h - c - x_u}$$

$$\varepsilon'_s = \frac{x_u - c}{x_u} \varepsilon'_c$$

$$\sigma'_s = E_s \varepsilon'_s$$

$$\sigma'_c = E_c \varepsilon'_c$$

$$\sigma_s = E_s \varepsilon_s$$

All parameters from formula.D.15 are known and  $x_u$  can be calculated from it, and consequently the internal forces and bending moment capacity:

$$M_u = N'_c(0.5h - \beta x_u) + N'_s(0.5h - c) + N_s(0.5h - c) \quad (\text{formula.D.16})$$

The factors  $\alpha$  and  $\beta$  depend on the strain of the concrete. If the strain of the concrete is smaller than 1.75‰ they are provided by:

$$\alpha = 0.5 \quad , \text{if } \varepsilon'_c \leq 1.75\text{‰}$$

$$\beta = 0.33 \quad , \text{if } \varepsilon'_c \leq 1.75\text{‰}$$

If the strain of the concrete is larger than 1.75‰ they are provided by:

$$\alpha = 1 - \frac{0.875}{\varepsilon'_c} \quad , \text{if } \varepsilon'_c > 1.75\text{‰}$$

$$\beta = \frac{0.5(\varepsilon'_c - 1.75)^2 + 0.875(\varepsilon'_c - 1.17)}{(\varepsilon'_c)^2 (1 - \frac{0.875}{\varepsilon'_c})} \quad , \text{if } \varepsilon'_c > 1.75\text{‰}$$

The bending moment capacity is compared with the artificial bending moment instead of the external bending moment. The unity check then yields:

$$\text{Unity check} = \frac{M_d^*}{M_u} \leq 1 \quad (\text{formula.D.17})$$

*Calculation of core*

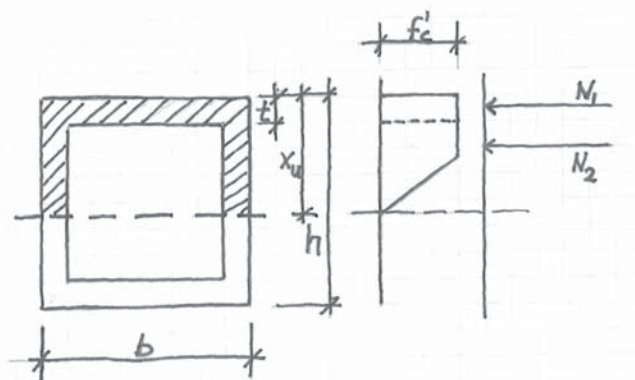

Figure.D.4 Concrete core axial force calculation with  $x_u > t$  and  $x_u < (h-t)$

For the calculations of the core, the same considerations hold as for the calculation of regular elements. Though, the calculation of the axial force in the concrete is different. Since the core has got a hollow rectangular cross section, it differs from a normal rectangular cross section. If the compressive zone is larger than the wall thickness of the core, the force can not be retrieved from  $N'_c = \alpha b x_u \sigma'_c$  since the concrete area is smaller ( $b(x_u > t) = 2t \neq b$ ). The stress diagram for concrete should be split into smaller pieces from which, from the individual parts, the axial force can be calculated. For instance,  $x_u > t$  and

## D.Unity checks for steel and concrete

$x_u < (h-t)$  can be split into 2 parts;

$$N_1' = tbf_c' \quad (\text{formula.D.18a})$$

$$N_2' = \alpha(x_u - t)2tf_c' \quad \text{with,} \quad (\text{formula.D.18b})$$

$t$  the wall thickness of the core [mm]

Then, the total force in the concrete is calculated from:

$$N_c' = N_1' + N_2'$$

### D.2 Stability

#### Steel

For steel elements, the following unity check is used to determine if the element will fail:

$$\text{Unity check} = 1.1 \frac{N_d'}{\frac{\sigma_c}{f_y} N_u} + 1.1 \frac{M_d}{1.0 M_u} < 1 \quad \text{with,}^{(1)} \quad (\text{formula.D.19})$$

$\sigma_c$  the Euler buckling stress of the element [N/mm<sup>2</sup>]

$N_d'$  the compressive axial force on the element [N]

#### Concrete

The calculation of stability for concrete elements is governed by a first or second order calculation. First, it should be determined if a second order calculation is needed. This can be done by calculating  $\alpha_n$  and  $\lambda_n$ .  $\alpha_n$  follows from:

$$\alpha_n = \frac{N_d'}{N_u} = \frac{N_d'}{A_c f_c' + A_s f_s} \quad (\text{formula.D.20})$$

$\lambda_n$  follows from:

$$\lambda_n = \frac{l_c}{h} \quad (\text{formula.D.21})$$

No second order calculation is needed if:

$$\lambda_n \leq 5 / \sqrt{\alpha_n} \quad \text{with} \quad \alpha_n \leq 0.25 \quad (\text{formula.D.22a})$$

$$\lambda_n \leq 10 \quad \text{with} \quad 0.25 < \alpha_n \leq 0.5 \quad (\text{formula.D.22b})$$

$$\lambda_n \leq 15 - 10 \alpha_n \quad \text{with} \quad \alpha_n > 0.5 \quad (\text{formula.D.22c})$$

If a second order calculation is not needed no further calculations have to be made to check the element. Though, if a second order calculation is needed an extra bending moment should be applied on the element by adding a certain eccentricity  $e_i$ :

(1) Note that for torsional buckling a factor of 1.0 is used and that torsional stability thus is not taken into account. Hence the capacity of the element will be overestimated.

$$e_t = (e_0 + e_c)\xi \geq e_0 \quad \text{with,} \quad (\text{formula.D.23})$$

$e_t$  the total eccentricity [mm]  
 $e_0$  the initial eccentricity [mm]  
 $e_c$  the additional eccentricity [mm]  
 $\xi$  a factor ( $\xi = 1$ )<sup>(2)</sup>

$e_0$  is the largest value of  $\frac{M_d}{N_d}$ , or  $\frac{l}{300}$ , or 10mm.  $e_c$  is calculated with:

$$e_c = 3[1.5h + e_0(4\psi - 3)]\left(\frac{\zeta l_c}{100h}\right)^2 \quad \text{if } e_0 < 0.5h \quad (\text{formula.D.24a})$$

$$e_c = 6h\psi\left(\frac{\zeta l_c}{100h}\right)^2 \quad \text{if } e_0 \geq 0.5h \quad \text{with,} \quad (\text{formula.D.24b})$$

$\psi$  the shape factor, for rectangular cross section:  $\psi = 1$   
 $\zeta$  reduction factor for buckling length of walls ( $\zeta = 1$ )

The extra bending moment on the element due to the total eccentricity is:

$$M_{d,buc} = e_t N_d' \quad \text{with,} \quad (\text{formula.D.25})$$

$M_{d,buc}$  the extra bending moment due to second order [Nmm]

This should be added to the original bending moment:

$$M_{d,tot} = M_d + M_{d,buc} \quad \text{with,} \quad (\text{formula.D.26})$$

$M_{d,tot}$  the total bending moment on the element [Nmm]

The unity check now yields:

$$\text{Unity check} = \frac{M_{d,tot}}{M_u} \leq 1 \quad (\text{formula.D.27})$$

### Core

The calculation of the stability of the core is similar to that of regular elements. It should be checked whether a first or second order calculation is needed. No second order calculation is needed if:

$$l_c \leq \sqrt{\frac{(EI)_d}{G}} \quad \text{with,} \quad (\text{formula.D.28})$$

$(EI)_d$  the design value for EI [Nmm<sup>2</sup>]  
 $G$  the weight of the building supported by the core [N]

(2) This factor is dependant on the eccentricities at the top and at the middle of the element and will result from the deformation of the element. Since in advance the deformed shape of the element is unknown the eccentricities are unknown and  $\xi$  is unknown. Hence  $\xi = 1$  is used.

## D.Unity checks for steel and concrete

The design value for EI is composed of the moment of inertia I and the effective modulus of elasticity for the core  $E_{ef}$ . This is dependant of  $\alpha_n$ :

$$E_{ef} = 2200 + 4400\omega + (24000 - 2200\omega\alpha_n) > 5000 \quad \text{If } \alpha_n \leq 0.5 \quad (\text{formula.D.29a})$$

$$E_{ef} = 21300 + 4950\omega(1 - \frac{2}{3}\alpha_n) \quad \text{If } \alpha_n > 0.5 \quad (\text{formula.D.29b})$$

$\omega$  the reinforcement percentage ( $A_s/A_c$ ) [-]

If a second order calculation is needed the following calculations of the eccentricity have to be made:

$$e_t = (e_0 + e_c)\xi \geq e_0 \quad \text{with,} \quad (\text{formula.D.30})$$

$e_t$  the total eccentricity [mm]

$e_0$  the initial eccentricity [mm]

$e_c$  the additional eccentricity [mm]

$\xi$  a factor dependant on the spring stiffness of the foundation of the core  
( $C=\infty \rightarrow \xi=1$ )

$$e_0 = \frac{M_d}{N_d}$$

$$e_c = 3[h + e_0(4\psi - 2)]\left(\frac{l}{100h}\right)^2 \frac{G}{N_d} \quad \text{if } e_0 < 0.5h \quad (\text{formula.D.31a})$$

$$e_c = 6h\psi\left(\frac{l}{100h}\right)^2 \frac{G}{N_d} \quad \text{if } e_0 \geq 0.5h \quad \text{with,} \quad (\text{formula.D.31b})$$

For non-rectangular cross sections,  $\psi$  can be found with:

$$\psi = 0.25\left(13 - 36\frac{l}{bh^3} - 12\frac{z_b}{h}\right) \quad \text{with,} \quad (\text{formula.D.32})$$

$z_b$  the distance from the neutral axis to the outer fiber of the cross section [mm]

If the total eccentricity is known, the extra bending moment due to second order can be calculated and the unity check can be calculated.

Apart from the total stability, also partial instability should be investigated with core calculations. It should be checked if a wall of the core will buckle by calculating it as an individual element. It is assumed the wall element is completely in compression and the bending moment capacity is provided by  $M_u = N_s z$ . For the buckling length it is assumed the floors will restrain the wall element, thus  $l_c = l$ , with  $l$  the length of the wall element between the floors. Further calculations are similar to that of a normal element.



# E.Codes

In this appendix the codes are provided from which the loads have been retrieved.

## E.1 Table C.3 of NEN6702:2007 (NNI, 2007, pp.139-141)

Tabel C.3 — Veranderlijke verticale belastingen op vloeren en daken

Gebuiksfunctie	$p_{rep}$ kN/m <sup>2</sup>	$\psi$	$F_{rep}$ kN	Opmerkingen
<b>Vloeren</b>	Extreem	Momentaan	Geconcentreerd	
a) Niet-gemeenschappelijke ruimten van een woonfunctie en van een logiesfunctie Vloeringen en zolders, niet bereikbaar langs vaste trap of met vrije hoogte van minder dan 2,2 m	1,75 0,7	0,4 0,7	3 0	1, 2, 3, 13 2
b) Kantoorfuncties, onderwijsfuncties en gezondheidszorgfuncties, een cellingebouw en de niet onder a) bedoelde ruimten van woongebouwen en logiesgebouwen	2,5	0,5	3	1, 5, 13
Voor keldervloeren met uitzondering van die van parkeerkelders	3,5	0,5	3	4
Voor de gedeelten van een gebuiksfunctie mede bestemd voor bezoekers	3	0,5	3	
c) Verkoopruimten van winkelfuncties	4,0	0,4	7	6, 13
d) Overige gebuiksfuncties voor het personenvervoer, bijeenkomstfuncties, sportfuncties en de gebuiksfunctie "bouwwerk, geen gebouw zijnde" met een gedeelte mede bestemd voor bezoekers	5,0	0,25	7	1, 7, 8, 13
Ter plaatse van oppervlakken waar zitplaatsen vast aan de vloer verbonden zijn	4	0,25	7	7, 13
e) Industriefunctie	$\geq 5$	0,8	10	1, 9, 13
Lichte industriefunctie, niet zijnde een tuinbouwkas	$\geq 5$	0,8	3	
f) Bibliotheken en archiefruimten	$p_{rep}$	1,0	7	11, 12
g) Belastingen op liftschachtwanden en vloeren in liftschachtputten moeten zijn ontleend aan 5.3 en 5.5 van NEN-EN 81-1 in het geval van een elektrisch aangedreven en aan 5.3 en 5.5 van NEN-EN 81-2 in het geval van een hydraulisch aangedreven personenlift		0		
h) Voor ruimten van geringe betekenis moet de belasting van de nevenfunctie of de belasting op het gebouw waarin de ruimte ligt, zijn aangehouden				
<b>Ontsluitingswegen</b>				
a) Niet-gemeenschappelijke ruimten van een woonfunctie en van een logiesfunctie en lichte industriefunctie, niet zijnde een tuinbouwkas	2	0,25	3	1, 2, 3
b) Kantoorfuncties, onderwijsfuncties en gezondheidszorgfuncties, een cellingebouw en de niet onder a) bedoelde ruimten van woongebouwen en logiesgebouwen	3	0,25	3	1

Zie vervolg

Figure.E.1 Table C.3 part1 of NEN6702:2007



Tabel C.3 (vervolg)

Gebruikersfunctie	$p_{rep}$ kN/m <sup>2</sup>	$\psi$	$F_{rep}$ kN	Opmerkingen
c) Verkoopruimten met winkelfunctie en ruimten met industrie functie	4	0,25	7	
d) Overige gebruiksfuncties voor het personenvervoer, bijeenkomstfuncties, sportfuncties en de gebruiksfunctie "bouwwerk, geen gebouw zijnde" met een gedeelte mede bestemd voor bezoekers en voetgangers- en fietsersbruggen	5	1,0	7	1, 7, 8
<b>Balkons, terrassen</b>	2,5	0,5	3	2, 13
<b>Opslagruimten</b>				
Van winkelfunctie	$\geq 5$	0,6	$\geq 7$	12
Bulkgoederen (zie formule)	$p_{rep}$			12
Overige opslagruimten	$\geq 5$	1	$\geq 10$	12
<b>Parkeergarages</b>				
Auto's tot 25 kN	2	0,7	10	
25 kN tot 120 kN	5	0,7	40	
Meer dan 120 kN	$p_{rep}$	0,7		
<b>Daken</b>				
Boven maaiveld	0 – 1	0	1,5	14, 15, 16, 17
Beneden maaiveld	4	0,5	7	
<b>OPMERKINGEN</b>				
1 Waarbij de groep van niet-gemeenschappelijke ruimten, gelegen binnen de omhullende van een andere gebruiksruimte die bijdraagt aan het functioneren van de beschouwde gebruiksfunctie, buiten beschouwing blijft.				
2 $F_{rep}$ werkt op een oppervlakte van 0,5 m × 0,5 m.				
3 Voor een overige gebruiksfunctie, behorende bij een woning, logiesverblijf of een woonwagen, zoals een buitenbergruimte of een garage, wordt aanbevolen van dezelfde vloerbelastingen uit te gaan. Volgens het Bouwbesluit mag de vloerbelasting echter zijn ontleend aan NEN 3859.				
4 Voor keldervloeren van een "overige gebruiksfunctie" mag volgens het Bouwbesluit naar analogie met NEN 3859 de vloerbelasting worden bepaald. Aanbevolen wordt van bovenstaande belastingen uit te gaan.				
5 Voor archief ruimten zie categorie f).				
6 Voor opslagruimten zie 8.3.2, voor vloeren niet behorend tot de verkoopruimte of de opslagruimte moet de representatieve waarde van de vloerbelasting zijn afgestemd op de gebruiksfunctie van de vloer overeenkomstig de omschrijving in de overige subonderdelen van 8.2.2.1.				
7 Bij tribunes moet bovendien rekening zijn gehouden met een veranderlijke gelijkmatig verdeelde horizontale belasting die kan optreden als gevolg van de bewegende mensenmassa. Deze horizontale belasting bedraagt 10 % van de verticale belasting en moet wat betreft de richting zijn beschouwd als een vrije belasting.				
8 Voor verblijfsruimten voor kinderopvang mogen de vloerbelastingen volgens a) zijn gehanteerd.				
9 De vloerbelasting moet mede zijn afgestemd op de belasting door opslag van materialen en producten (zie 8.3). Tevens moet rekening zijn gehouden met de belastingen door machines (zie 8.4) en voertuigen (zie 8.5). Ook moet rekening zijn gehouden met het mogelijk omvallen van gestapelde goederen. De in rekening te brengen belastingen mogen niet lager zijn dan de hier genoemde waarden.				
10 De belasting door bijvoorbeeld boeken in bibliotheken en archief ruimten moet zijn bepaald op basis van de hoogte en de overige afmetingen van de stellingen, zoals opgegeven bij de aanvraag van de bouwvergunning. De vrije ruimte tussen de inventaris moet als kantoorruimte zijn beschouwd met belastingen volgens tabel 7 categorie b). Het aldus verkregen belastingspatroon mag over de vloeroppervlakte zijn uitgemiddeld.				
11	$p_{rep} = \frac{A_1 \times \gamma_{bk} \times h + A_2 \times p_0}{A_1 + A_2}$			
	waarin:			
	$p_{rep}$ is de vloerbelasting, in kN/m <sup>2</sup> ;			
	$A_1$ is de vloeroppervlakte ingenomen door de stellingen, in m <sup>2</sup> ;			
	$A_2$ is de resterende vloeroppervlakte, in m <sup>2</sup> ;			
	$\gamma_{bk}$ is het volumiek gewicht van in de stellingen opgestlagen boeken; $\gamma_{bk} = 6 \text{ kN/m}^3$ ;			
	$p_0$ is de gelijkmatig verdeelde belasting tussen de stellingen; $p_0 = 2,5 \text{ kN/m}^2$ ;			
	$h$ is de hoogte van de stelling, in m.			
12 Bij vrije randen een lijnbelasting $q_{rep} = 5 \text{ kN/m}$ over 1 m, op niet meer dan 0,1 m evenwijdig van de buitenrand.				
13 $F_{rep}$ werkt op een oppervlakte van 0,1 m × 0,1 m, tevens rekenen met een stootbelasting volgens 9.5.				
14 Rekenen met lijnlast $q_{rep} = 2 \text{ kN/m}$ over een lengte van 1 m en een breedte van 0,10 m.				

Zie vervolg

Figure.E.2 Table C.3 part2 of NEN6702:2007

# E.Codes

Tabel C.3 (einde)

- 15  $p_{\text{top}}$  is afhankelijk van de dakhelling:
- |                             |  |
|-----------------------------|--|
| $0 \leq \alpha < 15^\circ$  | $p_{\text{top}} = 1,0 \text{ kN/m}^2$              |
| $15 \leq \alpha < 20^\circ$ | $p_{\text{top}} = (4 - 0,2 \alpha) \text{ kN/m}^2$ |
| $\alpha \geq 20^\circ$      | $p_{\text{top}} = 0 \text{ kN/m}^2$                |
- 16 Rekening moet zijn gehouden met wateraccumulatie.
- 17  $p_{\text{rep}} = \frac{F_{\text{eq,gds,tot}}}{A}$
- 18  $p_{\text{rep}} = \frac{G_{\text{voertuig}}}{A_{\text{voertuig}}}$ , gebaseerd op het zwaarst mogelijke voertuig dat van de parkeerplaats gebruik kan maken.

Figure.E.3 Table C.3 part3 of NEN6702:2007

## E.2 Parts of annex A of NEN6702:2007 (NNI, 2007)

### Bijlage A (normatief)

#### Figuren, tabellen, grafieken enz. behorend bij de bepaling van de windbelasting

##### A.1 Waarden voor de stuwdruk

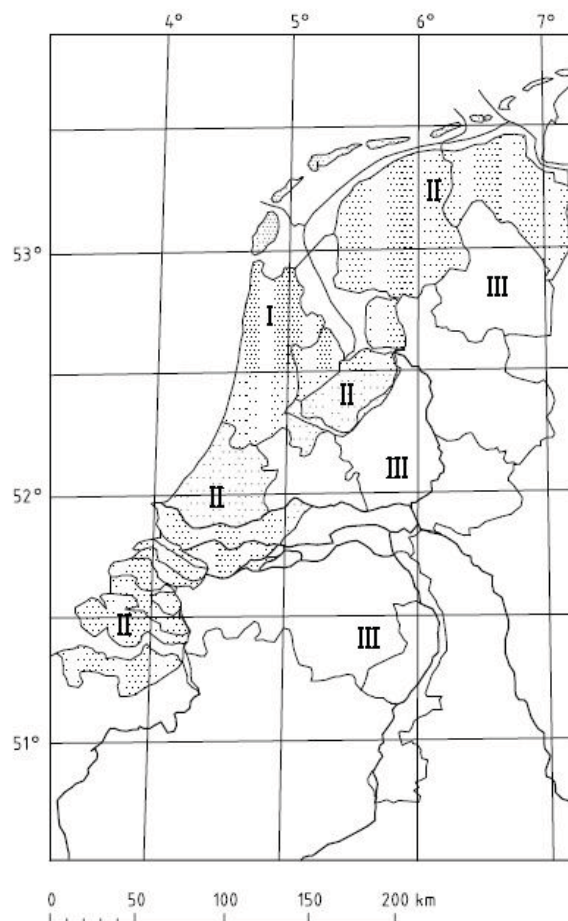

Figuur A.1 — Verdeling van Nederland in drie gebieden ten aanzien van de te hanteren stuwdruk

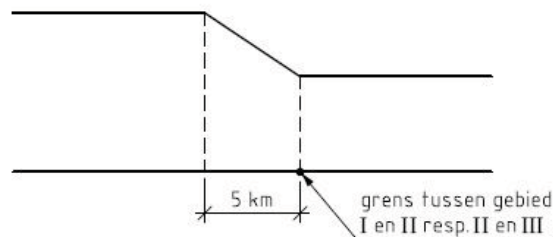

Figuur A.2 — Interpolatie van de stuwdruk bij de overgang tussen twee gebieden

Figure.E.4 Annex A.1 of NEN6702:2007

## A.3 Figuren met vormfactoren voor wind

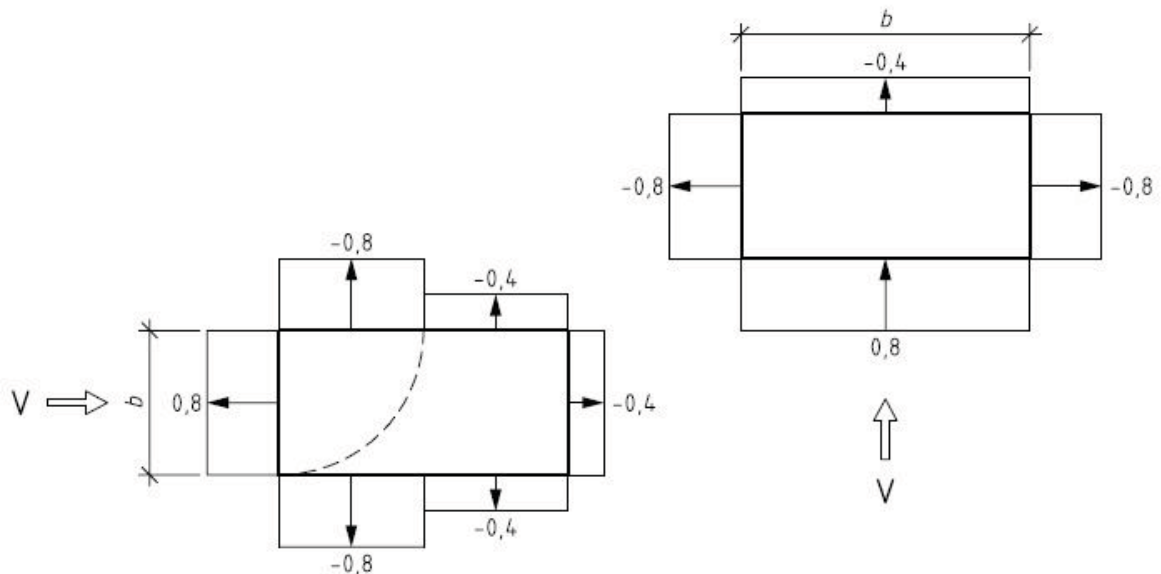

**Figuur A.4 — Windvormfactoren  $C_{pe}$  voor gevels van gebouwen met een rechthoekige plattegrond (voor delen met een oppervlakte groter dan  $10 \text{ m}^2$ )**

OPMERKING 1 Een positieve waarde van  $C_{pe}$  levert een belasting naar het vlak toe gericht (druk); een negatieve waarde van  $C_{pe}$  levert een belasting van het vlak af gericht (zuiging).

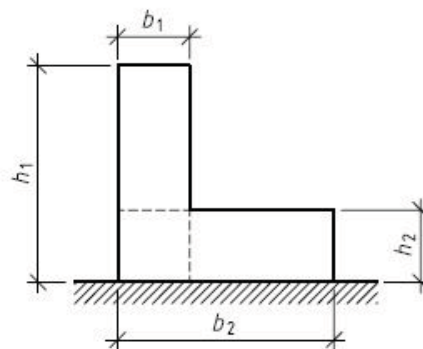

**Figuur A.5 — Bepaling van de stuwdruk op gevels van bouwwerken met verschillende hoogten**

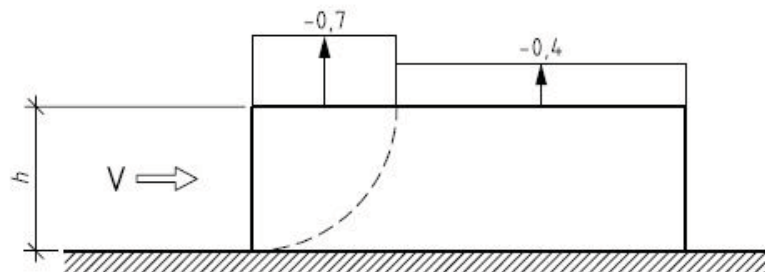

**Figuur A.6 — Windvormfactoren  $C_{pe}$  voor daken van gebouwen met een rechthoekige plattegrond met een hellingshoek kleiner dan  $10^\circ$  (voor delen met een oppervlakte groter dan  $10 \text{ m}^2$ )**

OPMERKING 2 Een positieve waarde van  $C_{pe}$  levert een belasting naar het vlak toe gericht (druk); een negatieve waarde van  $C_{pe}$  levert een belasting van het vlak af gericht (zuiging).

*Figure.E.5 Annex A.3 of NEN6702:2007*

## E.3 Parts of annex A of NEN-EN 1990:2002/NB:2007 (NNI, 2007-2)

### A1.2.2 Waarden van de $\psi$ -factoren

- (1) De volledige tekst moet als volgt zijn gelezen (normatief):

In tabel A1.1 zijn de waarden van de  $\psi$ -factoren voor gebouwen gegeven en moet als volgt zijn gelezen:

Tabel A1.1 — Waarden van de  $\psi$ -factoren voor gebouwen

Belasting	$\psi_0$	$\psi_1$	$\psi_2$
Voorgeschreven belastingen in gebouwen, categorie			
Categorie A: woon- en verblijfsruimtes	0,4	0,5	0,3
Categorie B: kantoorruimtes	0,5	0,5	0,3
Categorie C: bijeenkomstruimtes	0,25	0,7	0,6
Categorie D: winkelruimtes	0,4	0,7	0,6
Categorie E: opslagruimtes	1,0	0,9	0,8
Categorie F: verkeersruimte, voertuiggewicht $\leq 30$ kN	0,7	0,7	0,6
Categorie G: verkeersruimte, $30 \text{ kN} < \text{voertuiggewicht} \leq 160$ kN	0,7	0,5	0,3
Categorie H: daken	0	0	0
Sneeuwbelasting	0	0,2	0
Windbelasting	0	0,2	0
Temperatuur (geen brand)	0	0,5	0

Figure.E.6 Annex A.1.2.2 of NEN-EN 1990:2002/NB:2007

### A1.3.2 Rekenwaarden van belastingen in buitengewone en ontwerp- en berekeningssituatie

- (1) Tabel A1.3 moet als volgt zijn gelezen:

Tabel A1.3 — Rekenwaarden van belastingen voor het gebruik in buitengewone en aardbevingsbelastingcombinaties

Ontwerp-situatie	Blijvende belastingen		Overheersende buitengewone of aardbevingsbelasting	Veranderlijke belastingen gelijktijdig met de overheersende	
	Ongunstig	Gunstig		Belangrijkste (zo nodig)	Andere
Buitengewoon (Verg. 6.11a/b)	$1,0 G_{kj,sup}$	$1,0 G_{kj,inf}$	$1,0 A_d$	$\psi_{1,1} Q_{k,1}^a$	$\psi_{2,i} Q_{k,i} (i > 1)$
Aardbeving (Verg. 6.12a/b)	$1,0 G_{kj,sup}$	$1,0 G_{kj,inf}$	$1,0 A_{ek}$ of $1,0 A_{Ed}$		$\psi_{2,i} Q_{k,i} (i > 1)$

<sup>a</sup> Uitsluitend voor wind op de hoofddragconstructie; voor overige gevallen  $\psi_{2,1}$ .

Figure.E.7 Annex A.1.3.2 of NEN-EN 1990:2002/NB:2007

# F.Average lengths

The following table shows the distribution of the length of Dutch people (CBS, 2008). This table has been used to determine the average maximum lengths from which the deformation limit for the floors can be retrieved.

Tabel 1  
Lengte van de bevolking van 20 jaar of ouder, 2003/2006

Opgegeven lengte	20-24	25-34	35-44	45-54	55-64	65-74	75 jaar of ouder	Totaal
%								
<b>Mannen</b>								
Korter dan 163 cm	0,3	0,3	0,3	0,9	0,9	2,3	4,1	0,9
163-167 cm	1,1	1,3	2,0	2,4	3,6	5,8	7,7	2,8
168-172 cm	6,4	6,5	8,1	10,1	15,7	21,9	24,2	11,5
173-177 cm	12,6	13,6	14,1	17,4	20,6	25,7	26,0	17,4
178-182 cm	23,1	23,9	27,5	29,9	29,9	24,8	25,4	26,9
183-187 cm	26,4	28,0	27,0	24,9	20,4	14,1	9,8	23,4
188-192 cm	18,4	14,4	12,3	9,6	6,1	3,4	2,2	10,2
193-197 cm	9,3	8,9	6,7	3,8	2,5	1,7	0,5	5,2
198 cm of langer	2,3	3,1	2,0	1,1	0,2	0,3	0,1	1,5
<i>absoluut=100%</i>								
Totaal respondenten	1 220	2 800	3 333	2 917	2 401	1 449	855	14 975
<i>cm</i>								
Gemiddelde lengte standaardfout	183,4 0,2	183,1 0,1	182,0 0,1	180,5 0,1	178,7 0,1	176,4 0,2	175,0 0,2	180,6 0,1
<i>x 1 000</i>								
Totaal in bevolking <sup>1)</sup>	486	1 110	1 316	1 157	952	580	343	5 944
%								
<b>Vrouwen</b>								
Korter dan 153 cm	0,8	1,2	0,9	1,2	1,5	3,7	5,7	1,8
153-157 cm	2,9	2,9	3,4	5,3	6,4	7,2	12,5	5,3
158-162 cm	11,0	11,1	11,6	15,9	18,7	21,3	26,0	15,6
163-167 cm	21,1	20,7	22,8	25,3	28,3	31,4	25,2	24,7
168-172 cm	29,3	28,1	31,9	31,6	29,2	24,9	22,0	28,9
173-177 cm	20,8	21,9	18,7	14,1	11,3	8,7	6,2	15,3
178-182 cm	10,3	11,9	8,8	5,5	3,6	2,6	1,8	6,8
183-187 cm	3,2	2,2	1,8	1,0	0,9	0,2	0,2	1,4
188 cm of langer	0,6	0,0	0,2	0,2	0,3	0,1	0,3	0,2
<i>absoluut=100%</i>								
Totaal respondenten	1 187	2 731	3 169	2 811	2 329	1 627	1 288	15 142
<i>cm</i>								
Gemiddelde lengte standaardfout	169,8 0,2	169,6 0,1	168,9 0,1	167,4 0,1	166,3 0,1	165,0 0,2	163,4 0,2	167,5 0,1
<i>x 1 000</i>								
Totaal in bevolking <sup>1)</sup>	476	1 100	1 281	1 137	939	651	565	6 151

<sup>1)</sup> Exclusief institutionele bevolking.

Figure.F.1 Lengths of Dutch people

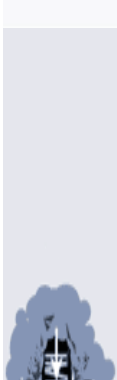
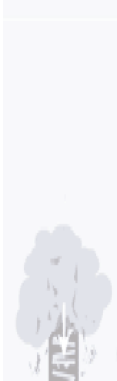

# G. Buckling analysis

In order to estimate the buckling length of columns more accurately, some buckling analysis have been performed with the FEA software. The results of that analysis are represented here. The analysis has been performed with different configuration types that will influence the buckling behavior of the elements. Different geometric configurations of the systems are investigated. The surrounding structure of a specific element from which the buckling length is investigated determines how the structure will deform and thus has great influence on the buckling mode of the specific element. Hence, the number of floors, the number of columns, the distance between the columns versus the distance between the floors, the bending stiffness of the floors versus the bending stiffness of the columns, or the stiffness of the stabilizing structure, are a few examples of parameters that will result in different buckling lengths. The analysis has been performed by applying a point load  $F = 1000$  N on top of one line of columns (see figure.G.1) and adjusting only one of the previously described parameters. The load is applied, either on the façade line or on a line of columns between the facades. Both cases will result in different buckling lengths, since on an exterior column less other elements are attached compared with an interior column.

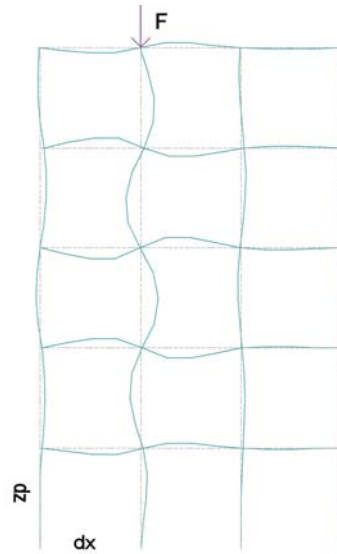

Figure.G.1 Buckling length analysis

For each case and specific mode a load factor  $\alpha$  can be retrieved from the analysis. This load factor gives the ratio for the applied load and the buckling load:

$$F_c = \alpha \cdot F \quad \text{with,} \quad (\text{formula.G.1})$$

$F_c$  the buckling load [N]  
 $\alpha$  load factor [-]  
 $F$  the applied force of 1000 N [N]

With the Euler buckling load formula (formula.9.1) the buckling length of a single column underneath the applied load can be calculated:

$$l_c = \sqrt{\frac{\pi^2 EI}{F_c}} \quad \text{with,} \quad (\text{formula.G.2})$$

$l_c$  buckling length [mm]  
 $EI$  the bending stiffness [Nmm<sup>2</sup>]  
 $F_c$  the buckling load [N]



## G.1 Floors

The following results are obtained by changing the amount of floors and using: 4 columns, HE140A (also floors), height =7m, width=7m.

System 1 Moment resistant framework

floors	load factor		L_c	
	façade	inner	façade	inner
1,00	1314,00	1277,00	3,91	3,97
2,00	982,20	956,10	4,53	4,59
3,00	894,70	865,80	4,74	4,82
4,00	856,70	827,40	4,85	4,93
5,00	836,40	807,10	4,91	4,99

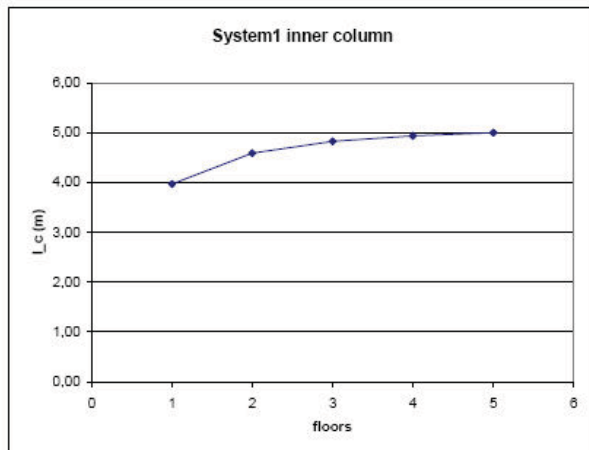
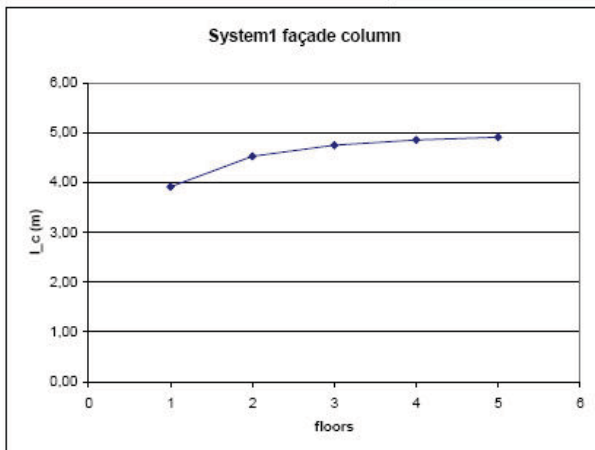

MODE 2:

floors	load factor		L_buc	
	façade	inner	façade	inner
1,00	2379,00	3573,00	2,91	2,37
2,00	1331,00	1961,00	3,89	3,20
3,00	1105,00	1677,00	4,27	3,47
4,00	1078,00	1572,00	4,33	3,58
5,00	1031,00	1524,00	4,42	3,63

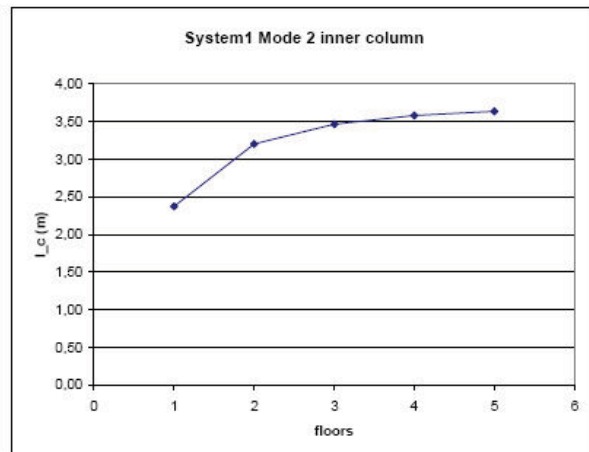
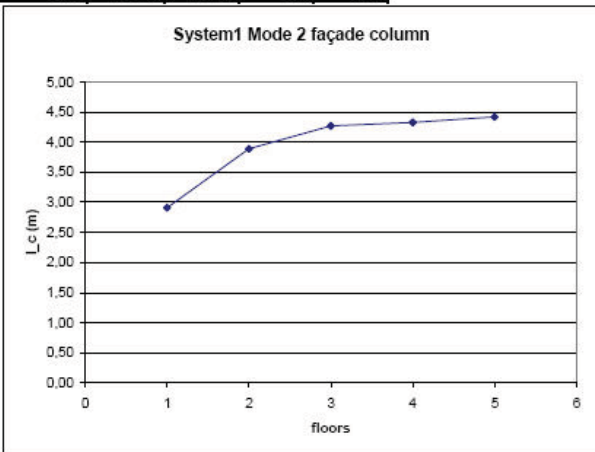
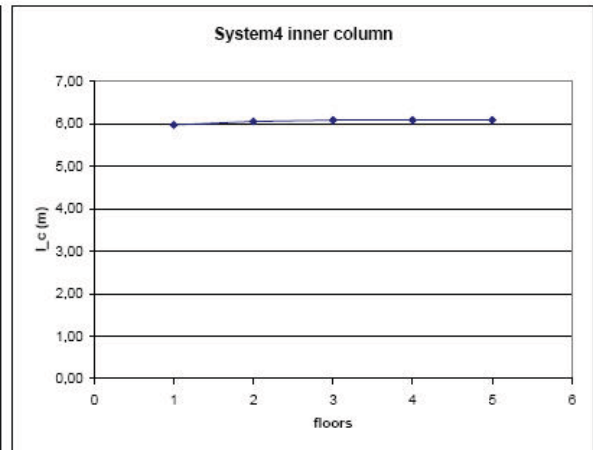
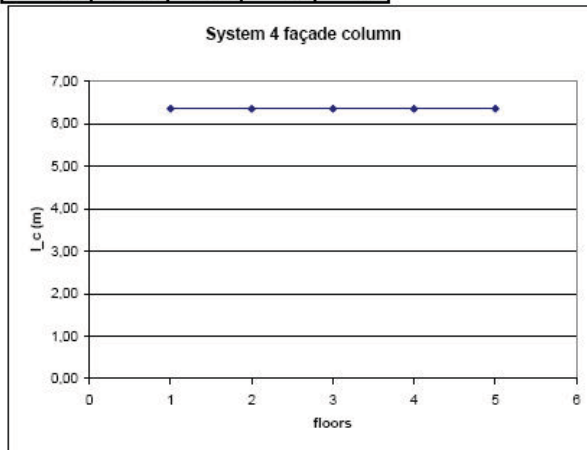

Figure.G.2 Buckling length, changing the amount of floors, system 1: 4 columns, HE140A (also floors), height =7m, width=7m

# G.Buckling analysis

**System 4 Pinned framework with stability bracing**

floors	load factor		L <sub>buc</sub>	
	façade	inner	façade	inner
1,00	499,70	564,90	6,35	5,97
2,00	499,70	550,70	6,35	6,05
3,00	499,70	544,70	6,35	6,08
4,00	499,70	545,30	6,35	6,08
5,00	499,70	545,30	6,35	6,08



**System 5 Pinned framework with stability bracing and outrigger**

floors	load factor		L <sub>buc</sub>	
	façade	inner	façade	inner
2,00	499,70	863,40	6,35	4,83
3,00	499,70	929,80	6,35	4,65
4,00	499,70	970,90	6,35	4,55
5,00	499,70	1001,00	6,35	4,49

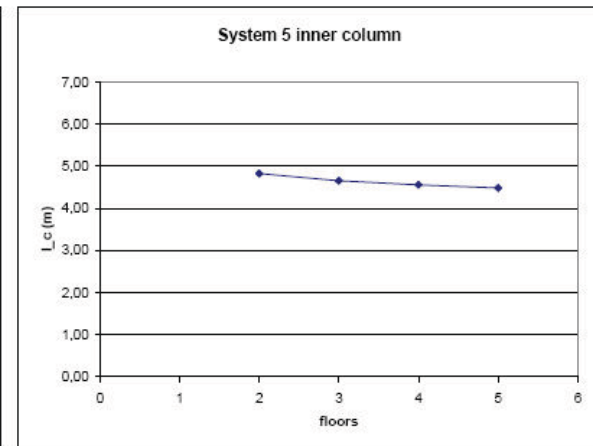
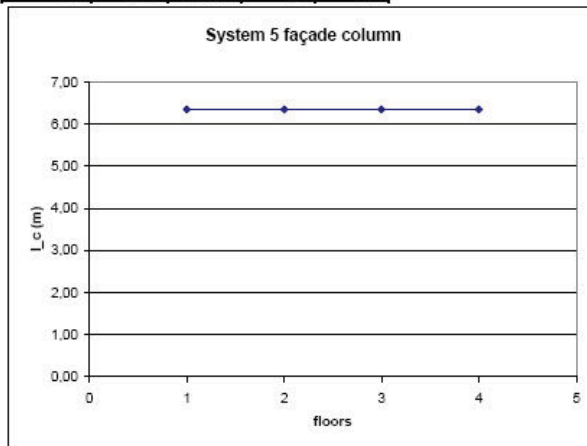
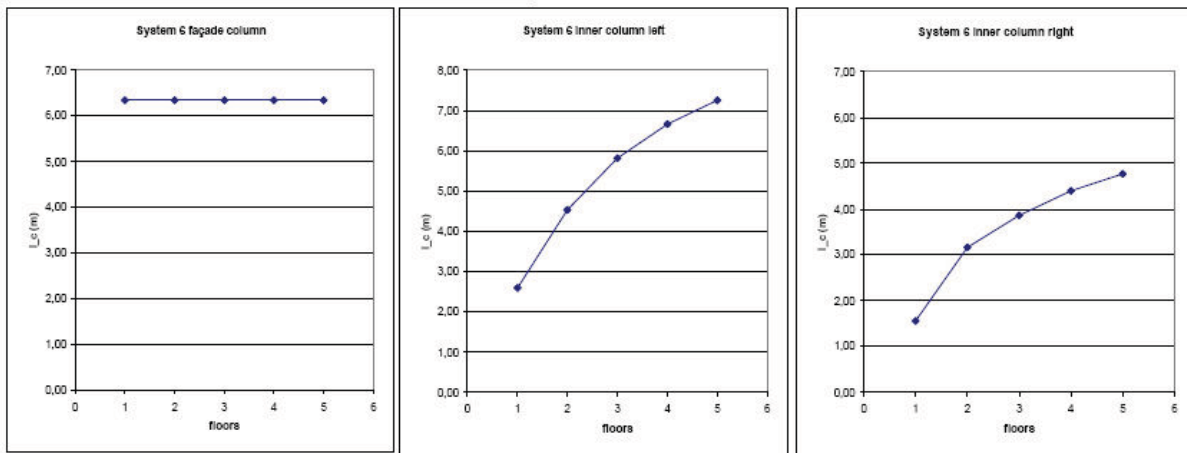

Figure.G.3 Buckling length, changing the amount of floors, system 4 and 5: 4 columns, HE140A (also floors), height =7m, width=7m

System 6 Pinned framework with stabilizing core

floors	load factor			I_buc		
	façade	inner left	inner right	façade	inner left	inner right
1,00	499,70	7499,00	8290,00	6,36	2,69	1,58
2,00	499,70	2462,00	2008,00	6,36	4,63	3,17
3,00	499,70	1493,00	1348,00	6,36	5,82	3,88
4,00	499,70	1137,00	1039,00	6,36	6,66	4,40
5,00	499,70	959,90	884,40	6,36	7,25	4,77



System 7 Pinned framework with stabilizing core and floors fixed to core

floors	load factor			I_buc		
	façade	inner left	inner right	façade	inner left	inner right
1,00	499,70	1115,00	1071,00	6,36	6,73	4,34
2,00	499,70	1208,00	2439,00	6,36	6,47	2,87
3,00	499,70	1178,00	2155,00	6,36	6,65	3,08
4,00	499,70	1149,00	2045,00	6,36	6,63	3,14
5,00	499,70	1123,00	1999,00	6,36	6,71	3,17

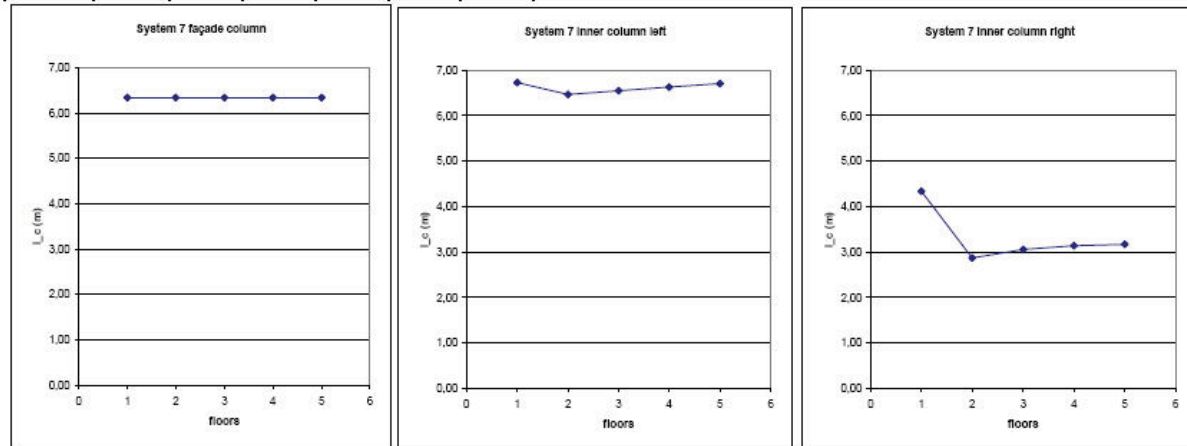

Figure.G.4 Buckling length, changing the amount of floors, system 6 and 7: 4 columns, HE140A (also floors), height =7m, width=7m

As can be seen from the graphs, for the different structural systems, the amount of floors has minor influence on the buckling length of the column. Only for the systems with stabilizing core, an increasing amount of floors will result in an increasing buckling length.

# G.Buckling analysis

## G.2 Columns

The following results are obtained by changing the amount of columns and using: 5 floors, HE140A (also floors), height =7m, width=7m, System1; Moment resistant framework.

System 1 Moment resistant framework

columns	load factor			l <sub>c</sub>		
	façade	first inner	second inner	façade	first inner	second inner
3	-	564,5	-	-	5,97	-
4	1031	807,1	-	4,42	4,99	-
5	1035	1044	1049	4,41	4,39	4,38
6	1038	1278	1248	4,40	3,97	4,02
7	1040	1506	1516	4,40	3,66	3,64
8	1041	1522	1542	4,40	3,64	3,61
9	1041	1522	1543	4,40	3,64	3,61
10	1042	1522	1543	4,40	3,64	3,61

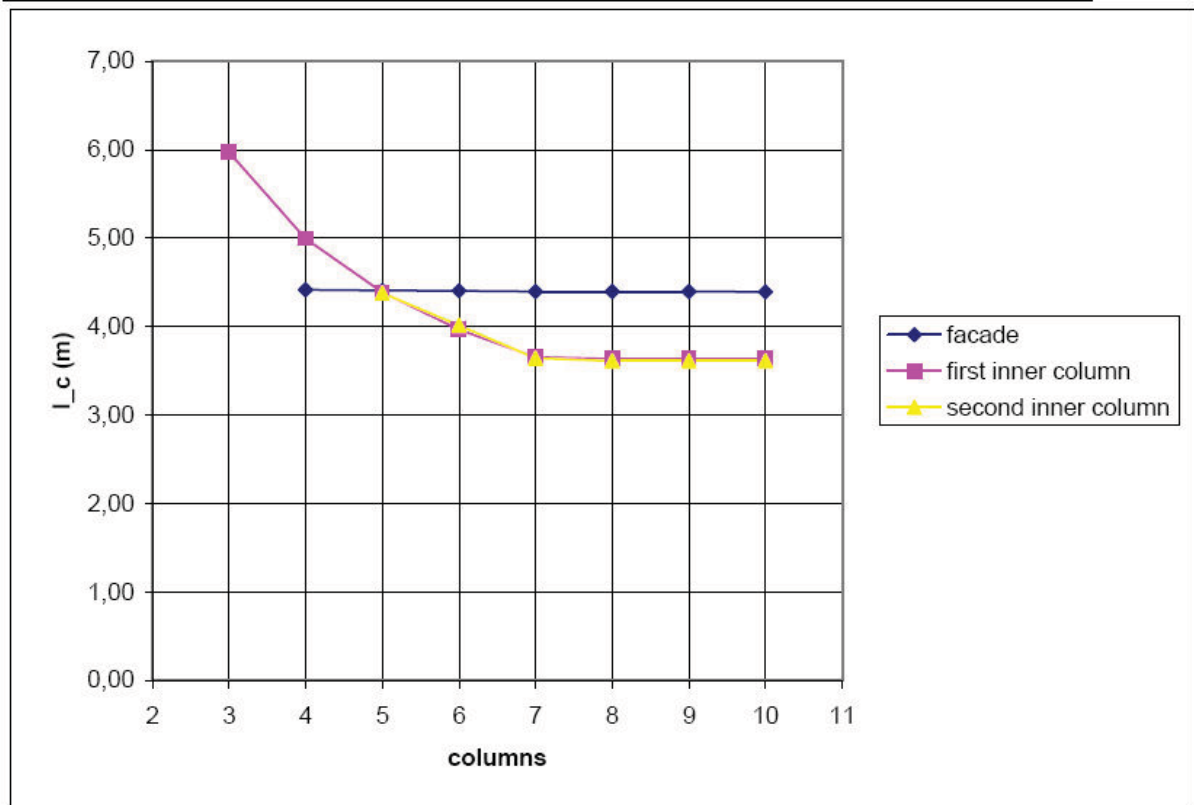

Figure.G.5 Buckling length, changing the amount of columns: 5 floors, HE140A (also floors), height =7m, width=7m

For the exterior column, the number of columns does not have any influence on the buckling length. The interior columns, on the other hand, show a change in buckling length if the number of columns is changed. A decreasing buckling length will result if more columns are applied. If more columns are applied, the surrounding structure will brace the considered column, hence reducing the buckling length. If seven or more columns are applied, adding more columns does not influence the buckling length.

## G.3 dx/dz-ratio

The following results are obtained by changing the dx/dz-ratio and using: 4 columns, 5 floors, HE140A (also floors) and height=7m .

System1 Moment resistant framework			loadfactor		l_c	
height (m)	width (m)	dx/dz	façade	inner	façade	inner
7	1	0,14	1129	1108	4,22	4,26
7	2	0,29	1196	1145	4,10	4,19
7	3	0,43	1125	1072	4,23	4,33
7	4	0,57	1043	994,2	4,39	4,50
7	5	0,71	965,4	923,8	4,57	4,67
7	6	0,86	896,8	861,7	4,74	4,83
7	7	1,00	836,4	807,1	4,91	4,99
7	8	1,14	783,3	758,8	5,07	5,15
7	9	1,29	736,4	715,8	5,23	5,30
7	10	1,43	694,8	677,5	5,38	5,45
7	11	1,57	657,8	643	5,53	5,60
7	12	1,71	624,5	611,9	5,68	5,74
7	13	1,86	594,6	583,7	5,82	5,87
7	14	2,00	567,5	558,1	5,96	6,01
7	21	3,00	431,9	427,9	6,83	6,86
7	28	4,00	350,5	348,5	7,58	7,60
7	35	5,00	296,2	295	8,25	8,26

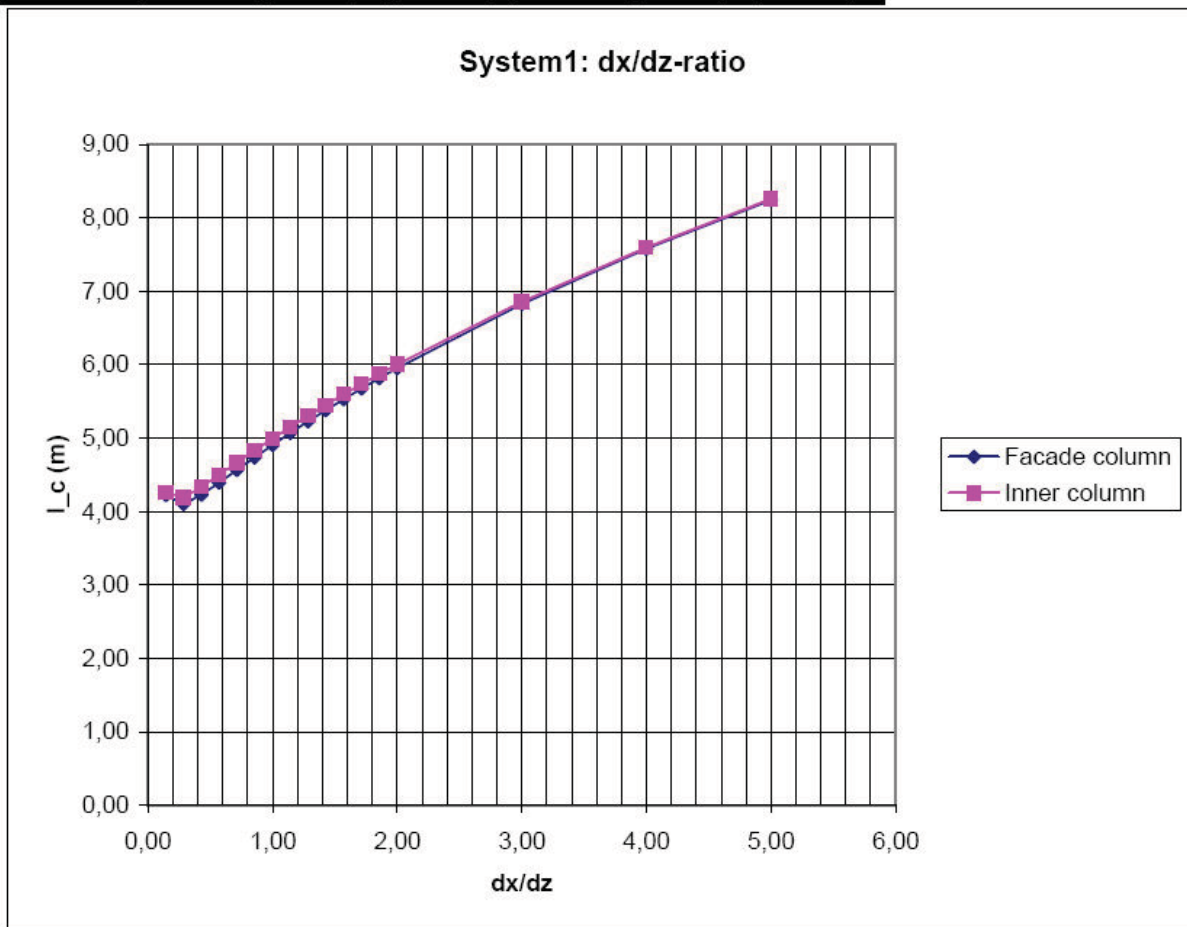

Figure.G.6 Buckling length, changing the dx/dz-ratio, system 1: 4 columns, 5 floors, HE140A (also floors), height =7m

# G.Buckling analysis

**System2 Moment resistant framework with stability bracing**

height (m)	width (m)	dx/dz	loadfactor	
			inner	l_c
7	1	0,14	3100	2,55
7	2	0,29	5479	1,92
7	3	0,43	4469	2,12
7	4	0,57	3527	2,39
7	5	0,71	2974	2,60
7	6	0,86	2610	2,78
7	7	1,00	2348	2,93
7	8	1,14	2149	3,06
7	9	1,29	1992	3,18
7	10	1,43	1864	3,29
7	11	1,57	1757	3,39
7	12	1,71	1666	3,48
7	13	1,86	1588	3,56
7	14	2,00	1520	3,64
7	21	3,00	1213	4,07
7	28	4,00	1052	4,38
7	35	5,00	951,8	4,60

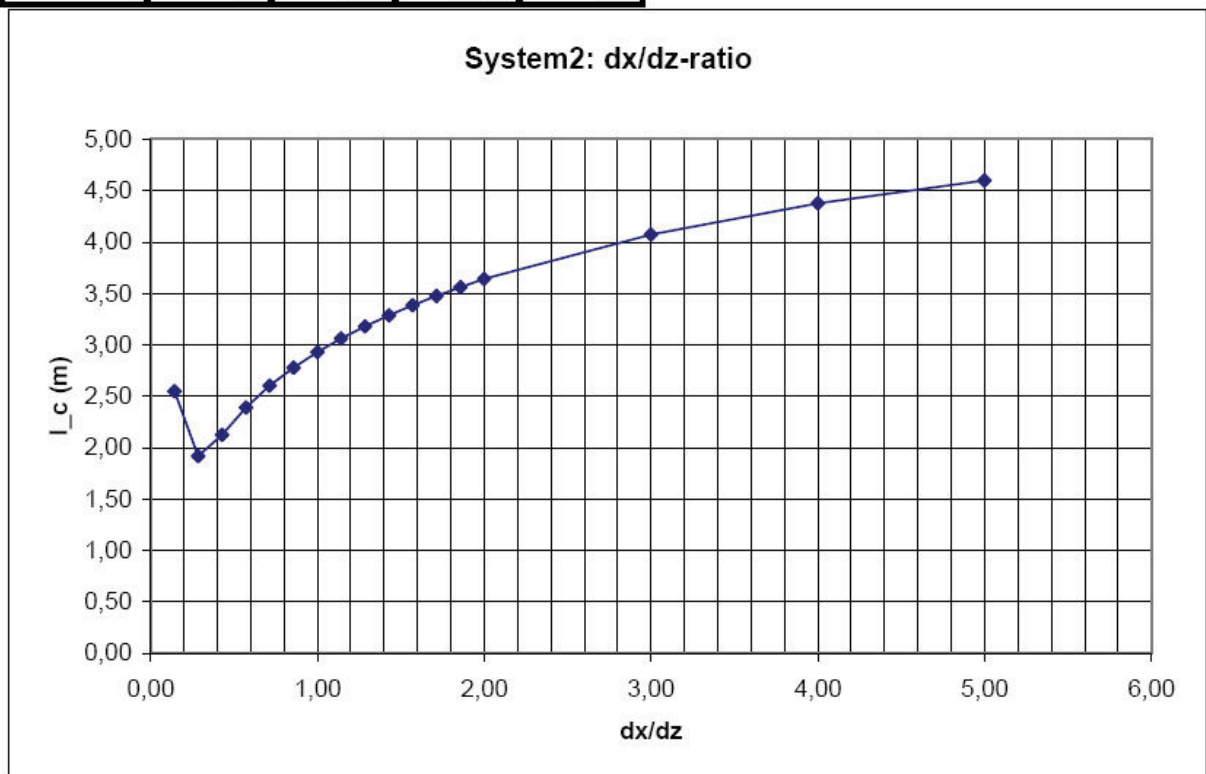

Figure.G.7 Buckling length, changing the dx/dz-ratio, system 2: 4 columns, 5 floors, HE140A (also floors), height =7m



**System4 Pinned framework with stability bracing**

height (m)	width (m)	dx/dz	loadfactor		L <sub>c</sub>	
			façade	inner	façade	inner
7	1	0,14	499,7	662,2	6,35	5,51
7	2	0,29	499,7	649,1	6,35	5,57
7	3	0,43	499,7	628	6,35	5,66
7	4	0,57	499,7	603,4	6,35	5,78
7	5	0,71	499,7	580	6,35	5,89
7	6	0,86	499,7	560,4	6,35	5,99
7	7	1,00	499,7	545,3	6,35	6,08
7	8	1,14	499,7	534	6,35	6,14
7	9	1,29	499,7	525,7	6,35	6,19
7	10	1,43	499,7	519,7	6,35	6,22
7	11	1,57	499,7	515,3	6,35	6,25
7	12	1,71	499,7	512	6,35	6,27
7	13	1,86	499,7	509,5	6,35	6,29
7	14	2,00	499,7	507,7	6,35	6,30
7	21	3,00	499,7	502,1	6,35	6,33
7	28	4,00	499,7	500,7	6,35	6,34
7	35	5,00	499,7	500,2	6,35	6,34

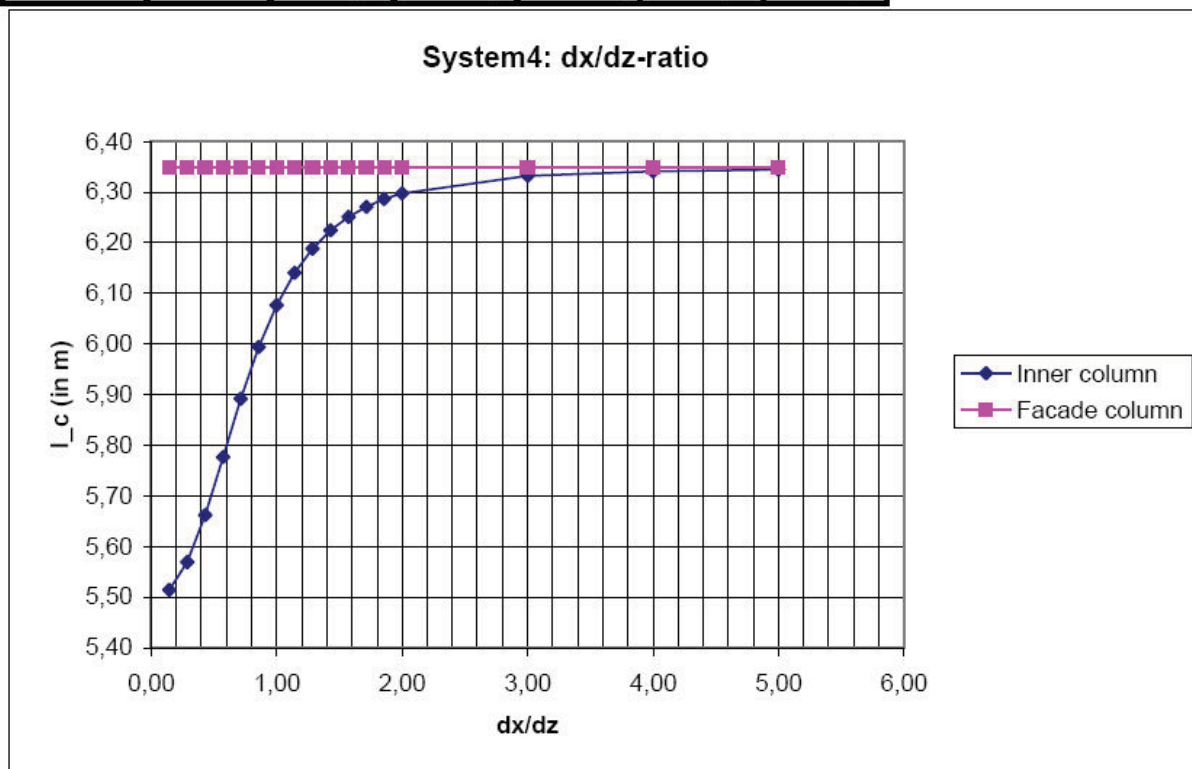

Figure.G.8 Buckling length, changing the dx/dz-ratio, system 4: 4 columns, 5 floors, HE140A (also floors), height =7m

# G.Buckling analysis

**System6 Pinned framework with stabilizing core**

height (m)	width (m)	dx/dz	loadfactor inner right column		l <sub>c</sub> inner right column	
			mode 1	mode 2	mode 1	mode 2
7	1	0,14	1061	1579	4,36	3,57
7	2	0,29	1016	1577	4,45	3,57
7	3	0,43	979,4	1575	4,53	3,58
7	4	0,57	949,4	1573	4,61	3,58
7	5	0,71	924,2	1572	4,67	3,58
7	6	0,86	902,8	1570	4,72	3,58
7	7	1,00	884,4	1569	4,77	3,58
7	8	1,14	868,3	1568	4,82	3,58
7	9	1,29	854,2	1566	4,86	3,59
7	10	1,43	841,6	1565	4,89	3,59
7	11	1,57	830,4	1564	4,92	3,59
7	12	1,71	820,3	1563	4,95	3,59
7	13	1,86	811,1	1562	4,98	3,59
7	14	2,00	802,8	1561	5,01	3,59
7	21	3,00	760	1554	5,15	3,60
7	28	4,00	733	1535	5,24	3,62
7	35	5,00	713,8	1549	5,31	3,61

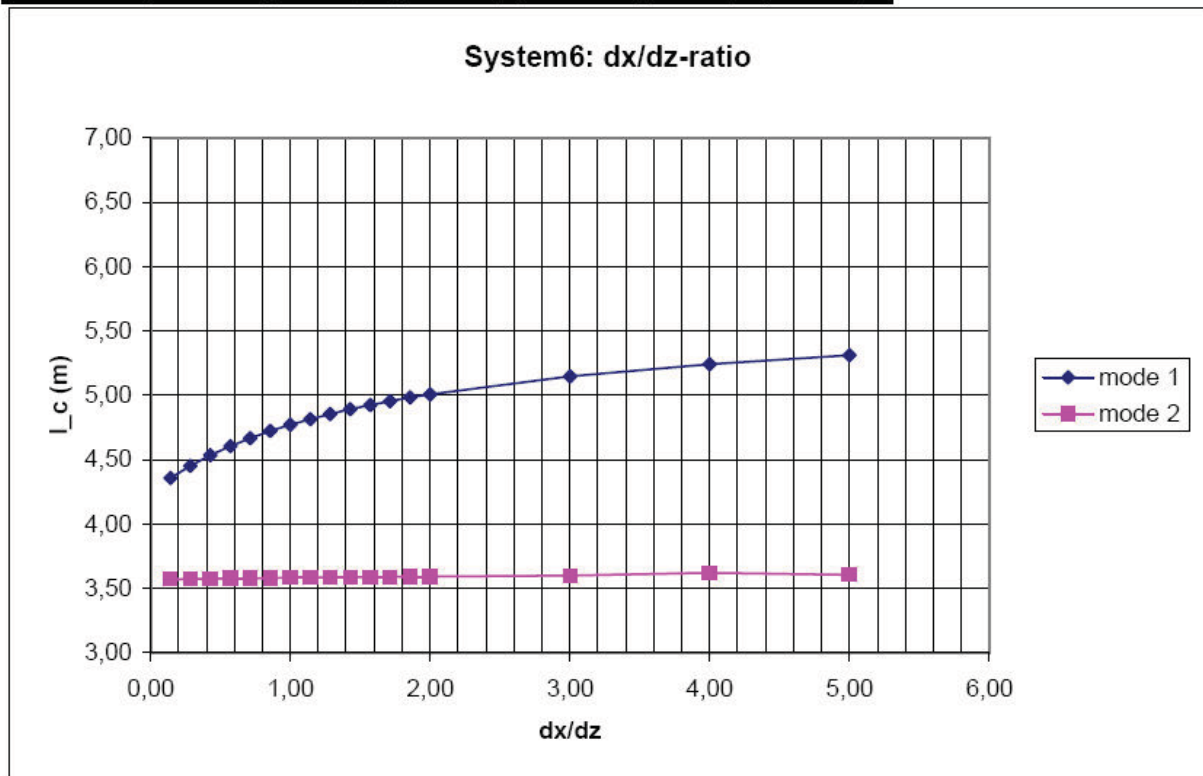

Figure.G.9 Buckling length, changing the dx/dz-ratio, system 6: 4 columns, 5 floors, HE140A (also floors), height = 7m

The ratio of the distance between the columns (dx), versus the distance between the floors (dz), shows different results for the different structural systems. System one and two, show an increasing buckling length on increase of the dx/dz-ratio. This can be explained by the fact that if the floor length is larger than the column length, the floor will behave less stiff, hence the connections will become less stiff, resulting in a larger buckling length. For system four, a constant relation between the buckling length and dx/dz-ratio can be found. The non-linear relation of the interior column can be explained by the fact that at the connections of these columns also the diagonal elements are attached. This will increase the



stiffness of the connections and consequently will result in a decrease of the buckling length. For system six, two buckling modes are presented. The first mode shows the horizontal sway of the entire structure, which is not of interest. Therefore, mode two should be considered which shows the buckling of a single element.

## G.4 dx/dz-ratio and columns

The following results are obtained by changing the dx/dz-ratio and the amount of columns and using: 5 floors, HE140A (also floors), System 1; Moment resistant framework.

4 columns

			loadfactor		l <sub>c</sub>	
height (m)	width (m)	dx/dz	inner column	inner column	inner column	inner column
7	7	1	807,1		4,99	
7	14	2	558,1		6,01	
7	21	3	427,9		6,86	
7	28	4	348,5		7,60	

5 columns

			loadfactor		l <sub>c</sub>	
height (m)	width (m)	dx/dz	inner column	inner column	inner column	inner column
7	7	1	1044		4,39	
7	14	2	728,8		5,26	
7	21	3	561,1		5,99	
7	28	4	457,8		6,63	

6 columns

			loadfactor		l <sub>c</sub>	
height (m)	width (m)	dx/dz	inner column	inner column	inner column	inner column
7	7	1	1278		3,97	
7	14	2	898,4		4,73	
7	21	3	693,6		5,39	
7	28	4	566,8		5,96	

7 columns

			loadfactor		l <sub>c</sub>	
height (m)	width (m)	dx/dz	inner column	inner column	inner column	inner column
7	7	1	1506		3,66	
7	14	2	1042		4,40	
7	21	3	824,4		4,94	
7	28	4	675,1		5,46	

8 columns

			loadfactor		l <sub>c</sub>	
height (m)	width (m)	dx/dz	inner column	inner column	inner column	inner column
7	7	1	1522		3,64	
7	14	2	1046		4,39	
7	21	3	881,4		4,78	
7	28	4	778,3		5,09	

9 columns

			loadfactor		l <sub>c</sub>	
height (m)	width (m)	dx/dz	inner column	inner column	inner column	inner column
7	7	1	1522		3,64	
7	14	2	1047		4,39	
7	21	3	883,2		4,77	
7	28	4	797,7		5,02	

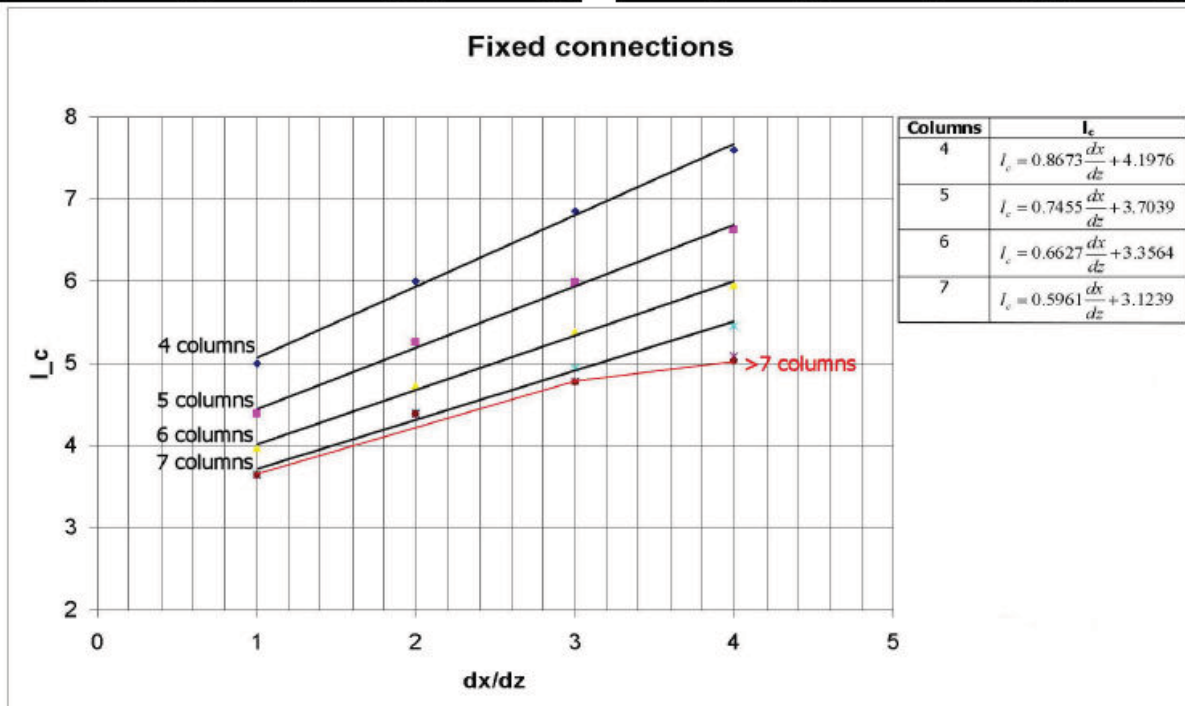

Figure.G.10 Buckling length, changing the dx/dz-ratio and amount of columns: 5 floors, HE140A (also floors), height = 7m

## G. Buckling analysis

As can be seen, a linear relation is derived. The more columns are applied, the lower the buckling length becomes. This can be explained by the amount of bracing. If just a few columns are applied, it will have less resistance to horizontal deformations and thus will almost be unbraced. If, on the other hand, more columns are applied the structure will become more braced. From basic buckling analysis (Hartsuijker, 2000), it follows that the buckling length of elements is shorter for braced structures compared with unbraced structures. If more than seven columns are applied, the buckling length is approximately the same as for seven columns. When the  $dx/dz$ -ratio is four it will start to deviate.

Although the determination of the buckling lengths seems to be accurate, it is not. A lot of inaccuracies are still neglected. As discussed earlier, a lot of configurations will influence the buckling length of an element which have not been investigated here. Hence, the different buckling length lines are merged into one approximated line from which the buckling lengths can be derived:

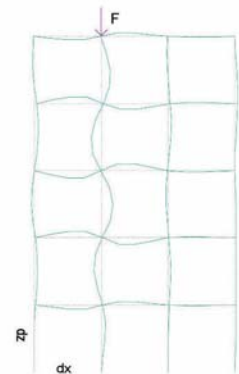
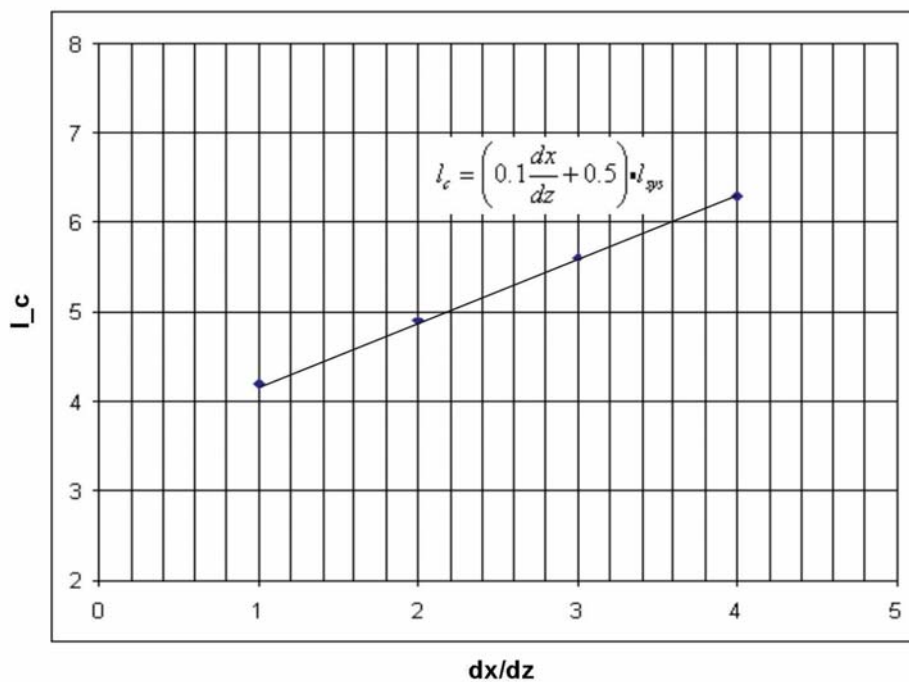

Figure.G.11 Relation of the buckling length and  $dx/dz$ -ratio used with the tool

## G.5 E2/E1-ratio

The following results are obtained by changing the stiffness ratio between the floors and columns and using: 5 floors, 4 columns, HE140A (also floors), height =7m, width=7m, System 1; Moment resistant framework.

E1 (columns)	E2 (floors)	E2/E1	loadfactor	
			inner column	l_c
		0	4,0	14,14
2,05E+11	2,05E+11	1	807,1	4,99
2,05E+11	4,10E+11	2	1052,0	4,38
2,05E+11	6,15E+11	3	1176,0	4,14
2,05E+11	8,20E+11	4	1254,0	4,01
2,05E+11	1,03E+12	5	1309,0	3,92
2,05E+11	2,05E+12	10	1441,0	3,74
2,05E+11	3,08E+12	15	1496,0	3,67
2,05E+11	2,05E+13	100	1643,0	3,50

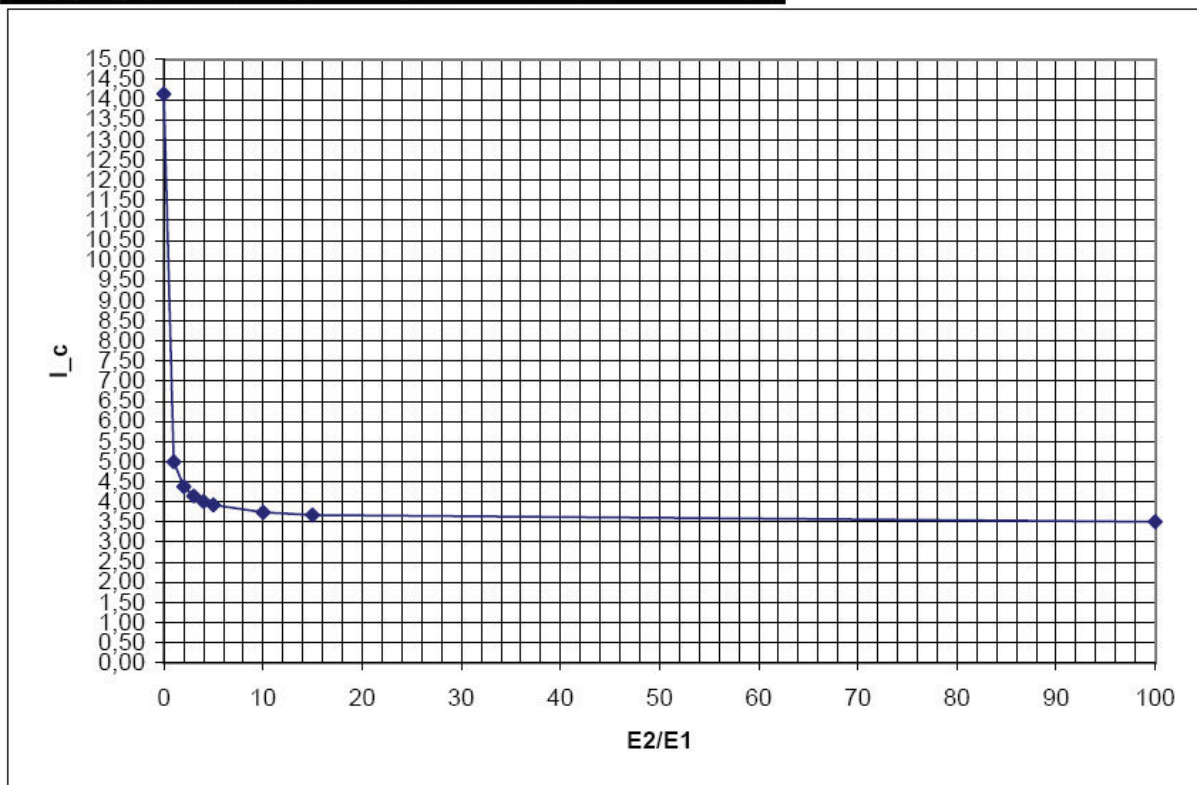

Figure.G.12 Buckling length, changing the stiffness-ratio between columns and floors, system 1: 4 columns, 5 floors, HE140A (also floors), height =7m

The ratio between the Youngs modulus of the floors (E2) and the Youngs modulus of the columns (E1), have an influence on the buckling length, corresponding to the  $dx/dz$ -ratio. If the stiffness of the floors becomes infinitely small ( $E2/E1$  approaches zero), the buckling length will be two times the system length of the column. This may also be expected. The floors connected to the columns can be neglected since their stiffness is very small. So the column is fixed at one side and unsupported at the other side. The resulting buckling length of such systems is two times the system length. If the Youngs modulus for the floors approaches infinity ( $E2/E1$  approaches infinity), the buckling length will become 0.5 times the system length. This may also be expected. The connections of the floors to the columns will behave very stiff. Hence, they will not rotate and act as fixed connections. Both sides of the column are thus fixed. A buckling length of 0.5 times the system length corresponds to this type of systems.

# H.Catenary action

An important modeling method in designing against progressive collapse, is catenary action. It describes the development of tensile forces in the floor slab, due to deformations as a consequence of the loss of one support for a two span floor slab. Significant rotation capacity of the connections, as well as large elongation capacity are required, hence only systems with pinned connections are considered.

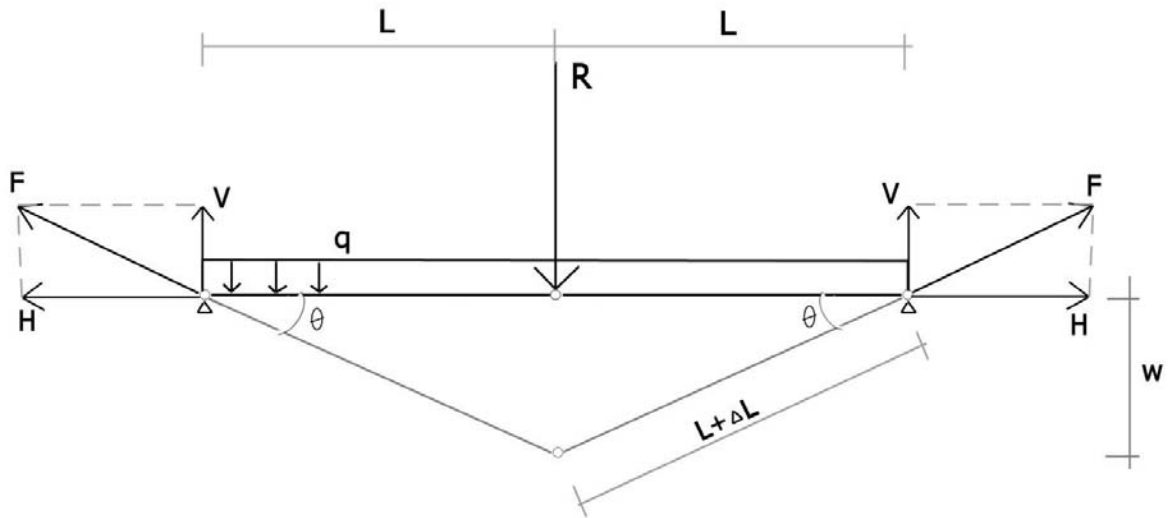

Figure.H.1 2D catenary action

The forces and displacements can be calculated with the following iterative steps:

1. Start with  $\theta = 0$
2. Apply small rotation with small increment:
 
$$\theta_1 = \theta_i + \Delta\theta \quad (\text{for 2D}) \quad (\text{formula.H.1.2a})$$

$$\theta_2 = \tan^{-1}\left(\frac{L}{s} \tan \theta_1\right) \quad (\text{for 3D}) \quad (\text{formula.H.1.2b})$$
3. Calculate elongation of elements  $\Delta L$ :
 
$$\Delta L = \frac{L}{\cos \theta_1} - L \quad (\text{formula.H.1.3})$$
4. Calculate force  $F$  in the element due to the elongation:
 
$$F = EA \frac{\Delta L}{L} \quad (\text{formula.H.1.4})$$
5. Calculate the displacement  $w$ :
 
$$w = L \tan \theta_1 \quad (\text{formula.H.1.5})$$
6. Calculate the horizontal component  $H$ :
 
$$H = F \cos \theta_1 \quad (\text{formula.H.1.6})$$
7. Calculate the vertical component  $V$ :
 
$$V_1 = F \sin \theta_1 \quad (\text{for 2D}) \quad (\text{formula.H.1.7a})$$

$$V_2 = F \sin \theta_2 \quad (\text{for 3D}) \quad (\text{formula.H.1.7b})$$
8. Check if the system is in equilibrium:
 
$$2V_1 \geq R \quad (\text{for 2D}) \quad (\text{formula.H.1.8a})$$

$$2V_1 + 2V_2 = R \quad (\text{for 3D}) \quad (\text{formula.H.1.8b})$$

If the last formula is not valid, steps 2 till 8 must be repeated. If the last formula is valid, the final state is reached and the occurring displacements and forces have been obtained.

## H.1 2D

For the 2-dimensional case and  $\Delta\theta=0.0001$ , the displacement  $w$  is calculated for different loads  $R$  and different steel profiles. As can be seen, the results obtained from a non-linear analysis with GSA correspond to the calculated results.

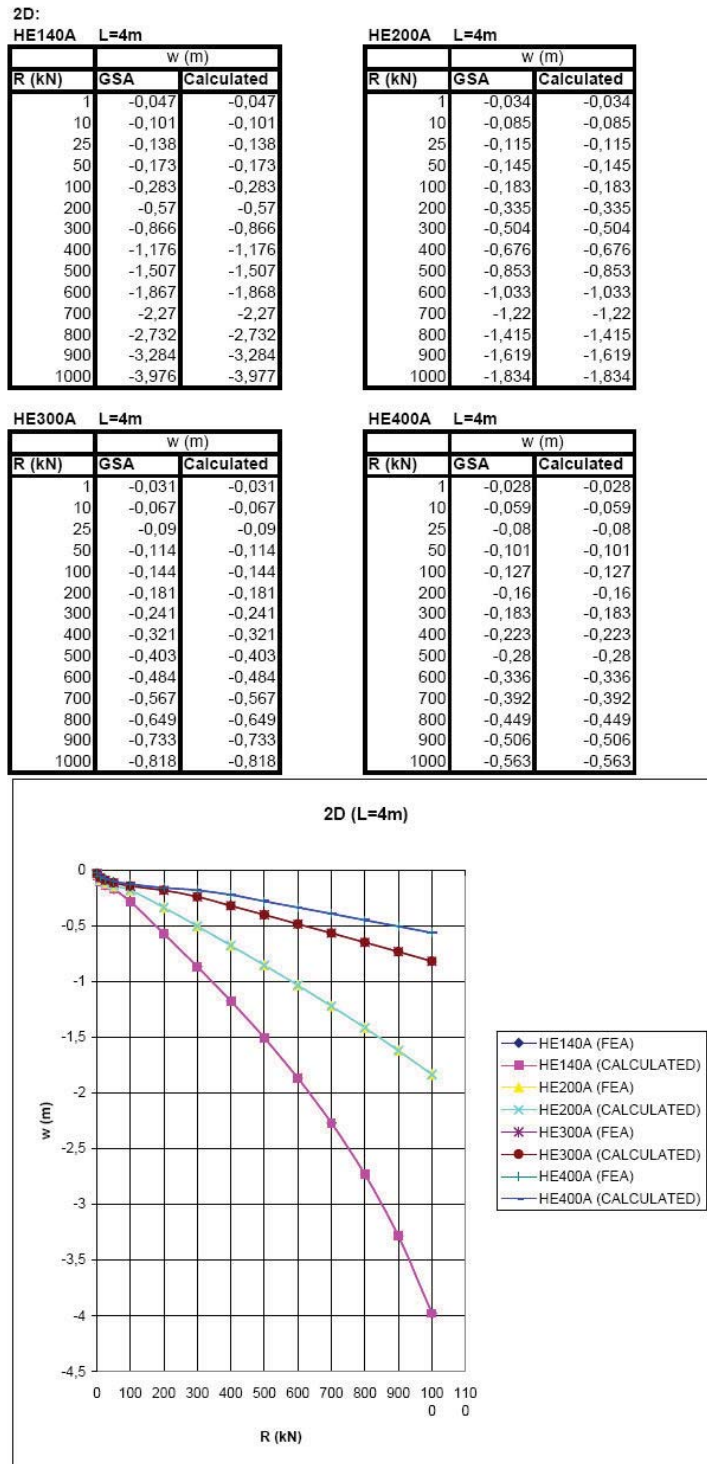

Figure.H.2 Comparison of displacements in a 2D catenary action calculation calculated with the tool and with the FEA

# H.Catenary action

## H.2 3D

For the 3-dimensional case and  $\Delta\theta=0.0001$ , the displacement  $w$  is calculated for different  $dy/dx$ -ratios, a load  $R$  of 1000kN and different steel profiles. The  $dy/dx$ -ratio is the distance between the bays versus the distance between the columns. As can be seen, the results obtained from a non-linear analysis with GSA correspond to the calculated results.

3D:

HE200A dx=4 dy=4

R (kN)	w (m)	
	GSA	Calculated
100	0,145	0,145
200	0,183	0,183
300	0,251	0,251
400	0,335	0,335
500	0,419	0,419
600	0,504	0,504
700	0,59	0,59
800	0,676	0,676
900	0,764	0,764
1000	0,852	0,853

HE140A dx=4 R=1000kN

dy	dy/dx	w (m)	
		GSA	Calculated
1	0,25	-0,65	-0,645
2	0,5	-1,026	-1,026
3	0,75	-1,296	-1,297
4	1	-1,507	-1,507
5	1,25	-1,678	-1,678
6	1,5	-1,822	-1,822
7	1,75	-1,945	-1,945
8	2	-2,052	-2,053
9	2,25	-2,147	-2,147
10	2,5	-2,232	-2,232
12	3	-2,376	-2,377
16	4	-2,598	-2,598

HE200A dx=4 R=1000kN

dy	dy/dx	w (m)	
		GSA	Calculated
1	0,25	-0,349	-0,35
2	0,5	-0,572	-0,573
3	0,75	-0,731	-0,732
4	1	-0,852	-0,853
5	1,25	-0,948	-0,948
6	1,5	-1,025	-1,026
7	1,75	-1,09	-1,09
8	2	-1,145	-1,145
9	2,25	-1,192	-1,192
10	2,5	-1,232	-1,233
12	3	-1,3	-1,3
16	4	-1,397	-1,397

HE300A dx=4 R=1000kN

dy	dy/dx	w (m)	
		GSA	Calculated
1	0,25	-0,077	-0,077
2	0,5	-0,149	-0,149
3	0,75	-0,345	-0,345
4	1	-0,403	-0,403
5	1,25	-0,447	-0,447
6	1,5	-0,484	-0,484
7	1,75	-0,513	-0,513
8	2	-0,538	-0,538
9	2,25	-0,559	-0,559
10	2,5	-0,577	-0,577
12	3	-0,606	-0,606
16	4	-0,648	-0,648

HE400A dx=4 R=1000kN

dy	dy/dx	w (m)	
		GSA	Calculated
1	0,25	-0,068	-0,068
2	0,5	-0,132	-0,132
3	0,75	-0,183	-0,183
4	1	-0,28	-0,28
5	1,25	-0,311	-0,311
6	1,5	-0,336	-0,336
7	1,75	-0,356	-0,356
8	2	-0,373	-0,373
9	2,25	-0,387	-0,387
10	2,5	-0,4	-0,4
12	3	-0,42	-0,42
16	4	-0,448	-0,448

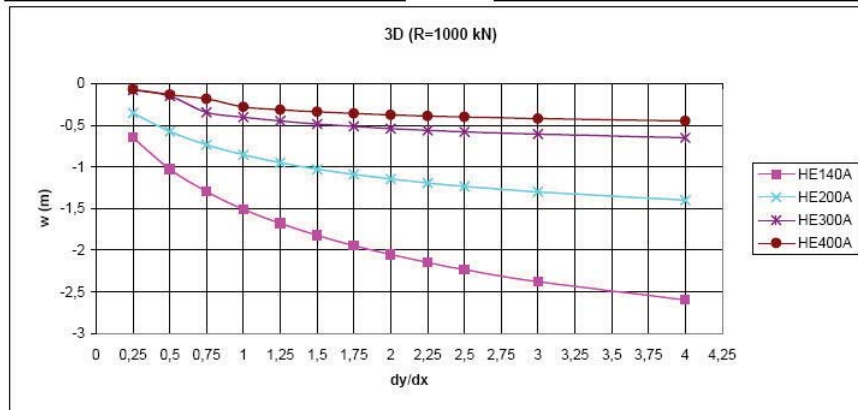

Figure.H.3 Comparison of displacements in a 3D catenary action calculation calculated with the tool and with the FEA

## H.3 Rotation increment

For the 3-dimensional case and changing rotation increments, the displacement  $w$  is calculated for different loads  $R$ . On decrease of the rotation increment, the calculated results approximate the results of the non-linear analysis with GSA with higher accuracy.

3D: Rotation increments  
HE200A dx=4 dy=4

R (kN)	w (m)							
	GSA	Calculated						
		theta=0,0001	theta=0,001	theta=0,01	theta=0,02	theta=0,025	theta=0,05	theta=0,1
100	-0,145	-0,145	-0,148	-0,16	-0,16	-0,2	-0,2	-0,401
200	-0,183	-0,183	-0,184	-0,2	-0,24	-0,2	-0,2	-0,401
300	-0,251	-0,251	-0,252	-0,28	-0,24	-0,3	-0,401	-0,401
400	-0,335	-0,335	-0,337	-0,361	-0,24	-0,401	-0,401	-0,401
500	-0,419	-0,419	-0,422	-0,442	-0,482	-0,401	-0,401	-0,401
600	-0,504	-0,504	-0,507	-0,523	-0,564	-0,401	-0,401	-0,401
700	-0,59	-0,59	-0,592	-0,605	-0,646	-0,401	-0,401	-0,401
800	-0,676	-0,676	-0,678	-0,687	-0,728	-0,401	-0,401	-0,401
900	-0,764	-0,764	-0,765	-0,769	-0,811	-0,401	-0,401	-0,401
1000	-0,852	-0,853	-0,853	-0,853	-0,894	-0,401	-0,401	-0,401

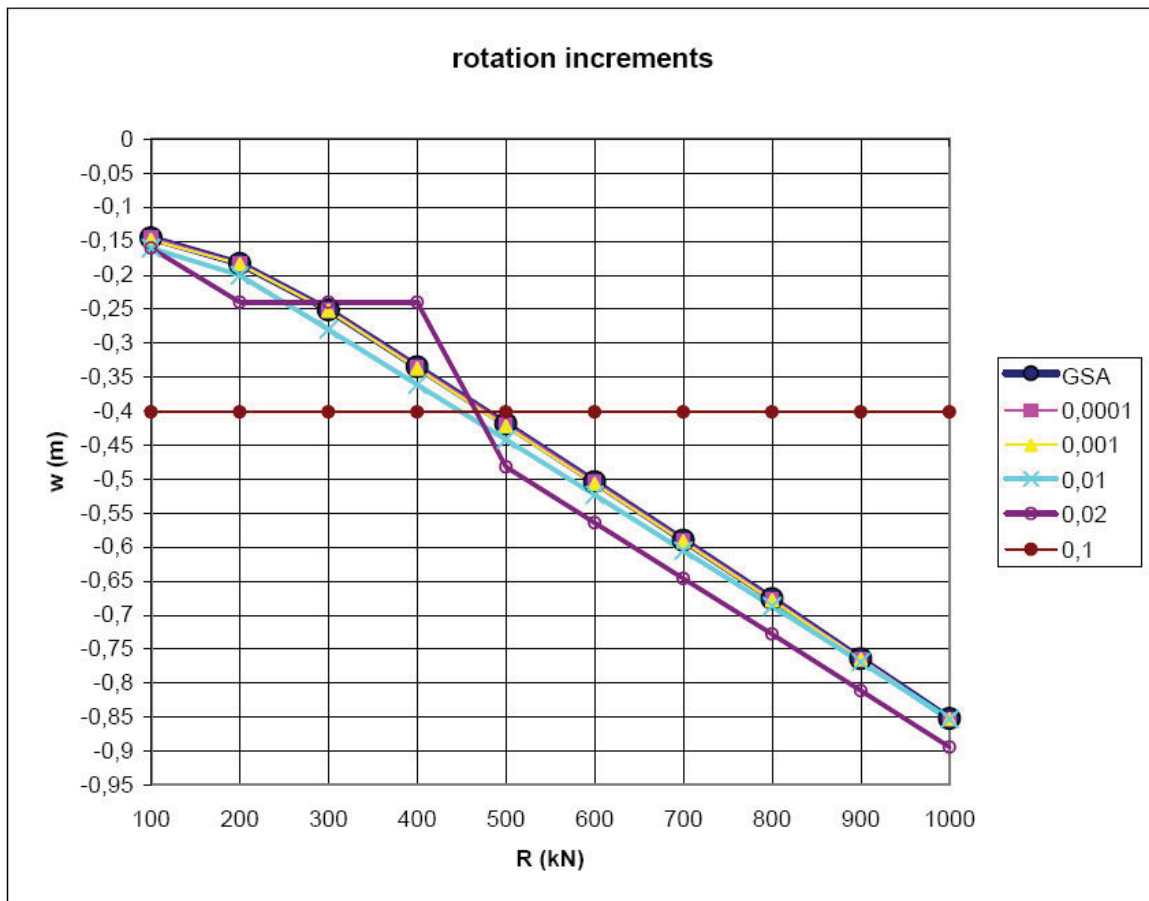

Figure.H.4 Influence of the rotation increment on the calculated results for a 3D catenary action calculation

# I.GUI PCI-tool

**Progressive Collapse Tool**

**Geometry**

Number of Columns: 6    C.t.c. between Columns: 7.2 m    Number of Bays: 4  
Number of Floors: 6    Height between Floors: 3 m    C.t.c. between Bays: 3.6 m  
Select Bay..

**Material**

**Columns**

Steel     Concrete  
Profile: HE 300A    Width (x-dir.): 300 mm  
Depth (y-dir.): 300 mm  
reinforcement perc.: 3 %

**Floors (Girders)**

Steel     Concrete  
Profile: HE 400A    Width (y-dir.): 300 mm  
Depth (z-dir.): 700 mm  
reinforcement perc.: 1.5 %

**Diagonal members**

**Cross-bracing:**  
Thickness: 50 mm    Height: 150 mm

**Outrigger:**  
Thickness: 100 mm    Height: 150 mm

**Core**  
width: 7200 mm    depth: 3600 mm  
wall thickness: 500 mm    reinforcement perc.: 3 %

**Structural System**

Moment Resistant  
 Moment Resistant with stability bracing  
 Moment Resistant with stability bracing and outrigger  
 Pinned with stability bracing  
 Pinned with stability bracing and outrigger  
 Pinned with stabilizing core  
 Pinned with stabilizing core and floors fixed to core  
 Pinned with stabilizing core and outrigger

**Mitigating measures**

Traffic barrier     No gas in building  
 Non-governmental building     Fire resistance > 90 min

**Calculations**

Include:  Catenary action     Check for global stability  
Simulations: 10    Iterations per simulation: 10  
Directory: C:\  
Filename: PCI  
**Calculate**

**Progress**

Figure.I.1 Graphical user interface (GUI) of the PCI-tool



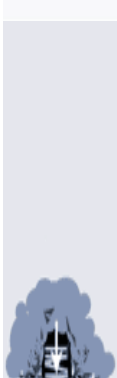
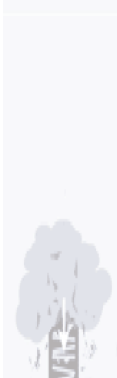

# J.Sensitivity analysis

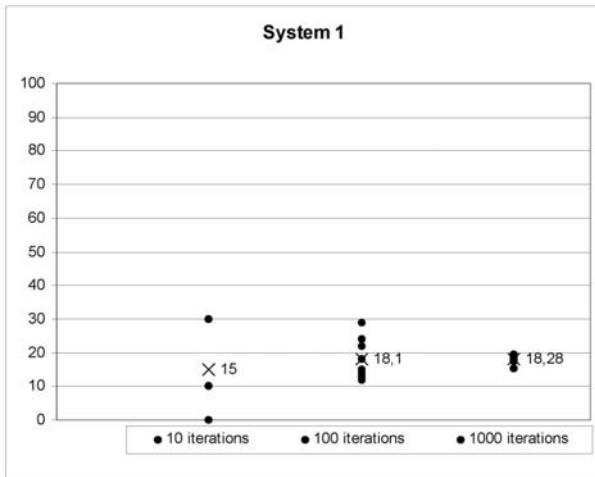

system	1		
iterations	10	100	1000
elapsed time (min.)	6	72	626
simulation	PCI (%)	PCI (%)	PCI (%)
1	10	22	18,8
2	10	18	17,3
3	0	12	19,4
4	30	13	18,9
5	10	24	19,2
6	10	22	19,3
7	10	15	17,7
8	30	14	15,3
9	30	29	18,1
10	10	12	18,8
average PCI (%)	15	18,1	18,28
Var(PCI)	105	31,09	1,43
SD	10,25	5,58	1,19

Figure.J.1 PCI's of moment resistant framework with different amount of iterations

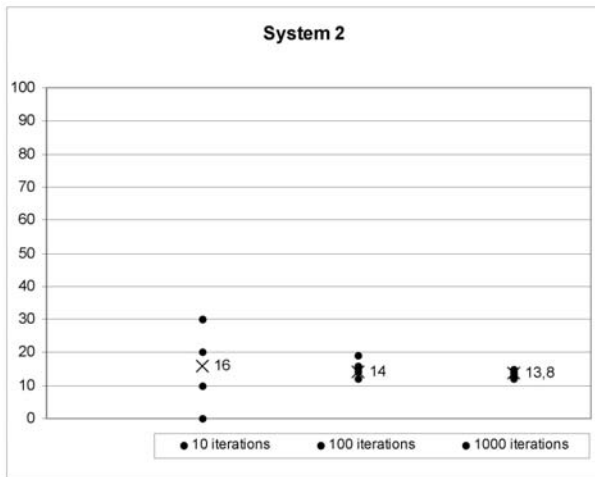

system	2		
iterations	10	100	1000
elapsed time (min.)	10	111	961
simulation	PCI (%)	PCI (%)	PCI (%)
1	20	12	13,6
2	0	14	13
3	20	16	14,9
4	30	14	11,9
5	30	15	12,4
6	20	15	15
7	0	19	12,7
8	20	12	12,8
9	10	16	14,1
10	10	14	13,8
average PCI (%)	16	14	13,8
Var(PCI)	104	3,81	0,98
SD	10,2	1,95	0,99

Figure.J.2 PCI's of moment resistant framework with stability bracing with different amount of iterations

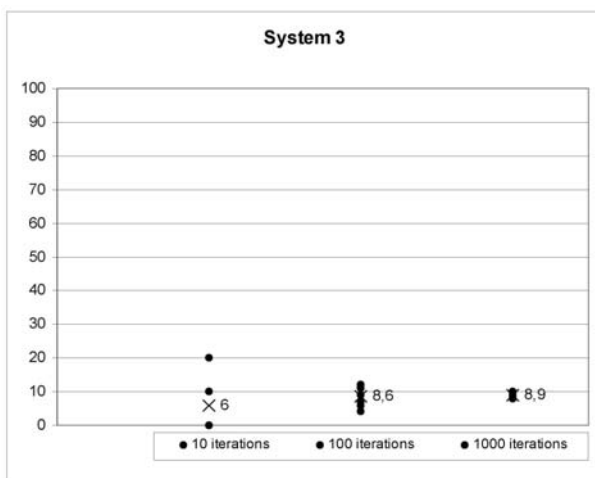

system	3		
iterations	10	100	1000
elapsed time (min.)	14	108	1346
simulation	PCI (%)	PCI (%)	PCI (%)
1	10	9	8
2	20	12	9,9
3	0	7	9,8
4	10	4	9,1
5	10	9	9,8
6	0	12	7,9
7	0	7	9,3
8	0	11	9,5
9	0	6	8,8
10	10	9	8,9
average PCI (%)	6	8,6	8,9
Var(PCI)	44	6,24	0,46
SD	6,63	2,5	0,68

Figure.J.3 PCI's of moment resistant framework with stability bracing and outrigger with different amount of iterations

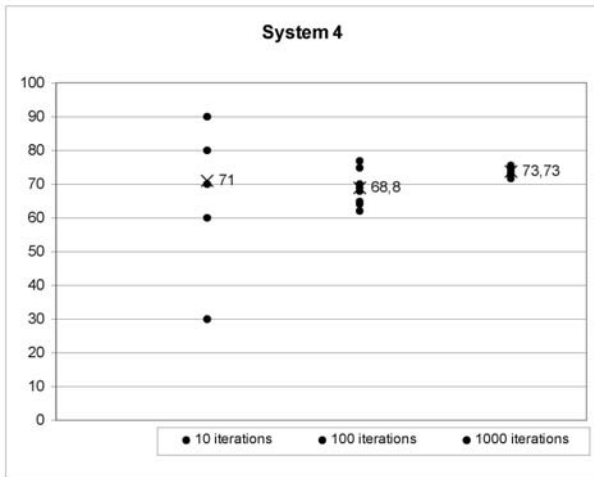

system	4		
iterations	10	100	1000
elapsed time (min.)	8	69	668
simulation	PCI (%)	PCI (%)	PCI (%)
1	70	65	75,1
2	90	68	75,4
3	60	75	74
4	80	68	73,5
5	80	64	73,3
6	90	70	73,1
7	70	70	73
8	30	77	71,8
9	70	62	72,8
10	70	69	75,3
average PCI (%)	71	68,8	73,73
Var(PCI)	269	19,36	1,3
SD	16,4	4,4	1,14

Figure.J.4 PCI's of Pinned framework with stability bracing with different amount of iterations

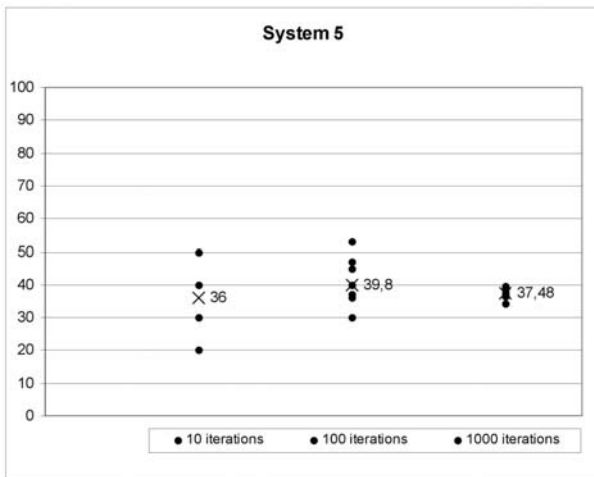

system	5		
iterations	10	100	1000
elapsed time (min.)	11	104	1004
simulation	PCI (%)	PCI (%)	PCI (%)
1	30	47	38,4
2	50	30	36,7
3	20	37	39,1
4	50	36	39,5
5	30	40	37,5
6	50	30	36,8
7	20	45	36,4
8	30	53	39,5
9	40	40	34,1
10	40	40	36,8
average PCI (%)	36	39,8	37,48
Var(PCI)	124	46,76	2,58
SD	11,14	6,84	1,6

Figure.J.5 PCI's of Pinned framework with stability bracing and outrigger with different amount of iterations

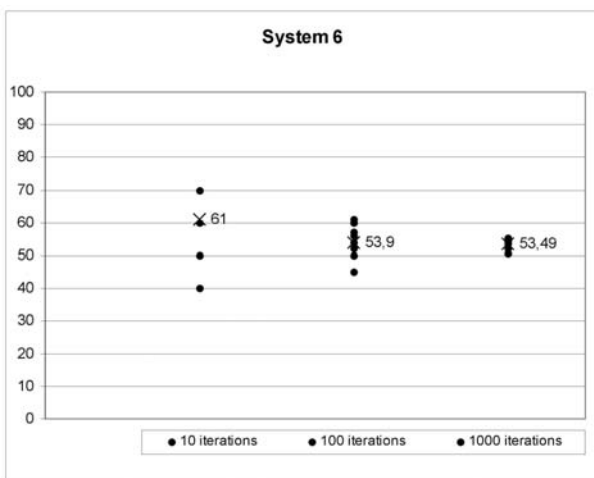

system	6		
iterations	10	100	1000
elapsed time (min.)	8	87	809
simulation	PCI (%)	PCI (%)	PCI (%)
1	50	52	54,2
2	70	57	53,5
3	60	56	53,4
4	70	61	55,1
5	70	54	52,3
6	70	60	55,4
7	40	50	54,6
8	60	52	52,2
9	70	52	50,7
10	50	45	53,5
average PCI (%)	61	53,9	53,49
Var(PCI)	109	20,69	1,88
SD	10,44	4,55	1,37

Figure.J.6 PCI's of Pinned framework with stabilizing core with different amount of iterations

# J.Sensitivity analysis

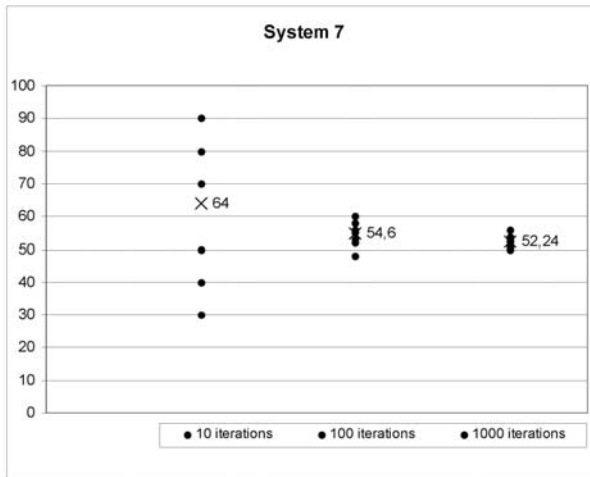

system	7		
iterations	10	100	1000
elapsed time (min.)	10	97	821
simulation	PCI (%)	PCI (%)	PCI (%)
1	40	55	55,7
2	80	48	51,4
3	90	60	52,2
4	50	53	52,2
5	70	58	50,4
6	70	55	49,9
7	70	52	51,3
8	30	53	53,6
9	50	56	52,5
10	90	56	53,2
<b>average PCI (%)</b>	64	54,6	52,24
<b>Var(PCI)</b>	384	10,04	2,53
<b>SD</b>	19,6	3,17	1,59

Figure.J.7 PCI's of Pinned framework with stabilizing core and floors fixed to core with different amount of iterations

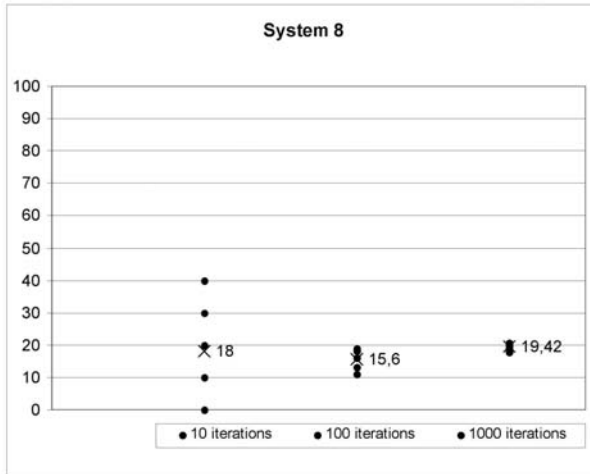

system	8		
iterations	10	100	1000
elapsed time (min.)	12	131	1350
simulation	PCI (%)	PCI (%)	PCI (%)
1	0	18	20,3
2	30	18	19,7
3	20	13	20,2
4	0	19	18,5
5	20	13	20,6
6	20	11	18,3
7	20	13	20,1
8	10	19	19
9	40	16	17,8
10	20	16	19,7
<b>average PCI (%)</b>	18	15,6	19,42
<b>Var(PCI)</b>	136	7,64	0,83
<b>SD</b>	11,66	2,76	0,91

Figure.J.8 PCI's of Pinned framework with stabilizing core and outrigger with different amount of iterations

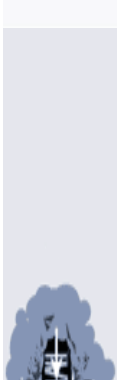
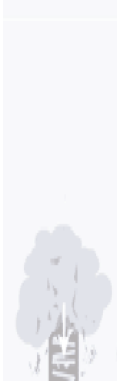

# K.Failure order

## K.1 Pinned framework with stability bracing

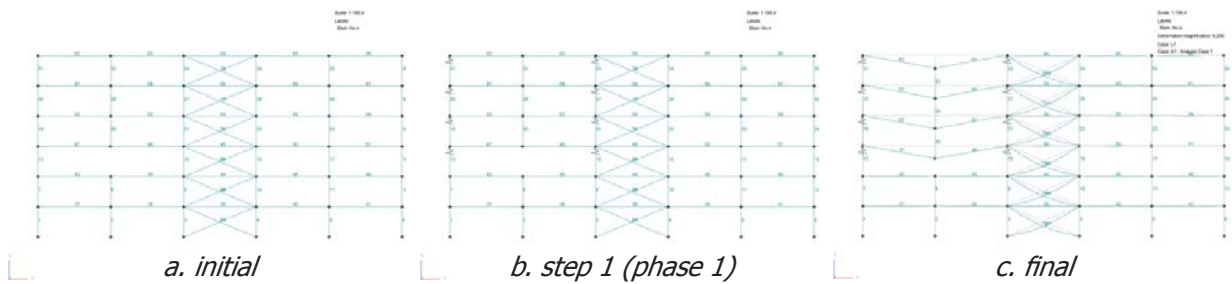

Figure.K.1 Failure order of elements with pinned framework with stability bracing and the occurring of catenary action

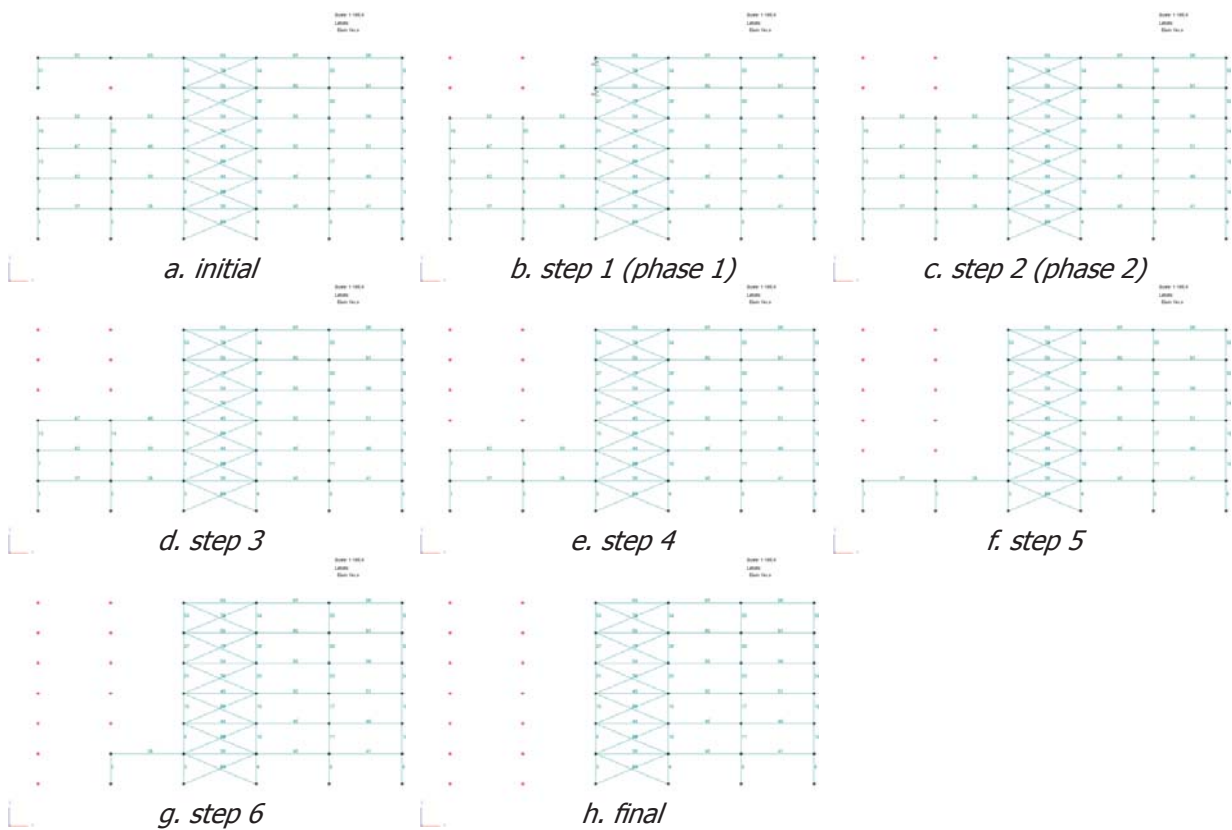

Figure.K.2 Failure order of elements with pinned framework with stability bracing

## K.2 Pinned framework with stability bracing and outrigger

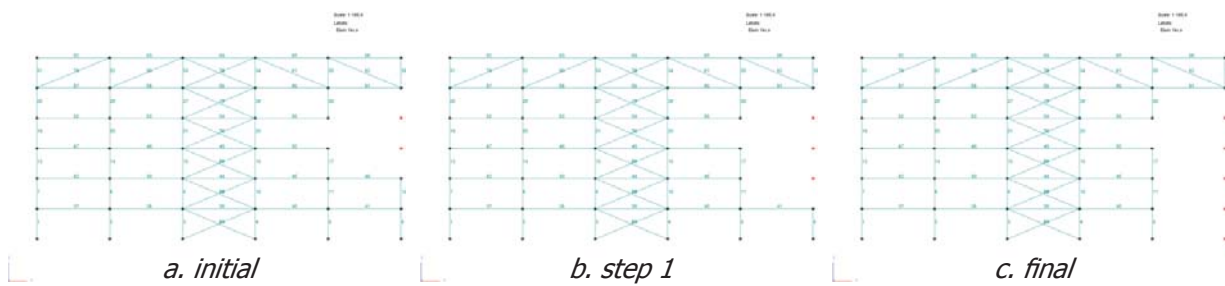

Figure.K.3 Failure order of elements with pinned framework with stability bracing and outrigger

## K.3 Pinned framework with stabilizing core

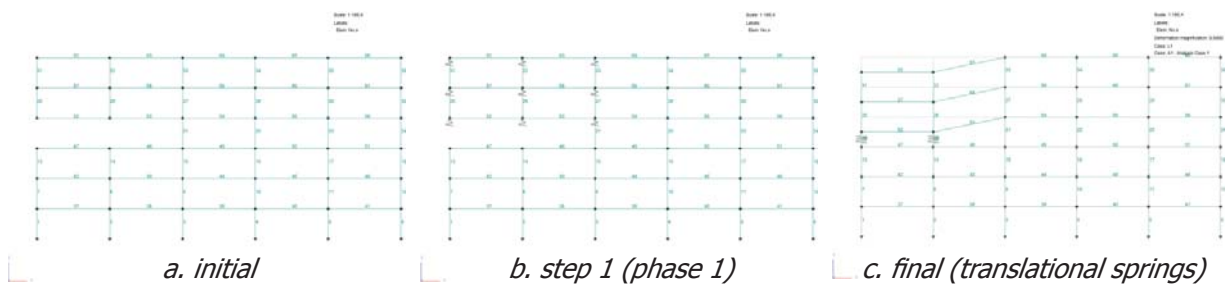

Figure.K.4 Failure order of elements with pinned framework with stabilizing core  
(core is the third column from right)

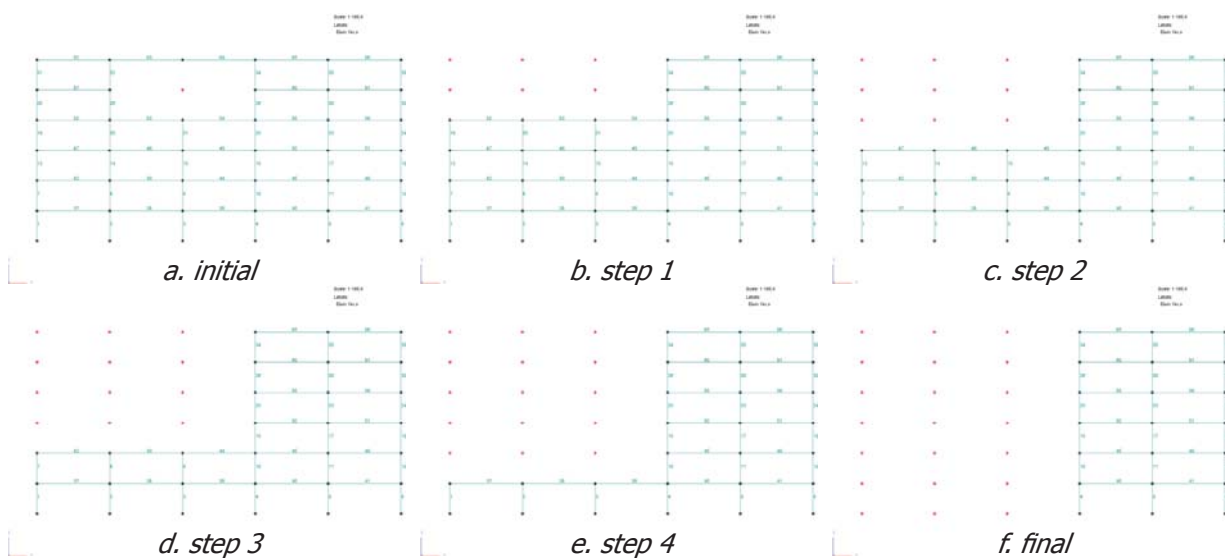

Figure.K.5 Failure order of elements with pinned framework with stabilizing core  
(core is the third column from right)



# K.Failure order

## K.4 Manual unity checks

On the following pages the manually calculated unity checks are presented. The following formulas are used;

for unity check 1:

$$Unity\ check = \frac{N_d}{N_u} + \frac{M_d}{M_u} \leq 1$$

for unity check 2:

$$Unity\ check = \frac{N_d}{N_u} - \frac{M_d}{M_u} \leq 1$$

for the stability:

$$Unity\ check = 1.1 \frac{N'_d}{\frac{\sigma_c}{f_y} N_u} + 1.1 \frac{M_d}{1.0 M_u} < 1 \quad \text{with,}$$

$$\sigma_c = \frac{\pi^2 EI}{l_c^2 A}$$

### K.4.1 Undamaged model

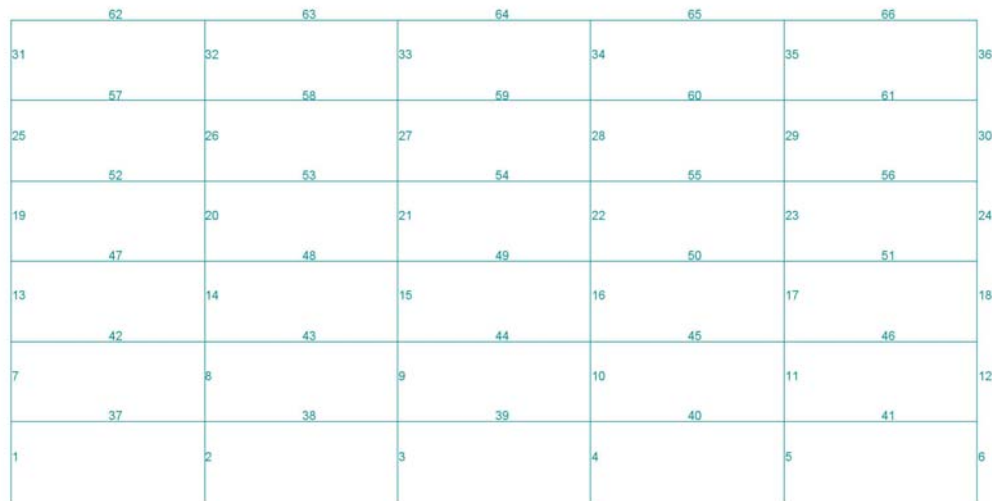

Figure.K.6 Undamaged model with moment resistant framework (column HE300A, floors HE400A)



# Appendices

<b>(HE300A)</b>		<b>(HE400A)</b>	
fy	235000000 N/m2	fy	235000000 N/m2
A	0,010627 m <sup>2</sup>	A	0,015272 m <sup>2</sup>
W	0,00126 m <sup>3</sup>	W	0,002311 m <sup>3</sup>
E	2,05E+11 N/m2	E	2,05E+11 N/m2
pi	3,14	pi	3,14
ic	2,7 m	ic	2,7 m
I	0,00017295 m <sup>4</sup>	I	0,0004326 m <sup>4</sup>
sigma c	4509665526 N/m2	sigma c	7853734735 N/m2
Mu	296100 Nm	Mu	543085 Nm
Nu	2497345 N	Nu	3588920 N

m	Nd	Md	Nd/Nu	Md/Mu	unity1	unity2	stability		
							1	2	tot
1	-453900	-10960	0,18	0,04	0,22	0,14	0,01	0,04	0,05
	-453300	-1765	0,18	0,01	0,19	0,18	0,01	0,01	0,02
	-452700	7427	0,18	0,03	0,21	0,16	0,01	0,03	0,04
	-452100	16620	0,18	0,06	0,24	0,12	0,01	0,06	0,07
	-451500	25810	0,18	0,09	0,27	0,09	0,01	0,10	0,11
2	-934100	174,5	0,37	0,00	0,37	0,37	0,02	0,00	0,02
	-933500	-185,4	0,37	0,00	0,37	0,37	0,02	0,00	0,02
	-932800	-545,3	0,37	0,00	0,38	0,37	0,02	0,00	0,02
	-932200	-905,2	0,37	0,00	0,38	0,37	0,02	0,00	0,02
	-931600	-1265	0,37	0,00	0,38	0,37	0,02	0,00	0,03
3	-921600	-270,1	0,37	0,00	0,37	0,37	0,02	0,00	0,02
	-920900	-102,2	0,37	0,00	0,37	0,37	0,02	0,00	0,02
	-920300	65,83	0,37	0,00	0,37	0,37	0,02	0,00	0,02
	-919700	233,8	0,37	0,00	0,37	0,37	0,02	0,00	0,02
	-919100	401,8	0,37	0,00	0,37	0,37	0,02	0,00	0,02
4	-921600	271,3	0,37	0,00	0,37	0,37	0,02	0,00	0,02
	-921000	103,9	0,37	0,00	0,37	0,37	0,02	0,00	0,02
	-920400	-63,53	0,37	0,00	0,37	0,37	0,02	0,00	0,02
	-919800	-231	0,37	0,00	0,37	0,37	0,02	0,00	0,02
	-919100	-398,4	0,37	0,00	0,37	0,37	0,02	0,00	0,02
5	-936500	-173,6	0,37	0,00	0,38	0,37	0,02	0,00	0,02
	-935900	187,1	0,37	0,00	0,38	0,37	0,02	0,00	0,02
	-935300	547,8	0,37	0,00	0,38	0,37	0,02	0,00	0,02
	-934600	908,5	0,37	0,00	0,38	0,37	0,02	0,00	0,02
	-934000	1269	0,37	0,00	0,38	0,37	0,02	0,00	0,03
6	-456400	10960	0,18	0,04	0,22	0,15	0,01	0,04	0,05
	-455800	1768	0,18	0,01	0,19	0,18	0,01	0,01	0,02
	-455200	-7426	0,18	0,03	0,21	0,16	0,01	0,03	0,04
	-454500	-16620	0,18	0,06	0,24	0,13	0,01	0,06	0,07
	-453900	-25810	0,18	0,09	0,27	0,09	0,01	0,10	0,11
7	-379800	-33330	0,15	0,11	0,26	0,04	0,01	0,12	0,13
	-379200	-16900	0,15	0,06	0,21	0,09	0,01	0,06	0,07
	-378600	-481,8	0,15	0,00	0,15	0,15	0,01	0,00	0,01
	-377900	15940	0,15	0,05	0,21	0,10	0,01	0,06	0,07
	-377300	32360	0,15	0,11	0,26	0,04	0,01	0,12	0,13
8	-776400	2350	0,31	0,01	0,32	0,30	0,02	0,01	0,03
	-775800	1424	0,31	0,00	0,32	0,31	0,02	0,01	0,02
	-775200	498,5	0,31	0,00	0,31	0,31	0,02	0,00	0,02
	-774600	427,3	0,31	0,00	0,31	0,31	0,02	0,00	0,02
	-774000	-1353	0,31	0,00	0,31	0,31	0,02	0,01	0,02
9	-768400	-58,86	0,31	0,00	0,31	0,31	0,02	0,00	0,02
	-767800	-64,68	0,31	0,00	0,31	0,31	0,02	0,00	0,02
	-767200	-70,51	0,31	0,00	0,31	0,31	0,02	0,00	0,02
	-766600	-76,33	0,31	0,00	0,31	0,31	0,02	0,00	0,02
	-766000	-82,15	0,31	0,00	0,31	0,31	0,02	0,00	0,02
10	-768500	57,06	0,31	0,00	0,31	0,31	0,02	0,00	0,02
	-767800	63,85	0,31	0,00	0,31	0,31	0,02	0,00	0,02
	-767200	70,64	0,31	0,00	0,31	0,31	0,02	0,00	0,02
	-766600	77,43	0,31	0,00	0,31	0,31	0,02	0,00	0,02
	-766000	84,22	0,31	0,00	0,31	0,31	0,02	0,00	0,02
11	-776400	-2353	0,31	0,01	0,32	0,30	0,02	0,01	0,03
	-775800	-1426	0,31	0,00	0,32	0,31	0,02	0,01	0,02
	-775200	-498,5	0,31	0,00	0,31	0,31	0,02	0,00	0,02
	-774500	428,7	0,31	0,00	0,31	0,31	0,02	0,00	0,02
	-773900	1356	0,31	0,00	0,31	0,31	0,02	0,01	0,02
12	-379800	33330	0,15	0,11	0,26	0,04	0,01	0,12	0,13
	-379200	16910	0,15	0,06	0,21	0,09	0,01	0,06	0,07
	-378600	482,3	0,15	0,00	0,15	0,15	0,01	0,00	0,01
	-378000	-15940	0,15	0,05	0,21	0,10	0,01	0,06	0,07
	-377300	-32370	0,15	0,11	0,26	0,04	0,01	0,12	0,13
13	-304200	-33000	0,12	0,11	0,23	0,01	0,01	0,12	0,13
	-303600	-16340	0,12	0,06	0,18	0,07	0,01	0,06	0,07
	-303000	319,8	0,12	0,00	0,12	0,12	0,01	0,00	0,01
	-302400	16980	0,12	0,06	0,18	0,06	0,01	0,06	0,07
	-301700	33640	0,12	0,11	0,23	0,01	0,01	0,12	0,13
14	-620600	36,57	0,25	0,00	0,25	0,25	0,01	0,00	0,01
	-620000	96,54	0,25	0,00	0,25	0,25	0,01	0,00	0,01
	-619300	156,5	0,25	0,00	0,25	0,25	0,01	0,00	0,01
	-618700	216,5	0,25	0,00	0,25	0,25	0,01	0,00	0,02
	-618100	276,5	0,25	0,00	0,25	0,25	0,01	0,00	0,02
15	-614900	76,08	0,25	0,00	0,25	0,25	0,01	0,00	0,01
	-614300	22,61	0,25	0,00	0,25	0,25	0,01	0,00	0,01
	-613700	-30,86	0,25	0,00	0,25	0,25	0,01	0,00	0,01
	-613100	-84,33	0,25	0,00	0,25	0,25	0,01	0,00	0,01
	-612500	-137,8	0,25	0,00	0,25	0,24	0,01	0,00	0,01
16	-614900	-77,86	0,25	0,00	0,25	0,25	0,01	0,00	0,01
	-614300	-23,48	0,25	0,00	0,25	0,25	0,01	0,00	0,01
	-613700	30,89	0,25	0,00	0,25	0,25	0,01	0,00	0,01
	-613100	85,28	0,25	0,00	0,25	0,25	0,01	0,00	0,01
	-612500	139,6	0,25	0,00	0,25	0,24	0,01	0,00	0,01
17	-620600	-38,78	0,25	0,00	0,25	0,25	0,01	0,00	0,01
	-619900	-97,64	0,25	0,00	0,25	0,25	0,01	0,00	0,01
	-619300	-156,5	0,25	0,00	0,25	0,25	0,01	0,00	0,01
	-618700	-215,4	0,25	0,00	0,25	0,25	0,01	0,00	0,02
	-618100	-274,2	0,25	0,00	0,25	0,25	0,01	0,00	0,02
18	-304200	33000	0,12	0,11	0,23	0,01	0,01	0,12	0,13
	-303600	16340	0,12	0,06	0,18	0,07	0,01	0,06	0,07
	-303000	-319,7	0,12	0,00	0,12	0,12	0,01	0,00	0,01
	-302400	-16980	0,12	0,06	0,18	0,06	0,01	0,06	0,07
	-301800	-33640	0,12	0,11	0,23	0,01	0,01	0,12	0,13
19	-227900	-34350	0,09	0,12	0,21	0,02	0,01	0,13	0,13
	-227200	-17060	0,09	0,06	0,15	0,03	0,01	0,06	0,07
	-226600	234,7	0,09	0,00	0,09	0,09	0,01	0,00	0,01
	-226000	17520	0,09	0,06	0,15	0,03	0,01	0,07	0,07
	-225400	34820	0,09	0,12	0,21	0,03	0,01	0,13	0,13
20	-465600	-657,8	0,19	0,00	0,19	0,18	0,01	0,00	0,01

m	Nd	Md	Nd/Nu	Md/Mu	unity1	unity2	stability		
							1	2	tot
	-465000	-270	0,19	0,00	0,19	0,19	0,01	0,00	0,01
	-464400	117,8	0,19	0,00	0,19	0,19	0,01	0,00	0,01
	-463800	505,6	0,19	0,00	0,19	0,19	0,01	0,00	0,01
	-463200	893,3	0,19	0,00	0,19	0,19	0,01	0,00	0,01
21	-461300	203,4	0,18	0,00	0,19	0,18	0,01	0,00	0,01
	-460700	90,87	0,18	0,00	0,18	0,18	0,01	0,00	0,01
	-460100	-21,62	0,18	0,00	0,18	0,18	0,01	0,00	0,01
	-459400	-134,1	0,18	0,00	0,18	0,18	0,01	0,00	0,01
	-458800	-246,6	0,18	0,00	0,18	0,18	0,01	0,00	0,01
22	-481300	-205,1	0,18	0,00	0,19	0,18	0,01	0,00	0,01
	-480700	-91,76	0,18	0,00	0,18	0,18	0,01	0,00	0,01
	-480100	21,62	0,18	0,00	0,18	0,18	0,01	0,00	0,01
	-459500	135	0,18	0,00	0,18	0,18	0,01	0,00	0,01
	-458800	248,4	0,18	0,00	0,18	0,18	0,01	0,00	0,01
23	-465600	655,6	0,19	0,00	0,19	0,18	0,01	0,00	0,01
	-465000	268,9	0,19	0,00	0,19	0,19	0,01	0,00	0,01
	-464400	-117,8	0,19	0,00	0,19	0,19	0,01	0,00	0,01
	-463800	-504,5	0,19	0,00	0,19	0,19	0,01	0,00	0,01
	-463200	-891,2	0,19	0,00	0,19	0,18	0,01	0,00	0,01
24	-227900	34350	0,09	0,12	0,21	0,02	0,01	0,13	0,13
	-227200	17060	0,09	0,06	0,15	0,03	0,01	0,06	0,07
	-226600	-234,7	0,09	0,00	0,09	0,09	0,01	0,00	0,01
	-226000	-17520	0,09	0,06	0,15	0,03	0,01	0,07	0,07
	-225400	-34820	0,09	0,12	0,21	0,03	0,01	0,13	0,13
25	-150900	-35160	0,06	0,12	0,18	0,06	0,00	0,13	0,13
	-150300	-17760	0,06	0,06	0,12	0,12	0,00		

# K.Failure order



m	Nd	Md	Nd/Nu	Md/Mu	unity1	unity2	stability			
							1	2	tot	
39	8885	55140	0.00	0.10	0.10	0.10				
	8885	80660	0.00	0.15	0.15	0.15				
	8654	81120	0.00	0.15	0.15	0.15				
	8654	55440	0.00	0.10	0.10	0.10				
	8654	31010	0.00	0.06	0.06	0.05				
	8654	8818	0.00	0.02	0.02	0.01				
	8654	-10130	0.00	0.02	0.02	0.02				
	8654	-10130	0.00	0.02	0.02	0.02				
	8654	-35610	0.00	0.07	0.07	0.06				
	8654	-44110	0.00	0.08	0.08	0.08				
	8654	-44110	0.00	0.08	0.08	0.08				
	8654	-35610	0.00	0.07	0.07	0.06				
	8654	-10120	0.00	0.02	0.02	0.02				
	8654	-10120	0.00	0.02	0.02	0.02				
	8654	8826	0.00	0.02	0.02	0.01				
	8654	31020	0.00	0.06	0.06	0.05				
	8654	55450	0.00	0.10	0.10	0.10				
	8654	81130	0.00	0.15	0.15	0.15				
	40	8886	80680	0.00	0.15	0.15	0.15			
		8886	55150	0.00	0.10	0.10	0.10			
8886		30870	0.00	0.06	0.06	0.05				
8886		8831	0.00	0.02	0.02	0.01				
8886		-9964	0.00	0.02	0.02	0.02				
8886		-9964	0.00	0.02	0.02	0.02				
8886		-35140	0.00	0.06	0.07	0.06				
8886		-43330	0.00	0.08	0.08	0.08				
8886		-43330	0.00	0.08	0.08	0.08				
8886		-34530	0.00	0.06	0.07	0.06				
8886		-8742	0.00	0.02	0.02	0.01				
8886		-8742	0.00	0.02	0.02	0.01				
8886		10360	0.00	0.02	0.02	0.02				
8886		32700	0.00	0.06	0.06	0.06				
8886		57290	0.00	0.11	0.11	0.10				
8886		83120	0.00	0.15	0.16	0.15				
41		9641	86740	0.00	0.16	0.16	0.16			
		9641	59340	0.00	0.11	0.11	0.11			
		9641	33180	0.00	0.06	0.06	0.06			
		9641	9264	0.00	0.02	0.02	0.01			
	9641	-11410	0.00	0.02	0.02	0.02				
	9641	-11410	0.00	0.02	0.02	0.02				
	9641	-40340	0.00	0.07	0.08	0.07				
	9641	-52290	0.00	0.10	0.10	0.09				
	9641	-52290	0.00	0.10	0.10	0.09				
	9641	-47240	0.00	0.09	0.09	0.08				
	9641	-25200	0.00	0.05	0.05	0.04				
	9641	-25200	0.00	0.05	0.05	0.04				
	9641	-7982	0.00	0.01	0.02	0.01				
	9641	12490	0.00	0.02	0.03	0.02				
	9641	35200	0.00	0.06	0.07	0.06				
	9641	59150	0.00	0.11	0.11	0.11				
	42	315.9	65360	0.00	0.12	0.12	0.12			
		315.9	40760	0.00	0.08	0.08	0.07			
		315.9	17400	0.00	0.03	0.03	0.03			
		315.9	-3713	0.00	0.01	0.01	0.01			
315.9		-21580	0.00	0.04	0.04	0.04				
315.9		-44920	0.00	0.08	0.08	0.08				
315.9		-51260	0.00	0.09	0.09	0.09				
315.9		-40620	0.00	0.07	0.07	0.07				
315.9		-12980	0.00	0.02	0.02	0.02				
315.9		-12980	0.00	0.02	0.02	0.02				
315.9		7043	0.00	0.01	0.01	0.01				
315.9		30310	0.00	0.06	0.06	0.06				
315.9		55820	0.00	0.10	0.10	0.10				
315.9		82570	0.00	0.15	0.15	0.15				
43		1630	81180	0.00	0.15	0.15	0.15			
		1630	55520	0.00	0.10	0.10	0.10			
		1630	31100	0.00	0.06	0.06	0.06			
		1630	8925	0.00	0.02	0.02	0.02			
		1630	-10010	0.00	0.02	0.02	0.02			
		1630	-35460	0.00	0.07	0.07	0.06			
	1630	-43930	0.00	0.08	0.08	0.08				
	1630	-35400	0.00	0.07	0.07	0.06				
	1630	-9886	0.00	0.02	0.02	0.02				
	1630	-9886	0.00	0.02	0.02	0.02				
	1630	9076	0.00	0.02	0.02	0.02				
	1630	31280	0.00	0.06	0.06	0.06				
	1630	55730	0.00	0.10	0.10	0.10				
	1630	81420	0.00	0.15	0.15	0.15				
	44	1567	81270	0.00	0.15	0.15	0.15			
		1567	55590	0.00	0.10	0.10	0.10			
		1567	31160	0.00	0.06	0.06	0.06			
		1567	8965	0.00	0.02	0.02	0.02			
		1567	-9981	0.00	0.02	0.02	0.02			
		1567	-9981	0.00	0.02	0.02	0.02			
1567		-35470	0.00	0.07	0.07	0.06				
1567		-43960	0.00	0.08	0.08	0.08				
1567		-43960	0.00	0.08	0.08	0.08				
1567		-35460	0.00	0.07	0.07	0.06				
1567		-9975	0.00	0.02	0.02	0.02				
1567		-9975	0.00	0.02	0.02	0.02				
1567		8973	0.00	0.02	0.02	0.02				
1567		31170	0.00	0.06	0.06	0.06				
1567		59690	0.00	0.10	0.10	0.10				
1567		81280	0.00	0.15	0.15	0.15				
45		1630	81440	0.00	0.15	0.15	0.15			
		1630	55750	0.00	0.10	0.10	0.10			
		1630	31300	0.00	0.06	0.06	0.06			
		1630	9086	0.00	0.02	0.02	0.02			
	1630	-9878	0.00	0.02	0.02	0.02				
	1630	-9878	0.00	0.02	0.02	0.02				
	1630	-35400	0.00	0.07	0.07	0.06				
	1630	-43930	0.00	0.08	0.08	0.08				
	1630	-43930	0.00	0.08	0.08	0.08				
	1630	-35470	0.00	0.07	0.07	0.06				
	1630	-10010	0.00	0.02	0.02	0.02				
	1630	-10010	0.00	0.02	0.02	0.02				
	1630	8915	0.00	0.02	0.02	0.02				
	1630	31090	0.00	0.06	0.06	0.06				
	1630	55510	0.00	0.10	0.10	0.10				
	1630	81170	0.00	0.15	0.15	0.15				

m	Nd	Md	Nd/Nu	Md/Mu	unity1	unity2	stability			
							1	2	tot	
46	315.5	82560	0.00	0.15	0.15	0.15				
	315.5	55810	0.00	0.10	0.10	0.10				
	315.5	30300	0.00	0.06	0.06	0.06				
	315.5	7036	0.00	0.01	0.01	0.01				
	315.5	-12990	0.00	0.02	0.02	0.02				
	315.5	-12990	0.00	0.02	0.02	0.02				
	315.5	-40620	0.00	0.07	0.07	0.07				
	315.5	-51260	0.00	0.09	0.09	0.09				
	315.5	-51260	0.00	0.09	0.09	0.09				
	315.5	-44920	0.00	0.08	0.08	0.08				
	315.5	-21580	0.00	0.04	0.04	0.04				
	315.5	-21580	0.00	0.04	0.04	0.04				
	315.5	-3708	0.00	0.01	0.01	0.01				
	315.5	17410	0.00	0.03	0.03	0.03				
	315.5	40770	0.00	0.08	0.08	0.07				
	315.5	65370	0.00	0.12	0.12	0.12				
	47	840.9	67980	0.00	0.13	0.13	0.12			
		840.9	43040	0.00	0.08	0.08	0.08			
		840.9	19330	0.00	0.04	0.04	0.04			
		840.9	-2138	0.00	0.00	0.00	0.00			
840.9		-20360	0.00	0.04	0.04	0.04				
840.9		-44390	0.00	0.08	0.08	0.08				
840.9		-51430	0.00	0.09	0.09	0.09				
840.9		-41480	0.00	0.08	0.08	0.08				
840.9		-14550	0.00	0.03	0.03	0.03				
840.9		-14550	0.00	0.03	0.03	0.03				
840.9		5128	0.00	0.01	0.01	0.01				
840.9		28050	0.00	0.05	0.05	0.05				
840.9		53210	0.00	0.10	0.10	0.10				
840.9		79610	0.00	0.15	0.15	0.15				
48		1278	80540	0.00	0.15	0.15	0.15			
		1278	54940	0.00	0.10	0.10	0.10			
		1278	30570	0.00	0.06	0.06	0.06			
		1278	8453	0.00	0.02	0.02	0.02			
		1278	-10420	0.00	0.02	0.02	0.02			
		1278	-35770	0.00	0.07	0.07	0.07			
	1278	-44120	0.00	0.08	0.08	0.08				
	1278	-35490	0.00	0.07	0.07	0.06				
	1278	-9860	0.00	0.02	0.02	0.02				
	1278	-9860	0.00	0.02	0.02	0.02				
	1278	9157	0.00	0.02	0.02	0.02				
	1278	31420	0.00	0.06	0.06	0.06				
	1278	55930	0.00	0.10	0.10	0.10				
	1278	81670	0.00	0.15	0.15	0.15				
	49	1199	81330	0.00	0.15	0.15	0.15			
		1199	55660	0.00	0.10	0.10	0.10			
		1199	31220	0.00	0.06	0.06	0.06			
		1199	9030	0.00	0.02	0.02	0.02			
		1199	-9917	0.00	0.02	0.02	0.02			
		1199	-9917	0.00	0.02	0.02	0.02			
1199		-35400	0.00	0.07	0.07	0.06				
1199		-4399								

# Appendices

m	Nd	Md	Nd/Nu	Md/Mu	unity1	unity2	stability			
							1	2	tot	
		1099	-10740	0.00	0.02	0.02	0.02			
		1099	-36000	0.00	0.07	0.07	0.07			
		1099	-44270	0.00	0.08	0.08	0.08			
		1099	-35550	0.00	0.07	0.07	0.07			
		1099	-9836	0.00	0.02	0.02	0.02			
		1099	-9836	0.00	0.02	0.02	0.02			
		1099	9224	0.00	0.02	0.02	0.02			
		1099	31530	0.00	0.06	0.06	0.06			
		1099	56080	0.00	0.10	0.10	0.10			
		1099	81870	0.00	0.15	0.15	0.15			
		1071	81380	0.00	0.15	0.15	0.15			
		1071	55700	0.00	0.10	0.10	0.10			
		1071	31270	0.00	0.06	0.06	0.06			
		1071	9075	0.00	0.02	0.02	0.02			
		1071	-9871	0.00	0.02	0.02	0.02			
		1071	-9871	0.00	0.02	0.02	0.02			
		1071	-35360	0.00	0.07	0.07	0.06			
		1071	-43850	0.00	0.08	0.08	0.08			
		1071	-43850	0.00	0.08	0.08	0.08			
		1071	-35350	0.00	0.07	0.07	0.06			
		1071	-9866	0.00	0.02	0.02	0.02			
		1071	-9866	0.00	0.02	0.02	0.02			
		1071	9082	0.00	0.02	0.02	0.02			
		1071	31270	0.00	0.06	0.06	0.06			
		1071	55710	0.00	0.10	0.10	0.10			
		1071	81390	0.00	0.15	0.15	0.15			
		1099	81880	0.00	0.15	0.15	0.15			
		1099	56090	0.00	0.10	0.10	0.10			
		1099	31540	0.00	0.06	0.06	0.06			
		1099	9233	0.00	0.02	0.02	0.02			
		1099	-9828	0.00	0.02	0.02	0.02			
		1099	-9828	0.00	0.02	0.02	0.02			
		1099	-35540	0.00	0.07	0.07	0.07			
		1099	-44270	0.00	0.08	0.08	0.08			
		1099	-44270	0.00	0.08	0.08	0.08			
		1099	-36000	0.00	0.07	0.07	0.07			
		1099	-10750	0.00	0.02	0.02	0.02			
		1099	-10750	0.00	0.02	0.02	0.02			
		1099	8086	0.00	0.01	0.02	0.01			
		1099	30160	0.00	0.06	0.06	0.06			
		1099	54480	0.00	0.10	0.10	0.10			
		1099	80050	0.00	0.15	0.15	0.15			
		154.6	77360	0.00	0.14	0.14	0.14			
		154.6	51230	0.00	0.09	0.09	0.09			
		154.6	26330	0.00	0.05	0.05	0.05			
		154.6	3677	0.00	0.01	0.01	0.01			
		154.6	-15730	0.00	0.03	0.03	0.03			
		154.6	-15730	0.00	0.03	0.03	0.03			
		154.6	-42140	0.00	0.08	0.08	0.08			
		154.6	-51560	0.00	0.09	0.09	0.09			
		154.6	-51560	0.00	0.09	0.09	0.09			
		154.6	-43980	0.00	0.08	0.08	0.08			
		154.6	-19420	0.00	0.04	0.04	0.04			
		154.6	-19420	0.00	0.04	0.04	0.04			
		154.6	-934.3	0.00	0.00	0.00	0.00			
		154.6	20800	0.00	0.04	0.04	0.04			
		154.6	44770	0.00	0.08	0.08	0.08			
		154.6	69990	0.00	0.13	0.13	0.13			
		6457	72740	0.00	0.13	0.14	0.13			
		6457	47280	0.00	0.09	0.09	0.09			
		6457	23060	0.00	0.04	0.04	0.04			
		6457	1079	0.00	0.00	0.00	0.00			
		6457	-17650	0.00	0.03	0.03	0.03			
		6457	-42710	0.00	0.08	0.08	0.08			
		6457	-50770	0.00	0.09	0.10	0.09			
		6457	-41850	0.00	0.08	0.08	0.08			
		6457	-15930	0.00	0.03	0.03	0.03			
		6457	-15930	0.00	0.03	0.03	0.03			
		6457	3227	0.00	0.01	0.01	0.00			
		6457	25630	0.00	0.05	0.05	0.05			
		6457	50280	0.00	0.09	0.09	0.09			
		6457	76170	0.00	0.14	0.14	0.14			
		4237	78470	0.00	0.14	0.15	0.14			
		4237	53050	0.00	0.10	0.10	0.10			
		4237	28870	0.00	0.05	0.05	0.05			
		4237	6936	0.00	0.01	0.01	0.01			
		4237	-11750	0.00	0.02	0.02	0.02			
		4237	-36730	0.00	0.07	0.07	0.07			
		4237	-44710	0.00	0.08	0.08	0.08			
		4237	-35700	0.00	0.07	0.07	0.06			
		4237	-9700	0.00	0.02	0.02	0.02			
		4237	-9700	0.00	0.02	0.02	0.02			
		4237	9503	0.00	0.02	0.02	0.02			
		4237	31950	0.00	0.06	0.06	0.06			
		4237	56640	0.00	0.10	0.11	0.10			
		4237	82580	0.00	0.15	0.15	0.15			
		3942	81420	0.00	0.15	0.15	0.15			
		3942	55750	0.00	0.10	0.10	0.10			
		3942	31320	0.00	0.06	0.06	0.06			
		3942	9124	0.00	0.02	0.02	0.02			
		3942	-9823	0.00	0.02	0.02	0.02			
		3942	-9823	0.00	0.02	0.02	0.02			
		3942	-35310	0.00	0.07	0.07	0.06			
		3942	-43800	0.00	0.08	0.08	0.08			
		3942	-43800	0.00	0.08	0.08	0.08			
		3942	-35300	0.00	0.06	0.07	0.06			
		3942	-9817	0.00	0.02	0.02	0.02			
		3942	-9817	0.00	0.02	0.02	0.02			
		3942	9130	0.00	0.02	0.02	0.02			
		3942	31320	0.00	0.06	0.06	0.06			
		3942	55760	0.00	0.10	0.10	0.10			
		3942	81440	0.00	0.15	0.15	0.15			
		4237	82590	0.00	0.15	0.15	0.15			
		4237	56660	0.00	0.10	0.11	0.10			
		4237	31960	0.00	0.06	0.06	0.06			
		4237	9512	0.00	0.02	0.02	0.02			
		4237	-9693	0.00	0.02	0.02	0.02			
		4237	-9693	0.00	0.02	0.02	0.02			
		4237	-35700	0.00	0.07	0.07	0.06			
		4237	-44710	0.00	0.08	0.08	0.08			

m	Nd	Md	Nd/Nu	Md/Mu	unity1	unity2	stability			
							1	2	tot	
		4237	-44710	0.00	0.08	0.08	0.08			
		4237	-36730	0.00	0.07	0.07	0.07			
		4237	-11760	0.00	0.02	0.02	0.02			
		4237	-11760	0.00	0.02	0.02	0.02			
		4237	6927	0.00	0.01	0.01	0.01			
		4237	28860	0.00	0.05	0.05	0.05			
		4237	53040	0.00	0.10	0.10	0.10			
		4237	78450	0.00	0.14	0.15	0.14			
		6458	78180	0.00	0.14	0.14	0.14			
		6458	50280	0.00	0.09	0.09	0.09			
		6458	25630	0.00	0.05	0.05	0.05			
		6458	3220	0.00	0.01	0.01	0.00			
		6458	-15940	0.00	0.03	0.03	0.03			
		6458	-15940	0.00	0.03	0.03	0.03			
		6458	-41850	0.00	0.08	0.08	0.08			
		6458	-50780	0.00	0.09	0.10	0.09			
		6458	-50780	0.00	0.09	0.10	0.09			
		6458	-42710	0.00	0.08	0.08	0.08			
		6458	-17650	0.00	0.03	0.03	0.03			
		6458	-17650	0.00	0.03	0.03	0.03			
		6458	1083	0.00	0.00	0.00	0.00			
		6458	23060	0.00	0.04	0.04	0.04			
		6458	47280	0.00	0.09	0.09	0.09			
		6458	72740	0.00	0.13	0.14	0.13			
		-29670	50720	0.01	0.09	0.10	0.09			
		-29670	27090	0.01	0.05	0.06	0.04			
		-29670	4703	0.01	0.01	0.02	0.00			
		-29670	-15440	0.01	0.03	0.04	0.02			
		-29670	-32350	0.01	0.06	0.07	0.05			
		-29670	-53740	0.01	0.10	0.11	0.09			
		-29670	-58140	0.01	0.11	0.12	0.10			
		-29670	-45560	0.01	0.08	0.09	0.08			
		-29670	-15980	0.01	0.03	0.04	0.02			
		-29670	-15980	0.01	0.03	0.04	0.02			
		-29670	5010	0.01	0.01	0.02	0.00			
		-29670	29250	0.01	0.05	0.06	0.05			
		-29670	55730	0.01	0.10	0.11	0.09			
		-29670	83450	0.01	0.15	0.16	0.15			
		-28910	81470	0.01	0.15	0.16	0.14			
		-28910	55800	0.01	0.10	0.11	0.09			

# K.Failure order

## K.4.2 Situation 1

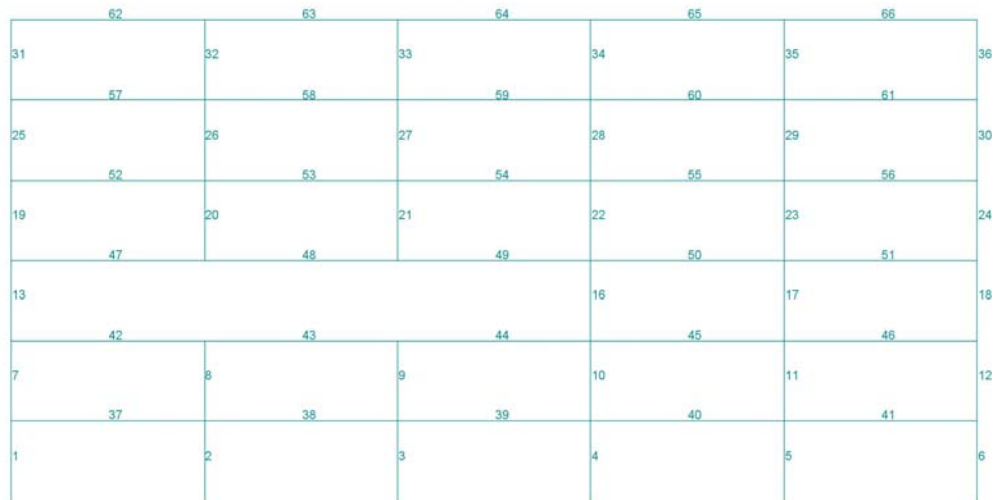

Figure.K.7 Situation 1: Initial generated damaged model with moment resistant framework

# Appendices

(HE300A)	(HE400A)
fy 235000000 N/m2	fy 235000000 N/m2
A 0,010627 m2	A 0,015272 m2
W 0,00126 m3	W 0,002311 m3
E 2,05E+11 N/m2	E 2,05E+11 N/m2
pl 3,14	pl 3,14
lc 2,7 m	lc 2,7 m
I 0,00017285 m4	I 0,0004326 m4
sigma c 450966526 N/m2	sigma c 7853734736 N/m2
Mu 296100 Nm	Mu 543085 Nm
Nu 2497345 N	Nu 3588920 N

m	Nd	Md	Nd/Nu	Md/Mu	unity1	unity2	stability		
							1	2/tot	
1	-1043000	-9821	0.42	0.03	0.45	0.38	0.02	0.04	0.06
	-1043000	-1604	0.42	0.01	0.42	0.41	0.02	0.01	0.03
	-1042000	6613	0.42	0.02	0.44	0.39	0.02	0.02	0.05
	-1041000	14830	0.42	0.05	0.47	0.37	0.02	0.06	0.08
	-1041000	23050	0.42	0.08	0.49	0.34	0.02	0.09	0.11
2	-318600	1721	0.13	0.01	0.13	0.12	0.01	0.01	0.01
	-315900	-144.6	0.13	0.00	0.13	0.13	0.01	0.00	0.01
	-315300	-2010	0.13	0.01	0.13	0.12	0.01	0.01	0.01
	-314700	-3876	0.13	0.01	0.14	0.11	0.01	0.01	0.02
	-314100	-5742	0.13	0.02	0.15	0.11	0.01	0.02	0.03
3	-315800	-2486	0.13	0.01	0.13	0.12	0.01	0.01	0.02
	-315200	-687.7	0.13	0.00	0.13	0.12	0.01	0.00	0.01
	-314600	1111	0.13	0.00	0.13	0.12	0.01	0.00	0.01
	-313900	2910	0.13	0.01	0.14	0.12	0.01	0.01	0.02
	-313300	4708	0.13	0.02	0.14	0.11	0.01	0.02	0.02
4	-1646000	-490.7	0.66	0.00	0.66	0.66	0.04	0.00	0.04
	-1646000	-376.4	0.66	0.00	0.66	0.66	0.04	0.00	0.04
	-1645000	-262.1	0.66	0.00	0.66	0.66	0.04	0.00	0.04
	-1645000	-147.7	0.66	0.00	0.66	0.66	0.04	0.00	0.04
	-1644000	-33.37	0.66	0.00	0.66	0.66	0.04	0.00	0.04
5	-824800	-534.2	0.33	0.00	0.33	0.33	0.02	0.00	0.02
	-824200	-185.9	0.33	0.00	0.33	0.33	0.02	0.00	0.02
	-823600	162.5	0.33	0.00	0.33	0.33	0.02	0.00	0.02
	-823000	510.8	0.33	0.00	0.33	0.33	0.02	0.00	0.02
	-822400	859.2	0.33	0.00	0.33	0.33	0.02	0.00	0.02
6	-472200	9899	0.19	0.03	0.22	0.16	0.01	0.04	0.05
	-471600	1287	0.19	0.00	0.19	0.18	0.01	0.00	0.02
	-471000	-7325	0.19	0.02	0.21	0.16	0.01	0.03	0.04
	-470400	-15940	0.19	0.05	0.24	0.13	0.01	0.06	0.07
	-469800	-24550	0.19	0.08	0.27	0.11	0.01	0.09	0.10
7	-971700	-26120	0.39	0.09	0.48	0.30	0.02	0.10	0.12
	-971100	-18890	0.39	0.06	0.45	0.33	0.02	0.07	0.09
	-970500	-11660	0.39	0.04	0.43	0.35	0.02	0.04	0.07
	-969900	-4424	0.39	0.01	0.40	0.37	0.02	0.02	0.04
	-969300	2809	0.39	0.01	0.40	0.38	0.02	0.01	0.03
	-968700	2486	0.39	0.01	0.07	0.05	0.00	0.01	0.01
8	-155300	1440	0.06	0.00	0.07	0.06	0.00	0.01	0.01
	-154700	394.5	0.06	0.00	0.06	0.06	0.00	0.00	0.01
	-154100	-651	0.06	0.00	0.06	0.06	0.00	0.00	0.01
	-153500	-1697	0.06	0.01	0.07	0.06	0.00	0.01	0.01
	-152900	-8356	0.06	0.03	0.09	0.04	0.00	0.03	0.03
	-152300	-3762	0.06	0.01	0.08	0.05	0.00	0.01	0.02
	-151700	830.9	0.06	0.00	0.07	0.06	0.00	0.00	0.01
	-151100	5424	0.06	0.02	0.08	0.04	0.00	0.02	0.02
	-150500	10020	0.06	0.03	0.10	0.03	0.00	0.04	0.04
10	-1500000	-6451	0.60	0.02	0.62	0.58	0.03	0.02	0.06
	-1500000	350.3	0.60	0.00	0.60	0.60	0.03	0.00	0.04
	-1499000	7151	0.60	0.02	0.62	0.58	0.03	0.03	0.06
	-1498000	13950	0.60	0.05	0.65	0.55	0.03	0.05	0.09
	-1498000	20750	0.60	0.07	0.67	0.53	0.03	0.08	0.11
11	-663900	3377	0.27	0.01	0.28	0.25	0.02	0.01	0.03
	-663300	800.7	0.27	0.00	0.27	0.26	0.02	0.00	0.02
	-662700	-1775	0.27	0.01	0.27	0.26	0.02	0.01	0.02
	-662100	-4352	0.27	0.01	0.28	0.25	0.02	0.02	0.03
	-661400	-6928	0.26	0.02	0.29	0.24	0.02	0.03	0.04
12	-398800	32580	0.16	0.11	0.27	0.05	0.01	0.12	0.13
	-398200	17580	0.16	0.06	0.22	0.10	0.01	0.07	0.07
	-397500	2574	0.16	0.01	0.17	0.15	0.01	0.01	0.02
	-396900	-12430	0.16	0.04	0.20	0.12	0.01	0.05	0.06
	-396300	-27440	0.16	0.09	0.25	0.07	0.01	0.10	0.11
13	-894000	-81120	0.36	0.27	0.63	0.08	0.02	0.30	0.32
	-893400	2352	0.36	0.01	0.37	0.35	0.02	0.01	0.03
	-892700	85820	0.36	0.29	0.65	0.07	0.02	0.32	0.34
	-892100	169300	0.36	0.57	0.93	0.21	0.02	0.63	0.65
	-891500	252800	0.36	0.85	1.21	0.50	0.02	0.94	0.96
16	-1360000	62680	0.54	0.21	0.76	0.33	0.03	0.23	0.26
	-1359000	2786	0.54	0.01	0.55	0.53	0.03	0.01	0.04
	-1358000	-57110	0.54	0.19	0.74	0.35	0.03	0.21	0.24
	-1358000	-117000	0.54	0.40	0.94	0.15	0.03	0.43	0.47
	-1357000	-176900	0.54	0.60	1.14	0.05	0.03	0.66	0.69
17	-497100	14410	0.20	0.05	0.25	0.15	0.01	0.05	0.06
	-496500	11130	0.20	0.04	0.24	0.16	0.01	0.04	0.05
	-495900	7852	0.20	0.03	0.23	0.17	0.01	0.03	0.04
	-495300	4573	0.20	0.02	0.21	0.18	0.01	0.02	0.03
	-494700	1294	0.20	0.00	0.20	0.19	0.01	0.00	0.02
18	-323700	40080	0.13	0.14	0.26	0.01	0.01	0.15	0.16
	-323100	19790	0.13	0.07	0.20	0.06	0.01	0.07	0.08
	-322500	-507.8	0.13	0.00	0.13	0.13	0.01	0.00	0.01
	-321900	-2060	0.13	0.07	0.20	0.06	0.01	0.08	0.08
	-321300	-4110	0.13	0.14	0.27	0.01	0.01	0.15	0.15
19	-678000	-333600	0.27	1.13	0.84	0.86	0.02	1.24	1.28
	-675400	-169400	0.27	0.57	0.84	0.30	0.02	0.63	0.64
	-674800	-5153	0.27	0.02	0.29	0.25	0.02	0.02	0.03
	-674200	159100	0.27	0.54	0.81	0.27	0.02	0.59	0.61
	-673500	323300	0.27	1.09	1.38	0.82	0.02	1.20	1.22
20	5311	-310900	0.00	1.05	1.05	1.05	0.00	0.00	0.00
	5925	-170000	0.00	0.57	0.58	0.57	0.00	0.00	0.00
	6539	-29110	0.00	0.10	0.10	0.10	0.00	0.00	0.00
	7152	111800	0.00	0.38	0.38	0.37	0.00	0.00	0.00
	7766	252700	0.00	0.85	0.86	0.85	0.00	0.00	0.00
21	4657	362900	0.00	1.23	1.23	1.22	0.00	0.00	0.00
	5270	197800	0.00	0.67	0.67	0.67	0.00	0.00	0.00
	5884	32650	0.00	0.11	0.11	0.11	0.00	0.00	0.00
	6497	-132500	0.00	0.45	0.45	0.44	0.00	0.00	0.00
	7111	-297600	0.00	1.01	1.01	1.00	0.00	0.00	0.00
22	-1028000	249900	0.41	0.84	1.28	0.43	0.02	0.93	0.95

m	Nd	Md	Nd/Nu	Md/Mu	unity1	unity2	stability		
							1	2/tot	
	-1027000	125900	0.41	0.43	0.84	0.01	0.02	0.47	0.49
	-1026000	1843	0.41	0.01	0.42	0.40	0.02	0.01	0.03
	-1026000	-122200	0.41	0.41	0.82	0.00	0.02	0.45	0.48
	-1025000	-246200	0.41	0.83	1.24	0.42	0.02	0.91	0.94
23	-373900	-9988	0.15	0.03	0.18	0.12	0.01	0.04	0.05
	-373300	-5561	0.15	0.02	0.17	0.13	0.01	0.02	0.03
	-372600	-1134	0.15	0.00	0.15	0.15	0.01	0.00	0.01
	-372000	3292	0.15	0.01	0.16	0.14	0.01	0.01	0.02
	-371400	7719	0.15	0.03	0.17	0.12	0.01	0.03	0.04
24	-242000	41510	0.10	0.14	0.24	0.04	0.01	0.15	0.16
	-241400	21130	0.10	0.07	0.17	0.03	0.01	0.08	0.08
	-240800	742.1	0.10	0.00	0.10	0.09	0.01	0.00	0.01
	-240200	-19640	0.10	0.07	0.16	0.03	0.01	0.07	0.08
	-239600	-40030	0.10	0.14	0.23	0.04	0.01	0.15	0.15
25	-432700	-328400	0.17	1.11	1.28	0.94	0.01	1.22	1.23
	-432000	-166800	0.17	0.56	0.74	0.39	0.01	0.62	0.63
	-431400	-4232	0.17	0.01	0.19	0.16	0.01	0.02	0.03
	-430800	158400	0.17	0.53	0.71	0.36	0.01	0.59	0.60
	-430200	321000	0.17	1.08	1.26	0.91	0.01	1.19	1.20
26	-15180	-228500	0.01	0.77	0.78	0.77	0.00	0.85	0.85
	-14570	-113300	0.01	0.38	0.39	0.38	0.00	0.42	0.42
	-13960	1998	0.01	0.01	0.01	0.00	0.00	0.01	0.01
	-13340	117300	0.01	0.40	0.40	0.39	0.00	0.44	0.44
	-12730	232500	0.01	0.79	0.79	0.78	0.00	0.86	0.86
27	-9624	259600	0.00	0.88	0.88	0.87	0.00	0.96	0.96
	-9011	129700	0.00	0.44	0.44	0.43	0.00	0.48	0.48
	-8397	-149.9	0.00	0.00	0.00	0.00	0.00	0.00	0.00
	-7783	-130000	0.00	0.44	0.44				

# K.Failure order

m	Nd	Md	Nd/Nu	Md/Mu	unity1	unity2	stability	
							1	2/tot
		3507	-45400	0.00	0.08	0.08	0.08	
		3507	-40690	0.00	0.07	0.08	0.07	
		3507	-18990	0.00	0.03	0.04	0.03	
		3507	-18990	0.00	0.03	0.04	0.03	
		3507	-1929	0.00	0.00	0.00	0.00	
		3507	18370	0.00	0.03	0.03	0.03	
		3507	40920	0.00	0.08	0.08	0.07	
		3507	64700	0.00	0.12	0.12	0.12	
	40	12420	71120	0.00	0.13	0.13	0.13	
		12420	46770	0.00	0.09	0.09	0.08	
		12420	23650	0.00	0.04	0.05	0.04	
		12420	2785	0.00	0.01	0.01	0.00	
		12420	-14840	0.00	0.03	0.03	0.02	
		12420	-14840	0.00	0.03	0.03	0.02	
		12420	-37880	0.00	0.07	0.07	0.07	
		12420	-43530	0.00	0.08	0.08	0.08	
		12420	-43530	0.00	0.08	0.08	0.08	
		12420	-32390	0.00	0.06	0.06	0.06	
		12420	-4256	0.00	0.01	0.01	0.00	
		12420	-4256	0.00	0.01	0.01	0.00	
		12420	16010	0.00	0.03	0.03	0.03	
		12420	39530	0.00	0.07	0.08	0.07	
		12420	65290	0.00	0.12	0.12	0.12	
		12420	92290	0.00	0.17	0.17	0.17	
	41	8523	89770	0.00	0.17	0.17	0.16	
		8523	62050	0.00	0.11	0.12	0.11	
		8523	35580	0.00	0.07	0.07	0.06	
		8523	11350	0.00	0.02	0.02	0.02	
		8523	-9641	0.00	0.02	0.02	0.02	
		8523	-9641	0.00	0.02	0.02	0.02	
		8523	-39210	0.00	0.07	0.07	0.07	
		8523	-51780	0.00	0.10	0.10	0.09	
		8523	-51780	0.00	0.10	0.10	0.09	
		8523	-47360	0.00	0.09	0.09	0.08	
		8523	-25960	0.00	0.05	0.05	0.05	
		8523	-25960	0.00	0.05	0.05	0.05	
		8523	-9050	0.00	0.02	0.02	0.01	
		8523	11100	0.00	0.02	0.02	0.02	
		8523	33500	0.00	0.06	0.06	0.06	
		8523	57130	0.00	0.11	0.11	0.10	
	42	101700	83930	0.03	0.15	0.18	0.13	
		101700	58370	0.03	0.11	0.14	0.08	
		101700	34040	0.03	0.06	0.09	0.03	
		101700	11970	0.03	0.02	0.05	0.01	
		101700	-6869	0.03	0.01	0.04	0.02	
		101700	-32130	0.03	0.06	0.09	0.03	
		101700	-40400	0.03	0.07	0.10	0.05	
		101700	-31670	0.03	0.06	0.09	0.03	
		101700	-5963	0.03	0.01	0.04	0.02	
		101700	-5963	0.03	0.01	0.04	0.02	
		101700	13100	0.03	0.02	0.05	0.00	
		101700	35400	0.03	0.07	0.09	0.04	
		101700	59950	0.03	0.11	0.14	0.08	
		101700	85740	0.03	0.16	0.19	0.13	
	43	103000	84040	0.03	0.15	0.18	0.13	
		103000	58480	0.03	0.11	0.14	0.08	
		103000	34160	0.03	0.06	0.09	0.03	
		103000	12090	0.03	0.02	0.05	0.01	
		103000	-6743	0.03	0.01	0.04	0.02	
		103000	-32000	0.03	0.06	0.09	0.03	
		103000	-40260	0.03	0.07	0.10	0.05	
		103000	-31530	0.03	0.06	0.09	0.03	
		103000	-5817	0.03	0.01	0.04	0.02	
		103000	-5817	0.03	0.01	0.04	0.02	
		103000	13250	0.03	0.02	0.05	0.00	
		103000	35550	0.03	0.07	0.09	0.04	
		103000	60100	0.03	0.11	0.14	0.08	
		103000	85900	0.03	0.16	0.19	0.13	
	44	96920	95910	0.03	0.18	0.20	0.15	
		96920	69050	0.03	0.13	0.15	0.10	
		96920	43430	0.03	0.08	0.11	0.05	
		96920	20050	0.03	0.04	0.06	0.01	
		96920	-83.56	0.03	0.00	0.03	0.03	
		96920	-83.57	0.03	0.00	0.03	0.03	
		96920	-27940	0.03	0.05	0.08	0.02	
		96920	-38810	0.03	0.07	0.10	0.04	
		96920	-38810	0.03	0.07	0.10	0.04	
		96920	-32690	0.03	0.06	0.09	0.03	
		96920	-9578	0.03	0.02	0.04	0.01	
		96920	-9578	0.03	0.02	0.04	0.01	
		96920	8182	0.03	0.02	0.04	0.01	
		96920	29190	0.03	0.05	0.08	0.03	
		96920	52440	0.03	0.10	0.12	0.07	
		96920	76920	0.03	0.14	0.17	0.11	
	45	7989	34990	0.00	0.06	0.07	0.06	
		7989	13990	0.00	0.03	0.03	0.02	
		7989	-5768	0.00	0.01	0.01	0.01	
		7989	-23280	0.00	0.04	0.05	0.04	
		7989	-37560	0.00	0.07	0.07	0.07	
		7989	-37560	0.00	0.07	0.07	0.07	
		7989	-53690	0.00	0.10	0.10	0.10	
		7989	-52840	0.00	0.10	0.10	0.10	
		7989	-52840	0.00	0.10	0.10	0.10	
		7989	-34990	0.00	0.06	0.07	0.06	
		7989	-156.7	0.00	0.00	0.00	0.00	
		7989	-156.7	0.00	0.00	0.00	0.00	
		7989	23470	0.00	0.04	0.05	0.04	
		7989	50330	0.00	0.09	0.09	0.09	
		7989	79440	0.00	0.15	0.15	0.14	
		7989	109800	0.00	0.20	0.20	0.20	
	46	7052	88460	0.00	0.16	0.16	0.16	
		7052	61470	0.00	0.11	0.12	0.11	
		7052	35730	0.00	0.07	0.07	0.06	
		7052	12230	0.00	0.02	0.02	0.02	
		7052	-8029	0.00	0.01	0.02	0.01	
		7052	-8029	0.00	0.01	0.02	0.01	
		7052	-36130	0.00	0.07	0.07	0.06	
		7052	-47240	0.00	0.09	0.09	0.09	
		7052	-47240	0.00	0.09	0.09	0.09	
		7052	-41370	0.00	0.08	0.08	0.07	

m	Nd	Md	Nd/Nu	Md/Mu	unity1	unity2	stability	
							1	2/tot
		7052	-18500	0.00	0.03	0.04	0.03	
		7052	-18500	0.00	0.03	0.04	0.03	
		7052	-859.8	0.00	0.00	0.00	0.00	
		7052	20020	0.00	0.04	0.04	0.03	
		7052	43150	0.00	0.08	0.08	0.08	
		7052	67520	0.00	0.12	0.13	0.12	
	47	107700	586400	0.03	1.08	1.11	1.05	
		107700	497700	0.03	0.92	0.95	0.89	
		107700	410200	0.03	0.76	0.79	0.73	
		107700	325000	0.03	0.60	0.63	0.57	
		107700	243100	0.03	0.45	0.48	0.42	
		107700	91610	0.03	0.17	0.20	0.14	
		107700	-42880	0.03	0.08	0.11	0.05	
		107700	-160400	0.03	0.30	0.33	0.27	
		107700	-260900	0.03	0.48	0.51	0.45	
		107700	-260900	0.03	0.48	0.51	0.45	
		107700	-305000	0.03	0.56	0.59	0.53	
		107700	-345800	0.03	0.64	0.67	0.61	
		107700	-384300	0.03	0.71	0.74	0.68	
		107700	-421700	0.03	0.78	0.81	0.75	
	48	295500	-110700	0.08	0.20	0.29	0.12	
		295500	-133800	0.08	0.25	0.33	0.16	
		295500	-155700	0.08	0.29	0.37	0.20	
		295500	-175300	0.08	0.32	0.41	0.24	
		295500	-191700	0.08	0.35	0.44	0.27	
		295500	-212000	0.08	0.39	0.47	0.31	
		295500	-215400	0.08	0.40	0.48	0.31	
		295500	-201800	0.08	0.37	0.45	0.29	
		295500	-171100	0.08	0.32	0.40	0.23	
		295500	-171100	0.08	0.32	0.40	0.23	
		295500	-149600	0.08	0.28	0.36	0.19	
		295500	-124900	0.08	0.23	0.31	0.15	
		295500	-97850	0.08	0.18	0.26	0.10	
		295500	-69600	0.08	0.13	0.21	0.05	
	49	75370	-432500	0.02	0.80	0.82	0.78	
		75370	-389700	0.02	0.72	0.74	0.70	
		75370	-345700	0.02	0.64	0.66	0.62	
		75370	-299500	0.02	0.55	0.57	0.53	
		75370	-250000	0.02	0.46	0.48	0.44	
		75370	-250000	0.02	0.46	0.48	0.44	
		75370	-138600	0.02	0.26	0.28	0.23	
		75370	-10250	0.02	0.02	0.04	0.00	
		75370	-10250	0.02	0.02	0.04	0.00	
		75370	135100	0.02	0.25	0.27	0.23	
		75370	297500	0.02	0.55	0.57	0.53	
		75370	297500	0.02	0.55	0.57	0.53	
		75370	384900	0.02	0.71	0.73	0.69	
		75370	475500	0.02	0.88	0.90	0.85	
		75370	568400	0.02	1.05	1.07	1.03	
		75370	662500	0.02	1.22	1.24	1.20	
	50	-10150	235600	0.00	0.43	0.44	0.43	
		-10150	198000	0.00	0.36	0.37	0.36	
		-10150	161700	0.00	0.30	0.30	0.29	
		-10150	127500	0.00	0.23	0		

# Appendices

m	Nd	Md	Nd/Nu	Md/Mu	unity1	unity2	stability		
							1	2/tot	
54	10650	-552000	0.00	1.02	1.02	1.01			
	10650	-498300	0.00	0.92	0.92	0.91			
	10650	-443400	0.00	0.82	0.82	0.81			
	10650	-386300	0.00	0.71	0.71	0.71			
	10650	-325800	0.00	0.60	0.60	0.60			
	10650	-325800	0.00	0.60	0.60	0.60			
	10650	-192600	0.00	0.35	0.36	0.35			
	10650	-42380	0.00	0.08	0.08	0.08			
	10650	-42380	0.00	0.08	0.08	0.08			
	10650	124800	0.00	0.23	0.23	0.23			
	10650	309000	0.00	0.57	0.57	0.57			
	10650	309000	0.00	0.57	0.57	0.57			
	10650	407400	0.00	0.75	0.75	0.75			
	10650	508900	0.00	0.94	0.94	0.93			
	10650	612700	0.00	1.13	1.13	1.13			
	10650	717700	0.00	1.32	1.32	1.32			
	55	10970	221800	0.00	0.41	0.41	0.41		
		10970	185500	0.00	0.34	0.34	0.34		
		10970	150500	0.00	0.28	0.28	0.27		
		10970	117700	0.00	0.22	0.22	0.21		
10970		88170	0.00	0.16	0.17	0.16			
10970		88170	0.00	0.16	0.17	0.16			
10970		41490	0.00	0.08	0.08	0.07			
10970		11810	0.00	0.02	0.02	0.02			
10970		11810	0.00	0.02	0.02	0.02			
10970		-891.1	0.00	0.00	0.00	0.00			
10970		3402	0.00	0.01	0.01	0.00			
10970		3402	0.00	0.01	0.01	0.00			
10970		11750	0.00	0.02	0.02	0.02			
10970		23350	0.00	0.04	0.05	0.04			
10970		37190	0.00	0.07	0.07	0.07			
10970		52270	0.00	0.10	0.10	0.09			
56		2393	57290	0.00	0.11	0.11	0.10		
		2393	33360	0.00	0.06	0.06	0.06		
		2393	10660	0.00	0.02	0.02	0.02		
		2393	-9788	0.00	0.02	0.02	0.02		
	2393	-26990	0.00	0.05	0.05	0.05			
	2393	-26990	0.00	0.05	0.05	0.05			
	2393	-48990	0.00	0.09	0.09	0.09			
	2393	-54010	0.00	0.10	0.10	0.10			
	2393	-54010	0.00	0.10	0.10	0.10			
	2393	-42030	0.00	0.08	0.08	0.08			
	2393	-13060	0.00	0.02	0.02	0.02			
	2393	-13060	0.00	0.02	0.02	0.02			
	2393	7633	0.00	0.01	0.01	0.01			
	2393	31570	0.00	0.06	0.06	0.06			
	2393	57740	0.00	0.11	0.11	0.11			
	2393	85160	0.00	0.16	0.16	0.16			
	57	40970	660200	0.01	1.22	1.23	1.20		
		40970	560000	0.01	1.03	1.04	1.02		
		40970	461000	0.01	0.85	0.86	0.84		
		40970	364300	0.01	0.67	0.68	0.66		
40970		270800	0.01	0.50	0.51	0.49			
40970		96220	0.01	0.18	0.19	0.17			
40970		-61560	0.01	0.11	0.12	0.10			
40970		202000	0.01	0.37	0.38	0.36			
40970		-325600	0.01	0.60	0.61	0.59			
40970		-325600	0.01	0.60	0.61	0.59			
40970		-381200	0.01	0.70	0.71	0.69			
40970		-433500	0.01	0.80	0.81	0.79			
40970		-483600	0.01	0.89	0.90	0.88			
40970		-532500	0.01	0.98	0.99	0.97			
58		56940	-64450	0.02	0.12	0.13	0.10		
56940		-85570	0.02	0.16	0.17	0.14			
56940		-105400	0.02	0.19	0.21	0.18			
56940		-123100	0.02	0.23	0.24	0.21			
56940		-137500	0.02	0.25	0.27	0.24			
56940		-153800	0.02	0.28	0.30	0.27			
56940	-153200	0.02	0.28	0.30	0.27				
56940	-135600	0.02	0.25	0.27	0.23				
56940	-101000	0.02	0.19	0.20	0.17				
56940	-101000	0.02	0.19	0.20	0.17				
56940	-77530	0.02	0.14	0.16	0.13				
56940	-50780	0.02	0.09	0.11	0.08				
56940	-21790	0.02	0.04	0.06	0.02				
56940	8438	0.02	0.02	0.03	0.00				
59	16430	-546600	0.00	1.01	1.01	1.00			
	16430	-493300	0.00	0.91	0.91	0.90			
	16430	-438800	0.00	0.81	0.81	0.80			
	16430	-382000	0.00	0.70	0.71	0.70			
	16430	-322000	0.00	0.59	0.60	0.59			
	16430	-322000	0.00	0.59	0.60	0.59			
	16430	-189500	0.00	0.35	0.35	0.34			
	16430	-40040	0.00	0.07	0.08	0.07			
	16430	-40040	0.00	0.07	0.08	0.07			
	16430	126400	0.00	0.23	0.24	0.23			
	16430	309800	0.00	0.57	0.58	0.57			
	16430	309800	0.00	0.57	0.58	0.57			
	16430	407800	0.00	0.75	0.76	0.75			
	16430	508900	0.00	0.94	0.94	0.93			
	16430	612300	0.00	1.13	1.13	1.12			
	16430	717000	0.00	1.32	1.32	1.32			
	60	-6362	210300	0.00	0.39	0.39	0.39		
		-6362	175000	0.00	0.32	0.32	0.32		
		-6362	141000	0.00	0.26	0.26	0.26		
		-6362	109200	0.00	0.20	0.20	0.20		
-6362		80650	0.00	0.15	0.15	0.15			
-6362		80650	0.00	0.15	0.15	0.15			
-6362		35950	0.00	0.07	0.07	0.06			
-6362		8245	0.00	0.02	0.02	0.01			
-6362		8245	0.00	0.02	0.02	0.01			
-6362		-2473	0.00	0.00	0.01	0.00			
-6362		3800	0.00	0.01	0.01	0.01			
-6362		3800	0.00	0.01	0.01	0.01			
-6362		13140	0.00	0.02	0.03	0.02			
-6362		25730	0.00	0.05	0.05	0.05			
-6362		40560	0.00	0.07	0.08	0.07			
-6362		56620	0.00	0.10	0.11	0.10			
61		5225	59910	0.00	0.11	0.11	0.11		
5225		35920	0.00	0.07	0.07	0.06			

m	Nd	Md	Nd/Nu	Md/Mu	unity1	unity2	stability		
							1	2/tot	
62	5225	13180	0.00	0.02	0.03	0.02			
	5225	-7330	0.00	0.01	0.01	0.01			
	5225	-24590	0.00	0.05	0.05	0.04			
	5225	-24590	0.00	0.05	0.05	0.04			
	5225	-46700	0.00	0.09	0.09	0.08			
	5225	-51820	0.00	0.10	0.10	0.09			
	5225	-51820	0.00	0.10	0.10	0.09			
	5225	-39960	0.00	0.07	0.07	0.07			
	5225	-11100	0.00	0.02	0.02	0.02			
	5225	-11100	0.00	0.02	0.02	0.02			
	5225	9538	0.00	0.02	0.02	0.02			
	5225	33420	0.00	0.06	0.06	0.06			
	5225	59540	0.00	0.11	0.11	0.11			
	5225	86900	0.00	0.16	0.16	0.16			
	63	-257800	434100	0.07	0.80	0.87	0.73		
		-257800	358400	0.07	0.66	0.73	0.59		
		-257800	284000	0.07	0.52	0.59	0.45		
		-257800	211800	0.07	0.39	0.46	0.32		
		-257800	142900	0.07	0.26	0.33	0.19		
		-257800	17460	0.07	0.03	0.10	0.04		
-257800		-90990	0.07	0.17	0.24	0.10			
-257800		-182500	0.07	0.34	0.41	0.26			
-257800		-256900	0.07	0.47	0.54	0.40			
-257800		-256900	0.07	0.47	0.54	0.40			
-257800		-288000	0.07	0.53	0.60	0.46			
-257800		-315700	0.07	0.58	0.65	0.51			
-257800		-341300	0.07	0.63	0.70	0.56			
-257800		-365600	0.07	0.67	0.75	0.60			
-427400		-92100	0.12	0.17	0.29	0.05			
-427400		-115600	0.12	0.21	0.33	0.09			
-427400		-137800	0.12	0.25	0.37	0.13			
-427400		-157700	0.12	0.29	0.41	0.17			
-427400		-174500	0.12	0.32	0.44	0.20			
-427400		-195500	0.12	0.36	0.48	0.24			
-427400	-199600	0.12	0.37	0.49	0.25				
-427400	-186600	0.12	0.34	0.46	0.22				
-427400	-156700	0.12	0.29	0.41	0.17				
-427400	-156700	0.12	0.29	0.41	0.17				
-427400	-135600	0.12	0.25	0.37	0.13				
-427400	-111100	0.12	0.20	0.32	0.09				
-427400	-84490	0.12	0.16	0.27	0.04				
-427400	-56600	0.12	0.10	0.22	0.01				
64	-213700	-402600	0.06	0.74	0.80	0.68			
	-213700	-366700	0.06	0.68	0.73	0.62			
	-213700	-329500	0.06	0.61	0.67	0.55			
	-213700	-290100	0.06	0.53	0.59	0.47			
	-213700	247400	0.06	0.46	0.53	0.40			
	-213700	247400	0.06	0.46	0.52	0.40			
	-213700	-149700	0.06	0.28	0.34	0.22			
	-213700	-35010	0.06	0.06	0.12	0.00			
	-213700	-35010	0.06	0.06	0.12	0.00			
	-213700	96690	0.06	0.18	0.24	0.12			
	-213700	245400	0.06	0.45	0.51	0.39			
	-213700	245400	0.06	0.45	0.51	0.39			
	-213700	325900	0.06	0.60	0.66	0.54			
	-213700	409700	0.06	0.75	0.81	0.69			
	-213700	495800	0.06	0.91	0.97	0.85			
	-213700	583000	0.06	1.07	1.13	1.01			
	65	-25890	280600	0.01	0.52	0.52	0.51		
		-25890	239900	0.01	0.44	0.45	0.43		
		-25890	200300	0.01	0.37	0.38	0.36		
		-2							

# K.Failure order

## K.4.3 Situation 2

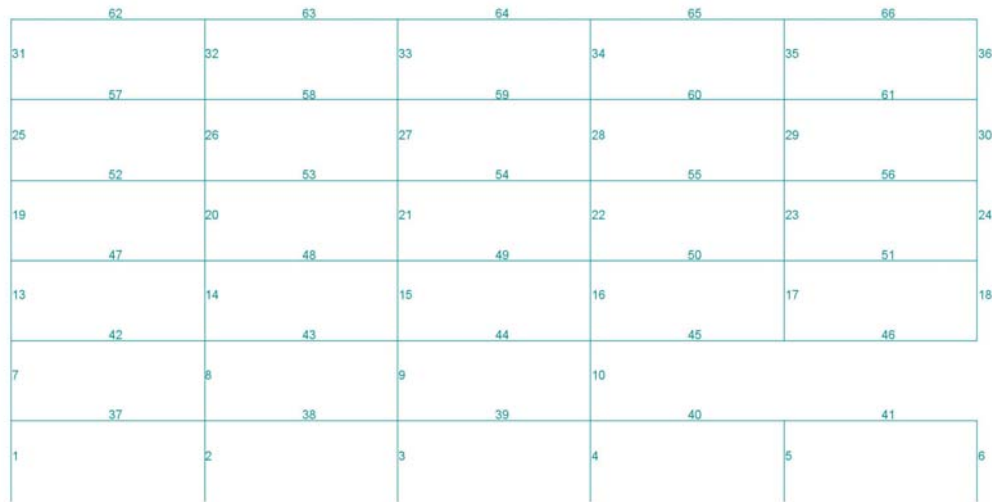

Figure.K.8 Situation 2: Initial generated damaged model with moment resistant framework



# Appendices

(HE300A)	(HE400A)
fy 235000000 N/m2	fy 235000000 N/m2
A 0,010627 m2	A 0,015272 m2
W 0,00126 m3	W 0,002311 m3
E 2,05E+11 N/m2	E 2,05E+11 N/m2
pl 3,14	pl 3,14
lc 2,7 m	lc 2,7 m
I 0,00017285 m4	I 0,0004326 m4
sigma c 450986526 N/m2	sigma c 7853734736 N/m2
Mu 296100 Nm	Mu 543085 Nm
Nu 2497345 N	Nu 3588920 N

m	Nd	Md	Nd/Nu	Md/Mu	unity1	unity2	stability		
							1	2	tot
1	4981	-10560	0,00	0,04	0,04	0,03			
	5595	4221	0,00	0,01	0,02	0,01			
	6208	19000	0,00	0,06	0,07	0,06			
	6822	33770	0,00	0,11	0,12	0,11			
	7435	48550	0,00	0,16	0,17	0,16			
2	-1009000	5042	0,40	0,02	0,42	0,39	0,02	0,02	0,04
	-1008000	5887	0,40	0,02	0,42	0,38	0,02	0,02	0,05
	-1008000	6732	0,40	0,02	0,43	0,38	0,02	0,03	0,05
	-1007000	7577	0,40	0,03	0,43	0,38	0,02	0,03	0,05
	-1007000	8422	0,40	0,03	0,43	0,37	0,02	0,03	0,05
3	-623400	-4361	0,25	0,01	0,26	0,23	0,01	0,02	0,03
	-622800	3459	0,25	0,01	0,26	0,24	0,01	0,01	0,03
	-622200	11280	0,25	0,04	0,29	0,21	0,01	0,04	0,06
	-621600	19100	0,25	0,06	0,31	0,18	0,01	0,07	0,09
	-621000	26920	0,25	0,09	0,34	0,16	0,01	0,10	0,11
4	-2749000	10070	1,10	0,03	1,13	1,07	0,06	0,04	0,10
	-2749000	3032	1,10	0,01	1,11	1,09	0,06	0,01	0,07
	-2748000	-4010	1,10	0,01	1,11	1,09	0,06	0,01	0,08
	-2747000	-11050	1,10	0,04	1,14	1,06	0,06	0,04	0,10
	-2747000	-18090	1,10	0,06	1,16	1,04	0,06	0,07	0,13
5	-170600	4200	0,07	0,01	0,08	0,05	0,00	0,02	0,02
	-170000	1934	0,07	0,01	0,07	0,06	0,00	0,01	0,01
	-169300	-332,6	0,07	0,00	0,07	0,07	0,00	0,00	0,01
	-168700	-2599	0,07	0,01	0,08	0,06	0,00	0,01	0,01
	-168100	-4865	0,07	0,02	0,08	0,05	0,00	0,02	0,02
6	-71730	17470	0,03	0,06	0,09	0,03	0,00	0,06	0,07
	-71120	3338	0,03	0,01	0,04	0,02	0,00	0,01	0,01
	-70500	-10790	0,03	0,04	0,06	0,01	0,00	0,04	0,04
	-69890	-24930	0,03	0,08	0,11	0,06	0,00	0,09	0,09
	-69280	-39060	0,03	0,13	0,16	0,10	0,00	0,15	0,15
7	65740	42030	0,03	0,14	0,17	0,12			
	66350	40920	0,03	0,14	0,16	0,11			
	66970	39610	0,03	0,13	0,16	0,11			
	67580	38700	0,03	0,13	0,16	0,10			
	68190	37590	0,03	0,13	0,16	0,10			
8	-854400	110700	0,34	0,37	0,72	0,03	0,02	0,41	0,43
	-853800	69380	0,34	0,23	0,58	0,11	0,02	0,26	0,28
	-853200	28050	0,34	0,09	0,44	0,25	0,02	0,10	0,12
	-852600	-13280	0,34	0,04	0,39	0,30	0,02	0,05	0,07
	-852000	-54610	0,34	0,18	0,53	0,16	0,02	0,20	0,22
9	-452000	98630	0,18	0,33	0,51	0,15	0,01	0,37	0,38
	-451400	56280	0,18	0,19	0,37	0,01	0,01	0,21	0,22
	-450800	13940	0,18	0,05	0,23	0,13	0,01	0,05	0,06
	-450200	-28410	0,18	0,10	0,28	0,08	0,01	0,11	0,12
	-449500	-70760	0,18	0,24	0,42	0,06	0,01	0,26	0,27
10	-2604000	-23300	1,04	0,08	1,12	0,96	0,06	0,09	0,15
	-2603000	61480	1,04	0,21	1,25	0,83	0,06	0,23	0,29
	-2602000	146300	1,04	0,49	1,54	0,55	0,06	0,54	0,60
	-2602000	231100	1,04	0,78	1,82	0,26	0,06	0,86	0,92
	-2601000	315800	1,04	1,07	2,11	0,03	0,06	1,17	1,23
13	74660	229900	0,03	0,78	0,81	0,75			
	75270	130500	0,03	0,44	0,47	0,41			
	75890	31010	0,03	0,10	0,14	0,07			
	76500	-68460	0,03	0,23	0,26	0,20			
	77110	-167900	0,03	0,57	0,60	0,54			
14	-683600	365100	0,27	1,23	1,51	0,96	0,02	1,36	1,37
	-683000	192100	0,27	0,65	0,92	0,38	0,02	0,71	0,73
	-682400	19050	0,27	0,06	0,34	0,21	0,02	0,07	0,09
	-681800	-154000	0,27	0,52	0,79	0,25	0,02	0,57	0,59
	-681200	-327000	0,27	1,10	1,38	0,83	0,02	1,21	1,23
15	-367400	417400	0,15	1,41	1,56	1,26	0,01	1,55	1,56
	-366700	220600	0,15	0,75	0,89	0,60	0,01	0,82	0,83
	-366100	23830	0,15	0,08	0,23	0,07	0,01	0,09	0,10
	-365500	-173000	0,15	0,58	0,73	0,44	0,01	0,64	0,65
	-364900	-369800	0,15	1,25	1,40	1,10	0,01	1,37	1,38
16	-2103000	-103900	0,84	0,35	1,19	0,49	0,05	0,39	0,43
	-2102000	-41550	0,84	0,14	0,98	0,70	0,05	0,15	0,20
	-2102000	20800	0,84	0,07	0,91	0,77	0,05	0,08	0,13
	-2101000	83140	0,84	0,28	1,12	0,56	0,05	0,31	0,36
	-2100000	145500	0,84	0,49	1,33	0,35	0,05	0,54	0,59
17	-33040	-689000	0,01	2,33	2,34	2,31	0,00	2,56	2,56
	-32430	-373200	0,01	1,26	1,27	1,25	0,00	1,39	1,39
	-31810	-57470	0,01	0,19	0,21	0,18	0,00	0,21	0,21
	-31200	256300	0,01	0,87	0,88	0,86	0,00	0,96	0,96
	-30590	574000	0,01	1,94	1,95	1,93	0,00	2,13	2,13
18	32760	-194800	0,01	0,66	0,67	0,64			
	33370	-103600	0,01	0,35	0,36	0,34			
	33990	-12480	0,01	0,04	0,06	0,03			
	34600	78990	0,01	0,27	0,28	0,25			
	35220	169500	0,01	0,57	0,59	0,56			
19	45630	173500	0,02	0,59	0,60	0,57			
	46250	87430	0,02	0,30	0,31	0,28			
	46860	1335	0,02	0,00	0,02	0,01			
	47470	-84760	0,02	0,29	0,31	0,27			
	48090	-170800	0,02	0,58	0,60	0,56			
20	-510900	341700	0,20	1,15	1,36	0,95	0,01	1,27	1,28
	-510300	171500	0,20	0,58	0,78	0,37	0,01	0,64	0,65
	-509700	1275	0,20	0,00	0,21	0,20	0,01	0,00	0,02
	-509100	-166900	0,20	0,57	0,77	0,37	0,01	0,63	0,64
	-508500	-339100	0,20	1,15	1,35	0,94	0,01	1,26	1,27
21	-276600	364100	0,11	1,23	1,34	1,12	0,01	1,35	1,36
	-276000	182400	0,11	0,62	0,73	0,51	0,01	0,68	0,68
	-275400	613	0,11	0,00	0,11	0,11	0,01	0,00	0,01
	-274700	-181100	0,11	0,61	0,72	0,50	0,01	0,67	0,68
	-274100	-362900	0,11	1,23	1,34	1,12	0,01	1,35	1,36
22	-1550000	-168100	0,62	0,57	1,19	0,05	0,04	0,62	0,66

m	Nd	Md	Nd/Nu	Md/Mu	unity1	unity2	stability		
							1	2	tot
	-1549000	-85260	0,62	0,29	0,91	0,33	0,04	0,32	0,35
	-1549000	-2431	0,62	0,01	0,63	0,61	0,04	0,01	0,04
	-1548000	80400	0,62	0,27	0,89	0,35	0,04	0,30	0,33
	-1547000	163200	0,62	0,55	1,17	0,07	0,04	0,61	0,64
23	-29190	-527600	0,01	0,88	0,79	1,77	0,00	1,66	1,66
	-28570	-262300	0,01	0,59	0,90	0,87	0,00	0,97	0,98
	-27960	-3020	0,01	0,01	0,02	0,00	0,00	0,01	0,01
	-27350	268300	0,01	0,91	0,92	0,90	0,00	1,00	1,00
	-26730	533600	0,01	1,80	1,81	1,75	0,00	1,98	1,98
24	11300	-182100	0,00	0,61	0,62	0,61			
	11920	-92180	0,00	0,31	0,32	0,31			
	12530	-2279	0,01	0,01	0,01	0,00			
	13140	87620	0,01	0,30	0,30	0,29			
	13760	177500	0,01	0,60	0,60	0,59			
25	16530	170900	0,01	0,58	0,58	0,57			
	17140	85040	0,01	0,29	0,29	0,28			
	17760	-868	0,01	0,00	0,01	0,00			
	18370	-86770	0,01	0,29	0,30	0,29			
	18980	-172700	0,01	0,58	0,59	0,58			
26	-340600	339100	0,14	1,15	1,28	1,01	0,01	1,26	1,27
	-339900	169300	0,14	0,57	0,71	0,44	0,01	0,63	0,64
	-339300	-354,3	0,14	0,00	0,14	0,13	0,01	0,00	0,01
	-338700	-170100	0,14	0,57	0,71	0,44	0,01	0,63	0,64
	-338100	-339800	0,14	1,15	1,28	1,01	0,01	1,26	1,27
27	-177300	359900	0,07	1,22	1,29	1,14	0,00	1,34	1,34
	-176700	181200	0,07	0,61	0,68	0,54	0,00	0,67	0,68
	-176000	2453	0,07	0,01	0,08	0,06	0,00	0,01	0,01
	-175400	-176300	0,07	0,60	0,67	0,53	0,00	0,65	0,66
	-174800	-355000	0,07	1,20	1,27	1,13	0,00	1,32	1,32
28	-1009000	-159500	0,40	0,54	0,94	0,13	0,02	0,59	0,62
	-1008000	-79860	0,40	0,27	0,67	0,13	0,02	0,30	0,32
	-1008000	-178,5	0,40	0,00	0,40	0,40	0,02	0,00	0,02
	-1007000	79500	0,40	0,27	0,67	0,13	0,02		

# K.Failure order

m	Nd	Md	Nd/Nu	Md/Mu	unity1	unity2	stability	
							1	2/tot
	-144300	-59910	0.04	0.11	0.15	0.07		
	-144300	-53130	0.04	0.10	0.14	0.06		
	-144300	-29350	0.04	0.05	0.09	0.01		
	-144300	-29350	0.04	0.05	0.09	0.01		
	-144300	-11260	0.04	0.02	0.06	0.02		
	-144300	19070	0.04	0.03	0.05	0.02		
	-144300	33650	0.04	0.06	0.10	0.02		
	-144300	58470	0.04	0.11	0.15	0.07		
40	-21870	63680	0.01	0.12	0.12	0.11		
	-21870	40680	0.01	0.07	0.08	0.07		
	-21870	18930	0.01	0.03	0.04	0.03		
	-21870	-580.1	0.01	0.00	0.01	0.01		
	-21870	-16860	0.01	0.03	0.04	0.02		
	-21870	-16860	0.01	0.03	0.04	0.02		
	-21870	-36990	0.01	0.07	0.07	0.06		
	-21870	-40140	0.01	0.07	0.08	0.07		
	-21870	-40140	0.01	0.07	0.08	0.07		
	-21870	-26290	0.01	0.05	0.05	0.04		
	-21870	4549	0.01	0.01	0.01	0.00		
	-21870	4549	0.01	0.01	0.01	0.00		
	-21870	26170	0.01	0.05	0.05	0.04		
	-21870	51040	0.01	0.09	0.10	0.09		
	-21870	78150	0.01	0.14	0.15	0.14		
	-21870	106500	0.01	0.20	0.20	0.19		
41	-18840	101600	0.01	0.19	0.19	0.18		
	-18840	72050	0.01	0.13	0.14	0.13		
	-18840	43710	0.01	0.08	0.09	0.08		
	-18840	17600	0.01	0.03	0.04	0.03		
	-18840	-5256	0.01	0.01	0.01	0.00		
	-18840	-5256	0.01	0.01	0.01	0.00		
	-18840	-38560	0.01	0.07	0.08	0.07		
	-18840	-54880	0.01	0.10	0.11	0.10		
	-18840	-54880	0.01	0.10	0.11	0.10		
	-18840	-54210	0.01	0.10	0.11	0.09		
	-18840	-36540	0.01	0.07	0.07	0.06		
	-18840	-36540	0.01	0.07	0.07	0.06		
	-18840	-21510	0.01	0.04	0.04	0.03		
	-18840	-3228	0.01	0.01	0.01	0.00		
	-18840	17300	0.01	0.03	0.04	0.03		
	-18840	39060	0.01	0.07	0.08	0.07		
42	-131100	-192400	0.04	0.35	0.39	0.32		
	-131100	-187000	0.04	0.34	0.38	0.31		
	-131100	-180300	0.04	0.33	0.37	0.30		
	-131100	-171500	0.04	0.32	0.35	0.28		
	-131100	-169300	0.04	0.29	0.33	0.26		
	-131100	-122700	0.04	0.23	0.26	0.19		
	-131100	-69030	0.04	0.13	0.16	0.09		
	-131100	1608	0.04	0.00	0.04	0.03		
	-131100	89230	0.04	0.16	0.20	0.13		
	-131100	89230	0.04	0.16	0.20	0.13		
	-131100	139300	0.04	0.26	0.29	0.22		
	-131100	192500	0.04	0.35	0.39	0.32		
	-131100	248000	0.04	0.46	0.49	0.42		
	-131100	304800	0.04	0.56	0.60	0.52		
43	-306700	-114900	0.09	0.21	0.30	0.13		
	-306700	-117300	0.09	0.22	0.30	0.13		
	-306700	-118500	0.09	0.22	0.30	0.13		
	-306700	-117400	0.09	0.22	0.30	0.13		
	-306700	-113100	0.09	0.21	0.29	0.12		
	-306700	-92000	0.09	0.17	0.25	0.08		
	-306700	-53940	0.09	0.10	0.18	0.01		
	-306700	1099	0.09	0.00	0.09	0.08		
	-306700	73130	0.09	0.13	0.22	0.05		
	-306700	73130	0.09	0.13	0.22	0.05		
	-306700	115400	0.09	0.21	0.30	0.13		
	-306700	160800	0.09	0.30	0.38	0.21		
	-306700	208500	0.09	0.38	0.47	0.30		
	-306700	257900	0.09	0.47	0.56	0.39		
44	-512600	-230700	0.14	0.42	0.57	0.28		
	-512600	-202100	0.14	0.37	0.51	0.23		
	-512600	-172300	0.14	0.32	0.46	0.17		
	-512600	-140200	0.14	0.26	0.40	0.12		
	-512600	-104900	0.14	0.19	0.34	0.05		
	-512600	-104900	0.14	0.19	0.34	0.05		
	-512600	-21920	0.14	0.04	0.18	0.10		
	-512600	78080	0.14	0.14	0.29	0.00		
	-512600	78080	0.14	0.14	0.29	0.00		
	-512600	195100	0.14	0.36	0.50	0.22		
	-512600	329100	0.14	0.61	0.75	0.46		
	-512600	329100	0.14	0.61	0.75	0.46		
	-512600	402300	0.14	0.74	0.88	0.60		
	-512600	478700	0.14	0.88	1.02	0.74		
	-512600	557400	0.14	1.03	1.17	0.88		
	-512600	637300	0.14	1.17	1.32	1.03		
45	-542600	1057000	0.15	1.95	2.10	1.80		
	-542600	929300	0.15	1.71	1.86	1.56		
	-542600	802800	0.15	1.48	1.63	1.33		
	-542600	678800	0.15	1.25	1.40	1.10		
	-542600	557500	0.15	1.03	1.18	0.88		
	-542600	557500	0.15	1.03	1.18	0.88		
	-542600	327900	0.15	0.80	0.75	0.45		
	-542600	115300	0.15	0.21	0.36	0.06		
	-542600	115300	0.15	0.21	0.36	0.06		
	-542600	-89340	0.15	0.15	0.30	0.00		
	-542600	-259000	0.15	0.48	0.63	0.33		
	-542600	-259000	0.15	0.48	0.63	0.33		
	-542600	-342100	0.15	0.63	0.78	0.48		
	-542600	-422000	0.15	0.78	0.93	0.63		
	-542600	-499600	0.15	0.92	1.07	0.77		
	-542600	-576000	0.15	1.06	1.21	0.91		
46	-121600	113000	0.03	0.21	0.24	0.17		
	-121600	68070	0.03	0.13	0.16	0.09		
	-121600	24400	0.03	0.04	0.08	0.01		
	-121600	-17030	0.03	0.03	0.07	0.00		
	-121600	-55210	0.03	0.10	0.14	0.07		
	-121600	-55210	0.03	0.10	0.14	0.07		
	-121600	-119200	0.03	0.22	0.25	0.19		
	-121600	-166100	0.03	0.31	0.34	0.27		
	-121600	-166100	0.03	0.31	0.34	0.27		
	-121600	-196100	0.03	0.36	0.39	0.33		

m	Nd	Md	Nd/Nu	Md/Mu	unity1	unity2	stability	
							1	2/tot
	-121600	-209100	0.03	0.39	0.42	0.35		
	-121600	-209100	0.03	0.39	0.42	0.35		
	-121600	-209400	0.03	0.39	0.42	0.35		
	-121600	-206400	0.03	0.38	0.41	0.35		
	-121600	-201200	0.03	0.37	0.40	0.34		
	-121600	-194800	0.03	0.36	0.39	0.32		
47	17840	-341400	0.00	0.63	0.63	0.62		
	17840	-319000	0.00	0.59	0.59	0.58		
	17840	-295300	0.00	0.54	0.55	0.54		
	17840	-269300	0.00	0.50	0.50	0.49		
	17840	-240100	0.00	0.44	0.45	0.44		
	17840	-169300	0.00	0.31	0.32	0.31		
	17840	-81500	0.00	0.15	0.16	0.15		
	17840	23290	0.00	0.04	0.05	0.04		
	17840	145100	0.00	0.27	0.27	0.26		
	17840	145100	0.00	0.27	0.27	0.26		
	17840	212200	0.00	0.39	0.40	0.39		
	17840	282500	0.00	0.52	0.53	0.52		
	17840	355100	0.00	0.65	0.66	0.65		
	17840	428900	0.00	0.79	0.79	0.78		
48	21590	-239700	0.01	0.44	0.45	0.44		
	21590	-225900	0.01	0.42	0.42	0.41		
	21590	-210800	0.01	0.39	0.39	0.38		
	21590	-193500	0.01	0.36	0.36	0.35		
	21590	-173000	0.01	0.32	0.32	0.31		
	21590	-119500	0.01	0.22	0.23	0.21		
	21590	-48960	0.01	0.09	0.10	0.08		
	21590	38530	0.01	0.07	0.08	0.06		
	21590	143000	0.01	0.26	0.27	0.26		
	21590	143000	0.01	0.26	0.27	0.26		
	21590	201500	0.01	0.37	0.38	0.37		
	21590	263100	0.01	0.48	0.49	0.48		
	21590	327100	0.01	0.60	0.61	0.60		
	21590	392300	0.01	0.72	0.73	0.72		
49	41660	-341600	0.01	0.63	0.64	0.62		
	41660	-299600	0.01	0.55	0.56	0.54		
	41660	-256300	0.01	0.47	0.48	0.46		
	41660	-210800	0.01	0.39	0.40	0.38		
	41660	-162000	0.01	0.30	0.31	0.29		
	41660	-162000	0.01	0.30	0.31	0.29		
	41660	-52020	0.01	0.10	0.11	0.08		
	41660	74920	0.01	0.14	0.15	0.13		
	41660	74920	0.01	0.14	0.15	0.13		
	41660	218900	0.01	0.40	0.41	0.39		
	41660	379800	0.01	0.70	0.71	0.69		
	41660	379800	0.01	0.70	0.71	0.69		
	41660	466500	0.01	0.86	0.87	0.85		
	41660	556400	0.01	1.02	1.04	1.01		
	41660	648500	0.01	1.19	1.21	1.18		
	41660	741900	0.01	1.37	1.38	1.35		
50	68970	1055000	0.02	1.94	1.96	1.96		
	68970	917700	0.02	1.69				

# Appendices

m	Nd	Md	Nd/Nu	Md/Mu	unity1	unity2	stability		
							1	2/tot	
54	4902	-322800	0.00	0.59	0.60	0.59			
	4902	-283300	0.00	0.52	0.52	0.52			
	4902	-242800	0.00	0.45	0.45	0.45			
	4902	-200100	0.00	0.37	0.37	0.37			
	4902	-154100	0.00	0.28	0.29	0.28			
	4902	-154100	0.00	0.28	0.29	0.28			
	4902	-496500	0.00	0.09	0.09	0.09			
	4902	717500	0.00	0.13	0.13	0.13			
	4902	717500	0.00	0.13	0.13	0.13			
	4902	210100	0.00	0.39	0.39	0.39			
	4902	365500	0.00	0.67	0.67	0.67			
	4902	365500	0.00	0.67	0.67	0.67			
	4902	449400	0.00	0.83	0.83	0.83			
	4902	536600	0.00	0.99	0.99	0.99			
	4902	625900	0.00	1.15	1.15	1.15			
	4902	716600	0.00	1.32	1.32	1.32			
	55	700.6	1039000	0.00	1.91	1.91	1.91		
		700.6	904300	0.00	1.67	1.67	1.66		
		700.6	770500	0.00	1.42	1.42	1.42		
		700.6	639000	0.00	1.18	1.18	1.18		
700.6		510700	0.00	0.94	0.94	0.94			
700.6		510700	0.00	0.94	0.94	0.94			
700.6		266500	0.00	0.49	0.49	0.49			
700.6		39370	0.00	0.07	0.07	0.07			
700.6		39370	0.00	0.07	0.07	0.07			
700.6		-170800	0.00	0.31	0.31	0.31			
700.6		-364000	0.00	0.67	0.67	0.67			
700.6		-364000	0.00	0.67	0.67	0.67			
700.6		-454400	0.00	0.84	0.84	0.84			
700.6		-541600	0.00	1.00	1.00	1.00			
700.6		-626500	0.00	1.15	1.15	1.15			
700.6		-710100	0.00	1.31	1.31	1.31			
56		-298.9	355700	0.00	0.65	0.66	0.65		
		-298.9	285600	0.00	0.53	0.53	0.53		
		-298.9	216800	0.00	0.40	0.40	0.40		
		-298.9	150200	0.00	0.28	0.28	0.28		
	-298.9	86850	0.00	0.16	0.16	0.16			
	-298.9	86850	0.00	0.16	0.16	0.16			
	-298.9	-27450	0.00	0.05	0.05	0.05			
	-298.9	-124700	0.00	0.23	0.23	0.23			
	-298.9	-124700	0.00	0.23	0.23	0.23			
	-298.9	-205100	0.00	0.38	0.38	0.38			
	-298.9	-268400	0.00	0.49	0.49	0.49			
	-298.9	-268400	0.00	0.49	0.49	0.49			
	-298.9	-293800	0.00	0.54	0.54	0.54			
	-298.9	-316100	0.00	0.58	0.58	0.58			
	-298.9	-336000	0.00	0.62	0.62	0.62			
	-298.9	-354800	0.00	0.66	0.66	0.65			
	57	-6334	-332900	0.00	0.61	0.61	0.61		
		-6334	-311500	0.00	0.57	0.58	0.57		
		-6334	-288800	0.00	0.53	0.53	0.53		
		-6334	-263800	0.00	0.49	0.49	0.48		
-6334		-235600	0.00	0.43	0.44	0.43			
-6334		-166800	0.00	0.31	0.31	0.31			
-6334		-81030	0.00	0.15	0.15	0.15			
-6334		21750	0.00	0.04	0.04	0.04			
-6334		141500	0.00	0.26	0.26	0.26			
-6334		141500	0.00	0.26	0.26	0.26			
-6334		207600	0.00	0.38	0.38	0.38			
-6334		277000	0.00	0.51	0.51	0.51			
-6334		348500	0.00	0.64	0.64	0.64			
-6334		421300	0.00	0.78	0.78	0.77			
58		-19910	-254400	0.01	0.47	0.47	0.46		
		-19910	-238500	0.01	0.44	0.44	0.43		
		-19910	-221300	0.01	0.41	0.41	0.40		
		-19910	-201900	0.01	0.37	0.38	0.37		
		-19910	-179200	0.01	0.33	0.34	0.32		
		-19910	-121500	0.01	0.22	0.23	0.22		
	-19910	-46720	0.01	0.09	0.09	0.08			
	-19910	45000	0.01	0.08	0.09	0.08			
	-19910	153700	0.01	0.28	0.29	0.28			
	-19910	153700	0.01	0.28	0.29	0.28			
	-19910	214300	0.01	0.39	0.40	0.39			
	-19910	278100	0.01	0.51	0.52	0.51			
	-19910	344100	0.01	0.63	0.64	0.63			
	-19910	411400	0.01	0.76	0.76	0.75			
	-55430	-321000	0.02	0.59	0.61	0.58			
	-55430	-282300	0.02	0.52	0.54	0.50			
	-55430	-242300	0.02	0.45	0.46	0.43			
	-55430	-200100	0.02	0.37	0.38	0.35			
	-55430	-154600	0.02	0.28	0.30	0.27			
	-55430	-154600	0.02	0.28	0.30	0.27			
-55430	-51310	0.02	0.09	0.11	0.08				
-55430	69000	0.02	0.13	0.14	0.11				
-55430	69000	0.02	0.13	0.14	0.11				
-55430	206300	0.02	0.38	0.40	0.36				
-55430	360600	0.02	0.66	0.68	0.65				
-55430	360600	0.02	0.66	0.68	0.65				
-55430	444000	0.02	0.82	0.83	0.80				
-55430	530600	0.02	0.98	0.99	0.96				
-55430	619400	0.02	1.14	1.16	1.13				
-55430	709500	0.02	1.31	1.32	1.29				
60	-43260	1033000	0.01	1.99	1.91	1.88			
	-43260	898300	0.01	1.65	1.67	1.64			
	-43260	784900	0.01	1.41	1.42	1.40			
	-43260	633800	0.01	1.17	1.18	1.15			
	-43260	505900	0.01	0.93	0.94	0.92			
	-43260	505900	0.01	0.93	0.94	0.92			
	-43260	262600	0.01	0.48	0.50	0.47			
	-43260	36280	0.01	0.07	0.08	0.05			
	-43260	36280	0.01	0.07	0.08	0.05			
	-43260	-173100	0.01	0.32	0.33	0.31			
	-43260	-365400	0.01	0.67	0.68	0.66			
	-43260	-365400	0.01	0.67	0.68	0.66			
	-43260	-455400	0.01	0.84	0.85	0.83			
	-43260	-542100	0.01	1.00	1.01	0.99			
	-43260	-626600	0.01	1.15	1.17	1.14			
	-43260	-709800	0.01	1.31	1.32	1.29			
	61	-670.6	362400	0.00	0.67	0.67	0.67		
		-670.6	292200	0.00	0.54	0.54	0.54		

m	Nd	Md	Nd/Nu	Md/Mu	unity1	unity2	stability	
							1	2/tot
62	-670.6	223400	0.00	0.41	0.41	0.41		
	-670.6	156800	0.00	0.29	0.29	0.29		
	-670.6	93380	0.00	0.17	0.17	0.17		
	-670.6	93380	0.00	0.17	0.17	0.17		
	-670.6	-20970	0.00	0.04	0.04	0.04		
	-670.6	-118300	0.00	0.22	0.22	0.22		
	-670.6	-118300	0.00	0.22	0.22	0.22		
	-670.6	-198700	0.00	0.37	0.37	0.37		
	-670.6	-262100	0.00	0.48	0.48	0.48		
	-670.6	-262100	0.00	0.48	0.48	0.48		
	-670.6	-287600	0.00	0.53	0.53	0.53		
	-670.6	-309800	0.00	0.57	0.57	0.57		
	-670.6	-329800	0.00	0.61	0.61	0.61		
	-670.6	-348600	0.00	0.64	0.64	0.64		
	120900	-202400	0.03	0.37	0.41	0.34		
	120900	-197600	0.03	0.36	0.40	0.33		
	120900	-191500	0.03	0.35	0.39	0.32		
	120900	-183300	0.03	0.34	0.37	0.30		
	120900	-171700	0.03	0.32	0.35	0.28		
	120900	-136300	0.03	0.25	0.28	0.22		
120900	-83870	0.03	0.15	0.19	0.12			
120900	-14440	0.03	0.03	0.06	0.01			
120900	71970	0.03	0.13	0.17	0.10			
120900	71970	0.03	0.13	0.17	0.10			
120900	121400	0.03	0.22	0.26	0.19			
120900	174000	0.03	0.32	0.35	0.29			
120900	228900	0.03	0.42	0.46	0.39			
120900	285100	0.03	0.52	0.56	0.49			
360700	-98450	0.10	0.18	0.28	0.08			
360700	-103300	0.10	0.19	0.29	0.09			
360700	-106800	0.10	0.20	0.30	0.10			
360700	-108100	0.10	0.20	0.30	0.10			
360700	-106200	0.10	0.20	0.30	0.10			
360700	-89950	0.10	0.17	0.27	0.07			
360700	-56710	0.10	0.10	0.20	0.00			
360700	-6465	0.10	0.01	0.11	0.09			
360700	60760	0.10	0.11	0.21	0.01			
360700	60760	0.10	0.11	0.21	0.01			
360700	100600	0.10	0.19	0.29	0.08			
360700	143600	0.10	0.26	0.36	0.16			
360700	189000	0.10	0.35	0.45	0.25			
360700	235500	0.10	0.43	0.53	0.33			
64	634600	-208600	0.18	0.38	0.56	0.21		
	634600	-177800	0.18	0.33	0.50	0.15		
	634600	-145800	0.18	0.27	0.45	0.09		
	634600	-111600	0.18	0.21	0.38	0.03		
	634600	-74070	0.18	0.14	0.31	0.04		
	634600	-74070	0.18	0.14	0.31	0.04		
	634600	13330	0.18	0.02	0.20	0.15		
	634600	117700	0.18	0.22	0.39	0.04		
	634600	117700	0.18	0.22	0.39	0.04		
	634600	239100	0.18	0.44	0.62	0.26		
634600	377500	0.18	0.70	0.87	0.52			
634600	377500	0.18	0.70	0.87	0.52			
634600	452900	0.18	0.83	1.01	0.66			
634600	531500	0.18	0.98	1.16	0.80			
634600	612400	0.18	1.13	1.30	0.95			
634600	694500	0.18	1.28	1.46	1.10			
65	516200	885500	0.14	1.63	1.77	1.49		
	516200	773600	0.14	1.42	1.57	1.28		
	516200</							

# L. Bibliography



BETONVERENIGING, 2006. *G.T.B. Complete uitgave 2006*. Gouda

CBS, DUTCH CENTRAL BUREAU OF STATISTICS, 2008. <http://www.cbs.nl/nl-NL/menu/themas/gezondheid-welzijn/publicaties/artikelen/archief/2008/2008-2367-wm.htm>

COENDERS, J.L. & WAGEMANS, L.A.G., 2005. *Proposal for a Quick Building Assessment Tool for Progressive Collapse*.

DoD, U.S. DEPARTMENT OF DEFENCE, 2005 (January). *UFC 4-023-03: Design of Buildings to Resist Progressive Collapse*. <https://pdc.usace.army.mil/library/ufc>.

ELLINGWOOD, B.R., 2002. *Load and Resistance Factor Criteria for Progressive Collapse Design*. Tech. rept. NIBS Multi-hazard Mitigation Council. National Workshop on Prevention of Progressive Collapse.

ELLINGWOOD, B.R. & DUSENBERRY, D.O., 2005. *Building design for abnormal loads and progressive collapse*. *Computer-Aided Civil and Infrastructure Engineering* 20(3): 194-205.

GSA, U.S. GENERAL SERVICES ADMINISTRATION, 2003 (June). *Progressive Collapse Analysis and Design Guidelines for New Federal Office Buildings and Major Modernization Projects*. <http://www.oca.gsa.gov>.

HARTSUIJKER, C., 2000. *Stabiliteit van het evenwicht, Constructiemechanica 3*. Collegedictaat. 5th ed. Delft: University of Technology.

HARTSUIJKER, C., 2001. *Toegepaste mechanica, Deel 2 Spanningen, vervormingen, verplaatsingen*. 1st ed. Schoonhoven: Academic Service.

HMSO, U.K. STATUTORY INSTRUMENT, 1991. *Buildings and Buildings. The Building Regulations 1991*. London.

LOWE, P.G., 2005. *Basic Principles of Plates and Slabs: for safer and more cost effective structures*. 1st ed. Caithness(UK): Whittles Publishing Ltd..

NIST, NATIONAL INSTITUTE OF STANDARDS AND TECHNOLOGY, 2007, *NISTIR 7396 Best Practices for Reducing the Potential for Progressive Collapse in Buildings*. U.S. Department of Commerce.

NNI, NETHERLANDS STANDARDIZATION INSTITUTE, 2005. *NEN6700(nl) Technical principles for building structures, TGB 1990, General principles*.

NNI, NETHERLANDS STANDARDIZATION INSTITUTE, 2006. *NEN-EN-1991-1-7 Eurocode1: Actions on structures, Part 1-7: General actions, Accidental actions*.

NNI, NETHERLANDS STANDARDIZATION INSTITUTE, 2007. *NEN6702(nl) Technical principles for building structures, TGB 1990, Loadings and deformations*.

NNI, NETHERLANDS STANDARDIZATION INSTITUTE, 2007-2. *NEN-EN 1990/NB National Annex to NEN-EN 1990, Eurocode, Basis of structural design*.

SHANKAR NAIR, R., 2004. *Progressive Collapse Basics: A rational look at today's building codes, with an eye on blast-resistant design*. The steel conference.

STAROSSEK, U., 2006. *Progressive Collapse of Structures: Nomenclature and Procedures*. *Structural Engineering International*, 16(2), 113–117.

STAROSSEK, U., 2007. *Typology of progressive collapse*. *Engineering Structures*, Vol. 29, No. 9, pp. 2302-2307, September 2007.

STAROSSEK, U., 2008. *Approaches to measures of structural robustness*. IABMAS'08, 4th International Conference on Bridge Maintenance, Safety and Management, July 13-17, 2008, Seoul, Korea.

STAROSSEK, U & HABERLAND, M., 2008. *Measures of Structural Robustness – Requirements & Applications*. ASCE SEI 2008 Structures Congress, Crossing Borders, April 24-26, 2008, Vancouver, Canada.

STUFIB, STUDIECEL, 2006. *Constructieve samenhang van bouwconstructies*



