



The redefined Social

Production in and of an eco-social condition

Pooja Mishra

Student No. 5335256

Heterogenous City : Architectural Design Crossovers Graduation Studio

Heterogeneous City
Architectural Design Crossovers Graduation Studio

2022 - 2023

Tutors:

Johan van Lierop

Florian Eckardt

Alper Alkan

Pooja Mishra

Student No. 5335256

Faculty of Architecture and the Built Environment

TU Delft

Contents

Part 1 - Research Plan

| | |
|--|----|
| 1. Introduction | 6 |
| 2. Research Questions | 11 |
| 3. Theoretical Framework | 13 |
| 3.1 Urban Agriculture | 13 |
| 3.2 Social Realm | 13 |
| 3.3 Productive Landscapes | 14 |
| 3.4 Self-sustenance | 17 |
| 4. Methodological Framework | 21 |
| 4.1 Literature Reviews | 21 |
| 4.2 Data Collection and Cartographic Mapping | 22 |
| 4.3 Ethnographic Research and Area Mapping | 25 |
| 4.4 Demographic Data Collection and Mapping | 27 |
| 4.5 Systemic and Network Diagramming | 28 |
| 4.6 Case Studies | 30 |
| 5. Research Diagram | 31 |
| 6. Argument on Relevance | 32 |
| 7. Bibliography | 35 |
| 8. List of Figures | 38 |

Part 2 - Research Essay / Production in and of an eco-social condition

| | |
|--|----|
| 1. Introduction | 40 |
| 2. Mutation of productive landscapes | 43 |
| 3. Redefining the social | 45 |
| 4. Food and its influence on cities, social spaces, and social relationships | 47 |
| 4.1 Cities | 47 |
| 4.2 Social Spaces | 48 |
| 4.3 Social Relationships | 50 |
| 5. Social repercussions of Industrialization | 54 |
| 6. The three pillars of the re-defined Agro-Social | 56 |
| 6.1 Productive landscapes as social space | 56 |
| 6.2 Restoring the experiential connection to land | 58 |
| 6.3 The Eco-Social Production | 59 |
| 7. Conclusion | 64 |
| 8. Bibliography | 65 |

Part 3 - Design Process and Appendix

68

Part 1- Research Plan

1. Introduction and Research Statement

Food is a constant rhythm in everyday life. Communities have been held together by a **fundamental infrastructure built on agriculture and food**.¹ As Carolyn Steel states in her book *Hungry cities*, “Man, and corn – it all comes back to that. Cultivation and civilization, city and country, paradise, and hell: food has always shaped our lives, and it always will.” Settlements have developed around food production.² Agriculture, therefore, is the fulcrum of urban development and food it’s **social binding force**. London’s relative size to its rural hinterlands diminished as it incessantly got urban densified. Moreover, the advancements in transportation infrastructure substantially distanced food production sites and its networks from settlements because they were no longer dependent on geographical context. This transition of London, from being self sufficient within its hinterlands to the disappearance of green belt, very much puts worth the question of the value of land. The land is merely being seen as a commodity of monetary value that overlooks its eco-social value. This has also paved way for unsustainable agriculture practices with increasing food miles, thereby resulting in wasteful food packaging. As a result, the **producer and consumer are no longer connected**. A close connection to how a city feeds itself and the source of our food is lost. London relies heavily on food imports. There are still areas with limited access to healthy foods, high-quality education, and the consequent lack of job opportunities. The reliance on a global food industry has caused us to become more socially and ecologically isolated. This disconnect has rendered the **social fabric of the cities disintegrated**.

In this research, I focus on the **socio-spatial dimensions** of productive landscapes in the urban fabric of London to bring worth its eco-social value. As Carolyn Steel arguably states in her book *Sitopia*, the feeding of cities has been the most significant force shaping civilization and it still is and to understand cities, we need to look at them through food. She stated the three layers that **food has the potential to transform – cities, social spaces and social relationships**. Productive landscapes in London have been a great social leveller as the history depicts in the collage shown in Figure 1. From dig for victory to the COVID 19 phase, the role of allotment gardens have changed from being used as a food security to

1 Belanger, P. (2009). *Landscape as infrastructure*. Vol.28. No. 1. University of Wisconsin Press

2 Steel, C. (2008). *Hungry City - How Food Shapes our Lives*. London UK: Chatto & Windus, Random House

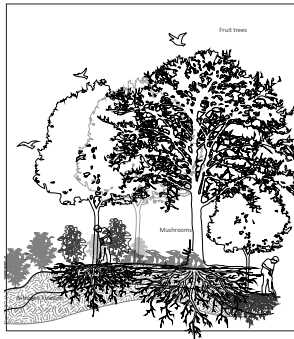

Pre - Industrial

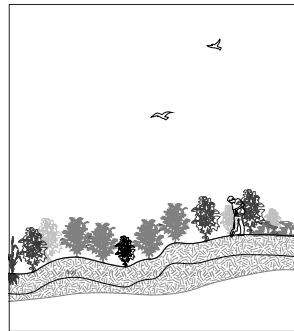

Present

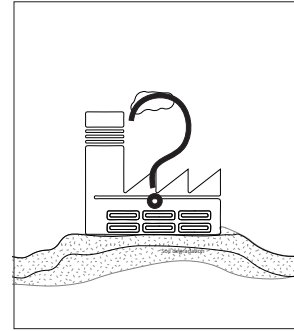

Post Anthropocene

community bonding space. The current agricultural activities in the form of allotments and community gardens carry out **growing as a collective leisure**. In a diverse metropolis like London, where around 24% of the population is of ethnic minority origin, social space is crucial for fostering social cohesion.³ Numerous community food-growing initiatives in London like Mercano Metropolitan and Healing Gardens allow individuals to connect, gain knowledge, identity, and friendships, contributing to the betterment of participants' quality of life.⁴ Such productive landscapes provide otherwise fragmented communities with a **multicultural identity** through participatory activities of growing, harvesting, cooking, eating and sharing knowledge.

Commercial developers are now taking over the land parcels previously set aside for allotments. The rise of “pseudo-public” areas has also led to a lack of appreciation for London's diverse density.⁵ As this resulted in the city identifying selective users, they expect to use the public spaces in a regulated manner. But people want to live in safe communities with efficient public services, stimulating cultural offerings, and efforts to reduce racial, socioeconomic, and ethnic disparities. Therefore, productive landscapes could be seen as communal green spaces that allow communities to bond and diminish disparities between communities with food as the binding force. In my research, I investigate and explore restoring the broken link between people with food and reweaving the city's social fabric, with the help of derelict areas having the potential to restore the link.

3 Petts, J. (2001). Urban Agriculture in London. Series on Urban Food Security. WHO

4 London Assembly. (2016). A Lot to Lose: London's disappearing allotments

5 Shenker, J. (2017, July 24). Revealed: the insidious creep of pseudo-public space in London. The Guardian; The Guardian. <https://www.theguardian.com/cities/2017/jul/24/revealed-pseudo-public-space-pops-london-investigation-map>



Fig 1. Food as a social leveller

Photo Source: The Telegraph. (2013, April 03). Dig for victory: vegetable growing during WWII in pics.

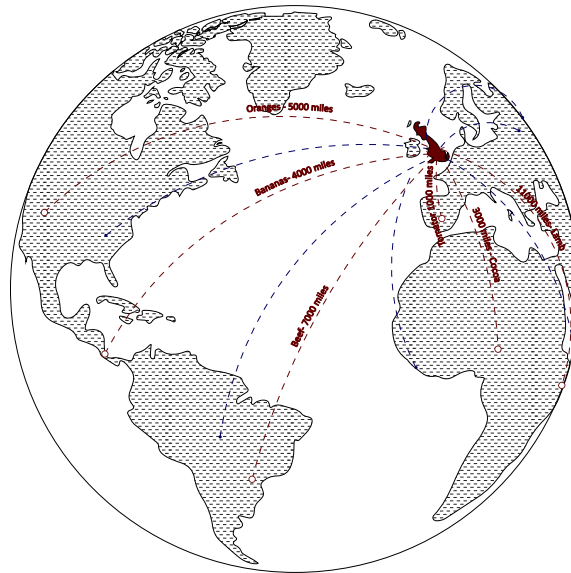

Figure 2. UK Food miles and virtual water imports

Source : Author

From being self-sufficient within their rural hinterlands, cities have transitioned to being reliant on an unsustainable global food network that substantially disconnects people from their food, disintegrates the community, and squanders resources and the environment.

2. Research Questions

The following central question serves as the basis for the research:

How can architectural intervention **integrate productive landscapes** into the city to **restore the broken link between people and food** ,thereby **bringing them together socially**?

Keywords: Productive landscapes, social realm, urban agriculture, self-sustenance, social cohesion,community bonding

The study assumes that the diversified population of London can benefit from a redefined community space that integrates urban agriculture and architecture. Creating a hybrid productive green space can serve as a food source and a potential community binder for a neighbourhood. The following sub-questions, which address different scales and layers,provide an overview of the steps necessary to support the research's primary argument. The questions are as follows;

- What are productive landscapes?
- What kind of mutation agriculture goes through when inserted into an urban context , and what is the perception of the value of this land in an urban context?
- How can productive landscapes reintegrate the social fabric of London?
- What patterns of spatial behavior can be induced by productive landscapes and where could it potentially be situated in London?
- How can the scales of various productive landscapes be merged to maximize the eco-social value of land and to serve more individuals so that it can compete with the uses that seek to eliminate it in exchange of commercial developments?

3. Theoretical Framework

To validate the potential of productive landscapes within London, I based my research on historical and thematic pieces of literature that helped identify my core concepts for this research. By doing that, I intend to define productive landscapes and the social realm in this study.

3.1 Urban Agriculture

Urban agriculture is an emerging concept in cities that refers to producing agricultural products in urban and suburban contexts and their processing and distribution. ¹ In the book *Hungry city*, Carolyn Steel repeatedly emphasizes the potential of food to transform cities. Her perspective comprehends the idea of urban agriculture through its implementation, classified into four categories: urban agriculture for survival, for the community, for the global market, and lifestyle. With the help of these lenses, I plan to spatially map agricultural activities such as growing, harvesting, cooking, and eating to better understand the behavioural patterns in such a context. This observational approach can develop into an ethnographical framework for field research.

3.2 Social realm

In his essay, Richard Sennett emphasizes the concept of an open city, which is based on a bottom-up approach with people as part of it. He states that an open city has a porous wall infused with pockets of spaces for activity. Henri Lefebvre defines these spaces in his book *The production of space*.

¹ Steel C.(2013). *Hungry City - How Food Shapes Our Lives*. 2nd edition. London: Vintage Books.

space as a social product. He situates the concept of the social realm at the nexus of lived, imagined, and experienced spaces.² In this study, I will focus on lived and experienced spaces, as these are the spaces used by users directly. Therefore, experienced spaces can reveal the relationship between food and realm and the induced behavioural patterns of people when subjected to the notion of time in Allotment and Community Gardens. Thus, the culmination of Henri Lefebvre's rhythm analysis and open city notion of Richard Sennett will be essential in exploring the socio-spatial behaviour induced in productive landscapes. With these notions, a social realm can be defined as a realm that belongs to people and fosters a social connection between strangers by establishing an invisible degree of attachment to the shared landscape by facilitating participatory activities.(Fig 4) In this research I will further explore the notion of open social realm as the foundation of a just productive landscape.

3.3 Productive Landscapes

The precedents, vision and theories of urban agriculture depict the mutation productive landscapes undergo in urban context based on food cultural shifts. Figure 2 illustrates the theories on a timeline basis. The very first theory of agriculture and cities was formulated by Von Thunen in his book *isolated state*, in which he illustrated the town in an isolated form because it is self-sufficient by bringing the city to farm. Garden city by Ebenezer Howard also follows the same notion, where residual space serves as public space after the farming layout. These notions followed agriculture for survival. But as cities grew, the size of hinterlands reduced, as seen in Broadacre city, where Frank W. Lyod established a divisional structure that pushed farms to the suburbs.

When urban agriculture was still a novel concept in 2004, Bohn & Viljoen Architects coined the term "CPUL." By creating a corridor of edible landscapes, a continuously productive urban landscape integrates the food system and architecture on a larger scale of city planning. It essentially connects current open areas and derelict sites into a linear landscape that fosters eco-social cohesion. The planning ideologies attempt to

2 Lefebvre,H. (1992). *The Production Of Space*. 1st ed. New Jersey: Wiley-Blackwell. pg. 38

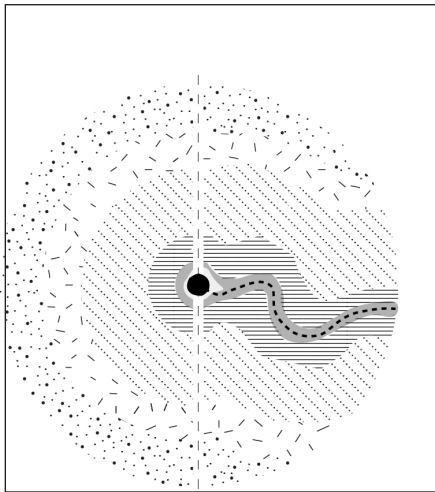

City around agriculture

Von Thunen Model - 1826

Thünen.V. (1826).

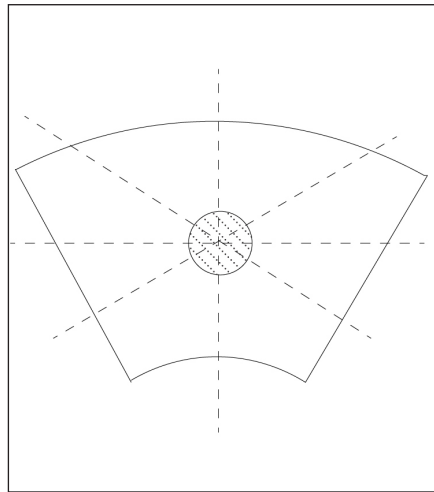

Residual space as public space

Garden City - 1902

Howard, E. (1946).

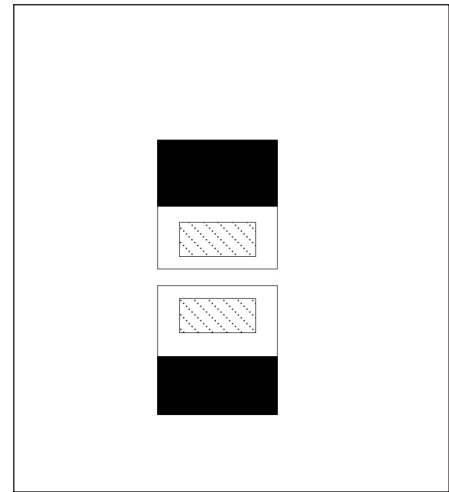

Divisional structure

Broadacre City - 1923

Wright.L.F

Fig 3. Mutation of Agriculture in Urban context - defining productive landscapes

Source : Author

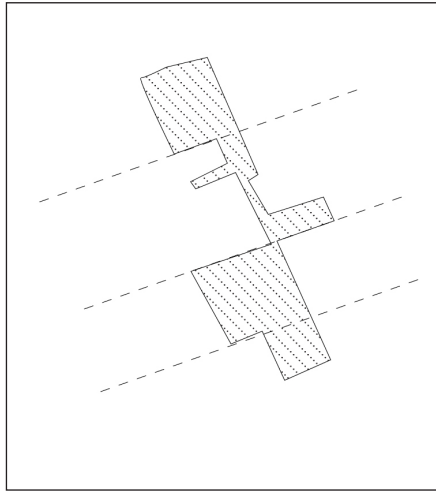

**A network of productive green landscapes
reviving derelict sites**

CPUL - 2004

Bohn, K. & Viljoen, A.

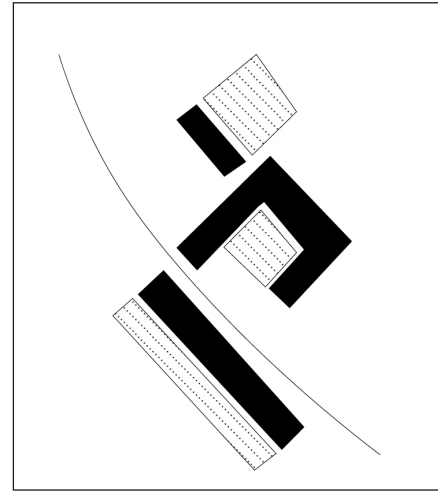

Societal relationship with Agriculture

Agricultural/Food Urbanism - 2010

De La Salle, Janine M., and Holland. M./ Verzone C.,
Woods C.

**Fig 3. Mutation of Agriculture in Urban context - defining pro-
ductive landscapes**

Source : Author

link fragmented parcels of land from inner to outer or urban to rural parts of the city. Following this, theories of food and agricultural urbanism surfaced that intended to bring the farm back to the city. It redefines the position of productive landscapes in an urban context by infusing agriculture and its aspects in the city. This position works with the fundamental components of a sustainable food system that creates distinctive, all-year-round agricultural and food-celebrating communities by incorporating tactics for local food processing, education and training programs. Thus, these two theories are essential foundations towards the design agenda to comprehend the spatial and commercial requirements that bring value to the community and environment. All these theories collectively define productive landscapes as a landscape comprising three elements - food, community and ecology.

Therefore productive landscape as a social realm can be defined as **a realm that belongs to people through the three elements- food, community and ecology, and fosters a social connection between strangers by establishing an invisible degree of attachment to a shared landscape facilitating participatory activities.**

3.4 Self-sustenance

Cities are a synthesis of ecosystems generated by the confluence of both material and immaterial flows. The food system, which has historically served as the foundation of civilizations, is crucial to a city's ability to sustain itself. The urban metabolism theory of Abel Wolman entails quantifying inputs and outputs and aggregating resources such as waste and energy in a city.³ It essentially aids in developing a circular approach for ecosystems, particularly the food system in cities where waste generation and consumption are at extremes.⁴ With this notion, I intend to instil

3 Kennedy, C., J. Cuddihy & J. Engel-Yan (2007). The changing metabolism of cities. *Journal of industrial ecology* 11.2 p. 43-59.

4 Pflieger, Geraldine, and Rozenblat. C. (2010). Introduction. *Urban networks and network theory: the city as the connector of multiple networks*. p. 2723-2735.

a circular and self-sufficient approach towards productive landscapes to reduce food miles and accentuate sustainable agricultural practices. Moreover, productive landscapes can be hybridized by integrating diverse functions that create a healthy relationship between community and environment. Therefore, the study also explores the possibilities of incorporating technology with conventional agriculture methods to illustrate the notion that there is greater potential output when the intersection of methods finds synergies.

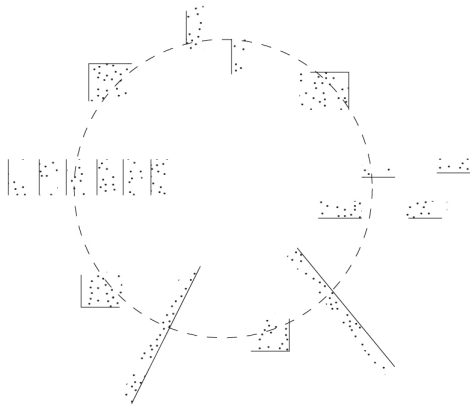

The 'Open City' is a bottom-up place. It belongs to the people."

Social nature of cities

Sennett. R.,(2006)

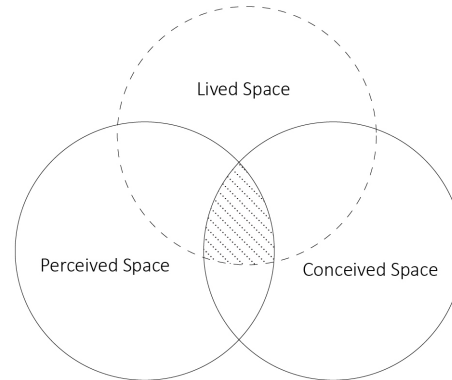

Invisible degree of people's attachment

Space as social product

Lefebvre,H. (1992).

Fig 4. Theories of Social Realm

Source : Author

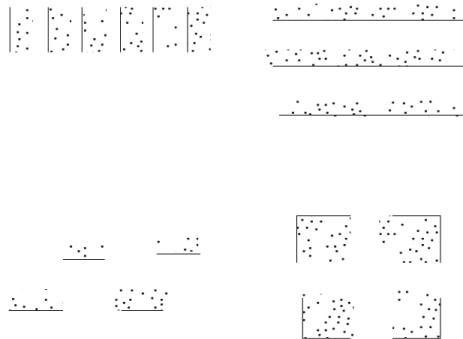

Connections over borders

Socio- Spatial Behavior

Sennett. R.,(2006)

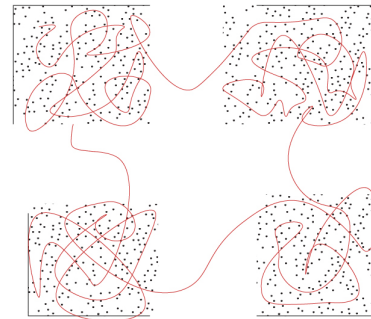

Rhythm analysis

Rhythm - with time as notion

Lefebvre,H. (2013).

Fig 4. Theories of Social Realm

Source : Author

4. Methodological Framework

In this research, I intend to investigate the potential(s) of productive landscapes as social realms. The fascination of perceiving food as a social binder was a starting point for this research. The methodological approach maintains three frames of understanding: Conceptual, theoretical, and contextual. These understandings will eventually designate the base for the design by research phase. The study operates a multi-scalar methodology that analyses each frame at macro, meso, and micro scales. A set of quantitative and qualitative methods and techniques used at each scale will, therefore, be determined by relevant constraints. Literature reviews will be used throughout the research.

The methods used to substantiate the analysis are as follows;

4.1 Literature Reviews

My initial step was to understand the city of London through food through a set of literary references. Therefore, the research initiated with the literature reviews of *Hungry City* and *Sitopia* by Carolyn Steel. This piece of literature provided me with a robust foundation of contextual understanding as well as conceptual and practical relevance of Urban Agriculture, the potential of food through history and its subsequent impacts in the city of London. The historical literature reviews aided in finding the relevant precedents that conceptualized agricultural patterns of productive landscapes in cities. Thematic literature reviews assisted in defining the productive landscapes and social realm within this study. Further, to comprehend the socio-spatial aspects of productive landscapes, relevant literature will be studied to establish the relation and patterns between food, productive landscapes, and people, which will be helpful towards the design intention.

Tools: Historical and Thematic Literature, Allotment Reports by London Assembly

4.2 Data Collection and Cartographic Mapping

The data of historical imagery from google earth, archival maps, photographs and surveys from the greater London authority aided in creating a visual representation of the urban sprawl of London to understand the shift in its rural hinterlands. Subsequently, systemic diagramming will be essential in decoding the notion of urban agriculture and productive landscapes to find overlaps. To understand the current state of green landscapes in London, the base map for this research started with identifying productive landscapes and rural hinterlands within the Greater London periphery. This was created using ordnance surveys, open street maps and GIS data. A series of sections based on this map gave further insights into the geomorphological conditions of such sites, highlighting allotments and community gardens as a point of interest. Such productive landscapes showcase the potential to establish a strong relationship between the community, built environment and economy.

Tools: GIS Maps, Google Earth, Archival Maps, Ordnance Survey Data, Open Street Map, Visual Graphics

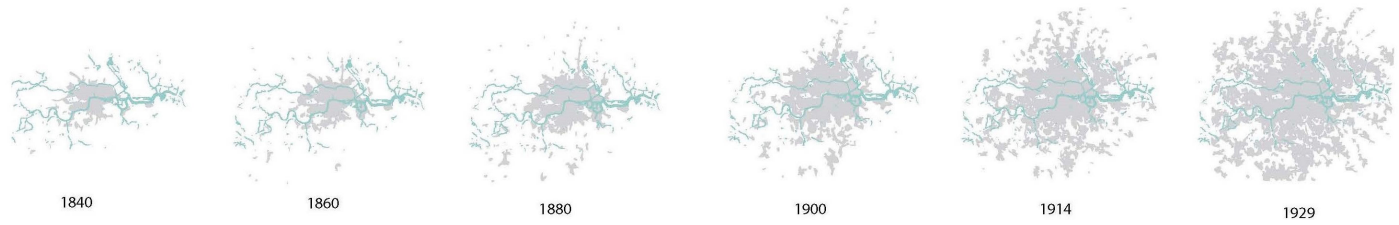

Figure 5. Urban sprawl of London

Source : Author

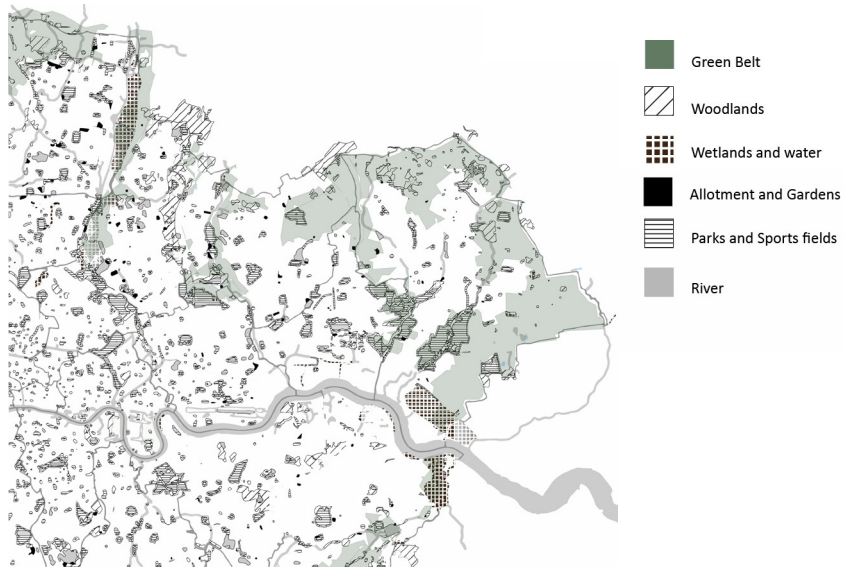

Figure 6. Green Landscapes within the city of London

Source : Author

4.3 Ethnographic Research and Area Mapping

Praxeology and phenomenology will be used for field research as the frames of value. I chose these two frames of values because Praxeology focuses on people's behaviour and culture. In contrast, phenomenology focuses on lived experiences and people's perspectives of spaces, which is essential to understanding productive landscapes' socio-spatial aspects. As allotments and community gardens are the focus of this study, I created a base map demarcating the allotments and community gardens in London. This map revealed that the boroughs within the inner city periphery had significantly less number of allotments as seen within the Greater London periphery.

Further, I will be studying the reports curated by the London Assembly. These reports have a set of narratives from allotment users— where people said that these allotments are their social centre. Therefore, these reports are substantial in overviewing the social value of productive landscapes from the participant's perspective. To further study the allotment gardens, I will create a matrix to understand their nature, the community it caters to, their activities, their size and the behaviour it induces at the neighbourhood level. An on-site study of allotments will follow the matrix study of allotments to understand the relation between daily activities around food, such as growing, cooking, eating, assembling, and disposing of, to trace the behavioural patterns induced from the plot to the plate. Ethnographic narratives of participants will be essential at this stage to understand the intangible layers of socio-cultural practices. On-site interviews, conversations and photographic essays will be the methods to follow at this stage to curate ethnographic research. The analysis of these data will establish the socio-spatial relationship within productive landscapes and its potential as a social realm.

Tools: Borough Council Data, GIS Maps, Allotment surveys, Interviews with plot holders and visitors, Sketching, Series of photographs made by mobile camera

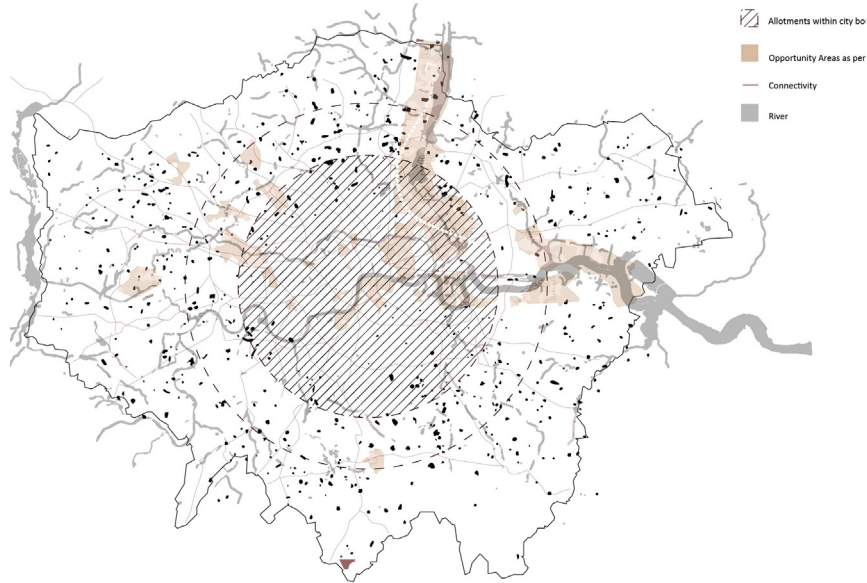

Figure 7. Allotment and Community Gardens within Greater London periphery

Source : Author

4.4 Demographic Data Collection and Mapping

The superimposing of demographic data such as density, ethnicity, food accessibility, food deserts and infrastructural network on the base map will aid in identifying potential areas of investigation and sites of interest. I will assess these sites on their degree of disconnectedness, where site conditions, social structure, cultivable degree of land and edges will be the deciding factors. Subsequently, I will conduct field research to study the socio-spatial conditions of these sites using photographic documentation. The socio-spatial site conditions would be uncovered by photographic documentation, spatial analysis, and site visits during the field research. A relevant constraint at this stage to filter the sites will be the boundaries of derelict spaces. As defined by the 'Capital Growth' initiative launched by the mayor of London in 2008, it includes unused green space on housing estates and other public land, riverbanks and railway land, inactive parks, and waterfronts.

Tools: GIS Maps and Data, Ordnance Survey Map, Google Earth Map, Greater London Authority documents and Maps, London Assembly Reports

4.5 Systemic and Network Diagramming

Based on the research on productive landscapes, I created an actor-network diagram to draw relations between food, its activities, people and ecology. This network will be used to understand the link between the visible and invisible socio-spatial dimensions of food in allotment gardens to expand its potential further at a larger scale by investigating pedagogical dimension.

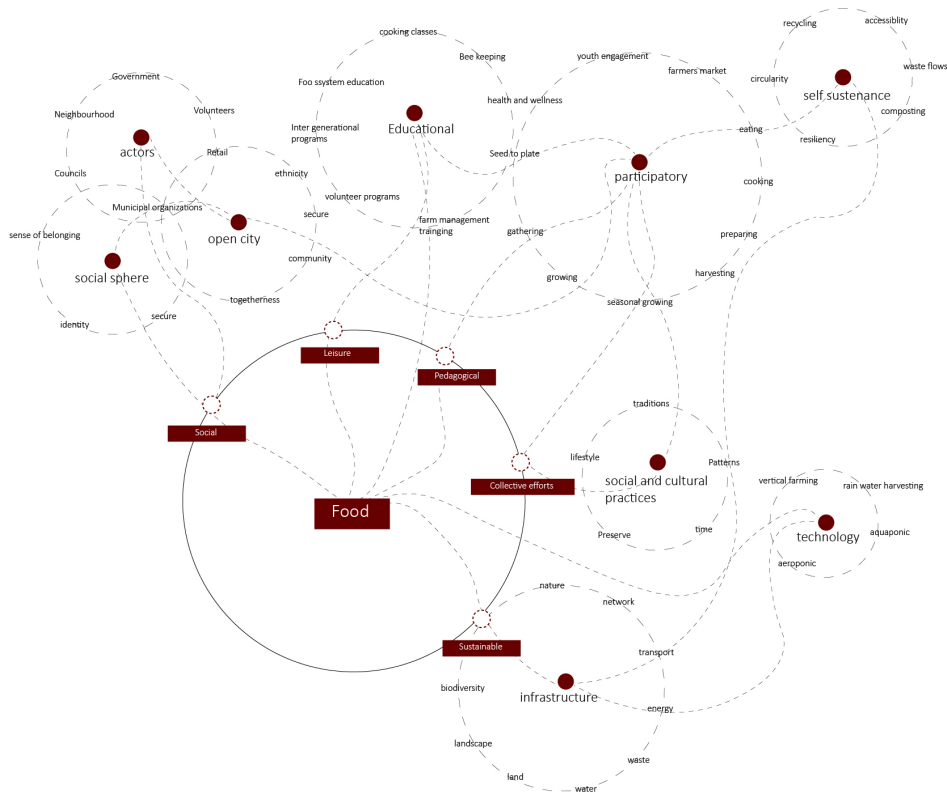

Figure 8. Network Diagram - Food, People and activities
Source : Author

4.6 Case Studies

I will use the case-study method to identify the potential and challenges of productive landscapes and understand the network diagram comprehensively within the city of London to work towards the design agenda and intentions. These potential case studies will be based on pedagogical, participatory, and circular approaches to comprehend the dynamics between different food production sites with their participants as understood by the network diagram. Additionally, I will curate data related to the seasonal growing of vegetables/edible flowers/fruits to categorise participatory activities around the notion of time.

The findings and in-depth understanding of this relationship will aid in designing strategies of an agro-social for-by-of the community in the upcoming design by research phases.

5. Research Diagram

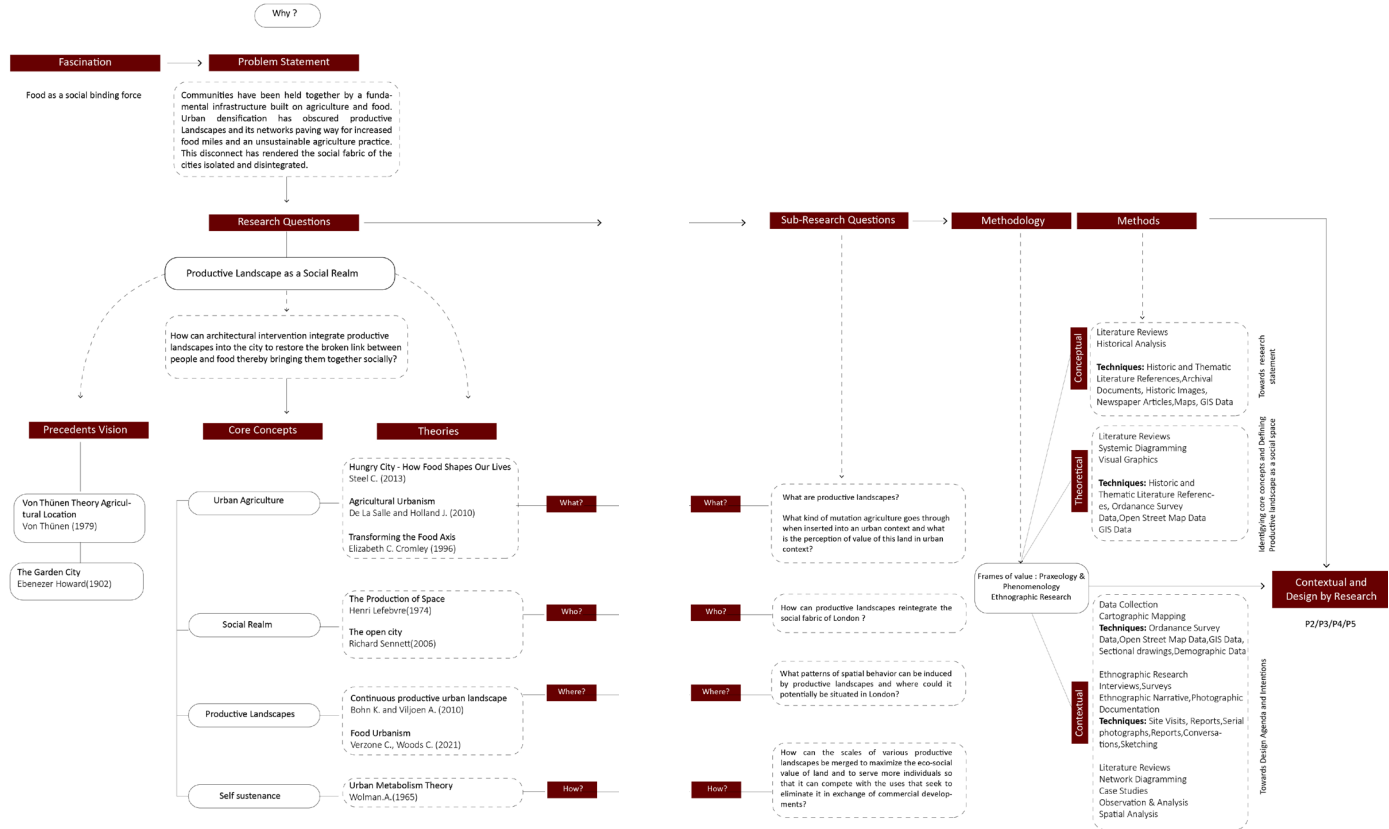

Source : Author

6. Argument on Relevance

The expansion of urban culture has led to a society of isolated individualism where people and families have become exclusive, isolated entities. This has led to a strain in the fabric of social cohesiveness. A contributing factor is the lack of common purpose around which communities can gather and unite in the fast-moving, distracted and discorded urban culture. The concept of Productive landscapes as a social realm can be the very mutual ground around which the communities can unite, as it revolves around the various aspects of food supply which is a concern for every individual across socio-economic boundaries.

The significance of “the community” is heavily emphasized by the London government. It has created several area-based initiatives in underprivileged communities to address specific local issues. These include the Single Regeneration Budget (SRB) and New Deal for Communities (NDC) programs, which combine initiatives to boost communal life while generating jobs, lowering crime rates, and improving housing.¹

Food has shaped cities, and the problem of the current system in the growing disconnect between food consumers and food production has led to the gradual depreciation in the social value and importance of land in food supply and thereby has made society more fragmented. This research is crucial as it intervenes beyond the food production capacity of allotments, as it would only partially justify the notion of egalitarianism. But if interwoven with the primary purpose of reintegrating the social fabric for community bonding, it stands the potential to transition into a social realm.

¹ Greater London Authority. (2018). The London Food Strategy. Healthy and sustainable food for London. <https://www.london.gov.uk/programmes-strategies/communities-and-social-justice/food/london-food-strategy-0>

Moreover, cities' food miles have drastically expanded due to population growth, climate change, and urban development. London imports 99% of the food it consumes, and excessive reliance on foreign countries may prove problematic when supplies are in case of crisis.² Assembly Report (Cultivating the Capital,2010) found that the green belt, primarily purposed for farming and comprised of 15% of the city's land, is not actively farmed. Creating a local-sustainable source of reliable food supply to minimize this dependence is of utmost importance and the need of the hour. People are now integrating techno-social synergies to transform food production to overcome this conundrum. The amount of open space in major metropolitan areas is decreasing because of the accelerated conversion of land into structures to meet the soaring demand for housing and other beneficial ventures. For cities to thrive sustainably, the relationship between agricultural and social integration must be restored.

Agriculture in cities can only exist if people interact with it on a personal level. By building this link through participation in food-related activities, productive landscapes could address the gap in the socio-spatial structure of metropolitan cities. This research is essential to discover a middle ground for a place-making strategy through productive landscapes in otherwise abandoned regions. The problem is vast and multifaceted, and the research does not provide an easy answer for connecting agriculture and people. However, the study aims to uncover the possibility of combining agriculture and architecture in a participatory way for the people.

2 London Assembly. (2021, November). ReLondon: An analysis of material flows, consumption-based emissions, and levers for climate action



Figure 9. Narrative of Participants in Allotment Gardens
Graphic Source: Author ; Narrative source: Allotments Report, Greater London Authority

7. Bibliography

Primary Literatures

Bohn, K. & Viljoen, A. (2009). Continuous Productive Urban Landscape (CPUL): Essential Infrastructure and Edible Ornament. Open House International

Belanger. P. (2009). Landscape as infrastructure. Vol.28. No. 1. University of Wisconsin Press

De La Salle, Janine M., and Holland. M. (2010). Agricultural Urbanism. Green Frigate Books

Cromley, EC.(1996). Transforming the Food Axis: Houses, Tools, Modes of Analysis. Material History Review,pp.8–20

Duany A. (2011). Garden cities: Theory & Practice of agrarian urbanism. Duany Plater-Zyberk & Company

Howard, E. (1946). Garden Cities of Tomorrow. London: Faber

Edible London. (2022, September 21). <https://ediblelondon.org>

Lefebvre,H. (1992). The Production Of Space. 1st ed. New Jersey: Wiley-Blackwell

Lefebvre, H.(2013). Rhythmanalysis - Space, Time and Everyday Life. London UK: Bloomsbury Academic

London Assembly. (2016). A Lot to Lose: London’s disappearing allotments

Sennett. R., 2006. “The Open City”.

Steel, C. (2008). Hungry City - How Food Shapes our Lives. London UK: Chatto & Windus, Random House

Steel, C. (2012). Sitopia Harnessing the Power of Food. London UK: Chatto & Windus, Random House

Thünen.V. (1826). *The Isolated State*. 2nd edition Modified

Verzone C., Woods C. (2021). *Food Urbanism: Typologies, Case Studies, Strategies*, Birkhäuser

Secondary Literatures and Articles

Angelil, M., Klingmann A. (1999). *Hybrid morphologies*, Daidalos Basel

Hunt J.D. (2000). *Greater Perfections: The Practice of Garden Theory*, Philadelphia: University of Pennsylvania Press. p. 32–75

Jane, B. (2010). *Edible Matter in Vibrant Matter: A Political Ecology of Things*. Durham and London: Duke University Press

Kim, S., & Kwon, H. (2018). Urban Sustainability through Public Architecture. *Sustainability*, p. 10, 1249. <https://doi.org/10.3390/su10041249>

London Assembly. (2006). *London's food footprint: An analysis of material flows, consumption-based emissions, and levers for climate action*

Lovell, S. T. (2010). Multifunctional urban agriculture for sustainable land use planning in the United States. *Sustainability* 2.8 2499–2522. <https://doi.org/10.3390/su2082499>

Mayor of London. (2019). *London Food Strategy*, London

Parham, S. (2015). Introduction. In *Food and Urbanism: The Convivial City and a Sustainable Future*. New York, NY: Bloomsbury Academic

Poole, S. (2006). *The Allotment Chronicles: A Social History of Allotment Gardening*. Silver Link Publishing, Kettering

Websites

The Telegraph. (2013, April 03). Dig for victory: vegetable growing during WWII in pics. <https://www.telegraph.co.uk/gardening/how-to-grow/9967597/Dig-for-victory-vegetable-growing-during-WWII-in-pics.html?frame=2525432>. [Accessed 15 October, 2022]

INSIDEflows. (2005). Pasona Urban Farming. <https://www.insideflows.org/project/pasona-urban-farming/>. [Accessed 15 October, 2022]

Mercato Metropolitano. (2022). Our MM Manifesto. <https://mercatometropolitano.com/our-mm-manifesto/> [Accessed 15 October, 2022]

Archdaily (2014). Value Farm. <https://www.archdaily.com/477405/value-farm-thomas-chung>. [Accessed 15 October, 2022]

8. List of figures

| | | |
|------------|---|---|
| Cover Page | Production in and of an eco-social condition | Source: Author |
| Figure 1 | Food as a social leveller | Source: The Telegraph. (2013, April 03). Dig for victory: vegetable growing during WWII in pics. https://www.telegraph.co.uk/gardening/howtogrow/9967597/Dig-for-victory-vegetable-growing-during-WWII-in-pics.html?frame=2525432 . [Accessed 15 October, 2022] |
| Figure 2 | UK Food miles and virtual water imports | Source: Author |
| Figure 3 | Mutation of Agriculture in Urban context - defining productive landscapes | Source: Author |
| Figure 4 | Theories of Social Realm | Source: Author |
| Figure 5 | Urban sprawl of London | Source: Author |
| Figure 6 | Green Landscapes within the city of London | Source: Author |
| Figure 7 | Allotment and Community Gardens within Greater London periphery | Source: Author |
| Figure 8 | Network Diagram - Food, People and activities | Source: Author |
| Figure 9 | Narrative of Participants in Allotment Gardens | Narrative Source: London Assembly Reports |

Part 2 - Research Essay

Production in and of an eco-social condition

1. Introduction

“Biodiversity is not a luxury, but a fundamental pre-requisite for our well-being. It is the foundation of our food systems and our health. We cannot afford to overlook our dependence on Nature or take her abundance for granted.” -Dr Cristiana Paşca Palmer ¹

In everyday life, food is a constant rhythm. A foundational infrastructure based on agriculture and food has kept communities together.² It all comes down to corn, as Carolyn Steel writes in her book *Hungry Cities*: “Man, and corn. Food has shaped our lives forever and will continue to do so. “Food has always shaped our lives, and it always will. Communities have grown up around the production of food. “³ Therefore, agriculture is the basis for urban growth, and food is the binding force.

From being self-sufficient within their rural hinterlands, cities have transitioned to relying on an unsustainable global food network that substantially disconnects people from their food, disintegrates the community, and squanders resources and the environment. This transition of London, from being self-sufficient within its hinterlands to the disappearance of green belt, very much puts worth the question of the value of land. The land is merely being seen as a commodity of monetary value that overlooks its eco-social value. This has also paved the way for unsustainable agriculture practices with increasing food miles, resulting in wasteful food packaging. As a result, the producer and consumer are no longer connected. A close connection to how a city feeds itself and the source of our food is lost, making the city and the land more distant than ever.

1 United Nations Decade on Biodiversity. (2019). *Our Biodiversity, Our Food, Our Health*. Convention on Biological diversity. UN Press

2 Belanger, P. (2009). *Landscape as infrastructure*. Vol.28. No. 1. University of Wisconsin Press

3 Steel, C. (2008). *Hungry City - How Food Shapes our Lives*. London UK: Chatto & Windus, Random House

Being ignorant that cities have survived because of the imminent commons - water, earth, air, and energy- we have pushed cities at a turning point where ecology and social dimensions are at stake because the political relevance is taking over. ⁴Land use patterns heavily prioritize human desires, establishing the conditions for an ecological collapse. The agri-food system portrays possibilities to address the disconnect between the land and cities, between people and food to produce an eco-social synergy. Considering the profound societal and economic changes, we need to make our cities more sustainable.

4 Zaera-Polo, A. et.al (2017). Imminent Commons: Urban Questions. Seoul Biennale of Architecture and Urbanism

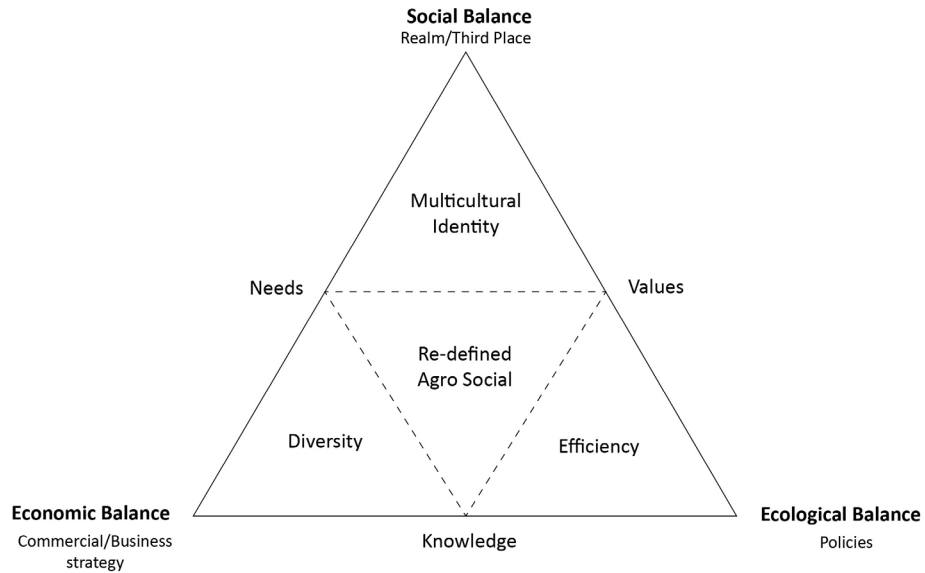

Figure 1. Balance through the re-defined Agro- Social

Source: Author

2. Mutation of productive landscapes

The emergence of human civilizations corresponded with the ability of communities to optimise the produce of the land to support extremely high population densities. Because most people were farmers and could predict when the environment would change, there was a clear relationship between the productivity of the land and the number of people a city could maintain. ¹As a result, people had a connection to their food, and land had ecological and social importance.

However, this balance changed with the changing perception of agriculture as a mere economic activity. The processes used to produce, market, consume, and discard food and other agricultural products are primarily to blame for ecological imbalance. These problems are brought up by the transition to the Anthropocene geological period, which necessitates a significant renewal of our agricultural system in the cities.

The term “urban agriculture” refers to the production of agricultural products in urban and suburban contexts and their processing and distribution. ²Carolyn Steel frequently underlines how food can change cities in her book *Hungry City*. Her view of urban agriculture is based on how it is practiced, which is broken down into four categories: urban agriculture for survival, for the community, for the global market, and lifestyle. ³

The precedents’ vision and theories of urban agriculture depict the mutation productive landscapes undergo in urban context based on food-cultural shifts that impact the land, which is the basis of production. This mutation, from evolving as a garden city to a heterogenous metropolitan, has significantly altered the soil biota. Urban culture’s expansion has produced a civilization of isolated individualism, where people and families

1 Mahaswa. R, et. al. (2021). Eco-agriculture and Farming in the Anthropocene Epoch: A Philosophical Review. E3S Web of Conferences

2 De La Salle, Janine M., and Holland. M. (2010). *Agricultural Urbanism*. Green Frigate Books

3 Steel, C. (2008). *Hungry City - How Food Shapes our Lives*. London UK: Chatto & Windus, Random House

have evolved into exclusive, isolated entities. The social fabric has been put under stress because of this. Lack of a unifying cause for communities to gather in the fast-paced, distracted, discordant metropolitan culture is a factor. Productive landscapes in the cities can generate an eco-social condition since it relies on food supply concerns, which affects everyone regardless of their socioeconomic status.

3. Redefining the social

Henri Lefebvre identifies spaces as a social product in his book *The Production of Space*.¹ He situates the concept of the social realm, where people actively interact in experienced spaces at the nexus of lived, imagined, and experiential environments. The social is often thought of as something that concerns people, but because human-nonhuman interaction is at the heart of all things, the imminent commons also belong to the social. Since the wind, bees, and flowers coexist to disseminate pollen, we need to redefine what it means to be social. This raises questions about the historical, ecological, and economic factors underpinning the design ideas currently used to create our social spaces. Latour's actor-network theory is crucial for rethinking the social since it forces us to re-evaluate how we research to understand the heterogeneous nature of social and physical transformations.² This network of material and immaterial flows, which places design at the centre of routine encounters between individuals and their surroundings, establishes a new realm by the conventional friction it causes. Both visible and invisible actors contribute to the creation of architecture, and because of their existence and impact on other actors' behaviours, both humans and nonhumans are continuing to change the direction of the post-Anthropocene trajectory.

I classified the green landscapes in the Greater London perimeter as forests, allotment gardens, parks, sports fields, community gardens, and waterfronts since an eco-social state combines the three fundamental aspects of food, ecology, and community. Community gardens and allotments' geomorphological conditions demonstrated all three aspects, demonstrating the possibility of forging a solid connection between the built environment, the community, and the economy.

1 Lefebvre, H. (1992). *The Production of Space*. 1st ed. New Jersey: Wiley-Blackwell

2 Latour, B. (2005). Introduction: How to Resume the Task of Tracing Associations." In *Reassembling the Social: An Introduction to Actor-Network-Theory*, Oxford: Oxford University Press. pp 1-17.

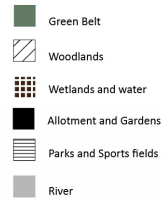
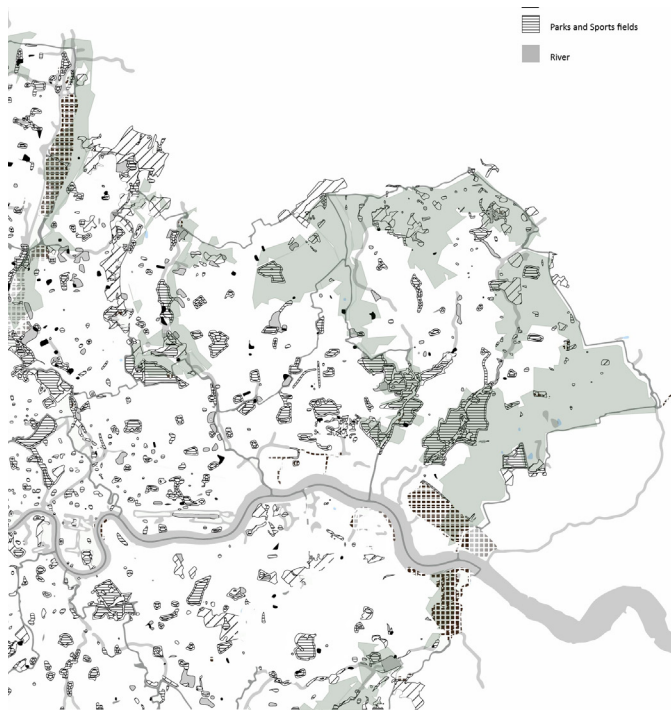

Figure 2. Green Landscapes in London
Source: Author

4. Food and its influence on cities, social spaces, and social relationships

The feeding of cities has undoubtedly been the most crucial factor influencing communities, and it still is. To comprehend cities, we must view them through the lens of food, as Carolyn Steel argues in her book *Sitopia*.¹She identified the three aspects; cities, social spaces, and social relationships—that food has the power to alter.

4. 1 Cities

Urban land cannot be determined exclusively by land use patterns concerning human functions because it involves topography, climate, and the bioactive layer of the soil. In addition, cities depend on the synthesis and resilience of life- human and non-human within the environment.

Cities are a synthesis of ecosystems generated by the confluence of both material and immaterial flows. The food system, which has historically served as the foundation of civilizations, is crucial to a city's ability to sustain itself.²The urban metabolism theory of Abel Wolman entails quantifying inputs and outputs and aggregating resources such as waste and energy in a city. It essentially aids in developing a circular approach for ecosystems, particularly the food system in cities where waste generation and consumption are at extremes.³With this notion, I intend to instill a circular and self-sufficient approach towards productive landscapes to accentuate the eco-social balance.

1 Steel, C. (2012). *Sitopia* Harnessing the Power of Food. London UK: Chatto & Windus, Random House

2 Kennedy, C., J. Cuddihy & J. Engel-Yan (2007). The changing metabolism of cities. *Journal of industrial ecology* 11.2 p. 43-59.

3 Pflieger, Geraldine, and Rozenblat. C. (2010). Introduction. *Urban networks and network theory: the city as the connector of multiple networks*. p 2723-2735.

Therefore, productive landscapes can be hybridized by integrating diverse functions that create a healthy relationship between community and environment. Incorporating technology with regenerative agricultural methods could illustrate greater potential output when the intersection of methods finds synergies.

4.2 Social Spaces

East London is most impacted by the centralization of the food system and urban sprawl; I determined this by overlaying the maps of deprivation, food deserts, infrastructure disconnectedness, and density which significantly highlighted Newham, Hackey, parts of Southwark as most affected. The reliance on the global food system, mainly supermarkets, is unsustainable because just four major British supermarket chains—Tesco, Sainsbury's, Asda, and Morrisons—control 70% of the country's grocery trade⁴. One may argue that regulating food gives one influence over people and space.

upermarkets pose as social spaces, but they are private property that do not embrace diversity. These are places that are not social, in contrast to anthropological places, like the street markets, which are steeped in tradition, hold memories, and evoke connections. ⁵ Land parcels that were originally designated for allotments are now also being taken over by commercial developers. There is also a lack of appreciation for London's diverse density because of the emergence of "pseudo-public" places. They anticipate regulated usage of the public spaces.⁶ However, individuals prefer to reside in racially, socioeconomically, and ethnically diverse communities that are safe, have effective public services, exciting cultural offerings, and try to lessen inequalities.

4 Savills Research. (2022). UK Grocery Report. Savills Commercial Research

5 Steel, C. (2008). Hungry City - How Food Shapes our Lives. London UK: Chatto & Windus, Random House

6 Shenker, J. (2017, July 24). Revealed: the insidious creep of pseudo-public space in London. The Guardian; The Guardian. <https://www.theguardian.com/cities/2017/jul/24/revealed-pseudo-public-space-pops-london-investigation-map>

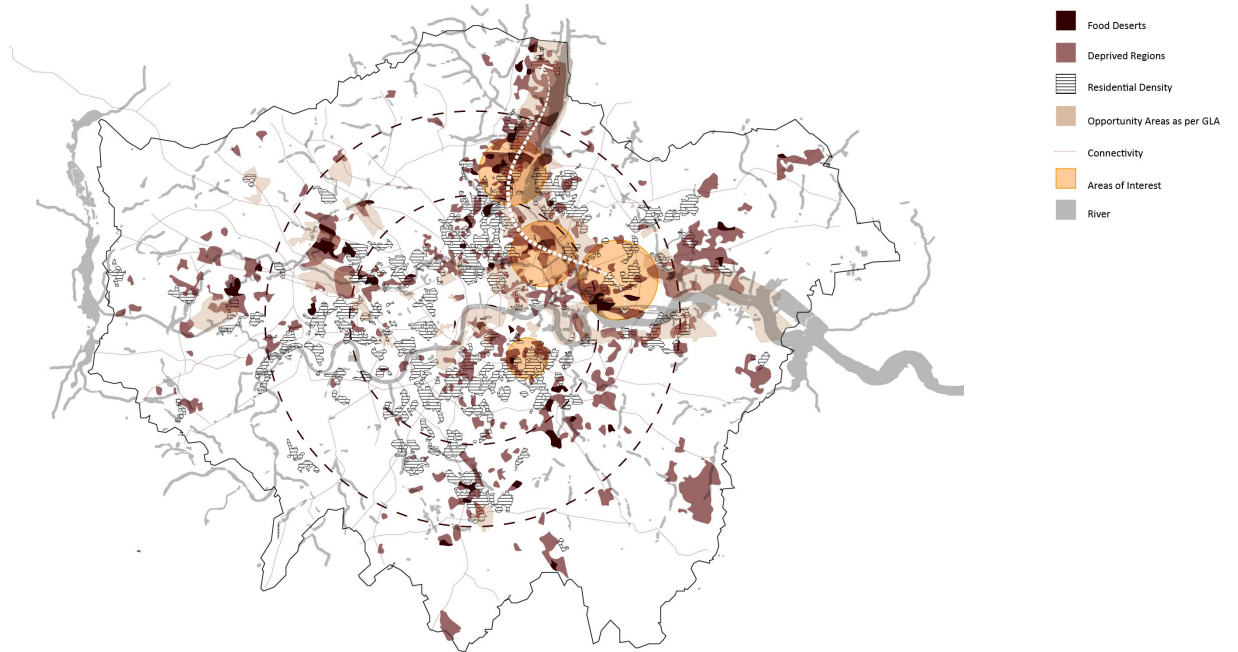

Figure 3. Sites of Investigation

Source: Author

A social space is one that is controlled by everyone and promotes social connections between strangers by creating an imperceptible level of attachment to a common environment and by enabling participatory activities. This attachment defines the actual social which embraces the ecology by serving as a foundation for a just productive landscape. Furthermore, as the history demonstrates, productive landscapes in London have been an effective social leveller. The function of allotment gardens has evolved from being used as a site for food security to one for fostering community ties from dig for victory to the COVID 19 phase. These productive landscapes give otherwise fragmented communities a multicultural identity via shared knowledge and activities along the food axis such as growing, cooking, eating, and composting.⁷

4. 3 Social Relationships

Through placemaking strategies, productive landscapes have the power to make food visible and improve the experiences associated with growing, harvesting, sharing, and learning about food.

City farms and community gardens in London are essential for giving locals access to nature, chances to grow their own food, and possibilities to build stronger community bonds and maintain the soil biota. True social condensers, like Newham City Farm, housed a variety of services that enable individuals to interact with their community and the natural world. The closure of the farm has clearly caused a separation with nature. Moreover, East London lacks allotment gardens, which foster closer bonds between people and a sense of ecological responsibility for the land. According to the Report on London's Disappearing Allotments, there are wait lists of more than 5 years to acquire a plot in the allotments.⁸ However, there are people who visit their friends at allotments like Kidbrooke Park Allotment even though they do not own a plot, indicating their role as social spaces in the neighbourhood regardless of socioeconomic status. The borough of Newham and the associations filed 5000 petitions to

⁷ Cromley, EC.(1996). Transforming the Food Axis: Houses, Tools, Modes of Analysis. Material History Review, pp.8–20

⁸ London Assembly.(2016). A Lot to Lose: London's disappearing allotments.

Photographic Documentation of the food axis

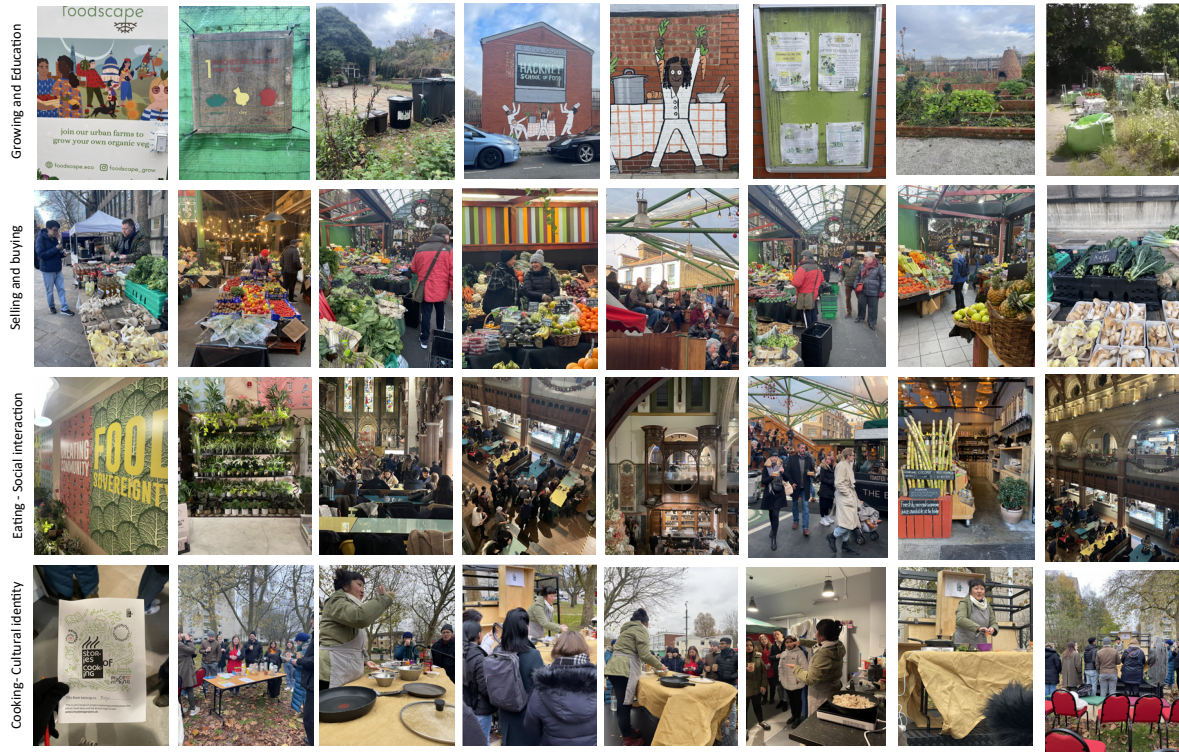

Figure 4. Creation and appropriation of urban space, civic engagement leading to transformations in the built and social environment ; Field research, London . Nov 2022

Source: Author

bring back the city farm which illustrates the significance of these spaces and its value to the community.⁹The two bottom-up programs, Edible London, and Capital Growth are bridging the gaps across many sectors to bring about change through knowledge, integration, and closing loops.

The surveys I took during the fieldwork revealed that the residents of the borough saw Farm as a vital community resource that gave generations of people access to nature and wildlife as well as therapeutic services for those who needed them. Most of the answers to questions about Newham's future vision involved having an important educational and social resource for food production. Compared to markets as active hubs of food trading, community gardens, city farms, and allotment gardens are more social agricultural areas. They serve as a "third place" for people to self-actualize and are essential for a person to become a part of their community and interact with people who share their interests.¹⁰They are not concerned with efficiency and profit, in contrast to industrial farms that produce food.

A variety of interactions are prominent here, but more social and private knowledge exchanges that strengthen societal links are especially prevalent. Because they are more hands-on and educational in nature, they have a longer-term positive impact on the development of urban farming and quality of life. Furthermore, this kind of urban organic gardening promotes biodiversity in cities.

9 My London News. 2021. Newham Council vote to close Newham City Farm despite community uproar. <https://www.sustainweb.org/news/sep21-petition-to-save-newham-city-farm/>
10 Paul, H. (2013). "Third places" and social interaction in deprived neighbourhoods in Great Britain. *J Hous and the Built Environ*, 8:221-236.

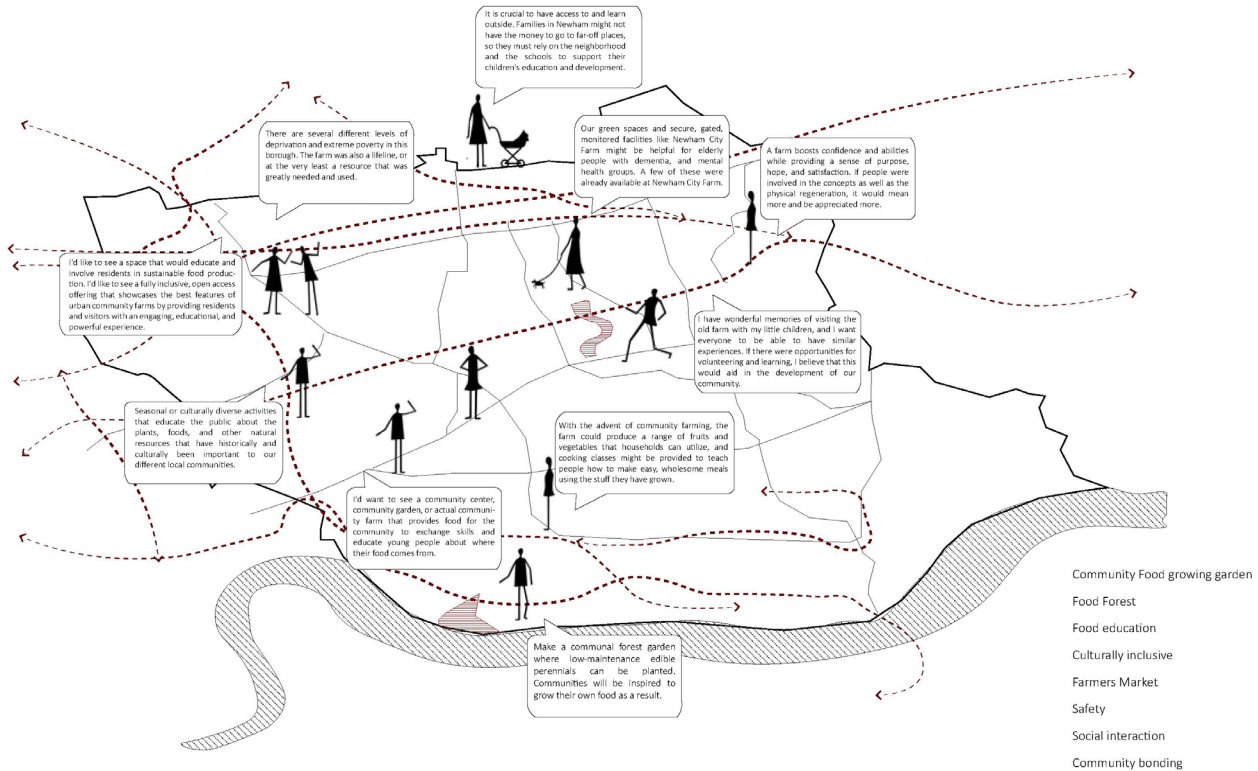

Figure 5. Social for the people of Newham

Source: Author

5. Social repercussions of Industrialization

Since the industrial revolution, we have made numerous technical advances, and with each one, we have gradually forgotten the labour-intensive work that goes into agriculture. In comparison to our hunter-gatherer predecessors, we become less capable of providing for ourselves, less able to defend ourselves, less aware of our environment, and less observant of change. Despite the abundance of secondary stimulation in our life, we lack primary interaction with the outside world. By depicting the symbiosis between city and country, the narrative of the positive and bad impacts of government serves as a constant reminder that food is what lays at the core of healthy governance. Instead, we have developed into metropolis of materialism, creating a rift with the environment that provided us with food.

Lack of high-quality training in the field may impede urban agriculture from playing its vital part in urban food systems, economies, and the living environment. The production of food is not given much attention in education, and the closure of Newham City Farm, which still enabled individuals to engage in agriculture, further alienated people from the field. Today's agri-food education typically puts the needs of agribusiness first rather than those of the smaller urban/suburban producer. Due to intensive production and dense habitation, urban agriculture must place a different emphasis on food production, with consideration of the Anthropocene epoch.¹

The growing gap between the farmland and city necessitates that humans comprehend the foundations of food production; else, yields will plummet. Because of the uncertainties, the productive landscapes must be dynamic, and humans must be knowledgeable about the food axis to drive it. Urban agriculture for the neighbourhood can be utilized as a social project, such community development or education in forms of allotments.

1 Mahaswa. R, et. al. (2021). Eco-agriculture and Farming in the Anthropocene Epoch: A Philosophical Review. E3S Web of Conferences

²It focuses more on the social aspects of urban agriculture rather than the actual food production considers improving social cohesiveness, fostering a sense of security, and raising people's awareness of and connection with food. All of these are tangible community aspirations that urban agriculture can help us achieve which can't be harvest at a commercial agri-food system.

6. The three pillars of the Re-defined Social

6.1 Productive landscapes as social space

The ethnic diversity of the people of Newham also necessitates a holistic approach to regeneration operations to meet a range of social and cultural needs. Unless social and cultural rehabilitation promoted citizens' active engagement with one another, physical regeneration and infrastructural development alone could not provide a shared sense of community identity. Reimagining strategies to connect people to the land and the ecology we share it with, including collaborative food production and the establishment and maintenance of biodiverse is necessary to dematerialize food production.¹ The practice of seasonally growing vegetables holds a special significance that intersects with the celebrations and festivals of different religions. This establishes a social value of land among the social who share them. Across various religious traditions, some festivals are linked to the timeline of nature and agricultural abundance. Seasonal growing of vegetables aligns with these festivities, as it allows individuals to cultivate and harvest crops specifically associated with times of the year. By practising seasonally focused cultivation, individuals connect with the natural cycles of growth and enrich their religious celebrations with the bountiful produce that aligns with their respective faiths. It reinforces the harmony between nature, spirituality, and cultural traditions, while fostering a deeper appreciation for the agricultural blessings bestowed upon us. In the food system and food sector, politics always plays a role. The localized agroecological food system has the power to generate strong and resilient communities. The opportunity to address structural inequality and egalitarianism is provided by the food axis, which encompasses all facets of food production and consumption. This necessitates identifying and critiquing how economic supremacy, privilege, and authority are held within our network, our projects, and the communities we work in. It also involves fighting against the appropri-

1 De La Salle, Janine M., and Holland. M. (2010). *Agricultural Urbanism*. Green Frigate Books

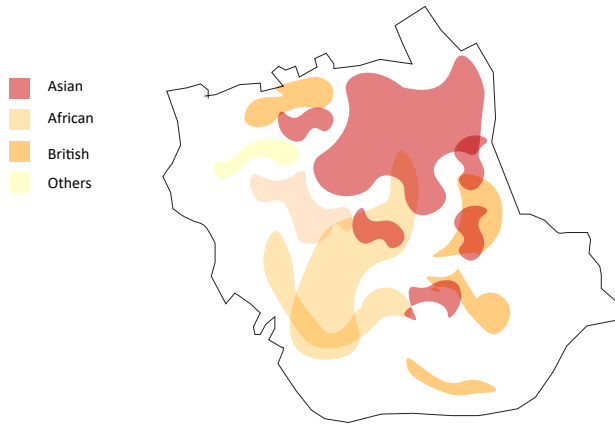

Ethnic diversity in Newham
Source: Author

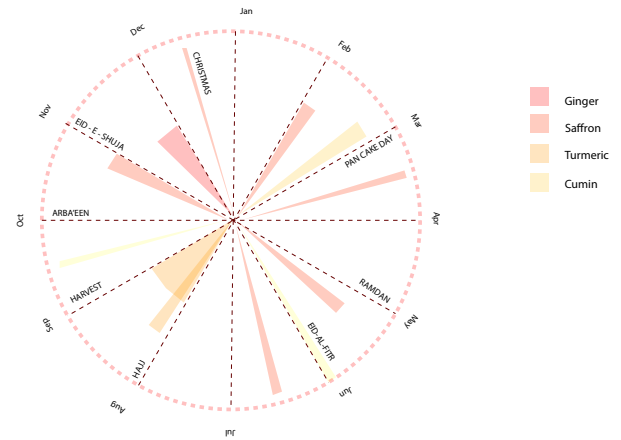

Harvesting Seasons
Source: Author

ation of local food production by corporate avarice.

6.2 Restoring the experiential connection to land

The production of an eco-social condition is coherent with the ideologies of the Danish Pavilion at the Venice Biennale in 2021, which placed special emphasis on water and its relationship to life on Earth as it passes through entities that change with the years.²The pavilion illustrates connection by displaying water through the concept of time. The sea carries time, disaster, life, and other things. It penetrates every space we share. Technology is used to link the display to both the weather in Venice and the surrounding environment. It is revealed as an active element of the exhibition as opposed to being hidden, acting as a form of functional transparency. It creates a condition that allows water to be experienced in tamed, processed, and boundless states where visitors can participate in the cyclic system while touring the exhibition's multiple areas by sipping tea made from herbal plants that draw water from the cyclic system.

The eco-social is a concept that seeks to establish an experiencing bond with soil through food as a social connector between imminent commons and people, adhering to the same experiential premise as the Danish Pavilion. It inclines towards the pedagogical perspective of enhancing people's knowledge towards food production, thereby establishing the eco-social value of productive landscapes. The integration of technology, food axis, social and tradition translates to the post-Anthropocene trajectory as it shows that human interventions and their effects on the biosphere may no longer be exploiting but rather celebrating the ecology.

One new area where the necessity of non-human existence for the formation and preservation of human life and its environs is being acknowledged is the soil conservation movement. As the alarm about the life-threatening degree of global soil degradation mounts, the farming industry

2 Dezeen. 2021. Danish Pavilion. <https://www.dezeen.com/2021/05/20/lundgaard-tranberg-architects-danish-pavillion-venice-architecture-biennale/>

is seeing soil biota as essential to securing agronomic and ecological futures.³

We will soon be forced to adapt the shift because of the natural reaction brought on by current Anthropocene acts. However, if we act right away, we may enhance the connection between people and the land by integrating urbanization and agriculture. Whatever the situation, agriculture will inevitably shift as illustrated in the theoretical approach. For geopolitical, economic, and economic concerns, it will be imperative to do so. According to the probable scenarios, the scale and intensity of the adjustments will differ. Yet, the emergence of the Anthropocene will compel a mandatory redefinition of agriculture to promote ecologically intensive agriculture. Users must be knowledgeable about the food axis to advocate for urban agriculture and local production is necessary to combat the growing food miles and reliance on the global food system. The core of ecologically intensive agriculture is improving the environment that supports production, such as the soil. Although humans serve as their drivers, soil, the centre of agricultural activity, has the intrinsic ability to create a positive and negative balance in its environment.⁴

6.3 The Eco-social production

“A setting with a connection to the imminent commons generates a sense of belonging to a larger whole and increases seasonal awareness.”⁵

Reducing the distance from farm to table to its smallest possible length to introduce the closed loop cycle and celebratory rituals of food axis which is many-food related activities – growing, cooking, harvesting, composting. An experiential atmosphere that celebrates soil and its innate capabilities of sustaining food and life, where birds hymn the music and aroma of fresh herbs and gathering of people at cherishing the seasonal

3 Farm to Bread Dara - World Food Programme (WFP), Food and Agriculture Organization (FAO) and United Nations Development Programme (UNDP). (2022). MENA Report.

4 T. Hartig, & H. Staats (2007). Preference for Nature in Urbanized Societies: Stress, Restoration, and the Pursuit of Sustainability. *Journal of Social Issues*, 63 (1), 79-96.

5 Terrapin. Improving Health & Well-Being in the Built Environment. <https://www.terrapinbrightgreen.com/reports/14-patterns/>

harvest co exists. The idea that people and plants may coexist has a long history, going back to concepts like Aristotle's philia theory and the Hanging Gardens of Babylon. The creation of views and actual linkages to natural systems, such as the presence of trees, blooming plants, friendly animals, signs of human habitation, and clean water bodies, are recurring themes in biophilia.

To develop an organic interaction between cities and the biosphere, it is essential to ensure a sustainable food production through ecologically intensive agriculture. The interaction between cities and its bioactive layer needs to be restored to support populations, reduce global energy usage, and improve atmospheres. There is a potential that the way our cities are planned will improve the relationship between individuals and food. Creating visual and physical access to food within the discourse of the food system's production, consumption and celebration, education, and waste recovery could help achieve this.

In the centralized agri-system that currently exists, environmental catastrophes and disruptions are likely to occur. The bulk of the world's population is expected to live in cities, therefore for metropolises to become robust and less reliant on global systems, they will need to generate more food locally. By creating a decentralized system and situating food production facilities in an urban setting, the supply chains will be shortened, and the distance travelled by food will be reduced. To provide continuous supply that prevents the growth of food deserts and integrates the urban tissue, a lattice-like structure of suppliers at various scales must be built.

Additionally, plant classification has the power to radically alter the soil biota. Legumes, for instance, are high in protein and can fix nitrogen in the soil. Other crops, including cereals, benefit from the growth of this nitrogen. However, plants such as legumes are not favoured due to economic constraints.

Careful curation of plant species can result in soil reclamation, which ultimately aids in the restoration of biodiversity. 12 plant species and 5

animal species produce 75% of the world's food today. ⁶Horticulturists have emphasized that there are hundreds of thousands of plant species of which thirty thousand are edible. An essential component of regenerative agriculture is the introduction of new or old species. This reintroduction should occur in fields and on farms in the urban context to restore the link between food and people.

6 United Nations Decade on Biodiversity. 2019. Our Biodiversity, Our Food, Our Health. Convention on Biological diversity. UN Press

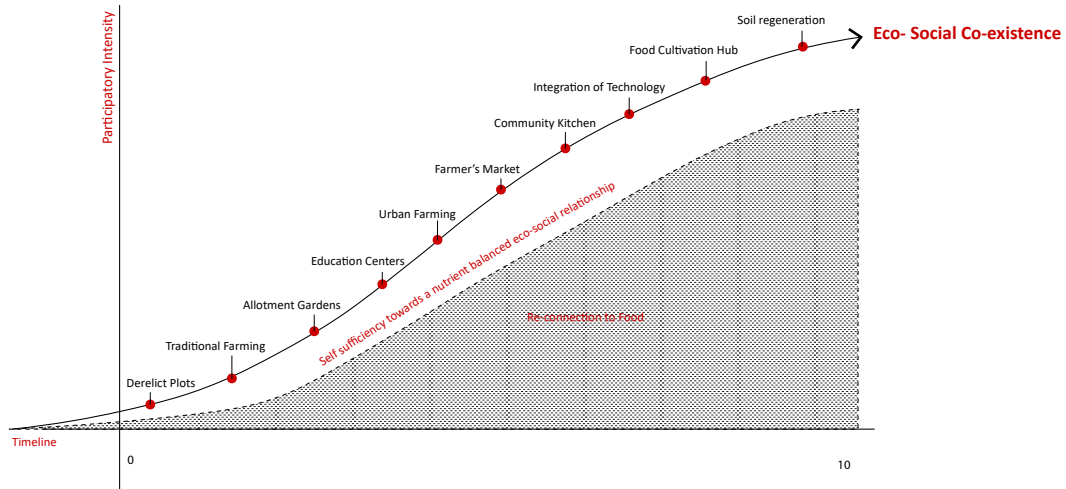

Figure 6. Merging scales with intensity of participation

Source: Author

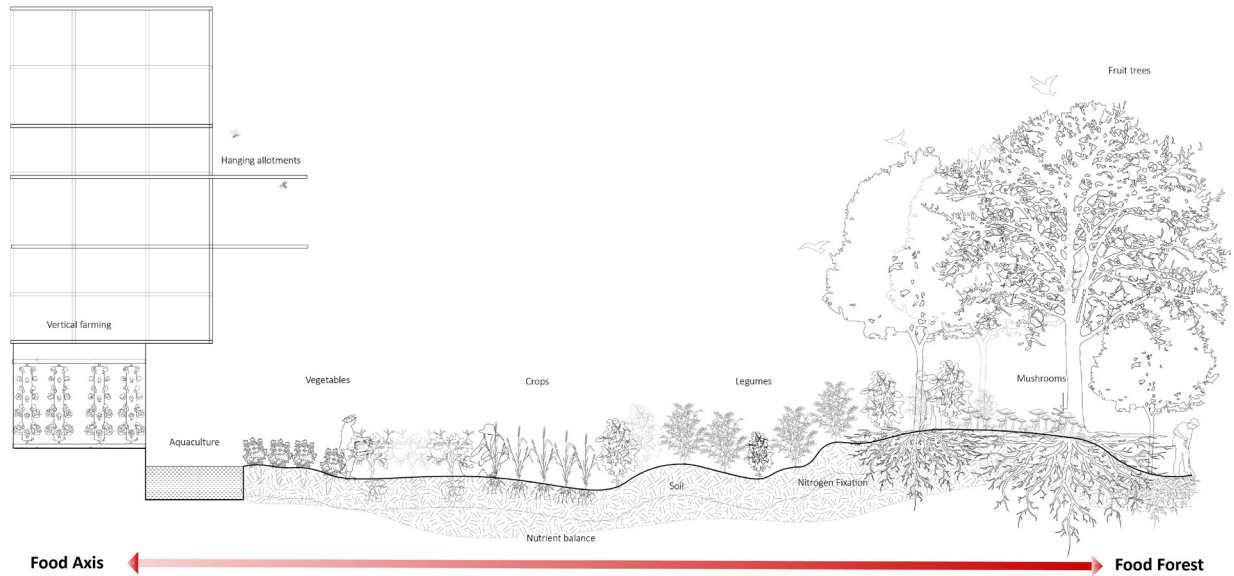

Figure 7. The re-defined Social
Source: Author

7. Conclusion

Cities have been shaped by food, and the current system's flaw in the widening gap between food consumers and producers has led to a progressive decline in the social value and importance of land in the production of food, further dividing society. This production of and in an eco-social condition is important because it intervenes beyond the productive landscape's ability to produce food because doing so would only partially support egalitarianism towards the actual social.

We must show consideration for the ecology and our environment. It falls on us, as architects, to create landscapes that are not only aesthetically beautiful but also supportive of the environment. Therefore, the reimagined Argo-social has the potential to include individuals in food production on a personal level to develop both new and current knowledge about the food axis. They will be better equipped to adapt to the varied behaviour of the land as a result. The agri-food systems require major reform, and a greater emphasis on environmental ethics is widely advocated. Because these are matters of legislation, policy, and societal resilience, it is crucial to integrate technology and social aspects.¹ The ability to customize food in different-sized facilities helps to diversify food sources and variations, which strengthens the resilience of food production. Urban farming has expanded due to new technologies like vertical farming, but it is up to us whether we will use this technology to improve or degrade the urban environment. We need to look for urban synergies in cities to balance out vertical farming's energy and water consumption. As a result, understanding ecological susceptibility becomes essential to the design goal. We must view agriculture as a vital activity that moulds our humanity and our way of life in the world, not only as a straightforward business activity. After all such productive landscapes generate the potential to evolve into an eco-social realm if integrated with the primary goal of reintegrating the productive landscapes towards an ecological and social balance.

1 Zaera-Polo, A. et.al (2017). Imminent Commons: Urban Questions. Seoul Biennale of Architecture and Urbanism

8. Bibliography

Belanger, P. (2009). Landscape as infrastructure. Vol.28. No. 1. University of Wisconsin Press

De La Salle, Janine M., and Holland. M. (2010). Agricultural Urbanism. Green Frigate Books

Dezeen. 2021 . Danish Pavilion. <https://www.dezeen.com/2021/05/20/lundgaard-tranberg-architects-danish-pavillion-venice-architecture-bien-nale/>

Kennedy, C., J. Cuddihy & J. Engel-Yan (2007). The changing metabolism of cities. Journal of industrial ecology 11.2 p. 43-59.

Latour, B. (2005). Introduction: How to Resume the Task of Tracing Associations.” In Reassembling the Social: An Introduction to Actor-Network-Theory, Oxford: Oxford University Press. pp 1-17.

Lefebvre, H. (1992). The Production Of Space. 1st ed. New Jersey: Wiley-Blackwell

London Assembly.(2016). A Lot to Lose: London’s disappearing allotments.

Cromley, EC.(1996). Transforming the Food Axis: Houses, Tools, Modes of Analysis. Material History Review, pp.8–20

Mahaswa, R, et. al. 2021. Eco-agriculture and Farming in the Anthropocene Epoch: A Philosophical Review. E3S Web of Conferences

My London News. 2021. Newham Council vote to close Newham City Farm despite community uproar. <https://www.sustainweb.org/news/sep21-petition-to-save-newham-city-farm/>

Paul, H. (2013). “Third places” and social interaction in deprived neighbourhoods in Great Britain. J Hous and the Built Environ, 8:221-236.

Pflieger, Geraldine, and Rozenblat. C. (2010). Introduction. Urban networks and network theory: the city as the connector of multiple networks. p. 2723-2735.

Shenker, J.(2017, July 24). Revealed: the insidious creep of pseudo-public space in London. The Guardian; The Guardian.<https://www.theguardian.com/cities/2017/jul/24/revealed-pseudo-public-space-pops-london-investigation-map>

Steel, C. (2012). *Sitopia Harnessing the Power of Food*. London UK: Chatto & Windus, Random House

Steel, C. (2008). *Hungry City - How Food Shapes our Lives*. London UK: Chatto & Windus, Random House

Thünen.V. (1826). *The Isolated State*. 2nd edition Modified

T. Hartig, & H. Staats (2007). Preference for Nature in Urbanized Societies: Stress, Restoration, and the Pursuit of Sustainability. *Journal of Social Issues*, 63 (1), 79-96.

Terrapin. *Improving Health & Well-Being in the Built Environment*.<https://www.terrabinbrightgreen.com/reports/14-patterns/>

Farm to Bread Dara - World Food Programme (WFP), Food and Agriculture Organization (FAO) and United Nations Development Programme (UNDP). (2022). *MENA Report*.

Verzone C., Woods C. (2021). *Food Urbanism: Typologies, Case Studies, Strategies*, Birkhäuser

Zaera-Polo, A. et.al (2017). *Imminent Commons: Urban Questions*. Seoul Biennale of Architecture and Urbanism

Secondary Literature and Articles

Angelil, M., Klingmann A. (1999). *Hybrid morphologies*, Daidalos Basel

Hunt J.D. (2000). *Greater Perfections: The Practice of Garden Theory*, Philadelphia: University of Pennsylvania Press. p. 32–75

Jane, B. (2010). *Edible Matter in Vibrant Matter: A Political Ecology of Things*. Durham and London: Duke University Press

Kim, S., & Kwon, H. (2018). Urban Sustainability through Public Architecture. *Sustainability*, p. 10, 1249. <https://doi.org/10.3390/su10041249>

London Assembly. (2006). *London's food footprint: An analysis of material flows, consumption-based emissions, and levers for climate action*

Lovell, S. T. (2010). Multifunctional urban agriculture for sustainable land use planning in the United States. Sustainability 2.8 2499–2522. <https://doi.org/10.3390/su2082499>

Mayor of London. (2019). London Food Strategy, London

Parham, S. (2015). Introduction. In Food and Urbanism: The Convivial City and a Sustainable Future. New York, NY: Bloomsbury Academic

Poole, S. (2006). The Allotment Chronicles: A Social History of Allotment Gardening. Silver Link Publishing,. Kettering

Part 3 - Design Process and Research Appendix
Design by research

Zones of Investigation

When embarking on my fieldwork investigation in London, I faced the exciting challenge of exploring a city I had never visited. To begin my research, I turned to Carolyn Steel's book "Hungry City," which provided valuable insights into how food has shaped urban environments, focusing on London. Steel's exploration of the city's history, from the garden city era to the Dig for Victory campaign and the current urban agriculture phase, inspired my investigation. Drawing from Steel's approach of viewing cities through the lens of food, which encompassed cities, social relationships, and social spaces, I applied a similar methodology. I employed filters such as social structure, infrastructure, food deserts, and deprivation as indicators to identify potential sites for my investigation. Through this analysis, I concluded the boroughs of Newham, Hackney, the Lea Valley area, and a portion of Southwark as zones that held significant potential for my research. These areas were selected based on their relevance to the themes I aimed to explore and the indicators I used to gauge their suitability.

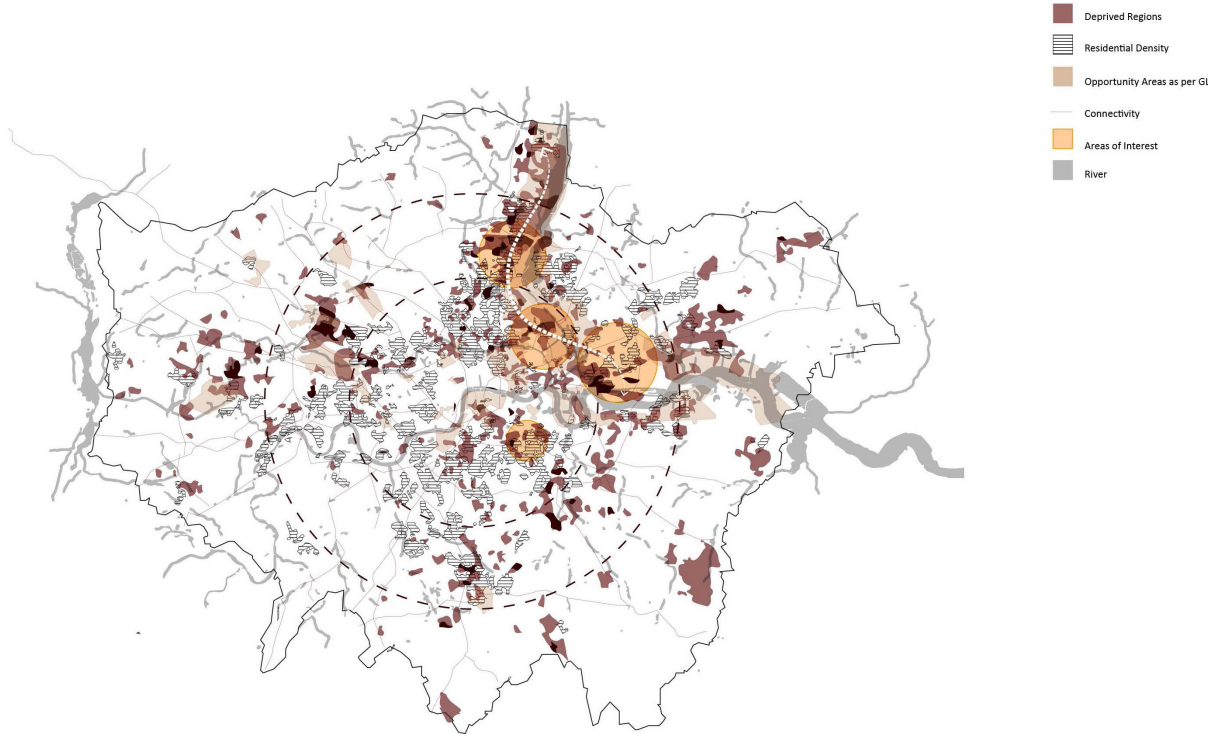

Sites of Investigation

Source: Author

Process of site selection

In my evaluation of various sites for investigation, I carefully assessed three key parameters: social structure, infrastructure, and derelict spaces. This helped me identify derelict parks in Newham, Hackney, and Lea Valley boroughs as Lyle Park, Beckton Park, Lower Lea Dockland, Manor Road and Bridge House Meadows.



Process of site selection

Source: Author

After a thorough analysis, I focused on the borough of Newham, specifically exploring Lyle Park and Beckton Park. These locations presented unique opportunities for study and intervention. However, during my field visits and interactions with residents, I truly understood the stark disconnection within the borough, particularly in Beckton. Despite being one of London's most diverse boroughs, Beckton seemed physically and socially isolated from the rest of the city. The lack of solid infrastructure and limited connectivity contributed to this disconnection, making it challenging for residents to engage with the broader London community fully. This realization emphasized the importance of studying and addressing Beckton's social dynamics and infrastructure gaps, aiming to foster a more cohesive and integrated environment that embraces diversity and strengthens community bonds.

On site observations

Newham borough, located in the vibrant city of London, is characterized by a mono-functional land use pattern contributing to a disintegrated social fabric. The borough's urban landscape is predominantly marked by a singular focus on specific functions, such as residential or commercial areas, with little integration of mixed-use spaces. This mono-functional approach has led to a need for more diverse gathering spaces and a limited range of activities, resulting in a fragmented social environment. In addition, the absence of interconnected spaces that foster community interaction and engagement has hindered the development of a robust social fabric within Newham. Efforts to promote mixed-use development, such as incorporating public spaces, community centres, and shared amenities, are essential to address this disintegration. By embracing a more inclusive and diverse approach to land use, Newham can create a cohesive social fabric that encourages community cohesion, interaction, and a sense of belonging among its residents.

Newham Borough

Site Visit - Royal Docks and Beckton Park



1. Beckton Park

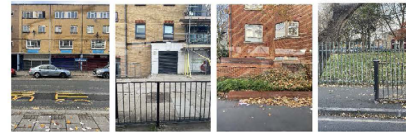

2. Stratford and Custom House

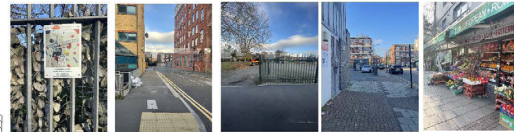

3. Canning town



4. Royal Docks and Silvertown

Site observations

Source: Author



Mono-functional Land use
Source: Author

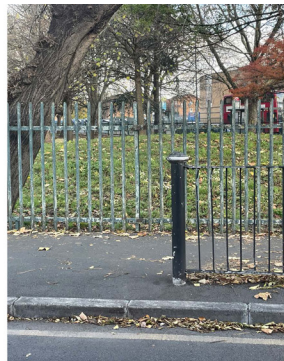

Inactive Parks
Source: Author



Extreme disparities

Source: Author

Part of the Beckton Park Re-development Plan by the Newham Council

After completing the initial phase of site investigations and narrowing down the options to Lyle Park and Beckton Park, I conducted a comprehensive survey to gather more information. To my surprise, I stumbled upon a significant development regarding the Newham City Farm, which had recently been closed down. The closure had sparked a wave of anger throughout the borough of Newham, creating a massive petition with fifty thousand signatures urging for its reinstatement. Intrigued by this public outcry, I delved deeper into the matter and discovered that Beckton Park was part of the Newham Redevelopment program. Additionally, it turned out that the Newham City Farm site I had chosen for my graduation thesis was already a real project being worked upon by East Architecture in London. Eager to better understand the user needs and the context surrounding the Newham City Farm, I reached out to East Architecture for a consultation. They graciously agreed to collaborate and invited me to participate in a workshop they conducted with the people of Newham. This workshop proved to be an eye-opening experience, as it uncovered a multitude of sensitivities associated with the site. Furthermore, engaging with the local community allowed me to comprehend their deep attachment to the Newham City Farm and the profound impact its closure had on their lives. This firsthand interaction provided invaluable insights that would ultimately shape the direction of my thesis and design approach.

The unexpected turn of events brought attention to the urgency of addressing the Newham City Farm's closure. It highlighted the intricate relationship between the community, the site, and the ongoing redevelopment efforts in the borough. Armed with this newfound knowledge and fueled by the collective passion for preserving the farm, I was determined to create a graduation thesis that would meet the users' needs and contribute to the larger narrative of urban development in Newham.



Beckton Park Redevelopment / Workshop
Source: Newham Council

Surveys

The surveys and interviews I conducted provided valuable insights into the challenges faced by the residents of Newham. The results revealed that a staggering 75% of the participants could not access an allotment garden where they could grow their own food. Furthermore, they expressed frustration with a waitlist that stretched over 10 years for a small plot measuring just 10 square meters. A recurring theme emerged when asked about what they missed in the borough. Most respondents mentioned the absence of the Newham City Farm, the lack of food growing spaces and opportunities for food education. Notably, when questioned about their vision for the future of Newham, safety was a common concern. However, respondents also expressed a strong desire for active green spaces, food forests' establishment, and initiatives promoting community inclusion and bonding. These responses reflect the community's aspirations for a borough that provides a secure environment, embraces sustainable practices, fosters a connection with nature, and cultivates a sense of togetherness among its residents.

Survey Results

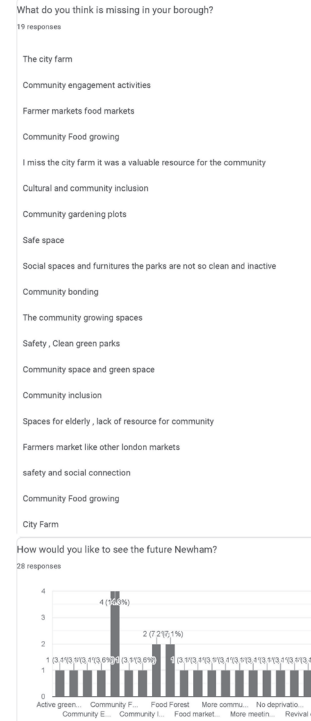
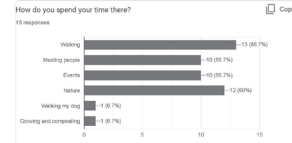
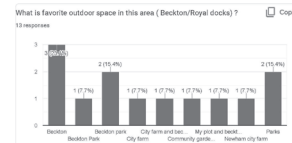
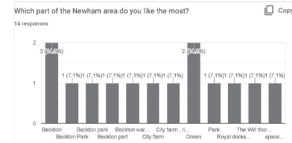
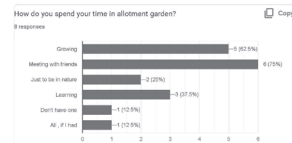
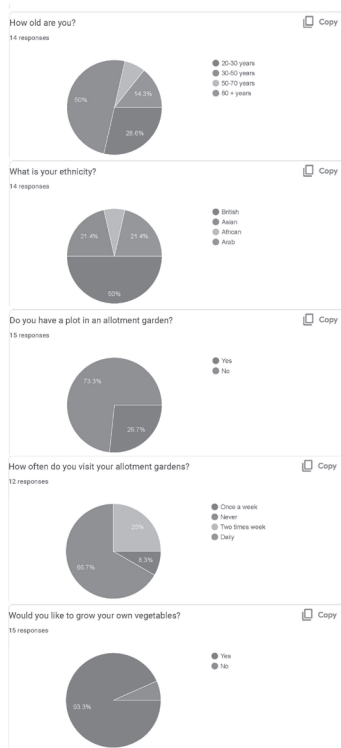

Survey Results

Source: Author

Understanding the relation between - Agriculture, Traditions and Time

The practice of seasonally growing vegetables holds a special significance that intersects with the celebrations and festivals of different religions. This establishes a social value of land among the social who share them. Across various religious traditions, some festivals are linked to the timeline of nature and agricultural abundance. Seasonal growing of vegetables aligns with these festivities, as it allows individuals to cultivate and harvest crops specifically associated with times of the year. For instance, in Hinduism, the festival of Makar Sankranti is celebrated with the harvest of winter vegetables like sugarcane, carrots, and leafy greens.

Similarly, in Judaism, the festival of Sukkot commemorates the fall harvest. It involves the use of “Four Species” – the etrog (citron), lulav (palm frond), myrtle, and willow – which are symbolic of the harvest season. By practising seasonally focused cultivation, individuals connect with the natural cycles of growth and enrich their religious celebrations with the bountiful produce that aligns with their respective faiths. It reinforces the harmony between nature, spirituality, and cultural traditions, while fostering a deeper appreciation for the agricultural blessings bestowed upon us.

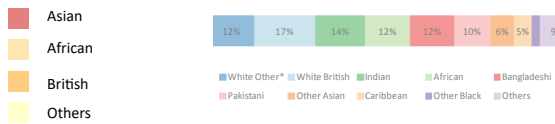
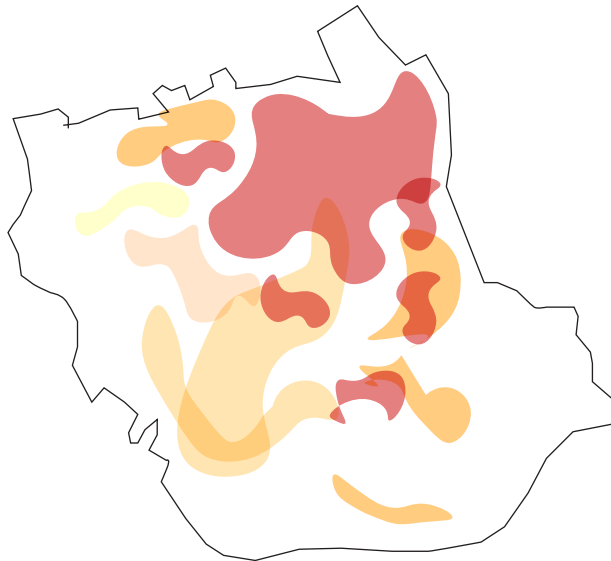

Ethnic diversity in Newham
Source: Author

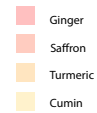
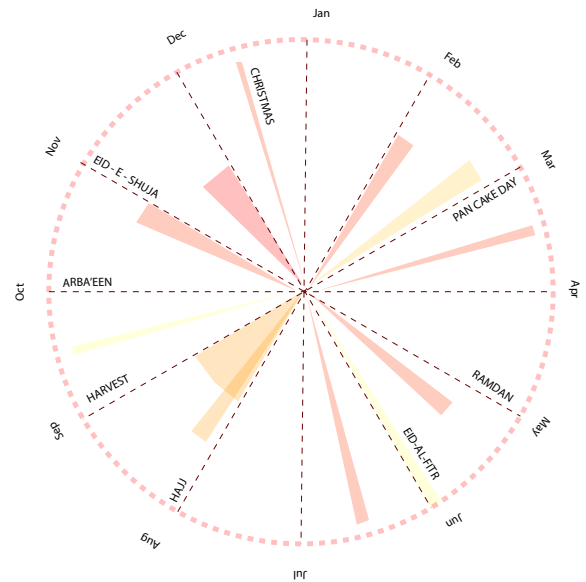

Harvesting Seasons
Source: Author

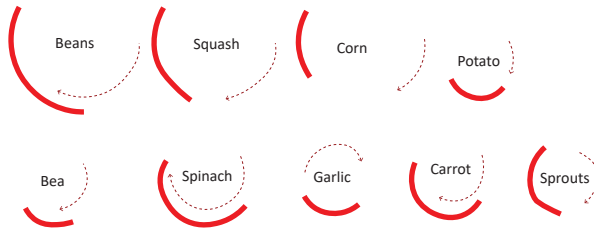

Companion Planting

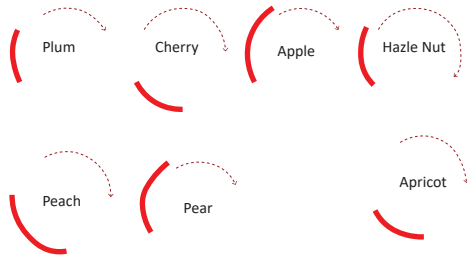

Food Forest



Maximising eco-social value through merging varying scales of productive landscapes

The concept of scale plays a significant role in productive landscapes and their relationship to the surrounding environment. Allotment and private gardens, operating at a micro-scale, are primarily intended for local consumption, and managed at the household level. These spaces allow individuals and families to grow their own food, promoting self-sufficiency and a deeper connection to their immediate surroundings. Moving to the meso scale, community gardens and greenhouses cater to socio-cultural needs and are often run by volunteers and associations. These spaces serve as community meeting points, fostering social interactions and knowledge sharing. Finally, on the macro scale, vertical farms emerge as large-scale, commercial operations aimed at maximizing crop production. These farms are typically managed by business organizations and contribute to food supply chains on a broader scale. A diagram illustrated below shows the merging of these scales to re-establish the link between the borough of Newham and its food sources in an educational and socio-cultural manner. This approach assisted in curating a range of productive landscapes and linked functions, incorporating elements from micro to macro scales, creating opportunities for local consumption, community engagement, and commercial viability. Such a design would encourage education, sustainability, and social cohesion, helping Newham residents rediscover the value of their food sources and promoting a holistic approach to productive landscapes.

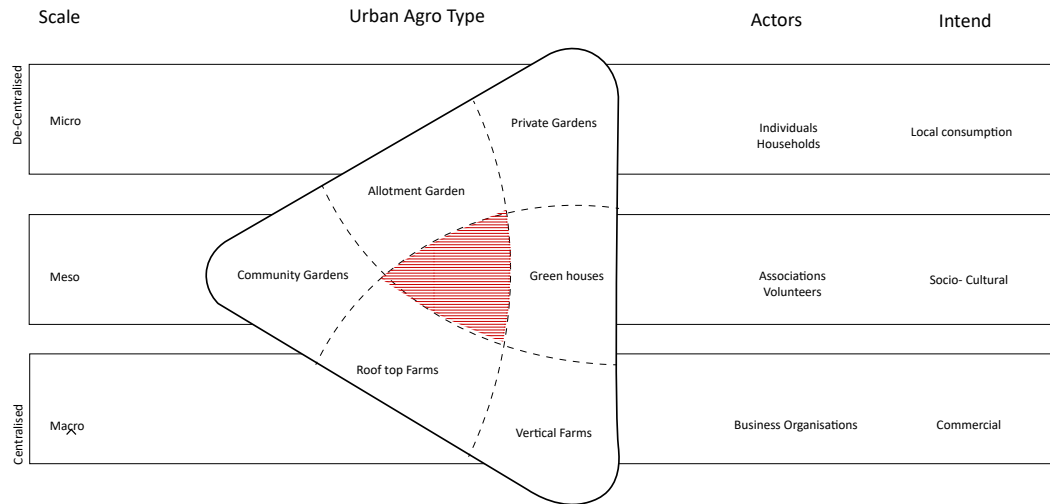

Relation of scale and productive landscapes

Source: Author

Understanding the relation between Functions, participation and timeline

The graph below illustrates the interconnectedness of various functions and their relationship to the level of participation within the neighbourhood, aiming to achieve sustainable eco-social coexistence. The progression begins at a small scale, where derelict or inactive green spaces are transformed into productive allotment gardens, serving as educational components that reconnect individuals with their food sources. This integration then expands to include urban farms within cities, where producing produce is not only for self-consumption but also for selling in farmer's markets, promoting local food economies. As the movement evolves, it establishes community kitchens and food cultivation hubs, fostering broader connections and social cohesion within the neighbourhood. Additionally, integrating technology within vertical farms allows for efficient and controlled food production while providing a timeframe of approximately 10 years for soil regeneration. This comprehensive approach ensures sustainable agricultural practices and supports the overall eco-social existence, creating a positive cycle of soil rejuvenation and fostering a harmonious relationship between communities and their environment.

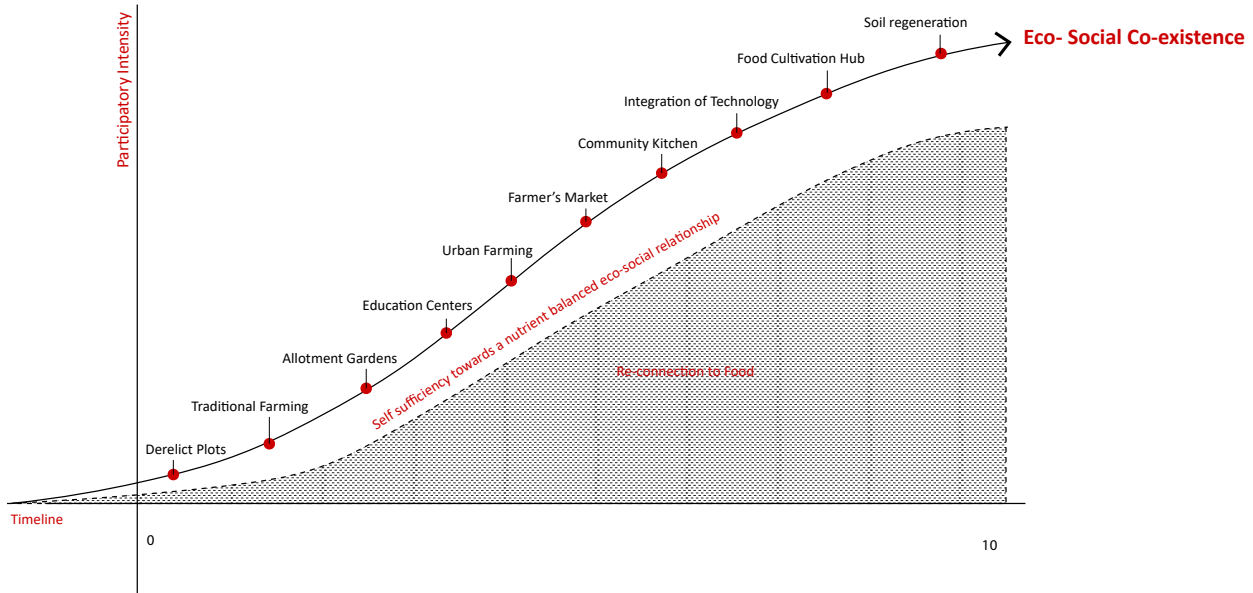

Merging of scales of productive landscapes and intensity of participation

Source: Author

Towards Design Agenda

The diagram presented below encapsulates the design agenda to create an eco-social Newham that fosters the emergence of ecopreneurs. The agenda revolves around several key aspects. Firstly, it emphasizes the importance of promoting knowledge and expertise in food production, empowering individuals to become self-sufficient in cultivating their own food. Additionally, it seeks to establish the eco-social value of land, recognizing its significance beyond a purely utilitarian purpose. This involves integrating sustainable practices, such as establishing a closed-loop system for energy and waste to achieve resource efficiency.

Moreover, the design agenda greatly emphasizes community-based autonomy, encouraging active participation and collaboration among residents. By fostering social inclusion, the design intends to create a sense of belonging within the community, enabling individuals to shape the development and utilization of their shared spaces. Ultimately, these collective efforts will redefine the agro-social fabric of Newham, generating a harmonious and interconnected relationship between agriculture and society. The envisioned outcome is the emergence of an eco-social condition where food production thrives, individuals are empowered, and the community flourishes.

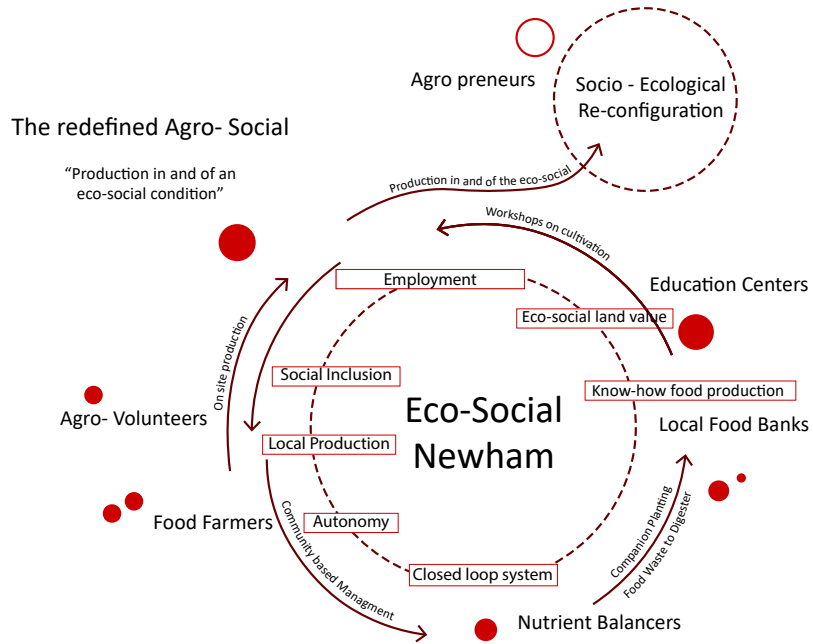

Design Agenda
Source: Author

Design and Site Development

The site development strategy for the deprived residential zone in Newham borough, London, focuses on creating a meaningful connection between the social and ecological zones surrounding the site. Situated between residential areas on the west and Beckton Park on the east, the strategy seeks to establish a sequence of functions along the food axis. By strategically linking the site to nearby schools, the scheme aims to foster a network that promotes food knowledge and awareness among students. Additionally, the development taps into the proximity of local farmer's markets and food banks, aiming to address food deserts within the borough. This approach not only encourages access to fresh produce but also contributes to the community's revitalization by bridging gaps between different social and ecological elements in the area.

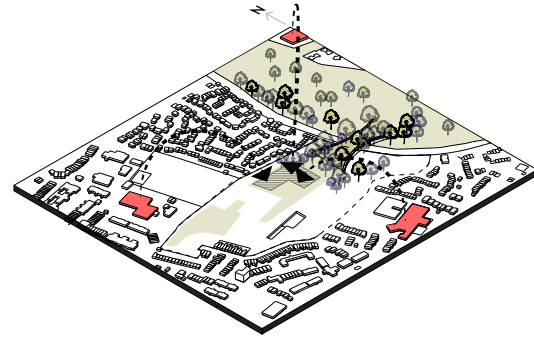
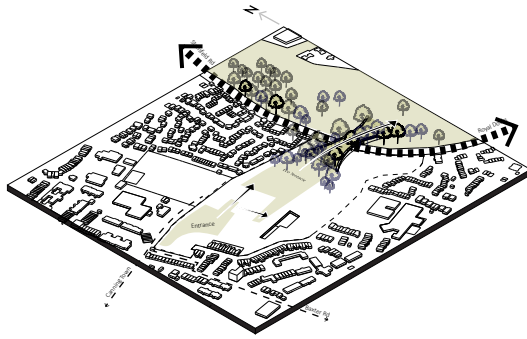

Strategy of linking education centers for creating awareness

Source: Author

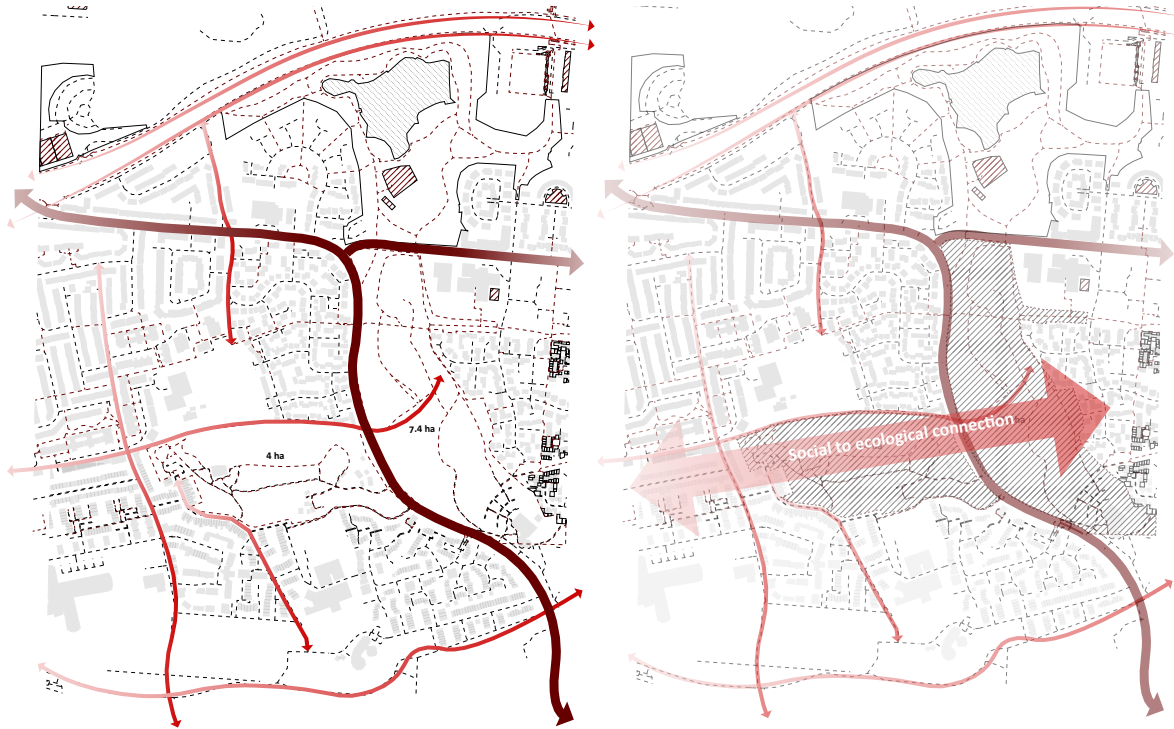

Conjunction with the development plans

Source: Author

The workshop with East Architecture in London

On March 11th, 2023, I had the opportunity to attend a thought-provoking workshop organized by East Studio in London, where neighbourhood members gathered to express their views on a particular site. It was truly inspiring to witness how deeply connected these individuals were to the location and their apprehension about any potential changes being made to it. The workshop turned out to be an eye-opening experience, as it highlighted a fundamental shift in people's priorities. Rather than seeking something entirely new or different, the participants revealed a strong desire to preserve the site's ecology and promote food education. It became evident that they valued the existing farm and recognized its potential as a platform for fostering a deeper understanding of sustainable food practices. The workshop served as a reminder of the significance of preserving our natural resources and nurturing a sense of community through initiatives that prioritize education and environmental stewardship.



Discussion on on site zoning and needed functions

Source: Author

This insightful workshop played a crucial role in shaping my understanding and curating a defined set of functions that redefined the social fabric through the lens of food and ecology. The discussions and interactions during the workshop shed light on the importance of reconnecting people with their food sources. The pandemic has exposed a significant disconnect between individuals and their food, prompting realizing the value of productive landscapes. The temporary closure of the Newham City Farm further emphasized the need for such spaces. It was reminiscent of the profound relationships formed in traditional allotments, where people had a direct connection to the land and the food they grew. The workshop inspired me to align a set of functions encompassing the entire food axis, from growing food to composting. By recognizing the significance of these productive landscapes and rekindling the connection between people and their food, we can redefine the social sphere and foster deeper relationships within our communities.

This workshop fundamentally transformed the design process by handing over the power to the Newham people themselves. The inclusion of sticky notes, filled with scribbled thoughts and ideas from the participants, provided them with a tangible means of influencing and assisting me as the architect in making informed and rational decisions. It was a collaborative effort, resulting in a design that truly reflected the needs and aspirations of the community. The workshop also revealed a stark reality—there is currently a 10-year waiting list for plots in allotment gardens, particularly in the food desert and deprived borough of Newham. This pressing issue underscored the urgent need to redesign allotments to ensure everyone has access to a parcel of land to grow their own food. The workshop's emphasis on inclusivity and equitable access empowered the community to shape a design not only by and for the people but also catalyzes positive change in addressing food scarcity and social disparities.

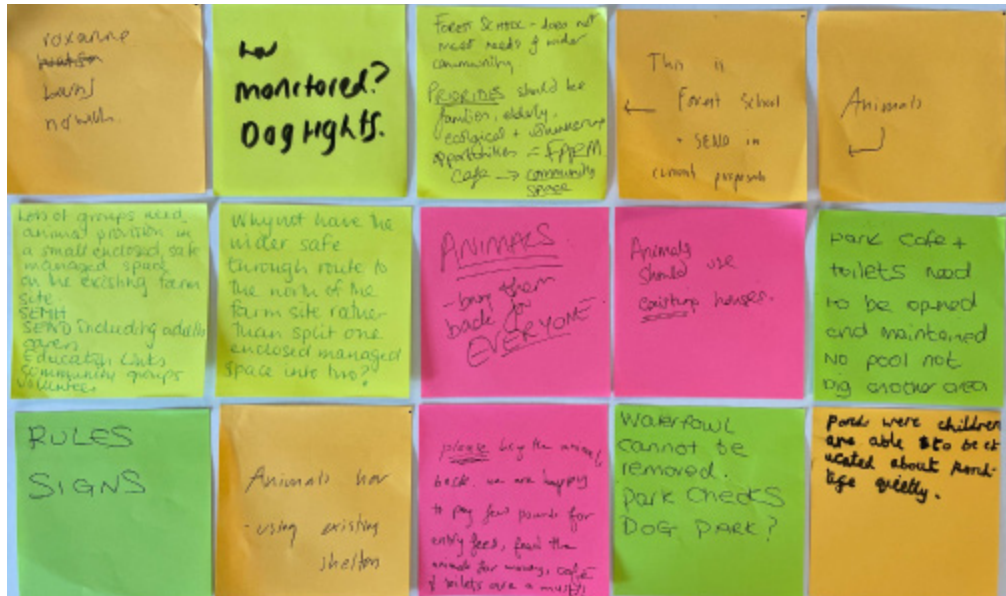

Feedback on the site zoning from neighbourhood

Source: Author

Integration of Landscape into design

Before attending the workshop, my vision for redeveloping the site involved transforming it into a productive landscape with a strong technology integration. However, the workshop provided a valuable perspective that shifted my understanding. It became clear that the local community had a deep emotional attachment to the site and desired to preserve it as much as possible, mainly the animal farm. This realization prompted me to approach the site's redesign from a landscape perspective, considering the community's sentiments and incorporating their desired functions. As the process unfolded, I recognized the importance of harmonizing the project's ecological and social aspects. It became evident that achieving a successful outcome required the simultaneous integration of environmental sustainability and community engagement, emphasizing the necessity of eco-social coexistence.

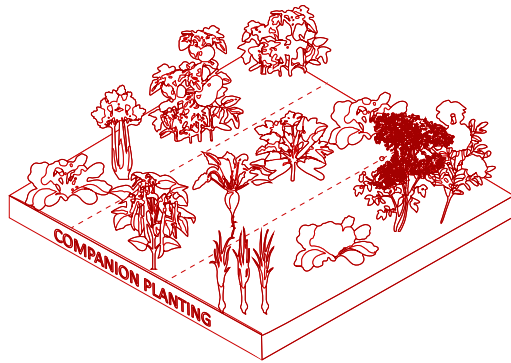

Companions : Beans , Corn, Squash, Cucumbers , Potatoes, Sunflowers



Companions : Beans, Marigold ,Potatoes



Companions : Cabbage, Celery , Tomatoes, Cauliflower



Companions : Spinach , Corn, Potatoes , Garlic

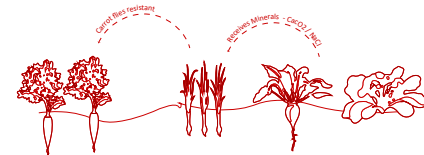

Companions : Carrot ,Onion, Garlic, Beet , Cabbage

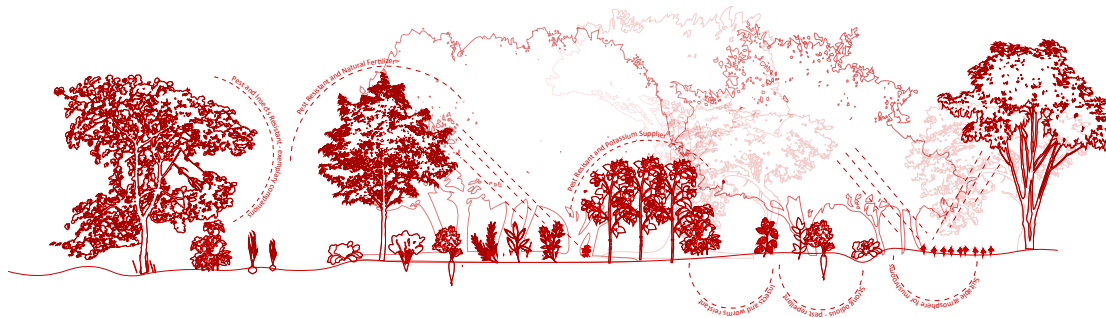
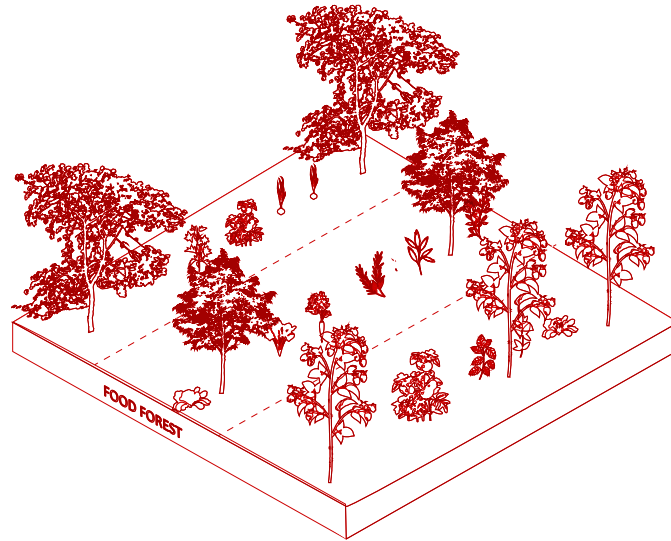

Companions : Apple - Tomato, Garlic, Cauliflower ; Apricot - Spinach, Carrot, Rosemary, Thyme ; Raspberry - tomatoes, basil ,chive, carrot, cabbage

Adjacencies and proximities

The design creates a solid social-to-ecological connection by strategically integrating various elements within site. Upon entering from the social side, a central plaza reminiscent of an agora becomes the focal point, bringing together all the functions at the heart of the site. As the plaza wraps around the staggered allotment modules on the right, the left side is dedicated to a community centre with spaces for communal dining, a kitchen, and classrooms.

The central plaza extends the double-height event space within the community center, providing a vibrant gathering space for social interactions and community events. The visual connection between the social and ecological aspects is established from the market area through a vertical farming hub. This component is an educational element, showcasing the sustainable practices and innovative techniques employed in urban agriculture. While the design prioritizes the retention of existing allotment plots and the animal farm, it also incorporates an elevated eco-tentacle that acts as a natural corridor amidst the surrounding trees. This experiential route leads visitors from the site towards the adjacent Beckton Park, where a food forest awaits, completing the connection from the social realm to the ecological segment.

The design fosters a seamless transition and interaction between the social and ecological components by carefully integrating these elements and creating visual and experiential connections. It encourages engagement, education, and a deeper understanding of the interdependence between human activities, community dynamics, and the surrounding environment.

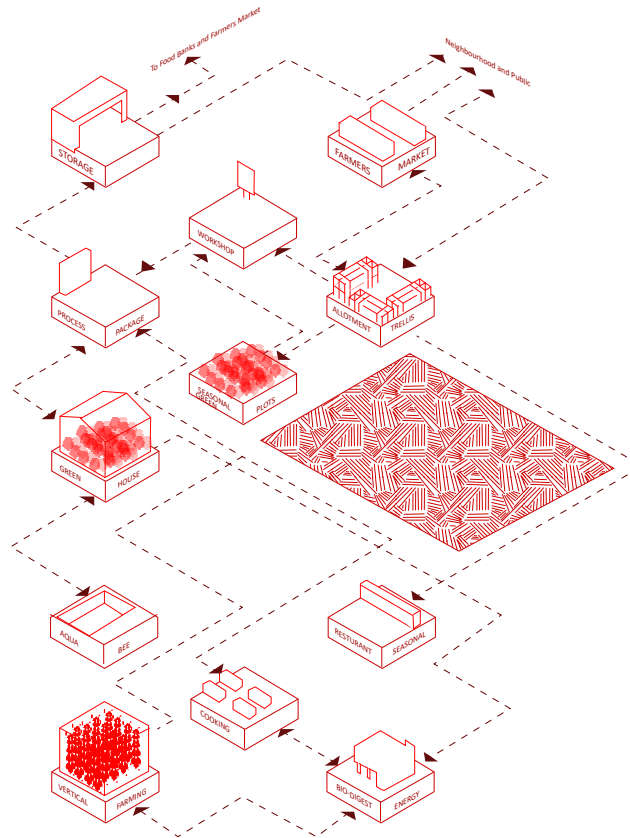

Adjacencies and proximities
Source: Author

Modularity in design

The design concept is rooted in the principle of modularity, where a grid system of 8 x 8 meters forms the basis for organizing the site. This grid system establishes three distinct modules of different scales: small, medium, and large, each serving specific functions. For example, the small-scale module is dedicated to allotment gardens, providing personal cultivation spaces for approximately 150 individuals, primarily for their consumption.

The medium-scale module encompasses community kitchens, communal dining areas, event spaces, and farmer's markets, accommodating around 200 people. This module encourages social interaction, shared meals, and community events, fostering a sense of togetherness and connection within the site. On a large scale, the module is designed for vertical farming, production and processing facilities, laboratories, and local distribution, catering to the needs of approximately 500 people. This module integrates innovative farming techniques, efficient production methods, and local distribution networks, ensuring a sustainable and accessible food system within the community.

Furthermore, at an even larger scale, the design envisions establishing a network for regional distribution, extending beyond the borough of Newham. This expansion further enhances the connectivity and resilience of the food system, fostering collaboration and exchange between different communities. By employing this modular approach, the design creates a flexible framework that can adapt and grow over time to meet evolving needs and demands. In addition, the grid-based system provides clarity, organization, and scalability, allowing for efficient allocation of resources and spaces within the site. Ultimately, this modular concept ensures a harmonious integration of functions and scales, promoting a diverse and inclusive ecosystem of productive landscapes within the borough.

S

M

L

XL

1-150 people

150- 250 people

750 - 1000 people

1000-15000 people

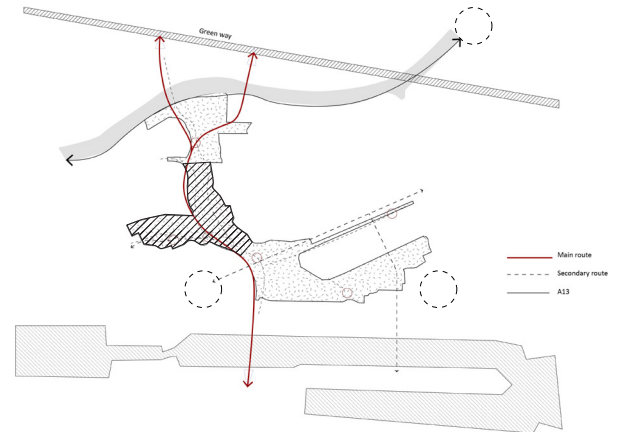
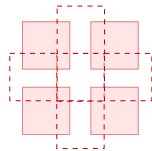
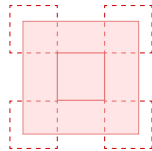
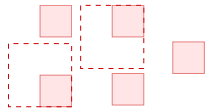

Modularity in design

Source: Author

Modules

The design concept is rooted in the principle of modularity, where a grid system of 8 x 8 meters forms the basis for organizing the site. This grid system establishes three distinct modules of different scales: small, medium, and large, each serving specific functions.

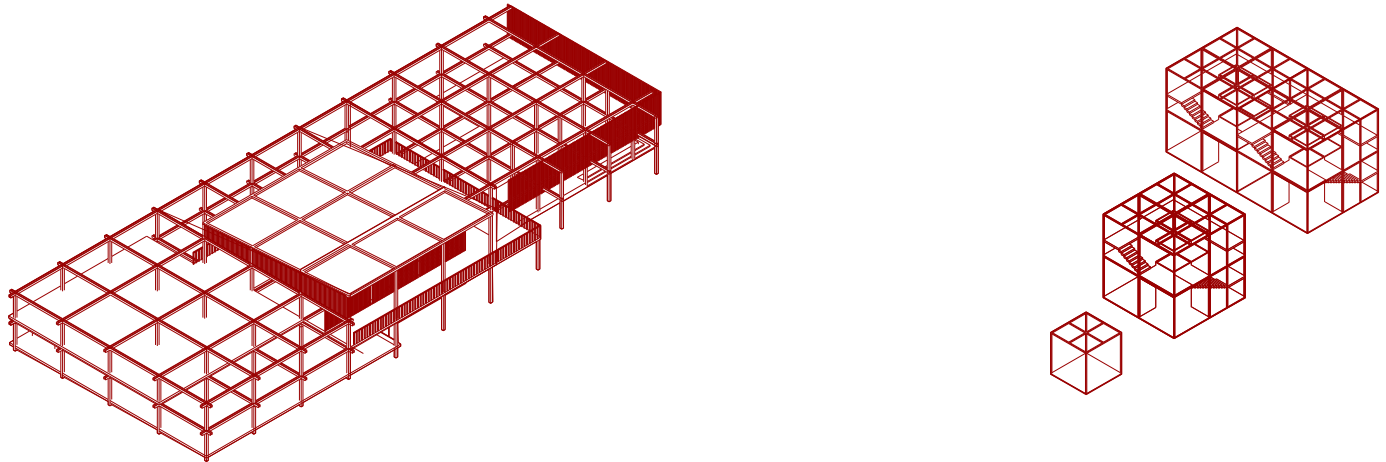

Heterogeneous City
Architectural Design Crossovers Graduation Studio

2022 - 2023

Tutors:

Johan van Lierop

Florian Eckardt

Alper Alkan

Pooja Mishra

Student No. 5335256

Faculty of Architecture and the Built Environment

TU Delft

Redefining the Social

This thought-provoking book presents a manifesto that challenges conventional notions of the social and delves into the intricate relationship between humans and the imminent commons. By acknowledging the vital role played by nonhuman entities like wind, bees, and flowers, it offers a fresh perspective on what it truly means to be social.

With a focus on the imminent commons—water, earth, air, and energy—it confronts the consequences of ignoring their significance in urban environments. It examines the historical, ecological, and economic factors that shape our social spaces, urging a reevaluation of the design principles governing our cities. Through compelling insights, it reveals the alarming ecological risks resulting from prioritizing human desires in land use patterns. However, it also proposes innovative solutions within the agri-food system to bridge the gap between rural and urban areas, reestablishing a meaningful connection between people and their food.

Against the backdrop of profound societal and economic changes, the book advocates for the transformation of cities into sustainable hubs. Tracing the journey of the heterogeneous city of London, which once thrived on self-sufficiency, it highlights the current reliance on an unsustainable global food network. This disconnect from our food sources erodes communities, depletes resources, and harms the environment.

By challenging the prevailing commodity-driven perspective, the book explores the intrinsic eco-social value of land, going beyond its monetary worth. It exposes the detrimental impact of unsustainable agricultural practices and the proliferation of food miles and packaging, further deepening the divide between producers and consumers and distancing cities from the land that sustains them.

At the heart of this exploration lies the recognition of the complex web of material and immaterial flows that shape our daily lives, with design taking center stage in our interactions with the environment. The research emphasizes the role of both human and nonhuman actors in shaping architecture, offering hope for redirecting our trajectory in the post-Anthropocene era.

Drawing on rigorous research and design principles, the manifesto establishes three fundamental pillars for redefining the social: productive landscapes as social spaces, restoring the experiential connection to land, and fostering eco-social production in the reimagined Newham City Farm and Beckton Park of Newham borough.

Embark on this transformative journey as the book unveils a new vision for the social, one that harmonizes human needs with the environment, paving the way for a sustainable future.