

Facilitating Collaborative Knowledge Workers to Improve Organizational KPIs

Using an Organization's Process Arrangement to Facilitate
Collaborative Knowledge Workers to Improve Organizational
KPIs

Ravesloot, Henriette

Delft University of Technology: Faculty Technology, Policy and Management



In cooperation with Nike EHQ



Facilitating Collaborative Knowledge Workers to Improve Organizational KPIs

Using an Organization's Process Arrangement to Facilitate Collaborative Knowledge Workers to Improve Organizational KPIs

Personal Details

Name: Henriette Ravesloot
Student Number: 4323432
Date: 29th of April, 2016
Master Program: Systems Engineering, Policy Analysis and Management
University: Delft University of Technology
Department: Technology, Policy and Management

Graduation committee

Chair: Dr. ir. Z. Lukszo
First Supervisor: Dr. M.E. Warnier
Second Supervisor: Dr. H.G. van der Voort

PREFACE

Even though it felt like this day would never come, I am very happy to finally write the preface of my master thesis which has kept me busy and awake for the past months, as a final project of my master studies in Systems Engineering, Policy Analysis and Management at the faculty of Technology, Policy and Management of the Delft University of Technology. I must admit that this was definitely my most challenging hurdle in completing my studies; however, in the true thought process of an engineer, a hurdle is there to be accepted, analyzed, re-designed and adapted until a sprinter can jump over it with all their will, hoping to land safely.

If a year ago, someone had told me I would be writing my thesis about knowledge workers I would have laughed, with a fresh memory of the course ‘organizational behaviour’ I followed in Groningen (no comment.) I was sure that my thesis would be a very technical, mathematical piece, remembering myself screaming out loud why I needed to learn about organizational behavior. Yet here I am, having written a whole bookwork about knowledge workers. To be clear, knowledge workers are important, studying knowledge workers is interesting, and having experienced being a ‘knowledge worker’ during my internship it is an extremely relevant issue where so many coworkers were feeling frustrated by systems not working, time limitations, running after information, etc.

The term ‘time limitation’ leads me to the aim of this section, where I would like to express my gratitude as there are certain people I would like to thank for making this research possible. Special thanks go out to my first supervisor Martijn Warnier. You have continuously provided me with refreshing ideas, quick replies, valid feedback, support and most importantly, you have always read a lot of my sometimes ‘lengthy’ texts. The meetings that we had provided significant value and I was always very happy that we shared the same vision concerning things that were ‘fluffy’ and always left your office with new ideas and motivation to continue. Next to this I would like to thank my graduation committee, Zofia Lukszo and Haiko van der Voort who always asked the rights questions and improved my research process. The significant amount of feedback received during our meeting allowed me to push my research further and further. Hopefully, with an improved result.

Next to my university supervision I would like to thank the employees at Nike who provided me with information, feedback and time during my internship. Special thanks to Bas van Rijnberk, Jorg van Geest, Veronique Sonsma and David Mackail.

Last but not least, I would like to thank my friends and family for the emotional support during this time. It has not always been easy and it may have turned me into a monster but I am thankful for everything that everyone has done for me and sometimes ‘letting me out.’

It is hereby that I present you the final version of my thesis with a minor whim of relief, and especially a significant feeling of pride for this accomplishment. I hope you enjoy reading it.

Henriette Ravesloot

Delft, April 2016.

EXECUTIVE SUMMARY

Knowledge workers are “part of institutions that determine and shape the work that is done” and within such institutions, **leadership, working environment, organizational culture and job design** should create conditions that facilitate knowledge workers to perform (Megill, 2013; Antikainen et al., 2006.) Essential to the success of a knowledge intensive-organization are **not only the knowledge reserves of the workers, but also what an organization is able to do with the latter** (Drucker, 1999.) Wall et al. (1992) explain that a worker’s performance is equal to ***ability * opportunity * motivation***, where if one of the factors is equal to zero, performance will be zero. Contrasting to the industrial age, organizational wealth and growth no longer relies on abundant raw materials but on knowledge workers’ performance, which can be the greatest determinant of the worth of their companies (Brocke & Rosemann, 2010.) However, despite the need for attention, knowledge work is yet to have had a researcher in the like of Frederik Taylor or Henry Ford to radically improve knowledge worker performance. Knowledge work is not easily observable or measurable (Matson & Prusak, 2010,) tasks are not fixed, and in contrast to manual work, there are no standard production time where tasks are performed differently among workers. A brain’s performance cannot be measured based on brain cells devoted per tasks, or creativity and there is no direct correlation between units of labor and units of output (Ramírez & Nembhard, 2005.) This means that rather than applying the common theme found in the Taylor- and economic productivity- approach which use universal performance measures to improve performance, knowledge worker performance is considered too difficult to measure, where up to today, there are no well-known universal effective and practical methods to measure knowledge worker productivity (Davenport, 2014; Hammer, et al., 2004; Ramírez & Nembhard , 2004; Davenport et al., 2002; Paradi, et al., 2002; Drucker, 1999.)

The challenge in improving knowledge worker performance lies in a necessary shift in management mindset where despite differences to manual workers, knowledge workers **“are still being managed with methods that were developed in the industrial age”** (Davenport, 1996.) According to Megill (2013) this is the biggest problem who states that **one cannot make knowledge using industrial modes of management and production, “it just does not work.”** Therefore, more research was required concerning how an organization can create conditions that facilitate knowledge workers to perform.

The aim of this research is therefore to answer the following question:

How can an organization’s process arrangement facilitate collaborative knowledge workers to improve organizational KPIs?

Figure 1 depicts the studied relationship between an organization requiring a knowledge worker’s ability and knowledge reserves as an input to create value, and an organization creating and defining conditions and process arrangements which enable knowledge workers to have the opportunity and motivation to exploit these abilities in order to improve organizational performance.

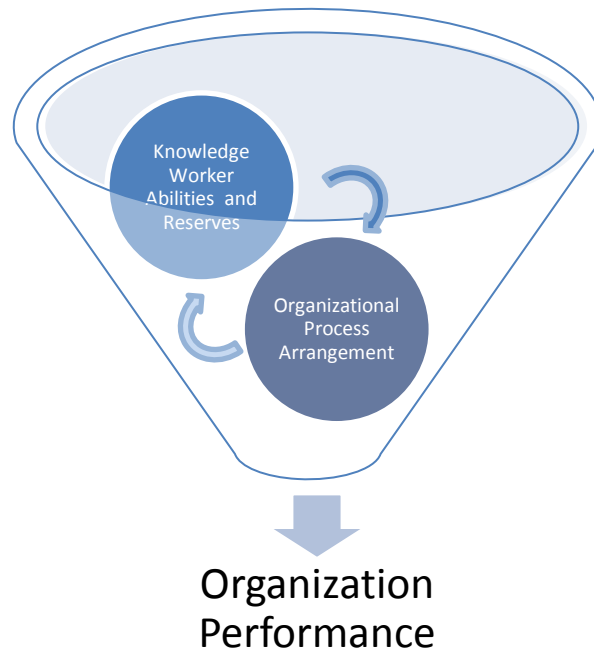

Figure 1 - Using organizational process arrangement to facilitate knowledge worker abilities and reserves to drive performance

First, organizational conditions which can facilitate knowledge workers to perform and ‘make knowledge’ to improve organizational KPIs are defined as follows:

An organization should attract knowledge workers with a significantly high **ability to execute cognitive actions and processes suited to the task**. An organization should **flourish** knowledge worker **ability by enabling them to grow, learn, and exchange knowledge**. **This should be achieved with the following:**

- Hire or train knowledge worker to have necessary skills and knowledge to perform job (Kelloway & Barling, 2000)
- Ensure transformational **leadership** as defined by Bass (1991) that educates through experience and interaction (Nonaka & Takeuchi, 1995) using individualized consideration to stimulate intellect by teaching, inspiring and promoting intelligence, rationality and careful problem solving.
- **Job design** should clearly define the task, organization cannot exploit knowledge worker abilities if knowledge worker does not know what he or she is pursuing for (Antikainen, 2006.)
- Establish opportunities for knowledge workers to **interact socially** for the purpose of sharing information and knowledge, social interaction enables knowledge workers to teach and learn from each other (Kelloway and Barling, 2000; Drucker, 1999.)
- **Organizational culture** should define expectations and reward structures that encourage knowledge workers to have a role-breadth self-efficacy and continuous learning by expecting and providing opportunities for knowledge workers to exploit their abilities (Kelloway & Barling, 2000.)
- **Organizational environment** should enable social interaction and teaching tools.

In order to drive a knowledge worker to apply their ability to define organizational success their **motivation** is required. This is driven by **personal development** together with a sense of **responsibility** for his or her **results and**

performance through task autonomy and the ability to organize and manage their own work (Drucker, 1999; Davenport, 2010; Blom et al., 2001; Kelloway & Barling, 2000.)

Referring back to a traditional production process, even if the best materials have been found, **a basic process must be in place to create a final product from the material. In this case, an organization’s process arrangement must provide a knowledge worker with the opportunity to exploit their ability.**

However, Figure 2 depicts the organizational dilemma between applying principles similar to manual work where efficiency gains are achieved by applying the appropriate levels of job design and control to physical labour versus providing knowledge workers with significant task autonomy and control over their own process in order to flourish creativity, motivation and commitment losing the control over inefficiencies in the form of knowledge workers waiting for, re-working or searching for resources (information.)

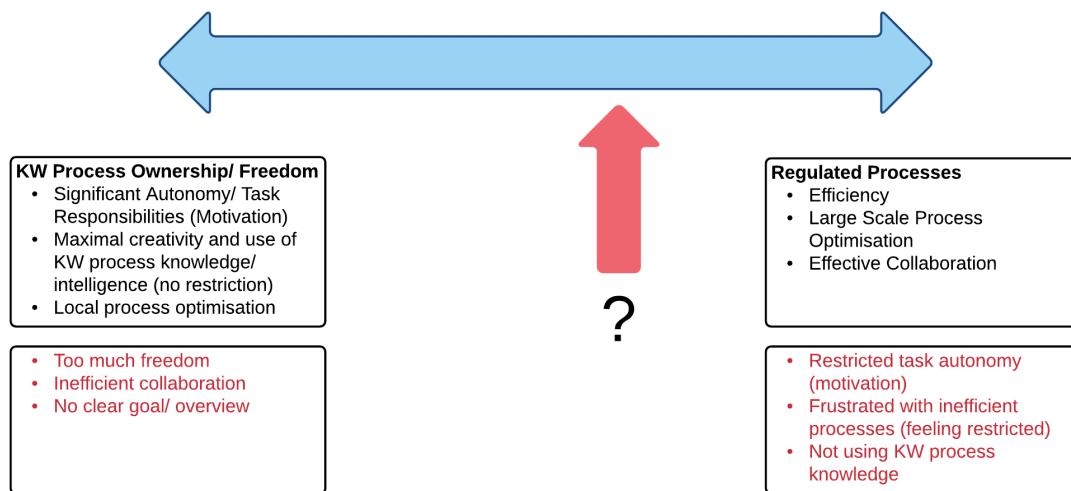

Figure 2- Defining the dilemma between providing a KW with process ownership/ freedom versus detailed organizational defined processes

In order to further define this balance, this thesis focuses on a knowledge worker’s main input, **information**. Where in order to facilitate a knowledge worker’s opportunity to perform, knowledge workers need timely access to the correct information (Drucker, 1999; Kelloway and Barling, 2002.) Knowledge workers make decisions based on information available, and if **information is unsatisfactory, unavailable or too late, outcomes of a knowledge worker’s process can be poor in quality** (Antikainen, 2006.) Therefore this paper answers the following question:

How can organizational processes that shape and determine a knowledge worker’s job organize the provision of information to facilitate knowledge workers to perform?

Davenport (2002) identifies 5 key issues, which companies are struggling with in handling knowledge work and improving knowledge worker performance. One major issue in the way of developing a useful management model lies in the “generic use of the term knowledge worker” (Davenport, 2002.) Substantial differences can be found between knowledge workers. **Therefore knowledge workers should be segmented according to the four models of knowledge work and their behavioral process in the form of knowledge creation, knowledge distribution and knowledge application.**

As displayed in Figure 3, if a knowledge worker defines his or her tasks with **knowledge distribution** and **application** and falls under the **integration and transaction model of knowledge work**, an organization should **structure the provision of information** according to their workflow process by clearly defining which information is required for the task, when it is required and according to which standards and format. By applying a structured approach to define information flow, Davenport (2011) states that **productivity** can rise up to 50 percent, **process improvement techniques** can be used to reduce a knowledge worker's ineffective time spent on searching and waiting for information or re-working information thus increasing his or her time available to apply knowledge (Davenport, 2010.) **A practice approach** should be applied to define a knowledge worker's process in order to provide sufficient autonomy and make use of a knowledge worker's knowledge, where in the end, knowledge workers are most knowledgeable about their own process.

If a knowledge worker adds value to the organization **by creating knowledge** and **innovative ideas** according to the **expert and collaboration model** of work an organization should invest in a **rich knowledge base** and focus on managing a **concentration of knowledge resources** at a certain space to share information rather than using a defined process to structure the provision of information. Applying structure to the provision of information would restrict a knowledge worker's creativity and innovativeness of ideas by imposing a predetermined sequence of tasks (Drucker, 1999) and therefore they should be provided with **free access to information and acquire effective skills in searching and distributing information effectively.**

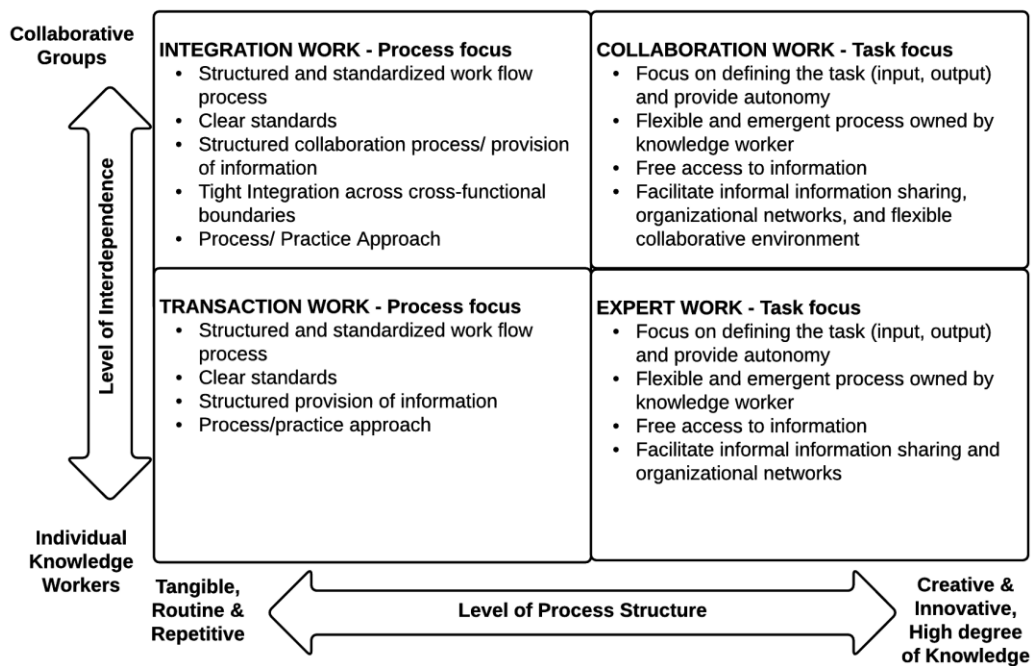

Figure 3 - Process orientation segmented according to Pantaleo & Pal's (2008) four models of knowledge work

As explained above an organizational dilemma can be found between providing full process autonomy to knowledge workers and losing control over an organization's processes and using a too structured approach which can restrict creativity. This thesis defends that a solution lies in segmenting knowledge workers accordingly, therefore a case study

at Nike is performed to define **how collaborative knowledge workers at Nike can be facilitated to improve forecast accuracy.**

Using the segmentation strategy described above, a solution is designed using Dym & Little's (2004) design cycle. A visual management board is designed which encourages teams and knowledge workers to define the level of structure and details of the work process themselves. Next to this, the visual wall provides visual cues to management to have an overview of the process and be able to detect knowledge worker frustrations and in-efficiencies.

The most significant advantages of the visual management wall are as follows:

- The visual management wall significantly helps to structure a demand planners workflow process by 76 – 100%
- The visual management wall significantly helps to standardize a demand planners workflow process by 51-75%
- The visual management wall significantly helps improve collaboration across functional boundaries by 51-75%
- The visual management wall significantly helps to improve access to the right information at the right time by 51-75%
- The visual management wall improves the quality of information which a demand planner requires to do work by 1-25%
- A demand planner believes that the visual management wall can improve the quality of his or her forecast submit by 51-75%
- A demand planner believes that the visual management wall can improve a structured approach to inter-functional collaboration by 51-75%

Next to this, the participants felt that the solution helps them to perform individual tasks, share process challenges, manage their work load and resource allocation and track information required for their work. The use of the wall did not make them feel restricted to perform their individual tasks or make them feel monitored. However, the wall was not flexible and easy enough to use and adapt and not clear enough to provide managers with visibility of the process.

The most relevant directions for future research are as follows:

- More research is required as to how knowledge worker performance should be measured, as a fair performance measurement system is a requirement to facilitate a knowledge worker's motivation to perform. Hereby, an idea would be to use a process-oriented approach to measure performance
- More research is required to measure the effect of time availability on knowledge worker performance.
- I believe that segmenting knowledge workers according to their characteristics can present great benefits to an organization where the segmentation can help to understand how to manage knowledge workers per category according to their general environmental, tool, information and process aggregation requirements. However, segmentation can be a sensitive subject for knowledge workers. Therefore more research should be performed as to how knowledge workers can best be segmented to facilitate their knowledge work and how this can be done in a fair manner. A quantification framework could be an idea to measure the work according to dimensions in order to manage accordingly.

Table of Contents

PREFACE	5
EXECUTIVE SUMMARY	7
List of Figures	16
List of Tables	18
1 Introduction	1
1.1 Research Scope	3
1.2 Knowledge Workers.....	5
1.2.1 Knowledge worker management	7
1.3 Problem Statement.....	8
1.4 Research Relevance	8
1.5 Research Questions	9
1.6 Research Methodology.....	10
1.7 Chapter Summary	14
PHASE 1 - Finding a practical relevant problem that has a research potential	16
2 Knowledge Work at Nike	16
2.1 Nike	17
2.2 Demand Planning.....	17
2.3 Demand Planning at Nike	18
2.3.1 Product Categorization.....	18
2.3.2 Product Design.....	19
2.3.3 Customer Demand Planning at Nike	19
2.4 Stakeholders Analysis	23
2.5 Performance Metrics at Nike, Inc.	25
2.5.1 Forecast Accuracy as a Metric.....	25
2.5.2 Process Root Causes for Forecast Accuracy.....	28
2.6 Chapter Summary	30
PHASE 2- Obtaining a general comprehensive understanding of the subject	32
3 How can Organizational Conditions Facilitate Knowledge Workers to Perform?	32
3.1 Defining Organizational Conditions that Facilitate a Knowledge Worker to perform Knowledge Work.....	33
3.2 Defining a Knowledge Worker’s Requirements to Perform	34

3.2.1	Ability.....	35
3.2.2	Motivation.....	36
3.2.3	Opportunity.....	37
3.3	Overview of Requirements to Perform Knowledge Work.....	38
3.4	Defining Organizational Conditions that Facilitate Requirements to Perform Knowledge Work	39
3.4.1	Kelloway & Barling’s (2000) Four Organizational Predictors.....	39
3.4.2	Extending Kelloway and Barling’s (2000) four Predictors	41
3.4.3	Organizational Conditions that Facilitate Knowledge Workers to perform Knowledge Work.....	42
3.5	Chapter Conclusion.....	44
4	Process-Oriented view of Knowledge Work	45
4.1	Using a Process-Oriented View of Knowledge Work to Define the Provision of Information	46
4.2	Segmenting Knowledge Work.....	48
4.3	Defining a Knowledge Worker’s Process.....	51
4.3.1	Four Models of Knowledge Work to define Process Orientation.....	52
4.3.2	Difference between Process and Practice in Knowledge Work.....	54
4.3.3	Knowledge Creation, Distribution or Application to define Process-Orientation.....	54
4.4	Using Knowledge Worker Segmentation to define the Provision of Information.....	56
4.5	Chapter Conclusion.....	59
	PHASE 3 – Design the constructs and solution	61
5	Case Study at Nike	62
5.1	Nike Sportswear Department.....	62
5.2	Using the Segmentation Approach to Define Demand Planning at Nike.....	62
5.2.1	Segmenting Demand Planners According to the Four Models of Knowledge Work.....	62
5.2.2	Segmenting Demand Planners According to their Knowledge Activity	65
5.3	Using Demand Planner Segmentation to define Process Orientation.....	65
5.4	Designing a Solution to Facilitate Collaborative Demand Planners at Nike to Improve Forecast Accuracy	66
5.4.1	Problem Definition	66
5.4.2	Problem Statement:.....	67
5.4.3	Objectives	67
5.4.4	Constraints.....	67
5.4.5	Conceptual Design.....	68
5.4.6	Designing a Solution according to Lean Principles.....	68
5.4.7	Actors Involved in the Design.....	70

5.4.8	Design Plan.....	70
PHASE 4: Implement the solution		76
5.4.9	Final Design.....	77
PHASE 5 & 6: Show the theoretical connections and research contribution of the solution concept and examine the scope of the applicability of the solution.		79
6	Results & Data Validation	79
6.1	Step 1: Testing the constructs validity using citation analysis (adapted from Pedersen, 2000).....	80
6.1.1	Construct 1 – Organizational Conditions Facilitate Knowledge Worker Performance.....	81
6.1.2	Construct 2 - Effective Information Sharing Enhances Knowledge Worker Performance.....	83
6.2	Step 2: Testing the usefulness of the constructs by using an example problem (adapted from Pedersen, 2000) 84	
6.2.1	Problem Relevance.....	84
6.2.2	Usefulness of the Method	85
6.2.3	Validating the design.....	86
6.3	Final Validation.....	87
7	Conclusion.....	88
8	Discussion, Recommendations and Future research directions	95
8.1	Limitations & Recommendations	95
8.2	Future Research Directions	96
8.3	Reflection	97
8.3.1	SEPAM Thesis	97
8.3.2	Assumptions.....	98
References		99
Appendix 1 – Director Interviews at Nike		104
Appendix 2 Knowledge Worker Definitions		107
Appendix 3 - Nike Business Process Overview		109
Appendix 4 - Organizational Chart of Demand Planning Department at Nike		113
Appendix 5 - Formulas used to Measure Forecast Accuracy		114
Appendix 6 – Nike Sportswear Case Study Department		115
Appendix 7 - Detailed Demand Planner Forecast Process per Gate.....		117
Appendix 8 Defining the Lean Constraint.....		121
Appendix 9 Results Conversations NSW Director and Project Manager		124
Appendix 10 Actors Involved in the Design.....		125

Appendix 11 Defining the Three Lean Tools, 5S, Kaizen Value Stream Mapping and Visual Management.....	126
Appendix 12 Design Selection.....	127
Appendix 13 A3 problem solving at NSW	132
Appendix 14 Notes from brainstorming session at NSW	133
Appendix 15 – Visual Management Wall Design.....	137
Appendix 16 – Priority Overview	142
Appendix 17 – Planning Calendar	143
Appendix 18 – Visual Management NSW Team Survey.....	145
Appendix 19 – Survey Results	146

List of Figures

Figure 1- Importance of Forecast Accuracy (Adapted from Nike, 2015).....	3
Figure 2 - Role of demand planning in customer value creation, circling the importance of knowledge application in demand planning which defines the focus of this thesis (Adapted from: Esper et al., 2009).....	5
Figure 3- Features of the Constructive Research Approach adapted from Kasanen et al., (1993).....	10
Figure 4 - 5 stage prescriptive model of the design process at Nike adapted from Dym and Little (2004).....	13
Figure 5- Constructive research approach to design solution to facilitate knowledge workers at Nike.....	14
Figure 6 - Design Process at Nike source: Nike, 2015	19
Figure 7- 7 Major Planning Deadlines at Nike source: Nike, 2015	20
Figure 8- High-level Supply Chain Process Highlighting the Demand Planning Focus of this Research	21
Figure 9- Causal Diagram of All Factors Influencing Forecast Accuracy, highlighting the Causal Influences of Demand Planners on Forecast Accuracy	27
Figure 10- Forecast Accuracy Root Cause Analysis (Nike, 2015).....	29
Figure 11 - Model of knowledge use in organizations (Kelloway & Barling, 2000).....	34
Figure 12 - Defining Ability, Motivation and Opportunity adapted from Kelloway & Barling (2000).....	35
Figure 13- Four Models of Knowledge Work (Pantaleo & Pal, 2008).....	49
Figure 14- Four Models of Knowledge Work adapted from Pantaleo & Pal (2008) & Ramirez & Steudel (2006)	51
Figure 15 - Process orientation segmented according to Pantaleo & Pal's (2008) four models of knowledge work.....	57
Figure 16 - 5 stage prescriptive model of the design process at Nike adapted from Dym and Little (2004).....	61
Figure 17 - Type of knowledge work performed by demand planners at NSW adapted from Pantaleo & Pal's (2008) four models of knowledge work	64
Figure 18 - 5 stage prescriptive model of the design process at Nike adapted from Dym and Little (2004).....	66
Figure 19- Visual Management Concept Design 4, February 4 th , 2016.....	77
Figure 20 – Using organizational process arrangement to facilitate knowledge worker abilities and reserves to drive performance.....	88
Figure 21 – Defining the dilemma between providing a KW with process ownership/freedom versus organization regulated processes.....	90

Figure 22- Nike Sportswear Organizational Chart.....	115
Figure 23- Stakeholder typologies adapted from Hillson & Simon (2012)	115
Figure 24- A3 problem solving used in step 2 to understand problem situation at NSW.....	132
Figure 25- NSW Brainstorm Session.....	136
Figure 26- Visual Management Wall Concept 1 20 January, 2016.....	137
Figure 27- Visual Management Wall concept 2 adapted and presented to entire team January 27, 2016.....	138
Figure 28- Visual Management concept 3, adapted after team feedback January 29, 2016.....	139
Figure 29- Visual Management Concept Design 4, February 4 th , 2016.....	140
Figure 30 - Best Practice Sharing and Results, February 23 rd	141
Figure 31- Visual Management Concept Design, 5 February 23, 2016.....	141
Figure 32- Task Priority Overview (Nike, 2015)	142
Figure 33- Planning Calendar January, February 2015 (Nike, 2015)	143

List of Tables

Table 1 - Forecast In-Accuracy Root Causes Indicating the Importance of Forecast Error, Limited Information and Category Specific Root Causes.....28

Table 2 - Knowledge Worker Segmentation (Pantaleo & Pal, 2008)50

Table 3- Articles defining the choice to focus on a knowledge worker’s opportunity, motivation and ability to perform81

Table 4- Articles defining a knowledge worker’s requirements to perform knowledge work and organizational conditions which facilitate this83

Table 5 – Articles defining construct 2, facilitate time to perform improves performance84

Table 6- Overview of Definitions of Knowledge Workers found in the Literature108

Table 7 - Five Principles of Lean Thinking121

Table 8 - Most important challenges decided by brainstorm session at NSW133

Table 9- Ten most importantly weekly tasks performed by a demand planner at NSW144

1 Introduction

Nike is active in the clothing and sport accessory industry and in 2014 noted an approximate production of 900 million units in footwear, apparel and equipment (Nike, 2015.) The multinational sporting goods company has doubled its revenue growth in the past 10 years, and continues to grow. Next to this, the approximate amount of 900 million units produced through their supply chain is made from more than 16,000 materials sourcing from 1500 different vendors, and from these materials, Nike products are manufactured in 785 contract factories, which are located in more than 40 countries (Nike, 2015.) Nike's massive scale of production and globalization requires a complex supply chain to get their products to consumers all over the world, paired with complex supply chain management. The company's high-level goal is to satisfy customer demand in a cost-effective manner, where demand is driven by the company's marketing strategy, macroeconomic factors such as product prices, competitor pricing, customer preferences, product type, trend, and so on (Ashayeri et al., 2005.) Supply chain management is driven by customer demand, which causes one of the largest uncertainties in supply chain management (Wagner, 2015.) Therefore manufacturing companies require customer demand planning as a critical business process which impacts all aspects of supply chain management and "the business bottom- line" (Ashayeri et al., 2005.) According to Moon et al (2000) one of the most critical drivers of supply chain success is "effective customer demand planning." This means that a company must be able to accurately forecast its business opportunities, and plan accordingly throughout its supply chain in order to exploit these opportunities. Several decision processes of supply chain management require accurate demand planning forecasts in order to choose proper actions relevant to production planning, sales budgeting and strategies (Danese et al., 2011.) **Poor accuracy in demand forecasting can cause widespread disruption, poor customer service and increased costs to organizations (Githens, 2005.)**

Therefore, this thesis will focus on customer demand planning forecasts executed by demand planners at NIKE EMEA headquarters, who forecast demand for all customers in Europe, the Middle East and Africa. A demand planner as defined in this thesis is responsible for creating a customer demand planning forecast. First, a statistical product demand forecast is created based on an initial estimate of future demand and historical data. Thereafter a statistical demand forecast becomes a customer demand-planning forecast, which is "an estimate of future customer demand derived by a consensus-driven review and approval of the forecast subject to several planning and verification processes" by applying own knowledge and relevant input from internal stakeholders (Githens, 2005.)

A demand planner at Nike is responsible for adapting an initial statistical customer demand forecast for each of their planning seasons by applying their own knowledge to the forecasting process and consolidating all forecasting relevant information such as historical data, consumer data, key customer account feedback, sales targets, promotional activities, market intelligence and merchandising forecasts from relevant stakeholders, using an efficient collaboration process to create a customer demand planning forecast that forecasts customer demand for the season and is accepted by all stakeholders (Wagner, 2015.) Nike uses two supply chain strategies: make-to-order and make-to-stock. This thesis will focus on the make-to-order products. In order to indicate the importance of demand planning at Nike EMEA, total units planned in the fiscal year 2014 amounted to 218 million (Nike, 2015.) This means that 12733 styles were planned and 34550 colour units were planned resulting in an average forecast accuracy of 57 percent (Nike, 2015.) Uncertainty of demand is an important characteristic for Nike. Although market intelligence is being used extensively, combined with aggressive

marketing and effective sales teams, consumer behaviour is hard to predict, especially in the fashion industry, where the market is very sensitive to trends and competitor products (Lohman, et al., 2004).

Nike follows a make-to-order supply chain strategy for products with a very short life cycle (one season) and therefore, the objective of the demand planning department at Nike is to optimize forecast accuracy for each of its planning seasons with the following process. First, an initial statistical customer demand forecast is created by the company's ERP system, which captures historical information for the products, product categorization and style level characteristics together with their previously forecasted numbers and sales records. This is then used as the input for a demand planner to consolidate a customer demand planning forecast. Unfortunately, due to the very short product life cycles of Nike's products, historical data only provides limited added value for a statistical forecast where mostly, there are no historical records available for each stock-keeping unit (SKU.) Therefore, demand planners apply their own knowledge to create a demand planning forecast; collaborate with sales and merchandising to receive customer insights, company strategies and promotional activities, market knowledge and key insights; and use further forecasting tools to consolidate a demand forecast in the form of a 'demand plan submit.' Chapter two will elaborate on the demand planning process at Nike.

As mentioned above, Nike currently achieves a demand planning forecast accuracy of 57%. In order to indicate the business importance of customer demand planning at Nike, in 2000-01, Nike attributed a 33 per cent shortfall in its estimated earnings due to an error made in customer demand planning (Wilson, 2001.) The most important impacts of poor customer demand planning are defined by Githens (2005) as follows:

- Poor customer service
- Excess inventory
- Excessive production changes
- Increased distribution costs

Next to this, Figure 4 shows the revenue impacts of forecast accuracy at Nike on coverage, close-out inventory, purchase order cancellation costs, inventory costs, airfreight and vessel surcharges. A high forecast accuracy improves coverage, meaning a high amount of products delivered to consumers in full and on time (DIFOT), which has a direct impact on revenue at Nike (Nike, 2015) Next to this the more accurate a demand planning forecast is, the less inventory left over at the end of the season (close out,) less money lost on materials that may have already been purchased and not used due to cancellations, less inventory held, less quick shipments required by air freight due to late orders and less additional costs for shipments costs for separate vessels (FOB.) The latter variables reduce the overall bottom line costs, and hence increase revenue at Nike.

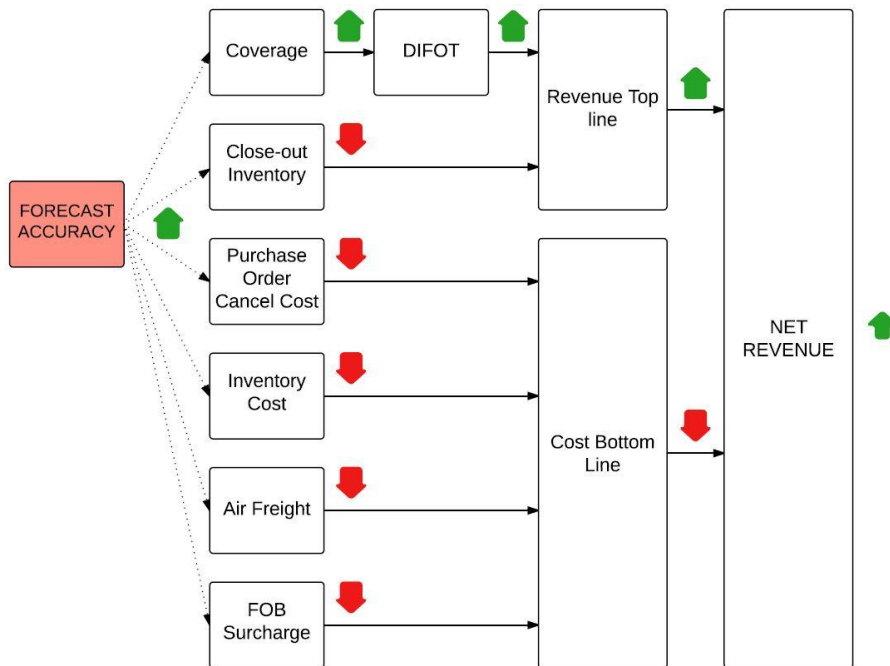

Figure 4- Importance of Forecast Accuracy (Adapted from Nike, 2015)

1.1 Research Scope

The latter section indicates the importance of forecast accuracy on business results at Nike, and incidentally, practitioners and academics have devoted particular attention to how demand plan forecasting can be improved to increase forecast accuracy (Wright et al., 1986; Wisner, 1994; Armstrong, 2001; Caniato et al., 2002; Caniato et al., 2002; Danese et al., 2010.) **Central to improving forecast accuracy is the performance of a demand planner (Armstrong, 2001.)** Interviews at Nike included in Appendix 1 depict that directors are struggling to improve and understand demand planner performance. Moreover, an analysis performed at Nike by Asipko (2015), which will be elaborated upon in chapter 2 shows that on average, 12% of the total 40% of forecast inaccuracy is due to demand planner forecasting errors. These are errors found in demand planning forecasts such as double counting forecasts, demand planners experiencing forecasting issues, missed input, reporting errors, human mistakes, wrong alignment decisions, wrong forecasting decisions, wrong interpretation of the history and/or current demand signals, target setting and so on. Together with this, 3% of the total forecast in-accuracy is due to demand planners missing information from relevant stakeholders such as merchandising and sales inputs and insights.

Forecasting management is a complex issue, and companies can decide to lever on different factors to define and improve their customer demand forecasting process (Mentzer and Bienstock, 1998; Moon et al., 2003; Danese et al., 2010.) A significant amount of academic studies have discussed the adoption of demand forecasting techniques, both quantitative and/or qualitative, as an important opportunity for elaborating accurate demand plan forecasts (Mentzer and Cox, 1984; Dalrymple, 1987, Sanders and Manrodt, 1994; Sanders and Ritzman, 2001; Danese et al., 2010.) However, several researchers suggest that merely adopting particular demand forecasting techniques is not enough to guarantee a demand planner to generate high forecast accuracy. According to previous publications, further studies on forecasting should also research other topics linked to how the forecasting process is managed and organized (Armstrong, 1987; 2001; Mentzer and Bienstock, 1998; Moon et al., 2003; Danese et al., 2010.) **Demand planner management as described in the previous sentence is enabling a demand planner to produce an accurate**

demand planning forecast with managerial decisions on demand planner processes, information gathering processes and tools, organizational approaches, collaboration and forecast accuracy measurement using a proper metric and by defining proper incentive mechanisms (Danese et al., 2010.) The latter authors research the impact of demand planner management on forecast accuracy and define the causal relationship between an organization's forecasting process and demand planner management and their resulting forecast accuracy.

Next to this, Esper et al (2009) highlight the importance of maximizing organizational wealth and successfully managing the supply chain to create customer value by extensively integrating demand-focused activities and supply-focused activities. In other words to effectively facilitate cross-functional integration between the demand side serving customers with added value, whilst understanding the constraints implied by supply transaction. Drucker (1973) refers to the disconnect between demand creation and supply fulfillment as the "Great Divide" which can be of great loss for a firm's success. **At Nike, demand planners are a focal point between integrating demand-side knowledge sourcing from merchandising, sales, and finance and the supply-side knowledge which involves understanding factory-capacities and -minimums by collaborating closely with inventory management. Leveraging the integration between demand-focused and supply-focused knowledge to achieve organizational wealth has stimulated further research on the process of knowledge creation and management within a cross-functional manufacturing organization (Esper et al., 2009; Nonaka and Takeuchi, 1995; Nonaka, 1994.)** The latter authors suggest that knowledge management involves distinct behavioral processes that collectively facilitate the capturing and leveraging of market information and business intelligence to achieve organizational wealth. In this case, characterized by demand planners who collect and apply all relevant organizational knowledge to produce a customer demand-planning forecast. This thesis continues to define the three behavioral processes as knowledge creation, knowledge distribution and knowledge application (Pantaleo & Pal, 2008; Dove, 1998; Davenport, 2002.)

Figure 5 shows a very high level overview of the behavioral processes, which create customer value in the integration of demand-focused and supply-focused knowledge at Nike. Next to this, the black dotted line in the figure highlights the research focus of this thesis.

The left side of

Figure 5 shows how stakeholders analyze demand-side opportunities, capabilities, customer value perceptions and constraints creating a seasonal strategy plan, together with stakeholders in the supply-side similarly creating a strategy plan according to current operational capabilities. Creating a seasonal strategy plan creates knowledge in the form of explicit knowledge that can be translated into initial high-level statistical forecasts. Based on the strategy created, an initial expected demand is forecasted together with a capacity forecast to define a firm's high-level targets, plans and strategies. This codified knowledge can then be distributed to, in this case, Nike's merchandising teams who use the codified knowledge to create a product line based on capacity and demand targets, plans and strategies. The designer's formerly tacit knowledge is expressed in the form of designs, drawings and eventually a finalized product assortment, which defines the created knowledge in the form of a product assortment. Once the product assortment has been finalized, it is transferred to demand planners who apply all relevant knowledge to forecast demand of the product assortment by submitting a customer demand planning forecast.

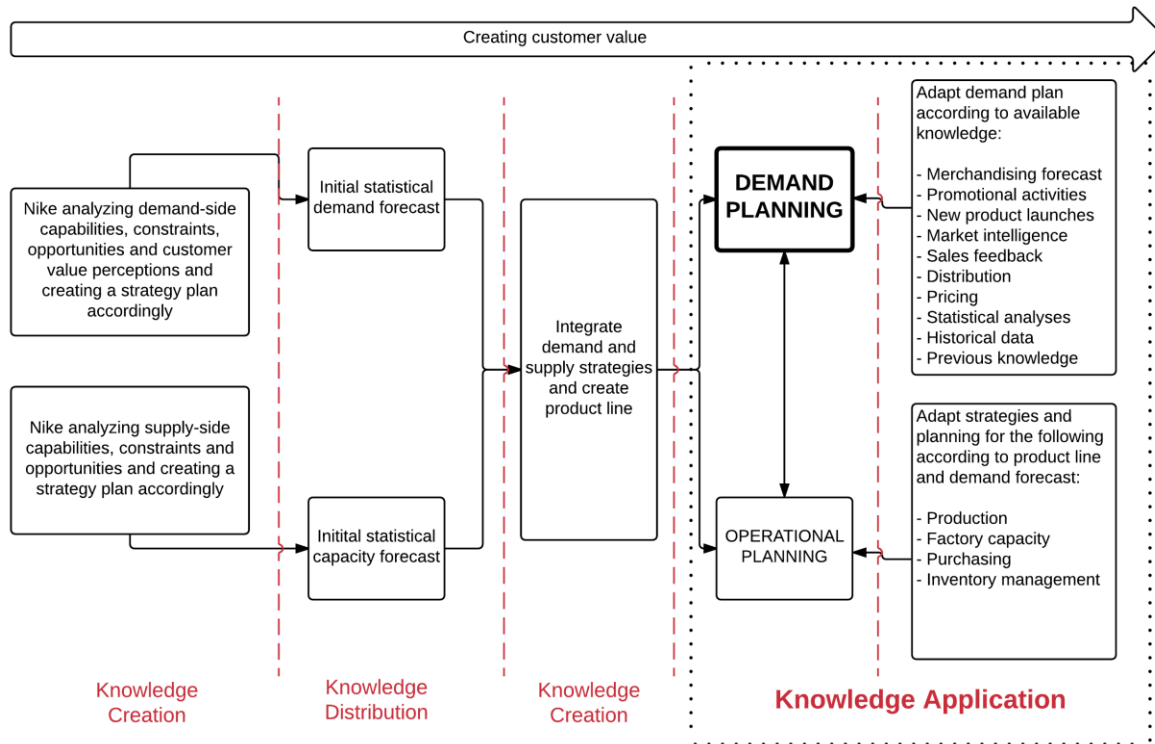

Figure 5 - Role of demand planning in customer value creation, circling the importance of knowledge application in demand planning which defines the focus of this thesis (Adapted from: Esper et al., 2009)

The dotted black box depicts the focus of this thesis where Danese et al., (2010) highlight that more research is required towards how to facilitate a demand planner to produce an accurate demand planning forecast using managerial decisions on demand planner processes, information gathering processes and tools, organizational approaches, collaboration and forecast accuracy measurement using a proper metric and by defining proper incentive mechanisms. Rather than focusing on how to improve quantitative forecasting techniques, this thesis will focus on how an organization can simulate effective knowledge sharing, define demand planning processes and tools and further organizational approaches that facilitate a demand planner to apply their respective knowledge through demand and supply-side integration in order to improve forecast accuracy.

As defined above, demand planners collect and apply all relevant organizational knowledge to produce a customer demand-planning forecast. Demand planners are thus responsible for **applying knowledge** and can further be characterized as **knowledge workers** who require respective management styles (Davenport, 1996; Davenport 2002; Drucker, 1999; Ramirez et al., 2004.) Therefore, the following section will define knowledge workers.

1.2 Knowledge Workers

Ever since Drucker (1979) first introduced the term “knowledge workers,” organizational practitioners, researchers and theorists have become increasingly interested in the term; yet despite this widespread and growing recognitions there is still little consensus as to what exactly constitutes a knowledge worker and how they are defined (Kelloway & Barling, 2000; Pyoria, 2005.) 0 provides an overview of the most important definitions found in the literature. These definitions were consulted and merged in order to provide a clear definition of knowledge work and knowledge

workers as referred to in this thesis. Based on Table 6, one can conclude that knowledge workers have two important characteristics. They are well educated, and their primary goal is to apply, create, or distribute knowledge. Education can source from formal education or from informal learning highlighted by Dove (1998) and Nickols (2000,) and their most important resource and form of production is knowledge. Therefore the definition of knowledge workers used in this paper will be Davenport's (2010) definition:

"Knowledge workers have high degrees of expertise, education or experience, and the primary purpose of their jobs involves the creation, distribution or application of knowledge. In short they think for a living."

Section 1.1., implies that knowledge workers require different management styles, compared to the management styles used in the industrial age. This is due to various reasons, where the most important reason is that knowledge work is very different to manual work (Davenport, 1996; Davenport 2002; Drucker, 1999; Ramirez et al., 2004.) Ramirez & Steudel (2008) identify eight dimensions that distinguish knowledge work from manual work as follows:

- 1) Structure
- 2) Autonomy
- 3) Tangibility
- 4) Knowledge
- 5) Creativity and innovation
- 6) Complexity
- 7) Routine and repetitiveness
- 8) Physical effort

Structure refers to the number of established rules and policies integrated in the execution of a task (Ramirez & Steudel, 2008.) Knowledge work is far less structured than production work and knowledge workers see their process as unstructured, hard to define and highly variable (Davenport, 2010.) Next to this, due to their high degrees of expertise, education or experience, knowledge workers don't like to be told what to do, in contrast to traditional production work (Megill, 2013). Knowledge workers enjoy a high degree of **autonomy**, which relates to the degree of control a knowledge worker has over how the task is performed (Ramirez & Steudel, 2008.) Moreover, task autonomy has a significant impact on a knowledge worker's commitment and motivation to perform knowledge work (Davenport, 2010.)

Together with knowledge work being less structured than production work, knowledge work is described as less **tangible** than manual work (Ray & Sahu, 1989; Drucker, 1999.) Knowledge workers are very difficult to measure, since it is impossible to know what workers are thinking, and to tell whether they are working or not (Ramirez & Nembhard, 2004.) This is because their brains are their production utilities, which are their own, not tangible and can be taken to any company (Davenport, 2010.) Only tangible results at the end of a work task can give the opportunity to evaluate what has been achieved (Davenport, 2008.) Tangibility as described by Ramirez and Steudel, (2008) is linked to the **knowledge** dimension, which differs from production work. Knowledge is the most important intangible resource of knowledge work. An important distinction is found between traditional industrial production and knowledge intensive work in the post-industrial society. Hereby, industrial production is based on cheap labour, energy, and heavy material investments, often locally sourced, as the sources of economic productivity. Compared to post-industrial societies where the use of information or knowledge is the most important source of wealth creation in current societies (Pyoria, 2005.) Related to this source of wealth is the **creativity and innovation** described by Ramirez & Steudel, (2008) which refers to the degree to which processes lead to creative and innovative outcomes. Due to the innovative nature of knowledge work, knowledge workers can be the key assets in achieving company

competitive advantage (Davenport, 2008.) Directly linked to the creativity and innovation of knowledge work is its **complexity**. Complexity refers to how difficult or complex a task is (Ramirez & Steudel, 2008.) This varies per type of knowledge work however in general; knowledge work is known to be more complex than manual work due to the high degree of knowledge required. Knowledge work is a broad term and can differ between highly complex tasks together with more routine and repetitive tasks, which are based on formal procedures (Ramirez & Steudel, 2008.) Last but not least knowledge work is often paired with minimal **physical** effort in contrast to manual work (Ramirez & Steudel, 2008.) However, this point can be disputed as knowledge workers can be confronted with more physical work such as surgeons, doctors, dentists and so on.

Based on the latter findings, this section concludes that demand planners, further categorized as knowledge workers, present significant differences to manual workers and therefore require different management styles to manual workers. Danese et al., (2010) highlight that more research is required towards how to facilitate a demand planner to produce an accurate demand planning forecast using managerial decisions on demand planner processes, information gathering processes and tools, organizational approaches, collaboration and forecast accuracy measurement using a proper metric and by defining proper incentive mechanisms. Therefore the following section will provide a brief description of existing literature concerning knowledge worker management in order to further define the scope of this research.

1.2.1 Knowledge worker management

In the early twenty-first century, it is assumed that a quarter- to a half- of the workers in advanced economies are knowledge workers (Davenport, 2010.) Even if this is not the majority of workers, they have the most influence on their companies and economies. This is because knowledge workers are paid the most; they add the most economic value and often, they are the greatest determinant of the worth of their companies (Brocke & Rosemann, 2010) and yet, knowledge workers are still claimed to be the greatest management challenge of the 20th century (Davenport, 1996; Davenport 2002; Davenport, 2013; Drucker, 1999; Ramirez et al., 2004; Megill, 2013.) Knowledge workers have a large responsibility in sparking innovation and growth, inventing new products, designing marketing programs, creating and adapting technology, creating strategy, planning demand etc. however, “they are still being managed with methods that were developed in the industrial age” (Davenport, 1996.) According to Megill (2013) this is the biggest challenge in understanding how to improve knowledge worker performance, stating that you cannot make knowledge using industrial modes of management and production, “it just does not work.”

Megill (2013) states that traditionally, a knowledge worker’s profession was characterized by the professional’s ability to control the work situation and set fees, where they do their work when, where and for how long they wish, selling their thinking. However, currently, few professionals set their own time and place of work. The authors states that even “doctors, lawyers, psychologists, accountants, consultants, planners etc. who once worked as independent professionals are part of institutions that determine and shape the work that is done” (Megill, 2013.) Within such institutions, managers and organizations coordinate the work of knowledge workers; however, managers and organizations are struggling to improve performance.

Similar to researchers suggesting that merely adopting particular demand forecasting techniques is not enough to guarantee a demand planner to generate high forecast accuracy (Armstrong, 1987; 2001; Mentzer and Bienstock, 1998; Moon et al., 2003; Danese et al., 2010.) Kelloway & Barling (2000) highlight that it is “only by identifying and changing the organizational conditions that enhance employee ability, motivation and opportunity” that one can truly engage in managing knowledge workers. Megill (2013) recommends improving knowledge worker performance by making work collaborative throughout the workplace, and developing “institutions and cultures that foster knowledge

work.” This requires research concerning how knowledge work is controlled and organized. Knowledge work is performed by those who are able to exercise their brains, creativity, thinking and knowledge, which implies that knowledge workers require “control of their environment and the communities in which they work, their work process.” This falls together with statements included in academic literature concerning forecast accuracy improvement where Danese et al., (2010) highlight that more research is required towards how to facilitate a demand planner to produce an accurate demand planning forecast using managerial decisions on demand planner processes, information gathering processes and tools, organizational approaches, collaboration and forecast accuracy measurement using a proper metric and by defining proper incentive mechanisms. Together with several academics stating that further studies on forecasting should research topics linked to how the forecasting process is managed and organized in order to improve forecast accuracy (Armstrong, 1987; 2001; Mentzer and Bienstock, 1998; Moon et al., 2003; Danese et al., 2010.) Therefore this thesis assumes that the organizational conditions in which knowledge workers perform can be used to improve knowledge worker performance and so, in order to define the research in the thesis the problem statement is formulated as follows.

1.3 Problem Statement

Demand planners at Nike plan an average of 230 million units per year with an average of 12800 styles and 35000 colour units resulting in an average forecast accuracy of 57 percent. On average, 12% of forecast inaccuracy is due to human forecasting errors such as missed input, double counting forecasts, forecasting issues, reporting errors, mistakes, wrong interpretation and wrong decisions. Further interviews at Nike indicate that demand planners at Nike feel restricted to perform at their full capabilities. Next to this, 3% of the total average forecast in-accuracy is due to demand planners missing information from relevant stakeholders such as merchandising and sales inputs and insights. A demand planner submits 7 forecasts per season, and forecasts for 3-4 seasons simultaneously. Demand planners, further categorized as knowledge workers who are part of institutions that determine and shape the work that is done, are however, still claimed to be the greatest management challenge of the 20th century (Davenport, 1996; Davenport 2002; Drucker, 1999; Ramirez et al., 2004.) Interviews at Nike define the challenge to improve knowledge worker performance and academics indicate that further studies on demand forecasting should research how a demand planner should be managed and facilitated in order to improve forecast accuracy (Armstrong, 1987; 2001; Mentzer and Bienstock, 1998; Moon et al., 2003; Danese et al., 2010.) Danese et al., (2010) highlight that more research is required towards how to facilitate a demand planner to produce an accurate demand planning forecast using managerial decisions on demand planner processes, information gathering processes and tools, organizational approaches, collaboration and forecast accuracy measurement using a proper metric and by defining proper incentive mechanisms. Therefore this thesis assumes that the organizational conditions in which knowledge workers perform can be used to improve knowledge worker performance, and so, this thesis will focus on how an organization’s managerial decisions on a knowledge worker’s process facilitate collaborative knowledge workers to improve organizational KPIs.

1.4 Research Relevance

The industrial age has shifted towards post-industrial societies as capitalist production modes have changed, reflecting the increasing importance of knowledge work (Davenport, 2010.) An important distinction is found between traditional industrial production and knowledge intensive work in the post-industrial society. Hereby, industrial production is based on cheap labour, energy, and heavy material investments, often locally sourced, as the sources of economic productivity. Compared to post-industrial societies where the use of information or knowledge is the most important source of wealth creation in current societies (Pyoria, 2005.) Important for economic wealth is that small

economies that are relatively disadvantaged in natural resources but skilled in production and exploitation of knowledge can now outperform larger rivals with abundant natural resources (Benner, 2003; Castells and Himanen; Pyoria, 2005.) Next to the studies named above, according to various international research studies on global economic studies (Holtshouse, 2010; Rigby and Bilodeau, 2007; Mandel, 2007; Kohut, 2007; Palmer, 2006) knowledge worker performance and knowledge management are still among the top executive challenges of the next decade. The ability of firms to grow and compete over the next decade, will increasingly depend on the performance and skills of knowledge workers, and their access to and utilization of relevant knowledge critical to firm operation (Holtshouse, 2010.)

Beside Drucker (1998) highlighting that a firm's ability to recognize and manage organizational knowledge will be the "single most important determinant of firm survival", Brocke and Rosemann (2010) quote that, "if our companies are going to be more profitable, if our strategies are going to be successful, if our societies and economies are going to become more advanced – it will be because knowledge workers did their work in a more productive and effective manner." Knowledge worker performance has a significant societal relevance impacting economic growth and success, contributing towards societal welfare (Davenport, 2010). Currently, firms with the highest degree and quality of knowledge work tend to be the fastest growing and the most profitable ones. An evident example of such a knowledge intensive firm is Microsoft, where company profitability is merely dependent on knowledge work. Next to this, Drucker (1999) states that improving knowledge worker performance is the "first survival requirement" of developed nations. Referring to the situation in the Netherlands, a developed nation, boasting a competitive knowledge economy and location of this research. In the past century, the growth of the Dutch economy was characterized with a growing knowledge workforce fed by increasing female work participation (van der Zee et al., 2015.) However, as the population continues to age and gender equality has modernized, in contrary to the past century, labor input will decrease instead of increase which means that improved knowledge worker performance is an important aspect of maintaining the Dutch economy (Van der Zee et al., 2015.) Moreover, the Dutch government's ambitions strive to give the Netherlands a place in the top 5 knowledge economies by 2020, based on the Global Competitiveness Index of the World Economic Forum (CBS, 2015.) Hereby their two focus points are competitor advantage and knowledge worker productivity (van der Zee, 2015.)

In order to understand how an organization can improve knowledge worker performance and facilitate knowledge workers to improve organizational KPIs the research questions are formulated in the following section.

1.5 Research Questions

How can an organization's process arrangement facilitate collaborative knowledge workers to improve organizational KPIs?

- 1) **How can organizational conditions facilitate knowledge workers to perform?**
 - a. What are the requirements for a knowledge worker to perform knowledge work?
 - b. Which organizational conditions facilitate the requirements for a knowledge worker to perform knowledge work?
- 2) **How can organizational processes that shape and determine a knowledge worker's job organize the provision of information to facilitate knowledge workers to perform?**
 - a. How can a structured process approach of knowledge work be balanced with a knowledge worker's autonomy required to perform?
 - b. How can a structured process approach facilitate effective information sharing?

- c. How can effective information sharing facilitate knowledge worker performance?
 - d. What are the requirements to facilitate collaborative knowledge workers in a structured process approach?
- 3) **How can collaborative demand planners at Nike be facilitated to improve forecast accuracy?**
- a. How can collaborative demand planners at Nike be facilitated to apply their knowledge?
 - b. How can the lean methodology be used to facilitate demand planners at Nike to improve forecast accuracy?

1.6 Research Methodology

Research presented in this thesis will be conducted using the constructive research approach, this means that a construction (solution) will be designed to define and solve a relevant problem sourcing from a knowledge gap in existing academic literature and a problem situation at Nike (Kasanen et al.,1993.) The latter authors present the constructive research approach as an applied study that aims to produce new knowledge as a normative application (Kasanen et al., 1993.) Next to this, Oyegoke (2011) states that constructive research is used to define and solve problems, as well as to improve an existing system or performance, “with the overall implication of adding to the existing body of knowledge.” Constructive research can be qualitative or quantitative or both and is typically applied using a case study. (Morris, 2010) Figure 6 displays features of the constructive research approach.

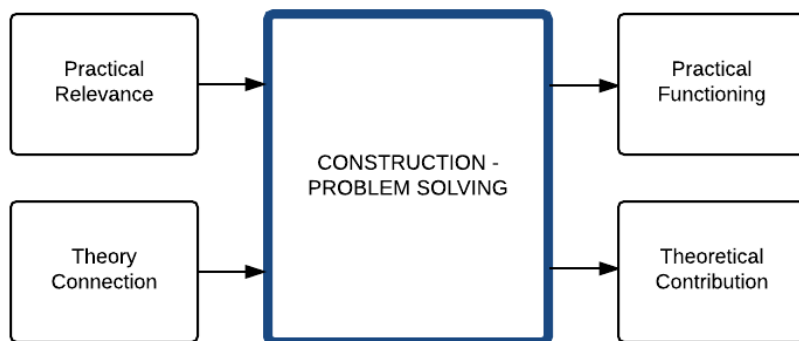

Figure 6- Features of the Constructive Research Approach adapted from Kasanen et al., (1993)

Another important methodology towards designing a solution is the Design Science Framework as described by Hevner (2007.) However, this thesis chose to use the constructive approach due to two reasons. First, due to the limited time frame insufficient time was available to fully achieve a complete feedback loop in the relevance and rigor cycle. Next to this, due to the managerial relevance of the task, the solution will be designed using co-production of knowledge between the industry practitioner and researcher which is an encouraged approach in the constructive research approach (Oyegoke, 2011)

The study presented in this thesis sources from a knowledge gap found in the literature (Davenport, 2013; Drucker, 1999; Ramirez & Nembhard, 2003; Armstrong, 1987; 2001; Mentzer and Bienstock, 1998; Moon et al., 2003; Danese et al., 2010) and problems arising from studying the Demand Planning and Inventory Management department at Nike. This is an important requirement of the constructive research approach, the problem resolution should have an impact on the current state of affairs and thus have instrumental value. The research begins with identifying practically relevant problems that have research potential, hereby; the problem itself can be raised either from a theoretical or a

practical dimension (Oyegoke, 2011.) Not all problem-solving exercises pass as constructive research. According to Kasanen et al., (1993) the research must combine problem solving and theoretical knowledge. One of the primary criteria for constructive research is the demonstration of practical usefulness, including relevance, simplicity and ease of operation by the business community (Kasanen et al., 1993.) The approach encourages co-production of knowledge between the industry practitioner and researcher throughout the research (Oyegoke, 2011.)

The constructive research approach suits the study performed in this thesis for the development of a solution to facilitate knowledge workers to perform. The need of the research arises directly from existing academic literature and results from the case study performed at Nike forming a practical and theoretical dimension. Moreover, due to the intelligence and suited autonomy of knowledge workers, co-production of the solution between the Demand Planning department at Nike and the research will be suited.

Phase 1 - Finding a practical relevant problem that has a research potential

Constructive research problems can be based on anecdotal evidence, evidence based on practical experience in an industry or from the practitioners in the industry or evidence from peers' theoretical work (Oyegoke, 2011.) A suitable research problem should offer opportunities for practical and theoretical contributions (Kasanen, 1993.) Therefore, the first step to define a problem is an in depth literature review and interviews and work floor observation.

Methodology:

- Case study at Nike to define problem and practicality
 - Explorative interviews with 9 managers and directors working within the demand planning and inventory management department (Appendix 1)
 - Company requirements
- Literature review
 - Example key-words: 'knowledge work' 'knowledge work manag*' 'knowledge worker performance' 'knowledge worker productivity' 'knowledge management' 'performance metrics' 'transactional environment' 'facilitat*'
 - Databases used: Scopus, Google Scholar, Web of Science, JSTOR and Science Direct.
 - Limited to peer-reviewed scientific papers found in the known databases of major publishers (Elsevier, Emerald, Springer, Wiley, etc.)

Chapter: 1/2

Phase 2 – Obtaining a general comprehensive understanding of the subject

This phase should provide the researcher with a thorough understanding of the research problem and its context (Oyegoke, 2011.)

Methodology:

- Case study at Nike to understand subject
 - Explorative interviews with 9 managers and directors working within the demand planning and inventory management department (Appendix 1)
 - Work-floor observation, researcher 'shadowed' two demand planners individually for 1 day
 - Informal conversations, observations working within department
 - Access to Nike knowledge base

- Literature review
 - Same rules as phase 1, in-depth literature review

Next to this, this phase will answer research questions 1 & 2:

- 1) **How can organizational conditions facilitate knowledge workers to perform?**
 - a. What are the requirements for a knowledge worker to perform knowledge work?
 - b. Which organizational conditions facilitate the requirements for a knowledge worker to perform knowledge work?
- 2) **How can organizational processes that shape and determine a knowledge worker's job organize the provision of information to facilitate knowledge workers to perform?**
 - a. How can a structured process approach of knowledge work be balanced with a knowledge worker's autonomy required to perform?
 - b. How can a structured process approach facilitate effective information sharing?
 - c. How can effective information sharing facilitate knowledge worker performance?
 - d. What are the requirements to facilitate collaborative knowledge workers in a structured process approach?

This will then define the input for phase 3 in order to build the solution.

Chapters: 2 & 3

Phase 3 – Design the constructs and solution

Constructs are suggested solutions to the selected research problem (Kasanen, 1993.) The design phase will be grounded in the knowledge gathered in the past two phases. Hereby, a solution at Nike will be designed in order to answer question 3:

- 3) **How can collaborative demand planners at Nike be facilitated to improve forecast accuracy?**
 - a. How can collaborative demand planners at Nike be facilitated to apply their knowledge?
 - b. How can the lean methodology be used to facilitate demand planners at Nike to improve forecast accuracy?

Methodology:

In order to design a solution chapter 5 will make use of the design cycle presented in Figure 7 which is adapted from Dym and Little (2004.) The author states that it is a “widely accepted model of the design process” and therefore this process will be followed in order to design the solution. The solution will be designed together with demand planners at Nike to ensure that the design process becomes a consultative iteration between the researcher and the practitioners to ensure the solution's suitability for practice.

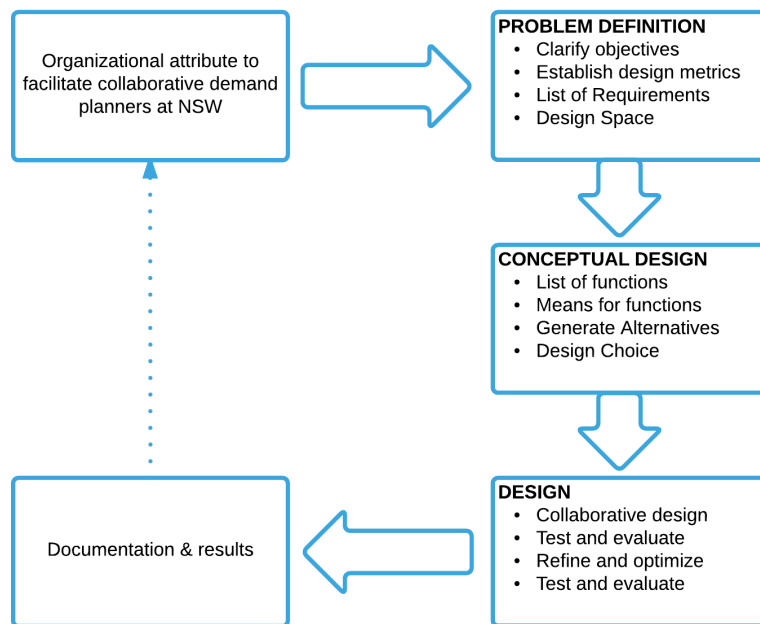

Figure 7 - 5 stage prescriptive model of the design process at Nike adapted from Dym and Little (2004)

Chapter: 4 & 5

Phase 4: Implement the solution and test whether the new solution works

According to Oyegoke (2011) the most appropriate method to test and improve a solution is by using a pilot case study. Therefore the solution will be implemented in the NSW department at Nike. Unfortunately, due to time resource constraints, only one case study will be performed. The constructs will be validated using surveys filled in by the users of the solution, and Pedersen's (2000) validation methodology

Methodology:

- Case study and solution implementation
- Surveys and Pederson's (2000) construct validation methodology

Chapter: 6

Phase 5 & 6: Show the theoretical connections and research contribution of the solution concept and examine the scope of the applicability of the solution.

The constructive research approach demands that the construct should add to the body of existing knowledge. The contribution should be specified and areas for further studies should be highlighted (Oyegoke, 2000.) This will be performed in:

Chapter: 7 & 8

Figure 8 provides an overview of the research approach in this thesis.

Constructive Research Steps	Methodology	Chapter
1. Selection practically relevant problem with research potential	Work floor observations and interviews at Nike & Literature Review	1 & 2
2. Obtaining a general, comprehensive understanding of the topic	Work floor observations and interviews at Nike & Literature Review	2 & 3
3. Design the solution	Case Study at Nike	4 & 5
4. Implement the solution test whether it works in practice	Case Study at Nike	6
5. Show theoretical connections and research contribution	Evaluation according to research requirements and literature review	7 & 8
6. Evaluate the scope of the solution's applicability	Evaluation according to research requirements and literature review	9

Figure 8- Constructive research approach to design solution to facilitate knowledge workers at Nike

1.7 Chapter Summary

To conclude, the following thesis will use the constructive research approach adapted from Kasanen (1993) in order to answer the following research question:

How can an organization's process arrangement facilitate collaborative knowledge workers to improve organizational KPIs?

The main question will be answered using the following sub-questions:

- 1) **How can organizational conditions facilitate knowledge workers to perform?**
 - a. What are the requirements for a knowledge worker to perform knowledge work?
 - b. Which organizational conditions facilitate the requirements for a knowledge worker to perform knowledge work?
- 2) **How can organizational processes that shape and determine a knowledge worker's job organize the provision of information to facilitate knowledge workers to perform?**
 - a. How can a structured process approach of knowledge work be balanced with a knowledge worker's autonomy required to perform?
 - b. How can a structured process approach facilitate effective information sharing?

- c. How can effective information sharing facilitate knowledge worker performance?
 - d. What are the requirements to facilitate collaborative knowledge workers in a structured process approach?
- 3) How can collaborative demand planners at Nike be facilitated to improve forecast accuracy?**
- a. How can collaborative demand planners at Nike be facilitated to apply their knowledge?
 - b. How can the lean methodology be used to facilitate demand planners at Nike to improve forecast accuracy?

In order to answer the questions a case study will be performed at Nike together with an elaborate literature review.

This thesis will be structured using the 6 phases as presented in Figure 8 from the constructive research approach and therefore the following chapter will complete phase 1, finding a practical relevant problem that has a research potential by using practical evidence from the work floor at Nike in order to properly define the problem at Nike.

PHASE 1 - Finding a practical relevant problem that has a research potential

Constructive research problems can be based on anecdotal evidence, evidence based on practical experience in an industry or from the practitioners in the industry or evidence from peers' theoretical work (Oyegoke, 2011.) A suitable research problem should offer opportunities for practical and theoretical contributions (Kasanen, 1993.) Therefore, the first step to further define the problem of this thesis is an in depth literature review, interviews- and work floor observation at Nike.

Chapter 1 used a literature review in order to frame the problem statement, the following key-words were the most relevant key-words used 'knowledge work' 'knowledge work manag*' 'knowledge worker performance' 'knowledge worker productivity' 'knowledge management' 'performance metrics' 'demand planning' 'facilitate*' 'forecast accuracy' 'forecasting' 'customer demand planning' 'demand- and supply-integration.' Next to this the databases used were Scopus, Google Scholar, Web of Science, JSTOR and Science Direct. In order to improve the validity of the literature review, literature used in this thesis is limited to peer-reviewed scientific papers found in the known databases of major publishers (Elsevier, Emerald, Springer, Wiley, etc.) The literature review ensured the theoretical relevance of the problem. However, next to the literature presented in chapter 1, more evidence is required from Nike ensuring the practical relevance of the problem.

Therefore, chapter 2 will present a case study at Nike, which will further define the problem and practicality of this thesis. In order to define the problem, explorative interviews with 9 managers and directors working within the demand planning and inventory management department were conducted (Appendix 1.) This was performed in order to understand more about the workings of the department and where challenges were being experienced. Next to this, the researcher who was studying and present at the department during the entirety of the research performed work floor observation and informal chats.

2 Knowledge Work at Nike

Even though numerous authors assume the potential stakes of understanding more about how knowledge workers should be managed to improve their performance 'enormous' (Davenport, 2014; Bisson et al., 2010; Matson & Prusak, 2010; Davenport et al., 2002; Drucker, 1999.) Research in the field has been a difficult task due to the complex nature of knowledge work and workers resisting any attempt to be measured or observed. Next to this, traditional performance measurement techniques have not been effective in identifying best practices due to the complexity and interrelations between the various factors to be considered by such workers (Paradi et al., 2002.) An important challenge in this research is the "human" aspect of managing knowledge workers, as all types of intervention should be in their best interest. In order to gain more understanding, more academic case studies are required (Davenport, 2013.) Therefore, knowledge work performed in the demand-planning department at Nike will be analyzed. This ensures that a relevant example of knowledge work is presented, together with challenges found in managing knowledge work, and that the human aspect of knowledge is considered, where most of the data will come from knowledge workers.

Most importantly is that during the work-floor observation, interviews and research interaction it was clearly explained

to knowledge workers and managers involved in this research that the focus was not to measure how they were performing, but to understand how research can help to facilitate them to perform and to understand more about how to improve their performance.

2.1 Nike

The case study is performed at Nike European Headquarters. The company has a dedicated Centre of Excellence team responsible for improving and assisting process performance within the Demand Planning and Inventory Management department combined with strategy deployment and program management.

Nike is active in the clothing and sport accessory industry. The company is organised around six lines of business: Football, Running, Nike Sportswear, Women's Training, Young Athletes and Basketball, Jordan, Tennis and Skateboarding. The demand planning departments are organized around the latter lines of business. The lines of business are divided into product lines, and each line is divided into style categories which are then divided into colours. Due to the organization of the business lines, demand planners work together with their line departments. This has resulted in varying planning methods between departments and planners, where all planners have the same deadlines and deliverables, yet use varying methods for their input. This is an interesting opportunity to understand more about knowledge work as the case involves collaboration, fixed deliverables and expert work. Managers in different departments will have varying methods to manage demand planners, as each line of business has a different director. This implied an interesting variety and will support a broad understanding of knowledge worker management currently.

The aim of chapter 2 is to provide an overview of demand planning at Nike. Hereby the following questions will be covered:

What is demand planning at Nike? (2.2)

What does the demand planning process look like at Nike? (2.3)

Who are the main stakeholders of the demand planning processes at Nike? (2.4)

What are the performance metrics of demand planning at Nike? (2.5)

2.2 Demand Planning

One of the critical drivers of supply chain success is effective customer demand planning (Moon et al., 2000.) This means that a company must be able to accurately forecast its business opportunities, and effectively plan throughout its supply chain to exploit those opportunities using a demand plan. The goal of demand planning at Nike is to forecast and project what customers will want, how much and when, by submitting 7 demand planning forecasts to ensure that Nike can take advantage of the demand for their products. This is achieved by allocating production capacity, fabric commitments, factories and so in order to build the required supply chain capacity to fulfill consumer demand.

From the moment that a single product is designed to the time it is delivered to the end consumer is approximately 2 years. Hereby, R&D and design characterize the first year, and demand planning, production and delivery characterize the second year. Nike is well known for its innovative materials and product designs, and therefore has a long lead-time from design to delivery.

In order to deliver Nike products to consumers, demand planning begins 46 weeks before the products are on the shelves. Based on demand planning forecasts, factory capacity is decided, materials are selected and ordered, and products are produced and transported. Forecasting demand is crucial for driving efficient operations management plans. Poor demand planning effects are stock outs or high inventory, low service level, obsolescence, rush orders, inefficient resource utilization and bullwhip effect through the upstream supply chain (Nenni et al., 2013.) Nike, Inc. products are sold in the sports, fashion industry where products are categorized by long replenishment lead times, short selling seasons and unpredictable demand which means that forecasting is crucial for organizational success due to the short selling season.

2.3 Demand Planning at Nike

As mentioned above, Nike is organized around 6 lines of business; Football, Running, Nike sportswear, Women's training, Young athletes and Basketball/ Jordan/ Tennis/ Skateboarding to ensure sports-specific knowledge expertise. In order to understand the organization of the company, product categorization will be explained in the following section.

2.3.1 Product Categorization

Following the six lines of business by which demand planners are segmented. Nike's products have two classifications upon which they are characterized: product engine and product category. Product engines are defined by the type of product, which is apparel, footwear or equipment, whilst product categories are characterized by the six lines of business.

Product Engines

Product engines are distinguished as apparel, footwear or equipment due to their differing manufacturing properties. This is because a t-shirt, which requires dyeing and sewing, requires different manufacturing processes to footwear, which consists of two different material parts, characterized by the sole and top of the shoe. Therefore demand planners are allocated per product engine, where different product engines will require different lead times.

Product Categories

Product categories are organized around the 6 lines of business. The main differences between the categories are their sports characteristics and external influences and markets. An example of this is the difference between Nike Sportswear and Running. Hereby, Nike Sportswear focuses on fashion features, with less functionality; therefore providing products for a more trend sensitive market, where running focuses on technical features to improve functionality and is less sensitive to fashion trends. Employees have specific in-depth knowledge per product category and per product engine. Therefore all demand plans and role responsibilities are organized per category and in the category, per product engine.

In-Line and Always-Available products

Next to the above-mentioned demand planning categorization, Nike distinguishes between inline products and always-available products. The traditional supply chain strategy at Nike follows a make-to-order strategy, which means that customers place orders 6 months before receiving product assortments. However, for certain products a make-to-stock strategy is used in order to have certain products, which are always available to consumers such, as socks, basic t-shirts, etc. These products have longer lifecycles than one season and should therefore always be available for

customer orders. Due to the supply chain strategy differing for always-available products this study will focus on inline products, the make-to-order strategy.

The supply chain process begins when merchandisers start designing product lines. Based on this, financial targets are made, global sourcing begins to manage factory capacity and demand planners start their first forecasts.

2.3.2 Product Design

Nike merchandisers design product lines for four seasons. New technology development initiates the evolution of new products and designs. Product design is an iterative process, where the design evolves from a silhouette model (chassis) to a model offering. Figure 9 shows the progress.



Figure 9 - Design Process at Nike source: Nike, 2015

In order to ensure cross-functional collaboration between departments, style codes are allocated to each product. This code includes information about material, print, graphic, price and marketing name (e.g. AW77 F7, Geo Print Game Day Duffel.)

Once models have been designed at style level during the assortment finalization, products are presented to demand planners and forecasts begin at style level. Using input from merchandisers, sales and demand planners color schemes and material details will be added to the products, which will result in style-color level forecasts.

2.3.3 Customer Demand Planning at Nike

As mentioned above, the planning horizon is divided into four seasons: Spring (Jan-Mar,) Summer (April – June,) Fall (July-September) and Holiday (October – December.) For each season, demand planners deliver a customer demand plan forecast on seven occasions. Demand planners use history and statistics, sales input, finance input, merchandising input and expertise from key stakeholders to complete a demand plan forecast per engine and category. The demand plan forecast becomes more and more accurate as the deadlines progress and bookings come in 23 weeks before the selling season starts.

In order to understand the demand planning process, a brief description will be given of the seven deadlines. The seven deadlines in chronological order are: Post Category Assortment Finalization (Post CAF), Post Seasonal Integration Meeting (Post SIM), Pre Go To Market (GEO), Post Go To market (Post-GTM), First Order Entry Deadline (F1), Second Order Entry Deadline (F2) and Third Order Entry Deadline (F3). The deadlines are triggered

by different Nike events, namely AF, SIM, GTM, F1, F2 and F3 respectively. Figure 10 visualizes the main deadlines and time until the selling season starts.

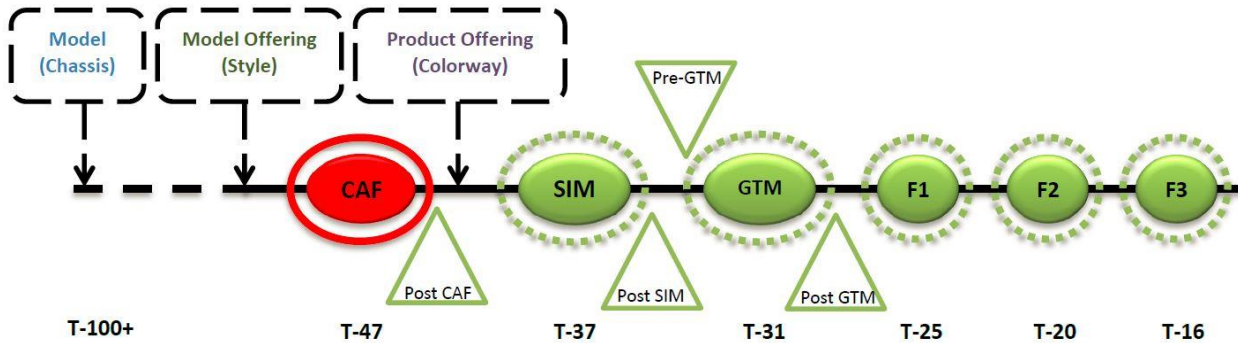

Figure 10- 7 Major Planning Deadlines at Nike source: Nike, 2015

Next to this, Figure 10 shows a high-level overview of the time lines, most important events, demand plan forecast submits and stakeholders. This study will focus on the pre-season process found on the left side of Figure 11 highlighted with the blue box. This means that the demand planning process used in this study runs from the moment that a demand planner receives the product assortment from merchandising, together with the statistical forecast sourcing from the company's ERP system until the last bookings have come in at F3, 11 weeks before the assortment lies in shops. Next to this, it is important to understand that demand planners are always forecasting customer demand for more than one season at a time.

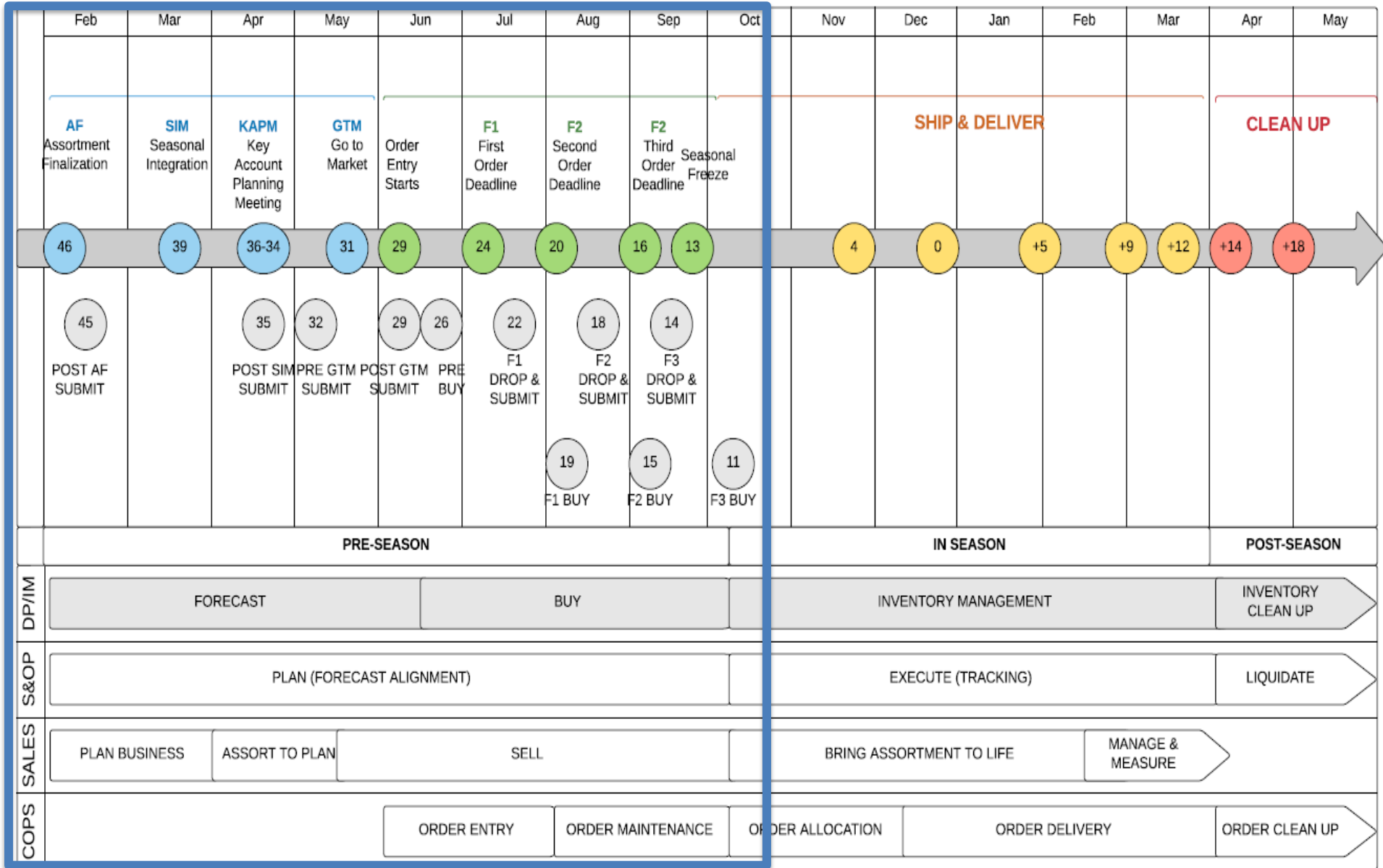

Figure 11- High-level Supply Chain Process Highlighting the Demand Planning Focus of this Research

Category Assortment Finalization (AF):

Forty-seven weeks before the selling season the final product assortment is presented by merchandising. This triggers, the first style level forecast, which is submitted by demand planners. The initial forecast sources from the company's ERP system and before demand planners begin to apply their knowledge, all product materials and codes should be active in MMX and ready in all systems. The AF forecasted demand plan submit impacts seasonal capacity for manufacturing and processing, tooling and allocations of styles.

At this point the selling price and marketing strategy of products is known. Based on the latter information merchandising provide demand planners with a merchandising style level forecast. Demand planners use historical information, statistics, top line growth sales and ranking input from merchandisers to submit a demand plan forecast at the Post-AF deadline.

Seasonal Integration Meeting (SIM):

Thirty-seven weeks before the selling season, GEO merchandising hands the line over to GEO Sales. Hereby category sales directors and key account customers see the line on retail brand presentation level and final tweaks are made to the products.

The post-SIM forecast impacts monthly capacity, pre build and build buys, long lead time and fabric commitments and allocations. Next to this, some products may be dropped due to more insight in the market and consumer requirements. Demand-planners submit a style-color level demand plan forecast based on all information used in the previous submit, and input from sales directors.

Go to Market (GTM):

Go to market is the most important input for demand planner's forecasted demand plan. Hereby, most information can be collected before actual bookings come in. Go to market, 31 weeks before the selling season, is a large event where all regional sales representatives see the product lines and marketing stories for the new season. Sales teams are then motivated, inspired and prepared to bring the category vision to life in the market place. Two demand plan forecasts are submitted around GTM, the GEO forecast and post-GTM forecast.

Before GTM, demand-planners submit a GEO forecasted demand plan. The main input for this demand plan forecast is the Key Accounts Planning Meeting (KAPM.) This seasonal meeting focuses on the geography's top 5, and regional top 10 accounts. Hereby the category sales and account team present the product assortment and brand stories to key accounts and receive feedback for the forecast. This demand plan forecast is most important for footwear as their forecast accuracy is measured between F1 and GEO forecast.

At GTM Category sales directors present the lines to their sales representatives and receive feedback about the line. This information is then communicated to demand planners in a meeting with category sales directors. The feedback is mostly qualitative and sometimes, large volumes are discussed quantitatively in order to provide a more accurate forecast.

The post-GTM customer demand planning forecast is the most important forecast due to its influences on the downstream supply chain. Next to this, for apparel, true forecast accuracy is measured between the GTM submit and time that actual bookings come in at F1. The style color forecast at GTM influences the monthly production capacity, long lead time & fabric commitments, allocations, drops and most importantly, blind

buys. Blind buys are orders placed at factories before receiving any orders or knowing true customer demand. These are often long-lead time products that need longer to produce than the time available between the first order entry deadline and the selling season start. Approximately, 5% of footwear products are blind buys, and 17 % of apparel buys are blind.

F1, F2 and F3:

Go to market is the start of the sales teams selling trajectory. Hereby, sales officials sell the line and have three chances to enter orders, at Order Entry Deadline (OED) 1, OED 2 and OED 3. Based on the three order entry deadlines, three customer demand plans, F1, F2 and F3 are submitted by demand planners. Respectively, at 25 weeks, 20 weeks and 16 weeks prior to the selling season. At F1, the demand planning forecast for the entire season is split into F1, F2, and F3 based on bookings, extra sales information and statistical application. The forecasts will act as input towards inventory planners who place purchasing orders.

In order to place buys inventory planners must take factory and production minimums into account. Unless a product is highlighted as an exception by merchandising, inventory planners must keep all minimums into account when buying. If the forecasted demand for the second and third month does not reach the minimum, the demand planning forecasts will be consolidated. At F3 there will be no demand forecast and bookings will be copied into the demand planners forecasted demand plan in order to measure final forecast accuracy.

Appendix 3- Nike Business Process Overview, shows a process overview of the latter deadlines and inputs. Next to this, stakeholders involved in the demand planning process are displayed in the BPM. These will be introduced in the following section.

2.4 Stakeholders Analysis

The customer demand planning forecasting process involves various stakeholders with competing objectives: Sales, Merchandising & Marketing, Finance, Global Sourcing, Inventory Management and Demand Planning. The stakeholders work together with demand planning in order to drive business operations. The following list will provide a brief description of the main stakeholders:

Sales

The Sales department is a large and important stakeholder in the demand forecasting process. Most importantly, due to their intimate contact with key accounts and consumers they can provide the most relevant information to demand planners. Before receiving the finalized assortment lines from merchandising, a target revenue and sales target is set. The main interest for sales is to achieve sales quotas and maintain good relations with key accounts and Nike clients. Therefore it is in their interest for the demand plan to be well-predicted, where higher forecast accuracy has an impact on coverage for their accounts. Next to this, at Go-to-Market sales teams realize which products need to be dropped and cancelled and can therefore have a greater impact on forecast accuracy.

Finance

The finance department depicts target revenue at the beginning of the season and makes sure that forecasted sales will generate sufficient cash flow to meet corporate financial obligations. Therefore, demand planners

are restricted by the budget available. The more accurate forecast, the more effectively finance can manage operating expenses and determine whether investments are appropriate.

Merchandising

Merchandising is responsible for finalizing the assortment and marketing stories around products. Merchandising provides the first demand-planning forecast for demand planners. This demand forecast is made based on expected product trends in presence of affecting factors such as the product's price, marketing strategy and product groups presented. Next to this, merchandising communicates exceptions and promotional articles to the demand planning team. This has a direct impact on a demand planner's forecast accuracy, as exceptions cannot be adapted by a demand planner and is therefore beyond their control. Next to this, due to the significant amount of work merchandisers put in to finalize an assortment, it can be difficult for demand planners and sales teams to discuss drops and adds at the beginning of the season. This can result in too late drops and adds with a higher impact on forecast accuracy.

Global Sourcing

Global sourcing is responsible for long term capacity planning with all factories, and most dependent of demand planners' demand planning forecasts together with merchandising material and production requirements. At AF, the forecast submitted by demand planners, determines the seasonal capacity. At SIM this evolves to the monthly capacity, long lead time and fabric commitments and at GTM blind buys already begin to occur. Global sourcing is therefore most active in the beginning of the cycle, even before AF, where some factories may require new equipment; more facilities or new factories may need to be sourced. Next to this, global sourcing ensures that demand and inventory planners have factory minimums, which they must consider. This means that products can only be ordered if their forecasted demand reaches the factory minimum, which is the minimum a factory can produce in order for it to remain profitable and worthwhile. Next to this, global sourcing manages significant factory production issues and aligns buy-plan requirements.

Sales & Operations (S&OP)

As can be seen in Appendix 3 - Nike Business Process Overview S&OP are responsible for cross-category alignment. These meeting are monthly meeting which include the general category manager, DP category director, merchandising category director, sales category director and S&OP director. Hereby the most important decisions, results and expectations are aligned.

Inventory Management

Inventory Management works very closely with the Demand Planning department and is most dependent on a demand planner's demand planning forecast to submit their purchase orders. Inventory management is responsible for the right balance between delivering products on time and costs in the form of close out inventory and air freight.

Based on demand planners' demand forecasts and OED submits, inventory planners generate detailed inventory requirements in the form of a buy-plan instructing when to buy what. Evaluating existing inventory levels, factory minimums, product production lead times, factory capacities and product priorities are used to create the latter. After this, inventory planners create purchase orders. Hereby, their buy-plan is converted into legal purchase orders, which include product quantities and sizes. When their purchase orders have been submitted and products are ordered, inventory planners ensure factory acceptance, making adjustments based

on factory or global feedback. Feedback can include factory problems such as natural disasters, strikes, fires, etc., factory capacity issues or quality issues. This must be communicated to demand planners who can adapt product offer dates. Inventory management tracks the on time coverage of products and decides on air freight shipments in case of too low coverage.

Once a season has finished, inventory management is responsible for the liquidation of stock. Hereby close-out is decided and communicated with sales. Inventory managers also align with Nike factory stores about shipping plans and which products will arrive in the factory stores. Nike factory stores are stores which sell Nike close out. In order to pull consumers to Nike factory stores, these stores offer a broad assortment of products which are not all close out. Therefore Nike factory stores are included in a demand planners forecast.

Demand Planning

Based on history and statistics, sales input, finance input, merchandising input and inventory management input, demand planners submit demand planning forecasts. Chapter 6 provides a detailed description of demand planning tasks.

Appendix 4 - Organizational Chart of Demand Planning Department at Nike shows the organizational structure of the departments and how demand planners are organized around products engines and categories.

2.5 Performance Metrics at Nike, Inc.

Important to any organization are key performance indicators, which measure how a department is performing according to their strategy. This is reflected in the aim of this thesis, where the main research question is how to facilitate knowledge workers to improve organizational KPIs. Nike has several KPIs to measure their organizational performance. For the scope of this thesis the most relevant KPIs for the demand-planning department and supply chain performance will be used and these are, days of sale inventory (DSI), supply chain costs, air-freight, coverage and customer service which are all impacted by the most significant KPI for demand planners, forecast accuracy. Chapter 1, p.3 provides a visual of the impact of the latter KPIs on Net Revenue.

2.5.1 Forecast Accuracy as a Metric

Forecast Accuracy is the most important metric for demand planners at Nike, and is the sole quantitative figure used to measure demand planner performance. Appendix 5 - Formulas used to Measure Forecast Accuracy outlines how forecast accuracy is calculated.

The metrics used to measure demand planner performance based on their demand planning forecast is **forecast accuracy**, a measure of how close the forecasted quantity is to the actual demand (absolute percentage,) **forecast bias** which measures the direction of the forecast error. This indicates whether a demand planner has over- or under forecasted as compared to actual demand and indicates the general tendency of over forecasting or under forecasting (percentage.) And **forecast volatility** which is the variance of the forecast from one submit to another submit (absolute percentage.)

Forecast accuracy can only be projected at the end of the season when actual bookings come in. This means that demand planner performance can be measured 4 times per year, but only 6 months after forecasting begins. In order to understand the importance of forecast accuracy, interviews were performed with all category demand planning directors. Concluding from the interview results included in Appendix 1 forecast accuracy is the only numeric metric used to measure employee performance. At this point of time, no other numeric metrics exist to measure employee or process performance. Managers added that they can subjectively measure their employee's understanding of the business through weekly meetings. Next to this, they often 'walk the floor' in order to see how employees are working, and hope that employees feel comfortable enough to share their challenges or difficulties. This acts as a signal for problems in the process where improvement may be needed. However, no true metric exists for the current process.

Based on interviews with 5 demand planners, a business analyst measuring forecast accuracy and an employee focusing on forecast accuracy root causes, a causal diagram of all variables, which influence forecast accuracy, was constructed. This is displayed in Figure 12 the blue circle depicts actual demand planner influences on forecast accuracy.

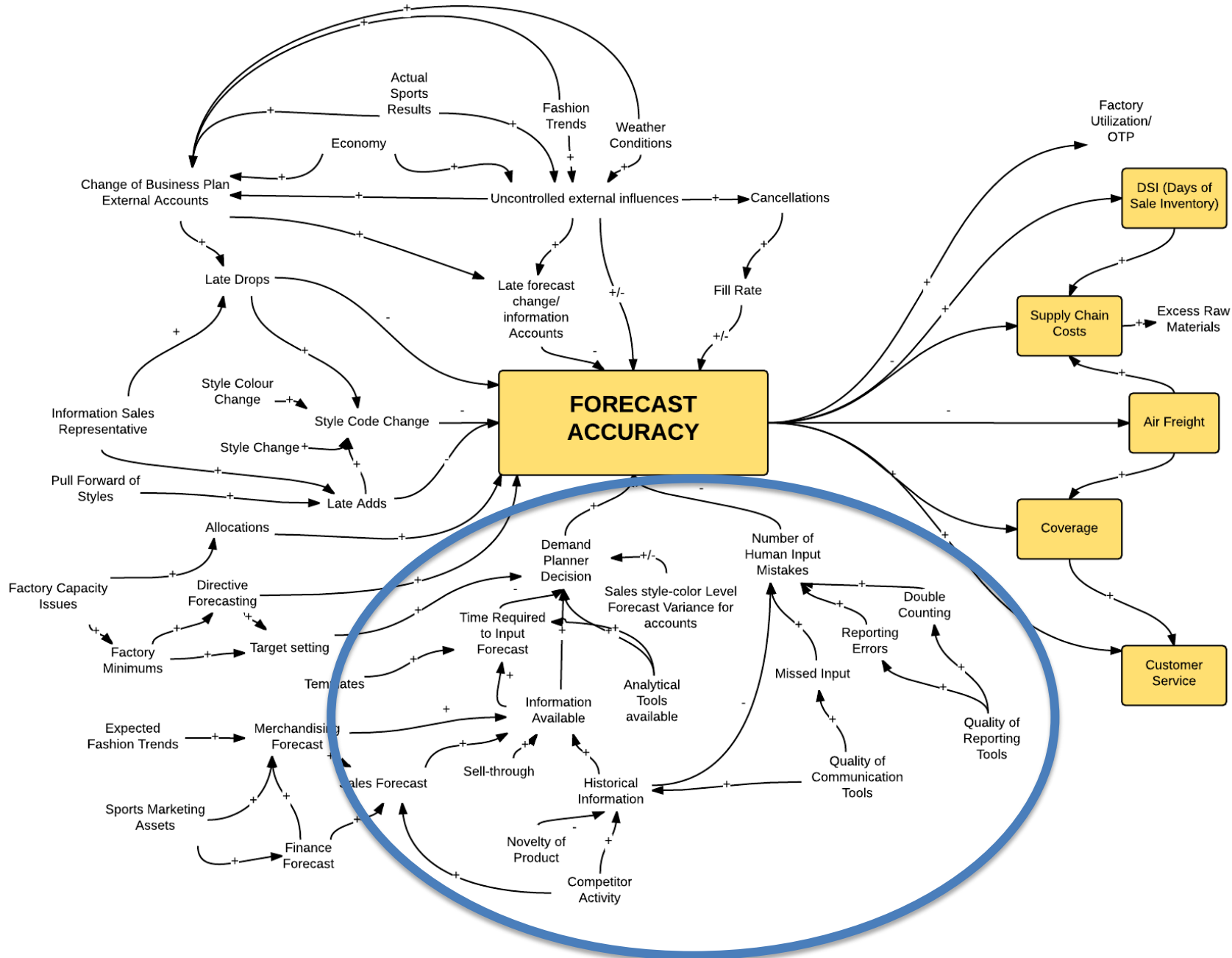

Figure 12- Causal Diagram of All Factors Influencing Forecast Accuracy, highlighting the Causal Influences of Demand Planners on Forecast Accuracy

The causal diagram highlights that forecast accuracy is influenced by a large amount of uncontrolled external influences. Evidently, if product lead times were to be shortened significantly, fewer products would have to be bought blind, capacity allocation could be performed later and purchase orders could be performed later based on bookings, resulting in less important forecast accuracy with less impact. However, this falls outside the scope of this research. Next to this there is a distinction between causal relationships, which can be influenced by changing the demand planning process, and external influences, which are outside the scope of this research. The following section will elaborate upon these differences.

The most important contribution of this causal diagram in Figure 12 is that forecast accuracy is influenced by many uncontrolled external variables, which are beyond the control of demand planner performance. This is elaborated upon in the following section.

2.5.2 Process Root Causes for Forecast Accuracy

Next to the causal diagram presented in Figure 12, research was performed in order to find the top 10 process root causes for demand planning forecast in-accuracy at Nike. The results were found by using qualitative input from all demand planners at Nike and analyzing their demand planning forecast submits. The top 10 root causes for forecast in-accuracy as found by (Asipko, 2015) at Nike, Inc. are as follows:

Root Cause	Explanation
Forecast Error	Double counting forecasts, forecasting issues, missed input, reporting errors, human mistakes, wrong alignment decisions, wrong forecasting decisions, wrong interpretation of the history and/or current demand signals, target setting, etc.
Limited Information	Styles impacted by limited/missing information (no Merch/Sales inputs/insights, no “like-4-like”, no market information, no sell-through information, no history of any kind, etc.)
Category Specific	Some category specific process/event/reason/issue/impact which influenced accuracy and cannot be assigned to any other root cause
Not Analyzed (includes AA):	Styles for which at least one color is AA. This root cause is used to limit a number of styles which need to be analyzed by Category DP teams.
Drops	These are styles which are impacted by dropping one or more colours where an entire colour-way is dropped.
Late Adds	Styles which are added to the line at a later stage in the category game plan than normally, resulting in an added code.
NFS/DTC	NFS/DTC dedicated styles (e.g. re-buys, exclusives, etc.)
Small Discrepancy	Styles for which unit forecast error is relatively small. Used to limit the number of styles which need to be analyzed by category Dp teams.
Account Specific	Styles forecasted based on insights for a specific account (SMU’s, exclusives)
Pull Forward	Ordering earlier than expected due to earlier delivery, mail orders, etc.
Allocations	Allocated styles

Table 1 - Forecast In-Accuracy Root Causes Indicating the Importance of Forecast Error, Limited Information and Category Specific Root Causes

Figure 13 indicates the percentage of seasonal error volume indicating that on average, 12% of forecast in-accuracy is caused by forecast errors caused by demand and not analyzed styles due to time limitation and 3% of forecast in-accuracy is caused by demand planners missing information.

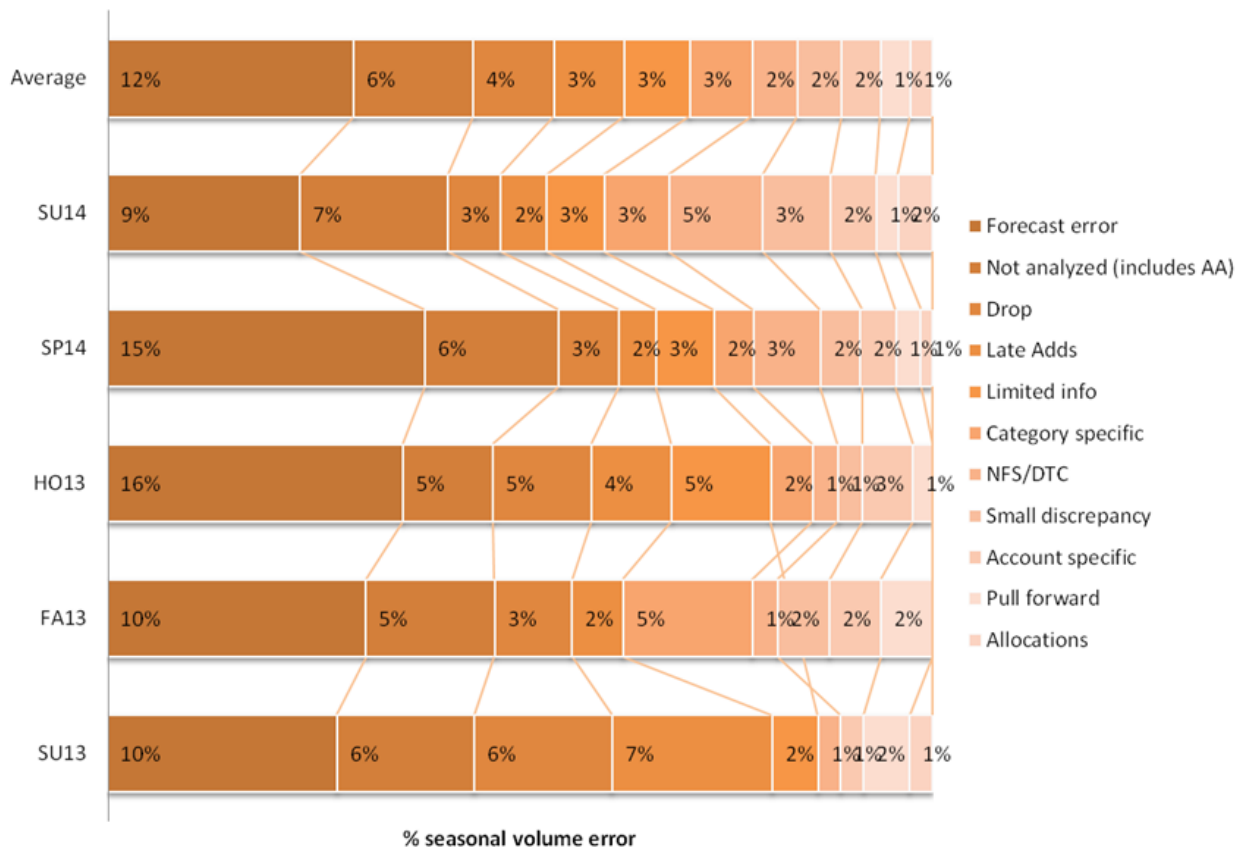

Figure 13- Forecast Accuracy Root Cause Analysis (Nike, 2015)

Figure 13 highlights the importance of forecast error as a root cause for forecast inaccuracy. As mentioned above there is a distinction between process-related root causes which will be considered in the scope of this research and root causes which occur either due to uncontrolled external influences or the way that forecast accuracy is measured. A clear example of forecast accuracy measurement restrictions is the impact of drops on forecast inaccuracy. In the case of drops and late-adds for example, the demand planner may have forecasted a product correctly; however, if a style code is added or changed, an accuracy of 0% will be calculated for that style due to the style code change. This study will not focus on how to improve the measurement of forecast accuracy to decrease such root causes that cannot be influenced by demand planner performance.

The focus of this study will be on the first three root causes listed in Table 1: Forecast Error, Limited Information and Category Specific issues. The reason to focus on these three is due to various reasons. The most important reason is because the 3 issues are process related issues; where demand planners are either missing information, making mistakes or double counting and so on. This signifies an issue in the demand planning process, and knowledge worker management as it is not clear why the process does not enable demand planners to access the correct information, have the right tools to avoid reporting errors, double counting, etc. Moreover, the seven other root-causes source either from external parties or forecast measurement restrictions. Such as account specific forecast input, drops and late-adds due to unexpected colour or style wishes. Even though demand planners must have the correct process to enable them to process drops and late-adds, the impact of the latter on forecast accuracy is an external influence, which will not be considered in the scope of this research.

The most important conclusion of this chapter is that forecast accuracy is influenced by too many other variables and therefore should not be used as the only performance metric for demand planners. It indicates that knowledge workers are lacking suitable measurement metrics and that even in such a successful company, managers are struggling to manage knowledge workers accordingly. Mistakes are being made and they are missing information, which indicates that they are being prohibited to perform according to their capabilities.

2.6 Chapter Summary

The aim of phase 1 is to define a practical relevant problem that has a research potential. Constructive research problems can be based on anecdotal evidence, evidence based on practical experience in an industry or from the practitioners in the industry or evidence from peers' theoretical work (Oyegoke, 2011.) A suitable research problem should offer opportunities for practical and theoretical contributions (Kasanen, 1993.) In order to ensure a constructive research problem, input sources from practical experience in the industry, practitioner's expertise and evidence from peers' theoretical work.

Practical experience in the industry:

Results indicate that an average of 18% of the total 40% forecast in-accuracy, (12% forecast error, 3% missing input and 3% category-specific issues) is caused by process-related issues. **This indicates an important issue, as Nike's process arrangement is prohibiting demand planners to apply knowledge in order to produce an accurate demand plan.** Appendix 3 shows a BPM of the demand planning process at Nike.

Evidence from peers' theoretical work:

Academics state that further studies on forecasting should research how a demand planner should be managed and facilitated in order to improve forecast accuracy (Armstrong, 1987; 2001; Mentzer and Bienstock, 1998; Moon et al., 2003; Danese et al., 2010.) Hereby, Danese et al., (2010) highlight that more research is required towards how to facilitate a demand planner to produce an accurate demand planning forecast using managerial decisions on demand planner processes, information gathering processes and tools, organizational approaches, collaboration and forecast accuracy measurement using a proper metric and by defining proper incentive mechanisms. Demand planners are defined as knowledge workers and therefore further literature about knowledge workers is used to ensure a relevant theoretical academic contribution.

The common theme in Taylor- and the economic productivity- approach is that they allow for universal performance measures, which are used to improve performance. Knowledge worker performance is considered too difficult to measure and according to Davenport (2013) universal measures are useless for knowledge workers. The appropriate measurement method for knowledge work will vary per industry, process and job and what matters are high quality outputs per time and cost (Davenport, 2013.) A brain's performance cannot be measured based on brain cells devoted per tasks, or creativity. Moreover, productivity cannot be measured when tasks are not fixed, there are no standard production times, tasks are performed differently among various workers and no standard process can guarantee a specific outcome. Therefore, this thesis believes that instead of using universal performance measures to improve knowledge worker performance, more research should be performed towards how an organization's process arrangement can facilitate knowledge workers to improve organizational KPIs.

Therefore, the scope of this research focuses on how the institutions that shape and determine the work that is done can facilitate knowledge workers to improve organizational KPIs. Davenport (2013,) an academic who has dedicated most of his research attention towards knowledge work states, “we’re in the early days of thinking and knowing about how to improve knowledge work... There is much more to be learned and every attempt to make it better should be an experiment.” His elaborate field studies within companies and research in academic literature have resulted in three important statements, “top-down re-engineering of knowledge work is unlikely to be successful,” “computers can be helpful to improve knowledge work, but not all jobs can be mediated by a computer because they are too unstructured or collaborative in nature,” “knowledge work performance improvement is an experiment” (Davenport, 2013.) A clear indication is given that little is still known about improving knowledge worker performance to improve organizational KPIs and therefore experimentation is still required in order to advance the academic understanding of knowledge worker performance to the existing literature.

This thesis will thus not attempt to re-engineer knowledge work, and will not attempt to define a universal performance measure to improve knowledge work, but will focus on how an organization’s process arrangement can facilitate collaborative knowledge workers to improve organizational KPIs using existing academic knowledge and a case study at Nike.

Framing the main question of this research:

How can an organization’s process arrangement facilitate collaborative knowledge workers to improve organizational KPIs?

PHASE 2- Obtaining a general comprehensive understanding of the subject

This phase should provide the researcher with a thorough understanding of the research problem and its context (Oyegoke, 2011.) In order to design a final solution at Nike and answer the main research question, sub-questions 1 and 2 must be answered. Therefore chapter 3 will answer sub-question 1, and chapter 4 will answer sub-question 2.

- 1) How can organizational conditions facilitate knowledge workers to perform?**
 - a. What are the requirements for a knowledge worker to perform knowledge work?
 - b. Which organizational conditions facilitate the requirements for a knowledge worker to perform knowledge work?
- 2) How can organizational processes that shape and determine a knowledge worker's job organize the provision of information to facilitate knowledge workers to perform?**
 - a. How can a structured process approach of knowledge work be balanced with a knowledge worker's autonomy required to perform?
 - b. How can a structured process approach facilitate effective information sharing?
 - c. How can effective information sharing facilitate knowledge worker performance?
 - d. What are the requirements to facilitate collaborative knowledge workers in a structured process approach?

3 How can Organizational Conditions Facilitate Knowledge Workers to Perform?

The aim of the following chapter is to answer which organizational conditions facilitate knowledge workers to perform. Megill (2013) states that traditionally, a knowledge worker's profession was characterized by the professional's ability to control the work situation and set fees, where they do their work when, where and for how long they wish, selling their thinking. However, currently, few professionals set their own time and place of work individually. Knowledge workers are "part of institutions that determine and shape the work that is done" and within such institutions, organizational conditions such as management, working environments, organizational culture, organization of decision-making, organization of work, organizational standards, and so on coordinate knowledge work (Megill, 2013; Antikainen et al., 2006.) Furthermore, Kelloway & Barling (2000) highlight that it is "only by identifying and changing the organizational conditions that enhance employee ability, motivation and opportunity" that one can truly engage in managing knowledge workers. The latter authors propose that performing knowledge work is enhanced by organizational practices that increase either an employee's motivation to use knowledge, employee's knowledge (ability) or an employee's opportunity to perform knowledge work in the workplace. Knowledge workers require different management styles to the industrial era; however, it is unclear which management styles drive knowledge worker performance (Drucker, 1999; Davenport, 2008; Ramirez & Nembhard, 2004).

Ramirez & Steudel (2008) identify eight dimensions that differentiate knowledge work from manual work. Knowledge work is a continuous level of work that is characterized "by the following non-mutually exclusive attributes: high levels of autonomy, knowledge, creativity and innovation and complexity; and low levels of structure, tangibility,

routine and repetitiveness and physical effort” (Ramirez & Steudel, 2008.) This is contrasting to manual work, which is characterized by low levels of autonomy, knowledge, creativity and innovation and complexity; and high levels of structure, tangibility, routine and repetitiveness and physical effort. Next to this, due to their high degrees of expertise, education or experience, knowledge workers don’t like to be told what to do, in contrast to traditional production workers (Megill, 2013). Knowledge workers enjoy a high degree of autonomy, which relates to the degree of control a knowledge worker has over how the task is performed (Ramirez & Steudel, 2008.) Task autonomy has a significant impact on a knowledge worker’s commitment and motivation to perform knowledge work (Davenport, 2010.) These are important discrepancies that differentiate management requirements, where manual work can be easy to manage, coerce and control because it is observable and measurable in contrast to knowledge work. By applying the appropriate levels of job design and control to physical labour, an employing organization can ensure that employees are operating in an efficient manner. In contrast to physical labour, Kelloway and Barling (2000) state that knowledge work is fundamentally unobservable. They explain that outcomes of a process are observed, and not the process of knowledge work. Therefore an organization cannot impose external controls, and must focus on creating conditions for enhanced performance of knowledge work. Next to this, Erne (2010) argues that managers of knowledge workers should not be concerned about controlling knowledge work aiming for productivity similar to managing manual work, but should focus on five success indicators: quality of results, organization of work, innovation behavior, quality of interaction and skill development.

A shift in mindset is required when managing knowledge workers. Drucker (1999) even argues that knowledge workers should be treated as assets to their companies instead of costs in production work. Hereby, the significant difference between costs and assets are that costs should be controlled and reduced in contrast to assets, which should be encouraged to grow Drucker (1999.) **Therefore, in order to further understand how an organization can facilitate knowledge workers to improve organizational KPIs, the following section will research the organizational conditions that facilitate knowledge workers to perform.**

3.1 Defining Organizational Conditions that Facilitate a Knowledge Worker to perform Knowledge Work

A knowledge-intensive firm requires human capital of employees as their most significant input where knowledge workers’ abilities, motivation and opportunities to convert knowledge into new solutions form the base for an organization’s operation (Antikainen et al., 2006.) Essential to the success of a knowledge intensive-organization are not only the knowledge reserves of the workers, but also what an organization is able to do with the latter (Drucker, 1999.) Wall et al. (1992) explain that a worker’s performance is equal to *ability * opportunity * motivation*, where if one of the factors is equal to zero, performance will be zero. Sourcing from this, Figure 14 displays Kelloway and Barling’s (2000) model of knowledge use in organizations, which highlights how knowledge workers’ ability, motivation and opportunities mediate the relationship between the use of knowledge in organizations and organizational predictors of knowledge use. The latter figure is generally applicable to an organization; however, more insight is required on the organizational conditions that facilitate the ability, motivation and opportunity of employees to perform their knowledge work.

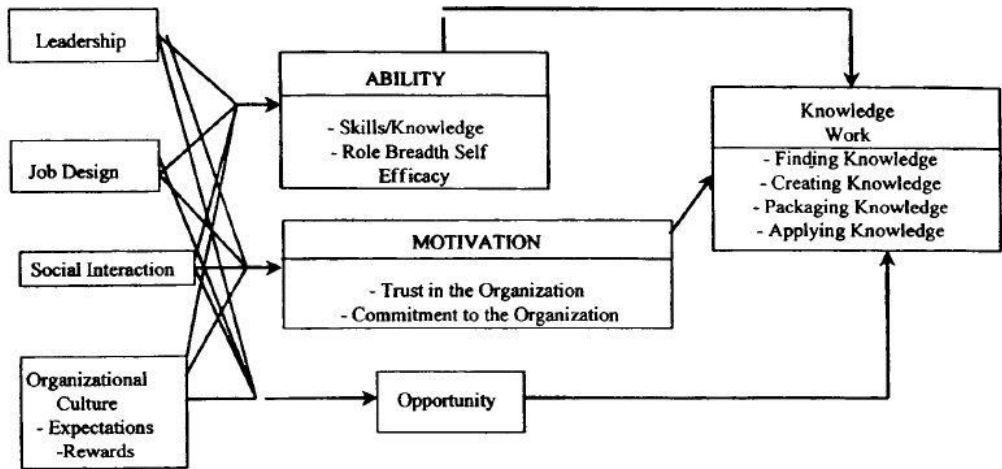

Figure 14 - Model of knowledge use in organizations (Kelloway & Barling, 2000)

Based on work-floor observations and informal conversations with employees at Nike, a worker’s ability, opportunity and motivation to apply knowledge will be elaborated upon, together with the findings provided by Kelloway & Barling (2000) and other authors.

In order to provide a clear scope of the research, this research will focus on **organizational conditions**, which facilitate knowledge workers to perform. It cannot be neglected that an employee’s motivation, opportunity and ability to apply their knowledge may also be influenced by non-organizational practices such as their personal situation or character. For example, a knowledge worker’s personal financial situation may influence a knowledge worker’s motivation, ability or opportunity to apply knowledge. Their financial situation may act as a motivation to work hard to earn money or not, or may have an impact on their opportunity to apply knowledge through the level of education which they can pay for. This non-organizational motivation is directly linked to one’s personal situation at home or outside the company where their personal situation and character will directly influence the 3 variables. However, even though this is relevant and more examples can be named, the focus of this paper is how organizational practices facilitate knowledge workers and not their personal attributes. An organization should ensure a comfortable environment for employees to work; however, character traits and personal circumstances will be considered outside the scope of this research.

3.2 Defining a Knowledge Worker’s Requirements to Perform

The first step to understand how knowledge workers can be facilitated to apply their knowledge is to define what a knowledge worker’s ability, motivation and opportunity is to perform and what they require to achieve this. Figure 15 displays the variables, which will be defined in this section.

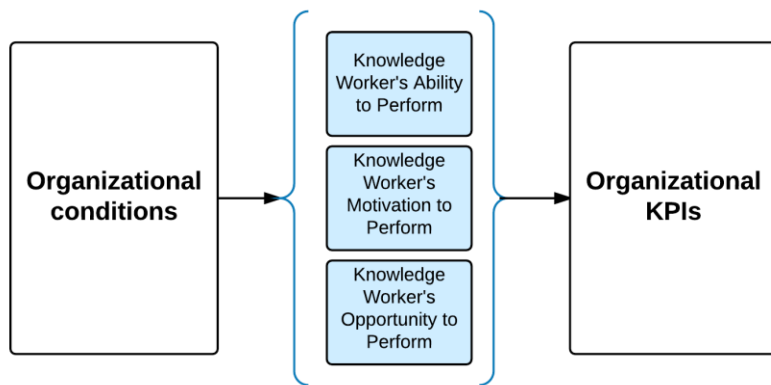

Figure 15 - Defining Ability, Motivation and Opportunity adapted from Kelloway & Barling (2000)

3.2.1 Ability

“One of the central requirements for employees to engage in knowledge work is that they have the ability to do so.” (Kelloway & Barling, 2000) This means that an employee should have the right training, education, knowledge and skills to perform the task (Drucker, 1999.) To ensure that employees have the required competencies organizations can either chose to make the required competencies through training and development or to select employees, which already have the competencies. This competent ability, often determined through human resource management, is a necessary condition for knowledge work (Drucker, 1999.) A knowledge worker’s ability to perform is a key to organizational success where often, in contrast to manual work, the production mechanism is the knowledge worker’s brain, and their ability to convert previous knowledge and experiences into new solutions (Davenport, 2008.) Therefore, an organization should create conditions that select able knowledge workers according to the task and develop and increase a knowledge worker’s abilities. According to Davis (2002) knowledge worker performance depends on their ability to manage themselves and learn, and their ability can be enhanced by learning from own experiences by being proactive and using one’s initiative, having high levels of interpersonal and problem solving skills, and being self-managing (Kelloway & Barling, 2000.) This falls in line with Parker’s (1998) research which concludes that role-breadth self-efficacy is the sense of confidence which “individuals have in their ability to carry out a broader and more proactive role, beyond traditional, prescribed technical requirements” and further develops their abilities to perform (Parker, 1998, p.835.) Moreover, Davenport (2008) and Drucker (1999) state that high-performing knowledge workers are learning all the time and that firms need to nurture their knowledge workers’ learning in order to gain competitive advantage. According to Drucker (1999) knowledge workers require continuous learning and teaching and should therefore be treated as an asset rather than a cost, and thus encouraged to grow and improve their ability to perform. Knowledge workers should feel confident to engage in activities beyond their job description and have the ability to affect the organization of their own work (Jackson, 1999; Blom et al., 2001; Antikainen et al., 2006.) Drucker (1999) states that because human memory is limited, knowledge workers should share their information with each other in order to learn from each other and hence improve their ability (Kelloway & Barling, 2000.) In order to define whether a knowledge worker has the ability to perform, the worker’s task must be clear and a knowledge worker must be hired and trained accordingly. Moreover, knowledge workers require teaching and learning in order to nurture and evolve their abilities to perform.

Directing a knowledge worker to apply their knowledge and individual skills to achieve organizational goals is the most important requirement in order to achieve organizational success. Therefore the task must be clear and knowledge workers must be provided with the opportunity and motivation to perform (Wall et al., 1992.)

Performance is equal to *ability * motivation * opportunity*. Therefore the following section will depict what factors are required to have the ability to perform knowledge work, these are found based on findings from the latter paragraph.

3.2.1.1 Ability Requirements to Perform Knowledge Work:

A-1: Knowledge worker needs skills and previous knowledge to execute cognitive actions and processes (Kelloway & Barling, 2000; Ramirez & Steudel; 2008; Appendix 1, 2015)

A-2: Knowledge workers require continuous learning and teaching (Drucker, 1999)

A-3: Knowledge worker should have role-breadth self-efficacy (Parker, 1998)

3.2.2 Motivation

Motivation is directly connected to ability and according to Amabile (1998) a worker's motivation determines whether they invest their competencies in an organization or not. This means that assuming that knowledge workers have acquired knowledge and the right skills to exploit that knowledge, why do they choose to use, or not to use their knowledge to achieve organizational goals? Referring back to Davenport's (1999) comparison of knowledge workers as investors and assets, one can assume that the more attractive an employee's rate of return is, the more likely that they will invest. Therefore, organizational practices should ensure an attractive rate of return, which ensures that knowledge workers are willing to use their knowledge and skills for organizational goals, which result in higher performance (Davenport, 2002.) Understanding what motivates employees to perform well has been the focus of many researchers following the publication of the Hawthorne study results. Five major approaches have led to the understanding of motivation theories. These are Maslow's need-hierarchy theory, Herzberg's two-factor theory, Vroom's expectancy theory, Adam's equity theory and Skinner's reinforcement theory (Rainall, 2004.) In order to form general requirements for motivation, the latter input will be used combined with recent scientific research performed by Nohria et al. (2008) and input from Kelloway & Barling's (2000) research which determine that knowledge workers require a sense of affective commitment towards their organization together with a job that challenges them and enables them to grow (Kelloway & Barling, 2000; Nohria et al., 2008.) Moreover, specific for knowledge workers is that they enjoy a high degree of autonomy, which relates to the degree of control a knowledge worker has over how the task is performed (Ramirez & Steudel, 2008.) Task autonomy has a significant impact on a knowledge worker's commitment and motivation to perform knowledge work and therefore forms an important requirement (Davenport, 2010.) Next to this, Jackson, (1999) and Blom et al., (2001) depict that a knowledge worker's ability to affect the organization of work can create an increased sense of responsibility and hence motivate a knowledge worker to feel responsible for results thus improving performance. Together with this knowledge workers need to trust their organization and management to be motivated to invest their knowledge and capabilities (Banker et al., 1996.) The following requirements depict organizational requirements that knowledge workers require to be motivated to perform.

3.2.2.1 Motivation Requirements to Perform Knowledge Work:

M-1: Knowledge workers need to trust their organization and management (Banker et al., 1996)

M-2: Knowledge workers need a sense of affective commitment towards their organization (Kelloway & Barling, 2000)

- M-3: Knowledge workers require a job that challenges them and enables them to grow and learn (Nohria et al., 2008)
- M-4: Knowledge workers require a high degree of task autonomy and ability to affect their organization of work (Davenport, 2010; Blom et al., 2001.)

3.2.3 Opportunity

Finally, even if employees have the ability to use their knowledge to attain organizational goals, and are motivated to do so; if they are not provided with the opportunity to use their knowledge in the workplace, their performance will not increase (Wall et al., 1992.) Limited academic literature was found concerning how to best provide knowledge workers with the opportunity to apply their knowledge due to the intangible and unstructured nature of knowledge work (Davenport, 2013; Kelloway & Barling, 2000.) The success of improving performance (productivity) in manual work derived from applying the appropriate levels of job design and control to physical labour, so that an employing organization could ensure that employees were operating in an efficient manner (Drucker, 1999.) However using such job design and control to knowledge work could inhibit a knowledge worker from performing (Drucker, 1999) which makes it challenging to understand how to facilitate a knowledge worker's opportunity to perform knowledge work. Antikainen (2006) for example states that innovative potential is grounded in employees' abilities, but must be brought about by different managerial actions. In this case management can define behavioral expectations from employees and thus knowledge workers require clearly defined tasks in order to have the opportunity to use their knowledge and apply their knowledge to the task. Next to this, even though Davenport (2010) and Blom (2010) describe knowledge work as something where the workers decide how they manage their tasks themselves, in every organization there are certain standards, routines and practices that have evolved in the course of time (Antikainen, 2006.) The latter are based on mental models shared by the members of an organization and often reflect the values, norms and beliefs of an organization (Stahle et al., 2004.) Most relevant is that according to various authors, these standards can either support work or hinder it (Antikainen, 2006; Davenport, 2010; Drucker 1999.) Therefore, in order to have the opportunity to perform knowledge workers require standards, routines and practices that support knowledge work. Similar to providing knowledge workers with the opportunity to perform with the latter standards and routines, knowledge workers also require time to perform. In knowledge work, "quality is the essence of the output" (Drucker, 1999) which is contrasting to manual work where traditionally, more output per unit of time defines the performance of the output. However, in knowledge work, there is a limit for "how much time can be decreased before the quality of work is eroded." (Antikainen, 2006.) Therefore, knowledge workers require the opportunity to perform by providing sufficient time to achieve a high quality outcome. For example, a knowledge worker may have the ability and motivation to perform; however, if a knowledge worker does not have the time to create ideas and innovative solutions the latter will not be created. Furthermore, inherent to knowledge work is that information acts as an input of their tasks, not only information gathered from the customer but also information that exists within the organization (Drucker, 1999.) Knowledge workers make decisions based on information available, and if the information is unsatisfactory, outcomes of a knowledge worker's process can be poor in quality (Antikainen, 2006.) Thus in order to have the opportunity to perform, knowledge workers require direct and timely access to the input of their process, information.

Last but not least, Haynes (2008) concludes that a knowledge worker also requires the correct working environment to have the opportunity to perform. Davenport (2002) emphasizes this, where a working environment 'at it's worst' prevents knowledge workers from doing their job and 'at it's best' can contribute to an innovative atmosphere and increased performance. The working environment as defined in this thesis does not only include physical facilities such as the office environment and tools but also the psychological atmosphere and organizational culture which can

for example define the acceptance of new ideas, values and goals, leadership and so on (Davenport, 2002; Antikainen, 2006; Haynes, 2008.)

3.2.3.1 Opportunity Requirements to Perform Knowledge Work:

- O-1: Knowledge workers need time to do knowledge work (Drucker, 1999; Antikainen, 2006.)
- O-2: Knowledge workers need the necessary tools to perform knowledge work (Haynes, 2008.)
- O-3: Knowledge workers need an environment which supports their knowledge work (Davenport, 2002; Atinkainen, 2006; Haynes, 2008)
- O-4: Knowledge workers need access to the correct timely information to perform knowledge work (Drucker, 1999; Kelloway and Barling, 2002.)
- O-5: Knowledge workers need standards, routines and practices that support knowledge work (Davenport, 2002.)

One of the dilemmas in understanding how to best provide knowledge workers with the opportunity to perform is that knowledge workers characterize their daily tasks with thinking, collaboration and iterative jobs, which makes it challenging to structure and characterize their work (Davenport, 2010.) In order to provide knowledge workers with the opportunity to perform according to their requirements, chapter 4 will elaborate further on how knowledge workers can be segmented in order to define their requirements. For example, knowledge workers will have alternating environmental requirements as their tasks vary from requiring an environment for collaboration to requiring a focused environment for individual work; therefore, this will be elaborated upon in chapter 4.

3.3 Overview of Requirements to Perform Knowledge Work

Section 3.2. defined the requirements for a knowledge worker to perform knowledge work. This section provides the answer to the sub-question 1a:

What are the requirements for a knowledge worker to perform knowledge work?

- A-1: Knowledge worker needs skills and previous knowledge to execute cognitive actions and processes (Kelloway & Barling, 2000; Ramirez & Steudel; 2008; Appendix 1, 2015)
- A-2: Knowledge workers require continuous learning and teaching (Drucker, 1999)
- A-3: Knowledge worker should have role-breadth self-efficacy (Parker, 1998)
- M-1: Knowledge workers need to trust their organization and management (Banker et al., 1996)
- M-2: Knowledge workers need a sense of affective commitment towards their organization (Kelloway & Barling, 2000)
- M-3: Knowledge workers require a job that challenges them and enables them to grow and learn (Nohria et al., 2008)
- M-4: Knowledge workers require a high degree of task autonomy and ability to affect their organization of work (Davenport, 2010; Blom et al., 2001.)
- O-1: Knowledge workers need time to do knowledge work (Drucker, 1999; Antikainen, 2006.)
- O-2: Knowledge workers need the necessary tools to perform knowledge work (Haynes, 2008.)
- O-3: Knowledge workers need a supportive psychological, physical and cultural environment (Davenport, 2002; Atinkainen, 2006; Haynes, 2008)
- O-4: Knowledge workers need access to the correct timely information to perform knowledge work (Drucker, 1999; Kelloway and Barling, 2002.)
- O-5: Knowledge workers need standards, routines and practices that support knowledge work (Davenport, 2002.)

3.4 Defining Organizational Conditions that Facilitate Requirements to Perform Knowledge Work

The aim of this chapter is to define which organizational conditions facilitate knowledge workers to perform in order to provide an in-depth understanding of how eventually; an organization can facilitate knowledge workers to improve organizational KPIs.

Therefore the aim of the following section is to define sub-question 1b.

Which organizational conditions facilitate the requirements for a knowledge worker to perform knowledge work?

Kelloway and Barling (2000) define organizational conditions, leadership, job design, social interaction and organizational culture, as predictors that contribute to increasing employees' motivation, opportunity and ability to apply their knowledge. Using the requirements defined in section 3.3. and the organizational conditions defined by Kelloway and Barling (2000) this section will provide a more elaborate overview of organizational conditions that facilitate knowledge workers to perform. This will then be used to further define the context of the research problem.

3.4.1 Kelloway & Barling's (2000) Four Organizational Predictors

3.4.1.1 Leadership

Kelloway and Barling (2000) name leadership as an organizational condition that can facilitate knowledge workers to perform. According to section 3.3. knowledge workers need to trust their leadership to be motivated M-1 (Banker et al., 1996,) require continuous learning and teaching A-1 (Drucker, 1999,) and require a supportive environment O-1 (Davenport, 2002; Atinkainen, 2006; Haynes, 2008.) Based on the literature review performed, leadership can create the appropriate conditions to facilitate the three requirements, defined in the following section.

Characteristic to knowledge work is the element of learning, where a knowledge worker's abilities can be increased by education but above all through experience and interaction (Nonaka & Takeuchi, 1995.) Bass (1991) presents a model of transformational leadership where successful knowledge worker performance is achieved when a leader has charisma, is inspiring, and provides intellectual stimulation and individualized consideration. The author states multiple benefits of transformational leadership and specifies that employees "do a better job when they believe that their supervisors are transformational leaders" (Bass, 1991.) With the use of individualized consideration, they play an important role in a knowledge worker's growth and development (Bass, 1991,) which is related to a diverse array of productivity and morale-related outcomes (Barling et al., 1996; Barling et al., 1998.) A transformational leader inspires workers through communicating high expectations and expressing important purposes in simple ways, stimulates workers intellectually by promoting intelligence, rationality and careful problem solving, and gives personal attention to employees with individualized consideration coaching and advising knowledge workers (Davenport, 2002) which facilitates a supportive environment required (O-1.) A leader that develops a knowledge worker's knowledge and experiences can enhance their ability to create solutions (Drucker, 1999) and is therefore further defined as an organizational condition that facilitates A-1. Furthermore, motivational requirements M-1 highlight that workers need to trust their organization and management and need a sense of affective commitment towards their organization. According to Bass (1991) & Kelloway & Barling (2000) a charismatic leader, "provides vision and a sense of mission, instills pride, gains respect and trust" which facilitates a knowledge worker to trust their management and gain affective commitment towards their organization. This defines the circumstances that leaders can provide to flourish

motivation (Nicholson, 2003.) To conclude, an organization should train leadership to act according to the transformational model in order to motivate, teach and support knowledge workers to perform.

3.4.1.2 Job Design

Job design is a fundamental, greatly researched human resource management activity. This refers to defining an actual job structure, defining the relevant tasks and activities required and allocating them across employees in a way that allows an organization to achieve benefits from knowledge worker specialization, as well as bundling job tasks in order to consider possible collaboration and synergies between tasks (Foss, 2009.) Even if knowledge workers have the ability and motivation to perform, results cannot be achieved if they do not know what they are pursuing for (Antikainen, 2006.) Assessing knowledge work should be based on “what is the worker’s actual task?” (Drucker, 1999) and therefore, using job design to define knowledge worker tasks is crucial for operational success (Drucker, 1999; Davenport, 2010.) Research has proven that jobs possess certain characteristics that have psychological implications. Parker & Wall, (1998) name the three critical psychological states as, experienced meaningfulness of the work, experienced responsibility for work outcomes and knowledge of the actual results of one’s work. Accordingly, Hackmann and Oldham’s (1976) job characteristics theory states that the five groups of core job characteristics activate the three psychological states through job autonomy, task variety, task significance, task identity and feedback. Next to this, there is widespread agreement that knowledge work is predicated on control and autonomy, where Drucker (1999) emphasizes that the role of autonomy and resulting sense of responsibility is critical when managing knowledge workers and achieving their motivation and commitment to perform (Drucker, 1999; Kelloway and Barling, 2000; Wall et al., 1990.)

However, even though knowledge work is predicated on control and autonomy, driving a knowledge worker’s commitment and motivation to perform (Drucker, 1999,) most knowledge workers operate as a part of a larger entity, which define standards, routine and practices and often creates interdependencies between different actors (Megill, 2013.) Davenport (2010) states that through careful organization it can be ensured that separate processes communicate and work together, and that understanding about how different processes relate to each other is important. However how should an organization ‘carefully define processes’ and design jobs to concentrate on capitalizing core competencies and efficient collaboration whilst allowing knowledge workers with a sufficient degree of autonomy and ability to organize their own jobs. The latter section presents a relevant dilemma in contradicting requirements, where according to the requirements defined in section 3.3. a knowledge worker should have a high degree of task autonomy (M-4), role-breadth self-efficacy (A-3) and an ability to affect the organization of his or her work (M-3, M-4) to achieve high levels of motivation and commitment versus their requirement to have the opportunity to perform by organizing their processes, routines, standards, tools and environment according to the specification of their job (O-1, O-2, O-3, O-4, O-5.) This section concludes that job design is an organizational condition, which has a significant impact on facilitating a knowledge worker’s opportunity and motivation required to perform. However further research is required concerning the balance between conditions that facilitate a knowledge worker’s opportunity to perform versus conditions that increase their motivation to perform. This will be defined in chapter 4.

3.4.1.3 Social Interaction

Social interaction is known to enable knowledge sharing, as when knowledge workers interact with each other they share their information and knowledge, which according to Drucker (1999) is relevant due to the limitations of human memory. Firms interested in increasing the use of knowledge “frequently establish opportunities for employees to gather either formally or informally for the purposes of sharing information and knowledge” where social interaction is known to enable knowledge workers to teach and learn from each other (Kelloway and Barling, 2000; Drucker, 1999.) Next to this Van Aken et al., (1994) highlight that groups directed towards social interaction are often put in

place to achieve objectives such as sharing information, learning from each other, solving problems and capturing improvement opportunities, identifying and addressing education and training needs and building trust and cohesiveness. Social interaction facilitates continuous learning and teaching (A-2) and can facilitate a supportive environment for knowledge work (O-3) (Drucker, 1999; Davenport, 2002; Atinkainen, 2006; Haynes, 2008.) Organizational conditions can enable formal social interaction by ensuring team work, focus groups, and collaborative work together with informal interaction such as social areas, social events and so on. These organizational conditions are facilitated through job design and an organization's environment and are therefore further categorized as jobs that facilitate formal social interaction and an environment and culture that stimulates informal social interaction.

3.4.1.4 Organizational Culture

Culture is not only intangible and illusive but it can also be observed at multiple levels in an organization. Organizational culture is reflected in values, norms and practices. Hereby, the values embedded in the depth of an organization, highlight tacit preferences about what an organization should strive to attain and how it should do so (David & Fahey, 2000.) Values' have an impact on behavior and therefore knowledge work. Next to this, Kelloway and Barling (2000) identify organizational culture as the expectations and reward structure of an organization. Organizations will encourage the use of knowledge by expecting and providing opportunities for skill/knowledge growth and by rewarding such opportunities accordingly. Based on work floor observations, organizational culture should value social interaction and create a proper context for social interaction and information sharing. Dictating the norms such as rules, expectations and penalties that govern social interactions between individuals primarily does this (David & Fahey, 2000.) Individuals should feel enabled to share information with their peers within and across departments and across horizontal and vertical levels. Knowledge workers should be able to share challenges, issues and ideas in order to create a culture of continuous improvement. Referring back to the requirements, organizational culture should hereby increase the ability of employees to apply knowledge and their motivation to apply it through organizational culture.

3.4.2 Extending Kelloway and Barling's (2000) four Predictors

Kelloway and Barling (2000) define four organizational predictors that determine a knowledge worker's ability, motivation and opportunity to perform. However, the requirements presented in section 3.3. define that a knowledge worker also requires the correct working environment to have the opportunity to perform (Davenport, 2002; Antikainen, 2006; Haynes, 2008.) Davenport (2002) emphasizes that a working environment 'at its worst' prevents knowledge workers from doing their job and at its best can contribute to an innovative atmosphere and increased performance. Moreover, Haynes (2008) explains that a knowledge worker's physical working environment has an effect on knowledge worker performance and namely researches the effect of a working environment on productivity. The author distinguishes four necessary factors and their attributes, which have an effect on knowledge worker performance. These are comfort (ventilation, heating, natural lighting, physical security, etc.,) office layout (informal meeting areas, formal meeting area, quiet area, privacy, personal space, work area, etc.,) interaction (social interaction, work interaction, atmosphere, office layout, etc) and distraction (interruptions, crowding, noise) (Haynes, 2008) and find the latter variables to have a significant impact on knowledge worker performance. Next to this, knowledge workers require the correct tools to perform their tasks where, similar to manual work, if tools required are unsatisfactory, the outcome of the process can be affected and knowledge worker productivity can be restricted (Haynes, 2008.) Therefore an environment should be created that provides the right tools required according to knowledge worker tasks. Together with the right tools, knowledge workers require timely access to the right information. This includes information that is not only gathered from the customer or from collaborative partners, but also information which already exists in the organization and is not specifically owned by a certain employee (Antikainen, 2006.) Information in the last form should be organized in a knowledge base that supports a knowledge

worker's tasks and processes to effectively exploit the information in their work (Stahle et al., 2004) This will further be defined in chapter 4.

Furthermore, in interviews included in Appendix 1 five Demand Planning managers were interviewed about the importance of the working environment at Nike. The most important conclusions from these interviews were the following. Knowledge worker performance is often measured by 'walking the floor,' hereby managers hope to see whether workers are performing their work and whether their employees are facing challenges or need help. Next to this, collaboration is crucial for their work. Enabling collaborative employees to sit in each other's vicinity increases the ease of communication and collaboration. Demand planners sitting together with their categories' merchandiser and sales representatives supported this. Hereby, informal collaboration and easier information access were seen as facilitating versus the more difficult collaboration and communication with inventory planners who are located in another building.

This indicates that a knowledge worker's environment can be defined as an organizational condition which facilitates knowledge workers to have the ability, motivation and opportunity to perform, and will thus also be considered in defining organizational conditions which facilitate a knowledge worker to perform their work.

3.4.3 Organizational Conditions that Facilitate Knowledge Workers to perform Knowledge Work

To conclude, there are four categories defined as organizational culture, organizational environment, job design and knowledge worker leadership that can create conditions to enhance a knowledge worker's ability to perform, flourish a knowledge worker's motivation to perform and provide a knowledge worker with the opportunity to perform.

In order to define the organizational conditions that facilitate knowledge workers to perform the conditions will be organized according to performance requirements.

3.4.3.1 Organizational Conditions that Facilitate a Knowledge Worker's Ability to Perform

Various organizational conditions can facilitate a knowledge worker's ability to perform where in short, organizational conditions should simulate knowledge worker growth and learning by developing a knowledge worker's knowledge and experiences to enhance their ability to create solutions (Drucker, 1999.) The following list define the requirements to facilitate ability:

- A-1: Knowledge worker needs skills and previous knowledge to execute cognitive actions and processes (Kelloway & Barling, 2000; Ramirez & Steudel; 2008; Appendix 1, 2015)
- A-2: Knowledge workers require continuous learning and teaching (Drucker, 1999)
- A-3: Knowledge worker should have role-breadth self-efficacy (Parker, 1998)

Based on the section 3.4.3., the following list gives an indication of organizational conditions that facilitate ability:

- Hire or train knowledge worker to have necessary skills and knowledge to perform job (Kelloway & Barling, 2000)
- Ensure transformational **leadership** as defined by Bass (1991) that educates through experience and interaction (Nonaka & Takeuchi, 1995) using individualized consideration to simulate intellect by teaching, inspiring and promoting intelligence, rationality and careful problem solving.

- **Job design** should clearly define the task, organization cannot exploit knowledge worker abilities if knowledge worker does not know what he or she is pursuing for (Antikainen, 2006.)
- Establish opportunities for knowledge workers to **interact socially** for the purpose of sharing information and knowledge, social interaction enables knowledge workers to teach and learn from each other (Kelloway and Barling, 2000; Drucker, 1999.)
- **Organizational culture** should define expectations and reward structures that encourage knowledge workers to have a role-breadth self-efficacy and continuous learning by expecting and providing opportunities for knowledge workers to exploit their abilities (Kelloway & Barling, 2000.)
- **Organizational environment** should enable social interaction and teaching tools.

3.4.3.2 Organizational Conditions that Facilitate a Knowledge Worker's Motivation to Perform

Knowledge worker motivation is driven by personal development together with a sense of responsibility for his or her results and performance through task autonomy and the ability to organize and manage their own work (Drucker, 1999; Davenport, 2010; Blom et al., 2001; Kelloway & Barling, 2000.) The requirements are formulated as follows:

- M-1: Knowledge workers need to trust their organization and management (Banker et al., 1996)
- M-2: Knowledge workers need a sense of affective commitment towards their organization (Kelloway & Barling, 2000)
- M-3: Knowledge workers require a job that challenges them and enables them to grow and learn (Nohria et al., 2008)
- M-4: Knowledge workers require a high degree of task autonomy and ability to affect their organization of work (Davenport, 2010; Blom et al., 2001.)

Section 3.4.2. provides a list of organizational conditions that can increase knowledge worker motivation to invest their knowledge and skills in an organization:

- **Leadership** and **job design** have a significant effect on knowledge worker motivation (Drucker, 1999; Kelloway and Barling, 2000; Wall et al., 1990; Rainlall, 2004; Nohria et al. 2008.)
- **Leadership** should provide individualized consideration and coaching to communicate high expectations to challenge and teach knowledge workers (Barling et al., 1996; Barling et al., 1998; Bass, 1991.)
- A **charismatic leader** should instill pride and gain respect and trust using fair performance measurement systems, share experiences and teach and develop (Kelloway & Barlin, 2000; Nicholson, 2003)
- A knowledge worker's tasks (**job design**) should activate the three critical psychological states defined as experienced meaningfulness of the work, experienced responsibility for work outcomes and knowledge of the actual results of one's work (Parker & Wall, 1998) with autonomy, task variety, task significance, task identity and feedback (Hackmann & Oldham, 1976)
- **Task autonomy** and the resulting sense of responsibility is critical to achieve motivation and commitment to perform (Drucker, 1999; Kelloway and Barling, 2000; Wall et al., 1990.)
- **Organizational culture** should create fair expectations and rewards (David & Fahey, 2000.)

3.4.3.3 Organizational Conditions that Facilitate a Knowledge Worker's Opportunity to Perform

One of the biggest dilemmas in understanding how to best provide knowledge workers with the opportunity to perform is that knowledge workers characterize their daily tasks with thinking, collaboration and iterative jobs, which makes it challenging to structure and define their work to facilitate their opportunity to perform with the suited tools,

time availability, environment, information and standards and routines according to their task requirements (Davenport, 2013.) The success of improving performance (productivity) in manual work derived from applying the appropriate levels of job design and control to physical labour, so that an employing organization could ensure that employees are operating in an efficient manner (Drucker, 1999.) However using such job design and control to knowledge work could inhibit a knowledge worker from performing (Drucker, 1999.) Therefore, the following list of requirements shows what knowledge workers need to have the opportunity to perform:

- O-1: Knowledge workers need time to do knowledge work (Drucker, 1999; Antikainen, 2006.)
- O-2: Knowledge workers need the necessary tools to perform knowledge work (Haynes, 2008.)
- O-3: Knowledge workers need a supportive psychological, physical and cultural environment (Davenport, 2002; Atinkainen, 2006; Haynes, 2008)
- O-4: Knowledge workers need access to the correct timely information to perform knowledge work (Drucker, 1999; Kelloway and Barling, 2002.)
- O-5: Knowledge workers need standards, routines and practices that support knowledge work (Davenport, 2002.)

The results in section 3.4.2., indicate that an organization's conditions can facilitate a knowledge worker's opportunity to perform by providing **timely access to information** (Antikainen, 2006,) an **environment** which 'contributes to an innovative atmosphere and increased performance' (Davenport, 2010,) **carefully defined processes that concentrate on capitalizing core competencies and efficient collaboration** (Davenport, 2010,) opportunities for knowledge workers to **gather informally and formally to share information and knowledge** (Kelloway and Barling, 2000; Drucker, 1999) and **correct tools** to perform their tasks (Haynes, 2008.) However, in order to further define the latter organizational conditions, more understanding is required about knowledge workers and their tasks in order to understand how the conditions can be adapted according to the type of work performed by knowledge workers without restricting their autonomy and motivation to perform.

3.5 Chapter Conclusion

To conclude, the aim of this chapter was to answer question 1:

- 1) ***Which organizational practices facilitate a knowledge worker to perform knowledge work?***
 - a. *What are the requirements for a knowledge worker to perform knowledge work?*
 - b. *Which organizational practices facilitate the requirements for a knowledge worker to perform knowledge work?*

Drucker (1999) argues that every knowledge worker is responsible for a "contribution that materially affects the capacity of the organization to perform and to obtain results" therefore an organization should create organizational conditions that facilitate a knowledge worker to have the motivation and opportunity to perform and drive performance by enabling knowledge workers to enrich their abilities through growth and development thus contributing to the 'human capital' of organizations (Davenport, 2010.)

Leadership, job design, social interaction, organizational culture and a knowledge worker's environment are organizational conditions that academics have found to facilitate a knowledge worker to perform by increasing a knowledge worker's motivation, abilities and opportunities to perform. However, the unambiguous nature of knowledge work being essentially unobservable makes it challenging to understand how an organization can facilitate a knowledge worker with the opportunity to perform, facilitating a process which enables sufficient time to perform, efficient collaboration, the correct environment according to their knowledge work requirements, the correct tools and the right information when the work is essentially unobservable. Next to this, knowledge workers are known to

require significant task autonomy and control over their own process; however, how can an organization define processes and tasks to concentrate on capitalizing core competencies and efficient collaboration and performance whilst allowing knowledge workers with the ability to organize their own tasks? Contrasting requirements can be found in an organization wanting to drive time-efficient knowledge work versus a knowledge worker requiring autonomy and control over his or her own process, to define his or her own performance. Therefore, the following section will focus on segmenting knowledge workers according to their requirements in order to define how knowledge workers can be facilitated with the opportunity to perform.

4 Process-Oriented view of Knowledge Work

The following chapter will answer the second sub-question of this thesis:

- 2) **How can organizational processes that shape and determine a knowledge worker's job organize the provision of information to facilitate knowledge workers to perform?**
 - a. How can a structured process approach of knowledge work be balanced with a knowledge worker's autonomy required to perform?
 - b. How can a structured process approach facilitate effective information sharing?
 - c. How can effective information sharing facilitate knowledge worker performance?
 - d. What are the requirements to facilitate collaborative knowledge workers in a structured process approach?

Chapter 3 defines how organizational conditions can facilitate knowledge workers to perform, by facilitating a knowledge worker's ability, motivation and opportunity to apply his or her knowledge. In order to have the opportunity to perform knowledge workers require the following:

- O-1: Knowledge workers need time to do knowledge work (Drucker, 1999; Antikainen, 2006.)
- O-2: Knowledge workers need the necessary tools to perform knowledge work (Haynes, 2008.)
- O-3: Knowledge workers need a supportive psychological, physical and cultural environment (Davenport, 2002; Atinkainen, 2006; Haynes, 2008)
- O-4: Knowledge workers need access to the correct timely information to perform knowledge work (Drucker, 1999; Kelloway and Barling, 2002.)
- O-5: Knowledge workers need standards, routines and practices that support knowledge work (Davenport, 2002.)

Drucker (1999) argues that every knowledge worker is responsible for a “contribution that materially affects the capacity of the organization to perform and to obtain results;” however, chapter 3 highlights that a managerial dilemma can be found between a common noted approach for knowledge workers “hire smart people and leave them alone” to obtain results (Davenport, 2002) versus an organization's desire to provide a knowledge worker with direct access to information and control over a knowledge worker's process to drive time-efficient knowledge work and the opportunity to perform to obtain results (Davenport, 2010.) The requirements stated above indicate that an organization should facilitate a knowledge worker to have the correct tools and environment according to their task requirements, time to apply their knowledge, standards, routines and practices that support knowledge work and timely access to the correct information but how can an organization ‘carefully define processes’ and tasks to concentrate on capitalizing core competencies and efficient collaboration whilst allowing knowledge workers with a sufficient degree of autonomy and ability to organize their own tasks and fulfill to the motivation requirement stated below?:

M-4: Knowledge workers require a high degree of task autonomy and ability to affect their organization of work (Davenport, 2010; Blom et al., 2001.)

This chapter will therefore, proceed to research and define the balance between an organization providing a knowledge worker with full ownership of his or her own process, where autonomous knowledge workers define and integrate their own information environment and task organization versus an organization defining a knowledge worker's workflow process, defining a structured provision of information and job tasks to drive time-efficient knowledge work. Due to their high degrees of expertise, education or experience, knowledge workers don't like to be told what to do, in contrast to traditional production workers (Megill, 2013). Task autonomy has a significant impact on a knowledge worker's commitment and motivation to perform knowledge work (Ramirez & Steudel, 2008; Davenport, 2010.) However, similar to manual work, a knowledge worker waiting, re-working or searching for resources can hinder a knowledge worker's productivity where a structured provision of knowledge could drive an organization's productivity (Davenport, 2008.) Therefore a balance must be defined between using control and job design to drive performance versus allowing a knowledge worker with full process ownership to define the organization's capacity to perform.

4.1 Using a Process-Oriented View of Knowledge Work to Define the Provision of Information

Before defining the balance between using a structured process approach to define the provision of information versus providing a knowledge worker with full process autonomy and free access to information the following question must be answered:

How can effective information sharing facilitate knowledge worker performance?

In order to facilitate a knowledge worker's opportunity to perform knowledge workers need timely access to the correct information (Drucker, 1999; Kelloway and Barling, 2002) (O-4.) This is because knowledge workers make decisions based on information available, and if information is unsatisfactory, unavailable or too late outcomes of a knowledge worker's process can be poor in quality (Antikainen, 2006.) Similar to manual work, waiting and searching for resources hinders productivity of a knowledge worker (Antikainen, 2006; Davenport, 2010.) Therefore an organization should ensure that valuable information and knowledge is acquired and exploited to its fullest extent by providing knowledge workers with access to valuable information (Hicks, 2008.) Due to the value of knowledge and information within an organization, managing effective information sharing can "yield significant operational benefits to all areas of an organization" and its overall efficiency, competitiveness and responsiveness (Chaffey & Woord, 2004; Dietel, 2000; Moran, 1999.) To indicate the importance of efficient access to information, a survey performed by Dance (2009) reveals that over a quarter of a knowledge worker's time is spent searching for information, and another research performed at Accenture (Accenture.com, 2016) found that only 16 percent of content within typical businesses is posted to locations where other workers can access it which has a significant impact on the outcome of a process. Davenport (2013) states that knowledge workers are often faced with constant access to an overload of information and waste a significant amount of time and resources to overcome the information overload (Edmunds and Morris, 2000.) By applying a structured approach to define information flow according to a knowledge worker's requirements, Davenport (2011) states that productivity (in this case measured by the completion of key tasks per unit of worker time) can rise up to 50 percent, process improvement techniques can be used to reduce a knowledge worker's ineffective time spent on searching and waiting for information or re-working information thus increasing

his or her time available to apply knowledge so that an organization can exploit a knowledge worker's abilities more effectively (Davenport, 2011.) Next to this, Drucker (1999) states that because human memory is limited, it is important that workers share their information with each other and learn from information sharing to improve their ability to apply their knowledge to solutions (Kelloway & Barling, 2000.) Therefore, by enabling effective information sharing knowledge workers can grow, learn and increase their abilities to perform as defined in chapter 3 (A-2.) Together with adding value to the customer by exploiting the value of information embedded in an organization.

To provide an example, a demand planner at Nike is responsible for adapting an initial statistical customer demand forecast for each of their planning seasons by applying their own knowledge to the forecasting process and consolidating all forecasting relevant information such as historical data, consumer data, key customer account feedback, sales targets, promotional activities, market intelligence and merchandising forecasts from relevant stakeholders, using an efficient collaboration process to create a customer demand forecast which is accepted by all stakeholders (Wagner, 2015.) In this case, using a structured process approach to define the information requirements per forecast submit can ensure that demand planner receive the right information at the right time and therefore demand planners will have more time to apply their relevant knowledge to reduce forecasting errors.

Next to this, in order to define the benefits of using a structured process approach to facilitate effective information sharing the following question should be answered:

How can a structured process approach facilitate effective information sharing?

A knowledge worker's ability to convert previous knowledge and experiences into solutions forms the base for organizations' operation (Antikainen, 2006.) Inherent to successful knowledge work is that information acts as an input, not only information gathered from the customer but also information that exists within the organization. A knowledge worker's workflow process can define a knowledge worker's information requirements and drive knowledge worker productivity by clearly defining which information is required for the task, when it is required and according to which standards and format. Organizations can apply process improvement and management to the flow of information, that have enabled firms in a number of industries to develop fast, efficient processes in areas such as product development, logistics and sales and marketing to gain competitive advantage (Takeuchi & Nonaka, 1991; Davenport, 2011.) Process improvement can respond to the need for better coordination and management of functional interdependencies (Reckart & Short, 1989)

The notion of ineffective information sharing can be considered to include additional actions required and any inactivity that arises as a consequence of not sharing information to provide "immediate access to an adequate amount of appropriate, accurate and up-to-date information" which is required (Hick, 2007.) By applying a structured process approach to define the flow of information, the efficiency of information flow and quality of information can be improved (Hick, 2007.) Hereby, a knowledge worker's abilities can be further exploited by reducing the resources and activities necessary to overcome a lack of information, ineffective time spent trying to identify which information is necessary, ineffective time required to overcome excessive information (Edmunds & Morris, 2000) and the resources and activities required to correct or verify information (Hick, 2006.) A structured provision of information to knowledge workers can therefore define the flow of information and increase effective information sharing.

However, how should the balance be chosen between providing a knowledge worker with full ownership of his or her own process, where autonomous knowledge workers define and integrate their own information environment and task organization versus an organization defining a knowledge worker's workflow process, defining a structured provision of information and job tasks to drive time-efficient knowledge work.

Davenport (2002) identifies 5 key issues, which companies are struggling with in handling knowledge work and improving knowledge worker performance. The author notes that one major issue in the way of developing a useful management model lies in the “generic use of the term knowledge worker” (Davenport, 2002.) Substantial differences can be found between knowledge workers. Therefore, in order to further define the balance between an organization using structured processes to drive efficient operation versus knowledge workers defining their own processes to drive performance the following section will present an overview of existing typologies that define the differences between knowledge workers.

4.2 Segmenting Knowledge Work

Various typologies have been made to segment knowledge work (Ramirez & Steudel, 2006; Pantaleo & Pal, 2008; Davenport et al. 2002; Thomson et al., 2001; Dove 1998). Chapter 1 provides a definition of knowledge workers who “have high degrees of expertise, education or experience, and the primary purpose of their jobs involves the creation, distribution or application of knowledge. In short they think for a living.” Davenport (2010.) Even though knowledge workers commonly ‘think for a living’ their tasks can differ from each other and therefore this section will segment knowledge workers according to their tasks performed.

Ramirez and Steudel (2006) define the 8 dimensions that differentiate knowledge work from manual work as follows:

Autonomy:	Degree of control of the worker on how a task is done.
Structure:	Degree of established rules, policies, or procedures on how a task is done.
Tangibility:	Degree to which a task is capable of being easily perceived using the five senses; especially by the sense of touch and sight.
Knowledge:	Degree to which having previous knowledge, executing cognitive actions and executing cognitive processes are part of the task.
Creativity and Innovation:	Degree to which cognitive processes are used to lead to the production or creation of something that is both original and worthwhile.
Complexity:	Degree to which a task offers great difficulty in understanding or has confusing interrelated sub-tasks.
Routine and Repetitiveness:	Degree to which a task is part of a regular or established procedure characterized by habitual or mechanical performance of tasks.
Physical Effort:	Degree to which a task requires body strength, coordination, and skill in order to be performed; the use of physical power.

Instead of merely referring to workers as either manual workers or knowledge workers one can assume that a continuum of work can be defined with two ends, manual work and knowledge work (Okkoner, 2004; Pantaleo & Pal, 2008; Davenport et al. 2002; Thomson et al., 2001; Dove 1998.) The 8 dimensions defined by Ramirez & Steudel (2008) support the continuum where work in a knowledge intensive organization can have varying degrees of the 8 dimensions. In the most “pure form” of knowledge work, work is characterized “by high levels of autonomy,

knowledge, creativity and innovation and complexity; and low levels of structure, tangibility, routine and repetitiveness and physical effort” (Ramirez & Steudel, 2008.) This is contrasting to the most “pure form” of manual work on the other end of the continuum, which is characterized by low levels of autonomy, knowledge, creativity and innovation and complexity; and high levels of structure, tangibility, routine and repetitiveness and physical effort (Ramirez & Steudel, 2008.)

Next to Ramirez & Steudel’s (2008) eight dimensions of work, Pantaleo & Pal (2008) use the table in Figure 16- Four Models of Knowledge Work (Pantaleo & Pal, 2008) to differentiate knowledge work by the complexity of work and by the level of interdependence it involves.

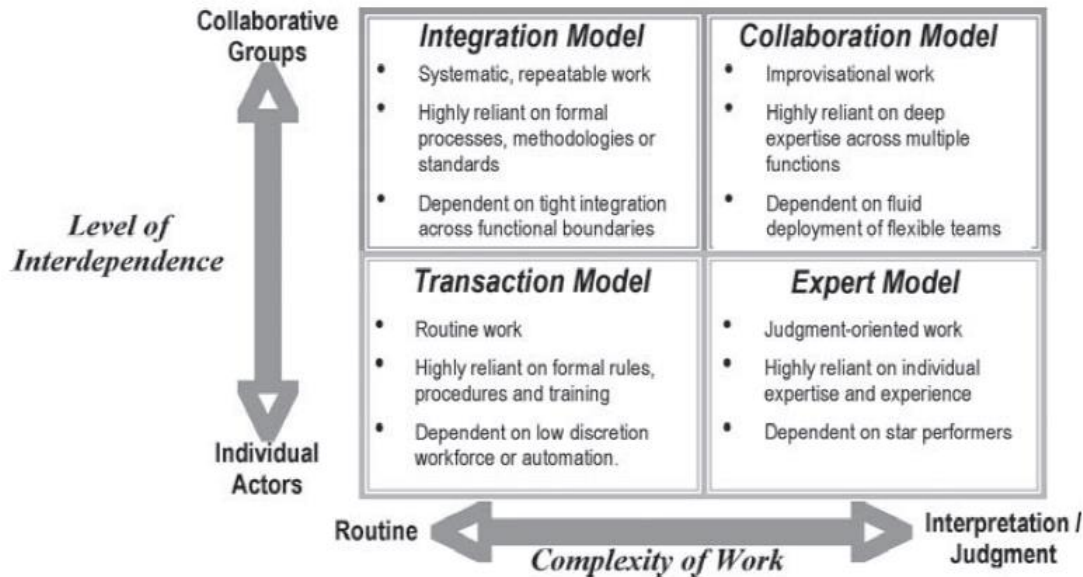

Figure 16- Four Models of Knowledge Work (Pantaleo & Pal, 2008)

Most significant to this table is that the degree of collaboration on the vertical axis often drives the degree of structure and computer mediation that is possible in a job. Next to this, the level of complexity of work can dictate how much knowledge is required to perform it successfully (Davenport, 2010).

The authors distinguish four basic types of knowledge work: (Pantaleo & Pal 2008)

1. *Transaction Workers* have jobs which are low in complexity and interdependence. The work is routine using formal rules, procedures and training, and the workers often work alone. An example would be an employee working in a call center.
2. *Integration Workers* have jobs which are low in complexity but have a high interdependence. The work is thus systematic and repeatable with formal processes and standards. They are dependent on integration across functional boundaries and need a high degree of collaboration. An example would be a low level computer programmer whose programs must fit into a broader context.
3. *Expert Workers* have highly complex jobs that require little interdependence. Much individual experience and expertise is required due to their judgement oriented work. An example could be an artist, engineer or designer.
4. *Collaboration Workers* have jobs that are high in complexity and interdependence. The task which they perform are improvisational that rely on deep expertise across functions. Such a worker could be found in an

investment bank where fluid deployment of flexible teams is essential for the job. More examples include investment bankers, consultants or attorneys working in large teams.

Next to this typology the authors also include the following five segmentation strategies to segment knowledge workers (Pantaleo & Pal 2008.)

Segmentation	Segment Examples
Knowledge activity Type of ideas with which workers deal	Finding, creating, packaging, distributing, applying New products, business models, strategic directions, minor improvements
Cost and scale How critical workers are to business	Amount of resources invested in worker compensation, number of those type of workers in organization More important for bottom line, critical for the execution of key strategies
Mobility	Stationary, Mobile

Table 2 - Knowledge Worker Segmentation (Pantaleo & Pal, 2008)

Another segmentation strategy is presented by Dove (1998) who segments knowledge workers into the following three ‘classes’ according to the type of knowledge which workers possess:

1. *Creation of knowledge work, based on innovation.* Workers such as engineers, managers and inventors don’t do pre-established tasks. They define and perform their task for the very first time, creating tools that will be used by other knowledge workers to do their jobs and create knowledge.
2. *Portable knowledge work, based on wide, immediate utility.* Workers possess generally applicable knowledge which can be used in various scenarios or organizations. Examples include graduating MBAs and software programmers who use their general knowledge to run operations or use previously designed tools in their job. As opposed to “class 1” workers, the latter use their knowledge to perform a task which has been established.
3. *Specialty knowledge work, based on narrow but high utility.* These workers are considered experts at what they do. They possess knowledge in applications that are specific to the task that they do. Their knowledge is not easily transferable to other areas. An example includes programmers that write code in a proprietary language.

Even though there are differences between the segmentation strategies, no universal typology exists to segment knowledge workers. However, many researchers believe that adjusting management systems to the different types of knowledge workers will be essential (Ramírez & Nembhard 2004; Davenport et al. 2002, Thompson et al., 2001; Dove, 1998.)

Therefore, this thesis will adjust the organizational recommendations concerning the balance between using control and job design to use a structured process approach to provide knowledge workers with the opportunity to perform versus allowing a knowledge worker with full process ownership, according to their segmentation. Davenport (2002) found that managers struggle to ‘segment’ employees due to the emotional sensitivity in segmenting knowledge workers, despite organizations having clear income differentials and substantial rewards and privileges. Therefore, this thesis will use Pantaleo & Pal’s (2008) four models of knowledge work together with Ramirez & Steudel’s (2008) eight dimensions of knowledge work, which segment knowledge workers according to the type of work that they perform, and segment knowledge workers according to their knowledge activity to use a more objective approach to knowledge worker segmentation. The term ‘complexity’ as used in the four models of knowledge work (Pantaleo & Pal, 2008) can be questioned as being a ‘sensitive’ and an especially subjective dimension. For example, surgeons may perform repetitive, routine surgeries reliant on strict standards and methodologies; however, the degree of complexity still

remains high with a high degree of knowledge required to complete the task. A surgeon will challenge the segmentation if their work is defined as routine, ‘low complex’ work. Therefore Figure 17 displays the adapted four models of knowledge work, which will be used in this thesis. The x-axis is characterized with the level of structure found in the process, which defines established rules, policies, or procedures on how a task is done. In this case, a doctor’s process is defined by standards imposed by medical institutions and therefore has a higher level of process structure versus improvisational collaboration work, which cannot impose a process structure to achieve a desired outcome.

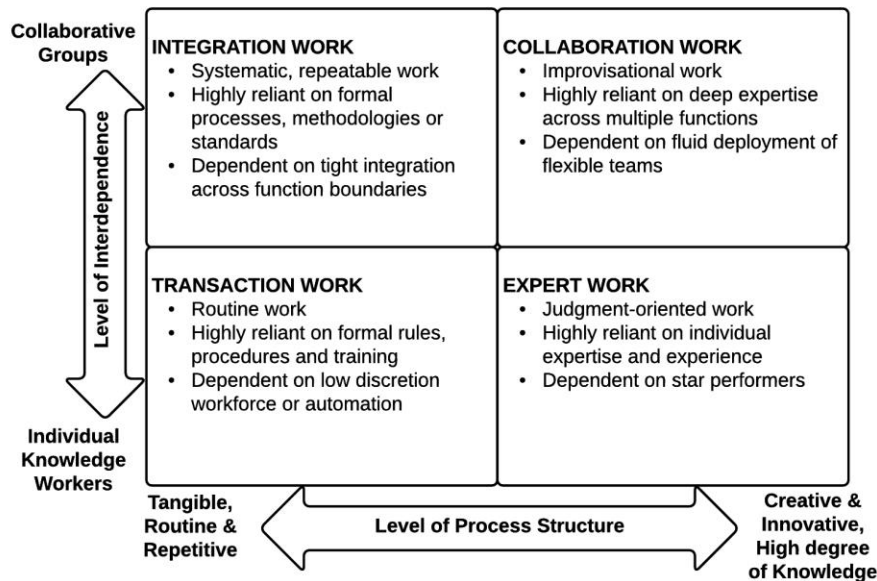

Figure 17- Four Models of Knowledge Work adapted from Pantaleo & Pal (2008) & Ramirez & Steudel (2006)

Together with segmenting the type of work performed by knowledge workers, according to their task description, Drucker (1999) argues that every knowledge worker is responsible for a “contribution that materially affects the capacity of the organization to perform and to obtain results,” this can be found in the form of knowledge creation, knowledge distribution and knowledge application (Esper et al., 2009; Nonaka and Takeuchi, 1995; Nonaka, 1994.) Where the latter three activities define an organization’s ability to exploit their knowledge to add value to the customer (Pantaleo & Pal, 2008; Dove, 1998; Davenport, 2002.)

In order to answer question 2, this thesis will use the four models of knowledge work displayed in Figure 17 with the type of knowledge activity involved being knowledge creation, knowledge application and knowledge distribution to answer the following question:

How can organizational processes that shape and determine a knowledge worker’s job organize the provision of information to facilitate knowledge workers to perform?

4.3 Defining a Knowledge Worker’s Process

In order to define the balance between an organization providing a knowledge worker with full ownership of his or her own process, where autonomous knowledge workers define and integrate their own information environment and task organization versus an organization defining a knowledge worker's workflow process, defining a structured provision of information and job tasks to drive time-efficient knowledge work more understanding is required concerning the process oriented requirements per segment.

4.3.1 Four Models of Knowledge Work to define Process Orientation

The four models of knowledge work as described in section 4.2. will define the structure and process orientation applicable per segmentation .

Transaction workers

Transaction workers' work typology scores high in the attributes of structure, tangibility and routine and repetitiveness together with a low level of interdependence showing similar characteristics to manual work (Pantaleo & Pal, 2008.) Due to the latter characteristics, by applying the appropriate levels of job design and a structured and standardized workflow process an employing organization can drive performance and productivity (Davenport, 2010.) Guidelines can even involve structured workflows or scripts, where knowledge workers benefit from having a structured workflow to follow. In this case the most valued output is not a creative, knowledge intensive idea or concept but a more tangible output in the form of a completed task. Since knowledge work is characterized with information as an input and output an organization should focus on providing a structured provision of information according to their process to ensure that knowledge workers are not wasting time waiting or looking for information (Megill, 2013.) Similar to manual work, waiting and searching for resources hinders productivity, therefore, using a knowledge worker's process flow and organization should focus on providing the right information at the right time in order to facilitate a knowledge worker to improve organizational performance (Antikainen et al., 2006.)

Integration workers

Integration workers score similar to transaction work as defined by the level of structure, tangibility and routine and repetitiveness found in their work process. However, the complexity of their process rises due to the level of interdependence involved. Castells (2000) argues that standardization of knowledge work processes intensifies when there is interaction between different actors in the process. Using a structured, standardized process approach can improve knowledge worker performance by facilitating efficient collaboration and an effective coordination of tasks by creating a structured collaboration process, which enables a structured provision of information (Davenport, 2010.) The more coordination and integration there is across functional boundaries, the less time is required for knowledge workers to coordinate, search and wait for information from collaborative actors.

The latter two models of knowledge work can be facilitated by focusing on process improvement and structured provision of information in order to drive a knowledge worker's time efficiency in waiting, searching and adjusting incomplete information. This facilitates the opportunity requirements, O-1: Knowledge workers need time to do knowledge work (Drucker, 1999; Antikainen, 2006,) O-4: Knowledge workers need access to the correct timely information to perform knowledge work (Drucker, 1999; Kelloway and Barling, 2002) and O-5: Knowledge workers need standards, routines and practices that support knowledge work (Davenport, 2002.) Even though driving knowledge worker-productivity using a structured approach can be an important organizational gain (Davenport, 2002) the challenge still remains that knowledge workers benefit from task autonomy, therefore section 4.2.2. will further define the challenge in using a structured process approach to improve knowledge worker performance.

Expert workers

Expert workers are found on the opposite side of the knowledge work continuum where their work is characterized with high levels of knowledge, creativity and innovation and complexity and little structure. In this case, rather than gaining a competitive advantage from productivity, an organization is highly reliant on leveraging a knowledge worker's expertise, creativity and innovative ideas to add value to their customers (Antikainen et al., 2006.) A detailed process flow may restrict a knowledge worker's creativity, motivation to use knowledge; therefore instead of focusing on how expert work is performed an organization should focus on what is the task? (Drucker, 1999.) A knowledge worker's process input in the form of clear task requirements should drive performance rather than defining the worker's process (Antikainen, 2006.) Chapter 3 states that task autonomy has a significant impact on a knowledge worker's commitment and motivation to perform knowledge work (Ramirez & Steudel, 2008; Davenport, 2010.) Megill (2013) states that those who are able to exercise their brains perform knowledge work, therefore they are most knowledgeable about their process and enjoy the control over their environment and communities in which they work. Therefore, in contrast to using a structured process-approach to facilitate knowledge worker's opportunity to perform with a structured provision of information an organization should simulate a free-access approach of information (Davenport, 2010.) In order to support the creation, application and distribution of knowledge, it is relevant that knowledge workers share their information and knowledge with each other (Drucker, 1999.) Therefore an organization should focus on facilitating informal information sharing, organizational networks as a part of intellectual capital and sufficient means to attain information needed in their work with the correct tools (Davenport, 2010; Antinkainen, 2006.)

Collaboration workers

Collaboration work is the most complex to characterize with a structured process, where adding to the high autonomy and discretion in their expert work, collaboration can ensure a more emergent process, dependent on flexible and fluid teams which often work in an iterative and unstructured manner (Davenport, 2010.) Similar to expert work a detailed workflow process can be restricting and inhibit flexible collaboration (Davenport, 2010.) However, Castells (2000) argues that standardization of knowledge work processes intensifies when there is interaction between different actors in the process, where collaboration and task coordination should be facilitated to ensure tight cross-functional integration. In order to support the creation, application and distribution of knowledge, it is relevant that knowledge workers share their information and knowledge with each other (Drucker, 1999.) Therefore an organization should focus on facilitating informal information sharing, organizational networks as a part of intellectual capital and sufficient means to attain information needed in their work with the correct tools (Davenport, 2010; Antinkainen, 2006.) Next to this, the environment should focus on facilitating collaboration with the right tools, working areas and flexible movement of people to facilitate flexible and fluid teams.

In contrast to the integration and transactional model of knowledge work, expert and collaboration workers should be provided with significant task autonomy and control over their own process. Expert and collaboration workers can feel restricted to perform when controlled using a structured workflow process (Davenport, 2010) therefore an organization should focus on facilitating the latter worker's motivation and positive feeling to invest their knowledge and increase their abilities (Davenport, 2010.) To ensure that a knowledge worker has the opportunity to perform, an organization should focus on facilitating informal information sharing, growth and development, organizational networks as a part of intellectual capital and sufficient means to attain information needed in their work with the correct tools (Davenport, 2010; Antinkainen, 2006) where a free-access approach can allow for creative responses to uncertainty and ambiguity (Davenport, 2013.) The challenge in the latter form is that productivity and time-efficiency lies entirely in a knowledge worker's control, where a knowledge work process does not entail a set of predetermined

tasks that determine the desired outcome. A survey performed by Dance (2009) reveals that over a quarter of a knowledge worker's time is spent searching for information, and another research performed at Accenture (Accenture.com, 2016) found that only 16 percent of content within typical businesses is posted to locations where other workers can access it. This indicates that an organization must focus on an effective knowledge base to facilitate a knowledge worker's time to perform and train their abilities to effectively search for information.

4.3.2 Difference between Process and Practice in Knowledge Work

Defining a knowledge worker's process and work flow can be challenging, as due to their high degrees of expertise, education or experience, knowledge workers don't like to be told what to do, in contrast to traditional production workers (Megill, 2013). Hereby, Brown and Duguid (2001) make a distinction between the process side of knowledge work and the practice side of knowledge work, where a balance must be achieved between process – the design for how work is to be done – and practice, an understanding of how individual workers react to the true world of work, and accomplish their assigned tasks. This should be considered when applying any attempt to change how knowledge work is done.

A process is defined as “a specific ordering of work activities across time and place, with a beginning, an end and clearly identified inputs and outputs: a structure for action.” (Markus et al. 2000) In terms of knowledge work, Davenport et al., (1996) provide the definition of a knowledge work process and describe it as untidy. Inputs and outputs of knowledge work such as ideas, interruptions, inspirations, and so on are less tangible and discrete. Davenport's (1996) view of knowledge process management is consistent with conclusions cited by Suchman (1987,) who, even in clerical and administrative work, documented unstructured processes. Next to this, Olikowski (1996) explains that however well planned an initial sequence of actions is, the situation which emerges from an action has new characteristics which calls for additional actions. Practice analysis of knowledge work is defined as a “well-informed description of how work is done today by those who actually do it” (Davenport, 2010.) In order to effectively design, improve and understand a knowledge worker's process a combination of a practice and process approach should be applied.

Referring back to the segmentation of knowledge workers depicted in the latter section, where transaction and integration model workers can benefit from using a structured provision of information together with a structured work flow process. Depending on a knowledge worker's process typology, the ratio of using a practice or/and process approach to improve and understand a knowledge worker's process can be chosen accordingly. Some processes can be designed by external stakeholders and be implemented successfully because they are relatively simple, structured and repetitive to begin with. Whereas jobs which become increasingly knowledge intensive can be too difficult for an external stakeholder to understand and design, and therefore require more practice orientation to ensure success. **In the end, knowledge workers are most knowledgeable about their own process and therefore should be involved in order to define their process.**

4.3.3 Knowledge Creation, Distribution or Application to define Process-Oriented

The four models of knowledge work are not the only way to segment knowledge work in terms of understanding how to balance a knowledge worker's requirement for autonomy and an organization's drive for time-efficient knowledge work. The latter approach analyses the interdependence and complexity of work; however, chapter 1 explains that knowledge work can also be segmented in terms of the knowledge activity involved. That is, whether workers create knowledge, distribute it or apply it. This segmentation can help to understand how different knowledge activities require different tools, time and environment according to their knowledge activity. A knowledge worker's process

can be defined by knowledge creation, distribution or application; this can then be combined with the four models of knowledge work.

Knowledge creation can be defined as a “creative, idiosyncratic, ‘black box’ activity that is difficult to manage as a process but not impossible” (Davenport, 2010.) An imposed sequence of tasks can restrict creativity (Megill, 2013) therefore knowledge creation should be facilitated with significant task autonomy and process ownership. The most used organization approach is to decompose a knowledge creation process into several pieces or stages to clearly divide knowledge worker tasks. An example of this is companies dividing their product development processes into a series of stages and steps in order to iteratively evaluate the design according to market feasibility factors. Nonaka & Konno (1998) highlight that knowledge creation being intangible, boundary-less and dynamic is very different to using tangible resources, which need to be distributed efficiently according to functions and goals. The use and creation of knowledge requires concentration of knowledge resources at a certain space and time enabling them to apply and develop inherent knowledge and therefore, instead of focusing on the knowledge creation process itself, an organization must ensure a structured concentration of knowledge resources at a certain space and time. Knowledge creation falls together with the expert and collaboration model type of work where performance is highly reliant on individual judgment and creativity. Similar to the latter type of work a detailed process flow may restrict a knowledge worker’s creativity, motivation to use knowledge and so on; therefore instead of focusing on how expert work is performed an organization should focus on what is the task? (Drucker, 1999.) Tasks and tasks division should be clear to ensure the correct input for the black box creative process together with tools that support creative knowledge work such as structured brainstorm sessions, environments with the right materials to collaborate and be creative and a structured output evaluation such as stage gate evaluations, customer requirement analysis, etc. Next to this, to ensure that a knowledge worker has the opportunity to learn and increase abilities, an organization should focus on facilitating informal information sharing, organizational networks as a part of intellectual capital and sufficient means to attain information needed in their work with the correct tools (Davenport, 2010; Antinkainen, 2006) where a free-access approach can allow for creative responses to uncertainty and ambiguity (Davenport, 2013.) Since knowledge creation is so dynamic a structured workflow process should be avoided (Megill, 2013.)

Knowledge distribution involves sharing or transferring knowledge; and turning it into tacit information. Knowledge is often embedded in people’s heads, in groups, in spaces and is intangible; however, in order for an organization to benefit from knowledge, knowledge should be separated from it’s owner and turned into information, which can be communicated independently (Nonaka & Konno, 1998.) This is an important aspect of many knowledge workers’ activities such as lawyers and consultants who not only create solutions, but also must share solutions. Sharing knowledge is difficult to enforce yet in many transactional environments can be crucial. Davenport (2010) highlights that it is most viable to manage the circumstances in which knowledge distribution is undertaken rather than the distribution process itself. This means that a process-oriented view should focus on when knowledge distribution is required and enable knowledge workers to own their own process in distributing their information to the respective owners. Knowledge workers need to know when they should distribute their information and be facilitated through the right tools and environment in order to distribute their knowledge. An organization should focus on facilitating informal information sharing, organizational networks as a part of intellectual capital and sufficient means to distribute knowledge (Davenport, 2010; Antinkainen, 2006.) such as high-level distribution process gates with standard meeting structures, the right communication tools and an environment supporting information distribution. Since the distributed information becomes tangible this can then be measured according to core customer requirements in the process.

Knowledge application involves applying knowledge to job tasks by filtering knowledge through the human brain. Hereby knowledge workers should apply knowledge by “taking data and information and applying their own experience,

judgment, know-how, assumptions (culture,) background and values in order to reach to a conclusion.” (Megill, 2013) Davenport (2010) highlights that in these cases, knowledge workers should not invent new knowledge, but apply existing knowledge to familiar or unfamiliar situations. This means that the goal of improving knowledge application is to reuse knowledge more effectively, which improves performance and reduces ineffective time wasted on creating existing knowledge (Antikainen, 2006.) An effective knowledge base is access to knowledge that is readily available in a timely manner for users to make timely, valid decisions that increase the productivity of work processes where knowledge is often embedded in organizations and not owned by an employee (Megill, 2013.) A process-oriented approach should be used to understand what kind of knowledge is required to fulfill job tasks and should make sure that the knowledge is easy to find and available to use for a knowledge worker and that the quality of the usable knowledge is high by investing in documentation, libraries, catalogs or modular structures for knowledge objects (Davenport, 2003.) Moreover, if information sources from collaborative actors, using a structured, standardized process approach can improve knowledge worker performance by facilitating efficient collaboration and an effective coordination of tasks by creating a structured collaboration process, which enables a structured provision of information (Davenport, 2010.) For knowledge application, information is the most important input and similar to manual work, waiting and searching for resources hinders a knowledge worker’s productivity; however, since their resources are only immaterial in nature it can be more difficult to specify a knowledge worker’s time used looking for information. Even though Kelloway & Barling (2000) state that outcomes of a knowledge worker’s process should be observed, rather than the process itself, knowledge workers make decisions based on information available, so if their information is for example wrong, incomplete, missing or unsatisfactory the outcome of the process can be poor in quality and thus impacted by the process (Atikainen et al., 2006.) This indicates that a structured provision of information can drive performance in knowledge application.

4.4 Using Knowledge Worker Segmentation to define the Provision of Information

Using the segmentation strategies presented above, question 2a can be answered:

How can a structured process approach of knowledge work be balanced with a knowledge worker’s autonomy required to perform?

Hammer (2010) states that “the most fundamental aspects of a process are the specification of tasks which are to be performed, by whom, when, in what locations, under what circumstances, to what degree of precision, with what information and so on.” This statement refers to a manufacturing process where the more detailed a process flow is, the easier it is to improve and monitor for an organization (Hammer, 2010;) however, the aim of this section is to enable an organization to understand at which level of aggregation a fundamental work process should be specified according to knowledge worker typologies in order to structure the provision of information.

Section 4.3 defines the two segmentation strategies, which are used to define the balance between using a structured process approach and providing a knowledge worker with full ownership over their own process per segment. Therefore the following section will present a step-by-step approach to enable an organization to understand the most suited process approach per segment.

Step 1

The first step towards understanding how to facilitate a knowledge worker using the suited process orientation is to segment a knowledge worker according to his or her type of knowledge work and level of interdependence. Figure 18

shows process-oriented organizational recommendations per knowledge worker segment using the findings presented in section 4.2.1.

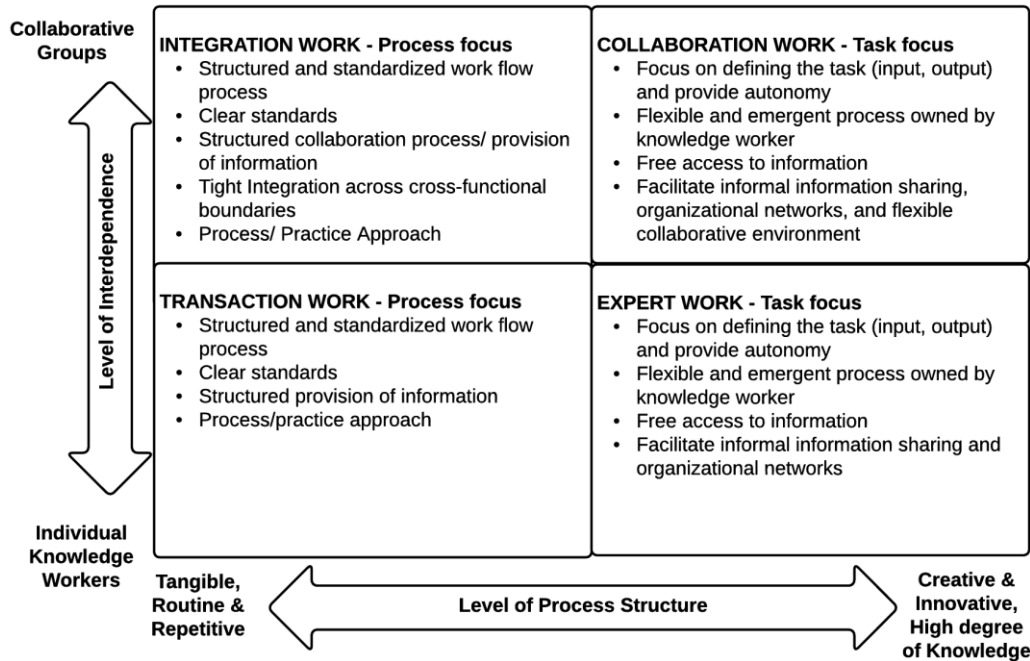

Figure 18 - Process orientation segmented according to Pantaleo & Pal's (2008) four models of knowledge work

If a knowledge worker's tasks are characterized as knowledge intensive, creative, innovative, intangible paired with a low degree of defined structure and repetitiveness an organization should stimulate task autonomy and focus on clearly defining the task (what should be done) rather than the process (how should the work be done) (Drucker, 1999.) An organization should focus on exploiting a knowledge worker's ability by providing clear task requirements to define expectations and provide significant task autonomy and process ownership to exploit their capabilities by facilitating their motivation and commitment to perform (Davenport, 2010.) Competitive advantage of an organization is the innovativeness and creativity of the idea sourcing from the knowledge worker's brain and therefore a set of pre-determined tasks will not guarantee a desired outcome (Drucker, 1999, Davenport, 2010.) An organization should provide organizational conditions that stimulate knowledge worker growth and learning by developing knowledge and experiences to enhance their ability to create solutions (Drucker, 1999) through leadership, organizational culture, social interaction and more as described in section 3.4.1. In order to support their opportunity requirements to perform information should be readily available through a free-access approach.

At the other extent of the continuum on the left, more structured and tangible tasks are found where an organization can focus on facilitating a knowledge worker's opportunity to perform by standardizing and optimizing their work process to have direct access to the right information at the right time. Hereby a set of tasks can guarantee a desired outcome if a knowledge worker is facilitated with the correct information, sufficient time and the right tools (Brocke & Rosemann, 2010.) Therefore process improvement can be used to drive time-efficient knowledge work (Davenport, 2010;) however, a practice orientation should be used to take advantage of a worker's process knowledge and define the process according to a "well-informed description of how work is done today by those who actually do it"

(Davenport, 2010.) Moreover, by involving the knowledge worker to define the process, the knowledge worker will experience job self-efficacy and feel more autonomy in defining their structured process (Megill, 2013.) The segmentation strategy presented in Figure 18 depicts organizational recommendations concerning how a structured process approach should be combined with task autonomy according to knowledge worker segmentation.

Step 2:

After an organization has used step 1 in order to understand the level of interdependence and process structure a knowledge worker is challenged with. An organization should characterize a knowledge worker's knowledge process by segmenting their knowledge activity according to knowledge creation, distribution or application. A knowledge worker responsible for creating knowledge falls under the same category as collaboration and expert work and requires a flexible and emergent process owned by the knowledge worker with a free access approach to information. On the other hand, knowledge workers whose main activity is to apply or distribute their knowledge benefit from a more structured process approach to structure the provision of information. Knowledge workers, whose main activity is to apply knowledge, add value by "taking data and information and applying their own experience, judgment, know-how, assumptions (culture,) background and values in order to reach to a conclusion." Therefore a structured process approach can facilitate the provision and information according to their requirements. Knowledge distribution involves sharing or transferring knowledge; and turning it into tacit information. Knowledge is often embedded in people's heads, in groups, in spaces and is intangible; however, in order for an organization to benefit from knowledge, knowledge should be separated from its owner and turned into information, which can be communicated independently (Nonaka & Konno, 1998.) Davenport (2010) highlights that it is most viable to manage the circumstances in which knowledge distribution is undertaken rather than the distribution process itself. This means that a process-oriented view should focus on when knowledge distribution is required and enable knowledge workers to own their own process in distributing their information to the respective owners.

Finally,

How can a structured process approach of knowledge work be balanced with a knowledge worker's autonomy required to perform?

In order to answer question 2, a suggestion is made per knowledge worker segmentation. Knowledge workers, which are characterized by the integration and transaction model of knowledge work, can be facilitated with a structured process approach; together with knowledge workers whose main activity is to apply and distribute knowledge. The major benefit in using a structured process approach to define the provision of information is productivity, where, similar to manual work, waiting and searching for resources hinders a knowledge worker's productivity (Antikainen, 2006.) According to Davenport (2012) productivity gains can reach up to 50 percent if knowledge workers spend less time searching, waiting and adapting information. Next to this, the author states that using a structured approach can increase the efficiency of collaboration by defining coordination of tasks and thus improving the quality of information received (Davenport, 2012.) The most important disadvantage of using a structured approach of knowledge work is that knowledge workers require autonomy and the structure can decrease informal information exchange which may reduce knowledge worker learning (Antikainen, 2006.) Therefore, this paper suggests that an organization uses a practice approach as defined by Brown and Duguid (2001) who define a distinction between the process side of knowledge work and the practice side of knowledge work, where a balance must be achieved between process – the design for how work is to be done – and practice, an understanding of how individual workers react to the true world of work, and accomplish their assigned tasks so that knowledge workers still feel responsible for their own process.

In contrast to the latter two segments, if knowledge work is characterized as creative, or falls under the expert or collaboration model of knowledge work an organization should provide a knowledge worker with full process ownership and free access to information. In this case, knowledge workers should manage and define their own work process and have full autonomy and ownership over their access to information. Nonaka & Konno (1998) highlight that knowledge creation is intangible, boundary-less and dynamic and can be restricted by applying formal rules and structure to the process. Using a structured approach to provide information would restrict the creativity and innovativeness of ideas and therefore instead of focusing on the process Drucker (1999) states that one should focus on clearly defining the task. Similar to a structured approach of information provision, limitations exist to the free-access approach when “organizations hire smart people, and leave them alone” (Davenport, 2002.) The most common limitation is that an organization cannot drive productivity through efficient processes and whilst knowledge workers may know how to use technology tools, they may not be skilled at searching for, using or sharing the knowledge (Davenport, 2011.) Therefore an organization must focus on training knowledge workers to search and share information effectively in order to restrict productivity losses. Next to this, in contrast to focusing on how the task is performed, to drive productivity for integration and transaction model type of work, an organization should focus on clearly defining the task in order to have clear measurement standards and a suited environment, tools and knowledge base. This leads to the following question:

What are the requirements to facilitate collaborative knowledge workers in a structured process approach?

To conclude, using a structured process approach of knowledge work to facilitate effective information sharing can drive a knowledge worker’s productivity by reducing time spent searching, waiting and re-working information (Davenport, 2010.) Similar to the flow of material in an organization, information flows and knowledge work is undertaken to add value to the information. Challenging this tangible flow of visible materials in a production environment is that information is less visible and the value of information is more difficult to define. Information can support decision-making, familiarization and background or act as an activator of further organizational processes (Hick, 2007.) Often, the customer receiving the information is the best measure to define the value of information by defining if the information was on time, according to the right quality standards, easy to access, accurate and therefore a knowledge worker will be most knowledgeable about their own information process.

In order to structure the provision of information according to knowledge worker requirements a knowledge worker should fall under the integration and transaction model of knowledge work and should define his or her main tasks with knowledge application and distribution. The process should be defined together with knowledge workers using a practice approach. If a knowledge worker falls under the collaboration and expert model of knowledge work and is responsible for knowledge creation, the latter should be provided with a free access approach of information. Using a structured approach to provide information would restrict the creativity and innovativeness of ideas by imposing a predetermined sequence of tasks (Drucker, 1999) and therefore should be provided with free access to information.

4.5 Chapter Conclusion

To conclude,

How can organizational processes that shape and determine a knowledge worker’s job organize the provision of information to facilitate knowledge workers to perform?

If a knowledge worker defines his or her tasks with knowledge distribution and application and falls under the integration and transaction model of knowledge work, an organization should structure the provision of information according to their workflow process by clearly defining which information is required for the

task, when it is required and according to which standards and format. By applying a structured approach to define information flow, Davenport (2011) states that productivity can rise up to 50 percent, process improvement techniques can be used to reduce a knowledge worker's ineffective time spent on searching and waiting for information or re-working information thus increasing his or her time available to apply knowledge (Davenport, 2010.) A practice approach should be applied to define a knowledge worker's process in order to provide sufficient autonomy and make use of a knowledge worker knowledge, where in the end, knowledge workers are most knowledgeable about their own process.

If a knowledge worker adds value to the organization by creating knowledge and innovative ideas according to the expert and collaboration model of work an organization should invest in a rich knowledge base and focus on managing a concentration of knowledge resources at a certain space to share information rather than using a defined process to structure the provision of information. Applying structure to the provision of information would restrict a knowledge worker's creativity and innovativeness of ideas by imposing a predetermined sequence of tasks (Drucker, 1999) and therefore they should be provided with free access to information and acquire effective skills in searching and distributing information effectively.

PHASE 3 – Design the constructs and solution

Constructs are suggested solutions to the selected research problem (Kasanen, 1993.) The design phase will be grounded in the knowledge gathered in the past two phases. Hereby, a solution at Nike will be designed in order to answer question 3:

How can collaborative demand planners at Nike be facilitated to improve forecast accuracy?

- a. How can collaborative demand planners at Nike be facilitated to apply their knowledge?
- b. How can the lean methodology be used to facilitate demand planners at Nike to improve forecast accuracy?

Methodology:

In order to design a solution chapter 5 will make use of the design cycle presented in Figure 19 which is adapted from Dym and Little (2004.) The author states that it is a “widely accepted model of the design process” and therefore this process will be followed in order to design the solution. The solution will be designed together with demand planners at Nike to ensure that the design process becomes a consultative iteration between the researcher and the practitioners to ensure the solution’s suitability for practice.

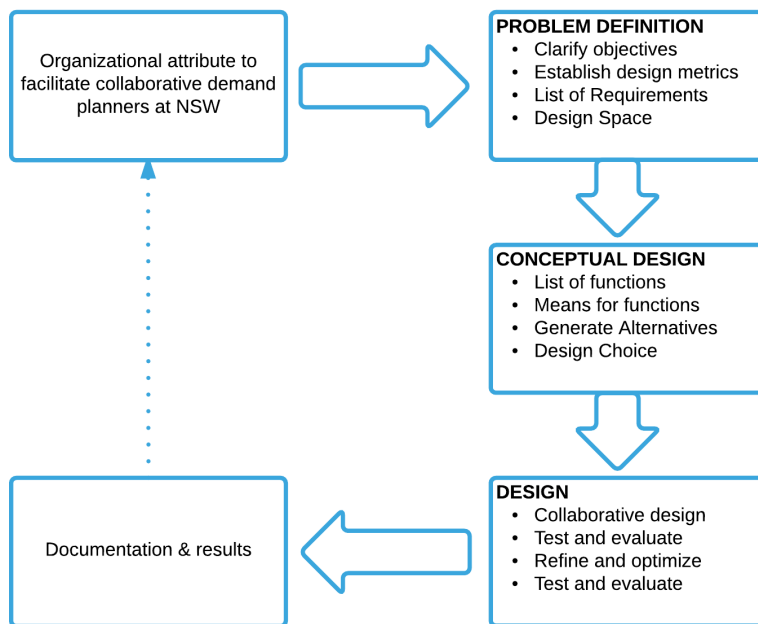

Figure 19 - 5 stage prescriptive model of the design process at Nike adapted from Dym and Little (2004)

5 Case Study at Nike

Chapter 3 defines that organizational conditions should facilitate a knowledge worker's opportunity, ability and motivation to perform in order to improve organizational performance. Thereafter, chapter 4 explains how an organizational process can organize the provision of information to facilitate knowledge workers to have the opportunity and motivation to perform according to their segmentation.

A selection of problem statement of this thesis states that:

Demand planners at Nike plan an average of 230 million units per year with an average of 12800 styles and 35000 colour units resulting in an average forecast accuracy of 57 percent. On average, 12% of forecast inaccuracy is **due to forecasting errors such as missed input, double counting forecasts, forecasting issues, reporting errors, mistakes, wrong interpretation and wrong decisions which indicates that demand planners at Nike are being restricted to perform. Next to this, 3% of the total average forecast in-accuracy is due to demand planners missing information from relevant stakeholders such as merchandising and sales inputs and insights.** A demand planner submits 7 forecasts per season, and forecasts for 3-4 seasons simultaneously. Interviews at Nike define the challenge to improve knowledge worker performance and academics indicate that further studies on forecasting should research how a demand planner should be managed and facilitated in order to improve forecast accuracy (Armstrong, 1987; 2001; Mentzer and Bienstock, 1998; Moon et al., 2003; Danese et al., 2010.) Danese et al., (2010) highlight that more research is required towards **how to facilitate a demand planner to produce an accurate demand planning forecast using managerial decisions on demand planner processes, information gathering processes and tools, organizational approaches, collaboration and forecast accuracy measurement using a proper metric and by defining proper incentive mechanisms.**

Therefore, phase 3 will design a construct in order to create a solution for the problem statement of this thesis.

5.1 Nike Sportswear Department

In order to the design the construct a case study is performed at the demand-planning department at Nike. Appendix 4 shows the organizational chart of the entire demand-planning department organized according to the 6 lines of business at Nike. Due to limited time and resources this study chose to focus on one department, Nike Sportswear. The reason to choose this department is explained in Appendix 6.

5.2 Using the Segmentation Approach to Define Demand Planning at Nike

5.2.1 Segmenting Demand Planners According to the Four Models of Knowledge Work

The first step towards defining how to facilitate demand planners at Nike NSW to improve forecast accuracy was to segment their work according to the segmentation strategies presented in chapter 4. In order to define the latter, various methods were used. Practice analysis of knowledge work is defined as a "well-informed description of how work is done today by those who actually do it" (Davenport, 2010) this is achieved through interaction with demand planners as follows:

1. The researcher 'shadowed' three demand planners on three separate days. This meant that the researcher sat next to the demand planner to observe how the work is performed.
2. The researcher joined team meetings, had informal chats with numerous demand planners about their process.

3. The researcher sat in the same area as the demand planners
4. The researcher interviewed 6 demand planning directors (Appendix 1)
5. The researcher created a BPM together with numerous demand planners to visualize the current high-level process. (Appendix 2)
6. Together with demand planners an initial process was defined included in Appendix 7.

Appendix 2 shows a high level BPMN model of a demand planner's process at Nike starting from AF, when demand planners receive the line assortment from merchandising until order entry deadline 3 when the last customer bookings are received. The BPMN shows the strong collaborative interdependence between internal cross-functional teams and demand planners. Demand planners collaborate regularly with sales, merchandising and inventory management in order to gain relevant and required input for their demand planning forecast. Even though demand planners are presented with a different product assortment every season, a basic, repeatable formal process is in place according to the seven submit deadlines (post AF, post SIM, GEO, GTM, F1, F2 ,F3.) Appendix 7, provides a detailed process description of a demand planner's forecasting tasks in order to complete forecast submits for post AF, post SIM, post GTM and F1. The appendix includes the collaboration required to get required information, meeting structure and the repetitiveness of the tasks per forecast. Important to note is that demand planners forecast three and sometimes even four seasons simultaneously due to the forty-six week lead time between the first forecast and the products being in store. This contributes to the complexity of their work and therefore tight cross-boundary integration is key.

The latter analyses depict that demand planners at Nike require information from collaborative partners in order to submit an accurate demand planning forecast submit and therefore score a high level of interdependence. In order to further segment NSW demand planner's knowledge work according to the four models of knowledge work presented in chapter 4, Ramirez & Steudel's (2008) 8 dimensions measure demand planner's tasks according to the knowledge work continuum.

Demand planners at Nike:

- Structure:** Appendix 7 depicts the degree of established rules and procedures on how a task is done to submit 7 demand plan forecasts per season. The degree of structure therefore scores highly.
- Tangibility:** A demand planner's tasks can be easily perceived using the five senses such as demand planning forecasts submitted using tangible information systems, meetings, etc. The degree of tangibility therefore scores highly.
- Knowledge:** In order to submit a demand planning forecast previous knowledge and executing cognitive actions and process are part of the task. Demand planning knowledge is required to understand the data, analyze the data and demand planner judgment defines the output. Therefore the tasks scores highly in the degree of knowledge required to perform the task.
- C & I:** The level of creativity and innovation is relatively low. Even though demand planners forecast demand for a new assortment of products every season, a forecasted demand plan always follows the same process and rather than creating innovative ideas to create a forecasting demand plan, previous knowledge should be applied to forecast innovative products.
- Complexity:** Complexity of the task is difficult to define where the latter dimension can vary extremely per actor. The complexity in demand plan forecasting is to correctly project what customers will buy and therefore task complexity is defined as medium level. This is based on the fact that the job requires workers that have completed a university masters degree, and possess high analytical skills; however,

one can argue that product design is characterized by more complexity where no established structure is in place.

R & R: Demand planner's tasks score highly on the degree to which their tasks are routine and repetitive. As denoted in Appendix 2 and 7 their tasks are part of an established procedure characterized by a routine and repetitive process to submit 7 demand planning forecasts per season.

Based on the latter characteristics knowledge work performed by demand planners at Nike is found in the **integration work segmentation**. Collaboration between merchandising, sales, S&OP and inventory management indicates the high level of collaborative cross-functional interdependence. Ramirez & Steudel's (2008) 8 dimensions applied to demand planner's work indicates that a demand planner's tasks are structured, routine, repetitive and tangible. On the other hand they display low levels of creativity and innovativeness yet do require a high degree of knowledge to complete the tasks and can be considered as relatively complex. In order to submit a high quality forecast submit, a demand planner is highly reliant on their judgment, expertise and forecasting experience. Individual tasks mentioned in Appendix 7 include statistical reviews, historical analyses based on color breakouts, market intelligence reviews and so on. Based on work floor observation performed during seven months it became clear that based on demand planner's market understanding, analytical skills and past experience their own forecasting success is decided. Based on the latter conclusions Figure 20 shows the segmentation of Demand Planners at Nike where the star indicates that demand planners perform integration work.

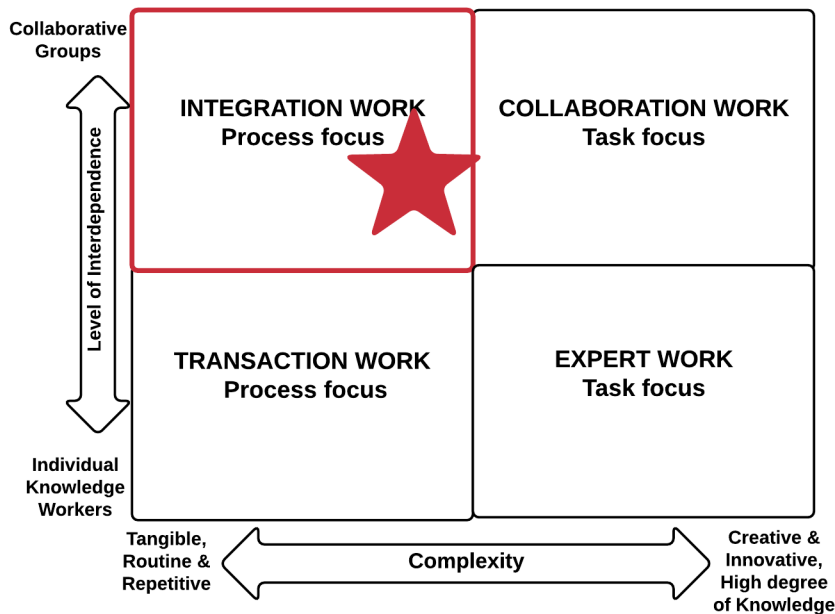

Figure 20 - Type of knowledge work performed by demand planners at NSW adapted from Pantaleo & Pal's (2008) four models of knowledge work

According to Figure 18 in chapter 4 integration work should use a structured process approach to facilitate knowledge workers to improve performance by providing a structured provision of information. Therefore, an organization should focus on:

- Structured and standardized work flow process
- Clear standards
- Structured collaboration process/ provision of information
- Tight integration across cross-functional boundaries
- Process/practice approach.

The conclusions in chapter 3 state that by applying a structured approach to define information flow, process improvement techniques can be used to reduce a knowledge worker's ineffective time spent on searching and waiting for information or re-working information thus increasing his or her time available to apply knowledge (Davenport, 2010.)

5.2.2 Segmenting Demand Planners According to their Knowledge Activity

Demand planning at Nike involves a degree of creation and distribution of knowledge; however, **their primary objective is to apply existing knowledge to familiar or unfamiliar situations instead of inventing new knowledge.** At Nike, demand planners are a focal point between integrating demand-side knowledge sourcing from merchandising, sales, and finance and the supply-side knowledge which involves understanding factory-capacities and -minimums by collaborating closely with inventory management. In this case, using a structured process approach to define the information requirements per forecast submit can ensure that demand planners receive the right information at the right time and therefore demand planners will have more time to apply their relevant knowledge to reduce forecasting errors thus providing demand planner with the opportunity to perform as defined in chapter 3. As depicted in Appendix 7, information is either obtained through collaboration or using a knowledge base in the form of a SharePoint and various tools provided by business analysts which provide quantitative data about previous seasons, market intelligence and forecast accuracy.

5.3 Using Demand Planner Segmentation to define Process Orientation

The aim of this section is to answer question 3:

How can collaborative demand planners at Nike be facilitated to improve forecast accuracy?

The latter section defines knowledge workers to apply knowledge according to the integration model of knowledge work. Therefore, an organization should use a structured process approach to structure the provision of information to demand planners and coordinate efficient collaboration. The process should be defined using a practice approach as demand planners will be most knowledgeable about their process. This will then facilitate a knowledge worker's opportunity to perform by reducing inefficient time spent waiting and searching for information. In order to design a construct the following question will be answered:

How can collaborative demand planners at Nike be facilitated to apply their knowledge?

The integration model of work and a process characterized by knowledge application forms the following requirements to facilitate knowledge workers to perform:

- Structured and standardized work flow process
- Clear standards
- Structured collaboration process/ provision of information

- Tight integration across cross-functional boundaries
- Process/practice approach.
- Focus on information quality

In order to validate whether the latter characteristics would indeed facilitate demand planners to apply their knowledge a participative design will be created which fits within the constructive research approach (Kasanen, 1993.)

5.4 Designing a Solution to Facilitate Collaborative Demand Planners at Nike to Improve Forecast Accuracy

In order to design the solution a descriptive ‘linear’ model of the design process is presented in Figure 21 adapted from Dym and Little (2004.) The author states that it is a “widely accepted model of the design process” and therefore this process will be followed in order to design the solution. Hereby, the outputs of each stage form the inputs towards the next stage. The final design will be designed with a practice-oriented approach and therefore, demand planners will be involved in the design process.

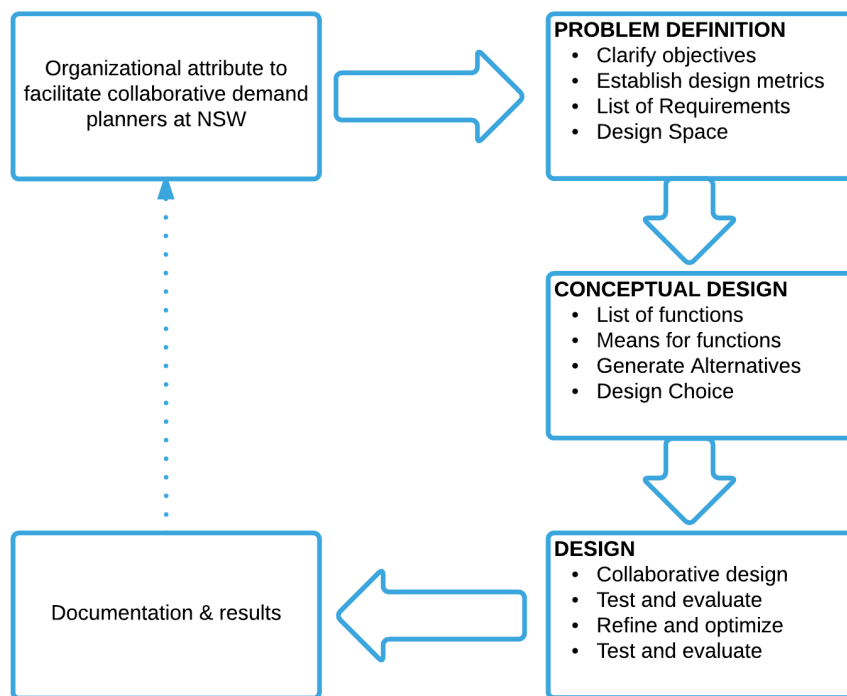

Figure 21 - 5 stage prescriptive model of the design process at Nike adapted from Dym and Little (2004)

5.4.1 Problem Definition

The first step towards designing a solution to facilitate knowledge workers to apply their knowledge in order to improve forecast accuracy is to define a problem statement, clarify the objective of the design, establish metrics for the objectives, define the list of requirements and define the design space. The design will be implemented within NSW, therefore NSW requirements will be considered in the design space.

The problem statement is defined based on the conclusions made in this thesis:

5.4.2 Problem Statement:

Demand planners at Nike plan an average of 230 million units per year with an average of 12800 styles and 35000 colour units resulting in an average forecast accuracy of 57 percent. On average, 12% of forecast inaccuracy is due to forecasting errors such as missed input, double counting forecasts, forecasting issues, reporting errors, mistakes, wrong interpretation and wrong decisions which indicates that demand planners at Nike are being restricted to perform. Next to this, 3% of the total average forecast in-accuracy is due to demand planners missing information from relevant stakeholders such as merchandising and sales inputs and insights. A demand planner submits 7 forecasts per season, and forecasts for 3-4 seasons simultaneously. This thesis defines that demand planners can be facilitated to improve forecast accuracy by using a structured process approach to improve the provisioning of information and thus increase time available for a demand planner to apply knowledge and reduce forecast errors. Design a solution that facilitates a demand planner at Nike's time available to apply their knowledge by reducing time required waiting and searching for information using a structured process approach to define the provision of information. The design should take advantage of a demand planner's knowledge about his or her own process and should improve forecast accuracy.

5.4.3 Objectives

The objectives of the solution are based on the requirements listed in section 5.3.

- O1. The solution should be used to structure and standardize a demand planner's work flow process for the seven submit gates
- O2. The solution should be used to structure the collaboration process between demand planners and relevant actors
- O3. The solution should be used to structure timely provisioning of information
- O4. The solution should improve the quality of information provided to demand planners to make their decisions
- O5. The solution should take advantage of a demand planner's knowledge
- O6. The solution should improve cross-functional integration across boundaries
- O7. The solution should help to define clear standards

5.4.4 Constraints

Constraints for the solution source from Nike and chapter 4:

- C1. It must not restrict a demand planner to apply their knowledge, use creativity or improvise
- C2. Its cost must not exceed 50 euros
- C3. It must be self-sustaining
- C4. It must fit within the lean methodology

Constraint C4 is a customer constraint. Currently, Nike targets to deploy lean within their transactional environment, using lean tools to synchronize internal operations with the needs of the market. **Therefore, due to Nike requirements, when designing a solution to facilitate knowledge workers to perform, the solutions must fit within the lean thinking methodology and toolbox.** Appendix 8, provides a brief description of the lean

methodology and how this is currently being deployed at Nike. Next to this, the applicability of the lean methodology in knowledge work will further be defined after the design requirements have been defined with the NSW team.

5.4.5 Conceptual Design

An assumption is made that knowledge workers will adopt new process designs and approaches because, intellectually they have been persuaded of the benefits of a better way to do work, and not because they are compelled to do so (Jarvenpaa et al., 1995.) Quantitative results at Nike indicate that on average 15% of total forecast inaccuracy was due to demand planner errors and process related issues as presented in chapter 2. However, in order to truly understand the challenges that demand planners at NSW were facing and whether the above stated objectives would be in a demand planner's interests, initial conversations were conducted with the director of NSW and the senior demand planner. Appendix 9, Results Conversations NSW Director and Project Manager shows transcripts of the questions asked and conclusions from the initial conversation. The most important conclusion from Appendix 9 is that demand planners at NSW are being confronted with issues which are directly correlated to the findings of this thesis where demand planners feel restricted to perform due to time wasted chasing after information and submitting demand forecasts without required input from collaborative partners. Therefore a solution based on the objectives presented in this chapter will fulfill to the actual needs of the department, and therefore workers will not have to be enforced to use the solution and will be more likely to adopt the approach as they will see the intellectual benefits in solving their challenges and issues. Together with the NSW team the solution was designed. The following section presents the step-by-step approach to create the conceptual design and the actors involved in the design process.

5.4.6 Designing a Solution according to Lean Principles

Section 5.4.4. states that the designed solution must be a lean tool as a strict design requirement. Nike targets to deploy lean within their transactional environment, using lean tools to synchronize internal operations with the needs of the market. The latter is a significant constraint for the design of the solution and therefore further research was required to determine whether using tools adapted to the lean methodology would be suitable for the problem statement of this thesis. A brief literature analysis was performed concerning the applicability of the lean methodology in knowledge work and process improvement.

The most important input for knowledge work and demand planning is information (Drucker, 1999.) Staats & Upton (2011) discuss whether using lean principles is suitable for knowledge work highlighting that in order to apply lean production principles to knowledge work, both outcomes and tasks must be specified. The authors find that applying lean principles to unambiguous and un-repetitive work can be frustratingly difficult yet if repetitive and structured process can be found, applying lean principles to knowledge work can “generate significant benefits: faster response time, higher quality and creativity, lower costs, reduced drudgery, and greater job satisfaction” (Staats & Upton, 2011.) Due to information being the most critical input in knowledge application further research was performed concerning applying lean principles to information management which is defined as “the creation, representation, organization, maintenance, visualization, reuse, sharing, communication and disposal of information” (Larson, 2005.) This involves adding value to information through its organization, visualization and representation and enabling the information to flow to the end-user through processes as sharing and collaboration (Hicks, 2007.)

Chapter 4 defines that a structured process-oriented approach can be used to facilitate a structured provision of information in order to reduce the time knowledge workers need to wait, search and re-work information. In contrast to the lack of methods known to facilitate knowledge workers to improve performance, there are various established techniques that support continuous process improvement in manufacturing and production systems. The latter

approaches generally aim to increase productivity and quality. The most widely adopted approach for process improvement include lean thinking and kaizen (Womack & Jones, 1990; Imai, 1986,) single minute exchange of die (SMED) (Shingo, 1985), Six Sigma (Pyzdek, 2003) and design for changeover (DFC) (McIntosh et al., 2001.) According to Hicks (2007) lean thinking has the potential to be applied to any system or process in order to identify critical areas of improvement and ultimately bring about process improvements. This can be challenged, where failed implementations are common (Shah and Ward, 2007) however, based on the assumption that Hick (2007) apply lean thinking to information management and see significant benefits, Staats & Upton's (2011) use lean principles in knowledge work and show significant benefits together with further successful use of lean beyond production processes in traditional manufacturing (Dasari, 2005; Haque and Moore, 2004; Ranky, 2005) this thesis assumes that lean principles are a suited approach towards improving the structured provision of information using a process approach. In the study performed by Staats & Upton (2011) who performed various case studies, the authors state that using lean principles was most effective in creating streamlined communications and process architectures. One of the companies used visual management boards in order to address the problems of process invisibility to help streamline communications as team members had visual representations of their dependencies. Other tools used to streamline communications included value stream mapping, single piece flow and heijunka where the most important benefit was to visualize the process (Staats & Upton, 2011.) The latter academic findings indicate that using the lean methodology for process improvement within knowledge work can be appropriate to improve a knowledge worker's access to information.

The concept of 'lean' first introduced by Womack & Jones (1990) provides a focused approach for continuous process improvements by eliminating waste and unnecessary actions by linking the steps that create value. The initial concept of lean was described by five key principles: specify value, identify value streams, make value flow, let the customer pull value and pursue perfection (Womack & Jones, 1996.) This was paired with eight deadly wastes found in manufacturing systems (Womack & Jones, 1996) defined as overproduction, waiting, transport, extra processing, inventory, motion, defects and unused employee creativity, which are described in Appendix 8. According to Hick (2007) the fundamental understanding of waste is critical to successful lean transformation.

In order to define value in demand planning at Nike, information flows through a process and knowledge work is undertaken to add value to the information in the form of a quantitative demand-planning forecast. Waste can hereby include a demand planner's resources and activities necessary to overcome a lack of information, ineffective time spent trying to identify which information is necessary, ineffective time required to overcome excessive information (Edmunds & Morris, 2000) and the resources and activities required to correct or verify information (Hick, 2007.) According to Hicks (2007) in the context of applying lean principles to information management waste includes additional actions or any inactivity that arises as a consequence of not providing the "information consumer immediate access to an adequate amount of appropriate, accurate and up-to-date information." The most important challenge in using information, as flow is that information is significantly less visible than material 'flowing' through a production process and the definition of adding value can be very subjective. Therefore Staats & Upton (2011) use visualization lean tools to visualize the flow of information.

Hick (2006) describes four fundamental causes of waste with respect to information flow:

1. Information cannot flow because it has not been generated, a process is broken, or a critical process is unavailable
2. Information cannot flow because it cannot be identified or shared processes are incompatible
3. Excessive information is generated or excessive information flows, and as a consequence the most appropriate and accurate information cannot be identified

4. Inaccurate information flows resulting in inappropriate downstream activities, corrective action or verification

The latter four causes of waste are interpreted as follows in order to relate to organizational conditions that restrict knowledge workers from performing as defined in this thesis:

1. Ineffective knowledge re-use: Davenport (2010) highlights that the goal of facilitating knowledge workers to effectively apply their knowledge, is not to force them to create new knowledge but to reuse knowledge more effectively in order to increase time available to apply their knowledge to create a solution. Hack (2007) defines the corresponding type of waste for 1. as ‘failure demand’ which includes the “resources and activities necessary to overcome a lack of information by generating new information.”
2. Unclear task definition: If a knowledge worker does not know what he or she is pursuing for a knowledge worker cannot exploit his or her abilities (Antikainen, 2006.) Hack (2007) defines the corresponding type of waste for 2. As ‘flow demand’ concerning the time and resources spent trying to identify the information elements that need to flow.
3. Information overload: A quarter of a knowledge worker’s time is spent searching for information (Dance, 2009.) Hack (2007) defines the corresponding type of waste for 3. As flow excess relating to the time and resources that are necessary to overcome excessive information
4. Inaccurate information: Knowledge workers make decisions based on information available, and if information is inaccurate outcomes of a knowledge worker’s process can be inaccurate (Antikainen, 2006.) Hack (2007) defines the corresponding type of waste for 4. As ‘flawed flow’ the resources and activities that are necessary to correct or verify information.

The latter section indicates that using the lean thinking methodology can identify wastes, which restrict a knowledge worker to perform as defined in chapter 3 and 4. Therefore, the constraint as imposed by Nike to use lean tools was accepted as a suitable approach to improve the structured provision of information. In order to clearly define the design requirements for the solution, a list of requirements was created together with the NSW team members.

5.4.7 Actors Involved in the Design

Appendix 10 defines the actors involved in the design process and the steps undertaken to create a list of requirements and conceptual design.

5.4.8 Design Plan

1. Define Research Design Requirements

Actors Involved: Researcher

Objective: Define the requirements of the design in order to validate the problem statement of this thesis

Research Requirements:

The solution should facilitate a demand planner at Nike to improve forecast accuracy using a structured process approach. The solution should structure the provisioning of information to demand planners and reduce time required waiting and searching for information.

Embedded in the research requirements is the practice-approach which maintains that demand planners must be involved in the solution and that the solution must take advantage of a demand planner’s knowledge about the process.

2. Project Kick-Off – Design Solution

Actors Involved: Project team

Objective: Create timeline and gates, formulate issues, and formulate high-level objectives of the design solution. During the kick-off meeting the objectives of the design were agreed upon together with the time commitment required from the team. High-level timelines and gates were decided upon in order to ensure time commitment.

3. A3 Creation – Structured problem solving to create solution plan

Actors Involved: Core team

Objective: Create problem description of A3, breakdown problem and depict current situation.

In order to clearly define the problem statement demand planners at NSW felt most comfortable to use the A3 problem solving methodology to define their problem, which fits within the lean thinking methodology. The A3 is included in Appendix 13 and was created with the core team. The theme of the A3 is to achieve structured collaboration between DP, merchandizing and sales in order to improve forecast accuracy.

Main gaps:

- DP is less capable in providing a high quality submit due to missing the right data at the right time
- A structured approach to collaboration between DP, Sales and Merchandising is missing

4. Define High-Level Design requirements

Actors involved: Project Team

Objective: Define a high-level list of design requirements in order to chose a suitable tool within the lean methodology.

Tools and techniques used in the lean methodology are referred to as the lean “building blocks” and include tools such as 5S, visual management, poka-yoka, cellular design, quick changeover, pull scheduling, kaizen single piece flow, heijunka and value stream mapping (Pojasek, 2001.) Important to note is that the NSW team has never used lean tools before; however, the NSW director, researcher and lean master had previous experience with the implementation of lean tools. Therefore the high level requirements of the solution were created with the project team. The high level requirements act as the requirements for choosing the first lean tool used for this study. From there, the entire team was trained to use the tool and decided upon the requirements and attributes of the tool, and thereafter more lean tools could be used but this was beyond the time frame and scope of this case study.

The high-level requirements of the solution were defined as follows, this was defined using 2 brainstorming sessions with the project team:

Functions:

- The solution should visualize a demand planner’s work flow process
- The solution should visualize a demand planner’s information requirements
- The solution should visualize a demand planner’s collaboration structure
- The solution should visualize the status of information flow

Research Requirements:

- The solution must take advantage of a demand planner's knowledge
- The solution must structure and standardize a demand planner's work flow process for the seven submit gates
- The solution must structure the collaboration process between demand planners, sales and merchandising
- The solution must structure timely provisioning of information
- The solution should improve the quality of information provided to demand planners to make their decisions

Nike requirements:

- Should be usable by multiple people simultaneously
- Should be created, defined and sustained by demand planners
- Should be easy to use
- Should promote team involvement
- Should be continuous/sustainable
- Should be easily adaptable
- Should provide an overview of occurring issues and challenges for improvement
- Must improve work flow processes
- Must empower team to improve process
- Should not require formal training in order to be used
- Should be usable by all demand planners who are unknown with the system
- Should be attractive to use and not have to be enforced
- Should allow for a range of future adaptations
- Should ensure management process visibility
- Should provide non-directive and non-restrictive guidance
- Must fit within the lean thinking methodology
- Should be sustainable and continuously usable
- Should be built together
- Should not cost money
- Should incorporate the frameworks and perspectives of several users
- Should have a sufficiently flexible architecture to allow major changes in the structure of the process
- Should provide a platform for knowledge workers to share resource and process-related challenges and issues
- Should help to find repeatable parts of a process and codify them
- Should provide a platform to share best practice
- Should track improvement and issues
- Should be accessible across boundaries

5. Lean Tool Choice

Actors Involved: Project team, lean team

Objective: Chose most suited lean tool for the project

In order to choose the most suited lean tool according to the requirements depicted above a multi-criteria analysis was performed using input from the lean experts and project team together with a checklist validation. The three tools, which were selected as a mean to achieve the functions described, were decided upon based on the research performed by Staats & Upton (2011) and Staats et al., (2011.) a brainstorming session with two lean masters at Nike and the requirements discussed during a conversation with the director at NSW. Staats & Upton (2011) conclude that visual management scored highest in streamlining communication and defining process architecture in 6 case studies performed at knowledge intensive organizations, together with value stream mapping and single piece flow. The lean masters had experienced most organizational results with the use of visual management and value stream mapping. Therefore the three tools analyzed in the multi criteria analysis were visual management, value stream mapping and single piece flow. Next to this, a checklist analysis was performed to verify which tool was most suited to the requirements depicted above. The results are included in Appendix 12, Design Selection. Visual process management was the selected tool, which has been developed by lean practitioners as a communication aid to help drive operations and processes in real time (Parry & Turner, 2006.)

The NSW team had decided that the main function of the solution was to visualize the process in order to fully understand the different aspects of the process and its status. Making a process transparent with the use of visualization enables immediate feedback of the current status and indicates where adjustment may be required in the process when a knowledge worker is being inhibited to perform (Womack and Jones, 1996; Bauch, 2004.) When trying to understand, design or manage a process, visualizing the process with value stream mapping or visual management is a core tool used by lean practitioners to enable people to see and communicate the process (Parry & Turner, 2006.) Currently, demand planners do not have an overview of when their information is required, due to the complexity of forecasting multiple seasons simultaneously their requirements was to make use of constant proves visualization rather than a one time value stream mapping session. This was the most significant reason to use visual management boards.

Visual management boards boast various advantages; the most relevant to this research are presented below:

Process Visualization – Visual management is an effective tool to make main process flows visible and comprehensible from start to finish (Koskela, 2002.) Hereby the goal of visualizing the process, and making the process more transparent is to substitute self-control of information and processes held in people's minds to visualizing the flow of information (Greif, 1991.) Process visualization and increased transparency by using visual management facilitates a manager and employee's process- understanding and –management by sight and can structure the provision of information (Parry & Turner, 2006; Staats & Upton, 2011.) Moreover, Moser and Santos (2002) summarize the benefits of improving transparency and visualization using visual management as the stimulation of informal contacts, rapid comprehension of challenges and problems by making them visible, an increased response to problems, an increase in the motivation of workers for improvement and visibility of errors and a more effective distribution of responsibilities.

Continuous improvement – Visual management serves as a base for continuous improvement (Suzaki, 1993; Imai, 1997) and most importantly stimulates employees to be involved in managing and improving quality (Flynn et al., 1994.) Visual management is an interactive process which can be used individually or in a group which serves as an effective platform for employees to communicate suggestions, see and understand problems, apply basic problem solving techniques and to communicate results and improvement efforts to external stakeholders (Mann, 2005.)

Task facilitation – Visual aids can facilitate job tasks for employees offering a quick, correct and holistic understanding of their job requirements (Greif, 1991; Suzaki, 1993.) Knowledge worker's chose how to define their wall; however, the wall should facilitate them to visualize their tasks in order to understand task requirements.

6. Training, A3 presentation and Brainstorm

Actors involved: Lean team, project team, NSW team

Objective: Give brief kaizen, visual management training, present A3 and decide whether whole team agrees on problem description and on improvement focus. After this, brainstorm problems and corrective actions as an input towards designing the visual management wall.

The project team chose visual management as the most suited communication tool to help drive processes in real time through visualization. The visualization should communicate which tasks need to be completed and which information is required and from who to complete the tasks. Demand planners should decide upon the content of the visual management board, therefore a 3 hour brainstorm session was held with the entire NSW team. Appendix 14 describes the issues highlighted during the brainstorm session and provides a further description of the brainstorming process. The brainstorming session as described in Appendix 14 defined the list of requirements below.

7. Final List of Requirements based on the brainstorm session

Objective: Improve forecast accuracy by improving a demand planner's timely access to required information

Functions:

- The solution should visualize a demand planner's work flow process
- The solution should visualize a demand planner's information requirements
- The solution should visualize a demand planner's collaboration structure
- The solution should visualize the status of information flow
- The solution should visualize submits moments and visualize issues to activate help
- The solution should prioritize tasks

Requirements:

- The solution must take advantage of a demand planner's knowledge
- The solution must structure and standardize a demand planner's work flow process for the seven submit gates
- The solution must structure the collaboration process between demand planners, sales and merchandising
- The solution must structure timely provisioning of information
- The solution should improve the quality of information provided to demand planners to make their decisions
- The solution should act as a communication platform to discuss best practices and issues
- The solution should provide a visual overview of submit moments

Functional requirements:

- Should be usable by multiple people simultaneously
- Should be created, defined and sustained by demand planners
- Should incorporate the frameworks and perspectives of several users
- Should be easy to use
- Should promote team involvement
- Should be continuous/sustainable
- Should be easily adaptable
- Should provide an overview of occurring issues and challenges for improvement
- Must improve work flow processes
- Must empower team to improve process
- Should not require formal training in order to be used
- Should be usable by all demand planners who are unknown with the system
- Should be attractive to use and not have to be enforced
- Should allow for a range of future adaptations
- Should ensure management process visibility
- Should provide non-directive and non-restrictive guidance
- Must fit within the lean thinking methodology
- Should be sustainable and continuously usable
- Should be built together
- Should not cost money
- Should have a sufficiently flexible architecture to allow major changes in the structure of the process
- Should provide a platform for knowledge workers to share resource and process-related challenges and issues
- Should help to find repeatable parts of a process and codify them
- Should provide a platform to share best practice
- Should track improvement and issues
- Should be accessible across boundaries
- Should provide a platform to share best practice
- Should track improvement and issues

PHASE 4: Implement the solution

8. Solution Design

Actors involved: Core team

Objective: Design a solution, which fulfills to research objectives and NSW requirements

The main requirements are to structure and eventually standardized a collaboration schedule, which ensures that demand planners get required information on time. To visualize deadlines, work process flows and information requirements in order to understand workflow process and to visualize issues for management to help.

In order to validate the research performed in this study, an important objective is that the solution takes advantage of a knowledge worker's process knowledge, and that the solution should be self-sustaining. The solution should be built by the knowledge worker and be built using his or her knowledge, and especially not be enforced on the knowledge worker.

Therefore, once the problem structure and focus was clear the core team was left free to create their own design. Hereby, the project facilitator (the researcher) was present at the brainstorming and designing meetings purely to facilitate material requirements, design ideas, experience and to answer any questions of hesitation; however, the project facilitator ensured that the demand planners designed the walls themselves. This made the wall more self-sustaining as once the project facilitator would leave, the solution should continue to be used.

Appendix 15– Visual Management Wall Design shows the progress of the concept designs created by the core team and described feedback given based on the design. This visualizes the last four steps of the design.

9. Present Solution

Actors involved: project team, lean team

Objective: Present solution and receive feedback

10. Adapt Solution

Actors involved: Core team

Objective: Improve solution based on feedback

11. Present Solution

Actors involved: Lean team, NSW team, project team

Objective: Gain feedback from team

12. Continuously adapt solution

Actors involved: Core team, NSW team

Objective: Use solution to structure the high-level process, structure collaboration and most importantly, facilitate a knowledge worker to perform.

5.4.9 Final Design

The aim of the visual management wall was to structure a demand planner's workflow process, and using this, create a standardized collaboration process with the aim of improving forecast quality as demand planners have timely access to required information. The wall should visualize deadlines, work process flows and information requirements in order to understand workflow process and to visualize issues for management to help.

The solution should be built by the knowledge worker and be built using his or her knowledge, and especially not be enforced on the knowledge worker. As mentioned in **step 9, solution design** once the problem definition, design-objectives, - requirements and -design space was clear the core team was left free to create their own design. The project facilitator (the researcher) was present at the brainstorming and designing meetings purely to facilitate material requirements, design ideas, experience and to answer any questions of hesitation; however, the project facilitator ensured that the demand planners designed the walls themselves. This made the wall more self-sustaining as once the project facilitator would leave, the solution should continue to be used.

Appendix 15– Visual Management Wall Design shows the progress of the concept designs created by the core team and described feedback given based on the design. This visualizes the last four steps of the design.

Figure 22- Visual Management Concept Design 4, February 4th, 2016 presented below shows the latest design of the wall.

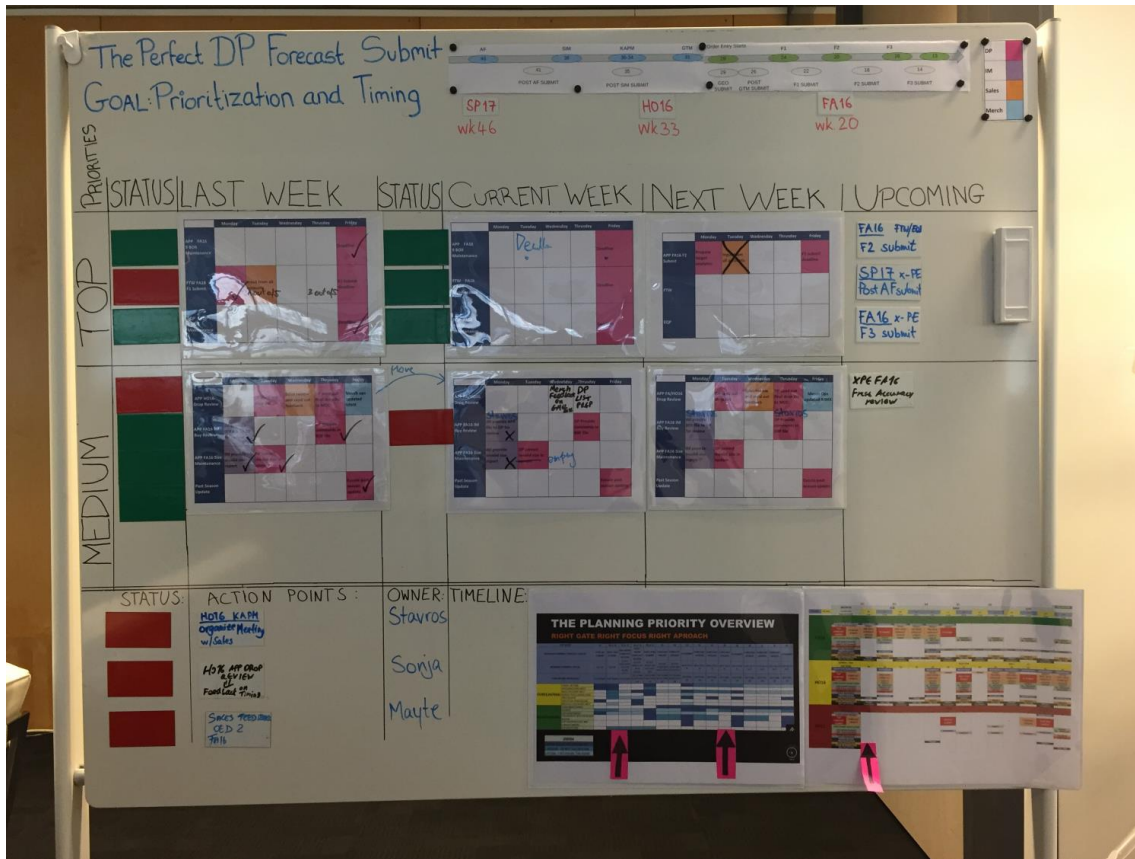

Figure 22- Visual Management Concept Design 4, February 4th, 2016

The following list will describe the most important attributes of this design:

- The left side of the wall is used to structure demand planner priorities. Demand planners struggle to structure their workflow due to multiple seasons being planned simultaneously. Therefore, the prioritization column should help to structure their workflow by understanding which tasks to prioritize.
- The status column is included to track challenges, issues, improvement and progress. Moreover, the status column provides a clearer overview of ‘management-by-sight’ meaning that process transparency is improved; a manager has a visual cue for when a demand planner’s process is off track. If a task is not completed, or if information is not obtained on time the status is tracked as red. This is to track when problems are occurring in order to improve the workflow structure and collaboration structure.
- The middle area of the wall provides visualization of the tasks to be performed in the three weeks. Using a partner color key, collaborative tasks are visualized and information requirements are structured. Demand planners structure the process workflow. The templates are created in excel listing the required tasks. The reason to do it this is that the team can then learn by doing. Since the process is too large to structure at once they focus on 3-week periods, where they visualize information requirements from collaborative partners, individual tasks and meetings hoping to codify a regular schedule which can then be used to standardize and structure collaboration and work flows.
- The action points, and upcoming tasks are included on the wall in order to add tasks, which are not included in the standard task set but must be undertaken. This then provides insight as to what extra tasks are being performed and where demand planners are assigning their time.

This wall depicts a conceptual design built in a short period of time and much improvement is still possible. Team members huddle around the wall weekly in order to discuss issues, challenges, help required or positive points. Next to this, the wall depicts information requirements meaning that demand planners can use the wall to clearly define when they require information input, what kind of information and from whom. Currently, the wall focuses on receiving information on time and ensuring that scheduled collaboration comes in place. The quality of information is not yet considered; however, this will be the next step once a structured collaboration process has been achieved. Hereby standardized templates, format and meeting structures should be established.

Appendix 15 shows the full description and images of the visual management wall. Together with the section created which tracks the results of the solution.

PHASE 5 & 6: Show the theoretical connections and research contribution of the solution concept and examine the scope of the applicability of the solution.

According to Oyegoke (2011) the most appropriate method to test, validate and improve a solution is by using a pilot case study. Unfortunately, due to time resource constraints, only one case study was performed. Therefore the solution will be tested together with validating the constructs used to design the solution

Moreover, the constructive research approach demands that the construct should add to the body of existing knowledge. The contribution should be specified and areas for further studies should be highlighted (Oyegoke, 2000.) Therefore the following section will validate the constructs and solution designed in this thesis together with a conclusion and reflection concerning the theoretical connections and research contribution.

6 Results & Data Validation

The aim of this thesis was to answer the following questions:

- 1) How can organizational conditions facilitate knowledge workers to perform?**
 - a. What are the requirements for a knowledge worker to perform knowledge work?
 - b. Which organizational conditions facilitate the requirements for a knowledge worker to perform knowledge work?
- 2) How can organizational processes that shape and determine a knowledge worker's job organize the provision of information to facilitate knowledge workers to perform?**
 - a. How can a structured process approach of knowledge work be balanced with a knowledge worker's autonomy required to perform?
 - b. How can a structured process approach facilitate effective information sharing?
 - c. How can effective information sharing facilitate knowledge worker performance?
 - d. What are the requirements to facilitate collaborative knowledge workers in a structured process approach?
- 3) How can collaborative demand planners at Nike be facilitated to improve forecast accuracy?**
 - a. How can collaborative demand planners at Nike be facilitated to apply their knowledge?
 - b. How can the lean methodology be used to facilitate demand planners at Nike to improve forecast accuracy?

The main question of this research is formulated as follows:

How can an organization's process arrangement facilitate collaborative knowledge workers to improve organizational KPIs?

In order to answer the main question of this thesis the 6 phases of the constructive research approach were applied. First question 1 was answered by defining how an organization can create conditions that enable a knowledge worker to have the motivation, opportunity and ability to perform. The results in chapter 3 indicate that knowledge workers require direct, timely access to information and therefore more understanding was required to define how

organizational processes that shape and determine a knowledge worker's job should organize the provision of information.

Using the findings in chapter 3 and 4 a solution was built for demand planners at Nike to structure and improve the timely provision of information using a visual management board to visualize the flow of information and use lean tools to remove waste from the flow of information in order to improve forecast accuracy. On average, 12% of forecast inaccuracy is due to forecasting errors such as missed input, double counting forecasts, forecasting issues, reporting errors, mistakes, wrong interpretation and wrong decisions which indicates that demand planners at Nike are being restricted to perform as their process does not allow for sufficient time to apply relevant knowledge. Next to this, 3% of the total average forecast in-accuracy is due to demand planners missing information from relevant stakeholders such as merchandising and sales inputs and insights. Therefore, by adapting an organization's process arrangement to provide an efficient provision of required information to facilitate collaborative knowledge organizational KPIs should improve.

According to Barlas and Carpenter (1990) verification refers to internal consistency (a logical problem) whereas validation refers to the justification of knowledge claims. Hereby, this study should be validated in the usefulness of the new knowledge with respect to its purpose. A challenging aspect of this research, and a common engineering design challenge is that it concerns open problems, which involve objective and subjective elements with no single right answer (Pedersen et al., 2000.) A formal, rigorous and quantifiable validation procedure would not be suitable for this study for various reasons; the first reason is that the study is too subjective in order to apply such a formal quantitative process, this is due to limited existing literature concerning knowledge worker facilitation, the human aspect of knowledge work and a limited number of participants. Next to this, chapter 1 explains that there is no universal method to measure knowledge worker performance. Therefore, other than measuring the impact of the design on forecast accuracy, no true quantitative measurement can be made concerning how the solution improved knowledge worker performance. This is a limitation of the study; however, an alternative validation will be made presented below.

Pedersen et al., (2000) study the validation of design methods and research suitable to subjective designs and research. This study makes use of engineering design by Dym and Little (2004,) hereby Pedersen et al., (2000) state that validation of engineering research works very well using mathematical modeling to validate engineering designs, however areas of engineering research that rely on subjective statements can make such a logical mathematical validation challenging. Therefore they present a validation square which validates a study by testing its scientific consistency and its external relevance based on its usefulness with respect to a purpose (Pedersen, 2000.) This research will adapt Pedersen et al's., (2000) validation methodology in order to validate this study. The following section will present the steps followed to validate the study.

6.1 Step 1: Testing the constructs validity using citation analysis (adapted from Pedersen, 2000)

The author states that in order to build confidence in the validity of the individual constructs constituting the conclusions made, literature can be used, based on the author and publisher, the number of references associated with the construct, and so on (Pedersen, 2000.) In order to advance the research various decisions, conclusions and research assumptions were made, these will be presented and validated below.

Due to restricted quantitative data concerning knowledge worker performance and limited existing literature about facilitating knowledge workers, this validation will make use of citation rates in order to indicate the validity of the

articles. Even though there are various limitations to using citation analysis, namely the subjectivity of how much more valid is a research if it is frequently cited, as a measure of relative scientific performance. Garfield (1979) states that citation rates say something about the contribution made by an individual's work "in terms of the utility and interest the rest of the scientific community finds in it" (cited by 555.) Citation analysis is a type of bibliometric analysis, which is widely used to "evaluate the impact of scientific research and researchers" (Hirsch, 2005.) Therefore, according to Greenseid et al., (2011) it is reasonable to consider citations analysis as a method for assessing the influence of research. Citation analysis consists of tracking the number of citations to published works usually using a citation database (Greenseid et al., 2011.) Google Scholar is a free, online and easy to use database where van Aalst (2010. P.399) states that Google Scholar is "a promising tool for assessing the impact of journal articles." Since no money was available in this research to use a paid citation analysis, Google Scholar will be used in order to value the number of times cited. Important to note is that the citations are checked to make sure these are merely scientific citations in well-established peer-reviewed journals. This will be used as a first step towards validating the results in this thesis. The most important constructs will be analyzed that define the most important conclusions made.

6.1.1 Construct 1 – Organizational Conditions Facilitate Knowledge Worker Performance

Kelloway & Barling (2000) state that knowledge worker **performance can be enhanced by organizational conditions that increase either an employee's motivation to use knowledge, employee's knowledge (ability) or an employee's opportunity to perform knowledge work** in the workplace. According to the latter findings this thesis assumes that by improving a knowledge worker's access to information, more time will be available to perform their core tasks and therefore improve organizational KPIs.

This sources from the following sentence:

"Performance is equal to ability*opportunity*motivation" (Wall et al., 1992)

Since knowledge worker performance is essentially immeasurable this definition of performance is assumed throughout the entire thesis where if one of the factors is equal to zero, performance will be zero. Table 3- Articles defining the choice to focus on a knowledge worker's opportunity, motivation and ability to perform shows the journals in which both articles are published and how many times the articles are cited. Both articles are frequently cited, indicating that the latter constructs were a valid starting point.

Article Title	Author	Journal	Number of times cited
Knowledge Work as Organizational Behavior	Kelloway & Barling (2000)	International Journal of Management Reviews	324
Operator work design and robotics system performance: A serendipitous field study	Wall, Jackson and Davids (1992)	Journal of Applied Psychology	181

Table 3- Articles defining the choice to focus on a knowledge worker's opportunity, motivation and ability to perform

For an organization to exploit the abilities of their knowledge workers, an organization should create organizational conditions that provide knowledge workers with the opportunity to perform, and motivate knowledge workers to invest their abilities in the organization. According to the motivation, ability and opportunity requirements organizational conditions were defined. Table 4 provides an overview of the most important articles quoted in the list of requirements and organizational conditions presented in chapter 3. Next to this, results from the interviews performed at Nike were used to define the requirements.

Article Title	Author	Journal	Number of times cited
Knowledge Work as Organizational Behavior	Kelloway & Barling (2000)	International Journal of Management Reviews	324
Enhancing role breadth self-efficacy: the roles of job enrichment and other organizational interventions.	Parker (1998).	Journal of Applied Psychology	602
Impact of work teams on manufacturing performance: A longitudinal field study	Banker, Field, Schroeder & Sintia (1996)	Academy of Management Journal	414
Employee motivation: A powerful new model	Nohria, Groysberg & Lee (2008)	Harvard Business Review	203
Enhancing role breadth self-efficacy: the roles of job enrichment and other organizational interventions.	Parker (1998).	Journal of Applied Psychology	602
From transactional to transformational leadership: learning to share the vision	Bass (1991)	Organizational Dynamics	3354
Employee motivation: A powerful new model	Nohria, Groysberg & Lee (2008)	Harvard Business Review	203
An evaluation of the impact of the office environment on productivity.	Haynes (2008)	Facilities	71
Transformational leadership and emotional intelligence	Barling, Slater & Kelloway	Leadership and Organization Development Journal	601
Effects of transformational leadership training on attitudinal and financial outcomes: A field experiment	Barling, Weber & Kelloway	Journal of Applied Psychology	1193
Development and test of a model linking safety-specific transformational leadership and occupational safety.	Barling, Loughlin & Kelloway	Journal of Applied Psychology	441
Encouraging knowledge sharing among employees: How job design matters	Foss, Minbaeva, Pedersen & Reinholt (2009)	Human Resource Management	169
Job and work design: Organizing work to promote well-being and effectiveness	Parker & Wall (1998)	Journal of Applied Psychology	432
Future work design research and practice: Towards an elaborated model of work design	Parker, Wall & Cordery (2001)	Journal of Occupational and Organizational Psychology	409
Motivation through the design of work: Test of a theory	Hackman & Oldham (1976)	Organizational behavior and human performance	6223
Knowledge worker productivity: the biggest challenge	Peter F. Drucker (1999)	California Management Review	1564
Affinity groups: The missing link in employee involvement	Van Aken, Monetta & sink (1994)	Organizational Dynamics	37

Diagnosing cultural barriers to knowledge management	David & Fahey (2000)	The Academy of Management Executive	1744
Organizational governance of knowledge and learning	Davenport et al. (2008)	Knowledge and process management	31
Knowledge work productivity assessment	Antikainen & Lonqvist (2008)	Institute of Industrial Management	32
Measuring knowledge work: the knowledge work quantification framework	Ramirez & Steudel (2008)	Journal of Intellectual Capital	37
A review of employee motivation theories and their implications for employee retention within organizations	Rainall (2004)	The Journal of American Academy Business	418
The six core elements of business process management.	Davenport, Brocke & Rosemann (2015)	Handbook on Business Process Management	400
A theory of organizational knowledge creation	Nonaka, Takeuchi and Umemoto (1996)	International Journal of Technology Management	593

Table 4- Articles defining a knowledge worker's requirements to perform knowledge work and organizational conditions which facilitate this

Table 4 depicts the most relevant literature used to define how organizational conditions can facilitate a knowledge worker's opportunity, motivation and ability to perform. **The literature used to answer question 1 have high citation indexes which indicate a valid construct.** In order to quantitatively validate all organizational conditions presented in chapter 3 an elaborate field study is required to test all variables. Hereby variables should be tested individually using nul-comparisons to determine the impact of using the organizational conditions in order to facilitate knowledge workers to perform. Next to this, in order to effectively validate the variables a method should be found to measure knowledge worker facilitation. Due to the difficulty of measuring knowledge worker performance this was considered as an important aspect of future research and not the focus of this study. Next to this, validating all variables should be performed in future research in order to truly validate the findings in chapter 3, however this section concludes that the citation analysis indicates a valid construct and therefore further research should be performed to truly validate the findings, but this indicates a valid construct and therefore the first construct is accepted for the further validation of the findings presented in this thesis.

6.1.2 Construct 2 - Effective Information Sharing Enhances Knowledge Worker Performance

Using the results in construct 1, an organization can facilitate a knowledge worker's access to the correct information at the right time according to task requirements (Drucker, 1999; Kelloway and Barling, 2000) Similar to manual work, waiting and searching for resources hinders productivity of a knowledge worker (Antikainen, 2006; Davenport, 2010.) Knowledge workers make decisions based on information available, and if information is unsatisfactory, unavailable or too late outcomes of a knowledge worker's process can be poor in quality therefore inhibiting organization KPIs (Antikainen, 2006.) A knowledge worker's workflow process can define a knowledge worker's information requirements and drive knowledge worker productivity by clearly defining which information is required for the task, when it is required and according to which standards and format. By applying a structured approach to define information flow Davenport (2011) states that productivity rises up to 50 percent. Based on the latter conclusions and findings in chapter 4, construct 2 defines that effective information sharing can improve organizational KPIs by ensuring that tasks are completed with all information required, and that knowledge workers will then have more time to apply knowledge to core tasks.

This last sentence is based on an important assumption made in this thesis that in knowledge work, “quality is the essence of the output” (Drucker, 1999) but there is a limit for “how much time can be decreased before the quality of work is eroded.” (Drucker, 1999; Davenport et al.; 2010; Antikainen, 2006.) An assumption is made that by facilitating a knowledge worker’s time to perform by reducing the time searching, waiting and reworking information, their performance increases which increases organizational KPIs. This assumption is based on the latter academic findings together with work floor observation at Nike, own experiences and the results presented in this thesis that 12% of forecast in-accuracy is due to human errors such as double counting forecast, copying numbers wrongly and so on which indicate a time limitation. The following table shows the citation index for the most articles used to define this construct. Moreover, it is assumed that information quality impact the outcome of the process (Hicks, 2007.)

Article Title	Author	Journal	Number of times cited
Knowledge worker productivity: the biggest challenge	Peter F. Drucker (1999)	California Management Review	1564
Knowledge work productivity assessment	Antikainen & Lonqvist (2008)	Institute of Industrial Management	32
Handbook on business process management	Davenport, van Brocke & Rosemann	Book (Springer)	452
Lean information management: Understanding and eliminating waste	Hicks (2007)	International Journal of Information Management	218

Table 5 – Articles defining construct 2, facilitate time to perform improves performance

The case study at Nike will validate this construct further; however, the citation indexes highlight that the construct comes from frequently cited articles indicating a valid construct.

6.2 Step 2: Testing the usefulness of the constructs by using an example problem (adapted from Pedersen, 2000)

The next step towards validating the framework and answers presented in chapters 1-4 is to use an example problem. Pedersen (2000) states that in order “to build confidence in the usefulness of the method” a representative example problem should be used. Metrics for usefulness of research can be linked to the degree that an articulated purpose has been achieved.

6.2.1 Problem Relevance

The most important purpose of this research is to define:

How can an organization’s process arrangement facilitate collaborative knowledge workers to improve organizational KPIs?

Constructive research problems can be based on anecdotal evidence, evidence based on practical experience in an industry, from the practitioners in the industry or evidence from peers’ theoretical work (Oyegoke, 2011.) A suitable research problem should offer opportunities for practical and theoretical contributions (Kasanen, 1993.) In order to ensure a constructive research problem, input sources from practical experience in the industry, practitioner’s expertise and evidence from peers’ theoretical work.

Practical experience in the industry:

Nike is struggling to manage knowledge workers and facilitate collaborative knowledge workers to improve organizational KPIs using their process arrangement. Results indicate that an average of 18% of the total 40% forecast in-accuracy, (12% forecast error, 3% missing input and 3% category-specific issues) is caused by process-related issues. Based on interviews at Nike included in Appendix 1, managers are struggling to find suitable performance or process-related metrics and rely on walking the floor to understand if demand planners are experiencing process-related issues.

Evidence from peers' theoretical work:

Demand planners, further categorized as knowledge workers are part of institutions that determine and shape the work that is done. They are however, still claimed to be the greatest management challenge of the 20th century (Davenport, 1996; Davenport 2002; Drucker, 1999; Ramirez et al., 2004.) Academics indicate that further studies on forecasting should research how a demand planner should be managed and facilitated in order to improve forecast accuracy (Armstrong, 1987; 2001; Mentzer and Bienstock, 1998; Moon et al., 2003; Danese et al., 2010.) Danese et al., (2010) highlight that more research is required towards how to facilitate a demand planner to produce an accurate demand planning forecast using managerial decisions on demand planner processes, information gathering processes and tools, organizational approaches, collaboration and forecast accuracy measurement using a proper metric and by defining proper incentive mechanisms. Davenport (2013,) an academic who has dedicated most of his research attention towards knowledge work states, “we’re in the early days of thinking and knowing about how to improve knowledge work... There is much more to be learned and every attempt to make it better should be an experiment.” His elaborate field studies within companies and research in academic literature have resulted in three important statements, “top-down re-engineering of knowledge work is unlikely to be successful,” “computers can be helpful to improve knowledge work, but not all jobs can be mediated by a computer because they are too unstructured or collaborative in nature,” “knowledge work performance improvement is an experiment” (Davenport, 2013.)

A practical problem at Nike indicated a knowledge gap concerning how to facilitate demand planners to increase forecast accuracy. Demand planners; further categorized as knowledge workers are claimed to be the greatest management challenge of the 20th century (Davenport, 1996; Davenport 2002; Drucker, 1999; Ramirez et al., 2004.) where every attempt to improve performance should be seen as an experiment. Therefore the relevant problem within Nike provides a relevant problem to experiment on improving performance by improving their timely access to information. **This is seen as a valid problem for the purpose of this research.**

6.2.2 Usefulness of the Method

A design is a suggested solution to the selected research problem (Kasanen, 1993.) The design phase is grounded in knowledge gathered in phase 1 & 2. Hereby, a solution at Nike will be designed in order to answer question 3:

In order to design the solution, the design cycle adapted from Dym and Little (2004) is used. The author states that it is a “widely accepted model of the design process” and therefore this process will be followed in order to design the solution. The solution will be designed together with demand planners at Nike to ensure that the design process becomes a consultative iteration between the researcher and the practitioners to ensure the solution’s suitability for practice.

The requirements are based on the following constructs as explained in the previous section:

- Effective information sharing facilitates performance
- Organizational conditions can facilitate information sharing with their process arrangement

Therefore the assumption is made that by using a process-oriented approach in the NSW team, access to information can be visualized and improve and thus improve the accuracy of the information by including all relevant information from stakeholders and provide more time to apply their knowledge to the forecast.

Based on the conversations performed with the NSW director and demand planning manager included in Appendix 9, work-floor observation, the A3 created in Appendix 13, the brainstorm results in Appendix 14 and the participation in the core team it became clear that the important requirement, timely access to information was not being facilitated and thus, knowledge worker's forecast performance was restricted because they were submitting forecasts with missing inputs. Next to this, demand planners state that they are running after information and 'firefighting' to get information, which is limiting their time to forecast and affecting their results. In order to ensure timely access to information a visualization of their process was required. The latter results indicate that construct 2 is valid.

6.2.3 Validating the design

In order to truly validate the design a much longer time period was required. When the researcher left the wall had only been used for 3 weeks, which meant that, the implementation was too early in the implementation phase to truly be validated. Moreover, forecast accuracy is only measured 3 months after the forecasting process, and as displayed in the causal diagram in chapter 2 is influenced by a significant amount of external variables. Therefore in order to provide a more holistic validation of the design and visual management boards many more experiments should have been performed. For example to implement visual management boards in three demand planning department and not in three other departments to determine whether an effect can be seen when comparing the two. Moreover, the visual management boards should be tested in various different departments. However this will be discussed in the further research chapter.

Since the visual management board cannot be used to validate the findings in this thesis, this section will use a survey presented in Appendix 18 to determine whether the visual management board was a suitable approach to support the objectives of the solution.

Objective: Improve forecast accuracy by improving a demand planner's timely access to required information

Functions:

- The solution should visualize a demand planner's work flow process
- The solution should visualize a demand planner's information requirements
- The solution should visualize a demand planner's collaboration structure
- The solution should visualize the status of information flow
- The solution should visualize submits moments and visualize issues to activate help
- The solution should prioritize tasks

Requirements:

- The solution must take advantage of a demand planner's knowledge

- The solution must structure and standardize a demand planner's work flow process for the seven submit gates
- The solution must structure the collaboration process between demand planners, sales and merchandising
- The solution must structure timely provisioning of information
- The solution should improve the quality of information provided to demand planners to make their decisions
- The solution should act as a communication platform to discuss best practices and issues
- The solution should provide a visual overview of submit moments

8 participants filled out the survey, which means that the results cannot be used to validate the design. The NSW team consists of only 9 members, where one was not able to fill in the survey. This means that the data is very limited and further implementations are required to validate the design. Appendix 19 shows the average results of the survey.

In order to determine the validity of the solution according to the lean methodology, an interview was performed with a lean master working at Nike included in Appendix 19. The results indicate that the use of the visual management wall is valid according to the lean methodology. However, the wall is in a very early development stage and therefore the expert believes that the wall can be a suitable approach to fulfill the design requirements in 6.6.3., however; the wall is still too high maintenance and therefore will require significant adaption in order to be used effectively.

Moreover, in order to validate the findings of this thesis more quantitative data was required concerning the time required currently whilst waiting, searching or reworking information and how this could change as an effect of the implementation; however, time and collaboration restrictions did not enable this.

6.3 Final Validation

To conclude the most important purposes of the research were:

- To provide a significant contribution towards existing academic knowledge about how to improve knowledge worker performance by understanding how an organization's process arrangement can facilitate knowledge workers to perform. Davenport (2013) states that little is known about how knowledge worker performance can be improved and that experimentation is required.
- To use the findings in this thesis about creating conditions that facilitate knowledge workers to perform, to design a solution at Nike that facilitates timely access to information.

Unfortunately the results in this thesis cannot be validated due to the following reasons:

- More research is required to define how to measure knowledge worker facilitation
- The case study was performed with limited resources and in a very short time period which meant that no comparisons could be made using two departments to indicate an improvement of difference
- Limited time restricted the development of the visual wall to achieve it's full potential
- Forecast accuracy can only be measured three months after the season which means that the results cannot be included in the results
- Limited participants means that the effectiveness of the design cannot be measured objectively
- Case study was only performed at one department type which restricts the validity of a universal approach

The most valid contribution of this thesis is that this thesis contributes a usable approach to facilitate knowledge workers to perform at their full knowledge capabilities providing a significant starting point for academics to test the approach in different areas. The citation analysis indicates that the constructs are valid and therefore this thesis should be used as a knowledge base and methodology to perform further ‘experiments’ as Davenport (2013) states to be required. This thesis has laid the foundations for academics to perform experiments and validate the findings in order to truly conclude whether the approach presented in this paper can facilitate knowledge workers to perform in order to improve organizational KPIs.

7 Conclusion

To conclude, the main question of this thesis is formulated as follows:

How can an organization’s process arrangement facilitate collaborative knowledge workers to improve organizational KPIs?

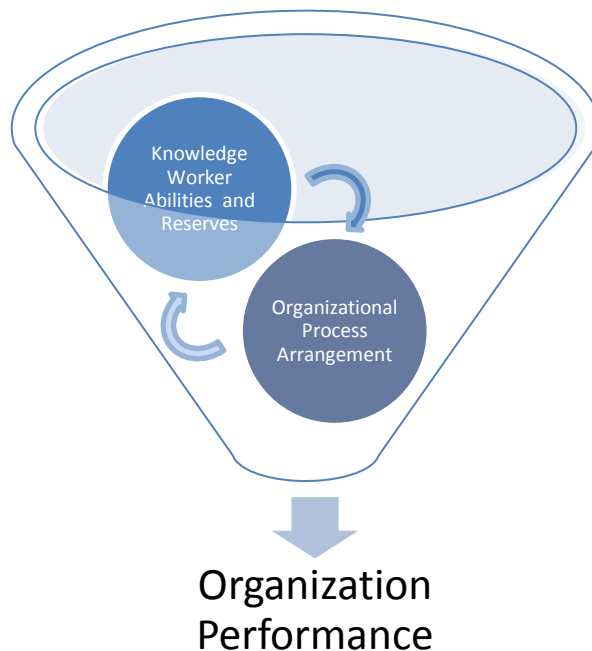

Figure 23 – Using organizational process arrangement to facilitate knowledge worker abilities and reserves to drive performance

Knowledge workers are “part of institutions that determine and shape the work that is done” and within such institutions, **leadership, working environment, organizational culture and job design should create conditions that facilitate knowledge workers to perform** (Megill, 2013; Antikainen et al., 2006.) **Essential to the success of a knowledge intensive-organization are not only the knowledge reserves of the workers, but also what an organization is able to do with the latter** (Drucker, 1999.) Wall et al. (1992) explain that a worker’s performance is equal to *ability * opportunity * motivation*, where if one of the factors is equal to zero, performance will be zero. Contrasting to the industrial age, organizational wealth and growth no longer relies on abundant raw materials but on knowledge workers’ performance, which can be the greatest determinant of the worth of their companies (Brocke & Rosemann, 2010.) Examples of the latter can be found in the form of successful companies such as Google, Microsoft and Netflix who add value by exploiting organizational knowledge reserves to create value. Knowledge

workers have a large responsibility in sparking innovation and growth, inventing new products, designing marketing programs, creating and adapting technology, creating strategy, planning demand etc and therefore an organization must create conditions which stimulate performance.

Figure 23 shows the relationship between requiring a knowledge worker's ability and knowledge reserves as an input to create value and an organization creating and defining conditions and process arrangements which enable knowledge workers to have the opportunity and motivation to exploit these abilities to increase organizational performance.

However, in order to answer the main question, first an understanding is required of which organizational conditions facilitate knowledge workers to perform:

Comparable to a traditional production-oriented organization achieving success by using the best materials to produce a product, an organization should attract knowledge workers with a significantly high **ability to execute cognitive actions and processes suited to the task**. An organization should **flourish knowledge worker ability by enabling them to grow, learn, and exchange knowledge**. **This should be achieved with the following:**

- Hire or train knowledge worker to have necessary skills and knowledge to perform job (Kelloway & Barling, 2000)
- Ensure transformational **leadership** as defined by Bass (1991) that educates through experience and interaction (Nonaka & Takeuchi, 1995) using individualized consideration to stimulate intellect by teaching, inspiring and promoting intelligence, rationality and careful problem solving.
- **Job design** should clearly define the task, organization cannot exploit knowledge worker abilities if knowledge worker does not know what he or she is pursuing for (Antikainen, 2006.)
- Establish opportunities for knowledge workers to **interact socially** for the purpose of sharing information and knowledge, social interaction enables knowledge workers to teach and learn from each other (Kelloway and Barling, 2000; Drucker, 1999.)
- **Organizational culture** should define expectations and reward structures that encourage knowledge workers to have a role-breadth self-efficacy and continuous learning by expecting and providing opportunities for knowledge workers to exploit their abilities (Kelloway & Barling, 2000.)
- **Organizational environment** should enable social interaction and teaching tools.

In order to drive a knowledge worker to apply their ability to define organizational success their motivation is required. This is driven by personal development together with a sense of responsibility for his or her results and performance through task autonomy and the ability to organize and manage their own work (Drucker, 1999; Davenport, 2010; Blom et al., 2001; Kelloway & Barling, 2000.)

Organizational conditions that can increase knowledge worker motivation to invest their knowledge and skills in an organization summarized as follows:

- **Leadership** should provide individualized consideration and coaching to communicate high expectations to challenge and teach knowledge workers (Barling et al., 1996; Barling et al., 1998; Bass, 1991.)
- A **charismatic leader** should instill pride and gain respect and trust using fair performance measurement systems, share experiences and teach and develop (Kelloway & Barlin, 2000; Nicholson, 2003)
- A knowledge worker's tasks (**job design**) should activate the three critical psychological states defined as experienced meaningfulness of the work, experienced responsibility for work outcomes and knowledge of the

actual results of one's work (Parker & Wall, 1998) with autonomy, task variety, task significance, task identity and feedback (Hackmann & Oldham, 1976)

- **Task autonomy** and the resulting sense of responsibility is critical to achieve motivation and commitment to perform (Drucker, 1999; Kelloway and Barling, 2000; Wall et al., 1990.)
- **Organizational culture** should create fair expectations and rewards (David & Fahey, 2000.)

Referring back to a traditional production process, even if the best materials have been found, **a basic process must be in place to create a final product from the material. In this case, an organization's process arrangement must provide a knowledge worker with the opportunity to exploit their ability.**

However, one of the biggest dilemmas in understanding how to best provide knowledge workers with the opportunity to perform is that **knowledge workers characterize their daily tasks with thinking, collaboration and iterative jobs, which makes it challenging to structure and define their work to provide them with the suited tools, time availability, environment, information and standards and routines according to their task requirements (Davenport, 2013.)** The success of improving performance (productivity) in **manual work** derived from **applying the appropriate levels of job design and control to physical labour, so that an employing organization could ensure that employees are operating in an efficient manner (Drucker, 1999.)** However using such job design and control to knowledge work could inhibit a knowledge worker from performing (Drucker, 1999.) Knowledge workers are known to require **significant task autonomy and control over their own process in order to flourish motivation and commitment; however, similar to manual work, a knowledge worker waiting, re-working or searching for resources can hinder a knowledge worker's productivity.** Further research was required concerning the balance between an organization providing a knowledge worker with full ownership of his or her own process, where autonomous knowledge workers define and integrate their own information environment and task organization versus an organization defining a knowledge worker's workflow process, defining a structured provision of information and job tasks to drive time-efficient knowledge work as displayed in Figure 24.

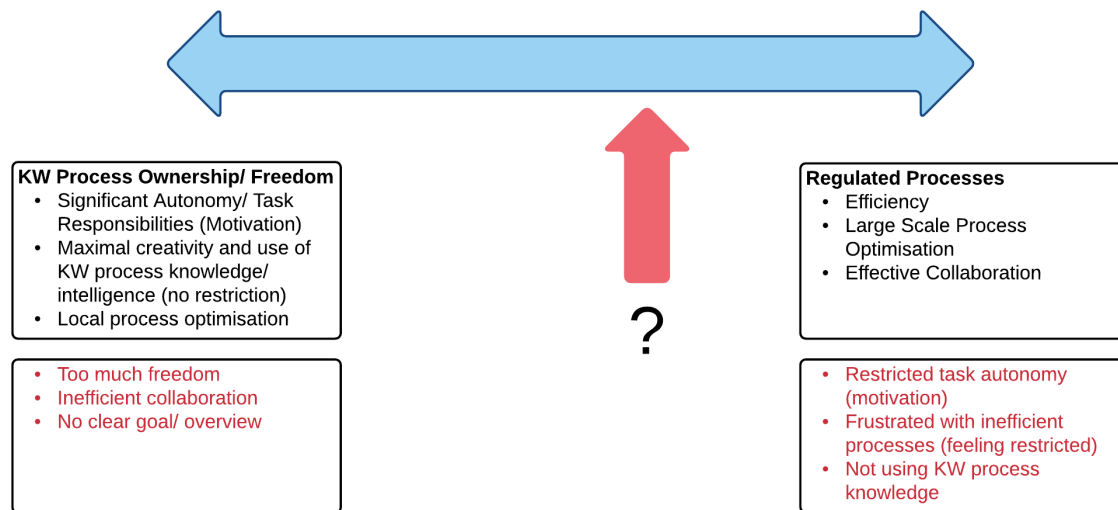

Figure 24 – Defining the dilemma between providing a KW with process ownership/freedom versus organization regulated processes

For both extremes of the axes displayed in Figure 24 significant benefits and limitations can be found. For example Netflix, a popular video streaming service is known to provide significant freedom and process ownership to their employees, which attracts many highly intelligent individuals. However, the employees are required to always handle in

the interest of the company and are restricted with an extreme requirement, ‘only the best is sufficient’ (NRC, 2015.) Even though in this case, the strategy works well, employees can feel overwhelmed by the freedom and therefore underperform, collaboration can be inefficient and an organization can lose track of control and a clear overview. On the other extreme of the axis, an organization can provide regulated processes which drive efficiency, effective collaboration, control and can facilitate large scale process optimization to use known improvement methods similar to traditional process optimization. However, in this case the risk is that employees will feel frustrated with inefficient processes, an organization can lose commitment and especially risk not fully exploiting knowledge worker’s abilities to their full extent as eventually, knowledge workers are most knowledgeable about their own process.

In order to provide a deeper understanding of the balance displayed in Figure 24 this thesis chose to focus on a knowledge worker’s main input, **information**.

Inherent to successful knowledge work is that **information acts as an input**, not only information gathered from the customer but also information that exists within the organization. **In order to facilitate a knowledge worker’s opportunity to perform, knowledge workers need timely access to the correct information** (Drucker, 1999; Kelloway and Barling, 2002) (O-4.) Knowledge workers make decisions based on information available, and if **information is unsatisfactory, unavailable or too late, outcomes of a knowledge worker’s process can be poor in quality** (Antikainen, 2006.) Similar to manual work, waiting and searching for resources hinders productivity of a knowledge worker (Antikainen, 2006; Davenport, 2010.) Drucker (1999) states that because human memory is limited, it is important that workers share their information with each other and learn from information sharing to improve their ability to apply their knowledge to solutions (Kelloway & Barling, 2000.) Therefore, effective information sharing not only ensures less time waiting and searching for information but also enables knowledge workers to grow, learn and increase their abilities to perform as defined in chapter 3 (A-2.)

In order to further define the dilemma presented in Figure 24 the following question is answered:

2 How can organizational processes that shape and determine a knowledge worker’s job organize the provision of information to facilitate knowledge workers to perform?

One major issue in the way of developing a useful management model lies in the “generic use of the term knowledge worker” (Davenport, 2002.) Substantial differences can be found between knowledge workers. **Therefore knowledge workers are segmented according to the four models of knowledge work and their behavioral process in the form of knowledge creation, knowledge distribution and knowledge application.**

A knowledge worker’s workflow process can define a knowledge worker’s information requirements and drive knowledge worker productivity by clearly defining which information is required for the task, when it is required and according to which standards and format. By applying a structured approach to define information flow Davenport (2011) states that productivity as measured by the completion of key tasks per unit of worker time can rise up to 50 percent. Organizations can apply process improvement and management to the flow of information, that have enabled firms in a number of industries to develop fast, efficient processes in areas such as product development, logistics and sales and marketing to gain competitive advantage (Takeuchi & Nonaka, 1991; Davenport, 2011.) Process improvement can respond to the need for better coordination and management of functional interdependencies (Reckart & Short, 1989) The notion of ineffective information sharing can be considered to include additional actions required and any inactivity that arises as a consequence of not sharing information to provide “immediate access to an adequate amount of appropriate, accurate and up-to-date information” which is required (Hick, 2007.)

However, how should the balance be chosen between providing a knowledge worker with full ownership of his or her own process, where autonomous knowledge workers define and integrate their own information environment and task organization versus an organization defining a knowledge worker's workflow process, defining a structured provision of information and job tasks to drive time-efficient knowledge work. Therefore the following question is answered:

What are the requirements to facilitate collaborative knowledge workers in a structured process approach?

In order to **structure the provision of information according to knowledge worker requirements a knowledge worker should fall under the integration and transaction model** of knowledge work and should define his or her **main tasks with knowledge application and distribution**. The process should be defined together with knowledge workers using a **practice approach**.

If a knowledge worker falls under the **collaboration and expert model** of knowledge work and is responsible for **knowledge creation**, the latter should be provided with a **free access approach of information**. Using a structured approach to provide information would restrict the creativity and innovativeness of ideas by imposing a predetermined sequence of tasks (Drucker, 1999) and therefore should be provided with free access to information.

Using the results from the latter section the third question can be answered:

3 How can collaborative demand planners at Nike be facilitated to improve forecast accuracy?

Demand planners primary objective is to **apply knowledge** by using data and information from sales, merchandising, business analysts, market intelligence, inventory planning and their SharePoint, and apply their own experience, judgment, know-how, assumptions, background and values in order to create a demand planning forecast and add value to the information received. Ramirez & Steudel's (2008) 8 dimensions applied to demand planner's work indicates that a demand planner's tasks are structured, routine, repetitive and tangible. On the other hand they display low levels of creativity and innovativeness yet do require a high degree of knowledge to complete the tasks and can be considered as relatively complex. Collaboration between merchandising, sales, S&OP and inventory management define a high level of collaborative cross-functional interdependence. Therefore knowledge workers are segmented according to the **integration model of knowledge work** and Nike should focus on facilitating the following:

- Structured and standardized work flow process
- Clear standards
- Structured collaboration process/ provision of information
- Tight integration across cross-functional boundaries
- Process/practice approach.
- Focus on information quality

In order to facilitate the latter a solution is designed according to Dym & Little (2004) design process together with demand planners at Nike. Currently, Nike targets to deploy lean within their transactional environment, using lean tools to synchronize internal operations with the needs of the market. **Therefore, due to Nike requirements, the solution must fit within the lean thinking methodology and toolbox**. Therefore the following question is answered:

How can the lean methodology be used to facilitate demand planners at Nike to improve forecast accuracy?

The concept of 'lean' first introduced by Womack & Jones (1990) provides a focused approach for continuous process improvements by eliminating waste and unnecessary actions by linking the steps that create value. In order to define value in demand planning at Nike, information flows through a process and knowledge work is undertaken to add value to the information in the form of a quantitative demand-planning forecast. Waste can hereby include a demand planner's resources and activities necessary to overcome a lack of information, ineffective time spent trying to identify which information is necessary, ineffective time required to overcome excessive information (Edmunds & Morris, 2000) and the resources and activities required to correct or verify information (Hick, 2007.) The most important challenge in using information, as flow is that information is significantly less visible than material 'flowing' through a production process. This was an important challenge experienced by NSW where their objective was to visualize a demand planner's work flow process in order to visualize information requirements and the status of information flow. Making a process transparent with the use of visualization enables immediate feedback of the current status and indicates where adjustment may be required in the process when a knowledge worker is being inhibited to perform (Womack and Jones, 1996; Bauch, 2004.) Visual management is an effective tool to make main process flows visible and comprehensible from start to finish (Koskela, 2002.) Therefore a visual management board was created with the objective of **increasing forecast accuracy by improving a demand planner's timely access to required information.**

The functions and advantages of the visual management wall are described as follows:

Functions:

- The solution should visualize a demand planner's work flow process
- The solution should visualize a demand planner's information requirements
- The solution should visualize a demand planner's collaboration structure
- The solution should visualize the status of information flow
- The solution should visualize submits moments and visualize issues to activate help
- The solution should prioritize tasks

The most significant advantages of the visual management wall are as follows:

- The visual management wall significantly helps to structure a demand planners workflow process by 76 – 100%
- The visual management wall significantly helps to standardize a demand planners workflow process by 51-75%
- The visual management wall significantly helps improve collaboration across functional boundaries by 51-75%
- The visual management wall significantly helps to improve access to the right information at the right time by 51-75%
- The visual management wall improves the quality of information which a demand planner requires to do work by 1-25%
- A demand planner believes that the visual management wall can improve the quality of his or her forecast submit by 51-75%
- A demand planner believes that the visual management wall can improve a structured approach to inter-functional collaboration by 51-75%

So, to conclude:

How can an organization's process arrangement facilitate collaborative knowledge workers to improve organizational KPIs?

An organization should create conditions that facilitate a knowledge worker's opportunity to perform, flourish a knowledge worker's motivation and invest in their human capital by creating conditions that enable knowledge workers to grow and learn in order to enhance their abilities. The conditions are defined as leadership, job design, social interaction, organizational culture and a knowledge worker's environment. In order to provide a knowledge worker with the opportunity to perform, knowledge workers require timely access to the correct information from their working environment. An organization's process arrangement can organize the provision of information in order to fulfill to a knowledge worker's requirements.

In order to respect the balance between driving a knowledge worker's ability, motivation and commitment to invest their knowledge in an organization versus an organization driving time-efficient knowledge work using regulated structured processes, knowledge workers should be segmented according to the four steps presented in this thesis. If a knowledge worker defines his or her tasks with knowledge distribution and application and falls under the integration and transaction model of knowledge work, an organization should structure the provision of information according to their workflow process by clearly defining which information is required for the task, when it is required and according to which standards and format. By applying a structured approach to define information flow, productivity can rise up to 50 percent (Davenport, 2010) process improvement techniques can be used to reduce a knowledge worker's ineffective time spent on searching and waiting for information or re-working information thus increasing his or her time available to apply knowledge (Davenport, 2010.) However, most important to using an approach to similar to industrial management styles is that a **practice** approach should be applied to define a knowledge worker's process. This means that processes should be defined and improved by knowledge workers themselves, to provide them with sufficient autonomy, and for an organization to exploit their process knowledge, where in the end, knowledge workers are most knowledgeable about their own process and should therefore be involved in defining the process. Using lean tools such as value stream mapping and visual management to involve knowledge workers can be an effective solution as seen at the NSW team.

If a knowledge worker's core activity is to create knowledge and innovative ideas according to the expert and collaboration model of knowledge work an organization should invest in a rich knowledge base and focus on managing a concentration of knowledge resources at a certain space to share information rather than using a defined process to structure the provision of information. Applying structure to the provision of information would restrict a knowledge worker's creativity and innovativeness of ideas by imposing a predetermined sequence of tasks (Drucker, 1999) and therefore they should be provided with free access to information and acquire effective skills in searching and distributing information effectively. In this case, a company's economic value lies in a knowledge worker's ideas, creativity and knowledge creation and rather than focusing on driving time-efficient work, a company should focus on a knowledge worker's **abilities** and ensuring a strong **incentive** to act in the interest of the company thus stimulating their abilities and motivation. An organization can be at risk of losing control or knowledge workers not collaborating, therefore, a knowledge worker's freedom should come paired with extremely high performance expectations.

8 Discussion, Recommendations and Future research directions

Even though this study forms a stepping stone towards understanding more about improving knowledge worker performance, much research is still to be performed and various limitations and areas for improvement can be found in the study. The following section will discuss the limitations of this study and recommend alternative solutions and further research directions in order to contribute as much as possible towards academic literature concerning knowledge worker performance.

8.1 Limitations & Recommendations

Limitation:

The most important limitation of this study is that in order to truly validate the findings a case study was also required in a department characterized by knowledge worker's who's main tasks is to create knowledge according to the collaboration and expert model of knowledge work. This thesis only provides an indication that integration and transaction model workers can be facilitated to improve organizational KPIs by improving a knowledge worker's timely access to information. Moreover, the challenge still remains that organizations still want to drive time efficient knowledge work for knowledge workers with full process ownership; however, this was beyond the scope of the research but is an important limitation.

Recommendation:

More research is required to define how an effective knowledge base can be created to facilitate a free access approach to information and what effect training knowledge workers to effectively search for information can have on improving organizational KPIs.

Limitation:

An important assumption is made throughout the entire thesis, that if a knowledge worker's access to information is facilitated a knowledge worker will have more time to perform and thus improve their ability to apply knowledge. However, the assumption is grounded on time impacting the quality of the outcome (Drucker, 1999.)

Recommendation:

More research should be performed to research the exact balance between providing sufficient time to perform tasks but not too much time to kill productivity.

Limitation:

Connected to this limitation is that no quantitative results could be achieved by measuring the difference in time waiting, searching and reworking information before and after the implementation

Recommendation:

Measure the time difference between before the implementation and after the implementation.

Limitation:

Moreover, based on the literature review and case study, it was concluded that there is no accepted method to measure a knowledge worker's performance, and therefore an organization must focus on facilitating knowledge workers to perform in order to improve organizational KPIs. However, in order to measure whether an organization is suitably facilitating knowledge workers to perform, a solution must be presented as to how to measure whether they are working at their full capabilities and this then relies on being able to measure knowledge worker performance. At

this point the only measurable improvement would be using business results such as in this case, the impact on forecast accuracy; however, the facilitation should be in a knowledge worker's interest and therefore a knowledge worker specific measure is required.

Recommendation:

An idea as to how to start measuring their facilitation is to use the visual management wall and their process to track performance. Hereby, more visibility will appear as to how quickly tasks are performed, task understanding, and the transparency can enable a manager to understand when knowledge workers can gain more tasks as more interaction and understanding occurs around the wall. Another possibility is to use the requirements presented in chapter 3 as a checklist towards understanding how facilitated knowledge workers feel to perform and where there is an area for improvement and to link this to business results. However, due to the limited time frame of this study this was not possible.

Limitation:

Another important limitation is that this study focused on facilitating a knowledge worker to have the opportunity to perform, using a process-oriented approach whereas an organization must also facilitate a knowledge worker by fulfilling their ability and motivation requirements. This research only focused on a small section of the facilitating organizational attributes and therefore much more research is required in order to validate and improve the findings in this research. Moreover, this thesis only focused on one company; however, many more cases should be studied in order to truly validate the framework and improve knowledge worker facilitation.

Recommendation:

This study recommends analyzing more of the facilitating attributes and that more case studies and knowledge worker observation should be performed in order to validate and improve the framework to facilitate knowledge workers.

Limitation:

The case study was limited to a lean transaction environment, which meant that the solution had to fit within the lean thinking methodology according to company requirements. Even though this formed a suitable design space for the solution, more solutions could have been created without the restriction. Moreover, if the solution had been applied to the more creative, expert collaboration model worker the use of the lean methodology would have been less suitable to apply process improvement.

Recommendations:

In order to truly design suitable solutions to facilitate knowledge workers, more case studies should be performed in varying organizations with different types of workers and knowledge processes.

Limitation:

The most important limitation of this thesis is that the method could not be truly validated due to time, resource and company restrictions. However, chapter 6 indicates that the assumptions made are valid, and therefore more experiment should be performed based on the results of chapter 1-5.

8.2 Future Research Directions

As mentioned above, this study acts as a first step towards understanding how to improve knowledge worker performance. Various directions can be suggested for future research, which will be presented below:

- More research is required as to how knowledge worker performance should be measured, as a fair performance measurement system is a requirement to facilitate a knowledge worker's motivation to perform. Hereby, an idea would be to use a process-oriented approach to measure performance
- More research is required to measure the effect of time availability on knowledge worker performance.
- I believe that segmenting knowledge workers according to their characteristics can present great benefits to an organization where the segmentation can help to understand how to manage knowledge workers per category according to their general environmental, tool, information and process aggregation requirements. However, segmentation can be a sensitive subject for knowledge workers. Therefore more research should be performed as to how knowledge workers can best be segmented to facilitate their knowledge work and how this can be done in a fair manner. A quantification framework could be an idea to measure the work according to dimensions in order to manage accordingly.
- Research should be performed to measure the effect of timely access to information on performance, and how much a visual management board can help to improve time waiting, searching and reworking information.

8.3 Reflection

8.3.1 SEPAM Thesis

Despite this research having a weak 'technical component', the results of this research can be significant in many technical, public and private sectors. The first example is seen throughout the thesis where an organization's process arrangement can facilitate demand planners to improve forecast accuracy by organizing the provision of information to perform. According to Moon et al (2000) one of the most critical drivers of supply chain success is "effective customer demand planning." This means that a company must be able to accurately forecast its business opportunities, and plan accordingly throughout its supply chain in order to exploit these opportunities. Several decision processes of supply chain management require accurate demand planning forecasts in order to choose proper actions relevant to production planning, sales budgeting and strategies (Danese et al., 2011.) Poor accuracy in demand forecasting can cause widespread disruption, poor customer service and increased costs to organizations (Githens, 2005.) This especially has an impact on the transport and logistics of products where forecasting demand incorrectly can disrupt transportation and logistics plans.

Similar to the importance of information in demand planning another example can be found in the port of Rotterdam. The port of Rotterdam is known to require significant innovative ideas and abilities to increase the capacity to accommodate the massive stream of products coming from all over the world. An engineer designing a solution for the port of Rotterdam would fall under the collaboration and expert model of knowledge work. As defined in this thesis, information acts as an input, the input for designing a new solution at the port of Rotterdam is knowledge sourcing from workers working in the port, economic insights, future company strategies, etc. where missing such information could trigger massive in-efficiencies as solutions are not designed according to true

requirements. According to the results presented in this thesis, an organizational should focus on an effective knowledge base, rich organizational networks to obtain information and informal information sharing where engineers are provided the opportunity to gain relevant knowledge from external parties. Rather than using a structured process approach to define the flow of information the task should be clearly defined and an organization should invest in ensuring that an engineer has efficient access to required information and is trained in networking, searching etc. Moreover, to indicate the all-round applicability of using visual management, a project manager could

use a visual management board to track progress and gates in order to also provide visibility to external parties which may realize the importance of their input.

8.3.2 Assumptions

Even though this research can be considered as a significant contribution towards the existing literature, various assumptions have been made which may be questioned.

The first point of discussion, which is not included in the scope of this research, is that when discussing how to facilitate knowledge workers, they are considered as ‘categories’ and ‘segments.’ Hereby, their personal attributes such as their own motivation, opportunity and ability to perform or their individual characteristics as to what facilitates them best was not considered in the scope. This may have a larger impact than considered.

Due to limited existing literature about knowledge worker facilitation, some assumptions and choices were made. The most important choice in this research was to focus on a process-oriented approach and to focus on providing knowledge workers with the opportunity to perform instead of motivation or ability. The reason for this was because little is known about knowledge worker processes and how this can be used to improve a knowledge worker’s opportunity to perform, therefore this was more interesting to research and of greater scientific relevance.

Furthermore, the validation of this study is weak. This is due to various reasons, the first was an important time limitation in the study, meaning that limited time was available to observe the wall and implement the wall, and the improvement in forecast accuracy could not be measured because this can only be measured three months after a submit. Nevertheless, forecast accuracy is dependent on so many factors that this would not be a reliable measurement. If more time had been available a better validation could have been performed in order to compare multiple moments in time as the wall progressed together with multiple implementations. The implementation was only performed for one team, ideally, more teams would have been involved, some with visual management tools and some with different tools where tools could be compared and the best solution could have been found; however, similarly time and resources were a restriction in this study.

The biggest restriction in this study is that in order to truly validate the study, many different knowledge worker departments should be tested, with different types of knowledge workers and different knowledge processes.

References

- Adler, P.S., McGarry, F.E., Irion-Talbot, W.B. and Binney, D.J., 2005. Enabling process discipline: lessons from the journey to CMM Level 5. *MIS Quarterly Executive*, 4(1), pp.215-227.
- Antikainen, R., & Lönnqvist, A. (2006). Knowledge work productivity assessment. *Institute of Industrial Management. Tampere University of Technology. PO Box, 541*, 79-102.
- Banker, R.D., Field, J.M., Schroeder, R.G. and Sintia, K.K., 1996. Impact of work teams on manufacturing performance: A longitudinal field study. *Academy of Management Journal*, 39(4), pp.867-890.
- Barling, J., Loughlin, C., & Kelloway, E. K. (2002). Development and test of a model linking safety-specific transformational leadership and occupational safety. *Journal of applied psychology*, 87(3), 488.
- Barling, J., Weber, T., & Kelloway, E. K. (1996). Effects of transformational leadership training on attitudinal and financial outcomes: A field experiment. *Journal of applied psychology*, 81(6), 827.
- Barling, J., Slater, F., & Kevin Kelloway, E. (2000). Transformational leadership and emotional intelligence: An exploratory study. *Leadership & Organization Development Journal*, 21(3), 157-161.
- Bass, B. M. (1991). From transactional to transformational leadership: Learning to share the vision. *Organizational dynamics*, 18(3), 19-31.
- Bateman, N. (2005), "Sustainability: the elusive element of process improvement", *International Journal of Operations & Production Management*, Vol. 25 No. 3, pp. 261-76.
- Benner, M. (2003), "The Scandinavian challenge: the future of advanced welfare states in the knowledge economy", *Acta Sociologica*, Vol. 46 No. 2, pp. 132-49.
- Bisson, P., Stephenson, E., & Viguerie, P. S. (2010). The productivity imperative. *McKinsey Quarterly*, 1-7. Retrieved from <http://www.cambramanresa.com/documents/958309479.pdf>
- Brown, J. S., & Duguid, P. (2001). Knowledge and organization: A social-practice perspective. *Organization science*, 12(2), 198-213.
- Brunet, A.P. and New, S. (2003), "Kaizen in Japan: an empirical study", *International Journal of Operations & Production Management*, Vol. 23 No. 12, pp. 1426-46.
- Busby, J. S., and A. Williamson. "The appropriate use of performance measurement in non-production activity: the case of engineering design." *International Journal of Operations & Production Management* 20, no. 3 (2000): 336-358.
- Castells, M. and Himanen, P. (2002), *The Information Society and the Welfare State: The Finnish Model*, Oxford University Press, Oxford.
- Davenport, T. H., Thomas, R. J., & Cantrell, S. (2002). The Mysterious art and Science of Knowledge-Worker Performance. *MIT Sloan Management Review*, 44(1).
- Davenport, B. T. H. (2014). *The Slow Automation of Knowledge Work*.

- Davenport, T.H., Jarvenpaa, S.L. and Beers, M.C., 1996. Improving knowledge work processes. *Sloan management review*, 37, pp.53-66.
- Davenport, T.H., De Long, D.W. and Beers, M.C., 1998. Successful knowledge management projects. *Sloan management review*, 39(2), pp.43-57.
- Davenport, Vom Brocke, J. and Rosemann, M. eds., 2010. *Handbook on business process management 1*. Springer-Verlag Berlin Heidelberg.
- Davenport, T.H., Thomas, R.J. & Cantrell, S., 2002. The Mysterious art and Science of Knowledge-Worker Performance. *MIT Sloan Management Review*, 44(1).
- David, W., & Fahey, L. (2000). Diagnosing cultural barriers to knowledge management. *The Academy of management executive*, 14(4), 113-127.
- Dimancescu, D. and Dwenger, K., 1996. World Class Product Development. *New York, AMACOM-American Management Association*.
- Drucker, P. F. (1999). Knowledge-worker productivity: The biggest challenge. *The knowledge management yearbook 2000-2001*.
- Drucker, P.F. (1969). *The age of discontinuity: guidelines to our changing society*.
- Dym, C. L., Little, P., Orwin, E. J., & Spijt, R. E. (2004). *Engineering design: a project-based introduction*. New York: Wiley.
- Foss, N. J., Minbaeva, D. B., Pedersen, T., & Reinholt, M. (2009). Encouraging knowledge sharing among employees: How job design matters. *Human Resource Management*, 48(6), 871-893.
- Garfield, E. (1979). Is citation analysis a legitimate evaluation tool?. *Scientometrics*, 1(4), 359-375.
- Greenseid, L. O., & Lawrenz, F. (2011). Using citation analysis methods to assess the influence of science, technology, engineering, and mathematics education evaluations. *American Journal of Evaluation*, 32(3), 392-407.
- Hackman, J. R., & Oldham, G. R. (1976). Motivation through the design of work: Test of a theory. *Organizational behavior and human performance*, 16(2), 250-279.
- Hammer, M., Leonard, D. & Davenport, T., 2004. Why Don't We Know More About Knowledge? *MIT Sloan Management Review*, 45(4), pp.14–18. Available at:
<http://ezproxy.leedsmet.ac.uk/login?url=http://search.ebscohost.com/login.aspx?direct=true&db=buh&AN=13758491&site=eds-live&scope=site>.
- Haynes, B. P. (2008). An evaluation of the impact of the office environment on productivity. *Facilities*, 26(5/6), 178-195.
- Haque, B., & James-Moore, M. (2004). Applying lean thinking to new product introduction. *Journal of Engineering Design*, 24, 1–31
- Hicks, B. J. (2007). Lean information management: Understanding and eliminating waste. *International journal of information management*, 27(4), 233-249.

- Hirsch, J. E. (2005). An index to quantify an individual's scientific research output. *Proceedings of the National Academy of Sciences*, 102, 16569-16572.
- Holtshouse, D., 2010. Knowledge work 2020: thinking ahead about knowledge work. *On the Horizon*, 18(3), pp.193-203.
- Imai, M. (1986). *Kaizen: (Ky'zen), the key to Japan's competitive success*. New York, London: McGraw-Hill ISBN 007554332X.
- Kelloway, E.K. and Barling, J., 2000. Knowledge work as organizational behavior. *International journal of management reviews*, 2(3), pp.287-304.
- Kohut, A. and 2007, A. (2008), Portrait of Generation Next: How Young People View Their Lives, Futures, and Politics, *PEW Research Center*, available at: www.people-press.org (accessed January 10, 2016).
- Larson, R. R. (2005). Information life cycle. A model of the social aspects of digital libraries. [/http://www.sims.berkeley.edu/courses/is202/f98/Lecture2/index.htm](http://www.sims.berkeley.edu/courses/is202/f98/Lecture2/index.htm)S.
- Lewis, M. (2000), "Lean production and sustainable competitive advantage", *International Journal of Operations & Production Management*, Vol. 20 No. 8, pp. 959-78.
- Lillrank, P. and Kano, N. (1989), *Continuous Improvement-Quality Control Circles in Japanese Industry*, University of Michigan, Ann Arbor, MI.
- Markus, M.L., Majchrzak, A. and Gasser, L., 2002. A design theory for systems that support emergent knowledge processes. *MIS quarterly*, pp.179-212.
- Brian H. Maskell, 1991. *Performance measurement for world class manufacturing: A model for American companies*. Productivity Press.
- Matson, E., & Prusak, L. (2010). Boosting the productivity of knowledge workers Knowledge workers make up more than 40 percent of the US work force . *Knowledge Creation Diffusion Utilization*, September, 1-4. Retrieved from <https://www.mckinseyquarterly.com/PDFDownload.aspx?ar=2671>
- Matson, E., & Prusak, L. (2006). Boosting the productivity of knowledge workers. *Business Review*.
- Mandel, M. (2007), "The future of work; which way to the future?", *Business Week*, August 20 and 27, p. 45.
- McIntosh, R., Culley, S. J., Mileham, A. R., & Owen, G. W. (2001). *Improving changeover performance: A strategy for becoming a lean, responsive manufacturer*. Oxford, UK: Butterworth-Heinemann ISBN 0750650877.
- Mentzer, J. T., & Moon, M. A. (2005). *Sales forecasting management: a demand management approach*. SAGE Publications, Incorporated.
- Meyer, M.W., 2003. *Rethinking performance measurement: beyond the balanced scorecard*. Cambridge University Press.

- Murata, K., & Katayama, H. (2010). Development of Kaizen case-base for effective technology transfer—a case of visual management technology. *International Journal of Production Research*, 48(16), 4901-4917.
- Nenni, M. E., Giustiniano, L., & Pirolo, L. (2013). Demand forecasting in the fashion industry: a review. *International Journal of Engineering Business Management*, 5(37), 1-6.
- Nidumolu, S.R., Subramani, M.R., 2003. Combining process and structure approaches to managing software development. *Journal of Management Information Systems* 20 (3), 159–196.
- Nohria, N., Groysberg, B. and Lee, L., 2008. Employee motivation: A powerful new model. *Harvard Business Review*, 86(7/8), p.78.
- Nonaka, L., Takeuchi, H., & Umemoto, K. (1996). A theory of organizational knowledge creation. *International Journal of Technology Management*, 11(7-8), 833-845. 593
- Palmer, A. (Ed.) (2006), Foresight 2020. Economic, Industry and Corporate Trends, *Economist Intelligence United*, London.
- Pantaleo, D. and Pal, N., 2008. *From Strategy to Execution*. Springer.
- Paradi, J.C., Smith, S. & Schaffnit-Chatterjee, C., 2002. Knowledge worker performance analysis using DEA: an application to engineering design teams at Bell Canada. *IEEE Transactions on Engineering Management*, 49(2), pp.161–172.
- Parry, G.C. and Turner, C.E., 2006. Application of lean visual process management tools. *Production Planning & Control*, 17(1), pp.77-86.
- Parker, S.K., 1998. Enhancing role breadth self-efficacy: the roles of job enrichment and other organizational interventions. *Journal of Applied Psychology*, 83(6), p.835.
- Parker, S. K., Wall, T. D., & Cordery, J. L. (2001). Future work design research and practice: Towards an elaborated model of work design. *Journal of occupational and organizational psychology*, 74(4), 413-440.
- Pyzdek, T. (2003). *The six sigma handbook: The complete guide for greenbelts, blackbelts, and managers at all levels*. Revised and Expanded Edition (2nd revised ed). New York: McGraw-Hill ISBN 0071410155.
- Pyöriä, P., 2005. The concept of knowledge work revisited. *Journal of Knowledge Management*, 9(3), pp.116-127.
- Rigby, D. and Bilodeau, B. (2007), “Management tools and trends 2007”, *Strategy & Leadership*., Vol. 35 No. 5, pp. 9-16.
- Rainlall, S., 2004. A review of employee motivation theories and their implications for employee retention within organizations. *The journal of American academy of business*, 9, pp.21-26.
- Ranky, P. (2005). Designing a lean infrastructure. *Manufacturing Engineer*, February 2005, 22–24.
- Ramírez, Y.W. & Nembhard, D. a., 2004. Measuring knowledge worker productivity: A taxonomy. *Journal of Intellectual Capital*, 5(4), pp.602–628.

- Ramirez, Y. W., & Steudel, H. J. (2008). Measuring knowledge work: the knowledge work quantification framework. *Journal of Intellectual Capital*, 9(4), 564-584.
- Rosemann, M., & vom Brocke, J. (2015). The six core elements of business process management. In *Handbook on Business Process Management 1* (pp. 105-122). Springer Berlin Heidelberg.
- Shah, R. and P. T. Ward (2007). "Defining and developing measures of lean production." *Journal of Operations Management* 25(4): 785-805.
- Shingo, S. (1985). *A revolution in manufacturing: The SMED system*. USA: Productivity Press ISBN 0915299038.
- Staats, B.R. and Upton, D.M., 2011. Lean knowledge work. *Harvard business review*, 89(10), pp.100-110.
- Staats, B. R., Brunner, D. J., & Upton, D. M. (2011). Lean principles, learning, and knowledge work: Evidence from a software services provider. *Journal of Operations Management*, 29(5), 376-390.
- Suarez-Barraza, M.F. and Lingham, T. (2008), "Kaizen within Kaizen teams: continuous and process improvements in a Spanish municipality", *The Asian Journal on Quality*, Vol. 9 No. 1, pp. 1-21.
- Suchman, L., 1987. Plans and situated action.
- Taylor, W., 1911. *The Principles of Scientific Management*,
- Van Aalst, J. (2010). Using Google scholar to estimate the impact of journal articles in education. *Educational Researcher*, 39, 387-400.
- Van Aken, E. M., Monetta, D. J., & Sink, D. S. (1994). Affinity groups: The missing link in employee involvement. *Organizational Dynamics*, 22(4), 38-54.
- Vom Brocke, J. and Rosemann, M. eds., 2010. *Handbook on business process management 1*. Springer-Verlag Berlin Heidelberg.
- Wall, T. D., Corbett, J. M., Clegg, C. W., Jackson, P. R., & Martin, R. (1990). Advanced manufacturing technology and work design: Towards a theoretical framework. *Journal of Organizational Behavior*, 11(3), 201-219.
- Wall, T.D., Jackson, P.R. and Davids, K., 1992. Operator work design and robotics system performance: A serendipitous field study. *Journal of applied Psychology*, 77(3), p.353.
- Womack, J. P., & Jones, D. T. (1996). *Lean thinking: Banish waste and create wealth in your corporation*, 1996. London: Simon and Schuster ISBN 0684810352.
- Womack, J. P., Jones, D. T., & Roos, D. (1990). *The machine that changed the world*. Toronto, Canada: Collier Macmillan ISBN 0892563508.

Appendix 1 – Director Interviews at Nike

Dear Respondant,

Currently, I am writing my master thesis about measuring work floor efficiency in an office environment. To collect data for this measurement tool I will be conducting interviews with DP managers and planners.

In order to make sure that all data is correct which I include in my thesis I will send you a copy of the most important conclusions I have made from this interview. Would you agree to read this and send a confirmation that you agree or disagree with the conclusions?

*Start recording

1. How do you know at the end of the week, whether your employees have worked well?
 - a. If you could measure this how would you measure it?
 - b. Would you measure your employees as an individual or whole team? Do you have any examples?
 - c. Would you consider to measure productivity of your employees? If so how?
2. How important is good communication and information sharing for good work performance in your team?
3. How is information transferred through your department?
 - a. Which communication tools does your department use?
 - b. Do you consider these tools efficient?
 - c. Do you see need for improvement in the information stream within your department? Could you name (an) example(s)
4. What do you think of the current tools/procedures used in your department to complete tasks?
 - a. Do problems occur with the tools/procedures/equipment?
 - b. Do employees inform you of these problems? If so how?
 - c. How many problems occur per week?
 - d. What would you improve about the tools if you could?
5. Do you think that office design has an effect on achieving tasks and communication?
 - a. Do you have an example?
 - b. (if negative ask about improvements)
6. Is there anything you would like to add?

Thank you very much for your time. Would it be ok for me to come back to you if I have further questions?

Interviews were conducted with 10 managers and directors at Nike. The results are consolidated into bullet points in order to summarize the most important results. Since the interviews were explorative interviews to define the problem, coding all interviews was seen as superfluous. The transcribed interviews are not included; however, can be requested for further clarification.

Question 1:

- Regular “walk the floor” at the end of the week to ask how everything is going, informal contact with employees.
- 2 sub-teams that each have a manager. Weekly meetings with both managers to keep track.
- No further measurement
- Weekly one-on-ones

- a) Business results (forecast accuracy)
Understanding of the further business (impact of forecast on supply chain)
Ability to learn quickly and adapt to new situations
No quantitative measurement
- b) All ten said 'individual' but would consider an employee's ability to collaborate as a necessity
- c) Would never want to measure productivity, monitoring productivity would act as a counter measure
Ideally measure performance according to business results (KPI, forecast accuracy)
Measure performance according to tasks completed according to deadline, but never productivity

Question 2:

The 10 managers' answers vary from very important to crucial for operational success.

Demand planning directors generally defined that information sharing and good communication is critical to demand planning. Demand planning supports the business providing the integral link between demand side knowledge (sales and merchandising) and supply knowledge (inventory management.) However, demand planners often do not receive necessary information, are not included in communication channels with forecasting relevant information, and often have to chase after information. A frequently cited issue is that many departments lack the further understanding of the impact of their information on processes further in the supply chain. Missing information has a big impact on demand plan forecasting. For example, if the sales team is aware that an account will not place a massive order which has been executed in previous years but does not inform the demand planning team, demand will be forecasted according to historical data, and therefore be inaccurate.

According to directors working in business analytics and the center of excellence, information input is also critical where in order to support the business, information from the demand planning and inventory management team are the key input to provide a solution.

Question 3:

- E-mails
 - Weekly one-on-ones
 - Team meetings
 - Phone calls
 - Walking the floor
- b) More training should be provided in order to define which tool is most suited according to the importance of the message. Important messages are often communicated via e-mail which has resulted in several mistakes
 - c) The tools are efficient, the way the tools are used are not always efficient
 - Meetings without clear agendas
 - Many e-mails back and forth versus one phone call
 - d) Do you see need for improvement in the information stream within your department? Could you name (an) example(s)
 - Yes a significant need.
 - Managers indicated that they would like the following improvements:
 - Visibility of what information is required

- Visibility of when a manager should take action in order to ensure that information is provided
- Training other departments concerning the impact of their information on demand planning
- A lot of in-efficient meetings without meeting agendas

Question 4:

- a) Many issues presented:
 - A lot of issues with excel
 - A lot of re-work performed on files which are created in the wrong format, read only files, etc
 - Information is sometimes very difficult to find, or requires a lot of re-work to use it
 - A lot of manual work copying, pasting, using v-lookups due to incompatibility between systems
 - APO numbers do not always match with numbers entered in the system
 - Data cubes make the excel files extremely slow
 - Very outdated systems
 - A lot of unnecessary manual work
- b) Really big problems which require escalation, yes
 - Sometimes express frustration in one on one
 - Or when walking the floor
 - Management struggles to provide help in such cases
 - But most problems are shared within team and not to management
- c) Daily
- d) Reduce manual work and frustration significantly
 - Make more use of data cubes
 - The use of SAP is used very ineffectively
 - Common planning files
 - More extensive tools than excel
 - More structured access to information
 - Common templates

Question 5:

All 10 interviewees indicated that office design has a significant impact on knowledge worker performance, namely seating arrangement and proximity. Sitting in proximity of each other is very important for communication. Examples came from the directors of the centre of excellence, and inventory management who are seated in a different building from their category.

Appendix 2 Knowledge Worker Definitions

Table 6 provides an overview of definitions of knowledge workers found in the literature. Important to note is that these are definitions, which were used at least twice in articles cited over 35 times.

Author	Year	Definition	Criticism or additional comments
Bentley	1990	“Those with high training and education to perform a job”	Limited definition linked to professional education
Davenport	2010	“Knowledge workers have high degrees of expertise, education or experience, and the primary purpose of their jobs involves the creation, distribution or application of knowledge. In short they think for a living”	This was expanded from his previous definition in 2000, “knowledge workers are those who create knowledge such as product development engineers or as those whose use of knowledge is a dominant aspect of their work such as financial auditors”
Drucker	1979	“Someone who knows more about his or her job than anyone else in the organization”	This could apply to any job (Davenport, 2010)
Drucker	1959	“Workers that work with intangible resources”	
Drucker	1994	“High-level employees who apply theoretical and analytical knowledge, acquired through formal education, to develop new products or services”	Nickols (2000), Dove (1998) believe that part of the knowledge can also come from an informal source of education
Fox	1990	“Individuals who work with information to make decisions”	
Harrigan & Dalmia	1991	“Knowledge workers are those who create intangible value-added assets”	
Harris & Vining	1987	“Workers that add value to products and services”	Very vague, could be any worker
Horvath	2001	Anyone who works for a living at the tasks of developing or using knowledge	Tasks for knowledge workers can be: planning, acquiring, searching, analyzing, organizing, storing, programming, distributing, marketing, deciding and numerous other tasks that require transformation of information from one form to another in order to produce the final product.
Kelloway & Barling	2000	“Workers who chose to use their knowledge to aid the organization”	
Nickols	2000	Knowledge workers apply knowledge obtained partly formally and partly from informal sources of education such as experience in a specific area, previous access and use of personal knowledge, organizational knowledge and external knowledge.	
Nomikos	1998	“A group that includes scientists, engineers, professors, attorneys, physicians and accountants”	Limited definition linked to occupations

Pyoria	2005	A knowledge worker has extensive formal education and learns on the job continuously, works with abstract knowledge and symbols, completes jobs with knowledge as a primary production factor.	This is an ideal type of a knowledge worker
---------------	------	--	---

Table 6- Overview of Definitions of Knowledge Workers found in the Literature

Appendix 3 - Nike Business Process Overview

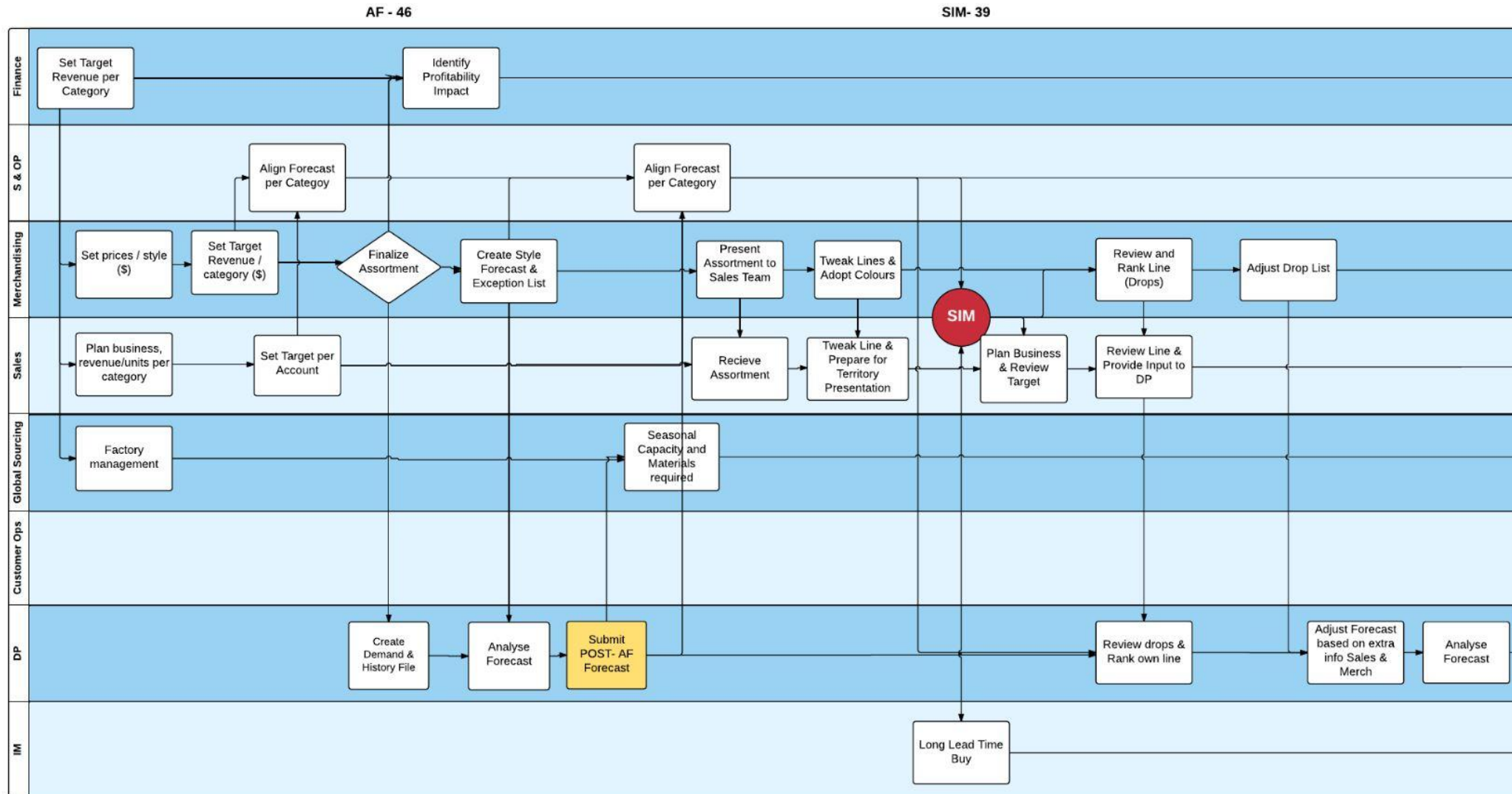

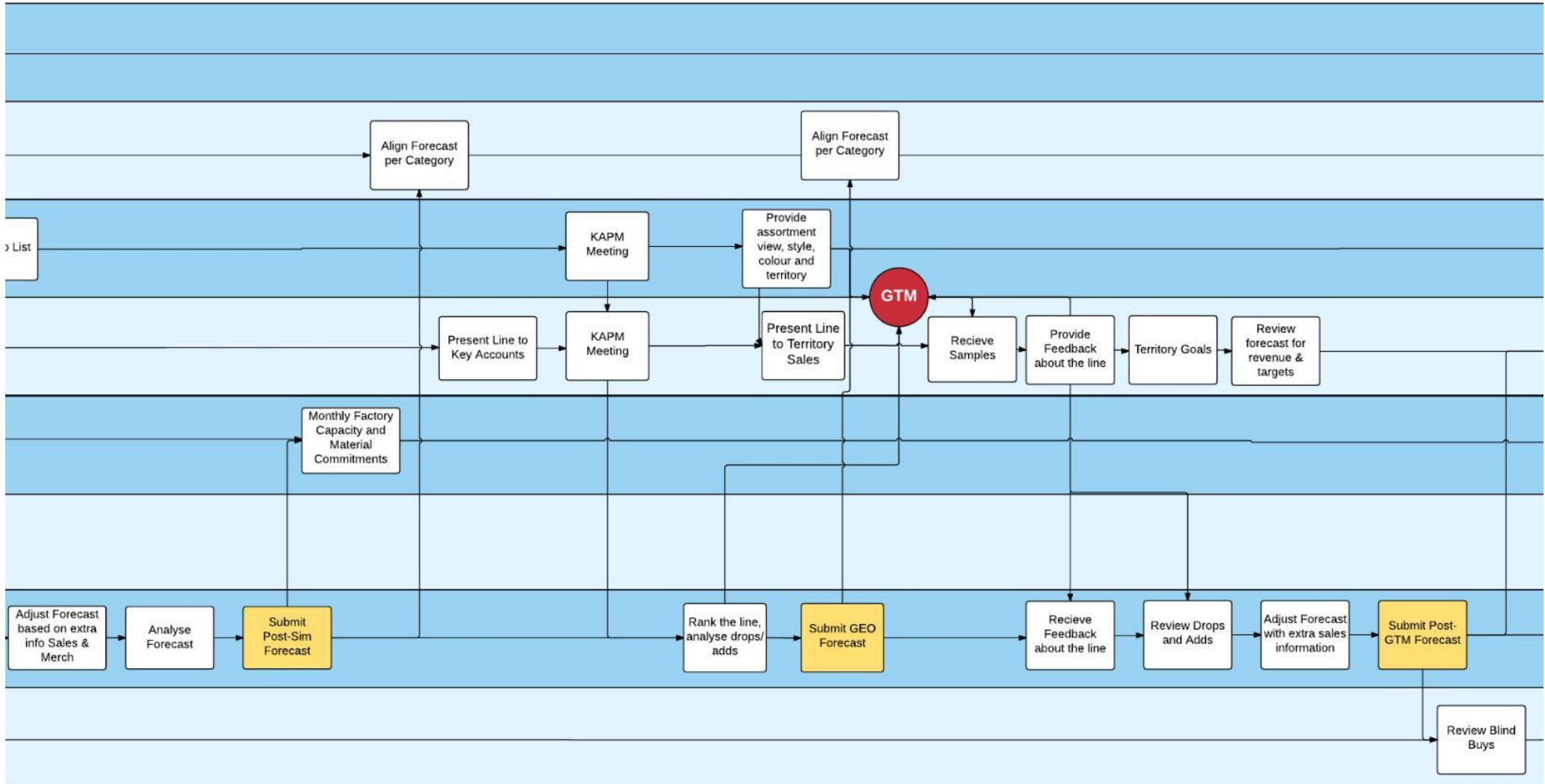

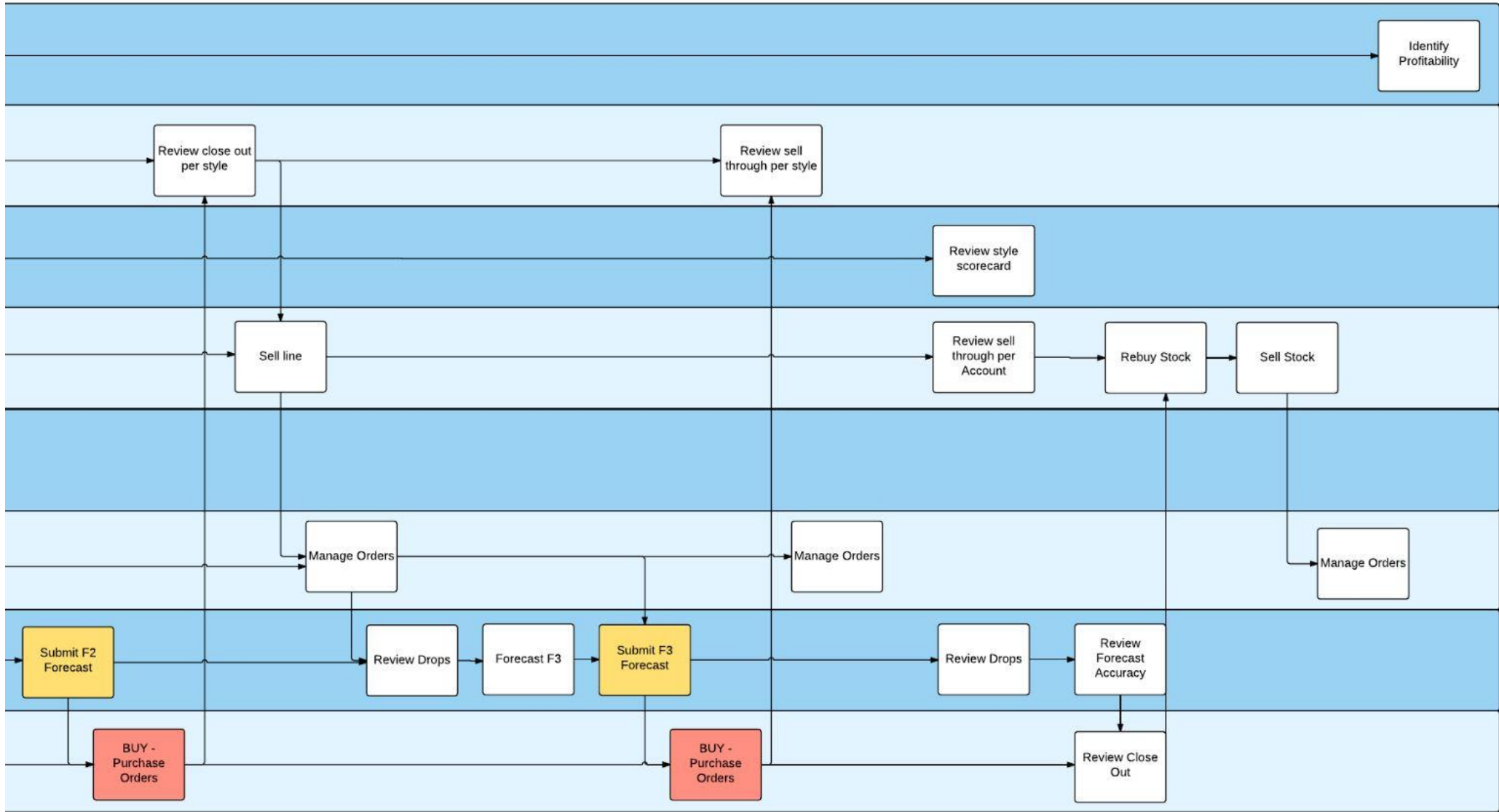

Appendix 4 - Organizational Chart of Demand Planning Department at Nike

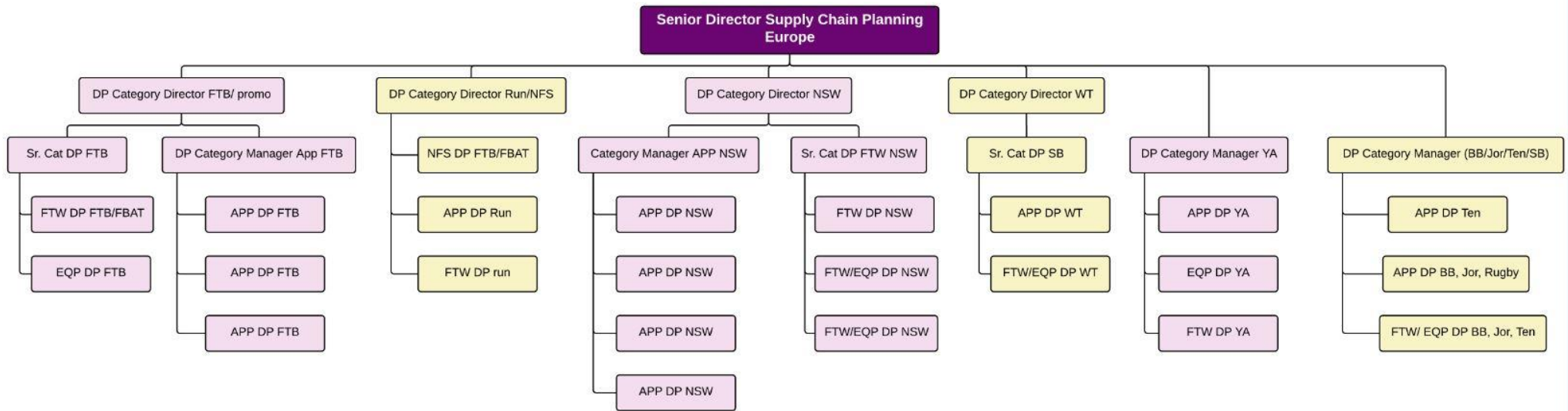

Appendix 5 - Formulas used to Measure Forecast Accuracy

In order to measure forecast accuracy, the following formulas are used.

1) Forecast (in-) Accuracy % (Absolute percentage)

Forecast (in-) Accuracy represents the magnitude of the forecast error. It is calculated as a mean absolute error point in time and is calculated as follows:

$$\text{Accuracy \%} = 1 - \text{Forecast Error \%}$$

$$\text{Forecast accuracy} = 1 - \left(\frac{\sum |\text{forecast qty} - \text{actual demand qty}|}{\sum \text{actual demand qty}} \right) * 100$$

This is measured at every demand planning forecast submit versus F1 to F4 actuals.

2) Forecast Bias % (Non Absolute)

Forecast bias represents the direction of the forecast error. This indicates whether demand planners have over- or under forecasted as compared to actual demand.

$$\text{Bias} = \frac{\sum (\text{forecast} - \text{actuals})}{\sum \text{actuals}} * 100$$

This is also measured at every demand planning forecast submit versus F1 to F4 actuals.

3) Volatility

Volatility measures the amount of forecast fluctuation over time, expressed as a percentage.

$$\text{Volatility} = \frac{\sum |\text{current forecast} - \text{previous forecast}|}{\text{previous forecast}} * 100$$

This is measured at every demand planning forecast submit versus the prior submit.

Appendix 6 – Nike Sportswear Case Study Department

This Appendix defines why the case study was performed at the Nike Sportswear department. **Error! Not a valid bookmark self-reference.** shows the organizational chart of the department.

The first most important reason to choose this department was due to their interest and attitude towards contributing to the research. In order to validate using a structured process approach to facilitate demand planners to improve forecast accuracy, time commitment was required from various stakeholders in the demand-planning department. These included directors and especially demand planners. Next to this, the study required participants, which agreed to be observed, and were open to process-oriented improvements and involvement in the process.

In order to fulfill the stakeholder requirements of this study Hillson & Simon's (2012) typology was referred to, highlighting that in order to achieve full participation, an influential stakeholder was required as displayed in Figure 26, a savior with a positive attitude towards the research, interest in the subject and power to ensure time commitment. This was the biggest hurdle, where as depicted in this thesis, time available to perform is an important requirement to have the opportunity to perform and therefore very limited.

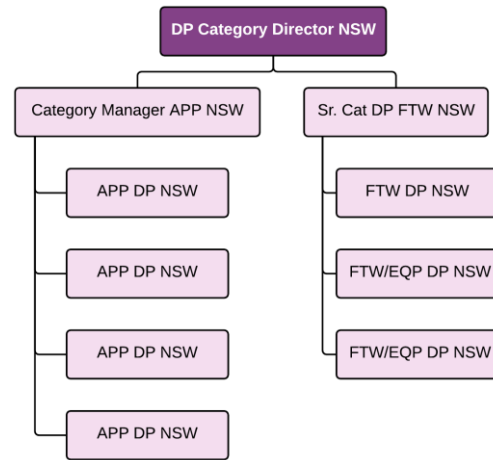

Figure 25- Nike Sportswear Organizational Chart

Attitude	Power	Interest	Type
+	+	+	Saviour
+	-	+	Friend
+	+	-	Sleeping Giant
+	-	-	Acquaintance
-	+	+	Saboteur
-	-	+	Irritant
-	+	-	Time bomb
-	-	-	Trip wire

Figure 26- Stakeholder typologies adapted from Hillson & Simon (2012)

The first step towards finding a savior was speaking to the 6 directors managing demand planners at Nike. The aim of the study was presented, to facilitate collaborative knowledge workers at Nike to improve forecast accuracy, together with the time commitment that the study would require and involvement.

The director leading the Nike Sportswear Team had an immediate interest in the research, a positive attitude and after discussing with various members of his team, the director indicated that his team members sometimes felt restricted to perform at their full knowledge capabilities and therefore felt a basic need to learn more about the subject. This was significant towards the research, as an external stakeholder, the process knowledge would have to come from study participants, demand planners, and therefore their participation was necessary to achieve valid results.

Next to their involvement, Nike Sportswear, counting 9 demand planners is the largest demand planning team at Nike, which means that more participants can contribute to the study. This contributes to the scientific relevance of this study and adds complexity for management.

Last but not least, rather than focusing on products with a high functionality for a specific sport, Nike Sportswear focuses on fashion features, therefore forecasting products for a more trend sensitive market. In the fashion industry, products are usually characterized by long replenishment lead times, short selling seasons and very unpredictable demand indicating the complexity of forecasting (Nenni et al., 2013.) In contrast to highly functional sporting goods, fashion products are more susceptible to impulse purchasing, where a shopper is stimulated to buy a product when confronted with it; “hence, the critical need for availability.” (Nenni et al., 2013) The latter authors state that demand for fashion products is rarely stable, being influenced by variables such as weather, films, marketing campaigns, sports stars, pop stars and trends. Together with high product competition, forecasting demand for Nike sportswear can be very challenging. Knowledge about consumer insights and company strategies are embedded in cross-category functions such as sales and merchandising teams indicating that a tight cross-functional integration is required.

Appendix 7 - Detailed Demand Planner Forecast Process per Gate

Adapted from Nike (Overman, 2015)

POST AF Forecast Update week 41:

Goal:

Create demand plan based on merchandising line plan, sales targets and statistical forecasting model on style color level.

Most important collaborative partners:

- Always Available planners [align forecast]
- Geo/Territory Sales [high level expectations]
- Merchandising [Story telling; innovations, campaign focus]
- Brand [Launch; strategy; consumer focus]
- DTC partners

Meetings:

- Sales - Merchandising forecast input/ Top 20 materials/ Classifications.
- Merchandising Pre-AF meeting; line presentation.
- Set-up meeting with Merch- Sales to identify allocation styles and align cross-functionally.

Level of forecasting:

- Category/time relevant attribute down to style
- From style to style/color based on historical split & trend assumption.

Main Tasks:

- Target setting S&OP
- Review line plan set up in MMX
- Check style count – Ask Merchandising when styles are missing.
- Contact AA and review shared styles- or line plan changes from inline to AA.
- Use statistical review to attribute level to create sub-targets at this level
- Base Style forecast based on merchandising forecast ranking order
- Review carry-over styles (styles from past season)
- Apply historical color analysis on the color breakout within the styles
- Fill rate setting in Category align with DP

Output:

- Style-color forecast in Gross Future DP on monthly level.
- DP recap
- Visibility on allocation

POST-SIM Week 36/35:

Goal:

Update demand plan based on info from SIM meetings and style review with merchandising demand plan by style-color/month.

Most important collaborative partners:

- Geo Sales [Territory forecast]
- Inventory planning [Lead Times & Minimums]
- Always Available planners [Align forecast]
- Merchandising [Line update]

Meetings:

- Category SIM session with IM & DP from Sales
- Key attribute review meeting with Merchandising/ Sales
- Drop review with Merchandising and inform Sales of drop decision.

Level of forecasting:

- Aggregated relevant attribute defined per category (silhouette/ classification/subcat/silo)

Main Tasks:

- Target setting S&OP
- Review line plan changes MMX
- Review key attributes with Sales.
- Align with AA on style color level
- Market intelligence review
- Statistical review, use latest input of previous season F1 bookings.
- Check total season flow after lineplan changes.
- Connect with IP on long lead times & production minimums, to assess product at risk.

Output:

Updated style-color forecast on monthly level created in Gross Fut DP multiplied by fillrate + counterbalancing creates a Net Fut DP.

Net DP = Promo + At Once + Net fut DP.

POST-GTM Week 27:

Goal:

Analyze updated line plan based on account forecast and re-forecast demand plan by style-color/month.

Most important collaborative partners:

- Accounts/DTC [Season forecast]
- Geo/Territory Sales [Territory forecast]
- Inventory planning [Review blind buy]
- Always Available planners [Align forecast]
- Merchandising [Line update]

Most important meetings:

Sales territory latest forecast input/ Top 20 materials/ G7 R10 accounts/ DTC total.

Level of forecasting

- Aggregated relevant attribute defined per category (silhouette/ classification/subcat/silo)
- Focus on style color split due to account input

Main Tasks:

- Target setting S&OP
- Review line plan changes MMX
- Review top 20 styles – attributes with Sales.
- Check bookings of the season for Hybrid models or early bookings
- If applicable apply fill-rate based on outcome fill-rate tool + counterbalance
- Align with AA on style color level
- Market intelligence review
- Statistical review
- Change flow where needed
- Collaborate with IP on blind buy

Updated style-color forecast on monthly level created in Gross Fut DP multiplied by fillrate + counterbalancing creates a Net Fut DP.

Net DP = Promo + At Once + Net fut DP.

F1 Week 23:

Goal:

Analyze bookings performance after the Sales Order Entry deadline in order to plan the remaining season more effectively. Update the forecast by style-color/month.

Most important collaborative partners:

- Inventory planning [review buy plan/drop list]
- Always Available planners [align forecast]
- Geo/Territory Sales [Territory forecast/ drop list]
- Merchandising [drop list/ mmx update]
- DTC

Most important meetings:

- Sales territory latest forecast input/ Top 20 materials/ G7 R10 accounts/ total.
- Discuss Allocation styles bookings to forecast, manage order book in cooperation with Sales team

Future bookings are considered to be 100% in for the first month, demand planner needs to re-forecast month two and three for the current season.

Main Tasks:

- Target setting on total level, based on S& OP
- Validate with Sales the current OED1 bookings. And gather feedback from Sales according to bookings to come for OED2 and OED3.
- Review with IP list buy issues (examples are unplanned capacity, unplanned due to minimum, buy ready, Air freight, align NET DP with allocation and or actual buy)
- Finalize the drop decision in forecast by marking as exception to be deducted from bookings.
- Set target by category/time relevant attribute *, this ensures volume still to come on top of current bookings, based on historical % booked evolution and sales insights.
- Filter on exception style/colors to freeze forecast based on % booked or volume still to come (i.e. allocation , CLE's, DTC styles and brand heat)
- Assign the balance of the target over the remaining style/colors
- Sense check to distribute the remaining forecast over the different months.
- Apply fill-rate towards the category fill-rate target, use fill rate tool.
- Share forecast for future AA styles with the AA planner

Updated style-color forecast on monthly level created in Gross Fut DP multiplied by fillrate + counterbalancing creates a Net Fut DP. Net DP = Promo + At Once + Net fut DP.

Appendix 8 Defining the Lean Constraint

According to Tsigkas (2013) “a lean enterprise is a business entity in which the internal organization and operations are always in synchronization with the needs of the market and geared to creating sustainable value for all stakeholders while eliminating waste in all activities.” The author depicts the advantages as follows (Tsigkas, 2013:)

1. Adaptation of production and administration processes driven solely by value adding, eliminating activities that do not add value
2. Self-regulated flows for work, material, information and cash
3. Direct decision-making at the point of value creation
4. Capacity for rapid displacement of the enterprise to cope with new market conditions

Nike sees company benefits in the latter advantages and strives for a strong lean maturity in 2020.

Lean manufacturing is a management philosophy sourcing from Toyota’s production system in the 1950’s focusing on the elimination of waste in business processes (Shah et al., 2007.) In *Lean Thinking* Womack and Jones (1996) described the five principles of lean thinking as displayed in Table 7 - Five Principles of Lean Thinking.

Principle	Description
Specify Value	The objective of Lean is to create value and prevent waste. The customer with regard to the product defines value, with its capabilities offered at a predefined time.
Identify and map value streams	To differentiate customer value from waste, the entire value stream should be mapped. Non-value adding and value adding activities must be distinguished.
Make value flow by eliminating waste	All value adding activities should be put in line and all wasteful activities should be eliminated to create a flow of value.
Respond to customer pull	Only produce when the customer actually wants it
Pursue perfection	One should continuously strive for perfection by removing layers of waste when they become visible. Wastes should be minimized using the latter four principles.

Table 7 - Five Principles of Lean Thinking

Following the five principles, Womack and Jones (1996) identify three categories of work activities. Value added, required non-value added and non-value added. Evidently the third category includes the activities to be eliminated from the process. Since value is seen through the customer’s eyes the most essential question when defining value is “What does the customer want from this process?” (Liker, 2005, p. 27)

A brief description of the activities is provided by Womack and Jones (1996:)

1. **Value Added (VA) Activities** should satisfy three conditions:
 - Material of information should be transformed, or uncertainty should be reduced.
 - The client should be willing to pay for the activity
 - The activity is done right the first time

2. **Required Non-Value Added (RNVA) Activities** do not satisfy the three conditions, but can't be removed due to various reasons such as: Law requirements, company mandate, contracts, technology, etc.
3. **Non-Value Added Activities** do not satisfy the conditions named in (1) or (2). These are wasteful activities that consume resources but don't create any value. These should be eliminated from the process.

Next to this, Womack & Jones (1996) present 7 types of waste. This list has been elaborated to 8 wastes and adapted to include examples found in the office environment.



Overproduction – producing more than the next process needs
 Examples: Too much information, engineering beyond precision required, over dissemination, sending information to too many people.

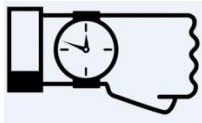

Waiting – Waiting for information or decisions, or the latter waiting for people
 Examples: Poor planning, scheduling, precedence, waiting for data, test results, information and decisions, long approval sequences, late delivery.



Unnecessary Transport or Conveyance – unnecessary movement of information
 Examples: Uncoordinated complex documents taking so much time to create that it's obsolete when finished, hands-off/ excessive information distribution.

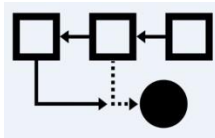

Over Processing – Doing unnecessary processing on a task or an unnecessary task
 Examples: Creating unrequested documents, redundant tasks, reinvention, process variation – lack of standardization, point design used too early causing iterations.



Excess Inventory – A buildup of information that is not being used
 Examples: Batching, system overutilization, arrival variation, lacking central release

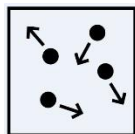

Unnecessary Movement: Excessive motion or activity during task execution
 Examples: Long travel distances, redundant meetings, people having to move to gain or access information.



Defects – Inspection to catch quality problems and fixing an error that has already been made.
 Examples: Killer “re’s”: rework, rewrite, redo, reprogram, recertify, recalibrate, retest, reschedule, recheck, re-inspect, return, re-measure, etc., incomplete ambiguous or inaccurate information.



Unused Employee Creativity – Losing time, ideas, skills, improvements, and learning opportunities by not engaging or listening to your employees.
Examples: No easy communication platforms,

Appendix 9 Results Conversations NSW Director and Project Manager

The most important conclusions from the conversations and discussions are as follows:

- *“The quality of a demand-planner’s submits is restricted due to missing information. This is because demand planners do not always have timely access to the right information and are forced to submit forecasts with missing information from collaborative partners, as there is no established process to gain required information. Moreover, demand planners are spending a lot of time chasing after information giving them less time to work on their forecast.”*

Reasons:

- *“Demand planner’s schedules are not aligned with other teams. Teams are often travelling; therefore information can be missed before a deadline. There is no aligned structure to obtain information from teams.”*
- *“Demand planners do not have insights in other team’s calendars.”*
- *“Demand planners do not always have a clear overview of when their information is required”*
- *“Time is wasted running after information, scheduling meetings, and missing information”*

The issues presented by the NSW demand planning director and senior demand planner were indicating a lack of cross-functional integration due to lacking collaboration, a clear structure was missing in obtaining information, information could not be accessed due to misaligned schedules and information requirements were not clearly defined. The latter issues fall together with the objectives of the solution depicted by the literature study of this thesis:

- O1. The solution should be used to structure and standardize a demand planner’s work flow process for the seven submit gates
- O2. The solution should be used to structure the collaboration process between demand planners and relevant actors
- O3. The solution should be used to structure timely provisioning of information
- O4. The solution should improve the quality of information used by demand planners to make their decisions
- O5. The solution should take advantage of a demand planner’s knowledge
- O6. The solution should improve cross-functional integration across boundaries
- O7. The solution should help to define clear standards

Main Problem:

Demand Planners do not always have the correct information at the right time from other departments.

Appendix 10 Actors Involved in the Design

Project team:

- NSW senior demand planner app
- NSW demand planner ftw/eqp
- Project facilitator (researcher)
- Lean master
- NSW director

Core-team (within project team:)

- NSW senior demand planner app
- NSW demand planner ftw/eqp
- Project facilitator (researcher)

NSW team:

- NSW director
- NSW senior demand planner app
- NSW category manager app
- NSW DP app
- NSW DP app
- NSW DP app
- NSW DP app
- NSW DP app
- NSW DP ftw
- NSW DP ftw/eqp
- NSW DP ftw/eqp

Lean team:

- Lean master
- Lean coach
- Lean coordinator

Appendix 11 Defining the Three Lean Tools, 5S, Kaizen Value Stream Mapping and Visual Management

5S Checklist –

The 5S components include Sort (Seiri), Set in Order (Seiton), Shine (Seiso), Standardize (Seiketsu), and Sustain (Shitsuke). Together, they provide a methodology for organizing, cleaning, developing, and sustaining a productive work environment. The 5S lean technique includes:

1. Sort (Seiri): Removing wastes and clearing the work area
2. Set in Order (Seiton): Designating and labeling locations of work tools
3. Shine (Seiso): Cleaning and improving the appearance of the workplace
4. Standardize (Seiketsu): Documenting the work method, using standard tools, and populating the best practices
5. Sustain (Shitsuke): Maintaining improvement, controlling work methods, and integrating the 5S's into the culture

Visual Management

Visual management boasts various advantages; the most relevant to this research are presented below:

- **Process Visualization** – Visual management is an effective tool to make main process flows visible and comprehensible from start to finish (Koskela, 2002.) Hereby the goal of visualizing the process, and making the process more transparent is to substitute self-control of information and processes held in people's minds. (Greif, 1991) Process visualization and increased transparency by using visual management facilitates a manager and employee's process- understanding and –management by sight. Moreover, Moser and Santos (2002) summarize the benefits of improving transparency and visualization using visual management as the stimulation of informal contacts, rapid comprehension of challenges and problems by making them visible, an increased response to problems, an increase in the motivation of workers for improvement and visibility of errors and a more effective distribution of responsibilities.
- **Continuous improvement** – Visual management serves as a base for continuous improvement (Suzaki, 1993; Imai, 1997) and most importantly stimulates employees to be involved in managing and improving quality (Flynn et al., 1994.) Visual management is an interactive process which can be used individually or in a group which serves as an effective platform for employees to communicate suggestions, see and understand problems, apply basic problem solving techniques and to communicate results and improvement efforts to external stakeholders (Mann, 2005.)
- **Task facilitation** – Visual aids can facilitate job tasks for employees offering a quick, correct and holistic understanding of their job requirements (Greif, 1991; Suzaki, 1993.) Knowledge worker's chose how to define their wall; however, the wall should facilitate them to visualize their tasks in order to understand task requirements.
- **Management by facts**

Appendix 12 Design Selection

Multi-Criteria Analysis

Criteria	Weight	VM	5S- Checklist	VSM Kaizen
Easy to use	4	3	4	2
Visualizes processes	3	5	2	5
Promotes team involvement	3	5	4	4
Continuous/sustainable	4	5	3	1
Adaptable	5	5	3	1
Structures Collaboration Process	5	4	1	3
Overview of occurring issues/challenges	4	5	2	2
Improves timely access to information	5	4	1	3
Structures workflow process	5	5	3	4
Standardizes workflow process	5	4	4	3
Improves cross-functional integration	5	3	1	1
Improves effectiveness of knowledge base	5	1	4	1
Total		212	139	127

Requirements Checklist

Visual Management

- O1. The solution should be used to structure a demand planner's high-level work flow process for the seven submit gates
- ✓ Should be attractive to use and not have to be enforced
 - ✓ Should not require formal training in order to be used
 - ✓ Should be usable by all demand planners who are unknown with the system
 - ✓ Should be usable by multiple people simultaneously
 - ✓ Should be created and sustained by demand planners
 - ✓ Should incorporate the frameworks and perspectives of several users
 - ✓ Should be created using demand planner process knowledge
 - ✓ Should be designed by demand planner
 - ✓ Should be sustainable
 - ✓ Should be continuous
 - ✓ Should have a sufficiently flexible architecture to allow major changes in the structure of the process
 - ✓ Should allow for a range of future adaptations
 - ✓ Should ensure process visibility
 - ✓ Should provide non-directive and non-restrictive guidance

- ✓ Should help to find repeatable parts of a process and codify them
 - ✓ Should help to
- O2. The solution should be used to standardize a demand planner's high-level work flow process for the seven submit gates
- ✓ Should provide a platform for knowledge workers to share resource and process-related challenges and issues
 - ✓ Should provide a platform to share best practice
 - ✓ Should provide a platform to improve process-related issues
 - ✓ Should track improvement and issues
 - ✗ Should improve template standards
 - ✗ Should improve forecast standards
 - ✗ Should improve output standards
- O3. The solution should improve cross-functional integration across boundaries
- ✓ Should help to structure collaboration process according to demand planner's information requirements
 - ✗ Should improve the quality of the information received from partners
 - ✓ Should support collaboration between their respective sales partners, merchandising partners and inventory management partners
 - ✗ Should be accessible across boundaries
- O4. The solution should improve the effectiveness of a demand planner's knowledge base
- ✓ Should improve effectiveness based on demand planners intuitions, without imposing a sequence of tasks
 - ✗ Should be used to understand a demand planner's knowledge requirements
 - ✗ Should improve access to market intelligence
 - ✗ Should improve access to business intelligence
 - ✓ Should improve access to account specific knowledge
 - ✗ Should improve the organization of the knowledge base
 - ✗ Should improve the quality of the knowledge base
- O5. The solution should take advantage of a demand planner's knowledge
- ✓ Should be built together

Kaizen Event – Value Stream Mapping

- O1. The solution should be used to structure a demand planner's high-level work flow process for the seven submit gates
- ✓ Should be attractive to use and not have to be enforced
 - ✓ Should not require formal training in order to be used
 - ✓ Should be usable by all demand planners who are unknown with the system
 - ✓ Should be usable by multiple people simultaneously
 - ✓ Should be created and sustained by demand planners
 - ✓ Should incorporate the frameworks and perspectives of several users
 - ✓ Should be created using demand planner process knowledge

- ✓ Should be designed by demand planner
 - ✗ Should be sustainable
 - ✗ Should have a sufficiently flexible architecture to allow major changes in the structure of the process
 - ✗ Should allow for a range of future adaptations
 - ✓ Should ensure process visibility
 - ✓ Should provide non-directive and non-restrictive guidance
 - ✓ Should help to find repeatable parts of a process and codify them
 - ✓ Should help to
- O2. The solution should be used to standardize a demand planner's high-level work flow process for the seven submit gates
- ✓ Should provide a platform for knowledge workers to share resource and process-related challenges and issues
 - ✓ Should provide a platform to share best practice
 - ✓ Should provide a platform to improve process-related issues
 - ✗ Should track improvement and issues
 - ✗ Should improve template standards
 - ✗ Should improve forecast standards
 - ✗ Should improve output standards
- O3. The solution should improve cross-functional integration across boundaries
- ✓ Should help to structure collaboration process according to demand planner's information requirements
 - ✗ Should improve the quality of the information received from partners
 - ✗ Should support collaboration between their respective sales partners, merchandising partners and inventory management partners
 - ✗ Should be accessible across boundaries
- O4. The solution should improve the effectiveness of a demand planner's knowledge base
- ✗ Should improve effectiveness based on demand planners intuitions, without imposing a sequence of tasks
 - ✓ Should be used to understand a demand planner's knowledge requirements
 - ✗ Should improve access to market intelligence
 - ✗ Should improve access to business intelligence
 - ✗ Should improve access to account specific knowledge
 - ✗ Should improve the organization of the knowledge base
 - ✗ Should improve the quality of the knowledge base
- O5. The solution should take advantage of a demand planner's knowledge
- ✓ Should be built together

- O1. The solution should be used to structure a demand planner's high-level work flow process for the seven submit gates
- ✗ Should be attractive to use and not have to be enforced
 - ✗ Should not require formal training in order to be used
 - ✗ Should be usable by all demand planners who are unknown with the system
 - ✗ Should be usable by multiple people simultaneously
 - ✗ Should be created and sustained by demand planners
 - ✗ Should incorporate the frameworks and perspectives of several users
 - ✗ Should be created using demand planner process knowledge
 - ✗ Should be designed by demand planner
 - ✗ Should be sustainable
 - ✗ Should have a sufficiently flexible architecture to allow major changes in the structure of the process
 - ✗ Should allow for a range of future adaptations
 - ✗ Should ensure process visibility
 - ✗ Should provide non-directive and non-restrictive guidance
 - ✓ Should help to find repeatable parts of a process and codify them
 - ✓ Should help to
- O2. The solution should be used to standardize a demand planner's high-level work flow process for the seven submit gates
- ✓ Should provide a platform for knowledge workers to share resource and process-related challenges and issues
 - ✗ Should provide a platform to share best practice
 - ✗ Should provide a platform to improve process-related issues
 - ✗ Should track improvement and issues
 - ✓ Should improve template standards
 - ✓ Should improve forecast standards
 - ✓ Should improve output standards
- O3. The solution should improve cross-functional integration across boundaries
- ✗ Should help to structure collaboration process according to demand planner's information requirements
 - ✗ Should improve the quality of the information received from partners
 - ✗ Should support collaboration between their respective sales partners, merchandising partners and inventory management partners
 - ✗ Should be accessible across boundaries
- O4. The solution should improve the effectiveness of a demand planner's knowledge base
- ✗ Should improve effectiveness based on demand planners intuitions, without imposing a sequence of tasks
 - ✗ Should be used to understand a demand planner's knowledge requirements
 - ✗ Should improve access to market intelligence

- ✘ Should improve access to business intelligence
 - ✘ Should improve access to account specific knowledge
 - ✓ Should improve the organization of the knowledge base
 - ✓ Should improve the quality of the knowledge base
- O5. The solution should take advantage of a demand planner's knowledge
- ✓ Should be built together

Appendix 13 A3 problem solving at NSW

THEME: STRUCTURED COLLABORATION BETWEEN DP, SALES AND MERCHANDISING TO IMPROVE FORECAST ACCURACY

Date: 2016-01-13, Version 1.0
OWNER:

PROBLEM SITUATION				TARGET STATE																							
<p>BUSINESS CONTEXT: Every season DP has recurring forecasting deadlines across multiple product engines. The deadlines differ per gate in the CGP and multiple seasons happen simultaneously. In order to submit the best possible forecast, DP relies on qualitative input from several counterparts in Merch and Sales.</p> <p>STANDARD:</p> <ul style="list-style-type: none"> The standard should be that Merch and Sales provide the right input for DP to use in a timely manner for the required DP submit in the CGP. Ideally Merch/Sales and DP have a standardized process in place for feedback and questions Based on the latest available knowledge, DP takes the right planning decision at each DP submit <p>CURRENT:</p> <ul style="list-style-type: none"> Currently DP is struggling to receive the input from Merch/Sales required for the respective submit in full and on time. Counterparts are not always available and calendars are not always aligned. DP submits don't always include the latest available knowledge of the category. DP spends too much time inefficiently by chasing and firefighting. PT is adding more workload and different (weekly) cadences <p>GAP:</p> <ul style="list-style-type: none"> DP is less capable in providing a high quality submit due to missing the right data at the right time. Structured approach to collaborate between Sales/Merch and DP is missing 				<p>GOAL / TARGET</p> <ul style="list-style-type: none"> Do what to what by when and how much? SMART <p>SOLUTIONS</p> <p>Short term: Contains the problem / Stops the bleeding Long term: Addresses root cause / Prevents problem from ever happening again for same root cause</p>																							
CURRENT SITUATION				ACTION PLAN																							
<ul style="list-style-type: none"> What is actually happening? 				<table border="1"> <thead> <tr> <th></th> <th>SOLUTION</th> <th>MEASURE</th> <th>WHO</th> <th>WHEN</th> </tr> </thead> <tbody> <tr> <td>1</td> <td></td> <td></td> <td></td> <td></td> </tr> <tr> <td>2</td> <td></td> <td></td> <td></td> <td></td> </tr> <tr> <td>3</td> <td></td> <td></td> <td></td> <td></td> </tr> </tbody> </table>					SOLUTION	MEASURE	WHO	WHEN	1					2					3				
	SOLUTION	MEASURE	WHO	WHEN																							
1																											
2																											
3																											
<table border="1"> <thead> <tr> <th></th> <th>PROBLEM</th> <th>MEASURE</th> <th>ROOT CAUSE</th> </tr> </thead> <tbody> <tr> <td>1</td> <td>DP doesn't have required input for the submit</td> <td>Information available during week of submit? Yes/No</td> <td>1. DP didn't request information on time 2. Misalignment about timely request 3. Lack of visibility in each functions calendar</td> </tr> <tr> <td>2</td> <td>No structure in place for collaboration</td> <td>Time spent to set up touchpoints</td> <td>1. Different functions operate individually from each other 2. Each function has different priorities throughout the season</td> </tr> <tr> <td>3</td> <td></td> <td></td> <td>1. 2.</td> </tr> <tr> <td>4</td> <td></td> <td></td> <td>1. 2.</td> </tr> </tbody> </table>					PROBLEM	MEASURE	ROOT CAUSE	1	DP doesn't have required input for the submit	Information available during week of submit? Yes/No	1. DP didn't request information on time 2. Misalignment about timely request 3. Lack of visibility in each functions calendar	2	No structure in place for collaboration	Time spent to set up touchpoints	1. Different functions operate individually from each other 2. Each function has different priorities throughout the season	3			1. 2.	4			1. 2.				
	PROBLEM	MEASURE	ROOT CAUSE																								
1	DP doesn't have required input for the submit	Information available during week of submit? Yes/No	1. DP didn't request information on time 2. Misalignment about timely request 3. Lack of visibility in each functions calendar																								
2	No structure in place for collaboration	Time spent to set up touchpoints	1. Different functions operate individually from each other 2. Each function has different priorities throughout the season																								
3			1. 2.																								
4			1. 2.																								

Figure 27- A3 problem solving used in step 2 to understand problem situation at NSW

Appendix 14 Notes from brainstorming session at NSW

First visual management training was given to the team by the lean team. Next the A3 was presented and discussed in order to be sure that the team agreed with the high-level problem description and would buy-in to the solution. Once this was finalized, a group brainstorm was started and facilitated using sticky notes to discuss problems and issues that the team are facing concerning why they are missing information inputs. Team members were given 10 minutes to individually write down issues, then the group huddled around the board and had 50 minutes to discuss their sticky notes and sort the sticky notes into categories.

The project team chose visual management as the most suited communication tool to help drive processes in real time through visualization. The visualization should communicate which tasks need to be completed and which information is required and from who to complete the tasks. Demand planners should decide upon the content of the visual management board, therefore a 3 hour brainstorm session was held with the entire NSW team. Appendix 10 describes the issues highlighted during the brainstorm session and provides a further description of the brainstorming process. Following the brainstorming session the NSW team chose which categories they would like to focus on, using visual management to solve the problems displayed in Table 8 - Most important challenges decided by brainstorm session at NSW. Visual management should improve timely access to information and create a standardized schedule/ collaboration structure, visual management should visualize their process in order to understand when their submits are and act as a communication platform to discuss issues/ challenges and best practice.

Classification	Problem/ Challenge
Timely Information/ Schedule	Not clear what the best timing is to collect info from merch/sales
	Securing top-20 input to be on time for our SIM DP passes constantly.
	Account forecast is missed in FA16 due to going through sales rather than directly
	Sales/account input not available on time for DP submits.
	Sales counterparts are not available for feedback.
	Despite already agreed upon business processes, it is hard to get time commitment from sales.
	Forecast alignment meetings happen irregularly
	DP does not receive automated forecast updates from sales/merch
	DP Submits are made with missing input (too late)
Internal process NSW	No time setup for forecast evaluation
	No clear overview of submit moments
	Submits are not aligned cross PE
Process Overview	Don't always know which number is being targeted for in submit
	Not sure how team is doing in submit week, so difficult to help

Table 8 - Most important challenges decided by brainstorm session at NSW

Classification	Problem/Challenge	Additional Comments
Input Quality/Format for DP	Sales and accounts provide different templates for input resulting in high manual work load for DP	Input format
	Input is unstructured (overload) and comes by e-mail which is insufficient	Input format
	Merch and Sales are unavailable for feedback close to submit, results in e-mail contact	Input format
	Post KAPM sales directors want to meet/are available but the qualitative feedback they get is hard to translate	Input quality
	Post GTM key account teams provide forecasts which SDs collect and send through but they are not fully aware of the totals or accuracy	Input quality
	Too many late changes, can Merch avoid it by being more on top of their deadlines?	Time/awareness?
	GTM and OED 1 communication is not enough.	Input quality
	Sales input is person dependent.	Input quality
	Senior merchandising leadership does not own the numbers, should DP not reach other persons with more understanding/ownership of the numbers?	Input quality
	There is no support from sales during drop review	Input Quality
	Sales and merch are not informing DP about business critical changes at any time in the CGP	Input
Internal process NSW	No time setup for forecast evaluation	
	No clear overview of submit moments	
	Submits are not aligned cross PE	
Awareness/ Education collaborative parties	Sales/Merch do not understand supply chain logic	
	Merchandiser is not always willing to drop product from line due to personal attachment (lack of supply chain understanding)	
	Sales/ Merch do not follow DP timelines and deadlines	
	Sales/Merch do not understand DP process	
	Merch require education about supply chain processes and reasons behind why DP is asking for input	
Partnership with sales and merch	Superior behavior from merch does not help to bridge gaps	
	DP is not being taken into account as a partner in seasonal line discussions	

	Merch want to be responsible, but do not feel accountable (drops)	
	DP feels excluded from merch process & sales CGP	
	There is no real partnership with sales/merch, the triangle sales/merch /DP is only mainly maintained by DP, based on info request.	
	DP are not sure about sales calendar and can't find it	
Process Overview	Don't always know which number is being targeted for in submit	
	Not sure how team is doing in submit week, so difficult to help	
PT	Due to PT, we are what info is required and when (drop decisions; account info for OED1).	
Timely Information/ Schedule	Not clear what the best timing is to collect info from merch/sales	
	Securing top-20 input to be on time for our SIM DP passes constantly.	
	Account forecast is missed in FA16 due to going through sales rather than directly	
	Sales/account input not available on time for DP submits.	
	Sales counterparts are not available for feedback.	
	Despite already agreed upon business processes, it is hard to get time commitment from sales.	
	Forecast alignment meetings happen irregularly	
	DP does not receive automated forecast updates from sales/merch	
	DP Submits are made with missing input (too late)	



Figure 28- NSW Brainstorm Session

Appendix 15 – Visual Management Wall Design

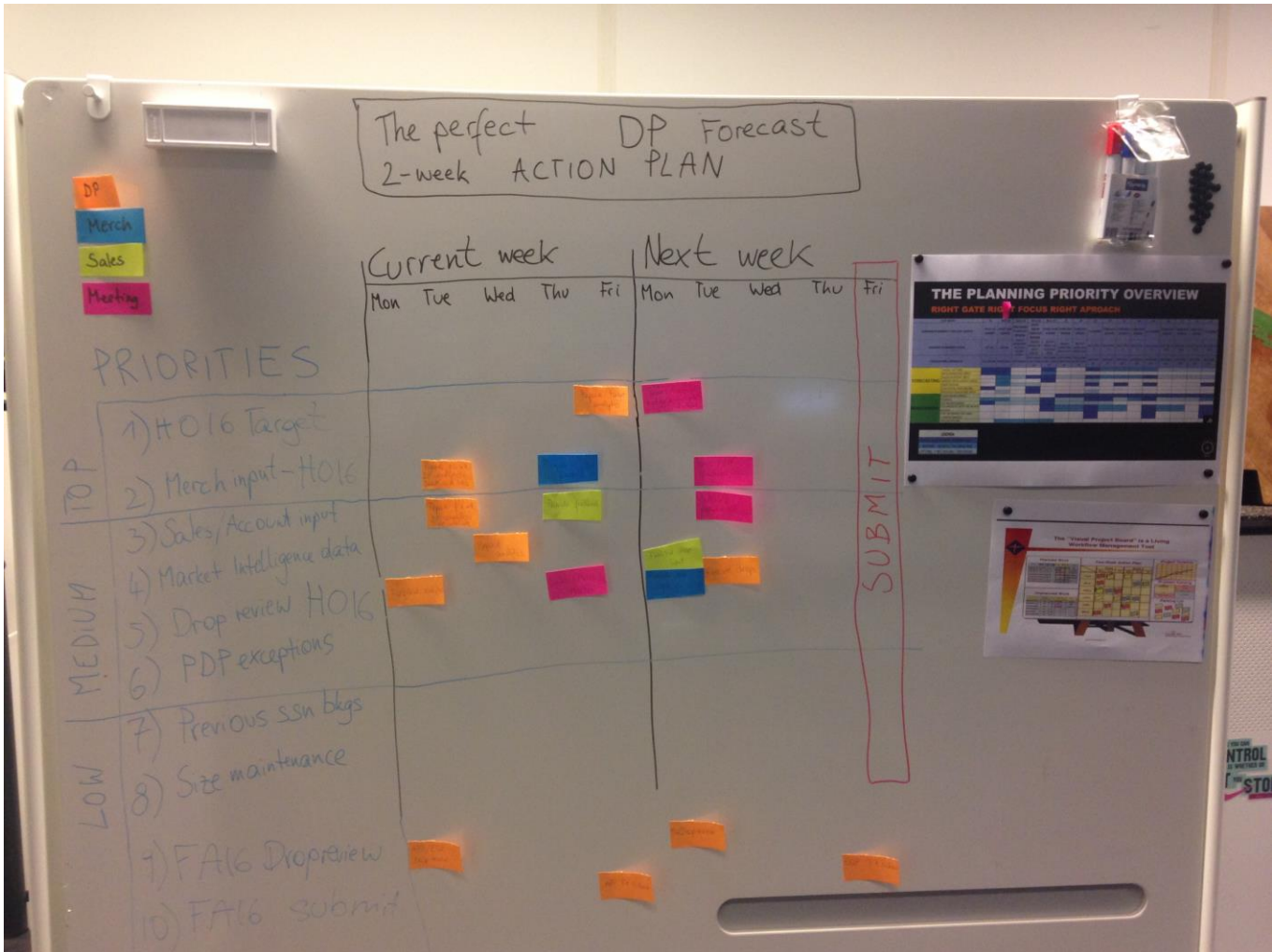

Figure 29- Visual Management Wall Concept 1 20 January, 2016

Concept 1 made use of a 2-week action plan in order to structure a demand planner’s workflow for the coming two weeks. In order to structure collaboration different colored post-it notes were used to depict who the information owner was and with which partners demand planners had to collaborate with. The orange post-its showed the tasks, which demand planners, had to complete in order to get access to the information.

Moreover, the left shows a prioritization list. Because demand planners have to work on different season simultaneously they were struggling to understand which tasks to prioritize and how to prioritize their time. Therefore this was added to the wall.

The main dis-advantages of this wall were that the wall required high-maintenance as tasks varied per weeks. It helped to structure the tasks; however, this would have to be done every week resulting in a high workload. Moreover, improvement could not be tracked and issues are not clear.



Figure 31- Visual Management concept 3, adapted after team feedback January 29, 2016

Concept 3 shows a significant improvement in maintaining the wall where the post it notes were replaced with task lists printed in excel. The aim of this is to codify and recognize repetitive tasks.

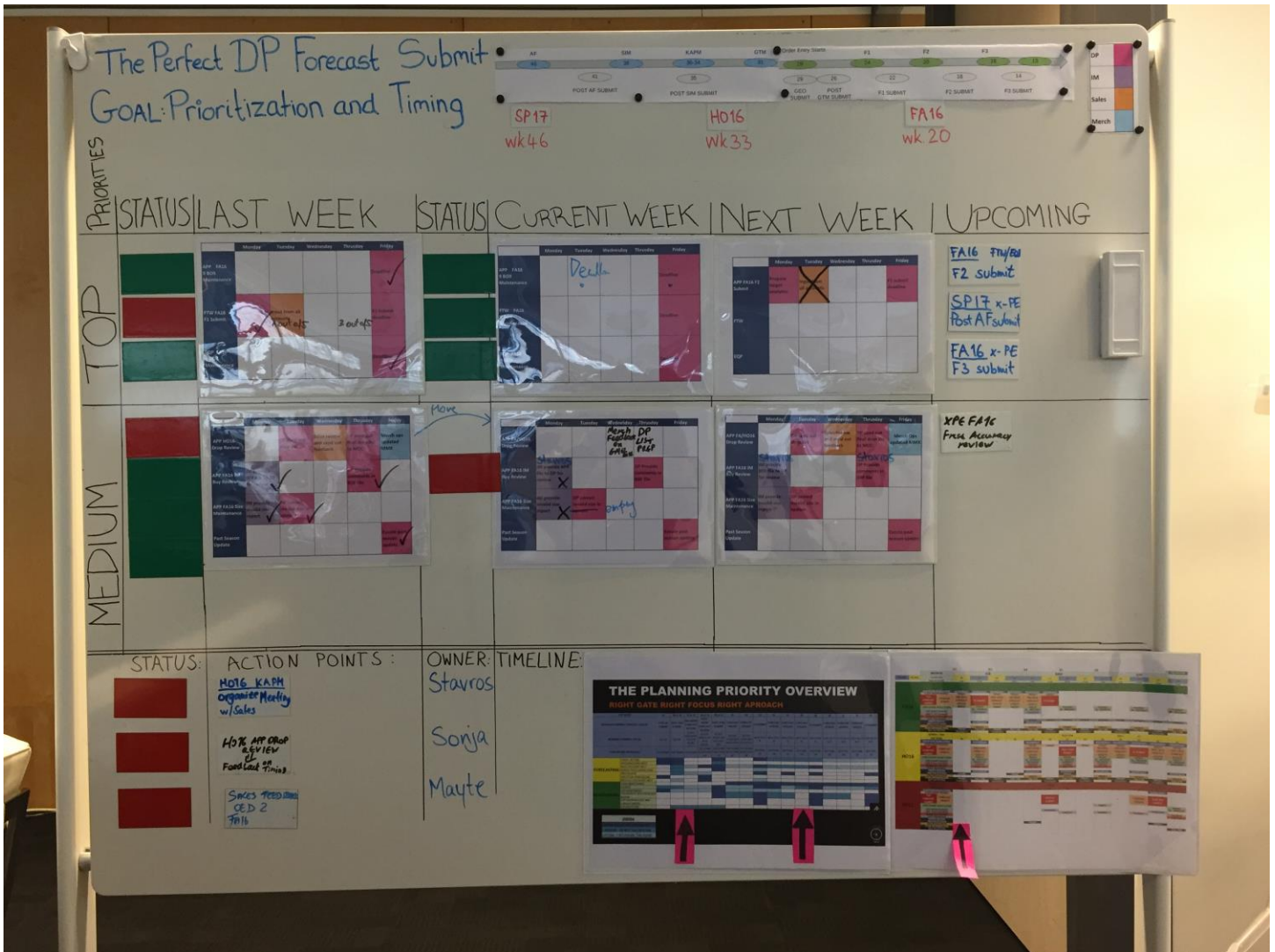

Figure 32- Visual Management Concept Design 4, February 4th, 2016

Figure 33 - Best Practice Sharing and Results, February 23rd shows how the results of the solution are being tracked. Unfortunately, due to the limited time frame that the researcher was present, this field was still empty when the researcher left Nike; however, Figure 34 shows the status on the 23rd of February.

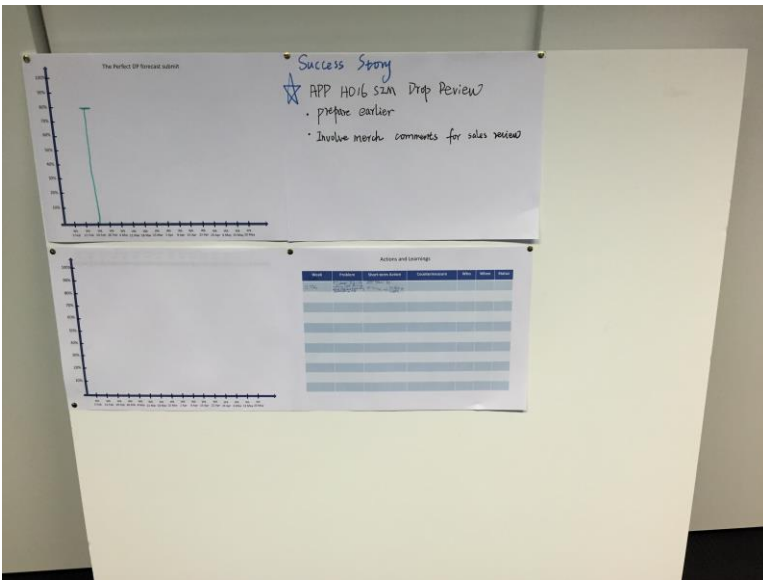

Figure 33 - Best Practice Sharing and Results, February 23rd

Next to this, Figure 34 shows the visual management wall on February 23rd. This shows the progression of the wall; however, at this point of time the researcher was no longer working in the department, therefore this concept design will not be used in the validation.

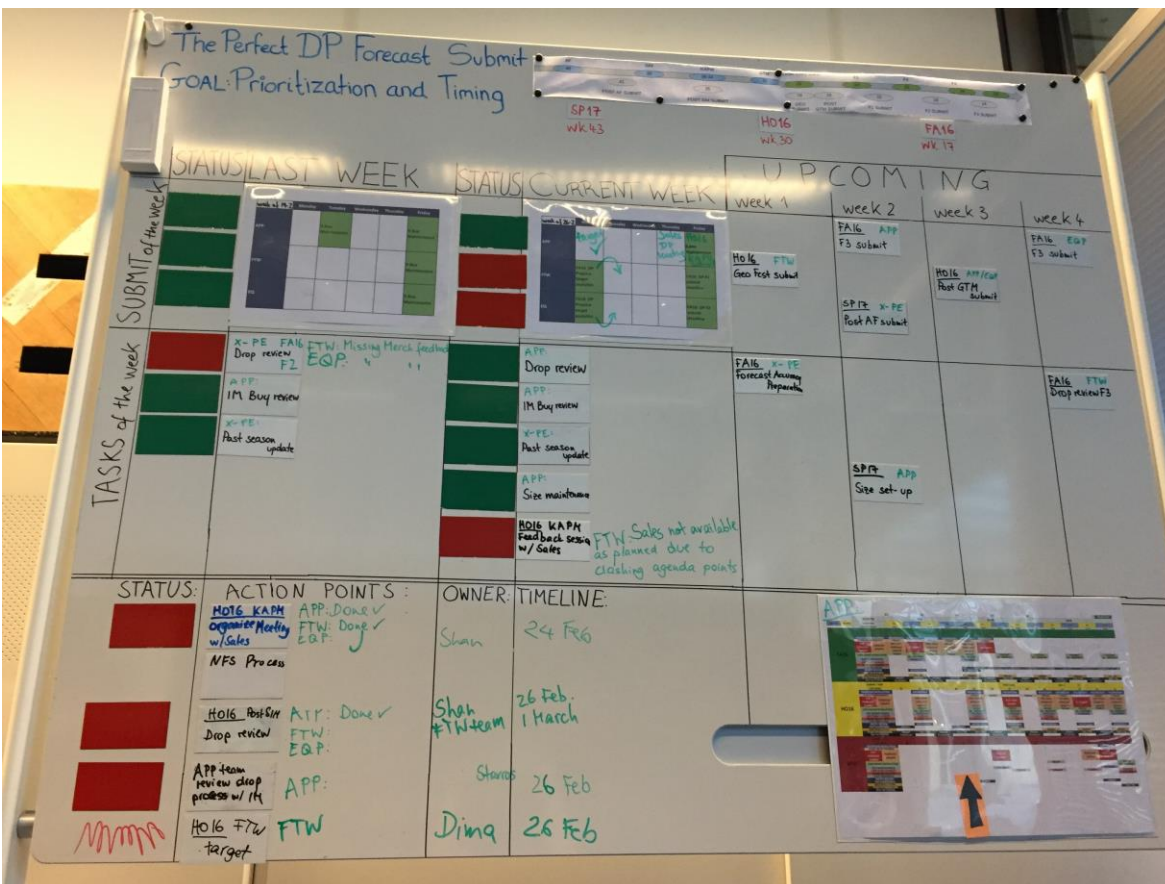

Figure 34- Visual Management Concept Design, 5 February 23, 2016

Appendix 16 – Priority Overview

This priority view is included on the wall. This shows an overview of task prioritization per submit created at Nike (2015.)

CGP WEEK		41	36 or 35	32 or 31	30 or 29	28 or 27	25	24	23	22	21	20	19	18	17	16	15
DEMAND PLANNING FORECAST UPDATE		POST-AF SUBMIT	POST-SIM SUBMIT	PRE-KAPM FORECAST REVIEW	POST-KAPM FORECAST REVIEW	POST-GTM SUBMIT	FORECAST UPDATE	FORECAST UPDATE	F1 SUBMIT	FORECAST UPDATE	FORECAST UPDATE	FORECAST UPDATE	F2 SUBMIT	FORECAST UPDATE	FORECAST UPDATE	FORECAST UPDATE	F3 SUBMIT
DEMAND PLANNING FOCUS		SET UP	REFINE	SMALL ADJUSTMENTS FOR BLIND BUREAU	ADJUST BASED ON NEW TARGET	ADJUST BASED ON ACCOUNT INFO	ADJUST USING BKG INDICATOR	ADJUST USING BKG INDICATOR	MULTIPLIER	MULTIPLIER	MULTIPLIER	MULTIPLIER	MULTIPLIER	COPY BK TO FCST	COPY BK TO FCST	COPY BK TO FCST	COPY BK TO FCST
FORECASTING APPROACH		TOP DOWN	TOP DOWN	TOP DOWN	TOP DOWN & BOTTOM UP	TOP DOWN & BOTTOM UP	TOP DOWN & BOTTOM UP	TOP DOWN & BOTTOM UP	BOTTOM-UP	BOTTOM-UP	BOTTOM-UP	BOTTOM-UP	BOTTOM-UP	BOTTOM-UP	BOTTOM-UP	BOTTOM-UP	BOTTOM-UP
FORECASTING	TARGET SETTING																
	MERCHANDISING INPUT																
	SALES/ ACCOUNT INPUT																
	MARKET INTELLIGENCE DATA																
	DROP REVIEW																
	STATISTICAL FORECASTING																
	PREVIOUS SEASON BKS INPUT																
MAINTAINING	9-BOX MAINTENANCE																
	FILLRATE																
	SIZE MAINTENANCE																
	COLLABORATE WITH IM ON BUY REVIEW																
	COPY BOOKINGS PAST AND CURRENT MONTH																
	PDP EXCEPTIONS																

Figure 35- Task Priority Overview (Nike, 2015)

LEGENDA
1.CRITICAL. MUST USE INPUT / PERFORM TASK
2. IMPORTANT. USE INPUT / TASK CAN BE DONE
3.OPTIONAL. IF INFO AVAILABLE / TASK POSSIBLE

Appendix 17 – Planning Calendar

MONTH		JAN				FEB				MAR	
PLAN WEEK	BUY WEEK	W2	W3	W4	W5	W6	W7	W8	W9	W10	W11
CALENDAR WEEK		08-Jan	15-Jan	22-Jan	29-Jan	05-Feb	12-Feb	19-Feb	26-Feb	04-Mar	11-Mar
FRIDAY OF THE WEEK											
SU16	SUBMIT / OED										
	CGP WEEK	11	10	9	8	7	6	5	4	3	2
	EXCEPTION RESOLUTION										
	9 BOX MAINTENANCE										
	CGP FORECAST SUBMIT	FORECAST UPDATE									
	UNPLANNED RESOLUTION		TUESDAY BL - MONDAY		TUESDAY BL - MONDAY		TUESDAY BL - MONDAY		TUESDAY BL - MONDAY		TUESDAY BL - MONDAY
	SDE MAINTENANCE										
	LINE PLAN CHANGES										
	BLIND BUY REVIEW										
	COFFY BOOKINGS	FRI	TUE	FRI	TUE	FRI	TUE	FRI	TUE	FRI	TUE
	DROPS REVIEW										
	POP EXCEPTIONS										
	ORX RESOLUTION		FRI		FRI		FRI		FRI		FRI
PLAN OPTIMIZATION	FRI	TUE / FRI	FRI	TUE / FRI	FRI	TUE / FRI	FRI	TUE / FRI	FRI	TUE / FRI	
BUY ACTIVITIES	THUR		THUR		THUR		THUR		THUR		
FA16	SUBMIT / OED	OED 1	F1			OED 2	F2			OED 3	F3
	CGP WEEK	24	23	22	21	20	19	18	17	16	15
	EXCEPTION RESOLUTION	WED	WED	WED	WED	WED	WED	WED	WED	WED	WED
	9 BOX MAINTENANCE	FRI	FRI	FRI	FRI	FRI	FRI	FRI	FRI	FRI	FRI
	CGP FORECAST SUBMIT	PRE OED1 FORECAST UPDATE	F1 SUBMIT	POST OED1 FORECAST UPDATE	POST OED1 FORECAST UPDATE	PRE OED2 FORECAST UPDATE	F2 SUBMIT	POST OED2 FORECAST UPDATE	PRE OED3 FORECAST UPDATE	PRE OED3 FORECAST UPDATE	F3 SUBMIT
	UNPLANNED RESOLUTION	FRI	FRI BL - MONDAY	FRI	FRI BL - MONDAY	FRI	FRI BL - MONDAY	FRI	FRI	FRI	FRI BL - MONDAY
	SDE MAINTENANCE		THUR		THUR		THUR		THUR		THUR
	LINE PLAN CHANGES										
	BLIND BUY REVIEW										
	COFFY BOOKINGS		WED		WED		WED		WED		FRI
	DROPS REVIEW										FRI
	POP EXCEPTIONS		FRI		FRI		FRI		FRI		FRI
	ORX RESOLUTION	FRI	TUE / FRI	FRI	TUE / FRI	FRI	TUE / FRI	FRI	TUE / FRI	FRI	TUE / FRI
BUY ACTIVITIES	THUR		THUR		THUR		THUR		THUR		
HO16	SUBMIT / OED			POST SIM							
	CGP WEEK	37	36	35	34	33	32	31	30	29	28
	EXCEPTION RESOLUTION			WED			WED			WED	
	9 BOX MAINTENANCE									FRI	FRI
	CGP FORECAST SUBMIT	FORECAST UPDATE		POST SIM SUBMIT			PRE KAPM FORECAST UPDATE			POST KAPM FORECAST UPDATE	
	UNPLANNED RESOLUTION				FRI BL - MONDAY		FRI BL - MONDAY		FRI BL - MONDAY		FRI BL - MONDAY
	SDE MAINTENANCE			THUR			THUR		THUR		THUR
	LINE PLAN CHANGES			TUE			TUE / FRI		TUE / FRI		TUE / FRI
	BLIND BUY REVIEW										
	COFFY BOOKINGS				TUE / FRI						
	DROPS REVIEW				WED		WED		WED		WED
	POP EXCEPTIONS			FRI		FRI		FRI		FRI	
	ORX RESOLUTION										
PLAN OPTIMIZATION				TUE / FRI		FRI		TUE / FRI		FRI	
BUY ACTIVITIES					THUR		THUR		THUR		

Figure 36- Planning Calendar January, February 2015 (Nike, 2015)

Figure 36- Planning Calendar January, February 2015 shows an overview of the standard weekly tasks per season. This is an overview included on the visual management wall. Table 9- Ten most importantly weekly tasks performed by a demand planner at NSW provides a brief description of the tasks which are being used on the wall.

Tasks	Description
Exception Resolution	Solve all exceptions found in the file - wrong bookings, offer dates adjustments, etc and errors for numbers which seem off-track.
9 Box Maintenance	Solve the 9 box check and rebalance forecast whenever required.
Forecast Submit	Submit seasonal forecast
Forecast Update	Review seasonal forecast
Unplanned Resolution	Solve unplanned issues by adjusting forecast or parameters
Size Maintenance	Set up size and resolve sizing issue
Line Plan Changes	Review adds & drops of the line
Blind Buy Review	Team review on the style that will be included in the next blind buy with IP
Copy Bookings	Copy bookings for whole demand stream (promo/ at-once/ futures)
Drops Review	Identify low performing product offers and discuss whether line should be dropped
PDP Exceptions	Identify styles for which a different PDP spread can be expected
DRS Resolution	Ensure that direct ship orders are covered and solve overconsumption

Table 9- Ten most importantly weekly tasks performed by a demand planner at NSW

Appendix 18 – Visual Management NSW Team Survey

On a scale of 1-5

1 not at all 2 1%-25% 3 26%-50% 4 51% - 75% 5 75% - 100%

By how much does the visual management support system improve the structure of your workflow process?	1	2	3	4	5
By how much does the visual management support system improve the standardization of your work flow process?	1	2	3	4	5
By how much does the visual management support system improve collaboration across functional boundaries?	1	2	3	4	5
By how much does the visual management support system improve your access to the right information at the right time?	1	2	3	4	5
By how much does the visual management support system improve the quality of information which you require to do work?	1	2	3	4	5
What improvement impact do you believe the visual management support system to have on the quality of your forecast submit?	1	2	3	4	5
By how much does the visual management support system improve a structured approach to inter-functional collaboration?	1	2	3	4	5

On a scale of 1-5:

1 Strongly Disagree 2 Disagree 3 Neither Agree nor Disagree 4 Agree 5 Strongly Agree

The visual management support system makes me feel restricted to perform my individual tasks	1	2	3	4	5
The visual management support system helps me to perform my individual tasks	1	2	3	4	5
The visual management support system enables me to comfortably share process challenges	1	2	3	4	5
The visual management support system helps us to manage our work load	1	2	3	4	5
The visual management support system helps us to manage our resource allocation	1	2	3	4	5
The visual management support system makes me feel responsible of my own process	1	2	3	4	5
The visual management support system is flexible enough to support major structure changes in the process	1	2	3	4	5
The visual management support system helps my manager to have a clear overview of the work process and our challenges	1	2	3	4	5
The visual management support system makes me feel like I'm being monitored	1	2	3	4	5
The visual management support system is adaptable at all times	1	2	3	4	5
The visual management support system is easy to use	1	2	3	4	5
The visual management system effectively tracks information flow required for your work?	1	2	3	4	5

Appendix 19 – Survey Results

On a scale of 1-5

1 not at all 2 1%-25% 3 26%-50% 4 51% - 75% 5 75% - 100%

By how much does the visual management support system improve the structure of your workflow process?	5
By how much does the visual management support system improve the standardization of your work flow process?	4
By how much does the visual management support system improve collaboration across functional boundaries?	4
By how much does the visual management support system improve your access to the right information at the right time?	4
By how much does the visual management support system improve the quality of information which you require to do work?	2
What improvement impact do you believe the visual management support system to have on the quality of your forecast submit?	4
By how much does the visual management support system improve a structured approach to inter-functional collaboration?	4

On a scale of 1-5:

1 Strongly Disagree 2 Disagree 3 Neither Agree nor Disagree 4 Agree 5 Strongly Agree

The visual management support system makes me feel restricted to perform my individual tasks	1
The visual management support system helps me to perform my individual tasks	4
The visual management support system enables me to comfortably share process challenges	5
The visual management support system helps us to manage our work load	4
The visual management support system helps us to manage our resource allocation	4
The visual management support system makes me feel responsible of my own process	4
The visual management support system is flexible enough to support major structure changes in the process	2
The visual management support system helps my manager to have a clear overview of the work process and our challenges	2
The visual management support system makes me feel like I'm being monitored	1
The visual management support system is adaptable at all times	3
The visual management support system is easy to use	3
The visual management system effectively tracks information flow required for your work?	4

