

URBAN COLLAGE POEM
RENOVATION PROJECT OF BELGRADE SUGAR FACTORY

changing the lost space of Belgrade riverside into an active urban area with original
value and new meaning.

Mohan Yuan
5008379



FOUND POEM/COLLAGÉ POEM

is a type of poetry created by taking words, phrases, and sometimes whole passages from other *sources* and *re-framing* them (a literary equivalent of a collage) by making *changes* in spacing and lines, or by *adding* or *deleting* text, thus *imparting new meaning*. The resulting poem can be defined as either treated: changed in a profound and systematic manner; or untreated: virtually unchanged from the order, syntax and meaning of the poem.

---Wikipedia

Collage Poem

All that is left

The factories sat vacant, to rust.

On the roof,

some of autumn past,

some of spring approaching fast,

They turn ducts to mazes, for moss swelling

elegance married To live in happier form again:

The artist refuse to abandon

summer winds Whispering in enamour'd tone

And pattering rain, and breathing dew,

silhouetted against the sky

High on the yellow silo,

like playgrounds for echoes of

the rain, melodies of birds

and the wind-swept vanished factories

To fill the hollow spaces with joy.

and their beauty.

"It looks like fun answers "

we wanted,

to stop for .

Original Resource :

252. To a Lady, with a Quill: P. B. Shelley: The Golden Treasury (2021): Bartleby. <https://www.bartleby.com/1/6/252.html>

Factories poems on: (n.d.). Hello Poetry. <https://hellopoetry.com/words/factories/>

Poets.org - Academy of American Poets. (n.d.). Abandoned Black Factory. Arkansas. Academy of American Poets. <https://poets.org/poem/abandoned-black-factory-arkansas>



I	Select	:	VALUABLE ELEMENTS	=	Space Character	FORMER
II	Operate	:	METHODS	=	Add,Delete,Replace	PRESENT
III	Generate	:	NEW MEANING	=	Cultural Complex	FUTURE

Urban Collage Poem - Design Process

Chapter I Former

Select Valuable Elements

Reflect Former Space Character



Lost Space in Urban Context



Location of the Sugar Factory



SUGAR FACTORY, ČUKARICA, BELGRADE

is a defunct industrial complex in Belgrade, the capital of Serbia. Built in 1901, it was the first sugar factory in Serbia. In 1984 it was placed under protection as the cultural monument.

--Wikipedia

Background Information

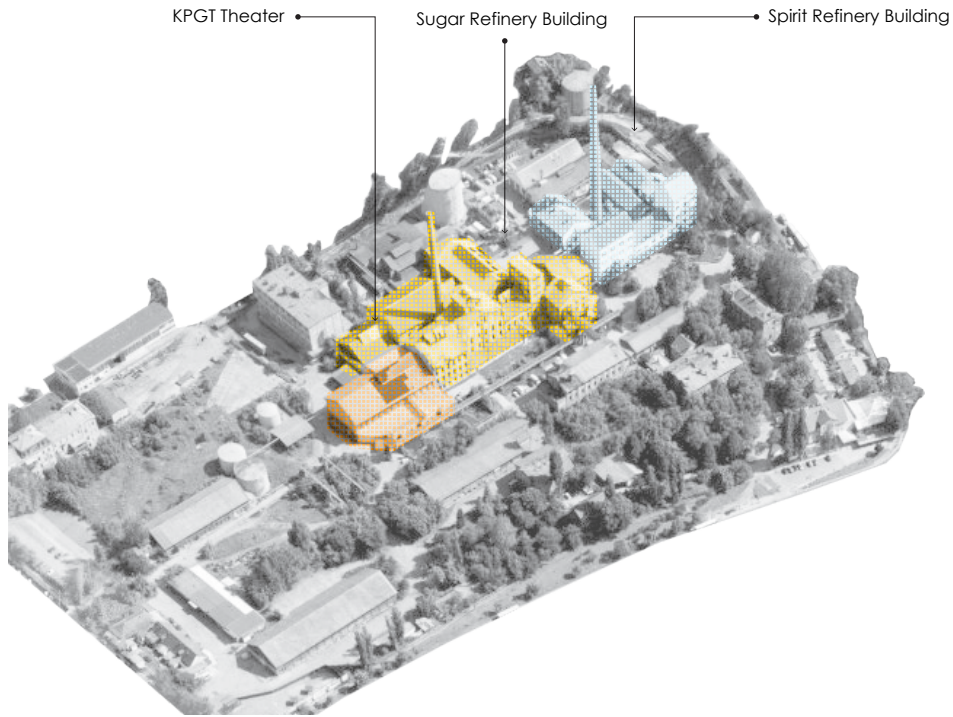

Belgrade Sugar Factory Main Production Building

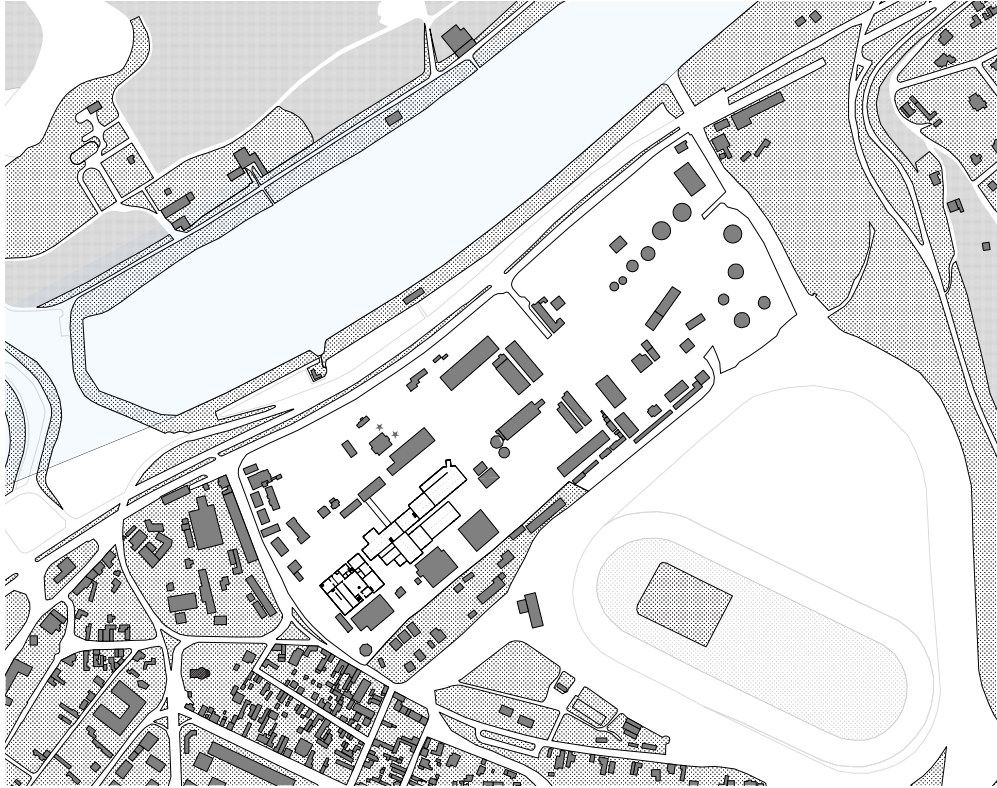

Site Context



19th Industrial Building



Spirit Extension



KPGT Theater



Lost Space

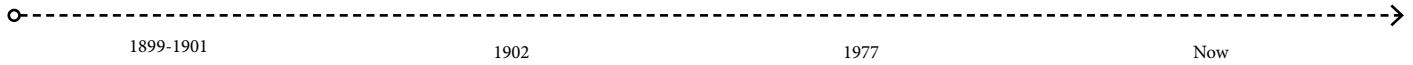

Timeline of Belgrade Sugar factory

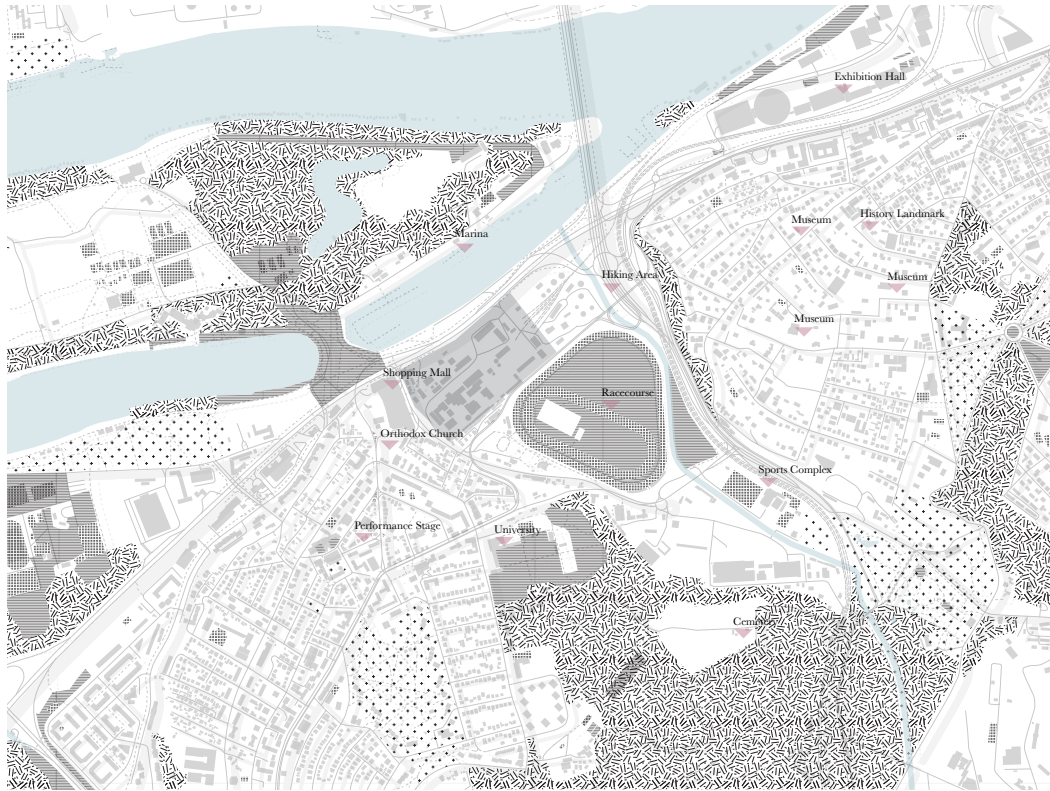

Cultural Facilities in the Neighborhood



Zoning

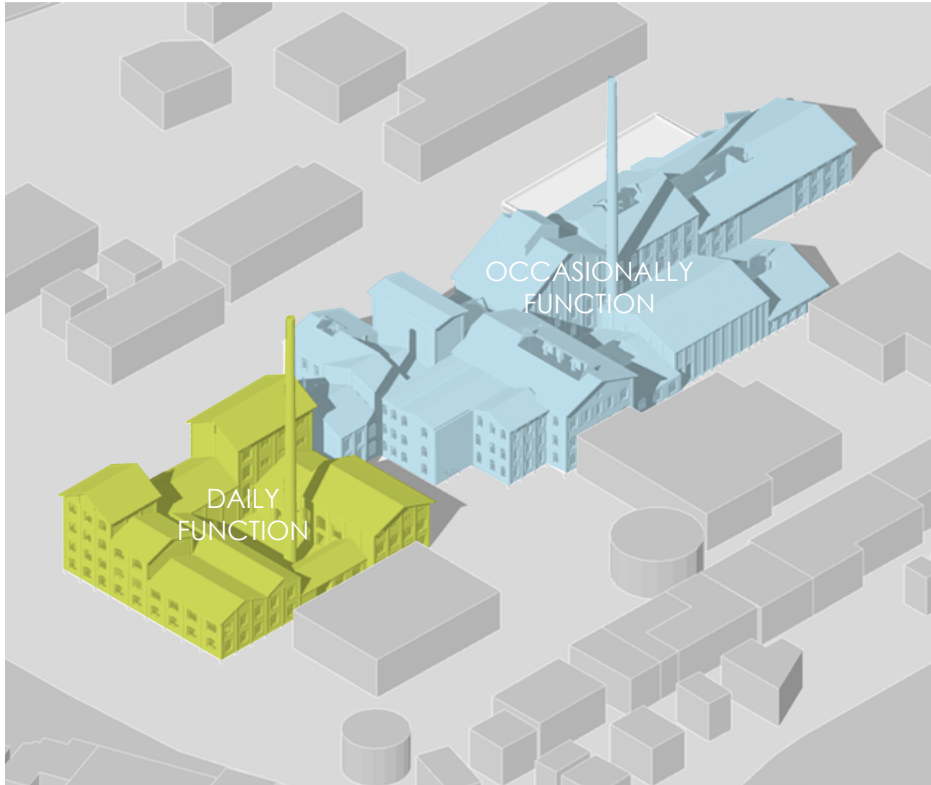

Allocate Update Functions

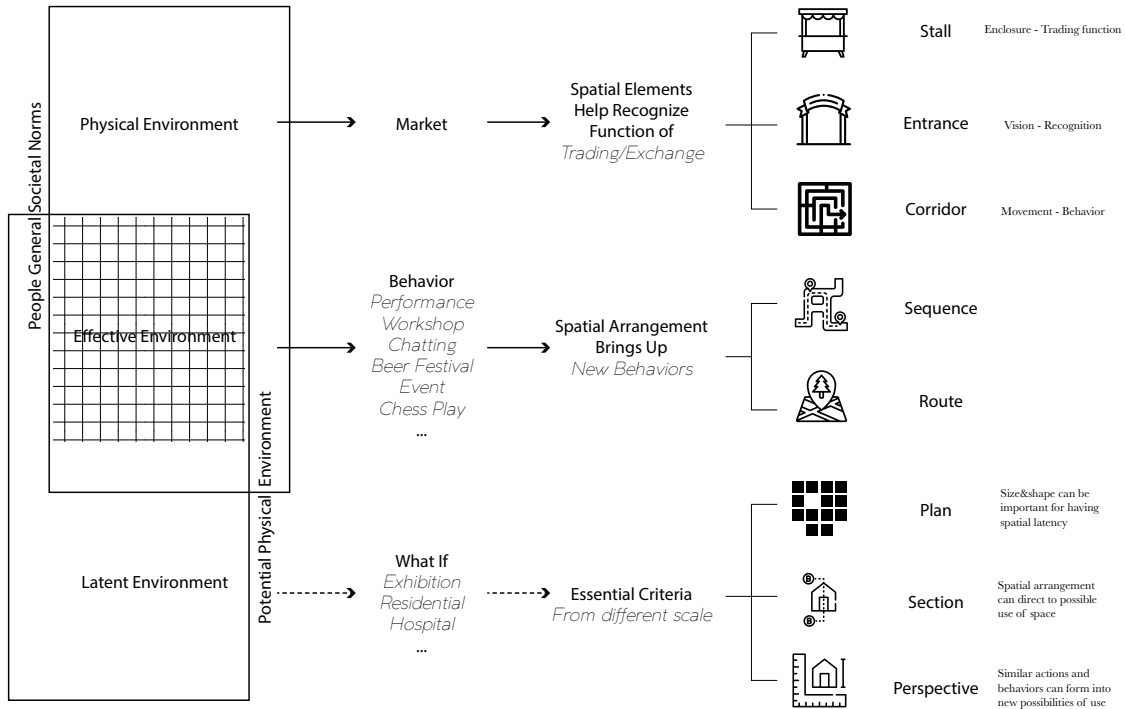

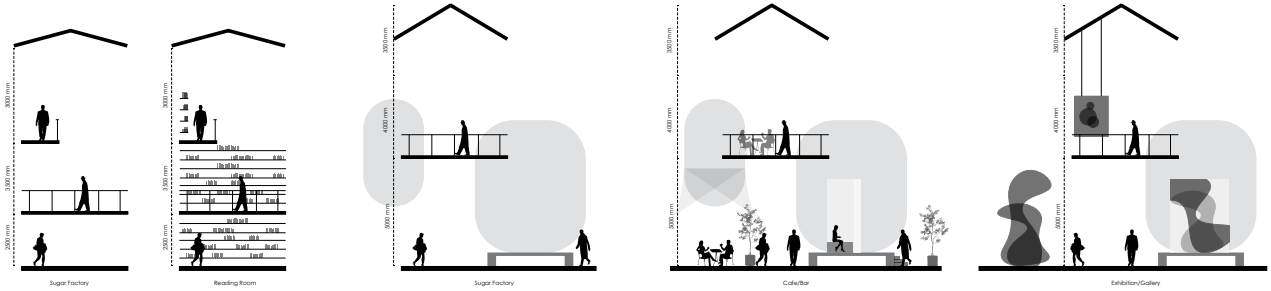
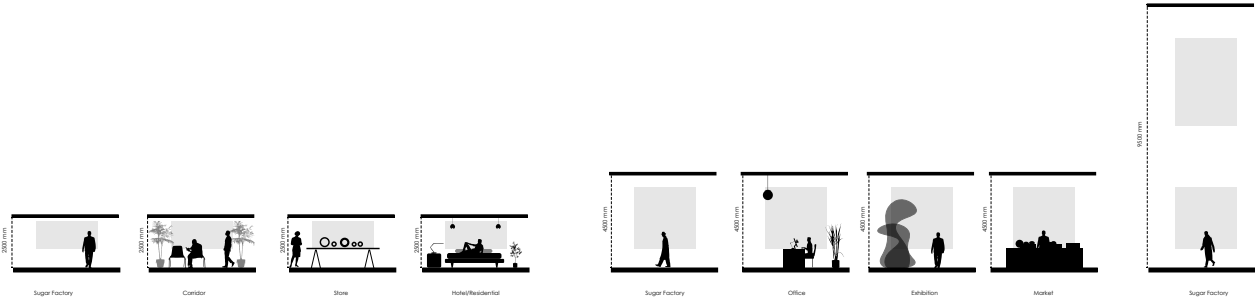

Behavior and Space Scale Study

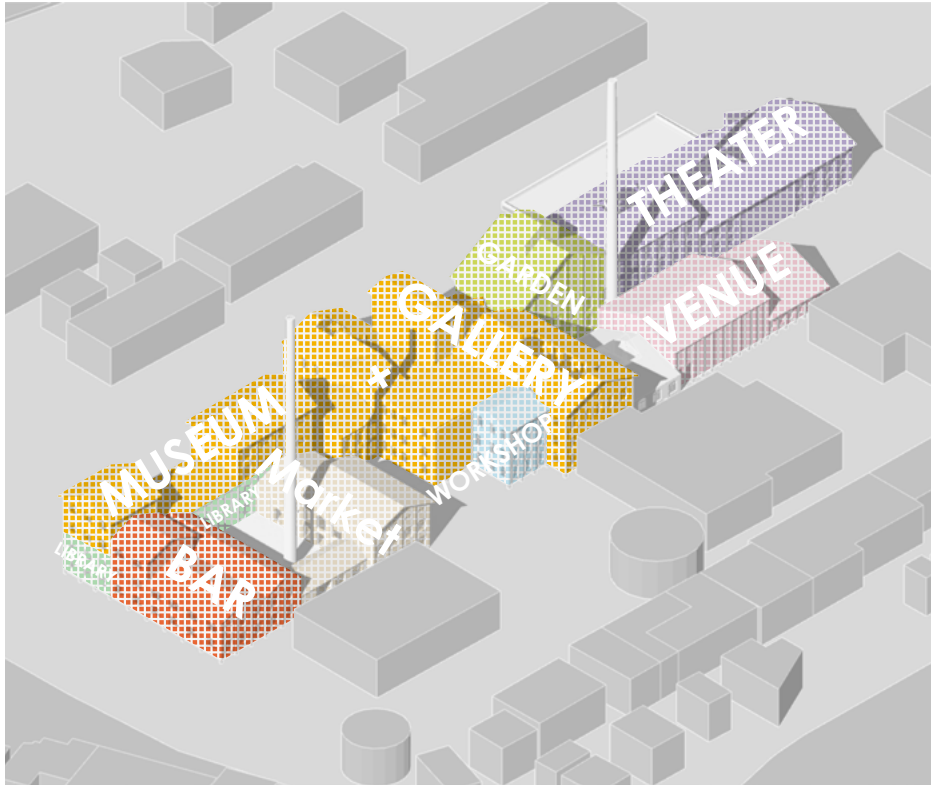

Allocate Update Functions

Appearance



Industrial Ruin Style

Function



Cultural History

Interior Quality



Large Span Space



Delicate Brick Facade



Production Facility



Skylight Roof

Urban Collage Poem - Elements

Chapter II Present

Operate Methods

Add Delete Replace

Present

Renovation



Industrial Ruin Style



Cultural History



Production Facility

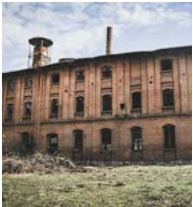

Delicate Brick Facade



Large Span Space



Skylight Roof



Greening



Transition Space

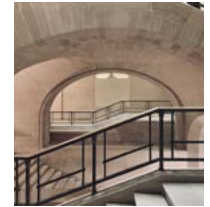

Sight Axis



Interactive Space



Viewing Platform

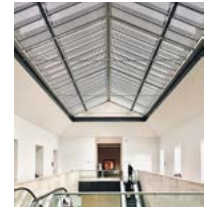

Daylight

Man-made - Steady

Natural - Active

Urban Collage Poem - Objectives

+



Connect
Repeat
Extend
...

-



Set Back
Remove
Open
...

=



Enhance
Shift
Keep
...

Urban Collage Poem - Operate Methods



Connect
Repeat
Extend
...



Set Back
Remove
Open
...



Enhance
Shift
Keep
...

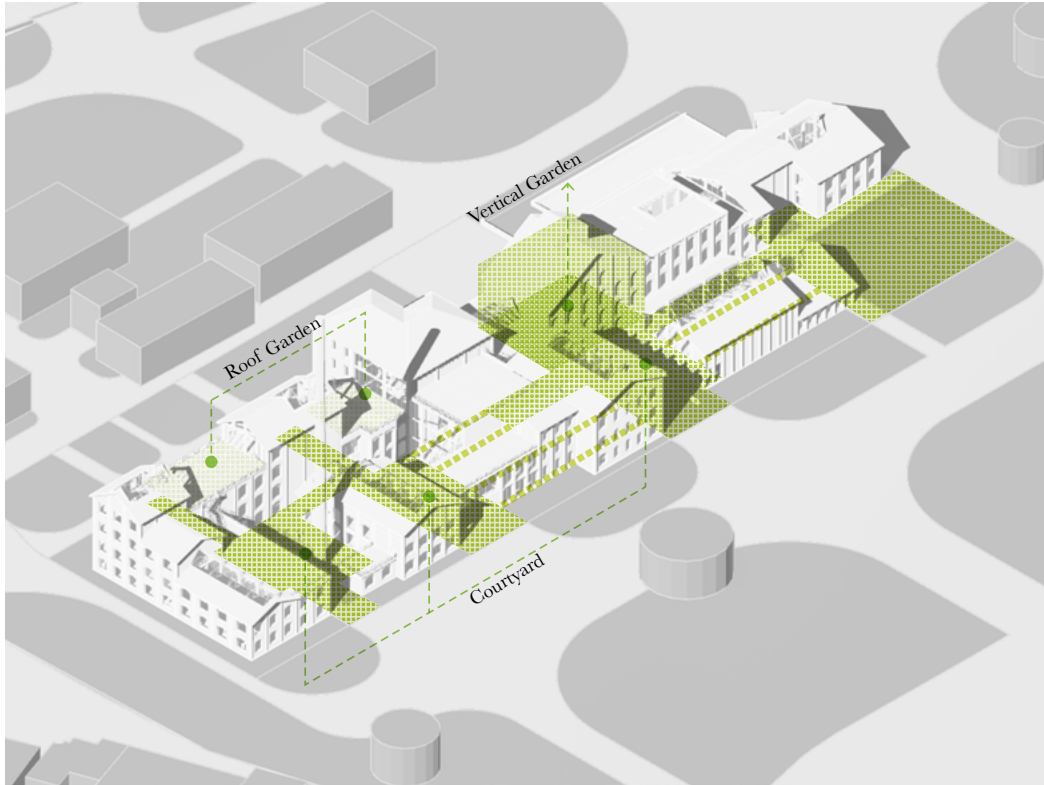

Add - Green Backbone

Present



Roof



Facade



Ground



Opening

Renovation



Roof

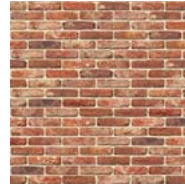

Facade



Ground



Opening



Oak



Cedar



Lilac



Bushes

Add - Green Backbone Elements

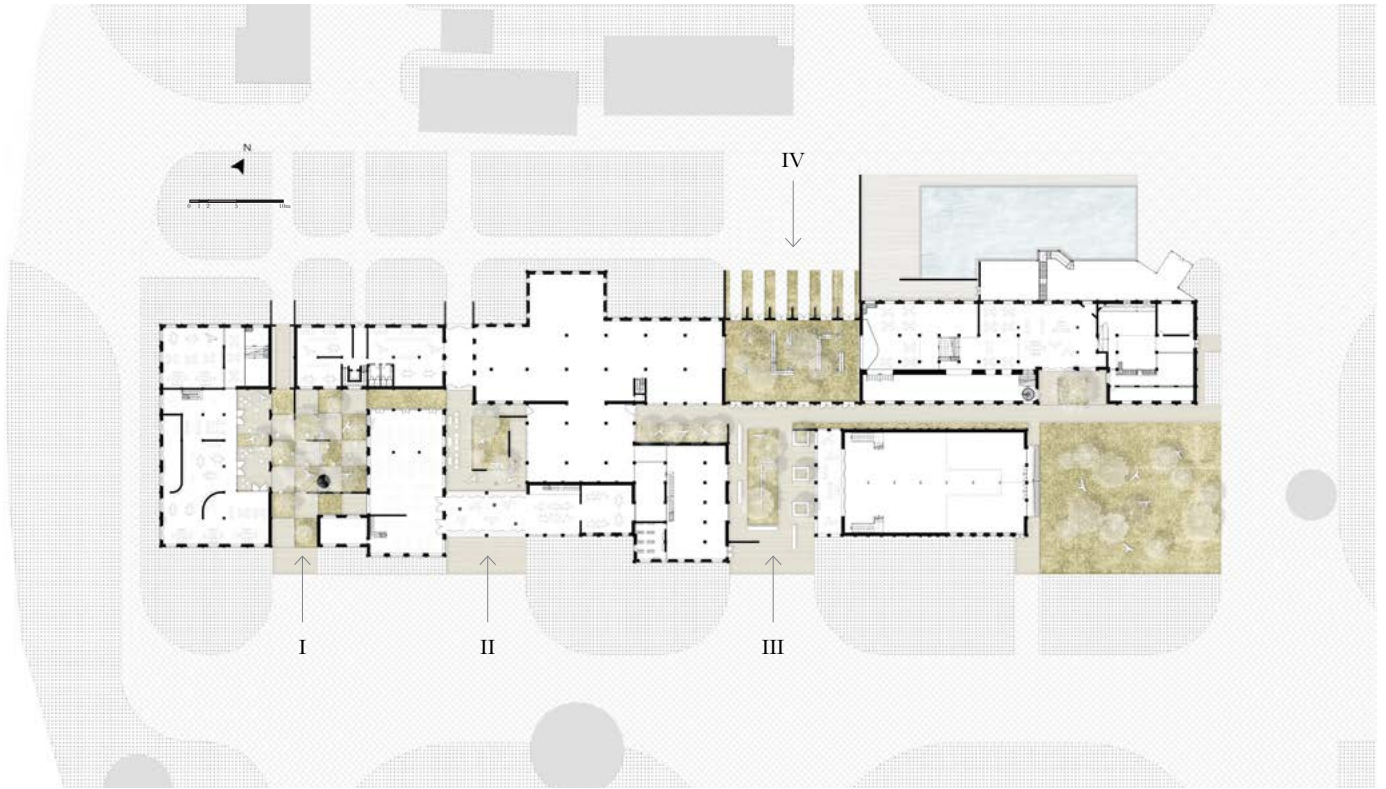

Add - Courtyard on Ground Floor

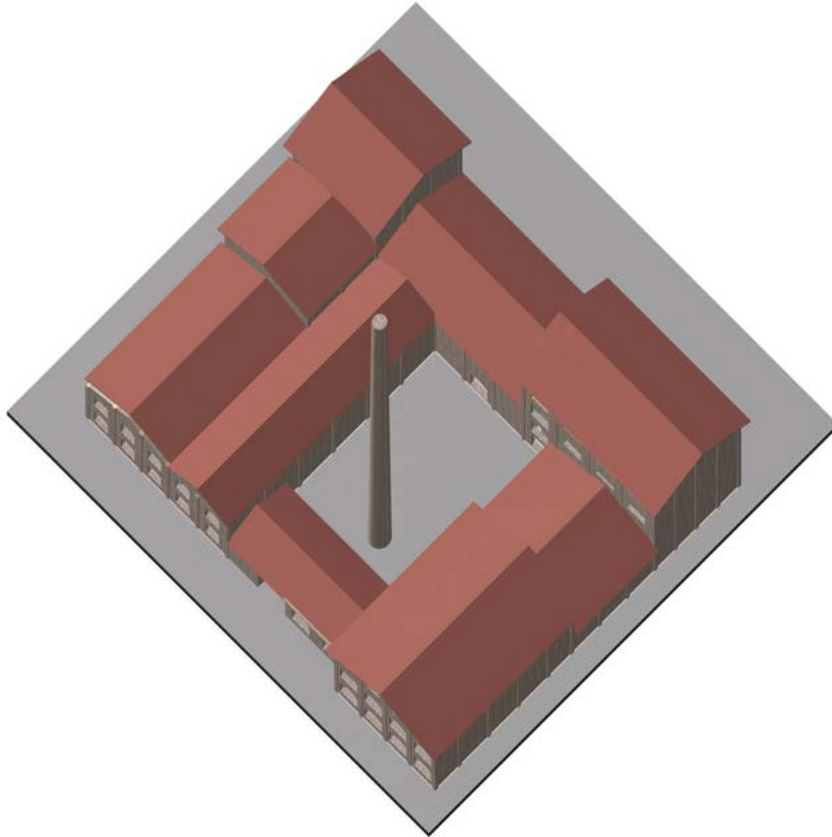

I - Former Condition

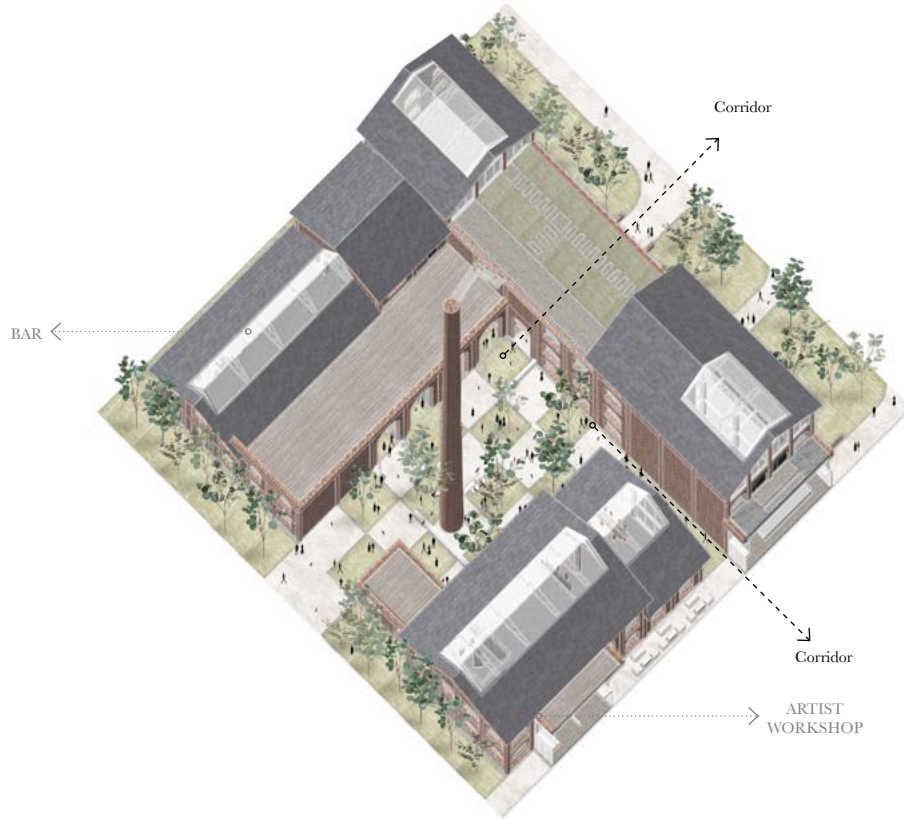

Add - I - Chessboard Courtyard



Former Condition



Add - I - Chessboard Courtyard Perspective

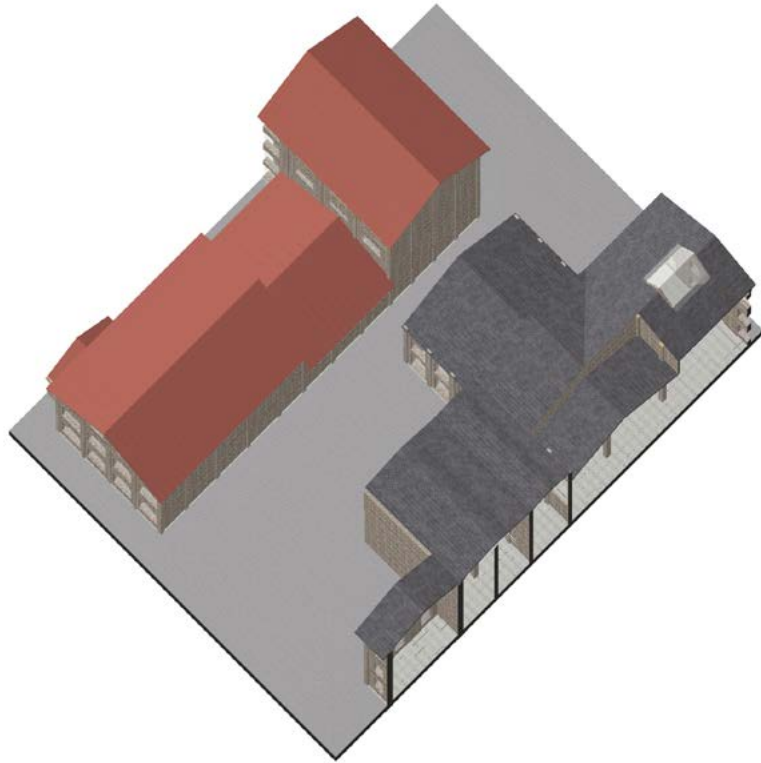

II - Former Condition



Add - II - Platform Courtyard



Former Condition



Add - II - Platform Courtyard Perspective

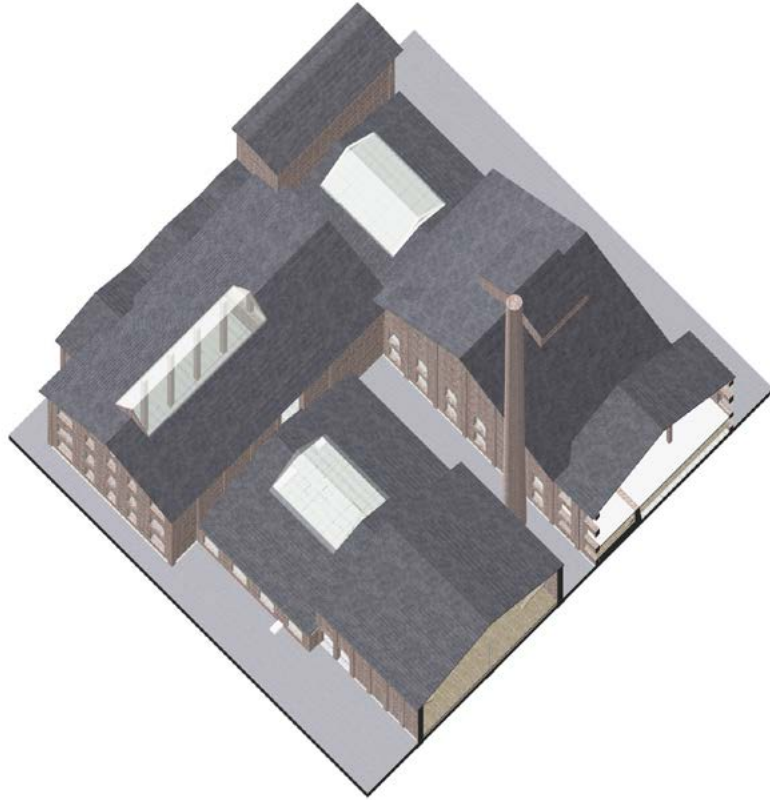

III - Former Condition



Add - III - Maze Courtyard

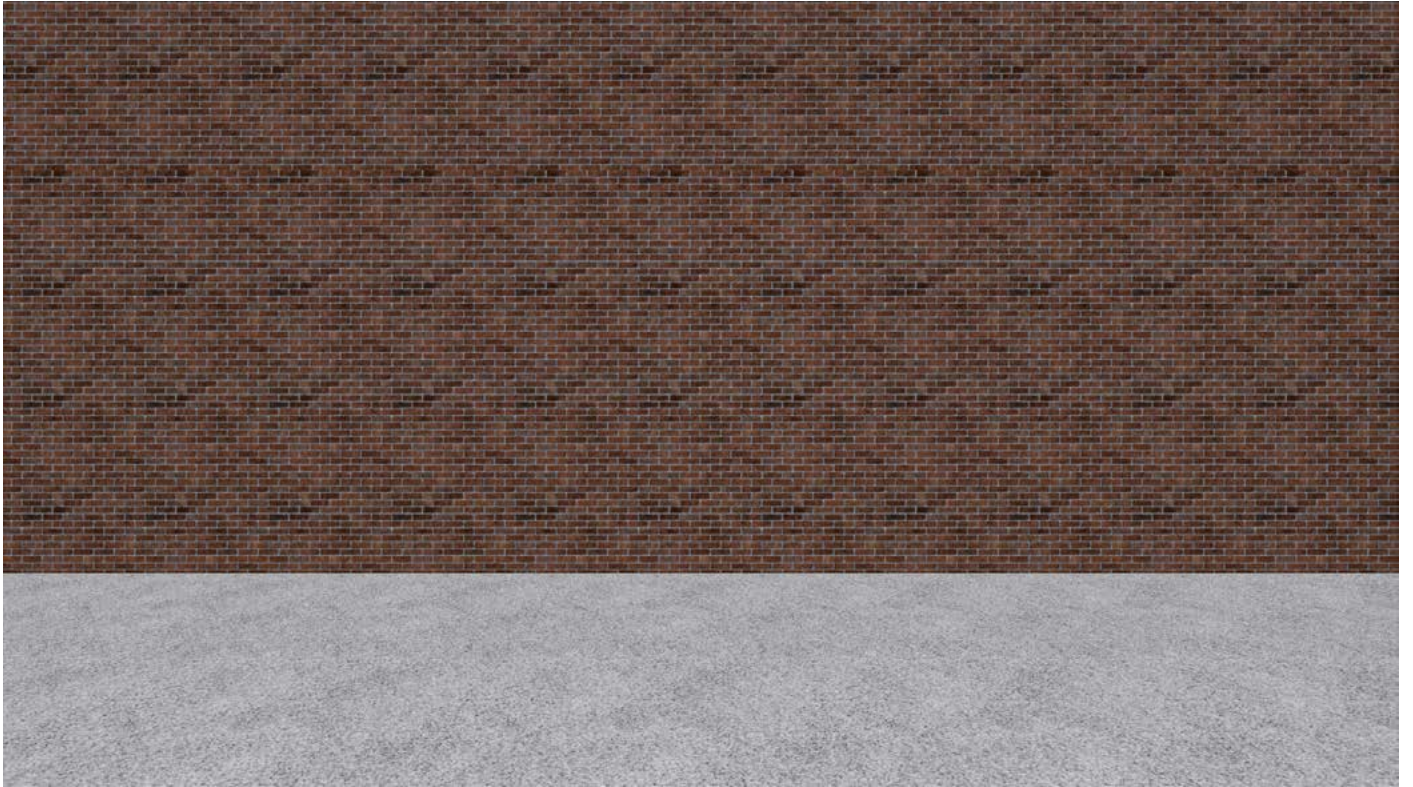

Former Condition



Add - III - Maze Courtyard Perspective

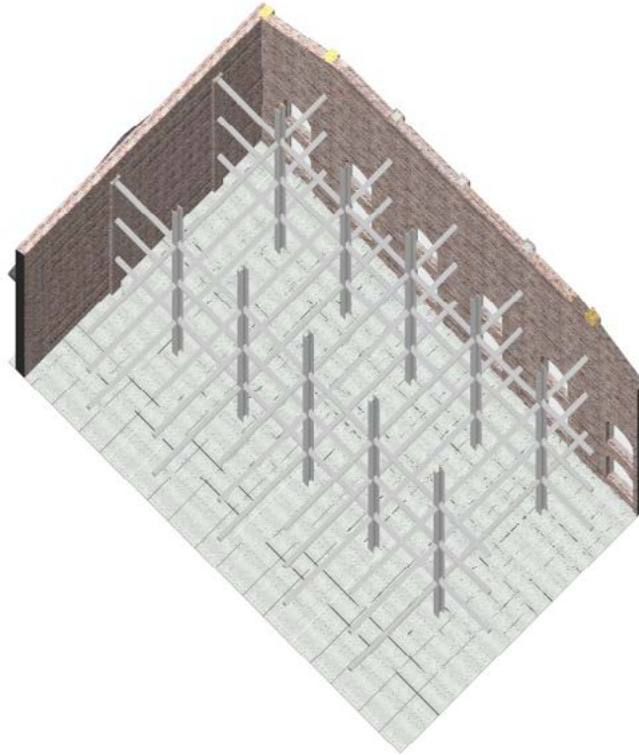

IV - Former Condition

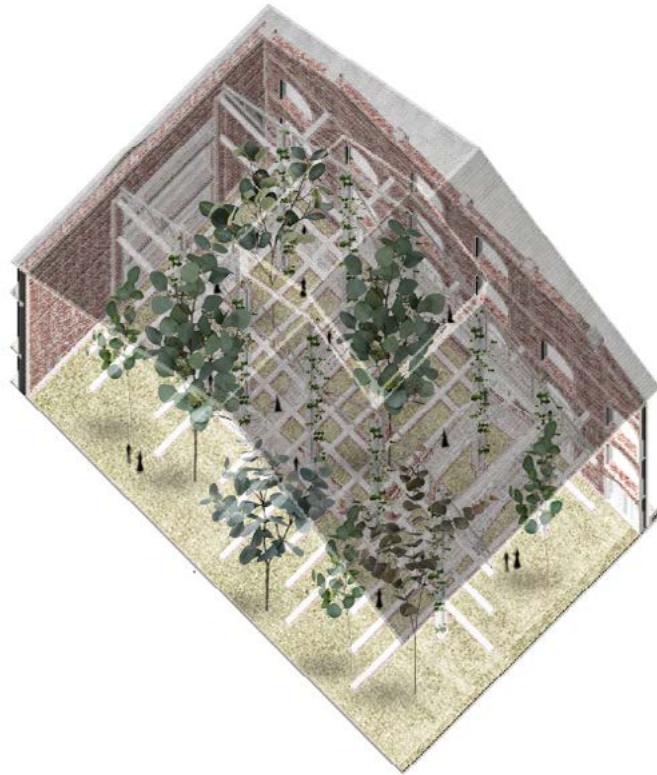

Add - IV - Vertical Garden

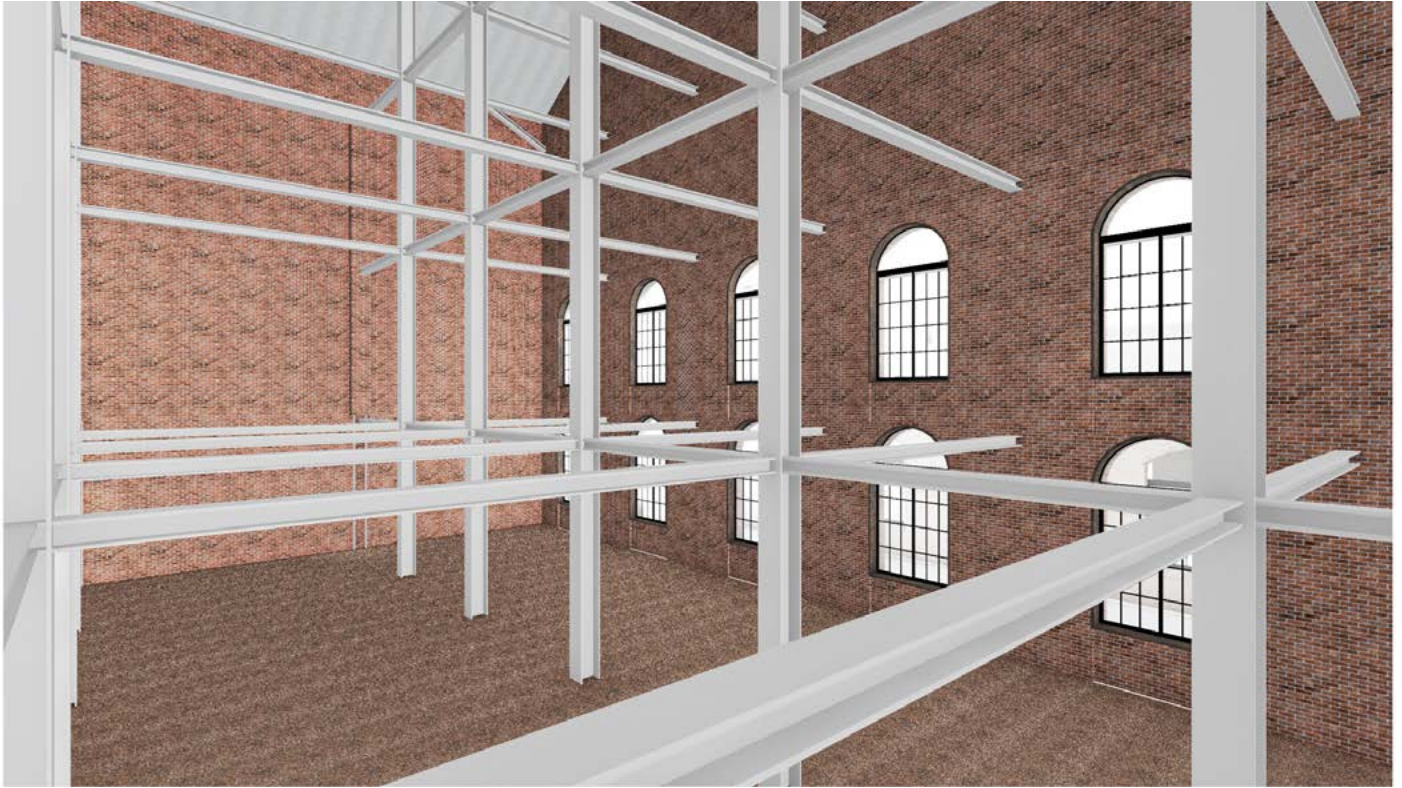

Former Condition



Add - IV - Vertical Garden Perspective

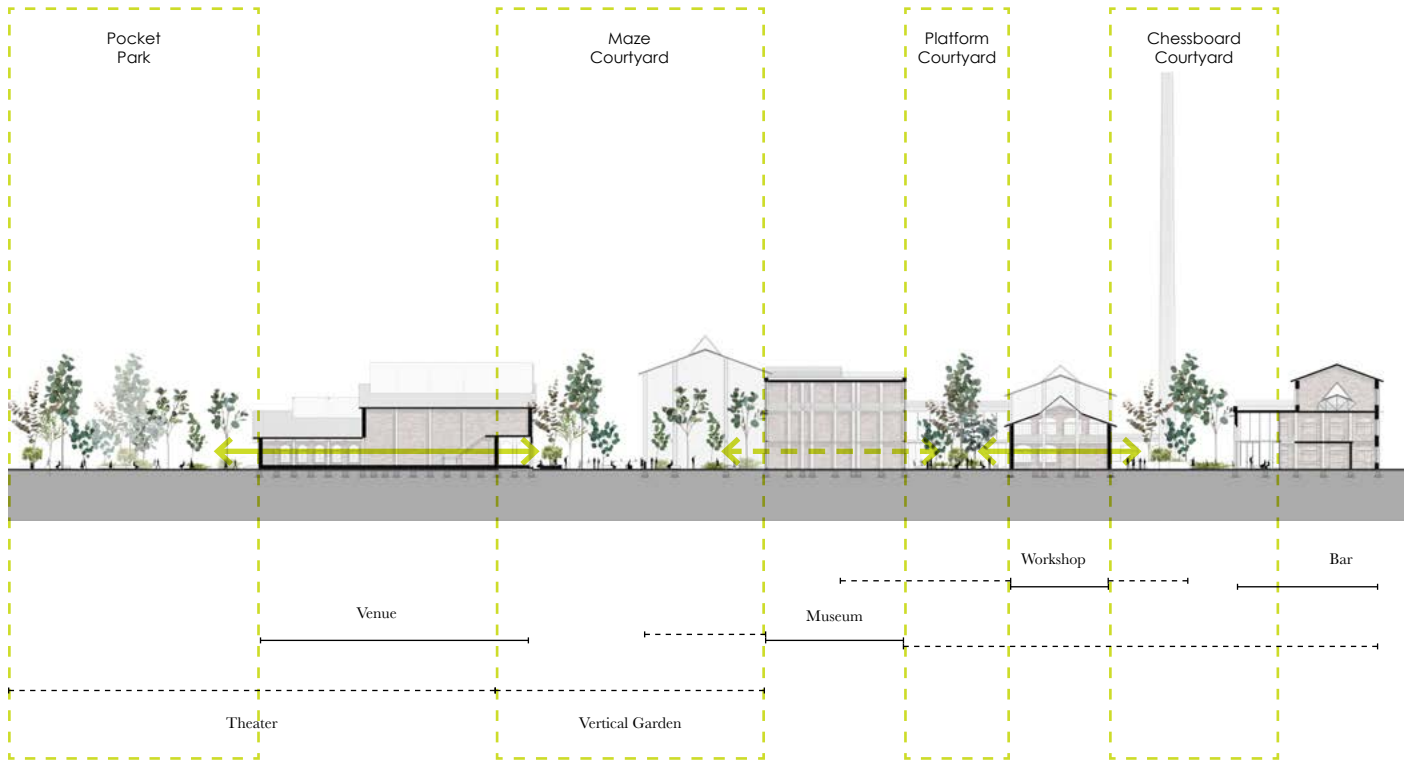

Add - Green Backbone



Connect
Repeat
Extend
...



Set Back
Remove
Open
...



Enhance
Shift
Keep
...

Urban Collage Poem - Delete

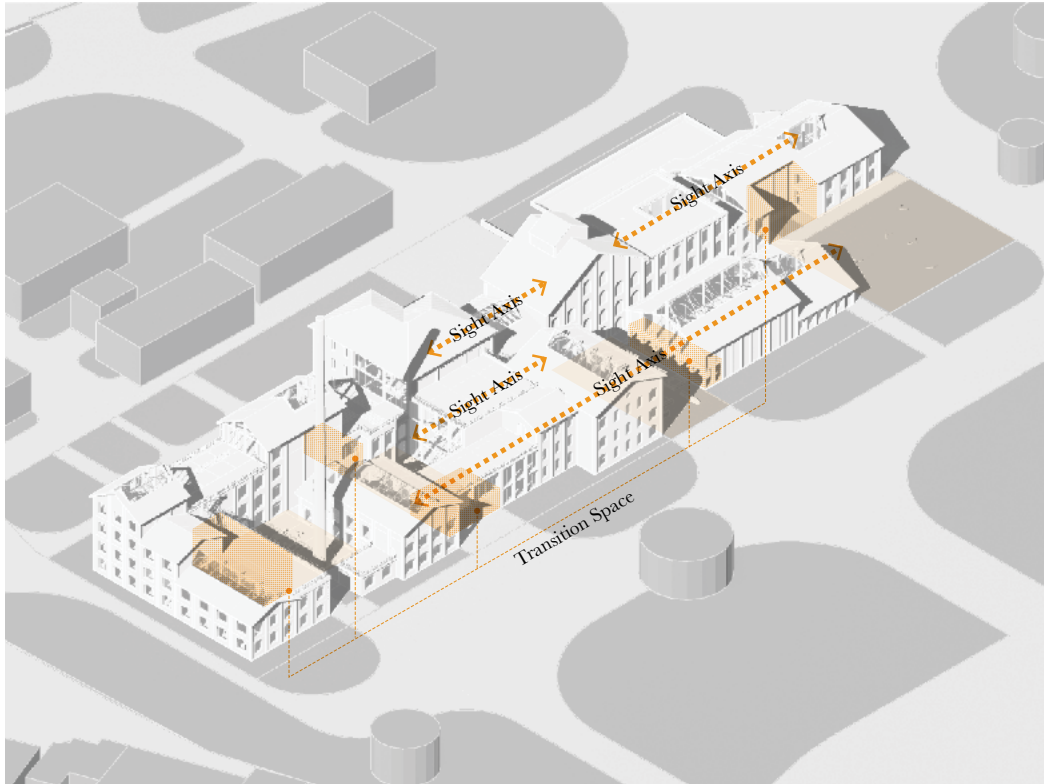

Delete - Open up Space

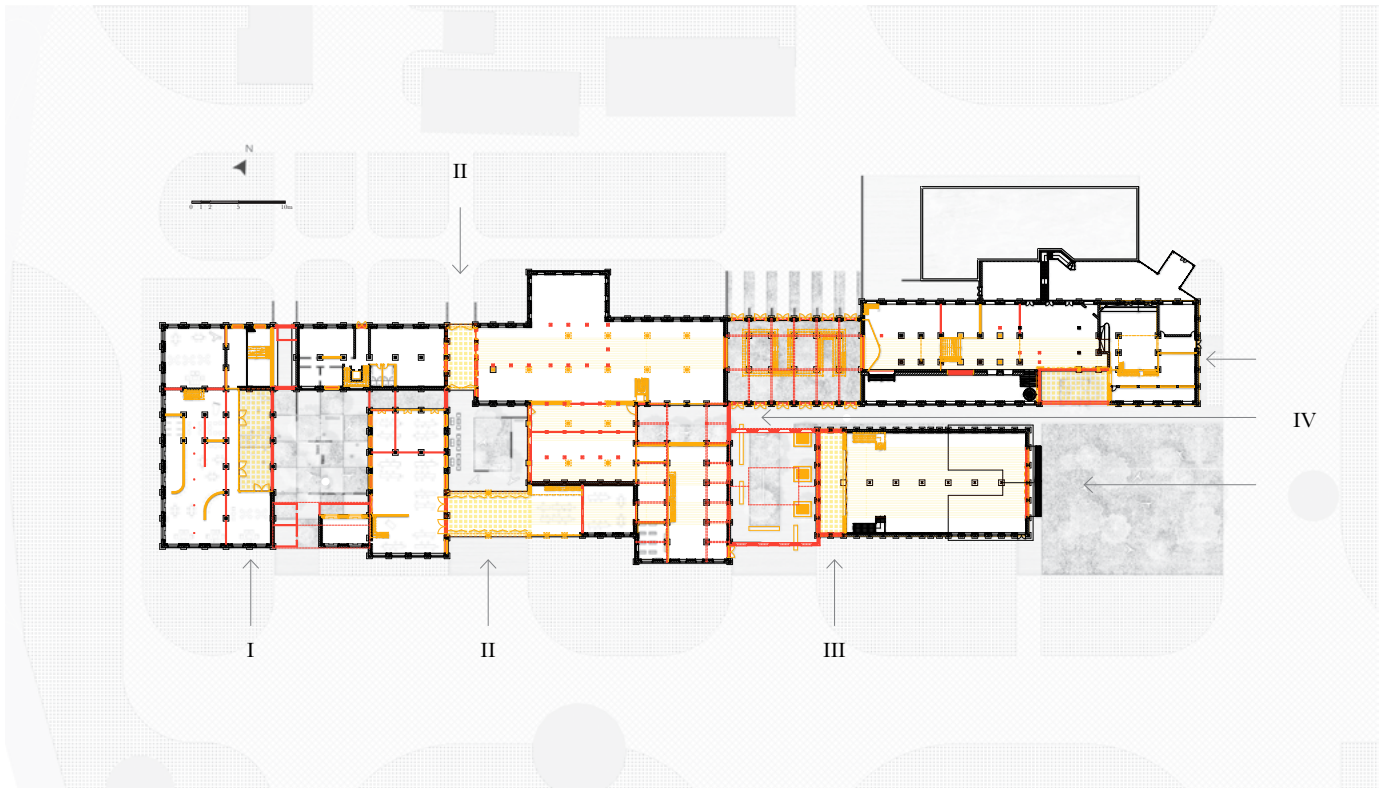

■ Existing

■ Demolish

■ Renovation

Delete - Open up Space

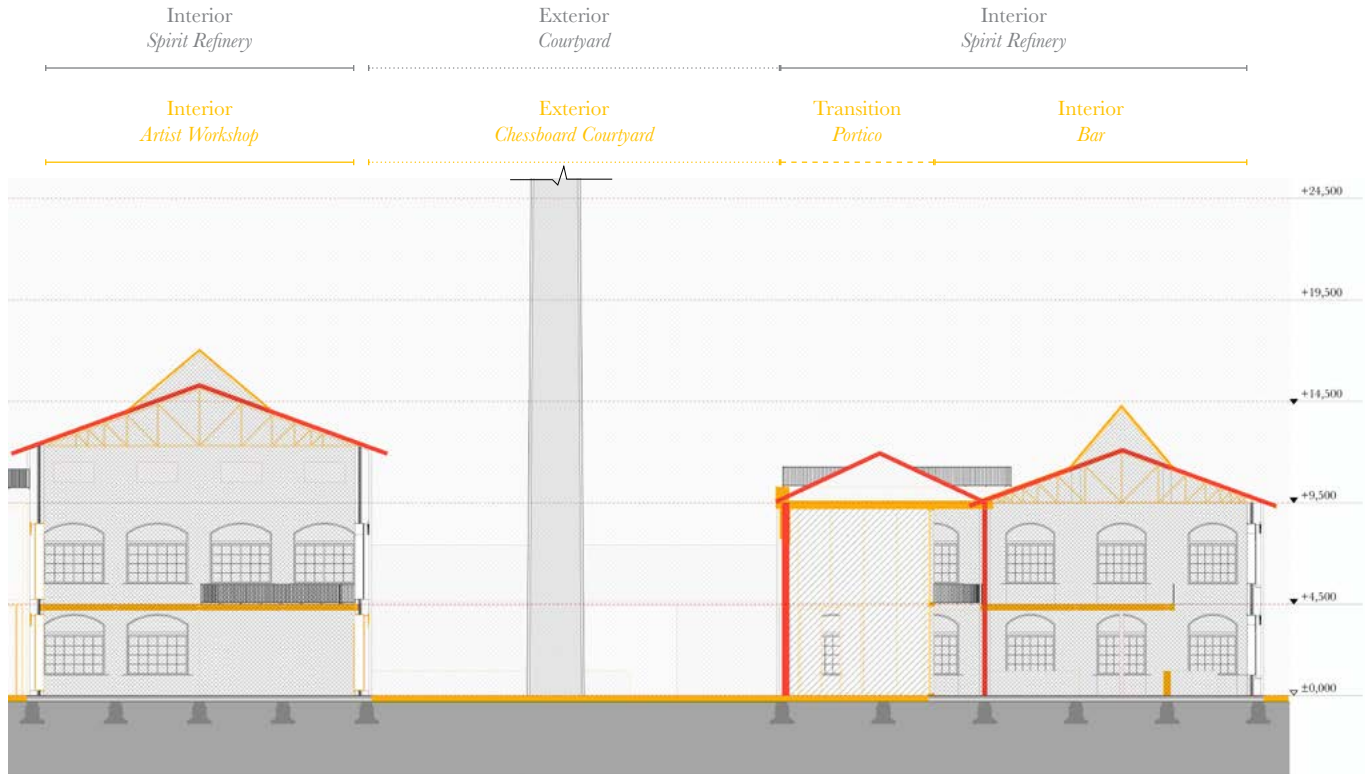

■ Existing

■ Demolish

■ Renovation

Delete - Transition Space I

Interior
Spirit Refinery

Exterior
Courtyard

Interior
Spirit Refinery



Delete - Former I

Interior
Artist Workshop

Exterior
Chessboard Courtyard

Transition
Portico

Interior
Bar



Delete - Transition Space I - Chessboard Courtyard

Exterior
Site

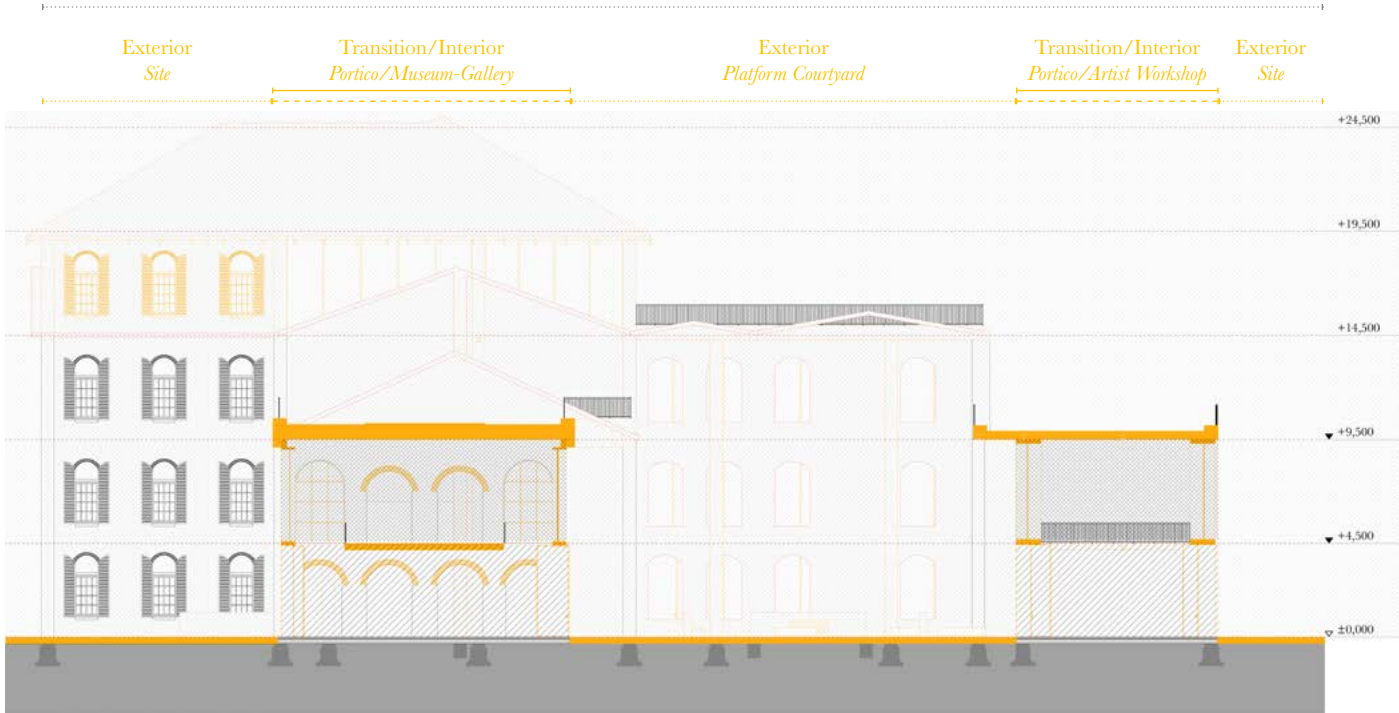

■ Existing

■ Demolish

■ Renovation

Delete - Transition Space II

Exterior
Site



Delete - Former II

Exterior
Site

Transition/Interior
Portico/Museum-Gallery

Exterior
Platform Courtyard

Transition/Interior
Portico/Artist Workshop

Exterior
Site



Delete - Transition Space II - Platform Courtyard

Interior
Sugar Refinery Building

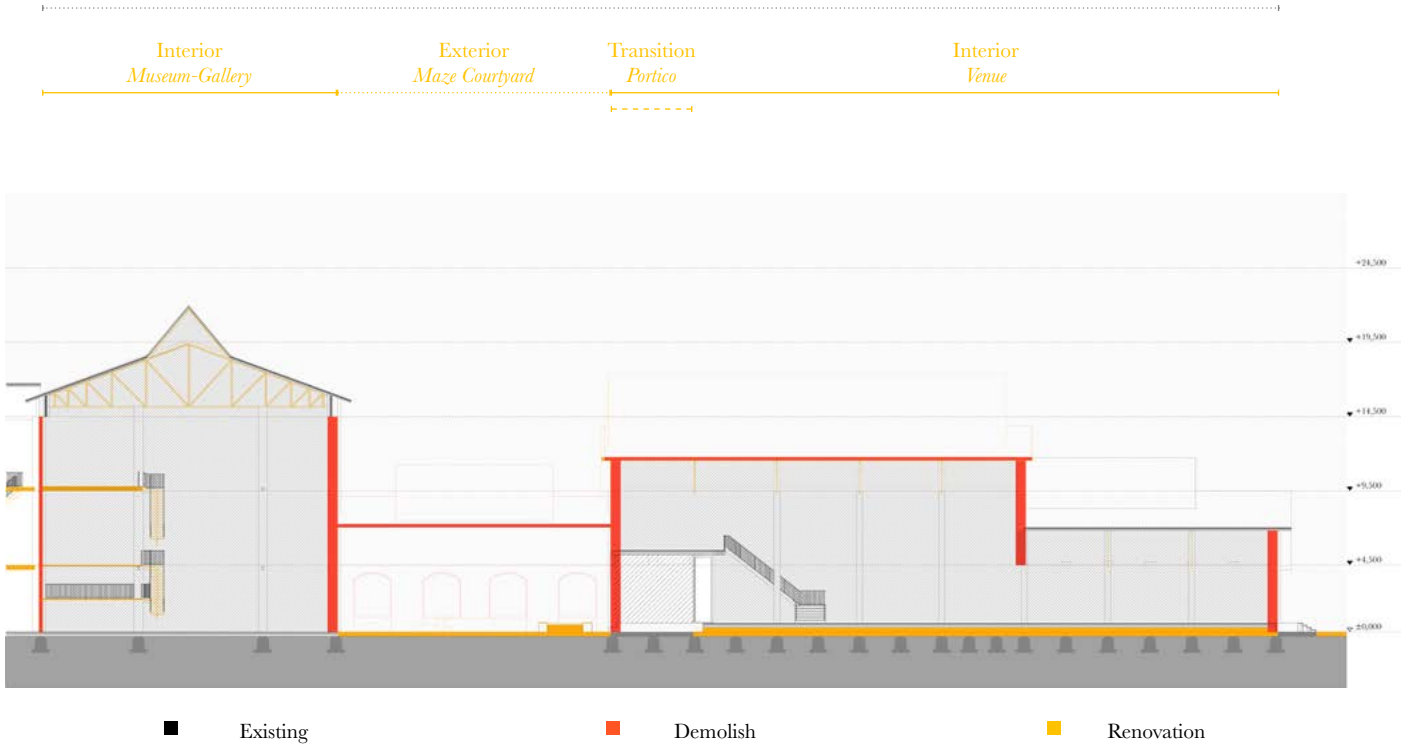

Delete - Transition Space III

Interior
Sugar Refinery Building



Delete - Former III

Interior
Museum-Gallery

Exterior
Maze Courtyard

Transition
Portico

Interior
Venue



Delete - Transition Space III - Maze Courtyard



Connect
Repeat
Extend
...



Set Back
Remove
Open
...



Enhance
Shift
Keep
...

Urban Collage Poem - Replace

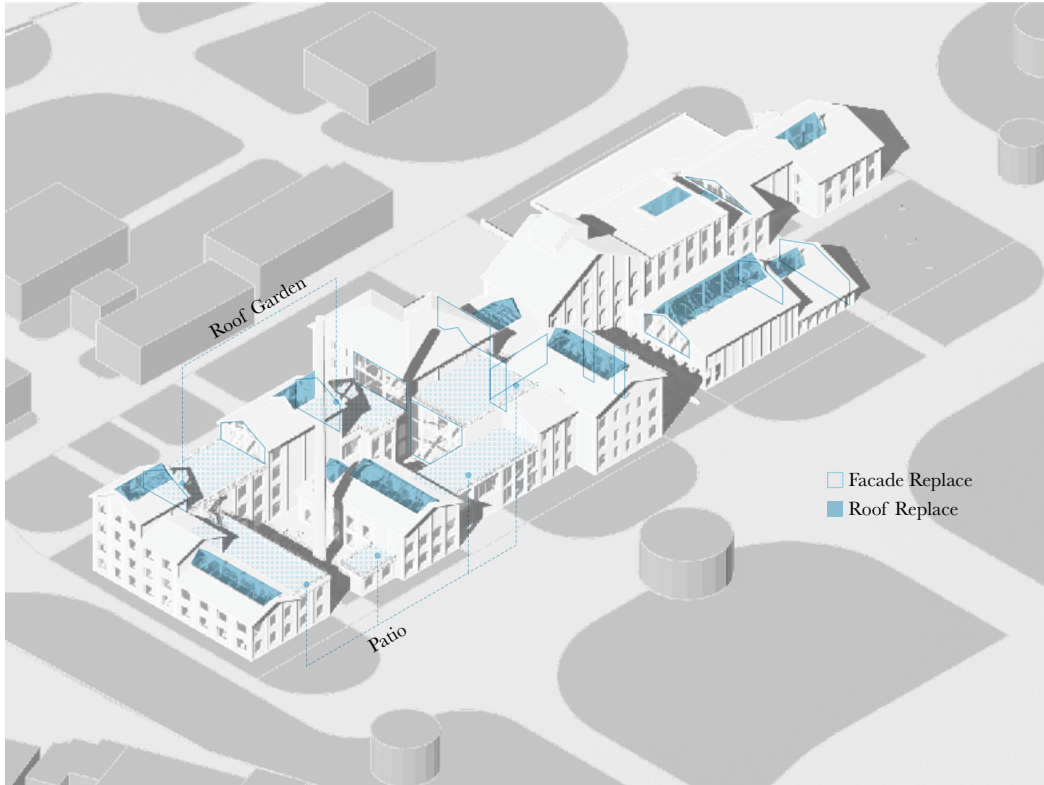

Replace - Enhance Quality

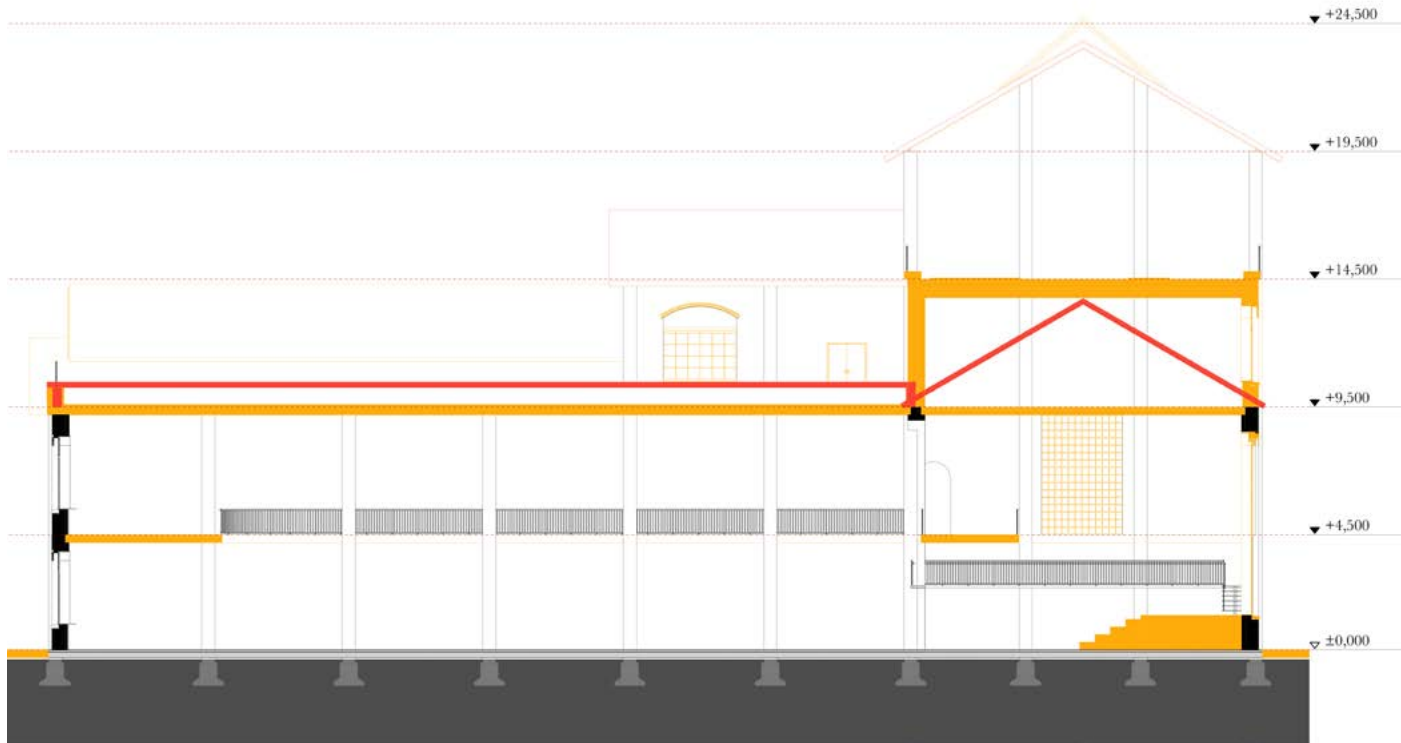

■ Existing

■ Demolish

■ Renovation

Replace - Interactive Space - Former I

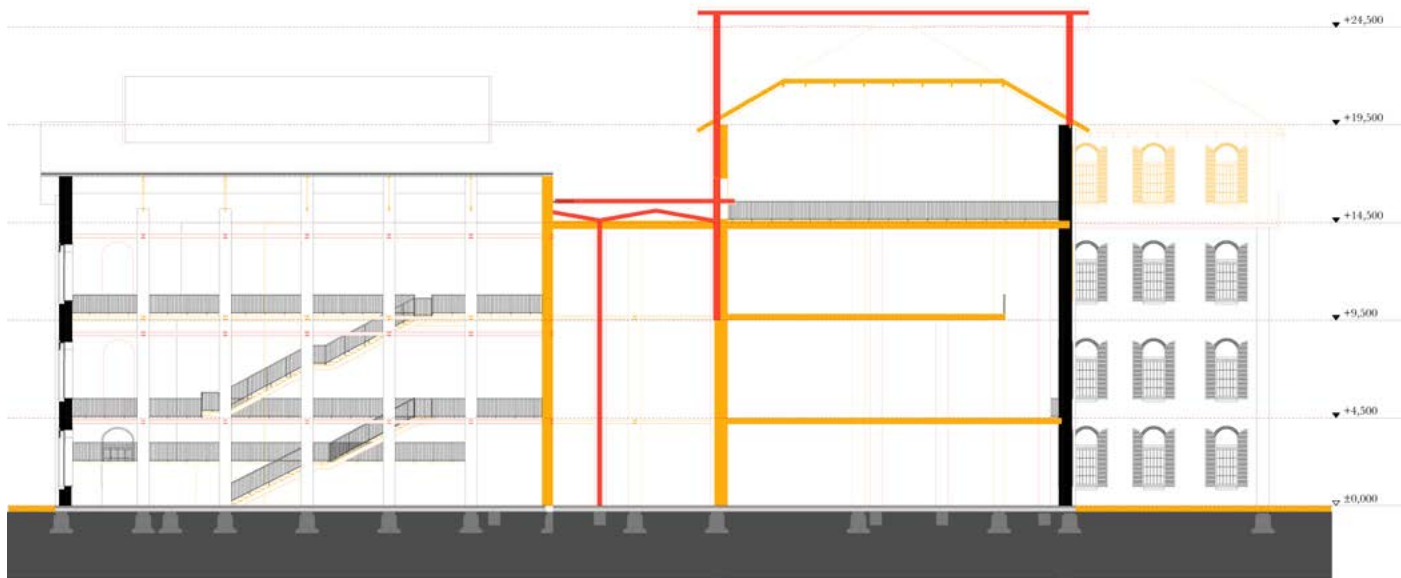

■ Existing

■ Demolish

■ Renovation

Replace - Interactive Space - Former II



Replace - Interactive Space II - Museum Hall



■ Existing

■ Demolish

■ Renovation

Replace - Interactive Space - Former III



Replace - Interactive Space III - Theater/Vertical Garden/Museum/Bar

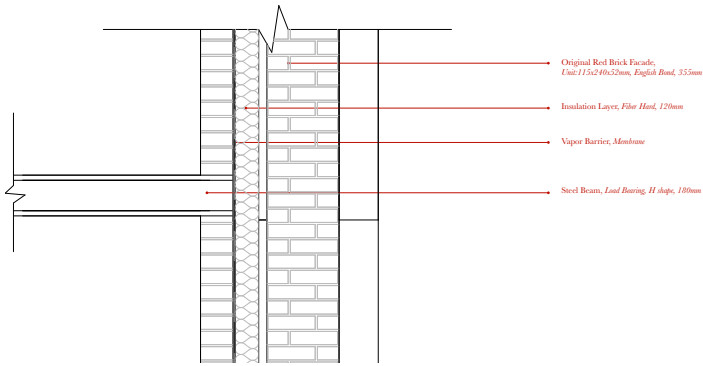

Load Bearing Beam

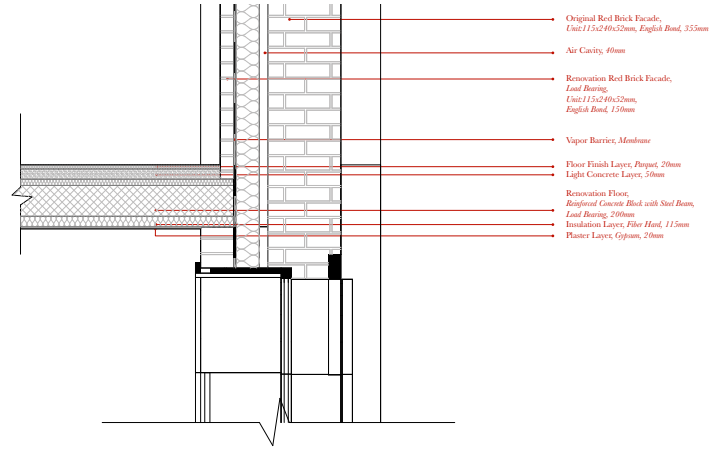

Adding Floor

Replace - Interactive Space - Construction Detail

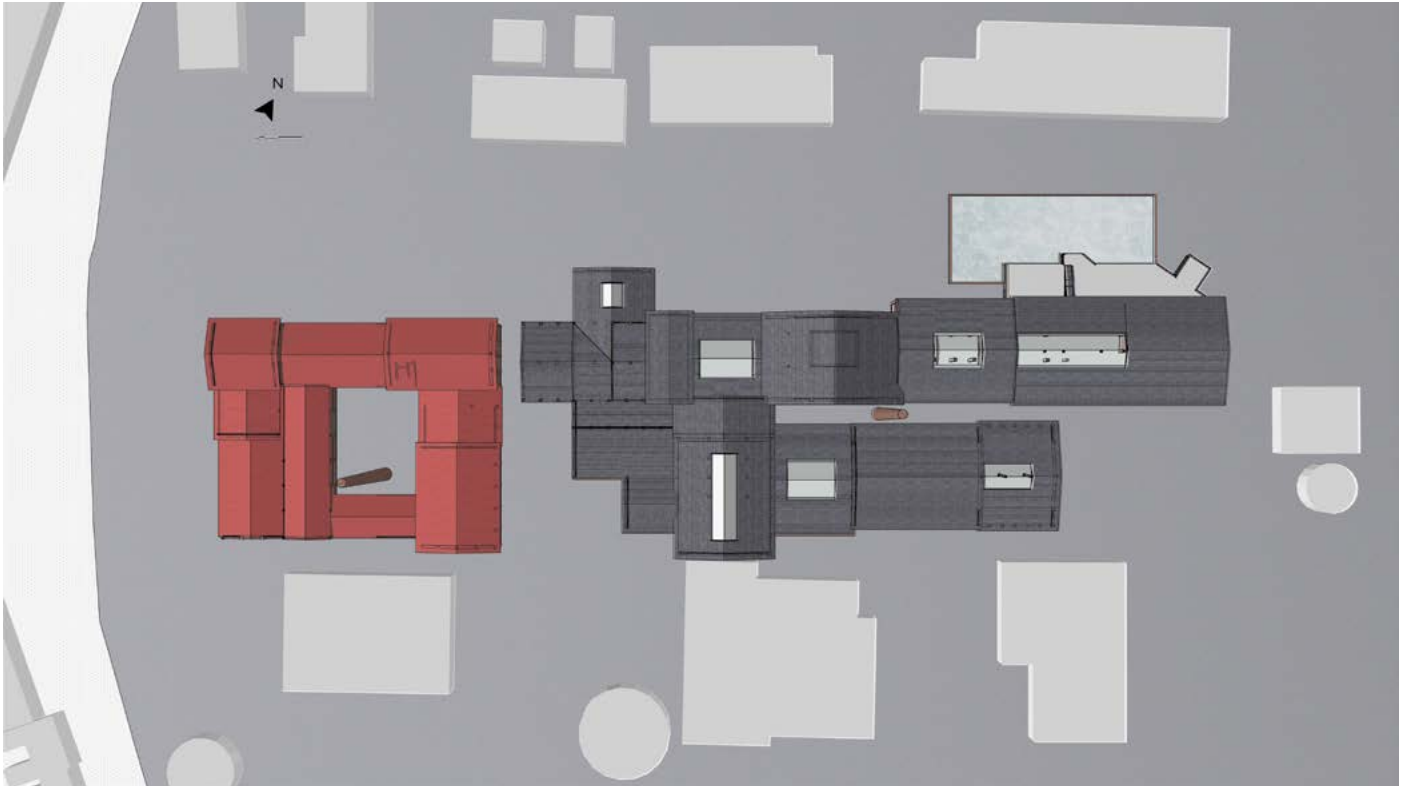

Replace - Former Roof Plan



Replace - Renovation Roof Plan - Patio and Roof Garden

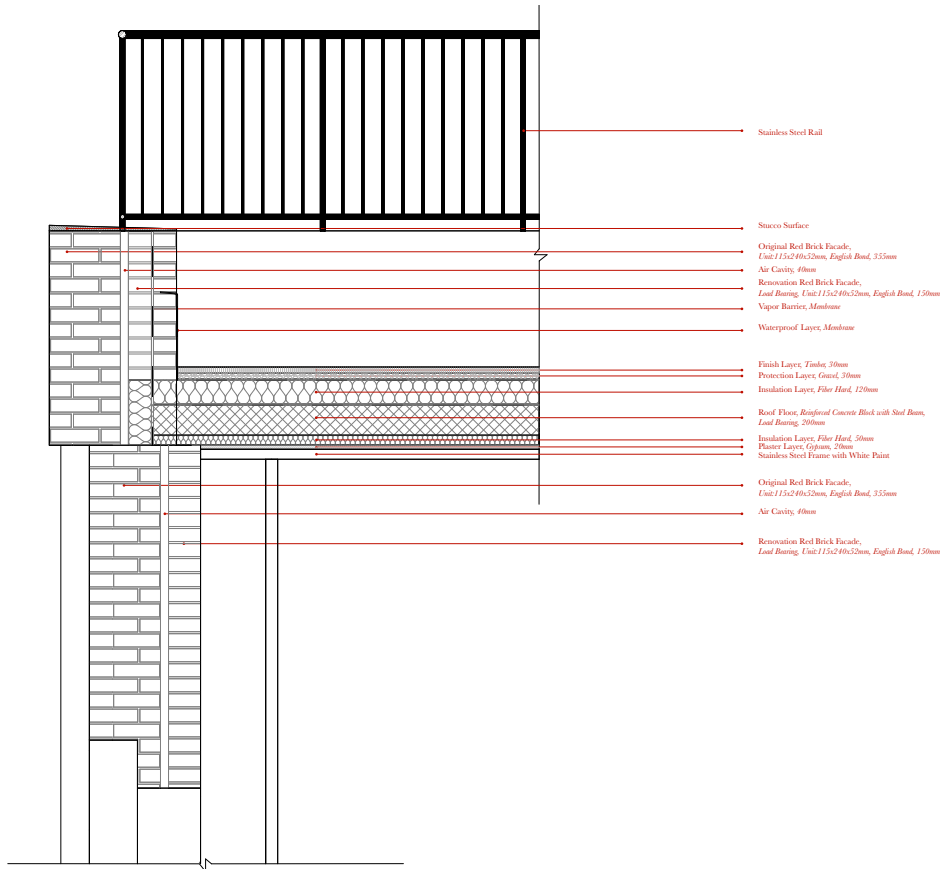

Replace - Patio - Detail

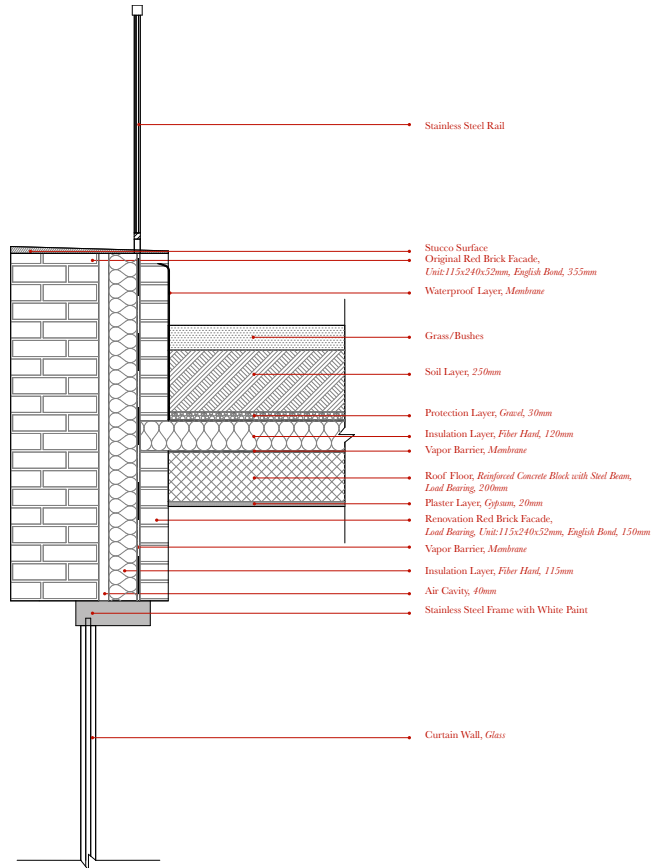

Replace - Roof Garden - Detail

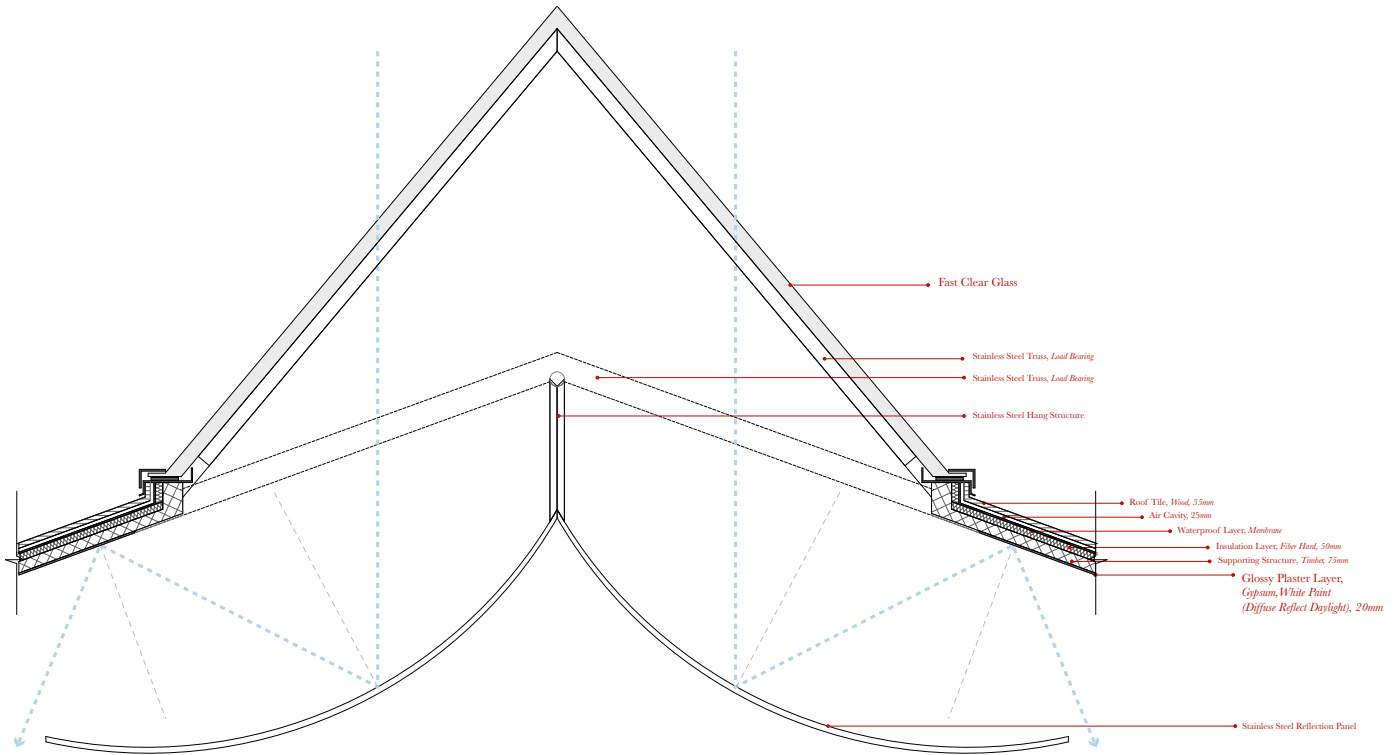

Replace - Skylight Enhance - Detail



Replace - Roof Garden & Viewing Platform

Chapter III Future

Generate New Meanings

Cultural Complex as Area Transition Activating Point

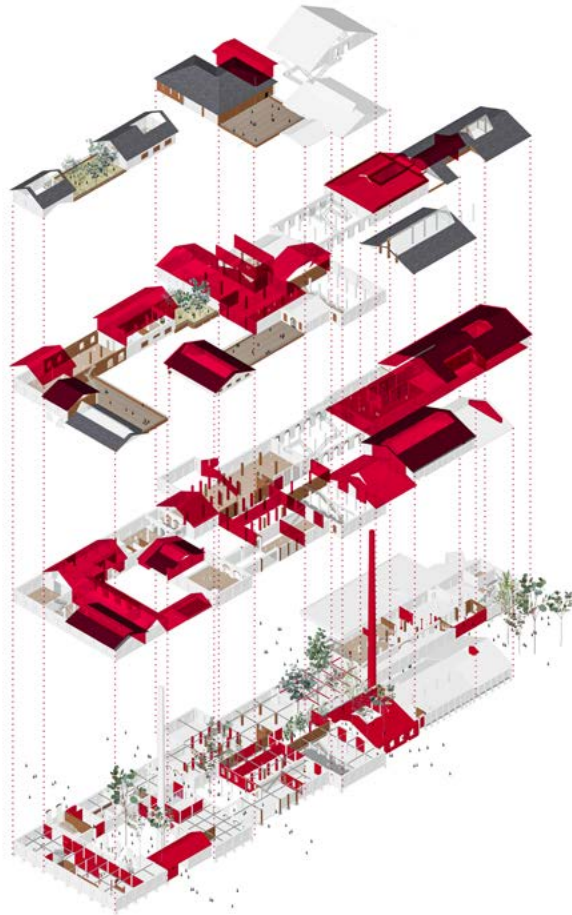

Urban Collage Poem - Renovation Operation

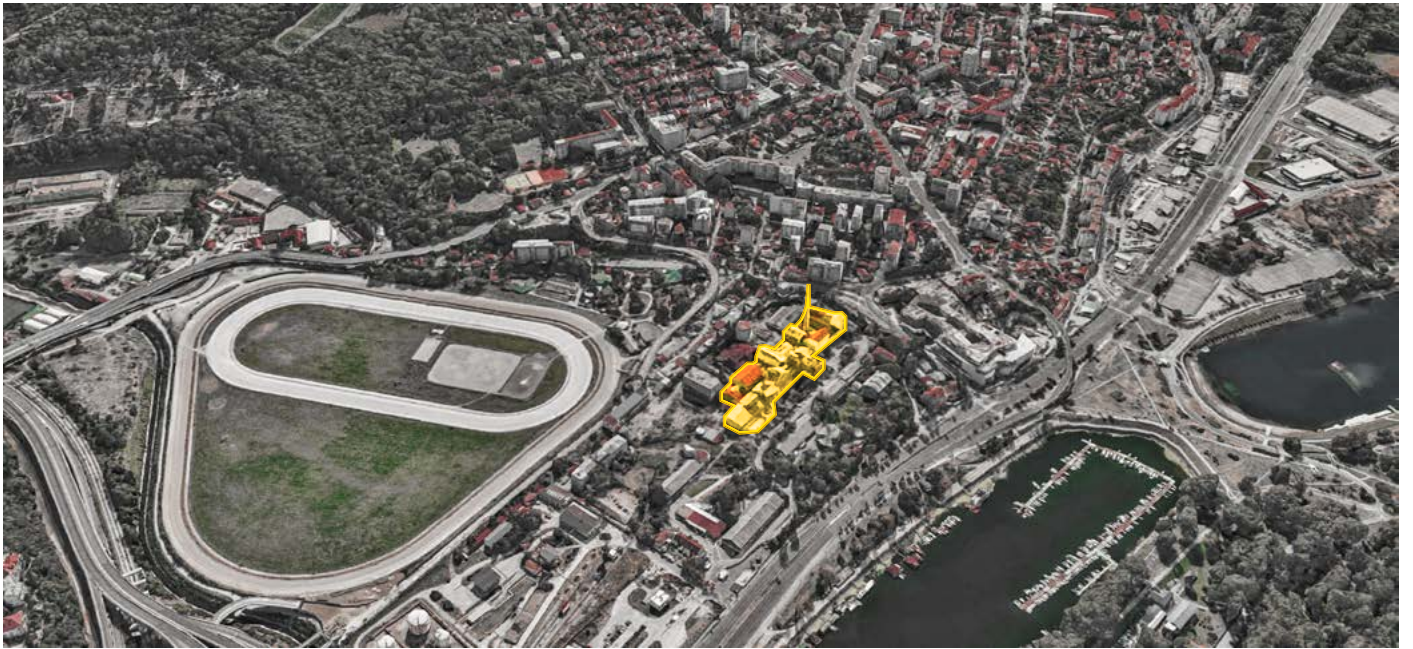

Urban Collage Poem - Former Condition



Urban Collage Poem - Bird-view



↑
Space Sequence - Urban Entrance



Space Sequence - Square



Space Sequence - Chessboard Courtyard Entrance



Space Sequence - Chessboard Courtyard



Space Sequence - Platform Courtyard



Space Sequence - Maze Courtyard



Space Sequence - Rooftop Viewing



Urban Collage Poem - Bar Interior



Urban Collage Poem - Activity Room



Urban Collage Poem - Neighborhood Reading Room



Urban Collage Poem - Local Market



Urban Collage Poem - Artist Workshop



Urban Collage Poem - Museum



Urban Collage Poem - Theater

Fin.

Urban Collage Poem Renovation Project

Appendix

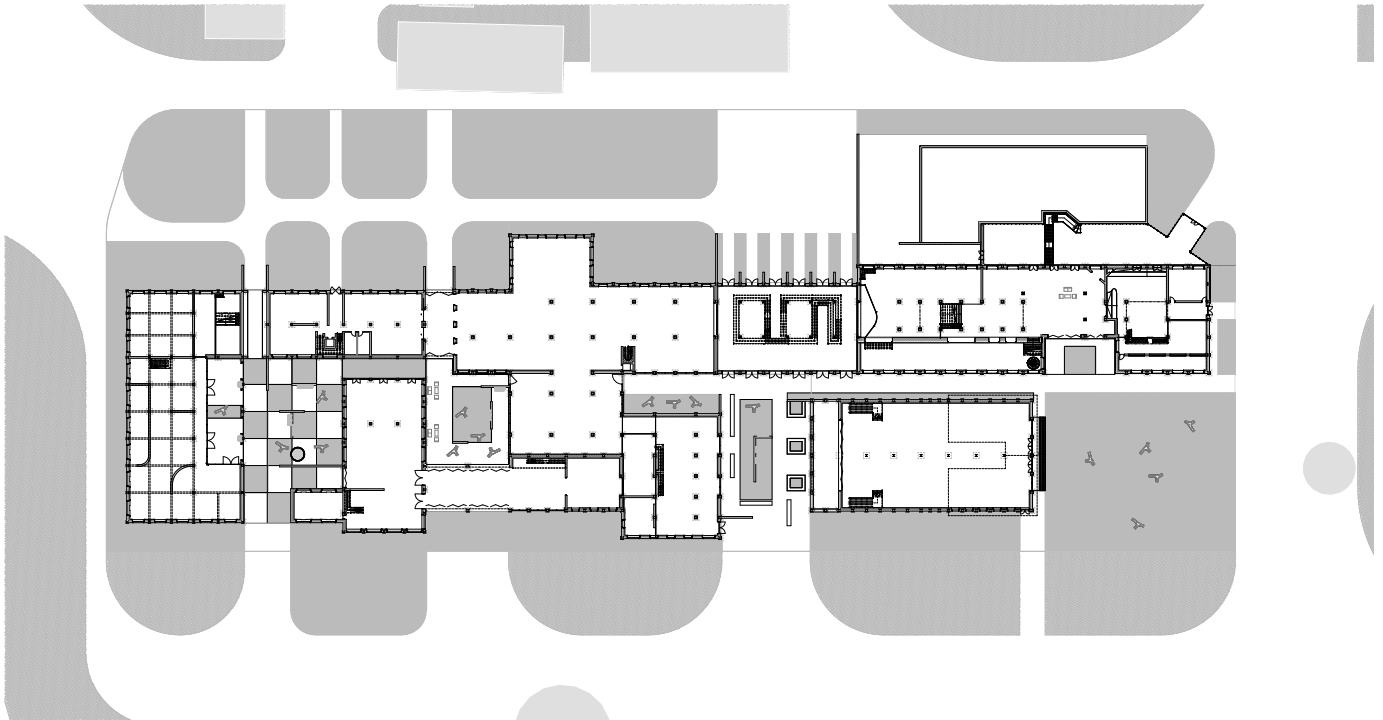

Ground Floor Plan



Existing



Demolish



Renovation

1st Floor Plan

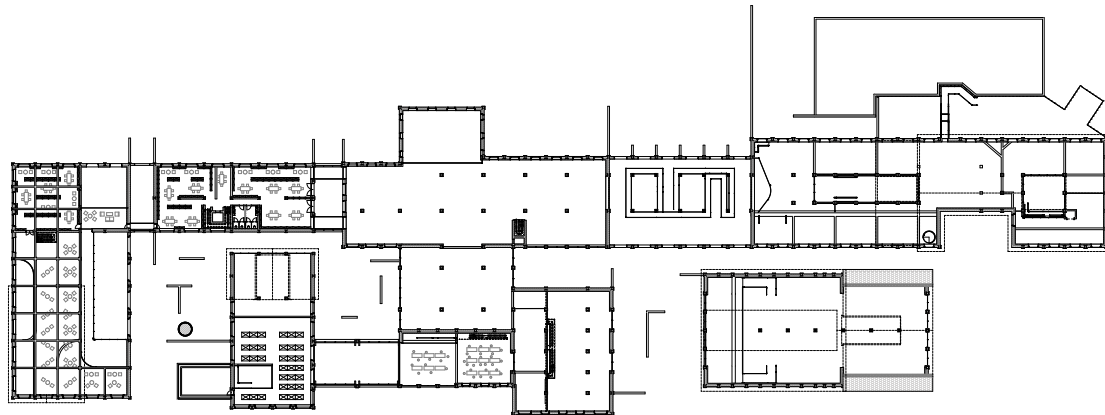

1st Floor Plan

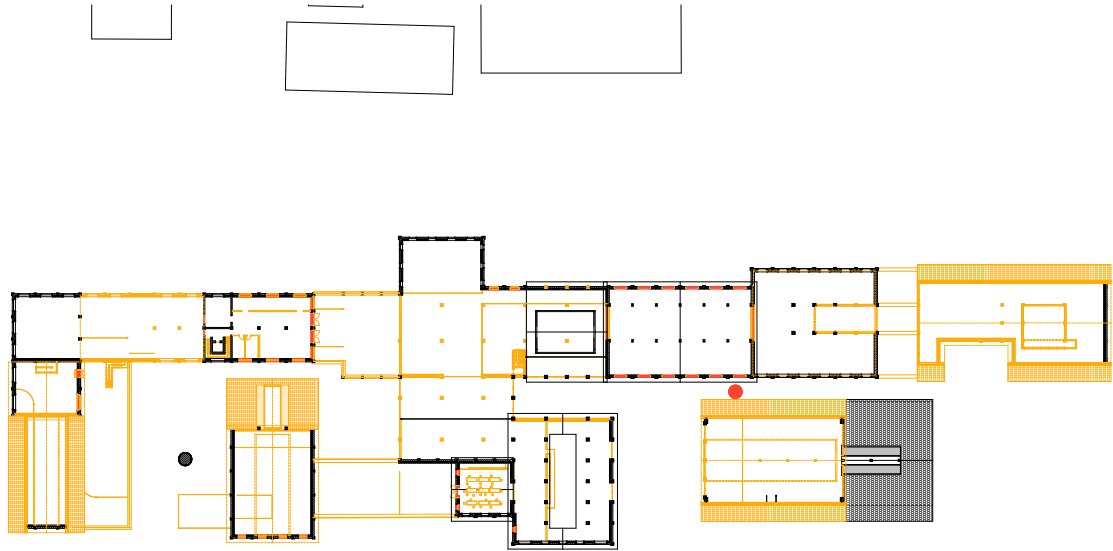

■ Existing

■ Demolish

■ Renovation

2nd Floor Plan

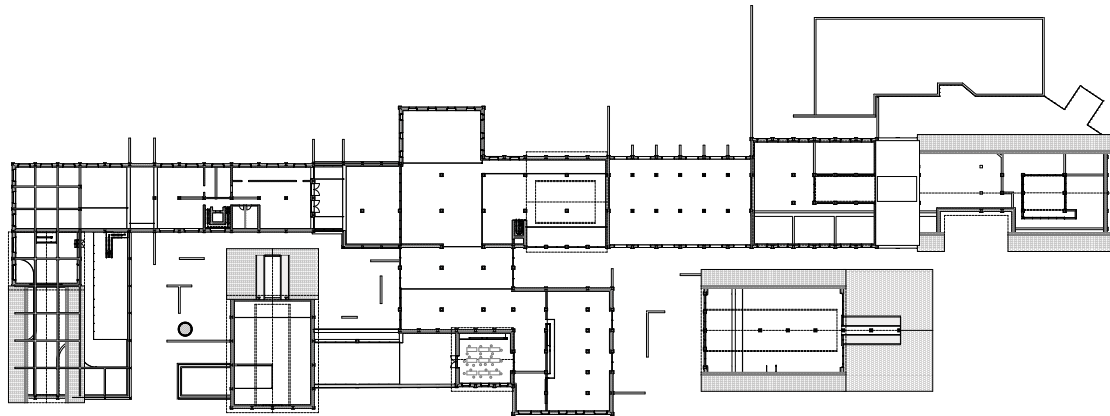

2nd Floor Plan

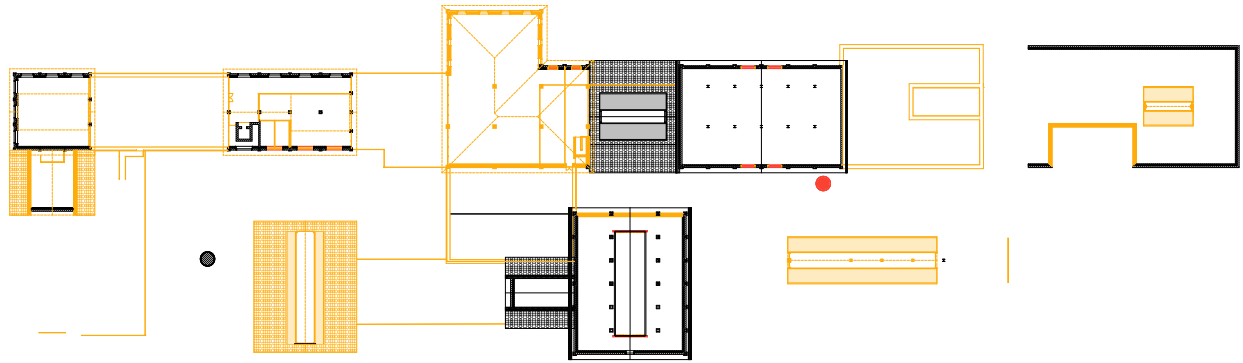

■ Existing

■ Demolish

■ Renovation

3rd Floor Plan

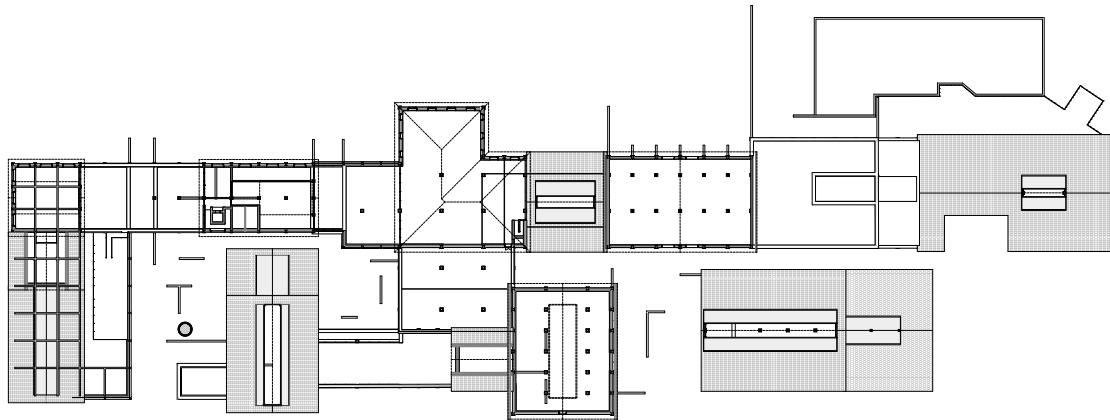

3rd Floor Plan

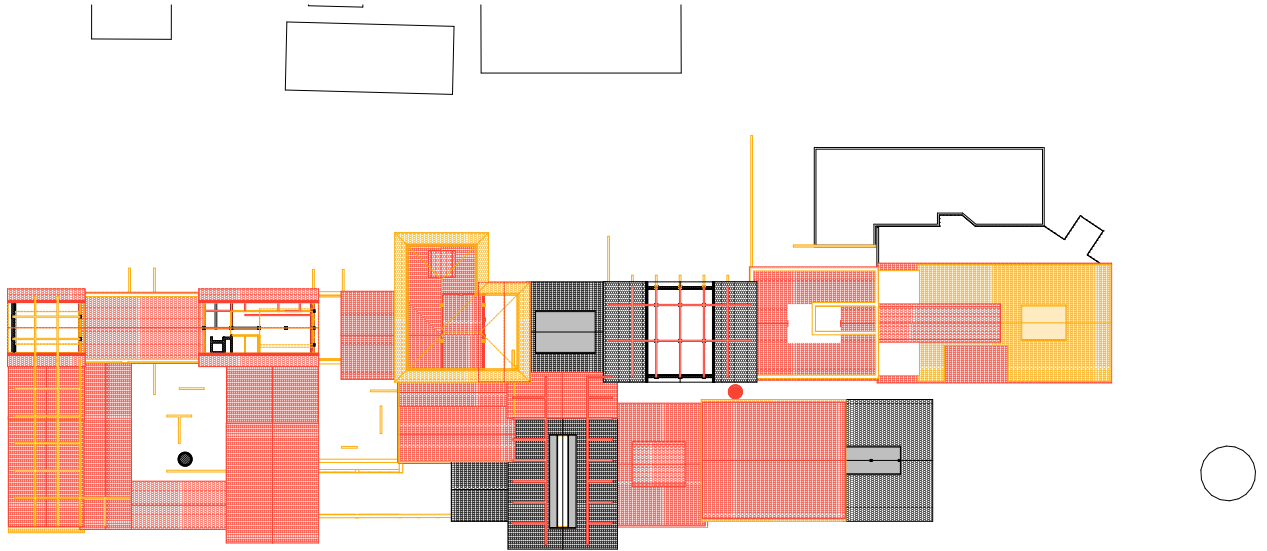

- Existing
- Demolish
- Renovation

4th Floor Plan

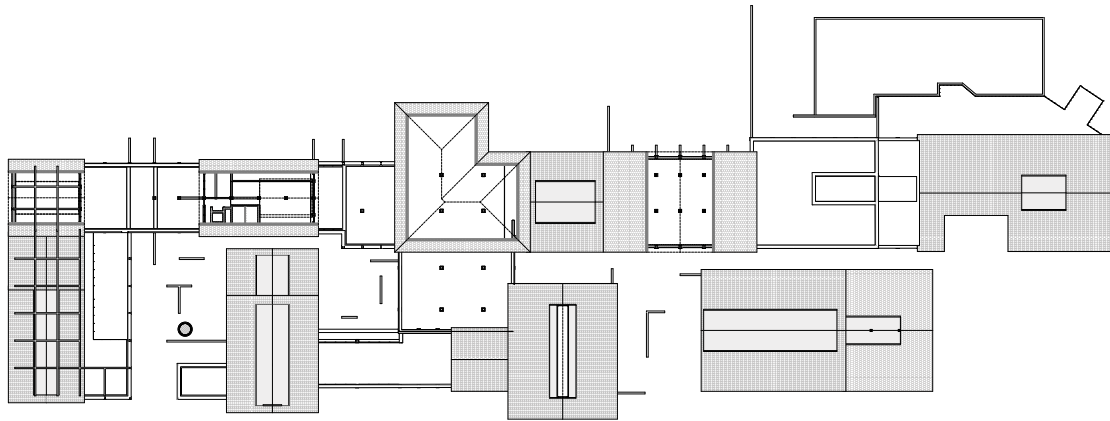

4th Floor Plan

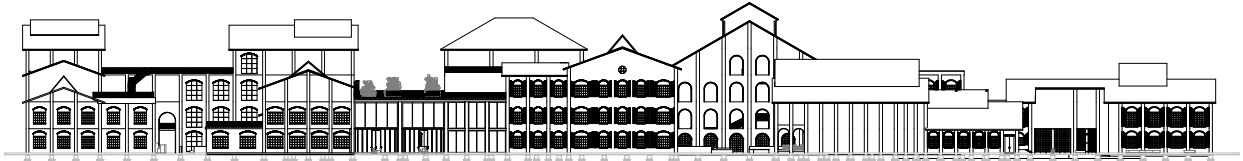

South Elevation



North Elevation

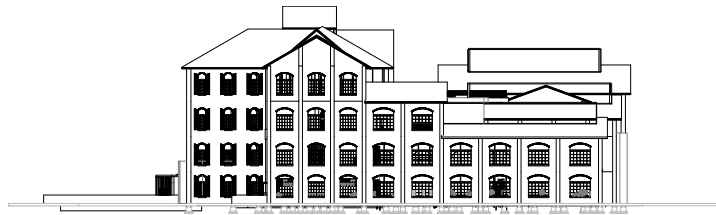

West Elevation

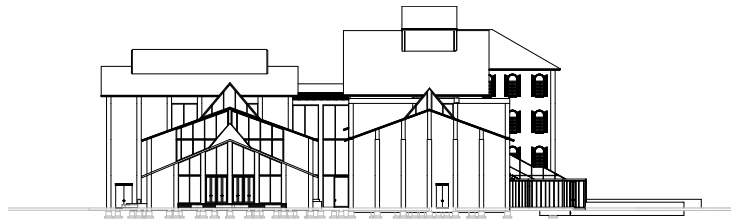

East Elevation

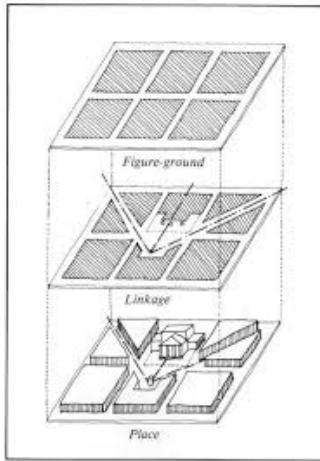

FINDING LOST SPACE
--- THEORIES OF URBAN DESIGN

ROGER TRANCIK

Lost space/antispaces :

...rapid expansion of highway, railway.

...abandoned industry or military buildings old urban center.

Lack connection with urban/nature context

Isolate area & fragment of urban space

Figure-ground Theory - Urban texture & order

Linkage Theory - Circulation & movement

Place Theory - Culture & identity

Theory-Lost Space

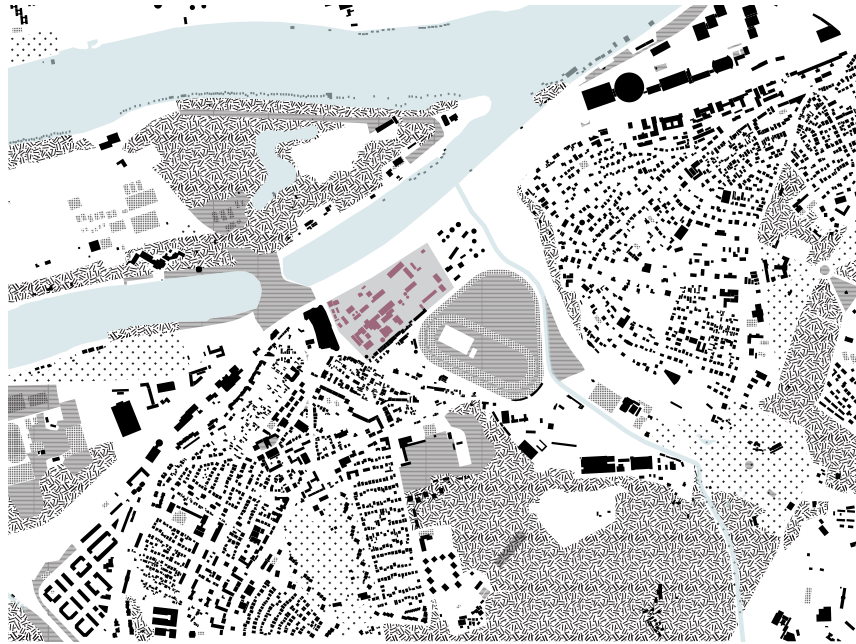
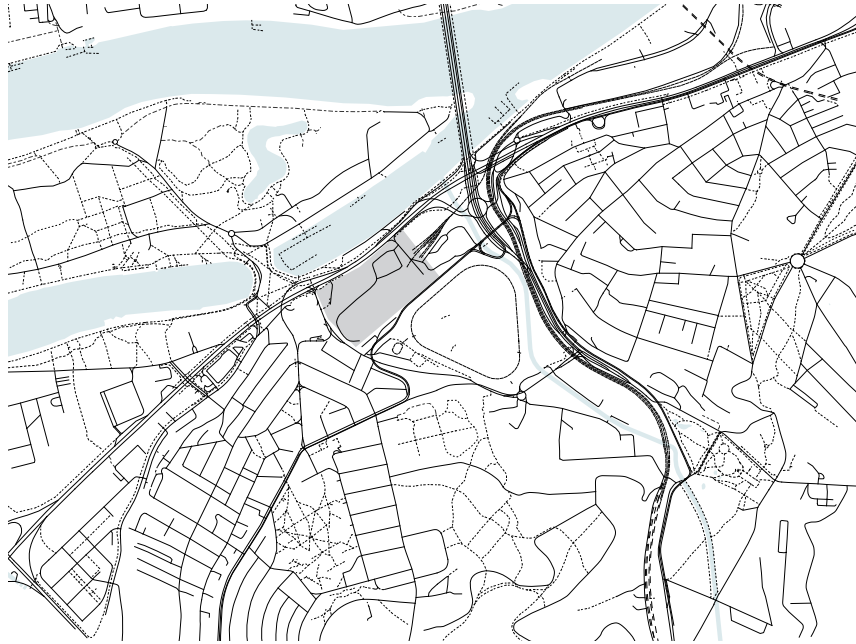
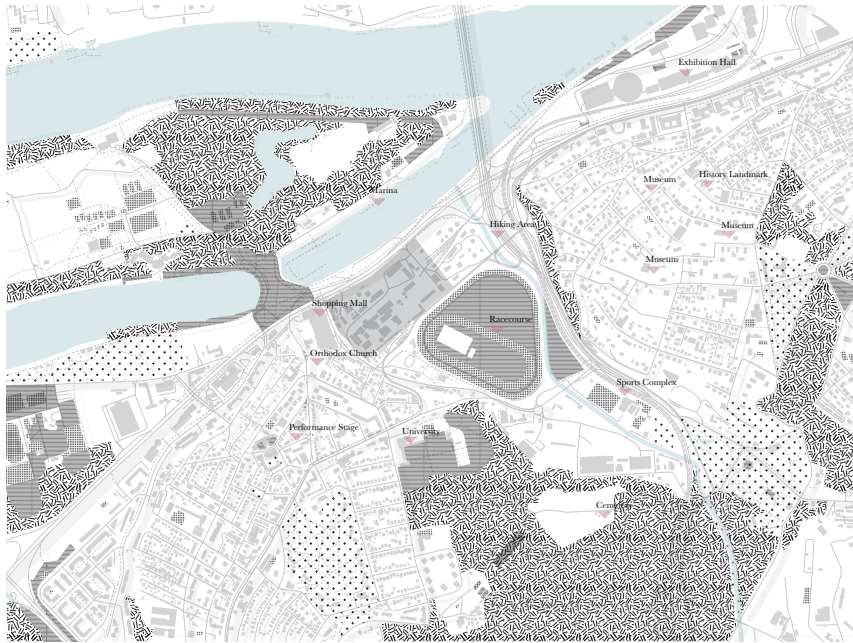

Figure-Ground Map



Linkage Map



Place Map

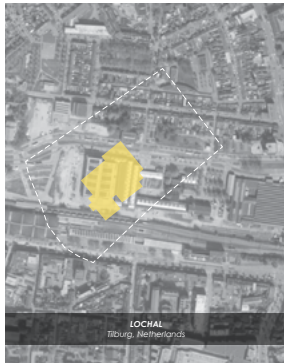

Scale Compare



Boiler House Libčice nad Vltavou / Atelier Hoffman
Boiler House > Exhibition



TaoCang Art Center / Roarc Renew
Granaries > Gallery

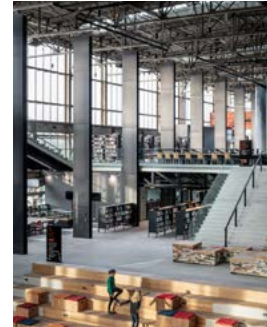

Lochal Library / CIVIC architects + Braakmsa & Roos architectenbureau
Railway Workhouse > Library, Art, Event Complex



National Museum of Roman Art / Rafael Moneo
former Iberian outpost of Emerita Augusta > Museum



Kolumba Art Museum of the Cologne Archdiocese / Peter Zumthor Museum
Late-Gothic Church > Museum

Precedents Study



Botanic Garden



Typical Industrial Building



Varying Interior Space



Historical Infrastructure



Key Production Machines



KPGT Theater

Valuable Elements

RESEARCH PLAN

URBAN COLLAGE POEM—RENOVATION PROJECT OF BELGRADE SUGAR FACTORY

	KALENIĆ MARKET	BELGRADE FAIR	SUGAR FACTORY	CONNECTING POINT OF URBAN&NATURE
CONTEXT STUDY				
OBJECT	STALL ENTRANCE CORRIDOR SEQUENCE SPACE BEHAVIOR	HALL 1 STRUCTURE	SCALE STYLE MATERIAL CASE STUDY CODING COMMUNITY	LINKAGE TEXTURE
TOPIC/CONCEPT	 SPATIAL LATENCY	 FORM	 SPACE BEHAVIOR	
THEORY	PEOPLE IN THE PHYSICAL ENVIRONMENT: THE URBAN ECOLOGY OF STREETS STANFORD ANDERSON RHYTHM ANALYSIS HENRI LEBEVRE		THE DEATH AND LIFE OF GREAT AMERICAN CITIES JANE JACOBS FINDING LOST SPACE-THEORIES OF URBAN DESIGN ROGER TRANCIK GENIUS LOCH TOWARDS A PHENOMENOLOGY OF ARCHITECTURE NORBERG-SCHULZ	
EPISTEME	PHENOMENOLOGY PRAXEOLOGY	MATERIAL CULTURE TYPOLOGY	PRAXEOLOGY PHENOMENOLOGY	
	1 What elements can help users recognize the space and take advantage of it. 2 How to identify the potential of the space.		3 How to implement the potential and transform the space to meet the present requirements.	

Lost Space in Urban Context

Anderson environments

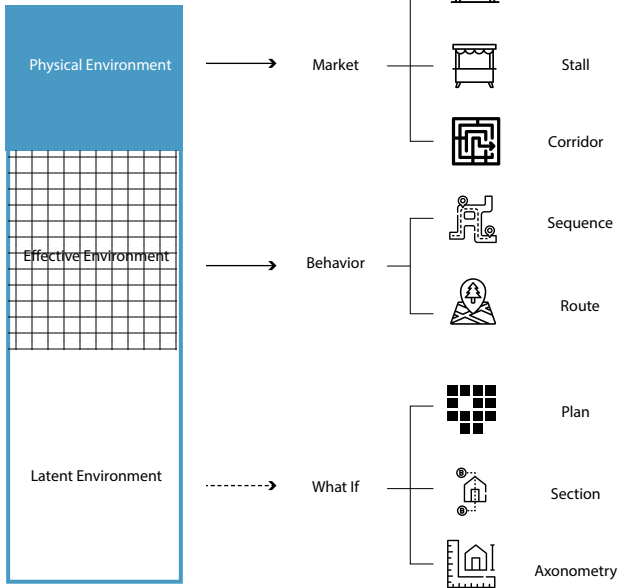

Analysis



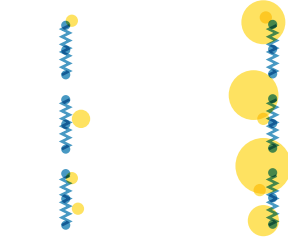
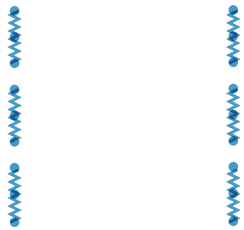
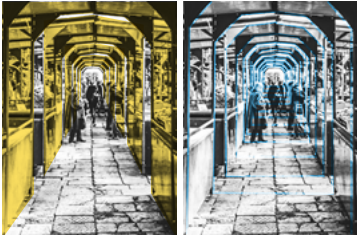

Group Research- Spatial Latency

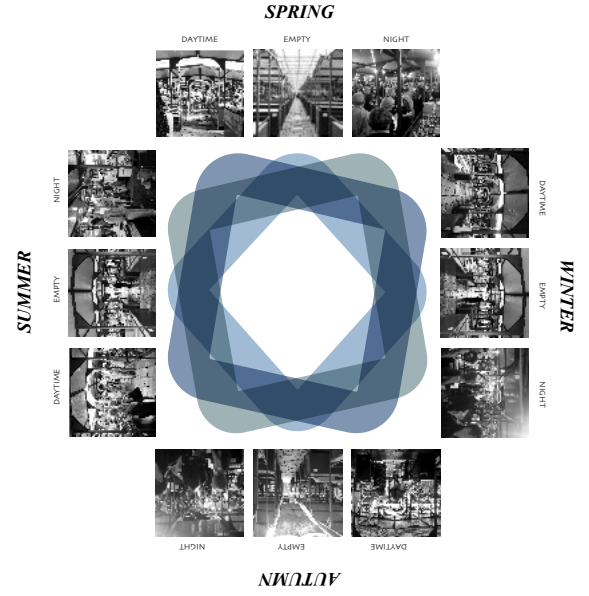

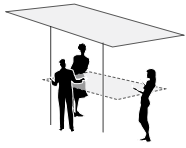

Conversation between vendors and customer

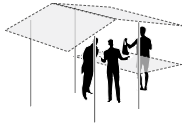

Exchange of goods between vendor and customer



Chess playing



Street music

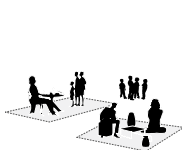

Street music



Street music

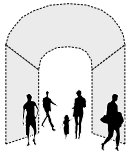

Enter/leave the market

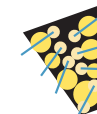
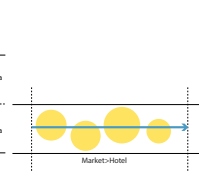
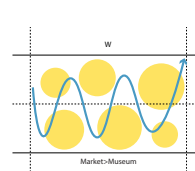
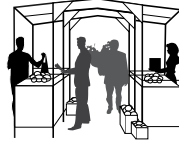
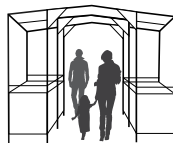

Group Research- Spatial Latency



1. The dome



2. The gallery

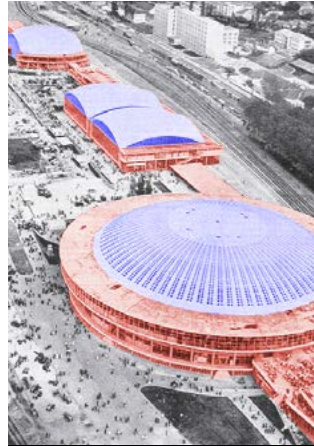

3. Trading Fair



4. Trading Fair



5. Car Fair



6. Book Fair



7. Fashion Show



8. Emergency Hospital

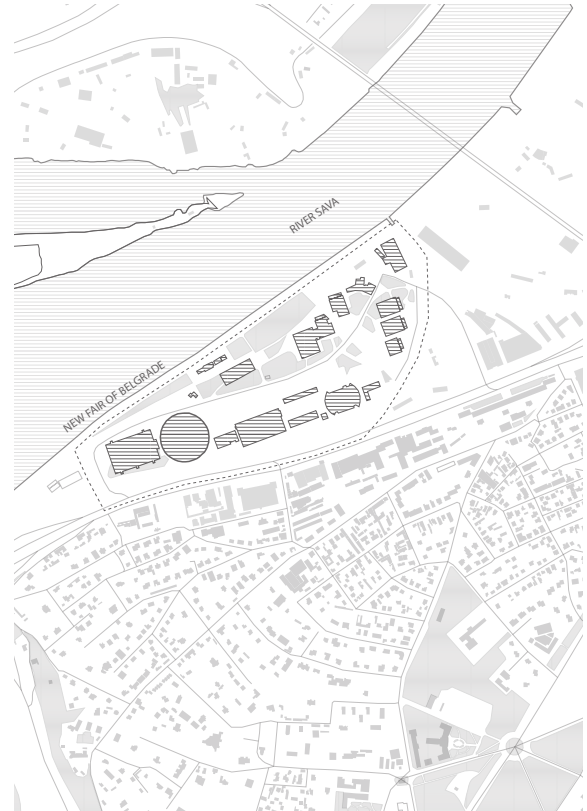
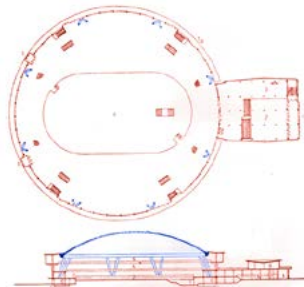

Precedent Study- Belgrade Fair Hall 1

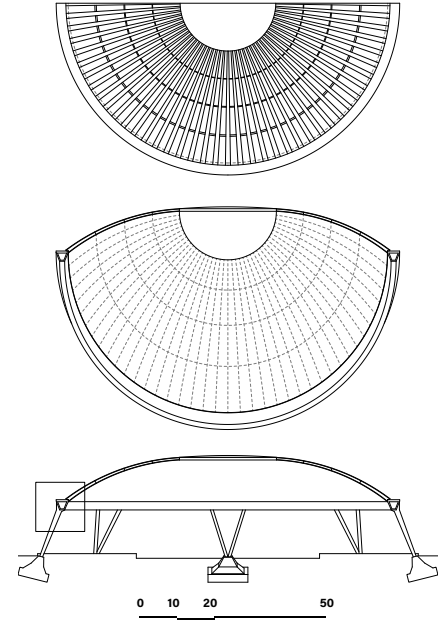
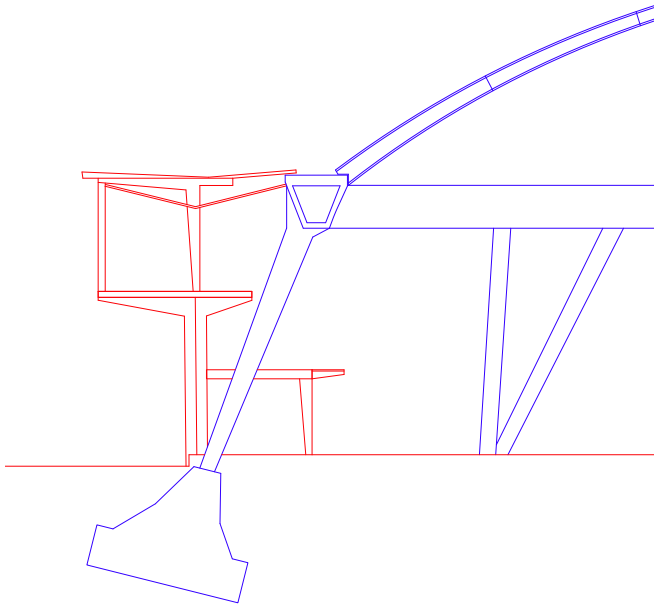

Precedent Study- Material and Form