

DESIGNING THE USED.



Enhancing the **consumer acceptance** of **refurbished** luxury personal care products; a **Philips Lumea Prestige** case study.

THANK YOU!

*Dat ik het ooit nog zou missen, die 'vervelende' faculteit
Hulde aan mijn studie vriendinnen^[3], door jullie was het daar altijd een bom gezelligheid*

*Alleen is wel saai, dat heb ik tijdens Corona helaas kunnen ontdekken
Mama als gebruiker, opa^[4] als expert, het was van de gekken*

*Want 'Oh oh wat was het leuk' en 'wat hebben we veel geleerd'
Ondertussen ben ik met bureau en al verteerd
En ik heb al thuiswerkend mijn familie^[2] maanden lang geterroriseerd*

*Toch moet ik aan mijn begeleiders^[5] mijn respect betuigen
Die me, ondanks soms matig werk, onvermoeid zijn blijven toejuichen*

*Maar trots zijn op jezelf, dat mag ook best gezegd
Ik bedoel, ik heb zelfs mijn sociale leven ervoor omgelegd*

DESIGNING THE USED

MASTER THESIS

Designing the used; *Enhancing the consumer acceptance of refurbished products*; a Philips Lumea Prestige case study

May 2021

AUTHOR

Senna Snel | 4362462

Double degree
Master Integrated Product Design
Master Strategic Product Design

Faculty of Industrial Design Engineering
Delft University of Technology

SUPERVISORY TEAM

Chair: Dr. Ir. S. F. J. Flipsen
Circular Product Design | IDE

Mentor: PhD candidate T. S. Wallner
Marketing and Consumer Research | IDE

Company contact: MSc. F. De Fazio
Circular Product Designer | Philips

*Bedankt Senna, voor je inzet, dat heb je toch maar mooi gedaan
Ruim 7 jaar studeren, 'ga der maar aan staan'*

*Maar het is eindelijk klaar, ik heb het doorstaan
Nu ga ik bijslapen in het strandhuisje en hele dagen naar de golfbaan*

[1] Slightly exaggerated, of course. It was a fun and interesting project to be able to combine both my masters. **I am very grateful for this opportunity** to develop myself into a refurbishment expert and shape myself as a designer.

[2.1] Sorry lieve **pap en mam**, dat ik mijn prototypes overall door het huis heb laten slingeren. Dat ik jullie hele nachten heb wakker gehouden met werk sessies. Dat ik jullie maar bleef stalken om mijn testjes uit te voeren en mee te denken. Jullie steun en toewijding aan mij en mijn studie heeft mij de ruimte gegeven om te worden wie ik wil zijn. Iets waardevollers bestaat niet.

[2.2] Aan **Sven**, die al mijn overwinningen met me heeft gevierd, maar ook woede uitbarstingen heeft doorstaan. Zonder jou was ik al zeker vijf burn-outs verder. Bedankt voor je frisse blik, op alles in mijn leven.

[3] Lieve **Roxanne, Lisa, Pip en Pauline**. Zonder jullie was ik zeker nooit naar college gekomen en jullie peer-reviews en brainstormen waren goud waard. Jullie hebben dit project naar een hoger niveau getild, wat een dreamteam.

[4] Aan mijn **opa**, op wie ik van PO1 tot aan mijn afstudeer project heb kunnen rekenen voor goed advies of het maken van een prototype. Deze diploma is ook een beetje van jou. Er is niks mooiers dan de liefde voor ontwerpen met jou te kunnen delen. Laten we dit voor altijd samen blijven doen.

[5.1] **Theresa**, je enthousiasme over het project was een genoegen om mee te werken. Ik wens je heel veel succes met het behalen van je PhD, met deze aandacht en toewijding komt dat helemaal goed.

[5.2] **Bas**, bij jou staat het welzijn van de student echt voorop, en dat is een hele fijne gedachte. Bedankt voor de perfecte balans tussen goede adviezen om vrijheid om dingen zelf uit te zoeken.

[5.3] **Francesco**, thank you for putting so much time and effort in answering all my questions and endless requests for more information. Your devotion the project and the process was a delight to work with.

[5.4] **Agustina, Christina, and all other Philips employees** that put their precious time in the project, your effort is valued and appreciated. Thank you.

SUMMARY

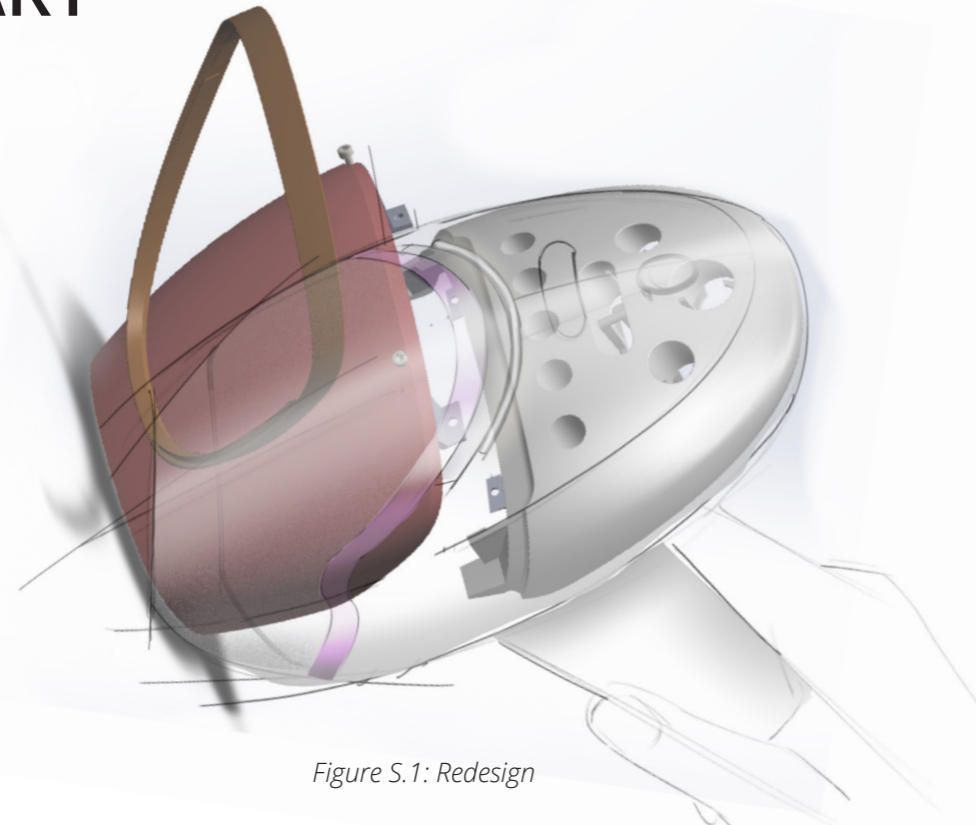

Figure S.1: Redesign

Refurbishment is a critical strategy in the circular economy (Bocken et al., 2016). Despite the environmental and financial benefits, refurbished products are not (yet) a popular consumer choice (Mugge et al., 2017). Refurbished products are seen as old, used and of low quality, and consumers worry that products are contaminated with traces of a prior user (Mugge et al., 2017). This lack of consumer acceptance is perceived as too risky for companies to make the financial investments needed for refurbishment. In theory, refurbishment can be implemented in any product category. But, not every product category is equally popular. Partly due to the lack of consumer interest, the refurbishment of personal care products remains unexplored (Mugge et al., 2017). Because of this, many products and components go to scrap before the end of their functional life. To exploit this potential, consumers need to see the value of refurbished personal care products.

To this end, this project has aimed to explore ways for designers to enhance the consumer acceptance of refurbished products through product design. A design research process was used, including interviews, surveys and an

in-depth product case study. Insights gathered throughout this project are combined into an illustrative product redesign and a tool. These should help designers to integrate the consumer perspective and cope with the complexity of design for refurbishment. The argument for this is that circular design thinking is a skill that should be trained and developed in practice.

To demonstrate how consumer centred research and design for optimal refurbishment can be combined into one design (fig. s1), a case product was optimized for refurbishment; the Philips Lumea Prestige. The Lumea is a hair removal product for personal care at home.

This raised the question of how hygiene perception influences the will to buy refurbished. Hygiene is related to the consumer's fear of contamination. Consumer interviews suggest that hygiene is mainly perceived in relation to complexity. Features like buttons, small corners, and split lines negatively influence the refurbished product's acceptance. This suggests that product complexity negatively affects the perceived ease of cleaning. Findings also show that the

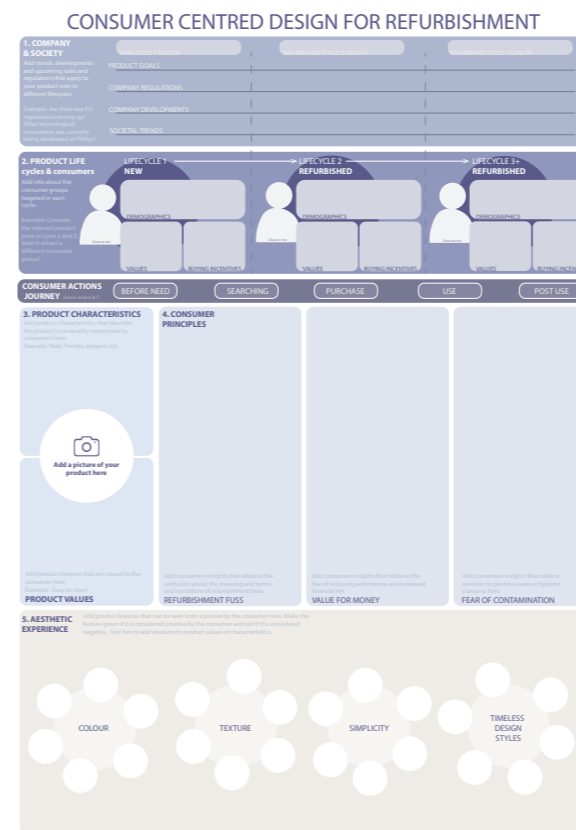
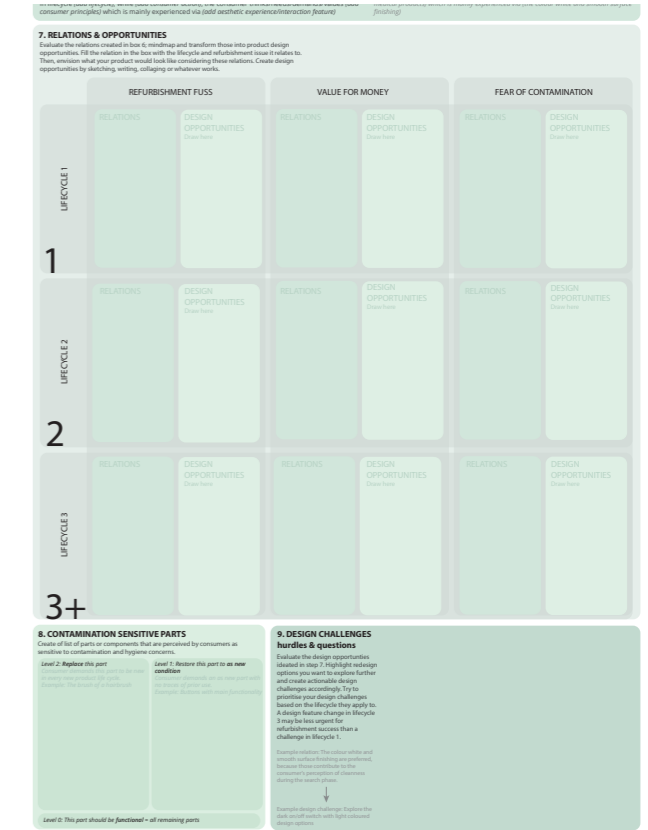

Figure S.2: Redesign

colour white and smooth surface finishing are favourable for a refurbished product due to their associations with hygiene and medical products. From this research, it can be stated that improving the hygiene perception will cause a slightly increased willingness to buy refurbished.

The research findings led to the following conclusion on the influence of design aesthetics on the acceptance of the refurbished product: 'Aesthetics influence the acceptance via associations but will not be the deciding aspect for solving the overarching societal problem that stands in the way of refurbished product acceptance; misconceptions about refurbishment'. That does not mean that aesthetics has no influence at all. Creating positive associations through aesthetics can increase the willingness to buy refurbished (Huang et al., 2020). This project concludes that, for the Lumea, especially associations with luxury, hygiene and durability positively influence the acceptance of the refurbished product.

Based on this redesign process, it was concluded that design for refurbishment is not



a quick fix or stand-alone design activity. It is a mindset best developed through experience and cooperation with other designers. Every product and context is unique. There are no guidelines or rules to follow, which apply in every situation. The proposed skills for designers to incorporate the refurbishment design mindset are (1) consumer empathy, (2) product lifetime management and (3) ecosystem thinking.

To help designers to develop these skills, a tool was created in the shape of a canvas (Fig. S.2). Each box on this canvas focuses on a different aspect of refurbishment, ranging from the different consumers in different lifetimes to ideation on aesthetics features and concerns. The canvas and its brainstorm questions are most relevant at the start of the design process, to incorporate refurbishment and its challenges from the beginning. Also, the tool can serve as a summary of the findings obtained during the project to stimulate internal communication. Finally, the tool is evaluated with Philips designers in practice. However, to fully validate the added value, it should be tested in multiple case studies with products from different categories.

Table of contents

Summary	4
Introduction	8
Project approach	10
1. Context Analysis	
1.1 Throwaway society	14
1.2 Refurbishment	16
1.3 Consumer acceptance of refurbished products	18
1.4 Aesthetic appearance of refurbished products	20
1.5 Refurbishing personal care products	21
2. Philips Lumea Prestige	
2.1 Philips Lumea Prestige; the basics	24
2.2 Getting to know the customer and the Lumea; approach	26
2.3 Consumer experience	28
2.4 A luxury personal care product	32
2.5 Problems to solve; consumer acceptance	34
2.6 Consumer concerns and opportunities	36
3. Lumea inside out	
3.1 Research approach	40
3.2 Contamination sensitive parts	42
3.3 Ease of inspection	44
3.4 Disassembly set up	46
3.5 Priority parts hierachy	48
3.6 Disassembly maps	50
3.7 Ease of Disassembly of the Lumea	52
3.8 Consumer safety; drop test	56
3.9 Refurbishing the Lumea	60
3.10 Problems to solve; refurbishability	61
4. Aesthetics and refurbishment; the consumer perspective	
4.1 Approach	64
4.2 Colour, texture and willingnesst to buy	66
4.3 The influence of aesthetics	68
4.4 Lumea design characteristics parameters	69

5. Case study; Redesign the Lumea for Refurbishment	
5.1 Problems and requirements	74
5.2 RTP; Consumer acceptance	75
5.3 RTP; Product architecture	76
5.4 RTP; Drop safety	82
5.5 RTP; economic and environmental value	84
5.6 RTP; Considerations and evaluations	85
5.7 D4TF; Recommendations new design	86
5.8 D4TF; Product architecture	88
5.9 D4TF; Design challenges	92
5.10 D4TF; recommendations	97
5.11 D4TF; Evaluation	99
6. Consumer centred design for refurbishment; a tool	
6.1 The consumer centred approach	102
6.2 Skills for designers	103
6.3 Developing a tool	104
6.4 Tool proposal	106
6.5 Tool in depth	110
6.6 Evaluation with designers	116
7. Conclusion and reflection	
7.1 Answering the research questions	120
7.2 Contributions and recommendations	122
7.3 Personal reflection	124
References	126
Appendices	131

READING GUIDE

A yellow block contains a **Definition**

A blue block contains a **Conclusion**

Introduction

Climate change is a hot topic these days; melting polar caps, drought and forest fires. The generated e-waste is predicted to exceed 74mt by 2030 (Forti et al., 2020). As stated by Sir Attenborough: *'When watching the news, the course our planet is on may sound like a doomsday scenario'*. Luckily, it is not too late to turn the tide. To reduce e-waste, we must optimize the use of resources. This can be achieved by going from a linear 'take make waste' model to a circular economy (Ellen MacArthur Foundation, 2020).

Over the past few years, the circular economy has gained traction, and more companies are interested in the opportunities circular strategies can bring. For these strategies to be implemented successfully, an approach tailored to the specific product and context is needed (Bakker et al., 2014).

Refurbishment is a key strategy in the circular economy since it retains more value than alternative end-of-use scenarios, such as recycling or remanufacturing (Bocken et al., 2016). Despite the environmental and financial benefits, refurbished products are not (yet) a popular consumer choice (Mugge et al., 2017). Refurbished products are seen as old, used and of low quality, and consumers worry that products are contaminated with traces of a prior user (Mugge et al., 2017). This lack of consumer acceptance is perceived as too risky for companies to make the financial investments needed for refurbishment.

Refurbishment is already standard practice for some product categories, think of cars and bikes. Currently, refurbished electronics devices like smartphones and laptops are gaining ground in the consumer market. In theory, refurbishment can be implemented in many

other product categories. But, not every product category is equally popular.

Who would want to buy someone else's used toothbrush? (Mugge et al., 2017) The insurance of hygiene is critical with these kinds of personal care products. Partly due to the lack of consumer interest, the refurbishment of personal care products remains unexplored mainly (Mugge et al., 2017). Because of this, many products and components go to scrap before the end of their functional life. This indicates great potential for bringing personal care products back in the loop.

To exploit this potential, consumers need to see the value of refurbished personal care products. However, what hygiene means to consumers and how the perception of hygiene influences the acceptance of refurbished products is unknown. Therefore the main research question is:

'How to enhance the consumer acceptance of refurbished (electronic personal hygiene) products via product design?'

To answer this question, a case study is conducted with the Philips Lumea Prestige (fig. 0.1); An IPL (intense pulse light) hair removal device for personal use. The Lumea is applied on hairy and private parts of the body and has a distinct design, making it an interesting product for this research.

The Lumea will be evaluated on both consumer acceptance and accessibility of the hygienic critical parts. The focus lies on how appearance features change the perception of hygiene of the refurbished product and how to ensure hygiene in multiple-use loops. After the evaluation, the Lumea is redesigned for refurbishment from a consumer perspective. The outcome of this case study is evaluated on a general design level to be able to write recommendations for new personal care products to be designed for refurbishment. During this research, the following sub-questions will be answered:

- What is the influence of hygiene (for the consumer) in the refurbished personal care products' buying decision?
- How can design appearance increase the consumer acceptance of a refurbished product?
- How to (re)design a personal care product for refurbishment?

Project approach

Earlier studies focused on why consumers are not interested in refurbishment and why some products are more accepted than others. This project aims to complement this field of research by providing an in-depth study on a single case; the Philips Lumea Prestige. This focus led to qualitative insights into how product appearance can influence consumers' perception of refurbished personal care products.

The main research question can be answered from different (design) angles. Consumer acceptance is a marketing or even psychological topic that involves consumer behaviour studies. On the other hand, designing a product that is easy to refurbish while still functional and safe is a technical challenge. Both perspectives should be taken into account to create a redesign that is desired by consumers and technologically feasible. Therefore, the research was divided into two foci; refurbishability and product appearance. These studies are conducted in parallel and form the base for redesigning the Lumea and creating the tool.

Due to the COVID-19 crisis, the university campus and company were not accessible. This made an internal experience of the company and its employees, face to face interviews or physical brainstorming impossible. Throughout the project, this had to be taken into account.

The set-up of the project is based on the classic Double Diamond model, which divides the design process into a research and a design phase.

1. Research

The first part of the project consisted of researching the Lumea, and its consumers. The research was a mix of different design research methods, taking both the product architecture and consumer perspective into account.

This phase started with forming a throughout understanding of the refurbishment concept through literature

research. The literature review defines the theoretical basis of the project and presents existing findings on consumer behaviour towards refurbishment.

Also, the product and its use were analyzed to get a complete understanding of the context. Based on this, in-depth consumer research was conducted. Through interviews with both new and second-hand consumers, the needs and values of consumers with different buying incentives and experiences were identified. These interviews revealed opportunities to enhance their acceptance of the refurbished product. A follow-up survey was conducted on the visual influence of colour and texture on the willingness to buy refurbished.

Parallel to the consumer research, a product architecture study was conducted. This research consisted of multiple methods; hotspot mapping, disassembly mapping and drop tests, to get a full understanding of the product's current refurbishability status. An additional focus throughout this research was the influence of fear of contamination on the product architecture.

2. Design

The second part of the project consisted of optimizing the Lumea for refurbishment. Based on the insights from the research phase, multiple solutions are presented that enhance both the consumer acceptance and the physical refurbishability of the Lumea Prestige. By using 3D printed prototypes and visualization techniques, ideas were rapidly tested and validated.

Based on the research insights and the redesign process, a tool was created for Philips design. Via build-measure-learn loops, the tool was either tested by design students or discussed with Philips designers and improved accordingly.

Finally, recommendations are formulated on how the concept and the tool could be further developed in the future.

CHAPTER 1 THEORETICAL BACKGROUND

CHAPTER 2 LUMEA PRESTIGE & ITS CONSUMER

RESEARCH QUESTIONS

- Q2.1: How do consumer experience the Lumea?
- Q2.2: What associations do consumers have with buying refurbished?
- Q2.3: What are the main hurdles consumer experience when considering a refurbished product?
- Q2.4: How can be Lumea's refurbished decision making experience be improved?

STUDIES

- 2.1 Interviews with consumers
- 2.2 Survey on Lumea characteristics

CHAPTER 3 LUMEA INSIDE OUT

RESEARCH QUESTIONS

- Q3.1: What are contamination sensitive parts, and where are they located in the Lumea?
- Q3.2: What are the priority parts of the Lumea?
- Q3.3: How many and what actions need to be taken to reach these priority parts?
- Q3.4: What are the most prominent product design hurdles that stand in the way of efficient refurbishment?
- Q3.5: What consumer safety requirements should the Lumea meet?

STUDIES

- 3.1 Hotspot mapping analyses
- 3.2 Disassembly map creation
- 3.3 Droptest

CHAPTER 4 AESTHETICS & REFURBISHMENT

RESEARCH QUESTIONS

- Q4.1: What aesthetics features do consumers favour for the refurbished Lumea?
- Q4.2: What characteristics positively influence the willingness to buy refurbished?
- Q4.3: What (aesthetic) features can be redesigned to enhance the acceptance of the refurbished Lumea?

STUDIES

- 4.1 Survey colours and textures
- 4.2 Lumea aesthetics analysis

CHAPTER 5 REDESIGNING THE LUMEA FOR REFURBISHMENT

RESEARCH QUESTION

- Q5.1 How to (re) design a personal care product for refurbishment?

STUDIES

- 5.1 Development and testing of a redesign for refurbishment

CHAPTER 6 CONSUMER CENTERED DESIGN FOR REFURBISHMENT TOOL

RESEARCH QUESTION

- Q6.1 How to (re)design a personal care product for refurbishment?

STUDIES

- 6.1 Development and testing of a tool for consumer centered design for refurbishment

CHAPTER 7 CONCLUSION AND DISCUSSION

Throw away society

- Products are discarded before the end of their functional life with little concern for the environmental (Cox, 2013).
- Consumers play a key role in early product replacement (Antonides, 1991).
- Growing amount of e-waste is mainly fueled by higher consumption rates (Forti et al., 2020).
- The recycling activities are not keeping up with the global growth of e-waste.

Circular economy

- *A circular economy is regenerative and aims to gradually decouple growth from the consumption of finite resources by keeping products, components and materials at their highest utility and value at all times.* (Ellen MacArthur Foundation, 2020)

Refurbishment

- *'Refurbishment is the process of returning a product to satisfactory working condition by replacing or repairing components that are faulty or close to failure, and making 'cosmetic' changes to update the appearance of a product.'* (British Standards, 2009; Ellen MacArthur Foundation, 2020)
- Economically beneficial for both company and consumer (Wallner et al., 2020).
- Companies are put off by the idea of high investment costs and low profit margins

Consumer acceptance

- Refurbished products are often perceived as old, used, and having reduced performance (Wallner et al., 2020)
- Despite the benefits like warranties and lower prices, most consumers do not consider refurbished products as a viable alternative to new ones ([1] Mugge et al., 2017).

Aesthetic appearance

- Consumers use visual factors, such as product appearance, to verify the quality (Mugge et al., 2012)
- Refurbished product buyers seek functionality instead of newness (Jiménez-Parra et al., 2014)
- Refurbished products should meet minimum functional requirements before other characteristics, like appearance, are taken into account (Luchs et al., 2012).
- Aesthetic appearance of refurbished products is considered less attractive than the appearance of new products (van Weelden et al., 2016)
- Timeless designs are preferred for refurbished products (Lobos, 2014)
- The neo-retro and the simplistic design style evoke positive perceptions and enhance the attractiveness (Wallner et al., 2020)

Refurbishing personal care products

- Personal care products are considered unfit for refurbishment ([1] Mugge et al., 2017)
- Refurbished products are considered less clean than new ones because of contamination concerns ([1] Mugge et al., 2017)

Research gap

- If and how the perceived contamination can be influenced via product design remains unexplored ([1] Mugge et al., 2017)
- Unknown how to develop refurbished products that are desired by consumers (Jiménez-Parra et al., 2014)

1.

CONTEXT

ANALYSIS



theory of Evolution.

CHAPTER 1.1

Throwaway society

Intro

In 1950s America, advertising firms found out that they could sell products based on novelty instead of function, quality, or durability. Products were sold as “new” or “modern,” whether or not the “innovations” offered any genuine value (Weyler, 2019). The throwaway society (Packerd, 2011) was born on the notion that “styles” changed every year. To appear “modern,” one must repeatedly buy new products (Weyler, 2019).

Today, consumers expect constant and rapid updating of products (Cox, 2013). Between 2007 and 2017, Apple introduced 14 new iPhone models, one every 37 weeks (Apple.com, 2020). Apple stopped supporting the first generation phones and continues to make previous phones unsupported. Apple is only one of many companies applying this strategy. These policies are not an accident or a necessity of technological advance (Park, 2010). They are marketing decisions explicitly designed to sell more products.

Replacement behaviour; Linear economy (throwaway society)

With this constant supply of new products, throwing away products before they fail has become the core of consumer behaviour (Cox, 2013). Products become outdated in terms of design or technology and are discarded before the end of their functional life with little concern for environmental consequences (Cox, 2013). However, it is up to the consumer whether they replace the product or not (Antonides, 1991). Therefore consumers play a crucial role in early product replacement (van den Berge et al., 2020).

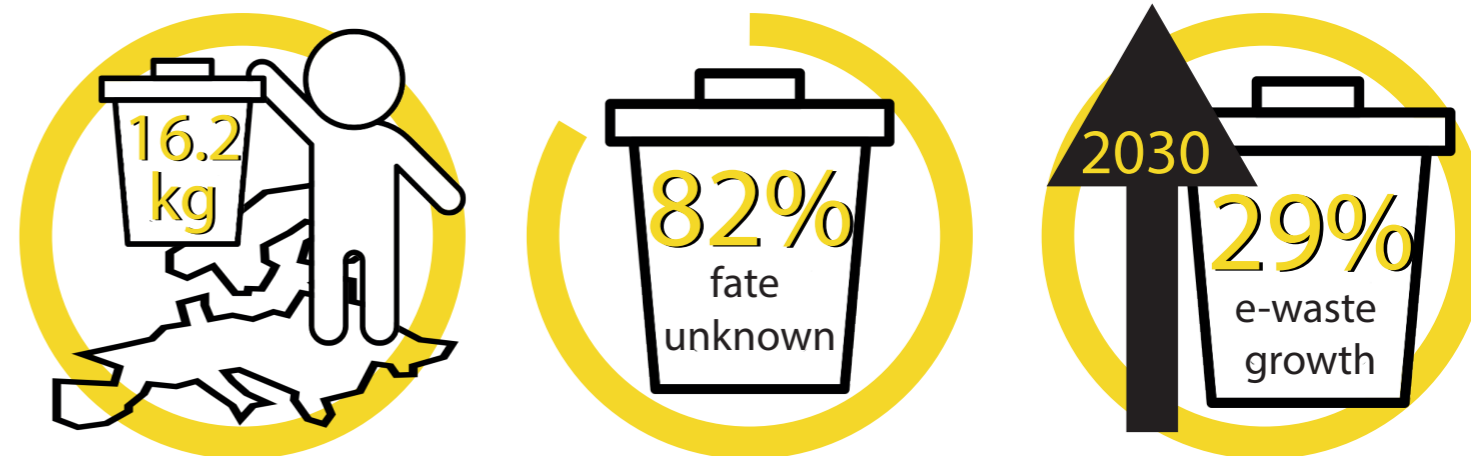

E-waste

This replacement behaviour contributes to resource depletion, emissions and physical waste (Cox, 2013; Bakker et al., 2014). About 2% of this waste is electronic waste or e-waste (Forti et al., 2020).

Definition

E-waste is anything with a plug, electric cord or battery (including electrical and electronic equipment) that has reached the end of its life, as well as the components that make up these end-of-life products. E-waste is also called waste electrical or electronic equipment, or WEEE for short (PACE, 2019).

Two per cent may not sound like much. Still, in 2019 approximately 53.6 million metric tons (Mt) of e-waste was generated, 7.3 kg per person on the planet (fig. 1.1.2; first circle) (Forti et al., 2020). The growing amount of e-waste is mainly fueled by higher consumption rates of electrical and electronic equipment, short life cycles and few repair options (Forti et al., 2020).

The formal documented recycling of e-waste was 17.4% compared to e-waste generated (UN annual report, 2020). Recycling grew by 1.8 Mt since 2014, an annual growth of almost 0.4 Mt. However, the total e-waste generation grows by nearly 2 Mt yearly (UN

annual report, 2020). Thus the recycling activities are not keeping up with the global expansion of e-waste.

The fate of 82.6% of e-waste generated in 2019 is unknown (fig. 1.1.2; second circle), and its whereabouts and environmental impact varies across the world (PACE, 2019). Ending up either in landfill or being informally recycled.

If we continue on this course, it is estimated that the amount of e-waste generated will grow by 29% by 2030 (fig. 1.1.2; third circle) (Forti et al., 2020).

fig. 1.1.1 Volkswagen add Beetle, against planned obsolescence (source: septisehere.com)

Refurbishment

Intro

In the circular economy, refurbishment is a promising strategy to regain value from discarded products. A definition and explanation of the principle of circular design can be found in Appendix A. Through **refurbishing it is possible to save (critical) raw materials and energy, and to avoid emissions** (e.g., CO₂) (Andrae, 2016).

Refurbishment is already common practise for some product categories. For example, car dealers who repair and fix-up pre-owned cars and put them up for sale. Currently, refurbished electronics devices like smartphones and laptops are gaining ground in the consumer market. Refurbisher Leapp, seller of refurbished Apple products, grew from start-up to a 30 million euros turnover business in 6 years (Camp, 2019). In theory, refurbishment can be implemented in many other product categories. However, setting up an infrastructure to make refurbishment possible requires financial investments. Which are only worth it if consumers buy the refurbished products. Consumers need to accept refurbished products as substitutes for new ones (Mugge et al., 2017). Unfortunately refurbished products are seen as old and used, and are not popular with consumers (van Weelden et al., 2016). This creates a **vicious cycle of prejudice and economical risks in which companies are not eager to get involved.**

Definition

'Refurbishment is the process of returning a product to satisfactory working condition by replacing or repairing major components that are faulty or close to failure even where there are no reported or apparent faults in those components, and making 'cosmetic' changes to update the appearance of a product'. (British Standards, 2009; Ellen MacArthur Foundation, 2020)

Pro's & Con's

The big advantage of refurbishment is the potential for energy and material conservation, which makes it a key strategy in the circular economy (Bocken et al., 2016). Once the refurbishment infrastructure runs successfully, it can be **economically beneficial for both company and consumer** (Mugge et al., 2017).

However, refurbishment has some boundaries that prevent companies from implementing this strategy. First and mainly, companies are put off by the **idea of high investment costs, low profit margins and market cannibalisation** (Abdulrahman et al.,

2014, Govindan et al., 2015,). A well-functioning refurbishment infrastructure is an **operational challenge**; Refurbishing facilities, technical capabilities, reverse logistics processes (Guide & Van Wassenhove, 2001) and skilled people are needed to make it work (Sharma et al., 2016). This, together with uncertainty about the availability and supply of used products, which is caused by the **consumers' unwillingness to return used products**, makes refurbishment challenging (Sharma et al., 2016).

All together this adds up to high investment costs and a lot of uncertainties. Costs that are, considering the low popularity of refurbished products with consumers, too high a risk for most companies.

Furthermore, there are no guidelines and standards for refurbishment (Sharma et al., 2016). Companies do not have profitable examples in their industry or the capability to create working guidelines themselves, which increases the perceived risk. This leads to a **great variety in product quality** and design issues (Sharma et al., 2016).

Successful implementation of Refurbishment

In the electronic appliances market, the BHS group launched a successful pilot with refurbished products; BlueMovement (more info in the square below).

The success of BlueMovement shows interest in this way of consuming products, especially by the younger generation. By retrieving products after use, BHS can see

what happens to their product during one lifetime on a large scale. This allows them to learn from users and innovate accordingly (Blue movement, 2020). It also proves that a refurbishment can be a viable business model for big appliances companies like Bosch, or in case of the Lumea, Philips in the near future.

BlueMovement

POWERED BY **BOSCH**

BlueMovement is a subscription service for home appliances in the Netherlands, offering washing machines, dryers and fridges as 'Hardware-as-a-Service' for a fixed price per month. BlueMovement offers both new and refurbished appliances, and recollects them at the end of the subscription with the aim of keeping products in the loop as long as possible.

BlueMovement is a success and therefore received recognition for being the most promising initiative towards the circular economy (Sitra, 2020). They started

last year in the Netherlands and will be expanding to Belgium and Germany in 2021 (BlueMovement, 2020). The number of subscribers grew in the last months of 2020, especially with people below the age of 25 (BlueMovement, 2020). 'At this moment, 21% of our subscribers are below the age of 25, and this number is growing. Therefore we focus on this younger generation, they will make the change' says Hypscher (owner of BlueMovement) (fig. 1.3.1).



Figure 1.3.1; Branding aimed at younger generation (BlueMovement, 2020)

Consumer acceptance

Unfortunately, it's not only companies that are doubtful about refurbishment. As mentioned before, refurbishment is not popular with consumers either. But why not?

Van Weelden et al. (2016) uncovered how consumers decide to choose for a refurbished smartphone (fig. 1.4.1). Their findings demonstrated that consumers weigh the benefits and the risks and only include a refurbished smartphone as a **potential option if the benefits outweigh the risks** (Mugge et al., 2017). Specifically, Van Weelden et al. (2016) demonstrated that, although the initial responses to refurbished smartphones are favorable, various aspects can prevent consumers from purchasing refurbished smartphones (Mugge et al., 2017).

Consumers mentioned the following motives to either accept or reject a refurbished product for a certain category: financial, functional quality, aesthetic quality, warranty, contamination, personalisation and lack of the thrill of newness (Van Weelden et al., 2016; [1] Mugge et al, 2017). Also, people are **not aware of the refurbished options**, or have misconceptions about what refurbishment is (Van Weelden et al., 2016).

Refurbished products are often perceived as old, used, and having reduced performance (Baxter, 2016).

Additionally, consumers worry that products are **contaminated with traces of a prior user** (Wallner et al., 2020). This high perceived risk and low perceived quality causes a low willingness to pay for refurbished products compared to new ones (Hamzaoui, Essoussi and Linton, 2010).

Consumers' willingness to accept refurbished products also depends on their understanding of the refurbishment concept. **Ambiguity about the refurbishment process feeds the lack of understanding and fosters low quality perceptions** (Hazen et al., 2012). Informing consumers on what procedures are executed during refurbishment increases trust in refurbished products, which positively influences acceptance ([1] Mugge et al, 2017).

For consumers, refurbished products are an economical beneficial choice because their market value is 10–50% lower than the market value of new products. The value depends on the market demand and the qualitative state the product is in ([1] Mugge et al., 2017). **Consumers do not appreciate refurbished products as a considerable substitute to new products**, despite the financial benefits and warranties ([1] Mugge et al., 2017).

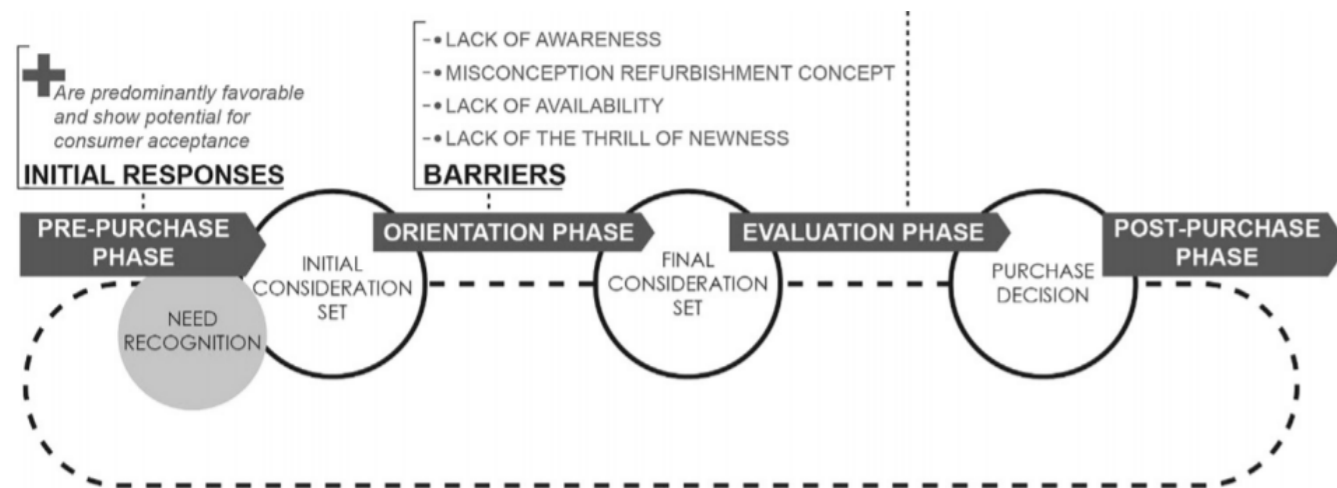

Fig. 1.4.1; Model of the consumer decision-making-process showing the main factors influencing consumer acceptance of refurbished mobile phones (van Weelden et al., 2016).

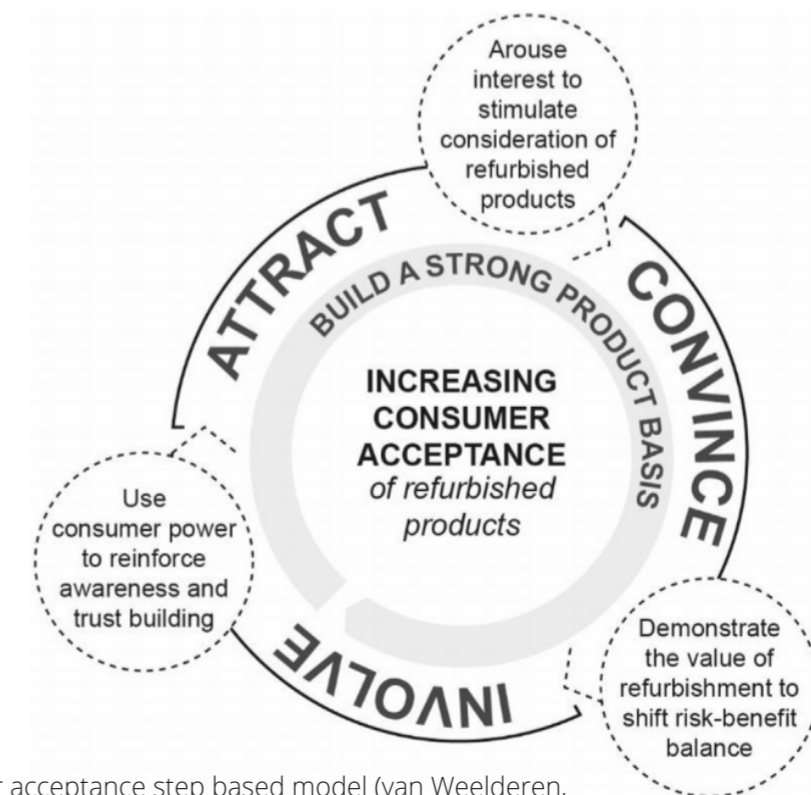

Fig. 1.4.2; consumer acceptance step based model (van Weelden et al., 2016)

Increasing the perception of refurbished products

Van Weelden (2016) proposes a step based approach to increase the consumer acceptance of refurbished products (fig.1.4.2):

Attracting consumers starts with building awareness and **making refurbished products widely known** as a high-quality alternative for new products. Also, to eliminate negative associations, product presentation and packaging can be used to develop a shopping experience that evokes desirability and a **thrill of newness** (Enneking et al., 2007).

After being attracted, the consumer needs to be convinced of the value of the refurbished product. To do so, consumers should be provided **transparent and accessible information** about both the refurbishment process and specific product properties ([1] Mugge et al, 2017). This information should communicate the functional, financial, and environmental benefits of refurbished products.

To significantly reduce the perceived risk related to refurbished products, companies should offer **high-quality service and warranty** that relieves consumers from any product performance-related concerns. To gain

consumers' trust, companies should support the product with **independent confirmations**, such as consumer reviews or quality labels (Harms and Linton, 2015).

The last step is to involve consumers in the use and growth of refurbishment. Companies should invest in building relationships with customers and use **customers as ambassadors of refurbished products**. Positive word of mouth and increased familiarity are crucial to build awareness and convince consumers of the value of refurbished products.

Other factors that can positively influence the consumer acceptance of refurbished products are **brand reputation**, which acts as an affirmation of product quality (Hamzaoui-Essoussi and Linton, 2014), and eco-certification (Harms and Linton, 2015).

Aesthetic appearance

Intro

Van Weelden's model (2016) (fig. 1.4.2) has a marketing perspective and does not cover product design or aesthetic appearance. But does appearance even have an influence on refurbished product acceptance?

The influence of product aesthetics

When buying a new product, objectively judging the performance quality is difficult for consumers. They are likely to turn to **visual factors such as product appearance to verify the quality** (Mugge and Schoorman, 2012). Appearance can communicate functional characteristics and ease of use, which are used as cues for quality judgement (Blijlevens et al., 2009; Haug, 2016). A product's appearance can have aesthetic and symbolic value for consumers, which influences the perceived desirability (Blijlevens et al., 2009). Both a product's desirability and novelty influence its perceived performance quality (Mugge and Schoormans, 2012).

Aesthetic appearance and refurbished products

It is known why consumers do not favor refurbished products, however, research on how to change their perception via appearance is limited (Mugge et al., 2017). Consumers interested in **refurbished products primarily seek for functionality instead of newness** or outstanding appearance (Jiménez-Parra et al., 2014). Consumers should first be convinced that **refurbished products meet minimum functional requirements before other characteristics, like appearance, are taken into account** (Luchs et al., 2011).

Differences can be seen between product categories. For certain product categories, like wallets, it is crucial that the product looks new because it is used to express the user's identity (Mugge et al., 2017). If the product is already personalized by the

previous owner, people are less likely to accept it ([1] Mugge et al., 2017).

For product categories that serve a primary practical function, like drills or irons, consumers would even consider visually damaged refurbished products ([1] Mugge et al., 2017).

Despite being shown the same product, the **aesthetic appearance of refurbished products is considered less attractive than the appearance of new products** (Wallner et al., 2020). This does not mean that the appearance of refurbished products has no influence on the acceptance, on the contrary ([1] Mugge et al., 2017). **Wear and tear signs lower the consumer's willingness to buy** refurbished products ([3] Mugge et al., 2017). Consumers worry that the product is contaminated with physical traces of previous owners ([3] Mugge et al., 2017). However, for product categories like furniture, visual wear and tear can give a 'vintage look' which can enhance the acceptance ([1] Mugge et al., 2017).

Wallner et al. (2020) researched the influence of different design styles on the acceptance of refurbished products. **Timeless designs are preferred for refurbished products** because changing consumer taste and hypes have less effect on products in this style (Lobos, 2014). **The neo-retro and the simplistic design style (fig.1.5.1) evoke positive perceptions** and enhance the attractiveness. Besides, consumers favored refurbished products with a solid appearance over a slender look (Wallner et al., 2020). Furthermore consumers preferred products made of **high-quality materials**, such as wood, leather, and metal because of their durability (Wallner et al., 2020). This report builds on this research by investigating other appearance characteristics in a more specific context.

Simplistic & timeless design

1958



2001



Fig. 1.5.1; Rams transistor radio (left) & Apple's first iPod (right) (medium.com)

Refurbishing personal care products

Generally, **personal care products are considered unfit for refurbishment**. Consumers are not interested in other people's used shavers or toothbrushes ([1] Mugge et al., 2017). Mugge et al. (2017) already suggested that hygienic products (products that are in contact with human skin) can cause **contamination concerns**.

Contamination is defined as: *"the idea that an interaction with an object can differ from its intended condition due to another interaction by someone or something"* (Baxter et al., 2016).

Contamination can involve hygienic concerns as **refurbished products were considered less clean than new ones** ([1] Mugge et al., 2017). To minimize those concerns, the ease of cleaning should be enhanced and the effort of cleaning and disinfection done during the refurbishment should be clearly communicated to consumers ([1] Mugge et al., 2017).

Research gap

In the field of refurbished personal care and hygiene products specifically, contamination is a proven issue. However, **if and how the perceived contamination can be influenced via product design remains unexplored** ([1] Mugge et al., 2017). Prior studies focus mainly on smartphones, which is a completely different product category than personal care. Specific benefits or risks can be more important for one category than for the other, and therefore can not be copied one on one (Mugge et al., 2017).

Also, a consumer perspective on refurbished products has been largely unexplored (Jiménez-Parra et al., 2014; van Weelden, 2017). To increase the share of refurbished products in the market, there is a need for in-depth insights on **how to develop refurbished products that are desired by consumers** (Jiménez-Parra et al., 2014).



2.

LUMEA

PRESTIGE

LUMEA & Philips

- The Lumea is a hair removal device that works with Intense Pulse Light (IPL)
- Refurbishment is a key focus point for Philips to achieve their circular goals

Consumer journey

Problem

- Consumers buy the Lumea because they experience a problem; unwanted body hair

Exploration

- Consumers prefer internet research, like reviews, evaluate a product
- People look for social confirmation
- Making sense of the product and creating an opinion towards it is based on aesthetic features

Evaluation

- Consumers weigh benefits and risks before taking a product into consideration
- Contextual factors, like the brand and price, have an influence of the evaluation of unknown products
- Insecurity about quality lowers the willingness to pay
- Mutual trust between the buyer and the seller is needed to sell second-hand products
- The financial benefit is the main motive for

buying second-hand

Purchase decision

- The product can be bought new, new via subscription (Try&Buy) or Second life (reprocessed) via Try&Buy.

First-time use

- During first time use, the use is 'overwhelming' and 'complicated'
- Looking back, consumer experience the Lumea as 'funny' and 'surprising'
- Covid-19 drives second-hand buyers to take extra product cleaning measures
- Second-hand buyers fear contamination and skin debris from the first owner

Use cycle

- Treatment can be time-consuming and perceived as boring
- For some users, treatment is ergonomically uncomfortable

Post use cycle

- Cleaning is considered necessary
- Cleaning the Lumea is perceived as precise and annoying work

End of life

- Not much is known
- Consumers think throwing the product away is a shame because of the cost
- Consumers leave the product laying around or sell it online

Lumea Prestige; the basics

The Philips Lumea Prestige is an IPL hair removal device. IPL stands for Intense Pulsed Light. IPL only works when the hair is in its growing phase, and not all hairs are in growing phase at the same time. Therefore a repeat cycle of about 8 weeks is needed for the optimal effect (Lumea manual, 2018).

The Lumea can be used on different parts of the body: face, legs, armpit, bikini line,

etc. However, the Lumea is not effective on light hair (blonde, red, grey) or dark skin.

The Lumea comes with three attachments; one for the legs and arms, one for the face and one for the armpits and bikini line.

Also, the device is hand-held and can be used wireless when charged.

SPECIFICATIONS

€439

General

Mass	0.48 kg
Height	22 cm
Width	16 cm
Depth	9.6 cm

Materials housing

Pink and white housing	PC
Shiny ring	Plastic (unknown)
White internal housing	PBT
Black internal housing	PA6-30%GF

Power and charging

Rechargeable Li-ion Battery	
Type S036Nx2400150 adapter (mains power)	
Charging time	1h 40 min
Battery life	12 h

Flash power

Light intensity levels	5
Flash length	< 1.5 ms

Safety classification

Shock safety class	II
--------------------	----



INPUT

OUTPUT

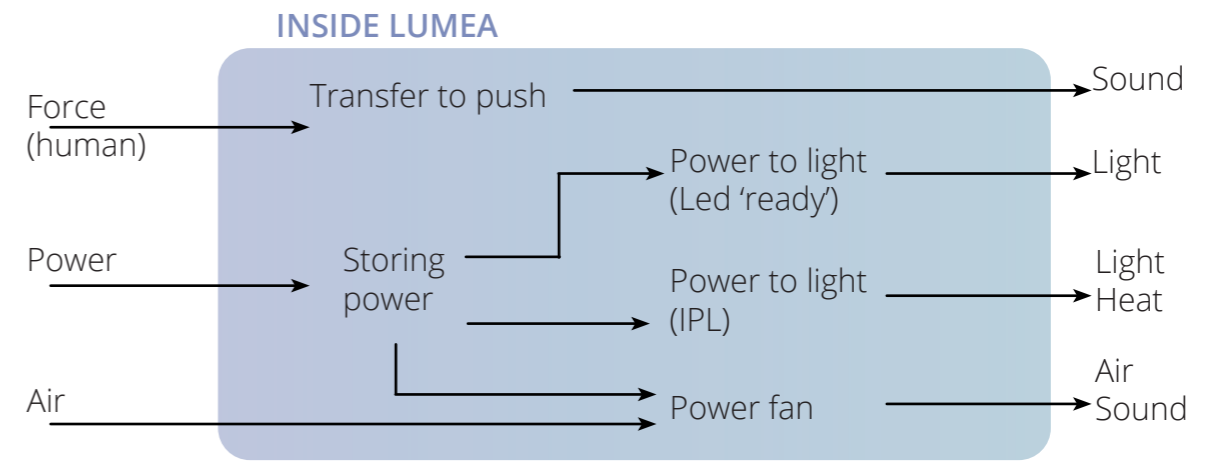

Fig. 2.2.2; input and output of Lumea

Working principle

The Lumea's main function is to prevent unwanted body hair from growing back. The Lumea applies pulses of light to the hair root, putting the follicle into a resting phase (Philips Lumea Prestige, 2020). As a consequence, the amount of hair the body grows gradually decreases (figure 2.1.1).

Figure 2.2.2 gives an overview of the Lumea's input and output. The Lumea's main output is the intense pulse light, but it also produces a warning light when the product is ready to flash. Besides light, a clicking sound and fan noise can be heard. Also air flows through the product for cooling.

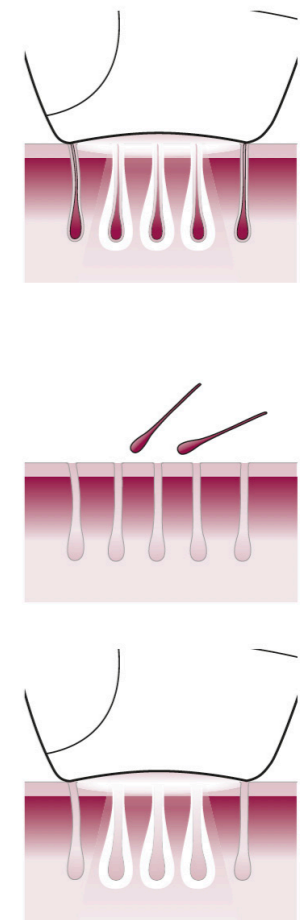

Fig. 2.2.1; IPL on skin (Lumea manual, 2018)

Second Life

The Second Life Lumea is a used Lumea Prestige that has been remanufactured (steps of the remanufacturing process can be found in chapter 3.3). The Lumea is put through a certification process to ensure the same quality standards as the new devices. Once certified by Philips, they are ready for a new life and have the same guarantee period as a new Lumea. The benefit for Philips is that, according to Philips, Second life has a 40% reduced environmental costs compared to the new Lumea, increases profit by 10% and opens doors to markets segments with less budget (Philips, 2020). The Second Life Lumea is currently only available via Try&Buy. In July 2020, 5800 consumers had a subscribed Lumea (personal communication, 2020). More information on Try&Buy and pricing can be found in Appendix B.

Getting to know the consumer and the Lumea; approach

Intro

Consumers base their perception of refurbished product quality mainly on what they see in the orientation phase of buying a product, as proven by van Weelden et al. (2016). However, this research was conducted with mobile phones, therefore the barriers identified in this study can not simply be copied to a personal care product like the Lumea (Mugge et al., 2017).

This research was set up to discover what these barriers are for the Lumea. This chapter explores the consumer's opinion on and experiences with the Lumea Prestige. The Lumea's product experience and dominant characteristics are investigated, based on the Model of the consumer decision-making-process (Van Weelden et al., 2016) and the product acceptance is investigated with the Framework of Product Experience (Desmet & Hekkert, 2007). This chapter concludes with presenting the three main hurdles consumers experience when considering a refurbished Lumea, opportunities for Philips and a project focus.

Research goals

- Develop consumer empathy
- Develop an understanding of consumers' values and concerns when buying refurbished personal care products, like the Lumea.
- To explore opportunities to improve the aesthetic experience of the refurbished Lumea.

Research questions

1. How do consumer experience the Lumea?
2. What associations do consumers have with buying refurbished?
3. What are the main hurdles consumer experience when considering a refurbished product?
4. How can be Lumea's refurbished decision making experience be improved?

Methodology

Interviews

The amount of people owning a Lumea Prestige is relatively small compared to, for example, people owning a normal shaver. Especially finding and recruiting those who own a Second Life (refurbished) Lumea is a challenge. A qualitative research method was chosen to obtain the most valuable insights with this small sample size. To reveal latent consumer needs, a qualitative and generative approach is most efficient (Sanders & Stappers, 2012). Also, the subject of unwanted body hair and personal care can be sensitive to participants. An informal, casual conversation format was chosen to create trust and a safe and environment in which participants can speak freely.

A test interview was conducted to test the interview guide, interview length and stimuli pictures used.

Due to the Covid-19 restrictions, the interviews are conducted online via video calls. To ensure in-depth consumer insights, the interview was divided into two parts;

- *Semi-structured interview* (interview guide can be found in appendix C). The main topics discussed were; use and routines, decisions making process, cleanness and appearance.
- *Dilemmas*; Different versions of the Lumea were shown (fig. 2.2.1), variables were; price (new price, refurbished price and second-hand price), physical state (new, light scratches or heavy scratches), colour (black or white) and surface finishing (smooth or rubberish). Participants were asked to choose between one of the two shown Lumea's and explain why. Six dilemmas were presented (see appendix C). This format was chosen to 'force' participants to make trade-offs between product features. This gave insight in what features weigh more in making a purchase decision and uncovered latent buying incentives.

Participant selection

Participants were selected through purposive snowball sampling and self-selection. Social media channels like Philips Facebook fan groups and personal sharing were used, mainly to find owners of a new Lumea. To find second-hand Lumea owners, an advertisement was posted on Marktplaats.nl (figure 2.2.2). The Second Life owners were recruited via a banner placed on the confirmation mail after purchase (figure 2.2.3). Because of the small target group, TU Delft made a bol.com voucher available to motivate people to participate in the interviews.

10 people in total were recruited (5 new, 5 second-hand). Although not specifically selected, all participants were female. This is probably due to the product's purpose and target group. Participants ranged from students to recently retired.

Data analysis

All interviews were audio recorded and transcribed by the researcher. Afterwards, interesting quotes were highlighted and memos were written on participants reactions and relations between answers. The quotes were categorized in themes to create an overview of the data.

Once this overview was created, the quotes of new and second-hand users were compared to uncover similarities and differences.



Fig. 2.2.1; Sample dilemma interview



Fig. 2.2.2; Marktplaats.nl advertisement

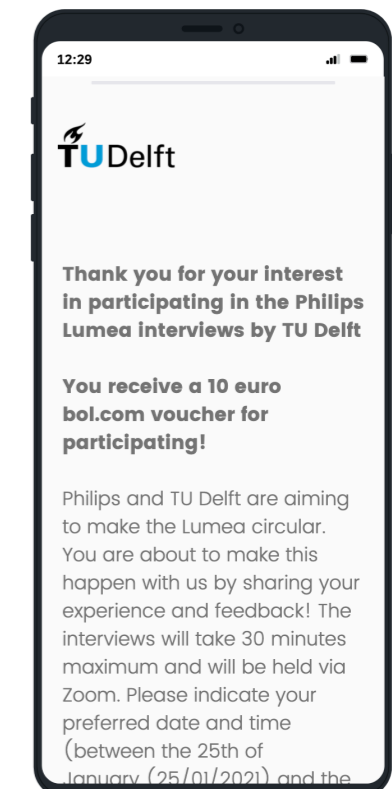

Fig. 2.2.3; Banner confirmation email

Consumer experience

To identify the differences between buying a new and a circular product, the complete purchase process should be taken into account. Consumer interviews (n=10, 5 new, 5 second hand) were used to identify consumer associations with the Lumea from different purchase perspectives. The quotes used are coded to participant number and purchase route. Consumers how bought the Lumea new are coded with 'n', 'SH' means second hand.

Before need

The main difference between new and Second Hand Lumea buyers is the awareness of the circular options. Most consumers who bought the Lumea new were simply not aware. *P4N: 'I know about the refurbished iPhones, but I didn't know about these types of products'*. Second-hand consumers mentioned being 'pro circular economy' (P4SH) and having positive experiences with previous second-hand sales. *P1SH: 'I am quite a Marktplaats.nl user, and 9 out of 10 times the product is in perfect condition'*. This is perceived as having a positive influence on the consumers' attitude towards the refurbishment.

Searching

For all consumers interviewed, the incentive to buy a Lumea is the same: unwanted body hair. *P3SH: 'There are different techniques for depilation, waxing, shaving, but that is all temporary. I'm looking for a more permanent solution'*. *PN2: 'I first went to the beauty salon, which is way more expensive than the Lumea'*. Also, consumers buy the Lumea as a present to themselves. There is a cheaper version on the market, the advanced, and consumers still chose the buy the expensive one. This indicates that the expression of luxury in the product has a positive influence on the willingness to buy, both new and refurbished. *P1N: 'It is a spoiling moment for yourself, buying an expensive product for personal care'*.

Before buying the Lumea, consumers do extensive research. The main reason to do so include high investment and unfamiliarity with the product use. *P4SH: 'I started orienting a few years ago... since the price is high and I had no idea if it would work on my skin, I doubted for a long time'*. Both new and second-hand consumers do thorough internet research before they decide to purchase. Ratings from independent websites are helpful when exploring options. *P3SH: 'I reviewed many different websites, but the Philips Lumea came out as one of the best every time'*. Because this concerns a personal care product, consumers also mentioned asking friends, family or medical experts for advice. *P4SH: 'My dermatologist recommended the Lumea to me'*. *PN3: 'my friend had brought it along, and she had good experiences'*. Second-hand consumers used other channels and sources to obtain information. They made second-hand options part of their purchase behaviour. *P2SH: 'A few years ago, I decided to buy everything second-hand. Now I first check marktplaats.nl before I check regular webshops'*.

Evaluation

Once the option of refurbishment was introduced, consumers initially responded positively. However, consumers always mentioned a 'but' (van Weelden et al., 2016). *P2N: 'Oh how funny, I did not know about it... I wouldn't consider the refurbished anyway'*.

The lumea is a woman in her 50ies who likes to go to the household fair. She knits on the weekends, has two cats and her husband only watches football ... That metallic light pink looks actually a bit like my grandma's flower curtain.

- Participant 2; Second hand

When asked what their rejection is based on, consumer mentioned feelings and emotions. *P4N: 'New ones last longer, I don't know what I base that on'*, *P1N: 'It is more of a feeling, there isn't something rationale behind it'*.

Second-hand buyers all mentioned price as their primary incentive. *P3SH: 'New is just too expensive for me, my budget does not allow it'*. When discussing the price reduction to new consumers, they say that 'it would not influence their decision'(N1). However, once the price difference is low enough, consumers are willing to go for refurbishment. *P1N: 'if the functionality is really the same, I would clean it myself for that price'*. This indicates that price is the main driver for decision making.

When deciding to buy a refurbished product, people consider benefits and risks (van

Weelden et al., 2016). For the Lumea, a major perceived risk is performance. Consumers do not know what functional state to expect from a refurbished product. *PN3: 'How long will it last?... If you buy a refurbished one and it breaks after a year, you can still buy a new one'*.

To be able to judge functionality, second-hand consumers mentioned looking at the ratings of the seller. *P3SH: 'I check whether the seller is reliable, acknowledged and has good reviews. I don't want to buy something that doesn't work'*. This indicates a need for trust and honesty from the refurbishers. Luckily, Philips is mentioned as being a reliable company, which positively influences the consumer's attitude towards refurbished products. *P2SH: 'I trust the brand, Philips delivers quality products that last'*. The product's shape is also associated with trust in the product. *P2SH: 'That loche design inspires confidence. This thing looks weird, so it must do the job well. If it was thinner, the product would be less reliable, how could it have all that laser power?'*. This indicates that robust shape have a positive influence on the perceived durability of circular products.

Other perceived concerns were hygiene and contamination. Since the Lumea is a product for personal care, circular options are a popular choice. *PN5: 'For products like this, I don't look at second-hand options. I want a clean and new product for myself'*. This fear, however, is not shared by all consumers. Consumers buying second hand show less fear of contamination. *P1SH: 'I clean the*

product at arrival and I don't care where it has been'. In general, hygiene is a less dominant factor in decision making than performance and price. PSH4: 'Reduced functionality outweighs that it is perhaps less hygienic'.

The try&buy was also introduced to consumers. Again, the initial response was positive. *PN1: 'The try & buy sounds good. If you don't like it, you can still send it back after a certain time'.* However, due to hygiene concerns, consumers drop out. *PN3: 'Leasing is not an option for me. If I buy such a personal product, it must be for myself'.*

Visible scratches tend to negatively affect the refurbished product desirability. *P2SH: 'Scratches make it look used and badly treated, I wonder if it still functions as it should'.* This indicates that scratches are associated with technological failure. The location of the scratches on the product influences associations consumers create of the prior use. *P3SH: 'Scratches can reduce functionality on the buttons and the attachment more than on the housing'.* Scratches on locations that are not in line with the intended use (e.g. 'scratches on top of the product'), lower the willingness to buy even more. *PN1: 'Light scratches, in terms of use, can happen when you slide it over the stones of your bathroom furniture. But with those heavy scratches I doubt whether the internal components have not broken'.* However, the difference between light and heavy scratches is not significant to consumers. Therefore, scratches and their negative associations should be avoided at all.

Colours are not mentioned as the main differentiator for refurbished products. *P4SH: 'I pay attention to other things. As long as it's clean and looks fine, the colours don't matter to me'.* As mentioned before, the main buying incentive for the Lumea is the function. This is also expressed in the perception of colour. *P3N: 'Functionality is most important for me, nobody sees it but me'; P4N: 'You don't buy the Lumea for house*

decoration, like a pretty mixer or coffee maker on your countertop'.

However, white and light colours are preferred, also considering the category and intended use. Consumers like that the product looks 'fresh and female'(P1N). From a hygiene point of view, consumers mention white as the preferred product colour. *PN4: 'This is not a product that should be black. That is a hygiene thing because spotting dirt is harder'.*

Use

Second life consumers expect less in terms of performance than new consumers. *P2SH: 'If I buy something second-hand, I do expect reduced product durability and use traces'.*

Consumers that bought a new Lumea create a self-care routine moment with the Lumea. *P3N: 'I grab my e-reader and a Netflix movie and take a moment for myself'. P1N: 'I'm pampering myself for a moment, kids in front of the tv, mom has me-time'.* The second-hand consumers interviewed tend to have a more practical approach. *P1SH: 'I just use it as I should and then it goes back into the closet'.* This difference might be due to the higher investment new consumers make to buy the product.

Hygiene perception

The Lumea is perceived as a hygienic product by both new and second-hand buyers. *P2SH: 'The smooth surface and light colours make the Lumea easy to clean, it reminds me of medical products, which meets my hygiene expectations for products in this category'.* The rounded shapes and corners are also mentioned as practical for cleaning. *P4N: 'Few corners or edges, what can get in between?'. Consumers say that 'bumps or holes'(PN3) like buttons, small corners and split lines are harder to clean. Findings suggest that product complexity negatively influences the perceived ease of cleaning.*

Summary findings:

Positive associations

- As new product appearance; no visible scratches
- Fresh and female product appearance
- The expression of luxury
- Robust product designs
- Distinctive product design
- Simplistic design styles
- White colours, associations with medical products
- Smooth surface finishing; emphasize the ease of cleaning
- Rounded shapes and edges

Negative associations

- Unaware of refurbished option
- New / unknown product use; harder to predict for consumer what wear and tear can be expected
- Personal care products are hygiene sensitive; consumers would rather personally own a new one
- Fragile design styles
- Scratches on housing
- Complex design styles
- Sharp corners and edges; harder to clean

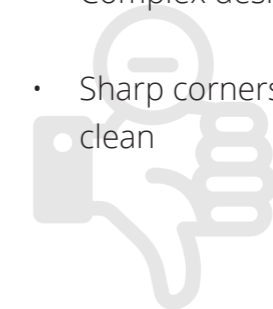
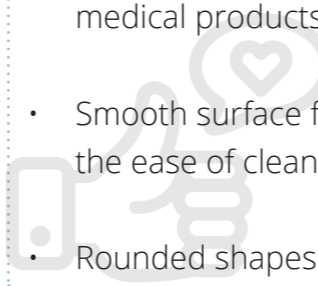

A Luxury personal care product

Now that we have discovered the consumer's attitude towards refurbished products, it is important to explore the perception of the Lumea in general.

With one look at a product, we know whether we want to own it or not (van Desmet & Hekkert, 2007; Weelden et al., 2016). Especially for refurbished products, **aesthetics cues are used to judge quality and performance**, which can make a difference in consumer acceptance (Jiménez-Parra et al., 2014; van Weelden et al., 2016). This part focuses on associations consumers have with the Lumea and how these relate to the acceptance of refurbishment.

Luxury product

The Lumea is a product from Philips' Prestige product line. This line should express luxury and quality and is targeted at women who want to spoil themselves with self-care (interview Philips designer, 2020). From the interviews, it can be concluded that consumers buy the Lumea Prestige not only for its function but also to pamper themselves with a luxurious care product. The fact that the cheaper Advanced model and more expensive Prestige can coexist proves this.

According to Heine & Phan (2011), luxury can be defined as: *'More than only necessary and ordinary characteristics compared to other products of their category, which include:*

- *relatively high level of price*
- *Premium quality*
- *aesthetics (unique)*
- *rarity*
- *extraordinariness*
- *symbolic meaning'*

Also, luxury products express a well-established brand identity (Phau & Pendergast, 2000).

To test the meaning consumers give to Lumea, a survey was conducted among people who have seen or experienced the physical product at least once (n=61). Participants were asked to rate personality traits on a scale from one to seven (based on a study conducted by Mugge, 2018). One being not applicable to the product at all and seven being completely descriptive. More details on the survey and complete results can be found in appendix G.

According to consumers, 'high quality, 'luxurious' are very applicable to the product, confirming the interview findings. 'Untidy', 'silly' and 'provocative' are least associated with the Lumea. Concluding, the Lumea expresses exactly what the designers intended.

Luxury products in the circular economy

The most common business model for luxury products is the 'classical long life model' (Bocken et al., 2016). Therefore, not many studies have been conducted on refurbishing luxury products. However, Bundgaard and Huulgaard (2018) state that there are links between high pricing, premium quality and durability of luxury products, and the circular economy's inner circles (maintenance, reuse, and repair).

Luxury personal care and refurbishment

To find out whether refurbishing the Lumea Prestige is desirable, the expressions of luxury and refurbishment values are compared:

- *High level of pricing*

Consumers mentioned the Lumea's high pricing as the main reason to go for a second hand instead of a new product. This high pricing is in line with the expression of luxury (Heine and Phan, 2011). However, consumers expect lower pricing for a refurbished product. If the price difference is not big enough, they are willing to take the risk. Therefore, a balance needs to be found between expressing luxury through price while making refurbishment a financially beneficial alternative. This challenge is likely more marketing than design related.



Fig. 2.4.1; Star Trek laser guns

- *Premium quality*

According to Heine and Phan (2011), quality relates to durability, materials, and components (a.o.). These characteristics are mainly experienced via the Lumea's design. Consumers mentioned that the product looks durable because of its robust and volumes shape. This also positively associated with refurbishment since consumers assume the Lumea can last a long time.

Brand image is related to extraordinariness (Phau and Pendergast, 2000). However, in case of the Lumea, consumers mentioned Philips in relation to the quality, which contributed to the acceptance of the refurbished product.

- *Unique aesthetics*

Consumers mention the appearance of the Lumea to be distinctive and 'futuristic'. The Lumea is, among others, associated with a 'Star Trek laser gun' (fig. 2.4.1) (appendix G for more examples). This distinctiveness is beneficial for the expression of luxury. And, according to the interviews, uniqueness is also beneficial for the acceptance of the refurbished product: 'This thing looks weird, so it must work well'. In this case, the 'weirdness' of the design is associated with high functional performance.

However, the timelessness of the design must be kept in mind. Enhancing the uniqueness of the design should not make it trendy or hype sensitive.

Also, the Lumea's design is described as female and soft because of the pastel, light colours and round shapes. In this case, it is related to sophistication. Whether this is positively associated with refurbishment is unknown. However, it is highly valued by the Lumea consumers because of the use and symbolic meaning (explained below).

- *Rarity*

Since the Lumea is a mass production product and can be bought in many (web) stores, rarity is not applicable.

- *Extraordinariness*

Extraordinariness can be found in the Lumea's design (as discussed before) and the innovation of the technology. An IPL laser at home is disruptive compared to the regular shaving routine and equipment. This, however, has a negative influence on the acceptance of the refurbished product. Consumers do not know how the product was used by the previous owner, which evokes trouble judging the durability and quality of the refurbished product (Mugge and Schoorman, 2012).

- *Symbolic meaning*

The *'me-time moment'* is the main symbolic values expressed in the interviews. The Lumea is a product that *'gives you a moment to make yourself look pretty'*. Consumers allow themselves to spend money on (and invest in) self-care, which is highly symbolic. From this study, the relation between high symbolic value and refurbishment can not be established.

Conclusion

The symbolic meaning of investing in a luxurious self-care product is, together with the functionality, the main reason to buy the Lumea Prestige. This feeling of luxury is mainly experienced via the uniqueness of the aesthetics.

For example, according to new consumers, the silver ring of the Lumea makes it look chic. However, second-hand users mention this shiny ring to be contagious to fingerprints and scratches, which is not beneficial for acceptance.

This indicates an interesting contradiction between the material expression of luxury and refurbishment values. **The refurbishability redesign should focus on finding the balance between those values.**

Problems to solve; Consumer acceptance

Table 2.5.1: Consumer acceptance problems

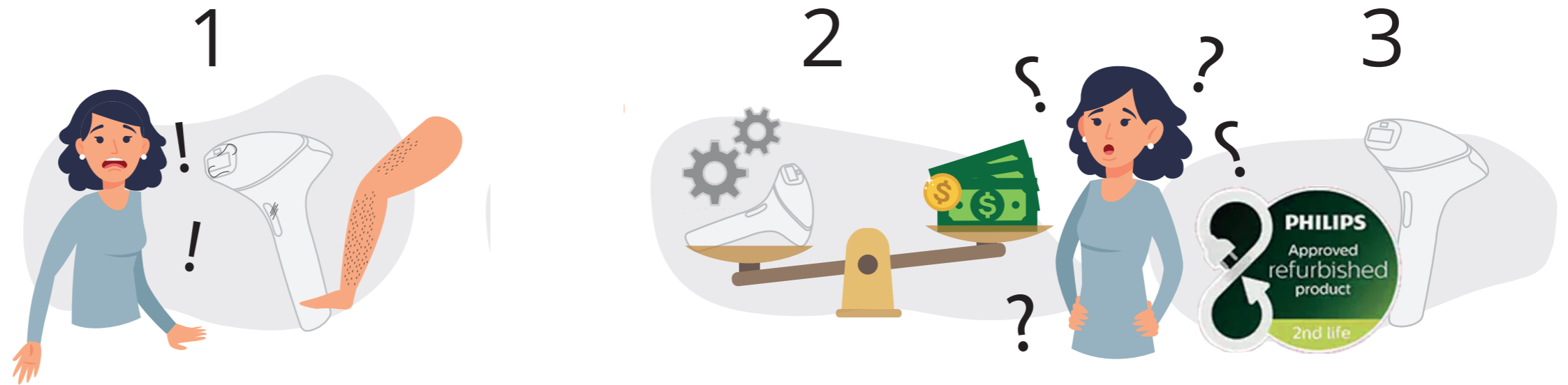

This chapter answers RQ1: *What are the main hurdles consumer experience when considering a refurbished product?* The following problems, resulting from the interviews, should be kept in mind when designing a product for refurbishment (fig. 2.5.1):

1. Fear of contamination

The interviews and survey suggest that the Lumea's design evokes positive associations with hygiene that need to be maintained.

However, as a personal care product, the Lumea is also sensitive to contamination concerns (Mugge et al., 2017). Consumers confirmed that buying a personal product like the Lumea Second Life is just not an option. The idea the someone else used it before is repulsive.

Some product parts are more sensitive to contamination than others. For example, consumers expect the attachment to be new, because this part might have touched the bikini-line of the previous owner. On the other hand, the housing is expected to function and may even have small scratches. This shows that contamination sensitivity can differ per component. Therefore, it is needed to **list the contamination sensitivity of all outer housing parts and assess the need for replacement and repair.**

In addition, Mugge et al. 2017 state that **enhancing the ease of cleaning** might also reduce the fear of contamination.

2. Financial & performance risk

The Lumea can be described as a high involvement, static product. According to Mugge et al. (2017), this means that consumers want to see value for their money and that the product's technology is less vulnerable to obsolescence.

According to consumers, this makes the Second Life Lumea less interesting. They often do not see the financial benefit and express a fear that the product is not as durable as a new one. The Lumea is described by consumers as '*marathon*' product that requires long term commitment and therefore the product should be functional for a long time. The idea of a used product lowers the perceived performance and with that the willingness to buy refurbished.

To tackle this hurdle, is important to **make consumers aware of the satisfactory aesthetic and functional qualities and the additional environmental benefits** (Mugge et al., 2017).

3. Refurbishment fuss

Confusion about the meaning of **Second Life** and the refurbishment process that forms the main hurdle. People assume it means something like second hand, which is undesirable for a personal care product.

Also, consumers have trouble judging the quality of refurbished products and do not know what to expect from the performance. **Consumers are unaware of their warranty rights when buying refurbished and are not willing to take the risk**, especially since the refurbished Lumea still requires high investment.

Most consumers who bought the Lumea new were **not aware of the refurbished option, nor were they interested.** This indicates a need for promotion and awareness campaigns on the topic. However, younger generations show less fear and are more informed on circular strategies. This indicates potential for future generations of buyers.

Consumer concerns & Opportunities

Answering RQ2: How can be Lumea's refurbished decision making experience be improved?

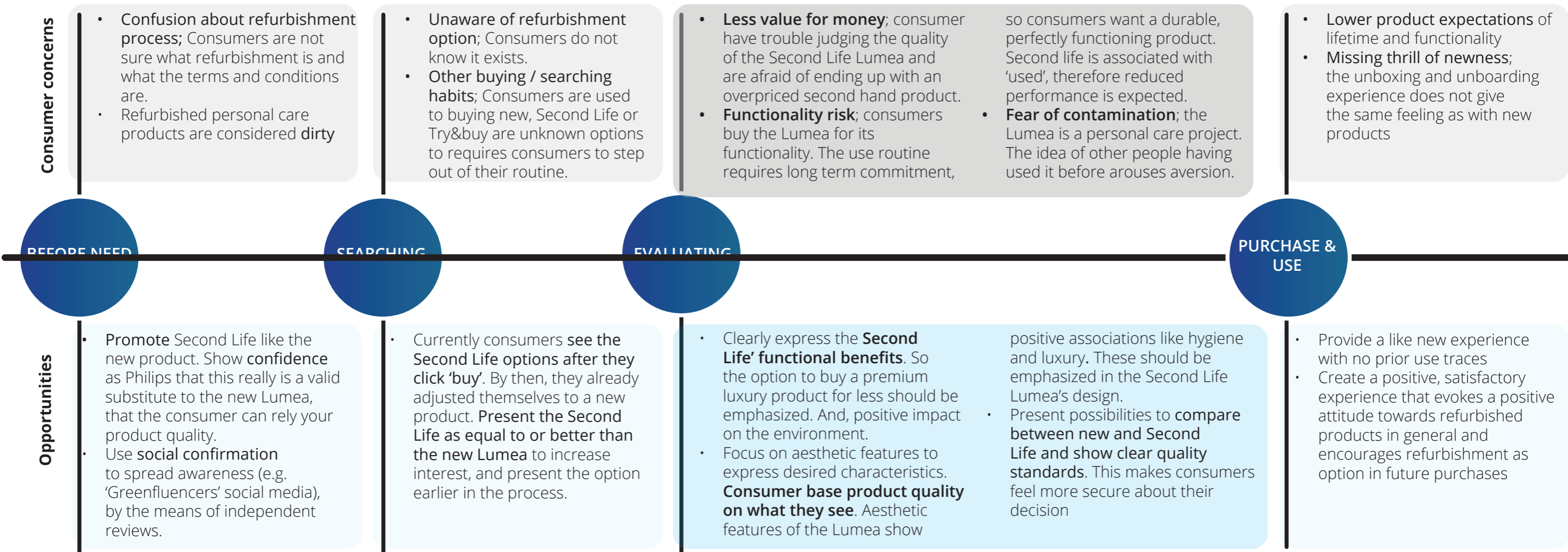

Conclusion enhanced consumer acceptance of refurbished Lumea

Avoid the creation of negative prejudices about the Second Life Lumea by avoiding prior use traces and stimulating positive associations through product design characteristics, which decreases the perceived financial and functional risk

Conclusion

At the moment, consumers are not keen on refurbished personal care products. They are considered unsanitary and undesirable. The price is too high for the leap consumer need to take out of their comfort zone. Also, because consumer are generally not well informed on the refurbishment concept and standards, like warranties, consumers are not willing to take the risk. **As short term fix, remanufacturing could be an option for the Lumea.** With this strategy, products may be sold as new, and therefore no negative associations are made with circular products.

However, the younger consumers were more familiar with refurbishment and expressed a more open attitude towards the concept. They were more used to buying second hand products and express less fear of contamination. Therefore, investing in the Second Life Lumea should be considered a long term project. **By starting the exploration and development of the perfect refurbished Lumea now, Philips will be ready when this younger generation enters the market.**

Project focus

When evaluating potential product options, consumers experience uncertainty about the product quality and contamination fear. This project aims to investigate whether product design features can influence these concerns and enhance the acceptance of the Second Life Lumea. Focussing on external and internal design solutions to be ready for coming generations of consumers.



3.

LUMEA

INSIDE OUT

Contamination and priority critical parts

Combining functionality and maintenance:

- Lightsource
- Glass
- battery
- Capacitor
- Fan
- PCB

Main problems

Opening the product

- Since three triple snap fits had to be broken before the Lumea could be opened (fig. 3.7.1)

Drop safety

- The product should comply to shock safety factor II; two layers of isolation (IEC 61140).
- The device is no longer safe to use for consumers when broken
- The device is broken when consumers can touch any inner part
- The device is broken when the UV filter of the light exit window (red glass) is broken
- The Lumea should be able to withstand 12 drops from p96 eye height without breaking



Research approach

Intro

To develop a successful refurbished product, both the consumer perspective and the technical product design need to be investigated. The last chapter identified the main hurdles consumers face when considering a refurbished product. It was concluded that listing contamination sensitive parts is needed for efficient refurbishment, just like increasing the ease of cleaning.

This chapter dives into the product architecture design and how this influences the ease of refurbishment for Philips. The ease of opening the product and reaching the contamination sensitive parts and technical priority parts is evaluated. These analyses provide opportunities and requirements for the redesign phase.

Research goals

- Understand the internal workings and product architecture of the Lumea
- Determine the current 'refurbishability' status of the Lumea and uncover points of improvement
- Determine consumer safety and disassembly requirements for the redesign

Research questions

1. What are contamination sensitive parts, and where are they located in the architecture of the Lumea?
2. What are the priority parts of the Lumea?
3. How many and what actions need to be taken to reach these priority parts?
4. What are the most prominent product design hurdles that stand in the way of efficient refurbishment?
5. What consumer safety requirements should the Lumea meet?

Methodology

Hotspot mapping & disassembly mapping (fig. 3.1.1) (chapter 3.3 - 3.8)

The ease of disassembly plays a crucial role in refurbishment. Parts with a high failure rate or high environmental or economic value should be easy to replace to ensure a cost-effective process (Flipsen et al., 2020). To redesign the Lumea for more efficient refurbishment, the current 'refurbishability' is assessed. This was done via the Hotspot mapping method (Flipsen et al., 2020). Hotspot mapping helps designers redesign products for ease of disassembly. The method provides insights into critical parts of the product and what actions should be taken to reach those parts. To do so, the product should gently be taken apart step by step (The disassembly set-up is described in chapter 3.4.). Data from each disassembly step, for example, the tools used or time needed, are filled in an included excel sheet. As a result, this excel sheet indicates hotspots.

To create a visual overview of the depth of hotspots and disassembly steps taken, Disassembly mapping was used (De Fazio, 2019). Disassembly mapping is a tool that visualises the disassembly process, depth of priority parts and hotspots. The disassembly map can be seen in chapter 3.6.

Insights from this study are used as input for the redesign process.

Drop test (fig. 3.1.2) (chapter 3.9)

Currently, the Lumea is designed for consumer safety. Consumers should not be able to reach the laser technology. To get insight into how safe the Lumea currently is, a drop test was done. This data was used to create requirements for consumer safety, that must be taken into account in the redesign.

Figure 3.1.1 Disassembly & hotspot mapping



Figure 3.1.2 Droptest

Contamination sensitive parts

Hygiene or so-called ‘contamination’ concerns with refurbished personal care products is a largely unexplored field. Partly because of these concerns, personal care products would just be considered unfit for refurbishment. However, by addressing these concerns via product design, a whole new world of possibilities could open up for personal care products in refurbishment.

Contamination sensitive definition

Contamination in terms of refurbished products is mainly explored through consumer research and not product design. The definition of Baxter et al. (2016) provides no clear description of up to what level a component is sensitive for fear of contamination. However, hygiene concerns with bringing medical products back in the loop have been evaluated with the Spaulding scale (Spaulding, 1970; Kane et al., 2018). According to this scale, the Lumea is a non-critical product since it only touches intact skin. This means that cleaning and low-level disinfection is sufficient to meet

medical hygiene standards for refurbishment (Spaulding, 1970).

The Spaulding scale, however, does not take the consumer’s contamination concerns into account since it was based on medical hygiene requirements for professional use. Also, this scale only concerns complete products and not separate parts.

Therefore, contamination sensitivity requires a different definition in the context of personal use. Based on the Spaulding model, the interviews with consumers (n=10) and adjusted to the hotspot mapping method (Flipsen et al., 2020), the definition of contamination sensitive is determined (table 3.2.1):

Level 2; critical <i>The consumer demands a new part/component</i>	A component in contact with hair growing skin (e.g. armpit, legs, bikini line etc.).	E.g. holes where dander/skin debris can get stuck, head attachment pieces
Level 1; semi-critical <i>The consumer demands an as new part/component with no prior use traces</i>	A component in contact with non-hair growing skin (e.g. hands).	E.g. buttons, housing
Level 0; non-critical <i>The consumer demands a functioning part/component</i>	A component with no skin contact.	E.g. Internal components

Table 3.2.1; definition levels contamination sensitive



Figure 3.1.2; contamination sensitive splitlines and corners

Cleaning difficulties

With refurbishing personal care products come hygiene standards from both the consumer and the company, as mentioned before. For successful refurbishment, both need to be taken into account. Currently, the Lumea is not being refurbished, but reprocessed. Reprocessing is defined as; ‘Inspecting and testing a used product for visual and functional deviations, after which the product is cleaned and brought back into the loop’ (Ellen MacArthur Foundation, 2020). To determine which parts are contamination sensitive and to what degree, both the reprocessor’s cleaning experience and consumer’s hygiene expectations were evaluated.

According to consumers, the front of the attachment is most prone to contamination since the user has to press it on the skin. Also, this part is hard to clean because of split lines and small corners. Other contamination sensitive parts mentioned were the optical

parts and the flash button, An in-depth analysis of the consumer’s cleaning routine can be found in appendix E.

The experience of the reprocessors confirmed that the attachment is hard to clean. Reprocessors currently use cotton swabs to clean the light transmitter hole (fig. 3.1.2), which is time-consuming and requires precision. A detailed description of the reprocessors cleaning routine can be found in appendix E. Table 4.1.2 in appendix F contains an overview of parts that consumers find contamination sensitive and what difficulties reprocessors may experience while cleaning. This table only contains outer parts since the internal parts are not accessible for consumers and therefore are not sensitive for contamination issues. This list of contamination critical parts is also integrated into the depth of priority parts table (table 6.9.1, page 64).



Figure 3.1.2; Cleaning splitlines

Ease of inspection

The Lumea was designed specifically not to be opened, which is inconvenient for repair. Trying to open the product will damage the housing to an unusable state. Therefore, the product is currently reprocessed, which requires only inspection and cleaning. An impression of the reprocessing facilities can be seen in figure 3.3.2.

The reprocessing process of the Lumea contains the following steps (fig. 3.3.3)(Philips, n.d.):

- Functionality test
- Inspection; The exterior of the Lumea is checked for damage and traces of use.
- Cleaning; Used Lumea's are thoroughly cleaned to new product standards. Second life Lumea's are actually 'cleaner' than newly produced Lumea's (personal communication Philips, 2020).
- Testing; The used Lumea's should meet the same performance and safety requirements as new Lumea's.
- Re-packaging; New packaging ensures that the product feels as good as new.

Inspection reprocessing

Ease of inspection refers to how much effort it takes to inspect the product's critical parts on malfunctions. The Lumea's inspection routine consists of a performance, visual and auditive test (D000376651 Philips, n.d). If the product fails any of the three inspections, it

goes to scrap. During the Visual inspection, attention lies on the following:

- Mechanical deviations, which indicate significant damage (broken/missing parts)
- The status of the attachment, particularly of the optical area (signs of burns, opacified filter, broken lamp)
- Scratches that affect the visual appearance of the device. A maximum of 5 scratches and dots are allowed (fig. 3.3.1; pass). Fingerprints and cracks are never allowed (fig. 3.3.1; fail).
- During the Auditive inspection, the sound the used Lumea makes is compared to a golden reference device. If the Lumea makes abnormal sounds or no sounds at all, the product goes to scrap.

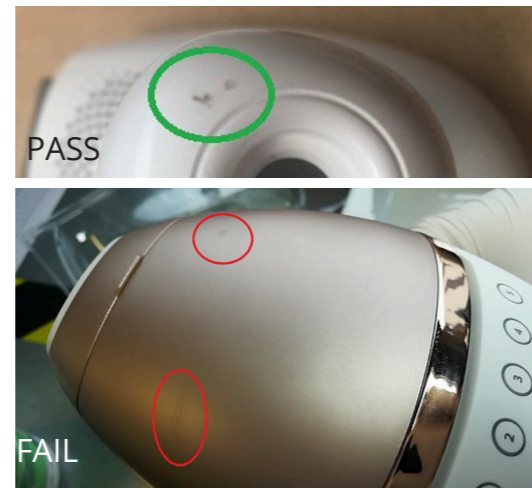

Figure 3.3.1; visual damage Lumea (Philips, 2018)



Figure 3.3.2; Testing and inspection facilities (Reprocessing lessons learned Philips, 2019)

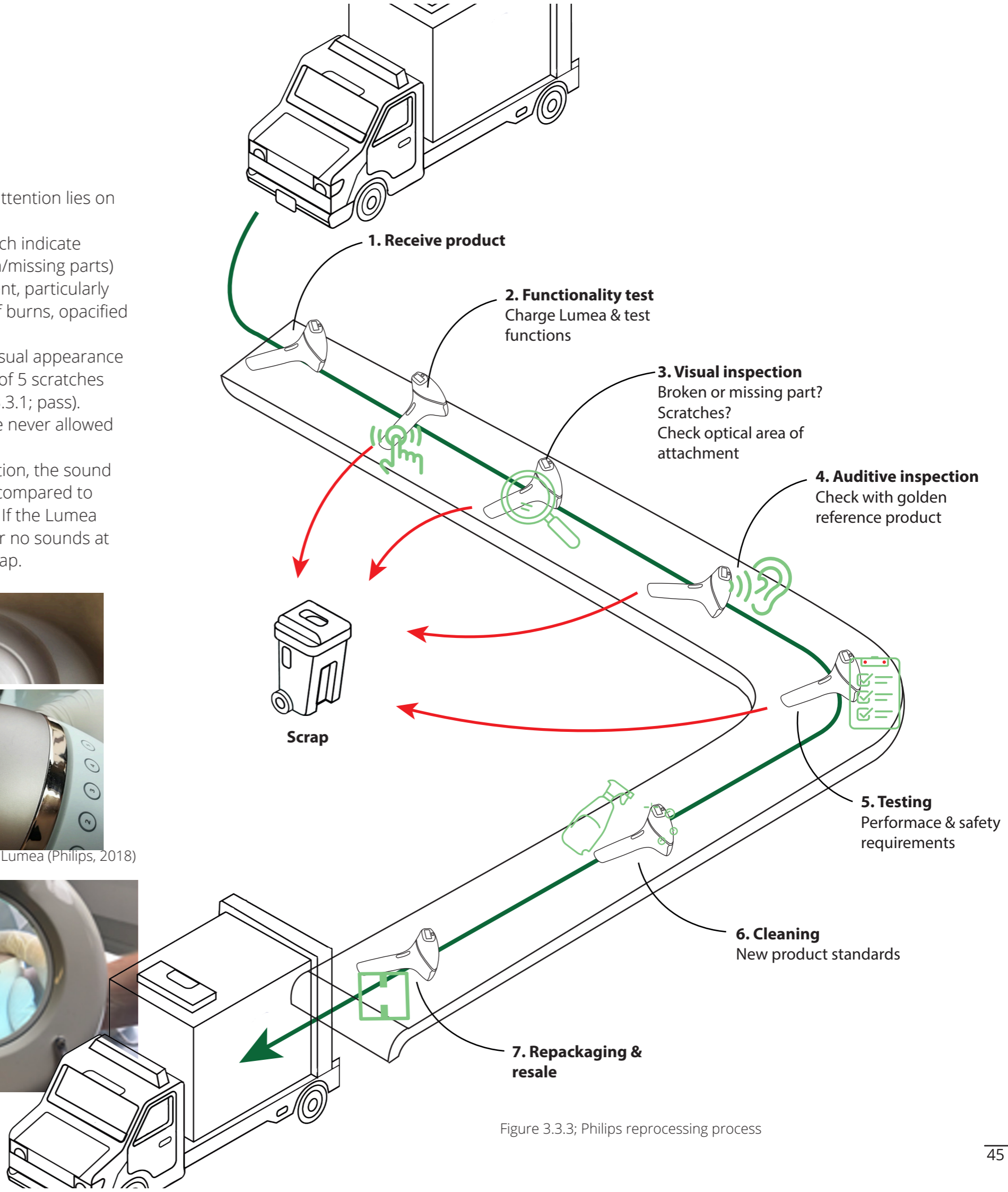

Figure 3.3.3; Philips reprocessing process

Disassembly of the Lumea; set up

The Lumea was disassembled using the hotspot mapping method. To do so, the following set-up was used. The Lumea was disassembled two times. The first time as exploration to fully understand the method and the product architecture. The second time to compare steps taken and time needed with more experience. Also, the second time hotspots were known in advance and could be investigated in more detail. This resulted in in-depth product architecture knowledge and insights in point to improve.

Research design & tools

Three people were involved in the disassembly process; two 'disassemblers' (to encourage thinking out loud and discussion during the process) and one 'Process manager' (fig.4.3.2). As stated in the hotspot mapping method, the product was taken apart step by step until only separate components were left. Complete assemblies (prefab purchasing parts) like the PCB or charging cable were considered as one separate component and were not disassembled further.

During the process, the following tools were used;

- Screwdriver small (Flathead, crosshead, Torx)
- Screwdriver large (Flathead)
- Hairdryer (heat gun)
- Scissors
- Soldering iron
- Utility knife
- Scale
- Stopwatch

Simultaneously, the 'Process manager' populated the Hotspot mapping spreadsheet. He made sure that, for each part, all topics in the spreadsheet were discussed and documented. To ensure complete documentation of the actions taken, two cameras filmed the process during the first disassembly. One with a top view and one with a front view (fig. 4.3.1). Afterwards, the videos were used to compare the data in the sheet (e.g. measured time, actions taken) with the process. The second disassembly, process was documented via a disassembly log and photography.

Limitations

Damaging and breaking parts takes time and force and can be done in different ways. These irreversible steps are indicated in the disassembly map by the damaged/broken part indicator (figure 4.5.2). Disassembling the product for the first time was an explorative and messy process. For example with opening the product, the housing had to be broken first to find out how it is fixed. After performing the disassembly for the first time, difficult steps were known and could be anticipated. The second disassembly was less chaotic and went a lot faster and smoother. This indicates a learning curve. In the case of disassembly, wisdom and dexterity come from experience. Therefore, the disassembly method should be performed multiple times to explore multiple options.

Because of the Covid-19 regulations, the disassembly had to be done from home. Therefore, we did not have the professional tools at our disposal that a Philips refurbishment facility would have. This could have influenced the disassembly method and time.

Additionally, the researchers in this disassembly are not product disassembly experts. The time to disassemble was measured in real-time since there is no prior data available for this product. This means that comparing the data from this research to the data from an experienced refurbisher was not possible. To increase the reliability of the data, the disassembly was performed twice. However, for more realistic outcomes, it is advised to redo this research with a professional refurbisher.



Fig. 4.3.2; Set up disassembly

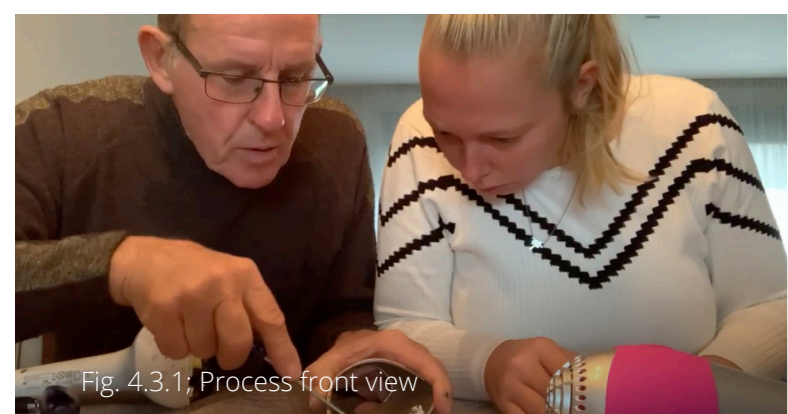

Fig. 4.3.1; Process front view

Priority parts hierarchy

Not all parts of a product are inspected during refurbishment. Otherwise, the process would take too long and would be too costly. Refurbishment is therefore focused on checking and replacing modules containing clusters of components rather than separate parts (Thierry et al., 1995). Therefore, prioritisation of parts is needed. Priority parts are parts that have high functional value and/or high maintenance need (EN45554). The priority parts of the Lumea Prestige have not been determined yet, since the product has not been assessed for the purpose of refurbishment before (Personal communication Philips, 2020).

To make this priority hierarchy, parts have been evaluated on functional importance, frequencies of failure, hygienic concerns, environmental impact and economic value. The data needed was subtracted from the Hotspot mapping spreadsheet (Flipsen, 2020; appendix H) and the contamination sensitive parts table (Table 4.1.2).

Functionally important parts

Hygiene is important, but if parts critical for the function fail, the product can not be used at all. Stripping the Lumea to its core functionality leaves the following components (fig. 3.5.1 in red):

- Optical protection glass
- Lightsource
- PCB
- Fan
- Battery
- Capacitor

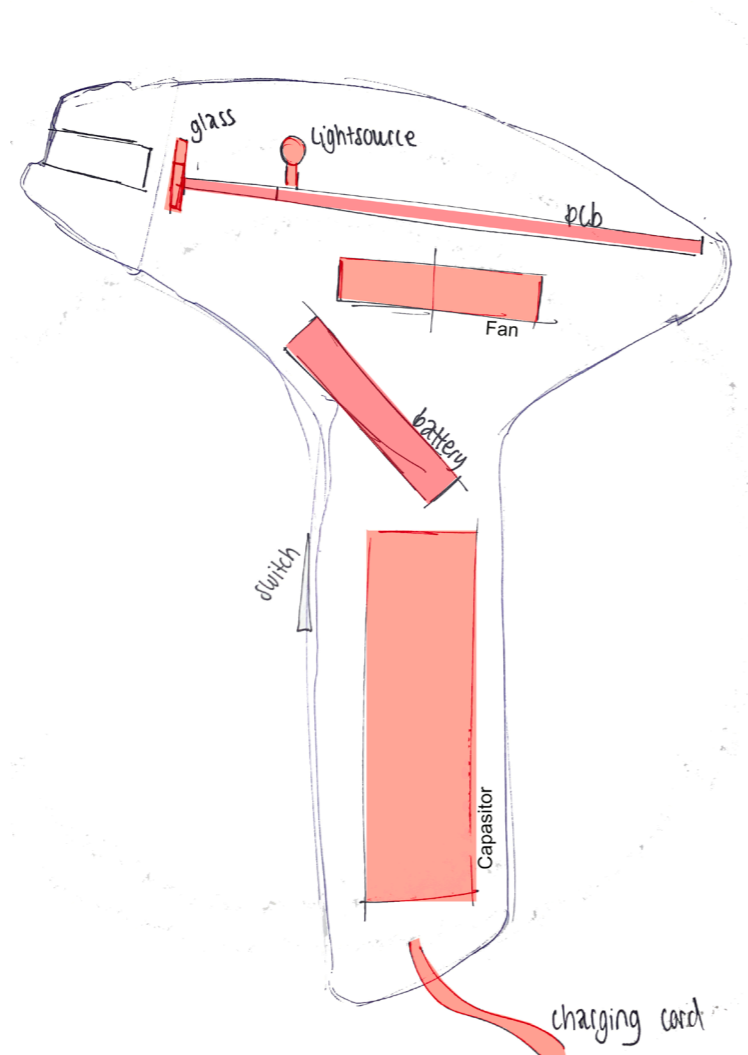

Fig. 3.5.1; core functionality Lumea

Environmental & economical impact

In general, electronics are the most environmentally and economically impactful components. For the Lumea, those are the PCB's, battery, capacitor and fan (Hotspot map, Eco-Audit performed in Granta Edupack). Because of the intense pulse light flash, the Lumea needs a heavy (and expensive) 420V capacitor. With recycling and part harvesting in mind, it is beneficial to be able to remove and replace this part.

The charging cable is also of high functional and economic value. But, since the cable is a prefab purchase part, it will not be included in the project.

The Eco-Audit indicated that the attachment is responsible for around 1% of the environmental impact of the Lumea. Also, cleaning and repairing are not profitable considering the hourly wage of refurbishers and the low production cost of this part (educated guess). Also, consumers indicated that the attachment is a contamination sensitive part (level 2), and therefore has low desirability. Altogether, it is advised to replace the attachment during refurbishment. Therefore, the attachment shall not be taken into account in the redesign phase.

Failure rates & product lifetime

According to Philips, in theory, the Lumea can last for 39 years (Personal communication, 2020). This was probably calculated under perfect circumstances. But, the majority of the components are made of durable materials like plastics, due to the purpose of the product. These kinds of materials are unlikely to fail and can last for multiple product lifetimes. These components are mainly used for housing purposes and thus not critical for functionality. However, for safety reasons (heat and intense light flash) the outer housing parts should remain intact.

Information on failure rates of the Lumea is limited. However, online consumer forums on frequent failures provided some insights. Most experienced failures on these fora are battery related. This could be due to the large periods of inactivity when the product is used once every three to six months, which lowers the battery's functionality. Also, when the Lumea is dropped, the optical parts are most likely to break first (outcome drop test, chapter 6.9). These parts are critical for functionality and consumer safety.

Exploded view

Parts:

Attachment

1. Metal clip (2x)
2. Housing attachment black
3. Metal measuring system
4. Metal light transmit
5. Housing light transmit
6. PCB attachment
7. Housing attachment pink
8. Housing attachment white

Main assembly

1. Ring
2. Cover pink
3. Inside housing buttons
4. Magnifying glass button
5. Arrow button
6. On-off button
7. Check mark button
8. Lid interface
9. Backside holder PCB
10. Seal 1
11. Housing lightsource cap black
12. Glass
13. Seal 2
14. Metal holder lightsource 2x
15. PCB
16. Lightsource
17. Lightmirror
18. Housing lightsource internal black
19. Fan
20. Screw 2x
21. Housing handle
22. Capacitor
23. Li-ion battery (2 Rechargeable Li-ion Battery UR18650W 3.7 1500mAh batteries)
24. Connector charging
25. Pcb pistol button
26. Pistol button
27. Ring backside
28. Inside housing battery assembly

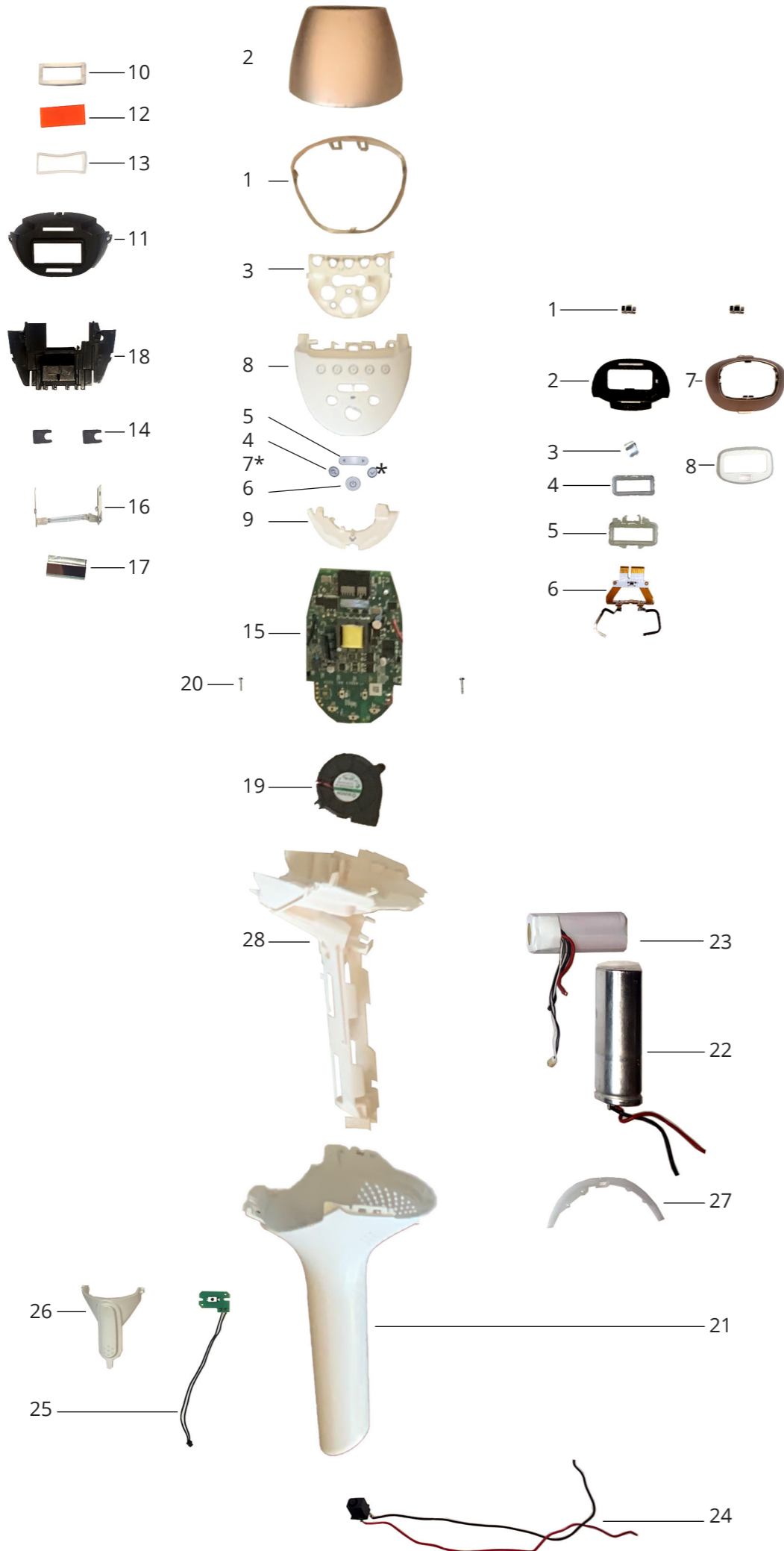

CHAPTER 3.6

Disassembly map

Legend

Tools:
 Sd = Screwdriver
 H = Hands
 Hd = hair dryer
 Si = Soldering iron
 Sc = scissors

Fit:
 FF = friction fit
 SF = Snap fit
 US = Unscrew

Priority parts:
 Hygiene priority = orange border
 Functional priority = blue border

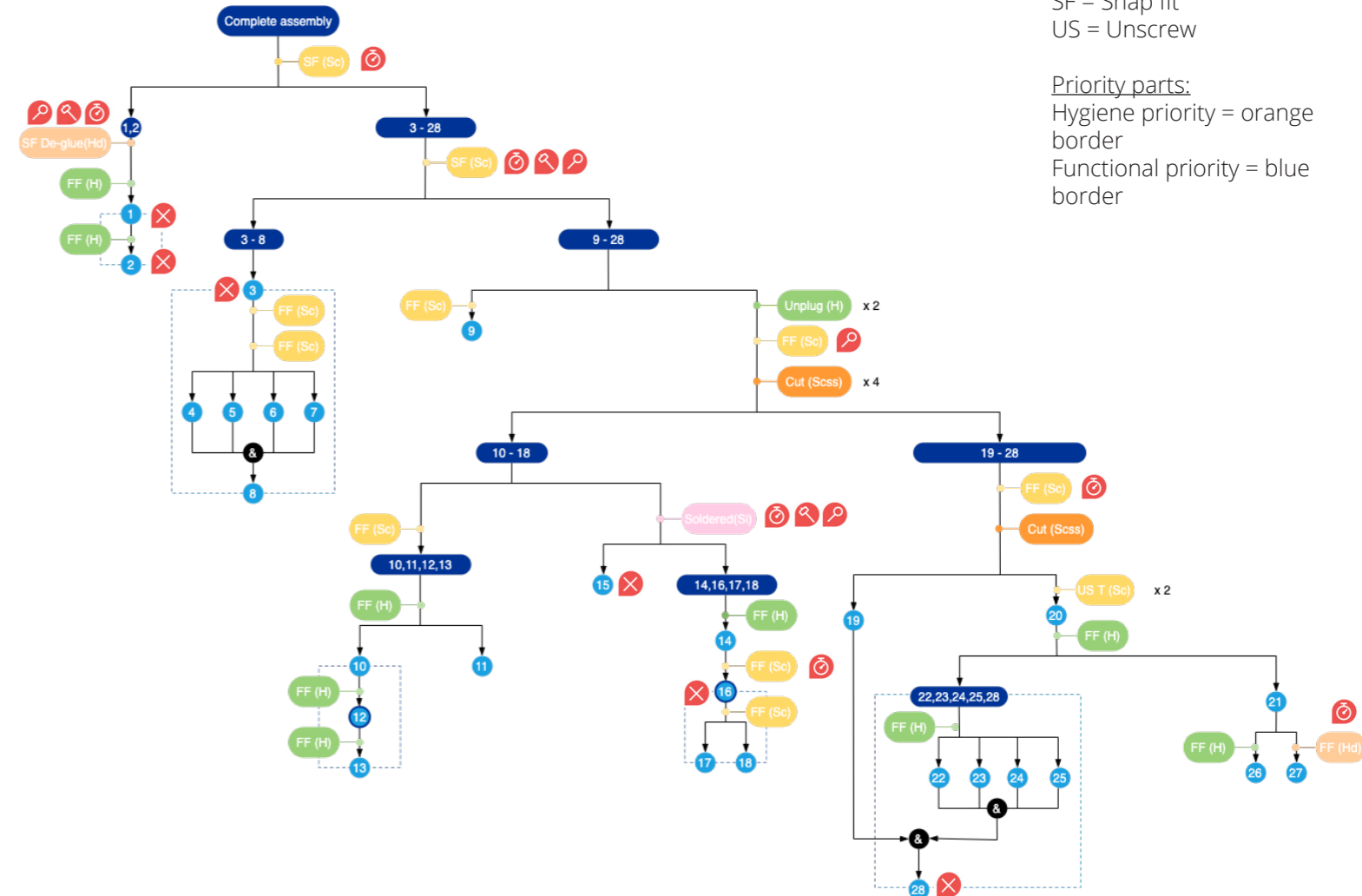

The disassembly is visualised in a disassembly map (De Fazio, 2019; Vermaat, 2020). This map shows the sequence of actions with the parts and tools involved. However, some alterations were made to fit this specific product. A detailed explanation of the labels can be found in appendix I.

The indicators (fig. 5.4.2) to clarify the nature of the hotspot in the map (based on De Fazio, 2019; Vermaat, 2020):

- *Time indicator*: activities that take 80+ percentile time to perform (Flipsen et al, 2020).
- *Force indicator*: Activities with 'heavy resistance', forearm muscles or two hands are needed, around 20 N (hotspot mapping guide, 2020).
- *Precision indicator*: Activities that require a high level of tool placement precision.
- *Damaged or broken part indicator*: Parts are either no longer functional or no longer visually acceptable for refurbishment.



Fig. 4.5.2; Indicators hotspots (Vermaat, 2020)

Ease of disassembly of the Lumea

Trying to disassemble the Lumea without breaking other parts was challenging. It is fair to say that this product was designed to be assembled once and never opened again.

To be able to draw conclusions on the current refurbishability and opportunities to improve this, the data from the Hotspot mapping datasheet was used. The Hotspot mapping datasheet of the Lumea can be found in appendix H. The depth of the priority parts, tool & fixings, disassembly time, consumer and refurbisher safety are assessed.

Part (nr disassembly map)	Depth (in disassembly steps)
Glass (12)	8
PCB (15)	6
Lightsource (16)	8
Fan (19)	7
Battery (23)	10
Capacitor (22)	10

Table 3.7; Depth of priority parts

A step is defined as an action in the disassembly map. For example in figure 3.7.0, removing a friction fit or deglueing is a step (shown in green and orange). Having a part or assembly in hand is not counted as step (shown as blue circles).

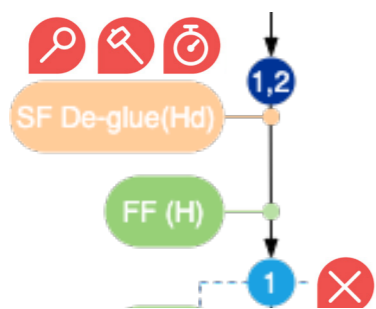

Figure 3.7.0; Definition step

Reaching the priority parts

Since three triple snap fits had to be broken before the Lumea could be opened (fig. 3.7.1), in theory, all priority parts are currently 'not removable' from a refurbishment perspective. Assuming this will be fixed in the redesign, we can take a deeper look inside the Lumea.

The depth is counted from the number of actions to reach a part. The last part is removed at a depth of 10. See table 3.7 for the depth of the priority parts indicated in chapter 3.4.

The main discovery is that the battery and capacitor, which are most prone to failure and have the highest environmental and financial value, are located at the very end of the disassembly. To reach these parts, especially in the initial steps, other parts were damaged and broken. This is inconvenient for repair and part harvesting.

The most contamination sensitive parts are located at the top of the disassembly sequence. The attachment housing parts are the first to be removed. With the help of a screwdriver, little force is needed to disassemble the attachment. It took 53 seconds in total to find the right tool position, open the snap-fit and remove the parts.

Fragile parts, like the protection glass and the light source, are protected with rubber

Fig. 3.7.1; opening the cover

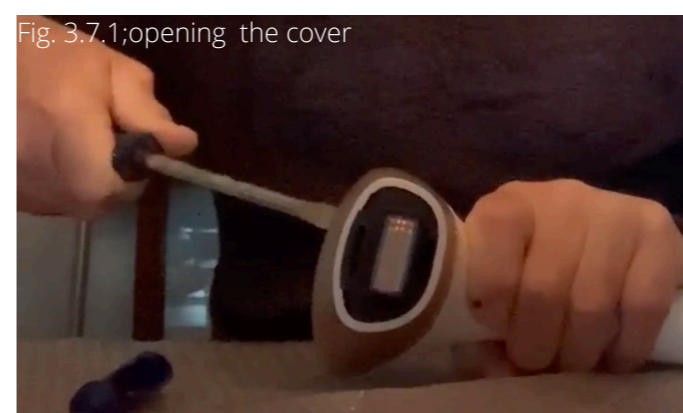

Fig. 3.7.2; Heating to remove broken snapjoints

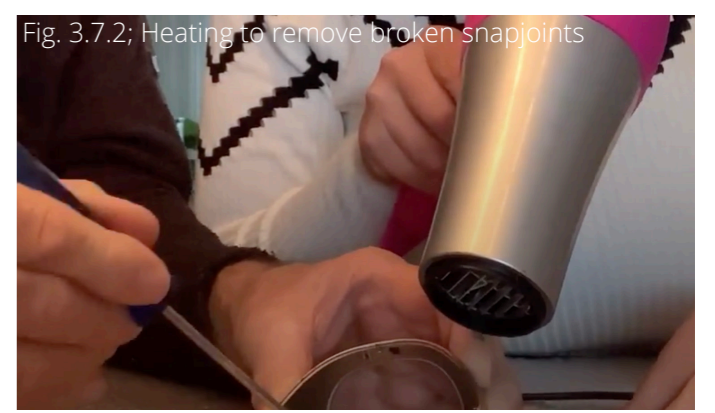
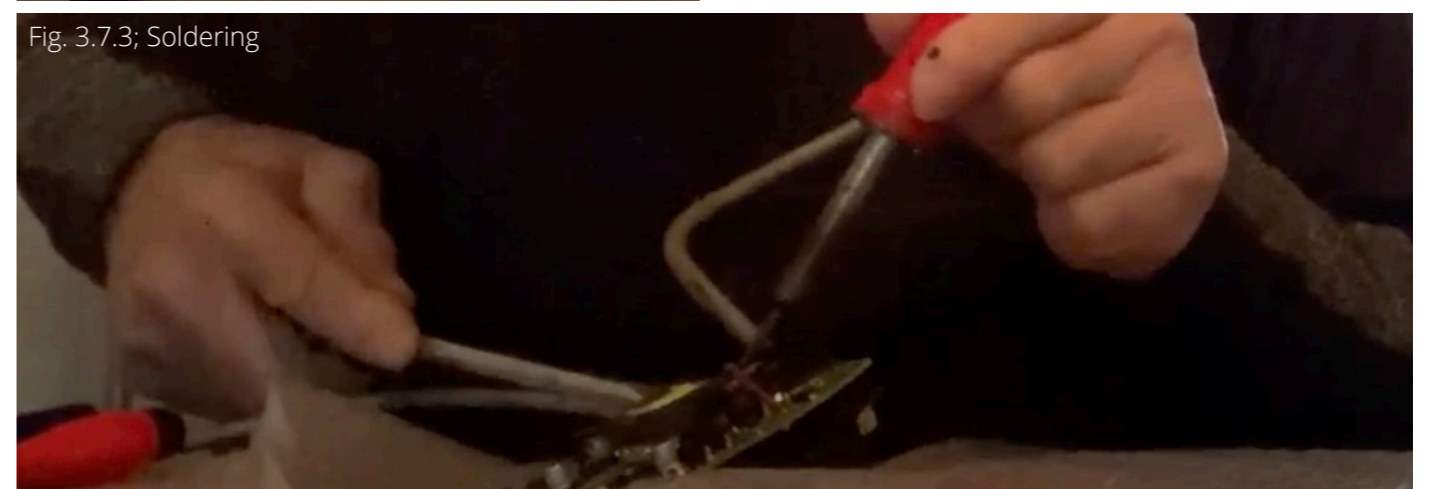

Fig. 3.7.3; Soldering



and plastic housing and are located 7 to 8 steps into the product. Removing these parts requires precision and patience since most snap fits are hidden and the light source has to be desoldered.

Tools & fixings

The housing is fixed with single use snap fits and glue, which is an irreversible connector. Breaking the glued triple snap fits takes high force and damages the product's housing, which is undesirable for refurbishment. Once the snap fits are broken, the glue has to be removed with a heat gun (fig. 3.7.2). This is an uncommon tool and time-consuming activity, which should be avoided.

Snap fits are used throughout the product to connect components to the housing. The snap fits that connect the outer housing are triple (see figure 3.7.4, next page) and can only be opened from the inside or broken with force. The remaining snap fits are singular and can be opened by hand or with a screwdriver.

The product mainly consists of friction fits that can easily be removed by hand or with a screwdriver as a liver.

The light source assembly is soldered to the PCB. This requires desoldering to remove the

PCB without breaking it (fig. 3.7.3). The wires that connect the battery and capacitor to the PCB are also soldered. These can be cut or desoldered to remove the PCB. A soldering iron is not considered an uncommon tool. However, it is a time-consuming activity and requires high temperatures, and should therefore be avoided.

The fan is connected to the battery assembly housing by two plastic tubes with are melded on top (figure 3.7.4; next page). The fan can be removed by pulling with force, however, it can not be reassembled. The battery assembly housing is fixed to the outer housing by two screws that can easily be reached and removed with a screwdriver. However, the screws are very small and need a special Torx screwdriver to be removed. It is assumed that Philips refurbishers possess such a screwdriver.

Disassembly time

The time all actions together took was 1332 seconds, around 23 minutes. However, in real-time, it took around 4.5 hours to disassemble the Lumea the first time. The second time, the disassembly was finished in 1.5 hours. The first time, time was lost finding the right tools and correct positions.

Fig. 3.7.4; Melded tubes

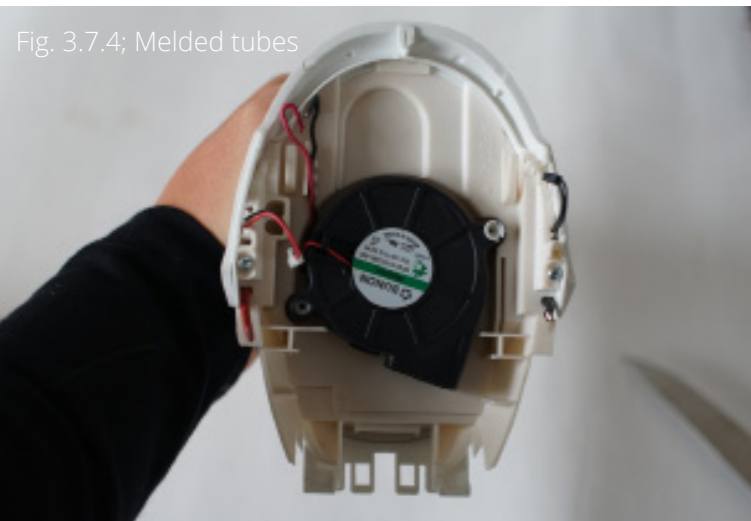

An experienced refurbisher with the right guidelines should be able to disassemble the complete product in an hour (educated guess by mechanical engineer).

Opening the Lumea is by far the most time-consuming activity. This is mainly due to the time it takes to find the right angle and break the fixings. Once this is done, the next time-consuming activities are removing fragile parts like the PCB (210 seconds) and the light source assembly (382 seconds). Once the PCB has been removed, the disassembly time significantly reduces. The remaining 13 (out of 28) parts can be taken apart in a matter of minutes (5 min and 26 sec).

Consumer and refurbisher safety

Surprising was that the Lumea was still charged during the disassembly. The 'disassembly Lumea' was broken, so power was not expected. But, as soon as the front housing was removed, the product started to smell like smoke and made short-circuit. It can not be said from this research whether the short circuit was designed or not. Also, the wires were still powered while cutting. Especially with capacitor this size, this power can be dangerous. All together can be concluded that disassembling the Lumea can cause an 'extremely hazardous situation for the user' (Philips Lumea manual, 2015), and should only be done by professionals with a clear guideline.

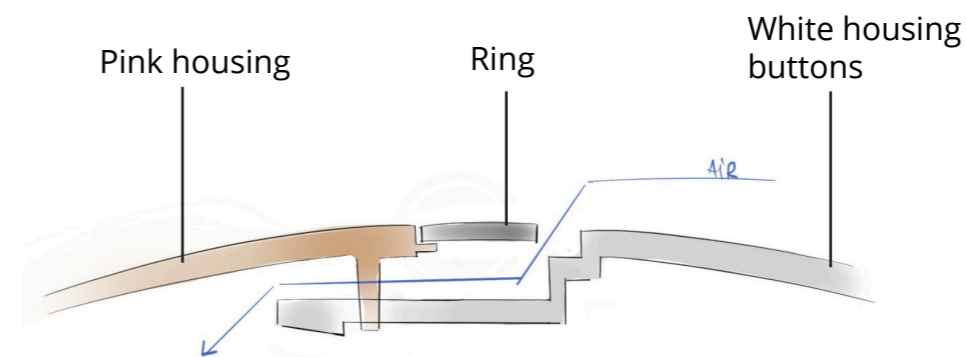
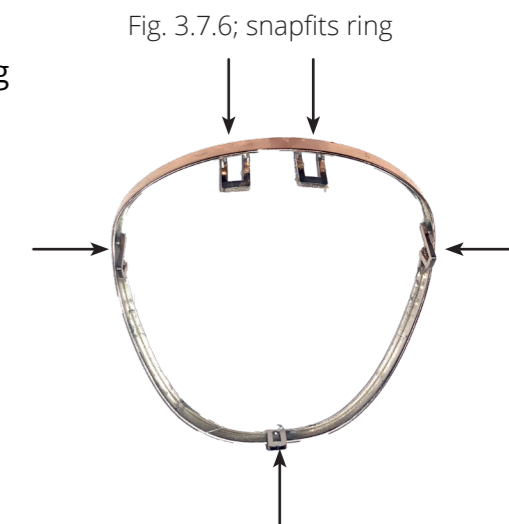

Fig. 3.7.5; schematic section of the opening airhole Lumea



Opening the product

As mentioned before, opening the product without damaging the housing permanently is vital to allow refurbishment. Finding a way to open the Lumea took almost half an hour of finding the right tool and angle. This should be reconsidered in the redesign. Therefore, the fits involved in opening the Lumea need to be investigated.

The housing is fixed with 3 triple snap fits and glue. These snap-fits are clamped from three sides (figure 3.7.4), the left, the right, and inwards. This means that the snap fits can only be opened from the inside, pushing the left and right together and the middle outwards. This is impossible with the current design when the product is closed. Also, two people are needed to perform the task. Therefore, the

snap-fits need to be broken in order to open the product.

The air inlet that was used as the position to open the product, is partly hidden by the plastic ring (fig. 3.7.5). This ring is attached to the housing with 5 single snap fits all around (fig. 3.7.6). The ring is one round piece that can only be removed once the product is open.

The Lumea was designed this way to ensure consumer safety. As mentioned before, opening the Lumea is potentially dangerous for consumers because of high power and laser light. Therefore, the Lumea should not open when it drops. To avoid all risk, the product is completely sealed. To ensure a safe refurbished product, the minimum drop safety requirements should be known.

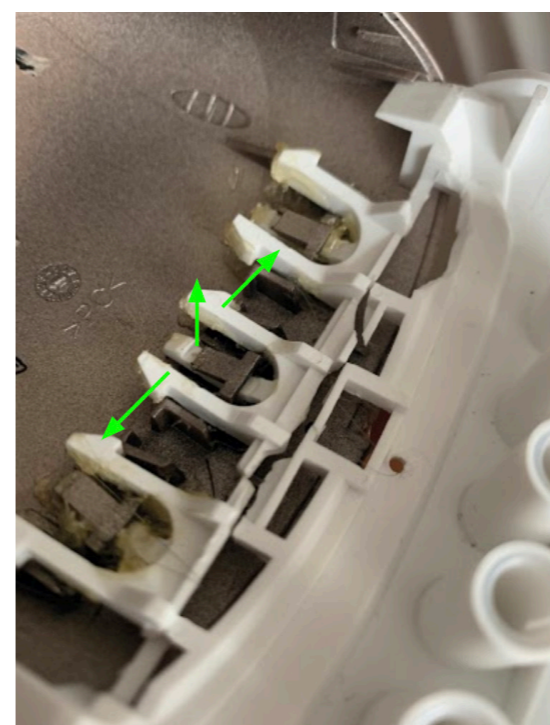

Fig. 3.7.4; Snapfits opening

Consumer safety; Drop test

One of the most common causes of failure for portable electronic products is from drop impact (Kim et al., 2020). The Lumea was designed for consumer safety, not refurbishment. To avoid any risk of opening, for example when dropped, the product is over defined for protection. Although understandable, this is an obstacle to efficient refurbishment. To ensure a safe refurbished product, the minimum drop safety requirements should be known. The problem is, there are no requirements available for the Lumea. This makes arguing about the removal of fittings difficult. Therefore, the fall safety requirements must first be determined. This was done by means of a drop test.

Redesign design and tools

This research examines the Lumea's drop impact response. To research the drop impact, the Lumea was dropped multiple times from a fixed height (Lim & Low, 2003; Zebra, 2020). This continued until the housing broke and internal components were reachable. The drops were filmed using a high-speed camera (front view) and a mobile phone in slomo mode (side view) at the applied labs at the IDE faculty (fig. 3.8.1). After each drop, the product was examined for damage and changes were logged. The high-speed camera footage provides insights into the impact orientation. The footage was analysed afterwards to indicate where

bending and cracks occur at impact. The product was oriented interface up, charge cable inlet down. The unit was turned off while dropped.

The following tools were used during the test:

- High-speed camera
- Camera
- Mobile phone with slomo film function
- Laptop with high-speed camera software
- Wooden floor piece
- Lumea



Fig. 3.8.1: Test set up; camera angles

Testing standards

Researching literature, there seem to be no norms or standards for personal care consumer electronics when it comes to dropping durability. Therefore, the Lumea Prestige manual (2015) is used to create requirements. Based on the manual; the following definitions can be stated:

The product should comply to shock safety factor II; two layers of isolation (IEC 61140).

The device is no longer safe to use for consumers when broken

- *The device is broken when consumers can touch any inner part*
- *The device is broken when the UV filter of the light exit window (red glass) is broken*

Now that the term 'broken' is defined, the number of drops the Lumea should be able to handle before it breaks should be determined. Internet research suggests that most existing standards are for mobile phones. Companies often create their own standards and tests. Comparing these tests, on average, phones should survive a minimum of around 6 drops without visual damage or data loss. Since there are no standards for personal care products like the Lumea, the phones standards are used as a rule of thumb. Considering the technology in the Lumea is heavier than that of a mobile phone, a safety factor of 2 is applied (Sagot et al., 2003).

Then there is the drop height. The face is the highest place on the body to use the Lumea. Therefore, the Lumea was dropped from the researcher's eye height (1.67 m) (fig. 3.8.1). According to DINEN (2020), this eye height includes 96% of Dutch women between 20-60. Product safety factors are usually designed

for the 5th to the 95th percentile (Sagot et al., 2003), which indicates that p96 is a sufficient safety factor. Based on this information, the following standard is set:

The Lumea should be able to withstand 12 drops from p96 eye height without breaking



Fig. 3.8.2: Drop test

Results drop test

Broken attachment

After three drops, the housing of the attachment was broken. However, it was still functional. For safety reasons the attachment was removed from the assembly for the remainder of the test.

3

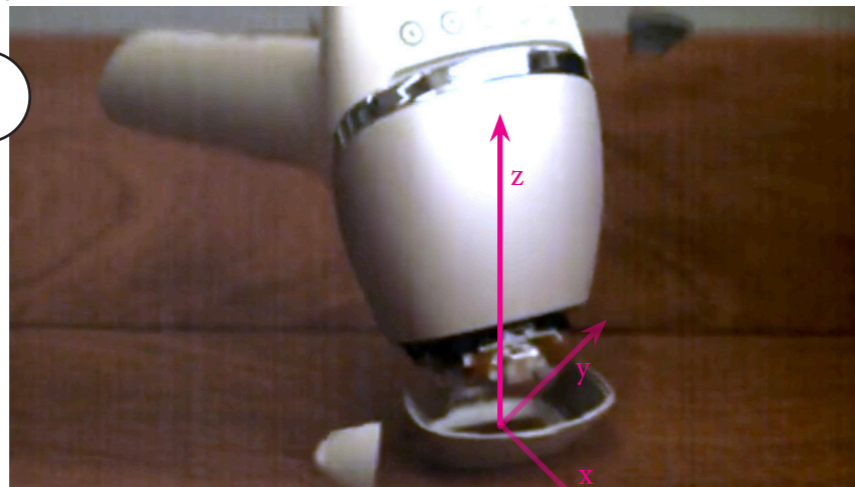

No longer functional

Visible cracks and broken light source.

The front of the pink housing showed visible cracks in the corners, indicating a weak spot. Since the Lumea is top heavy, most drops hit impact at the same position, the front. This could explain why the light source was the first critical component to fail.

8



Housing open; unsafe to use

The housing cracked open at the back side of the product. The snapfits were burst open by de impact. The picture on the left shows that the product opens below the PCB, giving access to the fan.

17



Housing broken

At this point, the pink housing completely cracked open and the test was ended. As can be seen in the picture on the right, the snapfits are still in tact and in position. Thus, it is more likely for the housing to fail under impact than the snap fits.

29

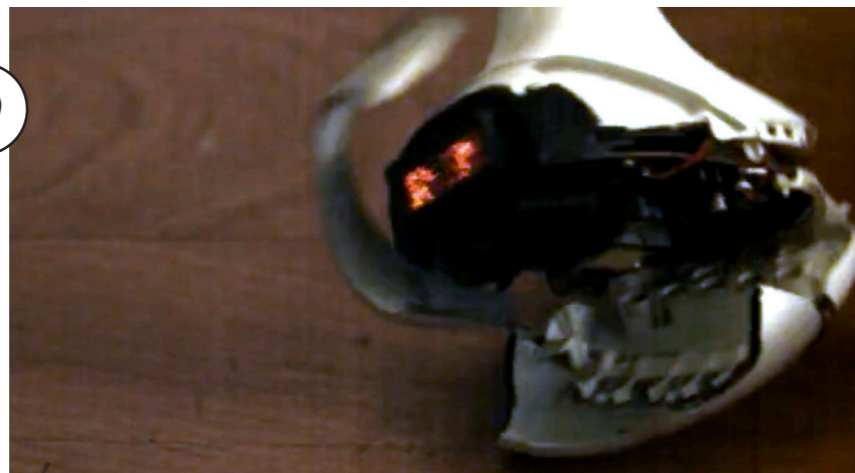

Test limitations and recommendations

Due to the limited amount of Lumea's available, the test was only conducted with one product. Other safety standards tests suggest using at least 3 devices for testing (Zebra, 2020; U.S. Military Standard, n.d.). Therefore it is advised to redo this test with multiple devices to increase the likelihood of the outcomes.

While drop testing validates that a device can withstand a limited number of impacts of a specific intensity, it cannot ensure that a device will survive all drop situations (Zebra, 2020). The Lumea had different impact locations during the test, distributing the damage over the housing. If the product was impacted on exactly the same location every time, the amount of drops the Lumea can withstand would probably have been less.

To validate the outcomes and gain more insights on impact power, sensors should be used to measure the impact. In this research, the footage was supposed to be analysed using Tracker software. However, because the footage was filmed in slomo, results were not reliable.

Conclusion

The results of the droptest are visualised in figure 3.8.3.

The Lumea should be able to withstand 12 drops from p96 eye height without breaking

It can be stated that the Lumea meets the aforementioned requirements. The internal components are accessible after 17 drops, which surpasses the requirement of 12. This suggests that there is room to redesign or remove fixings and still meet the safety requirements.

Also, the technical internal components are more likely to break than the housing. The attachment broke after 3 drops, which means that the product, or at least that attachment, should no longer be used. Considering that consumers can buy attachments separately (Philips.com, 2020; Marktplaats.nl, 2020), the test continued. The light source broke after 8 drops, making the main assembly dysfunctional. The light source is the first of the critical components list the fail.

The housing started to show cracks 8 drops, and met the broken definition after 17 drops. This means that consumers can no longer use the product due to functional failure before it reaches the aforementioned threshold of broken.

After 29 drops, the triple snapfits were still in tact. The housing, however, broke in two. This shows that the three triple snapfits are indeed over defined for consumer safety.

Due to the heaviness of the head, the Lumea landed on the front, creating impact and moment in the z direction (fig. 3.8.3, first picture). This means that connecting the housing parts in the x or y direction would be most secure.

Fig. 3.8.3: Results droptest

Refurbishability of the Lumea

The Lumea, in its current state, can not be refurbished efficiently. Opening the housing and the short-circuit caused so much damage that the refurbishment is no longer financially viable (educated guess by mechanical engineer).

The average force and precision needed to disassemble the Lumea are low, and the accessibility high (Hotspot mapping spreadsheet Flipsen, 2020). However, the disassembly time is long compared to other products in this category (Personal communication Philips, 2020). This is mainly due to the time spend on breaking snap-fits to open the product. But, once the Lumea is open, it consists of many assemblies that can be removed separately with little force and minimal tool use.

The main refurbishment issue is consumer safety. The safety of the consumer is of course paramount. However, the drop

test indicates that there is room to explore redesign options within the safety standards to enhance the refurbishability of the Lumea.

Following up on the issue of opening the Lumea. The need for a heat gun and soldering iron should be designed out of the product disassembly. These actions take too much valuable time.

Another issue is the depth of the battery and capacitor, which are priority parts. These components need to be easy to reach and replace to ensure viable refurbishment.

Table 3.9.1 answers the following research questions:

RQ1: What are contamination sensitive parts and where are they located in the Lumea?

RQ2: What are the priority parts of the Lumea?

RQ3: How many and what steps need to be taken to reach these priority parts?

Part (nr disassembly map)	Depth (in disassembly steps)	Functional priority?	Contamination sensitive?
Button interface assembly (3-8)	2		x→ level 1
Ring (1)	3		x→ level 1
Attachments housing pink (disassembly map attachment 7)	3	x	x → level 2
Attachments housing white (disassembly map attachment 8)	4	x	x→ level 2
Metal light transmit (disassembly map attachment 4)	5		x→ level 1
Housing light source cap black (11)	7		x→ level 1
Fan (19)	7	x	
Lightsource (16)	8	x	
Glass (12)	8	x	x→ level 1
Housing handle (21)	9		x→ level 1
Pistol button (26)	10		x→ level 1
Battery (23)	10	x	
Capacitor (22)	10	x	

Table 3.9.1: priority parts depth

Figure 3.10; problems to solve



Problems to solve; Refurbishability

RQ4: What are the biggest product design hurdles that stand in the way of easy refurbishment?

1. Opening the product's housing with less force, no damage and without compromising on consumer safety. Make reassembly possible. Solution focus: reversible fits.
2. Battery and capacitor depth: Components with the largest carbon footprint. Faster replacement/repair and fewer steps needed to ensure efficient refurbishment.
3. Ease of cleaning; many small corners and split lines

RQ5: What consumer safety requirements should the Lumea meet?

The device is no longer safe to use for consumers when broken

- The device is broken when consumers can touch any inner part
- The device is broken when the UV filter of the light exit window (red glass) is broken

The Lumea should be able to withstand 12 drops from p96 eye height without breaking



4.

AESTHETICS &

REFURBISHMENT

THE CONSUMER'S PERSPECTIVE

TAKEAWAYS

The influence of aesthetics

- Aesthetics influence the acceptance via associations but will not be the deciding aspect for solving the overarching societal problem that stands in the way of refurbished product acceptance; misconceptions about refurbishment (fig. 5.2.1).

Lumea design parameters

- Luxury
- Hygiene
- Durability

The influence of different characteristics on willingness to buy refurbished

- The shiny white version of the Lumea has a significantly higher WTB mean ($m = 4.74$; $p = <0.05$) compared to the current Lumea
- Regression analyses showed that 'simple' and 'hygienic' have a weak positive relation ($p = <0.05$) with WTB refurbished.
- A stepwise regression was done to explore the effects of the characteristics on the WIB identified **'hygienic' as the strongest predictor.**

Research Approach

Intro

The interviews (chapter 2.3) indicated that consumers have a preference for white (or light coloured) products. Also, smooth textures were mentioned as favourable for the refurbished Lumea. Textures were mainly mentioned in relation to fear of contamination or hygiene. And, shapes and design styles were related to the perceived quality.

These findings, however, are based on qualitative research. To prove their validity, these statements need to be quantified in a larger scale survey.

This chapter explores the influence of aesthetic features, colour and texture, on the consumer's willingness to buy refurbished. Six colour and textures variations of the Lumea were created (fig. 4.1.1) and tested on consumer acceptance compared to the current Lumea.

Research goals

- Find out whether colour and texture have a significant influence on the willingness to buy of the refurbished Lumea

Research questions

1. What aesthetics features do consumers favour for the refurbished Lumea?
2. What characteristics positively influence the willingness to buy refurbished?
3. What (aesthetic) features can be redesigned to enhance the acceptance of the refurbished Lumea?

Methodology

Variables

The following variables are tested in this survey:

1. Simple
2. Trendy
3. Robuust
4. Sustainable
5. Complex
6. Timeless
7. Fragile
8. Hygienic

'Trendy' and 'timeless' were chosen based on research by Wallner et al. (2020). Timeless should have a positive influence on the perception of a refurbished product. In that sense, trendy should have a negative influence on the perception. 'Simple' and 'complex' were also selected based on this research.

Research by Wallner et al. (2020) and the consumer interviews conducted in this project suggest that consumers prefer robust refurbished products over products with a fragile appearance. To test this statement, the characteristics 'robust' and 'fragile' were selected.

Various studies state that sustainability, or a sustainable image has no influence on the decision to buy refurbished (Michaud and Llerena, 2010; Abbey et al., 2015; van Weelden et al., 2016; Wewer et al., 2020). This is contradictory to the findings from the interview, in which consumers state that environmental concerns to influence their decision. A sustainable looking product and knowing that the product is refurbished and thus sustainable, are ofcourse, not the same. However, whether this statement is also valid for the personal care product, like the Lumea, has not been confirmed yet. Therefore, 'sustainable' was tested aswell.

Lastly, consumers base many of their buying decisions on their perception of hygiene and fear of contamination. To validate this statement, the characteristic 'hygiene' was also tested.

Procedure & stimuli

The questionnaire consisted of two parts; first rate the current Lumea on willingness to buy and characteristics. Than, rate of 6 variations on willingness to buy and the same variations.

The questionnaire started demographics and an introduction to the Lumea in the form of a video and a small text. Subsequently, the respondents were asked to rate the beforementioned characteristics based on the

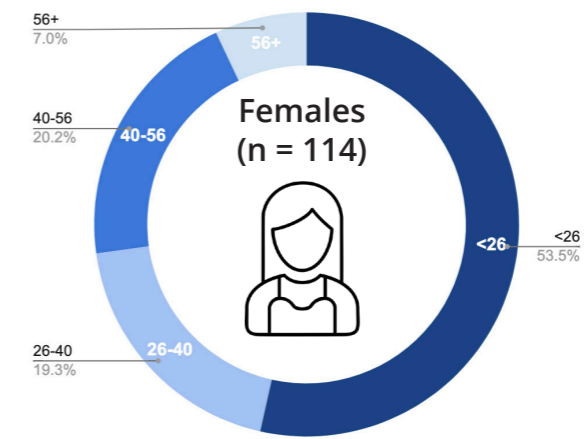

Figure 4.1.2; Age deviation participants

design of the current Lumea. All characteristics were measured on seven point Likert scales, from 1 ('strongly disagree') to 7 ('strongly agree'). Participants were also asked to rate their willingness to buy the current Lumea.

Next, Second Life was introduced with a process explanation from the Philips website. Consumers were given a scenario and a price and were asked to scale how likely they were to buy the current Lumea Second Life instead of new and explain why.

Afterwards Second Life is defined as refurbished. Participants were asked whether they had ever heard of refurbished, and if so, if they ever bought a refurbished product.

Finally, consumers were shown a picture and a scenario about one of the six design variations shown in fig. 4.1.1. These designs varied in colour and surface texture. Again, participants were asked to rate the beforementioned characteristics based on the

design and how likely they were to buy this Lumea refurbished instead of new.

Sample

The Lumea's target consumers are females, therefore only females were asked to participate in this research.

The online questionnaire was send out via personal social media channels like Facebook and Whatsapp groups.

The sample (n=114) consisted of different age groups, with the majority of participants was below 26 years old (54%) (fig. 4.1.2). This is probably due to the audience of the personal social media channels of the researcher. Sample consisted of both Dutch and non-Dutch speaking participants (23% non dutch speaking).

Each design variable was rated by at least 18 participants (fig. 4.1.1).

Figure 4.1.1; Variations Lumea



Colour, texture and willingness to buy

After closing the survey, the data was sorted and analysed using SPSS. Detailed results of this study can be found in appendix J. The following chapter discusses the results and indicates recommendations.

Aesthetic preferences

Figure 4.2.1 shows the means of the willingness to buy (referred to as WTB from now on) of the variations of the Lumea. Considering the variables were measured on a 7 point scale, it can be concluded that this sample has a positive attitude towards buying the Lumea refurbished (m total = 3.42). This is in line with studies conducted by Mugge et al. (2017), van Weelden et al. (2015) and the consumer interviews conducted in this project, where consumer showed a positive initial response to refurbishment.

The shiny white version of the Lumea has a significantly higher WTB mean (m = 4.74; p = <0.05) compared to the current Lumea. Participants from all age groups preferred the shiny white version. This is in line with the interview results, which also showed a preference towards shiny white products for contamination reasons. No significant differences in WTB can be found between the variations.

However, from this data, it can not be concluded whether consumers prefer the colour white for a refurbished personal care product or if they consider white as a more

suitable colour for the Lumea considering the product use. The white variations have a higher average WTB than the darker variations (fig. 4.2.2), but these differences were not significant. The interviews suggested that white is associated with medical equipment and household electronics. Since the Lumea fits both these descriptions, it could be that white is a more favourable colour for the Lumea in general, refurbished or not.

The same goes for shiny surface finishing. The study indicated a slight preference towards shiny products but not significant (delta mean = 0.27). Interviews pointed out that consumers associate smooth texture finishing with high ease of cleaning. Although shiny and smooth are not the same, they could be related in the eyes of consumers. Since the Lumea is a personal care product, this could be a general preference and not per-definition refurbishment related.

The influence of different characteristics on willingness to buy refurbished

Regression analyses showed that 'simple' and 'hygienic' have a weak positive relation (p = <0.05) with WTB refurbished, which was

Figure 4.2.2; the means of 'willingness to buy refurbished' on colours and textures

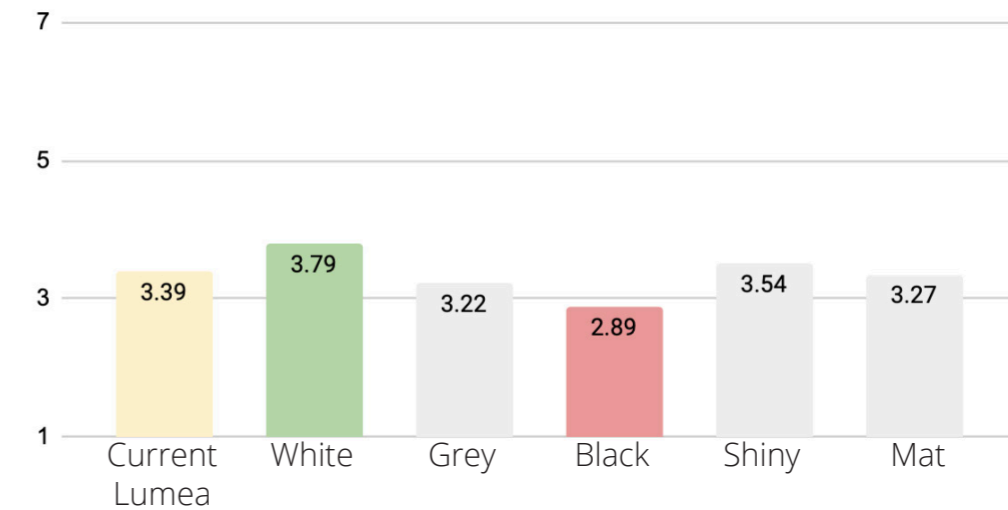

expected considering other studies (consumer interviews; Wallner et al., 2020). This suggests that the more simple and hygienic the product is, the higher the willingness to buy refurbished will be.

A stepwise regression was done to explore the effects of the characteristics on the WIB identified **'hygienic' as the strongest predictor**. This study doesn't prove that this relation is causal but it seems reasonable that improving hygiene perception will cause a slightly higher overall WTB of the refurbished product since this is in line with the consumer interview outcomes.

Surprisingly, no effect was found for the other characteristics; trendy, robust, sustainable, complex, timeless and fragile. For 'sustainability' this was expected, considering the results from earlier studies (Michaud and Llerena, 2011; Abbey et al., 2015; van Weelden et al., 2016; Wewer et al., 2020).

For 'timeless' and 'trendy' however, a positive effect was expected based on Wallner et al. (2020). This could be due to the fact that these terms are multi interpretable. Trendy could be interpreted as 'modern' or 'contemporary' as well as 'pretty' or 'fashionable'. This could lead to inconclusive results.

Age and willingness to buy

During the interviews, it was observed that younger participants had a more open attitude towards the idea of refurbishment. They were more informed on circular options and were less affected by performance and financial risk. The survey confirmed that the younger generation (<26) are significantly more willing to buy refurbished than older age

groups (26-40; 40-56; 56+) (p = <0.05).

Limitations and recommendations

This survey might not have been the best way to test textures. Textures can be seen and judged from pictures, however, it is mainly a tactile product design feature. Also, the textures were less prominently visible from the pictures than the colour. In that sense, they were not presented equally, which could have been the cause of inconclusive results on textures. It is recommended to test the influence of texture in qualitative studies with tactile prototypes, where consumers can experience the differences first hand. Or, in qualitative studies, compared only to other textures instead of to more visually dominant present features, like colours in this case.

The different Lumea variations were only tested by 18 to 20 participants each. This makes the results more dependent on individual answers. It is therefore recommended to repeat this study with a larger sample to enhance the reliability of the outcomes.

Building on this, the age groups were not equally distributed. The age group <26 represented 54% of all participants. Since this has a more positive attitude towards refurbishment, as argued before, this could have influenced the average willingness to buy.

In this study, the shape of the Lumea was not changed. To could have been the cause of the non-significant effects regarding robustness and fragility. However, interviews did suggest a potential relationship between the shape and perceived quality. For future research is might be interesting to explore this further.

Figure 4.2.1; the means of 'willingness to buy refurbished' from different Lumea variations

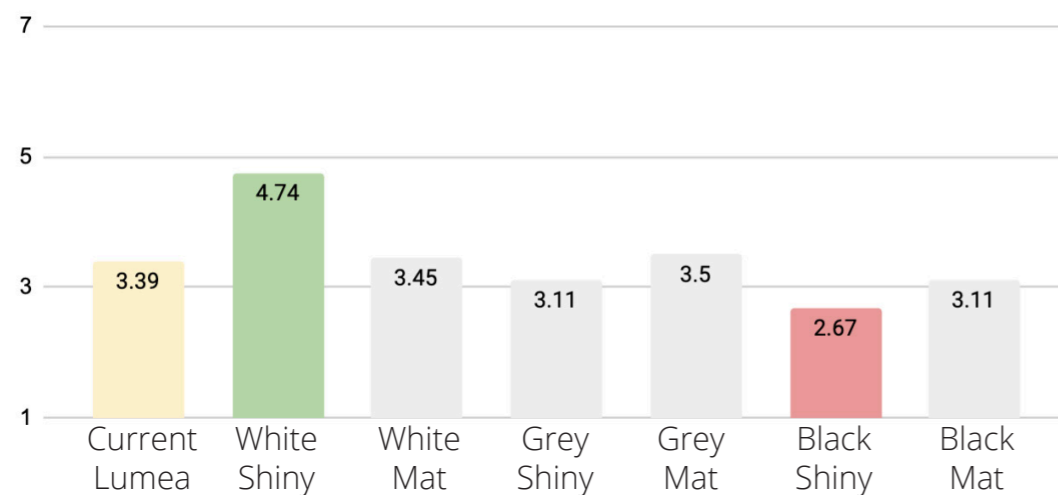

The influence of aesthetics

This chapter combines literature, survey results and insights from the consumer interviews into one conclusion on the influence of aesthetics on the consumer acceptance of refurbished products.

Consumer priorities

Price is by far the most prominent factor influencing acceptance. In the survey and the interviews, consumers express contamination concerns and functional qualities as hurdles not to buy refurbished. But, once the price reduction is significant enough, these considerations are overruled. The financial risk becomes so low that consumers are *'willing to take the functionality risk'*.

When shown a new and a refurbished Lumea with similar pricing, performance becomes the primary concern. Consumers consider the Lumea a 'marathon product', meaning it should last for years. This indicated a consumer need for reassurance and security on performance.

Societal stigma

Consumers experience insecurity about the durability of the Lumea and whether it will be worth their investment. Also, the consumer mention that the *'Second Life Lumea is too expensive for a used product'*. It can therefore be concluded that financial risk is related to the misconception about refurbishment. If consumers knew exactly what

refurbishment was, estimating the risks of buying a refurbished product would be easier. Therefore, societal stigma and low awareness have the highest impact on acceptance.

The influence of aesthetics

Aesthetic product features have little to no influence on considering refurbished during the search phase. In other words, specific aesthetics are not going to make refurbishment a considered option. First, the consumers most decide to consider refurbished. Then aesthetic features come into play. These aesthetic features help consumers judge whether this product meets contamination and functionality needs.

Product aesthetics is only one of the multiple factors that consumers use to balance benefits and risks. Other factors mentioned were warranty, service and brand trust. This indicates that the influence of aesthetics on the problem of refurbishment acceptance is minor compared to the societal stigma. However, that does not mean that there is no influence at all. Consumer expresses a clear preference towards characteristics associated with hygiene, like white colours and smooth textures. Therefore, creating associations with hygiene can increase the willingness to buy refurbished (Huang et al., 2020).

The best way to describe the effect of aesthetics on acceptance would be; ***Aesthetics influence the acceptance via associations but will not be the deciding aspect for solving the overarching societal problem that stands in the way of refurbished product acceptance; misconceptions about refurbishment (fig. 5.2.1).***

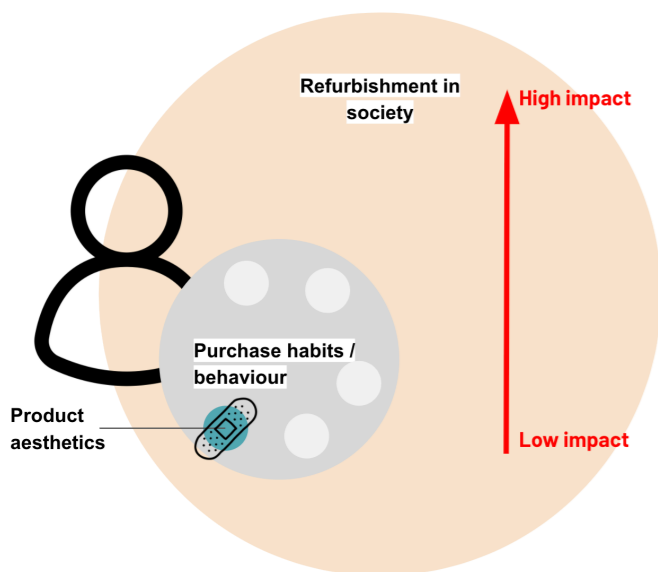

Figure 5.2.1; impact aesthetics on refurbishment

Lumea design characteristics parameters

As concluded in the previous chapter, the influence of aesthetics has mainly to do with associations. This chapter summarizes the highest valued characteristics and associations found during research in this project. Afterwards, the current Lumea is evaluated on these characteristics and opportunities are identified. To create positive associations with the refurbished product, the design should express the following characteristics:

1. Luxury

The expression of luxury is one of the Lumea's *raison d'être*, as argued in chapter 2.4. The symbolic meaning of investing in a luxurious self-care product is, together with the functionality, the main reason to buy a Lumea Prestige.

Therefore, the feeling of luxury should be maintained in the redesign. This can either be achieved via material expression, or via a distinctive design.

2. Durability

Durability can be expressed by a timeless design; not sensitive to consumer trends and time (Lobos, 2014) and stays relevant over time in terms of design and technology (upgradability), or via a sturdy look; the product does not break easily.

Timeless designs can be achieved by designing a product that can be repaired and upgraded in architecture. It is also related to creating a unique product, an archetype, that is not associated with popular aesthetic cues (Lobos, 2014). However, IPL is a relatively new product category. Therefore it makes sense that the Lumea scores around average on timeless (survey data). There is no archetype to relate to. But, looking at competitor products, the Lumea is well on its way to becoming an archetype by itself (interview Lumea designer, 2020). Competitor IPL devices show a similar shape. This indicates opportunities to optimise the distinctive shape and grow in perceived timelessness.

Also, the consumer interviews suggest that the Lumea looks sturdy, and the 'weird shape' evokes a feeling of trust.

Durability can also be achieved via simple design styles. A simple design aims to slim a product down to its core functionality. The survey suggests that simplicity has a positive effect on the willingness to buy of refurbished products. This, together with the potential of becoming an archetype, makes the overall shape a feature to keep.

3. Hygienic

Hygiene is the Lumea's most dominant characteristic, as confirmed by the interviews and survey. In terms of design, it can be found in the finishing and details.

The smooth surface finishing and light colours make the product (look) easy to clean, valued highly by consumers. Also, little complexity in terms of splitlines and sharp corners contribute to this perception. However, the shiny ring does not fit the hygiene description. It is contagious to fingerprints and scratches, which evokes negative associations with previous use. Since associations are about visual cues, scratch-free materials are not going to do the trick. To follow the Philips style guidelines (technology should be highlighted) and maintain the luxury feel, so other ways of achieving this should be explored.

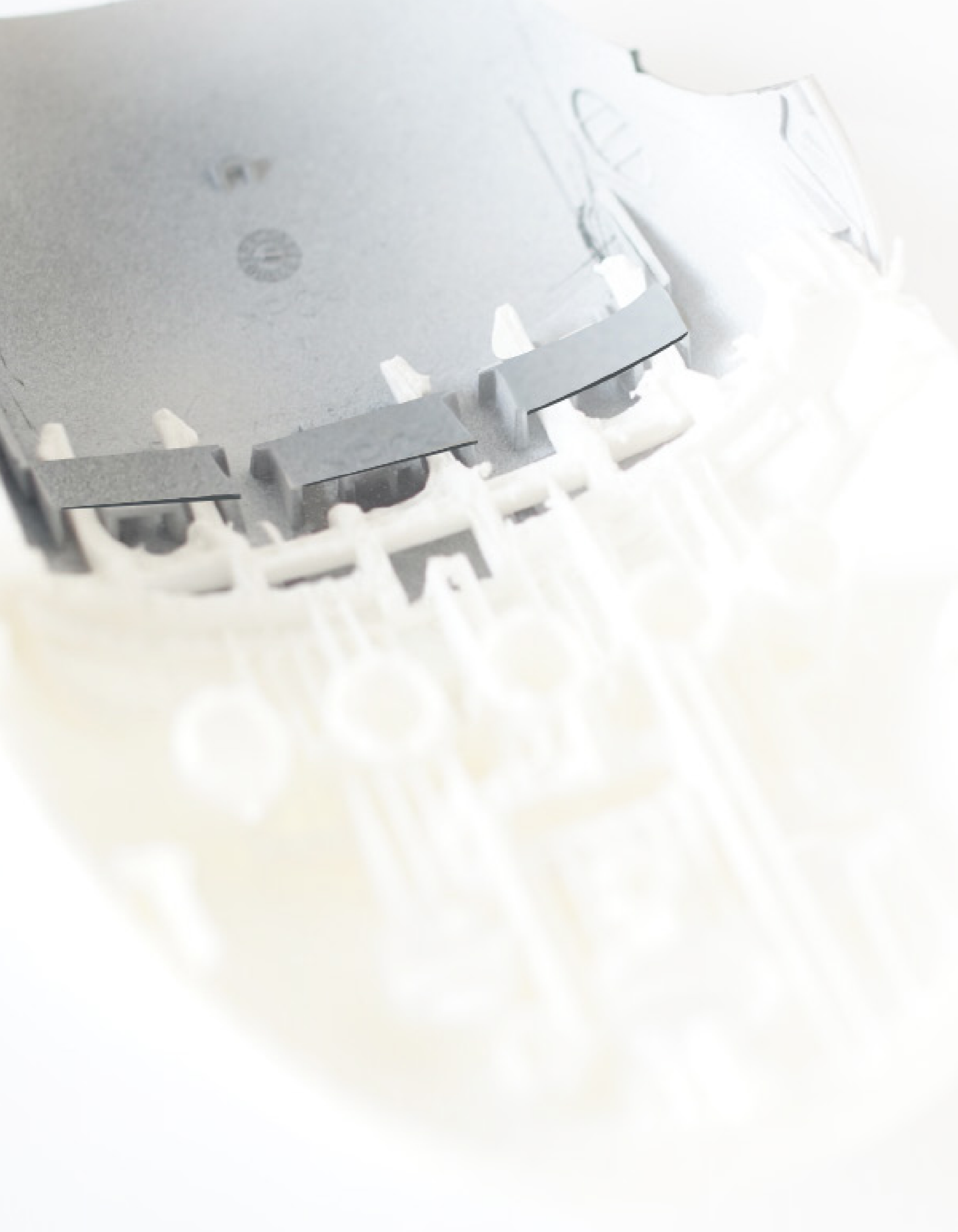

5.

Redesign the
Lumea for
refurbishment

Design for refurbishment; redesign

This chapter presents the redesign of the Lumea Prestige for refurbishment. The product-specific problems and insights found during research throughout the project are applied. From a consumer acceptance perspective as well as from a product architecture perspective, design solutions are presented. The redesigns are divided into two main concepts; (1) Repair the past, which can be implemented today with minimum mould and design changes, and (2) Design for the future (shown on the right, fig. 5.0.1), a conceptual redesign of the Lumea to optimize the refurbishment process and consumer acceptance. The design for the future solutions are elaborated to a conceptual level to inspire Philips designers on what to research and develop further. The designs are created to meet the wishes and demands of both new and refurbished consumers.

Consumer acceptance aesthetics

The redesign proposes multiple solutions to enhance consumer acceptance. Repair the past focuses mainly on removing negative associations within the limits of the current shape and moulds used. Design for the future proposes more aesthetic changes to create and emphasize positive consumer associations. The design shown on the right emphasizes positive associations by the expression of luxury, durability and hygiene.

Product architecture solutions

Also, product architecture solutions are proposed. The goal of repair the past is to redesign the opening sequence within the limits of the current design. By trimming fasteners, the disassembly sequence is simplified and shortened. The main challenge was to trim as many fasteners as possible without (1) compromising consumer safety and (2) giving consumers access to the internal components. This solution does not allow breaking parts to open the product, like in the current design. Also, the contamination sensitive housing parts are now easier to access and replace, to need the needs of the consumer.

Design for the futures explores more radical design changes to ease the opening of the product and increase the accessibility of critical parts, focussing on the battery and capacitor. Again, keeping the two aforementioned goals in mind. The redesign (shown on the right) shows the new opening sequence with two hidden screws. By clumping components, the disassembly time and actions to take have been shortened. The battery and capacitor are now reachable within five steps (ten steps needed in current design), with low force, no uncommon tools needed and no broken parts. Also, all housing components can now be removed and replaced within five steps to enhance the ease of repairing outer housing parts to as new state, as demanded by the consumers.

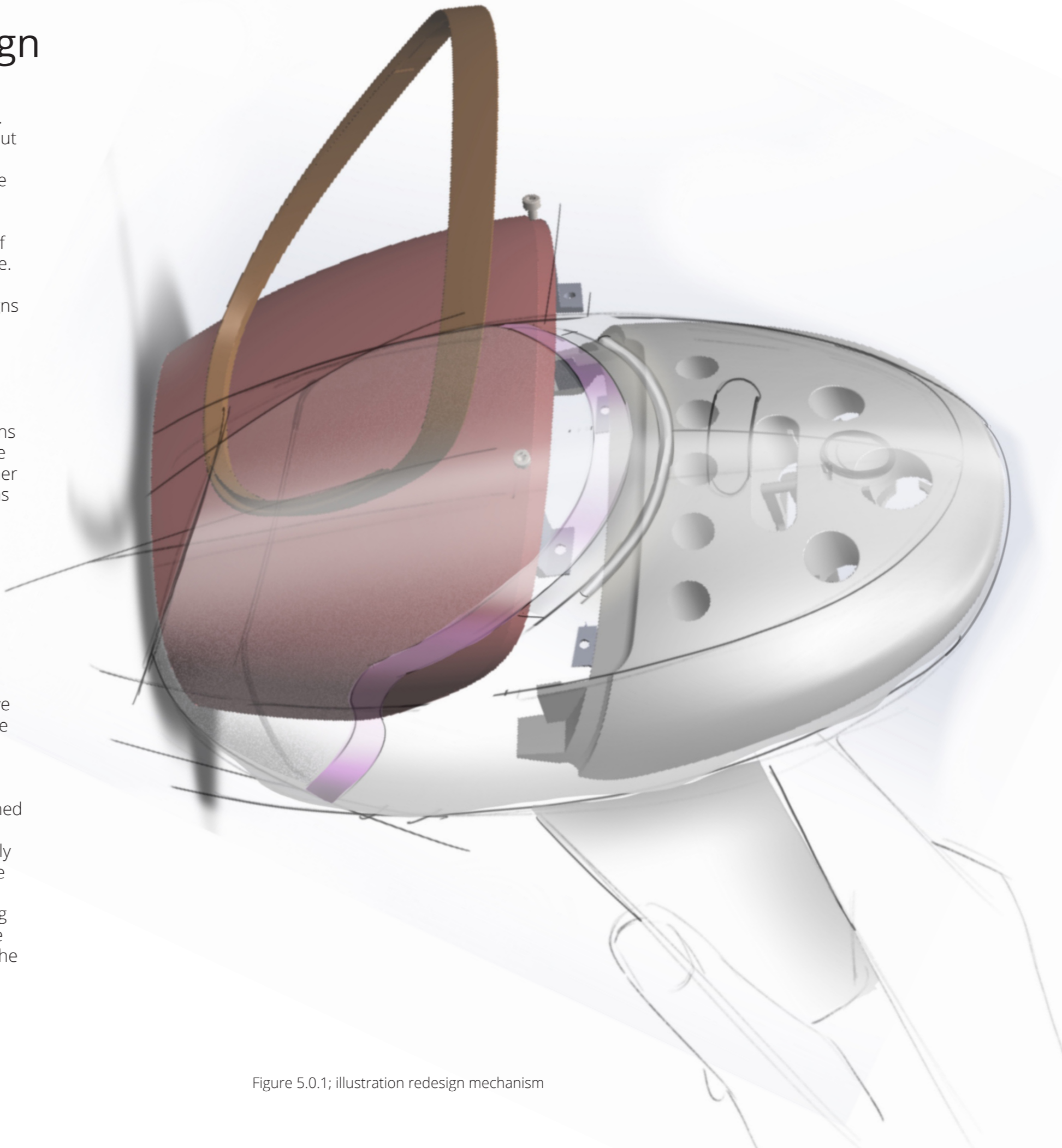

Figure 5.0.1; illustration redesign mechanism

Problems & requirements

As mentioned before, this chapter presents two redesigns. (1) Repair the past (RTP) and Design for the future (D4TF). Both redesigns were created via build-measure-learn loops. By the means of 3D printing, prototypes were created to test architecture solutions. Also, design drawing techniques were used to communicate aesthetical changes to consumers. A detailed description of the ideation approach and brainstorm outcomes can be found in appendix K. The redesign aim to solve the problems, and follow the requirements, mentioned below:

Problems to solve

- 1. Opening the product's housing** with less force, no damage and without compromising on consumer safety. Make reassembly possible.
- 2. Battery and capacitor depth:** Components with the largest carbon footprint. Faster replacement/repair and fewer steps needed to reach battery assembly.
- 3. Fear of contamination:** The Lumea's design evokes positive associations with hygiene that need to be maintained. However, some product parts are more sensitive to contamination than others
- 4. Financial & performance risk:** Consumers want to see value for their money. It is important to make consumers aware of the satisfactory aesthetic and functional qualities and the additional environmental benefits through product design
- 5. Refurbishment fuss:** Respond to confusion by designing positive associations that increase the perception of hygiene or luxury.

Requirements; Norms and standards

The following requirements were found during research, in the product manual and European commission website (ec.europa.eu, 2020):

- The product complies with IP30
- The product complies with shock safety class II regulation
- The product complies with EN45554
- The product complies with the EU plans for battery replacement
- The redesign should not increase the environmental impact compared to the current product
- The Lumea should be able to withstand 12 drops from p96 eye height without breaking
- The Lumea is broken when consumers can reach internal components
- Only a professional refurbisher with the disassembly guidelines should be able to open the product

Repair the past; consumer acceptance

This solution requires minimal design changes and can be implemented today. It focuses on incremental, but meaningful design changes within the limits of the current molds and shape design. The current design not be opened without breaking it to a non-repairable state. Therefore the main objective of this redesign is: **facilitating the opening of the product, without compromising the consumer safety or breaking any housing parts.** By the means of 3D printing, rapid prototypes were created to test the (dis)assembly sequence and consumer safety. Also, the design parameters identified in chapter 4.4, are applied to the product.

Applying design parameters

The research showed that the Lumea already scores relatively high on the design parameters; hygiene, high quality and luxury. Therefore, in repairing the past redesign. It can be chosen to maintain the current design and focus on architectural design problems and marketing related awareness problems.

However, to illustrate the study results, the insights have been summarized and processed into external design adjustments. The focus here is, therefore, mainly to remove uncertainty and negative associations. Since repair the past involves incremental changes, the mould should remain as is. Therefore the only colour can be considered, limiting the possibilities.

However, the survey and interviews showed that little changes could be meaningful. The survey showed a preference

for white colours and smooth surface finishing. This could therefore be the basis for the repair of the past design (fig. 5.2.1).

The silver ring was reported to be sensitive to scratches, enhancing fear of contamination. Therefore, the ring should be replaced with a feature that expresses luxury and highlights the technology but does not evoke negative associations regarding hygiene and prior use.

Keeping these requirements in mind, it may be an option to replace the material of the current ring with the material and colour used for the pink cover to adhere the Philips design guidelines. Giving the Lumea a more clean and medical look without losing the female touch. Also, the pink cover has a light shimmer, maintaining the perception of luxury.

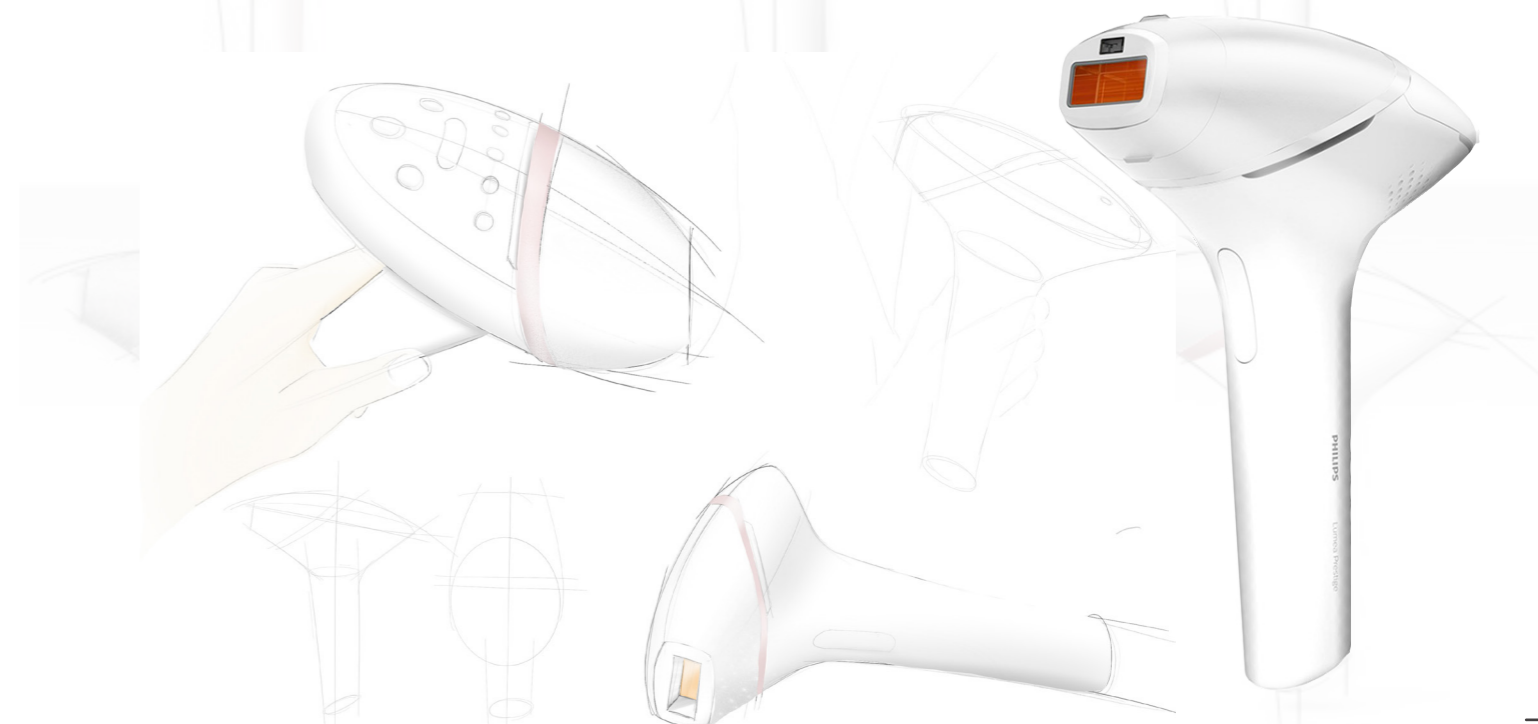

Figure 5.2.1; Incremental changes appearance

RTP: Product architecture

Focus

The main focus is to increase the ease of opening (compared to the current design) without compromising consumer safety. The current Lumea needs to be broken before they can be opened. The goal of this redesign was to make sure that the product can be opened without breaking any housing parts or irreversible snap fits. This was achieved by trimming fasteners step by step and designing the need for uncommon tools out of the disassembly.

The main challenge lies in designing an opening sequence that can only be completed if the person knows what steps to take. The product should not be able to be opened by accident during normal use or on intuition. Only a professional refurbisher with the manual should be able to do this.

The fear of contamination adds extra complexity to the problem. Since this redesign is an approach from a consumer perspective, their contamination needs must be included. Consumers demand that components touching the body are new, in this case, the attachments. Since it

was already argued in chapter 4 that these should be replaced as a whole, since repair would not be cost-efficient, these are no longer taken into account. The rest of the external housing should be in as new state, since scratches are related to functional failure. This indicates that the housing should be quick to reach and replace, which should be designed into the disassembly sequence.

Finally, disassembly is only one half of the work. Once the product is taken apart, it should be possible to reassemble it again. Due to the many broken snap fits and damaged parts, the product can currently not be fully reassembled. Especially the housing is no longer functional. This should be redesigned to allow for viable refurbishment.

All these challenges should be applied within the limits of the current design. The redesign should not require a completely new mould, only adjustments to the current design.

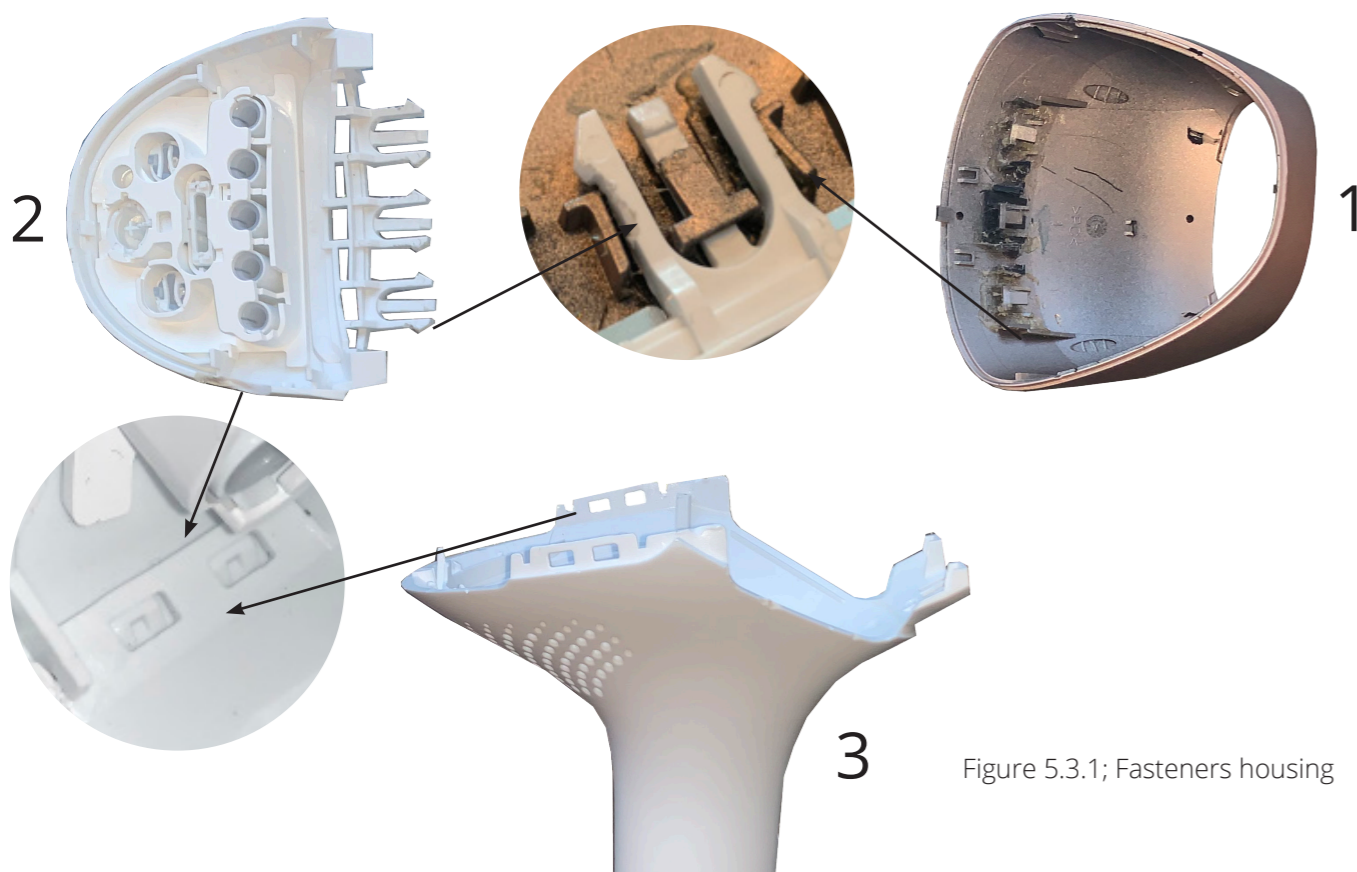

Figure 5.3.1; Fasteners housing

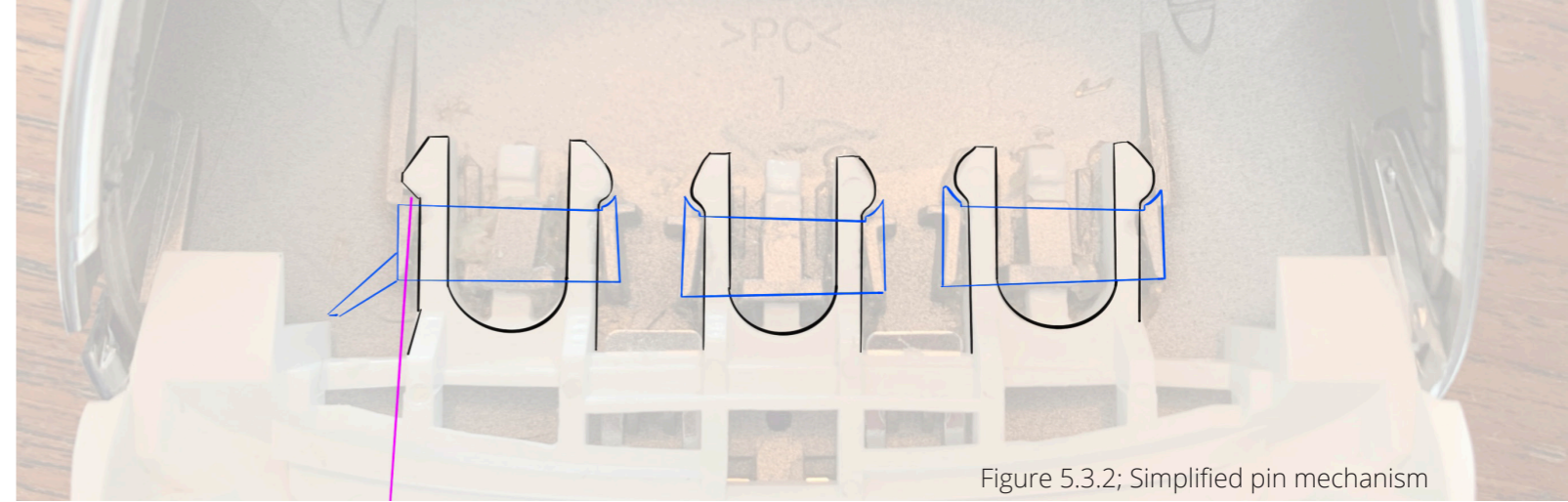

Figure 5.3.2; Simplified pin mechanism

Increase the ease of opening through trimming

Consumer safety can never be compromised. The current design is fixed with glue, three triple snap fits and two double snapfits (fig. 5.3.1), which can only be opened by breaking (as elaborated in chapter 3.7). However, the droptest indicated that there is room for trimming fixings within the safety requirements. Trimming involves decreasing the number of activities and time needed to reach priority parts (Flipsen, 2020). In case of the Lumea, the trimming technique was used to redesign the fasteners that connect the outer housing parts.

Components involved

Opening the initial assembly involves the following three components (fig. 5.3.1):

1. Pink housing
2. White interface housing
3. Handle Housing

Method

To make sure that consumer safety requirements were met, a build-measure-learn approach was used. Designs were built in CAD models, 3D printed and tested on (1) (dis)assembly sequence, and (2) on drop safety. The drop safety tests were conducted following a similar method as described in chapter 3.8. The outcomes of the drop test will be discussed in chapter 5.4.

Redesign; concept

By pushing a pin between the snapfit and the housing in the outer left corner, it will be unlocked. Afterwards, the pink housing can be pulled firmly to remove it.

This mechanism was chosen because it prevents consumers from opening the product. They would not know that a pin is needed, let alone where exactly to position it. Only professional refurbishers with a guide and the tool in the right shape can open the product.

Also, this locking system requires minimal design changes. The snap fits from the current design are adjusted so that the mould only needs to be feared and not completely replaced. The precise adjustments and their cost could be investigated in further development.

Lastly, the snap fits are still hidden, which means that this solution requires no external aesthetic changes.

A simplified version of the mechanism is shown in fig. 5.3.2. The purple pin is pushed between the snap joint and the housing to unlock it. This will allow for removing the pink housing by pulling firmly. All disassembly steps are discussed in the next chapter.

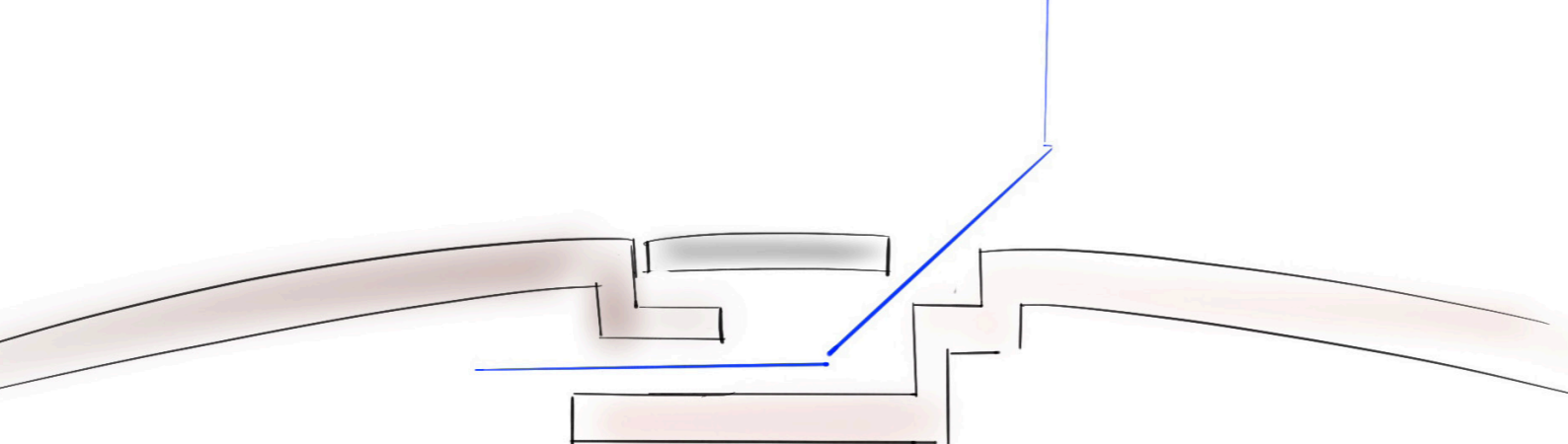

Figure 5.3.3; pin shape

Disassembly sequence

As described before, the housing can be opened by the use of a pin. The shape of the pin is shown in fig. 5.3.3. This shape was formed by shaping iron wire, and it did the job. Also, a thick needle can be used, however, that requires more precision since it does not have the optimized

angle. The steps that need to be taken to disassemble and reassemble the product are described and shown below.

To visualise the difference in steps and hotspots, a disassembly map for the initial steps was created (fig. 5.3.5).

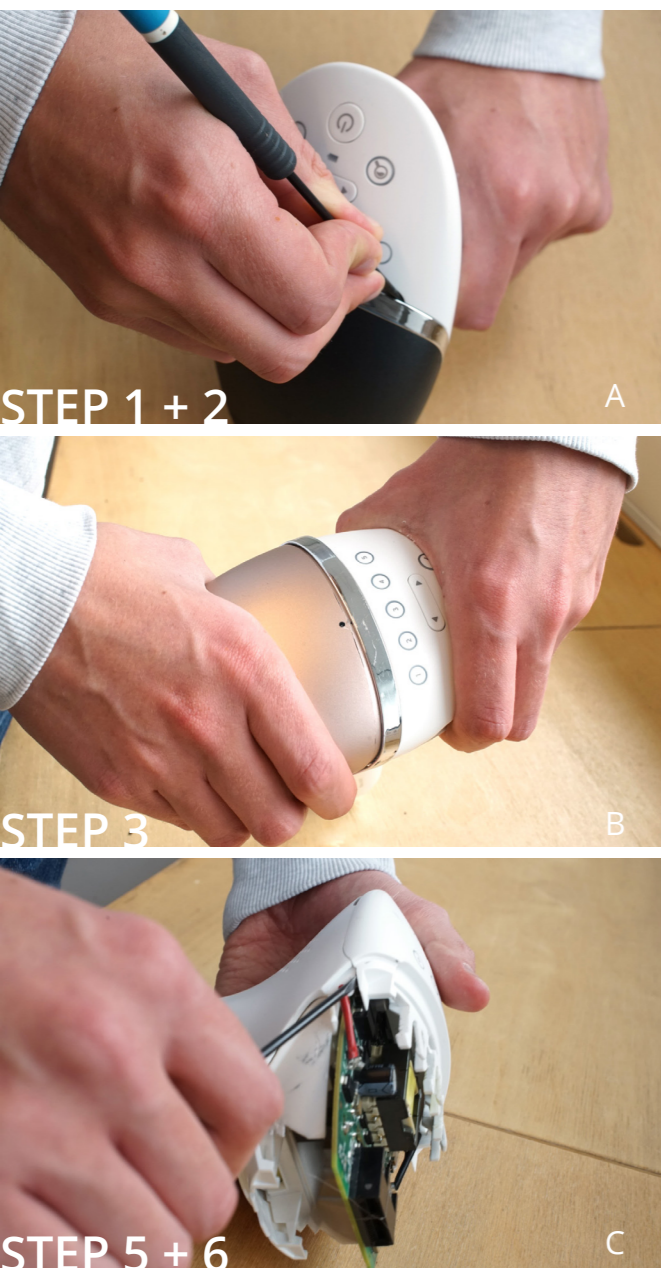

Disassembly

1. Place pin inside airhole (between the white and pink housing) on top of the assembly, on the outer left corner (fig 5.3.4A). The pin is guided between the snap fit and the housing by the trench (circled in red, fig. 5.3.2 p. 77). *Tool needed: pin.*
2. Push the pin, the snapfit will be opened. *Tool needed: pin.*
3. Pull with force, this will open the snapfits with rounded corners. *Tool needed: none (hands).*
4. Remove the pink housing and plastic ring *Tool needed: none (hands).*
5. Place a liver (screwdriver for example) on the inside between the handle housing and the white interface housing. *Tool needed: Screwdriver or other liver.*
6. Push liver, this will open the snap fits. *Tool needed: Screwdriver or other liver.*
7. Remove white interface housing. *Tool needed: none (hands).*

Reassembly

1. Place the white interface housing in the right position on the handle housing. *Tool needed: none (hands).*
2. Push snap fits in locked position. *Tool needed: none (hands).*
3. Place pink housing in the right position. *Tool needed: none (hands).*
4. Push snap fits in locked position. *Tool needed: none (hands).*

Figure 5.3.4; Disassembly sequence

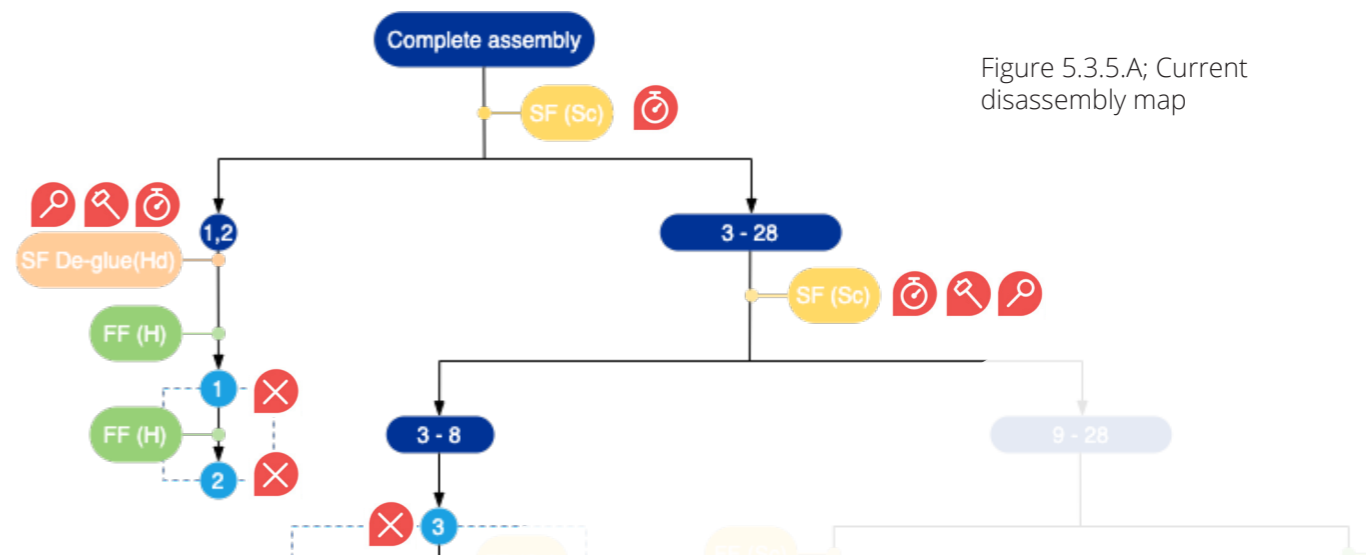

Figure 5.3.5.A; Current disassembly map

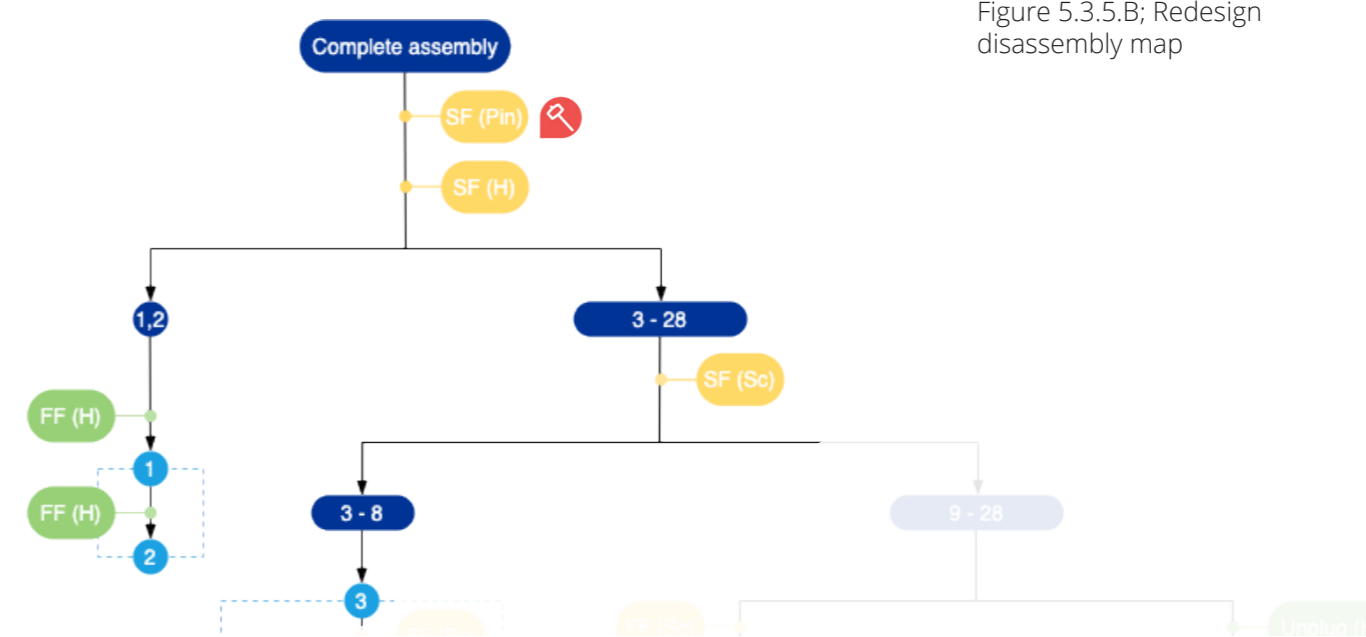

Figure 5.3.5.B; Redesign disassembly map

Disassembly and reassembly tests

To test the disassembly sequence shown above and spot differences in disassembly time and tools needed, a test was done. With this test, hotspots could be added to the disassembly map to provide a fairer comparison between the two sequences.

Method

By combining 3D printed prototypes of the redesigned housing with current internal Lumea parts, the disassembly and reassembly sequence could be tested on the following:

- Time it takes to perform actions
- Tools needed
- Force needed

Results

As can be seen, the steps needed to open the product have not been reduced.

However, the hotspots indicated have been reduced from ten to one. No parts were damaged or broken in the process, which is a big difference compared to the current product with all three housing parts broken.

The pink housing, ring and white interface housing were removed within 28 seconds, which is 181 seconds shorter than the current design. This is due to the removal of the glue and the reduced tool positioning time.

Positioning the pin was doable. However, applying force to that small pin was not comfortable. This should be looked into. Therefore, a force indicator was added to the map.

Reassembly could be done in around 10 seconds. Since the current product could not be reassembled due to a broken snap joint, this can not be compared.

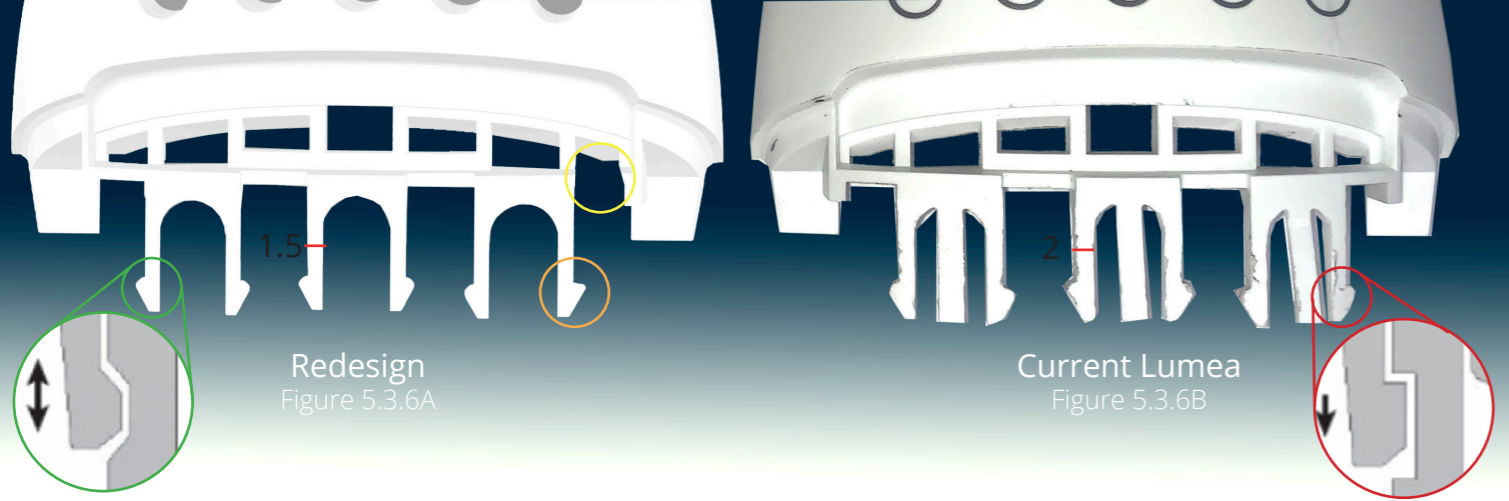

Adjustments per part

Now that the disassembly sequence is known, the adaptations necessary to realize must be considered. The following nine design adjustments are needed for this concept to work successfully.

Three of triple snapfits white housing (fig. 5.3.6A):

1. *Remove glue*: No more heat gun needed, reduces disassembly time.
2. *Smaller width of pins*: Reduce stiffness to be able to open the product with force. Current width = 2mm. New width = 1.5mm (fig. 5.3.6).
3. *Remove middle pin*: Removes snap fits pointing inwards.
4. *Round corners of snapfits*: Allow for disassembly by hand (fig. 5.3.6A; green circle). Only outer right snap joint (fig. 5.3.6B; orange circle) remains sharp. This is the locked snap joint that can only be opened with the pin. The outer right snap joint is chosen because this location makes positioning the pin easier. Also, it is impossible to touch the PCB with the pin from this position, avoiding unintended

damage.

5. *Remove snap joint support on right side* (fig. 5.3.6A; yellow circle). This is needed to position the pin.
6. *Round corners of the double snap joints handle attachment*. This makes the snapjoint reversible with less force and without damage. The optimal radius has not been determined and should be explored in further development.

Pink housing (fig. 5.3.7.A)

7. *Add 'bridges' over the snap joint* to prevent snap joint from sliding out of position upwards under pressure.
8. *Add trench rim* to guide pin into right position.

Handle housing (fig. 5.3.8.A)

9. *Round corners double snap fit holes*. This creates reversible snapfits that easily can be opened with a liver in the right position.



Figure 5.3.7.B; Redesign pink housing

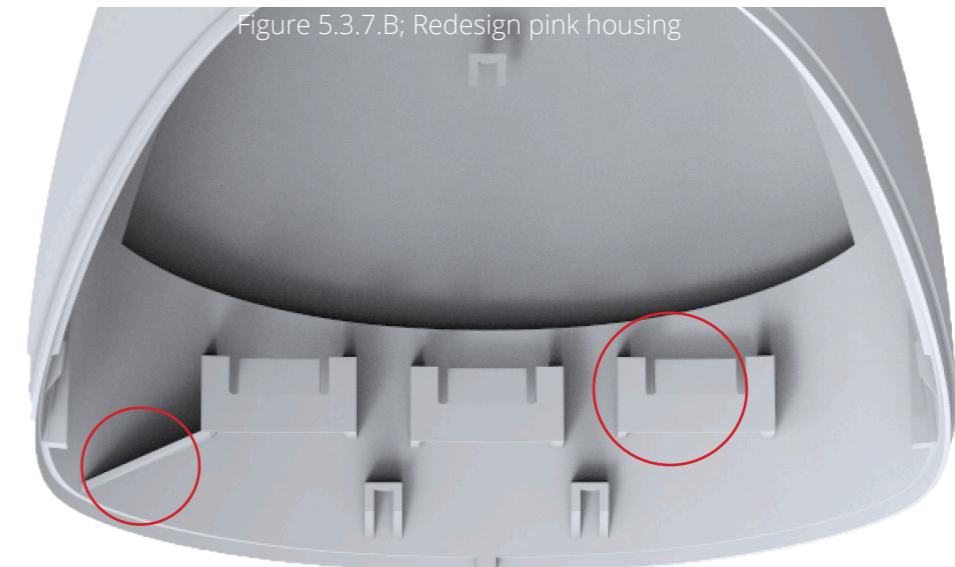
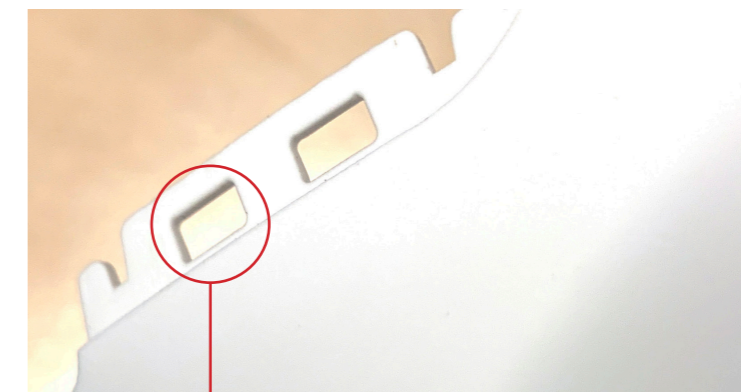

Figure 5.3.8.A; Current handle housing



Round the inside of these snap hooks

RTP: Drop safety

Once the disassembly sequence was proven to work successfully, the drop safety should be tested..

Method

In chapter 4, the test setup and outcomes of the current Lumea are described. During this test, a similar method was used. However, to test the redesign, a 3D printed prototype was created. The prototype used for the drop test can be seen in figure 5.4.1. The housing parts were assembled, and the weight of the Lumea was approximated by adding the capacitor and weights.

Results

The Lumea should be able to withstand 12 drops from p96 eye height without breaking

The prototype meets this requirement. The internal components are accessible after 13 drops, which surpasses the requirement of 12 (fig. 5.4.3). The housing started to show cracks in eight drops, similar to the current design. After 18 drops, the product was opened because the snap fits broke (fig. 5.4.4).

From this test, it can be concluded that this redesign meets the beforementioned safety requirements.

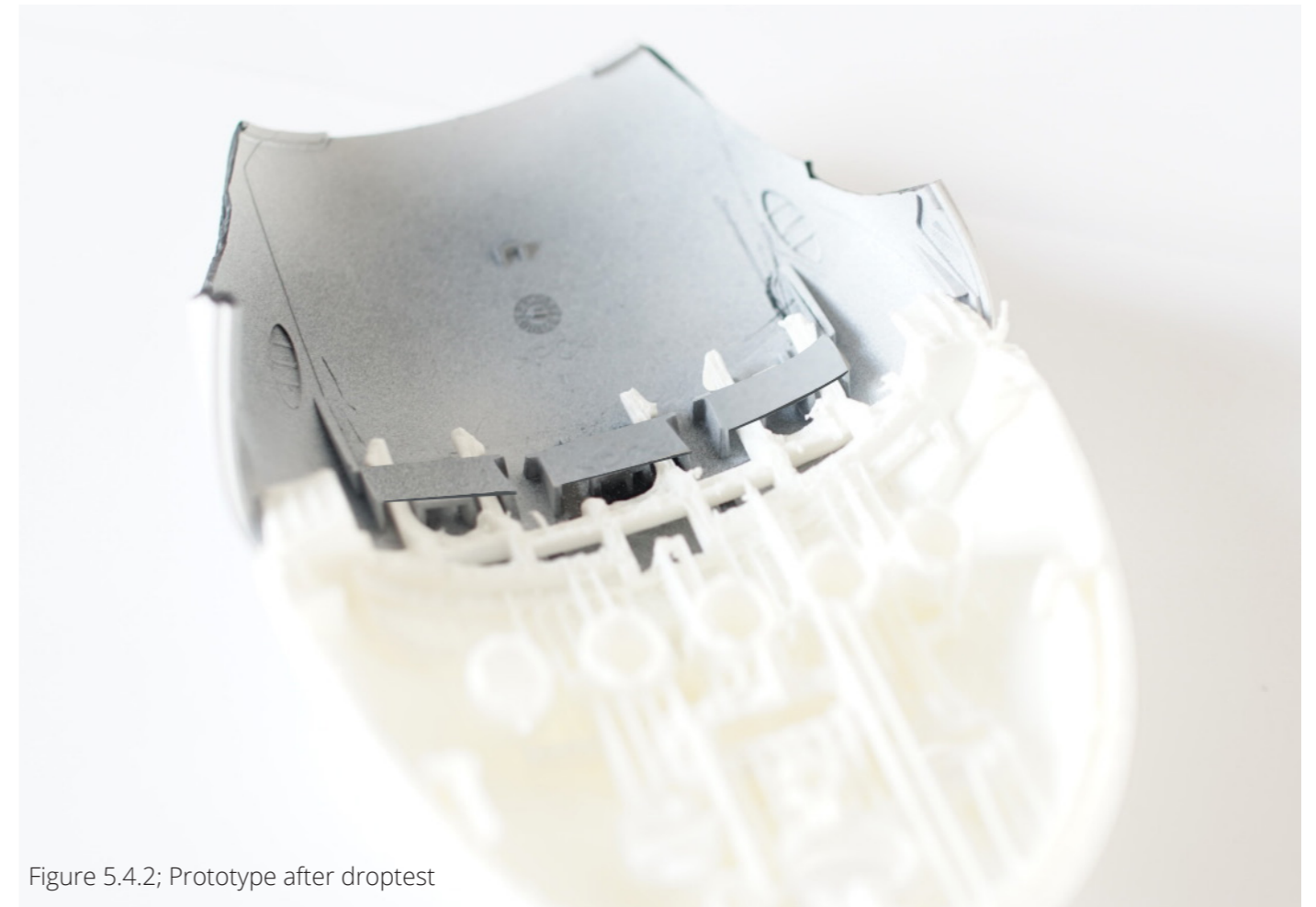

Figure 5.4.2; Prototype after droptest



Figure 5.4.1; Prototype droptest



Figure 5.4.3; drop 13



Figure 5.4.4; drop 18

RTP: Economic and environmental cost

By the means of an eco audit (Granta Edupack, 2019), the economic and ecological cost of the current design and the redesign have been compared. Both designs were compared on a specific scenario.

Environmental value

In this comparison, it is assumed that consumers own a Lumea for about six years (personal communication Philips), and the Lumea is refurbished two times before it goes to scrap.

Since the outer housing parts were redesigned, their weight changed. Therefore, these were also compared (table 5.5.1). The weight used for these calculations was retrieved from the Solidworks model.

As can be seen from the table, the current Lumea compared to one redesign, is only slightly lower. The real profit is achieved by using the same product three times, instead of three new ones. Cutting the environmental cost in three.

Financial value

Also, the estimated labour costs for disassembly and reassembly of the current Lumea and redesign were established and compared (table 5.5.2). To do so, this scenario was created:

A professional refurbisher has to replace the battery and silver ring to make the Lumea Prestige ready for its next owner.

This scenario takes the refurbisher 509 seconds to reach the battery and take it out and 389 seconds to reassemble it (hotspot excel sheet). Considering the Lumea is refurbished locally, the hourly wage is estimated at 32,30 euros (Eurostat, 2021). Which is combined a total of 8,06 euros labour costs

For the current Lumea, it has to be taken into account that the three outer housing parts have to be replaced as well, adding extra material costs (hotspot excel sheet). Altogether, this would cost 8,14 euros.

The redesign allows the refurbisher to reach and replace the battery in 328 seconds and reassemble it in 310 seconds (timed test, chapter 5.3). No new housing parts are needed except for the ring, adding up to 5,72 euros.

As can be seen in the table 5.5.2. The redesign design cuts labour costs and material costs by 2,42 euros per unit.

	Material	Current		Redesign	
		Weight (kg)	Impact (MJ)	Weight (kg)	Impact (MJ)
Pink housing	PC	0.03	3.2	0.034	3.63
White housing	PC	0.027	3.8	0.023	3.25
Ring	? (assumed PC)	0.0033	0.35	0.0021	0.23
Total		0.066	7.35	0.059	7.11

Table 5.5.1; Environmental impact materials

	Current		Redesign	
	Time (s)	Cost (€)	Time (s)	Cost (€)
Disassembly	509	4,57	328	2,94
Reassembly	389	3,49	310	2,78
	<i>Amount (n)</i>	<i>Cost (€)</i>	<i>Amount (n)</i>	<i>Cost (€)</i>
Replacement parts	4	0,076	1	0,003
Total		8,14		5,72

Table 5.5.2; Costs labor

RTP: Considerations and evaluation

The proposed redesign is a first exploration of the problems involved in refurbishing and how those can be addressed. This design allows Philips to optimise the current reprocessing process and take the first step into

Consumer acceptance

The changes made to the design are based on consumer acceptance studies conducted during this project. Based on that, it is assumed that this redesign is more desirable. However, the sample sizes of these studies were small. So doing a significant scale test with a bigger sample is needed in order to verify this increased acceptance.

Disassembly sequence

The radii of the snap joints used in this design are not optimised. Since optimising radii can be up to a tenth millimetre precise, this was not doable in the time scope of the project. 3D printing and drop testing every variations would simply take too much time. However, optimising this is the key to success for this redesign. The optimal balance between consumer safety and still being able to pull the snap joint out of position should be found.

The pin should be optimised. For the prototype, a piece of 1 mm iron wire was used to shape the pin. Now, the pin's shape is known. However, applying force to iron wire is not pleasant. Therefore, the ergonomics and precise form of this pin should be further developed.

Drop test

3D printed PLA is not the same as the injection moulded PC the Lumea is made of. 3D printed prototypes are considerably more fragile. For the drop test, this was allowed because if the prototype survives the drop test, so should the real product. However, for the disassembly, this works the other way around. Pulling the snap joints out of fixed position is easier with 3D printed models because these are less stiff. Therefore, these redesigns should

be tested with similar housing as the 'real' design.

Environmental and economic cost

The cost and environmental impact estimation made in the previous chapter is rough. Many assumptions had to be made, making the outcome not precise enough to base design decisions on. Therefore, this should be redone with more precise information to judge the redesign's actual refurbishment viability.

Also, the cost of the mould changes has not been evaluated. Which would make the redesign more expensive than presented here.

Design for the future; concept recommendations for the new Lumea

The repair the past concept works as a short term solution for opening the product. However, a design that is fully refurbishable goes beyond that. Consumers should not only accept the refurbished product. They need to desire it as a replacement for the new product. Also, the structure and reachability of all internal components must be optimized to make refurbishment a viable strategy, not just the opening procedure. This concept shows what a fully refurbished Lumea could look like and explores more radical design changes. The main objective of this redesign is: **inspiring Philips designers on how to create refurbishability concepts**. Since this redesign is mainly illustrative, renders and drawings are used to explain the idea. Firstly, the design parameters identified in chapter 4.4 are applied to the product. Secondly, a new concept for opening and disassembly is proposed. The main design challenges to solve these problems are discussed by means of concept ideas and recommendations.

Exploring design parameters

To be able to apply the parameters is must first be established how these parameters can be expressed in a design, specifically the Lumea. A brainstorm with design students and a discussion session with potential Second Life consumers were done to achieve this. Based on this, recommendations for the refurbished design are proposed.

Method

In a creative session with design students, options for applying the design parameters to the Lumea were explored. The design students were given roles to examine design directions (e.g. Philips designer, new consumer and Second Life consumer). Through inspirational pictures and drawing, the meaning of each of the parameters was established. The result of these brainstorms is summarized in appendix L.

Based on this brainstorm, aesthetic concepts were created in the shape of design drawings. These exploratory sketches were evaluated with three potential second life consumers. During the session, the redesign was adjusted until a shape was reached that balances hygiene, luxury and durability.

Outcomes discussion

Subjectivity

The design styles and expression evoked discussion between the design students and the potential consumers. This highlights that design styles and perceived characteristics are highly subjective. However, as supported by the survey, some aesthetics features can be applied like shades of white, rounded corners, low complexity and robust design styles.

The fine line between simple and timeless, and boring

During the discussion, it was mentioned that, on the one hand, consumers prefer a simple, white design for contamination concerns. On the other hand, they desire luxury. However, creating a design that fully expressed hygiene requires a simple design, was sometimes perceived as boring. This forms a contradiction with the expression of luxury, which often includes some variety in colours and textures. Trying to achieve this led to personal preference discussions.

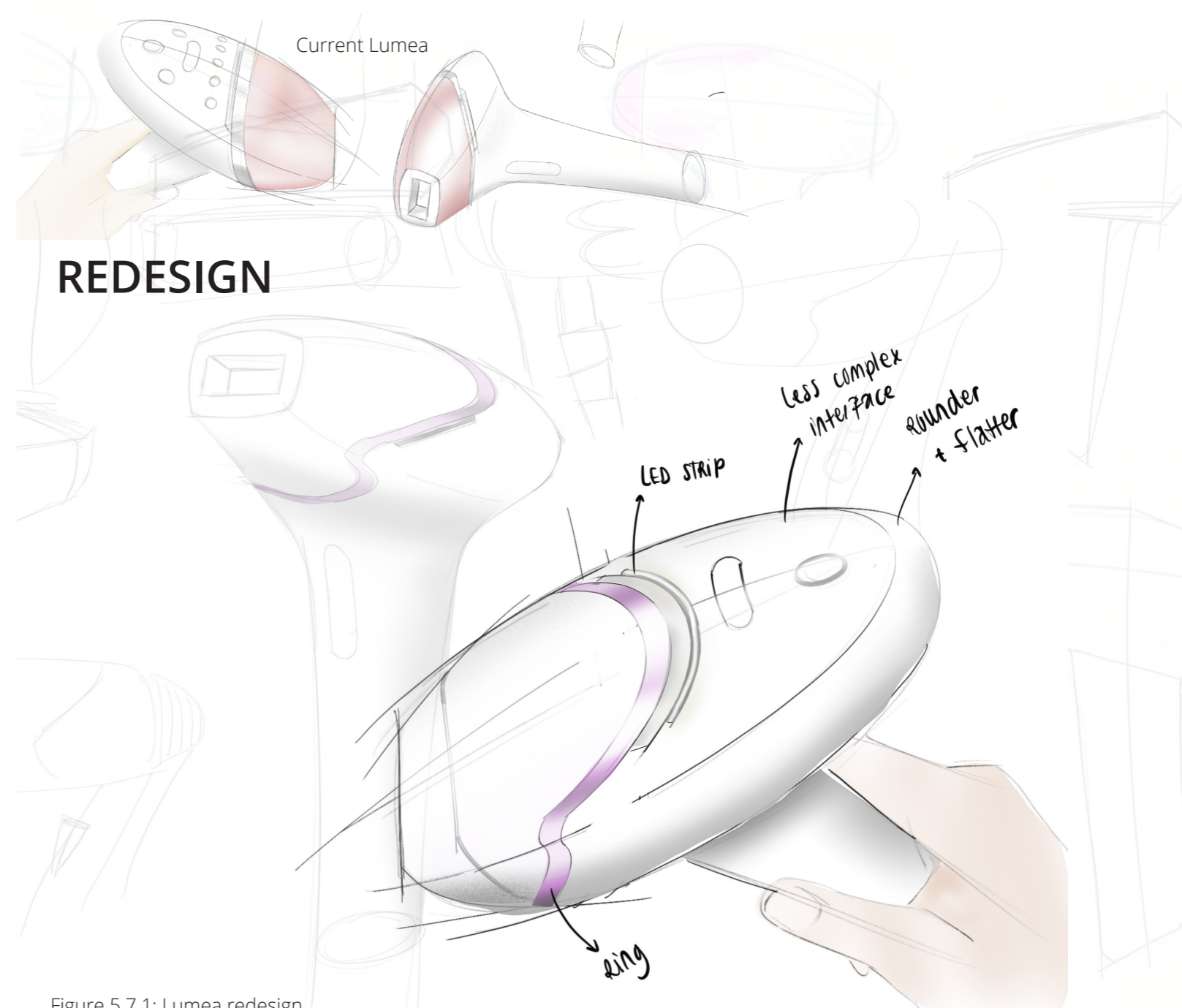

Figure 5.7.1; Lumea redesign

Preferred design

The result of the create session can be seen in figure 5.7.1. As suggested in the repair the past redesign, the association with metal has been removed and replaced with a pink highlight colour. The shape of the 'ring' forms the central point of interest. Instead of grabbing attention by the shiny material, it now sparks interest because of the shape detailing. Avoiding negative associations but keeping the expression of luxury.

According to the consumers, the redesign makes the Lumea more flat and double rounded instead of organic, expressing durability and timelessness. Since the aim was to make the Lumea an archetype, the main shape was kept. However, this more rounded design makes it move away from the archetype

hairdryer shape a bit more.

Also, the five lights have been replaced with one light strap that indicates the light levels. Making the product look more simplistic.

Based on these suggestions, is it advised to take the next step in the redesign process. This idea could be surface modelled to give a more realistic look than a drawing and test it again with consumers.

D4TF; Product architecture

With the aesthetic preference explored, it is time to go beyond the surface of the Lumea. In chapter 3, the product was taken apart completely and the main struggles were identified. Now, it is time to explore ways to build it back up. In this part, a new disassembly strategy for the Lumea is proposed. The conceptualisation process involved mainly physical conceptualisation activities, like 3D printed prototypes to ‘role play’ different disassembly and reassembly concepts. By doing so, problems were identified through experience, which made it easier to understand the complexity of all fasteners and components involved. This process allowed for quick testing and continues development. By doing so, the following disassembly strategy was created.

Disassembly strategy; clumping

According to Solomon et al. (1995), the level of disassembly of refurbishment goes to module level. During the process, all critical modules must be inspected and repaired or upgraded to specific standards. In this light, the clumping method was chosen to redesign the disassembly sequence. By clumping, critical components are grouped in subassemblies to make them easier to reach and remove (Flipsen, 2020). Components must be ‘clumped’ based on their frequency of failure and recycling options.

Subassemblies

The created subassemblies are shown in the yellow circles in figure 5.7.1. The Lumea already consists of some subassemblies, like the battery assembly (fig. 5.7.1; A) and the attachment (fig. 5.7.1; D). However, most components had to be broken en removed separately. For the creation of the subassemblies, the critical components identified in chapter 3.5 were kept in mind:

- Optical protection glass
- Lightsource
- PCB
- Fan
- Battery
- Capacitor

Disassembly steps

A scematic overview of the removal sequence of the subassemblies is shown in figure 5.7.1. These are the main steps involved:

1. Open the product (more details in chapter 5.9, Design challenge 1, 2 and 3). This is done by removing the hidden screws that now connect the pink housing and ring to the white buttons housing. This quick access is beneficial if the housing needs to be replaced due to prior use traces, meeting the consumer’s hygiene requirements.
2. Remove the buttons housing assembly (more details in chapter 5.9, Design challenge 4). This can now be slid off, removing the buttons and housing at once.
3. Remove the lightsource and optical glass subassembly (chapter 5.9, Design challenge 5). Currently soldered to the PCB. This removes the optical glass en light source assembly in one step.
4. Remove PCB by unplugging wires (Chapter 5.7; recommendation 1).
5. Remove battery, fan and capacitor assembly. Because of the shock safety class 2 needs to be met, the Lumea has a second isolation housing. This comes in handy for disassembly, because the battery, fan and capacitor are situated in an internal housing that can be taken out as a whole. Once this is done, these components can be removed in parallel.

The 6 subassembly are now seperated and can be replaced as a whole unit or disassembled futher if desired.

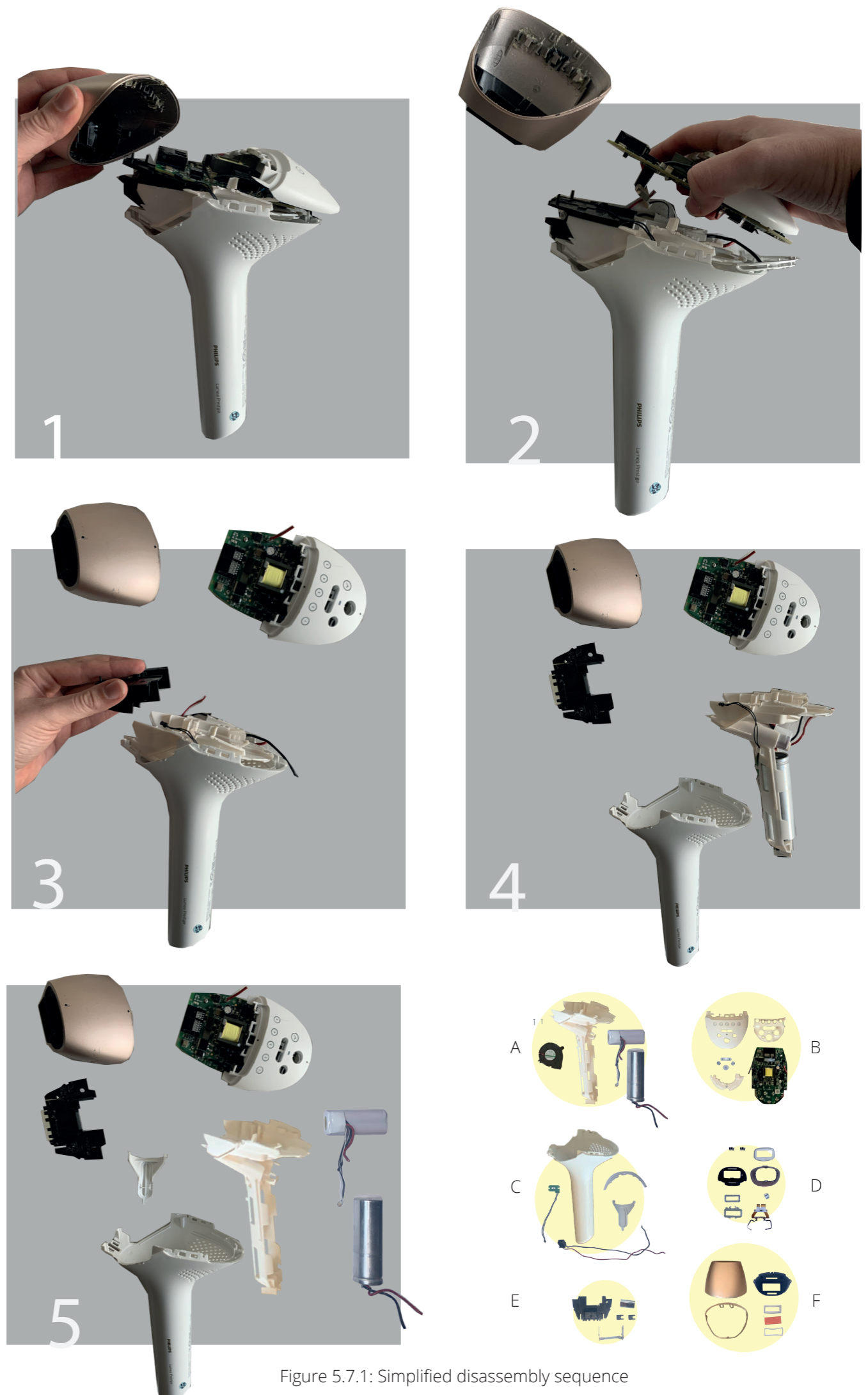
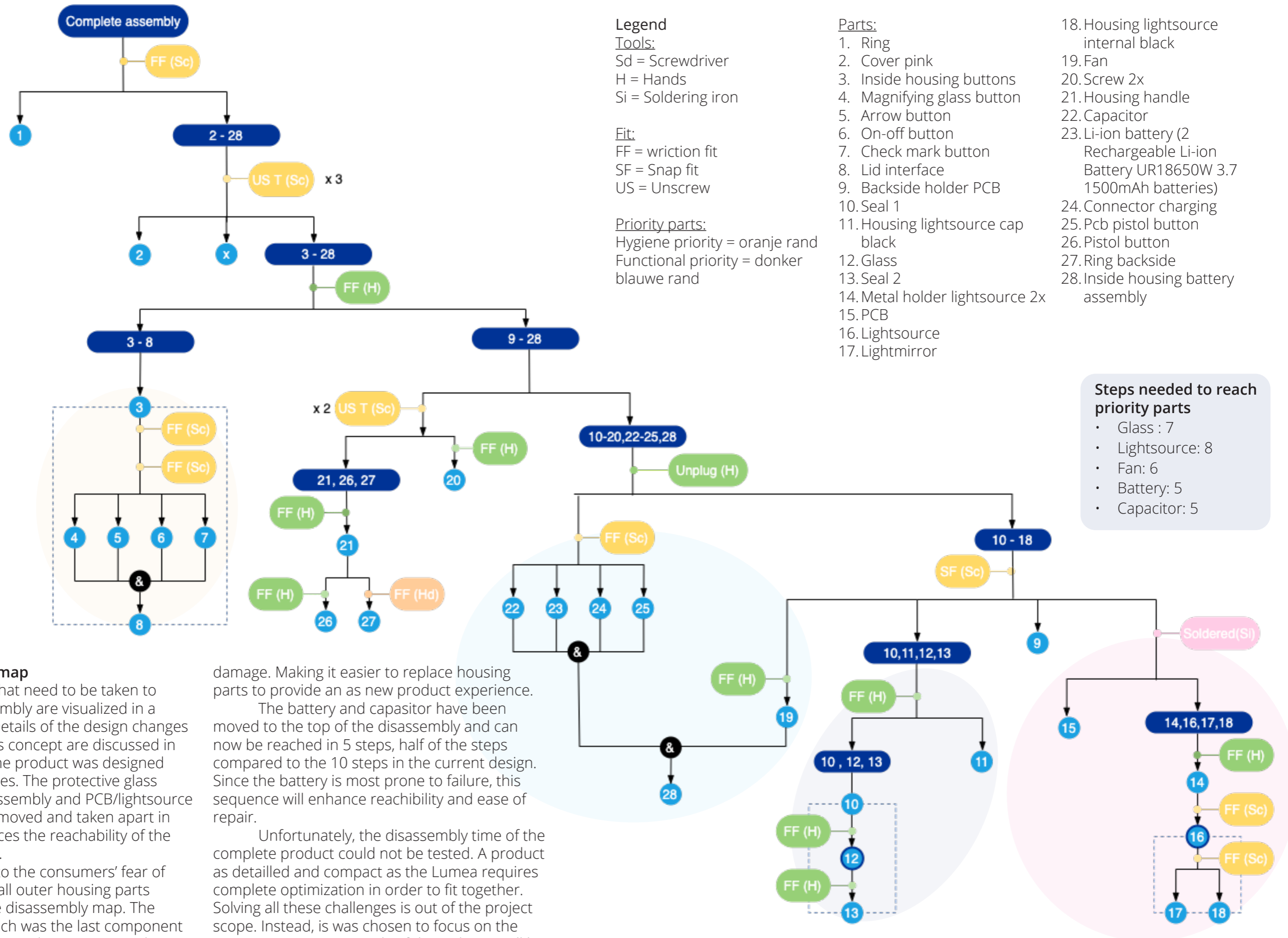

Figure 5.7.1: Simplified disassembly sequence

*text continues on page 88

The new Lumea's disassembly map



New disassembly map

The actions that need to be taken to execute the disassembly are visualized in a disassembly map. Details of the design changes need to execute this concept are discussed in the next chapter. The product was designed for parallel sequences. The protective glass assembly, battery assembly and PCB/lightsource assembly can be removed and taken apart in parallel. This enhances the reachability of the critical components.

Responding to the consumers' fear of contamination, the all outer housing parts are at the top of the disassembly map. The handle housing, which was the last component to remain in the current design, can now be removed in five actions. Also, the pink can be replaced after the first step without permanent

damage. Making it easier to replace housing parts to provide an as new product experience.

The battery and capacitor have been moved to the top of the disassembly and can now be reached in 5 steps, half of the steps compared to the 10 steps in the current design. Since the battery is most prone to failure, this sequence will enhance reachability and ease of repair.

Unfortunately, the disassembly time of the complete product could not be tested. A product as detailed and compact as the Lumea requires complete optimization in order to fit together. Solving all these challenges is out of the project scope. Instead, it was chosen to focus on the opening sequence. Details of the redesign will be discussed in the following chapter.

Figure 5.8.3: Screw positioning and air hole

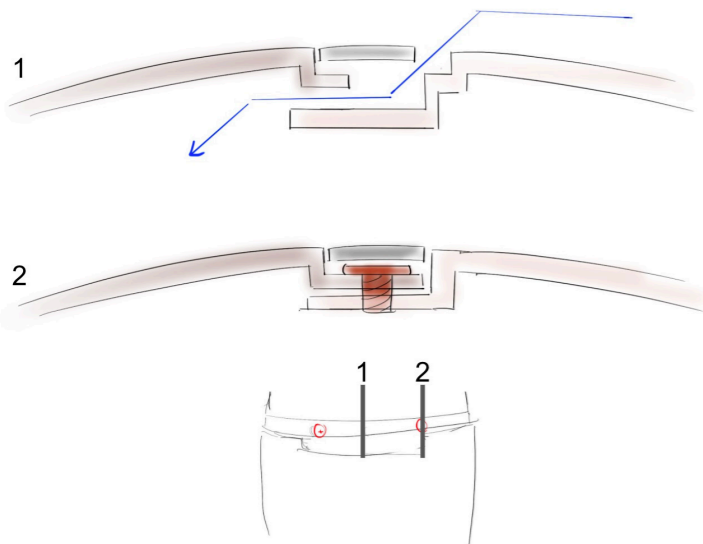

RD2; Hidden screws

Once the ring is removed, the two hidden screws are accessible. A scematic scaled section view of the screw and the housing parts can be seen in figure 5.8.4. As mentioned before, to fully cover the screws, the ring width should be enlarged by 2 mm. The snap fit connections are removed from the pink housing, and replaced by screw supports. The three triple snapfits of the white buttons housing have also been replaced by screw hole supports. Doing so, creates the fasteners shown in fig. 5.8.5. The reassembly and disassembly sequences are visualised in figures 5.8.6 and 5.8.7

The hidden screws are located on either side of the air hole (fig. 5.8.3). In this way the airflow of the product is not disrupted. The airhole was the preferred location because these are the only holes in the outer housing that large enough to position a screwdriver (fig. 5.8.4). Also, the Lumea is a compact product, meaning that the space to position screws is limited. The snapfits of the current design are located underneath the airhole. By removing these

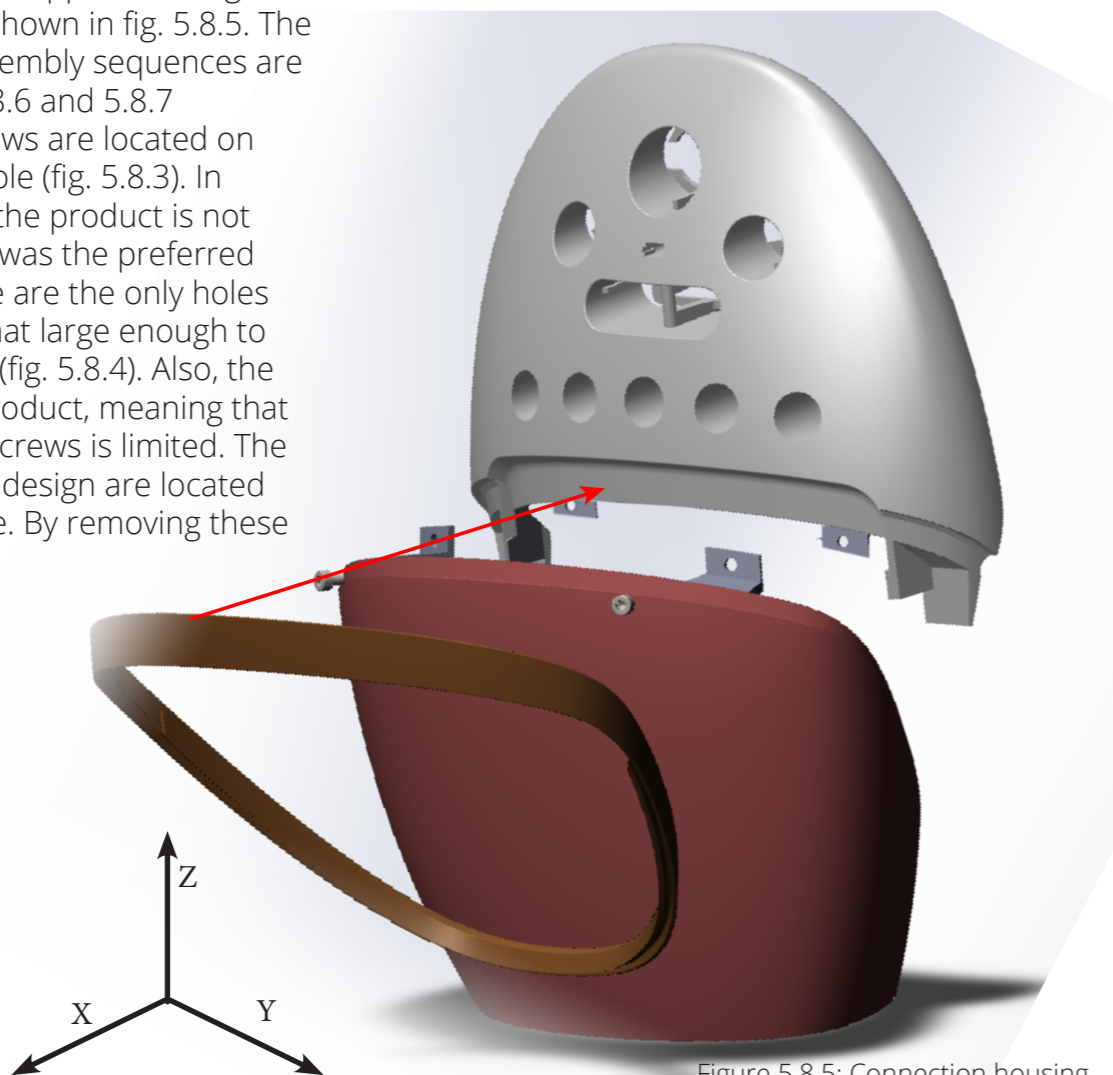
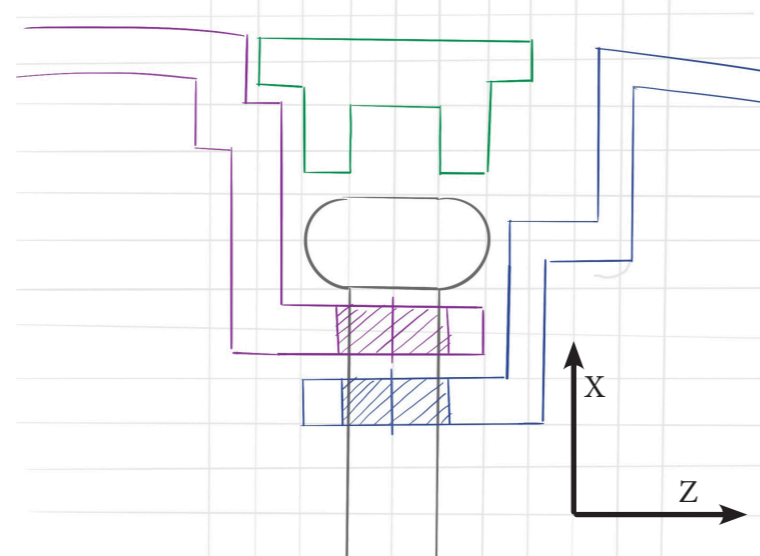

Figure 5.8.5: Connection housing

Figure 5.8.4: Scematic scale connector



snapfits, room was created for the screws. The screws are located in X direction (fig. 5.8.4; fig. 5.8.5) so that they are perpendicular to the most common impact positions discovered during the drop test. The screws used in this model are the same ones that are already used in the current design to connect the internal housing of the battery to the handle housing; two mm torq.

Disassembly

1. Break the plastic ring to uncover the screws (working on a plan to safe the ring)
2. Remove the screws
3. Remove the housing

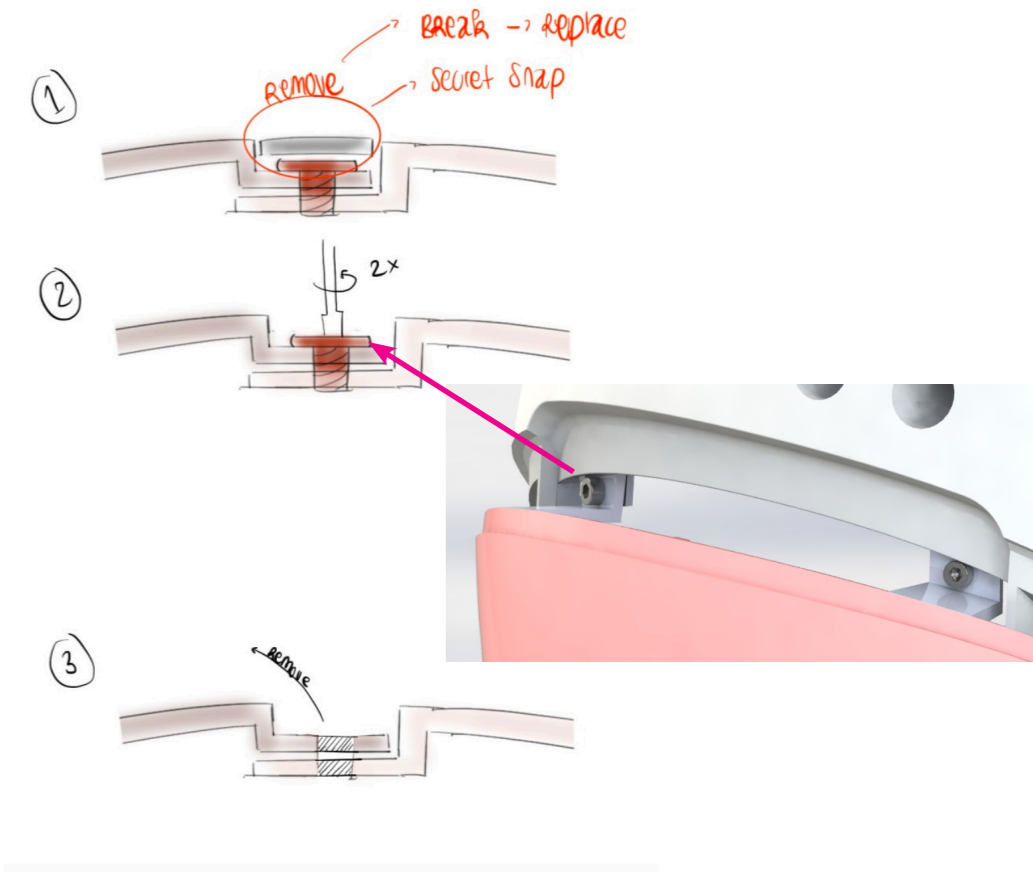

Figure 5.8.6: Disassembly

Reassembly

1. Place the housing parts in the right position
2. Place the screws
3. Slide the ring over the pink housing
4. Click ring in position

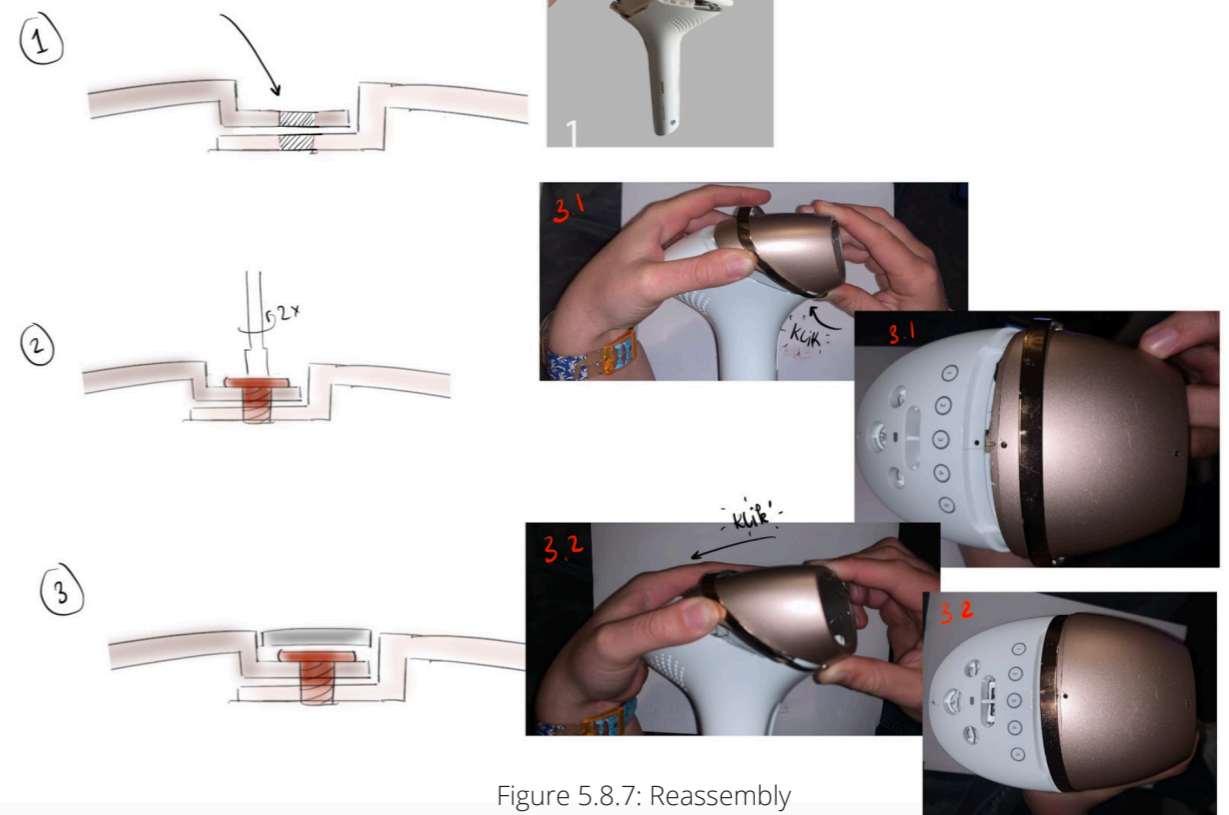

Figure 5.8.7: Reassembly

RD4; Sliding the buttons housing assembly

Once the screws and pink housing have been removed, the white buttons housing can be slid off. The current double snapfits of the handle housing and white buttons housing have been replaced by a slider. The slider connects the housing parts in the same direction as the current snapfits. The slider is kept in place by the screws, removing the need for snapfits. Figure 5.8.8 shows the location and the idea behind the slider.

Figure 5.8.8: Sliding housing



RD5: Trimming the housing fixings



Now that the housing is removed, the ease of disassembly can be enhanced by trimming snapfits. The first fit in the disassembly map that needs to be adjusted is the one connecting the white handle housing to the lightsource housing in the z direction (fig. 5.8.9).

The lightsource housing (and assembly) are already fixed to the PCB (soldered), which is fixed to the internal housing (friction fits), which is fixed to the white handle housing (screws). Making the z direction friction fit unnecessary. Also the lightsource housing is friction fitted inside the pink housing, making it impossible to move it some positioned (fig. 5.8.9).

By removing the z direction friction fit, the lightsource housing can be removed parallel to the battery assembly. This increases the reachability and disassembly speed.

Figure 5.8.9: Trimming fixings

CHAPTER 5.10

D4TF; Recommendations

It was simply not possible in the timeframe of this project to solve all refurbishability problems. However, to provide a complete overview of the problems that occur when executing this redesign, the following recommendations should be looked into:

Recommendation 1: unplug instead of cut

In the current design, five wires have to be cut in order to remove the PCB. This is inefficient for reassembly, since these wires would have to be replaced and resoldered. To remove this task, the use of plugs should be explored. There is room for plugs on the PCB as well as above the PCB. The fan is already connected by a plug (fig. 5.8.10). However, plugs add additional costs to the redesign that should be considered. The exploration of plugs was out of the scope of this project, however, looking into this is vital for fast reassembly.

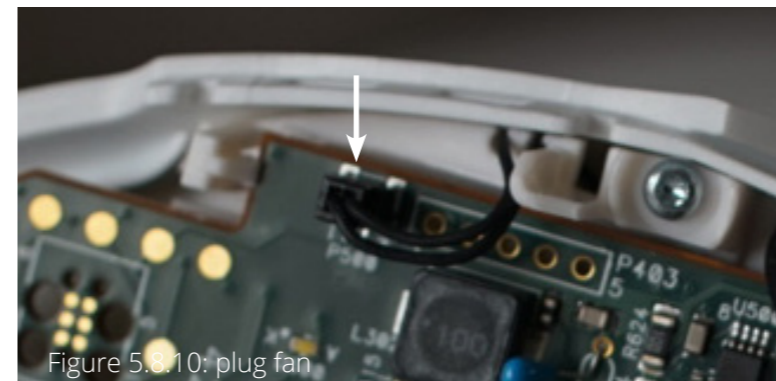

Figure 5.8.10: plug fan

Recommendation 2: Soldering needed?

The light assembly is currently soldered onto the PCB. Removing this fixing takes time and high temperatures, which is not desired. Therefore other options to connect the lightsource to the PCB should be explored. This can be done by plugs as well, however, these would need to be specifically designed for this product. Since this was out of the scope of this project, it is recommended to explore this further.

Recommendation 3: Fixing the fan

The fan is currently attached via two tubes that are heated and melted to keep the fan in position (fig. 5.8.11). By applying force below the fan, the fan can be tilted out of position. This is fine for disassembly. However, due to the melted state of the tubes, the fan cannot be repositioned again.

Considering the disassembly and the friction fit that keeps the fan in place. Heating to secure this is not needed. The fan is already fixed in position by the friction fits of the tubes. Therefore the heating action should be taken out of the assembly process.

It can also be considered to use the tubes as screw holes. These can be used to keep the fan in position and attach the PCB to the handle housing. However, this would require screwing through the PCB. Since the PCB was not investigated in this study, this option was not explored further. However, it can be an interesting option to connect three components with two existing screws, lowering the amount of actions needed to reach the fan.

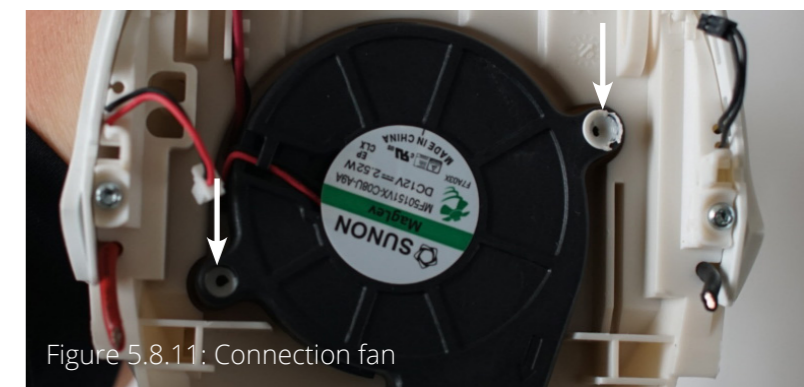

Figure 5.8.11: Connection fan

Other Recommendations

Integrating the aesthetic and refurbishability redesign.

The main limitation of this redesign is that the aesthetic redesign and refurbishability redesign are currently not integrated. The refurbishability enhancements are created with

Evaluation of the redesign

the current Lumea as starting point, not the aesthetic redesign. Due to Covid-19 restriction, the time to access the needed software was limited. Therefore a working model could not be finished. Now, it is assumed that the solutions proposed will work with the Lumea redesign as well, but this could not be tested. It is therefore recommended to explore if and how the aesthetic changes influence the disassembly sequence redesign.

Crash impact test

A crash impact test was not conducted. As mentioned before, a complete working model could not be created and therefore not all parts needed for the test could be 3D printed. Also, since this redesign is still in a conceptual phase, droptesting would be premature. Further development on the exact measurement of the fixings is needed in order for a droptest to be relevant.

Economical en environmental impact

Also because of the inspirational purpose and conceptual state of the redesign the added financial costs and environmental impact was not calculated. Up to this point the focus had been to design a fast and safe disassembly and reassembly sequence. Future development should focus evaluating this impact.

The redesign is compared to the current design in terms of consumer acceptance and refurbishability. This evaluation is done on the basis of the five problems to be solved listed in chapter 5.1.

1. Opening the product

This was the main objective of the product architecture redesign phase. Multiple ideas were tested, which led to this design. This design allows for fast disassembly and reassembly of the initial steps without damaging or broken any housing parts.

However, it should be mentioned that the precise Philips (safety) requirements were unknown. Therefore, this design might not fully comply with the Philips standards. The redesign approach used in this study could serve as for inspiration to Philips designers, to recreate (parts of) the study in line with the precise requirements.

2. Battery and capacitor depth

The battery and capacitor depth is reduced from ten to five steps. It can be concluded that the redesign positively influence the reachability of these critical components. Also, these five steps are faster and easier to perform than the actions needed for the current design.

However, there is still room for improvement. Options were explored for opening the product from the button up, for example. In theory, the battery would then be reachable in just two steps. In terms of parts harvesting and the replacement of frequent failure parts, it might be worth it to look into this option.

3. Fear of contamination

The exploratory redesigns focussed on reducing the fear of contamination. The current Lumea is already associated with hygiene. The goal was to maintain and expand this in the redesign. Discussing the redesign with consumer pointed out that the hygiene

was indeed maintained. However, consumers did not agree on if it is what really more hygienic than the current design.

Fear of contamination was also taken into account in the redesign for refurbishability. The housing parts were surfaced to the top of the disassembly to ensure fast removal and replacement. Therefore, it can be concluded that the redesign addressed this concern from multiple angles.

4. Financial & performance risk:

Whether the perceived financial risk and performance risk are reduced can not yet be said from this study. The insights found during the research, that should positively influence the perceived financial and performance risk were incorporated in the three concept design.

However, the redesign should be further developed into realistic renders and prototypes, and A/B tested with consumers on a large scale. For now, this problem is marked as unsolved.

5. Refurbishment fuss:

Refurbishment confusion is mainly a societal phenomenon. Since the creation of negative associations is minimized, it can be stated that the design will probably not aggravate this confusion. However, whether it makes consumer understand the concept of refurbishment better or spreads awareness is questionable. Also, it can not be said whether it has more or less influence on refurbishment fuss than the current design. Therefore, this problem was marked as unsolved.

As concluded in chapter 4.3, it can be discussed whether product aesthetics has any influence on the understanding of refurbishment and the acknowledgement in society. This dilemma should be validated in



6.

CONSUMER

CENTERED DESIGN

FOR REFURBISHMENT

TOOL

TAKEAWAYS

Circular product design mindset

- Design for refurbishment is not a quick fix or stand-alone design activity.
- It is a **mindset best developed through experience and cooperation with other designers.**
- Every product and context is unique. There are no guidelines or rules to follow, which apply in every situation.
- The insights from this study are combined into a tool intended to train this mindset by experience.

Design skills

- Consumer empathy
- Product lifecycle management
- Ecosystem thinking

Philips fit

- The canvas and the list of questions provided are created to kick start the circular mindset of the designers.
- The tool can also be used as a summary canvas for all project team members involved.
- Currently, the tool is being tested at Philips in the shape of a design workshop. The outcomes of which will be evaluated in future research.

A consumer-centred approach to refurbished product design

For most designers, designing with the consumer needs in mind sounds natural. However, design for refurbishment is a relatively new discipline. Designers and design researchers are still in an exploratory phase (internal communication Philips, 2020). When and how to implement refurbishment problems is unknown. Therefore, the consumer perspective in refurbishment is not a common practice yet.

The desirability of refurbished products, in general, is low (Mugge et al., 2017). Creating a perfectly functioning product is essential, but if nobody wants to buy it in the first place, that effort might be wasted. To make consumers consider refurbished products, the focus must lay on fulfilling the needs and addressing the concerns of the person that is going to buy it; the consumer.

Often, like with the Lumea, the product to be refurbished has already been successfully implemented on the market. It has proven its desirability and profitability. Therefore, the

focus of the design for refurbishment process lies in technical challenges like viable repairing and cleaning. However, consumer desirability in the first lifecycle (new) does not guarantee success in later cycles. The interviews suggested that consumers in later lifecycles have different concerns and incentives when buying a product, which is not taken into account in a linear design process. Involving consumer from different lifecycles is especially interesting in the business to customer market, where the demand is created by needs and desires (Wewer et al., 2020). Therefore, technical feasibility and consumer desirability are equally important for refurbishment success and should be equally addressed in the redesign process.



Design skills to incorporate refurbishment

Design for refurbishment is not a quick fix or stand-alone strategy. It is a mindset best developed through experience and cooperation with other designers. Every product and context is unique. There are no guidelines or rules to follow, which apply in every situation. Circular design should be more than weighing pros and cons or evaluating which strategy suits a product best. It should be a mindset that encourages new ways of exploring opportunities and solving problems. Therefore, the insights obtained during this project are combined into designer skills, which can be developed and trained by experience.

1 Consumer empathy / sensitivity



The skill of consumer empathy refers to the ability to understand your consumer, which is crucial to increase the acceptance of refurbished products (Bakker and Mugge, 2021). This way of thinking is known to most designers and could make refurbishment more accessible. However, different lifecycles have different target consumers that all want a satisfactory product that fits their needs. Designers should look beyond the first consumer and consider consumers needs and desires from multiple cycles in their design process (van Weelden et al., 2016). Designers should understand the consumer's expectations and perception of value and manage those over time (Moreno et al., 2016).

2 Product lifetime management



Regulations or technological developments in later product lifecycles may demand design changes. Instead of delivering a static product design, designs should be timeless with room for upgradability. This adds extra complexity to design decisions since they can impact different points in time. Therefore, designers should have the ability and anticipate how the product will evolve over multiple lifecycles (Moreno et al., 2016; Sumter et al., 2018). This ability does not only require consumer and context empathy, as mentioned in the first skill. It also requires technical insight in component wear and tear and how to create a durable product for multiple lifetimes.

3 Ecosystem thinking



Ecosystem thinking is a key skill for designers to implement refurbishment in their design process (Breuer et al., 2018). As mentioned before, refurbishment is not a separate activity. It involves multiple target consumers, stakeholders and service models that should all be understood. As design is rarely an individual practice, designers are used to working with various stakeholders on one project. However, refurbishment requires focusing on product design while keeping the complete circular business model in mind (Sumter et al., 2018). The company and consumers have now shared ownership of the product. Therefore, designers should be able to facilitate collaboration between internal and external stakeholders who play a role in the operationalising refurbishment (Sumter et al., 2018).

Developing a refurbishment tool for designers

Tool?

Philips designers and design students asked expressed a need for guidance and practical tools to implement refurbishment in their work. Designers often do not know where to start with refurbishment and what aspects should be considered. Designers need reliable tools that make them aware of refurbishment benefits and pitfalls in a practical way (Bakker and Mugge, 2021). Existing tools or methods for circular design either have a too broad perspective or do not fit the purpose of their process due to a linear perspective (Bakker and Mugge, 2021). There are no visual tools that create an overview of the product lifecycle and capture from multiple use cycles (Nußholz, 2018). Therefore, the insights obtained during the literature reviews, interviews and survey are combined into a tool that fills this gap.

Criteria

To be of value to designers and support them in incorporating refurbishment into their design process, the tool should meet the following criteria (based on literature reviews, interviews and the survey).

- Involve consumer refurbishment concerns in an early phase of the (re)design process
- Create an understanding of their product in the context of refurbishment
- Relate consumer refurbishment concerns to product aesthetics in an orderly manner
- Evaluate the influence of their design choices on the consumer acceptance of the product over time
- Develop the before mentioned design skills in a hands-on and visual way

Location in the design process

Considering the double diamond design process, the tool should be used at the turning point between the Discover and the Define phase (figure 4.2.1, red dot). By organising consumer insights uncovered in the fuzzy front end, product-specific design challenges can be defined. These challenges, however, might identify missing knowledge, which forces designers to go back to the Discover phase.

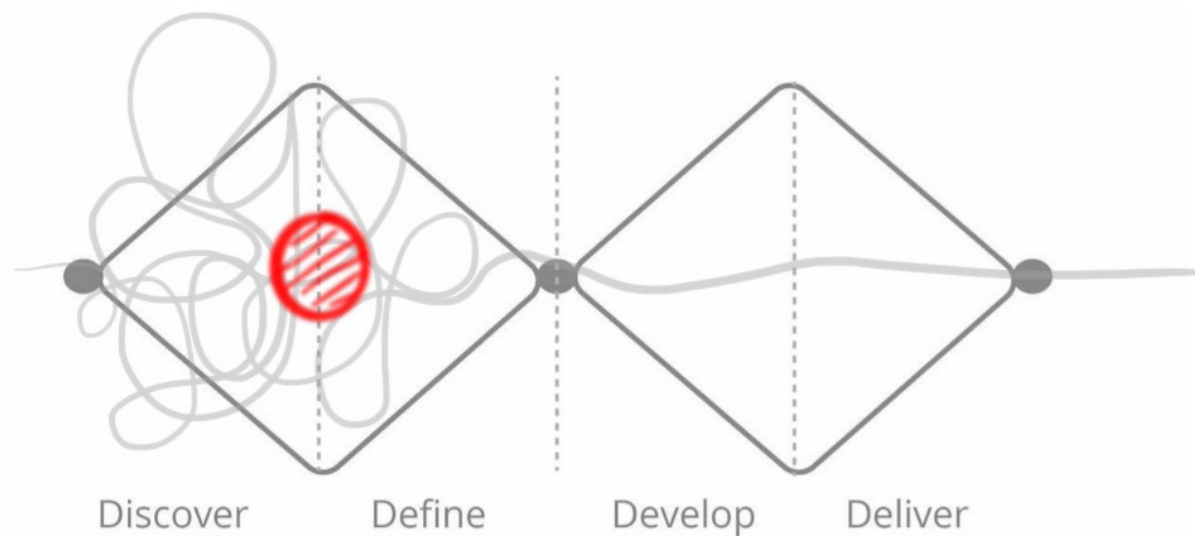
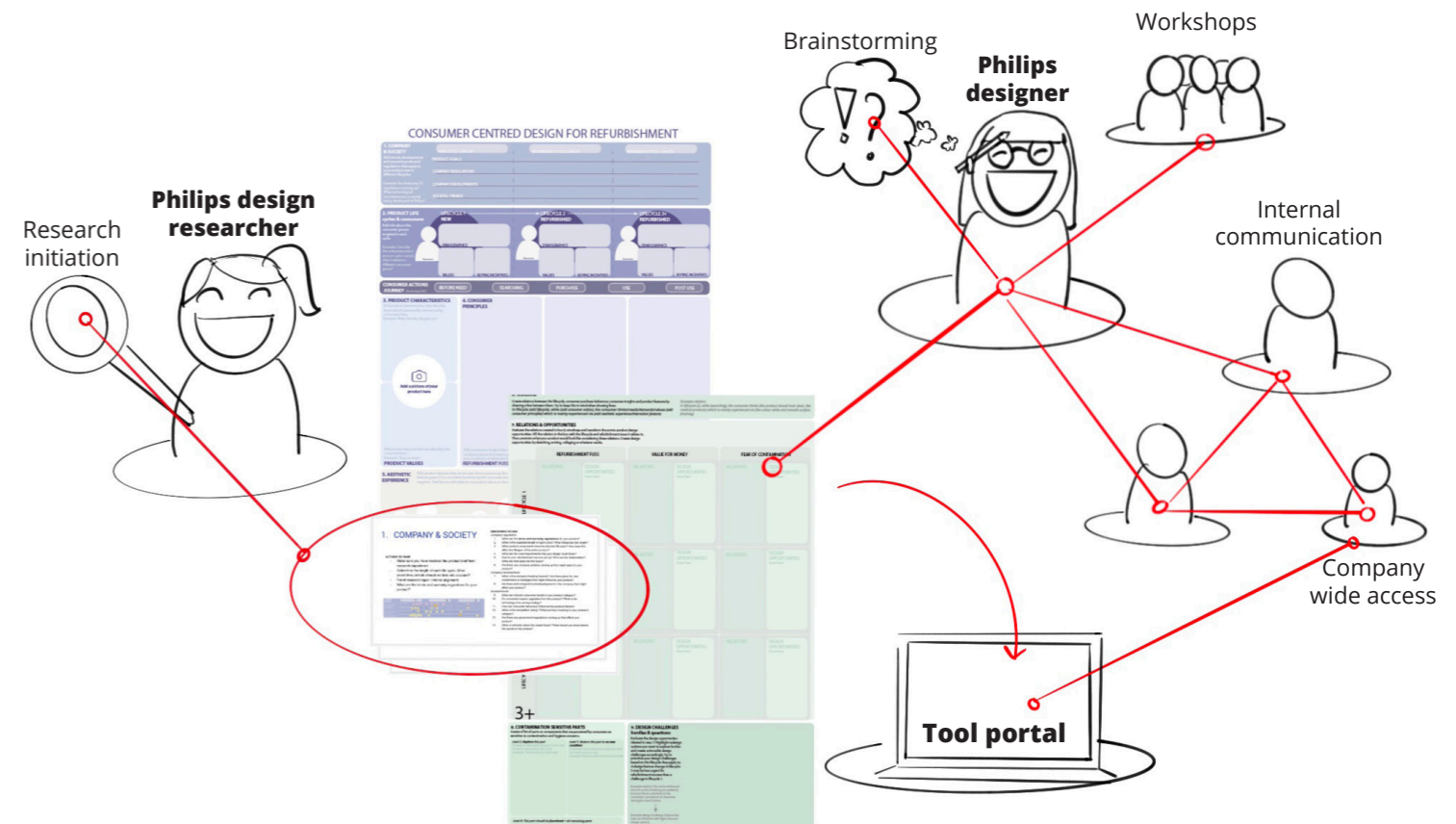

Figure 4.2.1; Tool in the design process

Figure 4.2.2; Position tool inside Philips



Research through design

The tool was developed with build-measure-learn loops. The first draft, based on the Business model canvas, was evaluated, adjusted and tested multiple times which resulted in this design. Design students and Philips designers used the tool both online via Miro and on paper, to test understandability, valuable outcome and visual elements. The arguments for the visual elements used can be found in appendix M.

The final design was evaluated with Philips designers and experts in refurbishment and tool design (chapter 4.6).

Philips fit

Philips designers are still finding out how and when to implement refurbishment in their design process. Designers indicated not to know where to start and what research questions to ask to consider refurbishment. The canvas and the list of questions provided are created to kick start the circular mindset of the designers. Different parts of the canvas may be more or less relevant for specific designers (fig. 4.2.2). For example, research designers can benefit most from the list of questions provided with the tool and the initial purple steps. Whereas product designers may benefit more from the brainstorming part in the green canvas.

Building on this, the tool can also be used as a summary canvas for all project team members involved. Insights and design ideas can be added to the canvas during the project to create a visual overview of all findings.

Currently, the tool is being tested at Philips in the shape of a design workshop. The outcomes of which will be evaluated in future research. Also, the tool will be presented to designers from different departments and uploaded to the tools portal for immediate use.

Consumer centered design for refurbishment

This tool was created with the philosophy that the consumer and their associations are essential for successful refurbishment, in contrast to current circular design tools, focusing mainly on either detailed technical aspects or high-level circular understanding (fig. 6.4.1). The tool puts the designer in the consumers' shoes in the first, second and third product lifecycle to understand their different buying incentives and associations.

The consumers are influenced by societal developments on the meta-level (outer ring), their purchase habits on the macro-level (middle ring) and the product aesthetics they see on a micro-level. The designer goes gradually from societal level to product aesthetics level to create a complete understanding of the refurbished product context.

All three experience levels influence the way consumers perceive product features and judge quality and financial value. In this tool, the acceptance of the refurbished product judged by how consumers experience the three main hurdles; refurbishment fuss, value for money and fear of contamination. These hurdles can be encountered in any ring and can influence any product feature. All these experiences and product features are carefully considered and structured in this tool.

What skills, as discussed in chapter 6.2 are addressed in the tool can be seen in fig. 6.4.2 on the next page.

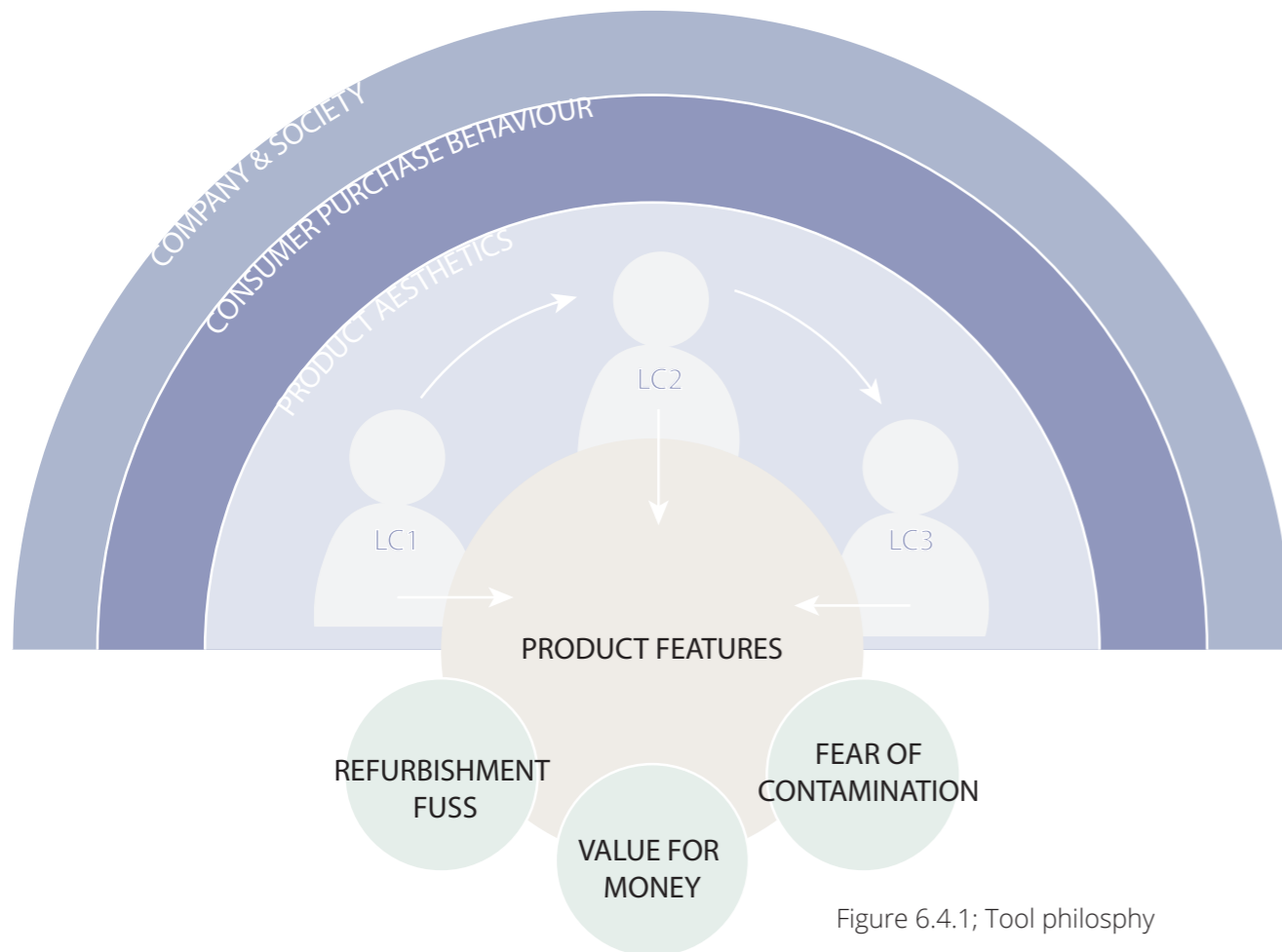

Figure 6.4.1; Tool philosophy

Tool design

The tool consists of two canvasses, and a list of questions designers can ask themselves during each step.

1. The purple canvas; supports problem and consumer understanding. This canvas guides designers through data structuring activities and encourages designers to make a visual overview.
2. The green canvas; takes this overview to the next level by supporting the creation of relations. Mapping mapping and drawing tasks support creative thinking and hands-on experience with design for refurbishment by visualising design opportunities.

Once the tool is completed, the designer should have a visual overview of the relations between aesthetic features and consumer concerns and first design opportunities. Based on this exploration, designers can judge the 'refurbishment fitness' of their product and identify design challenges to increase acceptance.

INPUT

- Knowledge of the product you want to redesign for refurbishment
- Consumer insights (surveys, interviews, feedback, ect.)

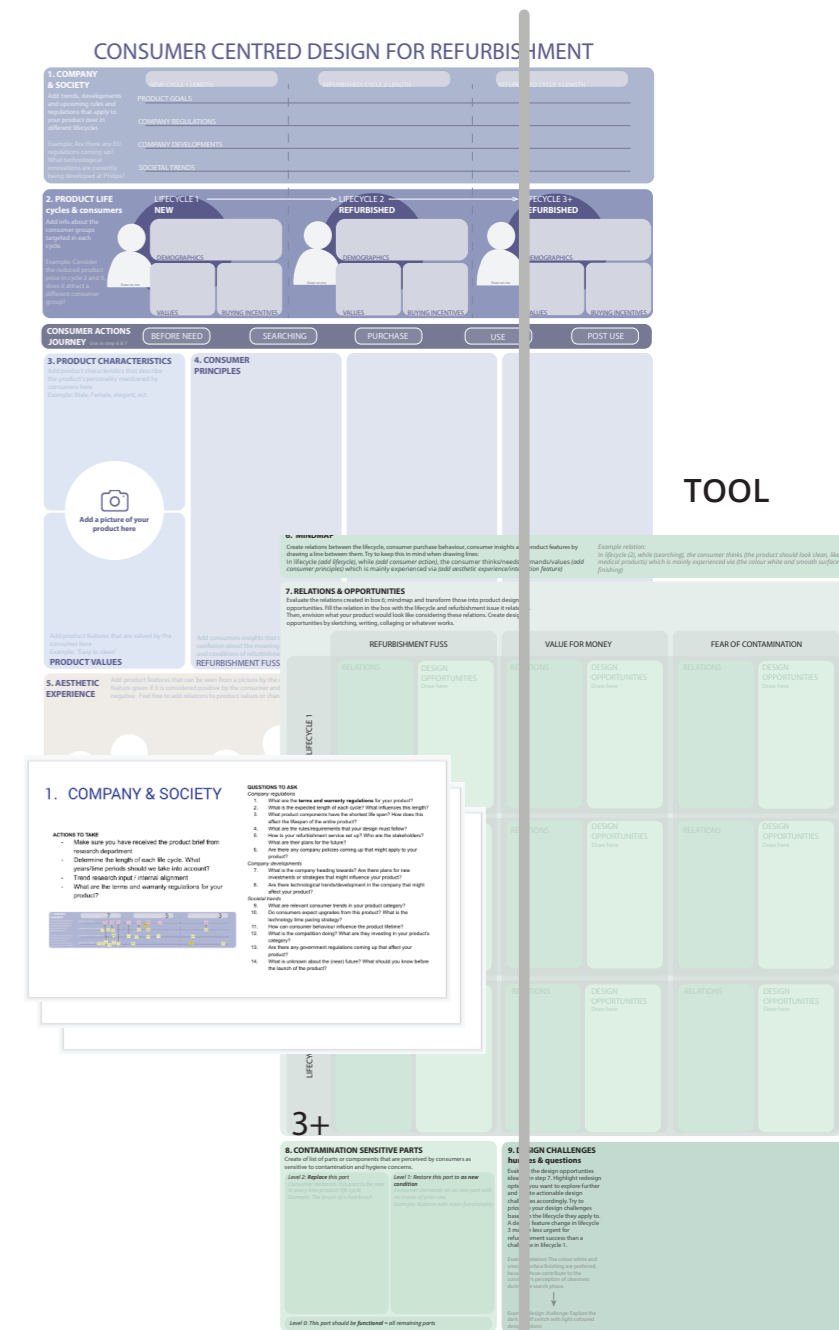

OUTPUT

- Understanding about consumer concerns in relation to refurbishment and your product
- Design opportunities for improved consumer acceptance in different lifetimes
- Design challenges for the next phase

figure 6.4.2: Tool with skills addressed in each activity box

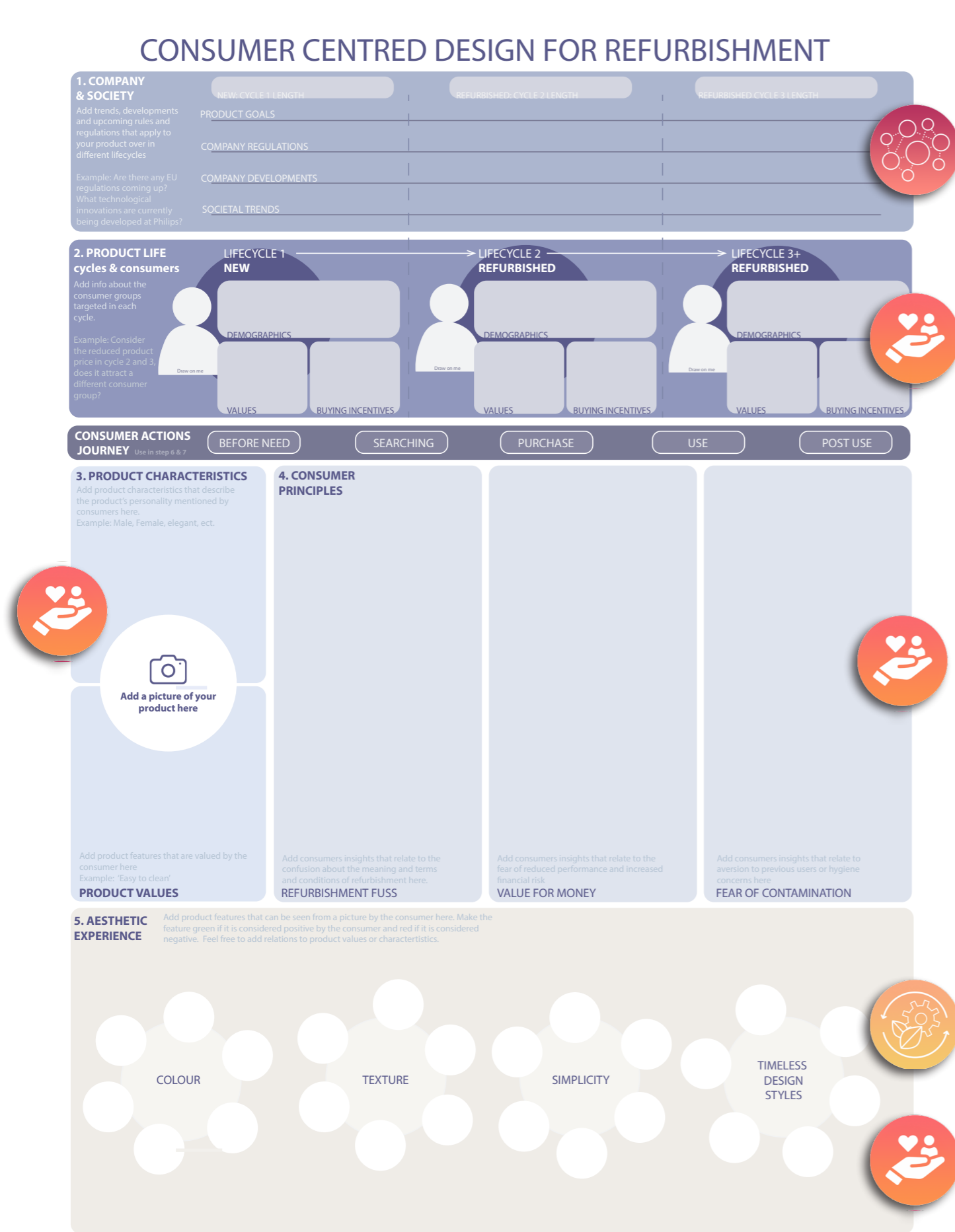

Tool in depth

Each canvas consists of multiple boxes with activities (fig. 6.5.1). These activity boxes are presented in order of use, and their goal, theory and outcome are discussed. Each box is based on a different skill and serves a different purpose, ranging from evaluation to generation. To help users fill the boxes and generate valuable outcomes, a guide with questions to ask is provided with the tool. This guide can be found in appendix N.

To clarify the execution of the activity, a Lumea case is provided. The guide, the tool and the Lumea case are placed in a Miro board, scan the QR code to go to the online version.

Scan this QR code to access the tool on Miro!



See both a completed and the empty canvas

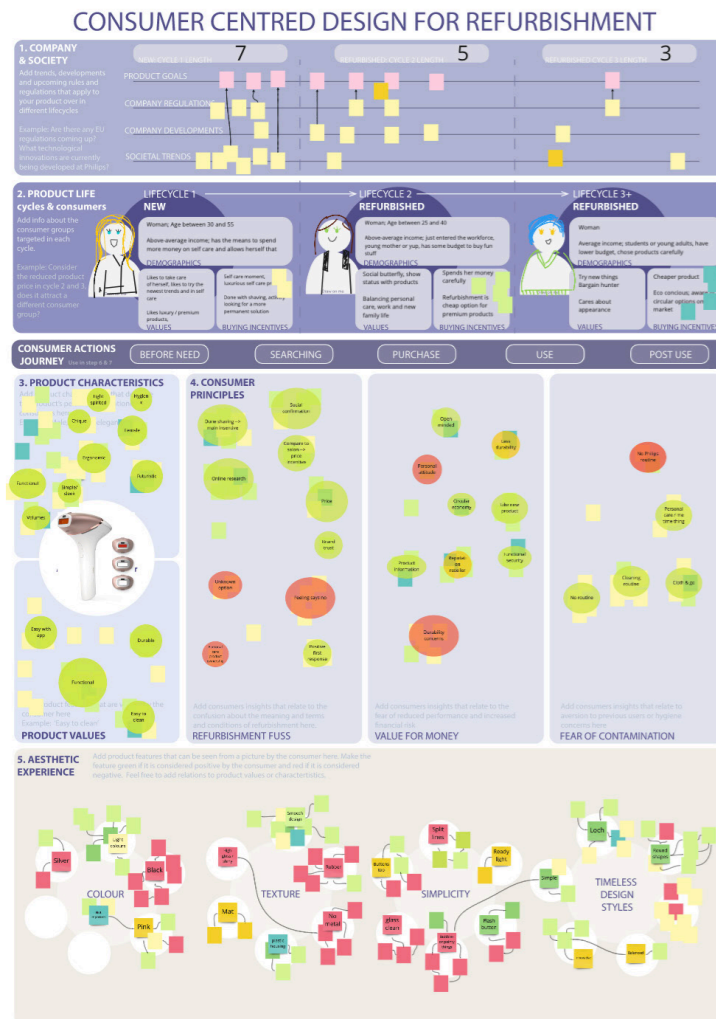
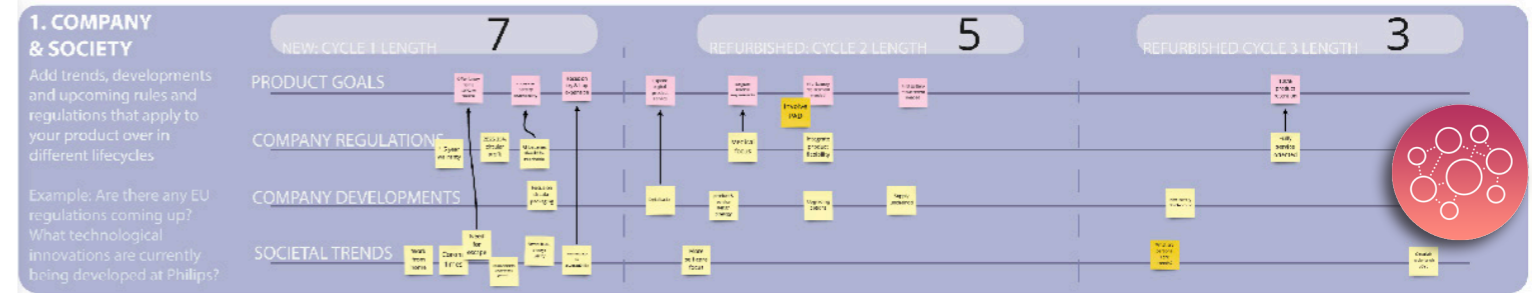

Figure 6.5.1; Completed tool Miro

Figure 6.5.2; Company & society



1. Company & Society

Company & Society is an explorative exercise. This box is inspired by the roadmapping method (Simonse, 2017). It is based on the notion that refurbishment is an ecosystem strategy. Doing this exercise trains a designer's understanding of ecosystems in order to make considered design decisions. Besides designing a product that is desirable and viable, refurbishment involves the time pacing of technological innovations and the stakeholders involved. Structuring those factors helps designers structure the complexity of such refurbishment ecosystems.

The exercise, as shown in figure 6.5.2, together with the questions (appendix M), guides the designer in mapping the factors over different lifecycles. As can be seen in figure 6.5.2, finding factors for later lifecycles might be more difficult than for the first one. This indicates uncertainties in future cycles which can then be evaluated and further explored if desired.

The outcome of this box is a visual overview of the time pacing strategies and contextual factors and how those apply on the product (fig. 6.5.2).

2. Product Life

Product Life aims to shift from the ecosystem view, to a consumer centred perspective by framing a consumer for each lifecycle. Creating a persona helps designers to empathise, and think about the impact of their design on the different consumers involved. By empathising in an early phase, the designer can keep these persona's in mind during the rest of the tool. *'What would this consumer think?'*, which is at the core of consumer centred design.

The box (figure 6.5.3) guides the designer through shaping persona by drawing, listing demographic facts, stating product related values and identifying buying incentives.

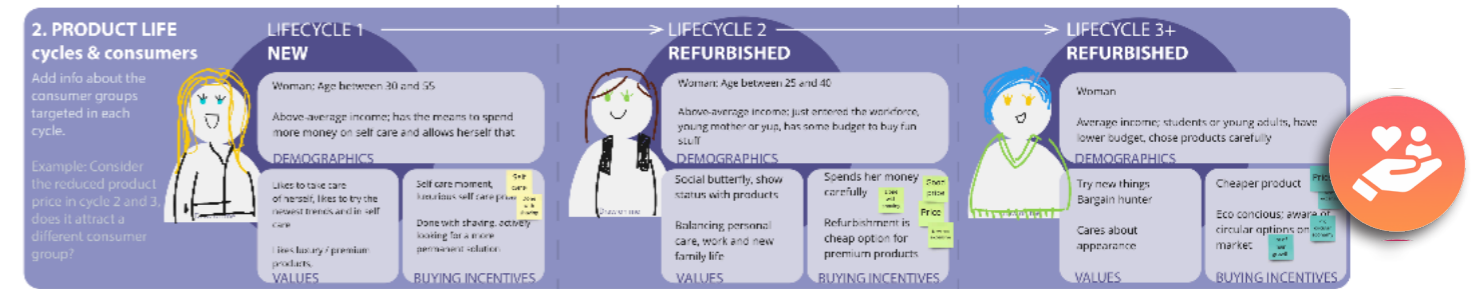
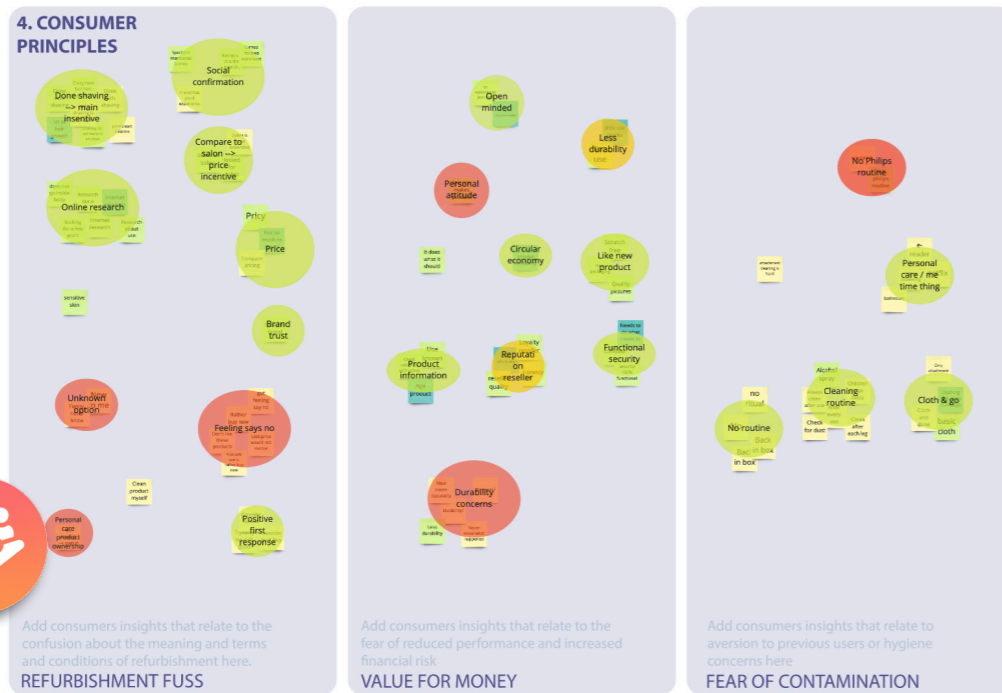

Figure 6.5.3; Product life

Figure 6.5.4; Product characteristics



Figure 6.5.5; Consumer principles



3. Product characteristics & values

Product characteristics and values is a data evaluation exercise based on the mindmapping. This exercise helps designers to structure the consumer insights provided from the perspective of the persona's framed in box 2. By identifying what product characteristics are perceived by which persona, a product perception over time can be shaped. This helps the designers understand what values to emphasize and what negative associations to anticipate on in the redesign.

The box (figure 6.5.4) divides the insights into characteristics and values. Characteristics are related to external design perceptions and personality threats, both positive and negative. The values box contains all positive associations consumers have with the product. This might also include specific functional features or brand values for example.

4. Consumer principles

Consumer principles is a data structuring exercise. This box based on the consumer hurdles identified in chapter 2.5. It is based on the idea that all refurbishment related consumer concerns are related to these overarching problems. Doing this exercise 'forces' the designer to interpret the data from a persona perspective and categorize it based on consumer's concerns. Doing this creates empathy for the nature of consumer insights, which increases the understanding of common hurdles.

The exercise, as shown in figure 6.5.5., together with the questions (appendix M), guides the designer in clustering the consumer's concerns. The outcome of this box is are clusters, combining insights from consumers from all lifecycles (fig. 6.5.5). Depending on the product, some concerns might contain more clusters than others. This can be an indication for what concern to focus on, since it was most dominanty present in the data.

5. Aesthetic experience

Aesthetic experience is a mindmapping exercise used to relate specific product appearance features to the consumer concerns. This box is based on the findings from literature, that suggests that simplicity and timeless design style have a positive influence on refurbishment (Wallner et al., 2020). And the consumer interviews and survey, that demonstrated that colour and texture influence creation of associations in the decision making process.

Aesthetic experience is about using empathy to uncover associations, and their influence on the consumer desirability. For example; 'smooth surface finishing', in the textures cloud, is associated with medical products and high ease of cleaning. These associations come from the consumer need for personal care products to express hygiene. Because the associations evoke a positive attitude towards the refurbished product,

they are coloured green. These insights are all visualised with arrows, to show the nature of the relation.

6. Mindmap

Mindmap is the first exercise on the green canvas and aims to evaluate and reflect on insights created on the purple canvas. This step is about discussing the relations from the viewpoint of the different persona's. This either be done by drawing visual lines between the findings (fig. 6.5.7), or via a group discussion with for example a 'role playing' format: *If I were persona 1, what would I think, feel or do? How would persona 2 handle this? Where do persona 1 and 3 (dis)agree?*

Conclusions can be written down in the 'relations' section of step 7. These relations are used to feed the ideation process.

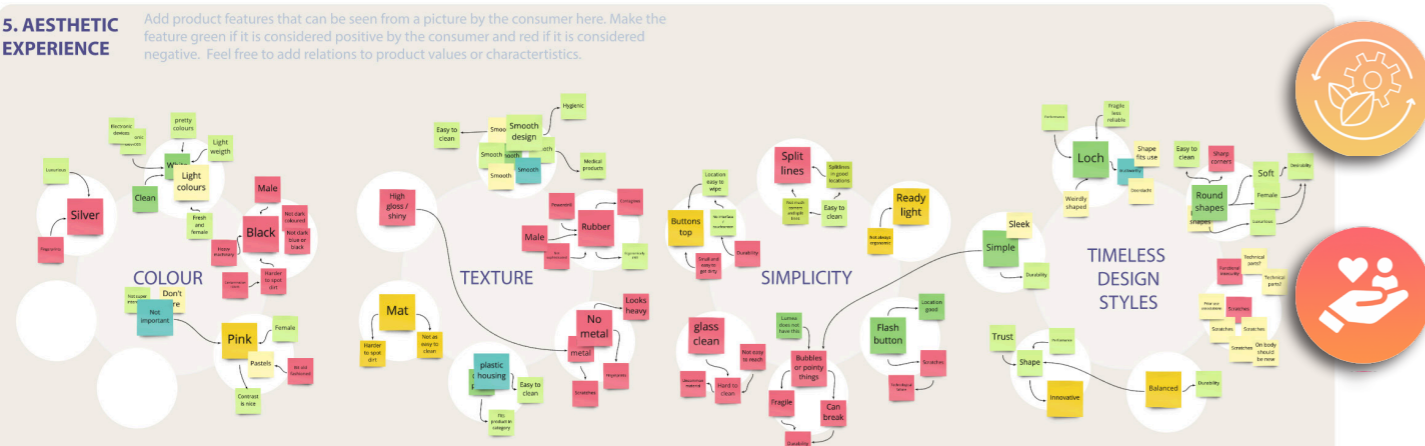
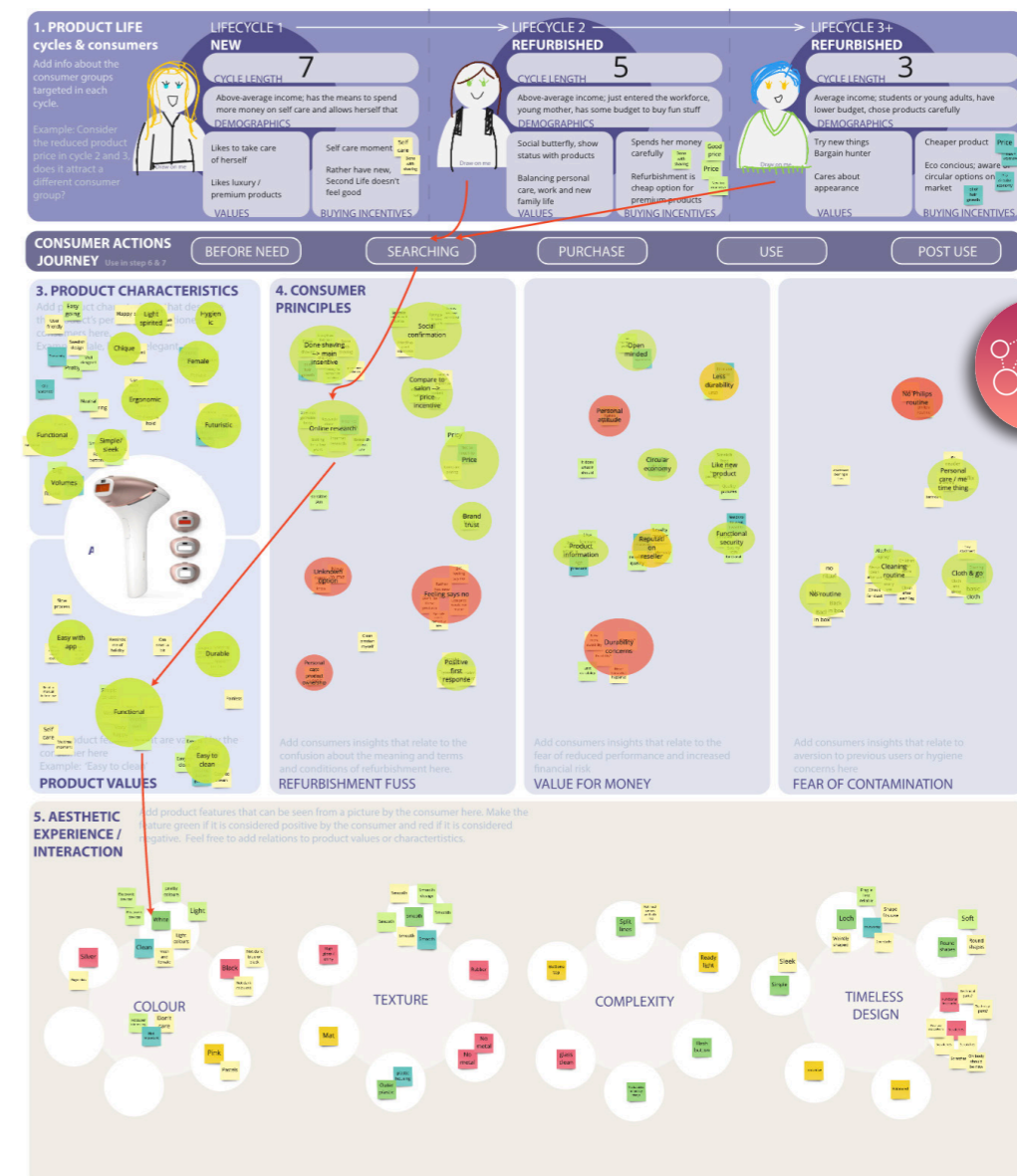

Figure 6.5.6; Aesthetic experience

Figure 6.5.7; Aesthetic experience

Evaluation with designers

Creating a tool is only useful if designers are really going to use it. To create common ground and increase the probability of use, the tool and the outcome of the Lumea case study were presented and discussed during several sessions with designers from different departments. Also, the tool was evaluated with Ruth Mugge, *professor of Design for Sustainable Consumer Behaviour*, and Pieter Jan Stappers, *Professor of Design Techniques*. Insights gathered during these discussions are evaluated based on purpose, content and form.

Purpose

Overall, it can be concluded that the purpose of the tool is clear to both Philips designers and experts. Being able to involve refurbishment early in the design process is valued by Philips designers, as it adds to the overall understanding of the concept.

As Mugge mentioned, the tool is especially relevant to designers who have little experience with such a circular strategies. For more experienced designers, it can be a way of structuring and complementing what they already know.

Also, the tool is valued as means for internal communication. As a designer mentioned: *'It is a nice tool to explain the importance of considering multiple lifecycles to other stakeholders (e.g. marketing)'*.

Content

Especially the consumer perspective is appreciated. As designers mentioned: *'I like the consumer horizons in terms of ownership'* and *'it is nice to consider how the same aesthetics feature can be perceived in different ways by different users in usecycles'*. This specific consumer centered focus can be especially relevant for experience designers. To build on this, a designer mentioned to integrate a way of *'comparing different consumer groups'*, to make the consumer empathise complete.

It is questioned by designers how the different refurbishment business models influence the tool and it's outcome. This would have to be tested and confirmed in multiple case studies.

As a point of improvement, designers expressed the need for *'measuring the environmental impact of the solutions shown'*. This is not included in the scope of the tool. However, it might be interesting to look into ways make the combination between multiple tools easier.

Also the framework could be expended to providing one overview of the circular options for one product. Because, for example, a refurbished product can also be recycled afterwards. Considering this, a designer suggested to add a *'framework where also other circular design aspects can be put side by side (E.g. Toothbrush button good because of medical feeling, but bad for recycling)'*.

Most of information sorted on the purple canvas is already provided to the designers in a business case, as stated by Philips designers in a feedback session. This makes emphasizing important, since designers do not experience the concerns first hand. Therefore, Philips designers have a preference for the green canvas. To the visualisation exercises of the consumer data are valuable for drawing conclusions.

It practise, designers may not always have the time or need to fill the complete tool. Therefore, the provided list of questions to think about may be of more practical value. As the research design team indicated: *'the provided list of questions provides us with a starting point to consider refurbishment in our surveys or interviews for example'*.

Form

As mentioned before, the complete visual overview of the finding is valued. A designer said: *'I like that the brief can be captured visually in one tool'*. Stappers added to this that the tool is well balanced between boxes (restrictions) and drawing (freedom). The form of a Miro board is appreciated by the designers. Especially due to the Covid remote working situation, online brainstorming tool are appreciated. In this format, a designer mentioned, *'the tool can easily be copy pasted and prepared for, for example, a workshop'*. A research designer mentioned that *'it would be helpful to create a Miro template, so that designers can combine and swap boxes to the needs of their project'*.

Both Stappers and Mugge said that it would add value to stimulate more drawing or mapping activities in the tool. The first steps to do so have been taken by adding the draw boxes in step 7. However, this could be taken a step further. For example with a suggestion made by one of the Philips designers: *'One section where the ideas/inputs for each use cycle are combined in one design to combine all cycles together'*. Another designer mentioned that *'it could be nice to add a visual experience flow'*. These options can be explored in future development.

Also, the desire for a visual summary was expressed: *'A section where different features for different usecycles can be clearly put side by side to highlight incongruences (E.g. finishing that works for user 1, but not user 2)'*. Although the relations show a summary of the outcome, it was not considered sufficient. A designer gave the following suggestion: *'A section with key requirements and enablers'*. These are all

form options that should be considered after the tool is tested by several different designers internally.

Another point of improvement here was to create *'a clearer overview what main aesthetics features are important for each use cycle and a clearer comparison between contrasting features'*. According to the designer, this should be highlighted more prominently, so that it can be used as part of the final outcome.

Further development

To fully validate the effect of the tool, it should be evaluated in real design projects. Currently, the tool is being tested internally. Philips designers are trying the tool in workshops. Gathering this feedback and adjusting the tool accordingly would be the first step to improve the tool.

Also, Mugge mentioned that the tool is currently focussed on hygiene and was clearly created from a personal care perspective. To take this prejudice out of the tool, the tool should be tested on other products from different categories and to compare the outcome.

Furthermore, the incentive for designers to use the tool should be investigated. Time is precious, especially for Philips designers. Therefore the outcome and purpose of the tool should be used for communication and promotion.

In further development, it might be interesting to involve psychologists in the development of the tool. This could help improve the educational value in terms of design for refurbishment skills, and the content on consumer behaviour and incentives.



7. CONCLUSION & REFLECTION

Answering research questions

The purpose of this thesis has been to discover, through in-practice explorations, how the consumer perspective can be incorporated in design for refurbishment. How this can be done and what this asks of designers is explained in chapter five and six. This thesis presents a redesign for refurbishment from a consumer perspective, and a tool for designers to train the skills and consumer-centred design process.

By combining the findings obtained during this project, the main research question can be answered by answering the sub-questions.

1. What is the influence of hygiene (for the consumer) in the refurbished personal care products' buying decision?

This study was conducted on a single case. Thus, the influence of hygiene on refurbished personal care products as a category could not be determined. However, the case study provided some interesting insights into what aesthetic features consumers relate to hygiene and how this affects the potential acceptance.

Hygiene is related to the consumer's fear of contamination. Personal care products are susceptible to contamination concerns (Mugge et al., 2017). Consumers confirmed that buying a personal product like the Lumea refurbished is undesirable. The idea that someone else used the product on personal body parts before is repulsive.

The interviews suggest that **hygiene is mainly perceived in relation to complexity.** Consumers mention that features like buttons, small corners, and split lines negatively influence the refurbished product's acceptance since these are considered difficult to clean. Findings suggest that product complexity negatively affects the perceived ease of cleaning.

Interviews suggest that the **colour white is related to hygiene due to its associations**

with medical products. Also, smooth surface finishing is mentioned as favourable for refurbished products since this enhances the ease of cleaning. However, a relationship between white, smooth and hygienic could not be concluded from the survey.

However, **'hygienic' has a weak positive relation ($p = <0.05$) with the willingness to buy refurbished and is the strongest predictor for buying refurbished.** This suggests that the higher the perceived hygienic is, the higher the willingness to buy refurbished will be. This study doesn't prove that the relationship between hygiene and willingness to buy is causal. Still, it seems reasonable that improving the hygiene perception will cause a slightly increased willingness to buy refurbished.

2. How can design appearance increase the consumer acceptance of a refurbished product?

As concluded in chapter 4: **'Aesthetics influence the acceptance via associations but will not be the deciding aspect for solving the overarching societal problem that stands in the way of refurbished product acceptance; misconceptions about refurbishment'**.

Interviews suggest that these aesthetic features help consumers judge whether the product meets contamination and functionality needs. Visual factors such as product appearance help consumers verify product quality (Mugge et al., 2012). However, product aesthetics is only one of many factors that consumers use to balance benefits and risks.

That does not mean that aesthetics has no influence at all. The survey suggests that consumers prefer characteristics associated with hygiene, like white colours and smooth textures.

Therefore, **creating positive associations can increase the willingness to buy refurbished** (Huang et al., 2020). This project concludes that, for the Lumea, especially associations with luxury, hygiene and

durability positively influence the acceptance of the refurbished product.

3. How to (re)design a personal care product for refurbishment?

Design for refurbishment is not a quick fix or stand-alone design activity. It is **a mindset best developed through experience and cooperation with other designers.** Every product and context is unique. There are no guidelines or rules to follow, which apply in every situation. Circular design is a mindset that encourages new ways of exploring opportunities and solving problems. The insights from this study are combined into an illustrative redesign and a tool intended to train this mindset by experience. Following the line of this project, designers should develop the following skills:

1. Consumer empathy; The ability to understand your consumer. **Different lifecycles have different target consumers that all want a satisfactory product that fits their needs.** Designers should look beyond the first consumer and consider consumer needs and desires from multiple cycles in their design process (van Weelden et al., 2016). Designers should understand the consumer's expectations and perception of value and manage those over time (De Los Rios and Charnley, 2016).
2. Product lifetime management; Regulations or technological developments in later product lifecycles may demand design changes. **Instead of delivering a static product design, designs should be timeless with room for upgradability.** Therefore, designers should have the **ability to anticipate how the product will evolve over multiple lifecycles** (De los Rios and Charnley, 2016; Sumpter et al., 2018). This ability does not only require consumer and context empathy. It also

requires technical insight into how to design a repairable product.

3. Ecosystem thinking; **Refurbishment involves multiple target consumers, stakeholders and service models that should all be understood.** Understanding this requires focusing on product design to component level while keeping the complete circular business model in mind (Sumpter et al., 2018). Therefore, designers should facilitate collaboration between internal and external stakeholders who play a role in the operationalising refurbishment (Sumpter et al., 2018).

Conclusion

'How to enhance the consumer acceptance of refurbished (electronic personal hygiene) products via product design?'

Every product and context are unique. There are no guidelines or rules to follow, which apply in every situation. Circular design is a mindset. However, from this study, the following can be concluded for the Lumea:

- Assess the contamination sensitivity of all outer housing parts based on contamination sensitivity level and conclude their need for replacement and repair. Also, list the functional critical parts and assess their location in the product, consider surfacing housing parts to increase the ease of replacement
- Focus on emphasizing the characteristics; luxury, hygiene and durability.
- Avoid associations with complexity, like buttons and split lines. Also, avoid fragile components and emphasise robust, distinctive designs to lower the perceived performance risk.
- Consider white housing with smooth surface finishing to create associations with easy cleaning.

Overlap with literature and additional findings

Consumer concerns

- + Consumer experience quality concerns: Do refurbished products really work “like new”? (Abbey et al., 2015)
- ± The refurbished product is forever tainted by traces of prior use (Abbey et al., 2015).
- + Consumers have a need for continued performance (Mugge et al., 2017)
- ± Personal care products are considered unfit for refurbishment ([1] Mugge et al., 2017)
- + Refurbished products are considered less clean than new ones because of contamination concerns ([1] Mugge et al., 2017)

Decision making

- ± Sustainability has no importance for the product choice (Michaud and Llerena, 2011; Abbey et al., 2015; van Weelden et al., 2016; Wewer et al., 2020)
- + Consumer are not familiar with refurbishment, which leads to misconception about the process and lowers the willingness to buy (van Weelden et al., 2016; Mugge et al., 2017; Wewer et al., 2020)
- + Performance risk has a negative impact on purchase intention (Mugge et al., 2017; Singhal et al., 2019)
- + Personal care products are hygiene sensitive; consumers would rather personally own a new one (Mugge et al., 2017)
- + Refurbished product buyers seek functionality instead of newness (Jiménez-Parra et al., 2014)
- ? **New / unknown product use; harder to predict for consumer what wear and tear can be expected**

Aesthetic influence

- + Consumers use visual factors, such as product appearance, to verify the quality (Mugge et al., 2012)
- + Refurbished products should meet minimum functional requirements before appearance is taken into account (Luchs et al., 2012).
- + Consumers evaluate refurbished products with visual information about prior use (i.e., wear and tear) more negatively (Mugge et al., 2017).
- + The simplistic design style evokes positive perceptions and enhances the attractiveness (Wallner et al., 2020)
- ± Refurbished products are often perceived as old, used, and having reduced performance (Baxter, 2016)
- + Timeless designs are preferred for refurbished products (Lobos, 2014)
- + **For refurbished personal care products, consumer prefer an as new product with no visible traces of prior use**
- + **White colour enhances the acceptance of refurbished personal care products since they are associated with medical hygiene**
- + **Smooth surface finishing enhances the acceptance of a refurbished personal care product because it emphasizes ease of cleaning**
- + **Robust, simplistic product design styles are preferred over complex and fragile products (Wallner et al., 2020).**
- ? **Distinctive product design positively influences the perceived performance quality**
- ? **The expression of luxury positively influences the consumer’s willingness to buy refurbished, since it lowers the perceived financial risk**

CHAPTER 7.2

Contributions & practical outcomes

Opportunities for further research

Combining the findings from this research to existing literature shows quite some overlap. Table 7.2 shows literature findings that were perceived as valid for this research. The statement partly supported are marked with (+/-). The results that can be concluded from the interviews and/or the survey are added in blue.

Some of these statements follow only from qualitative research. To enhance the validity of these statements, quantitative research should also be done. Also, this project provides multiple opportunities for future research, marked with (?).

? *Distinctive product design positively influences the perceived performance quality*

The interviews suggested that the distinctive shape of the Lumea has a positive effect on the perceived quality. This statement was not further investigated during this research. However, it would be interesting to examine the influence of shape on product acceptance further.

? *The expression of luxury positively influences the consumer’s willingness to buy refurbished, since it lowers the perceived financial risk*

According to the conducted survey, the characteristic ‘luxury’ is very applicable to Lumea, just like ‘high quality and ‘hygiene’. Earlier studies have explored the influence of hygiene and quality on purchase intention. For the Lumea, luxury is one of the primary buying incentives and, therefore, positively influences the willingness to buy in general. However, whether luxury products have a higher willingness to buy refurbished remains questionable.

Practical outcomes for Philips

This project approached refurbishment from two design angles, product architecture and consumer acceptance. Combining both perspectives into one case study gives an example of what should be looked into when redesigning for refurbishment.

Also, the tool created in this project provides Philips with a practical way to start implementing refurbishment in an early phase of the design process. The canvas and the list of questions provided are created to kick start the circular mindset of the Philips designers and evoke awareness amongst designers from different departments.

The tool can also be used as a summary canvas for all project team members involved. Currently, the tool is being tested at Philips in the shape of a design workshop. The outcomes of which will be evaluated in future research.

Contribution to design practise

The illustrative design shows findings from literature and research that can be implemented in product design. It presents how consumer concerns and considerations can be used to make design for refurbishment decisions. This design should support designers in understanding the different stakeholders and concerns of refurbishment and how these can be managed in product design.

The consumer centred design for refurbishment tool contributes to design practice by providing designers with the means to understand and engage with the refurbishment in an early phase of the design process. The aim of developing a tool was to stimulate designers to stop thinking about the complexity of refurbishment and start exploring the opportunities it can provide. This could help to lower the threshold to begin involving refurbishment in the design process.

Final thoughts; personal reflection

This was the first project in which I was able to combine both my masters skills. I had to show that I'm 'worthy' of the strategic- and integrated product design title and have a deeper understanding of both perspectives. During this project, my goal was to show that I can make well-considered choices, taking both disciplines into account. This was a challenge in terms of managing expectations and finding out what I wanted to do. But in the end, I'm happy with the learning curve. The project started as if I was running to graduation projects in parallel. Since Philips' main focus was the research, the disassembly felt like something I was doing on the side. For me, however, this was something I wanted to learn and was looking forward to. Not being able to discuss my disassembly findings with them made it hard to treat both as equal parts of the project. I ended up discussing the individual perspectives only with the experts and Philips designers interested in that perspective, leading to a fragmented project with no clear direction. I found out that this was happening relatively late in the project.

However, once I was made aware, I decided to pause the project and evaluate all the design activities I had done so far. I started combining interesting findings and creating relations, which led to an enrichment of the research and the project. In the end, I was able to develop a redesign and tool in which both disciplines are represented. The one perhaps more dominant than the other, but that is design. Not every design challenge can be solved with 50% strategy and 50% product engineering. It is about discovering which techniques fit the project's needs best and how you, as a designer, can be of most value. After this project, I'm convinced that my education in both perspectives makes me unique. But is knowing what skills to apply at what moment that will make me a good designer. This project helped me in this development, and I hope to continue learning how to position myself as a designer for the rest of my career.

Managing expectations

Being a semi intern at Philips made it hard to manage what to expect from them, and what they expected from me. To what extend are they able to help? What are they allowed to share? To what extend do they own the project? As a result, there have been quite a few misunderstandings in the course of the project. Fortunately, there has always been a lot of support from Philips for my many requests and my own choices.

The project's freedom allowed me to dive into refurbishment and become an expert in circular design thinking. Developing this skill was something I desired from the start as a learning goal, and I dare to say I succeeded. Through practise I was able to see how big

companies manage sustainable design. Also, I was able to develop the skills and way of thinking needed to understand the complexity of circular product design.

In terms of project approach, I would have done a lot of things differently afterwards. I found out that I got stuck in the research for too long, leaving me too little time to develop the design up to the level I wanted. I'm a perfectionist and don't like to move to other task without completing the task at hand first. However, this did reduce the momentum of the project. In coming projects, I would start designing in parallel despite not knowing everything in advance. This makes it is easier to spot knowlegde gaps and stick to what is really relevant to move forward.

Focus and motivation

For me, this was the first project which lasted longer than 20 weeks. In fact, a double degree project takes almost 8 months. Because of this, I found it difficult (especially in the beginning) to keep the goal in sight. I wasn't sure where to start and couldn't motivate myself very well. I solved this by coming up with a number of small tasks to do per day at the beginning of the week. I had to write down my findings in a logbook at the end of every day. This gave me an overview of what I had already done, which also motivated me to continue.

Also, I found the contrast between working in groups at the faculty all day and working alone from home confusing. I worked whenever it suited me. Sometimes, playing golf all day and then working 8 hours at night to compensate. This started to show in my project results. Therefore I decided for myself to work for one hour, and see what I had done. If I was in the workflow, I would continue. If not, I would take a physical exercize break and try again. This helped me to feel like I really did something with my day.

Communication

Because for every small question and discussion an appointment needs to sceduled a few days in advance, I tended to solve it on my own. As a result, I slowly got deeper into working alone and before I knew it a week went by without updating anyone. Since I was made aware of this by the end of the project, as mentioned before, I did not have much time to better this. However, from now on, I would scedule weekly or bi-weekly meetings

in advance with all parties involved. The bi-weekly with philips did help with this issue. Because of the bi-weeklys I had to prepare and present every other week and everyone stayed informed. But I do recognize that this is an area for improvement.

Because everything was online, I found out that I had difficulty communicating my ideas and plans to stakeholders. During the project I mainly did this in the form of presentations, as this is easiest online. In retrospect, I should have shown my visual process more, instead of summing everything in words. As a result, I would have been able to get the feedback I needed afterwards.

Later on I started working with Rhino, as I wanted to for my personal learning goals. However, starting from zero with this new CAD programme takes valuable time. I started trying things and it took me way too much time to get tasks done. To improve my basics, I decided to follow an online course. This took me about a week to complete, which seemed like a lot of wasted time at that moment. However, afterwards I was able to adjust the models so much quicker that it was worth it.

Consumer research

During this project, I found out that consumer research is a part of design I really enjoy. I like conducting product tests with consumers and validating results. This is something I would like to keep doing in my future career as designer.

REFERENCES

- Abbey, J. D., Meloy, M. G., Blackburn, J., & Guide, V. D. R. (2015). Consumer Markets for Remanufactured and Refurbished Products. *California Management Review*, 57(4), 26–42. <https://doi.org/10.1525/cm.2015.57.4.26>
- Abdulrahman, M. D., Gunasekaran, A., & Subramanian, N. (2014). Critical barriers in implementing reverse logistics in the Chinese manufacturing sectors. *International Journal of Production Economics*, 147, 460–471. <https://doi.org/10.1016/j.ijpe.2012.08.003>
- Andrae, A. S. G. (2016). Life-Cycle Assessment of Consumer Electronics: A review of methodological approaches. *IEEE Consumer Electronics Magazine*, 5(1), 51–60. <https://doi.org/10.1109/mce.2015.2484639>
- Antonides, G. (1991). An economic-psychological model of scrapping behavior. *Journal of Economic Psychology*, 12(2), 357–379. [https://doi.org/10.1016/0167-4870\(91\)90020-t](https://doi.org/10.1016/0167-4870(91)90020-t)
- Apple.com; Certified Refurbished. (2021). Geraadpleegd van <https://www.apple.com/nl/shop/refurbished>
- Bakker, C. A., Mugge, R., Boks, C., & Oguchi, M. (2021). Understanding and managing product lifetimes in support of a circular economy. *Journal of Cleaner Production*, 279, 123764. <https://doi.org/10.1016/j.jclepro.2020.123764>
- Bakker, C., Wang, F., Huisman, J., & den Hollander, M. (2014). Products that go round: exploring product life extension through design. *Journal of Cleaner Production*, 69, 10–16. <https://doi.org/10.1016/j.jclepro.2014.01.028>
- Baxter, W. L., Aurisicchio, M., & Childs, P. R. (2016). Materials, use and contaminated interaction. *Materials & Design*, 90, 1218–1227. <https://doi.org/10.1016/j.matdes.2015.04.019>
- Blijlevens, J., Creusen, M. E., & Schoormans, J. P. (2009). How consumers perceive product appearance: The identification of three product appearance attributes. *International Journal of Design*, 3(3)(27–35).
- BlueMovement; Groen leven zonder gedoe. (2020). Geraadpleegd van <https://www.bluemovement.com/nl-nl/onze-missie>
- Bocken, N., & Short, S. (2016). Towards a sufficiency-driven business model: Experiences and opportunities. *Environmental Innovation and Societal Transitions*, 18, 41–61. <https://doi.org/10.1016/j.eist.2015.07.010>
- Booth, A., Papaioannou, D., & Sutton, A. (2011). *Systematic Approaches to a Successful Literature Review*. Thousand Oaks, Canada: SAGE Publications.
- Breuer, H., Fichter, K., Freund, F. L., & Tiemann, I. (2018). Sustainability-oriented business model development: principles, criteria and tools. *International Journal of Entrepreneurial Venturing*, 10(2), 256. <https://doi.org/10.1504/ijev.2018.092715>
- Bundgaard, A. M., & Huulgaard, R. D. (2019a). Luxury products for the circular economy? A case study of Bang & Olufsen. *Business Strategy and the Environment*, 28(5), 699–709. <https://doi.org/10.1002/bse.2274>
- Bundgaard, A. M., & Huulgaard, R. D. (2019b). Luxury products for the circular economy? A case study of Bang & Olufsen. *Business Strategy and the Environment*, 28(5), 699–709. <https://doi.org/10.1002/bse.2274>
- Circular economy. (z.d.). Geraadpleegd op 3 november 2020, van <https://www.philips.com/a-w/about/sustainability/circular-economy>
- Cox, J., Griffith, S., Giorgi, S., & King, G. (2013). Consumer understanding of product lifetimes. *Resources, Conservation and Recycling*, 79, 21–29. <https://doi.org/10.1016/j.resconrec.2013.05.003>
- De Fazio, F. (2019). *Enhancing Consumer Product Repairability: A case study on vacuum cleaners*. Geraadpleegd van <http://resolver.tudelft.nl/uuid:810db9a6-9718-4451-8f8f-67ad0cdccad9>
- Desmet, P. M., & Hekkert, P. (2007). Framework of product experience. *International Journal of Design*, 1(1), 57–66. Published.
- DINED. (2004). [Dutch adults].
- Ellen MacArthur foundation; What is the circular economy? (2017). Geraadpleegd van <https://www.ellenmacarthurfoundation.org/circular-economy/what-is-the-circular-economy>
- EN45554. (2020). Geraadpleegd van https://www.cenelec.eu/dyn/www/f?p=104:110:1067850813015201:::FSP_ORG_ID,FSP_PROJECT,FSP_LANG_ID:2240017,65685,25
- Enneking, U., Neumann, C., & Henneberg, S. (2007). How important intrinsic and extrinsic product attributes affect purchase decision. *Food Quality and Preference*, 18(1), 133–138. <https://doi.org/10.1016/j.foodqual.2005.09.008>
- Eurostat. (2020). Geraadpleegd van <https://ec.europa.eu/eurostat>
- Flipsen, B., Bakker, C. A., & de Pauw, I. C. (2020). Hotspot Mapping for product disassembly: A circular product assessment method. *Electronics Goes Green 2020+(Virtual/online event due to COVID-19): The Story of Daisy, Alexa and Greta*. Published.
- Forti V., Baldé C.P., Kuehr R., Bel G. *The Global E-waste Monitor 2020: Quantities, flows and the circular economy potential*. United Nations University (UNU)/United Nations Institute for Training and Research (UNITAR) – co-hosted SCYCLE Programme, International Telecommunication Union (ITU) & International Solid Waste Association (ISWA), Bonn/Geneva/Rotterdam. (2021). Geraadpleegd van <https://www.ewastemonitor.info>
- Govindan, K., Soleimani, H., & Kannan, D. (2015). Reverse logistics and closed-loop supply chain: A comprehensive review to explore the future. *European Journal of Operational Research*, 240(3), 603–626. <https://doi.org/10.1016/j.ejor.2014.07.012>
- Granta Edupack. (2020). [Dataset].
- Guide, J. V. D. R., & Van Wassenhove, L. N. (2001). Managing product returns for remanufacturing. *Production and Operations Management*, 10(2), 142–155.
- Hamzaoui-Essoussi, L., & Linton, J. D. (2014). Offering branded remanufactured/recycled products: at what price? *Journal of Remanufacturing*, 4(1). <https://doi.org/10.1186/s13243-014-0009-9>
- Harms, R., & Linton, J. D. (2015). Willingness to Pay for Eco-Certified Refurbished Products: The Effects of Environmental Attitudes and Knowledge. *Journal of Industrial Ecology*, 20(4), 893–904. <https://doi.org/10.1111/jiec.12301>
- Haug, A. (2016). A Framework for the Experience of Product Aesthetics. *The Design Journal*, 19(5), 809–826. <https://doi.org/10.1080/14606925.2016.1200342>
- Hazen, B. T., Overstreet, R. E., Jones-Farmer, L. A., & Field, H. S. (2012). The role of ambiguity tolerance in consumer perception of remanufactured products. *International Journal of Production Economics*, 135(2), 781–790. <https://doi.org/10.1016/j.ijpe.2011.10.011>
- Heine, K., & Phan, M. (2011). Trading-Up Mass-Market Goods to Luxury Products. *Australasian Marketing Journal*, 19(2), 108–114. <https://doi.org/10.1016/j.ausmj.2011.03.001>
- Jiménez-Parra, B., Rubio, S., & Vicente-Molina, M. A. (2014). Key drivers in the behavior of potential consumers of remanufactured products: a study on laptops in Spain. *Journal of Cleaner Production*, 85, 488–496.

- <https://doi.org/10.1016/j.jclepro.2014.05.047>
- Kane, G. M., Bakker, C. A., & Balkenende, A. R. (2018). Towards design strategies for circular medical products. *Resources, Conservation and Recycling*, 135, 38–47. <https://doi.org/10.1016/j.resconrec.2017.07.030>
- Kim, S. J., Kwon, D., & Bae, S. J. (2020). A drop-impact reliability assessment of mobile display modules using a statistical modeling approach. *Journal of Mechanical Science and Technology*, 34(10), 3945–3955. <https://doi.org/10.1007/s12206-020-2204-y>
- Lobos, A. (2014). 'Timelessness in Sustainable Product Design', eds. Juan Salamanca et al., Universidad de Los Andes, Bogotá, pp. 169–176. in *The colors of care : proceedings of the 9th International Conference on Design & Emotion*. Published.
- Luchs, M. G., & Mooradian, T. A. (2011). Sex, Personality, and Sustainable Consumer Behaviour: Elucidating the Gender Effect. *Journal of Consumer Policy*, 35(1), 127–144. <https://doi.org/10.1007/s10603-011-9179-0>
- Lüdeke-Freund, F., Gold, S., & Bocken, N. M. P. (2018). A Review and Typology of Circular Economy Business Model Patterns. *Journal of Industrial Ecology*, 23(1), 36–61. <https://doi.org/10.1111/jiec.12763>
- Lumea Prestige. (2020). Geraadpleegd op 8 juni 2020, van <https://www.philips.nl/c-m-pe/ontharing/lumea-ipl>
- Marktplaats - De plek om nieuwe en tweedehands spullen te kopen en verkopen. (2021). Geraadpleegd van <https://www.marktplaats.nl/>
- Michaud, C., & Llerena, D. (2010). Green consumer behaviour: an experimental analysis of willingness to pay for remanufactured products. *Business Strategy and the Environment*, n/a. <https://doi.org/10.1002/bse.703>
- Moreno, M., De los Rios, C., Rowe, Z., & Charnley, F. (2016). A Conceptual Framework for Circular Design. *Sustainability*, 8(9), 937. <https://doi.org/10.3390/su8090937>
- Mugge, R. (2018). Product Design and Consumer Behaviour in a Circular Economy. *Sustainability*, 10(10), 3704. <https://doi.org/10.3390/su10103704>
- Mugge, R., de Jong, W., Person, O., & Hultink, E. J. (2018). 'If It Ain't Broke, Don't Explain It': The Influence of Visual and Verbal Information about Prior Use on Consumers' Evaluations of Refurbished Electronics. *The Design Journal*, 21(4), 499–520. <https://doi.org/10.1080/14606925.2018.1472856>
- Mugge, R., Jockin, B., & Bocken, N. (2017). How to sell refurbished smartphones? An investigation of different customer groups and appropriate incentives. *Journal of Cleaner Production*, 147, 284–296. <https://doi.org/10.1016/j.jclepro.2017.01.111>
- Mugge, R., & Schoormans, J. P. (2012). Product design and apparent usability. The influence of novelty in product appearance. *Applied Ergonomics*, 43(6), 1081–1088. <https://doi.org/10.1016/j.apergo.2012.03.009>
- Mugge, R., Schoormans, J. P. L., & Schifferstein, H. N. J. (2009). Emotional bonding with personalised products. *Journal of Engineering Design*, 20(5), 467–476. <https://doi.org/10.1080/09544820802698550>
- Niu, B., & Xie, F. (2020). Incentive alignment of brand-owner and remanufacturer towards quality certification to refurbished products. *Journal of Cleaner Production*, 242, 118314. <https://doi.org/10.1016/j.jclepro.2019.11.8314>
- Nußholz, J. L. (2018). A circular business model mapping tool for creating value from prolonged product lifetime and closed material loops. *Journal of Cleaner Production*, 197, 185–194. <https://doi.org/10.1016/j.jclepro.2018.06.112>
- PACE annual report. (2019). Geraadpleegd van <https://pacecircular.org/node/95>
- Packard, V. (2011). *The Waste Makers*. Zaltbommel, Nederland: Van Haren Publishing.
- Pérez-Belis, V., Braulio-Gonzalo, M., Juan, P., & Bovea, M. D. (2017). Consumer attitude towards the repair and the second-hand purchase of small household electrical and electronic equipment. A Spanish case study. *Journal of Cleaner Production*, 158, 261–275. <https://doi.org/10.1016/j.jclepro.2017.04.143>
- Phau, I., & Prendergast, G. (2000). Consuming luxury brands: The relevance of the 'Rarity Principle'. *Journal of Brand Management*, 8(2), 122–138. <https://doi.org/10.1057/palgrave.bm.2540013>
- Philips. (2020). *D000376651*. Geraadpleegd van <https://philips.com>
- Philips Lumea manual. (2015). Geraadpleegd van <https://www.handleidi.ng/philips/lumea-prestige-bri956/handleiding>
- Philips Lumea Prestige. (z.d.). Geraadpleegd op 10 juni 2020, van <https://www.philips.nl/c-m-pe/ontharing/lumea-ipl>
- Reike, D., Vermeulen, W. J. V., & Witjes, S. (2018). The circular economy: New or Refurbished as CE 3.0? — Exploring Controversies in the Conceptualization of the Circular Economy through a Focus on History and Resource Value Retention Options. *Resources, Conservation and Recycling*, 135, 246–264. <https://doi.org/10.1016/j.resconrec.2017.08.027>
- Rissman, J., Bataille, C., Masanet, E., Aden, N., Morrow, W. R., Zhou, N., . . . Helseth, J. (2020). Technologies and policies to decarbonize global industry: Review and assessment of mitigation drivers through 2070. *Applied Energy*, 266, 114848. <https://doi.org/10.1016/j.apenergy.2020.114848>
- Sagot, J. C., Gouin, V., & Gomes, S. (2003). Ergonomics in product design: safety factor. *Safety Science*, 41(2–3), 137–154. [https://doi.org/10.1016/s0925-7535\(02\)00038-3](https://doi.org/10.1016/s0925-7535(02)00038-3)
- Sanders, L. (2013). *Convivial Toolbox: Generative Research for the Front End of Design by Elizabeth B. N. Sanders, Pieter Jan Stappers (2012) Paperback*. Amsterdam, Nederland: BIS Publishers.
- Sharma, V., Garg, S. K., & Sharma, P. B. (2016). Identification of major drivers and roadblocks for remanufacturing in India. *Journal of Cleaner Production*, 112, 1882–1892. <https://doi.org/10.1016/j.jclepro.2014.11.082>
- Simonse, L., Iwanicka, B., & Whelton, J. (2018). *Design Roadmapping*. Zaltbommel, Nederland: Van Haren Publishing.
- Singhal, D., Jena, S. K., & Tripathy, S. (2019). Factors influencing the purchase intention of consumers towards remanufactured products: a systematic review and meta-analysis. *International Journal of Production Research*, 57(23), 7289–7299. <https://doi.org/10.1080/00207543.2019.1598590>
- Sitra; *Inspiring circular economy solutions from around the globe*. (2020, 13 november). Geraadpleegd van <https://www.sitra.fi/en/projects/inspiring-solutions/#39-solutions>
- Spaulding, A. (1970). The role of chemical disinfection in the prevention of nosocomial infections. *Proceedings of the International Conference on Nosocomial Infections*, 247–254.
- Sumter, D., Bakker, C., & Balkenende, R. (2018). The Role of Product Design in Creating Circular Business Models: A Case Study on the Lease and Refurbishment of Baby Strollers. *Sustainability*, 10(7), 2415. <https://doi.org/10.3390/su10072415>
- The Platform for Accelerating the Circular Economy (PACE). (2019). *A new circular vision for electronic products*. Geraadpleegd van http://www3.weforum.org/docs/WEF_A_New_Circular_Vision_for_Electronics.pdf
- Thierry, M., Salomon, M., Van Nunen, J., & Van Wassenhove, L. (1995). Strategic Issues in

- Product Recovery Management. *California Management Review*, 37(2), 114–136. <https://doi.org/10.2307/41165792>
- UN Annual Report 2020: Letter from the Executive Director. (2021). Geraadpleegd van <https://www.unep.org/resources/annual-report/letter-executive-director-2020-review>
- van den Berge, R., Magnier, L., & Mugge, R. (2021). Too good to go? Consumers' replacement behaviour and potential strategies for stimulating product retention. *Current Opinion in Psychology*, 39, 66–71. <https://doi.org/10.1016/j.copsyc.2020.07.014>
- van Loon, P., Delagarde, C., & Van Wassenhove, L. N. (2017). The role of second-hand markets in circular business: a simple model for leasing versus selling consumer products. *International Journal of Production Research*, 56(1–2), 960–973. <https://doi.org/10.1080/00207543.2017.1398429>
- van Nes, N., & Cramer, J. (2005). Influencing product lifetime through product design. *Business Strategy and the Environment*, 14(5), 286–299. <https://doi.org/10.1002/bse.491>
- van Weelden, E., Mugge, R., & Bakker, C. (2016). Paving the way towards circular consumption: exploring consumer acceptance of refurbished mobile phones in the Dutch market. *Journal of Cleaner Production*, 113, 743–754. <https://doi.org/10.1016/j.jclepro.2015.11.065>
- Vermaat, B. (2020). *Design for refurbishment of child car seats – Towards circular safety critical products*. Geraadpleegd van <http://resolver.tudelft.nl/uuid:1d77f13b-8005-4cac-aa8d-9350171f158c>
- Wallner, T. S., Magnier, L., & Mugge, R. (2020). An Exploration of the Value of Timeless Design Styles for the Consumer Acceptance of Refurbished Products. *Sustainability*, 12(3), 1213. <https://doi.org/10.3390/su12031213>
- Wang, F., Huisman, J., Stevels, A., & Baldé, C. P. (2013). Enhancing e-waste estimates: Improving data quality by multivariate Input–Output Analysis. *Waste Management*, 33(11), 2397–2407. <https://doi.org/10.1016/j.wasman.2013.07.005>
- Wewer, A., Bilge, P., & Dietrich, F. (2020). Examination of the attitude and assessment of new, used and overhauled products and the influence on the purchase decision- a survey. *Procedia CIRP*, 90, 121–126. <https://doi.org/10.1016/j.procir.2020.01.092>
- Weyler, R. (2019, 2 juli). *It's a Waste World - Rex Weyler*. Geraadpleegd van <https://www.greenpeace.org/international/story/23747/its-a-waste-world/>
- Zebra; *What is a Drop Test?* (2020). Geraadpleegd van <https://www.zebra.com/us/en/resource-library/faq/mobile-computing/what-is-a-drop-test.html>

APPENDIX

- A: Circular economy
- B: Try&Buy prices
- C; Interview guide
- D; Dilemma's interview
- E; Cleaning routine
- F; Contamination sensitive parts list
- G; Characteristics survey
- H; Disassembly spreadsheet
- I: Labels disassembly map
- J: Results SPSS survey
- K: Brainstorm outcomes
- L: Brainstorm design styles
- M; Visual elements
- N; Questions tool

Circular economy

Intro

The course our planet is on, as described in the last chapter, does not sound desirable. But luckily, something can be done. To reduce the generated (e-) waste we must **optimize the use of resources**. Renewable energy and energy-efficiency are the main focus of today's climate change challenge. However, meeting climate targets also requires **tackling the 45% of emissions caused by making products** (Ellen MacArthur Foundation, 2020). This can be achieved by going from a linear 'take make waste' model to a circular economy.

A third of the appliances are still working when they are thrown away (Cooper, 2004) and 23% of discarded electrical equipment is economically viable for resale, either in its current condition or with minor reparations (Waste and Resources Action Programme, 2011). This indicates **great potential for bringing e-waste back in the loop with the circular economy**.

Definition

The circular economy is a systemic approach to economic development, designed to benefit businesses, society, and the environment. In contrast to the 'take-make-waste' linear model, a circular economy is regenerative and aims to gradually decouple growth from the consumption of finite resources by keeping products, components and materials at their highest utility and value at all times. (Ellen MacArthur Foundation, 2020)

Circular strategies

To achieve these principles, there are several circular design strategies. These strategies **aim to keep products and materials in use** (British standard). Which strategy fits best depends on the product and its context. For **electronic products lifetime extension strategies are preferred** and should be tailored to the specific product (Bakker, 2014).

The amount of energy and resources each strategy consumes is visualised in the Value Hill (Bocken et al., 2016) (Figure 1.2.1). Value is added while the product moves "uphill". **Circular strategies keep the product at its highest value (top of the hill) for as long as possible**. The closer to the top, the more valuable the approach. Products should move downhill as slowly as possible so that its useful resources can still be of service to other systems (Bocken et al., 2016). This project focuses on Refurbishment. **Refurbishment is a post-use phase strategy that focuses on value recovery** (Bocken et al., 2016).

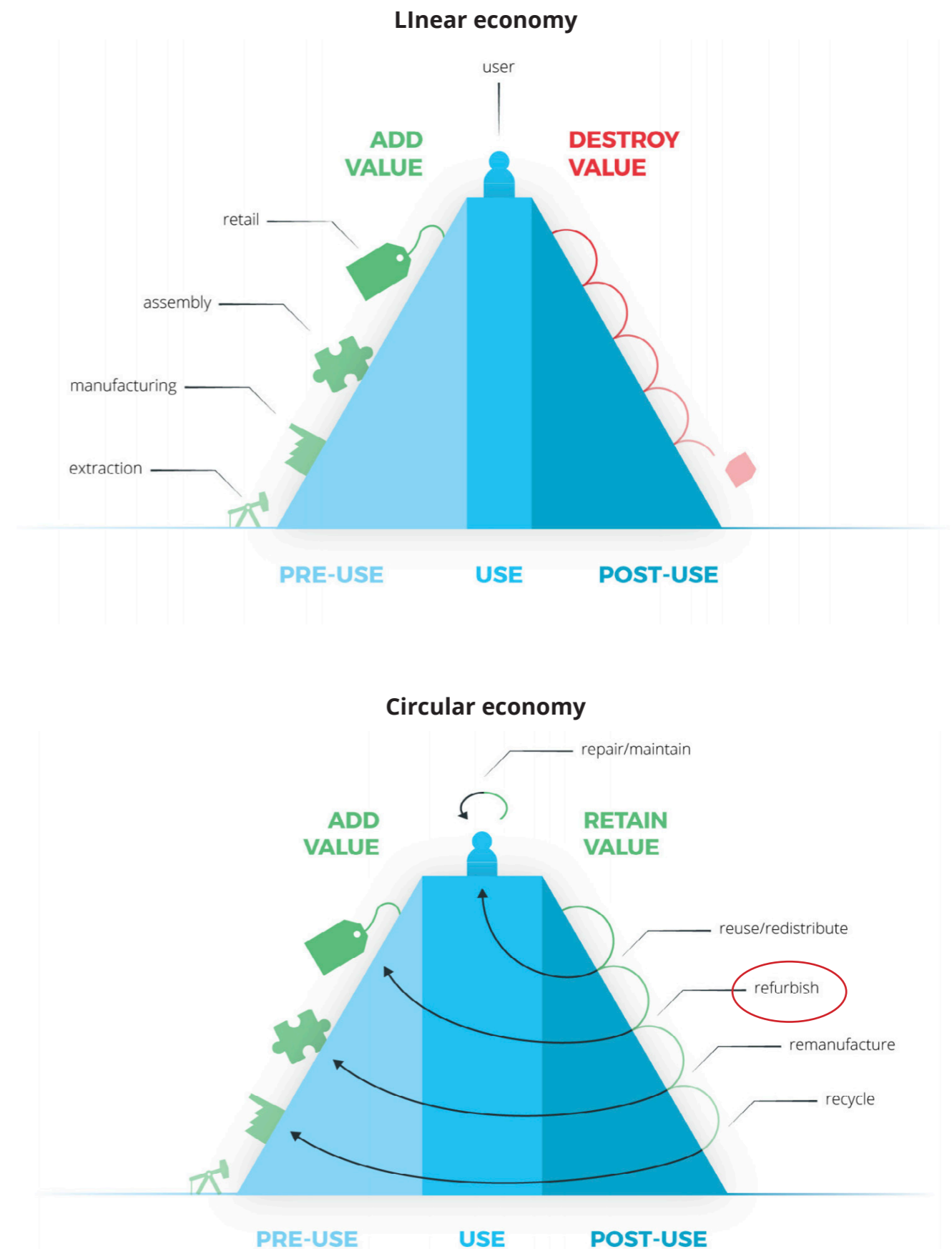

Figure 1.2.1; Value Hill (Bocken et al., 2016)

Try&Buy Lumea prices

Try&Buy

A Try&Buy subscriber receives the product with all attachments. Depending on the subscription type, consumers can return the product either at any time or after three months. Subscribers can decide to buy the Lumea for market value at any time. The Try&Buy stops after a maximum of 14 months, since the product is then paid off. In July 2020, 5800 consumers had a subscribed Lumea (personal communication, sept. 2020). Philips benefits from the Try&Buy because of increased Return of Investments. And, because of the Try&Buy, Philips retrieves over 2000 Lumea's a year (Philips, 2020), which means Philips can learn from consumer behaviour, spot problems at large scale and innovate based on that (Philips, 2020).

Price

The sales prices of the Lumea are shown in table 2.1. Comparing the prices of the new, remanufactured (Second life) and second-hand Lumea shows that the Lumea retains a high percentage of its financial value after one life cycle (see appendix C for definitions on new and Second Life). The biddings on the second-hand product are on average around 80% of the original retail price. The price of the Second Life Lumea is around 87% of the new subscription price. Apparently, the 7% more for cleaning, testing, and guarantee is not worth it for some consumers. This might be because consumers are not aware of the Second-life option or just assume that Philips is more expensive than buying second-hand.

Besides the Prestige, Philips sells the cheaper 'advanced' model of the Lumea.

New		€359,99
Try&Buy New	Cancelled immediately	€39,95
	3 months minimum	€34,95
Try&Buy Second life	Cancelled immediately	€34,95
	3 months minimum	€29,95
Second-hand (average 20 advertisements marktplaats.nl)		€289,60 (+/- 80% of sales price)

Table 2.1; Lumea sales prices (Philips.nl, 2020)

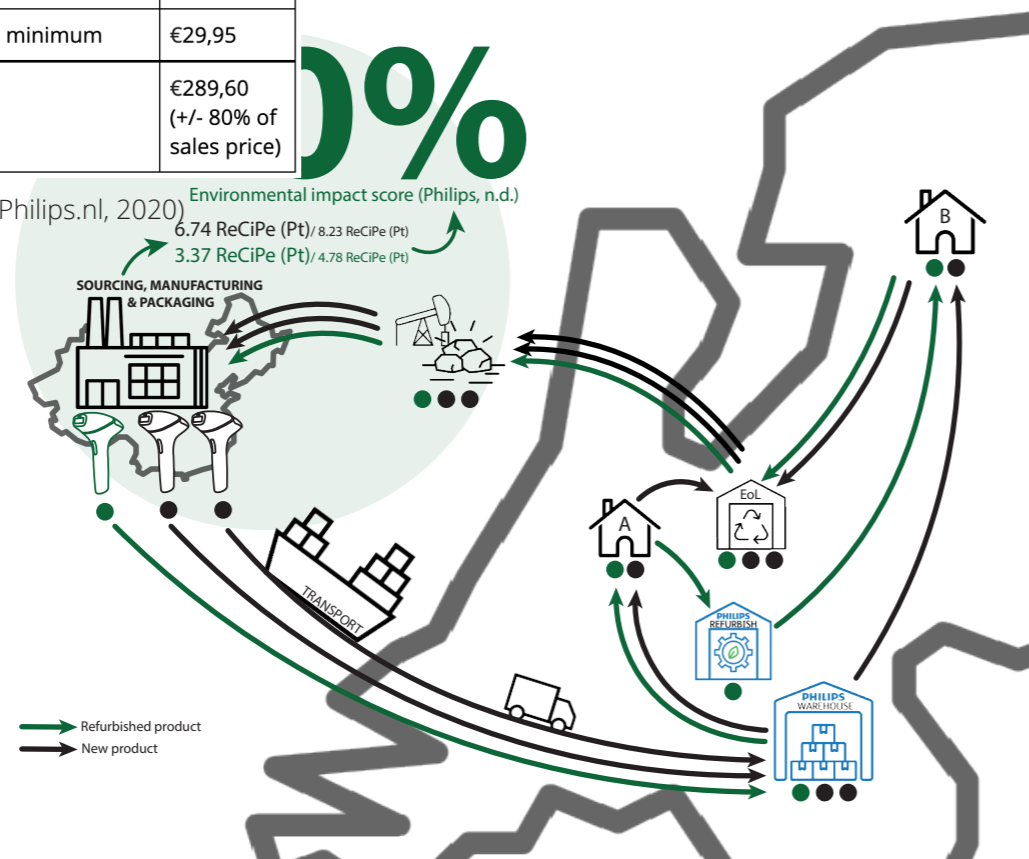

Koninklijke Philips n.v. is a Dutch company that aims to offer technological solutions across the entire world-wide health spectrum, from professional treatment in hospitals to personal care at home (Philips.nl, 2020).

Philips recognizes that they need to make a change today and has set multiple goals to shift towards a circular system. To reach these goals, Philips is involved in many sustainable projects and is praised for its commitment to the environment (Wall Street Journal, 2020; Ellen MacArthur Foundation, 2020).

Goals circular economy for 2025 (Circular economy Philips, 2020):

- Generate 25% of sales from circular products, services and solutions.
- Close the loop by offering a trade-in on all professional medical equipment, and taking care of responsible repurposing (either refurbished at Philips, or locally recycled in line with Philips policies). (fig. 2.2.2)
- Embed circular practices at their sites (including non-manufacturing sites, e.g. large offices, warehouses etc.) and send zero waste to landfill.

Refurbishment & Philips

Philips recognizes the importance of refurbishment in their goals, currently especially for large equipment. And, healthcare must do more with less budget (Mostert, 2020). By opting for circular propositions (e.g. leasing a refurbished CT scanner instead of buying a new one) a hospital saves money and deals more effectively with scarce raw materials. In this way, circularity contributes to affordable care (Mostert, 2020).

With their programme; 'Rethink what new means' Philips works together with hospitals on changing the stigma on refurbished products by showing their practicality in real life situations (Mostert, 2020).

The Lumea

The reprocessing of the Lumea is one of Philips' circular projects. However, the Lumea was not designed for the circular economy and therefore does not fully fit Philips' aimed strategy (interview Lumea Designer, 2020). Thus, the Lumea could benefit from a thorough analysis on circular product design opportunities to contribute to their circular goals.

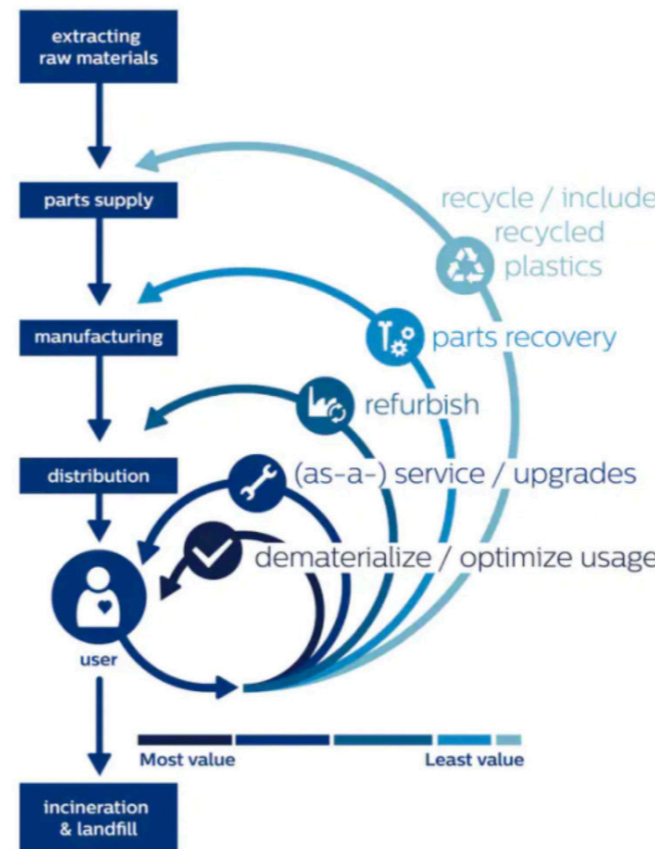

Fig. 2.2.2; Philips circular strategy (Philips.nl, 2020)



Interview guide; Consumer interviews

Landing page subscription:

https://tudelft.fra1.qualtrics.com/jfe/form/SV_8eNJ7G8q88X9VYx

Interview type: semi-structured

Number of interviewees: 10 per interviewer (10 Senna, 10 Theresa)

Set up: An online meeting with Theresa and the participant (Zoom, skype.. etc.)

Research topic:

Consumer acceptance of the 2nd life Lumea Prestige

Main research question:

How do consumers of the 2nd life Lumea Prestige experience the product and the Aesthetics?

Checklist before start:

- The participant has the (2nd life) Lumea Prestige and has used it at least once
- Recording device ready
- Observant or interviewer has notebook and pen to write memos
- The interviewer has questions on paper and read through all the notes

Intro script:

*Thank you for participating & welcome small talk
Is it okay if we record the audio of this interview?
(Read consent text and ask for agreement)*

Together with Theresa, I'm working on my graduation project for the TU Delft and I'm doing this interview because I am interested in how you experience the Lumea.

Subtopic 1 (warming up / intro): Use of the Lumea

Opening question: Why did you buy the Lumea?

Follow-ups/probes:

- Can you describe your first use experience with the Lumea?
- How often do you use the Lumea?

'We just talked about the use of the Lumea. Now I would like to ask you some questions about the decision to get a new/2nd life Lumea.'

Subtopic 2: Refurbished or 'normal product' decision-making process

**in case of new Lumea*

'2nd life products are products that have been recollected after their first use, have been cleaned and checked.'

- Why did you choose the new Lumea over the 2nd life one?
- Were you aware of the availability of 2nd life Lumea's?
- What are pro's and con's of a new Lumea compared to a 2nd life one?

**in case of 2nd life Lumea*

- What made you decide to buy a 2nd life Lumea instead of a new one?
- What were your expectations of the 2nd life Lumea?
- What are the positive and negative aspects of a 2nd life Lumea compared to a new one? Please elaborate on its pro's and cons.
- Would you recommend the 2nd life Lumea to friends? Why and why not?

'These were the questions about your purchase decision. I would now like to know more about how you use the Lumea.'

Subtopic 3: Perceived cleanness of the Lumea

Opening question: Could you describe your use routine?

- Do you clean the Lumea? Please explain how and why.
- If yes: How? How often?
- If no: Why not?
- Does the Lumea meet your hygiene expectations and needs?
- If yes: Why?
- If no: Why not?

**in case of a 2nd life Lumea*

- Did you pay attention to the condition of the product at arrival?

- Could you describe your impression of the products' condition?

'After having talked about hygiene, I would like to discuss the appearance of the Lumea with you'

Subtopic 4: Appearance of the Lumea

Opening question: How would you describe the appearance of the Lumea?

**in case of 2nd life Lumea*

- What did you like or dislike about the appearance of the Lumea?
- Is there anything that you would change about the appearance of Lumea?

Follow-ups/probes:

- What is your opinion on the shape of the Lumea?
- What does it remind you of? What feeling does it give?
- What do you think of the material the Lumea is made of?
- If you could order the Lumea with different materials, would you order another material?
- If yes: Could you give an example of the material of another product?
- If no: Why not?
- If the Lumea was available in different colours, would you order another colour?
- If yes: to what and why?
- If no: why not?
- What feeling does the Lumea evoke when you use it?
- How did it feel when you first used the Lumea?
- If you had to describe the Lumea as a person, what kind of personality would it have? What characteristics would you give the Lumea?

**MOVE OVER TO SCREENSHARE —> SHOW PRESENTATION WITH CHOICES*

Closure checklist:

Thank you for your help!

Is there anything you would like to add?

Stimuli dilemma's interview

Realistische krassen



€395
New state
Smooth
White



€290
Scratches
Smooth
White



€395
New state
Smooth
White



€395
New state
Mat
Black



C1.2:

€290
Scratches
(Button + attachment)
Smooth
White



€290
Scratches
(Housing)
Smooth
White



€450
New
Smooth
White



€290
Scratches
Smooth
White



€290
Scratches
Smooth
Black



€290
Scratches
Smooth
White



€290
Heavy scratches
Smooth
White



€395
Light scratches
Smooth
White



Cleaning routine

Contamination sensitive parts table













Level 2; critical			Level 1; semi-critical		
Part nr	Reason consumer	Refurbisher attention points	Part nr	Reason consumer	Refurbisher attention points
8- 	Pressed directly on the skin, which is considered dirty	Small corners	10- 	Contagious, easy to spot greasy fingerprints	Splitlines Air holes
7- 	Pressed directly on the skin, which is considered dirty	Splitlines Small corners	31- 	Easy to spot fingerprints, dust and skin debris	Splitlines (Hard to reach)
			26- 	Scratches on button reduce perception of product functionality	Splitlines
					Many small air holes
			12-  13-  14-  15*  16- 	Scratches on button reduce perception of product functionality	Splitlines
			4- 	Easy to spot fingerprints, dust and skin debris	Small corners (Hard to reach)

Table 4.1.2; desired parts to clean and issues

The three attachments are mentioned as one in the table because they are nearly identical in use and clean routine. For part numbers reference the exploded view on page 50.

Survey results Characteristics

Now that we have discovered what the consumer's attitude towards refurbished products is, it is important to explore the perception of the Lumea in general. With one look on a product, we know whether we want to own it or not (van Desmet & Hekkert, 2007; Weelden et al., 2016). Making sense of the product and creating an opinion towards it is based on aesthetic features (Desmet & Hekkert, 2007).

Especially for refurbished products, aesthetics cues are used to judge quality and performance, which can make the difference in consumer acceptance

(Jiménez-Parra et al., 2014; van Weelden et al., 2016). This part focuses on associations consumers have with the Lumea and what product characteristics are most applicable.

Product associations

To uncover what associations (affective meaning) consumers have with the Lumea, a qualitative survey was conducted among people who have seen or experienced the physical product at least once (n=61). Participants were reached via Philips fan groups on Facebook and via personal sharing. For around 1/5 of the respondents (13 out of 57), a hair dryer was the first thing they thought about when they saw the Lumea. However, another 1/5 of the respondents associated the Lumea immediately with a supermarket self-scanner (fig. 2.4.4). Other associations

mentioned were a police scanner (fig. 2.4.3), a head thermometer (Covid-19) (fig. 2.4.1) and a laser gun (like Star Trek) (fig. 2.4.2).

These associations have a similar product shapes. All involve a gun shaped product with a trigger and an outlet in a similar position (fig. 2.4.5). This means that **the position of components and the overall shape have a major influence in creating associations**. Colours, for example, were not mentioned at all and therefore are perceived to have a minor influence on the initial creation of product meaning.

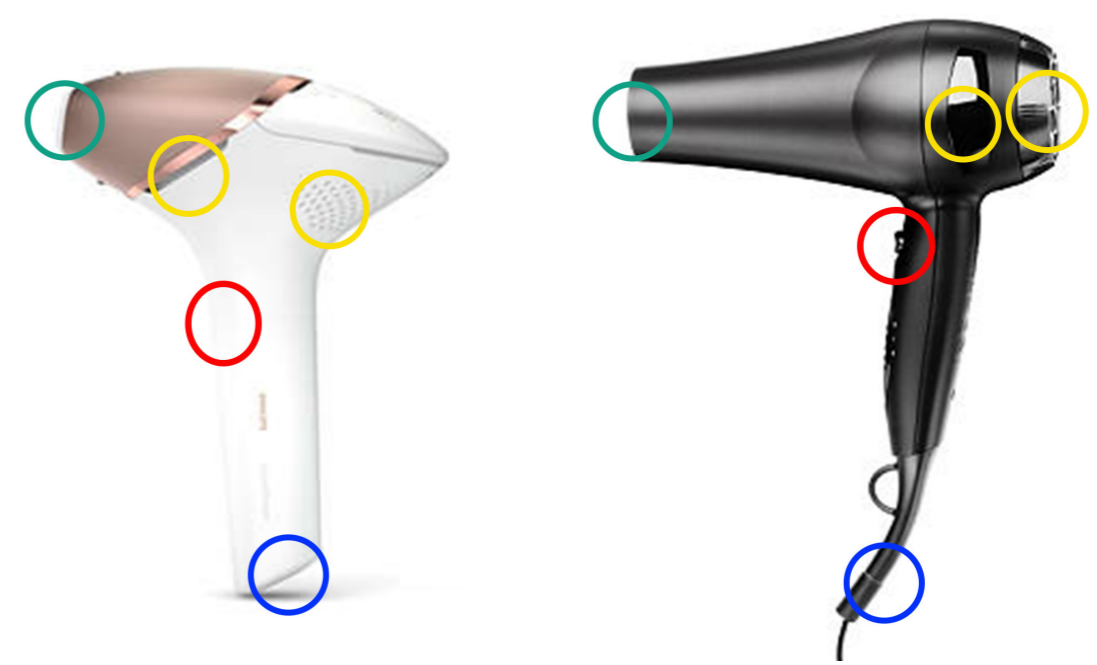

Fig. 2.4.5; Similarities in component position Lumea and hair dryer

Product characteristics

'Hygienic' is most applicable. When asked why they gave this rating, participants mainly mentioned the **'smooth' surface design**; *The design looks clean and smooth, which makes it look like it is easy to clean*. The **colours were also mentioned are related to the perceived hygiene**: *'Dirt and skin debris are easily spotted on light colours like white' and 'I associate white with medical devices'*.



Fig. 2.4.1; Corona thermometer



Fig. 2.4.2; Star Trek laserguns



Fig. 2.4.3; Police speedometer



Fig. 2.4.4; Supermarket self-scanner

Mean & Variance

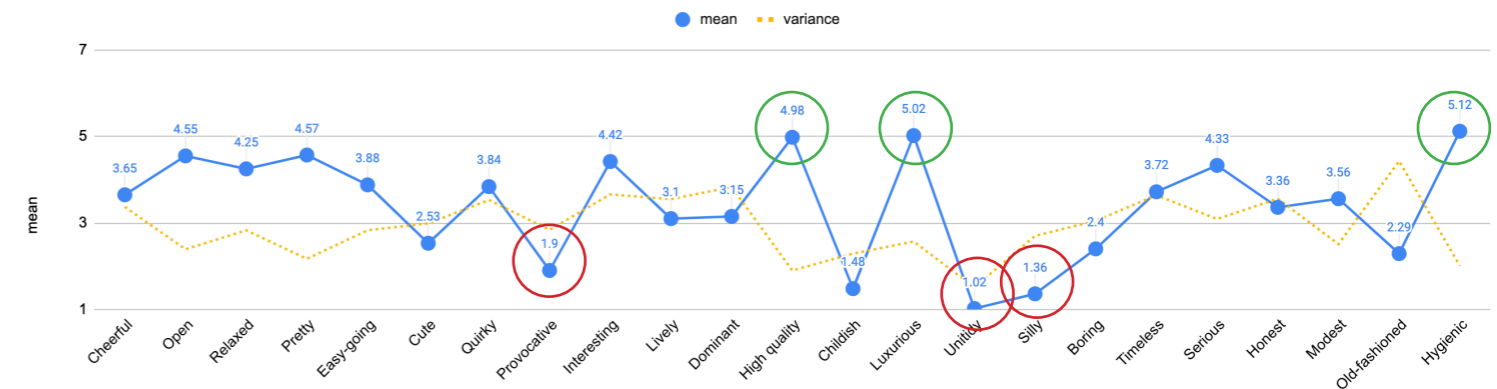

Fig. 3.4.5; Personality test results Lumea

Hotspot data sheet (Excel)

General project information

Brand name	Philips	Lumea Prestige
Product category	IPL hair removal	Personal care
Authors	Bonte, S. Snel, S. Knemeijer, C.D.	
Date	20-11-2020	
Location	Zwanenburg, Netherlands	

You can enter data in the light blue cells

Overall HotSpot Results

Total:		Average:	
- time to disassemble	1323 sec	- force	2 [1=low .. 5=high .. 10=extreme]
- number of tasks	27	- accessibility	2 [1=clear .. 5=moderate .. 10=difficult]
- number of steps	47	- positioning	3 [1=easy .. 5=moderate .. 10=difficult]
- number of tools	21		

Step number	Name	General properties		Activity properties			Difficulty of Access			Functional sensitivity			Material properties		HotSpot Indicators						
		Subassembly	Part of ...	Activity	Required tool	Tool size	Task frequency	Time to disconnect (sec)	Force	Accessibility	Positioning	Maintenance	Functionality	Hygiene	Material group	Weight (g)	Time	Activity	Priority part	Environmental	Economic
1	opzetstuk	yes	main assembly	Remove	Hands		1	1	level 0 - Light resistance	level 0 - Clear	level 0 - No-to-low precision	level 2 - Main functionality	level 2 - Very important	Thermoset							
2	binnenkant opzetstuk zwart	yes	opzetstuk	Remove	Screwdriver		1	7	level 0 - Light resistance	level 0 - Clear	level 1 - Moderate precision										
3	buitenkant opzetstuk wit		opzetstuk	Disconnect snapjoin	Screwdriver		4	43	level 1 - Moderate resistance	level 0 - Clear	level 1 - Moderate precision	level 0 - No-to-low maintenanc	level 1 - Sub functionality	level 2 - Very important	Thermoset	1,7					
4	buitenkant opzetstuk roze		opzetstuk									level 0 - No-to-low maintenanc	level 0 - No-to-low functionali	level 1 - Moderate	Thermoset	5,8					
5	metalen clips		binnenkant opzetstuk	Remove	Screwdriver		2	7	level 0 - Light resistance	level 0 - Clear	level 1 - Moderate precision	level 0 - No-to-low maintenanc	level 0 - No-to-low functionali	level 0 - Not important	Stainless Steel	0,1					
6	opzetstuk identifieer	yes	binnenkant opzetstuk	Remove	Hands		1	15	level 0 - Light resistance	level 0 - Clear	level 0 - No-to-low precision										
7	metalen doorkijgat		opzetstuk identifieer	Remove	Hands		1	2	level 0 - Light resistance	level 0 - Clear	level 0 - No-to-low precision	level 0 - No-to-low maintenanc	level 2 - Main functionality	level 0 - Not important	Steel	0,1					
8	metalen lichtgeleider		opzetstuk identifieer	Remove	Hands		1	1	level 0 - Light resistance	level 0 - Clear	level 0 - No-to-low precision	level 0 - No-to-low maintenanc	level 2 - Main functionality	level 0 - Not important	Steel	0,7					
9	plastic behuizing licht geleider		opzetstuk identifieer	Remove	Hands		1	1	level 0 - Light resistance	level 0 - Clear	level 0 - No-to-low precision	level 0 - No-to-low maintenanc	level 2 - Main functionality	level 0 - Not important	Thermoset	2,3					
10	pcb opzetstuk identifieer		opzetstuk identifieer	Remove	Hands				level 0 - Light resistance	level 0 - Clear	level 0 - No-to-low precision	level 0 - No-to-low maintenanc	level 2 - Main functionality	level 0 - Not important	Other Electronics	3					
11	cover deksel	yes	main assembly	Disconnect snapjoin	Screwdriver		4	109	level 2 - Heavy resistance	level 2 - Obstructed	level 2 - High precision										
12	ring		cover deksel	Remove	Hands		1	2	level 0 - Light resistance	level 0 - Clear	level 0 - No-to-low precision	level 0 - No-to-low maintenanc	level 0 - No-to-low functionali	level 0 - Not important	Thermoplastic	3,3					
13	Snapjoints triple 3x		cover deksel	De-glue	Heat		1	98	level 2 - Heavy resistance	level 0 - Clear	level 2 - High precision	level 0 - No-to-low maintenanc	level 0 - No-to-low functionali	level 0 - Not important	Thermoset	2,2					
14	roze cover		cover deksel	Remove								level 0 - No-to-low maintenanc	level 1 - Sub functionality	level 1 - Moderate	Thermoset	30					
15	deksel interface	yes	main assembly	Disconnect snapjoin	Screwdriver			51	level 2 - Heavy resistance	level 2 - Obstructed	level 2 - High precision										
16	binnenbehuizing Knoppen		deksel interface	Remove	Screwdriver		1	17	level 1 - Moderate resistance	level 0 - Clear	level 1 - Moderate precision	level 0 - No-to-low maintenanc	level 0 - No-to-low functionali	level 0 - Not important	Thermoset	10,7					
17	pijlknoop		deksel interface	Remove	Screwdriver			1	level 0 - Light resistance	level 1 - Recessed	level 1 - Moderate precision	level 0 - No-to-low maintenanc	level 2 - Main functionality	level 1 - Moderate	Thermoset	0,8					
18	aanuut knop		deksel interface	Remove	Screwdriver			1	level 0 - Light resistance	level 1 - Recessed	level 1 - Moderate precision	level 0 - No-to-low maintenanc	level 2 - Main functionality	level 1 - Moderate	Thermoset	0,6					
19	vink knop		deksel interface	Remove	Screwdriver			1	level 0 - Light resistance	level 1 - Recessed	level 1 - Moderate precision	level 0 - No-to-low maintenanc	level 2 - Main functionality	level 1 - Moderate	Mixed materials mainly plastic	0,5					
20	vergrootglas knop		deksel interface	Remove	Screwdriver			1	level 0 - Light resistance	level 1 - Recessed	level 1 - Moderate precision	level 0 - No-to-low maintenanc	level 2 - Main functionality	level 1 - Moderate	Mixed materials mainly plastic	0,4					
21	frame deksel interface		deksel interface									level 0 - No-to-low maintenanc	level 1 - Sub functionality	level 1 - Moderate	Mixed materials mainly plastic	27					
22	pcb assembly	yes	main assembly	Unplug	Screwdriver		3	215	level 1 - Moderate resistance	level 2 - Obstructed	level 2 - High precision										4x doorknippen van draden
23	achterkant houder pcb		main assembly	Remove	Screwdriver			5	level 0 - Light resistance	level 1 - Recessed	level 1 - Moderate precision	level 0 - No-to-low maintenanc	level 0 - No-to-low functionali	level 0 - Not important	Thermoset	2					
24	lichtbron kap	yes	pcb assembly	Remove	Screwdriver		1	16	level 1 - Moderate resistance	level 2 - Obstructed	level 1 - Moderate precision										
25	behuizing lichtbron kap zwart		lichtbron kap	remove	Hands			2	level 0 - Light resistance	level 0 - Clear	level 0 - No-to-low precision	level 0 - No-to-low maintenanc	level 1 - Sub functionality	level 0 - Not important	Thermoset	10,9					
26	seal 1		lichtbron kap	Remove	Hands			2	level 0 - Light resistance	level 0 - Clear	level 0 - No-to-low precision	level 0 - No-to-low maintenanc	level 1 - Sub functionality	level 0 - Not important	Rubber	0,4					
27	seal 2		lichtbron kap	Remove	Hands			2	level 0 - Light resistance	level 0 - Clear	level 0 - No-to-low precision	level 0 - No-to-low maintenanc	level 1 - Sub functionality	level 0 - Not important	Rubber	1					
28	rood glas		lichtbron kap	Remove	Hands			2	level 0 - Light resistance	level 0 - Clear	level 0 - No-to-low precision	level 0 - No-to-low maintenanc	level 2 - Main functionality	level 0 - Not important	Glass	2,9					
29	metal holder lichtbron		pcb assembly	Remove	Hands			1	level 0 - Light resistance	level 0 - Clear	level 0 - No-to-low precision	level 0 - No-to-low maintenanc	level 0 - No-to-low functionali	level 0 - Not important	Steel	0,05					
30	lichtbron	yes	pcb assembly	De-solder	Soldering Iron		2	382	level 1 - Moderate resistance	level 0 - Clear	level 2 - High precision										
31	lamp		lichtbron	Remove	Screwdriver			27	level 0 - Light resistance	level 1 - Recessed	level 1 - Moderate precision	level 1 - Part wears during use	level 2 - Main functionality	level 0 - Not important	Other Electronics	5,2					
32	lichtspiegel		lichtbron	Remove	Hands			1	level 0 - Light resistance	level 0 - Clear	level 0 - No-to-low precision	level 0 - No-to-low maintenanc	level 2 - Main functionality	level 0 - Not important	Steel	0,6					
33	behuizing lichtbron intern zwart		lichtbron	remove								level 0 - No-to-low maintenanc	level 0 - No-to-low functionali	level 0 - Not important	Thermoset	14,9					
34	pcb		pcb assembly									level 0 - No-to-low maintenanc	level 2 - Main functionality	level 0 - Not important	PCB	77					
35	ventilator		main assembly	Remove	Screwdriver			66	level 0 - Light resistance	level 0 - Clear	level 1 - Moderate precision	level 0 - No-to-low maintenanc	level 1 - Sub functionality	level 0 - Not important	E-motor	24					
36	behuizing handvat	yes	main assembly	Unscrew	Screwdriver		2	30	level 0 - Light resistance	level 0 - Clear	level 1 - Moderate precision										2 draden doorgeknijpt
37	pistoolknop		behuizing handvat	Remove	Hands			1	level 0 - Light resistance	level 0 - Clear	level 0 - No-to-low precision	level 0 - No-to-low maintenanc	level 2 - Main functionality	level 1 - Moderate	Thermoset	3					
38	ring achterzijde		behuizing handvat	Remove	Heat			180	level 1 - Moderate resistance	level 1 - Recessed	level 1 - Moderate precision	level 0 - No-to-low maintenanc	level 0 - No-to-low functionali	level 0 - Not important	Thermoplastic	2,2					
39	behuizing		behuizing handvat									level 0 - No-to-low maintenanc	level 1 - Sub functionality	level 1 - Moderate	Thermoset	75					
40	accu assembly	yes	main assembly	Remove	Hands			2	level 0 - Light resistance	level 0 - Clear	level 0 - No-to-low precision										
41	rechargeable lithium ion		accu assembly	Remove	Hands			2	level 0 - Light resistance	level 0 - Clear	level 0 - No-to-low precision	level 2 - High chance of breakir	level 2 - Main functionality	level 0 - Not important	Rechargeable	57,1					
42	pcb pistoolknop		accu assembly	Remove	Screwdriver			2	level 0 - Light resistance	level 0 - Clear	level 1 - Moderate precision	level 0 - No-to-low maintenanc	level 2 - Main functionality	level 0 - Not important	PCB	1,3					
43	condensator		accu assembly	Remove	Hands			17	level 0 - Light resistance	level 0 - Clear	level 0 - No-to-low precision	level 0 - No-to-low maintenanc	level 2 - Main functionality	level 0 - Not important	Other Electronics	111					
44	connector		accu assembly	Remove	Screwdriver			10	level 1 - Moderate resistance	level 0 - Clear	level 1 - Moderate precision	level 0 - No-to-low maintenanc	level 2 - Main functionality	level 0 - Not important	Other Electronics	3,3					
45	frame accu assembly		accu assembly	Remove	Hands							level 0 - No-to-low maintenanc	level 0 - No-to-low functionali	level 0 - Not important	Thermoset	47					
46	schroef 1		main assembly												Steel	0,2					
47	schroef 2		main assembly												Steel	0,2					

Labels disassembly map

The disassembly is visualised in a disassembly map (De Fazio, 2019; Verhoef, 2020). This map shows the sequence of actions with the parts and tools involved. However, some alterations to the disassembly maps by De Fazio and Vermaat.

Legend Disassembly map

The labels created by De Fazio (2019) and maat (2020) were used, in addition a label was created for contamination sensitive parts. The legend is shown in figure 5.4.1.

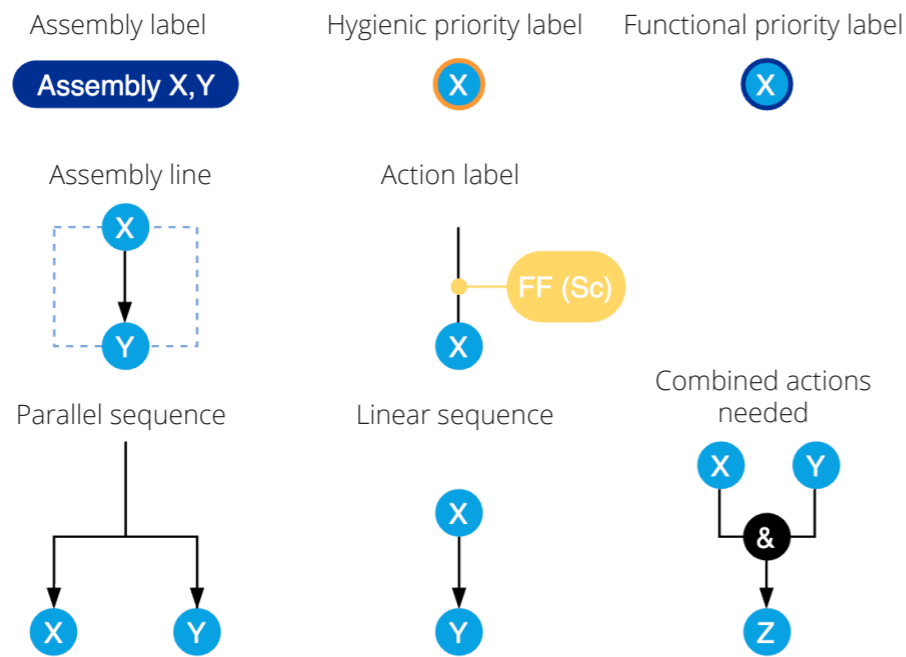
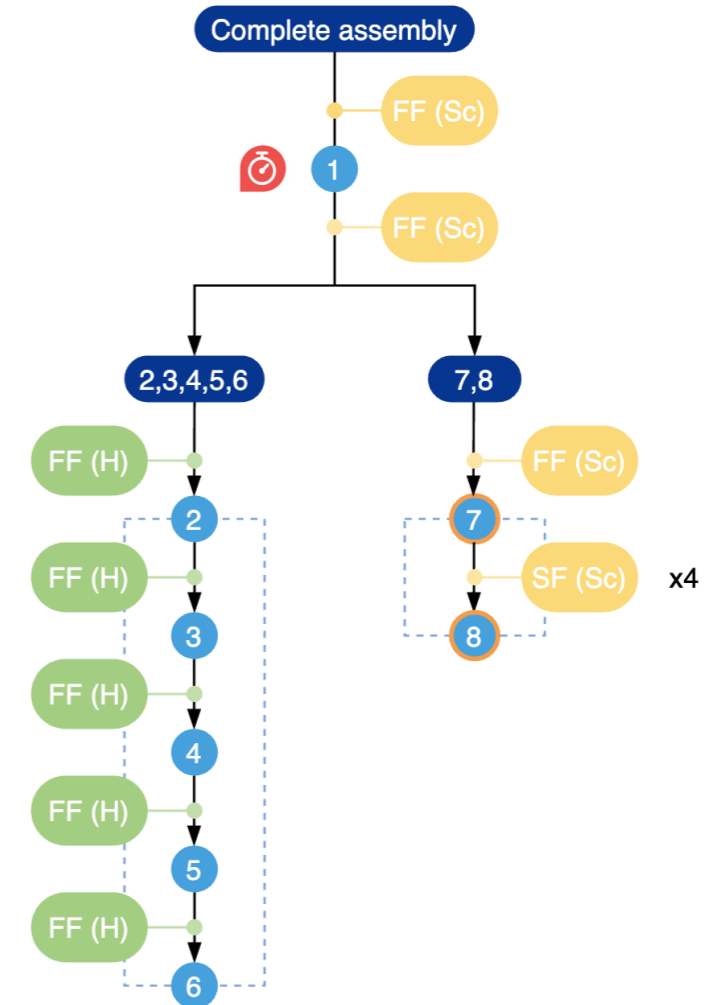

Fig. 4.5.1; Legend disassembly map (based on De Fazio, 2019; Verhoef, 2020)

Disassembly map Attachments



Legend

Tools
 Sd = Screwdriver
 H = Hands

Fit
 FF = wriction fit
 SF = Snap fit

Priority parts

Hygiene priority = oranje rand
 Functional priority = donker blauwe rand

Parts:

1. Metal clip (2x)
2. Housing attachment black
3. Metal measuring system
4. Metal light transmit
5. Housing light transmit
6. PCB attachment
7. Housing attachment pink
8. Housing attachment white

*Note: The attachment disassembled had no protective glass. Therefore the glass was not shown in the disassembly map.

Results survey colour and texture

Mean values

Figure 4.2.1 shows the means of the willingness to buy (referred to as WTB from now on) of the variations of the Lumea. Considering the variables were measured on a 7 point scale, it can be concluded that this sample has a positive attitude towards buying the Lumea refurbished (m total = 3.42).

The shiny white version of the Lumea has a high mean (m = 4.74) WTB compared to the current Lumea and other variations. A paired samples t-test confirmed that the difference between the WTB of the current Lumea design refurbished and the WTB of the shiny white variation is significant (p = <0.05).

Shiny black shows the lowest mean on WTB. However, no significant difference between the WTB of the shiny black Lumea and the current Lumea. Also, non of the other variations have a significantly different WTB from the current Lumea.

The influence of different characteristics on willingness to buy refurbished

The WIB was compared to the rating of the characteristics in a regression analysis. This analyses showed that 'simple' and 'hygienic' have a weak positive relation (p = <0.05) with WTB refurbished. This suggests that the more simple and hygienic are applicable to the product, the higher the willingness to buy

refurbished will be. No significant effects could be identified for other characteristics.

However, despite the significant difference between the WTB of the current and shiny white Lumea, the difference in hygiene and simplicity scores was not significant.

A stepwise regression was conducted to explore the effects of the characteristics on the WIB. The strongest predictor is 'hygienic': 1 point increase on the Likert scale is associated with a 0.494 point increase in WIB refurbished. This model doesn't prove that this relation is causal but it seems reasonable that improving the perception of hygiene will cause slightly higher overall WTB of the refurbished product. Surprisingly, no effect was found for other characteristics.

Age groups and their appearance preferences

Looking at the complete sample, 84% has heard of the term 'refurbishment' before.

Comparing the means of different groups shows that the lower age group.

A one way ANOVA test showed that there are no significant differences in the WTB of the different Lumea versions. However, comparing means (fig. 4.2.1) it can be stated that the shiny white Lumea has the highest average WTB of the six variations. Looking at these results, it can be suggested that colour

has a bigger influence on decision making than texture, since no mentionable differences can be spotted between means of the two different textures.

Due to the small number of 56+ respondents, not all Lumea variations were tested by that age group. Therefore, a preference for this group can not be concluded.

Colour and willingness to buy

Figure 4.2.2 shows the means of the WTB of colours and textures used for the Lumea variations compared to the current Lumea. From this graph it can be concluded that the differences per mean are little. On average, the white variations are slightly more popular than the black variations (delta m = 0.9), however, no significant difference can be identified.

The effect of texture on willingness to buy

The same counts for texture finishes. Shiny has a slightly higher WTB than mat variations, but not significant.

Current Lumea compared to...	Correlation	Sig.
<i>Shiny white</i>	0.892	.000
<i>Shiny grey</i>	0.880	.000
<i>Shiny black</i>	0.839	.000
<i>Mat white</i>	0.855	.000
<i>Mat grey</i>	0.835	.000
<i>Mat black</i>	0.649	.004

Refurbished + simple → significant weak positive correlation

Correlations			
		mean_all_refurb	mean_Hygienic_refurb
mean_all_refurb	Pearson Correlation	1	.272**
	Sig. (2-tailed)		.004
	N	112	111
mean_Hygienic_refurb	Pearson Correlation	.272**	1
	Sig. (2-tailed)	.004	
	N	111	111

** . Correlation is significant at the 0.01 level (2-tailed).

Refurbished + simple → significant weak positive correlation

Correlations			
		mean_all_refurb	mean_simple_refurb
mean_all_refurb	Pearson Correlation	1	.192*
	Sig. (2-tailed)		.043
	N	112	112
mean_simple_refurb	Pearson Correlation	.192*	1
	Sig. (2-tailed)	.043	
	N	112	112

*. Correlation is significant at the 0.05 level (2-tailed).

Figure 4.2.1; the means of 'willingness to buy refurbished' from different Lumea variations

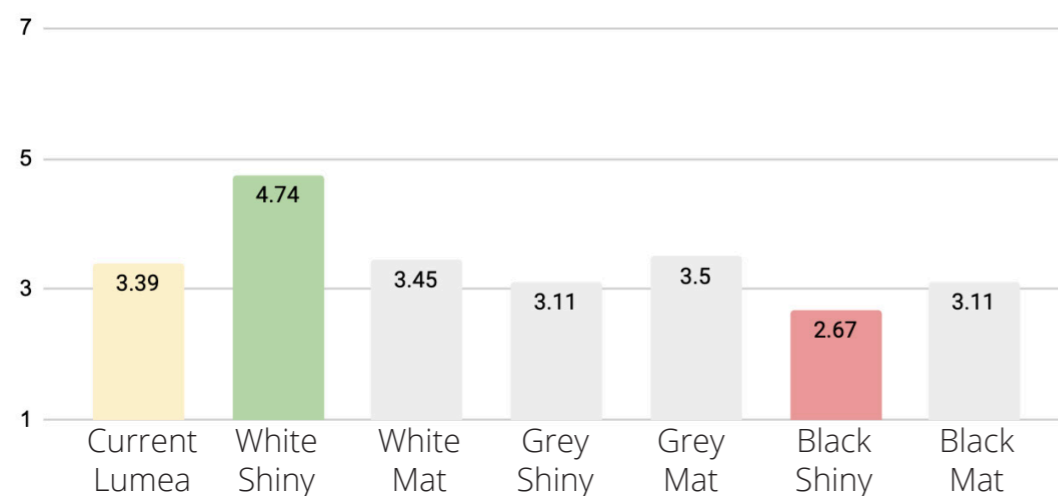
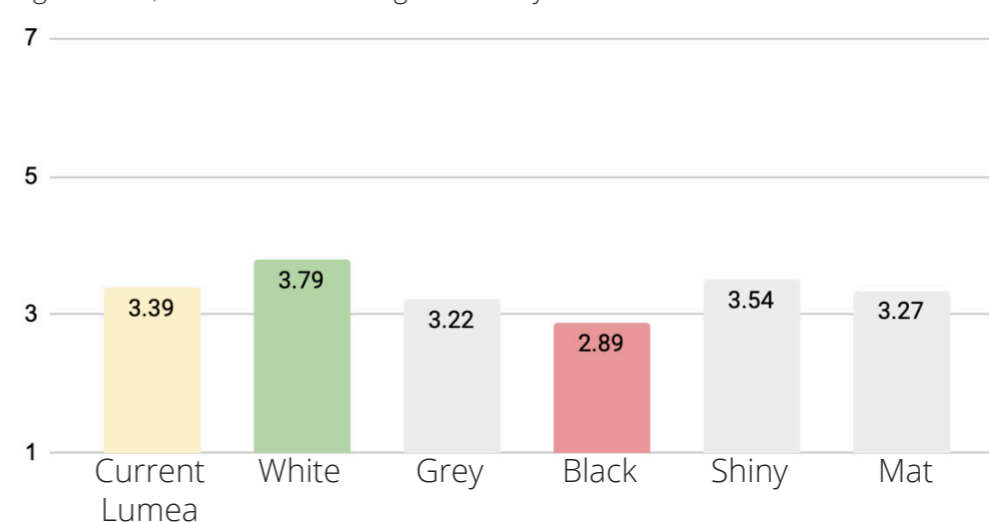

Figure 4.2.2; the means of 'willingness to buy refurbished' on colours and textures



Visual elements

Canvas

A requirement of the tool is that it creates an overview of the relevant consumer insights. Many tools have been created that provide an overview of data, like the Business model canvas (fig. below) and variations. The shape of this canvas with boxes to fill was used as a startingpoint.

Also, the tool should be functional online as well as offline. Due to Covid-19, many brainstorming sessions have moved from physical to digital platforms like Miro.

No open spaces were left blank. This was done to force users to make choices and interpret the data in this specific context.

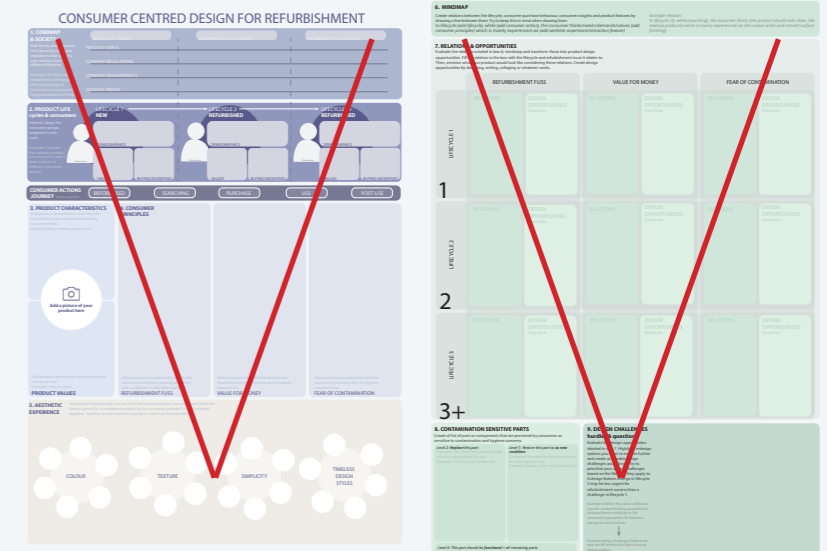
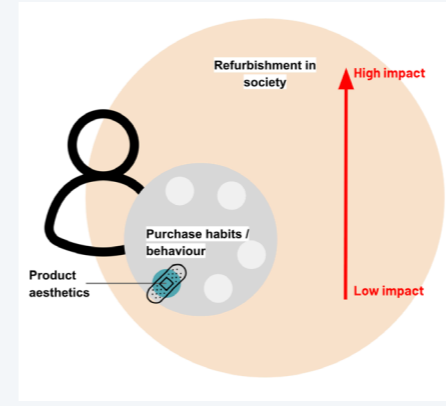
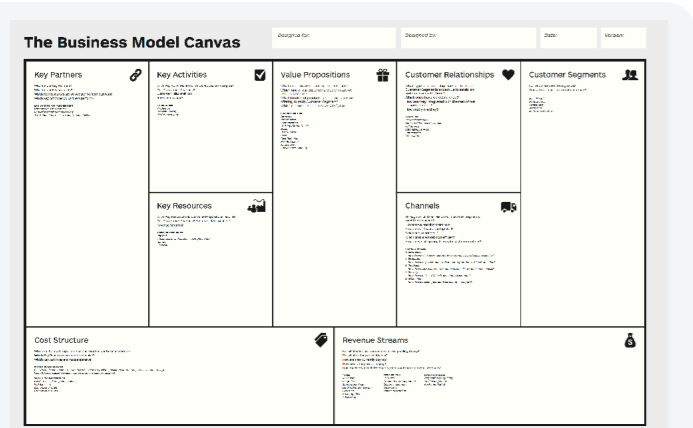

Broad vision to focussed conclusions

To encourage a broader perspective, the tool was designed to start broad and work towards focussed conclusions. This was based on the model presented in chapter 6.4, that states that societal developments and bias form the main base for refurbishment purchase decisions.

The top box of the purple canvas contains a societal developments. Moving down, the consumer and their behaviour towards refurbishment are key topics. The lowest box evaluates specific product features.

The green canvas has a similar approach. The first box encourages users to draw lines between insights and create interesting relations. The next box translates those relations into guidelines, which are evaluated on product feature level in the lower boxes.

Engaging users

The canvas aims to engage users in multiple ways, based on Sanders & Stappers, 2012. Different types of tasks and examples should encourage the user to fill the boxes. A sample of the first task box can be seen below in figure figure below.

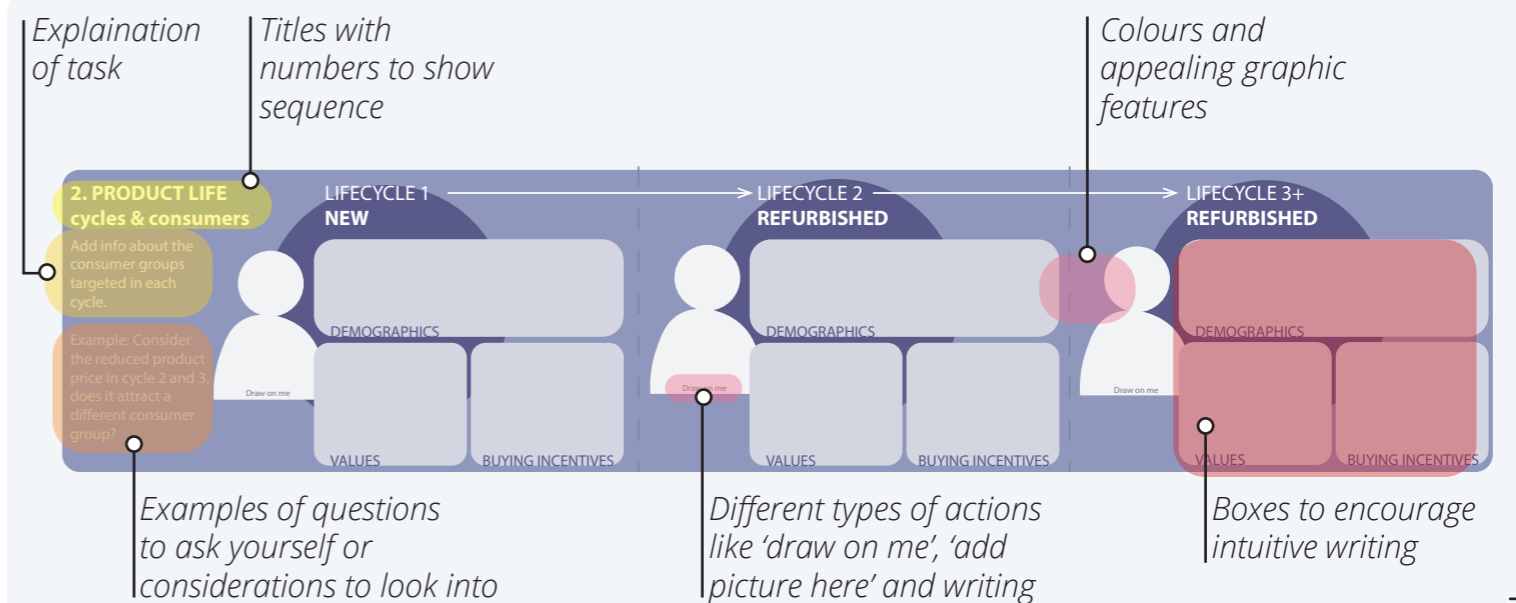

Questions tool

1. Company & society

Questions to ask:

Company regulations

- What are the terms and warranty regulations for your product?
- What is the expected length of each cycle? What influences this length?
- What is the length of the technical life of the product?
- How does the user influence the lifespan of the product? How long does the user expect the lifespan to be? Are there any trends that influence the life length?
- What product components have the shortest life span? How does this affect the lifespan of the entire product?
- What are the rules/requirements that your design must follow?
- How is your refurbishment service set up? Who are the stakeholders? What are their plans for the future?
- Are there any company policies coming up that might apply to your product?
- Company developments
- What is the company heading towards? Are there plans for new investments or strategies that might influence your product?
- Are there technological trends/development in the company that might affect your product?

Societal trends

- What are relevant consumer trends in your product category?
- Do consumers expect upgrades from this product? What is the technology time pacing strategy?
- How can consumer behaviour influence the product lifetime?
- What is the competition doing? What are they investing in your product's category?
- Are there any government regulations coming up that affect your product?
- What is unknown about the (near) future? What should you know before the launch of the product?

2. Product life; Cycles & consumers

Questions to ask:

- Who is the current target consumer? What do they value in their way of life that affects your product?
- What is the price reduction going to be for the refurbished version? What consumer can afford the product now?
- How are Second Life consumers different from new buyers? Demographically? Socially? Way of life/life phase?
- What are the consumer's buying incentives? Why do they buy this product? Why would they consider Second Life (or not)?
- What are buying incentives during the 2nd life? How are they different from the first time sale?
- What do consumers experience when buying the product? How is that experience different for Second Life consumers?

3. Product characteristics & values

Questions to ask:

- If consumers had to describe the product as a person, what personality would it have? How do those personality descriptions differ for new and Second Life consumers?
- How does this personality affect your product? What threats are experienced positively? Which negatively? How does this differ for new and Second Life consumers? (E.g. New consumers might find a product lock, while Second Life consumers can experience this as robust or durable)
- What does this product remind consumers of? Does it look like other products?
- What are competitors doing? What do consumers value in competitor products? How does that affect your product?
- What are product aspects that consumers value? How are those differences between new and Second Life?

- What are product aspects that should not change during the redesign phase?

4. Consumer principles

Questions to ask:

- What concerns affect your product most? Consider the category and product use, how does that affect the perception of the refurbished product?

Refurbishment fuss

- What does your target group currently know about refurbishment? If and how are they informed on the subject?
- What biases affect the consumer's perception of the refurbished product?
- What associations do consumers have with the word 'refurbished'?
- What is the consumer's initial reaction to buying this product refurbished? Are they positive or negative towards the concept?
- What information do you give consumers during the exploration phase?
- What do consumers question about your refurbished product?
- What should consumers know in advance? What do consumers need to make an informed decision?
- What benefits should be expressed that fit the consumers buying incentives?
- What actions do consumers take to find information by themselves? What are common information sources?
- How does the brand affect the buying decision? Is the brand experience different for consumers in different lifecycles?

Value for money

- What product durability do consumers expect? How long do consumers normally use this product?
- Is your product a high investment? If so, what is the financial value to consumers of buying this product refurbished?
- What is the consumer's perception of functionality? Is this influenced by the offer of refurbished products?

Fear of contamination

- What types of contamination do consumers fear for this product? (Digital, use, hygiene)
- What measures do consumers take to ensure contamination concerns themselves?
- How is the perception of contamination influenced? By the exterior of the product? Through product history? Or based on 'feeling'?

5. Aesthetic experience

Questions to ask:

Colour

- What colours can consumers see when buying the product?
- How are these colours perceived by consumers in relation to the aforementioned concerns? Do consumers have positive or negative associations?
- What colours do successful competitor products have? What associations do these evoke with consumers? How does that affect the refurbishability?

Texture

- What surface textures does your product have? How can these be judged from visual cues?
- How are these textures perceived by consumers in relation to the aforementioned concerns?
- What textures do successful refurbished competitor products have?

Simplicity

- What parts do consumers mention as durable? What looks sturdy or robust?
- What visual cues does your product communicate in terms of interfaces and buttons?
- How do these visual elements relate to the aforementioned consumer concerns? What concerns affect what components?
- Do the visual elements have a positive or negative influence on the Second Life perception?

Timeless design styles

- What parts or components do consumers mention as fragile? Or sensitive for damage?
- Is your product sensitive to trends, in terms of colour, product shape or technology?
- How is the product's design style perceived by consumers? What elements are mentionable or memorable?
- How do these memorable elements relate to the aforementioned consumer concerns?
- Consider the associations consumers have with your product (block 3), how are these perceived in relation to refurbishment?

6.Mindmap

Questions to ask:

- How are the consumer insights related?
- What are the differences between links from new and refurbished consumer experiences?

7.Relations and opportunities

Questions to ask:

Refurbishment fuss

- What refurbishment benefits fit your consumer best? How can these be expressed via product design?
- Do consumers from different life cycles value the same things in refurbished product? How can you combine and emphasize all values in your design?
- How can consumers be informed about refurbishment in the redesign? What product (or even component) specific concerns should be addressed?
- How can positively refurbishment related characteristics be emphasized in the design?

Value for money

- How can the product be designed to be less sensitive to trends? What sparks both new and Second Life consumer interest?
- How can financial benefit be expressed via product design? What makes

this product worth the money for consumers, both new and refurbished? What features raise the potential willingness to pay?

- How can fragile-looking product features be redesigned to express durability?
- What features can be trimmed? Or simplified?
- What design features should be emphasized to express durability to consumers in the second and third life cycle?
- How can the product be redesigned to allow upgradability? What upgrades do consumers from different lifetimes, or the years, expect from the product? How can these be implemented in the redesign?
- How can the design style of the product be simplified?
- Is your product a high investment? If so, what is the financial value to consumers of buying this product refurbished?

Fear of contamination

- What colours and textures do express hygiene? How can those be applied to your product?
- What colours and textures are related to the contamination? How can those be designed out of the product?
- How can hygiene concerns be tackled in the product design? Consider implementing measures consumers take to by themselves. How can the ease of cleaning be enhanced?

8.Contamination sensitive parts

Questions to ask:

- What parts should be replaced to ease consumer concerns? How is their current reachability?
- What hurdles stand in the way of easy replacement? What changes should be made to the design to allow this?
- What parts should be in 'as new' condition according to consumers? How is their current repairability?
- What changes should be made to the design to enhance repairability? What

design hurdles should be looked into?

9.Design challenges

Questions to ask:

- After doing this exercise, what questions are left unanswered?
- What research should be conducted to answer these questions? By whom/ what department?
- What design opportunities from block 7 shows potential or further exploration?
- What are the next actionable steps to take into the further development of the redesign of this product for refurbishment?