

Appendices

Appendix A

A0. Graduation Brief

A1. Contextmapping

- A1.1 Contextmapping Booklet
- A1.2 Contextmapping Interview Questions
- A1.3 Statement Cards of Interviews

A2. Concepts

- A2.1 Subtle Advice Giver
- A2.2 Hackable Hood
- A2.3 Personalized Planner

A3. Brainstorming Workshop Materials

- A3.1 Persona Cards
- A3.2 Manifestos
- A3.3 Service Design Map
- A3.4 Storyboard Templates
- A3.5 Procedure of Brainstorming Workshop

A4. Brainstorming Workshop Results

- A4.1 Subtle Advice Giver
- A4.2 Hackable Hood
- A4.3 Comprehensive Planner

Appendix B

B1. Feedback Report

B2. DIY Exchange Hubs

- B2.1 Building Manual
- B2.2 UI Screens of DIY Hubs

B3. Testing: Oosterwold Ontkiemt

- B3.1 Testing Procedure
- B3.2 Survey
- B3.3 Survey Results
- B3.4 Carpenter Communication Document

Understanding Food Growing Practices

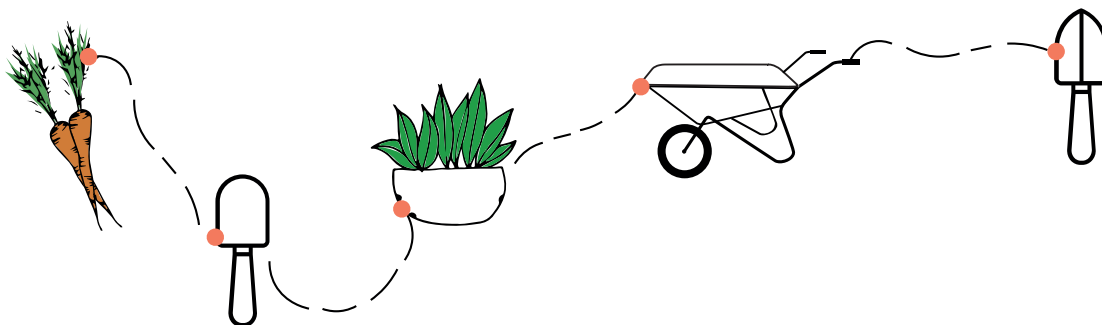

Hello! I am Yağmur. As you know, for my graduation project I am working for the individuals who grow their own food in Almere and you are one of them! Thank you for being part of my project!

By preparing this booklet, I want to understand you and your way of food growing. For this, I prepared some questions. There is no right or wrong answers so please feel free to write and draw to your booklet.

If you have any further question, feel free to call me from 0645644980.

1. Nice meeting you!

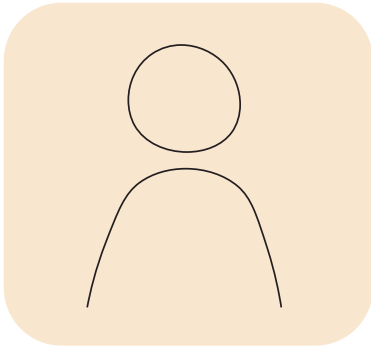

Name: _____

Profession: _____

Age: _____



I do it with ...

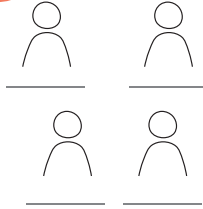

I do it at...



I enjoy it because...

1. _____
- _____
2. _____
- _____

I do it with ...

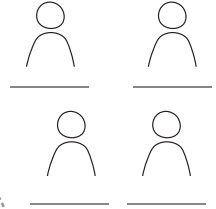

I do it at...



I enjoy it because...

1. _____
- _____
2. _____
- _____

In my spare time, I ...

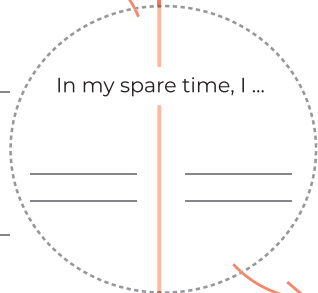

2. Your way of growing food

Now let's talk about the edible plants you grow. What kind of things do you grow on your own? What do you do with them later? And in general why do you grow your own food?

EDIBLE GROWING

The things I grow are:

.....
.....

I grow them for

.....

I do it usually with

.....
.....

For me it is important to

.....
.....



I grow my own food because

.....
.....

.....



WHAT I MAKE LATER

Now you can list down what you do with the food you grow

apricot	→	making jam
.....	→
.....	→
.....	→
.....	→

Can you draw how it looks when you take care of your food?



3. Your relationship with growing your own food

Now, let's dive deeper about your relationship with the food that you grow. How would you talk to your plant, what would you say to it? Below imagine a dialogue between you and your plant. Then, think of what exactly is the meaning of growing food for you? Write and draw them to the meaning cards.

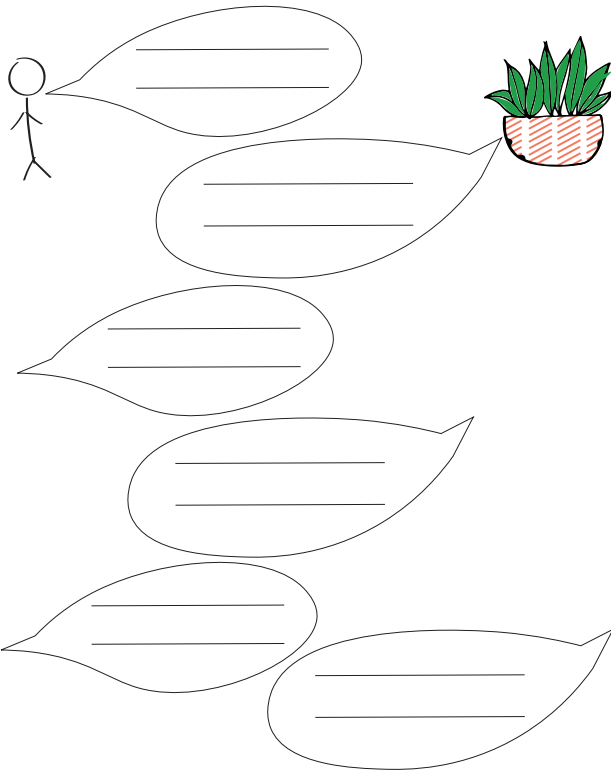

MEANING CARD

It means _____

to me. I feel _____
_____ when I take care of my own food.

MEANING CARD

It also means _____

to me. I feel _____
_____ when I take care of my own food.

4. How was your last memory?

Now let's think about the last time that you took care of your edible plants. How was it like? To the timeline below, try to write down and/or draw the things you did before, during and after taking care of your food plants. What kind of materials you used and how you did it?

before

during

after

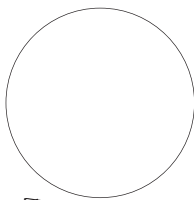

5. Pains and gains of growing your own food

Based on your last memory that you just described, what are the pains and gains of growing your own food? In other words, what are the good and bad moments during this process for you? Again, map them below by telling why as well.

before	during	after
1. I like doing _____ _____ _____		
positive	<hr style="border: 1px solid red;"/>	
negative		
1. I didn't enjoy _____ _____ _____		

6. "In a different world, growing my own food..."

Now we want you to imagine how would it look like to grow your own food in your ideal world. Whom would be around you, what would be the materials you use, how would it look like to take care of your own food?



I would be _____

The magical power I would have _____

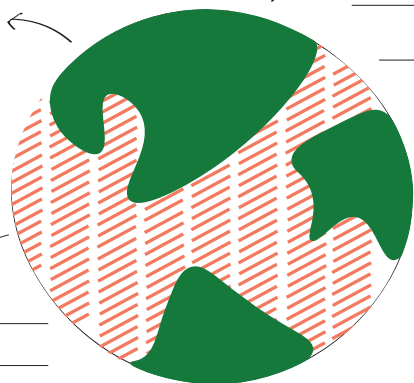

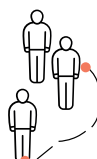

Overall, the world _____



Others around me _____







The materials that I use would be _____

7. Now your call

Based on the questions that you answer, are there any comments or remarks you want to make? This page for you to write down or draw!

Thank you!

A1.2 Contextmapping Interview Questions

Thank you for filling out the booklet, before we start I can ask; how was it for you to fill it in? Did you like it or not, were there any points you had trouble filling in..

1. Let's know you

All right. Now let's start with your first exercise. You listed here 2 activities, how often do you do these activities?

We also asked you to write down the reasons of why you enjoy them. Can you elaborate on these further? Why is it important for you to be with your family for example.

2. Your way of growing food

edible growing Now let's go to the other page. Here you listed the things you grow, is it the whole list?

You said that this is important for you. I would like to ask this a little further. Maybe in 4 steps. For you what is the most essential material/skil/person/emotion of growing food, the thing that should be there, otherwise you wouldn't grow?

what i make later About the things you make later, can you explain further one of them in detail.

drawing self I see you holding a tree, how do you feel there?

3. Your relationship with growing your own food

conversation Would you like to add anything to this?

meaning card I see here that you wrote down meaning here. Through doing what you think you express this meaning? I mean through what kind of behaviors, words, or approaches.

4. Your last memory

timeline I see that here you start with *this* and *this*. Is this always how you start or does it change from time to time? Why is that?

Looking to this timeline, which part is your favorite part? Why is that?

5. Pains and Gains of Growing your own food

timeline I see the negative moments here, why are they negative? How would you want them to be?

Would you like to change anything in this process and how? Why to you like this change to happen?

6. In a different world, growing my own food

I would be why this kind of a magical power?

materials why this kind of materials?

others why? are there any specific way that you don't want people to be?

world how would you describe this world? why?

Thing-Centered Ethnography

Let's locate these 3 cameras on 3 of your objects that you use while you take care of your food. They will just record while you do your activity.

Now I would like you to take care of your plants like you would do on a regular basis.

The reason that I do this kind of a study, is to see from the eyes of the objects. They may reveal unthought patterns or behaviors of the context/your practice.

A1.3 Statement Cards of Interviews

colorbar	After printing, please mark this field in your personal colour (for easy sorting)
paraphrase	They do gardening in an upscale way than a traditional approach

quote We are more like we want everything to be stylish and perfect

Space for notes during session	
--------------------------------	--

colorbar	After printing, please mark this field in your personal colour (for easy sorting)
paraphrase	Taking care of the vineyard takes a lot of time

quote I don't have any spare time this was a little bit sad. Every free or spare time we put in the vineyards.

Space for notes during session	
--------------------------------	--

colorbar	After printing, please mark this field in your personal colour (for easy sorting)
paraphrase	They take good care of their plants hoping that they will get back

quote Make sure that every plants get its attention because what you give is we hope to take back.

Space for notes during session	
--------------------------------	--

colorbar

After printing, please mark this field in your personal colour (for easy sorting)

paraphrase

When the plants are young, they need more attention. Taking care of new plants take a lot of time and effort.

quote

We don't have a lot of spare time at the moment because the grapes are still very young so we have to actually give them a lot of energy

Space for notes during session

colorbar

After printing, please mark this field in your personal colour (for easy sorting)

paraphrase

They like to get sun for their plants.

quote

Last year was a really good year. There are a lot of sun especially for the Netherlands

Space for notes during session

colorbar

After printing, please mark this field in your personal colour (for easy sorting)

paraphrase

In order to get more alcohol in your wine, the grapes should have high percentage of "uxle" (sugar)

quote

That's the percentage of sugar that is inside the grapes, the more percentage of "uxle"; the more percentage of alcohol you can produce.

Space for notes during session

colorbar After printing, please mark this field in your personal colour (for easy sorting)

paraphrase

High sugar level on grapes makes them harvest. High sugar misleads towards harvesting.

quote Some of the grapes they gave us more than 100 of uxley which is very high, so we decided to harvest our first grapes but it was actually a bit early.

Space for notes during session

colorbar After printing, please mark this field in your personal colour (for easy sorting)

paraphrase

50-60kg of grapes are not enough for them to make wine. Collaboration between producers is possible.

quote It was only 50-60kg, which makes it harder to produce wine and right now we blended it with another vineyard in Almere

Space for notes during session

colorbar After printing, please mark this field in your personal colour (for easy sorting)

paraphrase

They may consider to sell it for fun, in small amounts as a "publicity" of Oosterwold's wine.

quote We can actually sell it in the centre at the visit center where tourists visit that is nice to do but isn't like a business or something, just for fun

Space for notes during session

colorbar

After printing, please mark this field in your personal colour (for easy sorting)

paraphrase

They don't grow their plants with chemical substances.

quote

It is important to grow without chemicals

Space for notes during session

colorbar

After printing, please mark this field in your personal colour (for easy sorting)

paraphrase

In the current situation of food industry, things are overproduced.

quote

All of our vegetables and the most of our food is actually overproduced.

Space for notes during session

colorbar

After printing, please mark this field in your personal colour (for easy sorting)

paraphrase

They finished their garden in an organic way,

quote

We tried to do our whole garden just by nature

Space for notes during session

colorbar

After printing, please mark this field in your personal colour (for easy sorting)

paraphrase

Since gardening is not where they earn money, they experiment with how they grow their plants

quote

Because it is not a real business for us, we can just do a little bit of experiments, and experimental stuff. We tried with horse poop and then try to put it on the ground just to see how the ground will react.

Space for notes during session

colorbar

After printing, please mark this field in your personal colour (for easy sorting)

paraphrase

They experiment with their plants to see if the outcomes would be better.

quote

Just to be curious and just to say if it's really gives us more grapes or another type of grape or taste is different or growing is better etc.

Space for notes during session

To play with: Quantity, variety, taste quality, difficulty level

colorbar

After printing, please mark this field in your personal colour (for easy sorting)

paraphrase

Experimentation may not always result in a good way. However, they still appreciate the outcome.

quote

Because of the good weather last year we thought well lets give it a try and then we see because it is only like 50-60 kgs just try and mix it with the other grapes and then see what comes out of it. It's a little bit of surprise; but well..

Space for notes during session

A balance between experimentation and know-how is needed.

colorbar

After printing, please mark this field in your personal colour (for easy sorting)

paraphrase

A simple material can be used throughout the whole process.

quote

It would be scissors because we need that to make sure that you cut the end of the plant. Also to leave the plants out of its leaves because too many leaves just keeps the sun out of the grapes. It is the most important tool to use, very simple.

Space for notes during session

colorbar

After printing, please mark this field in your personal colour (for easy sorting)

paraphrase

The most essential skill is patience with love and care, to grow food.

quote

I think you need a lot of patience and the best thing is just tender love and care.

Space for notes during session

colorbar

After printing, please mark this field in your personal colour (for easy sorting)

paraphrase

They believe that when you take good care of plant, you will see good results.

quote

If you take care of your plants, then I am sure you're going to see it back; it pays back in the results.

Space for notes during session

Balance, tradeoff between human x plants

colorbar

After printing, please mark this field in your personal colour (for easy sorting)

paraphrase

To grow food, enthusiasm and being interested come before knowledge.

quote

You have to be enthusiastic, you have to be urban greenery and not like you need to know a lot of stuff about it.

Space for notes during session

After printing, please mark this field in your personal colour (for easy sorting)

To grow food, a lot of perseverance is needed.

You do need to have a lot of perseverance.

colorbar

After printing, please mark this field in your personal colour (for easy sorting)

paraphrase

They need help from people

quote

We actually need more hands to do it because we do it on our spare times and besides work; that is not enough time

Space for notes during session

Opportunity for collaboration

colorbar

After printing, please mark this field in your personal colour (for easy sorting)

paraphrase

**With an old tree, they can produce food faster.
They make cake and ciders**

quote

We bought the pear tree that is 40 years old, they produce pears so we can harvest them in October and then make cakes, cider..

Space for
notes
during
session

colorbar

After printing, please mark this field in your personal colour (for easy sorting)

paraphrase

**They need older trees to give food. That is why
they bought one.**

quote

We also have young pear trees and apple trees but they are too young to give fruit so that's why we brought the other one.

Space for
notes
during
session

colorbar

After printing, please mark this field in your personal colour (for easy sorting)

paraphrase

**They want to find new ways of how to lessen the
sugar but keep the taste same.**

quote

I did jams before but it is a lot of sugar so we have to sort it out how to make it with less sugar but tastes the same.

Space for
notes
during
session

colorbar

After printing, please mark this field in your personal colour (for easy sorting)

paraphrase

They want to experiment with what nature provides them in their garden.

quote

There are few people who do it biological way I know that they make all the preparations and so on.. But we like to do it ourselves just to see how it works, also experiment with flavors. Just take a look what nature gives you..

Space for notes during session

colorbar

After printing, please mark this field in your personal colour (for easy sorting)

paraphrase

They think that food is overproduced and not tasteful anymore.

quote

The whole world that we live in right now that everything is overproduced and not as tasteful as it was before.

Space for notes during session

colorbar

After printing, please mark this field in your personal colour (for easy sorting)

paraphrase

They think that food growing without real sun is artificial.

quote

You can taste the difference between tomatoes grown in here and in Spain or Italy, here everything goes under the glass so it is artificial.

Space for notes during session

Beliefs

colorbar

After printing, please mark this field in your personal colour (for easy sorting)

paraphrase

They want to see what their lands can provide to them naturally.

quote

I want to see what the nature here in the Netherlands can give us and just try to see what kind of mixtures you can make and hopefully it will taste better than all the stuff that we buy from supermarkets.

Space for notes during session

Low threshold of sufficiency.

colorbar

After printing, please mark this field in your personal colour (for easy sorting)

paraphrase

They know that they cannot grow everything on their own.

quote

I also buy and I use because it is very convenient also you cannot grow everything on your own

Space for notes during session

colorbar

After printing, please mark this field in your personal colour (for easy sorting)

paraphrase

Through growing their food, they learn to appreciate food. They say that their effort has a taste.

quote

It is more about being into food. You can actually taste everything that you put in. It is better because actually then you are going to value your food more.

Space for notes during session

colorbar

After printing, please mark this field in your personal colour (for easy sorting)

paraphrase

When you grow your own food, it increases your awareness towards environment and where your food comes from.

quote

All the hard work you put in, then you are going to be more aware. I think it's about awareness.

Space for
notes
during
session

colorbar

After printing, please mark this field in your personal colour (for easy sorting)

paraphrase

Having your own garden requires more responsibilities than having growing inside of house with couple of pots. It is harder.

quote

This is something totally different than we used to normally do. We used to just put tiles and just a few plants and no pain.

Space for
notes
during
session

colorbar

After printing, please mark this field in your personal colour (for easy sorting)

paraphrase

They want to do the good thing for the plant. They want to see good results of their efforts.

quote

We really hope that everything we do is a good thing for the plant but also for the efforts you put into it.

Space for
notes
during
session

colorbar

After printing, please mark this field in your personal colour (for easy sorting)

paraphrase

They may doubt after doing something whether they did good or not and this may create sadness/frustration..

quote

Also all the efforts you put into it. The first time we had to cut all the grapes after the winter; we were a little scared whether it was a good thing to do. I even cried. Should we'd done it differently or did we do a good thing?

Space for notes during session

colorbar

After printing, please mark this field in your personal colour (for easy sorting)

paraphrase

They see plants as their children. They want to take "good" and "correct" care of them.

quote

It is like having your 500 children and hoping that you're really going to take good care of them, do all the right stuff because otherwise well they will be dead.

Space for notes during session

Importance of "taking care" → reframing care.

colorbar

After printing, please mark this field in your personal colour (for easy sorting)

paraphrase

Through learning the whole process before, they gained the experience. After having that knowledge, the rest is trial and error.

quote

We had 4 months of class where we worked in a vineyard. You can actually see whats needed to be done from putting the plant into the soil to the harvest and making your own wine. And the rest is trial x error.

Space for notes during session

Know first then trial x error.

colorbar

After printing, please mark this field in your personal colour (for easy sorting)

paraphrase

There can be other factors which can harm your food, even if you do everything correct.

quote

You can only see if its' a wrong thing to do if the plant dies, or doesn't give grapes. Maybe there's a fly comes, or it can be some other factors we don't recognize or know..

Space for notes during session

Predictions, knowing is good but leave room for improvisation.

colorbar

After printing, please mark this field in your personal colour (for easy sorting)

paraphrase

In the relationship of human and nature, human can help nature to make it run smoothly according to its own balance.

quote

Nature lives on its own, sometimes just needs a little bit of help to get more sun or more water.

Space for notes during session

Nature x human relationship

colorbar

After printing, please mark this field in your personal colour (for easy sorting)

paraphrase

Growing your own food gives an understanding of balance in life.

quote

It is a balance in how you interpret life and your relationship with food. It is about how you take care and consume your stuff.

Space for notes during session

Human x world relationship

colorbar

After printing, please mark this field in your personal colour (for easy sorting)

paraphrase

Nature provides variety of possibilities. Organic food growing can contribute to change the existing food chain

quote

It means being aware of the possibilities of nature. I feel that I can contribute to the new biological possibilities within the food chain.

Space for notes during session

colorbar

After printing, please mark this field in your personal colour (for easy sorting)

paraphrase

Before they start dealing with their garden, things seem stressful to them

quote

Before you start, it seems hectic, stressful and even problematic

Space for notes during session

colorbar

After printing, please mark this field in your personal colour (for easy sorting)

paraphrase

They perceive food growing as a process and tradeoff. They put more effort at the beginning, which will decrease as time passes and results will increase.

quote

Now we try to do all the things right so it's going to be easier in 4-5 years; that means we need to put extra effort in the first years so later on it will give us more time. It is like a tradeoff.

Space for notes during session

colorbar

After printing, please mark this field in your personal colour (for easy sorting)

paraphrase

They perceive food growing as a process of learning.

quote

You will get to know all the things you have to do, you will find more ways to certain things. You will make things easier because you will see if that didn't work, you can do the other way.

Space for notes during session

Difficulty level, pace of activities

colorbar

After printing, please mark this field in your personal colour (for easy sorting)

paraphrase

Doing gardening makes them feel calmer and relaxed.

quote

While you're gardening it is more peaceful, calmer and relaxed. If you are outside working it is really fun to do.

Space for notes during session

colorbar

After printing, please mark this field in your personal colour (for easy sorting)

paraphrase

When they start taking care of their plants, they stop complaining and just enjoy outside.

quote

Looking outside 500 squaremeters , how am I going to do that by myself? Actually when I am doing it, I'm like "oh that's so nice, you can hear birds, sun is outside". Actually you forget all the work and just start doing it.

Space for notes during session

colorbar

After printing, please mark this field in your personal colour (for easy sorting)

paraphrase

They feel proud when they completed the day.

quote

When you finish it, you feel relaxed and proud to make such a switch in life so it is more like satisfied

Space for
notes
during
session

colorbar

After printing, please mark this field in your personal colour (for easy sorting)

paraphrase

Stepping outside to garden is like entering into a new world with slower pace and they like it.

quote

Because our lives inside is very hectic and can be stressful, looking outside is just making you more stressed. When you are outside it is like you enter into a new world that is still your but you can switch to a different pace. It is nature, clean air, wind, sun that slows down the pace.

Space for
notes
during
session

colorbar

After printing, please mark this field in your personal colour (for easy sorting)

paraphrase

In some of the seasons the work load intensifies, which makes growers fed up.

quote

You will have certain moments when you just fed up with growing your own stuff and because that's a lot of efforts and hard work especially during specific season depending on what you grow.

Space for
notes
during
session

colorbar

After printing, please mark this field in your personal colour (for easy sorting)

paraphrase

Dealing with garden slows down the fast day flow and brings relaxation.

quote

The first moment that I stepped out of the house into green is my favorite part, because that is the moment that I can switch into a relaxed flow, which is better.

Space for notes during session

colorbar

After printing, please mark this field in your personal colour (for easy sorting)

paraphrase

They like the whole journey as it is. Taking care of the plants by their hands, diy makes it challenging which is good.

quote

I would change nothing, I think the most beautiful part of the whole urban greenery is you do it by yourself. You feel your hands working with it and doing everything yourself makes it more challenging which I like.

Space for notes during session

Current food chain → easy but bad
Diy with your hands → hard but good

colorbar

After printing, please mark this field in your personal colour (for easy sorting)

paraphrase

They think that the more effort you put in food growing, the more you will appreciate the results. Things can be hard, dirty and slow, you have to accept and appreciate it.

quote

I think it is the problem that we have at the moment is that everything has to be easy and quick and clean; but actually it is not like that. More effort you put growing your own food and actually making something else; the more you are going to like the end result and appreciate more.

Space for notes during session

colorbar

After printing, please mark this field in your personal colour (for easy sorting)

paraphrase

They grow their own food based on permaculture

quote

What we are doing here is a little bit of a mixture; you'll have a large variety of vegetables and fruits; around 1500metersquares will be like that.

Space for
notes
during
session

colorbar

After printing, please mark this field in your personal colour (for easy sorting)

paraphrase

He likes to grow somehow already-there plants.

quote

I am not the type who would do it from scratch, I prefer to have ready-made small plants and then put them on the ground.

Space for
notes
during
session

colorbar

After printing, please mark this field in your personal colour (for easy sorting)

paraphrase

He prefers simple way of food growing, there shouldn't be too much effort.

quote

It shouldn't be too complicated so I just buy 10 or 20 different vegetables and I just put them in permaculture and then they grow

Space for
notes
during
session

colorbar

After printing, please mark this field in your personal colour (for easy sorting)

paraphrase

They care about the source of the ready-made plant; it should be biological.

quote

We buy ready made plants but it has to be biological and from a reliable source.

Space for notes during session

colorbar

After printing, please mark this field in your personal colour (for easy sorting)

paraphrase

He values the course of his food, he eats biological and in general self-sufficiency.

quote

It is important to be self-sufficient and to eat biological and also to know where the food you eat comes from.

Space for notes during session

colorbar

After printing, please mark this field in your personal colour (for easy sorting)

paraphrase

Hofwebwinkel is a cooperation that sells products of organic farmers and they buy from there for 12 years.

quote

We buy most of our products from Hofwebwinkel, it is a biological regional cooperation of organic farmers here in the polder. Since 2007 or something we buy most of our stuff from them.

Space for notes during session

colorbar

After printing, please mark this field in your personal colour (for easy sorting)

paraphrase

They have been eating organic and not processed food for more than 10 years.

quote

So for us biological food and knowing that its local and proper food; not processed etc is already from a long time.

Space for
notes
during
session

colorbar

After printing, please mark this field in your personal colour (for easy sorting)

paraphrase

For him, the urge to move to self-sufficiency started with the financial crises. He thinks that the whole system in society is corrupt.

quote

I try to be self-sufficient; and it goes back to the bank crisis where we realized that the whole system in society is pretty much corrupt and destroying the world.

Space for
notes
during
session

colorbar

After printing, please mark this field in your personal colour (for easy sorting)

paraphrase

He've heard of Oosterwold from the local newspapers; and he thought it can be the place to shift totally self-sustainable

quote

I don't really recall but it must have been from the local newspapers and I thought; oh that can be a chance to build a self-sustainable house.

Space for
notes
during
session

colorbar

After printing, please mark this field in your personal colour (for easy sorting)

paraphrase

He likes the tastes of the food the grow far better than anything

quote

I grow my own food because it tastes better. Have you ever tasted a tomato that you grow yourself?

Space for notes during session

colorbar

After printing, please mark this field in your personal colour (for easy sorting)

paraphrase

To him, growing his own food gives him independency from the big retailers.

quote

It also gives a feeling of independence. Independence from the big retailers.

Space for notes during session

colorbar

After printing, please mark this field in your personal colour (for easy sorting)

paraphrase

They still buy organic groceries from the market when they need; their idea is to change small malfunctionings for the better.

quote

We are not going to live on an island, we still buy groceries weekly but we buy from here or from the market. I am not a fundamentalist in that respect but it is slowly looking for where we can change for the better

Space for notes during session

colorbar

After printing, please mark this field in your personal colour (for easy sorting)

paraphrase

He expects from his plants to grow healthy

quote

What I would say to my plant.. "Ok, we gave you a very nice place here now grow and make sure you do it properly and to stay healthy"

Space for
notes
during
session

colorbar

After printing, please mark this field in your personal colour (for easy sorting)

paraphrase

Growing his own food brings autonomy to him.

quote

I feel autonomous, because it is a great deal I feel happy when I grow my own food and trees.

Space for
notes
during
session

colorbar

After printing, please mark this field in your personal colour (for easy sorting)

paraphrase

For him to connect with his plant, he has to see it growing.

quote

I don't connect with lettuce but I can connect with an acid tree or with pear tree, because they are there for long time and you see them grow.

Space for
notes
during
session

colorbar

After printing, please mark this field in your personal colour (for easy sorting)

paraphrase

He values the whole ecosystem. He believes he contributes to the ecosystem with planting trees, veggies since they become house for other species as well.

quote

It's also important that you have to understand it's the whole ecosystem that does it. We have a frog now, it makes us happy, the first bird passing and sitting on a branch of our tree, makes us happy.

Space for
notes
during
session

colorbar

After printing, please mark this field in your personal colour (for easy sorting)

paraphrase

He wants the taking care process to be simple and not too complex.

quote

It is also important that the tree shouldn't require a lot, it should be fairly simple and we don't have to do that much to make it grow and if it gives fruit then it's nice, if not then no.

Space for
notes
during
session

colorbar

After printing, please mark this field in your personal colour (for easy sorting)

paraphrase

For him, the most important tool is knowledge in the garden.

quote

The most important tool.. Knowledge, the know-how of how to do stuff.

Space for
notes
during
session

colorbar

After printing, please mark this field in your personal colour (for easy sorting)

paraphrase

They are dependent to their neighbors and other food growers when it comes to know-how about plants

quote

We are at the moment constantly dependent on others to tell us what to do, where and how to plant.. (talking to Vivien) you have your advice from the grower for example which trees should we plant, are they good in the soil etc.

Space for notes during session

colorbar

After printing, please mark this field in your personal colour (for easy sorting)

paraphrase

For him, the most important skill is patience.

quote

The most important skill you need to have is patience I think.

Space for notes during session

colorbar

After printing, please mark this field in your personal colour (for easy sorting)

paraphrase

He want his garden to be grown up already.

quote

This is all from scratch, all new.. But I am 54 and I don't have 20 years, I mean I have 20 years but I wanted this garden to be big already and grown up already

Space for notes during session

colorbar

After printing, please mark this field in your personal colour (for easy sorting)

paraphrase

They exchange knowledge through a whatsapp group. They also have books from the library about permaculture.

quote

We have different networks of permaculture. We have a whatsapp group, we exchange questions, knowledge, there are some people pretty experienced already. We also have books from the library

Space for notes during session

colorbar

After printing, please mark this field in your personal colour (for easy sorting)

paraphrase

Oogsterwold is a Facebook group that shares and cooperates with each other, also through workshops.

quote

The website of Oogsterwold, is for sharing and cooperating with each other through workshops.

Space for notes during session

colorbar

After printing, please mark this field in your personal colour (for easy sorting)

paraphrase

Oogsterwold is a Facebook group that shares and cooperates with each other, also through workshops.

quote

The website of Oogsterwold, is for sharing and cooperating with each other through workshops.

Space for notes during session

colorbar

After printing, please mark this field in your personal colour (for easy sorting)

paraphrase

To get more knowledge, he wants to attend to a 4-5 evenings of workshops.

quote

I want to do a course like 4-5 evenings; if there's this kind of 5 days or so course then I would like to join, I will follow that.

Space for
notes
during
session

colorbar

After printing, please mark this field in your personal colour (for easy sorting)

paraphrase

For him, the most important emotions are perseverance and inside motivation. Especially because you see results slower at the beginning.

quote

Perseverance you need. Also inside motivation, especially in the beginning because it is still a lot of work and the results are slower than normal. You would get instant gratification, but here you need to wait for 5 years.

Space for
notes
during
session

colorbar

After printing, please mark this field in your personal colour (for easy sorting)

paraphrase

For him, to think through all the details about food growing is complicated.

quote

It is complicated, what do you put on the ground and where; what should be the distance in between the plants, how long does it take in which season, then I thought it is complicated.

Space for
notes
during
session

Types of plant supplements, Interaction between plants (distance, substance transfer), seasonal changes

colorbar

After printing, please mark this field in your personal colour (for easy sorting)

paraphrase

He thinks he should know more about know-how about gardening

quote

Humankind has been doing this for over 10000 years and here I come and I know nothing; but there are a lot of things you should know

Space for notes during session

colorbar

After printing, please mark this field in your personal colour (for easy sorting)

paraphrase

For people who are not familiar with growing food, seeing an actual veggie grow can be fascinating.

quote

(talking about a computer geek).. he was flabbergasted, he took out a carrot from under the ground and he was like woohoo it actually grows.

Space for notes during session

colorbar

After printing, please mark this field in your personal colour (for easy sorting)

paraphrase

Food growing brings him great satisfaction and happiness.

quote

Overall it brings great satisfaction and happiness.

Space for notes during session

colorbar

After printing, please mark this field in your personal colour (for easy sorting)

paraphrase

His favorite parts are the physical preparations for the plants and harvesting parts.

quote

My favorite part is harvesting part, I also like the preparation part for the first tomatoes. I was looking forward to build a small wall, and I am still looking forward to finish it so we can start putting our plants.

Space for notes during session

colorbar

After printing, please mark this field in your personal colour (for easy sorting)

paraphrase

He doesn't want to think about planning, thinking and scheduling because he believes it is complicated .

quote

I don't like planning, thinking, having to schedule what needs to go where and when because it is complicated. For the preparations for example I don't need thinking, it is just building, take the soil put it there and voila!

Space for notes during session

colorbar

After printing, please mark this field in your personal colour (for easy sorting)

paraphrase

He doesn't like the need to be a lot of things thought through the process

quote

Before planting the first thing, seeds or small plants; okay which ones are we going to grow; which combines well, which doesn't; are we doing it too early; is April too soon etc.. I don't like this kind of thinking process in relation to food growing.

Space for notes during session

Which thing to plant, combination of the plants, best date to plant, best date to harvest

colorbar

After printing, please mark this field in your personal colour (for easy sorting)

paraphrase

Gardening requires active doing with a plan even though he doesn't like the latter, he know he has to do it.

quote

This is something that we should be doing actively in here. I want to just do it but you still need to have a plan. I could have put tomatoes on the ground but then people would be like, it is too early you should have done it on the 3rd week of April..

Space for notes during session

colorbar

After printing, please mark this field in your personal colour (for easy sorting)

paraphrase

Sometimes he forgets the things he learnt from his neighbors.

quote

We ask people when we need information but then I forget and I have to ask again, I hope Vivian remembers.

Space for notes during session

colorbar

After printing, please mark this field in your personal colour (for easy sorting)

paraphrase

He thinks when you have a good system in permaculture, you can actually get max. harvest with min. work

quote

The good thing about permaculture is that if you have a good system you will have the maximum harvest and minimum work.

Space for notes during session

colorbar

After printing, please mark this field in your personal colour (for easy sorting)

paraphrase

He prefers permaculture over nicely lined garden.

quote

Having a nicely lined garden, that is not what I want. It is a lot of work, requires more time; it is more like you go against nature and you can never win from there. In permaculture it is more proper ecosystem you go with the nature.

Space for notes during session

Reasons for that are (1) efficiency: time, and effort; also (2) sustainability: aligned with the balance of the nature.

colorbar

After printing, please mark this field in your personal colour (for easy sorting)

paraphrase

He doesn't like to not understanding why things do and don't happen

quote

I don't like when there are things don't work and I don't understand why. We have a few tomato plants and at certain point we found black dots on it and we couldn't understand why.

Space for notes during session

Unexpected things: disease, dead of plants

colorbar

After printing, please mark this field in your personal colour (for easy sorting)

paraphrase

He imagines a simple solution for the things he cannot understand in his plants.

quote

It has to be simple, and we came to the idea where you have a small garden like this and you ask the screen "ok screen tell me what should I do with my tomato plants" and it says "they need a little bit of water". Then I know what to do

Space for notes during session

colorbar

After printing, please mark this field in your personal colour (for easy sorting)

paraphrase

He wants to know the best moments to act for his plants

quote

That's another thing; you have lettuce and it grows but when is the best time to harvest? There is an optimum, after that it flowers and its gone.

Space for notes during session

Know-how: timing of plants (when to put to the ground, when to harvest?)

colorbar

After printing, please mark this field in your personal colour (for easy sorting)

paraphrase

He feels proud after he is done with the garden for the day

quote

Pride comes later, it is about feeling good about the hard work. The feeling that you've done something nice and useful

Space for notes during session

Post feelings

colorbar

After printing, please mark this field in your personal colour (for easy sorting)

paraphrase

He imagines to be fully self-sustainable, through exchanging products they grow & make with neighbors

quote

In my ideal world, we will be self-sufficient through the garden making. We would have enough money to sustain ourselves, no one goes to work and here we grow our stuff

Space for notes during session

colorbar

After printing, please mark this field in your personal colour (for easy sorting)

paraphrase

Copper material is very good for the soil; feeds the soil and also prevents from worms

quote

It is the best because it traces the grounds very fine copper particles, that copper tools leave to the soil. When you also put copper circular shapes it is both against the warms but also good for the soil

Space for notes during session

Material knowledge

colorbar

After printing, please mark this field in your personal colour (for easy sorting)

paraphrase

He has good contact with his neighbors to exchange knowledge.

quote

With my neighbors we have good contact. When I have a question, I ask him, when he needs something he comes as well

Space for notes during session

colorbar

After printing, please mark this field in your personal colour (for easy sorting)

paraphrase

He imagines that the overall food production chain will become self-sustained.

quote

My dream is that overall the world would become totally self-sustained food production instead of our current sick system.

Space for notes during session

colorbar

After printing, please mark this field in your personal colour (for easy sorting)

paraphrase

He thinks if food is grown locally, it should be consumed locally. Otherwise, it contributes to the sick system.

quote

...We grow very good onions which we export to South Africa and we import onions from New Zealand. That doesn't make sense, that's what I meant by the sick system. I think it's totally OK to import bananas if you don't grow them. But this kind of exploiting the soil to its max, leaving it for death that's the sick system.

Space for
notes
during
session

colorbar

After printing, please mark this field in your personal colour (for easy sorting)

paraphrase

Growing food brings happiness to him

quote

It brings happiness, well the older I get the happier it makes me feel.

Space for
notes
during
session

colorbar

After printing, please mark this field in your personal colour (for easy sorting)

paraphrase

He wants to grow a mixed garden, which doesn't require too much effort

quote

We want to make a mix of a beautiful garden and basically choosing as many different plants to grow fruits, and berries.. We are going to make a little bit of potatoes but not too much because it is all hard work again every year.

Space for
notes
during
session

colorbar

After printing, please mark this field in your personal colour (for easy sorting)

paraphrase

He believes in permaculture and that nature always gives something

quote

Nature can be there and gives something, it is similar to the permaculture approach that we have.

Space for notes during session

colorbar

After printing, please mark this field in your personal colour (for easy sorting)

paraphrase

He gave away all the extra food that was left from the previous farmer

quote

Because the farmer was making them; they harvested it but still there are a lot; I took it everywhere to friends, to my neighbors, giving away to the people

Space for notes during session

colorbar

After printing, please mark this field in your personal colour (for easy sorting)

paraphrase

He is against fertilizers

quote

I don't believe in the whole methodology of fertilizers. I think it's a big misconception to fertilize anything.

Space for notes during session

colorbar

After printing, please mark this field in your personal colour (for easy sorting)

paraphrase

He believes he only needs healthy soil with a layer of humus, composed of compost

quote

What we need is a healthy soil and a humus layer which is basically the compost

Space for notes during session

colorbar

After printing, please mark this field in your personal colour (for easy sorting)

paraphrase

He sees a parallel between his lifestyle and food growing

quote

Well obviously the more you grow, the more busy you get with the garden. With food growing it's also a choice being outside or inside. It is similar to my life that I don't go that much inside.

Space for notes during session

colorbar

After printing, please mark this field in your personal colour (for easy sorting)

paraphrase

He thinks that permaculture enables him to get the joy of outside by not spending too much effort

quote

If you have a permaculture approach then you can have the joy of garden but you don't have to spend too much time working outside.

Space for notes during session

colorbar

After printing, please mark this field in your personal colour (for easy sorting)

paraphrase

He doesn't expect to eat all from his garden. He believes that with taking care regularly but small each time; you can actually eat a lot from what nature brings you.

quote

I also don't make myself any illusion that it will make me eat all year but if you spend everyday sometime in your garden, you can actually eat a lot from what nature brings you.

Space for notes during session

colorbar

After printing, please mark this field in your personal colour (for easy sorting)

paraphrase

He thinks permaculture approach prevents diseases.

quote

(talking about his parents).. one thing they don't do right which is better with permaculture is through a lot of diversity in one spot, you can prevent a lot of diseases by having diverse group of plants.

Space for notes during session

Benefits of permaculture

colorbar

After printing, please mark this field in your personal colour (for easy sorting)

paraphrase

He believes we need to listen the nature and figure out what the plants like&dislike. Then we can adjust accordingly.

quote

I think this whole monoculture idea is not good. If we go with nature and see some parts don't work very well, then you can change the constellation of plants a little bit and then in the end you can have a beautiful garden which doesn't need a lot of help

Space for notes during session

Benefits of permaculture

colorbar

After printing, please mark this field in your personal colour (for easy sorting)

paraphrase

He is willing to exchange information about food growing

quote

There are many things that I don't know so I am always happy with people having ideas exchanging them especially with the experienced ones with permaculture.

Space for notes during session

colorbar

After printing, please mark this field in your personal colour (for easy sorting)

paraphrase

He gained experience / knowledge by staying in a biological farm in Kenya; which he appreciates.

quote

I've had the pleasure of doing 3 months of research in Kenya in 2 small scale farmers who were farming in a biological way. So I've learnt another way on how to do gardening different way than Dutch gardens.

Space for notes during session

colorbar

After printing, please mark this field in your personal colour (for easy sorting)

paraphrase

He doesn't have knowledge about the plants too much and he wants to gain that.

quote

I don't know many plants by name, I don't know about their chemical routes, you know, what they need, what they get from the other ones, interactions between plants

Space for notes during session

A2.1 Subtle Advice Giver

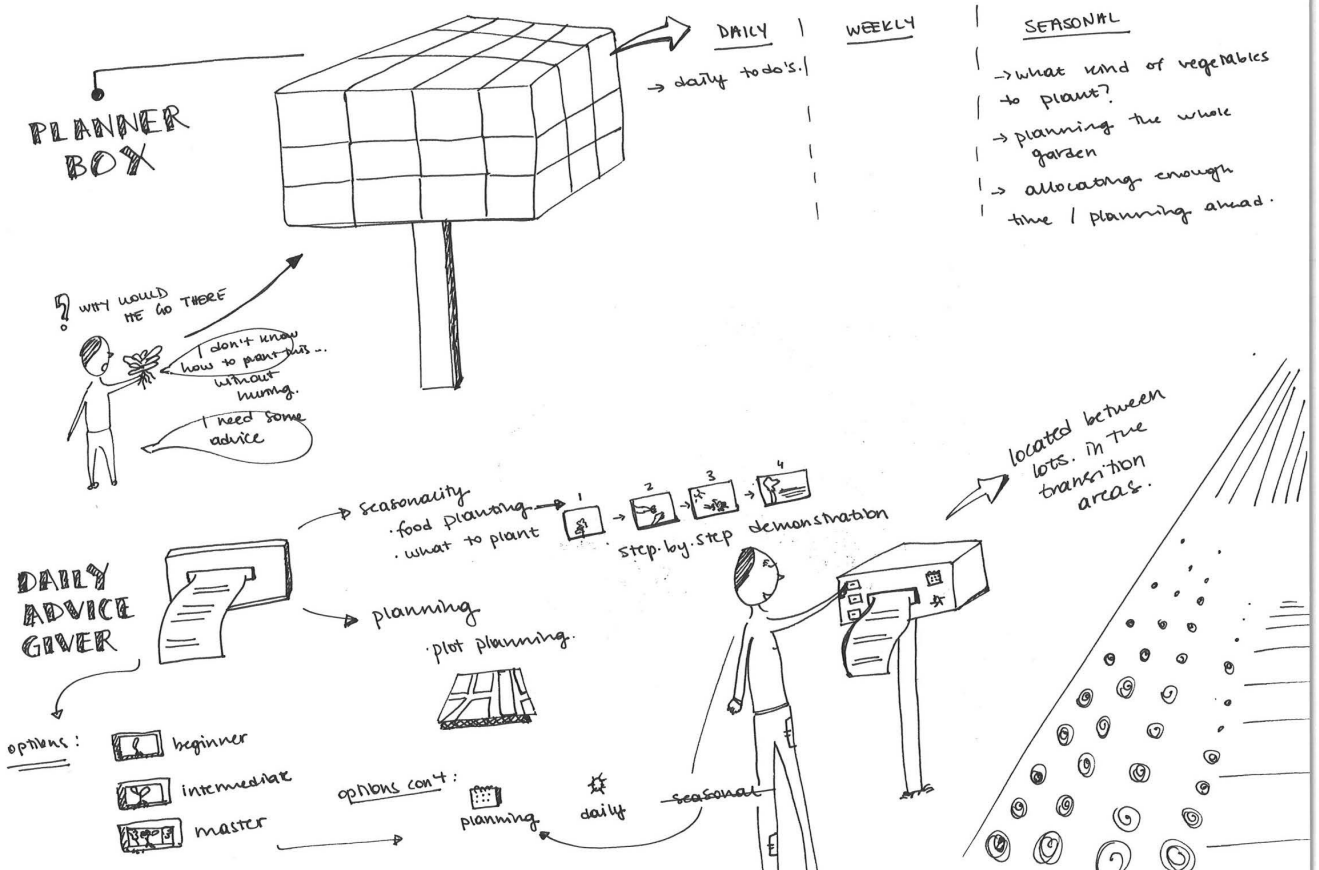
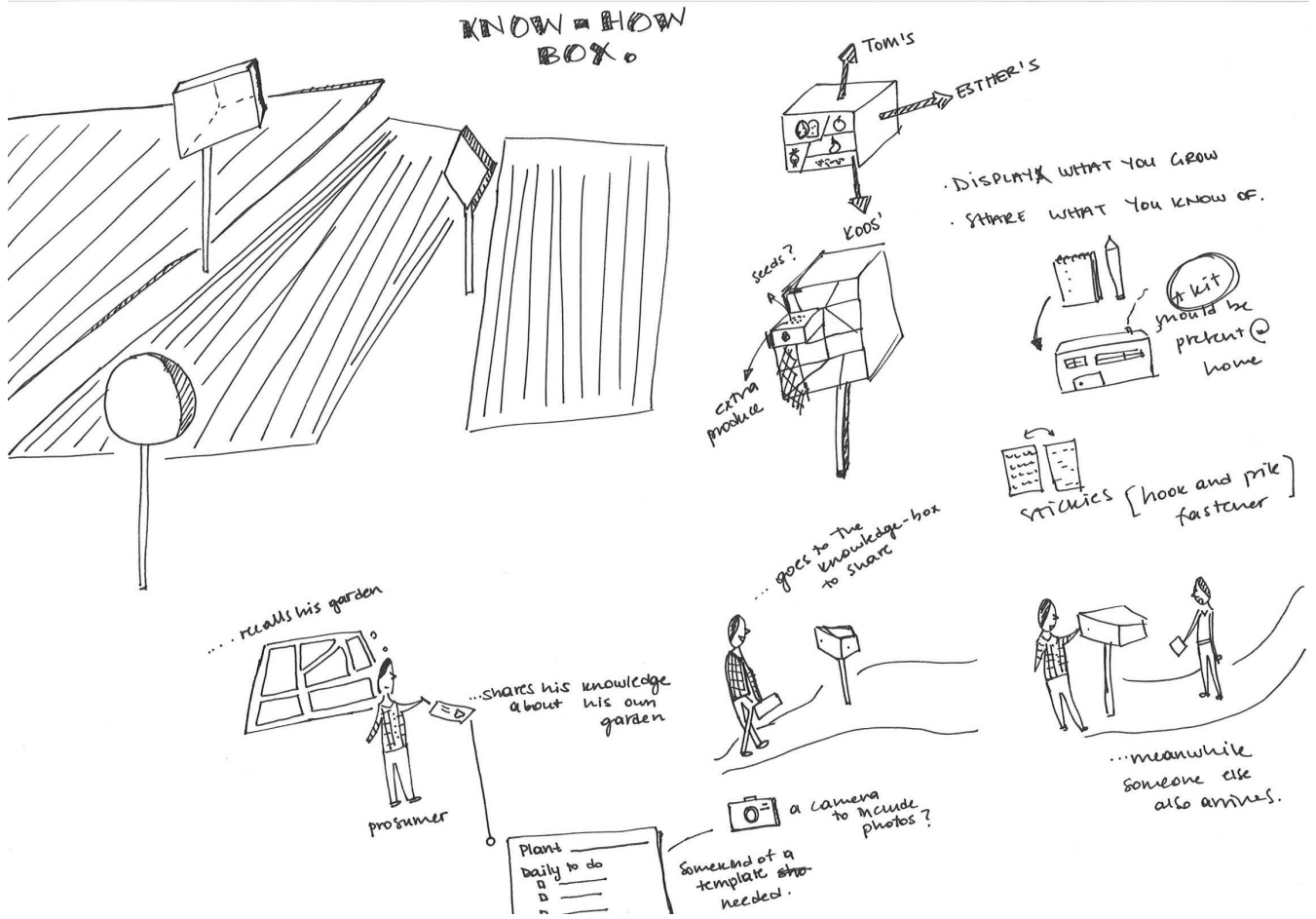



A prosumer shares her knowledge regarding compost making..



Another prosumer chooses the advice type she wants to have that day..



..there it is!



..tries the practical knowledge on her garden.



..shares it with her neighbors that she comes across..



She reads it..

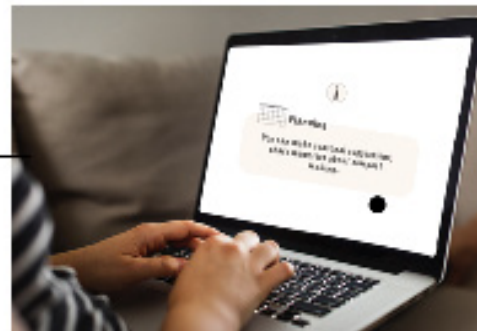

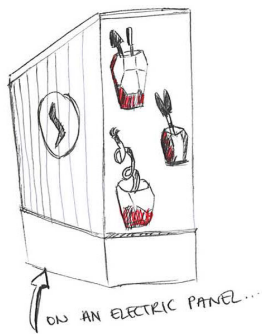

SHARED TOOLS ARE LOCATED ON THE PUBLIC SPACES OBJECTS

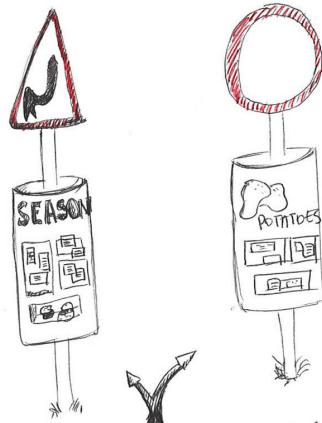

KNOW-HOW DASHBOARDS ARE AGAIN LOCATED ON PUBLIC OBJECTS.

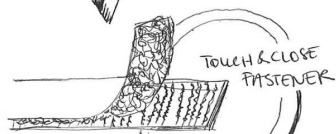

CAN BE EASILY ATTRACTED.

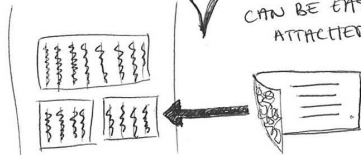

RELEVANT "STARABLES" ARE AVAILABLE AT PRO SUMMERS' HOUSE

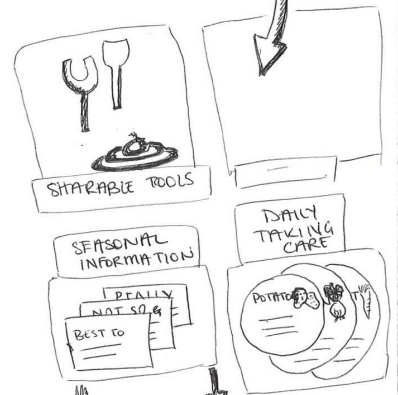

Prosumer sees a hackable station for her tool..



..she leaves her tool for others to use and pick a shovel she needed.



She uses the new tool to dig the soil..



..remembers that she can contribute with her knowledge



Other prosumers read about how the digging should be like.



..sticks her note there for others to see.



..goes to one of the hackable that is about plants..



She writes about how deep soil should be digged for potatoes..



A2.3 Comprehensive Planner

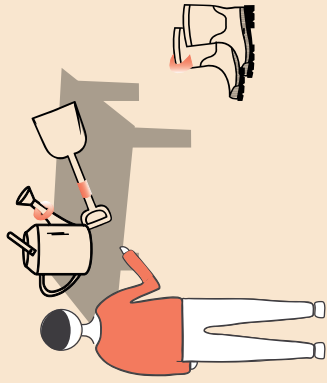

Choose the tools that will be used this time



Make sure to leave enough space!

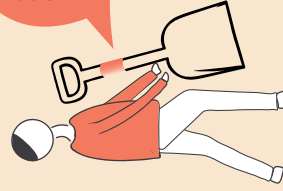

The tool gives advice depending on the gardening practice

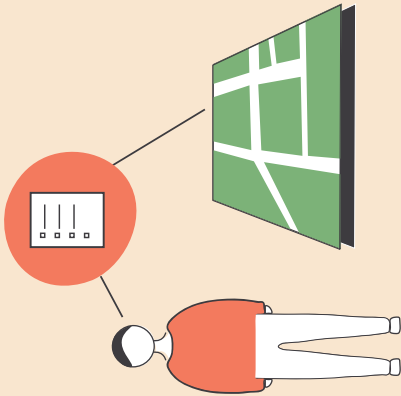

Access your garden plan from your house and make planning about it

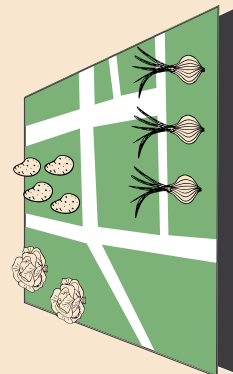
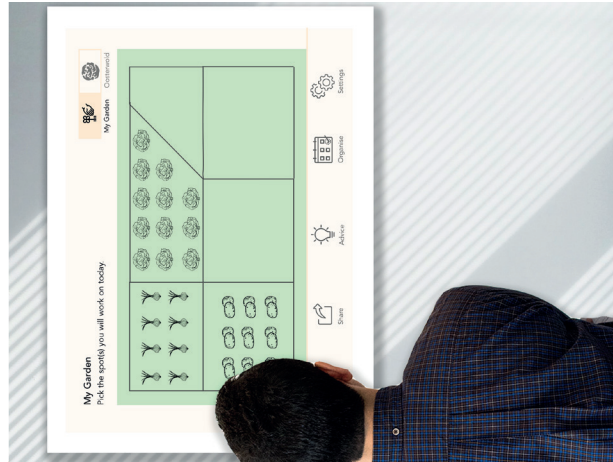

Being able to see your garden in sections and choose where you will work on

A3.1 Persona Cards



You moved to Oosterwold because it was way much cheaper compared to your previous apartment in Amsterdam.

Personal

Mindfulness:

Financial:

Health:

Collective

Social & Financial:

Environmental:



You moved to Oosterwold because you wanted to live in nature and grow your own food in a bigger space.

Personal

Mindfulness:

Financial:

Health:

Collective

Social & Financial:

Environmental:



You moved to Oosterwold because you want to become self-sufficient. You think our society is corrupted.

Personal

Mindfulness:

Financial:

Health:

Collective

Social & Financial:

Environmental:



You moved to Oosterwold because it was cheaper compared to your previous apartment in Amsterdam and it's also close to your work.

Personal

Mindfulness:

Financial:

Health:

Collective

Social & Financial:

Environmental:



You moved to Oosterwold because you wanted to be closer to soil and feel the connection with nature. You appreciate what nature gives you.

Personal

Mindfulness:

Financial:

Health:

Collective

Social & Financial:

Environmental:



You moved to Oosterwold to grow your own food. You eat only organic food, you apply biologic methods of gardening.

Personal

Mindfulness:

Financial:

Health:

Collective

Social & Financial:

Environmental:



Personal.

Name: Bob, the saver
Profession: Retired carpenter
Age: 66

Gardening

Edible plants: 5 fruit trees
Time spent: During weekends, as much as he wants
Experience level: Knowledge from childhood
Motivation: Looks good from outside



Personal.

Name: Dora, the earth lover
Profession: Retired teacher
Age: 62

Gardening

Edible plants: 12 fruit trees, 13 different herbs, 8 types of root vegetables, 6 types of grains
Time spent: Everyday 2-3 hours
Experience level: Expert
Motivation: Loves being in the nature and growing food



Personal.

Name: JK, the self-sufficient
Profession: Manager
Age: 47

Gardening

Edible plants: 5 root vegetables (still in the planning phase)
Time spent: Everyday 2-3 hours
Experience level: Beginner
Motivation: Lives self-sufficient and has plant based diet



Personal.

Name: Luke, the money maker
Profession: Finance specialist
Age: 34

Gardening

Edible plants: 2 fruit trees, 2 herbs
Time spent: During weekends, as much as he wants
Experience level: Knowledge by listening neighbors
Motivation: Everyone else is doing



Personal.

Name: Annuk, the mindful
Profession: Retired flight tenant
Age: 52

Gardening

Edible plants: 15 fruits, 16 different herbs, 8 types of root vegetables, 6 types of grains and beans
Time spent: Everyday 4-5 hours
Experience level: Expert
Motivation: Appreciate connection with soil



Personal.

Name: Bibi, the health guru
Profession: Yoga instructor
Age: 38

Gardening

Edible plants: 6 fruits, 12 root vegetables, 19 herb types, 5 types of grains, 4 types of beans
Time spent: Everyday 2-3 hours
Experience level: Experienced
Motivation: Healthy and organic lifestyle

A3.2 Manifestos

Workshop Manifesto #1

This manifesto will guide you through this workshop. It is a starting point that describes one of the concept ideas of prosumerism graduation project of Yağmur. You are expected to carefully read and understand below mentioned points and imagine experiences/interactions based on them.

Subtle Advice Giving

In the neighborhood, inhabitants contribute each other's know-how. Knowledge exchange is made in a surprising, simple and easy way. One should take the initiative to start the knowledge sharing loop and others will join. There is an unconscious interpersonal interaction among inhabitants, in other words shared knowledge is anonymous. Neighborhood becomes a hub where knowledge can be retrieved easily and in a surprising way.

Guidelines

Knowledge

- From one to many – Think of what can be a reason to start the loop, why taking initiative?
- How experiences and memories can be translated into knowledge?
- How would this knowledge be present in the neighborhood?
- What are the forms of knowledge retrieval in the public space?
- How can this knowledge sharing system be sustained?

Meaning

- How meaning can be embedded in this kind of a system?
- What if meanings would be visible within this neighborhood?
- What are the contributions of this system to individuals' value systems?

Workshop Manifesto #2

This manifesto will guide you through this workshop. It is a starting point that describes one of the concept ideas of prosumerism graduation project of Yağmur. You are expected to carefully read and understand below mentioned points and imagine experiences/interactions based on them.

"-Able"rs

Imagine the neighborhood becomes a public space for its inhabitants to make, create and hack for a shared wealth and specifically knowledge. Neighborhood becomes a communal resource and empowers people through the sense of communal ownership. People take active role as makers, hackers and other forms of doers. There is a visible community building going on in the public space.

Guidelines

Knowledge

- What are the forms of knowledge in this kind of a hackable environment?
- How would the neighborhood look like?
- How "making the knowledge" would be like?
- What are the "-ablers" for inhabitants?
- How may inhabitants DiY the neighborhood?
- Slow or fast – How would be the pace of making the neighborhood be like?
- How can we transform our personal resources into meaningful public experiences?
- How can the public space support inhabitants to enhance their gardening practice?

Meaning

- What are the motivations of inhabitants to make the city?
- How those motivations can be supported within the neighborhood?
- How would the meaning of the public space evolve over time?

Workshop Manifesto #3

This manifesto will guide you through this workshop. It is a starting point that describes one of the concept ideas of prosumerism graduation project of Yağmur. You are expected to carefully read and understand below mentioned points and imagine experiences/interactions based on them.

Comprehensive Planner

In this ideal smart world, you know everything regarding food growing. You can plan your garden through knowing interactions between plants, receiving seasonal tips and many more. You can even organize workshops, events and request participation to them. The other food growers' gardens are accessible to you and you can follow what they grow and how they make planning. You can even get tips and tricks from the *things you use* while you are in your garden.

Guidelines

Knowledge

- How would data contribute to the knowledge of growers?
- What if inhabitants know everything about each other's gardening practice?
- How does privacy is experienced in this kind of a system?
- What are the ways of generalizing data?
- What is the "correct" moment to retrieve what kind of knowledge in this kind of a smart environment?

Meaning

- What would the meaning of food growing become?
- How knowledge may affect meaning?
- Can it bring new meanings?
- How connection of growers with soil may be sustained?
- How would collaboration be like?

A3.3 Service Design Map

How's the form of your design and why is it that way?

What is the purpose of your design?

How your design contributes to knowledge sharing?

What are the critical issues that should be taken into account in your design?

Name / slogan:

Sketch it!

Draw your idea here. It can be system map, service offering, anything that explains your idea!

(a)realise it!

How would the qualities of your design look like? How would an area of it be like?

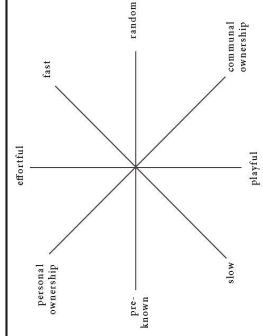

example:

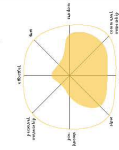

A3.4 Storyboard Template

Storyboard

The storyboard template consists of a large rectangular frame containing six smaller rectangular panels arranged in a 3x2 grid. Each panel is followed by three vertical lines, indicating a sequence of frames or steps in a story. The word "Storyboard" is written vertically on the left side of the frame.

A3.5 Procedure of Brainstorming Workshop

Welcome!

First please have a look at the consent forms and read it carefully.

Alright, now I want to briefly explain you the context of my project: Oosterwold and how it looks like.

show presentation

Personal growth is linked with the meanings that those people associated the practice of food growing with. Today in order to bring those meanings into the table, you will work with different personas that are in front of you.

Now please have a look at them for a moment. So, before we start, let's have an introduction round so that we know each other, the personas I mean, because you will work in pairs and you are from Oosterwold, it's good to know each other ☺ During the session, try to imagine and design from your persona's shoes.

persona introduction

Now I will pass out 3 different manifestos of which you will brainstorm and later design for.

give out manifestos

The manifestos include a brief explanation of the ideal world of your design in Oosterwold together with some questions that will help you to brainstorm and also take into account while designing. What would be your first impression of the described world in your manifesto? Now you can make a mindmap with the one sitting next to you. You will have around 10 minutes for that.

pass out empty sheets & record 10 minutes

Now based on your mindmaps, you can start making your ideas concrete through drawing your system/service into those sheets and make a storyboard to show the intended interaction. You have 15 minutes for that. Feel free to discuss with your mate.

pass out the other sheets & record 15 minutes

Now you can use the blocks, clay and postits to build your designs. You have 10 minutes for that. After that each pair will briefly explain what they did.

Give out making materials.

Perfect! Now let's present the ideas, who wants to start? You can also present your storyboard and service map.

Subtle Advice Giver

Group 2

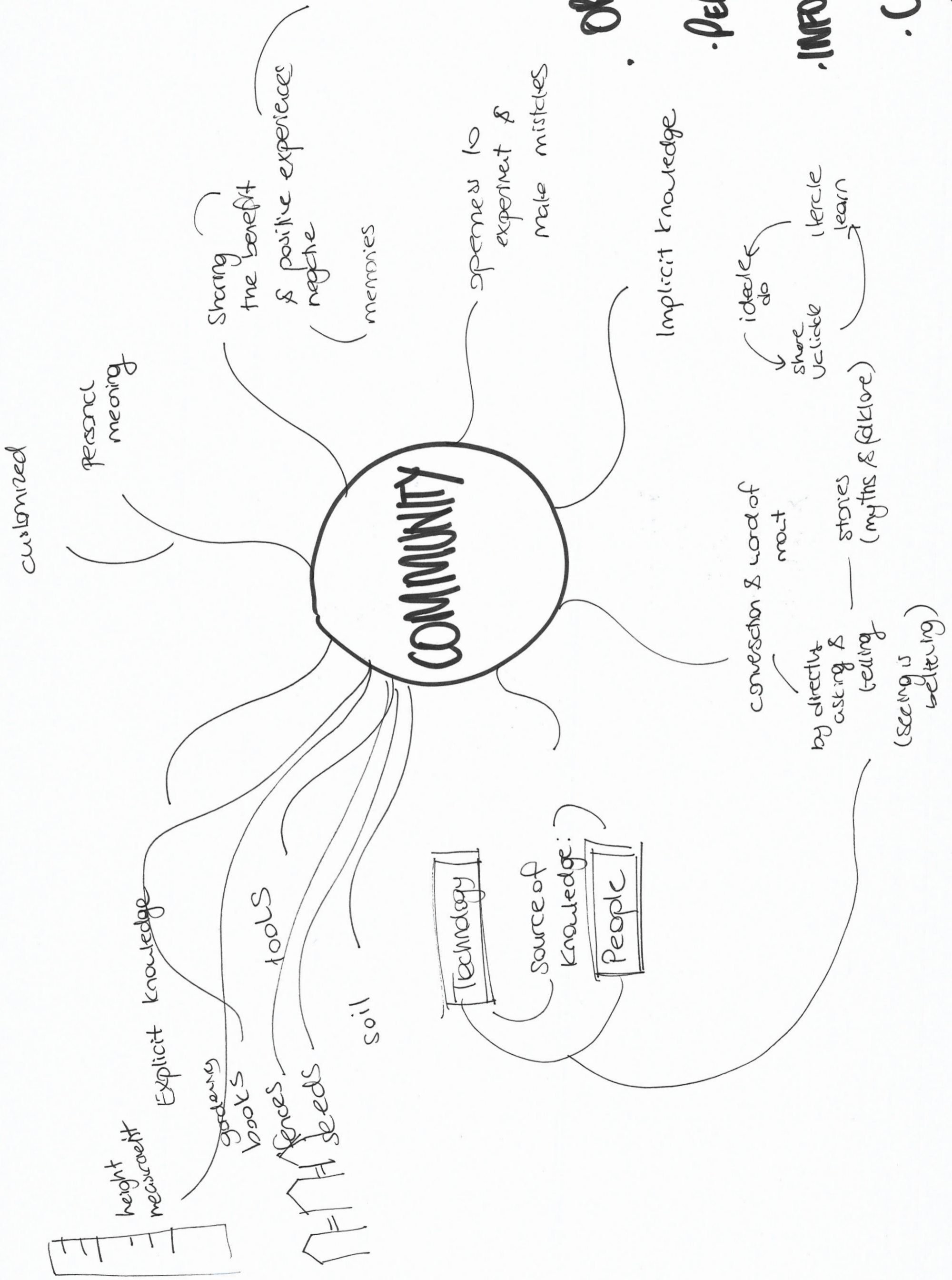

How's the form of your design and why is it that way?

it is the fence so that

everyone can share their

experiences - so all the markets can see "open source"

What is the purpose of your design?

To share knowledge & experience with the community

How your design contributes to knowledge sharing?

it contributes by creating a common ground / data collection system for everyone

What are the critical issues that should be taken into account in your design?

People may not want to share their negative experiences so it should be (the temple) ^{helpful} should frame the issue in a positive way.

Name / Slogan:

Fence-Cast!
(Your experiences)

Sketch it!

Draw your idea here. It can be system map, service offering, anything that explains your idea!

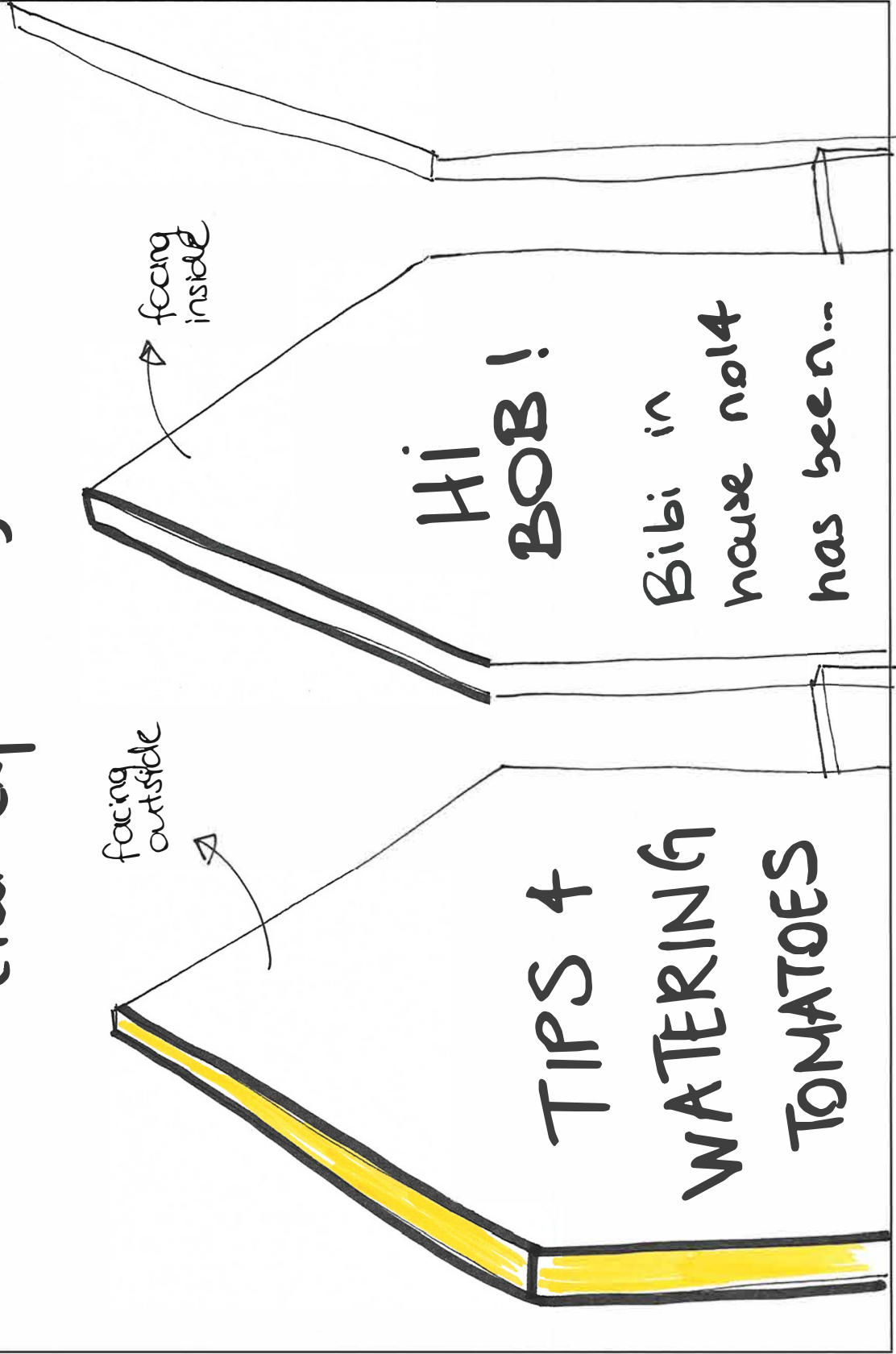

(a)realise it!

How would the qualities of your design look like? How would an area of it belike?

+

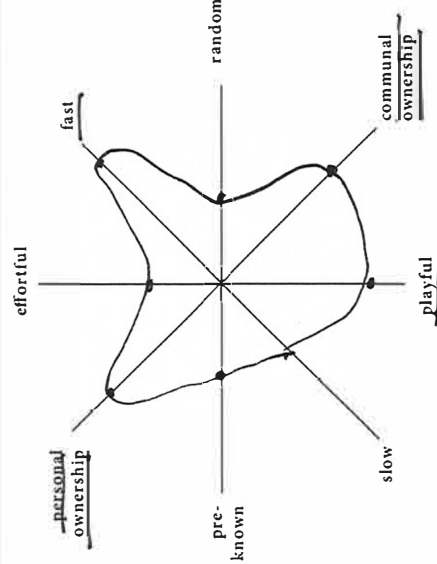

example:

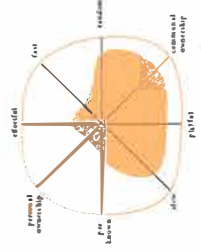

Storyboard

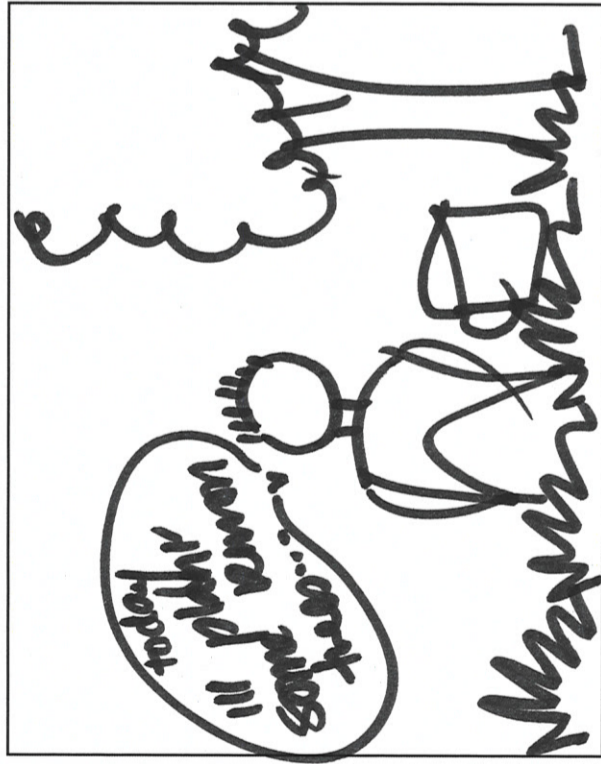

1. You are gardening in your home

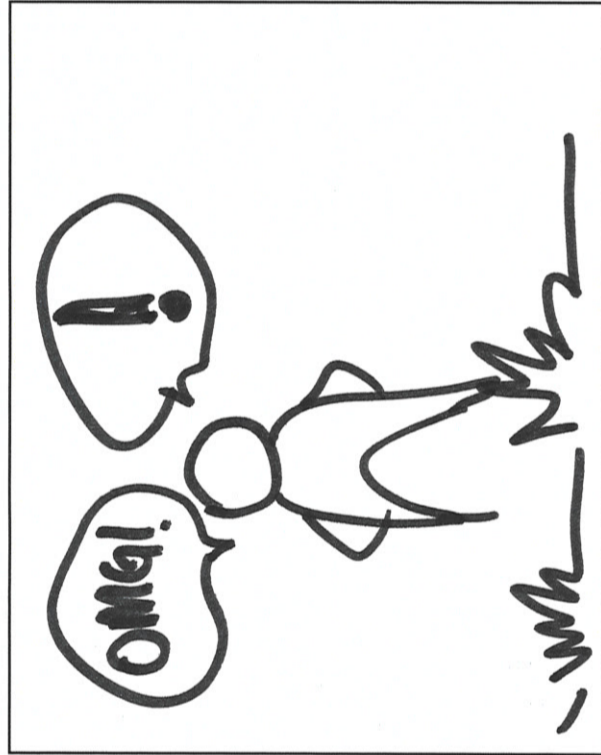

2. Had a new revelation! quickly find the template

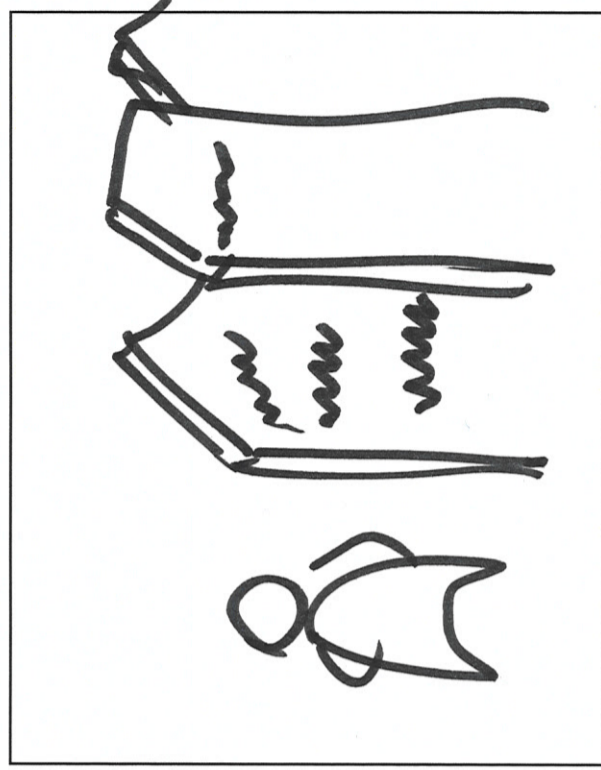

3. Add to your fence

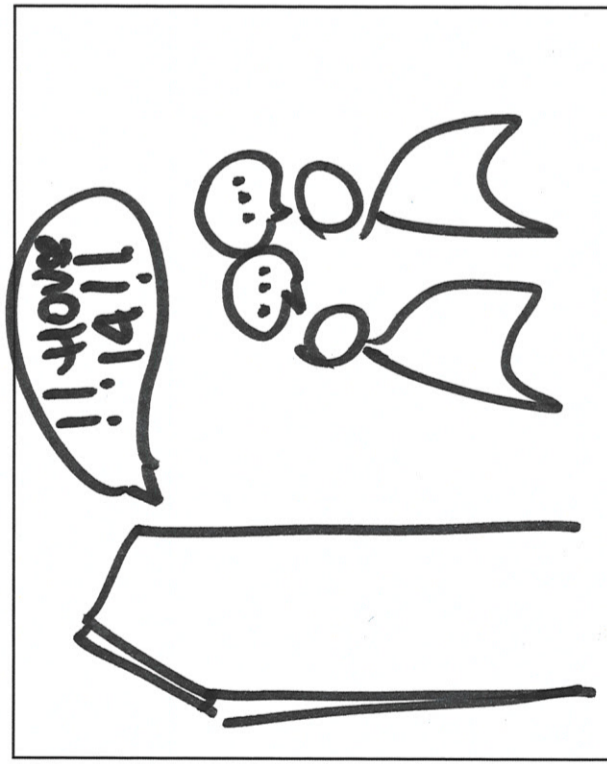

4. Connor with a neighbor that had a similar revelation.

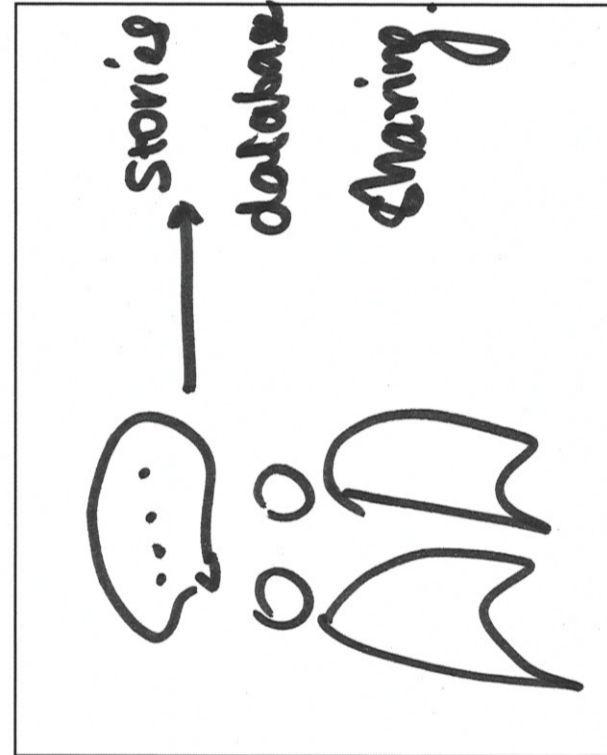

5. Show your stories and experiences and learn from it.



MANIFESTO #1
SESSION 1

Subtle Advice Giver Group 1

Storyboard



MAKE BOTH PEOPLE
UNDERSTAND THAT THEY
SHARE VALUES

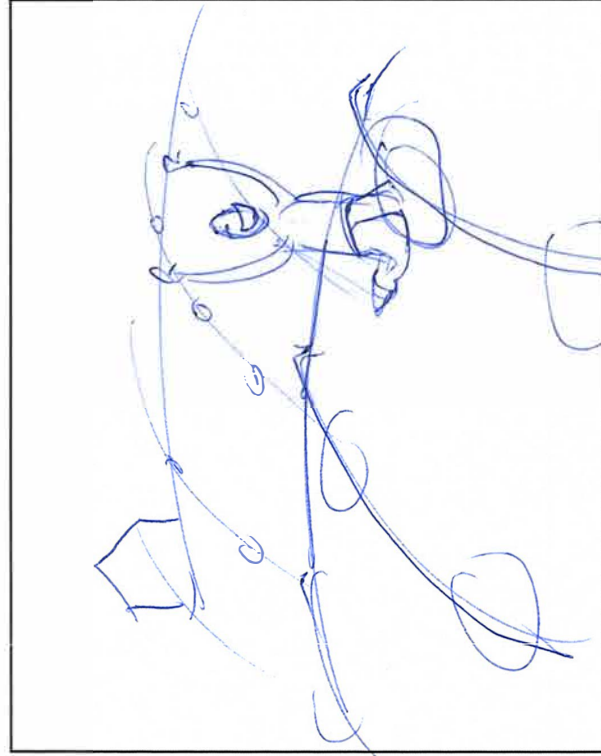
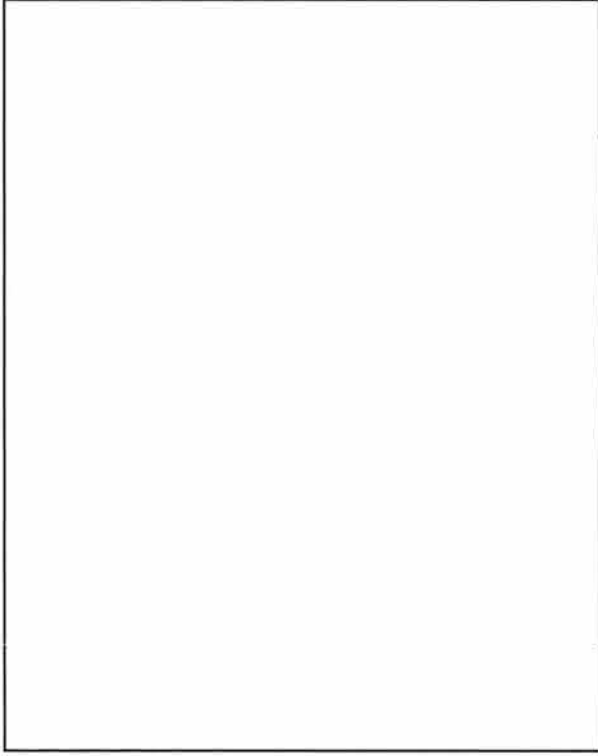
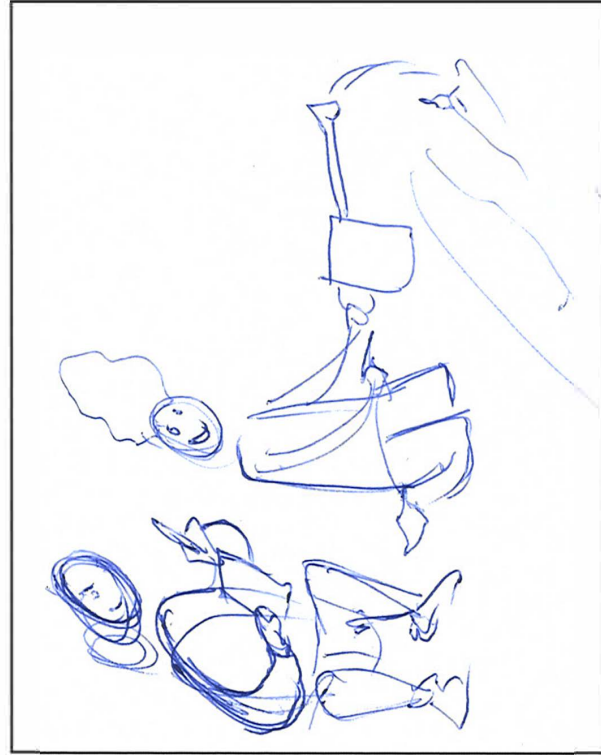
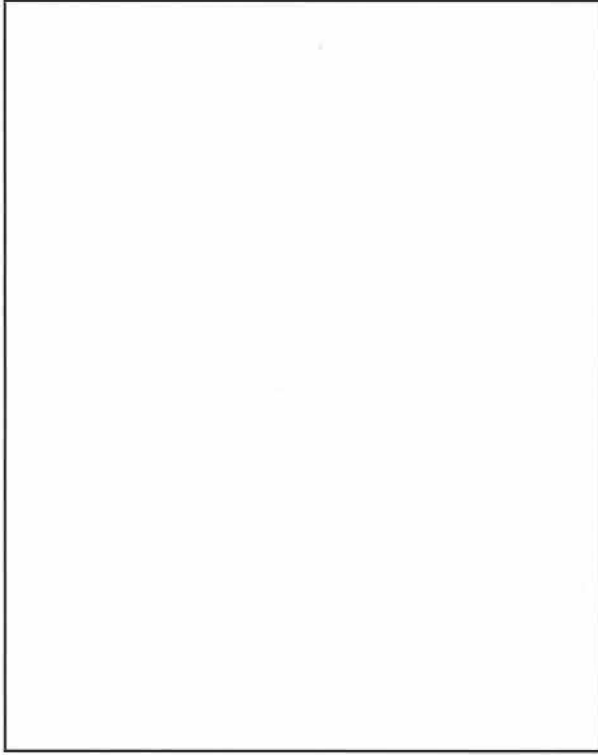
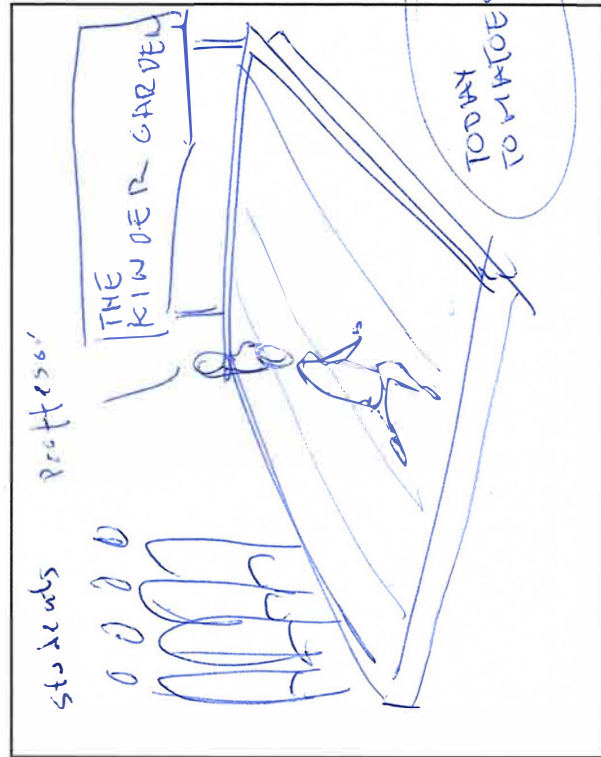

SHARING KNOWLEDGE !!
ABOUT GARDENING
AND STUFF.

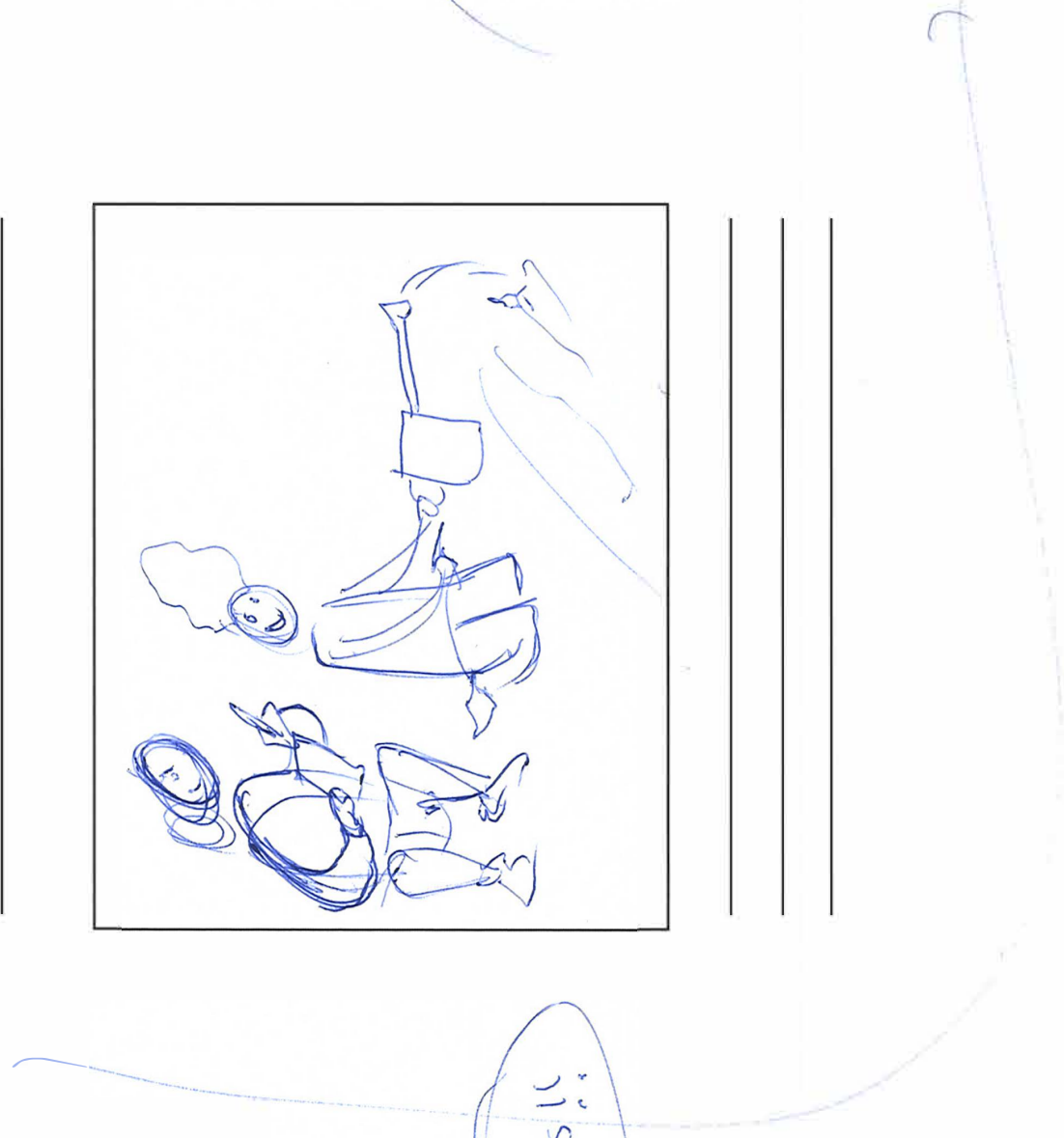

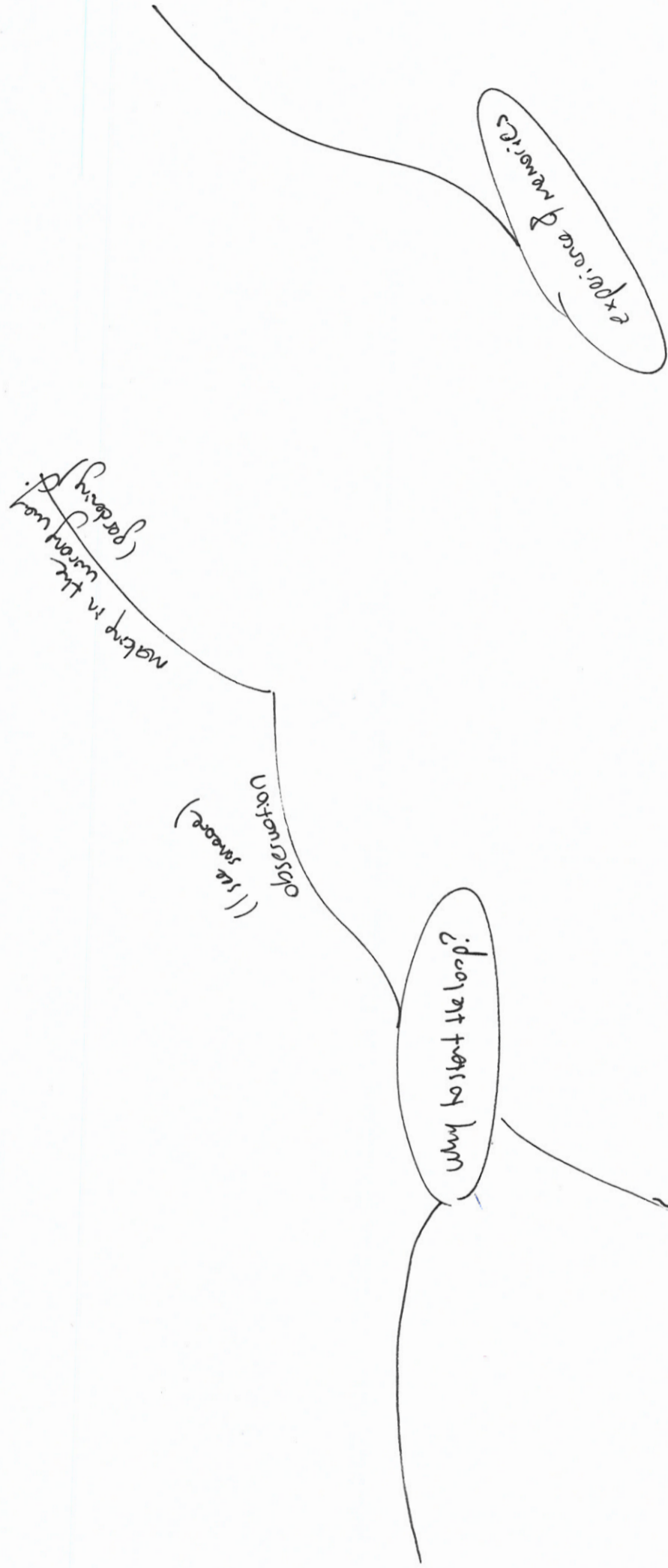

Boredom

same body
to talk with
your friends
reinforce

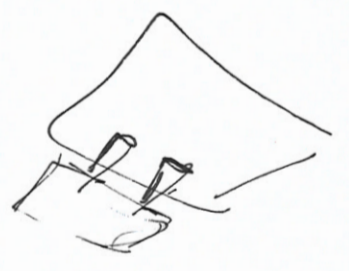

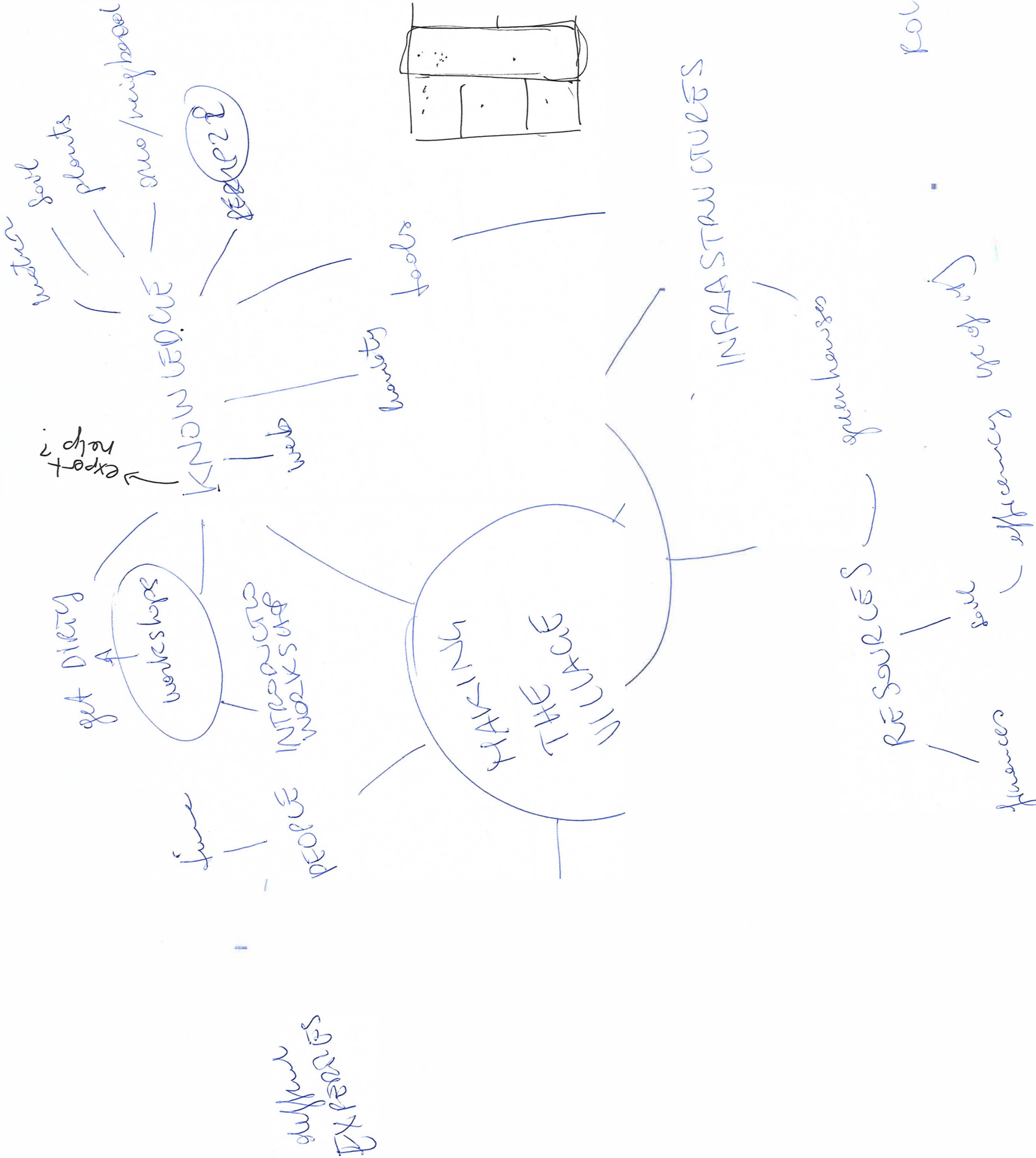

How's the form of your design and why is it that way?

Name / Slogan:

GET DIRTYER

Sketch it!

Draw your idea here. It can be system map, service offering, anything that explains your idea!

WATER MANAGEMENT (FIGHT)

BUILDING

FINANCES

ENV. IMPACT

What is the purpose of your design?

to give equal knowledge to each community ~~individual~~ individuals

How your design contributes to knowledge sharing?

create individual role which follows personal attitudes

What are the critical issues that should be taken into account in your design?

structure the colleges in an meaningful

(a)realise it!

How would the qualities of your design look like? How would an area of it belike?

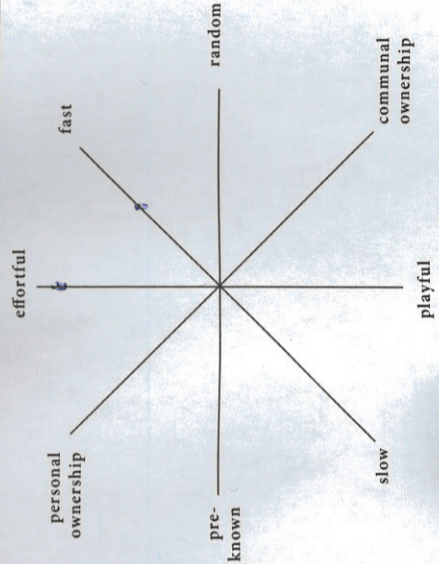

example:

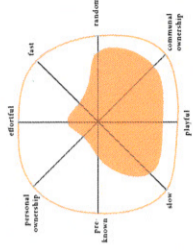

Storyboard

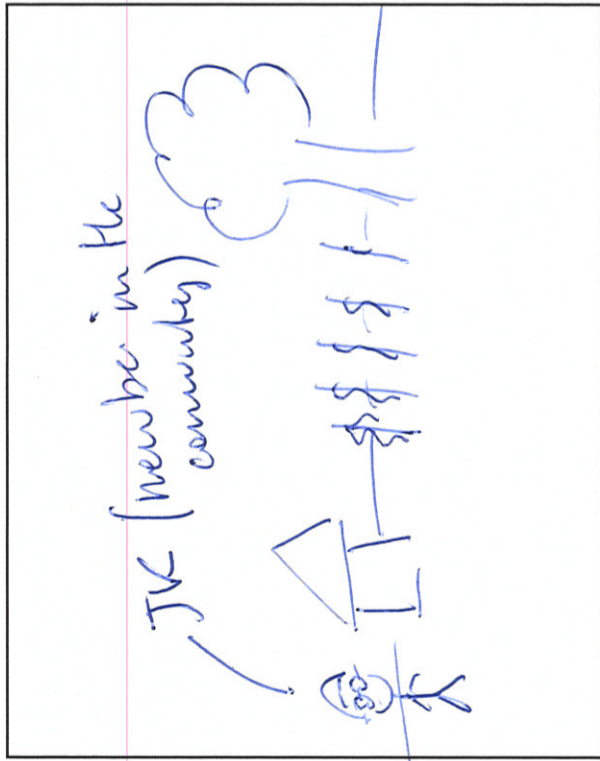

JK is a new member of the community. He needs to catch up with all knowledge

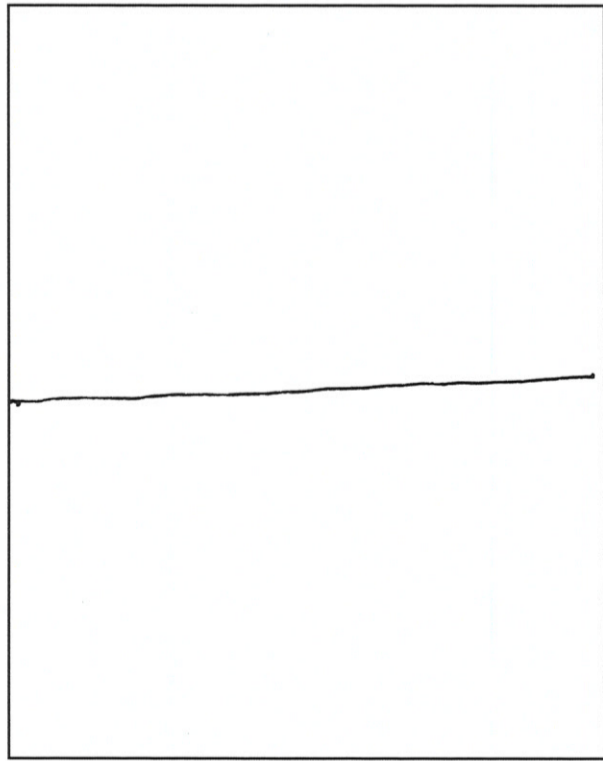

Eventually individuals can focus on something specific to get become more expert on it or they can engage roles in order to get knowledge about other things.

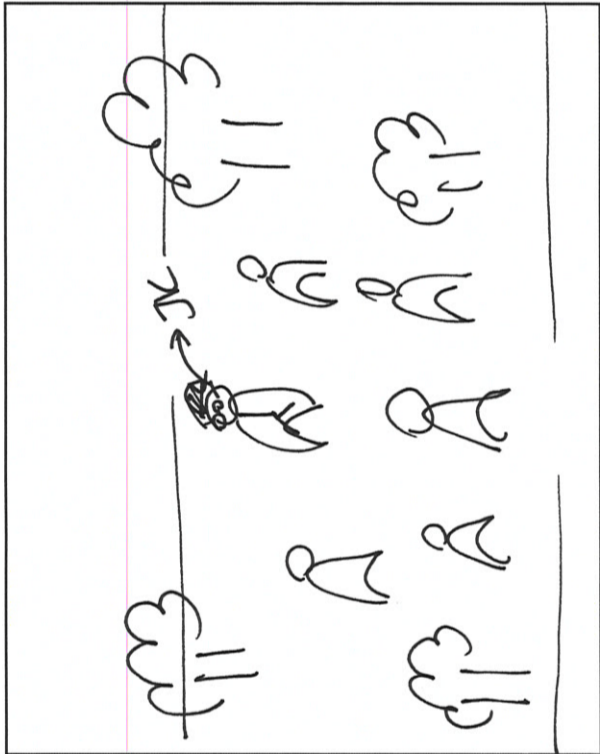

JK meets with the community to get to know each other. Then they start practical works (workshop) to gather info about the soil and seeds.

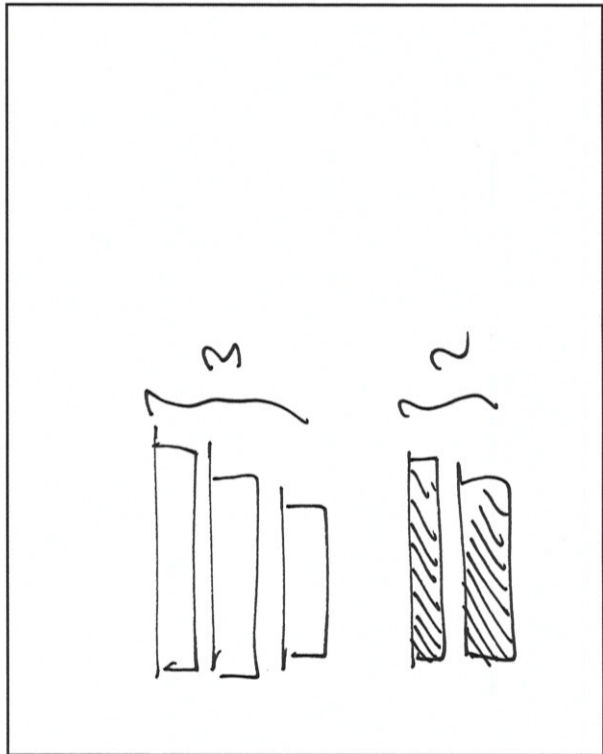

Each block of wood represents different tasks that individuals can work on.
 1 block = 1 " " } Eventually the number of blocks will determine how good you are about it.
 2 blocks = 2 " "
 3 " = 3 " "

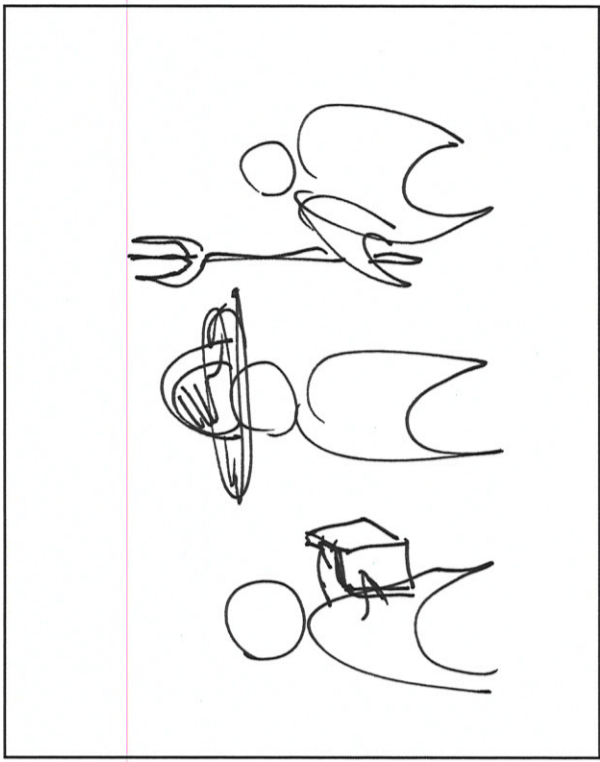

Role divisions are made so each individual can go and get help from certain person. (technical guy, tools, soil info etc.)

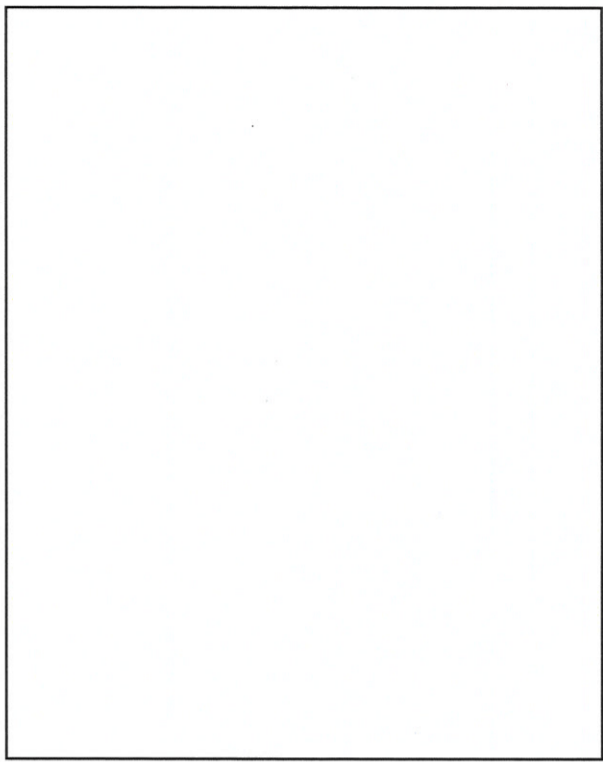

Hackable Hood
Group 1

How's the form of your design and why is it that way?

Something that's not pushing but mediated. 
(slow)

What is the purpose of your design?

Knowledge sharing about gardening, exchange of plants.

How your design contributes to knowledge sharing?

By exchanging plants, they share the knowledge of how you should grow/take care of the plants. Asking each other help about gardening (f.i. Carpentary)

What are the critical issues that should be taken into account in your design?

Misuse of the shared goods.
F.i. People might take the plant but don't offer help in exchange

Name / Slogan:

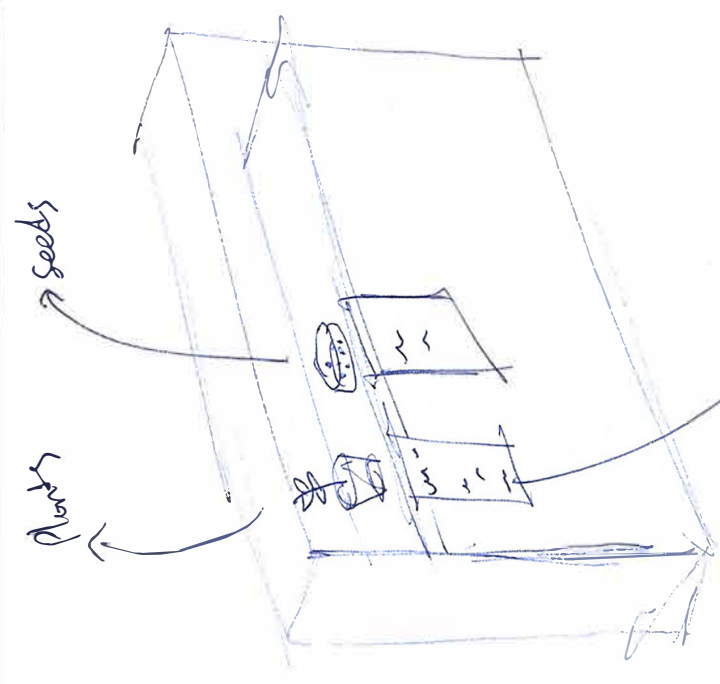

A table asks for help in exchange of plants/seeds etc.

Sketch it!

Draw your idea here. It can be system map, service offering, anything that explains your idea!

(a)realise it!

How would the qualities of your design look like? How would an area of it belike?

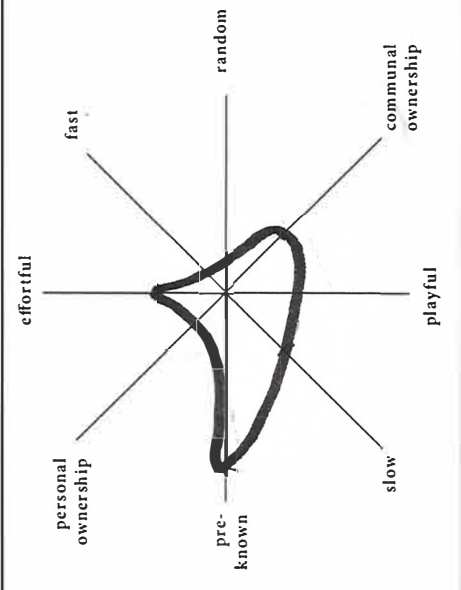

example:

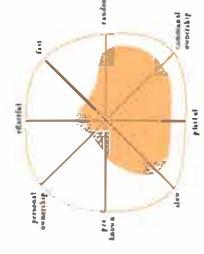

Storyboard

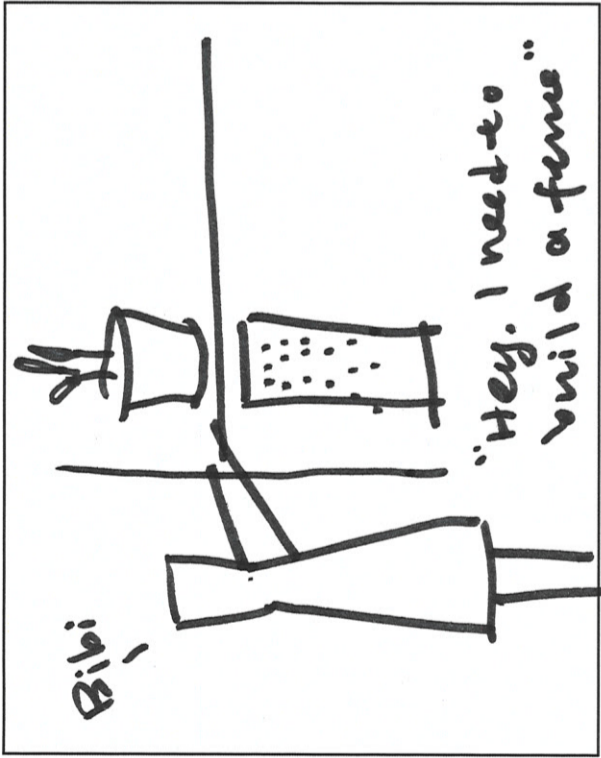

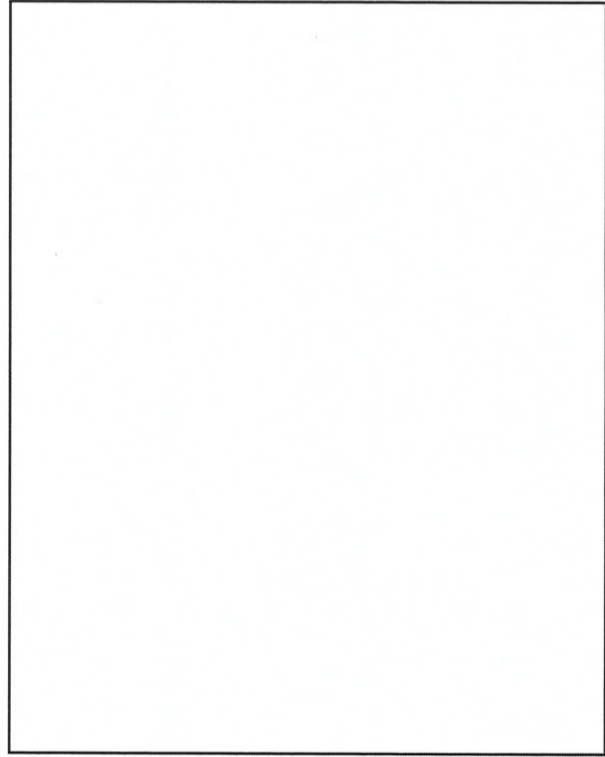

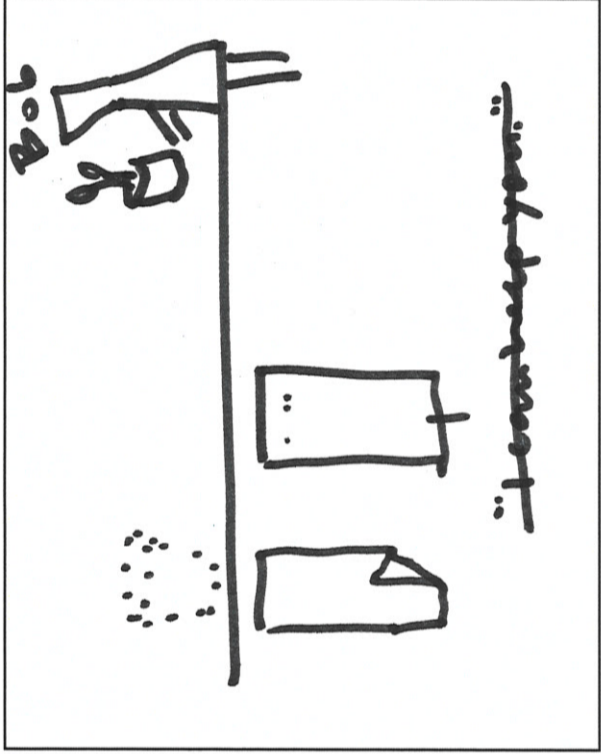



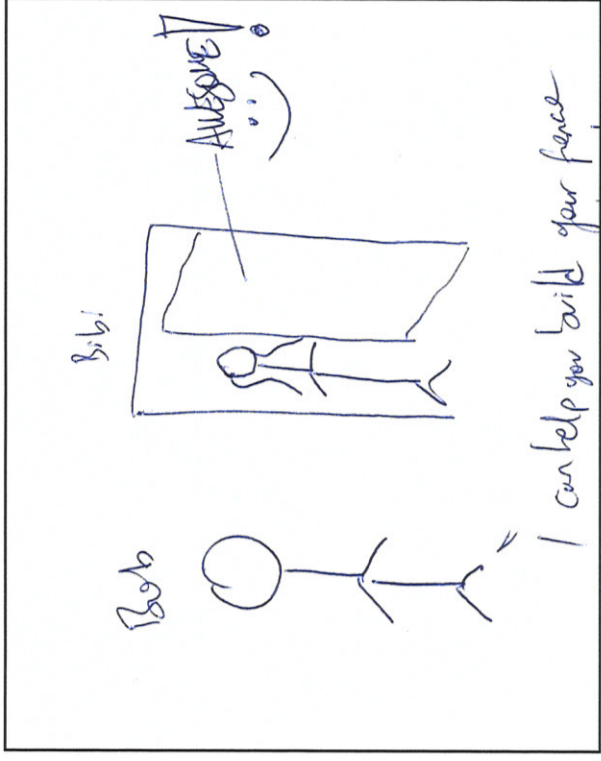

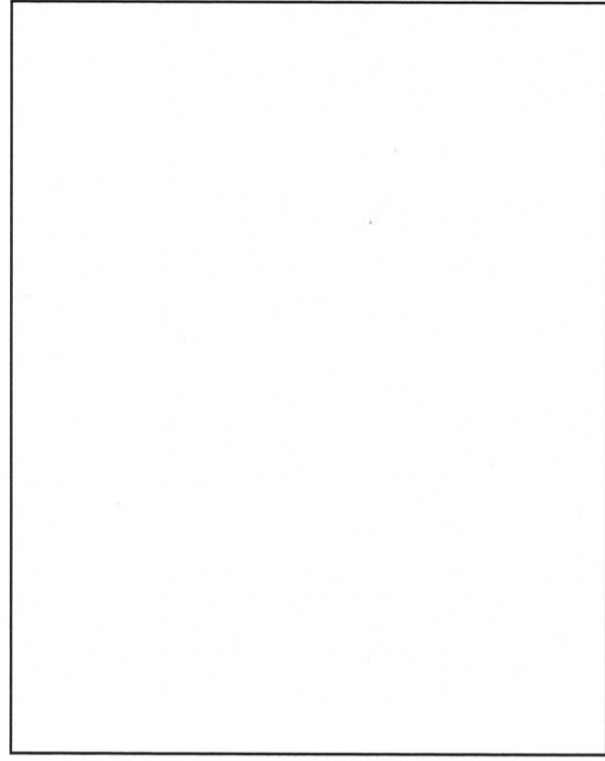

Comprehensive Planner
Group 1

How's the form of your design and why is it that way?
A public growing plant.
we have/rent our own small space
and ~~data~~ is the manager.

What is the purpose of your design?
Learn from the neighbour
to share with each other
plants & knowledge.

How your design contributes to knowledge sharing?
Everyone is responsible to their ^{space} ~~space~~.
Environment enables them a chance
to work together.

What are the critical issues that should be taken into account in your design?
Everyone should respect others
privacy.

Name / Slogan:
Share & Grow

Sketch it!
Draw your idea here. It can be system map, service offering, anything that explains your idea!

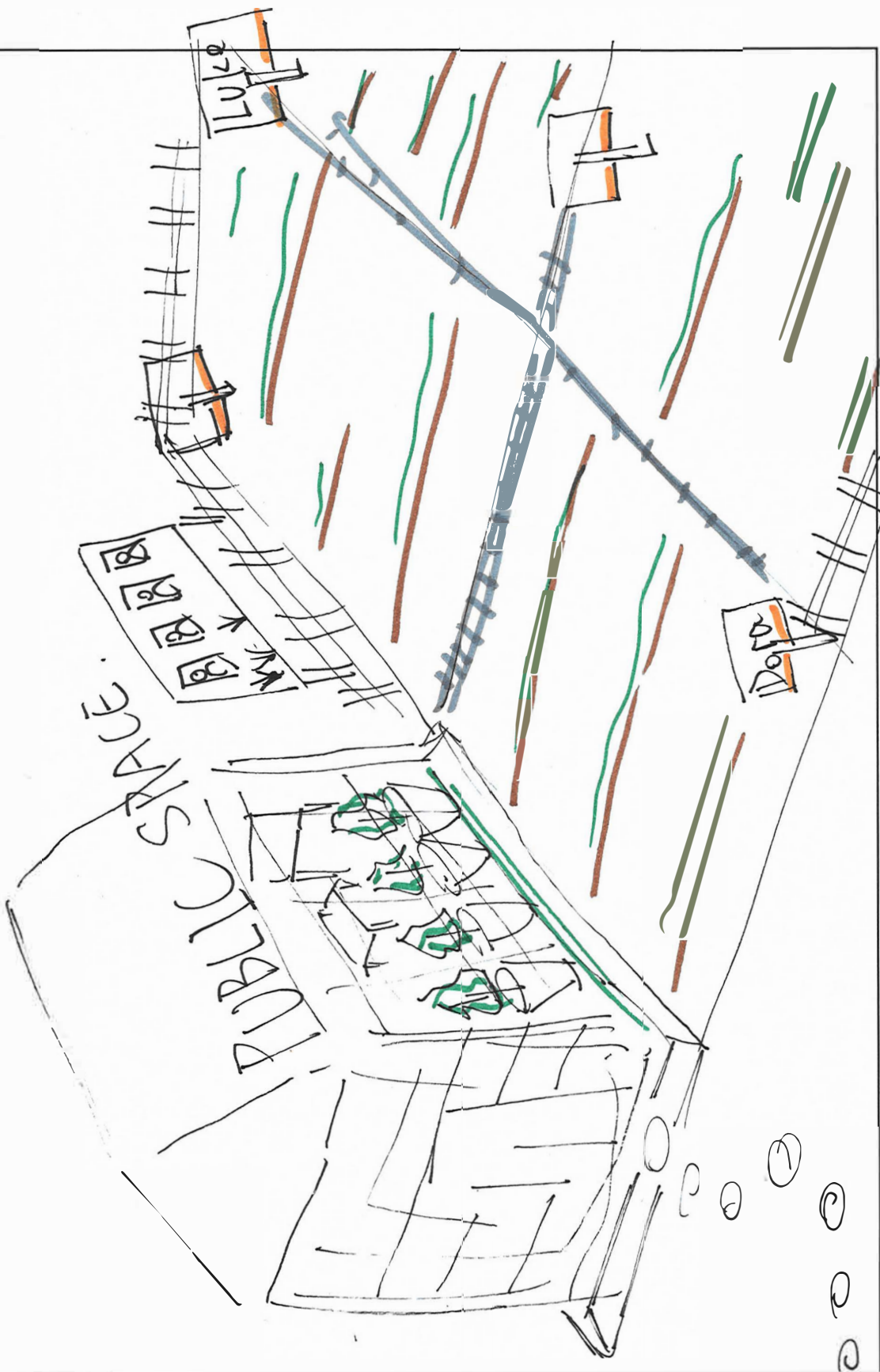

(a)realise it!
How would the qualities of your design look like? How would an area of it be like?

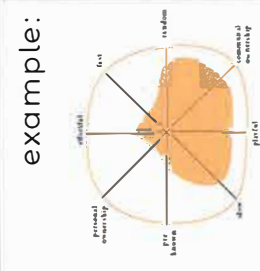
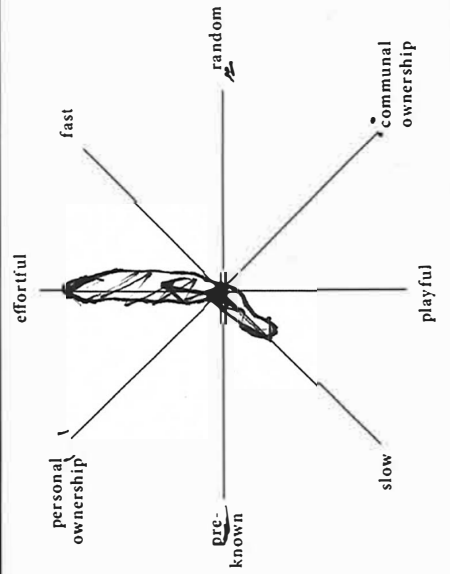

Storyboard

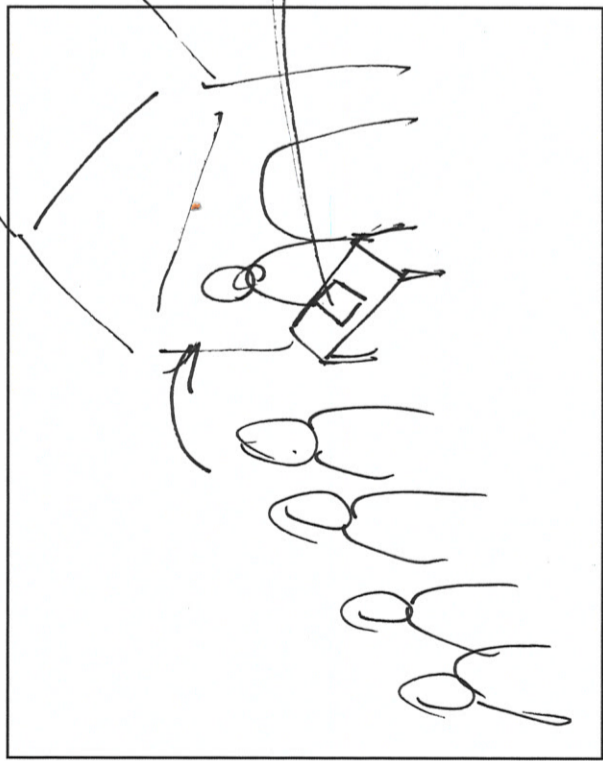

When the public space is defined,
people register to share the
area for gardening.

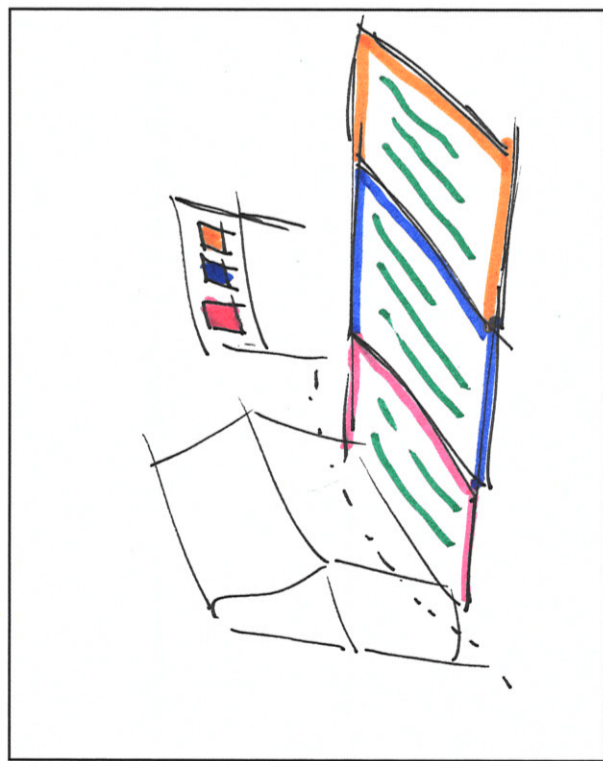

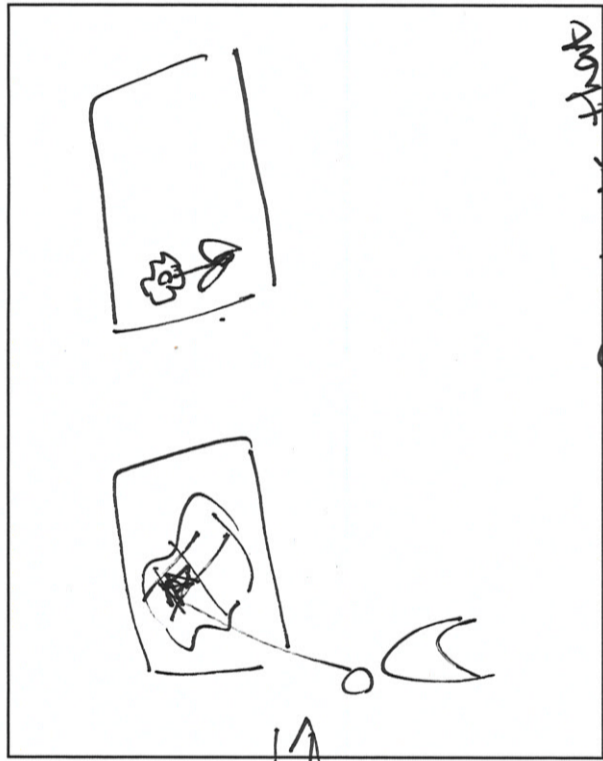

choose place & plants that
they want to use (gain some
initial knowledge of growing)

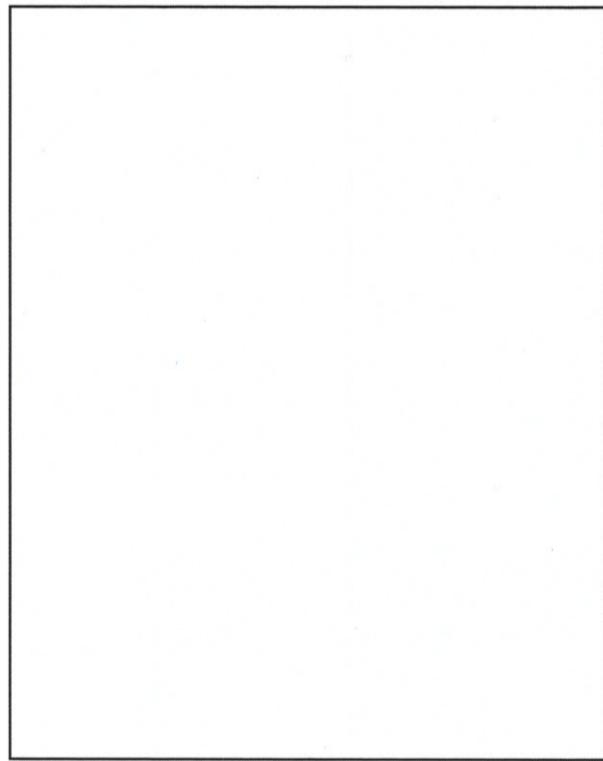

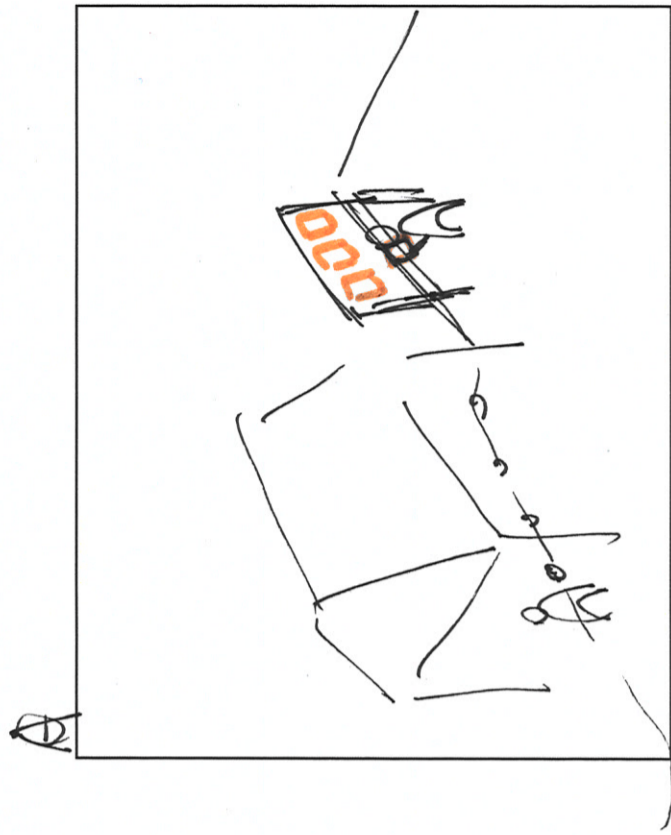

put their info (name & plants
& date of enrollment)

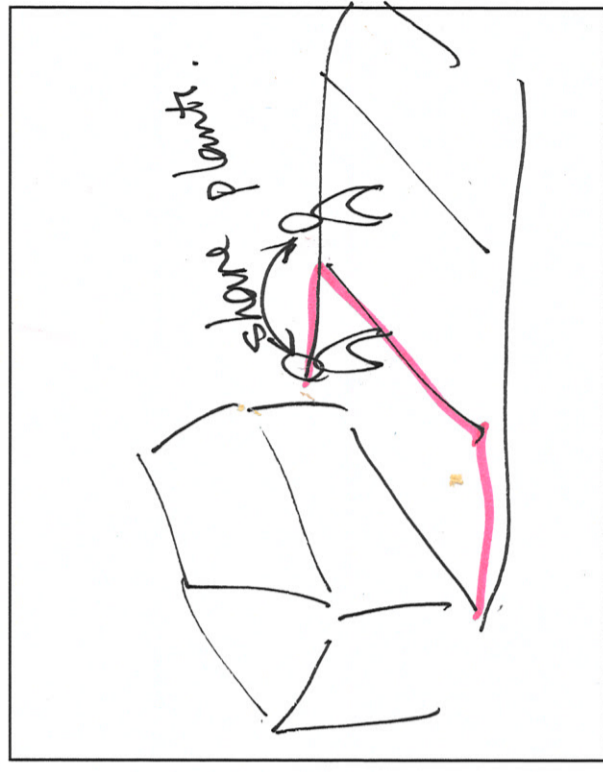

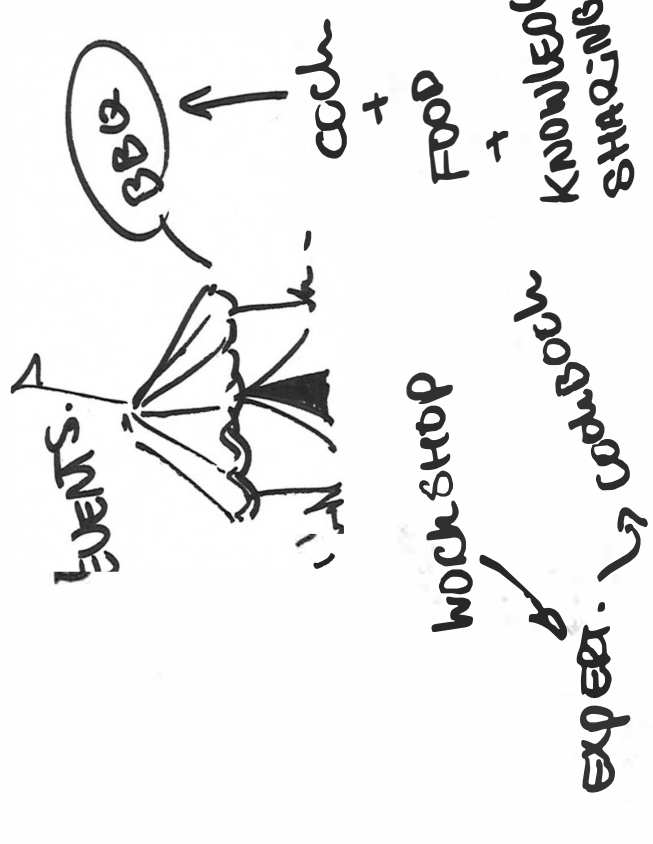
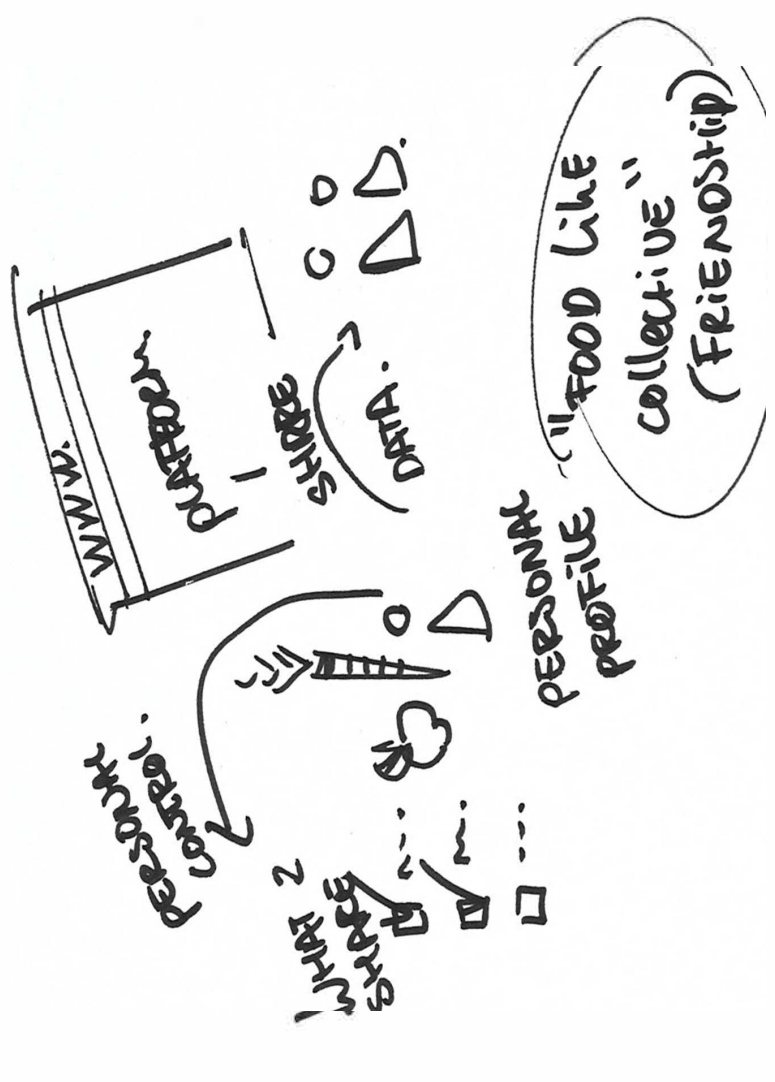
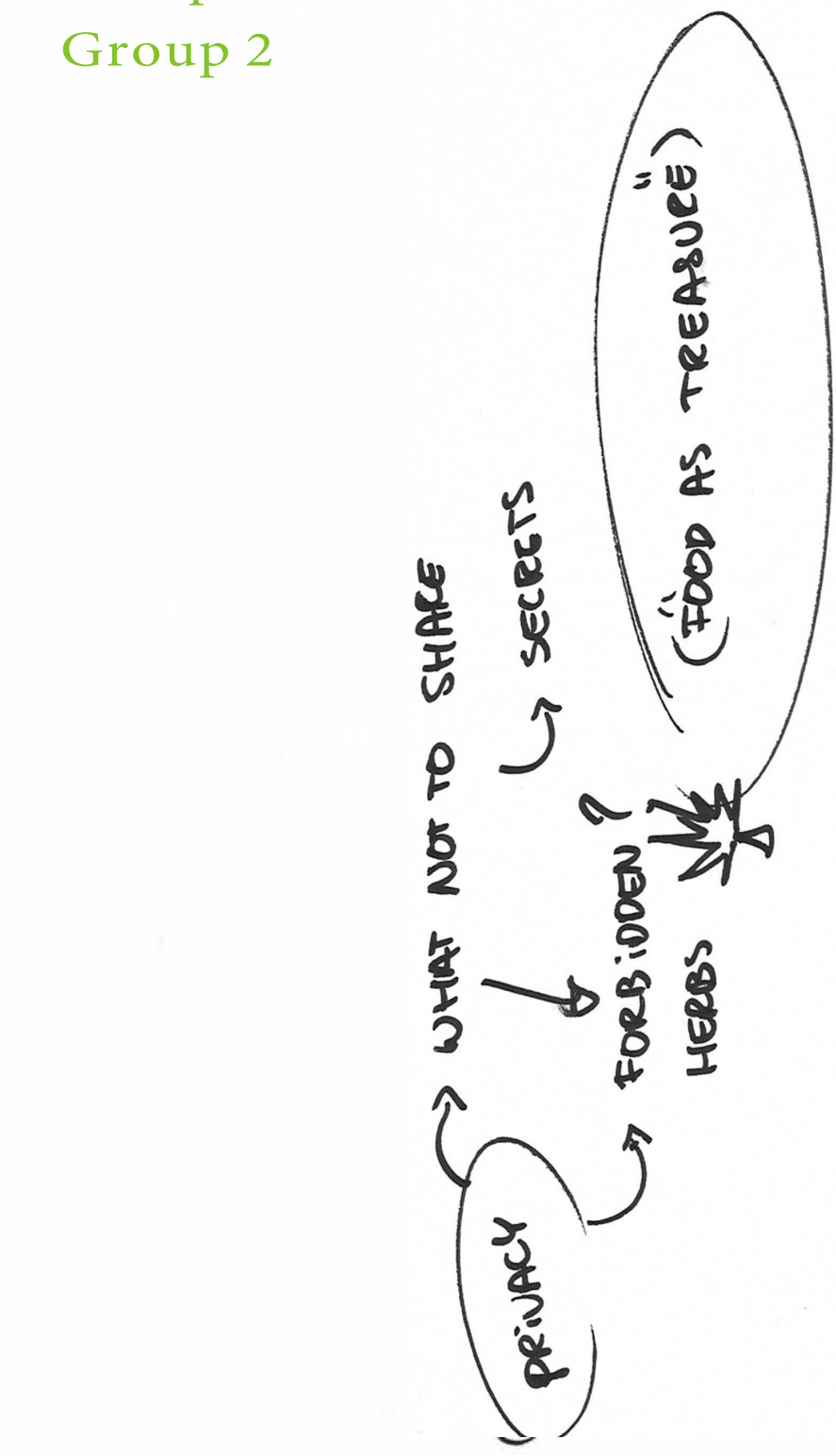

PROSUMERISM.
COMPREHENSIVE
PLANNER

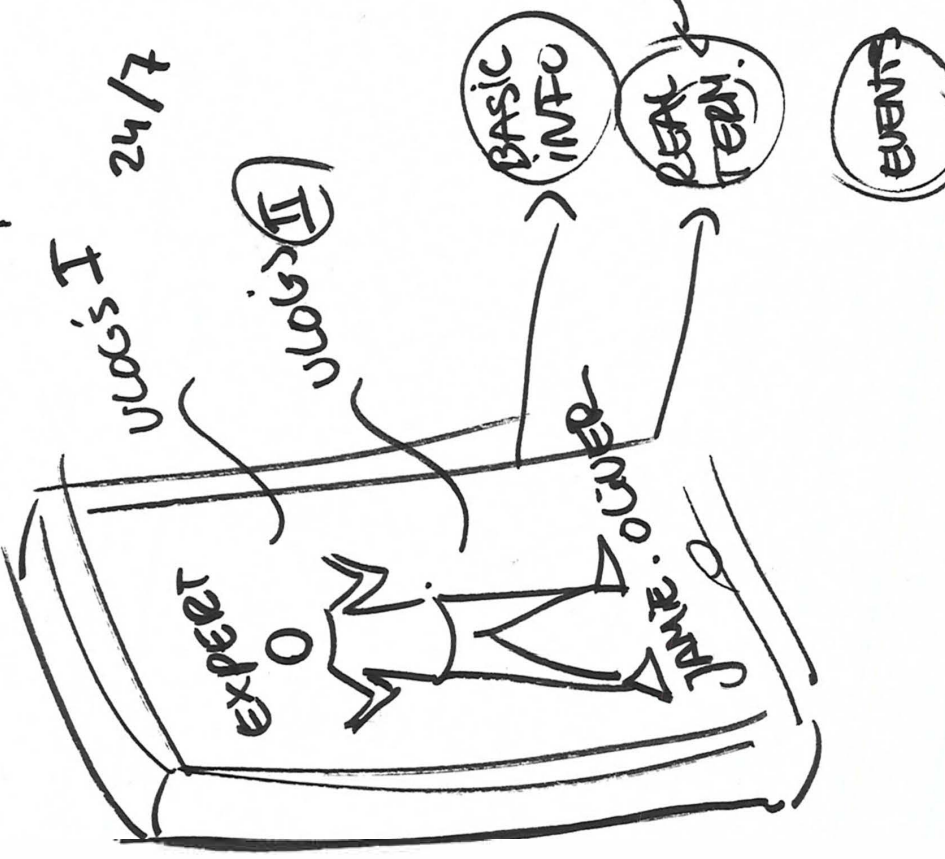
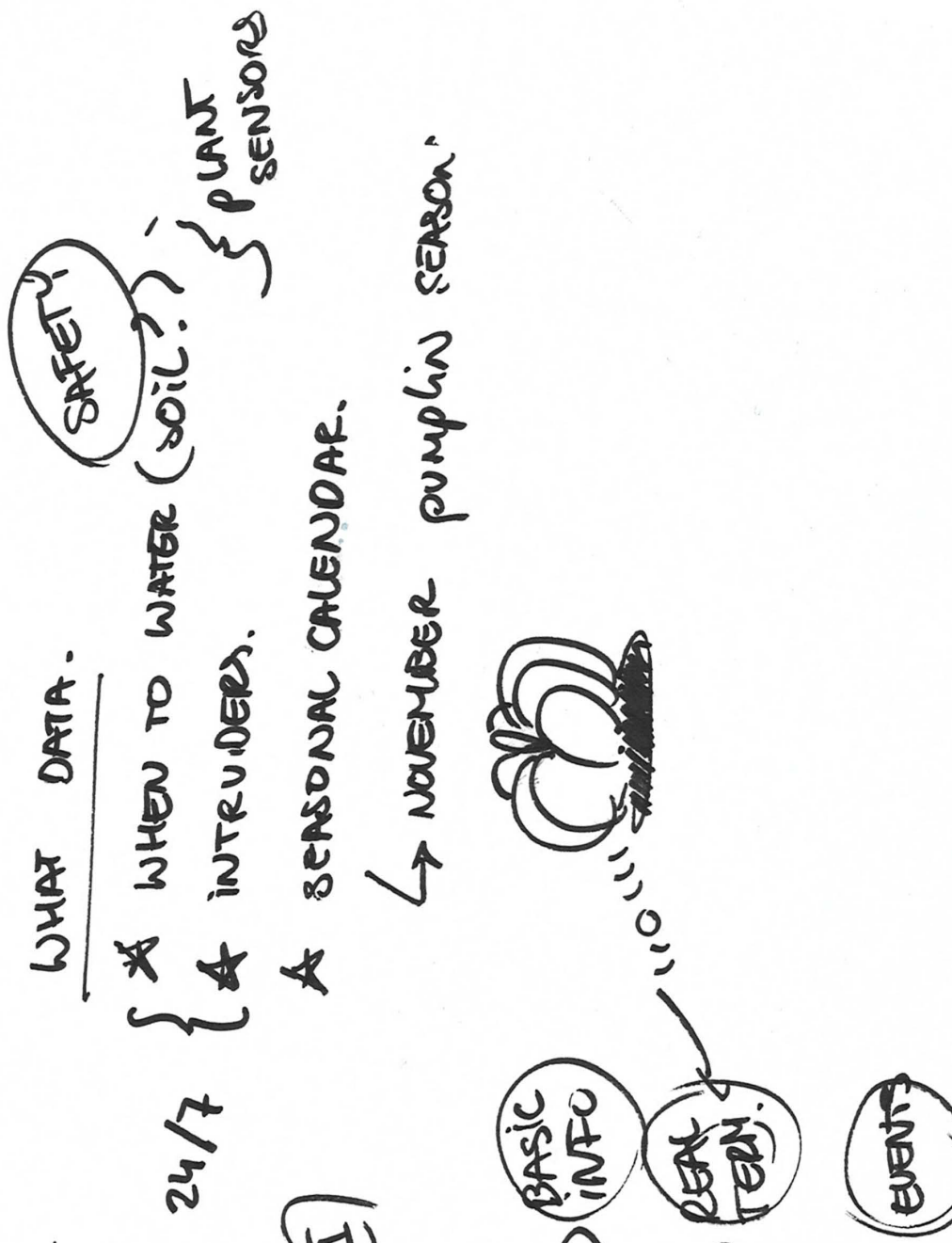

"CITY" - TOUR - FARMING TOUR.
"FOOD AS ENTERTAINMENT"

TIMESCHEDULE
HERBS

EVENTS

How's the form of your design and why is it that way?

IF EVERYTHING IS TRACKED

WHY NOT SAVE IT TO LOOK IT BACK: REFLECTION → WHAT WENT WELL
↳ WHAT DID NOT?

What is the purpose of your design?

CONVENIENCE

How your design contributes to knowledge sharing?

A COMPETITION → A!

What are the critical issues that should be taken into account in your design?

Name / Slogan:

PLATTFORM.

Sketch it!

Draw your idea here. It can be system map, service offering, anything that explains your idea!



BASIC KNOWLEDGE!

+ TUTORIAL.
+ SEASONAL INFO.

SHARED EXP.

+ TIPS & TRICKS.

+ HARVESTING TOGETHER.

+ ACCOMPLISHMENT BIGGEST PUMPKIN PRIZE

+ COMPETITION

↳ WIN NEW FRUITS



ENTERTAINMENT

A TOUR. DE FARMS
A JAMIE OLIVER SEASONAL TIPS WORKSHOP.

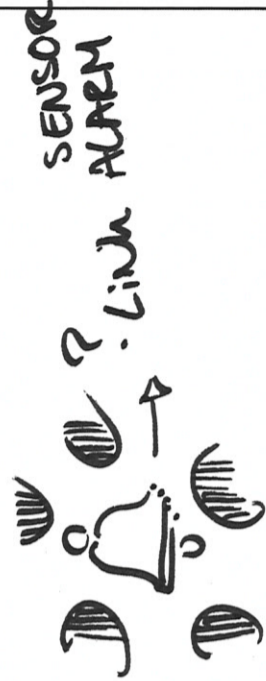

SENSOR ALARM

(a) realise it!

How would the qualities of your design look like? How would an area of it be like?

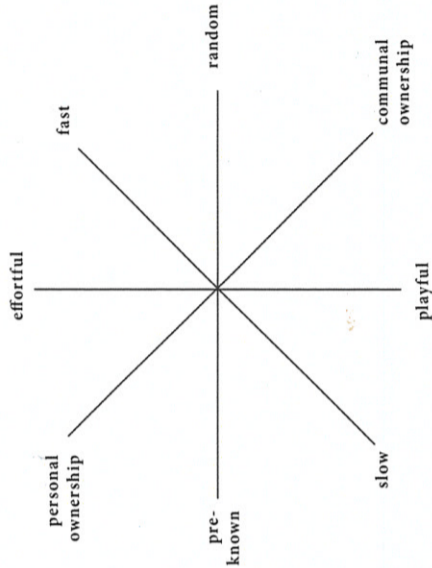

example:

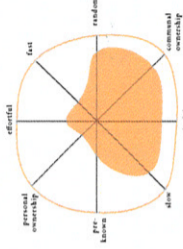

Storyboard

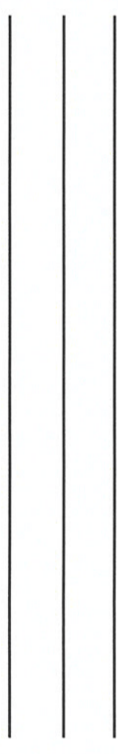
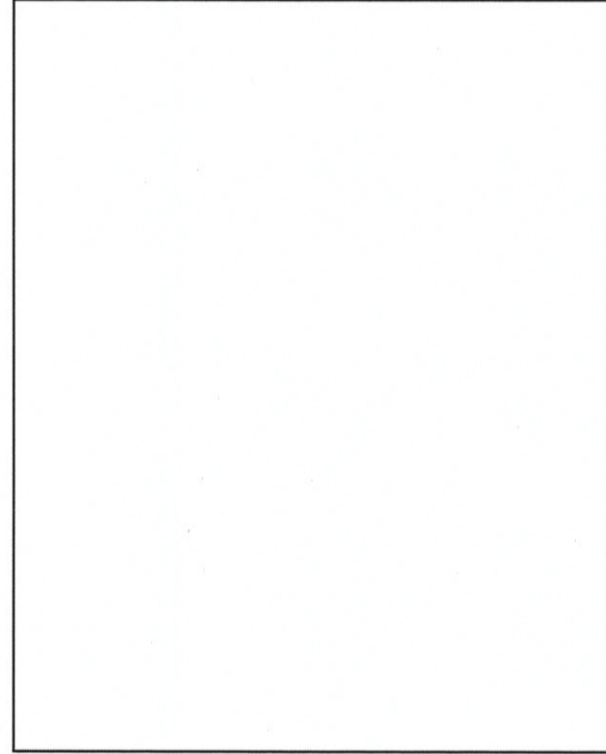
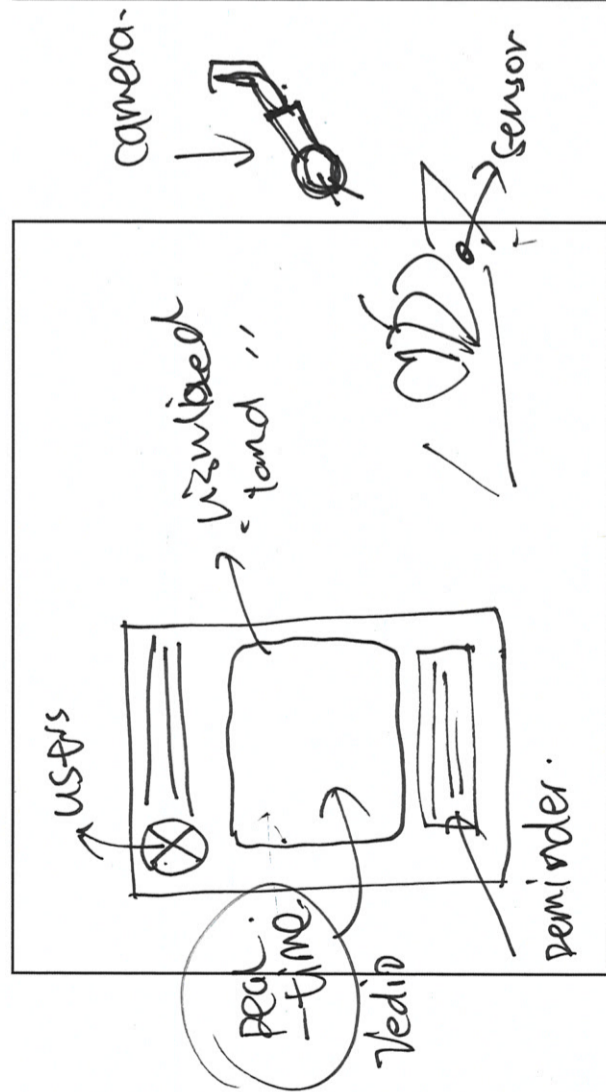
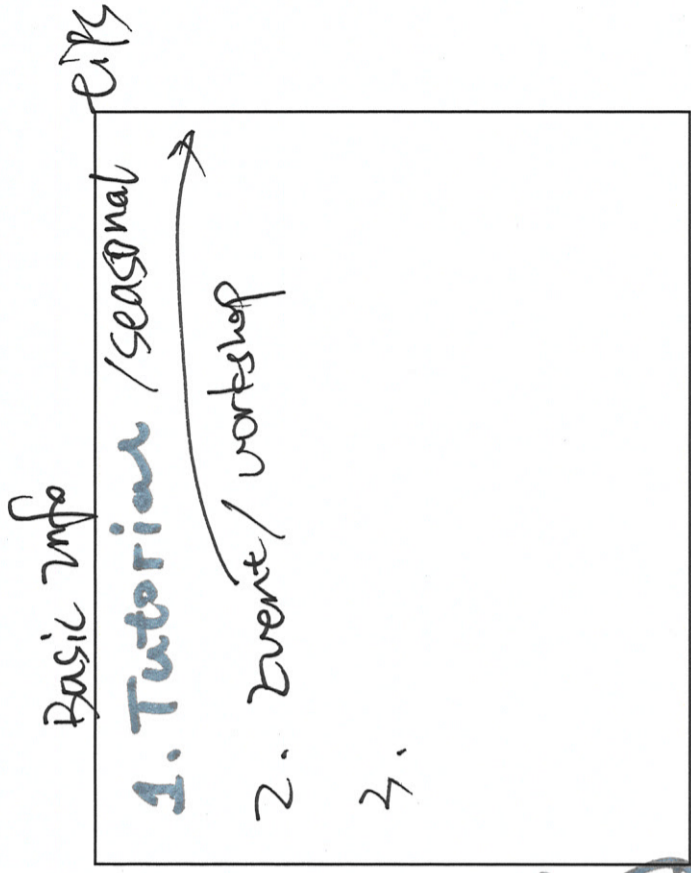
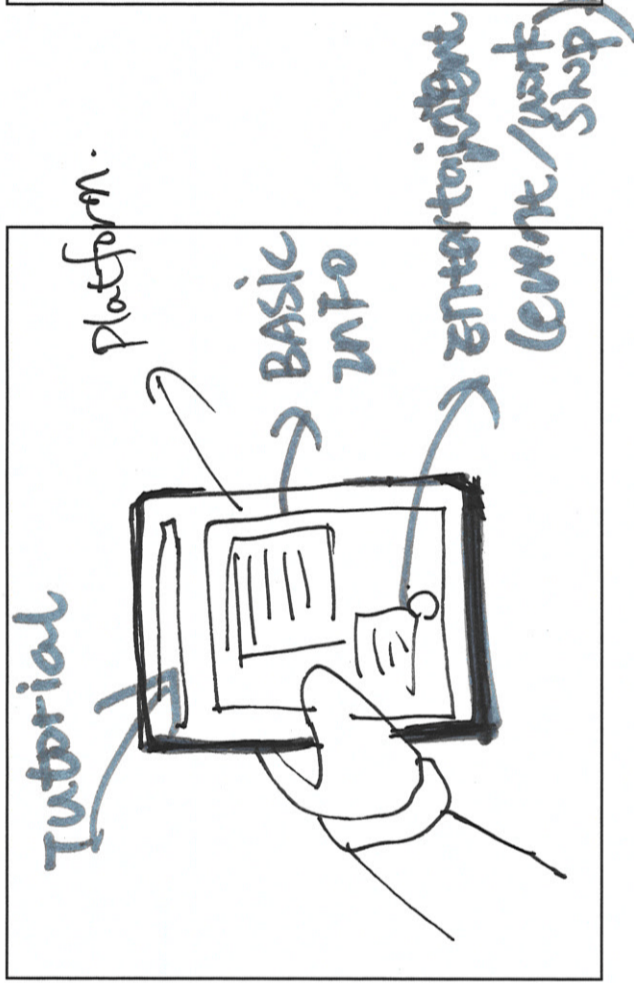

Feedback Report

Food Growing Practices in Oosterwold

Introduction

This report presents the initial concept directions of design research project of me, Yağmur Gökçe. It is prepared in order to receive feedback from you, in order to understand food growing practices in Oosterwold.

Once again, thank you very much for creating time and participating in my project. Without you, none of these would be possible.

Based on your feedbacks, my coaches' feedbacks and an ideation workshop with other design students, I am going to finalise my design in the upcoming month. If everything goes well, I am planning to be in Oosterwold on 22nd of June participating event of Stadslandbouwplein Oosterwold Ontkiemt.

I am looking forward to see you and your neighbors there to share my final design with you!

In this report first you will find a summary of my research findings. Following that, I will introduce four concepts with different design characteristics. Once you read them, then we can have chat about the concepts. While you are reading keep in mind that they are not finished designs, they just provide an overview of the possibilities that can be in Oosterwold. Also note that the word prosumer refer to someone who produce and consume her own food.

While you are going over the concepts, I kindly ask you to think about:

1. whether you would use it,
2. why would you use it,
3. what are the possible problems or misfunctionings that you think about
4. whether your neighbors would use it,
5. how it can be improved / changed

Sincerely yours,
Yağmur Gökçe

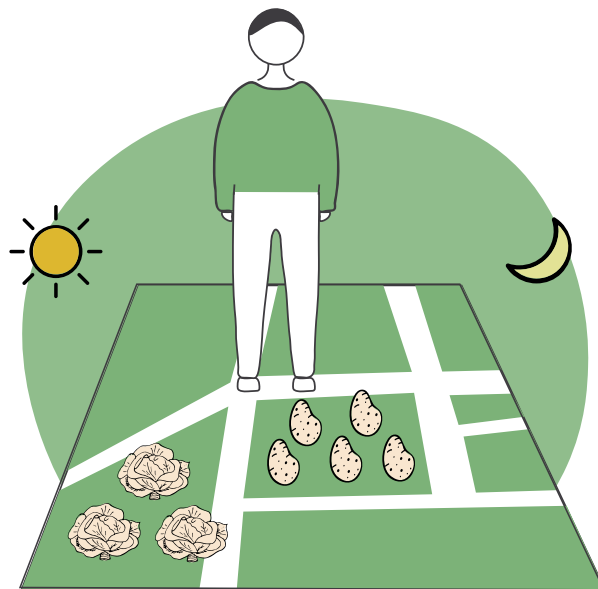

First impression of Oosterwold from my eyes.

Findings

The research study that I conducted in Oosterwold revealed that lack of knowledge is the main issue that hinders the practices of people who grow their own food in Oosterwold. This lack of knowledge is visible in two categories: plants and planning. Plants include interaction between plants, compost making, permaculture approach, seasonal tips and garden making in general. Planning covers the whole process of planting a vegetable or fruit, covering steps like buying seeds, growing before planting, planting, daily care taking and harvesting. As one of the elements of the gardening practice, competence in the case of Oosterwold has a lot of room for improvement.

Interestingly, the research findings show that the meanings people associated food growing with, tie them into the practice itself and enables it to prolong. In other words the meanings are people's motivations. Those meanings are either on a personal or collective level. People may consider gardening as a meditative practice, a practice to stay healthy and be one with nature, or a tool for money saving. Hence, spirituality, health and monetary concerns are examples of personal level motivations.

Collective motivations on the other hand are the issues that should concern the whole world. For example, people grow their own food as a way out from the globalised food and money system, a way to be against mass-production or the best thing for the environment. Collective concerns were thus social, financial or environmental.

Such meanings associated with gardening are pull-factors towards food growing practices in Oosterwold and they should be targeted in the future.

Accordingly, the design goal of the thesis project is formulated as: **How can we enable knowledge sharing of prosumers through supporting the meanings they associate with gardening?** Through that, the project aims to enable community building and increase in the number of people who grow their own food in Oosterwold.

Concepts

In order to translate findings of the previous sections into concrete ideas, this section presents initial design concepts of the graduation project. They are different ways of tackling the previously mentioned design goal with different design characteristics. Further the project will proceed with a brainstorming workshop with 12 designers together with the feedback from you in order to decide which concept or which combination is going to meet design goal the best.

1. Advice Giver

In this concept, knowledge exchange is made in a surprising, simple and easy way. The concept comprises of two parts. In the first step, through an online platform prosumers share their know-how regarding plants, planning or motivation. It is like filling out an online form but regarding their practical know-how, motivational memories or daily experiences. Image 1 shows how this online platform looks like.

Those forms then are transferred into the boxes that are located around Oosterwold, this is the second step of the design. Other prosumers, or inhabitants of Oosterwold may retrieve those forms through pressing the type of know-how they are looking for; planting, planning or motivation. This way, the neighborhood becomes a hub where knowledge can be gained in a surprising way. Images 2 and 3 illustrate the intended interaction with the concept.



Image 1. Online platform flow of advice giver



Image 2. Impression of advice giver in Oosterwold

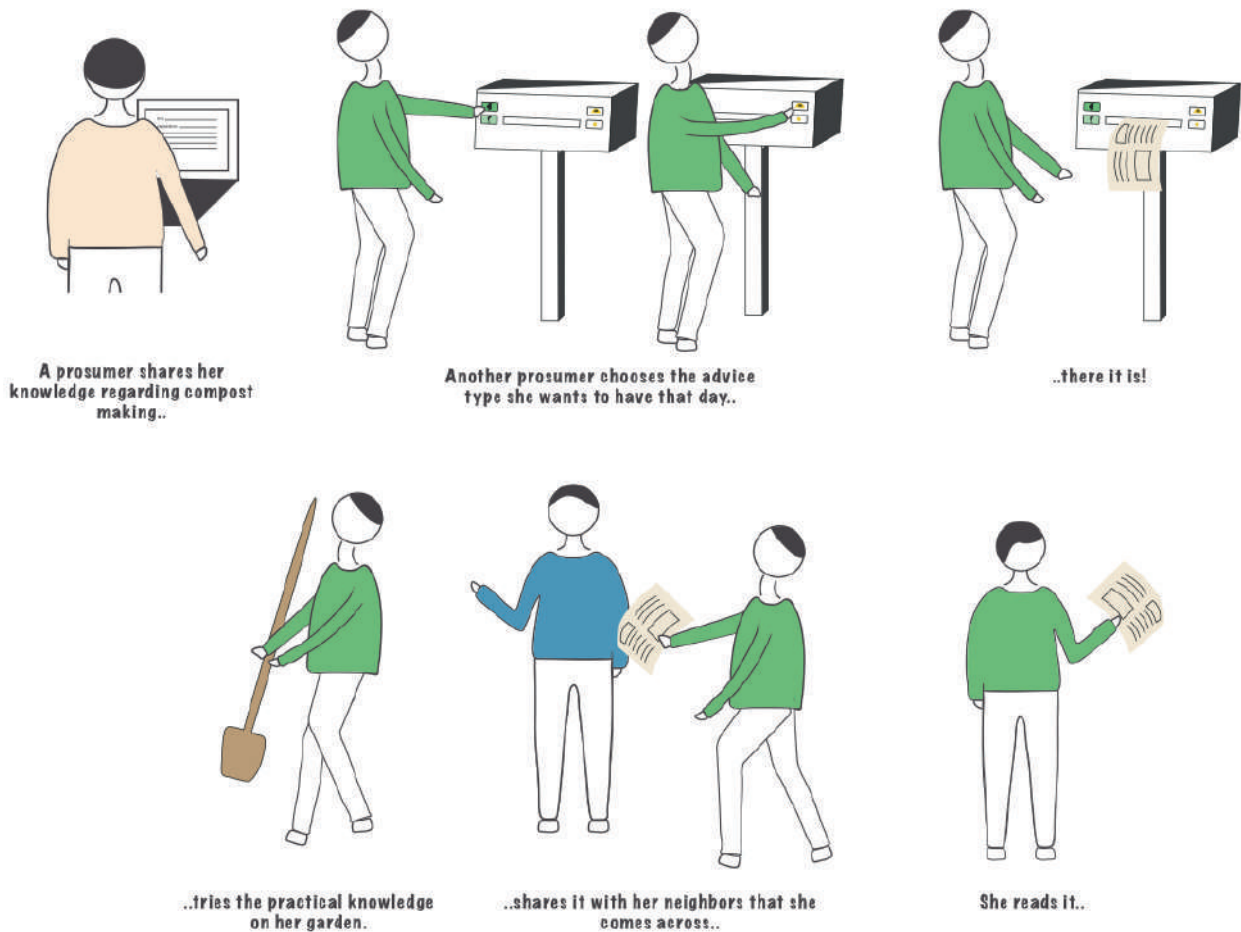

Image 3. Storyboard of advice giver

2. Attachable

'Attachable' comprises of (1) attachable paper templates and chains to attach it to gardening tools and (2) attachable boxes that are located around Oosterwold. Through writing on the papers and folding it based on the paper templates, prosumers may make origami-like shapes which they can attach on their tools and later share with each other through the boxes. In this concept, know-how about gardening is shared in a slow and careful way, like in the old times, as if we used to write letter to each other. By exchanging tools and information attached to those, 'attachable' aims to create a sharing network like illustrated in images 4 and 5.

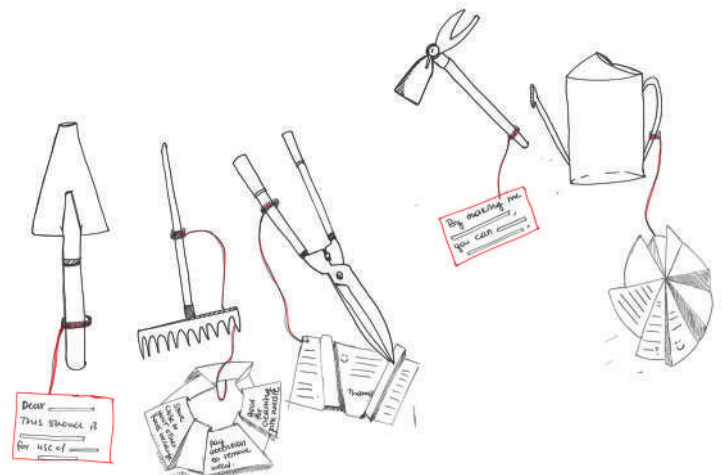

Image 4. Hand sketches of attachable

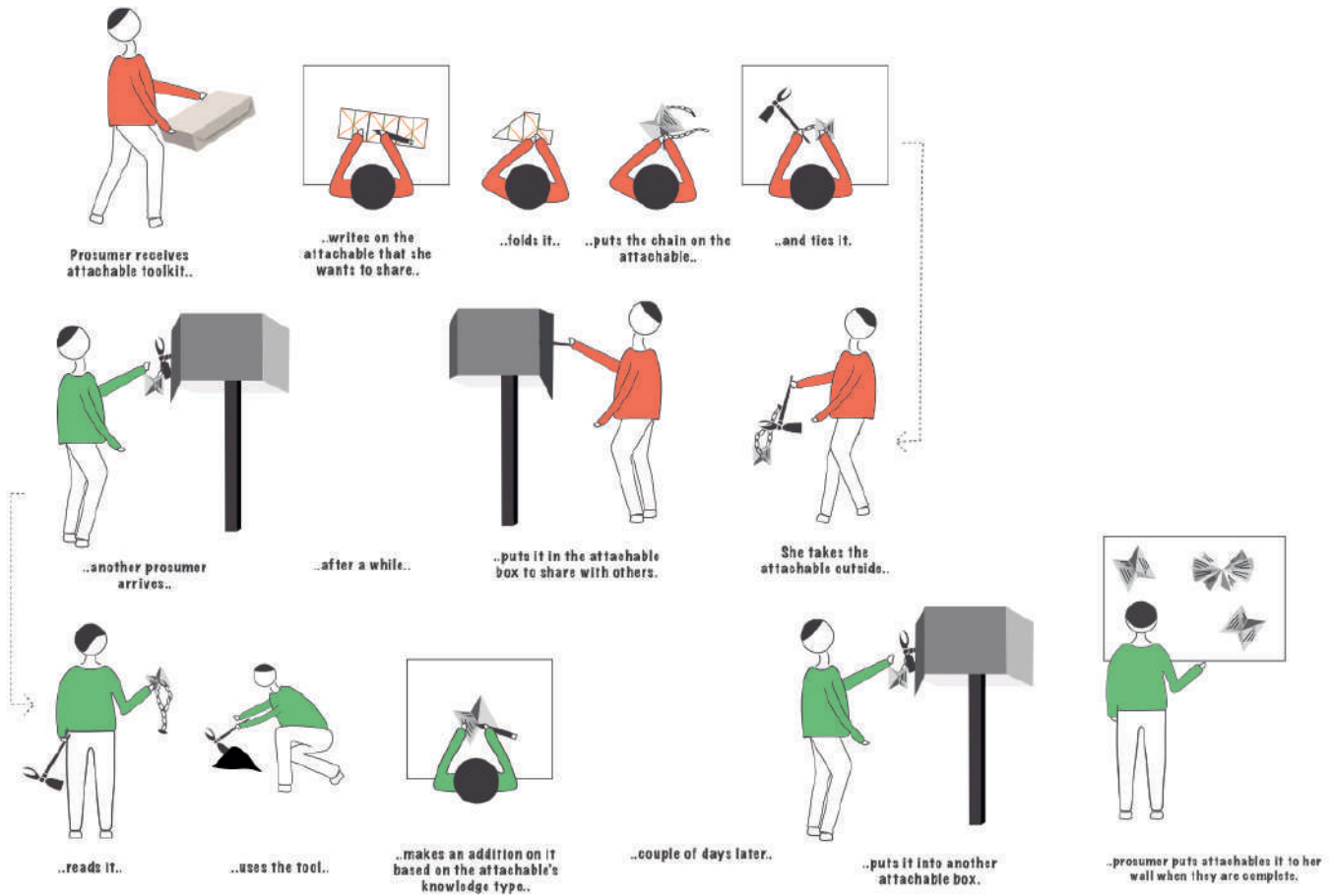

Image 5. Storyboard of attachable

3. Hackable

In a neighborhood, where you can hack the public space; how would knowledge look like? Started from this idea, the concept of hackable presents an Oosterwold that can be transformed into a living and visible know-how hub. Prosumers may exchange their tools, or practical knowledge regarding plants and garden planning through public space. By hacking the public objects such as, traffic lights, electric panels; prosumers create their knowledgeable Oosterwold. Image 6 and 7 illustrate how Oosterwold would look like.



Image 6. Impresion of Hackable

6



Image 7. Storyboard of hackable

4. Personalised Planner

This concept introduces a smart and comprehensive way of gardening through its personalised screen that are installed in prosumers' houses and smart clips that are attached onto gardening tools. Through the screen, prosumers may plan their garden, see what their neighbors plant, organise events, ask questions to others and decide daily work load on their garden. The benefit of this concept is that the screen and the clip communicate. In other words, the clip knows what the prosumer does while she is in the garden and it can give recommendations based on the activity type of prosumer. Image 8 and 9 gives an overview of the concept.

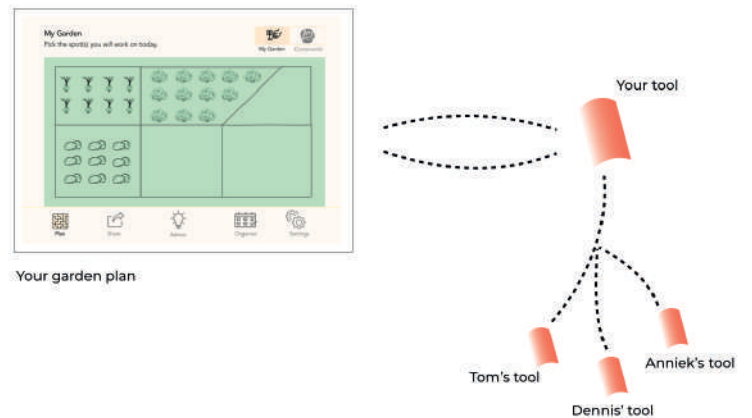

Image 8. System background of personalised planner

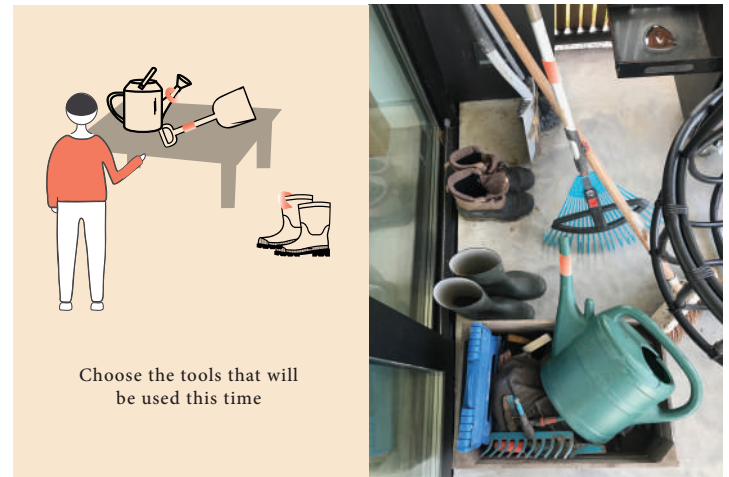
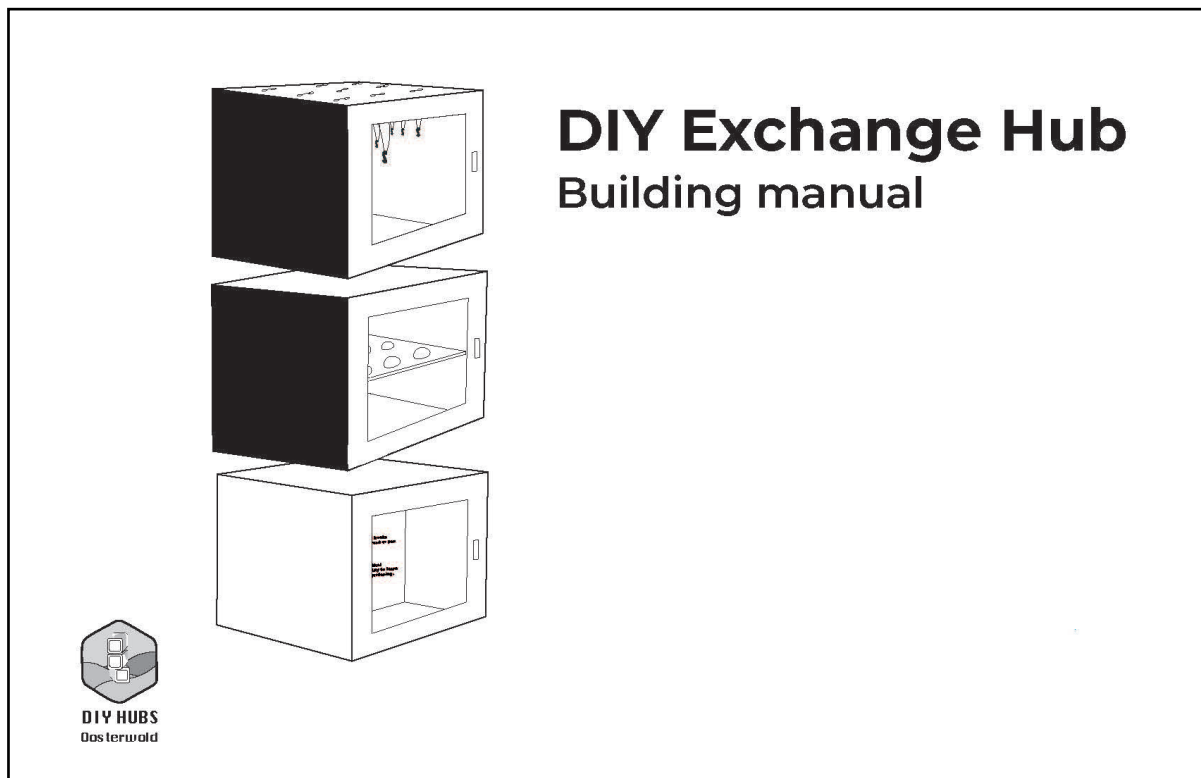

Image 9. Storyboard of personalised planner

Conclusion

This report presents outcomes of the ongoing design project of food growing in Oosterwold. Based on the findings of design research, lack of practical knowledge is found to be the most dominant drawback of the food growing practice in Oosterwold. This may cause low number of engagement with prosumerism, and further may demotivate community of Oosterwold. In order to tackle this issue, four concepts are presented with different design characteristics. The project will continue to further iterate on concepts and further develop one final design by the end of July 2019.



Before you start

This manual will guide you through building exchange hubs for Oosterwold. Through these hubs; gardening tools, seeds, excess produce and books can be exchanged. The manual shows basic and extended building ways; depending on what you want and need. Basic model describes a standard way of building of DIY Hubs. Extended features provide insights about how to increase visibility of the hubs as well as offering different options for storage and usability.

DIY Exchange Hubs is an outcome of a project specifically designed for Oosterwold in collaboration with WUR and TU Delft by a master student, Yagmur Gokce.

Contents

Basic Model	3
Materials	3
Building Guidelines	4
Extended Features	10
Coloring and Visibility	11
Shape & Functional Differentiation	15

Basic Model

Materials

base

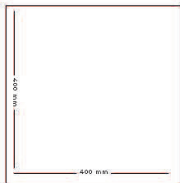

2x

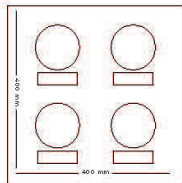

1x

ceiling

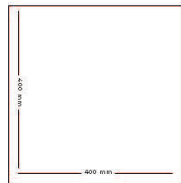

2x

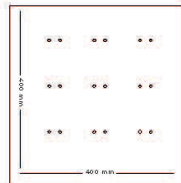

1x

side



1x

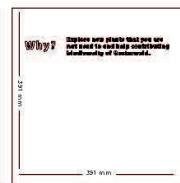

1x

back



1x

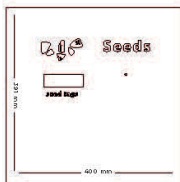

1x

dividers

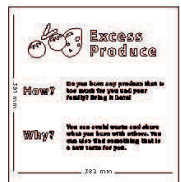

1x

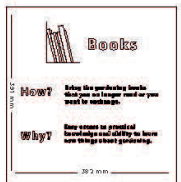

1x

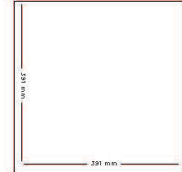

4x

door

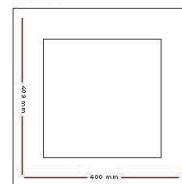

4x

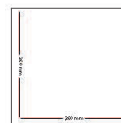

4x

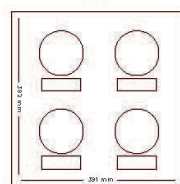
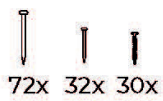

1x

Building Guidelines

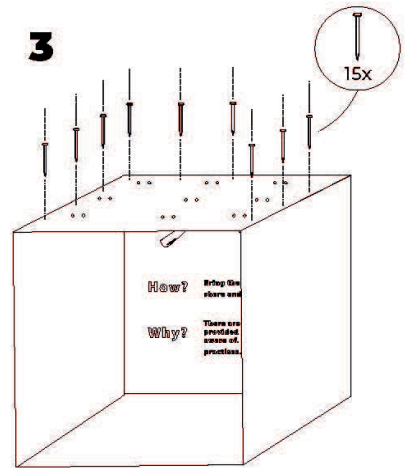
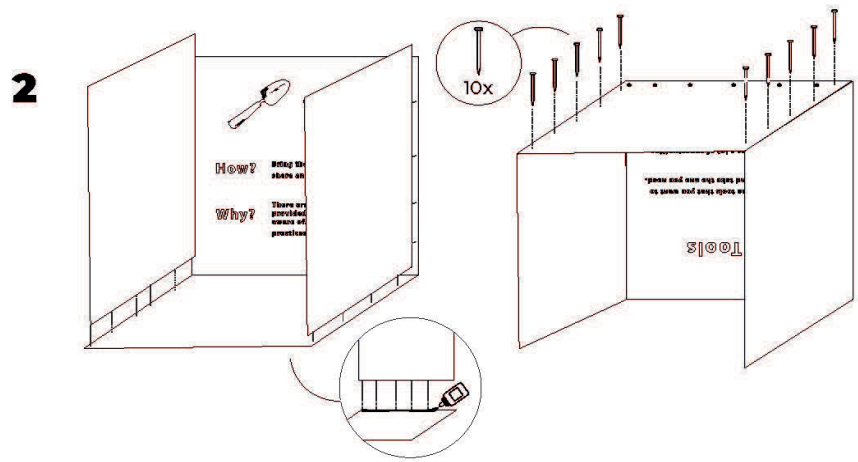
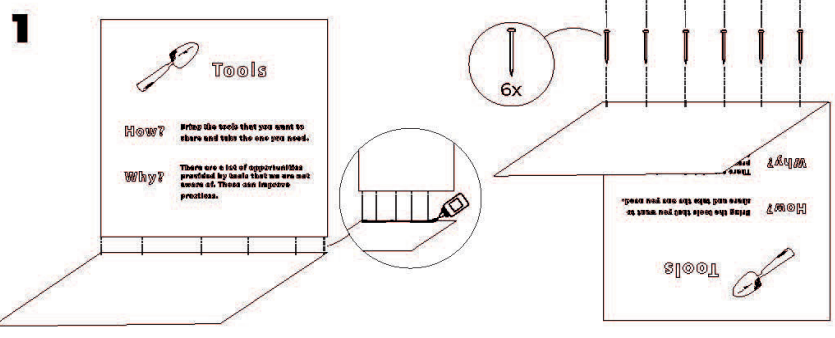

4

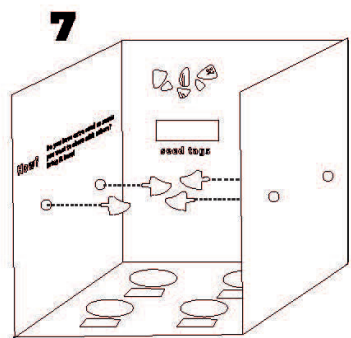
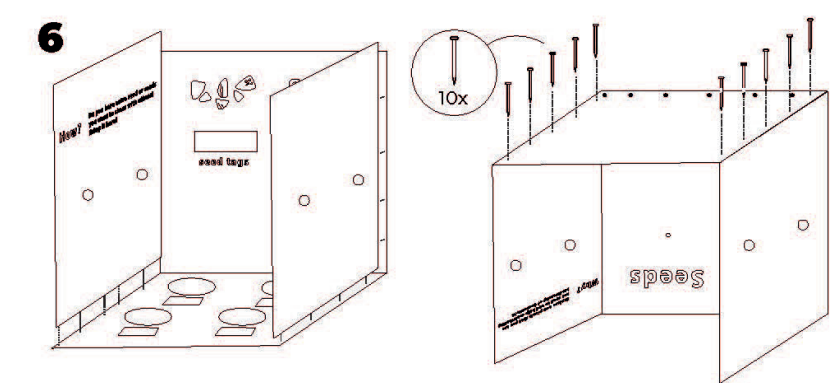
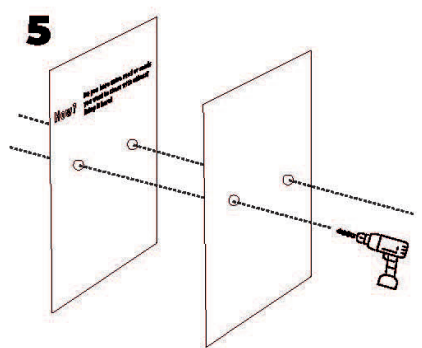
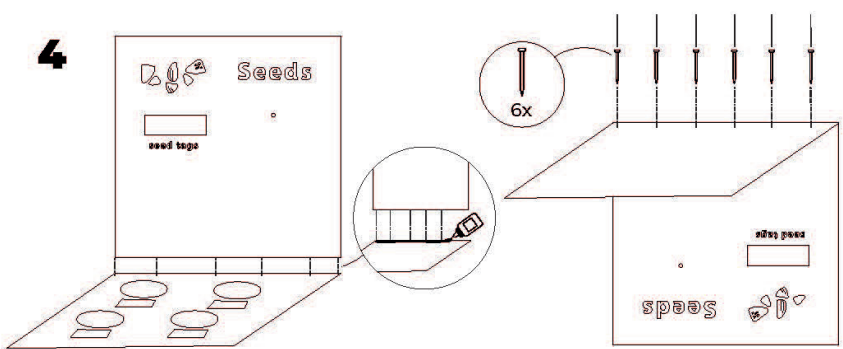

5

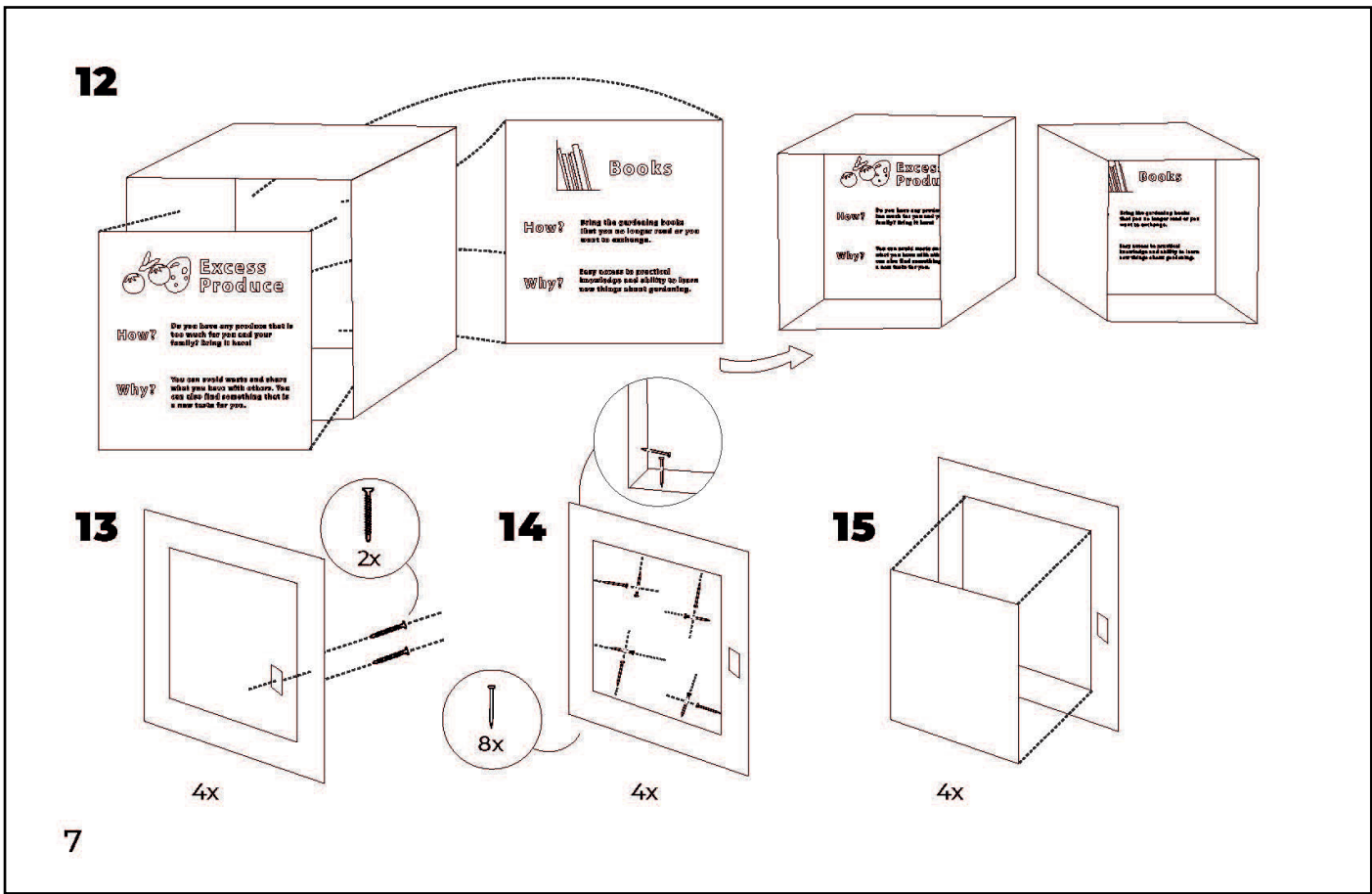
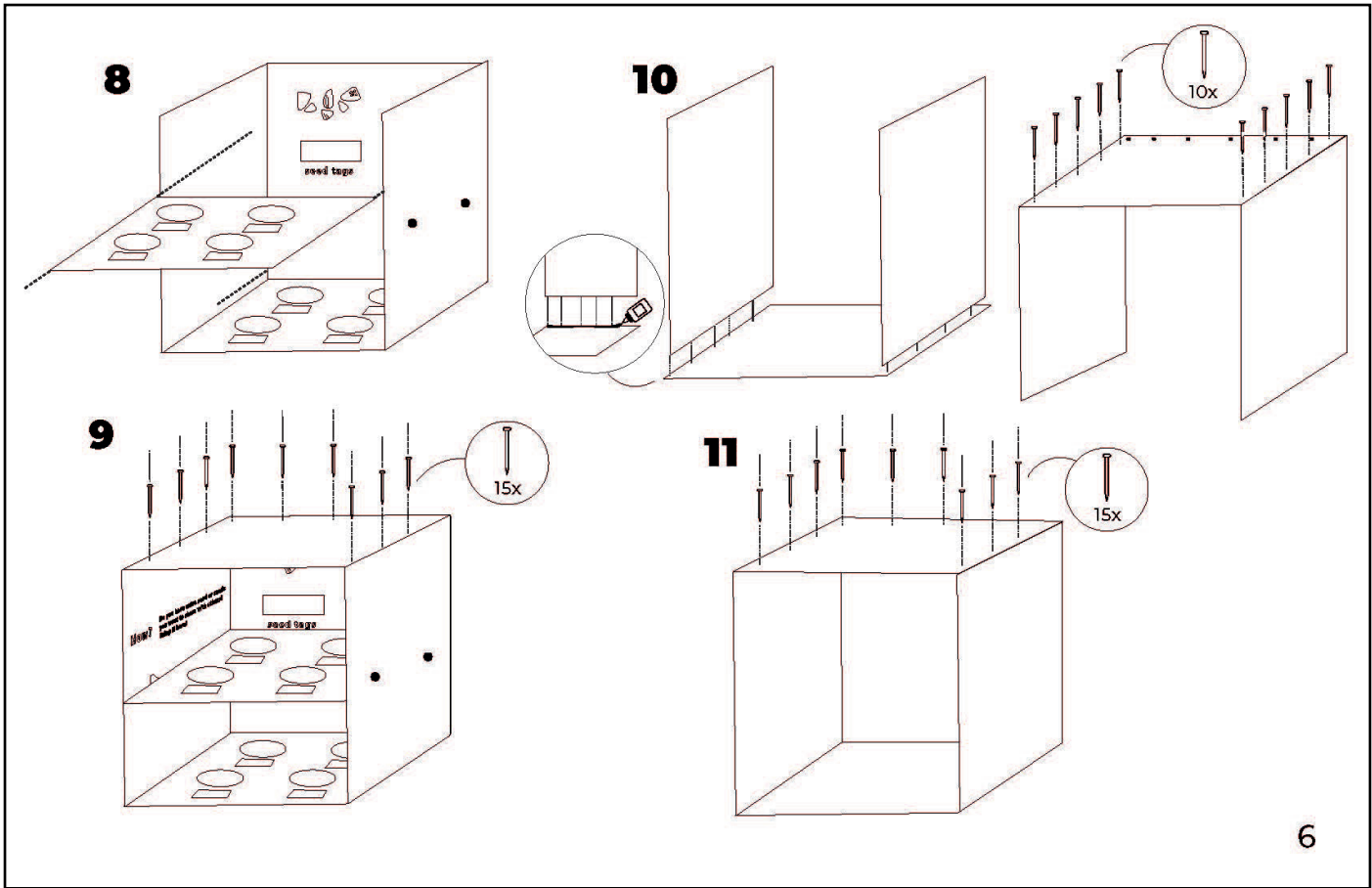

16

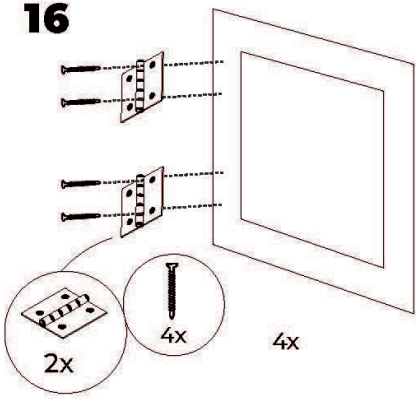

17

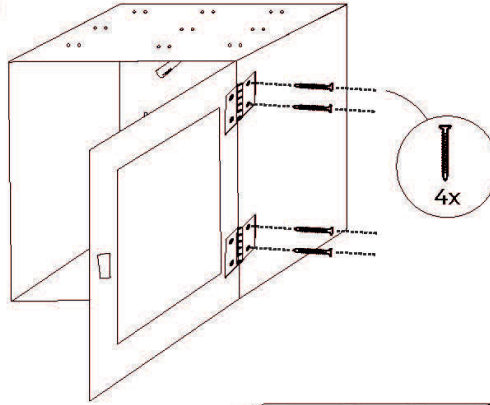

18

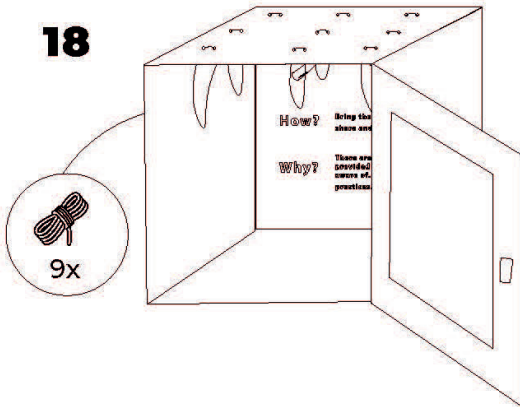

19

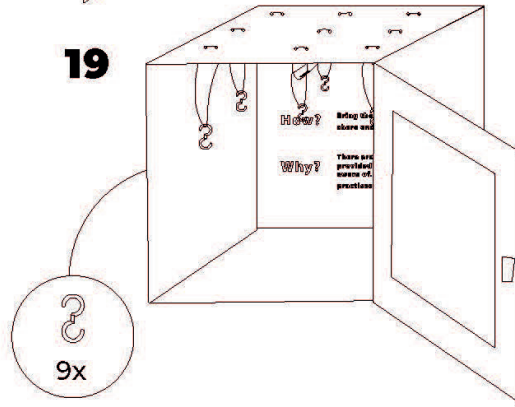

8

20

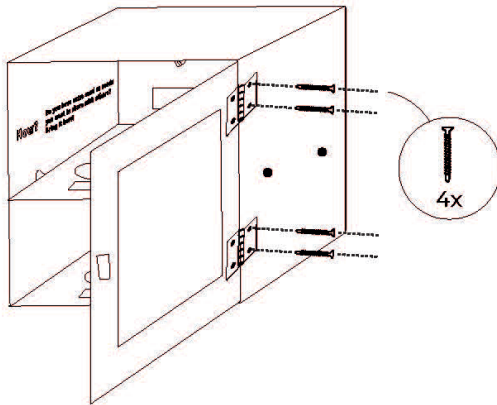

21

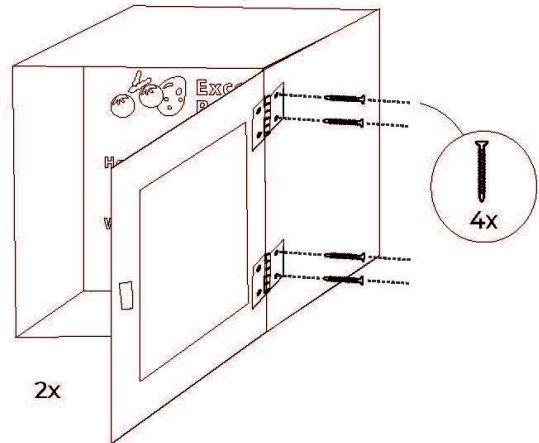

9

Extended Features

Coloring & Visibility

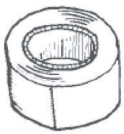

Duct Tape

Recommended Application & Installation

- ▶ **Circular ground:** Use tape to stripe outer sphere of DIY Hubs in a way that will create a circular zone.
- ▶ **Linear indication:** You can use the tape to create temporary indications that leads to DIY Hubs by cutting the tape into pieces.

Tips and Considerations

- ▷ Sweep or wash the street to remove dust and soil residuals before applying.
- ▷ Suitable for short term usage from 1 day to 1 week.
- ▷ Can become slippery if wet.
- ▷ Low cost option that is easy to source and remove.

Potential Sources

- ▷ Buy it from a local hardware store.



An example of linear indication to DIY Hubs



Black Floor Mat

Recommended Application & Installation

- ▶ **DIY Hub Mats:** Cut the black floor mat in a way that it will create a mat base for DIY Hubs.
- ▶ **Zoning:** You can use the mats to make zones around DIY Hubs; like chatting zone, maker zone or music zone.

Tips and Considerations

- ▷ Cheap, easy to create, and re-usable.
- ▷ Material can be cut with strong scissors if needed.
- ▷ Choosing a heavy mat material will prevent blowing ups from the wind.
- ▷ If you are looking for a cheaper alternative, black tar can be an option.

Potential Sources

- ▷ The material can be found at hardware or office supply hardware stores.



A floor mat example painted with blue lines.

12



Spray Chalk or Paint

Recommended Application & Installation

- ▶ **Path indication:** You can use the spray paint on the desired paths towards DIY Hubs.
- ▶ **Ground prints:** Spray paint can be used to strengthen the location of DIY Hubs by simply applying it to the ground with a template.

Tips and Considerations

- ▷ To remove, pressure water may be required.
- ▷ Will endure for a long period of time depending on the quality of the paint and weather conditions.
- ▷ Limit environmental impact by purchasing non-toxic, eco-friendly brands.

Potential Sources

- ▷ Purchase from hardware, craft or art supply stores.



Ground floor painted with spray paint in form of circles



Corn Starch

Recommended Application & Installation

- ▶ **Attractiveness:** Colorful mural surface treatments add beauty, space definition and can help attraction towards DIY Hubs.

Tips and Considerations

- ▷ Sweep or pressure wash the street to remove roadway debris before applying.
- ▷ Easy to wash away and it's non-toxic. Suitable for summer usage in the Netherlands.
- ▷ Mix equal parts corn starch and water, and add pigment using either tempera paint or food coloring.

Potential Sources

- ▷ Local supermarket or wholesale stores.



Paint made by corn starch to attract inhabitants

Shape and Functional Differentiation



Beer Crates

Recommended Application & Installation

- ▶ **Lifting DIY Hubs:** You can allocate beer crates below DIY hubs or in between two modules to make the hubs higher.
- ▶ **Temporary Storage:** Putting crates inside of a module will create an organised storage space for hub contents.

Tips and Considerations

- ▷ Adding layers from crates may improve aesthetics of the hubs since they bring color.
- ▷ Bottle sections can help an organised way of storing.
- ▷ Beware of durability of the crates. Open nature of surfaces will not allow you to store weather sensitive content.

Potential Sources

- ▷ Purchase from supermarket or transport supplier.



Using a beer crate to lift DIY Hubs

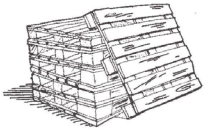

Shipping Pallets

Recommended Application & Installation

- ▶ **Sitting area:** They can be used to create sitting area around DIY Hubs. When combined with zone-making through black floor mat, they can create an environment for socialization.

Tips and Considerations

- ▶ You can find already used pallets from warehouses and/or big-box stores.
- ▶ For safety purposes, look pallets with a tag of HT (heat treated) instead of MB (treated with methyl bromide).
- ▶ You can put the pallets on top of each other to create a higher stall.

Potential Sources

- ▶ Reclaim from industrial and construction sites.
- ▶ For ideas and project instructions you can check 1001pallets.com & instructables.com



Flexible usage of the shipping pallets

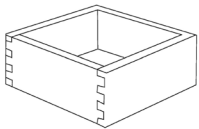

Joinery Cutting

Recommended Application & Installation

- ▶ **Closed boxes:** Easy way of making sectioning and also preservation boxes that can be installed inside of DIY Hubs.

Tips and Considerations

- ▶ This technique works best for wood materials that are thicker than 9mm.
- ▶ While cutting, make sure that the thickness of the material is the depth of your zigzags.
- ▶ To make the cutting, it would be beneficial to consult to your local carpenter or a laser-cutter.
- ▶ For stronger connections, use wood glue and/or nails.

Potential Sources

- ▶ Get in touch with your carpenter.
- ▶ You can make your own template via makeabox.io



How joinery cutting boxes may look like

B2.2 UI Screens of DIY Hubs

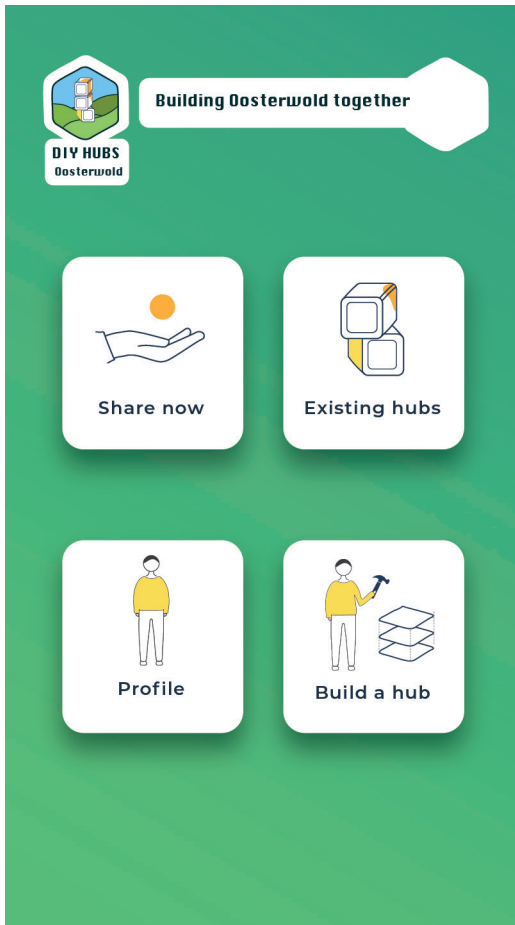

home screen

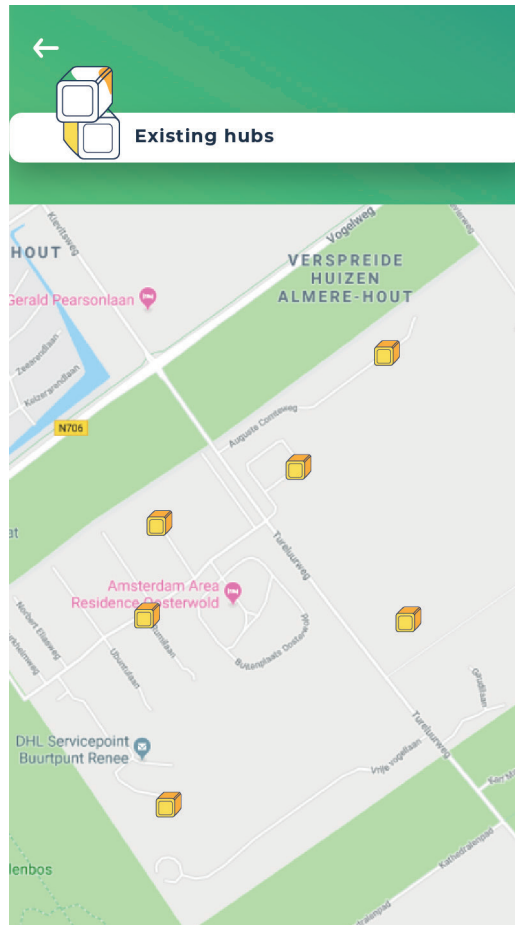

existing hubs



existing hubs

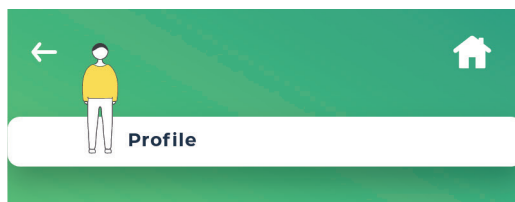

You exchanged:

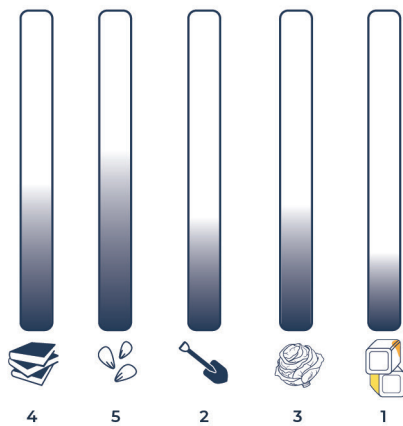

profile page



existing hubs

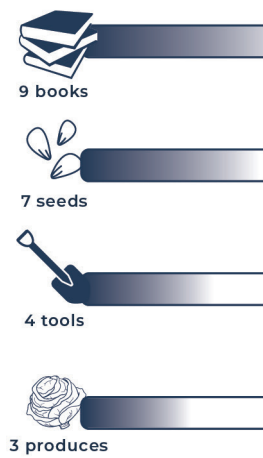

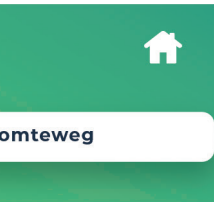

bs 1



books

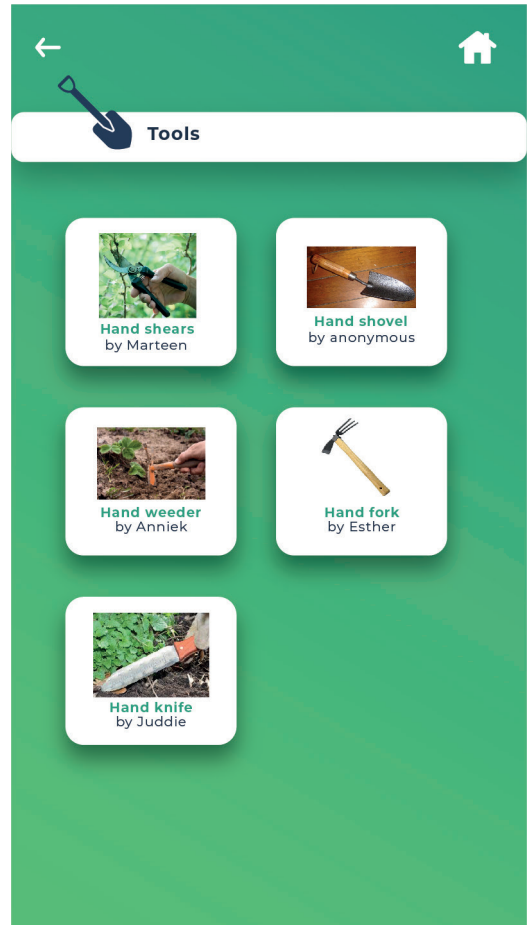

tools

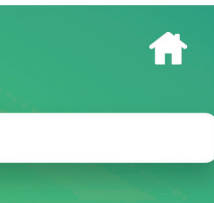

bs 2

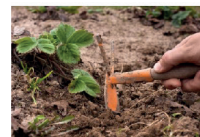
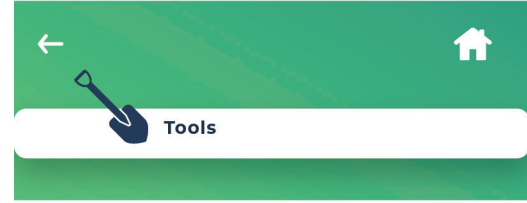

Hand weeder
Given by Anniek
This is a very old tool of mine to remove unwanted weed from the soil. It does its job very good still!

How should I use it? You can soften your soil by soaking it from the night before you will remove weeds. To start, poke the forked prong into the soil to loosen the soil around the root. Pull out the weed from its root.

When should I use it? There's no specific time to use the weeder. You can use it anytime weeds annoy you.

I take it!

tools explanation

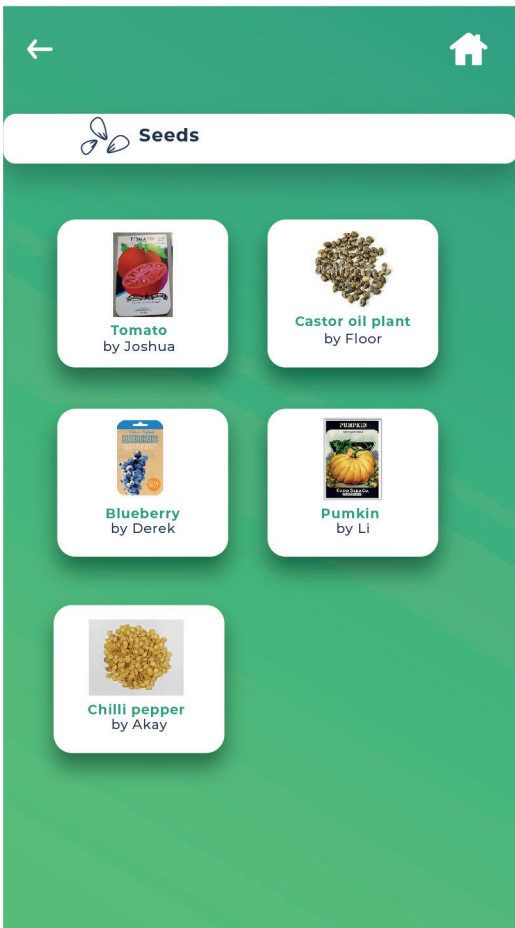

seeds



seeds explanation

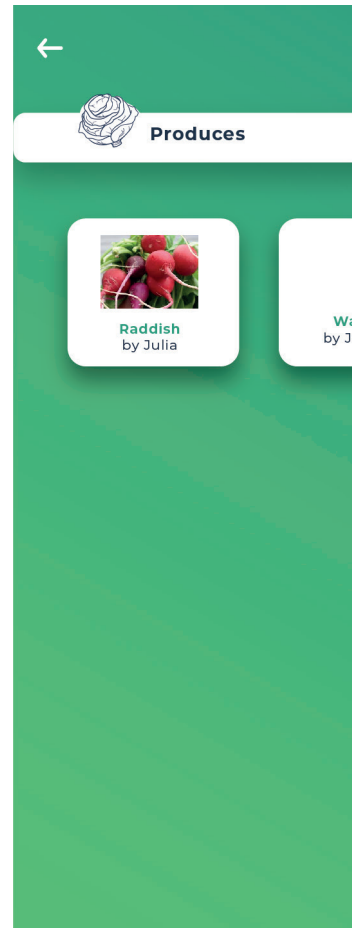

excess produce

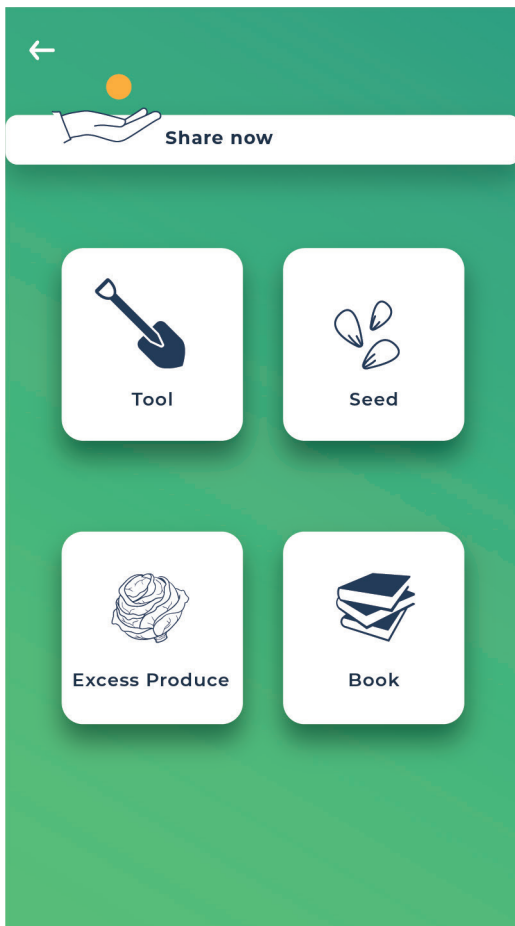

share now main page

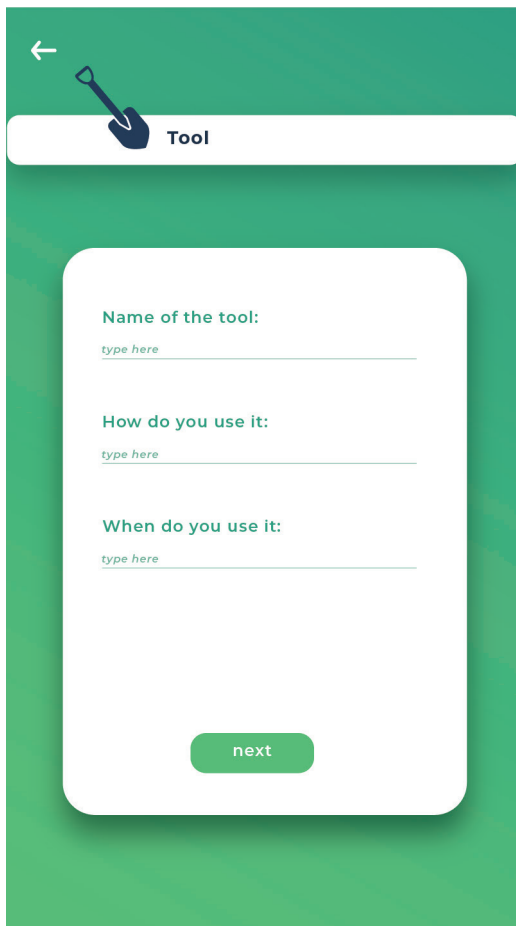

tools 1- for sharing

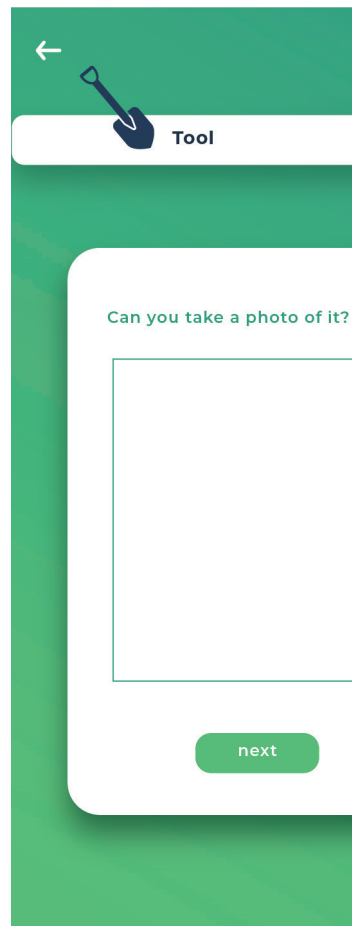

tools 2- for sharing

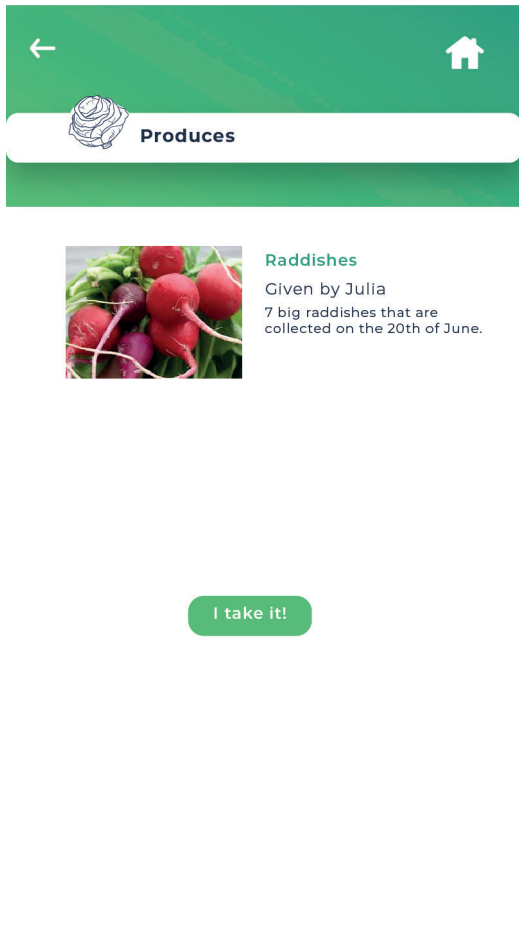

excess produce explanation

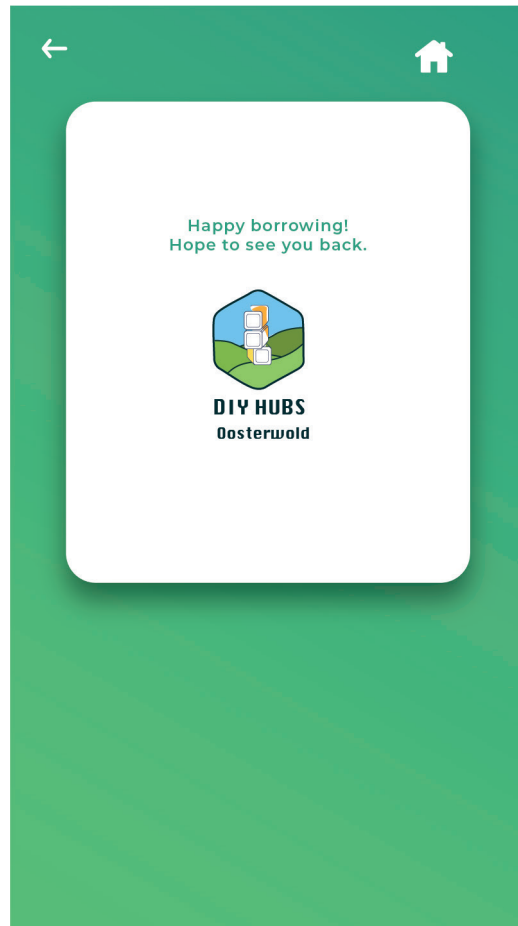

happy borrowing

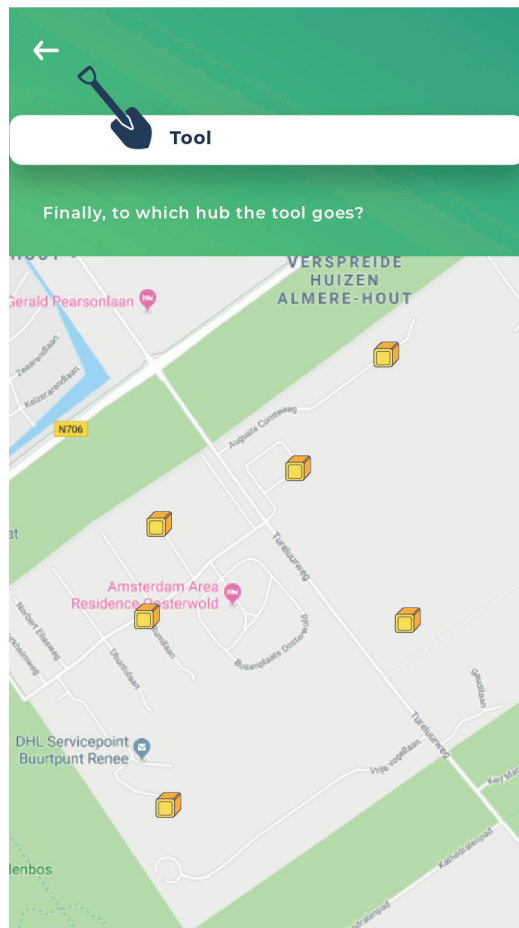
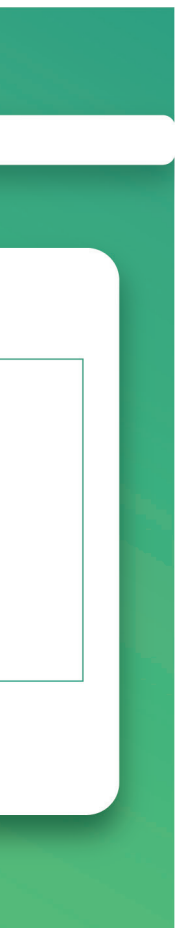

tools 3- for sharing

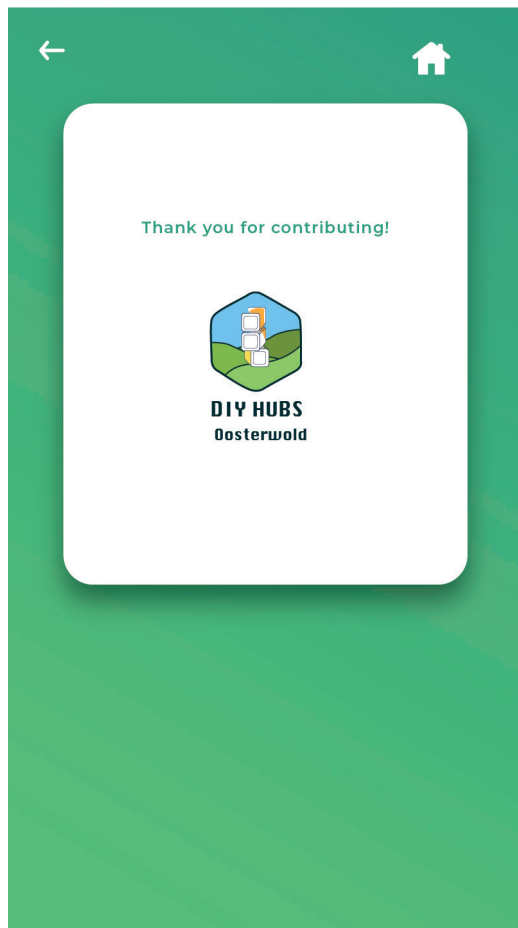

thanks for contributing

←

 **Seed**

Name of the seed:
type here

How do you plant it:
type here

How do you take care daily:
type here

next

seed 1 - for sharing

←

 **Seed**

Can you take a photo of it?

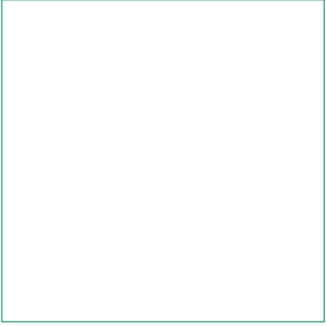

next

seed 2 - for sharing

←

 **Seed**

Finally, to which hub the seed

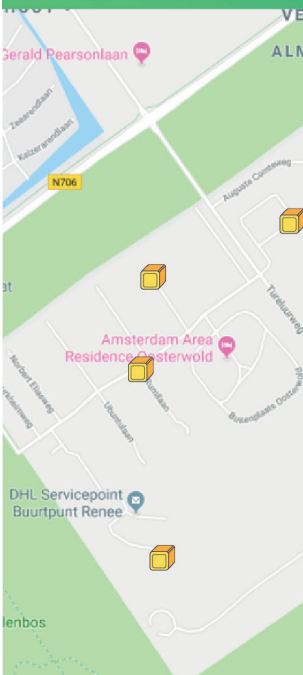

seed 3 - for sharing

←

 **Excess Produce**

What is the produce:
type here

How much you want to give:
type here

When did you harvest it?
type here

next

excess produce 1 - for sharing

←

 **Excess Produce**

Can you take a photo of it?

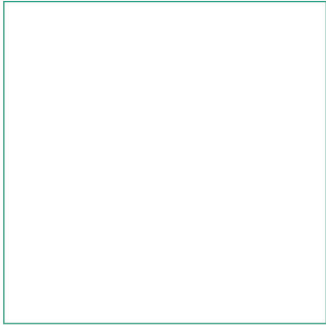

next

excess produce 2 - for sharing

←

 **Excess Produce**

Finally, to which hub the proo

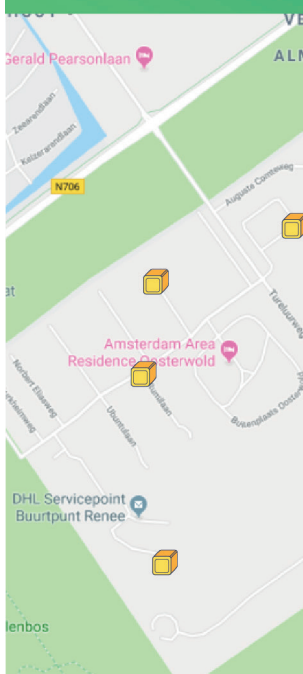

excess produce 3 - for sharing

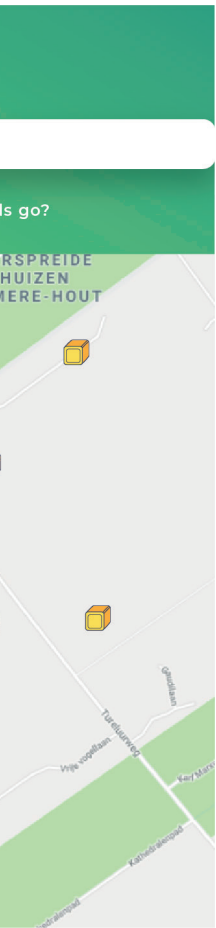

sharing

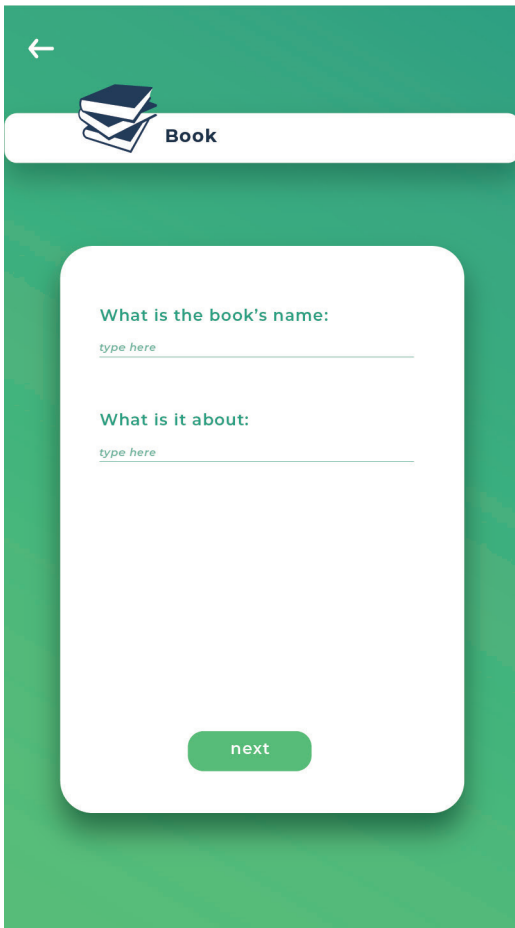

book 1 - for sharing

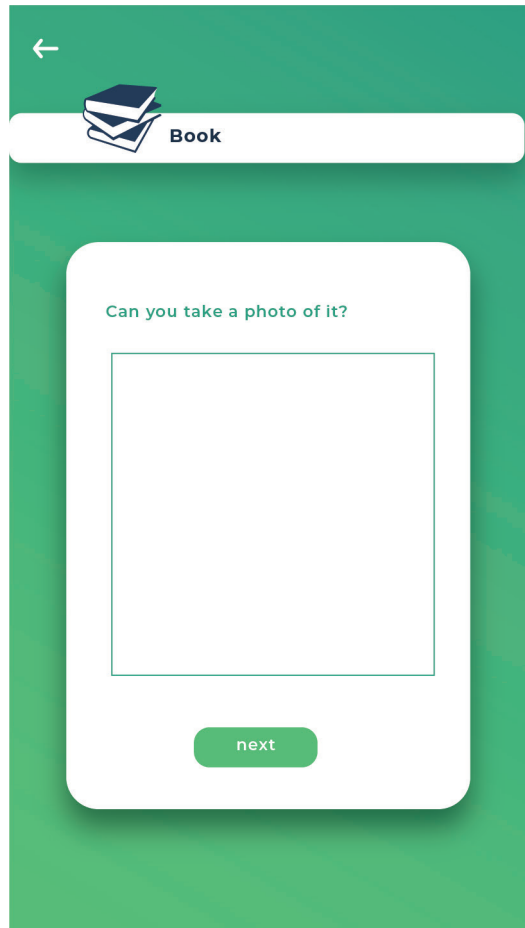

book 2 - for sharing

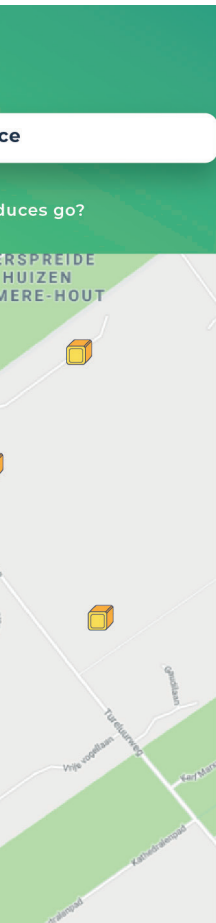

for sharing

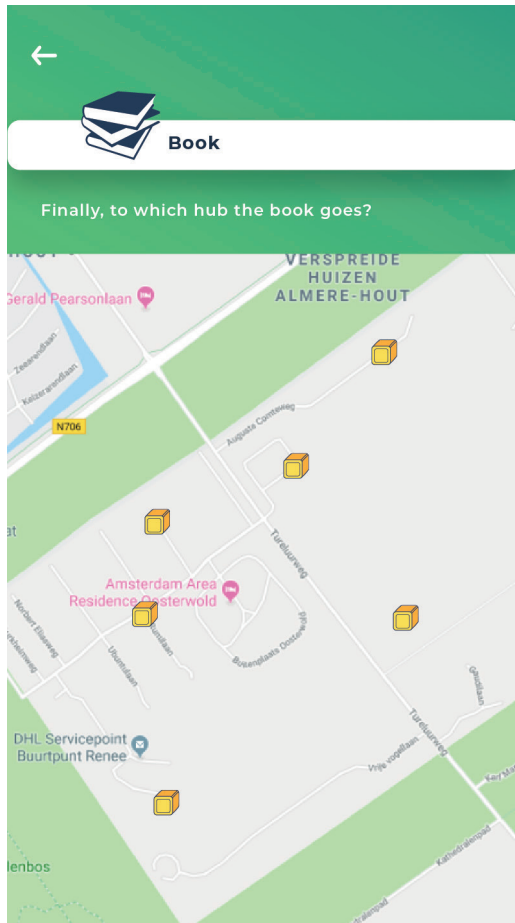

book 3 - for sharing

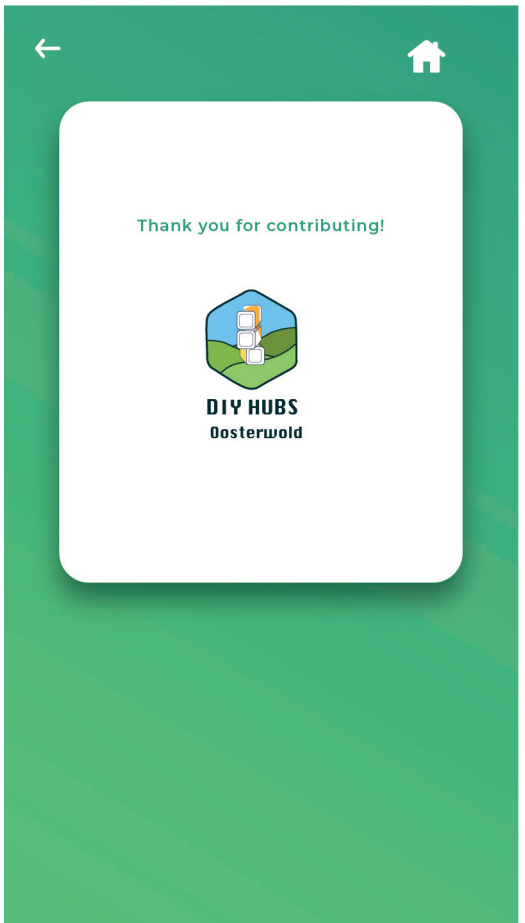

thanks for contributing

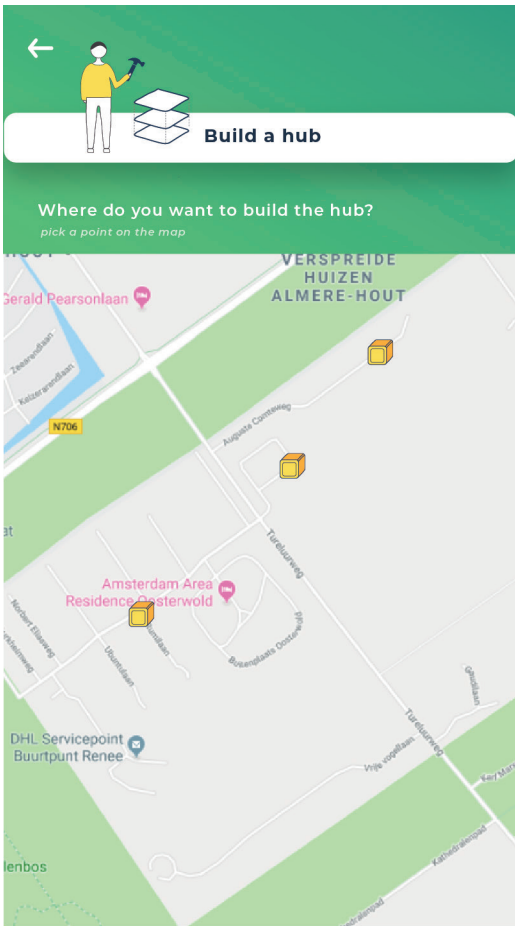

build now 1 - allocate hub

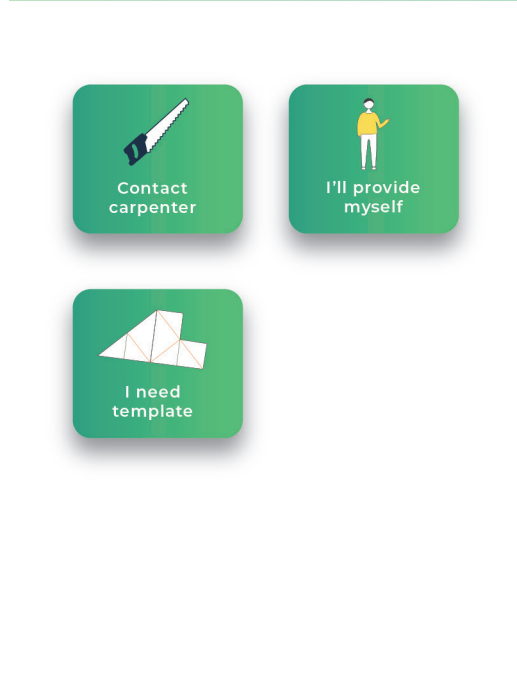

on my own 1 - how to build?

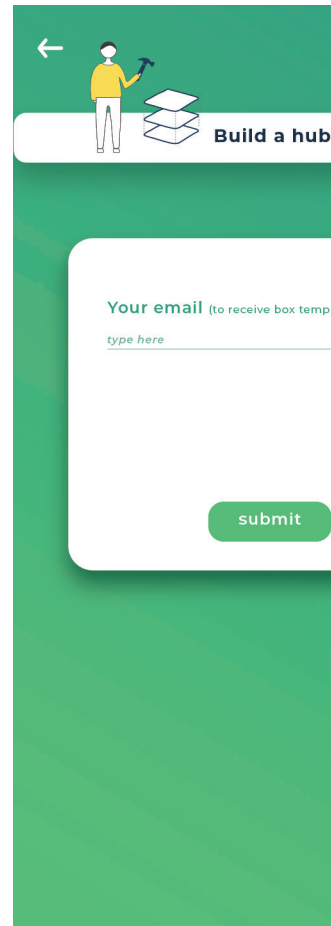

I need template

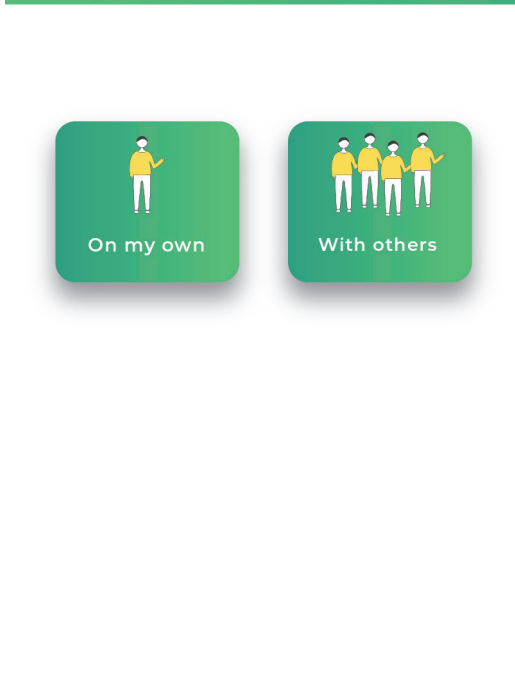
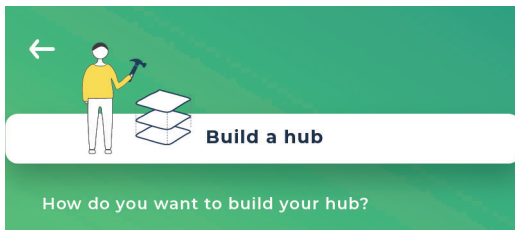

build now 2 - how to build?



te 1

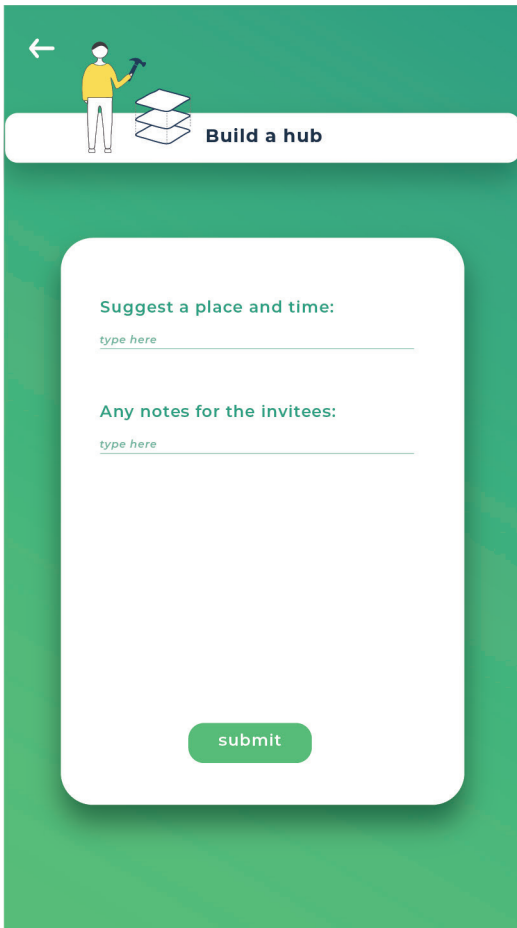

with others 1

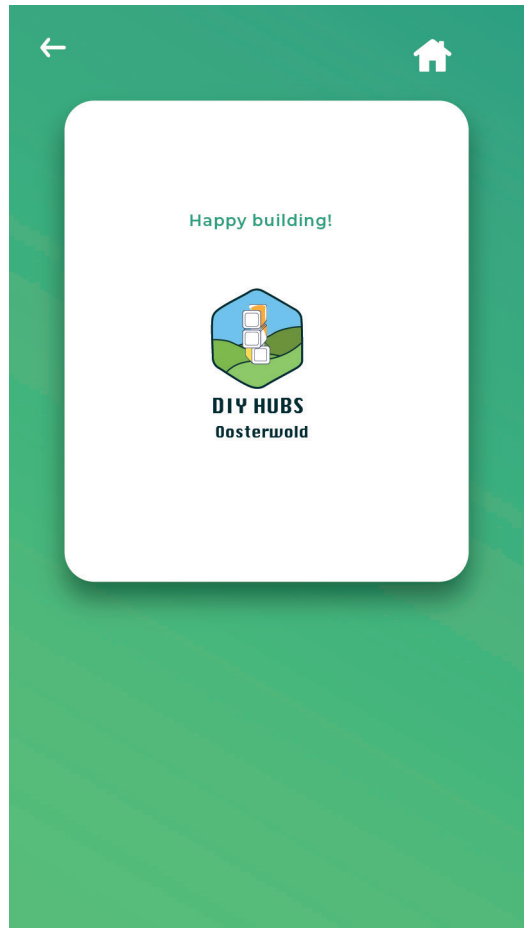

happy building

B3.1 Testing Procedure

This is DIY Exchange Hubs, modular boxes where you can exchange tools, excess produce, books and seeds with Oosterwolders. The way it works is you have this manual and with that, you build a hub, just like you do with Ikea products. You can either do it with your neighbors, friends, or alone this is up to you.

The manual explains how so, do you want to have a look at it?

Yes, then those hubs, once they are out there can be traced and tracked with a mobile application. Like this, so let's say you want to have chili pepper from the hubs. Let's perform this with the application.

Now we have a short survey, can you fill this out?

Q: Is this project real?

A: Depending on whether you like the concept or not, whether you will use it or not the concept may be implemented in the coming months. I would be available the week after to post materials for the basic model. It costs 62 euro per pack, so 3 hubs in total.

Scenarios for app:

- You want to give away one of your tools to a hub. You take the app and check the existing hubs.
- You would like to borrow some radish seeds from the hubs. How would you do that?
- You want to get the hand weeder from the hubs.
- You want to borrow chili peppers from the hubs.
- You want to initiate building on your own. To make it cut, you need a cutting template.

B3.2 Survey

Overall Experience of DIY Hubs

Please answer the following questions in a scale to 1-5; 1 being less likely, 5 being very likely.

1. **Currently, how many types of fruits and vegetables do you have in your garden?**

2. **In the future, I want to take initiative to build the hubs.**

Mark only one oval.

1 2 3 4 5

Not likely Very likely

3. **Once the hubs are built, I am going to use the hubs.**

Mark only one oval.

1 2 3 4 5

Not likely Very Likely

4. **Do you think DIY Hubs can be a part of Oosterwold?**

Mark only one oval.

1 2 3 4 5

Not likely Very likely

5. **Do you think DIY Hubs are convenient and accessible?**

Mark only one oval.

1 2 3 4 5

Disagree Agree

6. **How do you think DIY Hubs would affect your relationship with your neighbours?**

Mark only one oval.

1 2 3 4 5

do not change improve

7. How do you think your gardening skills will be affected with DIY Hubs?

Mark only one oval.

1 2 3 4 5

do not change improve

8. Do you think you will be more confident about Do-it-yourself approach?

Mark only one oval.

1 2 3 4 5

do not change improve

Manual & Application of DIY Hubs

9. The manual of DIY Hubs was

Mark only one oval.

1 2 3 4 5

complex understandable

10. The manual opened up new ways of creating DIY Hubs

Mark only one oval.

1 2 3 4 5

disagree agree

11. The manual encourages to build DIY Hubs

Mark only one oval.

1 2 3 4 5

disagree agree

12. How do you want to build the hubs

Tick all that apply.

- On my own
- With my family
- With my neighbours
- With my friends
- Other: _____

13. Do you think DIY Hub application guide you through the process of exchanging?

Mark only one oval.

1 2 3 4 5

Disagree Agree

14. Do you think DIY Hub application is convenient?

Mark only one oval.

1 2 3 4 5

Disagree Agree

Contact Details

If you want to build DIY Hubs in the future, please share your email address with us.

15. your email address

Powered by



B3.3 Survey Results

A	B	C	D	E	F	G	H
Timestamp	Op dit moment, hoeveel s	Ik wil in de toekomst initia	Als de hubs gebouwd zijn	Denk je dat DIY Hubs onc	Denk je dat DIY Hubs nar	Hoe denk je dat de DIY hi	Hoe denk je dat je tuinier vaar
22/06/2019 13:23:49	3	4	5	4	4	5	1
22/06/2019 13:46:15	3	2	3	3	4	1	1
22/06/2019 13:55:06	0	3	4	5	5	4	3
22/06/2019 14:01:41	25	4	5	5	2	5	5
22/06/2019 14:38:35	2	3	5	4	4	5	2
22/06/2019 14:48:11	0	3	4	5	4	5	5
22/06/2019 14:56:40	0	5	3	4	4	3	4
22/06/2019 15:06:56	10	4	4	5	3	4	4
22/06/2019 15:21:08	6	4	4	5	5	5	3
22/06/2019 15:21:52	42	5	5	5	5	5	4
22/06/2019 15:30:11	20	1	3	5	5	3	5
22/06/2019 15:38:44	15	3	5	5	5	4	4
22/06/2019 15:47:28	0	4	5	5	5	3	3
22/06/2019 15:53:54	20	5	5	4	2	4	4
22/06/2019 16:06:47	10	2	5	4	3	3	4
22/06/2019 16:15:52	0	4	3	5	3	3	3
22/06/2019 16:22:28	3	4	5	5	5	4	3
22/06/2019 16:32:54	20	5	5	4	3	4	2
22/06/2019 16:47:26	10	5	5	4	3	3	5
22/06/2019 16:59:01	0	4	3	5	3	3	3
22/06/2019 17:05:37	0	3	4	4	4	4	3
22/06/2019 17:23:04	0	4	5	4	4	5	5
	How many edibles you grow?	I want to take initiative to build the hub	once it's built, i am going to use the hubs	hubs can be part of oosterwold	hubs are convenient and accessible	hubs would affect relationship with neighbors	gardening skills will be affected
	HUB	HUB	HUB	GENERAL	HUB	HUB	GENERAL

I	J	K	L	M	N	O	P
Denk je dat je zelfverzekte	De handleiding van DIY h	De handleiding gaf inspiratie	De handleiding moedigt a	Hoe zou je de hubs willen	Vind je dat de DIY Hub af	Denk je dat de DIY Hub a	your email address
5	5	4	4	Zelf, Met mijn familie, Met	5	5	Marckauffman@gmail.com
3	5	3	3	Zelf, Met mijn familie, Met	3	3	
3	4	4	5	Zelf	3	5	harm.joann@gmail.com
5	5	5	5	Zelf	5	5	francinaannetje@yahoo.com
3	5	5	3	Zelf	5	5	
4	4	4	5	Zelf	5	5	
3	4	4	3	Zelf, Met mijn bure	3	5	nicovannus@hotmail.com
4	3	3	3	Zelf, Met mijn bure	5	4	winkelen2009@hotmail.com
3	5	5	4	Met mijn bure	5	3	djuttien@YAHOO.COM
3	5	3	5	Met mijn vrienden	5	3	berryvandewal@planet.nl
3	4	5	5	Zelf	5	3	yuroen@yahoo.com
2	4	4	4	Met mijn bure	4	3	
3	4	4	5		5	5	
2	4	4	4	Zelf	5	5	gerdienvanholst@gmail.com
5	3	3	3	Met mijn bure	4	4	
3	4	4	4	Zelf	4	4	
3	4	5	5	Zelf	5	5	
3	4	4	4	Zelf	5	5	gerdienvanholst@gmail.com
5	3	3	3	Met mijn bure	4	4	
3	4	4	4	Zelf	4	4	
3	3	3	3		3	4	caroline.vanveggel@gmail.com
4	4	4	3	Zelf, Met mijn familie	4	4	Daan.schieman@gmail.com
more confident about DIY approach	manual of the hub (complex-understandabl e)	manual opened up new ways of creating	the manual encourages to build hubs	on my own, family, neighbors, friends	application guide through the process of exchanging	application is convenient	
GENERAL	MANUALL	MANUALL	MANUALL	MANUALL	APP	APP	

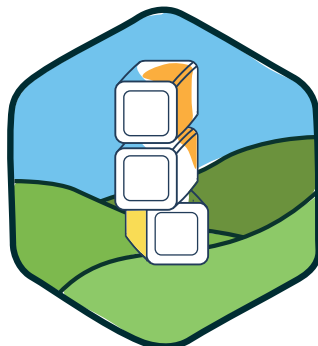

DIY HUBS

Oosterwold

Hi!

This document contains mutually agreeable points about the implementation plan of DIY Exchange Hubs in Oosterwold. Since my project is going to be over in two weeks, I am looking for local collaborators who will be willing to realize the project.

The document consists of the steps that should be taken and the roles of us during the process of implementation.

In case you would have further questions feel free to send me an email or give me a call from 0645644980 or +905364752066.

Below the chart explains the delivery process of DIY Hubs and different responsibilities of us during this process. The process starts by me sending you the existing Illustrator templates that I used for lasercutting and the building manual of the hubs. Then it continues with you building an example hub and the process goes on as shown below. Here it is important to note that one set of DIY Hubs consist of 3 boxes. In reality, we will not sell the boxes in a built way, we will only provide pieces and materials for them to build. Since the boxes are more or less the same, you can cut only one box and make price offer according to that. Since building process of the boxes may be different due to material difference, we would need to build one box to see how the pieces will come together. In case the building process is different, I need to make changes in the building manual of DIY Hubs.

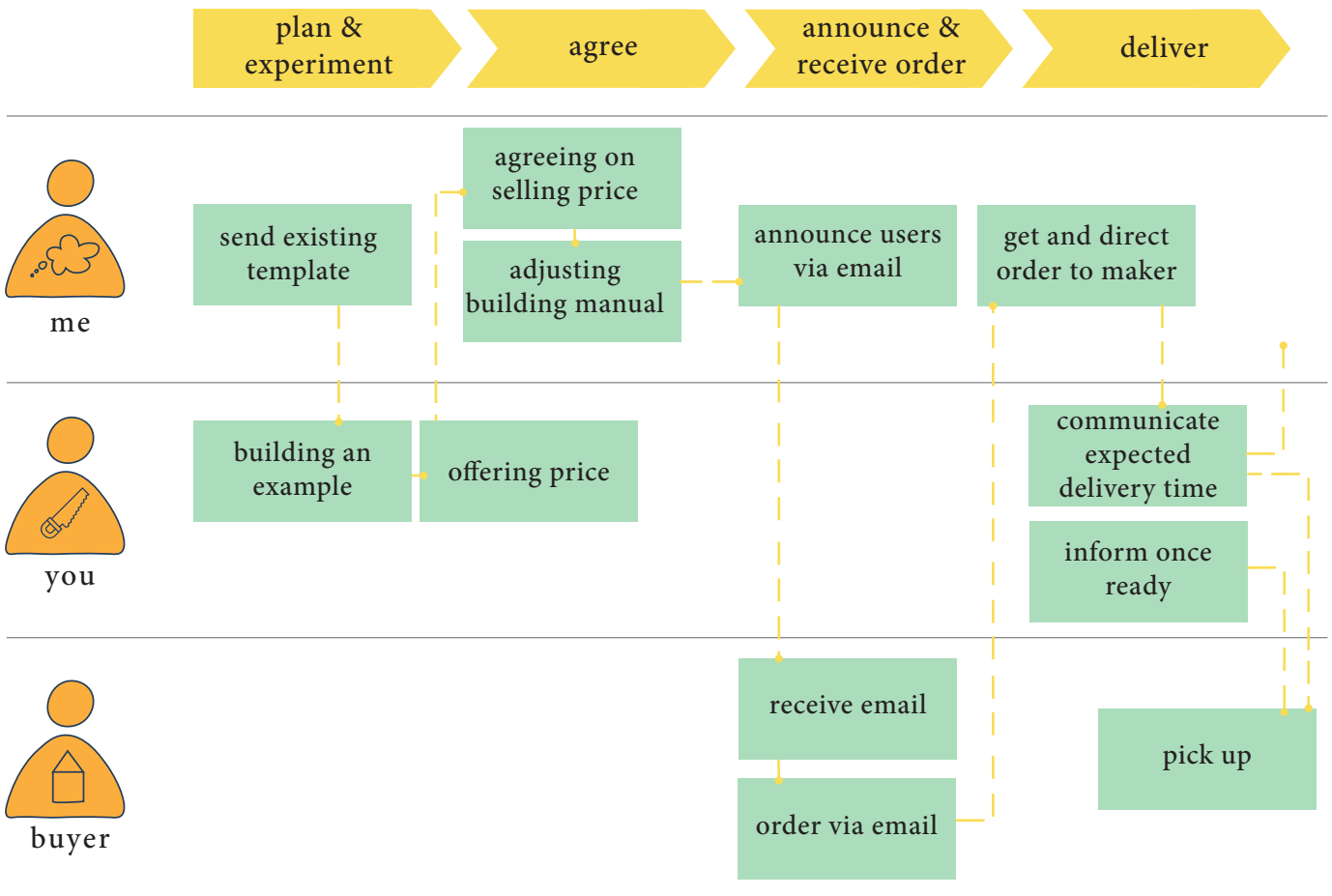

If this sounds like a plan to you, lets keep in touch!

Regards,

Yağmur Gökçe