

FRANK VAN DOESUM

MRI FOR AFRICA

THE DESIGN OF AN MRI FOR THE DIAGNOSIS OF
INFANT HYDROCEPHALUS IN UGANDAN HOSPITALS

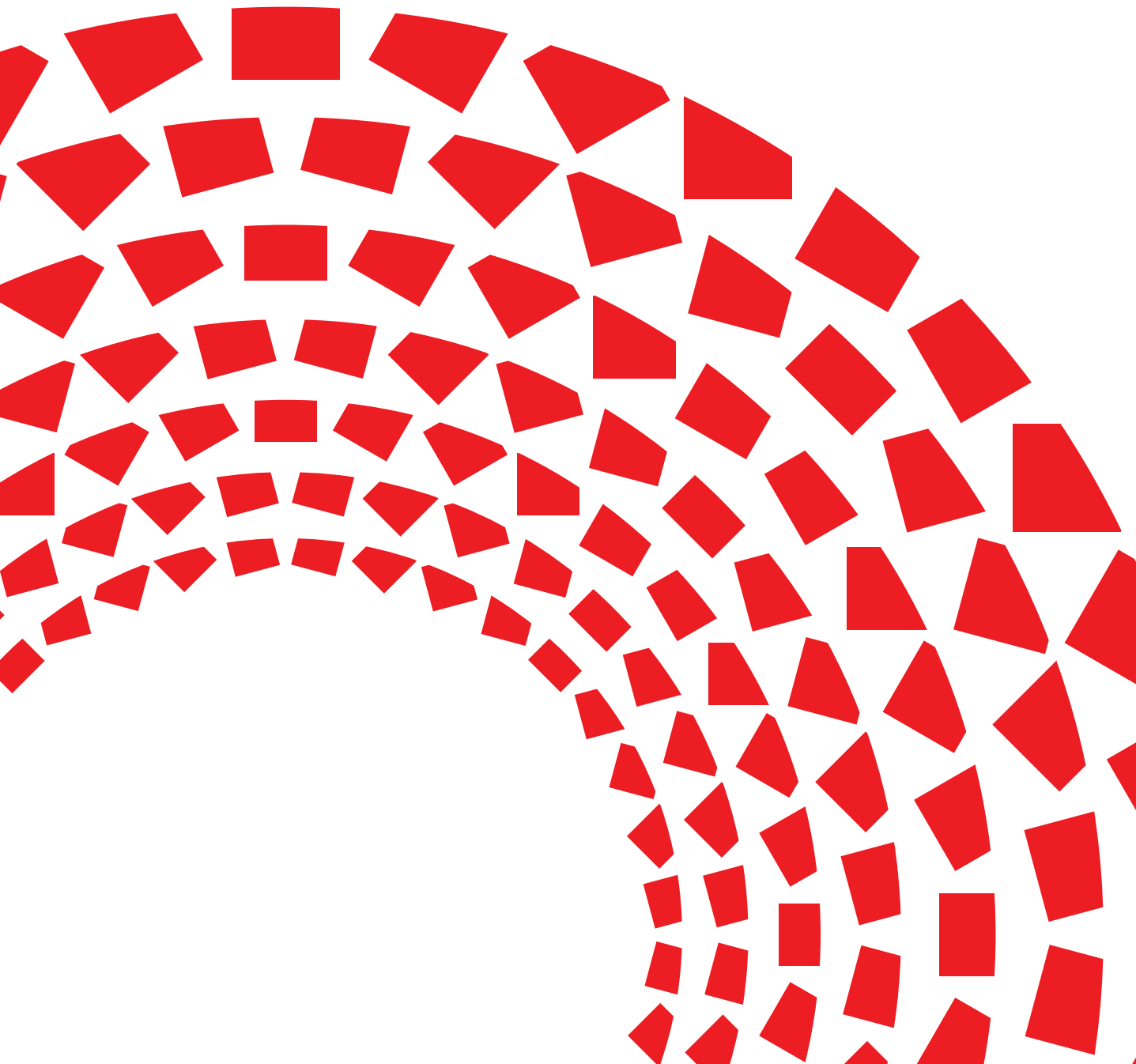

MRI FOR AFRICA

THE DESIGN OF AN MRI FOR THE DIAGNOSIS OF
INFANT HYDROCEPHALUS IN UGANDAN HOSPITALS

April 2nd, 2020

Frank van Doesum

frankvandoesum@gmail.com
Studentnr.: 4291026

MSc Integrated Product Design
Faculty of Industrial Design Engineering
Delft University of Technology

Supervisory team

Chair Dr. ir. Diehl, J.C.
Mentor Ir. Bakker, M.F.
Client Dr. ir. van Gijzen, M.B.

Delft University of Technology

Landbergstraat 15A
2628 CE
Delft, the Netherlands

For the degree 'Master of Science' at the Delft University of Technology,
Faculty of Industrial Design Engineering

EXECUTIVE SUMMARY

Magnetic resonance imaging (MRI) is a medical diagnostic imaging technology characterized by its high cost and infrastructure demands. This makes it unsuitable for implementation in low- and medium-income countries. Its costs are directly related to the strength of the system's magnetic field. Therefore, an MRI scanning technology dedicated for use in low- and medium-income countries has been developed by Delft University of Technology and Leiden University Medical Center that makes use of a low magnetic field. This low-field technology, that requires a smaller size magnet and yields lower resolution images, is already capable of diagnosing infant hydrocephalus, a frequently occurring condition in sub-Saharan Africa. For a successful implementation, it is crucial that this technology is integrated in an MRI system that adequately addresses challenges within the context of sub-Saharan Africa and is equipped with all necessary functionality to diagnose infants with hydrocephalus. From observations and interviews in the healthcare environment of Uganda, it was found that – in addition to high cost – poor infrastructure and challenges that occur during imaging procedures limit the implementation- and use-potential of current MRI systems and thus can affect the implementation of this new system. Poor pathways and unavailability of forklifts or cranes often cause breakage during installation and transport. Moreover, lack of space in hospitals hinders implementation of large systems that require dedicated, shielded rooms. During imaging, movement of the (infant) patient may affect the image, and often mothers are kept in the imaging room with the patient to calm her. Other challenges for the operation of these systems in this context include heat, humidity, dust, power outages and the presence of pests. A concept of a complete MRI system that integrates the developed technology and addresses these challenges is designed. This MRI system enables an ergonomic and safe operation, facilitates safe and comfortable insertion and removal of the patient from the machine, and allows mothers and operators to remain close and in visual contact with the patient. The entire concept takes up no more than 3 m², can be installed in any room with a power socket and features a plug and play installation. It can be carried over rough pathways without the need for a forklift or crane. Furthermore, the concept features a bed with sliding mechanism that optimizes the space inside the system, allowing hydrocephalus patients with significant expansion of the head to be imaged. With this concept, the first steps are taken towards implementation of the technology in hospitals in low- and medium-income countries. Through further development and testing in close collaboration with stakeholders, the concept can be optimized to enable diagnosis and treatment of infants with hydrocephalus and eventually many others, and hereby contribute to increasing the (e)quality of healthcare around the world.

CONTENTS

EXECUTIVE SUMMARY	4
INTRODUCTION	8
1.1 A STORY THAT RESONATES	10
1.2 APPROACH	12
PART I EXPLORE	
TECHNOLOGY EXPLORATION	16
2.1 MRI 101	18
2.2 LOW-FIELD, HI-TECH	22
DIAGNOSING HYDROCEPHALUS	26
3.1 MRI AND HYDROCEPHALUS	28
CONTEXT EXPLORATION	32
4.1 AN IMAGE OF UGANDA	34
4.2 HOSPITAL ENVIRONMENTS	38
4.3 DIAGNOSTIC PROCESSES	42
PART II DEFINE	
INTERMISSION	48
SYNTHESIS	50
5.1 BASIC FUNCTIONING	52
5.2 CONTEXT CHALLENGES	54
5.3 TOWARDS A DESIGN	56
PART III DESIGN	
THE JUMPING-OFF POINT	60
6.1 THE JUMPING-OFF POINT	62

CONCEPTUAL DESIGN	68
7.1 OPERATION	70
7.2 THE PACKAGE DESIGN	76
7.3 CONSTRUCTION	80
7.4 BED AND COIL SYSTEM	84
FINAL DESIGN PRESENTATION	90
8.1 OVERVIEW	92
8.2 OPERATION	94
8.3 INSTALLATION	98
EVALUATION	100
9.1 EVALUATION	102
9.2 VALIDATION	104
RECOMMENDATIONS	108
10.1 RECOMMENDATIONS	110
10.2 CONCLUSION	114
10.3 LIST OF REQUIREMENTS	116
REFERENCES	118
APPENDICES	
APPENDIX A	124
19" SUB-RACKS	124
APPENDIX B	126
UGANDAN HEALTHCARE ENVIRONMENT	126
APPENDIX C	132
OBERVATIONS AND INTERVIEW RESULTS	132
APPENDIX D	140
FEM-ANALYSIS OF 40X40 MM ALUMINIUM EXTRUSTION	140

CHAPTER 1

INTRODUCTION

1.1 A STORY THAT RESONATES

AN MRI FOR SUB-SAHARAN AFRICA

1.1.1 PROJECT BACKGROUND

The starting point for this thesis is a proven Low-Field Magnetic Resonance Imaging (MRI) technology for implementation in low- and medium-income countries (LMICs) developed by researchers from Leiden University Medical Center (LUMC), Technological University Delft (TU Delft), and Pennsylvania State University (PSU).

MRI is a medical imaging technology characterized by its high cost and infrastructure demands. This makes it often unsuitable for implementation in LMICs. In order to overcome these barriers for clinical application and proliferation of MRI systems in LMICs, Steven Schiff of Pennsylvania State University in the USA has proposed a specialized low-field MRI system that is context appropriate and disease specific. Schiff makes the case for an MRI system specialized for diagnosing infant hydrocephalus. Infant hydrocephalus is the most common neurosurgery in children, the easiest condition to image using MRI, and image resolution can be relatively poor yet still provide a reliable diagnosis in most cases. Moreover, with an estimated more than 45,000 new cases of infant hydrocephalus per year, sub-Saharan Africa could benefit from better means of diagnosis, argues Schiff.

1.1.2 PROJECT STAKEHOLDERS

The project was initiated by Steven Schiff in collaboration with Mbarara University of Science and Technology (MUST) and the CURE Children's Hospital in Uganda. The TU Delft and LUMC joined forces to improve the technology, and thus far, several prototypes have been designed by both the PSU team and the TU Delft/LUMC team.

1.1.3 THIS THESIS

Technology development has thus far been the focus for this project. As the technology now reaches a proof of concept level and clinically useful images can be obtained for the diagnosis of hydrocephalus and possible even more, the now prototypical design needs to become a product that is ready for implementation in developing countries. This marks the start of this thesis: the system's technological functionalities need to be integrated into a medical appliance that supports its implementation, operation, and survival in the conditions imposed on it by the context.

1.1.4 GOAL

The goal of this thesis is therefore to (1) explore the context of Ugandan hospitals, (2) assess how context factors influence the design of the integrated system, and (3) design a minimum viable product for implementation in this context.

1.2 APPROACH

THE GENERAL STRUCTURE OF THIS THESIS

1.2.1 GOAL SPECIFICATION

Currently, multiple versions of an MRI system exist within the research group. A version 1.0 made by researchers at PSU is currently being replicated and tested at MUST in Uganda, mainly for educational purposes. The version yielding the best results clinically is the current LUMC system (version 2.0, figure 1). This design is currently being optimized and a new, slightly larger third version of the LUMC system is being designed and produced during the writing of this thesis. This version will be referred to as version 3.0. This thesis considers the integration of version 3.0 technology into a suitable design for sub-Saharan Africa.

1.2.2 CONTEXT DEFINITION

The context of sub-Saharan Africa is specified to Uganda. Uganda has been chosen for the sole reason of practicality: main project stakeholders reside here, and this facilitates field research. It is left open for discussion whether the context of Uganda adequately reflects sub-Saharan Africa as a whole.

1.2.3 THESIS STRUCTURE

This thesis is structured in three phases that roughly reflect the design process: (1) Explore, (2) Define, and (3) Design.

Explore

To be able to assess how the system in its current state will perform, to what extent it needs to be adapted, and how the currently

absent parts should be designed a thorough understanding of the context in which the system will operate is necessary. Moreover, to assess how the system can be adapted to better fit this context, the system's technological specifications and characteristics need to be understood. In 'Explore', the context and the system are analyzed and explained.

Define

'Define' aims at gathering all the insights from 'Explore', combining them, and assessing their impact on the design in the form of design requirements. Here, the main focus for the design will be further specified in form of an initial design vision.

Design

In 'Design', the design requirements and design vision will lead to generate new ideas, conceptualize the system, and embody (parts of) it.



Figure 1. The current version of the low-field MRI. The picture shows the (permanent) magnet in which the patient's are inserted.

PART I
EXPLORE

CHAPTER 2

TECHNOLOGY EXPLORATION

APPROACH AND METHOD

Goals

Initial technological exploration is conducted which aims to identify basic MRI functioning, the basic components of the current system, their functions, and technological requirements.

At the time of writing this thesis, detailed technological documentation of the system and its components was unavailable. Moreover, version 3.0 was still being designed and produced. Therefore, in close collaboration with the LUMC and TU Delft research team, version 2.0 components and their place in the system were identified, after which assumptions about changes in version 3.0 were made. Moreover, components' technological specifications and requirements were analyzed.

Method

Interviews, conversations, and e-mail contact with Danny de Gans (DEMO, TU Delft), Martin van Gijzen (Applied Mathematics, TU Delft), and Tom O'Reilly (LUMC) were conducted. Wherever necessary, components were documented by taking photos. Additionally, literature and online sources were consulted.

2.1 MRI 101

BASIC WORKING PRINCIPLES & COMPONENTS

TO UNDERSTAND THE CURRENT VERSION 3.0 SYSTEM, IT IS REQUIRED TO GAIN A BASIC UNDERSTANDING OF THE UNDERLYING PRINCIPLES AND AN MRI SYSTEM'S BASIC COMPONENT AND ARCHITECTURE. THIS CHAPTER EXPLORES THESE BASICS OF MRI.

2.1.1 BASIC PRINCIPLES

Magnetic Resonance Imaging, or MRI, works according to the principles of nuclear magnetic resonance. Nuclear Magnetic Resonance (NMR) occurs in the nuclei of certain elements. The protons in these nuclei have a precession: a circular motion that is dependent on the proton's mass, size, and spin around its axis.

Due to the positive charge of the proton and its spin, it generates a magnetic moment. Therefore, when an external magnetic field is applied the precession of the proton will occur about the direction of this magnetic field. In other words: the proton is tipped off its natural precession, aligning it with the external magnetic field.

Whenever these protons' precessions are aligned to the magnetic field of an MRI scanner, a radiofrequency (RF) wave is introduced which forces the proton in a 90- or 180-degree misalignment with the magnetic field. The RF wave is then turned off, and when the proton realigns with the magnetic field, it releases energy in the form of electromagnetic

waves (figure 2). This magnetic resonance signal is measured by an RF receiver and this signal is used to create the image.

The MR signal is dependent on the induced nuclear magnetization and the rate of change of magnetic flux – which represents the signal of the precession frequency. Both scale linearly with the magnetic field strength. That means when taken together, the MR signal has a quadratic dependence on the magnetic field strength.

2.1.2 MRI: THE COMPONENTS

The basic components in an MRI system that allow for the detection and location of MR signals are:

- 1) The magnet
- 2) The gradient coils
- 3) The radiofrequency transceiver

Their functions will be explained in the following paragraphs.

The magnet

Some systems work with permanent magnets; however, these are not very common. Most MRI systems work by running a current through a superconducting solenoid. In order to create a high magnetic field – necessary to obtain a better signal and thus a better image – superconductors are used. In order to get the needed superconducting capacities liquid

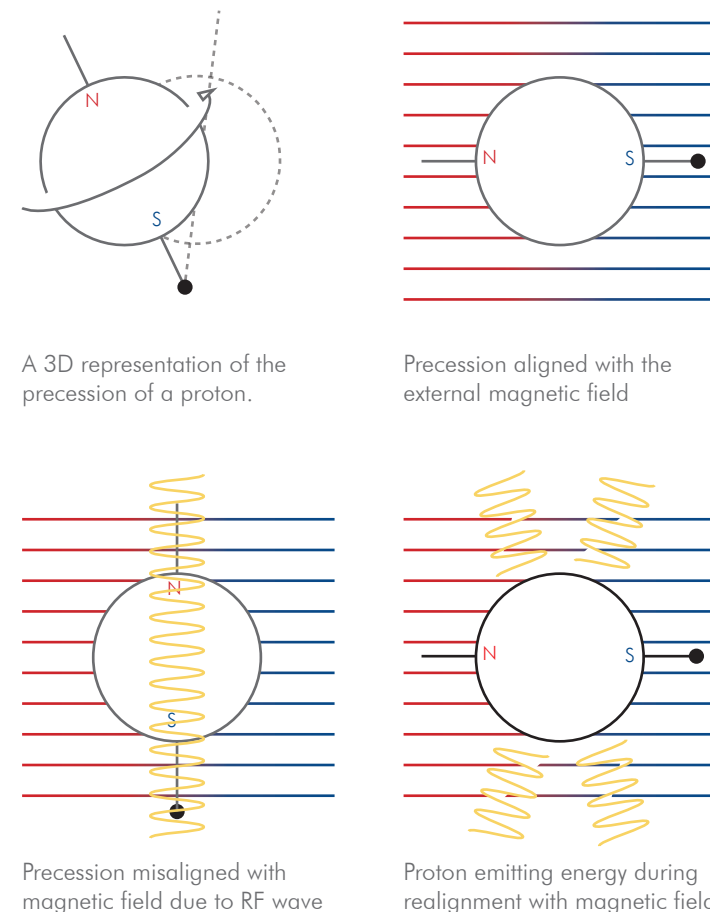

A 3D representation of the precession of a proton.

Precession aligned with the external magnetic field

Precession misaligned with magnetic field due to RF wave

Proton emitting energy during realignment with magnetic field

Figure 2. The basic principle of nuclear magnetic resonance, simplified.

helium is used to cool the magnet.

The center of the magnetic field is called the isocenter. This is where the magnetic field strength is most homogeneous. Inhomogeneity of the magnetic field causes distortion, shading, blurring, and other issues in the image. The magnetic field starts to rapidly degrade when moving away from this isocenter, therefore, the to be scanned object needs to be placed as close to the isocenter as possible.

The gradient coils

The (usually three) gradient coils are used to predictably alter the magnetic field in the x, y, and z orientations (figure 3). They produce a gradient magnetic field. Since the precession frequencies of the nuclei depend on the magnetic field strength, when altering the static

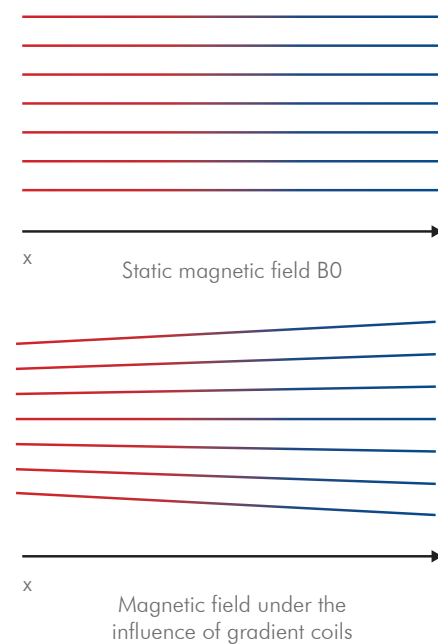

Figure 3. A simple representation of a linear magnetic field gradient.

magnetic field in a linear and predictable way the precession frequencies depend on their location in relation to this linear magnetic field gradient. Introducing this gradient magnetic field in three spatial planes makes it possible to calculate the location of the signal that is being received.

Radiofrequency transmitter/receiver

The radiofrequency (RF) transceiver is used to send the RF pulse that tips the protons out of alignment and receives the signal that the protons emit when they return to their aligned state.

When used as a transmitter, the RF coil generates a magnetic field (B1) that is perpendicular to the static magnetic field (B0). When B1 oscillates at a frequency that matches the natural precession frequency of the protons, they are tipped out of alignment with the static magnetic field.

When used as a receiver, the signal that the protons emit while they return to their natural spinning state (the oscillating magnetic flux) can be detected by the coil as this induces an electric current in the coil. This signal is passed through amplifiers, filters, and is digitized to extract frequency information.

Many modern MRI systems have a separate RF transmitter and receiver (figure 4).

2.1.3 THE PROS AND CONS

MRI is notably one of the best imaging technologies for diagnosing soft and hard tissues within the body with a high resolution. However, it has some downsides, the most important one being cost. Let's have a look: The human body consists of approximately 63% hydrogen atoms; hence these are the atoms that are used for MR imaging. This also means that MR imaging is particularly

useful for scanning soft tissue as this consists of mainly hydrogen atoms. Because of this, MRI is best used for diagnosing "internal derangement of joints, central nervous system abnormalities, and other pathologic processes in the patient with pain" [1].

However, also for diagnosing fractures MRI can be of use. For example, it can detect stress fractures long before an X-ray shows anything, and in some cases is used to distinguish between a bone fracture or soft tissue damage [2].

"[MRI IS] THE LOWEST RISK AND MOST EXPENSIVE MEDICAL DIAGNOSTIC TECHNOLOGY EVER DEVELOPED." [3]

Superior image resolution and multi-planar imaging, as well as the absence of ionizing radiation are among the advantages of MRI compared to other imaging modalities. However, the time to acquire an image is listed as one of the technology's main disadvantages [3]. Cost, time to prepare and

screen the patient, availability and accessibility are also frequently mentioned as downsides of MRI when compared to other imaging technologies.

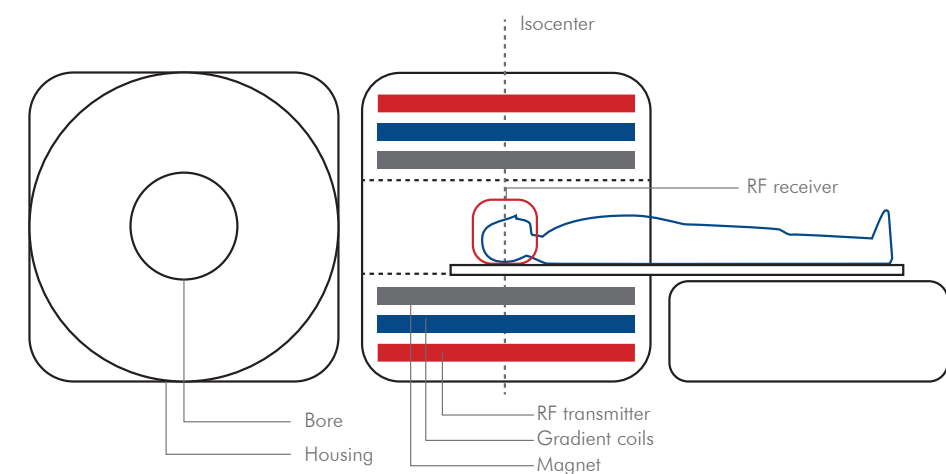

Figure 4. A simple representation of a regular high-field MRI one can find in western hospitals.

2.2 LOW-FIELD, HI-TECH UNDERSTANDING THE LOW-FIELD SYSTEM

NOW THAT THE BASIC PRINCIPLES ARE UNDERSTOOD, THE CURRENT LUMC VERSION 3.0 SYSTEM CAN BE EXPLORED. THIS CHAPTER EXPLORES ITS COMPONENTS AND THEIR FUNCTIONS.

2.2.1 COMPONENTS AND FUNCTIONS Magnet

The magnet's main function is to provide a static homogeneous magnetic field that allows for MR imaging.

The magnet (as shown in Figure 1, page 14) consists of circular PMMA rings that have been lasercut to fit 3125 small neodymium magnets (12x12x12 mm). The magnets are arranged in a Halbach-array; it increases the strength of the magnetic field on the inside of the rings and decreasing its strength outwards.

The magnet includes shims: the shims' main function are to improve the homogeneity of the magnetic field. They consist of an extra set of 238 magnets on the inside diameter of the magnet rings to improve the homogeneity of the magnetic field. These are part of the magnet assembly: inside of the magnet space is reserved for these.

The magnetic field strength at the isocenter is 60 mT. The length over which the magnetic field strength is homogeneous and strong enough to perform MR imaging (field of view) is 200 mm (100 mm in each direction from the isocenter).

Along the outside perimeter of the magnet, the magnetic field strength is as low as 5 mT, and at a distance of 50 mm from the magnet, the magnetic field strength decreases to approximately 1% of its maximum strength. Near the openings on each side it extends a bit further outward ($\pm 1\%$ at 100 mm). Within these distances from the magnet, ferromagnetic materials may influence the field's homogeneity, and are thus undesired.

The total weight of the current magnet is around 75 kg, the version 3.0 magnet is expected to be slightly heavier, but not exceed 100 kg.

Bore

The bore's main function is to act as a smooth cylinder to safely insert the patient. Moreover, it serves as a connecting part for the inner electromagnetic shielding and gradient coils.

The version 3.0 is made from a PMMA tube with an outside diameter of 300 mm, with a wall thickness of 4 mm gives an inner diameter of 292 mm. Its current length is 488 mm (with the magnet's isocenter at 244 mm).

Radiofrequency (RF) amplifier

The RF amplifier's (figure 5) main function is to amplify radiofrequency pulses that will be sent to or received from the RF transceiver coil.

The radiofrequency amplifier is capable of sending pulses of 1kW, yet only for short amounts of time (in the order of milliseconds). The average power usage during a scanning sequence (approximately 10 minutes) is around 10W. It operates on a 230V, 50 Hz power supply.

It is built in a 19" sub-rack of 355x267x427 mm (dxhxw). That equals a 6U height measurement for standard 19" rack cases. The sub-rack will be equipped with cooling fans. Additional details on sub-rack specifications can be found in appendix A.

Radiofrequency transceiver coil

The radiofrequency transceiver's function is to send radiofrequency pulses to excite the nuclei, and to receive the NMR signals from these nuclei.

It should be placed concentrically with the bore's axis, with its center located at the isocenter of the magnetic field. For optimal scanning of infant hydrocephalus, the center of the coil should be at the center of the patient's head (which is around the height of the ears).

To receive these weak signals, it is important that the coil is placed close to the body part that is being scanned. For this reason, coils with different diameters are being designed. Current coil dimensions are 150 mm diameter by 150 mm length. Other coils that are being developed are 200x200 and 250x200 mm. Future development may explore elliptical shapes to better accommodate the head.



Figure 5. The current electronics setup. Black cases: gradient amplifiers. Silver case: RF amplifier.

Metal (ferro or non-ferro) objects in close proximity (<40 mm) to the coil may cause issues while scanning, due to the generation of eddy currents.

The copper windings are wound on PMMA tubes or 3D-printed cylinders to create the coil. The coil itself has an M4 safety jack socket connection.

Gradient coils

The gradient coils' function are to impose a linear magnetic field gradient on the static magnetic field (for why this is done, see CH1.1, MRI BASICS). Three gradient coils control the field gradient in the x, y, and z direction.

The coils are made of copper wire and are connected to the outside diameter of the bore cylinder. They have a thickness of approximately 3 mm.

Gradient amplifiers

The gradient amplifiers (figure 6) amplify the pulses that are sent to the gradient coils.

In the duration of one scanning sequence (approximately 10 minutes) the gradient amplifiers use 60W on average. They require both 12 V and -12 V power supplies - a dedicated converter has been built in. The gradient amplifiers' components (for the x, y, and z gradients) are built in one 19" sub-rack from aluminium with dimensions of 295x133x427 mm (dxhwx). That equals a 3U height measurement for standard 19" rack cases. The sub-rack will be equipped with cooling fans.



Figure 6. The new gradient amplifiers (x,y,z) built into a 19" subrack of 3U height.

Spectrometer

The spectrometer functions as the system's brains. It regulates the pulses (from the gradient and radiofrequency amplifiers) and processes the received signals, connecting through a USB-connection to the computer. During a normal scanning sequence (approximately 10 minutes) it uses on average 40W. In the current system, the spectrometer is a Magritek Kea console. In the version 3.0 system, the spectrometer will be built into a

19" sub-rack. The dimensions are assumed to be (a maximum of) 295x133x427 mm (dxhwx), equaling a 3U height measurement. The sub-rack will be equipped with cooling fans.

Desktop computer and monitor

A desktop computer processes the data to construct the images. The monitor shows a basic user interface and allows to read out images.

The current desktop computer equips a quad-core CPU, 16 GB of RAM and a mid-range GPU. A dedicated GPU is a requirement due to the nature of the calculations that need to be performed. There are no specific requirements for the monitor.

Digital user interface

Its function is to allow the operator to select the appropriate MRI sequence, run test images, and read out the constructed MR images.

The user interface runs on the desktop computer. Currently, the system runs with a preliminary mock-up user interface.

Power source

Currently, power comes from a wall plug at 230V, 50 Hz. Amplifiers use a dedicated converter. Currently, no backup power supply is installed.

Electromagnetic shielding

The function of electromagnetic (EM) shielding is to shield the RF coil from electromagnetic noise (coming from other devices in the surroundings) that can negatively affect the image quality.

Currently, a 2 mm thick aluminium sheet

box (figure 7) is built around the entire magnet to provide EM shielding. It is closed off at one end. Moreover, the inside of the bore diameter is covered with a thin copper sheet.

In version 3.0, the aluminium box may be redundant as a copper mesh shield may be used inside the magnet (between the bore outside diameter and the gradient coils) and on the outer perimeter of the magnet. Tests have to determine whether that will suffice. For now, it is assumed that a 1 mm aluminium shielding is nevertheless preferred on the outer perimeter of the magnet. It is also preferred for the bore to remain closed off at one end.

Conductive blanket

The conductive blanket's function is to shield any of the patient's body parts sticking out of the machine during scanning. These body parts can act as an antenna to income electromagnetic signals; to increase SNR, they are currently shielded from all sides by the conductive blanket.

The blanket that is currently being used is costly: €1.500,- for a blanket with dimensions of 1.400 x 6.000 mm.

However, further testing should decide whether this blanket is a need-to-have or just a nice-to-have.

Cables and connectors

Cables and connectors are of various types. Connections are shown in figure 8.

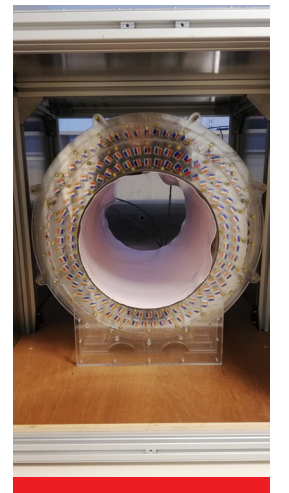

Figure 7. The magnet in its aluminium shielding.

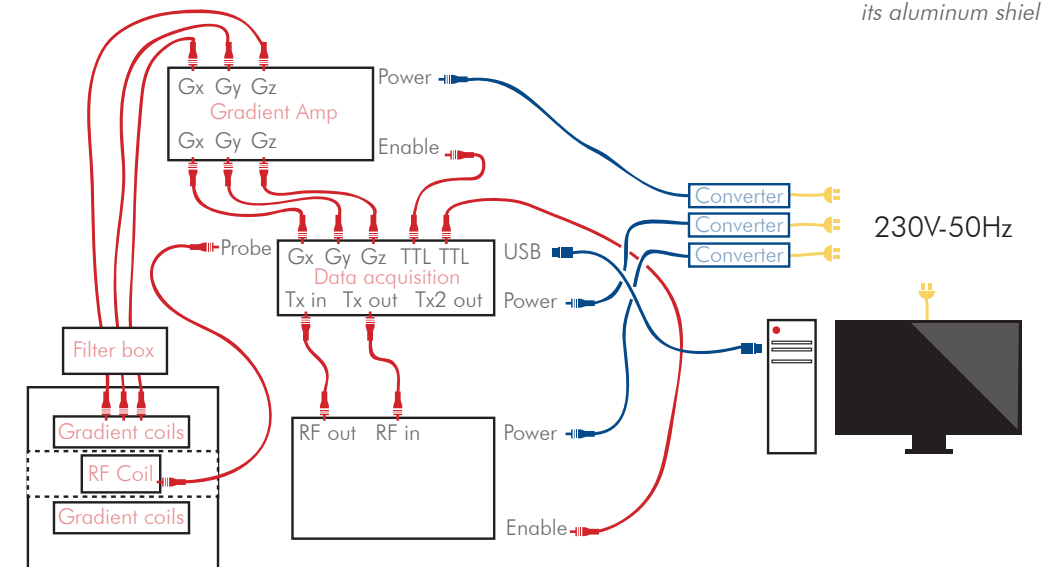

Figure 8. All cable connectors from and to components.

CHAPTER 3

DIAGNOSING

HYDROCEPHALUS

APPROACH AND METHOD

Goals

This chapter aims at gaining understanding of the low-field MRI system's initial usecase of hydrocephalus. More specifically, it seeks to understand the role of MRI in diagnosing this condition. This illustrates the clinical utility of MRI, and the value it can deliver to LMIC-hospitals. This opens up the discussion of what constitutes a minimum viable product, and emphasizes the 'viable' in this.

Method

Extensive literature research was used to analyze hydrocephalus and MRI's role in diagnosing it. Additionally, to directly involve the eventual target group, interviews with Ugandan hospital staff were conducted to better understand their need for diagnosing hydrocephalus and the role that MRI can play in the hospital's operations. Hospital staff included directors, administrators, radiographers, radiologists, nurses, and others.

3.1 MRI AND HYDROCEPHALUS

EXPLORING THE VALUE OF THE MRI SYSTEM

THIS CHAPTER IDENTIFIES CRUCIAL DRIVERS THAT INFLUENCE THE VALUE OF A HYDROCEPHALUS SPECIFIC DEVICE FOR LMICS.

3.1.1 HYDROCEPHALUS

The condition and its symptoms

Hydrocephalus, or sometimes referred to as ‘water on the brain’ [4], is a condition that causes cerebrospinal fluid (CSF) to accumulate in the brain’s ventricles (figure 9). Cerebrospinal fluid is continuously produced in these ventricles and in the Choroid Plexus and is usually in continuous circulation, being absorbed in the bloodstream. With hydrocephalus, the cerebrospinal fluid production is higher than the absorption rate, causing the ventricles to fill and pressure in the head to increase [5]. Hydrocephalus can be either congenital or acquired and can occur at all ages. In infants, the increased pressure in the skull often causes an abnormal expansion of the head as infant’s skull bones have not yet fully grown together [6].

Hydrocephalus can cause symptoms such as “headaches, vomiting, nausea, blurred or double vision, sun setting of the eyes, problems with balance, poor coordination, gait disturbance, urinary incontinence, slowing or loss of developmental progress, lethargy, drowsiness, irritability, or other changes in personality or cognition including memory loss” [6]. However, due to the open fontanelles

in young infants the head can expand, which compensates the buildup of intracranial pressure, reducing the symptoms’ severity or eliminating them altogether. It’s important that infant head circumference is measured as an indication of the condition [7].

3.1.2 COMMON DIAGNOSES

Different imaging modalities can be used to assess the severity and the nature of the condition and to assess treatment options.

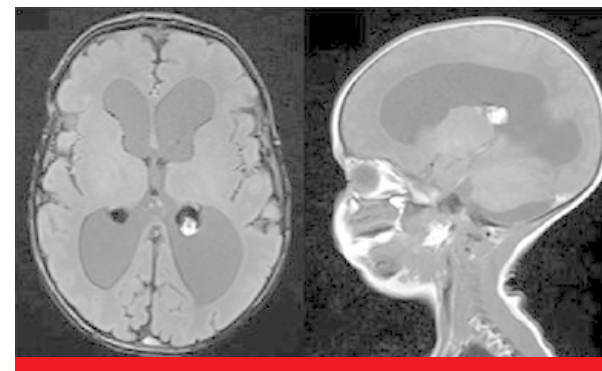

Figure 9. An MRI image of an infant with hydrocephalus in the transverse and sagittal planes. [B]

Ultrasound

The preferred technique for the initial assessment of hydrocephalus in infants is usually ultrasonography because of its portability (for imaging immobile patients) and lack of ionizing radiation [8]. It is also low-cost and exempts the need for anesthesia or sedation [9]. Ultrasonography is however

only possible when the anterior fontanelle is still open: ultrasonography cannot penetrate through bone [10].

CT and MRI

An MRI is usually warranted, even if ultrasound is also an option [11]. It provides more clinical information [12]; however, the clinical utility of ultrasound is comparable with MRI within the first months of the neonate’s life [13].

When the anterior fontanelle closes between the 12th and 18th month after birth (in full-term babies), MRI becomes the preferred choice of imaging since it does not expose the child to harmful radiation. However, CT is also still used in some cases. Even though it may be clinically superior in some specific cases, MRI is usually less accessible, more expensive, and requires more patient screening and preparation compared with CT. Moreover, the harmful effects of radiation have yet to be effectively quantified [14]. Even though these effects haven’t been effectively demonstrated, it remains advisable to follow the ‘as low as reasonably achievable principle’ (ALARA-principle) [14].

3.1.3 TREATMENT AND FOLLOW-UP

Ventriculoperitoneal Shunt (VPS)

A ventriculoperitoneal shunt (VPS) (figure 10) is the most common treatment option for hydrocephalus in the developed world. These shunts redirect the excess cerebrospinal fluid from the brain’s ventricles to other body parts that can more easily absorb the fluid, such as the abdomen. The shunt will remain in the body for the rest of the patient’s life.

Endoscopic Third Ventriculostomy + Choroid Plexus Cauterization

Endoscopic Third Ventriculostomy (ETV) is a recently developed procedure that eliminates the need for a shunt. Natural flow of CSF is

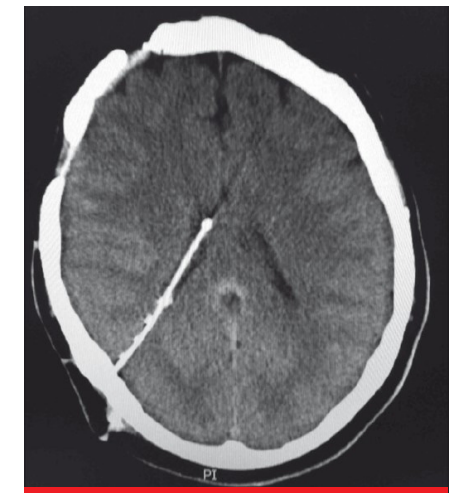

Figure 10. A CT-scan of a VP shunt. Transverse section of the brain. [A]

restored by creating an opening in one of the brain’s ventricles. The opening is calibrated for the required flow rate of the CSF. Often this procedure is combined with a Choroid Plexus Cauterization (CPC) which aims at reducing the production rate of CSF [15].

Monitoring

Especially patients treated with a ventriculoperitoneal shunt should carefully keep monitoring the condition and present for frequent check-ups as shunts may malfunction or cause infections [16]. In 43.6% of cases shunt failure occurs within first 2 years of placement (as cited in [17]), and the average lifespan of an infant shunt is 2 years [18]. This often requires multiple additional hospital admissions during the child’s lifetime [19]. Moreover, detection of shunt malfunctioning proves challenging as symptoms are similar to common illnesses [20]. Malfunctions may cause hemorrhage or returning symptoms of hydrocephalus [18]. Adult shunts can last even 8 years or more [18].

ETV could provide a safer alternative [17],

but even so, it is not a complete cure for hydrocephalus as late failure occurs in up to 40% of cases [21].

When children age, assessment and monitoring of the condition needs to be done with either MRI or CT. Both modalities can be used for monitoring, however, when ALARA principle is considered, MRI is preferable. Even so, shunt compatibility with MRI needs to be assessed, thus CT remains a valid option.

3.1.4 HYDROCEPHALUS IN AFRICA Prevalence

Sub-Saharan Africa has an estimated more than 45,000 new cases of infant hydrocephalus per year and Uganda has an estimated 1000 to 2000 new infant hydrocephalus cases each year [22]. In Uganda, hydrocephalus is in most cases an acquired condition caused by neonatal infection. In 60% of cases, hydrocephalus is caused by a cerebrospinal fluid infection and the majority of infections (76%) occur in the first month of life [17]. The postinfectious hydrocephalus may be related to perinatal conditions, obstetrical complications, premature labor or chorioamnionitis. Some local cultural practices may also cause infection (e.g. placing cow dung on the umbilical stump) [17]. Moreover, in rural areas only 52.8% of births have a skilled attendant present. In urban areas this increases to 89.1% [23].

As sepsis is one of the main causes of neonatal mortality (18.2%) [23], this emphasizes the need for solutions not only of prevention but also of its subsequent treatment.

Diagnosis

Not only the prevention of hydrocephalus

in Uganda provides challenges, so does its diagnosis and treatment. Despite the widespread availability of ultrasonography devices in Uganda [24, 26], initial diagnosis of infant hydrocephalus in Uganda remains problematic. Reasons for this include people's lack of financial means for diagnosis and subsequent treatment, transportation, discouragement from seeking help by the local community, cultural considerations causing misconceptions about the condition, and improper referral to treatment facilities [17]. As Benjamin Warff (2005) reported in a study, the mean time between the onset of symptoms and presentation for treatment may be as long as 7.46 months [17]. Measures of spread were not reported for this data.

Treatment

Even with proper and accessible diagnosis, treatment is difficult. East-Africa counts 27 neurosurgeons for a population of 270 million [25], and many countries don't even have any neurosurgeons. Uganda, on a population of 33 million, has 6 [25]. If treatment can be performed, issues may still arise afterwards. In developing countries this may be even more difficult to assess returning symptoms as consequence of shunt malfunctioning or ETV malfunctioning [17]. Signs of the condition

“A PEDIATRIC MRI IS VERY DESIRABLE, BUT AN MRI THAT ONLY DOES HYDROCEPHALUS IS NOT SO MUCH.”

- Jonathan Ssenwemba, radiographer, Mbarara hospital

returning need to be carefully monitored throughout the child's lifetime, and additional admissions may be required when symptoms return [19]. Even though ETV may reduce the need for follow-up treatment and is thus preferred in environments that hinder access to care, it is not always a feasible treatment option. However, one study shows that around 50% of patients could be treated without shunt

placement regardless of age and cause of hydrocephalus [17].

3.1.5 HOSPITAL FEEDBACK

Ugandan hospitals - public and private alike - are sceptical about these type of devices. Clinicians wish the best available equipment, and “do not want to settle for less” [27]. A disease specific device limits functionality in a context that benefits so much from generalist, versatile equipment such as ultrasound. Nevertheless, a small MRI may be valuable “if limbs and heads can be scanned” [28]. It then starts competing with CT [28]. Moreover, it is identified that an MRI specifically for pediatric cases is also desirable: imaging nervous systems and lungs [29] and spines [30] will significantly increase value attributed to the modality.

3.1.6 KEY TAKEAWAYS

- 3.1 Initial assessment of hydrocephalus is done with ultrasound
- 3.2 Follow-up assessment and monitoring of treatments after the closing of fontanelles (12-18 months) must be done with either CT or MRI
- 3.3 CT causes harmful radiation of which the effects on infants is not entirely clear
- 3.4 Radiation exposure must be kept as low as reasonably achievable
- 3.5 In Uganda, 76% of infections that cause hydrocephalus occur in the first month of life
- 3.6 In Uganda, the mean time between on-set of symptoms and presentation for treatment is 7.46 months
- 3.7 The compatibility of shunts with MRI is not always certain
- 3.8 A shuntless treatment such as ETV reduces the need for follow-up

treatment

- 3.9 50% of patients could be treated without shunts
- 3.10 Conversations with Ugandan hospital staff indicate that a hydrocephalus-specific device delivers insufficient value
- 3.11 Conversations with Ugandan hospital staff indicate that a small-size MRI system can provide value
- 3.12 Conversations with Ugandan hospital staff indicate that other areas that could be explored are: imaging of adult heads, limbs, lungs, or nervous systems, and full body pediatric MRI.

CHAPTER 4

CONTEXT

EXPLORATION

APPROACH AND METHOD

Goals

A context exploration was performed with the aim of identifying factors that may affect the implementation of the low-field MRI in Ugandan hospitals and Ugandan healthcare environment (APPENDIX B). The results of this exploration in the form of design requirements feed into the 'define' and 'design' sections of this report.

Method

Several public and private hospitals in Uganda were visited. Interviews with a broad mix of hospital staff namely nurses, radiographers, radiologists, biomedical engineers/mechanics, directors, administrators, and doctors were conducted. Moreover, observations were taken, and whenever necessary, documented in writing (APPENDIX C). Photos were taken whenever this was approved by hospital staff.

The scope was widened to 'Diagnostic Imaging', because of the current unavailability of MRI in Uganda.

Literature was used to support the field research.

Two initial design concepts were used as a tool to support interviews and to test user preferences and thereby identify strengths and weaknesses of initial hypothetical design directions.

4.1 AN IMAGE OF UGANDA

GENERAL CONTEXT FACTORS

FIRSTLY, A GENERAL OVERVIEW OF THE CONTEXT RELEVANT TO THE MRI IS MADE. THIS SECTION EXPLORES GENERAL CONTEXT FACTORS WHICH ARE APPLICABLE TO IMPLEMENTATION OF MOST MEDICAL IMAGING EQUIPMENT IN UGANDA.

4.1.1 GENERAL CHALLENGES

For a lot of medical equipment, accessibility to LMICs starts by reducing costs. However, high equipment cost is not the only challenge to overcome. The lack of health personnel and proper training, inconsistent power supplies, unavailability of spare parts and high cost of operation (maintenance and consumables) all hinder the implementation and operation of advanced medical equipment [32]. Well-intentioned donated medical devices are designed for use in a developed market, and often do not fit the context of a developing country. As 2010 Director-General of the World Health Organization Margaret Chan (2010) mentions: "About 70% of the more complex devices do not function when they reach their destination." [32] Moreover, 96% of imported equipment breaks down within the first 5 years of donation [33].

Lack of health personnel

Understaffing is a crucial problem in many of Ugandan hospitals. Only six from in total fourteen regional referral hospitals have one or two radiologists, and in total, Uganda counts some 37 radiologists [34] and 42 radiographers [35], of which the major portion is concentrated in the capital Kampala [35]. Moreover, there is a scarcity in personnel that are able to perform subsequent treatments, such as neurosurgeons. Sources indicate that there are between six and twelve neurosurgeons in a country that has 40 million inhabitants [36, 25].

Maintenance and repairs

Not only operation of equipment provides a (staffing) challenge, its maintenance does so as well. As replacement costs are high,

A CHEAPER OPTION THAN MRI

In developing countries, computer tomography (CT) (figure 11) is often used to replace MRI as it is a cheaper imaging modality (as cited in [31]). However, the same barriers and limitations apply to CT in developing countries. Moreover, CT causes a high amount of ionizing radiation, making it an undesired or even dangerous option for some medical conditions [31].

equipment faces high workloads and generally the equipment's lifetime is extended as long as possible. However: the older the equipment, the harder to find spares as OEMs discontinue their production [30]. Additionally, OEMs do not always deliver appropriate manuals and tools to perform repairs. If they do (in newer equipment), cost is still an issue [37]. Hospitals work with freelance maintenance workers when OEMs don't support the equipment's maintenance, however, these personnel are unsustainably expensive [37, 38].

Installation

Installation can be another costly challenge for hospitals to overcome before equipment finds its way into the hospital. Often, expert personnel are needed to install hi-tech equipment. The scarcity of personnel able to install such equipment causes high costs — often a substantial margin of the product's

purchasing price. Biomedical Engineer for ECUREI Joseph Sali mentions that costs can rise up to 25.000 euros for the installation of a CT scanner, as special personnel need to be found and accommodated [37]. Another significant expense is the shipping of large equipment, and taxes of up to 8% on the purchasing price can be expected [37].

4.1.2 CURRENT COUNTERMEASURES

Lack of health personnel

Staffing shortages are sometimes able to be effectively mitigated. Some hospitals have collaborations with external parties that can interpret diagnostic images [39]. Moreover, health personnel in some cases travels between regions in intervals, allowing the population of that region access to specific care otherwise unavailable to them [27]. However, lack of staff remains a crucial barrier to implementation of static equipment.

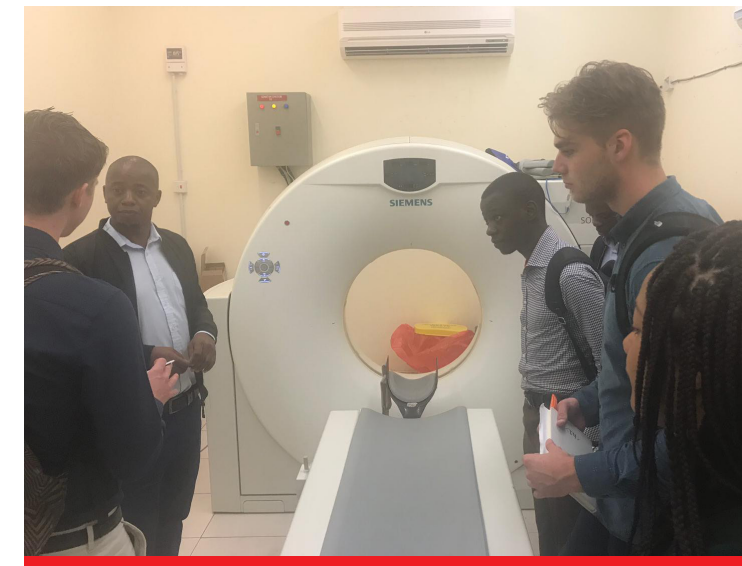

Figure 11. Radiographer David Mjuni in the CT-room in the Mbarara Regional Referral Hospital.

Maintenance and repairs

Some OEMs provide maintenance contracts which is arguably a better option than expensive freelance workers [38]. However, this is not always available and is dependent on the OEM and the equipment. Moreover, the Ministry of Health's Workshop Truck (figure 12) initiative tries to address staffing challenges. This Workshop Truck drives around hospitals repairing broken equipment. Whenever equipment cannot be repaired with the available tools in the truck, it is taken to a central workshop (Figure 13) for further inspection [40]. The scarcity of spare parts remains a problem with no clearly identified mitigation.

Installation

No current solution to the costs incurred as a consequence of transportation and installation was identified.



Figure 13. A broken microscope on the workbench in the Masaka Hospital medical equipment workshop. The workshop is the central repair facility for the hospital's broken equipment.



Figure 12. Masaka Hospital biomedical engineer Ali and his workshop truck that drives around the region to perform maintenance and repair broken medical equipment.

4.1.3 KEY TAKEAWAYS

- 4.1 Lack of health personnel causes a major challenge in the operation of advanced medical equipment
- 4.2 Lack of health personnel causes a major challenge in the interpretation of diagnostic images
- 4.3 Lack of health personnel causes a major challenge in the subsequent treatment of diagnosed patients
- 4.4 Collaborations with external parties that interpret diagnostic images address lack of health personnel
- 4.5 Health personnel travelling between regions address the lack of health personnel
- 4.6 Unavailability of spare parts is a currently unaddressed problem
- 4.7 Equipment's lifetime is extended as long as possible
- 4.8 Maintenance and repair personnel is expensive and scarce
- 4.9 OEM service contracts are not always available
- 4.10 A workshop truck that drives around the region performing repairs addresses the scarcity of repair personnel
- 4.11 Installation personnel is expensive and scarce
- 4.12 Transportation costs of large equipment is high
- 4.13 Taxes constitute a large portion of the purchasing costs

4.2 HOSPITAL ENVIRONMENTS

CHALLENGES IN UGANDAN HOSPITAL ENVIRONMENTS

THE ENVIRONMENT IN WHICH THE MRI WILL BE PLACED SHOULD BE ANALYZED TO IDENTIFY ANY CHALLENGES THAT MAY PRESENT AS A CONSEQUENCE OF THE HOSPITAL ENVIRONMENT. THIS SECTION EXPLORES THESE CHALLENGES.

4.2.1 CHALLENGES

This section's goal is not to illustrate the differences between private and public hospitals in Uganda. However, some minor differences have been identified that, wherever appropriate, will be pointed out throughout the paragraphs.

Poor pathways and road infrastructure

Poor road infrastructure hinders installation and movement of equipment (figure 14). Forklifts and cranes are not easily available. Installation personnel will therefore frequently try to lift or roll (when it's on wheels) equipment to its designated location, with a risk of it falling and damaging. As pathways between hospital buildings are generally of poor quality – usually unpaved, muddy, and with ramps – even for light equipment movement is often discouraged [27]. Pathways at private hospital facilities are often paved, yet steep ramps and curbs that can hinder movement are still present.

Lack of space

Space in hospitals is crucial. Equipment

such as a CT scanner that takes up a lot of surface area, needs a separate and shielded room, a dedicated control room and another dedicated equipment room is often difficult to implement [29]. When possible, rooms have multiple purposes, although classifications are made (e.g. imaging room).

Pests

Often, pests find their way into hospital buildings through open doors and windows. Sensitive equipment can be damaged when pests interfere with electronics. One case shows the severity of this challenge: rats chewed through the wiring and defecated over the electronics of the CT scanner, rendering it inoperable [42]. Bugs such as mosquitos and flies were present, as mosquito nets in front of windows were not present or damaged. Private hospitals managed to do a better job in keeping mosquitos and flies outside, as doors were kept shut and mosquito nets were installed and undamaged.

Heat and humidity

A hot and humid environment is common in hospital wards, consulting rooms, and some imaging rooms that are not equipped with air-conditioning. Heat and humidity can cause electronics to overheat and damage equipment.

Power supply

Hospitals have to deal with an inconsistent

power supply. Challenges with power supply of imaging equipment can cause uncertainties whether it will be operable [42]. Power surges and drops can all cause damage to equipment and makes a back-up power supply with stabilizer crucial to protect equipment and continue operations during blackouts [38, 41, 42, 43]. Such a back-up power supply often constitutes a generator and back-up batteries. It is desired that imaging equipment such as CT and MRI generally have their own dedicated back-up power supply [38]. Both public as private hospitals face this challenge, however, private hospitals generally seem to have better means to deal with it. Public hospital back-up power supplies have been said to be unreliable [42].

Mud, gravel and dust

The unpaved roads cause mud, gravel, and dust to enter the hospital when patients, doctors, or visitors enter without taking off shoes. Imaging

and equipment rooms were all entered with dirty footwear. This causes mud and gravel to accumulate in the rooms, possibly forming a threat to sensitive equipment. Moreover, unpaved pathways in combination with open doors and windows leave equipment exposed to dust accumulation.

4.2.2 CURRENT COUNTERMEASURES

Pathways and road infrastructure

No known countermeasures are currently being taken; light equipment is still being moved when necessary. Hospital budget does not allow large capital investments [44], so it is not expected that this will improve any time soon.

Lack of space

No known countermeasures are being taken. Hospital budget does not allow large capital investments [44], so it is not expected that this will improve any time soon.



Figure 14. Roads and pathways surrounding various hospital premises. Top: Masaka Hospital. Bottom, from left to right: Kampala Hospital, Mengo Hospital.

Pests

Observed countermeasures are closing doors and windows and installing mosquito nets in front of windows. Most of the visited hospitals had broken mosquito nets and kept doors open, even though signs were urging employees and visitors to keep them closed. In the rat-case, placement of foam around crucial components was used to mitigate the risk [42].

Heat and humidity

Air-conditioning is an observed countermeasure, however, not every room is air-conditioned. All of the CT-rooms and MRI-rooms that were visited were air-conditioned, as well as their equipment rooms for cooling purposes [41]. Control rooms were not air-conditioned.

Inconsistent power supply

Observed countermeasures are the installation of stabilizer and back-up generator and/or batteries [42]. Each public and private hospital was equipped with a back-up generator. All of the visited CT and MRI scanners had their own dedicated back-up power supply (figure 15). It was unsure whether power supplies were equipped with a stabilizer.

Mud, gravel and dust

No countermeasures were observed. The issue that this may affect equipment may not be acknowledged.

4.2.3 KEY TAKEAWAYS

- 4.14 Pathways are unpaved and poor
- 4.15 Equipment is moved over uneven, muddy, unpaved pathways
- 4.16 Cranes or forklifts are not readily available
- 4.17 Space in the hospital is scarce
- 4.18 The grid power supply is unstable, deeming a back-up power supply necessary
- 4.19 Pests are present in all hospital environments
- 4.20 Heat and humidity are a problem in rooms that are not air-conditioned
- 4.21 Imaging and equipment rooms are mostly, but not always, equipped with air-conditioning
- 4.22 Dust can accumulate in hospital rooms
- 4.23 Gravel and mud could accumulate in rooms



Figure 15. A back-up power supply unit for the CT-scanner in an air-conditioned room. Mbarara Hospital.

4.3 DIAGNOSTIC PROCESSES

EXPLORING DIAGNOSTIC IMAGING PROCESSES AFRICA

TO IDENTIFY CHALLENGES OCCURRING DURING THE IMAGING PROCESS, THIS PROCESS IS ANALYZED.

4.3.1 THE IMAGING PROCESS

The diagnostic imaging process can be split into three parts: pre-imaging, imaging, and post-imaging (figure 16).

Private and public hospitals do not seem to differ in their imaging processes.

Pre-imaging

During pre-imaging, the patient is prepared for the procedure (figure 17). Here, it is assumed that the patient has passed all previous screening and is eligible for the procedure. The preparation includes (1) informing the patient about the procedure, (2) preparing the patient by donning the appropriate garments, (3) moving the patient to the scanner, (4) preparing the MRI or CT bed for the patient, (5) laying down the patient on the bed and making her comfortable, (6) strapping the patient or to be scanned body part to ensure she/it lies still (7) administering contrast fluids when needed, (8) attaching necessary vital signs monitoring devices and oxygen supply, (9) administering anesthesia when needed.

Imaging

During imaging, the radiographer operates the imaging system from the safety of the control room (in the case of high-field MRI and CT).

The imaging procedure is straightforward: (1) the procedure the system needs to run in order to be able to obtain the images is selected by the radiographer, (2) low-resolution test images are made, (3) the actual scanning is started, (4) the patient is monitored visually from the control room and/or with cameras, and through vital signs monitoring systems (pulsoxymeter).

Post-imaging

(1) The patient is removed from the scanner, (2) moved back to the ward or a post-anesthesia care unit, and (3) the radiographer wipes down the bed with a sanitary wipe, (4) finally the images are printed or digitally sent to the radiologist for examination and assessment.

4.3.2 CHALLENGES

Nervous patients or parents

Patients (adults and children) or parents are sometimes afraid of medical machines or the procedures involved [39, 42, 45]. Claustrophobia occurs frequently in adult patients during MRI scanning [39]. During the scanning of their child, parents may become anxious and panicky [41].

Immobile patients

Immobile patients sometimes cause challenges when they need to be moved to the scanner [41, 46]. The patient's dependency on life support equipment often hinders her mobility [38].

Parents help with preparations

During preparations, parents of children that are being scanned often help out with preparatory works [47]. This does not cause any issues or challenges for the staff currently.

Lying still

Lying still is a challenge for most children. Even when anesthesia is used, the child may

need to be strapped down because she can have spasms [45].

4.3.3 CURRENT COUNTERMEASURES

Nervous patients or parents

Patients – and parents – generally have a lot of trust in doctors and the other hospital staff. Hence, to mitigate this challenge, parents are talked to and well informed by staff [42, 45,

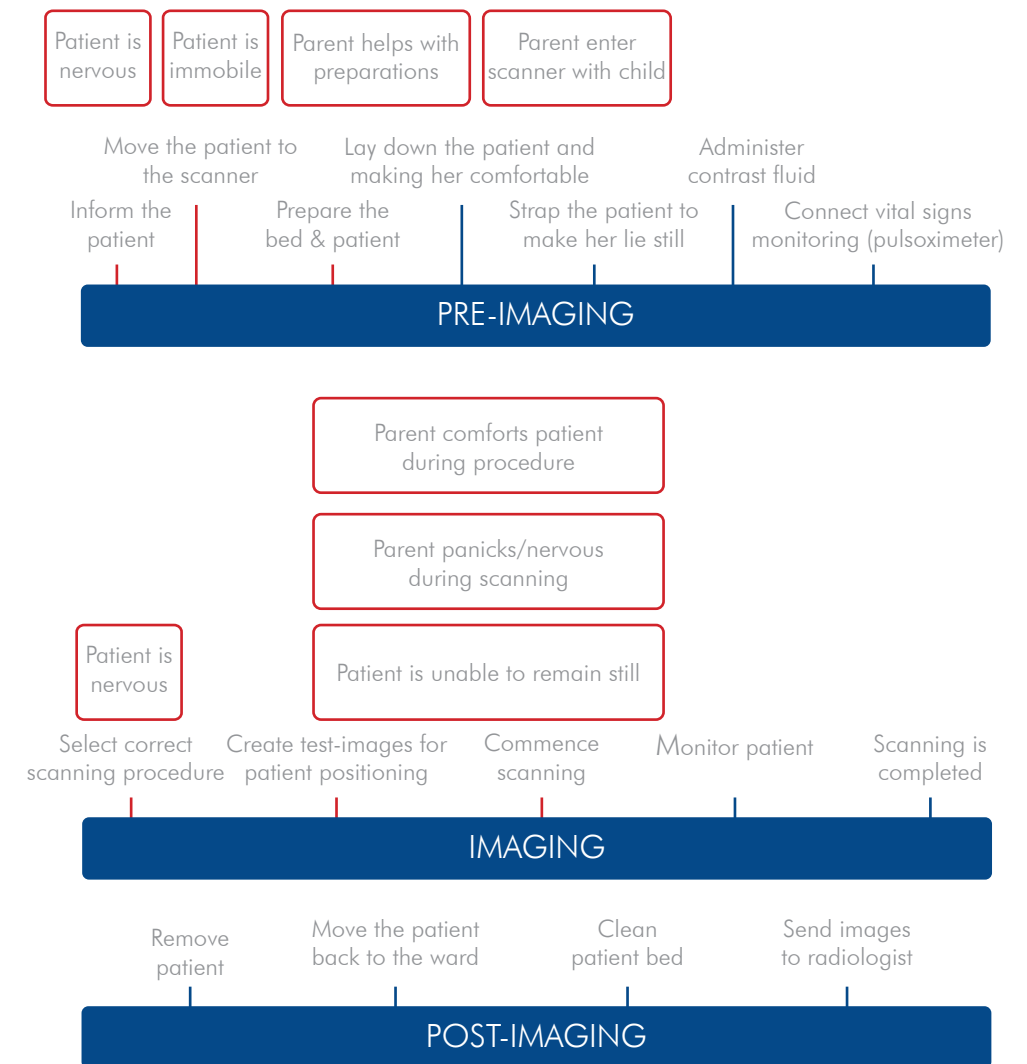

Figure 16. Some of the challenges occurring in the diagnostic imaging process.

46, 48]. Whenever parents get anxious during the procedure, the parents will be removed from or not admitted to the scanning room [45].

Immobile patients

Immobile patients are whenever possible transported on a mobile bed [41]. However, post-operation patients are often unable to leave the ICU [48].

Parents help with preparations

No countermeasures were taken to prevent parents from helping during preparations.

Patient moving during scanning procedure

In order to calm the child, the mother may keep close to her and touch her/comfort her. During CT scanning, mothers may even enter the (CT) scanner together with the child to keep her calm [46, 47]. Anesthetics is administered in children that have too much trouble lying still [38, 39, 47]. The child is also strapped and – at least when scanning the head – the body part is strapped inside a helmet-like headrest.

4.3.4 KEY TAKEAWAYS

- 4.24 It is common that patients (and their parents) are nervous
- 4.25 Patients are well informed by staff to deal with nerves
- 4.26 Immobile patients can sometimes be transported, but cannot always leave the ICU
- 4.27 Parents help prepare patients in the imaging room
- 4.28 Parents may enter the scanner with the child, or remain present in the room
- 4.29 Patients, especially children, frequently move during scanning
- 4.30 Patients are often strapped to keep them from moving
- 4.31 Patients are very trusting of hospital personnel
- 4.32 Sometimes, anesthetic may be used
- 4.33 Sometimes, vital signs monitoring has to be used
- 4.34 Sometimes, the patient needs external oxygen supply

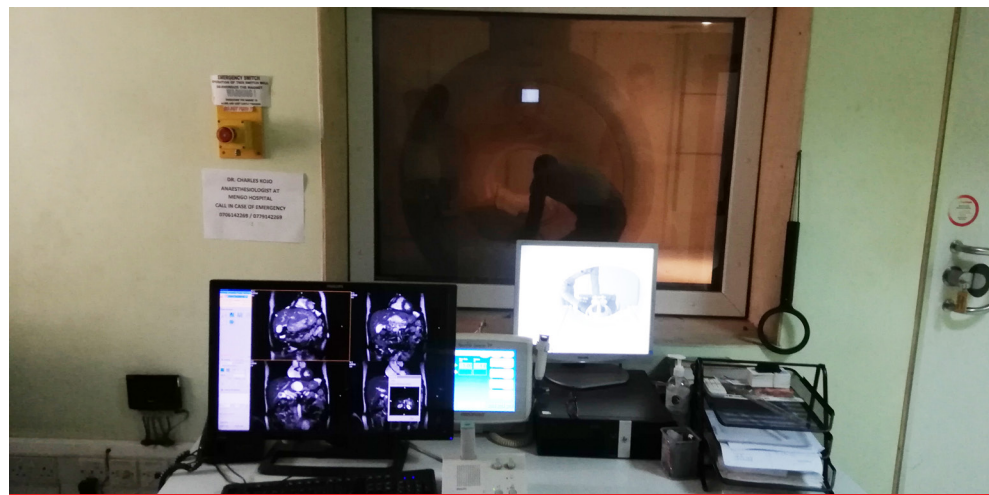

Figure 17. The MRI room at Kampala MRI Center - ECUREI. The scanner is being prepared for a patient.

PART II

DEFINE

INTERMISSION

A REVIEW OF THE INITIAL DESIGN GOAL

A REDEFINED THESIS GOAL

From the start of this thesis, we set out to design a minimum viable product of an MRI system for LMICs, specifically for Ugandan hospitals. Based on our current knowledge of the context and technological factors at play, we have to briefly reflect on the feasibility of achieving this goal during the remainder of this thesis. We do so by concluding whether we can adequately estimate the system's current value, what constitutes a minimum viable product, and how the system might need to be adapted to become viable within this context. Subsequently, an assessment is made whether the goal of designing an MVP is attainable, and if not, a new goal is formulated.

The system's current value

CH3 illustrates that initial diagnosis of hydrocephalus can be done with ultrasound, up to a child's age of between 12 and 18 months when anterior fontanelles close and the ultrasound can no longer penetrate through the skull. As CH3 also explained, most infections that cause hydrocephalus occur in the first month of life, and the mean time between onset of symptoms and presentation for treatment is 7.46 months. That allows us to conclude that currently, most of the patients that are presented for treatment have open anterior fontanelles and thus can be diagnosed using ultrasound. Now that functionally, a hydrocephalus-specific MRI competes with ultrasound, the question arises:

how is the MRI system clinically superior to an ultrasound system in the initial diagnosis of hydrocephalus? Due to the lack of clinical testing, this is currently unknown.

Expectedly, cost also plays a crucial role: as the current price of the system is estimated to be similar to that of an ultrasound system, it is argued that at that price it will not compete with ultrasound if it does not deliver better results.

Furthermore, CH3 testifies that both public and private hospitals seem unwilling to invest in the current disease-specific system, even though the system's price was not explicitly named.

However, it can be argued that the system offers some value in follow-ups and monitoring of treated patients. Monitoring is essential to prevent treatment from failing and the condition from returning, and in older children monitoring can no longer be done via ultrasound. However, at the system's current dimensions, children older than one year of age hardly fit. Moreover, shunt compatibility with the current system needs to be assessed.

CONCLUSION

Based on above arguments, the current system seems to lack an added benefit to Ugandan hospitals. On the one hand it competes with the much more versatile ultrasound

technology and it is still unknown whether its clinically superior. On the other hand, it cannot prevent the need for monitoring by CT or x-ray in older children. To address this, the system needs to either (A) provide clinical superiority over ultrasound (B) be able to diagnose more conditions and/or (C) be able to diagnose older children for monitoring purposes. More research has to be done to determine whether implementation of one or more of these solutions will give the system the added benefit it needs in order to be viable.

The design goal

Based on our current knowledge of the system and the hospital's requirements for it, what constitutes a minimum viable product cannot exactly be stated. Will it be sufficient if the system provides a better image than ultrasound in the diagnosis of hydrocephalus? Or should the system be able to diagnose all pediatric conditions, before hospitals are willing to invest in it? However, we can safely say that the system's current abilities are insufficient to constitute a minimum viable product.

That brings us to the initial goal of designing a minimum viable product. I propose a more detailed exploration to what constitutes a minimum viable product for this particular technology and this particular market, so that by minimally adapting the system it will become viable in public and private hospitals throughout Uganda. However, this goes beyond the scope of this thesis. As much is still unclear about the system's performance, we are still unable to assess its clinical value compared with other modalities. Moreover, more research needs to be done to identify other conditions that Ugandan hospitals need to diagnose with a potential MRI.

Considering the project's timeline, a most valuable addition now will be in designing

a first iteration of the entire system and all its components that addresses the found contextual challenges. By doing this, we hope to mitigate these challenges early on, while there is still enough freedom to adapt the technological system to the contextual system. This will result in a first iteration of an MRI for hydrocephalus that can be implemented in Uganda.

REDEFINED GOAL

- The design an MRI for the diagnosis of hydrocephalus that addresses the identified challenges and therefore constitutes the first version of a system that can be implemented in Ugandan hospitals.

CHAPTER 5

SYNTHESIS

APPROACH AND METHOD

Goals

This chapter combines all insights and turns them into design requirements. Subsequently, a selection of focus areas is made that are within the scope of this thesis and will be considered in the design phase.

Method

Firstly, based on the analysis, the system's currently missing functionalities, necessary adaptations, and technological requirements are identified. Secondly, the key (context) challenges are translated to requirements. Finally, generic design principles are formulated. The chapter concludes with a summary of these conclusions in the form of a table of requirements.

5.1 BASIC FUNCTIONING

KEY PRODUCT-SIDE REQUIREMENTS

THIS SECTION FOCUSES ON THE PRODUCT SIDE. KEY FUNCTIONALITY, TECHNOLOGICAL REQUIREMENTS, AND POSSIBLE ADAPTATIONS ARE CONCLUDED.

5.1.1 KEY MISSING FUNCTIONALITIES

CH2 illustrated that many of the technological components that allow the system to create MR images have been designed. However, these components do not facilitate the imaging of patients. The basic functionalities needed to facilitate the process of imaging a patient were identified in CH4.3. Below, these missing functionalities are summarized in form of design requirements:

- The product should enable the patient's to be scanned body part to be safely inserted into the system's bore
- The product should enable the patient's to be scanned body part to be safely removed from the system's bore
- The product should enable the patient's to be scanned body part to be placed at the magnet's isocenter
- The product should enable the patient's to be scanned body part to be placed at the center of the RF coil
- The product should enable the patient to remain comfortable during the imaging procedure

These requirements can be summarized in to following:

- The product should enable an ergonomic operation that reduces strain on the operator
- The product should enable a patient to be inserted, scanned, and removed safely

5.1.2 TECHNOLOGICAL REQUIREMENTS

As follows from CH2, the main requirements that are imposed on the system by the integration of the current technology, i.e. the magnet, coils, and electronic components are:

- No ferromagnetic materials may be used within 100 mm distance from the magnet's bore openings
- No ferromagnetic materials may be used within 50 mm surrounding the magnet's sides
- No metal (ferro or non-ferro) objects may be used within 40 mm surrounding the radiofrequency transceiver coil
- The RF coil should be concentric with the magnet's bore

5.1.3 POTENTIAL ADAPTATIONS

Some other challenges in the design are currently solved in a prototypical manner. Some of these solutions may need changing or improvement before they can function in the hospital context:

Shielding

The current system's conductive blanket seems hardly an ideal solution: with large numbers of patients each day, wear is significant, and whether it can be properly cleaned should still be determined. The blanket can also easily get lost. With the high cost of this particular blanket – and considering low-income countries – this is highly undesirable. However, the urgency for shielding patients' legs is unclear at this moment. Therefore, it is chosen to – at least for now – not consider this any further.

Digital user interface

The digital user interface has not been sufficiently developed. This presumably creates a high threshold for radiographers to operate the system. However, live testing of the MRI should determine the optimal settings for imaging in various scenarios. This means that the required functionality for such a digital user interface cannot yet clearly be defined, and therefore, the design of a digital user interface is not further considered.

5.2 CONTEXT CHALLENGES

KEY CONTEXT-SIDE REQUIREMENTS

THIS SECTION TRANSLATES THE MOST IMPORTANT IDENTIFIED KEY CHALLENGES IMPOSED BY THE CONTEXT INTO REQUIREMENTS.

KEY CHALLENGE

4.11 Installation personnel is expensive and scarce



The product should enable easy and low-cost installation

4.14 Pathways are unpaved and poor
4.15 Equipment is moved over uneven, muddy, unpaved pathways
4.16 Cranes or forklifts are not readily available



The product should be transportable and installable over rough pathways and uneven surfaces without the need for forklifts or cranes

4.17 Space in the hospital is scarce



The product should occupy as little space as possible
The product should not require placement in a separate, dedicated room

4.18 The grid power supply is unstable, deeming a back-up power supply necessary



The product should be able to adequately deal with an inconsistent power supply

4.19 Pests are present in all hospital environments



The product should prevent pests from damaging sensitive equipment as well as reasonably possible

KEY CHALLENGE

4.20 Heat and humidity are a problem in rooms that are not air-conditioned
4.21 Imaging and equipment rooms are mostly, but not always, equipped with air-conditioning



The product should provide active cooling for patients inside of the bore
The product should enable adequate cooling for electronics by their built-in cooling fans

4.22 Dust can accumulate in hospital rooms
4.23 Gravel and mud could accumulate in rooms



The product should be resistive to dust and mud
The product should be able to prevent dust from entering electronics compartments

4.27 Parents help prepare patients in the imaging room
4.28 Parents may enter the scanner with the child, or remain present in the room



The product should allow a relative to remain in contact with the patient during the imaging procedure
The product should prevent bystanders from being exposed to a harmful levels of magnetic field strength as well as reasonably possible

4.29 Patients, especially children, frequently move during scanning
4.30 Patients are often strapped to keep them from moving



The product should prevent the patient from moving during the entire imaging sequence

5.3 TOWARDS A DESIGN

DESIGN PRINCIPLES AND TABLE OF REQUIREMENTS

THIS SECTION FORMULATES A SET OF GENERIC DESIGN PRINCIPLES AND SUMMARIZES THE RESULTS OF THE CHAPTER IN A TABLE OF REQUIREMENTS.

5.3.1 DESIGN PRINCIPLES

The challenges imposed on the system by the context are not all specific to this particular MRI system. Some can be generalized, and are relevant to the design of any part within this system. Therefore, the need arises to formulate these challenges as a separate group, not to be included in the table of requirements yet crucial to consider in each component and in each step of the design. This group will be called design principles, and consists of three simple rules:

Cost-effective design

An accurate (sales)price estimate for the system is challenging to identify in this stage, thus cost is hard to quantify in a requirement. However, it was found that in this context, cost-effectiveness of solutions is particularly desired. This impacts chosen production methods and subsequent optimization for cost-effective production of all parts.

Design for durability and reliability

The relatively harsh and uncontrolled environment increases the stresses that any product is exposed to. It is essential that any product in this context is designed to be durable and reliable. Products in this context

should prevent the use of maintenance-sensitive components or many moving parts sensitive to wear.

Design for repairability

The scarcity of spare parts and maintenance personnel renders broken products useless more often and longer than necessary. Products in this context benefit from using standardized parts and enabling easy access to wear-sensitive components, enabling easier repair.

5.3.2 TABLE OF REQUIREMENTS

The identified main design requirements are summarized in Table 1.

ID	REQUIREMENTS
	Main product-side requirements
P01	The product should enable an ergonomic operation that reduces (physical) strain on the operator
P02	The product should enable a patient to be inserted and removed safely
P03	The product should enable easy and low-cost installation
P04	The product should be transportable and installable over rough pathways and uneven surfaces without the need for forklifts or cranes
P05	The product should occupy as little space as possible
P06	The product should not require placement in a separate, dedicated room
P07	The product should allow bystanders to remain close to the patient
P08	The product should provide active cooling for patients inside of the bore
P09	The product should prevent the patient from moving during the entire imaging sequence
	Main context-side requirements
C01	The product should enable adequate cooling for electronics by their built-in cooling fans
C02	The product should prevent pests from damaging sensitive equipment as well as reasonably possible
C03	The product should be able to adequately deal with an inconsistent power supply
C04	The product should be resistive to dust and mud
	Main technological requirements
T01	No ferromagnetic materials may be used within 100 mm distance from the magnet's bore openings
T02	No ferromagnetic materials may be used within 50 mm surrounding the magnet's sides
T03	No metal (ferro or non-ferro) objects may be used within 40 mm surrounding the radiofrequency transceiver coil
T04	The RF coil should be concentric with the magnet's bore

Table 1. Table of main requirements.

PART III

DESIGN

CHAPTER 6

THE JUMPING-OFF POINT

INTRODUCTION

This chapter explores two principal design solutions for the MRI system. These first two design solutions are an initial view at the design from the perspective of the context. They were evaluated within the context and parts were tested with actual stakeholders in Ugandan hospitals. The aim for this chapter is to set a design vision based on these tested solutions that serves as a jumping-off point for subsequent ideation and detailing.

6.1 THE JUMPING-OFF POINT

INITIAL DESIGN EXPLORATION

6.1.1 PRINCIPAL DESIGN SOLUTIONS

The principal solutions have been developed during the field research. By taking identified challenges in the early stage and translating them to initial designs, these designs could then be tested within the field early on. Note that these designs do in no way fully abide by the requirements nor do they address all of the challenges that were described in the earlier chapters of this thesis. They were but a step in the iterative process of exploration, providing a tool for early stage validation of ideas and a steppingstone towards actual development.

The principal solutions will be assessed on the following:

- The ease at which installation can be done
- The fit with the hospital environment
- The ease with which it can be operated by hospital staff

Each solution's key features are listed in figure 18. Table 2 and 3 show the strengths and weaknesses of each solution, as identified within the context.

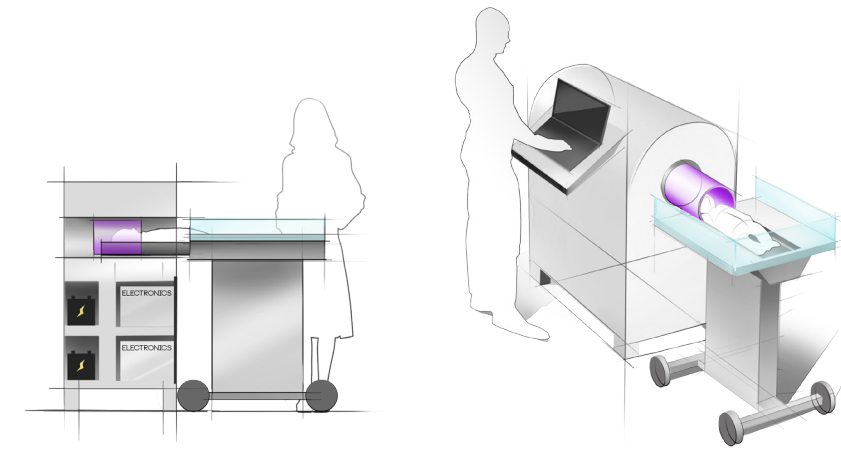

SOLUTION 1

Key features

- Standing operation
- Laptop connection
- Mobile bed
- Integrated electronics
- Plug & play installation

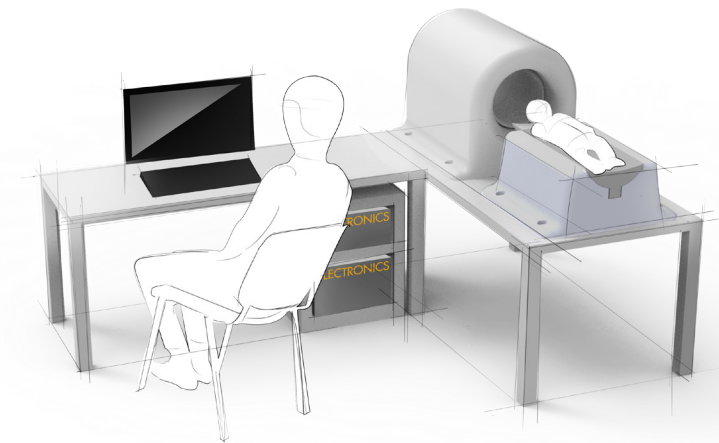

SOLUTION 2

Key features

- Sitting operation
- Desktop PC, fixed
- Static bed and magnet
- Separate electronics
- Table top installation

Figure 18. Each solution's key features.

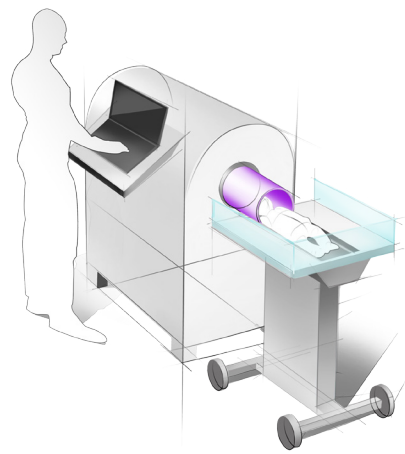

SOLUTION 1

	Strengths	Weaknesses
The ease at which installation can be done	<ul style="list-style-type: none"> • Easy to install because few connections have to be made (plug & play) 	<ul style="list-style-type: none"> • Hard to install because of large, heavy components
The fit with the hospital environment	<ul style="list-style-type: none"> • Smallest possible footprint, space saving • Mobile bed allows for transporting patients • Laptops are widely available, no need for additional investment in dedicated PC 	<ul style="list-style-type: none"> • Mobile bed can get damaged during moving, misused, or lost • Laptops may not always be readily available or be taken away, rendering the device inoperable
The ease with which it can be operated by hospital staff	<ul style="list-style-type: none"> • Standing operation allows a good view of the patient, and ergonomic position for preparation • Operator standing next to the patient adds safety 	<ul style="list-style-type: none"> • Standing operation puts strain on staff with high work loads

Table 2. The strengths and weaknesses of solution 1.

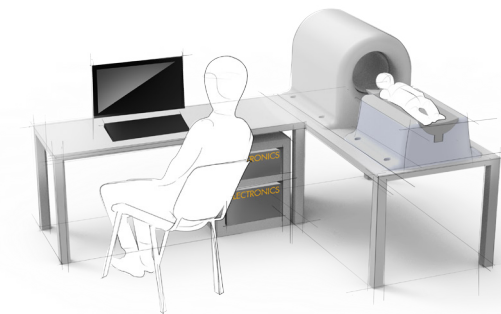

SOLUTION 2

	Strengths	Weaknesses
The ease at which installation can be done	<ul style="list-style-type: none"> • Easy to install because components can be transported individually, reducing weight 	<ul style="list-style-type: none"> • Hard to install because components need many connections • No control in how it is installed due to dependence on availability of tables
The fit with the hospital environment	<ul style="list-style-type: none"> • Static bed and P.C. ensures system's operability • Flexibility to place tech. equipment anywhere 	<ul style="list-style-type: none"> • Takes up some unnecessary space • Static bed does not allow transport of patients • Freedom to place tech. equipment anywhere may result in undesired configurations
The ease with which it can be operated by hospital staff	<ul style="list-style-type: none"> • Sitting operation allows more comfort and rest for operator • Sitting allows for good view of the patient • Operator sitting next to the patient adds safety 	<ul style="list-style-type: none"> • Proper ergonomics depend on type of table on which it is installed • Sitting may not be a desired position to prepare and handle the patient

Table 3. The strengths and weaknesses of solution 2.

6.1.2 CONCLUSION

Both solutions have their strengths and weaknesses. The challenge now is not to select one just option, but rather try and include the strengths of each option in an integrated design without much compromise. That yields an interesting starting point; let us see what this first exploration towards the design has yielded:

Installation

Integrated electronics and equipment is desired, ensuring proper placement and preventing misuse, ensuring operability of the system at all times, and reducing the time and effort required to install. However, that brings with it one key concern: weight. As we saw in CH3, poor infrastructure hinders transport of heavy and large equipment. Integrating all components may yield a design that cannot even make it into the hospital. The challenge: how do we ensure easy connection and installation while maintaining system transportability?

“A PLUG AND PLAY SOLUTION IS THE DESIRED SOLUTION.”

- Dr. Stephen Ttendo, Mbarara Hospital

Moreover, the system's installation should not be dependable on any available hospital equipment. There is no guarantee that tables, such as depicted in solution 2, are readily available, and the quality of the tables cannot be guaranteed. However easy, low-cost, and universal a tabletop installation may seem, it brings with it some huge concerns regarding safety and system functioning. What is the risk if tables are old and crooked? Will the system function when the tabletop is uneven? Delivering special type of tables defeats the purpose of a tabletop design and will likely incur additional cost.

Fit with hospital environment

Freedom to place technological equipment anywhere should be avoided, as misplacement and misuse may cause malfunctioning. The same goes for laptops or desktops. Sudden unavailability of a laptop — the doctor really needs to finish his game of Space Invaders — may render the system inoperable.

Moreover, space is crucial. Since we want to integrate all system's components, this becomes less of a problem. However, it still needs careful consideration, and remains challenging: how can we integrate the system's component so that the system takes up the lowest surface area?

Operation

The position of the operator can go both ways: sitting is definitely preferred, as workloads are high, and personnel should not stand an entire day. However, the patients — infants — are often carried and brought in by parents. At least one bystander should have space to touch the child. The operator must also prepare the

bed and the child. Unless everything is within his hands' reach, the operator will stand and walk around the machine for that. That leaves a challenge: can the system be designed so that patients can be prepared while standing, yet the scanning itself provides the operator with a place to sit? The operator should at least be able to monitor the patient during the procedure, so the position of the operator should be close to the system or other ways of monitoring should be provided.

In some cases, patients are not able to be transported to the scanner. A mobile bed, or even a mobile MRI system could provide a

“THERE ARE A LOT OF CASES, SO STANDING ALL DAY WOULD BE TIRESOME.”

- Radiographer Brenda Kamwesigye, Masaka Hospital

solution. However, having loose components could render the system inoperable whenever the component is misplaced or misused. Mobility increases also the wear of the system, especially on the poor pathways seen in the hospital. Especially in the case of this system, the bed should carefully align with the magnet. Some tolerance is allowed, but when moving it between rooms, this alignment can no longer be guaranteed, whereas installing it once so that all components are aligned ensures the system's proper functioning. Therefore, making anything mobile is not preferred. Immobile patients will — at least for now — have to find a different way of transportation.

6.1.3 THE JUMPING-OFF POINT

To conclude, there are two key design challenges to be overcome in order for the conceptual solution to work: 1) can we design a system that allows for a combination of a sitting and standing operation that keeps the operator in visual contact to the patient and 2) can we design a fully integrated, fixed-in-place solution while overcoming significant barriers for installation of such a solution?

That concludes this chapter in a design vision for the design and detailing of the conceptual solution:

“To integrate all components in one plug & play, fixed-in-place MRI system, that's easily transportable, occupies little space, and which the radiographer can operate ergonomically while remaining in visual contact to the patient.”

CHAPTER 7

CONCEPTUAL DESIGN

INTRODUCTION

This chapter explains the conceptual design decisions that were made while integrating the components of the MRI system. The conceptual design will firstly focus on the operation of the system within the Ugandan hospital context and solutions to these challenges will be covered. Subsequently, the chapter will cover the installation of the system in Ugandan hospitals, and explore the design decisions to overcome challenges during installation in Ugandan hospitals.

7.1 OPERATION

EXPLORING ERGONOMICS

Currently, the system sits on a tabletop in a lab set-up. A user-centered approach is chosen to lead the process to design a hospital-ready system. We identified the main challenges to overcome during the system's operation by users: 1) reducing strain on operating staff as consequence of workload, 2) ensuring patient and bystander safety, and 3) prevent patients from moving during imaging. This section will cover challenge 1 and challenge 2. Challenge 3 will be covered in section 7.4.

7.1.1 COMFORT AND SAFETY

The system's main components that the operator needs to interact with are the patient bed in relation to the system's bore and the digital user interface (monitor). It is crucial that a comfortable and safe position is created for the operator as well as the patient, therefore these components need to be positioned accordingly.

Patient, operator, and bystander safety

There are several factors impacting safety, namely the magnetic field strength exposure to operator and bystander, and the ability of the operator to monitor the patient while she is inside the scanner.

First of all, in an integrated system where the operator remains close to the system during scanning, we need to ensure that the continuous exposure of the operator to the magnetic field does not exceed health

guidelines. As the system's magnetic field does not exceed 60 mT and scanning time is around fifteen minutes, it is argued that the patients will not exceed any exposure limits since high field MR imaging often takes longer at higher fields. WHO advises a continuous exposure limit of 40 mT [53]. However, WHO also states that "ferromagnetic implants and implanted electronic devices should avoid locations where the field exceeds 0.5 mT. Also, care should be taken to prevent hazards from metal objects being suddenly attracted to magnets in field exceeds 3 mT." [49]. As few precautionary measures were observed for bystanders entering imaging rooms, it is crucial to their safety that these limits are not exceeded.

The magnetic field strength of the current magnet decreases rapidly with distance: at 50 mm, the strength has been reduced to around

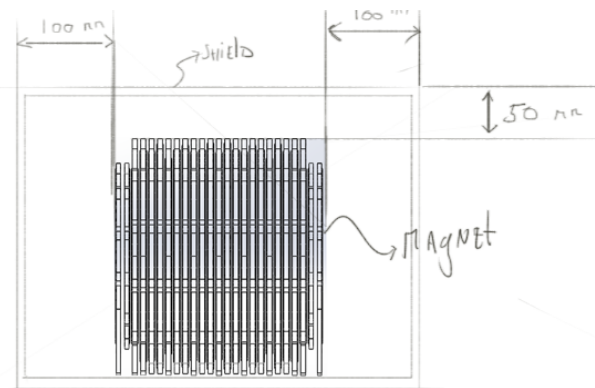

Figure 19. Shield with the minimum margins around the magnet for safety.

1% of its maximum, though at the system's openings, this level of reduction occurs at around 100 mm. That means having a shield with margins of 100 mm (front and rear) and 50 mm (sides) around the perimeter of the magnet (figure 19) should prevent bystanders as well as operators from coming too close, effectively preventing them to be exposed to magnetic field strengths higher than 0.6 mT (= 1% of 60 mT). A bigger reduction is not deemed necessary: to impact electronic implants would mean the bystander's implant is hugging the scanner, and even then, the magnetic field strength exposure is likely less than 0.5 mT.

Patient safety

Monitoring the patient during imaging is crucial to detect any occurring emergencies. There are several ways of patient monitoring that can be identified, namely (1) via camera, (2) via (electronic) vital signs monitoring equipment, or (3) via direct visual monitoring

by the system operator. Table 4 highlights all (dis)advantages of each, and a selection is made.

Direct visual monitoring is chosen as a sufficiently reliable method for monitoring the safety of the patient. This method is one that can be easily implemented in the design as the operator keeps close to the system and patient during imaging. Merely placing the operator in a correct position while performing the scan should enable him to see the patient. A camera – which may not even show the patient well enough due to lack of space in the system – may therefore also be redundant. However much benefit vital signs monitoring equipment may serve, it can never be exclusive: there is always need for visual feedback. Moreover, it has to be explored whether it can work with the current system, as it introduces disturbances to the NMR signal. In case the system allows for it, this type of monitoring can easily be added to complement the direct visual feedback.



TYPE	ADVANTAGE	DISADVANTAGE
 Direct visual monitoring	<ul style="list-style-type: none"> Fairly easy to implement No impact on the technological system 	<ul style="list-style-type: none"> Safety due to magnetic field exposure needs to be considered when operator remains close-by Position of operator should be well considered and fail-proof
 Via camera monitoring	<ul style="list-style-type: none"> Possibly a more extensive way of monitoring, if properly installed 	<ul style="list-style-type: none"> Can introduce noise/signal disturbances Potentially impossible to install in a useful position due to lack of space inside the bore
 Vital signs monitoring equipment	<ul style="list-style-type: none"> Accurate information on patient health Ability to see when something is wrong even without visual cues 	<ul style="list-style-type: none"> Cannot be an exclusive method: a visual monitoring is always necessary Can introduce noise/signal disturbances

Table 4. Three types of monitoring that can be implemented in the system.

7.1.2 OPERATOR POSITION

We have shown that with minor additions to the system, the operator (and bystanders) can safely remain close to the system at any time. We have also shown that when the operator remains close to the system, a direct visual link to the patient by the operator is a sufficient method for monitoring that is fairly easy to implement and does not cause technical difficulties. The position in which the operator should be in relation to the magnet (and the patient inside of it) now needs to be optimized so that this visual monitoring is facilitated – and we get an idea of where the components should be located in space. Two important requirements for an ergonomic position were identified: 1) the operator should be standing during preparatory work and 2) the operator needs to be able to sit during the imaging procedure.

An ergonomic standing position is where the worker's elbows are in a 90-degree angle with the 'standing desk', and the forearms parallel to the surface [50]. The 'standing desk' here is the patient bed. An ergonomic sitting position is with the elbows in a 90-degree angle so that forearms are parallel to the desk and the feet are resting flat on the floor. The screen should be on eye level directly in front of you [51]. There are two basic options for the bed and screen placement: either a static or an adjustable system. Table 5 presents their

relative score on ancillary criteria (which are based on analysis).

A static system

The decision for a static system brings one challenge: how to size it so that most people can use it? Based on ergonomic data we optimize sizing:

- Elbow height standing of P5 female (smallest): 982 mm
- Elbow height standing of P95 male (tallest): 1215 mm
- Popliteal height + eye height sitting of P5 female: 494 + 834 mm = 1328 mm
- Popliteal height + eye height sitting of P95 male: 543 + 895 = 1438 mm [52]

Since the patient is always aligned with the center of the system's bore, the height of this bore in relation to the floor can now be chosen. Since the actions are different than working at a standing desk (keyboard work vs. moving patient), it is argued that a somewhat lower desk height is desired. Also, it would be easier for taller people to operate a lower desk than vice versa. 100 mm higher or lower should also not pose a huge problem for working ergonomically, though not ideal. Moreover, sizes are now based on Dutch dimensions. It can be argued that the Dutch are taller than the Ugandan people,

CRITERIA	STATIC SYSTEM	ADJUSTABLE SYSTEM
Low maintenance	■ ■ ■	■
Low cost	■ ■ ■	■ ■
Ergonomic comfort	■ ■	■ ■ ■ ■

Table 5. Criteria for selection of an adjustable or static system. Each square represents a score on one of the criteria. The static system, although lower on ergonomics, wins.

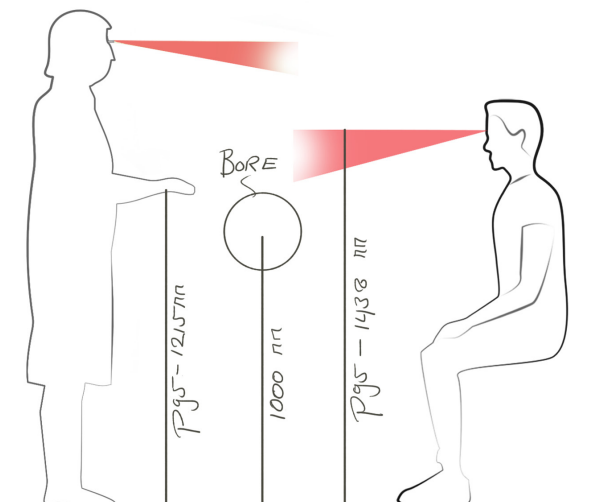
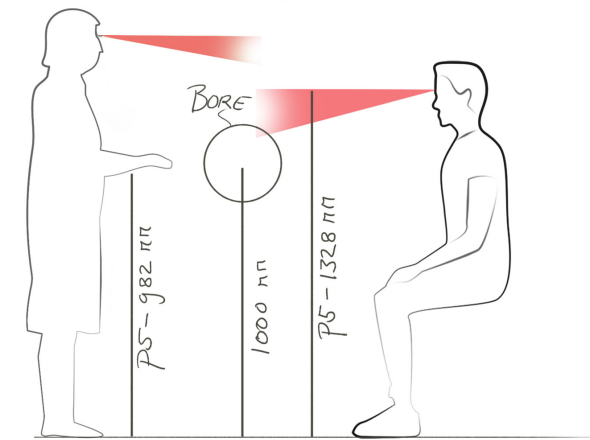

Figure 20. P5 female and P95 male drawn to scale with the desired bore height. Normal line of sight is depicted in red.

therefore, we take the lower end of these measurements. Choosing a bore height of 1000 mm should therefore allow most people to comfortably reach the patient (figure 20). Moreover, it should allow all people to stay in visual contact with the patient based on eye height sitting (not considering any obstructions). The selection for bore height automatically dictates the placement of the bed, namely aligned with the bore.

FIELD OF VISION

Central field of vision (horizontal) covers between 50- and 60-degree angle. Visual limits reach larger angles, however, objects seen outside of the central field of vision are not seen sharply, with little depth perception and color discrimination. Vertical field of vision is around 55 degrees. Normal line of sight is at 10 degrees down from the horizontal axis while standing and 15 degrees while sitting [53].

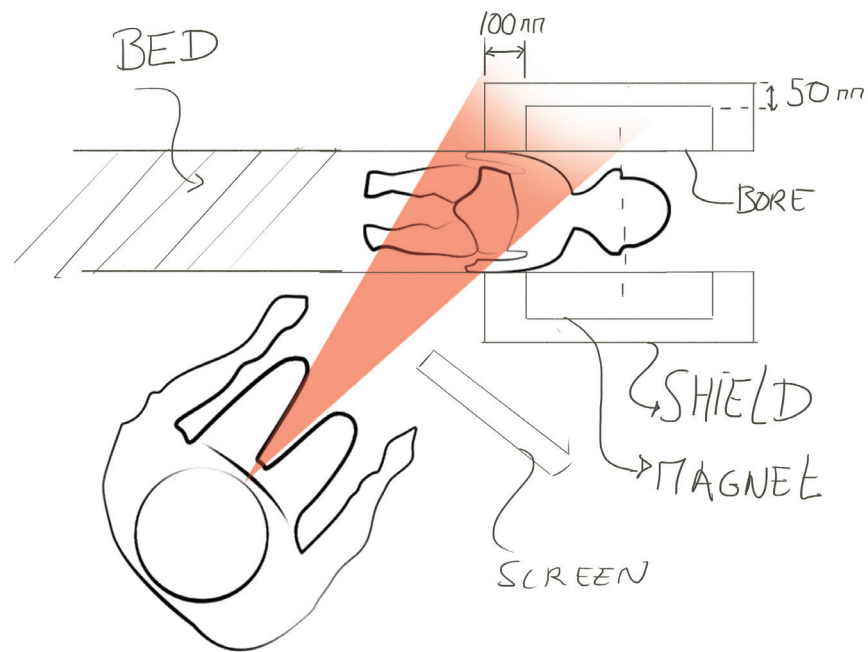

Figure 21. A part of the person's viewing angle is in line with the patient's chest, enabling sufficient monitoring. The potential screen position is shown as well. Figures drawn to scale.

When we do consider obstructions, we have to explore view angles and the magnet's shielding to find an optimal position for the operator to sit, and based on this, we can add a location in space for the screen (figure 21).

Concluding

We see that considering obstructions (we cannot place the operator in line with the bore, since the bed should be there) and current margins around the magnet, whenever the patient's head is centered in the magnet, a sideways position of the operator enables him to still see the patient inside partially (without turning the head). We can then place

a screen in an ergonomic position next to that so that the operator will in practice also take the desired position. When sitting on a wheeled chair, this position will obviously change slightly depending on the operator. In any case, direct visual monitoring is facilitated by this position more than any other position.

7.2 THE PACKAGE DESIGN

EXPLORING COMPONENT CONFIGURATION

Based on the current locations of the screen, magnet (bore), shielding, and bed it is possible to start adding the other components the operator has no direct interaction with. These are the electronics: gradient amplifier, RF amplifier, spectrometer, and computer. As identified, one key component still needs to be added: the uninterruptible power supply. The gradient coils are integrated in the magnet assembly. The RF coil will be considered in a chapter 7.4.

7.2.1 COMPONENTS DEFINITION

All electronics except the computer are currently integrated in 19" rack cases. The rack cases currently comprise a total of 12U (height units, 1U = 45.45 mm). To be able to design the package, some definitions for the uninterruptible power supply and the computer need to be taken firstly.

Uninterruptible power supply

An interruptible power supply (UPS) should be chosen to sufficiently power all components in case of a power outage. We won't go into much detail about the selection of this UPS; however, we know that the UPS should at least be able to deliver short 1 kW power pulses and an average of 110 W during at least 15 minutes of imaging. It is argued that a 19-inch rack-mounted unit is desirable since this is the configuration of all other electronic components. 19-inch rack mounted UPS systems that can handle these power outputs generally come within 1U or 2U casings. That gives a total of 14U maximum 19-inch rack casings.

Computer

The computer can be either a rack mount or an all-in-one combination with the monitor. A rack mounted computer takes around 2U space, so a rack mounted is a viable option, however, an all-in-one monitor should be just as feasible. A suitable option can be selected by the project team based on these two options.

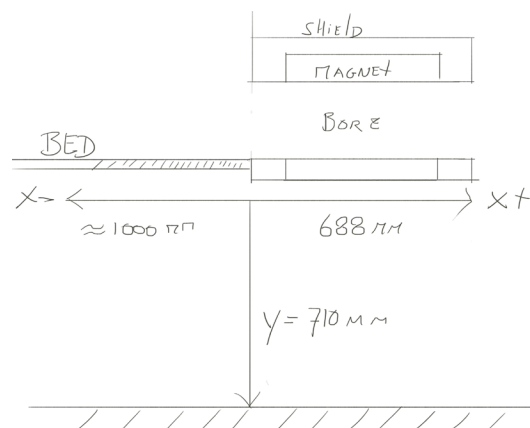

Figure 22. Electronics can be built into roughly two ways. Under the magnet, or under the bed.

7.2.2 THE PACKAGE

Some thought has gone into the package design, where various configurations and options for components were explored – even beyond the previously defined dimensions of the system – in order to find an optimal tradeoff between configuration, the need for custom designed casings, and dimensions. The rack cases can be placed separate from each other. There are the following case dimensions used:

- Two 19-inch cases of 3U, 295 mm deep
- One 19-inch case of 6U, 355 mm deep (cannot be placed vertically)
- One 19-inch case of 2U, 355 mm deep

Based on the previously defined dimensions, there are two basic options for placing the electronics: into the x- direction, or into the x+ direction (figure 22). Y is defined by the previously defined position of the magnet: 710 mm.

Since there is one rack that cannot be placed vertically (technological reasons), it makes sense to try and place all racks horizontally to avoid the need for additional or custom racks. A height of 14U cannot all be stacked in a

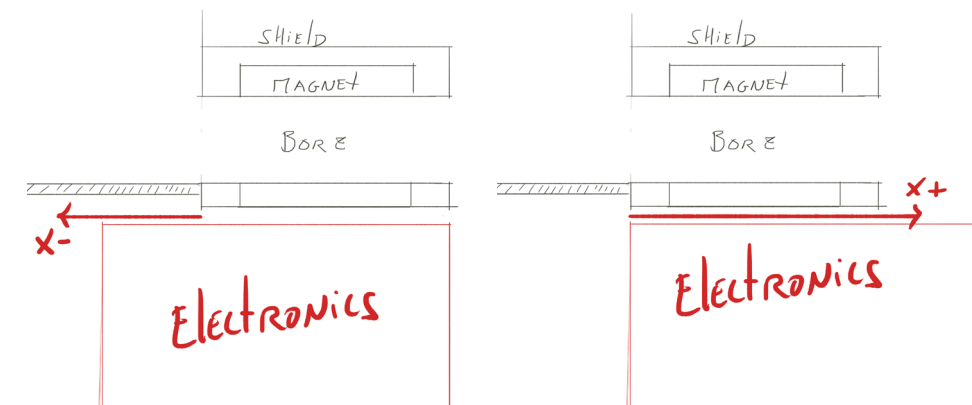

Figure 23. Electronics will always stick out from under the magnet, due to dimension limitations.

The direction

Choosing option x- has the benefit that the electronics fit beneath the bed. The electronics stick out for only $710 - 688 = 22$ mm if no material thickness, structure, and cables or cooling space is considered. Adding that all up however, may add up to 300 mm (100 mm per side of cooling/cables + 100 mm total for the structure). Something sticking out for 300 mm is not necessarily undesired when only infants are being scanned. However, keeping in mind the potential imaging of limbs, e.g. arms, one may foresee a problem: if the hand needs to be in the center of the system, with this set-up, the center of the system is at 644 mm from the edge at where the patient can sit. In other words: the patient needs at least an arm of 644 mm. If the system should in the future be used for scanning limbs, it is desirable to consider that in the design already.

The x+ option has no such implications. It simply makes the system a bit longer. The added benefit is that in the rear of the system,

at the part that sticks out, we can lengthen the bore and fill this space usefully: we can add a cooling fan. Since this fan needs to be shielded additionally from the magnet, the space of 300 mm perfectly suits it (figure 24).

The electronics case

A custom design rack-case is not necessary for this design. Browsing some webshops, several rack-cases can be identified that fit the requirements and as added benefit offer some protection for the electronics. For now, the decision was made to integrate two 8U rack cases with dimensions 565x570x430 mm (figure 25) [54].



Figure 25. Thomann.de 8U rack case - €75.00 each [54].

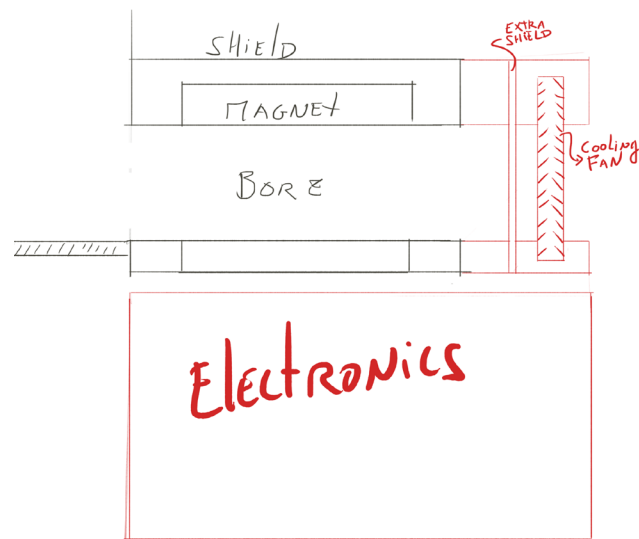

Figure 24. The best option is to utilize the leftover space by installing a cooling fan, which is required anyway.

7.3 CONSTRUCTION

EXPLORING THE SYSTEM'S EMBODIMENT

This section summarizes the construction of the magnet and electronics assemblies.

7.3.1 MAGNET SUBASSEMBLY

Main requirements to fulfil:

The main requirements to fulfil as formulated in CH5.3:

- Should facilitate carrying by at least four people
- Should be surrounded by aluminum shielding of at least 1 mm thickness and with 100 mm margins from the bore's openings and 50 mm margins surrounding the sides of the magnet
- Should contain cooling for patients
- Should not use of ferromagnetic materials

Design

In the magnet subassembly (figure 26) the magnet is enclosed by 3 mm aluminum sheets on all sides which serve as shielding. They are bent to follow the contours of the magnet and are thereby a relatively low-cost option. 3 mm is deemed necessary to increase stiffness – the shield may not bend whenever people lean against it.

To enable carrying, a substructure is needed that can handle the load. Since ferromagnetic materials are not allowed, this is built from 40x40 aluminum extrusion profiles all around, and two placed underneath the magnet. These profiles can easily carry the

load without displacement or yield (APPENDIX D). Subsequently, an aluminum handlebar is attached to facilitate lifting. It is attached at several points to the substructure to divide the load. By running around the entire perimeter, it provides ample space for at least four people to lift it on the sides. It is possible to be detached after installation, however, not encouraged since it provides a good barrier that can protect the magnet and other components against impacts of for example hospital beds.

Cooling for patients is added in the rear, including an additional 0.5mm mesh shield that prevents the cooling fan from causing interference with the NMR signal.

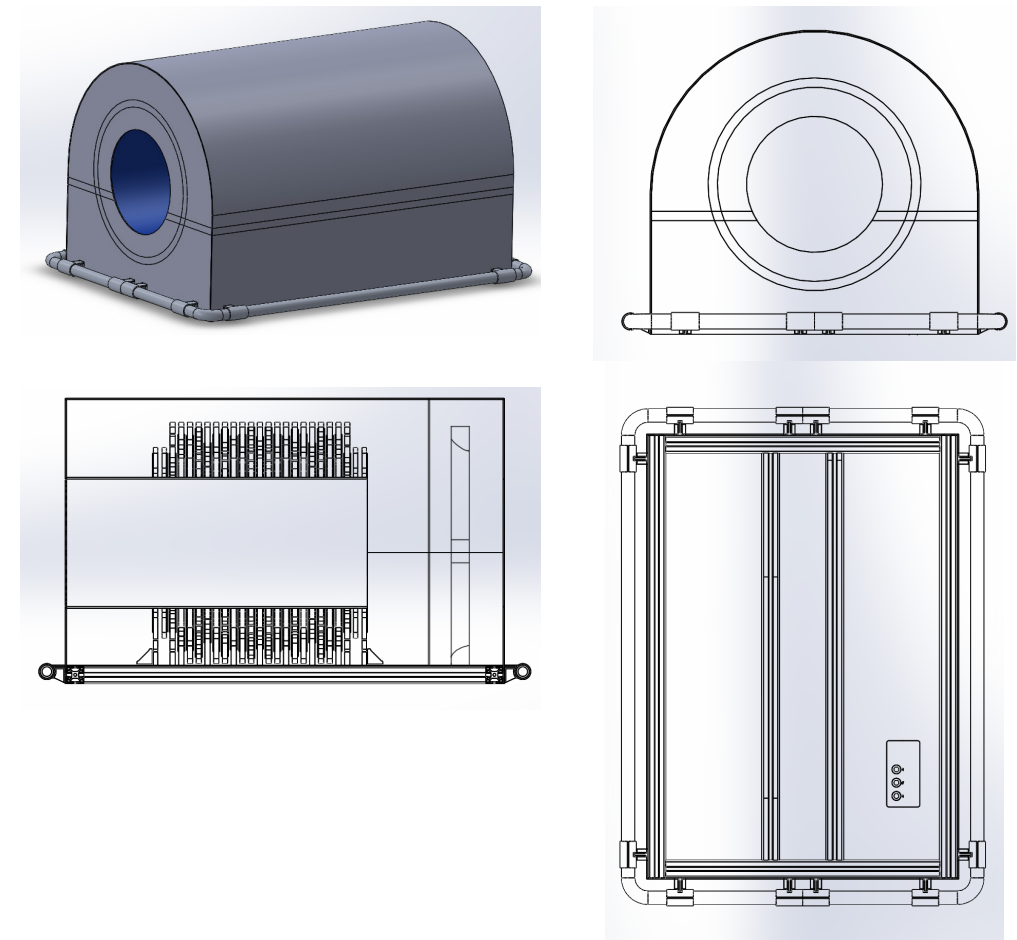

Figure 26. Top left: isometric view of magnet assembly. Bottom left: cross-section with magnet, bore, and cooling fan visible. Right: front and bottom view with handle bar and aluminum substructure visible.

7.3.2 ELECTRONICS ASSEMBLY

Main requirements to fulfil

The main requirements to fulfil as formulated in CH5.3:

- Should facilitate carrying by at least two persons
- Should block access to pests
- Should be dust resistant
- Should enable the cooling of electronics
- Should enable access to electronics in case of maintenance or repairs
- Should not contain ferromagnetic materials

The design

The Thomann 19-inch rack cases have been previously defined to hold all electronics. These types of cases are easily carryable and are durable. However, they cannot bear the weight of the magnet, thus a subframe is needed to integrate electronics and serve as a mount for the magnet. For this enclosure, 40x40 mm aluminum extrusion profiles are used for similar reasons as stated above. The frame is square, with sufficient space to fit both 19-inch rack cases. Cases can be open on both sides or just one side. Cables can connect the components through the middle (figure 27). The entire enclosure is closed off by aluminum sheets, 3 mm, bolted to the sides. In this way, electronics are not accessible by anyone, but can be easily accessed for maintenance or repairs by removing one of the side plates. During installation, the side plates need to be removed to be able to bolt the magnet to the enclosure. Electronics can come pre-mounted (and possibly pre-connected) in the rack cases.

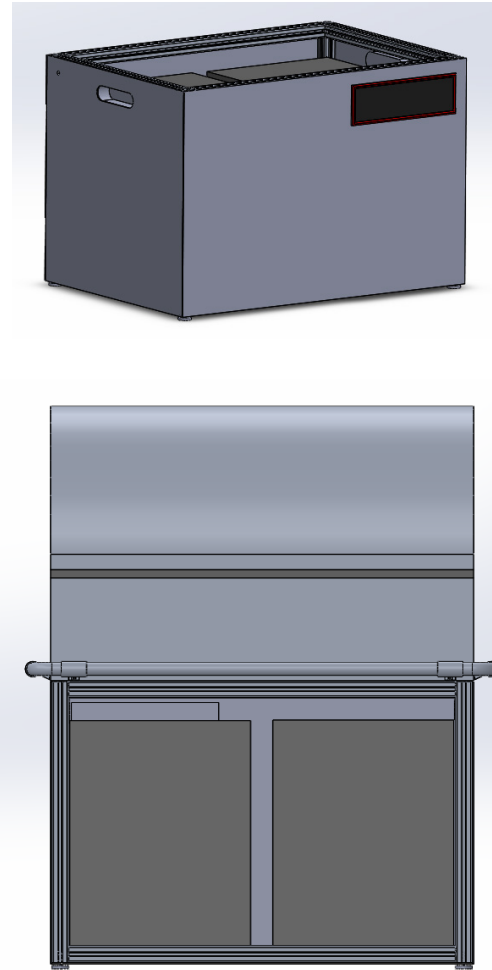

Figure 27. Top: the electronics subframe. Bottom: the magnet on top of the subframe, side panel removed. The grey boxes represent the 19-inch rack cases in which electronics are placed.

7.4 BED AND COIL SYSTEM

DETAILING THE PATIENT BED

We have previously defined the interaction of the operator with the system and the system's basic embodiment. Now it is time to involve the patient and the user's interaction with the patient: the design of the patient bed. This chapter starts by explaining the challenges involved in the design of this component and the main design considerations.

7.4.1 THE CHALLENGES

Main functionalities

The main interactions of the system with the patient were identified in previous chapters. These interactions can be translated to main functionalities that need to be included:

- The patient needs to be inserted and removed from the bore
- The RF coil needs to be placed over the patient's head
- The center of the patient's head needs to be positioned in the center of the RF coil
- The center of the RF coil needs to be positioned in the center of the bore
- The RF coil needs to be concentrically aligned with the bore
- The head needs to be prevented from moving during scanning

Head size

Head diameter of a child with hydrocephalus can be as large as 204 mm [55]. As the bore has an inner diameter of

292 mm, not much space is left to design in. Within this space of 88 mm (44 mm around all sides), an RF coil is needed, a bed that can insert and remove the patient is needed, all while ensuring a decent interaction by the operator and comfort of the patient.

The RF coil

The radiofrequency coil has to be placed concentrically with the bore. Moreover, it has to be placed over the infant's head, and its maximum diameter (as designed by the LUMC team) is limited to 250 mm. The infant's head has to be inserted into this space, and with a maximum head diameter of 204 mm, there is not much play. Caution has to be taken so that the child's head does not collide with the coil. Additionally, the coil needs to be easily replaceable because various sizes exist that allow for scanning of different head sizes.

The bed

When a coil of 250 mm diameter is the largest available, the bed's maximum dimensions should be between 250 mm and 292 mm.

HEAD CIRCUMFERENCE

Due to lack of data about hydrocephalus head sizes it is needed to deduce the head diameter from the circumference. However, head circumference is a misleading measurement: it says nothing about the maximum head diameter of the patient. The deduction may not be accurate, so it serves to make the system as big as reasonably possible.

Larger than 292 mm and it will not fit at all, smaller than 250 mm and the position of the child becomes uncomfortable as the head and the body are not in alignment. That however gives only $250 - 292 = 42$ mm space on all sides, meaning the bed can have a maximum thickness of only 21 mm (FIGURE X). All while having a length that can fit most infants up to 1 year of age (813 mm, P99 [56]). Strength, stiffness and durability can therefore become challenging.

The materials and production

Both ferro- and non-ferro metals are prohibited in any of the parts that enter the bore. Only the use of non-ferro metals is allowed outside of the bore. The small available space in combination with the inability to use metals makes the design of a robust and durable part complicated. Some plastics manufacturing methods are also exempt due to cost: injection molding allows intricate, strong and durable parts yet is too capital intensive for this small series production.

The moving parts problem

The RF coil needs to be easily replaceable. It also needs to be conveniently inserted into and removed from the bore, which means it has to be attached to the bed in one way or another. A detachable connection is needed, however, in such a small design space, with restrictions on material usage, it is tough to make a durable non-permanent connection. To add to that problem, the coil has to move in and out, be attached, be easily replaced, and facilitate easy insertion of the infant's head. The bed has to move in and out as well. All these moving parts can cause considerable wear when not properly constructed. This construction, as mentioned, poses a significant challenge.

The solution direction

If these limitations prevent us from making something sufficiently durable, we have to design something that is easily repairable or replaceable. Making use of 3D printing (FDM) accessible in most makerspaces and basic materials, parts can be mostly reproduced locally. Moreover, preventing moving parts as much as possible helps reduce unnecessary wear. Using these methods will simultaneously keep costs low.

Thereby, the main design drivers for design of the bed are as follows:

- Use 3D printing as a production tool
- Use basic and standardized components
- Reduce moving components
- Maximize space inside the bore
- Ensure patient comfort
- Ensure operator usability

7.4.2 THE DESIGN

Bed assembly

This bed concept (figure 28) is designed from four parts: a 3D-printed rear end, an aluminum middle section, another 3D-printed front section and a 3D-printed bed-carriage mount. Size limitations and material costs for FDM 3D-printing are the reason for adding an aluminum middle section. This aluminum section will not enter the bore, thus pose no issues. The two 3D-printed parts can be printed on most printers (e.g. Ultimaker 2+) with minimum print-bed size of 223x223, height 200 mm. In the design of the printed parts, material saving was considered.

The bed is a semi-circular design that follows the diameter of the bore. This is the most space-saving design.

Bed movement

The bed should slide in the bore, be fixed in the scanning location, and be removed again after scanning. An IGUS WW10-40-10 rail and carriage system is chosen (figure 31) [57]. Many linear rail systems contain steel

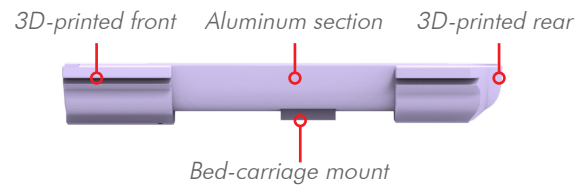

Figure 28. Bed assembly.

characteristics remove the need to add an additional maintenance-heavy locking system to keep the bed in place during scanning. The system allows loads that are more than sufficient for carrying a (moving) infant (figure 29).

Top plate

An HDPE top plate of 20 mm thick is chosen. The bed slides over the HDPE top plate (figure 30). The bed is thereby supported by the top plate (figure 31). Rather than just being fixated on the rail's carriages, which may cause breakage of the 3D-printed parts there, the load is countered on three points, reducing stresses in the 3D-printed material. This is needed as 3D-printed material is prone to unpredictable breaking under loads due to its anisotropic properties. HDPE is a fairly low-cost and reasonably available material.

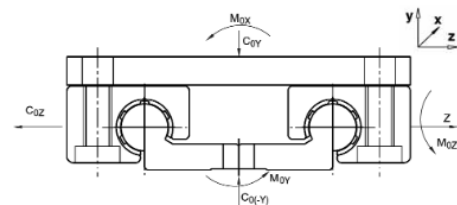

Figure 29. IGUS rail carriage load allowance: CoY 4800 N; CoZ 4800 N; MoX 96 Nm; MoY 170 Nm; MoZ 170 Nm [57].

and use dust sensitive ball-bearings guides. This IGUS rails works with maintenance free plastic bearings and is almost entirely aluminum (its carriages contain zinc, which is also not ferromagnetic). Moreover, its sliding

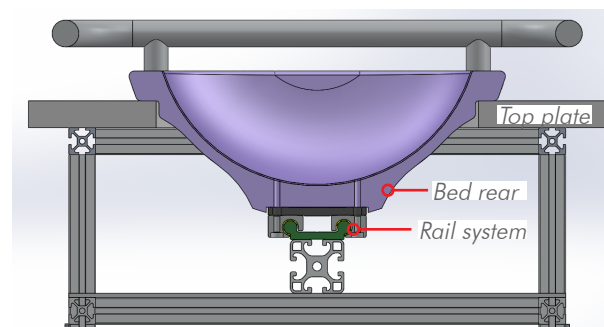

Figure 30. Cross-section of the bed attached to the rail system, and resting on the top plate.

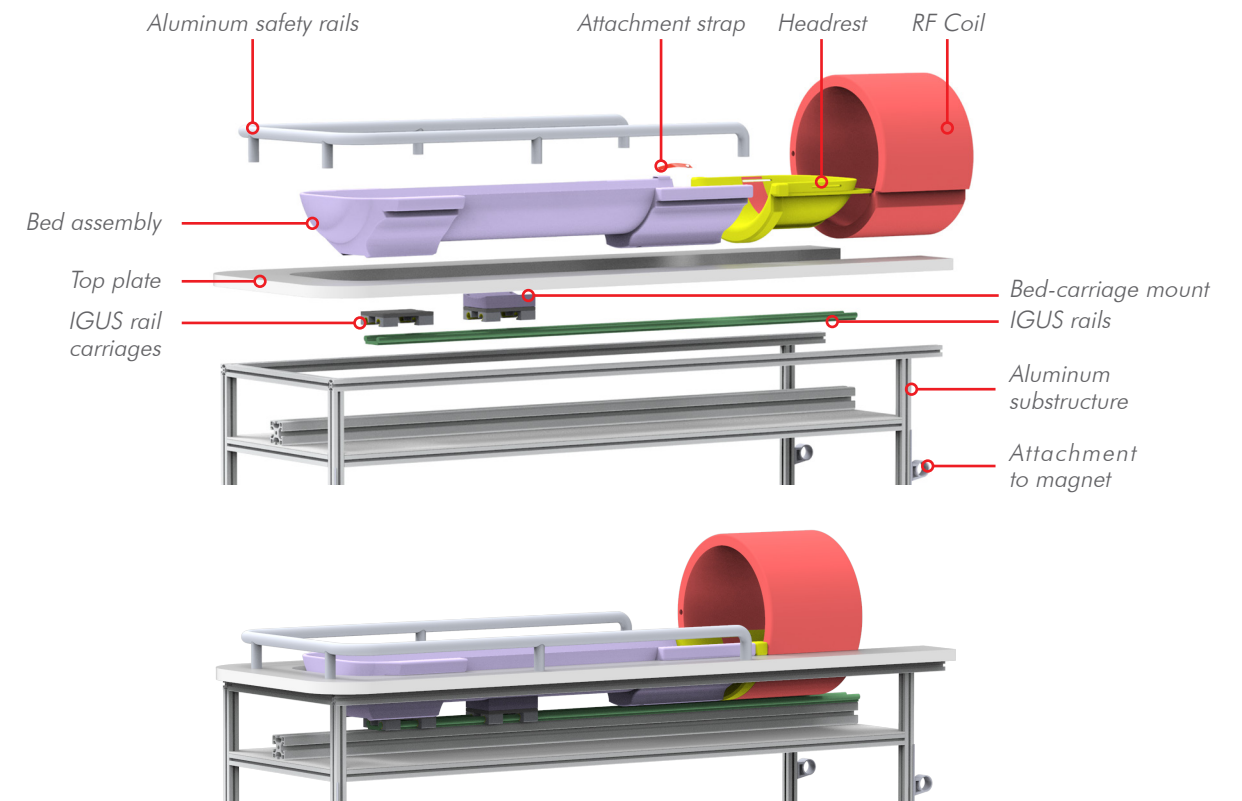

Figure 31. Top: an exploded view of the full bed assembly with its most important parts (screws, bolts and covers are not included). Bottom: the assembled bed system without covers.

Coil and headrest assembly

A coil of 250 mm (inner) diameter is chosen to maximize space for the patient's head. The coil should 1) slide over the patient's head and 2) slide into the bore with the bed. The design of the coil was made in unison with the design of the bed and sliding system. A detachable system that integrates the sliding system with the coil is not preferred as it introduces parts that are sensitive to wear (attaching and detaching parts). The added benefit of the top plate over which the bed slides is that it can also be used for the coil to slide over. Thereby, the coil does not need any attachment to a sliding mechanism: it can simply be placed onto the top plate.

Sliding the patient's head into the coil is an inconvenient operation, especially if there is little space between the head and the coil, and there is uncertainty whether the head is in the right position. Moreover, there may not be enough space for the operator to reach and fixate the head with a strap when the head is already inside the coil. To solve this, the head should be placed in appropriate position outside the coil, and then the coil should be slid over the head. A dedicated headrest integrated with the coil is designed for this (figure 32). However, another sliding system is needed as the coil needs to slide over the headrest. This is integrated into the coil and headrest, while ensuring to save space inside the coil (figure 33). The effective inner diameter of the coil including headrest is 225 mm.

The reason the headrest is attached to the coil and not the bed is that headrest dimensions and design depends on the coil size used: each coil can have its own fitting headrest, without the need for adjusting or adapting the bed in any way. Moreover, now it always supports on two points (top plate and coil) whenever the coil is in extracted position.

The headrest enables a Velcro strap to be placed for fixating the patient's head. In order to remove the headrest and coil whenever the bed is pulled out of the bore, the headrest is attached to the bed by a simple strap including a plastic press-button. The headrest is in turn connected to the coil by two straps, ensuring that it is pulled out straight (figure 34). This design accomplishes a telescopic way of extracting the coil: when the bed is entirely pulled out, the patient's head is automatically revealed. Straps are usually durable and easily replaceable.

The aluminum substructure

The structure of the bed is made up of 20x20 mm aluminum extrusion profiles and is fixated to the magnet's handlebars to ensure proper alignment and stability. Empty space below the bed is used as shelving to store additional coils, cleaning equipment, or other MRI necessities.

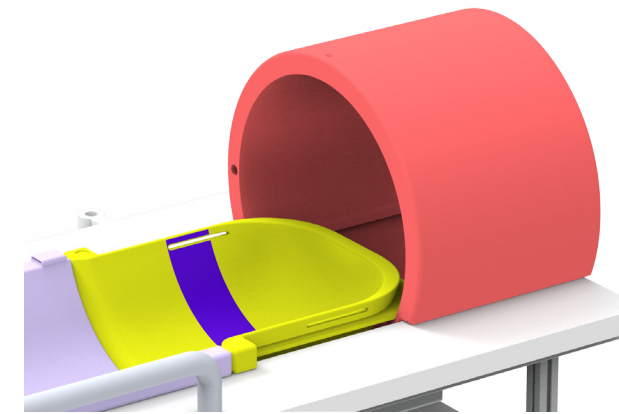

Figure 32. Coil (red) and Headrest (yellow and blue). The blue part indicates where the center of the patient's head should be.

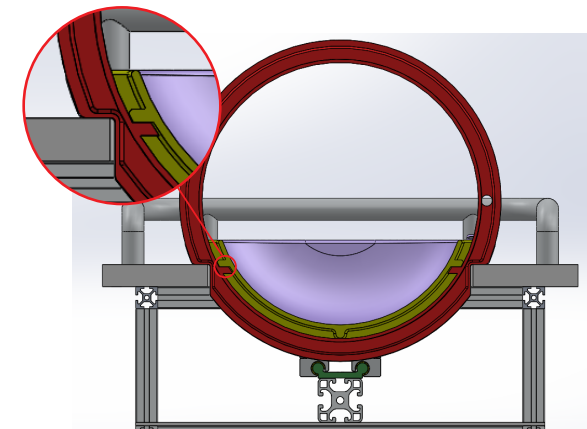

Figure 33. The headrest slides over narrow guides, and is supported by the bore. This keeps space in the coil to a maximum.

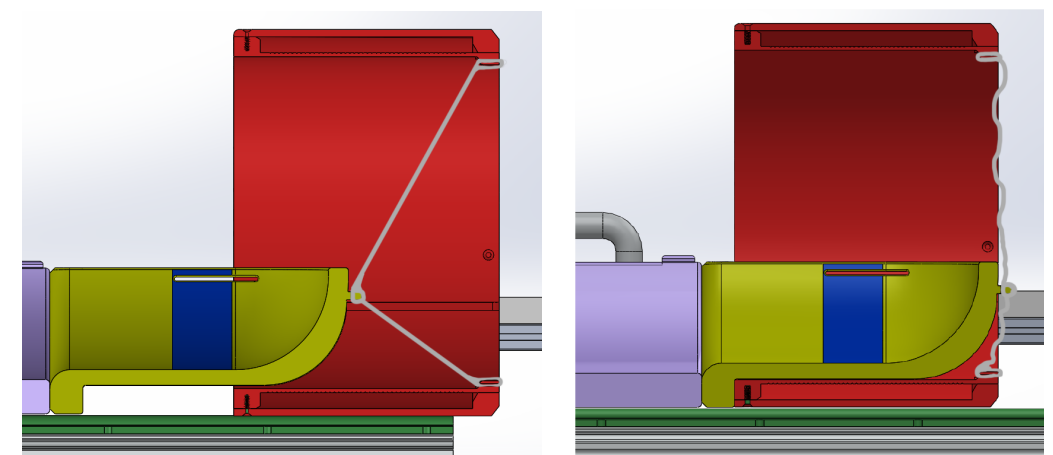

Figure 34. Left: headrest slid out of coil. Right: headrest slid into coil. The headrest is attached to the coil by cotton straps with constant length.

CHAPTER 8

FINAL DESIGN PRESENTATION



INTRODUCTION

This chapter presents the final design of the integrated MRI system. It starts with an overview of the entire system in which specific features will be highlighted. Subsequently, the chapter zooms in on some of these features, namely the system's operation and its installation.

8.1 OVERVIEW

THE MRI SYSTEM'S MAIN FEATURES

THIS SECTION PRESENTS (THE INTEGRATION OF) ALL OF THE SYSTEM'S COMPONENTS AND THEIR GENERAL FEATURES.

8.1.1 THE DESIGN'S INTRODUCTION

The system (figure 35) is comprised of five main components: (1) Magnet assembly, (2) Bed assembly, (3) electronics frame, (4) electronics casings, and (5) monitor and mount. These components are separable from one another, reducing the maximum liftable weight to only 100 kg and so enabling easy installation and transport over rough pathways often found in Ugandan hospitals. Moreover, thanks to its low static magnetic field and total weight no special infrastructure such as a shielded room or fortified flooring is required for its placement. Its relatively small size (for an MRI) (figure 36) is another advantage that enables flexible placement and reduces expensive infrastructure requirements.

Magnet assembly

The heart of the system, the magnet, is enclosed in an aluminum shell (1 mm) to shield the system from outside (electromagnetic) noise. At 100 kg, it's the system's heaviest component, however, its design facilitates lifting by several strong men or women. Thanks to this, it is able to be transported over rough pathways without need for heavy equipment such as forklifts or cranes – often unavailable to Ugandan hospitals. Additionally, it equips active cooling for patients in case air conditioning is not present (figure 35).

Bed assembly

At 30 kg light, the bed assembly is significantly less challenging to transport over rough pathways. The bed assembly's function is to slide the patient in and out of the bore, and therefore it is the only component with a moving part. The only moving part in the system is a dust-resistant aluminum sliding rail system (figure 35). The space below the bed is utilized to serve as storage for any necessary imaging equipment, such as RF coils, pillows, and blankets.

Electronics frame and casings

The electronics frame is separated from the electronics for transport. It weighs around 30 kg. Inside, two 19 inch rack cases (each 8U high) (figure 35) are installed for mounting of the amplifiers, data acquisition unit, computer, and uninterruptible power supply. The electronics come pre-mounted in the casings for protection during transport. The frame has rosters on both sides to allow ample airflow to cool the electronics in case the system is placed in a room that is not air conditioned – something that frequently occurs in Ugandan hospitals. The rosters prevent pests and bugs from entering.

Mounted monitor

The touch screen monitor is the interface to the operator. It is placed on an adjustable mount so that anyone can work ergonomically with it.

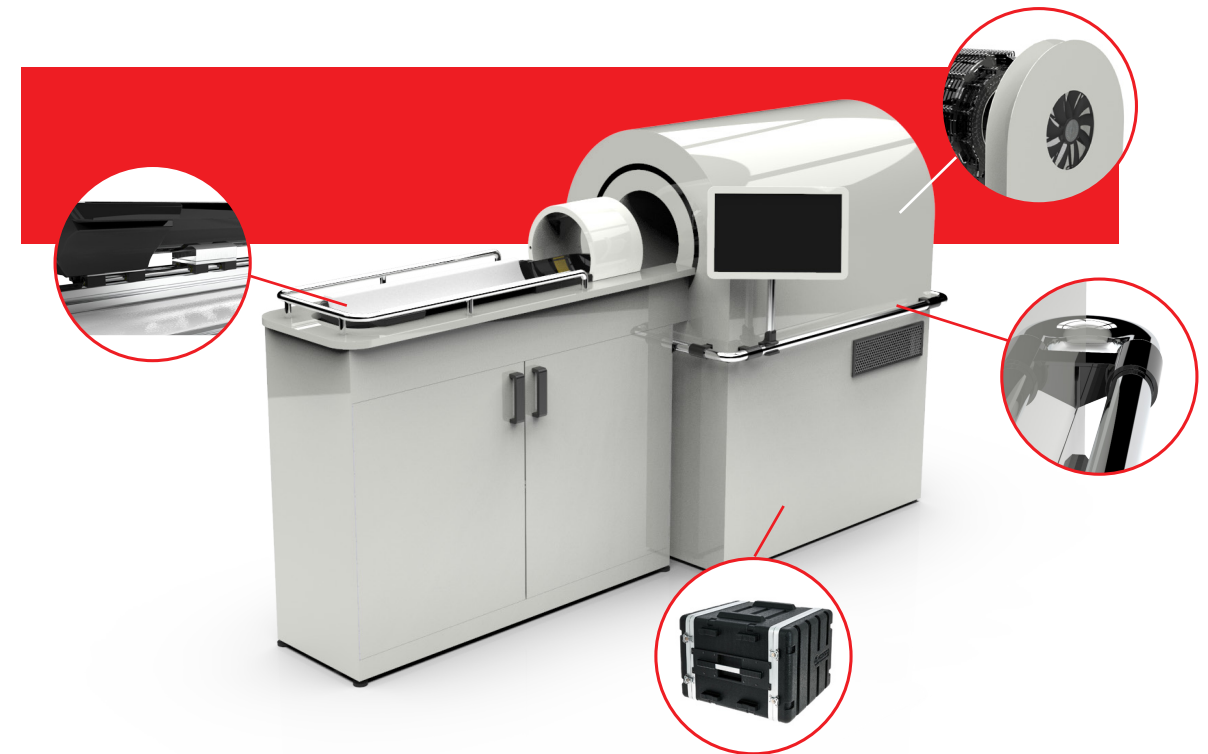

Figure 35. Clockwise: dust-resistant sliding rail, active cooling fan, handles for lifting, durable electronics casings.

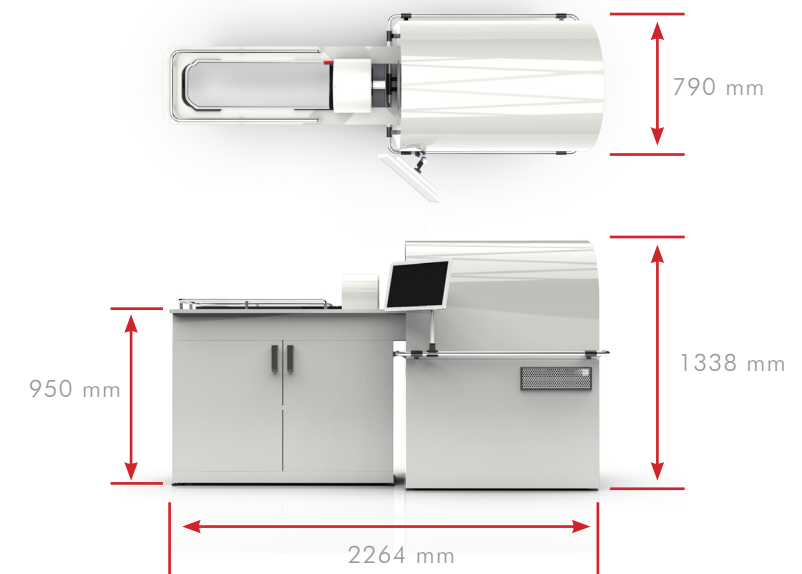

Figure 36. The system's relatively small size allows it to be placed flexibly.

8.2 OPERATION

THE MRI SYSTEM DURING SCANNING

THE FOLLOWING SECTION FOCUSES ON THE SYSTEM'S OPERATION. FIRSTLY, IT EXPLAINS HOW THE OPERATOR INTERACTS WITH THE SYSTEM DURING PREPARATION AND IMAGING OF THE PATIENT. FINALLY, IT EXPLAINS INTERACTIONS WITH THE PATIENT BED.

8.2.1 ERGONOMY AND SAFETY

Ergonomy

The system's operator can comfortably reach and prepare the patient while standing. The operator will often run around the room or in between rooms to gather the necessary equipment while preparing the patient. To reduce strain during preparation of the patient, a comfortable height of the bed is chosen so that the operator can comfortably reach the patient.

However, while scanning the operator has the possibility to ergonomically operate the system while sitting down. As the scanning process can last up to fifteen minutes and there are often multiple procedures per day, standing may tire the operator. While sitting, this design ensures that the patient is still visible (figure 37 and 38), increasing safety. However, the operator is discouraged from interacting with the patient while sitting as he can hardly reach the patient comfortably.

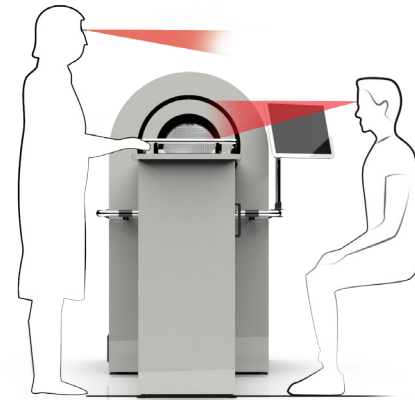

Figure 37. The bore is in the central field of vision while seated. Standing up, the operator can comfortably prepare the patient.

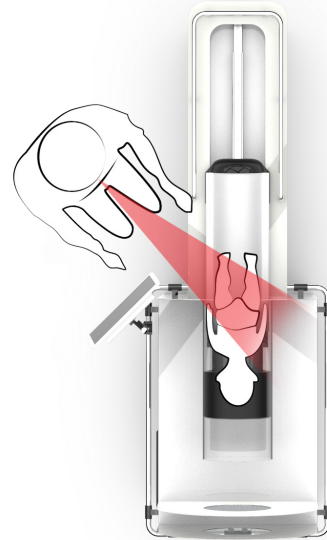

Figure 38. The patient is sufficiently visible from a comfortable position for the operator.

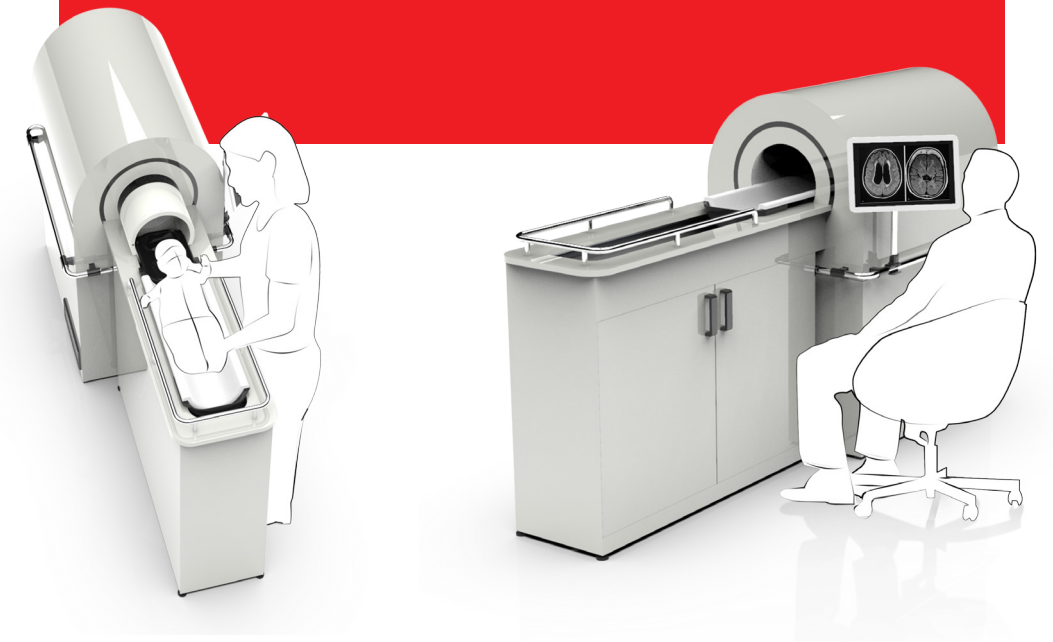

Figure 39. The bed height is comfortable for handling the patient while standing and allows the operator to still see and visually monitor the patient while performing the scan.

Safety and accessibility

Thanks to the design's unique setup, the operator can remain close to the patient during the entire imaging process, increasing patient safety (figure39). As the sliding rail mechanism does not require a brake to keep in place, the patient can be quickly removed from the scanner by simply pulling the sliding bed backwards. Moreover, mothers are enabled (and encouraged) by this design to keep close to their child: the wish of mothers to remain close was one of the notable things found during the analysis phase.

The design also takes a safe margin around the perimeter of the magnet to ensure these bystanders as well as operators aren't exposed

to unsafe levels of magnetic field. The magnetic field strength at the outer perimeter of the magnet is not more than 5 mT, well below recommended safety guidelines.

8.2.2 PATIENT POSITIONING

The bed- and coil-system

Since the sliding mechanism cannot enter the bore (because aluminum would cause interference with the signal, and its size alone would reduce the already limited space inside the bore), the coil and bed are both suspended on side walls (figure 40). Aligning the coil concentrically with the bed in this way allows the bed to push the coil along into the bore, without losing the rigidity and stability of the sliding rail system. This system hereby allows changing the coil without having to attach it to a rails (adding parts that can wear out easily), or without losing crucial space in the bore (which occurs in the case of placing the coil simply on the bed – something that's done in current MRI systems).

By taking the coils outside of the magnet, it is more easily interchangeable, and it enables the operator to slide it gently and controlled over the patient's head, preventing it from colliding with the patient's head.

The coil still needs to be pulled out together with the bed, so a single attachment must be made. This is done by a strap that connects the coil's headrest and the bed together (figure 41). The coil's headrest is subsequently attached by straps to the coil itself. These straps cannot be removed, the coil and the headrest are inseparable components, simply because the one cannot function without the other. Headrests are also coil-specific: they do not fit other coil sizes.

Patient movement

A Velcro strap around the patient's head will prevent the patient from moving during scanning (figure Y). Movement can often cause issues with the MR image and being able to fixate the head will increase chances that the image is successful without needing

anesthetic. Straps are currently used for this purpose in many imaging procedures in Ugandan hospitals.

Patient positioning

To help the operator position the patient, the headrest has a visual indicator as to where the center of the patient's head should be placed. Moreover, the bed's sliding rails have only one position: whenever the bed is slid all the way in, the coil is placed at the magnet's isocenter (figure Y).

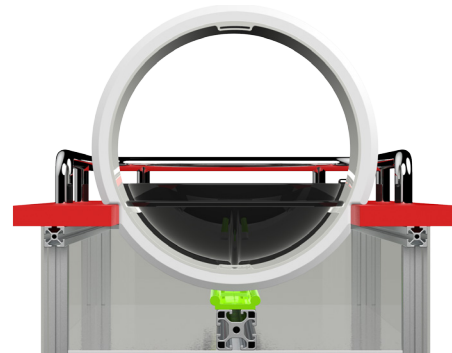
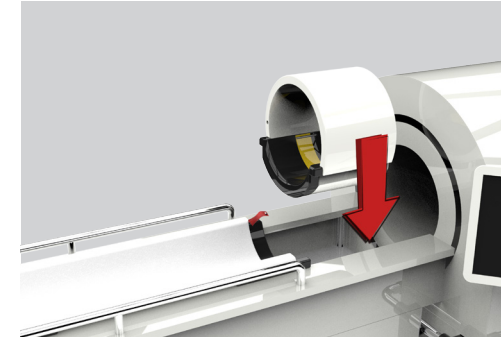
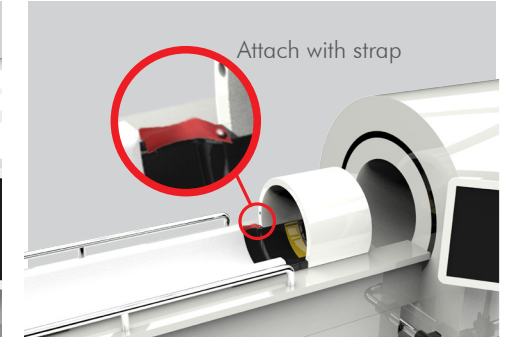

Figure 40. The suspended coil in front view. The black part is the headrest. The red part is the top plate of the bed. The green is the sliding rails. The coil is only suspended on the top plate and not attached to the rails.

1. PLACE HEAD COIL AGAINST BED



2. ATTACH COIL TO BED



3. SLIDE COIL BACKWARDS

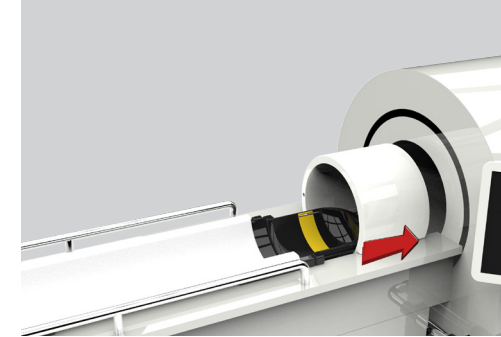

4. PLACE PATIENT ON HEADREST

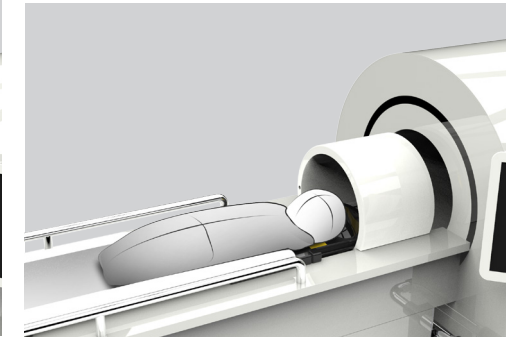

5. STRAP BABY'S HEAD

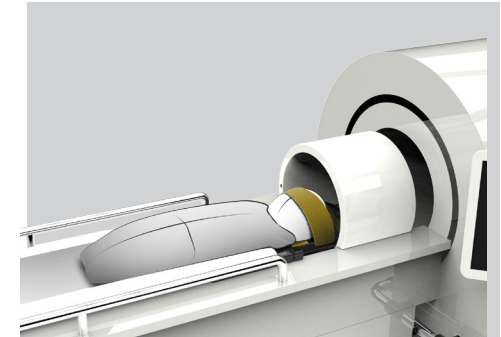

6. SLIDE COIL OVER HEAD

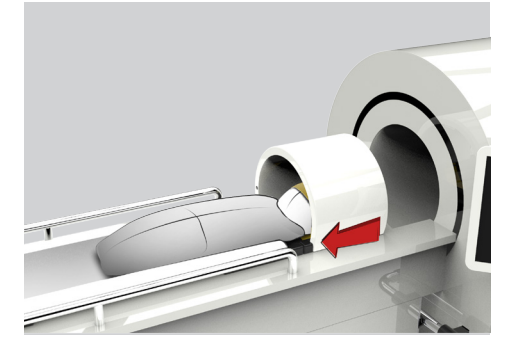

7. SLIDE BED IN UNTIL IT STOPS

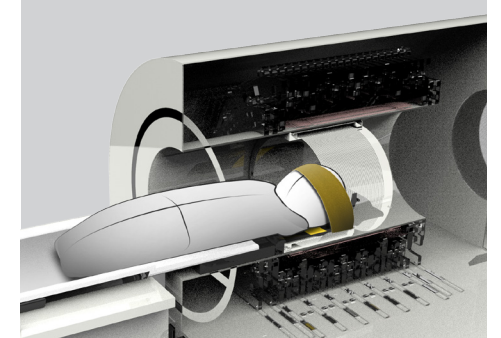

8. REVERSE ORDER TO REMOVE



Figure 41. The process of placing a patient. The interchangeable coil can be slid over the head, and the head can be then strapped.

8.3 INSTALLATION

OVERCOMING INSTALLATION BARRIERS

THIS SECTION EXPLAINS THE DESIGN'S UNIQUE PORTABILITY, AND HOW IT IS SET-UP AND PARTS FIT TOGETHER.

8.3.1 TRANSPORT & INSTALLATION

As mentioned in CH7.1, the design is comprised of five separable components. Their design that includes handles facilitates lifting (figure 42). As identified in the analysis, forklifts and cranes are often not present. As pathways and roads leading up to the hospital are rough and uneven, driving it on wheels is just as challenging. Thus, when designs do not sufficiently facilitate lifting the system may fall over and break whenever installation personnel tries to lift it.

Sensitive electronics are easily and safely transported inside the separate 19-inch case. Simply placing them in the electronics frame and connecting them appropriately (figure 43) enables a plug and play way of installing.

Subsequently, the magnet can be placed on top of the electronics (figure 43). The three cables that connect to the magnet's gradient coils can then be connected. For this, any side panel can be removed to access the electronics after the magnet is placed on top. The cable that runs towards the RF coil can be

routed through to the front of the electronics frame and attach it to the holder on the bed (figure 44) so that it can be easily connected to the coil's front connection for imaging.

The bed can be easily aligned with the magnet's bore and then attached rigidly to the magnet sub-assembly (figure 43). Now also the monitor can be mounted in the desired location on the magnet's handlebar, and the system is ready to go.

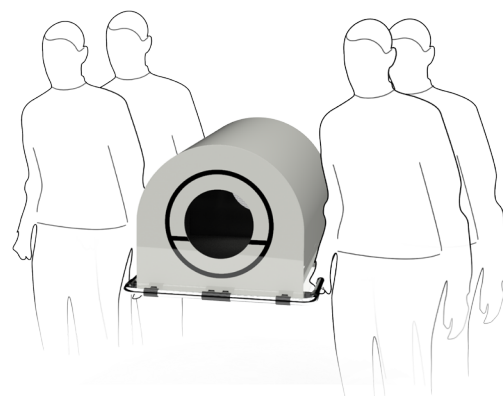

Figure 42. The magnet, despite its weight of 100 kg, can still be lifted by a sufficient number of people when necessary.

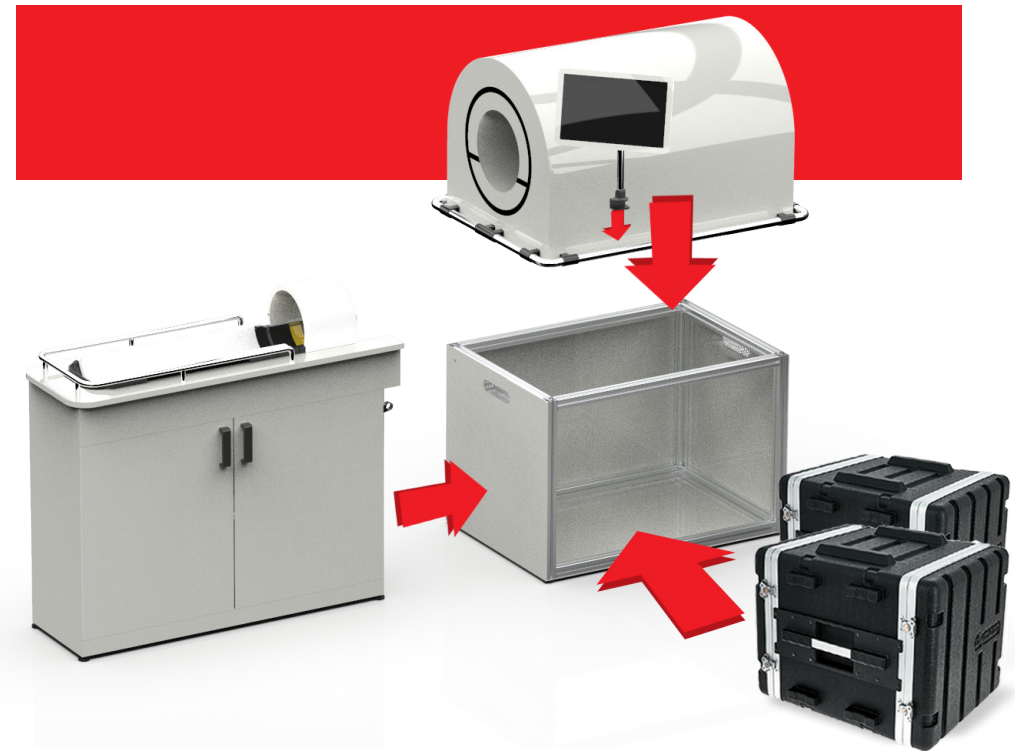

Figure 43. The magnet assembly is placed on the electronics frame, the electronics are inserted, and the bed and monitor mount are attached.

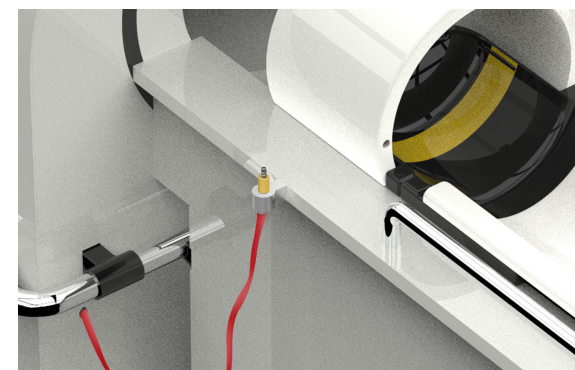

Figure 44. The cable connector running from the front of the electronics enclosure to a holder in the bed. The connection hole in the coil is also visible.

CHAPTER 9

EVALUATION

9.1 EVALUATION TESTING THE DESIGN

9.1.1 EVALUATION AGAINST REQUIREMENTS

Table 6 shows the evaluation against the main requirements as formulated in chapter CH5.

Discussion

Nearly all main product functionalities have been integrated and thereby the main product requirements have been met while main technological requirements have also been satisfied. However, main environmental requirements have only partially met. The focus of the product design phase was on integrating the functionalities, thereby considering the implications that the context imposes on the product. Pests, heat, humidity, dust, and an unstable power supply have all been considered conceptually, and indicative solutions have been proposed within the product design. However, these have not been sufficiently detailed to say that the requirements are satisfied. The detailing of these conceptual solutions is a matter of optimizing airflow, selecting an appropriate UPS, or adding air filters. This optimization may turn out to be crucial to the system's durability, however, due to insufficient data about the system's current state of functioning in regard to these context factors, have been excluded from the design for now. It is argued that the detailing does not dramatically impact the design, and therefore acceptable to leave this optimization open.

- ✓ Requirement met
- ≈ Requirement partially met
- ≠ Requirement not met

REQUIREMENTS	ASSESSMENT
Main product-side requirements	
The product should enable an ergonomic operation that reduces (physical) strain on the operator	✓
The product should enable a patient to be inserted and removed safely	✓
The product should enable easy and low-cost installation	✓
The product should be transportable and installable over rough pathways and uneven surfaces without the need for forklifts or cranes	✓
The product should occupy as little space as possible	✓
The product should not require placement in a separate, dedicated room	✓
The product should allow bystanders to remain close to the patient	✓
The product should provide active cooling for patients inside of the bore	✓
The product should prevent the patient from moving during the entire imaging sequence	≈
Main context-side requirements	
The product should enable adequate cooling for electronics by their built-in cooling fans	≈
The product should prevent pests from damaging sensitive equipment as well as reasonably possible	≈
The product should be able to adequately deal with an inconsistent power supply	≈
The product should be resistive to dust and mud	≈
Main technological requirements	
No ferromagnetic materials may be used within 100 mm distance from the magnet's bore openings	✓
No ferromagnetic materials may be used within 50 mm surrounding the magnet's sides	✓
No metal (ferro or non-ferro) objects may be used within 40 mm surrounding the radiofrequency transceiver coil	✓
The RF coil should be concentric with the magnet's bore	✓

Table 6. The design's main requirements.

9.2 VALIDATION

PROTOTYPE AND STAKEHOLDER VALIDATION



Figure 45. Prototype of the bed assembly, 1:1 scale.

THE DESIGN WAS TESTED IN TWO WAYS: BY A PHYSICAL PROTOTYPE AND BY INTERVIEWS WITH MEDICAL STAFF OF THE CURE CHILDREN'S HOSPITAL IN UGANDA AND A BIOMEDICAL ENGINEER FROM MUST.

9.2.1 PROTOTYPE

A 1:1 prototype (figure 45) of the bed assembly was made in order to test the design on the following aspects: 1) use and interaction and 2) structural. The prototype was not tested by the intended user-group nor by using live patients. Instead, it was tested by the author by using a life-size doll (doll with anthropometric dimensions of a 3-month-old child).

Use and interaction

The placement of the coil and headrest onto the bed goes as intended (figure 46). Headrest slides out easily, and placement of the patient on the headrest goes well. Placing

straps around the patient's head also works as intended. So does the strap and press-button to connect the headrest to the bed. Sliding the coil over the patient's head goes easily (figure 47). Sliding the bed forward and backward requires an uncomfortable amount of force.

The pillow is missing in the prototype, which may cause discomfort to the patient. The Velcro head strap has lots of play (figure 47), and it is argued that it cannot be tightened sufficiently to keep the patient's head still.

Attachment of the headrest to the bed with the red strap is crucial, as without it the bed will slide from under the patient. Users may forget this. In the worst case, the patient will remain inside of the bore with the coil, while the bed slides backward.

All sliding parts cause an annoying sound due to their 3D-printed layer-structure.



Figure 46. The coil can be easily placed and taken.

STRUCTURAL

A minor point for attention is the attachment of the headrest to the coil with straps. The headrest can slide out of the coil if it is held upside down. When this happens frequently, the straps or attachment points may break.

The 20x20 mm aluminum structure in combination with the 20 mm HDPE top plate bend somewhat when leaning on it.

9.2.2 INTERVIEWS

Interviews through videoconferencing were conducted with Edith Mbabazi Kabachelor (Director of Research, CURE), Ronald Mulondo (MD, CURE), and Ivan Muhumuza (Biomedical Engineer, MUST). The CAD model of the MRI scanner, its use and features were presented to the interviewees. The interviewees then had time to discuss and comment.

Ronald and Edith – CURE

Were both interviewed simultaneously. The fact that the operator is in the same room as the patient was well received, and both were very positive. Moreover, the fact that thereby the mother can also be there to calm the child was noted as a positive feature. The sliding mechanism was noted being "ingenious".



Figure 47. The crucial red strap, the placement of the patient, and the sliding of the coil over the patient's head.

Further, it was noted that head, knees, and shoulders of the patients all need to be strapped. Both emphasized the need to prevent sedation, and proposed the use of music to calm the child for this cause. Safety railings on the side were noted as a nice-to-have, but if there are straps for the child may not be needed. If there, the railings were preferred to be retractable to increase access to the child. For installation as well as operation, a mobile solution was proposed, adding wheels. For post-operation patients, moving the patient is difficult while you want an immediate image. A mobile system can prevent an entire ICU team from escorting the post-op patient to the

imaging room, it was argued. For installation, carrying was noted as acceptable, but it was misunderstood why wheels weren't added. Additionally, it was noted that a separate location for placing the oxygen tank is needed. It was rightly commented that when sliding the coil over the entire bed, the entire body of the infant can be scanned provided it fits through the coil. This would increase the value of the system significantly.

Carrying was noted as being "fairly difficult" due to the 100 kg weight. It was proposed that the design should facilitate lifting by forklift as well. It was noted that the flat bottom of the magnet assembly is likely sufficient to facilitate forklift carrying. Headphones were proposed as a solution to keep noise down for the patient. Finally, a safety issue with battery packs underneath the magnet was noted. It was proposed to place back-up batteries in a separate room.

"THE DESIGN LOOKS VERY NICE. THE FACT THAT THE PERSON ACQUIRING THE IMAGE IS IN THE ROOM IS VERY GOOD, IT'S SAFE FOR THE PATIENT."

- Ronnie Mulondo, MD, CURE

Ivan - MUST

Structure of aluminum profiles was well received. The fact that the bed can slide in only one position was well received. Additionally, the system being fixed was judged as better than a mobile system, as a mobile system would affect the positioning. Another reason that was mentioned for why a fixed system is better is that immobile patients can be wheeled to the MRI room and then moved onto the MRI bed.



Figure 48. A somewhat larger 'head' has much less play between the strap.

9.2.3 DISCUSSION

The system was found to be user-friendly. However, attachment of the red strap was found to be crucial in this prototype. If this is forgotten, the child may slide off the bed while pulling it backward. However, the current prototype does not have pillows. It is argued that pillows may increase the friction of the child with the bed, and thereby prevent the patient from sliding off. Moreover, adding extra straps around knees and shoulders (preferred according to the interviewees) may also prevent sliding of the patient. These solutions should be tested. The system should be fail-safe: in the case the strap gets forgotten, the child may not have the risk of being harmed. The play around the head-strap can be explained by the head-size of the used doll. The head diameter is approximately 140 mm, whereas the coil is intended for larger heads. Tested with a placeholder of around 200 mm (not a head, figure 48), there is much less play. The strap needs to be further tested with an actual head.

Strap and attachment points between RF coil and headrest (figure 49) should be made strong enough. Testing is required to determine

"ADDING A PLACE FOR THIS OXYGEN TANK IS A VERY CREATIVE ADDITION AND WILL EXPAND ITS USABILITY."

- Edith Mbabazi Kabachelor, Director of Research, CURE



Figure 49. The coil and headrest. The straps work as intended, and do not get entangled or get in the way. The straps and attachments must be sufficiently strong to resist wear.

noise. Music may be easily added by adding an internal speaker to both calm the child and thus prevent sedation and reduce noise.

Safety was emphasized. By removing battery packs from the integrated system, a risk is avoided. However, that would imply an additional, separate room is needed, with connections running to the system, reducing installation flexibility. It is argued that when the operator can remain close during the scanning, there is no significant risk in keeping batteries integrated in the system.

what level of wear they can handle in their current design, and if needed, they need to be optimized to reduce the risk of failing.

The annoying sliding sound can be resolved by smoothing or finishing the surfaces (sanding, coating) or by using pieces of Teflon tape on the contact areas.

The overall design was positively received. Especially the added safety of the operator being next to the scanner while scanning was praised. A mobile instead of fixed system repeatedly came up in the interviews. Although a mobile system may reduce ICU staff workload in post-op patients, the frequency of these kinds of imaging procedures is too low to justify the possible extra wear on a mobile system, so is argued.

Additionally, preventing sedation and patient comfort is a recurring theme. Proposed solutions were headphones/music. Headphones will reduce the available space in the machine. Although an interesting option, space should be prioritized over reducing

Carrying the magnet was noted to be difficult, however, a mobile system is not preferred. We argue that facilitating several options for transporting the system will reduce its chance of breakage during installation. It needs to be further explored whether a forklift can adequately lift the system or that the design needs to be adapted to facilitate that.

CHAPTER 10

RECOMMENDATIONS

10.1 RECOMMENDATIONS

RECOMMENDED DESIGN ALTERATIONS

10.1.1 RECOMMENDATIONS

Installation of electronics

Connection of electronics may prove challenging for people unfamiliar with the system. When installation needs to be as easy as possible, instructions should be considered. A simple instruction manual can be added, and color-coded cables could make things even simpler.

Shorter bore possible

A shorter bore could benefit the child patient: it could possibly facilitate airflow, reduce anxiety, and increase patient visibility. The current total length is chosen to follow the dimensions of the electronics underneath the magnet, and to free up space to install a cooling fan. One can consider placing the cooling fan elsewhere and use channels to direct the airflow. Moreover, layout of the electronics will likely be optimized in future versions, thereby removing the need for two 19-inch casings to mount them. A shorter bore can then be quite easily achieved, without any implications to the rest of the design.

Bore shoulders of child

The system may eventually be used for imaging older children or even adult heads. When scanning children older than a certain age (e.g. P95, 4 year-old [52]), their shoulders become too wide to fit into the bore. However, the head may still fit. When we allow the shoulders to run all the way to the edge of

the magnet, the head may just be in the right position for it to be imaged. As we see in figure 50, the scanning region (field of view, F.O.V.) starts at 144 mm from the magnet's edge. A P95 head (12-year-old) is 232 mm high [52]. This implies, excluding neck length, that $232 - 144 = 88$ mm of the head is in the scanning region when shoulders are pressed to the edge of the magnet. For a P5 12-year-old (200 mm head height), that is only 56 mm. It needs to be further explored in what cases shoulders do no longer fit, what then is the head height and does this allow sufficient area of the head to be scanned when shoulders are at the edge of the magnet.

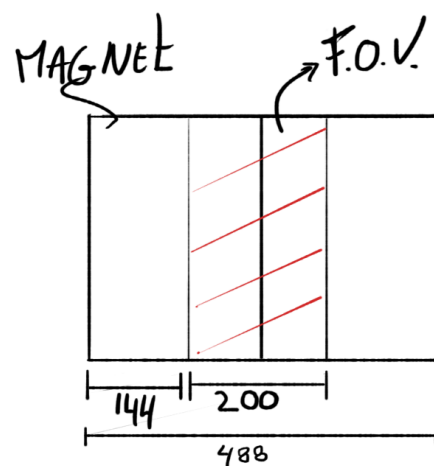

Figure 50. Magnet's field of view starts at 144 mm from its edge.

Pediatric full body scanning

Edith Mbabazi (Director of Research, CURE Children's Hospital) rightly pointed out that when the RF coil can slide all the way over the bed, an infant's full body may be scanned (as long as the body fits inside the maximum diameter coil). This can be done with a few adaptations. The bed can no longer slide over the top plate (figure 51), therefore it likely needs additional strength and stiffness to prevent it from breaking under loads. A solution may be to use a composite design (glass-fiber or similar) to achieve desired specifications.

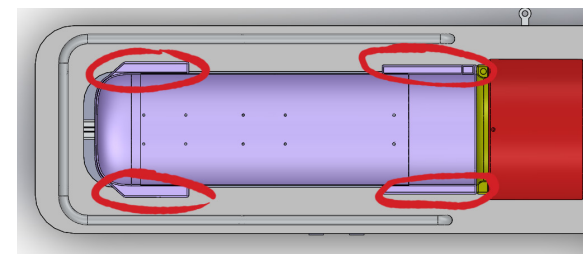

Figure 51. Removing these support points will allow the coil to slide over the bed.

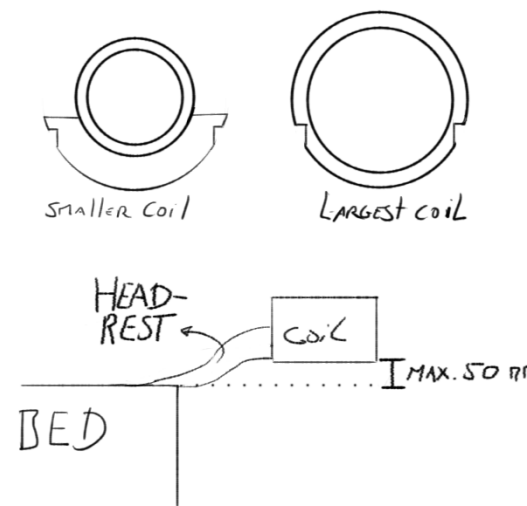

Figure 52. A solution to keeping coils concentric within the current design. A gradually sloping headrest supports the shoulders.

Adding oxygen tank placement

As also pointed out by Edith Mbabazi, "Adding a place for [an] oxygen tank is a very creative addition and will expand its usability." An oxygen tank is a metallic product, therefore cannot be placed too close to the magnet. It is however used frequently, thus creating a dedicated place for it on the system where it cannot influence the magnetic field is needed.

Prevent movement

Ronald Mulondo (MD, Cure Children's Hospital) noted that currently (in the CT-scanner), patients are fixated at the head, shoulders, and knees by straps to prevent moving. Additional straps may need to be included in the bed design to reduce movement of the patient.

Cleaning

Aluminum extrusion profiles may be especially difficult to clean due to their geometry. Even though they are covered by an outer embodiment (plates), they can become dirty. Other solutions may have to be found, although this is currently not crucial. What is more important is the optimization of the patient bed for cleaning. A detachable pillow is now used, however, dirt (think of a sick child – vomit), may still end up underneath the pillow. A watertight bed should ensure that secretion is contained in the bed, and does not end up in for example the magnet assembly which is notably harder to access for cleaning.

Different coil sizes

The different sizes of coils should be designed so that they remain concentric while offering a comfortable position for the patient. The current design with a dedicated headrest for each coil enables the design of these additional coils. By dimensioning the coil so that it rests on the top plate while concentrically aligned with the bore, the headrest can be used to overcome the height difference with the bed (figure 52).

System alignment

Alignment of the bore with the bed is crucial, as a slight deviation may block the bed from sliding in. Two solutions can be explored: 1) include a proper alignment tool into the design that ensures accurate alignment during installation, even on crooked floors or 2) increase the margins between the components so that accurate alignment is less of an issue and blockage does not occur when the bed is misaligned. Some alignment tool and bed attachment already exist in the current design, however, need further detailing. Moreover, it is also advised to explore solution 2, as accurate alignment may not always be possible.

CE certification and medical equipment regulations

A crucial recommendation is to test the current setup against the requirements for a CE certification and medical equipment regulations in regard to clinical testing and hospital implementation. These requirements were beyond the scope of this thesis, and therefore the impact of these requirements on the design is currently unknown.

10.2 CONCLUSION

CONCLUSION AND FINAL REMARKS

The design set out to create a first version of a low-field MRI system that can be used within the context of Ugandan hospitals. The new design successfully integrates all components, adding missing functionalities that are crucial to the system's use in hospitals and addressing some of the major challenges for its implementation and operation in an African context. A way to operate the system and inserting the patient into the system were the key missing functionalities that were addressed. It was also discovered that the infrastructure in Ugandan hospitals often does not support the implementation of MRI systems. Installation is costly due to the lack of expert personnel and space, and transporting large systems over rough and uneven pathways is causing breakage. Ugandan context also puts additional strain on components: heat, humidity, dust, power outages and pests cause additional wear of equipment.

First and foremost, the design integrated the separate components in a way so that it can be ergonomically and safely operated by hospital staff. Moreover, the design does not require installation in a separate room and takes up no more than 3 m², reducing the system's infrastructure requirements significantly compared to current MRI systems. Each of the components facilitates carrying, thereby facilitating its transport over rough pathways that are often found near hospitals where forklifts cannot operate, reducing installation

costs and preventing damage caused during transport. The sliding bed is designed to save space inside the system, so that many infants – also the ones with an expanded head – can be diagnosed.

MRI is a scarce modality in Uganda and the rest of sub-Saharan Africa. By addressing all the challenges that this context imposes on these MRI systems, the concept reduces the threshold for implementation. It is argued that by reducing the barriers for implementation, the imaging modality can become more widely available in low- and medium-resource countries. By increasing the availability of these crucial diagnostic technologies, more patients can be helped and even lives can be saved. Conditions can be better diagnosed and better understood, not only by healthcare workers but also by the general population when these systems are more widely used. Thereby, it is hoped that consequentially, the population will better understand the measures needed to prevent certain conditions such as hydrocephalus, and a decline in its prevalence can be achieved.

Summarizing: by implementing this solution, it is hoped that healthcare equity around the world is improved, the number of infant lives saved is increased and their quality of life is improved, thereby contributing to giving these future generations a fighting chance to further improve the world for others.

10.3 LIST OF REQUIREMENTS

THE MAIN PRODUCT REQUIREMENTS

E = Requirement
W = Wish

The product should enable an ergonomic operation that reduces (physical) strain on the operator

- E1 The product allows a standing preparation the patient
 - E1.1 The bore should be at 1000 mm height from the floor
- E2 The product allows a sitting operation during imaging
 - E2.2 The monitor should be adjustable in height between 800 and 1000 mm
 - E2.3 The monitor should be adjustable in four directions (four D.O.F. (degrees of freedom))
- E3 The product should allow bystanders to remain close to the patient
- E4 The product should prevent the magnetic field from reaching >0.5 mT at a distance of 50 mm from the product
 - E4.1 The product should not be able to fall over when a person leans against it

The product should enable a patient to be inserted and removed safely

- E5 The product should enable operators to keep visual contact with the patient
- E6 The product should provide active cooling for patients inside of the bore
 - E6.1 The product should have a dedicated fan that sucks air out of the bore
 - E6.2 The fan should be placed behind a non-ferro metal mesh shield of 0.5×0.5 mm
- E7 The product should prevent the patient from moving during the entire imaging sequence
- E8 The product should be equipped with fixating straps for the patient's knees, shoulders, and head
- E9 The product should be able to be cleaned properly
 - E9.1 The bed should be watertight
 - E9.2 Pillows on the bed should be able to be removed
- E10 The product should have a detachable pillow for comfortably placing the patient on the bed
- E11 The product should have an indication that shows how the patient should be placed
- E12 The product should be equipped with safety rails to prevent the patient from falling off
 - E12.1 The safety rails should be retractable
- E13 The product should enable the operator to quickly remove the patient from the bore
- E14 The product should enable the RF coil to be easily mounted over the patient's head
 - E14.1 The RF coil should be donned outside of the bore
 - E14.2 The RF coil should have no permanent attachment to any other part
 - E14.3 The RF coil should be able to be attached to the bed
- E15 The product should enable a bed to be slid into the bore
 - E15.1 The bed should be attached to the magnet assembly
 - E15.2 The bed should move with 1 D.O.F.
 - E15.3 The bore should equip linear guides to guide the bed once it is inside

The product should enable easy and low-cost installation

- E16 The product should be transportable and installable over rough pathways and uneven surfaces with-out the need for forklifts or cranes
- E17 The product facilitates carrying by at least four persons
- E18 The product's maximum carryable weight is 100 kg
- E19 The product does not require expert personnel to be installed
 - E19.1 The electronics should come pre-assembled
 - E19.2 The product should include instructions on connecting the various parts
- E20 The product should not require placement in a separate, dedicated room
 - E20.1 The product should have its own shielding against noise
 - E20.2 The product should weigh no more than 200 kg in total
- E21 The product should not exceed a footprint of 3m² surface area
- E22 The product should be able to operate in a non airconditioned environment with temperatures of maximum of 30 degrees Celsius

W1 The product requires as few connections as possible for on-site installation

The product is easily maintainable and repairable

- E23 The product provides easy maintenance access to internal electronics
- E24 The product provides easy access to mechanical components that are subjected to wear

W2 The product is made of as many standardized components as possible

Durability and reliability

- E25 The product should enable adequate cooling for electronics by their built-in cooling fans
 - E25.1 The product should have a cool air inlet
 - E25.2 The product should have a hot air outlet
 - E25.3 The electronics should have sufficient space between them
- E26 There should be at least 50 mm between the electronics cooling fan side and the start of another component
- E27 The product provides protection against dust and mud
 - E27.1 The product's cooling channels should be equipped with particle filters
 - E27.2 The product's moving/mechanical components should be shielded from dust

W3 The product should prevent pests from damaging sensitive equipment as well as reasonably possible

Technical

- E28 The RF coil should be concentric with the magnet's bore
- E29 No metal (ferro or non-ferro) objects may be used within 40 mm surrounding the radiofrequency transceiver coil
- E30 No ferromagnetic materials may be used within 50 mm surrounding the magnet's sides
- E31 No ferromagnetic materials may be used within 100 mm distance from the magnet's bore openings
- E32 The product is equipped with aluminum shielding of at least 1 mm around the magnet

The product should be able to adequately deal with an inconsistent power supply

- E33 The product has a dedicated backup power supply that can be mounted onto a 19"-rack mount, with a maximum height of 2 Units

REFERENCES

- [1] Chou, E.T., Carrino, J.A. (2007). Chapter 10 – Magnetic Resonance Imaging. Pain Management, 1(1), 106-117. <https://doi.org/10.1016/B978-0-7216-0334-6.50014-5>
- [2] Stress Fractures. (n.d.). Retrieved from <https://www.mayoclinic.org/diseases-conditions/stress-fractures/diagnosis-treatment/drc-20354063>
- [3] Schiff, S.J. (2018). ISMRM Lecture Paris 2018 [Video File]. Retrieved from https://www.dropbox.com/s/c6e2vd0efd07hz8/ISMRM%20Lecture%20Paris%202018_720p.mov?dl=0
- [4] Brazier, Y. (2017). What is hydrocephalus, or water on the brain? Retrieved from <https://www.medicalnewstoday.com/articles/181727.php>
- [5] Hydrocephalus. (n.d.). Retrieved from: <https://www.hydroassoc.org/hydrocephalus/>
- [6] Hydrocephalus Fact Sheet. (2020). Retrieved from <https://www.ninds.nih.gov/Disorders/Patient-Caregiver-Education/Fact-Sheets/Hydrocephalus-Fact-Sheet>
- [7] Morgado, T., Figaji, A. (2014). Hydrocephalus in spina bifida. SAMJ: South African Medical Journal, 104(4), 315. Retrieved from http://www.scielo.org.za/scielo.php?script=sci_arttext&pid=S0256-95742014000400032
- [8] Hydrocephalus. (n.d.). Retrieved from <https://armandoh.org/disease/hydrocephalus/>
- [9] Gupta, P., Sodhi, K. S., Saxena, A. K., Khandelwal, N., & Singhi, P. (2016). Neonatal cranial sonography: A concise review for clinicians. Journal of pediatric neurosciences, 11(1), 7–13. <https://doi.org/10.4103/1817-1745.181261>
- [10] Kiesler, J., Ricer, R. (2003). The Abnormal Fontanel. American Family Physician, 67(12), 2547-52. Retrieved from <https://www.aafp.org/afp/2003/0615/p2547.html>
- [11] Engelhard, H.H., (2017). Neurosurgery for Hydrocephalus. Retrieved from <https://emedicine.medscape.com/article/247387-worku>
- [12] Levine, D. (2001). Ultrasound versus magnetic resonance imaging in fetal evaluation. Topics in Magnetic Resonance Imaging: TMRI, 12(1), 25-38. <https://doi.org/10.1097/00002142-200102000-00004>
- [13] O’Shea, T.M., Counsell, S.J., Bartels, D.B., Damann, O. (2005). Magnetic resonance and ultrasound brain imaging in preterm infants. Early Human Development, 81(3), 263-271. <https://doi.org/10.1016/j.earlhumdev.2005.01.004>
- [14] Robson, C.D., MacDougall, R.D., Madsen, J.R., Warf, B.C. (2017). Neuroimaging of Children With Surgically Treated Hydrocephalus: A Practical Approach. American Journal of Roentgenology. 208(2), 413-419. Retrieved from <https://www.ajronline.org/doi/10.2214/AJR.16.16870>
- [15] Hydrocephalus Treatments. (n.d.). Retrieved from <https://www.stanfordchildrens.org/en/service/hydrocephalus/treatment>
- [16] Hydrocephalus. (n.d.). Retrieved from <https://www.mayoclinic.org/diseases-conditions/hydrocephalus/diagnosis-treatment/drc-20373609>
- [17] Warf, B.C. (2005). Hydrocephalus in Uganda: the predominance of infectious origin and primary management with endoscopic third ventriculostomy. Journal of Neurosurgery, 102(1), 1-15. <https://doi.org/10.3171/ped.2005.102.1.0001>
- [18] Roth, E. (2017). Ventriculoperitoneal Shunt. Retrieved from <https://www.healthline.com/health/ventriculoperitoneal-shunt#outlook>
- [19] Understanding Hydrocephalus in Youth. (n.d.) Retrieved from <http://mybrainwaves.ca/hydrocephalus-in-youth/>
- [20] Smith, J., Cheater, F., & Bekker, H. (2015). Parents’ experiences of living with a child with hydrocephalus: a cross-sectional interview-based study. Health expectations : an international journal of public participation in health care and health policy, 18(5), 1709–1720. <https://doi.org/10.1111/hex.12164>
- [21] Pople, I.K., (2002). HYDROCEPHALUS AND SHUNTS: WHAT THE NEUROLOGIST SHOULD KNOW. Journal of Neurology, 73(1), 17-22. Retrieved from https://jnnp.bmj.com/content/73/suppl_1/i17
- [22] Warf, B.C. (2010). Pediatric Hydrocephalus in East Africa: Prevalence, Causes, Treatments, and Strategies for the Future. World Neurosurgery, 73(4), 296-300. <https://doi.org/10.1016/j.wneu.2010.02.009>
- [23] Maternal and Newborn Health Disparities Uganda. (2016). Retrieved from <https://data.unicef.org/resources/maternal-newborn-health-disparities-country-profiles/>
- [24] Rouger, M. (2019). Spotlight on radiology in Uganda. Retrieved from <http://blog.myesr.org/spotlight-on-radiology-in-uganda/>
- [25] Fuller, A., Tran, T., Muhumuza, M., Haglund, M.M. (2016). Building neurosurgical capacity

in low and middle income countries. *eNeurologicalSci*, 3(1), 1-6. <https://doi.org/10.1016/j.ensci.2015.10.003>

[26] Institute for Health Metrics and Evaluation (IHME). Health Service Provision in Uganda: Assessing Facility Capacity, Costs of Care, and Patient Perspectives (2014). Retrieved from https://www.healthdata.org/sites/default/files/files/policy_report/2014/ABCE/Uganda/ABCE_Uganda_full_report_2014.pdf

[27] Obungoloch, J. (2019). Personal interview.

[28] Ttendo, S. (2019). Personal interview.

[29] Ssenwemba, J. (2019). Personal interview.

[30] Tugume, I. (2019). Personal interview.

[31] Obungoloch, J., Harper, J.R., Consevage, S., & Schiff, S.J. (2018). Design of a sustainable prepolarizing magnetic resonance imaging system for infant hydrocephalus. *MAGMA*, 31(5), 665-676. <https://dx.doi.org/10.1007%2Fs10334-018-0683-y>

[32] Chan, M. (2010). Medical devices: an area of great promise. Retrieved from https://www.who.int/dg/speeches/2010/med_device_20100909/en/

[33] Robert A Malkin (2007) Barriers for medical devices for the developing world. *Expert Review of Medical Devices*, 4(6), 759-763. <https://doi.org/10.1586/17434440.4.6.759>

[34] Wandera, D. (2018). Uganda has only 37 radiologists – records. Retrieved from <https://www.monitor.co.ug/News/National/Uganda-has-only-37-radiologists-records/688334-4309954-v9e8i8/index.html>

[35] Walukamba, A. (2015). Lack of Experts, Equipment Dents X-ray Services. Retrieved from <https://ugandaradionetwork.com/story/lack-of-experts-equipment-dents-x-ray-services>

[36] Fatuma, M., (2018). Uganda stuck with only 12 neurosurgeons. Retrieved from <https://journalism.mak.ac.ug/?q=news/011118/uganda-stuck-only-12-neurosurgeons>

[37] Sali, J. (2019). Personal interview

[38] Kirumira, F. (2019). Personal interview

[39] Lubowa, S.K. (2019). Personal interview

[40] Ali. (2019). Personal interview

[41] Allena. (2019). Personal interview

[42] Ochora, M. (2019). Personal interview

[43] Erickson, T. (2019). Personal interview

[44] Onyachi, N. (2019). Personal interview

[45] Kamwesigye, B. (2019). Personal interview

[46] James, K. (2019). Personal interview

[47] Mjuni, D. (2019). Personal interview

[48] Kabachelor, E.M. (2019). Personal interview

[49] Electromagnetic fields and public health. (2006). Retrieved from <https://www.who.int/peh-emf/publications/facts/fs299/en/>

[50] Standing workstation: What you need to know. (n.d.). Retrieved from <https://www.mayoclinic.org/healthy-lifestyle/adult-health/in-depth/standing-workstation/art-20088544>

[51] How to sit at your desk correctly. (n.d.). Retrieved from <https://www.nhs.uk/live-well/healthy-body/how-to-sit-correctly/>

[52] TU Delft. (n.d.). DINED / Anthropometry in design. Ergonomic database archived at <https://dined.io.tudelft.nl/en>

[53] Horizontal field of view. (n.d.). Retrieved from https://www.epd.gov.hk/eia/register/report/eiareport/eia_2522017/EIA/html/Appendix/Appendix%2011.1.pdf

[54] Thomann Rack Case 8U. [Image file]. Retrieved from https://www.thomann.de/nl/thomann_rack_case_8u.htm?sid=d19cee243b01d985de26f68ea3f1240a

[55] Santos, M.M., Rubagumya, D.K., Dominic, I., & Härtl, R. (2017). Infant hydrocephalus in sub-Saharan Africa: the reality on the Tanzanian side of the lake. *Journal of Neurosurgery*, 20(5), 423-431. <https://doi.org/10.3171/2017.5.PEDS1755>

[56] Child Growth Standards. (n.d.). Retrieved from https://www.who.int/childgrowth/standards/hc_for_age/en/

[57] DryLin W Flexible Linear Guide System Data. (n.d.). Datasheet retrieved from <https://nl.rs-online.com/web/p/guide-blocks-guide-carriages/4885136/>

[A] Rahman, M.I., Raveendran, S., Kaliaperumal, C., Marks, C. (2012). Pseudotumor cerebri following traumatic brain injury in a 29-year-old man. *The Journal of Natural Science, Biology and Medicine*, 3(1), 105-7. <https://doi.org/10.4103/0976-9668.95987>

[B] Szpecht, Dawid & Frydryszak, Dagmara & Miszczyk, Norbert & Szymankiewicz, Marta & Gadzinowski, Janusz. (2016). The incidence of severe intraventricular hemorrhage based on retrospective analysis of 35939 full-term newborns—report of two cases and review of literature. *Child's Nervous System*. 32. <https://doi.org/10.1007/s00381-016-3164-5>.

APPENDICES

APPENDIX A

19" SUB-RACKS

- 19" Subrack, EuropacPro, Kit, Unshielded, 3U, 84, 295 mm, 133 mm, 427 mm, 11.61 "



Manufacturer:	SCHROFF
Manufacturer Part No:	24563-133
Order Code:	1455788
Technical Datasheet:	24563-133 Datasheet
See all Technical Docs	

Image is for illustrative purposes only. Please refer to product description.

[Add to compare](#)

Product Information

<input type="checkbox"/> Rack U Height:	3U	<input type="checkbox"/> External Width - Metric:	427mm
<input type="checkbox"/> Rack HP Width:	84	<input type="checkbox"/> External Depth - Imperial:	11.61"
<input type="checkbox"/> External Depth - Metric:	295mm	<input type="checkbox"/> External Height - Imperial:	5.24"
<input type="checkbox"/> External Height - Metric:	133mm	<input type="checkbox"/> External Width - Imperial:	16.81"
		<input type="checkbox"/> Product Range:	-

Figure X. Farnell 3U subrack. (Farnell Subrack. Retrieved from: <https://uk.farnell.com/schroff/24563-133/subrack-3u-295mm-84hp/dp/1455788>)

- 19" Subrack, EuropacPro, Kit, Shielded, 6U, 84, 355 mm, 267 mm, 427 mm, 13.98 "

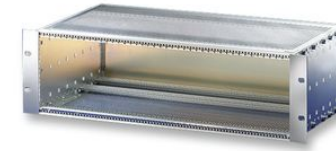

Manufacturer:	SCHROFF
Manufacturer Part No:	24563-444
Order Code:	1455807
Technical Datasheet:	24563-444 Datasheet
See all Technical Docs	

Image is for illustrative purposes only. Please refer to product description.

[Add to compare](#) [Write A Review](#) [Ask A Question](#)

Product Information

<input type="checkbox"/> Rack U Height:	6U	<input type="checkbox"/> External Width - Metric:	427mm
<input type="checkbox"/> Rack HP Width:	84	<input type="checkbox"/> External Depth - Imperial:	13.98"
<input type="checkbox"/> External Depth - Metric:	355mm	<input type="checkbox"/> External Height - Imperial:	10.51"
<input type="checkbox"/> External Height - Metric:	267mm	<input type="checkbox"/> External Width - Imperial:	16.81"
		<input type="checkbox"/> Product Range:	-

Figure X. Farnell 6U subrack. Farnell Subrack. Retrieved from: <https://uk.farnell.com/schroff/24563-444/subrack-shielded-6u-360mm-84hp/dp/1455807>

APPENDIX B

UGANDAN HEALTHCARE ENVIRONMENT

HEALTH CARE FACILITIES

Village health team (VHT)/Community medicine distributors

Often first point of contact for patients seeking medical aid. Village health team advises patients and can refer them to health centers (probably HC II).

This VHT serves as primary, village-level healthcare facility for all villages in Uganda. Their members are able to relay basic information to villagers, and refer to the right locations for various levels of healthcare. Village health teams are there to provide basic preventive health care to rural villages. The VHT covers the size of the 'Local Council 1' (LC1 is Local Council I, the smallest administrative unit of Uganda, Each village is run by a local council 1 and is governed by a local council 1 chairman).

The Village health teams consist of volunteers and are trained by government officials and volunteers such as from the Uganda Village Project (UVP).

Each village is supposed to have these VHTs, but they are still either non-existent or do not have any drugs (Kavuma, 2009).

At least 4/10 people who reach the health center are referred by the VHTs (Kananura, 2012).

Clinics

Privately owned, distribution of drugs to patients for a fee. Sometimes perform outpatient services.

Health Center II (HC II)

Every parish is supposed to have one of these HC IIs. (A parish is the next level up from Village, and contains several villages; it is run by an LCII that consists of a.o. the LCI chairmen). These HC IIs serve a few thousand people, is able to treat common diseases and offering antenatal care (e.g. malaria). It's an outpatient clinic (treating patients that do not require a bed).

- Serve as basic health centers and interface to the formal health sector for communities
- Catchment area of around 5,000 (the community)
- Largely only outpatient care
- Usually more services in areas with fewer HC IIIs or HC IVs.

Health Center III (HC III)

Every sub-county should have a HC III. (A sub-county (or division?) is made up of a number of parishes and is run by sub-county chief and an elected Local council III).

These centers have around 18 in staff, it has a functioning laboratory and an outpatient clinic and maternity ward.

- For a catchment area of up-to

20,000 people

- Provide supervision and referral services to HC IIs under their management
- Provide basic outpatient preventive and curative care, and inpatient care mainly through general and maternity wards.
- Many also provide laboratory services

Health Center IV

This HC serves a county or parliamentary constituency (the county is made up of sub-counties, and is represented in national parliament by an elected member (an MP), the LC IV consists of the LC III executive members). This HC is able to admit patients (no longer only outpatient), and have wards for men, women and children in addition to all the services found at HC III.

- For catchment area of around 100,000 people
- Offer basic preventive and curative outpatient services, in-patient care, life-saving medical, surgical, obstetrics, blood transfusions, caesarians.

Note: an example by the guardian indicates that not all HC IVs have doctors or theatres, and this indicates the HC state in Uganda that: yes – it should have doctors, but in practice it is not there.

General Hospitals or District Hospitals

Each district has a hospita (a district is made up of several counties, and is led by an elected local council V (LC V). Uganda has 80 districts (2009) but this number keeps growing.

It should have all services offered at HC IV, plus specialized clinics (e.g. mental health and dentistry), and consultant physicians. These general hospitals support referrals from health

centers and lower levels of care.

- For a catchment area of 500,000 people
- Offer preventive and curative outpatient services, inpatient care, emergency surgery, obstetrics, gynecology, lab services.
- Also provide in-service training, consultation, and research at lower levels of care (on behalf of community-based health programs).

Regional referral hospitals

offer preventive and curative outpatient services, obstetrics, gynecology, inpatient care, and, laboratory services, psychiatry, pathology, radiology. higher-level surgical and medical care than what is found at district hospitals, teaching, and research.

- Act as referral hospitals to district/general hospitals.
- Catchment area of 200,000

National referral hospitals (Mulago National Referral Hospital in Kampala)

Act as referral centers for regional referral hospitals. The only one, according to the MoH is Mulago.

- Intended to serve all Ugandans (catchment area = all of Uganda)
- Offer curative outpatient services, inpatient care, obstetrics and gynecology, laboratory services, surgery, psychiatry, pathology, radiology, comprehensive specialist services, teaching, and research.

(Based on: "Assessing Facility Capacity, Costs of Care, and Patient Perspectives", 2014. Retrieved from: https://www.healthdata.org/sites/default/files/files/policy_report/2014/ABCE/Uganda/ABCE_Uganda_full_report_2014.pdf)

Private hospitals (for profit and not-for-profit)

There are 63 private-not-for-profit hospitals and 27 private hospitals for profit (65 are government owned). (source: MoH Uganda).

The total number of hospitals (public and private) in Uganda is 155. Of these 2 are National Referral Hospitals (Mulago and Butabika), 14 are Regional Referral Hospitals (RRHs) and 139 are General Hospitals (GHs). 65 government owned, 63 PNFP (private-not-for-profit) and 27 private for profit (PFP).

(Based on "Hospitals" (n.d.). Retrieved from: <https://health.go.ug/moh/hospitals>)

MEDICAL EQUIPMENT SUPPLIERS AND DISTRIBUTORS**MediMark Uganda Ltd**

<https://medimarkuganda.co.ug/services/>
products from dental equipment, medical imaging, lab equipment, to medical consumables. Services: installation, servicing, repairs, consultations.

Matrix Uganda

<https://www.gmdu.net/corp-337034.html>
Import & distribute pharmaceuticals, medical equipment. Based in Kampala.

Dash-S Technologies Inc

<http://www.dash-s.com/dashes/index.php/site-map>
Distributor of medical devices, consumables, but also office equipment.

OTHER NOTABLE PARTIES**Ecurei**

Ernest Cook Ultrasound Research and Education Institute
<http://ecurei.com/>
Trains medical imaging and provides patient care services.

Meduprof-S

<https://www.meduprof-s.com/>
Dutch company providing medical education in developing countries.

UNAHME (Association for Medical and Hospital Engineering)

<http://unamhe.ug/our-vision-2/>
Not for profit organization to support exchange of medical and hospital engineering technology.

RAD-AID

Organization to promote imaging in LMICs.
<https://www.rad-aid.org/countries/africa/uganda/>

GOVERNMENTAL**Ministry of Health (MoH)**

Ministry of Health financially supports faith-based private hospitals (PNFP), but not private for profit hospitals.

Figure 3 Availability of services in health facilities, by platform, 2012

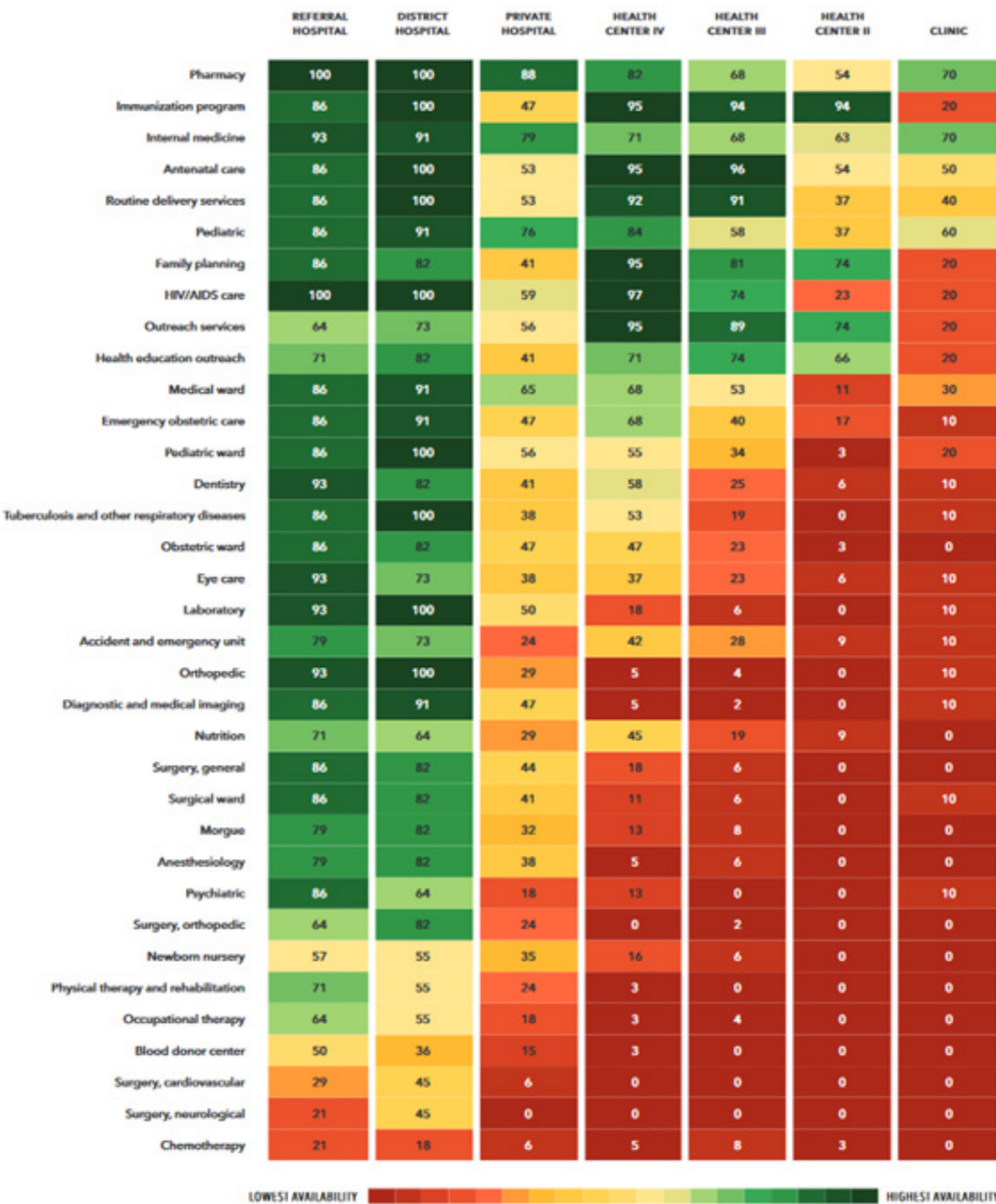

Note: All values represent the percentage of facilities, by platform, that reported offering a given service at least one day during a typical week.

Table X. Availability of services in health facilities. ("Assessing Facility Capacity, Costs of Care, and Patient Perspectives", 2014. Retrieved from: https://www.healthdata.org/sites/default/files/files/policy_report/2014/ABCE/Uganda/ABCE_Uganda_full_report_2014.pdf)

Figure 4 Composition of facility personnel, by platform, 2011

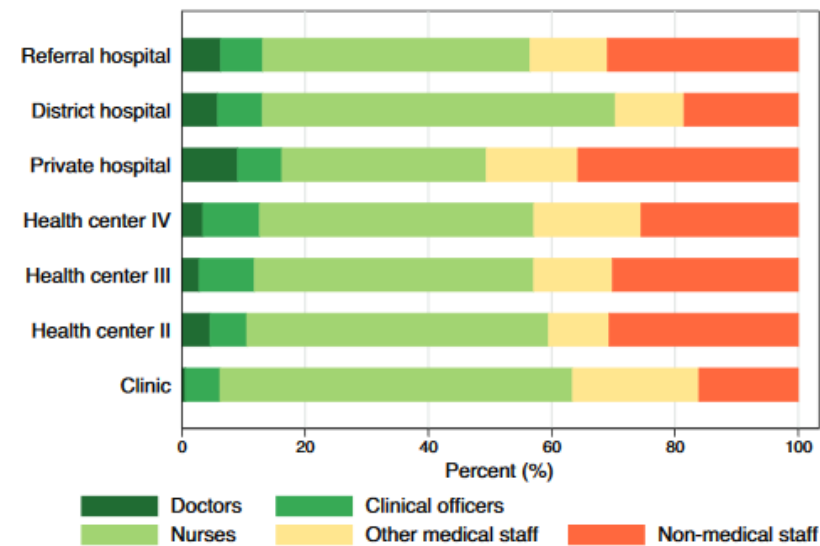

Table X. Composition of facility personnel. ("Assessing Facility Capacity, Costs of Care, and Patient Perspectives", 2014. Retrieved from: https://www.healthdata.org/sites/default/files/files/policy_report/2014/ABCE/Uganda/ABCE_Uganda_full_report_2014.pdf)

APPENDIX C

OBSERVATIONS AND INTERVIEW RESULTS

Hospital environment

Space is crucial. Public hospitals lack space and rooms; a CT scanner that occupies a single room is often difficult to implement. (Jonathan Ssenwemba, radiographer, Mbarara regional referral hospital (MRRH)).

Hand sanitizers are next to the doors before each room, however, some are empty or not present at all. (Observation MRRH)

CT room is AC'ed. (Observation MRRH)

There are several 'multipurpose' rooms. (Observation MRRH)

The hospital is hot and damp, and smelly. Windows are open so bugs fly inside. Mosquito nets are broken. (Observation, MRRH)

The walls of the pediatric ward are painted blue and are sea-themed, with fish and seahorses. (Observation, MRRH)

The flooring is level and smooth in some places, but crossing between wards requires to take small passages, ramps, and uneven terrain including mud (it was raining). (Observation, MRRH)

Muddy shoes are not cleaned before entering CT room or hospital ward. (Observation, MRRH)

The ICU looks in a good state: beds are in good states and on wheels. Equipment looks new. (Observation, MRRH)

A bed without a patient is moved across the floor. The floor has a crack in it, but the bed is moved easily across. The floor is smooth except for the crack. (Observation, MRRH)

There is one fly inside. Mosquito nets in front of windows and doors. Doors are closed and not kept open for long (upon leaving the door open after entry, it's almost immediately asked to close it by staff). (Observation, CURE)

The flooring is level and smooth with few steep ramps or doorsteps. (Observation, CURE)

The CT room door is not always closed. When coming in, patients and staff don't take shoes off or rinse hands with sanitizers. There is no doormat to clean shoes either. (Observation, CURE)

CURE is renovating a location for the MRI. There will be a permanent place for it. (Tim Erickson, Executive Director, CURE)

Rats peed on the motherboard and chewed the cables of the CT. For prevention we now put foam around these parts so that rats cannot get near them. (Tim Erickson, Executive Director, CURE)

Windows and doors had mosquito nets. However, doors were open. Mosquitos and flies inside, though not many were seen. (Observation, Holy Innocents Hospital (HIH))

People are working on laptops. Desktop

computers are also available. Desktop computers are on non-movable desks (i.e. no wheels). (Observation, HIH)

The MRI room is airconditioned. Its control room is not. (Observation, ECUREI)

The treatment facility has a ramp. (Observation, ECUREI)

The MRI is featured with a camera in the back for monitoring of the patient. It gives a livestream to the control room. (Observation, ECUREI)

The MRI room looks very clean and tidy. No loose (power) cords. All equipment neatly stored away. There is a separate closet for auxiliary equipment (e.g. coils, respirators). An oxygen supply is also present. (Observation, ECUREI)

Pricing & Cost

General pricing of treatments range between 70 000 and 1 mln. Where surgeries are between 800000 and 1 mln UGX. (Roberto, Surgical Assistant, HIH)

Some treatments are offered for free in this hospital. (Roberto, Surgical Assistant, HIH)

The cost of an MRI scan could be a maximum of 100.000 UGX (25 euros). (Karugaba James – Nursing Director, HIH)

It is approximately 120 – 200 euros per MRI scan for a patient. (Joseph Sali – Biomedical Engineer medical equipment installation and maintenance, ECUREI)

Transportation costs are a huge issue. Usually shipping is at least 90.000 euros already, then another 45.000 euros for taxes. There's 6% import taxes on medical equipment, and another 2% taxes for the regulator. (Joseph

Sali – Biomedical Engineer medical equipment installation and maintenance, ECUREI)

Cost and maintenance are the main issues. (Dr. Stephen Ttendo)

Masaka Hospital has a budget allocated of 2 BLN UGX for capital expenditures (mainly equipment and buildings). (Administrator – Masaka RRH)

Usually public hospitals have around 1.5 – 2 BLN UGX yearly budget for all capital expenditures. (Administrator – Masaka RRH)

In 2018 we spent 167 MLN on equipment. (Administrator – Masaka RRH)

Above 100 MLN UGX we ask the suppliers for quotations, and above 200 MLN UGX we do tenders.

Machines get outdated quickly, so currently we prefer contracts for placement and then a lease or subscription so that equipment is replaced when it's outdated. (Administrator – Masaka RRH)

Currently, we have no need for an MRI for brains because there are no neurosurgeons. But when we have an MRI, the neurosurgeons might be attracted. So the first step may be getting a machine here. "The presence of a machine is a stimulant to attract neurosurgeons". (Administrator – Masaka RRH)

80 MLN UGX, we can put that aside. But if we're talking about BLN UGX then no. (Administrator – Masaka RRH)

There is no experience with MRI, so training is required. We have no budget allocated for the trainings. (Administrator – Masaka RRH)

The maintenance budget is 100 MLN.

(Administrator – Masaka RRH)

We usually prefer to pay in installments. (Dr. Leonard Bantura (clinical operations manager, Kampala Hospital))

Diagnostic imaging processes

The radiographer is the one who prepares the machine and patients. Anesthetic is administered in babies that can't stay still. Usually it is administered in the CT-room. (David Mjuni, radiographer, MRRH)

Children usually go into the CT together with their mother. This is to calm the baby. The mother wears a protective vest against the radiation. The child is not often anesthetized. (David Mjuni, radiographer, MRRH)

Usually, when scanning children, the parents start helping out with preparations. (David Mjuni, radiographer, MRRH)

Currently, the hospital uses CT scans for diagnosis of hydrocephalus. This is because there are few other options. It is inconvenient to transport the patient to the hospital's only ultrasound in the pediatric ward. (Dr. Moses Ochora, MRRH)

A headrest for the child is placed on the CT bed. It keeps the child's head in a stable position. (Observation, CURE)

A mother carries her child out of the CT room as we enter. Scared look on her face. (Observation, CURE)

The CT bed is not cleaned before the next patient, only a clean blanket/sheet is laid down over it. It looks like an urgent case as the patient is moved quickly into position. (Observation, CURE)

The operator comforts the patient's head with pillows and covers him with a blanket. Contrast fluid is taken from the control room to the CT room and is administered to the patient. (Observation, CURE)

The CT room is equipped with a printer; printouts of images are laid out on the printer. (Observation, CURE)

Some patients are not in a position to move to the CT room. (Karugaba James – Nursing Director, HIH)

Mothers usually keep close to the babies to comfort them, and this keeps the babies calm while imaging so that they don't move. (Karugaba James – Nursing Director, HIH)

We use anesthetics a lot when scanning children, to keep them still. (Fred Kirumira, Administrator, ECUREI)

Problems during scanning are claustrophobia, restless patients. Adults are usually comforted by talking to them, explaining them the process. The children are often anesthetized. (Doctor Samsom Kamy Lubowa, senior radiologist, ECUREI)

Mothers usually do not go into the MRI room with the child when the child is anesthetized. The mother can panic or is nervous if she is there, because they want to know how their child is doing. (Allena, Radiographer, ECUREI)

ECG is not used for monitoring of the patient. Usually the pulseoxymeter is attached to the finger, and sometimes a device that measures breathing is attached to the abdomen. The camera is also used to see how the patient is doing. (Allena, Radiographer, ECUREI)

We have this bed on wheels to transport patients from the ward to the MRI for scanning. This is done for patients that cannot move. The bed can be swapped with the one attached to the MRI to easily place the immobile patient. (Allena, Radiographer, ECUREI)

Nurses usually prepare the patients, talk to them, instruct them, dress them properly. Then the radiographer takes over when the patient enters the MRI room and makes them comfortable on the bed. (Allena, Radiographer, ECUREI)

For children it would be good if the MRI is mobile. The movement of children may pose an issue; most children don't get scanned because they can't be moved. This is due to necessary life support and monitoring. (Fred Kirumira, Administrator, ECUREI)

There is a preference to sit during the procedure. There are a lot of cases, so standing all day would be tiresome. (Brenda kamwesigye – Radiographer)

We need to be able to see the child. (Brenda Kamwesigye – Radiographer)

During CT, lots of children need sedation to prevent movement. (Brenda Kamwesigye– Radiographer)

Currently, straps around the head are keeping the head still. Parents are usually fine with it when the procedure is explained to them. (Brenda Kamwesigye– Radiographer)

Sometimes, both sedation and straps are needed because of spasms of the child. (Brenda Kamwesigye– Radiographer)

The older children often need a bit of encouragement, and then they are willing to cooperate. (Brenda Kamwesigye –

Radiographer)

Power supply

CT is often used, but there are challenges with power supply for this device. "when power is off, you pray" (Dr. Moses Ochora, MRRH)

Batteries used as backup PSU. There is a separate room for the backup PSU. Room is AC'ed and backup PSU has active cooling fans. When power goes out; smell of diesel generator. (Observation, MRRH)

There is a need to filter out spikes in the current due to the frequent power outages to prevent the machine from breakage. This is done by a backup generator and stabilizer. There is also a battery backup. (Tim Erickson, Executive Director, CURE)

There is a dedicated backup generator for the MRI that keeps it running if the power drops. The equipment room is airconditioned because of cooling. (Allena, Radiographer, ECUREI)

Patient trust

Patients generally have a lot of trust in doctors, and therefore also in medical devices when doctors explain that it benefits their healing process. (Dr. Moses Ochora, MRRH)

Patients mostly fear medical machines such as phototherapy machines. Parents may be hesitant to put their babies in machines. Often, this is independent of looks: it's mainly because it is a 'Machine' that makes people scared. (Dr. Moses Ochora, MRRH)

Patients don't care so much about details. As long as they feel that they can trust the doctor, then they will go along with the procedures. (Edith Mbabazi Kabachelor, Director of research, CURE)

Patients trust in the doctors, as long as the doctor is willing to perform the diagnosis with a device, then the patients trust him, and they are willing to undergo the procedure. (Karugaba James, Nursing Director, HIH)

Installation and maintenance
 With some OEMs, they have maintenance contracts, with other machines they hire freelance maintenance workers. (Fred Kirumira, Director, ECUREI)

The biggest issue is the power source. The power fluctuations cause breakage. A dedicated (backup) power supply is a great plus. (Fred Kirumira, Administrator, ECUREI)

The OEMs usually provide all the education and tools necessary to install and maintain the equipment. The only problem here is cost. (Joseph Sali – Biomedical Engineer medical equipment installation and maintenance, ECUREI)

Installation costs are around 25.000 euros (for a single CT scanner), because engineers that are able to perform installation are scarce. (Joseph Sali – Biomedical Engineer medical equipment installation and maintenance, ECUREI)

We have a workshop truck that drives around hospitals to fix broken equipment. Repairs that cannot be done in a day are often taken back to the central workshop at Masaka Hospital. (Ali – Biomedical Engineer, Masaka RRH)

The workshop truck looks messy. (Observation, Masaka RRH)

Equipment is moved to the workshop truck, then it is stalled outside of the truck and often worked on outside the truck because there is more space and more comfortable. (Ali – Biomedical Engineer, Masaka RRH)

The truck carries a generator, can be connected to grid power, and has a welding generator. (Ali – Biomedical Engineer, Masaka RRH)

The repairs are assisted by suppliers/OEMs, they deliver manuals and parts. (Ali – Biomedical Engineer, Masaka RRH)

Preventive maintenance is often preferred so that the product does not break in the first place. (Ali – Biomedical Engineer, Masaka RRH)

The problem is the resources; spare parts are scarce. Also, there is no information for some machines (for repairs). (Ali – Biomedical Engineer, Masaka RRH)

The CT has operated for 7 years. Now it's hard to get spare parts because it's an old machine. (Innocent Tugume, Kampala Hospital)

There are image quality issues in the MRI because the head coil is defective. (Innocent Tugume (head of radiology), Kampala Hospital))

They have relied a lot on freelance maintenance workers but they are too expensive to continue. (Innocent Tugume (head of radiology), Kampala Hospital))

The workload for the CT scanner is very high. (Dr. Leonard Bantura (clinical operations manager, Kampala Hospital))

Currently, the x-ray tube is worn. There is no spare part available. (Dr. Leonard Bantura (clinical operations manager, Kampala Hospital))

The head coil of the MRI is malfunctioning, but unsure if this is the real problem. (Dr. Leonard Bantura (clinical operations manager, Kampala Hospital))

Manufacturing
 UIRI is the organization for prototyping partnerships with startups, and has experience with medical devices (Philippa Makobore, Dept. Head, Instrumentation Division UIRI)

A new location is about to open in January 2020 focused on larger scale manufacturing (more details to be provided). (Philippa Makobore, Dept. Head, Instrumentation Division UIRI)

Treatment
 There are regular reviews necessary for children treated for hydrocephalus because of the shunt. (Johnes Obungoloch)

Value Add
 Clinicians “want the best, so why should we settle for less”. There is a lot of skepticism from clinicians in using these kinds of devices. (Johnes Obungoloch)

If limbs and heads can be scanned, this is very valuable. Moreover, scanning adult heads makes sense, because MRI is used mainly for head traumas. Scanning small children [full body] is also valuable. (Dr. Stephen Ttendo)

If the MRI can be used to scan adult heads it will start competing with CT. (Dr. Stephen Ttendo)

“All RRHs and heavy-duty hospitals should have this [the low-field MRI].” (Dr. XXX, Ministry of Health)

The spine is a very important for MRI. (Innocent Tugume, Kampala Hospital)

A pediatric MRI is very desirable, but an MRI that only does hydrocephalus is not so much. (Jonathan Ssenwemba – Radiographer (Ultrasound))

There is a need for a device that can scan more than just hydrocephalus. For example looking at nerves. Especially helpful will be scanning of chest in infants for pneumonia, which is a frequently encountered condition. (Jonathan Ssenwemba – Radiographer (Ultrasound))

Other
 FREO2: working with it is very easy, generally no need for instructions. (Dr. Moses Ochora, MRRH) (general observation: instructions are placed on the wall next to the machine).

The control light turning green/yellow/red to indicate the FREO2's functioning works fine and is intuitive – well understood by personnel. (Dr. Moses Ochora, MRRH) (about the FREO2, a new oxygen supply system)

Some cases of hydrocephalus come in late, and the head has expanded significantly. (Edith Mbabazi Kabachelor, Director of research, CURE)

CT scanners last around 10 years, at least 7 years. The MRI should at least last 7 years. (Tim Erickson, Executive Director, CURE)

The CT scanner has been here for 7 years and has operated without breakdowns until now. (Innocent Tugume (head of radiology), Kampala Hospital))

Radiologists already travel between hospitals because they are scarce. If the MRI is easily operable and image is easily interpretable then it's a big plus, so you no longer need

specialists. (Karugaba James – Nursing Director, HHH)

MRI would make it easier to diagnose hydrocephalus, since images can be read more easily. (Michael Kawooya, Professor Dept. of Radiology at School of Medicine, Makerere University)

The MRI device will only have a benefit over Ultrasound in hydrocephalus diagnosis if the MRI can be functional MRI. (Michael Kawooya, Professor Dept. of Radiology at School of Medicine, Makerere University)

A mobile system might be preferred so that movement between hospitals is possible. Sometimes there are announcements of treating a specific condition at a specific time at a specific hospital, so that people can come from that region to the hospital for treatment. The same could be done with this MRI. (Dr. Johnes Obungoloch)

A plug and play solution is the desired solution. (Dr. Stephen Ttendo, MRRH)

The administration of oxygen should be enabled in the room where the MRI stands. This is currently difficult because of high magnetic field strength. (Dr. Stephen Ttendo, MRRH)

Sometimes roads are bad. One time, we couldn't transport oxygen cylinders because it had rained. (Dr. Johnes Obungoloch)

For importing parts, contact the URA. (Innocent Tugume (head of radiology), Kampala Hospital))

Software licenses is a problem. It stops working. We don't have new licenses. (Innocent Tugume

(head of radiology), Kampala Hospital))

Work with HHI (investment company) from the Netherlands. (Dr. Leonard Bantura (clinical operations manager, Kampala Hospital))

Currently have 6 senior radiologists, 1 interventional radiologist, 8 radiographers. (Dr. Leonard Bantura (clinical operations manager, Kampala Hospital))

Currently, the machines are the bottleneck for the workload; they don't work well. (Dr. Leonard Bantura (clinical operations manager, Kampala Hospital))

APPENDIX D

FEM-ANALYSIS OF 40X40 MM ALUMINIUM EXTRUSSION

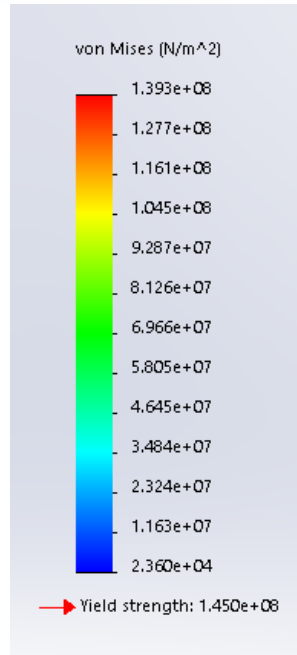
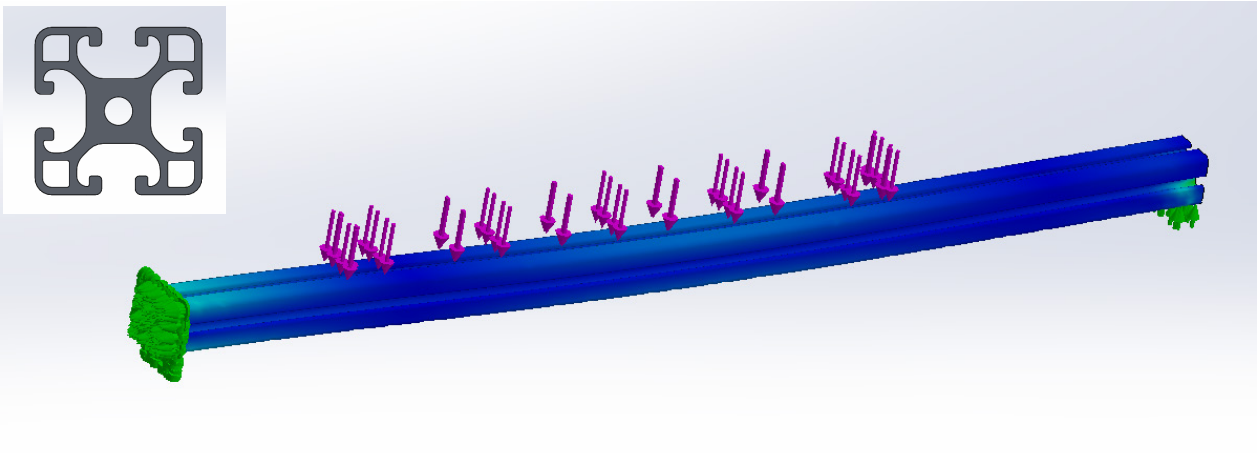

Figure X. FEM-analysis of support profile under magnet. Left graph shows internal stress. Load (purple arrows): 1200 N. Fixtures (green arrows): fixed (left), roller/slider (right).

