

THE BRIDGE MARKER KEY AUTOMATIC
SWITCHING SYSTEM

3/147

THE BRIDGE MARKER KEY AUTOMATIC SWITCHING SYSTEM

PROEFSCHRIFT
TER VERKRIJGING VAN DE GRAAD
VAN DOCTOR IN DE TECHNISCHE WETENSCHAP
AAN DE TECHNISCHE HOGESCHOOL TE DELFT
OP GEZAG VAN DE WAARNEMEND
RECTOR MAGNIFICUS IR J. A. GRUTTERINK,
HOOGLEERAAR IN DE AFDELING DER MIJNBOUWKUNDE,
VOOR EEN COMMISSIE UIT DE SENAAT
TE VERDEDIGEN OP WOENSDAG 28 MEI 1947
DES NAMIDDAGS TE 4 UUR

DOOR

ROELOF MAARTEN MARIE OBERMAN

WERKTUIGKUNDIG EN ELECTROTECHNISCH INGENIEUR

GEBOREN TE LEIDEN



'S-GRAVENHAGE • ALGEMENE LANDSDRUKKERIJ

1947

1023240

DIT PROEFSCHRIFT IS GOEDGEKEURD DOOR
DE PROMOTOR
PROF. DR IR W. T. BÄHLER

ERRATA

- pag. 2.7 onderschrift fig 2.9, regel 2, tot; lees: to
- pag. 2.12 onderschrift fig 2.14; lees: is between + or — 1 volt.
- pag. 2.14 regel 14 v.o.; lees: The input tube B_1 is non conducting when
 the control wiper gives a negative voltage to
- pag. 2.15 De draadkruising boven de anode van de buis B_1 in fig 2.16
 maakt contact.
- pag. 3.2 regel 11 v.o. contact a; lees: contact a^1
- pag. 3.3 fig 3.3; rustcontact cr_2 ; lees: cr^5
- pag. 4.2 regel 11 v.o. acces; lees: access
- pag. 4.5 regel 19 a; lees: are
- pag. 5.3 regel 4 point; lees: points
- pag. 5.5 regel 14 v.o. operetes; lees: operates
- pag. 5.5 regel 10 v.o. lees: can be replaced by
- pag. 5.6 regel 9 v.o. Brigde; lees: Bridge
- pag. 5.8 regel 9 line; lees: lines
- pag. 5.11 regel 1 acording; lees: according
- pag. 6.3 regel 3 ebing; lees: being
- pag. 6.3 regel 19 tions; lees: ions
- pag. 6.3 laatste regel operators; lees: operators
- pag. 7.6 regel 6 v.o. subscriber's; lees: subscribers
- pag. 8.6 regel 10 subscriber's; lees: subscribers.
- pag. 10.1 regel 10 v.o. ng; lees: ing
- Stelling VII regel 2; lees: tijdens de ontvangst
- Stelling XI regel 2; beiden; lees: opdrachtgever en uitvinder

Aan de nagedachtenis van mijn Vader

Aan mijn Moeder en mijn Vrouw

Aan Ir J. D. Tours

1

INTRODUCTION

2

THE WHEATSTONE BRIDGE

3

THE CONTROL OF SELECTORS AND FINDERS

4

THE SUBSCRIBER'S LINE CIRCUIT

5

THE TRANSMISSION OF SELECTING CRITERIA BY MEANS OF
BRIDGE MARKINGS

6

PBX LINES

7

THE CORD CIRCUIT AND THE REGISTER

8

SMALL AND BIG EXCHANGES

9

CONCLUSIONS

10

SUMMARY

THE BRIDGE MARKER KEY AUTOMATIC SWITCHING SYSTEM

1.

INTRODUCTION

In different countries during the last few years, new developments of automatic switching have come into being in the field of automatic telephony and telegraphy as well as in telemechanics. It is remarkable that in these developments the principles are based on the same ideas. In this thesis however only the development will be dealt with which has been made in the Laboratories of the Netherlands P.T.T. on this subject of new automatic switching systems.

The usual automatic telephone switching systems can be divided into two main groups:

- a. The step-by-step systems with selectors which are positioned directly by the dialled impulses.
- b. The register systems with storage of the series of dialled impulses before the selectors are positioned under the control of the stored impulses re-emitted by the register.

The whole development, which is described hereafter, is specially made for register systems.

The first part has reference to the positioning of a uniselector of a type which in an anterior system cannot be directly positioned by a series of impulses. Initially a trial was made to avoid this exchange of impulses by using alternating current of given voice frequencies. At that time it was not possible with the available means to find a practical solution.

It was already known how to control a selector in different selecting stages by a register with the aid of normal direct current markings and normal test relays with the restriction that no other registers simultaneously controlled other selectors. The control of more than one group selector at the same time could cause faulty connections in that system. A first solution of the problem mentioned was obtained by removing the cause of the wrong positioning of the group selectors.

It proved possible to concentrate in the register all important functions of the control of group and final selectors so that all selector circuits became equal, necessitating one or two relays only. This means an important simplification in the construction of an exchange versus only a minor complication of the registers. A telegraph switching system has been fitted up for trial with this system.

The designed system however did not give complete satisfaction. It was abandoned as it appeared that much greater possibilities in the control of selectors and finders could be obtained by the use of direct current Wheatstone Bridges notwithstanding the complication in the register caused by high vacuum tubes with filaments. The control of line finders, group selectors and final selectors in this system can also be concentrated in the register; the above discussed advantages accruing from the identity of the group and final selector stages may also be fully realised when applying Wheatstone Bridge direct current circuits.

It appeared from an investigation, that the principle of the application of the Wheatstone Bridge on automatic switching systems had been known for a long time. Thomas Lenaghan described in the U.S. patent 1.472.604 (application filed April 28, 1920) a switching system with a characterising of the selector outlets with resistances, which are successively connected by the control wiper to one winding of a differential relay. The other winding of this relay is connected to one of the selecting resistances in the subscriber's set. The selector is stopped by demagnetising the differential relay when the control wiper tests the corresponding resistance.

John E. Gardner described in the U.S. patents 1.736.259, 1.736.283 and 1.761.115 (applications filed in 1927) an improved telephone switching system based on the same principle as the hereabove mentioned U.S. patent 1.472.604. All these systems were not practical, for the detection of the bridge balance was always executed by means of differential relays or marginal effects. This problem however only can be solved in a practical manner when using modern high slope high vacuum tubes.

The second part of the development refers to the subscriber's line circuit. In the existing systems this circuit normally contains a line relay, which attracts its armature when the subscriber initiates a call, and a cut-off relay which disconnects the line relay after the line finder or the final selector has been positioned.

The British patent 474.990 (1935) first shows the possibility of designing a subscriber's line circuit with rectifiers and resistors only. The Bell Telephone Mfg Co improved on this system. The rectifiers and the resistors can be assembled in a little plug for the strips in the horizontal side of the main distributing frame. This means a big space saving in switching equipment without any increase in the size of the main distributing frame.

The subscriber's line circuit with resistors and rectifiers fits in exactly with the positioning of selectors and finders by means of the balance of direct current Wheatstone Bridges. It proved possible to give special properties to the said line circuit, which

are based in the same way on the application of the Wheatstone Bridge. These properties, as for example, that a subscriber's line is immediately engaged when a call is initiated or the attaching of special features to the subscribers, are of great importance in a modern automatic switching system.

The third part of the development concerns the transmission of the selecting criteria from the subscriber's set to the register of the automatic exchange. In the usual systems this is done with trains of impulses consisting of regular interruptions of the current in the line between the subscriber's set and the automatic exchange by the dial contact. For this purpose also it is possible to avoid dialling pulses and to transmit the selecting criteria of the subscriber with the aid of the balance of direct current Wheatstone Bridges. The subscriber's set then no longer has a dial, the speed of which has to be adjusted within certain limits, but a simple keystrip to connect different resistances in the subscriber's line.

John E. Gardner described in the U.S. patent 1.982.290 (application filed December 24, 1927) a remarkable receiver with ten tubes and ten differential relays and a variation with one tube and ten differential relays for the receiving of selecting criteria transmitted by means of the balance of Wheatstone Bridges. These circuits however are not well suited for practical application because of a too extensive use of marginal effects.

Some circuits developed for this purpose, not using marginal effects, will be described hereafter. The selecting criteria are stored in combinations of four relays. With these receivers it is possible to transmit a maximum of 20 digits per second against an average of 1 per second in dial systems.

Further it has proved possible to apply the system to very small exchanges belonging to a main exchange in a rural automatic network as well as to very big trunk exchanges. This makes the new system suitable for all applications throughout a completely automatised network. The system, explained hereafter, uses only the balance of direct current Wheatstone Bridges for all possible purposes throughout the complete switching system, as for instance the control of selectors and finders, the call detection, the characterising of different kinds of subscribers, the transmission of selecting criteria, etc.

THE WHEATSTONE BRIDGE

The principle of the application of the self adjusting Wheatstone Bridge to the positioning of selectors and finders in telegraph and telephone switching systems is shown in fig 2.1. The bridge circuit consists of two branches each having the resistances R_1 to R_4 . The two branches are connected with the battery V_1 . The connection points of the resistances with corresponding numbers have equal or approximately equal voltages.

A subscriber controls the position of the marking switch MS in a way not shown. The wiper of the marking switch indicates a certain voltage. After positioning the preceding selectors (not shown), the driving magnet DM of the selector S is magnetised. The wiper of the selector moves and tests successive voltages as determined by the resistances R_1^1 to R_4^1 .

A zero voltage discriminator ZS, which is called a „zero switch”, is connected to the points A and B of the bridge circuit. The zero switch interrupts the circuit of the driving magnet DM by the contact t and stops the selector S in the wanted position when the wiper tests a contact having a voltage equal or approximately equal to that indicated by the marking switch MS.

The principle shown can be developed in different ways and applied to different functions of telegraph and telephone switching systems.

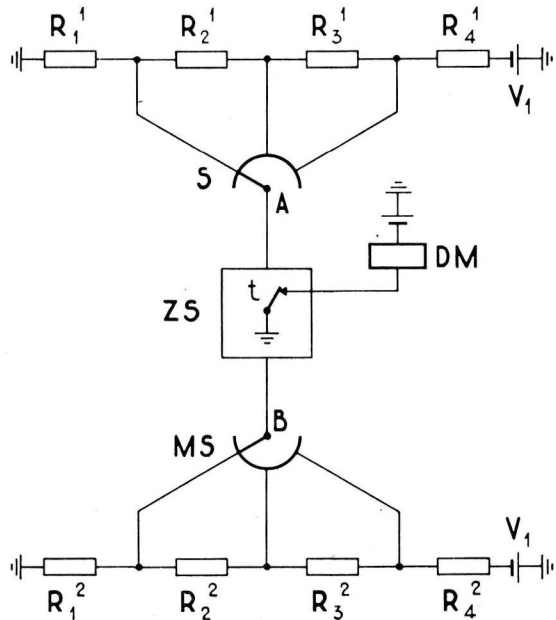

Fig. 2.1 Principle of the application of the self adjusting Wheatstone Bridge to the positioning of selectors and finders.

2.2

The principle according to fig 2.1 concerns the positioning of a selector or a finder in one exchange. With a slight variation it can be applied also to the positioning of a marking switch in a register by the subscriber. The principle is shown in fig 2.2.

The resistances R_{1-n} are now located in the distant subscriber's telephone circuit. The remaining part of the diagram shows part of the register. The bridge circuit is in

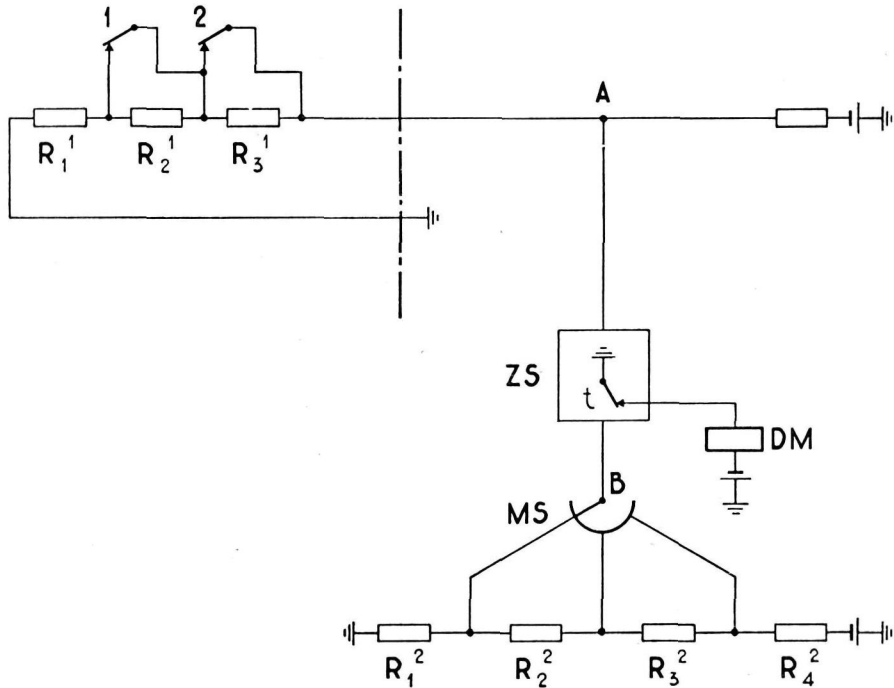

Fig. 2.2. Principle of the application of the Bridge Marking principle to the positioning of a marking switch in a register by a subscriber.

balance in the position shown. The circuit of the driving magnet DM is interrupted. The balance of the bridge circuit is disturbed by inserting one of the resistances R_1^1 to R_3^1 of the subscriber's circuit into the line. This closes the circuit of the driving magnet DM of the marking switch MS. The control wiper moves over the contacts until bridge balance is again obtained, resulting in the interruption at contact t of the driving magnet DM circuit by the zero switch. The subsequent marking switch is connected in a way not shown to the bridge circuit when the depressed key in the subscriber's set is released. The registration of the next selecting criterion can follow.

The possibilities of the application of the principles here above mentioned to the positioning of selectors, finders and marking switches depend entirely on the construction of the zero switch ZS. This apparatus must have several special features.

2.3

- a. The input resistance has to be so high, that different selectors can test a control voltage at the same time without disturbing this voltage. The control voltages of other selector outlets must not be disturbed by the test of an outlet when the control voltages of the different selector outlets are obtained from the same voltage divider.
- b. Small voltage differences for instance of two volts must be detected with safety to give a sufficient number of markings. The developed system needs at least 20 different markings, so that to give some reserve, 24 marking or control voltages are provided, giving in a 48 volts system, voltage differences of 2 volts.

An extensive investigation has been made in circuits for zero switches using high vacuum electronic tubes. The simplest design of a zero switch is shown in fig 2.3. The switch contains one high vacuum tube B_1 with relay TR in it's anode circuit. If the control voltages to be tested by the wiper of the selector S in fig 2.1 are arranged in such a way that with respect to point A of the zero switch, point B gets a decreasing negative voltage during the movement of the wiper over the contacts, the testing tube B_1 is sufficient conductive and magnetises a test relay to stop the movement of the wiper when testing the contact with zero or approximately zero voltage with respect to the marking voltage. The input voltage of the zero switch can also have a slight positive value due to inaccurate resistances in the bridge circuit. In order to protect the testing tube B_1 in this case against overloading and to assure a sufficiently high input resistance, a resistance of 10^6 ohms is connected in the wire to the control grid.

The tube in this diagram associated with the testing facility is used principally in a different way from that used in normal amplifier practice. The working point is at zero volts control grid voltage and no amplification of voice frequencies is used as the tube functions only as an electronic relay.

As can be seen from the input voltage/anode current characteristic of a pentode tube EFF 50 in fig 2.4 the anode current remains practically constant with high anode resistances, even for high positive input voltages.

The protection of the test circuit tube against overloading due to positive voltages on the control grid can be improved with the circuit of fig 2.5. The diode D_1 is connected in the wire to the control grid in the place of the resistance R_2 in fig 2.3. The resistance R_2 , of 10^6 ohms now is connected between the control grid and the cathode of the tube B_1 .

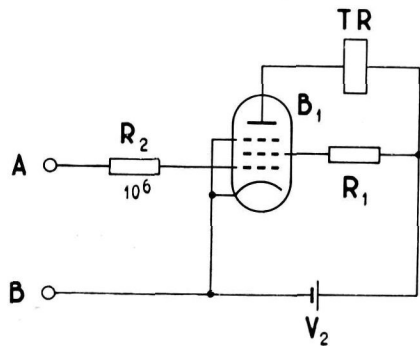

Fig. 2.3. Simplest zero switch.

2.4

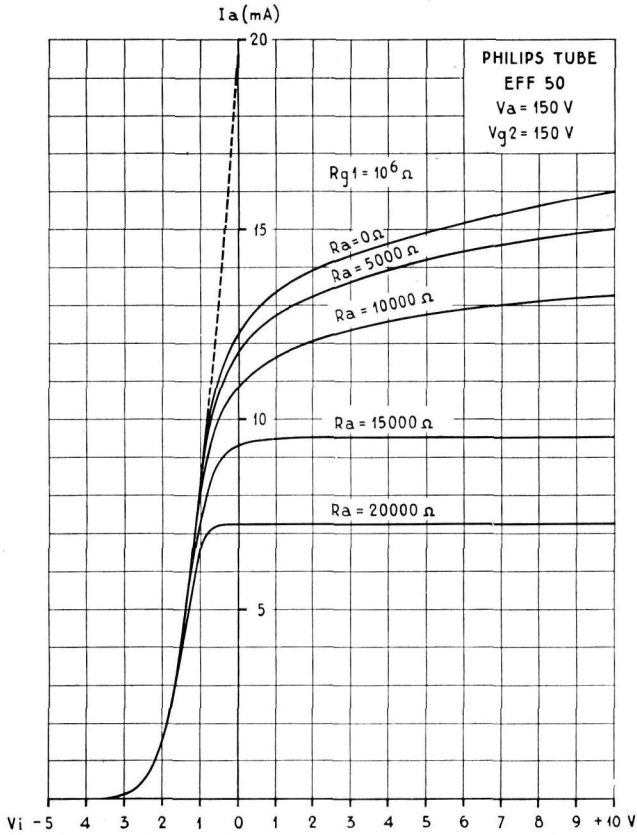

Fig. 2.4. Input voltage/anode current characteristic of a zero switch according to fig. 2.3. The anode current of the pentode remains practically constant with high anode resistances, even for high positive input voltages.

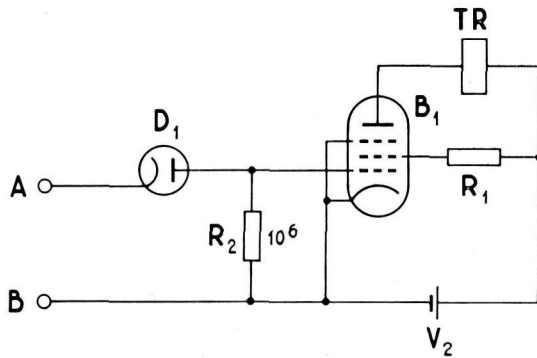

Fig. 2.5. Zero switch circuit with a diode as a protection of the testing tube against overloading due to positive input voltages.

The input voltage/anode current characteristic of this circuit for the pentode tube EFF 50 is shown in fig 2.6 as a full line. The broken line shows the normal static characteristic of this tube. The introduction of the diode has the effect that the static characteristic of the tube is shifted by the amount of the direct current voltage drop across the diode the characteristic becoming exactly horizontal at zero input voltage and remaining so up to the highest positive input voltages.

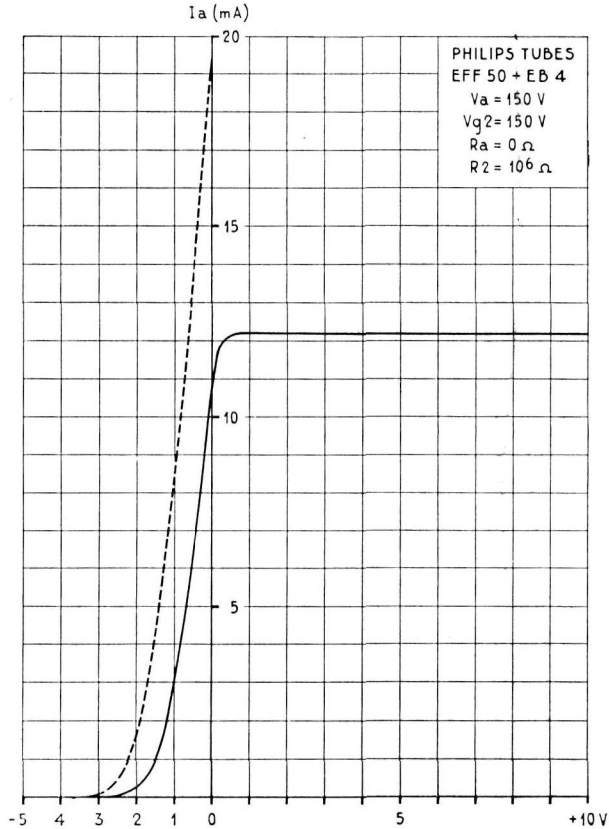

Fig. 2.6. Input voltage/anode current characteristic of the zero switch according to fig.2.5. (full line). The characteristic becomes exactly horizontal at zero input voltage and remains so up to the highest positive input voltages. The broken line shows the normal static characteristic of the testing tube.

remaining so up to the highest possible input voltages. The anode current of the testing tube B₁ thus remains exactly constant from zero volts up to the highest admissible positive input voltage.

The circuit element according to fig 2.5 is suitable for all the applications to be described hereafter. The resistances of 10⁶ ohms in the wires to the control grid of the

tubes shown in the following figures may with advantage be replaced by diodes. The characteristic of fig 2.6 may be shifted by connecting a small voltage source in series with one of the input leads. A shift to the left gives the effect that the anode current of the testing tube remains constant with slight errors in the bridge balance due to inaccurate resistances determining the control and marking voltages. The speed of

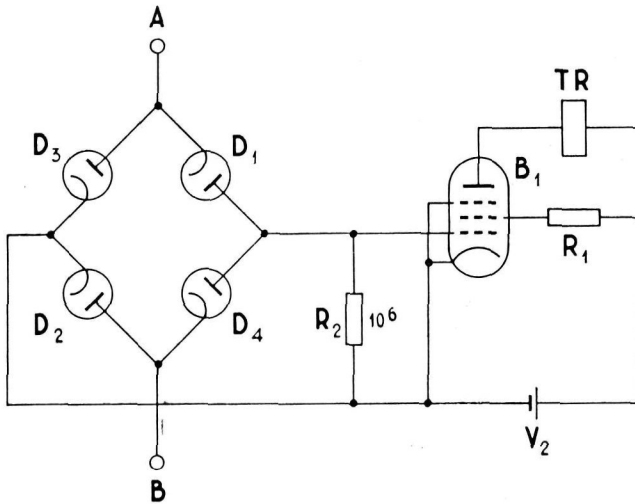

Fig. 2.7. Zero switch circuit for the test of one determined voltage. The diodes are connected in such a way that the control grid voltage of the testing tube B_1 always remains negative.

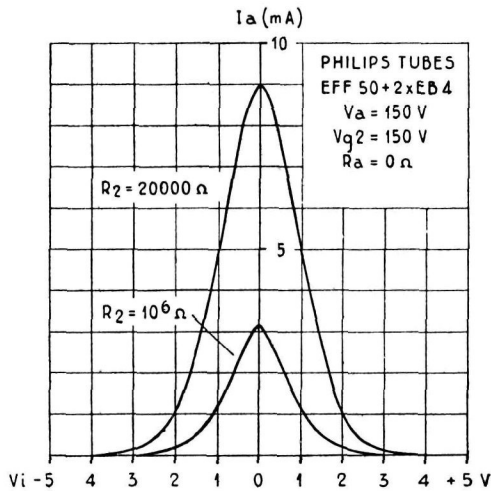

Fig. 2.8. Input voltage/anode current characteristic of the circuit according to fig. 2,7.

operation of the test relay, which interrupts the selector movement, cannot then be influenced by variations of the resistance values determining the control voltages.

The circuits according to the figures 2.3 and 2.5 may only be used as zero switches when a control wiper of the switch e.g. a uniselector, tests the control voltages in ordered sequence from high negative input voltages to zero volts on point A of the zero switch. This will normally only happen when using the Wheatstone Bridge according to the principle shown in fig 2.2. It will also happen for the positioning of first line finders, for the control wiper then has only to test one determined voltage characterising a calling subscriber's line.

The circuit of the zero switch has to be changed for the control of group selectors and final selectors. The zero switch has to test one determined voltage when controlling selectors and

must remain insensitive for all other control voltages giving a negative or a positive input voltage. In principle this is possible with the circuit shown in fig 2.7. The diodes D_1 to D_4 are connected in such a way that the control grid voltage of the testing tube B_1 always remains negative, so that the input voltage/anode current characteristic of the circuit is of the shape shown in fig 2.8.

The first trials with the Wheatstone Bridge control of selectors were made with a circuit according to fig 2.7. The circuit did not contain a test relay TR, but was coupled with a thyatron circuit for the electric control of the selectors (Siemens and Halske motor uniselectors).

Apart from the less favourable form of the curve (fig 2.8) the circuit had this unsuitable characteristic, that with the bridge in balance the cathode of the testing tube B_1 is earthed via a high but indeterminate resistance and via the low resistances, not shown, determining the marking or control voltages. This probably caused the thyatron circuit coupled with the zero switch to be sensitive to disturbances from outside.

Better results were obtained with the circuit having the cathodes of the high vacuum tubes directly connected to one of the input leads. The circuit is shown in fig 2.9. This zero switch contains two testing tubes B_1 and B_2 with the cathodes connected together

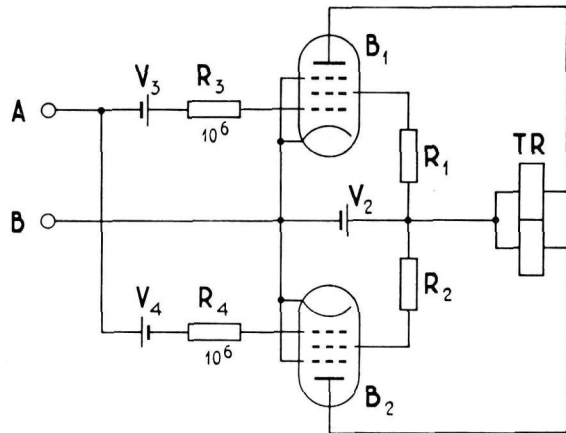

Fig. 2.9. Zero switch circuit with two testing tubes. The anode current characteristics of both tubes are shifted with respect to each other with the aid of the auxiliary voltages V_3 and V_4 . The testing tube B_1 only becomes conducting on bridge balance.

to one input lead and the control grids respectively connected via the auxiliary voltage sources V_3 and V_4 to the other input lead. The anode circuits of both tubes each contain a winding of the differential relay TR. The anode current characteristics of both tubes are shifted with respect to each other, as shown in fig 2.10, with the aid of the auxiliary voltage sources V_3 and V_4 . The testing tube B_1 becomes conducting on a small negative input voltage and the tube B_2 becomes conducting on a small positive input voltage. The differential relay TR attracts its armature by magnetising the winding in the anode circuit of the testing tube B_1 whenever the zero switch finds bridge balance. The test relay TR cannot attract its armature on zero switch input voltages more negative than a determined small negative value, both testing tubes then being in a non conducting condition. Both testing tubes are conductive on input voltages more positive than a determined small value. In these circumstances relay TR cannot attract its armature as both windings are equally but oppositely magnetised. A circuit according to fig 2.9 has been tried out in conjunction with a thyatron circuit for the electrical control of selectors.

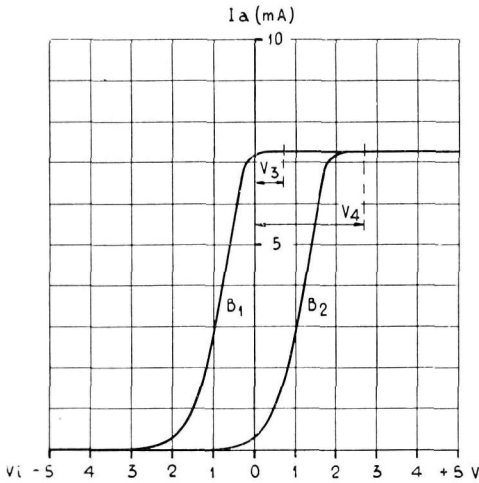

Fig. 2.10. Shifted characteristics of the two testing tubes of the zero switch according to fig. 2.9. The differential test relay attracts its armature only when the testing tube B_1 becomes conducting.

The thyatrons are an unsatisfactory element in this kind of circuit because of their property of remaining conductive after they have been once ionised by a disturbance. This property is common to all kinds of gasfilled tubes.

The construction of high speed test relays with differential windings is difficult and the use of gasfilled tubes is undesirable. Therefore a zero switch circuit has been developed using, inter alia, similar high vacuum tubes and a high speed test relay with one winding. Before describing this circuit, fig 2.11 has to be explained.

The circuits according to figs 2.3 and 2.5 do not allow a discrimination between voltages only differing slightly. It is necessary however to make this discrimination very sharp. This can be done with the circuit according to fig 2.11. The anode of the testing tube B_1 is connected to the positive pole of the battery V_2 via the anode resistor R_2 and also to the negative pole of the battery V_3 via the voltage divider consisting of the high resistances R_3 and R_4 . The voltage of battery V_3 is approximately equal to that of battery V_2 . When point A of the circuit is sufficiently negative with respect to point B the testing tube B_1 is non conducting. The voltage of point a_1 is then nearly equal to

that of the battery V_2 . The voltage of point b of the voltage divider, consisting of the resistors R_3 and R_4 , can be made to be positive with respect to the cathodes of the tubes by appropriate choice of the values of the resistors. The anode voltage of the tube B_1 varies according to the characteristic a_1 in fig 2.12 by reduction of the input voltage of the circuit. The resistors R_3 and R_4 connected with the battery V_3 can be dimensioned

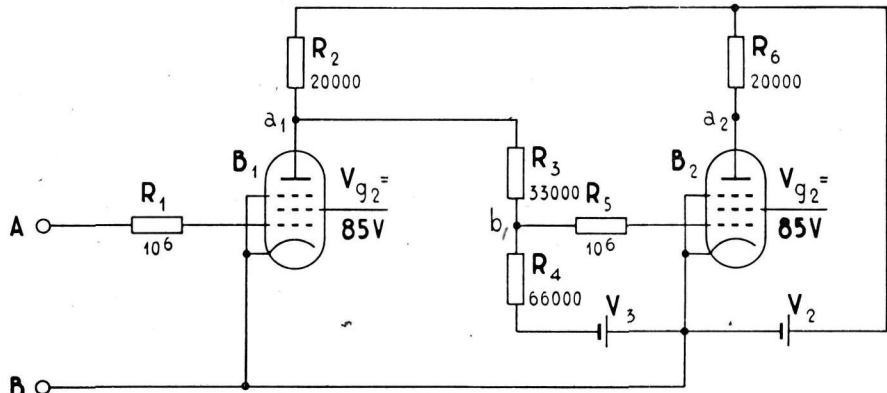

Fig. 2.11. Amplified zero switch circuit.

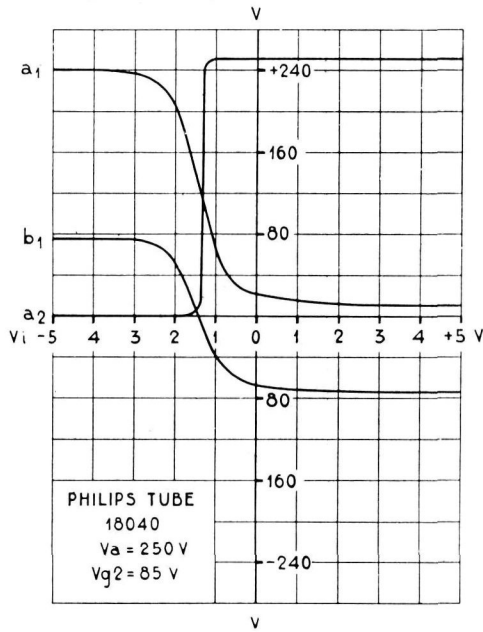

Fig. 2.12. Input voltage/anode current characteristics (a_1 and a_2) of the amplified zero switch circuit. The anode voltage a_2 of the final tube changes in a small input voltage interval from a small to a high value.

in such a way that the voltage of point b with respect to the cathodes, (tube B_1 being conductive) is equal to, but of opposite polarity to that with the tube B_1 in a non conducting condition. The voltage of point b is, at the same time, the control grid voltage of the final tube B_2 . The voltage of point b becomes in a small interval of the input voltage (at about -1 volt) sufficiently negative to render the final tube non conducting. The voltage a_2 of the tube B_2 will also change in a small interval of the input voltage from a small to a high value.

The circuit according to fig 2.11 gives the possibility, as is shown in fig 2.12, of making a very sharp discrimination between the various input voltages.

The selector control zero switch, which has to test the control voltages in an arbitrary sequence, is shown in fig 2.13. This circuit, an extension of that according to fig 2.11, gave excellent results during the trials.

The tubes B_1 and B_2 have in principle the same function as those shown in fig 2.9. The anode voltage characteristic a_1 of the tube B_1 is shown in fig 2.14 as a function of the input voltage of the circuit. Tube B_3 merely reverses the phase of tube B_1 . This can be done by connecting point b_1 to the cathode lead via a relatively low resistance (R_6) and by giving slightly different values to the resistances R_4 and R_5 as compared with

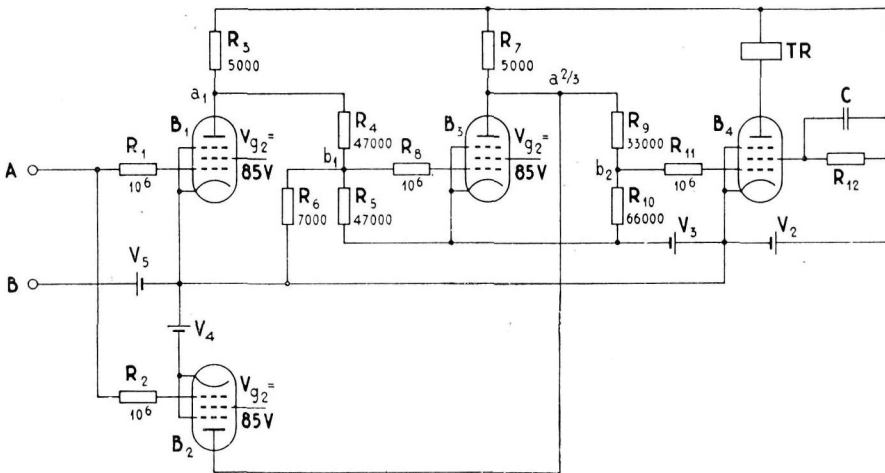

Fig. 2.13. Amplified zero switch circuit for the test of one determined voltage. The anode voltage of the testing tube B_2 and that of the tube B_3 (reversed anode voltage of testing tube B_1) together control the final tube B_4 which has a normal test relay in the anode circuit.

the amplifier circuit. The values are shown in the diagram. The resistances R_4 , R_5 and R_6 in the anode circuit of the tube are dimensioned in such a way that the control voltage of the tube B_3 (curve b_1) gives an anode voltage graph ($a_2/3$), which is the reverse of the same graph of tube B_1 with corresponding input voltages (-2 to zero volts).

The anodes of the tubes B_2 and B_3 are connected together and with the voltage divider consisting of the resistors R_9 and R_{10} . With the aid of the voltage sources V_4 and V_5 the graph of tube B_2 is shifted with respect to that of tube B_1 in such a way that the tube B_2 becomes conducting when changing the input voltage from zero to $+2$ volts. The anode voltage of this tube then changes according the right hand part of the graph a $2/3$ shown in fig 2.14.

The voltage of the connected anodes of the tubes B_2 and B_3 controls a final tube B_4 via a resistance circuit as described in fig 2.11. The curve a_4 in fig 2.14 shows the anode voltage characteristic of the final tube B_4 as a function of the input voltage of the zero switch. Anode current only flows in the final tube when the input voltage of the zero switch is between $+1$ or -1 volt.

A circuit according to fig 2.13 has been made with Philips tubes type 18040 (fig 2.13A)¹⁾. The voltages V_4 and V_5 in this circuit were produced from the battery V_3 with the aid of resistances. All screen grid and anode voltages, except those of the final tube, were stabilised. The voltage of the filament was not stabilised. The characteristic of the anode current of the final tube B_4 as a function of the input voltage of the zero switch for various mains voltages is shown in fig 2.15. This characteristic remains practically constant. The variations in the anode current of the final tube can be removed by stabilisation of the anode voltage of this tube.

The tubes 18040 have a normal anode current of 20 mAmps. This is too small to magnetise a high speed testing relay. However it is possible to generate an anode current peak in the final tube by shunting the screen grid resistance in fig 2.13 with a condenser. The final tube then has, in the first moment after becoming conducting, a high screen grid voltage, which decreases subsequently

¹⁾ In the latest development this zero switch circuit contains two tubes.

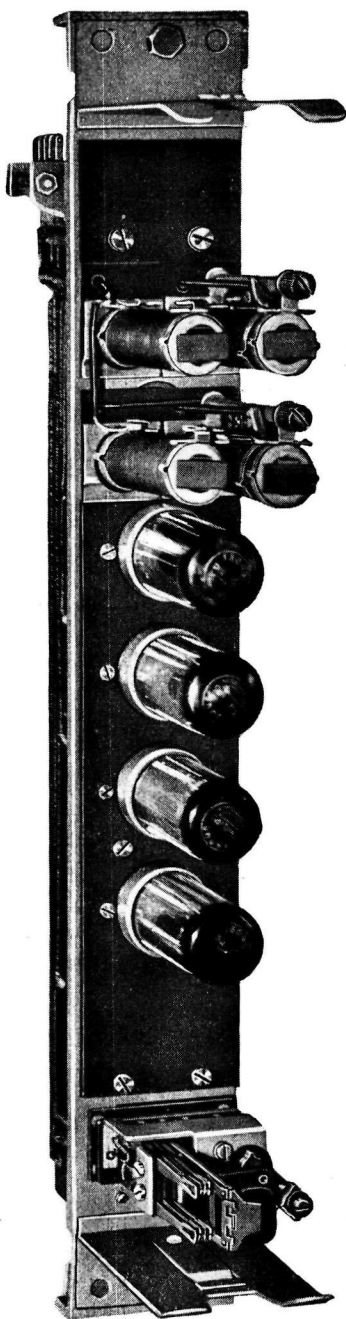

Fig. 2.13a. Zero switch.

due to the charging of the condenser to the value determined by the screen grid resistance.

A number of variations in the zero switch circuits can be made when using tubes with a build-in diode according to the diagram of fig 2.5. Philips Radio Ltd made some of those tubes on special request.

The circuit according to fig 2.13 works, as is shown in the characteristic, for input voltages between + and - 1 volt. These limits can be adjusted and varied according to the desired application. The voltages, which are indicated by the marking switches in the register, can be fixed accurately. When using voltages at intervals of 2 volts for the control voltages, the battery having the nominal voltage, the voltages actually tested by the control wiper of a line finder or a selector may vary + or - 1 volt due to

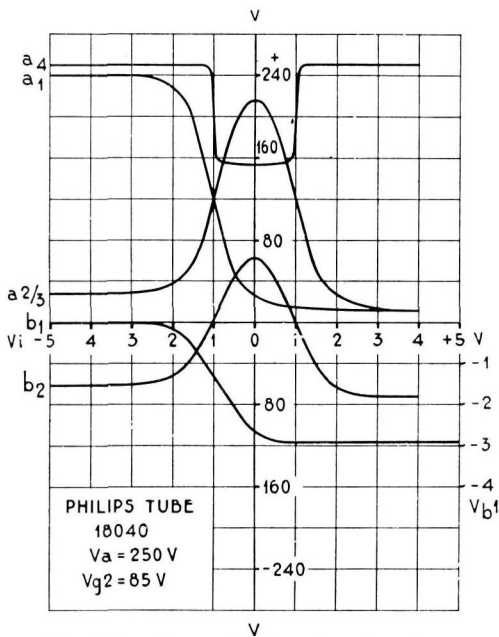

Fig. 2.14. Input voltage/anode voltage characteristics (a_1 , $a_{2/3}$ and a_4) of the tubes B_{1-4} of the circuit according to fig. 2.13. Anode current flows in the final tube when the input voltage is + or - 1 volt.

to inaccuracies in the resistances determining the control voltages. Variations in the battery voltage have a slight influence notwithstanding the use of a bridge method. The working limits of the zero switch do not change with the battery voltage. This fact has to be taken in account when determining the maximum errors in the resistors. The maximum deviation in the control voltages has to be chosen for instance at + or - 0,9 volts, with voltage intervals of 2 volts and nominal battery voltages. It is also possible to derive the working limits of the zero switch from the battery giving the control voltages.

The zero switch developed can be applied without alteration to the positioning of selectors and finders having control wipers moving practically without interruption from one contact to another. Unfortunately the zero switch comes into action when the control wiper is not connected to a contact for

the length of time the wiper is moving from one contact to another. An admissible maximum for this interruption of the circuit of the control wiper may be about 0.1 millisecond when using high speed test relays with a switching delay at the break contact of 0,5 milliseconds, as it is necessary for the control of motor uniselectors (Siemens Brothers) with a speed of 200 steps per second or more. No interruption in

the control circuit is admissible when using an electrical selector control by means of thyratrons. The thyratrons fire on the slightest interruption in such a circuit.

The motor uniselectors of Siemens Brothers and Siemens and Halske have two types of wipers namely bridging and non bridging wipers. The second type of wipers may be used in conjunction with the zero switch as developed. All contacts of the control bank then have to be connected to a definite control voltage.

When using non bridging wipers special measures are necessary to hold the zero switch in the position of rest during the time the control wiper moves from one contact to another. In principle this can be done by connecting point A of the zero switch or the wire to the control wiper of the moving selector or finder via a high resistance, the restart resistance, with one of the poles of the battery giving the control voltages. The input of the zero switch is then connected to earth via a low resistance during the time the control wiper tests a contact. The voltage connected to the input via the high restart resistance then cannot influence the zero switch. This voltage however holds the zero switch in a normal condition when the control wiper moves from one contact to another. It is not necessary in this system to connect all contacts of the control bank of the selectors and finders to a control voltage.

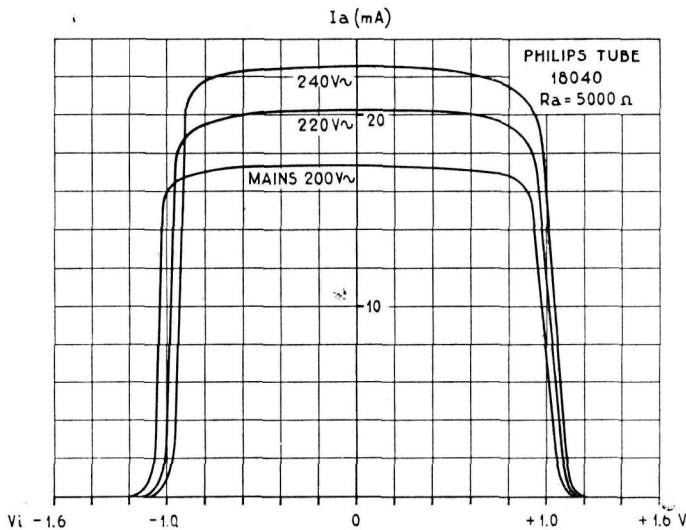

Fig. 2.15. Anode current of the final tube as a function of the input voltage of the zero switch (fig. 2.13).

The restart resistance has another important function in the control of selectors and finders with non bridging wipers. It is possible that the zero switch will operate on a contact which becomes free just before the control wiper leaves it. The selector can then stop with the control wiper between the contacts if neither a restart resistance nor a mechanical centration of the wipers is used. At the moment the control wiper

leaves the contact, the restart resistance brings back the zero switch to the condition of rest. This restarts the selector.

It is preferable to provide the selectors and finders with a mechanical centration device so that no stopping on intermediate positions of the wipers is possible.

The elementary restarting circuit as described above, can give difficulties when the control wiper tests control voltages giving to the zero switch input voltages of opposite polarity to the voltage connected with the restart resistance. The restart voltage brings the zero switch from one rest position with the two testing tubes in a non conducting condition through the working condition, into the other with both the tubes in a conducting condition during the time the control wiper moves from one contact to another. This transition through the working condition is relatively slow. The transition time is determined by the values of the restart resistance and the capacitance of the cable between the zero switch and the control wiper. The short working time of the zero switch may cause difficulties, especially in systems with full electronic control.

The solution of these difficulties may be obtained by automatically changing the polarity of the voltage source connected with the restart resistance under the control of that of the input voltage of the zero switch. Fig 2.16 shows the principle of a zero switch with an automatic change of the restart voltage.

The input tubes B_1 and B_2 are connected according to fig 2.13. The other tubes of the normal zero switch are not shown in fig 2.16. The anode of tube B_1 is connected to a control grid of tube B_3 in the same way as is described for the coupling of the testing tube B_1 and the final tube B_2 in the amplifier circuit of fig 2.11.

The anode circuit of tube B_3 is connected to a voltage divider (R_2/R_3), the other side being connected to the negative pole of the battery V_3 . The shunt point is connected to point A of the input of the zero switch via the restart resistance R_1 .

The input tube B_1 is conducting when the control wiper gives a positive voltage to point A of the zero switch with respect to the marking or reference voltage connected to point B. The tube B_3 is conducting in that condition of the zero switch. Point X of the circuit then has a positive voltage with respect to the cathodes of the tubes, which are connected to point B of the circuit. When the control wiper of a selector or finder moves between two contacts giving a positive input voltage to point A of the zero switch the input voltage remains positive due to the restart voltage of point X having the same rest condition.

When the zero switch tests a contact having reversed polarity, the change from one rest condition to the other is so rapid that no difficulties occur since all resistances of the control voltage dividers have small values compared with the restart resistance. The testing tube B_1 then becomes non conducting, the tube B_3 becoming conducting. The resistors R_2 and R_3 have the same values as those in the amplifier circuit of fig 2.11. The restart voltage of point X reverses from negative to positive with respect

to the cathodes. The input voltage of the zero switch now remains negative when the control wiper leaves a contact with a negative input voltage.

The zero switch remains in the same rest position. With the circuit described it is not possible to pass at slow speed through the working condition of the zero switch.

The zero switch circuits having a restart voltage can be applied without difficulties

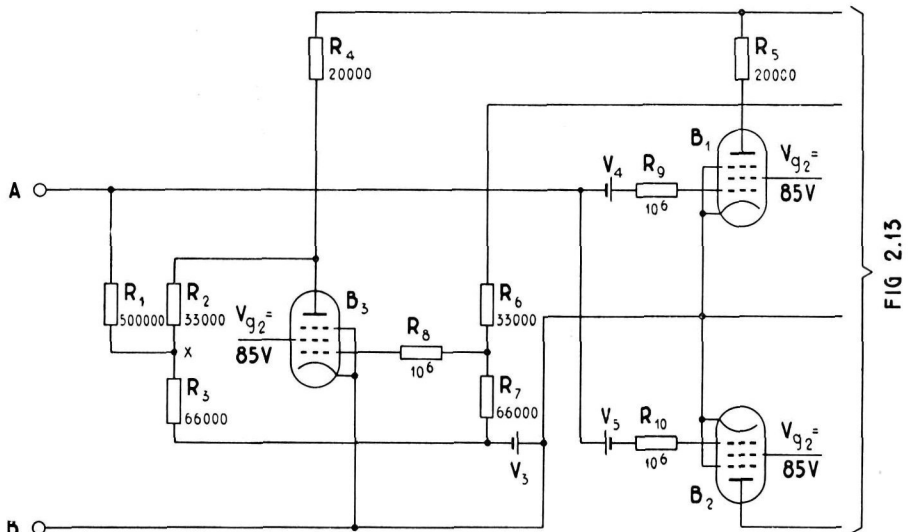

Fig. 2.16. Principle of a zero switch circuit with an automatic polarity reverse of the restart voltage.

to the positioning of selectors with control wipers moving without bounce or contact resistance at the wiper. During the trials difficulties were experienced with a number of Siemens and Halske motor uniselectors. Some of these selectors showed a heavy wear of the bank contacts and at the same time a very high contact resistance between wiper and bank contacts notwithstanding correct adjustments. Motor uniselectors of the same design, but manufactured by Albiswerk Zuerich Switzerland did not show this defect.

THE CONTROL OF SELECTORS AND FINDERS

The principle of the control of selectors and finders based on the balance of direct current Wheatstone Bridges is shown in fig 2.1. The selector and finder circuits will be described in detail in this chapter.

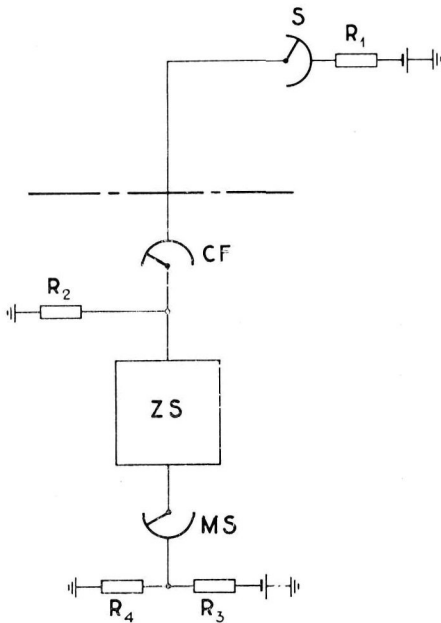

Fig. 3.1. Characterising a selector outlet by a fixed resistance.

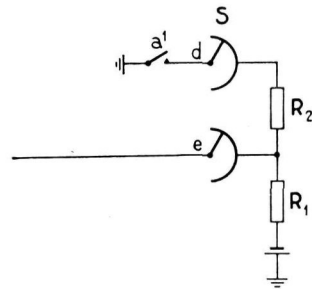

Fig. 3.2. Characterising a selector outlet by a voltage divider.

The control voltages which are to be tested by the wipers of the selectors and finders can be obtained in four different ways:

- a. The battery can be provided with the necessary taps. The control of final selectors needs at least nineteen different control voltages as will be explained hereafter. To provide nineteen different taps on the battery in a switching system presents practical difficulties.

- b. The outlets of a selector may be characterised individually by a fixed resistance for a determined outlet or group of outlets. A fixed resistance R_2 (fig 3.1) in the register is connected to the wire between the control wiper of the moving selector and the register. The characterising resistance R_1 of the selector outlet is connected in series with the resistance R_2 in the register during the test, giving a determined control voltage to the zero switch. The resistances R_1 and R_2 have to be so dimensioned that a simultaneous test of an outlet by two or more registers when two or more resistances R_2 in parallel are connected to a single resistance R_1 , changes the control voltage tested into an inexistant one. None of these zero switches works when testing a wanted outlet nor does any zero switch operate when testing simultaneously an outlet in an unwanted group. In this way it is impossible for two zero switches to work simultaneously on the same outlet.

This system cannot be applied to the positioning of final selectors for a too small number of control voltages is available owing to the large number of selections required. In addition it cannot be allowed that the working of a zero switch be disturbed when testing a wanted outlet when controlling group selectors. The control voltages of final selectors must not be disturbed by a busy test, for the zero switches of other registers then cannot stop on a determined subscriber's line because of the disturbance of the numerical selection. It is however necessary that a final selector shall stop on a determined subscriber's line for announcing calls by an operator and the control of the special features of the line concerned, etc.

The characterising of an outlet of a selector with a determined resistance can be applied with advantage to the attaching of special features to the subscriber's line circuits, as will be described in detail in the following chapter.

- c. The outlets of a selector can be characterised individually by a voltage divider determining the control voltage. This control voltage divider can be connected for instance as is shown in fig 3.2. In this diagram two wipers of a selector or finder are shown with a control voltage divider consisting of the resistors R_1 and R_2 . The selector shown has 100 outlets and all these 100 outlets are individually provided with a voltage divider. Contact a is closed when starting the selector. The circuits of the voltage divider are then only closed during the test by the d-wiper. The zero switch tests the control voltage via the e-wiper.

The circuit according to fig 3.2 is well suited for the positioning of group selectors, cord finders and line finders. It may be also used for the control of final selectors (fig 3.2a)

For instance, the outlet of a group selector with an individual control voltage divider can be made busy by connecting the e-wiper to one of the poles of the battery. The zero switches of other registers testing for an outlet in the group concerned cannot work on this outlet. With this system it is not necessary to provide a separate wiper for the normal busy test. A separate busy test is however necessary in final selectors for the control of a subscriber's line circuit.

d. The control voltages of the final selectors can be obtained from a voltage divider with 19 taps common to a number of these switches for these voltages must not be disturbed by a busy test. It is easy to close the circuit of this common voltage divider when seizing one of the final selector circuits concerned and to interrupt it after the positioning of the final selector and the switching through of the final selector circuit.

An example of a group selector is shown in fig 3.3. The register switching elements associated with this circuit are not shown in detail. The distribution of the various functions over the the available wires between the register and the selector circuits can be made in various ways. Fig 3.3 shows only one of the possible ways. The circuit contains two relays. Relay A is operated by connecting the a-wire in the register to earth via contact sr^1 . The circuit is prepared for the control of the group selector when this relay is operated. Contact a^5 breaks the holding circuit via a low resistance winding of a register control relay CR connected between earth and the e-wire from the register to the selector circuit. The control relay releases. As a result the e-wire is connected in the register to the negative pole of the battery via contact cr^2 . The driving magnet

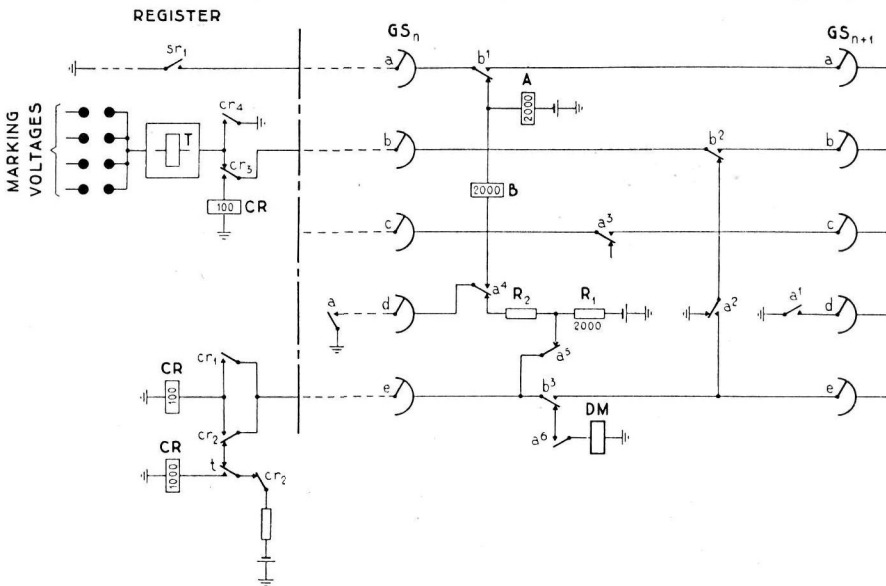

Fig. 3.3. Group selector circuit.

of the group selector, preferably a uniselector, is now magnetised. The selector moves.

The zero switch ZS of the register is connected with the control wiper of the selector concerned via contact a^2 . Contact a^1 closes the circuit via the d-wiper, the zero switch can test the control voltage divider R_1/R_2 of the succeeding selector via the e-wiper.

The selectors of the described system are preferably uniselectors with one control magnet, such as are used in the Bell system. The Siemens Brothers motor uniselectors are very well suited for this new design of a switching system (fig 3.3a).

The test relay T of the zero switch is magnetised at the moment the control wiper tests a contact characterised with the right voltage. Contact t of this relay breaks the

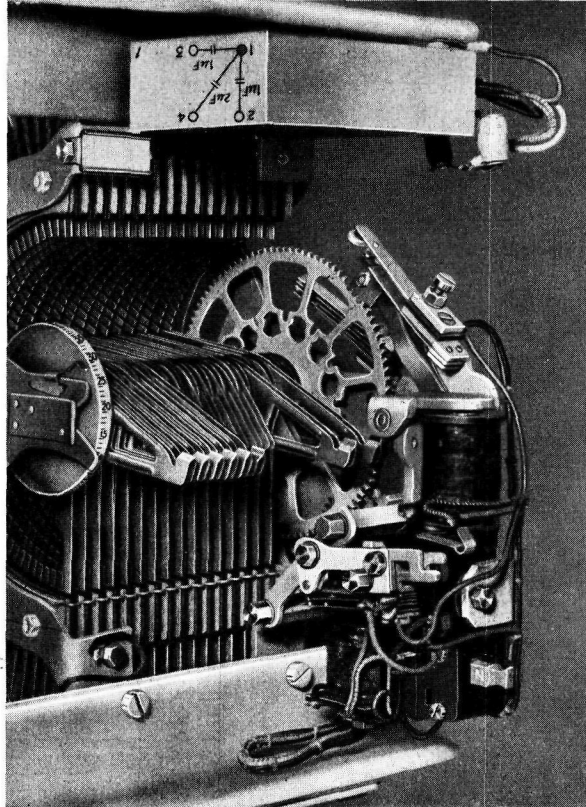

Fig. 3.3a. Siemens Brothers motorunselector.

circuit of the driving magnet DM for cutting the drive of the selector and the wipers are stopped, preferably centred in a mechanical way. The make side of the contact of the test relay closes the circuit of a winding of the auxiliary relay CR, which disconnects the zero switch and the wire to the control wiper in the register and connects this wire, say, to earth. The tested outlet thus is made busy. Another contact of the auxiliary relay interrupts the circuit via the a-wire of relay A in the group selector circuit. Relay B of the group selector circuit is now magnetised in series with relay A in a circuit which is connected to earth via the d-wiper of the preceding selector and contact a¹ of that

selector circuit. The register circuit has to be made in such a way, that the earth in the register connected via the b-wire to the e-wiper is transferred to the e-wire after magnetising relay B. The earth may be removed only when the seized selector circuit is definitely made busy by the operation of its A relay, which disconnects the control voltage divider from the selector contacts with contacts a⁴ and a⁵.

The seized selector circuit is released by opening contact a¹ of the preceding corresponding circuit. A selector circuit can only be seized for a new call after relay A has completely released its armature. There is no possibility that a selector circuit can be seized before relay A has completely released its armature after interrupting the holding circuit.

There is a short time between the test of an outlet and the earthing of the b-wire to busy the seized outlet. It is not possible to busy the tested contact immediately when combining the control and the busy test on one wiper. The zero switch must have tested with safety that the control wiper did stop on a contact with the right control voltage and not between contacts or on a succeeding contact. This short time gives the possibility that two or more selectors may stop on the same outlet. This is of less importance because the busy earth which is connected to the control wiper by the first zero switch, puts the zero switch connected to the second selector back in the normal condition immediately. This interrupts the circuit of the auxiliary relay mentioned, and restarts the second selector. The probability of double connections can be made negligible in this way.

The group selector circuit according to fig 3.3 is not provided with means for moving this switch to a home position after release, although this can be done in a simple way. Investigations of ir. M. van Dobben de Bruyn and Dr. ir. L. Kosten have shown that a system having non homing group selectors, with respect to the efficiency of the use of the lines, need not be inferior to a system with homing group selectors. In such a system the necessary multiple connections can be designed by the use of simple rules. These investigations do not belong to the scope of this work.

The use of group selectors without home positions gives the advantage of reduced wear. Further the selectors are immediately available for a new call. The moving time taken for positioning the group selectors can be reduced in a number of cases by connecting the lines of the different outlets of the same groups not on succeeding positions but on regularly spread positions as is possible in the designed system.

It is possible to provide the selector circuits with one relay when using non homing selectors or finders, but it is preferable to use two relays in view of the consequent better utilisation of the wipers of the selectors and finders in the way shown for instance in fig 3.3. The e-wiper of the selector is used in this diagram for the control wiper and for the magnetising circuit of the driving magnet DM. The c-wire has no function in the positioning of group selectors in this diagram, except when the control and busy test are not combined. The c-wire is in each case necessary for the control of final selectors.

The final selector circuit, which must be used in conjunction with the group selector circuits previously described, is shown in fig 3.4. The diagram is substantially analogous to that of fig 3.3. The circuit is seized in the same way and the switching through after the testing of the called subscriber is similar in both circuits. The e-wire of the final selector circuit is different, for the e-wiper of the group selector has not to be connected

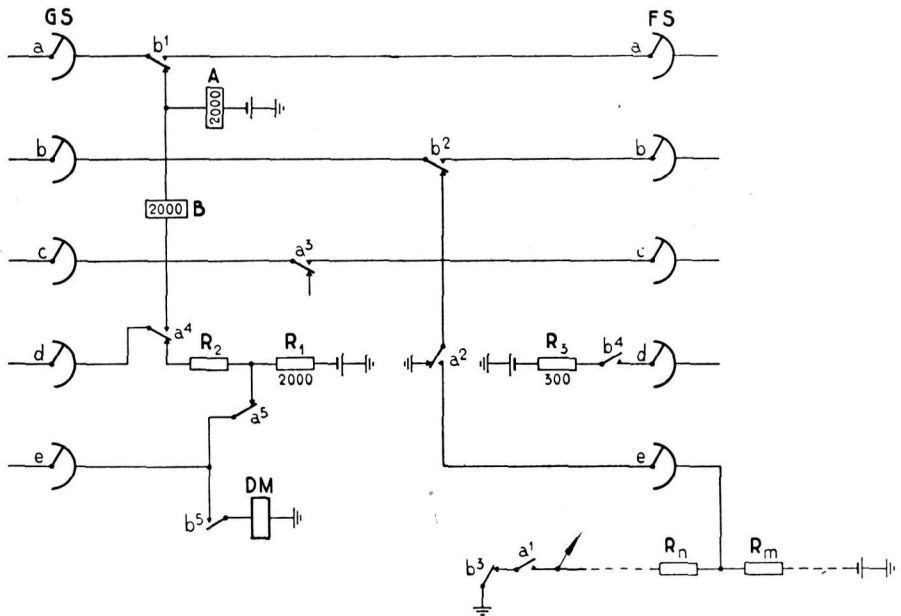

Fig. 3.4. Final selector circuit.

to the e-wiper of the final selector after the operation of relay B of the selector circuit. Further, the negative pole of the battery is connected to the subscriber's line circuit via the d-wiper after the positioning of the final selector and the test. This will be explained in the following chapter.

The control voltages of the final selector circuits are connected to the contacts of the e-bank of the final selector. The contacts 11, 21, etc. up to 01 are connected to a series of 10 voltages differing each from the next by two volts for the control of the movement of the final selector according to the tens digit. The groups of nine contacts between those of the tens are systematically connected to another group of nine voltages spaced at intervals of two volts for the positioning of the final selector according to the units digit. The nineteen control voltages can be made with a voltage divider with 20 resistances, common possibly to a rack with final selectors. In the fig 3.4. only the resistances R_m and R_n are shown. Contact a^1 closes the circuits of this voltage divider when a selector circuit is seized, contact b^3 breaks this circuit when magnetising

The control of the first line finder (fig 3.5) differs a little from those already described for group and final selectors. A subscriber's line circuit when normal marks the contact in the d-bank of its first line finder with -ve battery voltage. A call decreases the control voltage of the d-contact from -ve battery voltage (for instance -60 volts) to -30 volts. The zero switch has only to test this last voltage for the positioning of the first

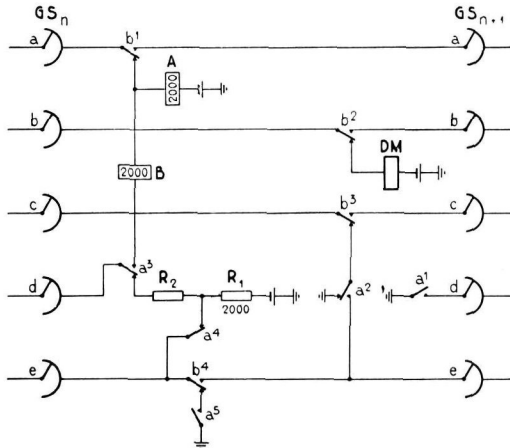

Fig. 3.6. Group selector circuit.

line finder. The circuit is switched through after the positioning of the line finder. The d-wire of the subscriber's line circuit is then connected to the negative pole of the battery via the d-wiper of the first line finder, contact b^4 and a resistance of 300 ohms for example. This neutralises the calling condition of the line circuit. No other line finders can stop on this subscriber's line.

The connection of the negative pole of the battery via the d-wiper of the final selector, as already mentioned before, has the purpose

of preventing the subscriber's line circuit from simulating the calling condition when the called subscriber lifts his handset after he has been rung.

The meter in the subscriber's line circuit is connected with the cord circuit via the e-wire.

It is possible to make all the previously described selector circuits identical. The necessary differences can be made for instance by local strapping. This has a big advantage for it simplifies manufacture and the amount of material for the selector circuit is decreased as compared with all existing step-by-step and register systems. The control voltages of the various selector circuits can be adjusted in a simple way by changing the resistances R_2 (fig 3.3 to fig 3.5). These resistances can be manufactured in the form of plugs mounted in the selector circuit or on the intermediate distributing frame.

The distribution of the various functions over the connection wires between the registers and the selectors is made otherwise in fig 3.6 than in the corresponding circuit of fig 3.3. The a- and b-wires of the circuits according to fig 3.6 can be made balanced in both the normal and the working condition. These wires in the circuits shown in fig 3.3 can be balanced in the position of rest of the selector circuit only by the insertion of a second winding of relay A in the connection of the breakside of contact a^2 to earth.

The a- and b-wires of the selector circuit of fig 3.6 can be balanced only for those types of selectors having relay-type driving or control magnets. The Bell Telephone Mfg. Co at Antwerp has developed a new selector of this kind.

The control wiper is connected to the register via the c-wire. The wire via the e-wiper is switched through to the succeeding stage without fulfilling any special

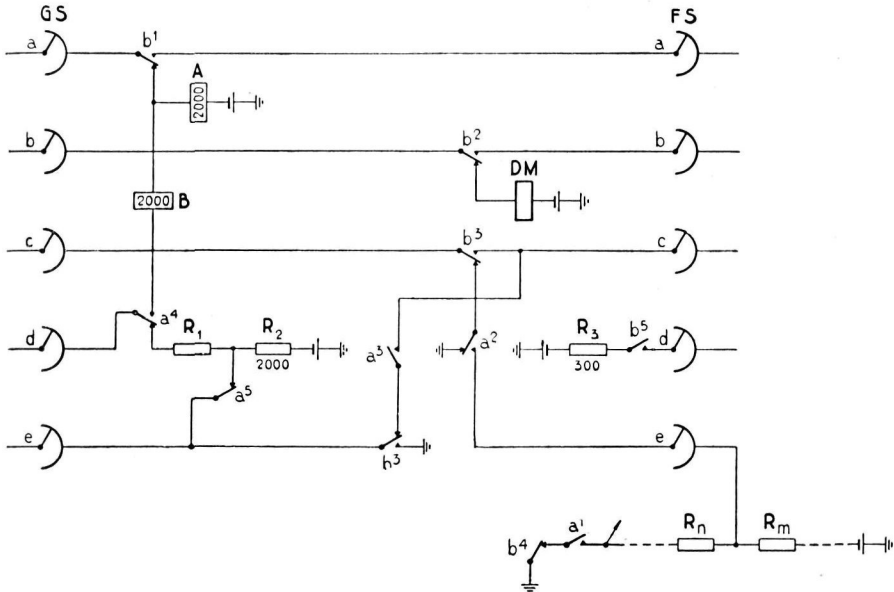

Fig. 3.7. Final selector circuit.

function in group selector circuits. The corresponding final selector is shown in fig 3.7. This circuit need not be described after what has already been said. Only the e-wire needs some attention. The e-wire of the last group selector is connected to the c-wiper of the final selector after the seizure of the latter. The register controls, over this wire and wiper, the condition of the line circuit of the called subscriber. It is necessary to take care that the voltages used on this wire of the subscriber's line circuit do not coincide with one of the ten group selector control voltages.

The designed Bridge Marker Switching System allows of the combination of the first line finder circuit with the final selector circuit as is shown in fig 3.8. This combination has the advantage that less switching apparatus is necessary. The combined line finder/final selector only needs one wiper more than either of the separate switches. The circuit also has either one or two relays but these have more contacts than those in the separate circuits. This is of no importance when modern relays are used. The Bell U-type relay for instance has a maximum of 24 springs.

The circuit in fig 3.8 is developed from the final selector circuit according to fig 3.7.

A combination of the circuits shown in fig 3.4 and fig 3.5 gives difficulties especially when the controlling register and the combined selector/finder circuit are not in the same exchange. The function of the combined circuit however is determined by whether it has been seized from a group selector or from a second line finder. In the first case the f-wiper is connected to the zero switch in the register; in the second case it is con-

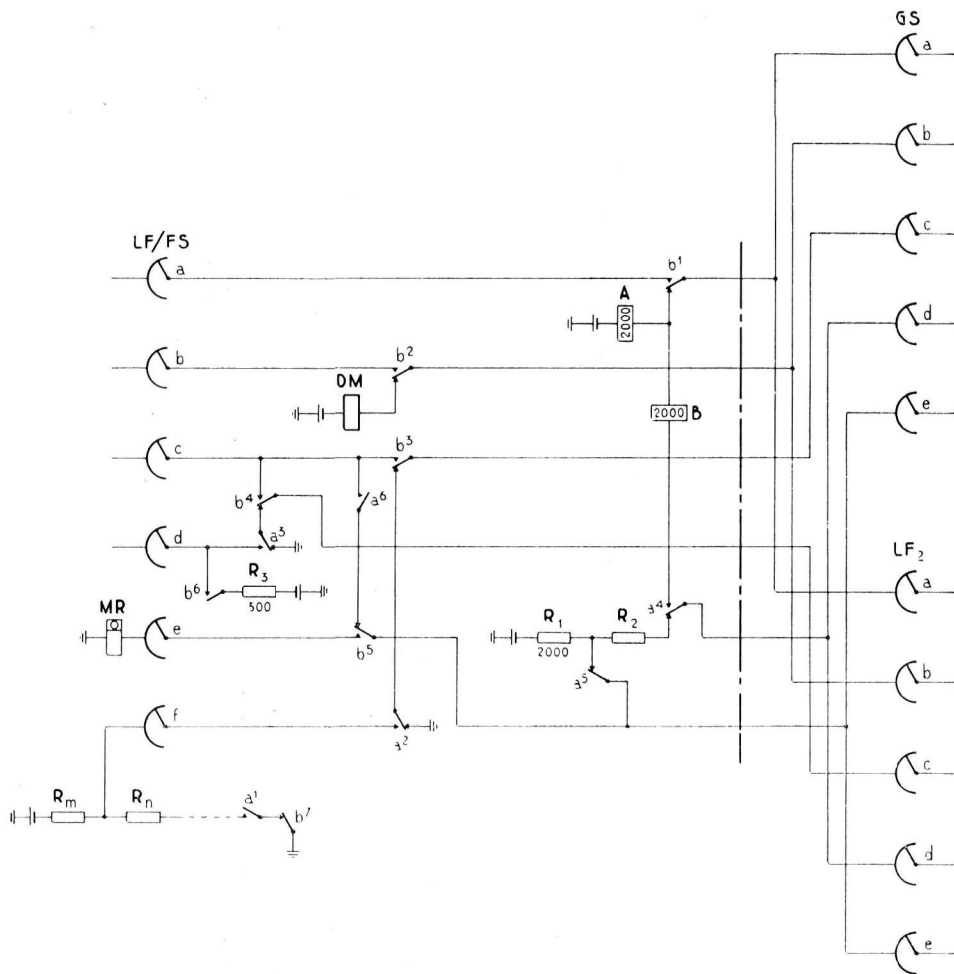

Fig. 3.8. Combined line finder and final selector circuit.

nected to the d-wiper. The two connecting wires of these control wipers are connected to each other after the magnetising of relay B. The speaking wires are unbalanced if the b-wires are used for this purpose as can be seen from the c-wires in fig 3.8. There is however no objection to this in the case of the c-wires in the remote combined selector/finder circuit.

Some trial circuits were made in order to investigate the interconnection of the developed zero switches and the proposed selector circuits. At first the selector circuits were provided with one control relay. After that all trial circuits were made with two relays to make better use of the available wipers. Motor uniselectors manufactured by Albiswerk Zuerich, Switzerland, were used (fig 3.9). These selectors have a slightly different control circuit as shown in the various diagrams. This variation in control will not be described here because the motor uniselectors in question are, despite their excellent construction, not well suited for the designed system because of their electrical braking. These motor uniselectors could be controlled up to a speed of about 230 steps per second by a zero switch used in conjunction with a test relay having a switching delay at its make contact of 1 millisecond. The whole was very stable up to this working limit. Some further tests were made with a Siemens Brothers motor unselector having a normal speed of 220 steps per second. These motor uniselectors are very suitable for the Bridge Marker Key Telephone Switching System for they have only one control magnet, which lifts the mechanical brake and centering device, the latch; and closes the motor circuit. This motor unselector also is stopped by demagnetising the control coil. The wipers are mechanically braked and they stop centered on the contacts. This selector is at present the only available high speed selector fitting in well with the designed system especially when the dial is replaced

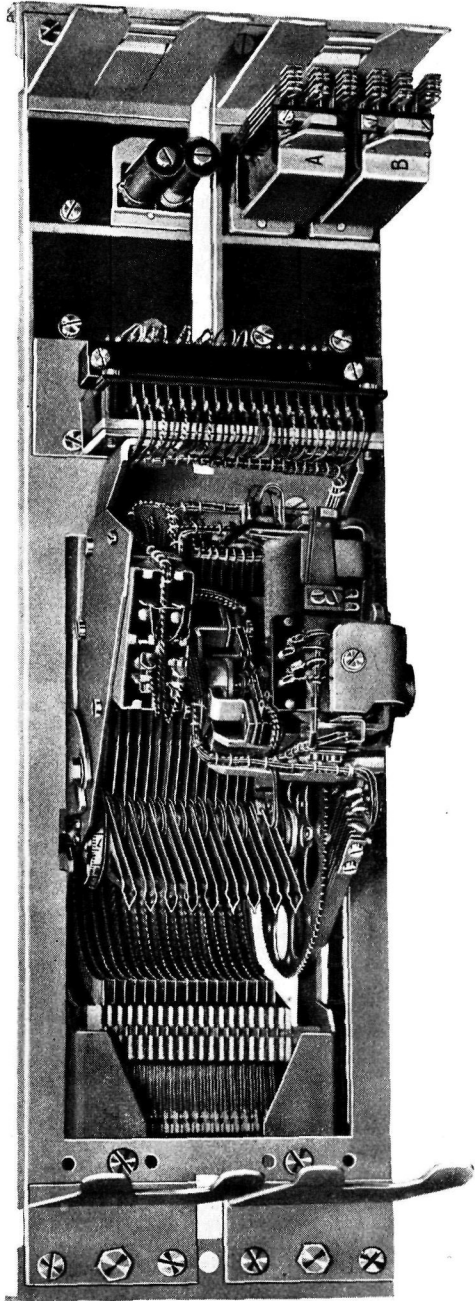

Fig. 3.9. Motorunselector.

by keys. The Bell uniselectors with a common drive as are used in the 7D system, which are started by magnetising the clutch magnet and thus coupling the wipers with the driving shaft via a flexible gear, are also well suited for the purpose. These selectors however have a low speed (about 60 steps per second).

THE SUBSCRIBER'S LINE CIRCUIT

Use can be made of the balance of a Wheatstone Bridge for the detection in an exchange of a call from a subscriber's line or calls from lines in other exchanges. The line and cut-off relays, as they are applied in the existing systems, being no longer necessary.

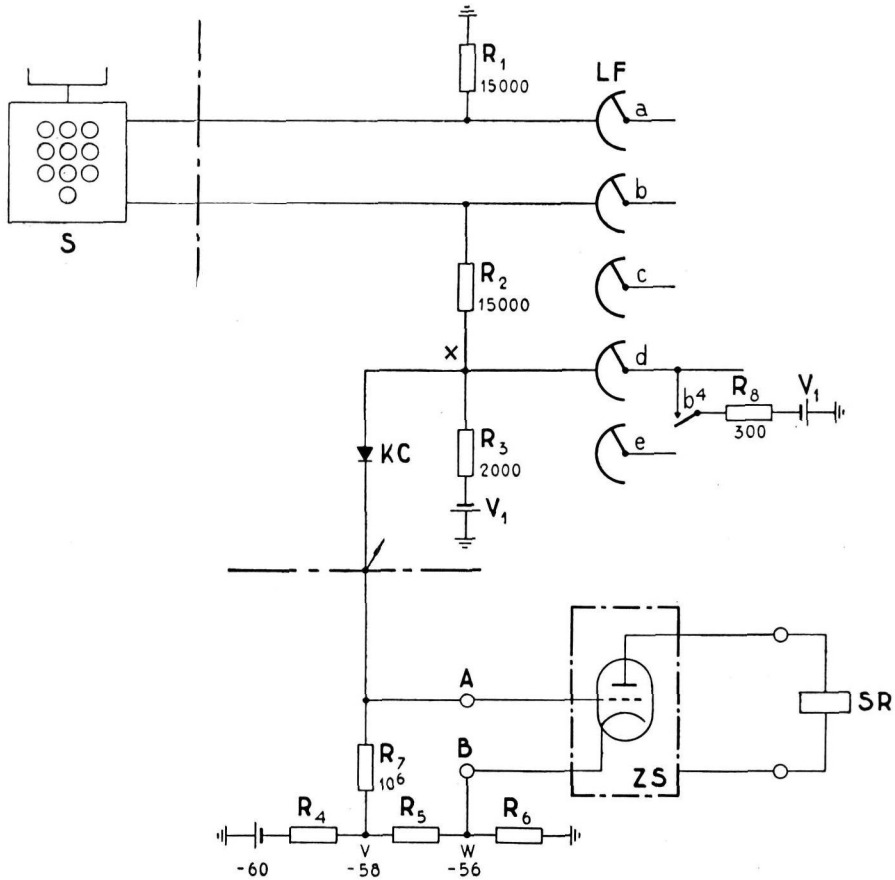

Fig. 4.1. Principle of subscriber's line circuit and call detector.

The principle of call detection is shown in fig 4.1. In this figure are shown the subscriber's set S, a line finder LF and the call detector. The diagram further contains two equal resistances R_1 and R_2 which may be, for example, 15,000 ohms each and which are connected with the a- and b-wires in the exchange and a resistance R_3 connecting R_2 to the negative pole of the battery, in the same way as that designed by the Bell Telephone Mfg Co at Antwerp. The connection point X of the resistances R_2 and R_3 is connected to the call detector via the rectifier KC. This point also gives a control voltage to the corresponding contact in the d-bank of the line finder. The coupling of the various subscriber's line circuits on the call detector (which may be common for a group of 50 or 100 subscribers) is shown in the fig by the multiple arrow.

The call detector contains a zero switch element ZS having a similar circuit to that in fig 2.5 or 2.10. The call detector has a voltage divider R_4 to R_6 for the reference voltage.

The cathode of the tube of the call detector has, with a battery voltage of -60 , a potential of, say, -56 volts from the tap W of the voltage divider. Point A of the call detector has a voltage of -58 via the high resistance R_7 (10^6 ohms). The tube of the zero switch element is then in the non conducting condition. The rectifiers of all subscriber's lines not in a calling condition are likewise in the non conducting condition. The voltage of point X changes, due to the closure of the line circuit in the subscriber's set when a call is initiated, in this instance from -60 to -56 volts. Only the rectifier of the calling line then comes into the conducting condition. Point A of the zero switch

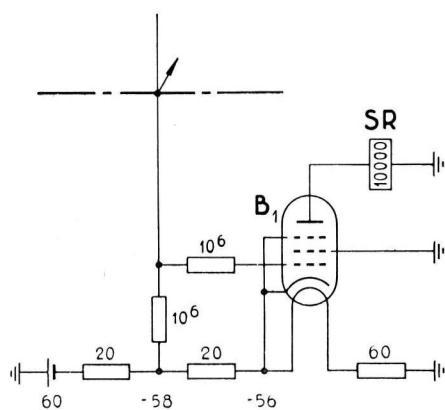

Fig. 4.1a. Call detector.

gets a voltage of -56 , because the resistance R_7 is high compared with other resistances in the subscriber's line circuit. The zero switch comes into action because bridge balance is obtained. The starting relay SR is magnetised, a register hunts via a cord finder and a second line finder, for a circuit of a first line finder which has access to the calling line. The call detector gives, in a way not shown, two marking voltages to the register, namely, one for the positioning of the cord finder to a free cord, which has access to the group of line finders of the calling line, and one

for the positioning of the second line finder to a free first line finder of the group of hundred or fifty subscribers which includes the calling one.

With this control method at any one time only one first line finder of the group of one hundred subscribers associated with the call detector can move to a calling line in that group.

When the first line finder is positioned, the calling signal is neutralised by the operation of relay B. Negative battery voltage is then connected to point X of the subscriber's line circuit via a resistance of for example 300 Ohms and contact b⁴. The rectifier KC is brought back into the non conducting condition, so that the call detector is reset to normal, provided that no other calls exist in the group concerned.

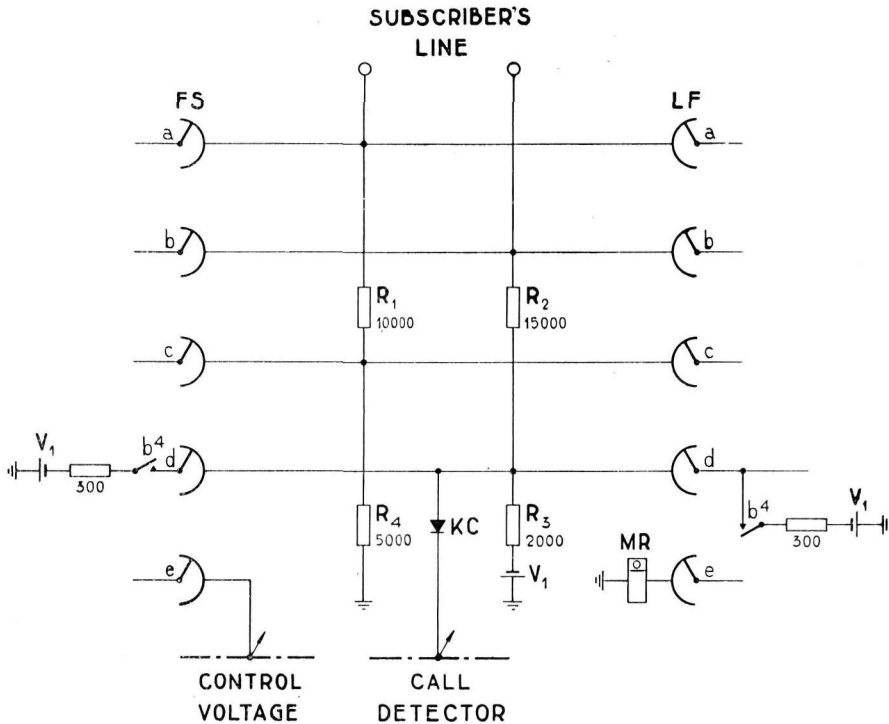

Fig. 4.2. Subscriber's line circuit.

The circuit is so arranged, that all subscriber's line circuits associated with a call detector are independent of each other. Only the rectifier of the calling line is brought to the conducting condition when a call is originated. The rectifiers KC of the other subscriber's lines are brought even further into the non conducting condition. In these circumstances there cannot be any mutual disturbance of the subscriber's line circuits in the speaking condition, for point X is connected to the negative pole of the battery via a low resistance. This makes the subscriber's line circuits balanced.

The diagram of the call detector becomes very simple when using a tube type UBL 21 as shown in fig 4.1a. This tube has a filament current of 100 mA at 50 volts. A normal telephone relay can be operated in the anode circuit if an anode voltage of 50 is used. In the diagram shown the filament of the tube is used as part of the voltage divider, which gives the reference voltages.

The call detector is affected by line leak, as this reduces the voltage of point X. In the example the lower limit of this voltage may be taken to be -58 . The rectifier C, if of the selenium type, may not be kept continuously in the conducting condition. The admissible insulation resistance to earth of the b-wire in the example is $50,000$ ohms. The call detector is then completely in the condition of rest and only comes into action with insulation faults of less than $50,000$ ohms.

With the principle developed it is possible to design subscriber's line circuits with special features such as are necessary in modern switching systems. For example when initiating a call it is necessary to make a subscriber's line immediately busy against seizure by a final selector. This must not be delayed during the short time required for the register to find the calling subscriber's line. This requirement originates from the interconnection of private branch and public exchanges. It is possible during the short

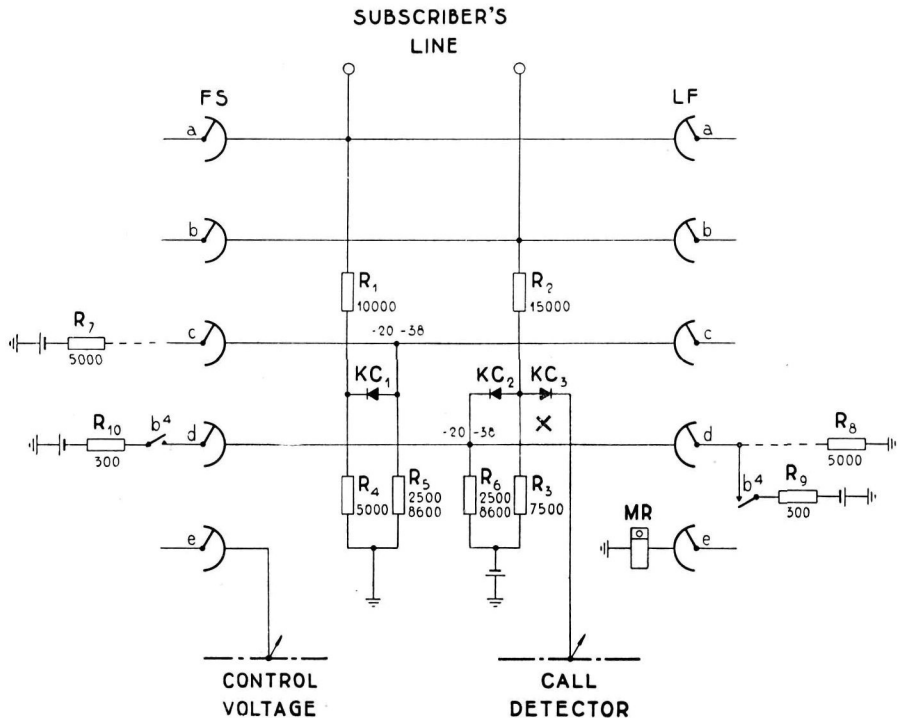

Fig. 4.3. Subscriber's line circuit with special features.

time mentioned, that some arbitrary extension of the private branch exchange waiting for the dialling tone from the public exchange is connected to a subscriber of the public exchange, who in general does not want that particular extension. This fault can be prevented in an easy way as is shown in principle in fig 4.2 in which the banks of a line finder, a final selector and their mutual connections are shown. The resistances R_1 and

R_2 controlling the call detector, are connected in the same way as is shown in fig 4.1. The resistance, which is connected to the a-wire in fig 4.1 is in fig 4.2 changed to a voltage divider. The tap is connected with the corresponding contacts in the c- banks of the line finder and final selector. The register tests, after the positioning of the final selector, the c-wire of the subscriber's line circuit. The subscriber is free when the c-wire has earth potential and is busy in all other cases. The busy condition is obtained in this circuit immediately a call is initiated. When determining the working limits of the testing device, one has to take in account that the c-wire can have a slight negative potential due to the loop leak.

It is necessary in modern automatic switching systems to distinguish various kinds of subscriber's lines, as for instance lines of a PBX, lines with restricted service, coin or non-coin box lines and so on. An example of a subscriber's line circuit of an automatic telephone switching system is shown in fig 4.3. The subscriber's line can be provided with special features as calling and called party in an independent way. This circuit also contains the feature of being immediately busied when a call is initiated.

The circuit of the resistances R_1 and R_4 is the same as that of the correspondingly numbered resistances in fig 4.2. The connecting points of the two pairs of resistances R_1/R_4 and R_2/R_3 are joined respectively to the c- and d-wires of the subscriber's line circuit via the rectifiers KC_1 and KC_2 . These wires are connected to the poles of the battery via so called characterising resistances (R_5 , R_6).

The resistances R_3 and R_6 as well as R_4 and R_5 are connected in parallel when the subscriber's line is in the calling condition, for the rectifiers KC_1 and KC_2 are then both in the conducting condition.

The register (not shown) hunts for the calling line in a group during the positioning of a first line finder by testing the d-wire of the subscriber's line circuit. Relay B (fig 3.5) is not magnetised immediately after the positioning of the first line finder and the calling condition of the subscriber's line is not neutralised immediately. This gives no difficulties, for the restriction is made that no more than a single first line finder of a group of, for instance, 100 subscribers can be positioned at any one a time. The d-wire is connected to earth in the register for the examination of the characterising resistance R_6 via a fixed resistance R_8 of e.g. 5.000 ohms. The resistance R_6 has such a value that the voltage on the d-wire is positive with respect to that of point X. The rectifier is thereby brought into the non conducting condition. The value of the characterising resistance R_6 can now be determined in the register independently of the rest of the circuit. The characterising resistance can for instance be varied from 2.500 ohms to 8.600 ohms, so that the voltage varies from -20 to -38 .

The investigation of the characterising resistance by the register can be done in principle in the way that is described for fig 2.2.

The line finder circuit is switched through by the operation of the B relay after the register has determined the character of the call. The resistance R_8 of the register is

then disconnected. The negative pole of the battery is connected to the d-wiper of the line finder via the low resistance R_9 . The rectifier KC_2 is brought into the conducting condition during the call. This neutralises the calling signal, and the call detector restores to normal if there are no other calls in the group concerned.

The characterising resistance R_5 of the called subscriber is connected in the same way as R_6 . The resistance R_5 can also be varied from 2.500 to 8.600 ohms. After positioning the final selector, the register tests the c-wire for earth potential or for a voltage which is for instance more negative than 2 volts. In the first case the subscriber's line is free; in the second case the line is busy. Line leak up to a voltage of the c-wire of -1 does not affect the free condition. The busy voltage of the c-wire in the calling condition of the subscriber's line circuit is affected by the values of both characterising resistances (R_5 and R_6). The busy voltage is at a minimum about -3 with the most unfavourable combination of the various values of the characterising resistances.

A resistance of 5.000 ohms is connected in the register via the c-wire to the subscriber's line circuit when the called subscriber is free. This makes the seized subscriber's line circuit busy. At the same time the c-wire obtains a determined voltage depending on the value of the characterising resistance. This characterising voltage can vary between -20 and -38 with the resistance values given, so that ten features may be given to the subscriber as a called party, when voltage intervals of 2 volts are admissible. The rectifier KC_1 is in the non conducting condition during this test.

After disconnection the resistance R_7 in the register is replaced by the winding of a control relay in the cord circuit. This winding also has a resistance of 5.000 ohms, so that a register can investigate the characteristic of a busy subscriber's line circuit, this being necessary for example on PBX-lines.

The double functions of the c-wire of the final selector do not affect each other. The same applies to the double functions of the d-wire of the line finder. The rectifiers KC_1 and KC_2 are in the non conducting condition during the test of the feature concerned, so that possible insulation faults of the subscriber's line cannot affect this test. The rectifier KC_2 is kept in a conducting condition during the call either by the line finder circuit when the subscriber concerned is the calling party, or by the final selector circuit, when the subscriber concerned is the called party. The rectifier KC_1 on the other hand is kept in the non conducting condition during the call either via the c-wiper of the line finder or via the c-wiper of the final selector and the previously mentioned 5.000 ohms winding of the control relay in the cord and so to the negative pole of the battery. In this way the a- and b-wires of the subscriber's line are balanced in the speaking condition.

The two resistances of 15.000 ohms connected to the speaking wires give a small but negligible speech loss. This can be reduced by increasing the values of these resistances, which can be done at the cost of increasing the minimum admissible insulation

resistance of the line. Also it is possible to disconnect these resistances from the a- and b-wires in the speaking condition by means of rectifiers. This, however needs more complicated line circuits.

The subscriber's line circuit for use with combined line finders and final selectors is practically identical to that according to fig 4.3.

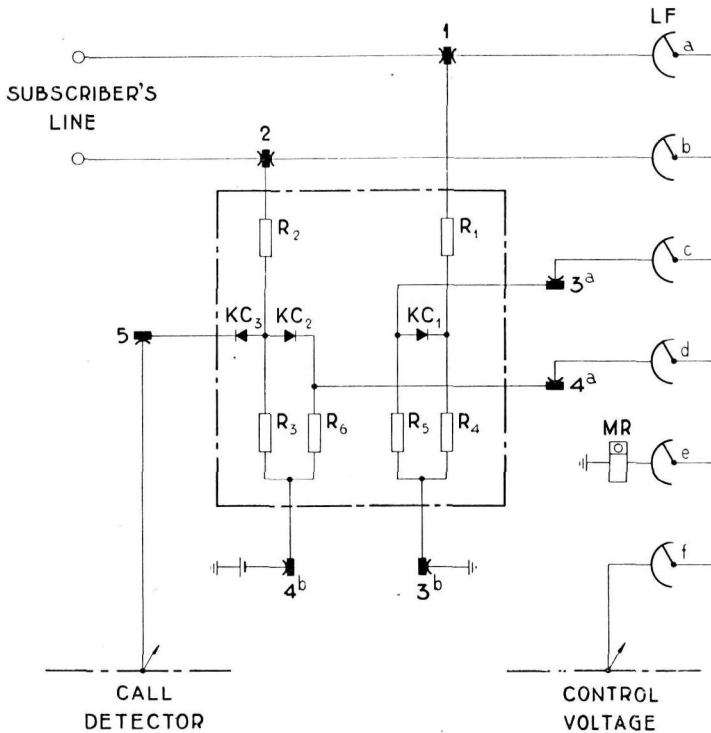

Fig. 4.4. Subscriber's line plug.

The resistances and rectifiers can be mounted in a plug, which can be placed on the horizontal strips of the main distributing frame, as proposed by the Bell Telephone Mfg Co. It is possible to obtain an important space saving in the described system with this plug arrangement.

Fig 4.4 gives the diagram of a subscriber's line circuit according to fig 4.3 for a combined line finder and final selector. In this figure the way in which the rectifiers and resistors can be mounted in a plug is shown. Using the constructional principle of the horizontal strips of Siemens and Halske's main distributing frames, the plug suitable for the diagram of fig 4.4 can be made with 5 double pins.

It is possible with this plug circuit to disconnect the subscriber's line from the automatic exchange entirely.

Further it has to be remarked that the combination on the c-wire of the characteristic condition of a called subscriber with the busy-ing-without-delay feature has the disadvantage that a characteristic appears on this wire after the register has positioned the line finders and is connected through with the subscriber's line circuit. The determining of the characteristic is subject to some delay in this case.

THE TRANSMISSION OF SELECTING CRITERIA BY MEANS OF BRIDGE MARKINGS

The selecting criteria of A subscriber's set can position a marking switch in the register by means of the balance of a Wheatstone Bridge as is described in principle in fig 2.2. The positioning of the marking switches however needs such a long time, that the keys in the subscriber's sets, inserting the various resistances in the line, need

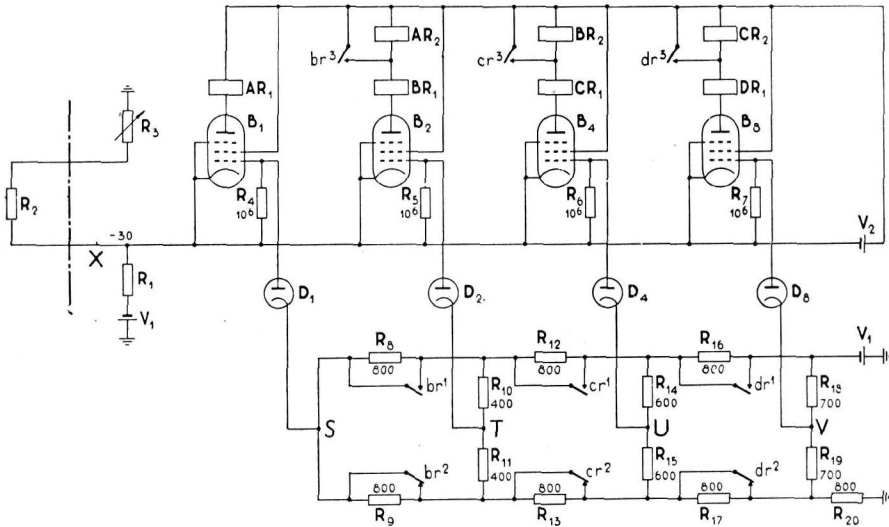

Fig. 5.1. Diagram of a Bridge Marker receiver for 15 selecting criteria.

electro-mechanical locking. In order to avoid the complication of marking switches, a receiver is designed using tubes, relays and resistors only.

A marking switch has to test in sequence ten different Wheatstone Bridges as a maximum when using ten selecting criteria. It is possible to make an instantaneous test of the inserted resistance of the subscriber's set by using ten zero switches, each with its own reference voltage. These receivers are too expensive, because a high vacuum

tube is necessary for each selecting criterion. In another solution marginal effects are necessary, which do not give a practical solution.

It is however possible using ten different variations of the operated and non operated positions of four telephone relays to design a receiver for 15 selecting criteria having such a high speed, that the keys of the subscriber's sets do not need special locking. The diagram of such a receiver, suitable for fifteen different selecting criteria is shown in fig 5.1.

The a- and b-wire of the subscriber's line are connected in the receiver to the resistances R_1 and R_3 . The set is indicated by resistance R_2 only. Resistors R_1 and R_2 of chapter 4 are, as before, connected to the a- and b-wires. Their values are calculated in the resistors R_1 and R_3 of this chapter. Resistor R_1 is connected to battery V_1 . The voltage drop in the resistance R_1 can be adjusted by means of the register resistance R_3 to, say 30 when the subscriber's line is looped by the instrument, i.e. before dialling tone has started. Resistance R_3 is automatically adjusted to its proper value before the transmission of dialling tone from the register.

The cathode lead of the tubes B_1 to B_8 of the receiver shown in fig 5.1 is connected to the b-wire of the subscriber's line. The control grid leads are connected to tappings on a voltage divider network by means of the resistances R_8 to R_{20} via a protective resistance or diode (D_1 to D_4).

This voltage divider is also connected to the battery V_1 . The control grid leads of the tubes B_1 to B_8 in the looped condition of the subscriber's line have voltages of -32 , -34 , -38 and -46 respectively. These voltages can be calculated easily from the network R_8 to R_{20} shown in fig 5.1, because the currents in the branches indic-

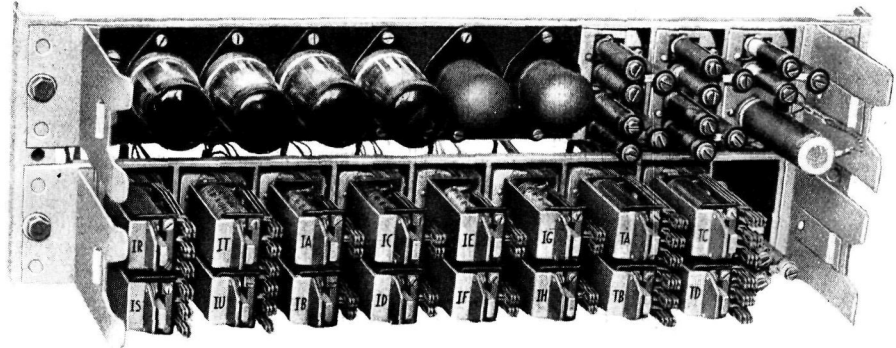

Fig. 5.1a. Bridge Marker receiver and impulse counting relay chain.

ating the reference voltages to tubes B_1 to B_8 respectively are chosen 5, 5, 10 and 20 mA, the battery voltage being 60. They respectively differ 1, 2, 4 and 8 times 2 volts with respect to the normal voltage of -30 . The interval of two volts is determined by the properties of the applied tubes. The tubes are non conducting at a negative control grid voltage of -2 .

The reference voltages of the zero switch elements B_1 to B_8 can be changed by contacts of test relays BR to DR of the elements B_2 to B_8 . Contacts br^1 and br^2 change the voltage of point S by four volts by transferring resistor R 8 to the other side of the tap. Contacts cr^1 and cr^2 shift the voltages of point S and T in the same way by 8 volts, and contacts dr^1 and dr^2 change the voltages of points S, T and U by 16 volts. The control grid leads of the tubes B_1 , B_2 and B_4 in this way always get the correct marking voltages during the determination of the received selecting criterion.

The proportions 1, 2, 4 and 8 between the voltage differences mentioned originate from the application of the variations of the operated and non operated conditions of four telephone relays. Suppose that these two conditions are presented respectively by + and —.

The two conditions of relay (AR) are then shown by:

AR
—
+

The variations of two relays (AR and BR) are then:

AR	BR
—	—
+	—
—	+
+	+

The variations of the conditions of four relays (AR, BR, CR and DR) are:

	AR	BR	CR	DR
number	1	2	4	8
0	—	—	—	—
1	+	—	—	—
2	—	+	—	—
3	+	+	—	—
4	—	—	+	—
5	+	—	+	—
6	—	+	+	—
7	+	+	+	—
8	—	—	—	+
9	+	—	—	+
10	—	+	—	+
15	+	+	+	+

The number of variations is doubled by the addition of each succeeding relay, as can be easily seen in the above table. The variations can be numbered in a special way, which has a particular meaning in the receiver designed. If the values 1, 2, 4 and 8 are given respectively to the relays AR, BR, CR and DR in operated condition, the number of the variations is given by the sum of these values. This operation code of the relays is known as the 1,2,4,8-code. The same code is also found in relay counting chains with four pairs of relays, which successively present all possible variations of the operated conditions of these four pairs of relays.

The designed receiver measures, so to speak, if the received selecting criterion (minus 30 volts) is 14 volts and less, or 16 volts and more. Relay DR (value 8) operates in the last case and reduces the voltage to be tested by 16 volts.

On testing a voltage of 14 volts and less, in which case relay DR remains unoperated, the receiver examines whether it is 6 volts and less, or 8 volts and more. In the case relay DR being operated the reduced voltage also is examined on the limits 6 volts and less, or 8 volts and more. Relay CR (value 4) operates if the voltage is 8 volts and more (but less than 16 volts!). The voltage to be tested now is reduced by 8 volts, etc.

The transmitted voltage (minus 30 volts) can be tested in this way by dividing it in halves in four successive stages on a normal criterion and 15 selecting criteria.

The diagram of the receiver will be further explained hereafter, beginning at the selecting criterion of the lowest voltage ($30 + 2$). Only one element of the receiver, which contains relay AR (value 1) then comes into action.

In principle the receiver contains four zero switch elements with four different balance conditions. These four zero switch elements are locked in the non conducting condition by the control grid lead voltages previously mentioned. Battery V_2 supplies anode and screen voltages.

The windings of the four detector relays AR to DR are connected in the anode circuit of the four tubes B_1 to B_8 . The relays AR to CR have differential windings. Each relay has one winding connected in the anode circuits of two successive tubes. As none of the tubes is in the conducting condition in the normal condition of the receiver none of the relays AR to DR is operated.

The voltage of point X can be changed for instance to -32 on the first selecting criterion by inserting another resistor R_2 in the subscriber's set. Tube B_1 now becomes conducting and relay AR attracts its armature. The other tubes remain non conducting.

The second selecting criterion can be transmitted for instance by inserting such a resistance in the subscriber's set that point X gets a voltage of -34 . This brings both tubes B_1 and B_2 to the conducting condition. Relay AR is now magnetised equally and in opposition on both windings, so that it cannot operate. Relay BR is magnetised only over the first winding, and so it operates. Tubes B_4 and B_8 remain non conducting. Contacts br^1 and br^2 connect resistances R_8 and R_9 of the voltage divider in

such a way, that the voltage of point S changes from -32 to -36 . Tube B_1 again becomes non conducting. Contact br^3 short circuits the second winding of relay AR, so that AR remains released after relay BR has operated.

The third selecting criterion gives a voltage of -36 at point X. This brings both tubes B_1 and B_2 to the conducting condition. Relay BR operates initially, relay AR remains released as it is magnetised over both its differential windings. Contacts br^1 to br^3 effect the changes described in the circuit. The voltage of the control wire being -36 , which is the same as point S, tube B_1 remains conducting. Relay AR operates owing to the magnetisation of its first winding in the anode circuit of tube B_1 . Relays AR and BR are then both operated on the third selecting criterion in the described sequence.

The fourth selecting criterion changes the potential of point X to -38 volts. Then relay CR operates alone in a similar manner. The effects of further criteria may follow from the diagram.

In diagram 5.1 the four zero switch elements with the tubes $B_{1, 2, 4}$ and B_8 receive 15 criteria in such a way that the number of the selecting criterion transmitted is equal to the sum of the tube numbers shown for the working zero switch elements.

In any desired combination the relays AR to DR do not operate simultaneously. The operations occur in reversed sequence to the relay indices. The receiver so to speak tests the received selecting criterion in order to fit in voltage differences of 16, 8, 4 or 2.

Depending on the relays used, the positioning time of the receiver described is 30 to 40 milliseconds. The release time of the receiver is about 10 ms.

The receiver controls a relay register with groups of four relays, which are connected for instance via contacts of a sequence switch to a make contact of the corresponding receiving relay (AR to DR). A register relay then operates when the corresponding receiving relay operates. The receiving relays restore to normal when the key in the subscriber's instrument is released, and the sequence switch connects another group of register relays to the receiver when all receiving relays are unoperated.

The receiver according to fig 5.1 is shown with a zero switch of simple type. These zero switch elements by can be replaced the amplifier circuit of fig 2.11. When designing such a receiver slight alterations have to be made in the diagram because the final tube in this circuit is conducting on negative input voltages.

An experimental receiver according to the diagram of fig 5.1 has been made (fig 5.1a) using tubes EFF 50 and diodes EB 4. The receiver has fulfilled all expectations.

The experimental receiver controlled a relay register for the storage of four digits. (fig 5.1b). The register relays were also operated in the 1,2,4,8-code. Further a relay counting device was joined to this register to receive normal series of dialling impulses and to store them by means of the same code as that used by the bridge marker receiver in the register. It is possible with such a register, to use key and dial subscriber's sets

on the same exchange. The function of the register has then to be altered by a characteristic indicating the nature of the calling instrument.

The a- and b-wire of the subscriber's line are connected in the receiver of fig 5.1 to the poles of the battery V_1 via the resistor R_1 and R_3 . It is possible to make these resistances high compared with the resistance of the a- and b-wires in order to eliminate

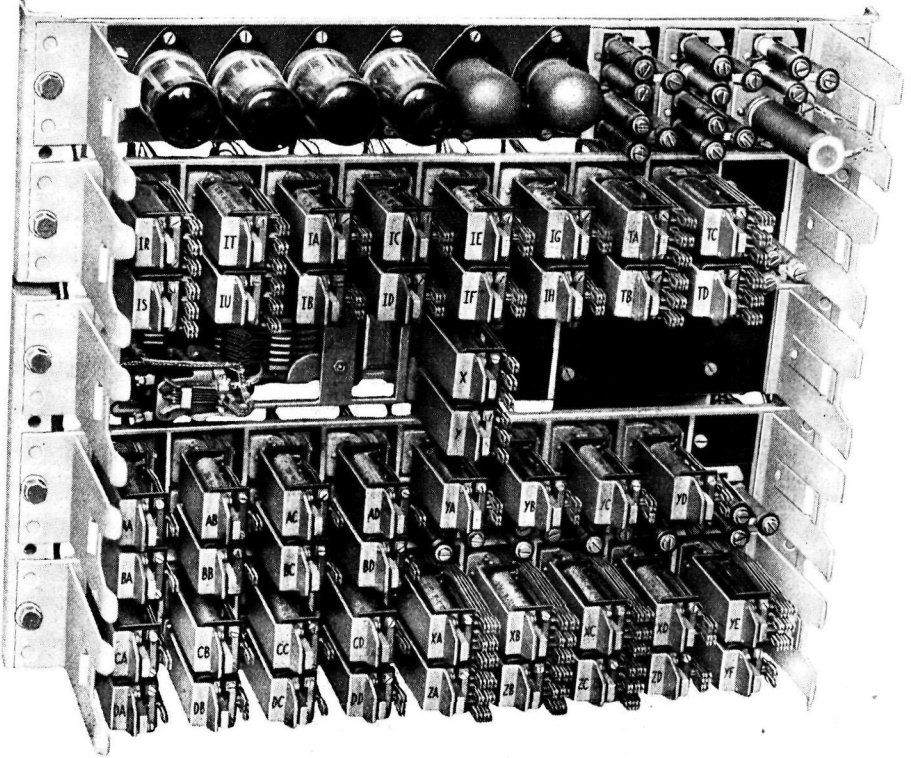

Fig. 5.1b. Bridge Marker receiver and impulse counting relay chain and four digit register.

the influence of differences in the length of subscriber's lines and resistance variations due to seasonal temperature variations.

Bridge circuits with high resistances can only be used when the subscriber's lines have sufficiently high insulation resistance, and the chance of external disturbances is small. In a high resistance bridge circuit the transients on inserting a resistance become too slow when the line length exceeds a certain value. These difficulties can be avoided by using a low resistance bridge circuit.

As has been stated already, on the connection of a subscriber's line to a receiver in the register the resistances R_3 in fig 5.1 has to be automatically adjusted in such a way, that the voltage of point X is -30 . On completion of this adjustment the register transmits dialling tone.

The individual making up of the resistances of the subscriber's lines to some predetermined value is not sufficient to ensure that the bridge balance is maintained in all circumstances requiring bridge stability, because the resistance of a subscriber's line can vary by + or - 8% due to normal seasonal temperature variations.

The principle of automatic compensation of the resistance of subscriber's lines is

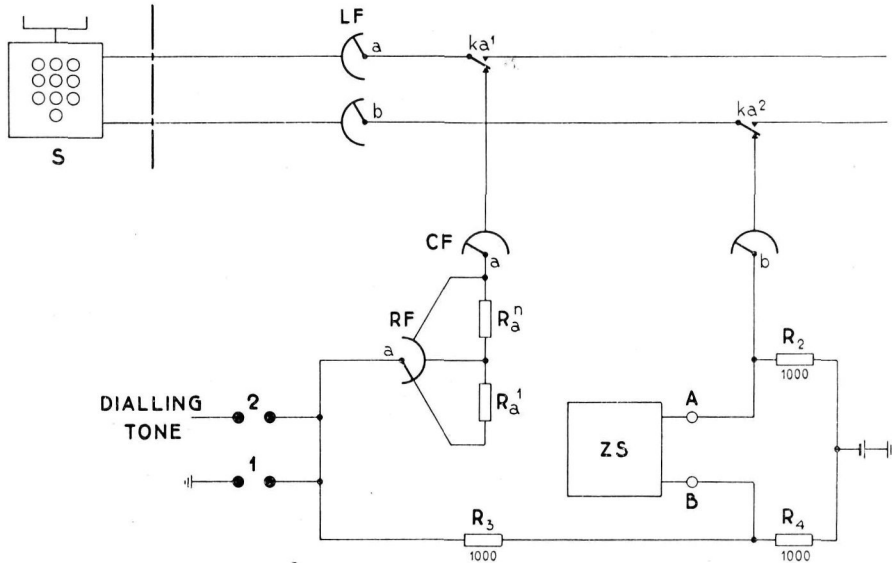

Fig. 5.2. Resistance finder circuit for compensation of the subscriber's line.

shown in fig 5.2. The a- and b-wires of the subscriber's line are connected to the compensation bridge circuit in the register via the line finders and the cord finder. The resistance of the a-wire can be compensated by all or a part of the resistances R_a^1 to R_a^n . These resistances are connected to the bank contacts of the finder RF, the resistance-finder. This finder is of the homing type. The zero switch functions when the control wiper of the resistance finder is joined to a contact on which the resistance is such that the sum of the resistance of the subscriber's line, the set with lifted telemicrophone and the compensation resistance equals R_2 (1000 ohms).

The zero switch according to fig 2.13 can be used for the compensation when the resistances R_3 and R_4 are chosen in such a way that the voltage of point B is -29 or -31, because the working limits of this zero switch are + or - 1 volt. The resistance finder always has to start from a home position with all or none of the compensation resistances connected in series to the subscriber's line. One of the input tubes B_1 or B_2 has to be locked for this compensation.

The quality of the compensation can be improved by locking B_2 and by using tube B_3 not only as a phase inversion tube, but also as an amplifier tube. The use of B_3 as

amplifier tube in a zero switch circuit for the positioning of selectors is not necessary. It results in an unsymmetrical characteristic. Better discrimination, which is obtained by using B_3 as amplifier tube, however is necessary for the compensation of subscriber's lines resistances. The 7.000 ohms resistance R_6 has to be disconnected, and resistances R_4 and R_5 have to be chosen 33.000 ohms and 66.000 ohms respectively. The characteristic of the zero switch then can be made practically square.

The compensation resistances R_a are 5 ohms each. The normal resistance finders have 100 points, so the compensation resistance can be varied between zero and 500 ohms. It is advisable to make up all short subscriber's line to a unified value e.g. 500 ohms. The resistance of the subscriber's lines with lifted handset then may be 1.000 ohms as a maximum. A higher value may be chosen by a different dimensioning of the bridge circuit. The precision of the compensation is such, that the bridge circuit is less than + or - 0.1 volts out of balance.

The compensating resistance of the subscriber's line for the transmission of selecting criteria is inserted in series with the a-wire. The balance of the circuit can be improved by inserting resistances in both the a-wire as well as the b-wire. The resulting voltage differences of the various selecting criteria in this case are smaller than with a compensation of the a-wire only. Earth faults of the b-wire of the subscriber's line affect the transmission of the selecting criteria in a Bridge Marker System. Faults on the a-wire do not affect the selecting criteria as long as these faults can be neutralised by the resistance compensation. The lowest admissible earth fault of the a-wire is about 1.000 ohms. An earth fault of $5 \cdot 10^4$ ohms on the b-wire is still tolerable. This gives an error of nearly one volt on the tenth selecting criterion for which the highest resistance of the subscriber's set is normally inserted.

Earth faults on the b-wire give an unidirectional voltage shift. For this reason it is advisable to shift the marking voltages of the voltage divider R_8 to R_{20} of fig 5.1 with respect to the transmission voltages by half a volt in such a direction that slight earth faults give a correction of the bridge balance obtained by the various zero switch elements.

The receiver of the Bridge Marker System according to fig 5.1 with resistances $R_1 = 1.000$ ohms and $R_2 + R_3 = 1.000$ ohms works correctly even with insulation faults on the b-wire of approximately $5 \cdot 10^4$ ohms. The error in the twelfth selecting criterion, for which a resistance of 8.000 ohms has to be inserted in the subscriber's set, then is 0.95 volts. The limit is 1 volt.

With respect to errors in the compensation of the subscriber's line and tolerances of the resistances of the subscriber's instrument, the limit of the insulation resistance of the b-wire to earth has to be chosen at about 10^5 ohms, giving an error in the twelfth selecting voltage of 0.5. The resistance compensation of the subscriber's line in steps of 5 ohms (R_3) can give an error in the normal voltage at point X (fig 5.1) of + or - 0.075 volts. The zero switch of the resistance compensation may have a variation of

its working limits of about + or - 0.025 volts, resulting in a maximum compensation error of + or - 0.1 volts.

A tolerance in the resistances of the subscriber's instrument of 4 % introduces an error in the twelfth selecting criterion ($R_2 = 8.000$ ohms) of + or - 0.2 volts. A tolerance of 1 % in the resistances of the voltage divider network of the receiver results in an error of the highest reference voltage (- 46) of 0.25 as a maximum. The error in the lower reference voltages can be a little larger.

It is advisable to fix the tolerances of these groups of resistances respectively at 2 % and 0.1 % in order to hold the total of all these possible errors in the selecting voltages well within the limit of 1 volt.

It is easy to intermix subscriber's sets having keys with those having dials as already mentioned. Long lines with a resistance of more than 1.000 ohms and lines having poor insulation may be provided with dial sets.

An example of a key strip which can be used in the subscriber's sets of the Bridge Marker System, and of the type fitted on some Ericsson sets, is shown in fig 5.3 and 5.3a. The keys are placed in the same way as is usual on counting and perforating machines in the Hollerith system. Two keys for special purposes are added to the key strip of fig 5.3 in addition to those for the normal ten digits. One of these keys can be used as a starting key when the register is designed in such a way that the positioning of the selector does not begin before all digits are received. Telephone numbers with differing numbers of digits can be used. Further no selectors or lines are engaged unnecessarily. Such a system is only admissible when using high speed selectors.

A special release key can be provided to release engaged subscriber's lines. Further it is possible to provide a special key on the subscriber's sets of the small exchanges in the neighbourhood of a big city so that, when this key is depressed, the register of the small exchange is immediately positioned according to the city exchange number. The starting key can lock all other keys till the end of the call. Then the selecting keys are unlocked by depressing the switchhook of the subscriber's set.

The selecting system described introduces some difficulties in the subscriber's sets. If the microphone of the set remains in circuit with the subscriber's line during the compensation and during the succeeding transmission of the selecting criteria, the

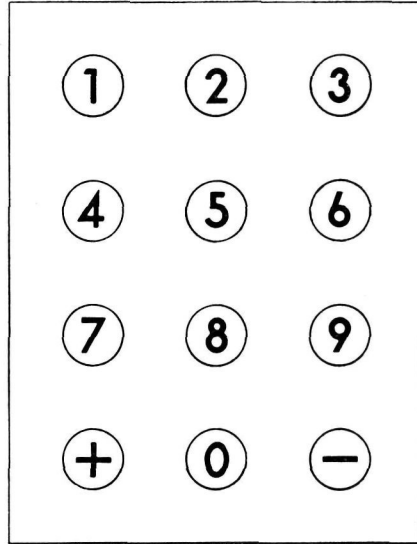

Fig. 5.3 Keystrip of subscriber's instrument.

correct functioning is completely upset by the very variable resistance of this component. This difficulty can be solved by using the set shown in fig 5.4.

The microphone *M* is connected in series with the rectifier *KC*. The a-wire of the subscriber's line is connected to earth in the exchange both before and during the transmission of the selecting criteria. The rectifier *KC* then is in a non conducting condi-



Fig. 5.3a. Subscriber's instrument.

tion so that the microphone is disconnected. The b-wire is connected to earth in the exchange after the transmission of the selecting criteria and also on an incoming call. Rectifier *KC* is then in a conducting condition and the set is in a speaking condition.

The series connection of the microphone and the rectifier gives a small and negligible speech loss. This series connection of a rectifier and a microphone is already used for other purposes in special sets of the Local Telephone Service at Rotterdam.

It will be observed in fig 5.4 that the resistances R_1 to R_{10} are inserted in the subscriber's line by means of break keys. The use of change-over keys for this purpose is not desirable, for an excessively long interruption of the line may occur when a key is depressed too slowly.

The values of the resistances R_1 to R_{10} may be easily calculated when using a steady transmission voltage at point *X* of — 30 and a total resistance of the subscriber's line, the set with lifted telemicrophone and the compensation resistance of 1.000 ohms.

The receiver according to fig 5.5 is designed for the use of a zero switch according to fig 2.11 or 2.13 with an input tube locked. This receiver contains the relays A to K, a voltage divider (R_8 to R_{20}) similar to that of fig 5.1 and a zero switch. The subscriber's set, for simplicity shown as the resistance R_2 , is the same as that shown in fig 5.1. The resistance of the subscriber's line also has to be compensated to a fixed

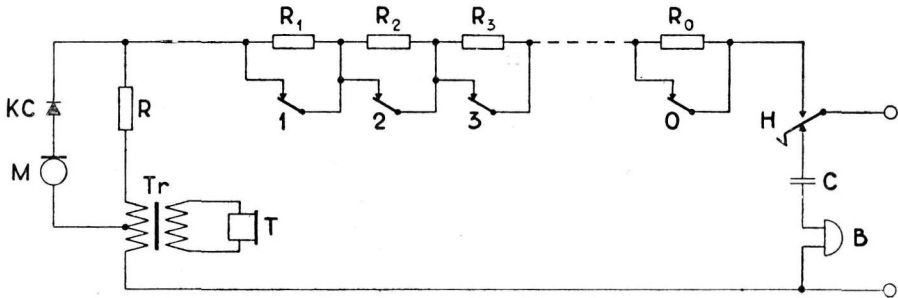

Fig. 5.4. Subscriber's instrument circuit.

value by means of a resistance finder in the register. The steady voltage of point B also is arranged to be -30 and the various transmission criteria have voltage differences of two volts. The first transmission criterion then is -32 volts.

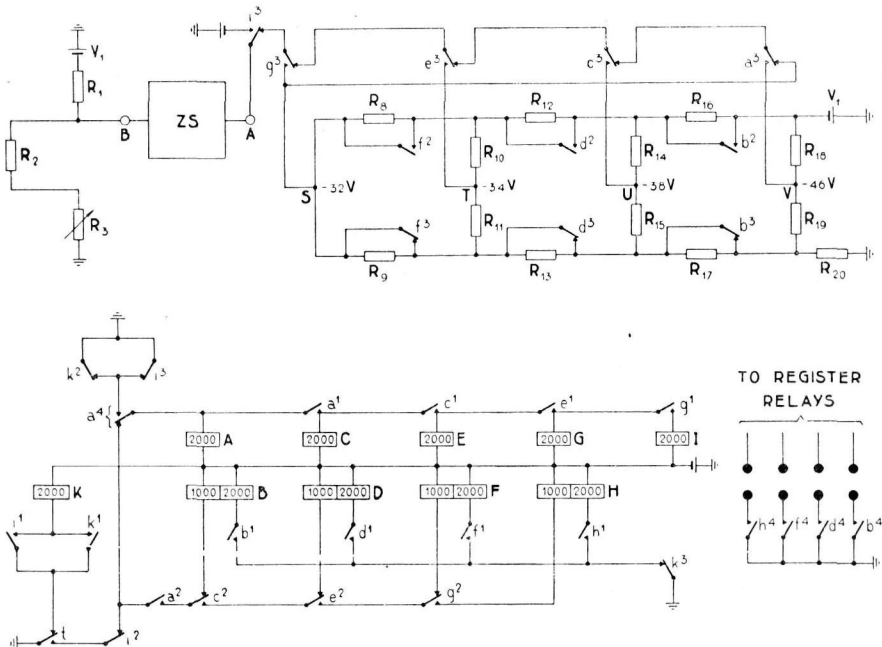

Fig. 5.5. Diagram of a Bridge Marker receiver with one zero switch element and a relay chain.

The zero switch has in its normal condition a potential of -30 volts at point B, and a marking voltage of -32 at point A, which voltage is determined by the voltage divider. The input voltage of the zero switch is then -2 . The zero switch is in the condition of rest because the working limit is -1 volt.

When a key in the subscriber's set is depressed, a transmission voltage of at least -32 will be received. Test relay T in the anode circuit of the final tube of the zero switch circuit operates whatever the selecting criterion may be. Contact t is changed over from the position shown and closes a circuit for relay A. Contact a⁴ puts a permanent earth on the relay chain A, C, E, G and I. Each of these relays closes an operating circuit for the succeeding one. Contact a³ gives a marking voltage of -46 to point A, of the zero switch. If the transmission criterion received has a voltage of -46 or more contact t remains in the changed-over position. If on the other hand, this voltage is smaller than -46 , contact t goes back to the position shown. Only in the first case is a circuit closed for relay B via contact a². Relay B attracts the armature and with contacts b² and b³ changes the rest voltage of point U from -38 to -54 .

The operate times of relays A, C, E, G and I being greater than those of relays B, D, F and H, relay C operates after relay B. Contact c³ changes the voltage of point A of the zero switch from -46 to -54 , relay B being operated. If relay B does not operate due to the transmission criterion concerned having a voltage less than -46 , the voltage of point A of the zero switch is changed to -38 . The zero switch again tests the transmission criterion, i.e. whether the voltage is either positive or negative

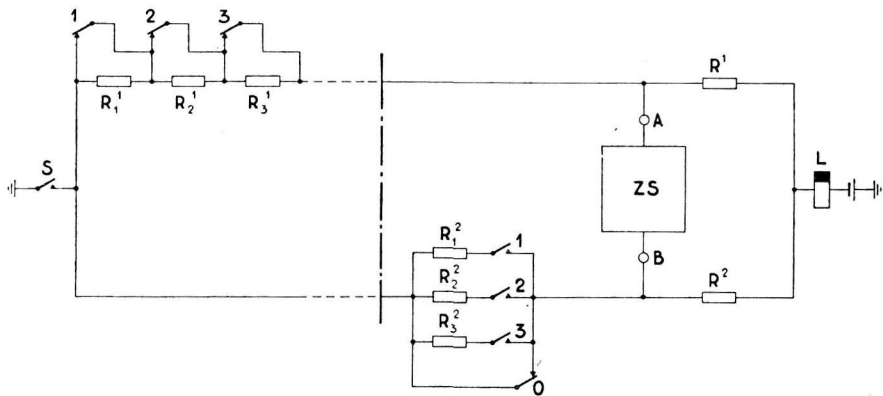

Fig. 5.6. Principle of receiver bridge circuit without compensation of subscriber's line resistance.

with respect to the marking voltage of point B. Depending on this, relay D will be magnetised or not. Because relays B and D have operated, relay E eventually connects to point A of the zero switch the changed marking voltages of point T of the voltage divider network, and so on.

The determination of the transmission criterion is ready when relay I has attracted

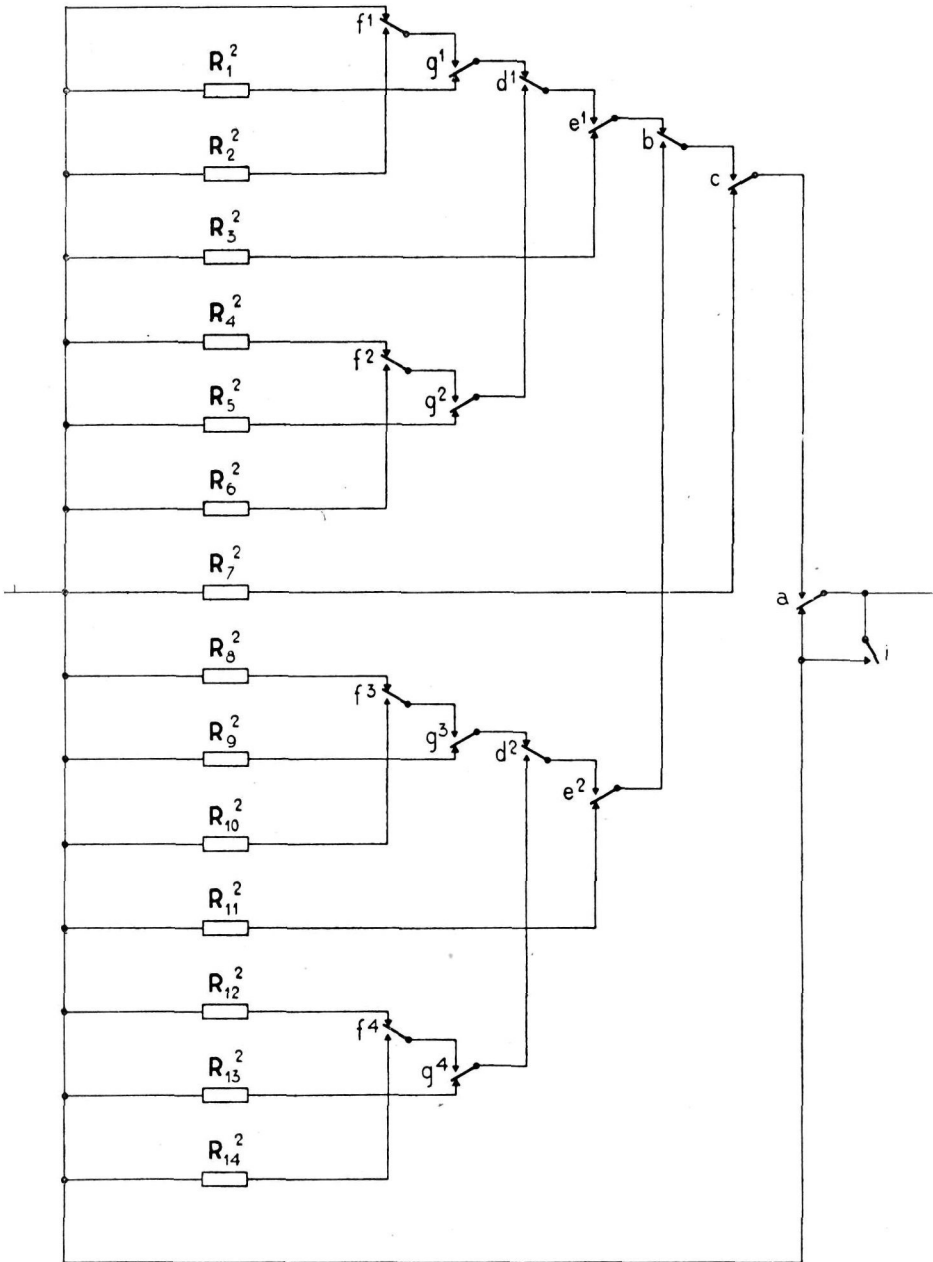

Fig. 5.7. Compensation resistors.

its armature. Relays B, D, F and H are operated in a certain combination, depending on the voltage of the transmission criterion. When giving the values 8, 4, 2 and 1 to the relays B, D, F and H the sum of the values of the relays magnetised is the number of the transmitted selecting criterion. Relay I prepares, at contact i^1 , the operating path for relay K. Contact i^2 interrupts the relay chain, contact i^3 changes the marking voltage of point A to -32 , so that contact t on the end of the determination is always changed over from the position shown in the diagram.

When the depressed key is restored the voltage of point B will change to -30 , so that the potential of point A is at least 2 volts negative with respect to point B. Contact t now comes back to the position shown. Relay K attracts its armature and with contacts k^2 and k^3 respectively interrupts the circuit of relays A, C, E, G, I and that of relays B, D, F and H. The next selecting criterion may now be transmitted.

A condition for the functioning of the receiver according to the diagram of fig 5.5 is that relays A, C, E, G and I must be slower than relays B, D, F and H. This can be obtained by making the windings dissimilar. It is also possible to design the circuit in such a way that all switching sequences are interlocked. Depending on the circuit design the testing time of the selecting criteria can then under certain circumstances become larger than that of the receiver of fig 5.5, which has a constant testing time for each selecting criterion. Alternatively the relay chain of relays, A, C, E, G and I can be replaced by a motor unselector or the like with a control depending on the position of the armature of the test relay.

The transmission of the selecting criteria from a subscriber's set to a register can also be done without automatic resistance compensation. The principle is shown in fig 5.6. The bridge circuit shown is formed after connecting the subscriber's line to the register. Key S of the subscriber's set (which is shown in principle only) is depressed after the receipt of dialling tone. The method of feeding the tone is not shown. As a result of this key operation the dialling tone is cut off. The guard relay L in the register operates to indicate that selection may begin.

The set contains a number of resistances R_1 to R_n in the a-wire. The bridge circuit in the register contains a similar group of resistances in the b-wire. When a subscriber's set key is depressed these resistances in the register can be inserted in the b-wire one after the other by the contacts shown, until bridge balance is obtained.

The bridge circuit has the property that the resistance of the subscriber's line need not be compensated, for the line resistance appears equally in both bridge branches.

In most applications the successive testing of all resistances R_1 to R_{10} needs too much time. It is possible however to use the relay circuit according to fig 5.5 and to determine the resistance of the subscriber's set in four successive tests, similar in principle to that described for that circuit. The resistances in the b-wire of the register can for example be connected as is shown in fig 5.7. Normally the b-wire is connected

through without any resistance. The zero switch starts when a key in the subscriber's set is depressed. The relay chain then connects a resistance in the b-wire according to the seventh resistance of the subscriber's set. The zero switch then tests if the resistance inserted in the subscriber's set is larger or smaller than the resistance inserted in the b-wire. If the zero switch finds the inserted resistance to be greater than the seventh

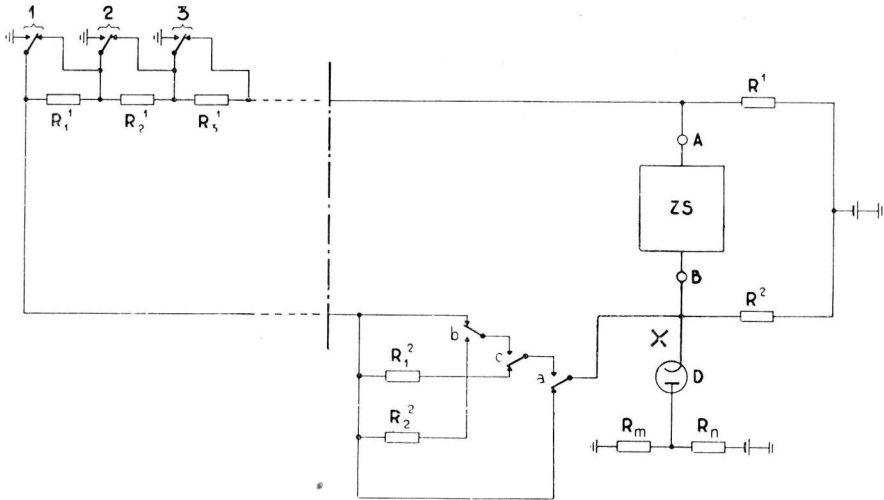

Fig. 5.8. Principle of receiver bridge circuit using make-before-break contacts in the subscriber's instrument.

one, relay B operates and the second test investigates if the inserted resistance is larger or smaller than the eleventh resistance of the subscriber's set.

If in the first test, the zero switch finds the inserted resistance in the subscriber's set to be smaller or equal to the seventh resistance of the subscriber's set, relay B is not operated, and the second test investigates if the inserted resistance is larger or smaller than the third resistance of the subscriber's set. In this way the selecting criteria are determined in four successive stages. The received selecting criterion is determined by the variations of the operation of four relays (B, D, F and H of fig 5.3) in the so-called 1,2,4,8-code.

An experimental circuit according to figs 5.5 and 5.7 has been made. It worked according to expectations.

Further by using make-before-break contacts to earth for inserting resistances in the a-wire, as is shown in principle in fig 5.8, it proved possible to eliminate the key S in fig 5.6 which has to be depressed after the receipt of dialling tone. The microphone can be disconnected by an auxiliary contact not shown. The difficulty in this diagram is however, that during the transmission of the selecting criteria precautions must be taken against the subscriber restoring his handset. In order to detect this a diode D

is connected between point X of the bridge circuit and the tap of the voltage divider R_m/R_n . With a battery voltage of -60 , the voltage of point X for example is less than -56 during the transmission of the selecting criteria. The voltage divider R_m/R_n then indicates a voltage of, e.g. -57 , so that the diode D is in the non conducting condition. When the calling subscriber hangs up during the transmission of the selecting criteria, the loop via the subscriber's instrument is opened and the diode D becomes conducting. The voltage of point X then changes in e.g. -58 volts. The zero switch is not in balance. The relay chain connecting the resistances R_1 to R_n in the b-wire then tries to connect the highest possible resistance in the b-wire of the subscriber's line. Relays B, D, F and H will all be operated in this case. The same occurs in the other circuits described.

Dialling tone can be induced on the subscriber's line in one of the usual ways. Because of its low voltage and high frequency (0.12 volts, 450 Hz) the tone does not disturb the balance of the bridge.

PBX-LINES

The provision of P.B.X.-lines is important for the usefulness of automatic switching systems. In most of the existing systems a number of consecutive subscriber's lines can be taken together as P.B.X.-lines with the number of the first line as the group number. The final selector in these systems has switching means such that when dialling the group number, the successive lines of the group are tested until a free line is found, or until the test wiper has reached the last line of the P.B.X.-group.

In several systems auxiliary start and stop-positions not connected to subscriber's lines are necessary on final selectors for marking the lines of a P.B.X.-group. In other systems these special positions are not necessary. In some cases a stop position can be combined with the start position of the successive P.B.X.-group. Other systems are made in such a way that the successive lines of a P.B.X. are only searched for a free line when the group number is dialled; but when the number of one of the intermediate lines is dialled the final selector will be positioned on that special line, the group test of succeeding lines not being made in this case. This is important for use with those lines of a P.B.X., which are connected through for special services after office hours.

The restriction in the grouping of P.B.X.-lines, e.g. that only consecutively numbered lines may be used as such, and some systems moreover that these lines have to be chosen in a single decade, is not desirable; as, especially in big city exchanges a large number of final selector outlets has to be reserved for the extension of P.B.X.-lines.

In the Local Telephone Service at Amsterdam an exchange has been developed to meet these P.B.X.-line requirements. By means of motor uniselectors it is possible to group subscriber's lines of any hundreds group into a single P.B.X.-number regardless of the numbering in the group. If necessary an arbitrary number of lines outside the numbering scheme may be provided; these lines can not be individually selected.

A common requirement of a modern automatic switching system is the provision of P.B.X.-lines throughout the whole exchange without the use of auxiliary positions on the final selectors. A further requirement may be the availability of an unrestricted number of lines of a P.B.X.-group. Facilities for the individual selection of each line of a P.B.X. may be desired. It is desirable with respect to the restriction of the number reserve of P.B.X.-lines, that the lines within a hundred can be joined in an arbitrary

way to P.B.X.-groups, in some cases together with some unnumbered lines. This latter possibility may be restricted to some special hundreds.

P.B.X.-lines in the Bridge Marker System can be provided in a simple way in the final selector circuits described (fig 3.4, 3.7 and 3.8) in cooperation with the subscriber's line circuits (fig 4.3). Resistance R_5 of the subscriber's line circuit characterises a called

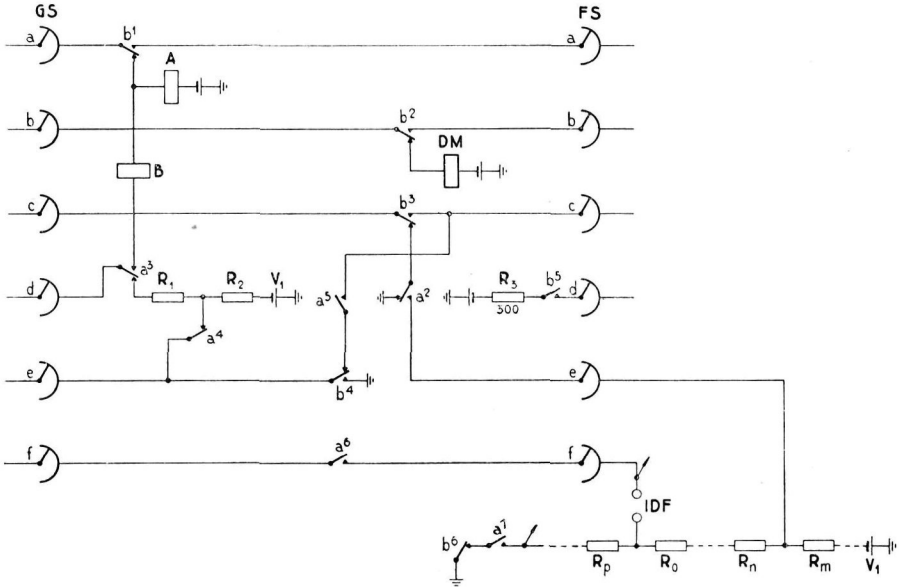

Fig. 6.1. P.B.X. final selector circuit.

subscriber. This feature means for example that the line concerned is the first or starting line, an intermediate line or the last or stopping line of a P.B.X.

When a register stops the final selector on the wanted position the test of the characteristic of the called subscriber's line follows. That is, whether the subscriber's line tests free after the seizure of the line or whether the line is characterised as busy by means of that feature of the subscriber's circuit. In order to test the conditions there is in both cases a resistance of 5.000 ohms (R_7 in fig 4.3) in the register connected to the c-wire of the subscriber's line circuit. This gives a characterising voltage to the c-wire, which is determined by the value of the characterising resistance R_5 (fig 4.3). This voltage can be tested by means of the receivers described in chapter 5. The characterising voltage of the c-wire of the first line of a P.B.X. can, for instance, be fixed at -32 . The voltage of the intermediate lines at -34 and that of the last line at -36 . Normally a P.B.X.-line has earth potential on the c-wire of its subscriber's line circuit. When the line is engaged this changes to one of the three voltages mentioned.

When the register has determined the busy line feature to be that of the first line of a P.B.X., two zero switches are connected in the register to the c-wire of the

subscriber's line circuit, one for the control of the busy condition of the intermediate lines and the other for the stopping of the selector on the characterising voltage of the last line. The first of these zero switches is a busy test device, being for example, a tube circuit according to fig 2.11. This circuit can only determine whether the c-wire is at earth potential or not. The working limit of the testing device has to be fixed at -1 volt input. The second zero switch is a normal one similar to that in fig 2.13, which has a marking voltage of -36 , so that it only works when testing the characteristic voltage of the stop line of the P.B.X. in its busy condition. The final selector hunting for a free line in a P.B.X. under the control of the two zero switches mentioned only stops on a free line or on the stop line.

The P.B.X.-lines in the described Bridge Marker System needs just as many final selector positions as lines. This has no unfavourable influence on the number capacity of an exchange. A P.B.X. can eventually take all hundred lines of a final selector. The smallest P.B.X. consists of two lines. When the lines are grouped in the most favourable way a final selector may contain 50 of the P.B.X.'s each having two lines.

It is also possible to create P.B.X.-lines by disturbing the control voltage of the start line and the intermediate lines. The intermediate lines in this system need the same control voltage, when not engaged, as the start line. The final selector then functions in the same way as the group selectors. This method however has the disadvantage that the subscriber's lines and the stop lines are not individually numbered.

The final selector circuit of fig 6.1 gives complete liberty in grouping P.B.X.-lines. This circuit differs from the selector circuits already shown, in that a sixth wiper is added which is connected to the circuits in the register via a separate wire. The contacts of the final selector bank corresponding to the sixth wiper are connected with an auxiliary distributing frame. By means of this distributing frame it is possible to combine arbitrary positions of the final selector into a single P.B.X.-group with the aid of the same auxiliary control voltage connected to the relative contacts of the sixth bank of the selector.

The register now tests, after the positioning of the final selector and the busy test of the subscriber's line concerned using a receiver as described in chapter 5, the auxiliary voltage of the f-wire of the subscriber's line circuit. This voltage being reproduced in the register, is connected to the zero switch. The final selector is now restarted and hunts for the reproduced auxiliary P.B.X.-control voltage.

The movement of the final selector may be interrupted only when the zero switch tests the auxiliary control voltage of the f-wire and simultaneously the testing device, connected to the c-wiper of the final selector, tests the line concerned as not engaged. The final selector in this way hunts continuously for a free subscriber's line in the P.B.X.-group concerned. It is possible to interrupt the continuous hunting and to stop the final selector on a determined outlet. This may be necessary for offering calls by operators.

6.4

It is possible without other means to add auxiliary lines outside the numbering scheme to a P.B.X.-group when the final selectors have 200 positions divided into four sections of 50, the final selector circuit needs a wiper switching relay. This system is not well suited for exchanges with standardised selector circuits.

Selectors having 120 tot 130 outlets are preferable with respect to a regular distribution of the P.B.X.-lines within the 100-groups of an exchange. One hundred outlets are then used for ordinary subscriber's lines, and the other 20 or 30 positions can be used as auxiliary P.B.X.-lines.

It is also possible when using selectors with 100 positions to divide certain hundreds into two groups of 50 numbers, 50 being lines of the normal numbering scheme and 50 auxiliary lines.

THE CORD CIRCUIT AND THE REGISTER

After being started by a call detector a register hunts for a free cord by means of a cord finder which is positioned by the Bridge Marker method described in chapter 3. The complete cord circuit (fig 7.1) consists of a (second) line finder and a first group

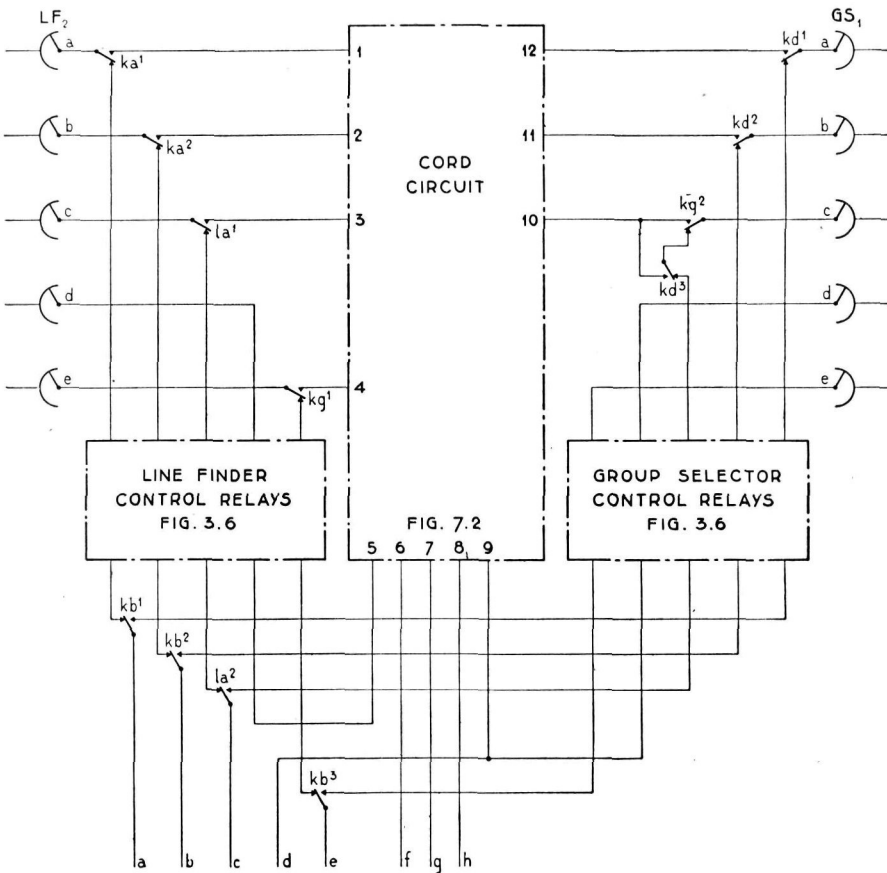

Fig. 7.1. Cord circuit.

finder and the cord finder. The wires are first used for the positioning of the line finders by the register; subsequently the a- and b-wire are used for the transmission of selecting criteria between subscriber's set and the register.

When using high speed motor uniselectors it is permissible to delay the positioning of the successive selecting stages until all digits are received in the register. The a, b, c and e wipers of the cord finder can then be switched over by the circuit of the control relays of the first group selector by connecting the f-wiper to earth, so that a corresponding relay in the cord circuit is operated. This switch over is effected by contacts kb¹ to³ and la². The calling subscriber then is connected by contacts ka¹, ka² and la² to the cord circuit proper. The positioning of the successive selecting stages now begins.

If the positioning of the selecting stages has to be started during the receiving of the selecting criteria, it is impossible to switch over the a- and b-wipers of the cord finder for these have to serve for the transmission of the selecting criteria. In this case the cord finder has to be provided with two more wipers. By combining various functions on the same wire, the number of wipers can be reduced to eight or nine.

The circuits connected with the line finder and group selector control relays, which are coupled straight to the cord circuit, can be made identical to the control circuits already described. The control voltage divider characterising the input of the group selector circuit, has to be disconnected in this case. It is also possible to take these control circuits up into the cord circuit proper.

An example of the diagram of a cord circuit is shown in fig 7.2. This circuit can be designed in various ways, depending on the properties desired in the switching system. It is convenient to give a short description here in order that an insight into the construction and functioning of an exchange according the described development may be obtained.

Relay KE is operated by the register when the latter engages the cord circuit. This relay prepares the various circuits and remains operated during the whole period of cooperation between the register and the cord circuit. The register transmits dialling tone after positioning the line finders (ev. resistance finder) and after determining the characterising features of the calling subscriber. The calling subscriber transmits the selecting criteria. After receiving all the digits, the register closes the circuit of relay KA (2.000). Contacts ka¹ and ka² (fig 7.1) connect the subscriber's line to the winding of the feeding relay LA. Contact la¹ connects the c-wire of the subscriber's line circuit to the holding winding of relay KA (5.000). This gives the characterising voltage to the c-wire. Contact la³ closes the circuit of the slow releasing auxiliary relay KB (2.000), which completes the switching over of the control wires of the selector circuits, the switching being already initiated by contact la². Contact kb⁵ breaks the magnetising circuit of relay KA (2.000) as a sign of the completion of the switch over. After that the register positions the selecting stages. The register interrupts the circuit of relay KE of the cord circuit if the called subscriber is busy or if the

building up of the connection does not succeed. Contact ke^1 closes a circuit for the busy tone which is induced on the speaking wires via the closed contact la^4 and via a second winding of the coil Sm . Relay LA restores when the calling subscriber hangs up. Contact la^1 then breaks the holding circuit of relay KA (5.000) which also releases the circuit of the auxiliary relay KB being already interrupted at contact ke^2 . The holding circuit of the control relays OA and OB of the second line finder is interrupted by contact ka^3 . These relays release. The circuit of the first line finder engaged by the cord circuit is also released.

If the called subscriber is free a circuit in the register is closed for relay KD in the cord circuit. Contacts kd^1 and kd^2 connect the speaking wires to the cord circuit proper. Contact kd^4 closes the circuit of relay KF from earth via contact ke^4 , winding KF 2.000, contacts kd^4 , kg^4 , kn^4 , resistance R_2 of 400 ohms to negative battery. Contacts kf^1 and kf^2 connect the called line to the ringing generator via the winding of a control relay KG 500. Contact kf^4 interrupts the circuit of relay KE . This gives a check to the register that the cord circuit is actually in the ringing condition. Relay KE demagnetises with possibly a delay of one second. The way in which the delay is obtained is not shown in the diagram. It is possible to control this delay by means of electrolytic condensers. The called subscriber now receives a first ringing tone with a duration of the one second mentioned.

After relay KE restores, ringing goes on in the normal way, until the called subscriber answers by lifting the handset from the switchhook. Relay KG now attracts its armature due to the direct current of the subscriber's line. Contact kg^1 (fig 7.1) connects through the metering wire and contact kg^2 connects through the c-wire between the cord circuit proper and the final selector. Contact kg^3 interrupts the operating circuit of the ringing relay KF , and closes a holding circuit for its own winding. Contacts kd^5 and kg^4 close a holding circuit to earth for the control relays of the first group selector and the line finder. An operating circuit for the feeding relay LB of the called subscriber is now closed via contacts kf^1 and kf^2 and the speaking wires via the groupselectors and the final selector. The connection is now in the speaking condition.

Contact kf^4 interrupted the operating circuit of relay KE when starting the first ringing tone. This is the criterion for the register to release.

The cord circuit is designed in such a way, that the connection is immediately released when the calling subscriber hangs up. The connection is released with a delay of some seconds when the called subscriber hangs up. When the calling subscriber hangs up the feeding relay LA is restored. Contact la^1 interrupts the holding circuit of relay KA . Contact ka^5 closes the circuit of the metering wire. Contact ke^4 restores the slow releasing relay KG . Contact kg^1 (fig 7.1) then interrupts the metering wire and the call is metered. The line finder circuits are now released by the interruption of wire 5 (fig 7.2) because contacts ka^3 , ke^3 and kg^6 are all open.

The called subscriber who has not yet hung up receives busy tone which is transmitted in a circuit via the closed contacts lb^2 , ke^1 and ka^6 . As soon as the called subscriber hangs up, relay LB releases its armature. Relay KD also releases its armature, contacts la^5 and lb^3 now being both opened. Contact kd^5 breaks the holding circuit of the engaged group selectors. The cord circuit is released.

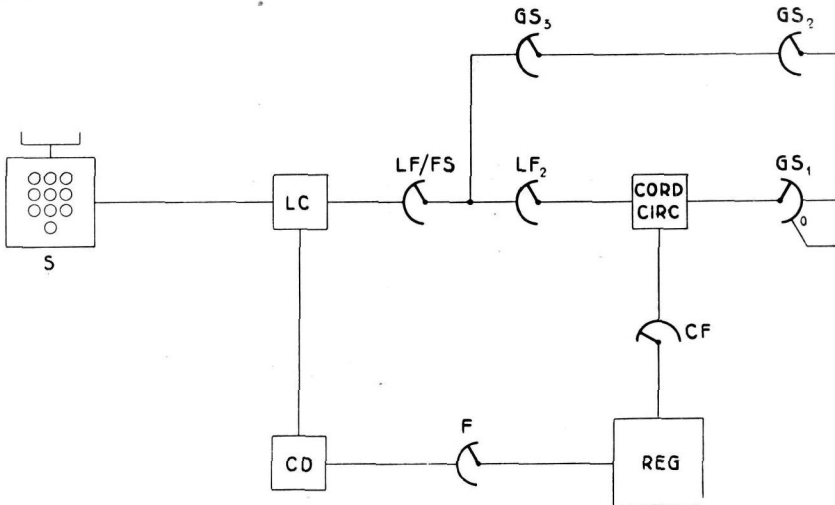

Fig. 7.3. Junction diagram of local exchange.

The called subscriber released relay LB when he hangs up. If the calling subscriber does not replace his handset a thermo relay is enabled to function via the closed contact lb^1 , which interrupts the holding circuit of relay KD (500) after a delay of some seconds. Busy tone is now transmitted to the calling subscriber and the selecting stages are released by the opening of contact kd^5 . The armature of relay LA is released when the calling subscriber replaces his handset. Consequently, relay KA releases, and after some delay relay KG follows. This transmits a metering impulse to the subscriber's meter in a way already described.

An existing connection can be released by connecting the c-wire of the subscriber's line circuit to negative battery. Relay KA or relay KD of the cord circuit is then released depending on whether the calling or the called subscriber is being disconnected. Busy tone is then transmitted immediately to the unwanted subscriber.

Moreover it is possible in an easy way to provide the cord circuit with special features such as means for multiple metering means for transferring the metering from the calling subscriber to the called subscriber and so on.

Other ways of releasing the connection can be applied to the designed cord circuit. It is not the purpose of this thesis to describe in detail these facilities which can be obtained by means of normal circuit arrangements.

After the above description a short reference to the functions of the register may suffice. A detailed specification has to contain a dry enumeration of all successive circuits, which are constructed with the normal switching means. These switching means connect the zero switch at the right moment to the right circuits for determining a bridge balance. The description of the various devices has probably shown that practically all functions of the normal telephone switching systems which are transmitted by means of impulses or impuls series, can also be performed with the balance of direct current Wheatstone Bridges. The interworking with a complete register of the devices described belongs to normal switching techniques, and is beyond the scope of this thesis.

A register contains mainly:

- a.* A receiver according to fig 5.1 or 5.5 for receiving the selecting criteria and for determining the special features of the subscriber's circuit.
- b.* Optionnally, a relay counting device in the 1,2,4,8-code for receiving series of dialling impulses.
- c.* A relay register with four relays for each digit to be stored.
- d.* A sequence switch for the successive distribution of the received digits to storage relays.
- e.* Optionnally, a sequence switch for the control of the positioning of the successive selecting stages.
- f.* Optionnally, a resistance finder for the compensation of the subscriber's line resistance when using the receiver according to fig 5.1.
- g.* A zero switch according to fig 2.13.
- h.* A test device for the busy control of subscriber's line circuits with the tube circuit as mentioned under point a or g.

The following functions have also to be performed by registers:

1. The registers hunt for an operated call detector by means of a finder (fig 7.3). The call detector gives two marking voltages to the register, one for the positioning of the cord finder and one for the control of a second line finder.
2. The positioning of a cord finder on a free cord circuit having access to the group of subscriber's comprising the calling one.
3. The positioning of a second line finder on a circuit of a free first line finder belonging to the group of subscriber's which contains the calling one.
4. The positioning of a first line finder (optionnally combined with the final selector) on a calling subscriber's line without connecting the line finder circuit through to the selecting stages.

7.7

5. Determination of the characterising feature of the calling subscriber.
6. Throughconnecting of the line finder circuit, which balances the subscriber's line circuit and neutralises the call detector when no other calls exist in his group of subscribers.
7. Compensation of the resistance of the subscriber's line.
8. Transmission of dialling tone.
9. Reception and storage of the successive digits, eventually followed by a starting criterion.
10. Switching over of the control wires in the cord circuit from the relay circuit of the second line finder to that of the first group selector, when the positioning of the selectors is started after the receipt of the complete number.
11. Positioning of the group selectors.
12. Positioning of the final selector, without connecting the final selector circuit through to the speaking condition.
13. Busy testing and engaging of the called subscriber by changing the voltage of the c-wire of the subscriber's line circuit.
14. Determination of the characterising voltage of the c-wire.
15. Optionnally restarting of the final selector on P.B.X.-lines.
16. Through connecting of the final selector circuit.
17. Disconnection of the register. (The cord circuit performs all further functions, e.g. ringing etc.).

MAJOR AND MINOR EXCHANGES

The described control system based on the balance of direct current Wheatstone Bridges is limited to a single exchange as far as the positioning of selectors by a register is concerned. However it is possible to transmit the selecting criteria from one exchange to another by means of the system described in chapter 5 providing a direct current path is available. Selectors in another exchange can be positioned by means of an input register in that exchange. The positioning of a selector in one exchange under the control of a register in another exchange raises difficulties caused by differences in battery voltage, differences in earth potentials and so on. The construction of small terminal exchanges and main exchanges is too expensive when the junction lines have to be provided with registers.

The expected number of subscriber's lines in many of the terminal exchanges of the rural automatic networks in the Netherlands will most probably remain under 100 or 200 even in the distant future. These terminal exchanges are permanently unstaffed. These small exchanges become too expensive because of the relatively large number of registers required when the exchanges are designed to be independant exchanges according to the principles described in the thesis.

Traffic research has shown that for the circumstances prevailing in the Netherlands only a small internal traffic is to be expected in these small rural exchanges. It is then admissible to lead the entire traffic via the main exchange so that all registers are concentrated in the latter. This gives the advantage that the total number of registers decreases; moreover they are installed in a permanently staffed exchange.

The combined line finder and final selector circuit of fig 8.1 is well suited for installation outside the main exchange in satellite or terminal exchanges. The transfer of such a combined circuit from the main exchange to a terminal exchange requires, as may be seen in fig 8.1 six wires in each case.

The voltage divider giving the control voltages for the positioning of the final selector can be connected to the battery in the main exchange via a common pair. This may be done as long as the distance between main and terminal exchanges is such that the resistance variations of the feeding wire of the voltage divider give only negligible errors in the control voltage. The system can be applied as a rule when the current in

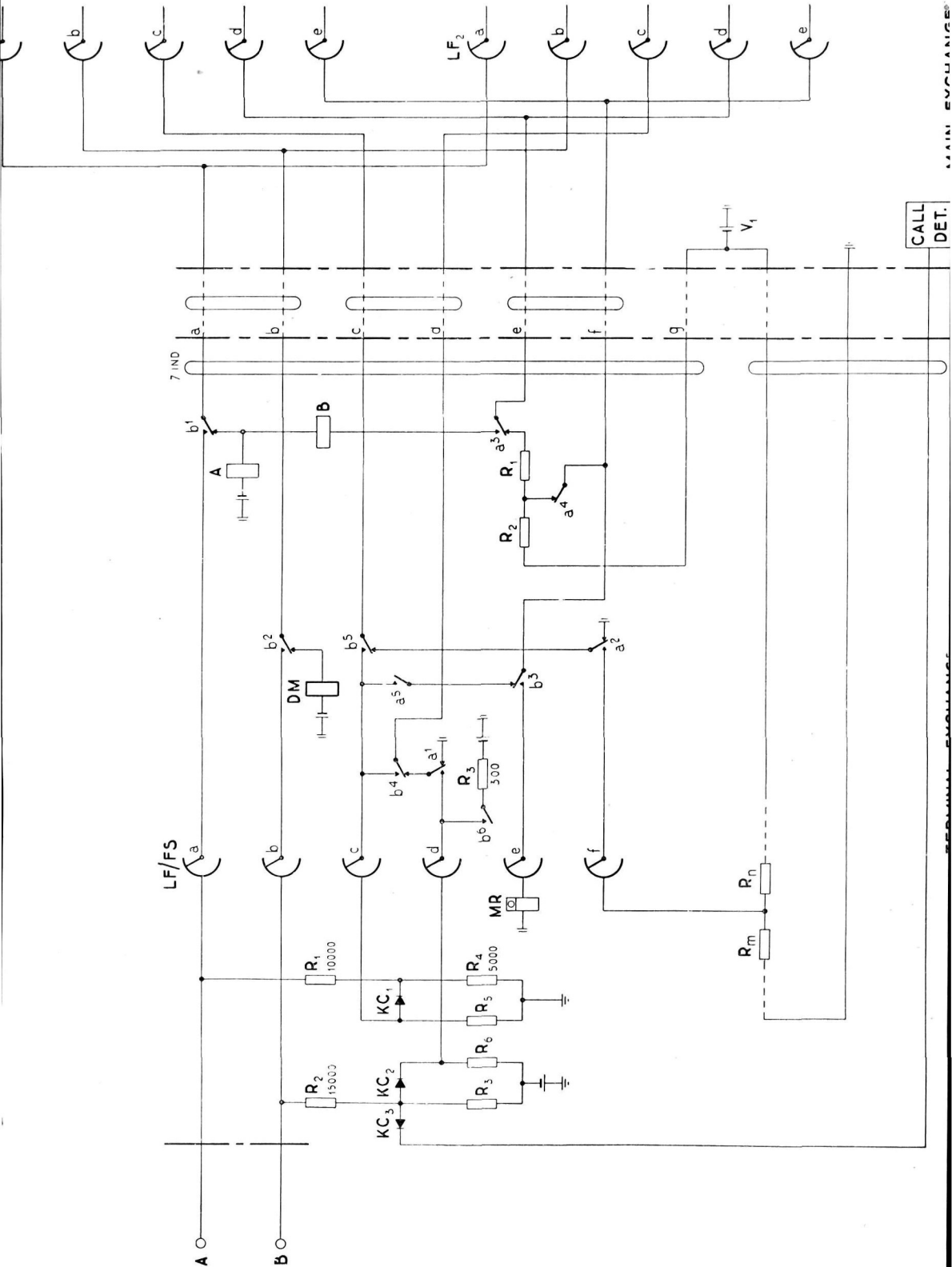

Fig. 8.1. Combined line finder/final selector circuit.

the control voltage divider is 10 mA. The interconnection of terminal and main exchanges gives no difficulties in principle when combined line finder and final selector circuits are used.

The voltage divider R_1/R_2 , which determines the control voltage of the input of the combined circuit may not be connected to the feeding wires of the control voltage divider of the final selector for it represents a variable load. These voltage dividers are connected to the feeding wires when the second line finder or the last group selector hunts for a free outlet in the group concerned. It is therefore possible that a number of second line finders and last group selectors move simultaneously in the group. This difficulty can be solved in two ways.

- a. By individually connecting the control voltage dividers R_1/R_2 to the main exchange via a seventh individual wire.
- b. By placing the control relays A and B of the combined finder selector circuit in the main exchange. In the terminal exchange only the selector/finders with their driving magnets are mounted. This solution also requires seven wires per circuit.

The call detector can also be mounted in the main exchange. This only costs one double wire for a whole terminal exchange of 100 numbers. In this way it is possible to construct subsidiary exchanges without registers and control circuits, their design being simpler than those according to the existing systems. They need, however, a larger number of connecting wires per selector circuit.

The solution above mentioned may not always be effective, in cases for example where the distance between the main and terminal exchange becomes too large and when various exchanges have to cooperate with the selecting stages in another exchange as happens in the networks of big cities.

The principle of a general solution of the direct interworking of a register in one exchange and a selecting stage in another exchange is shown in fig 8.2. This figure shows the circuit of a group selector situated in a different exchange from that of the controlling register. The wires f and g in this figure, the so called voltage reproduction wires, connect both poles of the control voltage source V_1 of the selector in the distant exchange to the so-called voltage reproducer in the controlling register. This device, in principle known from the technique of stabilisation of power supply, contains a tube B_1 , the voltage source V_2 not being connected to earth and a number of loading resistances connected in series or parallel from which four (R_3/R_6) are shown for example in fig 8.2. The control grid of tube B_1 is connected to the other reproduction wire.

The functioning of tube B_1 is such, that the anode current assumes such a value that the output voltage of the voltage reproducer minus that of the control voltage source is equal to the negative control grid voltage for that value of the anode current. When the voltage V_1 increases the voltage V_3 of the voltage reproducer also will increase, so that this device responds according to its name.

8.4

For further explanation of the operation of the diagram is assumed that the voltage difference between the voltage sources V_1 and V_3 is negligible.

The Wheatstone Bridge is built up in the case shown in fig 8.2 from the branches R_m and R_n belonging to the control voltage divider in the distant exchange and the resistances R_3 to R_6 in the register, which are joined together via the f-wire. This

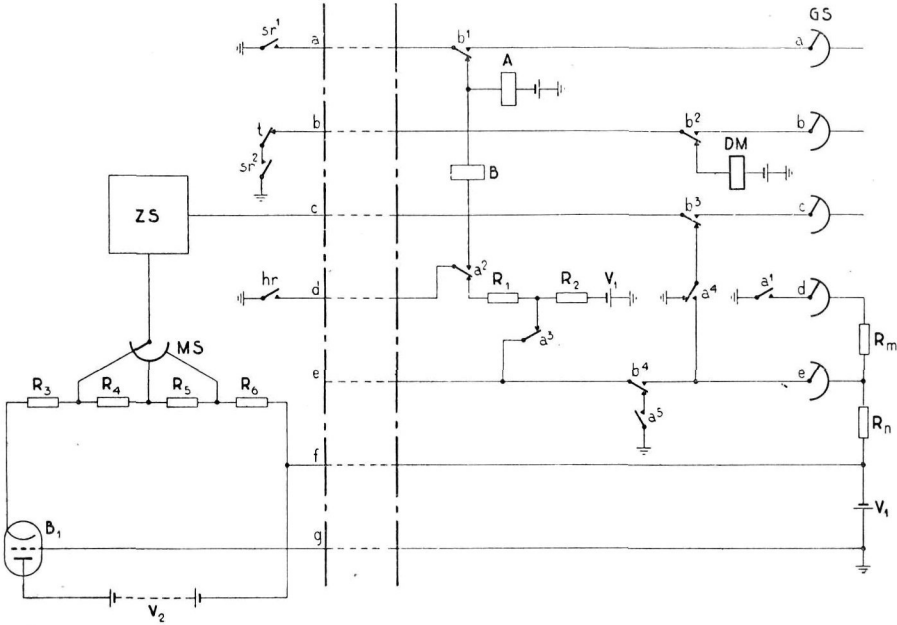

Fig. 8.2. Principle of the positioning of a selector in a terminal exchange.

single connection is sufficient to obtain the cooperation of two branches, which are coupled to two different voltage sources, so as to give equal voltages in the manner of a normal Wheatstone Bridge. The positioning of the group selector according to fig 8.1 is thus accomplished entirely without the aid of the control voltage battery in the register exchange.

The voltage reproducer according to fig 8.2 does not reproduce the voltage of the battery in the distant exchange with the utmost accuracy. There remains a slightly varying difference between the reproduced voltage and the voltage to be reproduced. This reproducer with one tube may suffice in some cases when using a tube with a very high slope (20 mA/v).

The diagram according to fig 8.3 satisfies all possible requirements. This diagram contains three tubes type 18040 (Philips). Tube B 3 is the voltage reproducing tube proper. Tubes B_1 and B_2 are connected in a normal amplifier stage according to fig 2.11.

There is however a difference in principle in the action of the amplifier stage of fig 8.3 and that of fig 2.11 used as a zero switch. The tubes in the zero switch circuit of fig 2.11 are either completely conducting or completely non conducting. In the application of this amplifier circuit to the voltage reproducer of fig 8.3 the tubes are used in the variable part of the characteristic, for they have to serve as a regulation device.

The voltage V_b to be reproduced is connected to the input of the amplifier circuit (tubes B_1 and B_2 of fig 8.3). The output of this amplifier is coupled to the regulator tube B_3 . The voltage reproducer according to fig 8.2 gives a slightly varying voltage difference between the reproduced voltage and that to be reproduced. This difference consists of the negative control grid voltage of the regulator tube in the working point, while the variation of the difference is determined by the slope of the regulator tube. This variation can be eliminated by connecting an amplifier, for example according to fig 2.11 to the regulator tube of fig 8.2. A constant difference between the reproduced voltage and that to be reproduced, originating from the negative control grid voltage of the input tube B_1 of the amplifier circuit then remains. This can be compensated by coupling the cathode of the amplifier tubes B_1 and B_2 to that of the regulator tube B_3 via a constant voltage, which is obtained in fig 8.3 by the voltage divider R_1/R_2 . This voltage divider is connected to a stabilised voltage of an auxiliary power supply. The voltage reproducer now can be adjusted in such a way by varying resistance R_1 ,

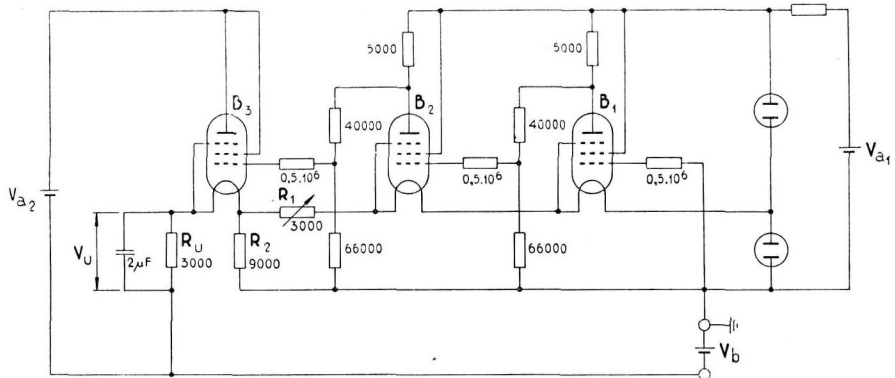

Fig. 8.3. Voltage reproducer circuit

that the reproduced voltage V_u is equal to the normal voltage to be reproduced. The voltage drop across resistance R_1 is then equal to the negative control grid voltage of the input tube B_1 of the amplifier circuit.

The following table gives some results of the accuracy of the voltage reproducer according to fig 8.3, obtained by a compensation method.

$V_{a_2} = 200 \text{ V}$	$R_u = 3000 \text{ ohms.}$
V_b	V_u
80,00	79,93
70,00	69,96
60,00	60,00
50,00	50,04
40,00	40,05
30,00	30,05

The reproduction can be improved by increasing the voltage V_{a_2} . The accuracy of the voltage reproducer is however sufficient for all practical purposes in the designed switching system. The reproduction is sufficiently constant with variations of the different voltage sources. Variations in the characteristics of tubes B_2 and B_3 have practically no effect on the operation of the reproducer. Changes of the characteristic of the input tube B_1 give a voltage difference between both voltages, which can be eliminated by readjusting resistance R_1 .

The circuits shown of the voltage reproducer have the disadvantage that two separate voltage sources V_{a_1} and V_{a_2} are necessary.

The subscriber's may be provided, as is described in chapter 4, with a number of special characterising features by means of resistances in the subscriber's line circuit. These resistances give a characterising voltage when connected in series with a determined fixed resistance, the value of which voltage has to be determined in the register

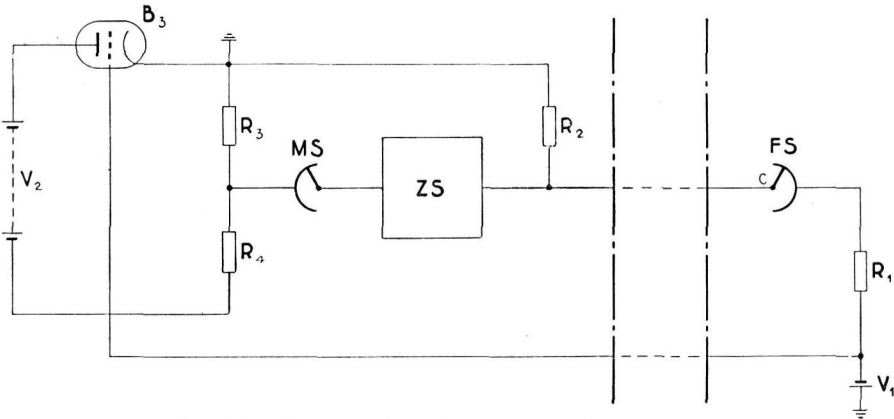

Fig. 8.4. Circuit for determining characterising resistances.

of the main exchange when the subscriber of a terminal exchange is the one concerned. In that case it is possible to provide the same service to the subscriber's of the small terminal exchanges as to those of the big exchanges.

The circuit for determining a characterising resistance R_1 in the case of a subscriber in a terminal exchange by means of a register in the main exchange is shown in fig 8.4.

The characterising resistance R_1 is connected to the zero switch in the register via the c-wiper of the final selector and c-wire shown. The other input wire of the zero switch is connected to the wiper of marking switch MS which tests the marking voltages of the voltage reproducer. The c-wire is connected via resistance R_2 to one pole of the voltage reproducer in the register, so that the normal bridge adjustment can be made. This was described with reference to fig 8.2.

The actual voltage to be reproduced is, in the example, equal to the battery voltage V_1 plus or minus the possible earth potential difference between both exchanges. This earth potential difference has no effect, for it is connected in series with the battery V_1 and is therefore part of the total voltage which is reproduced with great accuracy.

It is not necessary to detect the characterising features by means of a marking switch MS. For this purpose the methods described in the last part of chapter 5 for the reproduction of selecting voltages may also be used.

The variations of the resistance of the c-wire, such as are caused by temperature variations, influence the accuracy of the detection of the feature. The methods described may be used as long as these variations remain small in respect to the value of the characterising resistance R_1 (which has to be adapted to the length of the c-wire).

As it is not easily possible to determine the special features of the remote subscriber when voltage differences of two volts are used unless a voltage reproducer is employed, it will be necessary to provide the registers in the main exchanges with such apparatus. The voltage reproducer may be omitted in some cases when it is permissible to reduce the number of the characterising features of the subscribers at the terminal exchanges.

In this case it is necessary to increase the voltage differences of the features. The type of satellite or terminal exchanges described here above can only be made when the control magnet of the combined line finder/final selector has the properties of a normal relay, as is the case in a newly developed selector of the Bell Telephone Mfg Co at Antwerp.

Besides the problem of the small terminal exchanges, there is in the development of an entire switching system the problem of the construction of very big automatic trunk exchanges. However, when using hundred point uniselectors and a number of outgoing trunks which is a little more than one hundred, it is not possible without the application of special means to provide full availability groups of outgoing trunks. A solution of this problem for a limited number of trunks may be obtained by using group finders instead of group selectors. Figs 7.3 and 8.5 together show the complete junction diagram of an automatic exchange according to the system designed.

The calling subscriber in fig 7.3 starts the call detector CD via the line circuit LC, to engage a register for finding back the calling detector. The engaged register hunts for the calling line by means of a cord finder, a second and a first line finder. The calling subscriber transmits the selecting criteria after receiving dialling tone. Connection to the trunk exchange is obtained by dialling zero. The subscriber then is connected to a trunk register (fig 8.5) via the tenth level of the first group selector (fig 7.3). This trunk

register can be started by a call detector to search for the calling line in the same way as is described for subscriber's lines. The subscriber thereupon transmits the number of the wanted exchange to the trunk register (TREG) when the system is designed in such a manner that a subscriber has to wait for the second dialling tone after transmitting zero. This is the simplest solution. When no second dialling tone is used, the local register has to retransmit to the trunk register the exchange number received.

The trunk register is permanently connected to a first group selector GS_1 , which has access to the second group selectors GS_2 . These latter group selectors have access only to the trunk lines in a given direction and to the corresponding overflow lines.

The register engages a free outgoing trunk line in the wanted direction via the group selectors. Subsequently the further building up of the connection may be executed via the group selectors positioned in any desired manner. The trunk register simultaneously positions both the group finders shown by means of a Bridge Marker method in such a way, that the engaged trunk line is now connected to the corresponding incoming line of the tenth level of the first local group selector. As the register knows the group of group finders (GF_1) by the position of the cord finder CF (fig 8.5) it is possible to direct the group finder GF_2 to a free outlet in that group. The group finder GF_1 is directed to the position which is already connected via the cord finder CF to the register concerned by means of a marking voltage determined by the register itself.

The group selectors GS_1 and GS_2 are released as soon as the positioning of the group finders is complete. The further building up of the connection in the distant exchanges may now be executed via the group finders.

With respect to the fact, that the so called 1,2,4,8-code for the registration of the

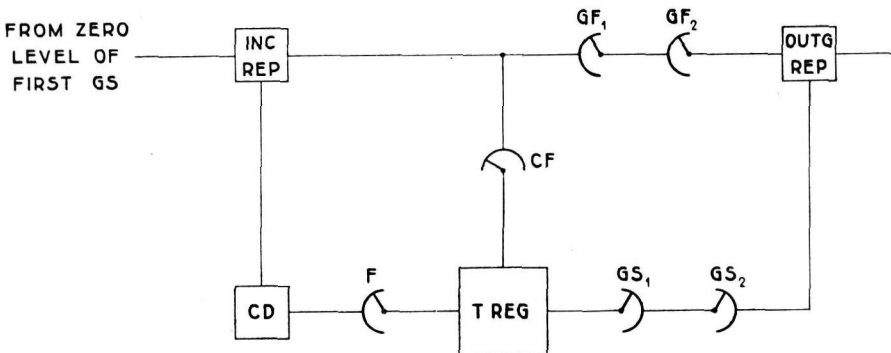

Fig. 8.5. Junction diagram of trunk exchange.

digits on four relays naturally originates from the Bridge Marker System, it is preferable to use a transmission of the selecting criteria between exchanges by means of four voice frequencies when no direct current connection links are available.

The Bridge Marker System thus may be applied in the biggest as well as in the smaller exchanges. The latter become very simple.

CONCLUSIONS

Before drawing technical conclusions from this thesis, the economics of the small terminal exchanges developed will be discussed. As already stated the number of these small terminal exchanges is an important fraction of the total number of the rural terminal exchanges as may be seen in the following table. This table shows the number of existing small rural terminal exchanges in the Netherlands automatic network and the installed number capacity.

Number of terminal exchanges	Installed number capacity
315	50 or 100
152	150 or 200
48	250 or 300
24	400
Total 539	

The small terminal exchanges according the Bridge Marker System, which have combined line finder/final selector stages connected as a satellite to a main exchange offer some practical advantages as compared to the terminal exchanges of the step-by-step system.

- a. Simplicity and compactness of design and construction, resulting in small maintenance costs.
- b. The number of terminal exchanges is not limited to nine (which is also the case in all register systems).
- c. The subscribers of the terminal exchanges can be provided with the same facilities as those connected to a main exchange.

The terminal exchanges according the Bridge Marker System however have a disadvantage, because the microphone current has to be supplied by the cord circuit in the

main exchange when the subscriber's instruments are provided with keystrips. This means an extra loss in speech power due to reduced microphone current. This is of less importance when the distance between terminal exchange and main exchange is small. This difficulty may be overcome by regulating the subscriber's line current to a practically constant value by means of a resistance barretter or a pentode tube.

The economic side of both systems mentioned will be investigated hereafter in short survey, using the price level of the years 1937 to 1939. It proved not well possible to use another basis of comparison due to the different factors of the problem. The prices hereafter calculated should be handled with care.

The prices of complete terminal exchanges according to the Siemens F step-by-step system, as they are used in the Netherlands automatic network, can be estimated as follows:

Number capacity of the exchange	Price of technical equipment in guilders	Price in guilders including the building, etc.
100	7800	12000
200	10500	14700
400	15700	20900

These exchanges have in general a number of selectors as shown in the table below:

Number capacity of the exchange	Number of first GS	Number of inc. first GS	Number of FS per 100 subs.
100	5	3	5
200	7	4	5
400	9	6	5

A rural terminal exchange of the step by step system with 5 final selectors per 100 subscribers can handle a traffic of about $1\frac{1}{2}$ Erlang in this selecting stage with a blocking factor of 1%. Assuming that a line finder stage for 100 subscribers of such a rural exchange has the same traffic, the combined line finder/final selector of a Bridge Marker rural terminal exchange has to be calculated on a calling rate of 3 Erlang, resulting in 8 finders/selectors per 100 subscribers and a blocking factor of 1%. This figure gives a reasonable basis for the comparison of the two types of exchanges.

The estimated prices of Bridge Marker terminal exchanges, designed with Siemens motor uniselectors and relays, are given in the table below. These prices, concerning exchanges with 8 combined line finders/final selectors per 100 subscribers, are calculated in the same way as the prices given here above of step-by-step terminal exchanges.

Number capacity of the exchange	Price of technical equipment in guilders
100	2900
200	4850
400	9000

This type of terminal exchange is by its small size up to a capacity of 200 numbers very well suited for ironclad mounting in a room of the local Post Office. The provision of a separate small building, as erected in the Netherlands network, is not necessary for the 100 and 200 number type. An air conditioning installation as installed in these buildings, will not be necessary in a suitable ironclad construction.

The estimated price differences in technical equipment between both types of terminal exchanges is about 5000 guilders in favour of the Bridge Marker System. This difference is about 9000 guilders when the cost of the building is taken into account. There will be a decrease of exchange maintenance costs when the Bridge Marker system is installed, but this decrease cannot be readily computed. A further remark on the price calculation is, that the time-zone-metering apparatus in the main exchange, which belongs individually to a connecting line between main and terminal exchange has not been taken into account. In the existing time and distance fee system this apparatus is calculated in the price of the terminal exchange concerned. As it is very probable that the time distance fee system will be replaced by another system with simpler zone discrimination and as it is also very probable that register systems will be used in trunk switching, it is not considered necessary to take the high costs of the time-zone-metering repeaters of the existing system into account.

The Bridge Marker System needs more connection wires per circuit between main and terminal exchange than the step-by-step system, and the total number of connection circuits is also larger because of the internal traffic of the terminal exchange which is handled via the main exchange.

The table below gives an impression of the total costs of the laying of cables between main and terminal exchanges in guilders per kilometer and in guilders per pair and kilometer.

Number of pairs	Wire diameter in mm					
	0.8		1.0		1.¼	
20	1700	85	1850	92½	2100	105
24	1800	75	2000	83½	2300	96
30	1950	65	2200	70½	2600	86½
54	2600	48	2950	54½	3500	65
96	3500	36½	4000	41½	5100	53

The connection circuits of step-by-step exchanges need 3 wires or a pair and a three wire/two wire repeater with a neon tube on both ends. These repeaters are inserted as a rule when the distance is more than four km, and when no more cable wires are available. Because of the small price difference between cables of 10 and 20 pairs, cables of 20 pairs are always laid, even in those cases where a cable of 10 pairs would suffice for a long time.

The cable costs of step-by-step terminal exchanges are given in the table below. The mean of the number of connection circuits with the main exchange generally installed is also shown.

Number cap. of exchange	Number of outg. trunks	Number of inc. trunks	Pairs	Cable	Cable cost per km (wire diam. 1 mm)
100	3	3	9	20	1850 gld.
200	4	4	12	20	1850 ..
400	6	6	18	20	1850 ..

A cable of 20 pairs can be laid for all three types of step-by-step terminal exchanges. There is still a large number of unused connection circuits for the 400 number type when using three wire/two wire repeaters and two wire connection circuits.

The cable costs of Bridge Marker terminal exchanges, using 6 wire connection circuits, are given in the table below.

Number cap. of exchange	Number of pairs (8 conn. circs. per 100 subs.)	Number of pairs in cable	Cable cost per km (wire diam. 1 mm)
100	24	30	2200 gld.
200	48	54	2950 ..
400	96	96	4000 ..

According to the above calculation there is a difference in cable costs in favour of the step-by-step terminal exchanges of 350, 900 and 2150 guilders per km for exchanges of 100, 200 and 400 numbers respectively. When the difference in costs of the technical equipment and the building may be expended to the higher cable costs, the prices of the two systems equal each other for distances of 26, 11 and 5 km. As the mean distance between terminal exchanges and main exchanges in the Netherlands network is about 8 km, it may be concluded that Bridge Marker terminal exchanges having a number capacity of 200 are justified.

It is possible to develop a more favourable type of terminal exchange when common wires are used for example for the control magnets of the line finders/final selectors of a group of subscribers, so that only one finder or selector of that group can be posit-

ioned at the same time. There is less objection against such a system for small terminal exchanges, because in these only one of a group of 100 subscribers can start a register for hunting back the calling line. Such a system needs only four connection wires per selector/finder circuit, and some common wires per group of selector/finders.

The development of the switching technique of automatic exchanges with a register positioning the successive selecting stages by means of a marking system offers the possibility of uniform design of the selector and finder circuits. The saving in manufacturing costs can be used with advantage to adopt an entirely ironclad construction of the selector racks, thereby affording protection against dust and against mechanical damage.

Having regard to the optional introduction of key sets, it is desirable to use high speed selectors for reducing the positioning delay. Selectors with an individual drive and a single control magnet to start and to stop the selectors are preferable.

The wipers of these selectors preferably have a mechanical brake and a mechanical centering of the wipers on the contacts as designed for instance in the motor uniselectors of Siemens Brothers. This motor uniselector, which runs at 220 steps per second, however suffers from the objection that the magnetisation energy of its control magnet is too high to be controlled by a register in the main exchange, when it is used as combined final selector/line finder in a terminal exchange.

The total disappearance of the usual line and cut-off relays of the automatic exchange without the introduction of equally bulky parts means an important space saving especially as compared with the Bell 7 D Rotary system. The comparison here after given of different systems is not quite apt in so far that the Bell 7 D system is designed for rural networks and not for a local self contained exchange. A comparative calculation of a local self contained exchange with 9000 numbers without any possibility for interconnection shows as a result, that the floor space of the Bridge Marker System, the Siemens (Berlin) F-system and the Bell 7 D system having the normal height of racks was respectively 60, 75 and 150 m². When in the Siemens F-system and in the Bell 7 D system the apparatus for trunk traffic, such as is necessary in a complete exchange, is taken into account, an important correction in this proportion is obtained in favour of the Bell Register System, for this system does not need extensive time-zone-metering apparatus; the floor space of the Siemens system then stands to that of the Bell System as 1 : 1½.

The resistors and rectifiers by which the line and cut-off relays are replaced, can be mounted in plugs on the horizontal strips of the main distributing frame. The cost of the main distributing frame will be increased by this provision. But against this increase the facility of changing the characterising features of the subscribers by changing plugs should be considered. The resistances of these plugs (formerly for example Siemens Karbowid) could be obtained with an accuracy of 1 % with a temperature coefficient of $0,4 \cdot 10^{-4}$.

The registers in the Bridge Marker System will take up more space than those in the existing systems by the introduction of tube circuits and their associated power supplies. In the beginning of the development described there existed objections mostly based on prejudice against the use of high vacuum tubes with filaments in automatic switching systems. The very extensive use of these tubes for different purposes in

repeater stations has shown that these elements can be used with advantage as links in automatic switching systems.

In the beginning of the experiments Philips EFF 50 type tubes were used. These tubes were not constant enough and differed too much to be practicable. Better results were obtained with a special Philips telephony tube type 18040 (fig 9.1). It is possible to design all the circuits described with this one type of tube. The registers need as a rule four tubes for a zero switch and two tubes for a testing device. The trunk registers simultaneously testing lines in both main and overflow directions have six tubes. It may be expected that the maintenance costs of the tubes will remain small. The life of the type 18040 tubes with continuously working filaments is expected to be two to five years.

The six tubes of a register need a permanent filament power of about thirty watts. The power supply can be derived from selenium rectifiers. The total power consumption of a register, when the efficiency of the rectifiers is taken into account is about 60 watts. Against this continuous load must be put the decrease of the power consumption of the battery because of the drastic reduction of the number of relays in the exchange. It is possible to enumerate further advantages and disadvantages. Only from a practical trial will the full possibilities be learned.

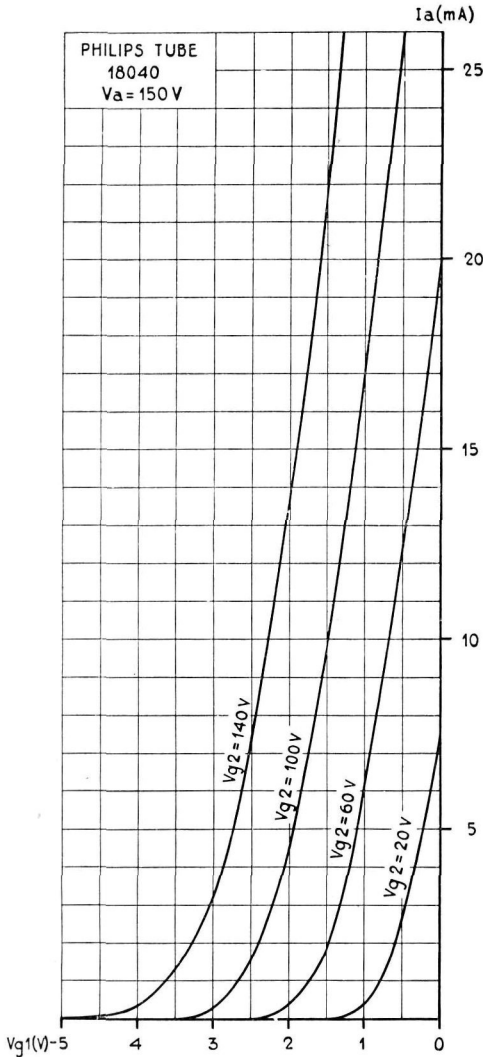

Fig 9.1. Characteristic of Philips tube type 18040.

SUMMARY

The development of an automatic telephone switching system is described in which all important functions as for example the positioning of selectors and finders, the transmission of selecting criteria, the determination of special features of lines and subscribers are performed under the control of Wheatstone Bridges. The possibility of such a system was suggested variously already in the period of 1920 to 1930, but due to lack of high vacuum electronic tubes as they are nowadays available, it was then not well possible to give a practical form to the system.

In the thesis is first described, starting from elementary high vacuum tube circuits for the test of direct current voltages, the development of more complicated circuits, by means of which voltages differing by two volts in the range between zero and -60 can be discriminated in a Wheatstone Bridge. It proved possible with these zero voltage discriminators to control all selectors and finders of an exchange by a register and to design all selector and finder circuits practically on the same basis.

The call detection of a line and the investigation of characteristic features of that line can also be performed by means of the balance of Wheatstone Bridges and the zero voltage discriminators described.

A semi static receiver and some variations are designed for the transmission of the selecting criteria between subscribers and registers and between registers of different exchanges. These receivers are controlled by means of key strips or relay contacts inserting different resistances in a direct current loop. It is possible to transmit the selecting criteria with a very high speed (20 digits per second as a maximum), while the number of different selecting criteria is not limited to ten.

The circuits of an automatic exchange can be developed with the aid of the principles described without impulses or impulse series as they are used in the existing switching systems.

P.B.X.-lines can be provided in different ways. It is possible to join the lines of a final selector group of 100 numbers in an arbitrary way to P.B.X.-lines, which can be selected by their group number or by their individual number.

Small terminal exchanges can be designed, which are entirely controlled by a register in the main exchange concerned. These small terminal exchanges are constructed with

10.2

a combined line finder/final selector stage, which is connected to the main exchange via a relatively large number of wires per selector circuit. The control of these line finder/final selectors in the terminal exchanges and the determination of the characteristics of the subscriber's lines is also effected by means of the balance of Wheatstone Bridges and a device, which reproduces in the main exchange the battery voltage of the terminal exchange via a pair of wires, which is common for the whole terminal exchange.

Big trunk exchanges also can be designed in the developed system.

A rough estimate is made of the foundation costs of Siemens rural terminal exchanges, which are used for a major part of the Netherlands rural automatic network and the estimated costs of small terminal exchanges in the developed system, both on the basis of prices in the period 1937—1939. This estimate shows that a useful field exists in the Netherlands rural network for the small terminal exchanges for the developed system notwithstanding the relatively large cable to the main exchange. This field may be enlarged by using common control wires for a number of finders/selectors, so that the number of connection wires per selector circuit decreases.

SAMENVATTING

De ontwikkeling van een automatisch telefoonstelsel, waarin alle belangrijke functies als b.v. het instellen van kiezers en zoekers, het overbrengen van kiescriteria, het bepalen van bijzondere kenmerken van lijnen en abonné's, worden verricht met behulp van het evenwicht van Wheatstone'se bruggen, wordt beschreven. De mogelijkheid van een dergelijk stelsel blijkt reeds bekend in de periode van 1920—1930, echter door het ontbreken van hoogvacuum electronenbuizen, zoals die thans beschikbaar zijn, was het toen niet wel mogelijk een praktische vorm aan het stelsel te geven.

In de dissertatie wordt eerst beschreven, uitgaande van de elementaire schakelingen voor het onderzoek van gelijkspanningen met behulp van hoogvacuum electronenbuizen, de ontwikkeling van de meer samengestelde buizenschakelingen, met behulp waarvan twee Volt verschillende gelijkspanningen, b.v. liggende tussen 0 en — 60, kunnen worden gediscrimineerd in een Wheatstone'se brugschakeling. Het blijkt onder toepassing van een dergelijke nulspanningsdiscriminatie-inrichting mogelijk alle kiezers en zoekers van een automatische centrale door een register te besturen en alle kiezer en zoeker stroomlopen praktisch op dezelfde manier uit te voeren.

Het signaleren van een oproep op een lijn, alsmede het determineren van bijzondere kenmerken van die lijn, kan eveneens met behulp van het evenwicht van Wheatstone'se brugschakelingen en de ontwikkelde nulspannings discriminatie inrichtingen geschieden.

Een semi statische ontvanger en enkele variaties daarop zijn ontworpen voor het overbrengen van de kiescriteria tussen abonné's en registers en tussen registers van verschillende centrales. Deze ontvangers worden bestuurd met behulp van door druktoetsen of relais contacten in een gelijkstroomlus ingeschakelde weerstanden. Het is mogelijk om zeer snel met een dergelijke inrichting te kiezen (max 20 cijfers per seconde), terwijl het aantal over te brengen verschillende kiescriteria niet tot 10 beperkt hoeft te blijven.

Met behulp van de beschreven beginselen kan een automatische centrale worden ontwikkeld, welke geheel zonder de in de gebruikelijke automatische systemen toegepaste impulsen of impulsseries werkt.

Groepsaansluitingen kunnen op verschillende manieren worden aangebracht. Het

is mogelijk om de aansluitingen binnen een eindkiezergroep van 100 nummers willekeurig tot één of meer groepsaansluitingen samen te nemen, welke of onder het groepsnummer, of individueel gekozen kunnen worden.

Kleine eindcentrales kunnen worden ontworpen, welke geheel door het register in de bijbehorende knooppuntscentrale worden bestuurd. Deze centrales zijn gebouwd met een gemeenschappelijke oproepzoeker/eindkiezer-trap, welke met het knooppunt verbonden wordt over een relatief groot aantal draden per kiezerstroomloop. De besturing van deze oproepzoeker/eindkiezers in de eindcentrales en het onderzoek van de kenmerken van de abonneelijnen kan eveneens met behulp van het evenwicht van Wheatstone'se bruggen geschieden onder toepassing van een inrichting, welke de batterijspanning van de eindcentrale, over een voor die eindcentrale gemeenschappelijke dubbeldraad, in het knooppunt reproduceert.

Grote interlocale centrales kunnen eveneens in het ontworpen systeem worden gemaakt.

Een globale vergelijking is gemaakt van de stichtingskosten van landelijke eindcentrales volgens het Siemens F-systeem, waarmede een groot deel van de Nederlandse landelijke automatisering is voorzien, en de geschatte kosten van kleine eindcentrales in het ontwikkelde systeem, beide volgens het prijsniveau van 1937—1939. Deze schatting toont, dat er voor kleine eindcentrales volgens het ontwikkelde systeem, ondanks de vrij kostbare verbindingskabel met het knooppunt, in de Nederlandse automatisering een bruikbaar toepassingsgebied bestaat. Dit gebied kan ruimer worden gemaakt door toepassing van voor een aantal kiezerstroomlopen gemeenschappelijke insteldraden, waardoor het aantal verbindingdraden per kiezerstroomloop geringer wordt.

REFERENCE

A. *Direct current systems*

1. U.S. patent 1.472.604 Oct 30, 1923 (filed April 28, 1920) Automatic Telephone System, Thomas Lenaghan.
2. U.S. patent 1.736.283 Nov 19, 1929 (filed July 14, 1927) Automatic Telephone System, John E. Gardner.
3. U.S. patent 1.736.259 Nov 19, 1929 (filed May 11, 1927) Automatic Telephone System, John E. Gardner.
4. U.S. patent 1.761.115 June 3, 1930 (filed Sept 2, 1927) Automatic Telephone System, John E. Gardner.
5. Br. patent 474.990 May 27, 1936 (filed May 31, 1935) Improvements in or relating to Automatic or Semi Automatic Telephone and like Telecommunication or Signalling Systems.
6. U.S. patent 2.295.032 Sept 8, 1942 (filed July 24, 1939) Communication Exchange System, Gerald Deakin.
7. U.S. patent 2.351.016 June 13, 1944 (filed Sept 14, 1942) Electrical Control System, Gerald Deakin.
8. U.S. patent 2.354.668 Aug 1, 1944 (filed May 6, 1943) Electric Selection Controlling Circuit, Gerald Deakin.
9. U.S. patent 2.381.727 Aug 7, 1945 (filed Feb 12, 1944) Automatic and Semi automatic Telephone Exchange System, Gerald Deakin.
10. U.S. patent 2.410.050 Oct 29, 1946 (filed April 21, 1944) Telecommunication Switching System, Gerald Deakin.
11. Netherlands patent 57.800 Sept 15, 1945 (filed April 15, 1941) Electrisch einstelling, Bell Telephone Mfg Co, Antwerp.

12. Netherlands patent 57.917 Oct 15, 1945 (filed June 12, 1942) Telefoonstelsel of soortgelijk stelsel met voor het opbouwen der gewenschte verbindingen dienende eindkiezers met enkelvoudige beweging. Bell Telephone Mfg Co, Antwerp.
13. Netherlands patent 57.908 Oct 15, 1945 (filed March 13, 1942) Telefoonstelsel of soortgelijk stelsel met in één of een aantal opvolgende trappen toegepaste groepkiezers. Bell Telephone Mfg Co, Antwerp.
14. Netherlands patent application 114.006 (filed Nov 15, 1943) Automatisch Telegraaf- of Telefoonstelsel, waarin de instelcriteria voor de kiezers overgebracht worden met behulp van potentiaalmarkeeringen. Staatsbedrijf der P.T.T.
15. Netherlands patent application 116.427 (filed April 25, 1944) Ontvanginrichting voor seinstelsel, waarmede criteria worden overgebracht volgens een brugmarkeermethode.
Staatsbedrijf der P.T.T.
16. Netherlands patent application 118.618 (filed Aug 22, 1944) Brugmarkeerontvanger. Staatsbedrijf der P.T.T.
17. Netherlands patent application 120.968 (filed Sept 3, 1945) Schakeling voor een telefoon- of soortgelijk stelsel. Staatsbedrijf der P.T.T.
18. Netherlands patent application 120.969 (filed Sept 3, 1945) Schakeling voor het aanbrengen van bijzondere kenmerken in een lijnstroomloop. Staatsbedrijf der P.T.T.
19. Netherlands patent application 121.132 (filed Sept 4, 1945) Nulspanningsonderzoekinrichting. Staatsbedrijf der P.T.T.
20. Netherlands patent application 121.536 (filed Oct 13, 1945) Seinstelsel met groepsaansluitingen. Staatsbedrijf der P.T.T.
21. Netherlands patent application 124.281 (filed March 3, 1946) Nulspanningsonderzoekinrichting. Staatsbedrijf der P.T.T.
22. Netherlands patent application 124.338 (filed March 26, 1946) Schakeling voor de besturing van een kiezerstroomloop. Staatsbedrijf der P.T.T.
23. Netherlands patent application 125.773 (filed June 5, 1946) Gecombineerde oproepzoeker/eindkiezerstroomloop. Staatsbedrijf der P.T.T.
24. Netherlands patent application 126.542 (filed July 16, 1946) Schakeling voor het instellen van het evenwicht van een gelijkstroombrug van Wheatstone, waarvan één of meer takken verwijderd zijn opgesteld. Staatsbedrijf der P.T.T.
25. La sélection par détecteur de potentiel appliquée à la commutation automatique. M. Ribaud. l'Information Technique, April 1946.

B. Alternative current systems

1. Netherlands patent 57.799 Sept 15, 1945 (filed March 7, 1941) Schakeling voor het besturen van apparatuur in seinstelsels in het bijzonder voor de instelling van schakelaars in centrales voor telefoonstelsels. Bell Telephone Mfg Co, Antwerp.
2. Netherlands patent 57.905 Oct 15, 1945 (filed May 20, 1941) Telefoonstelsel of soortgelijk stelsel. Bell Telephone Mfg Co, Antwerp.
3. Netherlands patent 58.220 April 15, 1946 (filed June 10, 1941) Schakeling voor telefoonstelsel en dergelijke met instelling der eindkiezers met behulp van markeercontacten, die elk een voor dien kiezerstand karakteristieke potentiaal bezitten. Bell Telephone Mfg Co, Antwerp.
4. Netherlands patent 56.430 Dec 15, 1943 (filed July 11, 1941) Seinstelsel, in het bijzonder telefoonstelsel met ontladingsbuizen voor de instelling der de verbinding opbouwende kiezers. Bell Telephone Mfg Co, Antwerp.

STELLINGEN.

I.

Alle functies uit een automatisch stelsel, welke met behulp van impulsen of impulsseries worden verricht, kunnen ook met behulp van het evenwicht van gelijkstroombruggen van Wheatstone worden uitgevoerd.

II.

Het gebruik van hoogvacuumbuizen met gloekathodes biedt voordeelen in automatische stelsels, waarin gelijkspanningsmarkeeringen worden toegepast.

III.

Het gebruik van gasgevulde buizen als schakelement in automatische telegraaf- en telefoonsystemen is ongewenscht.

IV.

Het registreeren van kiescriteria in automatische telefoonstelsels met behulp van bekrachtigingscombinaties van relais in de 1-2-4-8-code is gewenscht.

V.

Amplitude-gemoduleerde telegrafie draaggolf-systemen met automatische niveau-regeling voldoen in het binnenlandsche Nederlandsche telegraafverkeer aan alle normaal te stellen transmissie-eischen.

VI.

De ontwikkeling van de automatische telegrafie wordt geremd door het ontbreken van een goedkoop verreschrijver.

VII.

Een ontvangmechisme voor arhythmische verreschrijvers volgens het beginsel van de successieve draaiing van een typenrad tijdens den ontvangst van de elementen van een seinteken, biedt de mogelijkheid tot het verkrijgen van een goedkoop toestel.

VIII.

Integreerende aftasting van de teekenelementen van een telegrafie-seinteken geeft in de lijntelegrafie geen voordeelen boven momentaftasting.

IX.

Automatisch aanlopende noodstroom-generatoren zijn noodzakelijk in de belangrijkste centra van het telefoon- en telegraafverkeer.

X.

Noodstroomgeneratoren dienen parallel te kunnen werken met het sterkstroomnet, hetwelk zij in geval van storing moeten vervangen.

XI.

Het is in het algemeen onjuist, dat een opdrachtgever geen rechten heeft op een voor hem gedane uitvinding als er geen dienstverband tusschen beiden bestaat.

XII.

Het is wenschelijk, dat de Octrooiraad bindende schema-teekenvoorschriften uitgeeft voor de teekeningen behorende bij de octrooien.

XIII.

De teekenformaten en vouwvoorschriften van de Hoofdcommissie voor de Normalisatie zijn onpractisch voor in mappen op te bergen of bij beschrijvingen in te voegen teekeningen.

XIV.

Een centrale planning-afdeeling is voor een groot bedrijf onontbeerlijk.

XV.

Brandbluschapparaten met een vulling van tetra-chloor-koolstof dienen te worden uitgevoerd met een door een looden foelie afgesloten spuitopening en met een stikstof drukpatroon, welke bij het in werking stellen van het toestel de voor het verbreken van de foelie en voor het uitspuiten van de vloeistof benodigde druk levert.

