

SMART SHARED MOBILITY HUB

REDESIGN MILAN CENTRAL RAILWAY STATION



MILAN



MILAN-HIGH MOBILITY CITY



Resource: EU Urban Mobility Observatory

PREFER PRIVATE TRANSPORTATION

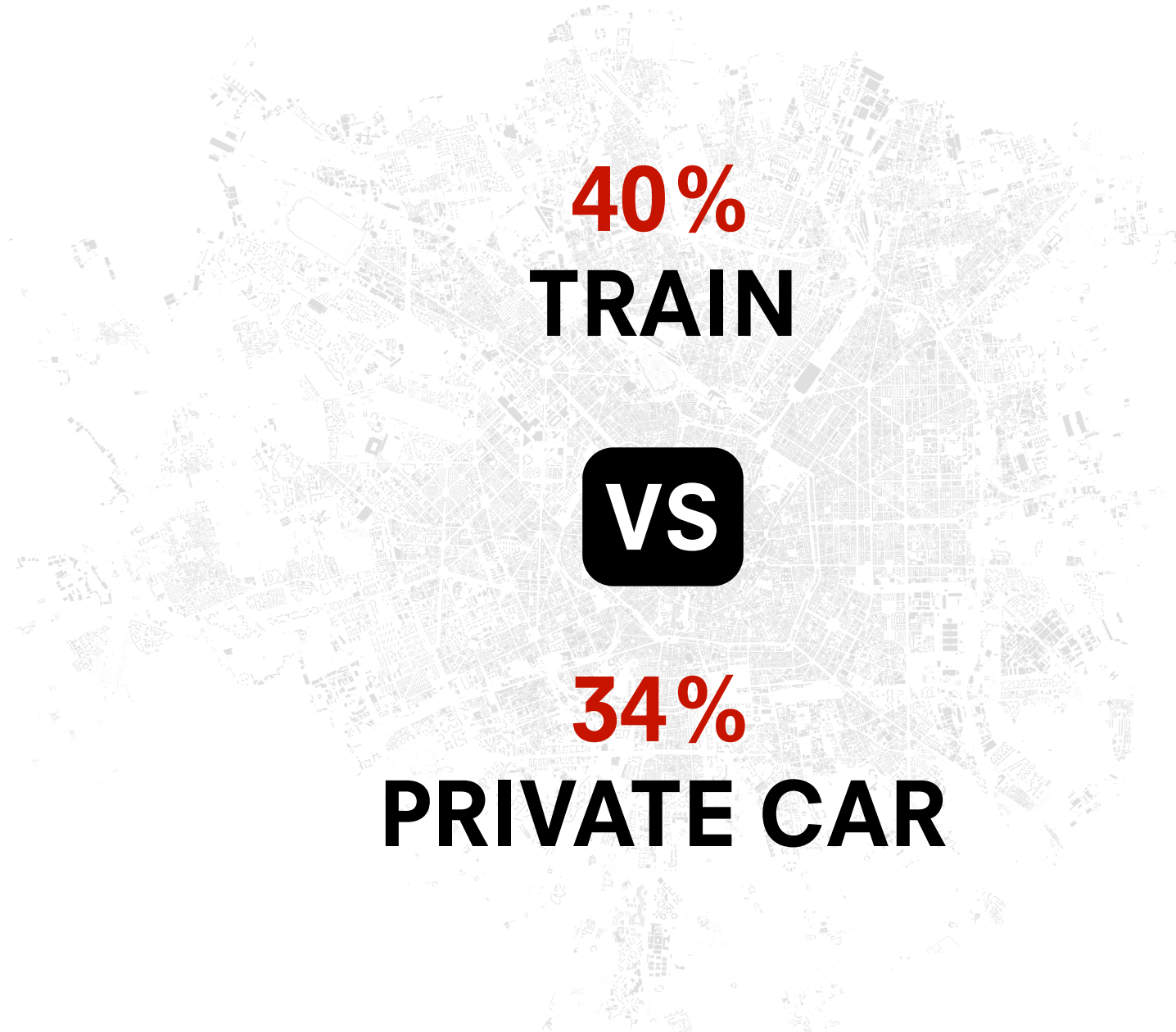

Resource: EU Urban Mobility Observatory

PREFER PRIVATE TRANSPORTATION

40%

TRAIN

WHY?

34%

PRIVATE CAR

So why do people in Milan use private cars so often?

TO BE IMPROVED

TRAIN TYPE	DELAY % ≤ 5'	DELAY % >5'	DELAY AVERAGE (MINUTES)
Long-Distance	89.4%	10.6%	7.7 mins
International	76.4%	23.6%	8.6 mins
Regional	94.4%	5.6%	1.8 mins

Train strikes, delays and cancellations are common in Milan
 Punctuality; Inclement Weather; Routes Not Being Served; Routes Getting Cancelled; Systems Glitching

Resource: Trenitalia service quality 2018 report, 2018

TO BE IMPROVED

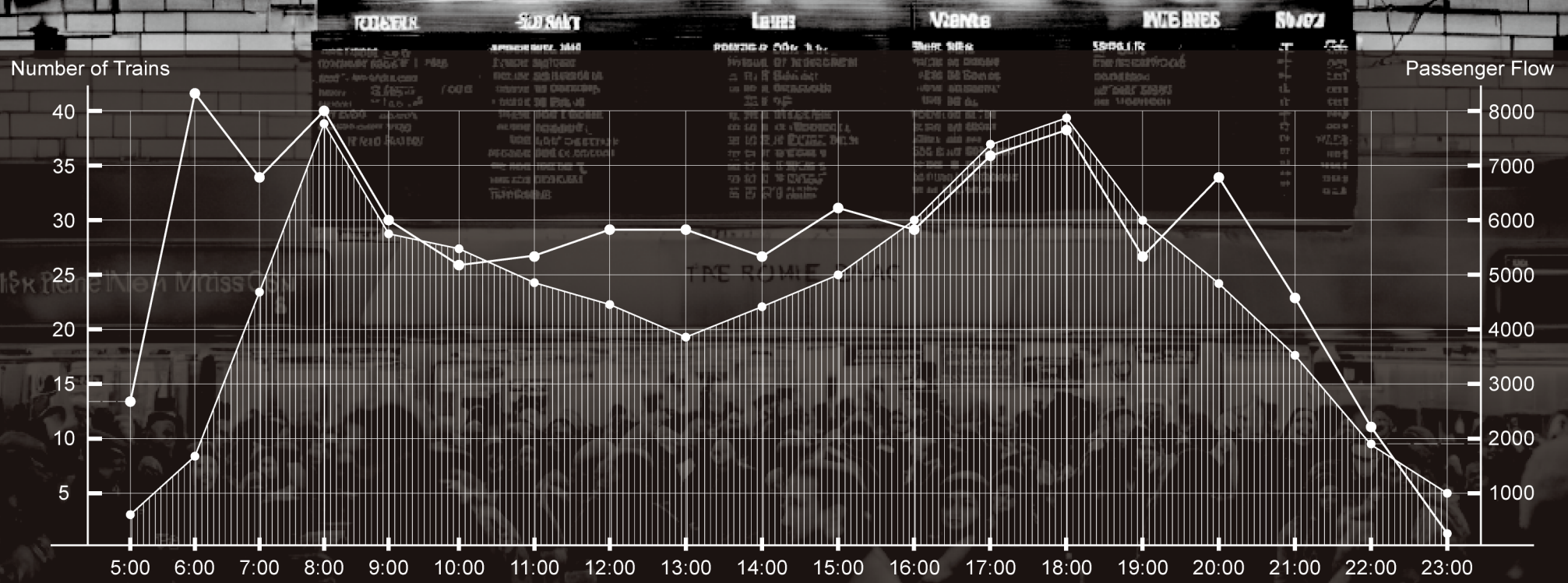

Milan train station is crowded during rush hour.
Lack of Personal Space; Security Concerns

Resource: Google Map, 2025

TO BE IMPROVED

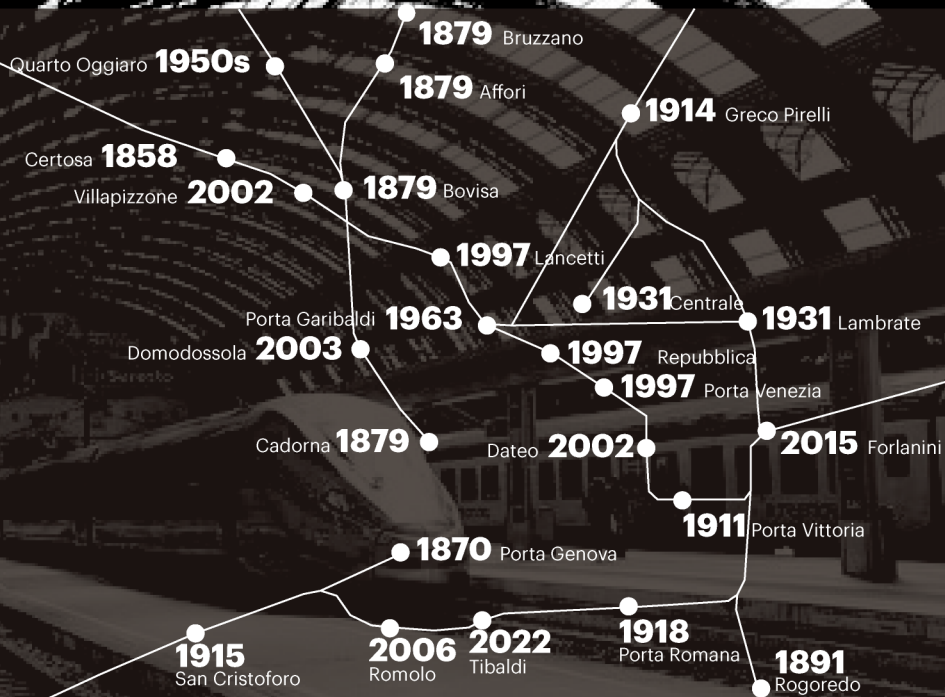

Milan train station facilities need to be improved.
Transfers Being Stressful; Limited Availability of Mobility Options

RESULT-HIGH RATE OF CAR OWNERSHIP

Passenger Cars/
1000 Inhabitants

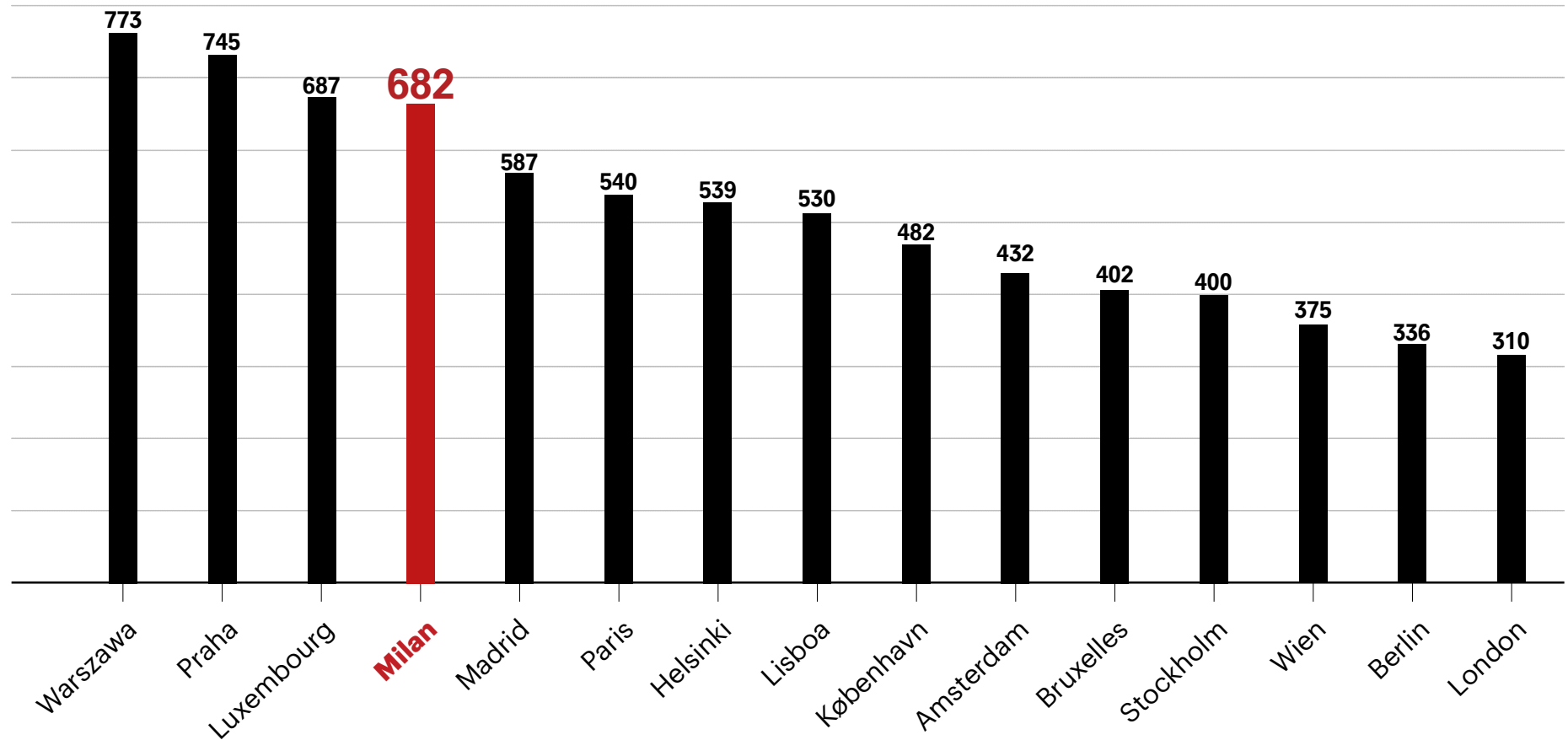

Milan has one of the highest European rates of car ownership.

Resource: NUTS 2 region, 2021

Introduction

PROBLEMS

 **Emissions**
(yearly)

902kg
CO2 emitted

160kg due to congestion

 **Travel time**
(yearly)

276h
time spent driving

137h due to congestion

 **Fuel price**
(yearly)

751eur
money spent

133eur due to congestion

 **Parking Area**
(daily)

15.41km²
urban road space occupied

70% of Milan's total road



Resource: Tomtom, 2023

SOLUTION-SMART SHARED MOBILITY



EN

Search

EU Urban Mobility Observatory

Home | About | News & Events | Resources | Sustainable Urban Mobility Plans

Home > News & Events > News > Milan embraces smart mobility and implements an innovative platform to manage shared mobility

NEWS ARTICLE | 26 March 2024 | Milan | 1 min read

Milan embraces smart mobility and implements an innovative platform to manage shared mobility

The City of Milan has chosen to implement the 'Populus Mobility Manager platform' to enhance the management of its shared bicycle and scooter programmes. Partnering with Amat, the Environment and Territory Mobility Agency, Milan aims to address challenges such as parking compliance and infrastructure utilisation in its efforts to optimise urban mobility.

The Mobility Manager platform will support the city in reducing traffic congestion, improving air quality, and enhancing overall quality of life for residents and visitors. The collaboration reflects a shared vision between Populus and the City Milan, to create more efficient mobility ecosystems and shape the future of transportation in the city.

Milan's decision to work with Populus comes as the city actively seeks a robust, data-driven platform to manage the increasing number of operators deploying e-scooter and bicycle fleets. The Mobility Manager platform is a comprehensive solution to address urban mobility challenges and help cities navigate the complexities of modern transportation. Additionally, this data-driven approach supports the city of Milan to take more evident-based urban planning and mobility decisions, that contribute to reach its long-term sustainability goals.

2025

Resource: European Commission, 2024

HOWEVER!

View the development of Milan Central Station

DEVELOPMENT OF MILAN CENTRAL

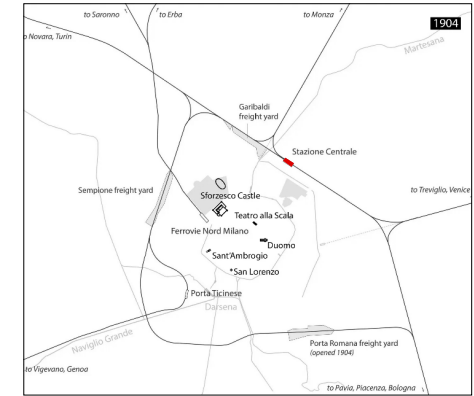
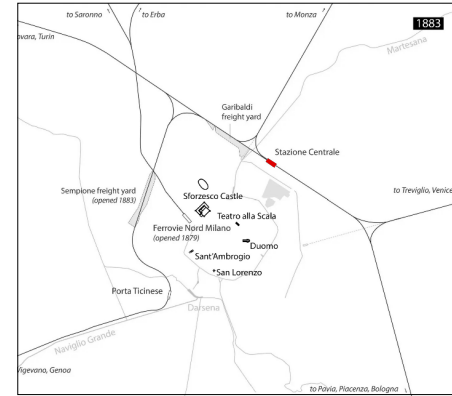
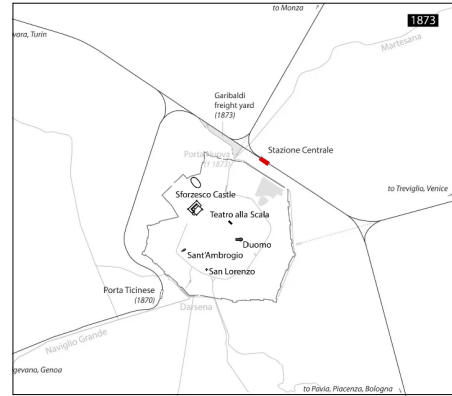
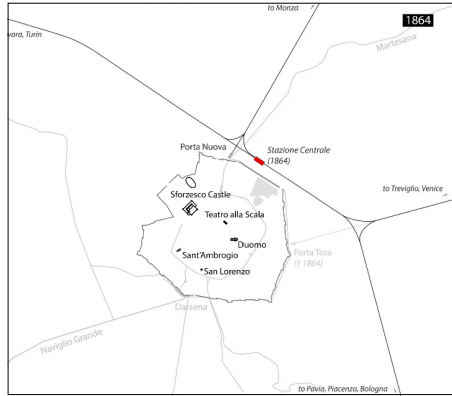

1881

1893

1905

1910

1966

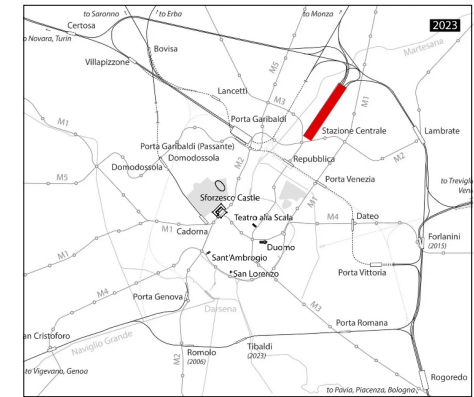
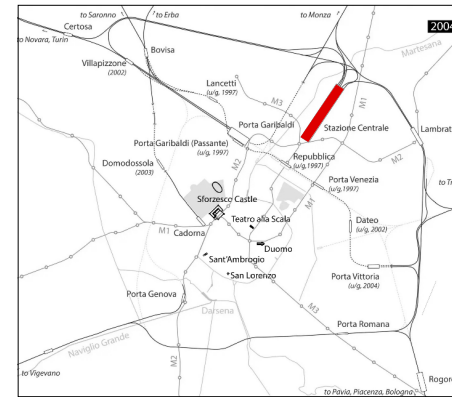
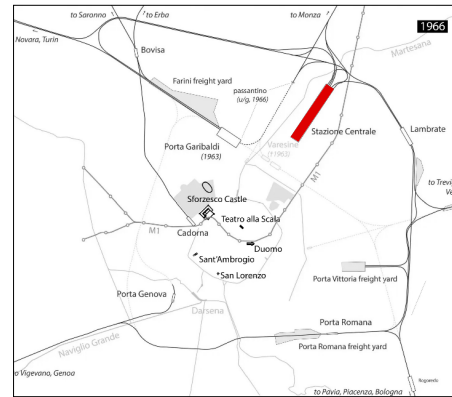
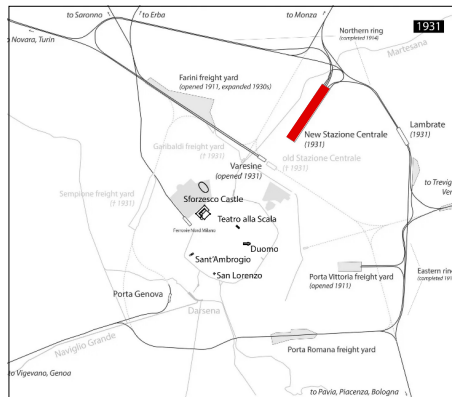

1966

2008

2015

2018

2024

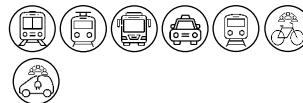

Over the past century, Milan's transportation system has evolved a lot. But the Milan Central Station, built in 1931, remains largely unchanged, with minimal upgrades

RESEARCH QUESTION

How can Milan Central Station evolve into a transportation **hub, better support the development of **smart shared mobilities** in the future?**

WHAT IS SHARED MOBILITY

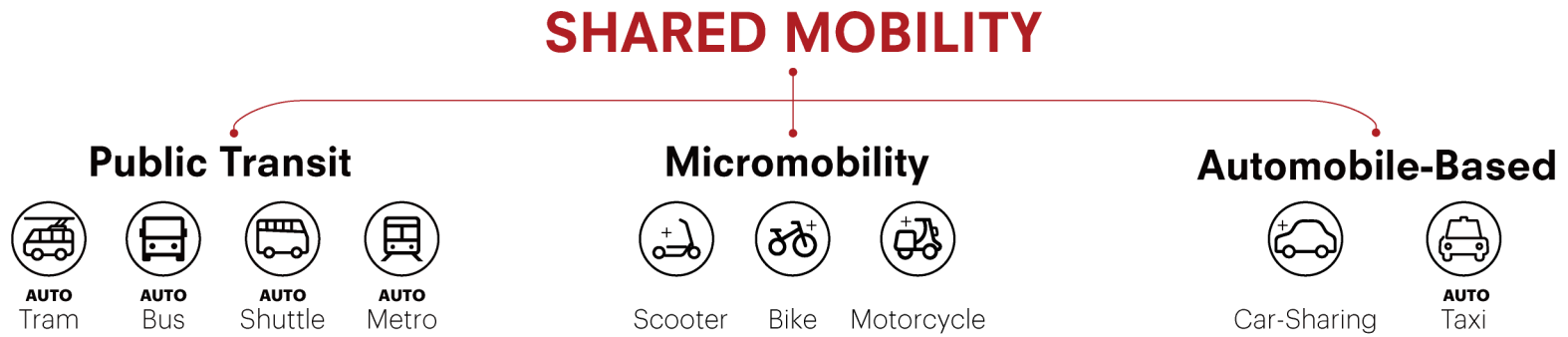

WHAT IS SMART

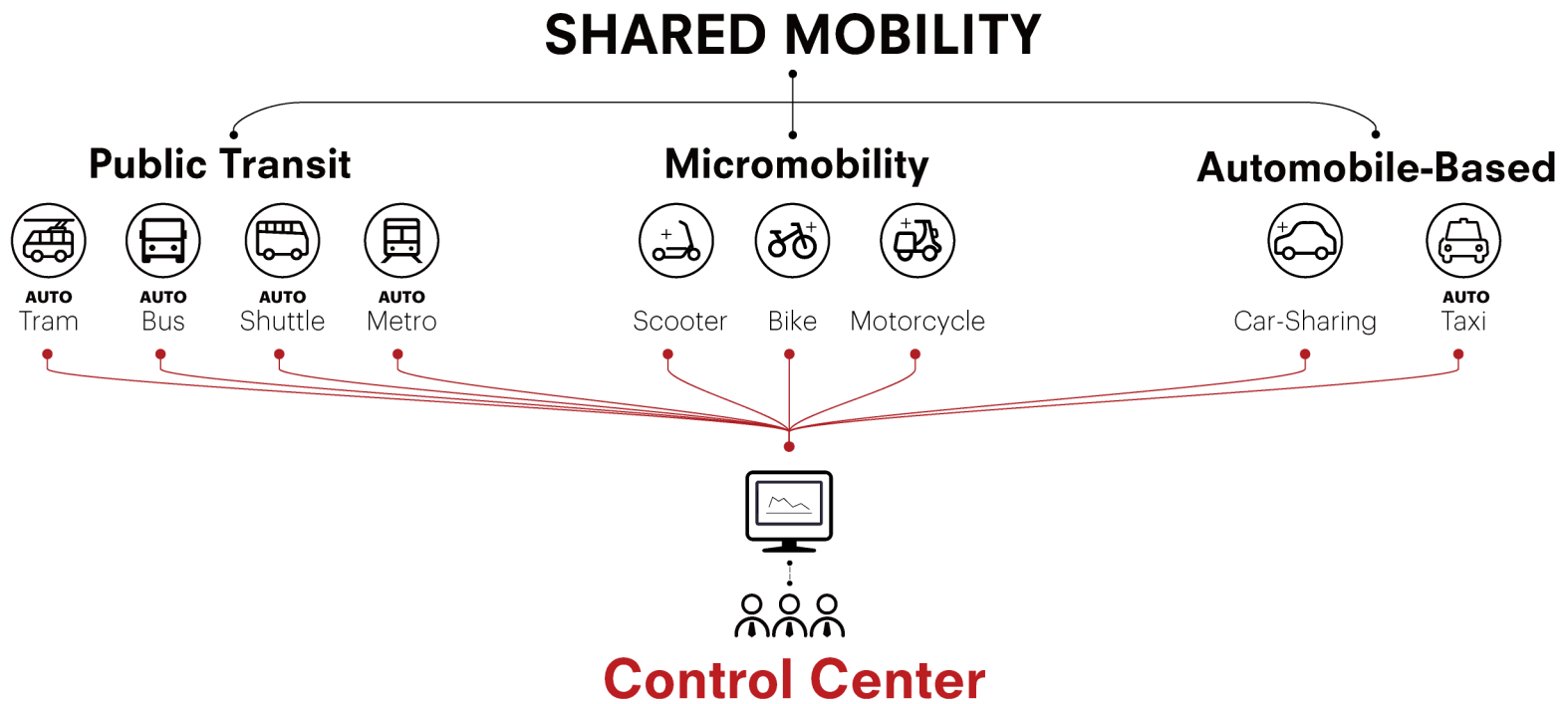

It means having a control center that can manage and coordinate Milan's entire shared mobility system.



RAILWAY STATION

HOW TO SUPPORT?

SHARED MOBILITY

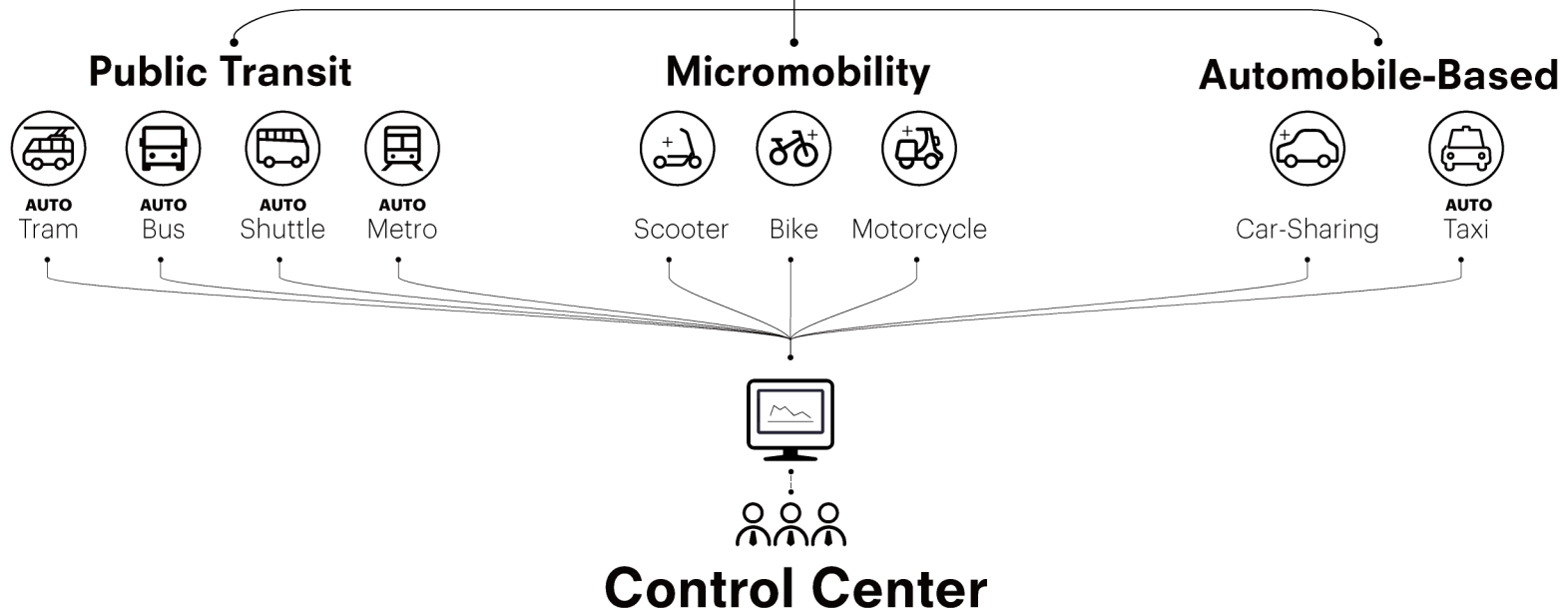

Train Station



HUB

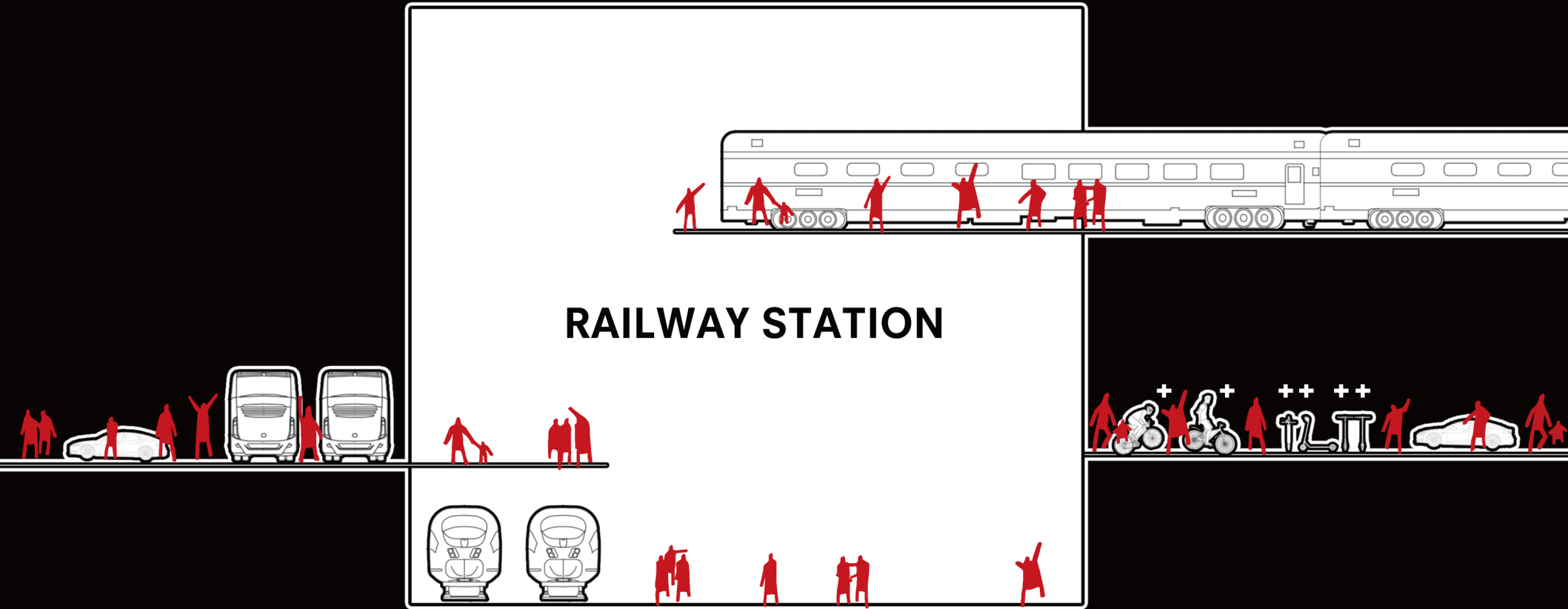

RAILWAY STATION

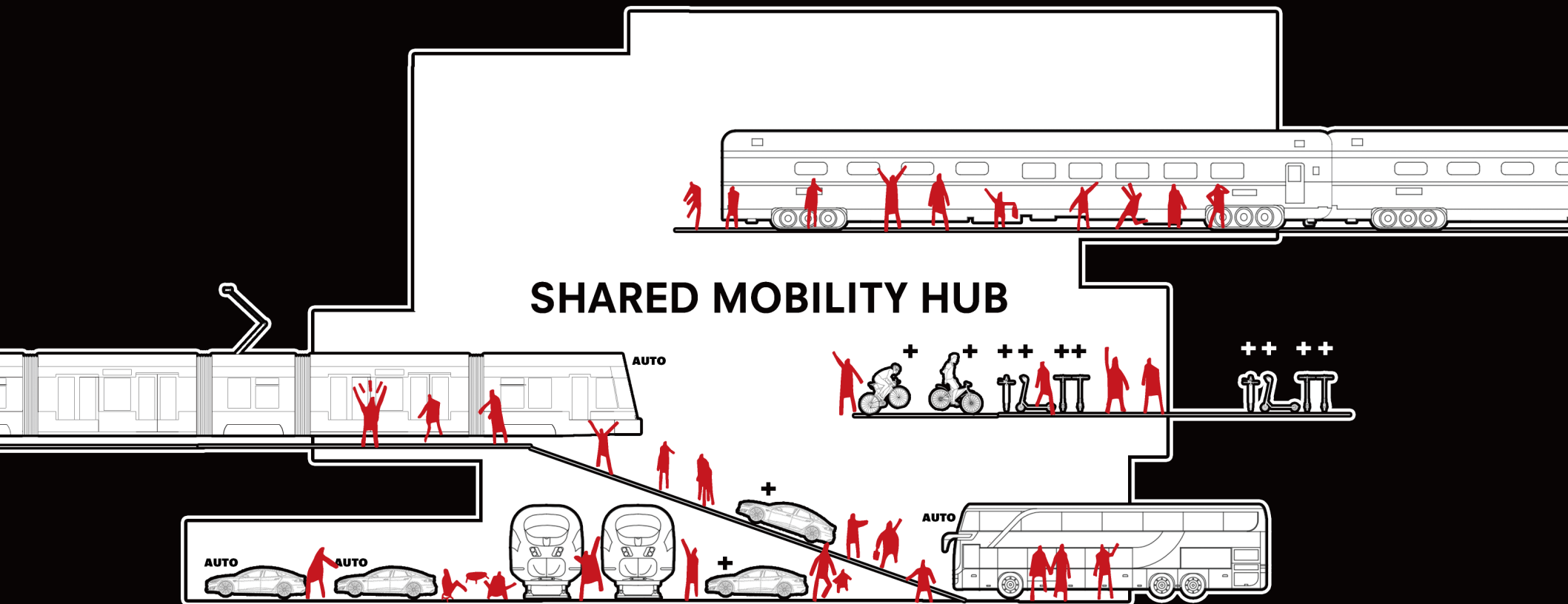

SMART CONTROL CENTER

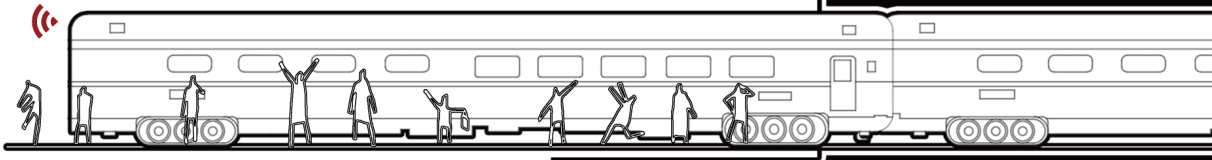

SHARED MOBILITY HUB

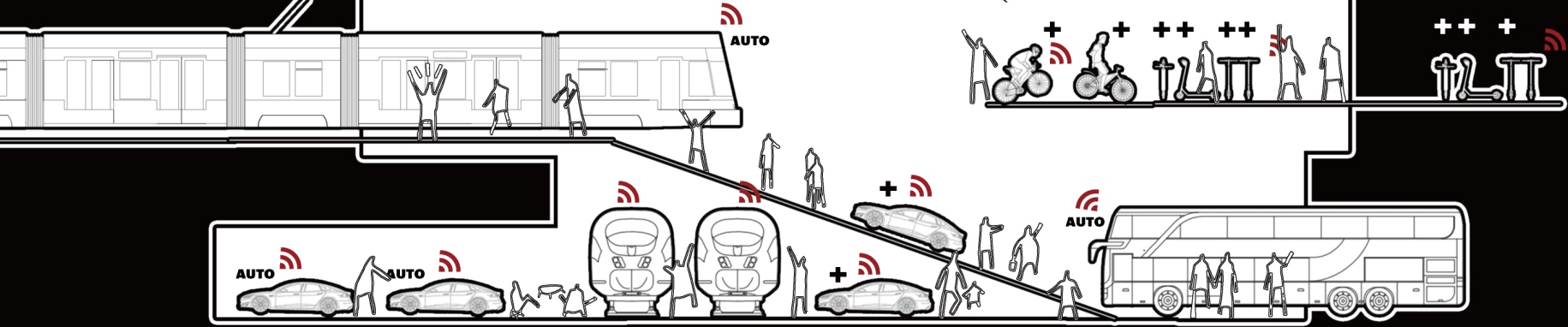

CONCLUSION



RESEARCH DESIGN BRIEF

RESEARCH METHOD & DESIGN BRIEF

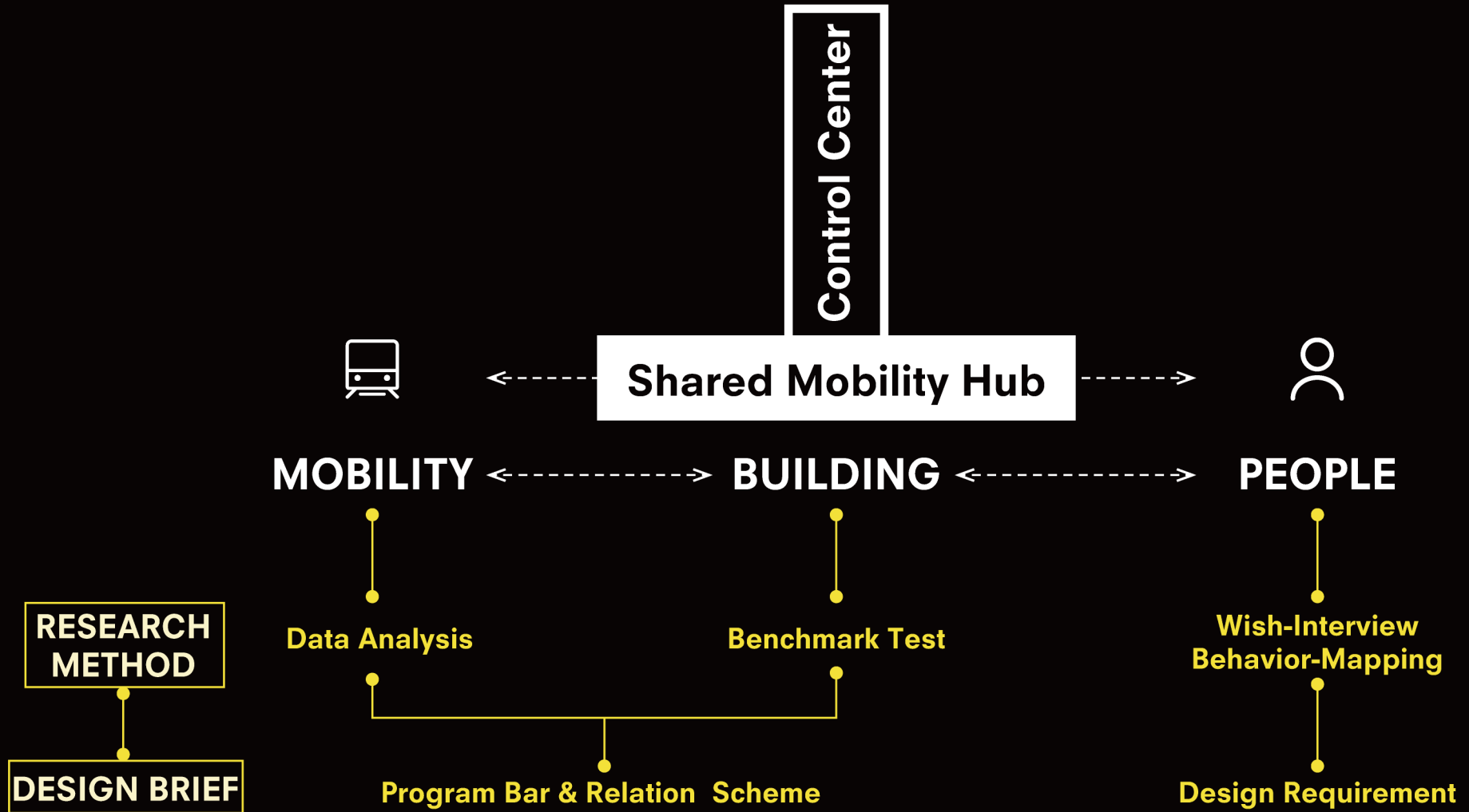

METHOD-MOBILITY-DATA ANALYSIS

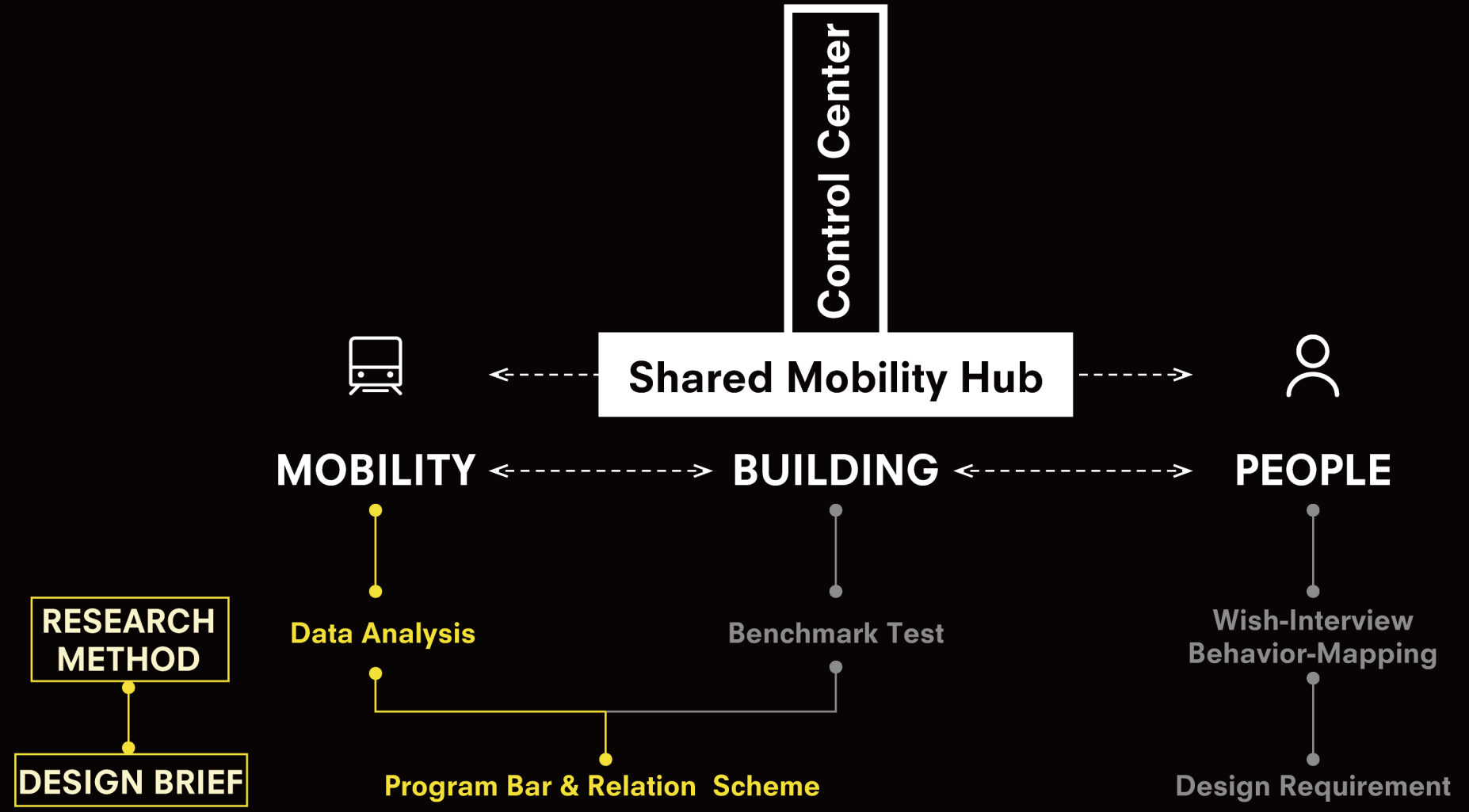

ALL THE MODES OF MOBILITIES INCLUDED IN THE HUB

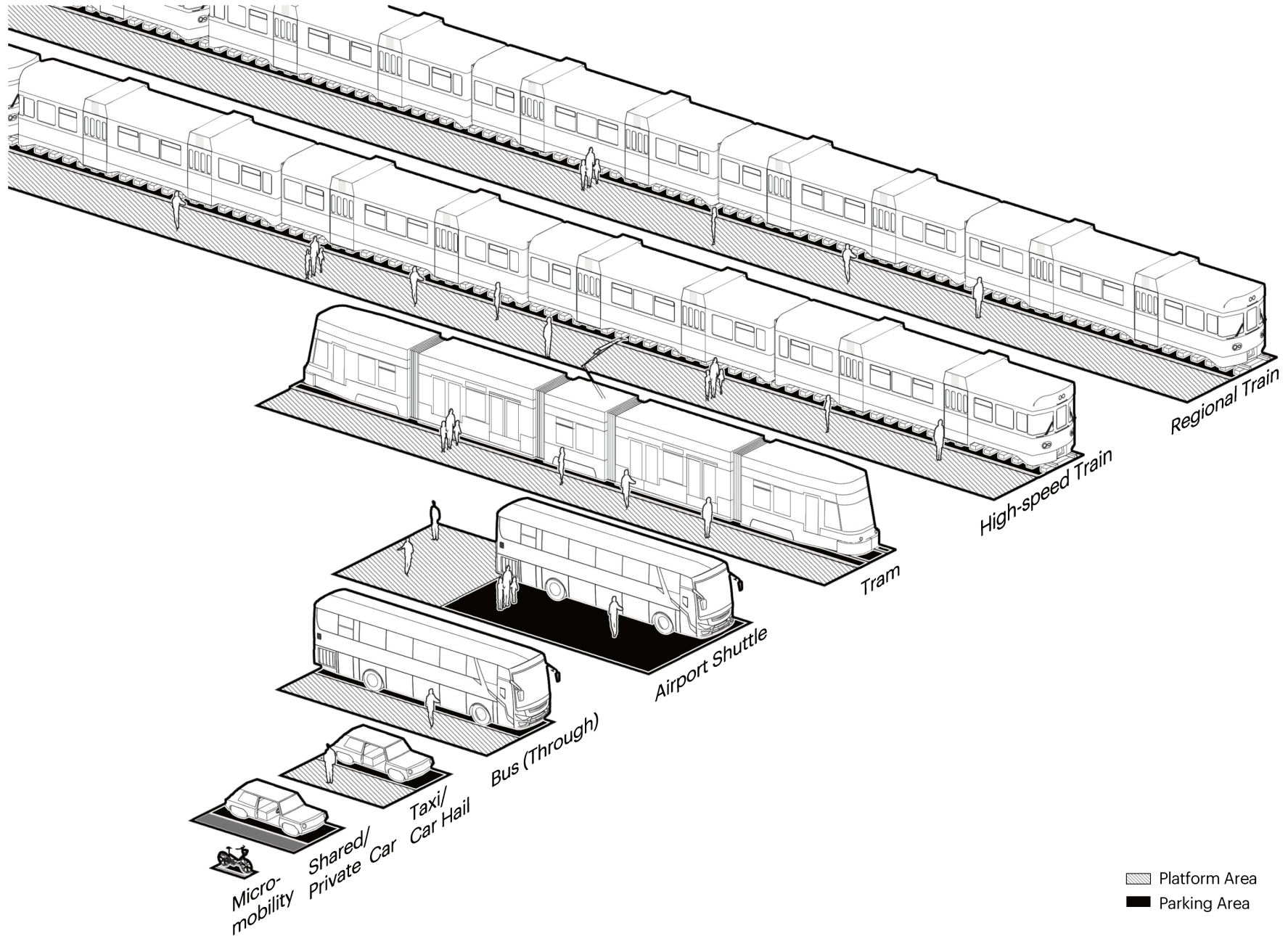

DIMENSIONS OF MOBILITY

Mobility	Type	Dimensions (L×W×H, m)	Number of Vehicles	Platform Area (m ²)	Parking Area (m ²)
Train	Regional	150×3×4	12 Trains	900m ² per track	900m ² per track
	High-speed	350×3×4	12 Trains	500m ² per track	500m ² per track
Tram		30×2.5×3.4		90m ² per track	90m ² per track
Bus	Airport Shuttle	15×2.5×3.2	5 Shuttles	45m ² per shuttle.	90m ² per shuttle.
			3 Shuttles		
			4 Shuttles		
	Bus (Through)	12×2.5×3.2		30m ² per bus	30m ² per bus
Car	Taxi	5 × 1.8 × 1.5		15m ² per car.	15m ² per car.
	Car Hail		Every 24 Cars		
	Shared Car		500 Cars	22.5m ² per car.	
	Private Car		100 Cars		
Micromobility	Rent Bike	1.8 × 0.5× 1.2	1500 Bikes		2.15m ² per bike
	Shared Bike		1500 Bikes		
	Shared Scotter		500 Scotters		
	Shared Motorcycles		500 Motorcycles		

To calculate the area occupied by each type of transportation

ESTIMATION OF PARKING CAPACITY

Railway Station	Hamburg Hauptbahnhof	Munchen Hauptbahnhof	Milan Central Station	Berlin Hauptbahnhof	Gare de Lyon	Amsterdam Centraal	Antwerp Central Station
Passenger Flow	550,000	450,000	320,000	300,000	270,000	250,000	150,000
Car Parking Capacity	1,800	1,000	600 ↓	900	1,100	500	750

Railway Station	Milan Central Station	Amsterdam Centraal	Utrecht Centraal Station	Rotterdam Centraal Station
Passenger Flow	320,000 p/day	250,000 p/day	207,360 p/day	104,840 p/day
Bicycle Parking Capacity	5,500 ↓	7,000	12,500	5,190

In order to figure out the appropriate number of the parking capacity of shared cars and bicycles in the hub, I conducted a benchmark analysis by comparing daily passenger volumes and parking capacity at other train stations.

Research & Design Brief

CAPACITY REQUIREMENT

Mobility	Type	Dimensions (L×W×H, m)	Number of Vehicles	Platform Area (m ²)	Parking Area (m ²)
Train	Regional	150×3×4	12 Trains	900m ² per track	900m ² per track
	High-speed	350×3×4	12 Trains	500m ² per track	500m ² per track
Tram		30×2.5×3.4		90m ² per track	90m ² per track
Bus	Airport Shuttle	15×2.5×3.2	5 Shuttles	45m ² per shuttle.	90m ² per shuttle.
			3 Shuttles		
			4 Shuttles		
	Bus (Through)	12×2.5×3.2		30m ² per bus	30m ² per bus
Car	Taxi	5 × 1.8 × 1.5		15m ² per car.	15m ² per car.
	Car Hail		Every 24 Cars		
	Shared Car		500 Cars	22.5m ² per car.	
	Private Car		100 Cars		
Micromobility	Rent Bike	1.8 × 0.5× 1.2	1500 Bikes		2.15m ² per bike
	Shared Bike		1500 Bikes		
	Shared Scotter		500 Scotters		
	Shared Motorcycles		500 Motorcycles		

This is the estimated number of parking spaces in the hub.

PARKING SOLUTION-AUTOMATED MECHANICAL SYSTEM



People don't need to walk into the parking lot to park, it is good for separation between pedestrians and vehicles.

PARKING SOLUTION-AUTOMATED MECHANICAL SYSTEM

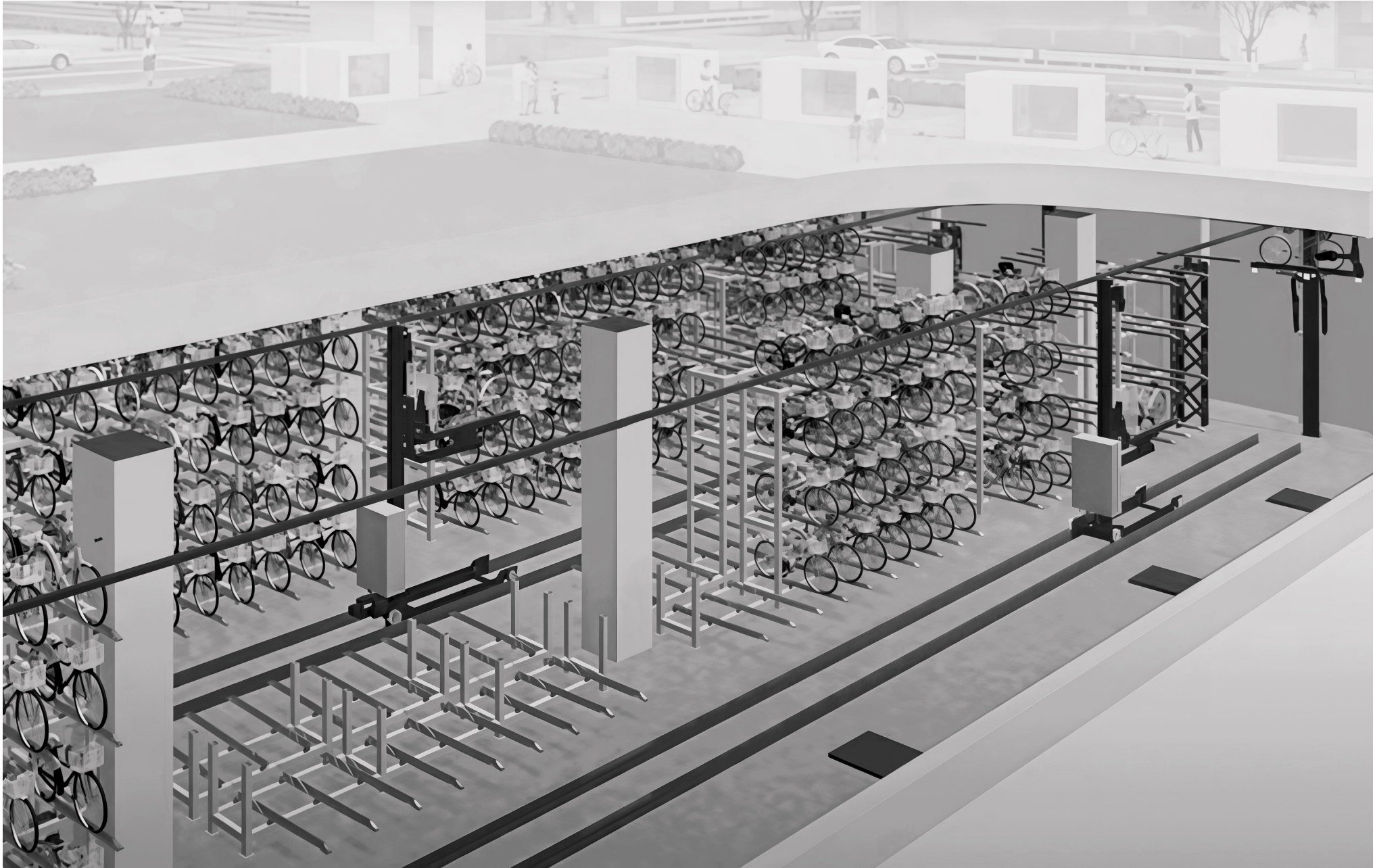

The same goes for bike parking.

AUTOMATED MECHANICAL PARKING SYSTEM

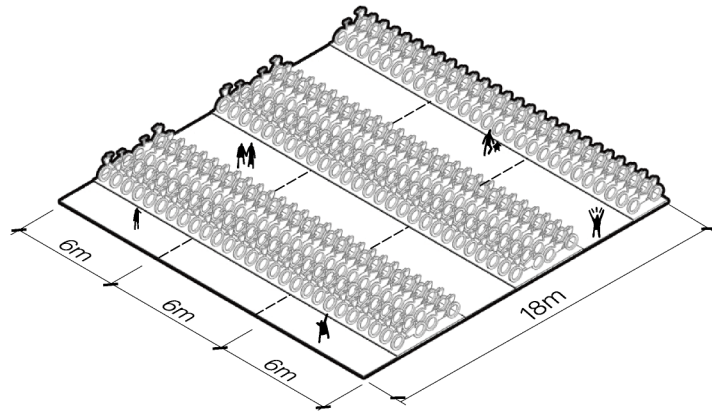

Shared Micromobility Parking

137 Bikes

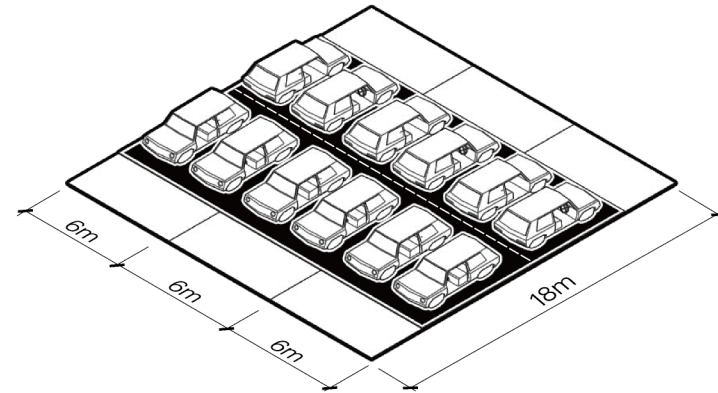

Shared Car Parking

12 Cars

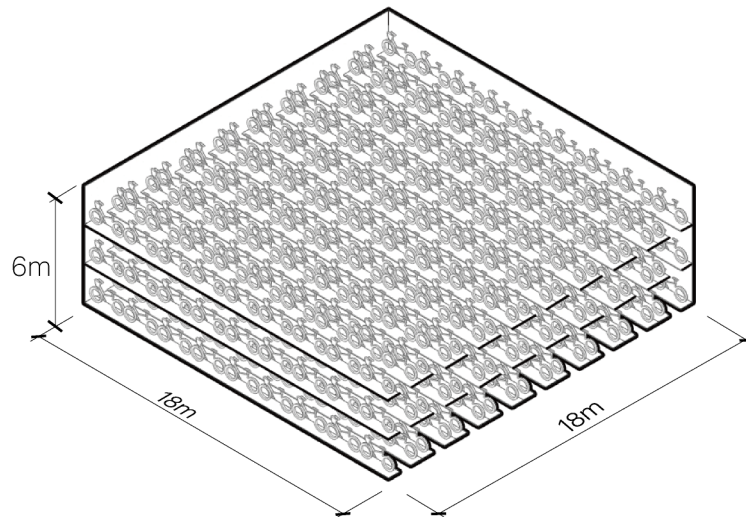

Smart Auto-Micromobility Parking

3x162 Bikes

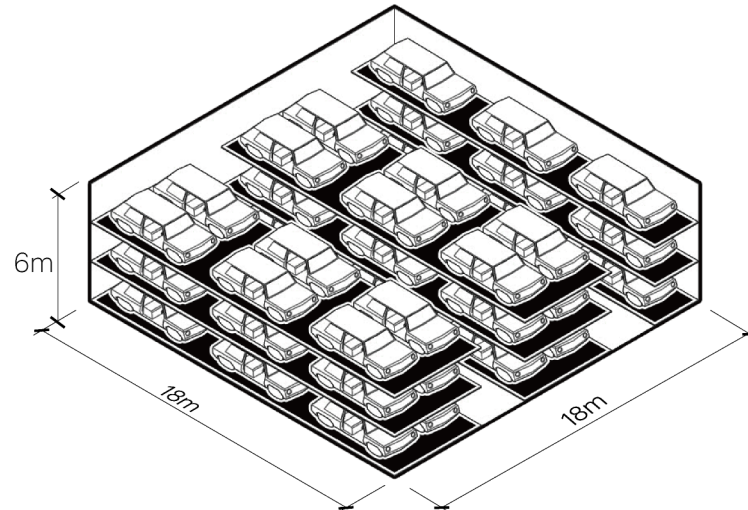

Smart Auto-Shared Car Parking

3x15 Cars

Besides, this parking system can also makes efficient use of parking space, reducing the overall area needed.

AREA REQUIREMENT OF ALL MOBILIES

Mobility	Type	Dimensions (L×W×H, m)	Number of Vehicles	Platform Area (m ²)	Parking Area (m ²)
Train	Regional	150×3×4	12 Trains	900m ² per track	900m ² per track
	High-speed	350×3×4	12 Trains	500m ² per track	500m ² per track
Tram		30×2.5×3.4		90m ² per track	90m ² per track
Bus	Airport Shuttle	15×2.5×3.2	5 Shuttles	45m ² per shuttle	90m ² per shuttle
			3 Shuttles		
4 Shuttles					
	Bus (Through)	12×2.5×3.2		30m ² per bus	30m ² per bus
Car	Taxi	5 × 1.8 × 1.5		15m ² per car	15m ² per car
	Car Hail		Every 24 Cars		
	Shared Car		500 Cars	22.5m ² per car	
	Private Car		100 Cars		
Micromobility	Rent Bike	1.8 × 0.5× 1.2	1500 Bikes		2.15m ² per bike
	Shared Bike		1500 Bikes		
	Shared Scotter		500 Scotters		
	Shared Motorcycles		500 Motorcycles		

DESIGN BRIEF- PROGRAM BAR

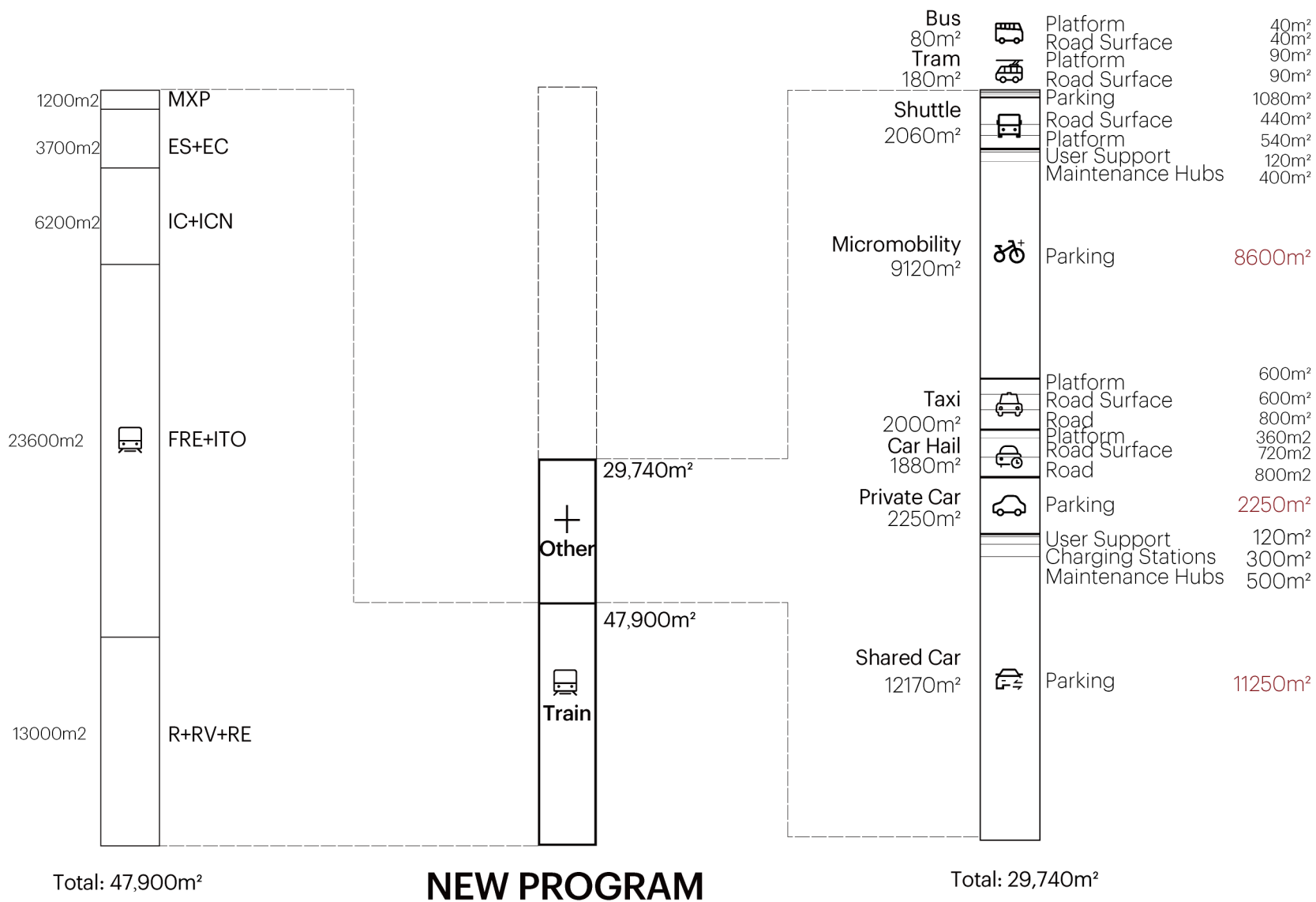

I completed the mobility section in my new program bar.

METHOD-MOBILITY-DATA ANALYSIS

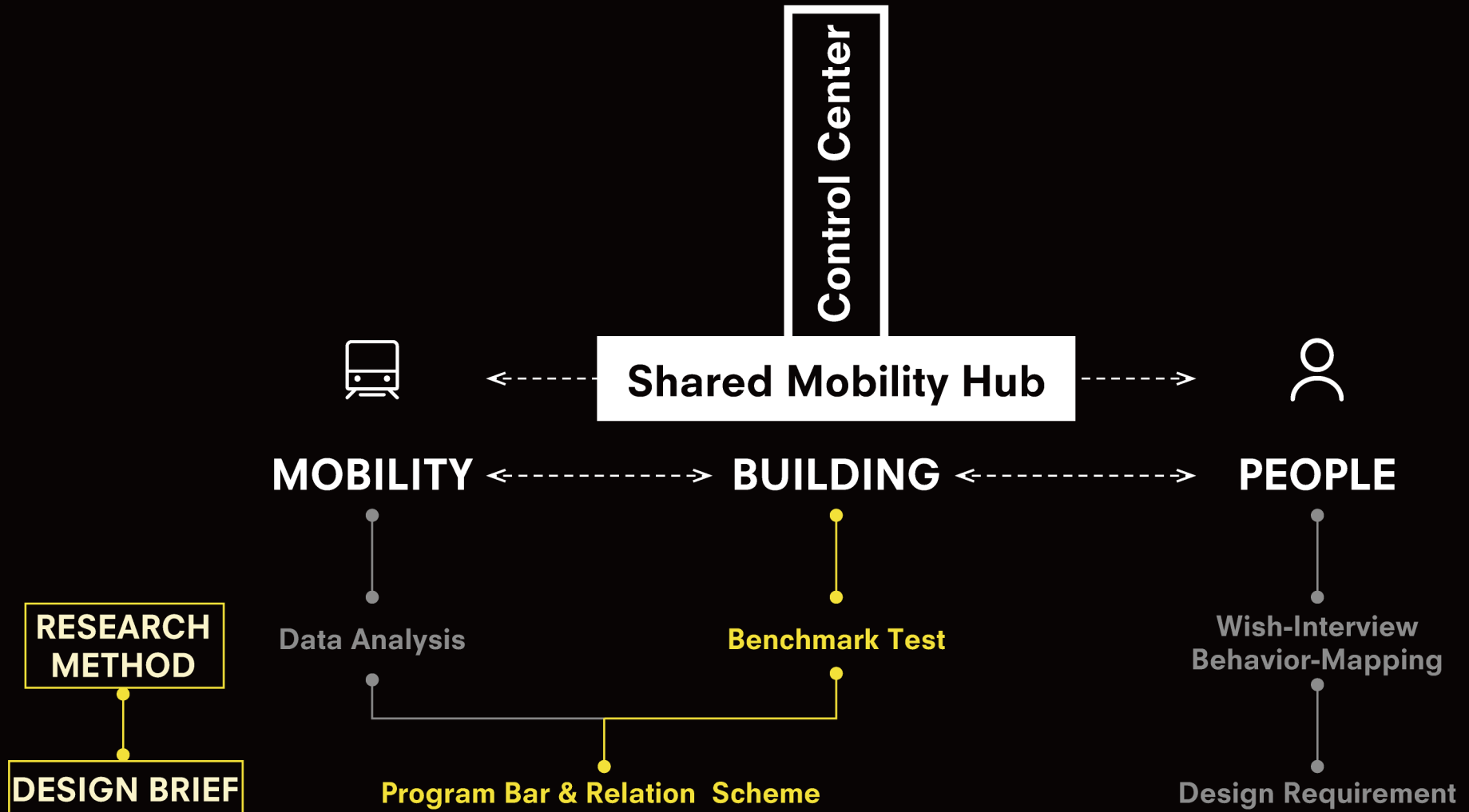

BENCHMARK- RAILWAY STATION

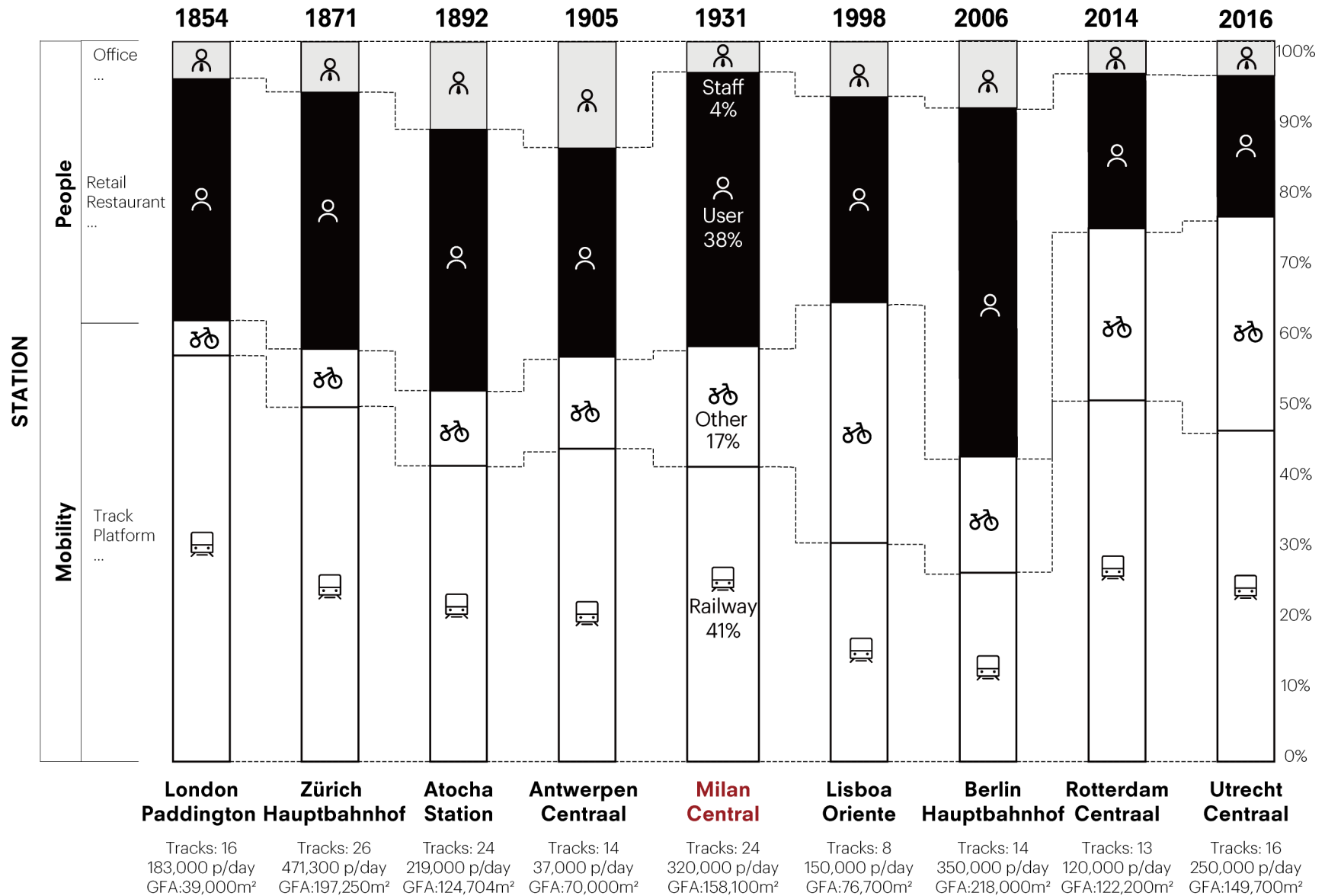

I selected nine major European train stations and conducted a benchmark analysis comparing their daily passenger volumes and functional areas.

DESIGN BRIEF-PROGRAM BAR OF HUB

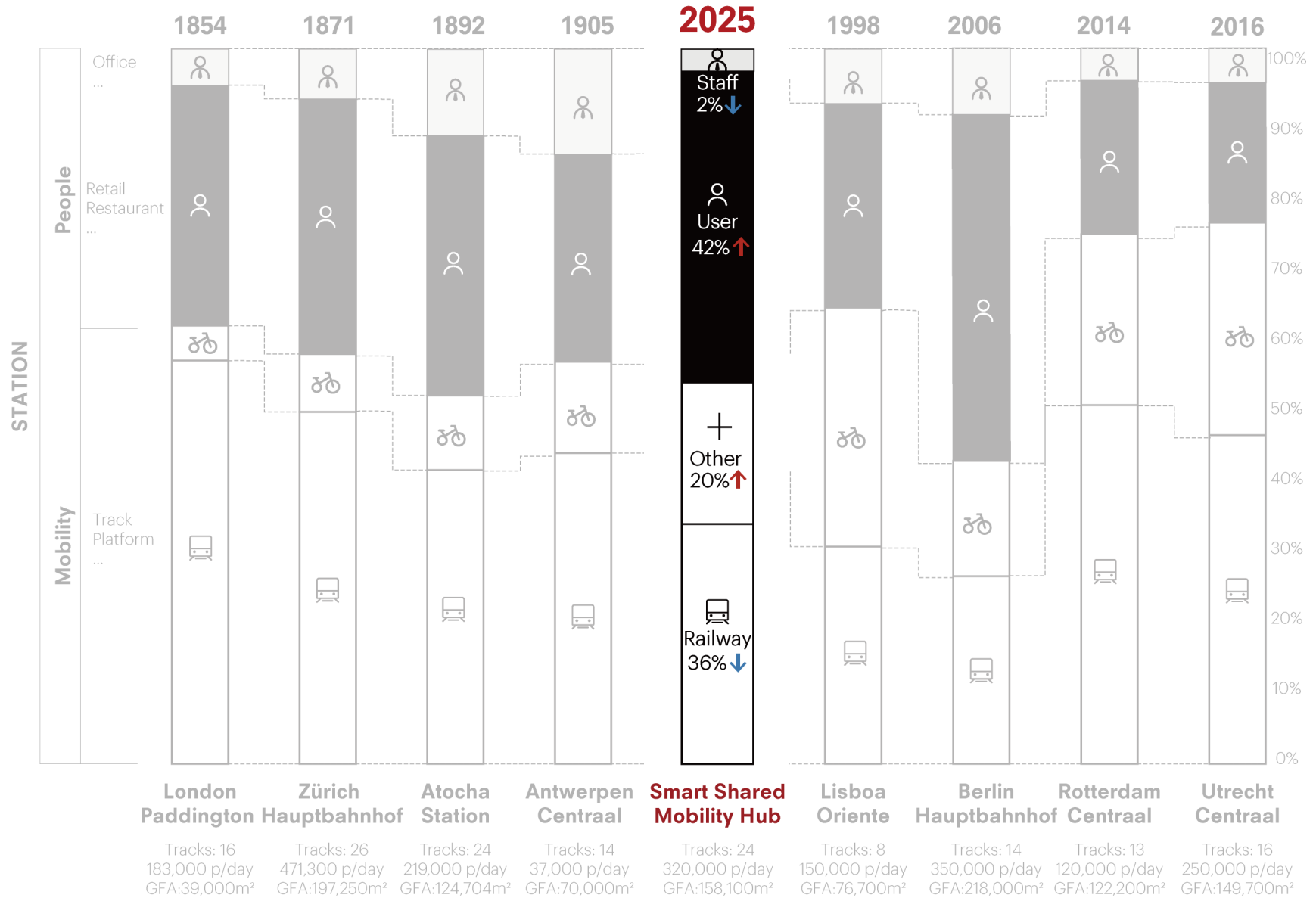

It is better to increase the space for passengers and other transport modes, while optimizing the areas used by trains and staff.

DESIGN BRIEF-PROGRAM BAR OF HUB

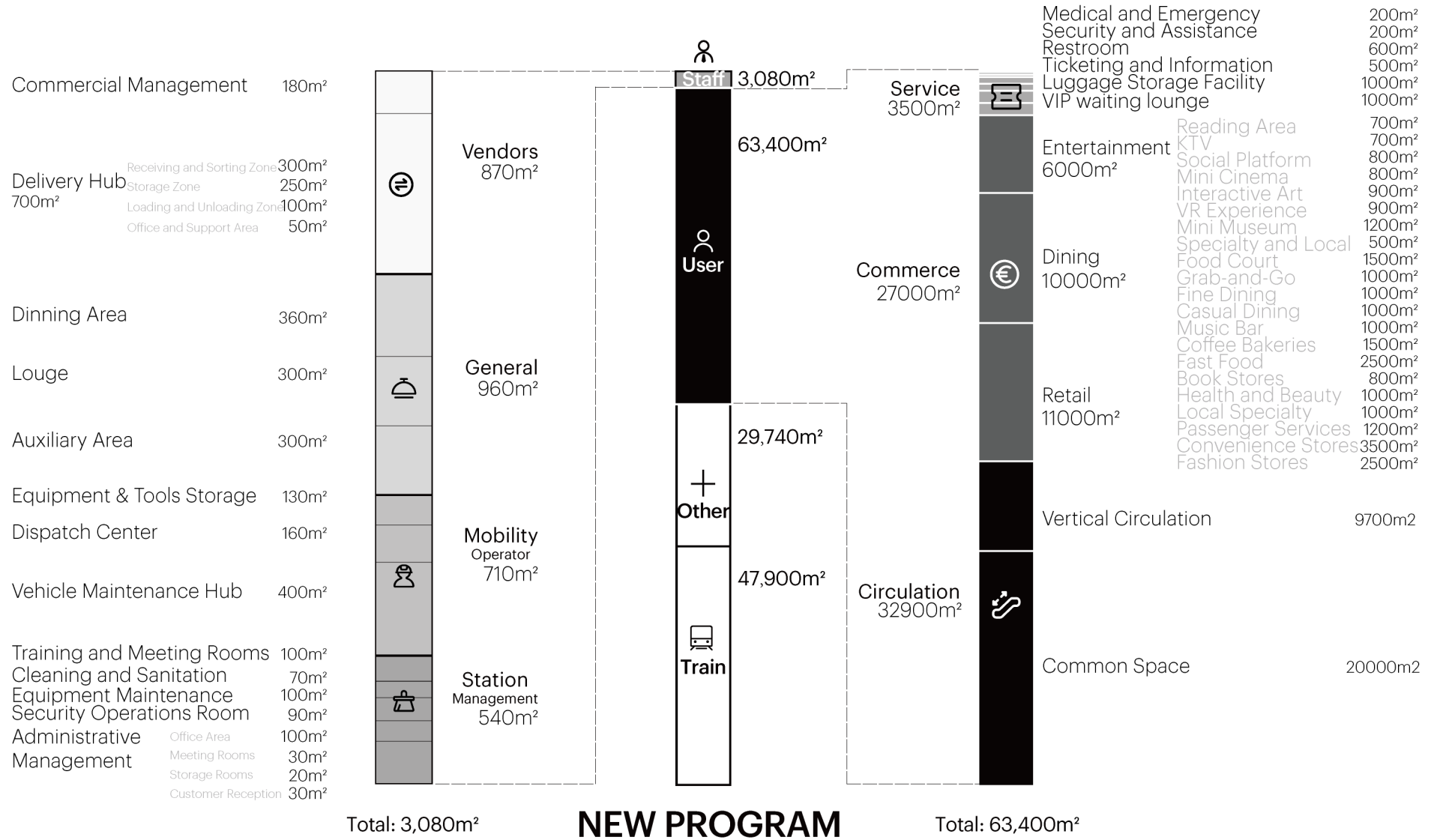

I completed the user and staff section in my new program bar.

BENCHMARK- CONTROL CENTER

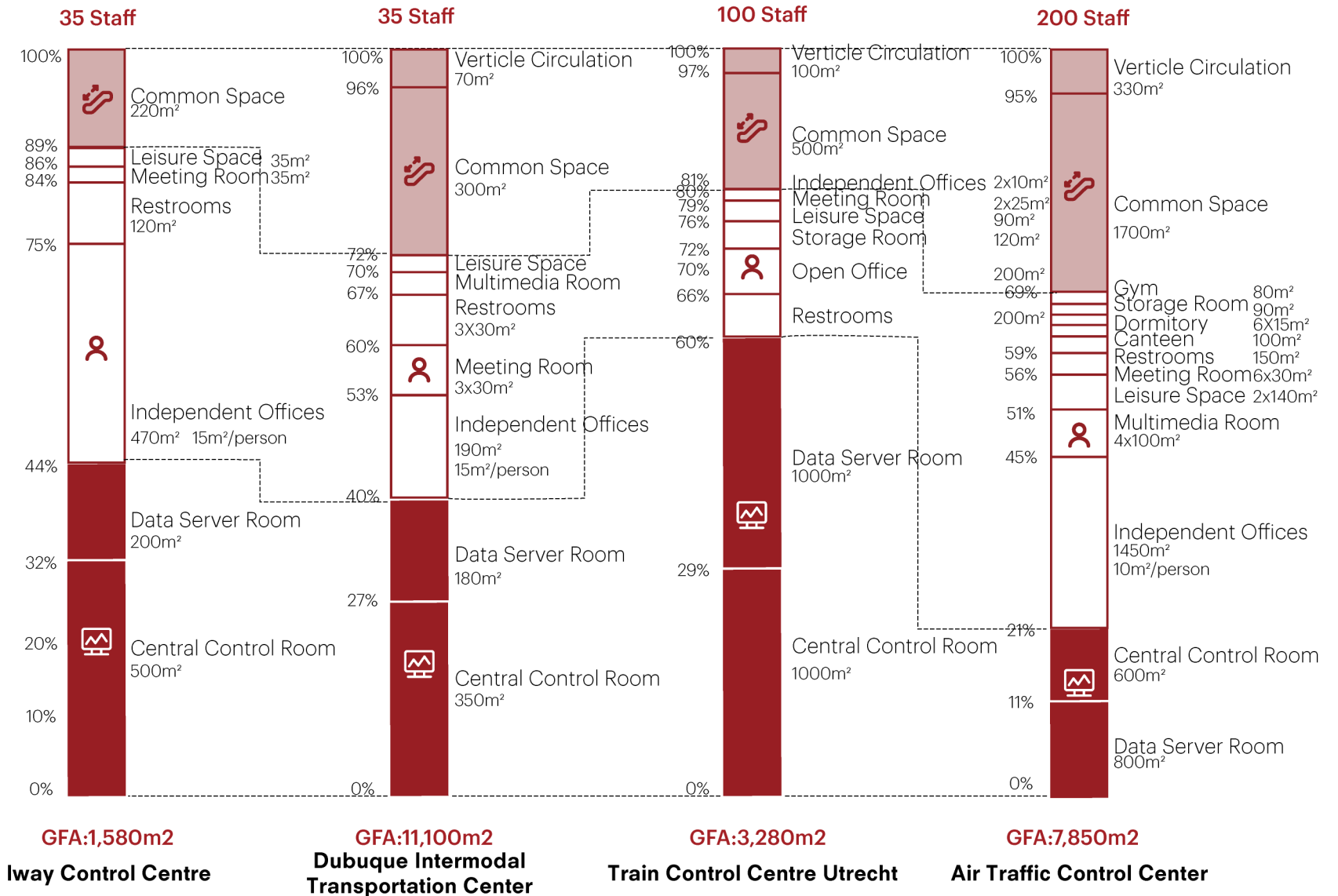

DESIGN BRIEF-PROGRAM BAR OF CONTROL CENTER

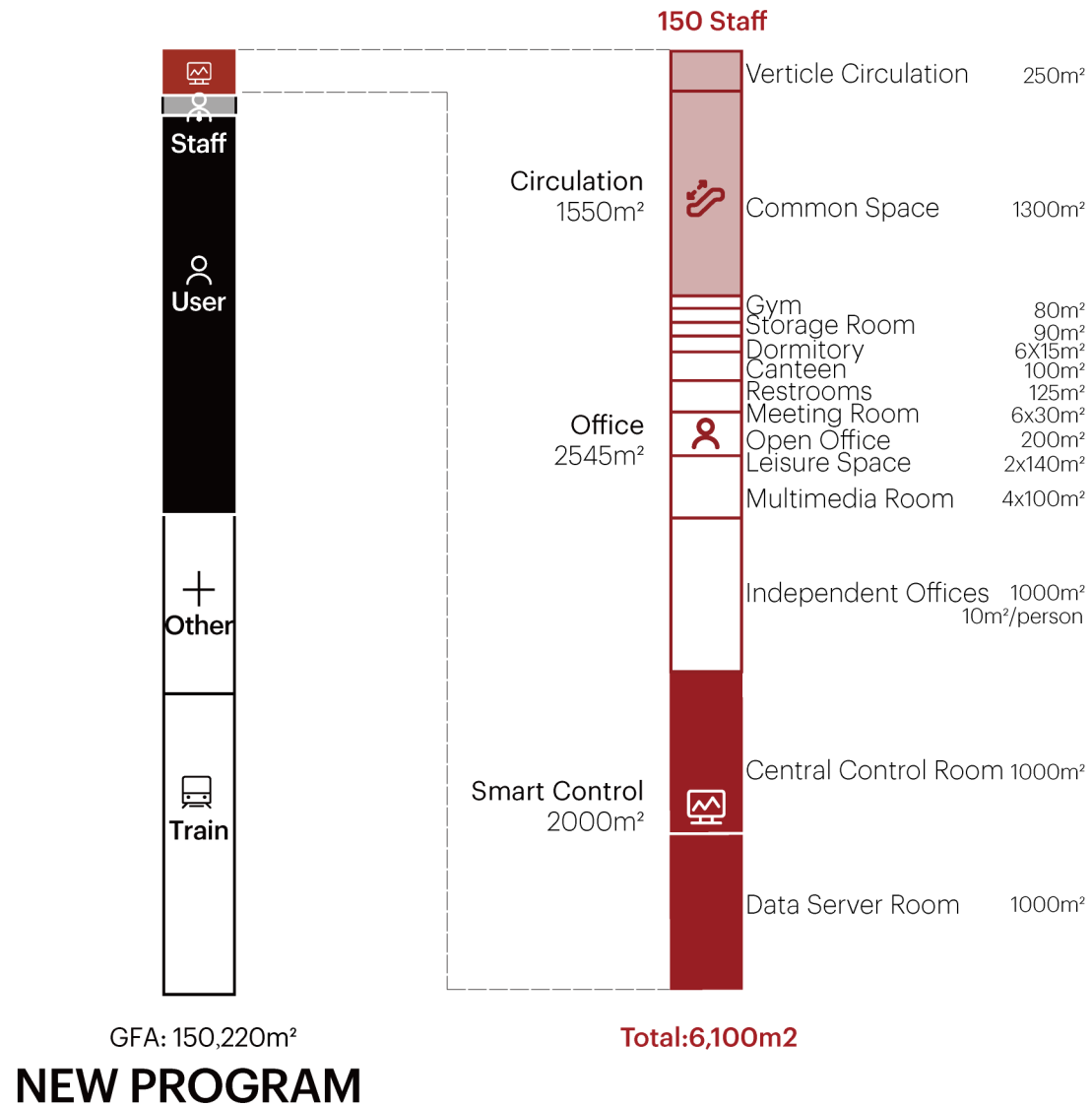

The final result shows that this project requires 150 staff members. The functional areas are mainly divided into offices and control rooms.

CONCLUSION-PROGRAM BAR

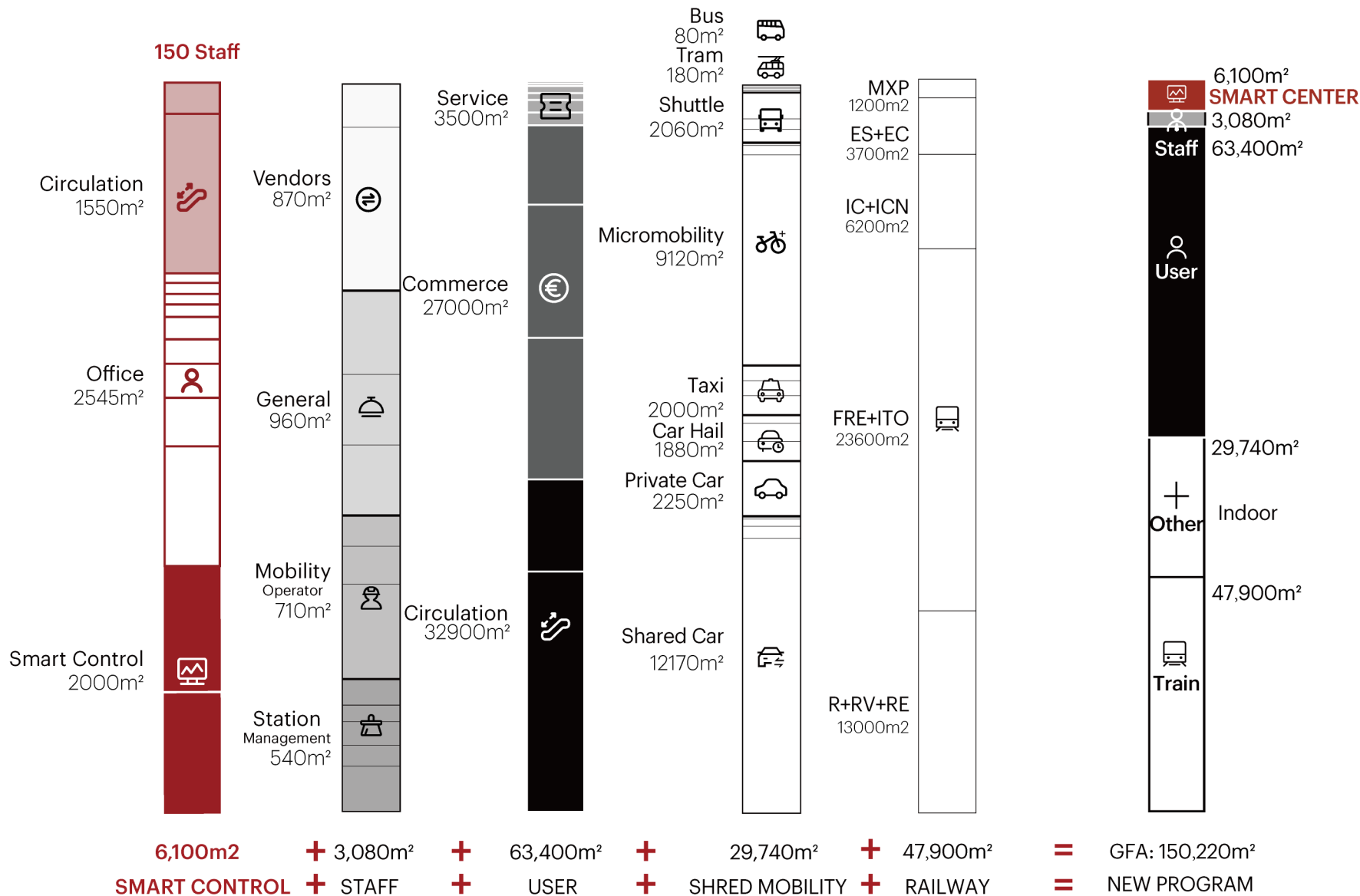

Research & Design Brief

FUNCTION AREA

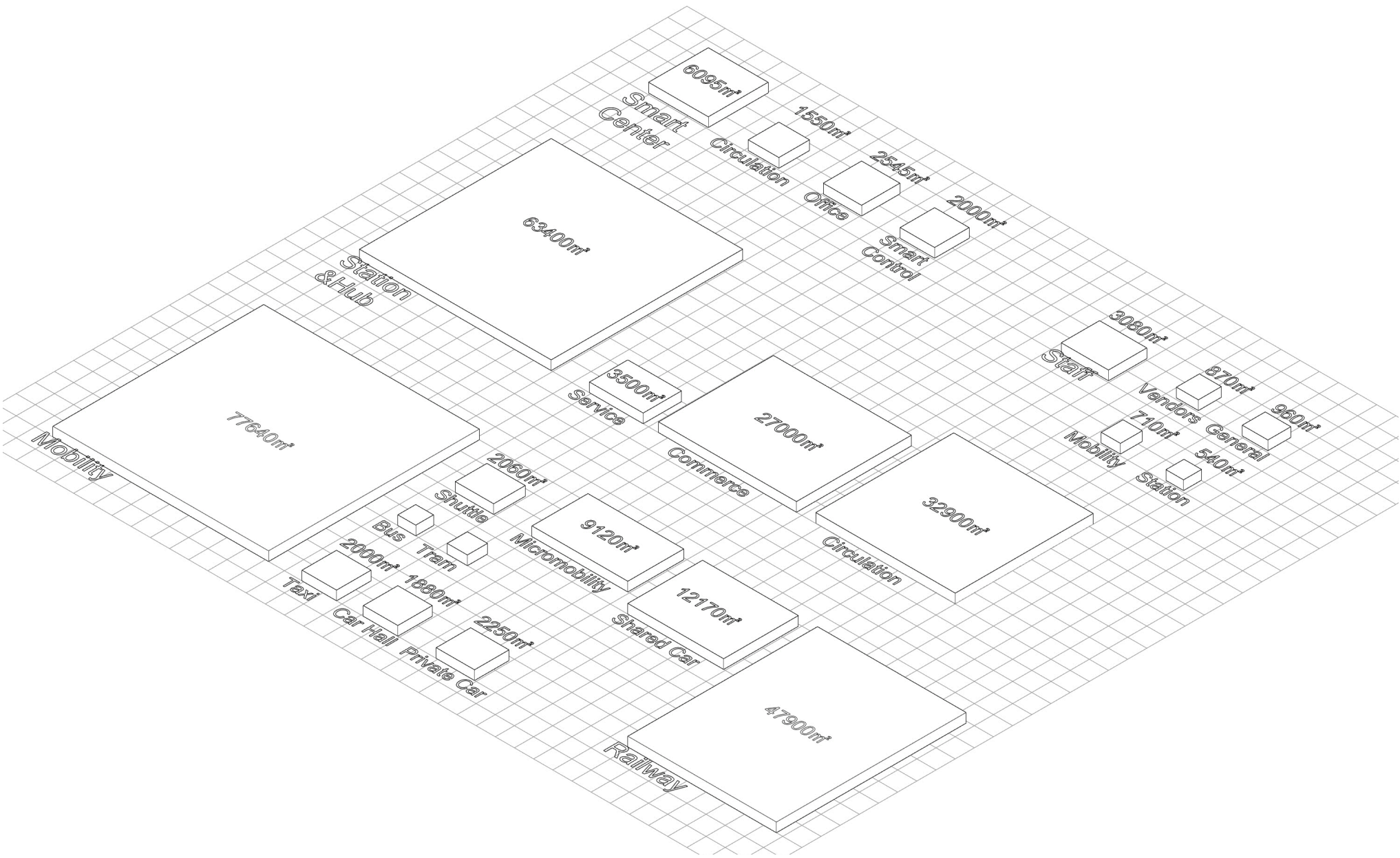

Research & Design Brief

RELATION SCHEME

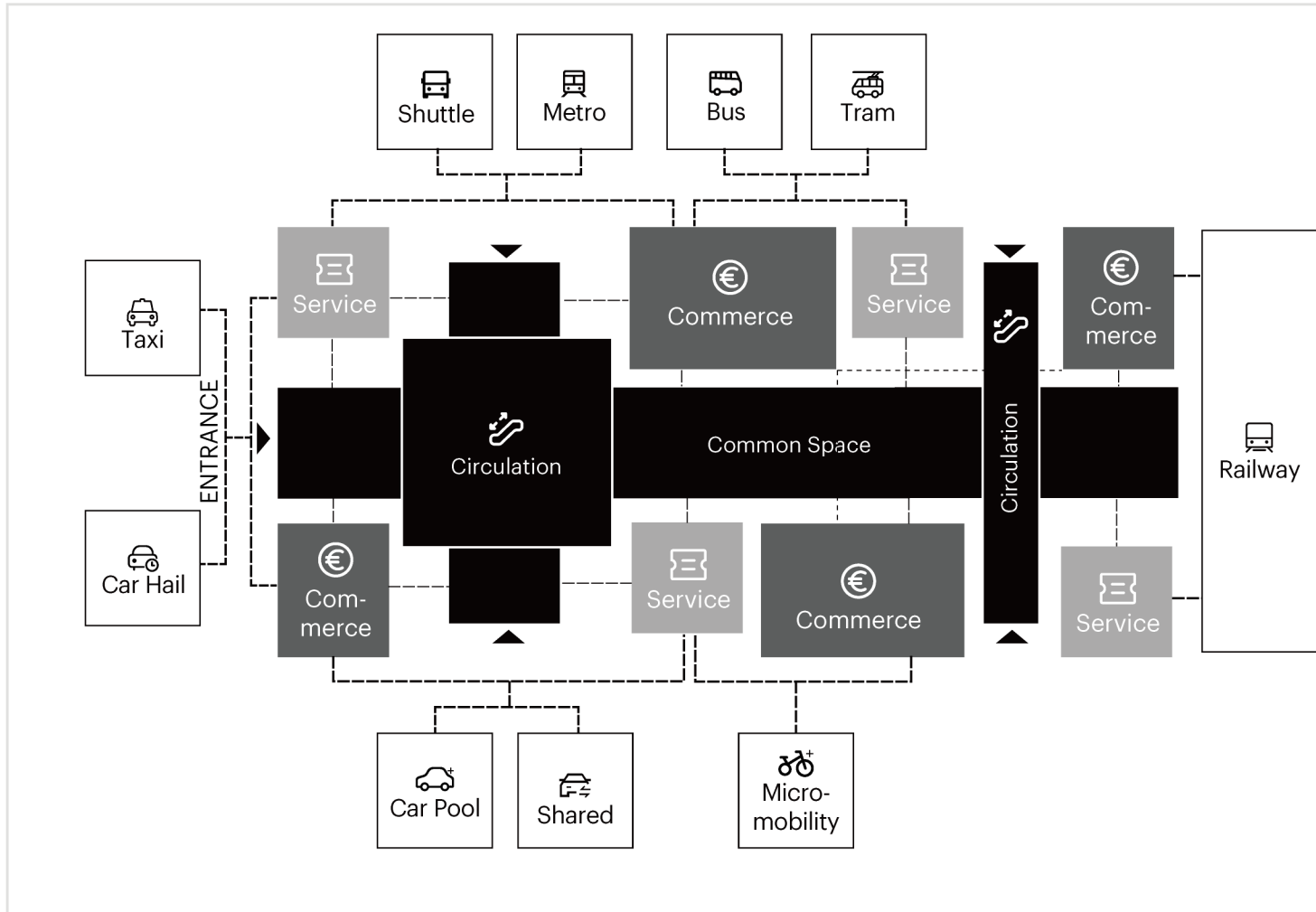

Research & Design Brief

RELATION SCHEME

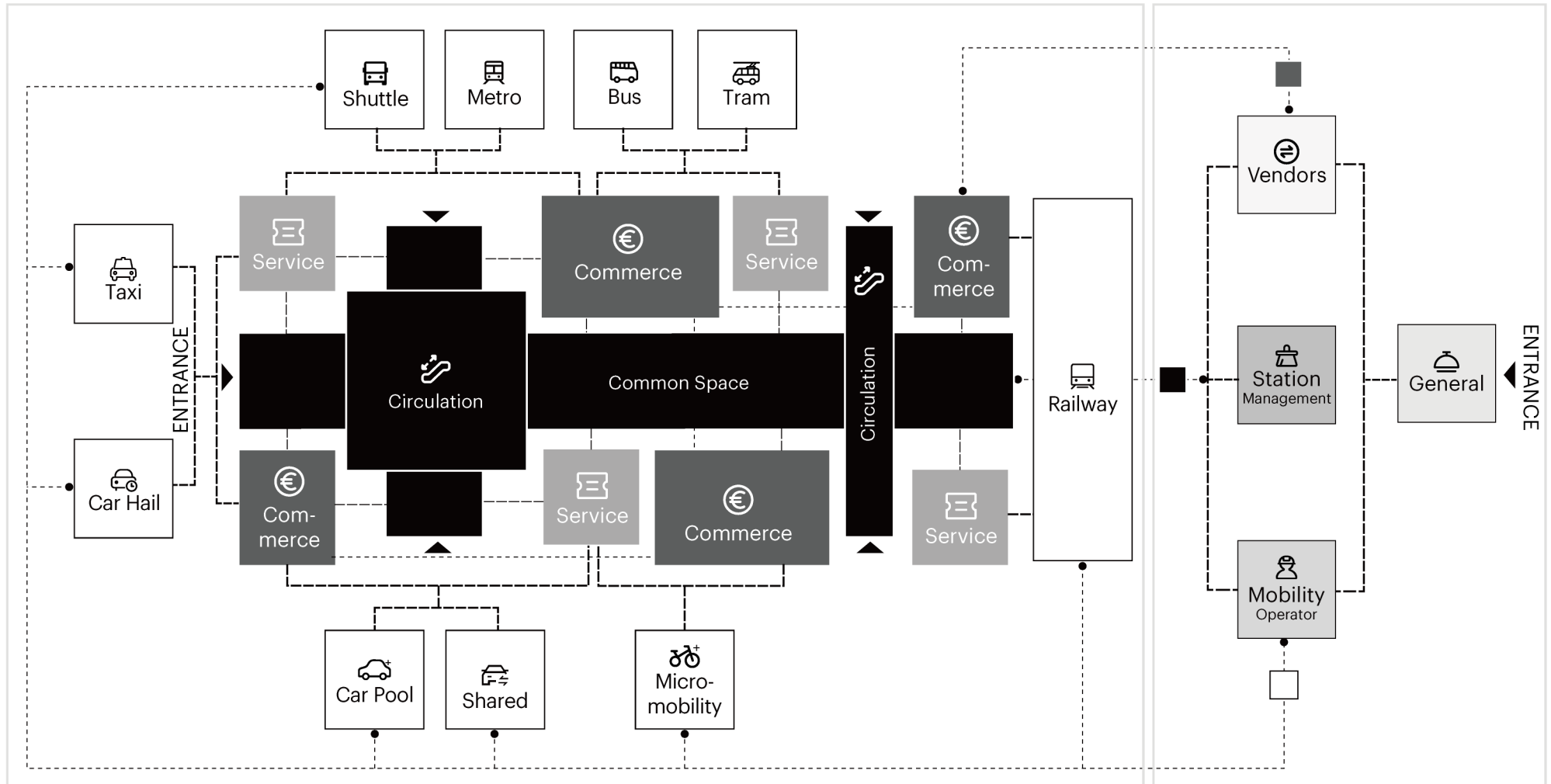

SMART CENTER

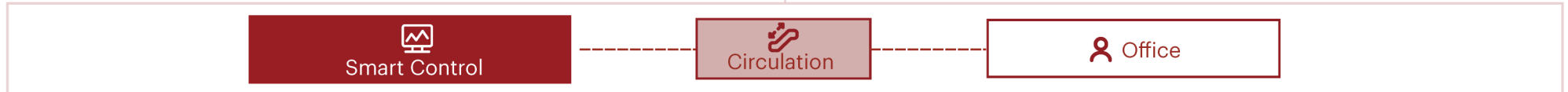

ENTRANCE

This program also add some extra back-of-house spaces and a control center area. And what need to be mentioned is the control center has restricted access for security reasons.

Research & Design Brief

RELATION SCHEME

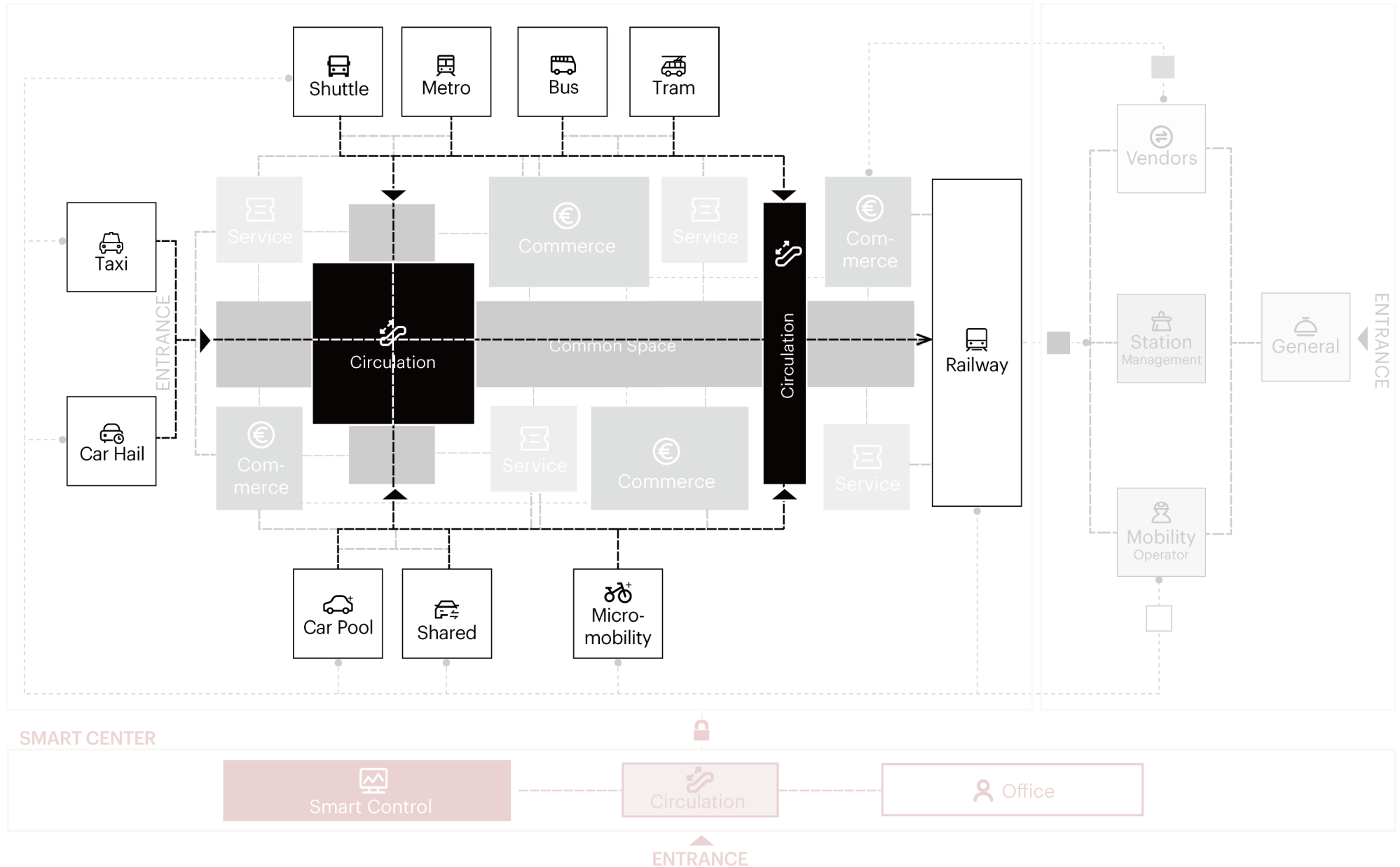

There will be a main key circulation space to gather and organize flows from all mobilitie, along with secondary circulation routes for fast pathways.

Research & Design Brief

RELATION SCHEME

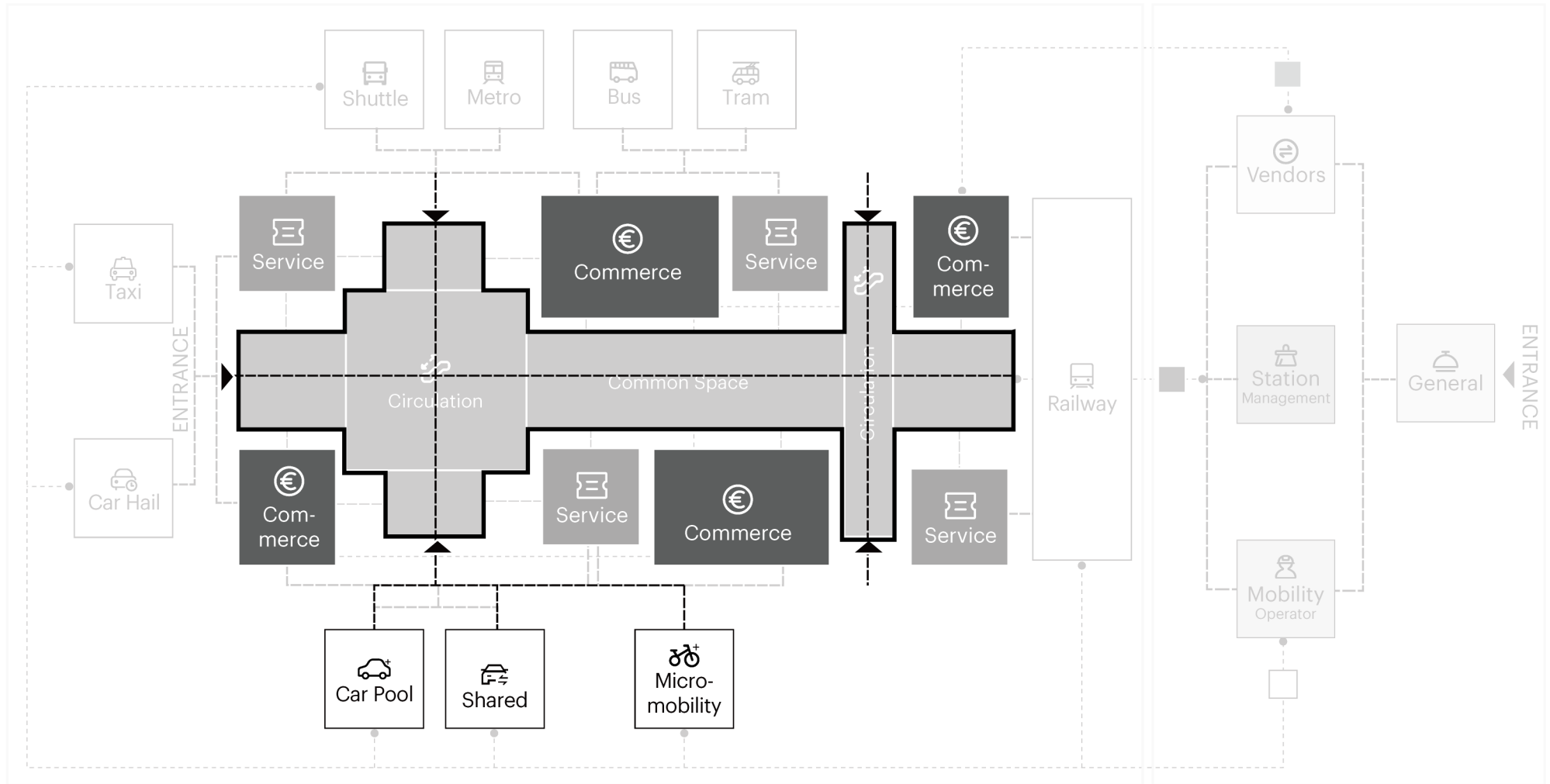

SMART CENTER



Commerce and service areas will be located alongside the circulation paths.

METHOD-PEOPLE-INTERVIEW&MAPPING

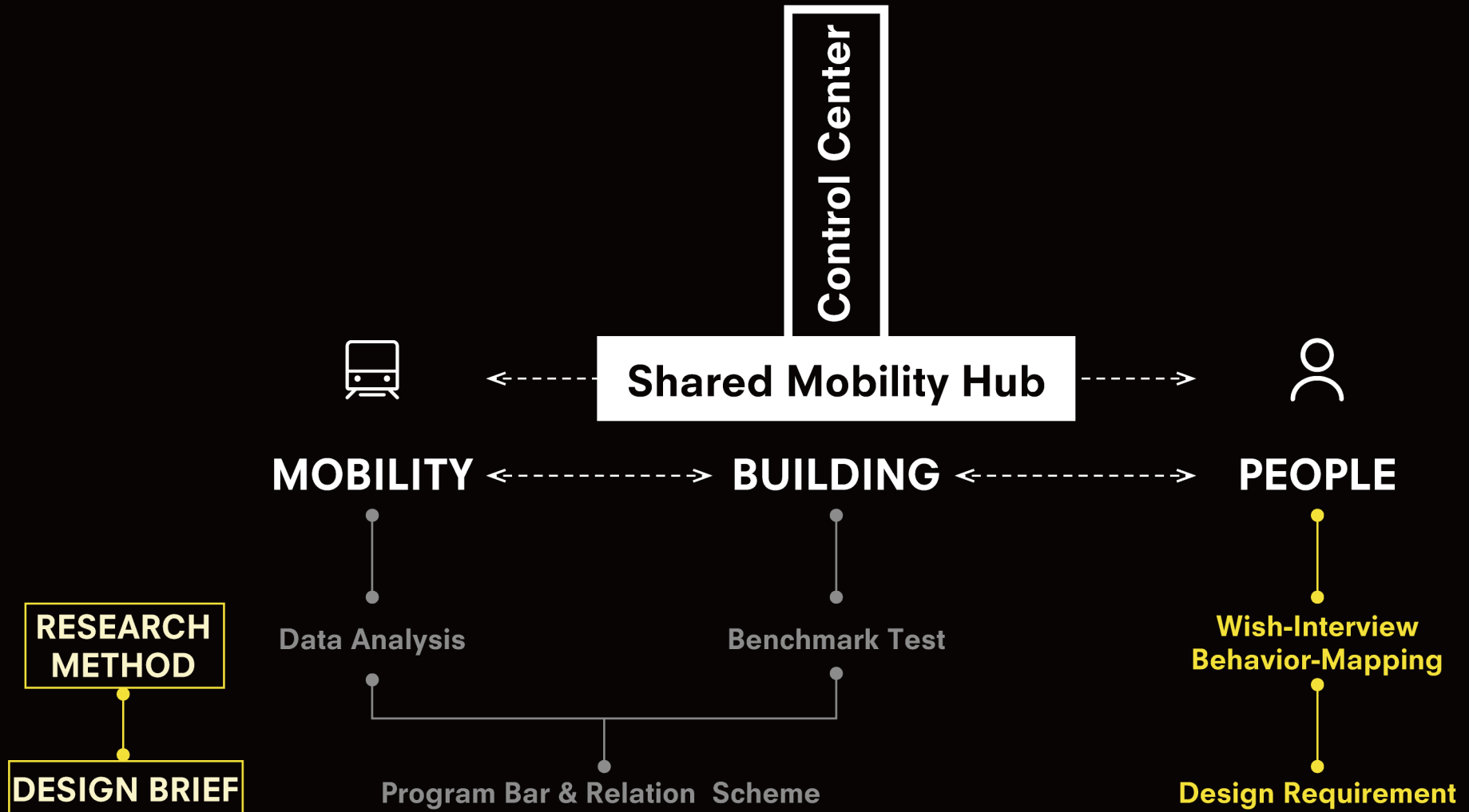

USER



Commuter



Traveller



City Dweller

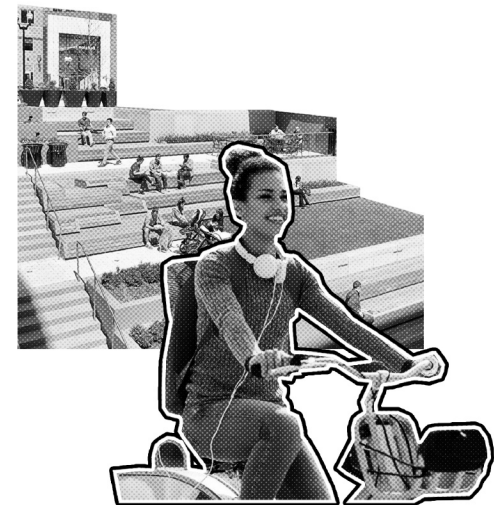

LOMBARDIA-REGIONAL TRAIN

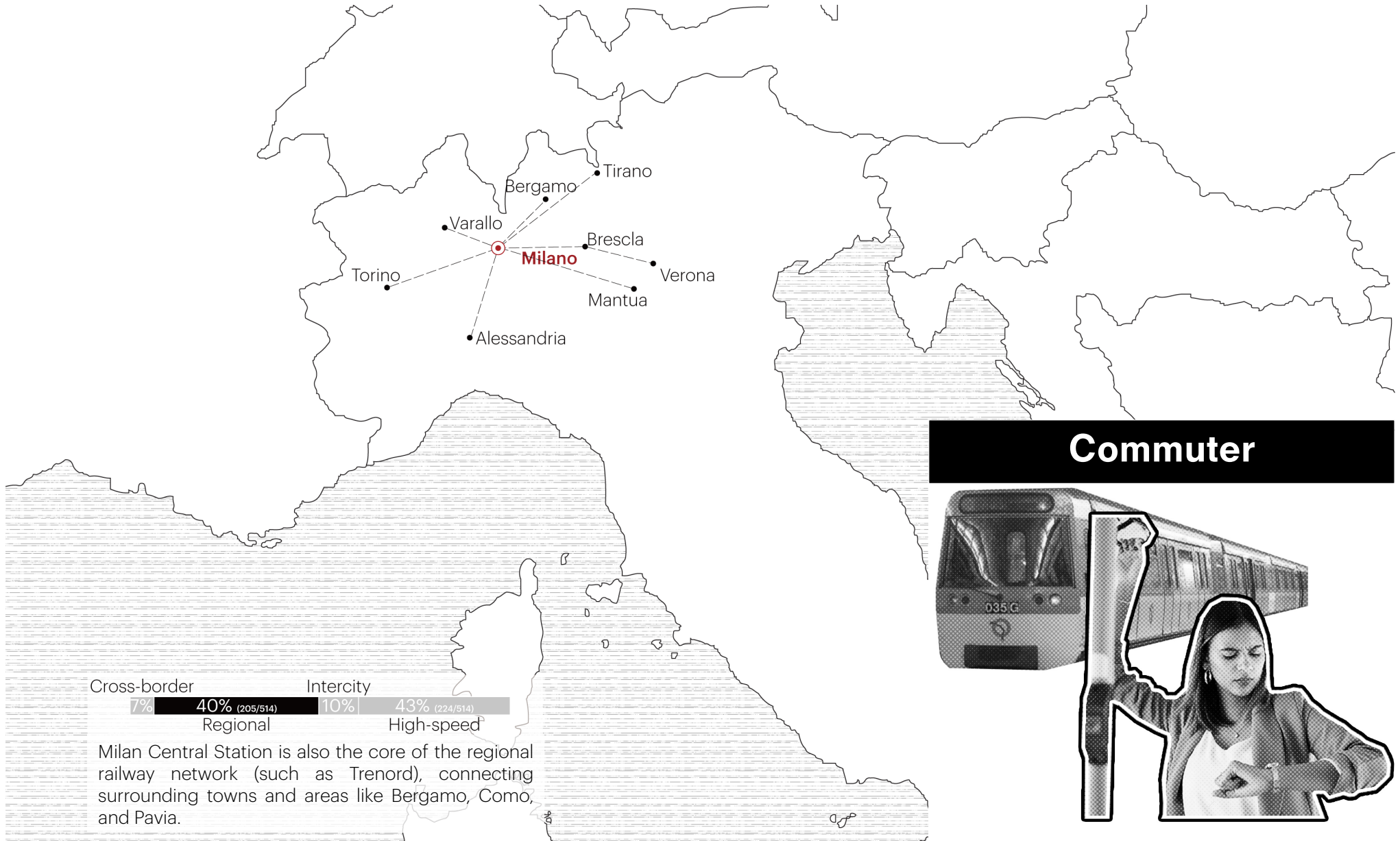

Milan Central Station is also the core of the regional railway network (such as Trenord), connecting surrounding towns and areas like Bergamo, Como, and Pavia.

Commuter



Milan, as the largest city in Lombardy, anchors the regional rail network

Research & Design Brief

DOMESTIC-HIGH SPEED

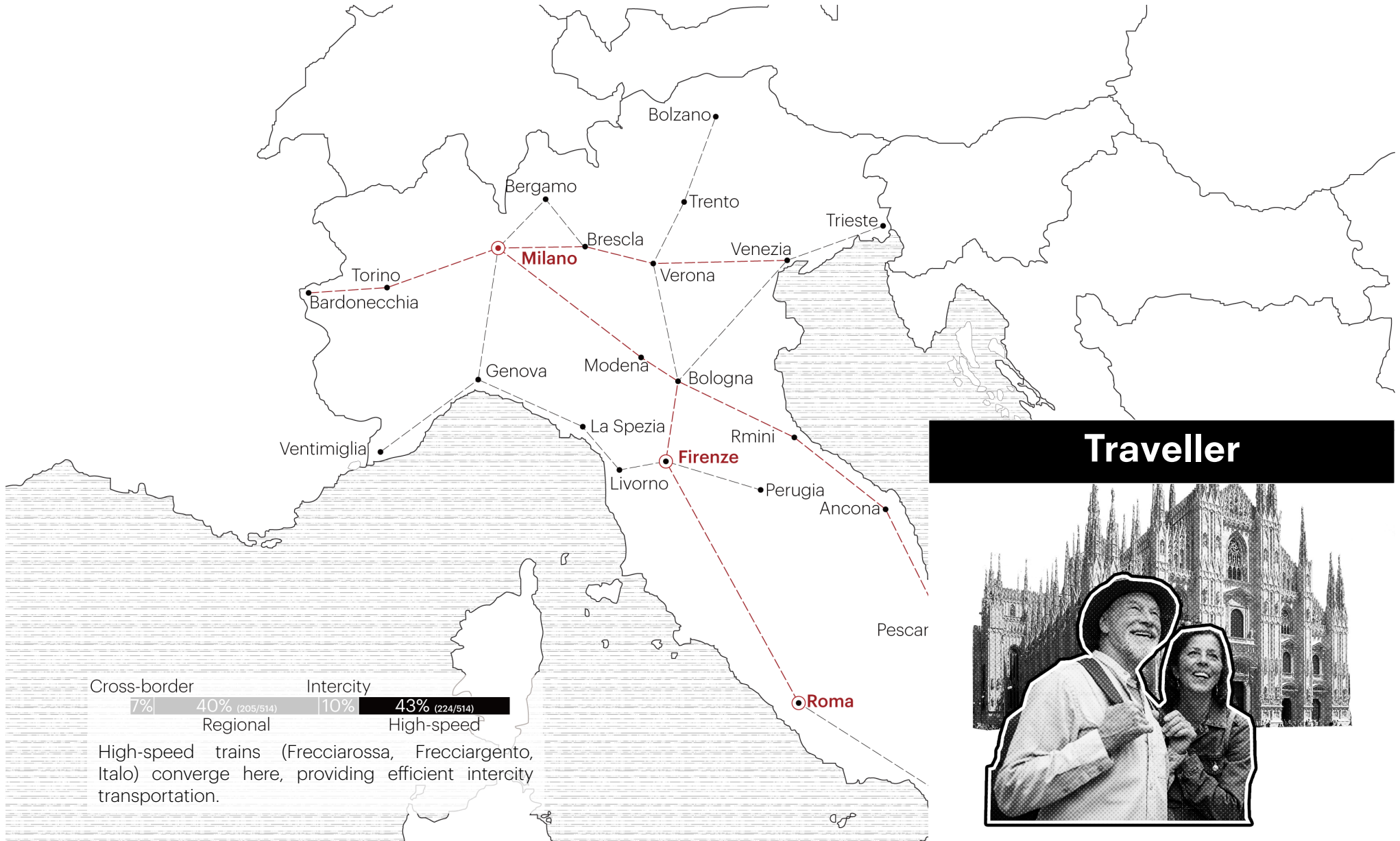

Milan, as a gateway to Italy, it drives national high-speed domestic transport



Research & Design Brief

POPULATION DENSITY

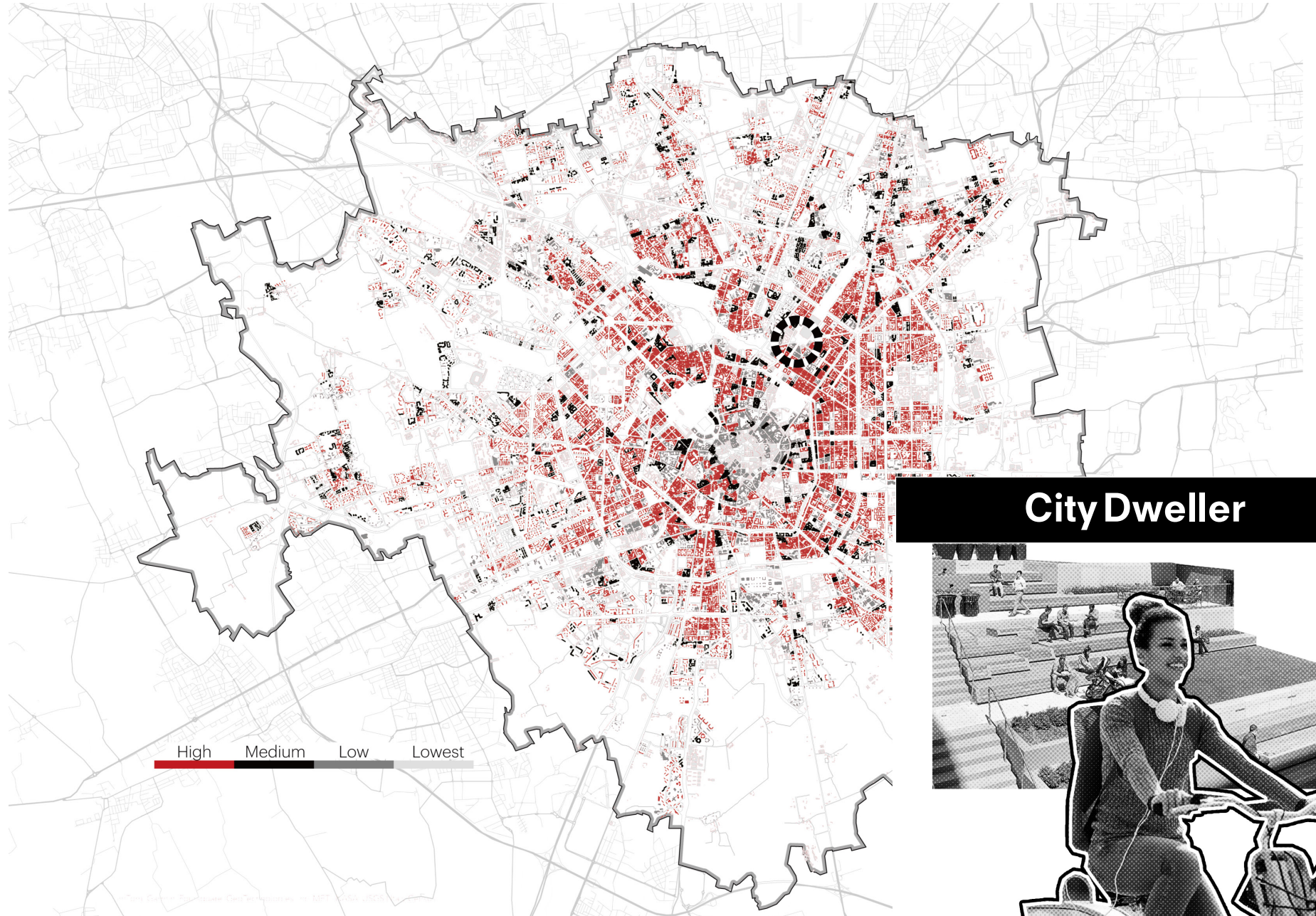

Milan train station is located in a densely populated residential area.

USERS' WISH



Commuter



Traveller



City D dweller



Research & Design Brief

USERS' WISH-COMMUTER



Commuter

TRANSFRE

SEAMLESS

EFFICIENCY

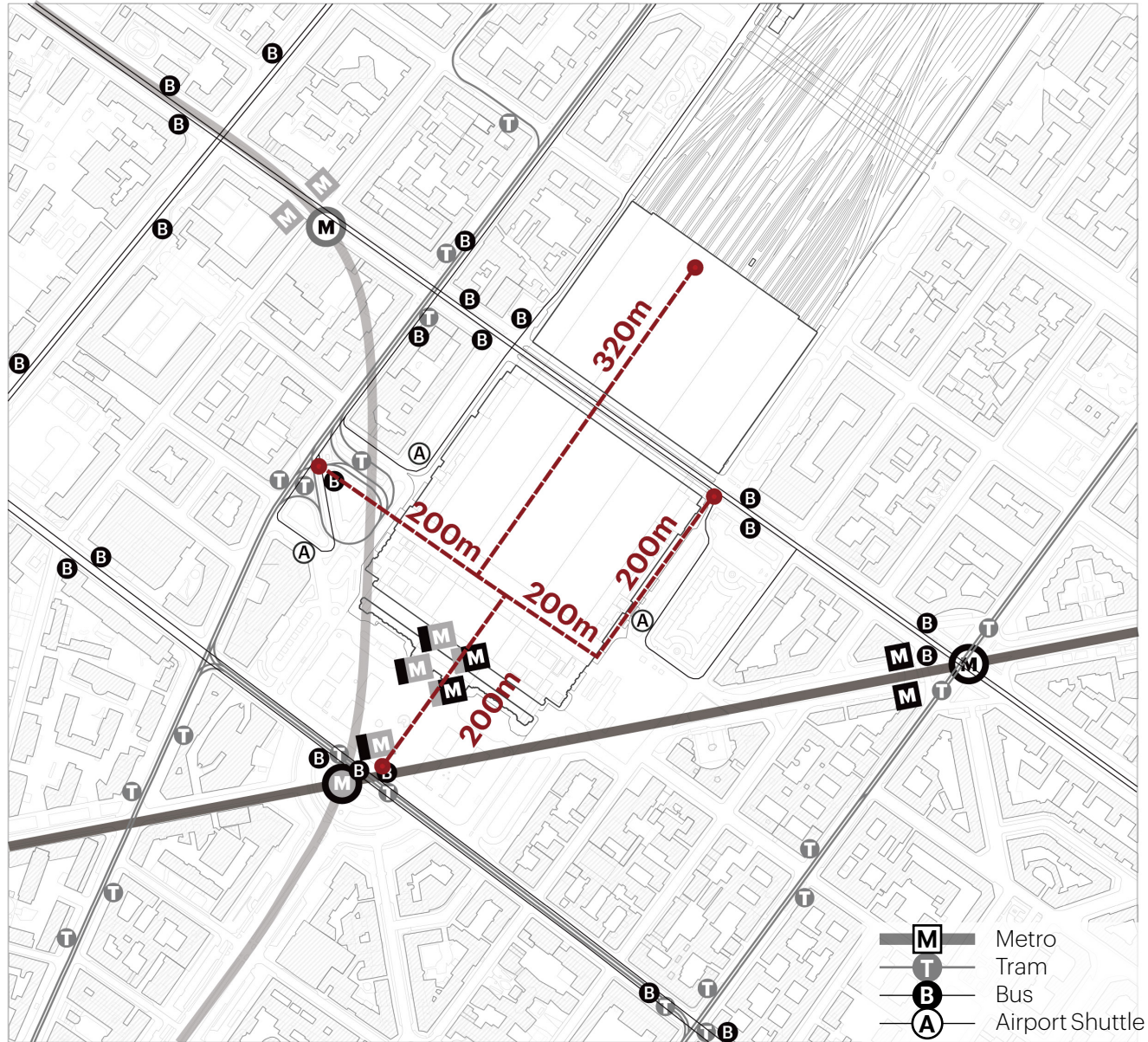
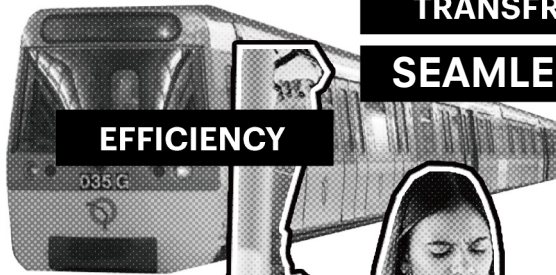

USERS' WISH-CITY DEWELLER



City Deweller

PUBLIC SPACE

CONVENIENCE

SAFETY



Nowadays, there's a lot of traffic around Milan Central Station. There is no separation between pedestrian and vehicle traffic.

USERS' WISH-TRAVELLER



Traveller

EVENT

MILAN IDENTITY
ENVIRONMENT

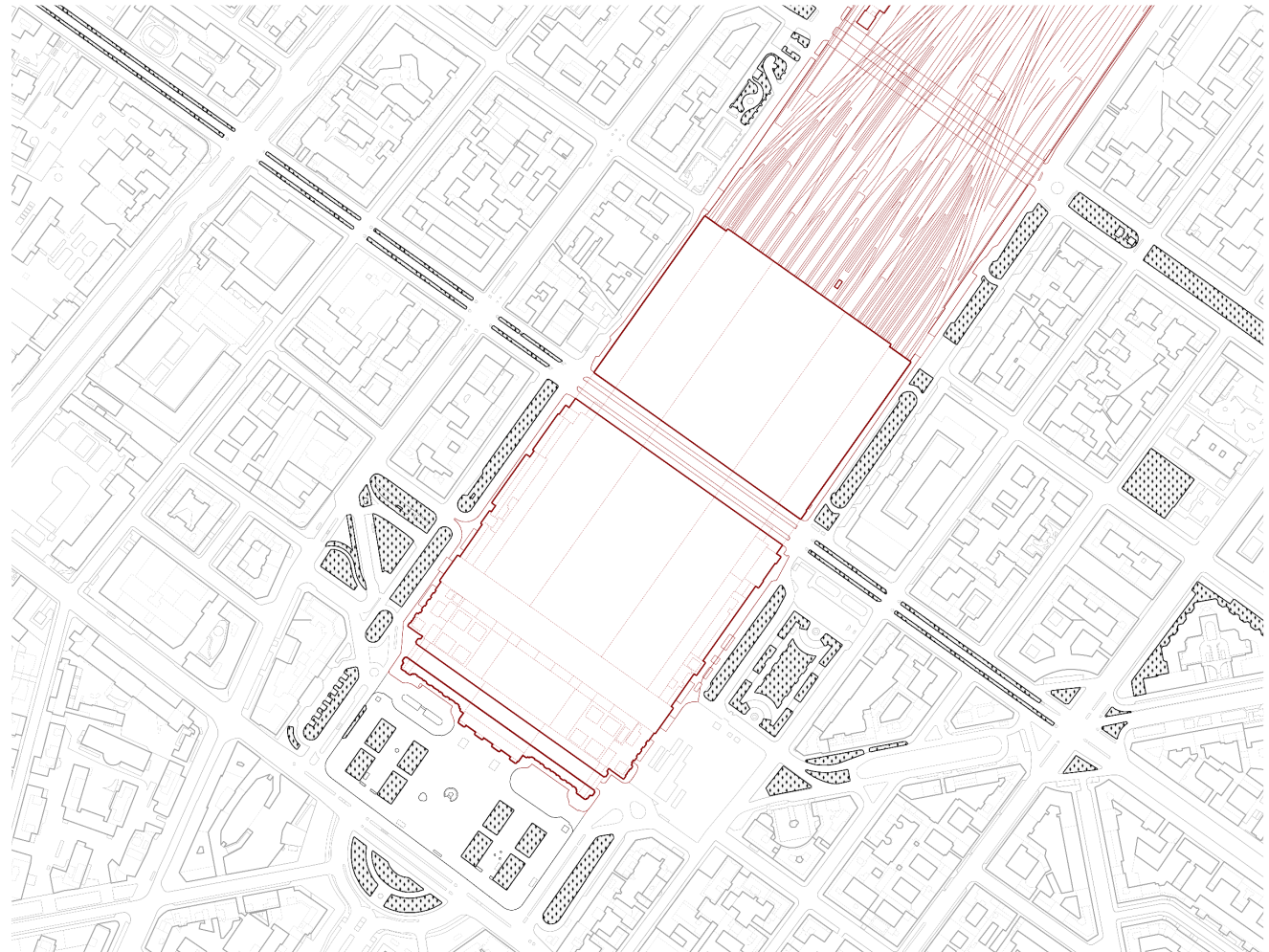

Travellers often expect a green environment and see Milan Central Station as part of Milan's identity. However, the green spaces around the station today are underused.

CONCLUSION-USERS' REQUIREMENT

USERS'

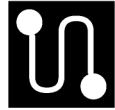

EFFICIENCY

Reduce the **walking distance** between various mobilities within the building.



SAFETY

Separation of the routes of **pedestrian and vehicles**.



GREEN

The **green space ratio** reaches 25%.

Research & Design Brief

STAKEHOLDERS

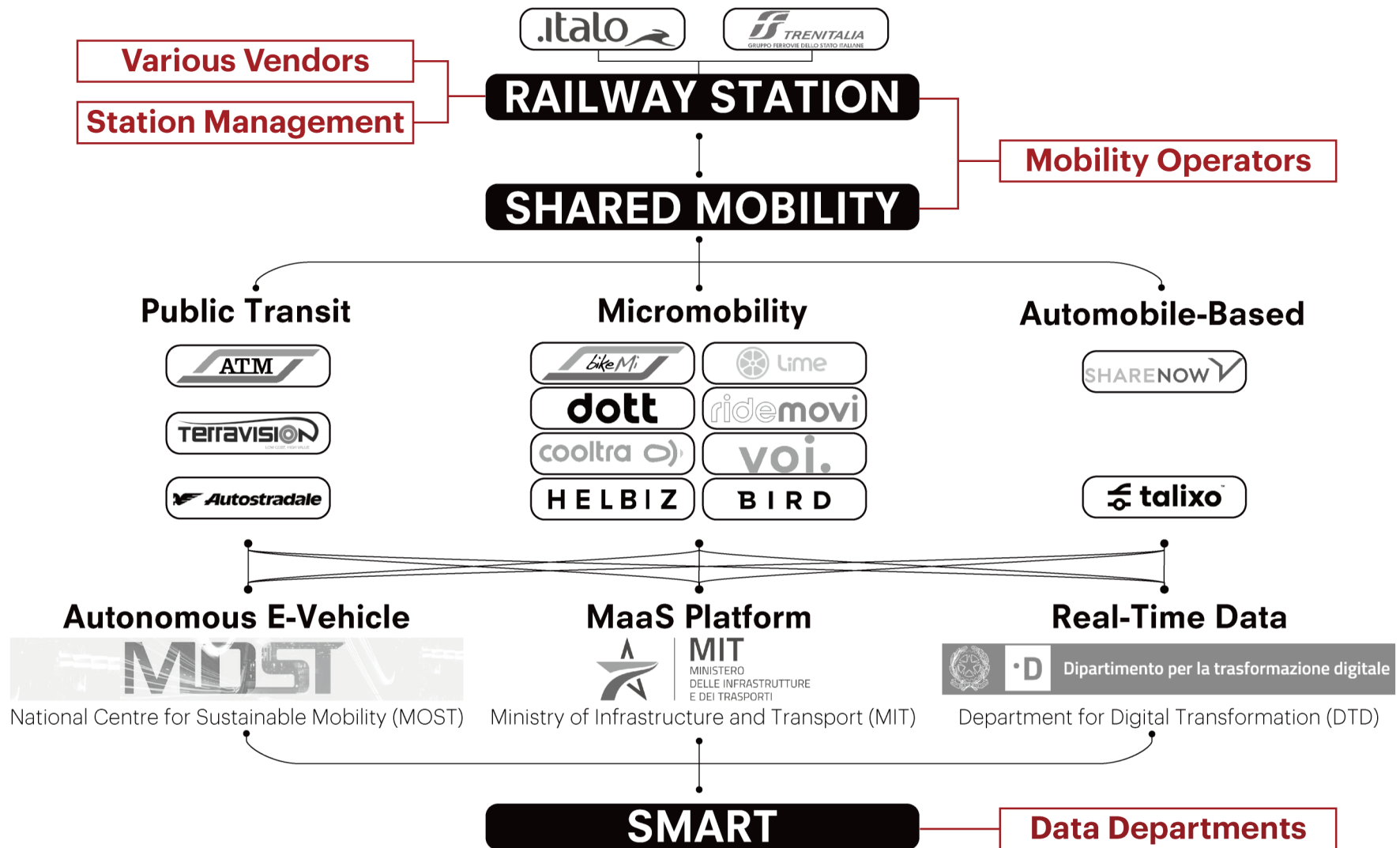

STAKEHOLDERS' WISH-ENERGY SAVING

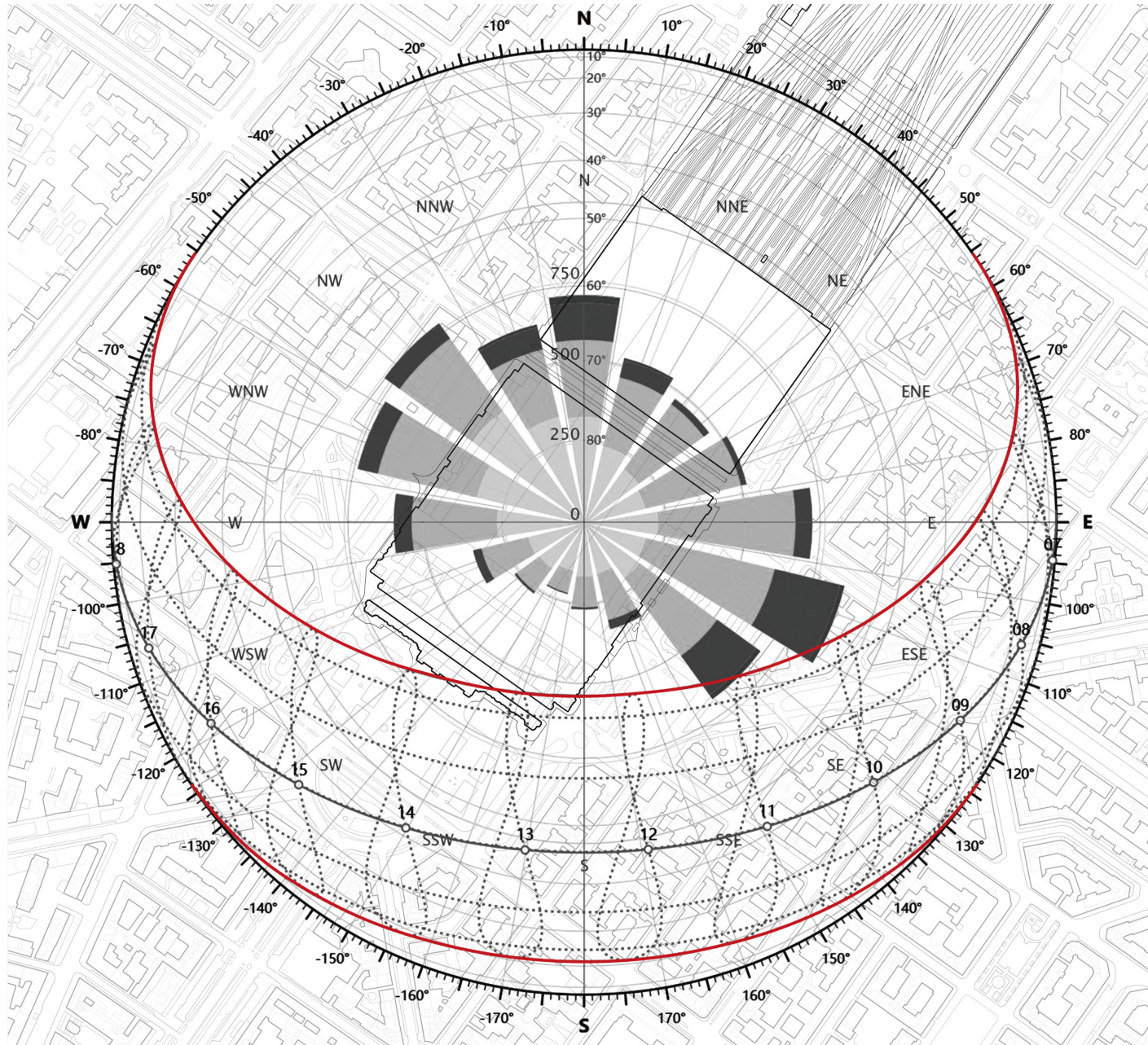

Their wish is for the building to be energy-saving, achieving cost reduction while also generating profit.

STAKEHOLDERS' WISH-KEY OUTSIDE VIEWS

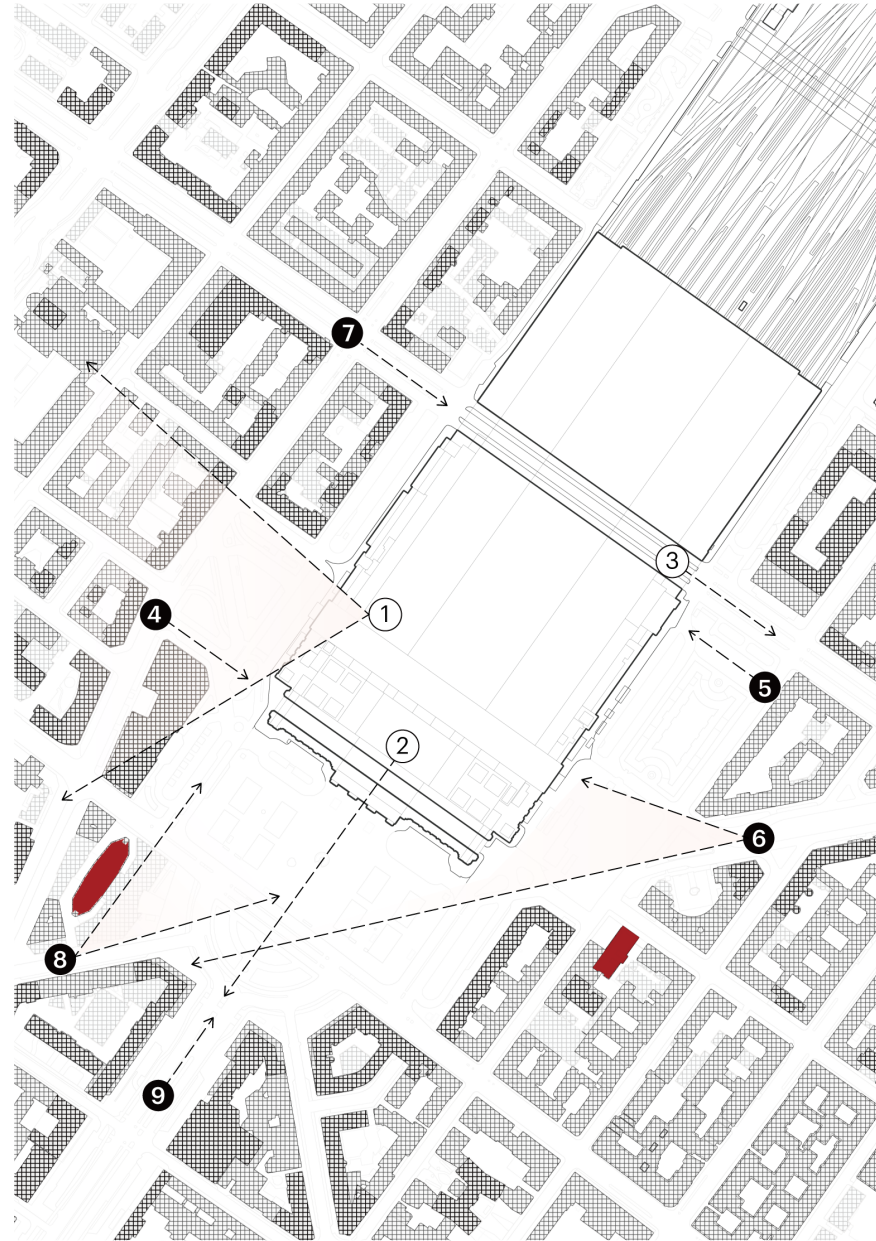

They still want the building to be a landmark of Milan, so the city's sightlines and views of the building are very important.

STAKEHOLDERS' WISH- KEY INSIDE VIEWS



CONCLUSION-STAKEHOLDERS' REQUIREMENT

USERS'

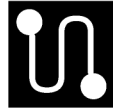

EFFICIENCY

Reduce the **walking distance** between various mobilities within the building.



SAFETY

Separation of the routes of **pedestrian and vehicles**.



GREEN

The **green space ratio** reaches 25%.

STAKEHOLDERS'



CLIMATE

The building optimizes **ventilation, drainage, and solar energy utilization** to create a comfortable indoor environment and achieve energy efficiency.



LANDMARK

This hub is envisioned as a new **urban landmark** for Milan.

CONCLUSION-REQUIREMENT

USERS'

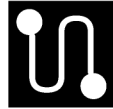

EFFICIENCY

Reduce the **walking distance** between various mobilities within the building.



SAFETY

Separation of the routes of **pedestrain and vehicules.**



GREEN

The **green space ratio** reaches 25%.

STAKEHOLDERS'



CLIMATE

The building optimizes **ventilation, drainage, and solar energy utilization** to create a comfortable indoor environment and achieve energy efficiency.



LANDMARK

This hub is envisioned as a new **urban landmark** for Milan.

MATERIAL LENS



MATERIAL

30% of the building materials are **low-carbon and recyclable.**



CONSTRUCTION

Utilizing **modular**, easily assembled and disassembled materials technology

CONCEPT

Concept
VERTICAL LEVEL

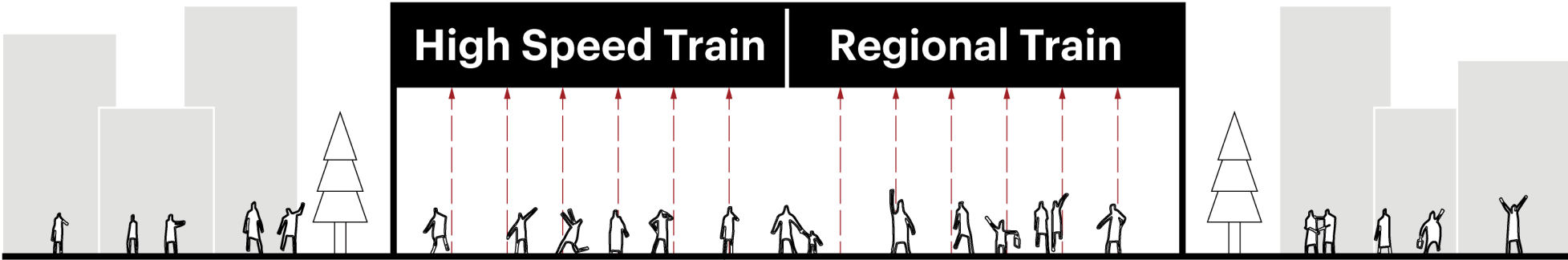

This is what the original Milan Central Station looked like. Due to the city's road layout, the trains were set on elevated tracks.

STEP1 VERTICAL LEVEL

MASS COMPRESSION!



FREE UP OUTDOOR SPACE

Concept

STEP1 VERTICAL LEVEL

CLEAR & INTUITIVE CIRCULATION

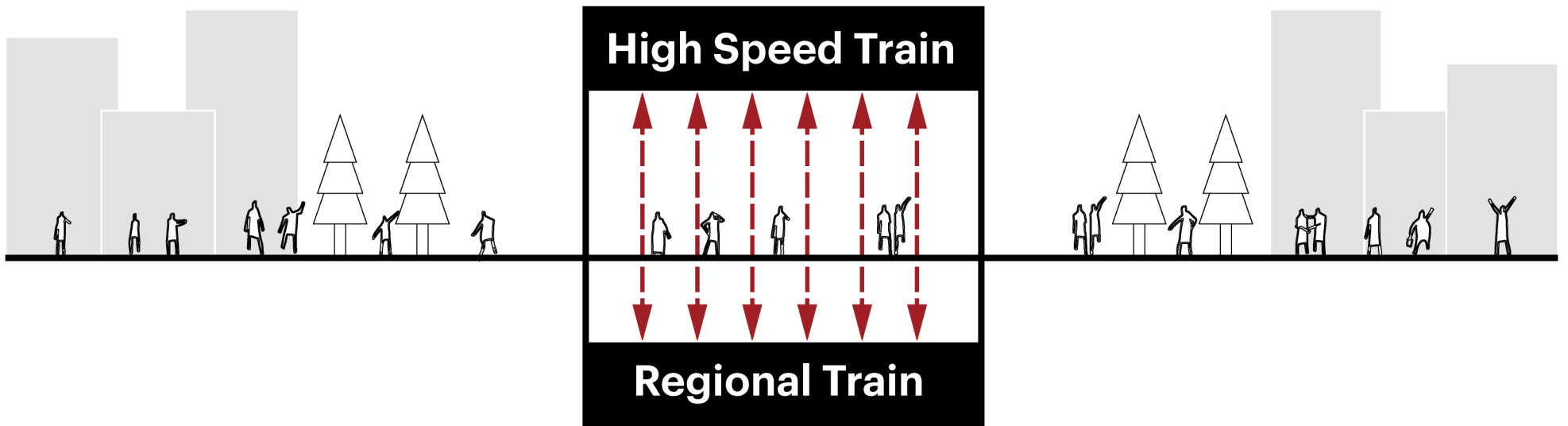

Concept
STEP1 VERTICAL LEVEL

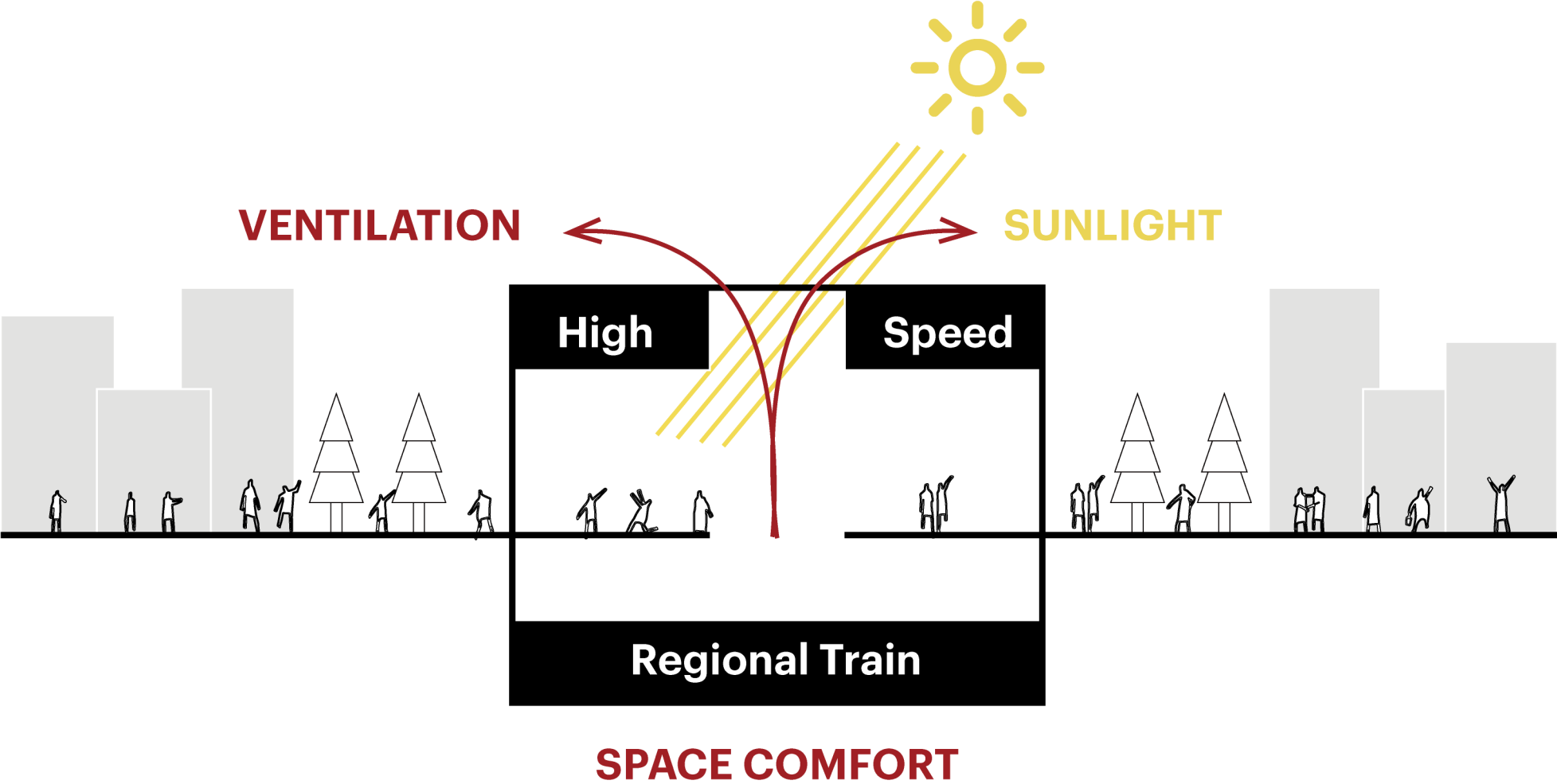

Concept
STEP1 VERTICAL LEVEL

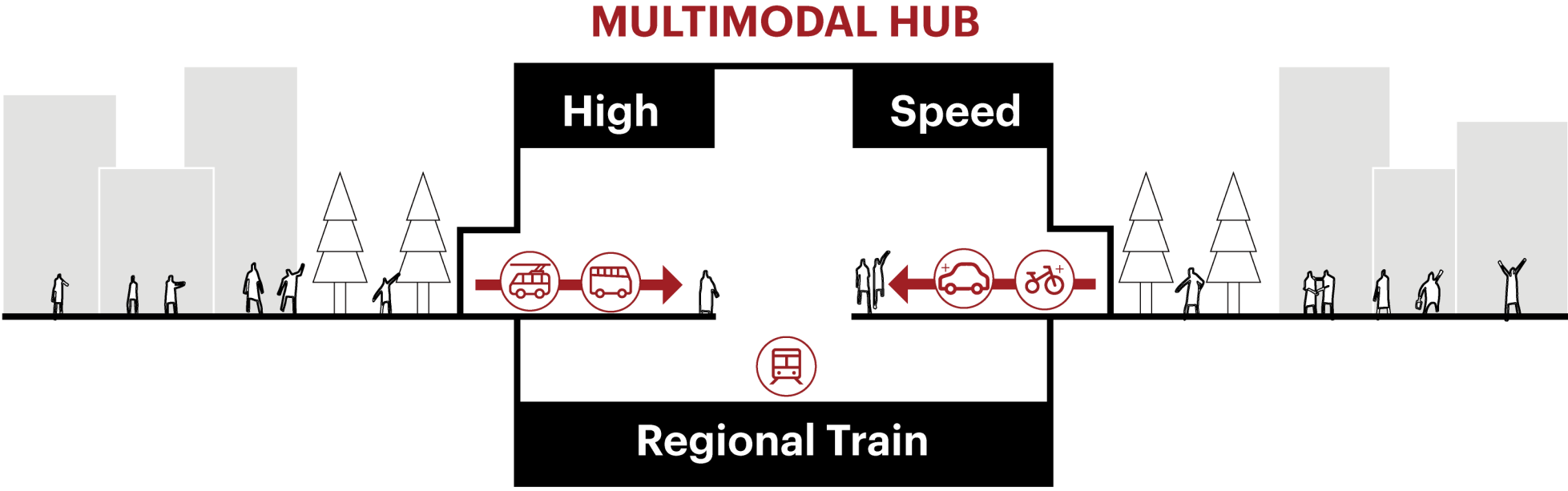

The form of the multimodal hub is designed to better accommodate various types of transportation

Concept
STEP1 VERTICAL LEVEL

CONTROL CENTER

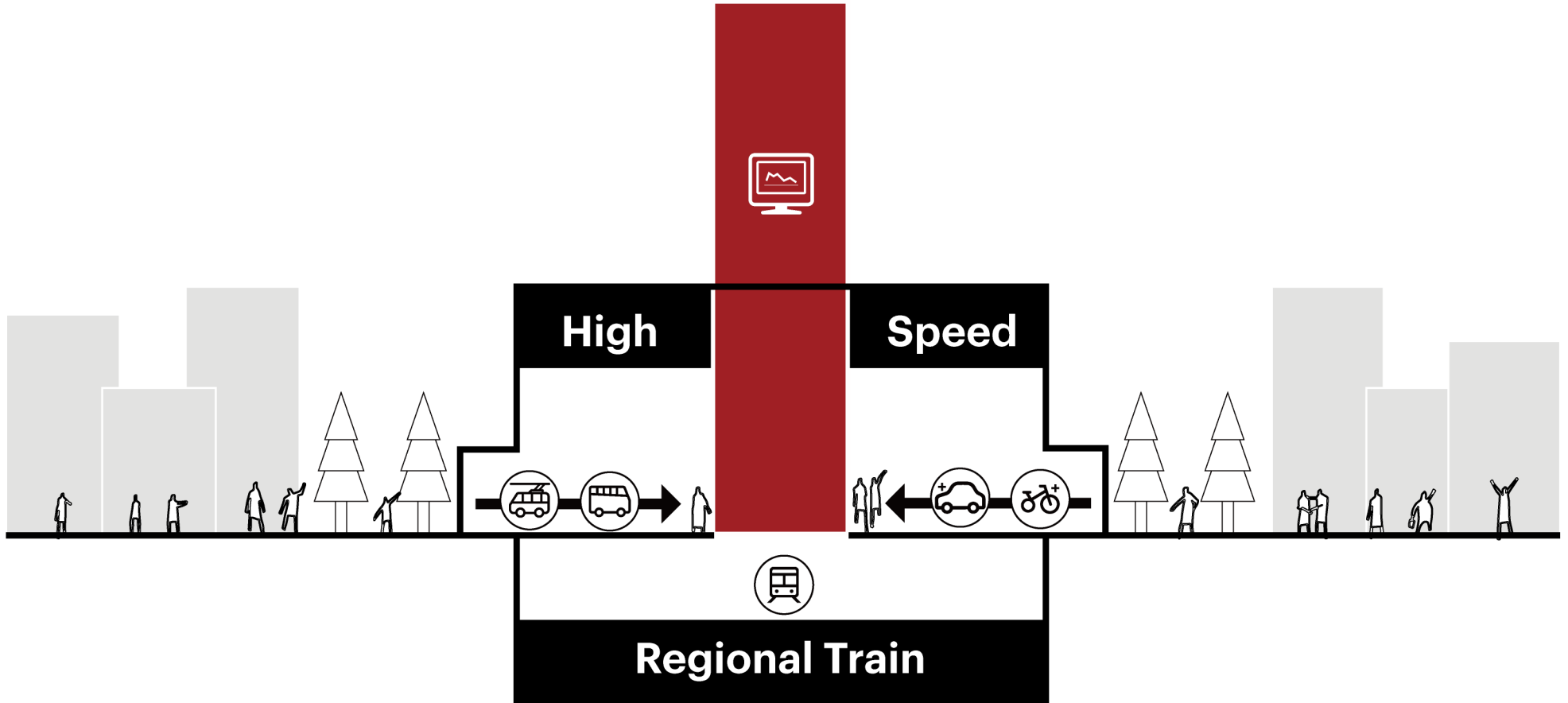

Concept

VERTICAL LEVEL CONCLUSION

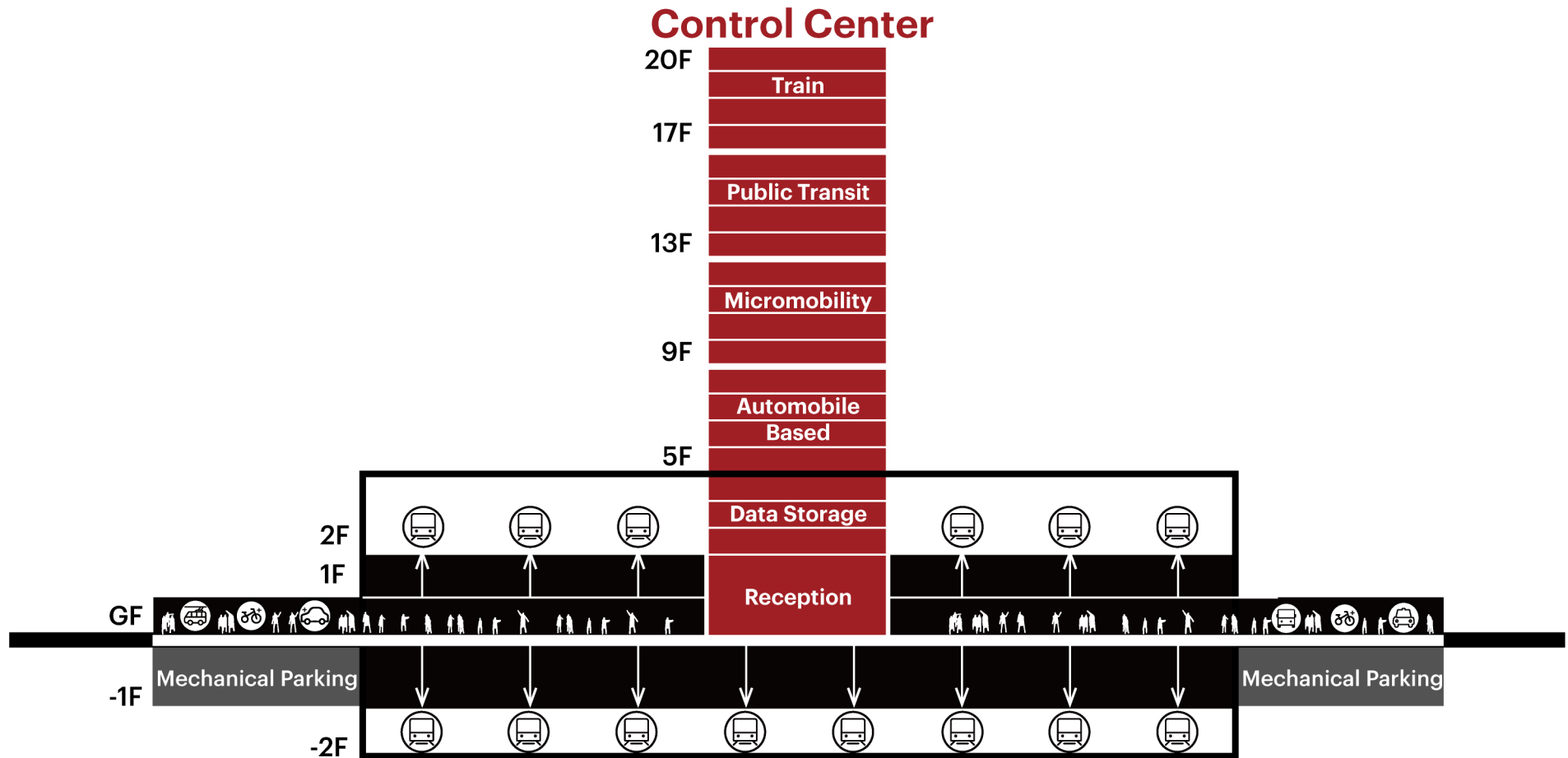

The tower is divided into units of four floors each, allocated to different transportation departments

Concept
STEP2 PLAN LEVEL

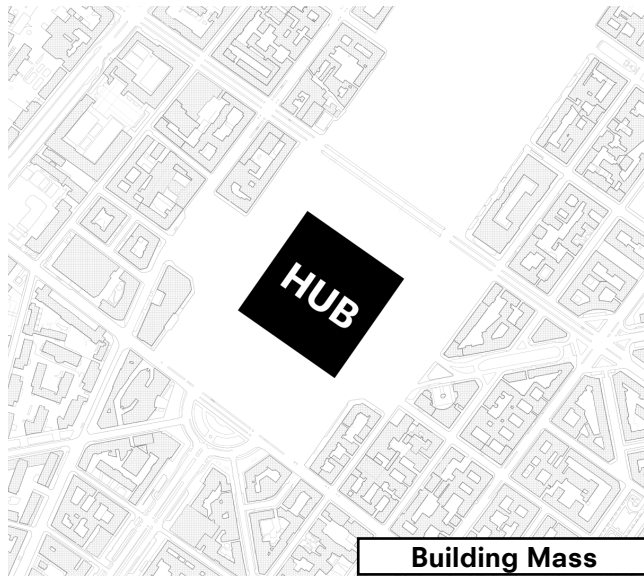

Concept
STEP2 PLAN LEVEL

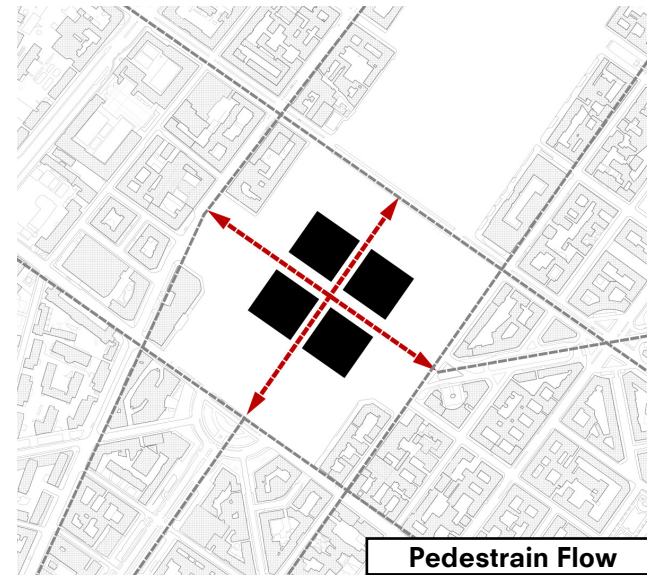
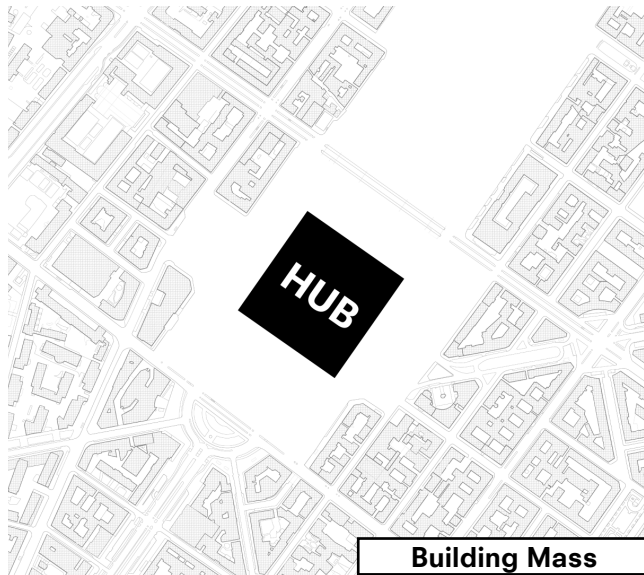

I split up the building volumes according to the main pedestrian flow.

Concept
STEP2 PLAN LEVEL

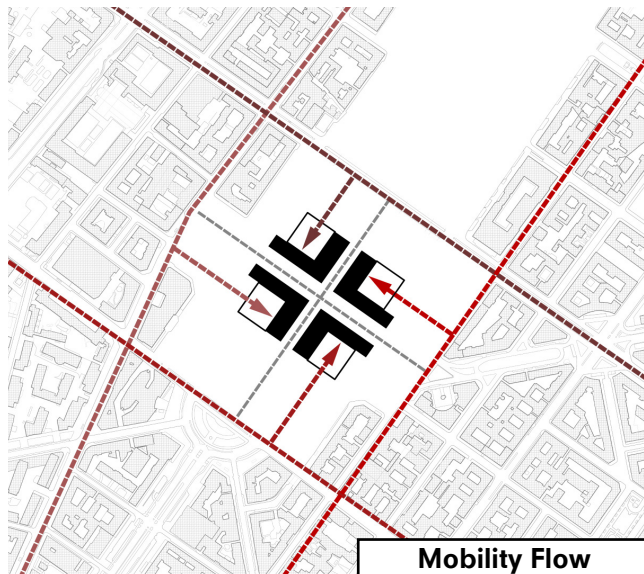
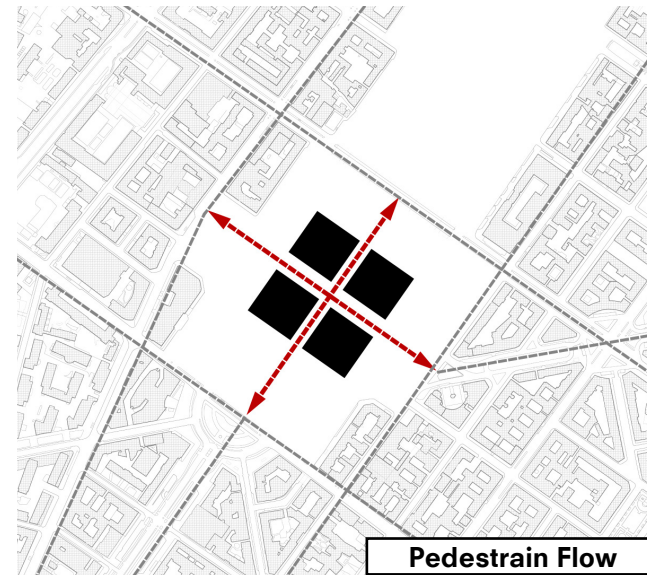
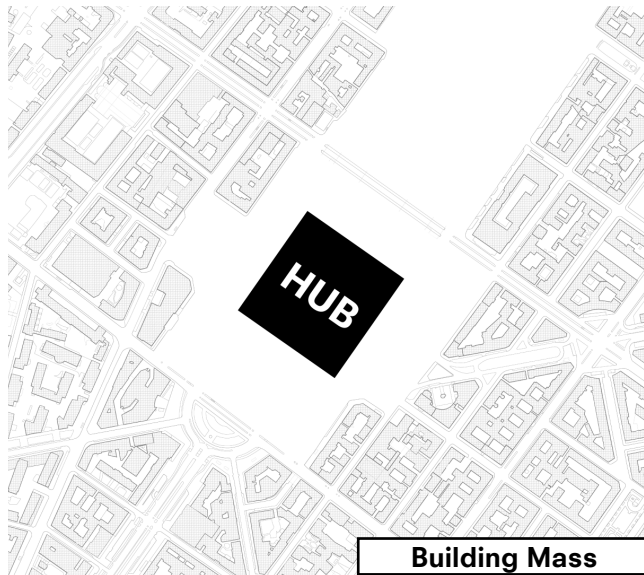

Following the principle of separating pedestrians and vehicles, I defined the spatial layout and circulation routes for mobility

Concept
STEP2 PLAN LEVEL

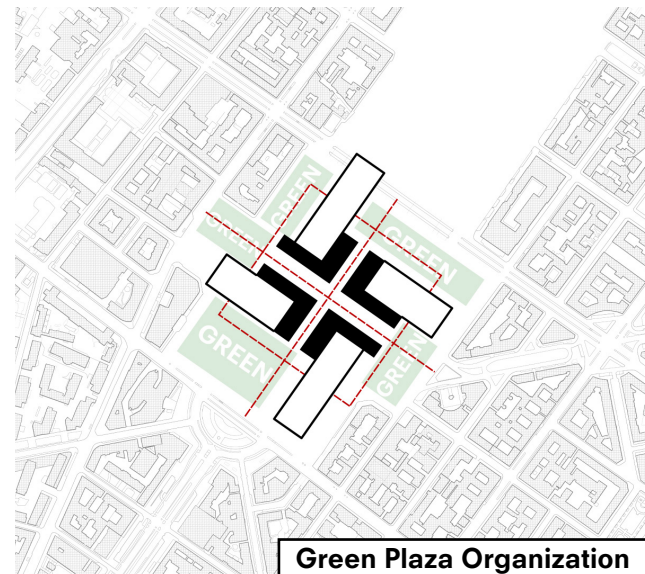
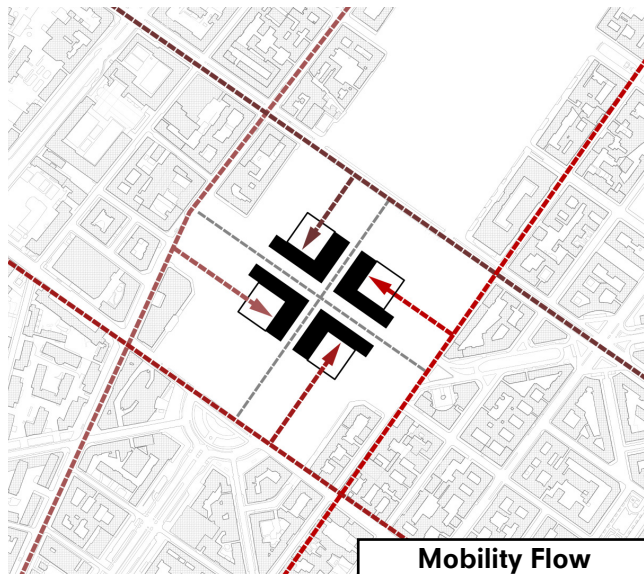
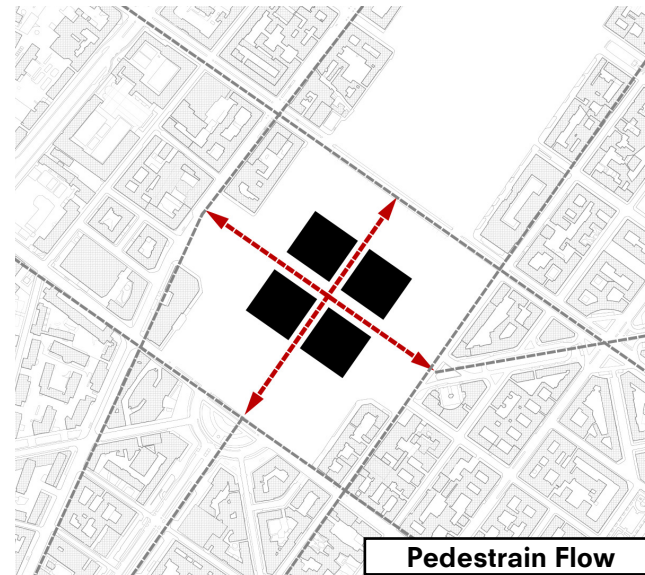

Finally, I adjusted the building's plan form so that it can actively organize the surrounding outdoor public spaces, creating various green plaza

SITE PLAN CONCLUSION

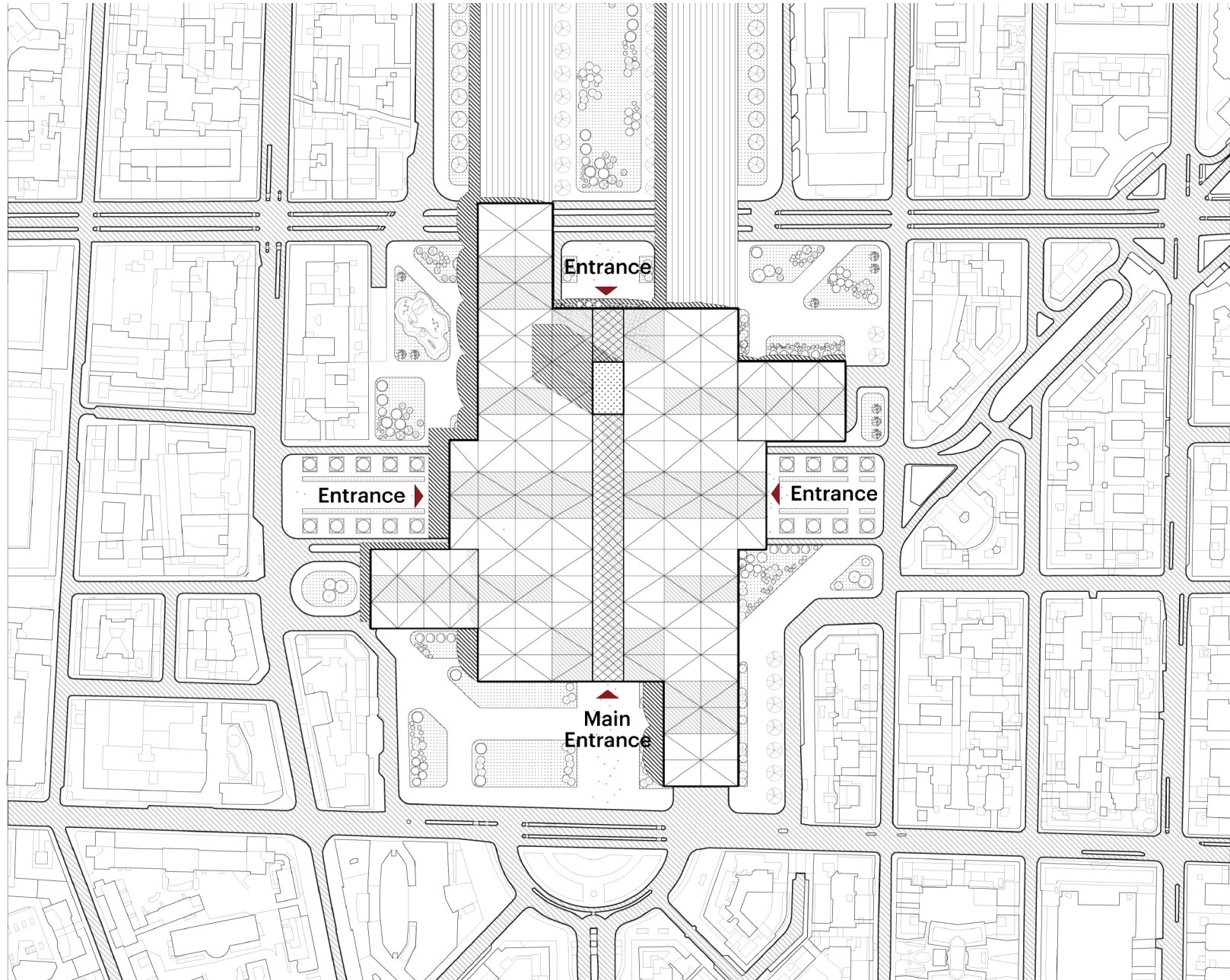

This is the site plan developed based on the design logic mentioned above.

Concept

STEP3-PROGRAM

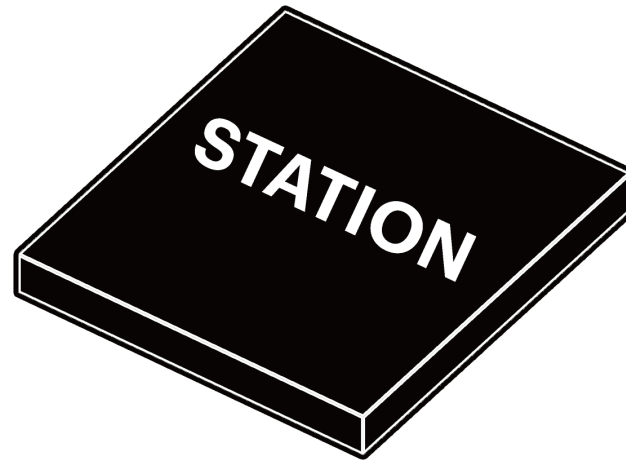

Concept

STEP3-PROGRAM

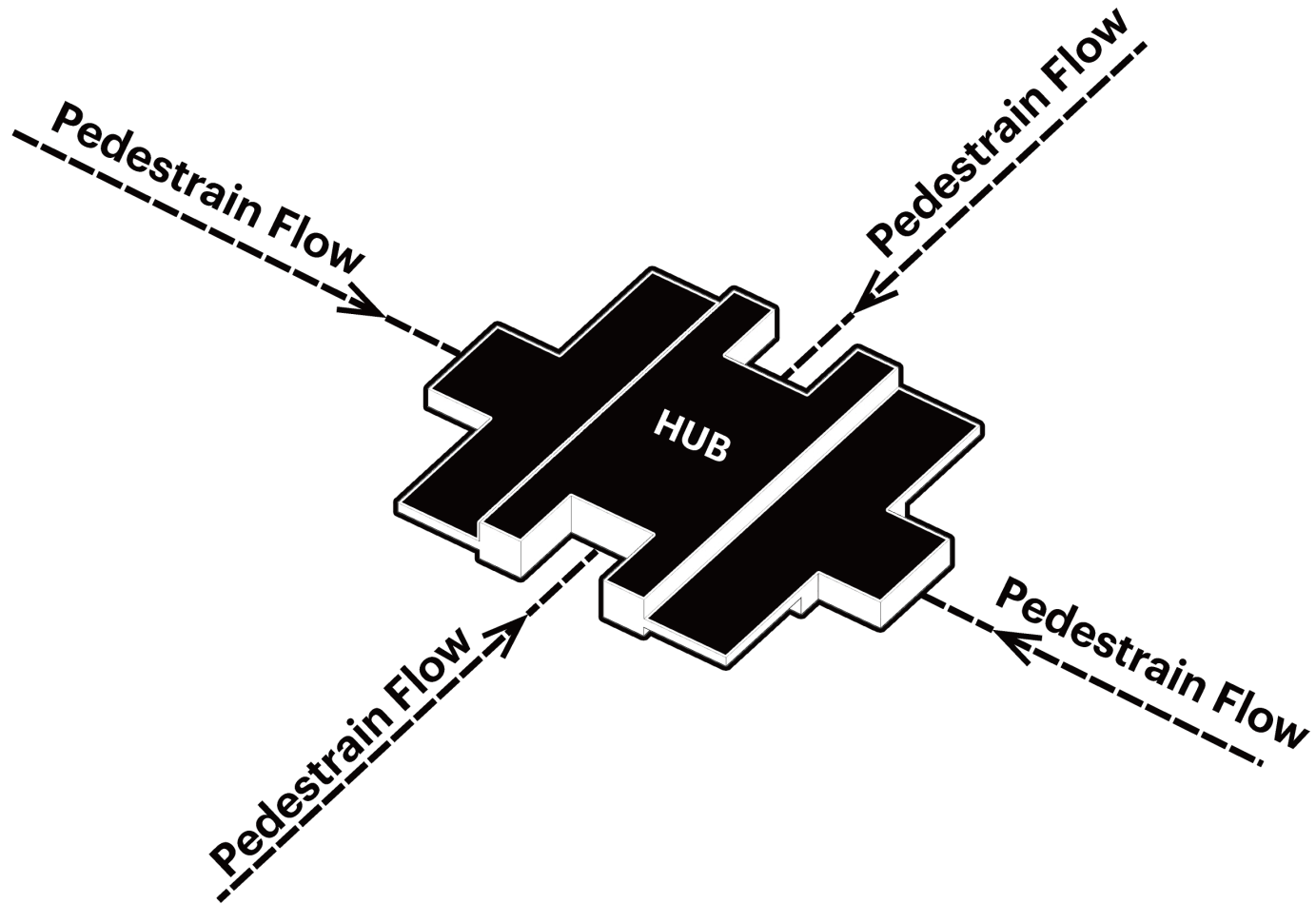

Make the station's form adapt to the circulation flow

Concept
STEP3-PROGRAM

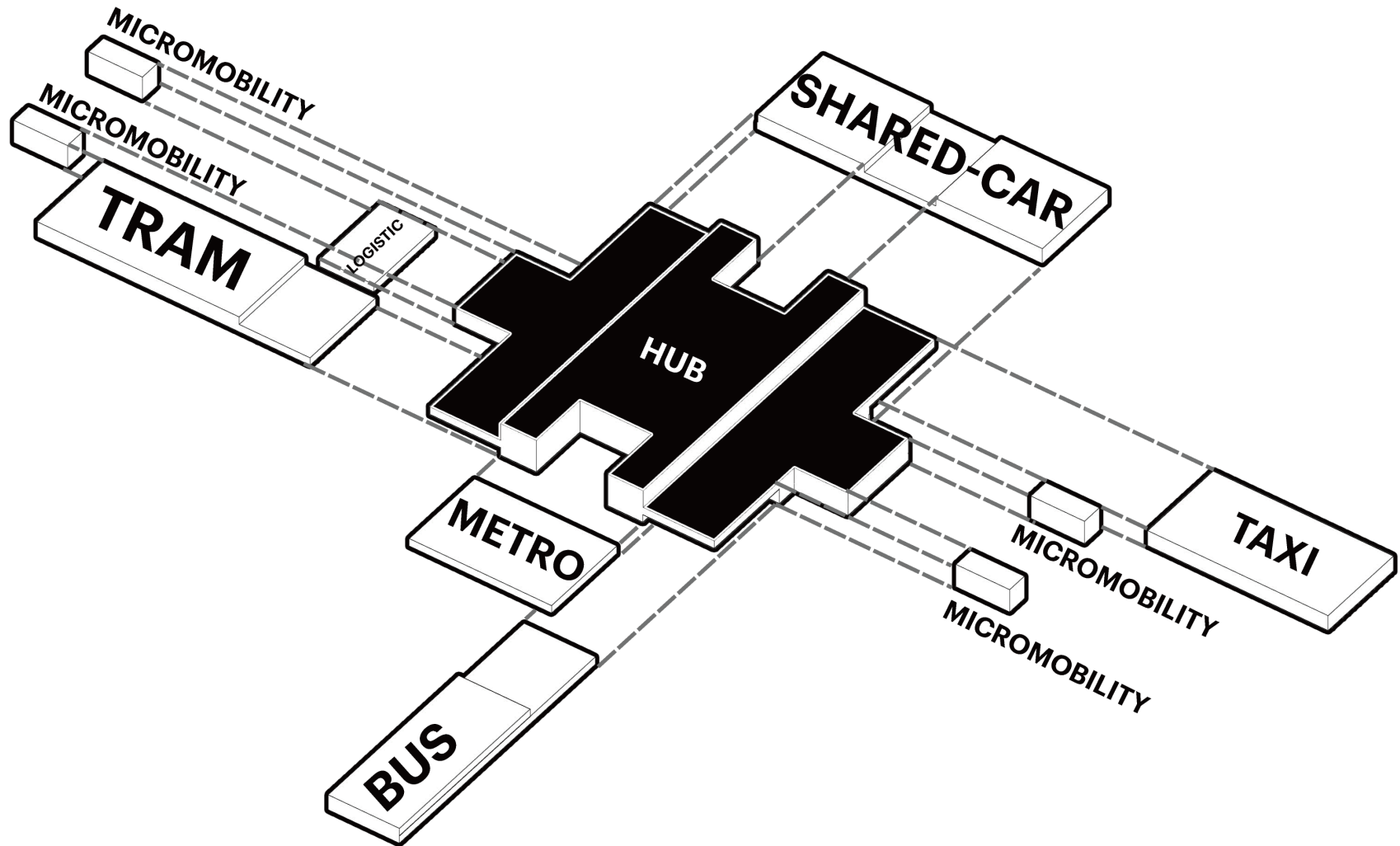

All the mobility-related masses will be integrated inside the station.

Concept

STEP3-PROGRAM

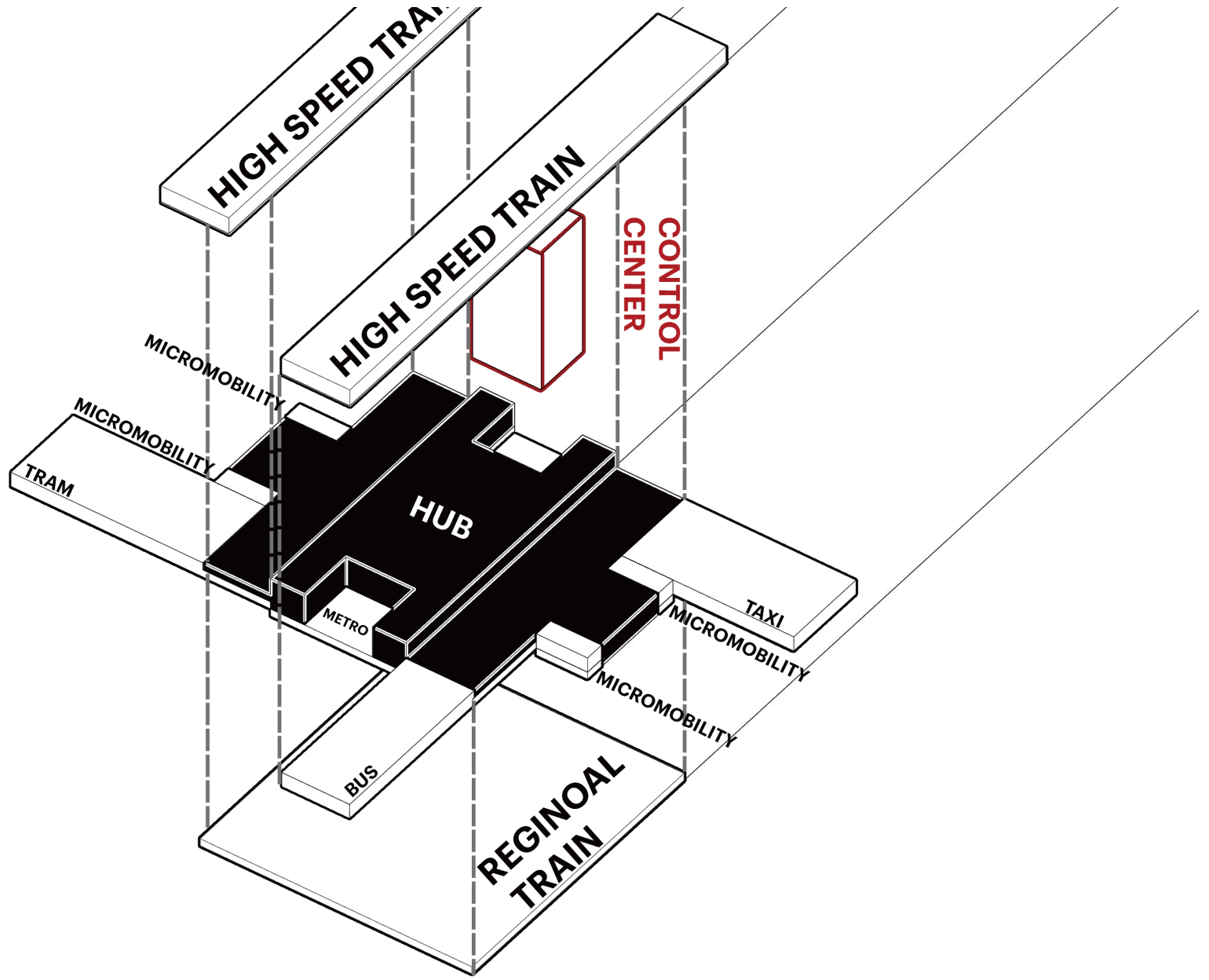

Concept

STEP3-PROGRAM

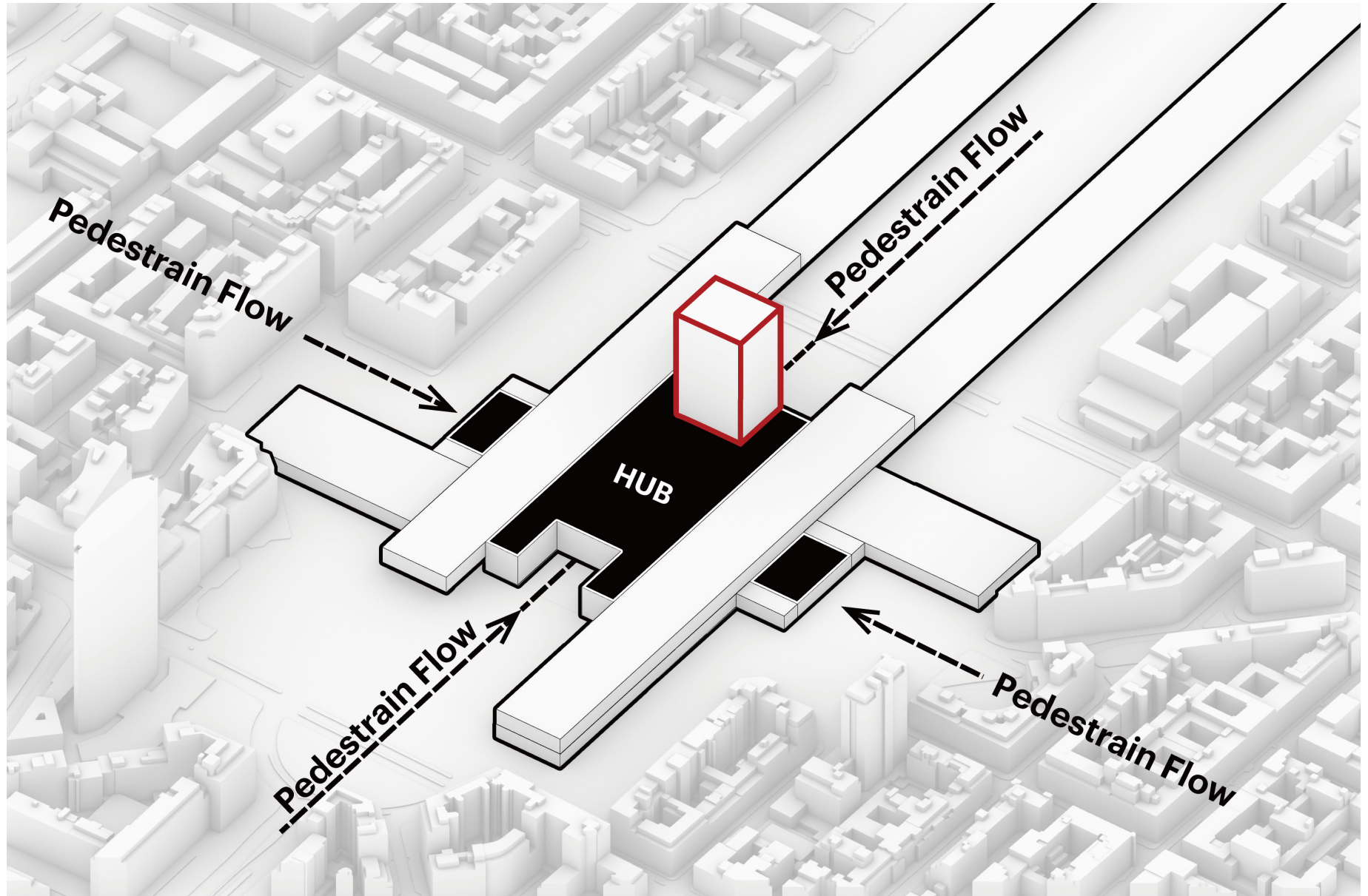

The tower sits right at the end of the main road, making it a natural focal point that really stands out as a landmark, like a beacon guiding the city.

CONCLUSION-AMBITION OF A SHARED MOBILITY HUB

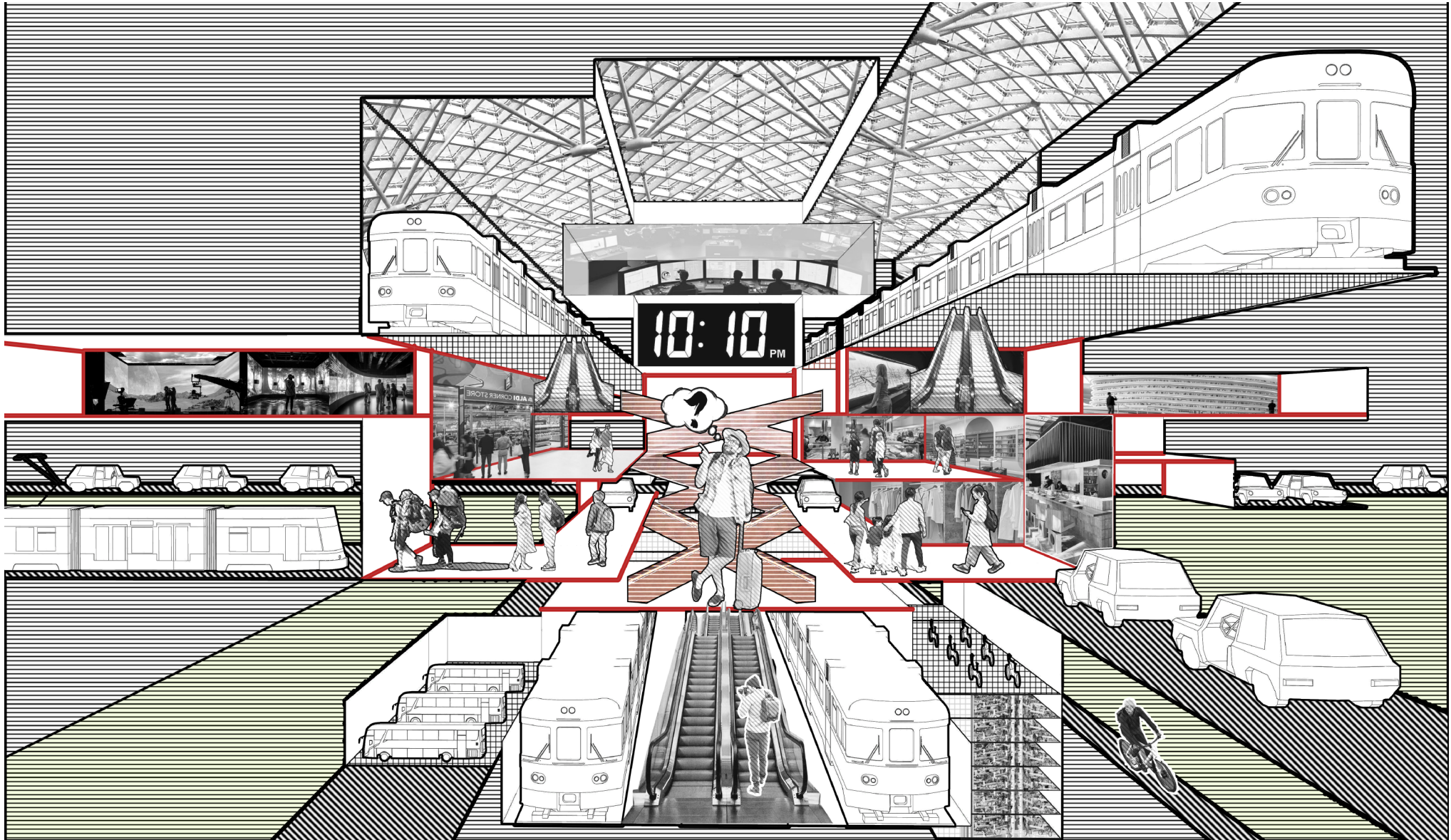

DESIGN

DESIGN SHARED MOBILITY HUB

Design-Shared Mobility Hub
GROUND FLOOR PLAN

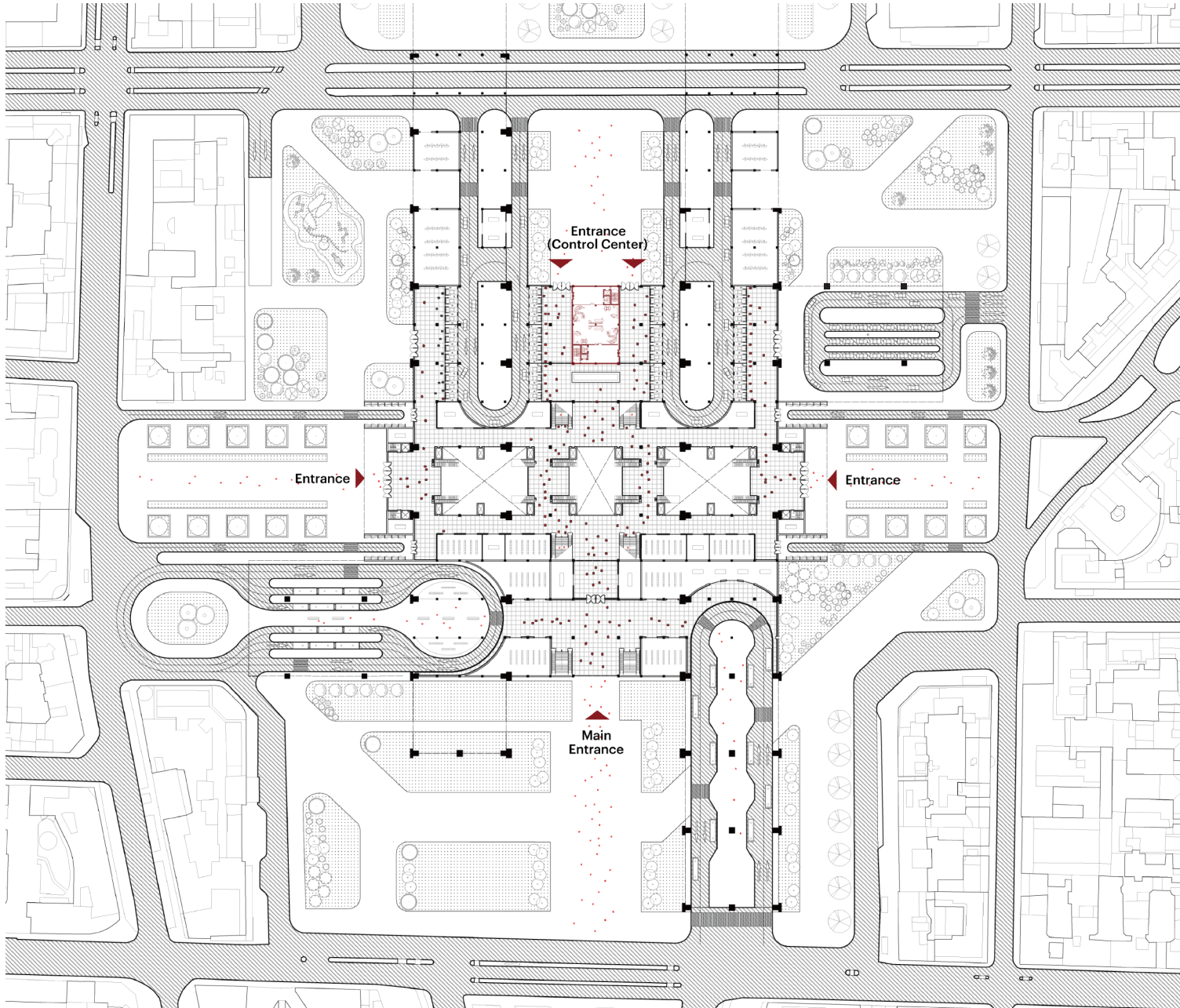

FUNCTION

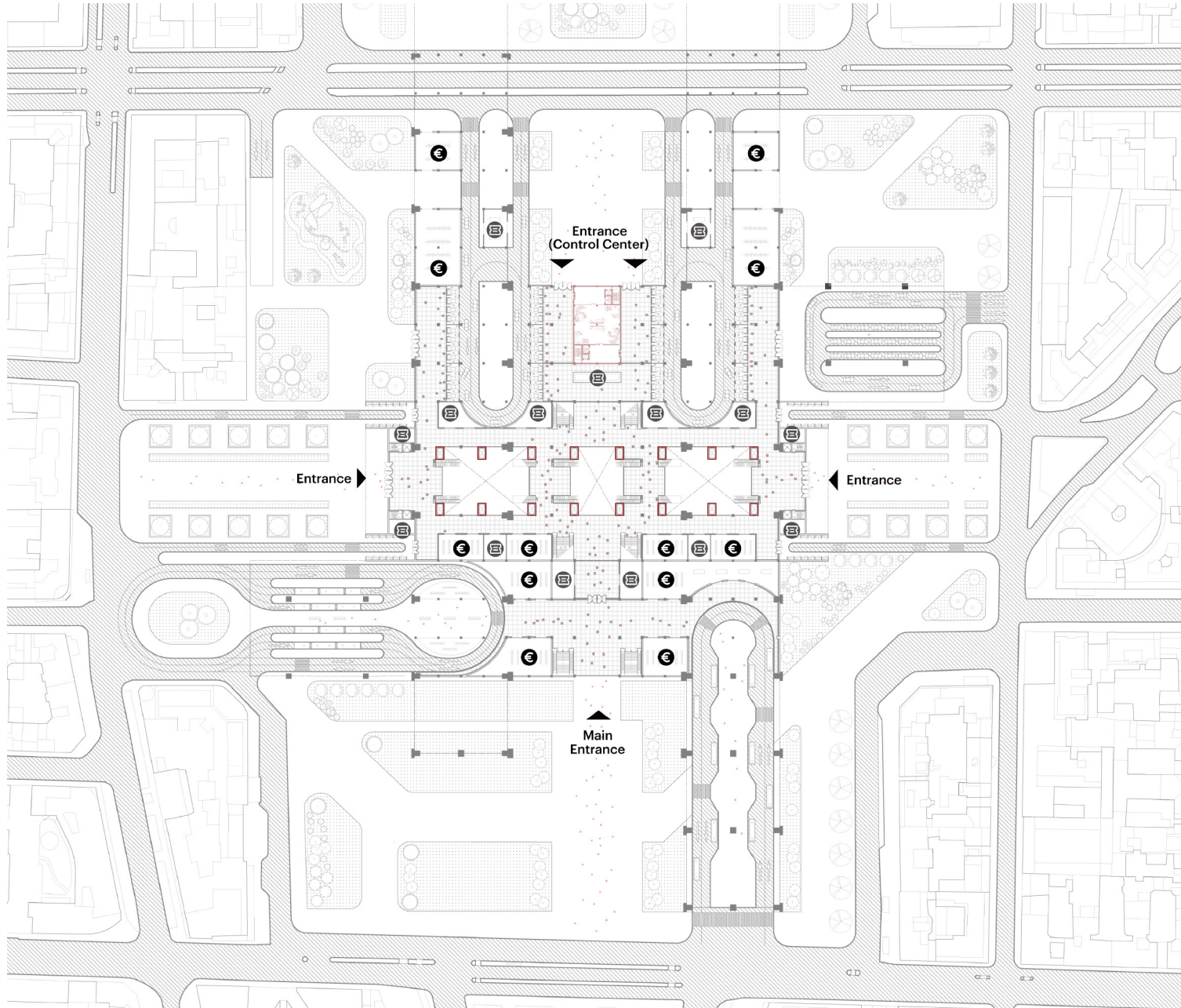

Commerce and service areas are located alongside the circulation paths.

Design-Shared Mobility Hub

FLOW-MOBILITY

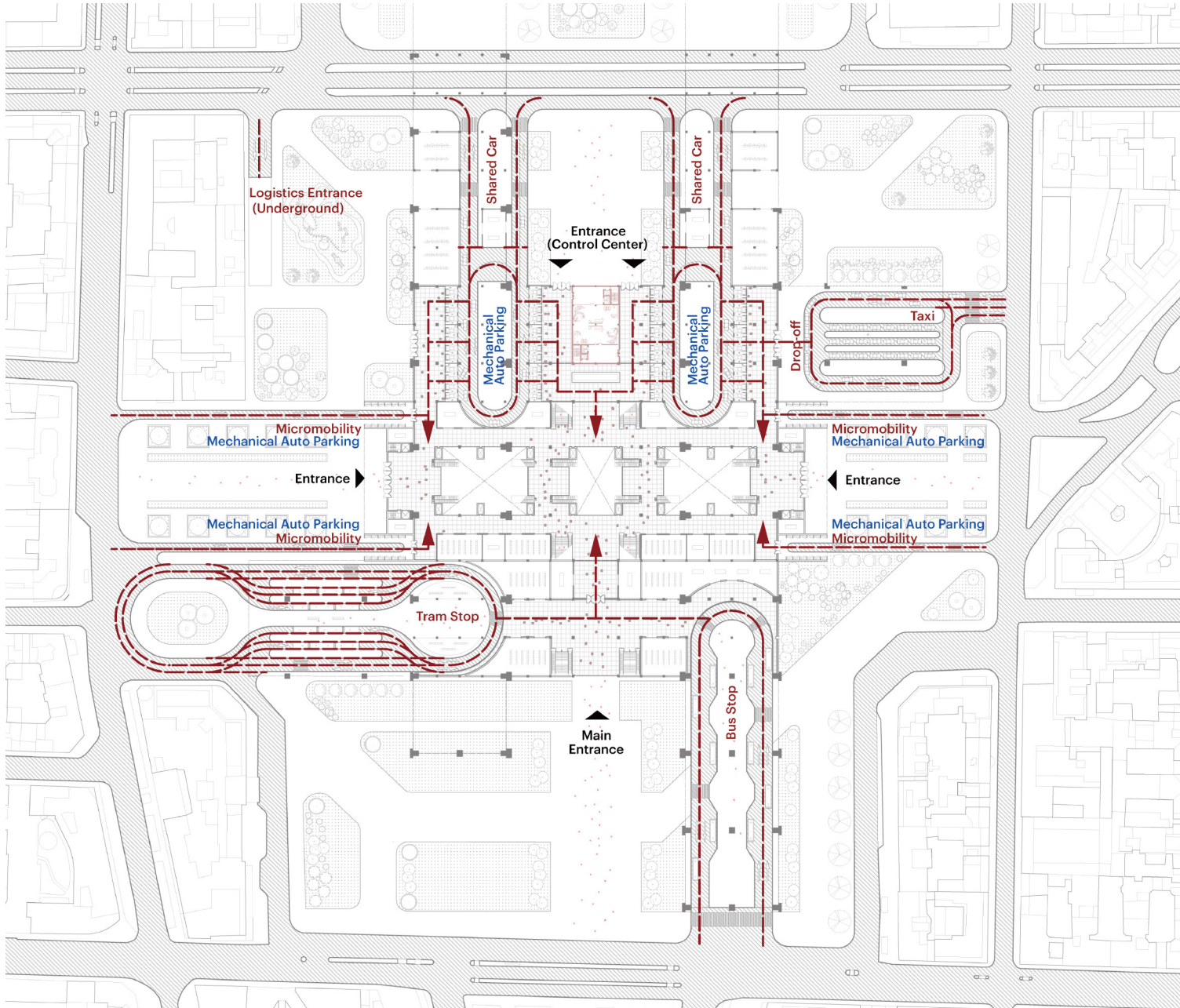

People coming from all different modes of transportation will gather in this central atrium.

Design-Shared Mobility Hub

CANOPY-BUS STOP & SHARED CAR

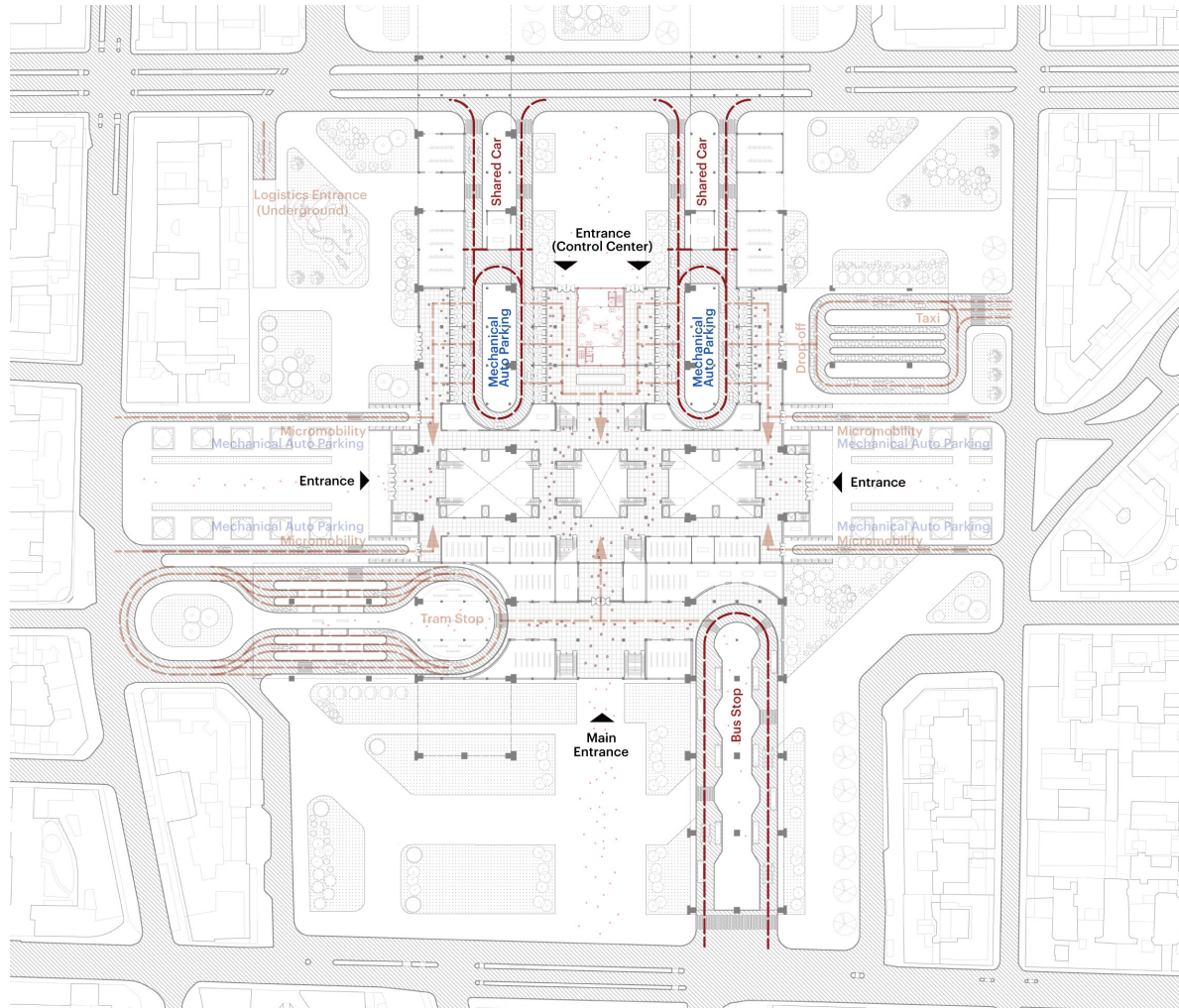
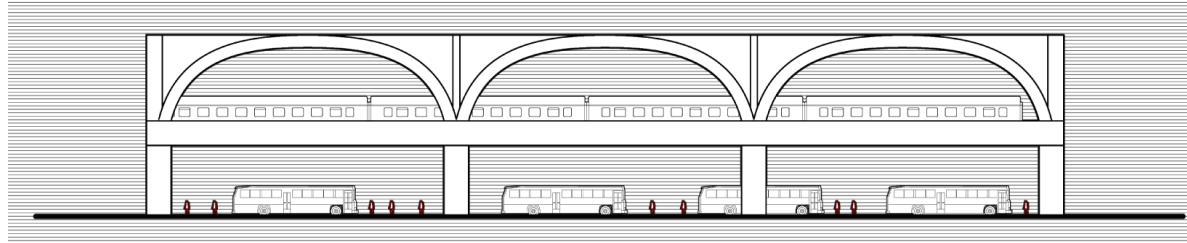

The bus stop and the shared cars makes use of the space underneath the elevated train tracks.

Design-Shared Mobility Hub

CANOPY-TRAM&TAXI

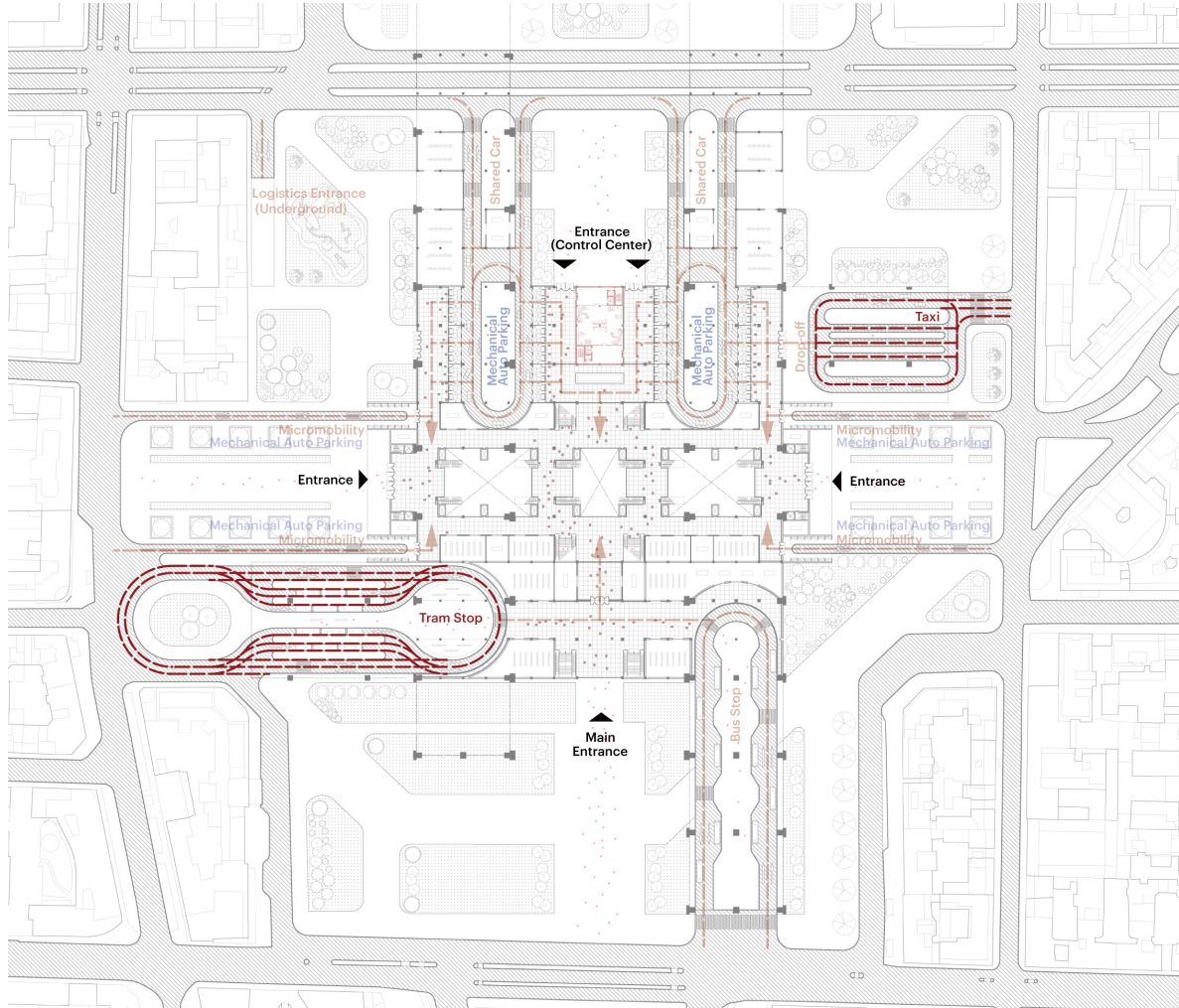
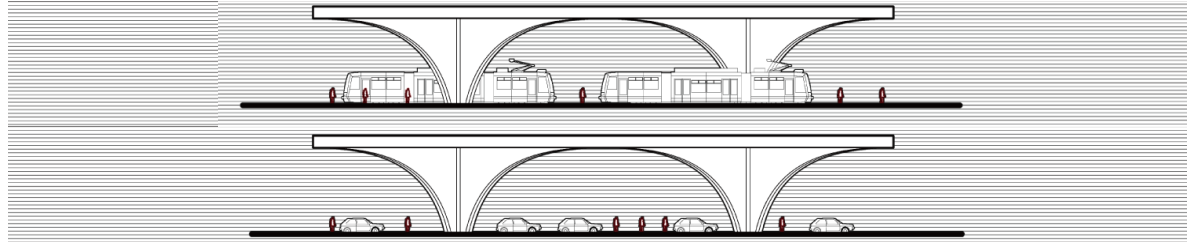

The taxi and tram canopy extends from the train station's roof, making use of its continuity—I'll explain this part later.

Design-Shared Mobility Hub

FLOW-PEDESTRAIN

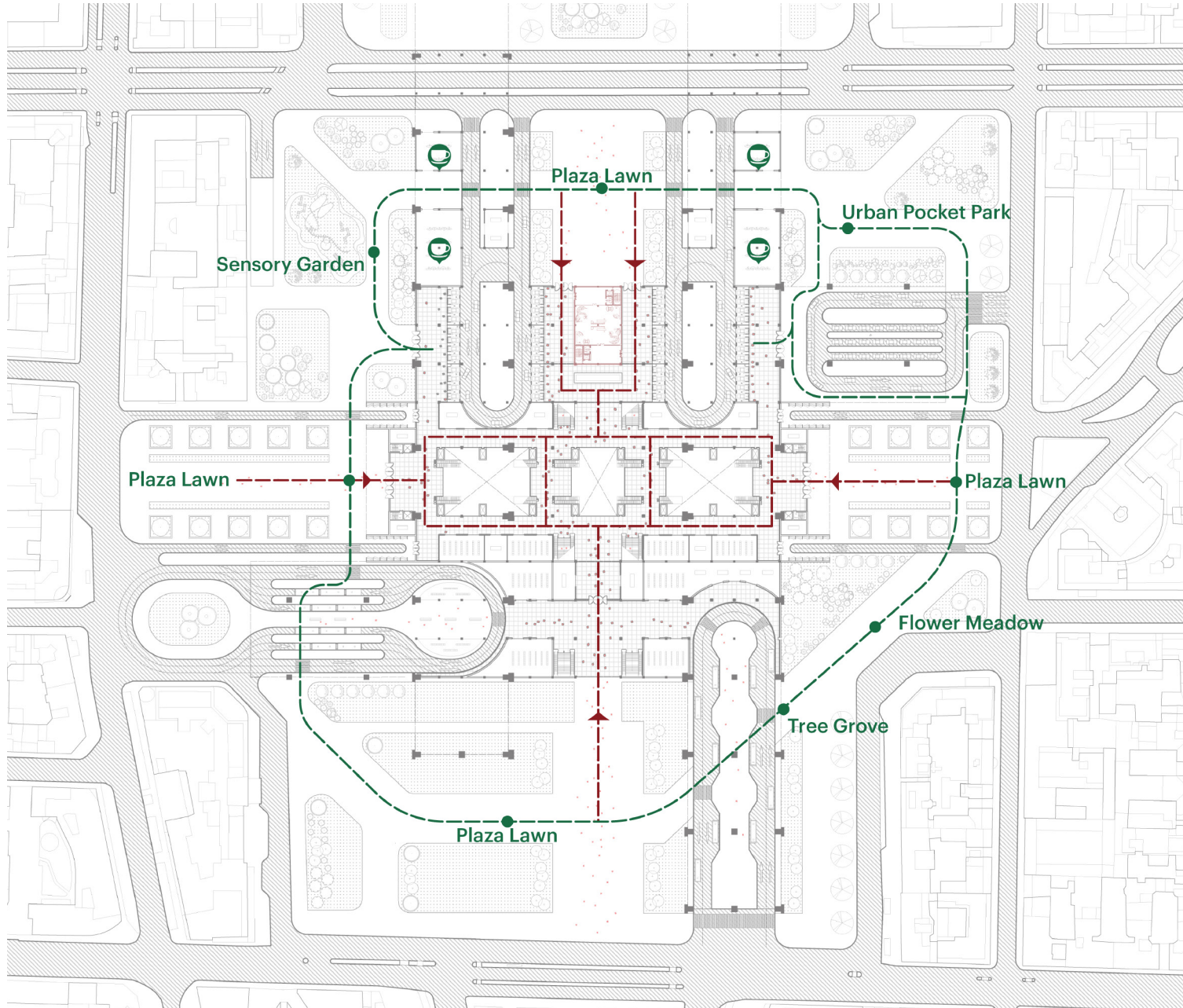

People can circulate around the building site through different green area. While at the back of the site, there is a garden with more diverse plant species, complemented by cafes and dining areas.

GREEN



MAIN CIRCULATION CONCOURSE

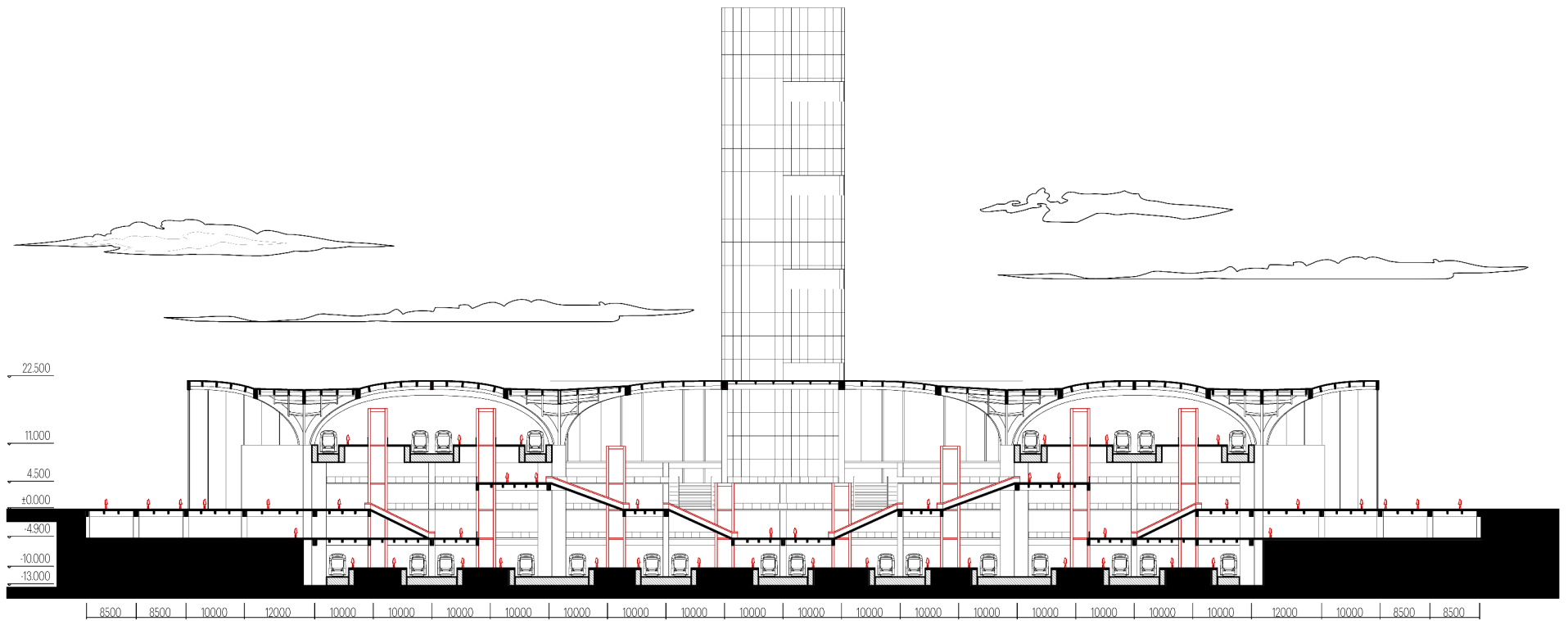
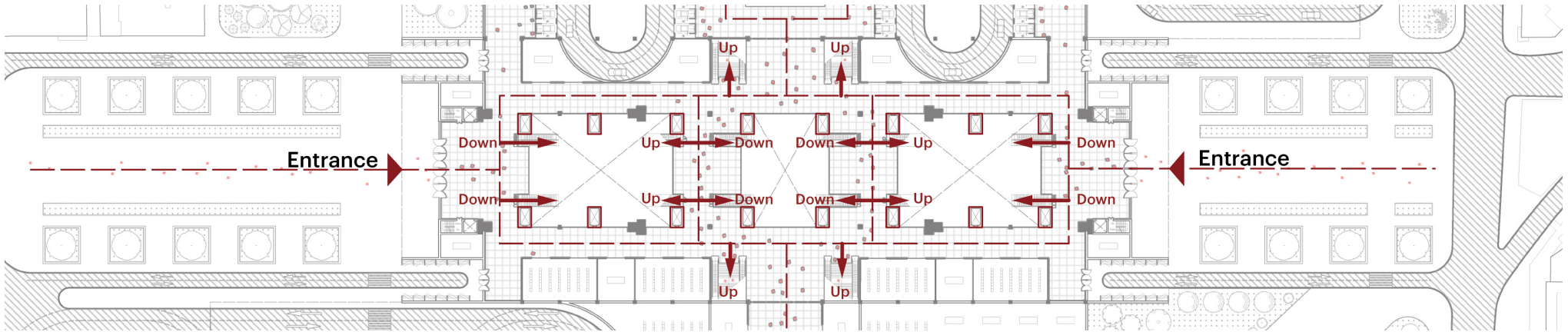

MAIN CIRCULATION CONCOURSE

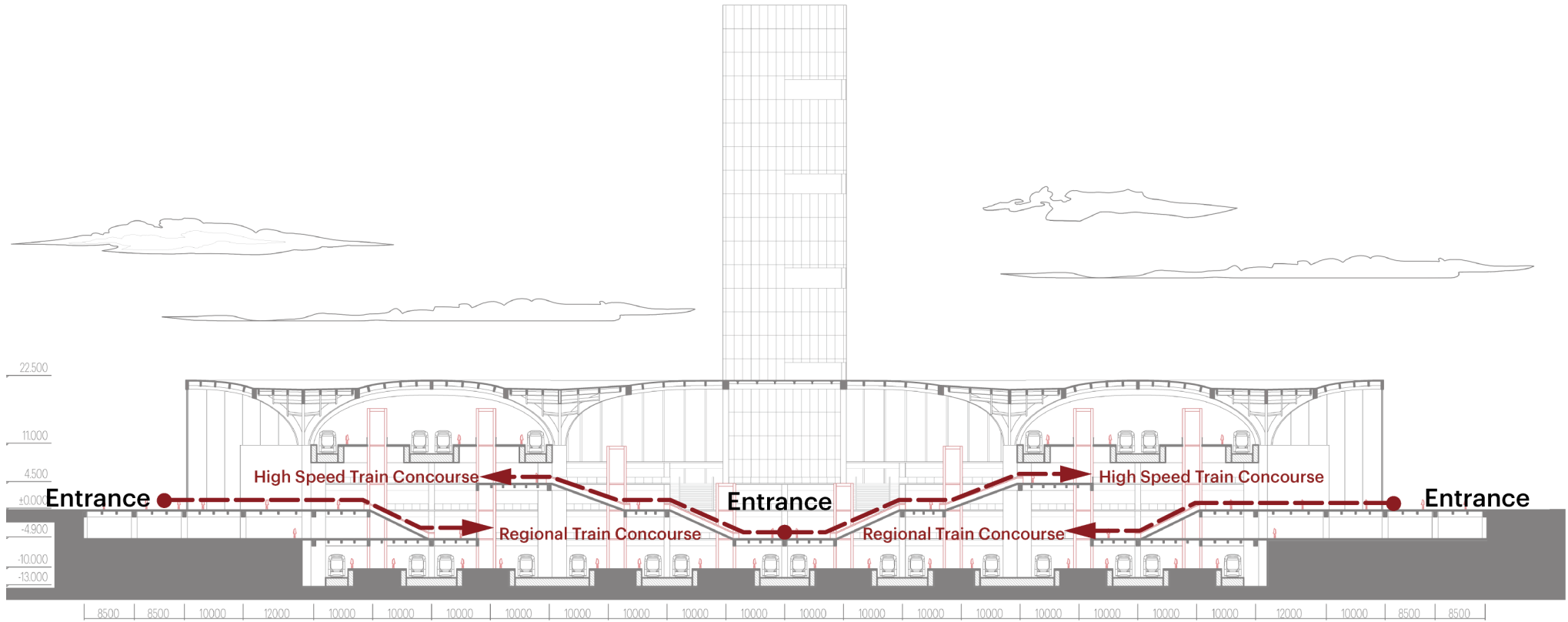

Design-Shared Mobility Hub

MAIN CIRCULATION CONCOURSE

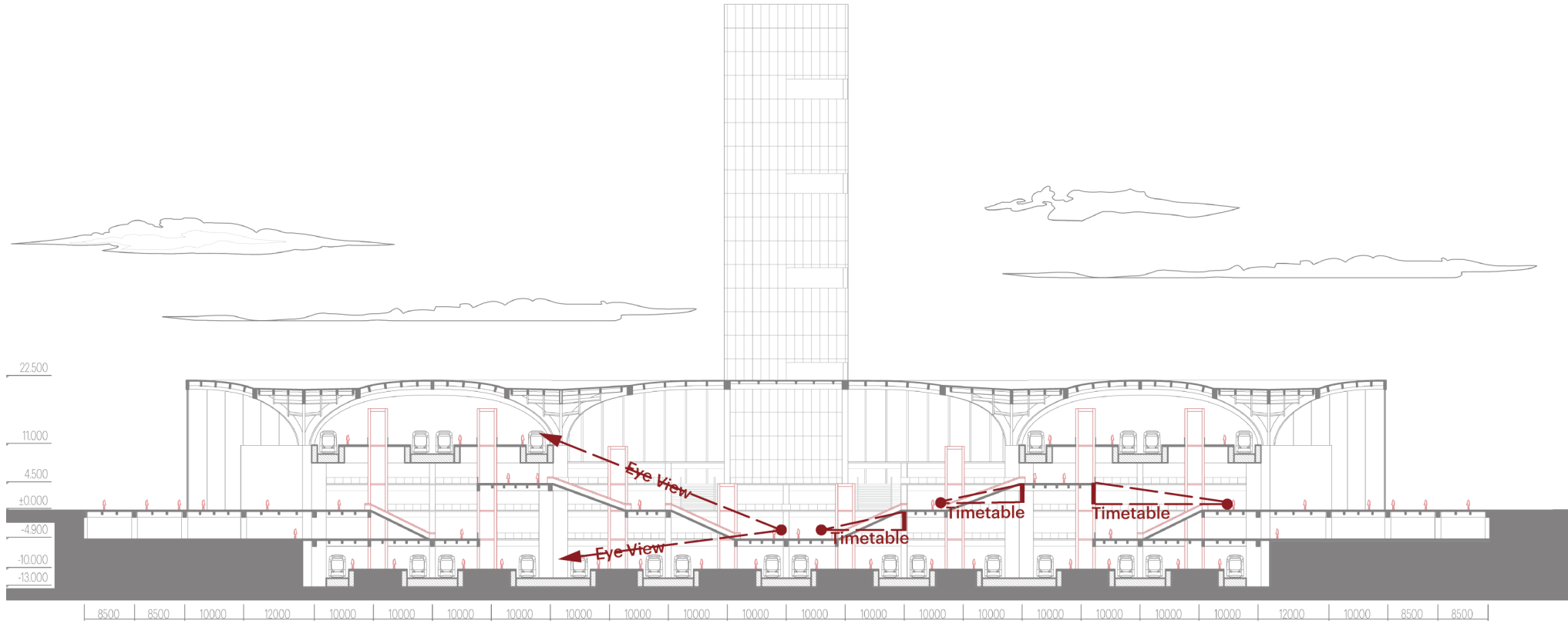

This kind of stepped atrium works really well for showing the station's timetable — it's right in people's sightline and easy to see from different levels.

Design-Station

GO DOWNSTAIRS

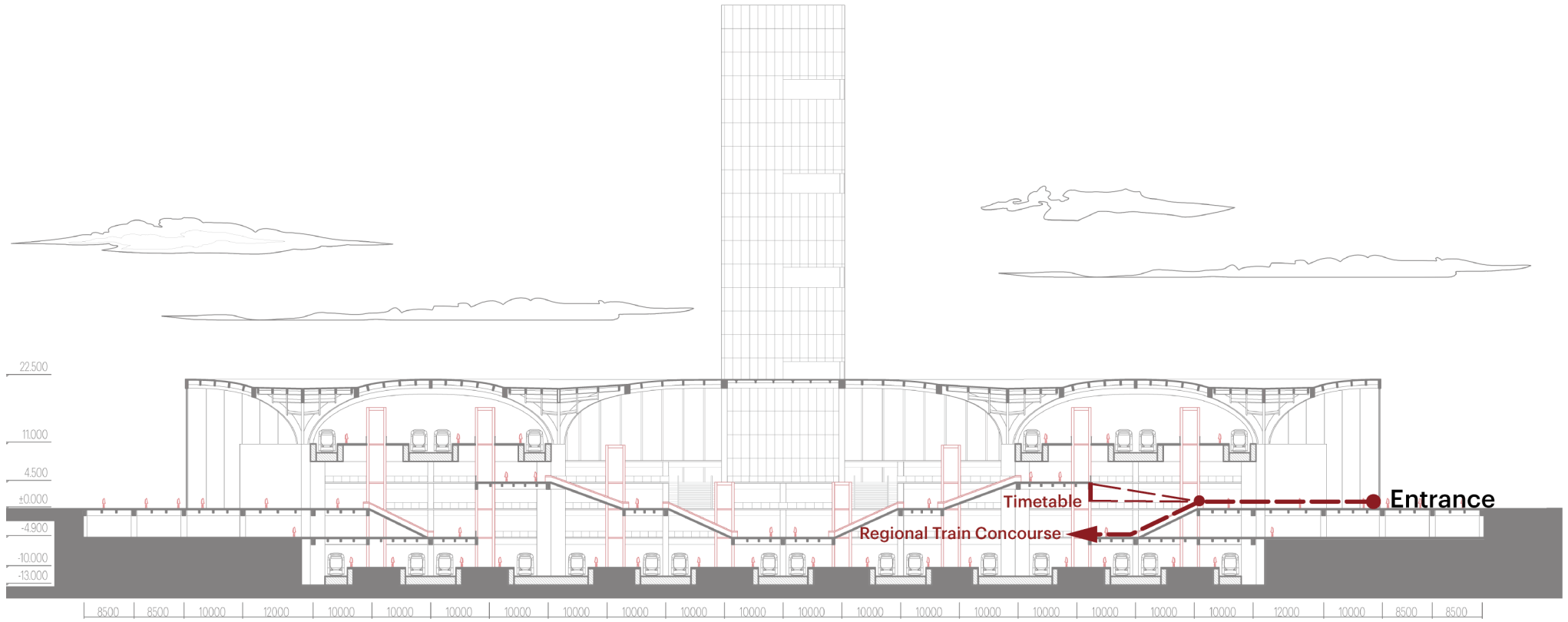

Design-Shared Mobility Hub
SIDE ENTRANCE



UPON ENTERING THE SIDE ENTRANCE...

Destination	Status	Time
NEVERLAND	ON TIME PLAT 5	05:58
HOGWARTS	ON TIME PLAT 9%	06:06
SHERWOOD FOREST	DELAYED +2HR	09:42
EMERALD CITY	ON TIME PLAT 2	07:59
NARNIA	ON TIME PLAT 3	09:30
WHOVILLE	CANCELLED	
WONDERLAND	ON TIME PLAT 12	11:50
GRANDMA'S HOUSE	ON TIME PLAT 4	13:25
100 ACRE WOOD	DELAYED +15MIN	14:17
SHREK'S SWAMP	ON TIME PLAT 1	16:37
THE NORTH POLE	DELAYED +1XNR	28:50
FAR FAR AWAY	ON TIME PLAT 6	21:45
TOAD HALL	CANCELLED	

Destination	Status	Time
NEVERLAND	ON TIME PLAT 5	05:58
HOGWARTS	ON TIME PLAT 9%	06:06
SHERWOOD FOREST	DELAYED +2HR	09:42
EMERALD CITY	ON TIME PLAT 2	07:59
NARNIA	ON TIME PLAT 3	09:30
WHOVILLE	CANCELLED	
WONDERLAND	ON TIME PLAT 12	11:50
GRANDMA'S HOUSE	ON TIME PLAT 4	13:25
100 ACRE WOOD	DELAYED +15MIN	14:17
SHREK'S SWAMP	ON TIME PLAT 1	16:37
THE NORTH POLE	DELAYED +1XNR	28:50
FAR FAR AWAY	ON TIME PLAT 6	21:45
TOAD HALL	CANCELLED	

Design-Shared Mobility Hub

-1/-2 BASEMENT FLOOR

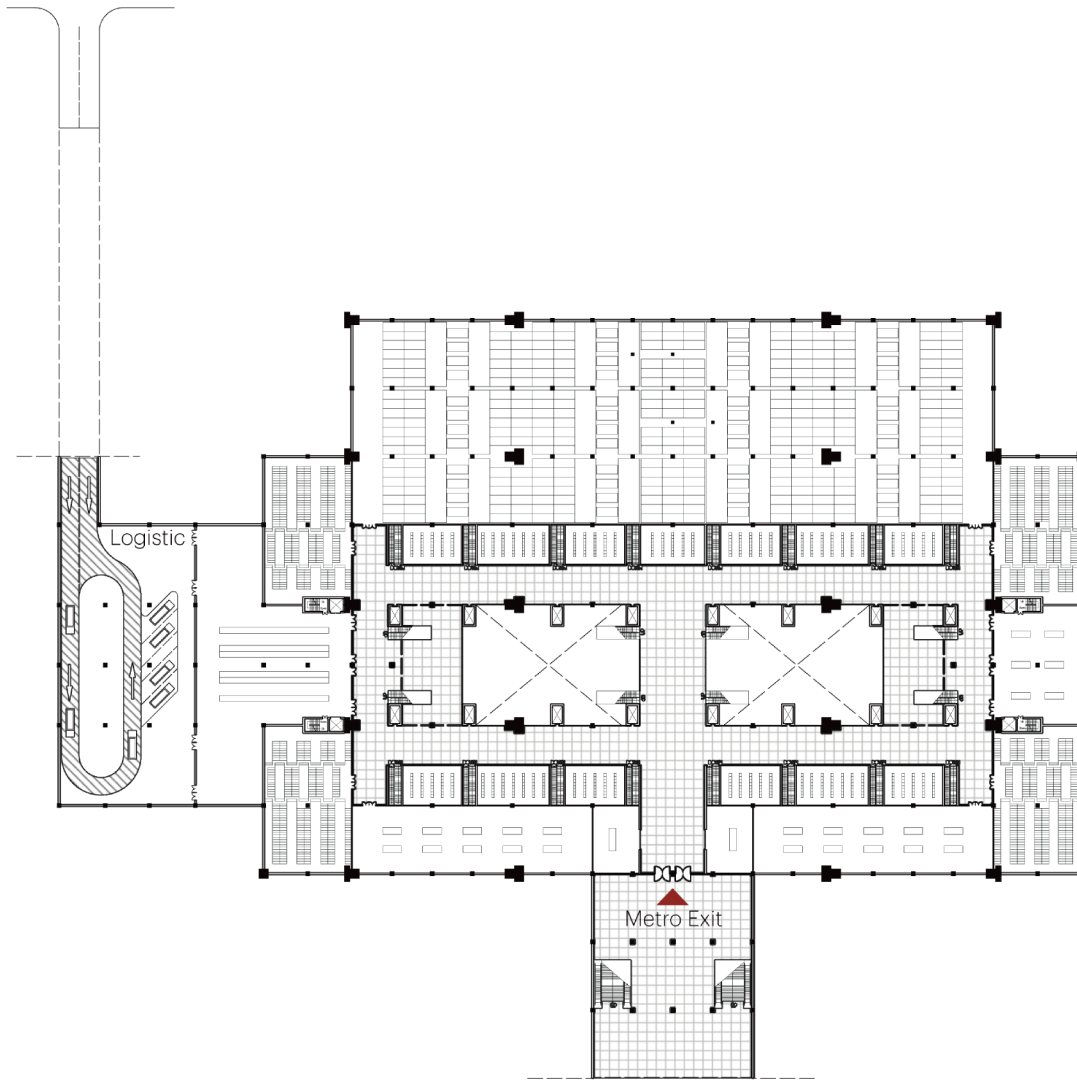

-1 Floor—Regional Train Concourse

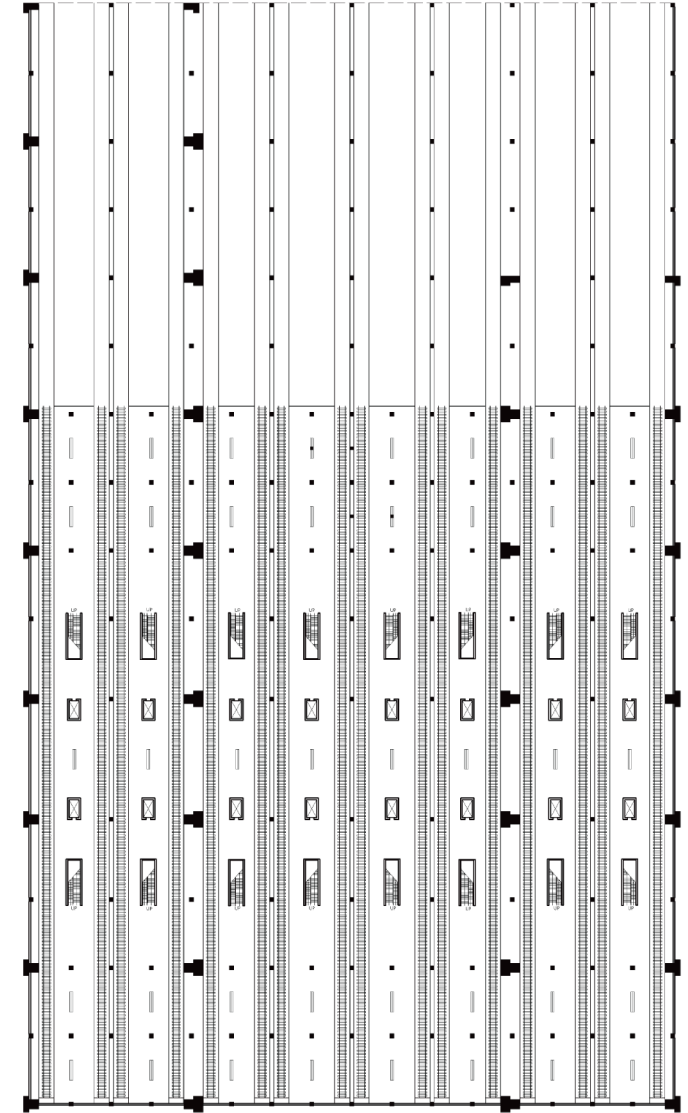

-2 Floor—Regional Train Platform

-1/-2 BASEMENT FLOOR FLOW

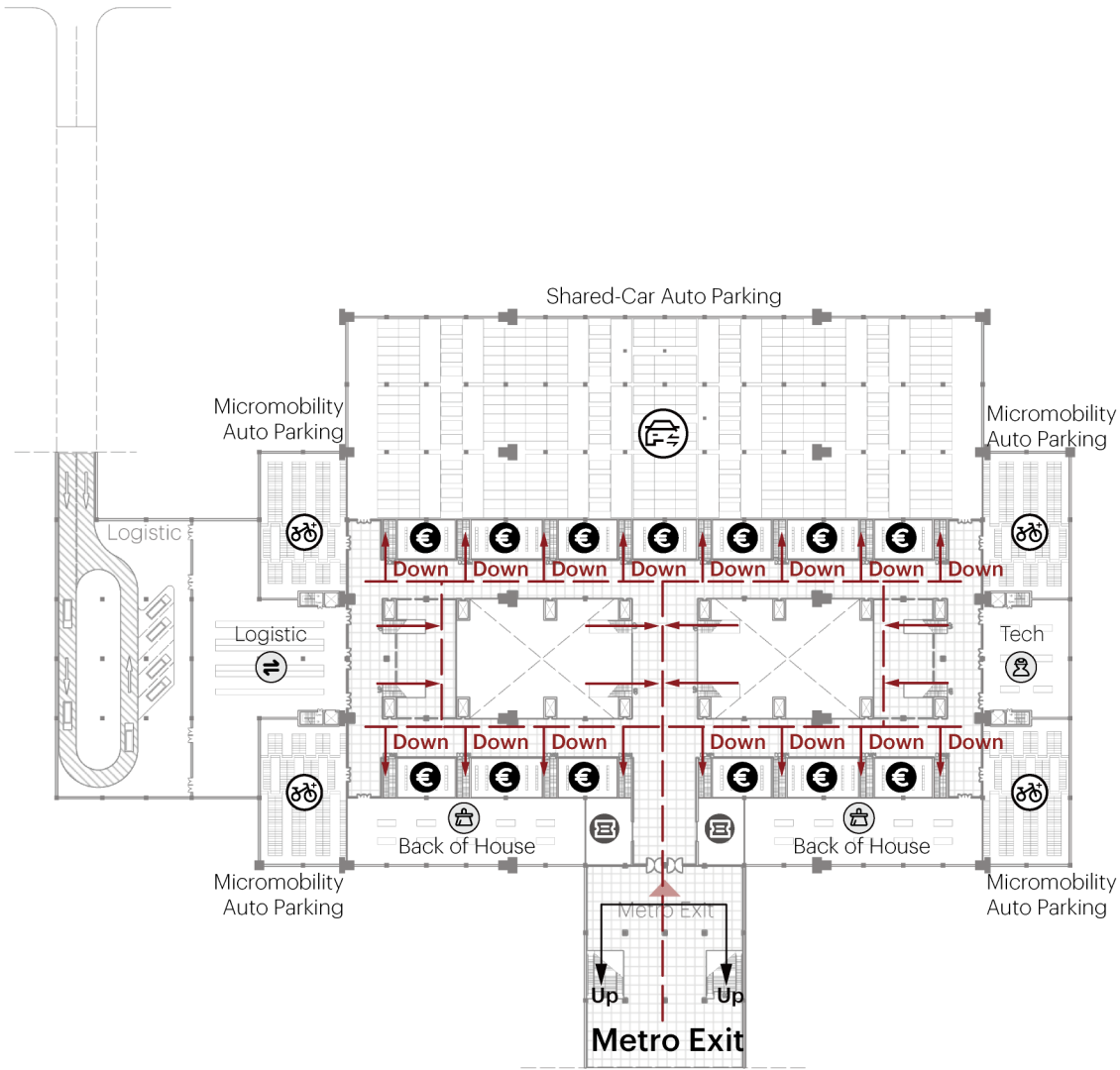

-1 Floor—Regional Train Concourse

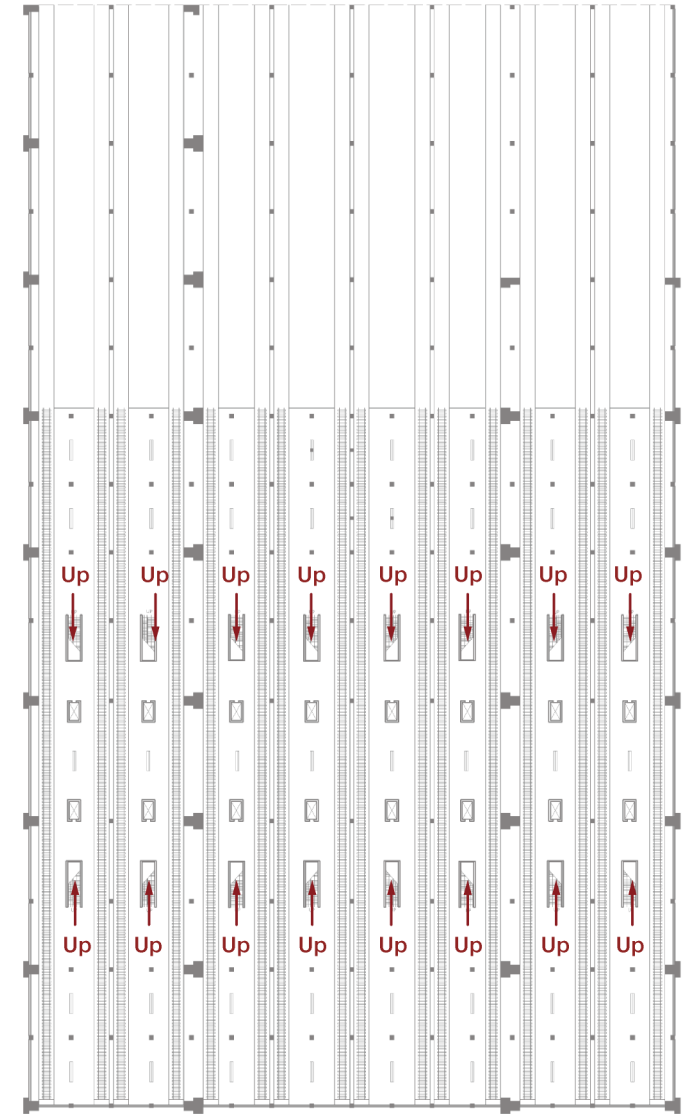

-2 Floor—Regional Train Platform

The basement level is mainly used for parking...

GO UPSTAIRS

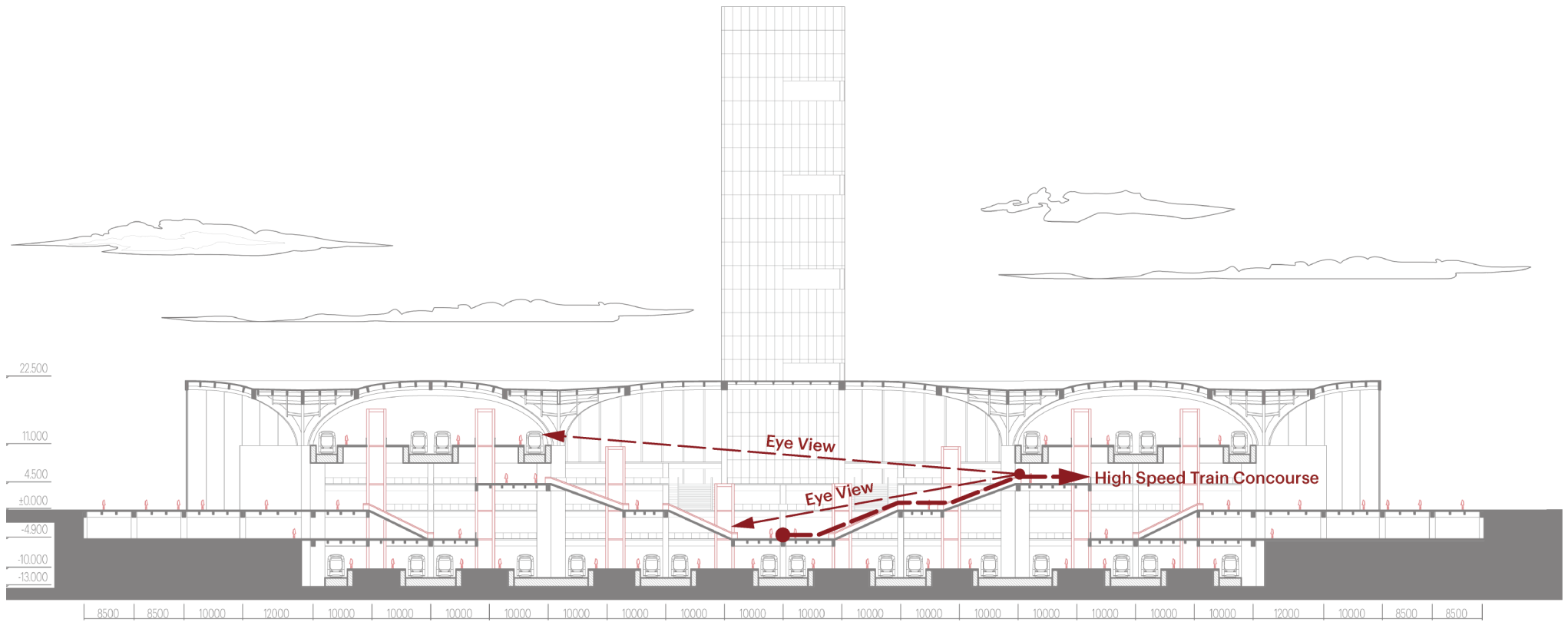

ARRIVE AT THE FIRST-FLOOR HIGH-SPEED TRAIN CONCOURSE..

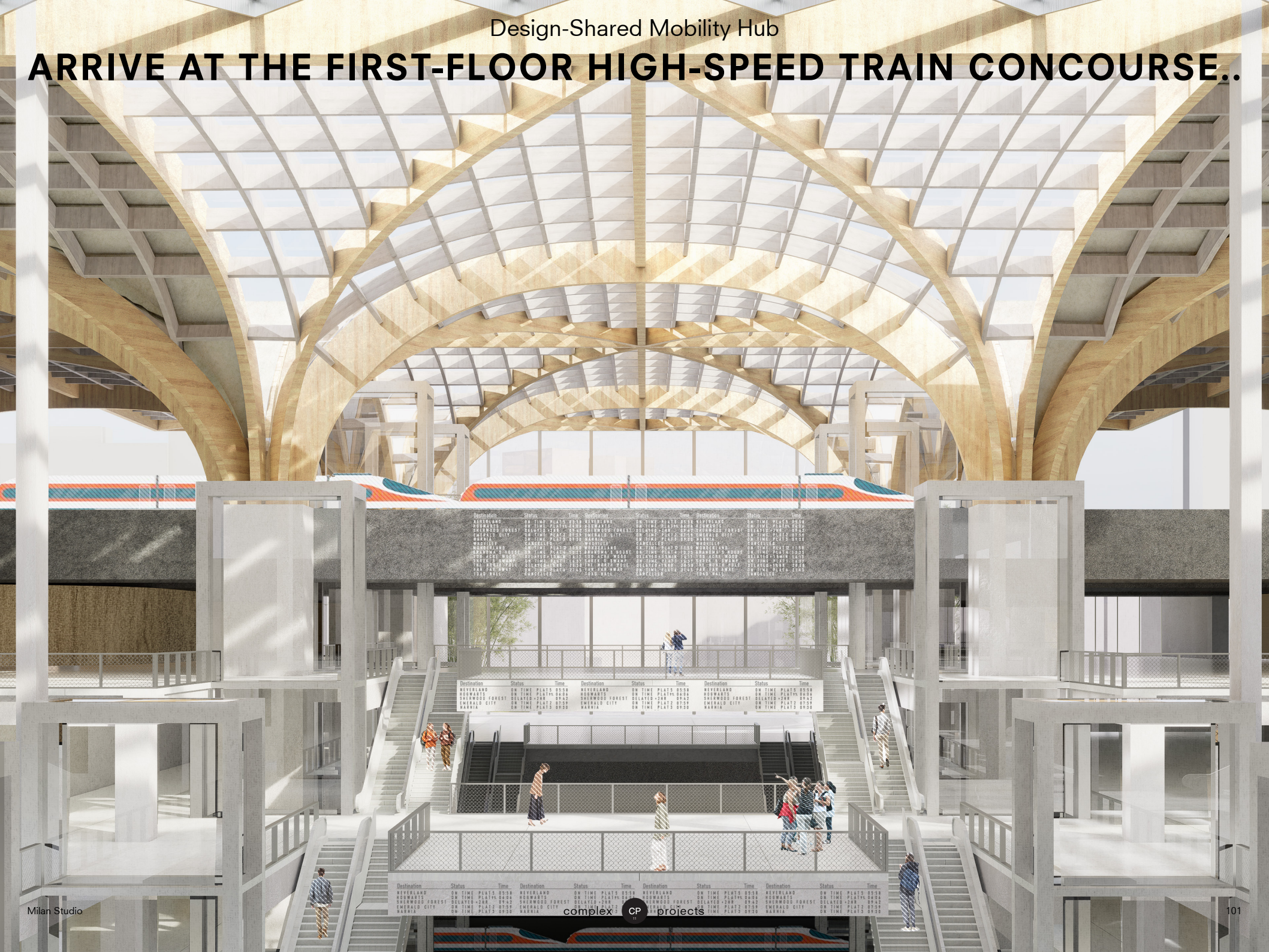

Destination	Status	Time	Destination	Status	Time	Destination	Status	Time
NEVERLAND	ON TIME	PLATS 0558	NEVERLAND	ON TIME	PLATS 0558	NEVERLAND	ON TIME	PLATS 0558
HOWARDS	ON TIME	PLATS 0604	HOWARDS	ON TIME	PLATS 0604	HOWARDS	ON TIME	PLATS 0604
SHERWOOD FOREST	DELATED	2HR 0942	SHERWOOD FOREST	DELATED	2HR 0942	SHERWOOD FOREST	DELATED	2HR 0942
EMERALD CITY	ON TIME	PLATS 0700	EMERALD CITY	ON TIME	PLATS 0700	EMERALD CITY	ON TIME	PLATS 0700
MARBIA	ON TIME	PLATS 0700	MARBIA	ON TIME	PLATS 0700	MARBIA	ON TIME	PLATS 0700

Destination	Status	Time	Destination	Status	Time	Destination	Status	Time
NEVERLAND	ON TIME	PLATS 0558	NEVERLAND	ON TIME	PLATS 0558	NEVERLAND	ON TIME	PLATS 0558
HOWARDS	ON TIME	PLATS 0604	HOWARDS	ON TIME	PLATS 0604	HOWARDS	ON TIME	PLATS 0604
SHERWOOD FOREST	DELATED	2HR 0942	SHERWOOD FOREST	DELATED	2HR 0942	SHERWOOD FOREST	DELATED	2HR 0942
EMERALD CITY	ON TIME	PLATS 0700	EMERALD CITY	ON TIME	PLATS 0700	EMERALD CITY	ON TIME	PLATS 0700
MARBIA	ON TIME	PLATS 0700	MARBIA	ON TIME	PLATS 0700	MARBIA	ON TIME	PLATS 0700

Destination	Status	Time	Destination	Status	Time	Destination	Status	Time
NEVERLAND	ON TIME	PLATS 0558	NEVERLAND	ON TIME	PLATS 0558	NEVERLAND	ON TIME	PLATS 0558
HOWARDS	ON TIME	PLATS 0604	HOWARDS	ON TIME	PLATS 0604	HOWARDS	ON TIME	PLATS 0604
SHERWOOD FOREST	DELATED	2HR 0942	SHERWOOD FOREST	DELATED	2HR 0942	SHERWOOD FOREST	DELATED	2HR 0942
EMERALD CITY	ON TIME	PLATS 0700	EMERALD CITY	ON TIME	PLATS 0700	EMERALD CITY	ON TIME	PLATS 0700
MARBIA	ON TIME	PLATS 0700	MARBIA	ON TIME	PLATS 0700	MARBIA	ON TIME	PLATS 0700

1/2 FLOOR

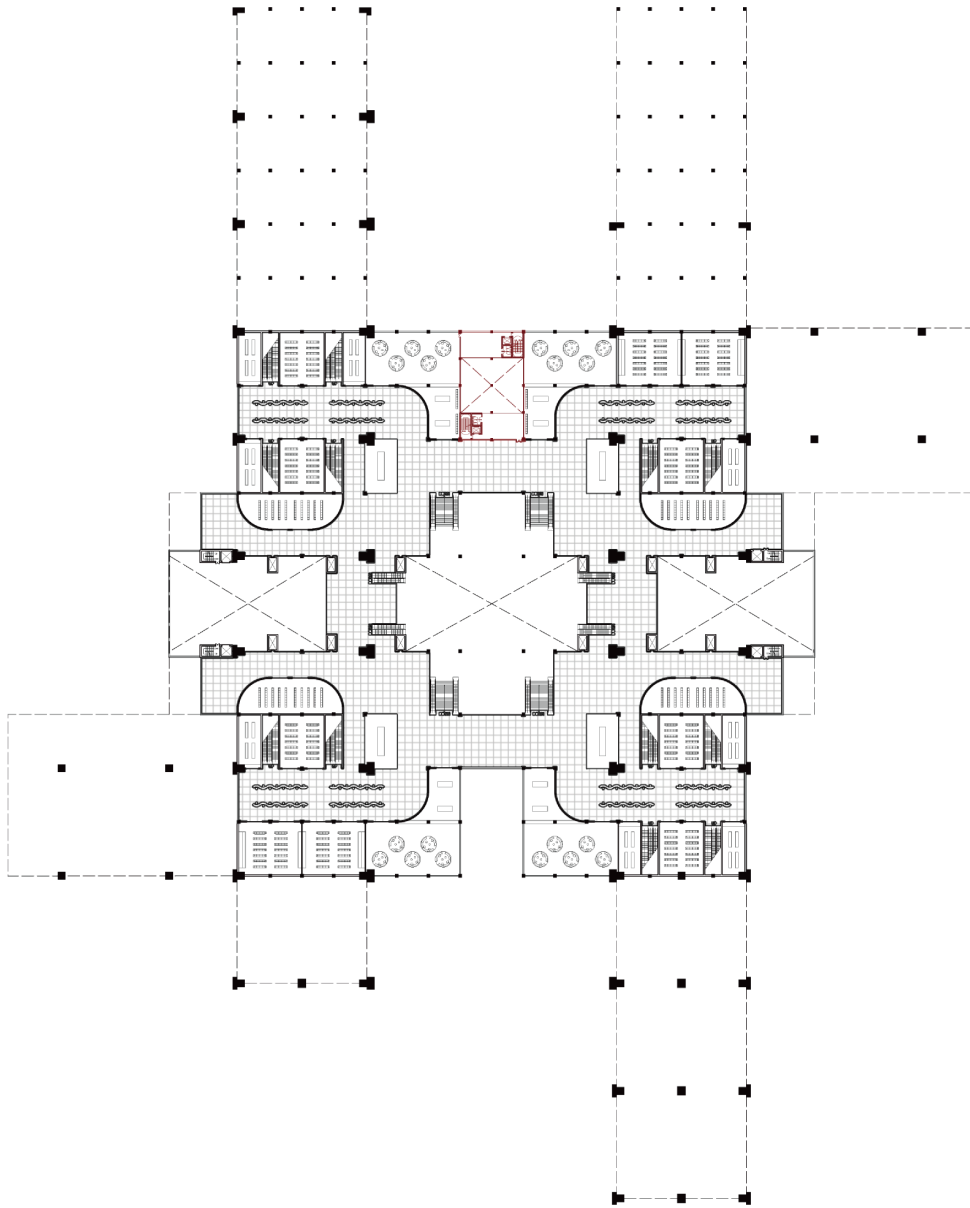

1 Floor—High-Speed Train Concourse

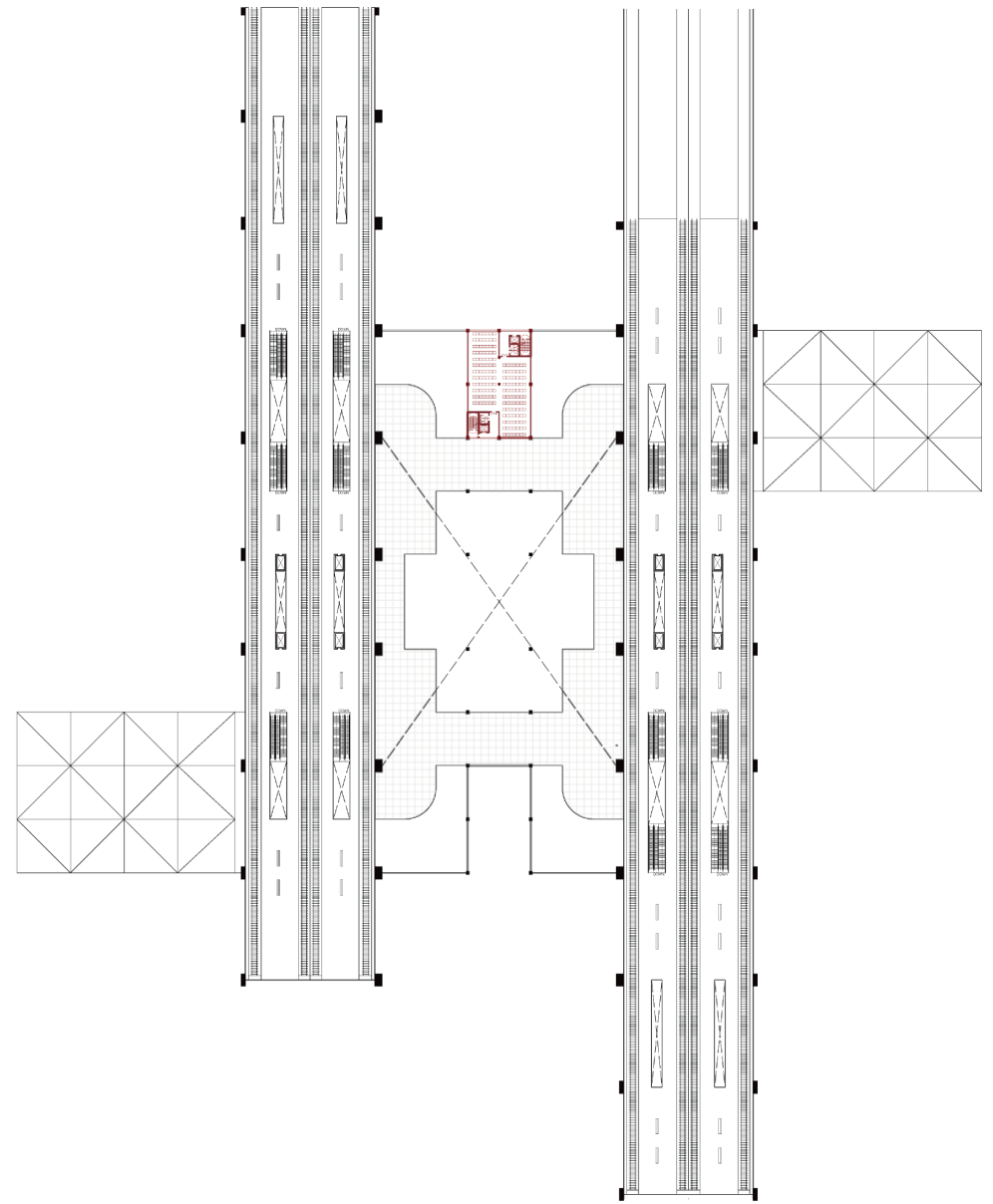

2 Floor—High-Speed Train Platform

1/2 FLOOR

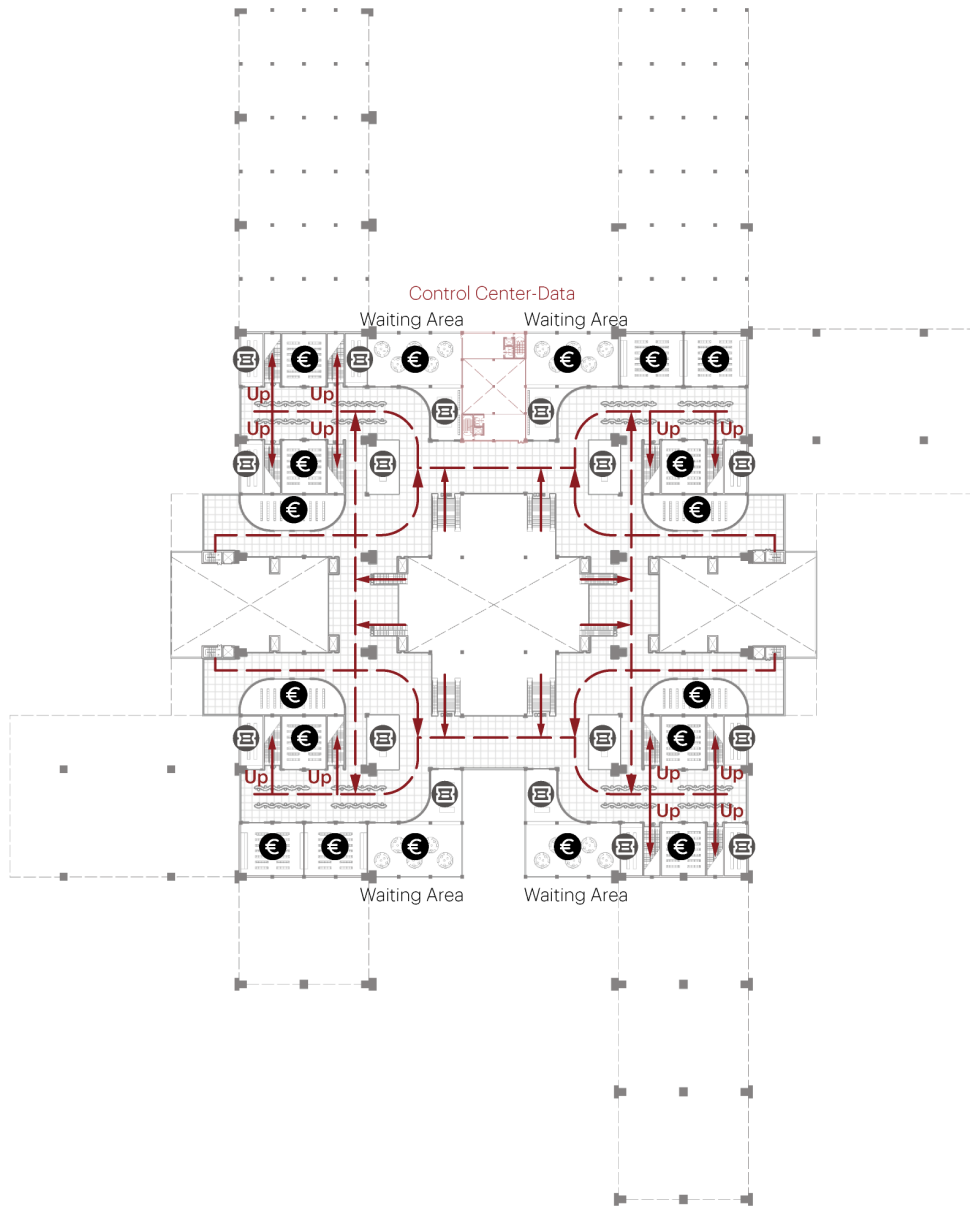

1 Floor—High-Speed Train Concourse

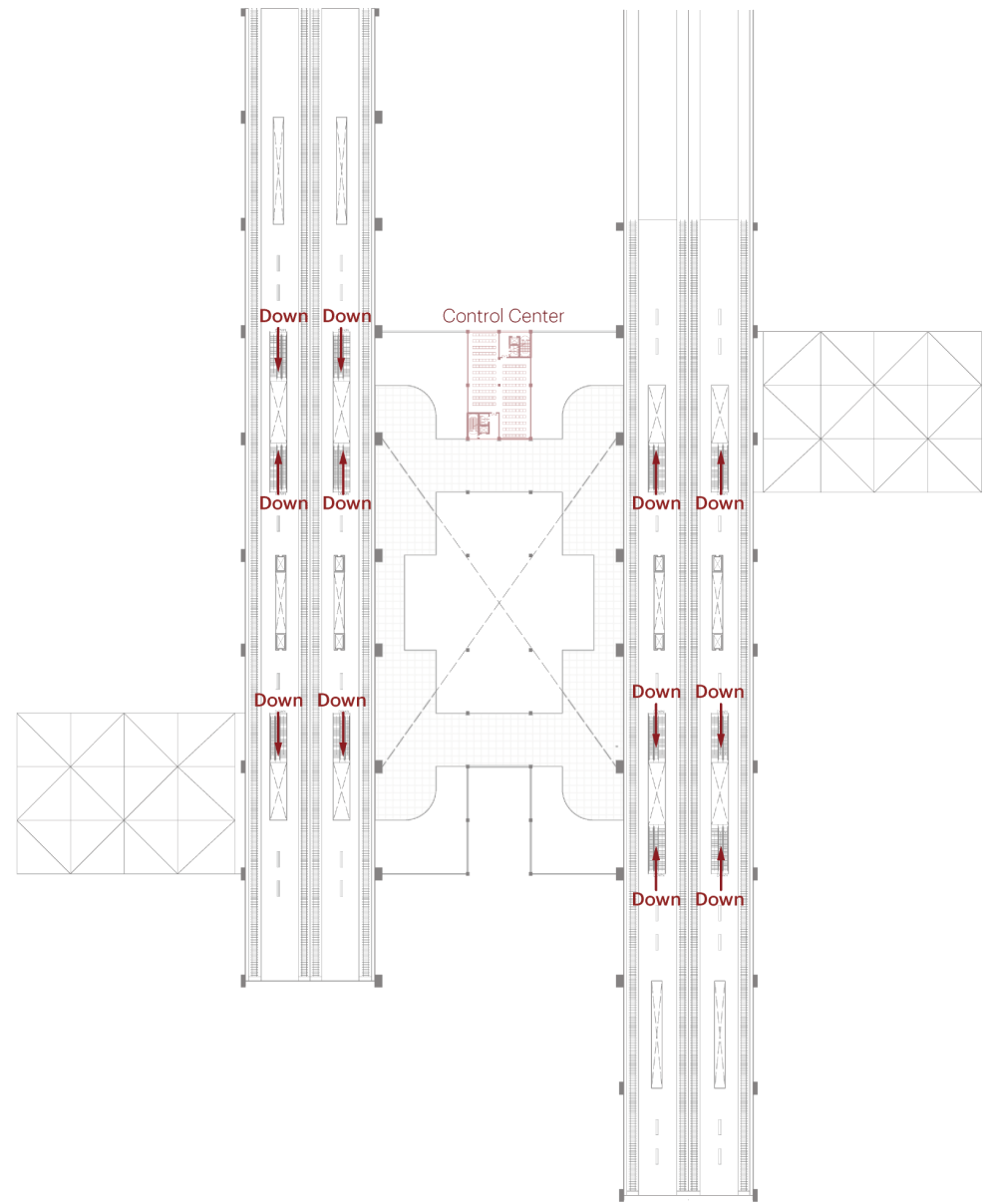

2 Floor—High-Speed Train Platform

Design-Shared Mobility Hub

HIGH SPEED TRAIN PLATFORM



SECTION OF MAIN ENTRANCE AND CONTROL CENTER

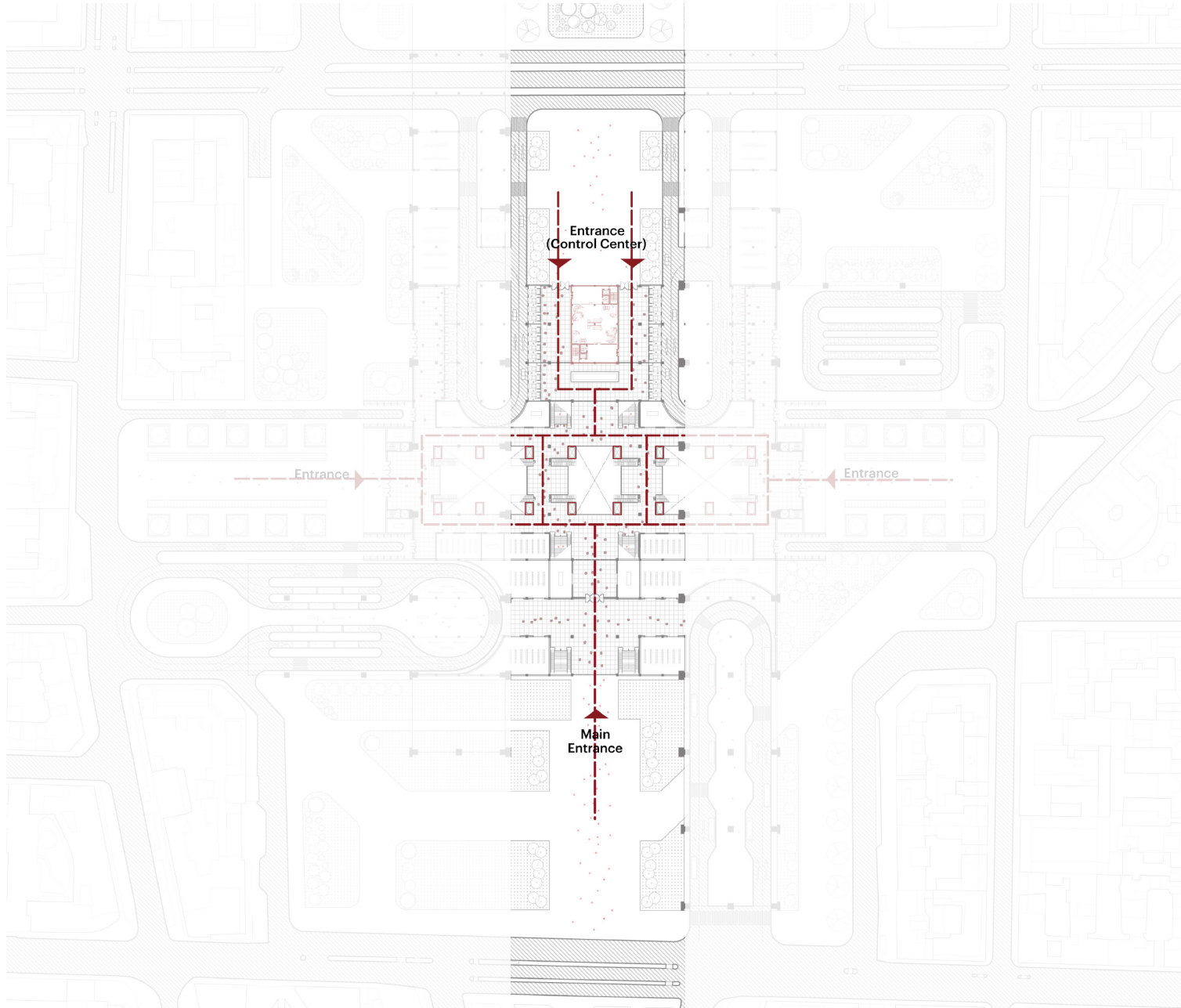

Design-Shared Mobility Hub
SECTION OF MAIN ENTRANCE

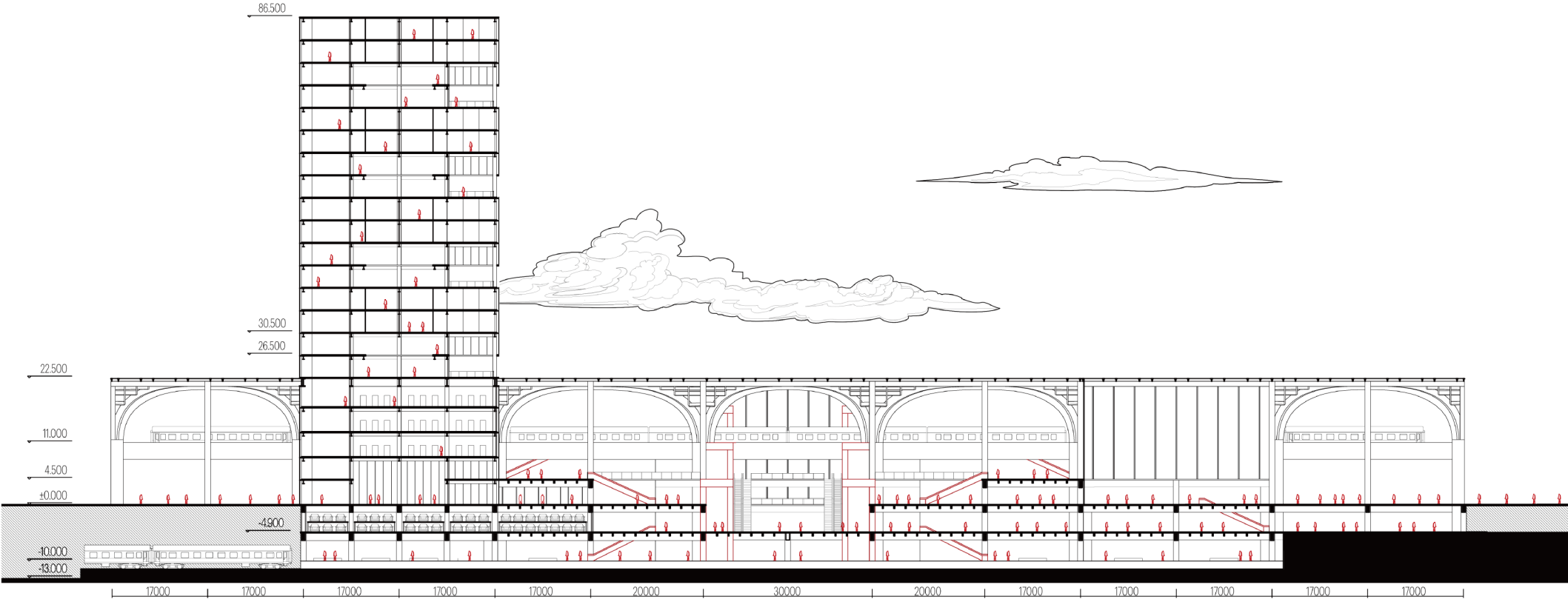

Design-Shared Mobility Hub

CIRCULATION

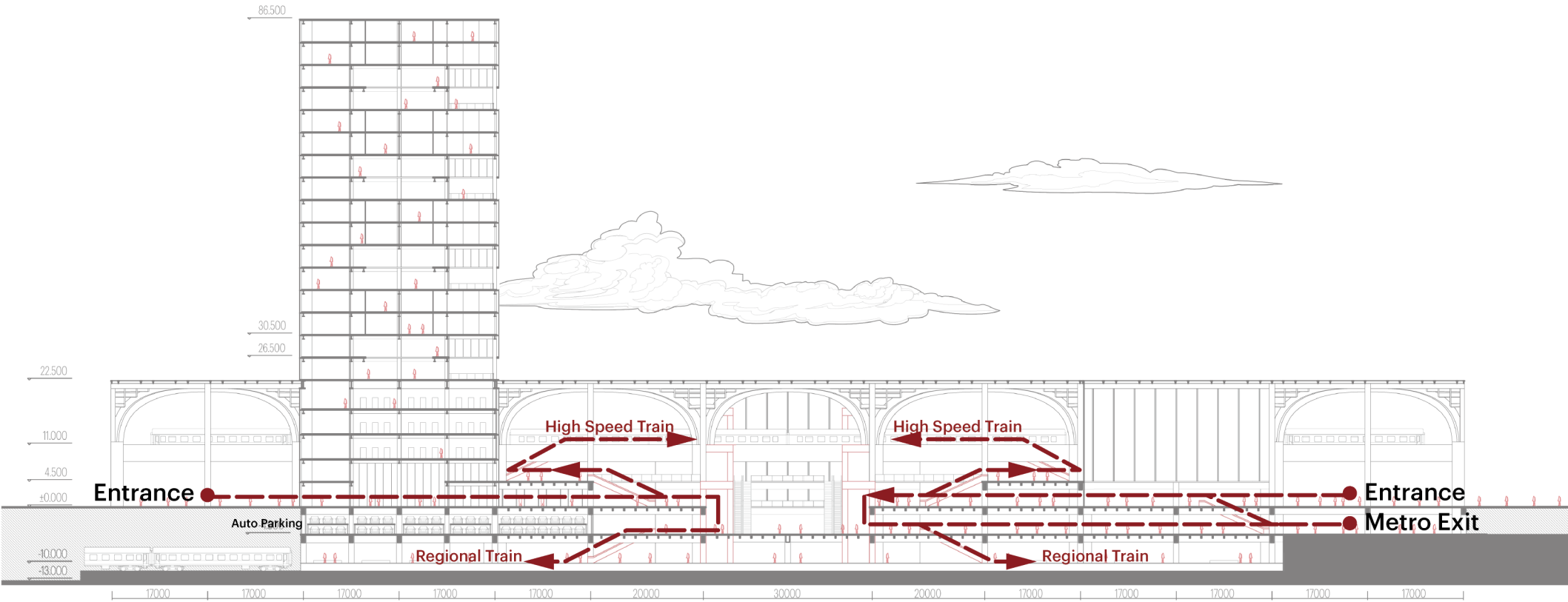

MAIN ENTRANCE



UPON ENTERING THE MAIN ENTRANCE...



DESIGN -CONTROL CENTER

Design-Control Center

FUNCTION

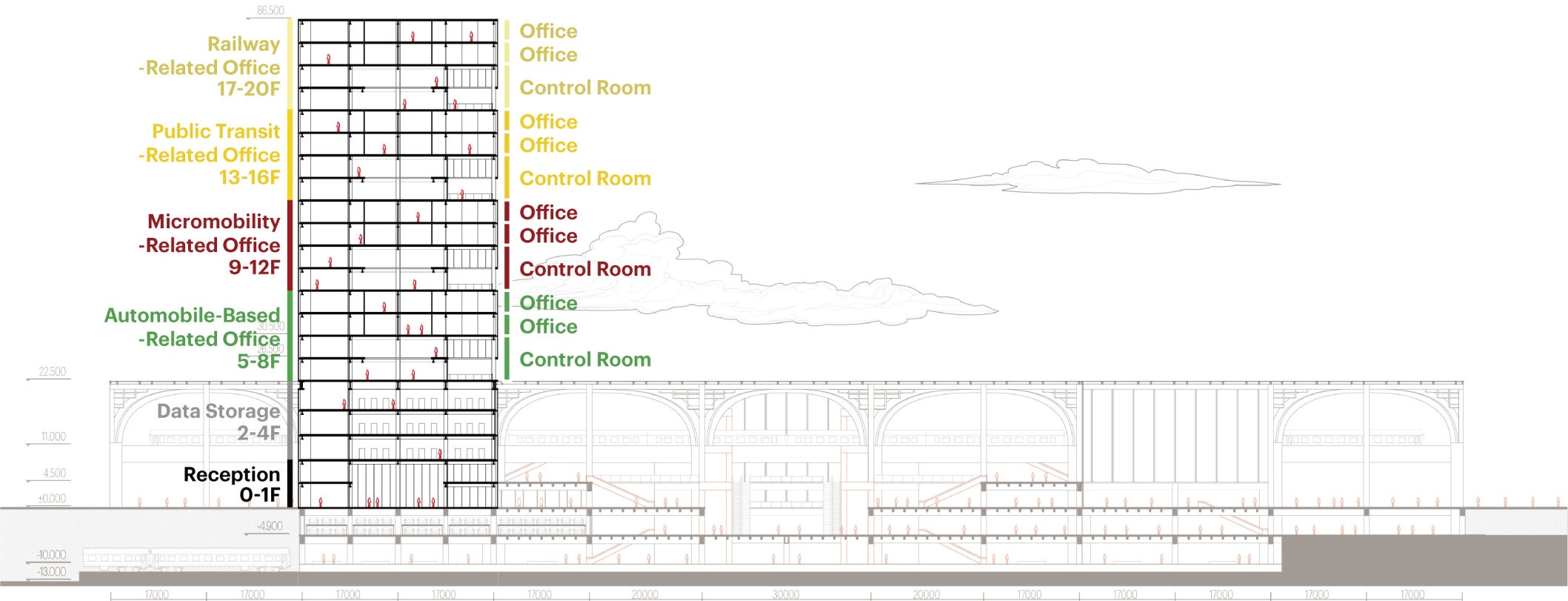

The tower is divided into units of four floors each, allocated to different transportation departments. There is double-height level for the control room, including a mezzanine, and two floors for office space.

Design-Control Center FLOOR PLAN

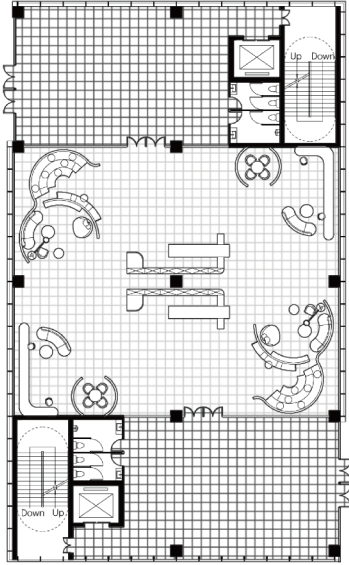

GF Reception

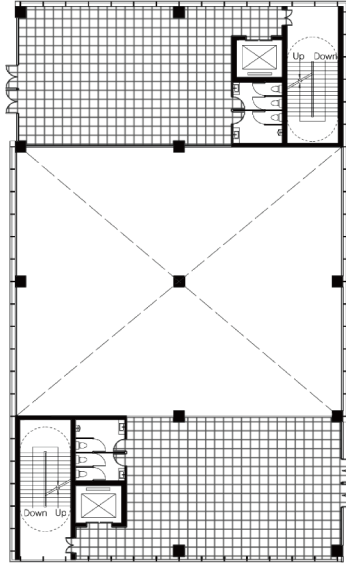

1F Reception

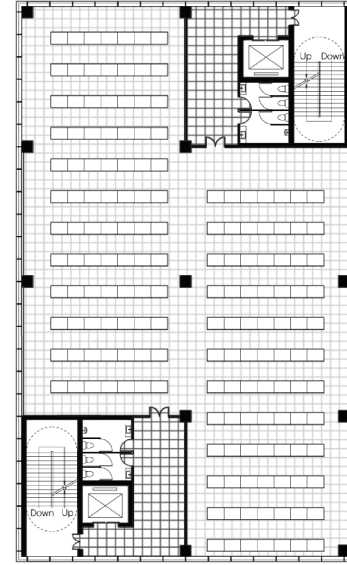

2-4F Data storage

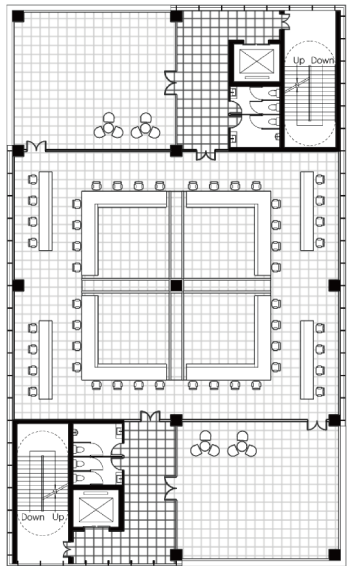

5F Control Room

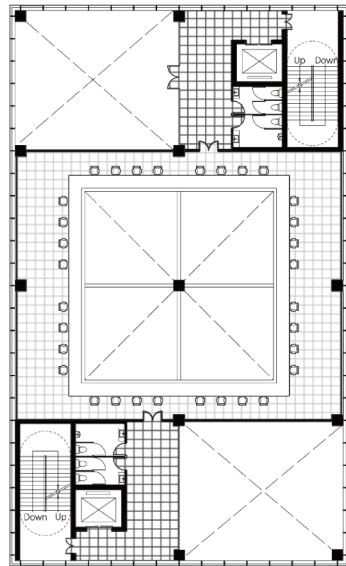

6F Control Room

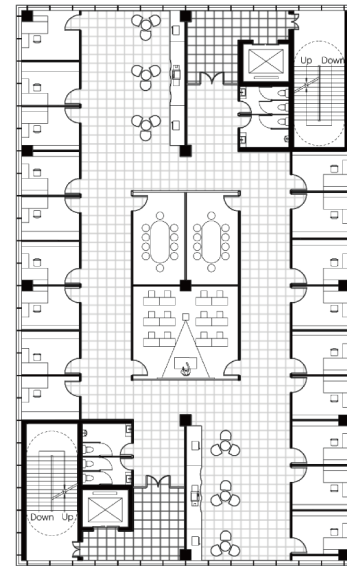

7-8F Office

Design-Control Center

RAILWAY-RELATED OFFICE FRAGMENT

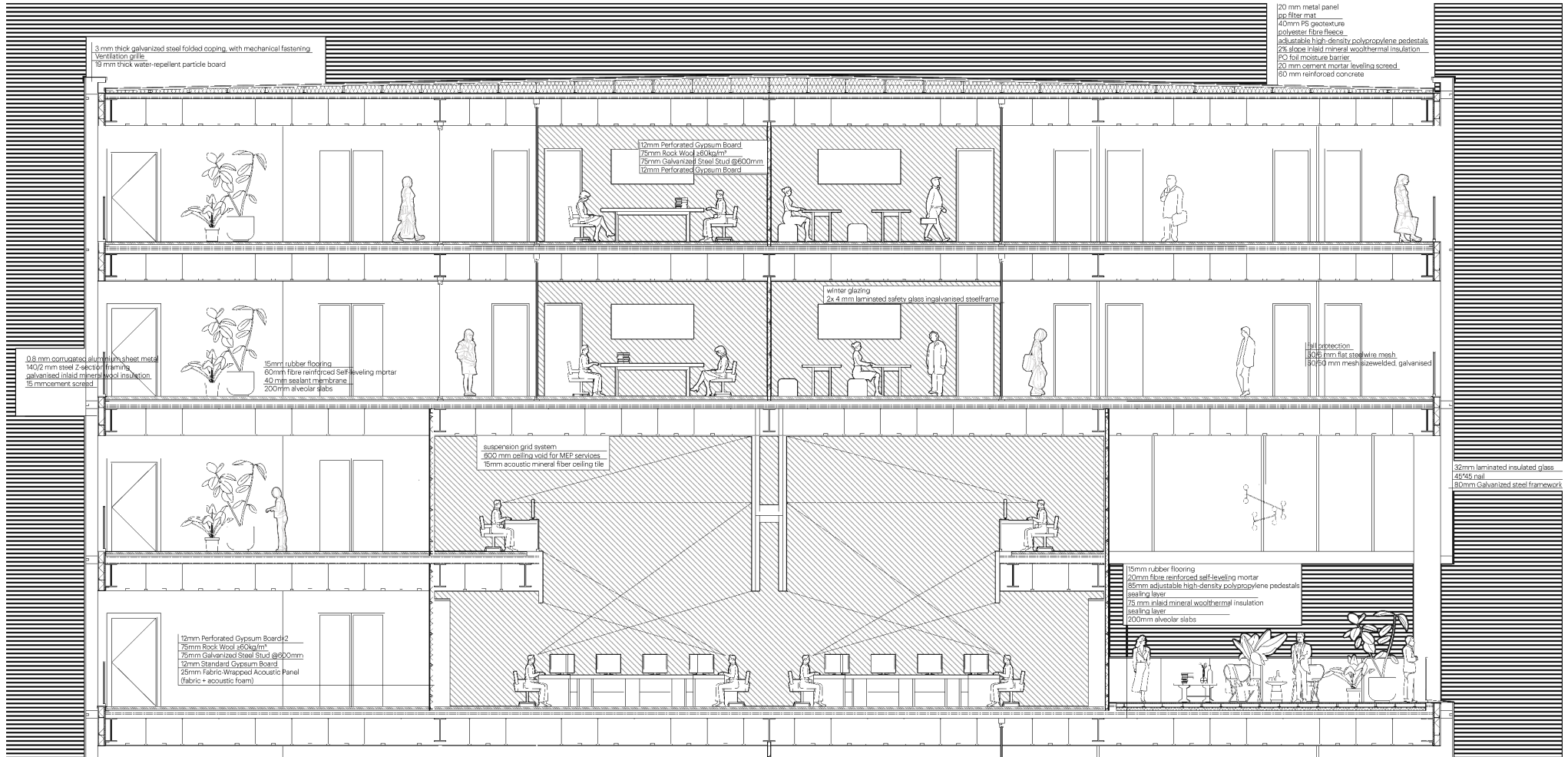

The overall structure uses concrete columns and steel I-beams. Inside, fabric-wrapped acoustic panels and perforated gypsum boards are installed on the walls to ensure proper sound insulation for the control center offices.

Design-Control Center

CONTROL CENTER FACADE DESIGN

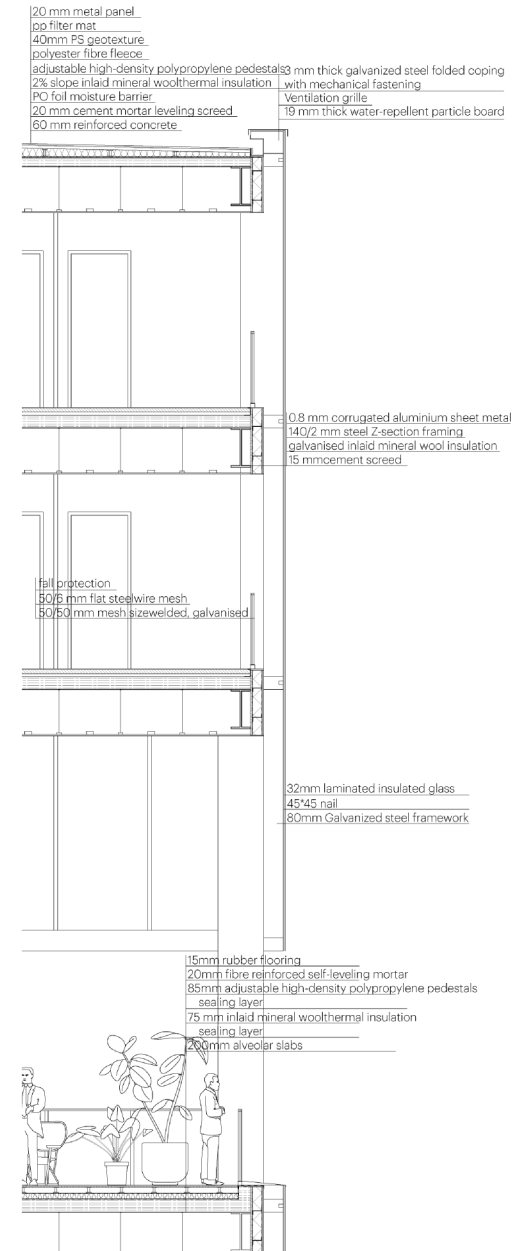
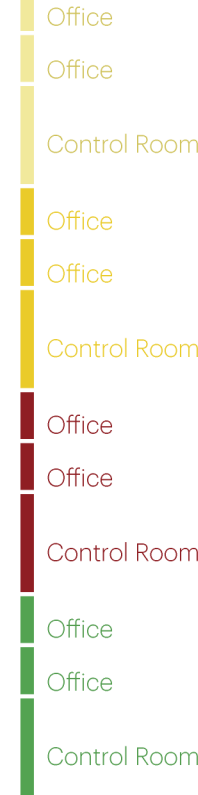
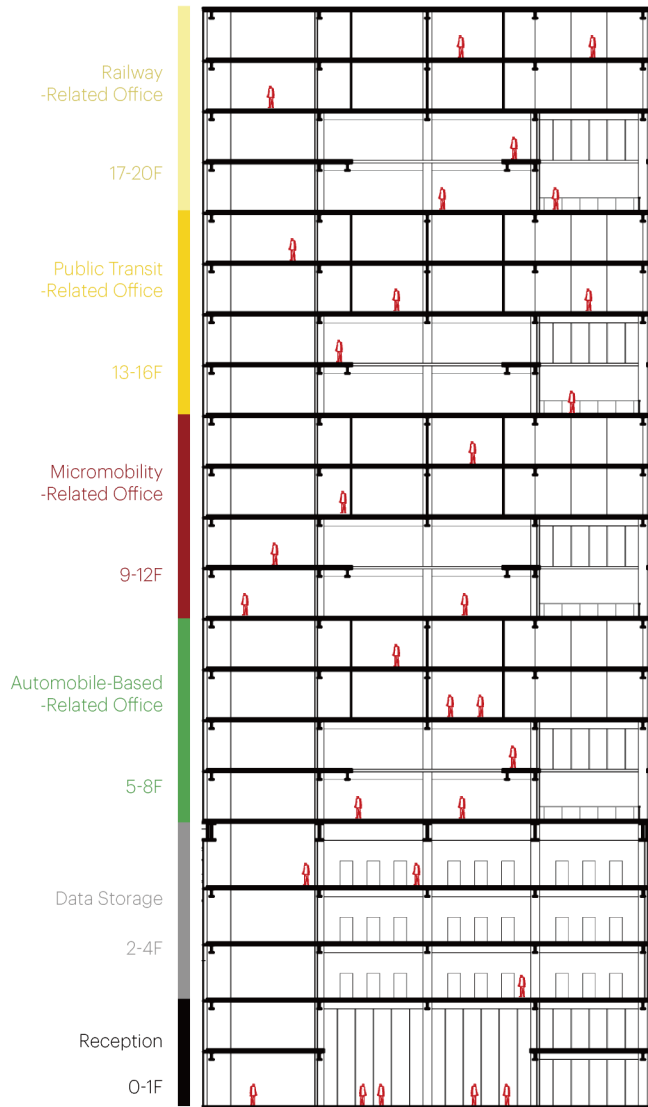

From the facade, different colors of gypsum board are used to differentiate the various transport departments, The interior walls combined with the exterior glass curtain wall provide effective sound insulation

Design-Control Center
A LANDMARK FROM THE MAIN ROAD



DESIGN STRUCTURE

TO BEGIN WITH CANOPY

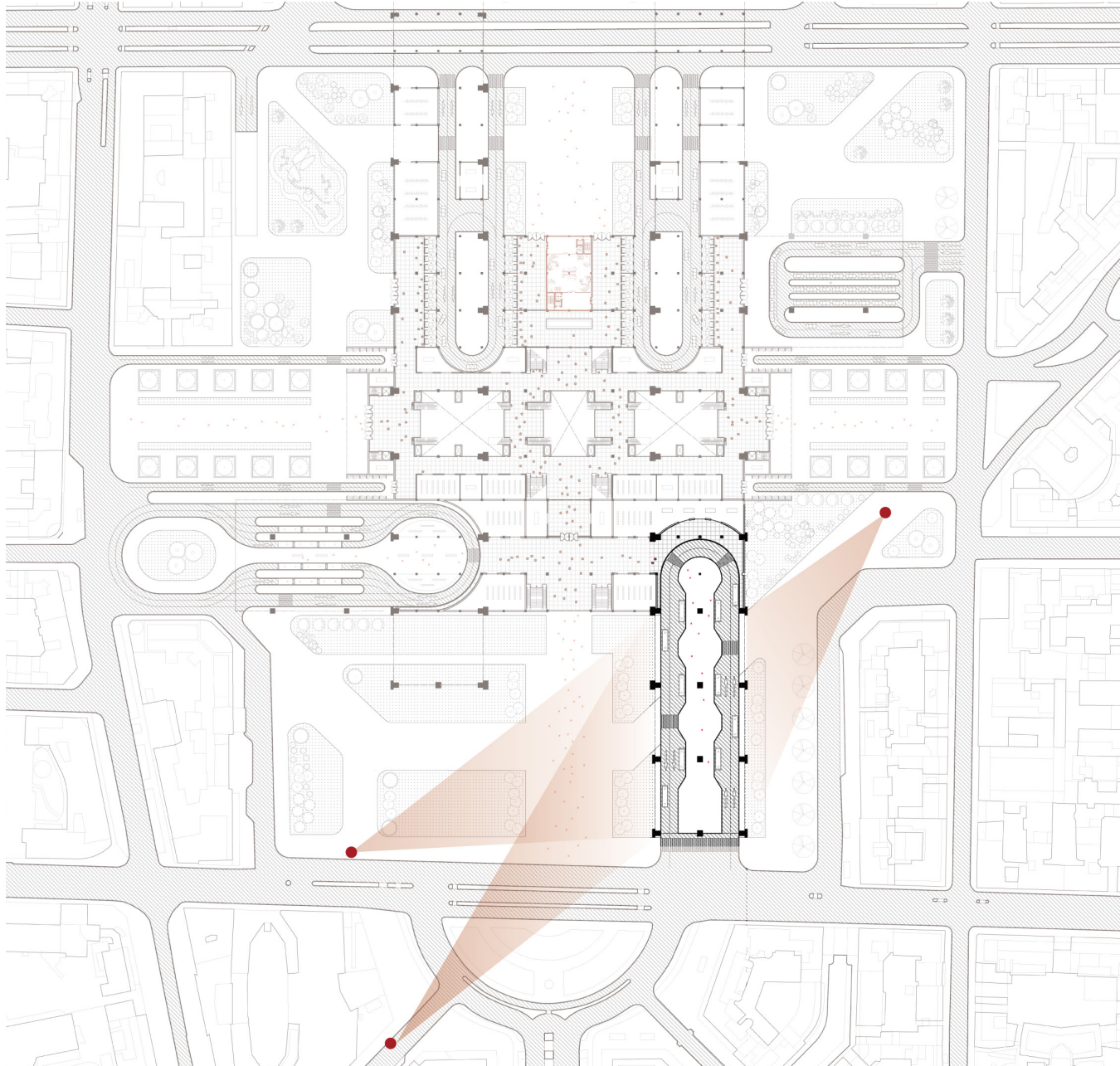

CANOPY DEVELOPMENT

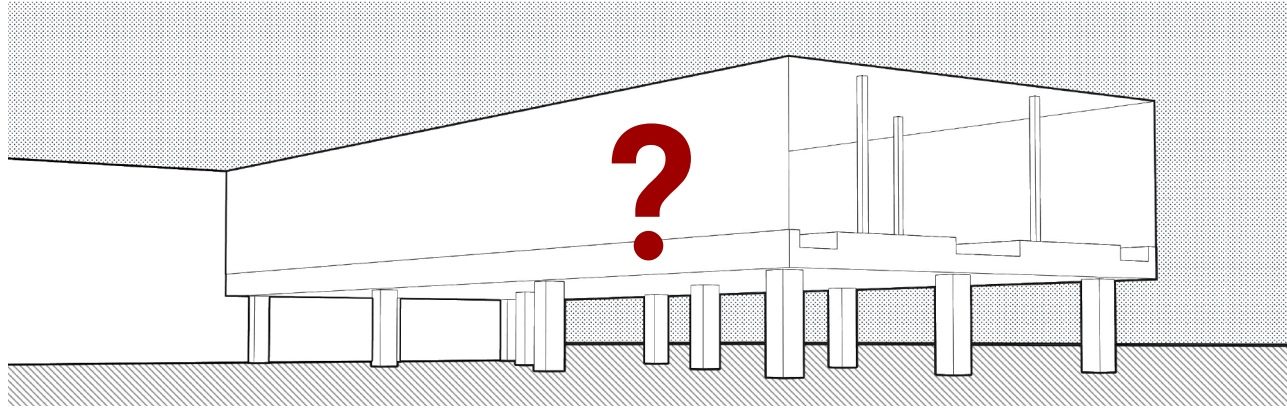

CANOPY DEVELOPMENT

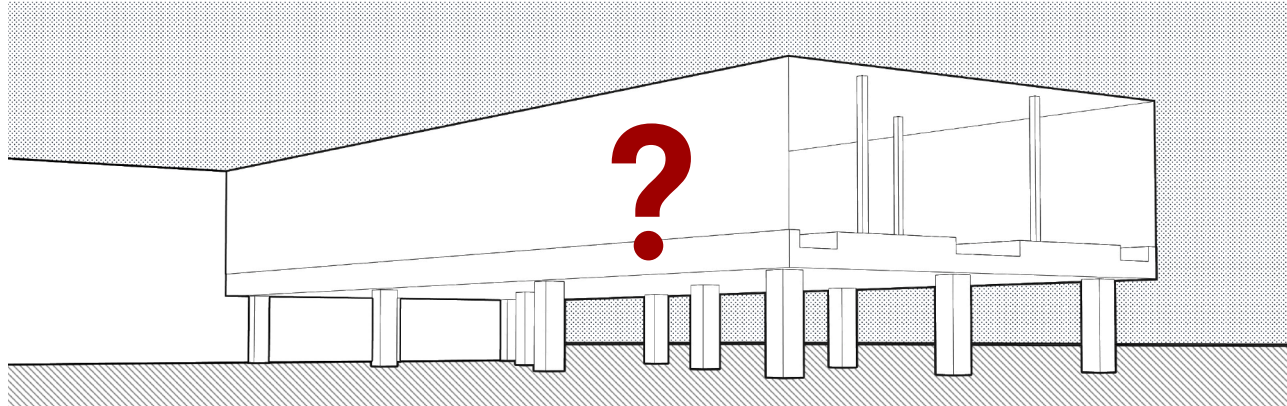

Column-Free Structure

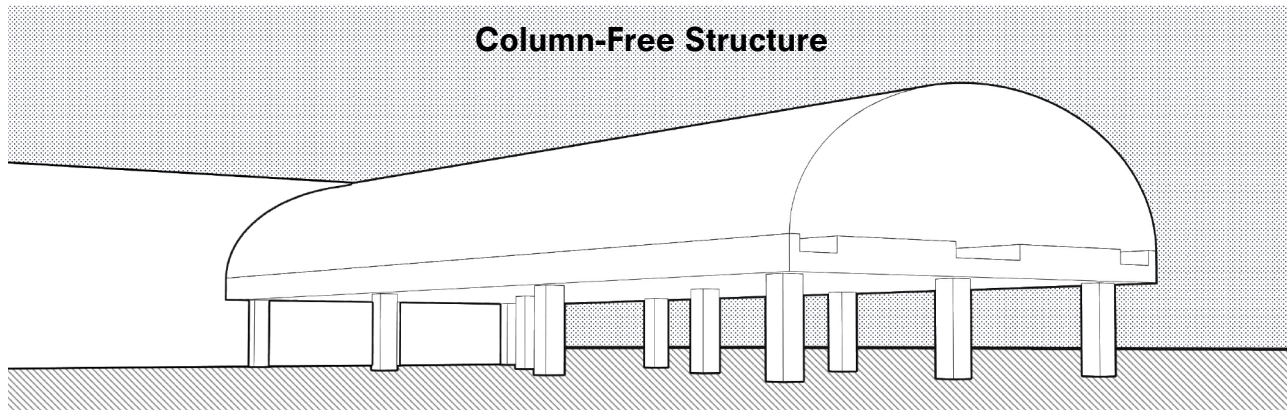

CANOPY DEVELOPMENT

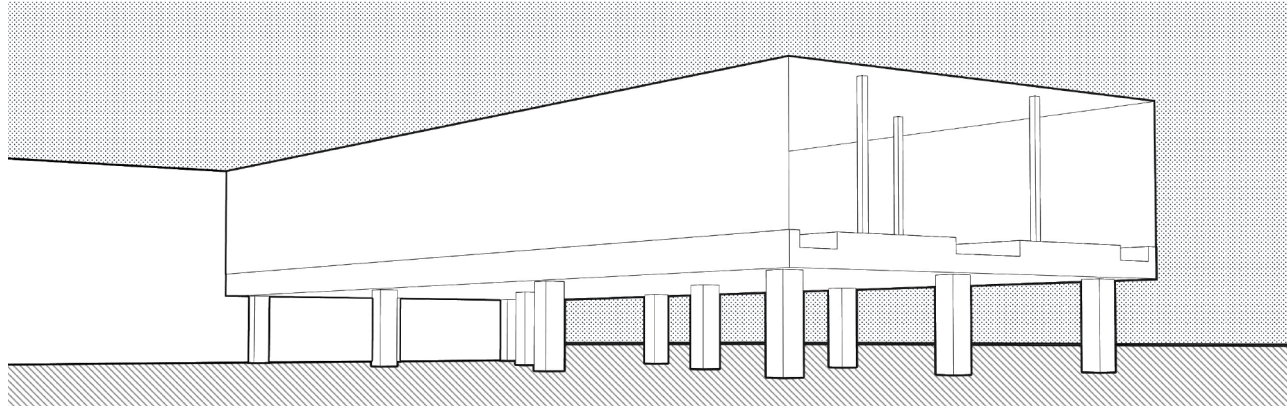

Column-Free Structure

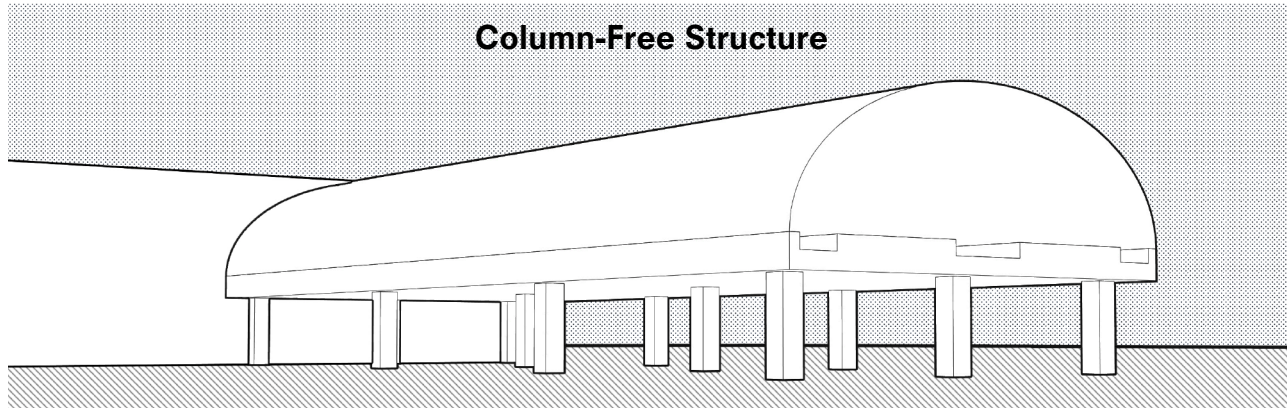

Open on the Side

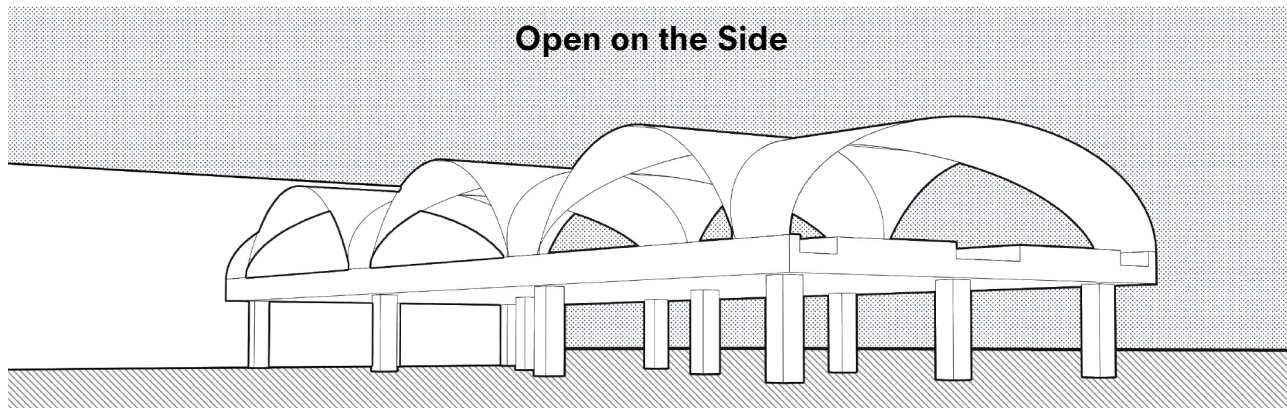

Design-Structure
CONCLUSION CANOPY



2 TYPES OF MODULAR ROOFS

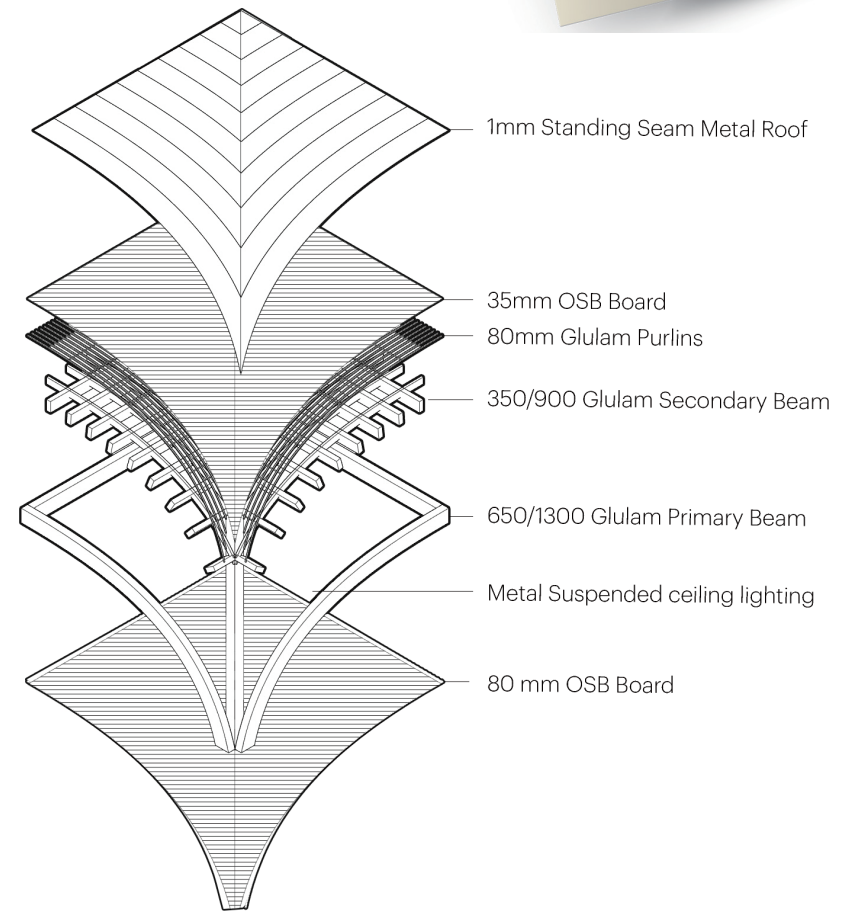
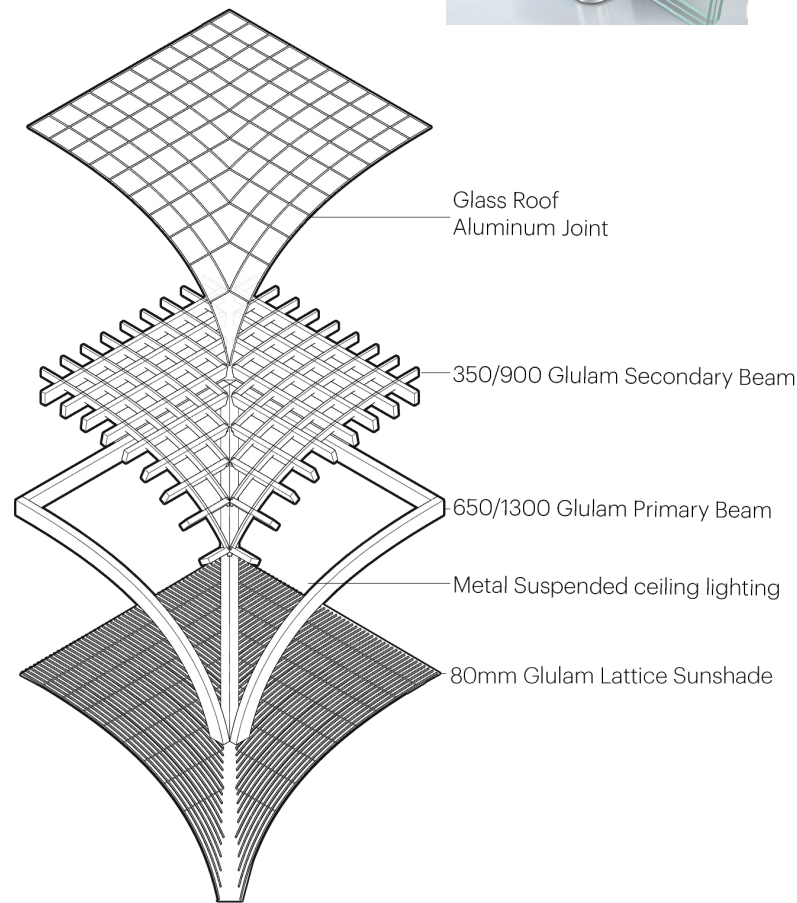
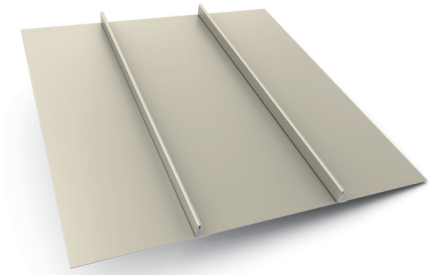

They all have glulam wooden beam structures, with sunshade grids installed beneath the glass modular roof.

2 TYPES OF MODULAR ROOFS

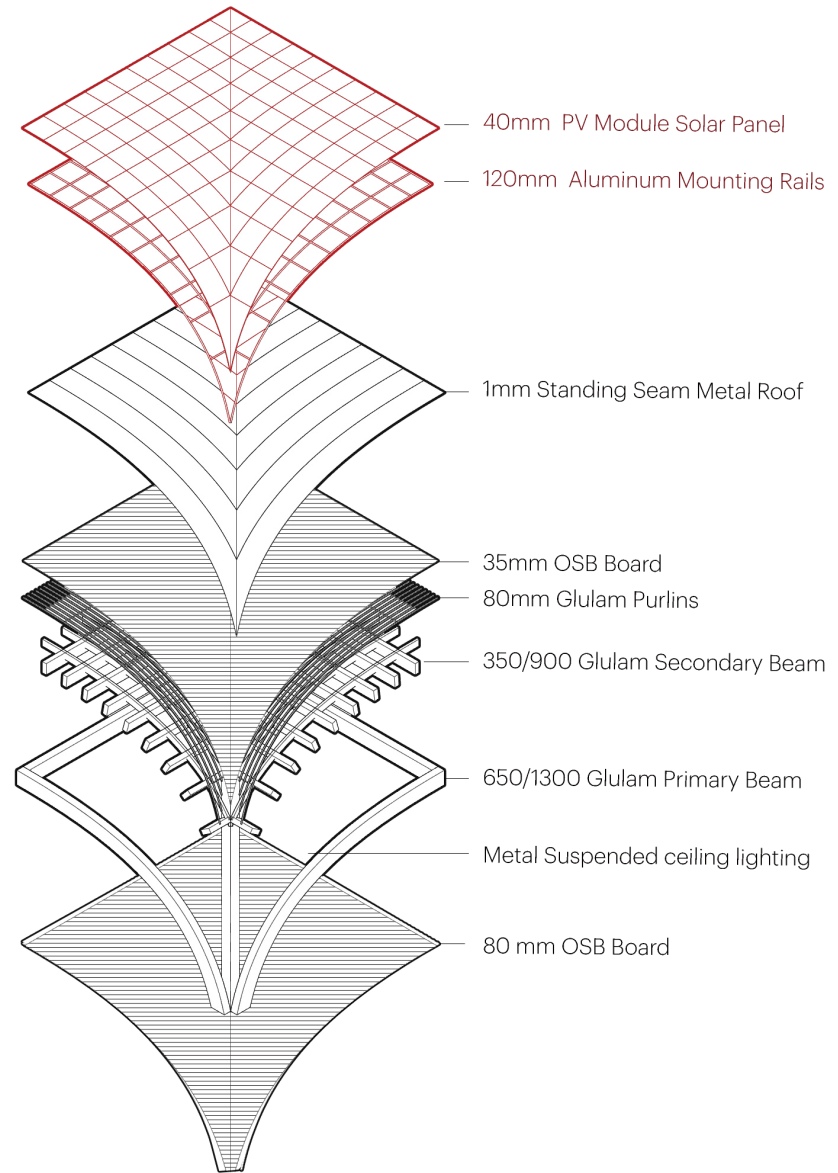
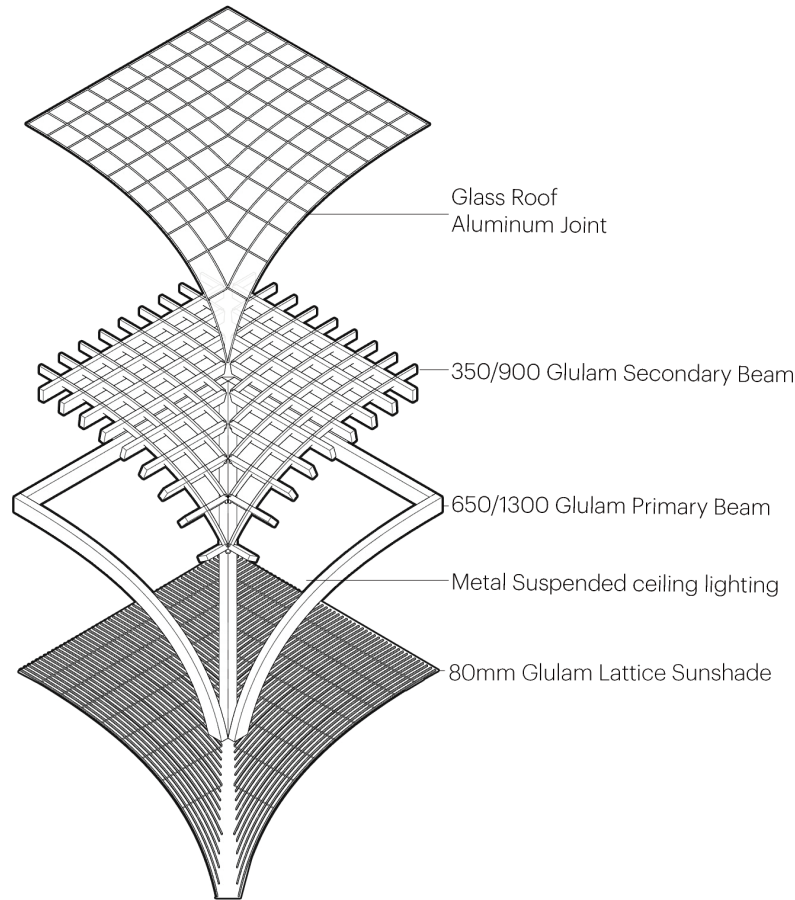
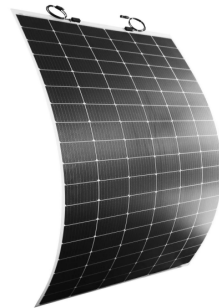
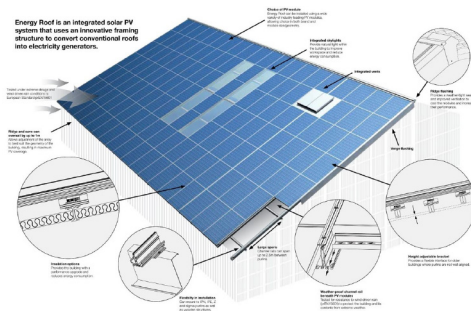

What's more, some of the metal modular roof can be fitted with PV solar panels on top to harness solar energy.

2 TYPES OF MODULAR ROOFS

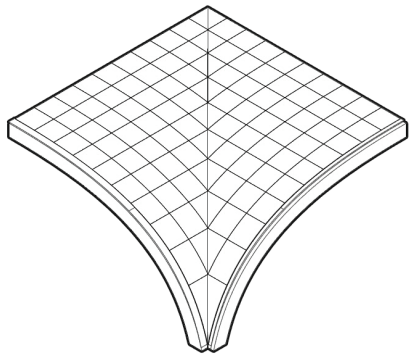

Glass Roof

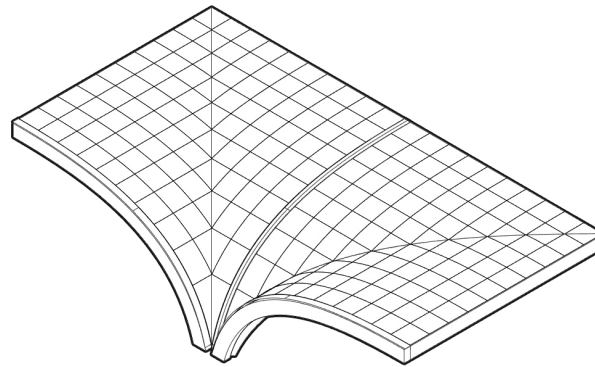

Glass Roofx2

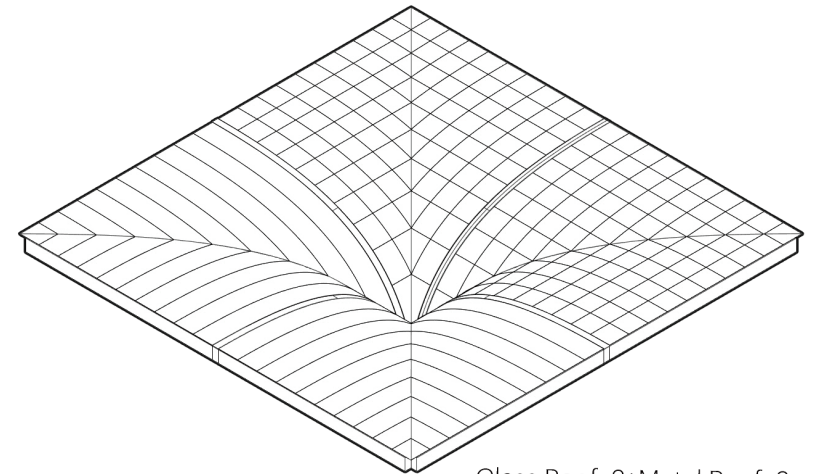

Glass Roofx2+Metal Roofx2

Later on, we can use steel components to connect all the modular roofs

Design-Structure

STRUCTURE DEVELOPMENT

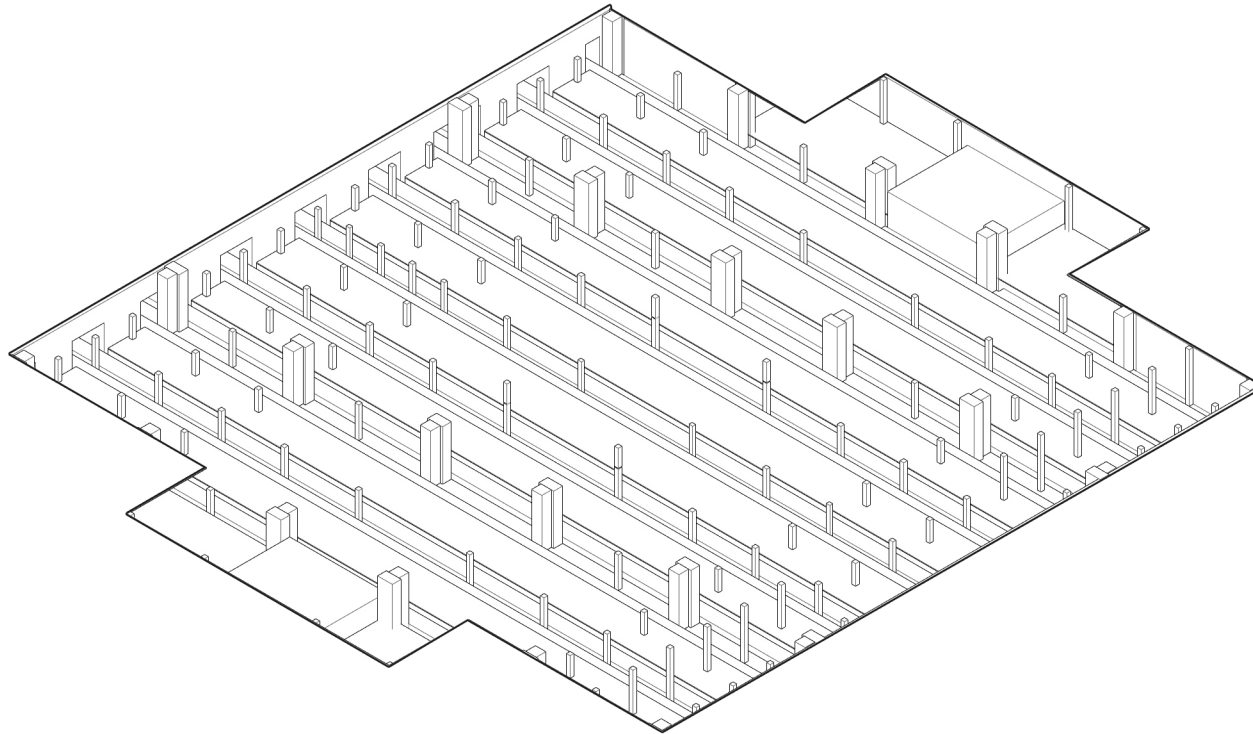

Basement

Station: Reinforced Concrete Beam-Column Structure

STRUCTURE DEVELOPMENT

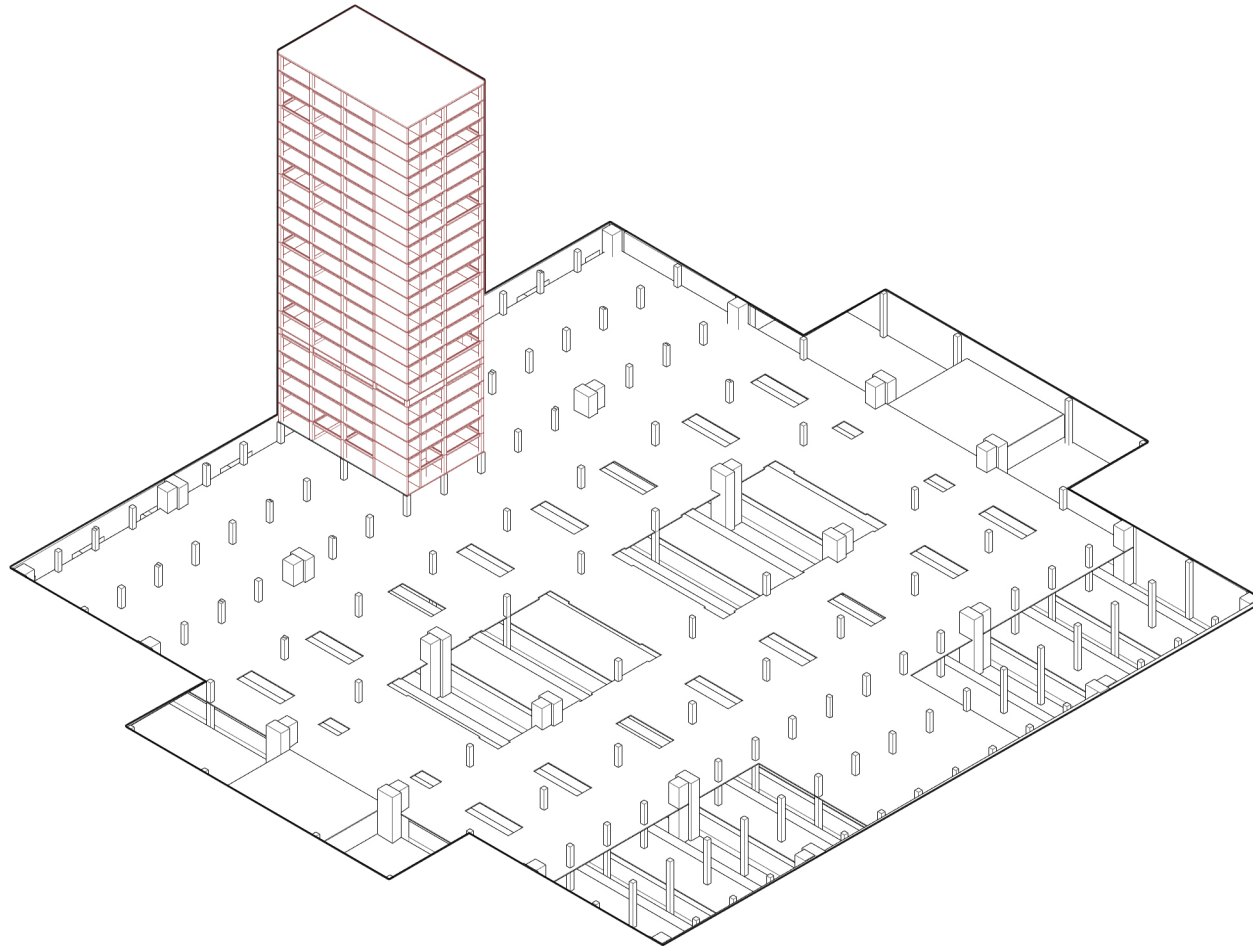

Basement

Control Center: Composite Structure With Concrete Columns And Steel Beams
Hub: Reinforced Concrete Beam-Column Structure

STRUCTURE DEVELOPMENT

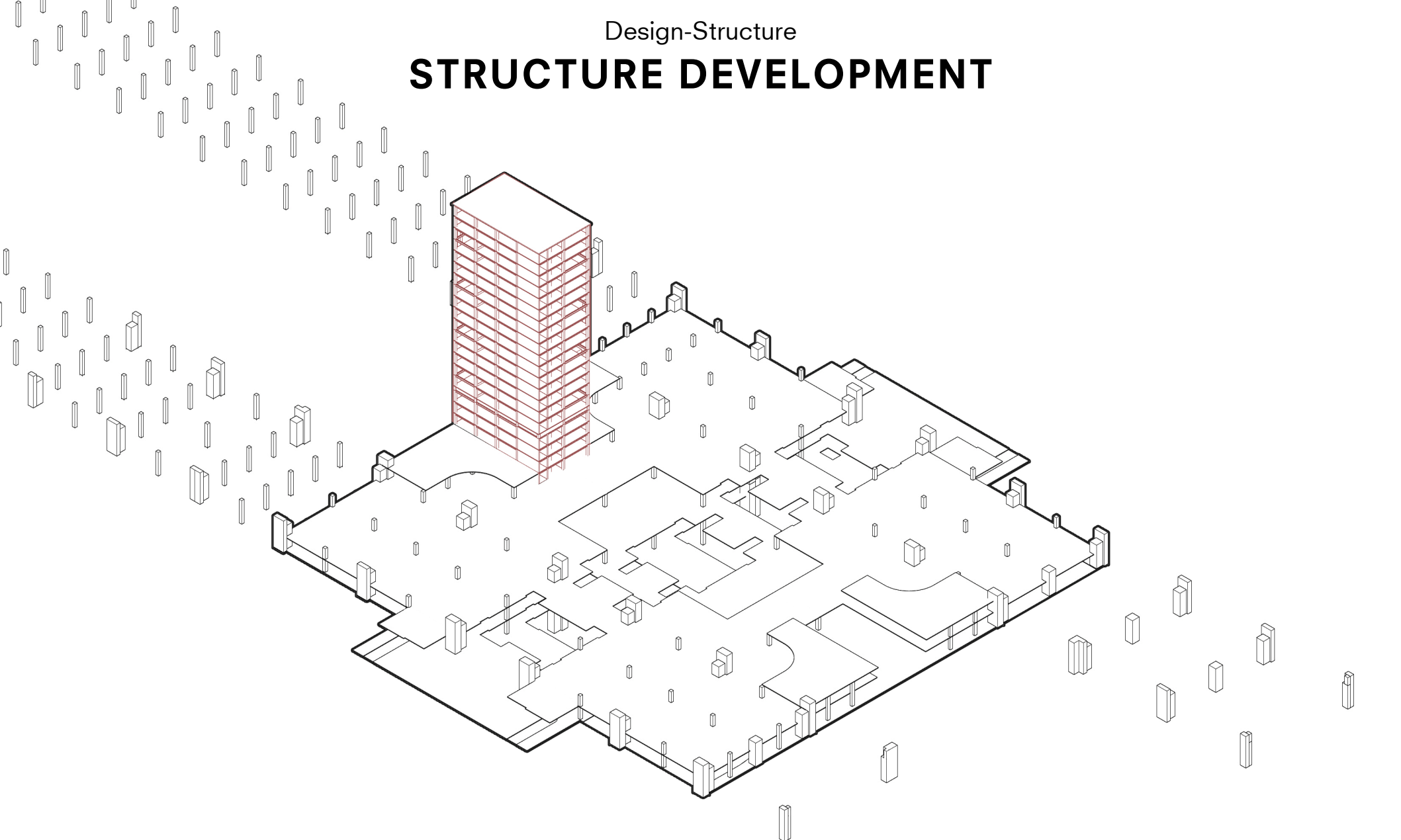

The **Concrete** Column Of The Railway Track And The Structure Of The Atrium

Design-Structure

STRUCTURE DEVELOPMENT

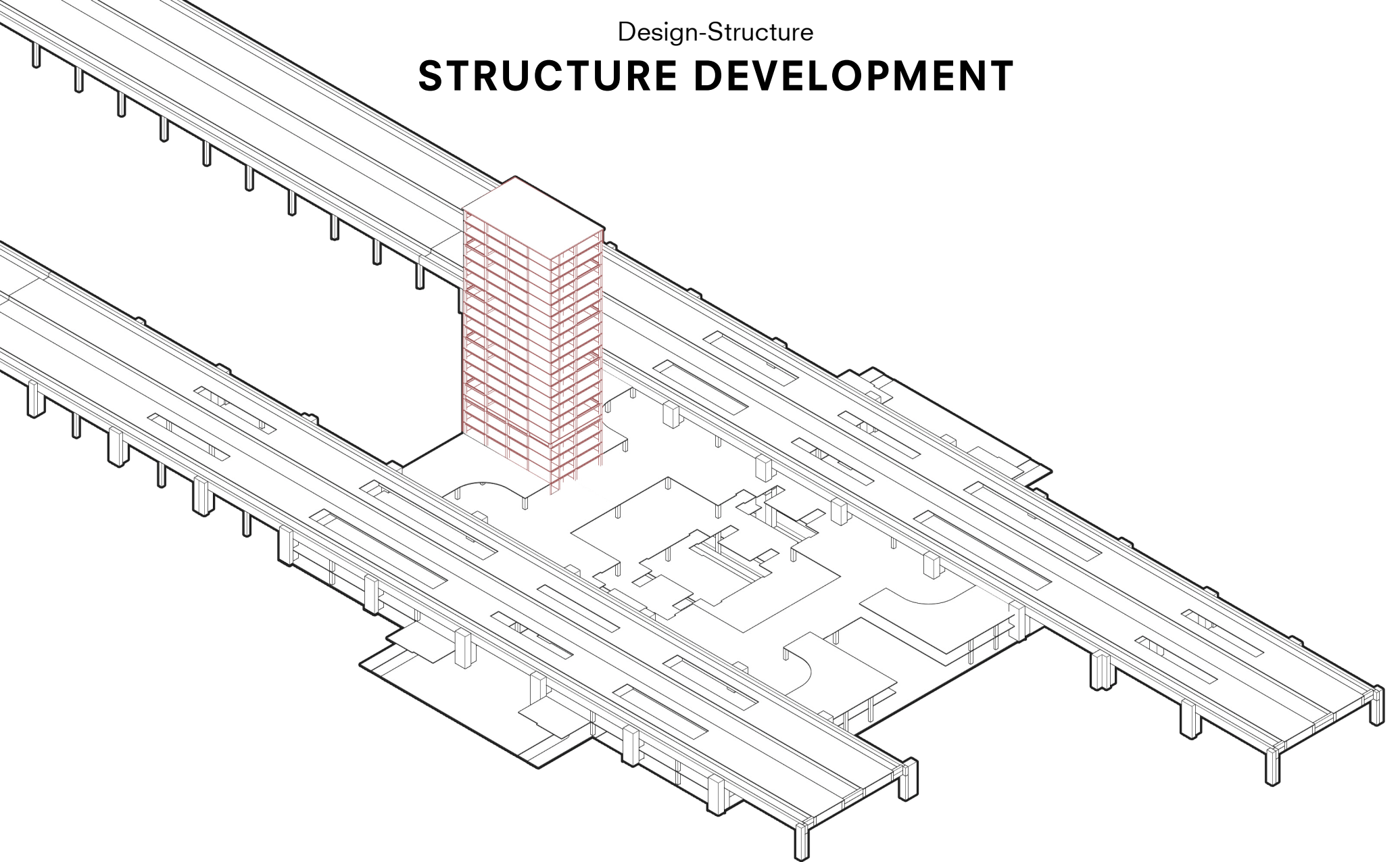

Supporting Structure Of The Railway Track

Design-Structure

STRUCTURE DEVELOPMENT

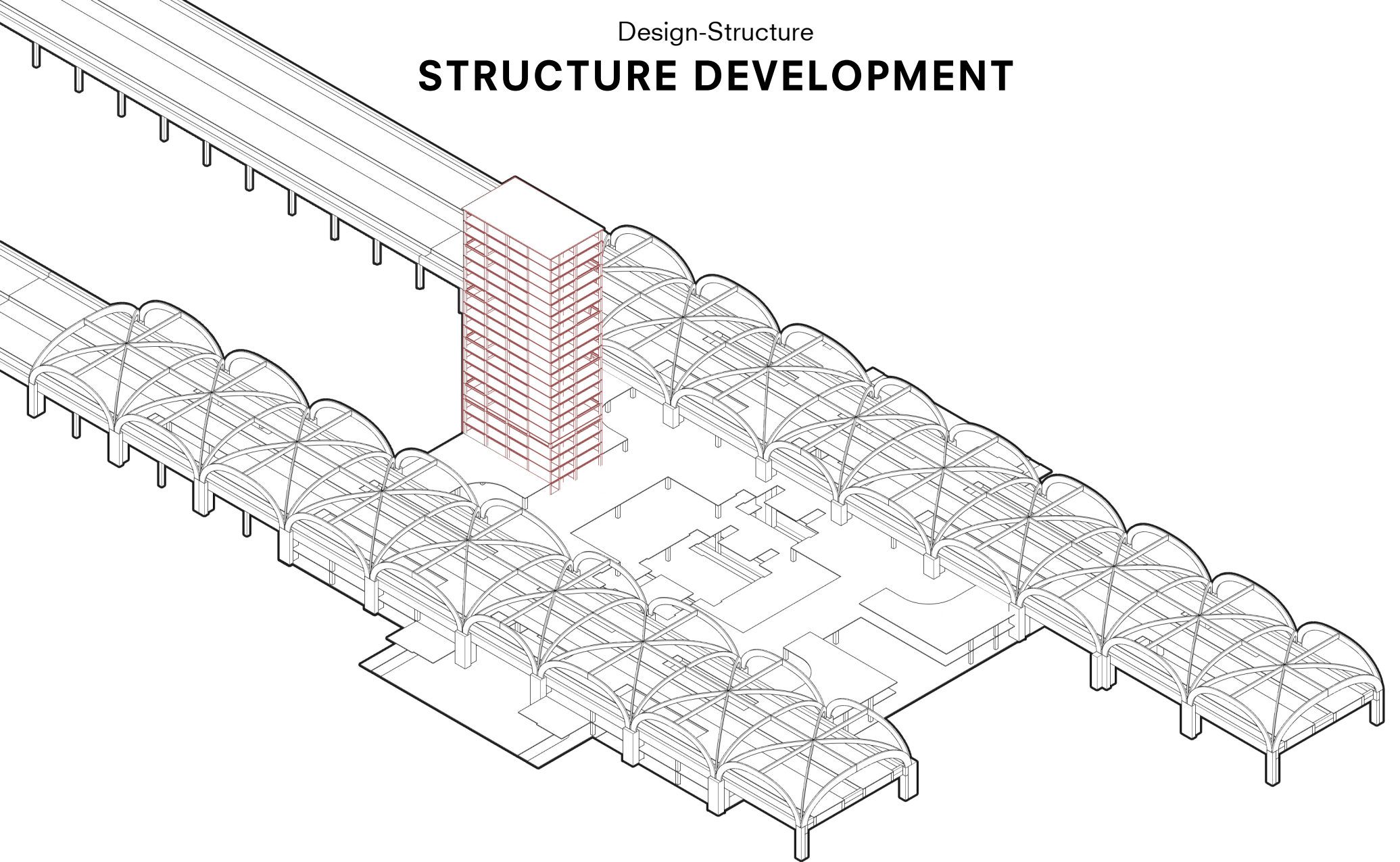

The **Modular Wooden Canopy Structure** Of The Train Station

STRUCTURE DEVELOPMENT

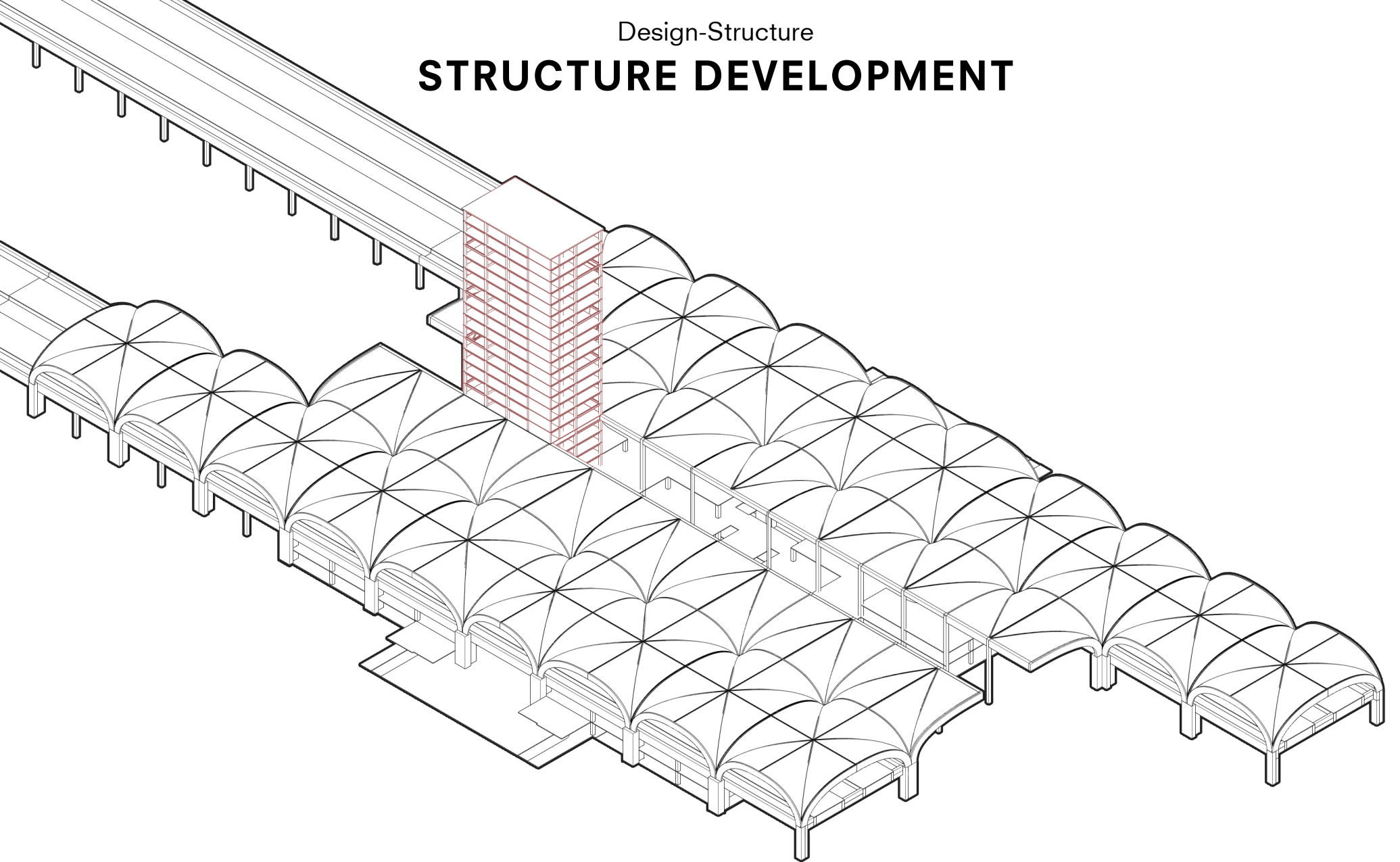

Replicate This Kind Of Structure To Highlight The Building's Entrances

STRUCTURE DEVELOPMENT

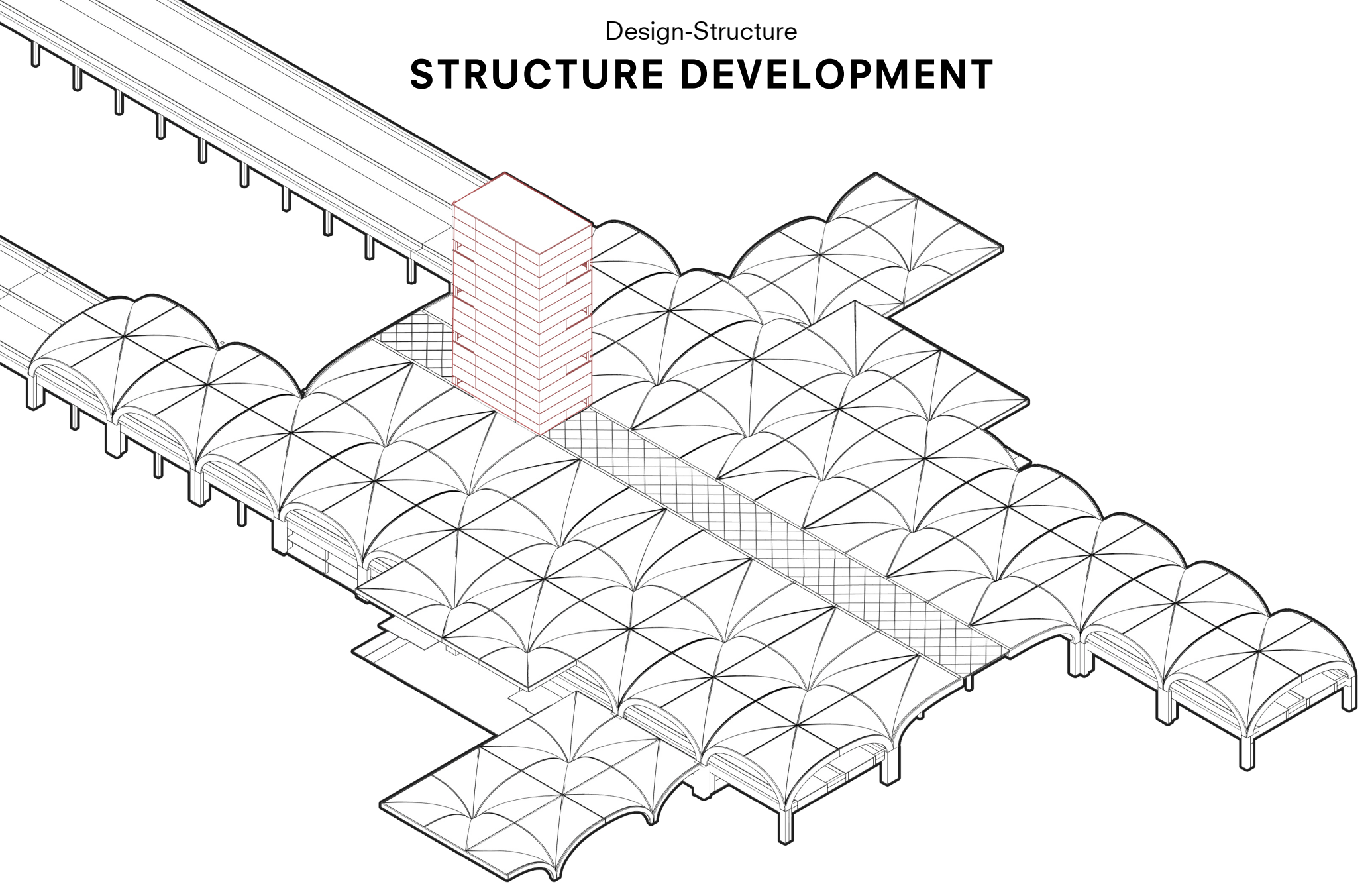

The Roof Along The Central Axis Of The Building Uses **Aluminum-framed glass curtain walls.**

DESIGN CLIMATE

Design-Climat
SKYLIGHT

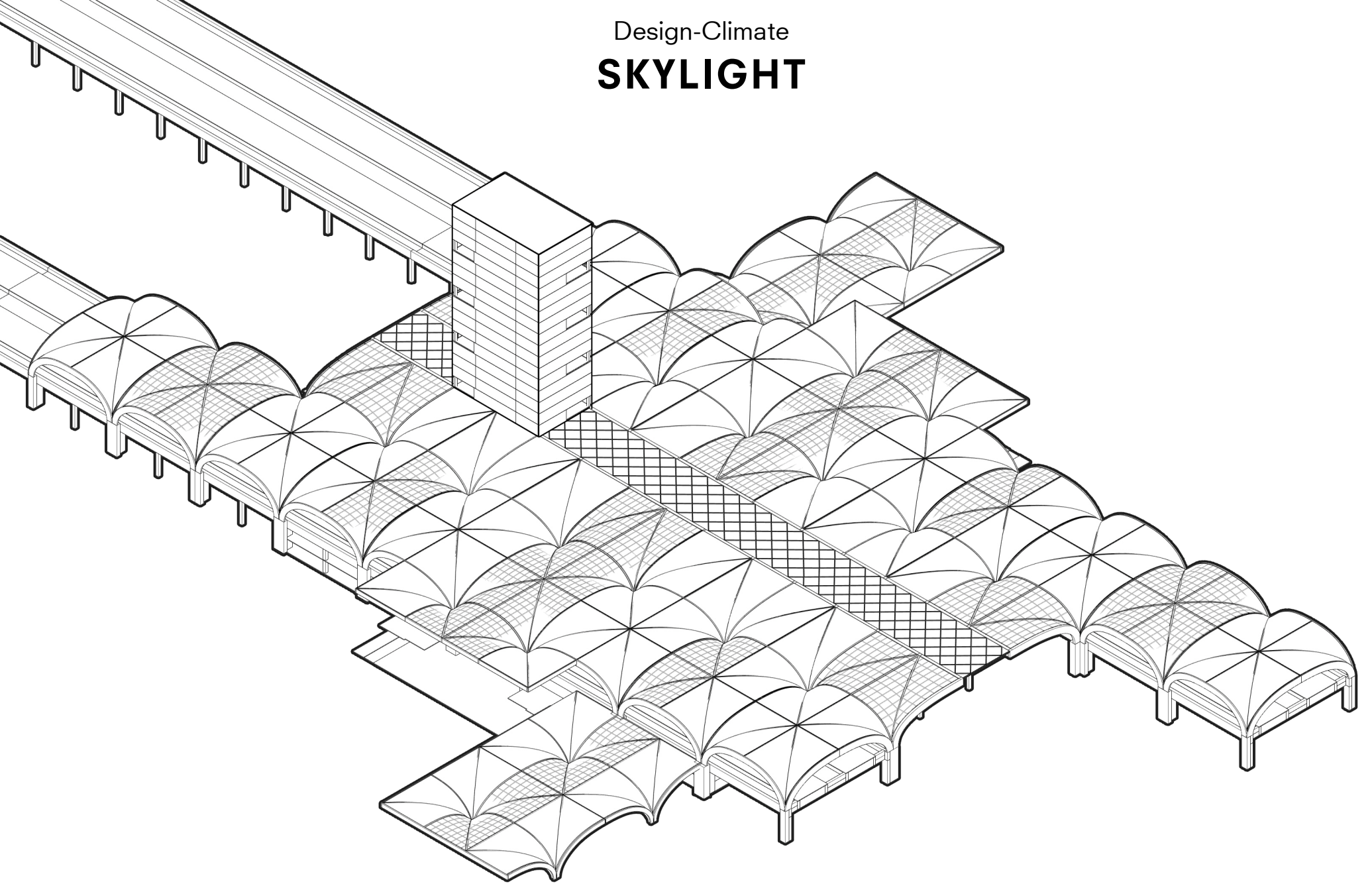

The roof above the main circulation route is made of glass, using natural light to guide movement.

SOLAR PANEL

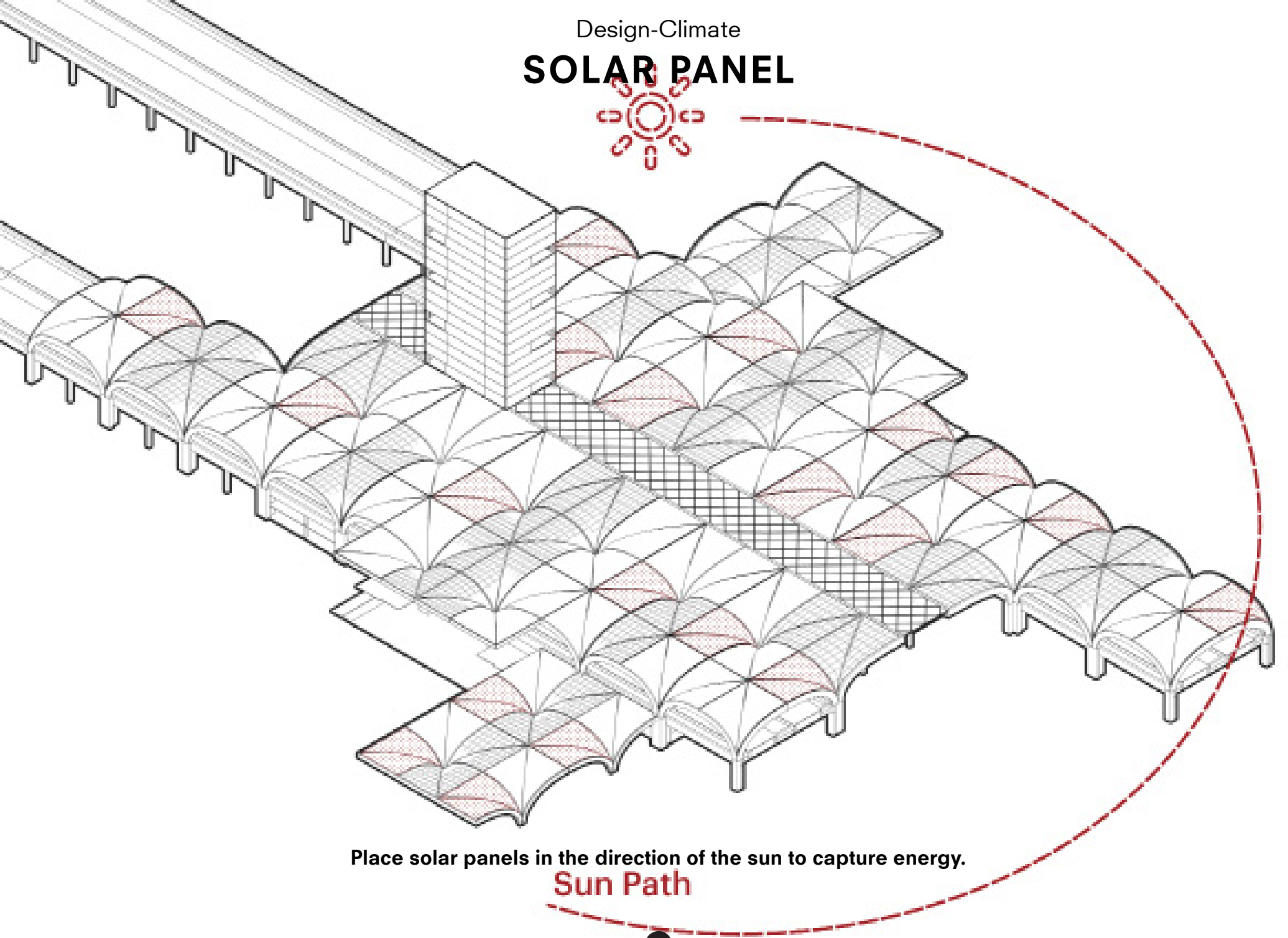

Place solar panels in the direction of the sun to capture energy.

Sun Path

Design-Climate
VENTILATION

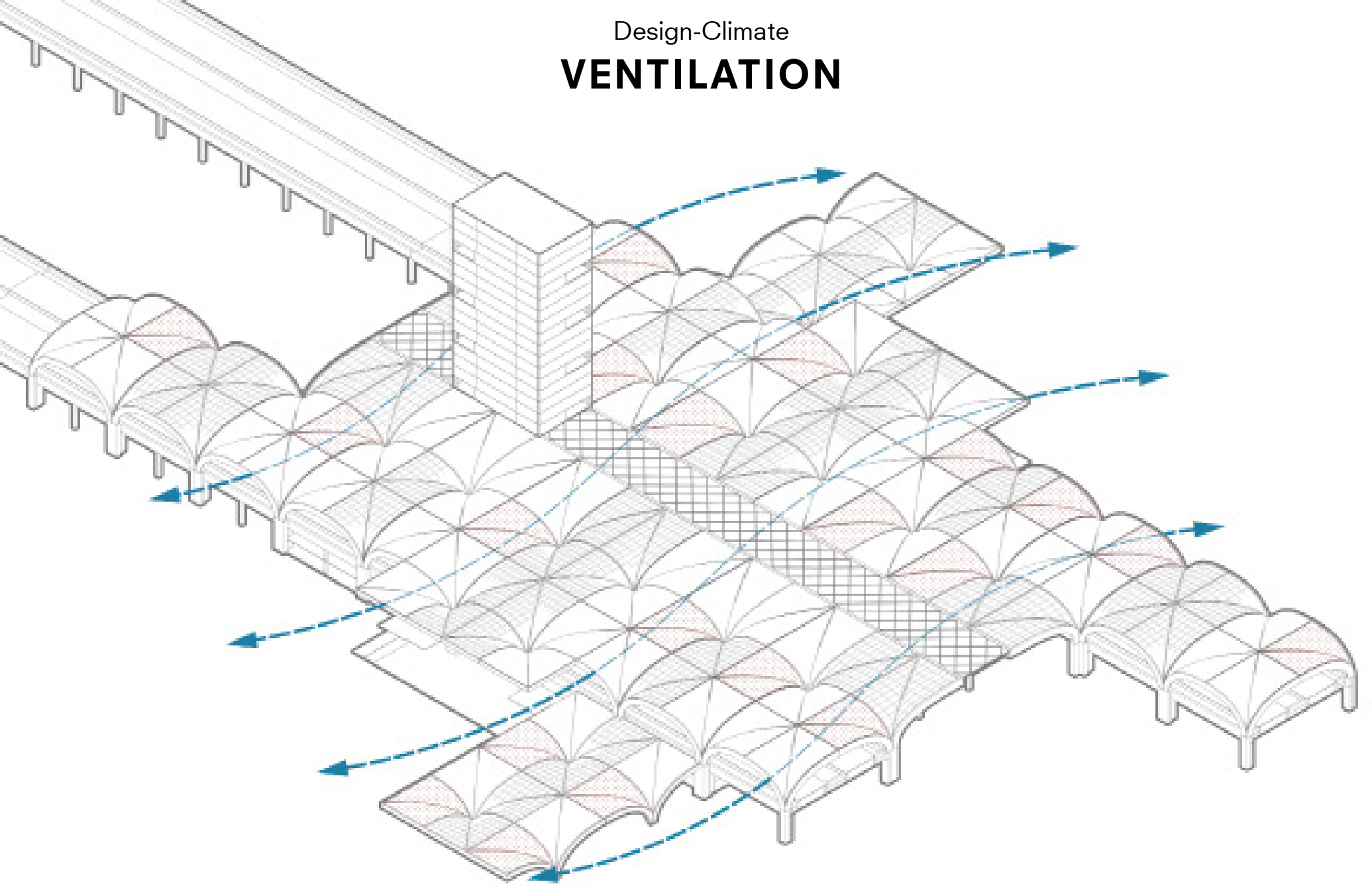

The building itself remains open due to the movement of trains.

RAIN DRAINAGE

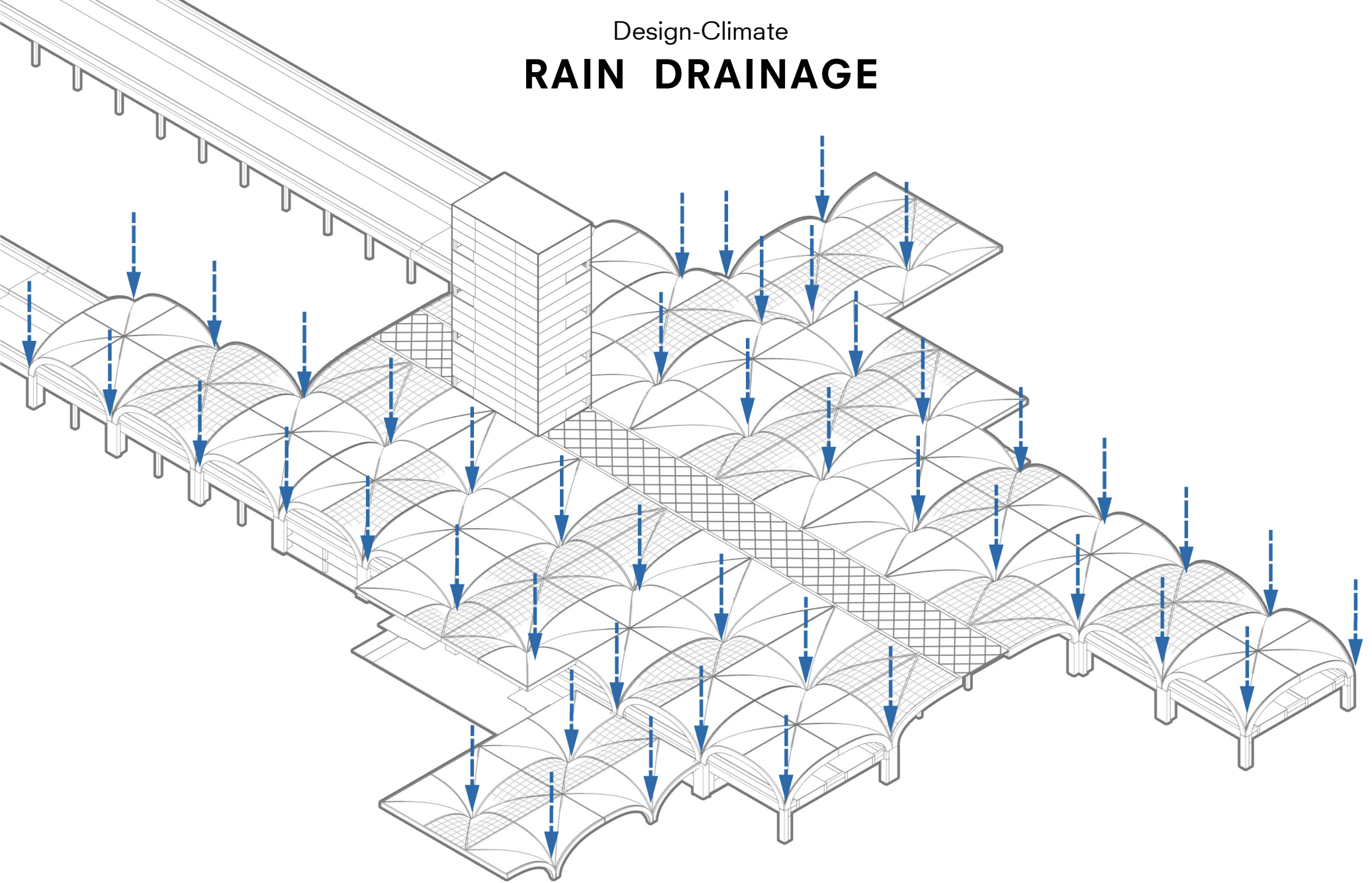

The roof design is great for collecting rainwater

GREENERY IRRIGATION

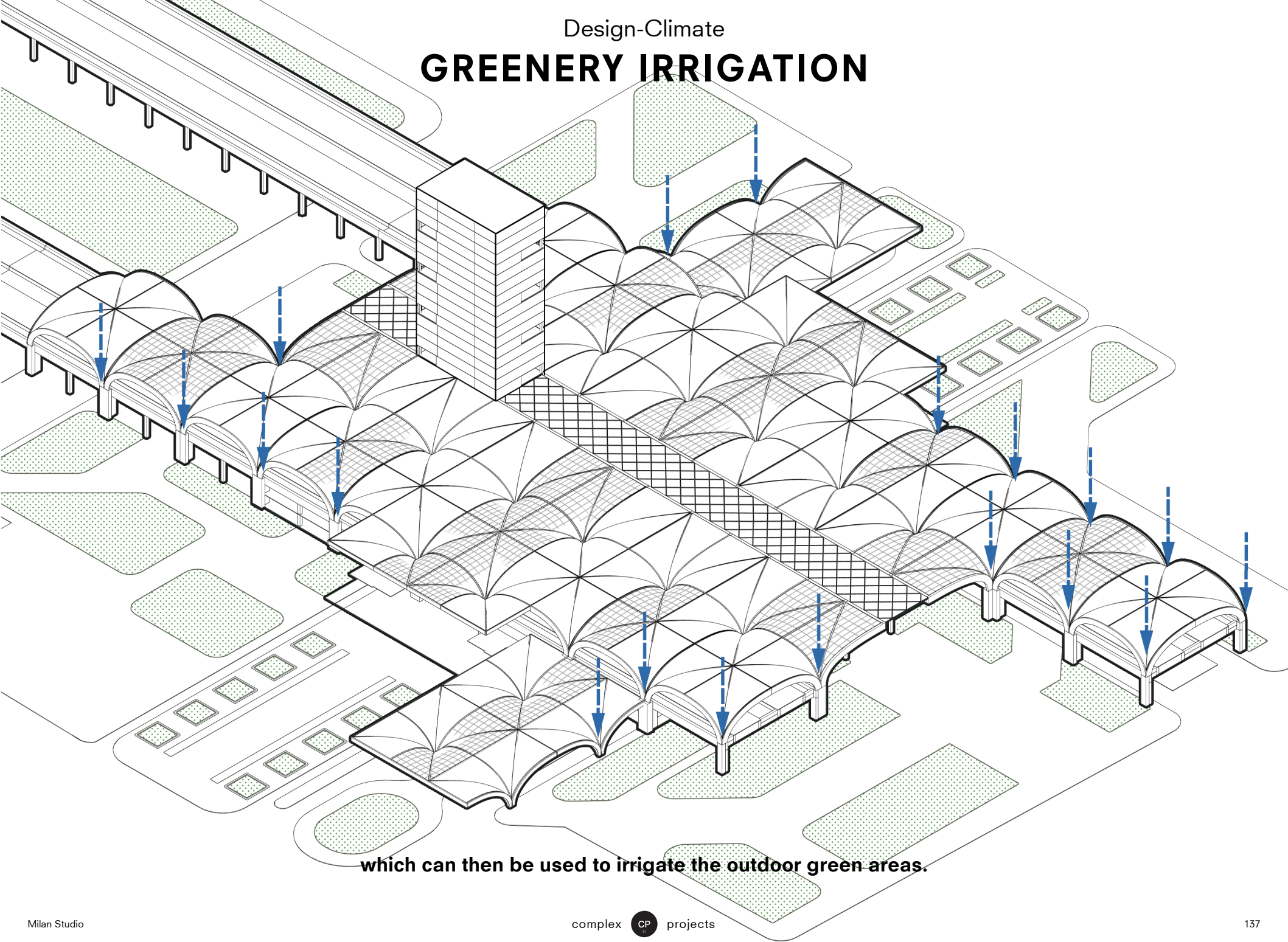

which can then be used to irrigate the outdoor green areas.

DRAINAGE DETAIL

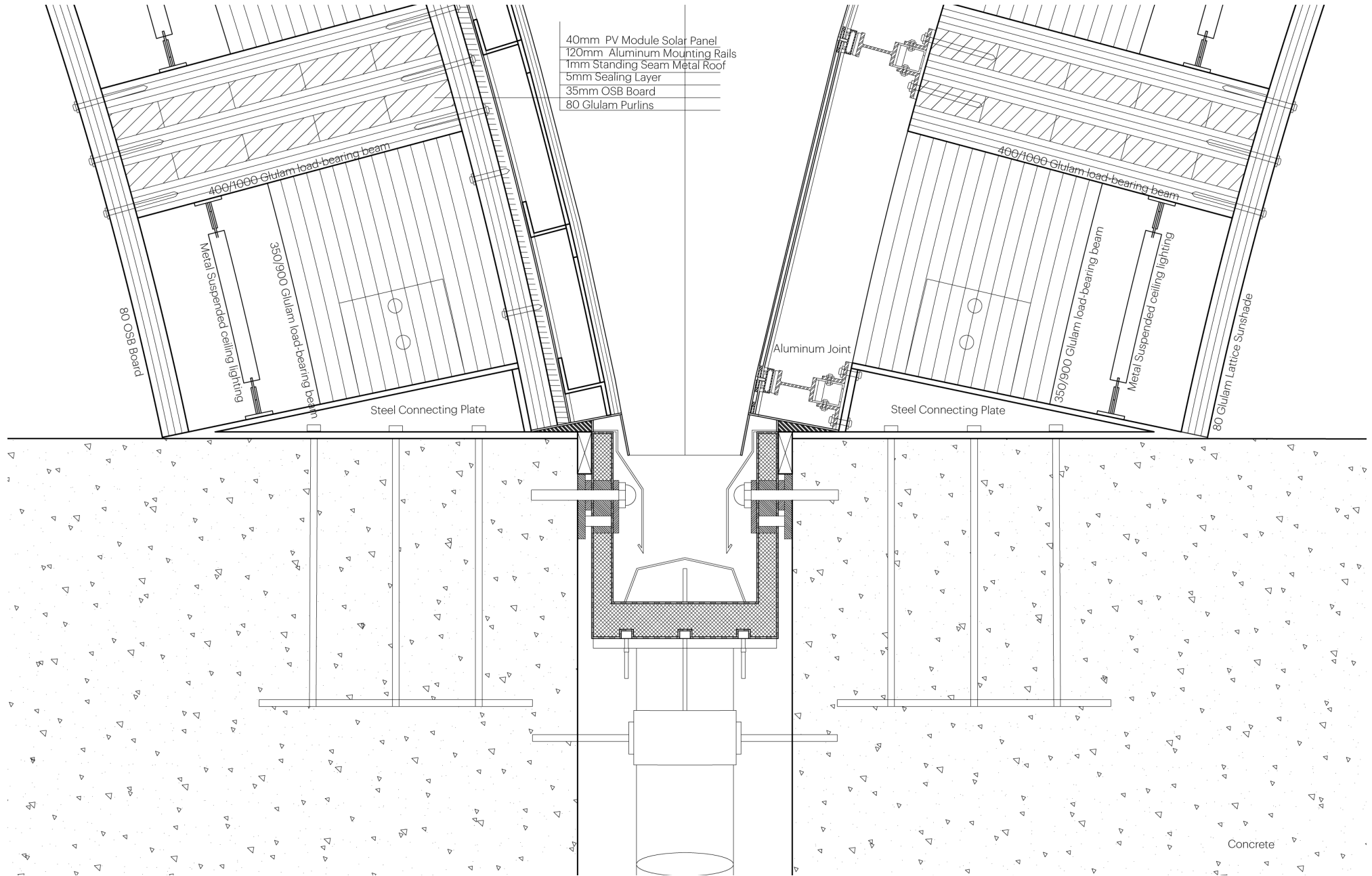

This shows the drainage detail at the junction between two modular roofs.

THANK YOU

REDESIGN MILAN CENTRAL STATION



Qianchen Yan
2/7/2025