

Date 2014
Author Bordogna, G., D.J. Markey, R.H.M. Huijsmans,
Keuning, J.A. and F.V. Fossati
Address Delft University of Technology
Ship Hydromechanics and Structures Laboratory
Mekelweg 2, 2628 CD Delft



Delft University of Technology

**Wind-assisted ship propulsion: A review and
development of a performance prediction program
for commercial ships.**

by

**Bordogna, G., D.J. Markey, R.H.M. Huijsmans,
J.A. Keuning and F.V. Fossati**

Report No. 1925-P

2014

**11th International Conference on Hydrodynamics, ICHD,
2014, Singapore**

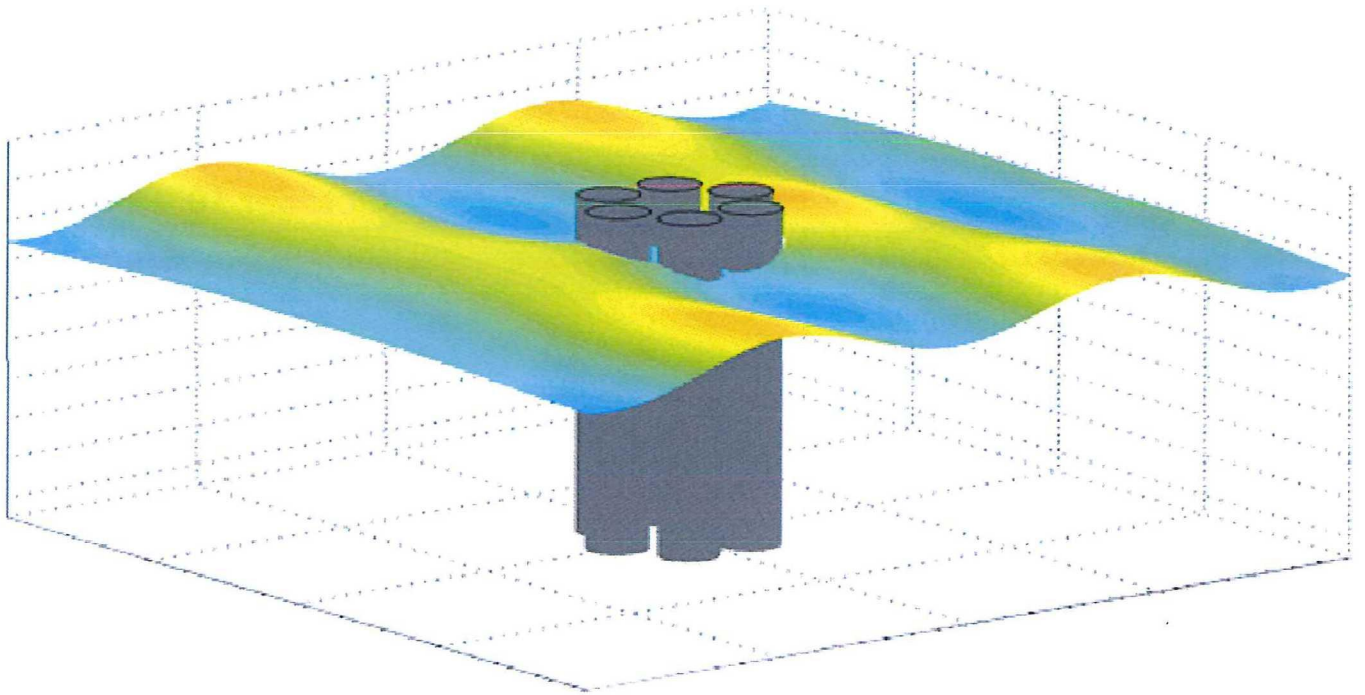

**Proceedings of the 11th International Conference on Hydrodynamics
(ICHHD 2014)**



**19 – 24 October 2014
Nanyang Technological University
Singapore**





Proceedings of the 11th International Conference on
Hydrodynamics (ICHD 2014)
October 19 – 24, 2014
Singapore

Editors:

TAN Soon Keat, WANG Xikun, GHO Wie Min & Joy CHUA

Organised by:

Maritime Research Centre
Nanyang Technological University

Sustainable Earth Office
Nanyang Technological University



Supported by:



Proceedings of the 11th International Conference on Hydrodynamics (ICHD 2014)

E-book

Date of publication: 17 October 2014

Copyright © 2014 by ICHD

ISBN 978-981-09-2175-0

PREFACE

Hydrodynamics has always been an important and fundamental subject for many disciplines involving the science of forces acting on or exerted by fluids, and engineering applications including ship and marine engineering, ocean and coastal engineering, mechanical and industrial engineering, environmental engineering, hydraulic engineering, petroleum engineering, biological & biomedical engineering, and so on. While many engineering questions have been answered, there are still many more that need to be addressed through field trial, verification and fundamental research and development (R&D).

The International Conference on Hydrodynamics (ICHHD) is the forum for participants from around the world to review, discuss and present the latest developments in the broad discipline of hydrodynamics and fluid mechanics. The first International Conference on Hydrodynamics (ICHHD) was initiated in 1994 in Wuxi, China. Since then, 9 more ICHHD conferences were held in Hong Kong, Seoul, Yokohama, Tainan, Perth, Ischia, Nantes, Shanghai and St Petersburg. Evidently the ICHHD conference has become an important event among academics, researchers, engineers and operators, working in the fields closely related to the science and technology of hydrodynamics. We are honoured to organise the 11th ICHHD (ICHHD 2014) in Singapore from 19 to 24 October 2014.

This set of conference proceedings collects all the papers (130+) presented at ICHHD 2014 and covers a wide range of topics, including hydrodynamics of offshore & marine structures, coastal engineering, hydraulic engineering, environmental fluid mechanics, Sustainable Urban Water Environment, Computational Fluid Dynamics, ship hydrodynamics, wave dynamics, tsunami, ocean energy, fluid-structure interaction, etc., on the forefront of hydrodynamics R&D with analytical analysis, experimental models and numerical simulations. The proceedings will be a valuable reference book for researchers, engineers and practitioners working on the field of hydrodynamics.

TAN Soon Keat
WANG Xikun
GHO Wie Min
Joy CHUA

Nanyang Technological University, Singapore
October 2014

EXECUTIVE COMMITTEE

Y.S. Wu (Chairman, China)

S.Q. Dai (China)	S.J. Lee (Korea)
H. Liu (China)	R. Huijsmans (Netherlands)
C. Lin (Taiwan, China)	O.M. Faltinsen (Norway)
J.H.W. Lee (HK, China)	A. Pustoshny (Russia)
Marcelo A.S. Neves (Brazil)	S.K. Tan (Singapore)
X.B. Chen (France)	N. Sandham (UK)
J. Friech (Germany)	G.X. Wu (UK)
S.A. Mavrakos (Greece)	R.C. Ertekin (USA)
C. Lugni (Italy)	C.C. Mei (USA)
T. Kinoshita (Japan)	C. Yang (USA)
M. Kashiwagi (Japan)	S.C. Yim (USA)
Y.H. Kim (Korea)	T.Y. Wu (Honorary member, USA)

INTERNATIONAL SCIENTIFIC COMMITTEE

L. Cheng (Australia)	C. Lugni (Italy)
S.P. Zhu (Australia)	T. Kinoshita (Japan)
S.-Q. Yang (Australia)	H. Tanaka (Japan)
S.Q. Dai (China)	K. Mori (Japan)
D.Z. Wang (China)	Y.H. Kim (Korea)
S.T. Dong (China)	S.J. Lee (Korea)
Y.S. He (China)	R. Huijsmans (Netherlands)
J.H.W. Lee (HK, China)	O.M. Faltinsen (Norway)
J.Z. Lin (China)	C. Guedes Soares (Portugal)
H. Liu (China)	S.K. Tan (Singapore)
C.O. Ng (HK, China)	N.-S. Cheng (Singapore)
B. Teng (China)	Y. M. Chiew (Singapore)
J.F. Tsai (Taiwan, China)	A. Incecik (UK)
Y.S. Wu (China)	S.D. Shao (UK)
K. Yan (China)	Q.X. Wang (UK)
X.B. Chen (France)	G.X. Wu (UK)
P. Ferrant (France)	R.C. Ertekin (USA)
V. Bertram (Germany)	C.C. Mei (USA)
J. Friech (Germany)	P.L.F. Liu (USA)
S.A. Mavrakos (Greece)	T.Y. Wu (USA)
V. Sundar (India)	C. Yang (USA)
P. Cassella (Italy)	S.C. Yim (USA)

LOCAL ORGANISING COMMITTEE

TAN Soon Keat, MRC, NTU (Chairman)
CHUA Lian Heong, Joy, SEO, NTU (Secretary)
Adhityan APPAN, IES, Singapore
CHENG Nian-Sheng, NTU
CHIEW Yee Meng, NTU
Tom FOSTER, DHI (S)
GHO Wie Min, MPR, Singapore
HUANG Zhenhua, NTU
LIONG Shie-Yui, TMSI, NUS
Daniel Zhang, SMI, Singapore
Alfred WONG, IES, Singapore
ZHANG Xiaoli, BCA, Singapore
Subrata CHANDA, MOT, Ngee Ann Polytechnic
Arun Kr DEV, MAST, Newcastle University (Singapore)
Tommy WONG Sai Wai, MRC, NTU
WANG Xikun, MRC, NTU
GAO Yangyang, MRC, NTU
Aziz Merchant, KOMTech, Singapore
DAI Ying, MRC, NTU (Secretariat)
LE Tuyet Minh, NEWRI, NTU (Secretariat)



List of Paper IDs and Titles

Keynotes	
Paper ID	Title
K1	Hydrodynamics of marine and offshore structures
K2	Recent progress in CFD studies associated with naval architecture and ocean engineering
K3	Environmental hydraulics of chlorine disinfection for the Hong Kong Harbour Area Treatment Scheme
K4	Multi-physics and multi-scale modeling for eco-environmental characteristics of coastal water
K5	Catastrophic Tsunamis and hurricanes in the last decade
K6	Development and applications of the homotopy analysis method
K7	Two ISPH modeling techniques in hydrodynamics: coastal and river simulations
K8	Non-spherical multi-oscillations of a bubble in a compressible liquid
Session Papers	
Paper ID	Title
#2	Flow structure and hydrodynamic forces of a near-wall cylinder of different cross-sections
#3	Basic Performance Checks of Twelve-Wire Probe
#5	Natural Convection in a Vertical Polygonal Duct With Both Walls Exhibiting Superhydrophobic Slip and Temperature Jump
#6	The use of coarse sediment transport hydraulics to estimate the peak discharge of catastrophic floods
#7	Flow Behavior around a Coated Pipeline Embedded Partly in a Permeable Seabed
#8	Flow field and density variation for an internal solitary wave evolution over a trapezoidal topography
#11	Transversal internal seiches in basin of variable depth and continuous stratification
#12	Prediction of Steady Performance of Contra-Rotating Propellers including Wake Alignment
#13	Using specialized natural condition maps and hydrodynamical simulation results to be based on marine spatial planning of Phu Quoc – Con Dao Islands areas
#14	Identification speed of sea level rise at observed stations in Eastern and Western coast of Vietnam Southern Part
#16	Numerical Modelling of the Circulation Flow Movement of the Zhoushan LNG Berth and Improvement Scenarios
#17	Numerical Simulation on Coupled Effect between Ship Motion and Liquid Sloshing under Wave Action
#20	Wave drift forces estimation for the preliminary design of dynamic positioning systems
#21	Comparison of different scaling methods for model tests with CLT propellers
#23	Dimension control of the ventilated supercavity in the maneuvering motion
#24	Hydrodynamic analysis on the typical underwater gliders
#25	Numerical study of wave interaction with two bodies in close proximity

#26	Rudder-propeller interaction: Analysis of different approximation techniques
#27	Simulating Flooding in Complex Underground Spaces with GPU-based SPH Method
#29	Effects of the vertical launching parameters on the underwater vehicle movement
#31	The response of hydrodynamics to Caofeidian Project in 2012
#33	Application of different design and analysis tools for a propeller in axial cylinder
#35	Analysis on wave actions on two closely spaced floating boxes
#37	Numerical and theoretical analysis on the collapse effect of the partial cavitation around decelerating underwater vehicle
#39	Computing the free surface hydrodynamic coefficients of high speed blended wing body vehicle based on semi-relative reference frame and implicit VOF method
#40	Study On The Reverse Advancing Collapse Phenomenon At Cavitation Bubbles Closure In Underwater Vertical Launching Process
#42	Numerical simulation for unsteady propeller performance with inclined shaft propeller arrangement using CFD
#43	Influence of different gas-injection conditions on ventilated cloud cavitation
#44	Significant Wave Height Retrieval from Synthetic Radar Images
#46	Numerical Study on Open-Channel Bifurcations with Topographic Obstacles
#47	Modelling harbour resonance with an improved open boundary condition
#48	A practical system for hydrodynamic optimization of ship hull form using parametric modification function considering operational condition
#49	Lagrangian particle simulation of lock-exchange flow
#51	Hydroelastic investigation on floating body near islands and reefs
#52	Higher order synchronization outside primary lock-in of circular cylinder oscillating in streamwise
#53	Numerical Simulation of Dam Breaking Flows by Overlapping Particle Method
#54	Parallel MPS Method for 3D Wave-body Interaction Flows
#55	Partial validation and verification of the Neumann-Michell Theory of ship waves
#63	Cavitating Flow Simulation with Mesh Development using Salome Open Source Software
#65	Computational analysis of contra-rotating podded propulsors using a hybrid RANSE/BEM model
#66	PIV Measurements of Wake Flow Characteristics behind a Rotating Cylinder
#67	A Generalized 3D Numerical Wave Tank for Practical Wave-Structure Interactions in Steep Waves
#68	The development of shoulder cavitation when a vehicle flying through water surface
#69	Convective instability and diffusion in isothermal ternary gas mixtures at various pressures and viscosity
#70	Experimental study on dynamics of buoyant jets and plumes in linearly stratified environment
#72	Cross-flow transverse force and yaw moment on a semi-displacement vessel with forward speed and drift angle
#73	Evaluation of roll damping for PCTCs considering the center of roll motion
#74	Theoretical and Numerical Analyses of the ventilation mass's similarity for finite-length cavities based on volume criteria
#75	One numerical approach on the ventilated cavitating flow with the two-fluid multiphase flow model

#77	The Radiation Hydrodynamics Equations and the developed Program coupled Neutron Mass Transport Effect
#78	Simulation of a fast speed boat motion in regular waves with help of CFD
#81	A Numerical Study of Flexible Hydrofoil in Water Tunnel
#86	Cavitation performance of exposed bolt head fastener configurations
#87	Numerical Analysis on the Wind Pressure Characteristics of Combinatorial Hemisphere
#88	Effect of regular seabed shape on the pressure distribution below hull bottom
#89	Three-dimensional numerical modeling of wind-driven circulation in the Taihu Lake
#91	Causal Representation of Wave Forces For Time-Domain Simulation of Maneuvering And Seakeeping Problems
#93	Effect of Propeller Wash on Distribution of Natural Sedimentation around the Marina Bay Cruise Centre in Singapore
#94	Analysis of fule tank baffles to reduce the impact generated from liquid sloshing
#96	Moisture Content Limit of Iron Ore Fines for the Prevention of Liquefaction in Bulk Carriers
#97	Studies on hydrodynamics and modeling for a supercavitating body in transition phase
#100	Simulation of Parametric Roll by Using a Semi-Analytic Approach
#101	Experimental Study on Added Resistance for Different Bow Shapes of KVLCC2
#103	Aero-hydroelastic instabilities on an Offshore Fixed-Bottom Wind Turbine in severe sea state
#105	Wave interaction with floating flexible circular cage system
#110	Trapping of surface waves by a submerged trapezoidal breakwater near a wall
#111	A Cavitation Aggressiveness Index (C.A.I) within the RANS methodology for Cavitating Flows
#113	A time domain panel method for the prediction of nonlinear hydrodynamic forces
#114	A Propeller Design Procedure Considering the Interaction between Ship Hulls and Propulsion Devices
#115	Development of the Horizontal Axis Marine Current Turbine Blade Design Procedure
#116	Sigma-ZED: A Computationally Efficient Approach to Reduce the Horizontal Gradient Error in the EFDC's Vertical Sigma Grid
#119	Measurement of velocity field around a circular cylinder near plane boundary undergoing vortex-induced vibration
#123	Shear stress acting on the bed with vertical circular cylinders in open-channel flow
#124	Calibration of MEMS Shear-Stress Sensors Array in Water Flume for Underwater Applications
#125	A combined viscous and potential method for the computation of added resistance in head waves
#126	Hydroelasticity analysis of ships in waves
#127	The base ratio perturbation on transient waves in a 3D regular tank due to oblique horizontal excitation
#128	Numerical and semi-analytical methods for optimizing wave energy parks
#129	Experimental study of drag reduction on rough cylinders
#130	Force and flow characteristics of a circular cylinder with grooved surface
#131	Hydrodynamic Optimization of a TriSWACH
#132	Natural frequency of 2-dimensional horizontal cylinders heaving on free surface
#133	The combining effects of inlet guide vanes and blade setting angles on performance of axial-flow pump system

#136	The characteristic analysis of propeller disturbed flow field
#137	Numerically Calculating Method for the Unsteady Hydrodynamic performance of Podded Propellers
#138	Probability Sensitivity Analysis of Extreme Second-order Roll Motion Predictions for A Turret Moored FPSO
#139	Utilizing CFD as a tool for sump model design
#141	Added Mass and Damping Coefficients for a uniform flexible barge using VoF
#142	Design and Analysis of a Flow-through Bag Aquaculture System
#147	A model for inhomogeneous oscillations near the stopping angle in an inclined, granular flow
#151	Numerical simulation of two-phase flows with the Consistent Particle Method
#154	Recent advancement in Tendon Technology for Deepwater Application
#156	Challenges and potential of extended tension leg platform in ultra-deepwater
#157	The New Generation Semi-Submersible Drilling Tender (SSDT)
#158	Performance Analysis of Massively-Parallel Computational Fluid Dynamics
#160	Tidal-and density-driven flows in submerged vegetation
#162	Prediction of Responses of Floating Production Systems using the Multi Gaussian Maximum Entropy Method
#163	Drag Reduction in Water by Superhydrophobicity Sustained Leidenfrost Vapor Layers
#165	Simulating water waves generated by underwater landslide with MPS and WC-MPS
#166	Modelling of oil-water flow patterns and pressure gradient in horizontal pipes
#167	Oil Recovery Enhancement via Different Gas Injection Scenarios in Fractured Reservoirs
#168	Dynamics of slurry setting during land reclamation
#171	Study on the Destruction of Tip Vortex Cavitation on Propeller of 13,000 TEU Class Container Vessel
#172	E-SEMI - Feasible Solution for Dry Tree Application in Deepwater
#173	Review of Riser Techniques for Deepwater Application
#174	Experimental Study on Live Load Dependent Hydrodynamic Behavior of Floating Body
#175	Wind-assisted ship propulsion: A review and development of a performance prediction program for commercial ships
#177	Investigation on three interacting pipe jets at inclination angle of 30 degree
#178	Experimental Study of Cavitating Flow inside Diesel Nozzles with Different Length-Diameter Ratios Using Diesel and Biodiesel
#179	Investigation of the internal flow and spray characteristics from diesel nozzle with different needle shapes
#182	Transformation of representative wave heights using parametrical wave approach
#184	Numerical simulation of the energy dissipation failure of the aqueduct free overfall
#185	Airgap Calculation and the Effects of Wave Diffraction and Higher Order Waves
#197	The High-Order Path-Conservative Scheme for A Saurel-Abgrall Model of Compressible Non-Conservative Two-Phase Flow
#198	An operational approach for the estimation of a ship's fuel consumption
#199	Nonlinear Dynamic Analysis of SCR with Effects of Hysteretic Seabed
#201	Steadily translating Green function with viscosity and surface tension effects

#203	Vibration response analysis of an underwater submersible
#205	Experimental and numerical analysis of two-dimensional steady-state sloshing in a rectangular tank equipped with a slatted screen
#207	Methodology for the ship to ship hydrodynamic interaction investigation applying the CFD methods
#208	The Experiment Investigation of Large Scale of Turbulent flow in the Channel Bottom Layer Using DPIV
#209	To investigate the techniques of gas bubble detection in pore water for shallow subsoil conditions
#210	Physical hydraulic modelling of controlling foaming at cooling water outfall



WIND-ASSISTED SHIP PROPULSION: A REVIEW AND DEVELOPMENT OF A PERFORMANCE PREDICTION PROGRAM FOR COMMERCIAL SHIPS

G. BORDOGNA, D.J. MARKEY, R.H.M. HUIJSMANS, J.A. KEUNING

*Section of Ship Hydromechanics and Structures, Delft University of Technology, Mekelweg 2
Delft, 2628 CD, The Netherlands*

F.V. FOSSATI

*Dipartimento di Meccanica, Politecnico di Milano, Via la Masa 1
Milan, 20156, Italy*

In this paper the state-of-the-art on wind-assisted propulsion for commercial ships is presented. The review shows that, albeit a considerable amount of research has been carried out over the years, there is still a substantial lack of knowledge on the actual performance of wind-assisted ships. Especially the aerodynamic interaction effects of wind propulsion systems as well as the hydrodynamic phenomena heel, leeway, sideforce and yaw balance are often simplified or neglected. A performance prediction program is presented and it aims to be a versatile design tool to better evaluate the use of wind energy as an auxiliary form of propulsion for commercial ships.

Introduction

The shipping industry is highly influenced by the omnipresent rise of the oil price and the increasing awareness towards environmental issues.

The high fuel consumption and accompanying emissions of ships ensure that innovative solutions need to be found. The maritime sector puts much emphasis on reducing fuel consumption and this is usually done by employing already existing standard practices such as hull-propeller optimisation and engine improvements.

However, in recent years, also due to the ever stricter regulations regarding the reduction of emissions, major improvements towards sustainable ships are sought. The possibility to employ wind energy as an auxiliary form of propulsion for commercial ships has again become of great interest and might be a viable alternative in the near future.

In this paper the state-of-the-art on the concept of wind-assisted ship propulsion is presented. It appears that most of the research carried out on this topic focusses more on the operational feasibility of wind-assisted propulsion rather than addressing the complex scientific novelty that such a concept involves. The physical aspects related to the prediction of the performance of a wind-assisted ship, which is the first and essential step necessary for a sound operational evaluation, are generally oversimplified.

The possible savings, both in terms of cost and pollution emissions, by exploiting wind energy, can only be assessed with the support of a versatile and reliable tool capable of predicting the performance of wind-assisted ships.

The characteristics of such a performance prediction program are outlined in this paper by drawing a parallel with the velocity prediction programs used in the field of sailing yachts. This is done to gain a better understanding of the suitable calculation methods which can ensure fast, yet reliable results for a generic wind-assisted ship. In this paper, particular emphasis is given to the aerodynamic and hydrodynamic challenges that need to be tackled.

State-of-the-art

The possibility of using wind-assisted propulsion as an actual alternative for conventional ship propulsion arose to the surface during the oil crisis in the seventies, making it a popular research topic in the 1980s. This resulted in the Comsail [60], WindTech [61] and BWEA [37] symposia. Most papers in that time focussed on the operational challenges of wind assist, such as the practical and economic viability of the concept. An overview of the scientific developments on the physics of wind assist is presented below.

A lot of effort was made into discovering possible wind propulsion systems to use. The potential of the kite [6] and the new Lj-rig [20] was investigated using some simple formulations. The wing sail [28], the wind turbine [3] and the Turbosail [8] were investigated using wind tunnel experiments.

Comparison studies were performed by Nance [55] who stated that especially the lack of data was a concern. Later Clayton [9] performed a preliminary research study on the wing sail and the Flettner rotor using wind tunnel tests. Palmer [57] did full scale measurements on different soft-sail rigs. Finally Palmer [21] performed an elaborate comparison of the performance of five different rigs: Prolls rig (the precursor of the Dynarig), wing sail, Flettner rotor, wind turbine and kite.

The study of the aerodynamics of different wind propulsion systems has to be combined with the hydrodynamic phenomena to arrive at an equilibrium position. At that time, the balance calculations were generally performed for a specific ship while drastically simplifying the physics. The results however were used to assess the general performance of wind-assisted ships.

The performance of a wind turbine placed on a trimaran [35] and on a small cargo ship [59] was calculated using an analytical wind turbine theory. To retrofit a chemical tanker, Firestein [12] investigated a wing sail design using lifting strip theory. A more basic model was applied by Fiorentino et al. [11], who calculated a thrust reduction for different wing sails and then applied it for a specific voyage. Bradbury [36] used experimentally-derived aerodynamic coefficients on graduated trim of wing sails to apply it on a specific ship. Ingham and Tersløv [17] combined wind tunnel and manoeuvring tests to estimate the mean reduction in power consumption for a wing sail arrangement installed on a bulk carrier.

Schenzle [63] realised the necessity of a thorough service speed prediction before any economical assessment of different systems would be relevant. For this he improved the very first computer program to predict sailing service speed of wind-assisted ships by Wagner [76]. While Schenzle's method was based on experimentally derived hydrodynamic and aerodynamic coefficients, Shaefer and Allsopp [64] identified the need to use dimensionless parameters, for which he used some basic calculations to arrive at a kite/hull performance chart.

A more analytical approach, namely the Linear Windship Theory, was developed by Satchwell [23] to describe principal non-dimensional coefficients: the effective power coefficient and the effective drive coefficient. Later Satchwell [62] used this to optimise the design of various wind propulsors. Also Schenzle [24] used a mathematical parametric model to calculate an average propulsive force. He then combined this with different wind propulsors to arrive at a non-dimensional performance ratio of power and force per unit sail area.

Bergenson and Greewald [2] summarised six years of analytical and experimental developments on wind-assisted propulsion supported by the US Maritime Administration. They showed the feasibility of multiple rigs on conventional ships from a performance and economic perspective. Also Palmer [57] used his performance calculation of three wind propulsion systems (Sprit sail rig, Flettner rotors and multi-wing sails) to arrive at costs per unit area of each system.

The research focus was mainly on the aerodynamic part of the force balance. Often the aero-hydrodynamic force balance was limited to basic relations. One of these relations was improved by the research of Wilson [30] who reviewed the methods of added resistance of ships in a seaway such that a more detailed resistance investigation would lead to a better estimation of power requirements.

The new hydrodynamic phenomenon of leeway on a wind-assisted ship was investigated by Bradbury [4] using flow visualisations experiments as well as a systematic series of hull-like blocks to arrive at the influence of parameters such as beam, draft and trim on the performance of the ship. Another important phenomenon, namely the yaw balance, was investigated by Skogman [25]. Finally Molland [52] investigated the effect of wind-assisted ship propulsion on the efficiency of propellers and machinery operation.

In 1986, Satchwell [74] performed a preliminary analysis of real life log data and eight years later, in 1994, Lambrecht et al. [19] investigated wind-assisted ship propulsion applied to standard tankers using wind tunnel and towing tank experiments.

After these symposia the interest in wind-assisted ship propulsion faded out due to the sudden oil price drop, the discovered complexity of the subject and the lack of a strong awareness towards the environment.

In the years 2000, however, the interest started to pick up again with the prospect of a sail-assisted fishing boat [32]. Wind-assisted ship propulsion then came back in the picture when Fujiwara et al. [42] presented the development of a new wind propulsor, namely the hybrid-sail with square soft sail. Minami et al. [51] also investigated the effect of an underwater fin arrangement on steady sailing characteristics of a wind-assisted ship.

This work was followed by research investigating the hull-hull and hull-sail interaction ([14]), where the importance of interaction effects was showed. Fujiwara et al. [15] also looked at the performance of a hybrid-sail assisted bulk carrier and actually investigated in more detail some of the many complex hydrodynamic phenomena involved in wind-assisted propulsion.

More recently the high oil price and especially the emission regulations again fuelled the research interest in wind-assisted ship propulsion. Burden et al. [69] did a preliminary but broad analysis on a fast sail assisted feeder container ship. In the same manner all kind of performance evaluations occurred for specific wind propulsor systems, like the wind turbine [34], the Flettner rotor [67], the kite [53] and [31], the Dynarig [66] and the wing sail [56]. The obtained results are then always applied to a specific ship in a simple manner. Smith et al. [65] described an analysis process to fairly evaluate the performance of a wind-assisted ship using wind tunnel and CFD calculations to arrive at both aerodynamic and hydrodynamic performance results.

Concluding the state-of-the-art of the wind assist concept, the following remarks can be made. From an aerodynamic point of view, the complex interactions between multiple propulsors mounted on the deck of the ship and the interaction between the propulsors and the ship itself are always neglected. From a hydrodynamic perspective the equilibrium equations are approached in a very basic way and the effects of heel, leeway and the yaw balance on the overall performance of the ship are estimated either with simple formulations or not taken into account at all. The experience gained over the years in the field of sailing yachts as well as the results presented by Fujiwara et al. [14], show that neglecting these phenomena leads to an unrealistic simplification and therefore unreliable results.

Performance Prediction Program

The development of practical and commercially viable wind propulsion systems to partially or fully propel a ship is nowadays hampered by the difficulties of modelling the sophisticated aerodynamic and hydrodynamic aspects involved.

The use of wind propulsion systems to transform wind energy into forward thrust results in the introduction of accompanying aerodynamic forces that need to be balanced by the corresponding hydrodynamic forces. The solution of this equilibrium needs to be found for several weather conditions (i.e. several true wind angles and true wind speeds).

The output of the computation is the forward speed of the ship. It is worthy to note that, in the case of wind-assisted ships, the additional wind-generated forward speed can be used in two ways. On one hand it can be used to increase the operational speed of the ship. On the other hand the use of the main engine can be decreased while the ship maintains its original operational speed. The latter solution is generally considered the most interesting from an operational perspective.

In the field of sailing yachts an analogue situation is found. Velocity prediction programs are in fact used to solve the equilibrium between the aerodynamic and hydrodynamic forces [38]. Such programs make use of semi-empirical formulas to calculate the forces. The Delft Systematic Yacht Hull Series ([43] and [47]), and the Hazen/IMS model [70] are well-established examples. This methodology appears to be very suitable for wind-assisted ships. It in fact ensures to obtain sufficiently accurate and quick results for any ship whose main characteristics are within the envelope of the experiments on which the regression formulas have been built on.

However, the difference in hull form, operating profile and aerodynamic phenomena involved, calls for the development of new and more suitable formulas particularly tailored for wind-assisted ships.

Similarly to velocity prediction programs, the performance prediction program is intended to be used as a design tool to give the user the opportunity to explore different design possibilities in a quick and straightforward

manner. This calls for a program which handles the difficult trade-off between generality and accuracy. The user in fact should be able to obtain a reliable indication for the solution which best fits his needs. Whenever necessary, data obtained externally by means of CFD computations and experiments can be used in the program. This means that, by using more refined data externally provided, the program can be used throughout the entire design loop: from a first estimate calculation to the final design.

Aerodynamic aspects of wind-assisted ship propulsion

To make the performance prediction program a versatile design tool, the users should have the possibility to evaluate designs which employ different types of wind propulsion systems. Several types of propulsors have been proposed over the years. Arguably, the most common are the Dynarig, the Flettner rotor, the Turbosail, the kite, the wing sail and the wind turbine.



Figure 1. Render of the Ecoliner equipped with Dynarigs. Dykstra Naval Architects.

There have been several studies on the aerodynamics of the propulsion systems mentioned above. In particular on the Turbosail [8], on the Flettner rotor [2] [18] [27] [10] [68], on the wind turbine [3] [34], on the wing sail [26] [44] and on the kite [53] [54]. These studies however always concerned a single propulsor. An exception is the Dynarig, for which wind-tunnel tests and CFD calculations have been performed also considering multiple rigs ([58] and [40]).



Figure 2. "E-Ship 1" of Enercon equipped with Flettner rotors (picture by Carschten).

When multiple propulsors are installed on the deck of a ship, it is a common practice to simply multiply the aerodynamic forces generated by the single propulsor by the number of propulsors installed. Some examples can be found in [34] and [67]. To obtain reliable aerodynamic forces and thus an accurate evaluation of the performance of a wind-assisted ship, the interaction effects need to be taken into account. This is not true for the kite as it flies above the deck of the ship.

The interaction effects that occur on board of a wind-assisted ship can be divided into two categories: the interaction between several propulsors mounted on the deck of a ship and the interaction between the propulsors and the ship itself. These effects mainly concern the following phenomena:

1. Reduction of the incoming flow velocity.
2. Change of the flow angle of incidence caused by the downwash.
3. Generation of turbulence.

The first two effects can be associated with the production of lift, while the third effect can (primarily) be associated with drag. The main effect of the drag-generated turbulence on the velocity field is the reduction of the flow velocity. Therefore, it can be assumed that the interaction effects alter the velocity field mainly in two ways: reducing the incoming flow velocity and changing the incoming flow angle of incidence.



Figure 2. "Alcyone" of Cousteau equipped with Turbosails (picture by Entomolo).

The majority of the wind propulsion systems that have been considered possible candidates for wind assist may be deemed to work on the same fundamental principles, i.e. they are primarily lift generators. The wind turbine and the kite need to be treated differently. The former because of its rotatory motion while the latter can be left out of the present discussion since it does not suffer of any interaction effect. Due to the generation of lift, the propulsors interact with each other by both reducing the incoming flow velocity and by changing the incoming flow angle of incidence.

A convenient starting point to assess the interaction effects between the propulsors seems to be the method proposed by Roncin and Kobus [22] which study the influence of a yacht sailing in proximity of another. In their investigation, the authors use the horse-shoe method combined with semi-empirical formulas to calculate the perturbed velocity field. The method works for any apparent wind angle: when the yacht is sailing upwind, the lift is dominating and the interaction effects are mostly captured by the vortex model. When sailing downwind, the semi-empirical viscous model becomes more significant since the lift is decreasing and the drag is increasing. Although being simple, the method of Roncin and Kobus proved to give encouraging results when compared to a 3D Vortex Lattice Method [7] and wind-tunnel experiments [22].

Another approach should be used for the wind turbine. Fortunately, the so-called 'wake effect' of a wind turbine is a well know problem during the design phase of wind farms. Several models, which can estimate the reduction of the flow velocity and the wake diameter behind the turbine, are already available and can be used for a preliminary analysis. These are for instance the Jensen [71] and the Frandsen [13] model, which are based on analytical formulas, or the Larsen [72] and the Ainslie [1] model, which are respectively based on boundary layer and Navier-Stokes equations.

Regarding the interaction between the propulsors and the ship, it should be noted that the structures of the ship (e.g. hull, crew house, containers, etc.) are usually blunt bodies not meant to generate lift, which cause the flow to separate. This in turn generates drag. Thus, it can be assumed that the main effect of the ship structures on the velocity field is to reduce the incoming flow velocity.

To obtain the final velocity field, the interaction effects caused by the ship structures have to be properly combined with the effects caused by the interaction between multiple propulsors.

So far only the influence of the ship on the forces generated by the propulsors has been studied. However, albeit it is expected to be less significant, the influence of the propulsors on the aerodynamic forces generated by the ship, i.e. on the windage of the ship, should also be investigated.

One very convenient feature of the presented method is that it computes the effects of the aerodynamic interaction on the velocity field rather than directly on the forces generated by each propulsor. This means that the interaction effects can be studied independently from the propulsors which caused them, considerably reducing the number of calculations needed. The aerodynamic forces of the single propulsor can then be inputted in the perturbed velocity field in order to obtain the actual force it would generate in the real sailing condition on board of a ship.

Ultimately, the method outlined above will be used to generate a large amount of data on which to perform a regression analysis. From this analysis, suitable regression formulas will be elaborated with the goal of accurately and quickly computing the aerodynamic forces generated by a given wind-propulsion system on board of a generic ship.

Hydrodynamic aspects of wind-assisted ship propulsion

Sailing with an auxiliary wind propulsion system on board certainly has a major impact on the behaviour of a ship. The aerodynamic forces acting on the ship need to be balanced by the hydrodynamic forces to obtain an equilibrium which results in a steady forward speed. This balance generates all kind of new phenomena unknown to conventional ships.

The same process is found in the field of sailing yachts, where the sophisticated balance between these forces has been investigated in the past decades. It has been shown that the hydrodynamic phenomena of importance are heel, leeway, sideforce and yaw balance. These aspects therefore also need to be investigated on commercial ships, where a difference is found with respect to speed (low Froude number rather than high), sideforce production (non-optimal lift generator because of the blunt hull form) and yaw balance (different block coefficient and wind propulsor positions).

The upright resistance of a wind-assisted ship can be captured by the well-known semi-empirical formula of Holtrop and Mennen [16]. The effect of heel however originates a change in waterline length and wetted surface which, together with the new asymmetric waterplane shape, need to be taken into account [46]. Also leeway has an effect on the resistance, both in terms of lift production as well as vortex separation [4].

Keuning et al. [49] developed a regression formula to describe the added resistance due to waves for sailing yachts. At the ship hydromechanics laboratory of Delft University of Technology, an in-house investigation of the influence of heel and sideforce on the added resistance due to waves is carried out for a conventional ship by one of the authors. Preliminary results show that while sideforce influence is negligible, heel does have some influence on the added resistance.

Wind-assisted ship propulsion also causes sideforce, and thereby induced resistance, to occur. Keuning and Sonnenberg [47] revised earlier formulas arriving at an approximation method called the "effective span" to correlate the induced resistance with sideforce. A formula for wind-assisted vessels however is not easily derived, as no permanent keel is present, nor is the shape of the hull very beneficial to generate sideforce.

Another associated hull force is the yaw balance of the ship and then in particular the viscous effect called Munk Moment [73]. An initial study on the lateral balance for a wind-assisted ship was performed by Skogman [25]. The challenge of obtaining a good yaw balance is also identified and investigated by Keuning and Vermeulen [48]. The findings of Claughton et al. [39] on the yaw balance of superyachts are particularly interesting, as the hull shapes are one step closer to actual wind-assisted vessels.

Finally the propeller performance of a wind-assisted ship will differ due to atypical inflow conditions. While the effect of heel has not been addressed before, the effect of drift is considered in the field of manoeuvring research. Broglia et al. [5] showed that to model the performance of a propeller in oblique flow, unsatisfactory predictions were obtained by employing models that do not account for the sideforce developed by the propellers. More recently Dubbioso et al. [41] numerically showed the impact of incorporating relevant in-plane loads on the propeller due to oblique flow.

The off-design propeller condition is closely linked to the rudder performance ([50] and [33]) and can have a large influence on the dynamic response of the vessel. Also the earlier mentioned yaw balance affects the course stability and turning ability of the ship. This shows the necessity to assess the manoeuvring capabilities of a ship in the performance prediction program, although these dynamic effects will have to be considered in a steady-state manner. Moreover it is expected that the wind propulsion systems on board of the ship will have a (dynamic) effect on the motions [75] and this also needs to be investigated.

It is shown that a range of different hydrodynamic phenomena need to be tackled to arrive at the performance prediction. This means that the approach of each individual aspect needs to be put in perspective regarding time, accuracy and uncertainty compared to the others. The result is not an optimisation for each separate phenomenon, but the optimal total combination. To attain this goal, the regression formulas based on the Delft Systematic Yacht Hull Series [43] [45] [47] are a good methodology to adopt.

Conclusions

In this paper a review of the past and more recent developments on wind-assisted propulsion is presented. Although a considerable amount of research has been carried out on this topic, it appears that there is still a substantial lack of knowledge regarding the actual performance of a wind-assisted ship.

The studies on the performance of wind-assisted ships made over the years share two main drawbacks: they are tailored for a specific ship and they greatly simplify the complex physical aspects associated with this new technology. Before any sound evaluation on the use of wind energy in the shipping industry can be made, the performance of a wind-assisted ship must be properly predicted. This should be possible for a generic ship sailing along any given route.

From the state-of-the-art the areas that deserve more attention in order to improve the overall accuracy of the performance prediction have been identified. For the aerodynamic part of the force balance, the interaction effects between the propulsors itself and between the propulsors and the ship definitely need to be taken into account when computing the aerodynamic forces. For the hydrodynamic part the effects caused by heel, leeway, sideforce and yaw moment on the resistance of the ship and on the efficiency of the propeller, are phenomena unknown to commercial ships that require a thorough investigation.

The literature shows that in velocity prediction programs for sailing yachts semi-empirical formulas to compute the aero-hydrodynamic forces have been successfully applied. These formulas are based on a combination of analytical expressions and data obtained experimentally. This methodology seems to be particularly suitable also to assess the performance of a generic wind-assisted ship.

In conclusion, the performance prediction program outlined in this paper aims to fill the gap between the scarcity of reliable data available and the great interest towards wind-assisted propulsion. The program intends to be a versatile design tool that can help the users to explore several different solutions in a reliable, yet quick manner. This will help to better evaluate the use of wind energy as auxiliary form of propulsion for commercial ships.

References

1. J. F. Ainslie, *Wind Engng. and Industrial Aerodynamics*, **27**, 213 (1988).
2. L. Bergenson and C. K. Greewald, *Wind Engng. and Industrial Aerodynamics*. **19**, 45 (1985).
3. B. L. Blackford, *Wind Engng. and Industrial Aerodynamics*. **20**, 267 (1985).
4. W.M.S. Bradbury, *Wind Engng. and Industrial Aerodynamics*. **20**, 227(1985).
5. R. Broglia, G. Dubbioso, D. Durante and A. Di Mascio, *Applied Ocean Research*. **39**, 1 (2013).
6. N. Burgin and P.A. Wilson, *Wind Engng. and Industrial Aerodynamics*. **20**, 349 (1985).
7. M. Caponetto, *Int. Shipbuilding Progress*, **44**, 241 (1997).
8. B. Charrier, J. Constans, J. Cousteau, A. Daïf, L. Malavard, J. Quinio, *Wind Engng. and Industrial Aerodynamics*. **20**, 39 (1985).
9. B. R. Clayton, *Wind Engng. and Industrial Aerodynamics*. **19**, 251 (1985).
10. T. Craft, N. Johnson, B. Launder, *Flow Turbulence Compost.* **92**, 413 (2014)
11. A. Fiorentino, L. Lecce, A. D'Antonio, G. Del Core, A. Maglione, F. Marulo, *Wind Engng. and Industrial Aerodynamics*. **19**, 115 (1985).
12. G. Firestein, *Wind Engng. and Industrial Aerodynamics*. **20**, 23 (1985).
13. S. Frandsen, R. Barthelmie, S. Pryor, O. Rathmann, S. Larsen, J. Højstrup and M. Thøgersen, *Wind Energy*, **9**, 39 (2006).
14. T. Fujiwara, G.E. Hearn, F. Kitamura and M. Ueno, *Official Journal of the Japan Society of Naval Architects and Ocean Engineers (JASNAOE)*. **10**, 82 (2005).
15. T. Fujiwara, G.E. Hearn, F. Kitamura, M. Ueno and Y. Minami, *Official Journal of the Japan Society of Naval Architects and Ocean Engineers (JASNAOE)*. **10**, 131 (2005).
16. J. Holtrop and G.G.J. Mennen, *International Shipbuilding Progress*. **29**, No. 335 (1982).
17. P. Ingham and O. Tersløv, *Wind Engng. and Industrial Aerodynamics*. **20**, 169 (1985).

18. S. J. Karabelas, *Heat and Fluid Flow*. **31**, 518 (2010).
19. M.K. Lambrecht, J.W. Klintworth, M.G. Jordaan and E.A. Bunt, *N&O Joernaal*. **10**, 3 (1994).
20. O. Ljungström, *Wind Engng. and Industrial Aerodynamics*. **19**, 285 (1985).
21. C. Palmer, *Wind Engng. and Industrial Aerodynamics*. **19**, 311 (1985).
22. K. Roncin and J. M. Kobus, *Sports Engineering*. **7**, 139 (2004).
23. C.J. Satchwell, *Wind Engng. and Industrial Aerodynamics*. **20**, 1 (1985).
24. P. Schenzle, *Wind Engng. and Industrial Aerodynamics*. **20**, 97 (1985).
25. A. Skogman, *Wind Engng. and Industrial Aerodynamics*. **20**, 201 (1985).
26. F. Smulders, *Wind Engng. and Industrial Aerodynamics*. **19**, 187 (1985).
27. J. Seifert, *Progress in Aerospace Sciences*. **55**, 17 (2012).
28. J.G. Walker, *Wind Engng. and Industrial Aerodynamics*. **20**, 83 (1985).
29. J.F. Wellcome, *Wind Engng. and Industrial Aerodynamics*. **20**, 111 (1985).
30. P. A. Wilson, *Wind Engng. and Industrial Aerodynamics*. **20**, 187 (1985).
31. M. Traut, P. Gilbert, C. Walsh, A. Bows, A. Filippone, P. Stansby, R. Wood, *Applied Energy*. **113**, 362 (2014).
32. Y. Yoshimura, *Fisheries science*. **86**, 1815 (2002)
33. C. Badoe, A. Phillips and S.R. Turnock, *Proc. of 15th Numerical Towing Tank Symp.* Cortona (2012)
34. E. Bøckmann and S. Steen, *Proc. 2nd Int. Symposium. on Marine Propulsors*, Hamburg (2011).
35. N. Bose, *Symp. on wind propulsion of commercial ships*, London (1980).
36. W.M.S. Bradbury, *Symp. on wind propulsion of commercial ships*, London (1980).
37. British Wind Energy Association, *Proc. of the first wind assisted ship propulsion symposium*, Glasgow (1985).
38. A. Claughton, *Proc. 14th Chesapeake Sailing Yacht Symposium*, Annapolis (1999).
39. A. Claughton, R. Pemberton and M. Prince, *Proc. 22nd Int. HISWA Symposium. on Yacht Design and Yacht Construction*, Amsterdam (2012).
40. T. Doyle, M. Gerritsen and G. Iaccarino, *Proc. 17th Int. HISWA Symposium. on Yacht Design and Yacht Construction*, Amsterdam (2002).
41. G. Dubbioso, R. Muscari, A. Di Mascio, *Proc. 3rd Int. Symposium. on Marine Propulsors*, Launceston (2013).
42. T. Fujiwara, K. Hirata, M. Ueno and T. Nimura, *Proc. of the 13th International Offshore and Polar Engineering Conference*, Hawaii (2003).
43. J. Gerritsma, R. Onnink and A. Versluis, *Proc. 7th Int. HISWA Symposium. on Yacht Design and Yacht Construction*, Amsterdam (1981).
44. K. Graf, A. v. Hoeve and S. Watin, *Proc. 3rd Int. Conf. on Innovation in High Performance Sailing Yachts*, Lorient (2013).
45. J.A. Keuning and M. Katgert, *The 1st Int. Conference on Innovation in High Performance Sailing Yachts*, Lorient (2008).
46. J.A. Keuning and M. Katgert, *The 2nd Int. Conference on Innovation in High Performance Sailing Yachts*, Lorient (2010).
47. J.A. Keuning and U. B. Sonnenberg, *Proc. 15th Int. HISWA Symposium. on Yacht Design and Yacht Construction*, Amsterdam (1998).
48. J.A. Keuning and K.J. Vermeulen, *Proc. 17th Int. HISWA Symposium. on Yacht Design and Yacht Construction*, Amsterdam (2002).
49. J.A. Keuning, K.J. Vermeulen and H.P. ten Have, *2nd Int. Symp. on Design and Production of Motor and Sailing Yachts*, Madrid (2006).
50. T. Lücke, *Proc. 3rd Int. Symposium. on Marine Propulsors*, Launceston (2013).
51. Y. Minami, T. Nimura, T. Fujiwara and M. Ueno, *Proc. of the 13th International Offshore and Polar Engineering Conference*, Hawaii (2003).
52. A.F. Molland, *Proc. of the International Symposium on Windship Technology*, Southampton (1985).
53. P. Naaijen, W. Shi, J.G. Kherian, *Proc. of the 1st workshop on "development of advanced ship support system using information technology"* (pp. 21-34), Tokyo (2009).
54. P. Naaijen, W. Shi, J.G. Kherian, *Proc. of the ship design and operation for environmental sustainability* (pp. 27-37), Londen (2010).
55. C.T. Nance, *Symp. on wind propulsion of commercial ships*, London (1980).
56. K. Ouchi, K. Uzawa, A. Kanai and M. Katori, *Proc. 3rd Int. Symposium. on Marine Propulsors*, Launceston (2013).
57. C. Palmer, *Proc. of the International Symposium on Windship Technology*, Southampton (1985).
58. T. Perkins, G. Dijkstra, Perini Navi, D. Roberts, *Proc. 18th Int. HISWA Symposium. on Yacht Design and Yacht Construction*, Amsterdam (2004).

59. R.C.T. Rainey, *Symp. on wind propulsion of commercial ships*, London (1980).
60. The Royal Institution of Naval Architects, *Symp. On wind propulsion of commercial ships*, London (1980).
61. C.J. Satchwell (Editor), *Proc. of the International Symposium on Windship Technology*, Southampton (1985).
62. C.J. Satchwell, *Proc. of the International Symposium on Windship Technology*, Southampton (1985).
63. P. Schenzle, *Symp. on wind propulsion of commercial ships*, London (1980).
64. G.W. Shaefer and K. Allsopp, *Symp. on wind propulsion of commercial ships*, London (1980).
65. T. Smith, P. Newton, G. Winn, A. G. La Rosa, *Proc. Conf. on Low Carbon Shipping*, London (2013).
66. D. Sparreboom, M. Leslie-Miller, *Proc. 22th Int. HISWA Symposium. on Yacht Design and Yacht Construction*, Amsterdam (2012).
67. M. Traut, A. Bows, P. Gilbert, S. Mander, P. Stansby, C. Walsh and R. Wood, *Proc. Conf. on Low Carbon Shipping*, Newcastle (2012).
68. W. Zhang, R. Bensow, M. Golubev and V. Chernoray, *Proc. 51st AIAA Aerospace Sciences Meeting*, Grapevine (2013).
69. A. Burden, G.E. Hearn, T. Lloyd, S. Mockler, L. Mortola, I.B. Shin and B. Smith, *Fast sail assisted feeder container ship*, University of Southampton (2010).
70. G. Hazen, *A model of sail aerodynamics for diverse type of rigs*, SNAME (1980).
71. N. O. Jensen, *A note on wind generator interaction*, Risø National Laboratory, Denmark (1983).
72. G. Larsen, *A simple wake calculation procedure*, Risø National Laboratory, Denmark (1988).
73. M.M. Munk, *The Determination of the Angles of Attack of Zero Lift and of Zero Moment, Based on Munk's Integrals*, National advisory committee for aeronautics (1923).
74. C.J. Satchwell, *Preliminary analysis of log data from the Fiji windship 'Cagidonu'*, Ship Science Report No. 24, University of Southampton (1986).
75. G.T. Skinner, *Sailing vessel dynamics: investigations into aero-hydrodynamic coupling*, MIT Massachusetts (1982).
76. B. Wagner, *'Windkräfte an Überwasserschiffen'*, Jahrbuch Schiffbautechnische Gesellschaft (1967).

