



# TIMBER TOWN

AN INCLUSIVE MIXED-USE AREA IN WINTERSWIJK,  
BUILT FOR AND OUT OF WOOD

**INTRODUCTION**

**ANALYSIS**

**VALUES**

**THE IDEA**

**DESIGN**

**CONCLUSION**

---

# **INTRODUCTION**

---



WINTERSWIJK

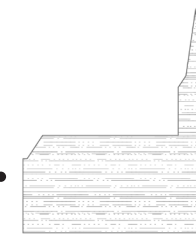

JACOBUSKERK



RAADHUIS

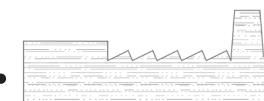

INDUSTRY



BOOGIE WOOGIE



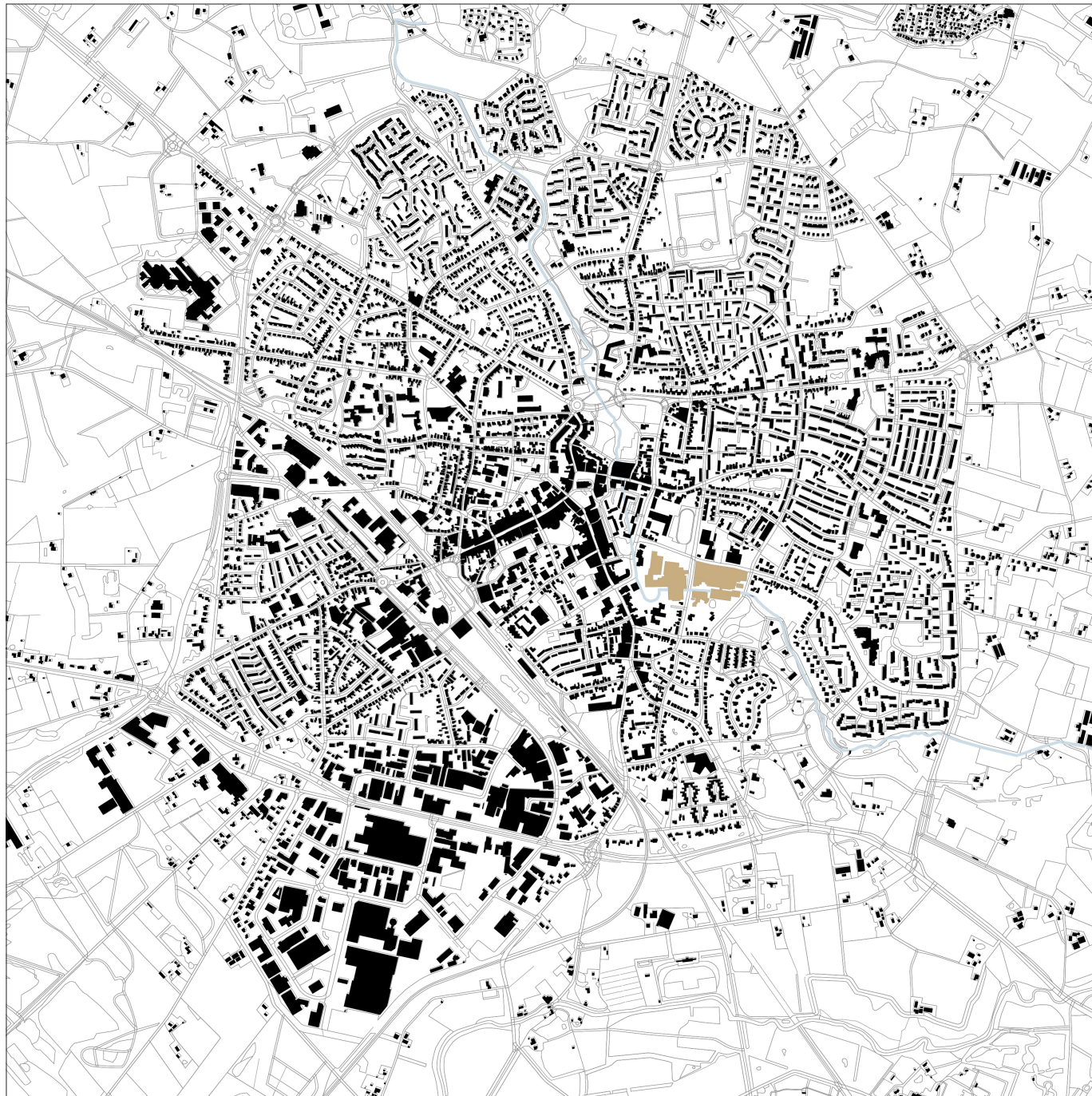

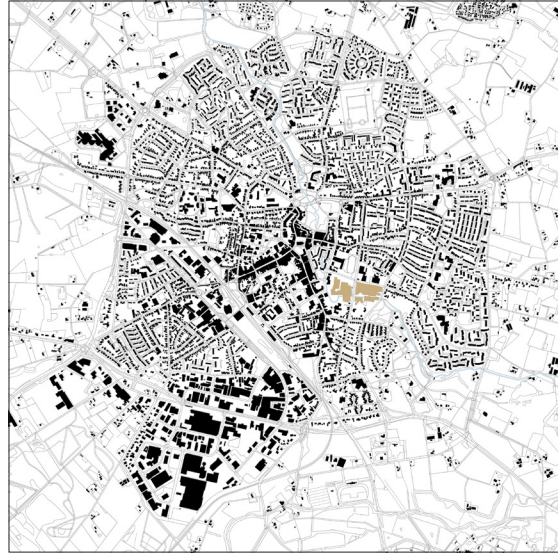



50 m









50 m







50 m







50 m



---

# ANALYSIS

---





2 km





'SCHOLTE' FARMERS

FLAX FARMING, WEAVING



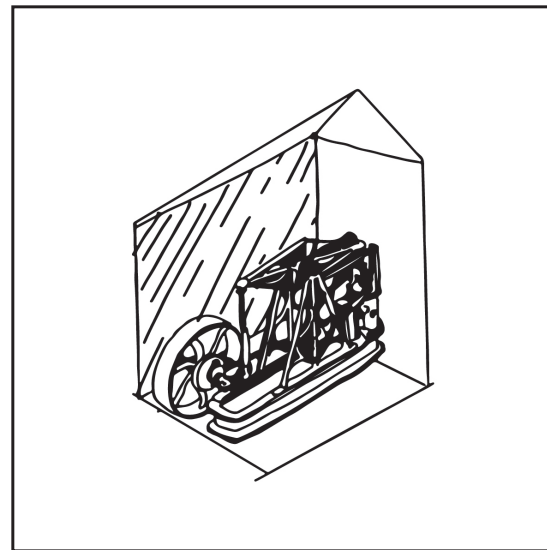
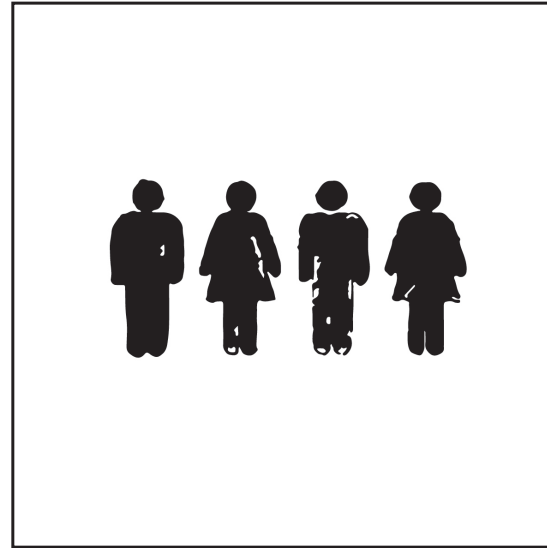
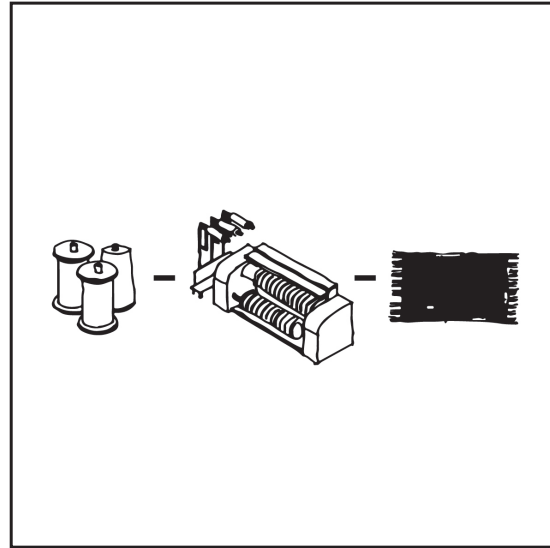

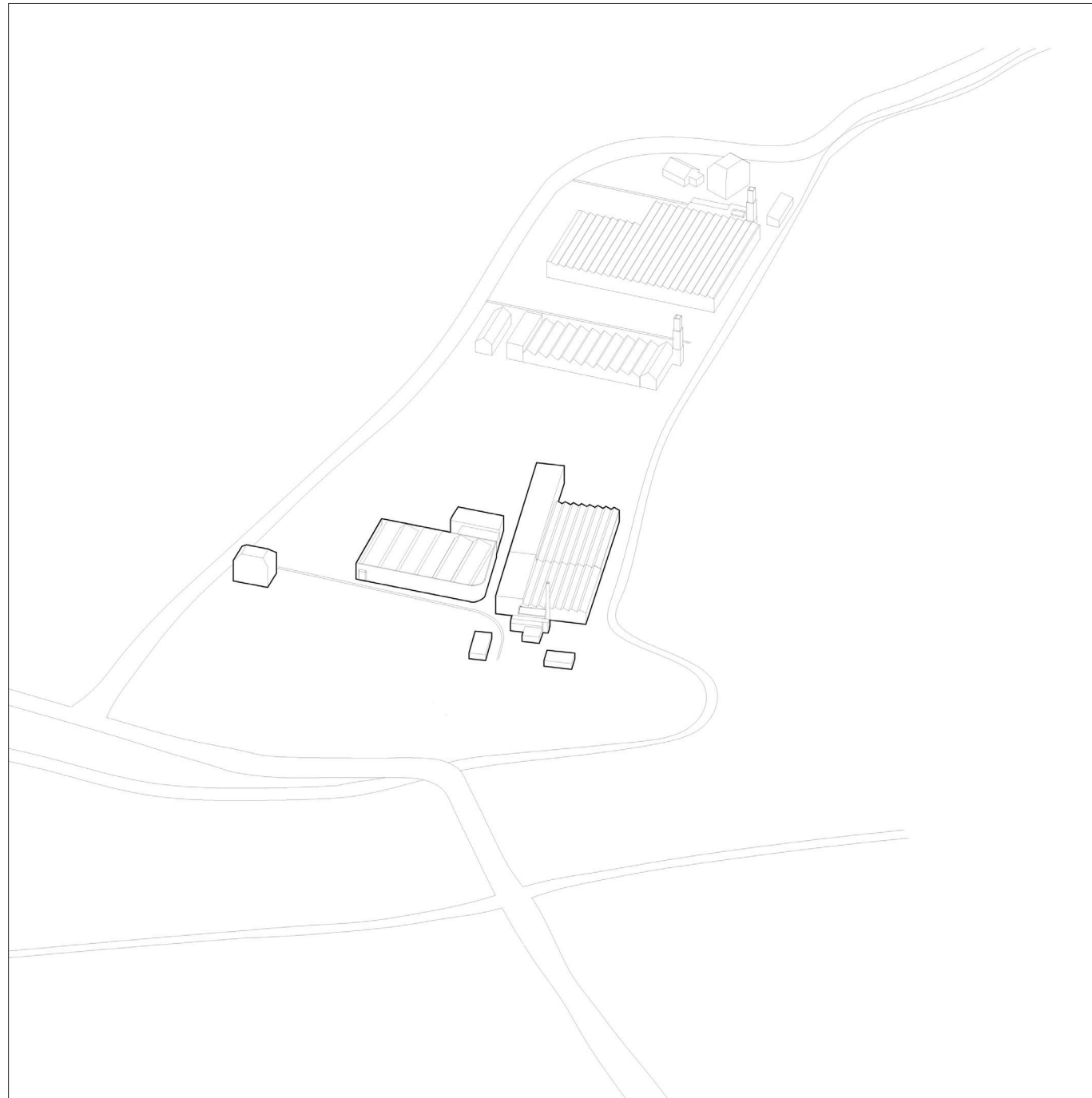

40 m



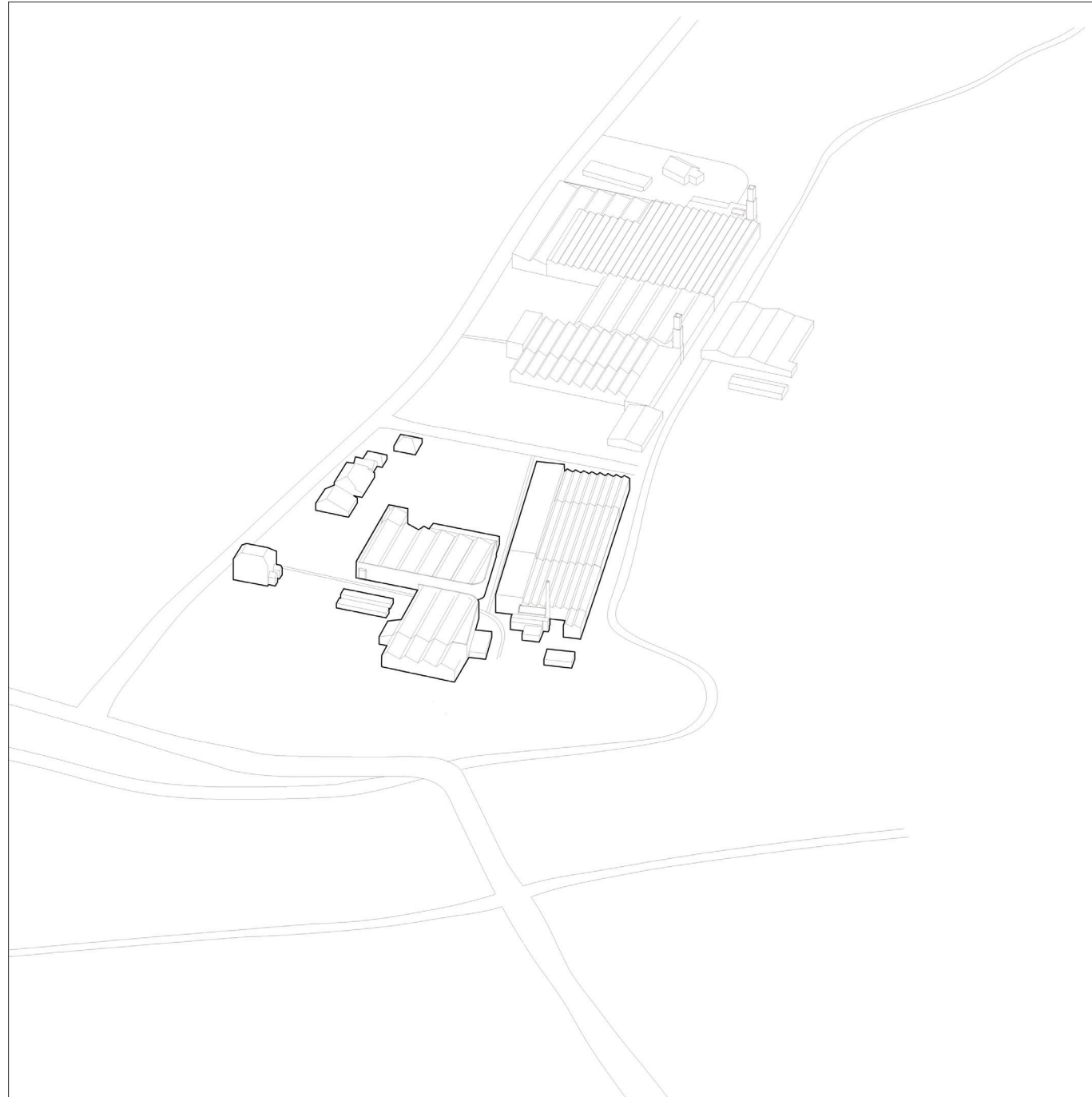

40 m



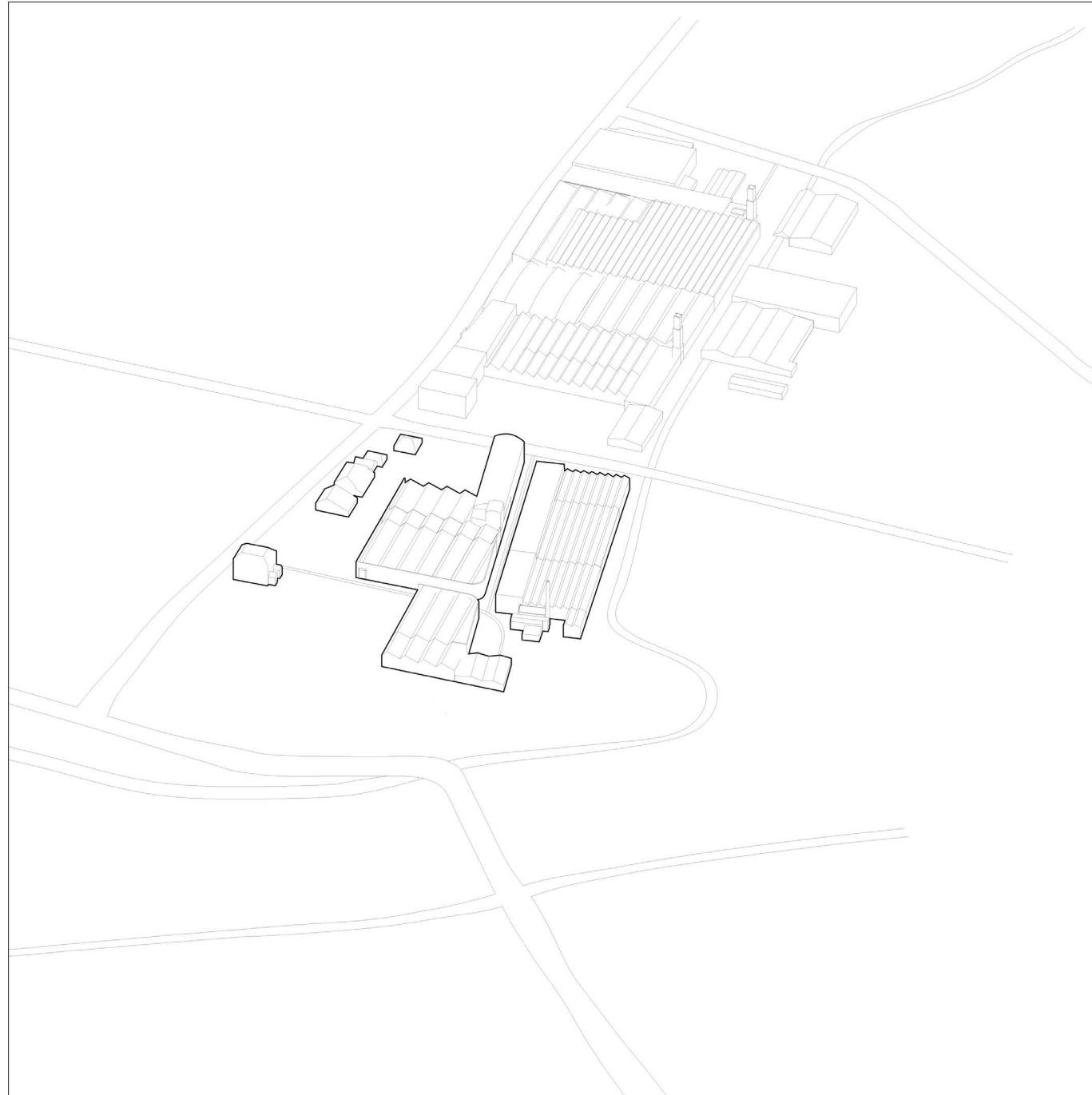

40 m







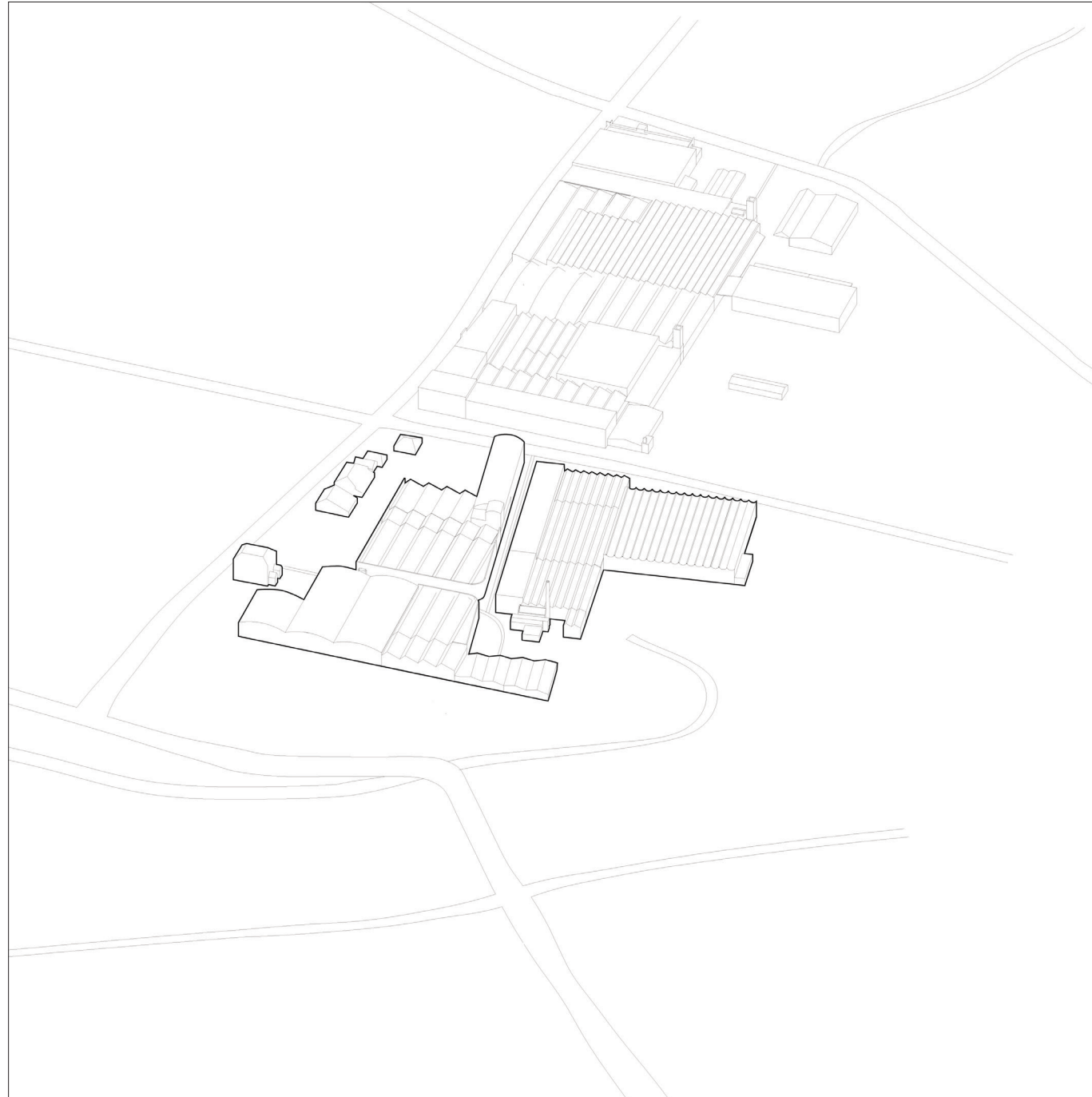

40 m





40 m



















---

**VALUES**

---

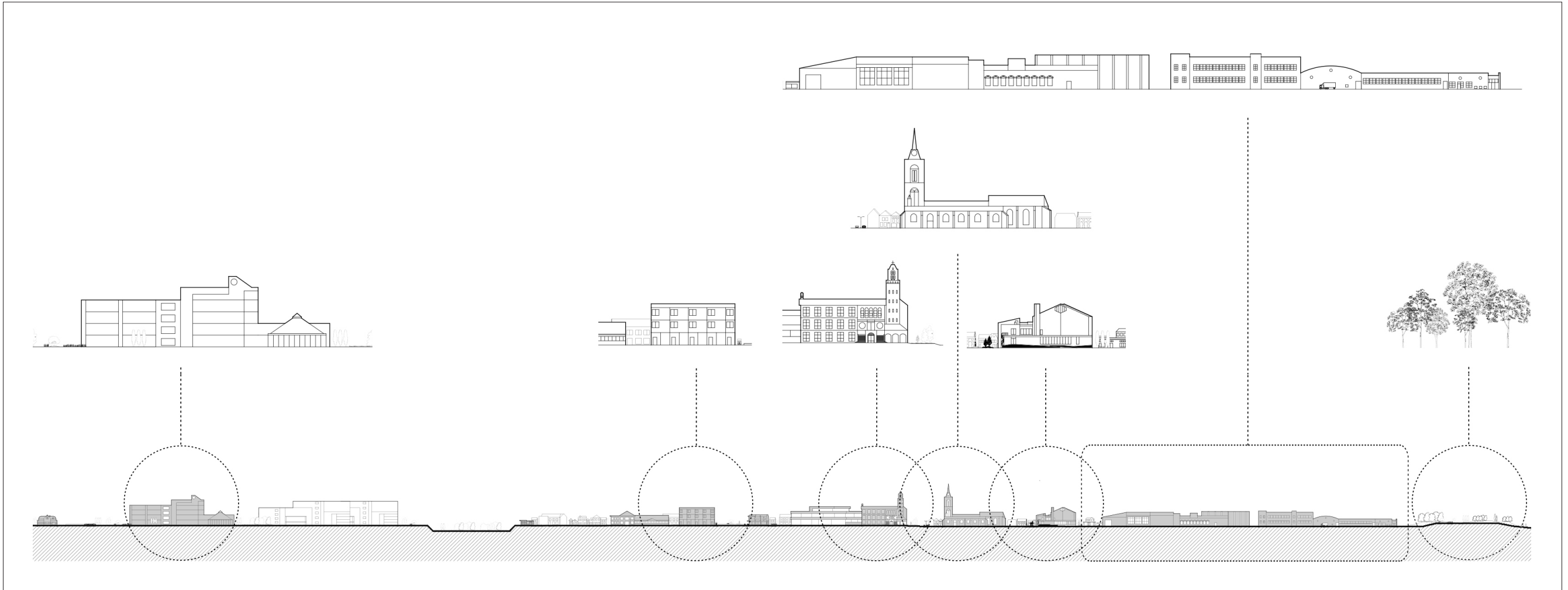

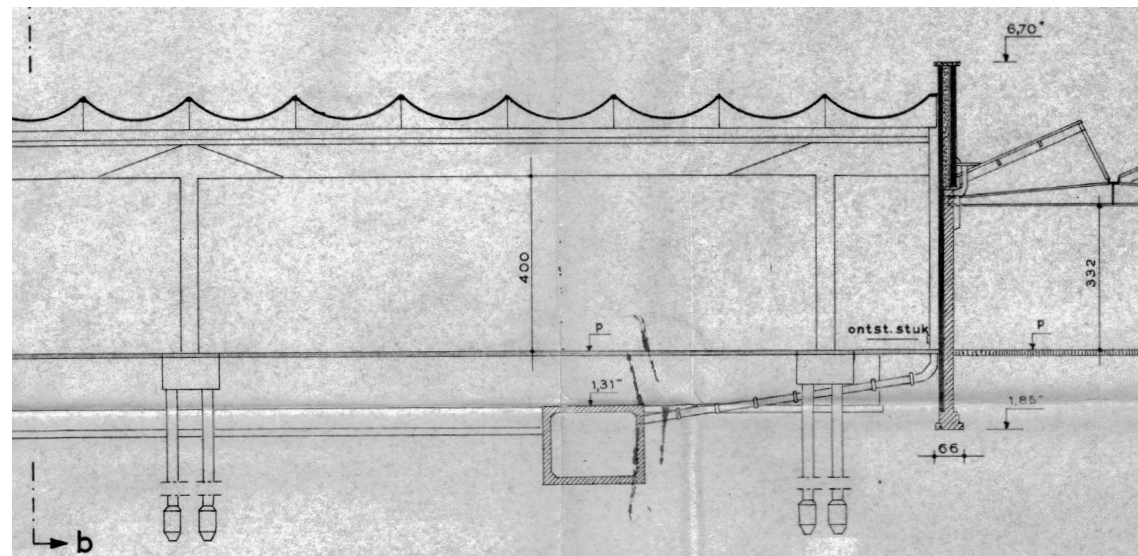



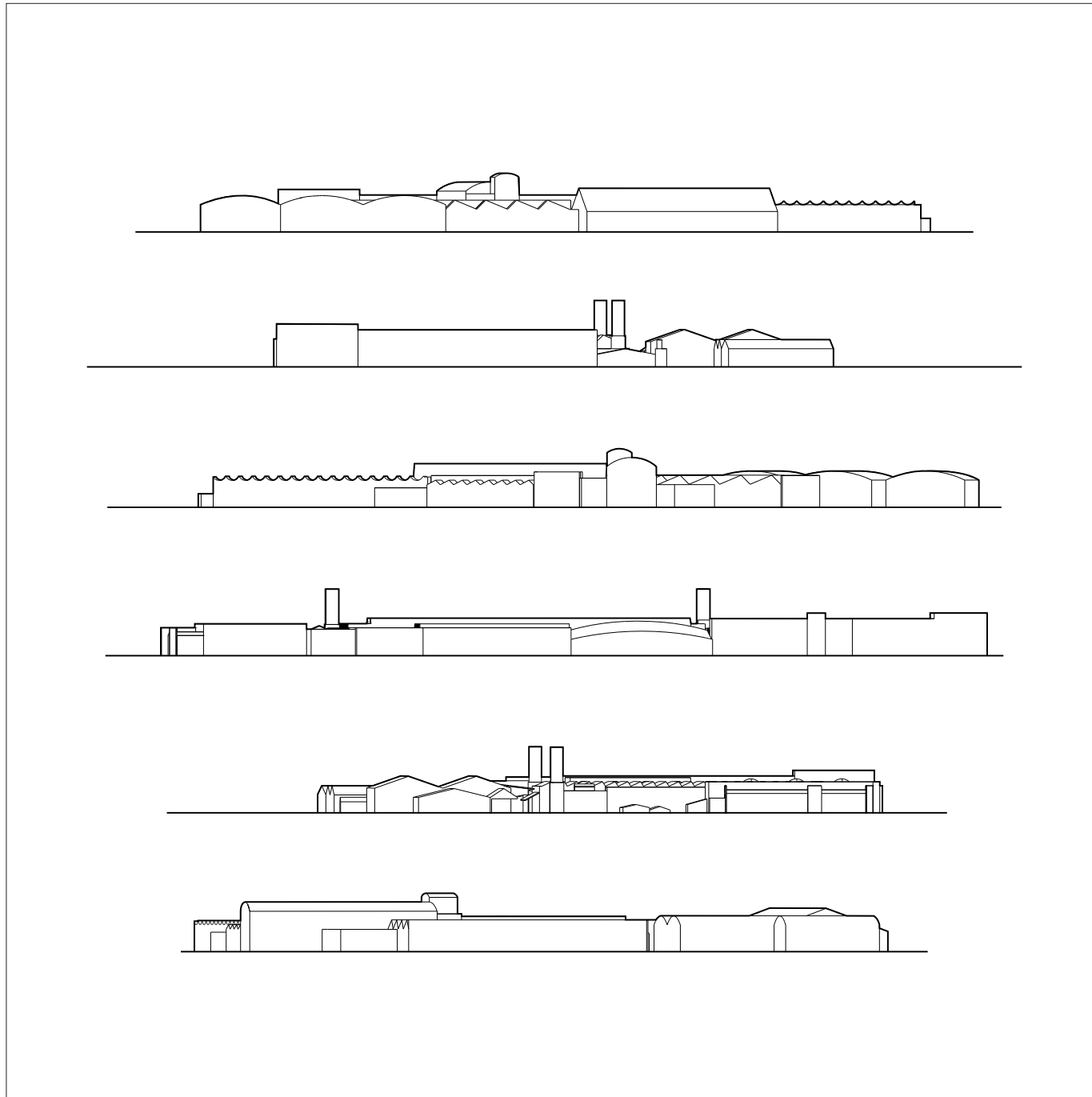

---

# THE IDEA

---

RESEARCH QUESTION:

HOW CAN THE INDUSTRIAL ENSEMBLE REGAIN ITS PURPOSE BASED ON PAST AND FUTURE  
CRAFTSMANSHIP, FULFILLING THE FUNCTION OF PRIDE OF THE VILLAGE?



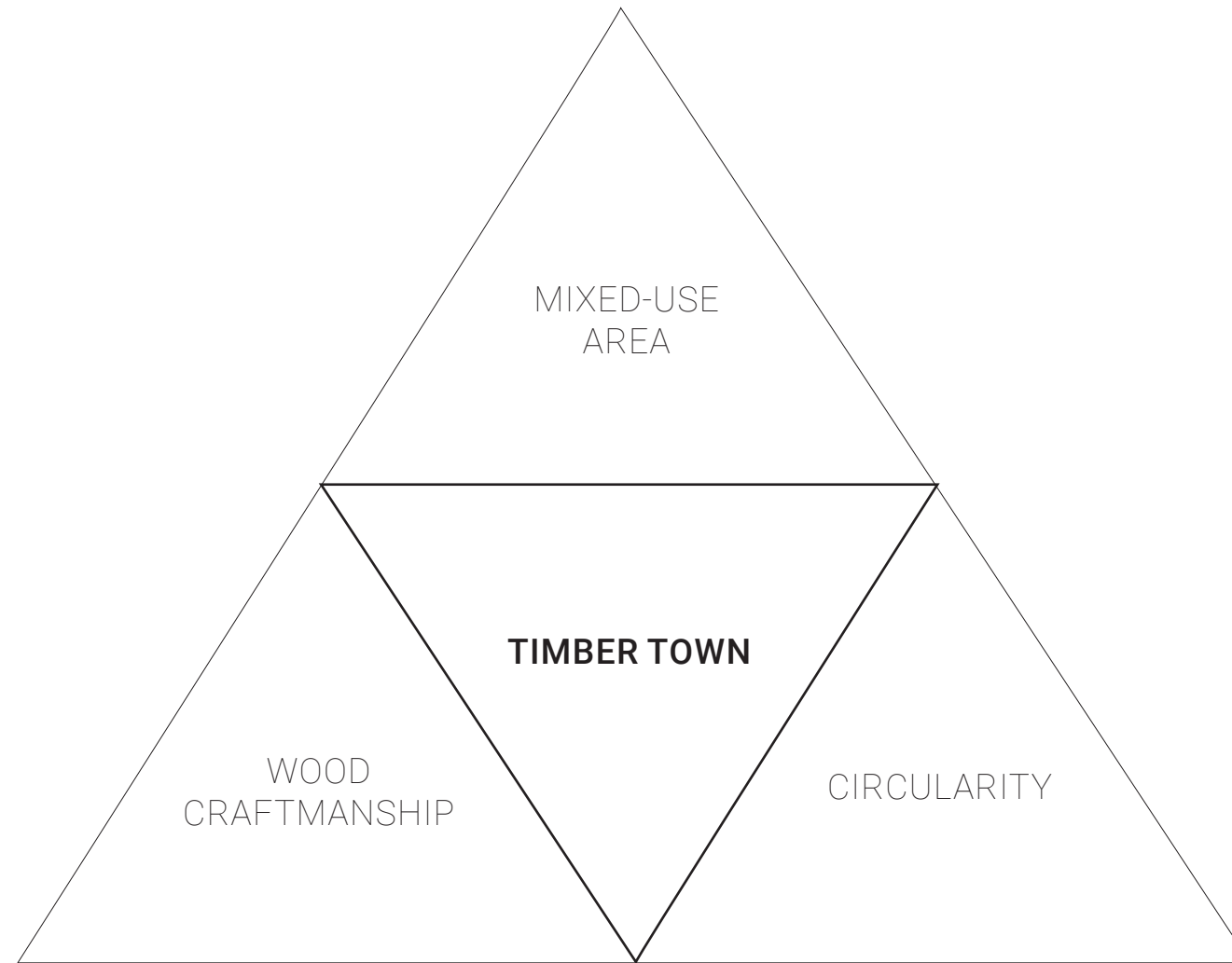

*- Marsepoort and Gaudium (Hazewind) function together as the centre of craftsmanship*

*- The new pride of Winterswijk*

---

# DESIGN

---

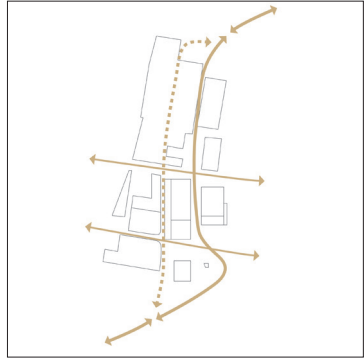

**STRENGTHEN THE URBAN SITUATION AND INVOLVE THE HINTERLAND**

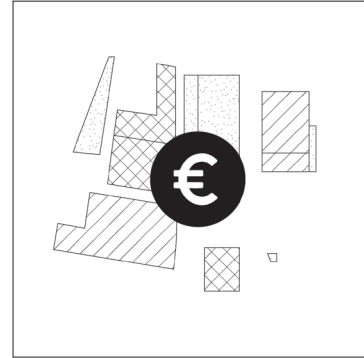

**INSTALL MIXED-USE FUNCTIONS AND CREATE ECONOMIC FEASIBILITY**

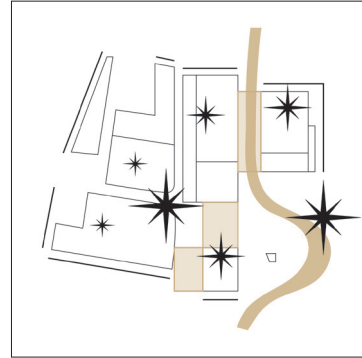

**CULTURAL VALUE INTERVENTION STRATEGY**

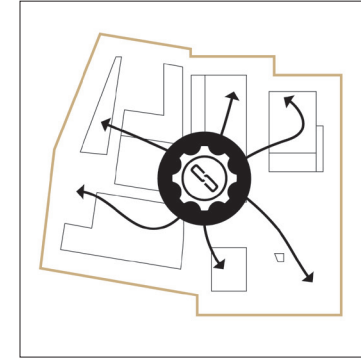

**FOCUS ON CIRCULAR AND DURABLE INTERVENTIONS**



**CREATING SYNERGY WITHIN THE ENSEMBLE**

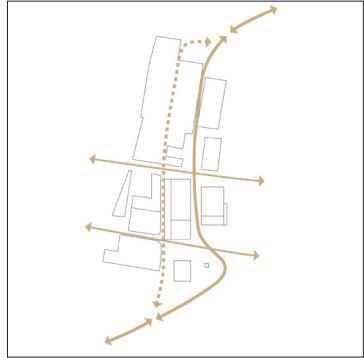

**STRENGTHEN THE URBAN SITUATION AND INVOLVE THE HINTERLAND**

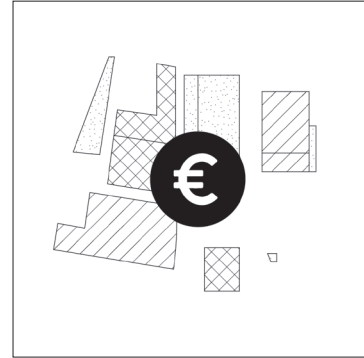

**INSTALL MIXED-USE FUNCTIONS AND CREATE ECONOMIC FEASIBILITY**

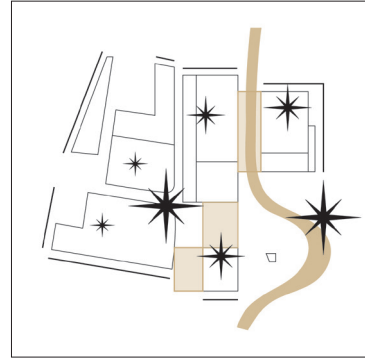

**CULTURAL VALUE INTERVENTION STRATEGY**

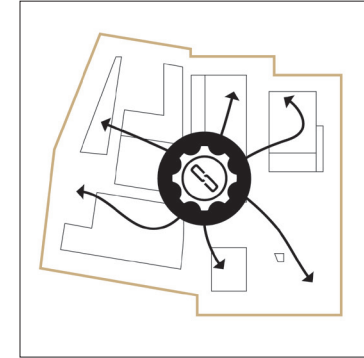

**FOCUS ON CIRCULAR AND DURABLE INTERVENTIONS**



**CREATING SYNERGY WITHIN THE ENSEMBLE**



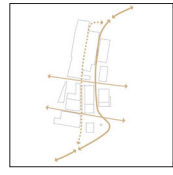
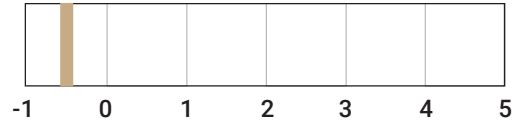

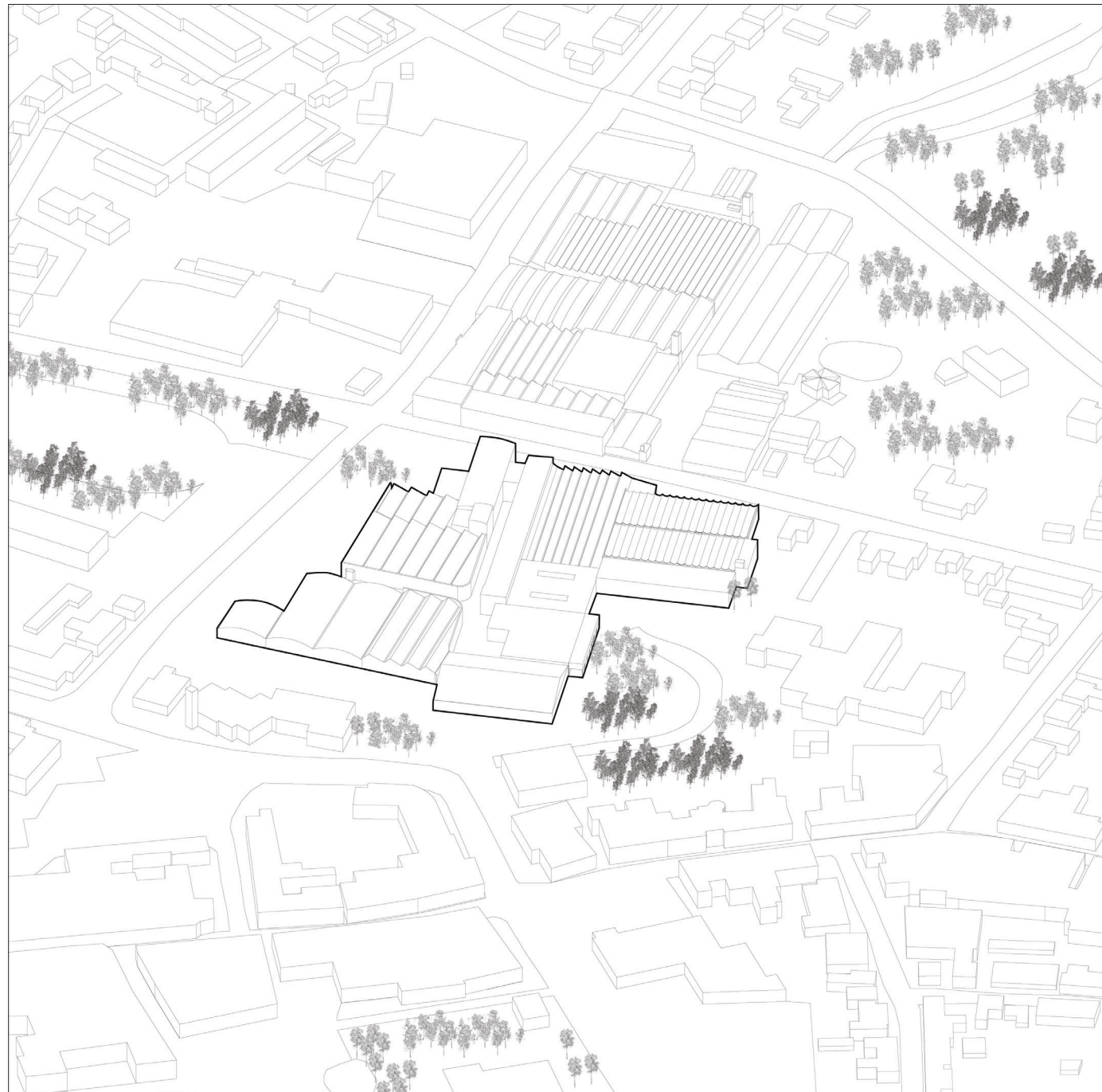
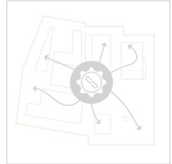
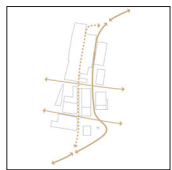
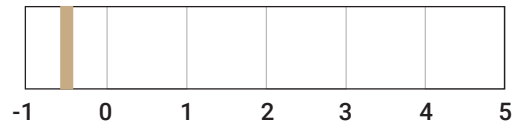

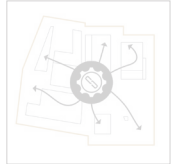
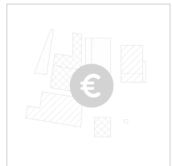
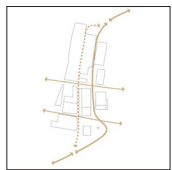
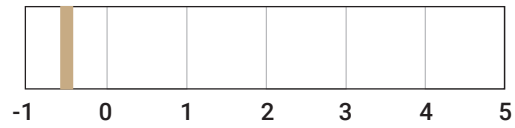

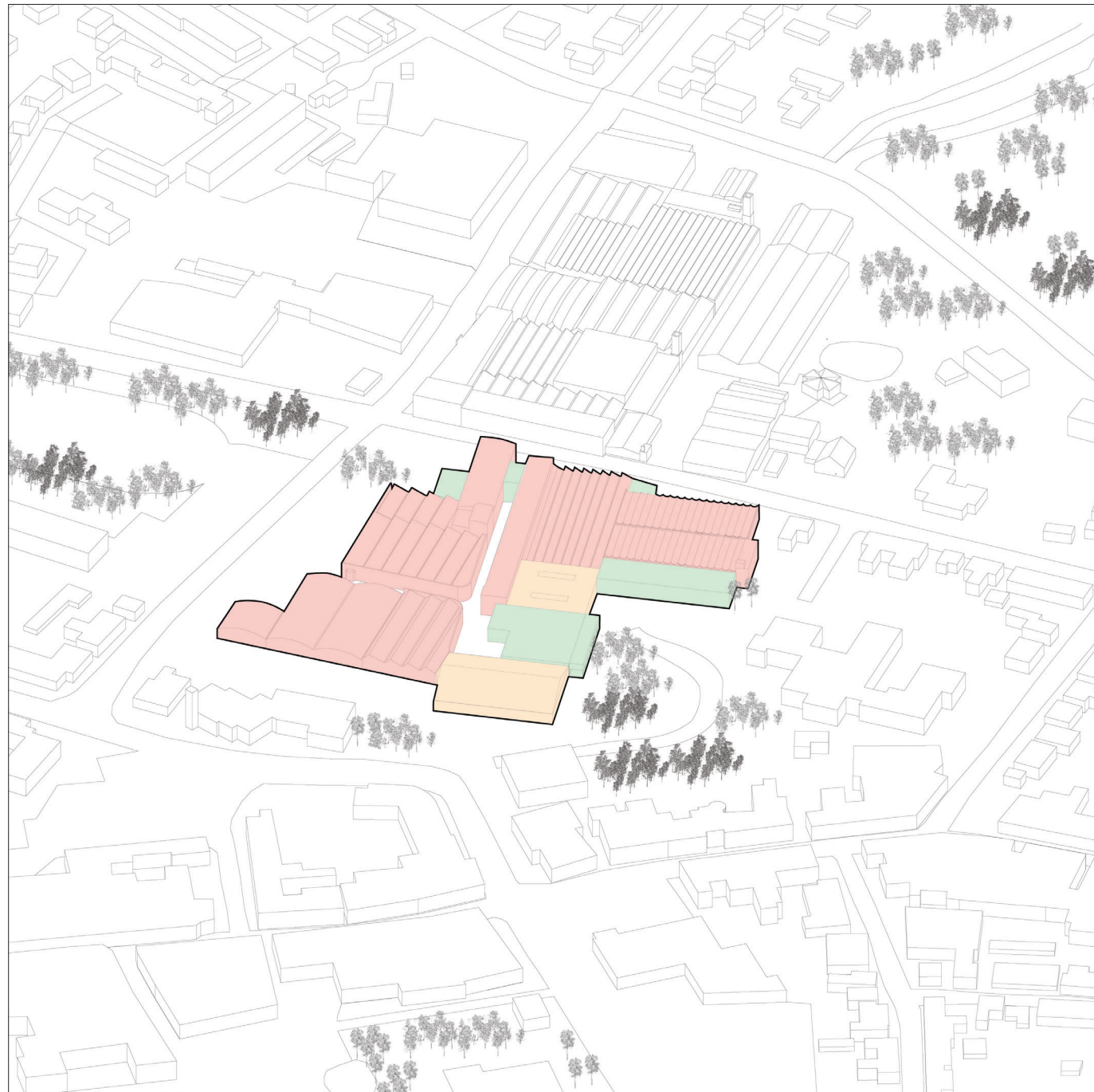
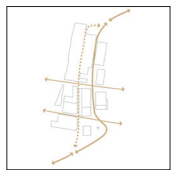
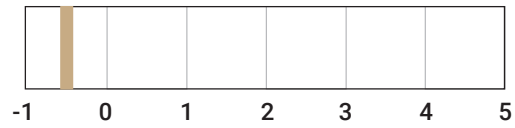



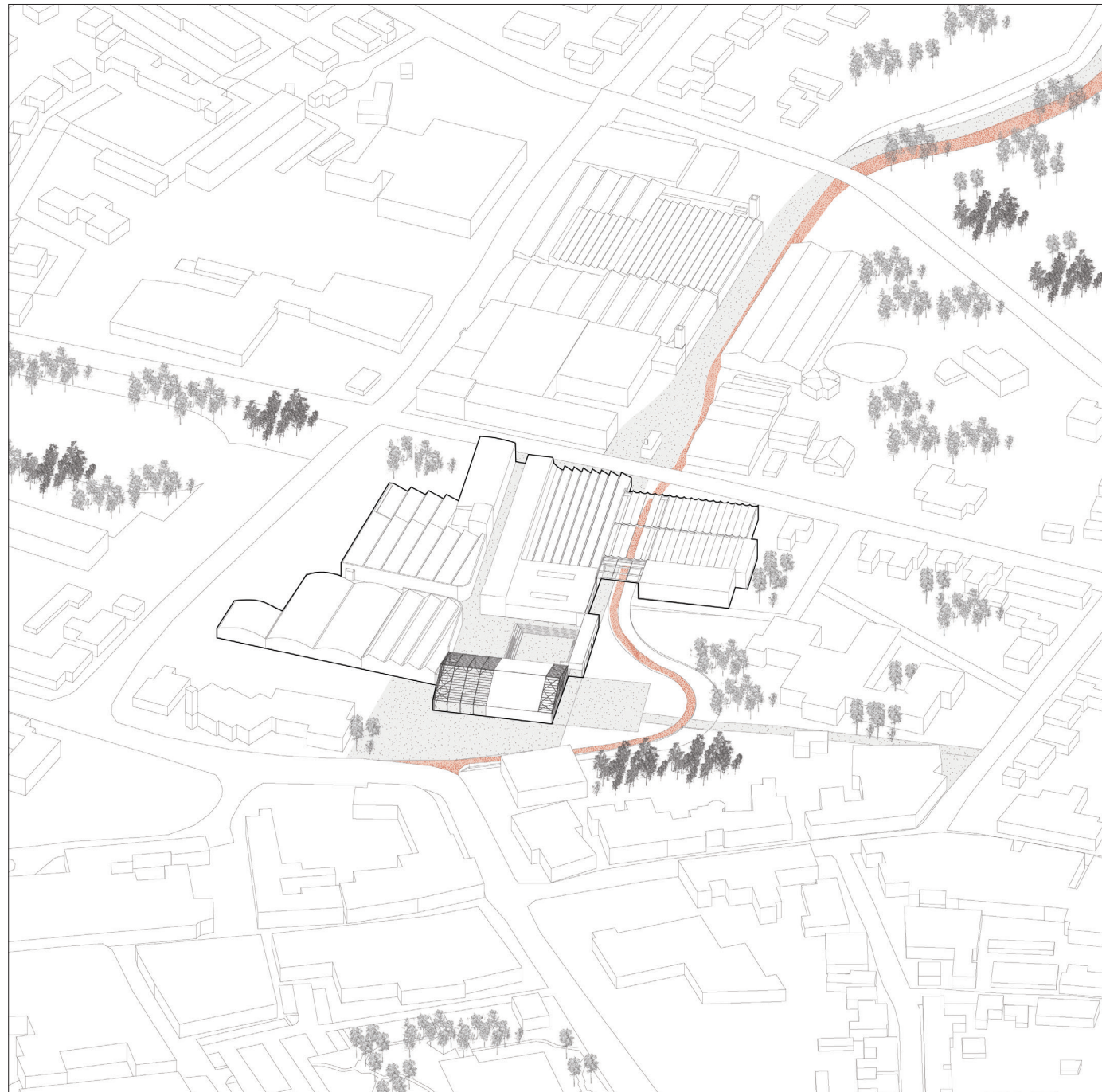
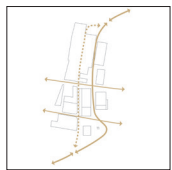
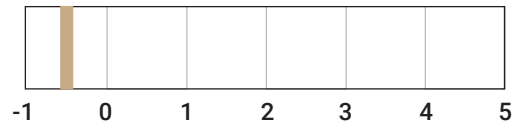

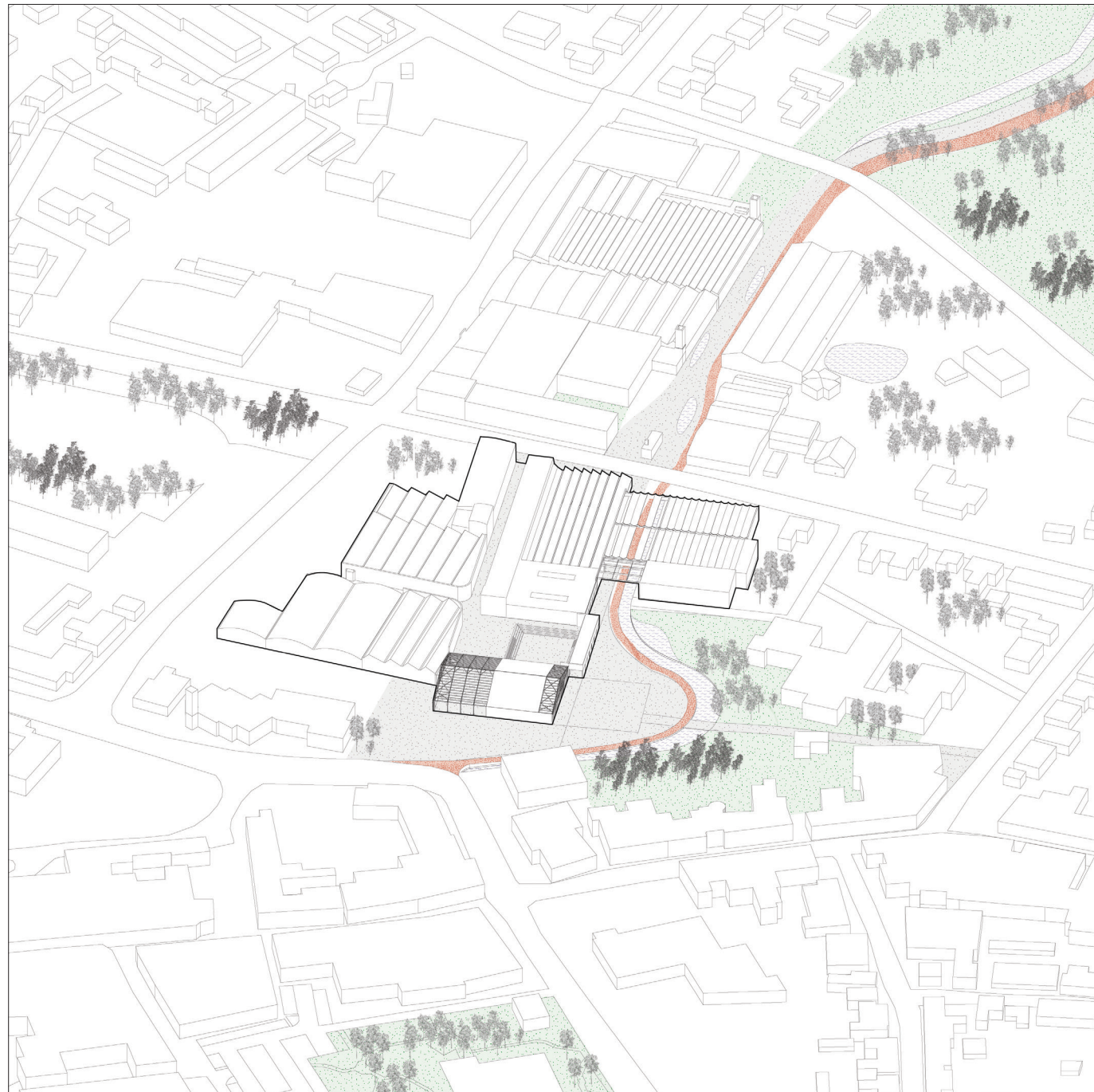
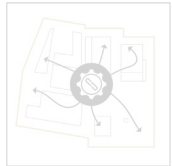
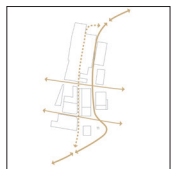
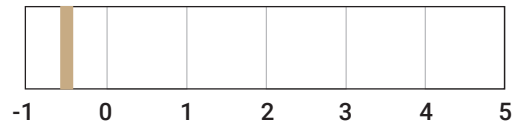

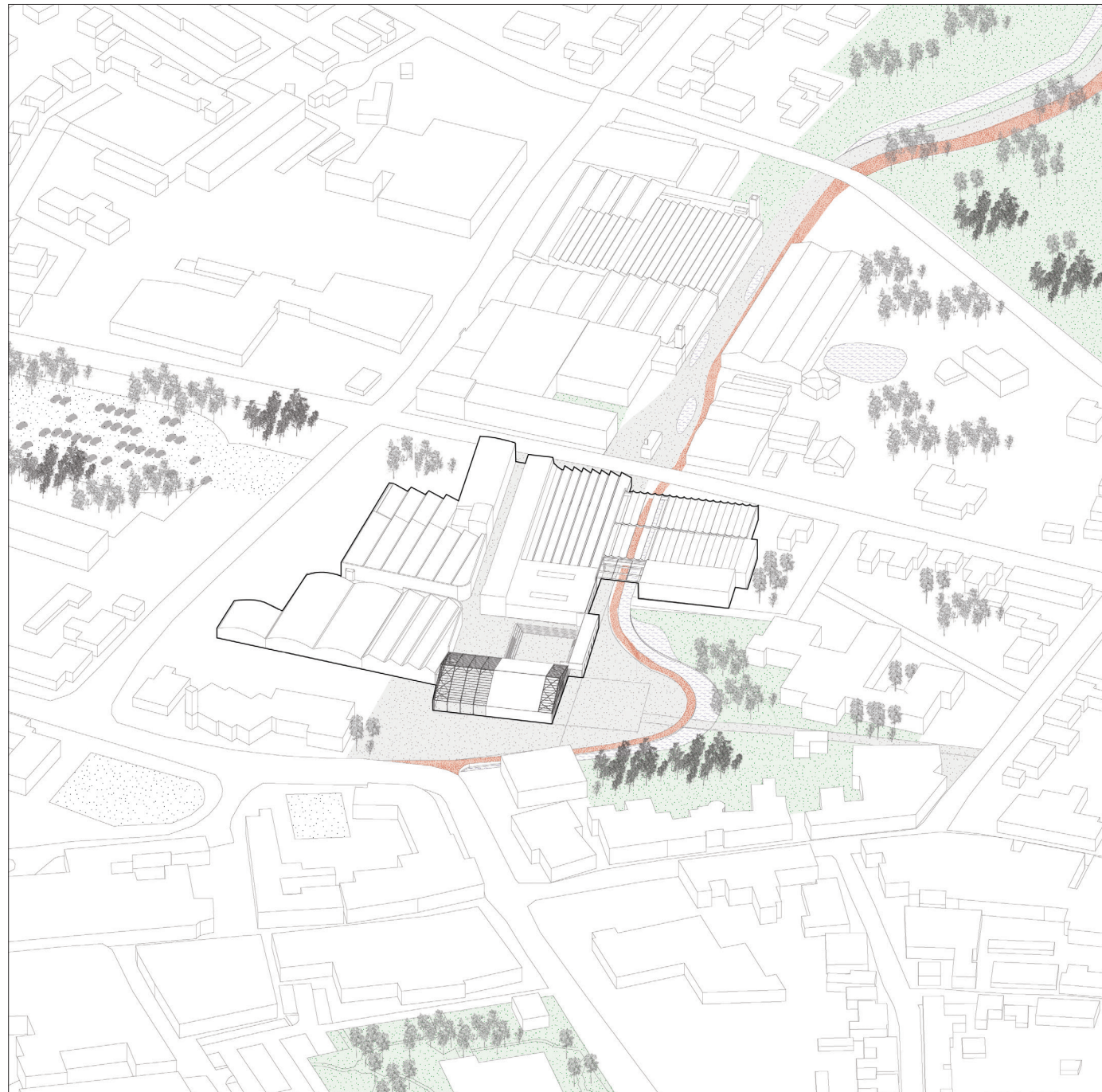
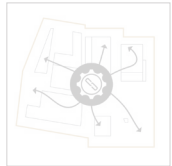
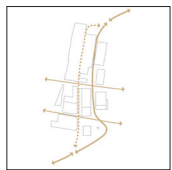
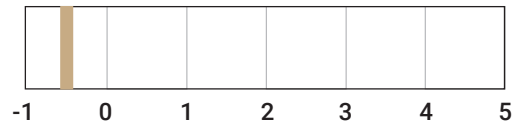

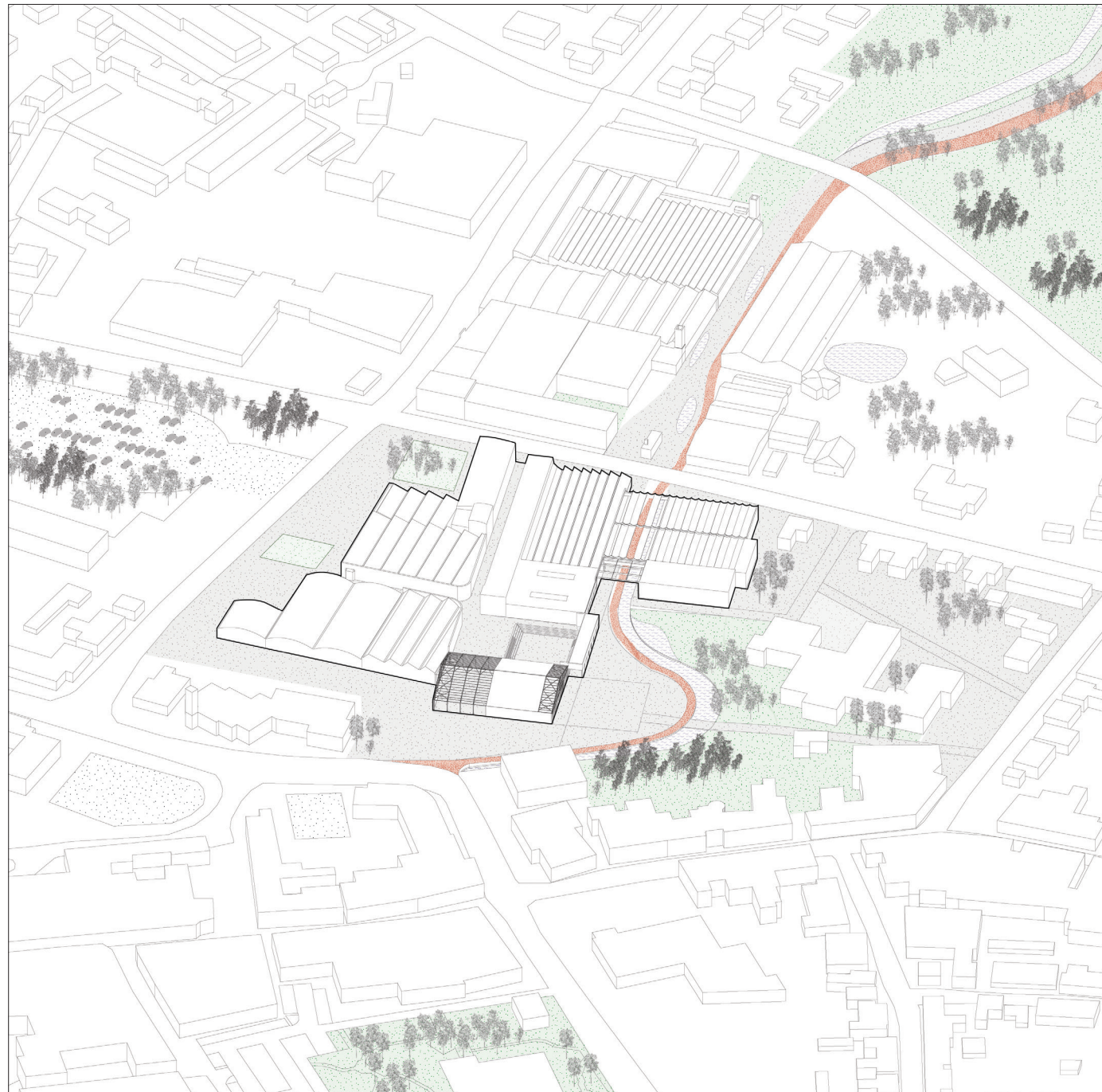
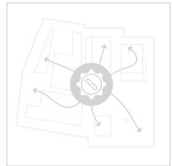
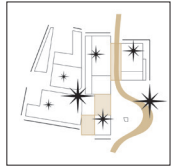
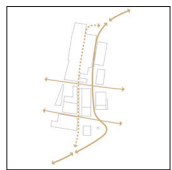
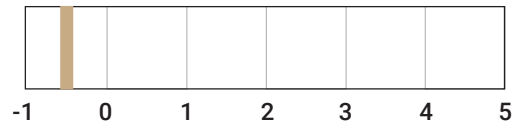

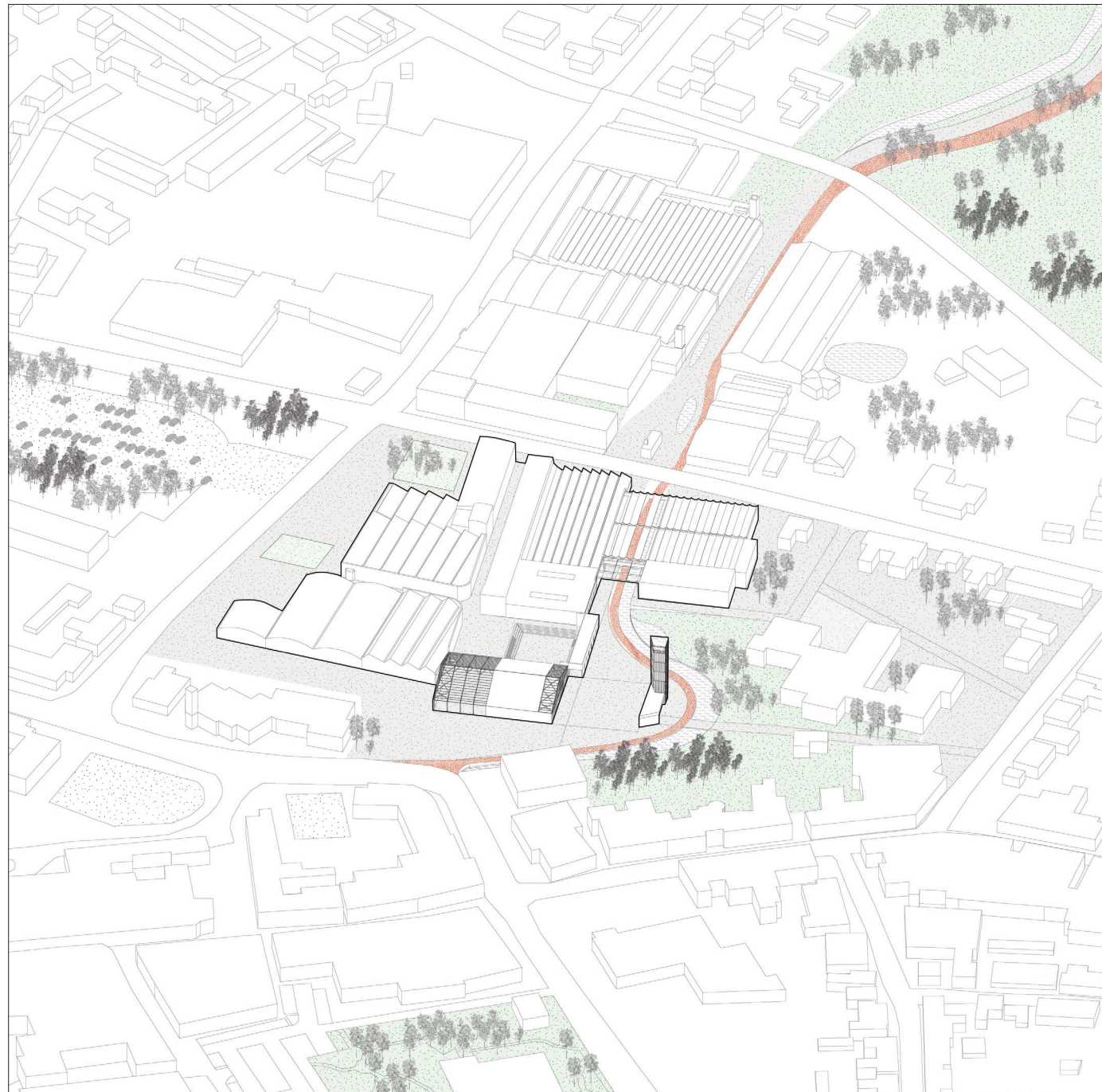
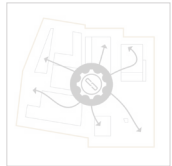
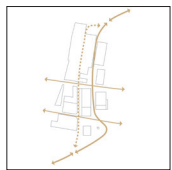
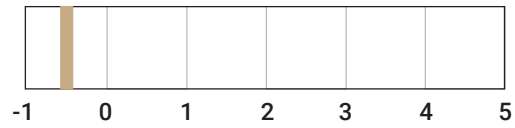

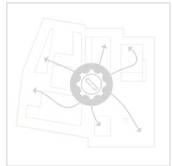
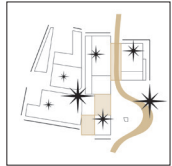
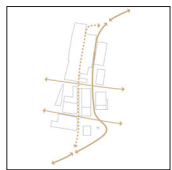
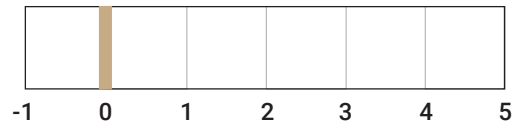

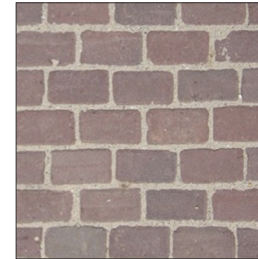
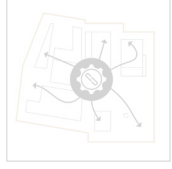
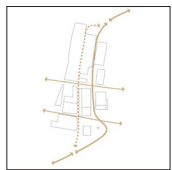
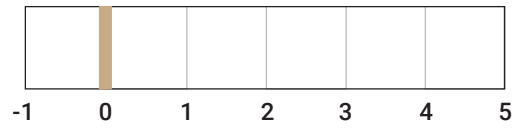

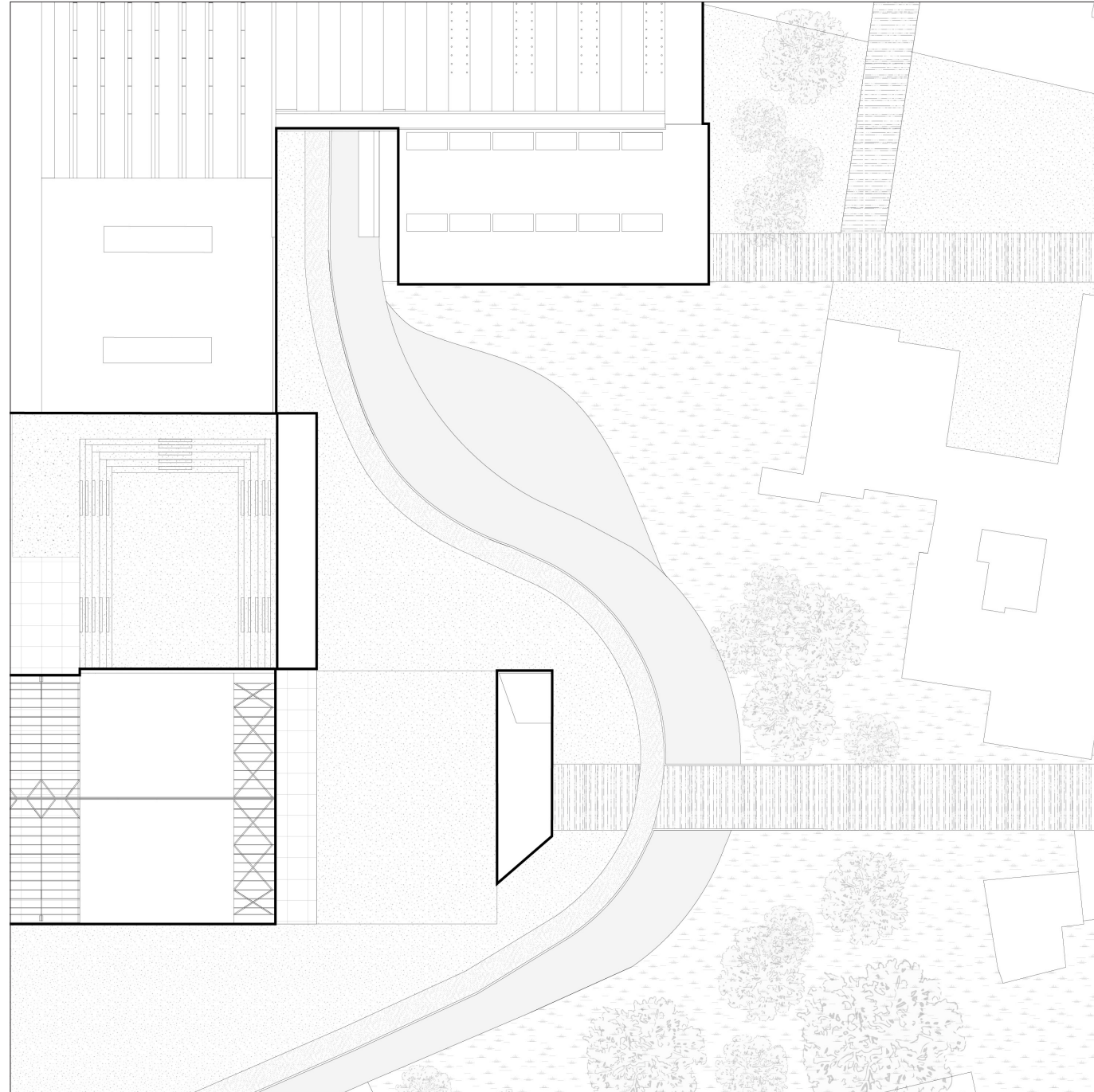
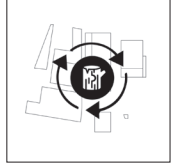
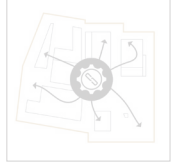
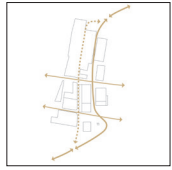
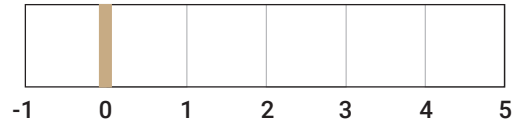



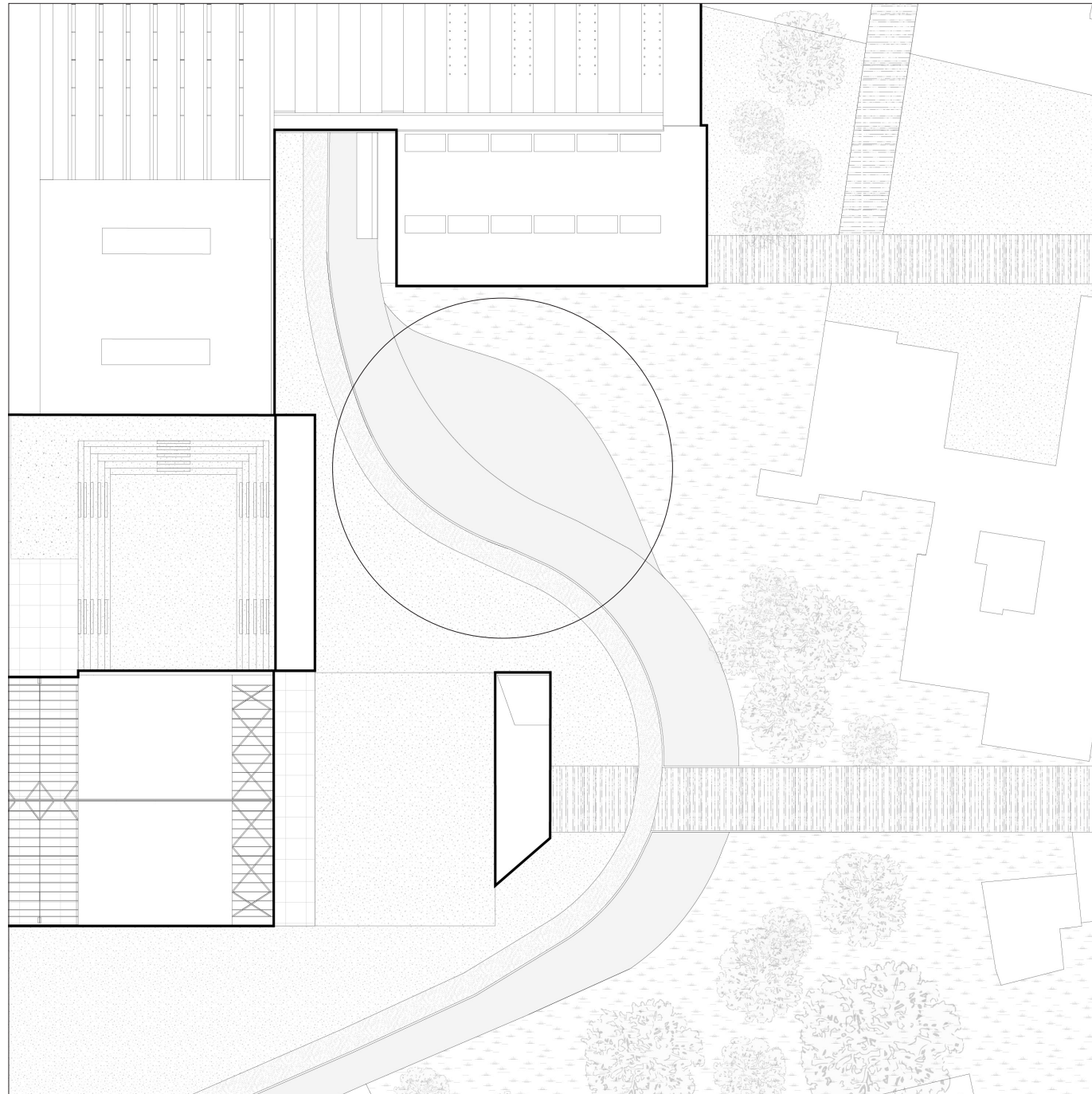
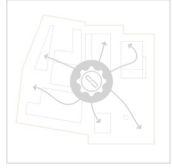
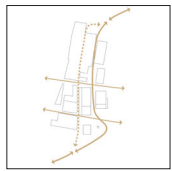
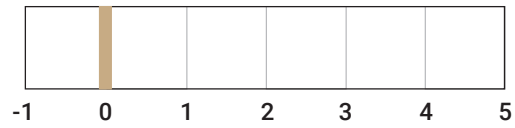

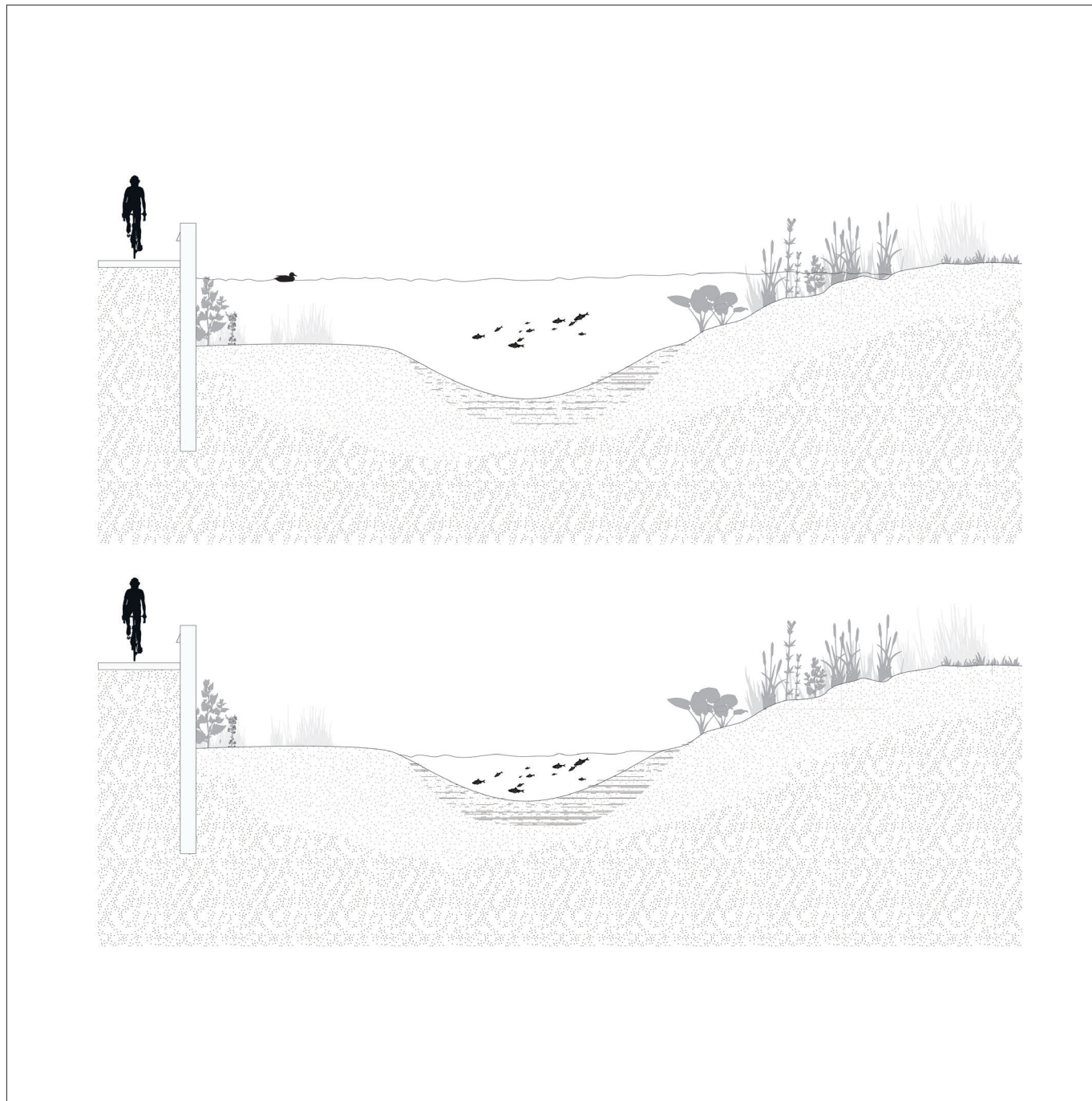
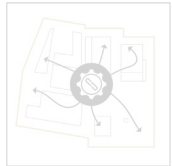
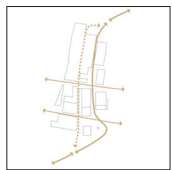

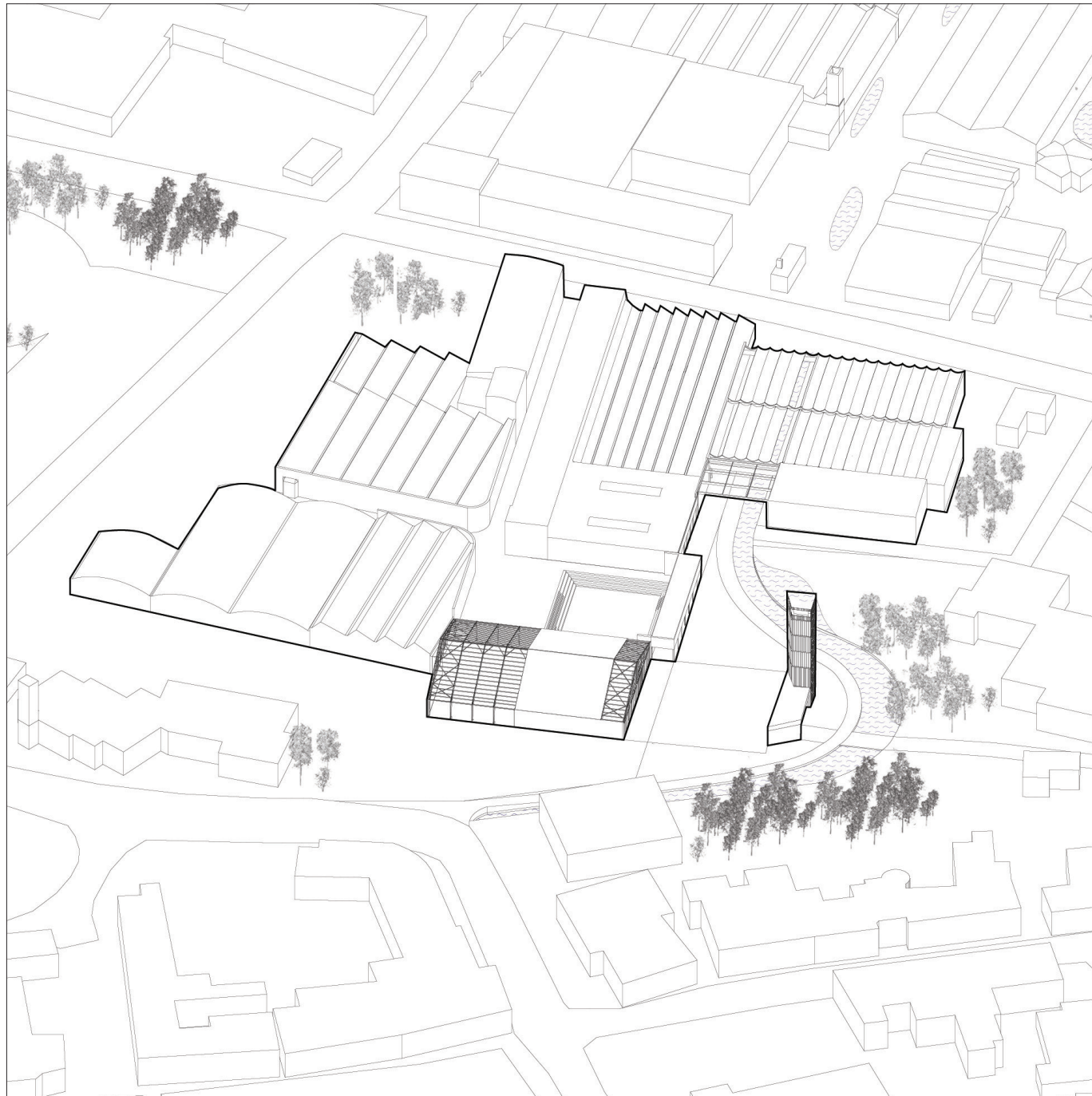
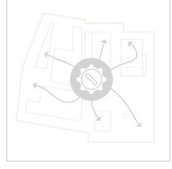
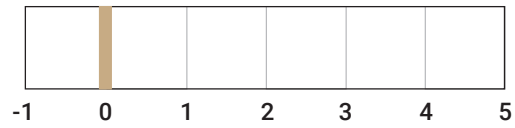

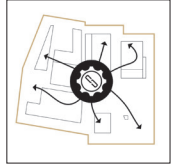







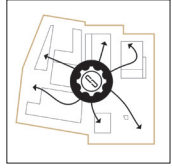
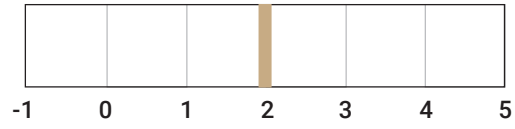









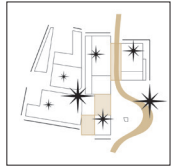
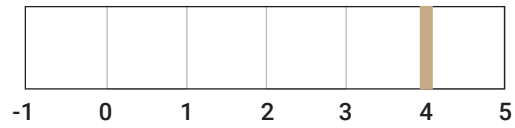

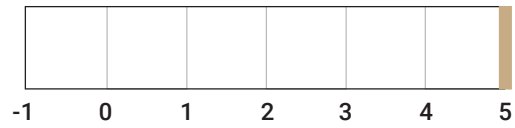

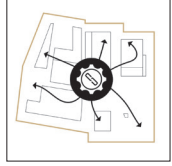
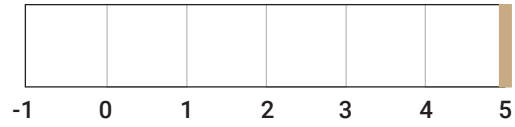

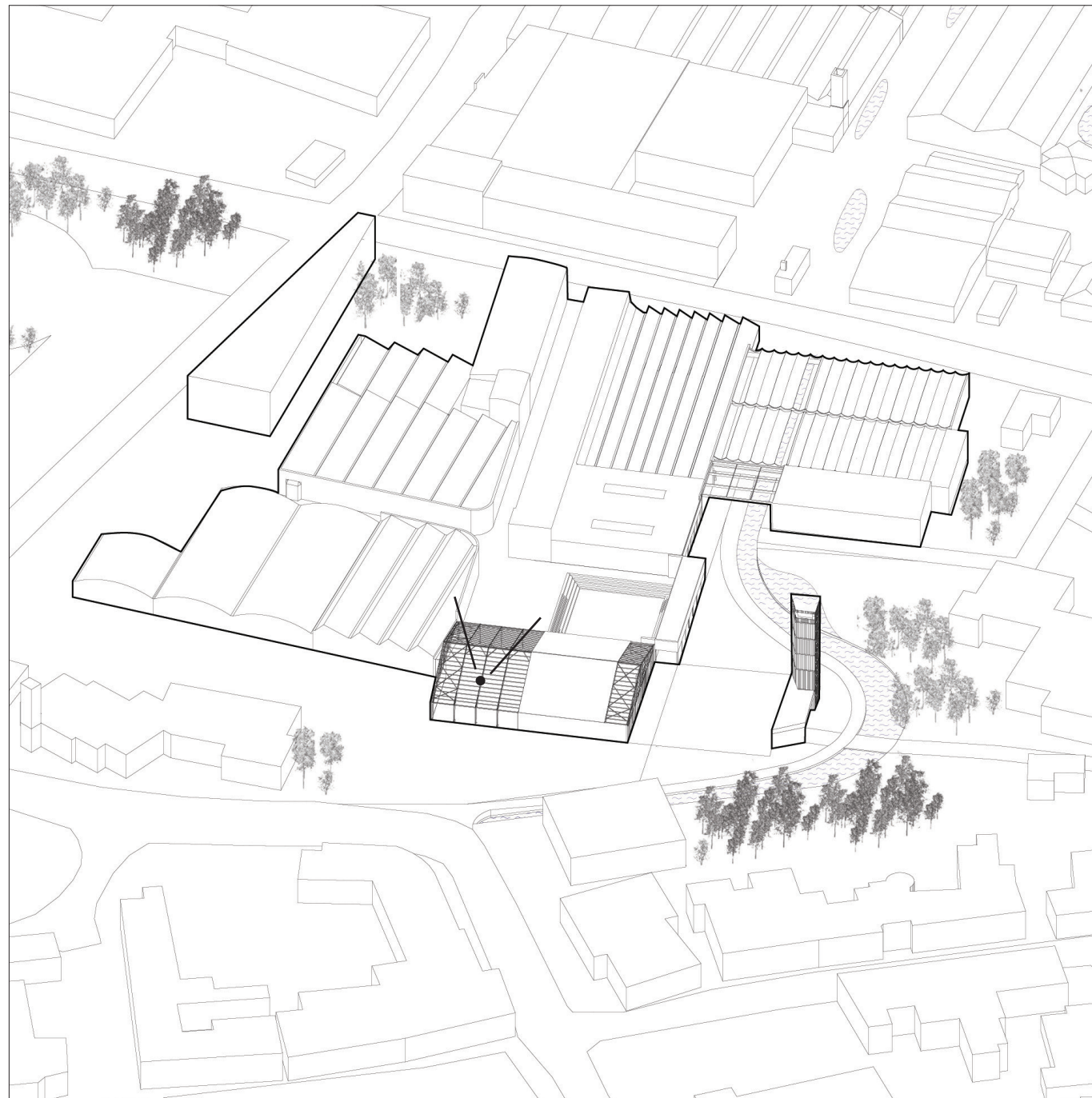
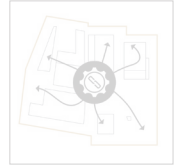





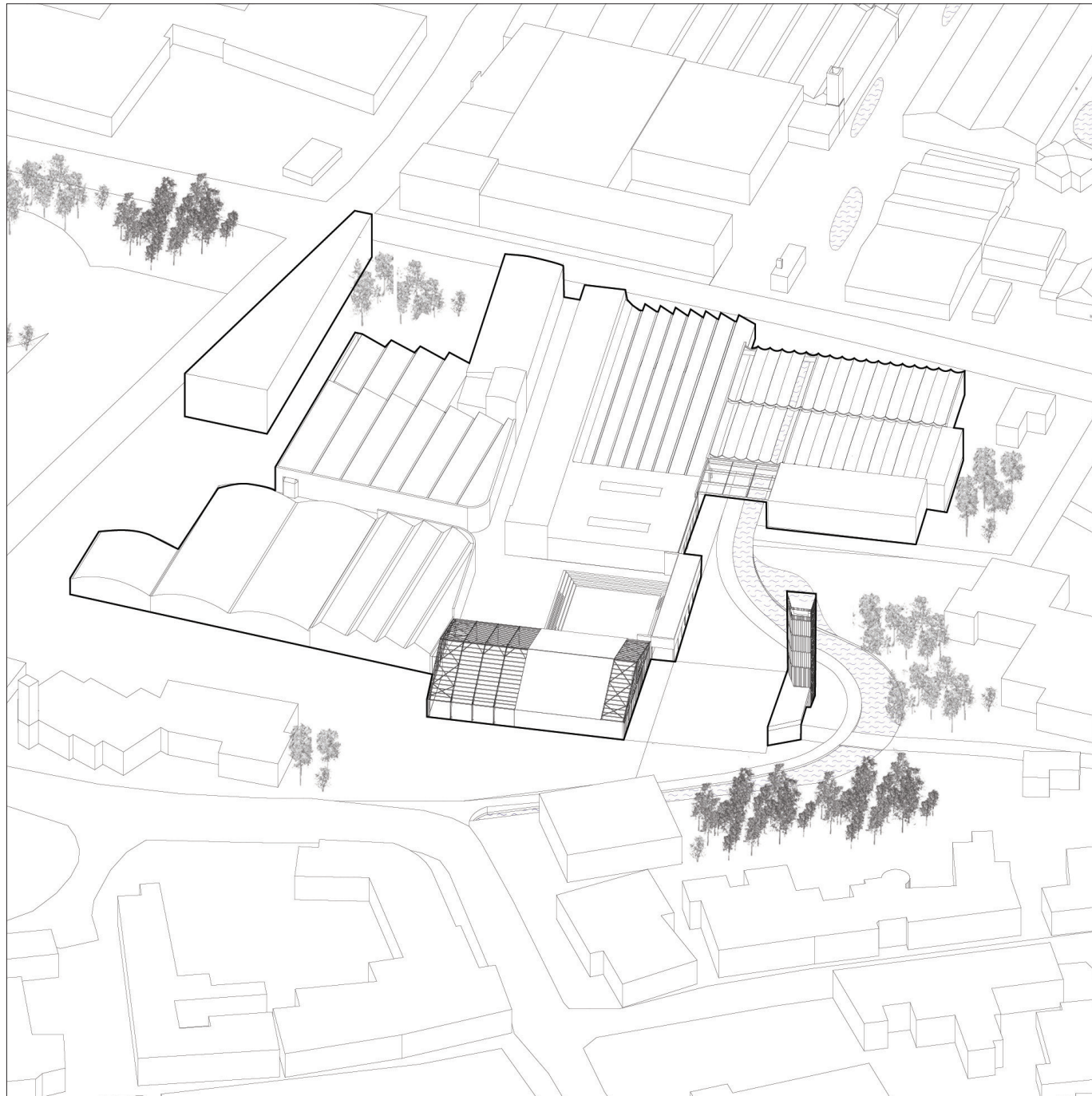
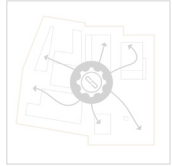
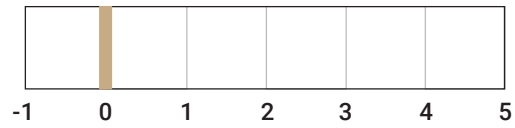

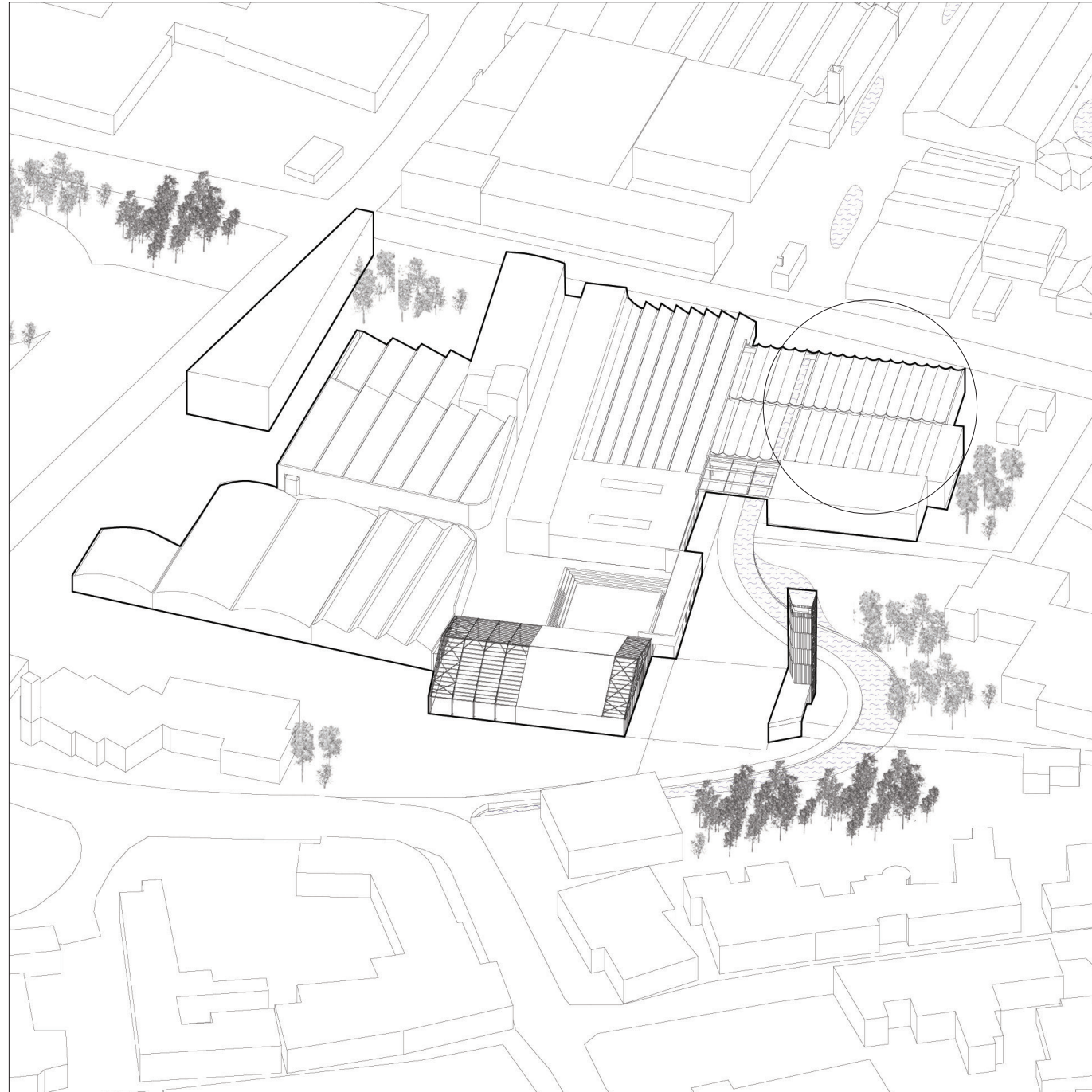
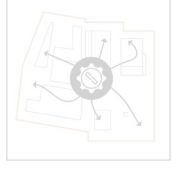
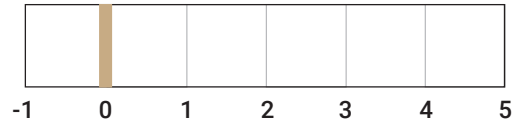



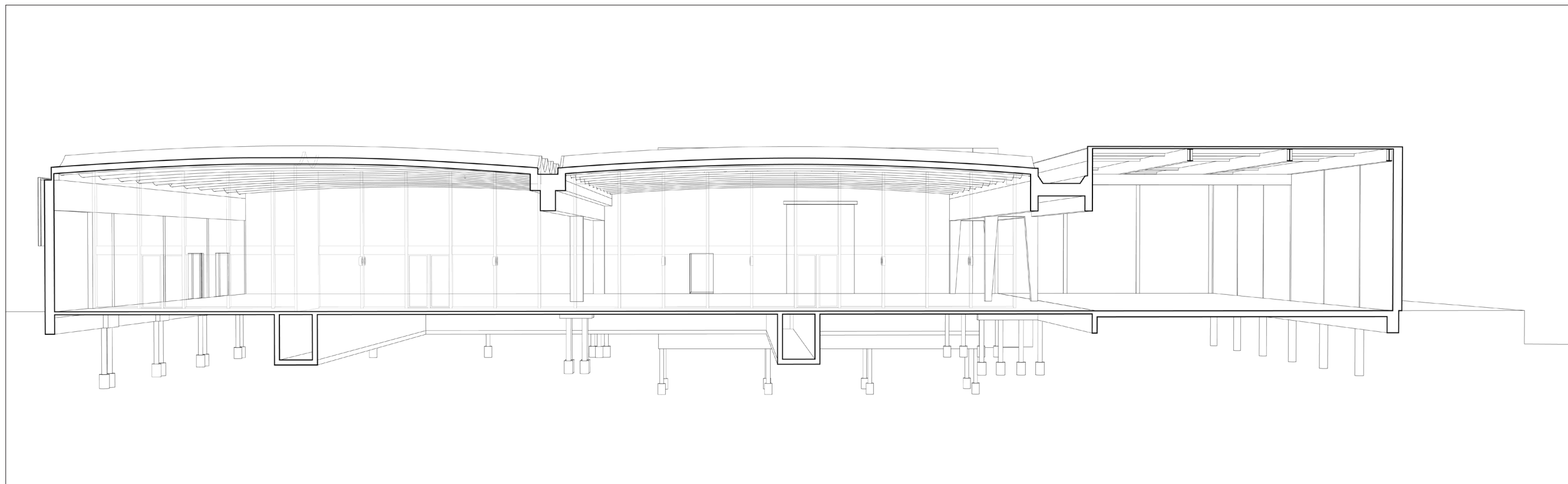
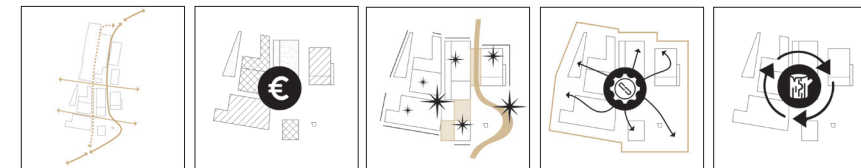
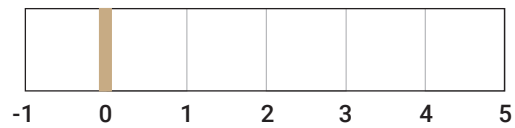

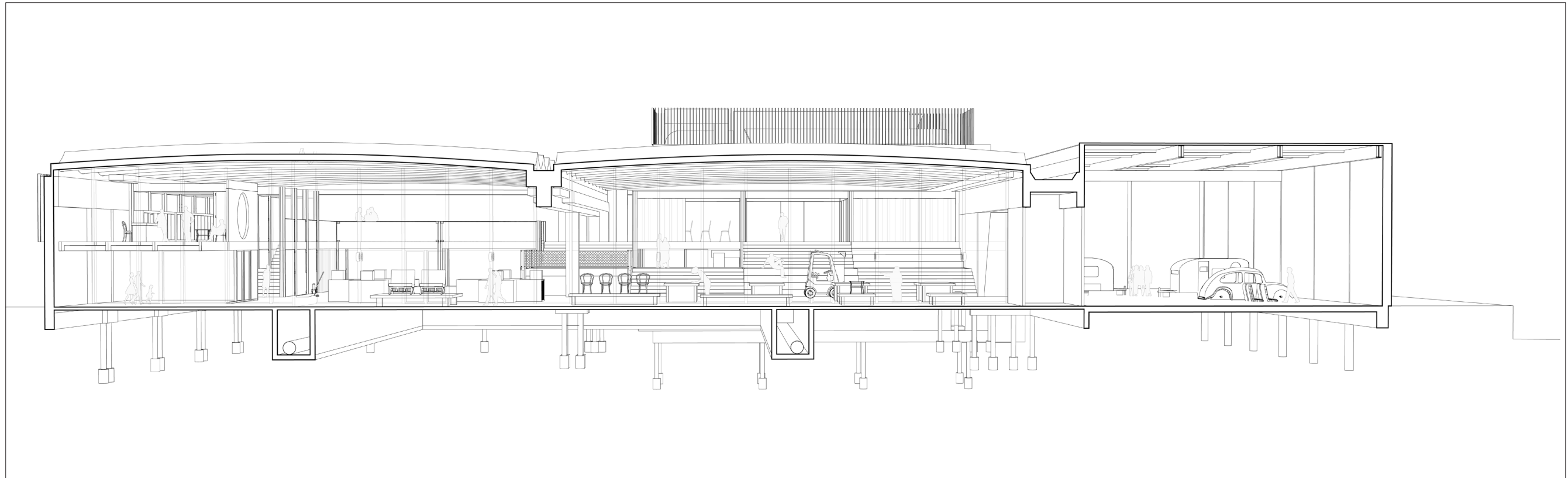
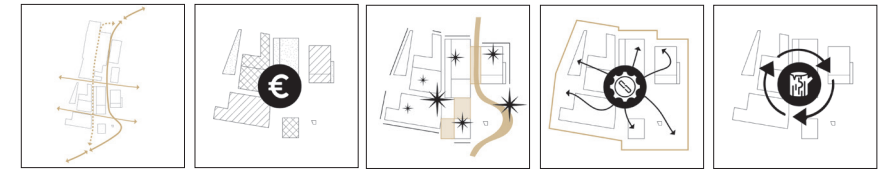
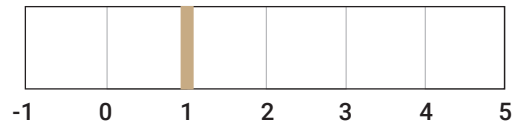

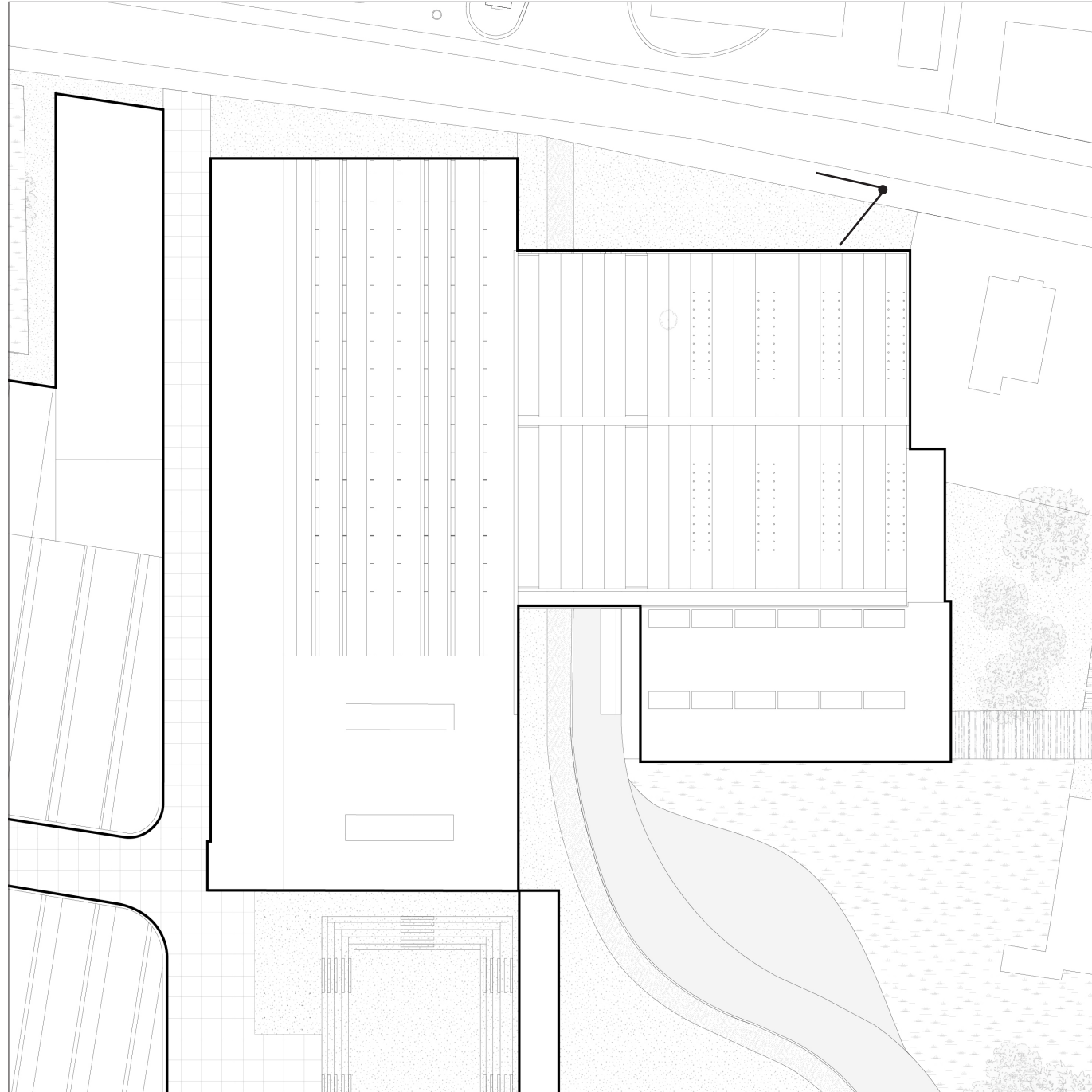
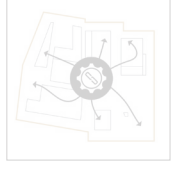
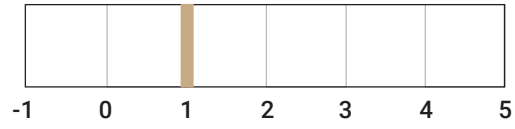



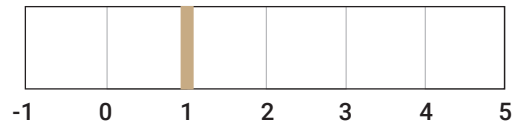





# DE WERKPLAATS

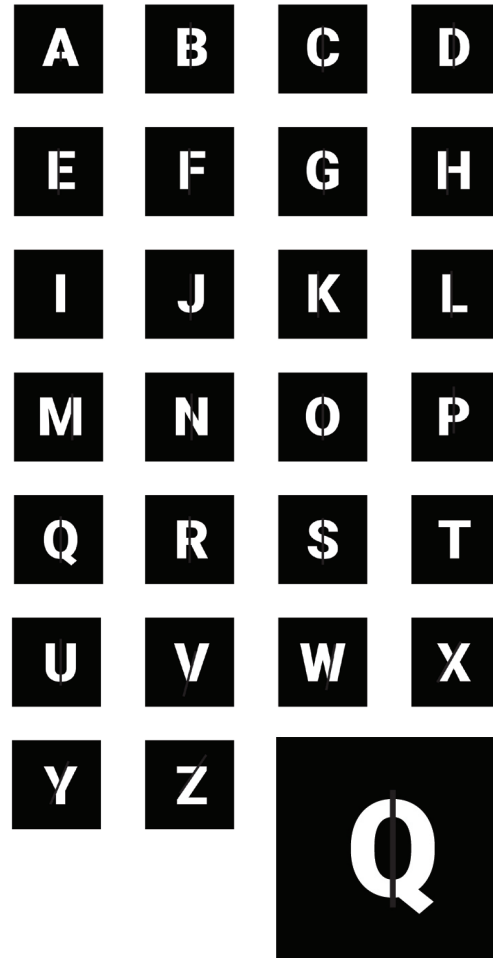

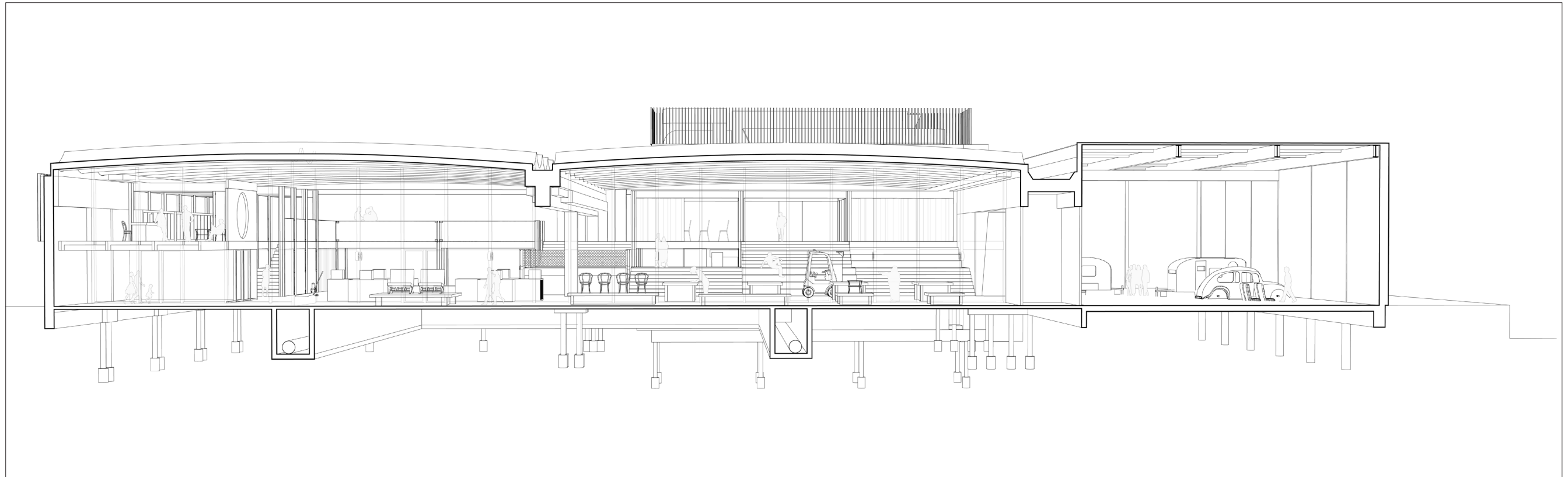
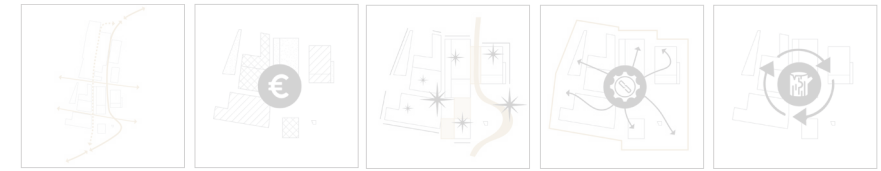
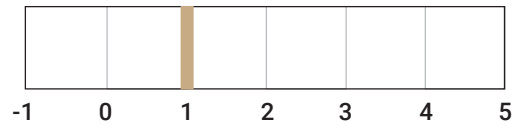

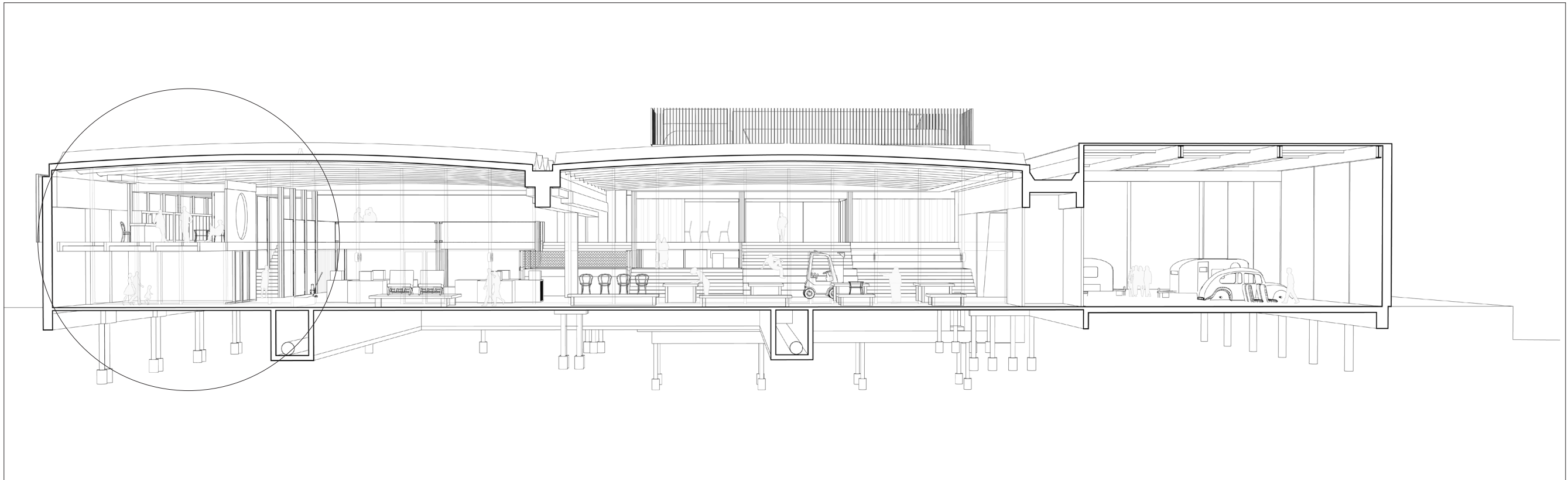
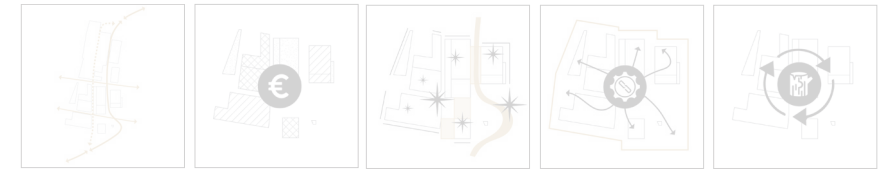
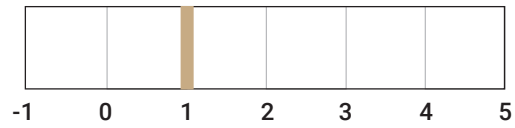

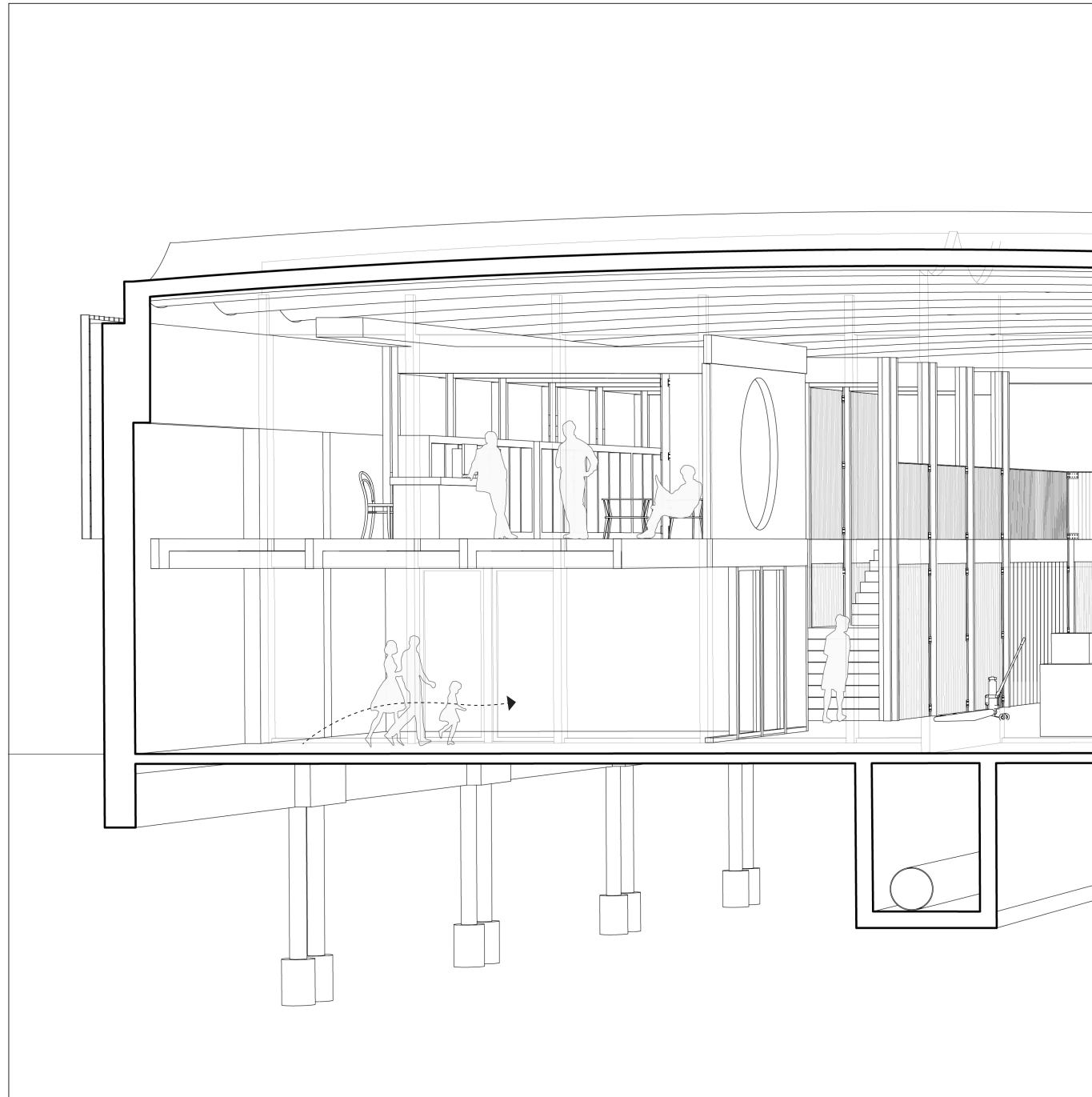
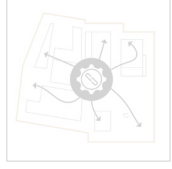
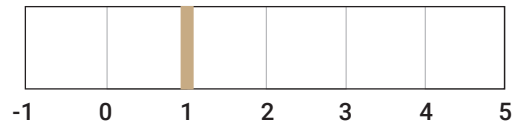

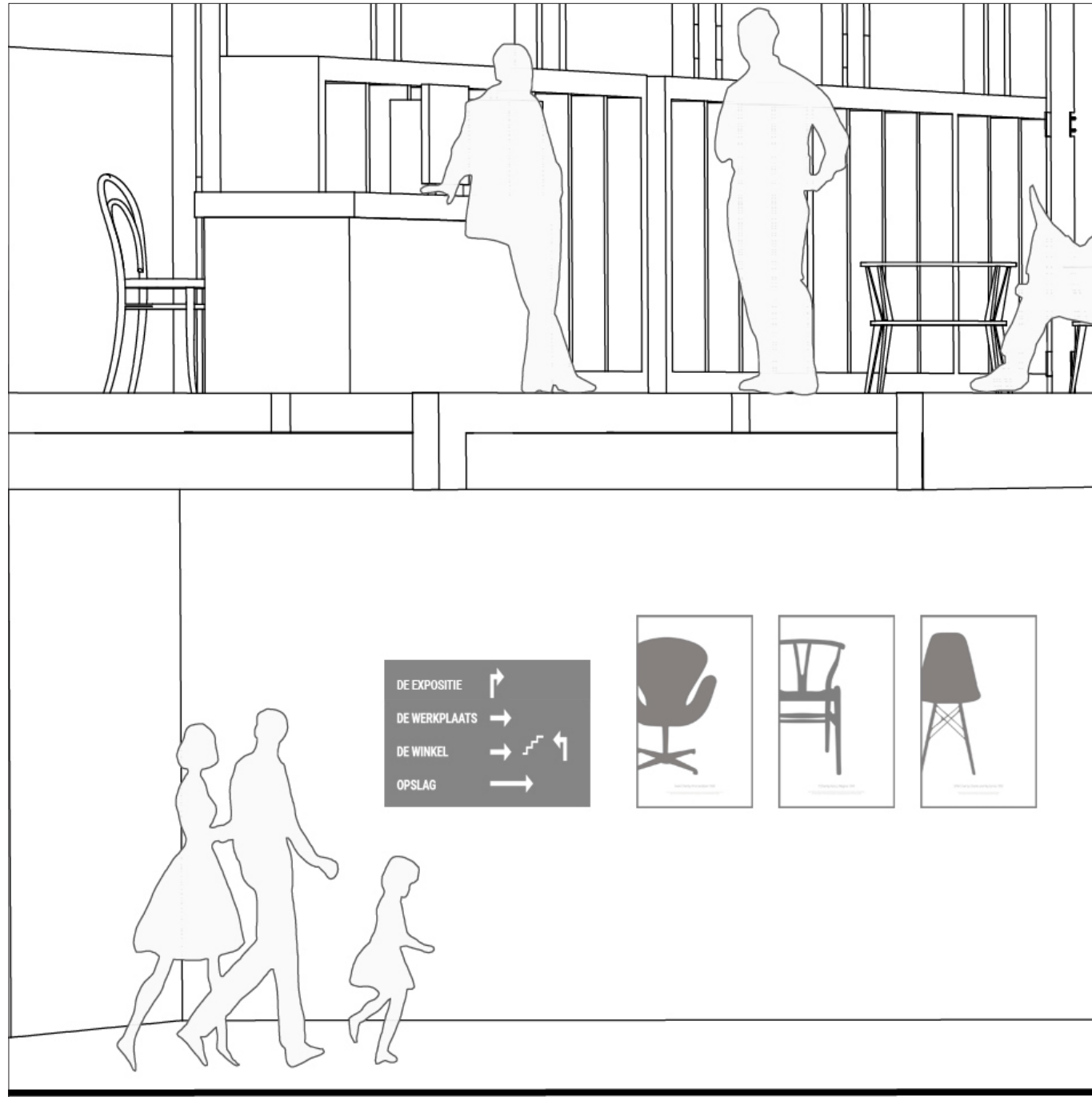
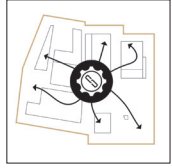
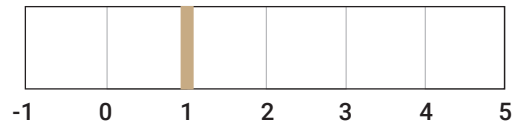

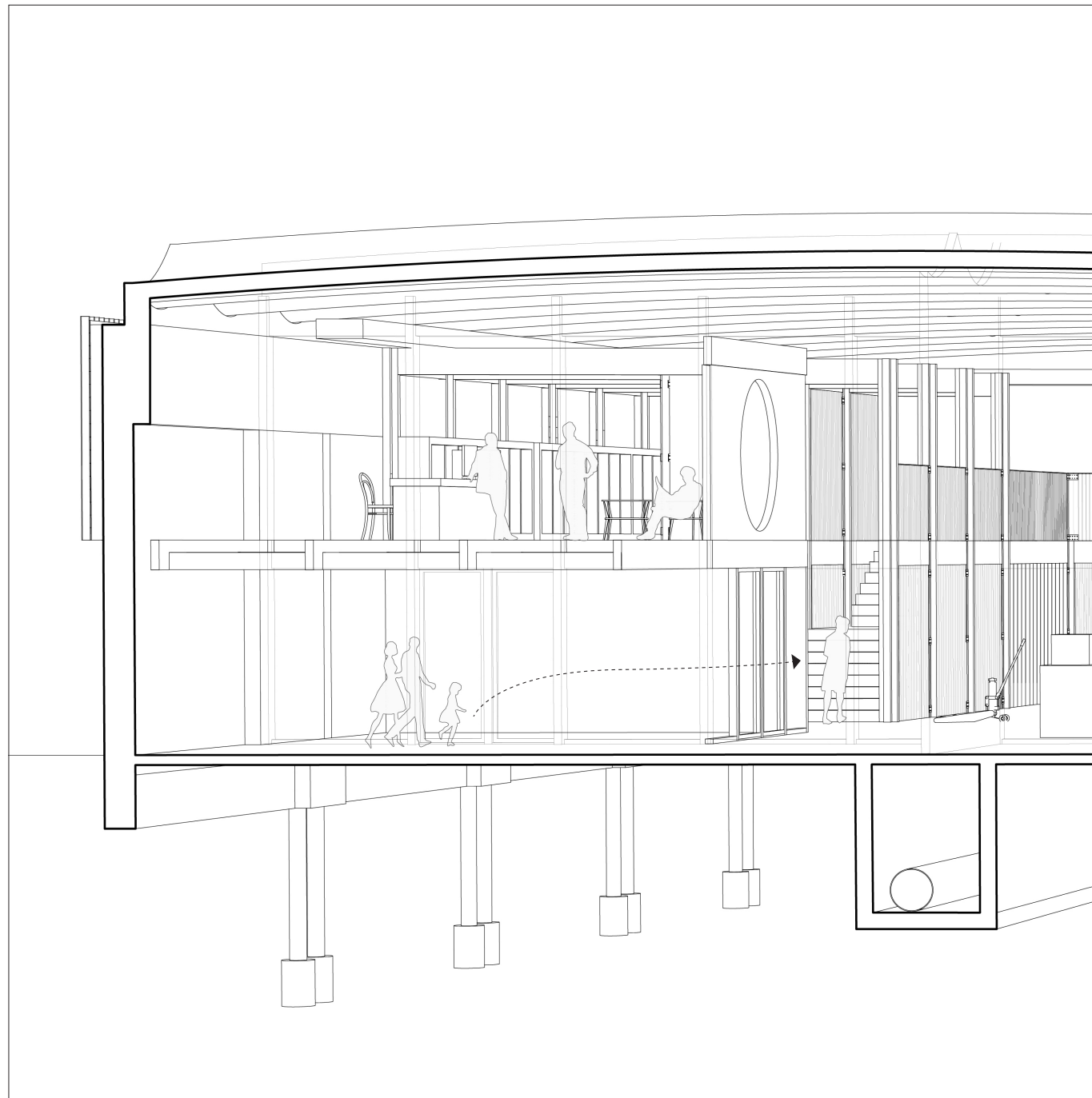
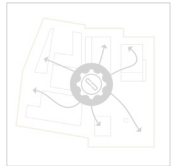
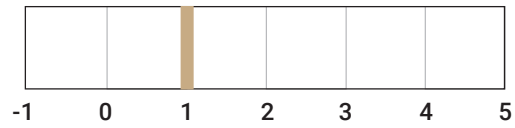





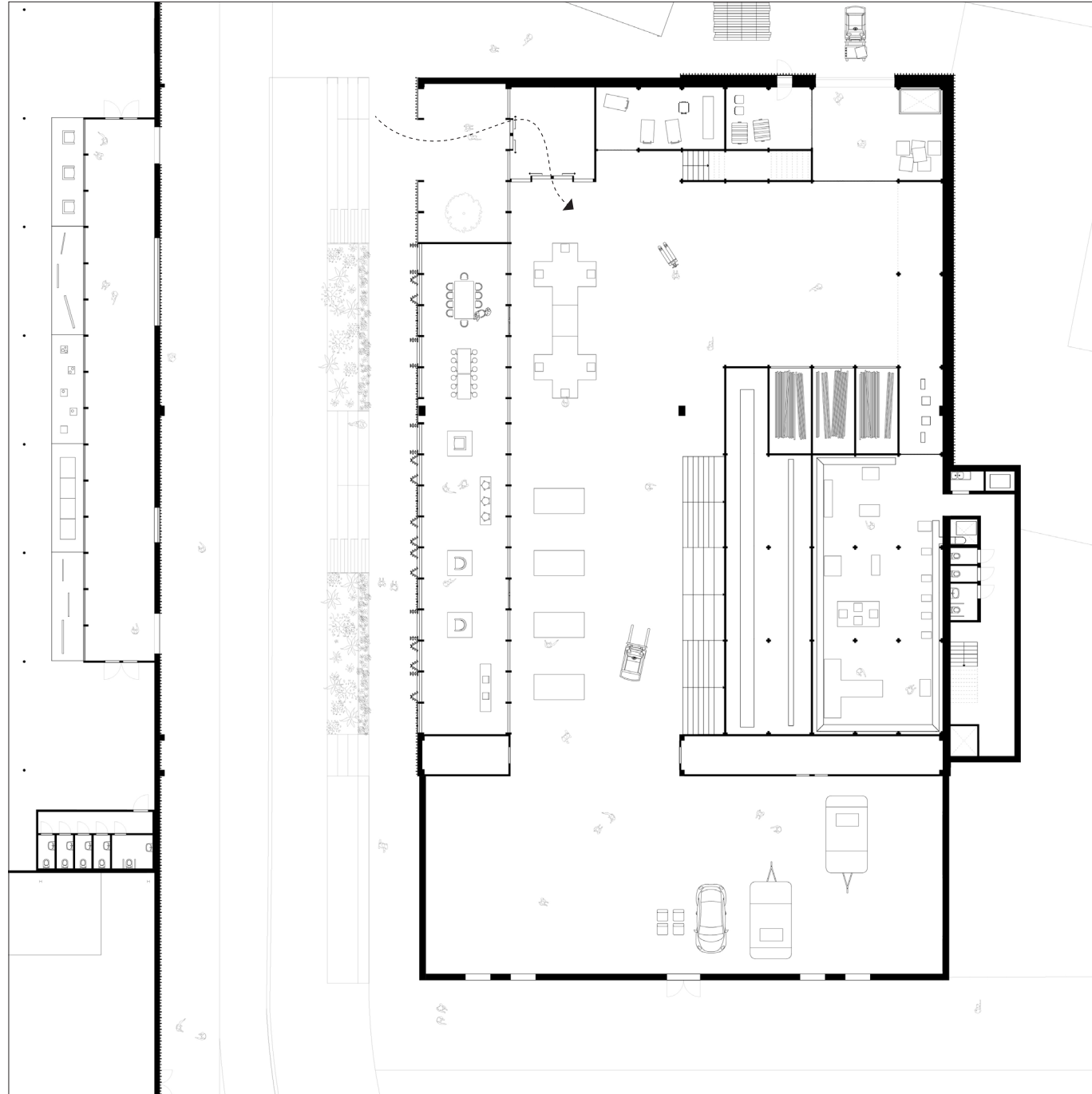
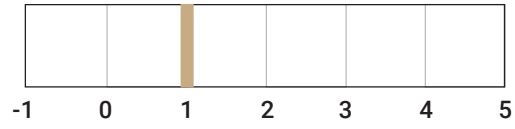

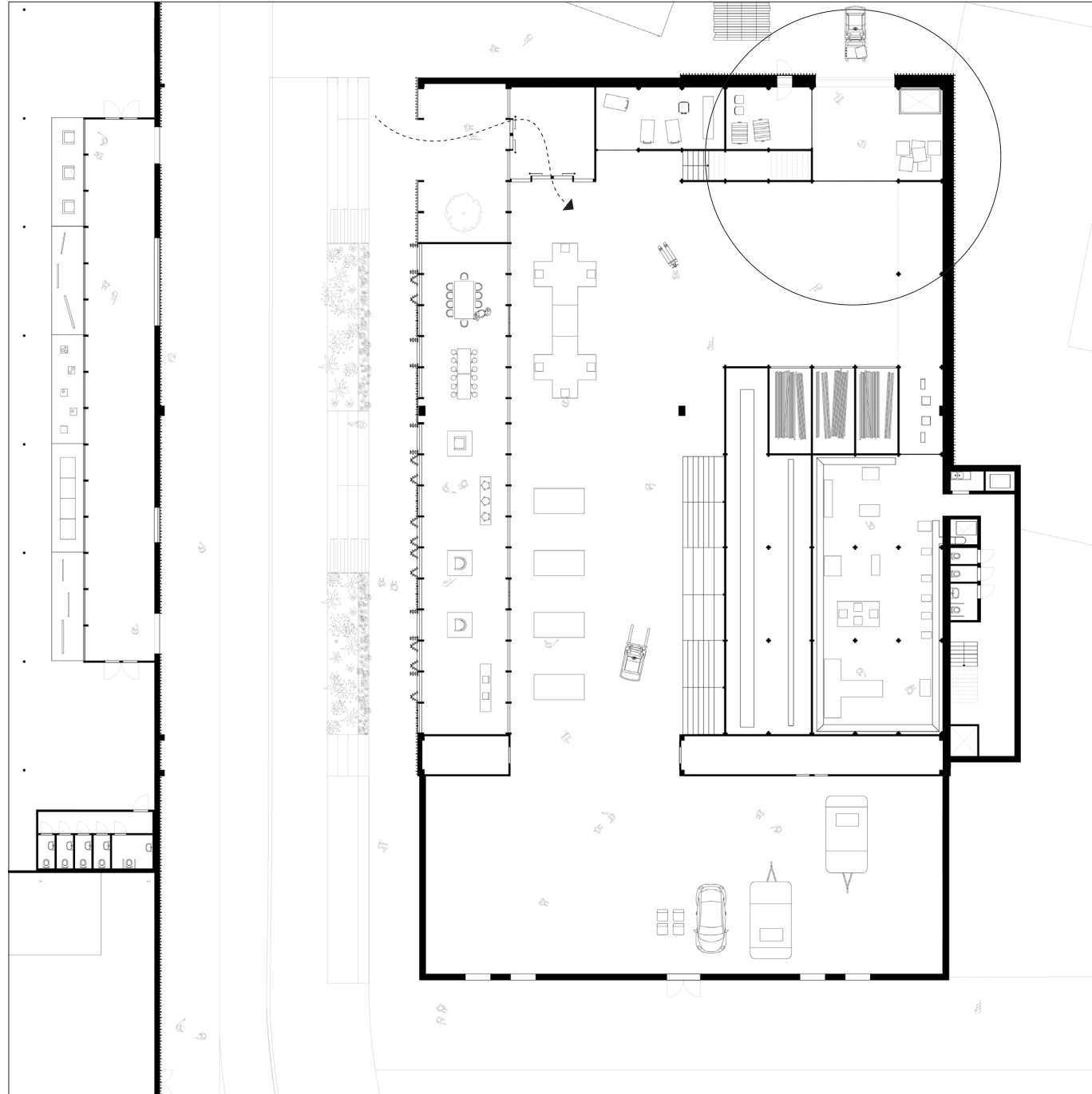
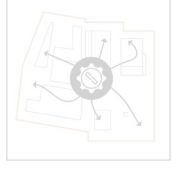
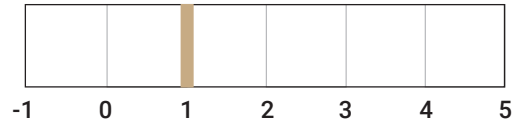

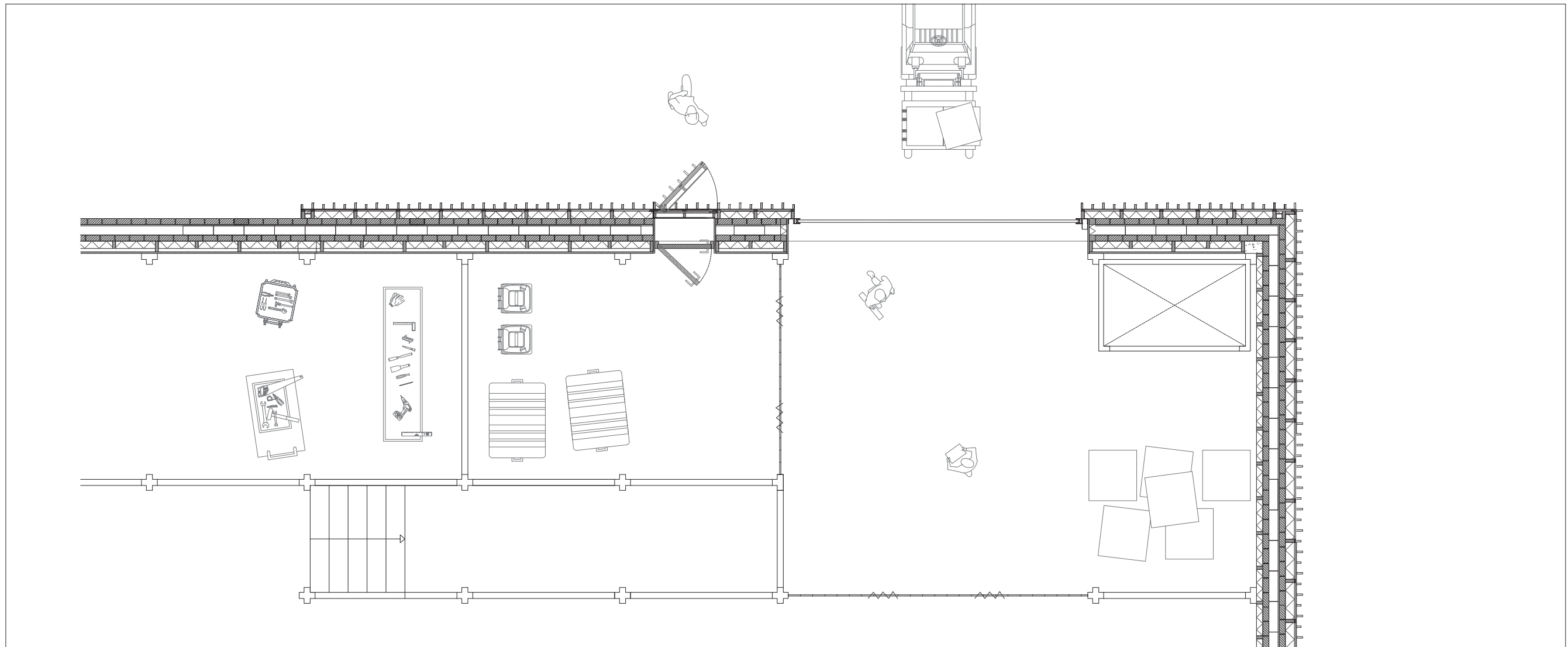
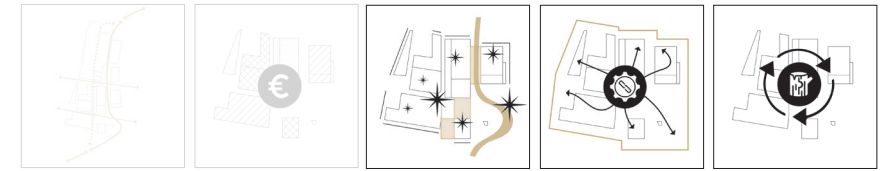
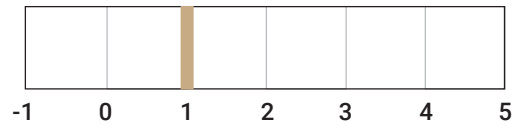

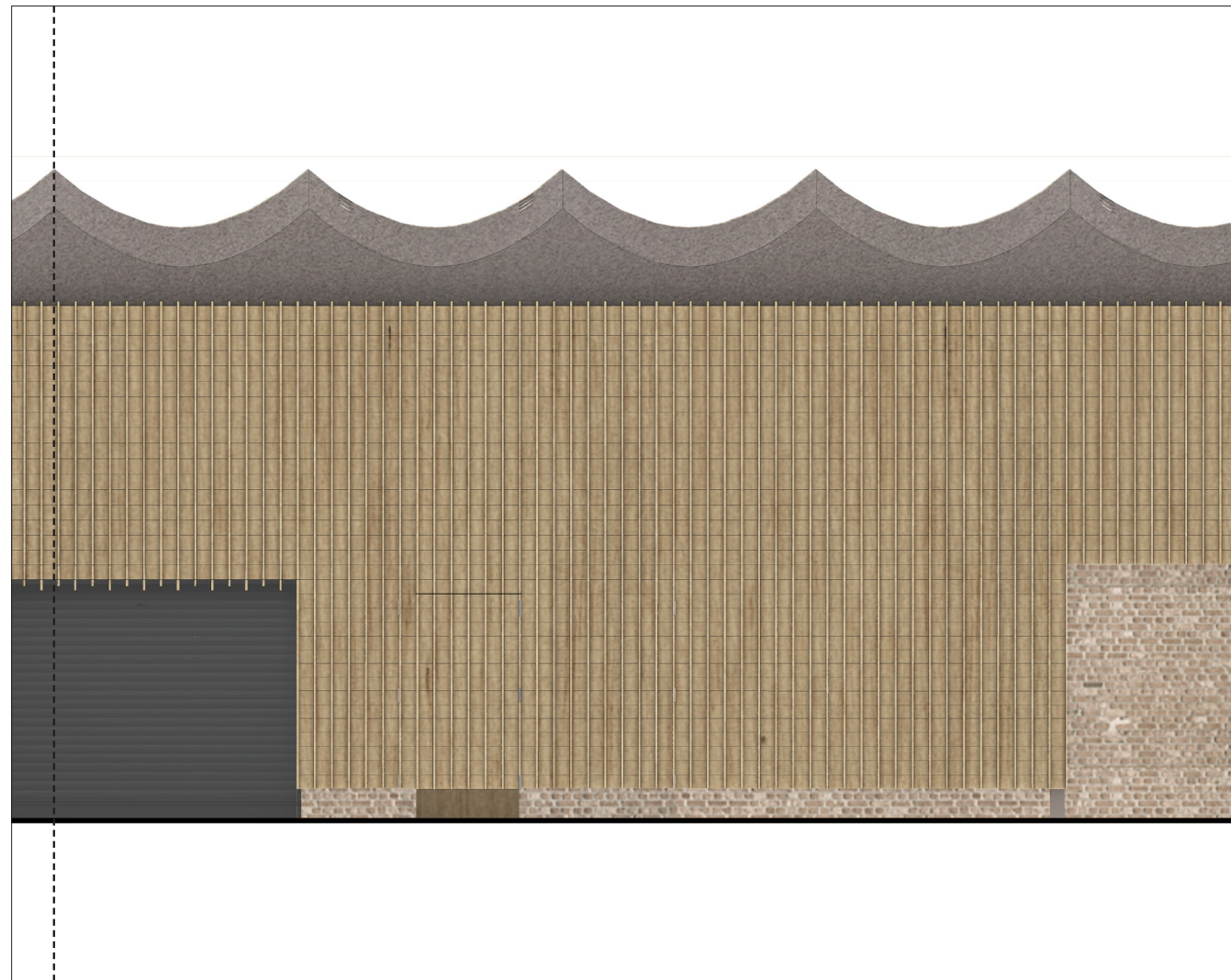
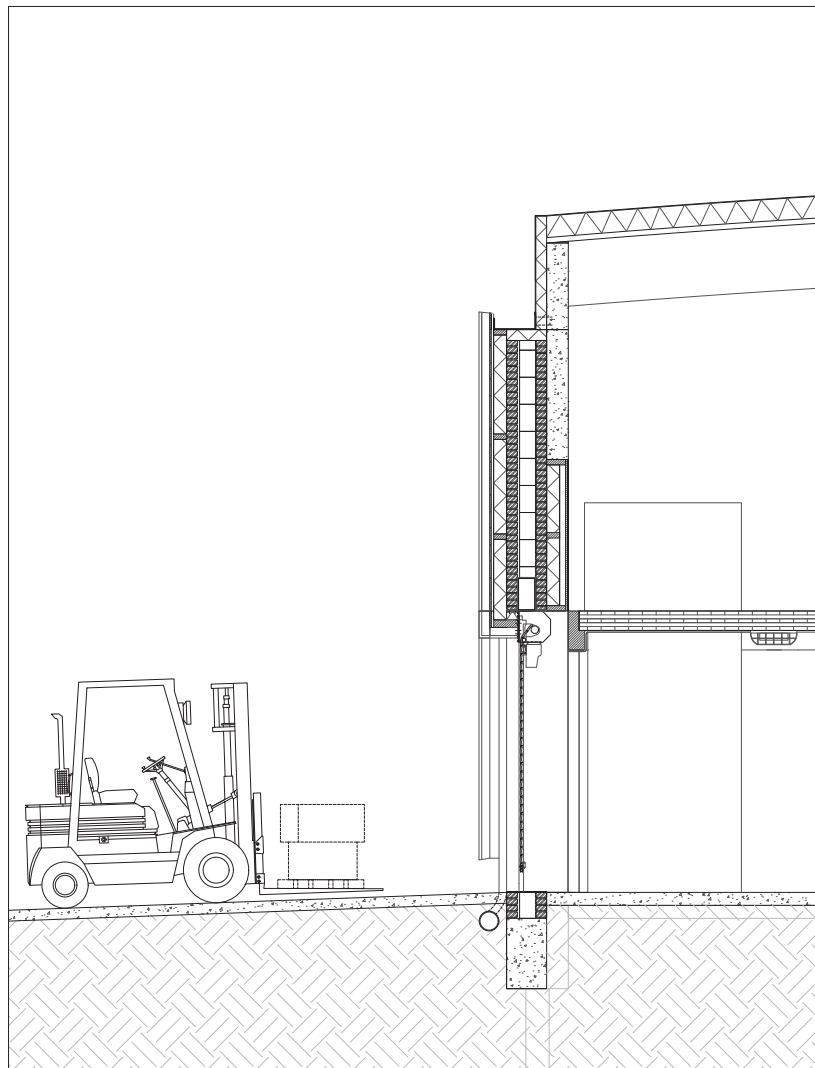
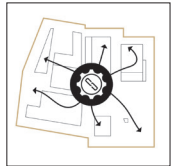
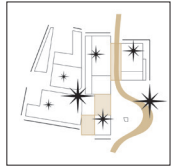
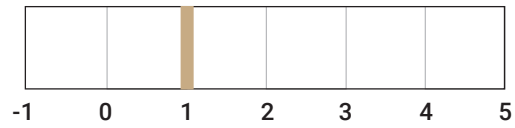

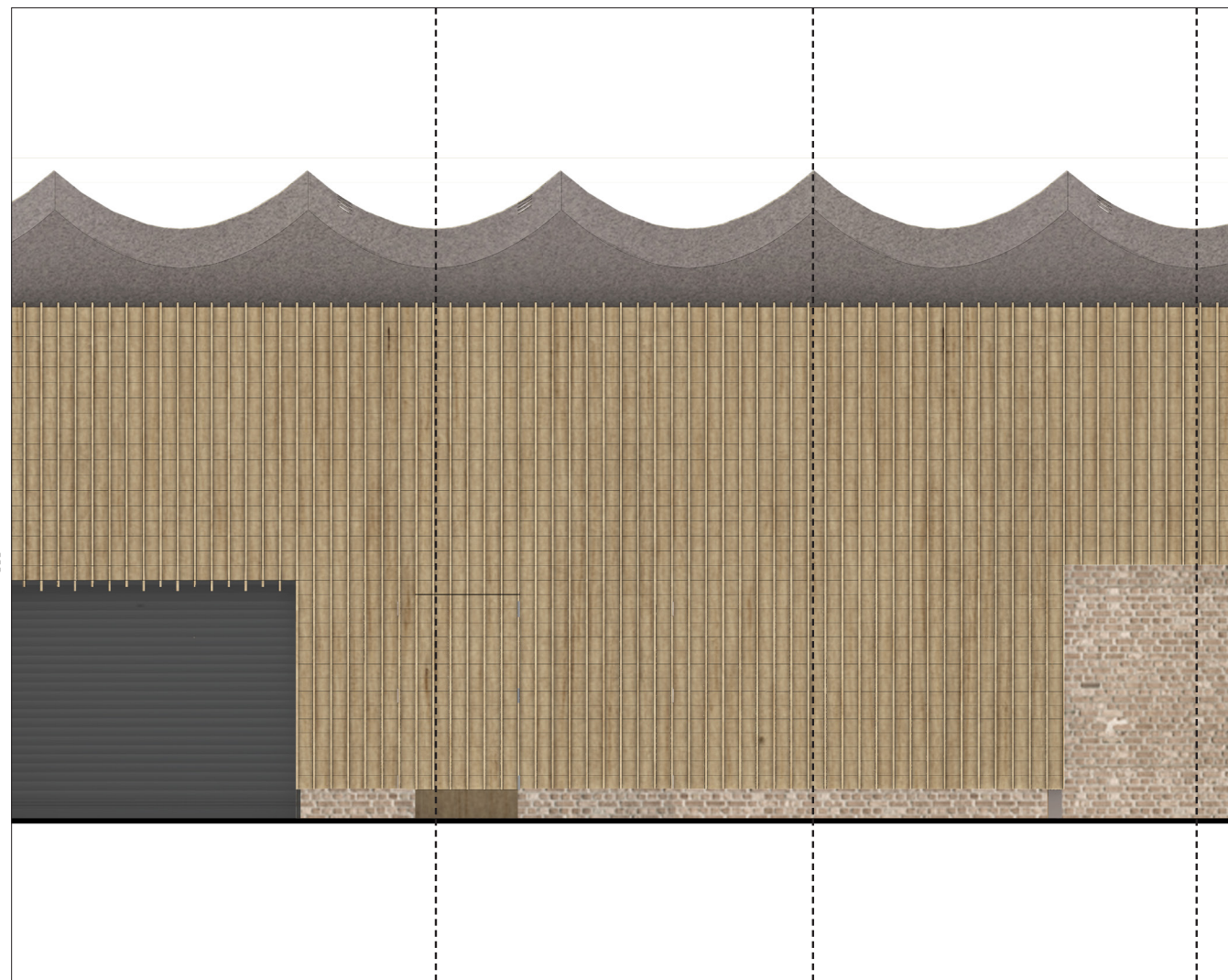
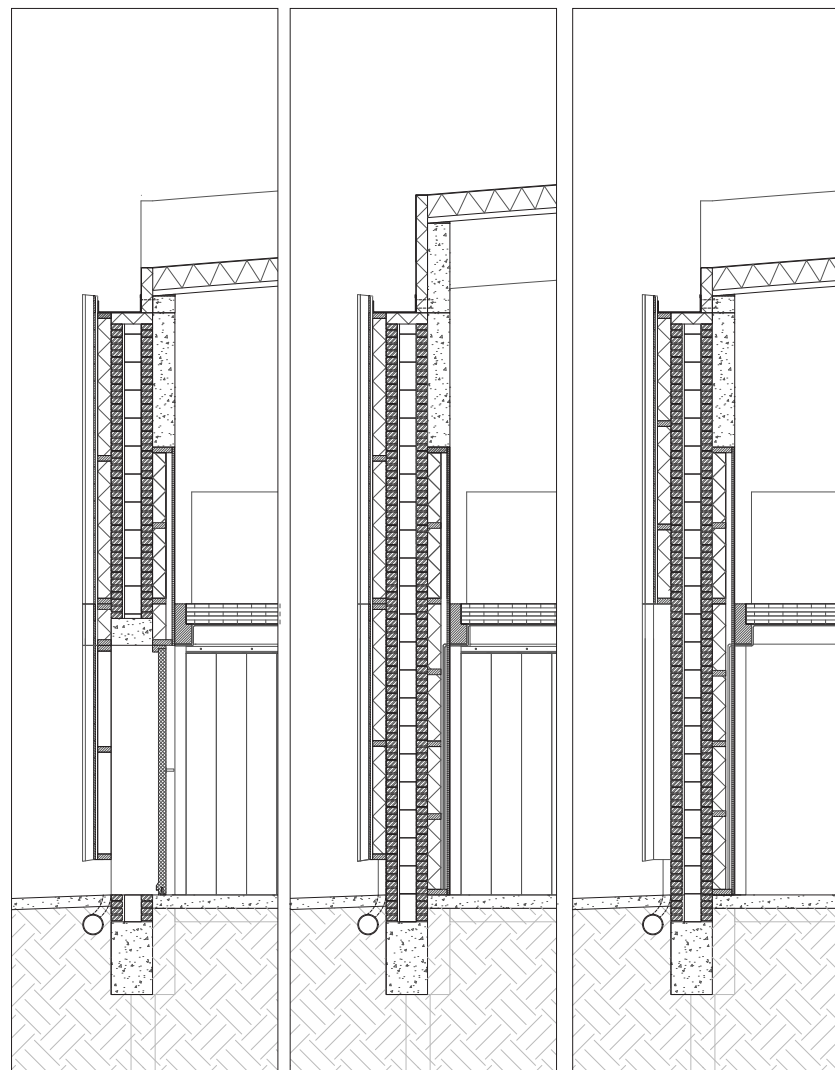
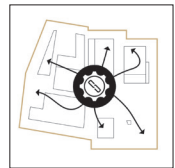
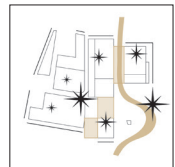
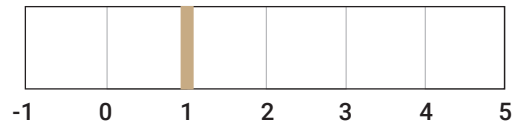

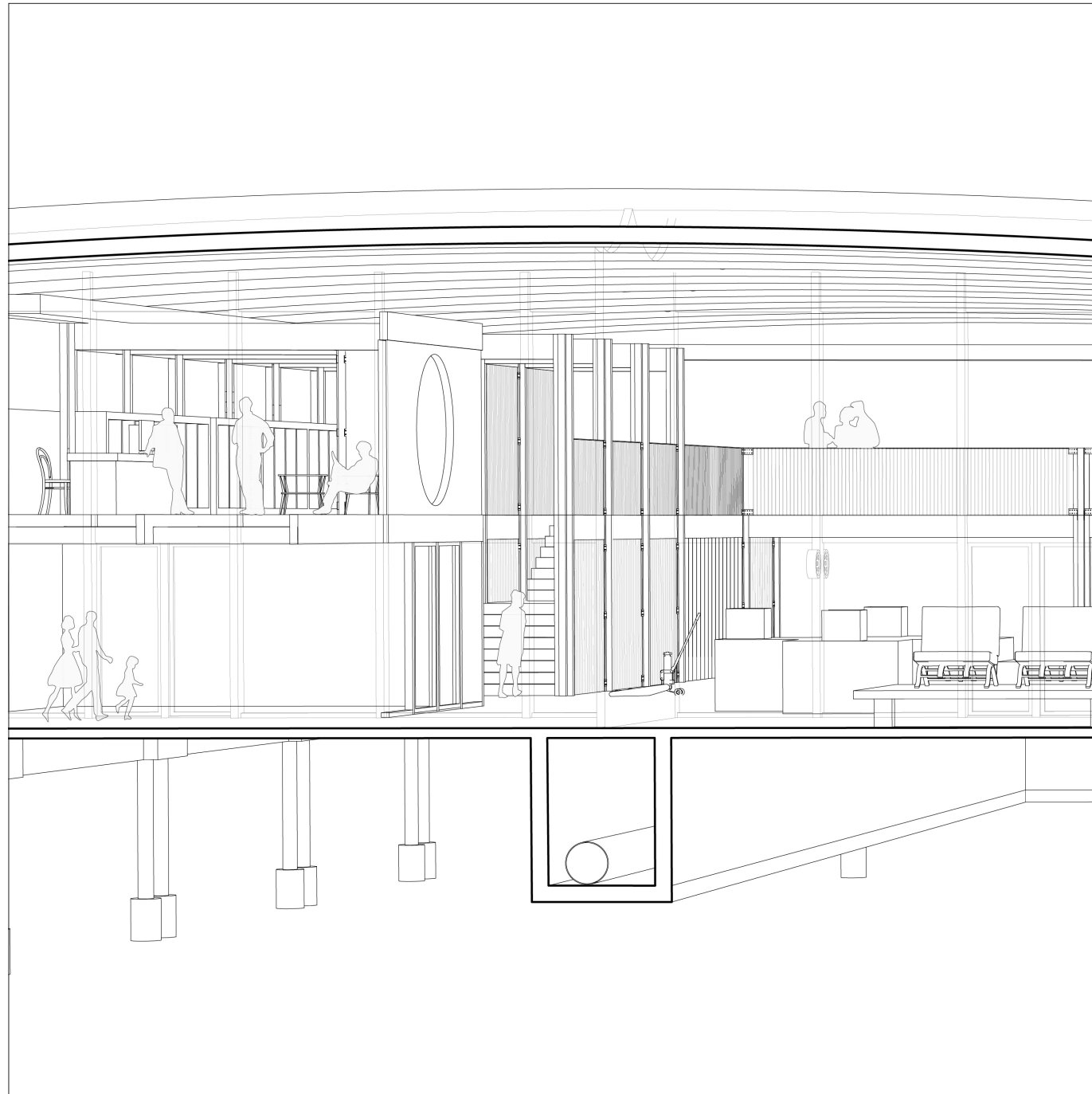
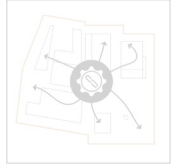
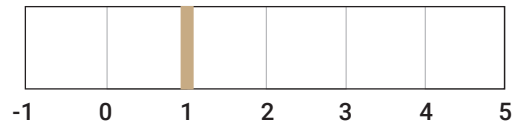













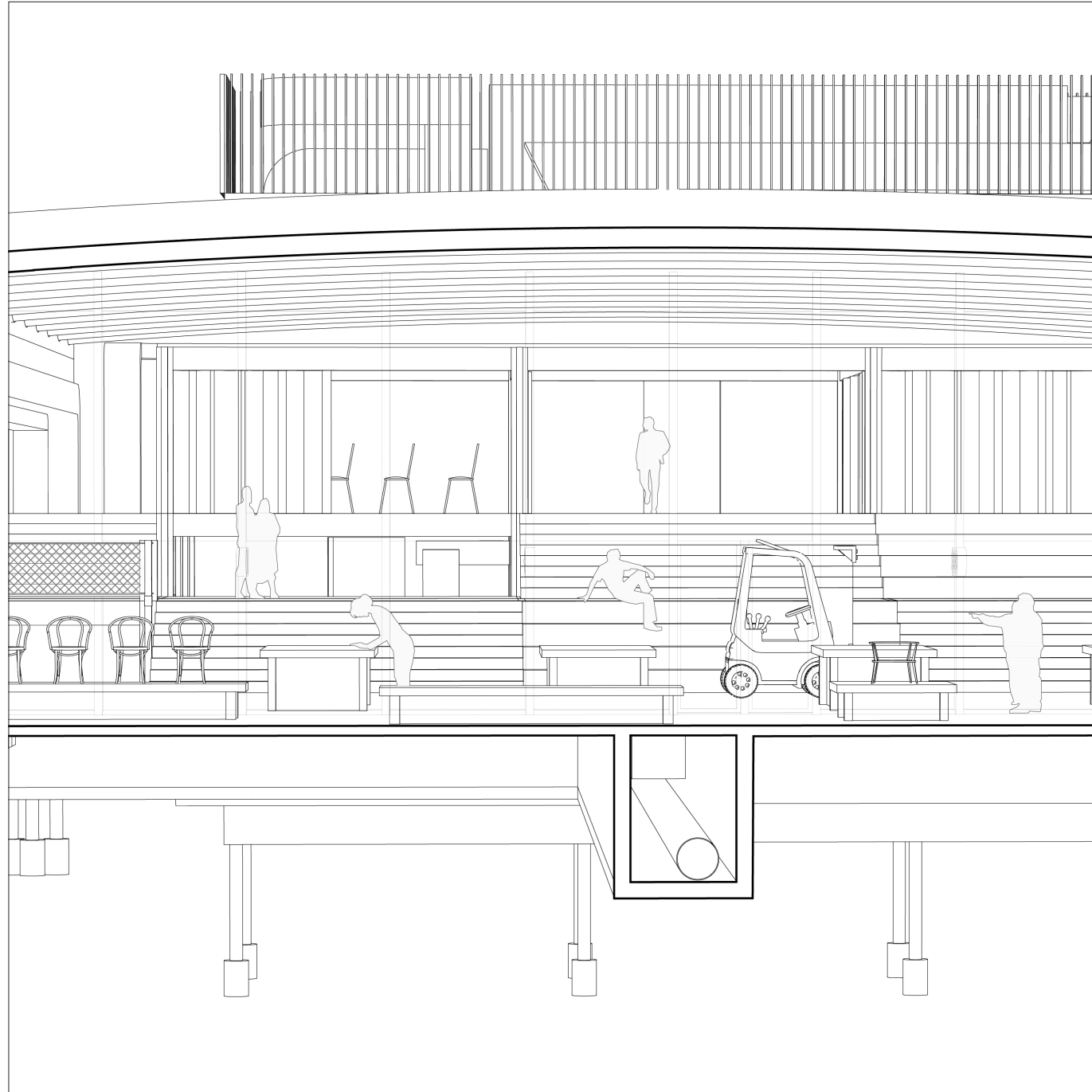
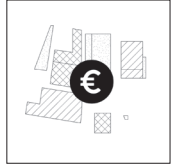



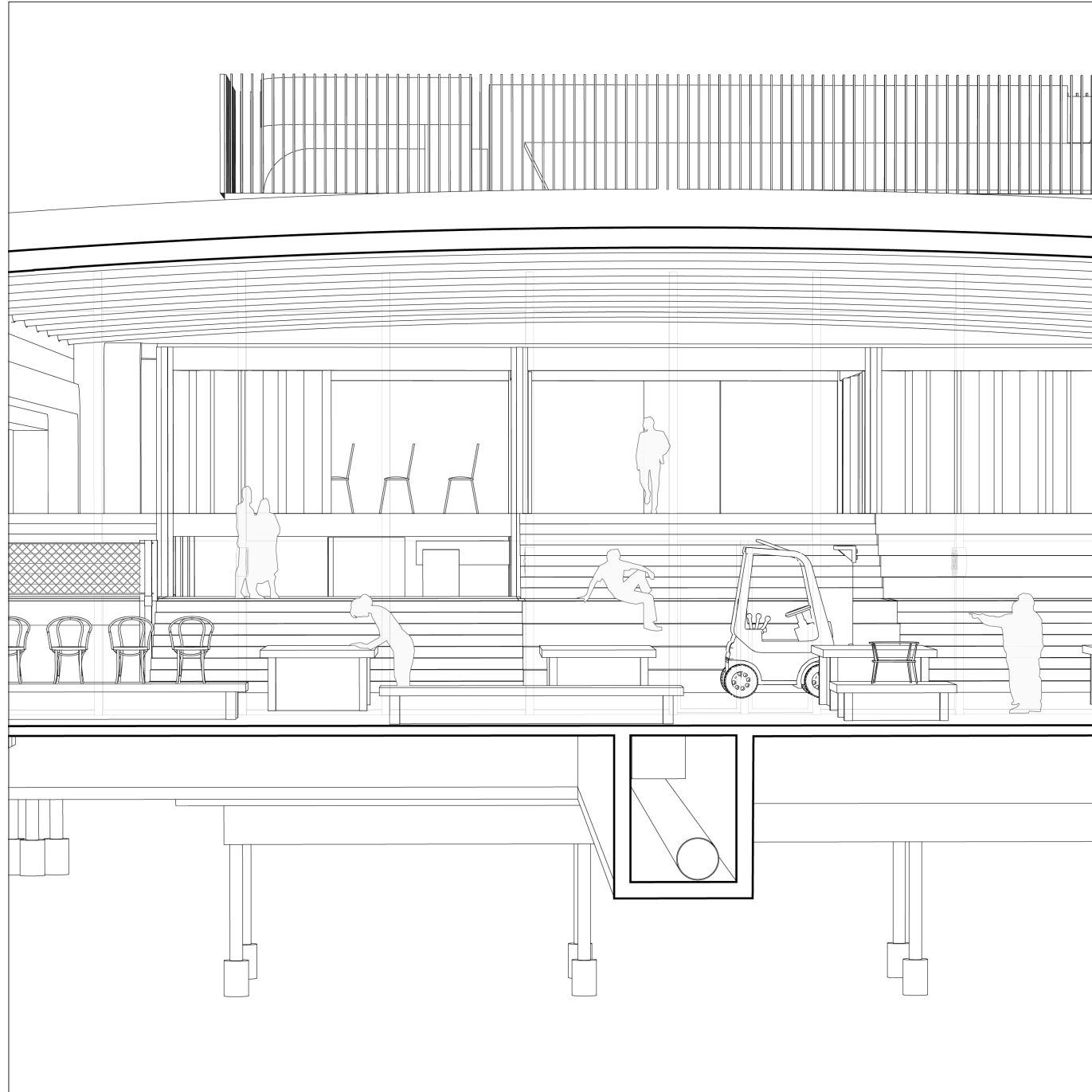
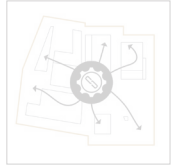
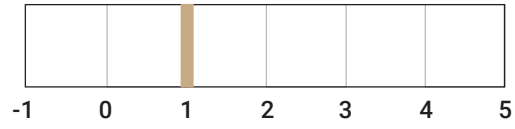

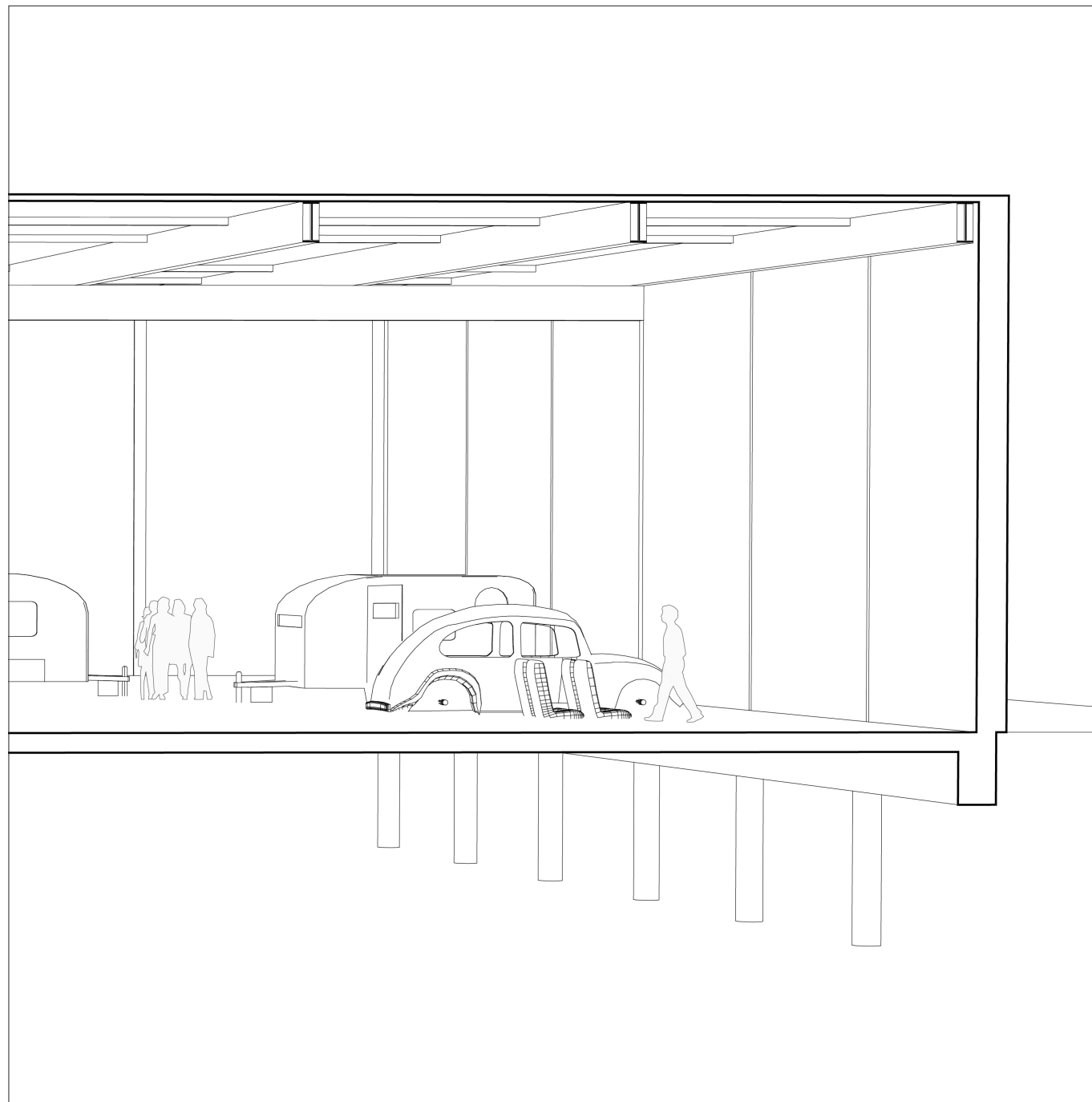
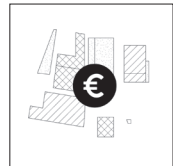
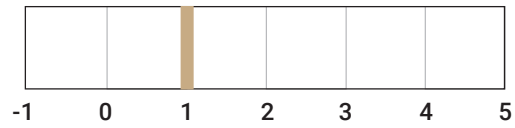

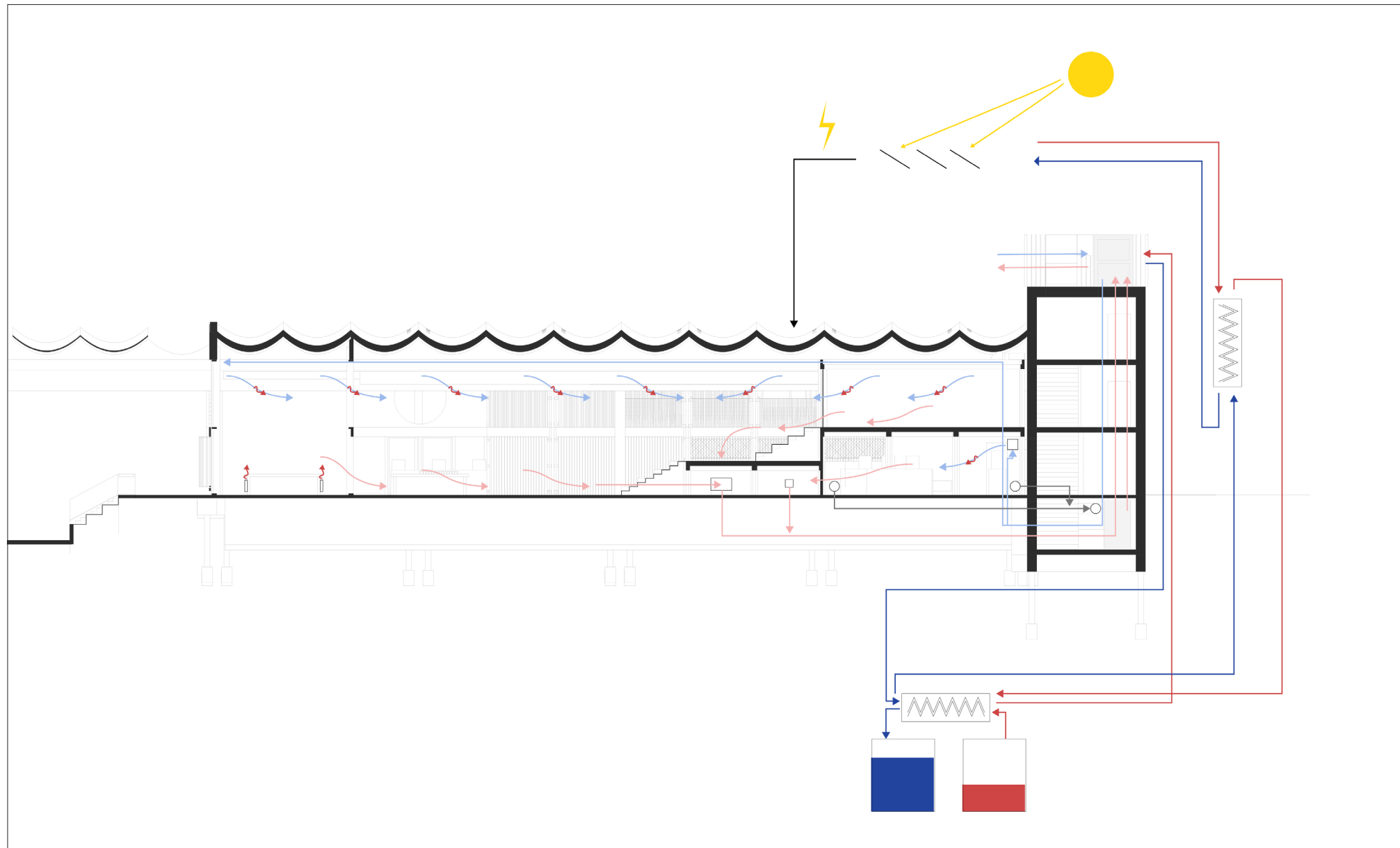
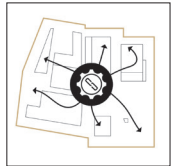
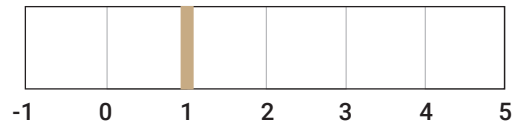



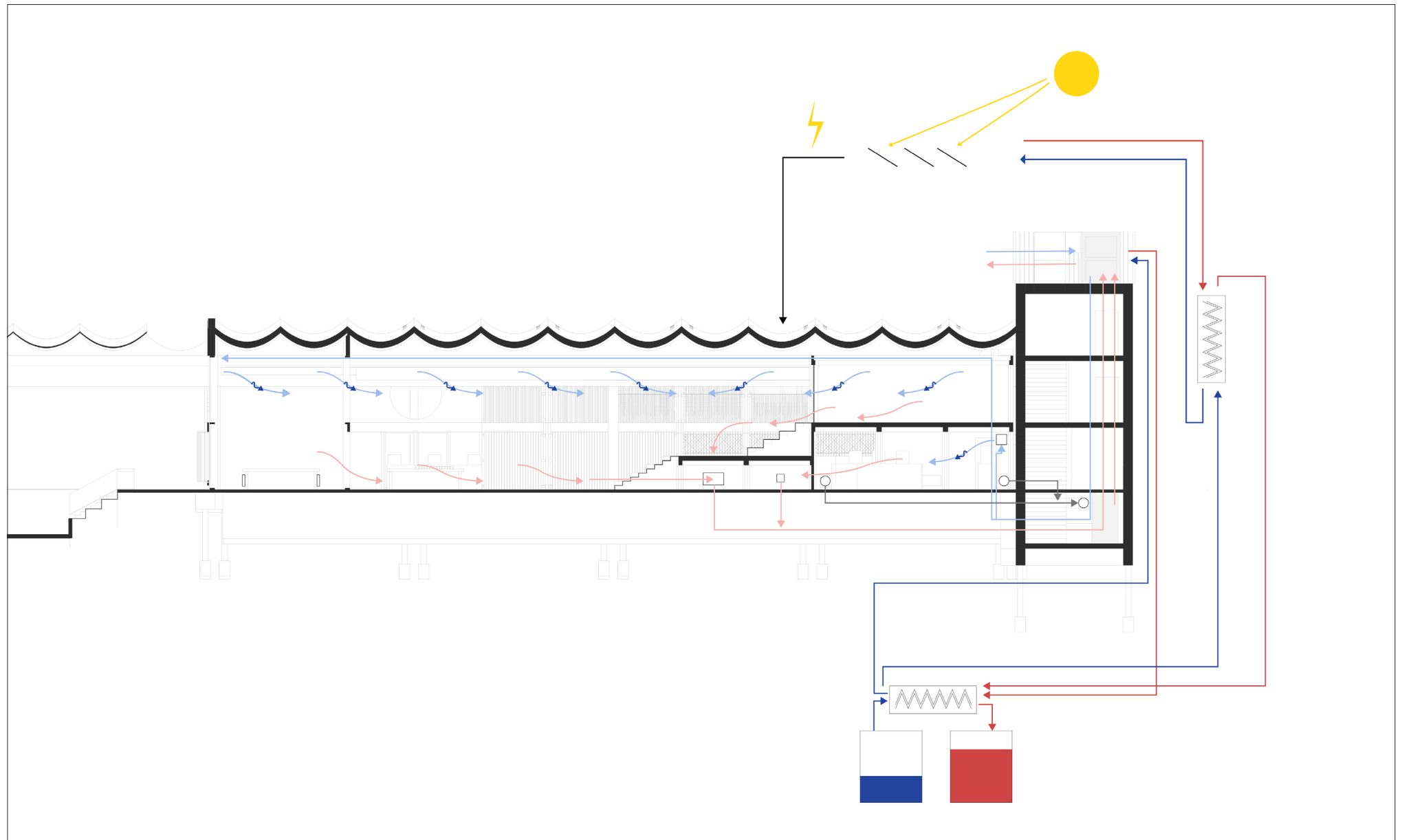
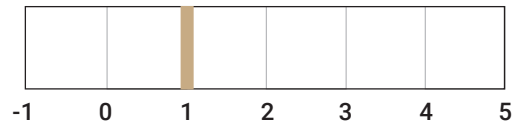

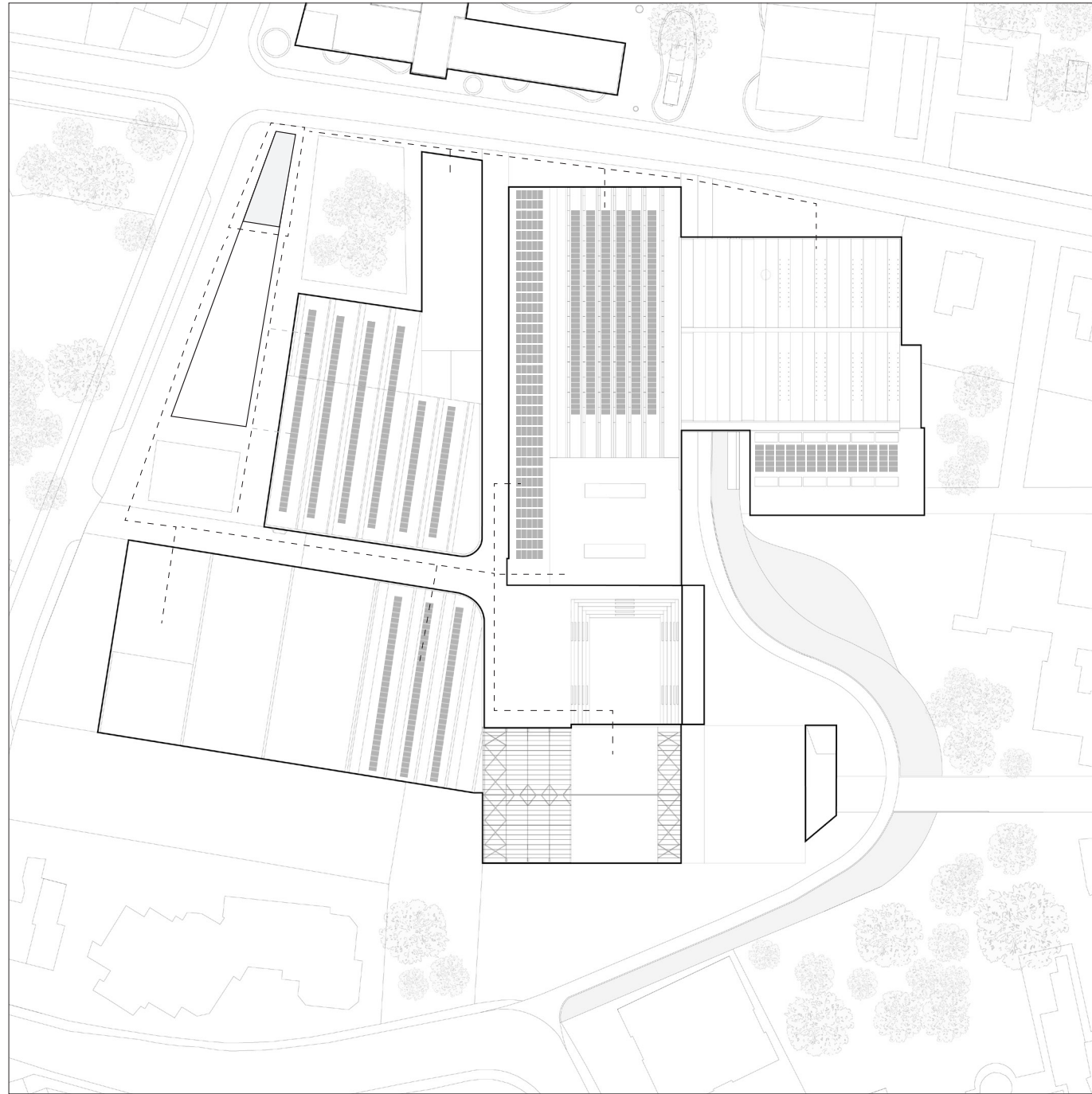
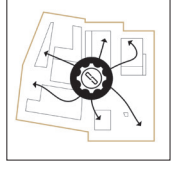
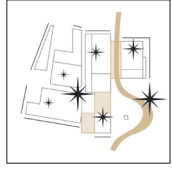
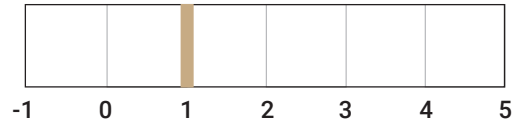

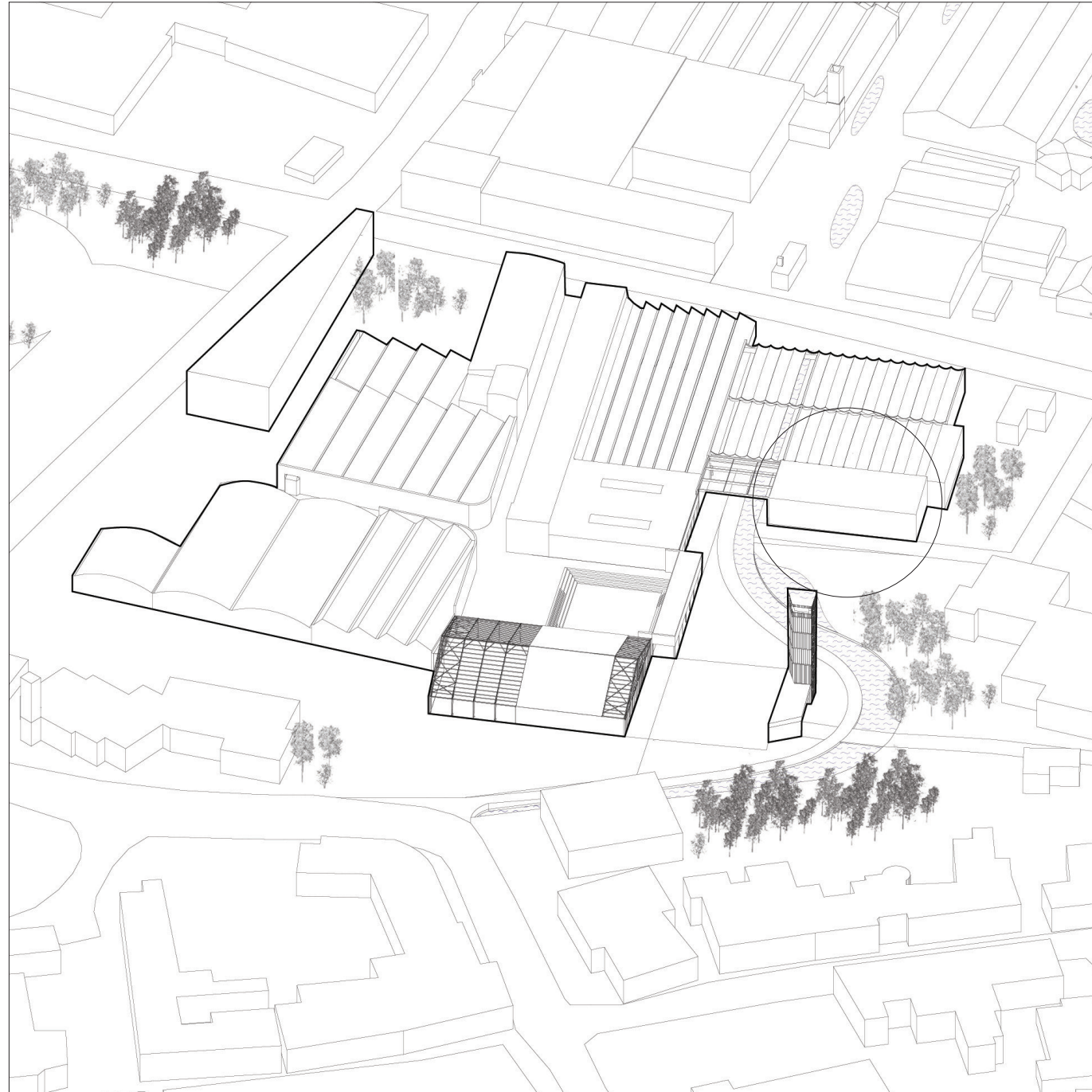
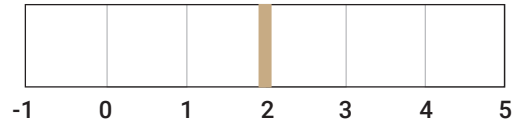



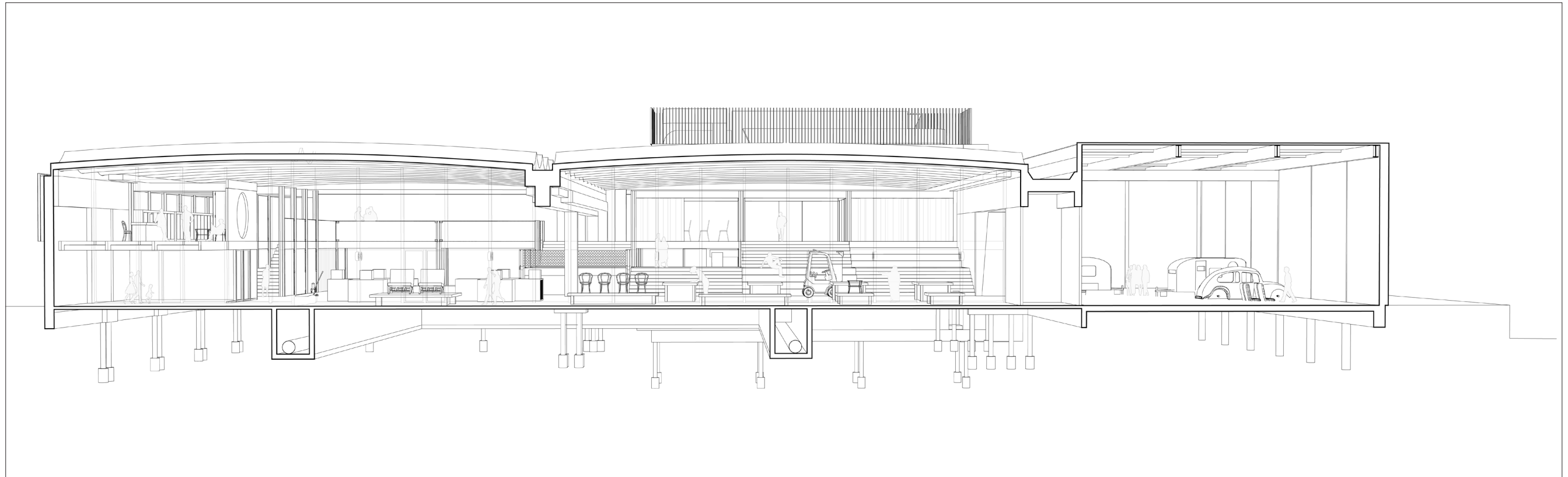
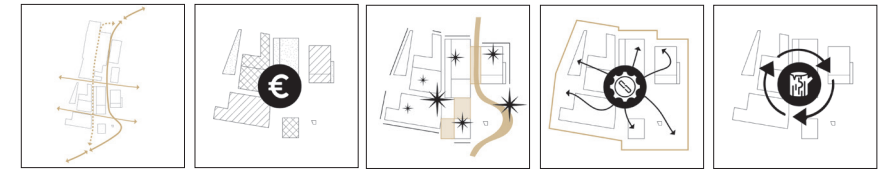
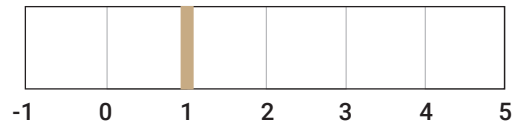

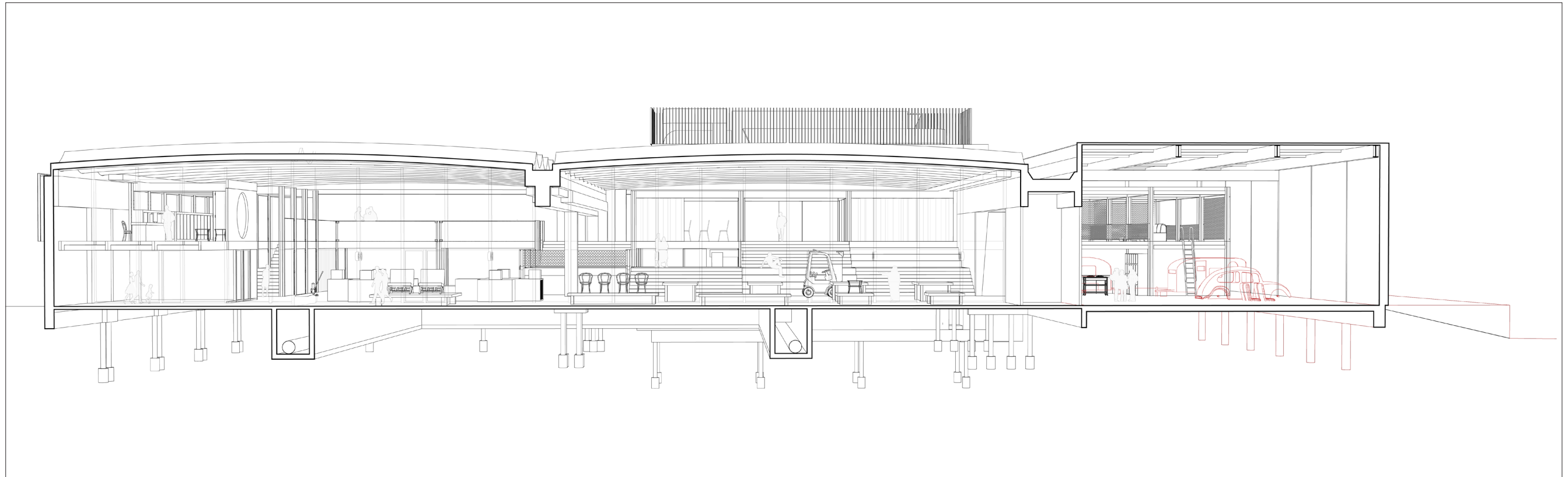
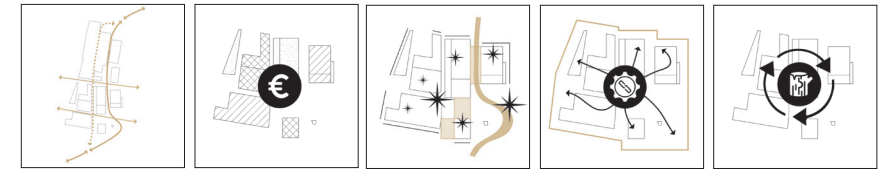
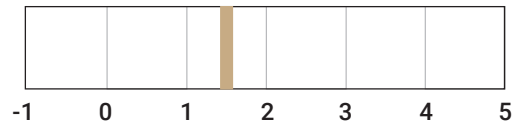

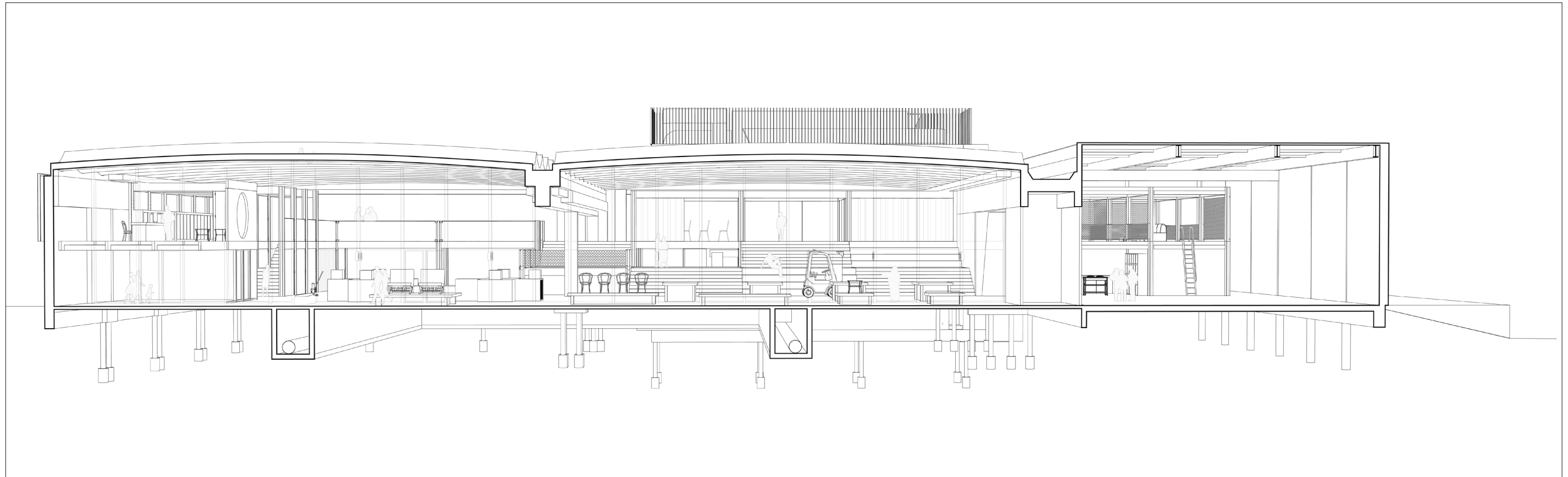
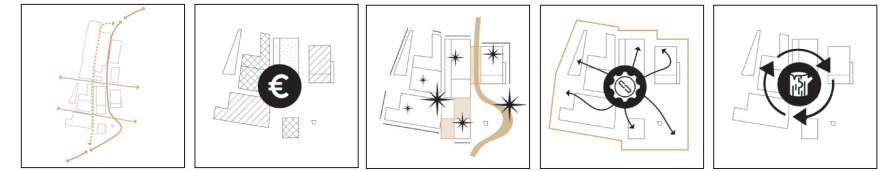
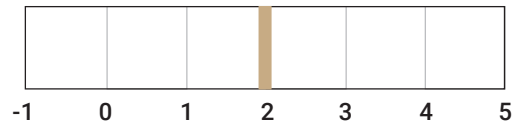

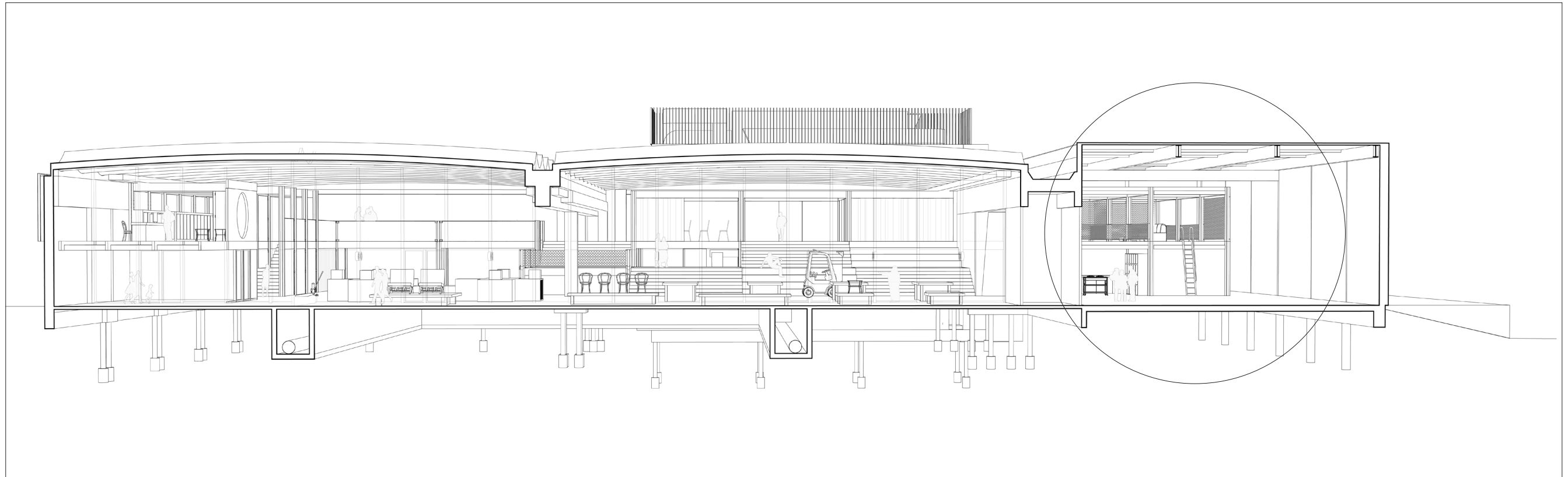
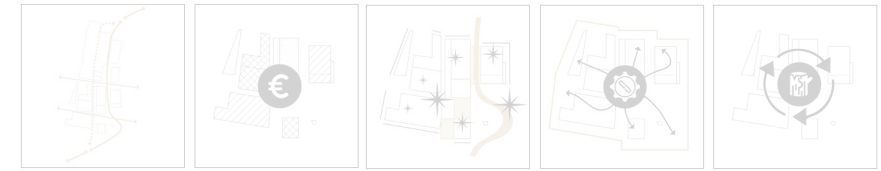
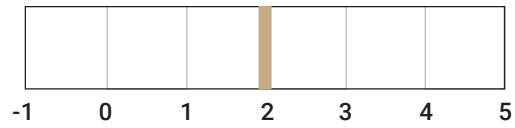



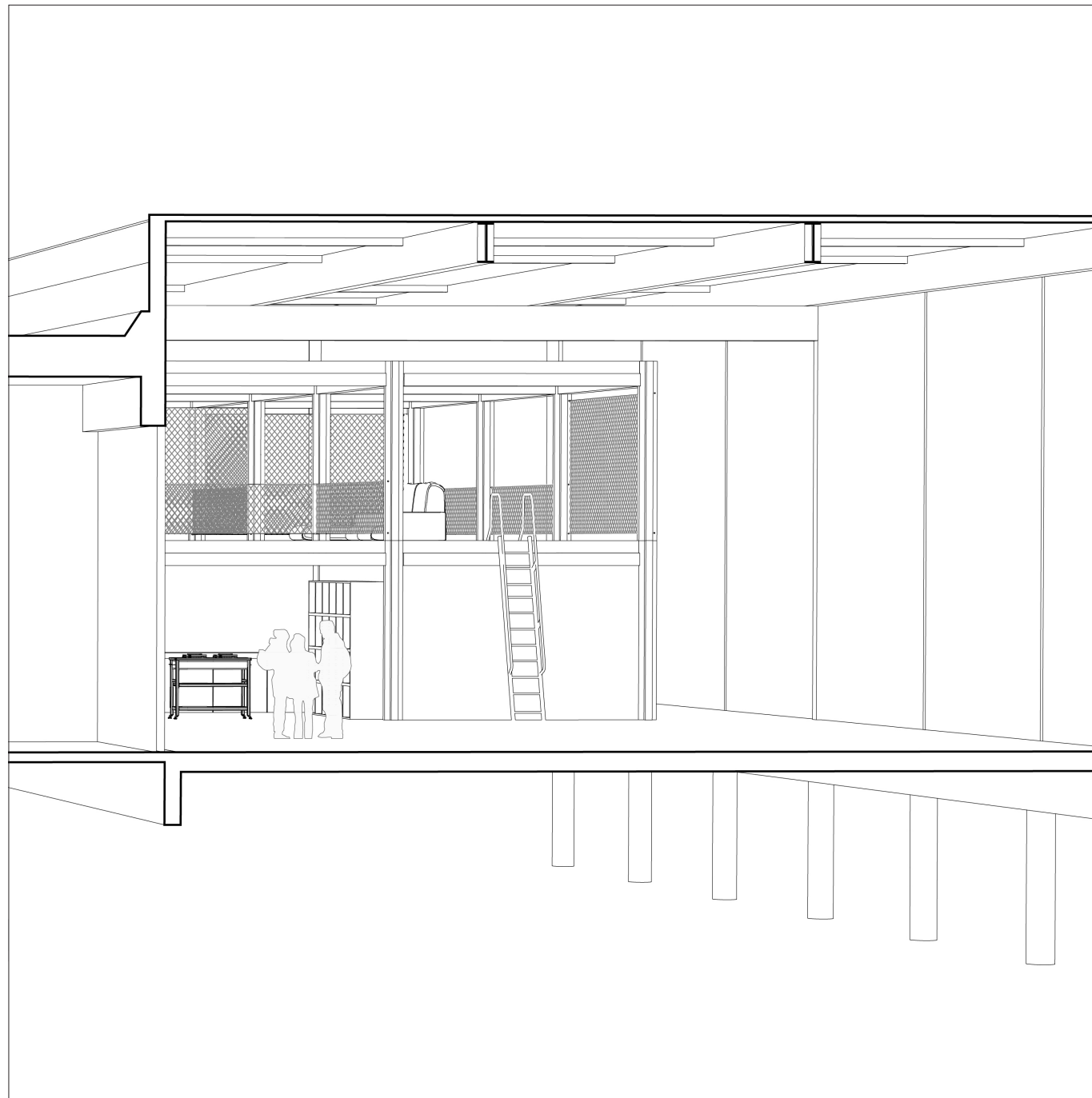
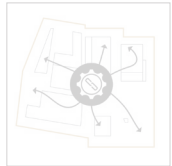
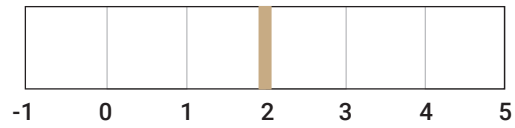



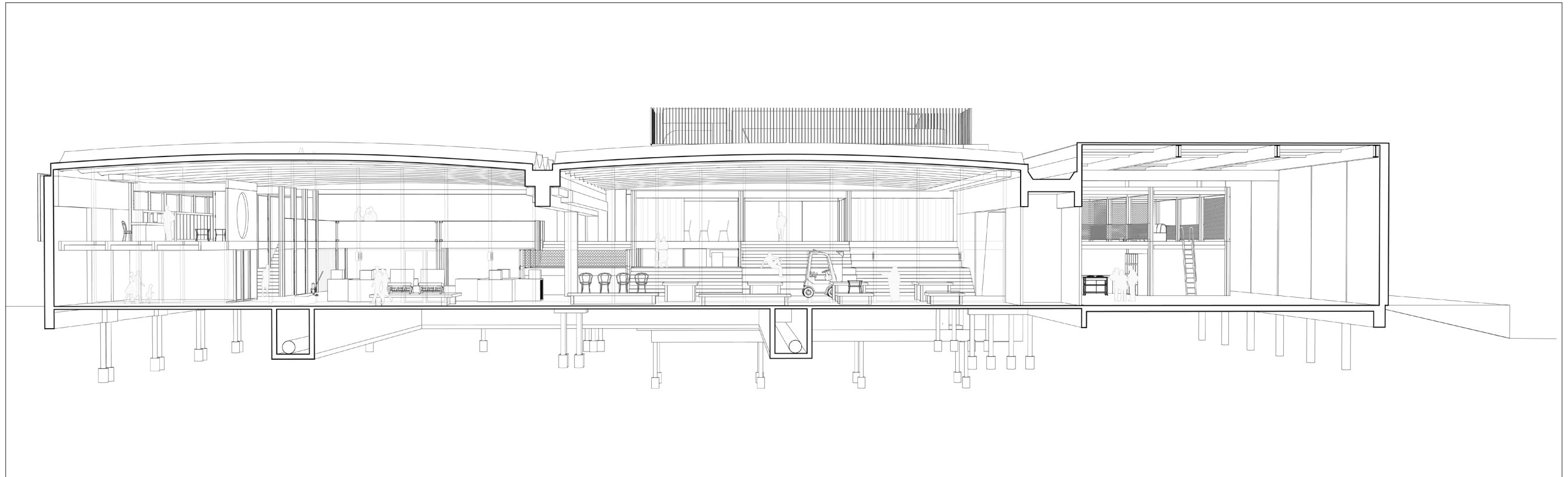
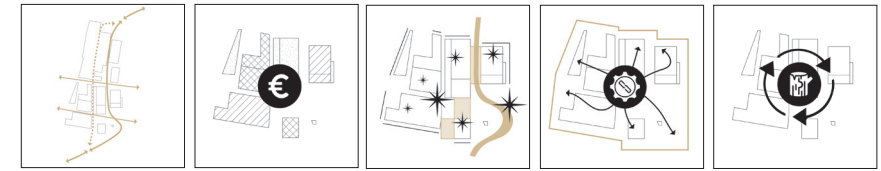
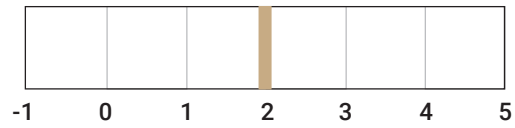

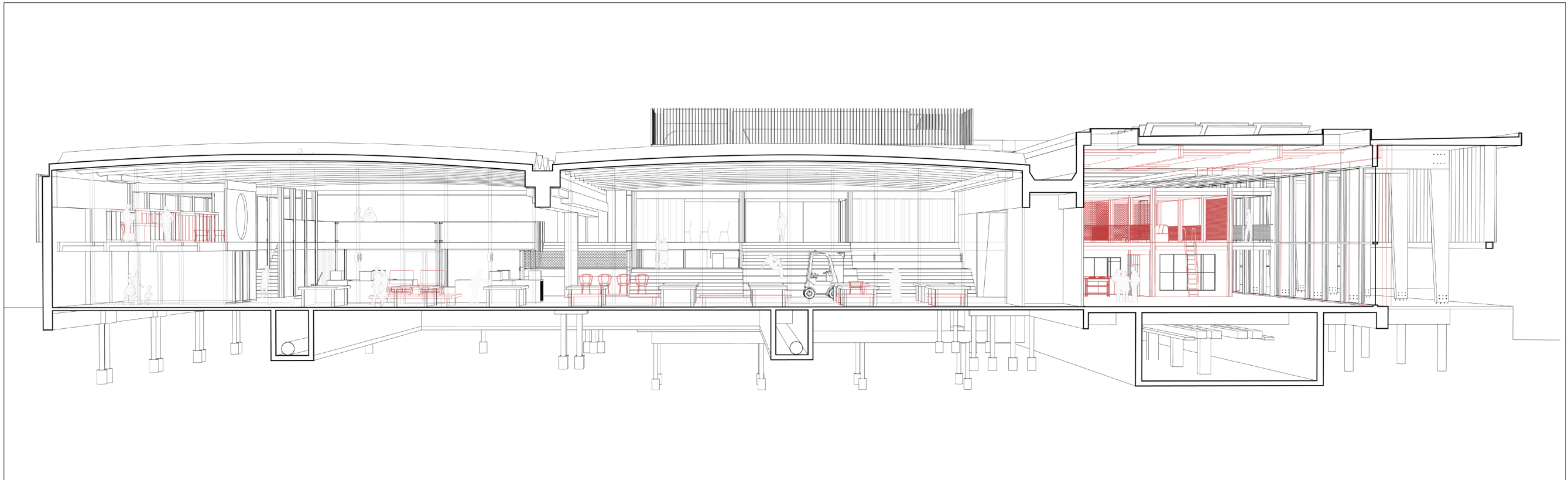
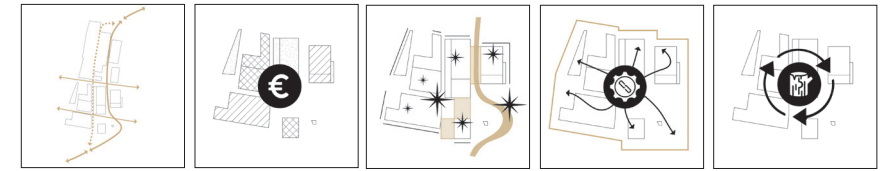
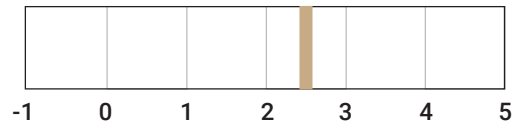

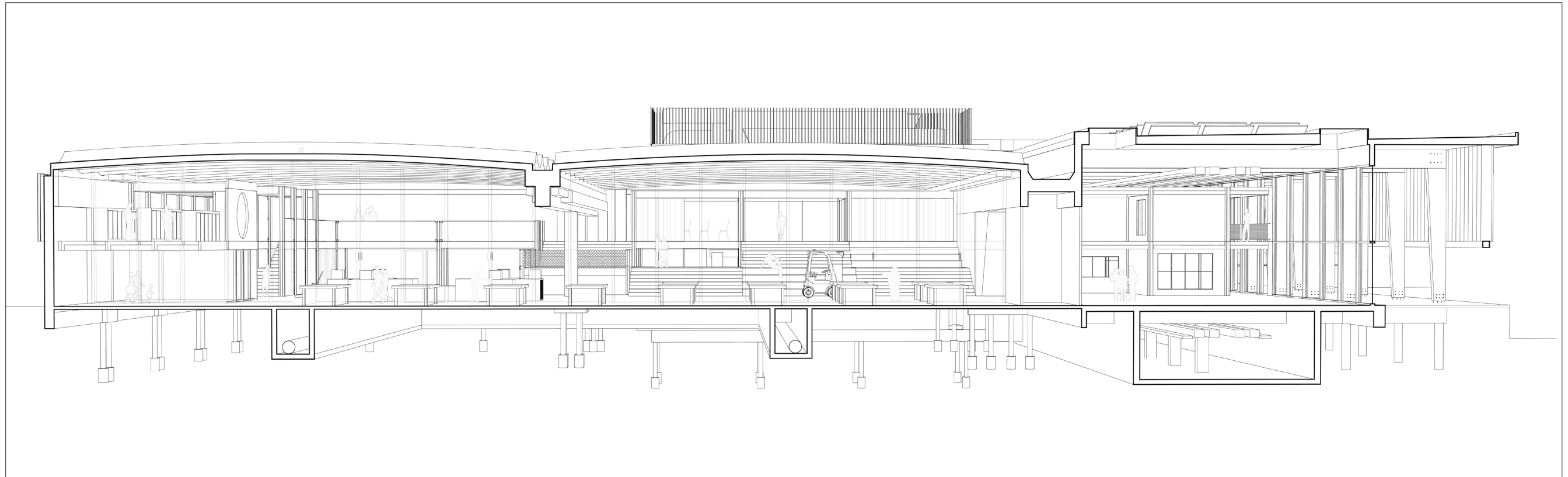
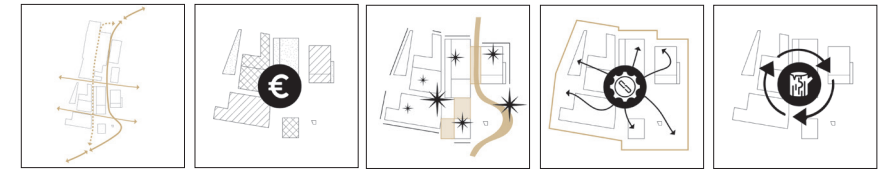
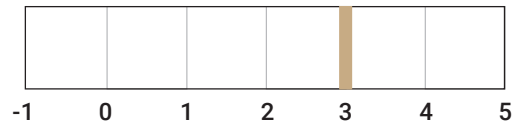



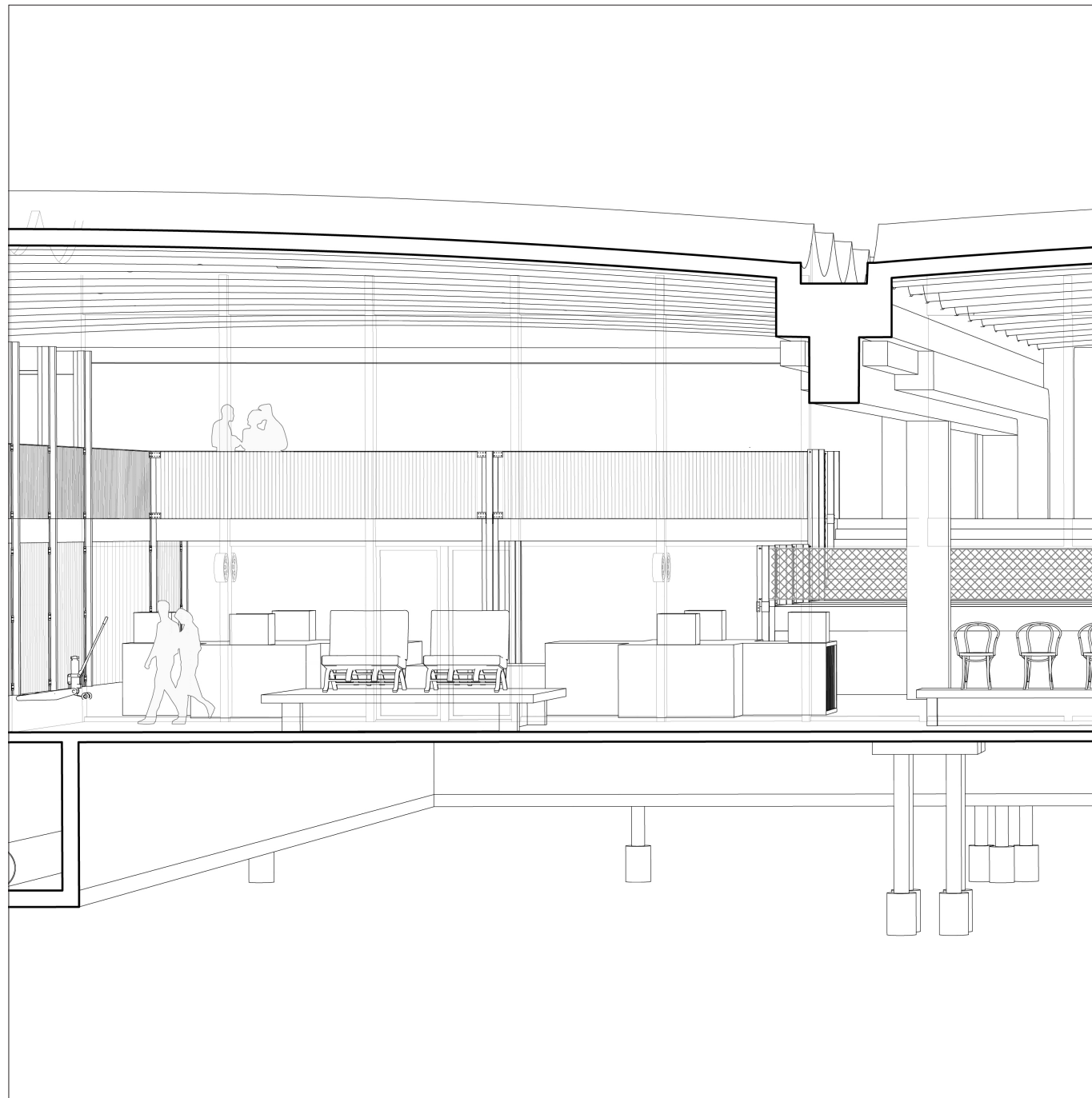
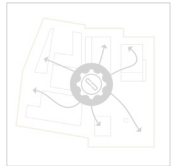
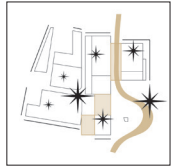
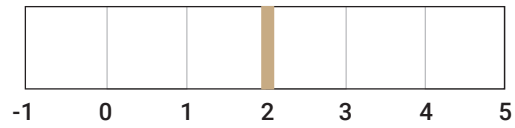

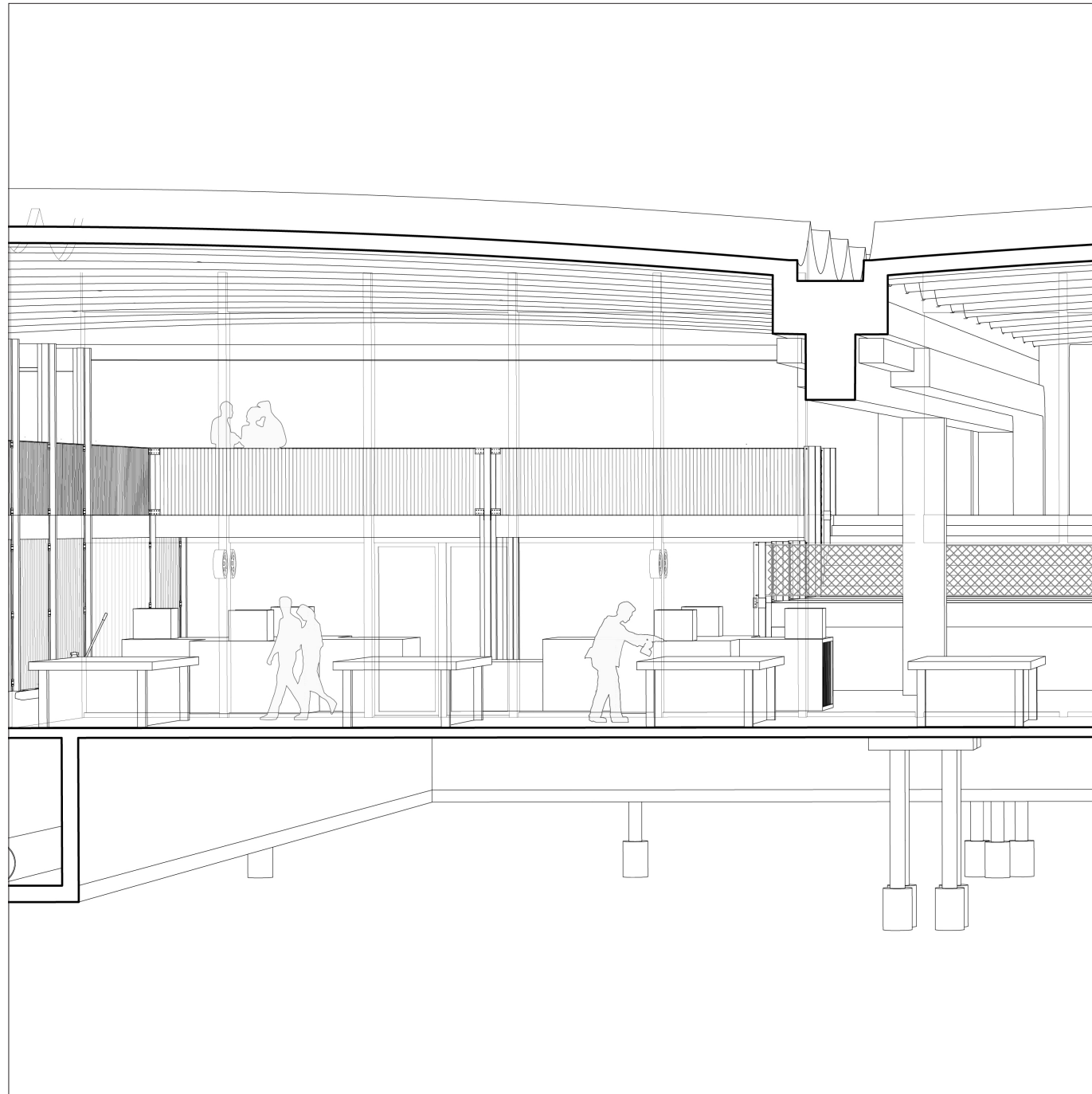
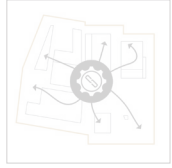
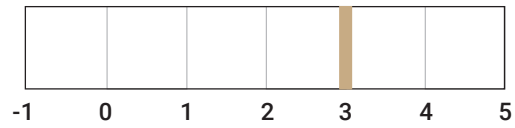



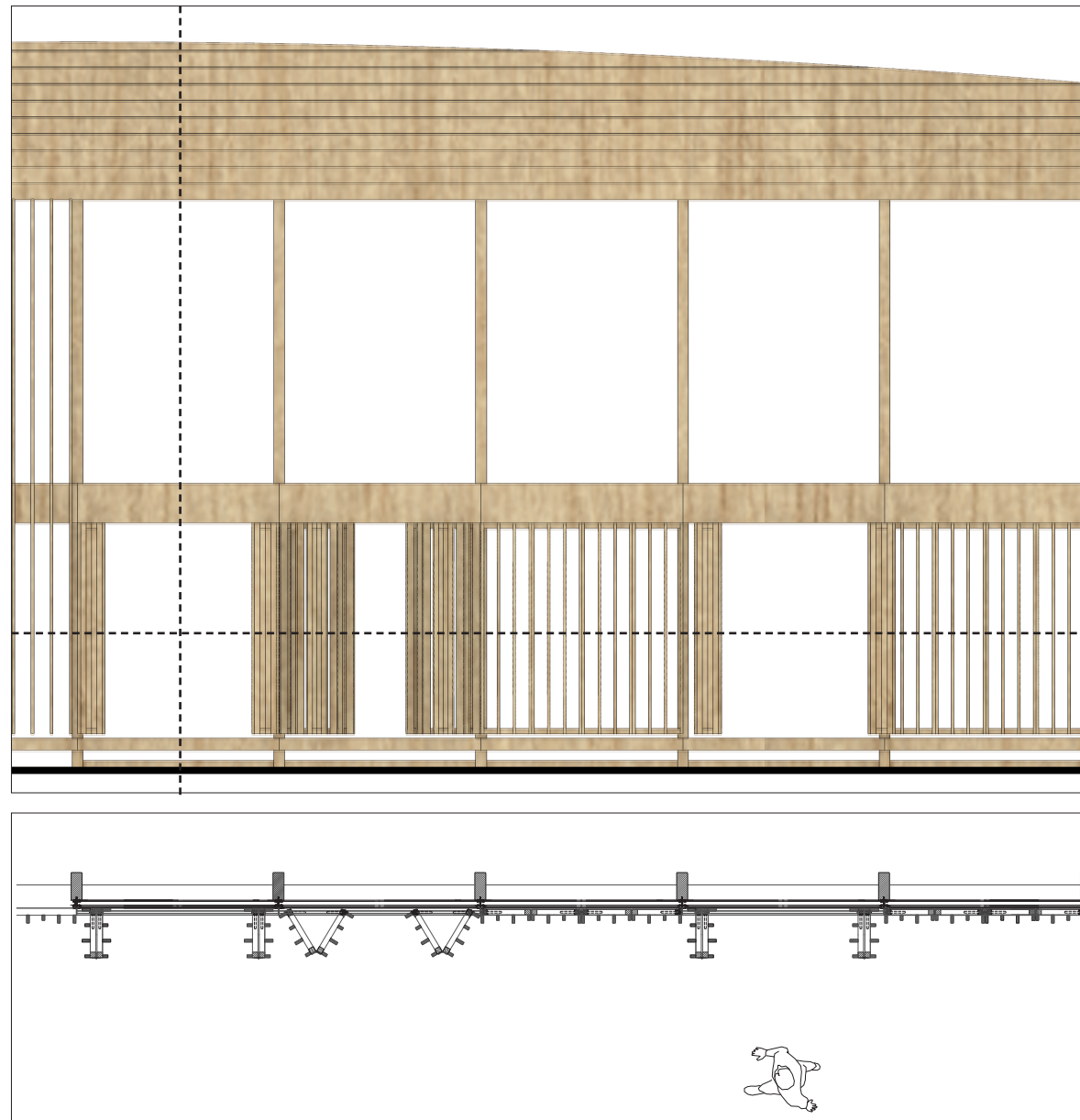
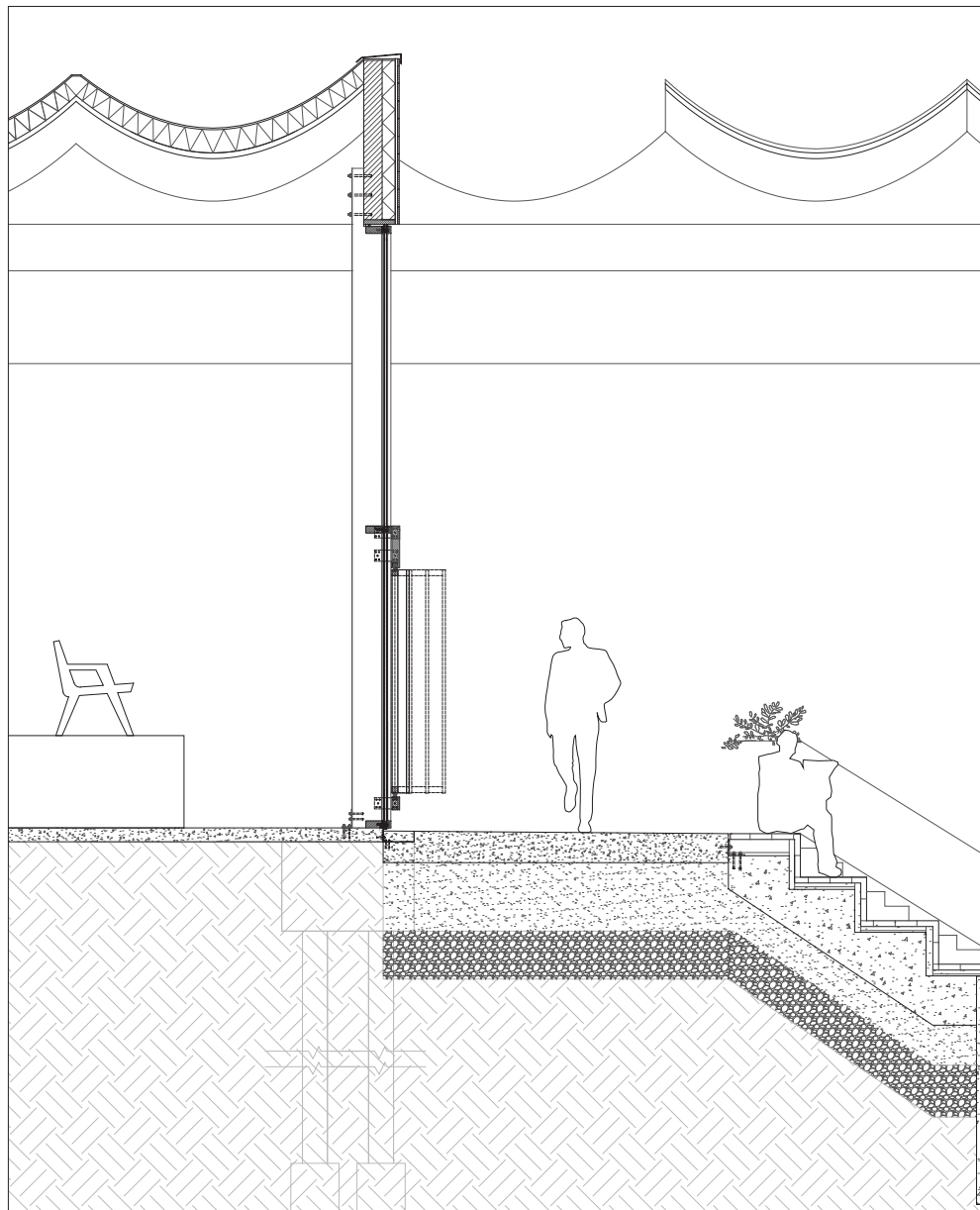
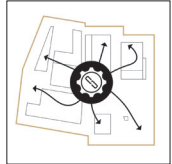
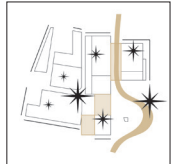
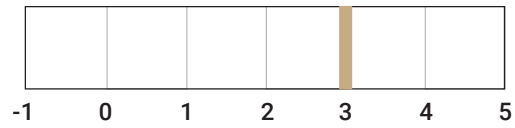

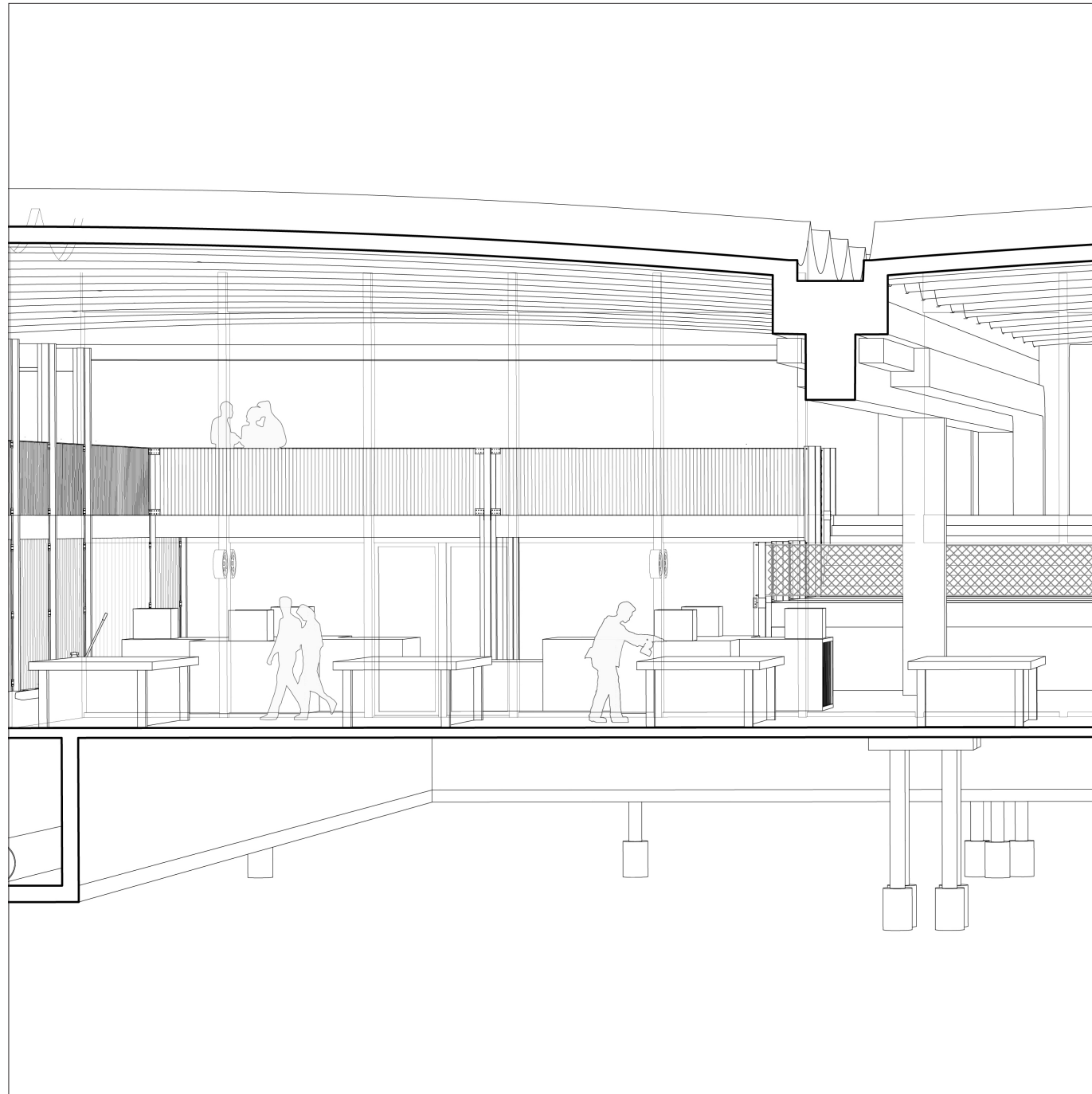
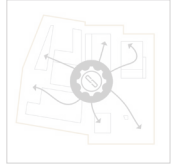
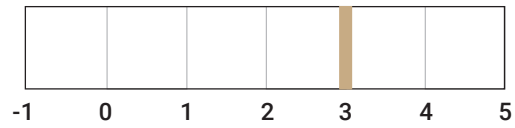

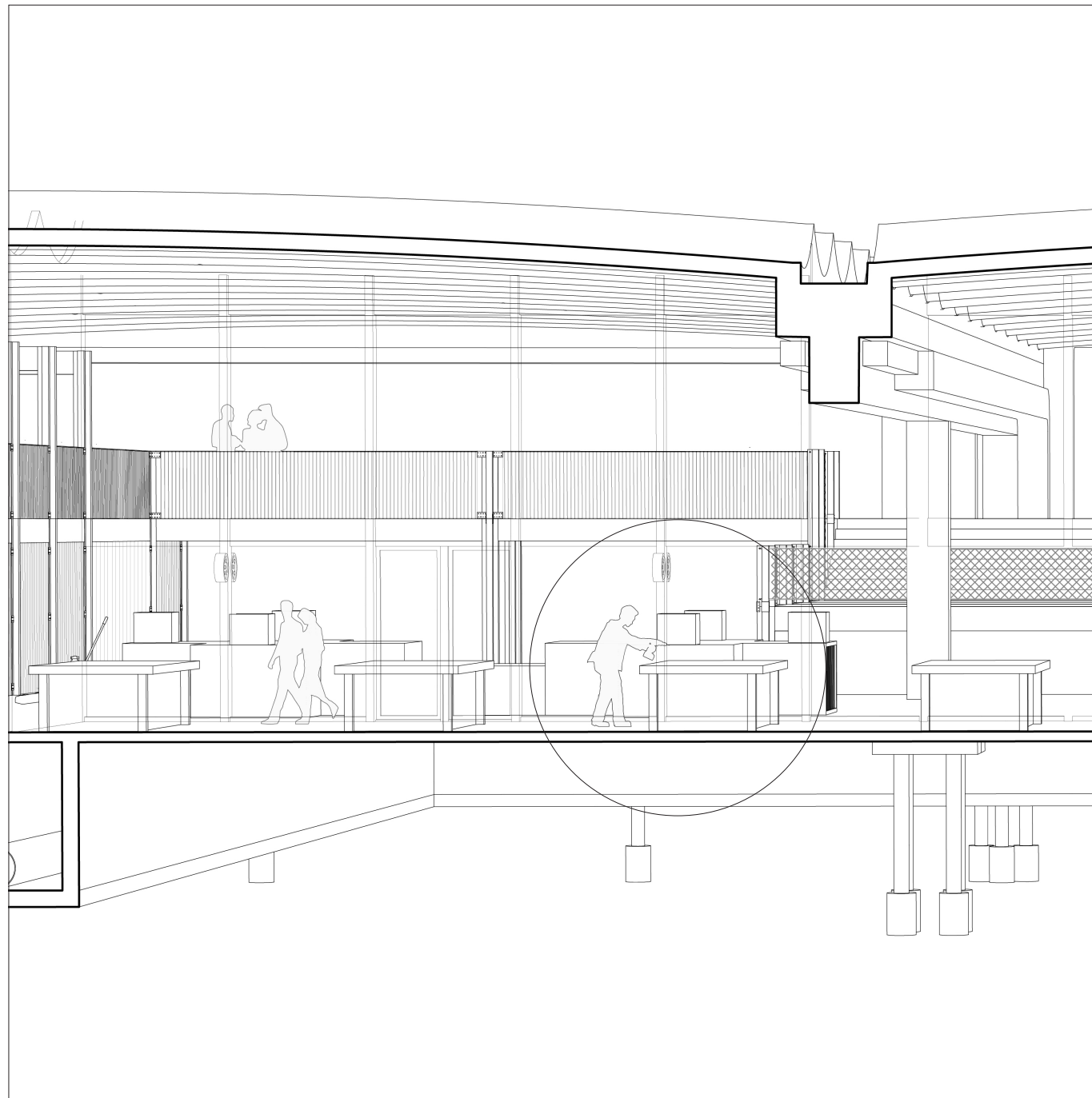
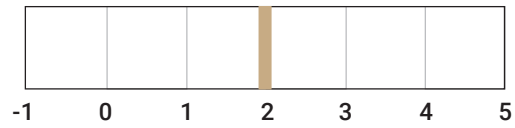

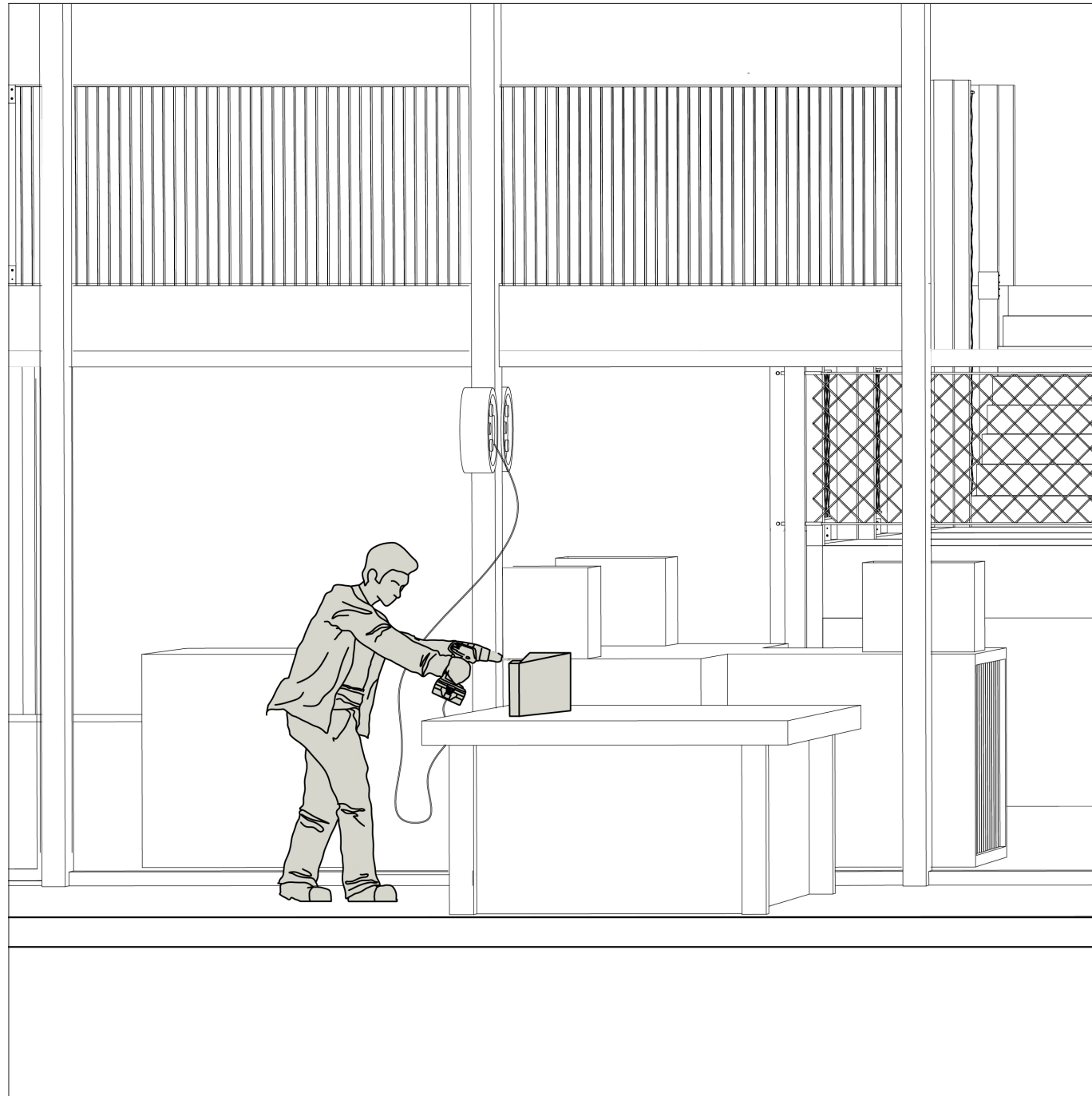
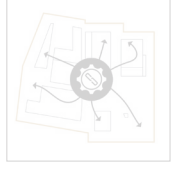
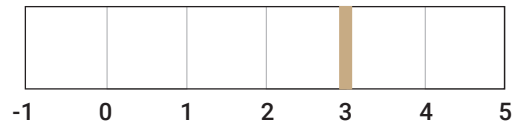

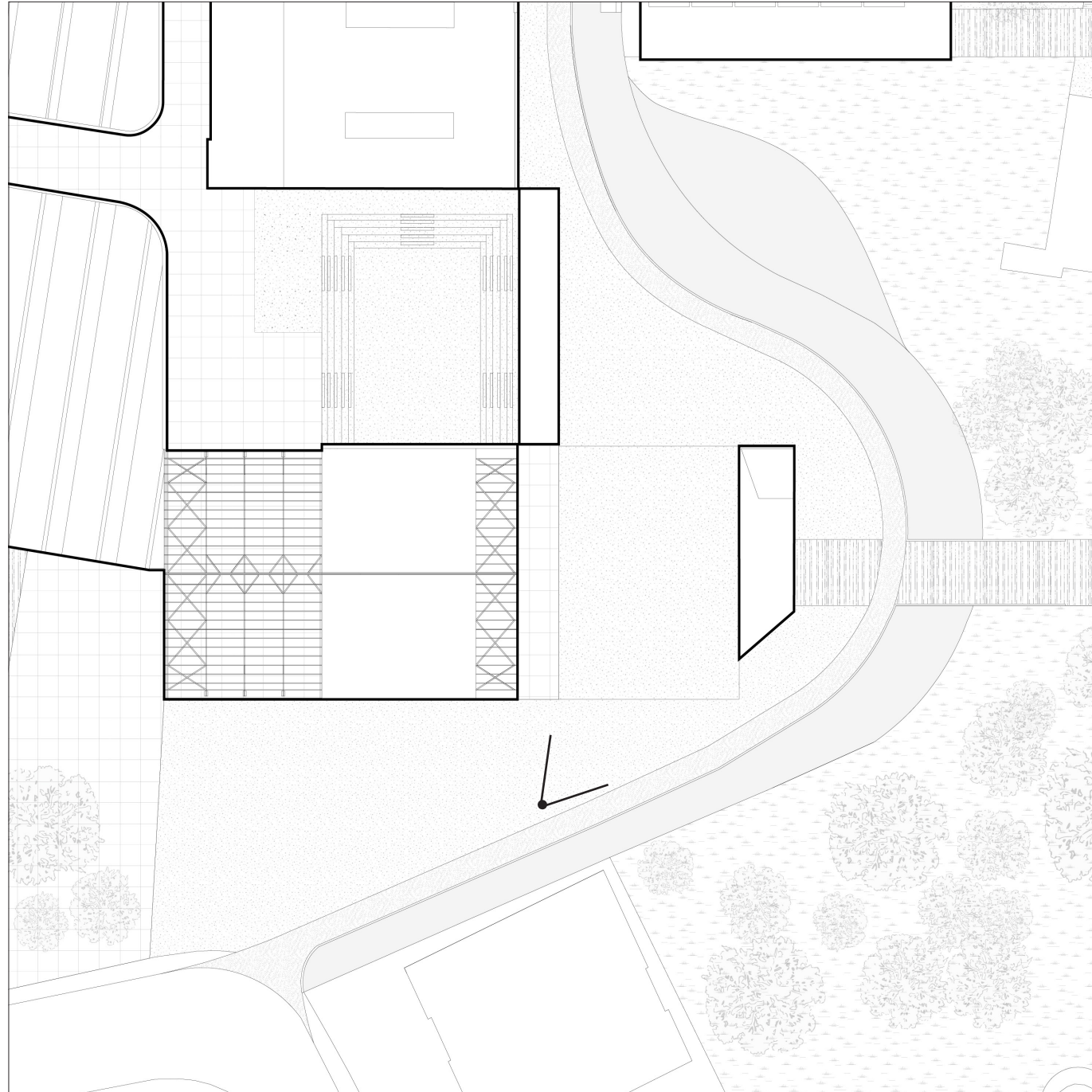
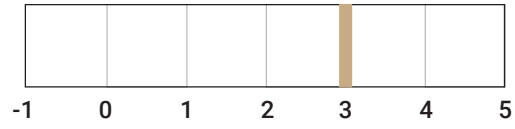



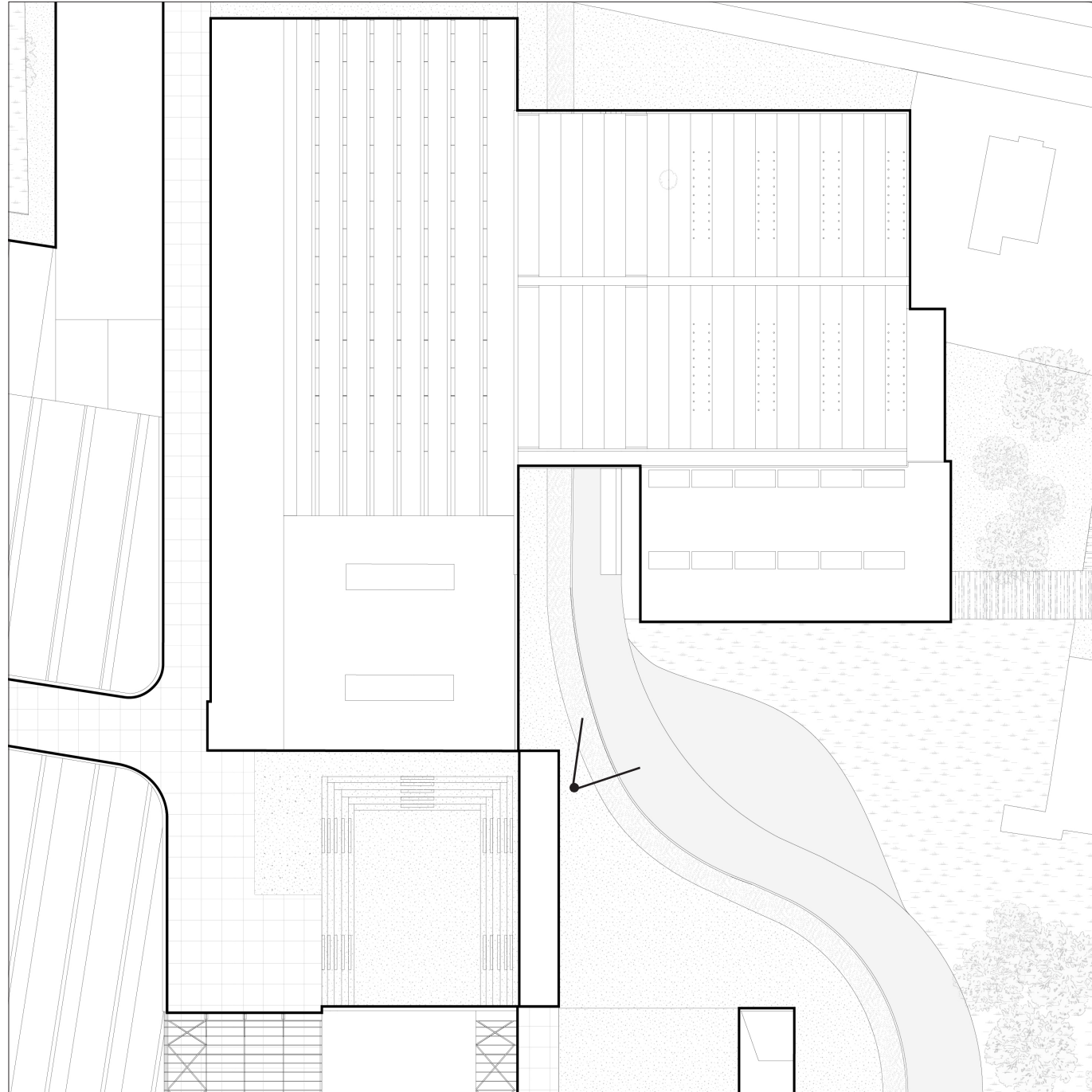
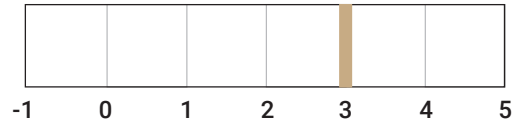







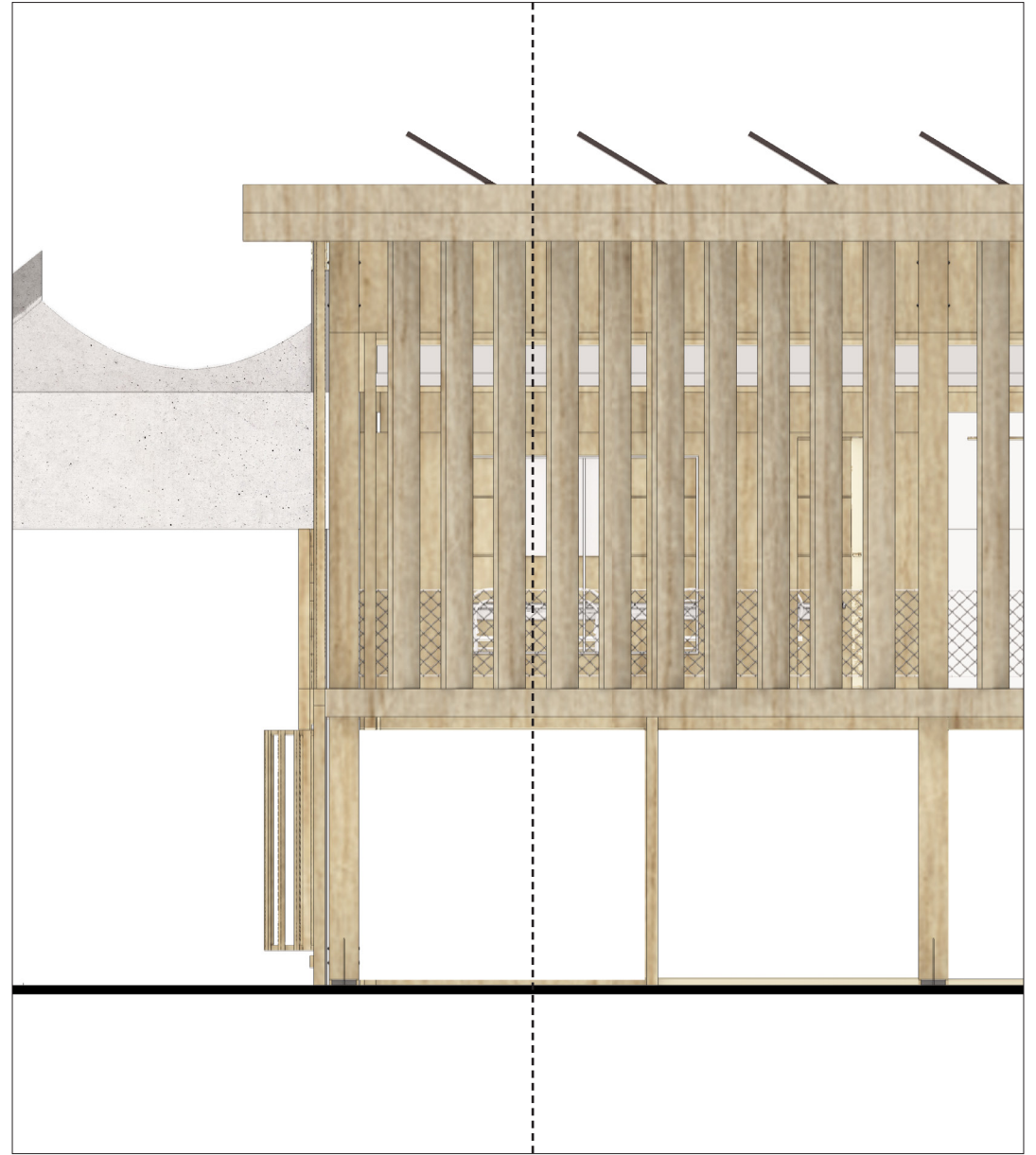
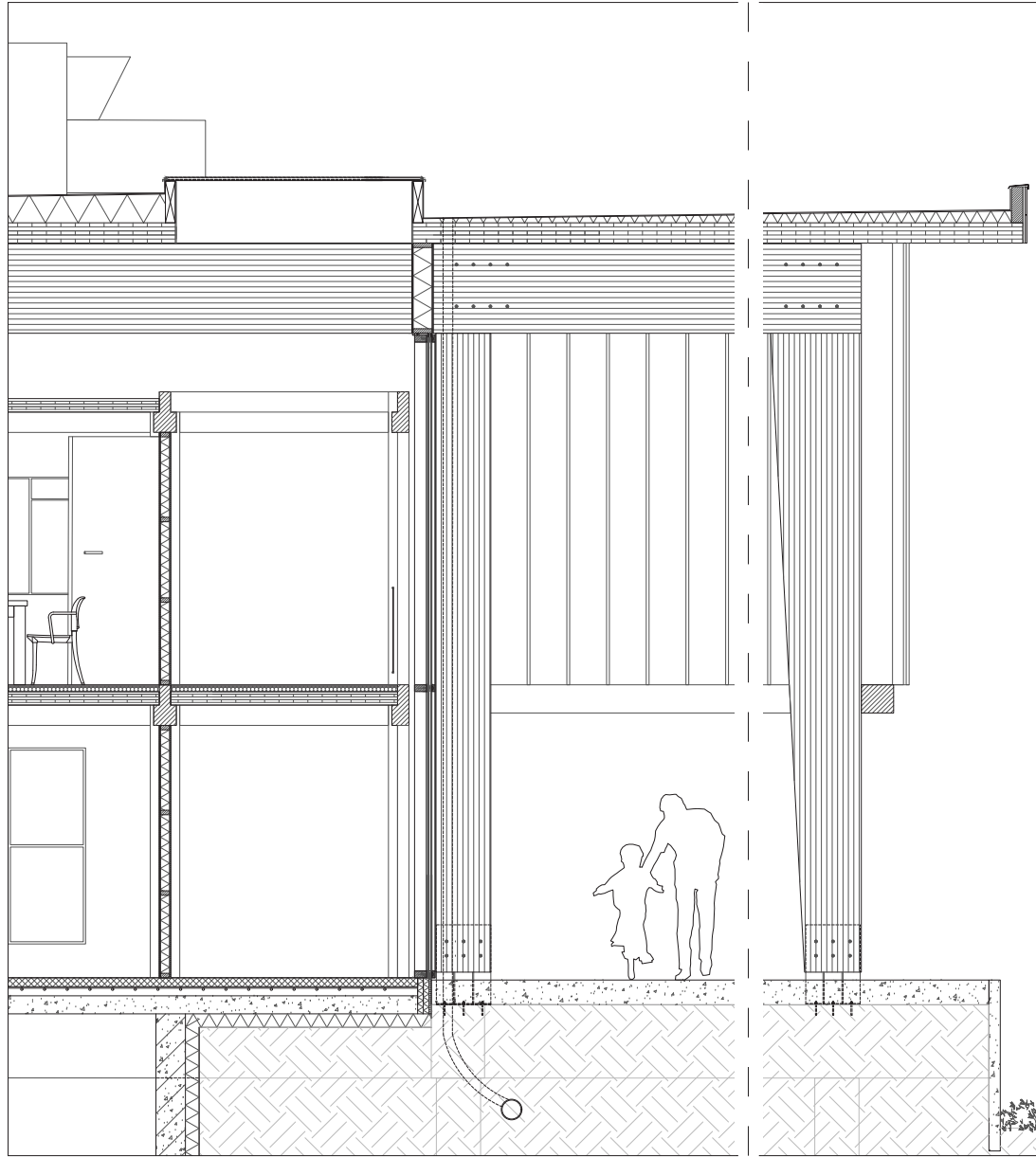
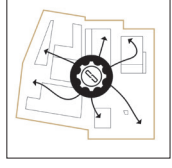
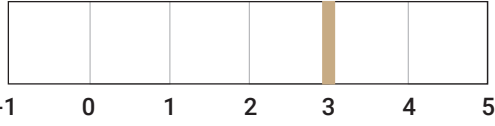

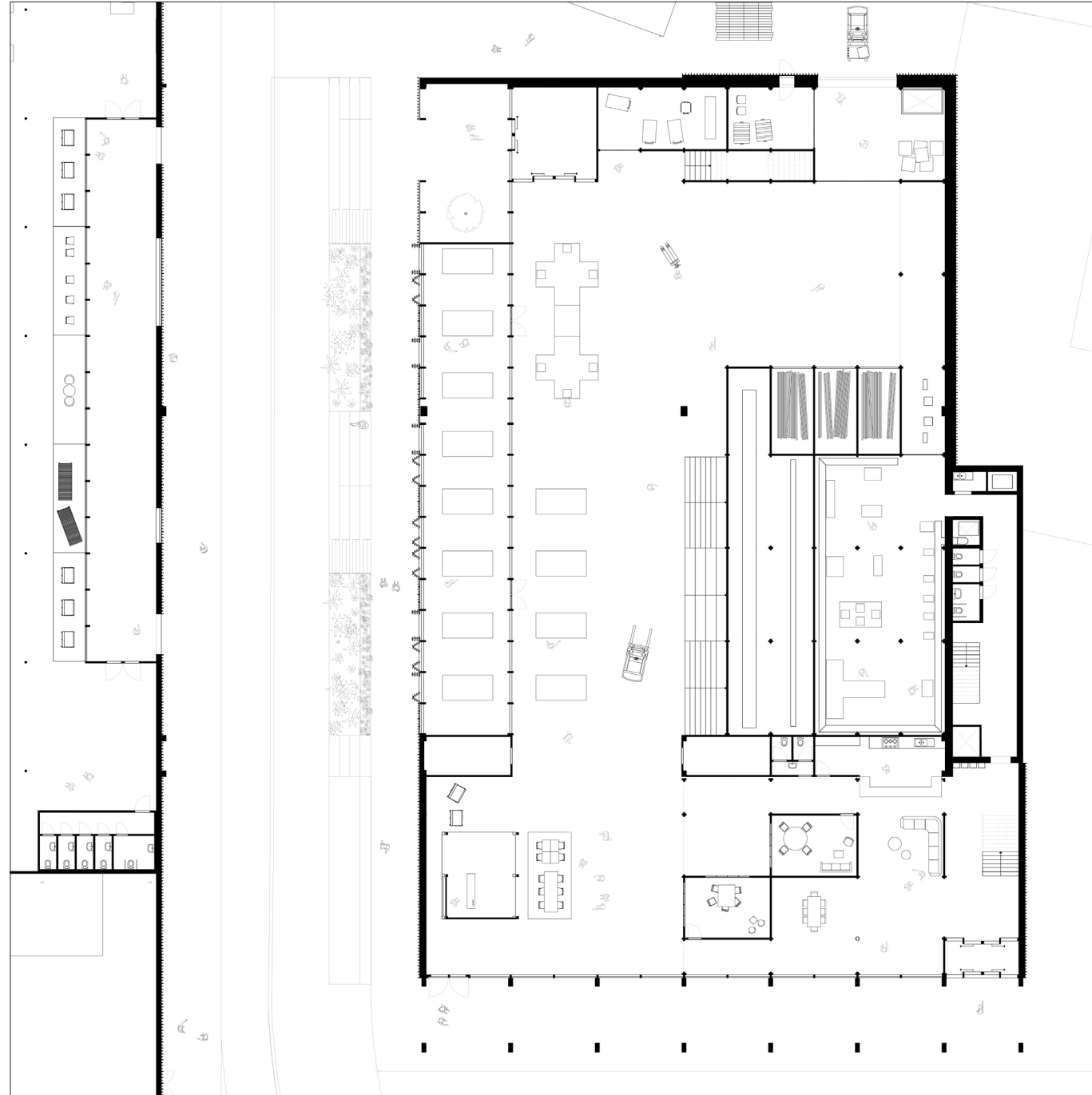
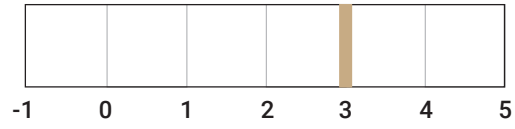

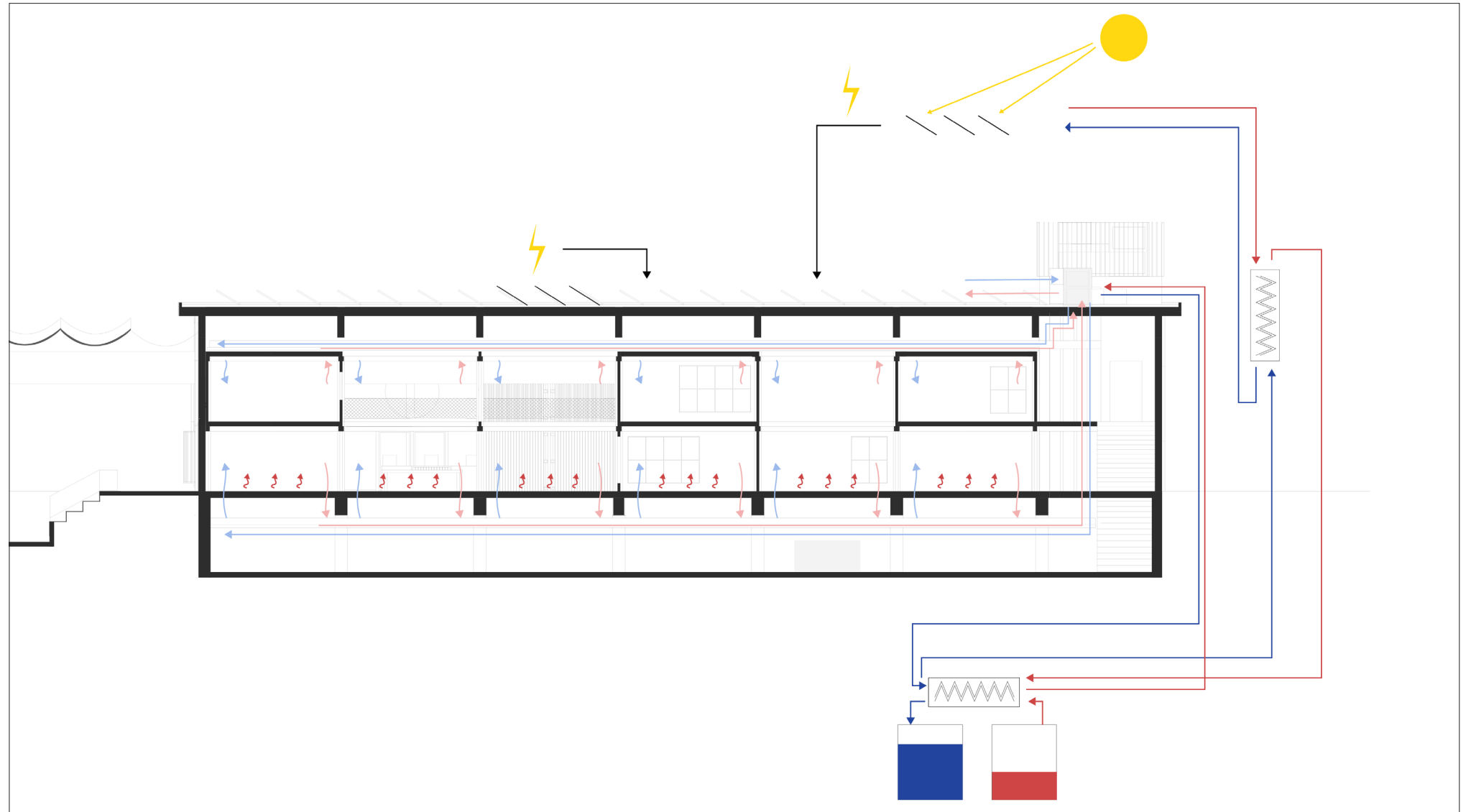
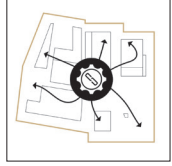
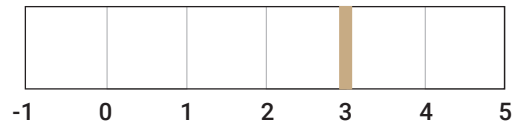

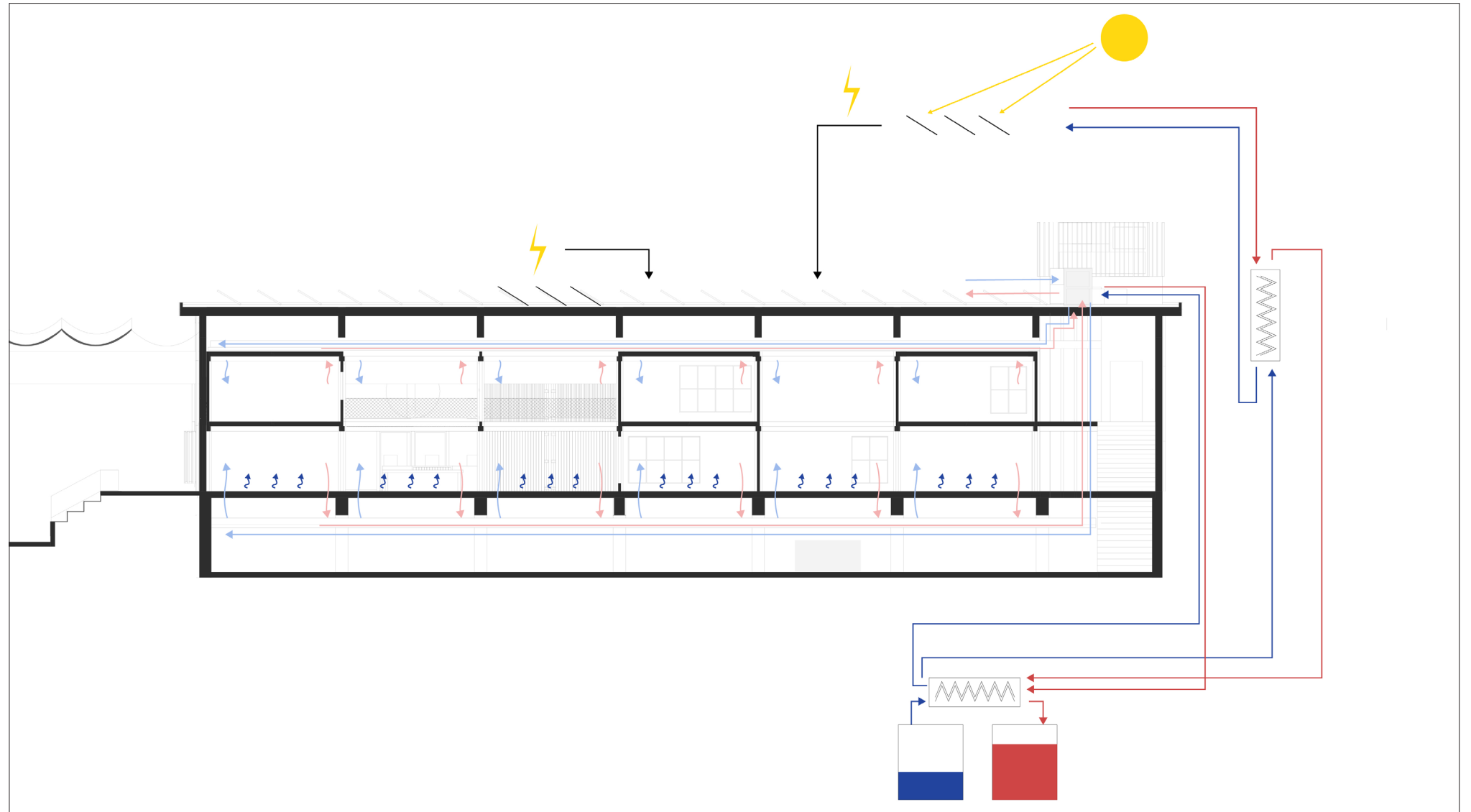
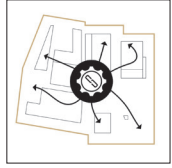
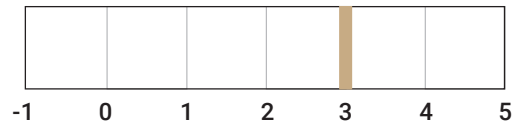



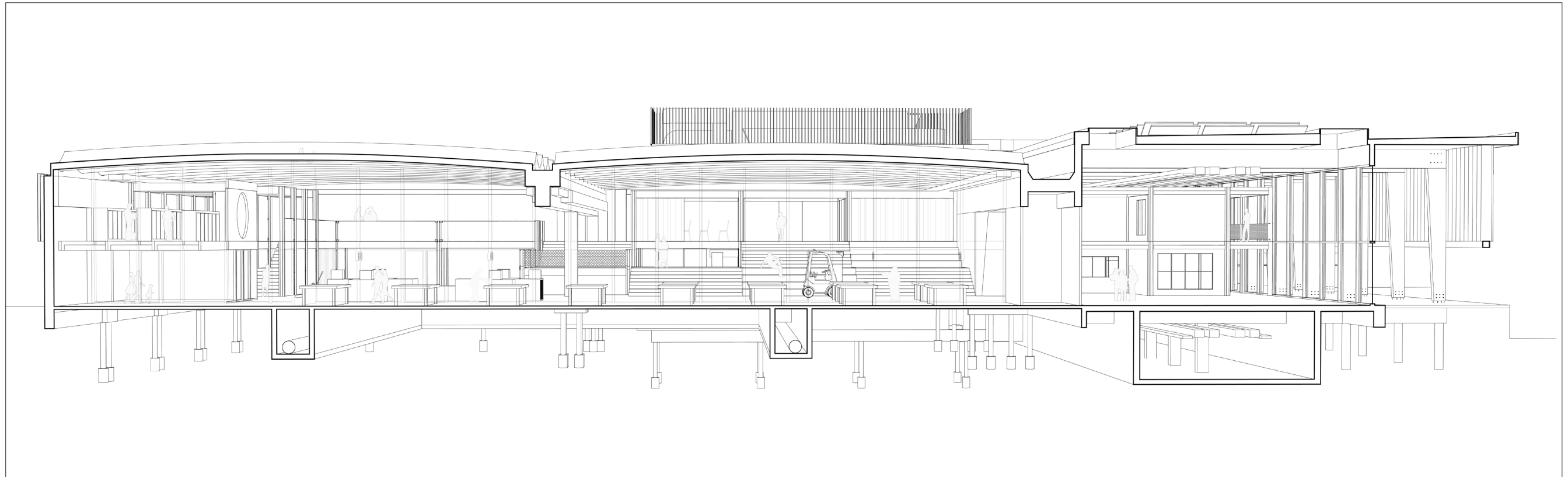
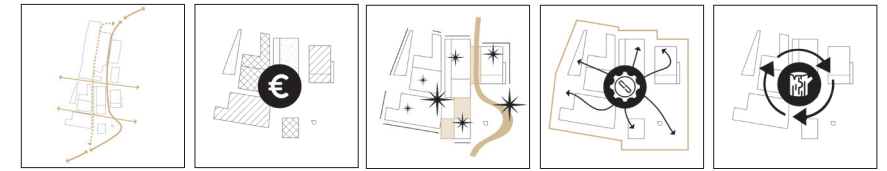
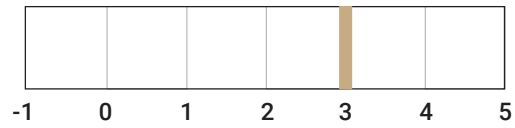

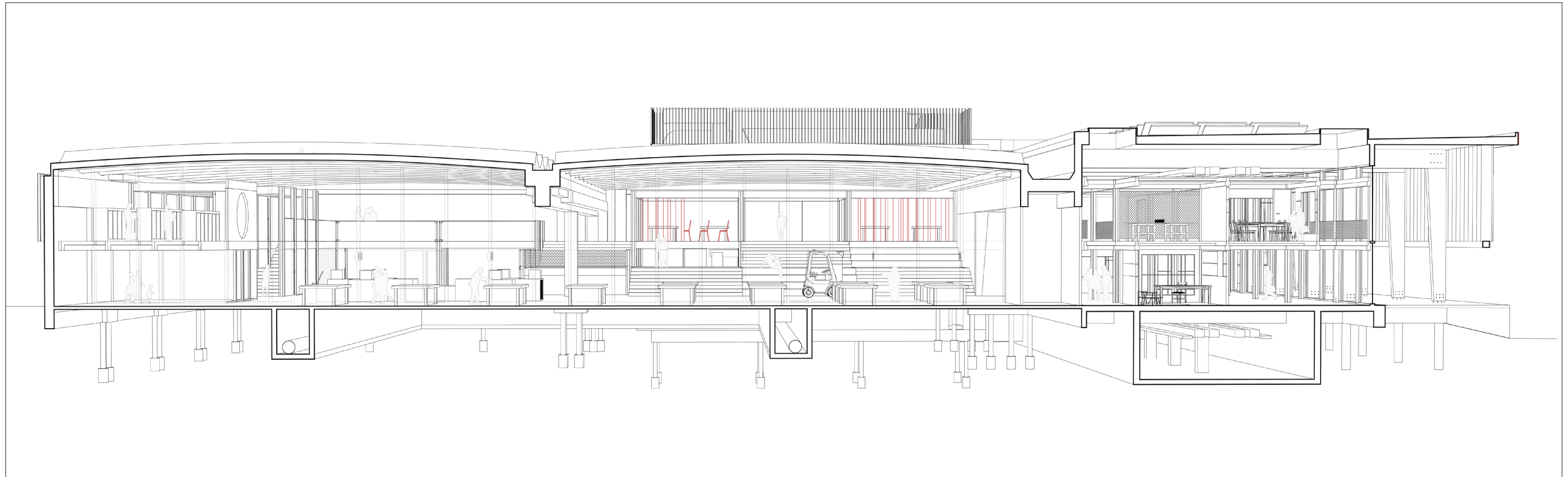
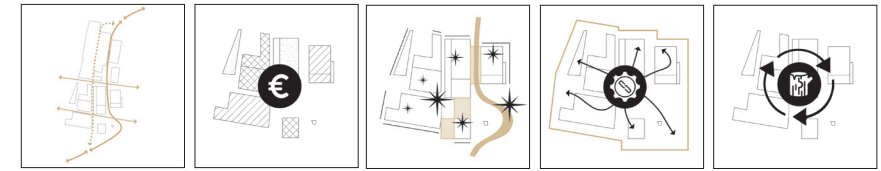
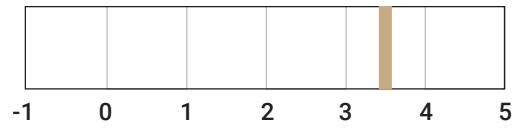



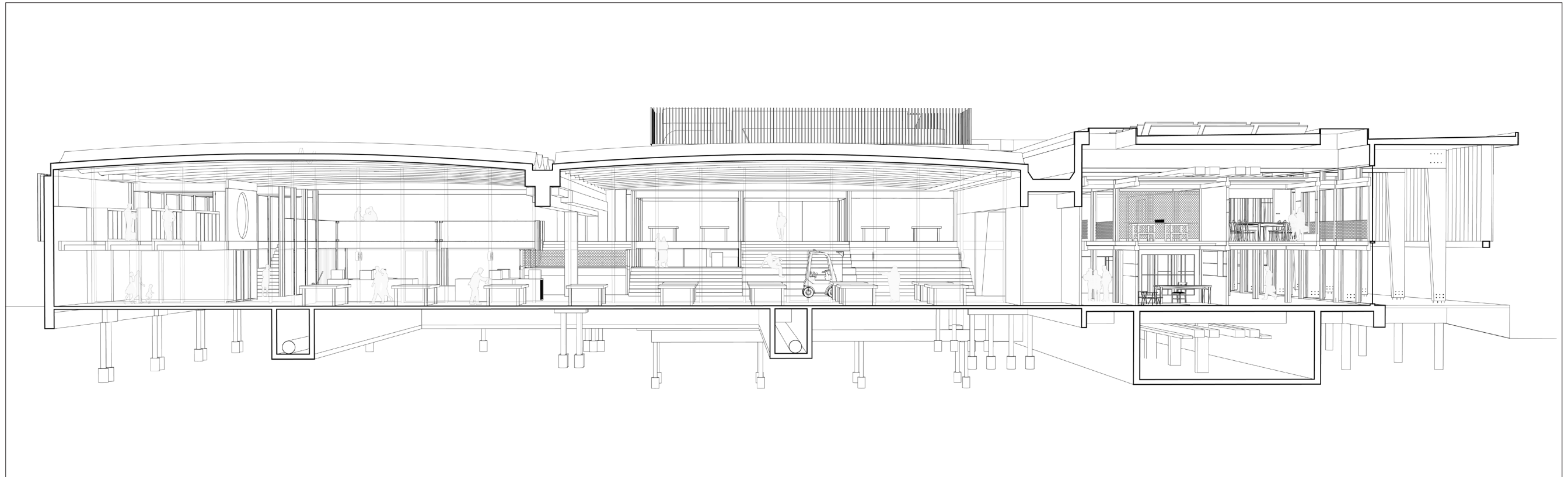
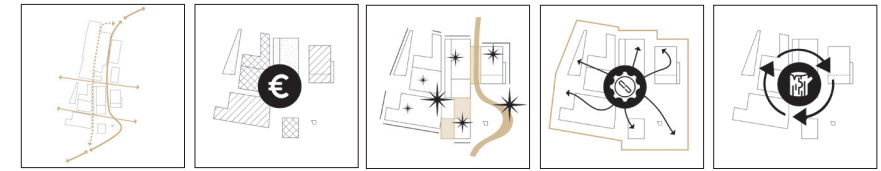
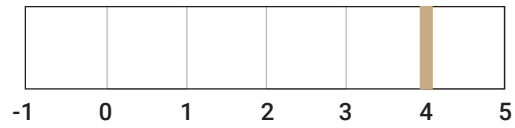

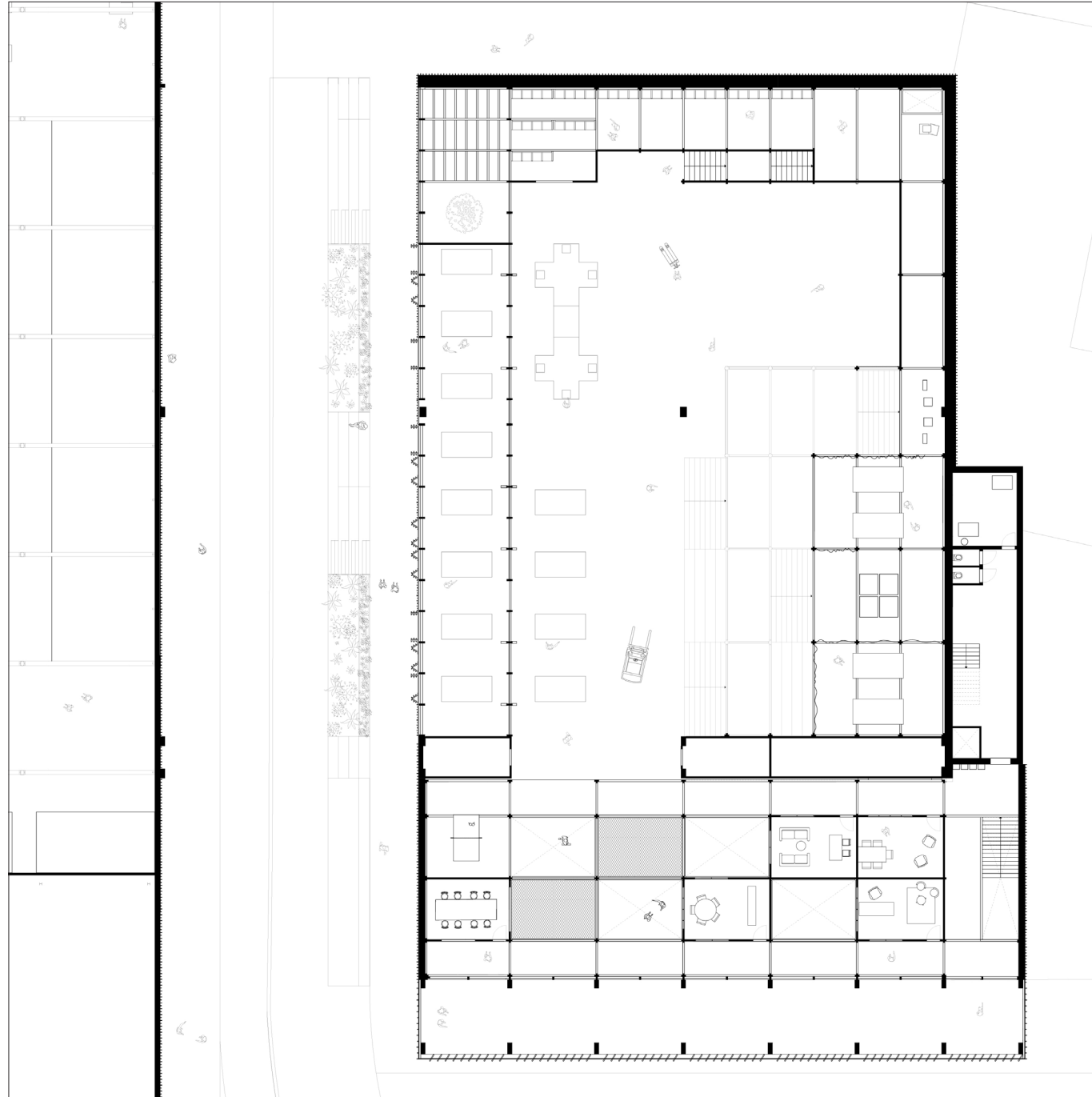
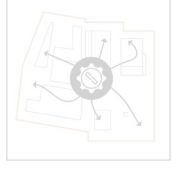

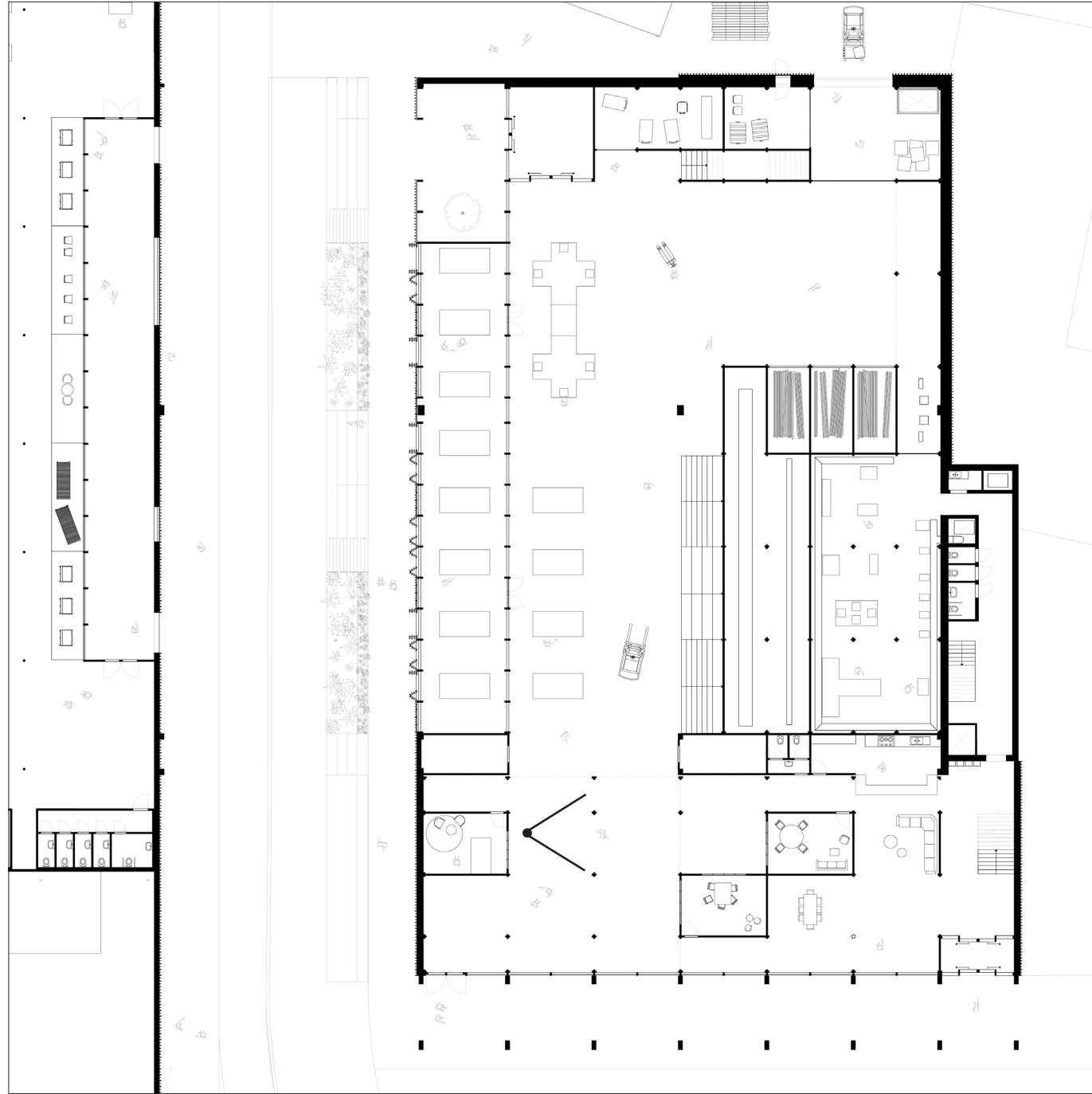
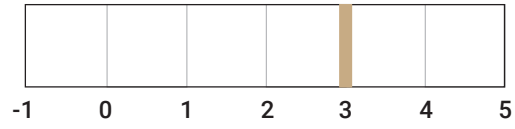



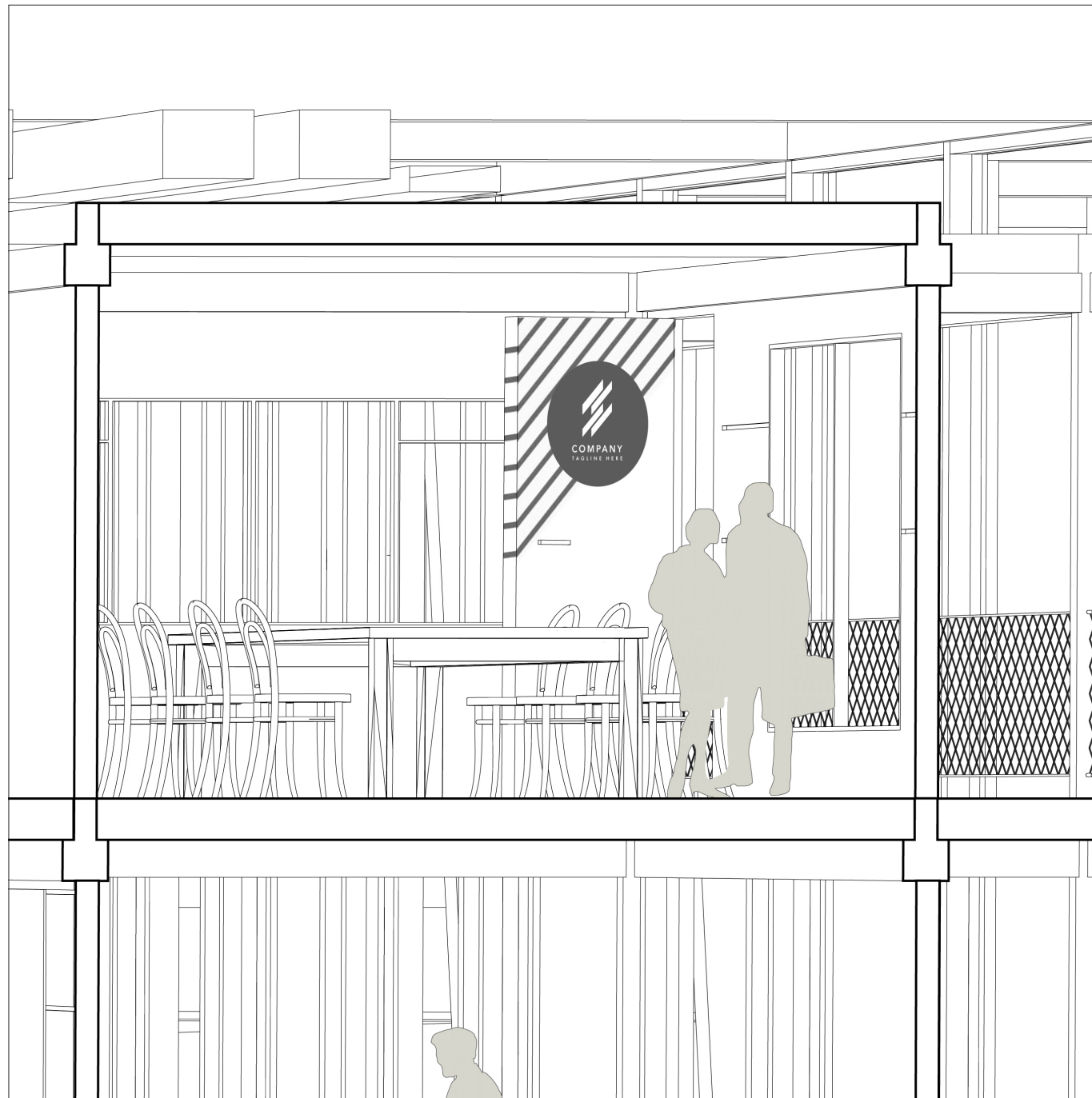
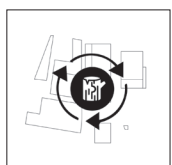
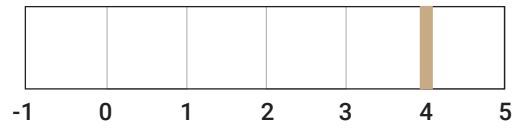

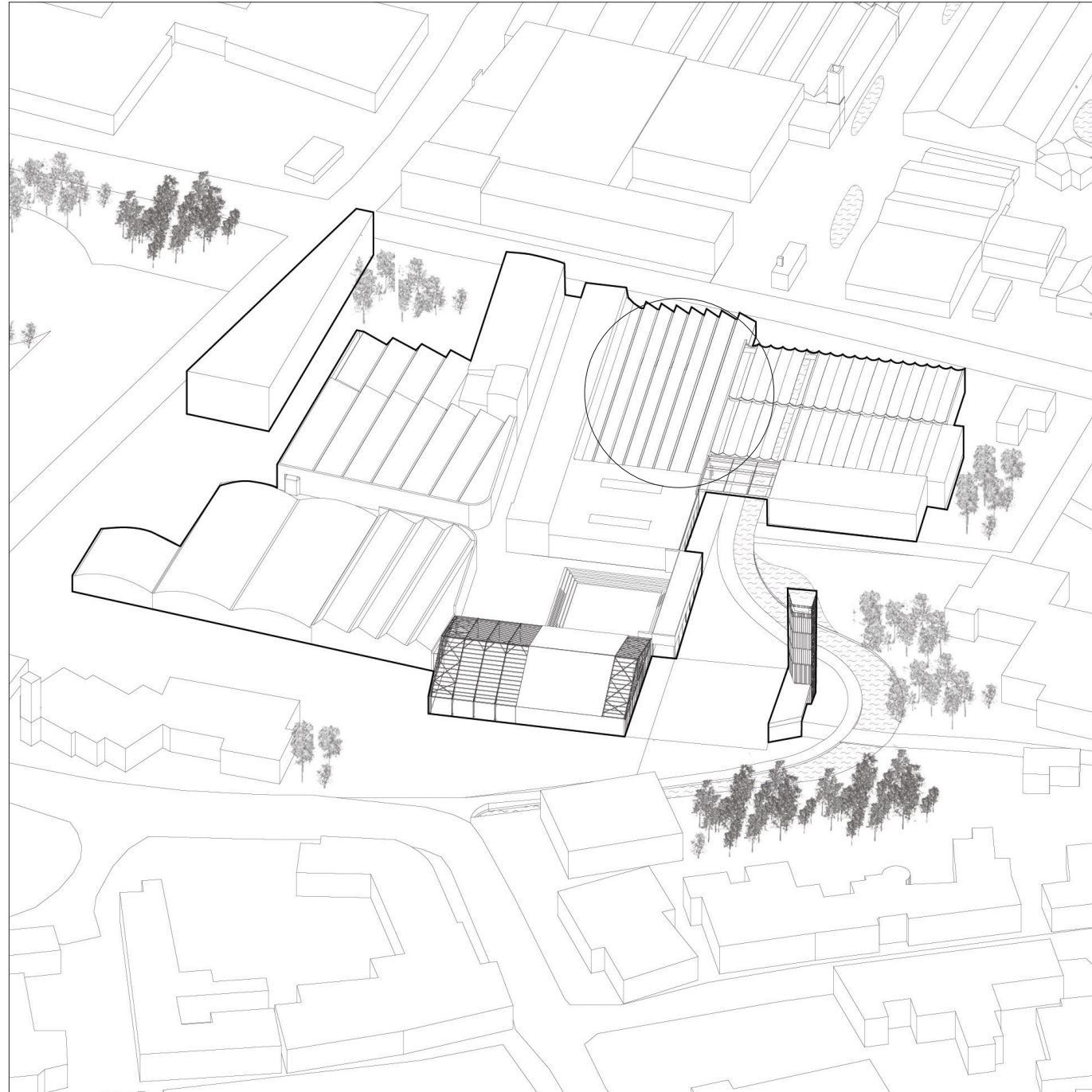
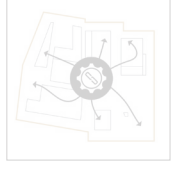
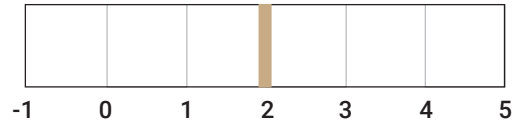



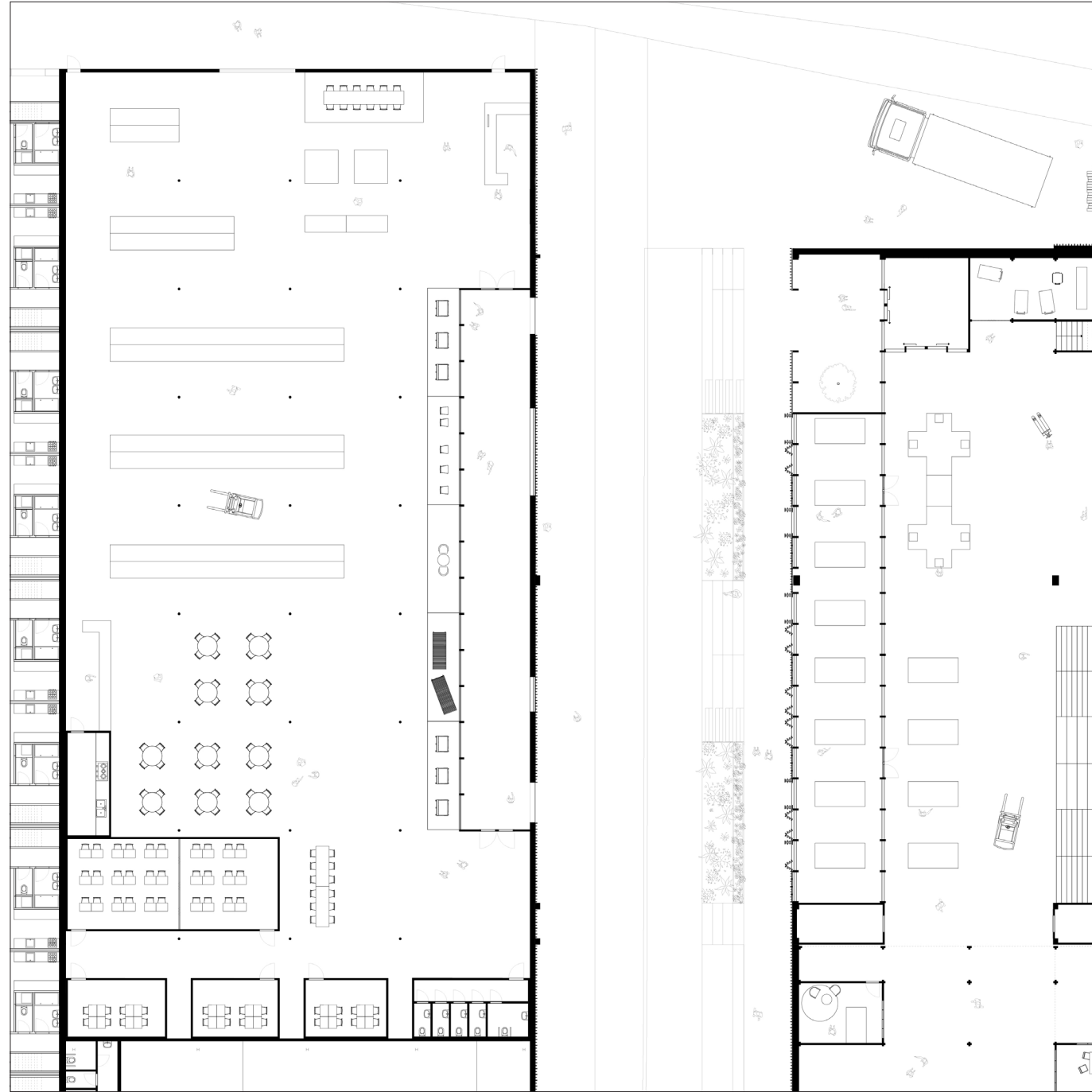
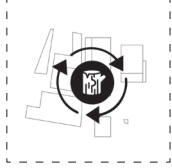
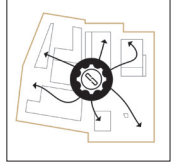
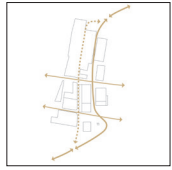
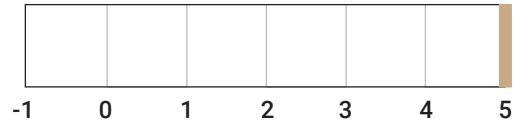



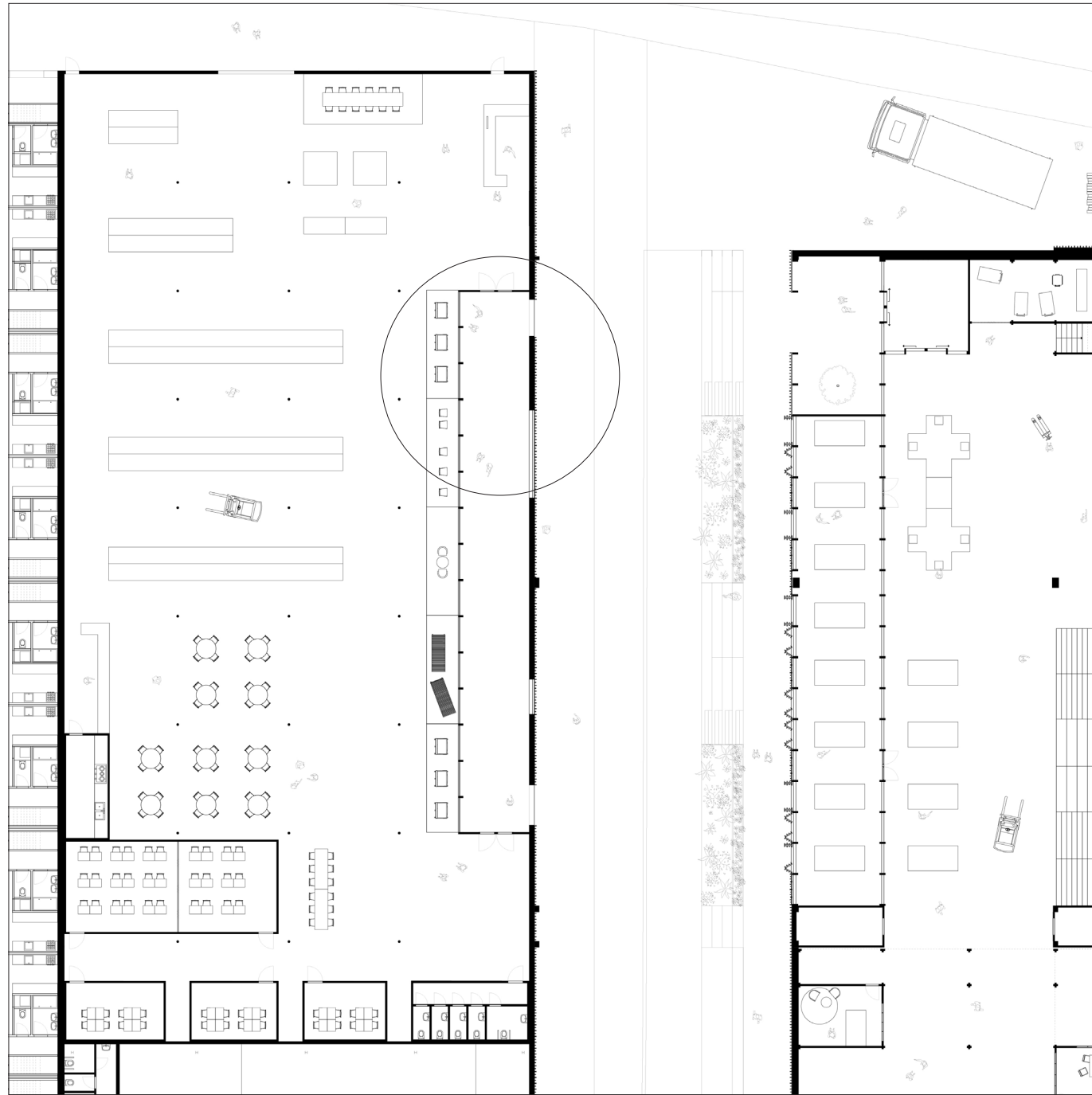
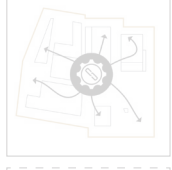
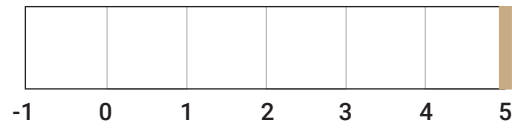

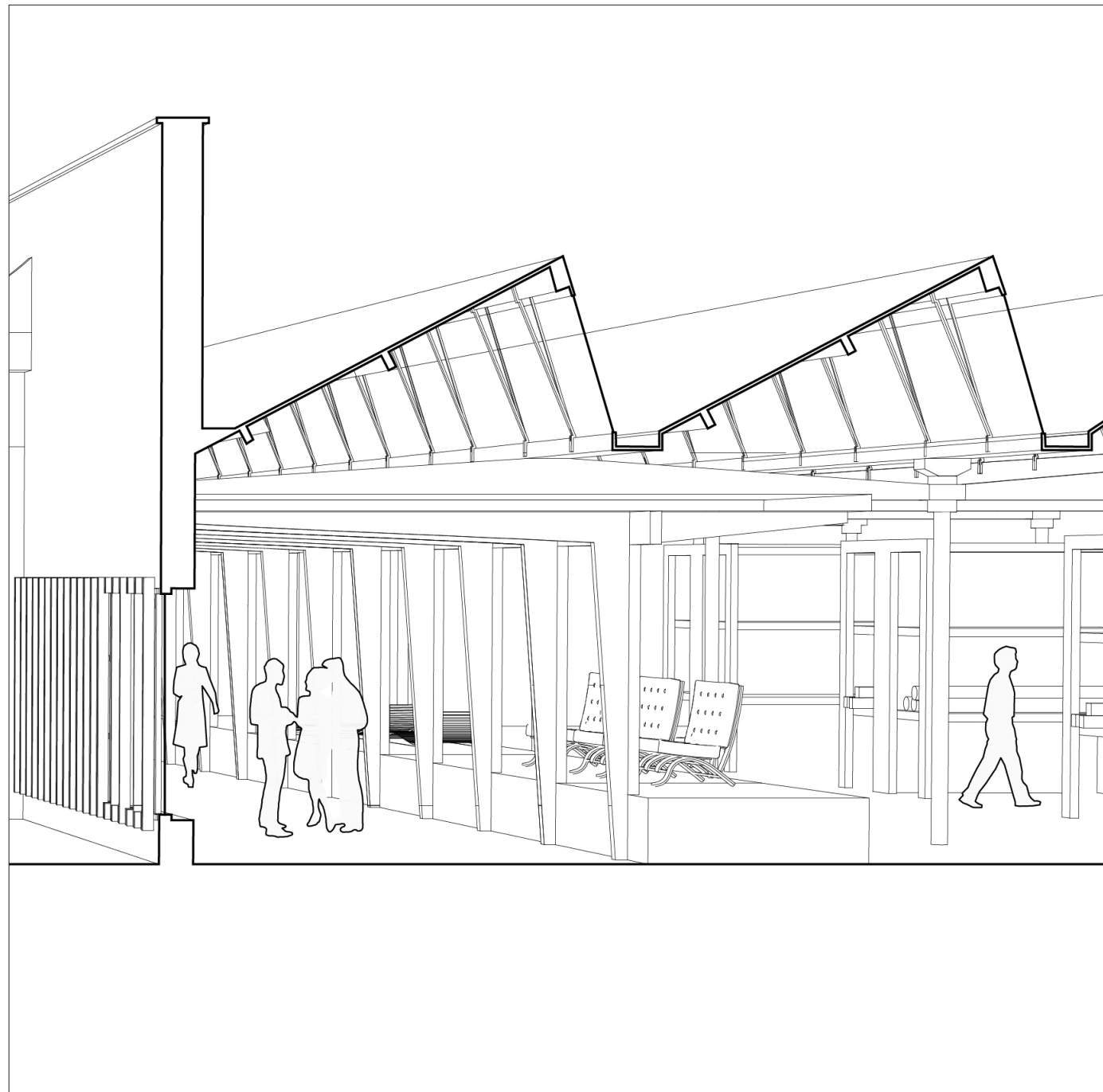
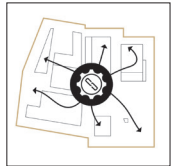
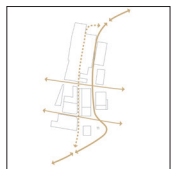
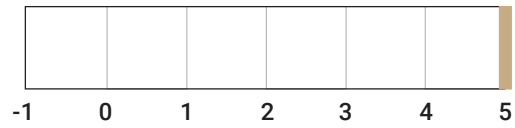



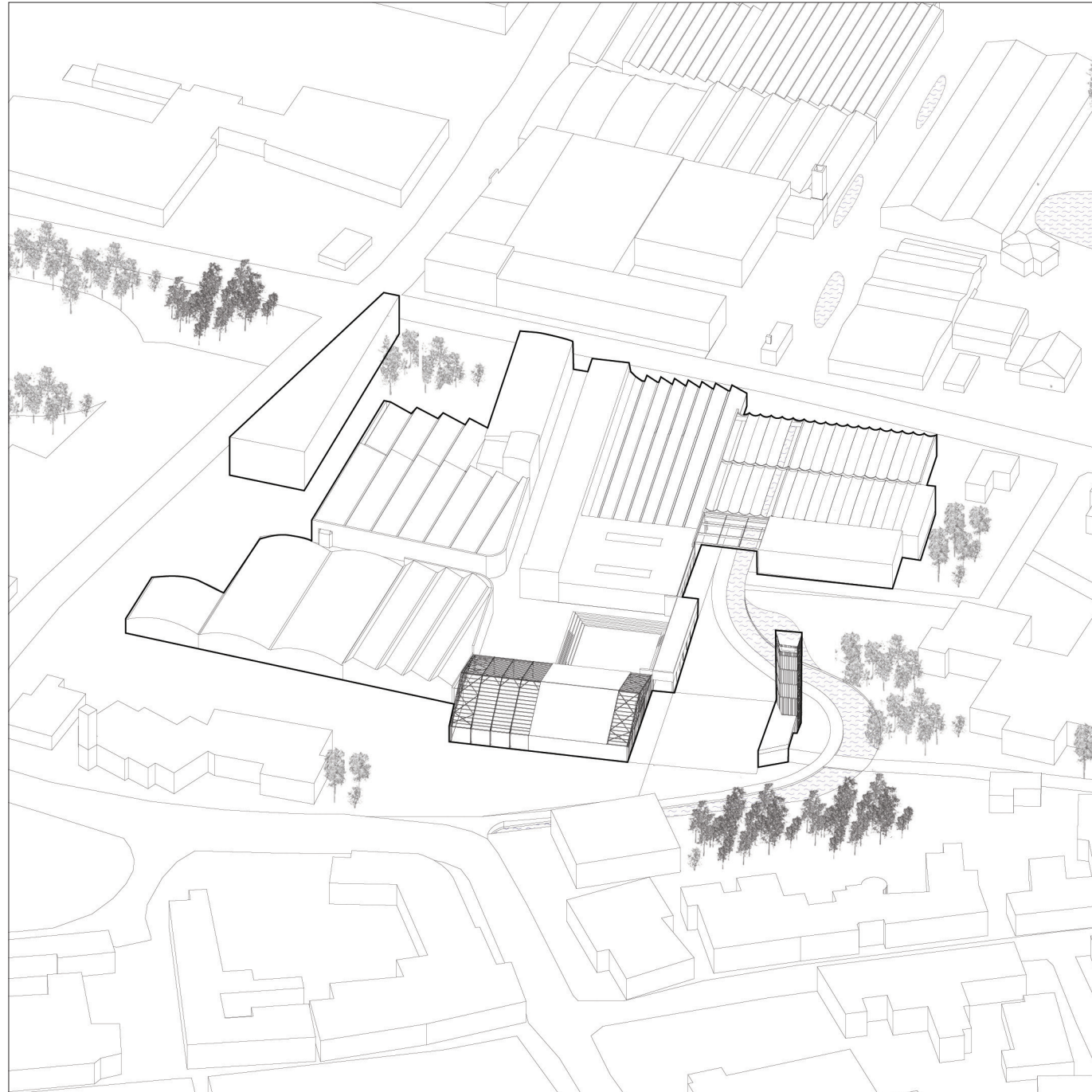
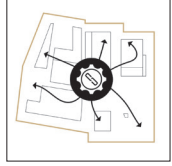
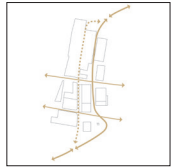
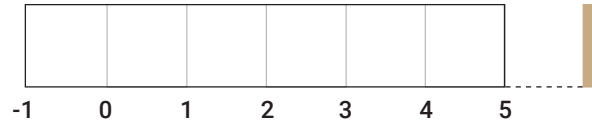

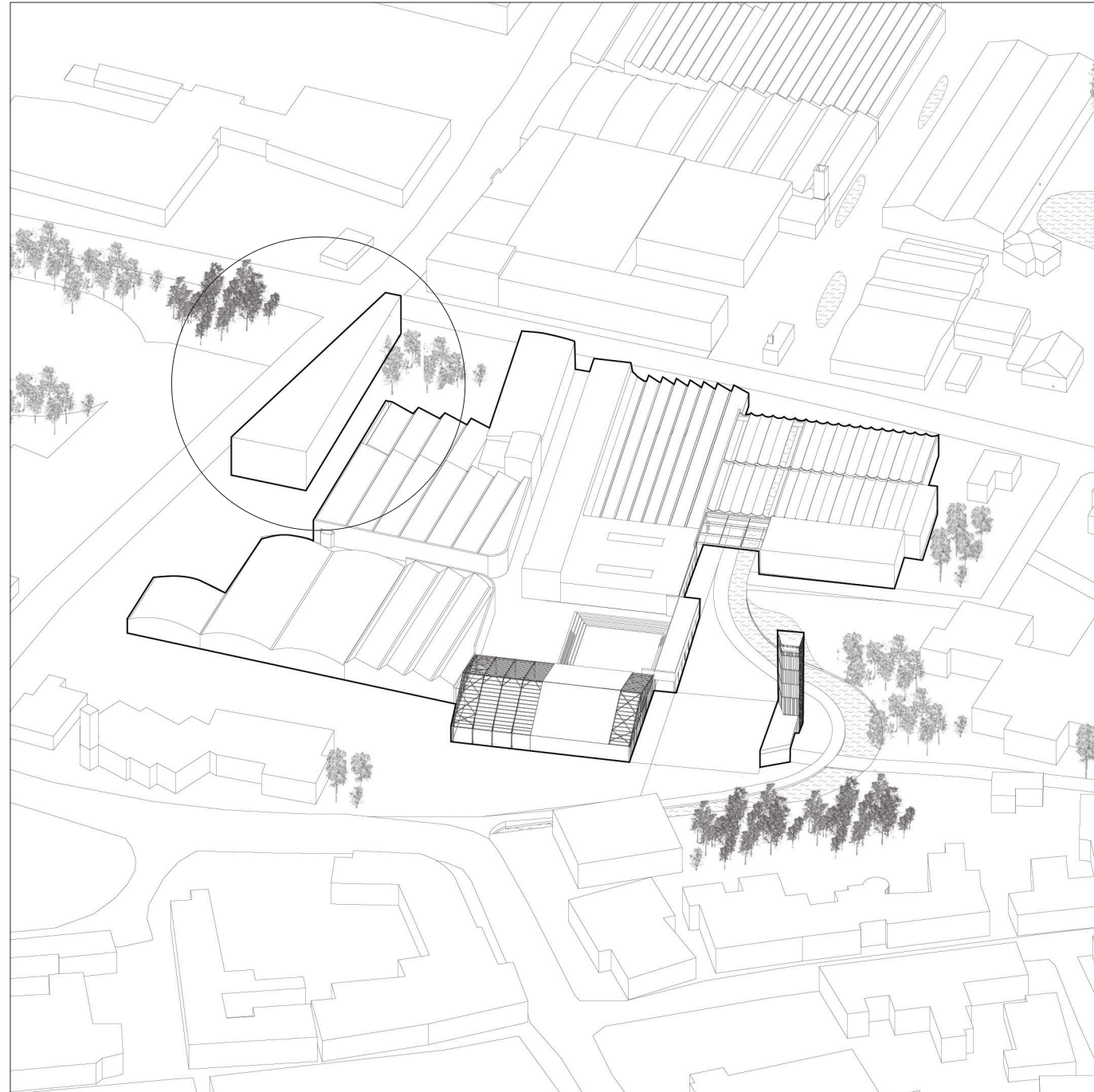
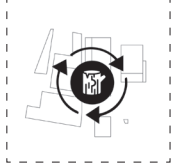
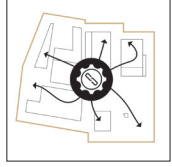
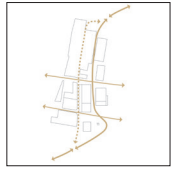
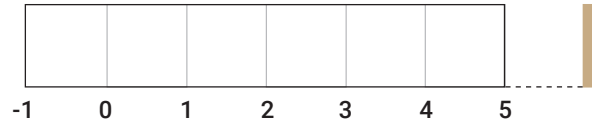

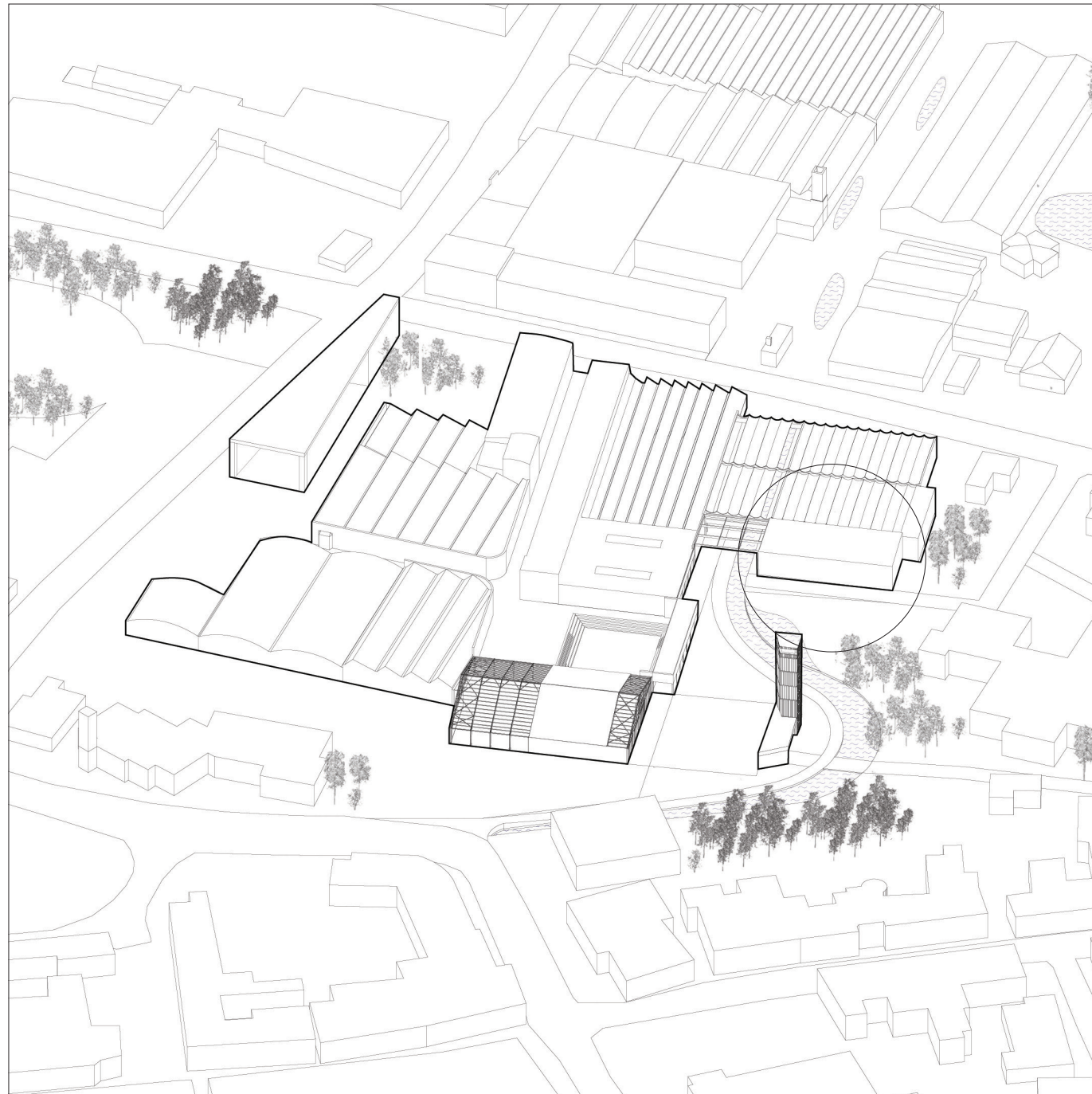
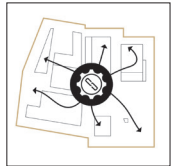
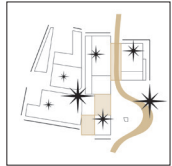
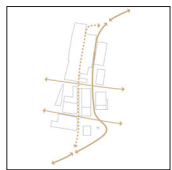

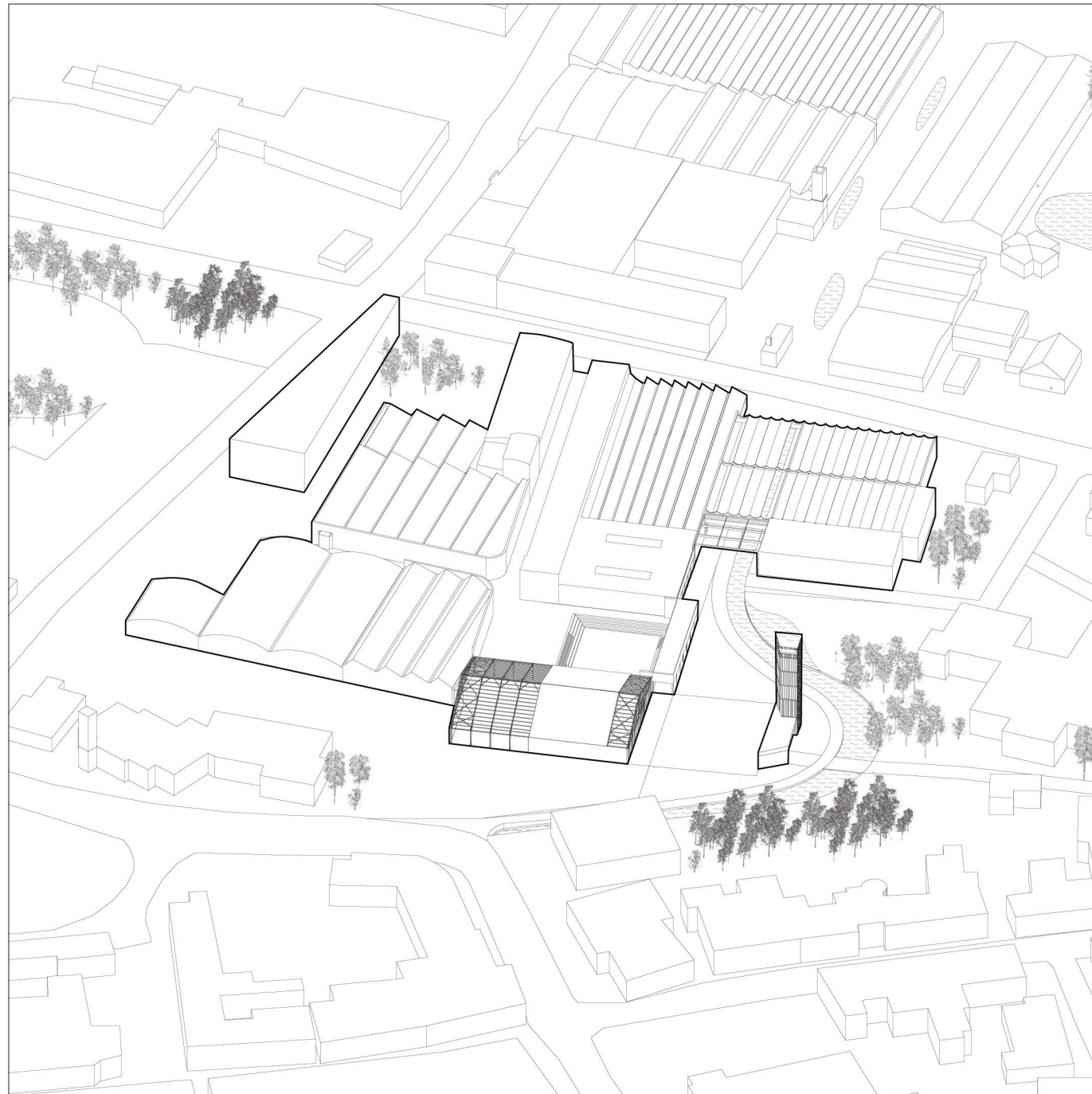
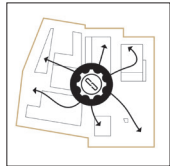
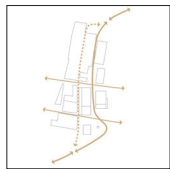

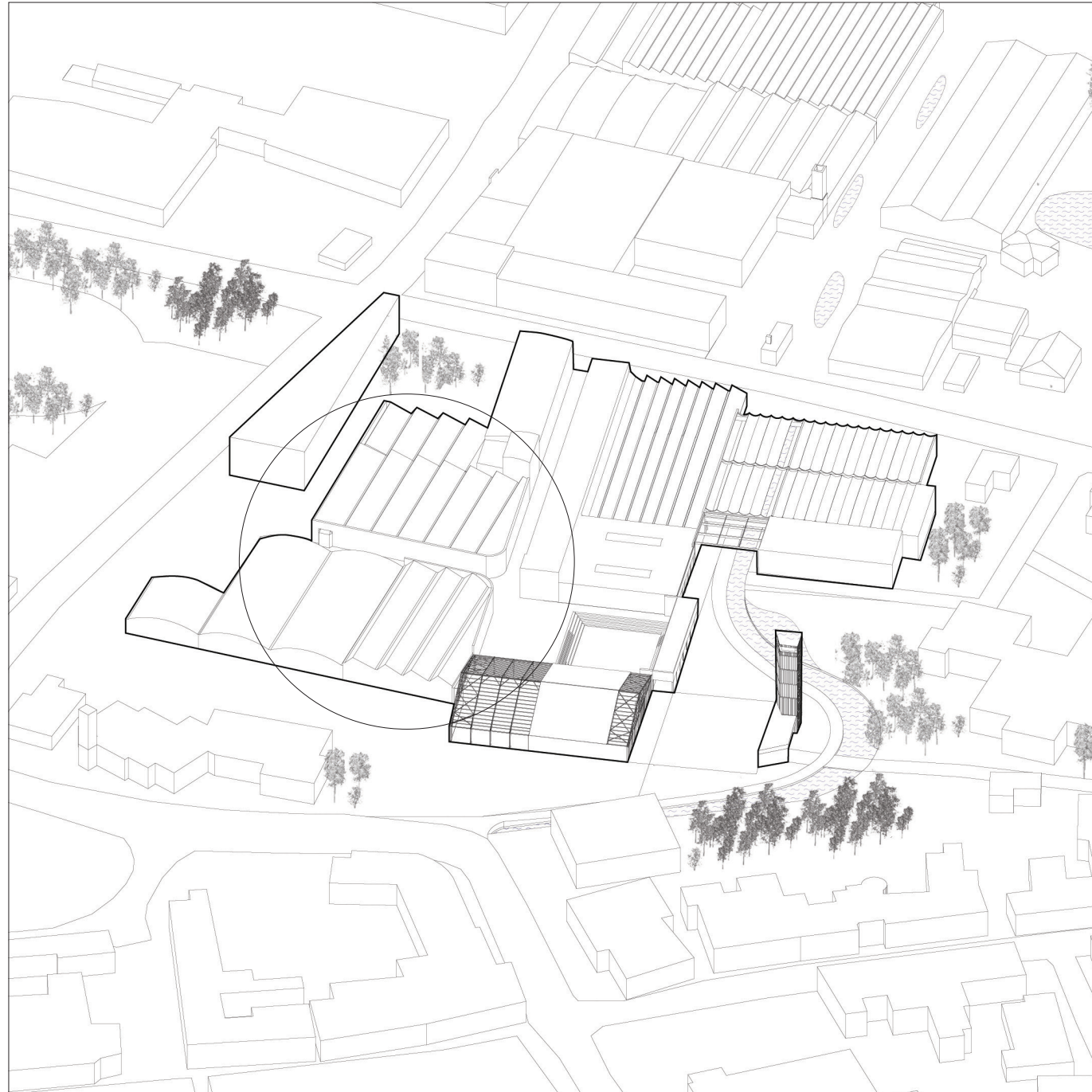
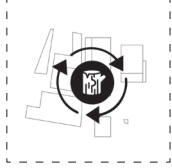
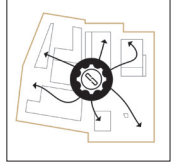
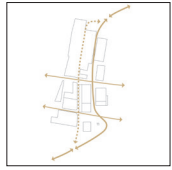
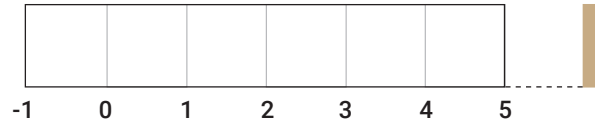



---

# CONCLUSION

---

HOW CAN THE INDUSTRIAL ENSEMBLE REGAIN ITS PURPOSE BASED ON PAST AND FUTURE CRAFTMANSHIP, FULFILLING THE FUNCTION OF PRIDE OF THE VILLAGE?

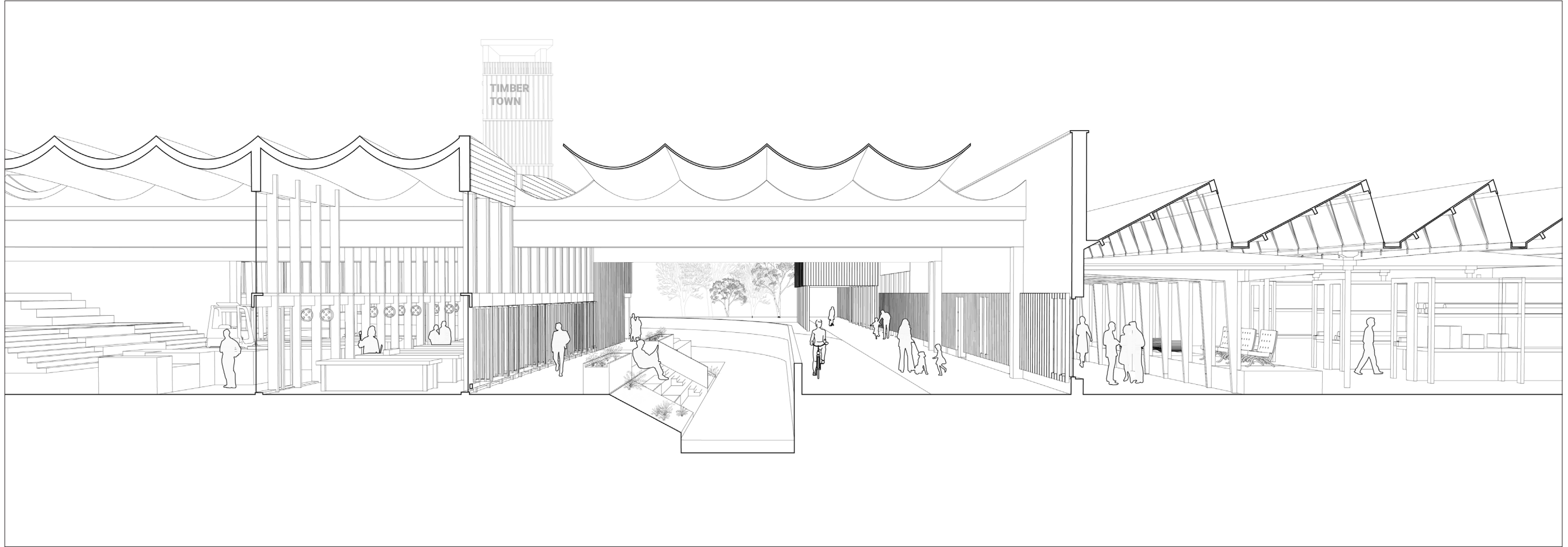

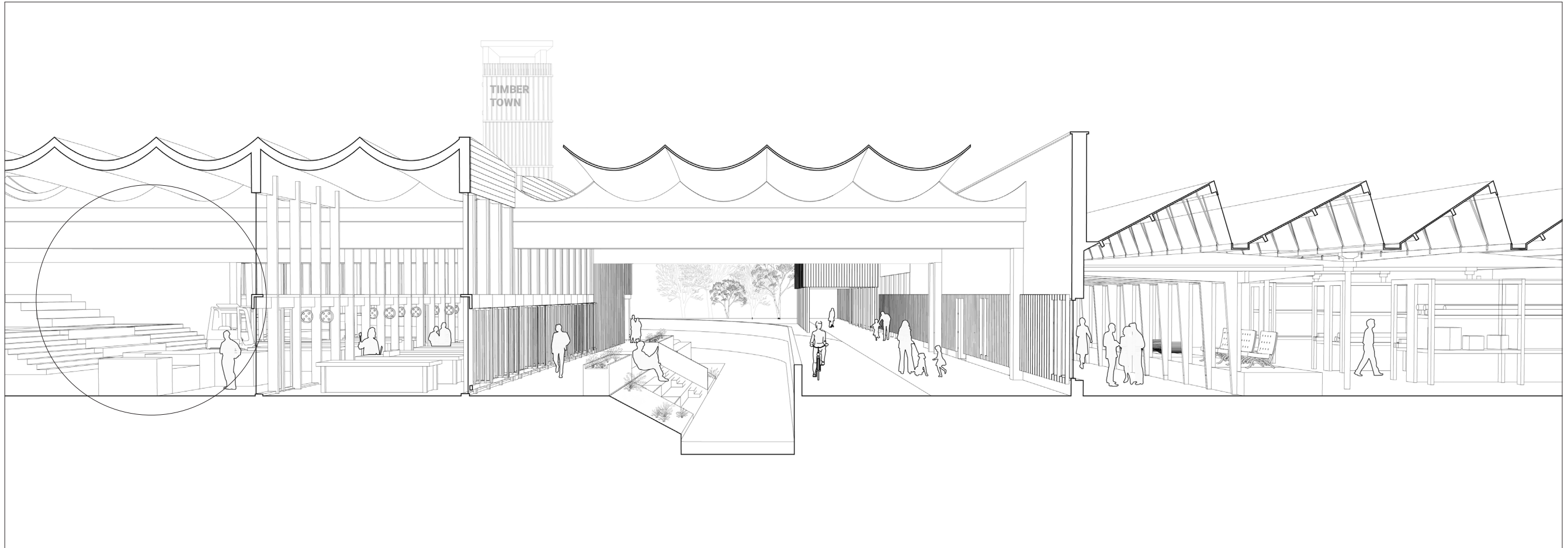

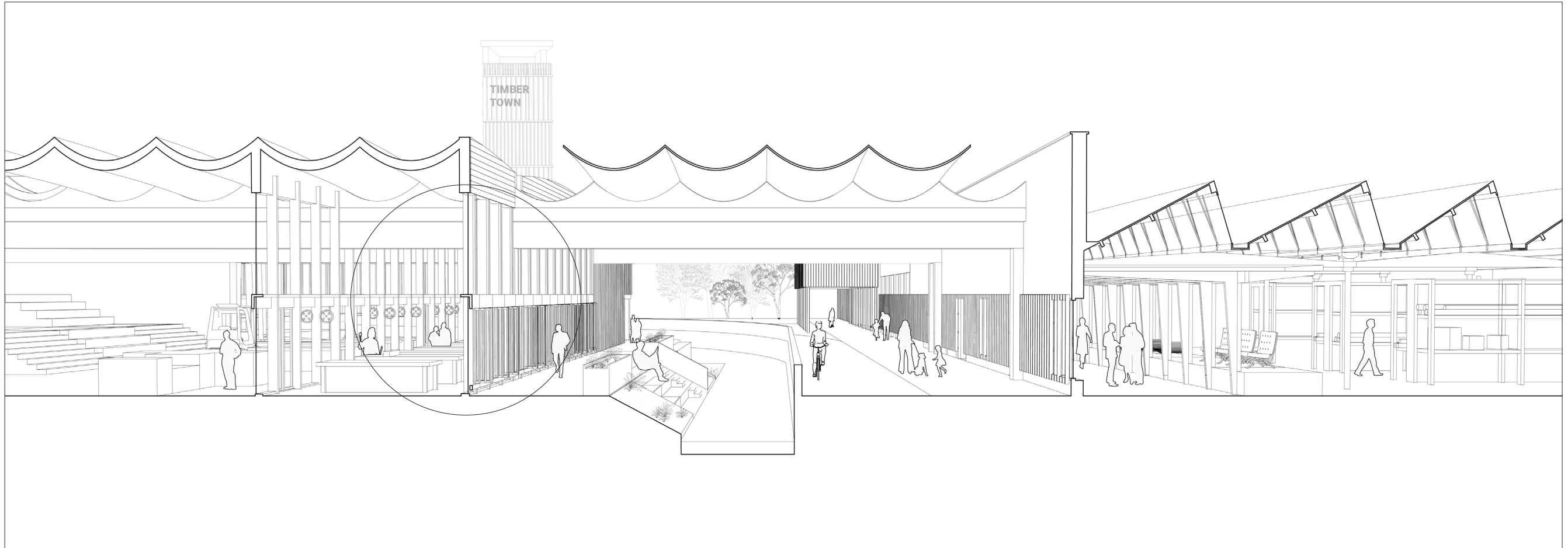

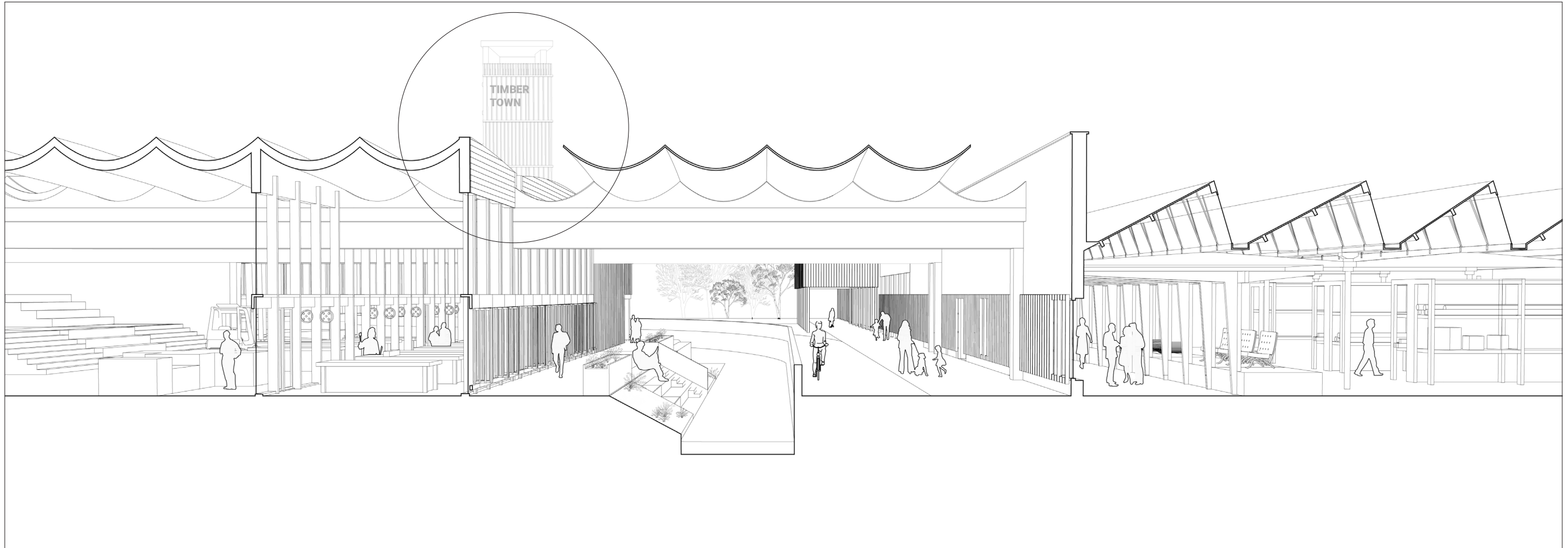

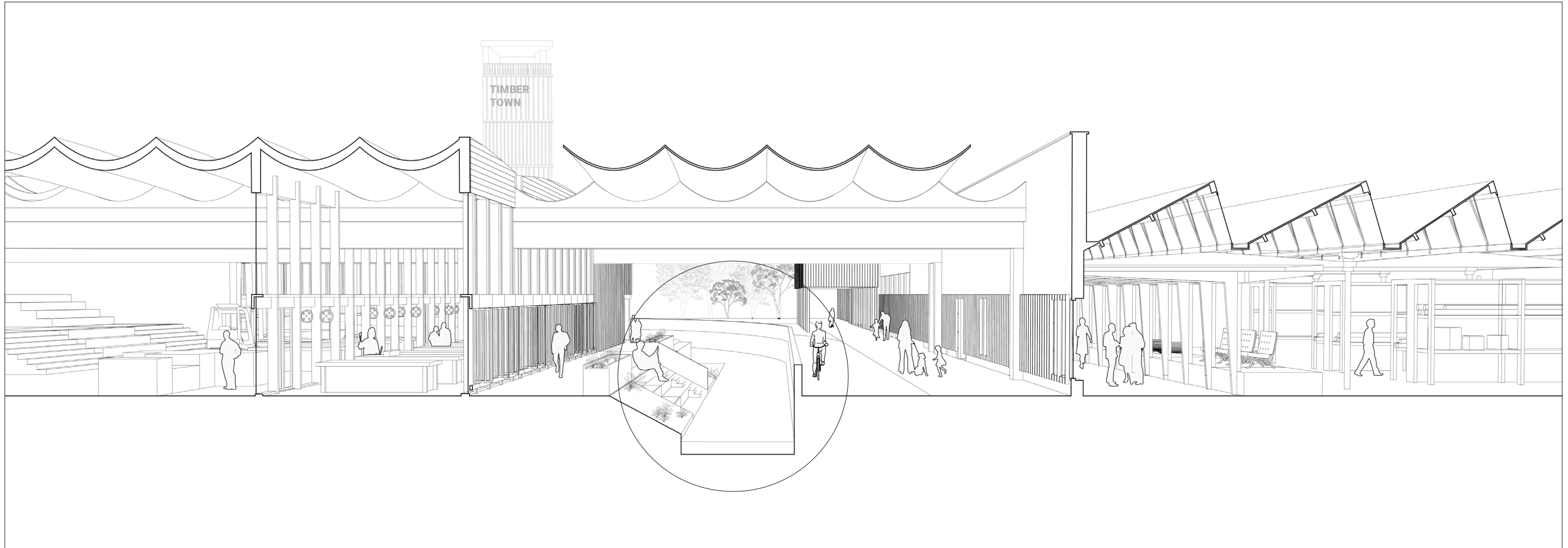

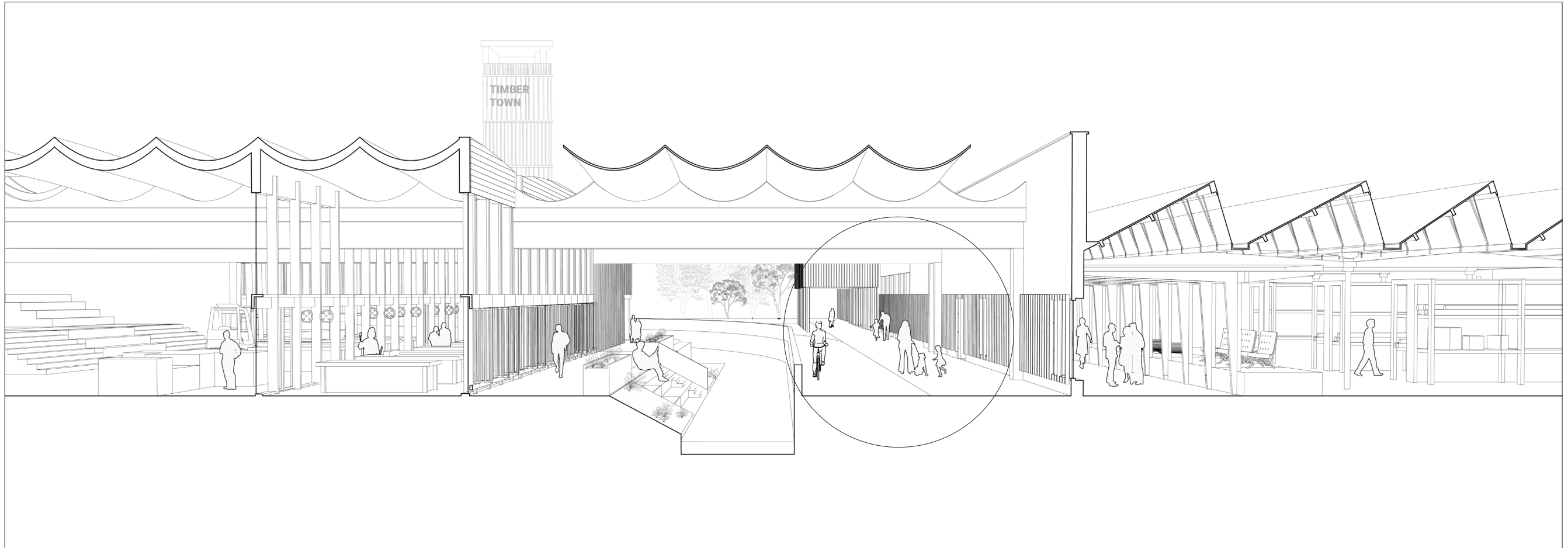



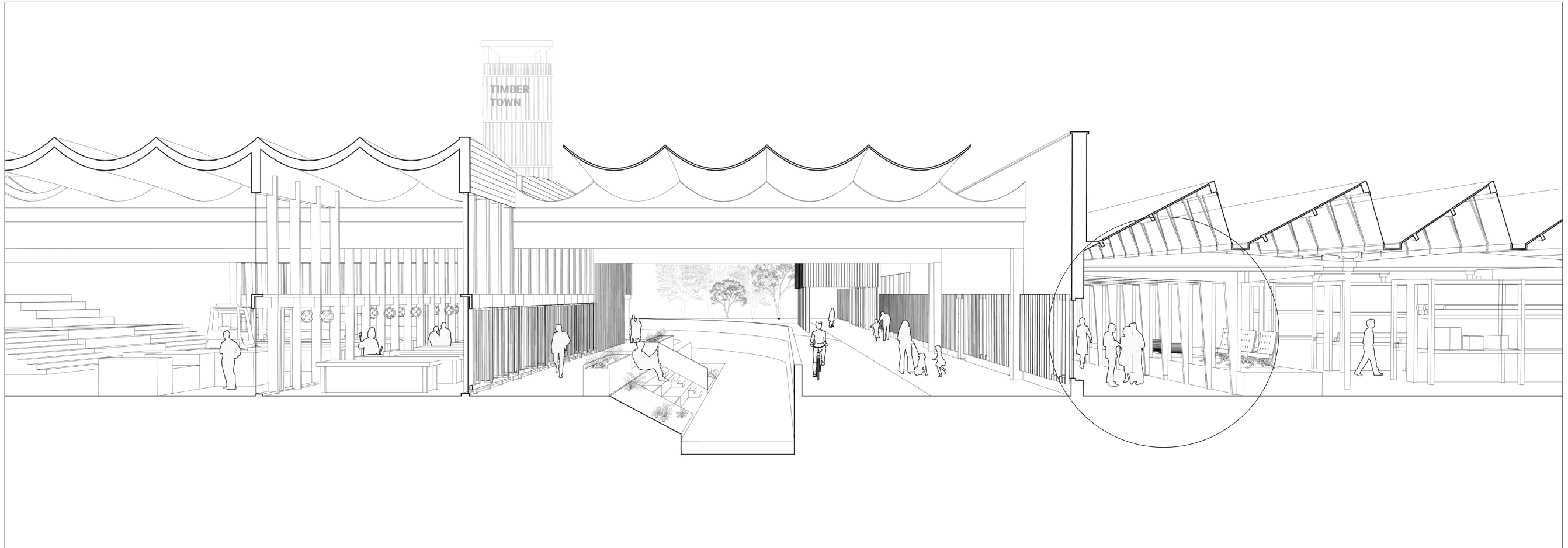

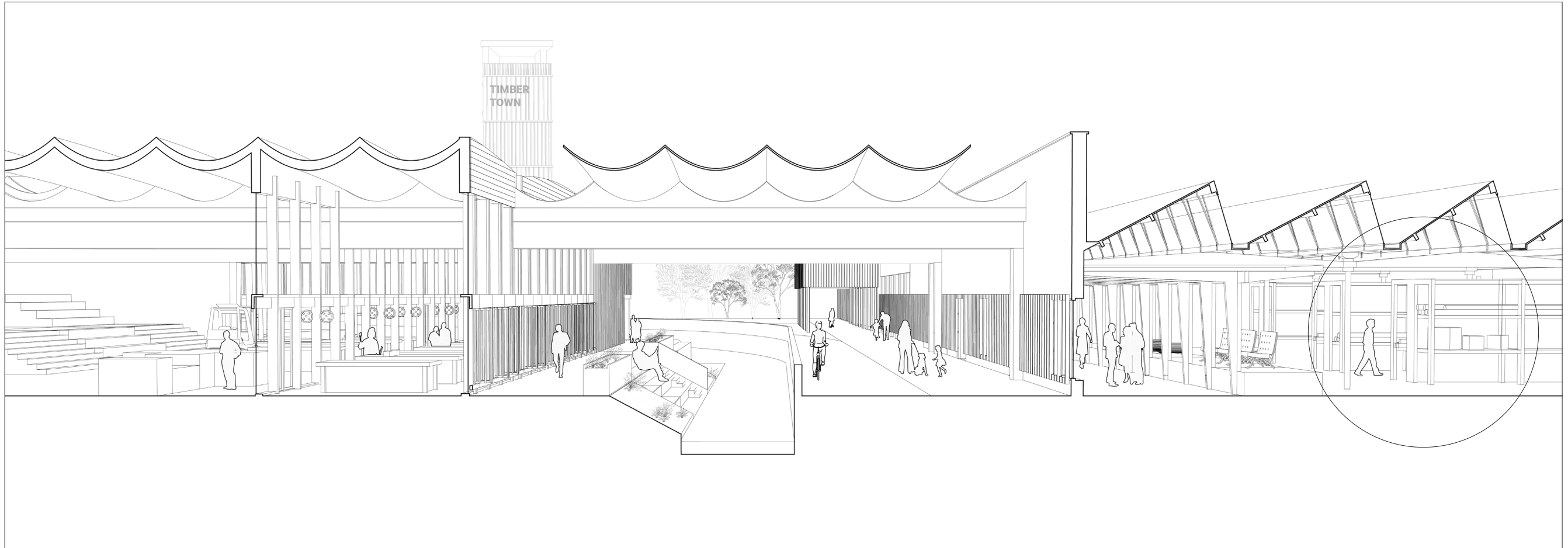

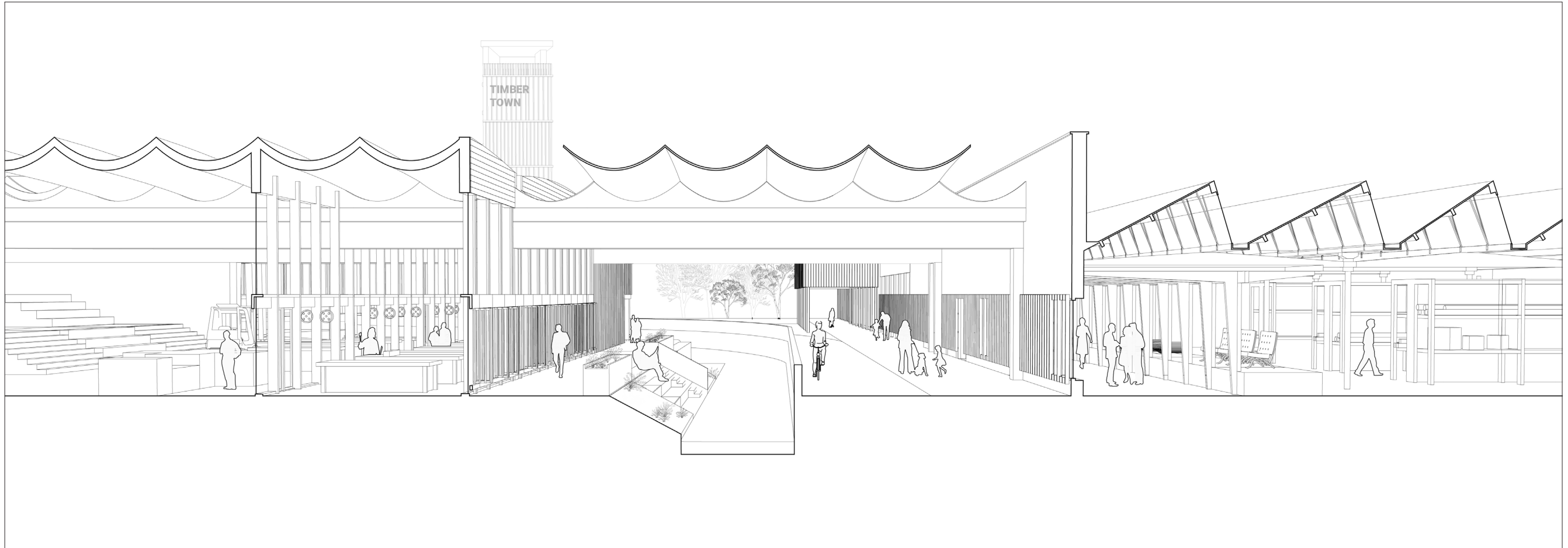

P5: JULIËTTE ZEGERS 4281683  
22-06-2020

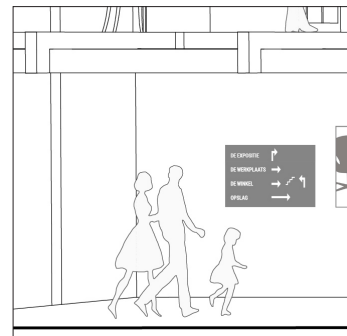
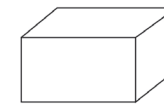
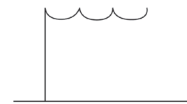
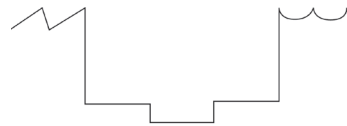
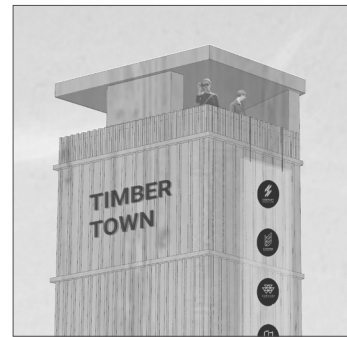
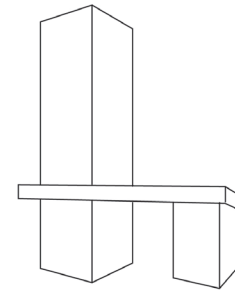
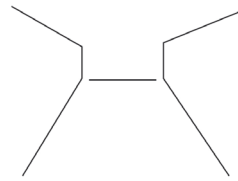

# ECONOMICAL PERSPECTIVE - BALANCE

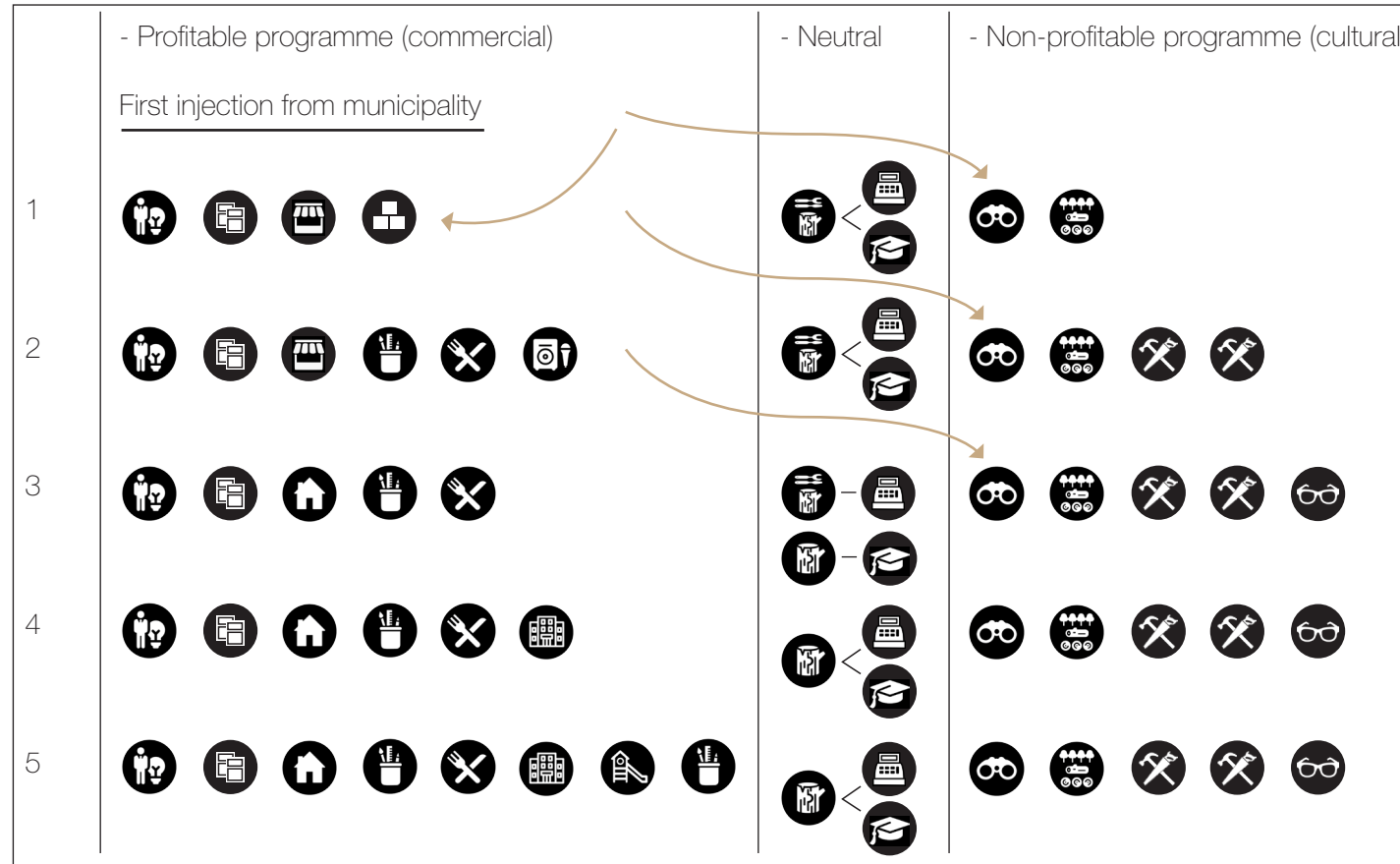

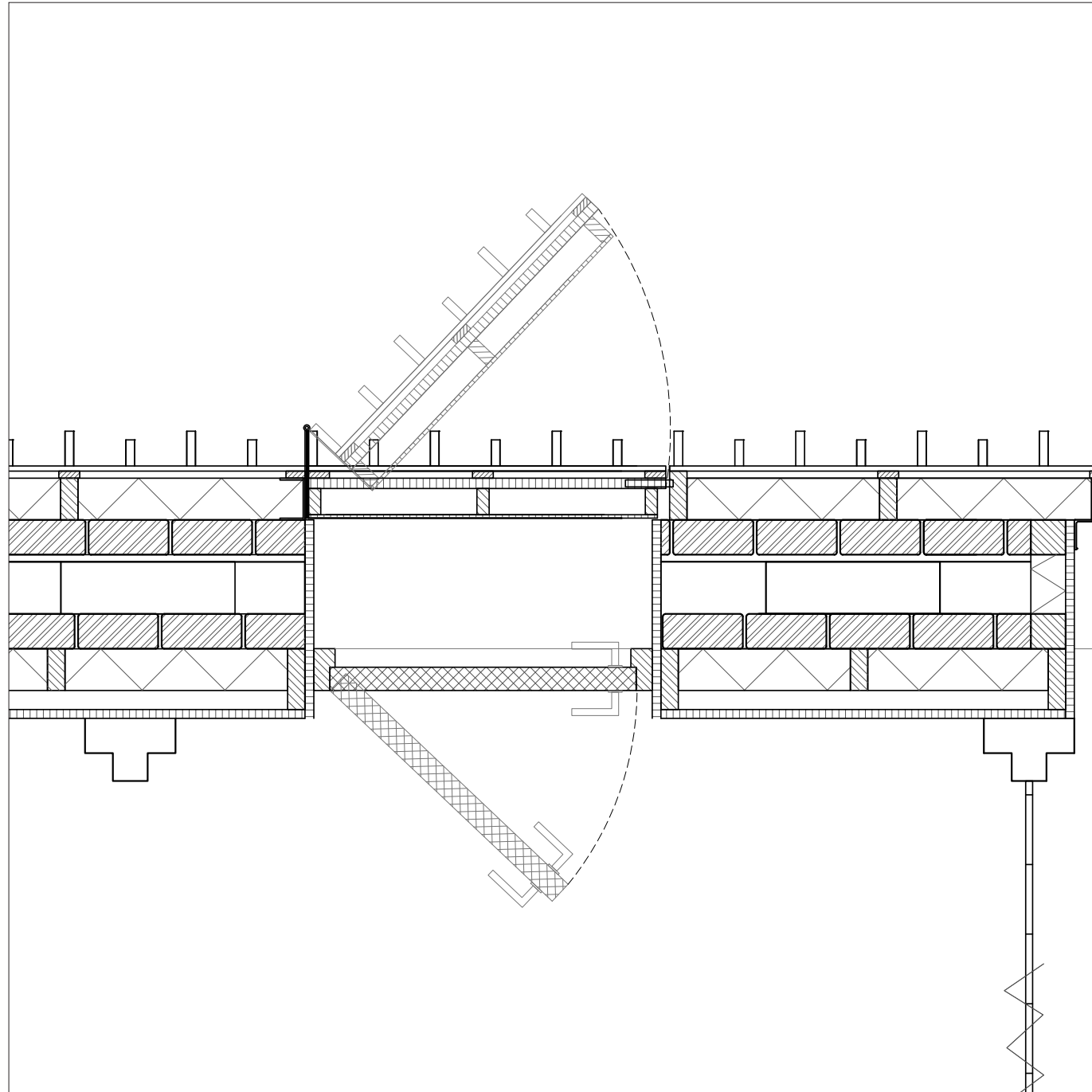

## Winterswijkse ondernemer Willy weet het wel: zo bouw je energieneutraal

DOETINCHEM - Vraag ondernemer Willy Smit uit Winterswijk naar het bouwen van de toekomst en zijn antwoord is helder. „Energie neutraal. Geen afval, geen uitval. Hergebruik van materialen en mensen. Je moet elk bouwwerk kunnen remonteren en elders neerzetten. Het maakt niet uit of het om huizen, scholen, zorggebouwen of kantoren gaat. Het kan van alles zijn.”

Erik Hagelstein 09-12-19, 11:52 · Laatste update: 12:20

f 4    t 3    3    1 Reactie

De 62-jarige Smit, hij heeft bouwkunde en weg- en waterbouw gestudeerd, is directeur en mede-eigenaar van WAM&VanDurenBouwgroep in Winterswijk en Binx Smartility in Groenlo. Pakweg 250 medewerkers voeren projecten uit in de bouw en installatietechniek.



▲ Kringloop en hergebruik van materialen zijn essentieel voor het bouwen in de toekomst, zegt de Winterswijkse ondernemer Willy Smit. © Theo Kock

Hij is zo goed als vrijgesteld van operationele managementtaken, werkt als innovatiemanager. Is bezig met een nieuw bedrijf om zijn ambitie te verwezenlijken. „We moeten de omslag maken van een lineaire naar een circulaire economie”, zoals hij dat noemt.

Inmiddels is Willy Smit kartrekker en spinner/verbinder van Cirkelregio De Achterhoek. De Regio 8RHK, waarin de overheid (zeven gemeenten), ondernemers, maatschappelijke organisaties (onderwijsinstellingen en woningcorporaties) samenwerken.

Deze zogenoemde 30's hebben de plannen goedgekeurd. Doel: zorg dat er in de toekomst op een verantwoorde manier wordt gebouwd in de regio. Zonder afval, plug & play (stekkerbaar), van bezit naar gebruik, milieuvriendelijk, toekomstbestendig.

### Lange weg te gaan

De weg is nog lang, maar er is geen alternatief, zegt Smit. „We moeten zoveel mogelijk af van fossiele grondstoffen. Veel cement en zand, amper her te gebruiken. Kies voor houtgelijmde constructies, zoals CLT-hout.

In Duitsland Oostenrijk en Scandinavië al heel gebruikelijk, wij kennen het amper. Het is milieuvriendelijk, neemt CO2 op en Europa heeft er genoeg van in huis. Je kunt het overal voor gebruiken.”

Cirkelregio De Achterhoek moet voor de 30's het kenniscentrum voor circulair bouwen worden. Welke materialen zijn er, hoe moet ik ze gebruiken, hoe zorg ik dat gebouwen en huizen energieneutraal worden? Gebruikers raadplegen een materialenmarktplaats, ondernemers maken gebruik van elkaars kennis, kunde en spullen.

### Aanhaken bij landelijk beleid

„Landelijk hebben diverse grote steden al een Cirkelstad gevormd, er zijn er ongeveer 16 op dit moment”, weet Smit. „We wilden ons aansluiten, maar ze zeiden: jullie zijn geen stad, hebben geen structuur.

Die hebben we wel, heb ik gezegd. Dat is de Regio 8RHK. De zeven gemeenten tellen samen 280.000 inwoners, we hebben de omvang van een stad. Toen konden we aanhaken”, aldus Willy Smit.

De plannen worden nader uitgewerkt, in Varsseveld is vorige week het startsein voor Cirkelregio De Achterhoek gegeven. Smit is één van de 8RHK Ambassadeurs, als lid van de thematafel circulaire economie en energietransitie. „Er moet één loket komen waar mensen met vragen terecht kunnen. Er is al zoveel kennis, die maken we voor iedereen toegankelijk.”

### Concrete projecten als doel

Belangrijk is dat er concrete projecten komen, weet de succesvolle ondernemer. „In Arnhem en Nijmegen hebben ze het altijd over grootschalige dingen, maar dat hoeft van mij niet. Als ik een blokje van zes huizen kan laten zien dat op de nieuwe manier is gebouwd, vind ik dat al mooi.”

## Circulaire economie wat moet ik ermee?



**Circulaire economie: u hoort er steeds vaker over. Maar wat is dat nu precies? Moet ik als ondernemer hier iets mee? Zo ja, wat dan en hoe pak ik dat aan? Wie kan mij daarbij helpen? En welke kansen liggen er voor ondernemers in Oost-Nederland?**

Door toenemende schaarste en instabiliteit in de wereld zullen de prijzen van energie en grondstoffen gaan stijgen. Ook is er steeds meer aandacht voor het beperken van het gebruik van giftige stoffen en de uitstoot van broeikasgassen als CO<sub>2</sub>. Klanten vragen om schoon en duurzaam geproduceerde artikelen. Overheden stellen bij aanbestedingen steeds strengere eisen. Dat heeft allemaal gevolgen voor uw bedrijfsvoering. Tegelijkertijd verspillen we enorm veel grondstoffen

en energie. En laten we veel natuurlijk potentieel onbenut liggen. Dat kan anders, dat kan veel beter!

### Circulaire economie werkt

Stel, uw bedrijf heeft warmte of restmateriaal over. Meestal doet u daar niets mee. Maar in een circulaire economie wordt dit 'afval' als grondstof gebruikt door een ander bedrijf. Of een ander voorbeeld: u ontwikkelt samen met toeleveranciers een product, dat u na de levenscyclus gemakkelijk kan demonteren. Dan blijft de waarde van de grondstof behouden. Dat noemen we ketensamenwerking.

In een circulaire economie werkt u ook met hernieuwbare grondstoffen (biobased). En uiteraard het liefst met hernieuwbare energie van zon en wind.

Met circulaire economie maakt u zich minder afhankelijk van grondstoffen en energie uit andere delen van de wereld. U neemt het heft in eigen handen. Dat is slim. Want goed ondernemerschap is vooruit zien. Ook worden normen voor grondstoffengebruik, uitstoot en afval steeds strenger. Dat kan niet anders.

### We verbruiken teveel

Een simpel rekensommetje leert, dat we op wereldschaal nu al meer grondstoffen gebruiken dan er voor alle bewoners beschikbaar is. Afgezien van de morele overwegingen - de aarde goed achter laten voor komende generaties - is een nieuwe manier van organiseren dus onontkoombaar. Daarom moeten we van een lineaire naar een circulaire economie. De vraag is niet óf het gebeurt, maar wanneer. Beweegt uw bedrijf op tijd mee?



## Circulaire economie biedt nieuwe kansen in Oost-Nederland

**Circulaire economie levert voor het bedrijfsleven nieuwe kansen op.**

Overschakelen naar circulair ondernemen betekent in Oost-Nederland voor de komende tien jaar een omzet van meer dan 1 miljard Euro en naar schatting 10.000 nieuwe banen.

Oost-Nederland heeft een enorme potentie voor circulair innoveren dankzij een hoogwaardige maakindustrie, een sterke cleantechmarkt, een grote bouwsector, vooraanstaande kennisinstellingen en een actieve overheid.

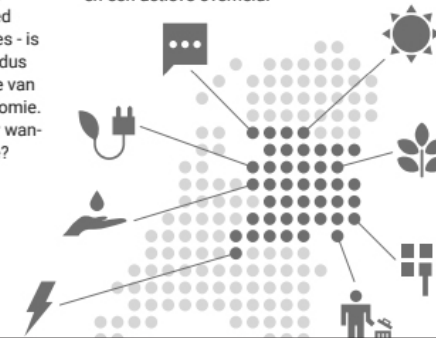





## Cirkelregio De Achterhoek

Cirkelregio is een netwerk van publieke en private partijen die elkaar actief opzoeken om gezamenlijk hun ambitie waar te maken. Werk maken van steden zonder afval, zonder uitval. En dat laten zien met tal van voorbeeldprojecten.

Cirkelregio De Achterhoek verbindt regionale circulaire initiatieven en initiatiefnemers. De regionale Communities of Practice zijn de basis. Om met partijen kennis te maken en kennis te delen. Daarnaast legt Cirkelregio De Achterhoek verbindingen met CIRCLES, het ACT en met het landelijke netwerk van Cirkelstad.

 [Sluit je aan](#)

## Design-meubelfabriek Arco uit Winterswijk wil project Local Wood wereldwijd uitrollen

WINTERSWIJK - Meubels gemaakt van bomen uit de eigen omgeving. Design-meubelfabriek Arco uit Winterswijk wil die aanpak wereldwijd gaan uitrollen. "Er wordt te veel met hout geslept."

Redactie 29-08-15, 16:02 Laatste update: 20:08 Bron: tubanlia



Arco is een topmerk in meubelland, dat thuishoort in het rijtje Leolux, Gelderland en Gispen. De meubels uit Winterswijk kenmerken zich door een strak en rank ontwerp, waar topontwerpers uit binnen- en buitenland hun signatuur aan hebben gegeven. "Daarom moet alles bij ons perfect zijn, ook het hout waar we onze meubels van maken", vertelt directeur Jorre van Ast.

### Local Wood

"Maar dat betekent dat je veel aanbod dus niet kunt gebruiken, en we vinden het toch al zonde dat Nederlands hout, toch een schaars product, vaak versnipperd wordt of als brandhout gebruikt wordt, terwijl wij ander hout uit het buitenland hierheen slepen. Dus we dachten: laten we het eens helemaal omdraaien. In plaats van dat alles er perfect en gelikt uit ziet, ontwerpen we een meubel waar je de imperfecties, zoals de noesten en scheurtjes, juist ziet. Dan kun je veel hout uit de buurt dat anders ongeschikt is, ineens wel gebruiken."

Zo werd twee jaar geleden Local Wood geboren. Het hout - op dit moment alleen nog eiken - komt uit productiebossen in een cirkel van een uur rijden rond Winterswijk en wordt ook in de regio tot planken gezaagd, gedroogd en vervolgens bij Arco tot tafelblad of bankje bewerkt.

### Afkomst

Arco heeft afspraken gemaakt met houtleveranciers als de Stichting Geldersch Landschap en Kasteelen, die 150 natuurgebieden en landgoederen beheert. Ook zijn er al partijen hout uit Bentheim gebruikt. "We moeten dat hout wel anderhalf jaar van te voren kopen, omdat het lang moet drogen. Uit welk bos elke afzonderlijke tafel komt, kunnen we nu nog niet zeggen, maar die vraag krijgen we al wel. Winterswijkers zouden bijvoorbeeld het liefst aan een tafel uit de Bekendelle of Ratum zitten. Daar willen we op den duur wel naar toe."

### Internationaal

Inmiddels zijn er al exemplaren aan klanten uit onder meer Australië verkocht. "Het bracht ons op het idee om de productie van Local Wood ook elders regionaal te gaan organiseren. Ik kom net terug uit Australië en verwacht dat we daar nog dit jaar met lokale partijen een keten kunnen opzetten om de meubels daar onder onze vlag te maken en verkopen. Dat concept willen we dan ook in andere landen uitrollen." Arco hoopt zo op meerdere plekken in de wereld lokale productie onder de merknaam Local Wood te organiseren. "We moeten het heen en weer slepen van grondstoffen over de wereld zien terug te dringen. Je merkt dat mensen terug willen naar de herkenbaarheid van producten uit de eigen streek."

### Cursussen

- The Green Circle
- Cursus informatie
- Aanmelden

Daan de Leeuw  
Bijzondere Houtbewerkingen

Hanekampweg 33b  
7104 AW Winterswijk

Mob: +31 (0)6 20254317  
E-mail:  
[info@bijzonderehoutbewerkingen.nl](mailto:info@bijzonderehoutbewerkingen.nl)

### Cursussen en Workshops

De nadruk van de Cursussen en Workshops die Daan de Leeuw geeft liggen vooral op het leren van technieken terwijl men iets maakt. De manier waarop Daan zijn cursussen geeft zijn gebaseerd op de ervaringen die hij heeft opgedaan in Wales en Engeland "Learning by doing". Ook het nieuwe seizoen gaat hij door met het geven van houtbewerkingscursussen.

Daarnaast heeft Daan The Green Circle opgericht, Buitenatuier voor Ambacht en Kunst, waarin hij verschillende workshops in de natuur faciliteert en een platform creëert voor vakmensen en het hedendaagse ambacht. Hijzelf geeft in de zomermaanden de workshops Vers Hout op het natuurerrein van "The Green Circle". Voor meer informatie over The Green Circle kijk op [de website van The Green Circle](#).

Kijk voor meer informatie op de cursus en workshop informatie links op de navigatiebalk.

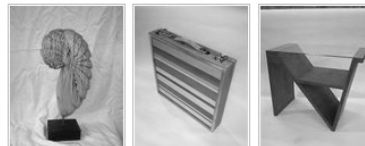

Nieuws Aanbieding Over ons De zagerij Afnemers Houtsoorten

Neem contact op 

# NIJWEIDE

## HOUTHANDEL - ZAGERIJ

→ Aanbieding



**Producten**

- Afasteringshout
- Balkhout
- Heelvenhout
- Ongeschaafde gevelplanken
- Picknicktafels

Nijweide Houthandel - zagerij  
Kottenseweg 158  
7115 AE Winterswijk  
Tel. 06-30 52 02 00  
info @ houthandelnijweide.nl

Lariks Douglas hout, Eikenhout, klimaatkamer gedroogd Eikenhout (voor o.a. trappen, tafels en kasten), tuinhout, rabatdelen, (prefab) tuinhuisjes, veranda's, houten bijgebouwen, schuttingen, houten afrasteringen, pergola's, tuintafels, tuinbanken, picknicktafels, eettafels, salontafels, boomstamtafels.

## Welkom bij houthandel De Holtplas !



Meerdink  Winterswijk in de houthandel

HOME AZOBE ZAGERIJ TOEPASSINGEN CONTACT VACATURES 

## Verantwoord duurzaam

Azobé (EN: Ekki D; Bongossi) is een bijzonder harde, zeer duurzame houtsoort. Azobé heeft een paarsbruine kleur en is afkomstig van Lophira alata Banks ex Gaertn.f. (familie Ochnaceae). De boom komt voor in West- en Midden-Afrika en wordt tot maximaal 50 meter hoog. Het wordt vooral gebruikt voor zware constructies die niet alleen weer en wind moeten doorstaan, maar ook grote krachten moeten opvangen zoals sluisdeuren en palen waar schepen tegenaan kunnen varen (dukdalven, remmingwerken e.d.).



**Houtzagerij**



Meerdink zaagt in haar eigen zagerij in Winterswijk de hardhoutsoort Azobé, ook wel Ekki of Bongossi genoemd. Hierbij kunnen wij korte tot zeer korte levertijden garanderen.

Meer...>>

**Houthandel**



Azobé hebben wij in rondhout op voorraad. Dit betekent dat we u korte levertijden kunnen bieden in diverse kopmaten en lengten.

Meer...>>

**Houtconstructies**



Meerdink is specialist en leverancier van hardhout constructies op maat. Een hierbij veel gebruikte houtsoort is Azobe, ook wel Ekki of Bongossi genoemd.

Meer...>>

**Azobe**



In Engelstalige landen heeft men het over Ekki en in Duitsland over Bongossi als men Azobé bedoelt. Red Ironwood is een andere Engelse term voor deze houtsoort.

Meer...>>

U bent hier: [Home](#) > [Over Ons](#)

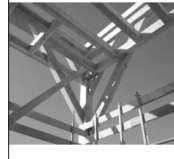
## Over Ons

Gebinten.nl is een Initiatief van [Huis Kamp Bouwbedrijf](#) in samenwerking met de historische houtzagerij 'De Lintumsmolen'. De houtzagerij is oorspronkelijk gesticht door bewoners van het scholtengoed 'Het Lintum' in Winterswijk. Een scholtengoed is ontstaan als een beheersinstituut voor de graven van Getre teneinde de landerijen te ontginnen en agrarisch te gebruiken, met de medewerking van verschillende pachtboeren, waarbij een deel van de opbrengst moest worden afgedragen aan het hof. De naam 'Scholte' betekent dan ook 'schuldig' voor het af te dragen gedeelte van de oogst.

Door de bosrijke omgeving van Winterswijk werden voor het onderhoud en de nieuwbouw van gebouwen ter plekke zagerijen en steenbakkerijen gesticht. Hiervan is 'De Lintumsmolen' een voorbeeld.

## De Lintumsmolen

Bij houtzagerij 'De Lintumsmolen' bevindt zich de timmerwerkplaats van [Huis Kamp Bouwbedrijf](#). Hier werken bedreven timmerlieden die beschikken over historische vakkenis die niet overal aanwezig is. Zij weten alles over originele constructies en de daarbij behorende verbindingen en afwerkingen.

## Geschiedenis

Wanneer [Huis Kamp Bouwbedrijf](#) precies is opgericht is onbekend, maar de oudste factuur dateert uit 1897.

### Daarom kies je voor Gebinten

- ✓ Team van vakmensen
- ✓ Jarenlange ervaring
- ✓ Ambachtelijke werkwijze (zonder CNC machines)
- ✓ Authentieke details

### Mogelijkheden



## Per 2020 vernieuwde opleiding Hout & Restauratietechniek op MBO-3 niveau in Gelderland

12 december 2019 • 215 • Door Redactie • Bron: Persbericht Gelders Restauratie Centrum en Graafschap College



Hout & Restauratietechniek op MBO-3 niveau Foto: Gelders Restauratie Centrum

Het Gelders Restauratie Centrum en het Graafschap College bieden per 2020 een vernieuwde opleiding Hout & Restauratietechniek op MBO-3 niveau aan in Gelderland. De nieuwe 'cross-over'-opleiding combineert gedegen kennis van houtrestauratie met moderne (ICT)technieken en soft skills. Die worden steeds belangrijker in de moderne restauratiepraktijk.

### Grote behoefte aan een moderne restauratie-opleiding

In Gelderland is grote behoefte aan een moderne, brede houtrestauratie-opleiding op MBO-3 niveau. De driejarige opleiding Hout & Restauratietechniek is een 'cross-over' tussen de opleidingen allround timmerman en allround meubelmaker. Vanuit een gedegen basis van traditioneel timmerwerk worden slimme, creatieve houtspecialisten goed op de toekomst van het restaureren voorbereid.

### Belangrijkste onderdelen

De opleiding bevat drie belangrijke onderdelen:

1. Restauratie-timmeren in theorie en praktijk.
2. Moderne (ICT)technieken als CNC, 3D-printen, infrarood-scannen en het gebruik van drones.
3. Soft skills zoals communicatie, leiding geven en onderhandelen.

Na zes maanden theoretische grondslag gaan de studenten drie dagen per week in de praktijk werken bij de Gelderse Kennis & Kunde-bedrijven.

### Een restauratie-timmerman/vrouw die écht van wanten weet

De ontwikkelingen in de restauratiebouw gaan snel. De opleiding Hout & Restauratietechniek sluit daar naadloos op aan. Volgens opleidingscoördinator Roy Jansen is het 'eindproduct' een MBO-3 restauratietimmerman, die écht van wanten weet in de moderne restauratiepraktijk. "Wij willen dat onze studenten de kracht zien van de combinatie van het oude ambacht en moderne technieken. Wij brengen ze daarmee in aanraking. Wij gaan laten zien wat je allemaal nog meer kan doen. Er komt ruimte om te experimenteren en we maken de verbinding met schilderen, metselen en zelfs het groen. En we maken de verbinding met de installatietechniek, want dat heeft allemaal invloed op het restauratie-vak, zoals het zich nu ontwikkelt."

### Voor Gelderse studenten en professionals, zeker ook voor meisjes

De opleiding richt zich op onder-instroom uit het VMBO en HAVO en zij-instroom van MBO'ers en vakmensen uit de praktijk. Het is mogelijk deze opleiding als BOL of BBL te volgen. Ook meisjes/vrouwen zijn van harte uitgenodigd zich aan te melden. Studenten en professionals uit heel Gelderland kunnen zich aanmelden. De kosten zijn afhankelijk van leeftijd en vooropleiding.

### Partners

Hout & restauratietechniek is een samenwerking van het Gelders Restauratie Centrum, het Graafschap College, de provincie Gelderland en de Gelderse Kennis & Kunde-bedrijven. Door de samenwerking met de beste Gelderse aannemers kunnen de studenten de theorie direct in de praktijk brengen. Daardoor wordt het leereffect versterkt.