

Document Version

Final published version

Citation (APA)

Vergoossen, R., & Jilissen, D. (2025). Concrete Regulations Stand in the Way of Sustainability Ambitions. In J. A. O. Barros, V. M. C. F. Cunha, H. S. Sousa, J. C. Matos, & J. M. Sena-Cruz (Eds.), *4th fib International Conference on Concrete Sustainability (ICCS2024): Volume 1* (Vol. 1, pp. 89-95). (Lecture Notes in Civil Engineering; Vol. 573 LNCE). Springer. https://doi.org/10.1007/978-3-031-80672-8_11

Important note

To cite this publication, please use the final published version (if applicable).
Please check the document version above.

Copyright

In case the licence states "Dutch Copyright Act (Article 25fa)", this publication was made available Green Open Access via the TU Delft Institutional Repository pursuant to Dutch Copyright Act (Article 25fa, the Taverne amendment). This provision does not affect copyright ownership.
Unless copyright is transferred by contract or statute, it remains with the copyright holder.

Sharing and reuse

Other than for strictly personal use, it is not permitted to download, forward or distribute the text or part of it, without the consent of the author(s) and/or copyright holder(s), unless the work is under an open content license such as Creative Commons.

Takedown policy

Please contact us and provide details if you believe this document breaches copyrights.
We will remove access to the work immediately and investigate your claim.

Green Open Access added to TU Delft Institutional Repository

'You share, we take care!' - Taverne project

<https://www.openaccess.nl/en/you-share-we-take-care>

Otherwise as indicated in the copyright section: the publisher is the copyright holder of this work and the author uses the Dutch legislation to make this work public.



Concrete Regulations Stand in the Way of Sustainability Ambitions

Rob Vergoossen^{1,2(✉)} and Danny Jilissen¹

¹ Royal HaskoningDHV, Rotterdam, The Netherlands
Rob.Vergoossen@rhdhv.com

² Delft University of Technology, Delft, The Netherlands

Abstract. The Dutch Concrete Act [1] sets ambitious goals for sustainability, including significant CO₂ reduction and high-quality reuse of concrete by 2030. Rijkswaterstaat, the Directorate-General for Public Works and Water Management, aims for circular practices by this time. Structural engineers play a crucial role in assessing existing structures. But too often it leads to the replacement of a structure because it is at the end of the designed service life. Concrete regulations influence engineering decisions, with changes increasing the use of reinforcement, although they may offer more flexibility than perceived. Structural engineers can influence sustainability by professionally assessing existing structures, potentially avoiding unnecessary replacements. However, there's a tendency to prematurely classify structures as old, leading to conservative assumptions and modelling methods that may underestimate the structural safety. Despite limited technological advancements in concrete and reinforcement steel, existing structures often exceed strength requirements for new structures. Shear force requirements have evolved, yet structures without shear reinforcement are feasible under current regulations. The emphasis on reuse over new construction is proposed, urging a reconsideration of the necessity of shear reinforcement. Structural engineers can optimize material use by carefully considering modelling methods, structure dimensions and reinforcement amounts, aligning with the basic principles of reinforced concrete techniques while following the regulations.

Keywords: Design codes · Shear resistance · Modelling

1 Introduction

1.1 The Dutch Concrete Act

In the Dutch Concrete Act [1], various ambitions have been established, including a 30% CO₂ reduction in 2030 compared to 1990, 100% high-quality reuse of emerging concrete in 2030, and an immediate minimum of 5% replacement of the total volume of aggregates by concrete waste streams. The Directorate-General for Public Works and Water Management (Rijkswaterstaat) has the ambition to work circularly as early as 2030. The influence of the structural engineer extends further than many people think. He plays a role in the assessment of existing structures. The question can be asked why existing structures are often replaced, while there is a lack of significant technological development.

Of course, the concrete regulations play an important role for that structural engineer. In general, due to the changes in these regulations over the years, including in the field of shear force, the application of reinforcement has increased, which does not benefit sustainability. Yet these regulations sometimes offer more possibilities than you would think at first glance.

1.2 Unjust Disapproval of Existing Structures

A structural engineer can have an impact on sustainability, through a professional assessment of existing structures. This can prevent the construction of a new structure. Many new structures are built to replace an existing structure. In those cases, this existing structure is classified as old.

Often, unjustly, in the design and upon reassessment, the lifespan of a structure is assumed. This lifespan is needed to determine the size of the representative loads. These loads are determined from the probability of exceeding them in this anticipated time period. But this does not mean that a structure has died after this period has passed. A structure does not live and therefore does not die.

If a structure is classified as old, a negative classification is (perhaps it is unconsciously) attached to it. Old and worn out, old and given up. Due to a lack of knowledge about existing structures and the design principles used, such as drawings and calculations, ‘conservative’ assumptions and modeling methods are chosen. It is then concluded based on this model that an existing structure does not meet current requirements. This would then have ended the functional lifespan. An additional advantage of giving up an existing structure is that something new can be designed. Where there are more freedoms and where the ultimate decision-maker (the politician) can have a publicity moment at the opening.

Also, a very large technological development is missing: the development in concrete and reinforcement steel is relatively limited. The current steel quality is indeed about a factor 2 higher than in the 1950s. We also ask for higher concrete strengths as a structural engineer nowadays. On the other hand, due to the ongoing strength development of the concrete, the current strength of existing structures [2] (for example C35/45), is often higher than is asked for new structures (for example C25/30 or C30/37).

Furthermore, it has only been since the 1990s that the design standards talk about a reference period for loads. Structures from before that period are therefore indirectly designed for eternity, as long as the structure can provide sufficient resistance to the loads acting on it.

1.3 Reuse Over New Construction

Of course, in some cases, a new structure is still needed. If a highway is widened, viaducts over this road must provide space for this. However, the design often already takes into account widening by one lane. However, the increase in traffic is sometimes so large that the structure no longer suffices after three or four decades.

To limit the inconvenience for the road user, an existing structure is usually demolished as quickly as possible, so that traffic is obstructed as briefly as possible. The existing

concrete is then processed into concrete rubble granulate. However, in the Netherlands, approximately half of all viaducts consist of prefabricated parts. These elements are, with some effort, dismantlable. Moreover, because of the design principle of no tensile stress under the then prevailing characteristic load combination, they are very robustly designed. As a result, under the current characteristic load combination, the tensile stress remains smaller than the tensile strength of the concrete so that the cross section remains mathematically uncracked. This meets both the current crack width requirements and the fatigue requirements, both of which require a change in stress in the prestressing steel. In current designs, these requirements are often decisive above the ultimate limit states.

2 Shear Force

Many structural engineers suggest that the shear force requirements have changed and that there is often no (or insufficient) shear reinforcement in existing structures. But structures without shear reinforcement are also possible according to current requirements. In reinforced and prestressed slab structures, according to Article 6.2.2 of Eurocode 2 [3], it can be demonstrated in some cases that these elements do not require calculated shear reinforcement. The second paragraph of this article states that in the parts of statically determined prestressed elements that are uncracked due to bending, the shear force resistance is limited by the tensile strength of concrete. In other words: the maximum principal tensile stress in a prestressed element must be less than the design value of the tensile strength. This is the same method of calculation, based on allowable stresses, as in the old Dutch concrete regulations GBV 1912 to GBV 1962 and the Prestressed Concrete Guidelines 1957 and 1967.

The only difference is that the safety philosophy at the time assumed allowable (shear tensile) stresses of 0.96 MPa with a strength class K600 (approx. C40/50). According to the Eurocode, the design value of the tensile strength for a cylinder compressive strength of $f_{ck} = 40$ MPa is: $f_{ctd} = 1.64$ MPa. Indirectly, a total safety factor with a value of $1.64/0.96 = 1.71$ was therefore calculated in the design. This applies to both permanent loads such as own weight and live loads. Furthermore, further hydration of the concrete shows an increase in the characteristic cube compressive strength of precast beams to an average $f_{ck;cube} = 90$ MPa [5].

The design value of the tensile strength, including the factor $k_t = 0.85$, increases to an average of $f_{ctd} = 1.86$ MPa, so that an average of 13% extra safety is provided. The doctoral research of Roosen [6] proposes an additional capacity of 28% on top of this.

For existing structures, sufficient shear capacity can often be demonstrated and therefore no shear reinforcement is required from arithmetic perspective. A shift to a new motto should therefore be introduced such as ‘Reuse over new construction’, or ‘Reuse unless ...’.

2.1 Shear Reinforcement in New Structures

One may also wonder why so much shear reinforcement is used in new structures. This actually may not be always necessary. In statically determined prestressed structures,

limitation of the principal tensile stress ($\sigma_1 \leq f_{ctd}$) can still be assumed. Naturally, for reasons of robustness, some reinforcement in transverse direction in the form of stirrups is necessary. But this can be kept to a minimum. With this minimum much less than the value in the current Eurocode article 9.2.2, which assumes that the resistance delivered by the shear reinforcement is more than the resistance of the concrete.

For solid slab structures that are linearly supported, a plate factor to increase the calculated shear capacity of the concrete ($V_{Rd,c}$) could also be used for new structures in the future. In Belgium, for example, this is already permitted via the national annex. In the Netherlands this is allowed for the assessment of existing structures via national codes and guidelines [2].

3 Modelling

With the method of modelling, the structural engineer has an influence on the reinforcement to be used and any prestressing.

3.1 Abutments

Nowadays, an abutment is schematized as a beam over several (spring) supports representing the foundation piles. As a result, the structure behaves like a Euler-Bernoulli (flexure) beam and shear reinforcement is required. Due to the detailing regulations in the Eurocode, even if no shear reinforcement is required from a calculation point of view, the legs of shear reinforcement must be spaced a maximum of 300 mm apart in the longitudinal direction. In addition, the centre-to-centre distance of the legs in transverse direction must be a maximum of 500 mm. For an abutment with a width of 2.5 m, at least 6-legged stirrups are required in the transverse direction (Fig. 1).

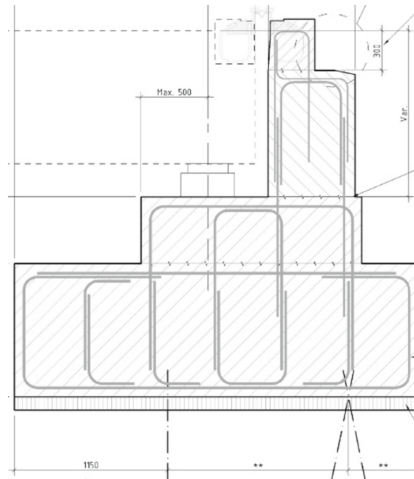

Fig. 1 Principle of reinforcement in abutment according to bending theory and Eurocode

Arithmetic, horizontal forces also cause torsion in the modelled beam. As a result, an overlap in the vertical part of the outer stirrup is not allowed. At abutment foundations, the horizontal component causes bending in two directions. This often results that the minimum shear reinforcement is also applied in the horizontal direction. However, Eurocode 2 states in paragraph 9.8.1: ‘The reinforcement in a foundation should be calculated using the most suitable method: either with a strut and tie model or with bending theory’. If a structural engineer chooses the method with strut and tie models, all shear reinforcement and torsional reinforcement can often be omitted, and the same reinforcement as in existing foundations will suffice (Fig. 2).

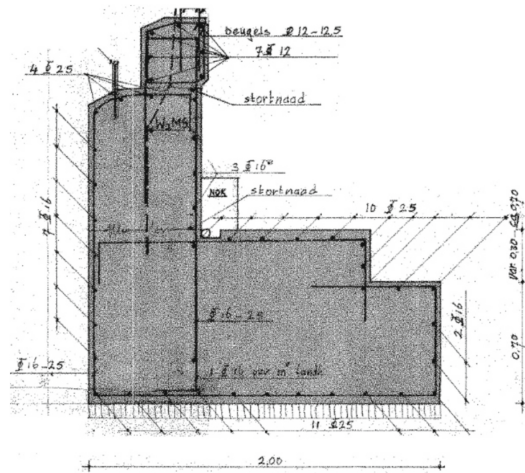

Fig. 2 Reinforcement in existing abutment (1973) according to strut and tie model

3.2 Prefabricated Prestressed Girders

A comparison between the amount of reinforcement and prestressing in girders in an overpass from 1980 (Fig. 3) and girders for the extension of the same overpass, designed with the Eurocode (Fig. 4), shows that the newer girders contain 33% more prestressing steel than in the existing girders. Despite this greater amount of prestress, the amount of stirrup reinforcement has also increased by more than a factor of 1.4. This despite the relatively high amount of stirrup reinforcement for girders of that time of $\text{Ø}10\text{--}300$ in the 1980 design. Moreover, longitudinal/flank bars of a total of 22 kg/m^3 have been used in the new girders, which are completely absent in the 1980 design.

From a recalculation of the beams from 1980, it appears that these, with the load factors according to the new construction level, can be demonstrated by using Eurocode [3] article 6.2.2(2) that no calculated shear reinforcement is needed in new prefab girders. Therefore, the minimum stirrup reinforcement from detailing (approx. $\text{Ø}8\text{--}275$) also does not need to be checked for fatigue. The condition is that strands, as was customary in the past, are pressed down instead of straight and detached, as is customary today.

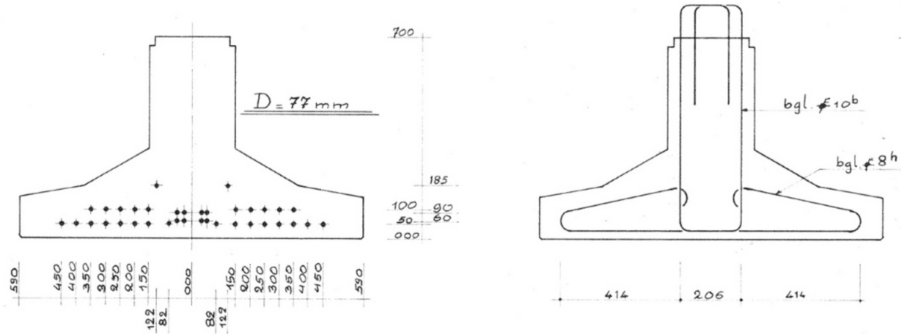

Fig. 3 Prestressing strands (36×12.7 mm) (left) and reinforcement (right) in girder from 1980

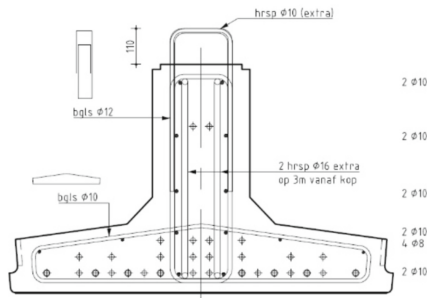

Fig. 4 Reinforcement and prestressing strands (30×15.9 mm) in girder according to Eurocode

The girders from 1980 not only meet the ultimate limit states, including fatigue for another 100 years of residual life, but also meet the requirements for crack width. The concrete cover requirements on reinforcing steel and prestressing steel also comply with the Eurocode for 100 years of design life. After 40 years of use, it appeared that negligible (to none) penetration of chlorides and carbonation had occurred. The measured carbonation depth was less than 1 mm. The chloride level in the outer 10 mm was less than 0.1% (mass) on cement. This is due to the high quality of these prefabricated girders.

3.3 Influence as a Structural Engineer

By carefully considering the dimensions of a concrete structure and the amount of reinforcement, an optimum use of raw materials can be achieved [7]. With the right choice of modelling, a structural engineer can save tens of percents on reinforcement. As was already stated in 1918 in the Dutch concrete code GBV 1918 [4]: ‘The intention of the regulations is to promote the technique of reinforced concrete. It is therefore not the intention that new construction methods should not be used or that they should be forced into the framework of these regulations for the calculation.’ It is therefore good to remember that ‘a good structural engineer must be able to design a good structure even without any regulations’ [8].

4 Discussion

One of the starting points of the second generation of Eurocodes was enhancement of ease of use. On the one hand this will promote standardization and can contribute to less failure costs. On the other hand, as stated in this paper, this probably will increase the reinforcement in structures. From a sustainability viewpoint less reinforcement is more sustainable. Therefore, structural engineers should take action and design new structures with only the reinforcement needed for structural reasons. In the selection of the structural model and the stiffnesses within this model a structural engineer can have a huge influence into the necessary reinforcement. Therefore, a structural engineer has to make this choice consciously.

References

1. Betonakkoord voor Duurzame groei (*Concrete Agreement for Sustainable Growth*). Nootdorp, 10 juli 2018, www.betonakkoord.nl
2. Richtlijnen Beoordeling Kunstwerken (RBK) (*Guidelines Assessment of Existing Structures*). RTD 1006:2022 versie 1.2.1 definitief, Rijkswaterstaat, 16 November 2022
3. NEN-EN 1992-1-1: Eurocode 2: Design of concrete structures–Part 1–1: General rules and rules for buildings, including amendment sheet A1:2015 and Dutch national annex 2016 including amendment sheet A1:2020. (2005)
4. Van der Vooren, A.A., Tweede druk, Veen Uitgever, L.J.: Koninklijk Instituut van Ingenieurs: Gewapend beton voorschriften (G.B.V. 1918) (*Reinforced concrete regulations 1918*) voorzien van toelichtingen en tekstfiguren door. Amsterdam (1925)
5. TNO-rapport: Analyse van de materiaaleigenschappen voor de bepaling van het afschuifdraagvermogen van bestaande betonnen kunstwerken (*Analysis of the material properties for the determination of the shear capacity of existing concrete structures*). TNO-060-DTM-2011-01450-2, maart 2012
6. Marco Roosen: Shear failure of prestressed girders in regions without flexural cracks. PhD-research TU Delft, March 2021
7. Lonneke van Halen: Milieubelasting betonkolom, rekenen in de praktijk (12) (*Environmental impact of concrete column, calculation in practice (12)*). Cement, Aneas (2020)
8. Walraven: In memoriam Ton Bruggeling. Cement 7, Aneas (2015)