

Spatial Building Typology

Vacant Heritage: Police Real Estate | The Netherlands

MSc3/4 AR3AH105 - Fall 2021-2022

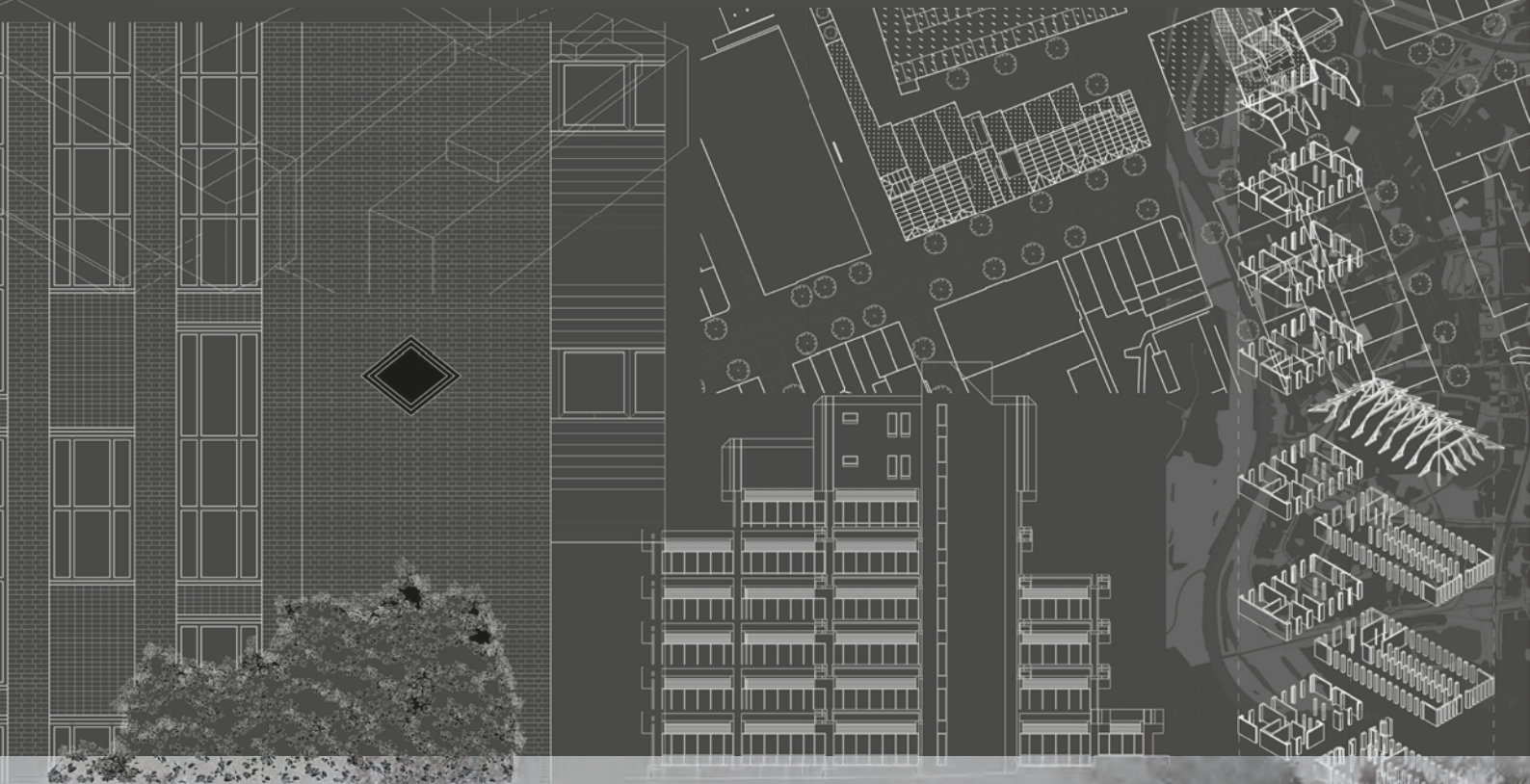

TU Delft OPEN

Spatial Building Typology

Volume 2

Vacant Heritage: Police Real Estate | The Netherlands

Colophon

Spatial Building Typology Volume 2
Vacant Heritage: police real estate in the Netherlands

Editors:

Hielkje Zijlstra, associate Professor Heritage & Design, Architecture and the Built Environment, TU Delft
Lucca Fischer, master student, Architecture and the Built Environment, TU Delft
Noah van Asselt, master student, Architecture and the Built Environment, TU Delft
Tjeu de Gouw, master student, Architecture and the Built Environment, TU Delft

Authors:

Noah van Asselt, Arne Boenders, Annemiek Braunius, Salieh Eldewieh, Lucca Fischer, Tjeu de Gouw, Mick van den Hoek, Mathyn Klein, Aistè Mankutė, Lidy Meijers, Michail Mexis, Aistė Rakauskaitė, Hilko Riepema, Ruben Schonewille, Robin Simons, Hielkje Zijlstra

Keywords:

Space, Buildings, Typology, Vacancy, Analyses. Re-design, Architecture

Published by:

TU Delft OPEN Publishing | Delft University of Technology, The Netherlands

ISBN: 978-94-6366-533-9

DOI: <https://doi.org/10.34641/mg.29>

Copyright statement:



This work is licensed under a Creative Commons Attribution 4.0 International (CC BY 4.0) licence
© 2022 published by TU Delft OPEN on behalf of the editors

Cover design made by Lucca Fischer

Disclaimer:

Every attempt has been made to ensure the correct source of images and other potentially copyrighted material was ascertained, and that all materials included in this book have been attributed and used according to their license. If you believe that a portion of the material infringes someone else's copyright, please contact TU Delft OPEN Publishing

PREFACE

The Dutch Police is one of the largest owners of public real estate in the Netherlands. From police station to forensic laboratory, from listed buildings in the centre of The Hague to large-scale facilities next to the motorway in Driebergen: the task of accommodating the Police is as diverse as it is challenging. Themes such as innovation and sustainability, health and safety, as well as identity, flexibility and affordability are all of relevance for the Police's accommodation strategy. Efforts are being made to strike a new balance between the physical, mobile and digital workplace.

In September 2020 the Police entered into a four-year cooperation contract with TU Delft's Campus Research Team from the department of Management in the Built Environment (MBE). One of the spearheads in the cooperation is to involve the Netherlands Police in educational projects across the Faculty of Architecture and the Built Environment. The studio Heritage and Architecture has chosen police real estate as the central case in their graduation laboratory this year.

Since the formation of the National Police, there has been an enormous challenge to accommodate the organization. In realizing this task, the police has the ambition to raise the quality of police buildings as well as the experience users have in the buildings. At the same time, the police is at the heart of an ever changing society:

The accommodation needs to meet the requirements posed by several developments such as the energy transition, climate change and digitization. How do these developments influence the task of future-proofing (cultural) heritage? Which role can our heritage buildings play in these transitions?

Building in a sustainable manner is higher on the agenda than ever. At the same time, the rapid digitization of society – offering opportunities in terms of customer access through online services, but also vulnerabilities in terms of cybercrime – has a major impact on daily police work. How do these developments impact the interaction between the work and private sphere? How do we safeguard or build accommodation that stimulates well-being and is future-proof? Can we, driven by our need for accommodation, steer to a better result in cooperation with stakeholders and their spatial agendas?

The key lies in our present actions coupled with the lessons of the past. Different approaches on Built Heritage will open our eyes and help with today's issues. To see what is valuable. Will the decisions made in the past be our strength or pitfall? How will objects developed in the past, exposed to today's spatial developments, help us? Through the power of imagination, the Studio Vacant heritage from Heritage and Architecture proudly reveals many possibilities.

Atelier Politiebouwmeester

Lennaert van Capelleveen
Politiebouwmeester (acting)

Casper Bovy
Architecture expert

Faculty of Architecture and the Built Environment department Management in the Built Environment

prof.dr.ir. Alexandra den Heijer
professor Public Real Estate

dr.ir. Monique Arkesteijn
associate professor Real Estate Management

drs. Daniel van Staveren
PhD researcher managing Public Real Estate

INDEX

GENERAL INTRODUCTION

- 10** Introduction
- 11** Research approach
- 13** Methodology
- 15** General References

PART 1 LOCATION ANALYSIS

- 18** Den Haag
- 64** Rotterdam
Witte de With
- 108** Rotterdam Haven
- 152** Haarlem
- 196** Eindhoven
- 240** Groningen
- 282** Middelburg
- 324** Warnsveld

PART 2 ASPECT COMPARISON

- 372** Inner City
- 382** Urban Block
- 392** Building Object
- 404** Building Envelope

**PART 3
INDIVIDUAL RESEARCH**

411 Annemiek

413 Aistè M.

415 Aistè R.

417 Arne

419 Hilko

421 Lucca

423 Mathyn

425 Michail

427 Mick

429 Noah

431 Robin

433 Tjeu

**PART 4
RE-DESIGN OPTIONS**

437 Annemiek

441 Aistè M.

445 Aistè R.

449 Arne

453 Hilko

457 Lucca

461 Mathyn

465 Michail

469 Mick

473 Noah

477 Robin

481 Tjeu

**PART 5
REFLECTION ON
DESIGN SOLUTIONS**

486

**PART 6
FINAL CONCLUSIONS**

494



Den Haag (Photo: Michail Mexis)



Haarlem (Photo: Tjeu de Gouw)



Rotterdam Witte de Withstraat (Photo: Aistė Mankutė)



Rotterdam Haven (Photo: Tjeu de Gouw)



Eindhoven (Photo: Lucca Fischer)



Groningen (Photo: Aistė Rakauskaitė)



Middelburg (Photo: Robin Simons)



Warnsveld (Photo: Noah van Asselt)

Figure 1: The ten locations from the Real Estate portfolio of the Dutch Police available for HA Re-design.

INTRODUCTION

The National Police in the Netherlands faces a major housing challenge. In the next ten years, approximately 700,000 square meters of real estate will be divested and about 200,000 square meters of new construction. In addition, buildings will be renovated or adapted functionally. The police want to adapt its accommodation to the new organization and the changed structure of the services, with larger teams, in fewer places and work more digitally. *“The focus will be on greater effectiveness in relation to technological developments, government policy and legal regulations. For the building assignment, the aim is to achieve a good relationship between functional, technical, spatial, aesthetic and financial requirements. The task should result in savings of 76 million euros per year.”* The duties of the ‘Atelier Politie Bouwmeester’ include safeguarding spatial and functional quality in the implementation of the housing program and providing support in the management of market parties. They will also contribute to the translation of the housing policy into concepts and instruments, for example, and to stimulate the professionalization of the housing organization.¹

At the TU Delft, faculty of Architecture and the Built Environment, the Heritage & Architecture (HA) graduation studio Vacant Heritage is about revitalising Police divested buildings in collaboration with the department MBE and the Atelier Politie Bouwmeester. 30% of real estate objects owned by the police in the Netherlands needs to be redeveloped. HA and MBE are invited by Atelier Politie Bouwmeester to challenge students to come up with ideas. Ten locations: Haarlem; Warnsveld; Groningen; Rotterdam (head office); Rotterdam (Harbour); Rotterdam (Witte de Withstraat); Den Haag; IJmuiden; Eindhoven; and Middelburg are selected. They offer a collection of buildings with Heritage value in need for new programs. HA asked the students by research and design to come up with proposals. They could discuss with people from the Atelier Politie

Bouwmeester, researchers from MBE and full professors of HA like Prof. Wessel de Jonge. It is about identity, adaptability, values, feasibility and sustainability. The research contributes to the broader question of Vacant Heritage: can you find indicators for building typologies that will become obsolete and what are general concepts for revitalisation?

One of the research themes in the studio is about Spatial Building Typology (SBT). It addresses in general the question ‘how and why do spatial aspects influence the re-design options of buildings originally designed for a specific function?’ However, as the function and use of the original buildings change nowadays, a new approach is needed to investigate building typologies. Instead of functions, space becomes central. Research into similarities and differences in spatial characteristics of a collection of buildings, which were realized for a specific function, yields a series of spatial properties that can give direction to the possibilities for re-design. So. Spatial Building Typology is the study of types and will systematically classify types of buildings according to their common spatial characteristics and qualities. Over the years, various buildings originally designed for one specific function have been the subject of education and research at Heritage & Architecture (HA). As there are: churches, monasteries, department stores, museums, factory buildings for production, educational buildings, etc. The research builds on the research carried out by HA in the tradition of Building Analysis. The first SBT studio focused on vacant department stores of V&D in the Netherlands (Zijlstra et al., 2021-01). The results were published in the SBT / MBE book series by TU Delft open. The Real Estate from the Dutch Police will be the second Volume in this series.

¹Based on Weesies, R. Politiebouwmeester gezocht, 31 August 2017. <https://architectenweb.nl/nieuws/artikel.aspx?ID=41267> retrieved 4 March 2021.

RESEARCH APPROACH

The Spatial Building Typology (SBT) research is linked to the Heritage & Architecture Graduation LAB of the TU Delft and particularly in the studio Vacant Heritage. Buildings with a historical impact will be researched and re-designed to adapt new functions in the future. In the previous studio (Fall 2020 – 2021) Department Stores of V&D in the Netherlands were addressed. One year later (Fall 2021 – 2022) the Real Estate from the Dutch Police is subject of SBT research. The research outcomes and the re-designed solutions from the students will contribute to a sustainable future of built heritage with respect to historical en societal values of the buildings itself and their environment.

Goal

So, this research is about spatial building typologies. Traditional research methods into typologies in architecture almost always assume typologies based on functions. But functions and use of buildings will change nowadays so, a different approach is needed to investigate building typologies. Instead of functions, space becomes the continuous factor. Research into similarities and differences in the spatial characteristics of a collection of buildings, which were originally built for one specific function, yields a series of spatial properties that can give direction to the possibilities for re-design. Over the years, various buildings originally designed for one specific function have been the subject of education and research at Heritage & Architecture (HA). As there are: churches, monasteries, department stores, museums, factory buildings for production, educational buildings, offices, etc. The research builds on the research carried out by HA in the tradition of Building Analysis reframed as Spatial Building Typology (SBT).

Process

In the VH studio Fall 2021 – 2022 the building complexes owned by the Dutch Police will be the topic. Striking, large-scale buildings at different locations are becoming vacant or temporary out of use or need an update. At various locations (eight) the police owned buildings will be examined at four scale levels, with three aspects linked to each scale level. This research yields results per location and across all locations per aspect. Conclusions are drawn from spatial typological features that are ultimately

important for re-design options for a location or for some locations in general. The research output consists of five parts: Part 1, the location-specific analyses made for each location in which all twelve aspects are listed and worked out in drawings and text; Part 2, results of locations are compared per aspect, so generic, spatially typological, conclusions can be drawn; Part 3, individual research topics related to the spatial aspects will be worked out in an abstract per student; Part 4, Re-design options from the student's re-design options are discussed and finally in Part 5 those re-designs options are compared to distinguish a re-design typology of the building complexes formally used by the Dutch Police.

Location choices

The worked out eight locations (from ten) in the SBT Vol 2 research are: Haarlem, Warnsveld, Groningen, Rotterdam (Harbour), Rotterdam (Witte de Withstraat), Den Haag, Eindhoven and Middelburg. The choice of locations for the HA graduation studio is based on the selection criteria the HA studio supervisors and de Politie Bouwmeester defined: historical significance, urban setting (or estate), covering different time periods and different sizes of buildings spread over the Netherlands. For the SBT Vol 2 research eight buildings were chosen to be analyzed in four groups. Instead of the previous SBT Vol 1 research this time we decided to cover two buildings completely in every group instead of eight buildings on one scale level in each group.

Research questions

During the first semester, research about the Spatial Building Typology of department stores is performed under the guidance of myself (Hielkje Zijlstra). It is a collective effort of 13 students, subdivided in smaller groups who for each scale level produce analytical drawings of a preset number of buildings. Parallel to this collective research, students work on their individual research topics. The general research question for the SBT research can be defined as follows: how and why do specific series of spatial characteristics on all scale levels influence the design possibilities regarding the re-design of a specific group of buildings realized for a specific function.



Research Outline MSc3/4 HA Vacant Heritage POLITIE Bouwmeester

Delivarables SBT BOOK		Location Analyses	Compare Aspects	Spatial Topics	Redesign Options	Redesign Types	Conclusions References	Context Index
Scale level	Aspect	PART 1	PART 2	PART 3	PART 4	PART 5	PART 6	FINAL BOOK
		Loc 1	City	Stud 1	Stud 1	Type II		
		Loc 2	Block	Stud 2	Stud 2	Type II		
		Loc 3	Building	Stud 3	Stud 3	Type III		
		Etc.	Envelope	Etc.	Etc.	Type IV		
A	Inner City	I Historic Development						
		II Building Age						
		III Road Networks						
B	Urban Block	I Composition						
		II Streets						
		III Accessibility						
C	Building Object	I Spatial Layout						
		II Spatial Relations						
		III Load-bearing Structure						
D	Building Envelope	I Configuration						
		II Composition						
		III Materiality						
		P1	P2	P2	P4	P4	P4	P5

Figure 2: Research outline Spatial Building Typology (Zijlstra et al., 2021-22)

For the Spatial Building Typology research on Real Estate from the Dutch Police we formulated the next research questions in particular:

- Can the analysis of scale related (A-D) spatial characteristics (1-12) lead to a spatial typology of the buildings of the Dutch Police?
 - A. Inner City
 1. Introduction
 2. Development
 3. Networks
 - B. Urban Block
 4. Block information
 5. Streets
 6. Accessibility

- C. Building object
 7. Spatial layout
 8. Spatial relations
 9. Structure
- D. Building Envelope
 10. Configuration
 11. Composition
 12. Materiality

- Can this spatial building typology provide guidance for the possibilities for the re-design of these buildings?
- Can a re-design typology be derived for the buildings of the Dutch Police more in general based on the design options from the design projects from the students?

METHODOLOGY

Theoretical framework

As mentioned in the introduction, there is a need to develop a building typology that is based on space rather than functions. A lot of buildings are vacant and could be re-designed for a different purpose, function and future use. They need to be reprogrammed. In order to clarify the qualities and aspects of the possibilities for the re-design an analysis of the available spaces is indispensable. The research Building Analyses is the founder of this research. This methodology of academic research has a long history within the Faculty of Architecture at TU Delft. Jan Molema supervised many exercises in this area in the years 1970-2000. Students studied work from architects like Gaudí, Goff, Duiker and others (Molema et al., 1979 and 1982). Usually, a group of students researched the oeuvre of one architect. In the education tradition of the faculty, the analyses of buildings (De Delftse Methode) are taught as a basic teaching method, particularly throughout the bachelor phase by Maarten-Jan Hoekstra, Willemijn Wilms Floet and others. In the graduation studios of the Heritage & Architecture section, building analysis as a research method is applied always in the studio's to explore and understand the locations for re-design. The analysis is divided between the domains Architectural Design, Building Technology and Cultural Values. In my own PhD research, the analysis of buildings was a guiding principle for arriving at the 'ABCD in time research method' to analyse, in particular, post-war buildings on their qualities before the re-design phase (Zijlstra, 2009).

Research into building typology starts with Durand in the 18th century. Both Durand in 1799 and De Quincy 1788 to 1825, define typologies of buildings based on use and character (Madrazo, 1985; Güney, 2007 and Moneo, 1978). Studies into typologies have also been carried out on the basis of form, such as Fonatti in 1982, or series of floor plans for houses are grouped on the basis of dimensions and accessibility like Schneider in 1994. But, in the scope of the change in functions and use when buildings become vacant, there is a need for a typology based on space because space doesn't change. Over the years, I have evaluated numerous methods for researching, analysing and evaluating the spatial qualities of buildings. I go into this in detail in the introductory lectures for

the Vacant Heritage Spatial Building Typology Research studio. Various methods for drawing techniques, schematizing and comparing spatial qualities are possible. This is shown for instance by Komossa in 2011 with *Tekenboek Stadsgebouwen*; Lewis in 2016 with the *Manual of Section*; by Bacon in 1974 with *Design of Cities*. Graff and Fortier respectively show an integrated approach for Nice in 2000 and buildings in an urban context in Paris in 1989. Eisenmann in particular in 2003 and in 2008 and Unwin in 1997 and 2010 apply their analysis methods on individual buildings.

On single building level, the methods of Radford in 2014 and Haraguchi in 1988 are useful because they provide insight into the understanding of the buildings through a simplification in drawing technique (Radford) and a total comparison of aspects of all buildings (Haraguchi). However, most useful example was shown in the exhibition and the accompanying 2017 publication on the Haussmann's interventions in Paris (Jallon & Naplitano, 2017). Through this, the spatial implications at all scale levels from city to building detail are accurately analysed and compared by drawing, after which conclusions are formulated. Also more generic topics are added such as daylighting, durability and resilience. This way of working 'Hausmann Method' has been chosen as the method to use in the Spatial Building Typology in the HA Vacant Heritage studio. It examines in the current studio Fall 2021 – 2022 the foreseen vacant buildings from the Real Estates portfolio of the Dutch Police at eight locations. In addition to this 'Hausmann Method', the students could use the SBT Vol 1 research on vacant Department Stores (Zijlstra et al., 2021-1) and they were free to look closely at the drawing techniques that are discussed in other methods in order to develop the style and methodology for the SBT research further. The eight police buildings have been subjected to this method, comparisons are made on twelve aspects and the research is strongly related to design. Individual research topics of the students related to spatial aspects are worked out in detail and contributes to their individual design of one of the case studies. So, the possibilities for the re-design are elaborated and the final design solutions are analysed to define a re-design typology for police buildings more in general.

Method and Result

After the choice of locations, information about the eight chosen locations is collected, selected, ordered, and shared through archival research and literature research (and other sources). The twelve aspects are further explored in literature through individual topics and areas of special interest. At the level of analysis of the information at scale and aspect level, drawings are used as much as possible. Reduction drawings and diagrams will be made for the final output. Only small blocks of texts are added. During the research the students made use of one layout and a guideline for scale and format based on the “Haussmann Method” (Jallon & Napolitano, 2017) and the previous SBT-Vol 1 (Zijlstra et al., 2021-1). By using one layout and drawing style the locations are comparable. This is

supplemented by some text blocks for the introduction, explanatory text for each aspect and a concluding text for each scale level. The final product is the book: *Spatial Building Typology on Real Estate from the Dutch Police*. During the process of the graduation project the book will be updated at each presentation / exam (P1, P2, P3, P4 and P5). Finally, it will be published as the second volume in the SBT BOOK series by TU Delft OPEN and free accessible at BK-BOOKS.

Hielkje Zijlstra

*research mentor of the HA Vacant Heritage graduation studio
Fall 2021-2022*

GENERAL REFERENCES

- Bacon, E.N. (1974). *Design of Cities*. Harmondsworth: Penguin Books.
- Eisenmann, P. (2008). *Ten Canonical Buildings 1950-2000*. New York: Rizzoli.
- Eisenman, P. (2003). *Giuseppe Terragni Transformations Decompositions Critiques*. New York: The Monacelli Press.
- Fortier, B. (1989). *La Metropole Imaginaire. Un Atlas de Paris*. Brussels: Pierre Mardaga
- Fonatti, F. (1982). *Elementare Gestaltprinzipien in der Architektur*. Vienna: Akademie der Bildende Künste.
- Graff, Ph. (2000). *L'Exception Urbane. Nice: de la Renaissance au Consiglio d'Ornato*. Marseille: Editions Paranthèse.
- Güney, Y.I. (2007). Type and Typology in architectural discourse. In: *BAÜ FBE Dergisi*, Temmuz 2007, 3-18.
- Haraguchi, H. (1988). *A Comparative Analysis of 20th-Century Houses*. New York: Rizzoli. Jallon, B., & Napolitano, U. (2017). *Paris Haussmann*. Paris: Park Books.
- Komossa, S., Marzot, N., & Floris, J. (2011). *Tekenboek Stadsgebouwen. Functie-stapelingen, publieke binnenvelden, in één blok*. Rotterdam: AIR.
- Lewis, P., & Tsurumaki, D., & Lewis, J. (2016). *Manual of Section*. New York: Princeton Architectural press.
- Madrazo, L. (1995). *The Concept of Type in Architecture*. Zürich: PhD Thesis 11115 ETH.
- Molema, J. ea (1979). *Gaudí rationalist met perfecte materiaalbeheersing*. Delft: DUP. Molema, J. ea (1982). *J. Duiker bouwkundig ingenieur*. Rotterdam: Stichting Bouw.
- Moneo, R. (1978). On Typology. In: *Oppositions*, MIT press 13 (1978) 22-45.
- Radford, A. (2014). *The Elements of Modern Architecture*. London: Thames and Hudson. Schneider, F. (1994). *Floor Plan Atlas*. Basel: Birkhäuser.
- Zijlstra, H. (2009). *Analysing Buildings from Context to Detail in time: ABCD (in time) research method*. Amsterdam: IOS Press.
- Zijlstra, H., et al. (2021-1). *Spatial Building Typology - Vacant Heritage: Department Stores | V&D's*. Delft: BK-BOOKS <https://books.bk.tudelft.nl/press/catalog/book/790> .
- Zijlstra, H. & L. Meijers & W. Quist & J. Dos Santos Gonçalves (2021-2). *Studio Tekst. HA Vacant Heritage Politie Bouwmeester. Fall 2021 – 2021*.

PART 1
LOCATION ANALYSIS

1.1. DEN HAAG

1.1.1. INNER CITY

1.1.1.1. INTRODUCTION

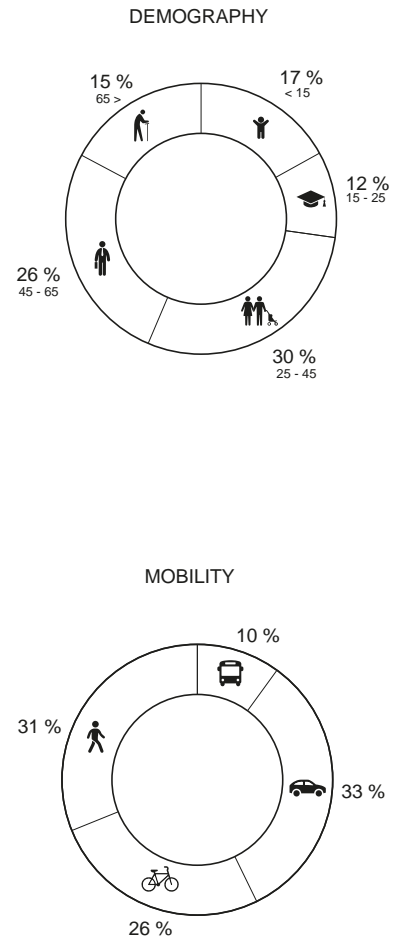

Den Haag

Den Haag is the third largest city of the Netherlands with 548.320 inhabitants and it is the capital of the province Zuid-Holland. The city of Den Haag started in the Middle Ages around the Binnenhof and the Hofvijver, which forms the center of today's Dutch politics. The Dutch government and parliament are located in the city, and it is the residence of the royal family. Next to that, most embassies, all ministries and the Supreme Court are located in Den Haag. The city is also home to several national and international courts, including the

International Court of Justice in the Peace Palace and the International Criminal Court. It also hosted the two Hague Peace Conferences around the year 1900, where important international agreements on the law of war were reached.

The demography of Den Haag is quite mixed with the biggest group being between 25-40 years old. The most used form of transport in Den Haag is the car with 33% followed by walking with 31% and then the bike with 26%. Only 10% of the traveling is done with public transport.

1.1.1.2. DEVELOPMENT



Vacant Heritage - Police Real Estate | The Netherlands

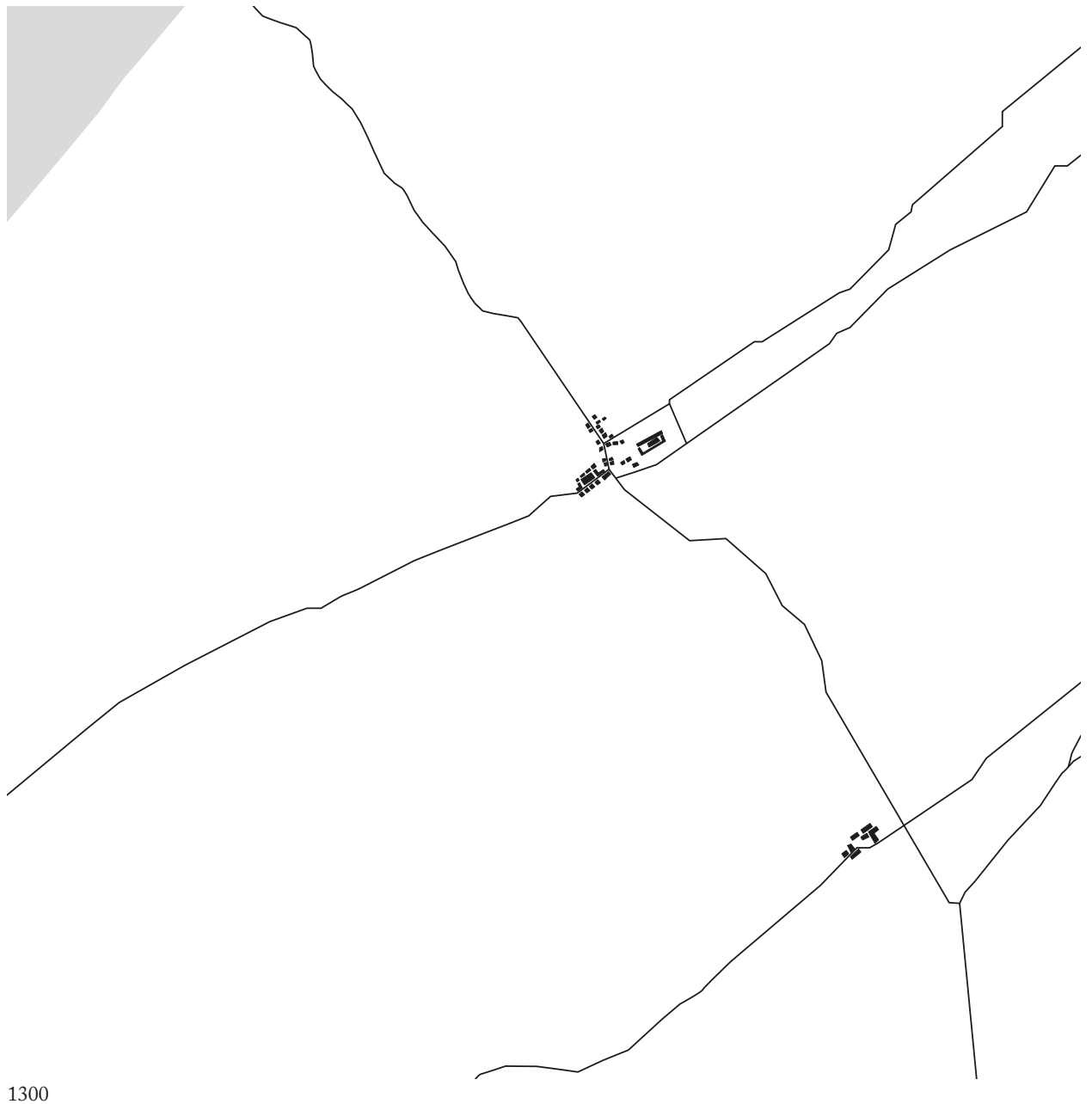

HISTORIC DEVELOPMENT

Den Haag started in 1300 as an ensemble of buildings around the Vredespaleis (a palace). It grew around this center to a small town in 1500. Until 1800 the city grows circular around the old center and starts to expand towards the sea. In 1900 the city has developed around some natural parks which form open spaces in the city fabric. The direction of the new neighborhoods is

closely related to the manmade water structure that was already present in 1300. Between 1900 and 1950, Den Haag underwent a huge expansion in all directions, still following the structure of the canals and avoiding natural parks. In 2000 some new neighborhoods were developed, but substantially less than the time period before.



0 1000M



1500

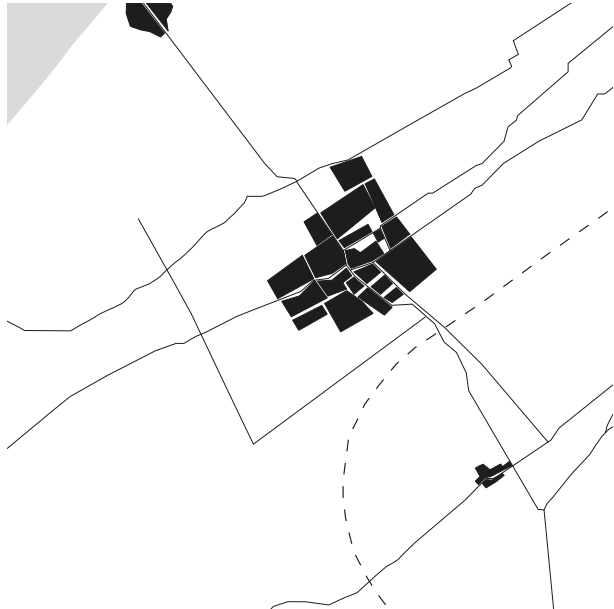

1800

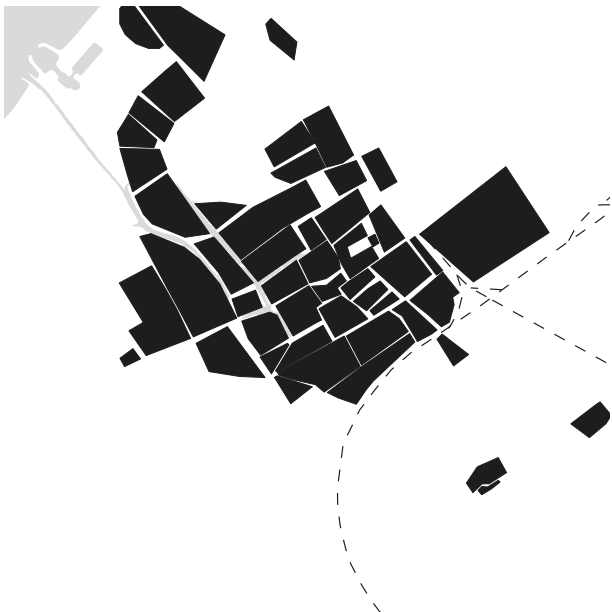

1900



2000



0

1000M

Vacant Heritage - Police Real Estate | The Netherlands



BUILDING AGE

Regarding the building age, certain conclusions can be drawn about the development of Den Haag. There is a concentrated area with building realized before the 19th & 20th century, while before the first half of the

20th century, significant construction underwent in the outskirts of Den Haag. The last decades, far less new buildings have been constructed and these are located evenly on the urban fabric.



0 1000M



1800-1899



1900-1949



1950-1999



2000-

1.1.1.3. NETWORKS



0

1000M



Vacant Heritage - Police Real Estate | The Netherlands



All roads

ROAD NETWORK

The road system indicates a city that was built over time, not following a strict orthogonal grid. Concerning the accessibility to the police station, it is apparent that the building is easily accessible, as a primary road passes in

front of it. What else is suggested by these diagrams is the relation of the roads, to the levels of safety and noise in each area, but also the facilitation of commercial activity.



0

1000M



Primary roads

Den Haag



0

1000M



Vacant Heritage - Police Real Estate | The Netherlands



Secondary roads



0

1000M



Den Haag

Tertiary roads



0 1000M

Public squares Green Water



Vacant Heritage - Police Real Estate | The Netherlands

Green, water and public squares

GREEN, WATER AND PUBLIC SQUARES

This diagram indicates the public spaces by means of public squares and not parks, so there can be a distinction about the public parks and the public spaces designed purely for public interaction. These spaces are formed by the enclosure of open spaces within the urban fabric. Not far from the police station, relatively large public areas are

located, which could be used as an element in the design process.

Despite the density of Den Haag, there are numerous green areas within the urban fabric, and especially at the vicinity of the case study. Also, the existing canals, influence the positioning of the road system.

1.1.2. URBAN BLOCK

1.1.2.1. COMPOSITION

Vacant Heritage - Police Real Estate | The Netherlands



(Mexis, 2021)



Den Haag

HISTORIC DEVELOPMENT

The development of the urban block originated from an ensemble of rows of houses. Between 1952 and 1959 a new building was created to house the police, in front of one of these rows. In this period of time some new rows of buildings were added to the south of the urban block

as well. For the extension of the police station in 1981, a part of the urban block was demolished after which a large extension was build, making the police station by far the biggest building in this urban block.



0 50M



1945-1952



1952-1959

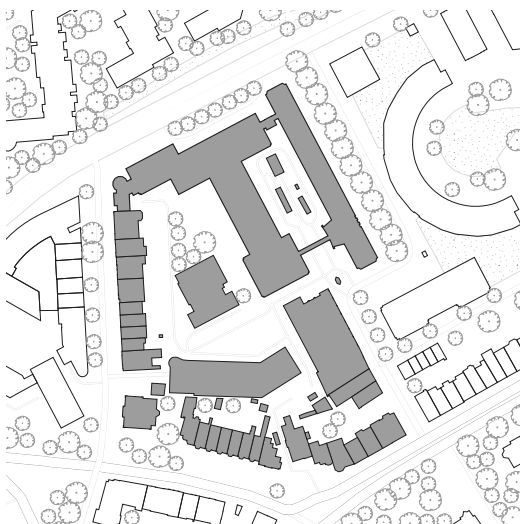

1981-

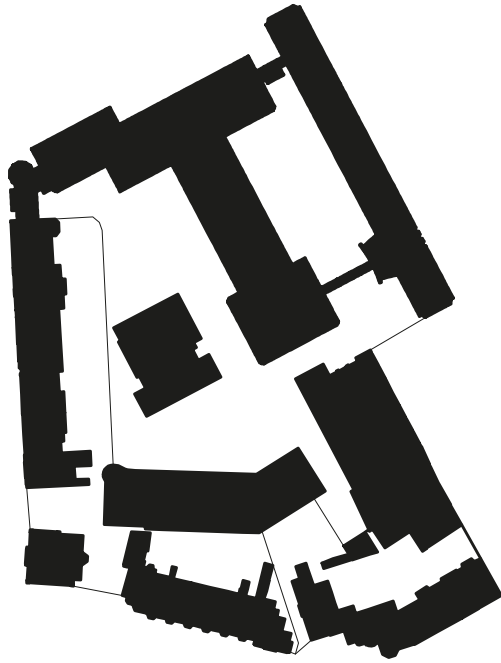

Built area
15366 m²



Empty area
13800 m²

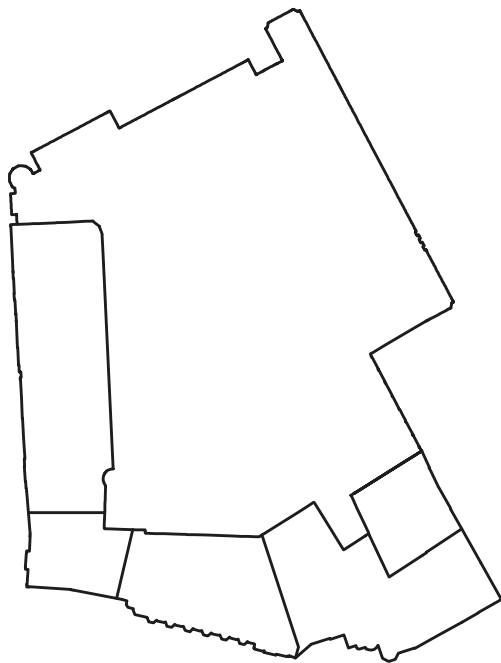

Parcels
6

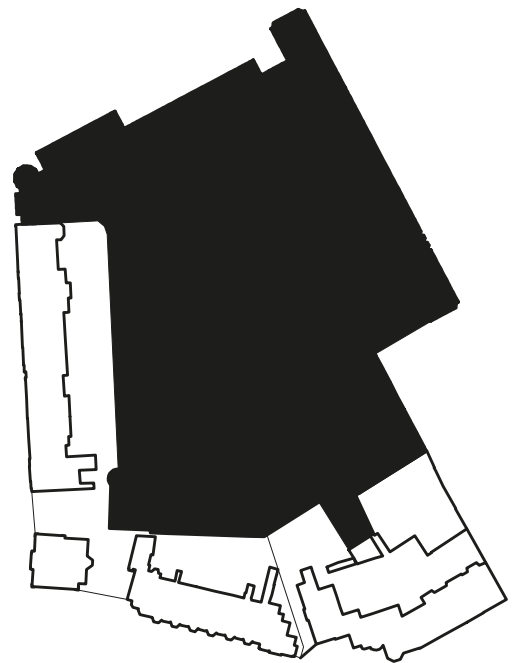

Police real estate
18756 m²

BLOCK INFORMATION

The urban block of Den Haag's police station is an irregular block of approximately 30.000 sq.m. Half of the block is occupied by the police and the other buildings,

whereas the rest is empty. Five parcels are used for residences, whereas the bigger one belongs to the police.



0

50M

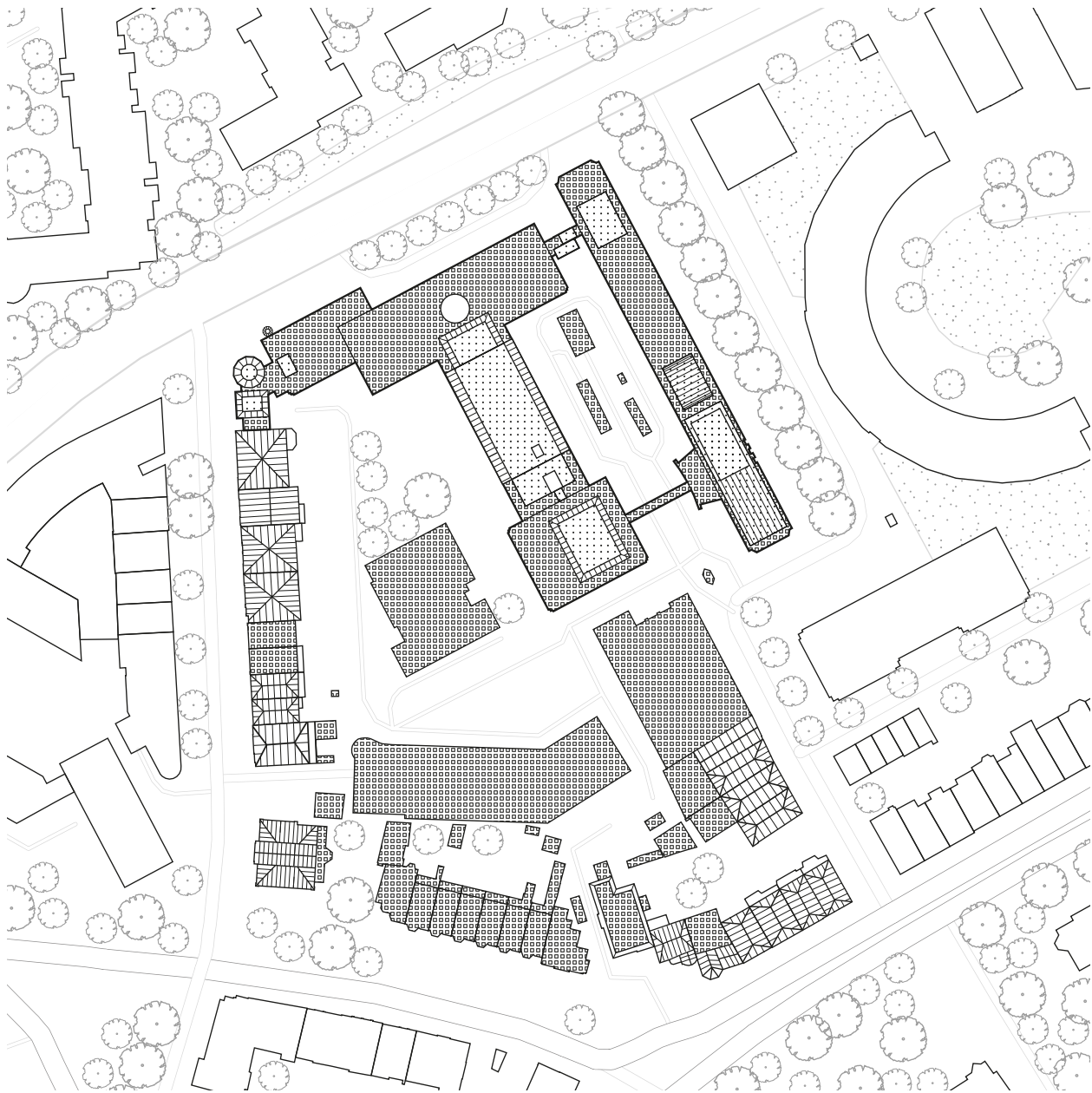

Den Haag

Roof structure

ROOF STRUCTURE

The roof structure of the urban block is closely related to the historical development of the block. The original

older buildings mostly have pitched roofs, while the newer added buildings have flat roofs.

1.1.2.2. STREETS

0 20M

■ Façade openings

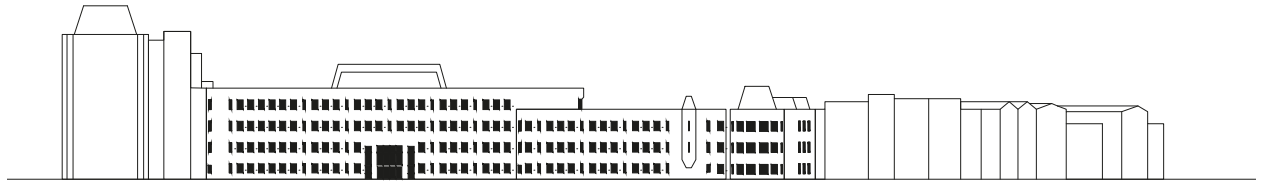

Burgemeester Patijnlaan



Alexanderveld

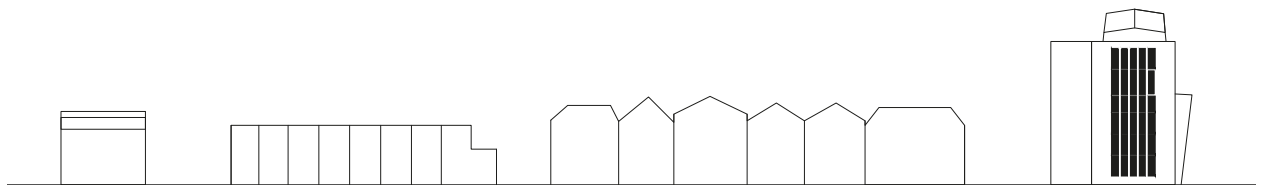

Scheveningseweg

Javastraat

Alexanderplein

Vacant Heritage - Police Real Estate | The Netherlands

STREET ELEVATIONS

From the street elevations, the most critical conclusion that can be drawn is the height and building-scale relation of the police station, compared to the rest of the buildings

of the urban block. There is a significant height difference of the monumental building, which changes substantially the roovescape of the urban block.



0 20M



Den Haag

Parcels and façades

PARCELS AND FAÇADES



Vacant Heritage - Police Real Estate | The Netherlands

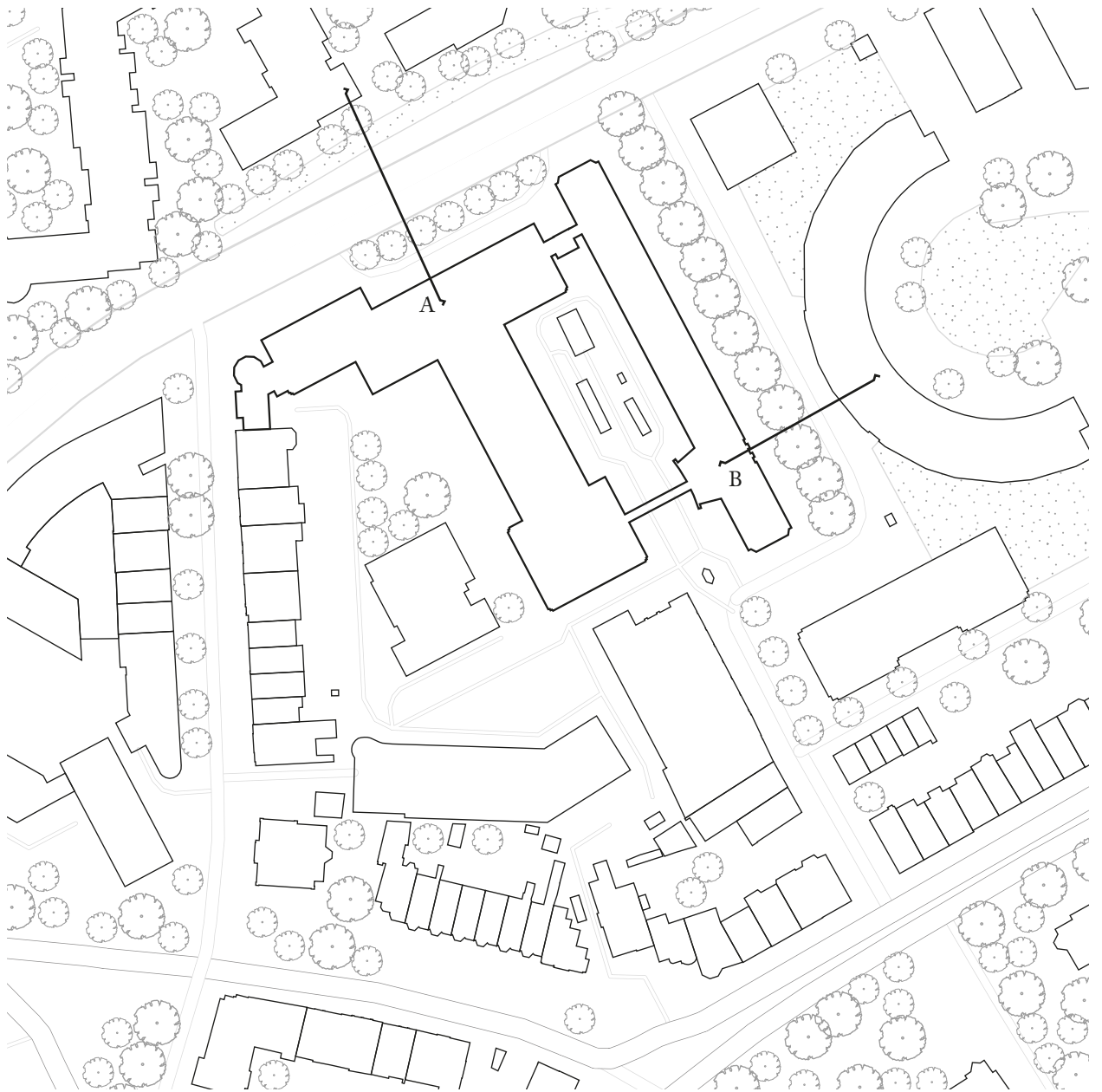

Location of street sections

STREET SECTIONS

The street sections indicate the clear spatial difference that is created by the two buildings that compose Den Haag's station. On the one hand, the monument, almost double

the height of the extension, creates a much more enclosed urban outdoor space, whereas the lower extension, with ample of space in front, creates a more open public space.

0 5M

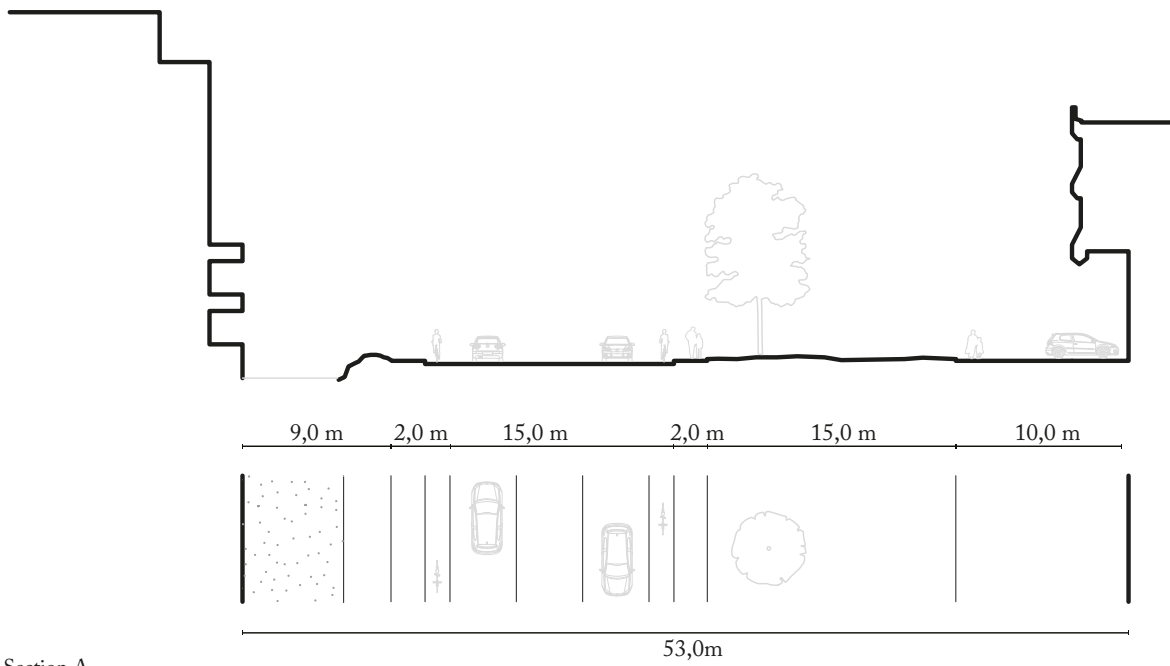

Section A
Burgemeester Patijnlaan

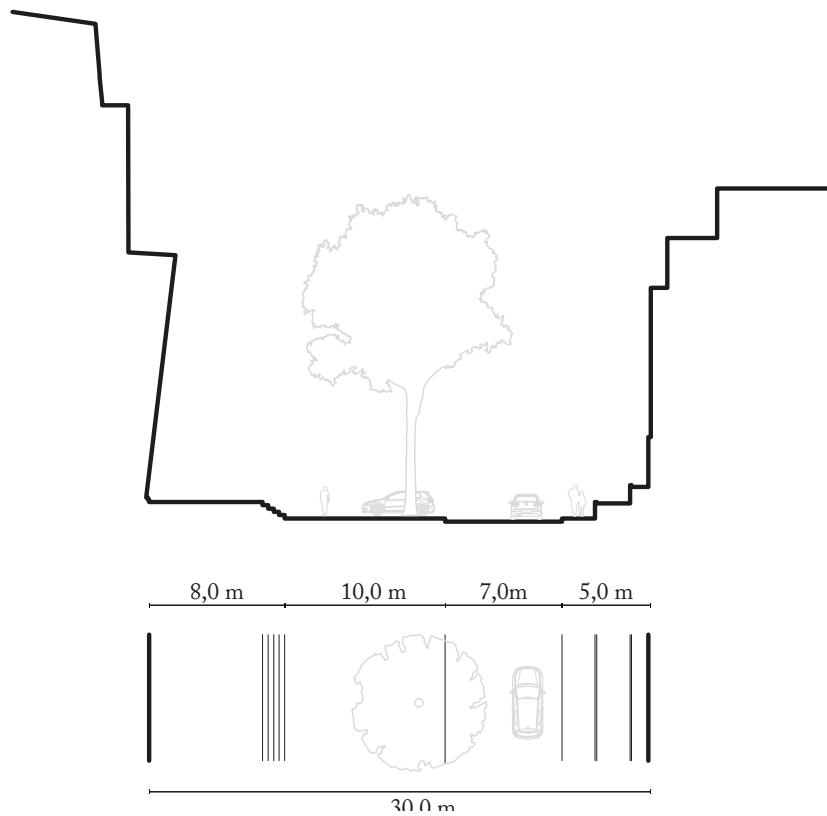

Section B
Alexanderveld

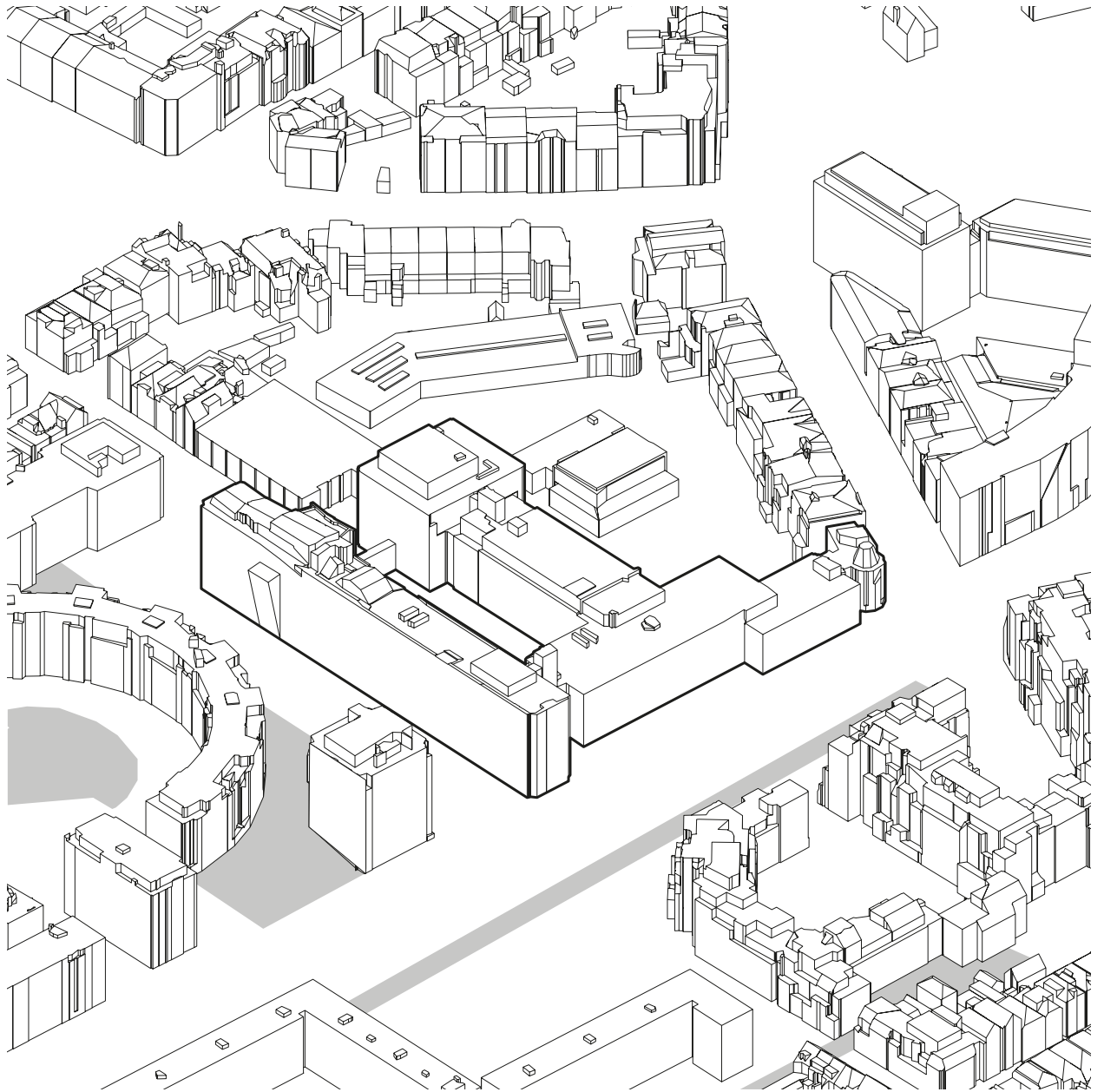

Isometric of urban block in surroundings

ISOMETRIC

1.1.2.3. ACCESSIBILITY



■ Car parking ▲ Entrance 🚲 Bicycle parking

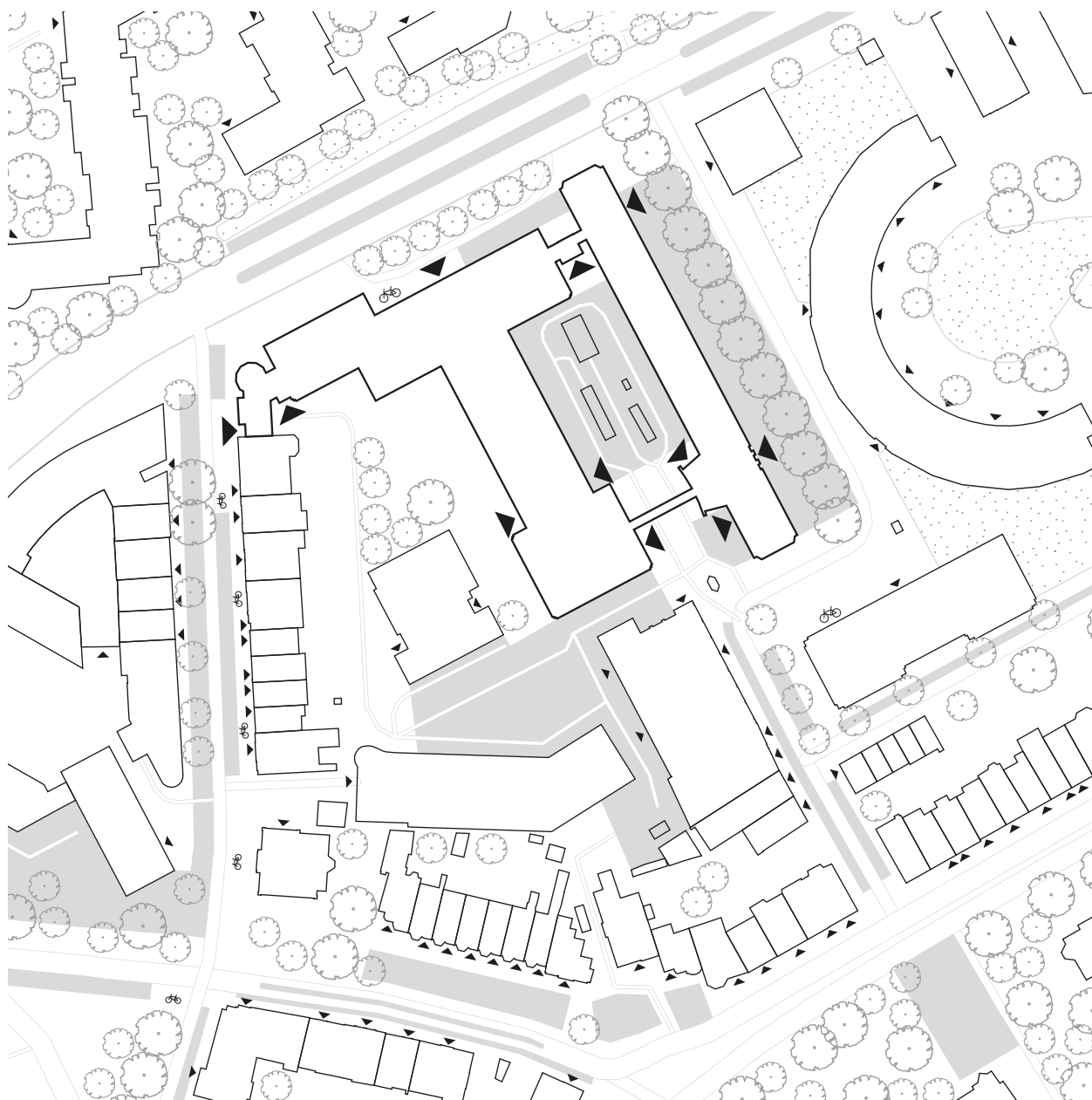

Den Haag

Parking and entrances

PARKING AND ENTRANCES

The parking is located along the streets and in the middle of the urban block. The buildings in the urban block almost all have entrances on the street side, with the

exception of the police building, which is also accessible from the courtyard.



Public Semi public Private

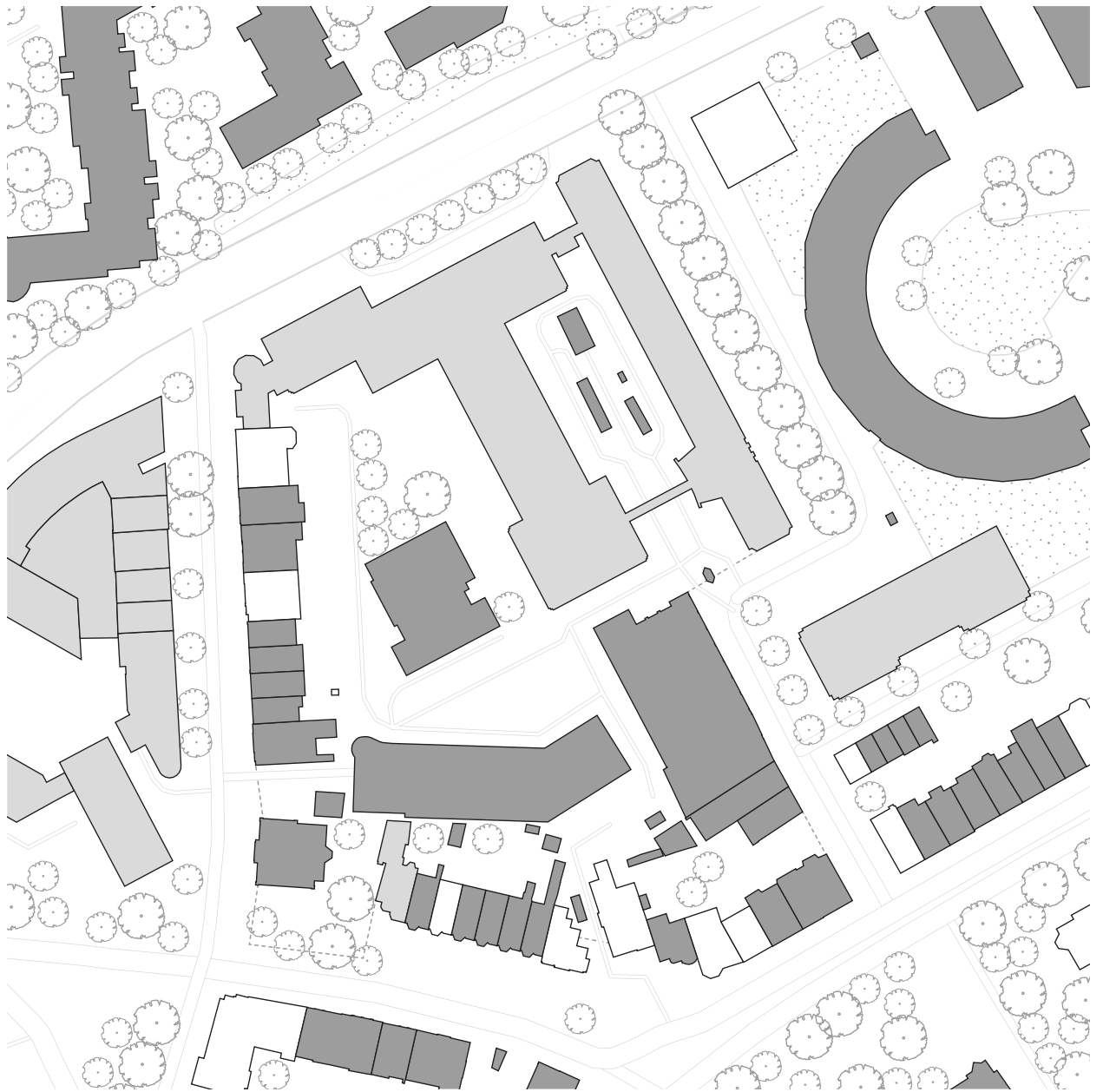

Vacant Heritage - Police Real Estate | The Netherlands

Public, semi-public and private buildings

PUBLIC, SEMI-PUBLIC AND PRIVATE BUILDINGS

Most of the buildings in the urban block and surroundings are private, as they have housing functions. The courtyard inside of the urban block is also private as it is enclosed

by a guarded fence. The police station and offices are indicated as semi-public and the embassies are public.

1.1.3. BUILDING OBJECT

1.1.3.1. SPATIAL LAYOUT



0 20M

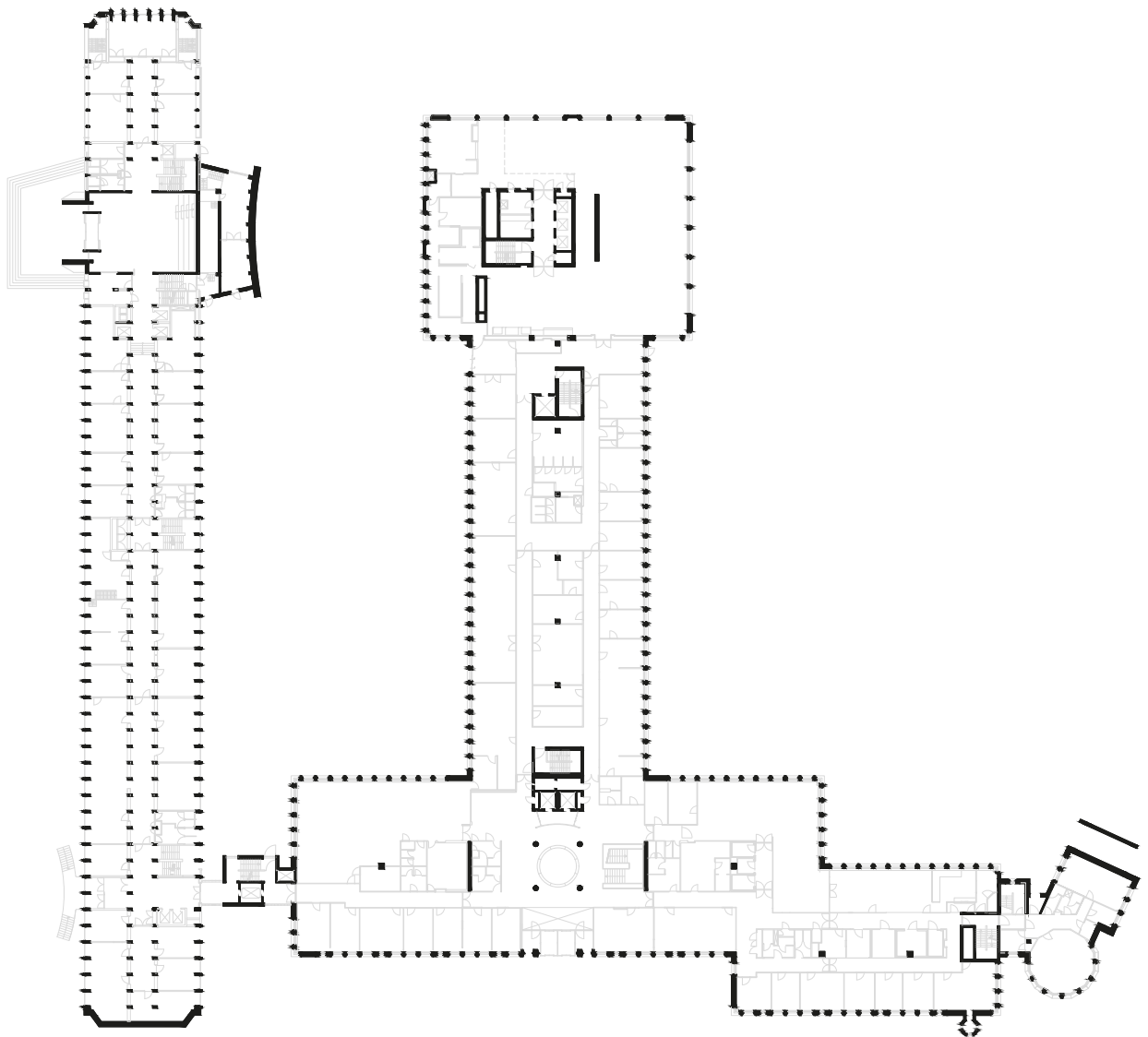

Ground Floor

FLOOR PLANS

The police station consists of two buildings, and five floor levels. At the left, the long, monolithic block was initially built and afterwards a more fragmented extension was added, designed by the same architect (Den Haag, n.d.). The first building (the monument) features a monumental entrance, which is unique for the typology of police

stations, but also a lecture hall on the top level. On the other hand, the new extension is more introverted with no public functions, and features cells on the top level for security purposes. On both buildings the interior space is defined and divided by non-structural wall partitions.



0 20M

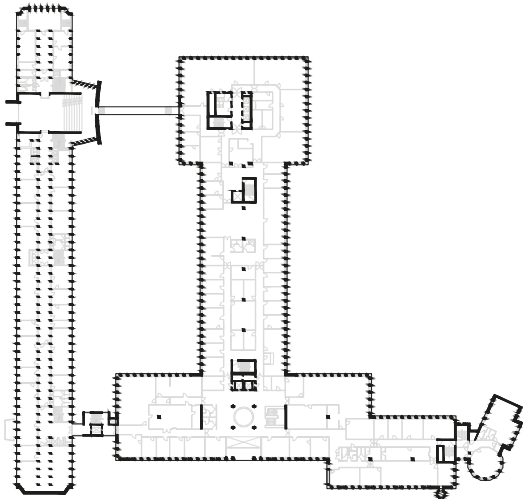

First Floor

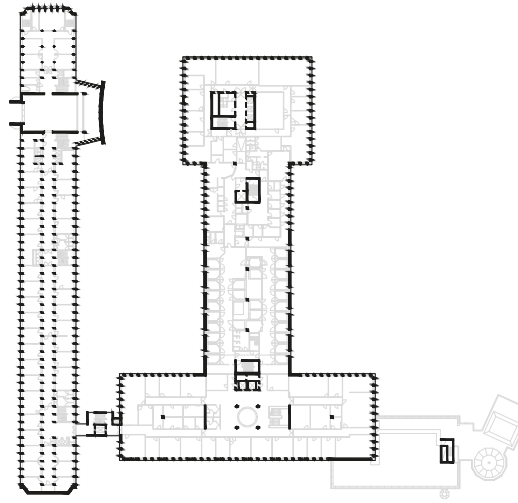

Third Floor

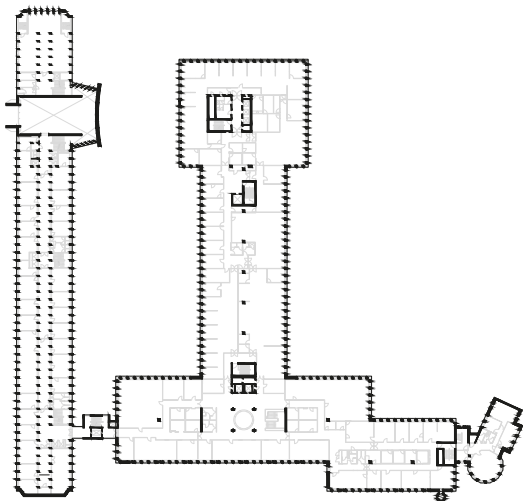

Second Floor

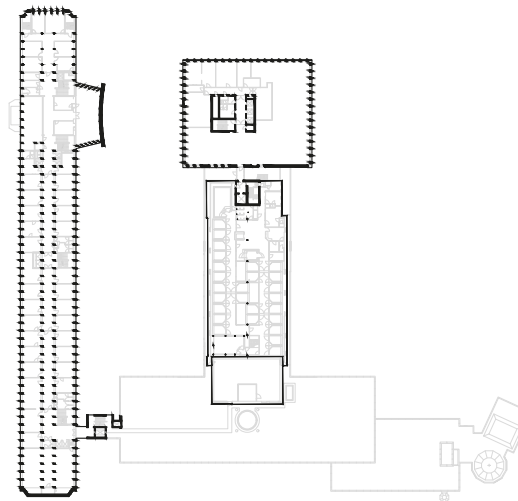

Fourth Floor

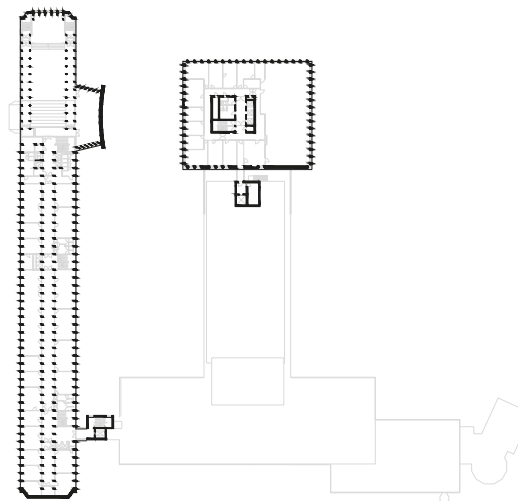

Fifth Floor

0 20M

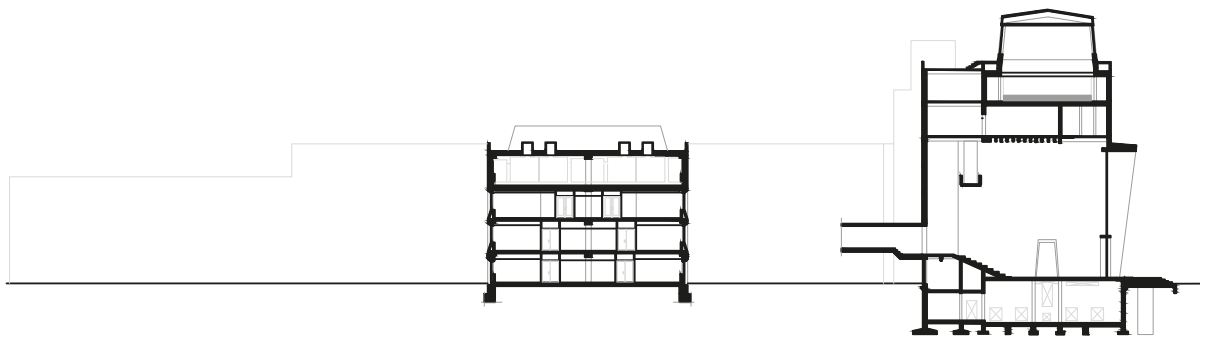
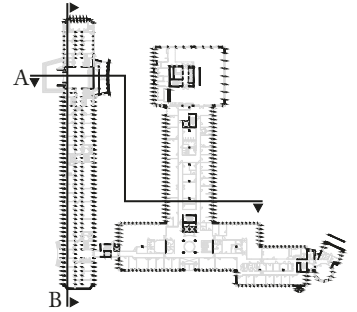

Section A

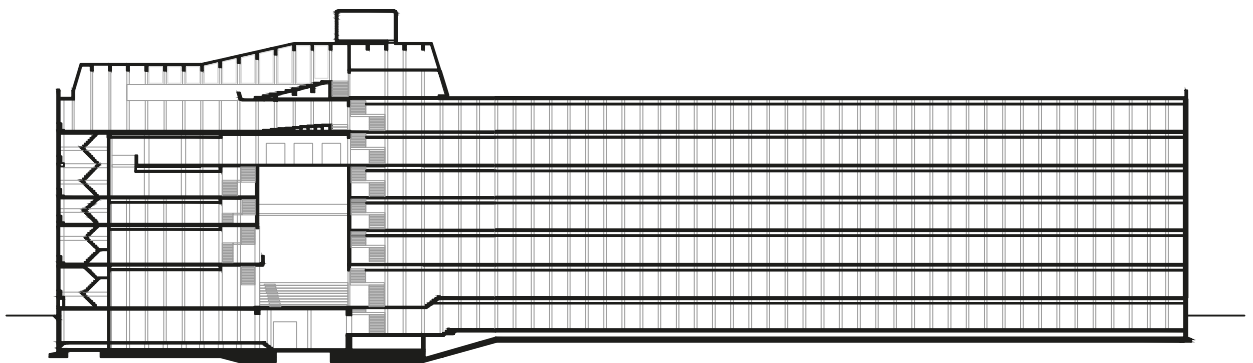

Section B

SECTIONS

In the section of the monument, the difference between the office spaces and the main entrance and auditorium is clearly visible, as these are the two open spaces in a further densely structured building. The section of the

newer building part shows the relation between the different spaces inside of the building, with the large open parking garage in the basement, the offices in between and the small cells at the top.

0 20M

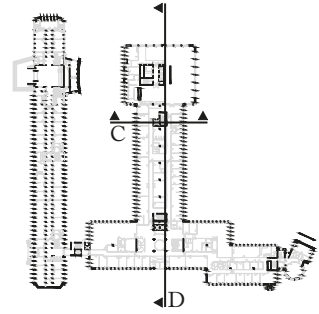

Section C

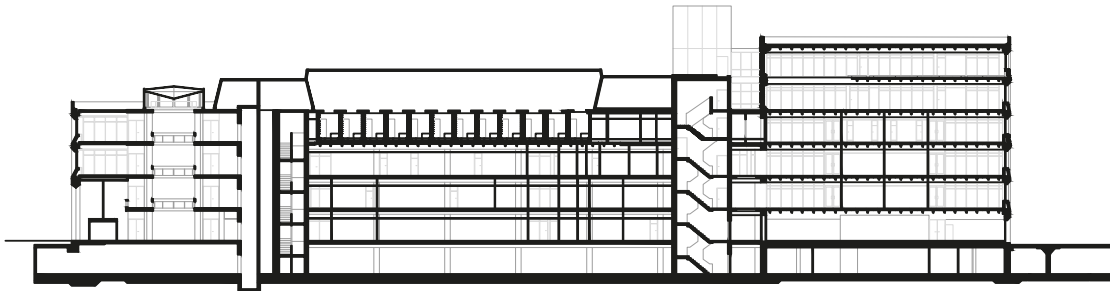

Section D

1.1.3.2. SPATIAL RELATIONS

Vacant Heritage - Police Real Estate | The Netherlands

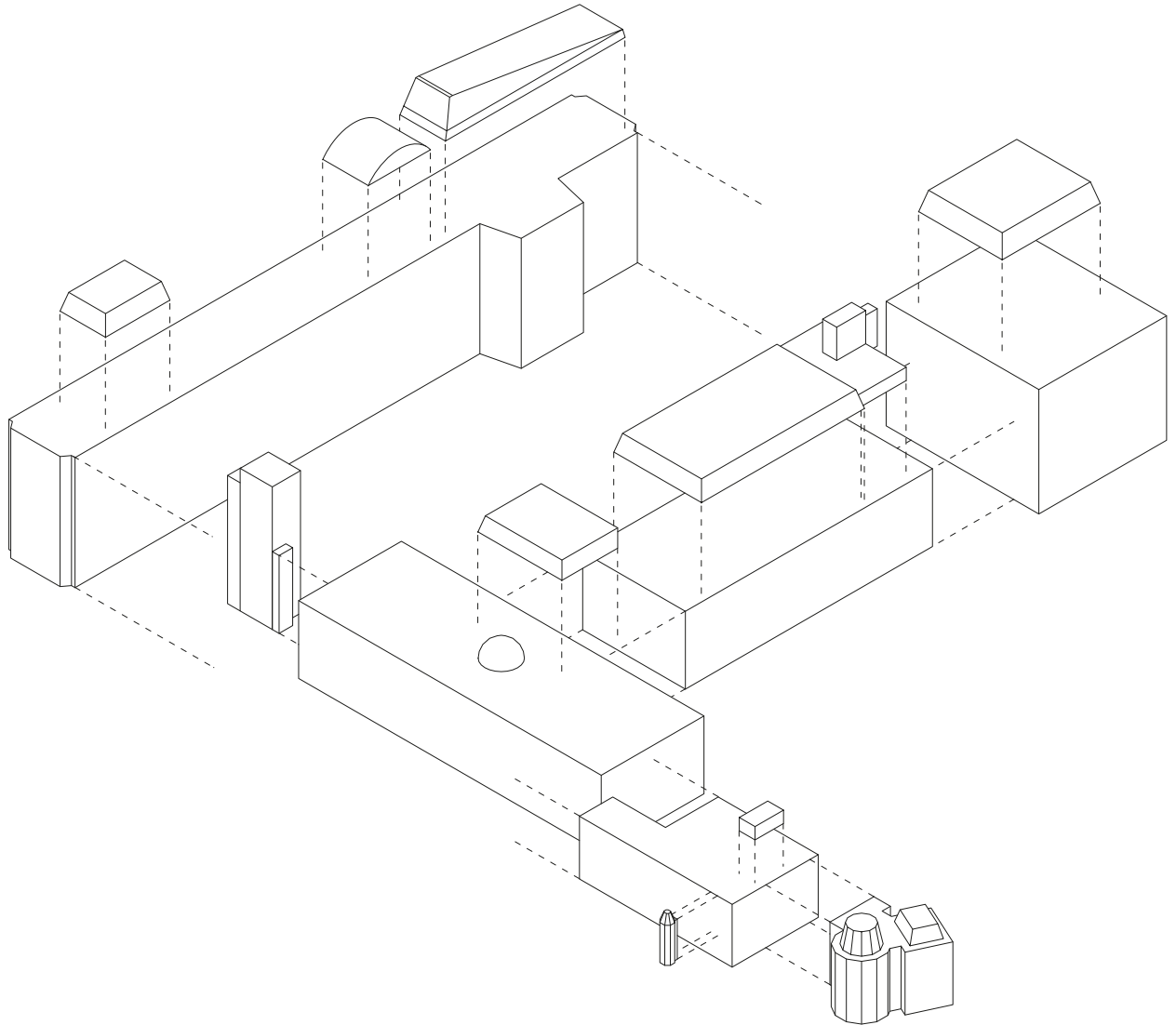

Building volume

BUILDING VOLUME

The building exists of two time layers where the monumental building is formed by one rectangular mass with some roof extensions. The newer building is formed

by multiple rectangular masses with some exceptions like the round towers at the corner and some roof extensions.

● Start Route ▲ Ascending vertical route

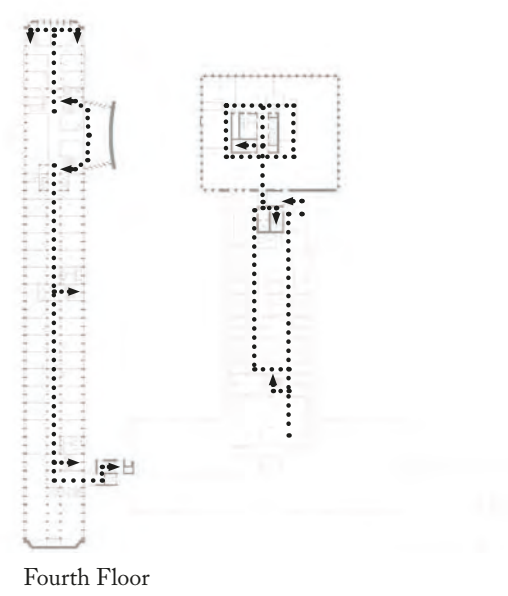
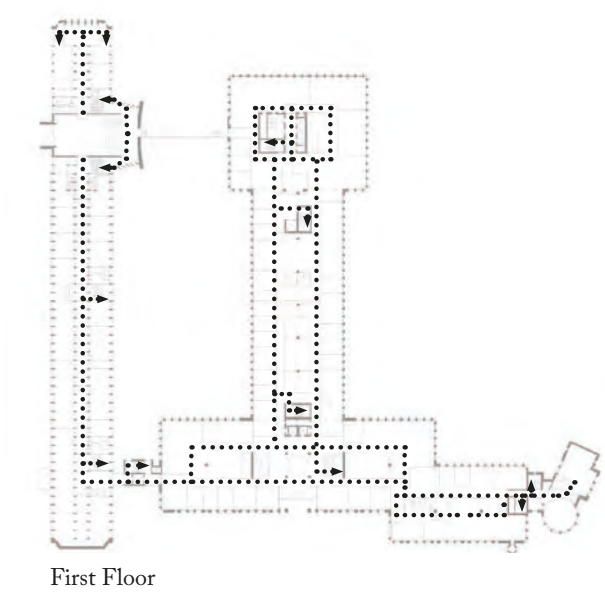
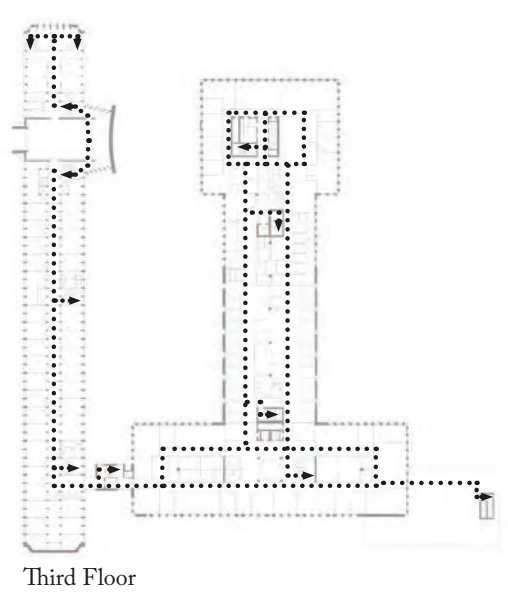
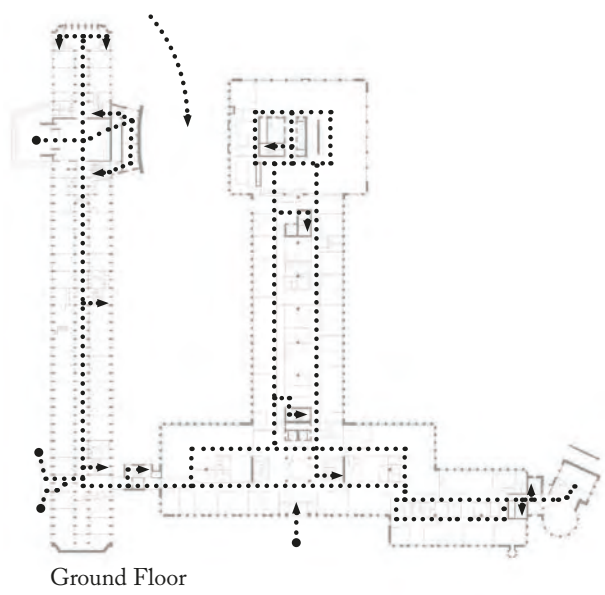

Circulation plans

CIRCULATION

Regarding circulation, it can be observed how differently the two buildings organize space. On the monument, a linear axis defines the circulation, whereas the deeper and wider volumes of the extension, create circular circulation

routes. Also, there are different entrances for public and private use, though it can be concluded that there is a strict circulation route due to privacy and safety issues of the police department.

1.1.3.3. STRUCTURE



Vacant Heritage - Police Real Estate | The Netherlands

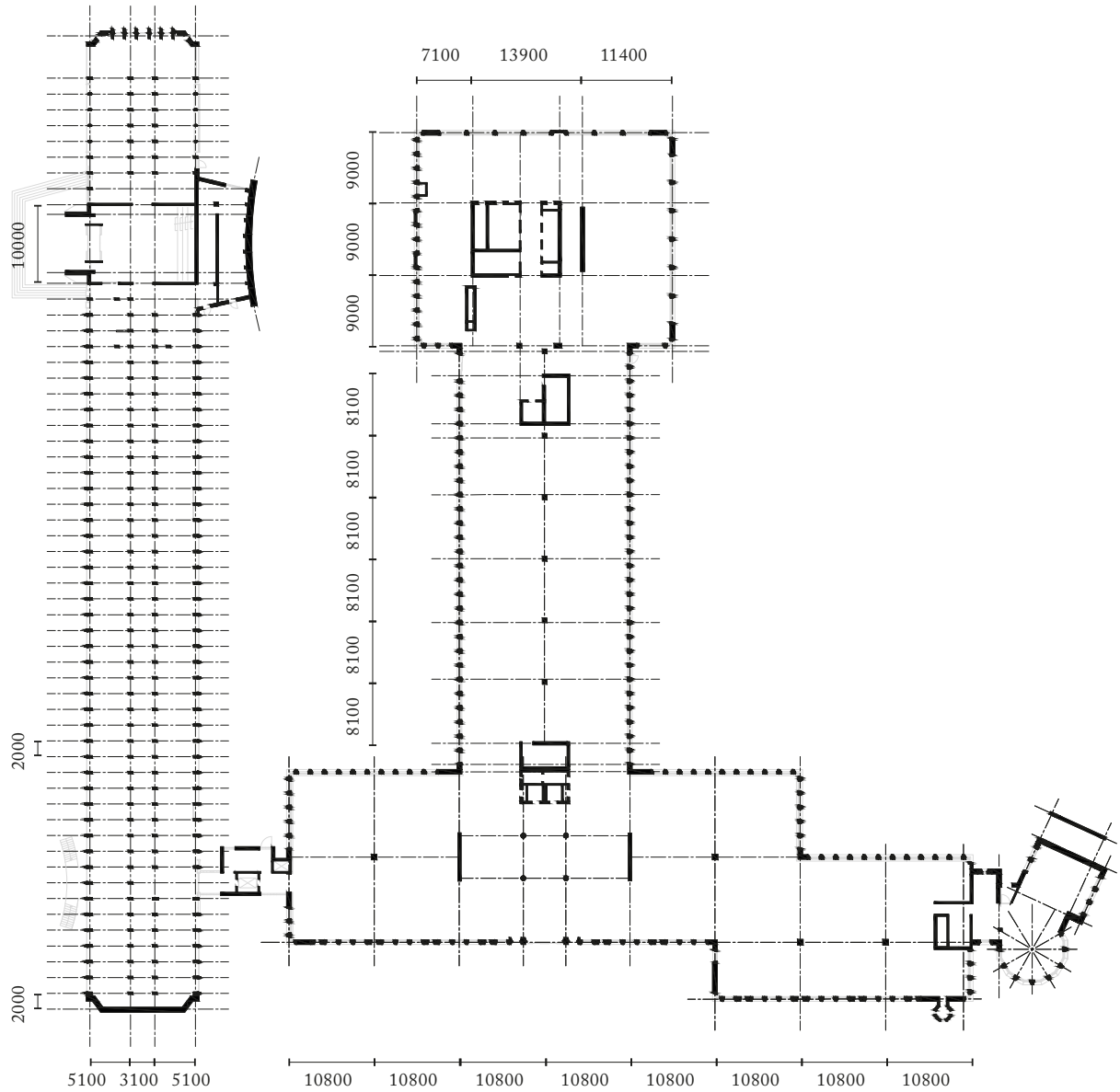

Structural grid

LOAD-BEARING STRUCTURE

Two main observations can be made regarding the structural grid; The monumental part has a dense column grid of concrete columns, with 2m span and it is associated with the modular façade partitions that compose the grid

of the façade. On the other hand, the newer extension's structure consists of floor slabs that rest mainly on the load-bearing façade and on few concrete columns.

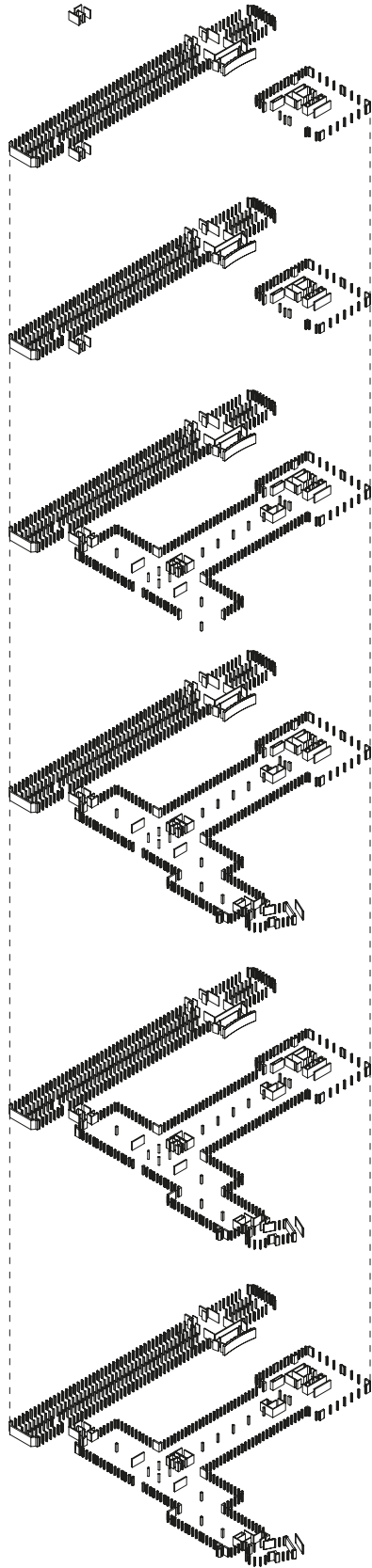

Load-bearing structure axo

1.1.4. BUILDING ENVELOPE

1.3.4.1. CONFIGURATION



Vacant Heritage - Police Real Estate | The Netherlands

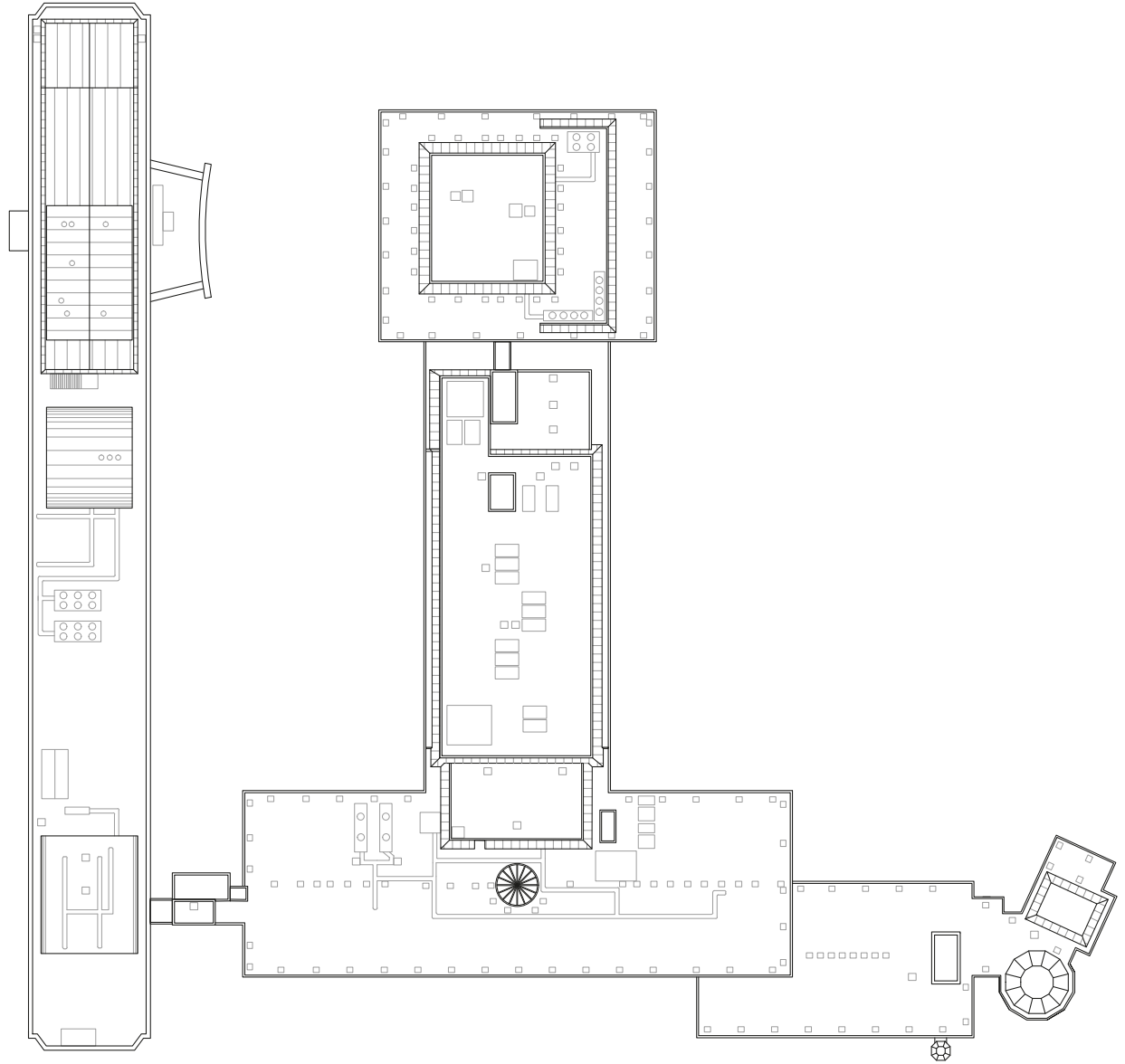

Roofplan

ROOFPLAN

The roof structure of the two buildings is dominated by roof extensions and technical installations. The roof of the building is mostly flat with the exception of the

sloping roof of the auditorium, an arched roof of one of the extension, the two cone shaped roofs of the towers and the glass dome above the main entrance.

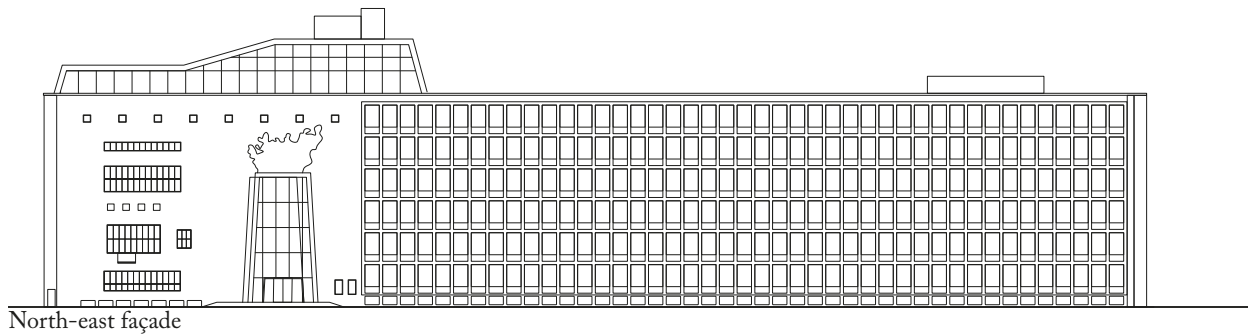

North-east façade



North-west façade

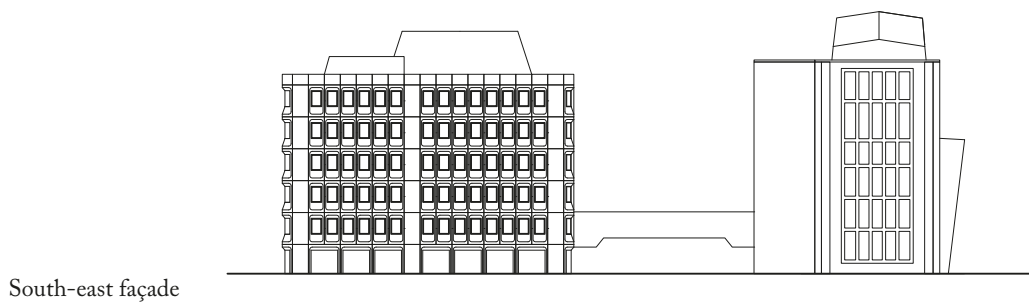

South-east façade

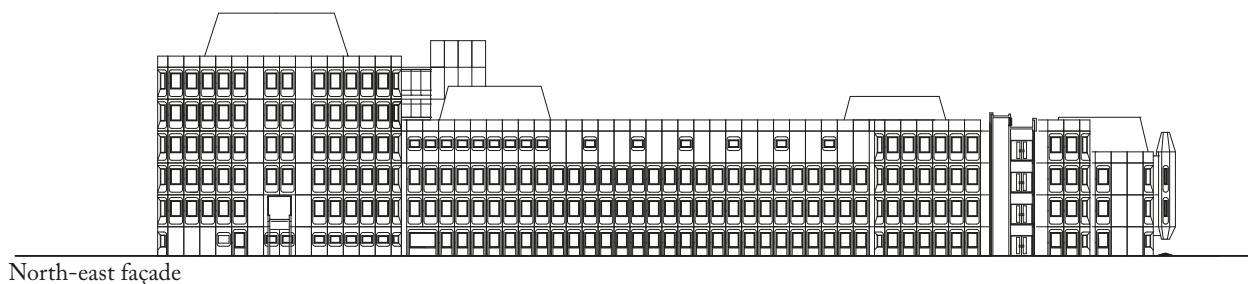

North-east façade

FAÇADES

Important to notice is how the façades relate in terms of scale; The 124 x 30m monumental façade is almost double the height of the north façade of the new extension, which is the main façade of the police station. Therefore, the architect wanted to introduce a less intimidating building, though, on the south façade, it is obvious that

the enlargement of the new volume, intends to relate in height with the monumental building. The façades indicate how the exterior is related to the interior; the group of windows imply that behind the envelope, workspaces are located that need adequate daylight.

1.1.4.2. COMPOSITION

0 20M

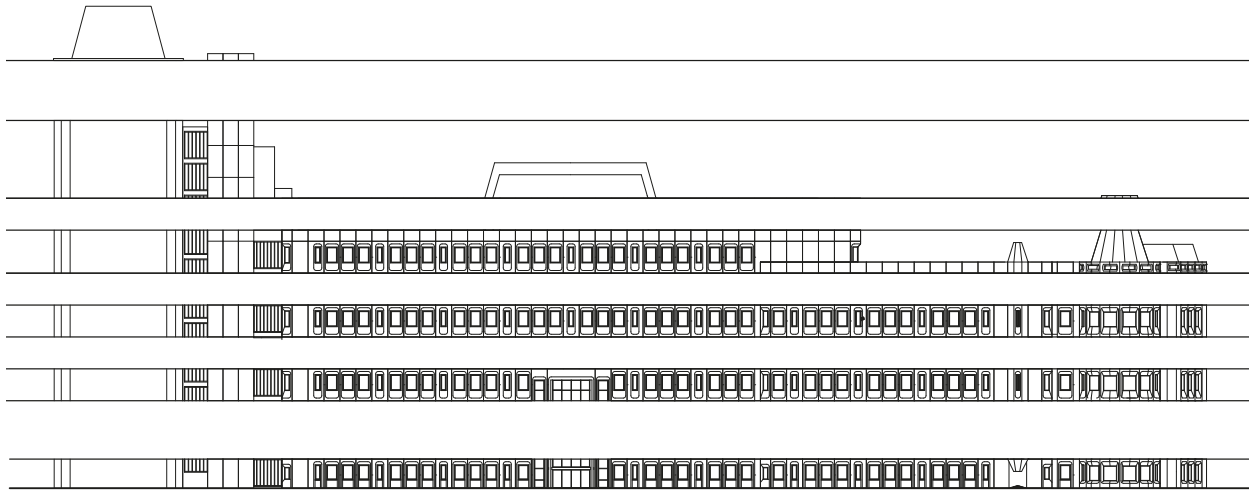

North-west façade

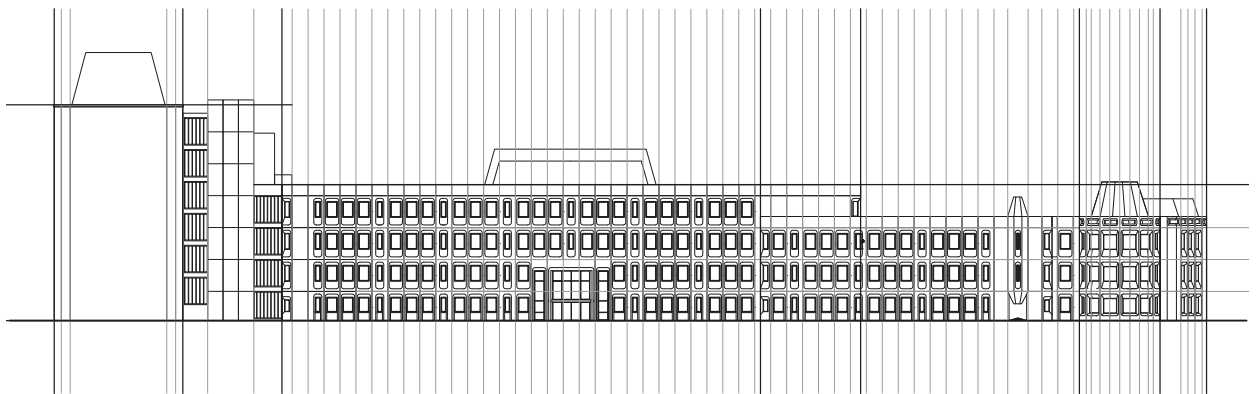

North-west façade

COMPOSITIONS

The monumental building is characterized by a tripartite division, organizing visually the huge façade planes. Thus, a base, a shaft and a capital can be distinguished in the overall façade composition. Also, the structure is reflected on the façades and becomes an architectural element. The expression of the grid is strong in both buildings, and in the newer extension, it is reflected through the expansion

joints. Both buildings are not simple ground- extrusions, but they feature a more playful roof-architecture. The monument has an amphitheatre that does not follow the strict orthogonal geometry of the overall volume and in the newer addition, the top floor is marked by two volumes made of contrasting, inclined planes that have an offset from the perimeter of the envelope.

0 20M

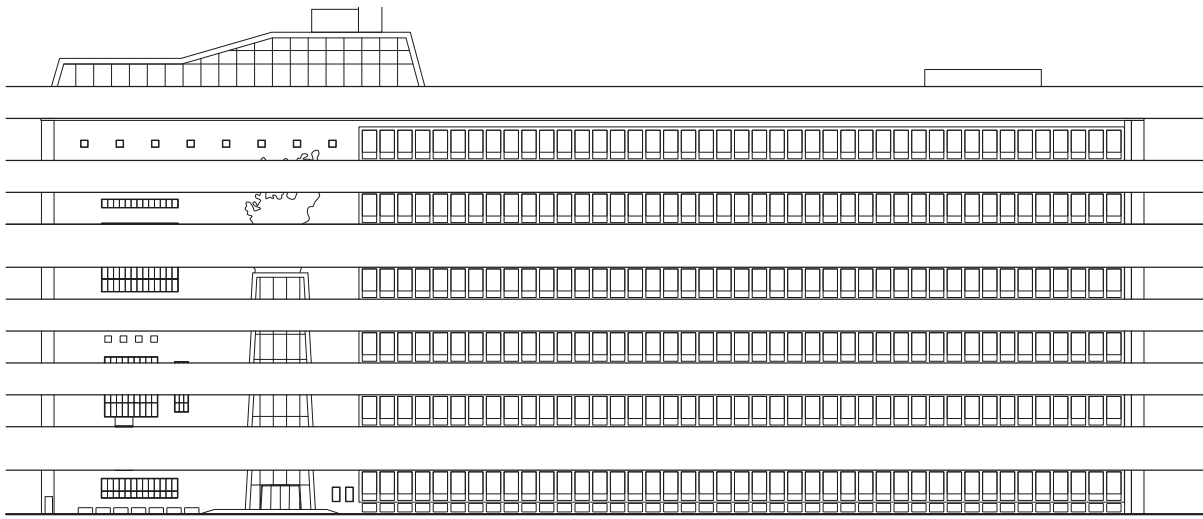

North-east façade

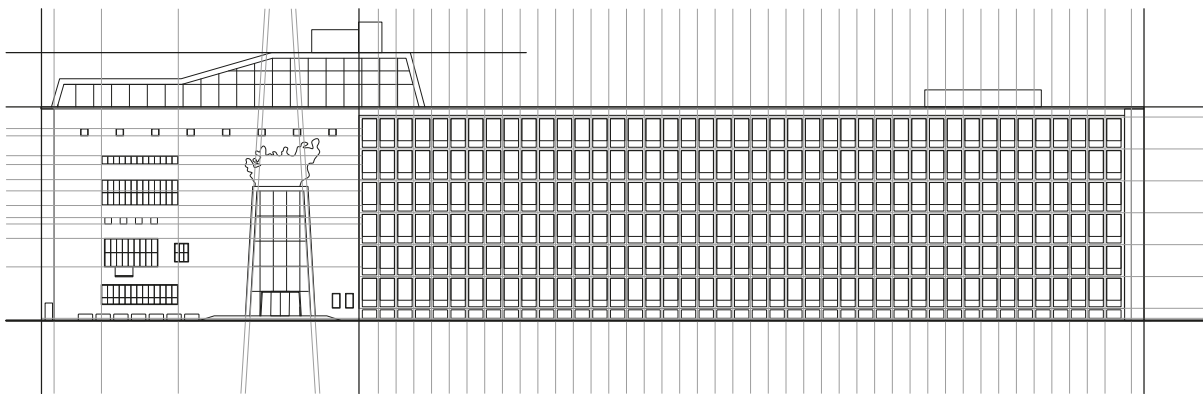

North-east façade

1.1.4.3. MATERIALITY

0 20M

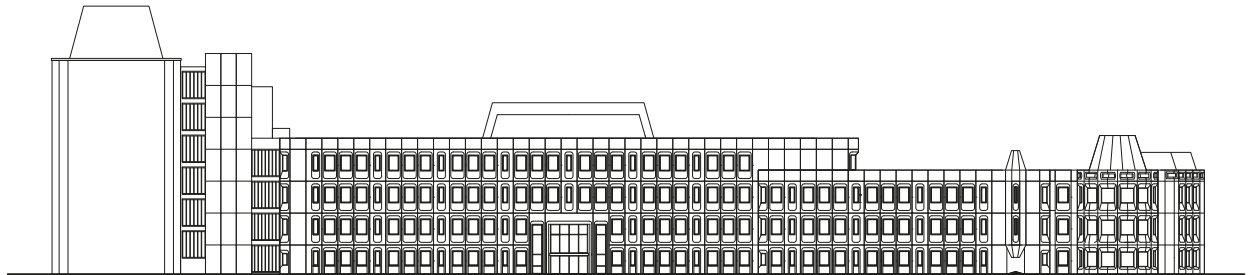

North-west façade

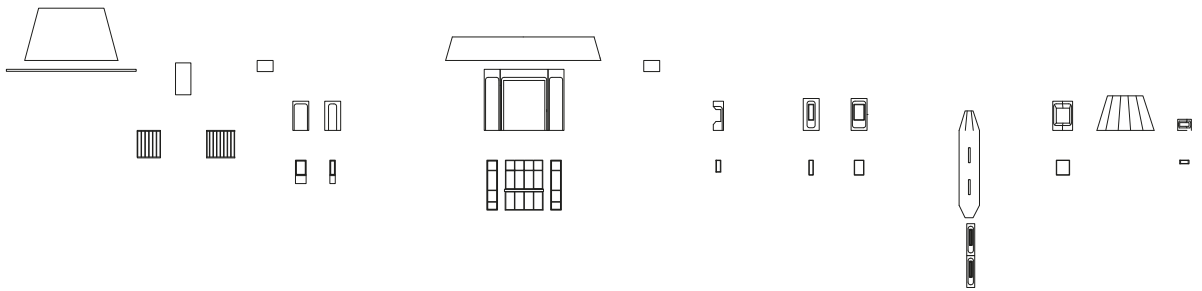

Vacant Heritage - Police Real Estate | The Netherlands

COMPONENTS

Two different languages are used in the two buildings, with modularity being a common theme, which is found on the façade panels of the monument and the load-bearing façade blocks of the new extension. The repetition of different elements is contrasted in the monument, by the different sized windows of the east façade, and the

monumental entrance with the prominent sculpture sitting on top. Though, the use of grid plays an important role in determining the position of each element. The language of the newer extension is less elaborated but enriched by the two circular elements that remind of a sandcastle.

0 20M

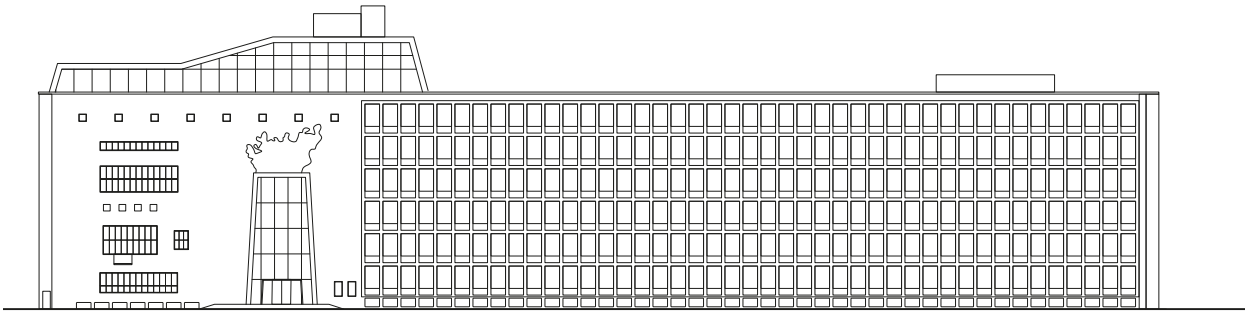

North-east façade

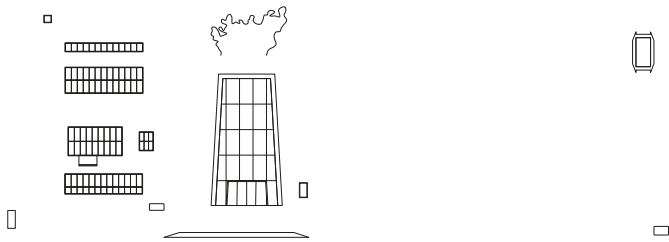
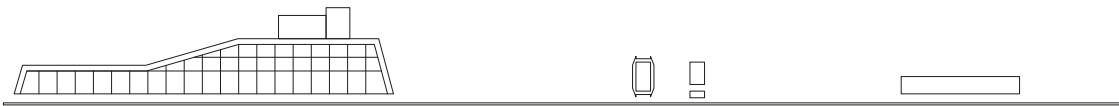

Den Haag

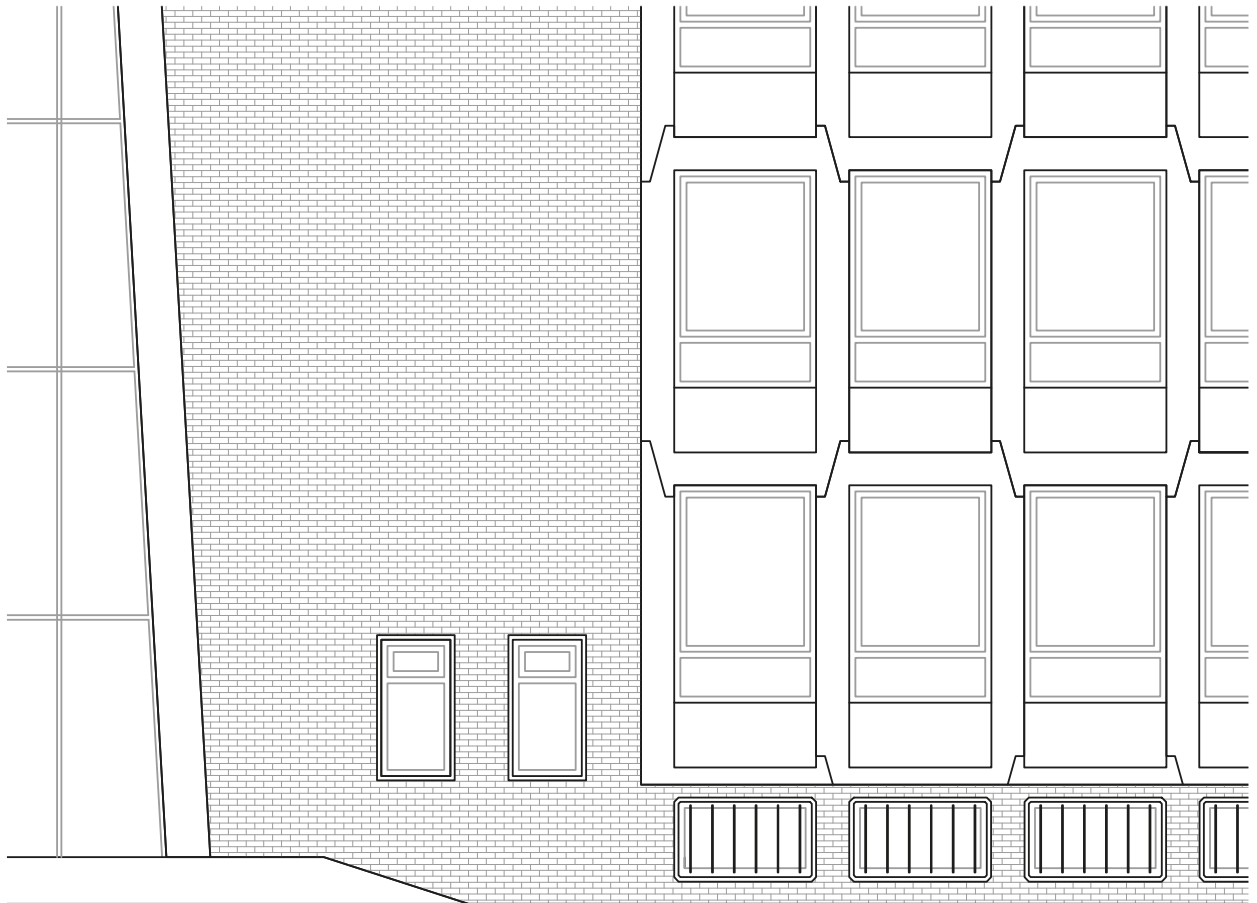

Façade fragment analysis

TEXTURES

The materials are used to express the function behind the façade. The monumental representative entrance and auditorium are covered with elongated yellow brown bricks. The office part of the building is covered by concrete prefab “Schokbeton” elements, which are

placed in a checkboard pattern on the façade. Inside these modules the windows are placed with a serpentine stone panel below the window. The canopy of the main entrance is made out of in situ poured concrete.



(Boenders, 2021)

1.1.5. CONCLUSIONS

The Eenheidsbureau is located at the edge of the city centre of Den Haag. Den Haag is a city developed around the Binnenhof from the 13th century onwards. The city houses the Dutch government and represents itself as city of international peace and justice. Located near the beach, the city did not have a large river around which the city developed. But it is because of the sea on the westside that the city was only able to develop to the west. The new buildings and neighborhoods do however follow the water structure of the man-made canals in the landscape. Large parks form open green spaces inside in the dense built landscape. The police station itself is located near one of these large public parks.

The police was first housed in a wide range of buildings in the urban block, but was centralized into one building after the construction in 1959. The rectangular shaped building has a larger scale than the other buildings which make up the urban block. This building is yet listed as a monument. Another part of the urban block was demolished in order to construct an extension of the police station in 1981. This T-shaped extension cuts up the inner courtyard of the urban block in two parts.

In terms of spatial organization, a different approach is used, which is directly influenced by their structure. The monument features a linear organization with a central corridor and a triple-height entrance. This is formed by a 2 x 5 meter structural grid, with two colonnades and a load-bearing façade (Schokbeton). The extension is a more complex layout and consists of different buildings. It features significantly larger spans, thus deeper spaces with less daylight, but an overall more flexible space plan. This is mainly achieved by a single, central colonnade and the load-bearing façades that support the floor plates.

Dominant and common themes of the architectural language of both buildings, become modularity, prefabrication, and the thick-heavy structural elements. In terms of representation, the scale difference of the two buildings is important, as it aims to create a less intimidating perception of the police station. The relation between interior and exterior becomes clear, which is further expressed through the buildings' materiality, which consists of bricks, and concrete prefabricated panels (Schokbeton). Although the two buildings may appear rather different, certain compositional elements, such as prefabrication and materiality, link strongly the two buildings.

1.2. ROTTERDAM WITTE DE WITH

1.2.1. INNER CITY

1.2.1.1. INTRODUCTION

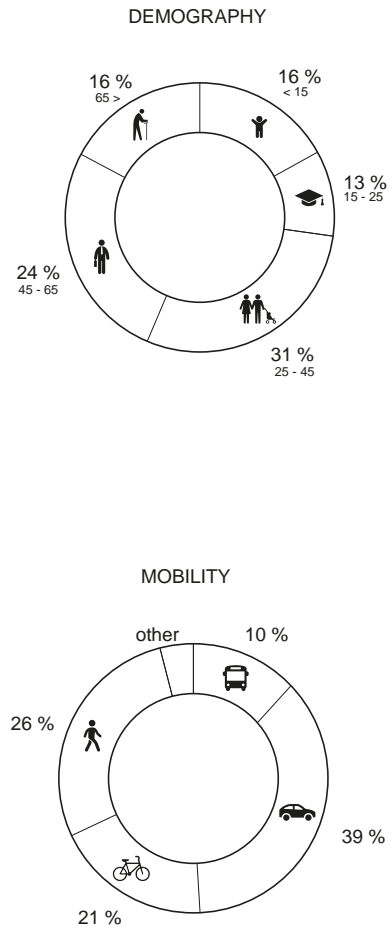

The name Rotterdam originates from the construction of a dam on the river Rotte in the thirteenth century, which thrived on fishing and officially became a city in the year 1340. After the developments in the sixteenth and seventeenth centuries, Rotterdam became more important thanks to its harbour, which became even more evident after the city started growing outside of the original triangular city centre. While the city suffered heavy losses during World War II, the harbour remains one of the largest in the world and the original city centre is still part of the structure.

With 652.541 inhabitants, Rotterdam is the second largest municipality in the Netherlands, Amsterdam. Despite this, it has a surprisingly low density, with 2.995 inhabitants per square km. The largest age group is 25–45 years old.

Compared to other Dutch cities, Rotterdam is more car-dependent, with a relatively high percentage of journeys by car (45%). Only 16% of trips are made by bike, with public transportation accounting for the same percentage.

1.2.1.2. DEVELOPMENT



0

1000M



1815

HISTORIC DEVELOPMENT

Rotterdam originated from the dam on the river Rotte and developed southwards, towards the river Maas during the revolt against the Spanish, in order to improve their defences. This resulted in the creation of the city triangle, which remained to be the city centre for many years. Any urban expansion outside this city triangle had to wait until 1850, after Rotterdam had grown within this area for centuries. One of these expansions included the annexation of Delfshaven, which was founded along the canal that connects Delft to the river Maas. The Rotterdam Haven is located more towards Delfshaven district than

the city triangle, in a neighbourhood that is now known as the Lloydkwartier.

After these expansions, three other events were important for the development of Rotterdam: the bombing in World War II, which destroyed most of the buildings in and around the city triangle (The previous Witte de With street 25 building was destroyed by the bombing – was on the very edge of bombed territory in the centre of Rotterdam), the rapid expansion of the harbour along the river Maas and the leap across the river towards the southern bank.



0 1000M



1850



1900



1975



2020



BUILDING AGE

The building age maps clearly show the result of World War II, with most of the buildings in the city triangle (the black-coloured part in 1950-1999 map) being built during or after the second half of the twentieth century. The Witte de Withstraat 25 police building was on the very edge of the bombed city centre area. The buildings forming the Witte de Withstraat were mostly constructed during the 19th century in the west part of the street, and the eastern part was re-built starting in 1950 (after World

War II). The Witte de Withstraat 25 police building was also built in that period (1959).

However, the neighbourhoods around the triangle are older, including parts of Delfshaven. The Lloydkwartier, where the Rotterdam Haven is located, is generally more recent. After being located on the water itself, the main building was built in the first half of the twentieth century, followed by an addition in 1994.



0 1000M



1800-1899

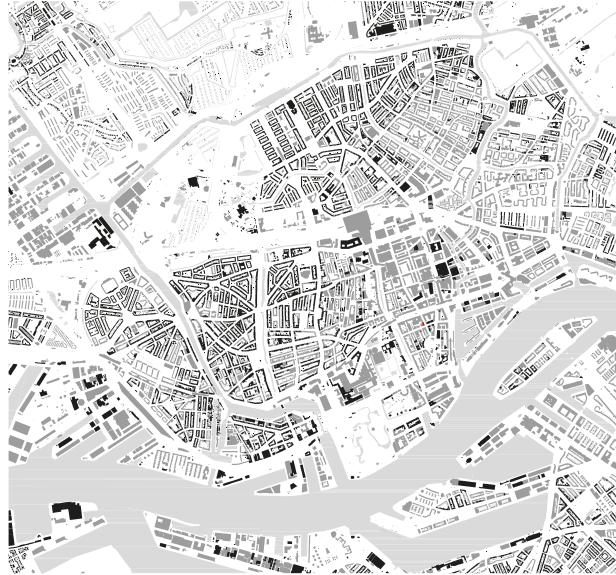

1900-1949

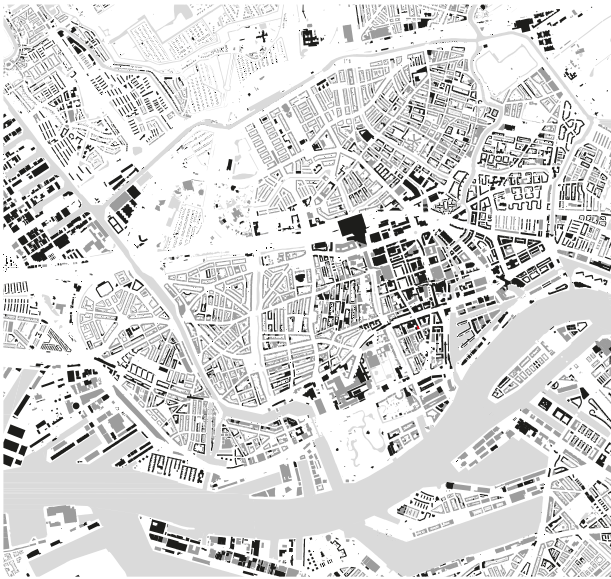

1950-1999

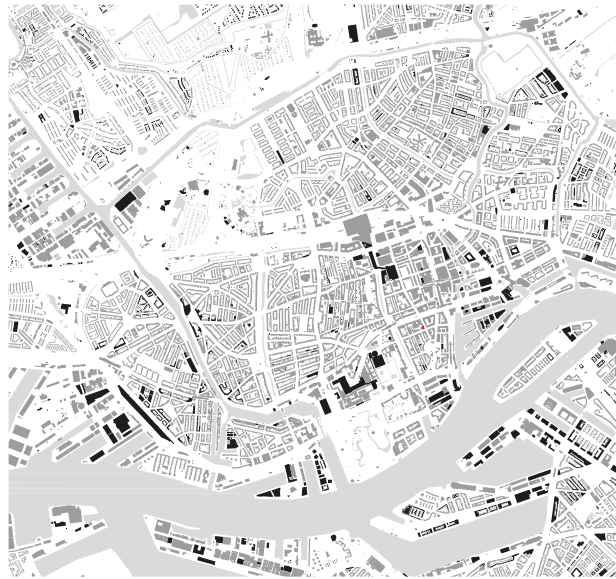

2000-

1.2.1.3. NETWORKS



0

1000M



All roads

Vacant Heritage - Police Real Estate | The Netherlands

ROAD NETWORK

As Rotterdam was almost completely rebuilt after World War II, the main roads were designed to conveniently serve the cars. The overall road network map concludes that the railway and metro lines in the city make up a

dense and convenient network both on the north side of the river and in contact with the south side. The wide primary streets, together with the dense railway and metro lines, are the spatial qualities of Rotterdam.



0

1000M



Primary roads

Rotterdam Witte de With



Vacant Heritage - Police Real Estate | The Netherlands



Secondary roads



0

1000M



Tertiary roads

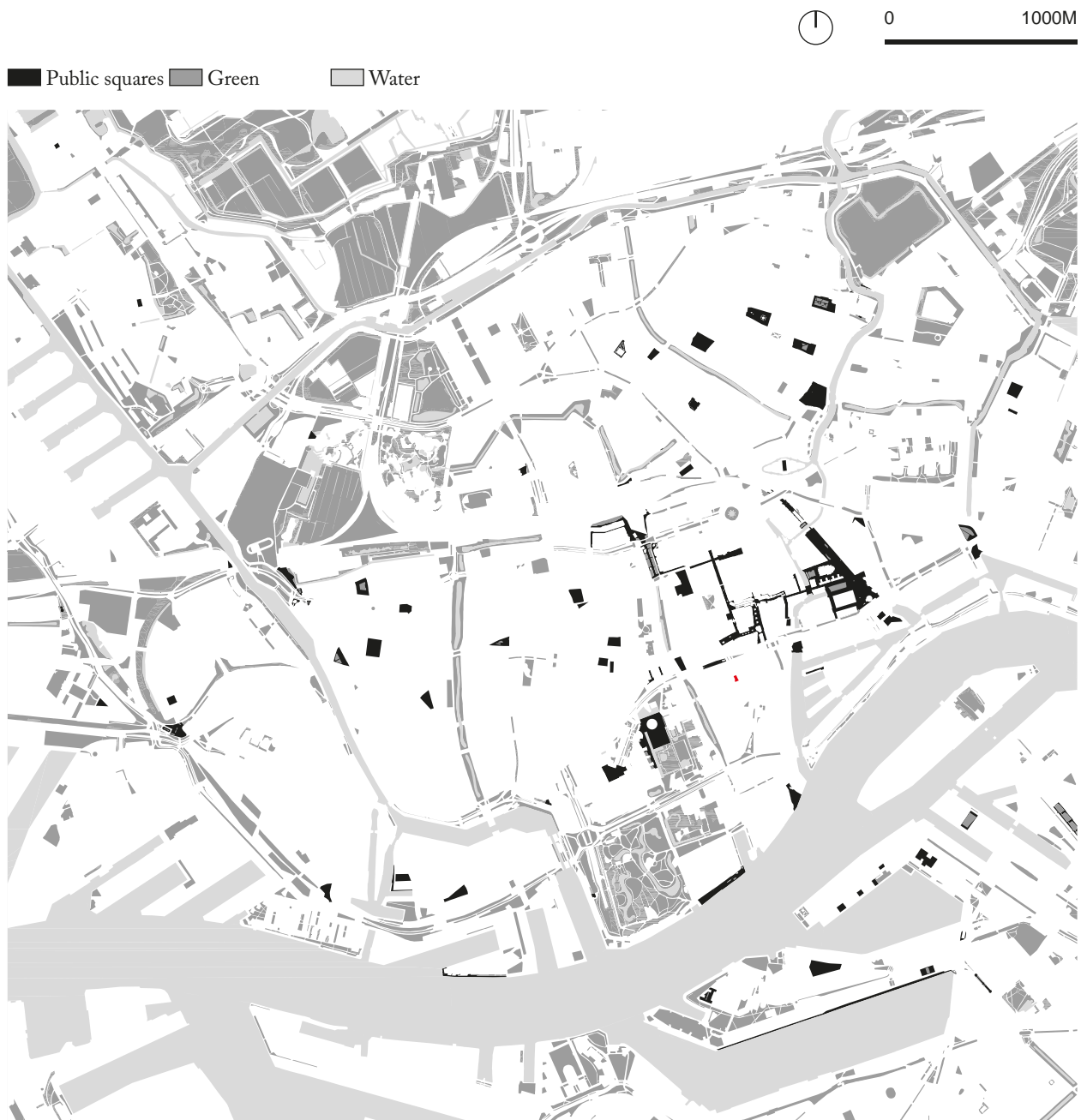

GREEN, WATER AND PUBLIC SQUARES

Public space – squares and parks – is where Rotterdam’s city life flourishes. The main squares here are dedicated to markets, cafes, festivities, and also playgrounds for children. The most popular and well-known squares are the following: the main market square next to the Markthal building, the Pathé Schouwburg square next to the Pathé cinema building, Station Square in front of the Rotterdam central station, and the museum square connected to the Museum park.

The police building at Witte de Withstraat 25, is located on the route between the two squares mentioned – the main market square and the museum square. Witte de

Withstraat is itself a very popular street among the public during the night. The building is also only a 5-minute walk away from the biggest city’s shopping area and the Maritime Museum.

However, the location of the Rotterdam Haven station is somewhat different in terms of its type of urban proximities. Surrounded by green public spaces, including one of the biggest parks in the city—Het Park—on the eastern side and water (Parkhaven harbour), the site is in touch with both urban life (medium-sized residential blocks and large office buildings) and nature.

1.2.2. URBAN BLOCK

1.2.2.1. COMPOSITION

Vacant Heritage - Police Real Estate | The Netherlands



(Mankutè, 2021)



Rotterdam Witte de With

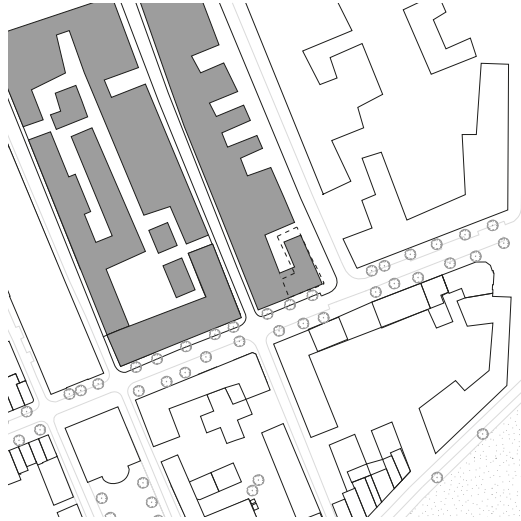

1870-1939



1946-1958

HISTORIC DEVELOPMENT

Before World War II (until 1939), this urban block was made up of two long urban blocks (the northern part of which would now be located on the busy Westblaak street). During the war, the side mentioned was heavily destroyed by bombing, including the Witte de Withstraat 25, a building on the southeast corner of the block. In the 1960s, traffic widening measures were taken on Westblaak, which also resulted in a new large-scale

building on the north side of this block, making the urban block one. To this day, the remaining part of the destroyed street (separating the two blocks) is accessible from the Witte de Withstraat (south part of the block), but it is only used by the block residents. Recently (in 2009), the eastern side of the block was finished with a narrow, long building (as seen in the last image). The police station, Witte de Withstraat 25, was build in 1960.



0 50M



1959-1970

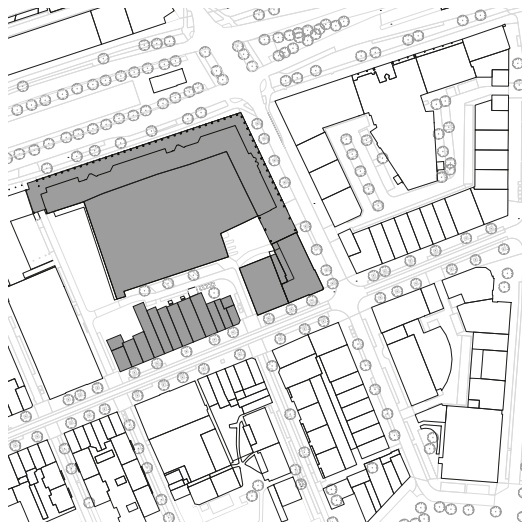

1971-2000

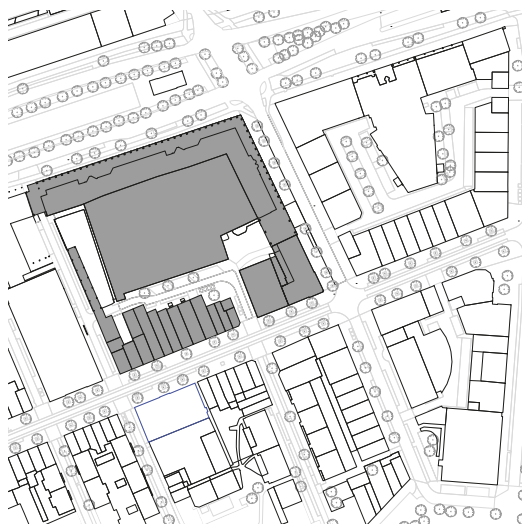

2000-

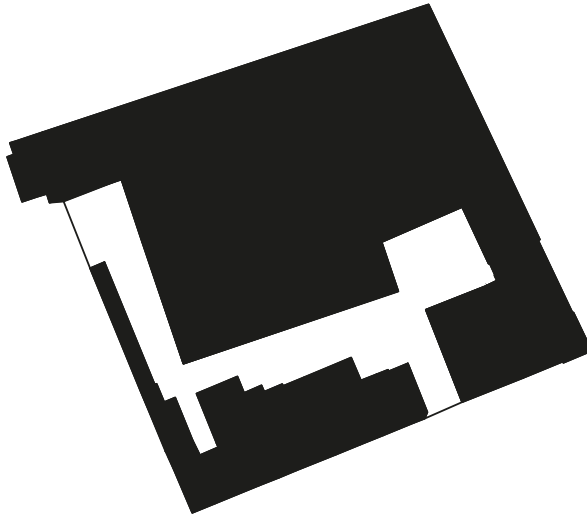

Built area
10433 m²

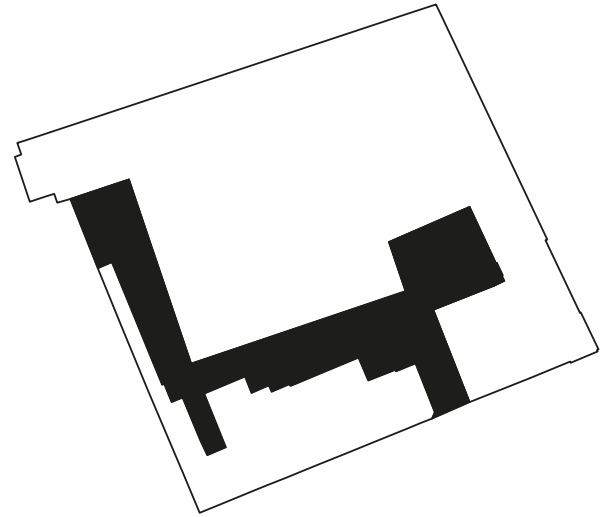

Empty area
2580 m²

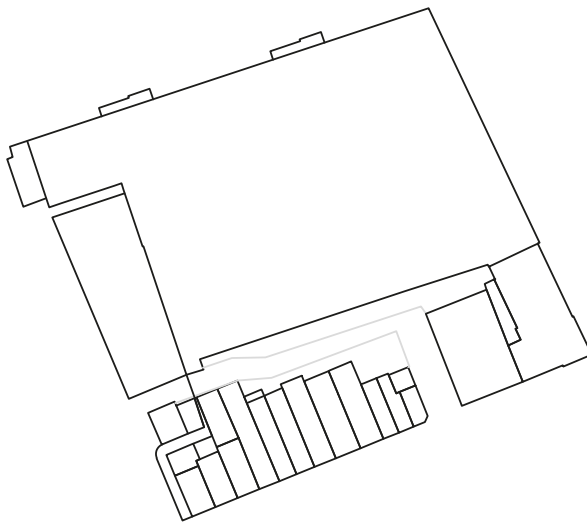

Parcels
28

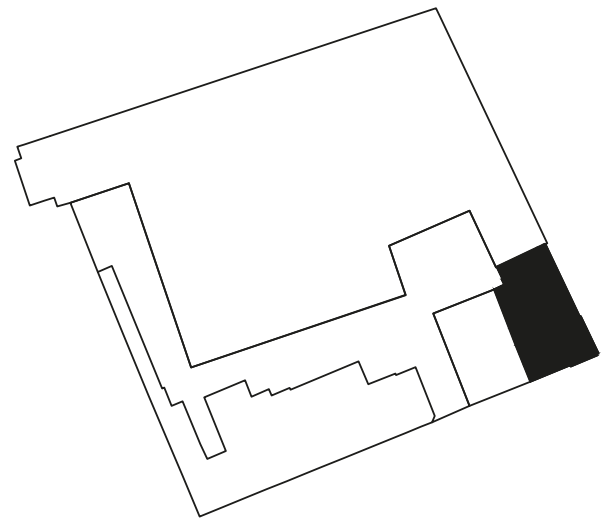

Police real estate
593 m²

BLOCK INFORMATION

The police building at Witte de Withstraat 25, plays an important role in terms of the spatial configuration of the block: despite its small size compared to the northern part of the block, it forms an important corner between two intense small-scale streets. The location of the narrow street that originally separated two urban blocks can now still be noticed in the place where the Witte de Withstraat elevation (south side) is lacking a building. There is a noticeable difference between the smaller size of the pre-war buildings with their parcels and the two-thirds of the

area occupied by the parcel on the northern part of the block (the huge building with the parking garage built in the 1970s). Mostly due to the large space occupied by the 9-story high parking garage, the block lacks quality spaces like nice inner courtyards or terraces. It can be said that the building block is dominated by the building mass on the northern side, but one cannot feel it from the Witte de Withstraat, where the traditional narrow buildings line up the perimeter of the block.



0

50M

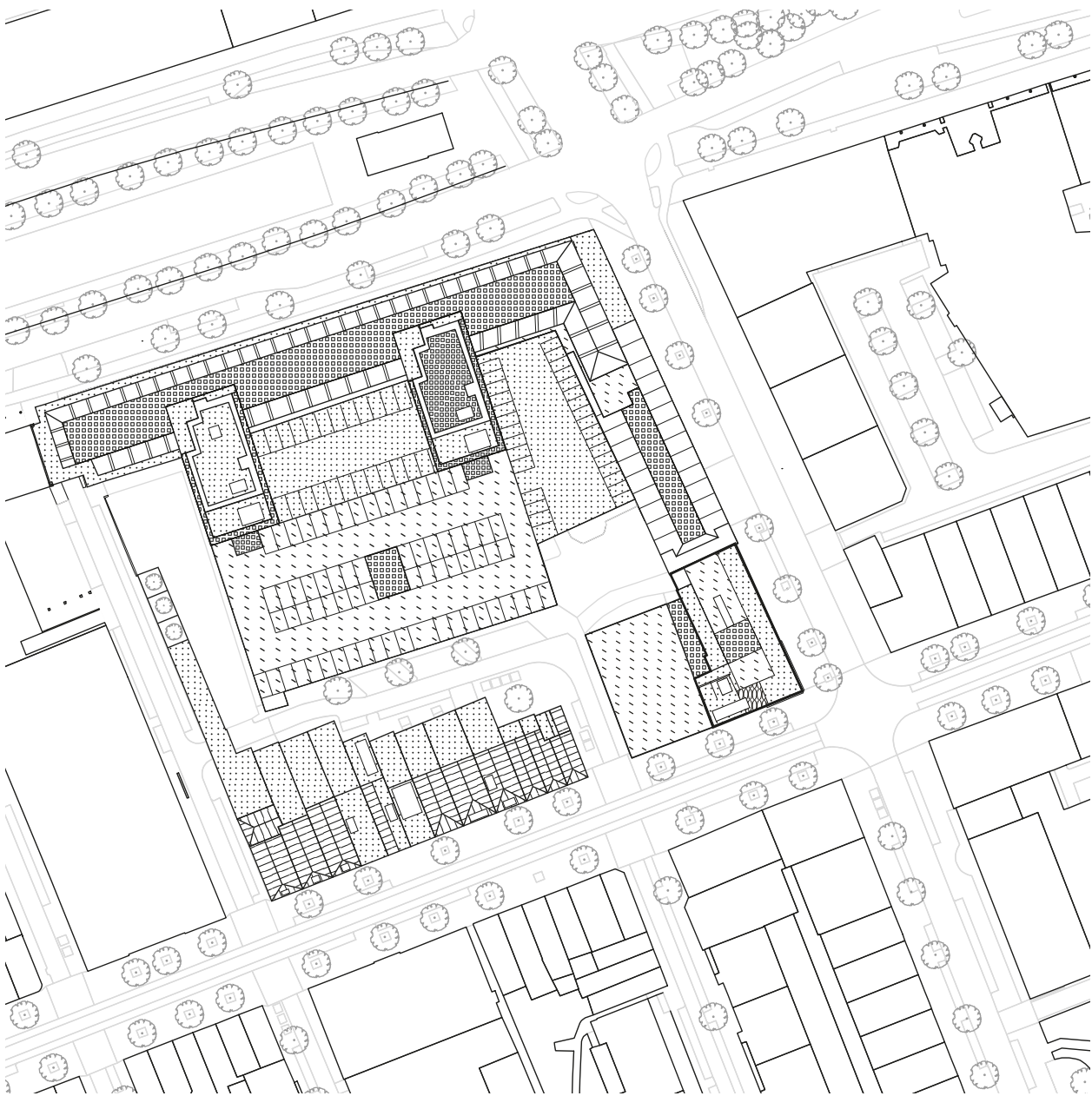

Rotterdam Witte de With

ROOF STRUCTURE

Two defining elements of this urban block in both the configuration and the roof structure are the row of traditional Witte de Withstraat houses and the parking garage building with its façades in Westblaak and Harmanstraat. The roof structure says a lot about the construction period of the buildings in this urban block. The row of pitched roofs in the southern part of the block represents the tradition of pre-war Dutch houses, while the

flat roofs indicate which buildings were built in modern times (after World War II until now). A large portion of the roofs in the inner part of the urban block are used as parking lots. In the southeast corner, the police building (flat roofs) was overloaded with additional elements over time: a large part of the roof is occupied by ventilation equipment, and an installation room was added on top of the fifth floor.

1.2.2.2. STREETS

0 20M

■ Façade openings



Witte de Withstraat

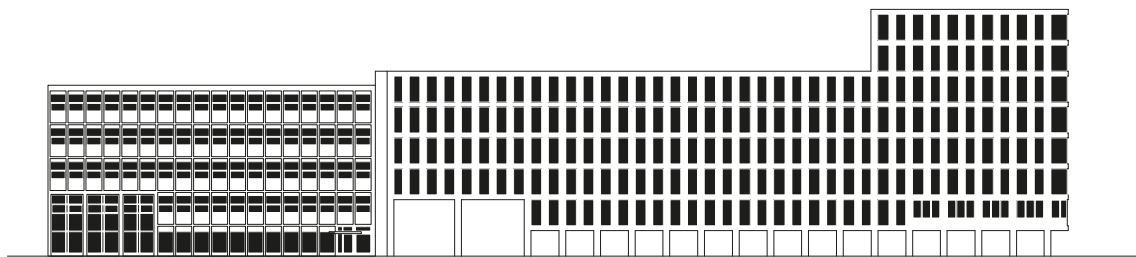

Hartmansstraat

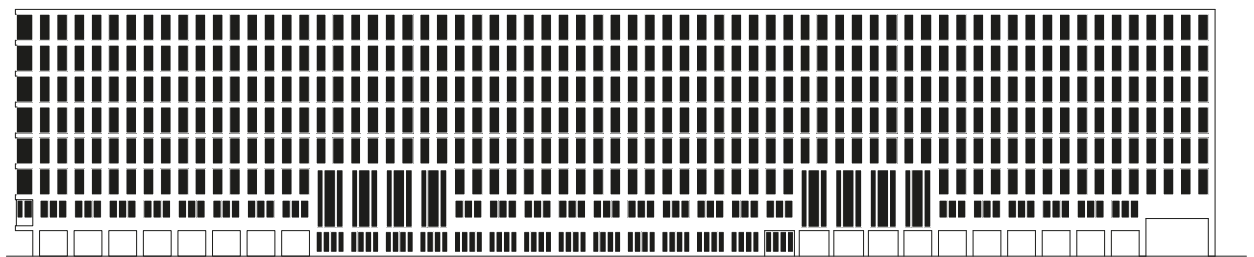

Boongaardsstraat

Vacant Heritage - Police Real Estate | The Netherlands

STREET ELEVATIONS

The diagram of the continuous street façades of the block demonstrates the openness and accessibility of the façades. The façades of this block along the Westblaak and Harmanstraat streets have very monotonous glazing which contribute to the commercial atmosphere of this block from north and east sides. The street elevation

of Witte de Withstraat showcase more dynamic use of openings as the buildings belong to different parcels and was designed separately. The plinth is more open in all the buildings of the block which is typical of the city center block.



0

50M

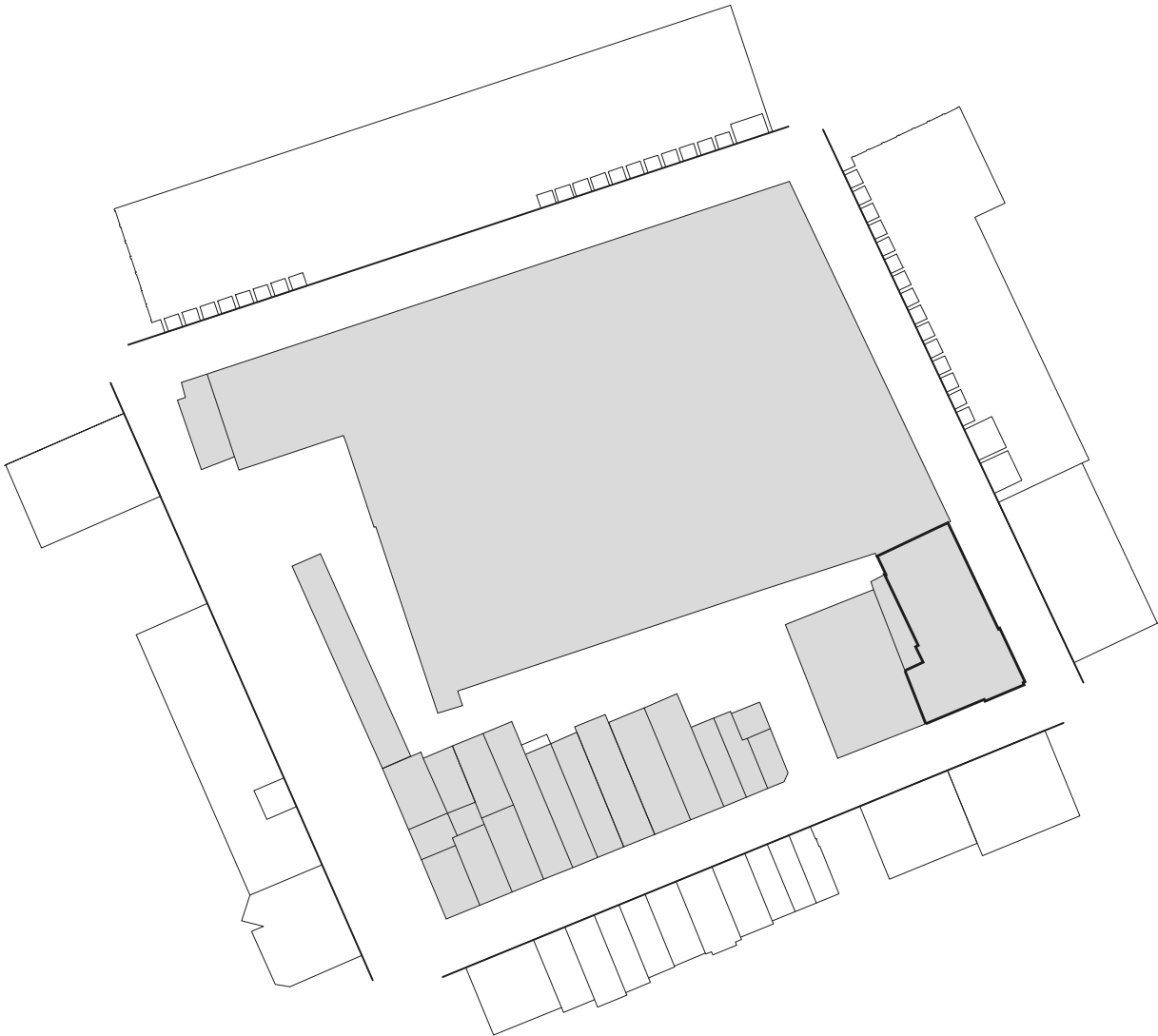

Parcels and façades

PARCELS AND FAÇADES



Vacant Heritage - Police Real Estate | The Netherlands



Location of street sections

STREET SECTIONS

Witte de Withstraat and Hartmansstraat are both very old streets. However, it is not always evident in the street profiles since some buildings were rebuilt after being bombed during World War II. The police at the intersection of those two streets is also one of the modern (post-war) buildings. Two spatial street sections show the police building in comparison to pre-war and post-war

building sections. While the Witte de Withstraat section showcases the relation between very spatially similar buildings (both are from the 60s), we can clearly see the contrast in the Hartmansstraat section, where the pitched roof and set-back plinth make the building more human-scale and inviting in comparison to the police building.

0 5M

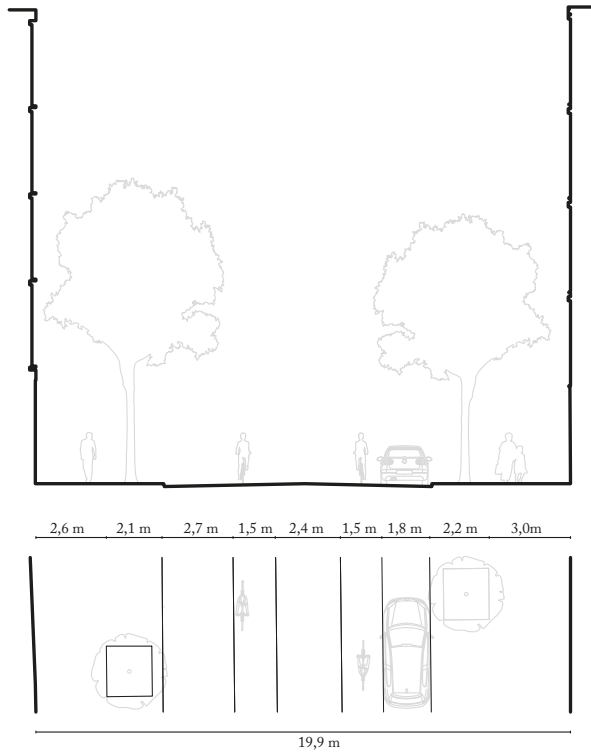

Section A
Witte de Withstraat

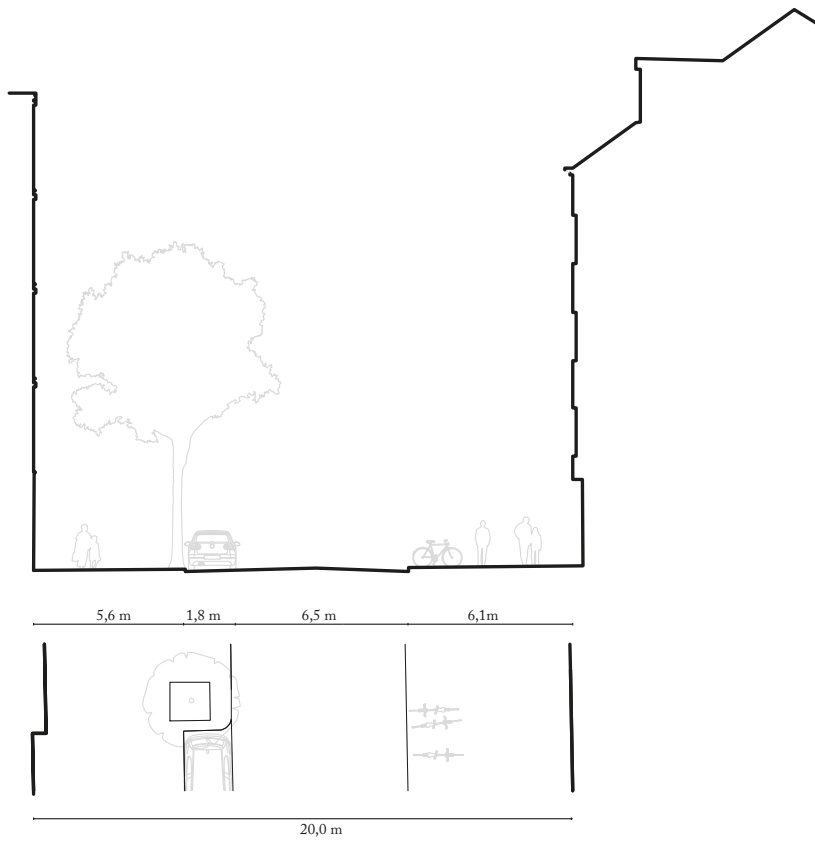

Section B
Hartmansstraat

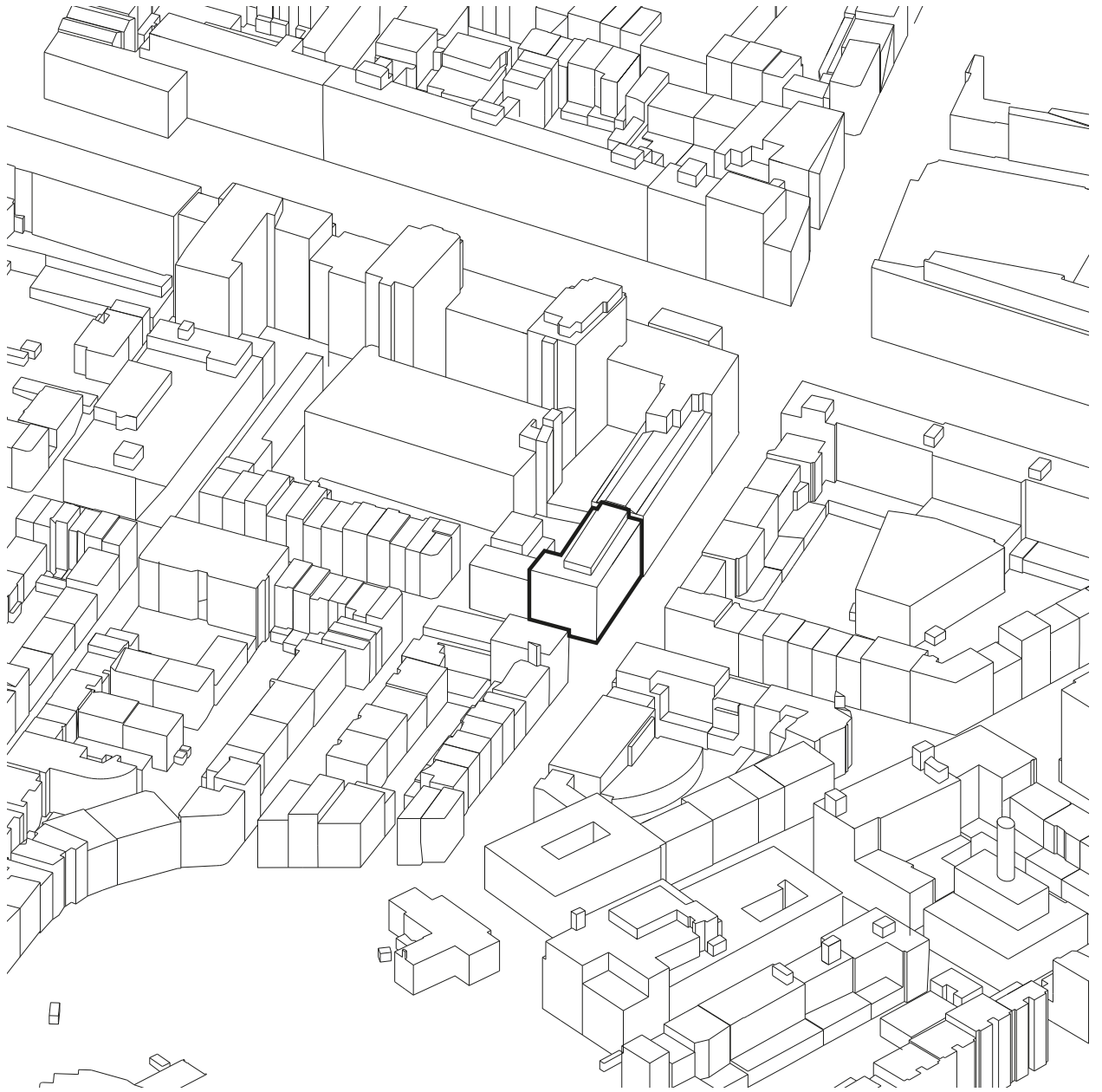

Isometric of urban block in surroundings

ISOMETRIC

1.2.2.3. ACCESSIBILITY



■ Car parking ▲ Entrance 🚲 Bicycle parking

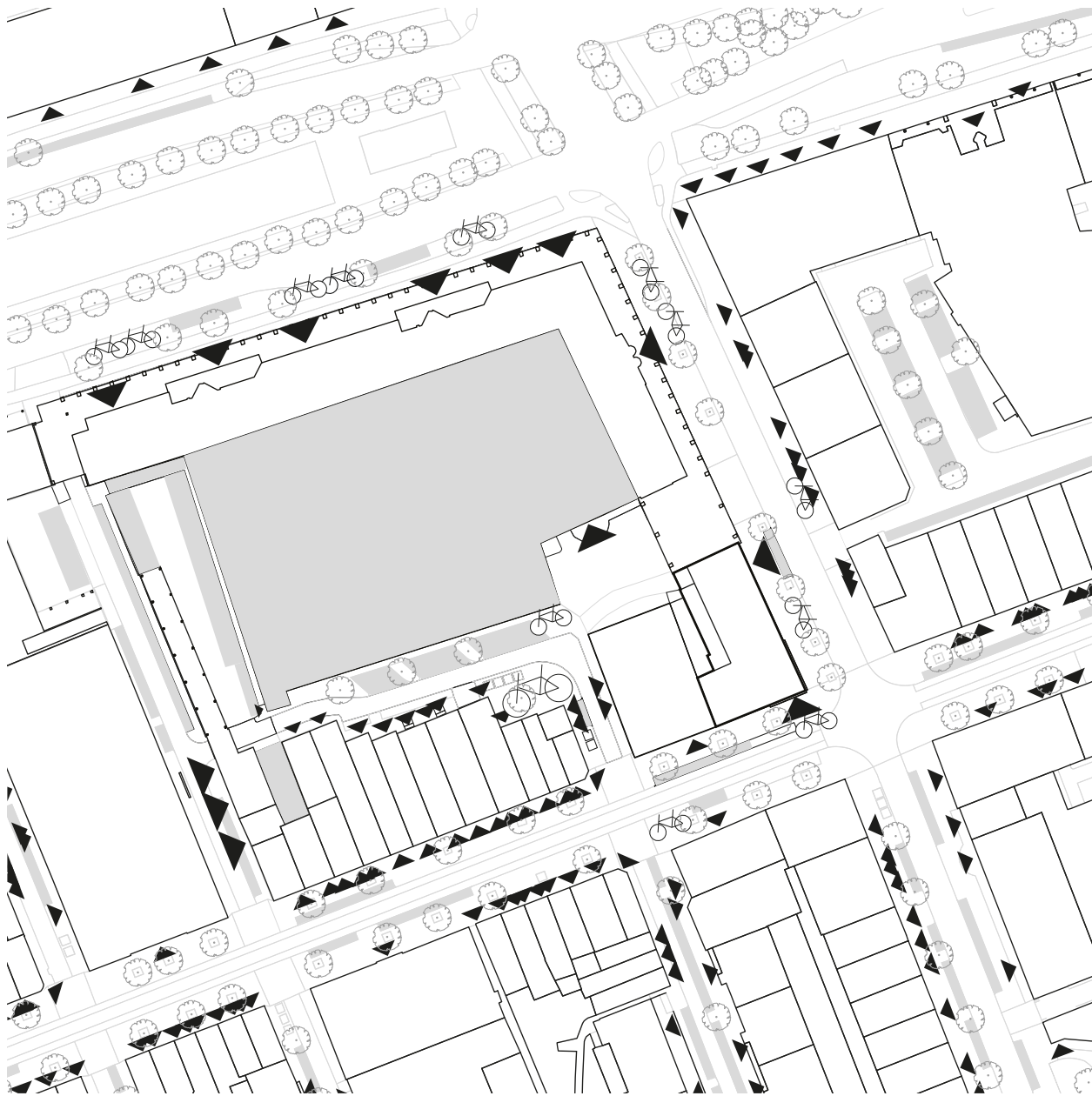

Parking and entrances

Rotterdam Witte de With

PARKING AND ENTRANCES

Even though car access is limited in the area, this urban block has plenty of car parking options, including a nine-story car parking building in the inner courtyard of the block. The means of transport promoted in the city center are bicycles; therefore, bicycle storage facilities are installed on sidewalks, in the inner yard of the block,

and in private ones in the buildings. The entrances to the buildings in the block show the principles of using the block: the densely arranged entrances in Witte de Withstraat show more human interaction, and the inner courtyard also has many back entrances that are useful for staff working in the cafes and other establishments.

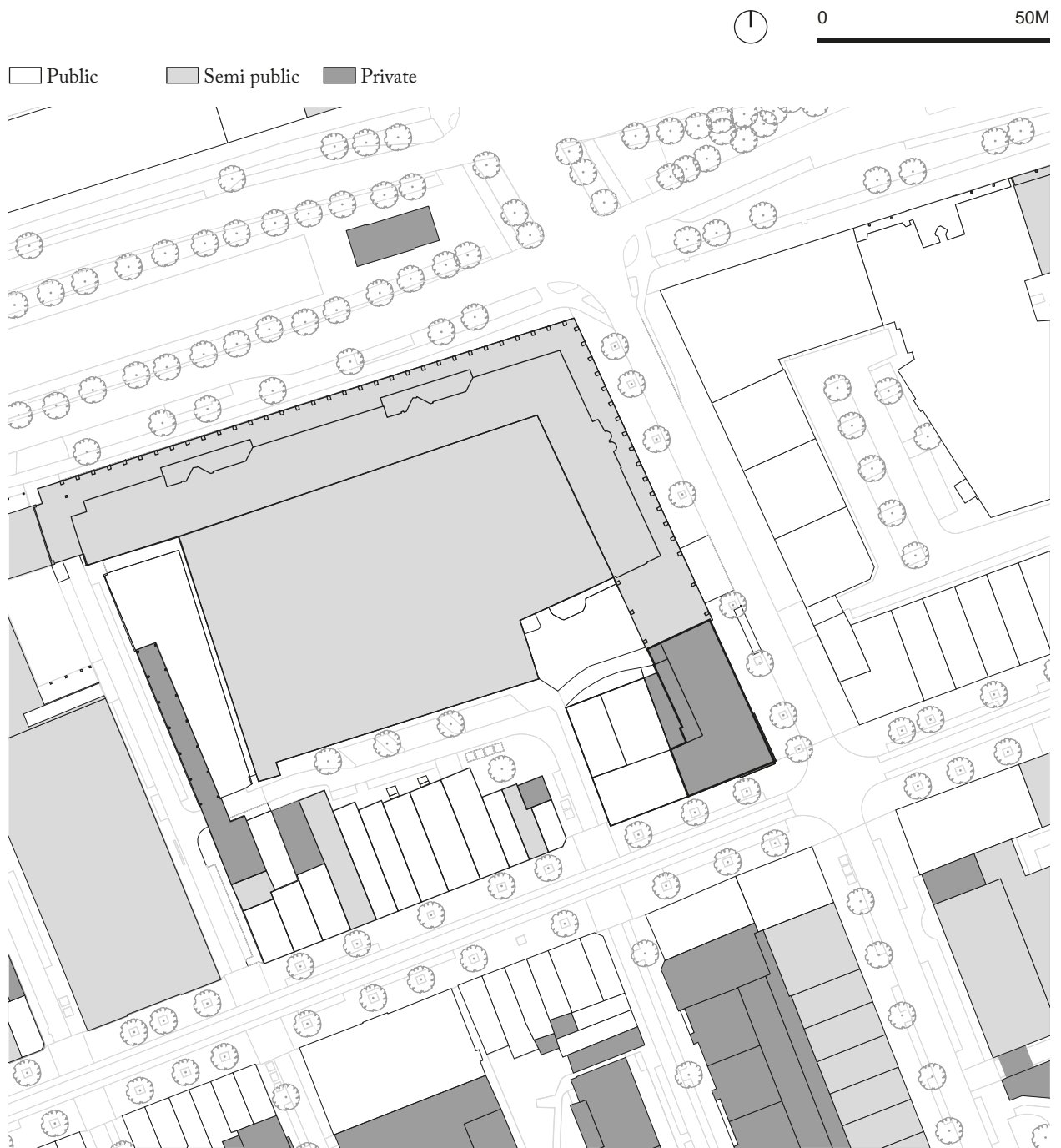

Public, semi-public and private buildings

PUBLIC, SEMI-PUBLIC AND PRIVATE BUILDINGS

Looking at the use of the ground floor in the area, a high concentration of public space can be observed, especially in the Witte de Withstraat. Meanwhile, the police building

on the corner of the block is currently not open to the public, thus disregarding the common context.

1.2.3. BUILDING OBJECT

1.2.3.1. SPATIAL LAYOUT



0

10M

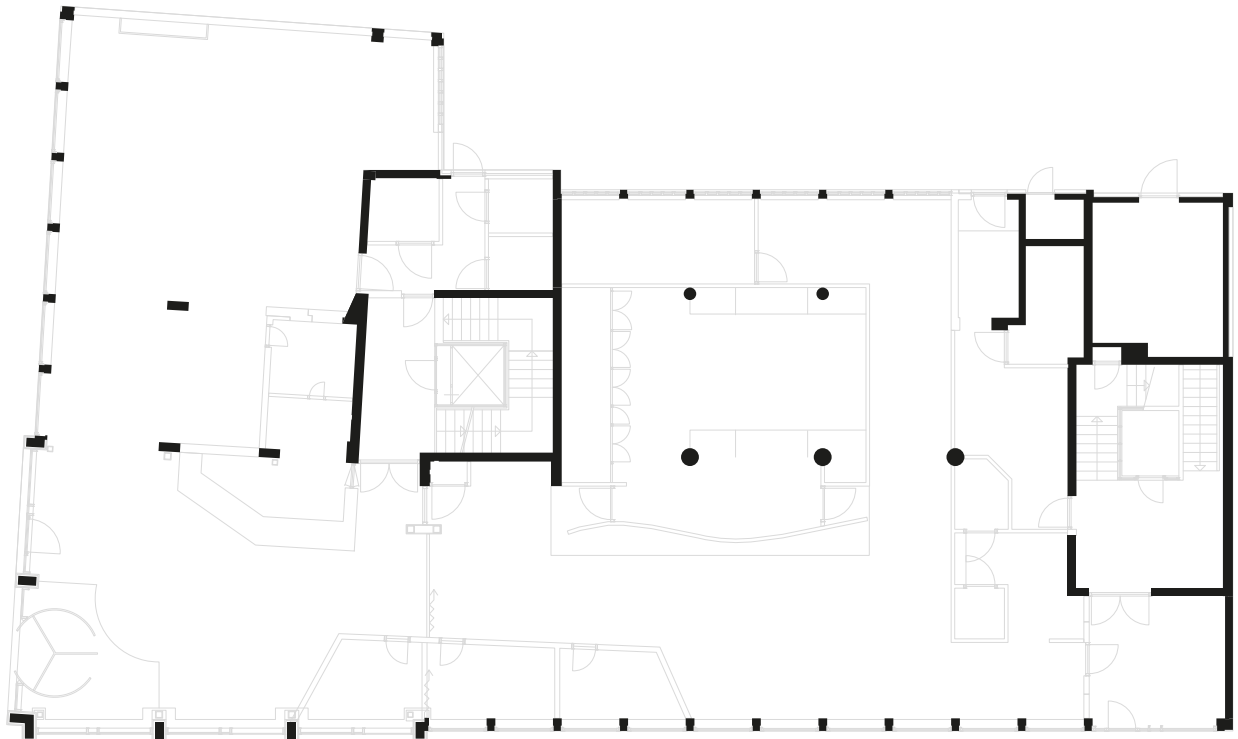

Ground Floor

FLOOR PLANS

The building consists of 6 floors including the basement and there is an installations room on top of the fifth floor which is reachable only by ladder. Regarding the monumental entrances that are unique to the police building typology, in this building, it is also expressed by the arching exterior elements. The main entrance of the building is located in the corner of the building. With the move of the police into the building, the original setback of this corner entrance was removed changing the experience of the building. Furthermore, the double-height entrance foyer was removed.

The entrance brings you into a foyer with a reception desk. This space connects to an open plan office space to the left of the entrance and to a couple of private rooms straight ahead. The largest room on the ground floor is a small auditorium.

Continuing along past the auditorium, one can find the

second entrance to the building. This was originally intended to be used by the employees of the newspaper. Here one can find the second stairwell giving access to the rest of the building. The elevator shaft in this stairwell is of a larger than the other, as it was designed as an elevator for goods.

The rest of the floors is divided in offices along the façade with a hallway running down the centre of the building. The partition walls are non-loadbearing, so it allows for some flexibility in that regard. Only the first floor is a little bit different as it contains some holding cells. These are currently not in use anymore.

The fifth floor holds what was originally the canteen of the building. It is an open plan with a closed kitchen at the northside of the building. Originally employees did have access the roof, however this is not the case anymore.



0 10M

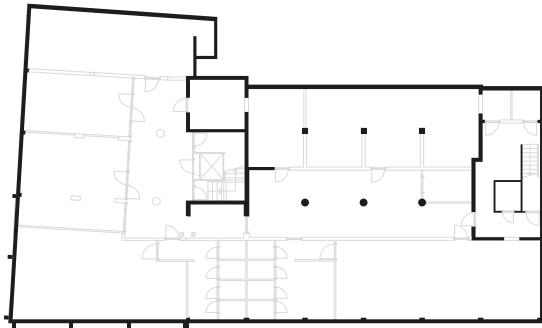

Basement

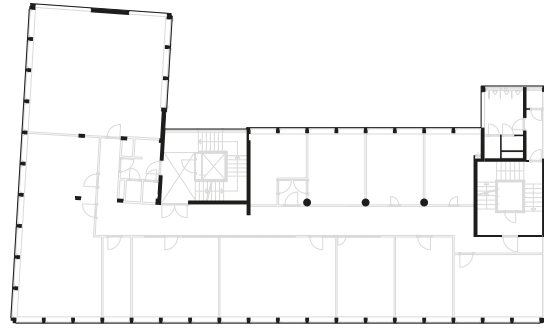

Fourth Floor

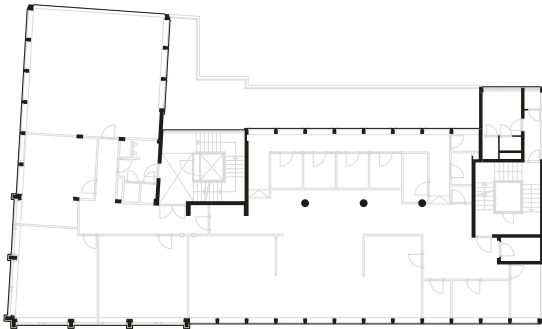

First Floor

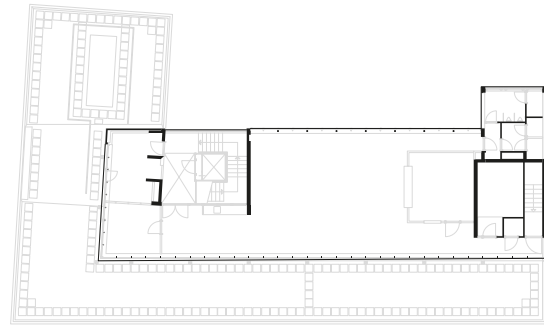

Fifth Floor

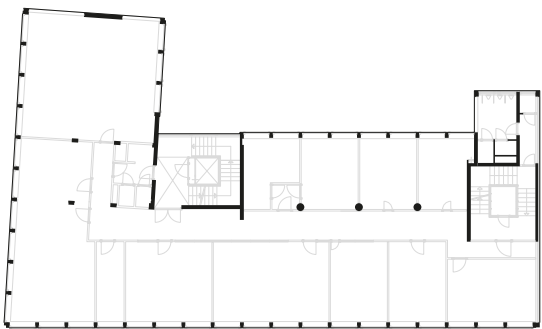

Second Floor

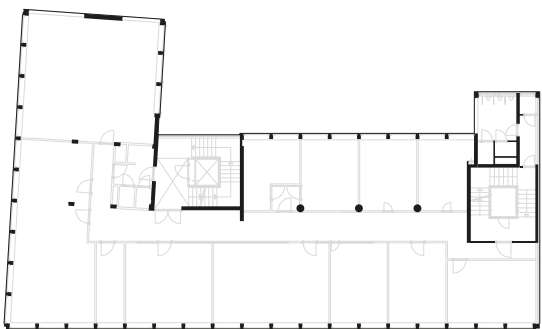

Third Floor

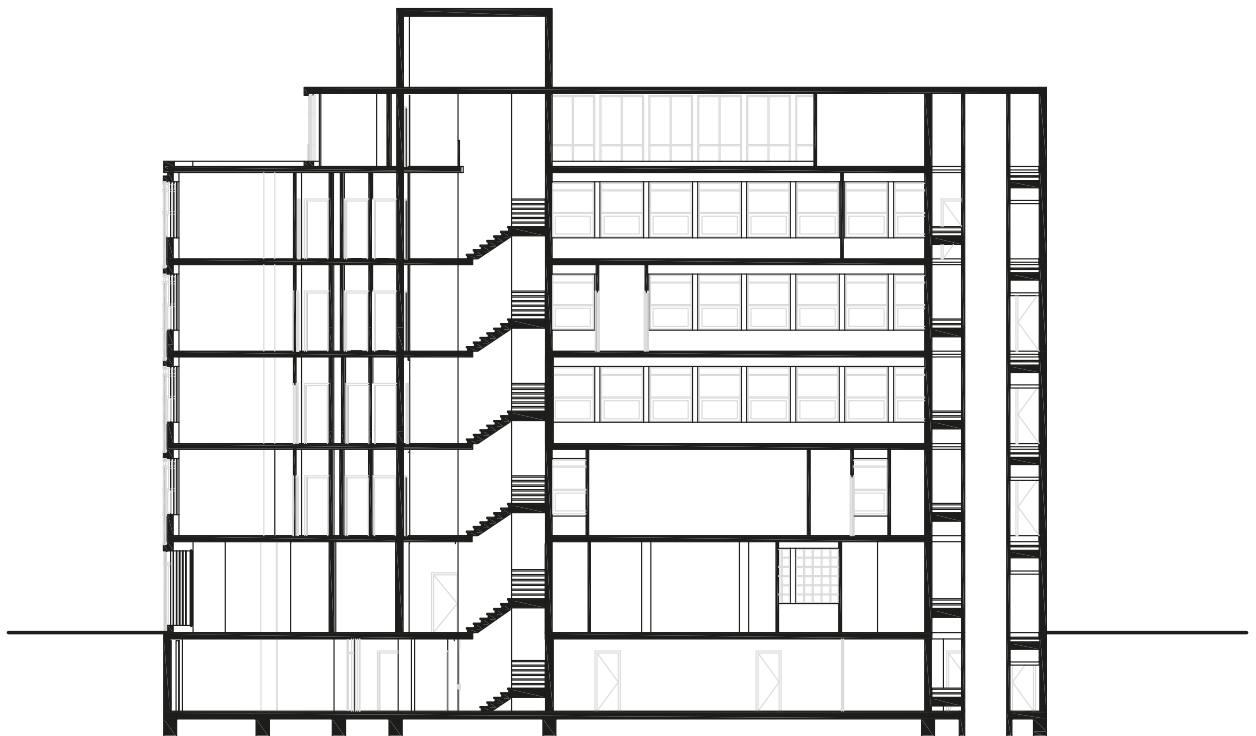
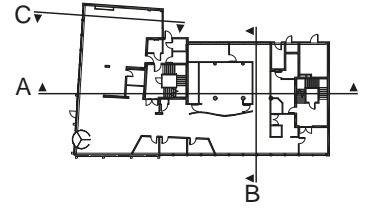

Section A

SECTIONS

The police building is a beam-column structure with six floors above ground and a one-story basement. The building has a total of seven floors connected by two cores with elevators as the main vertical circulation links. The emergency stairs on the side of the building do not act as secondary but as one of the staircase. Of all the floors, the ground floor is the highest height (3.45 m),

the first-fourth floors are 3.3 m, and the fifth floor is 2.8 m (basement height 2.7 m). Elevator service spaces were created in the pits in the basement. All the façades of the building have quite a lot of windows, except for those that border with the neighbouring buildings by the closed-off firewall.

0 10M

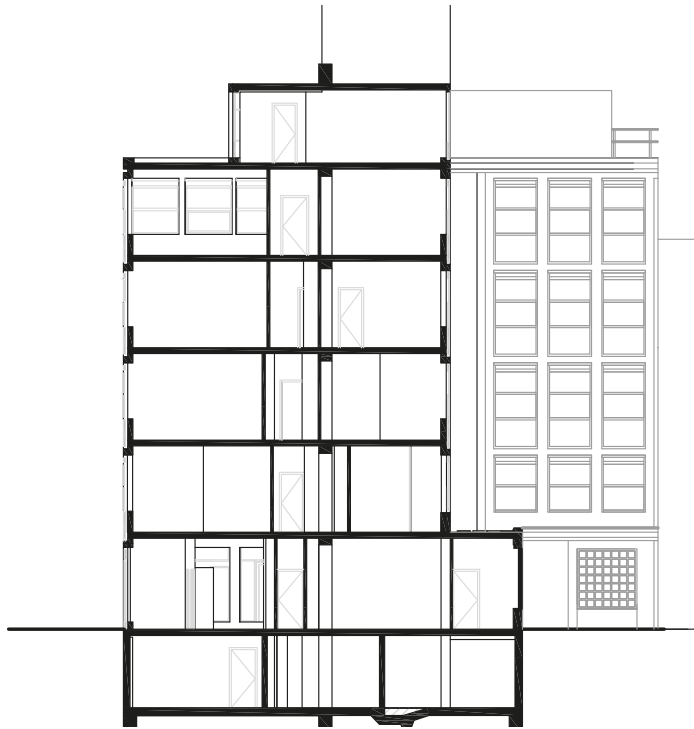

Section B

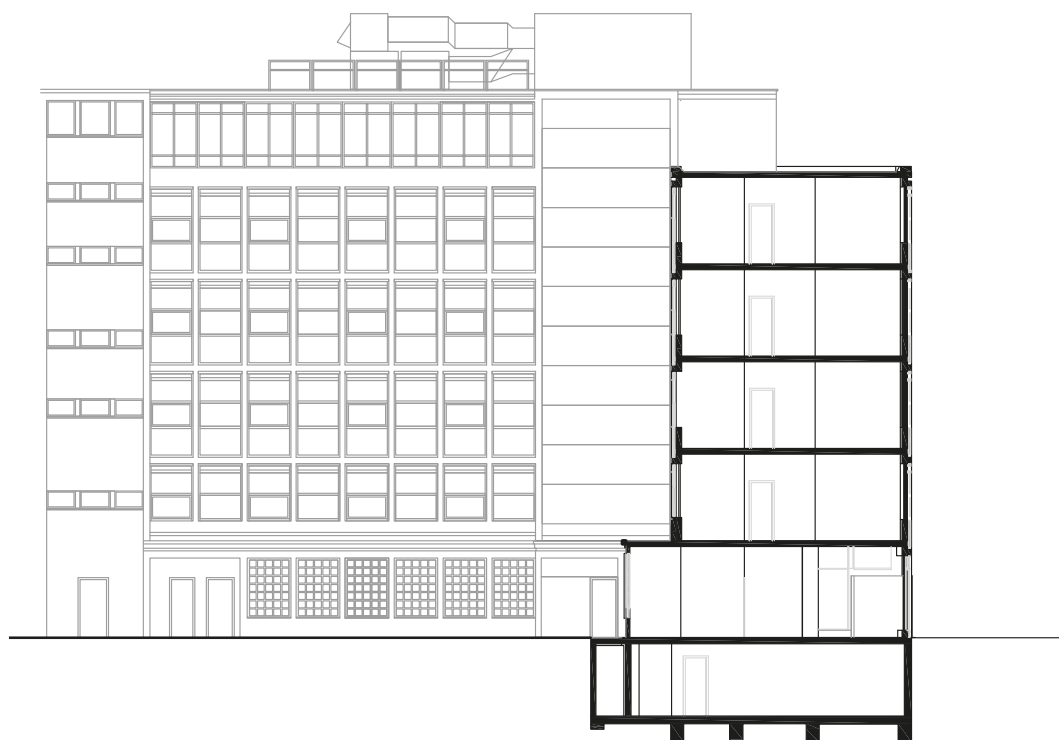
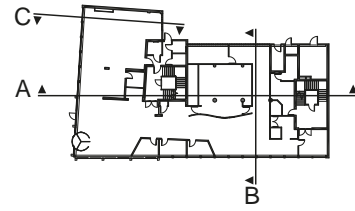

Section C

Rotterdam Witte de With

1.2.3.2. SPATIAL RELATIONS

Vacant Heritage - Police Real Estate | The Netherlands

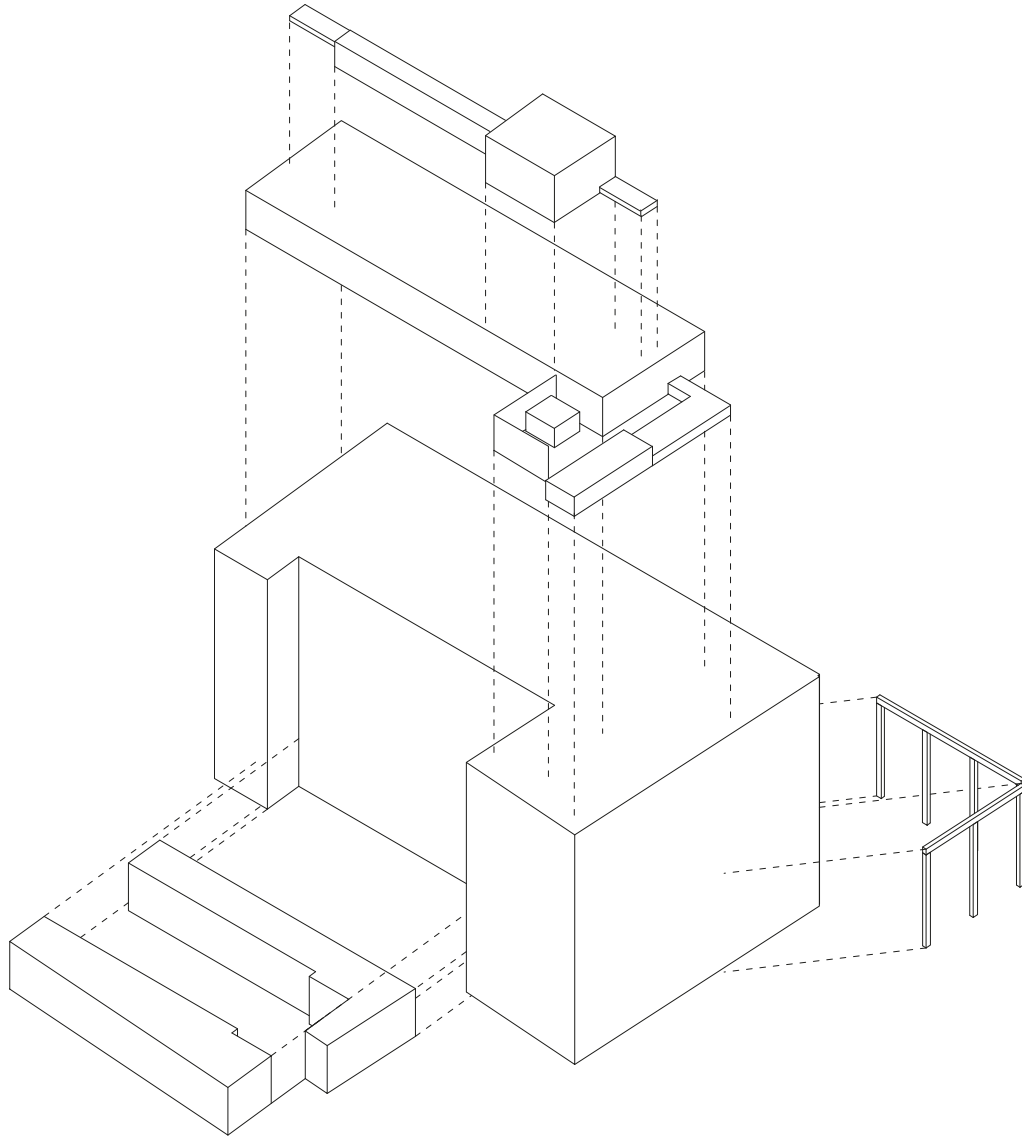

Building volume

BUILDING VOLUME

The 3D exploded view above shows the spatial components of the police building in Witte de Withstraat 25, Rotterdam. The outline of the main volume is repeated from the ground floor to the 4th floor (the basement also follows the same outline). On the 5th floor, more space is left for the roof terrace, therefore the volume of this level

is smaller. On the top of the 5th floor, there is a small room for installations. The backyard of the building has an extended volume on the ground floor and a covered space for bike parking. The last essential spatial element of this building is the arching double-height entrance on the corner which represents the building on the crossroad.



0 10M

● Start ●●● Route ▲ Ascending vertical route



Basement

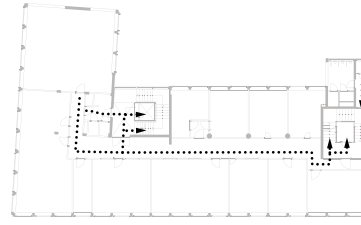

Third Floor

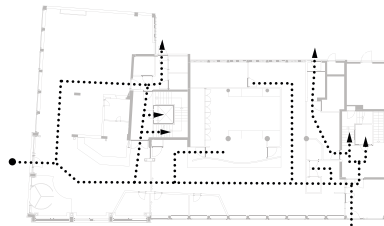

Ground Floor

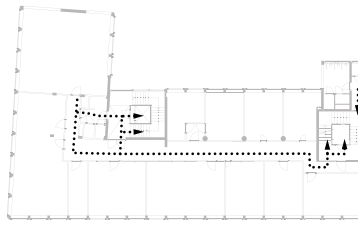

Fourth Floor

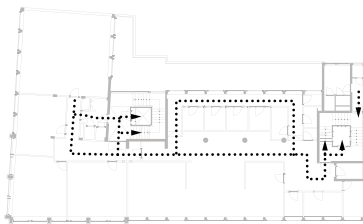

First Floor

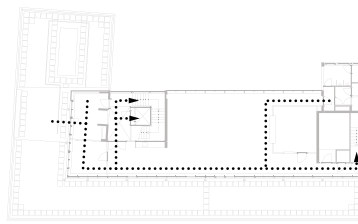

Fifth Floor

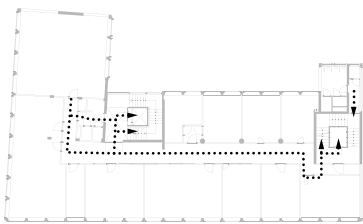

Second Floor

Rotterdam Witte de With

CIRCULATION

The police building in Witte de Withstraat has two entrances – the main entrance from the Witte de Withstraat with turnstile (the glazed door next to it is used instead of the turnstile) and secondary from the Hartmansstraat. On the ground floor, the main routing is in between the cores (the conference room is in between) and around the main core because there is a computer-working area there. From the 1st to 4th floor, the circulation is limited by the corridor and repeats alike the same on every floor except the first floor, where five small glazed rooms for keeping short-time detainees create a new route around them. The police officers were mainly the ones using the

building, but occasional detained people's routing was limited to the ground floor and the first floor.

On the 5th floor, the former canteen is located which was not in use anymore, however, the access to the rooftop terrace is reachable from this floor. Even though the corridors are wider in the basement level, they still define the same routing between two cores as in the typical office floor. The routing becomes more local in the shower and locker-room area because the locker-rooms have no direct access from the main corridor.

1.2.3.3. STRUCTURE



0

10M

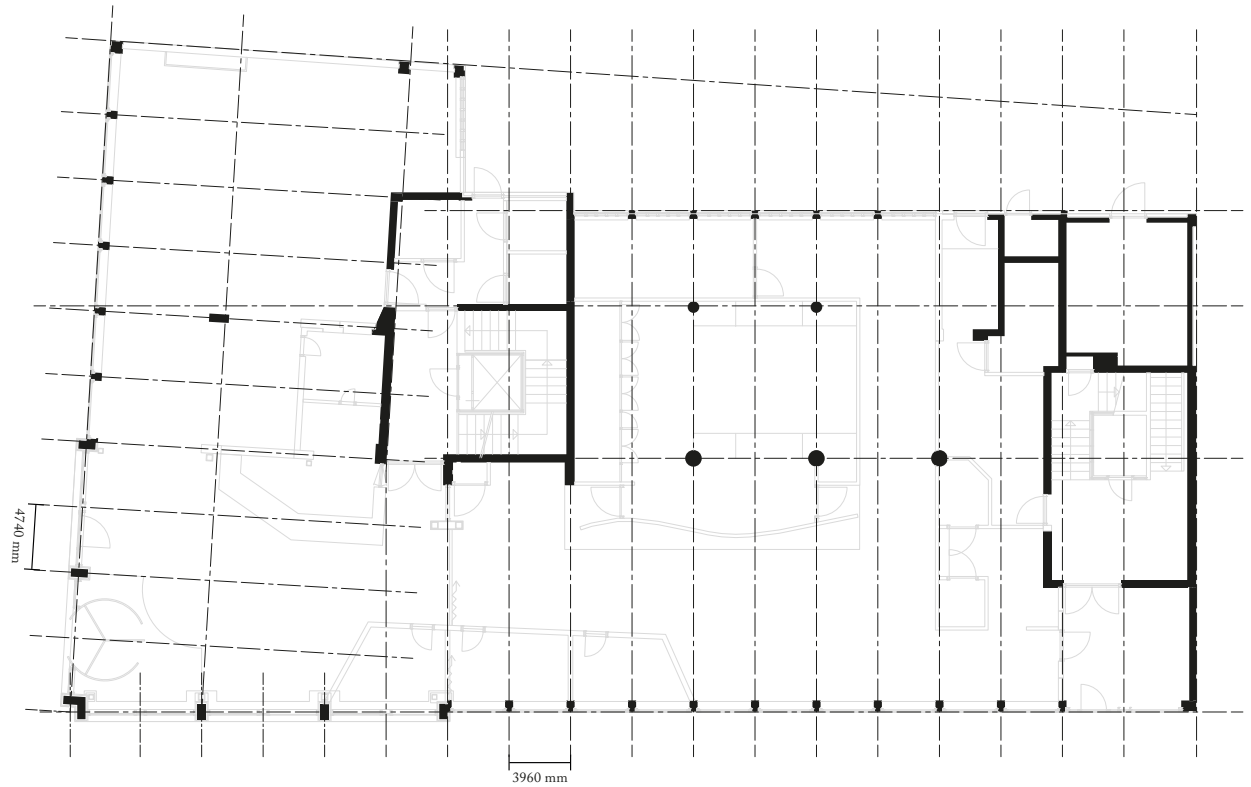

Structural grid

LOAD-BEARING STRUCTURE

The grid lines of the building are located parallel to and in the façades. The building is L-shaped, so there are two structural axis systems in two different directions. The façade grid along the Hartsmansstraat has 1,86m spacing while the one along the Witte de Withstraat – 1,98m. The concrete slabs along the Witte de Withstraat span 7,66 m and 4,74 m, along the Hartsmansstraat – 3,96m and 9 m.

Slabs of the floors are lying on supporting beams, which rest on the single-standing columns or the structural façade. Moreover, there are two concrete cores for the staircase and elevators that stabilize the structure on both sides. As the vertical structure of the building exist of columns and the cores, and none of the internal walls are load bearing, the floor plan of the building is flexible.

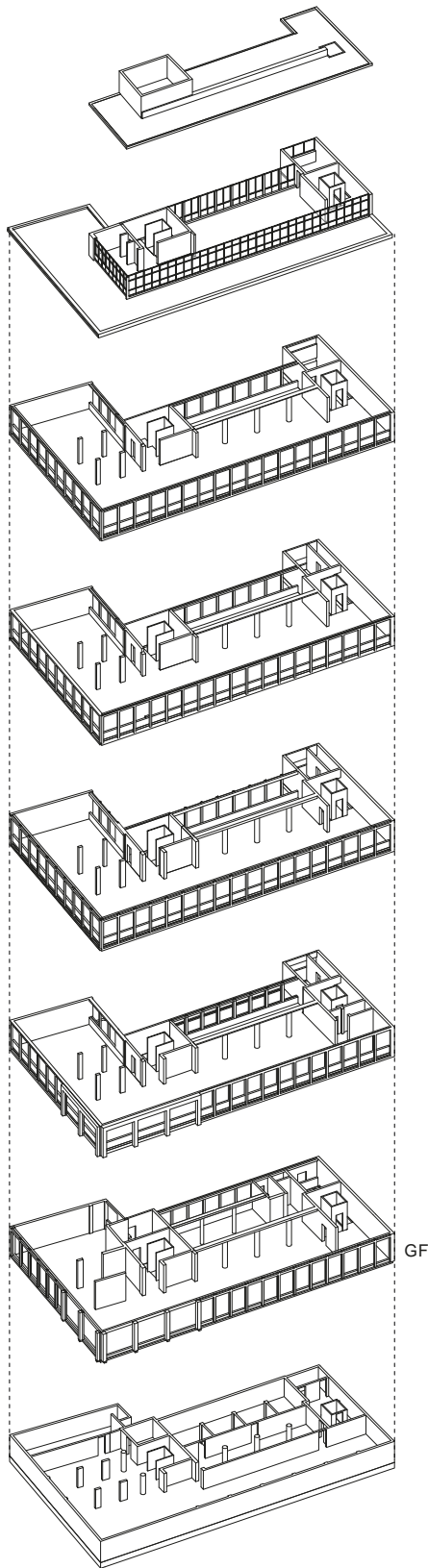

Load-bearing structure axo

1.2.4. BUILDING ENVELOPE

1.2.4.1. CONFIGURATION



0

10M

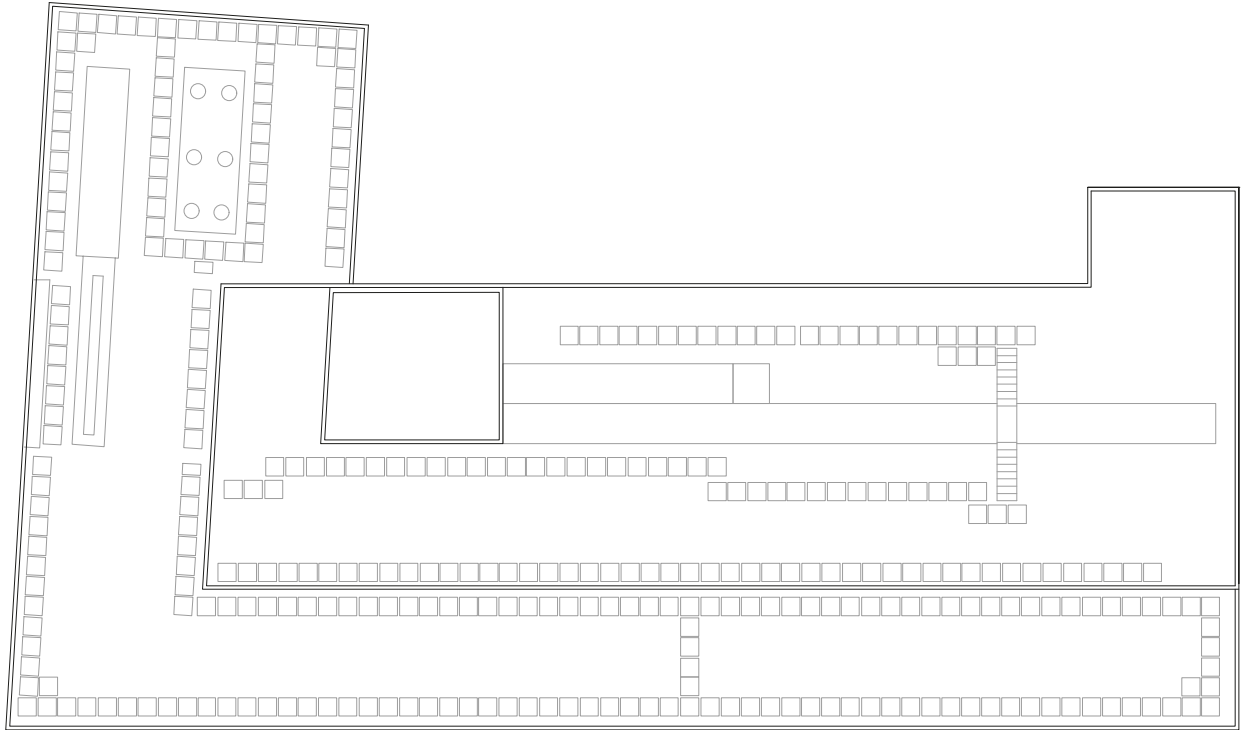

Roofplan

ROOFPLAN

The 5th floor of the building houses the canteen since the original use of the building. This canteen used to give access to the roof terrace for the employees, but it is

not accessible for the building's users anymore. The roof houses the technical installations that were not intended in the original design but were added during renovations.

0 10M

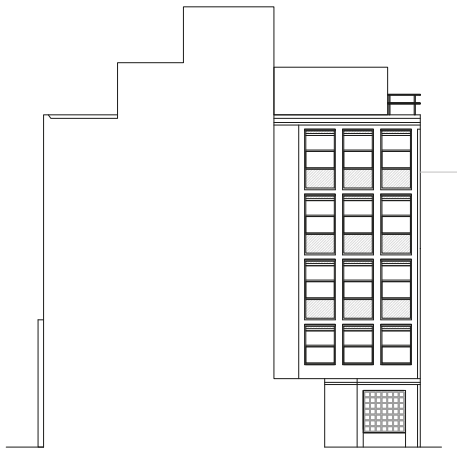

North façade



East façade



South façade

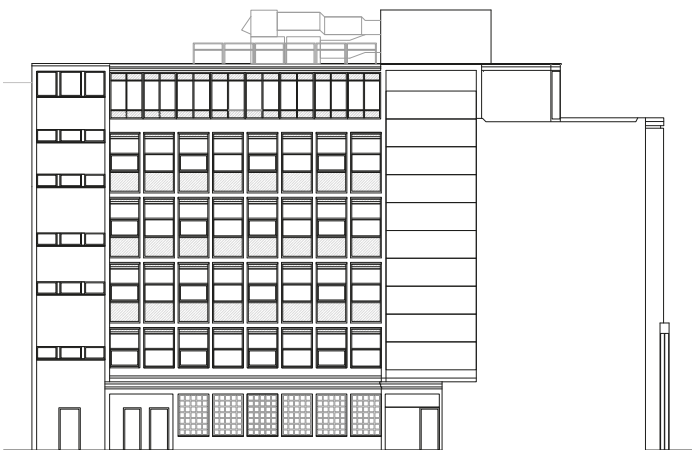

West façade

Rotterdam Witte de With

FAÇADES

The façade of the building is comprised of a concrete grid structure. The spacing of the centre lines of the vertical elements on the façade of the Hartmansstraat and the façade of the Witte de Withstraat are different, respectively 1.85 m and 1.98 m. The concrete grid of the façade is “filled in” with prefab Colorbel sandwich panels. These panels consist of an anthracite-coloured glass parapet, glass panels, and mullions coloured in dark blue.

Every other panel contains an openable window part. There are two parts of the façade that are different; the accentuated corners and the canteen on the roof. The accentuated corner is doubled in height. The concrete elements are also larger in scale than the rest of the façade. The police chose to embellish the corner of the building with the additional metal structure hanging from the façade for the logo plate.

1.2.4.2. COMPOSITION

0 10M

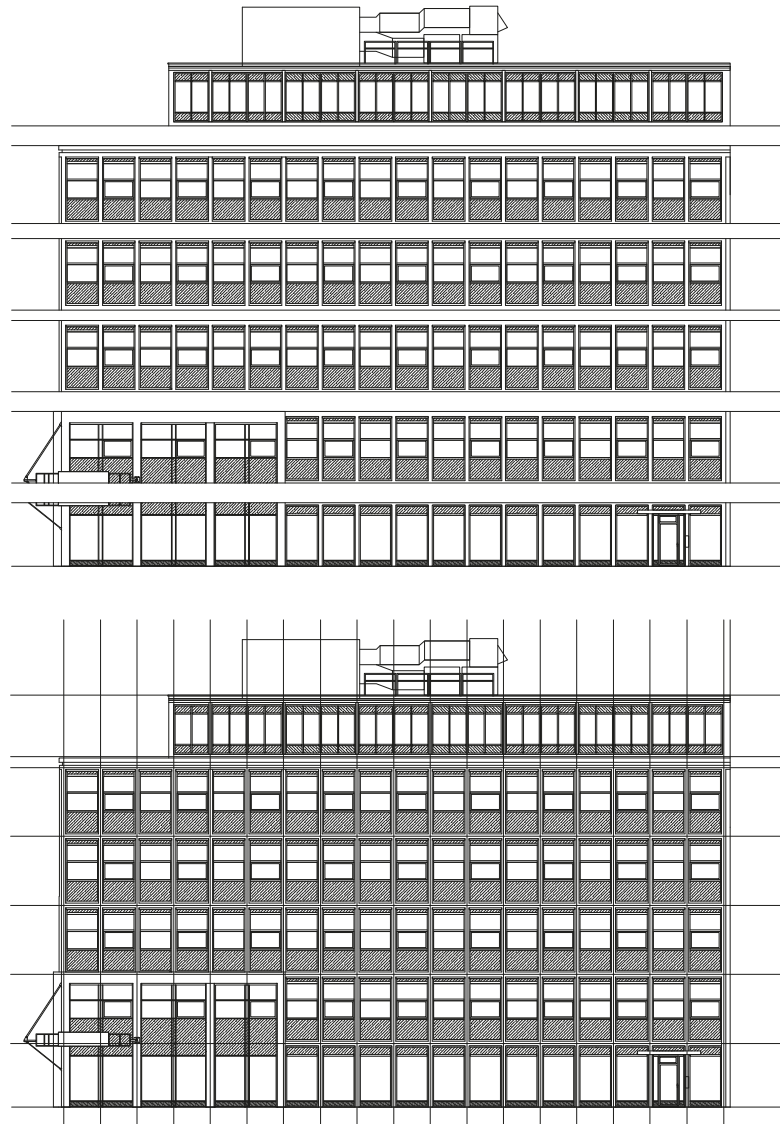

East façade

COMPOSITIONS

The façade composition of the building is very regular as it is a grid. The only departure from this grid, while staying in line of the grid, are the elements that mark the corner of the building.

The windows of the canteen are placed within the grid but have a different characteristic. However, from a street level, this delineation from the form is not visible as it is set back from the main façade.

1.2.4.3. MATERIALITY

0 10M

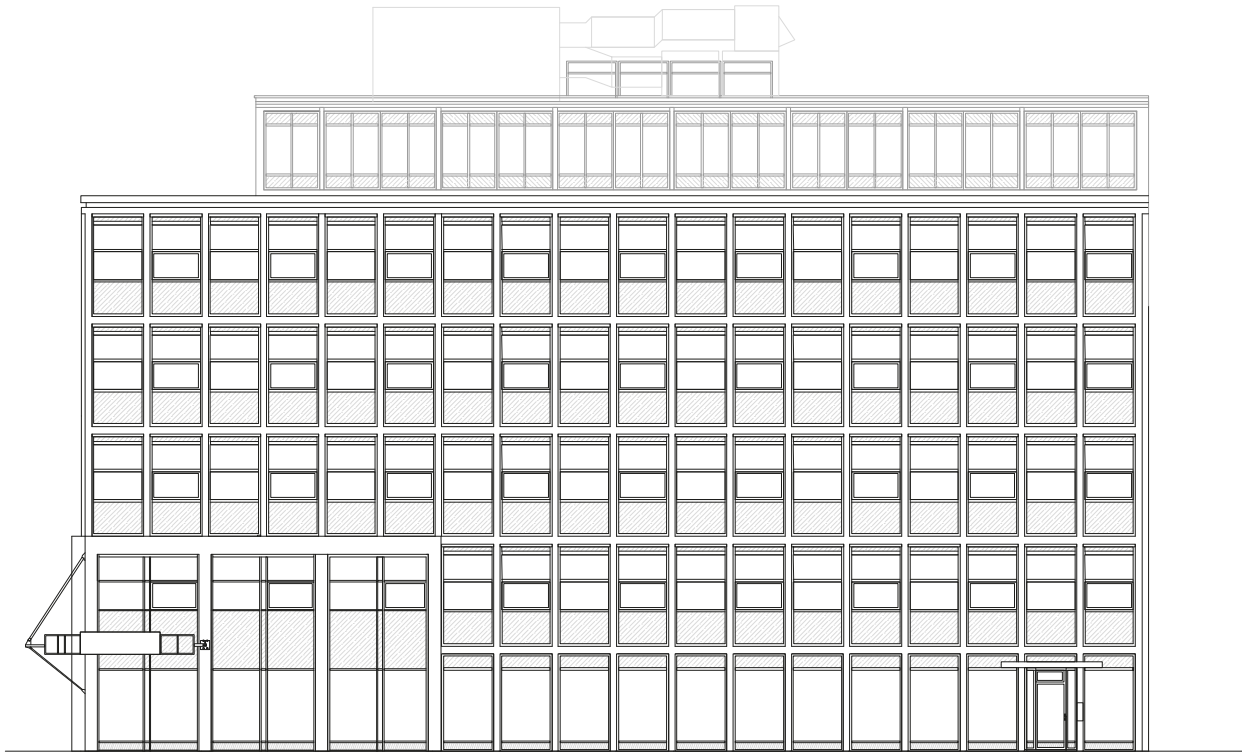

Rotterdam Witte de With

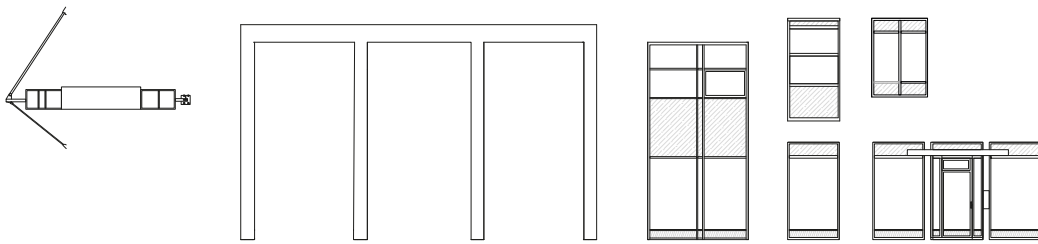

East façade

COMPONENTS

The main theme of the building façades is modularity. The modules of the glazing system are identical from the first to the fourth floor (all these floors are the same height). Other modules are found on the ground floor (which is higher than the others) and the fifth floor (which is lower

than the typical ones). Other types of elements are also found at the entrances. The most distinctive component of the façade is the corner entrance element, with custom-glazed modules and a signboard.



Façade fragment analysis

TEXTURES

The façade is expressed in the contrast of light and dark colours. The concrete grid structure is coloured in a light grey-white colour. The sandwich panels are made up of dark-blue mullions, non-coloured glass, and anthracite-coloured glass parapets. There are some metal elements on the façade for signage. Originally, the materialisation was a bit different. The glass sections of the building were much larger than they are now. Therefore, the building

must have seemed a bit more transparent. However, there was a similar style of parapet. The parapet on the façade consisted of small black tiles. In total, around 250.000 tiles were used for the whole building. This was done in Italy. The workers here placed these tiles one by one on a sheet of paper. These sheets of paper were then delivered to Schokbeton to be put in the molds for the façade elements (“Een kwart miljoen zwarte tegels”, 1958).



Rotterdam Witte de With

(Mankutè, 2021)

1.2.5. CONCLUSIONS

The Witte de Withstraat 25 building is located in the older part of the city, in the neighbourhood around the city triangle. The previous building that stood there was destroyed during World War II. The street, which after the war was known for journalism, is now a very popular gathering place among the public, not only in the daytime (for galleries, shops, and cafés) but even more so in the night (for restaurants, bars, and night-life). The location of the building is approximately a 5-minute walk to the shopping area, the Museum Park, or the Maritime Museum.

The police building at Witte de Withstraat 25, plays an important role in terms of the spatial configuration of the block: despite its small size compared to the northern part of the block (the huge office building on Westblaak street with the parking garage on the inside of the urban block), it forms a block corner between two important streets – Witte de Withstraat and Hartmansstraat. While the 9-story parking garage takes up a lot of space, it can also be an interesting opportunity for the re-design of the urban block. The Hartmansstraat – a connecting street between the small-scale old town street Witte de Withstraat and the larger-scale architecture of Westblaak street – is very interesting in terms of this contrast, which is Rotterdam's trademark.

The building is L-shaped and consists of six floors above ground and a one-story basement. The main entrance of the building is located in the corner of the building on the Witte de Withstraat side. The building contains two cores for vertical circulation. The typical floor is divided into office rooms along the façades, with a hallway running down the centre of the building. The police building has a beam-column structure. The slabs lie on supporting beams, which rest on the single-standing columns or the structural façade, resulting in the flexible building plan. Moreover, there are two concrete cores for the staircase and elevators that stabilize the structure on both sides.

The façade of the building is comprised of a concrete grid structure “filled in” with prefab glazing panels. The main theme of the building façades is modularity. The modules of the glazing system are identical from the first to the fourth floor (all these floors are the same height). The most distinctive component of the façade is the corner entrance element. The concrete grid structure is coloured in a light grey-white colour. The sandwich panels are made up of dark-blue mullions, non-coloured glass, and anthracite-coloured glass parapets. In the original design, the glass sections of the building were larger than they are now. Therefore, the building must have seemed a bit more transparent.

1.3. ROTTERDAM HAVEN

1.3.1. INNER CITY

1.3.1.1. INTRODUCTION



DEMOGRAPHY

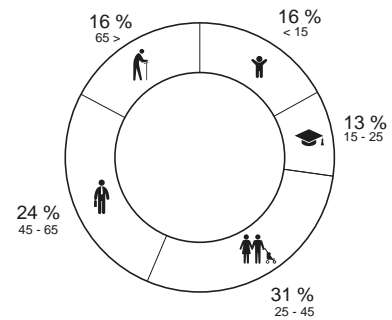

MOBILITY

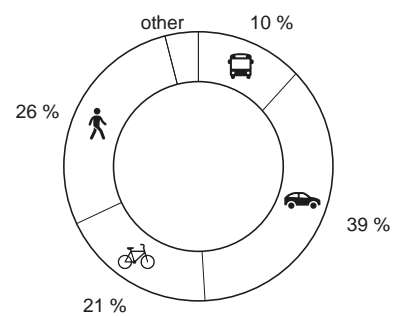

The name Rotterdam originates from the construction of a dam on the river Rotte in the thirteenth century, which thrived on fishing and officially became a city in the year 1340. After the developments in the sixteenth and seventeenth centuries, Rotterdam became more important thanks to its harbour, which became even more evident after the city started growing outside of the original triangular city centre. While the city suffered heavy losses during World War II, the harbour remains one of the largest in the world and the original city centre is still part of the structure.

With 652.541 inhabitants, Rotterdam is the second largest municipality in the Netherlands, Amsterdam. Despite this, it has a surprisingly low density, with 2.995 inhabitants per square km. The largest age group is 25–45 years old.

Compared to other Dutch cities, Rotterdam is more car-dependent, with a relatively high percentage of journeys by car (45%). Only 16% of trips are made by bike, with public transportation accounting for the same percentage.

1.3.1.2. DEVELOPMENT



0

1000M



1815

HISTORIC DEVELOPMENT

Rotterdam originated from the dam on the river Rotte and developed southwards, towards the river Maas during the revolt against the Spanish, in order to improve their defences. This resulted in the creation of the city triangle, which remained to be the city centre for many years. Any urban expansion outside this city triangle had to wait until 1850, after Rotterdam had grown within this area for centuries. One of these expansions included the annexation of Delfshaven, which was founded along the canal that connects Delft to the river Maas. The Rotterdam Haven is located more towards Delfshaven district than

the city triangle, in a neighbourhood that is now known as the Lloydkwartier.

After these expansions, three other events were important for the development of Rotterdam: the bombing in World War II which destroyed most of the buildings in and around the city triangle (The previous Witte de With street 25 building was destroyed by the bombing – was on the very edge of bombed territory in the centre of Rotterdam), the rapid expansion of the harbour along the river Maas and the leap across the river towards the southern bank.



0 1000M

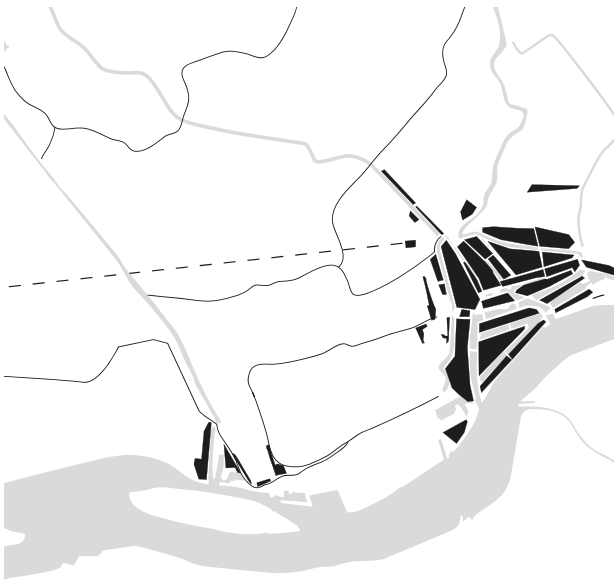

1850



1900



1975



2020



BUILDING AGE

The building age maps clearly show the result of World War II, with most of the buildings in the city triangle (the black-coloured part in 1950-1999 map) being built during or after the second half of the twentieth century. The Witte de Withstraat 25 police building was on the very edge of the bombed city centre area. The buildings forming the Witte de Withstraat were mostly constructed during the 19th century in the west part of the street, and the eastern part was re-built starting in 1950 (after World

War II). The Witte de Withstraat 25 police building was also built in that period (1959).

However, the neighbourhoods around the triangle are older, including parts of Delfshaven. The Lloydkwartier, where the Rotterdam Haven is located, is generally more recent. After being located on the water itself, the main building was built in the first half of the twentieth century, followed by an addition in 1994.



0 1000M



1800-1899

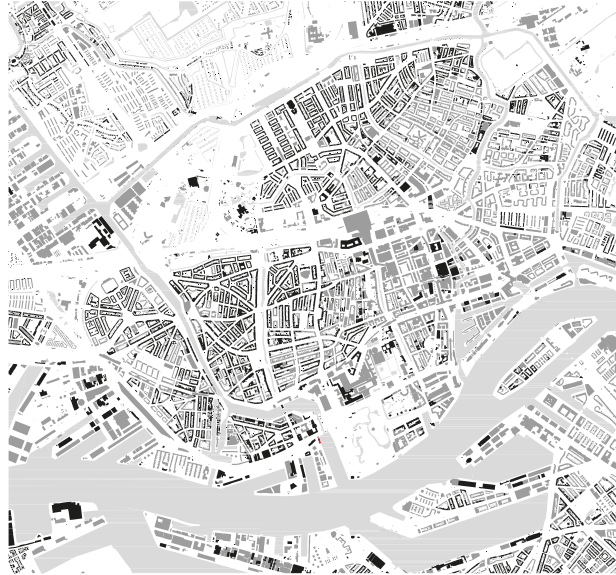

1900-1949

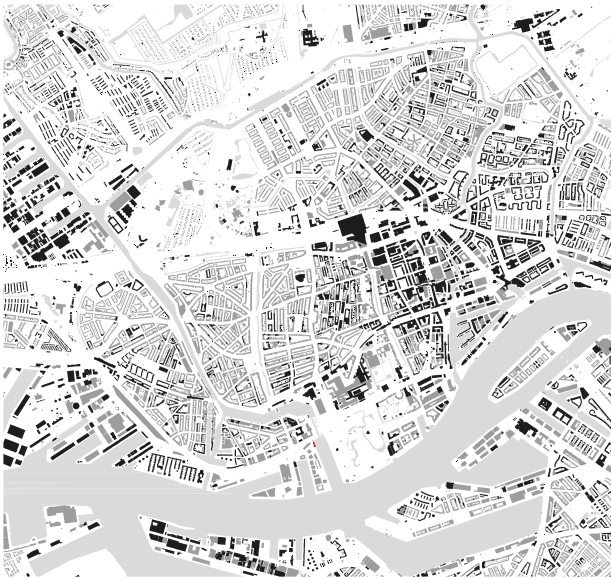

1950-1999

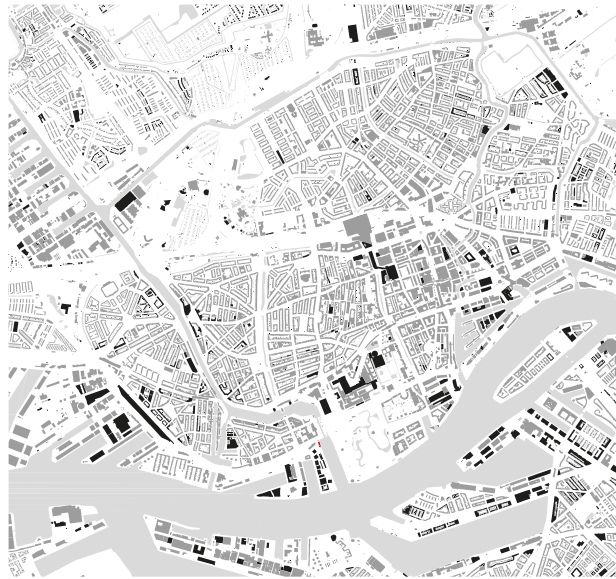

2000-

1.3.1.3. NETWORKS



0

1000M



Vacant Heritage - Police Real Estate | The Netherlands

All roads

ROAD NETWORK

As Rotterdam was almost completely rebuilt after World War II, the main roads were designed to conveniently serve the cars. The overall road network map concludes that the railway and metro lines in the city make up a

dense and convenient network both on the north side of the river and in contact with the south side. The wide primary streets, together with the dense railway and metro lines, are the spatial qualities of Rotterdam.



0

1000M



Primary roads

Rotterdam Haven



Vacant Heritage - Police Real Estate | The Netherlands



Secondary roads



0

1000M



Rotterdam Haven

Tertiary roads



GREEN, WATER AND PUBLIC SQUARES

Public space – squares and parks – is where Rotterdam’s city life flourishes. The main squares here are dedicated to markets, cafes, festivities, and also playgrounds for children. The most popular and well-known squares are the following: the main market square next to the Markthal building, the Pathé Schouwburg square next to the Pathé cinema building, Station Square in front of the Rotterdam central station, and the museum square connected to the Museum park.

The police building at Witte de Withstraat 25, is located on the route between the two squares mentioned – the main market square and the museum square. Witte de

Withstraat is itself a very popular street among the public during the night. The building is also only a 5-minute walk away from the biggest city’s shopping area and the Maritime Museum.

However, the location of the Rotterdam Haven station is somewhat different in terms of its type of urban proximities. Surrounded by green public spaces, including one of the biggest parks in the city—Het Park—on the eastern side and water (Parkhaven harbour), the site is in touch with both urban life (medium-sized residential blocks and large office buildings) and nature.

1.3.2. URBAN BLOCK

1.3.2.1. COMPOSITION

Vacant Heritage - Police Real Estate | The Netherlands



(De Gouw, 2021)



Rotterdam Haven

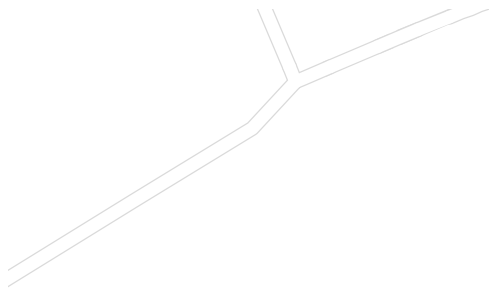

1850-1911

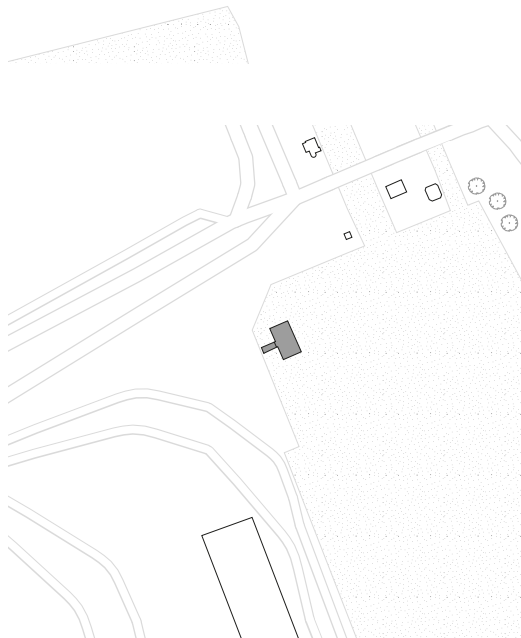

1912-1938

HISTORIC DEVELOPMENT

The building of Rotterdam Haven (sea harbour police) is located in Delfshaven. The origin of Delfshaven goes back to 1389, when people were digging a canal from Delft towards the Maas, so Delft could have its own harbour. The lay-out of this harbour has been changed many times, but between 1850-1911 the first harbour activities took place in this urban area as shown on the first drawing (Topotijdreis, 1880).

The River Police itself has been housed within the harbour since 1911, first on a floating pontoon and from 1933

within the building at Sint Jobsweg. During World War II, the bombardment that reduced the center of Rotterdam, left Delfshaven untouched, however, the offices of the River Police were in the hands of the German troops. Due to the increasing size of the port of Rotterdam after World War II, the River Police was forced to open another office in the harbour. After a while, also the office at Sint Jobsweg became too small and in 1994 they built a new building next to it (Winkelen in Delfshaven, 2017). From 2000 onwards the name of the River Police changed into the Seaport Police.



0 50M

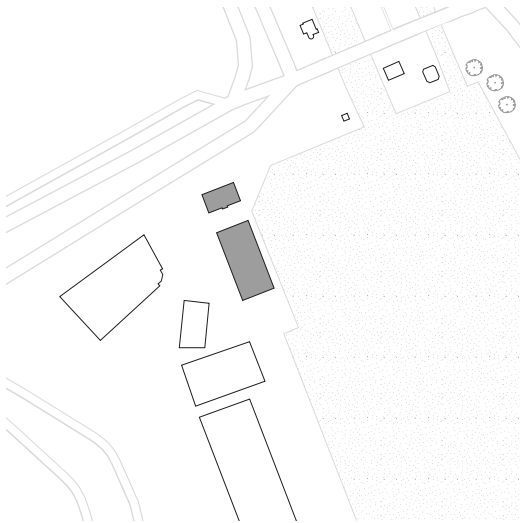

1939-1994

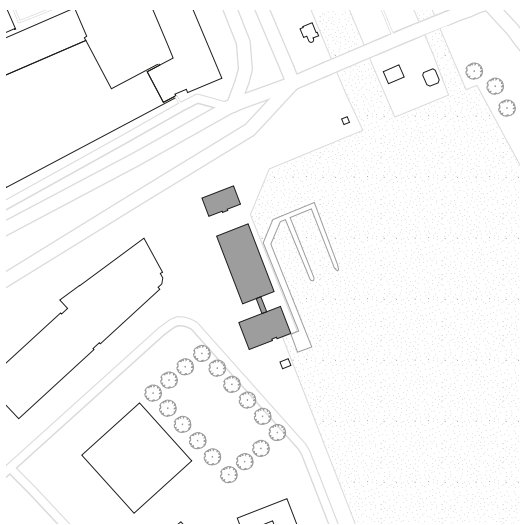

1995-2020

Rotterdam Haven

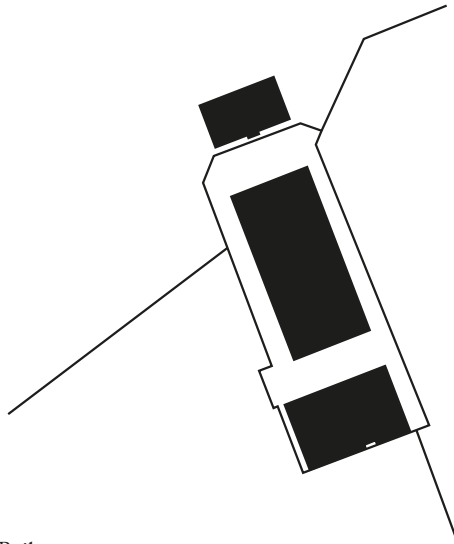

Built area
1006 m²

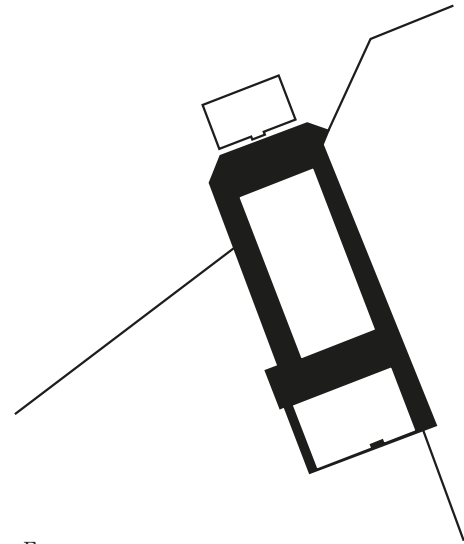

Empty area
1112 m²

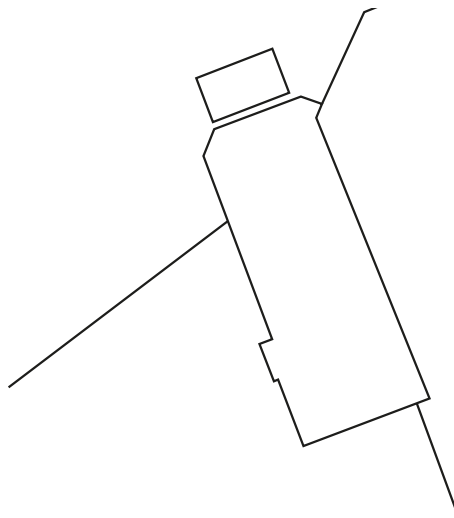

Parcels
5

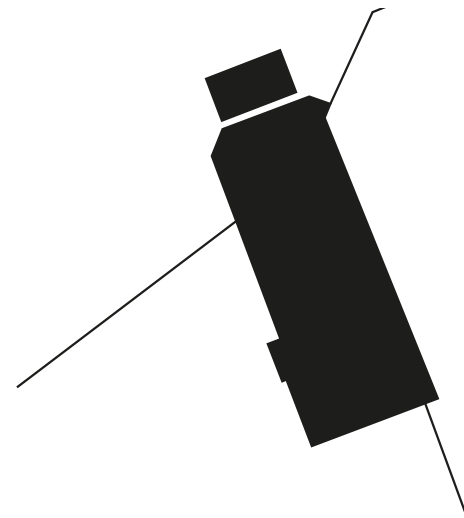

Police real estate
2118 m²

Block information

BLOCK INFORMATION

The police estate in Rotterdam Haven is an island on its own in the surrounding. It consists out of 2 parcels. In

total the empty area almost equals the built area.



0

50M

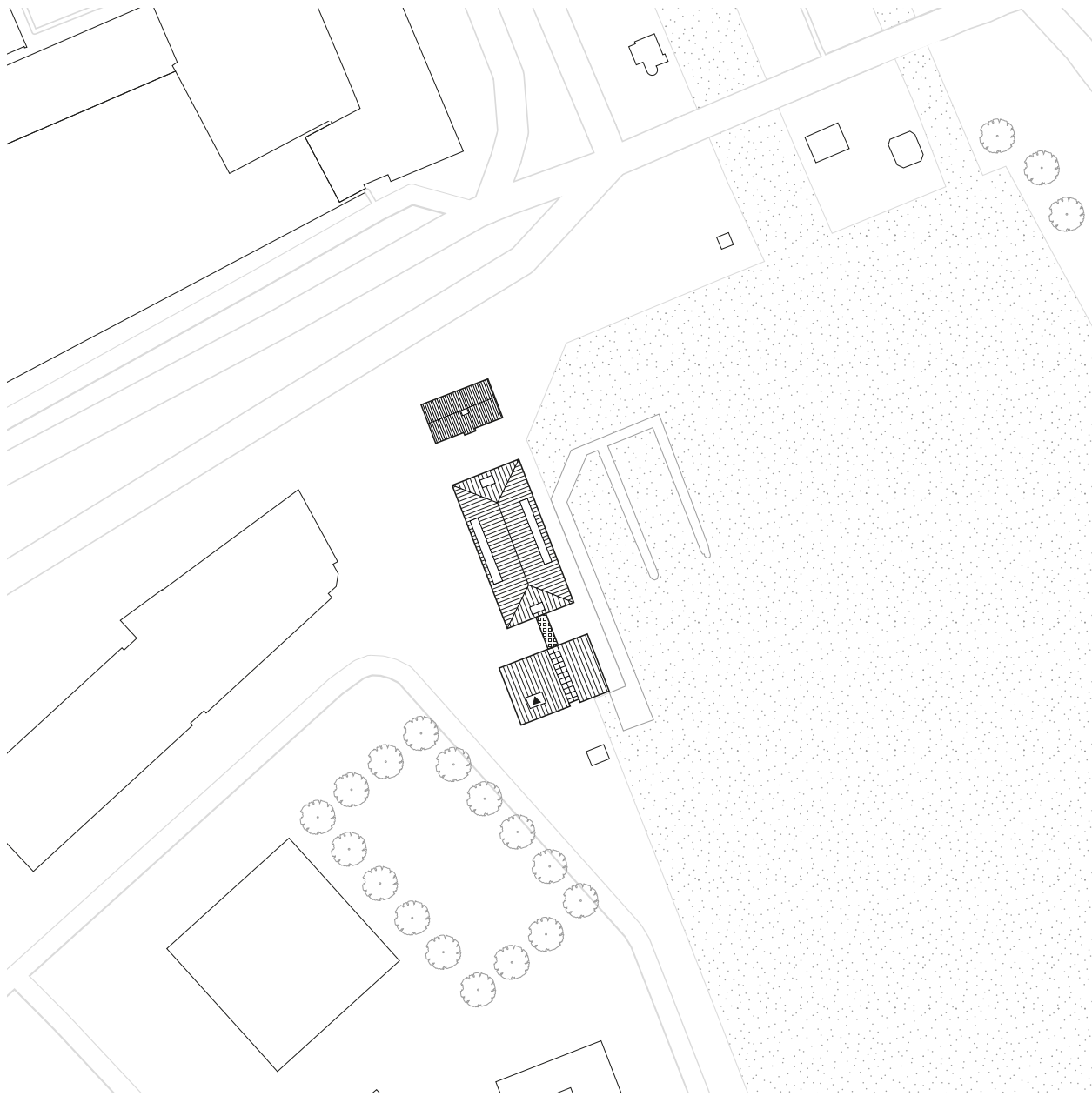

Rotterdam Haven

Roof structure

ROOF STRUCTURE

The three buildings each have their own type of roof, while at the same time they all have a sloped roof. The highest building to the south has shed roof, with the

highest point to the south and the lowest point towards the other buildings. The building in the middle has a hip roof and the little building to the north has a gable roof.

1.3.2.2. STREETS

0 20M

■ Façade openings

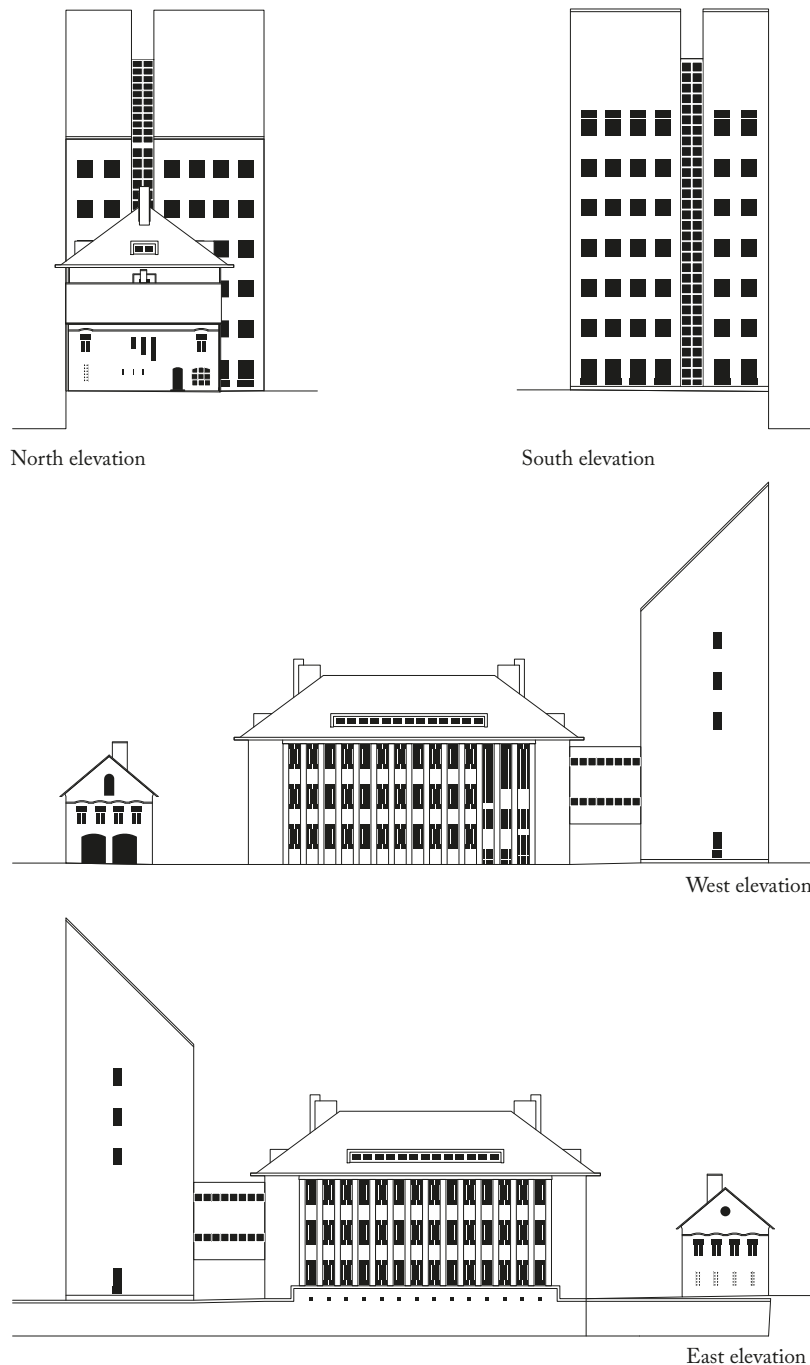

STREET ELEVATIONS

The façades in the diagram on the left show the openness and accessibility of the façades. A clear difference in the types of openings can be seen for the various building volumes. The smallest volume, used as a dwelling before is the only of the three volumes that has entrances facing to the outside of the block. A clear rhythm can be seen in all of the volumes, however this rhythm is not in all volumes

oriented towards the same direction. The window on the west side the middle volume change in length compared to the other windows in this volume, which relates to the staircase on the interior. The most openings of the highest volume are oriented towards the north and south side of the building, providing an overview over the water, the domain of the Seaport Police.



0 20M

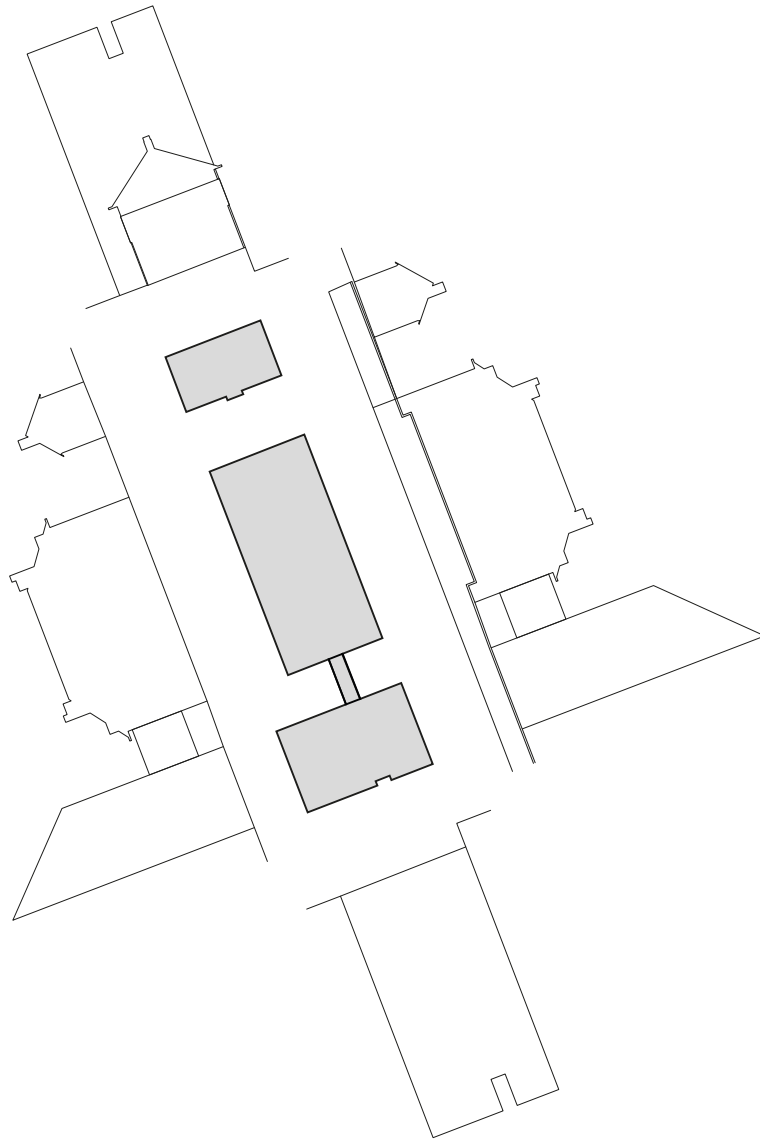

Parcels and façades

PARCELS AND FAÇADES

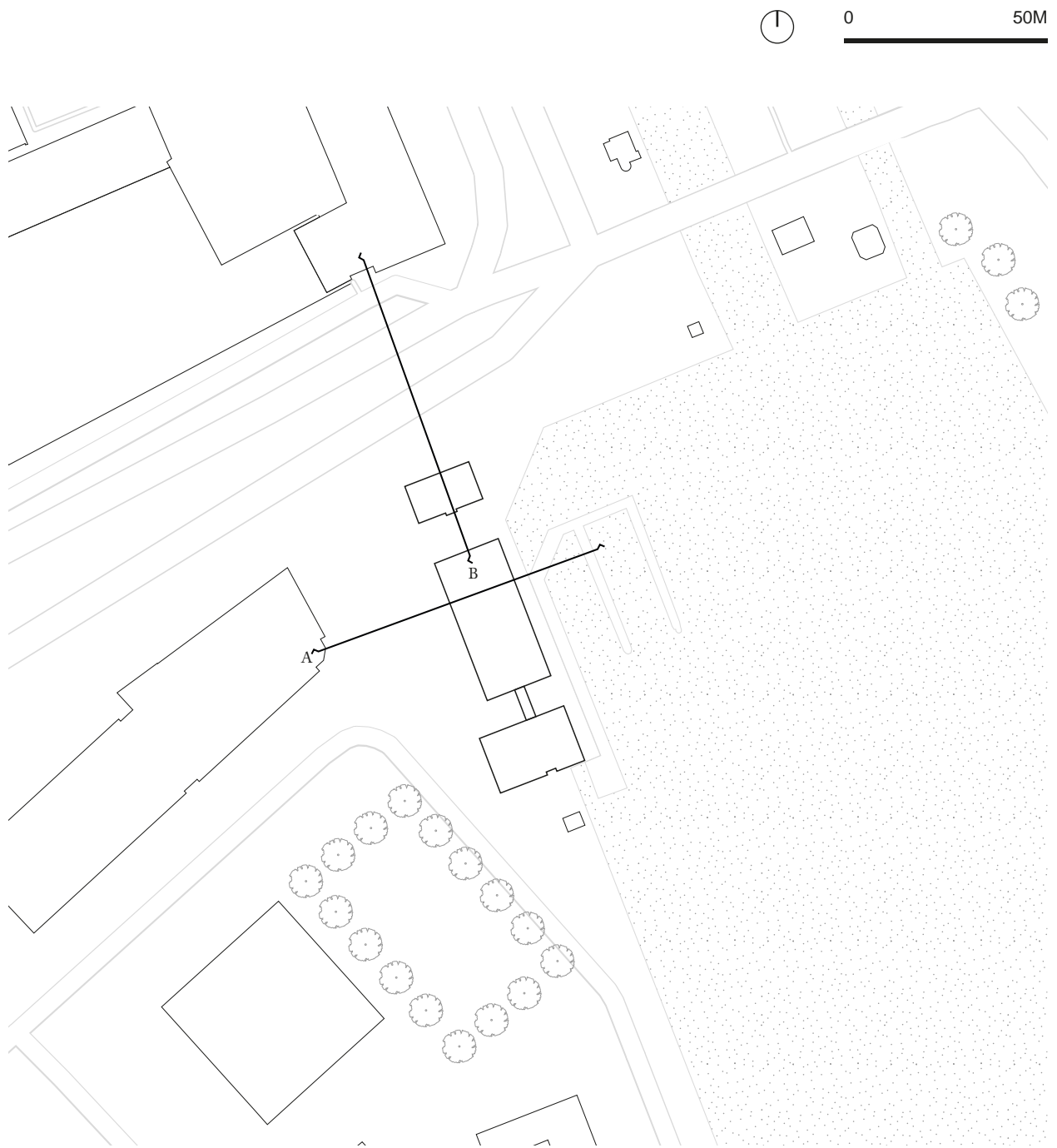

Location of street sections

STREET SECTIONS

The building ensemble of Rotterdam Haven is located along the north-western edge of the Parkhaven. At the docks connected to the building the ships of the harbour police are moored. To the north lies the wide Westzeedijk, one of the main flood barriers for the city of Rotterdam. It is also one of the main traffic arteries of the city with

multiple lanes of car traffic and a tram line. The part of the Sint-Jobsweg in front of the building is used for parking and access to the building. The other half of the street is used by pedestrians and cyclists to ascend to the Westzeedijk.

0 5M

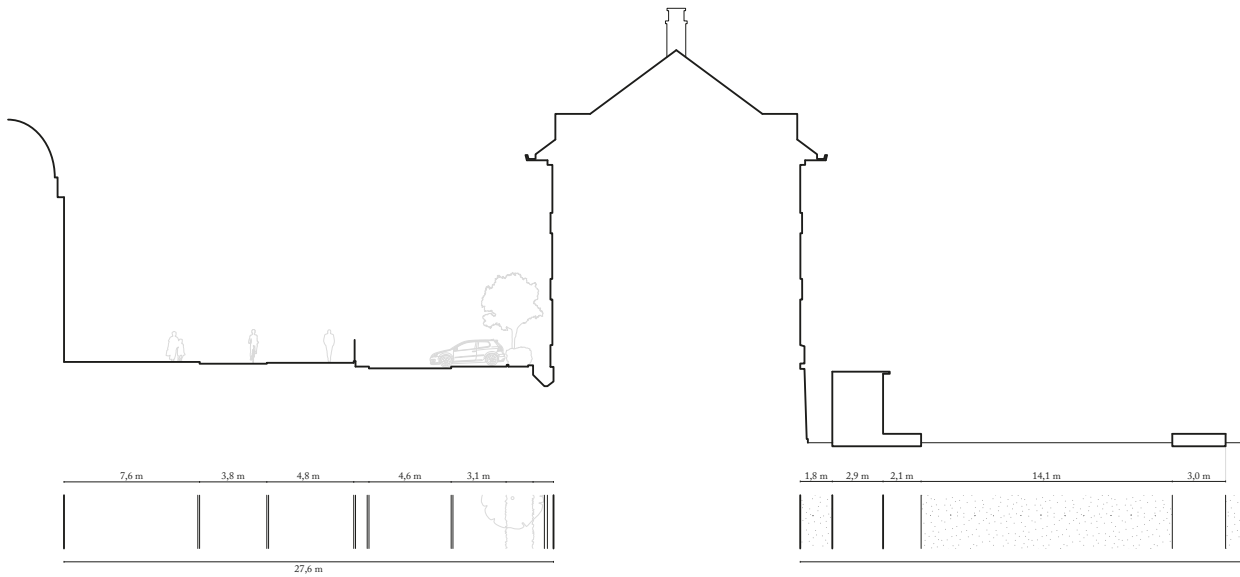

Section A
Sint-Jobsweg

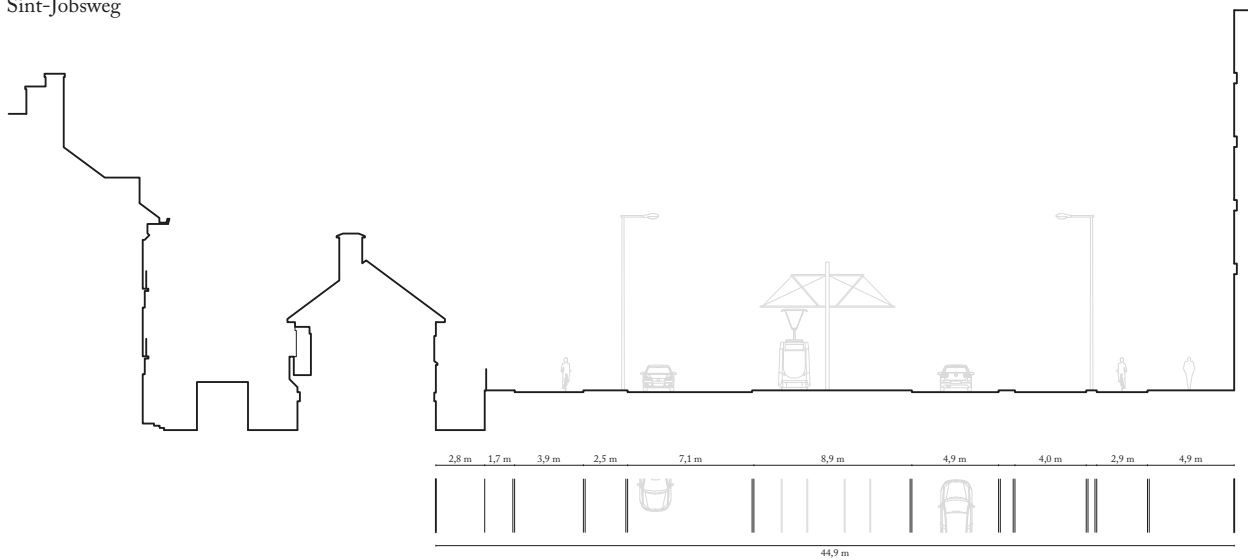

Section B
Westzeedijk

Rotterdam Haven

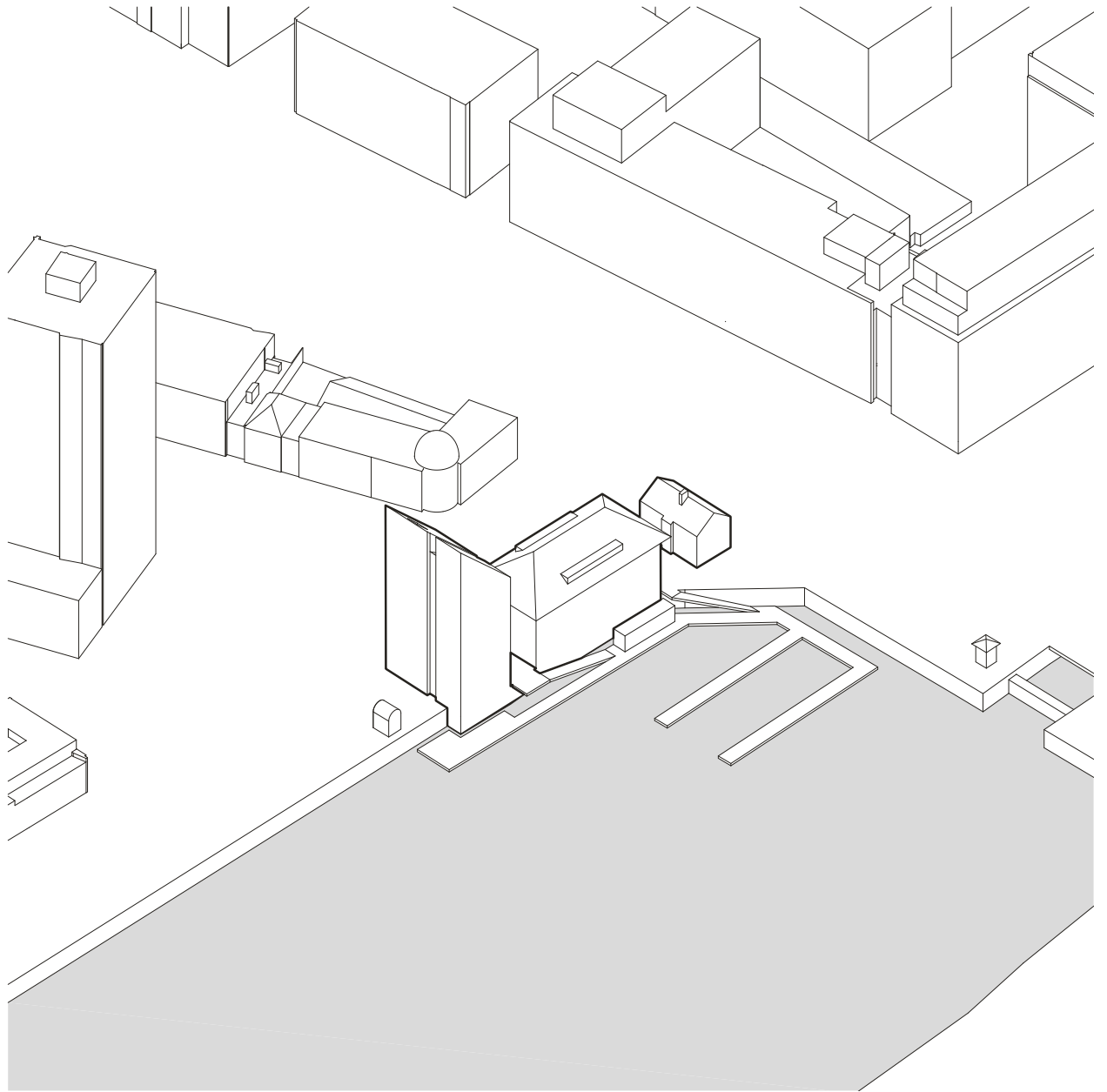

Isometric of urban block in surroundings

ISOMETRIC

1.3.2.3. ACCESSIBILITY



0

50M

■ Car parking ▲ Entrance 🚲 Bicycle parking

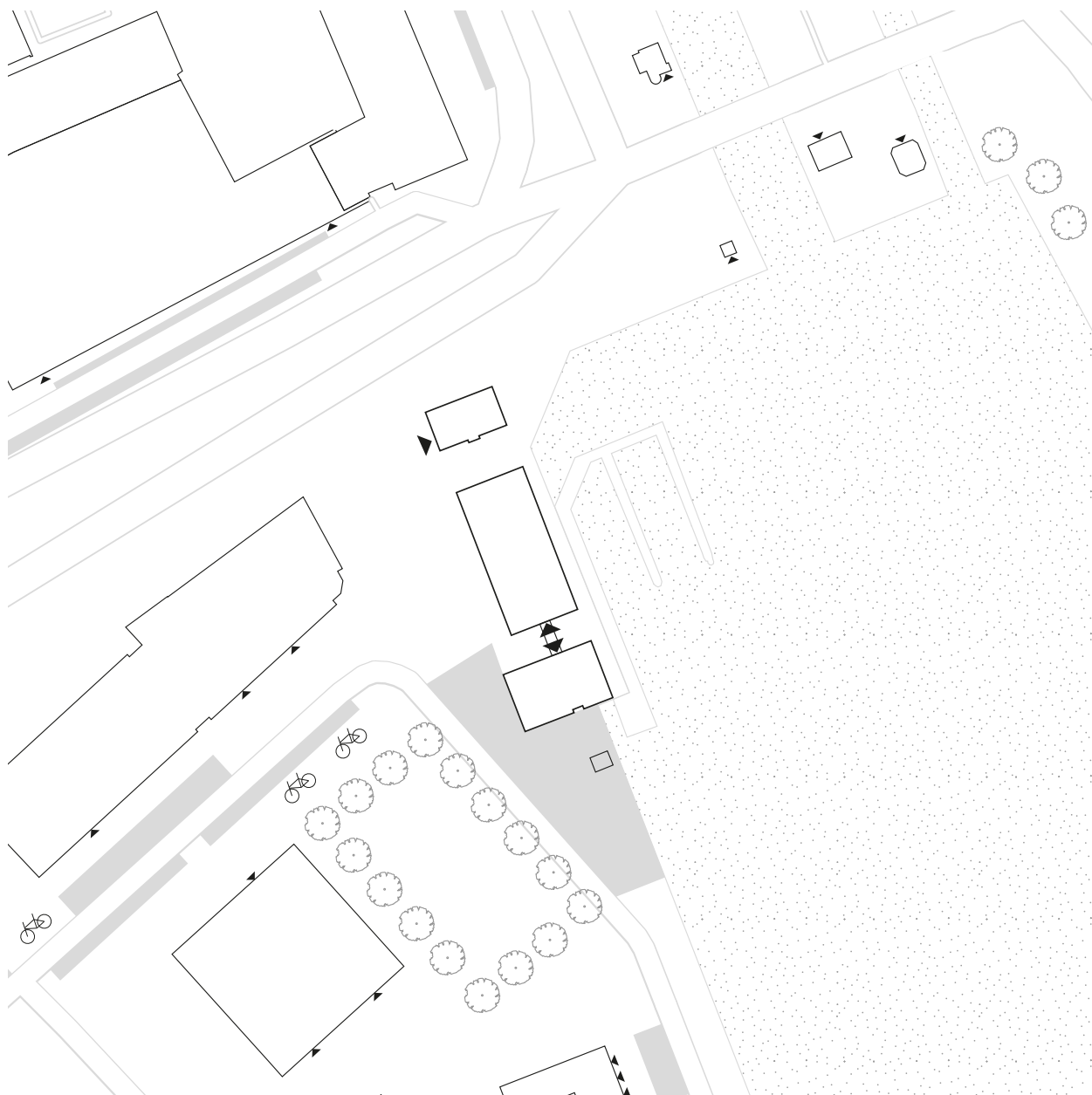

Parking and entrances

Rotterdam Haven

PARKING AND ENTRANCES

The parking in the area of the Rotterdam Haven building is mostly located along the streets. The bigger indicate grey area directly next to the building is used as private parking for the police and surrounded by fences. The

entrances of the older volume and tower are located between the buildings in the façades that face each other and thereby are less visible from the street.

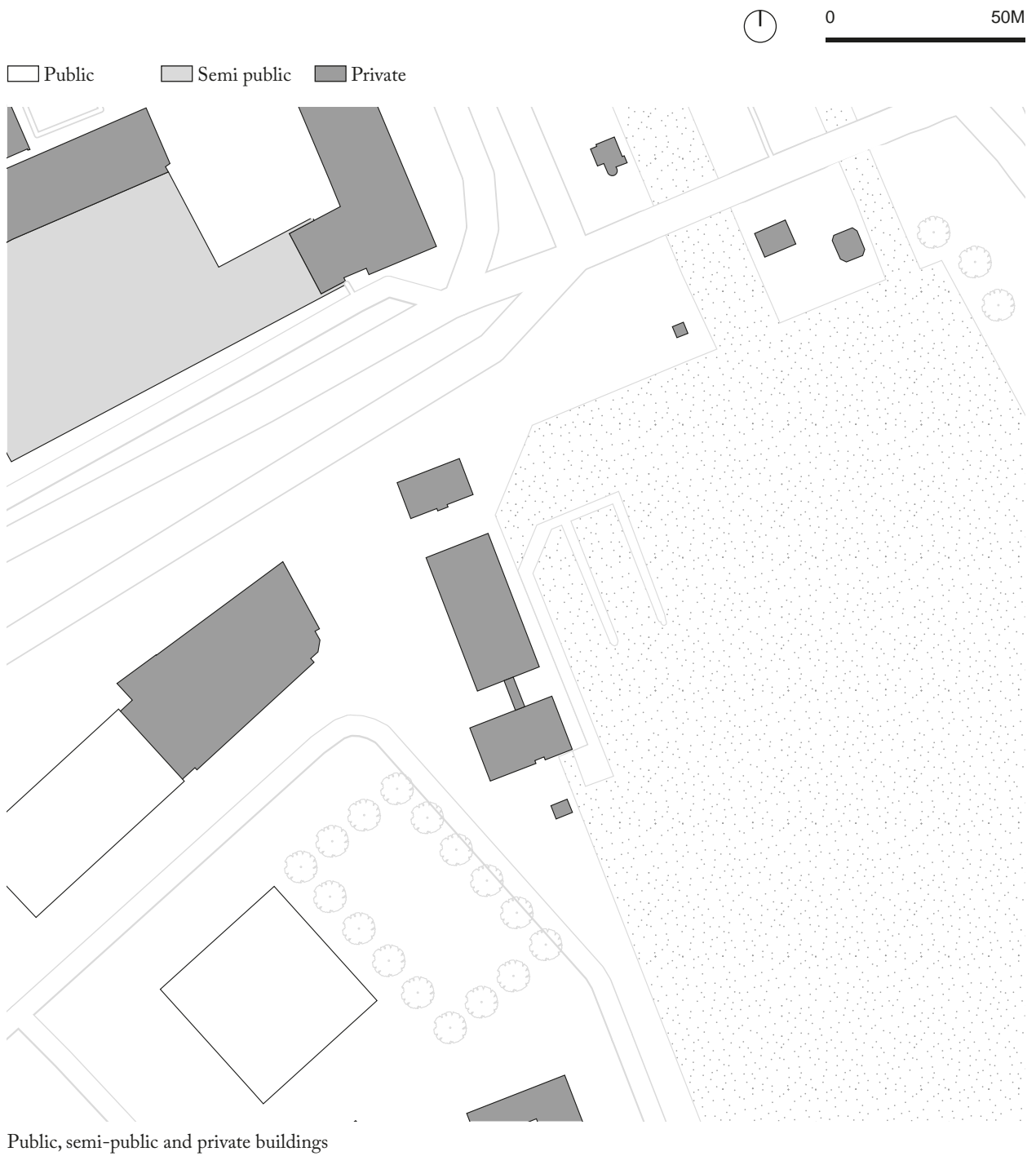

Public, semi-public and private buildings

PUBLIC, SEMI-PUBLIC AND PRIVATE BUILDINGS

The buildings surrounding the Rotterdam Haven building show a mix of public, semi-public and private functions. The public rectangular volume on the left in the image is

the Maaspodium used for theater and dance. The public squared building only has accessible functions on plinth level with housing function on the floors above.

1.3.3. BUILDING OBJECT

1.3.3.1. SPATIAL LAYOUT

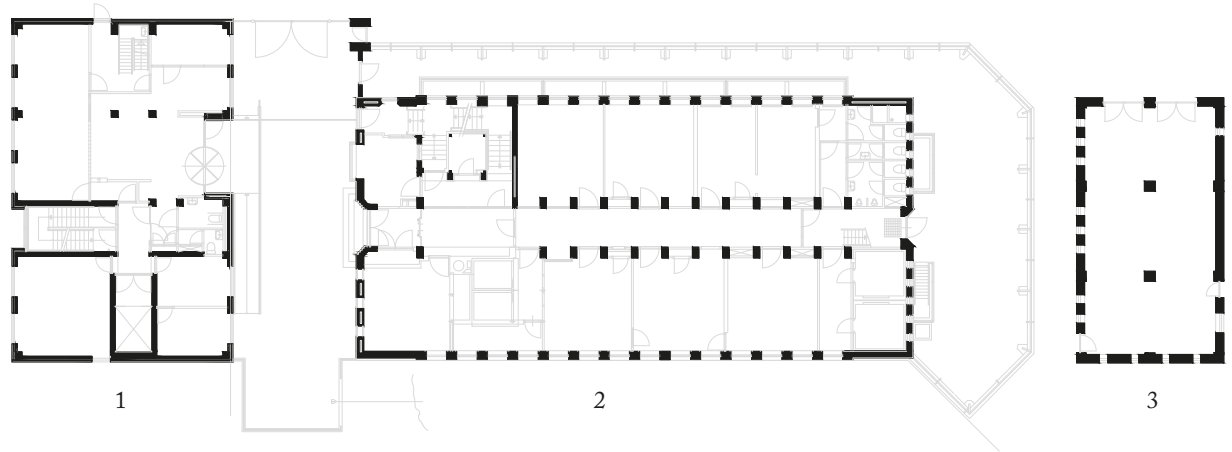

Ground Floor

Vacant Heritage - Police Real Estate | The Netherlands

FLOOR PLANS

The Rotterdam Haven station consists of three buildings; two main buildings (1 & 2) and an additional small storage building (3). Each building has its own lay-out and number of floor levels. The older, slightly bigger building on the right has 5 floors, from which one is a

basement and one of them the attic. The other building, added in 1994 has 10 floor levels. The two buildings each have their own entrance, but the buildings are connected on the first and second floors. Both buildings are housing offices for the police.

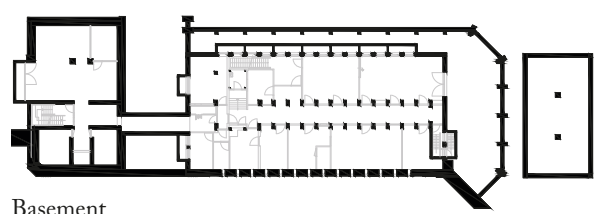

Basement

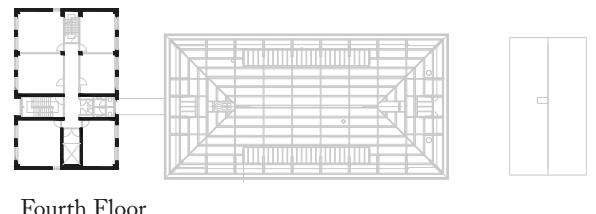

Fourth Floor

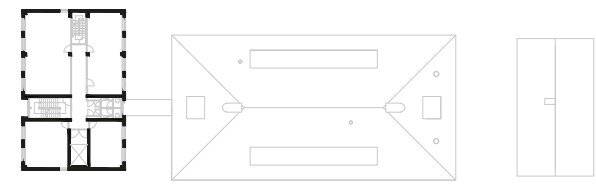

Fifth Floor

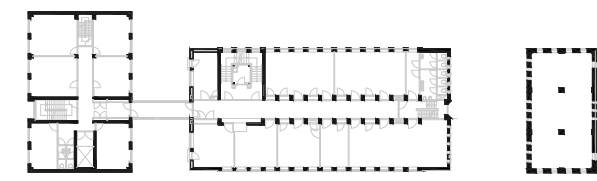

First Floor

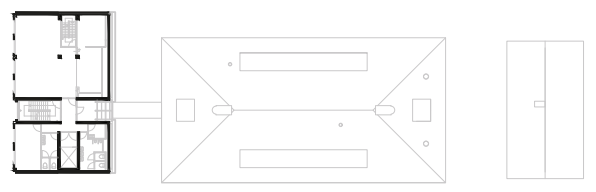

Sixth Floor

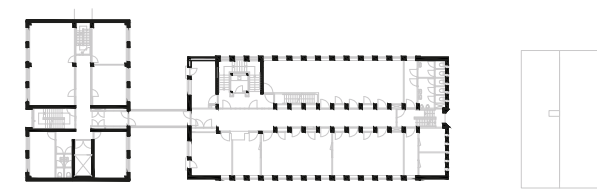

Second Floor

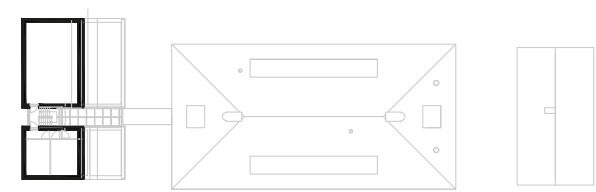

Seventh Floor

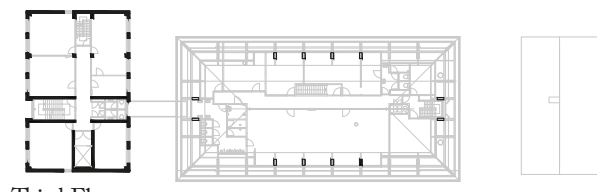

Third Floor

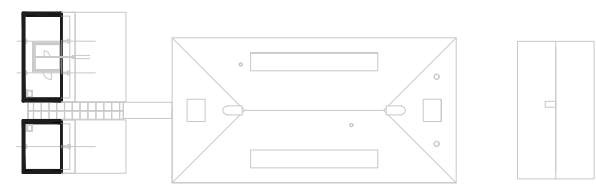

Eighth Floor

Rotterdam Haven

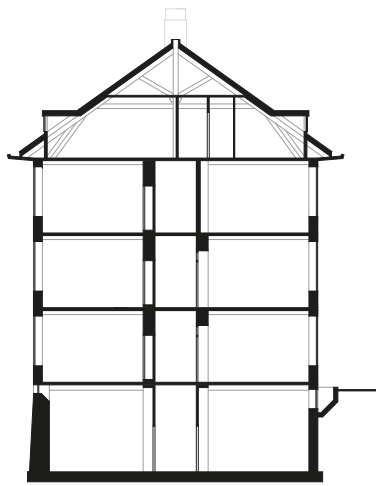

Section A

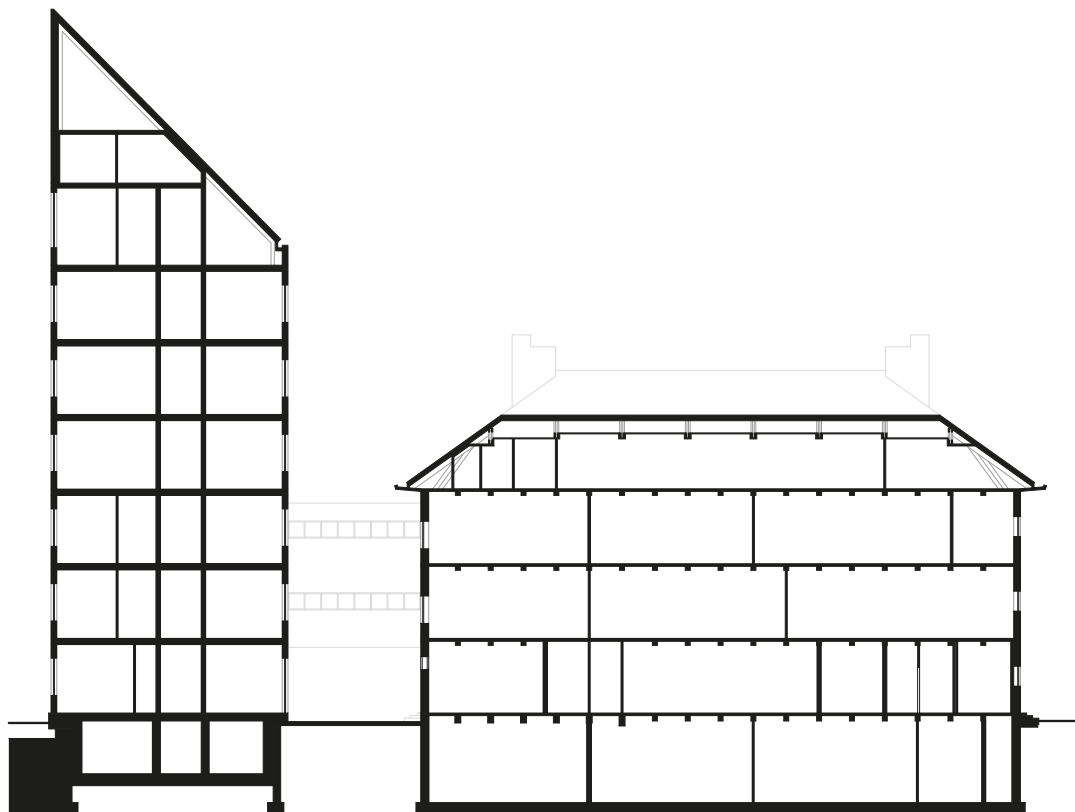
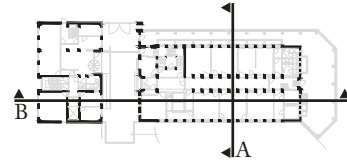

Section B

SECTIONS

The older building consists of five layers, including a high basement and an attic. The floors of concrete and concrete beams are divided into separate spaces in some instances by modular wall systems and in others by

walls of masonry. Through a bridge the older building is connected to the newer tower extension on the first and second floor. The tower consists of seven floors plus a basement and two smaller spaces under the angled roof.

1.3.3.2. SPATIAL RELATIONS

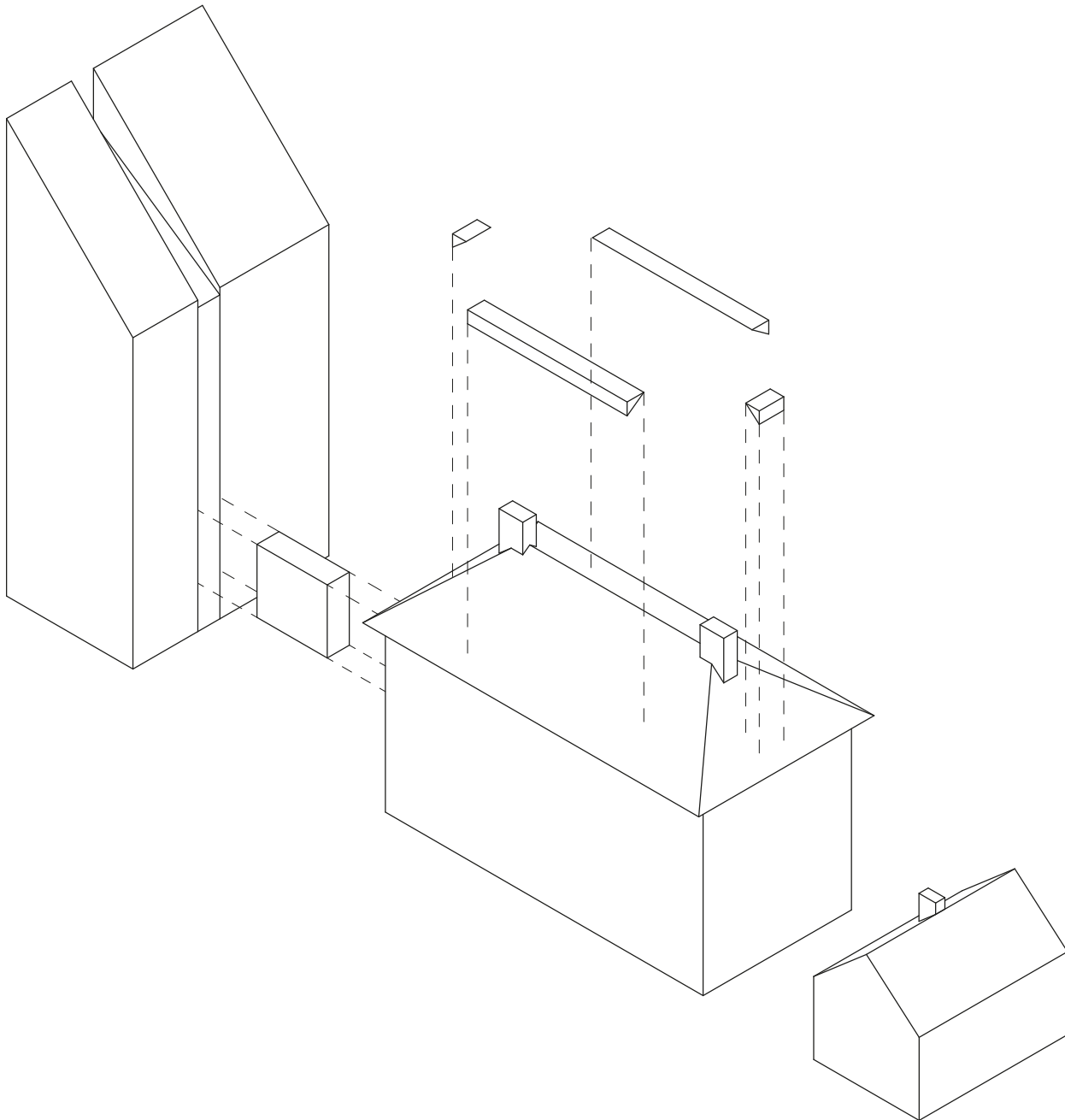

Building volume

BUILDING VOLUME

The 3D view above shows the spatial relation between the three volumes part of the Rotterdam Haven building. The older volume in the middle and the newer tower are

connected with a bridge on the first and second floor. The smaller building on the right has no direct connection to the other two volumes.

● Start ····Route ▲ Ascending vertical route

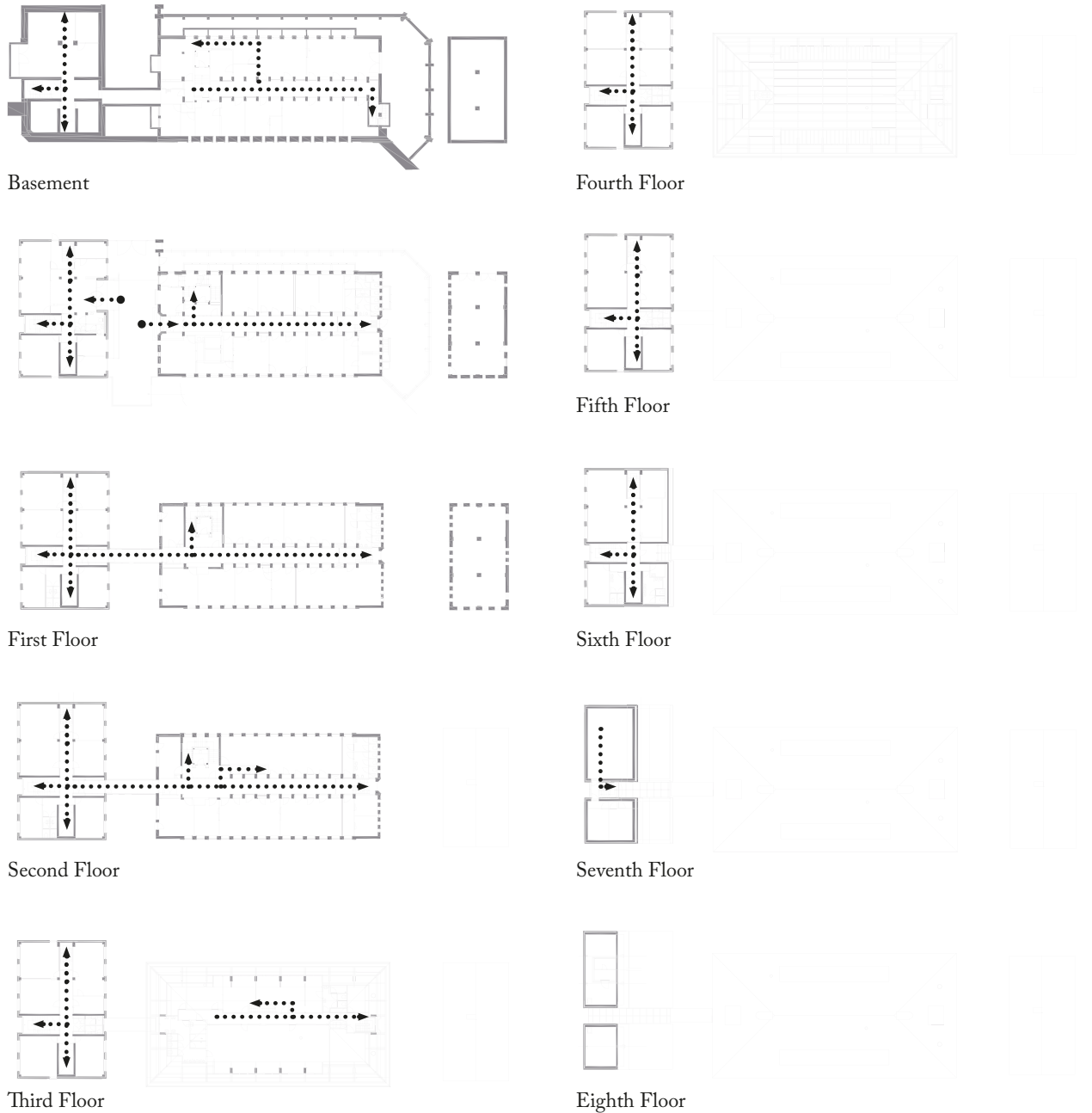

Vacant Heritage - Police Real Estate | The Netherlands

CIRCULATION

Both buildings have their own linear axis that defines the circulation of the two different buildings. These two axes are perpendicular to each other. Only on the first and second floor the two buildings are connected and follow

the circulation axis of the older building. Besides, there are different entrances for public and private use. The older building can only be entered by policemen, whereas the newer building has a public entrance.

1.3.3.3. STRUCTURE

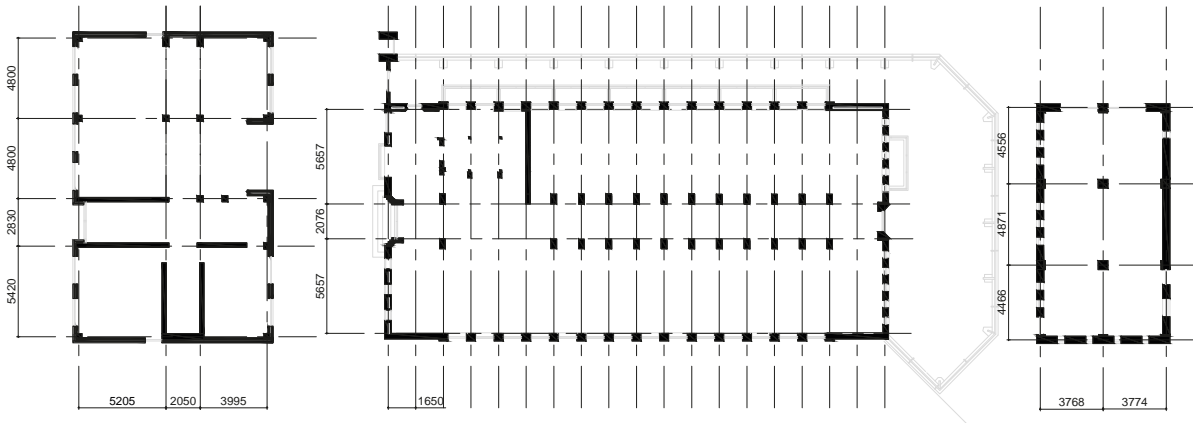

Structural grid

LOAD-BEARING STRUCTURE

The two buildings both have their own structural grid. The older building is completely built with the concept of loadbearing masonry walls and has a basis of 1,65 x 5,610 meter. This grid can especially be seen on the East

and West façade. The taller building has a column grid of concrete columns and a few concrete walls to bring stability to the structure.

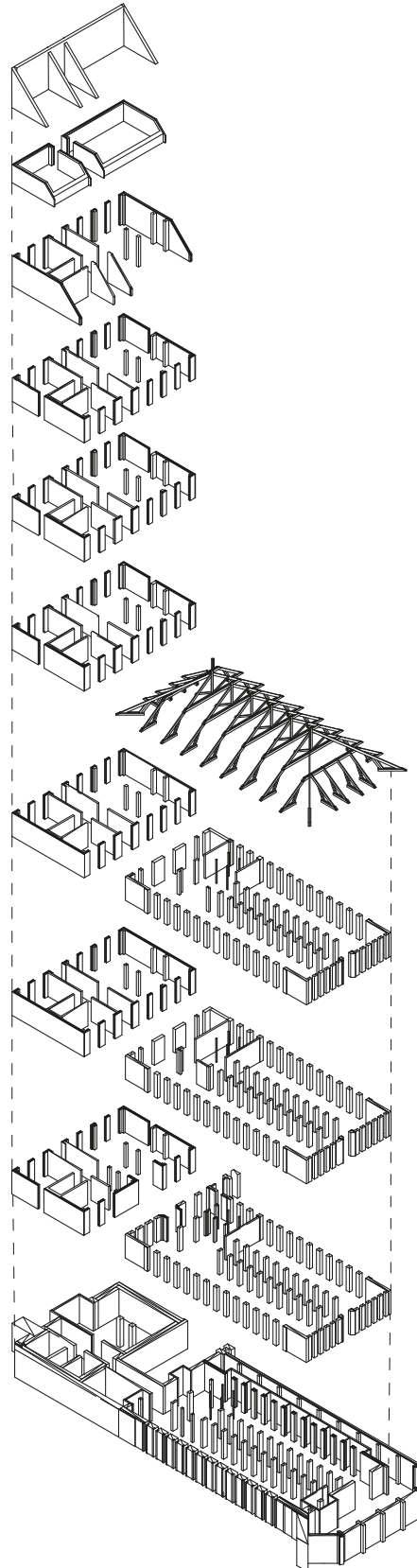

Load-bearing structure axo

1.3.4. BUILDING ENVELOPE

1.3.4.1. CONFIGURATION

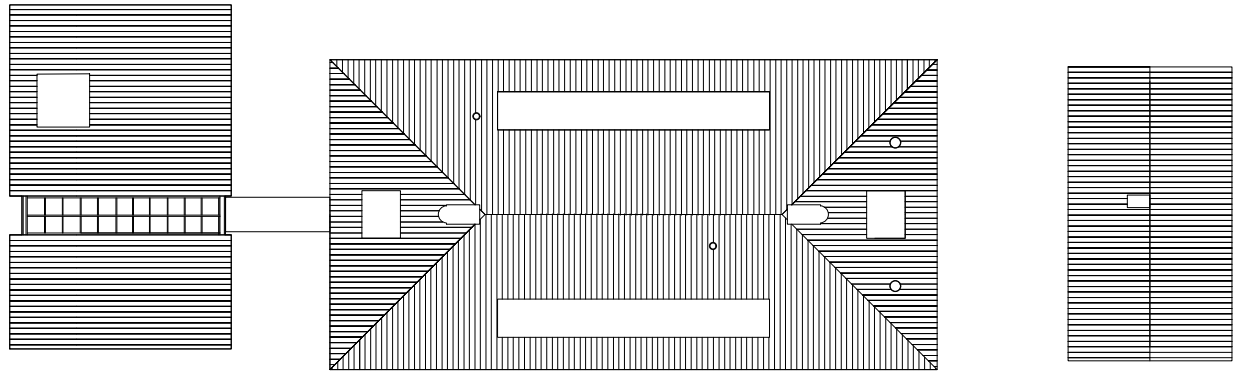

Roofplan

ROOFPLAN AND FAÇADES

The two main buildings of the Rotterdam Haven ensemble feature 8 façades, 6 of which are the main façades and the other two façades are facing each other in the middle. Within both buildings, each façade that is parallel to one another has the same visual identities. The window openings in the older building are mainly oriented towards the East and West, whereas the window openings in the newer building are oriented towards

the North and the East. Both buildings are using brick as the materialisation for the façade. The old building is using relief in the masonry pattern to give identity to the building and the new building is making distinctions by using different coloured bricks. Besides, the old building has a pitched roof on both sides and the new building has a pitched roof to one side.

0 10M

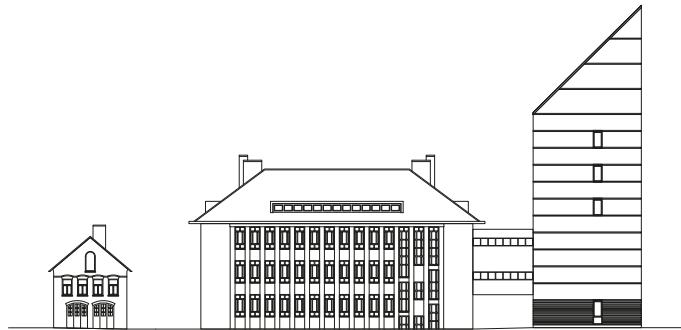

West façade

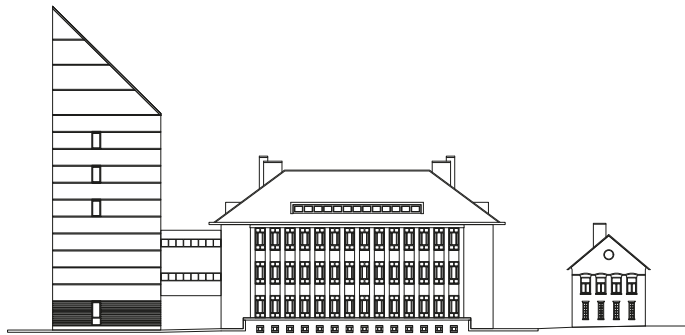

East façade



South façade

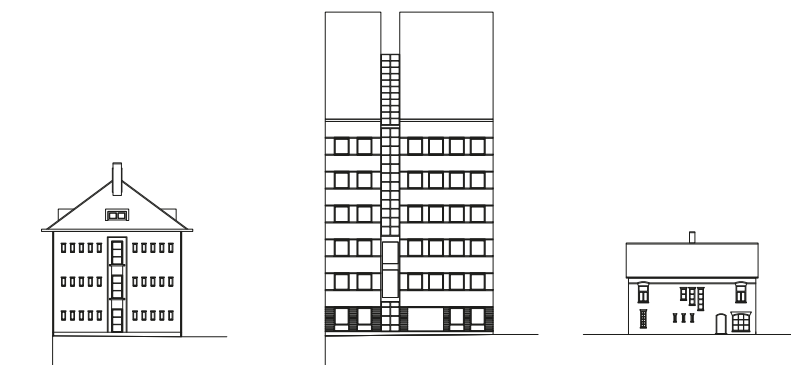

North façade

1.3.4.2. COMPOSITION

0 10M

Vacant Heritage - Police Real Estate | The Netherlands

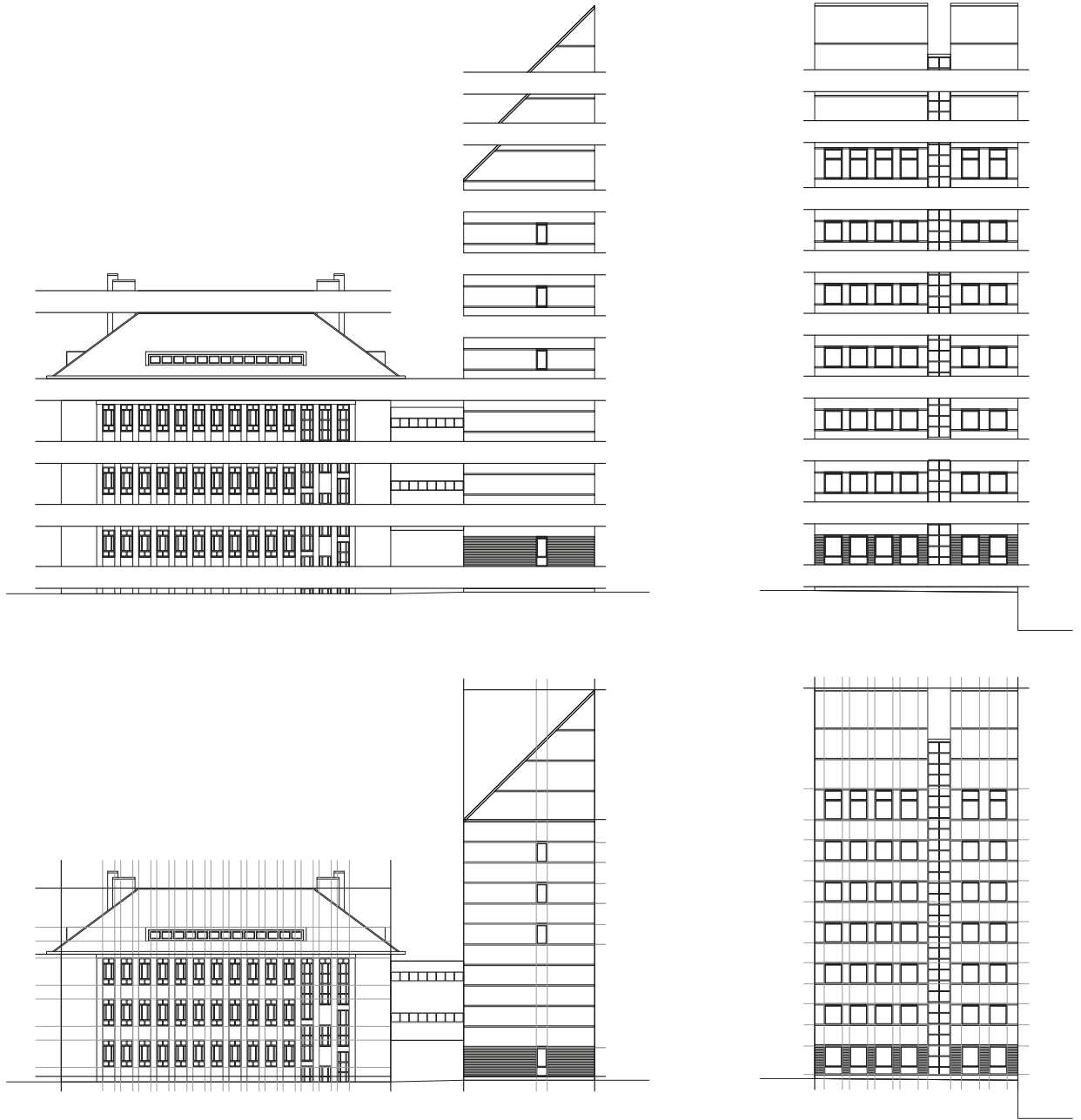

West façade

South façade

0 10M

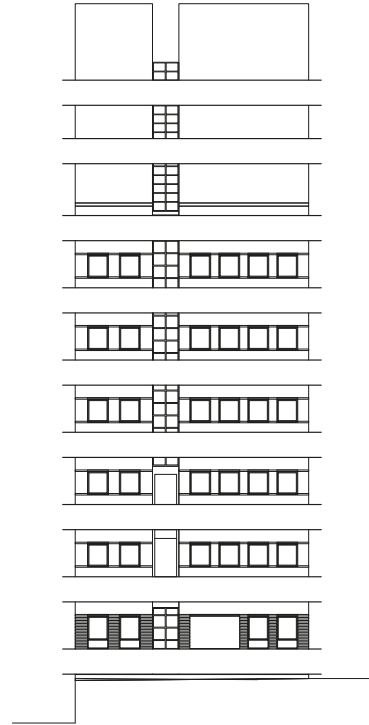
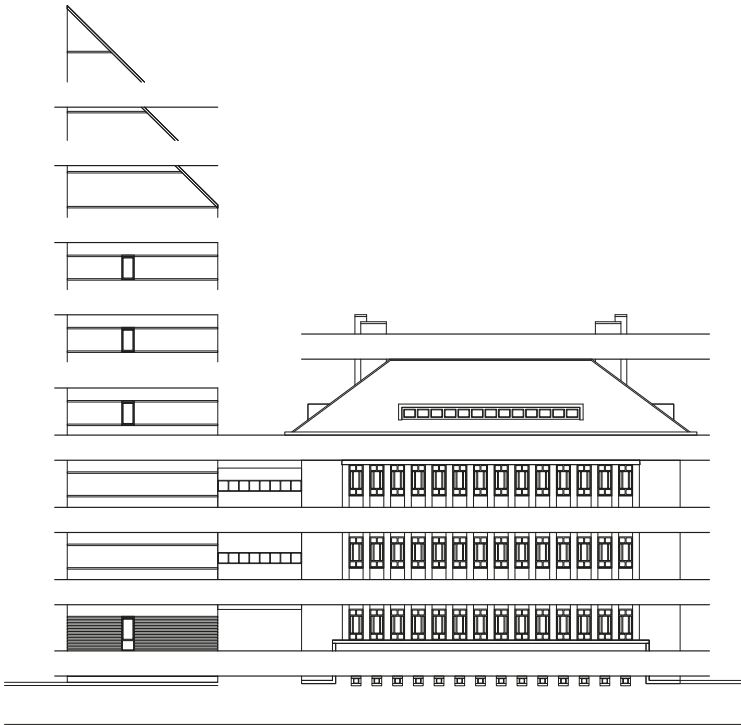

Rotterdam Haven

East façade

North façade



North façade

South façade

COMPOSITIONS

The windows of the older building are both horizontally and vertically aligned. However, each set of three vertically aligned windows is set back in the façade. This leaves the brickwork in-between as protruding pilasters, and gives the overall façade a predominantly vertical orientation. The vertically oriented windows in front of the stairwell add to the verticality of the façade. The eaves of the roof extend relatively far out, making a strong horizontal element in the overall composition and contrasting the vertical elements in the façade. The newer tower building is slender and tall in comparison to the original building.

Horizontal lines of two bricks high have been added to the brickwork in the façade, extending from the tops and bottoms of the window openings. The angled roof of the tower reflects the angled roof of the older building. It also creates a more gradual transition between the low-rise of the original and adjacent buildings and the high-rise of the tower and the rest of the Müllerpier. In summary, the original building, wider than it is high, can be described as a horizontal volume with vertical façade elements, whereas the tower is a vertical volume with façade elements that emphasize the horizontal.

1.3.4.3. MATERIALITY

0 10M

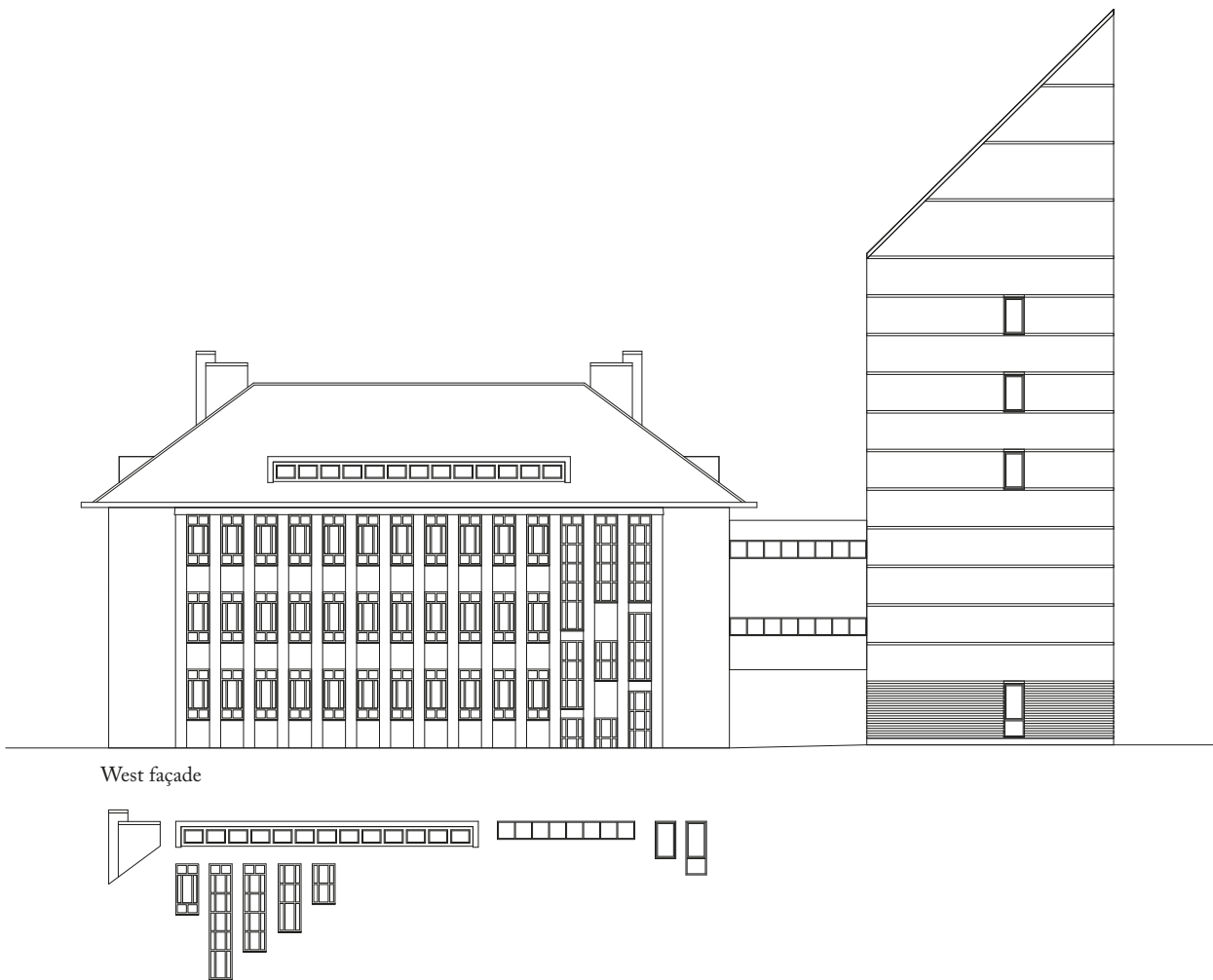

COMPONENTS

The main façade components of the Rotterdam Haven building ensemble are the windows. The windows of the original building have more architectural expression, as they are subdivided in two panes on the

top and bottom, and three panes in the centre with the middle one being larger than the side panes. The windows in front of the stairwell in the older building are variations on this window.

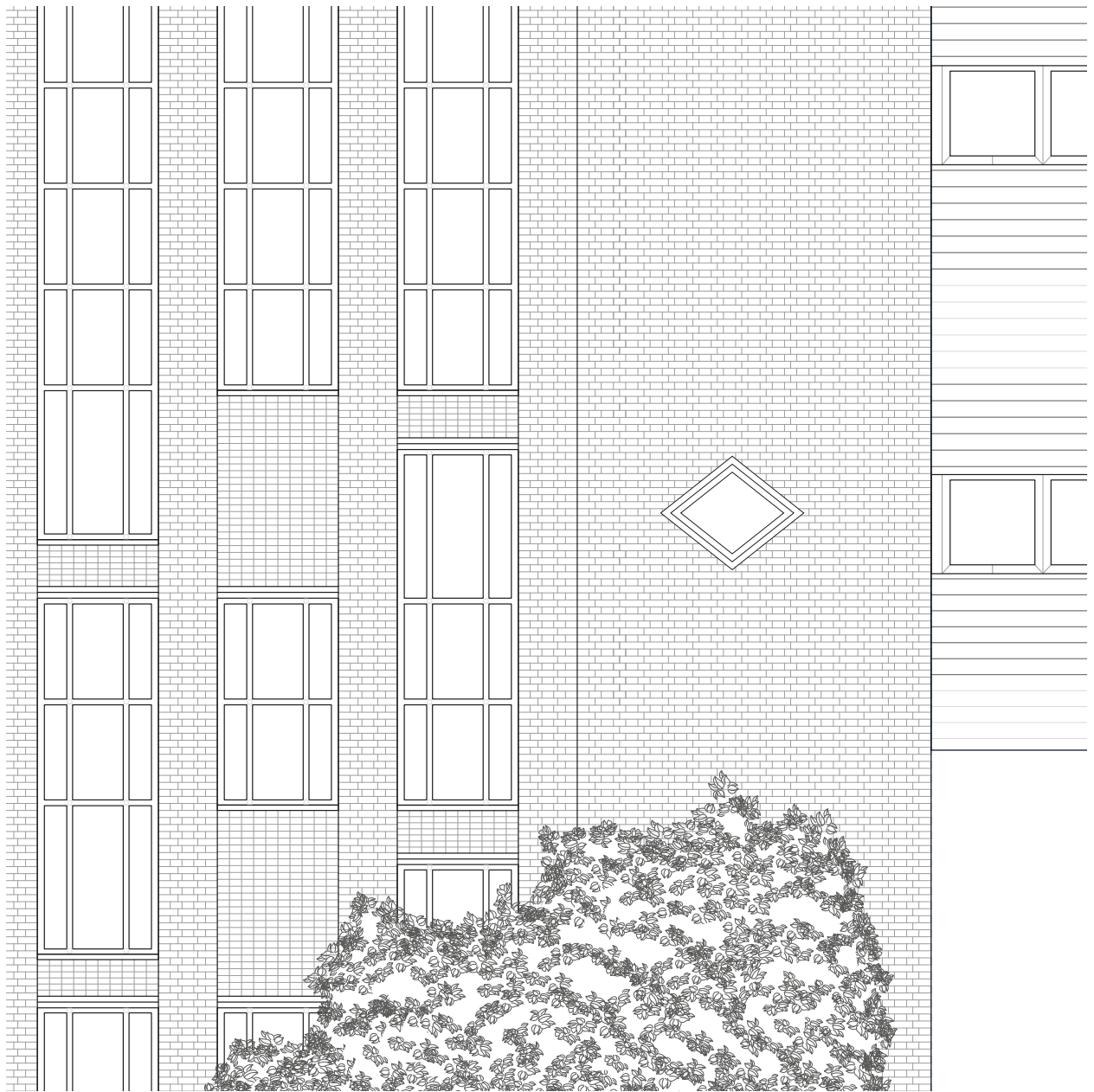

Façade fragment analysis

TEXTURES

Both the façade of the older building and the tower consist of brickwork masonry. The bricks used in the façade of the older building have a rough surface and a dark brown colour. The bricks in the façade of the tower are very rough, and have an orange colour. Occasionally,

dark grey bricks of the same texture are used. The window openings in the tower are topped with a lintel of light coloured concrete. The sills are the same colour and material as the aluminium window frames.



(Braunius, 2021)

1.3.5. CONCLUSIONS

The Rotterdam Haven police building is located in the Lloydkwartier, a neighbourhood between the old city triangle of Rotterdam and Delfshaven. The expansion of the city towards Delfshaven started around 1850 and rapidly grew along the river of the Maas. The bombings in World War II destroyed most of the buildings in and around the city triangle but did not affect the Lloydkwartier.

The river police itself has been housed within the harbour since 1911, first on a floating pontoon and from 1938 within the building at Sint Jobsweg. During World War II, the offices of the river police were in the hands of the German troops. Due to the increasing size of the port of Rotterdam after World War II, the river police was forced to open another office in the harbour. After a while, also the office at Sint Jobsweg became too small and in 1994 they build a new building next to it. From 2000 onwards the name of the river police changed into the Rotterdam Haven police.

The Rotterdam Haven police is an island on its own within the surroundings, and it consists of 3 buildings. The buildings were built in different years and each has its characteristics. The oldest two buildings were built in

1938, the smaller volume has two floors and the larger volume has 5 floors. The façades of both buildings consist of brickwork masonry. The bricks used in the façade have a rough surface and a dark brown colour. Patterns and relief within the masonry give identity to the buildings. There is a clear rhythm within both façades and the window openings, which are mainly oriented towards the east and west, have a strong architectural expression. The larger building in the middle has a hip roof and the smaller building to the north has a gable roof.

The building built in 1994 has 10 floors, a separate entrance from the larger building in the middle of the plot, but these two buildings are connected on the first and second floors by a bridge. The façade consists of brickwork masonry and has an orange colour. Occasionally, dark grey bricks of the same texture are used to divide the façade into planes. In comparison with the other two buildings, most window openings are oriented towards the north and southside of the building, providing an overview over the water. The windows of this volume are simplistic and consist of a single glass plane. The building has a shed roof with the highest point to the South and the lowest point towards the other buildings.

1.4. HAARLEM

1.4.1. INNER CITY

1.4.1.1. INTRODUCTION

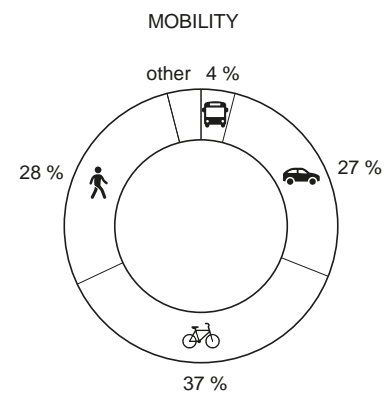
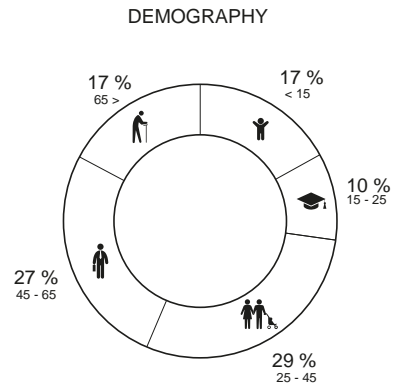

Haarlem is both a municipality and the capital of the province of North Holland, situated along the river Spaarne in the South Kennemerland region. Compared to other cities in the Randstad, it is a medium-sized city. As of 2021, Haarlem has 162.526 inhabitants, which makes it the 12th biggest municipality of the Netherlands while being the third most dense, with 5.573 inhabitants per square km.

The first mention of Haarlem can be found in a document from the 10th century, while it received city rights from Willem II of Holland in the year 1245. At the end of the Middle Ages, Haarlem became one of the most important cities in Holland. In the Industrial Revolution the city developed industrially as a textile city and culturally as a city of painters.

Its location along the river Spaarne has given the city the nickname ‘Spaarnestad’. A resident of the city is called an Haarlemmer, but is also referred to as a mug (mosquito). Its origin is not known with certainty, but ‘mug’ was already used as a swear word in the 14th or 15th century. Haarlem has acted as an ‘overflow’ of Amsterdam since the late 1990s. Because houses in Amsterdam are scarce and expensive, more and more former Amsterdammers moved to Haarlem. House prices in Haarlem have therefore risen. This also explains why Haarlem has such a large group of inhabitants between the age group of 25 and 65. Haarlem is also one of the cities with the highest percentage of journeys done on foot in the Netherlands.

1.4.1.2. DEVELOPMENT



Vacant Heritage - Police Real Estate | The Netherlands



1300

HISTORIC DEVELOPMENT

Haarlem initially grew along the west bank of the river Spaarne and was acknowledged as a city in 1245 by receiving city rights. From that moment onwards, Haarlem grew to become one of the most important cities in Holland. From the beginning of the 15th century until the mid 16th century defence works were build around

the city. After the defence works of the seventeenth century were demolished, Haarlem experienced many new developments. The city grew even more along the river Spaarne, including an expansion on the eastern side of the river.



0 1000M

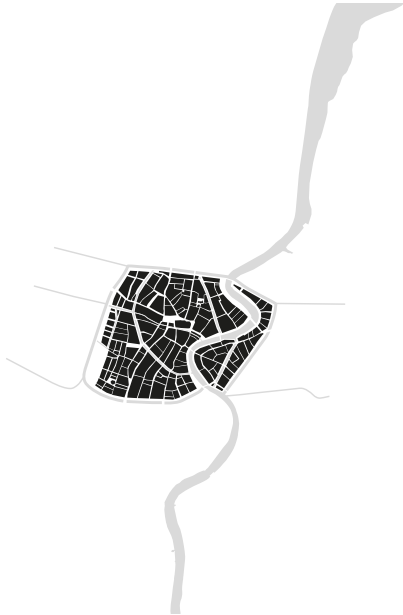

1500



1800



1900



2000

Harlem



0

500M

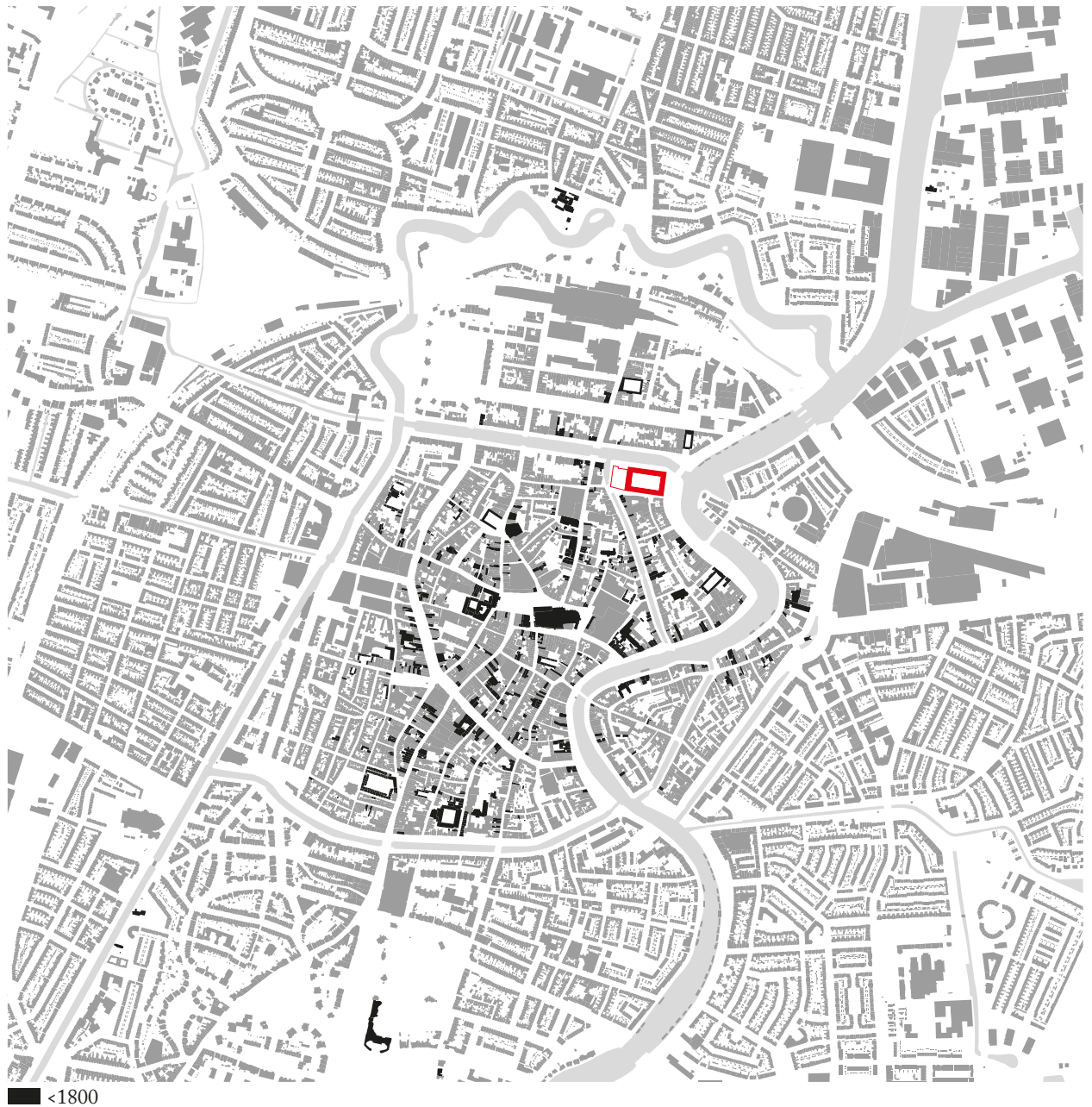

BUILDING AGE

The old centre of Haarlem is mostly concentrated around the Grote Markt, which has been there since the 10th century. Due to its function as a garrison town and provincial capital, Haarlem grew during the 19th century. This was also when our case study, the police station at Koudenhorn, was transformed from an orphanage into a

garrison. The police station at the Koudenhorn is situated at the very edge of the oldest part of the city, along the Nieuwe Gracht which formed the border of the city before the city centre expanded northwards in the seventeenth century.



0 500M

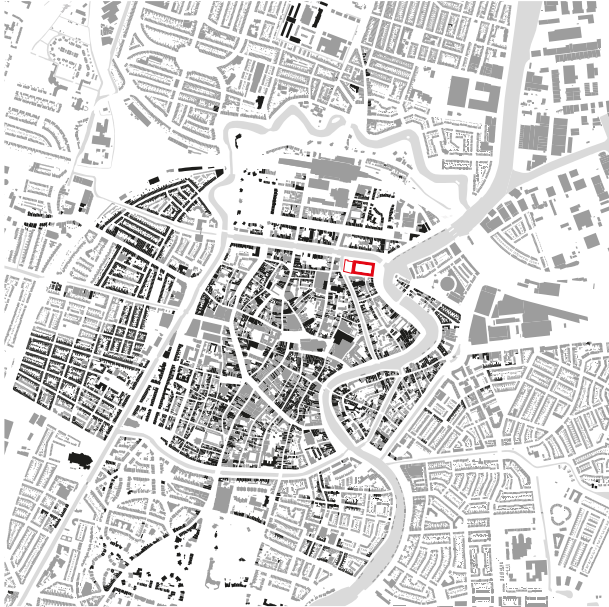

1800-1899

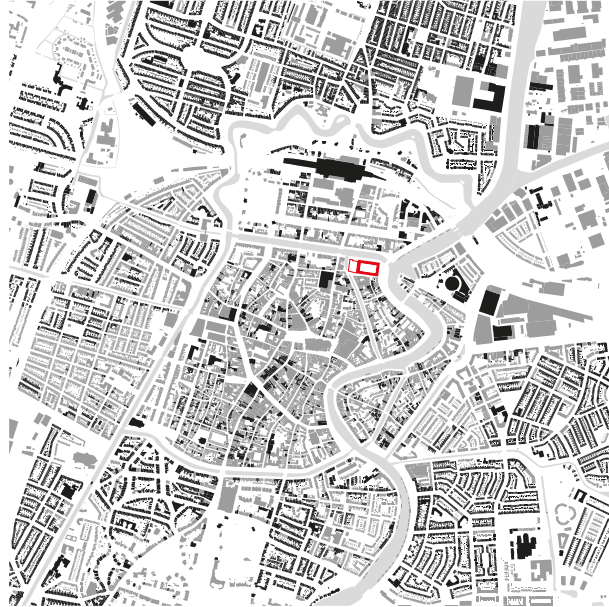

1900-1949

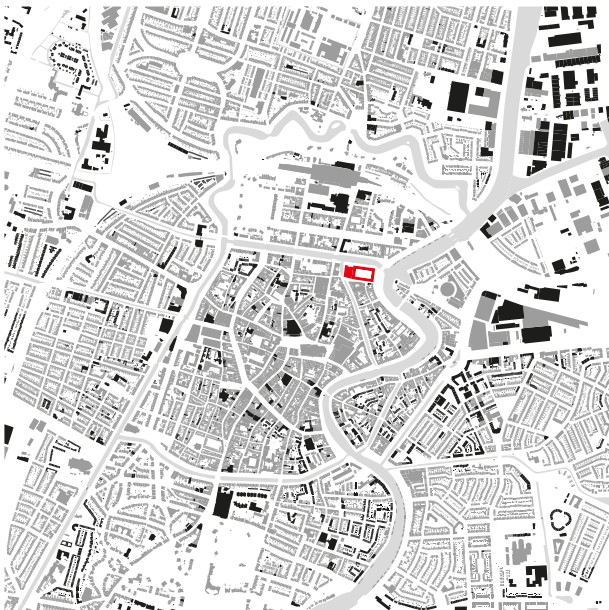

1950-1999

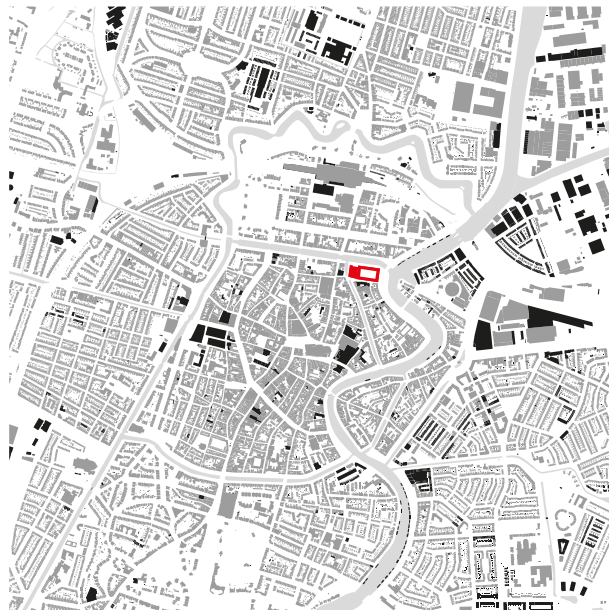

2000-

1.4.1.3. NETWORKS



0

500M

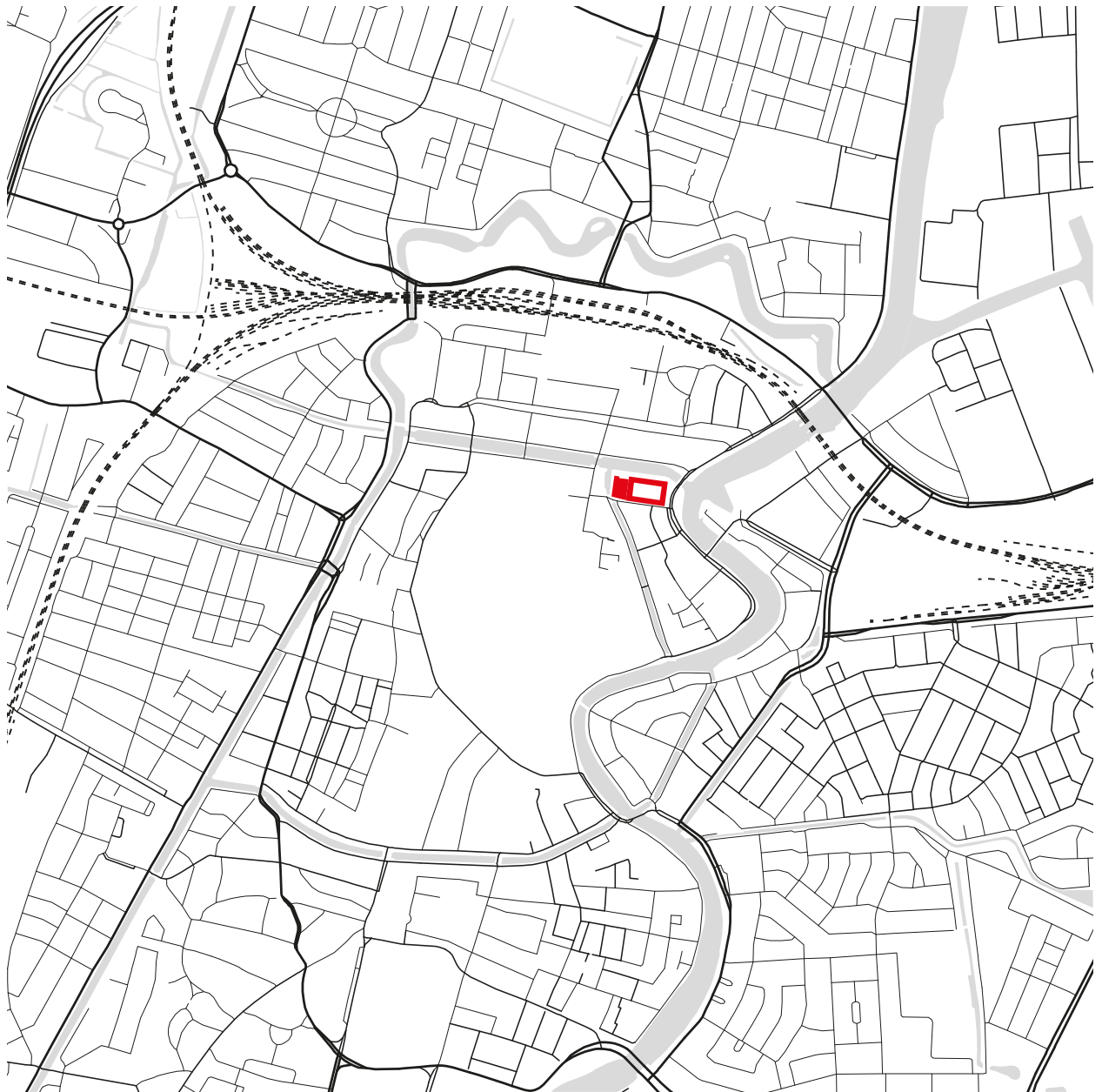

Vacant Heritage - Police Real Estate | The Netherlands

All roads

ROAD NETWORK

Because of its dense inner city, the roads that belong to the tertiary network in the city centre are mostly narrow streets or alleys. Roads along the canals are generally wider than others, leaving space for car parking along

the sides. The secondary network connects these smaller streets to the primary network, which runs along the Spaarne and most of the larger canals such as the Nieuwe Gracht and the old ramparts.



0

500M

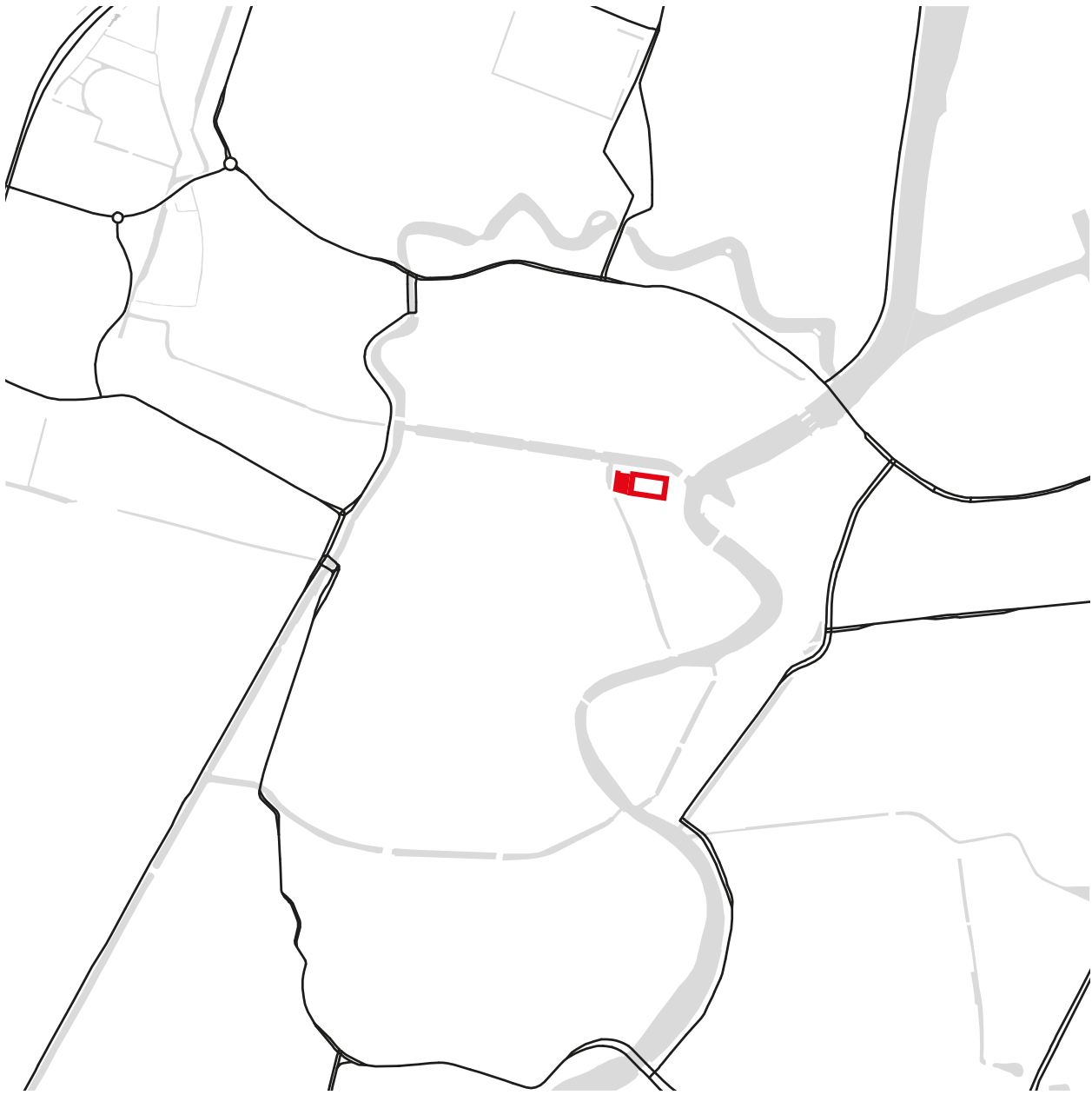

Harlem

Primary roads



0

500M



Vacant Heritage - Police Real Estate | The Netherlands



Secondary roads



0

500M

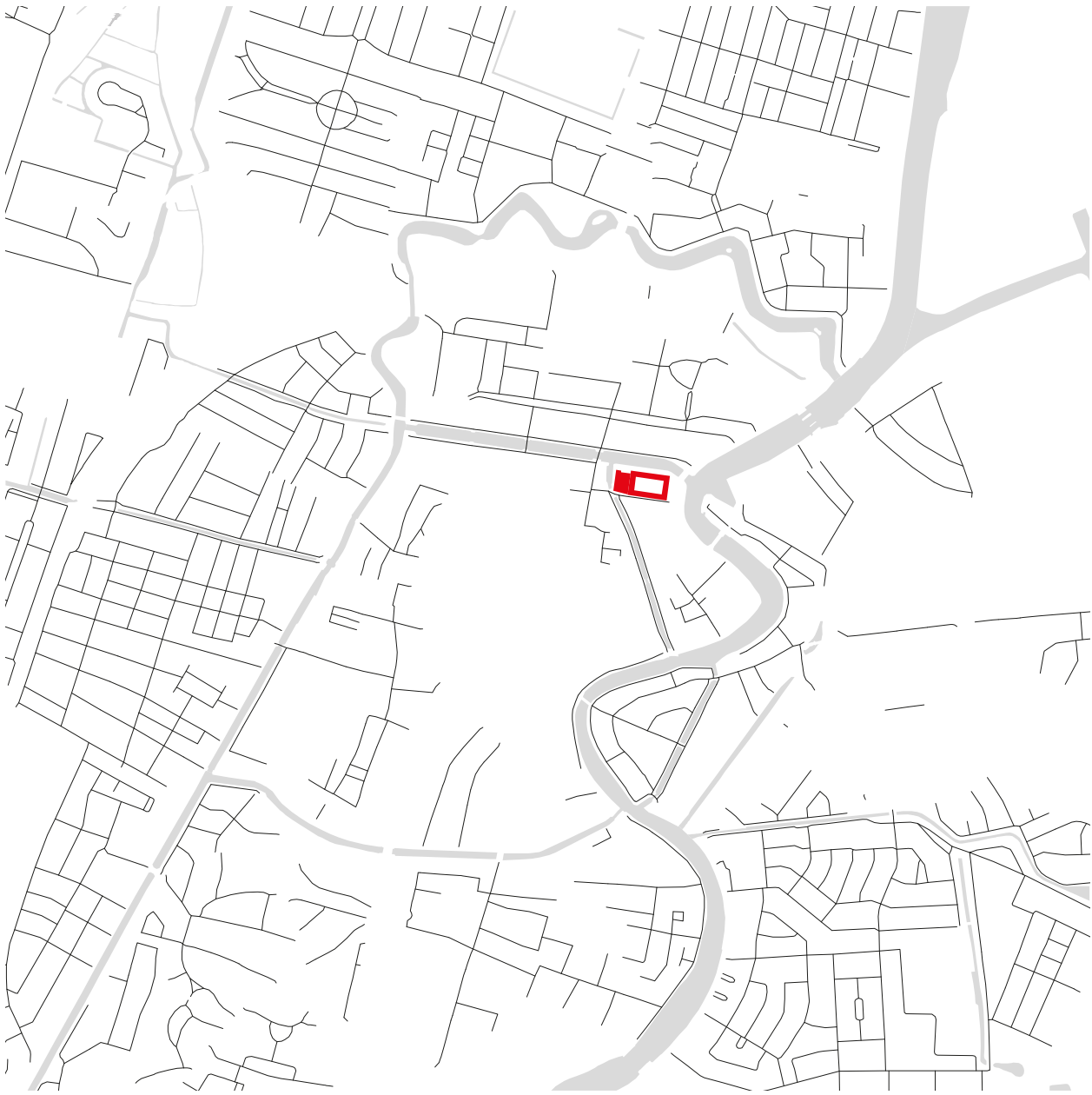

Harlem

Tertiary roads

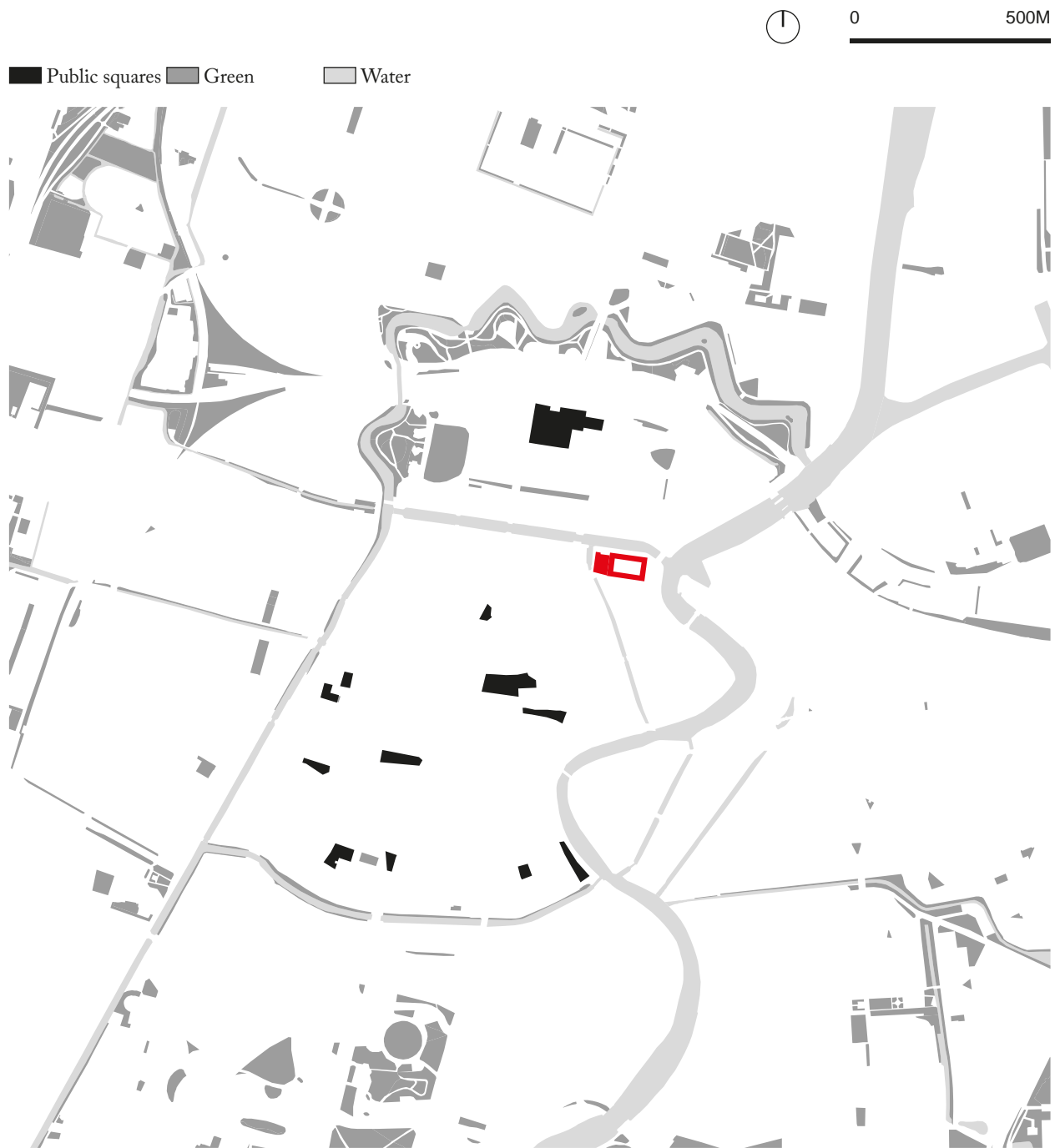

GREEN WATER AND PUBLIC SQUARES

The police station at Koudenhorn is located where the Nieuwe Gracht stems from the river Spaarne. Apart from the river Spaarne, the structure of Haarlem is greatly influenced by its canals. Several of these canals were once part of the defensive works that were built throughout different periods in history, which makes the different developments of Haarlem easier to spot. A clear example is the water along the remnants of the seventeenth century bastions.

Apart from several parks, there are two types of green spaces that are significant in the case of Haarlem: the courtyards and the parks along the former seventeenth

century ramparts. The courtyards are more secluded but still part of the structure, situated within the urban blocks.

Most notably is the Grote Markt in the historic city centre, next to the Grote Kerk. This square creates a space for markets, festivals and concerts that are held here throughout the year. Haarlem is known for its many courtyards dotted throughout the centre, although many of these courtyards are hidden away inside urban blocks. The police station at Koudenhorn houses a courtyard, but in this case it is completely closed off from the public.

1.4.2. URBAN BLOCK

1.4.2.1. COMPOSITION

Vacant Heritage - Police Real Estate | The Netherlands



(De Gouw, 2021)



Harlem



1700-1770

1770-1850

HISTORIC DEVELOPMENT

Before the building block of the Koudenhorn was built, there was an ox market located until 1756. From that moment onward, the ox market was relocated to another place in the city to make way for the new diaconiehuys (a poorhouse or chaplaincy house). From 1768-1771 the diaconiehuys was built as shown in the first drawing. The Koudenhorn was built to house 670 poor old people, 150 poor children and 80 commensals. However, it became clear soon that the building had too much space, so from 1786 onwards the building also housed the city's poor inhabitants (Rijksmonumenten, 2020).

In 1810 the building was put into use as barracks during the Napoleonic war by the French, and the residents had to be relocated to another place in the city. The Koudenhorn retained this function until 1960, with an interruption between 1946-1950. Between 1960-1970 the courtyard was transformed in a practice space for traffic situations and the adjacent building has been removed. In 1971 the police headquarters was established in the old barracks, and a new building was built next to it in 1971 (Noords Hollands Archief, 2020).



0 50M

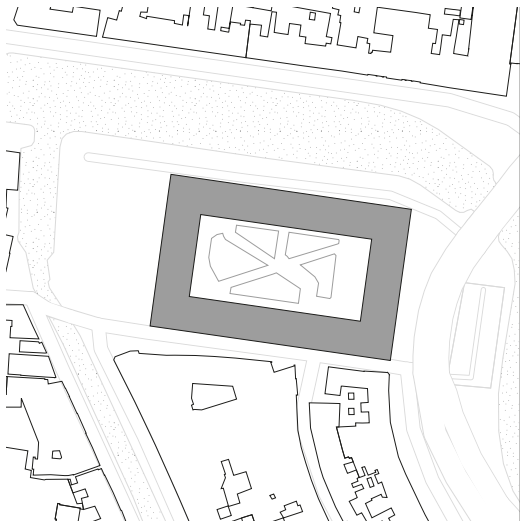

1960-1970

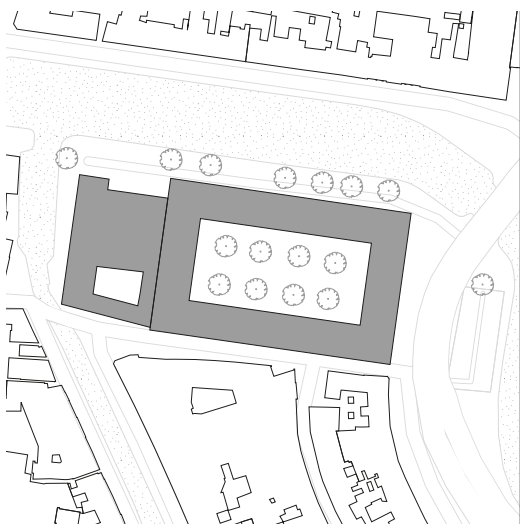

2010-2020

Harlem

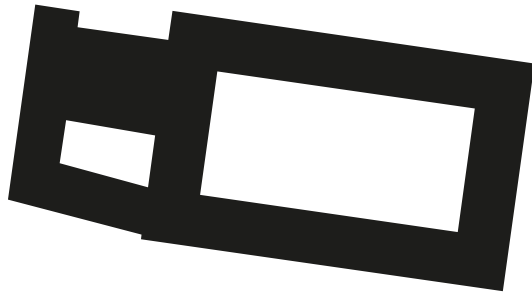

Built area
5451 m²



Empty area
2519 m²

Vacant Heritage - Police Real Estate | The Netherlands

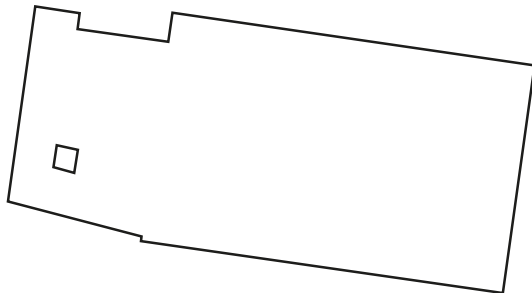

Parcels
2



Police real estate
7970 m²

BLOCK INFORMATION

The Koudenhorn building is a distinctive building in its surroundings, while the building on its own forms a complete urban block compared to other building blocks

that are constructed of multiple parcels. The complete police estate covers 7970 m², from which one third functions as two courtyards within the buildings.



0

50M

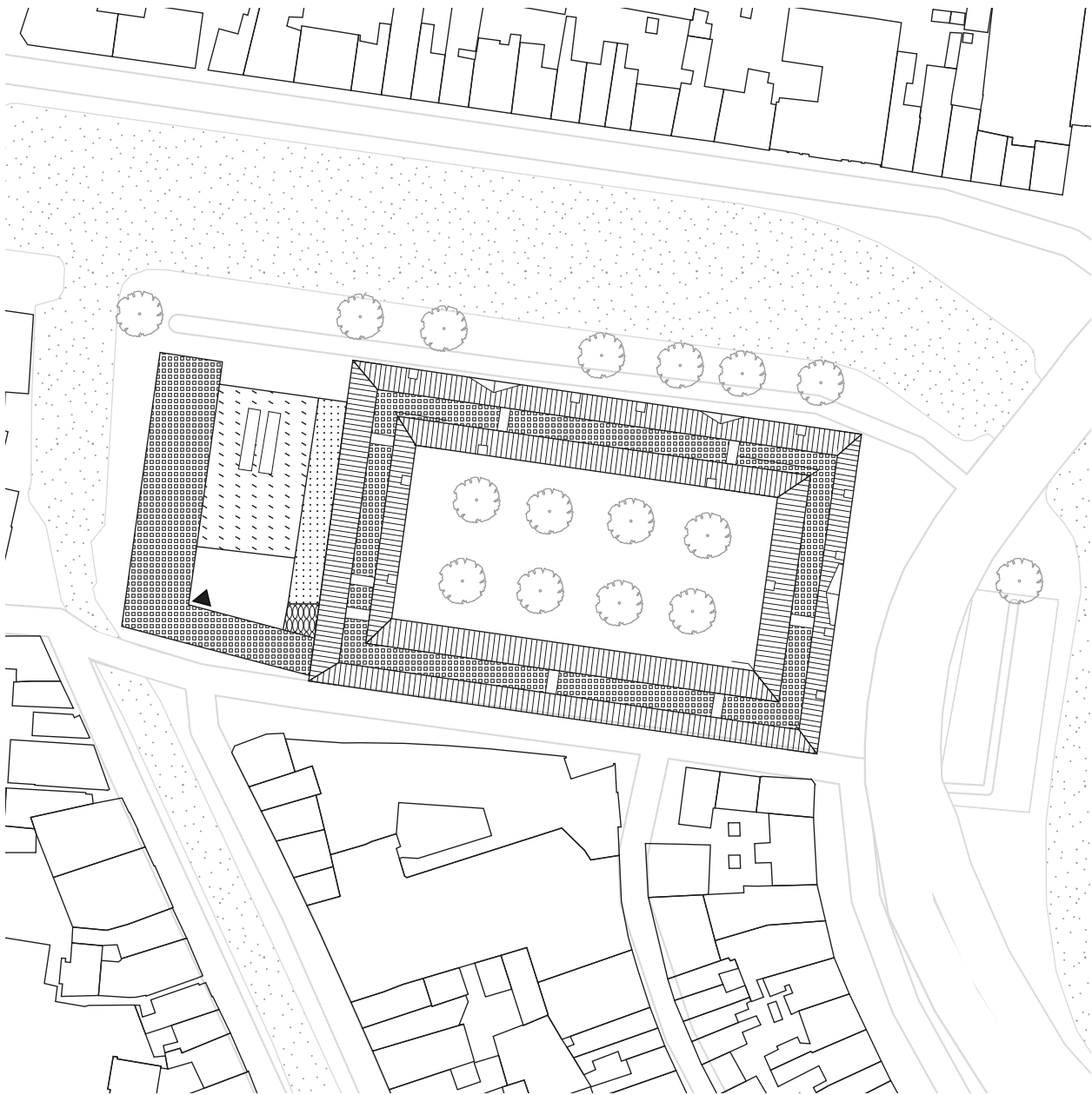

Harlem

Roof structure

ROOF STRUCTURE

The Koudenhorn building has a pitched roof towards both the street (1/3) and the courtyard (1/3), with a flat piece in the middle (1/3). The roof is constructed from

wood and materialized with roof tiles. The roof of the newer volume is flat and has some sky lights.

1.4.2.2. STREETS

0 20M

■ Façade openings

Koudenhorn

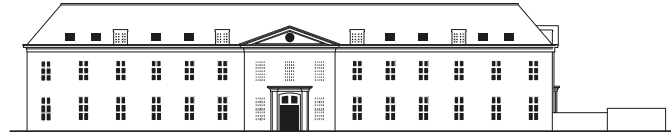

Nieuwe Gracht

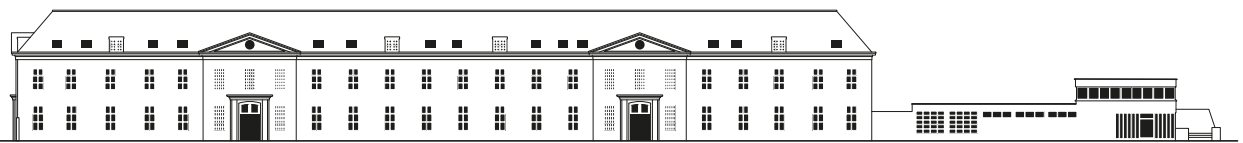

Zakstraat

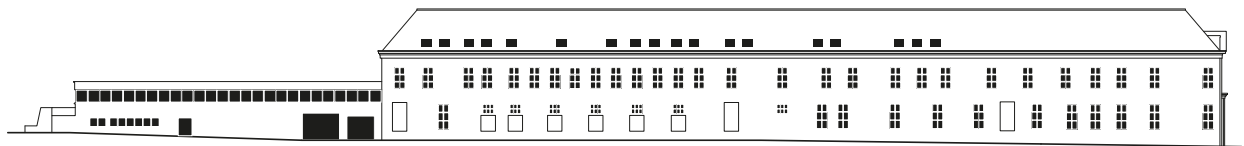

Baknessergracht

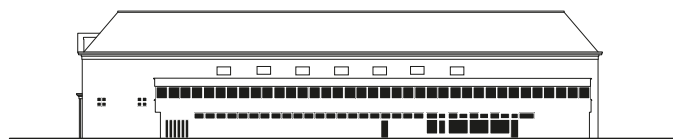

STREET ELEVATIONS

The diagram of the façades of the urban block demonstrates the openness and accessibility of the façades. The three monumental entrances on the Nieuwe Gracht and Koudenhorn are distinctive elements in the façade not only due to the ornamentation, but also the difference in windows compared to the other openings of the building. The openings of the older part of the building follow a

clear rhythm, however some changes in this rhythm can be seen in the façade along the Zakstraat. On this façade some openings have been filled in with masonry as well. The use of openings in the newer volume is different than the openings in the older part, with two large entrances and horizontal strip of windows on the first floor.



0 20M

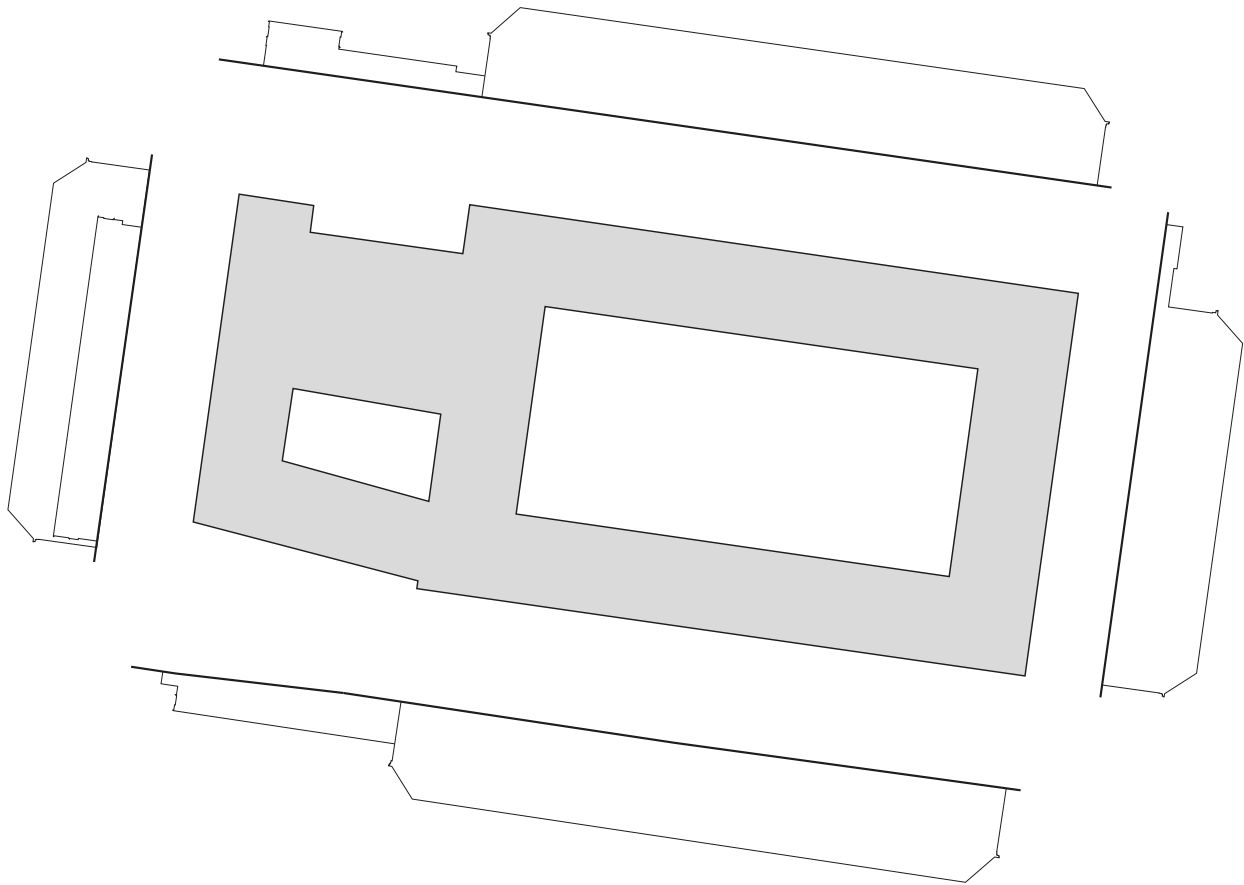

Parcels and façades

Harlem

PARCELS AND FAÇADES



Location of street sections

STREET SECTIONS

The Koudenhorn police station is located in the historic city centre of Haarlem, along the western bank of the Spaarne river. On this wide bank there is a sidewalk in front of the building's main entrance, the Koudenhorn road which is part of one of the main motorized traffic arteries of the city and a small parking area. To the north the plot is defined by the wide canal of the Nieuwe

Gracht. Along the quay, which is used by the police for parking, there are lush trees and bushes. There is no functional connection to the water. The Zakstraat at the southern side of the building is quite narrow in relation to the height of the surrounding buildings. In combination with their closed character this gives the Zakstraat the appearance of an alley.

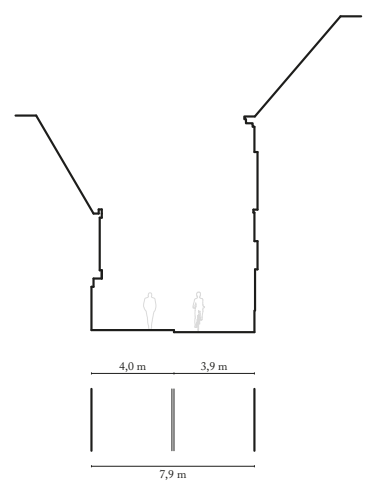

Section A
Zakstraat

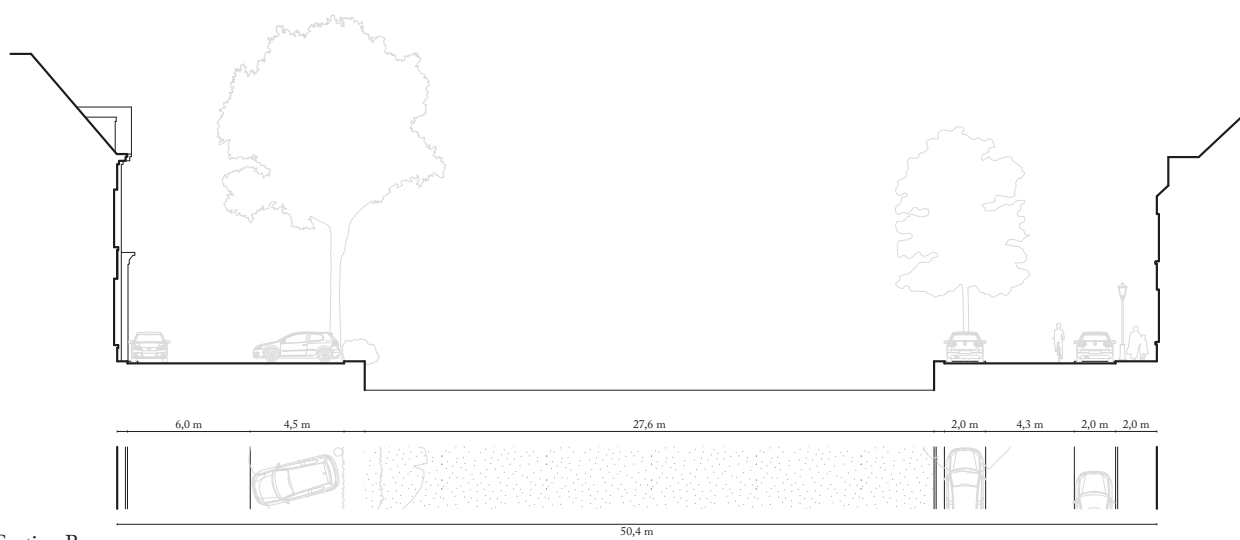

Section B
Nieuwe Gracht

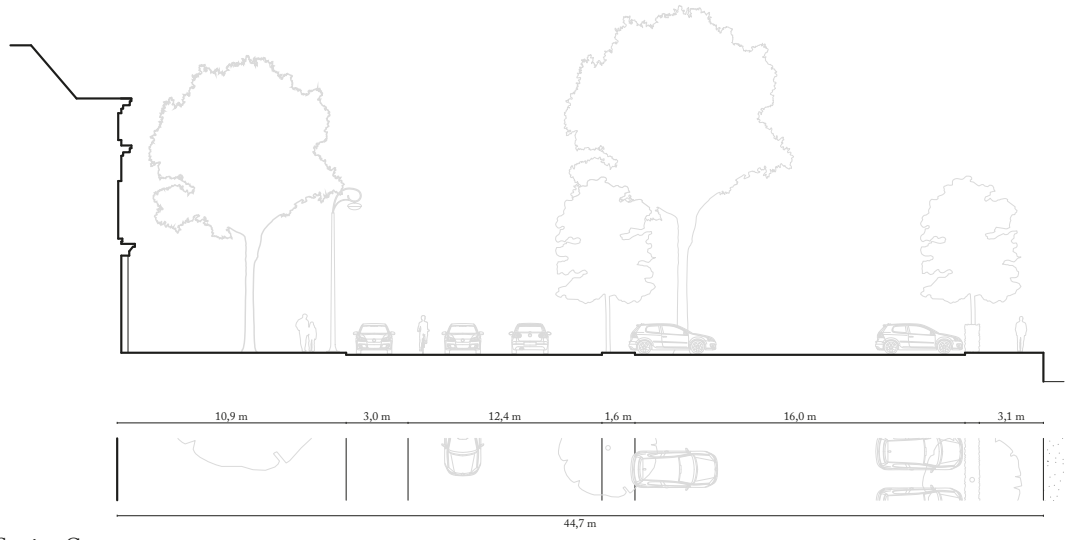

Section C
Koudenhorn

Harlem

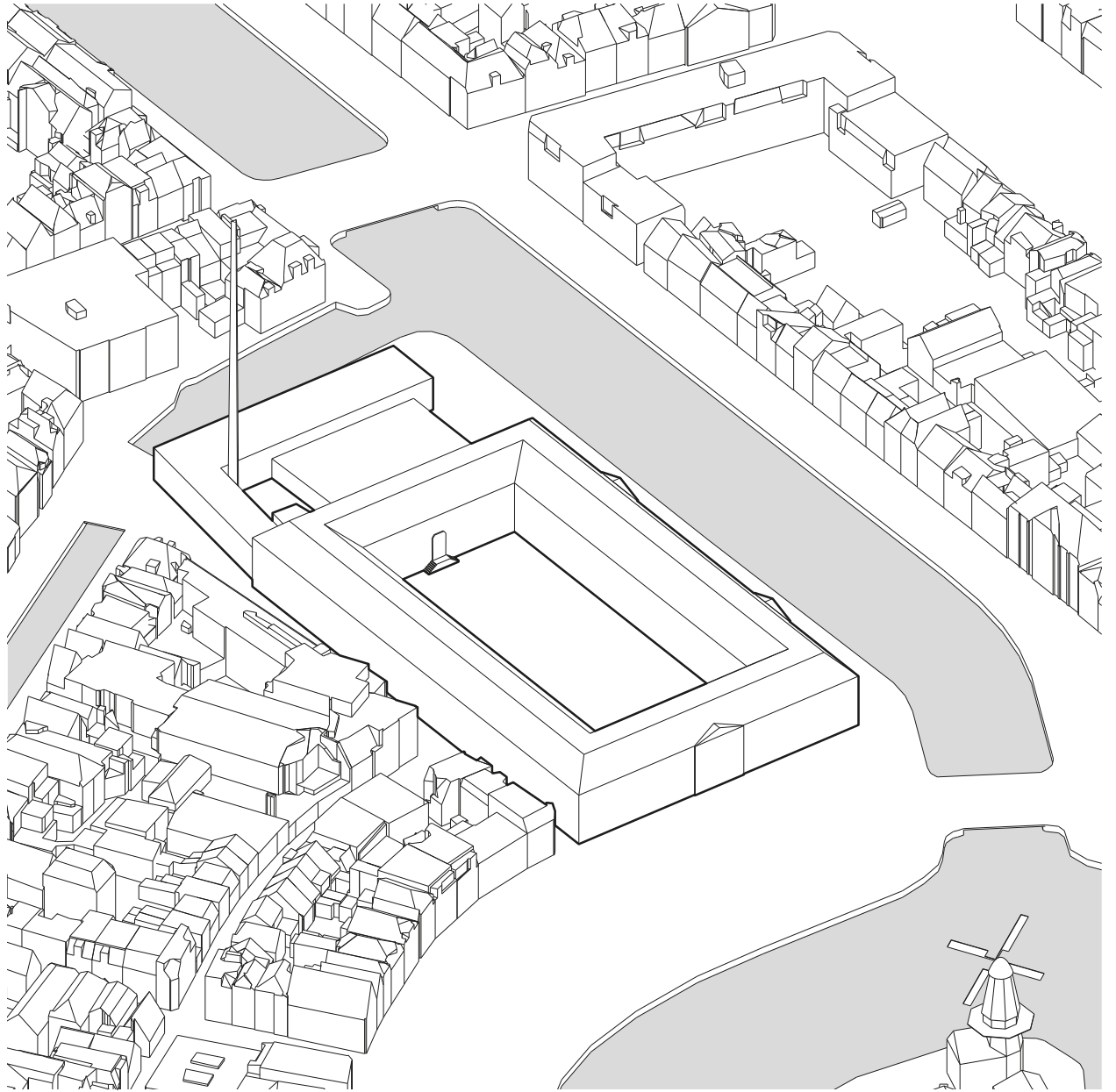

Isometric of urban block in surroundings

ISOMETRIC

1.4.2.3. ACCESSIBILITY



0

50M

Car parking
 Entrance

 Bicycle parking

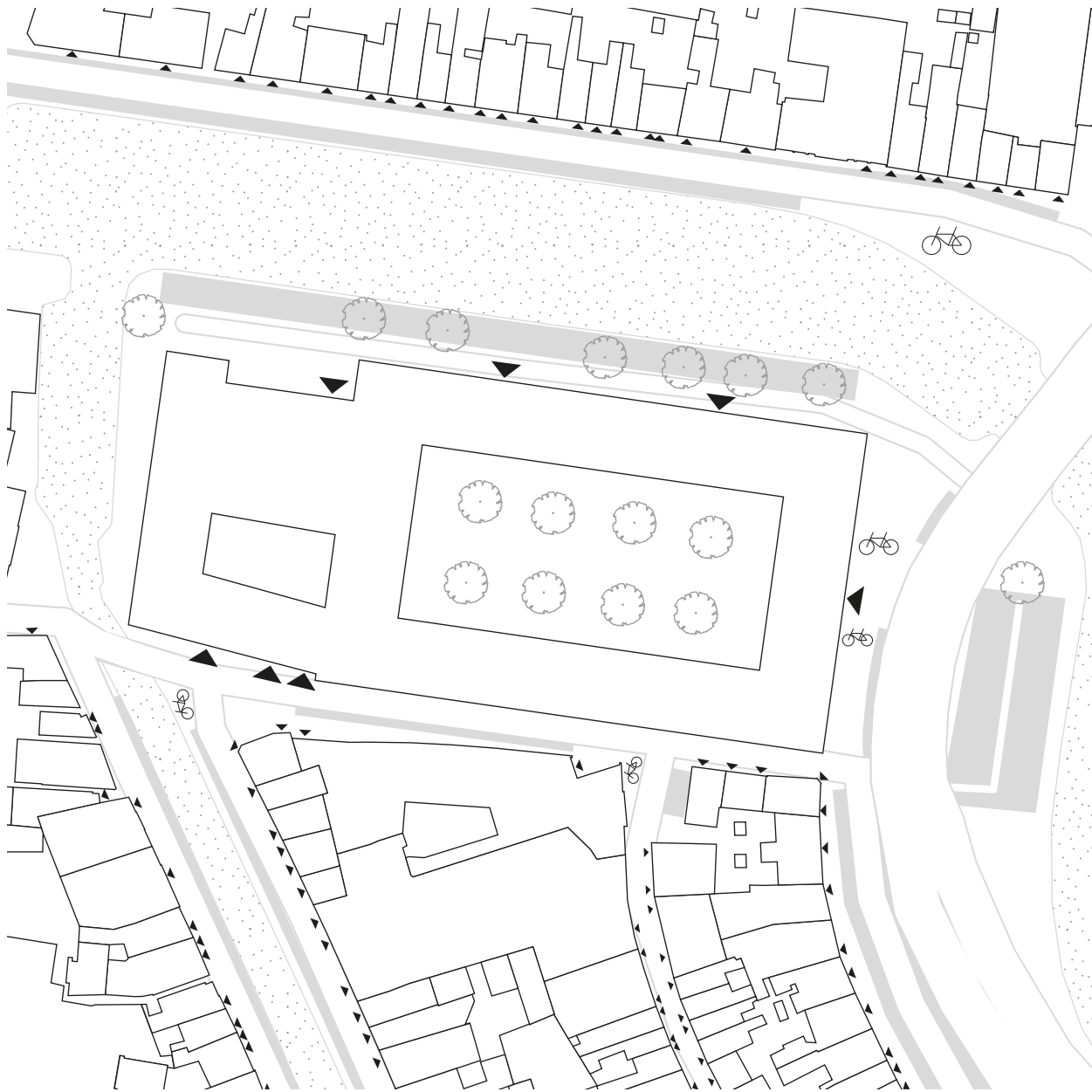

Parking and entrances

PARKING AND ENTRANCES

The parking is located along the water and streets. The parking on the quay in between the Koudenhorn and Nieuwe Gracht is used as private parking for the police and closed off with a gate. The older volume is clearly

oriented towards the Nieuwe Gracht and Koudenhorn with its three ornamented entrances. The newer volume is also accessible from the Zakstraat.

Harlem



Public, semi-public and private buildings

PUBLIC, SEMI-PUBLIC AND PRIVATE BUILDINGS

Most of the buildings in the surrounding of the urban block have a housing function and are therefore private. The courtyard inside the building volume is

also only privately accessible. The only public functions surrounding the Koudenhorn are a few shops.

1.4.3. BUILDING OBJECT

1.4.3.1. SPATIAL LAYOUT

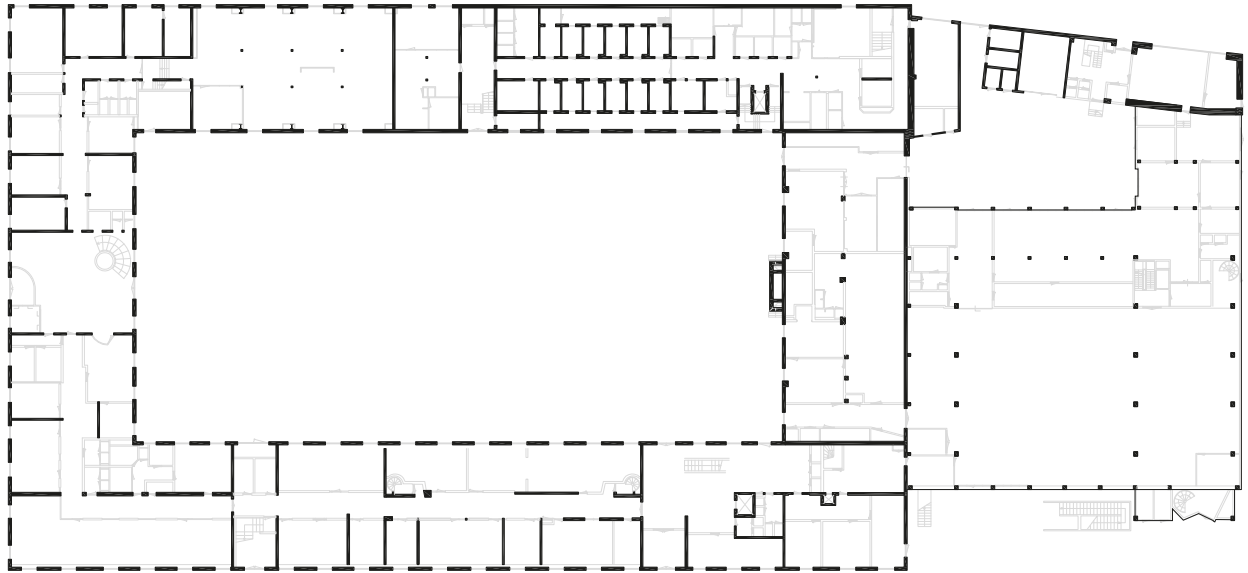

Ground Floor

FLOOR PLANS

The Koudenhorn building consists of five floors, including a basement below the newer volume and an entresol in the older volume between the ground floor and first floor. In some parts of the building, ladders provide access to spaces in the attic above the second floor used for installations. Despite several changes on the interior layout in the past, the spatial layout still reminds of the original situation with a central hallway with spaces on both sides. Some exceptions on this layout are the larger spaces on the ground floor and entresol in the upper wing

and the canteen in the right wing of the older volume. The canteen is located in the former dining hall, which was a double height space, but currently an extra floor with a void is added in this space on the same level as the first floor.

The newer volume has several bigger spaces on the ground floor compared to the spaces in the older volume. However, on the first floor, the newer volume follows the same spatial principle as the older volume with a central hallway with spaces on both sides.



0 20M

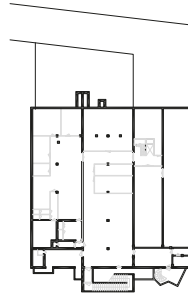

Basement

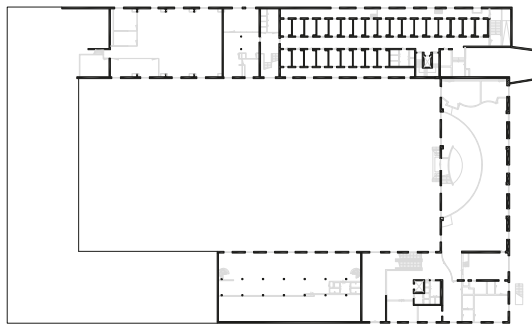

Entresol

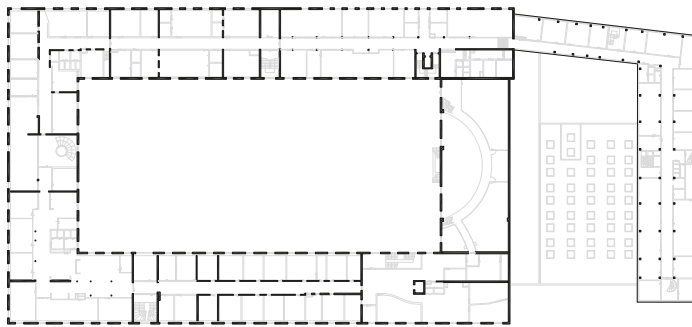

First Floor

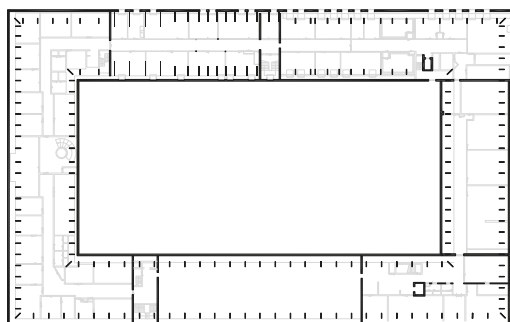

Second Floor

Harlem

0 20M

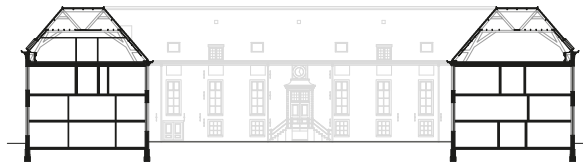
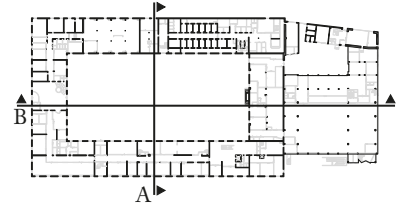

Section A

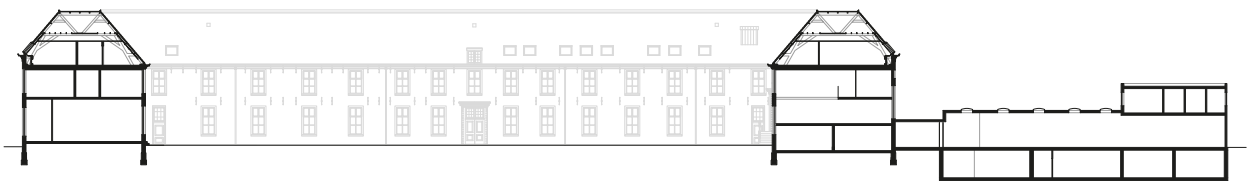

Section B

SECTIONS

From the sections, the overall rectangular shape of the original building becomes apparent. Four wings enclose a central courtyard. The north and south wings are longer than the east and west wings, making for a rectangular shape. Originally, the wings had a high ground floor, a first floor and a second floor on roughly the same height as the roof edge in the courtyard. The mezzanine floor has been added between the ground and first floor. This has caused

the windows of the ground floor to no longer correspond to the floors. Some spaces still maintain the original floor height, most notably the dining hall. The section shows the wooden roof structure, and the difference in height between the angled parts of the roof. The 1970's addition shows an open space with roof lights for the garage space. Underneath this space is the nuclear bunker and partly on top of it are the office spaces of the addition.

1.4.3.2. SPATIAL RELATIONS

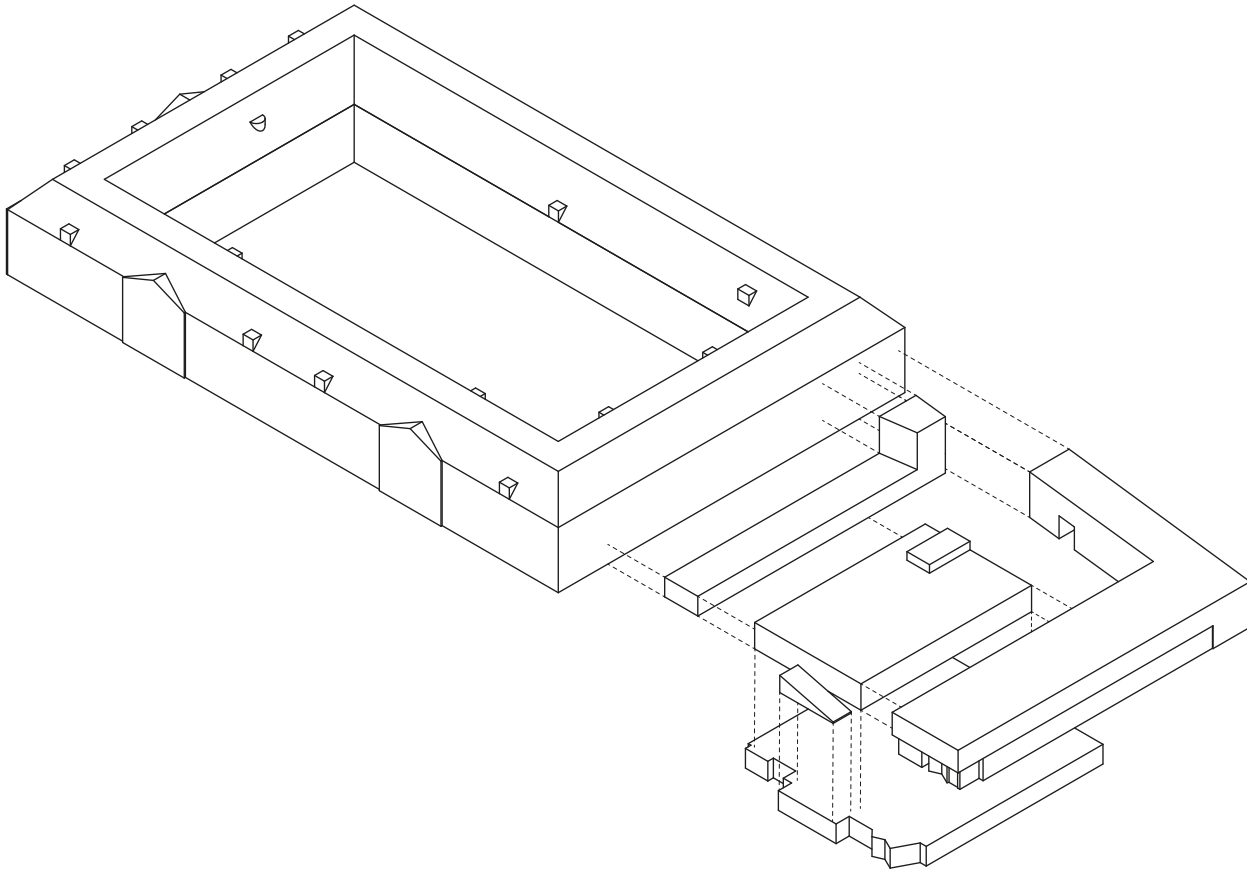

Building volume

BUILDING VOLUME

The 3D view above shows the spatial relation between the older and newer volume of the Koudenhorn. The older volume consists of four wings enclosing a courtyard. The newer volume can be divided in several smaller volume due to the differences in height. A smaller courtyard

enclosed in the newer volume connects to the ground floor of the Koudenhorn. On the first floor, the corridor of the Koudenhorn's south wing connects to the corridor on the first floor of the newer volume. The newer volume also contains a basement.



● Start •••• Route ▲ Ascending vertical route

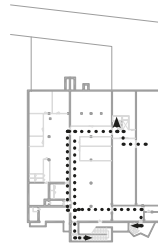

Basement

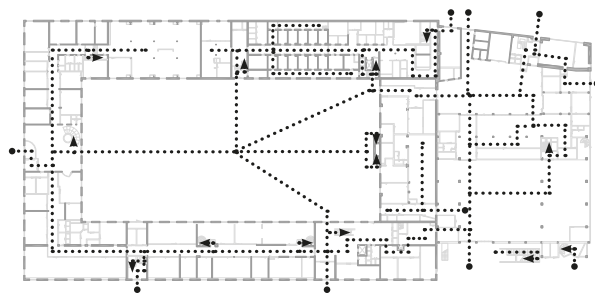

Ground Floor

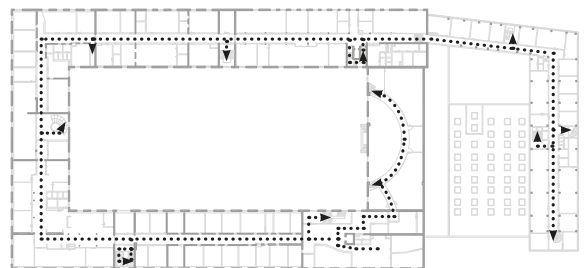

First Floor

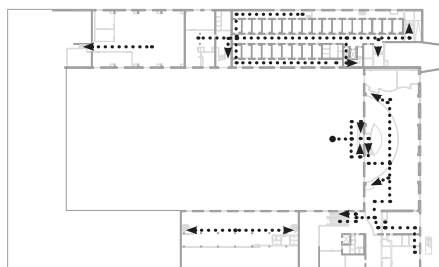

Entresol

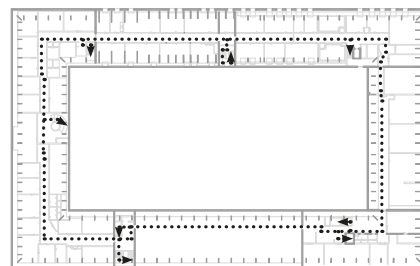

Second Floor

CIRCULATION

The Koudenhorn has a total of nine entrances, of which three are the monumental entrances providing direct access to the older volume. The three entrances in the newer volume that are located closest to the older volume are bigger gates to provide access to the parking area in this building part for cars. The entrance located on the left side is the only entrance open to visitors and provides access to the entrance hall with reception. Due to the spatial layout of the older volume, the central hallway is the circulation spaces that connects to smaller spaces on both sides. However, it is not possible to make an entire

loop on all floors, so then a routing through the courtyard or a routing with vertical circulation over another floor connects several spaces that are located next to each other on the same level. The first floor of the newer volume follows the same circulation principle as the older volume, however on the ground floor and basement there is no clear circulation space in the form of a hallway. On those two floors, the circulation happens through spaces that can be used in other ways, such as storage space, at the same time.

1.4.3.3. STRUCTURE

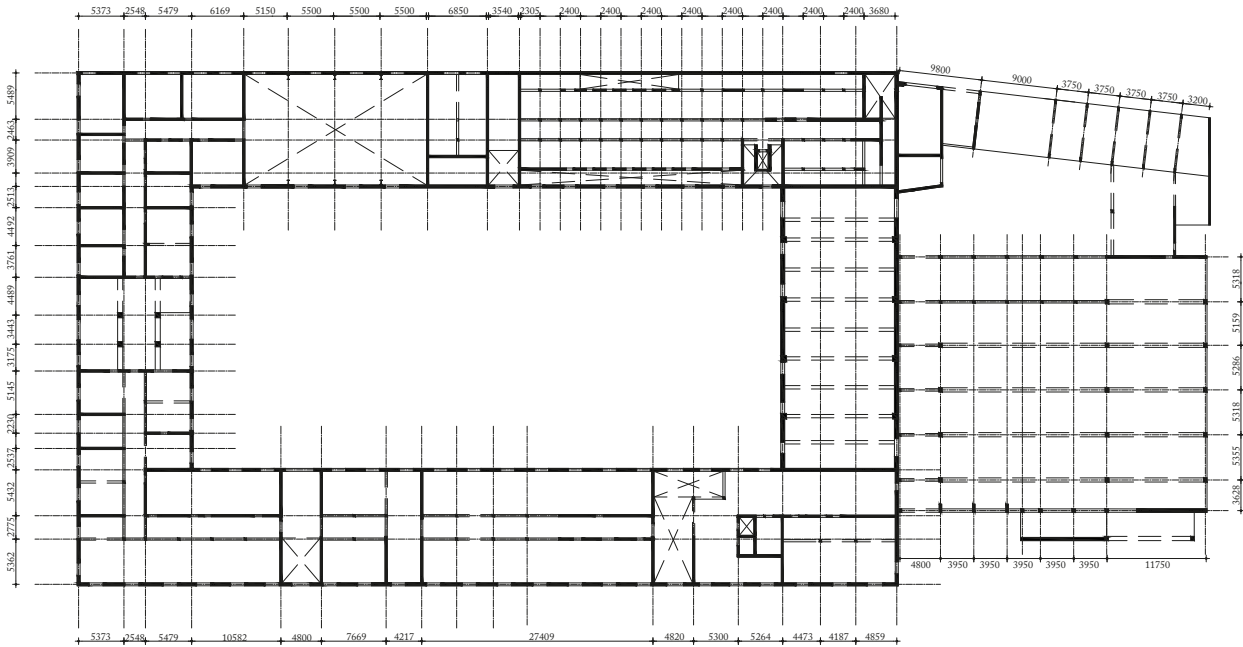

Structural grid

LOAD-BEARING STRUCTURE

The structure of the original building consist of the original load bearing exterior and interior walls of brick masonry, that together with additional concrete columns and beams support the concrete floors. In order to construct the mezzanine floor, additional structural elements have been placed. There is no consistency in grid size of the structural elements in the original building, with the exception of the cell blocks and the steel structures placed to create larger open spaces.

The load-bearings structure of the 1970's addition consist mainly of concrete columns and beams carrying the concrete floors. The structural concrete walls places in two directions structural provide stability. In the longitudinal direction, there is consistency in the structural grid size. However, this is not the case in the latitudonal direction. This is likely due to the connection with the original building, where the existing structure and wall openings obstructed a consistant grid size.

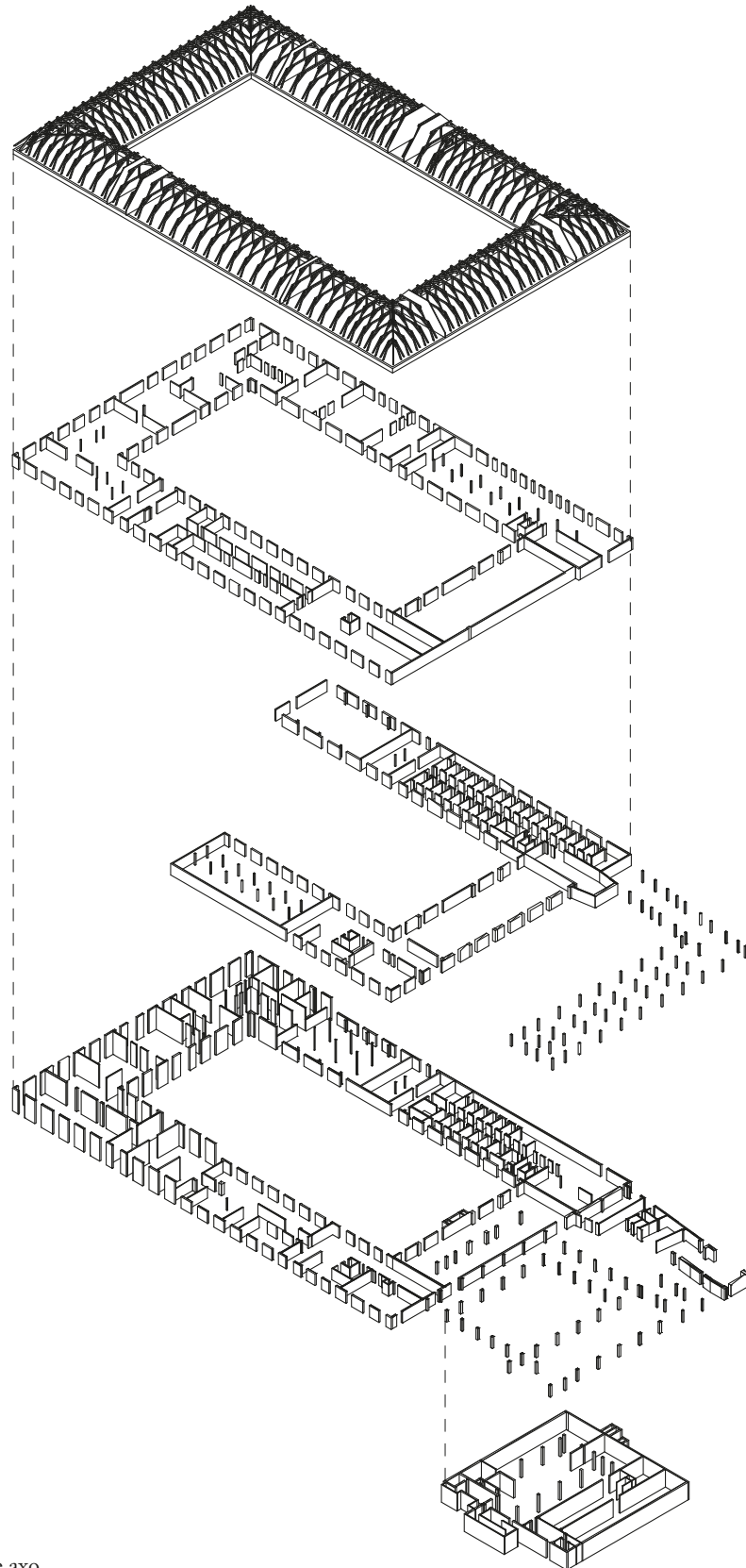

Load-bearing structure axo

1.4.4. BUILDING ENVELOPE

1.4.4.1. CONFIGURATION



0

20M

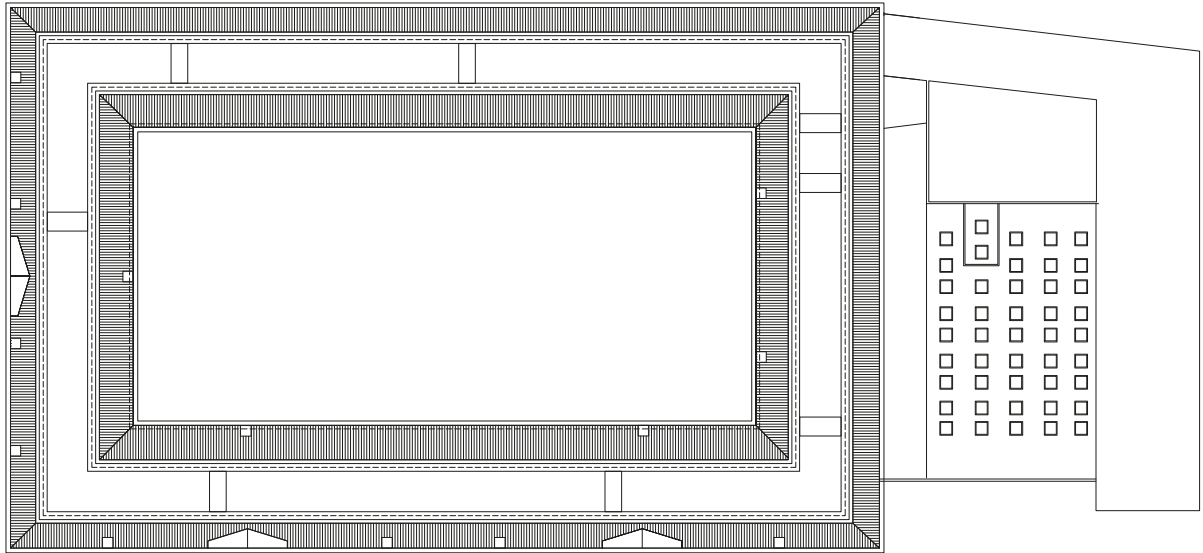

Roofplan

ROOFPLAN AND FAÇADES

Technically, the police building at the Koudenhorn features 13 different façades. The 5 exterior façades of the whole building, the 4 façades of the courtyard in the Koudenhorn and the 4 façades of the smaller patio within the in 1971 added addition. The original building has a strong identity throughout the whole façade, both on the outside of the building as for the façades in the courtyard.

The entrances on the outside are emphasized with more details and a tympanum above the entrance. The addition to the side has a completely different identity because of the rhythm, colours, openings and materials used in the façade. Besides, the old building has a pitched roof on both sides and the new building has a flat roof.

0 20M



Nieuwe Gracht

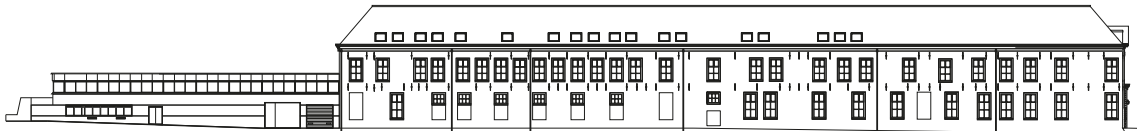

Zakstraat



Koudenhorn



Baknessergracht



Courtyard Zakstraat

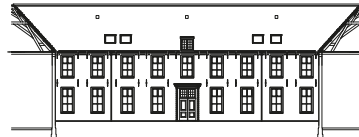

Courtyard Koudenhorn

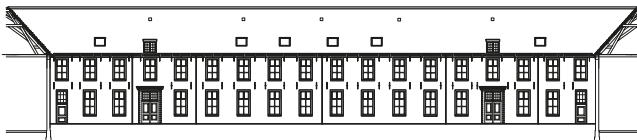

Courtyard Nieuwe Gracht

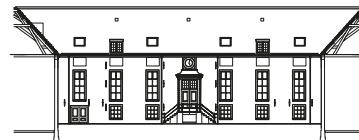

Courtyard Baknessergracht

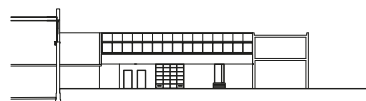

Inside Zakstraat



Inside Nieuwe Gracht



Outside Baknessergracht

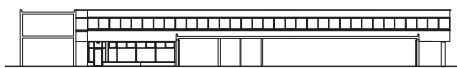

Inside Baknessergracht

1.4.4.2. COMPOSITION

0 20M

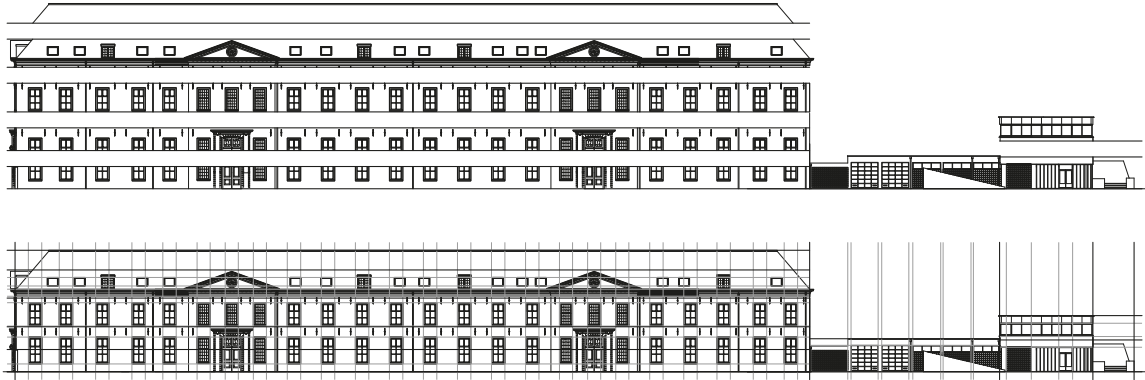

Nieuwe Gracht



Koudenhorn

Bakenessergracht

COMPOSITIONS

The façade of the main building is divided between the breakfronts which emphasize the entrances and the parts of the façade in between. The two lines of window frames are vertically and horizontally aligned. They do not however relate to the floors; the height of the newly added floor makes it appear behind the bottom row of windows. On the south façade window openings have been moved

and completely or partially closed to facilitate changes in use of the interior. This has led to several misalignments between the top and bottom windows, upsetting the original composition. The composition of the modern extension is made up by the difference between the openness of the windows of the first floor and the closed ground floor.

0 20M

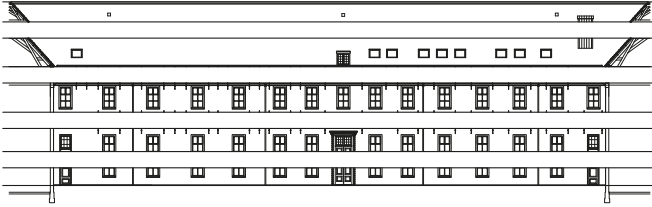

Courtyard Zakstraat

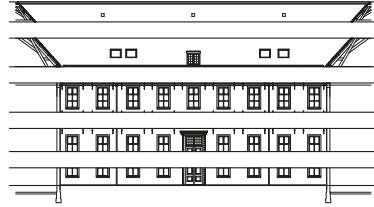

Courtyard Koudenhorn

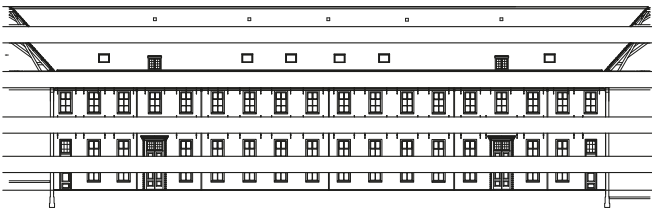

Courtyard Nieuwe Gracht

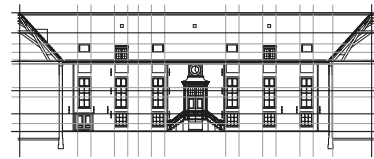
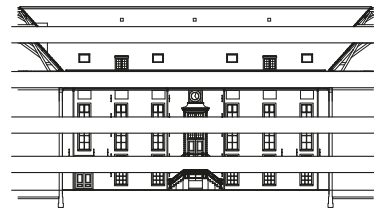

Courtyard Bakenessergracht

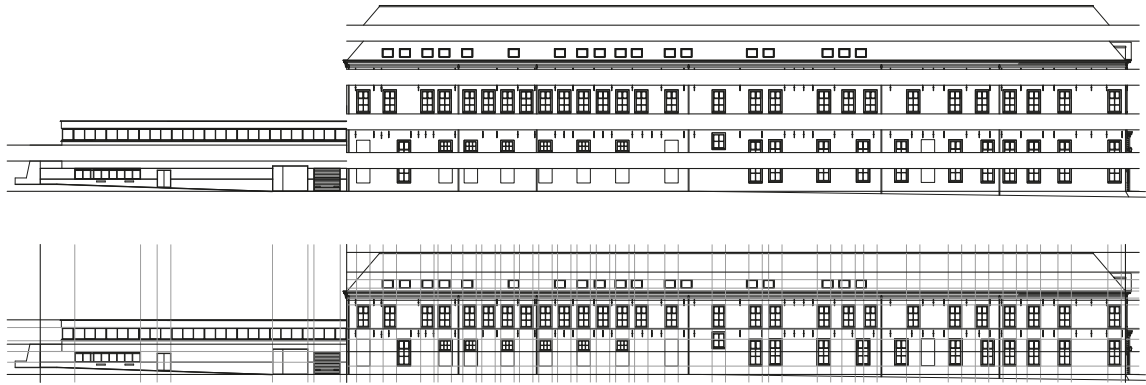

Zakstraat

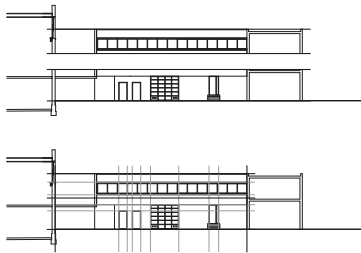

Inside Zakstraat



Bakenessergracht

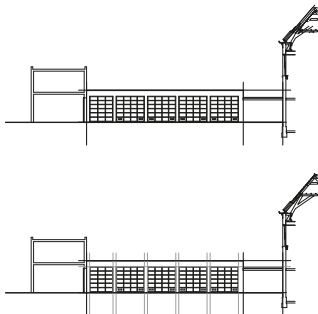

Inside Nieuwe Gracht

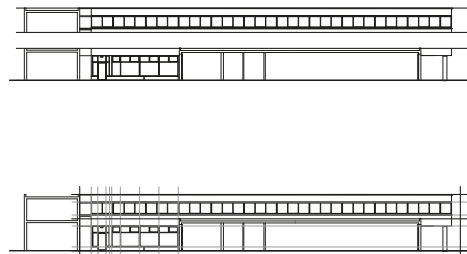

Inside Bakenessergracht

1.4.4.3. MATERIALITY

0 10M

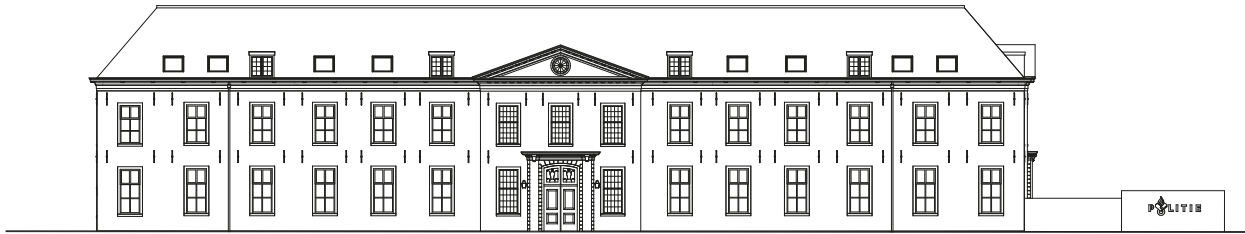

Koudenhorn

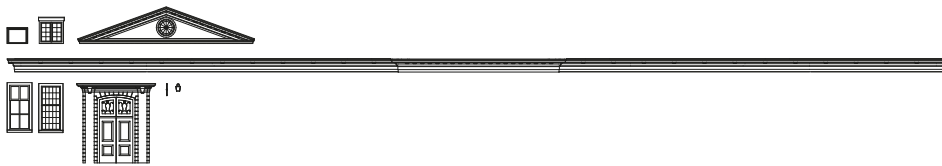

COMPONENTS

The ornamentation of the main building's façade through its components is focussed mainly on the breakfronts. The windows of the breakfronts consist of smaller window panes, making them more pronounced and adding to the ornamental character. The pediments with oculus

window draw even more attention to the breakfronts. The semi-columns and cornice around the entrance doors emphasize the entry points to the building. The many-layered eaves form the boundary of the top side of the façade.



Façade fragment analysis

TEXTURES

The façade of the original volume is made up out of brickwork, whereas the extension has a concrete façade. The colour of the brickwork is that of the material itself, with some discolouring caused by age. The concrete façade has two colours painted over it. The old bricks have a course texture. The concrete itself has some

roughness to it, but relative to the brick it is quite smooth. The concrete façade has been textured by the addition of alternating protruding and set-back vertical strips. This vertical orientation contrasts with the horizontal orientation of the brickwork façade



Harlem

(Braunius, 2021)

1.4.5. CONCLUSIONS

The Koudenhorn police building is located in the historic inner city of Haarlem, on the west bank of the the Spaarne river. The road along the river is one of the main traffic arteries of the city. The water of the Nieuwe Gracht, which marks the edge of the 17th century expansion of the city to the north, runs along the northern side of the building. The southern edge of the building runs along the narrow Zakstraat. The large size of the building, basically forming an urban block by itself, contrasts with the finer grain size and high density of the urban fabric in the inner city.

The Koudenhorn police building was built on the site of an ox market. It was originally constructed in 1776 as a deaconess-house, providing housing for impoverished elderly and children. From 1810 onwards the building was used as a military barracks. In 1971 the regional police headquarters was established in the building and an extension of the build constructed on the west side of the building.

The original building consists of four wings enclosing a central courtyard. The roof is slanted to both sides with a flat top in the middle. It contains five floors, including an attic used to house technical installations. A mezzanine floor is located between the ground and first floor. The floor plan is generally organized as a central corridor with

functional spaces on both sides, with the exception of several larger open spaces. The dining hall has maintained its original height, although an entresol has been added. The monumental entrance on the east façade is the main entrance to the building. Two more of the same entrances are located in the northern façade, which is only accessible to people working in the building. The extension building consists of two-storey L-shaped volume in combination with a ground floor volume. The L-shaped volume houses offices on the first floor and has a central corridor layout. The ground floor volume contains larger garage and storage spaces.

The façades of the original building, both on the exterior and in the courtyard, consist of original brickwork masonry. The window openings follow a consistent pattern, except on the south façade where several interventions have upset the pattern. The monumental entrances are decorated with semi-columns and cornices. They are located in breakfronts, which include pediments with oculus windows, making them the most ornamental parts of the building. The façade of the extension building contrasts sharply with the façade of the original building. It consists of concrete, textured by the addition of protruding and set-back vertical strips and painted in two horizontal planes of off-white and a shade of blue-green.

1.5. EINDHOVEN

1.5.1. INNER CITY

1.5.1.1. INTRODUCTION

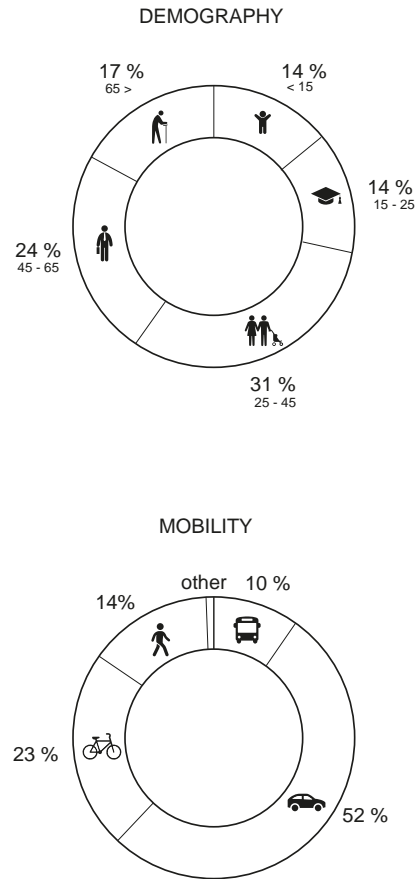

Eindhoven

Eindhoven is the fifth largest city in the Netherlands with a population of 235,707. It is located in the province of Noord-Brabant and was founded on an elevated area where the Dommel and Gender rivers meet. At the time, this position was on the trade route between Holland and Liège. The town was granted town and market rights in 1232, but was initially not of particular importance. Today's city developed mainly as a result of industrialisation due to its importance as the location of the Philips light bulb factory and later DAF (car manufacturer).

The inhabitants of Eindhoven are called Eindhovenaar. Their demographics are very mixed with slightly more older than younger people, but the amount of 25-45 year olds is particularly noticeable. This is due to the city's importance as a university city: Besides the Eindhoven University of Technology, the Fontys Hogescholen and the Design Academy Eindhoven are also located in the city.

Finally, Eindhoven is also an important railway junction and has an airport. Regarding the relevance of the police in Eindhoven, the AD Misdaadmeter (Van Lare, 2019) shows the second highest crime rate in the Netherlands after Amsterdam.

1.5.1.2. DEVELOPMENT

Vacant Heritage - Police Real Estate | The Netherlands

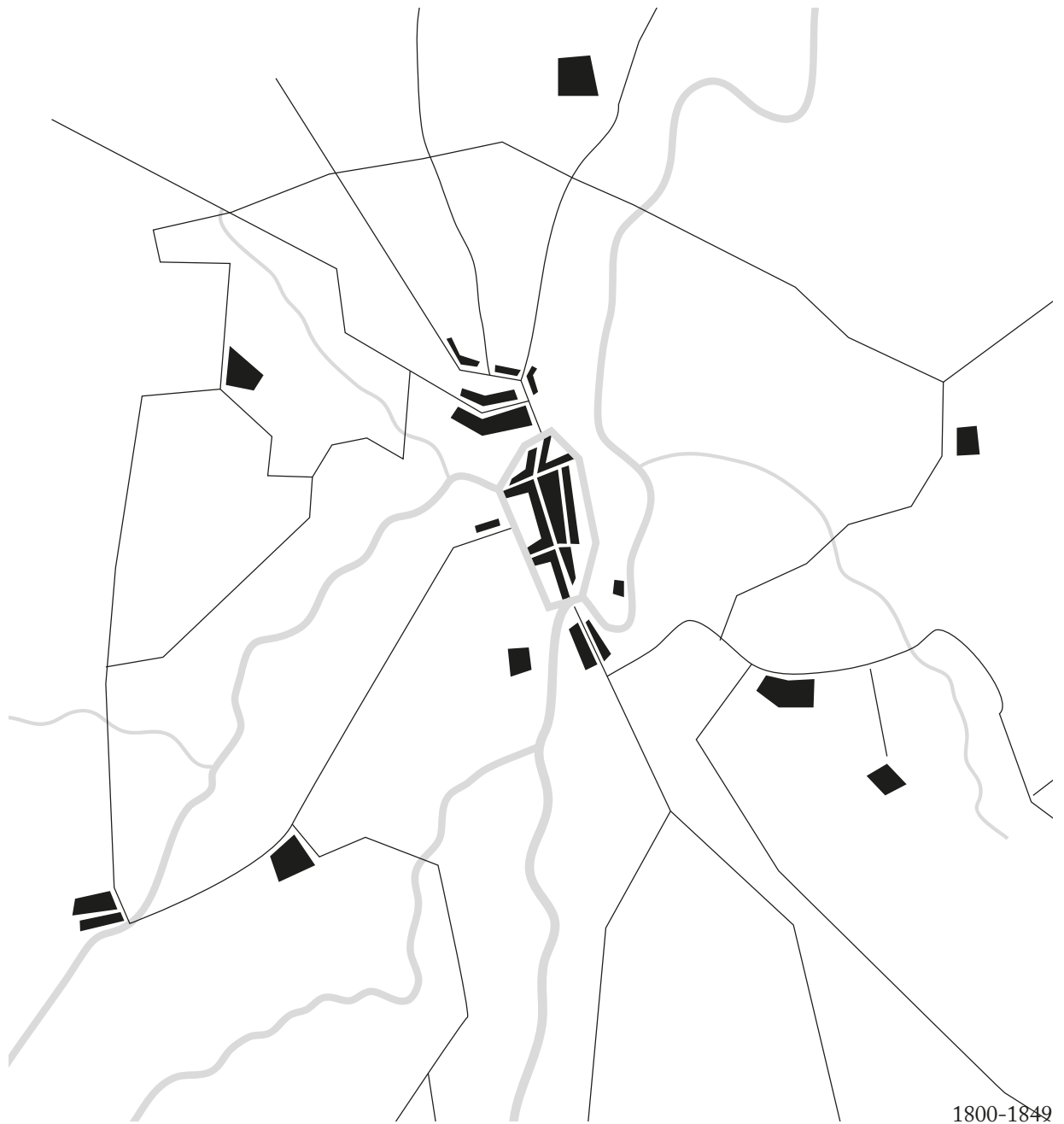

HISTORIC DEVELOPMENT

The historical urban development of Eindhoven was in the form of a star. For a long time, the town developed as individual settlements along a network of roads. In the middle of the 16th century, a great fire burnt down about three quarters of the settlements, but they were rebuilt. The city of Eindhoven, as we know it today, grew out of multiple communities only at the beginning of the 20th century in the course of industrialisation.

Important for this historical development of the city was its economy: In 1891 The electric company Philips was found in Eindhoven. Most of the buildings are still standing today and have been converted into the inner city locations Strijp S and Strijp R (Strijp-S, n.d.).

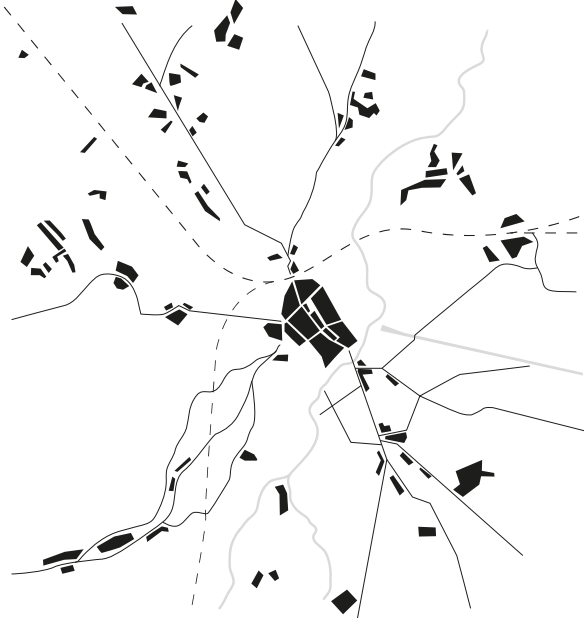

1850-1899



1900-1949



1950-1999



2000-2022



BUILDING AGE

Only a very small number of buildings from the period before 1800 have been preserved. The two most prominent buildings have remained and are used as museums today, the Philips building and parts of the DAF Museum. Especially in the southern and western parts of the city, many buildings from the pre-war period have been preserved, most of which are small-scale residential buildings. But the PSV stadium also dates from 1913. After World War II, mainly large residential and office complexes were built.

The city centre of Eindhoven is densely built and the historic star shape growth is still visible along the main road network. The least dense is the area of the Campus of the University in the northeast of the City Centre as well as the area around the train line while the commercial centre marks the highest density. Consequently the police building lays in an area that directly contrasts high and low density.



0 1500 M



1800-1899



1900-1949



1950-1999

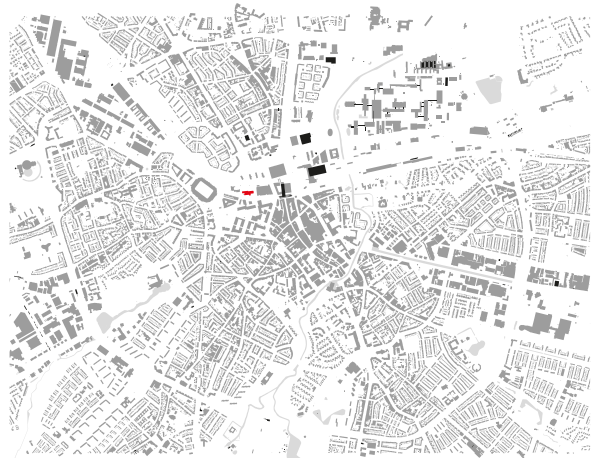

2000-

1.5.1.3. NETWORKS

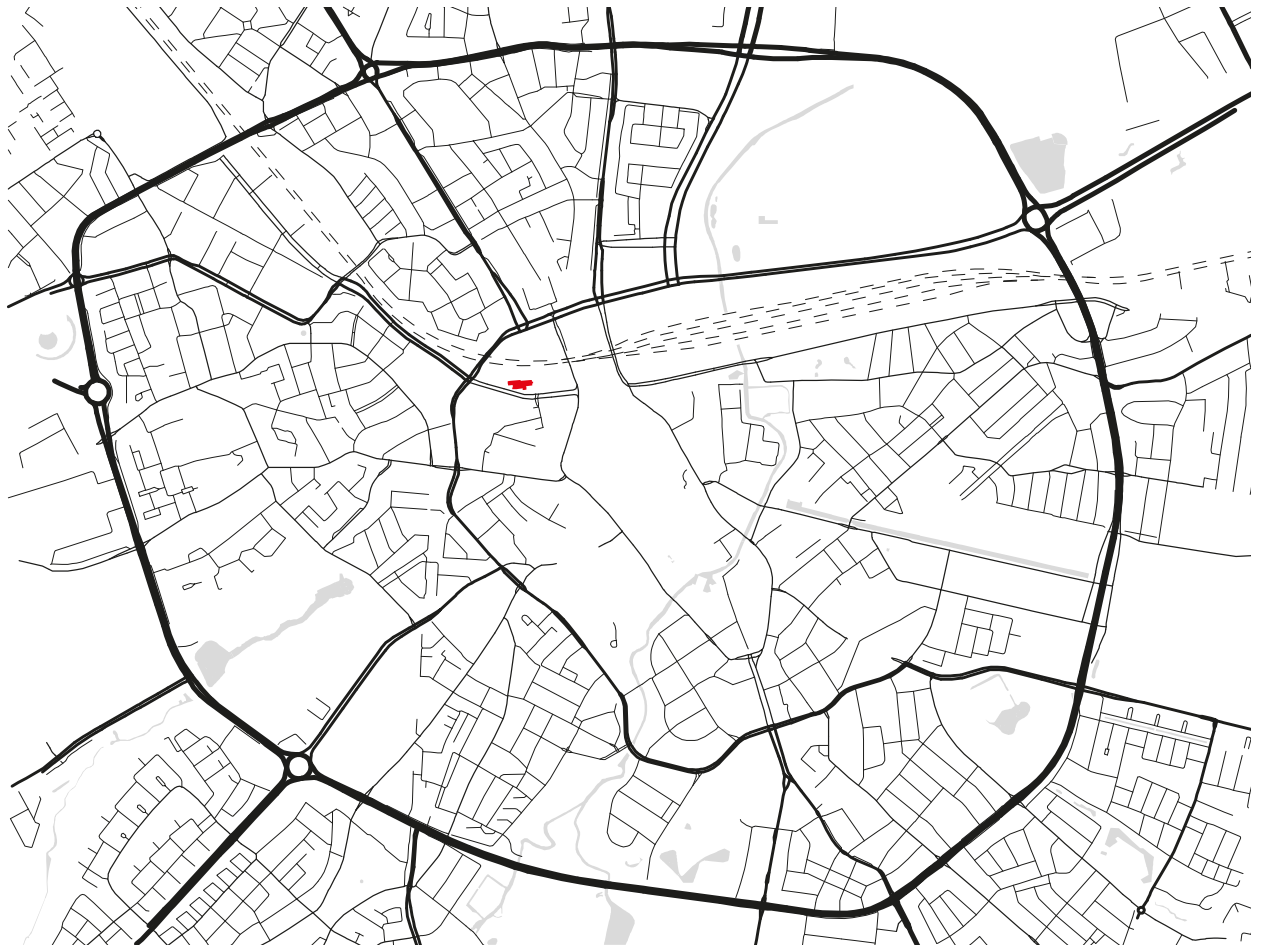

All roads

ROAD NETWORK

Four major roads run roughly in each direction from the ring road to the nearest motorways. The primary network within the city runs in a star shape from an inner half ring to the outer ring. The eastern side is left out. The secondary network connects the main routes and also passes through the city centre. The network of tertiary routes leaves out the city centre and the university area. The primary road system is the ring around the city. It includes not only the city centre but the entire urban area of Eindhoven and leads the traffic in all directions. In this way, a large part of the traffic is routed around the city. The secondary roads are largely connected to the outer

ring of primary roads and form the main traffic axes into the city centre. Particularly striking is the half-ring, which runs in a loop from northeast to southeast and runs slightly outside the city centre. The east side is left out so that no complete ring is formed. The streets to the west are derived from this half-ring. The tertiary roads have less distinctive features than the secondary road system. They lead the traffic from the main roads into the residential areas. Their shape also shows the type of urban development in some areas. By looking at areas without tertiary roads, one can also identify larger parks and the city centre.

0 500 M

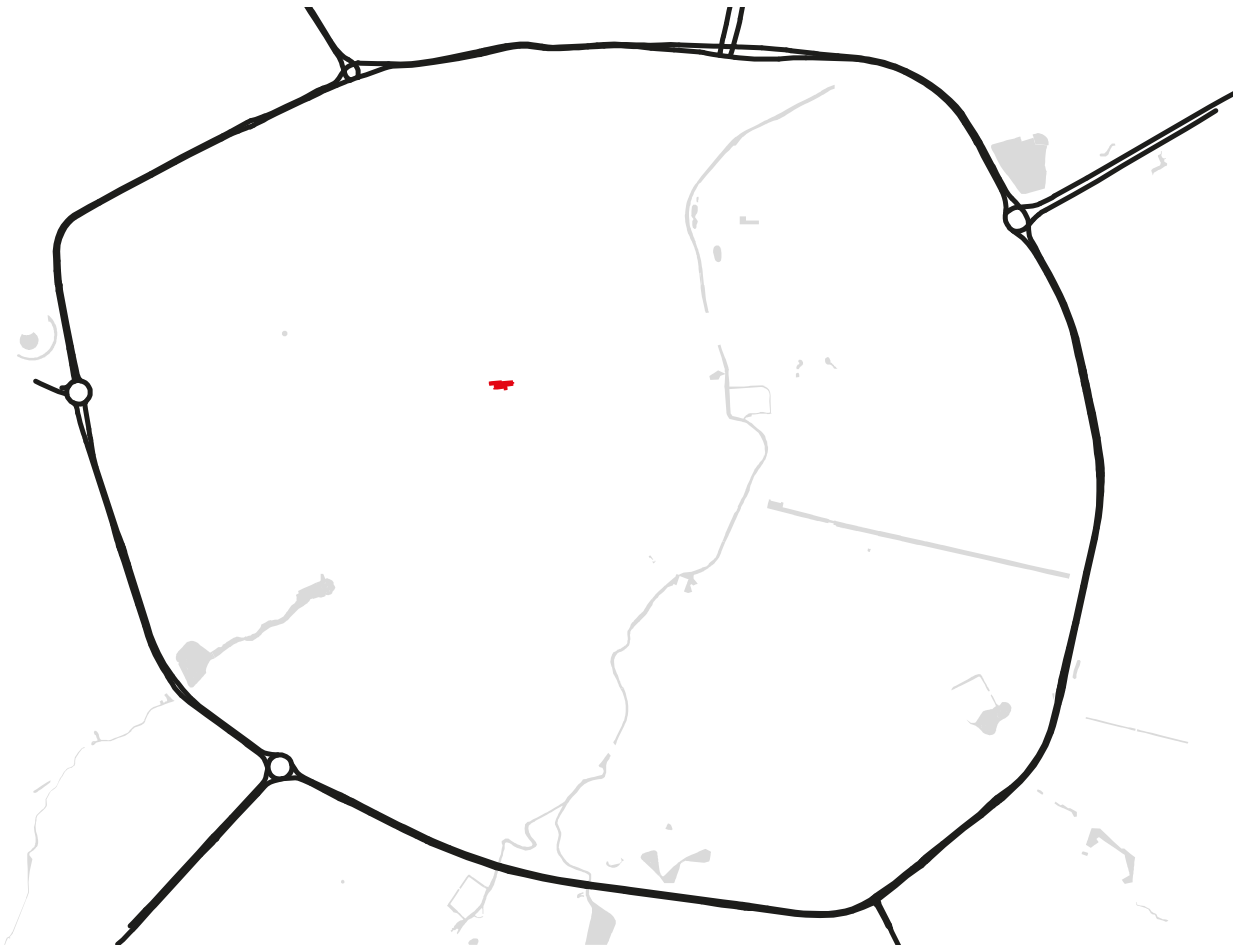

Primary roads

Eindhoven



Vacant Heritage - Police Real Estate | The Netherlands

Secondary roads

0 500 M



Eindhoven

Tertiary roads

Public squares Green Water

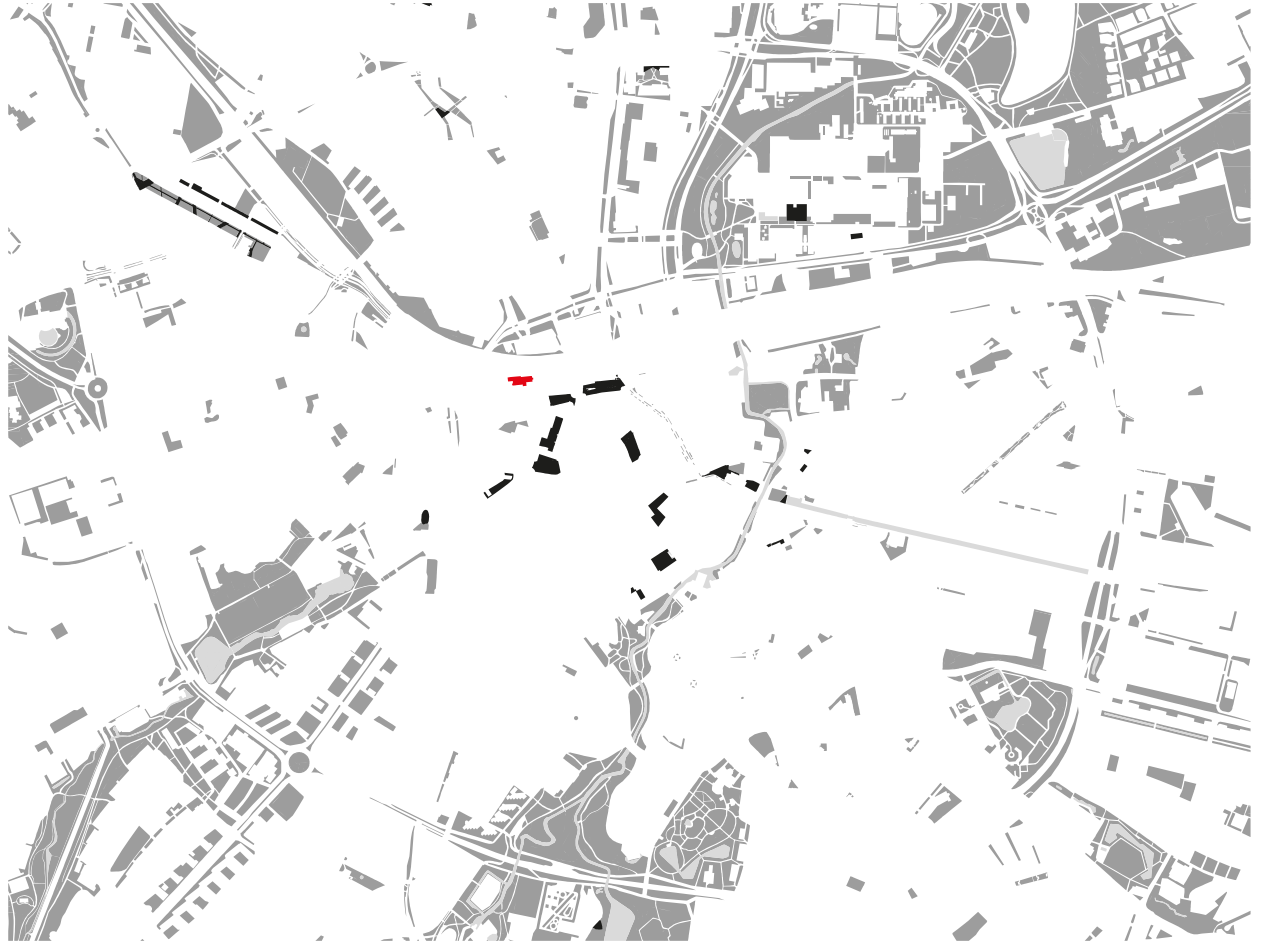

Green, water and public squares

GREEN, WATER AND PUBLIC SQUARES

Due to its location in the southeast of the Netherlands, Eindhoven is not formed by canals. Nevertheless, the Dommel and a branching gracht called 'Doode Gracht' run through the city on the north-south axis. The 'Eindhovenens Kanaal' leads eastwards from the Dommel. The 'Beatrix Canal' in the southeast runs along the Gender and in this area there are also several lakes. The police building in Mathildelaan is not located in direct proximity to water.

There are only a few green areas in the direct city centre. Most of the green fingers are near the water. The largest area is on the university campus and from there towards

the outside of the city. Another larger green area with even small scale forestation is around the Dommel. It is noticeable that on each side of the Mathildelaan police building there is a larger green area, but this is not connected in the area of the railway.

Public squares are mainly located in and around the city centre. An exception is a square on the university campus. Fewer squares are located in places where there is more greenery. These can be places that are used similarly, as places for social interaction. Other places with few public spaces are industrial or commercial areas outside the city centre.

1.5.2. URBAN BLOCK

1.5.2.1. COMPOSITION

Vacant Heritage - Police Real Estate | The Netherlands





Eindhoven

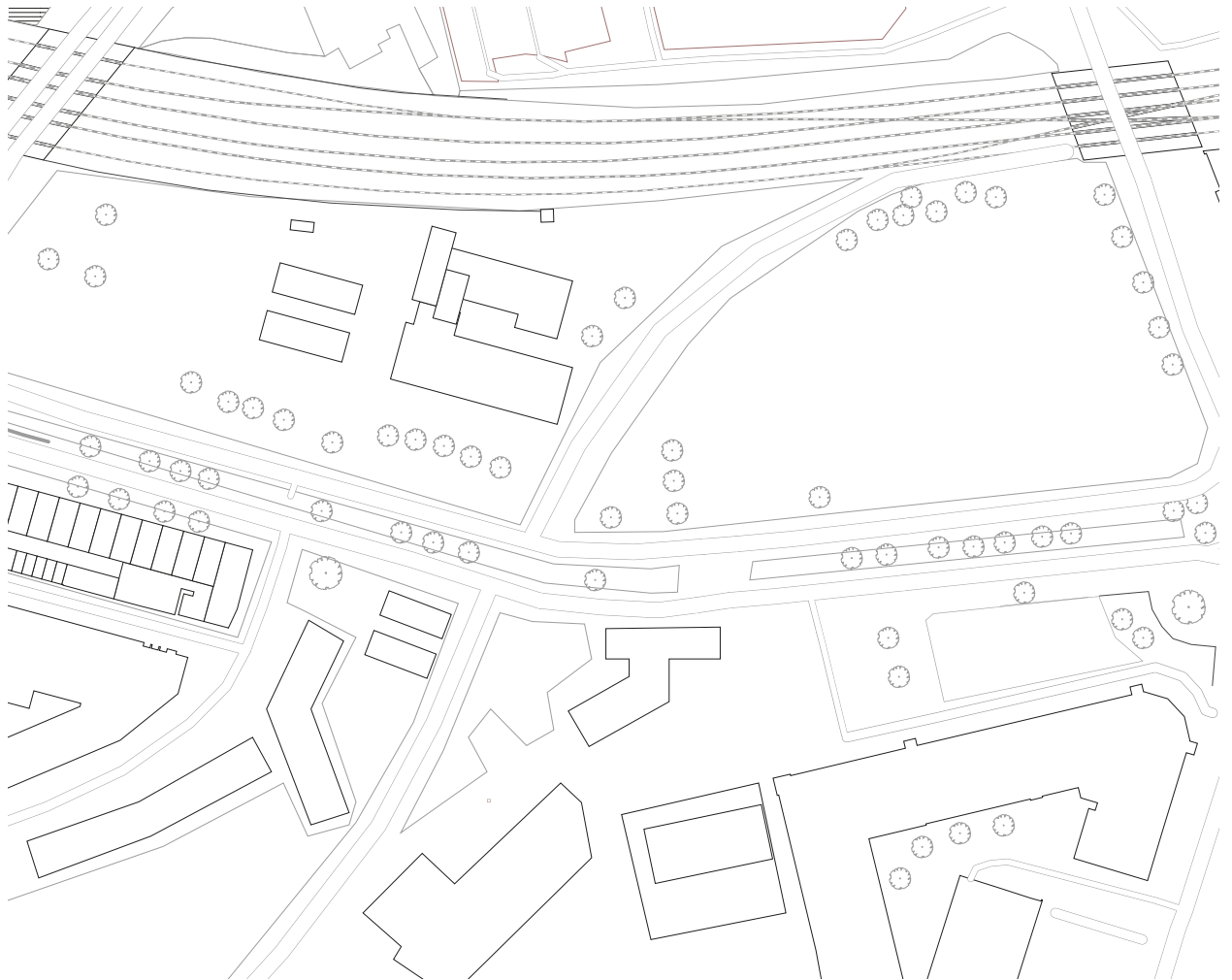

1960

HISTORIC DEVELOPMENT

One of the oldest buildings in this block is the Witte Dame building of Philips Fabriek, which was built in the 1930s. Until the 1960s, the tax office of Eindhoven was located at the building site of the police building, which had to make way for the new police building in 1981. The additional building, which includes a sports hall, dog

kennels and stables, followed shortly after. After 2000, the opposite building to the police building was enlarged and its façade was re-designed. The Onyx Tower, which was added in 2018 on the same site, is the tallest building in the block with 84 meters.

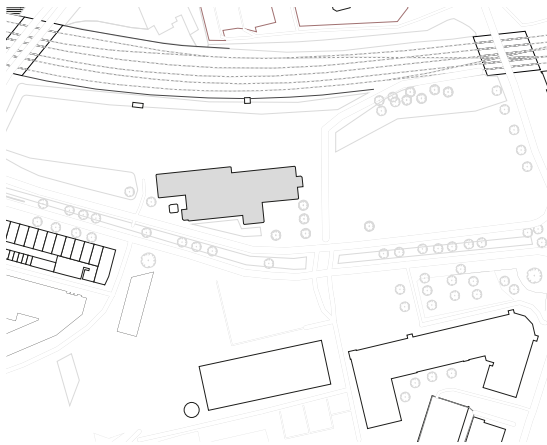

1980

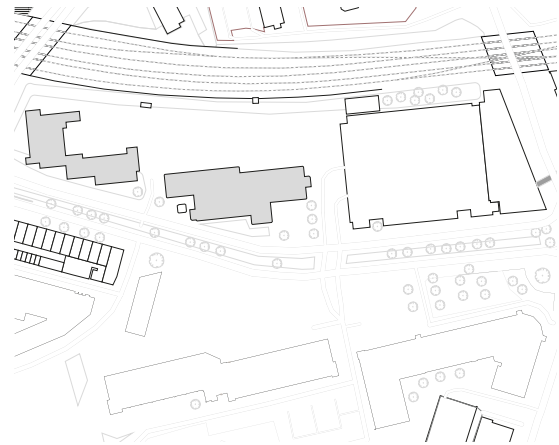

1980-1990

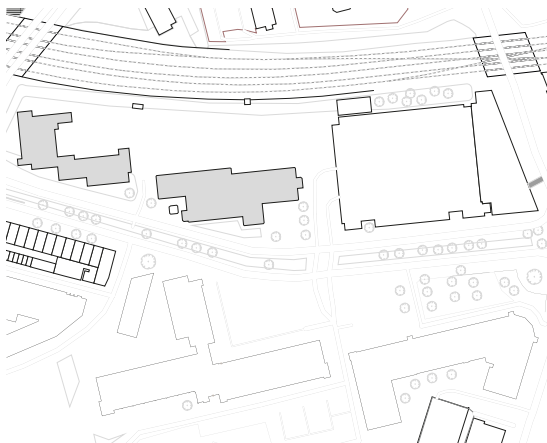

2000-2009

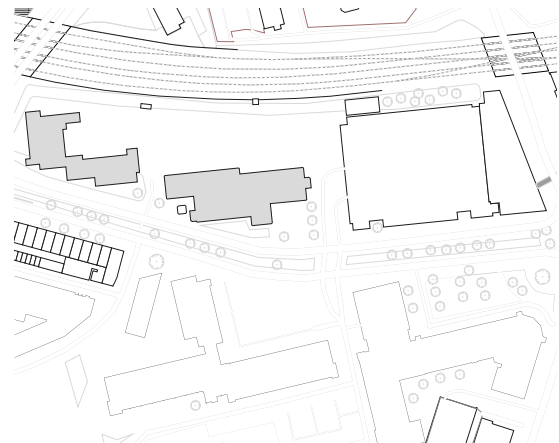

2009-2018

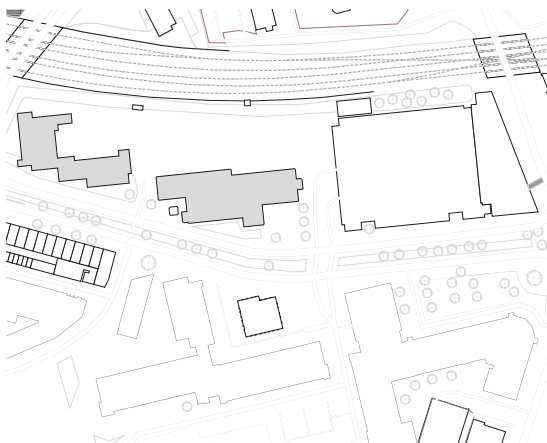

2018-2022

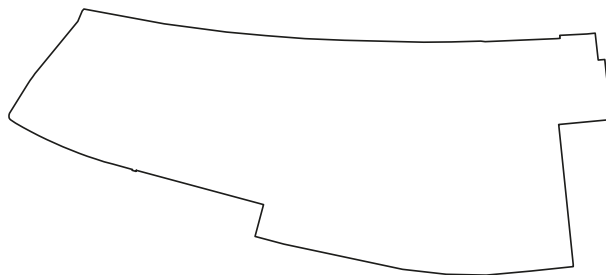

Parcels
1

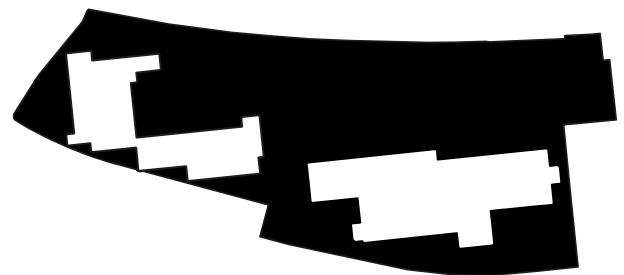

Empty area
7687 m²

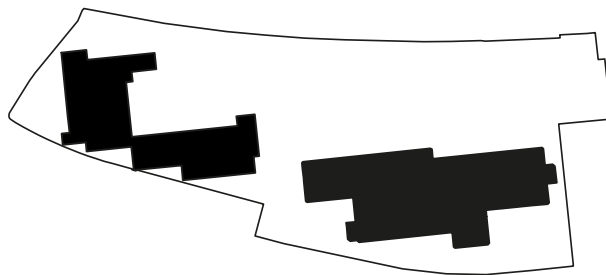

Built area
2760 m²



Police real estate
10447 m²

Vacant Heritage - Police Real Estate | The Netherlands

BLOCK INFORMATION

The plot on which the police building was built is quite large, measuring 10447 square meters. It represents the actual urban block, while for the present research, because of the necessary information and impact on the studied

building, other surrounding buildings were in some cases included as well. The built-up area is not even one third of the total area of the plot. Nevertheless, the largest part of the area is sealed and is mainly used as a parking lot.

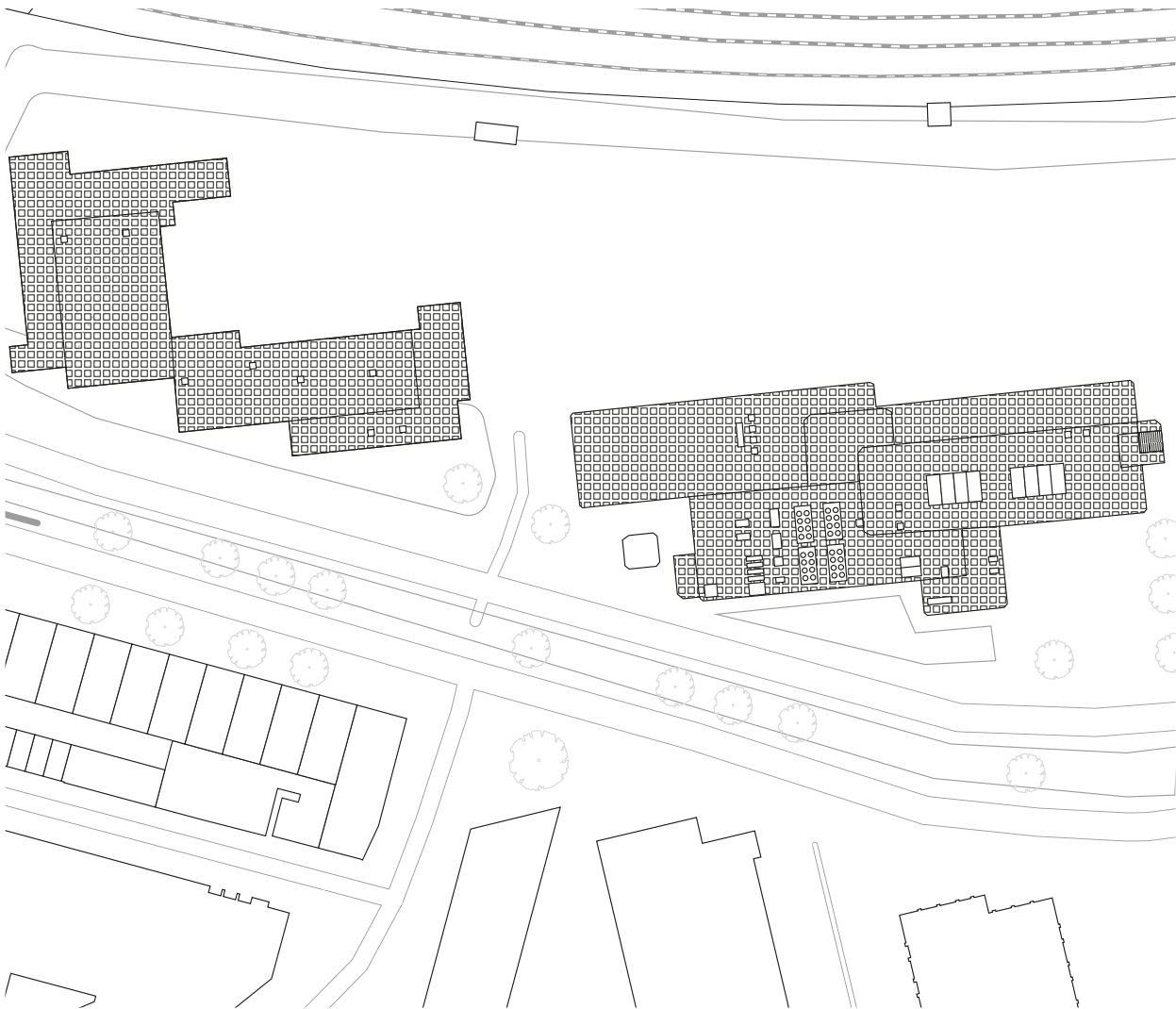

Roof structure

ROOF STRUCTURE

The roof structure shows the height composition of the individual parts of the building. All the roofs are flat, both on the main building and on the additional one. The building services are located on the second highest roof of the main building, while on the highest roof there are

two large skylights. Finally, the stair case tower in the east overlooks the highest part of the roof and provides access to it. The antenna mast is also located on the highest part of the building. Like the balconies, the roofs are accessible only for maintenance purposes.

1.5.2.2. STREETS

0 20 M

■ Façade openings

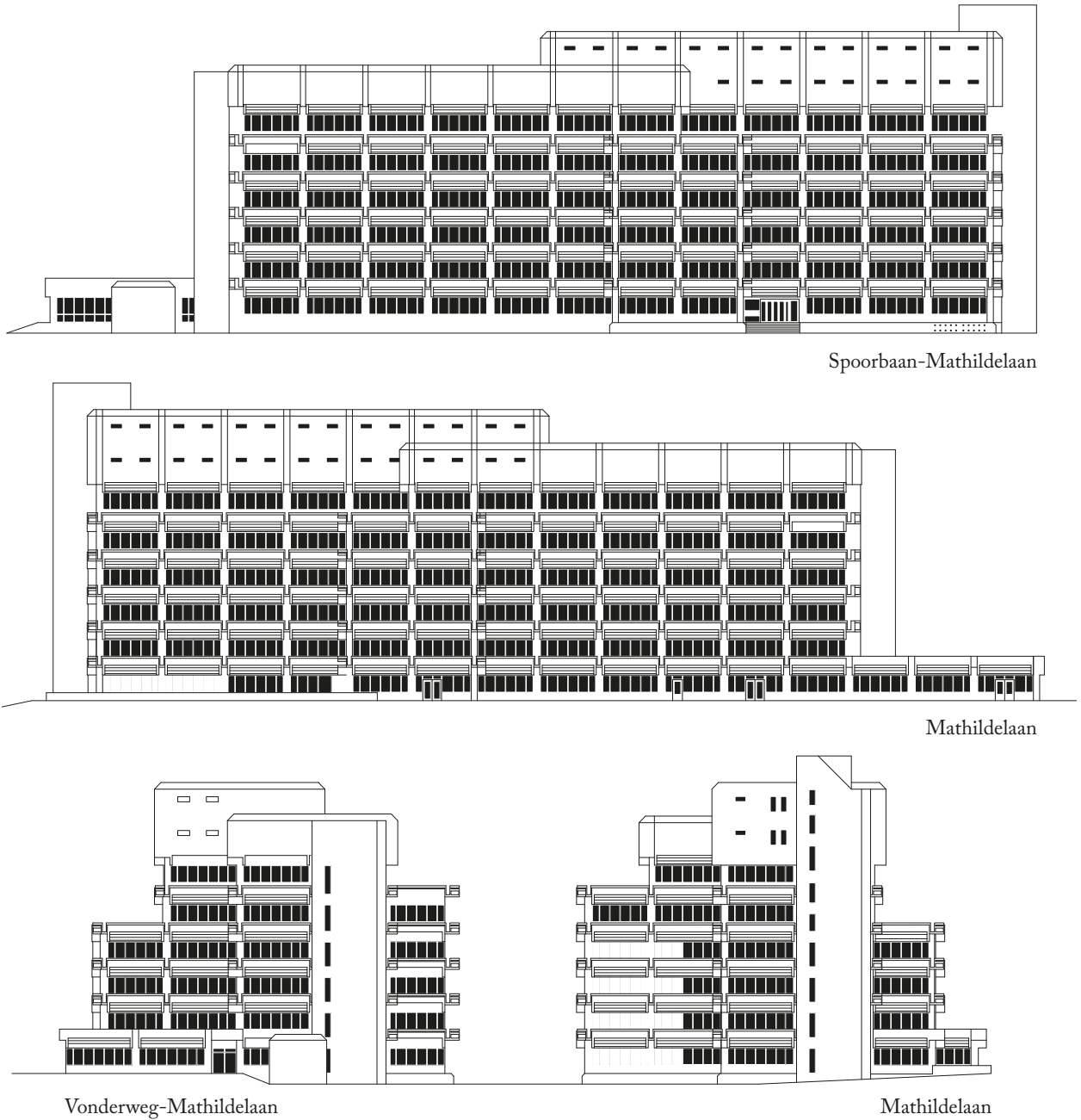

Vacant Heritage - Police Real Estate | The Netherlands

STREET ELEVATIONS

The only but very prominent street with a direct connection to the block is the Mathildelaan. If the number of turning lanes is added, it is in part six lanes wide. There are also parking lots on the side of the police building and a bicycle lane on both sides. On the side facing away from the police, this is separated by a green strip. There is also a green strip in the middle of the street. In front of the entrance to the police building there is a public

square with seating and trees located, and an evergreen bed separates the sidewalk from the police buildings. In addition, a four-lane parking garage entrance separates the parcel from the neighbouring parcel. The police parking area can also be accessed from this driveway. Another entrance and exit is located on the western side.

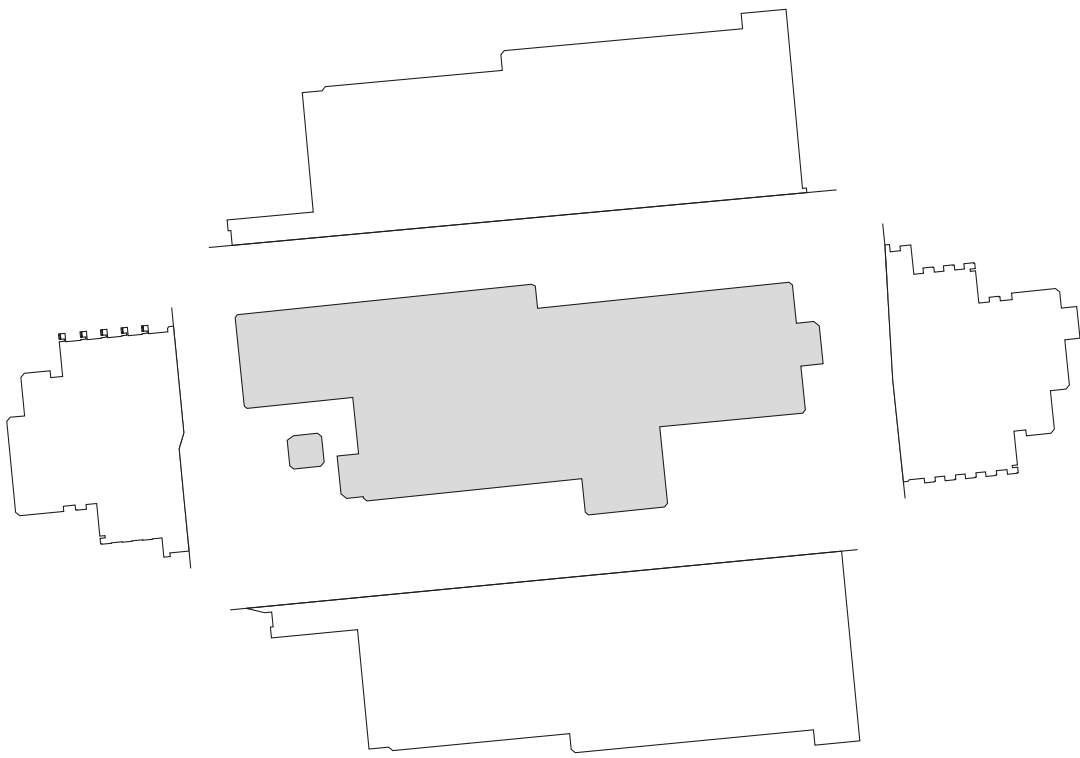

Eindhoven

Parcels and façades

PARCELS AND FAÇADES



Vacant Heritage - Police Real Estate | The Netherlands

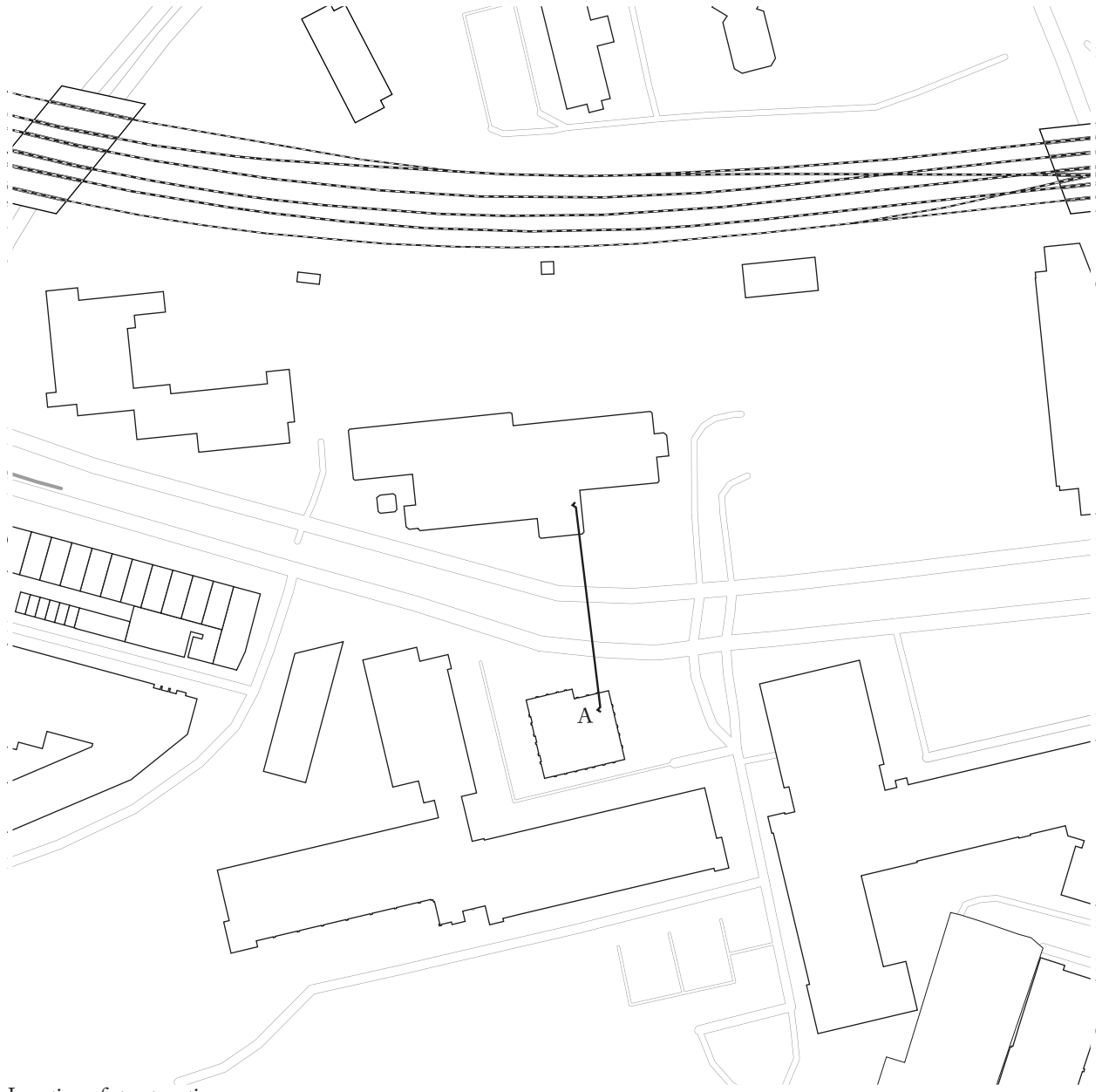

Location of street sections

STREET SECTIONS

The following drawings show how the building compares to the surrounding buildings. The recently built tower opposite the police is much taller and more monolithic. The modern buildings further to the south-east, which

are not visible here, also show this development. The older residential buildings in the area behave completely opposite. These are much smaller and lower. This shows the height development of the city.

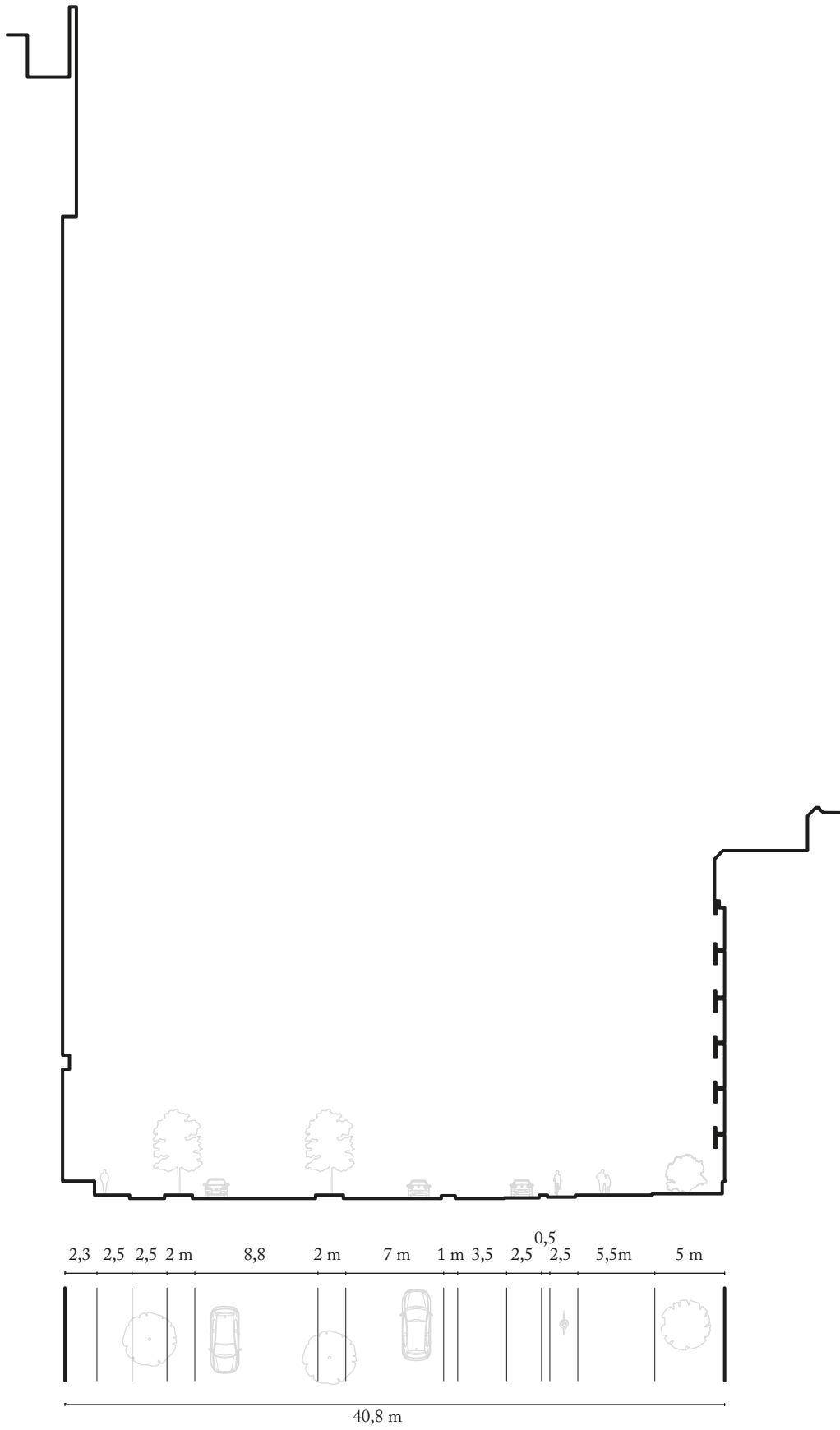

Section A

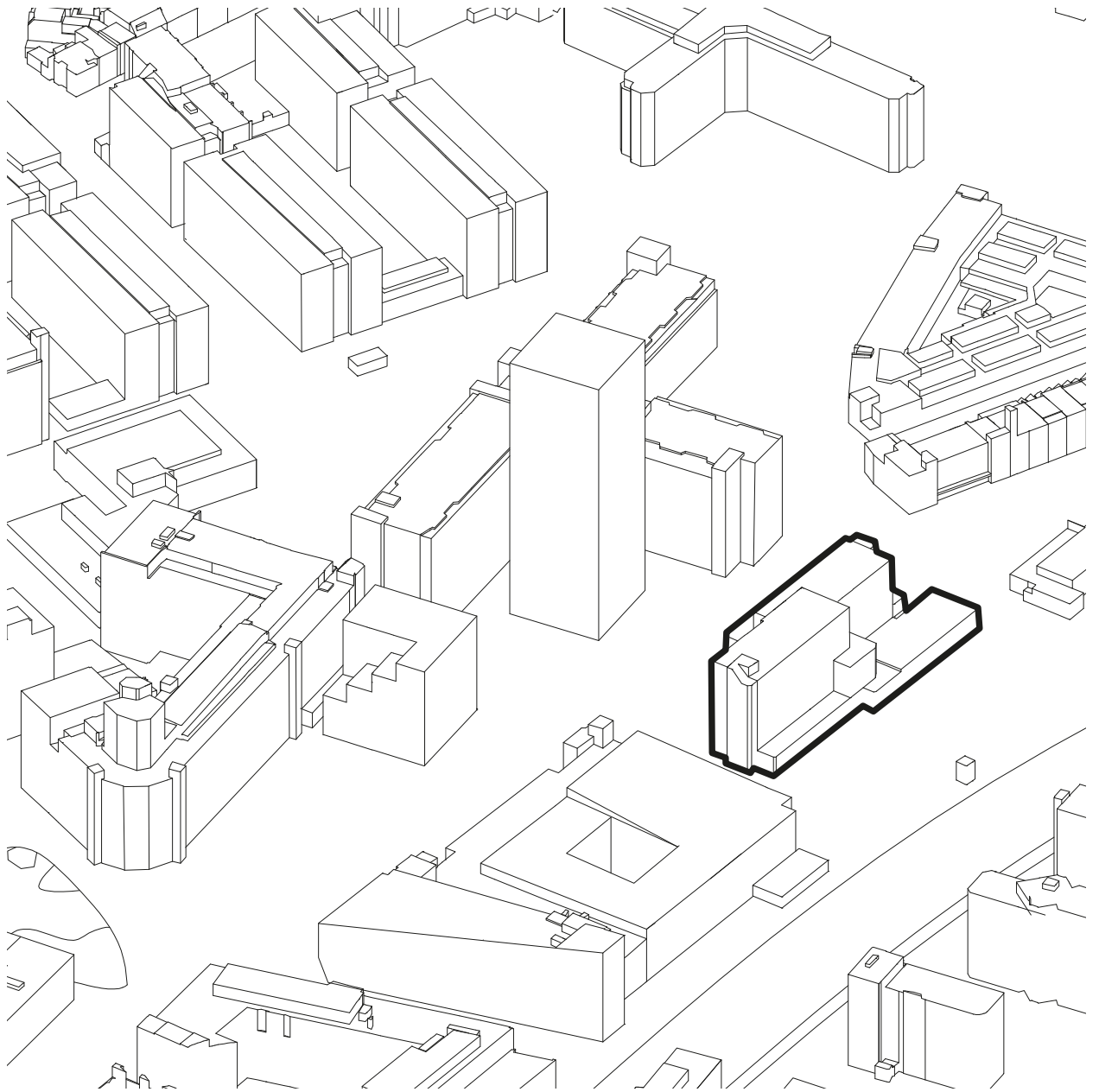

Isometric of urban block in surroundings

ISOMETRIC

1.5.2.3. ACCESSIBILITY



■ Car parking ▲ Entrance 🚲 Bicycle parking

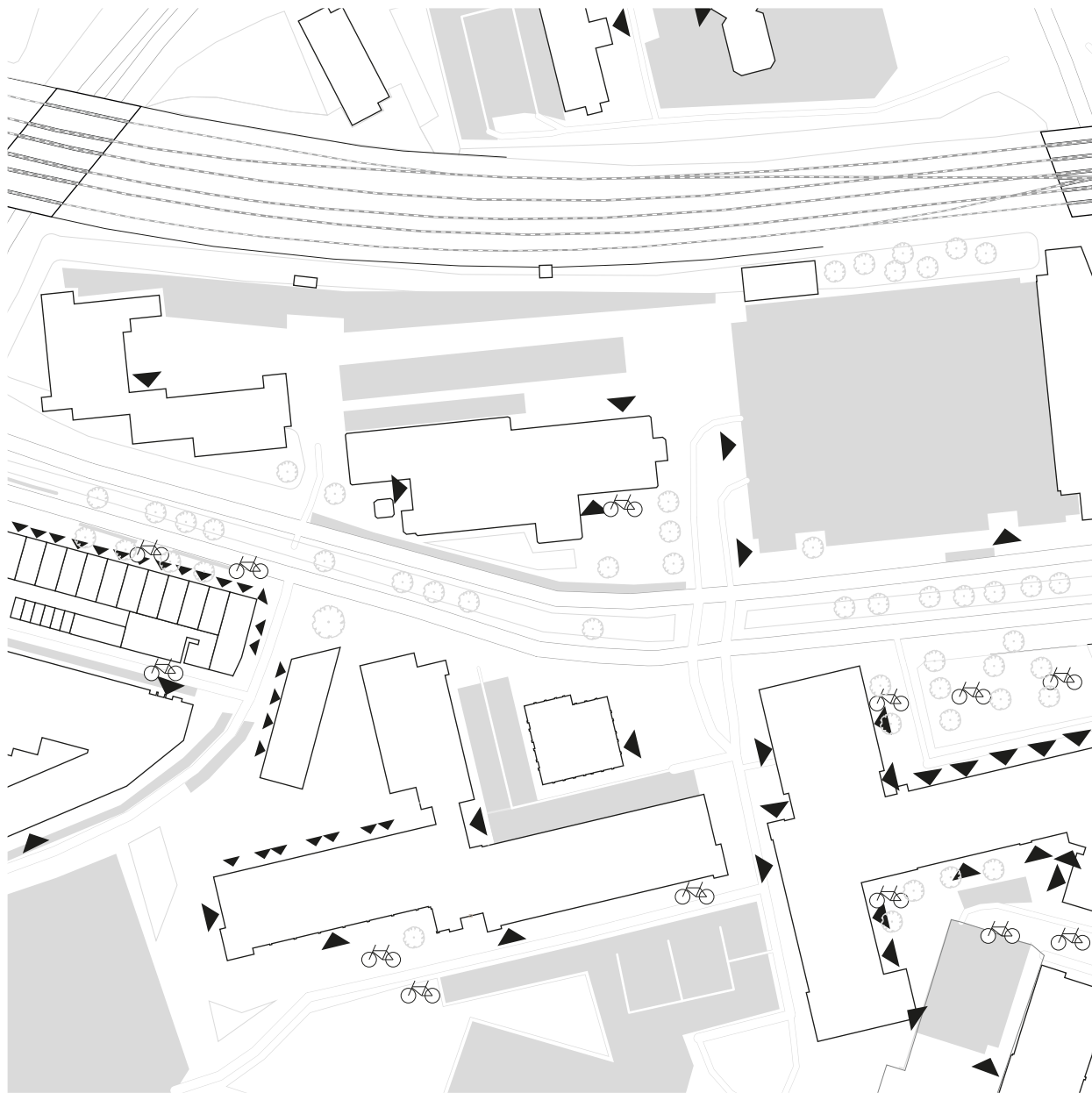

Eindhoven

Parking and entrances

PARKING AND ENTRANCES

It is clear from the amount of parking options that the block around the Eindhoven police is predominantly dedicated to transportation by car. In addition to numerous separate parking spaces and large parking areas, there is a five-story parking garage and two underground garages in the immediate proximity. But there are also numerous bicycle parking spaces which are particularly located next to the Witte Dame building. Entrances to

the buildings are surprisingly often not located on the sides of the buildings directly facing Mathildelaan, but they are visible from there. Only in the row of residential buildings to the west the entrances face the street, as does the entrance to the police building itself. But even in the case of the latter, it is set back from the street by the square in front of it.

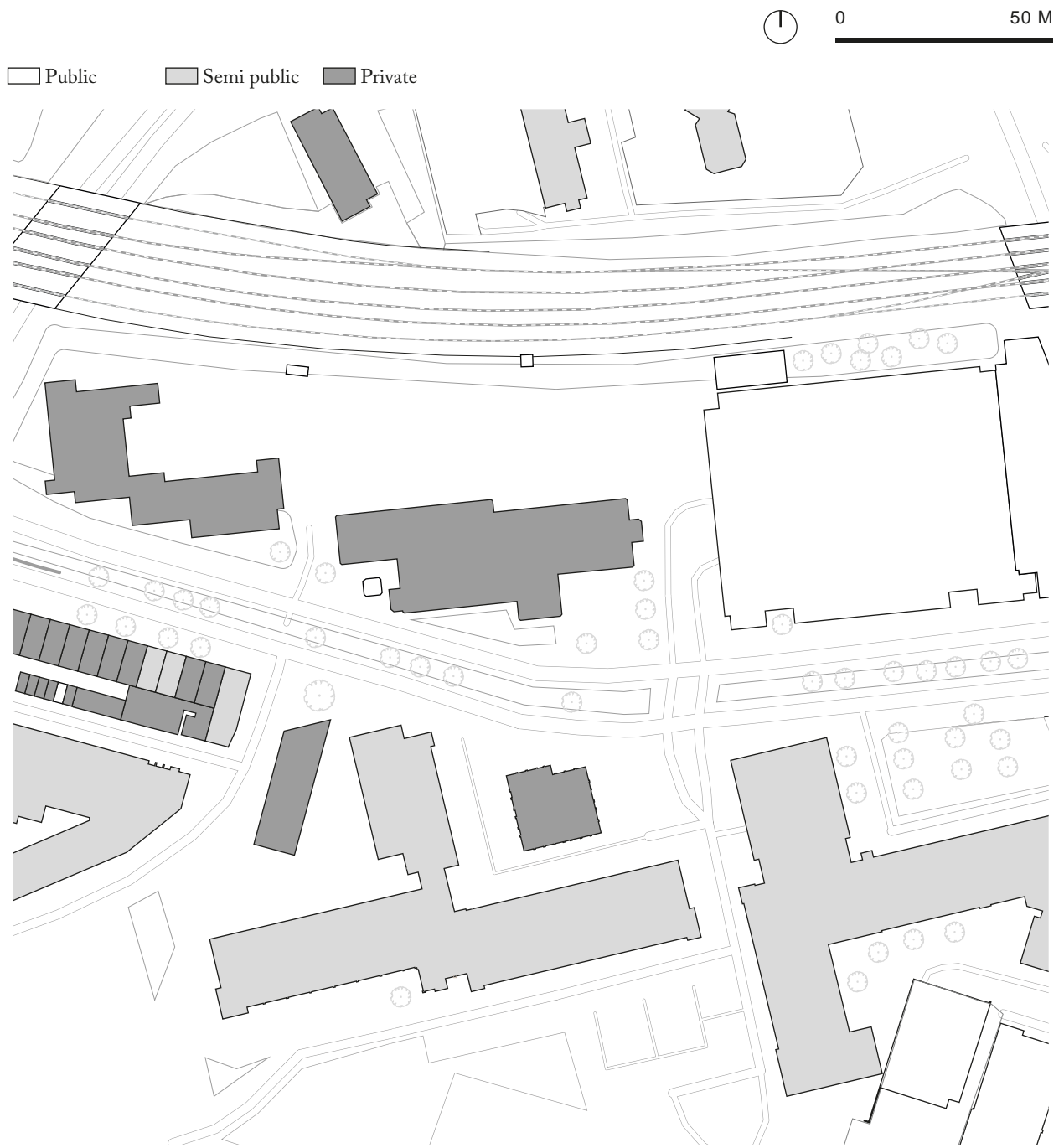

Public, semi-public and private buildings

PUBLIC, SEMI-PUBLIC AND PRIVATE BUILDINGS

The only entirely public building is the parking garage. Most of the other buildings are semi-public, the smallest buildings and the Onyx Tower are private, as is the police

building itself. Instead, the green spaces around the buildings are all open to the public, except for the row houses in the west.

1.5.3. BUILDING OBJECT

1.5.3.1. SPATIAL LAYOUT



0 20 M

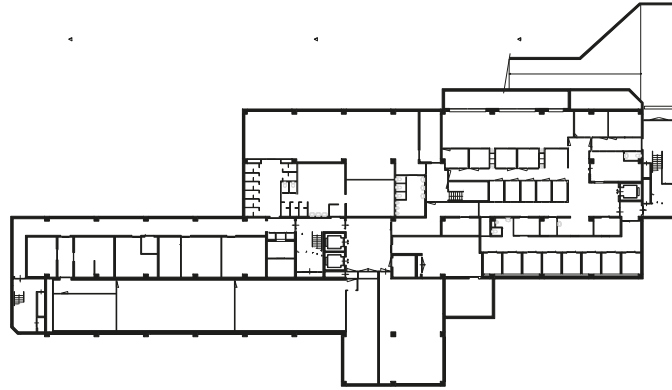

Ground floor

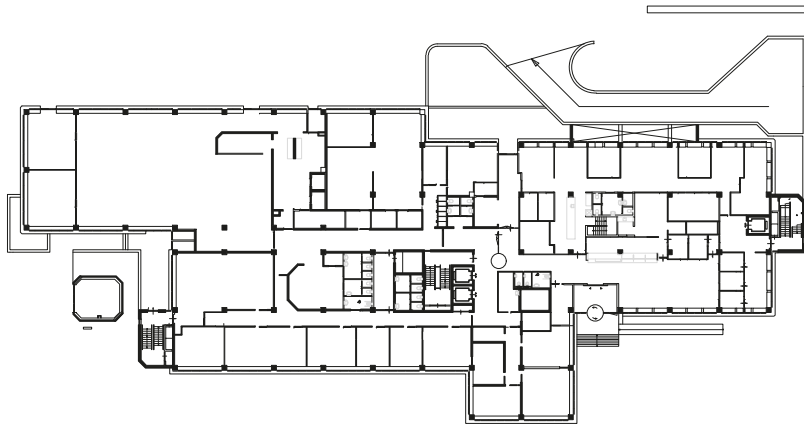

First floor

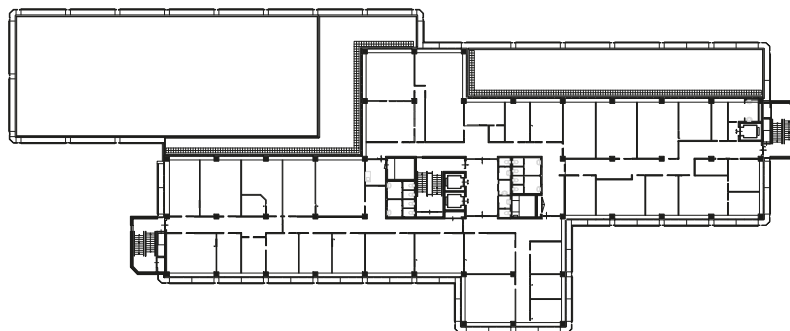

Second floor

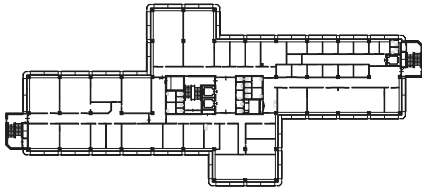

Third floor

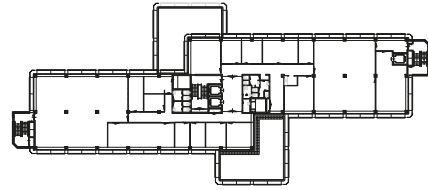

Sixth floor

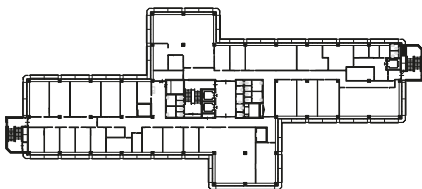

Fourth floor

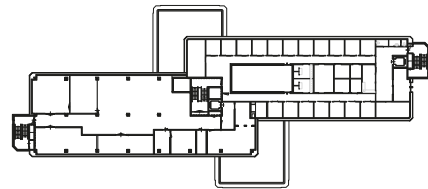

Seventh floor

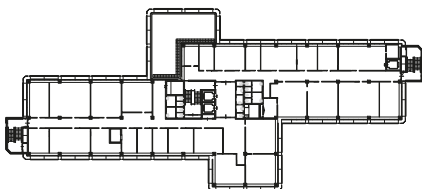

Fifth floor

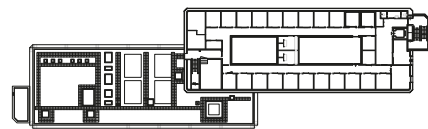

Eighth floor

FLOOR PLANS

The entrance area is very small compared to other spaces. The access cores are arranged in the east and west on one corner of each of the two building blocks that are offset the central symmetric line. A further access core with lifts is located in the centre of the building. These access cores are connected by corridors that run centrally through the

building parts and lead to rooms of different sizes. The structure of the building is based on a slightly irregular grid with 60x60 cm columns at the points of intersection. A striking detail are the corners sloped to a 45 degree angle.

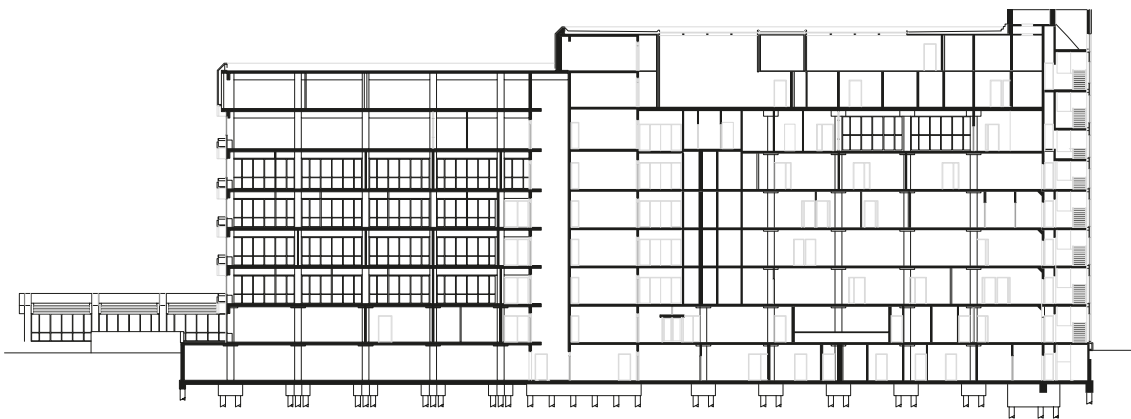
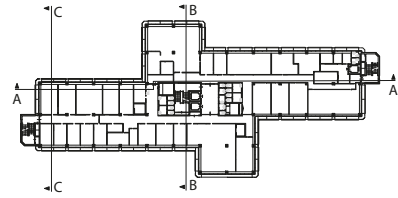

Section A-A

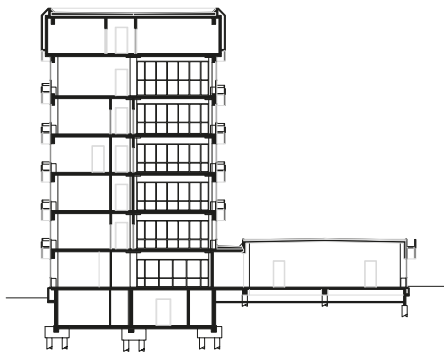

Section B-B

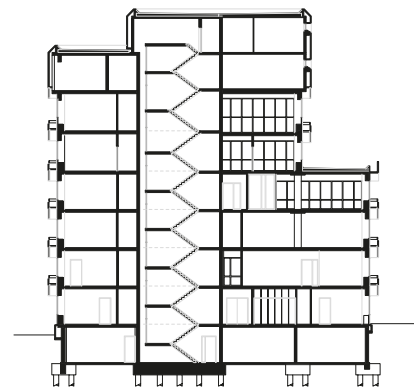

Section C-C

SECTIONS

In the sections one recognises the functional design. All floors are of the same height. The 40cm thick floors are supported by a regular grid of columns. Except for the

central stair core and the cellular wings, the partition walls are thin lightweight walls.

1.5.3.2. SPATIAL RELATIONS

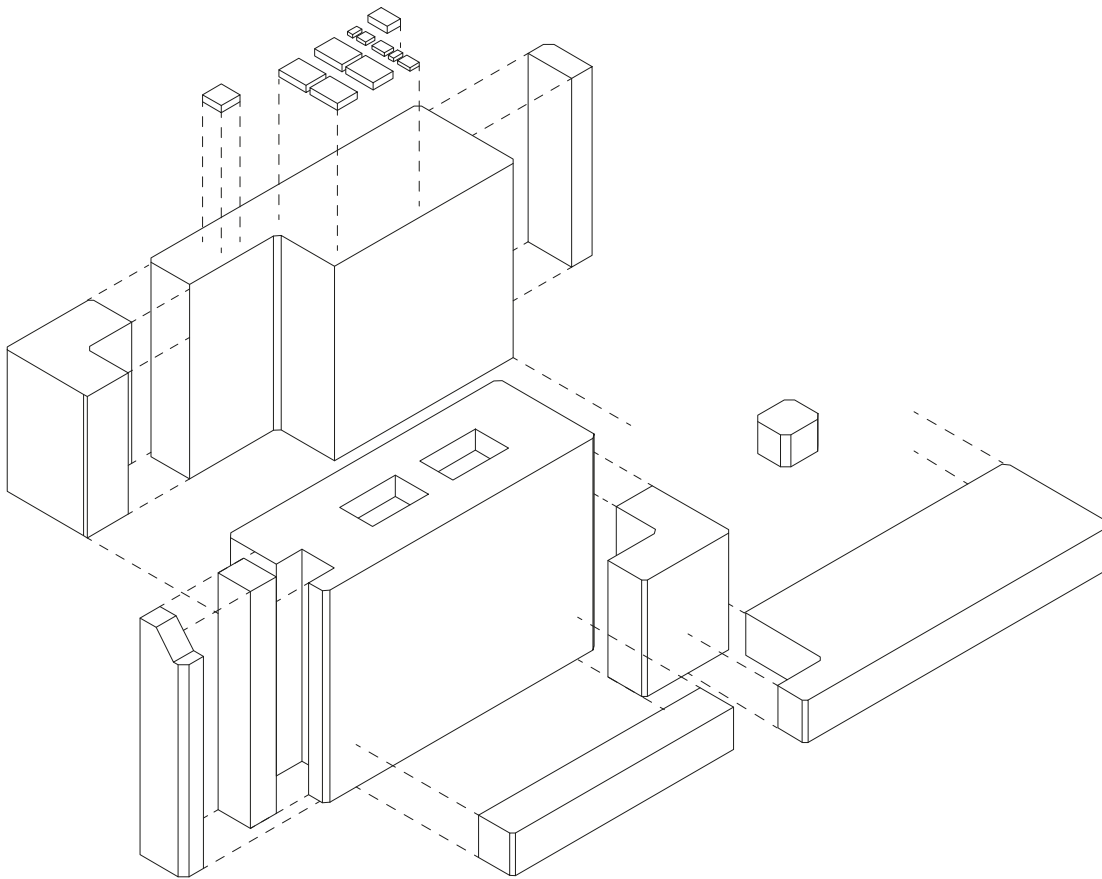

Building volume

BUILDING VOLUME

The building is a complex composition of several rectangular blocks that are linked together. They vary in height. The outer stair towers are each recognisable from

the outside and are set apart in their design. The canteen is also visible as a separate lower block. The central parts form a rotation-symmetrical figure.



0 20 M

- Start
- ⋯⋯ Route
- ▲ Ascending vertical route

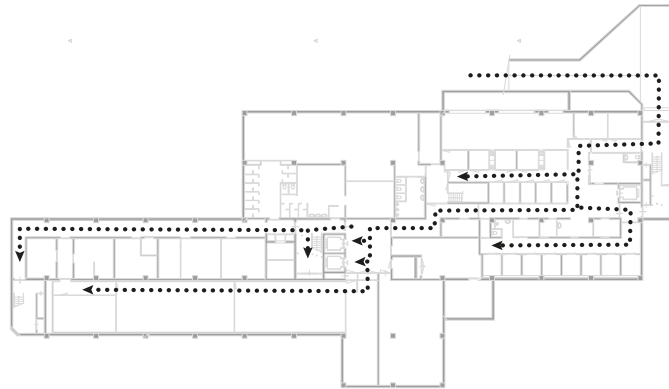

Ground floor

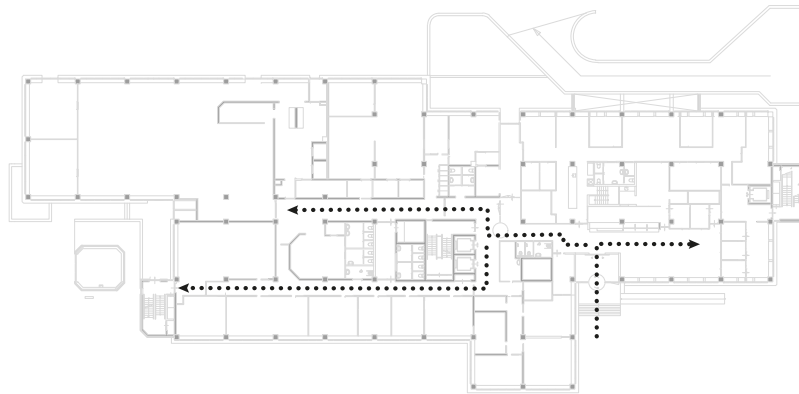

First floor

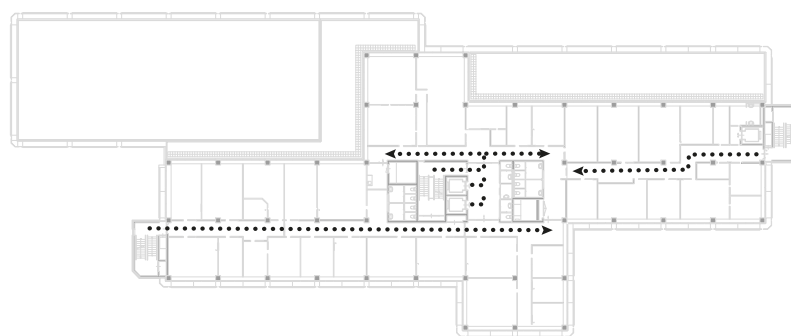

Second floor

Vacant Heritage - Police Real Estate | The Netherlands

CIRCULATION

The circulation through the building is regular, with the exception of the ground floor. Long corridors usually lead from the entrances to each floor or from the staircases outside into the core area, from which the rooms are

separated. The floors, including the main entrance, can be reached by ramps and lifts and are therefore all barrier-free.

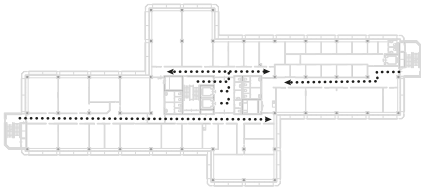

Third floor

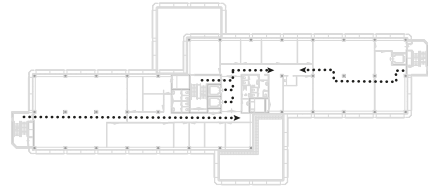

Sixth floor

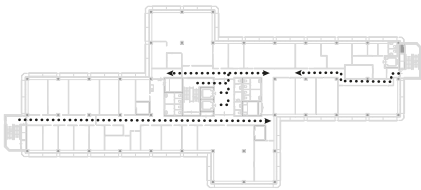

Fourth floor

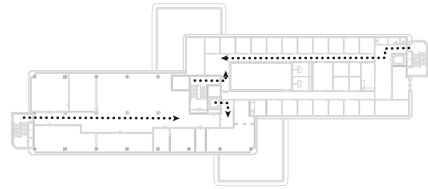

Seventh floor

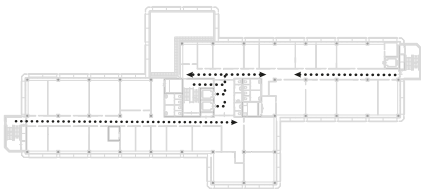

Fifth floor

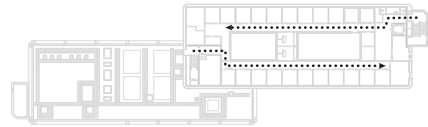

Eighth floor

1.5.3.3. STRUCTURE

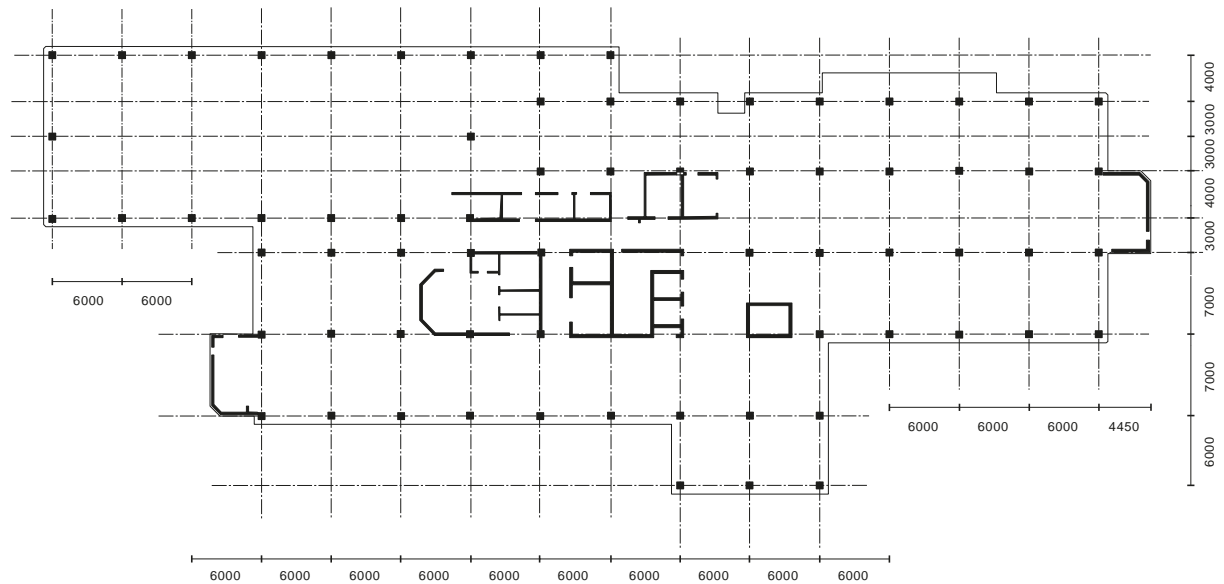

Structural grid

LOAD-BEARING STRUCTURE

The supporting structure is very solid. The storey heights are all equal and are supported by columns arranged in a slightly irregular grid. Only the central core is supported

by load-bearing walls instead of columns. The outer stair cores are also solid. The whole structure is based on a grid of 6 m x 7 m.

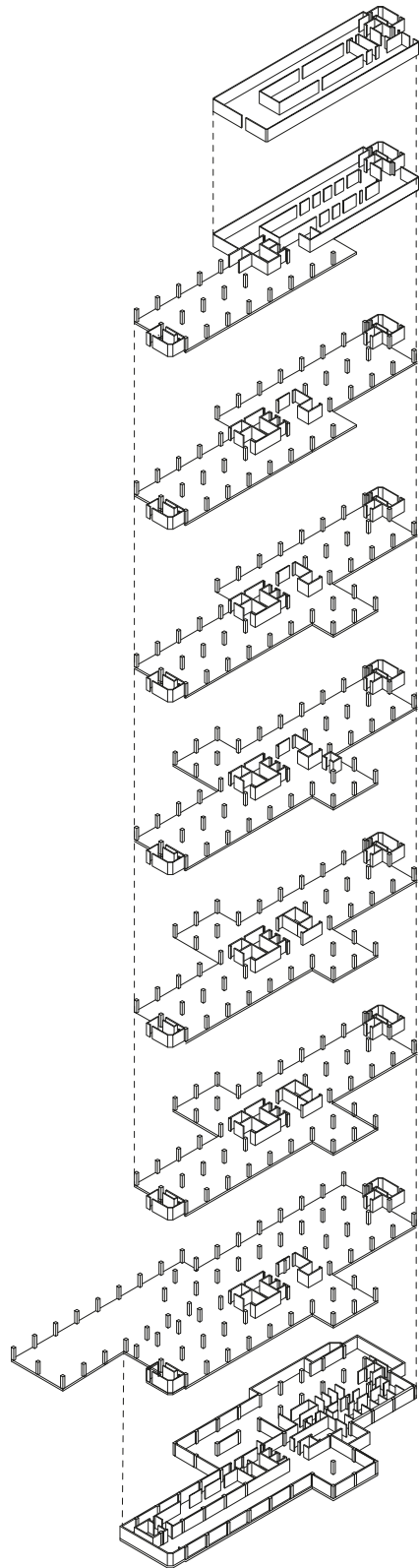

Load-bearing structure axo

1.5.4. BUILDING ENVELOPE

1.5.4.1. CONFIGURATION

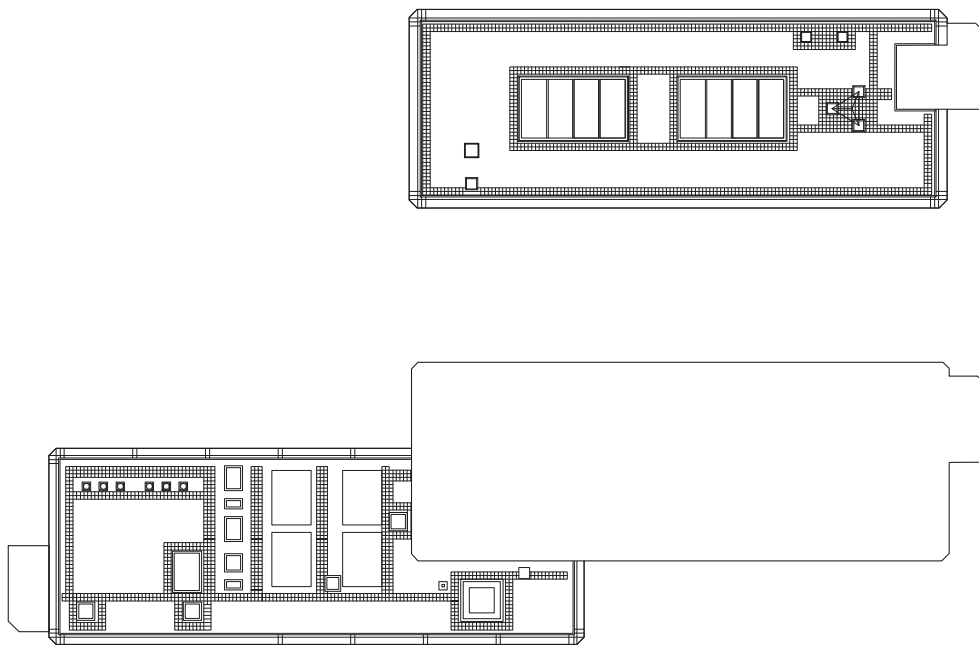

Roofplan

Vacant Heritage - Police Real Estate | The Netherlands

ROOFPLAN

All roofs are flat. The technical installations are located on the second-highest roof and two large skylights and the antenna tower are positioned on the highest. The roofs

can be walked on for maintenance and have paths in a gravel bed marked by pavement slabs. However, there is no other use of the roofs than for maintenance purposes.

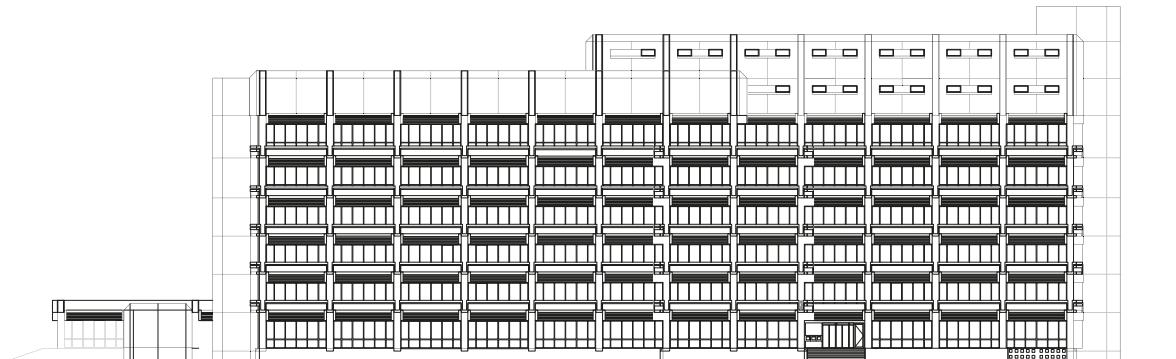

North façade

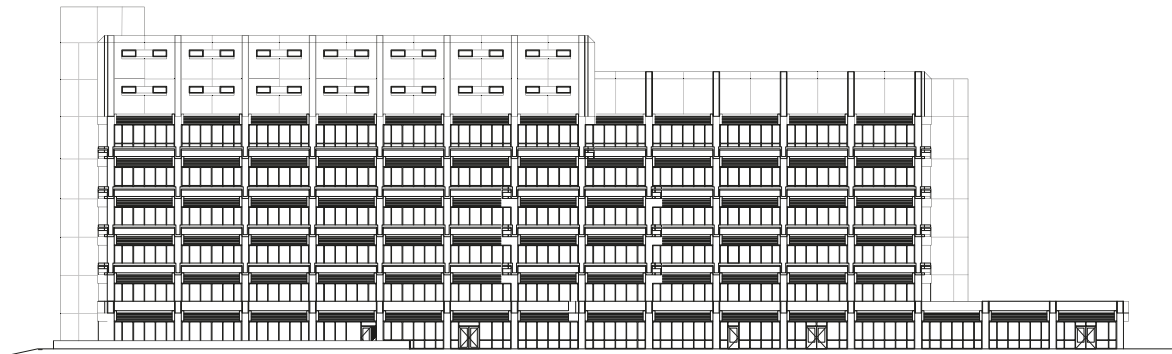

South façade



West façade

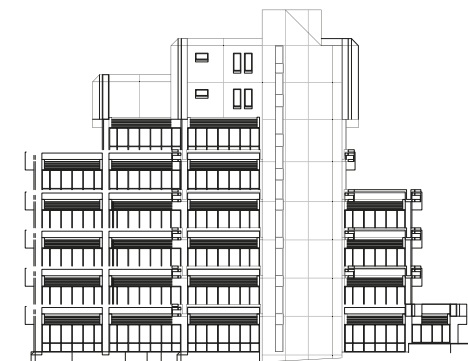

East façade

FAÇADES

In the façades, one can see the height variation of the individual building blocks. The height increases from south to north. In the east and west views, the staggering is towards the centre. The uses of building parts inside the building can be identified from the outside. While the

office-like functions are situated behind a regular curtain wall with balconies in front, the base and the two upper floors in which the cell wings are located are situated behind solid concrete walls. The stair towers also stand out and are encased in concrete panels.

1.5.4.2. COMPOSITION

0 20 M

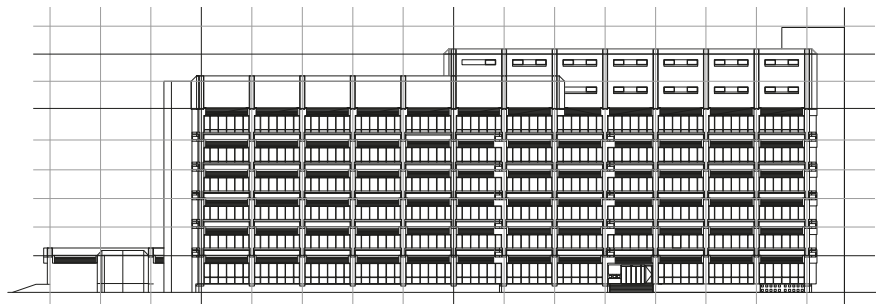
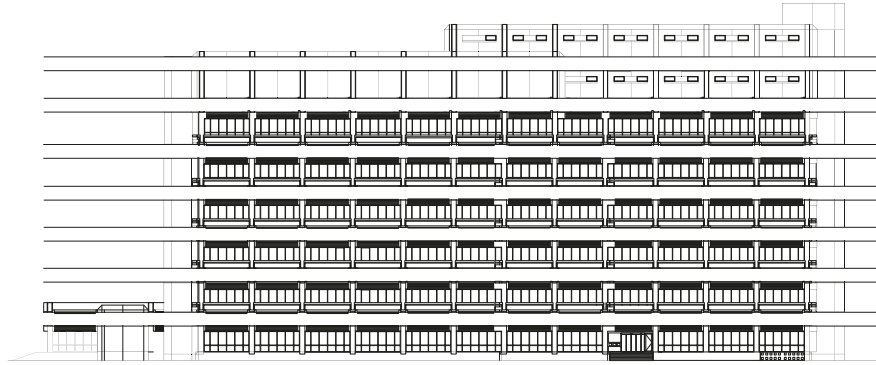

North façade

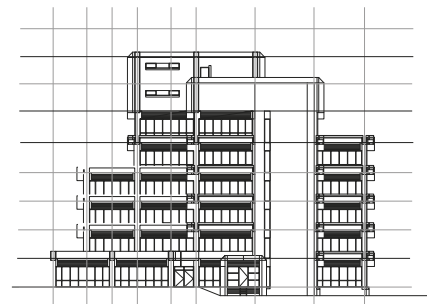

West façade

COMPOSITIONS

The façade composition is absolutely regular due to the precast modules. The grid is accentuated horizontally by the concrete balconies and sunshades, and vertically by red sheet metal elements on the upper floors and within the balcony railings.

The protruding parts of the building can be recognised by the balcony edges, which are sloped to 45 degree angles. The long window openings in the highest part of the building and the relatively small entrance area are noticeable. Only the stair towers completely interrupt the balconies that are all around the building.

1.5.4.3. MATERIALITY

0 20 M

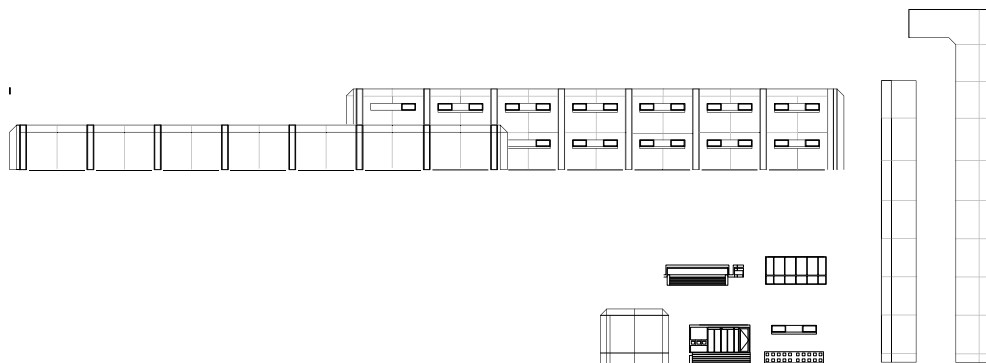
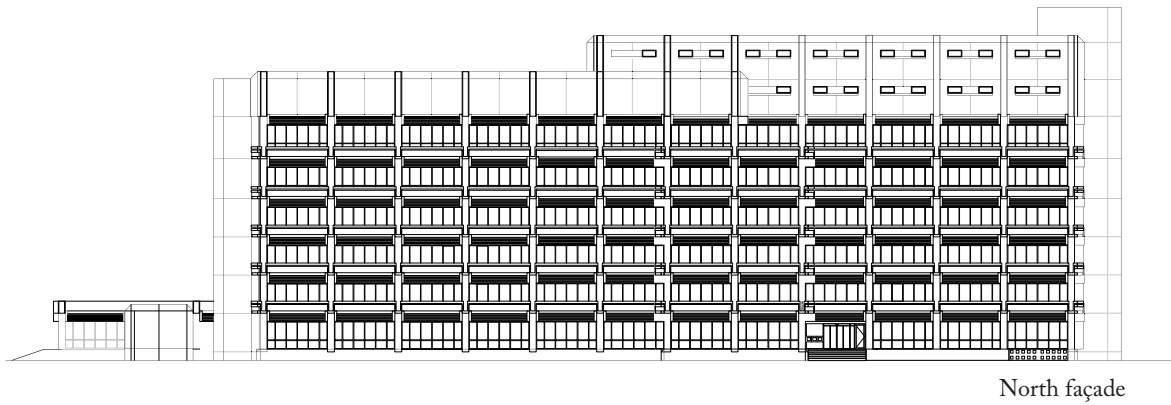

COMPONENTS

The two patterns used stand out clearly from each other: the curtain wall and balconies with their delicate design convey a rather open impression. In contrast, the closed precast concrete façades appear introverted and enclosed.

They convey security and stability. The order of the grid, however, was applied evenly in both parts and appears uniform.



Façade fragment analysis

TEXTURES

Glass, metal and concrete were used in particular on the outside of the building. The balconies are shaped to create a kind of pattern. All elements were prefabricated and all parts were painted in the colours of the police: blue and orange-red. Whether the current yellowish beige colour of the concrete parts and the black highlighting of the

edges of the façade correspond to the original appearance from the 1980s is not likely. Older pictures suggest that the concrete was initially left raw. In the inside one can also find wooden elements such as hand-rails, doors and ceiling covers.



(Fischer, 2022)

1.5.5. CONCLUSIONS

The city is relatively young. Most buildings date back from after World War II, also the police building in Eindhoven has just been built in the 1980s. It developed from smaller cities that in the course of industrialization grew together.

The city is surrounded by much greenery also many green areas in the cities. The core of the city and also the area around Mathildelaan are comparatively less green.

The city centre is of high density while the university and train area are the least dense. The network is not determined by water but rather develops in a star shape connecting two city rings which still marks Eindhoven's development from multiple settlements.

The plot on which the building is built is large and not very densely built. Surrounding buildings that were built before or at about the same time as the police stations are about the same height or lower than the police building while the newer buildings are higher.

A very good parking situation shows that the area is dedicated to transportation by car but there are also several bike parking spaces. The area is predominantly private or semi-public only the parking garage next to the police building is entirely public.

The building is a composition of 2 rectangular and 2 square formed blocks join in an almost rotation symmetric figure. Floor plans and structure are determined by a grid of 60cm x 60cm columns, a central core and two staircases on each rectangular block. There are ramps and elevators for better access.

All over the façade is a regular pattern of prefabricated modules which are sloped to a 45 degree angle on the edges. Glass, metal and particularly concrete are the dominant materials outside while inside also wood is used for railings and ceilings.

1.6. GRONINGEN

1.6.1. INNER CITY

1.6.1.1. INTRODUCTION

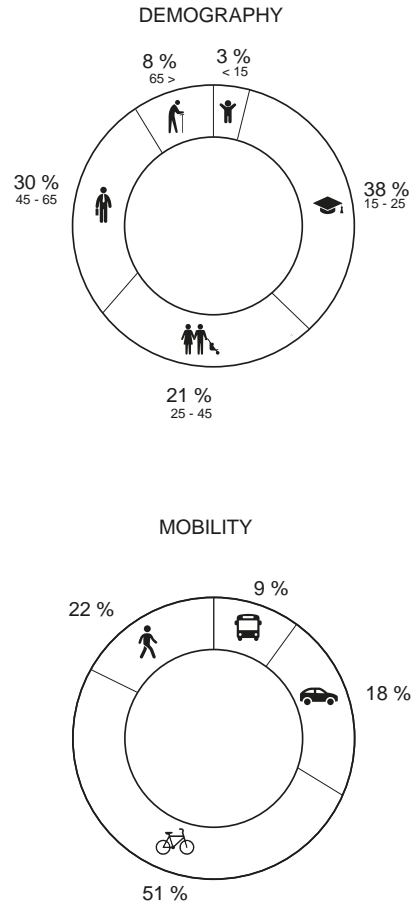

Groningen

Groningen is the largest city in the Northern part of the Netherlands, with 222.336 inhabitants. The city is growing very fast: according to the statistics, the municipality of Groningen has grown by more than 50.000 inhabitants in the period of 10 to 15 years. The population of the inner part of the city is 22.743 inhabitants. Around 38% of it is students. While in general, 25 % of the whole municipality of Groningen are students. The city

has the highest rate of students in the Netherlands. The University of Groningen was opened in 1614. It is the second oldest university in the country. One more university was established in 1986. The Henze University of Applied Sciences is focused more on technical fields. The number of students has constantly been growing in recent years, so the municipality has a considerable student housing shortage.

1.6.1.2. DEVELOPMENT



Vacant Heritage - Police Real Estate | The Netherlands



<1800

HISTORIC DEVELOPMENT

Groningen was an important trade centre of the Netherlands since the 13th Century. At the time fortress was built around the inner part of the city to mark its authority and provide security. Since then, the city has been rapidly growing. The city was partially destroyed

during the WWII, in April 1945. The police building is located in the old town of Groningen. The building marks the end of a busy shopping area. Next to the site, the moat and the contour of the former historical defensive wall was located.



0 1500 M



1800-1899



1900-1949



1950-1999



2000-

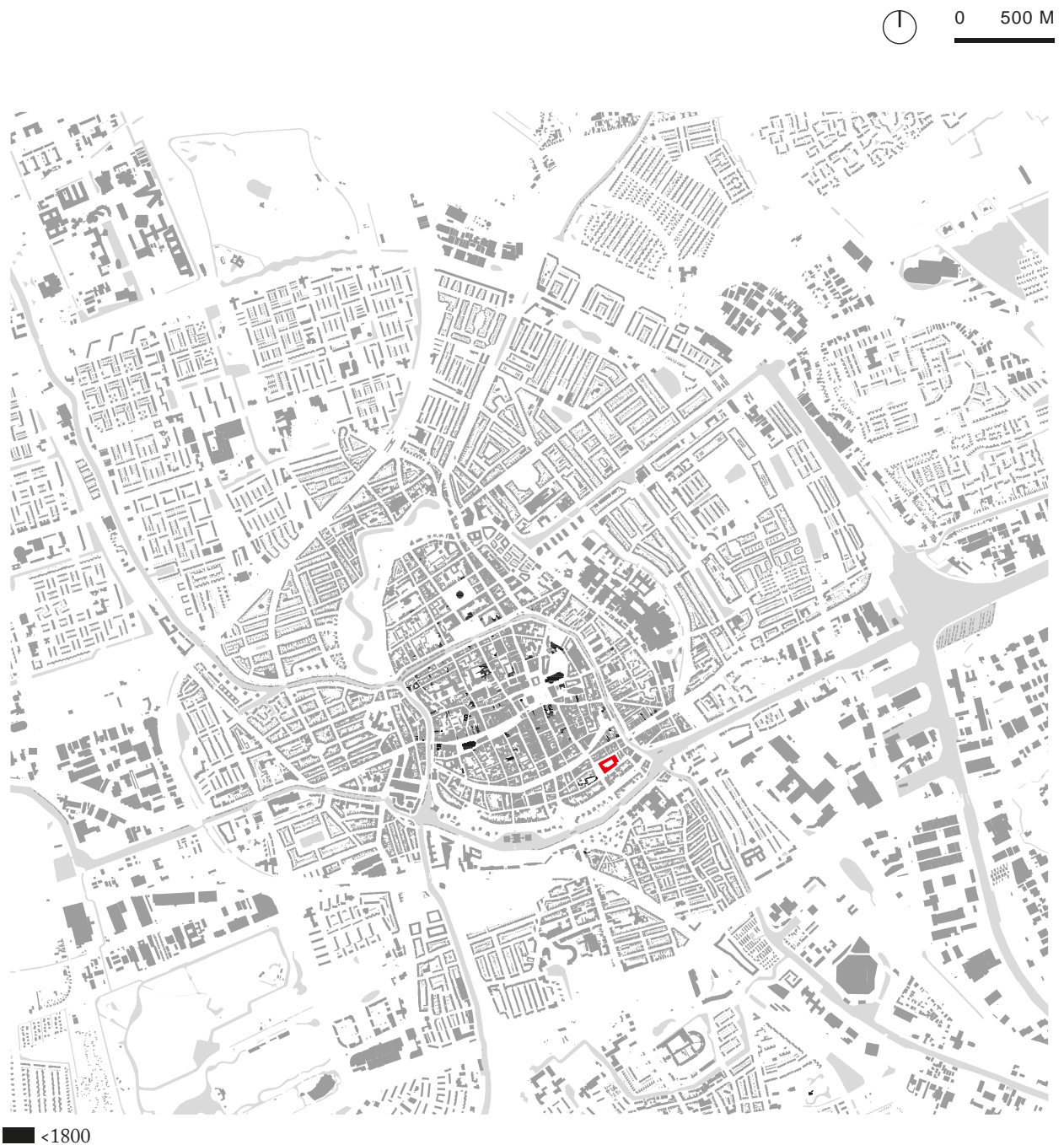

BUILDING AGE

Groningen, in the thirteenth century, became the powerful trading centre of the North of the Netherlands. For expressing its authority and protection reasons, the defensive wall and moat were needed. That helped to form the centre of Groningen. The wall itself was a significant driver for densification. Strict boundaries controlled the

growth of the city. During centuries Groningen's urban fabric rapidly changed. However, the old town part of the city remained its densification as seen in the plans. The view of Groningen radically changed during World War II. A massive amount of buildings were destroyed, façades of historical buildings were not recognizable anymore.



0

1500 M

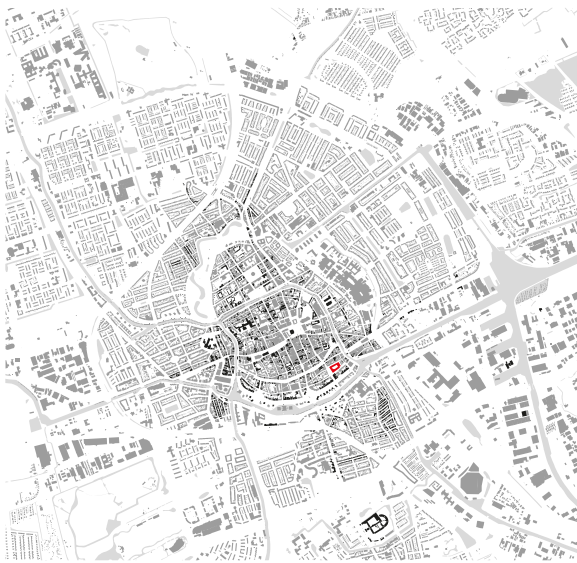

1800-1899



1900-1949

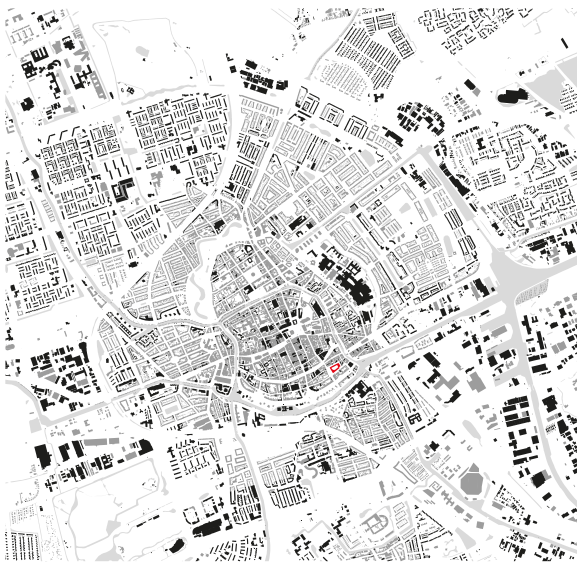

1950-1999

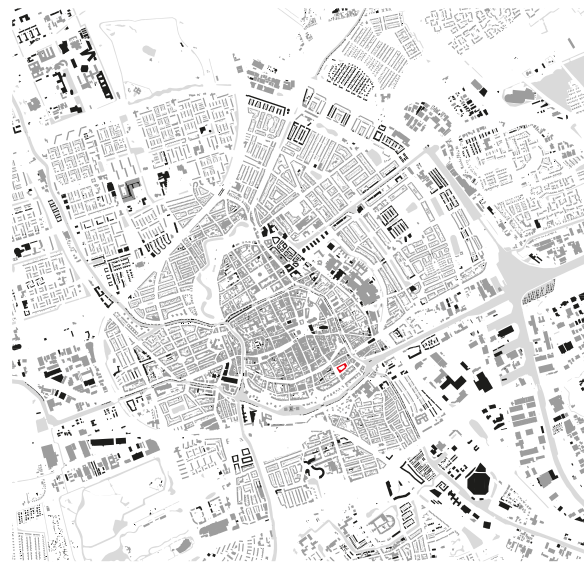

2000-

1.6.1.3. NETWORKS



Vacant Heritage - Police Real Estate | The Netherlands



All roads

ROAD NETWORK

The primary routing of Groningen is shaped by the central canals and the old town of the city. Direct routing does not cross the area of the city centre but goes around the historical moat and former defensive wall edge. The main highway goes from the North West towards the

South Eastside. Secondary roads and primary roads go around the city centre while all the tertiary streets are located in the old town area. They are mostly narrow one-streets in between the historic buildings.



0 500 M



Groningen

Primary roads



Vacant Heritage - Police Real Estate | The Netherlands



Secondary roads



Groningen

Tertiary roads

Public squares Green Water

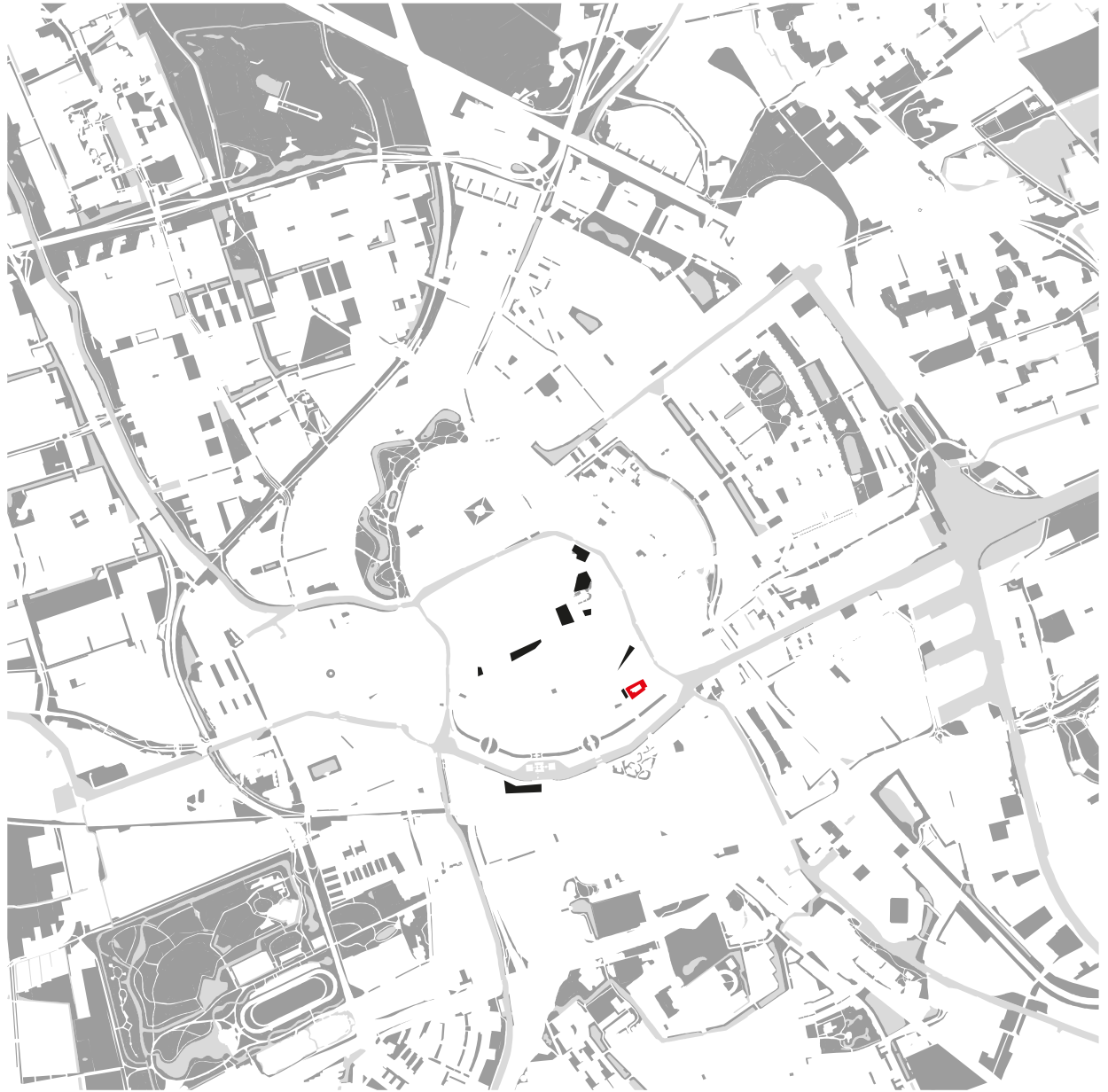

Vacant Heritage - Police Real Estate | The Netherlands

Green, water and public squares

GREEN, WATER AND PUBLIC SQUARES

In the suburbs, greenery dominates, providing areas for activities such as agriculture, sports facilities. While in the urbanised centre of the city it lacks green spaces. An

important green zone in the city center is the remains of the former defense works or fortifications, which are clearly recognizable in the northwest of the city center.

1.6.2. URBAN BLOCK

1.6.2.1. COMPOSITION

Vacant Heritage - Police Real Estate | The Netherlands



(Rakauskaitė, 2022)



HISTORIC DEVELOPMENT

The building block is surrounded by four streets: Kostergang, Moeskersgang, Radebinnensingel and the Redemarkt with a setback that forms a square in the front of the main entrance. After the existing buildings were demolished, the newly designed police building formed an entire isolated block. The construction of the building started in 1968. In 1971, after three years, three out of

four blocks were completed. After a year, the last fourth wing closed the courtyard and formed the entire block in Groningen's old town urban fabric. Police building was renovated in 1996 by De Zwarte Hond architecture office. The main renovation aspects were related to the opening of the ground floors and façades of the building.



0 50 M

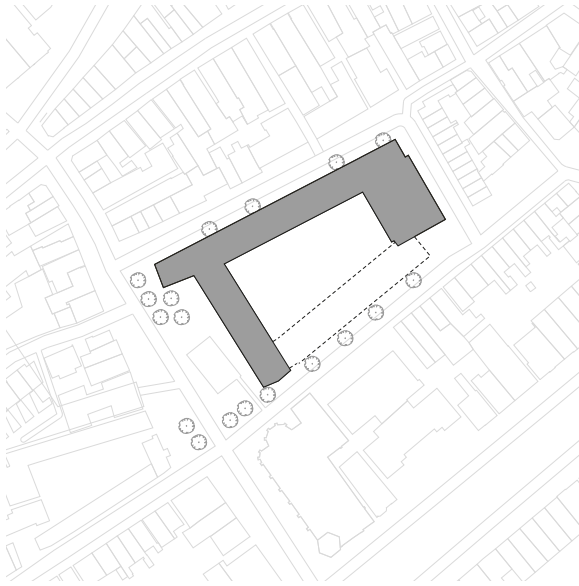

1971

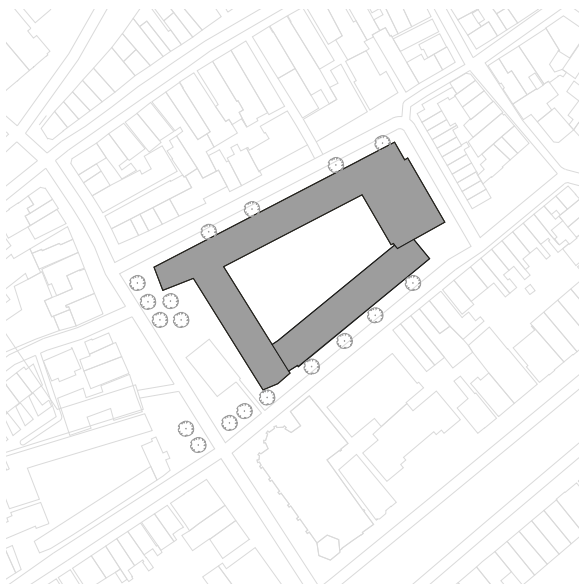

1972

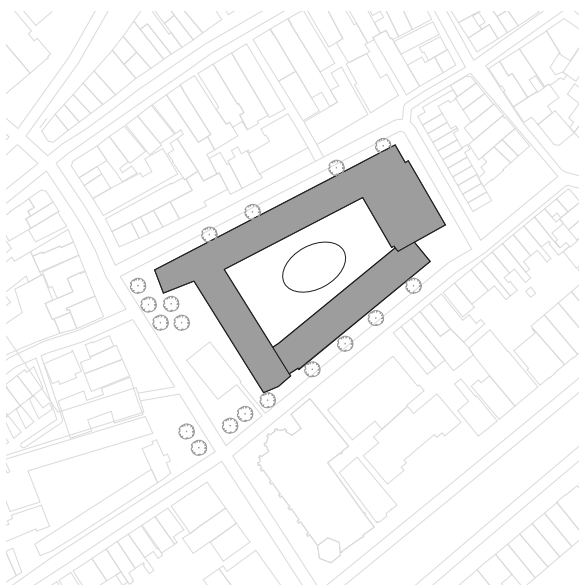

1996

Groningen



Vacant Heritage - Police Real Estate | The Netherlands

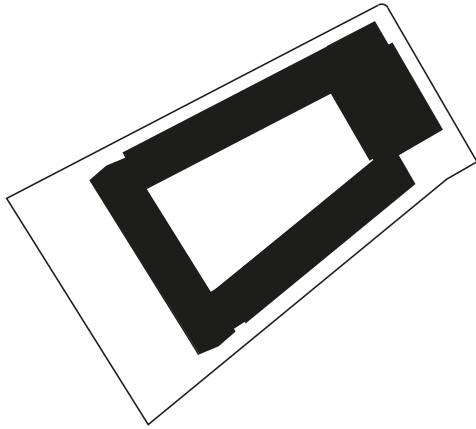

Built area
2951 m²



Empty area
4455 m²

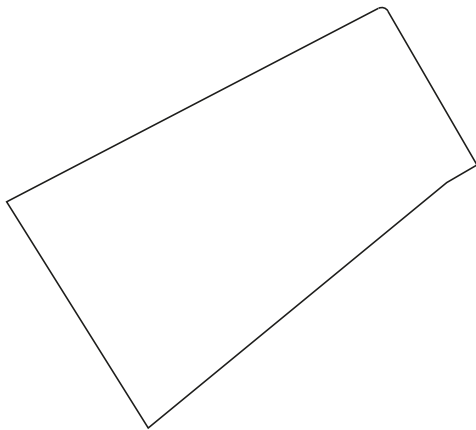

Parcels
1

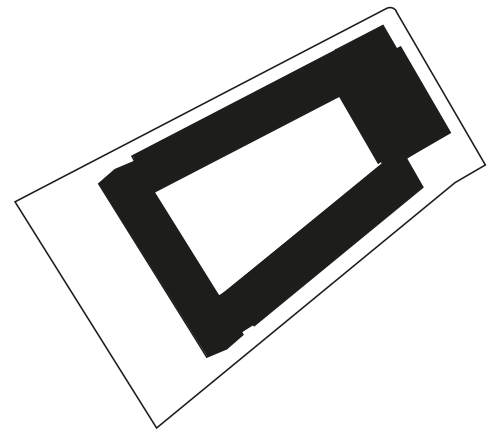

Police real estate
2951 m²

BLOCK INFORMATION

The multiple wings creating the total building volume of the police station of Groningen cover an entire urban block in the old town urban fabric of the city with smaller parceling. The volume along the Rademarkt is set back creating a square in front of the main entrance. The four

wings of the building enclose a private courtyard. The building and square in front cover a total area of around 7.400 m² and around one third of this total area is covered by the building volume of the police station.



0

50 M

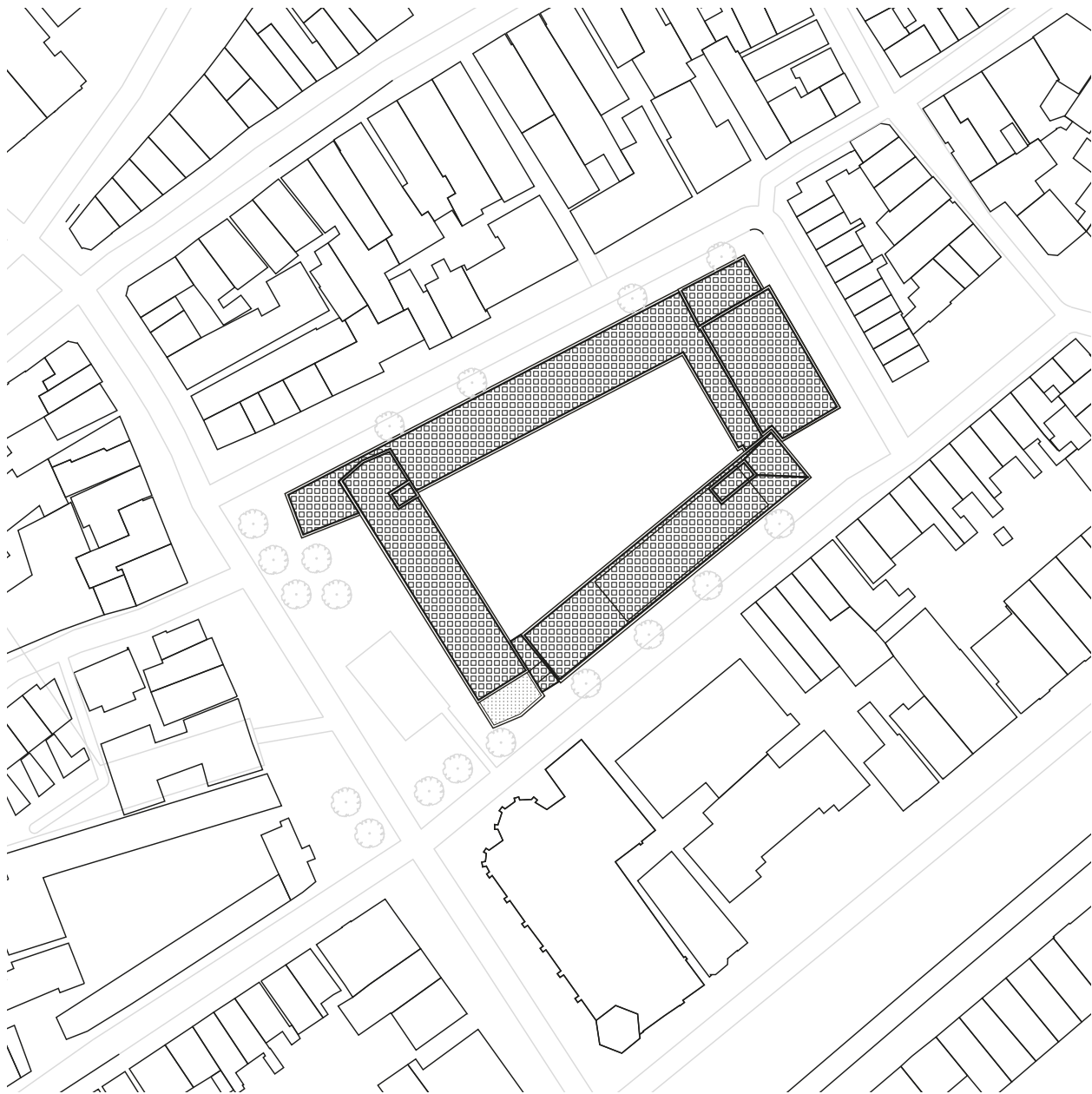

Groningen

Roof structure

ROOF STRUCTURE

The roof structure drawing indicates the differences in height between the various volumes of the Groningen police station. All individual volumes of the building have a flat roof, with the lowest volume located along the

Kostersgang and the highest volume located along the Rademarkt. Also height differences within the wings can be recognized while some parts of the volumes are one floor higher.

1.6.2.2. STREETS

0 50 M

■ Façade openings

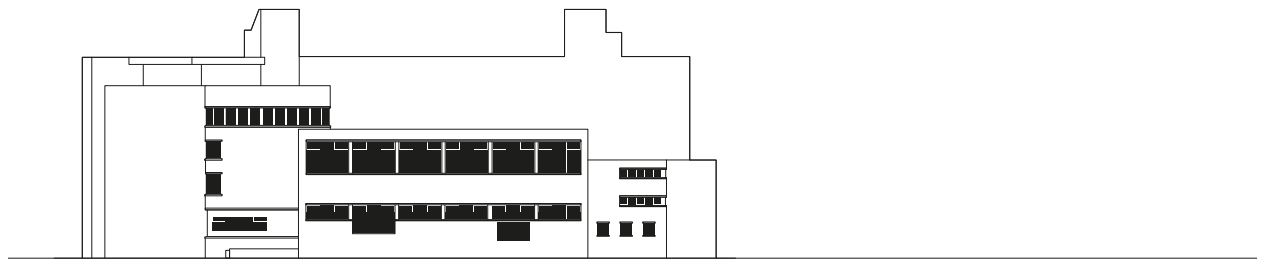

Moeskersgang



Radebinnensingel

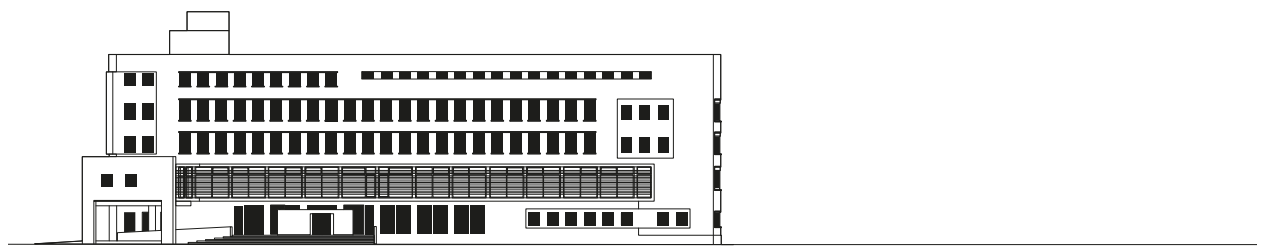

Rademarkt

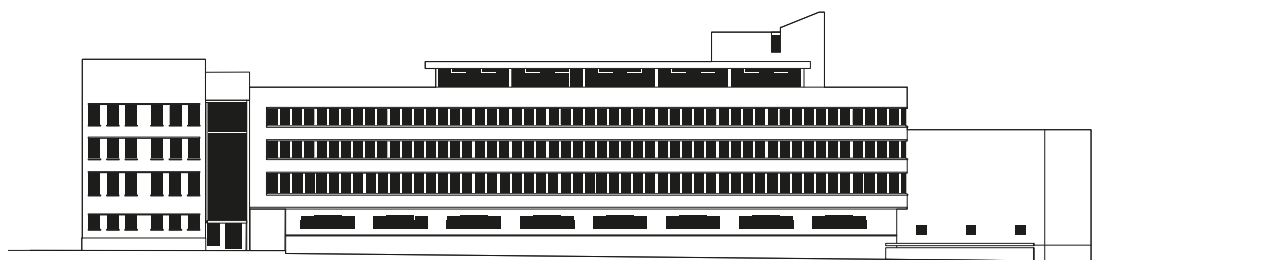

Kostersgang

STREET ELEVATIONS

The diagram of the street façades of police station in Groningen indicate the openness and accessibility of the façades. The entrances, and especially the main entrance on the Rademarkt, are clearly recognizable in the façade due to their size compared to the windows. The windows

on the ground floor level also differ from the windows on the higher floors on all façades. Also the sizes and rhythm of openings differ for each of the wings of the building. In general the plinth of the building is more closed than the other floors, besides the part where entrances are located.

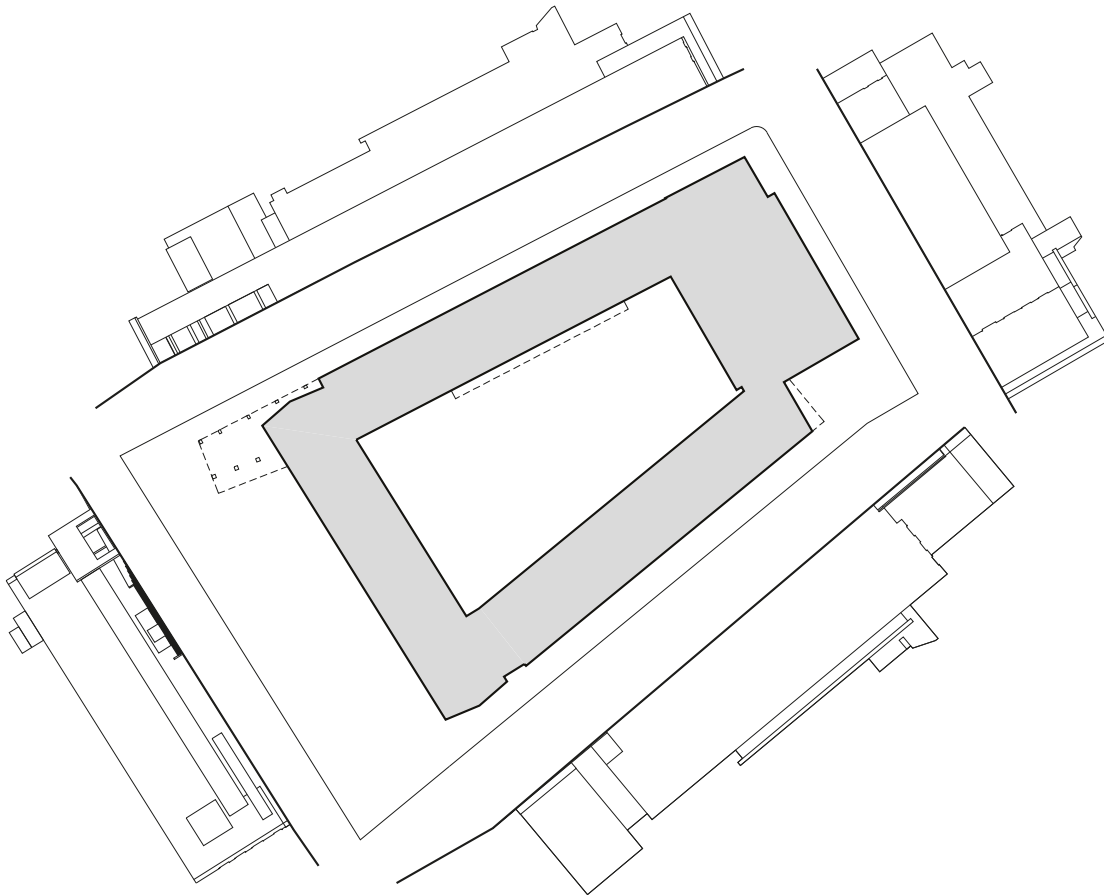

Parcels and façades

Groningen

PARCELS AND FAÇADES



Location of street sections

STREET SECTIONS

The street sections indicate a clear spatial difference that is created by the various volumes that compose the police station of Groningen. The volume along the Rademarkt is the highest volume of the building, but is also set back

to create a larger open space in front of the entrance. The multiple sections show this relation between the height of the volume of the police station and the width of the streets.

0 20 M



Section A

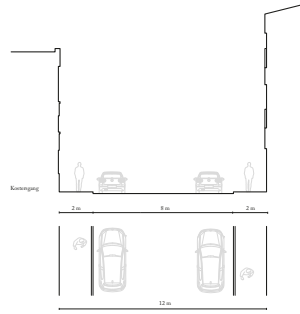

Section B

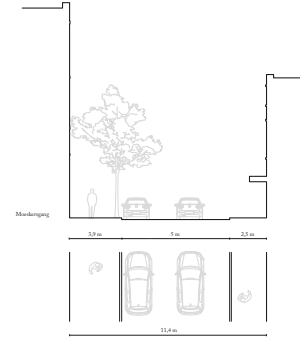

Section D



Section C

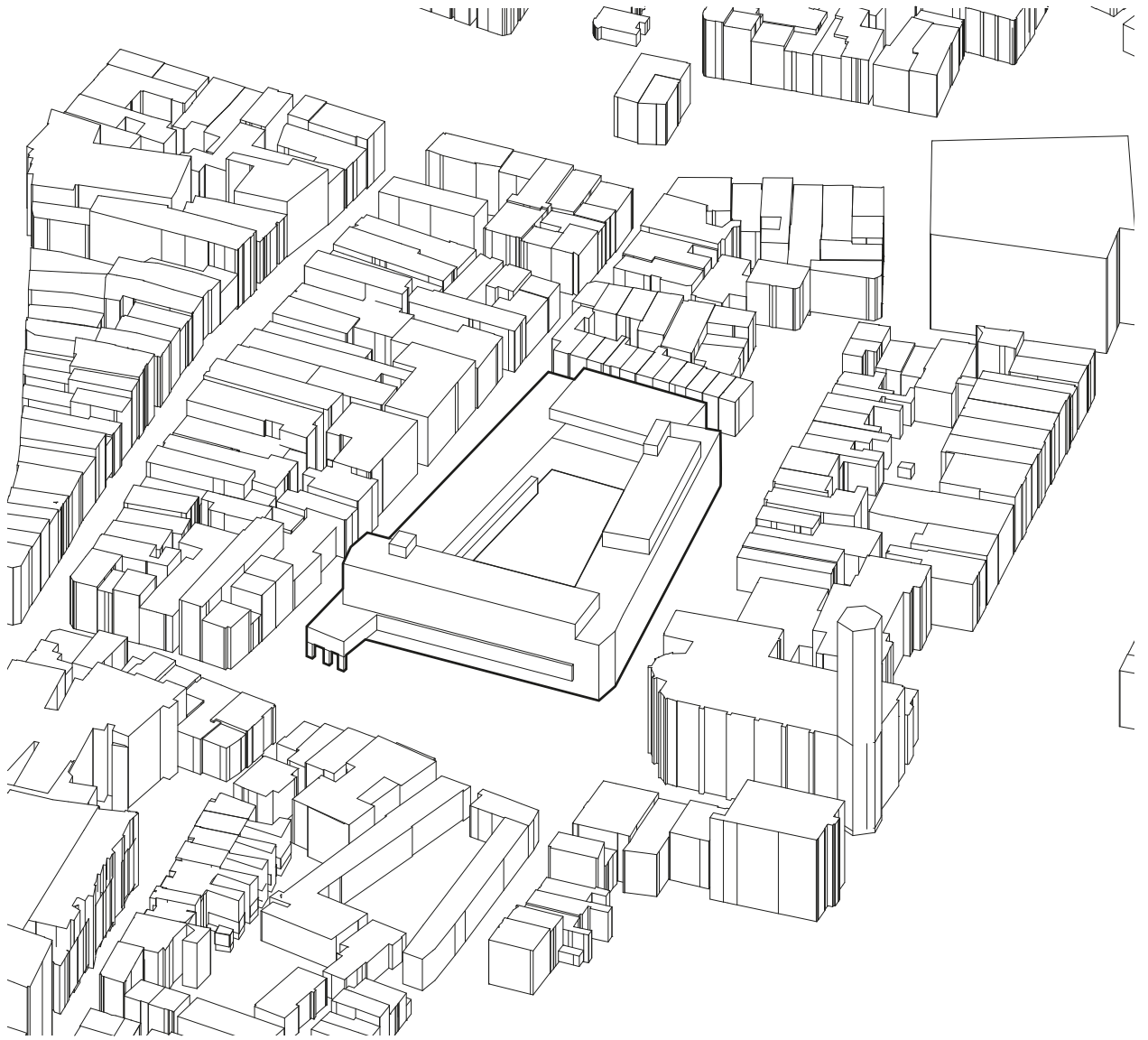

Isometric of urban block in surroundings

ISOMETRIC

1.6.2.3. ACCESSIBILITY



■ Car parking ▲ Entrance 🚲 Bicycle parking

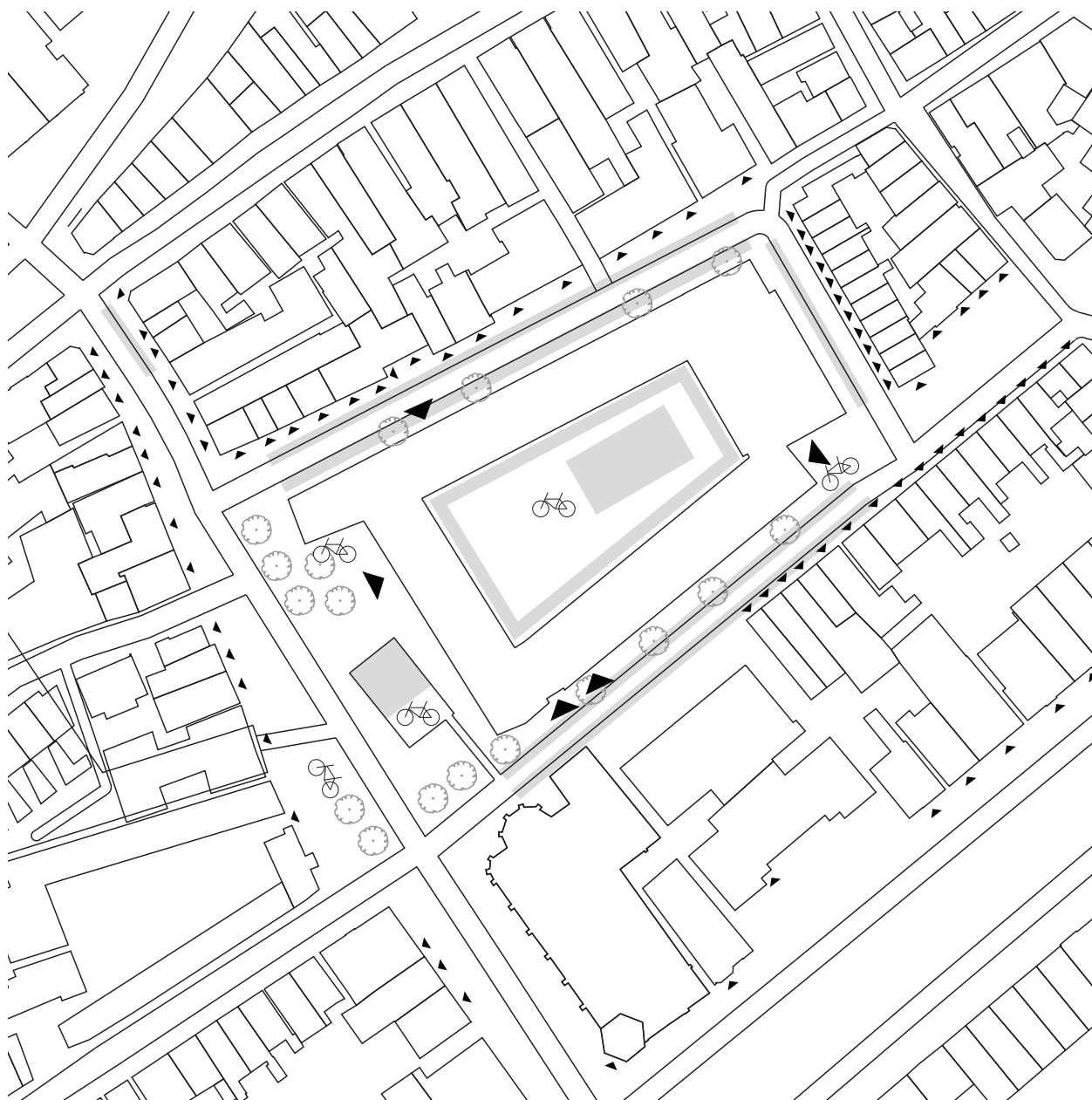

Parking and entrances

PARKING AND ENTRANCES

The parking spaces are located along the streets surrounding the urban block. The courtyard of the police station is used for private parking of the police and on

the Rademarkt in front of the building a small parking space is visible. The main entrance of the building is also located along the Rademarkt.



Public, semi-public and private buildings

PUBLIC, SEMI-PUBLIC AND PRIVATE BUILDINGS

Most of the building located directly next to the urban block of the police station are private, as they have a housing function. One street further to the north, most buildings are public, while they have a commercial

function on the ground floor. The courtyard of the building is also private as it is completely enclosed by the building.

1.6.3. BUILDING OBJECT

1.6.3.1. SPATIAL LAYOUT

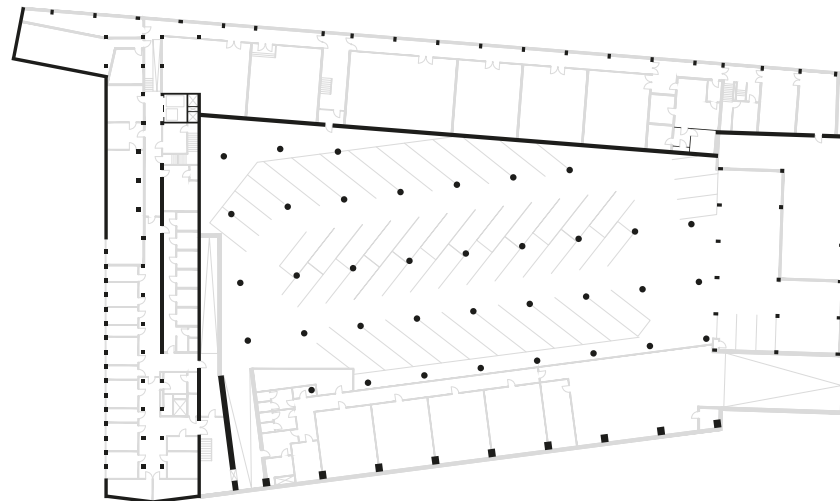

Basement



Ground floor

FLOOR PLANS

Floor plans have a similar layout: the main corridor and divided office rooms are on the sides. The only double-height spaces are the entrance hall and canteen. The building is divided into four different wings. Each wing has a different number of floors. The tallest block is the

six-floors height (underground floor is included). The second most elevated block has five floors (together with basement). It contrasts with an old town environment and smaller scale buildings around the police building block.



0

20 M

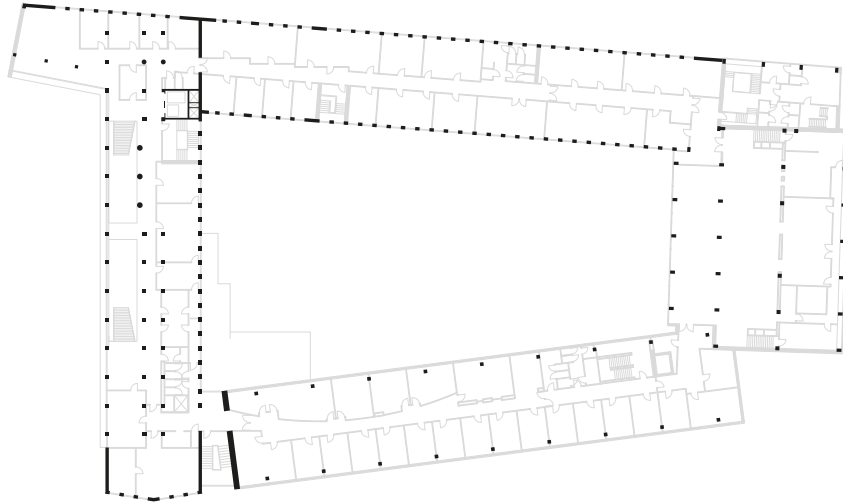

First floor

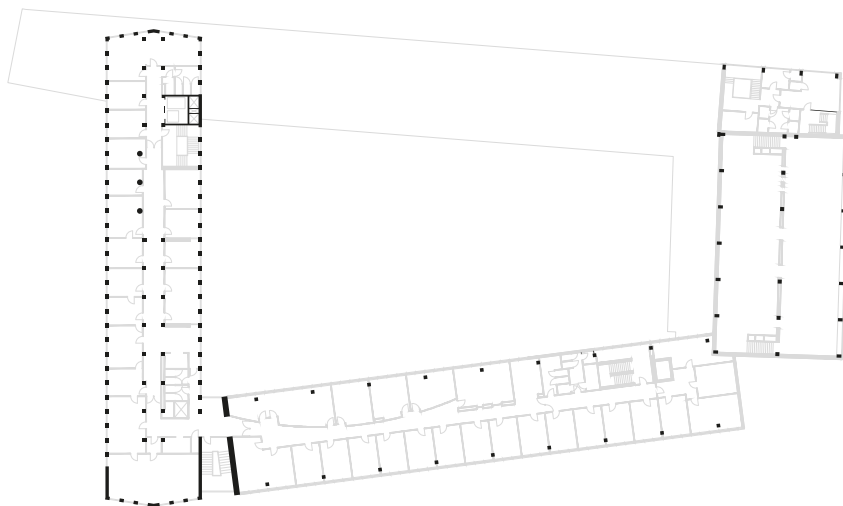

Second floor



Third floor

0 20 M

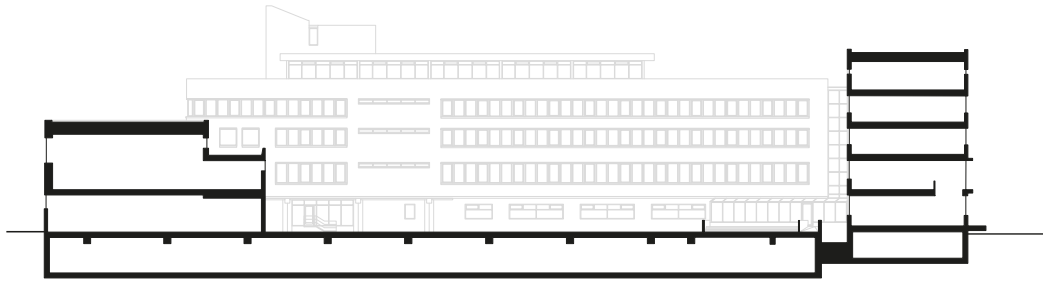
Section A

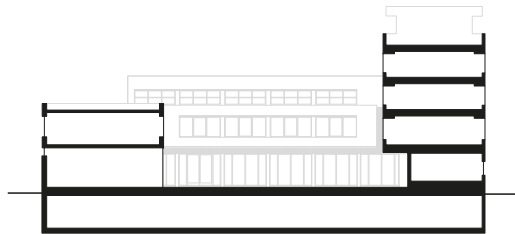

Section D

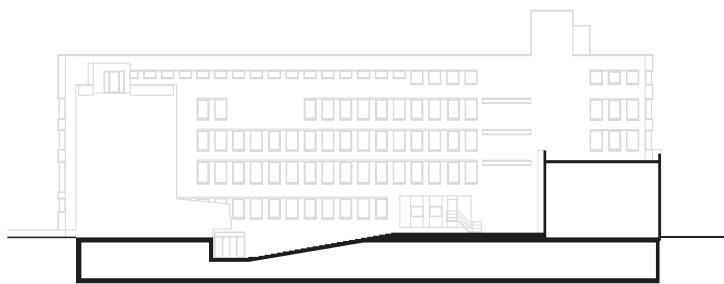
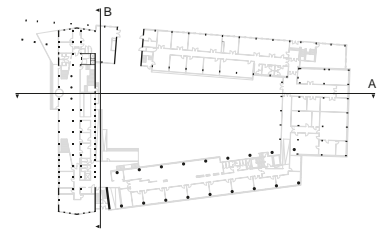

Section B

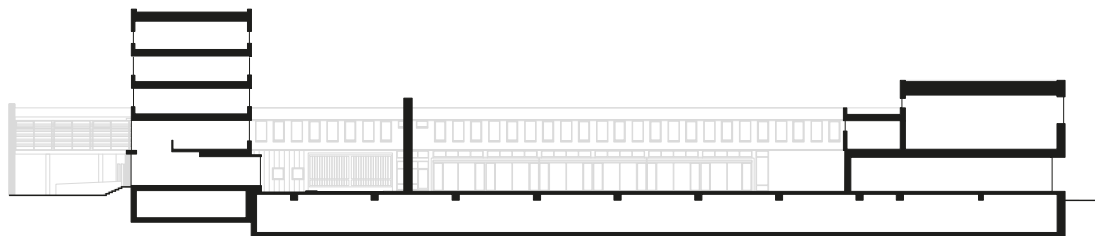
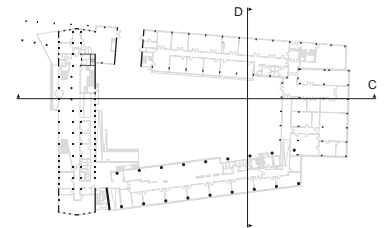

Section C

Vacant Heritage - Police Real Estate | The Netherlands

SECTIONS

Each wing has its vertical connections: stairs or elevators. The only elevator that goes down to the basement is on the tallest block. Moreover, the free height between the

floors mainly is from 2.5 m to 3.2 m. Free height is 3.2 m in the basement.

1.6.3.2. SPATIAL RELATIONS

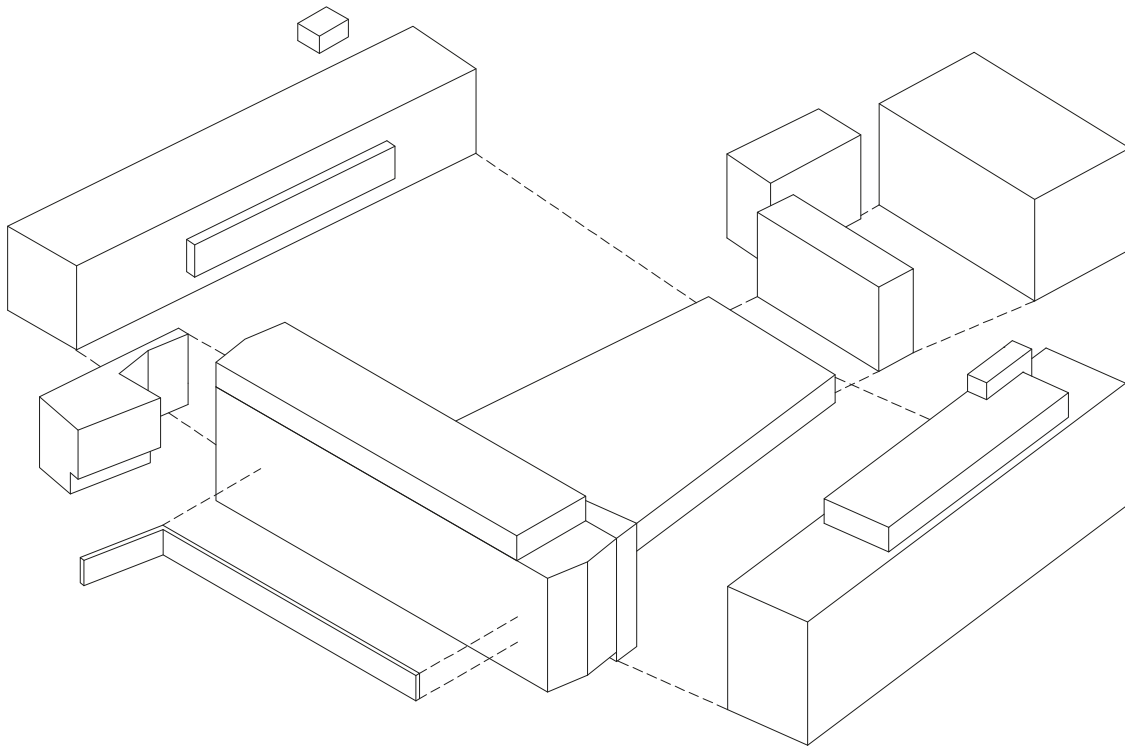

Building volume

BUILDING VOLUME

The exploded view above shows the building volumes of the police building. The building is divided into the four main blocks that surround the courtyard. Each wing of the building has additional smaller volumes attached to the

building. They work as extended floor spaces, additional floors on the top or are escape stair blocks leading to the top of the building. The block visible in the courtyard is an underground parking lot that is not visible outside.



● Start Route ▲ Ascending vertical route

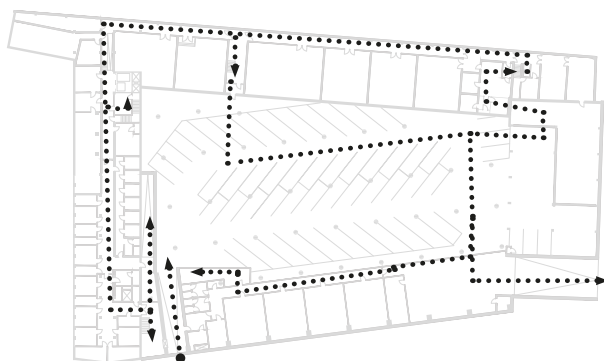

Basement

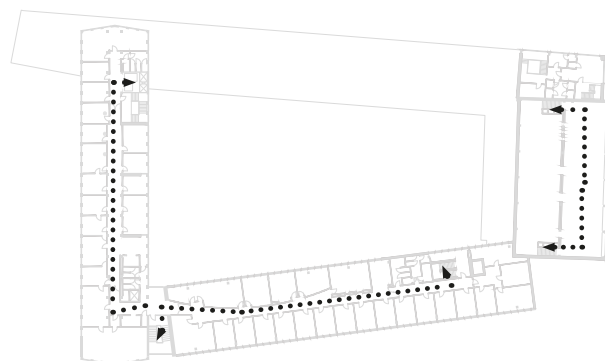

Second floor

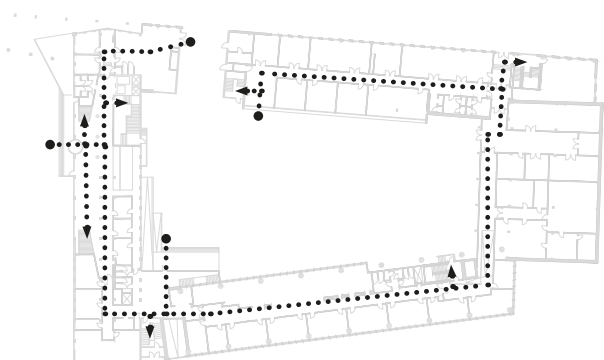

Ground floor

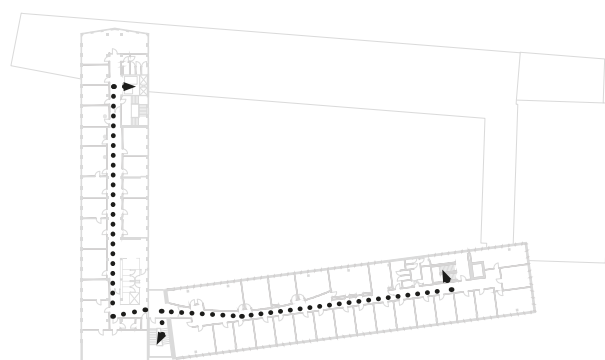

Third floor

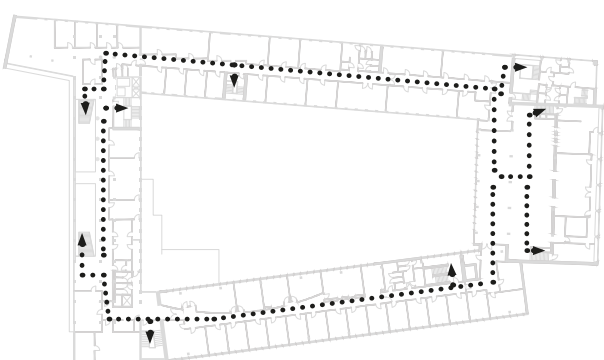

First floor

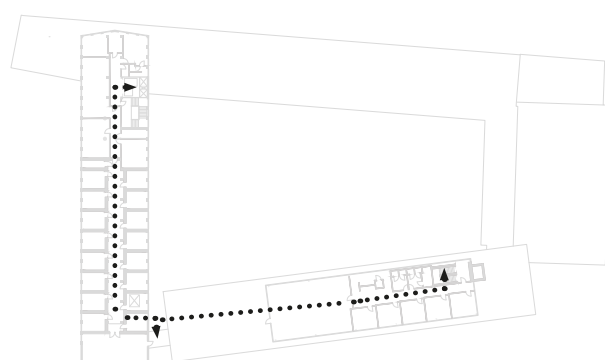

Fourth floor

Vacant Heritage - Police Real Estate | The Netherlands

CIRCULATION

The police building has only one public entrance, while all the other entries lead to the underground parking garage or the courtyard. Those are available only for the police officers. Circulation in the building is circular (except

the top floors) because all the blocks are interconnected through the main corridor. As it was mentioned before, all four wings have individual vertical connections: stairs or elevators.

1.6.3.3. STRUCTURE

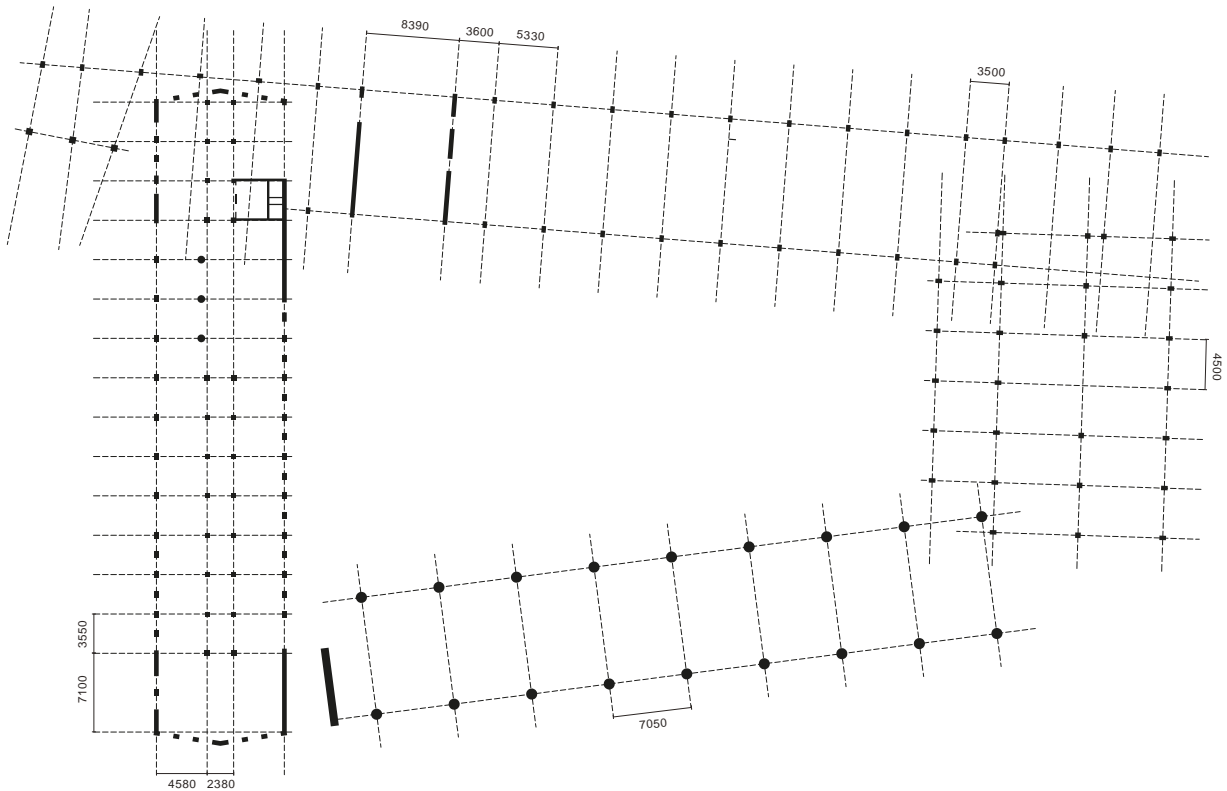

Structural grid

Groningen

LOAD-BEARING STRUCTURE

Supporting structure is consisted of supporting façades and columns in between the spaces. Only the South and East sides do not have supporting façade structures. Moreover, load-bearing walls are located next to the vertical connections as stairs or elevators. The structural

grid varies per block on each side, but mainly the space in between is from 5.5 m to 7 m. All the columns are rectangular shapes except the ground floor and basement, where round ones are located.

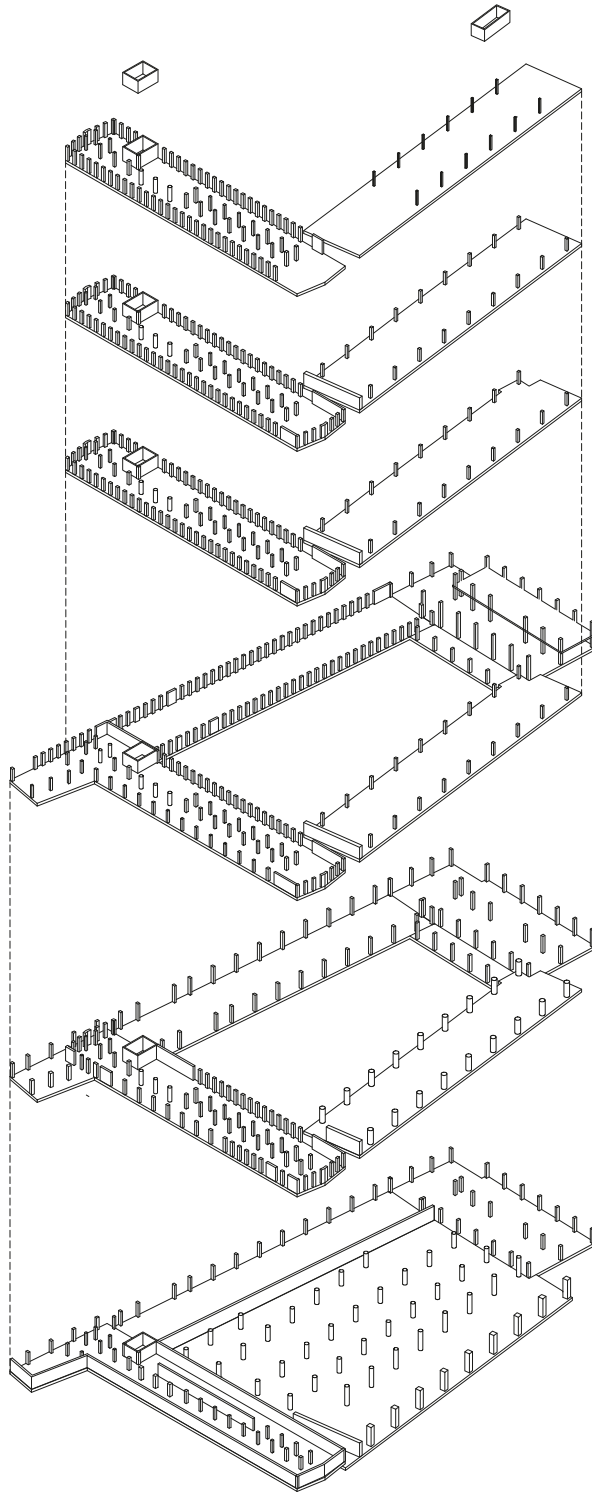

Load-bearing structure axo

1.6.4. BUILDING ENVELOPE

1.6.4.1. CONFIGURATION



Vacant Heritage - Police Real Estate | The Netherlands

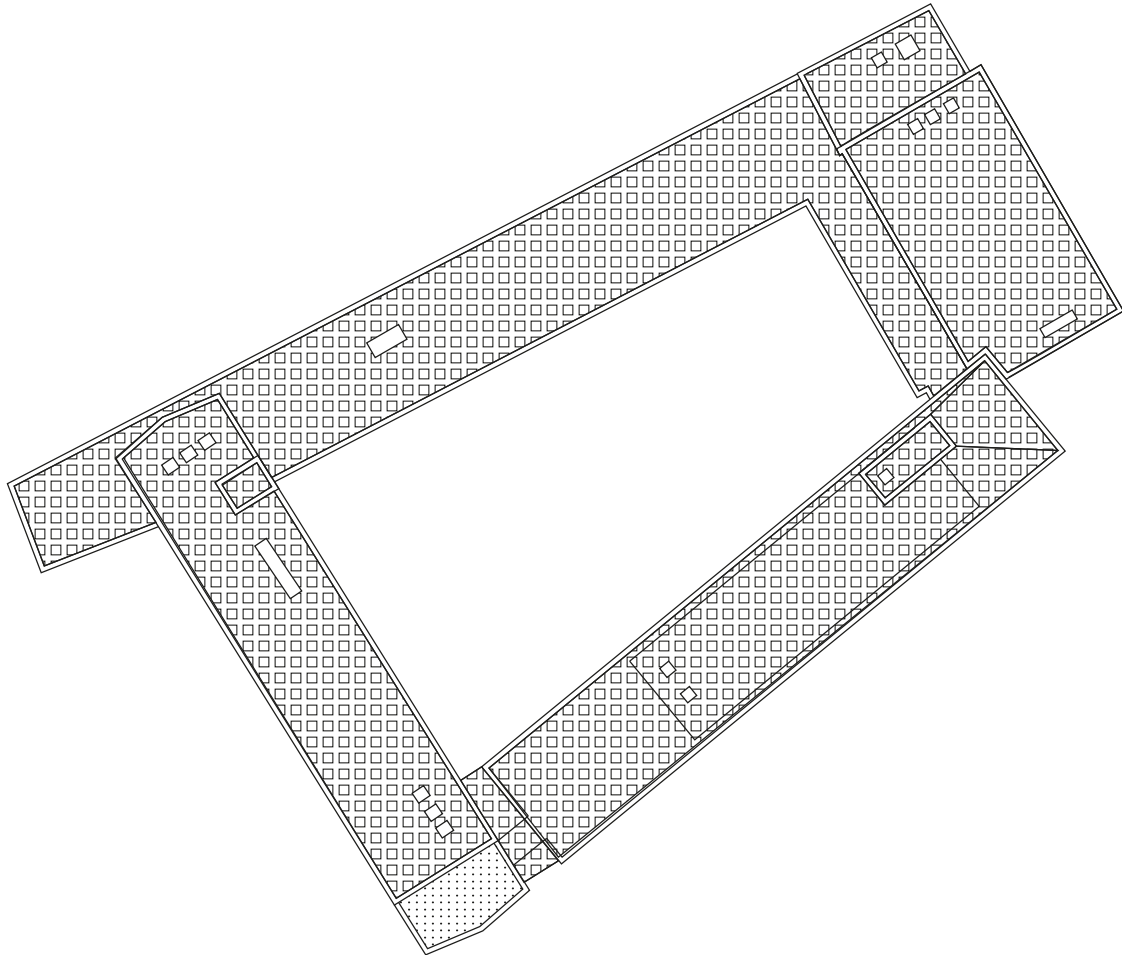

Roofplan

ROOFPLAN

The police building represents the modernist style: precise forms, no ornamentation or non-functional details. The building was built in 1971 and renovated in 1996. During the renovation, the façades changed drastically: the Northside wing and Eastside were painted in blue, while

the Southside and Westside were covered by white plaster. Also, some windows on the main façade (the Westside block) were shaded by adding metal shutters from the outside. All the roofs are flat, there are no skylights.

0 20 M

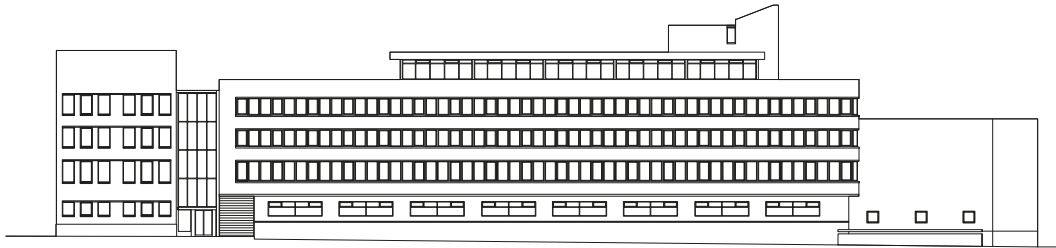

South-east façade

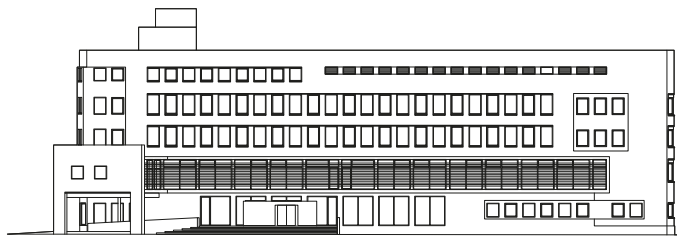

South-west façade

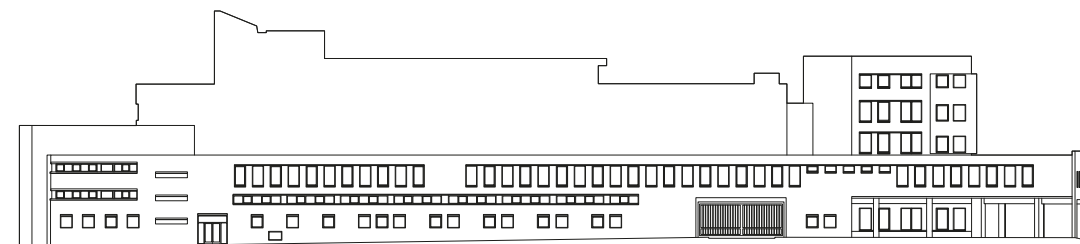

North-west façade

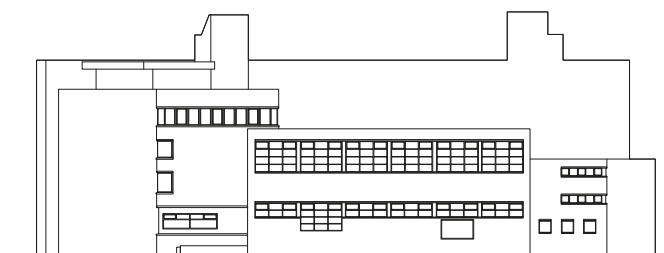

North-east façade

Groningen

FAÇADES

The multiple volumes creating the building of the Groningen police station can be recognized in the façade drawings of the building, while they all follow their own rhythm and make use of different kind of window openings. The south-east façade includes the horizontal

strip windows on all floors besides the ground floor level, while the other façades have separated windows. The ground floor is more closed in the multiple volumes due to a use of smaller windows, which also enhances the entrances to the building.

1.6.4.2. COMPOSITION

0 20 M

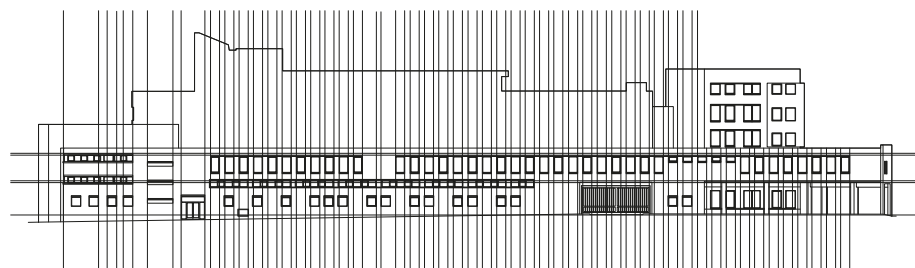
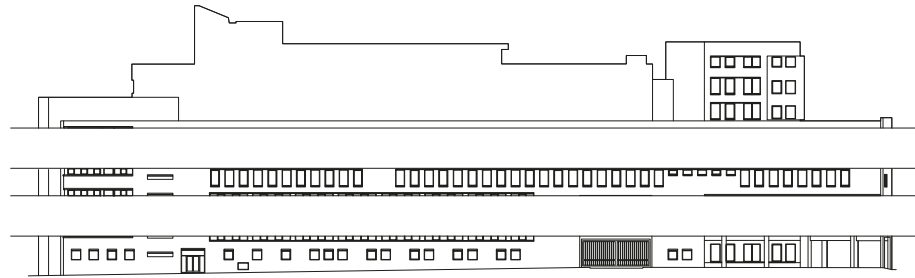

North façade

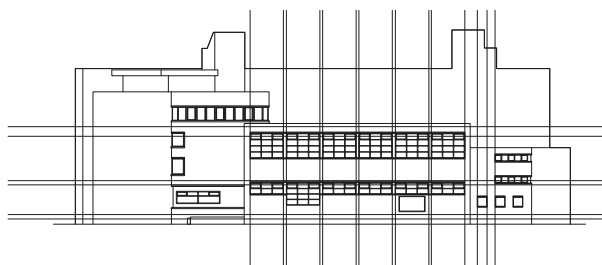
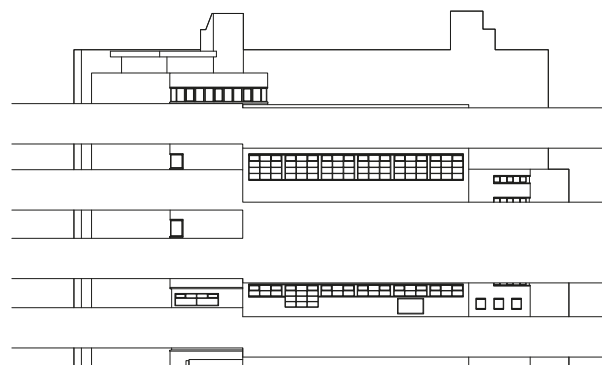

East façade

COMPOSITIONS

The configuration of façades is simple – a clear grid is visible. In all of the façades, the window line is expressed horizontally more than vertically. At some parts, windows

are connected visually by adding a linear detail above them.

0 20 M

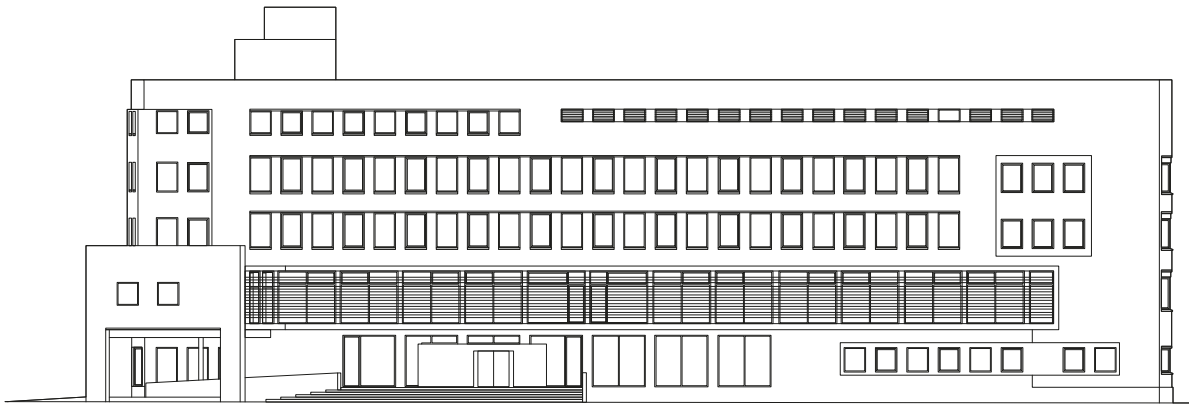

West façade

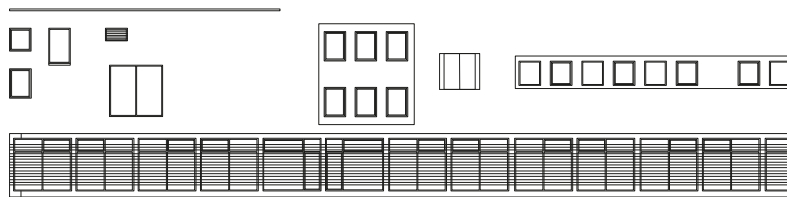

Groningen

COMPONENTS

The façades of the building are composed of a relatively small amount of components as a result of repetition. There are only a few different types of windows visible, but with some exceptions. Also a difference in the kind of

components can be recognized on the various floor levels of the building. The ground floor has larger openings to create the entrance. Also the first floor shows an exception with a large more open part in the façade with louvers.

1.6.4.3. MATERIALITY

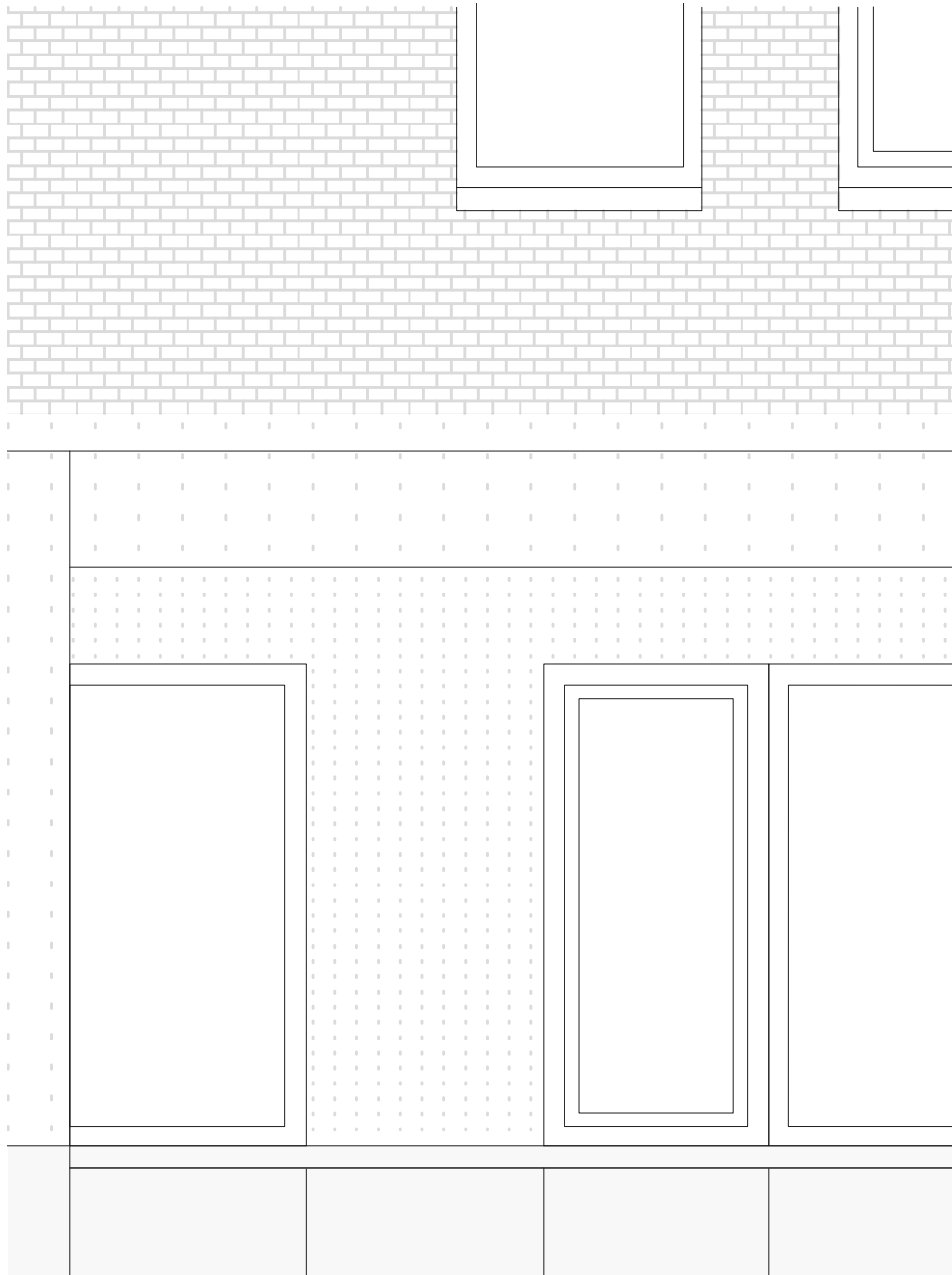

Façade fragment analysis

TEXTURES

Before the renovation in 1996, all the façades of police building were covered by red bricks. After the renovation, façades of two blocks were plastered and other two blocks were painted in blue. Blue as a color was chosen to mark the identity of the police. The ground floor partially was

covered by serpentine cladding. Some parts were also covered by mahogany wood or zinc panels. Windows were shaded by using slattered elements. In general, after the renovation, the façade represented a mix of various materials.



(Rakauskaitė, 2022)

1.6.5. CONCLUSIONS

The police building block is located in the centre of the city next to the street leading to the main and the most vibrant square in Groningen. Four blocks surround the police building courtyard on each side. Those blocks have not been changed drastically during the renovation in 1996. All the main parts and architectural expression of volumes remained the same.

The urban block of police building was formed after typical historical city centre buildings were demolished in the plot. The newly formed modernist block did not reflect on the historic architectural style, and the scale was comparably too massive to the smaller scale houses in the surroundings.

Façades of police building represent typical modernist expressions: the strict rhythm of windows is repeated on all the sides of the blocks.

The building is divided into the four main blocks that surround the courtyard

Each block has a similar layout: the main corridor divides offices spaces. Vertical connections are located on the sides. The total height of each block is different while the height between the floors is the same.

Façades and columns are the main structural elements in the police building.

Circulation in the building is circular (except the top floors) because the blocks are interconnected through the main corridor.

The police building represents a modernist style and contrasts with its historical surroundings. Precise forms and no ornamentation or non-functional details are visible on the block. Façades were renovated in 1996, and the appearance changed drastically: they were painted in blue and some parts plastered in white, bigger openings of windows were made as well. All of the roofs of the police building are flat.

1.7. MIDDELBURG

1.7.1. INNER CITY

1.7.1.1. INTRODUCTION



DEMOGRAPHY

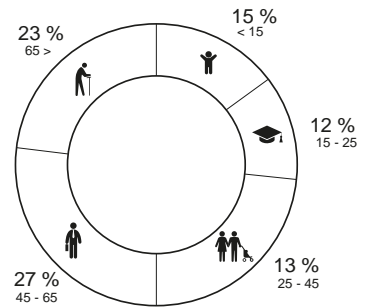

MOBILITY

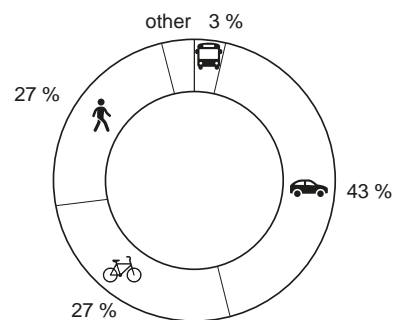

Middelburg

Middelburg is the capital of the municipality Middelburg and of the province Zeeland. The province of Zeeland consists of peninsulas, islands, and an area next to Belgium. This area, Zeeuws-Vlaanderen, is from The Netherlands only accessible via the Westerscheldetunnel or ferry. Middelburg is located on the island Walcheren. It has a very long history that starts in the ninth century. The city received its city rights in 1217. In the Golden Age was this location of the V.O.C. (Vereenigde Oost-Indische Compagnie) the largest and most powerful after the main location in Amsterdam. At the end of World War II almost a quarter of the city has been destroyed by a bombing.

With 42.190 (2021) inhabitants it is a small city with a low density of 795 inhabitants per square km. The younger age categories inhabitants of 0-15 and 15-25 match well with the nationwide percentages. But the category 25-45 is below nationwide average with 13% in comparison with 25%. This is the largest discrepancy. The categories 45-65 and 65+ match well with the nationwide average. It looks like Middelburg is a good place for older people, but that young families prefer to move to a different place. The mobility chart show that the car and bicycle are well used. Inhabitants make less use of public transport. Most likely because the public transport network is less dense in this province.

1.7.1.2. DEVELOPMENT



Vacant Heritage - Police Real Estate | The Netherlands



1850

HISTORIC DEVELOPMENT

Around 1850 the city of Middelburg only consist of the historic city centre surrounded with the 'singels', which were part of the defence system of the city. The city is connected to sea via a canal, called the Nieuwe Haven Kanaal. Around 1880, a train connection is established. After 1900, the city expanded outside these singels. The

former Nieuwe Haven Kanaal is extended to Vlissingen, and renamed as the Kanaal door Walcheren. From the 1960's onwards the city starts growing quicker, and new neighbourhoods outside the historic city centre were built.



0 1000 M



1912



1963



2022

Middelburg



BUILDING AGE

The maps on the side show the ages of the buildings in Middelburg. Middelburg is an old town that received its town charter in 1217. The maps show that a large proportion of the buildings in the town centre date from before 1800. In the following century, new buildings were added to the town centre and construction began outside the town's moat. In the years 1950 to 2000, this expansion continued far beyond the city centre. In 1940,

a major part of the inner city was destroyed as a result of German bombing. A number of buildings were rebuilt and restored. In the following decades, an explosive expansion of the city took place in all directions outside the inner city and in the inner city itself. After 2000, construction was spread throughout the town and there were major town extensions in the north and the south of Middelburg.



0

1500 M



1800-1899



1900-1949



1950-1999



2000-

1.7.1.3. NETWORKS



Vacant Heritage - Police Real Estate | The Netherlands

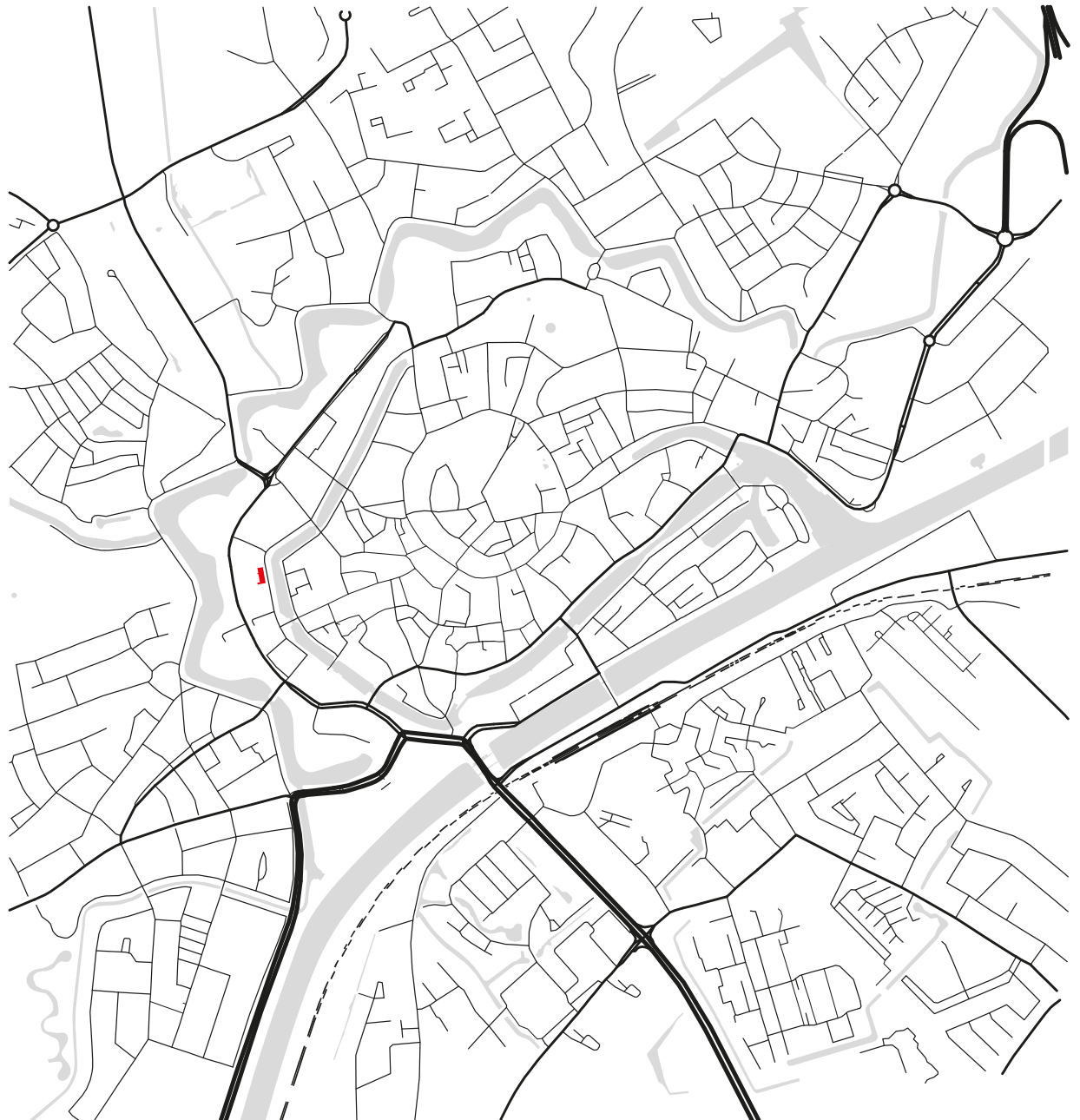

All roads

ROAD NETWORK

The maps show the railways and roads in and around the city. It shows that there is a railway with a train station just south of the city centre. The primary roads are mainly located outside the city centre and extend in all directions.

A primary road also runs around the inside of the old defence moat, close to the police station. Subsequently, the primary road network branches into a finer meshed and evenly distributed secondary and tertiary network.



0

500 M



Middelburg

Primary roads



Vacant Heritage - Police Real Estate | The Netherlands



Secondary roads



0

500 M



Middelburg

Tertiary roads



GREEN, WATER AND PUBLIC SQUARES

The green spaces in the inner city consist of the defense works, which forms an ecological loop in the city, the large Molenwater Park and Parkje Zuidsingel. The Kanaal door Walcheren, which is connected to the southern part of the town centre, runs straight through the city. Several harbours that end in the inner city are connected to this canal, such as: the Buiten- en Binnenhaven, the Prins Hendrikdok and the Fittinghaven. In addition, in the west of the centre there is the Binnengracht, on which the

police station is located. The old defence canal called the Vest is still largely intact and runs along the north side of the inner city. In addition, there are some ditches located in the outskirts of the city. The large squares are mainly positioned in the heart of the city centre. These squares are mainly located in front of the Town Hall, in front of or in the church and in former market squares. Smaller public spaces can be found outside the city centre.

1.7.2. URBAN BLOCK

1.7.2.1. COMPOSITION

Vacant Heritage - Police Real Estate | The Netherlands



(Simons, 2021)



Middelburg

HISTORIC DEVELOPMENT

The police building in Middelburg has been built in 1967-1968, in the same period as the neighbouring buildings on the north and south of the police station. Originally, these three buildings were more or less the same size. Only a few small buildings, mostly houses, at the south side of the building block are left from before the 1960's.

Between 1970 and 1980, a new building was built, to the northwest of the police station. The buildings direct north and south of the police building were extended in this period. Between 1990 and 1922 both building north of the police building were extended further.



0 50 M

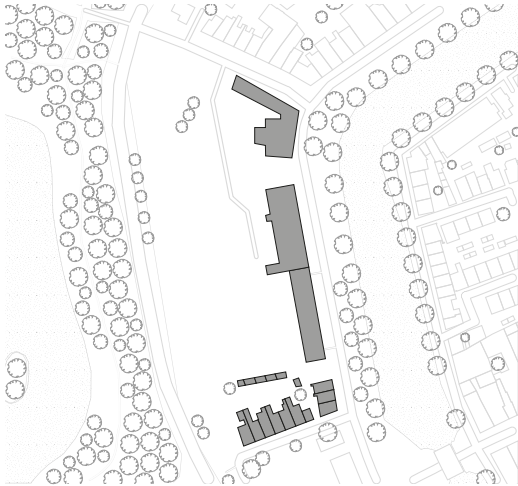

1960-1970

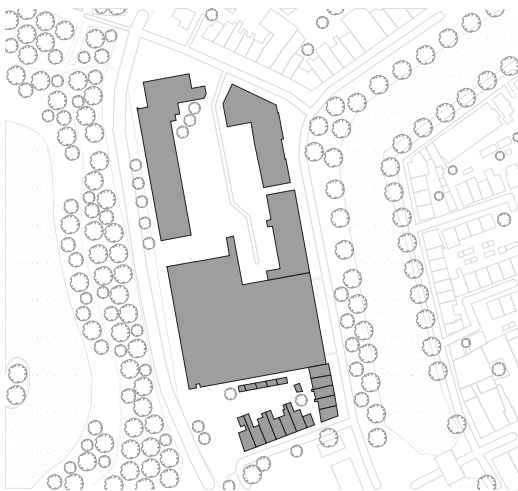

1970-1980



1990-2022

Middelburg

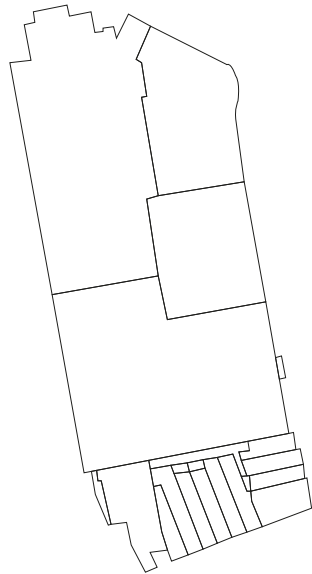

Parcels
21

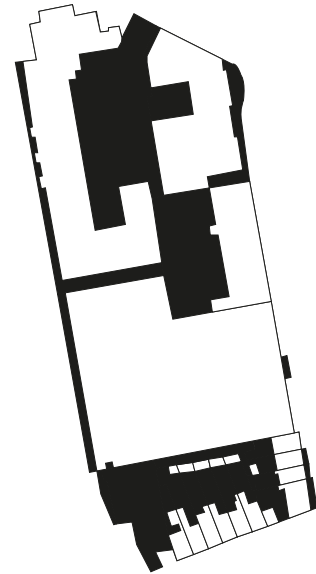

Empty area
3216 m²

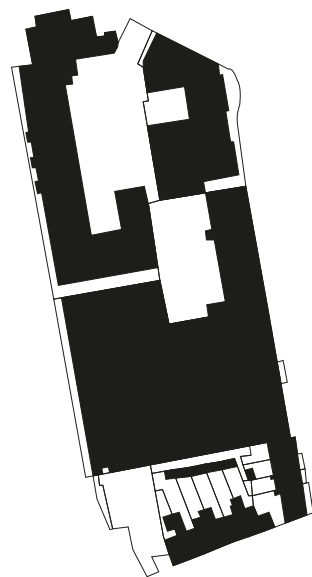

Built area
7270 m²

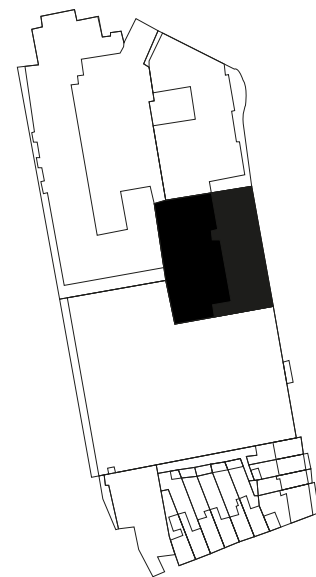

Police real estate
1175 m²

BLOCK INFORMATION

The urban block consists of 21 plots of varying sizes. The plots on the south side of the block are smaller than those on the north side. This can be explained by the fact that the plots on the south are private homes and on the north are semi-public functions. A large part of the urban block

is built up, but there is also plenty of empty space. The police station plot also has a lot of undeveloped space. This plot occupies a large part of the urban block.



0

50 M



Middelburg

Roof structure

ROOF STRUCTURE

The roof structure drawings indicate the differences in roof shape between the various buildings of the urban block of which the police station of Middelburg is part. The buildings located along the Achter de Houttuinen street

all have a pitched roof, matching the roof shape of the other buildings along this street and in the surroundings. The buildings behind this first row of buildings mostly have a flat roof.

1.7.2.2. STREETS

0 20 M

■ Façade openings

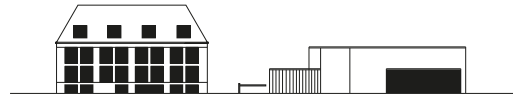

Armeniaans Schuitvlot

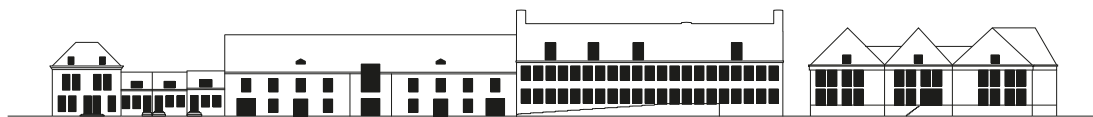

Achter de Houttuinen

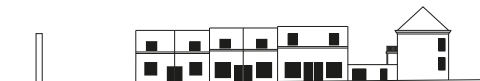

Baanstraat



Looierssingel

STREET ELEVATIONS

The diagram with street façades indicates the openness and accessibility of the façades composing the urban block of which the police station of Middelburg is part. Each building part of this urban block is recognizable as a result of the differences in shape of the volumes and the

differences in size and rhythm of the façade openings. Also there is a clear difference between the façades facing towards the inner city at the Achter de Houttuinen street and the façades facing to the Looierssingel.



0

50 M

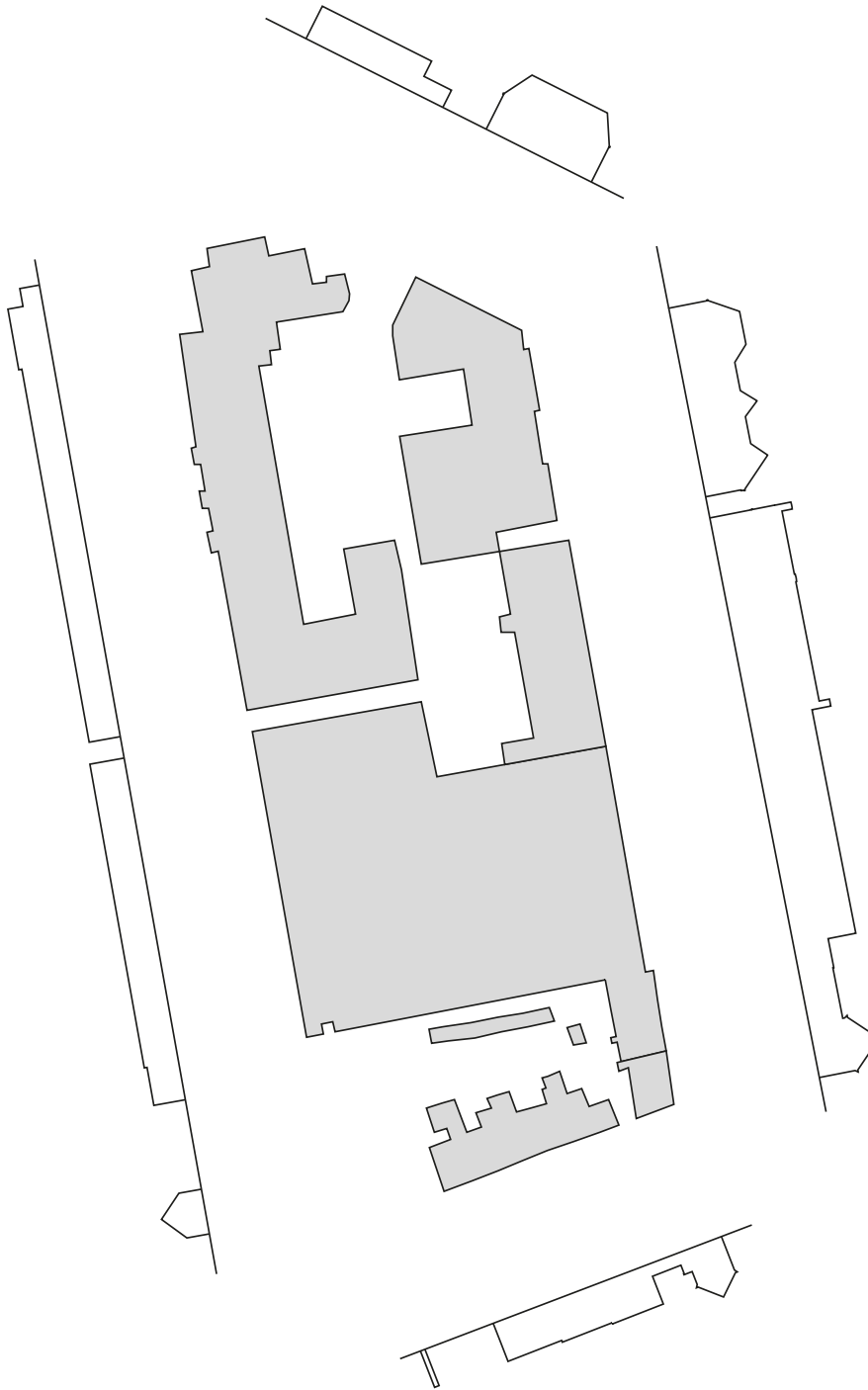

Middelburg

Parcels and façades

PARCELS AND FAÇADES



Location of street sections

STREET SECTIONS

The building faces two different streets. Section A, in front of the station, is a very broad profile consisting of several different elements. The profile crosses two streets, Achter de Houttuinen and Molenberg and a canal, the Herengracht. Starting from the police station, first thing we see is a sidewalk, then the road and parking places. Besides the parking places is a narrow strip of grass, with trees. Then another sidewalk, and the canal with at both

sides a hedge. On the other side of the canal is a narrow road, and again a sidewalk. The section at the back of the police station, section B, shows the police parking and the access road to this parking. On both sides of the profile are parking places, and in the middle is the access road. The parking places are located underneath a carport.

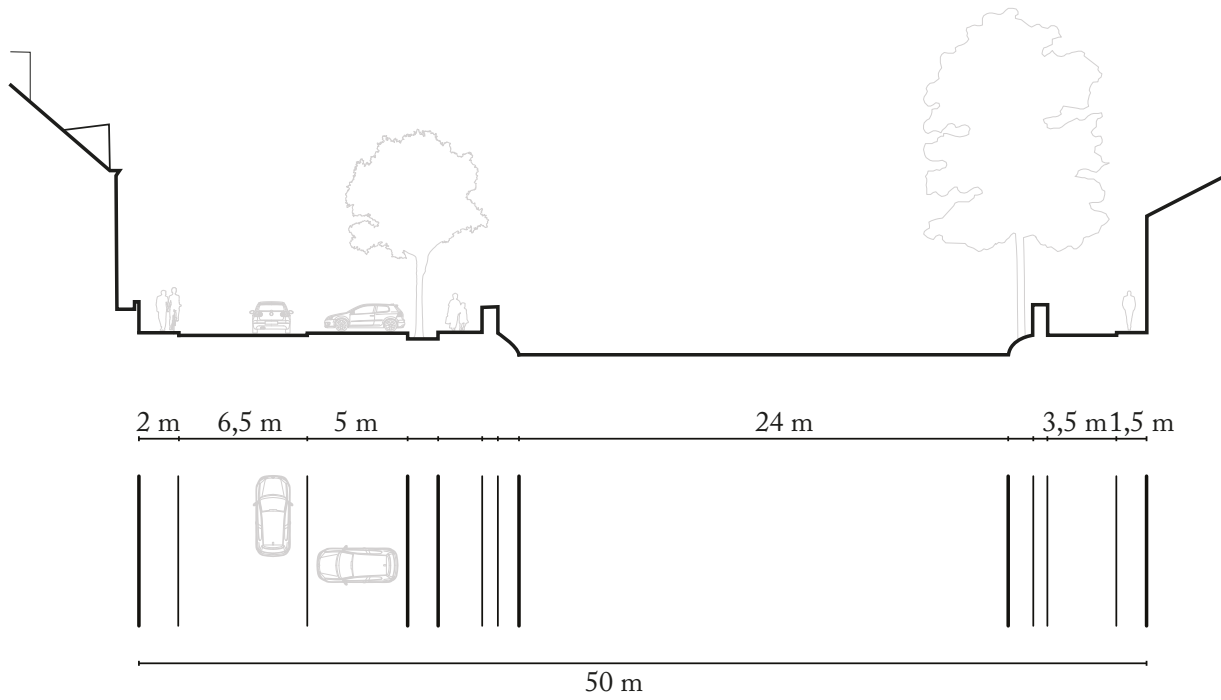

Section A

Middelburg

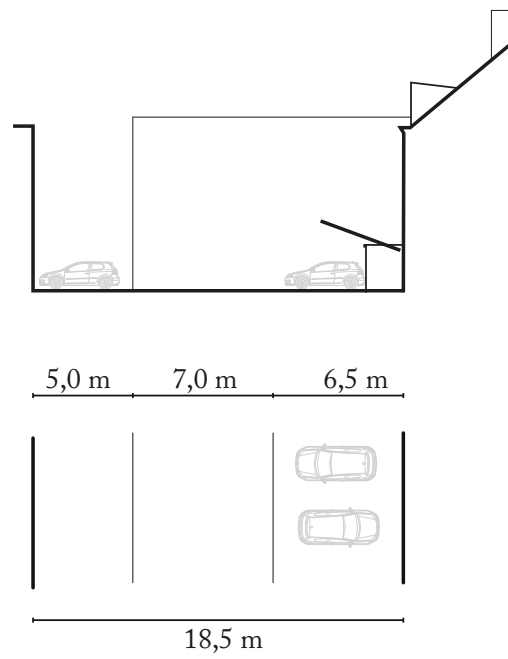

Section B

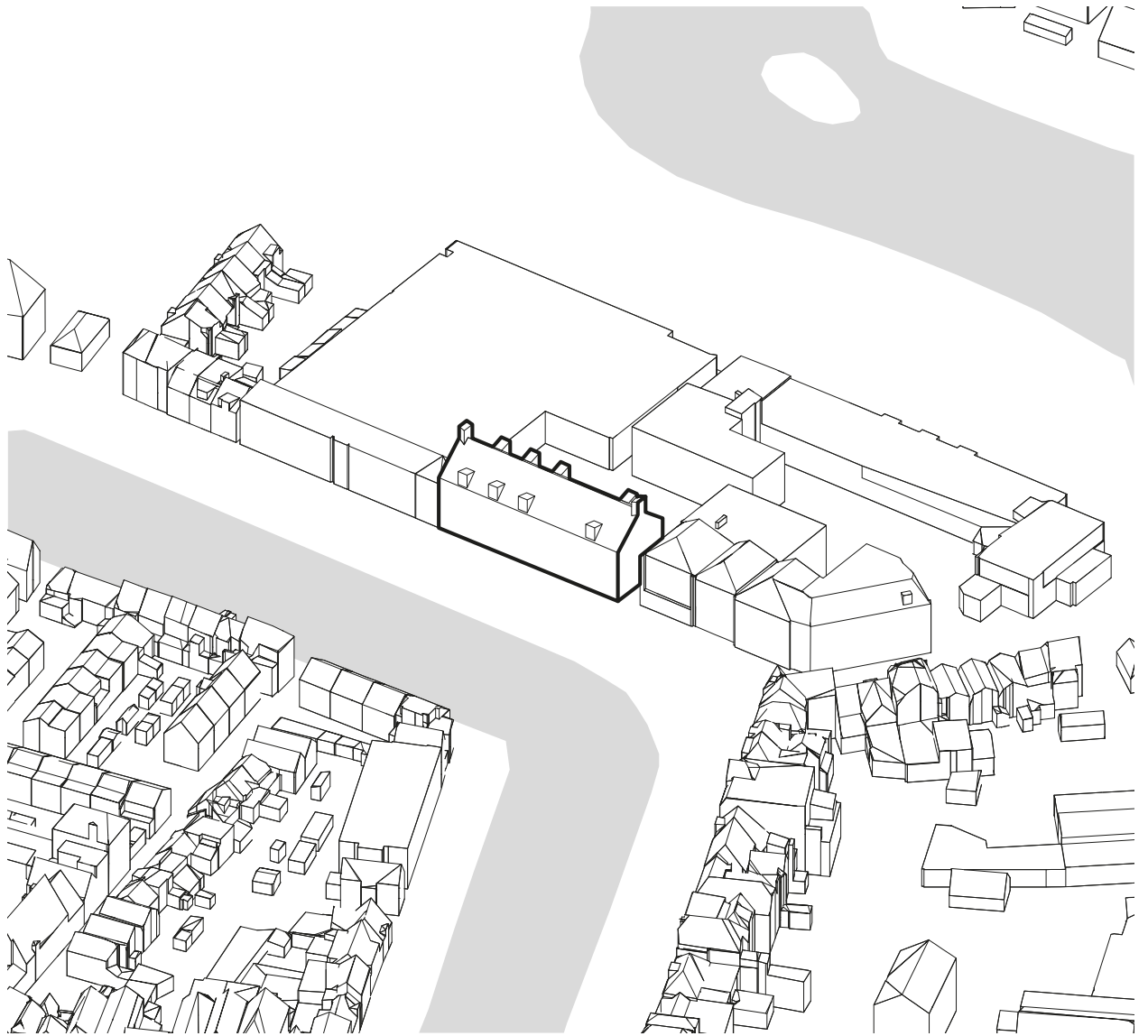

Isometric of urban block in surroundings

ISOMETRIC

1.7.2.3. ACCESSIBILITY



0

50 M

■ Car parking ▲ Entrance 🚲 Bicycle parking



Parking and entrances

Middelburg

PARKING AND ENTRANCES

The parking spaces are located along the streets surrounding the urban block and on the quay along the water in front of the police station. Private parking for the police is located within the urban block. The main

entrance of the police station is located along Achter de Houttuinen and several private entrances are located at the backside of the building.

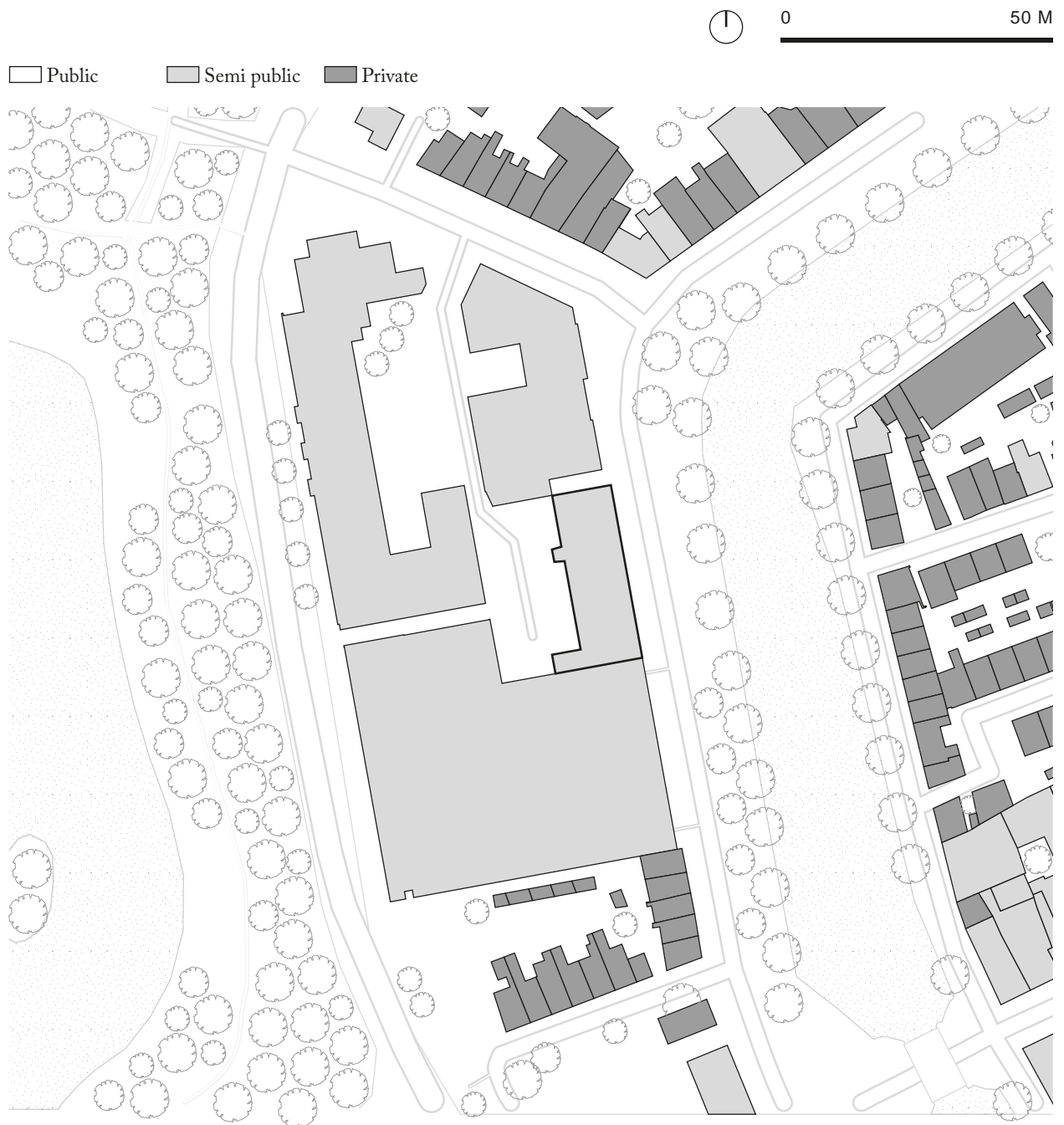

Public, semi-public and private buildings

PUBLIC, SEMI-PUBLIC AND PRIVATE BUILDINGS

The map shows the extent to which the buildings are accessible to the public. In the urban block, mainly large semi-public and private functions are present. These are meeting, office, accommodation, sports, shopping and

housing functions. The police building itself also belongs to the semi public functions. The same can be seen in the immediate vicinity of the urban block.

1.7.3. BUILDING OBJECT

1.7.3.1. SPATIAL LAYOUT



Vacant Heritage - Police Real Estate | The Netherlands

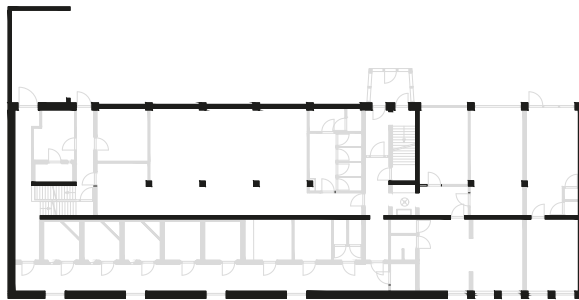

Souterrain

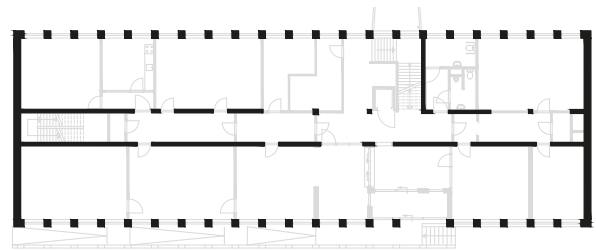

Ground floor

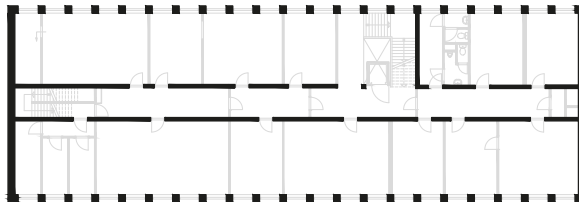

First floor

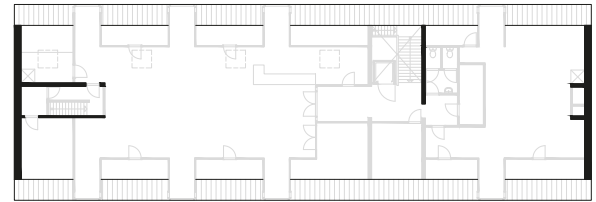

Second floor

FLOOR PLANS

The Middelburg police station consists of four floors, including a souterrain located below the raised ground floor level. The building makes use of a spatial layout with a central corridor that connects to spaces that vary in size

on both sides. The second floor is an exception as a result of the structure of the building, so a larger open space is visible on this floor.

0 10 M

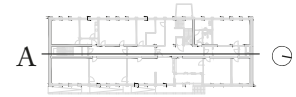

Middelburg

Section A

SECTION

The section shows the spatial layout of the building with its central corridor and total of four floor levels including the souterrain. This indicates that the entrance is located on the higher located ground floor level of the building.

The staircase visible on the left positioned connects the central corridors on the three lower levels of the building. The second floor allows for a larger open space.

1.7.3.2. SPATIAL RELATIONS

Vacant Heritage - Police Real Estate | The Netherlands

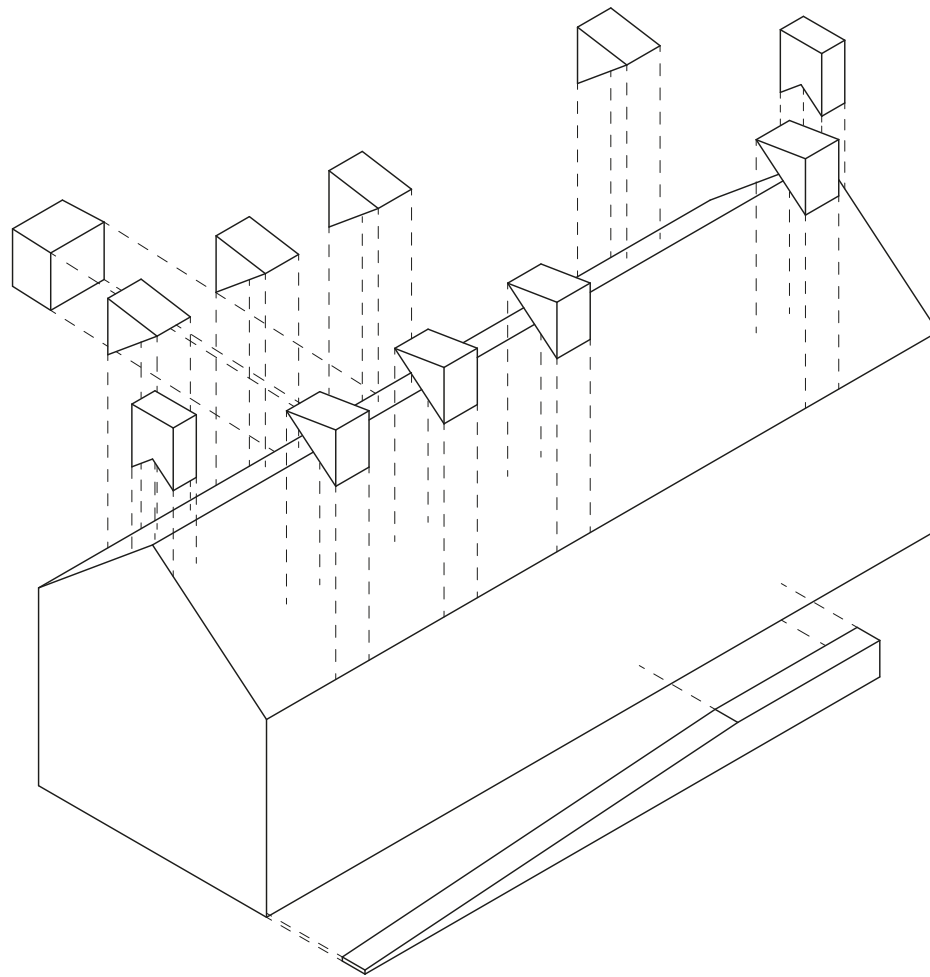

Building volume

BUILDING VOLUME

The Middelburg police station consists of a rectangular main volume with dormers added on the roof. A slope

and stair are added in front of the building to connect the entrance on the raised ground floor with the street level.



● Start Route ▲ Ascending vertical route

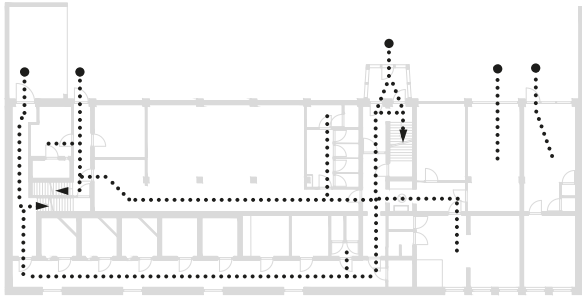

Basement

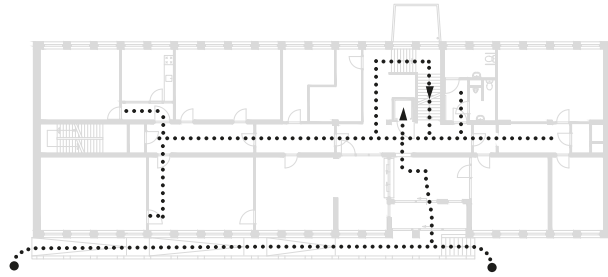

Ground floor

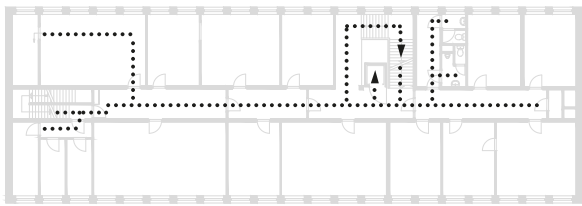

First floor

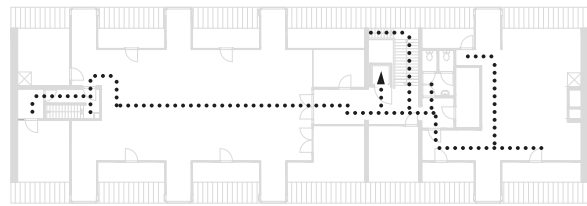

Second floor

Middelburg

CIRCULATION

The figures show the circulation of the Middelburg police station. The main entrance can be reached via a ramp or stairs at the front of the building. On the ground floor and first floor, there is a long corridor to which the various rooms are connected. Also connected to this is a

stairwell with a lift. On the second floor, a large canteen room is connected to the corridor. In the basement, there are five entrances to the building. There is a cell complex here, consisting of a corridor with rooms connected to it, which can be reached via a separate entrance.

1.7.3.3. STRUCTURE

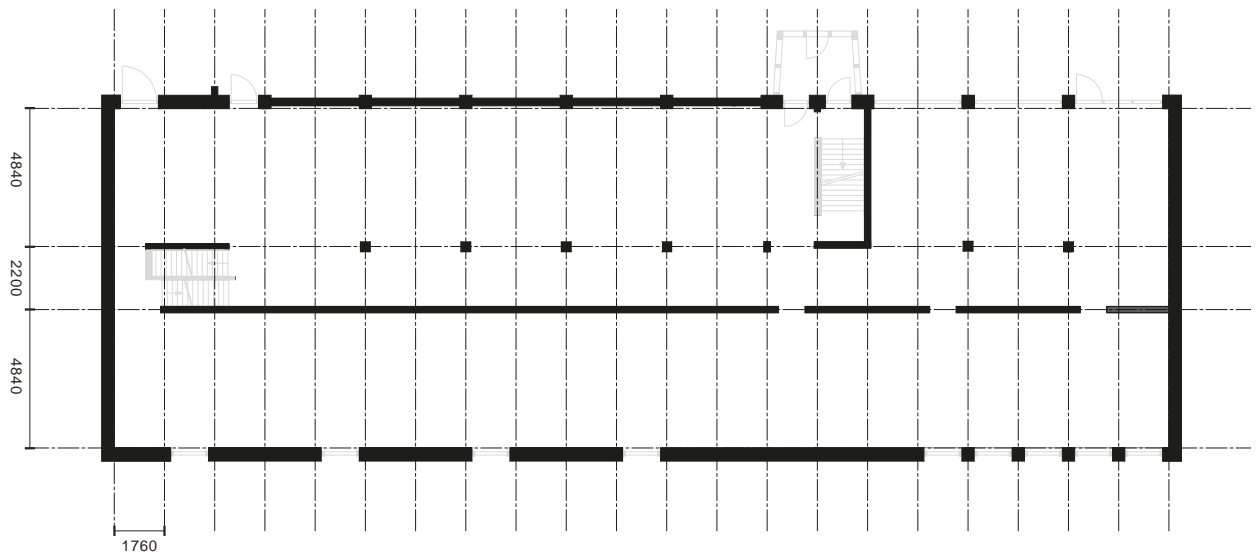

Structural grid

Vacant Heritage - Police Real Estate | The Netherlands

LOAD-BEARING STRUCTURE

The building is based on a structural system of 1,76 m x 4,84 m. It consists of load-bearing façades with an inner corridor that supports the floors with mainly structural

walls and some columns and beams. The main structural material is brickwork.

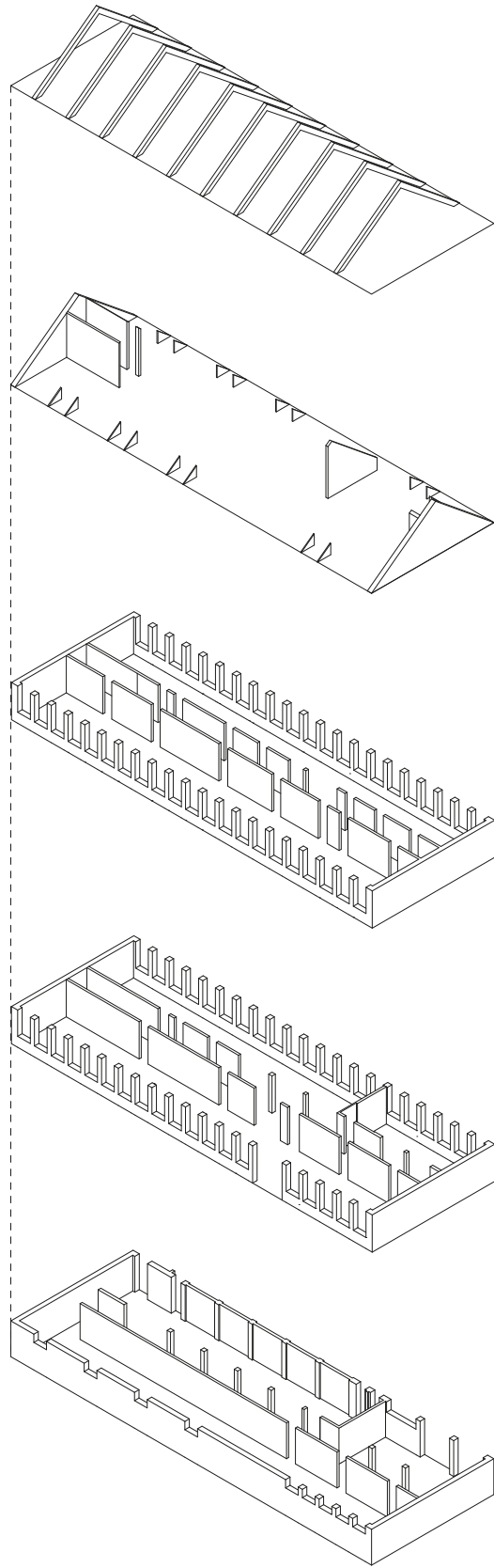

Load-bearing structure axo

1.7.4. BUILDING ENVELOPE

1.7.4.1. CONFIGURATION

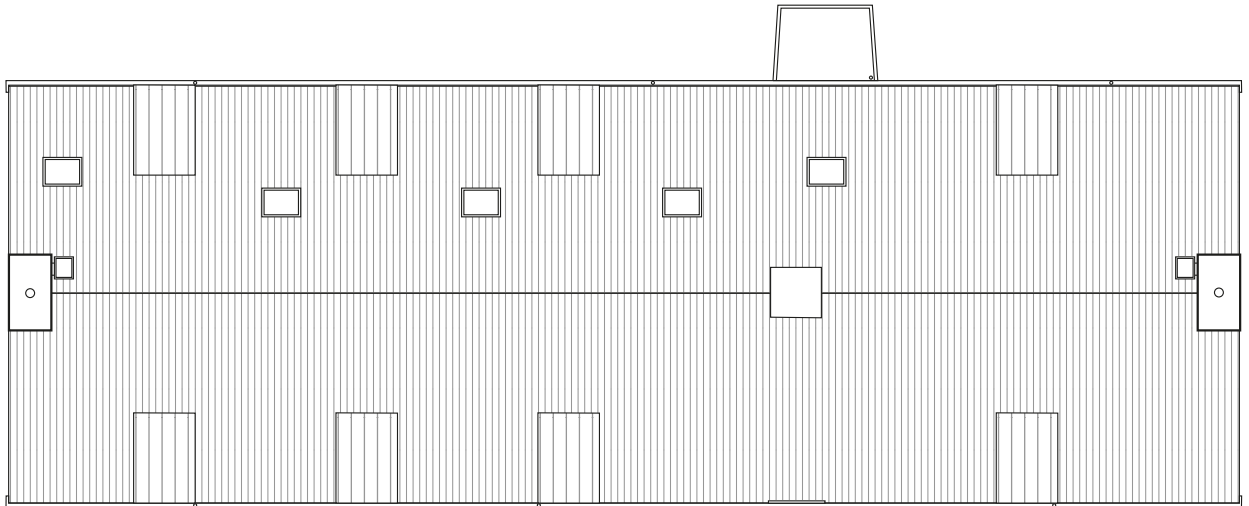

ROOFPLAN AND FAÇADES

The roof of the Middelburg police station is a gabled roof with the pitched parts facing towards the Achter de Houttuinen street and the back of the building. Two chimneys are positioned on the outer edges of the roof-ridge. Four dormers are visible on each side of the roof, but not all of them match to the rhythm of façade openings below.

The façades of the building follow a clear rhythm and are composed out of masonry, prefabricated elements and windows. The masonry wall of the stairs and slope in front of the building follows the same rhythm. The west façade shows more differences in the façade, especially on the souterrain level.

0 10 M

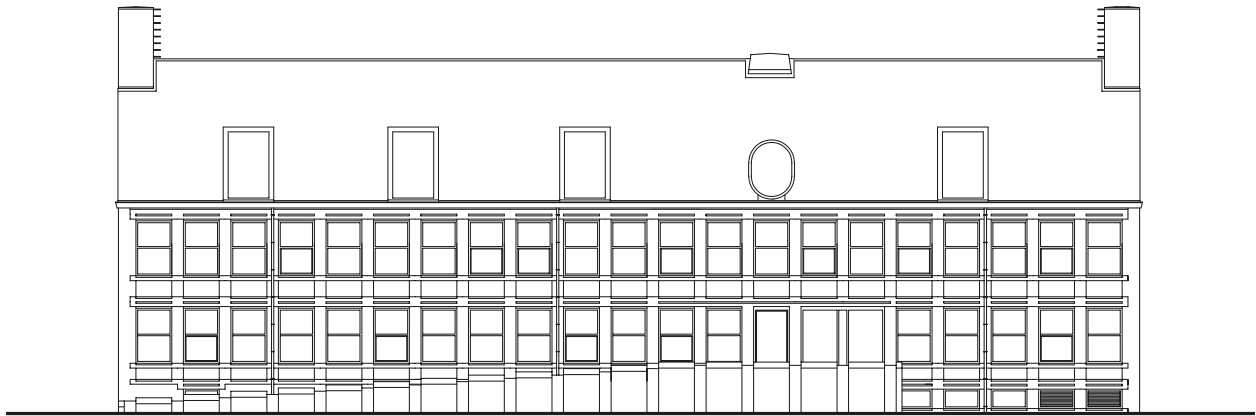

East façade



West façade

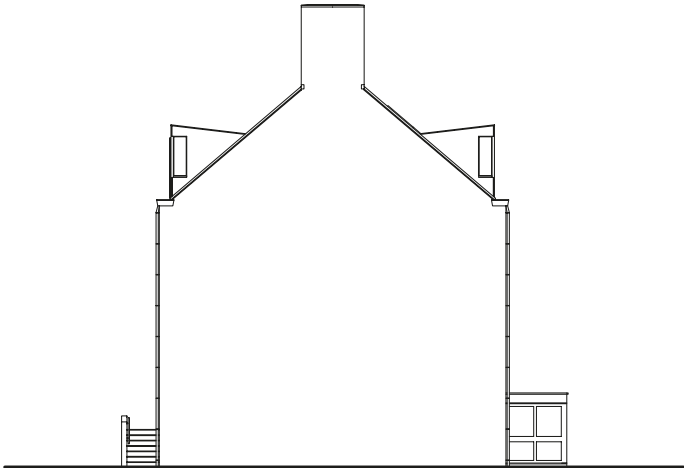

North façade

Middelburg

1.7.4.2. COMPOSITION

0 10 M

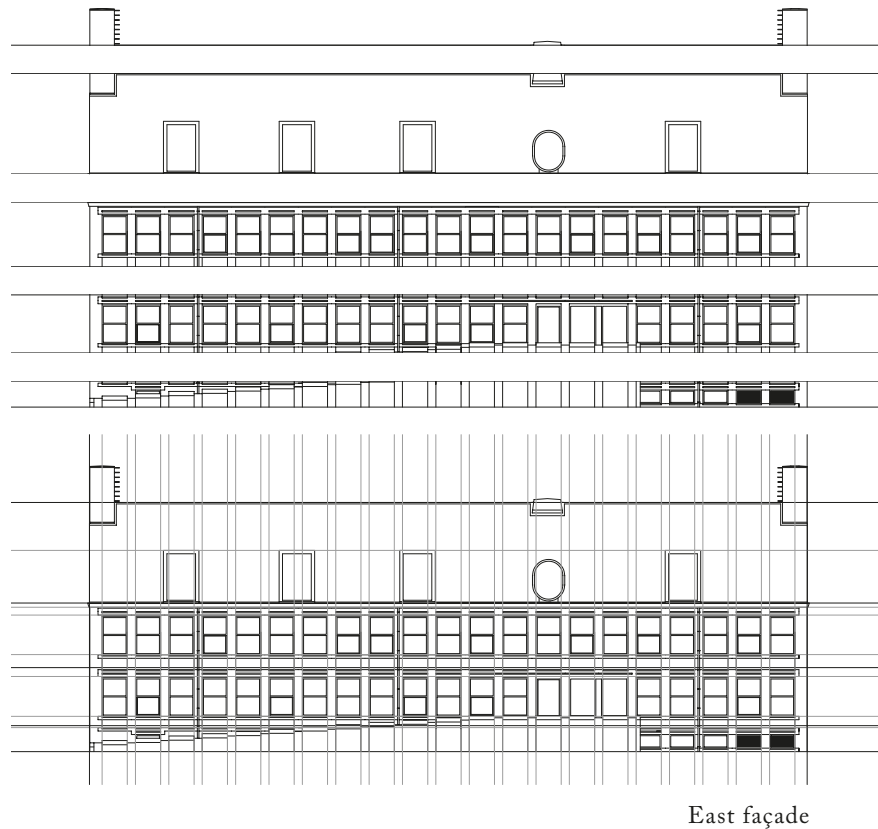

East façade

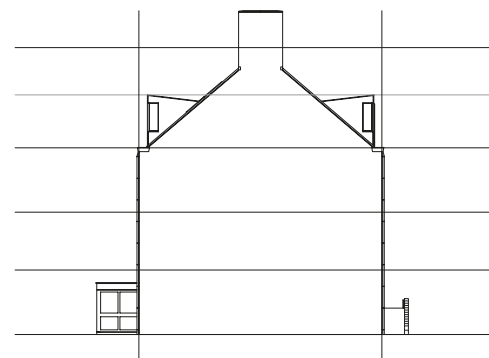
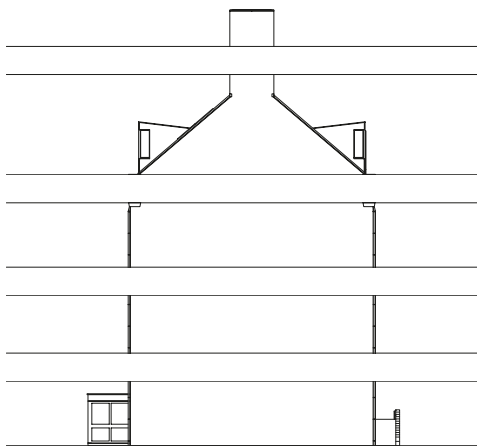

North façade

COMPOSITIONS

The police building in Middelburg was built in 1967 and designed by Berghoef, Hondius and Lamers, an architectural firm located in Aalsmeer. This firm mainly designed public buildings such as town halls and churches, but also homes. The building in Middelburg consists of four floors, the souterrain, the ground floor, second floor and the attic. From the front side, the building can be accessed at the ground floor. From the back, the building is accessed via the souterrain. The composition of the

front façade is more or less similar to the back façade, but very different from the side façade. The front façade has strict grid, consisting of the windows, concrete bands, and recessed masonry. The only exemptions are the entrance, which fits in the window grid but contains a larger opening and the dormers, that do, remarkably, not follow the grid. The side façade is almost completely empty; it only consists of flat masonry and there aren't any windows at all, except for the dormers.

1.7.4.3. MATERIALITY

0 10 M

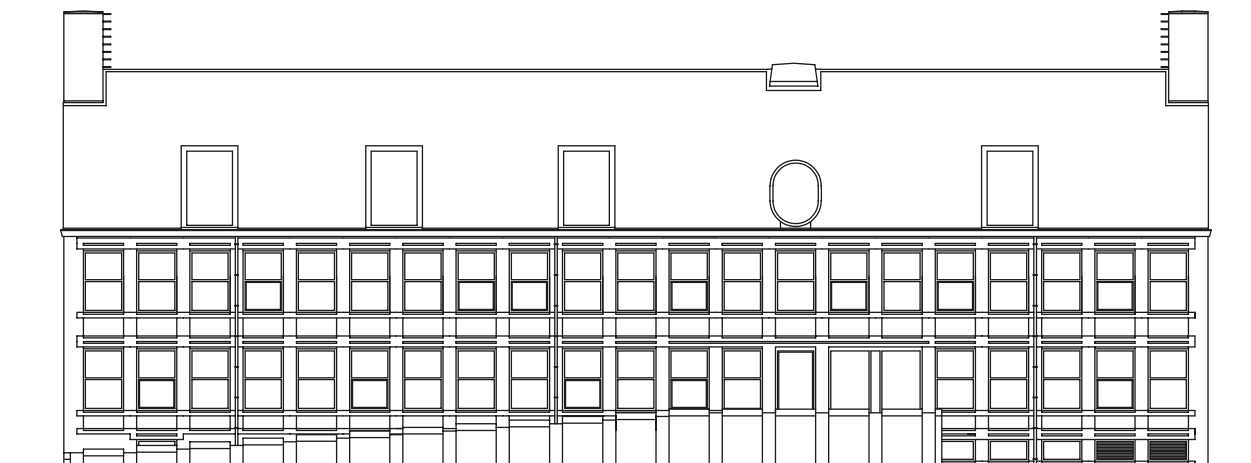

East façade



Middelburg

COMPONENTS

The façade is composed of a relatively small amount of components, due to its repetitive character. There are only two different types of windows, one that can be opened and one that cannot. But, even these two types

quite similar. Also all the dormers are all the same. Three different types of concrete elements are used in the façade, one above the windows, one underneath and one above the entrance.

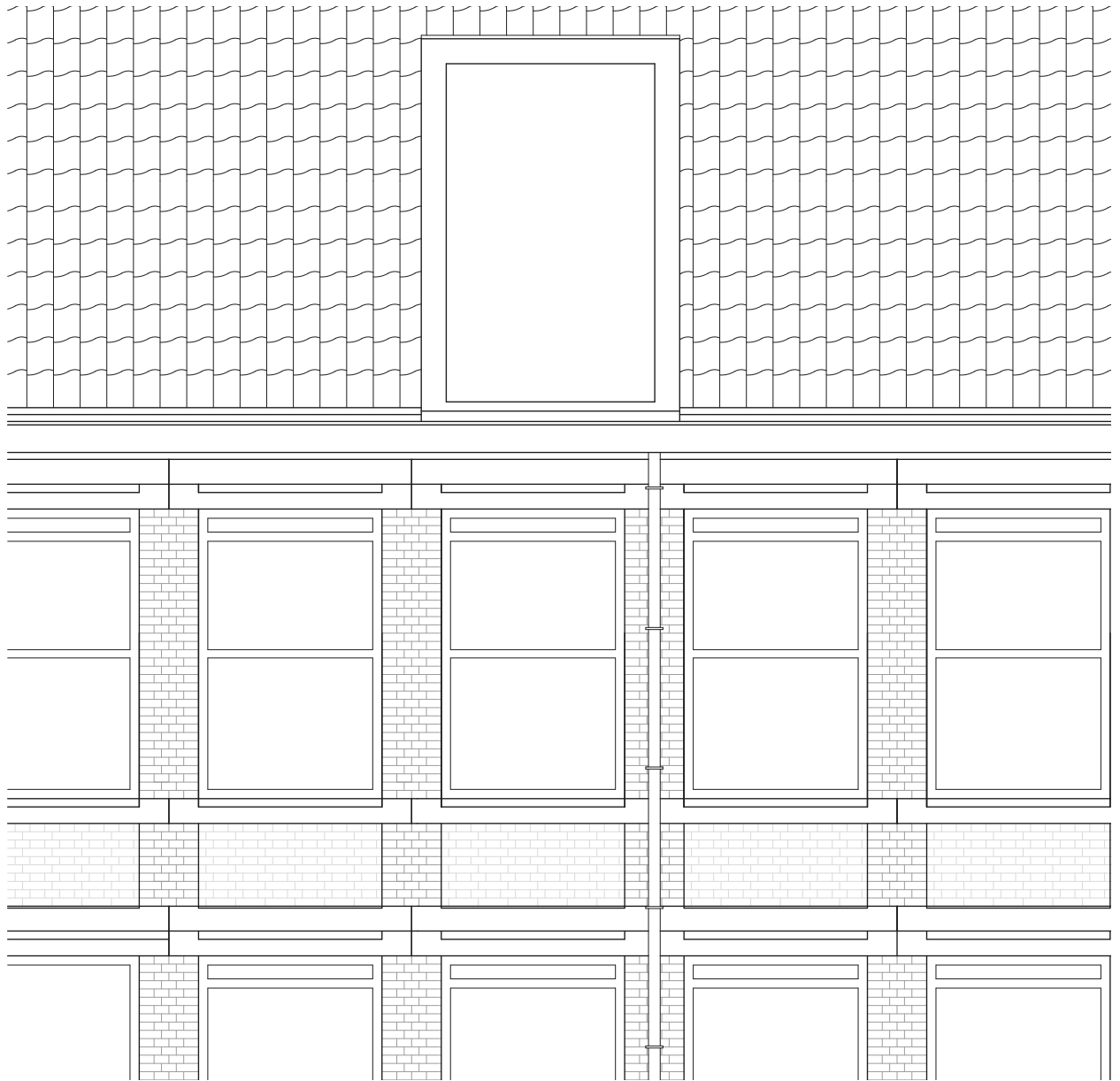

Façade fragment analysis

TEXTURES

The front façade of the police building in Middelburg is constructed out of brick and concrete. The combination of these two materials is characteristic for buildings designed by Berghoef, Hondius and Lammers. All horizontal elements are made of concrete. All vertical elements are made out of red brick. In between the

horizontal and vertical bands, yellow brick has been used. All masonry has been laid in English bond. The window frames are made out of aluminium, except for the dormers which are made out of different types of plastics. Both the window frames and the dormers are still original. The roof is finished with roof tiles.



(Riepema, 2021)

1.7.5. CONCLUSIONS

Middelburg is an old city, which received its city rights in 1217. Until 1850, the town was located within the defensive moats. After 1900, the town underwent major urban expansions outside the defensive moats. In the inner city, there is a lack of public green spaces. The inner city is bordered in the south by the Kanaal door Walcheren. A number of canals and moats are connected to this, which run through the inner city. Large squares are mainly located in the inner city. A train station is located south of the town centre.

A large part of the urban block is built up. However, there are still a number of large open spaces. The police lot is one of those places with a lot of open space. In front of the police station, there is a wide street profile consisting of a pavement with a road next to it, on which perpendicular parking spaces have been placed. Behind this is a narrow green strip, a footpath and a green slope to the canal. The urban block generally consists of private and semi-public functions. The police building is one such semi-public function.

The police building was built in 1967-1968 and designed by Berghoef, Hondius and Lammers. The building has a simple compact rectangular shape with a gable roof. The building has four floors, one of which is underground. The height of the ground floor and first floor correspond, the top floor is higher. In the building there are many

storage rooms and offices. In the basement there are large changing rooms and a bicycle storage. On the top floor is a large meeting room/ canteen. The façades are load-bearing, as are the internal walls parallel to the façade. In the basement, the load-bearing internal walls have been replaced by columns and beams. The walls next to the stairwell provide the stability of the building. The main entrance is accessed via a ramp and stairs at the front of the building. In addition, there are five other entrances located in the basement. Inside the building, a central corridor connects the various rooms. There are two vertical circulation spaces in the building and a lift. This lift connects the different floors with each other, except for the basement.

The front and back façades of the building follow a strict grid, consisting of windows, concrete bands and recessed masonry. This structure is interrupted at the entrance. In the façade, a limited number of building components are present because of the many repetitions in the façade. The façade of the police building consists of concrete and bricks. The combination of these two materials is characteristic of Berghoef, Hondius and Lammers. All horizontal façade elements are made of concrete and all vertical ones of red and yellow brickwork. The window frames are replaced with aluminium except for the dormers. The roof is tiled.

1.8. WARNSVELD

1.8.1. INNER CITY

1.8.1.1. INTRODUCTION



DEMOGRAPHY

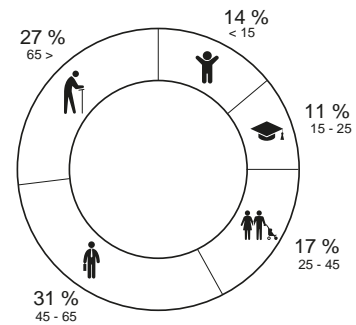

MOBILITY

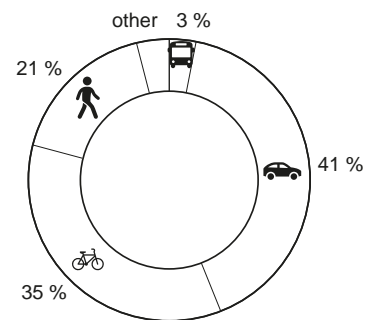

The town Warnsveld is assumably founded with the construction of the Martinuschurch in the tenth century. It belonged to the diocese of Utrecht. For a long time the village consisted only of a church and a number of houses and farms. Other than that, only estate Huis 't Velde belonged to it. The connection with the city Zutphen has always been strong. Zutphen was originally a Germanic city with more than 1700 years of history. In the Middle Ages it was one of the larger Hanseatic cities. The city got their city rights in 1190. Zutphen was originally a fortified city until 1874. That is why in the nineteenth century rich families from Zutphen decided to build better residences in the suburbs of the town Warnsveld and the reason why Warnsveld grew. Even now the town is growing due to the overflow of residents from Zutphen.

Warnsveld has only 8,390 inhabitants (2021), Zutphen in total 48,099 (2021). The young population between 0 and 45 are below national average. Especially the category 25-45 is below average with 17% compared to 25% nationwide. The oldest category 65+ is well presented with 27% in comparison with the nationwide 19%. The public transport is less dense, this is reflected in the chart with a very low percentage of 3 percent. For example have the big cities in Noord-Holland and Zuid-Holland a percentage between 10-15%. Because of the small villages, people have to travel a longer time to their work. This is well presented in the ratio between bicycle and car. The car is well used in comparison with the nationwide percentage of 36%.

1.8.1.2. DEVELOPMENT



Vacant Heritage - Police Real Estate | The Netherlands



1850

HISTORIC DEVELOPMENT

Until 1850, the city of Zutphen only consisted of a historic city centre with an extensive water structure surrounding it as a defense mechanism. On the westside of the city was the river IJssel. Around this time, Warnsveld only consist of a few houses, farms and estates. Zutphen gets

a connection to the rail road around 1865. Around 1900, the defense structure of the city starts to fade away, and a few buildings were built outside the former 'singels'. After World War II, the city of Zutphen grew quite a lot.



0 1500 M



1904



1956



2022

Warrsveld



BUILDING AGE

Zutphen has an old medieval core regarding the drawings of the building age. Warnsveld was not there yet, but would develop on the eastern side of the city. According to Anja Guinée (2019) Warnsveld only consisted of a few nobiliary houses. Also Huis 't Velde was one of them. From the twentieth century onwards the city of Zutphen started to grow. A lot of neighbourhoods in

Zutphen were built and also Warnsveld started to grow. After World War II the industrial areas in the north of Zutphen expanded and a few large city districts were built in the southern part. In the twenty-first century the city of Zutphen, including Warnsveld, are not really expanded, although a lot of buildings are built inside the existing structure. A densification has taken place.



0

1500 M



1800-1899



1900-1949



1950-1999



2000-

1.8.1.3. NETWORKS



Vacant Heritage - Police Real Estate | The Netherlands

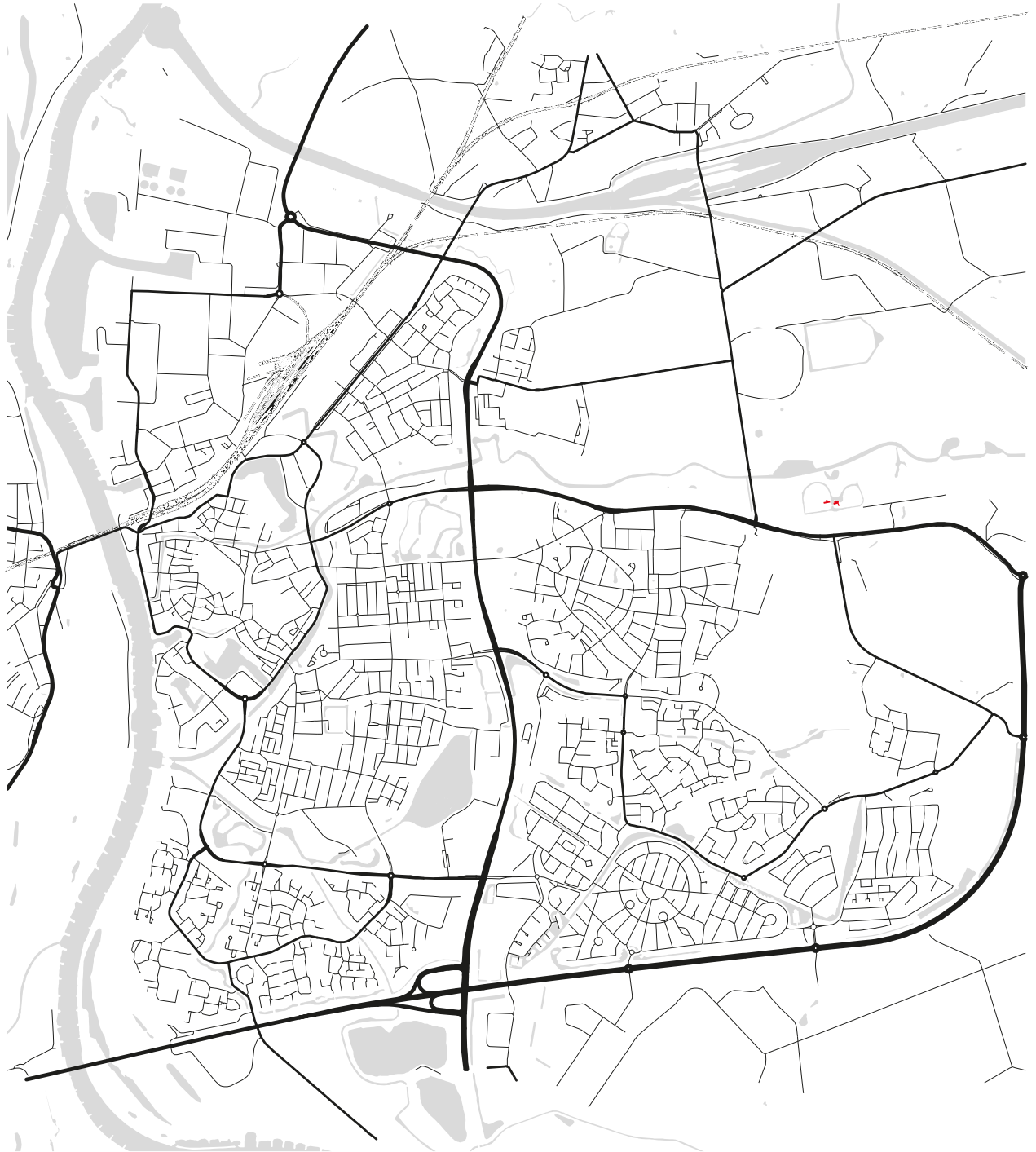

ROAD NETWORK

There are mainly two types of roads in the surroundings of Zutphen and Warnsveld; primary- and tertiary roads. The primary roads connect the villages and have a high speed limit of 80 or 100 km/h. In the denser built environments there are tertiary roads with lower speed

limits. There are almost no secondary roads in the area because the primary roads connect the neighbourhoods and in the less dense areas people and farmers live next to these roads. Concerning Huis 't Velde this building is good accessible via a primary road.



0 500 M



Warnsveld

Primary roads



Vacant Heritage - Police Real Estate | The Netherlands



Secondary roads



0 500 M



Warnsveld

Tertiary roads

Public squares Green Water



GREEN, WATER AND PUBLIC SQUARES

The public squares of Zutphen and Warnsveld are mostly in the city centres. The big squares in the old centre of Zutphen are transformed to a marketplace several times a week. The squares mostly function as public space situated nearby a church, townhall or shopping centre.

Within the area around Zutphen and Warnsveld there is plenty of greenery and water. The estates, of which Huis 't Velde is one, form the transition between urban and rural areas and function as recreational space outside the city, due to the number of walking- and cycling paths.

1.8.2. URBAN BLOCK

1.8.2.1. COMPOSITION

Vacant Heritage - Police Real Estate | The Netherlands



(Van Asselt, 2021)



Warrsveld

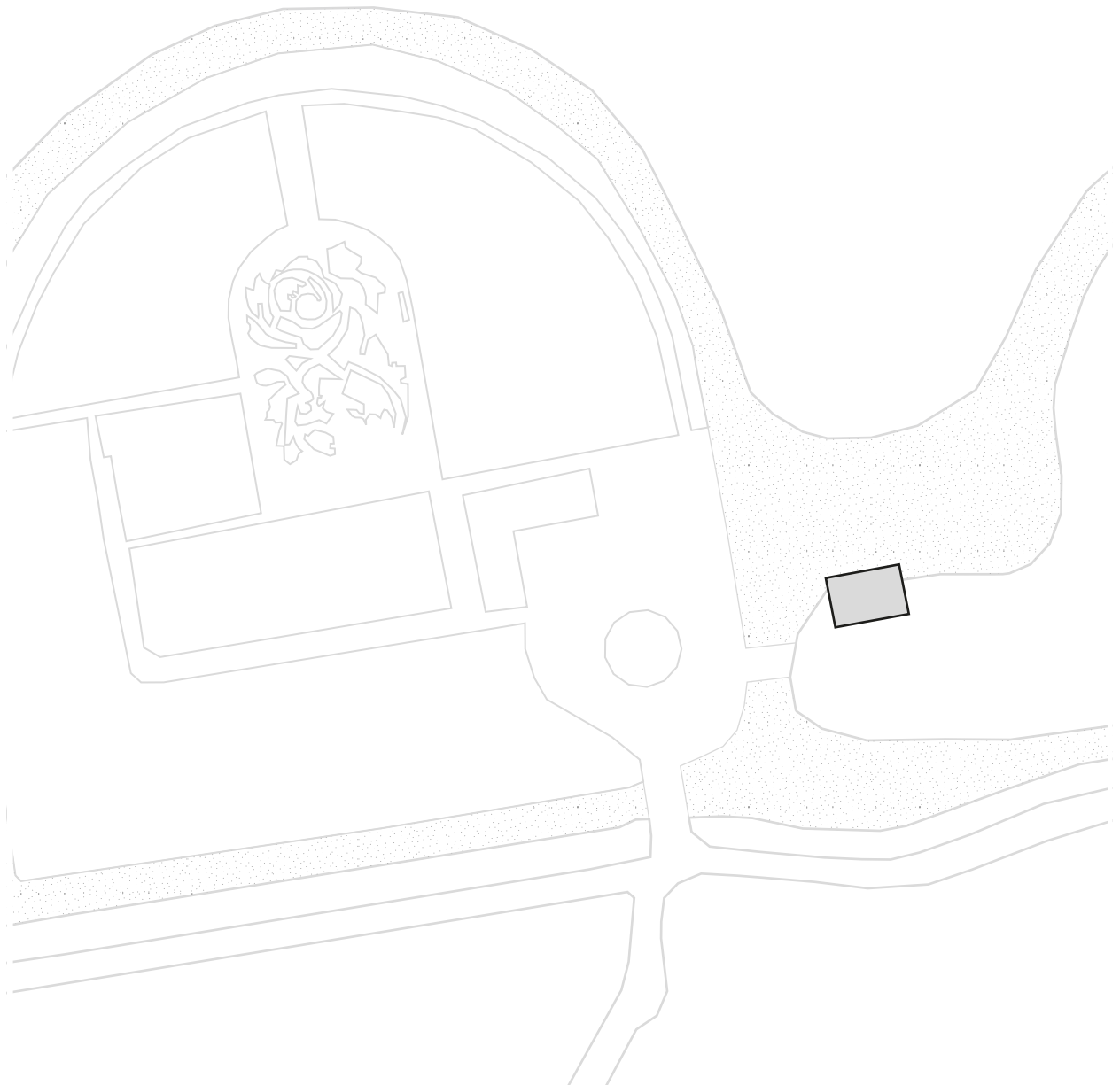

ca. 1550

HISTORIC DEVELOPMENT

The building process of the complex of police buildings in Warnsveld starts with a central, tower-like, house around 1550. This has first been extended with two wings on the back, that we can recognize nowadays on their characteristic stepped façades. Not much later, also a wing on the front side has been added, together with two towers, making most of the still remaining composition complete around 1620. Later, the coach house, including

a house, and a dovecote were added to the complex. The second tower has been demolished. In the 1980's, a house has been added at more or less the other side of the complex. The center of the estate shows various timelayers and differentiation in garden designs as well. The memorial garden of the police is the most recent addition in the landscape and has national significance, as an obituary is held once a year.

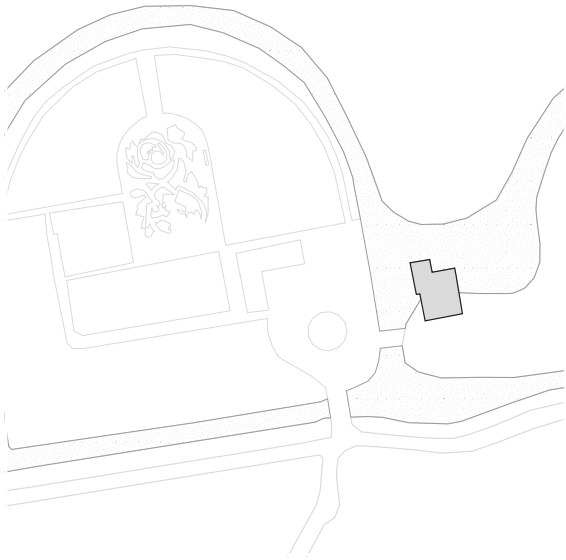

ca. 1590-1600

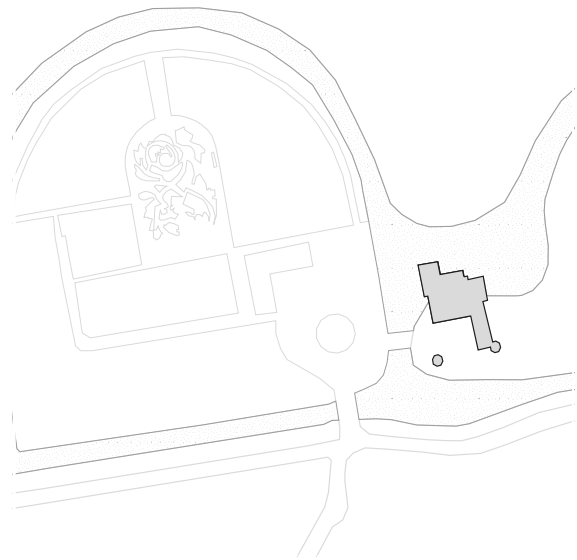

ca. 1600-1620

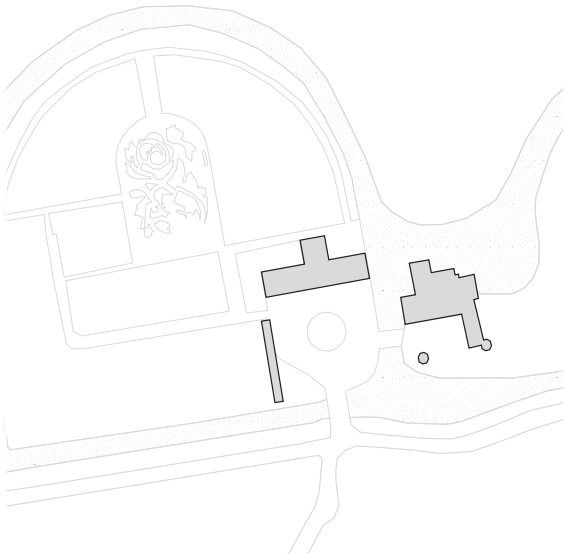

ca. 1700-1740

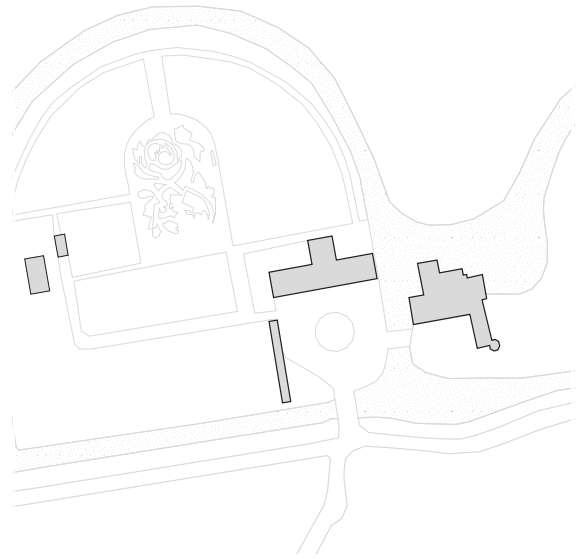

ca. 1985-2000

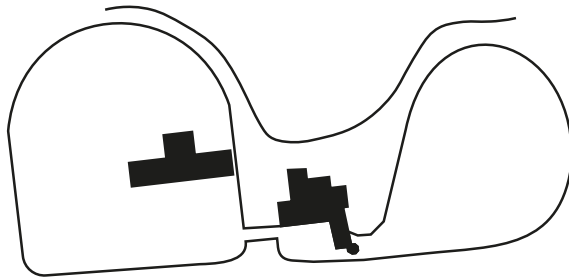

Built area
950 m²

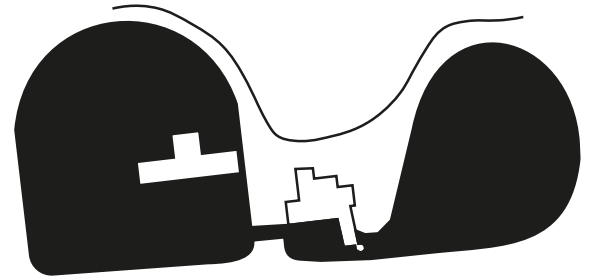

Empty area
25660 m²

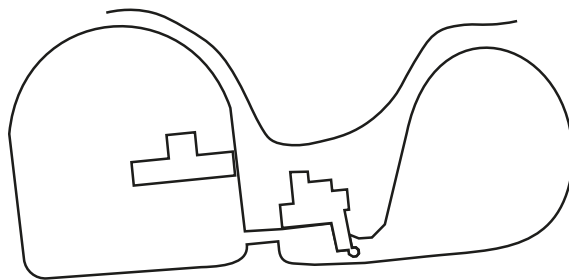

Parcels
2 buildings + garden

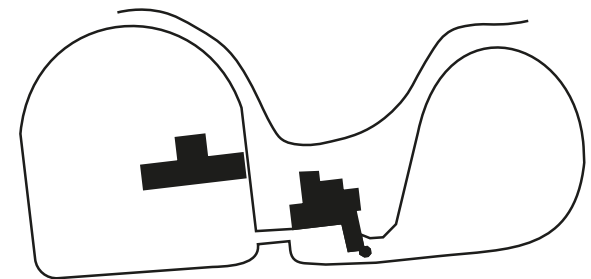

Police real estate
26610 m²

Vacant Heritage - Police Real Estate | The Netherlands

BLOCK INFORMATION

The urban block of Huis 't Velde is different from the other police buildings. It consists of a large garden with an inner and outer zone. The inner zone of two islands is drawn in the diagram. An island of approx. 26,000 square

meters consists of two police buildings, aviary and another small house. Only 950 square meters is built by the two main buildings: Coach house and Huis 't Velde itself. The total area is approximately 328,000 square meters.



sloped roof 

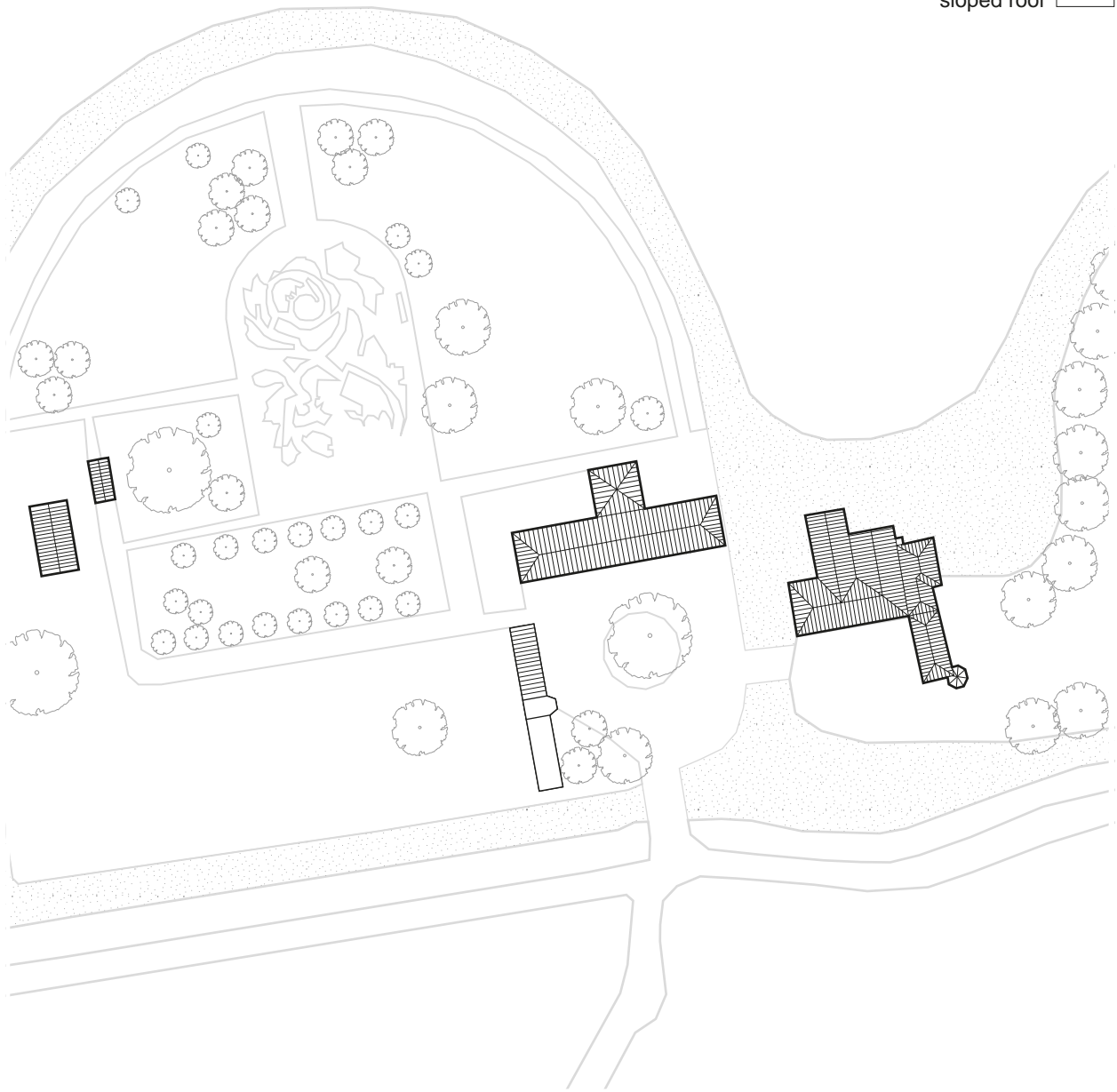

Warrsveld

Roof structure

ROOF STRUCTURE

The roofs of all buildings are gabled roofs. This is related to the old construction of the houses. During the time of construction men was not able to make flat roofs. The

roofs are orientated in all directions. In the case of the main building, the edges of the wide roof of the front façade are highlighted with big chimneys.

1.8.2.2. STREETS

0 10 M

■ Façade openings

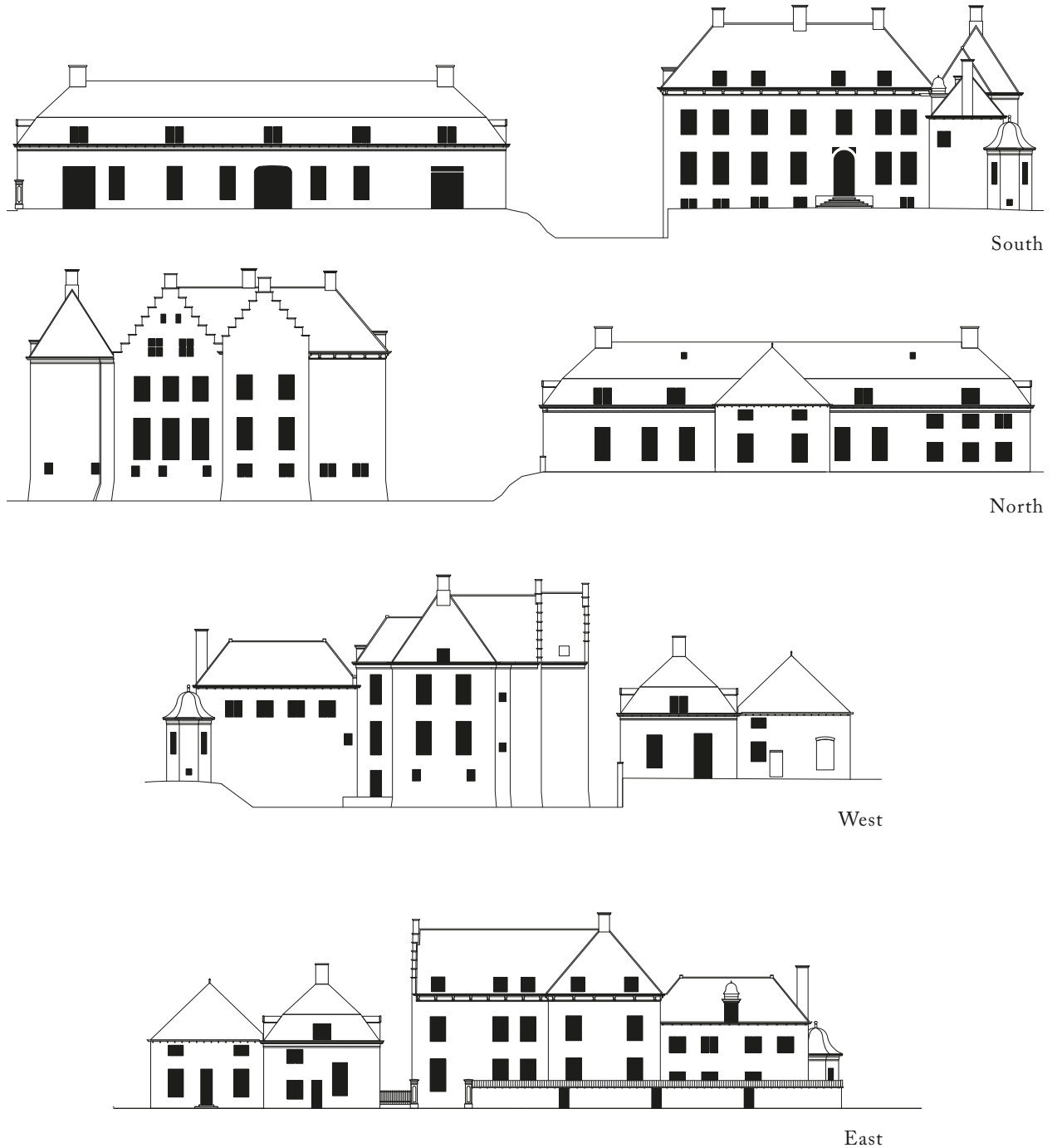

Vacant Heritage - Police Real Estate | The Netherlands

STREET ELEVATIONS

From the elevations, the conclusion can be drawn that there is no connection between the façades and other surrounding buildings. That is because there are no other buildings connected to this urban block. Every building

on the estate is a block for itself. It is also noticeable that every façade except the east façade functions like a main front façade. The buildings are orientated to every side.



0

100 M

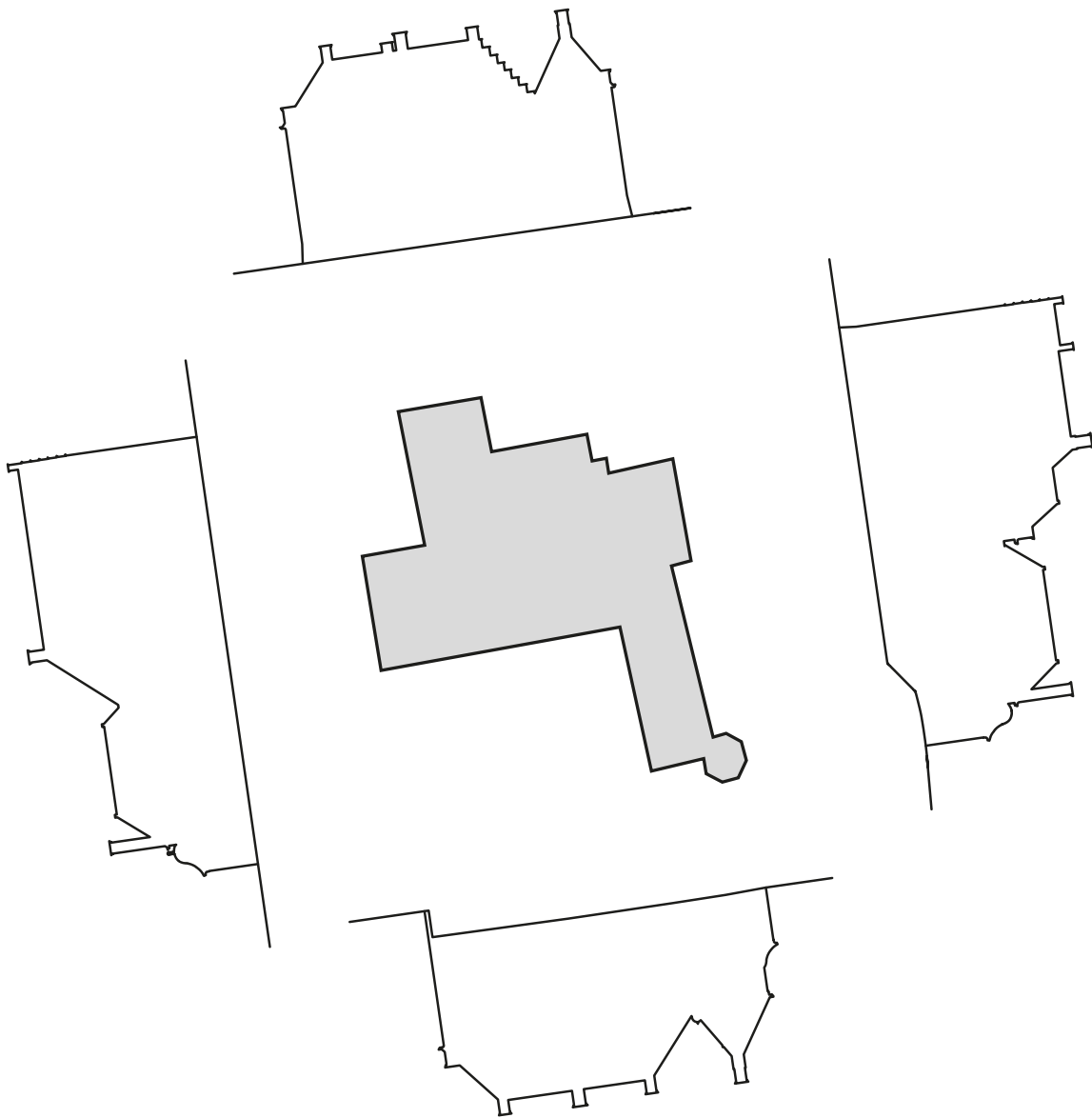

Warrsveld

Parcels and façades

PARCELS AND FAÇADES



Vacant Heritage - Police Real Estate | The Netherlands

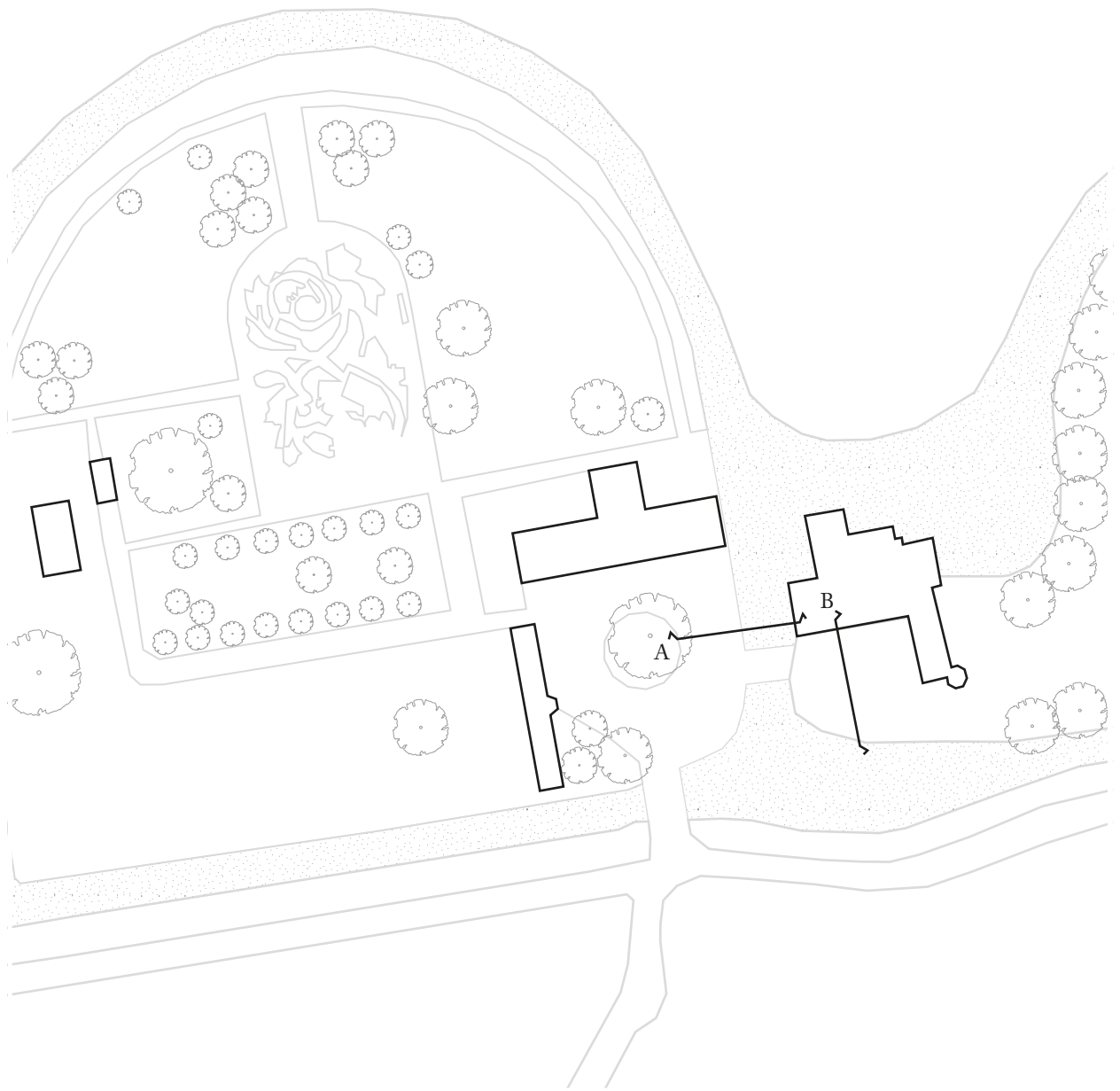

Location of street sections

STREET SECTIONS

The first section, section A, that has been made shows the front size of Huis 't Velde, the forecourt and the canal around the house. In the background, the façade of the front wing of the house is visible. In front of this façade stands a tree. The forecourt is paved in clinker bricks, and between the water and the forecourt is a relatively flat

slope covered with grass. Second street profile, section B, shows the canal directly beside the house, a slightly steeper slope, and a garden with different types of plants. Besides this garden is the access road to the complex. In the background, the coach house is visible.

0 10 M

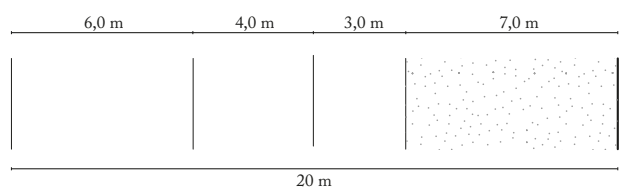
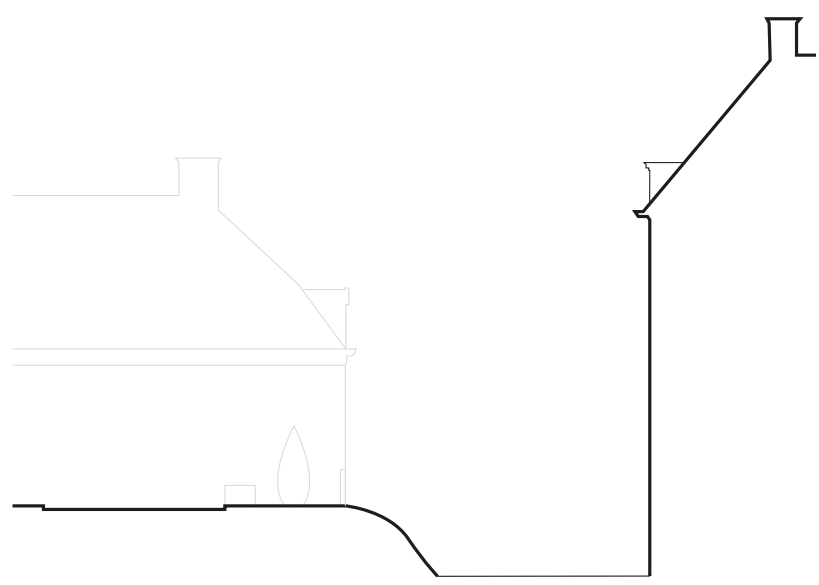

Section A

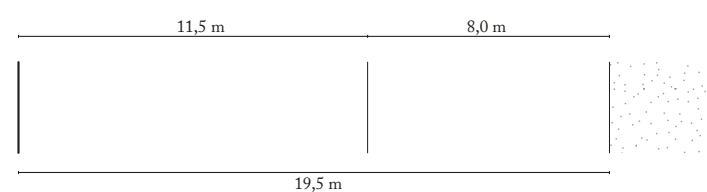
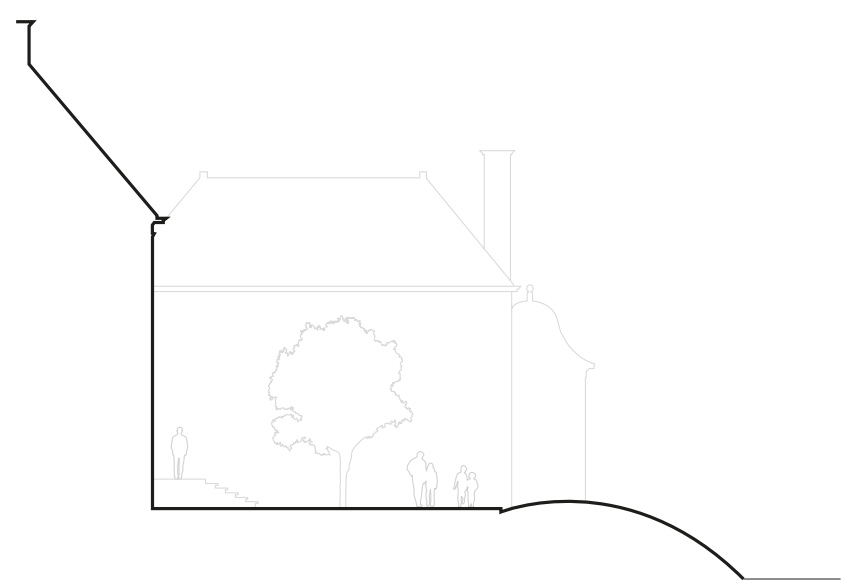

Section B

Warrsveld

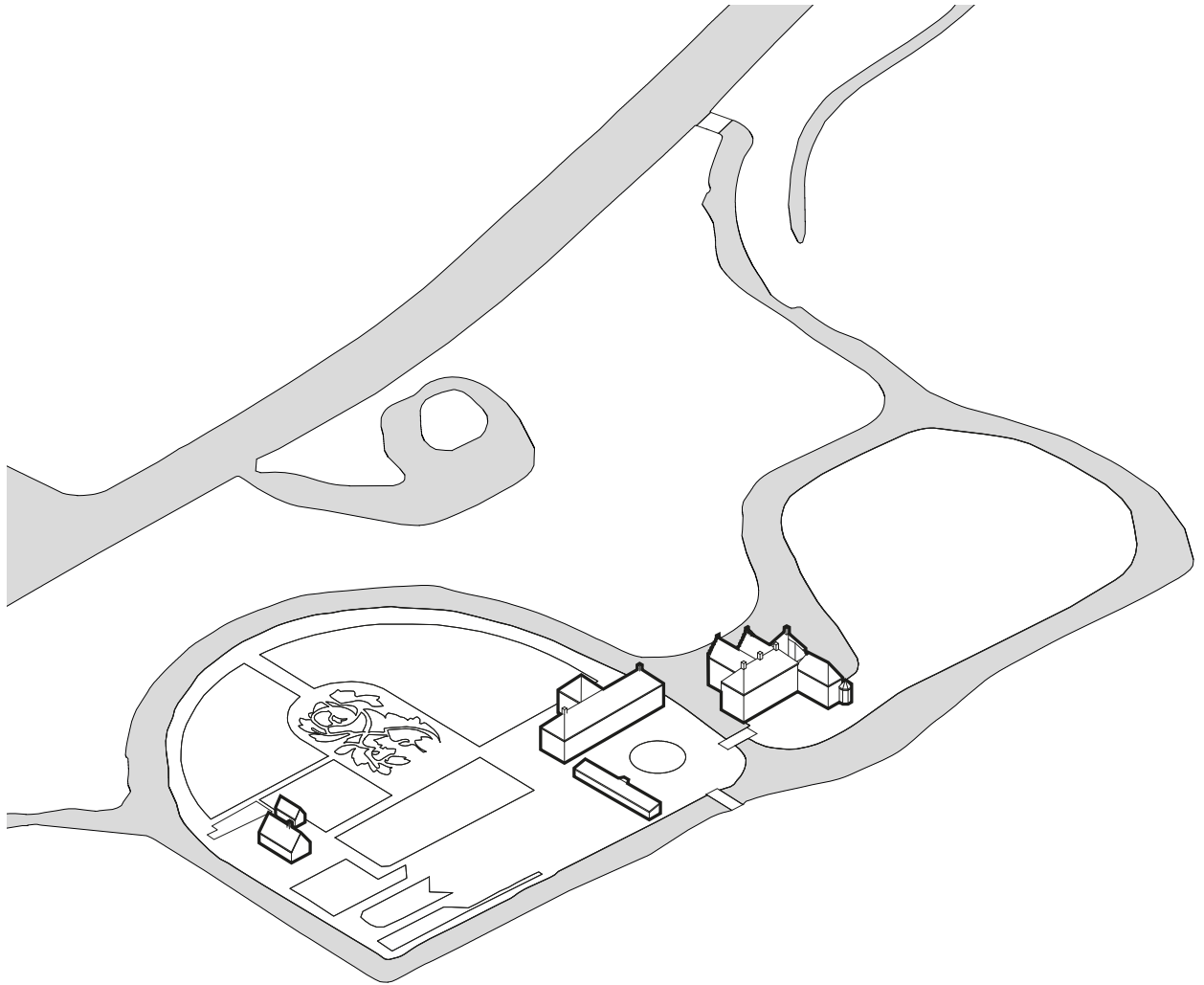

Isometric of urban block in surroundings

ISOMETRIC

1.8.2.3. ACCESSIBILITY



■ Car parking ▲ Entrance 🚲 Bicycle parking

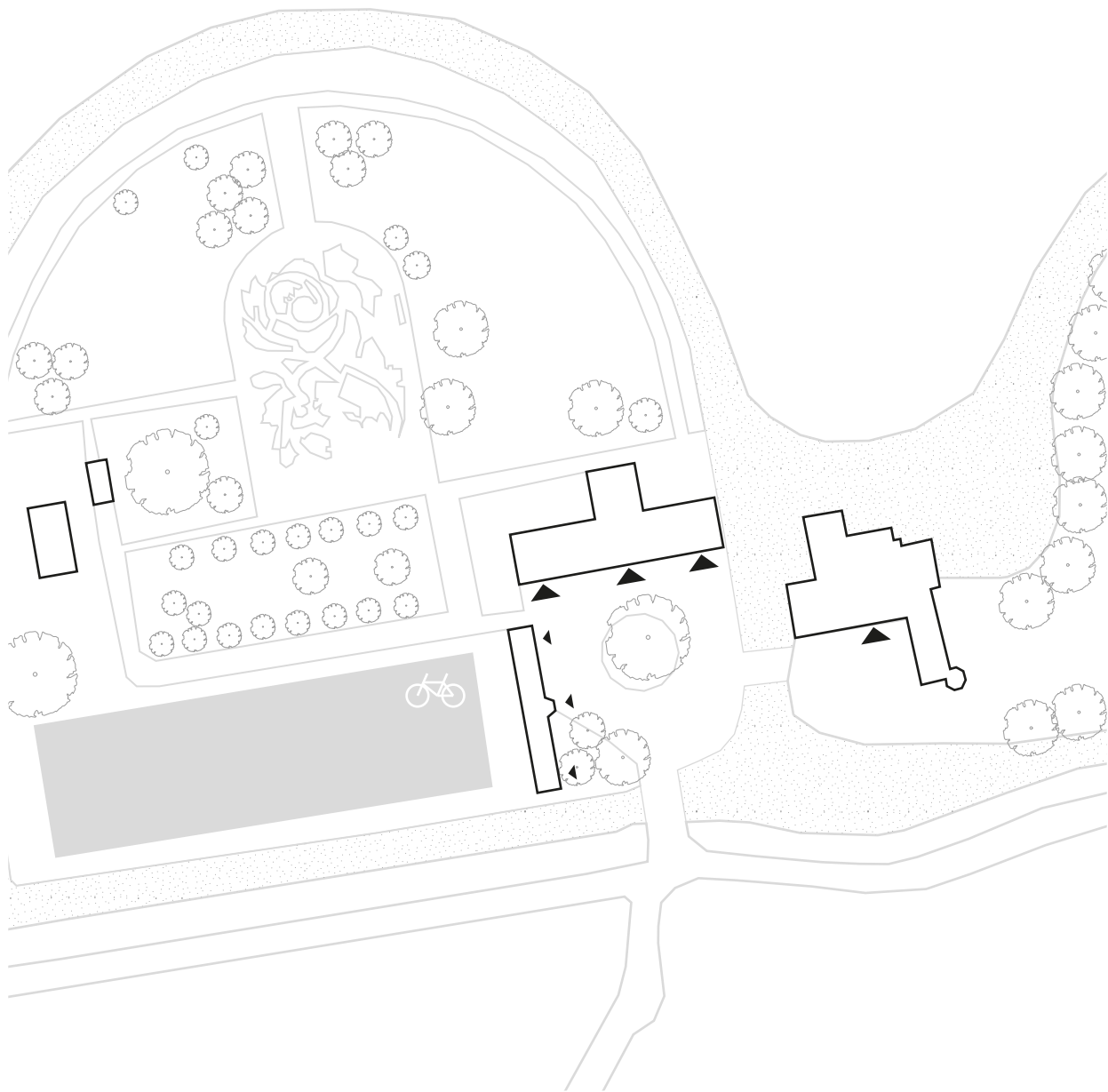

Parking and entrances

PARKING & ENTRANCES

The parking is located on the inner island on the left side. It is a little bit out of sight and separated from the house and coach house by a large wide shed. On the south side is a brick wall that hide the parking lot from the driveway.

A couple of big trees block the view on the cars from the first floor of the main building. The parking lot is mostly used by cars and a little corner is reserved for bicycles.

Warrsveld



□ Public □ Semi public □ Private

Vacant Heritage - Police Real Estate | The Netherlands

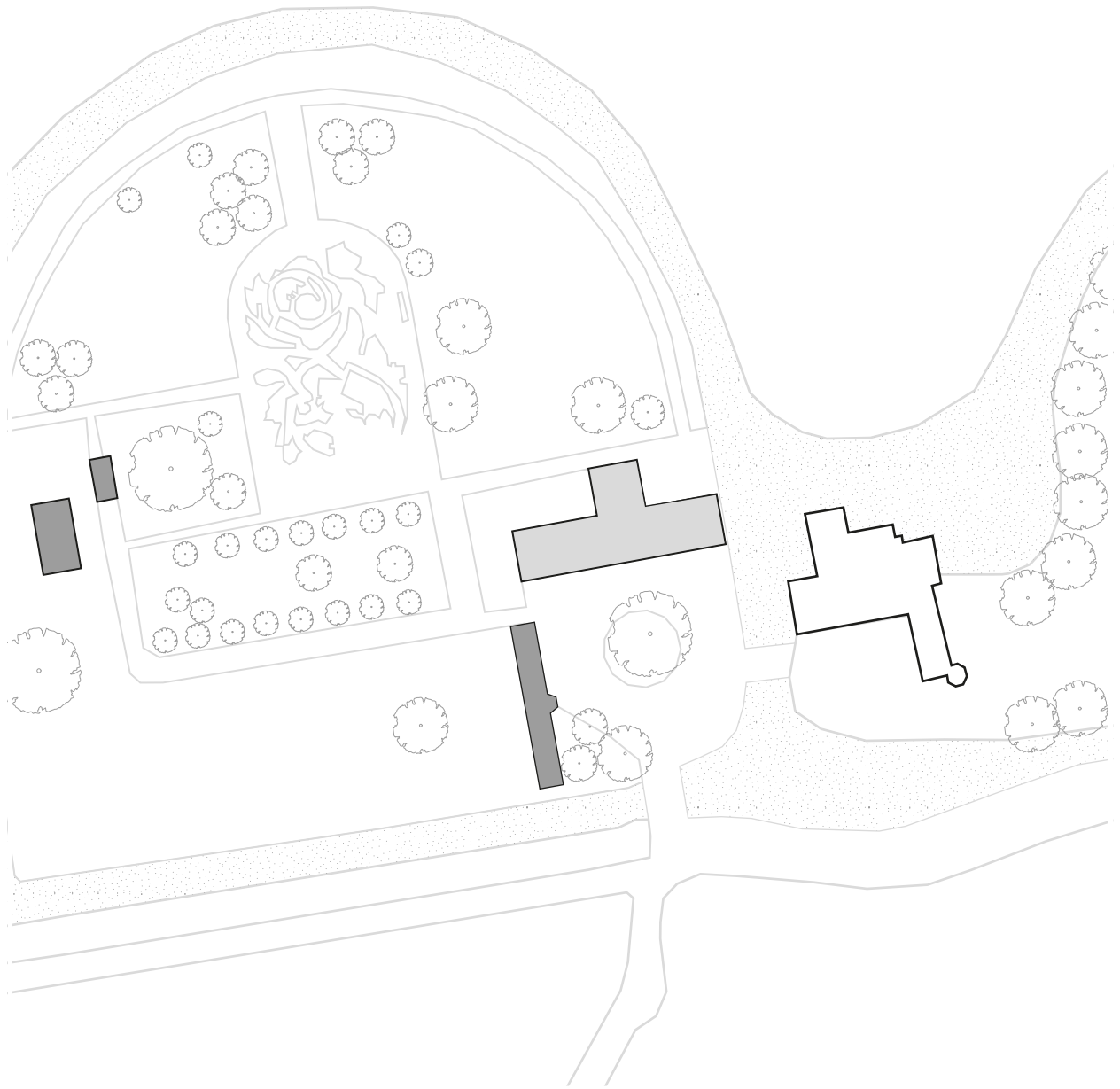

Public, semi-public and private buildings

PUBLIC, SEMI-PUBLIC AND PRIVATE BUILDINGS

The main building is a public building. It is accessible for everyone with a restaurant in the basement. The coach house is semi-public because it is only accessible for people who make use of the hotel. The small house on the left island is private because of the private residential

function. In the former days the coach house and main building were completely private and the small house did not exist. Only visitors of the family were able to enter the inside of the residence.

1.8.3. BUILDING OBJECT

1.8.3.1. SPATIAL LAYOUT



- 1 Main building
- 2 Coach house



FLOOR PLANS

Huis 't Velde consists of two buildings, the main house and the coach house. The main building has four storeys and an attic. The coach house has two storeys and an attic. The main building has the typology of an old 18th century mansion with a central entrance hall and a separate stairwell. The rooms are successively connected one after the other. This is similar to the typology of an

enfilade, but in the case of 't Velde there are not enough rooms in a row to really speak of an enfilade. The coach house interior is completely refurbished around 1995-2005, which is visible in the structure of the layout. Corridors provide access to the hotel rooms with a central entrance hall in the middle. In the top left corner is a small mezzanine floor to create more space.

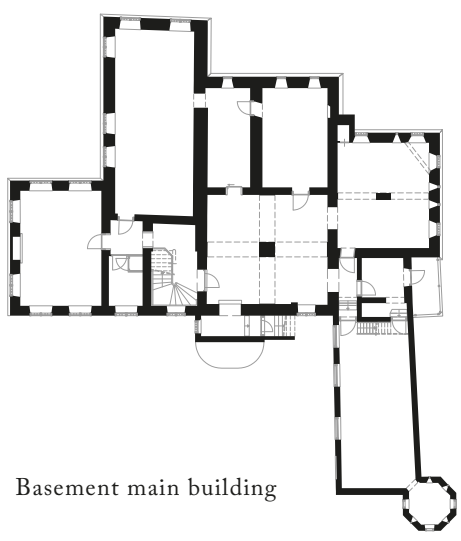

Basement main building

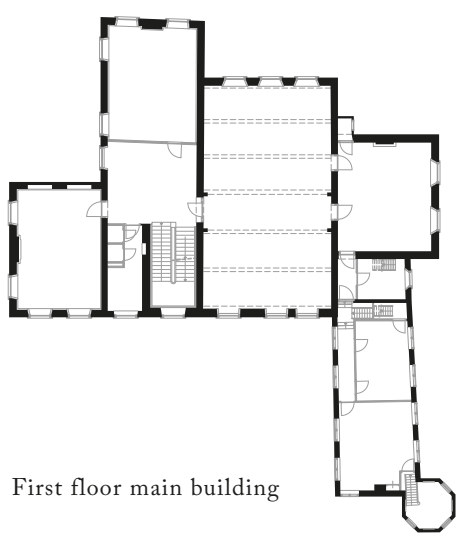

First floor main building

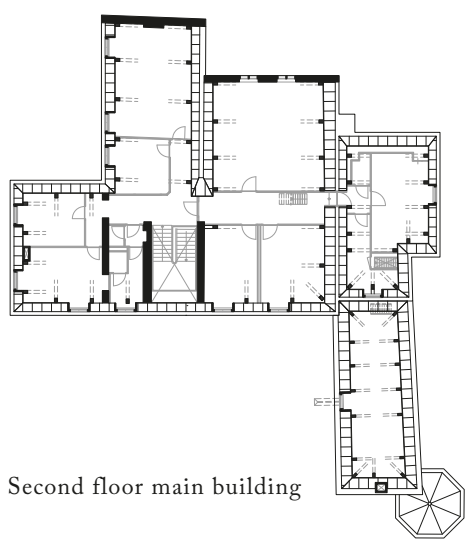

Second floor main building

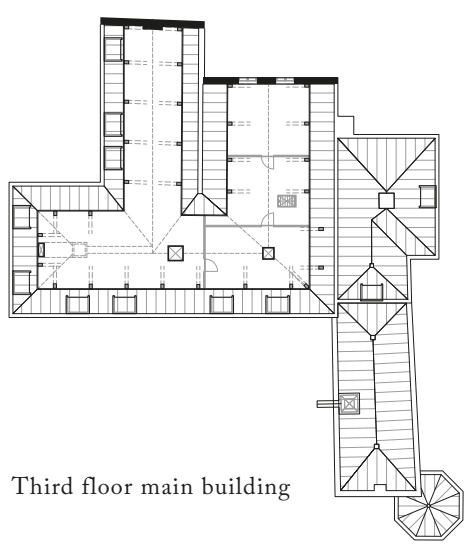

Third floor main building

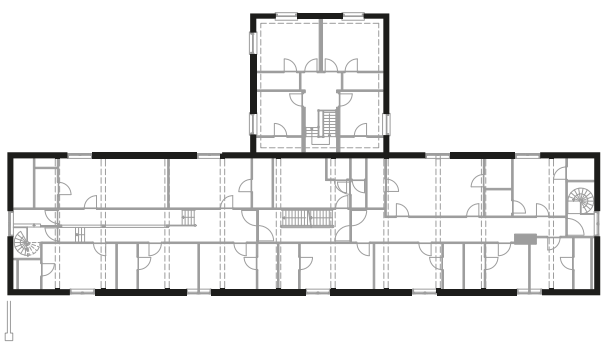

First floor coach house

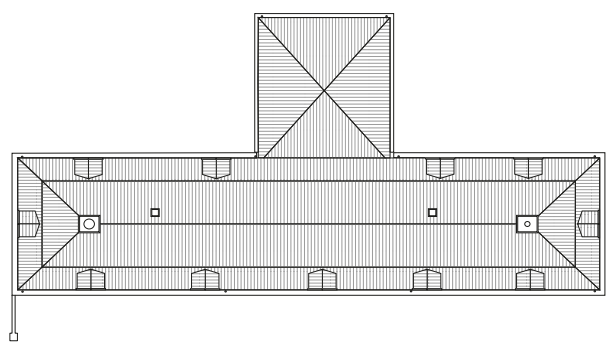

Second floor coach house

0 10 M

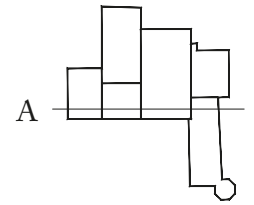

Section A

SECTION

In the section it is visible that there is a hierarchy in the storeys. The basement has a low height while the ground floor (bell-etage) has a big height of almost 4 meters. The first floor has the same height. The attic is considerably lower. The conclusion can be drawn that the house still contains the old typology of a mansion where the ground

floor and first floor are the most important floors. Here, the rooms had to impress the guests. The owners and important guests only came on these storeys. The basement and attic had less importance and were only used by the staff.

1.8.3.2. SPATIAL RELATIONS

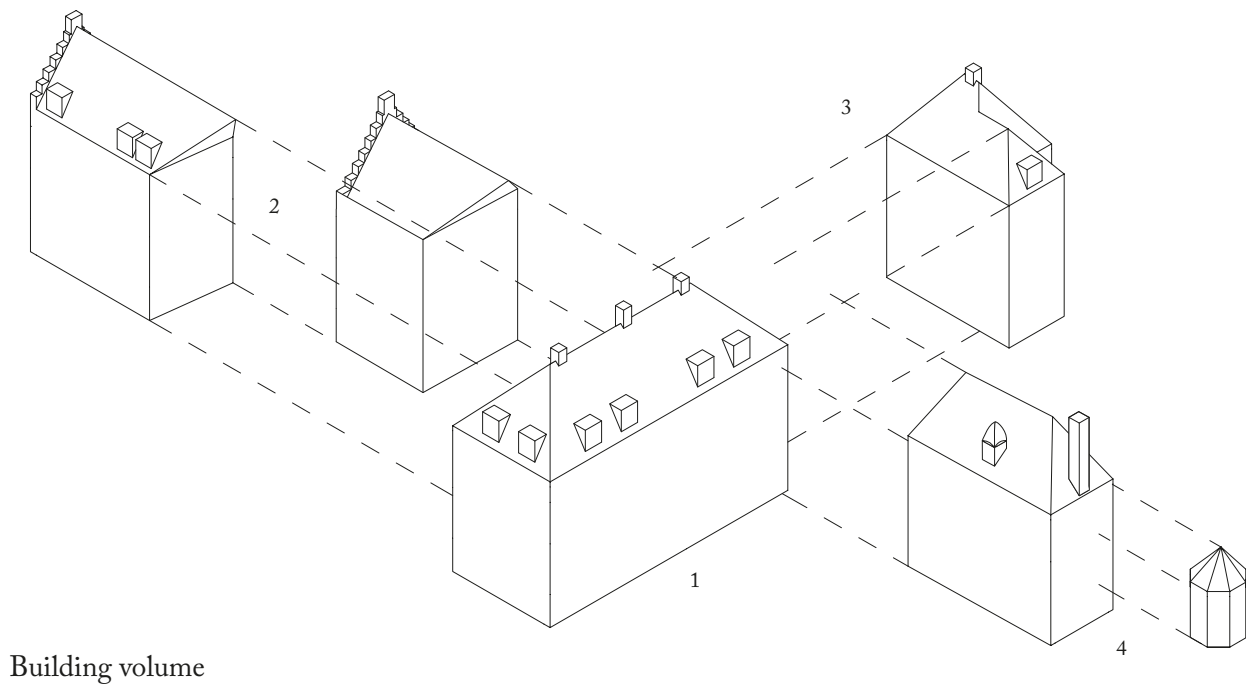

Building volume

BUILDING VOLUME

The building exists of four main time layers. The numbers on the image above conceptually represent the order of the volumes throughout history. The forms of the old building and expansions are mainly visible in the exploded view

with the two wings on the north, expansion on the east side and expansion on the south side with a new wing and tower.



● Start Route ▲ Ascending vertical route

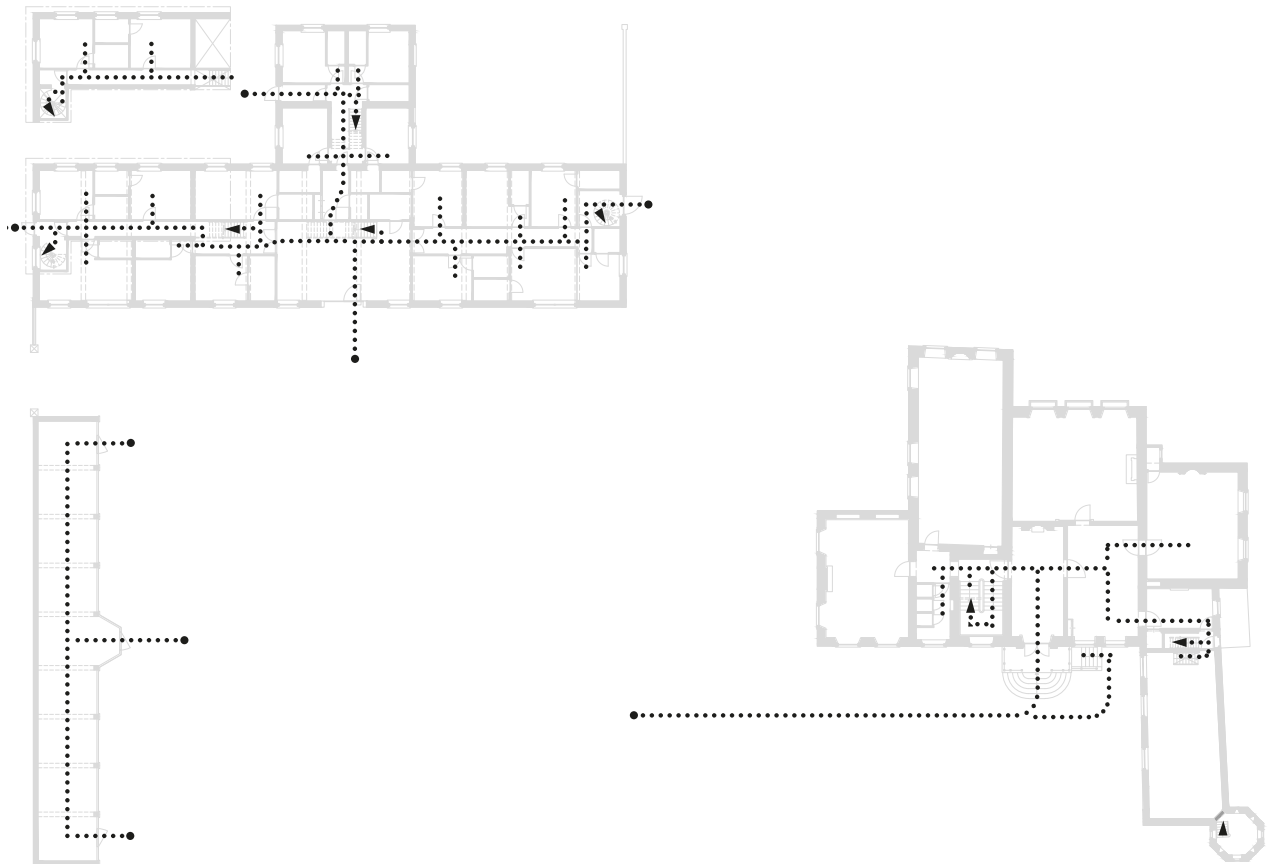

Ground floor of coach house and main building

Vacant Heritage - Police Real Estate | The Netherlands

CIRCULATION

The figure shows the circulation of the Warnsveld police station. Through the staircase on the southside of the building the main entrance is reached. This leads to a space where several rooms are connected. There are numerous stairs in the building, but no elevator. There is also a single

other passageway to the basement. The coach house has four entrances that lead to a central corridor, to which rooms are connected. The rear part is a central hall to which the rooms are connected.

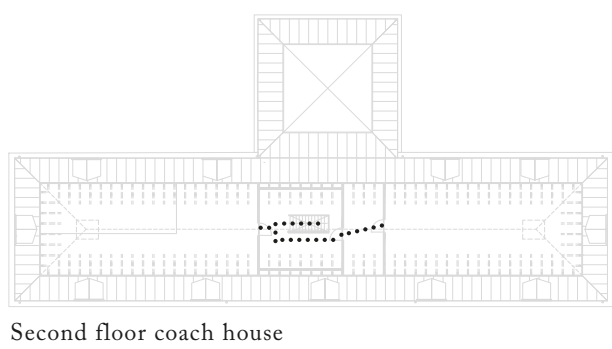
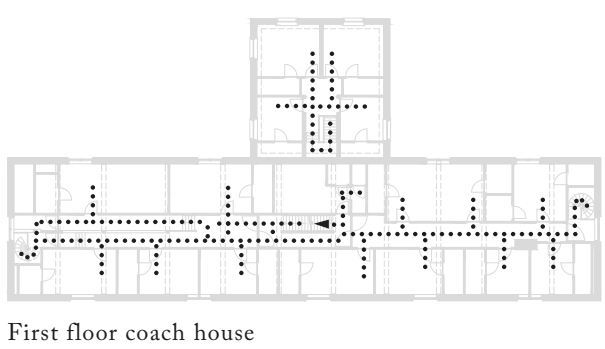
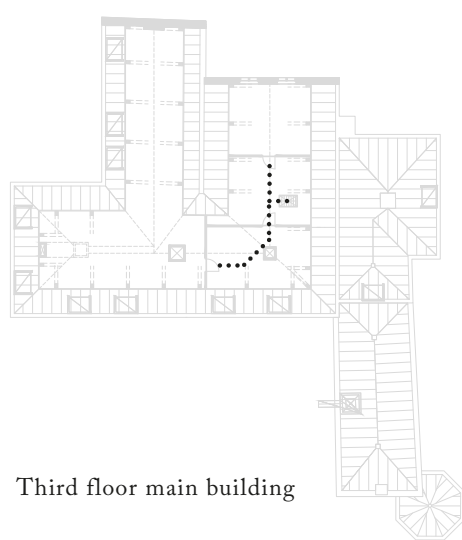
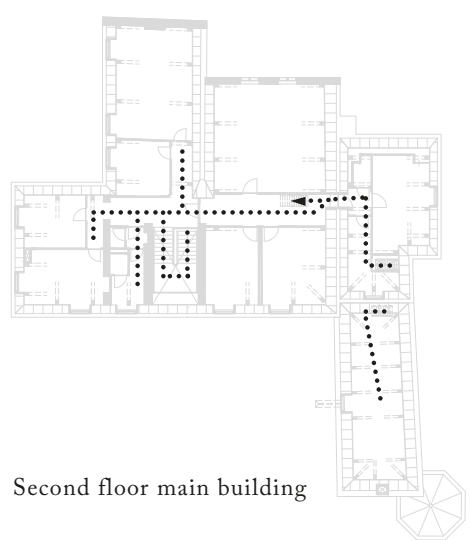
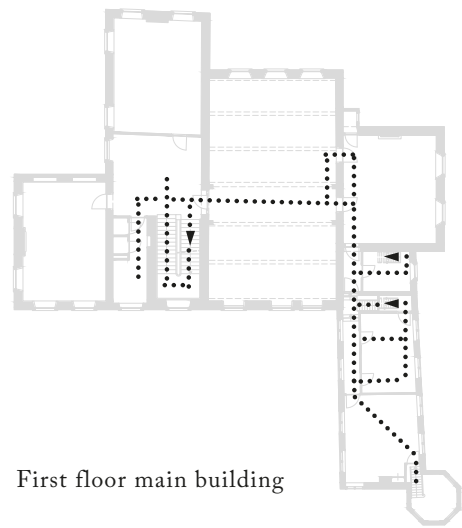
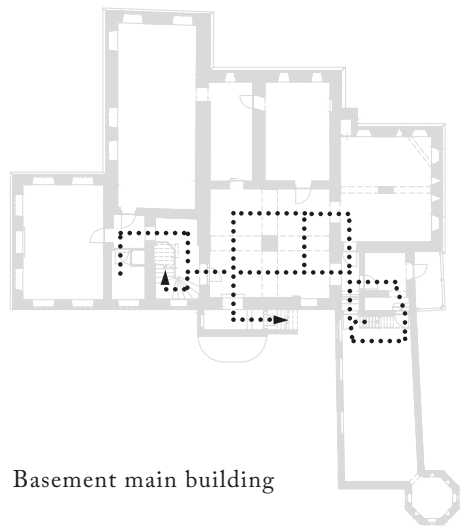

1.8.3.3. STRUCTURE

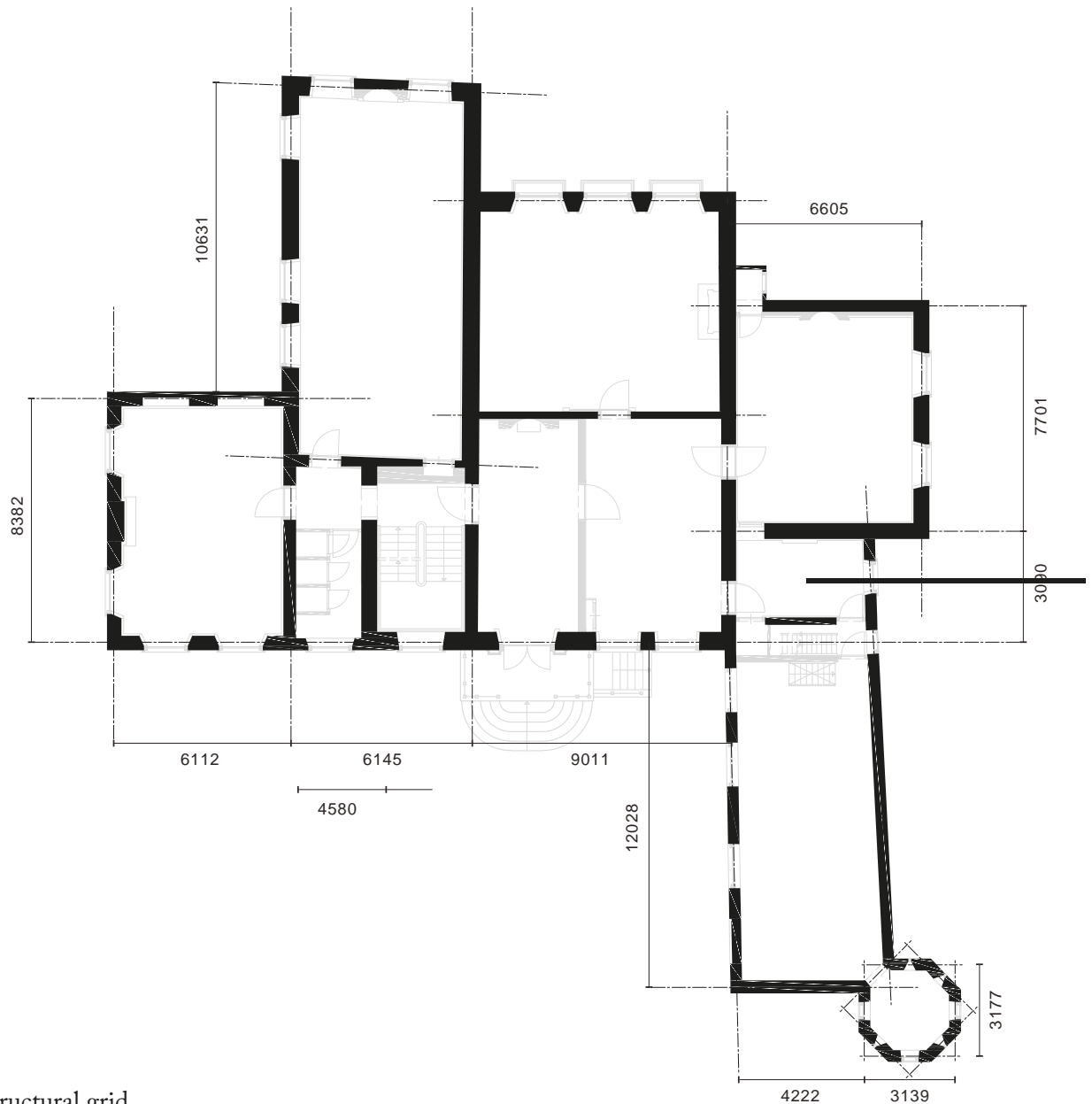

Structural grid

LOAD-BEARING STRUCTURE MAIN BUILDING

Two main conclusions regarding the construction are that the floors are made of wooden beams and that most of the thick brick walls are load-bearing walls. Every façade and the thick inner walls (drawn in black) are load-bearing. The beams are located in the shortest direction of the

room as seen in the axonometric drawing.

In the basement most of the rooms have brick vaults that support the floor of the bell-etage. The space between the vaults and ground floor is filled with sand to equally spread the loads.

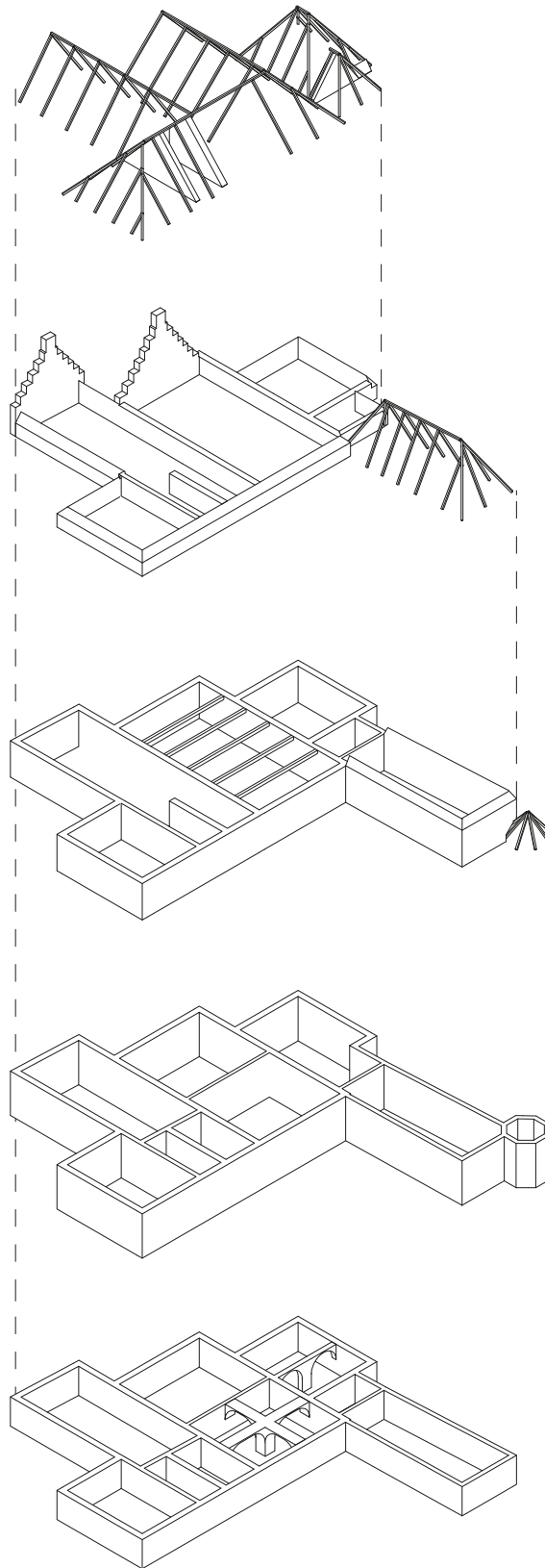

Load-bearing structure axo main building

1.8.4. BUILDING ENVELOPE

1.8.4.1 CONFIGURATION



- 1 Main building
- 2 Coach house

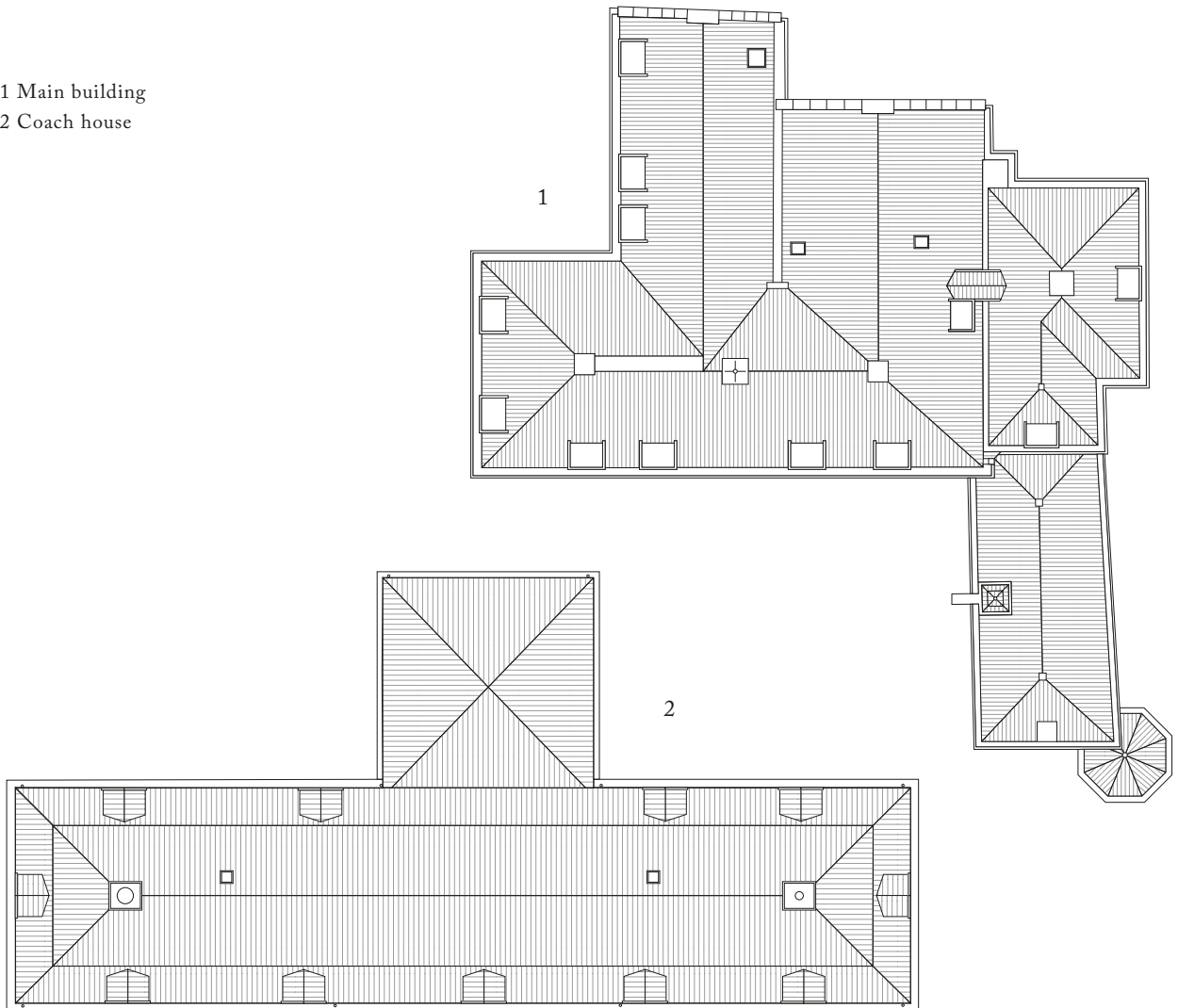

ROOFPLAN AND FAÇADES

All roofs are gabled roofs. Oriented to various sides. The main building has a number of chimneys which are very striking. The dormer windows are not aligned to the vertical axes of the windows in the façade. They are aligned with the full width of the façade.

Each façade of the main building has its own lay-out, which can be seen in the elevations. It is important to notice the differences in dimension, rhythm and style. The north façade has a medieval character with balconies

orientated to the garden, while the main (south) façade has a more 18th century classicism style with an extra accent on the entrance and a court.

The coach house connects to the main building in colour and material. Also this building is made out of masonry and is painted white. The windows have the same style and the gutter contains a cornice. It is clear that the architect wanted to match the architecture with the architectural style of the main building.

0 10 M



North façade main building



North façade coach house

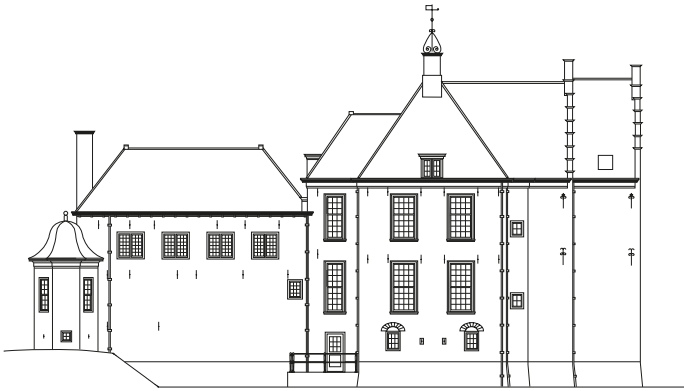

East façade main building



East façade coach house



South façade main building

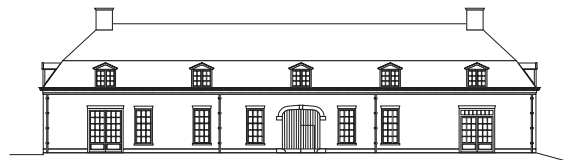

South façade coach house

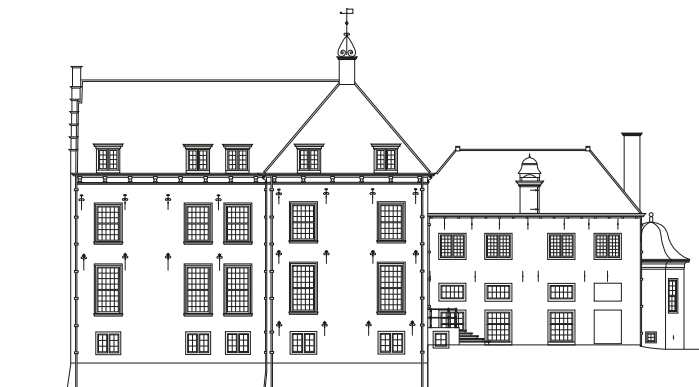

West façade main building



West façade coach house

1.8.4.2. COMPOSITION

0 10 M



West façade main building

COMPOSITIONS MAIN BUILDING

Huis 't Velde has five floors including the souterrain, the beletage and the attic. Both the front and the side façade have an irregular grid. Most windows are lined out, but there is no standard distance between the windows. It is

striking that in the side façade, the dormers are following the grid of the windows, but in the front façade the dormers are placed symmetrical on the roof, and therefore not following the grid.

0 10 M

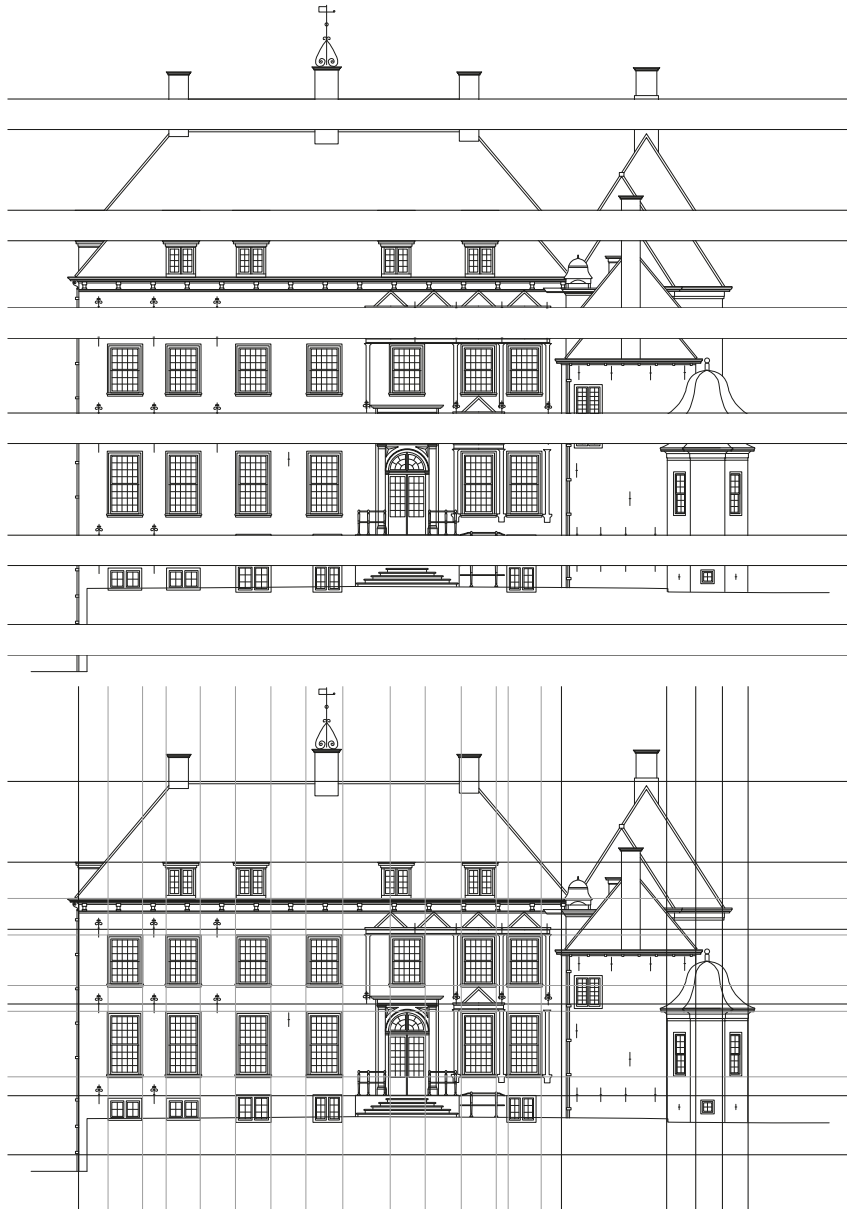

South façade main building

Warnsveld

1.8.4.3. MATERIALITY

0

10 M



South façade main building

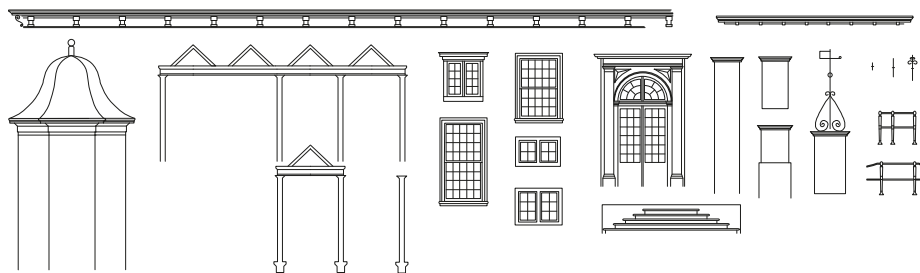

COMPONENTS MAIN BUILDING

Looking at the front façade of the Huis 't Velde, we can distinguish several components that play a major role in the architectural language of the building. There are several groups of elements that look similar, such as the windows, but are in fact slightly different. Above the brick wall is a long gutter and a hip roof. Specifically in

the front façade, the entrance is very important. To access the entrance door, one has to climb a few steps made out of natural stone. On the brick façade, several different iron wall-cramps are visible. The front façade of the coach house consist of less, but more or less similar elements as the main house.

0 10 M

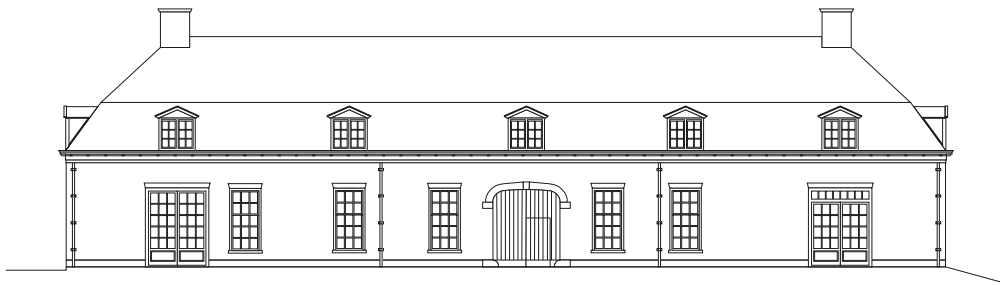

South façade coach house

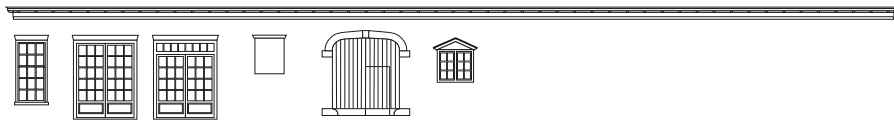

Warnsveld



Façade fragment analysis

TEXTURES

Most of the front façade of Huis 't Velde is constructed in brick. All brickwork has been painted in white. Most of the roofing consist of roof tiles, except for the tower on the south west end of the building, of which the roof is fitted with slates. All window frames are made out of

wood and painted in white and grey, except for the door where green is used instead of white. Also the gutter is constructed out of wood and painted in grey. In the brick wall are decorations visible, made in natural stone combined with tiles.



(Riepema, 2021)

1.8.5. CONCLUSIONS

Until 1850, the city of Zutphen was situated within the defensive moat and surrounded by the river IJssel on the western side of the inner city. At that time, the neighbouring town of Warnsveld consisted of a few houses, farms and estates. Around 1900, large town expansions started outside the defensive moat. After World War II, this accelerated. There are mainly primary and tertiary roads in the surroundings of Zutphen and Warnsveld. Concerning Huis 't Velde this building is good accessible via a primary road. The public spaces of Zutphen and Warnsveld are mostly in the city cores. In Warnsveld and the outlying neighbourhoods of Zutphen are several squares which function as a public space. In both Zutphen and Warnsveld, there is a lot of green and water spread throughout the city.

The urban block consists of a large island of 26,000 square metres, on which a number of buildings have been placed. The main building and the coach House only have a footprint of 950 square metres. The island is surrounded by a large estate of 328,000 square metres. The building process of the complex of police buildings starts with a central, tower-like house. This volume was expanded in the following years on the west side. Then the wing in the east including two towers. After that, the coach house, the dovecote and the house in the west were built. A generous parking area for cars and bicycles is located on the west side of the island. The main building has a public function, the coach house a semi-public function and the house to the west of the island a private function.

Huis 't Velde has a long history of owners, with the first mention in 1326. The whole estate and its buildings is owned by Stichting Geldersch Landschap & Kasteelen since 1959, who rents out the main building and coach house to the police.

The main building is used as conference center and has various meeting rooms and office spaces. The coach house differs in function, hosting hotel rooms for guests and police students. Both buildings do not have an elevator, making the upper floors inaccessible to disabled people. Both the main building and the coach house have a similar construction, which consists of a load-bearing façade with locally a load-bearing inner wall and provided with a wooden roof construction.

Each façade of the main building has its own character that is created by the difference in dimensions, rhythm and style. Each façade, except the east façade, functions as a main front façade. Both the front and the side façade have an irregular grid. In the main building and the coach house, there are a number of different building elements that fit together well. The façades are brick and painted white. The buildings have wooden window frames. The majority of the roof consists of a tile roof except for the tower in the east wing, which has slates.

PART 2
ASPECT COMPARISON

2.1. INNER CITY

2.1.1. ROAD NETWORK



DEN HAAG



EINDHOVEN



HAARLEM



GRONINGEN



0 200 M



MIDDELBURG

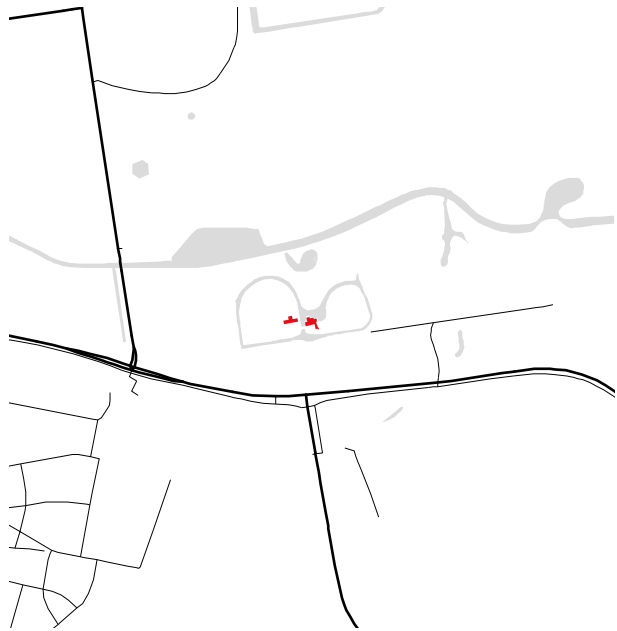

WARNSVELD



ROTTERDAM WITTE DE WITH

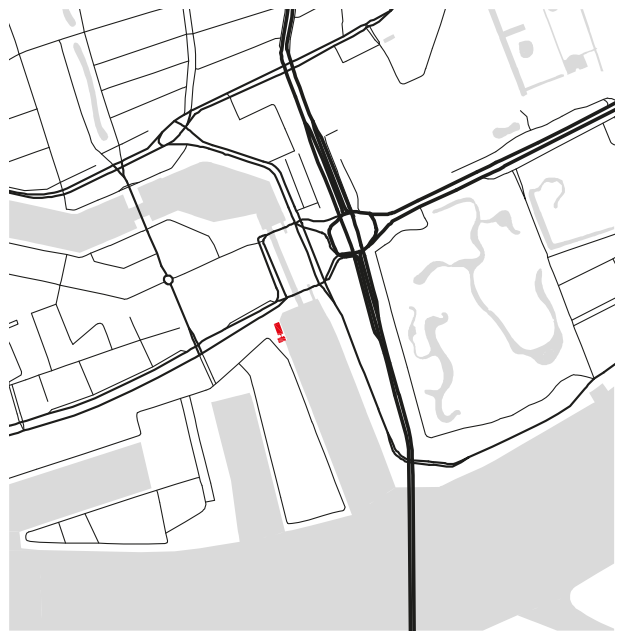

ROTTERDAM HAVEN

Aspect comparison

2.1.2. CITY DENSITY



DEN HAAG

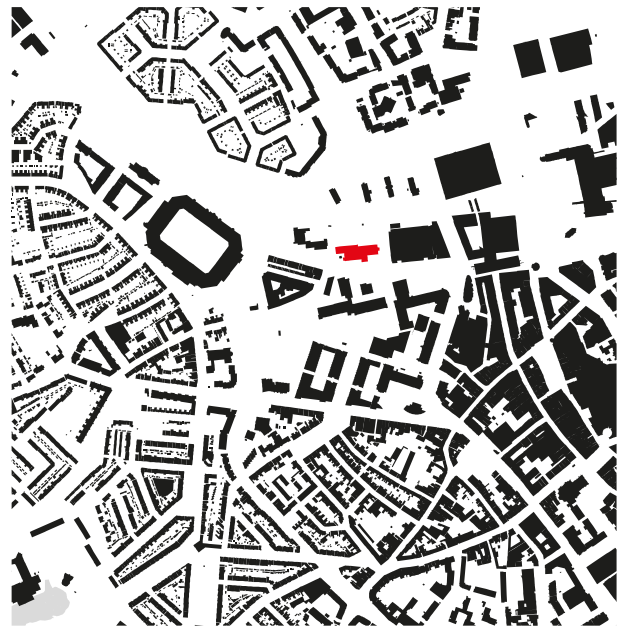

EINDHOVEN



HAARLEM



GRONINGEN



0 200 M



MIDDELBURG



WARNSVELD



ROTTERDAM WITTE DE WITH



ROTTERDAM HAVEN

Aspect comparison

2.1.3. GREEN, WATER AND PUBLIC SQUARES

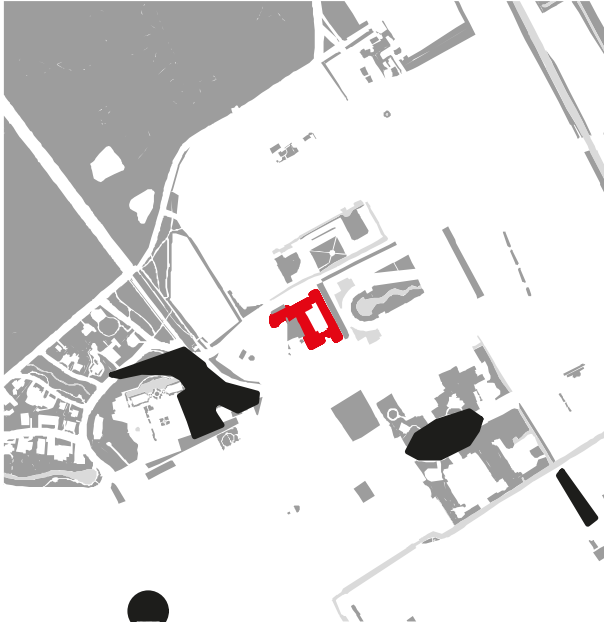

DEN HAAG



EINDHOVEN

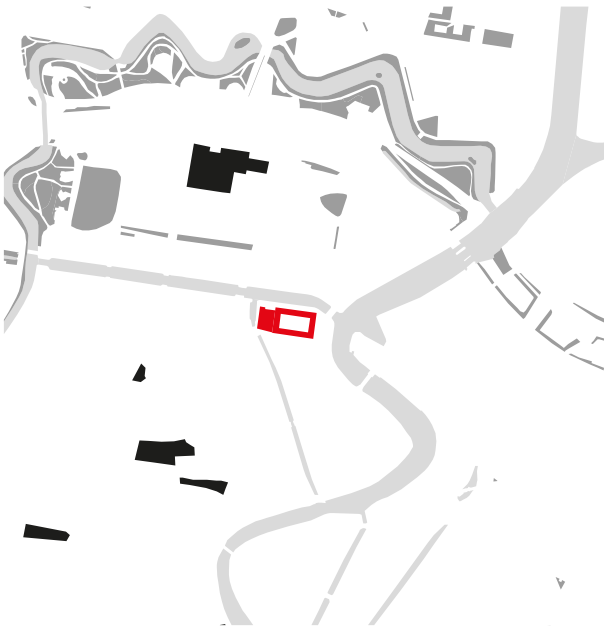

HAARLEM

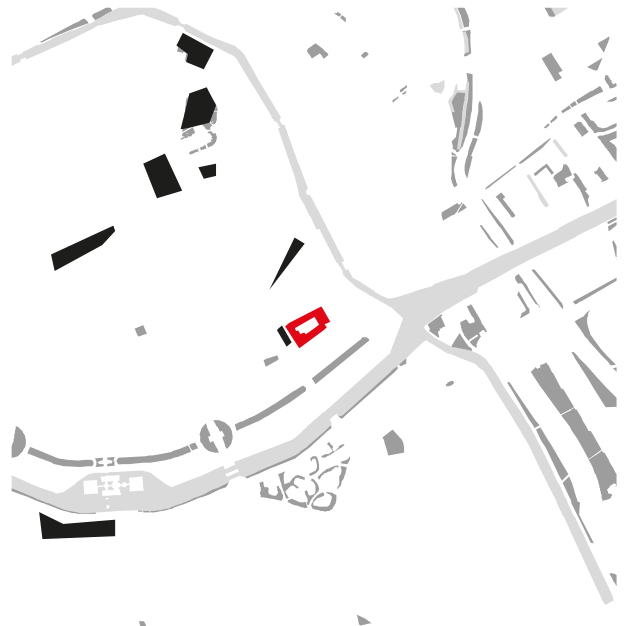

GRONINGEN



0 200 M



MIDDELBURG



WARNSVELD

Aspect comparison



ROTTERDAM WITTE DE WITH

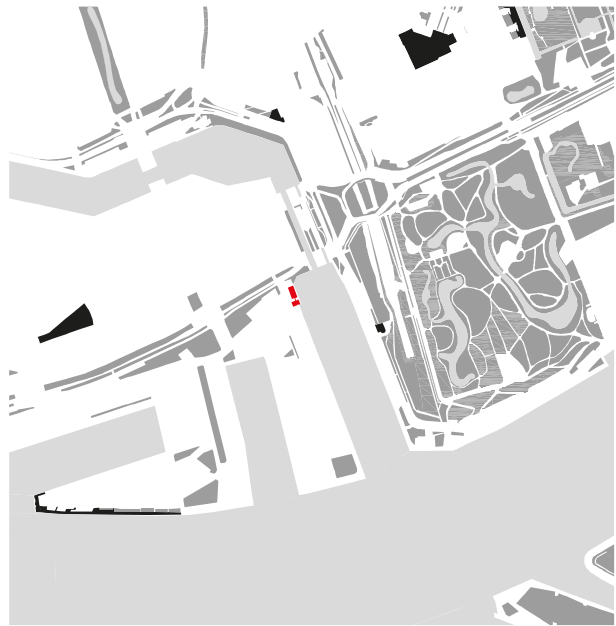

ROTTERDAM HAVEN

2.1.4. CONCLUSIONS

ROAD NETWORK

In the formerly fortified cities like Haarlem, Middelburg, Groningen, Eindhoven and even the inner city of Rotterdam, the historic canals shape the leading networks in the inner cities. In most of these cities, the road network follows the historic water structure. However, the inner city of Rotterdam does not have these historic canals anymore, but the road network is based on the old structure of these canals. For the harbour of Rotterdam, the road network follows the river of the Maas that runs through the city. Within the inner city of Eindhoven, the historic network is almost not visible anymore. Only a few

roads follow the old structure of the fortified structure. Warnsveld and Den Haag have different road networks. Both buildings are located outside of the inner city and these networks were made to simply move from one place in the city to another.

In addition, most of the police estates are situated at a primary network of their city. Most buildings are not positioned in the heart of each city but at the edges or borders of the centre. The only exception to this is the building of Warnsveld, which is situated in a rural area.

CITY DENSITY

Due to the initial lack of space for expansion caused by the fortification, the inner cities of Groningen, Haarlem and Middelburg have a relatively high density. The first city expansions adjacent to the city centres are lower in density. Eindhoven has a similar decrease in density outward from the inner city, but since there were no limiting fortifications the decrease is more gradual. The exceptions in these city centres are made by canals that

were closed, creating wider streets in the urban fabric. The density of the area around the Witte de With location in Rotterdam and the one in Den Haag are similar. The harbour police station in Rotterdam is located on the base of the Mullerpier, which has been developed after 2000 with a relatively lower density. The Warnsveld location clearly has the lowest density, since it is not located in an urban context.

GREENERY, WATER, PUBLIC SQUARES

During the process of defortification, the fortifications of the cities of Haarlem and Middelburg have been transformed into public green spaces. The moats around these fortifications still form the water structure around the inner cities. Groningen has undergone similar developments, but only parts of the moat and fortifications have been maintained or transformed into public green space respectively. The green spaces near the police stations in Rotterdam and Den Haag consist of public parks surrounded by an urban context. Besides the Maas as the main body of water in Rotterdam, the parks have smaller scale water structures in the form of ponds and ditches. Den Haag has some insignificant ponds. The main water and green structure of Eindhoven is the small river Dommel and the green on its banks running through the city. The police in Warnsveld is located

outside city limits on its own publicly accessible grounds, surrounded by green fields and patches of trees.

In the formerly fortified cities of Groningen, Haarlem and Middelburg the public spaces consist mainly of church squares and markets. Eindhoven has a similar structure of individual squares. In Rotterdam, the public space is made up of the connected streets of the shopping area and the parks. In Den Haag the public squares near the police station are traffic-dominated, with the exception of the grounds of the Peace Palace. In Warnsveld and the surroundings of Zutphen there is a lot of public space in the form of greenery and water, mainly in the form of recreational area for walkers and cyclists. Huis 't Velde in particular also had the memorial garden, which is an element in the landscape with national significance.

2.2. URBAN BLOCK

2.2.1. BLOCK INFORMATION



Built area
15366 m²

DEN HAAG

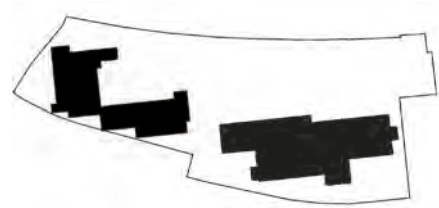

Built area
2760 m²

EINDHOVEN



Built area
5451 m²

HAARLEM

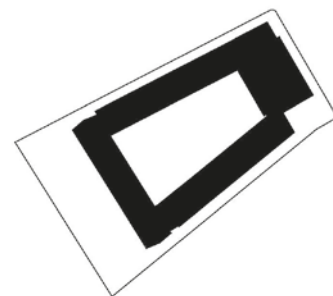

Built area
2951 m²

GRONINGEN



0 50 M

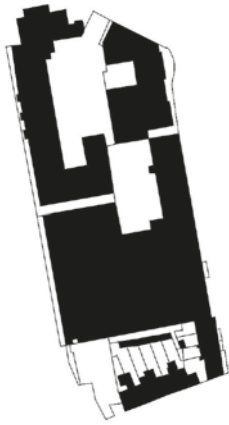

Built area
7270 m²

MIDDELBURG

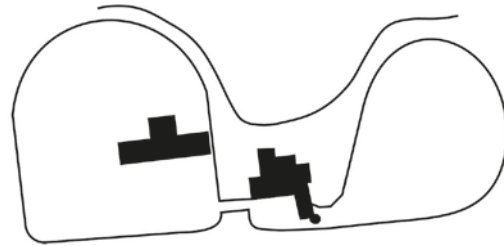

Built area
950 m²

WARNSVELD

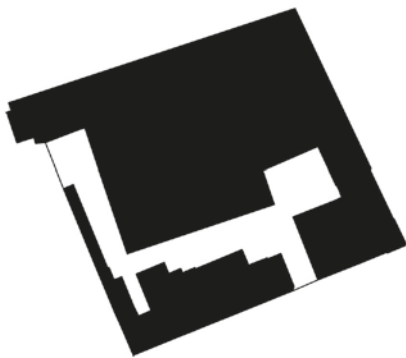

Built area
10433 m²

ROTTERDAM WITTE DE WITH

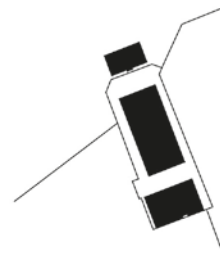

Built area
1006 m²

ROTTERDAM HAVEN

Aspect comparison

2.2.2. FAÇADES

0 50 M

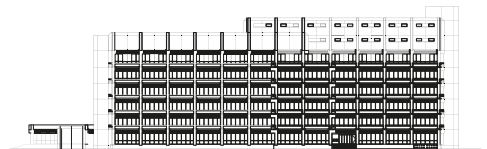
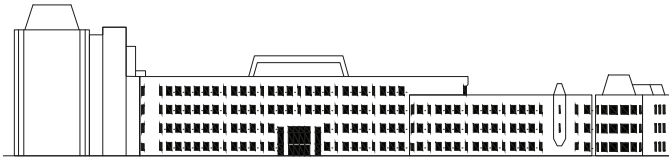

DEN HAAG

EINDHOVEN

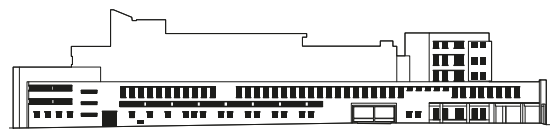

HAARLEM

GRONINGEN

0 50 M

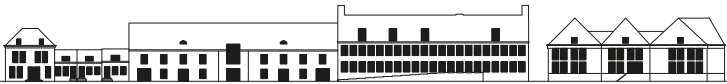

MIDDELBURG

WARNSVELD

Aspect comparison

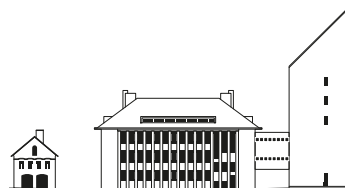
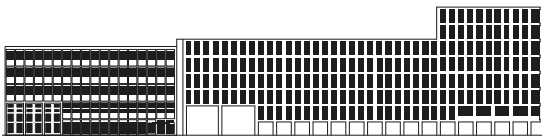

ROTTERDAM WITTE DE WITH

ROTTERDAM HAVEN

2.2.3. ISOMETRICS

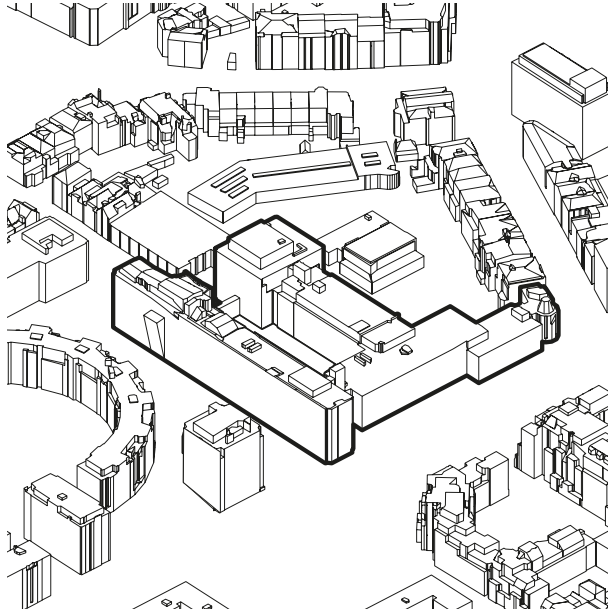

DEN HAAG

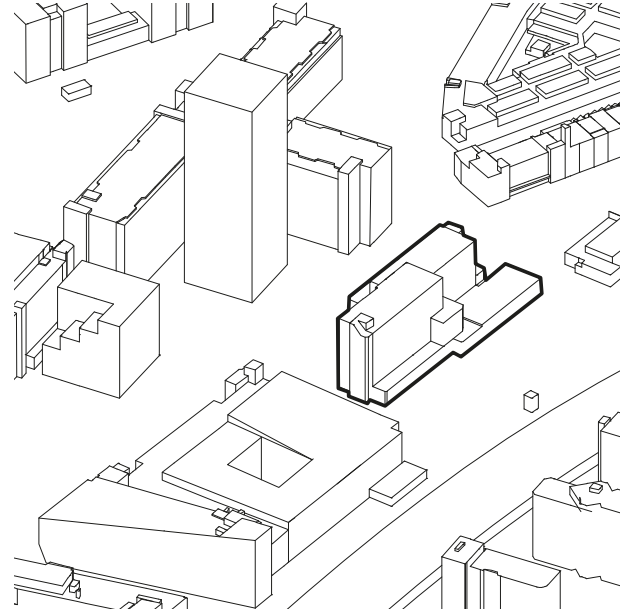

EINDHOVEN

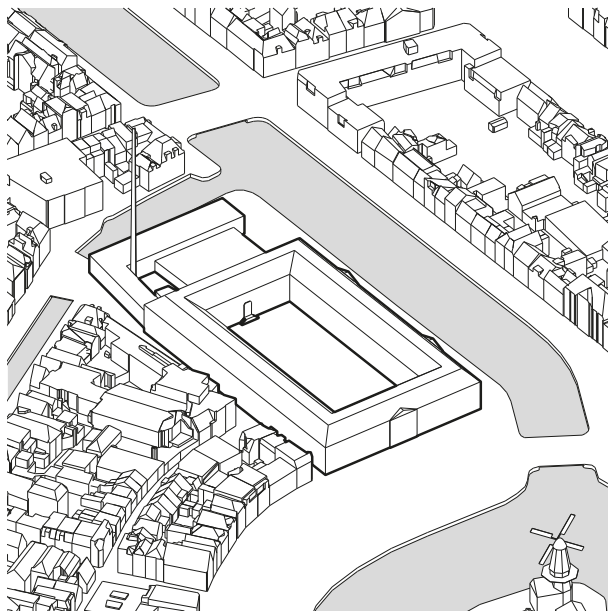

HAARLEM

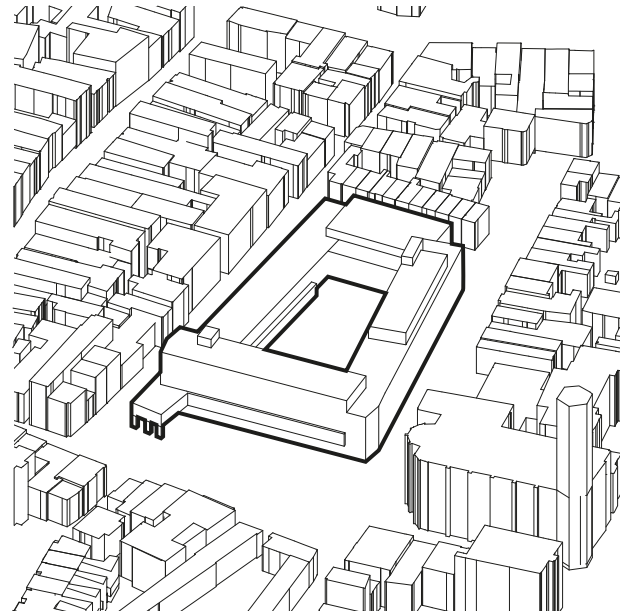

GRONINGEN

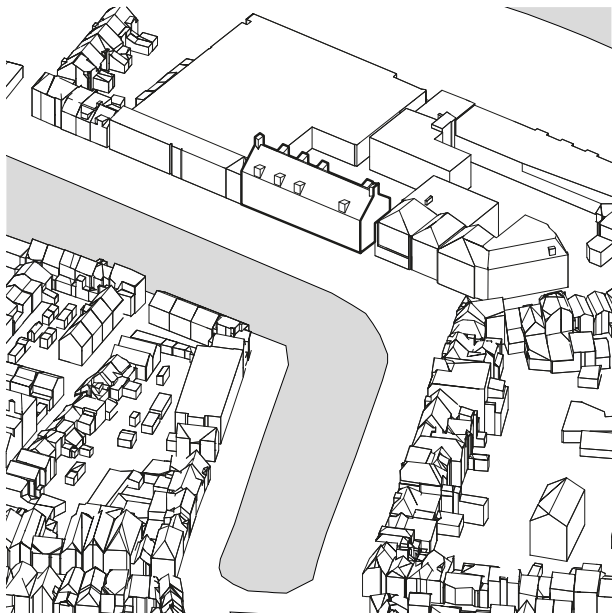

MIDDELBURG

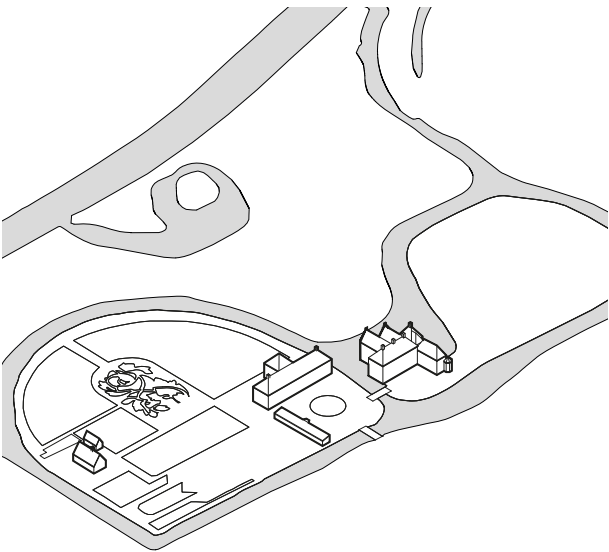

WARNSVELD

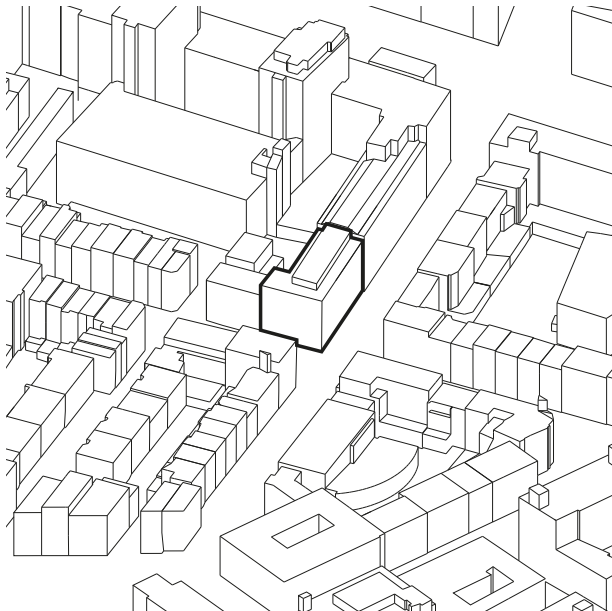

ROTTERDAM WITTE DE WITH

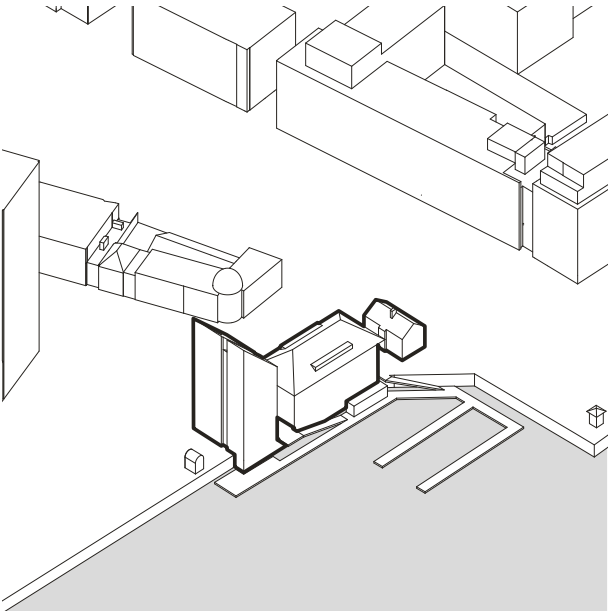

ROTTERDAM HAVEN

Aspect comparison

2.2.4. CONCLUSIONS

BLOCK INFORMATION & ISOMETRICS

When looking at the built area of the eight buildings, big differences are noticeable. The number of square meters of the building blocks varies a lot.

This is because some buildings are a block on its own and some are part of a building block existing of more buildings. Den Haag, Rotterdam Witte de With and Middelburg stand out with the biggest sizes, since only a part of the building block is occupied by the police. In Den Haag this is almost half of the building block, but in Middelburg and Rotterdam Witte de With only a small part is in use.

The buildings in Groningen, Warnsveld, Eindhoven, Haarlem and Rotterdam Haven form building blocks on their own and are therefore smaller in size. Both Rotterdam Haven and Eindhoven are tall buildings, so the ratio between the gross floor area and the smaller footprint is big. Warnsveld is the biggest exception within the group of buildings with a big plot of approximately 32 hectare and a small built area of 950 m².

FAÇADES

When observing the façades of the building blocks in which the police buildings are located, several things stand out. In the first place, the scale of the different blocks. The length of all blocks varies considerably. The blocks in Warnsveld and Rotterdam are the shortest. The block in Middelburg is the longest, but also the lowest. Also the blocks Haarlem and Warnsveld are relatively low. The biggest differences in height inside a block, are visible in Groningen, Rotterdam Haven and Den Haag. Another interesting aspect is the size of the police buildings compared to the rest of the building block. The building (complexes) in Groningen, Warnsveld, Eindhoven, Haarlem and Rotterdam Haven are building

The eight analyzed police stations could be grouped into two main types of building volumes. The first one is free-standing building volumes, and the second is building blocks forming a central courtyard. The first group consists of locations like Warnsveld and Rotterdam Haven where the buildings are spread through the area and become part of the existing formed urban block. The second type could be applied to Groningen and Haarlem, where volumes of the building form partially enclosed yards. In some cases these even form urban blocks on their own, like Haarlem and Groningen.

The spatial configuration of volumes is complicated to compare, since the variation is diverse. The most identifiable similar aspect is the presence of precise building volumes, as is the case in Middelburg, Rotterdam Witte de With and Haarlem.

blocks in themselves. The building in Middelburg forms a relatively small part of the block, and is surrounded with buildings of the same scale. The building in Den Haag forms a large part of the building block, and is surrounded with a lot of smaller buildings. The building block of Rotterdam Witte de With contains both buildings that are larger than the police station and smaller buildings. Another interesting aspect is the openness of the façade of the police buildings. The façades of the buildings in Den Haag and Haarlem are relatively closed. The façade of the buildings in Rotterdam Witte de With and Eindhoven are the most open.

2.3. BUILDING OBJECT

2.3.1. FLOOR PLANS

0 50 M

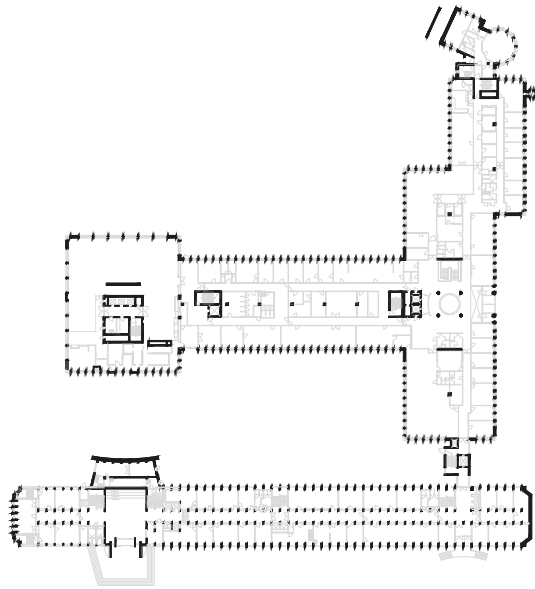

DEN HAAG

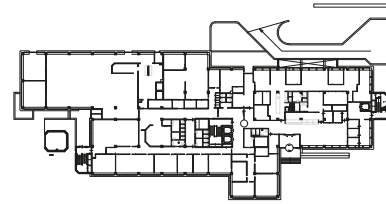

EINDHOVEN



HAARLEM

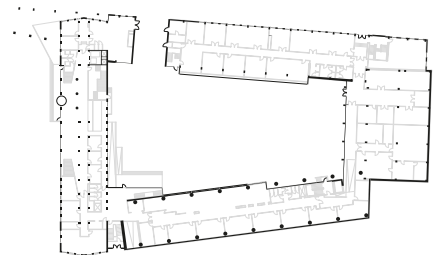

GRONINGEN

0

50 M

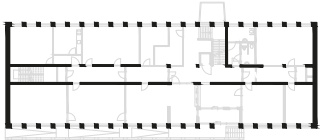

MIDDELBURG

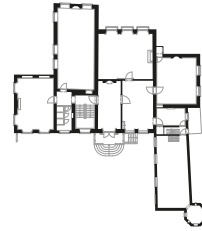

WARNSVELD

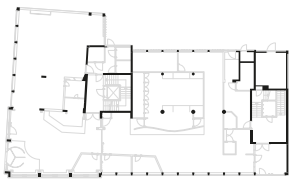

ROTTERDAM WITTE DE WITH

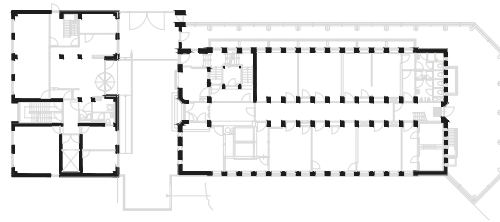

ROTTERDAM HAVEN

Aspect comparison

2.3.2. SECTIONS

0 20 M

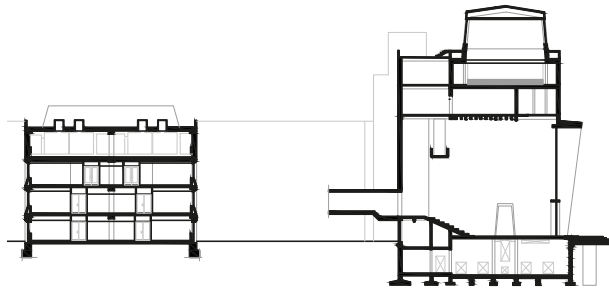

DEN HAAG

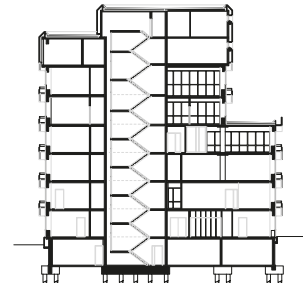

EINDHOVEN

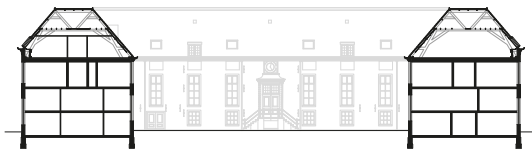

HAARLEM

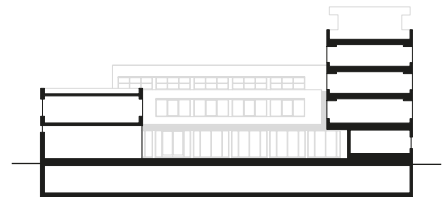

GRONINGEN

0 20 M

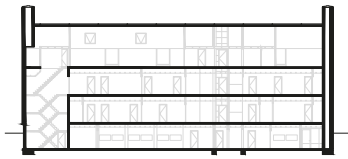

MIDDELBURG



WARNSVELD

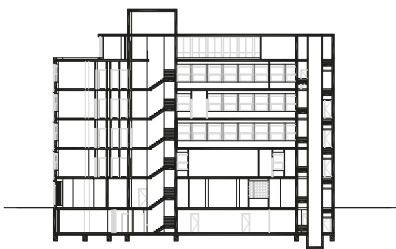

ROTTERDAM WITTE DE WITH

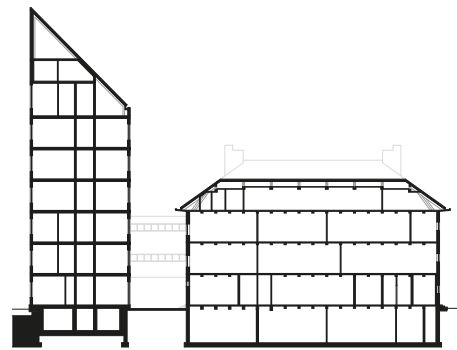

ROTTERDAM HAVEN

Aspect comparison

2.3.3. SPATIAL RELATIONS

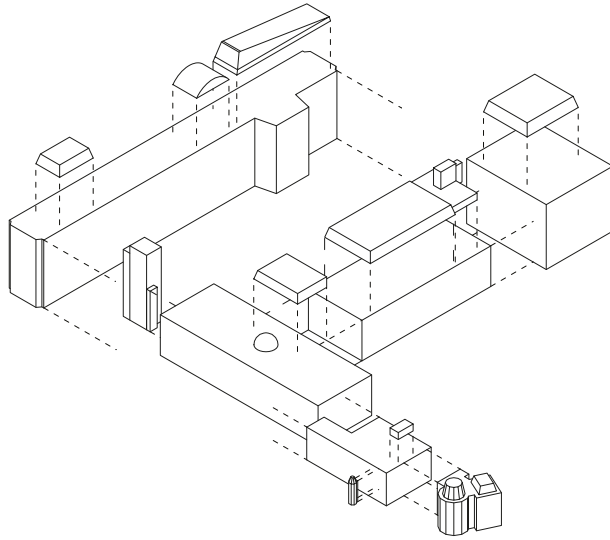

DEN HAAG

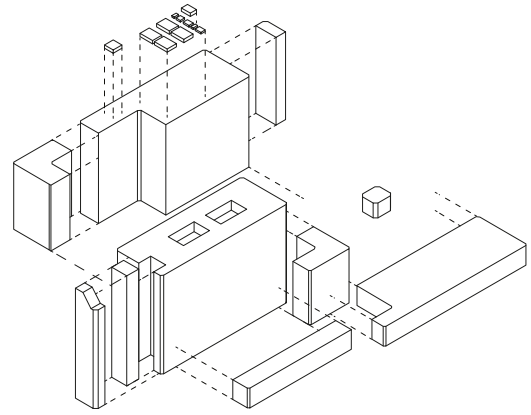

EINDHOVEN

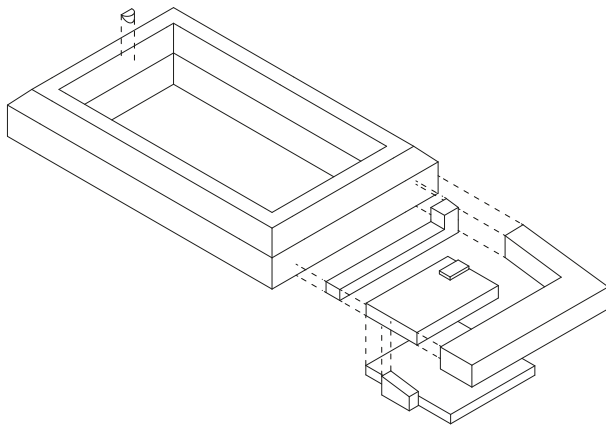

HAARLEM

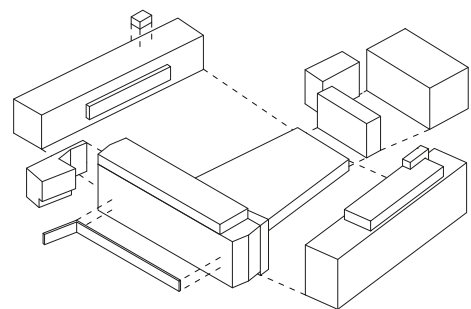

GRONINGEN

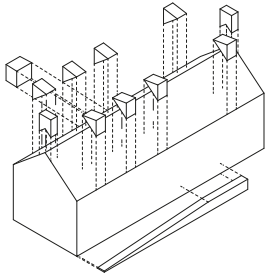

MIDDELBURG

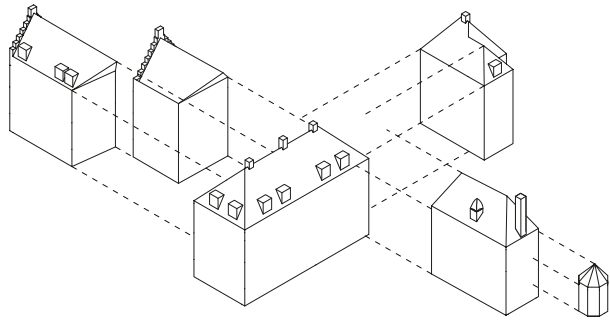

WARNSVELD

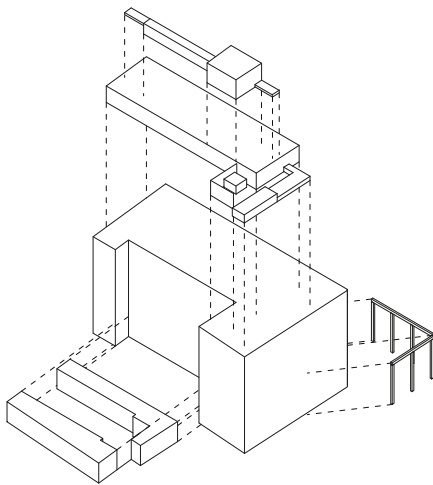

ROTTERDAM WITTE DE WITH

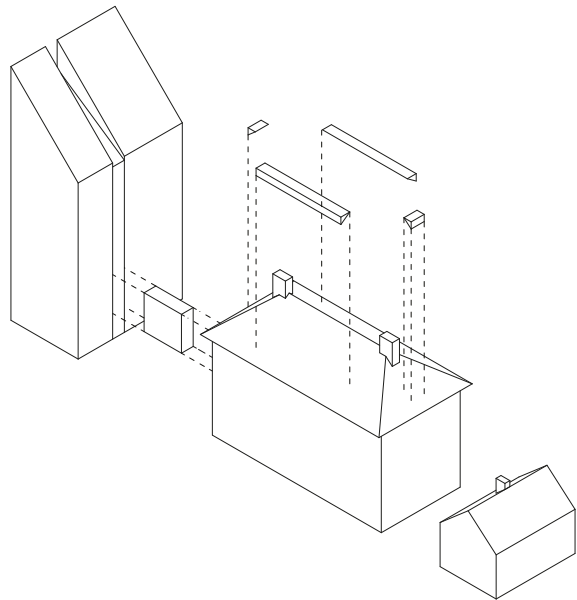

ROTTERDAM HAVEN

2.3.4. STRUCTURAL PLANS

0 50 M

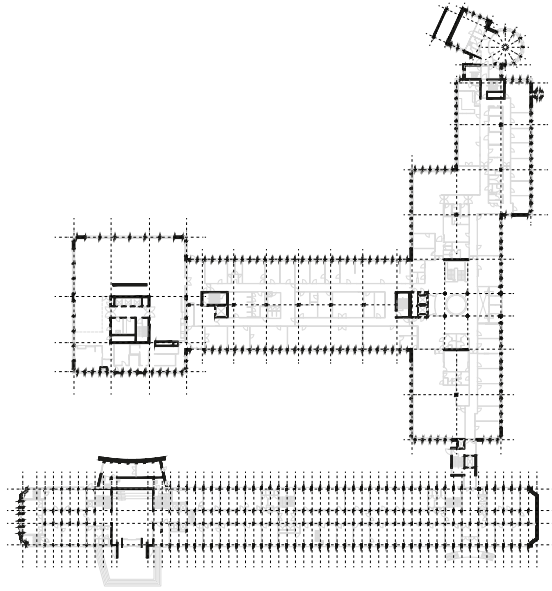

DEN HAAG

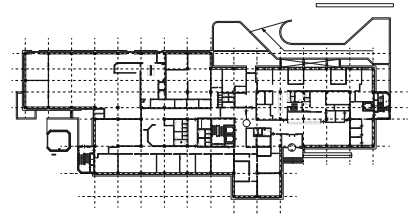

EINDHOVEN

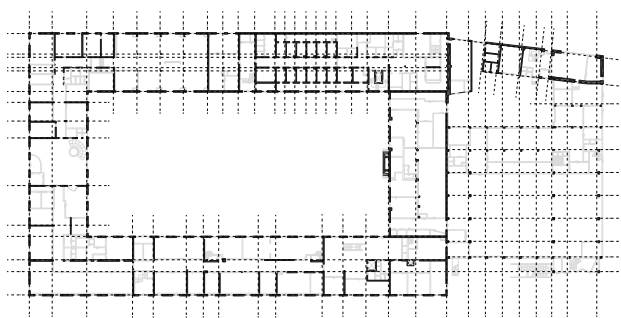

HAARLEM

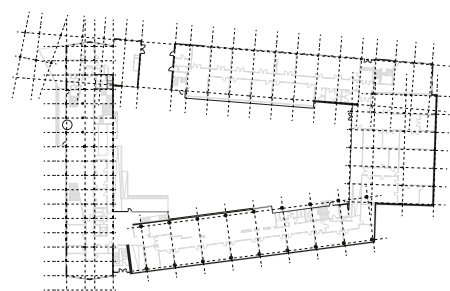

GRONINGEN

0

50 M

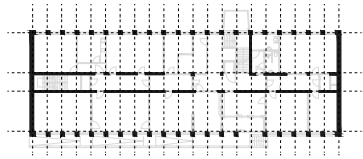

MIDDELBURG

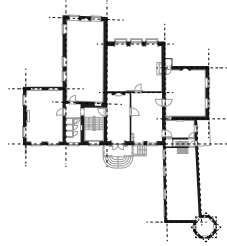

WARNSVELD

Aspect comparison

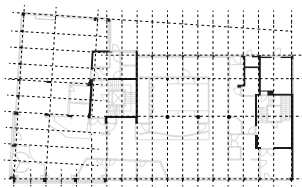

ROTTERDAM WITTE DE WITH

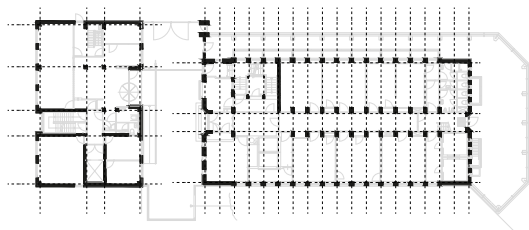

ROTTERDAM HAVEN

2.3.5. CONCLUSIONS

FLOOR PLANS

The ground floor plans of the police stations illustrate the different organization methods of the buildings. Starting with the circulation through the building a clear distinction in three types can be made. The first type of buildings are accessible through an internal central corridor, which can either be one corridor roughly in the middle (Groningen, Middelburg, part of Den Haag) or two corridors with internal spaces in between (other part of Den Haag). The second type of buildings are made of a sequence of spaces without a clear corridor, where the spaces directly enter into another space (Warnsveld, Rotterdam Witte de With). The last type of buildings is a hybrid of the first two types as it is a mix of corridors and sequence of spaces (Haarlem, Eindhoven, Rotterdam Haven). This type the building has different parts were sometimes the rooms are accessed with an internal corridor and in other parts the spaces form a sequence.

The shapes of the ground floor plans can be divided into four types. The first type is an building with a rectangular shape (Middelburg, Rotterdam Witte de With). The second type are the buildings that are made up out of multiple rectangular volumes (Den Haag, Rotterdam Haven). The third type is the courtyard shape (Groningen, Haarlem). The last type has a more irregular shape (Warnsveld, Eindhoven).

An evident similarity between the floor plans of most of the case studies is the size of the spaces. Although in most of the ground floor plans there is a larger open space except for Warnsveld and Middelburg, the majority of the spaces are rather small rectangular shaped rooms.

STRUCTURAL PLANS

Observing the structural plans, several similarities and differences can be found in the group of case studies. Specifically, the focus should be on the structural grid, span dimensions and core location. Independent of the scale of the case studies, the buildings' structures are composed either by column-systems, load bearing walls (Warnsveld), or a combination of the two (Den Haag, Middelburg, Haarlem). This is justified by the constructions methods and materials available at the time the buildings were realized.

As a result, these structures compose plan libre plans or enclosed spaces by load-bearing walls. Consequently, this affects the future spaces' adaptability. Rotterdam Witte de With, Groningen and Den Haag, do reflect the modernism ideas of open and flexible plans. The largest spans can be found in Groningen and Den Haag, of approximately 11 meters. Though, especially in the latter case, the daylight implications on the deep spaces should be examined in parallel to the section.

The placement and distance between the load bearing elements, follow either a strict grid (Eindhoven), or a traditional office layout, forming a central corridor (Haarlem, Middelburg, Rotterdam Haven, Den Haag). In this case, the space plan is significantly less tolerant to layout transformation. Also, the span and column's positioning is associated with the façade articulation, as in Den Haag's case.

Close relation to the structural plan, have the circulation cores. In all cases, the cores are formed by load-bearing elements, mostly concrete, that enhance the building's stability towards lateral wind load. Their position in the space plan enhances efficiency, but also in the case of Witte de With and Eindhoven, their central placement, exempts the façade from load-bearing elements.

SPATIAL RELATIONS

An overview of all the police station buildings shows that each of these buildings is made up of many units either originally designed or acquired over time. There is a tendency for volume units of larger scale buildings to be more similar in size to each other; this can be observed in Eindhoven or Groningen buildings. Whereas, in the smaller-scale buildings like Warnsveld, the size difference is more substantial. There are exceptional police properties that consist of only one major volume, such as Middelburg and Rotterdam Witte de With. These two locations consist of one main unit with significantly smaller additional elements. This is due to the scale of the buildings themselves - the smaller the scale, the less need there is to architecturally divide them into separate units closer to the human scale.

None of the eight buildings is symmetrical, even though Middelburg is the closest to such compositional characterisation. Some buildings within their volume units form a more or less horizontally noticeable balance. For instance, Rotterdam Haven forms a line of a bigger main volume and two on either end of the sides, and in Eindhoven, the three main connected volumes of the building are arranged parallel to each other. In contrast, in other buildings that have been noticeably extended throughout their lifespan (Den Haag) or that are part of a larger urban block in the city centre (Witte de With), the balance in volume composition is not easily noticeable.

There is a rather important difference between pitched-roof buildings and those with flat roofs. On flat roofs,

there are many unforeseen volumes that have occurred over time, out of necessity, such as ventilation equipment or other devices. Because of their poor aesthetic value or non-composition in the overall architectural appearance, these units of volume are sometimes attempted to be concealed, as was done in the Witte de With building. Meanwhile, the sloped roof volumes in their form prevent such additional volume interventions. On pitched roofs, only the designed dormer window volumes were added. One reason for this is the attic, which can accommodate additional equipment installed over time.

Some buildings stand out in the overview for instant recognition. If we look at the simplified spatial configuration of volumes not from the point of view of a bird's eye, but from the point of view of a passer-by, we would notice elements of small architecture that would help us recognize some buildings much faster. The corner towers, the long ramp in the Middelburg building, and the column arches on the corner of the Witte de With building are all small-scale volume units that allow the passer-by to remember the particular building and later relate to it.

The Rotterdam Haven stands out from all the other buildings as its highest volume acts as a noticeable element of the building. Interestingly, these memorable elements help to recognize the building only from its volumetric design, regardless of other properties such as colors or openings (e.g., memory of the building with the tower on the corner).

SECTIONS

Looking at the sections of the different buildings, it can be seen that all locations have a single floor below ground level. In addition, the building with the most floors has a total of 10, these are Rotterdam Haven, Eindhoven and Den Haag. The least number of floors is 4 and this can be found in Middelburg, followed by Haarlem and Warnsveld, both with 5 floors. The highest building is Rotterdam Haven with 35.9m and the lowest is

Middelburg with 15.1m. The only building in which the storey height remains fairly constant is Witte de With in Rotterdam. Deviating storey heights can be found in all other buildings. The highest storey height is found in Den Haag with 15.4m and the lowest in Haarlem with 2.9m.

2.4. BUILDING ENVELOPE

2.4.1. COMPONENTS

0 10 M

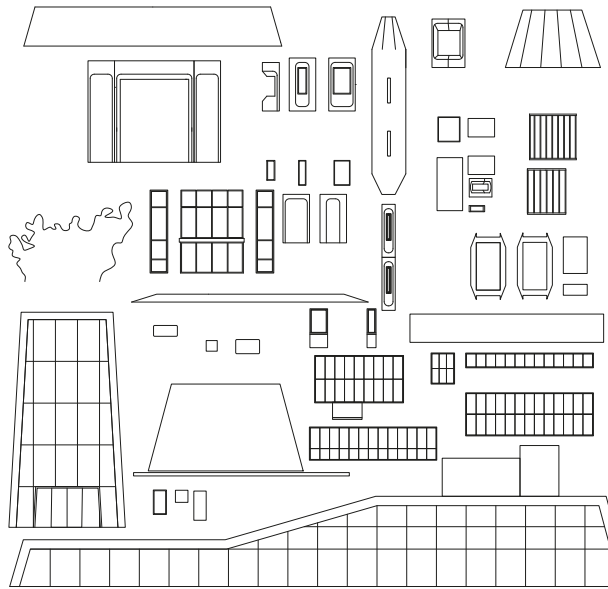

DEN HAAG

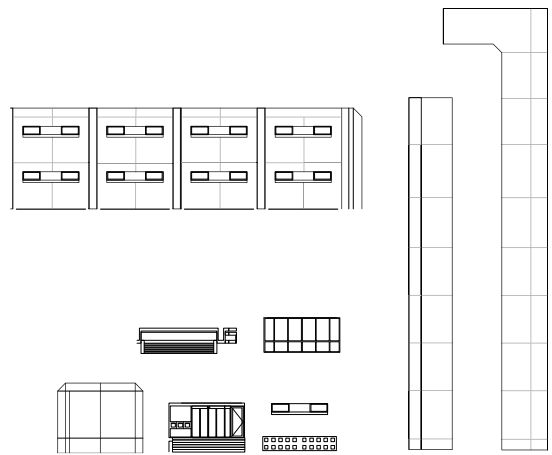

EINDHOVEN

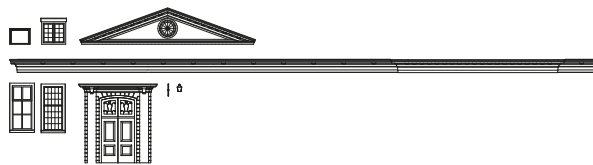

HAARLEM

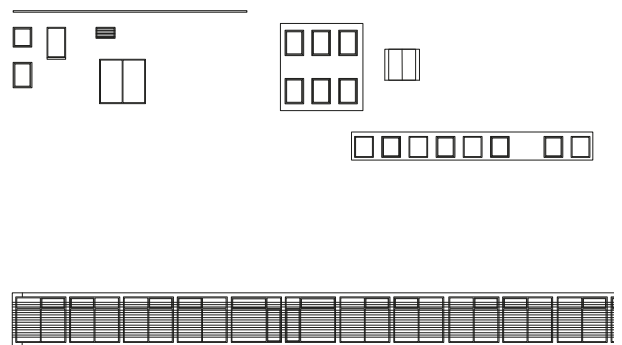

GRONINGEN

Vacant Heritage - Police Real Estate | The Netherlands

2.4.2. TEXTURES

Vacant Heritage - Police Real Estate | The Netherlands

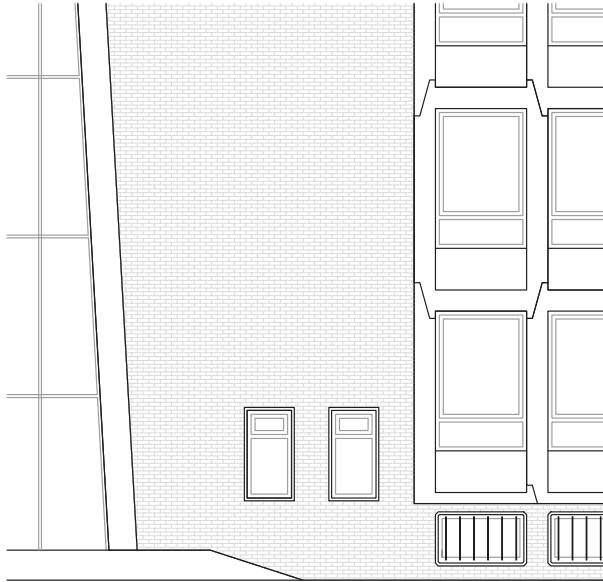

DEN HAAG



EINDHOVEN

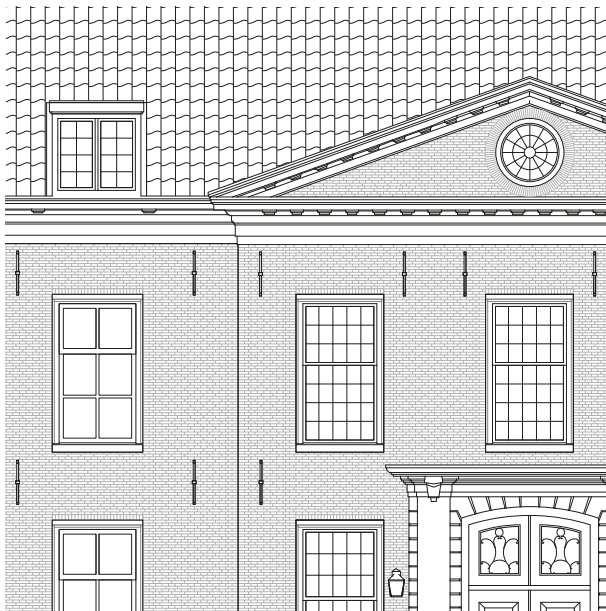

HAARLEM

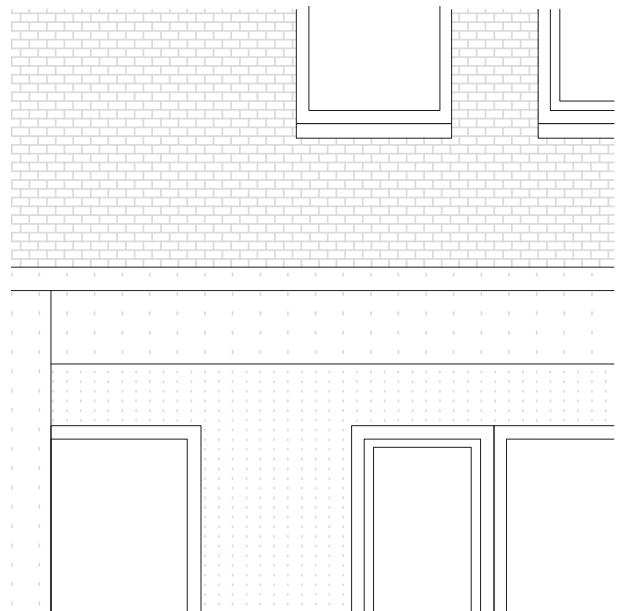

GRONINGEN

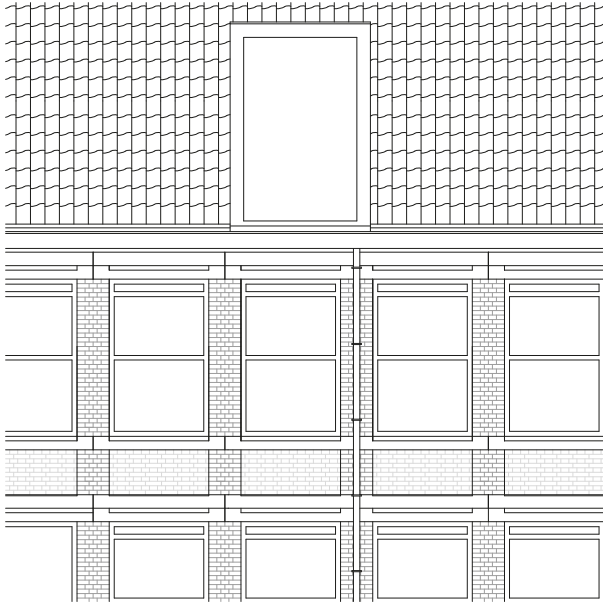

MIDDELBURG



WARNSVELD



ROTTERDAM WITTE DE WIT

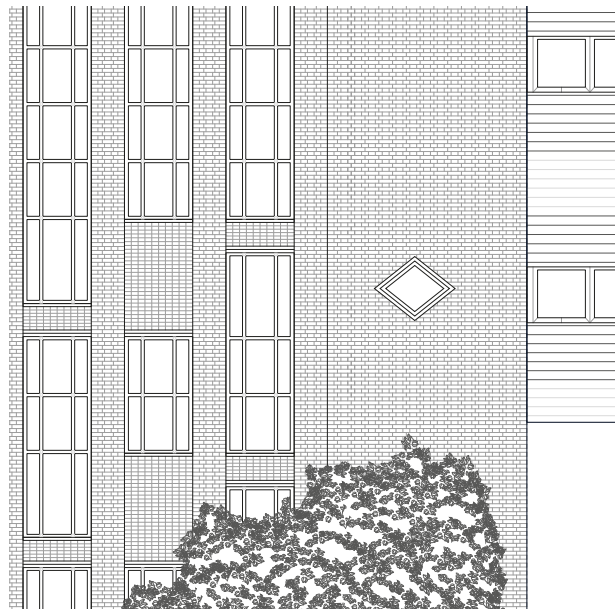

ROTTERDAM HAVEN

Aspect comparison

2.4.3. CONCLUSIONS

COMPONENTS

When looking at the components that are used in the façades of the buildings, we can see a large difference in the richness of the components and the numbers of unique components. Warnsveld and Den Haag are the buildings with the largest number of unique elements. Even though the façade of the building in Den Haag is quite regular with the use of grid, the architect has used different architectural elements added to emphasise special moments in the building.

The building components in Warnsveld stems naturally from the architectural style of that time. Herein decoration was an important part and characteristic of

the architectural expression of the building. Alongside Warnsveld, Haarlem falls into the traditional use of decoration. It differs from the Warnsveld buildings though as the decoration is kept to a limit. We could see the Middelburg building, build in Traditionalist style, as an outlier within this group of traditionalist buildings. The modern buildings use more pre-fabricated elements in the façades, having more repetition and thus less unique components. Besides the fact that there are less elements, the size of the elements increases and thus reduce the finesse of the façades. Eindhoven is at the top of the list with this.

TEXTURES

Looking at the characteristics of the materials that make up the façades of the police buildings, different use in materialisation can be seen. It is noticeable that the newest buildings have more glass surface than the older buildings. As for instance is seen in the comparison between Rotterdam Witte de With and Warnsveld. The exterior finish material of five of the eight police buildings is brickwork, with the other three having concrete as main finish for the closed façade elements.

The two oldest buildings in the comparison are Warnsveld (1640) and Haarlem (1770). Both buildings are made of brickworks, have a sloped roof with roof tiles and wooden eaves. Besides, both main entrances are very decorated. From the other six buildings that are all constructed in the 20th century, three of them are mainly made out of brickwork. The Rotterdam Haven police building (1932) and the police in Middelburg (1968) both have a brick

façade with protruding elements and a sloped roof. The police estate in Middelburg has also concrete elements in the façade under and above the windows. Visible in the three oldest buildings is the decoration with natural stone along the façade, and the division of the window frames into smaller ones. The Groningen police (1971) has a brick façade that is partly plastered in white and partly painted in blue.

The police buildings of Eindhoven (1931), Den Haag (1959) and Rotterdam Witte de Wit (1960) are made of concrete. Eindhoven and Den Haag both have prefabricated concrete elements that give the aesthetic to the façade. However, the building of Den Haag also uses a bit of masonry on one side of the building. The Rotterdam police building consists of casted concrete and has a lot of glass surface.

PART 3
INDIVIDUAL RESEARCH

PERMANENT SPACE // CHANGEABLE USE

How could the space plan of a monument like the Koudenhorn in Haarlem be re-designed to accommodate changes in use over time?

Keywords: heritage, transformation, reuse, permanent frameworks, generic space, adaptability, user.

We live in an environment where it is normality to buy or make something new once it is broken and we forgot how to give a new purpose to things. While at the same time, climate change has become more present every year and we have been using more materials than are available on this planet, which becomes shockingly visible in research done by the Global Footprint Network (2021). Therefore, we need to adjust to the time we are living in and focus on the existing building stock rather than designing new buildings.

Problem statement

When designing, an architect has the task to give a definite form to something for an unpredictable amount of time. Because of this, there is a growing number of typologies where the function is often defining the form of a building. With as a result that it becomes normal once buildings become functionally, technically or economically obsolete no one wants to take care of them anymore. But what if the solution is to focus on a re-design taking adaptability as the main starting point. To create architecture that takes change as a departure point for re-designing within the permanent.

To re-design a building in such a way that it can be variously used and interpreted over time, is the starting point for this research. A re-design within the permanent in which the users need to become more adaptable, since the use of a building is never definitive and will always be organic and changeable.

Theoretical research

Many studies into adaptability focus on the flexibility, changeable and moveable elements. However, there is also an architecture that proceeds from the permanent space like the examples written down in the book *Frame and Generic Space* by Leupen (2006), or the open building

concept principles developed by John Habraken (2000). Within these designs, the permanent more durable components of the building, like the structure, functions as a frame in which the user can be adaptable.

The next question is how this principle could be adapted to the existing building stock since the above-mentioned concepts are only used for designing new buildings. Would it not be possible to take the existing space as a starting point when re-designing, to change the way we use the building, that the people using the building need to be more flexible? How much and how often do we want to change a building, if the requirements of users change so fast, that it perhaps cannot be used anymore within a few years?

Initial conclusions

The initial conclusions made are generic conclusions from literature, case study research and interviews. Four different frameworks can be distinguished in which, even when the use of these buildings would change, the framework remains the same. These frameworks are structure, skin, roof (or hall) and the user (or placemaking). Besides, for re-designing a space plan taking the changeable into account, three different design approaches can be used within these frameworks:

1. Re-design a building with an adaptable infill, in which the infill has a short lifespan and is therefore moveable, demountable or biodegradable.
2. Re-design the space plan of a building creating a generic space in which the user can adapt those to using the open building principles. For this specific sizing of rooms is important to use spaces in different ways or create placemaking.

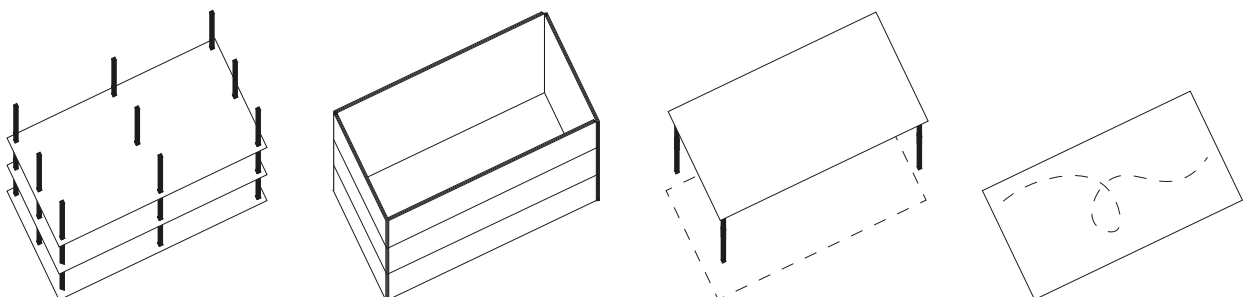

Figure 1: The four different frameworks structure, skin, roof and user

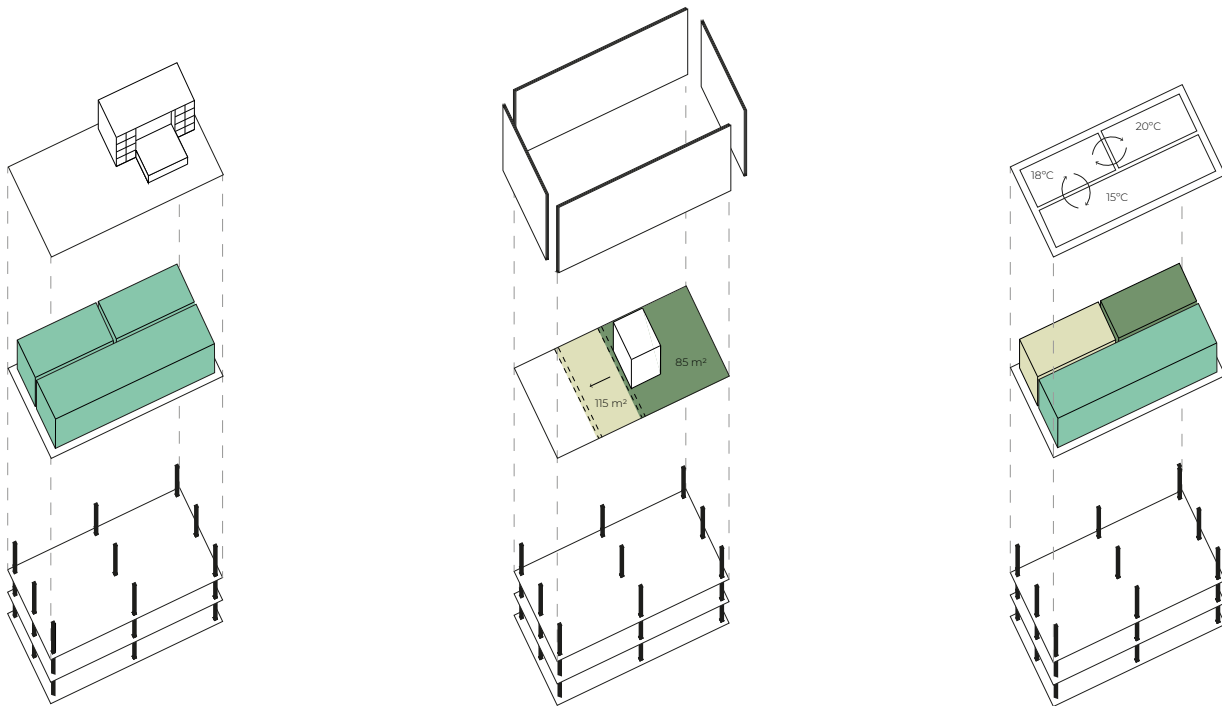

Figure 2: Three design approaches for the different frameworks

3. Re-design with a focus on energy demands of the user. Locate the additional permanent elements like systems and other vertical shafts at smart places throughout the building.

Re-designing a building by creating an adaptable infill (1) or with a focus on energy demands and the user (3) are strategies that have been used and developed already within vacant heritage. Therefore, the challenge for this research will mainly focus on re-designing the space plan by creating a generic space. This, however, is something that will need to be developed further during research by design.

Research by design

Answers to the research question can only be formulated by implementing the initial conclusions from the research into the design process. Because acknowledging the design as research on its own, could help generate a set of considerations to be used when re-designing (Van Duin & Claessens, 2009). There will be a lot of challenges and limitations for re-designing the space plan of the Koudenhorn in Haarlem to accommodate changes in use over time, which will be investigated in the final design. This design and more information about this research can be found on the TU Delft Repository.

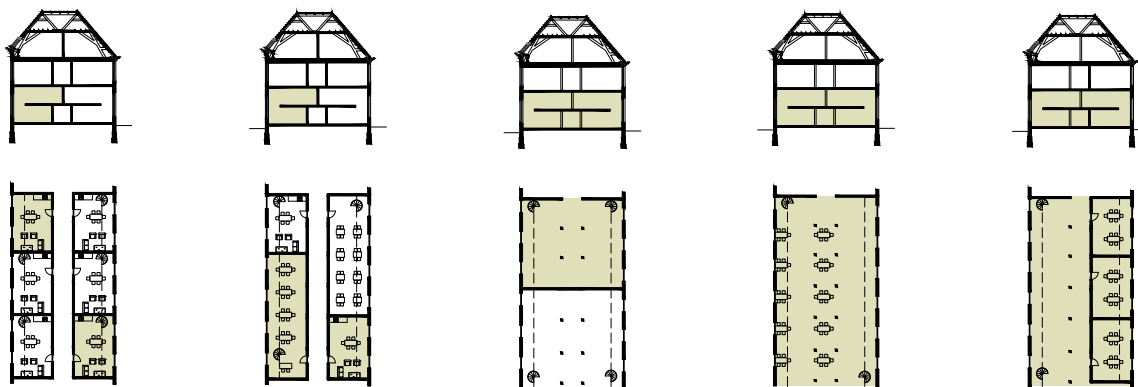

Figure 3: Changeable typologies within the same re-design

Global Footprint Network. (2021). Earth Overshoot Day. Overshootday. Retrieved 26-10-2021, from <http://www.overshootday.org/>
 Habraken, N.J. (2000). *The Structure of the Ordinary*. MIT Press.
 Leupen, B. (2006). *Frame and generic space*. Rotterdam: 010 Publishers.
 Van Duin, L., & Claessens, F. (2008). *OverHolland. Vol. 7. Architectural studies for the Dutch city*. Nijmegen: Vantilt.

ACTIVATING THE “GLASS BOX”

How can the building at Witte de Withstraat 25 contribute to the future challenges of the city centre of Rotterdam (in the context of densification)?

Keywords: post-war reconstruction, authenticity, open plan, densification, adaptability for future uses, active plinth, urban agriculture, Open Building.

Today we have to deal with the challenge of vacant police buildings because the police want to adapt their real estate to the new organization and the changed structure of the services, with larger teams, in fewer places, and more digital presence. This reorientation to denser locations is also taking place outside of police institutions on a larger scale, both nationally and globally.

Today, over 50% of the of the world's population lives in urban areas. By 2050, with the urban population more than doubling its current size, nearly 7 out of 10 people in the world will live in cities (The World Bank, 2020).

Rotterdam city is clear in its urban strategy : densification here is already taking shape in high-rises. Denser construction reduces transit emissions by adding more stories and provides more livable and usable area in the same amount of space.

However, the city center is not a tabula rasa - it has a characteristic that consists of built heritage. So how can existing buildings not be a barrier but the key to a comprehensive city of tomorrow?

Addition to current legacy

Each building has its own authenticity (related to a design concept or a social value), which represents the original function and ideas of the time it was constructed. This research examines young potential heritage that will not necessarily be included in the monuments' lists and looks for the authenticity of the building even if it hasn't been yet stated by the experts in the field. When dealing with the architecture of post-war modernism, a designer needs to not only consider preserving it because of the embodied energy it stores, but also to allow possibility

for an assessment of this heritage in the future over time (recognizing the temporality of our interpretations of this recent past) (Prudon, 2008).

As I was looking for the authenticity of this building, I figured that it was based on the conceptual design idea rather than materials (characteristics of functionalism). Firstly, this building is best defined as part of a famous horeca street. Secondly, the elements that make this building authentic are the façade grid and its emphasized corner entrance. So, the street, in this case, has as much importance as the building.

Because today the building's plinth seems very uninviting, I was curious whether the ground floor of the building was more active before. From my research, it turned out that, starting from the original design as a newspaper office in 1958, the corner was very much connected to the street by the set-back entrance. Later, when the different newspaper came in, it was less open, until it was decided to completely close it off when the police station moved in. According to architect and urbanist Jan Gehl, in order to engage with street life, the ground floor of the buildings must have a physical connection to the public space (Gehl, Kaefer & Reigstad, 2006).

One of my aims is to activate the building on the ground level – re-connect it to the street, which will eventually be car-free, by making the ground floor façade more open, approachable and introducing public functions.

Addition to the future

In order to tackle the future challenges, I'm introducing urban agriculture and accommodation as new functions for the building.



Figure 1: Sketch of the inviting and open ground floor



Figure 2: Sketch of the re-design concept

As the street is full of restaurants, in order to tackle environmental problems, it requires rethinking the food miles, food supply chains, and food waste. Producing the goods locally in a vertical indoor farm, which would share resources with proximities, will contribute to the circular urban economy.

Additionally, I propose an inclusive living program – social housing that would include spaces for social community functions and job opportunities in the urban farm, restaurant, or shop. The communal spaces with private vertical gardens will help networking so that neighbours are encouraged to help each other, e.g., babysit single mom’s children or share their skills.

Possibilities for combining the old and the new

Structurally and architecturally, it is not an easy task to place a tower addition on the existing building, as seen in the image below (figure 3). However, exploring these different ways is crucial to finding a suitable opportunity for the case. The number of previous owners and the adjustments made to the building show that buildings need to be adaptable for various uses. In the re-design project, I will reuse and improve what is there and introduce the Open Building idea. It promotes the long-lasting structure called a shell with easily adjustable infill – the things that change with every new owner. This way, it allows adaptability for different future uses of the building.

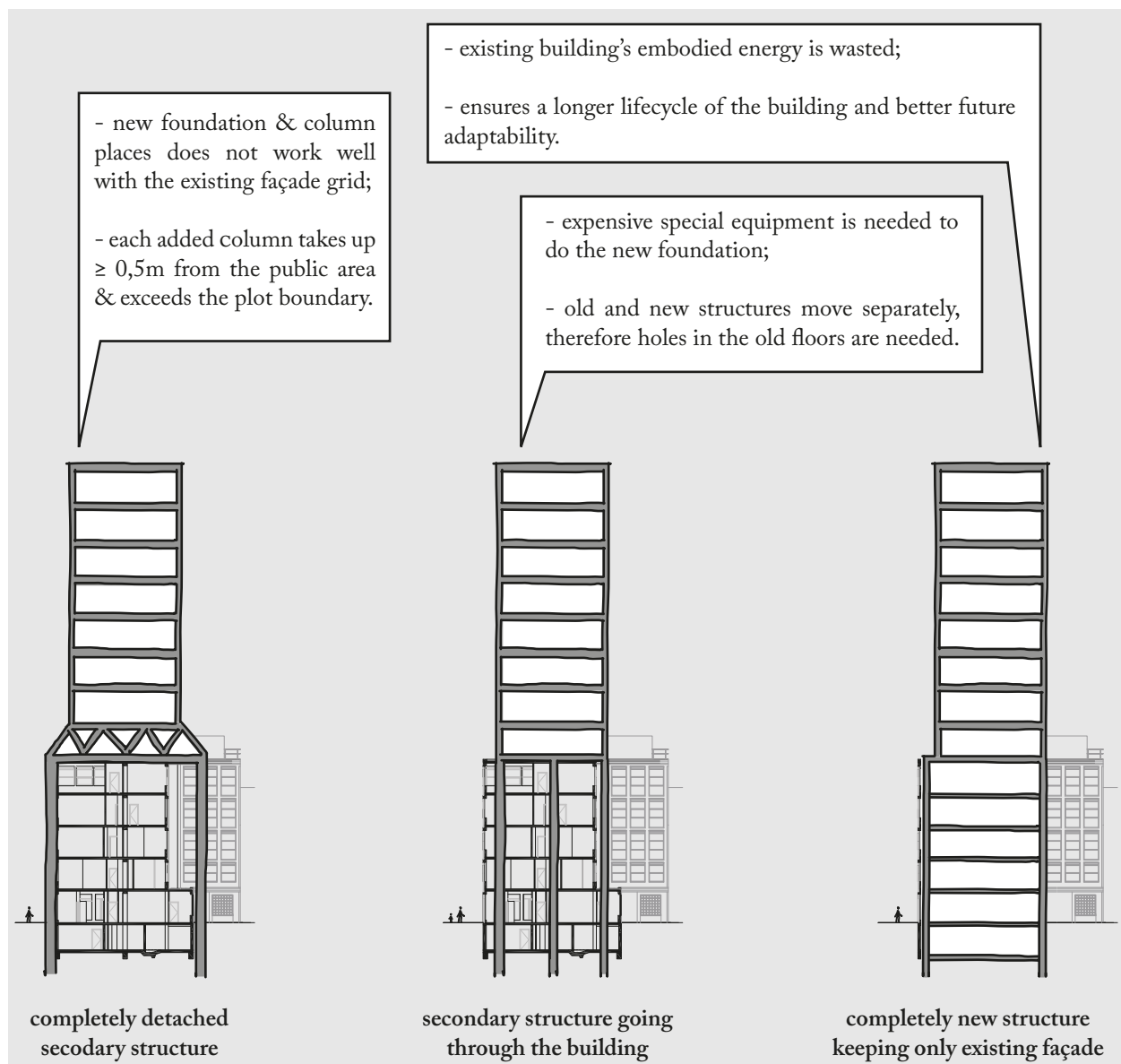

Individual research

Figure 3: Different possible methods of how the tower can be built on top of the existing structure shown in section + arguments about each of the method.

ISOLATED ISLAND IN THE CENTRE OF GRONINGEN

How could the interaction between buildings and residents influence the livability of the former police station in Groningen?

Keywords: Community, connection, isolated block, vibrant spaces, liveliness.

Historical background

In 1995, a Dutch newspaper *Nieuwsblad van het Noorden* published an article: “Schoolchildren created a work of art”. It is a story about a community project, in which local kids were invited to draw on the construction site wall of the police building one year before finishing its renovation. The construction site fence became a long colourful painting, making the whole environment lively and vibrant. In addition, the project helped kids to interact with their living environment and made them feel involved in the creation of its identity. The project developers found a way to invite the community to be part of the redevelopment changes.

However, the article later explains that at the end of the renovation, the fence will be torn down (“Schoolkinderen maken kunstwerk”, 1995). Upon the project completion, a fully isolated façade of Politiebureau Rademarkt appeared: the walls were solid and closed, the windows were above the human eye level, and the doors looked heavy and unwelcoming. Such an architectural solution did not connect the Politiebureau Rademarkt block with its surroundings. The monofunctional office building stood on its own in Groningen’s old town urban fabric just as before the renovation.

Block as a barrier

The old town of Groningen is the most vibrant and busy area in the city. While there are many inviting spaces such as cafés, restaurants, shops, workshops, and lively streets, the area next to the police station contrasts its surroundings. Streets around the police station block remains empty. At first sight, it seemed like a negative thing for me as a visitor until I decided to dig deeper and focus my research on the interviews with locals and neighbours of the police station block.

Some residents living around the block described the area as “dull” and “cold” – primarily due to the police station exterior façade that is fully isolated and coloured in a bright blue distinctive colour. However, one of the residents’ answers changed my mind about “dullness” and “coldness” being negative aspects. She said that the block works as a barrier from too noisy, full of people city centre. So it is nice to have such a privilege to stay in an area without hearing music from pubs and being calm about your kids safely playing around. Even though, she said, it would be way nicer to see some liveliness of the block instead of an isolated wall in front of your house every day.



Figure 1: Photo from *Nieuwsblad van het Noorden*. (1995, April 26th). *Schoolkinderen maken kunstwerk*. (p. 9)



Figure 2: Interviews with locals and residents living around the block

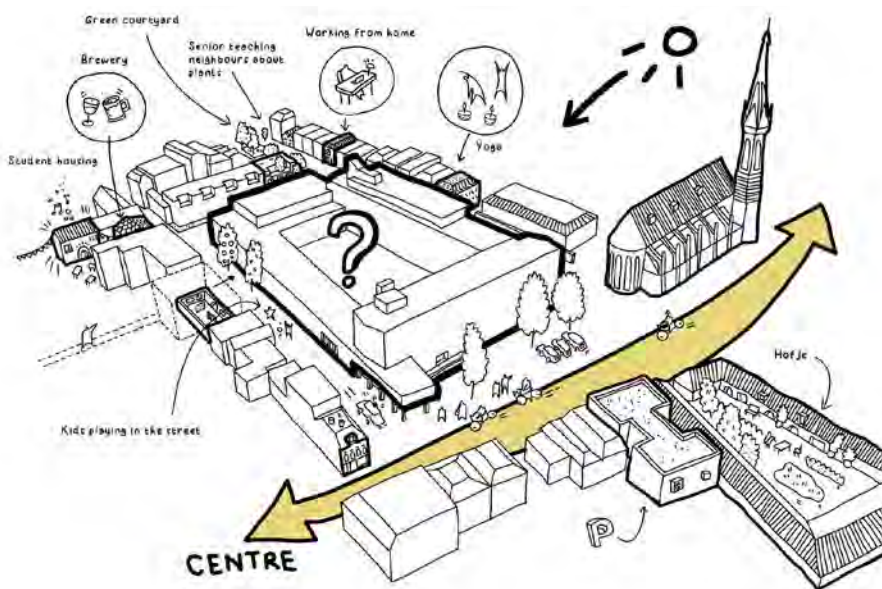

Figure 3: Existing situation

Research aims

Research into the police station in Groningen is based mainly on community experience of the block and approach to it. By studying the importance of the connection between buildings and community, I want to answer the following research question:

- How could the interaction between buildings and residents influence the livability of the former police station in Groningen?

By trying to answer the question, I focus on users experience: people who live around the block, future residents of the building and their daily behaviour, strangers who pass by the block and their perception of the building. Information was collected by visiting the

location, interviewing residents living around the block and trying to perceive Groningen as local. The future design aims to reflect on those aspects and share the “user first” idea. Design is influenced mainly by target groups like students and families and their daily use of the building. The strategy aims to cover the housing crisis in Groningen by creating an adaptable design, reusing materials and implementing a strategy for daily cycles such as organic waste, rainwater and greywater management.

HOW WILL WE LIVE TOGETHER?

How can an architect transform the Eenheidsbureau in Den Haag in order to create a symbiotic urban metabolism in the neighborhood?

Keywords: ecology, heritage, community, urban metabolism, symbiosis, wellbeing

Disconnection between humans and nature

The disconnection between humans and nature is causing many societal challenges. In order to tackle this disconnection a new way of living needs to be found. Heritage can play an important role in restoring the balance between humans and nature.

Methodology

The goal of the research is to create a transformation framework to guide the re-design from both an ecological perspective and a social cultural perspective. Including both the natural and the cultural human environment in the design, to find a new way of living together. The research starts with a literature study into ecological design, systems theories, and urban metabolism, resulting in a framework for an urban metabolism analysis of the Archipelbuurt. Based on this urban metabolism studies case studies are analysed to research how the current cycles can be closed and symbiotic relationships can be created. This results in an urban metabolism transformation framework. The social cultural perspective is researched with a value assessment, which results in a heritage value transformation framework.

Ecological design & systems theories

The conclusion from the literature research about the ecological design and systems theories is that the new stepped strategy from Andy van den Dobbelsteen (2008) is the best systems theory to guide the design. The scale on which this method is applied should however be expanded to the neighborhood level to close cycles more

efficiently. To find out which flows are present in the neighborhood, the concept of urban metabolism is used.

Urban metabolism analysis

The urban metabolism analysis is conducted on the Archipelbuurt in Den Haag. The defined categories of energy, water, biotic factors, and materials are researched and visualized in flow diagrams. This analysis gives the current status of the flows in the Archipelbuurt.

Urban metabolism framework

With the analysis of case studies, elements were defined that could close cycles. These elements are the production of energy connected to energy storage (electricity / heat / cold), a water treatment (grey water / black water) with water storage, and an organic waste treatment used for fertilizing the food production. Based on these elements, a urban metabolism transformation framework is created in order to close the cycles in the Archipelbuurt.

Cultural value framework

The social cultural perspective is analysed with a value assessment. The input for this assessment is the spatial building typology research and a detailed building analysis, both can be found in a separate booklet. The assessment itself is structured according to a combined framework with eight primary values from Tarrafa Pereira da Silva & Pereira Roders (2012) in relation to nine spatial layers from Kuipers & De Jonge (2017). This assessment results in transformation framework by signifying the values and the related spatial elements.

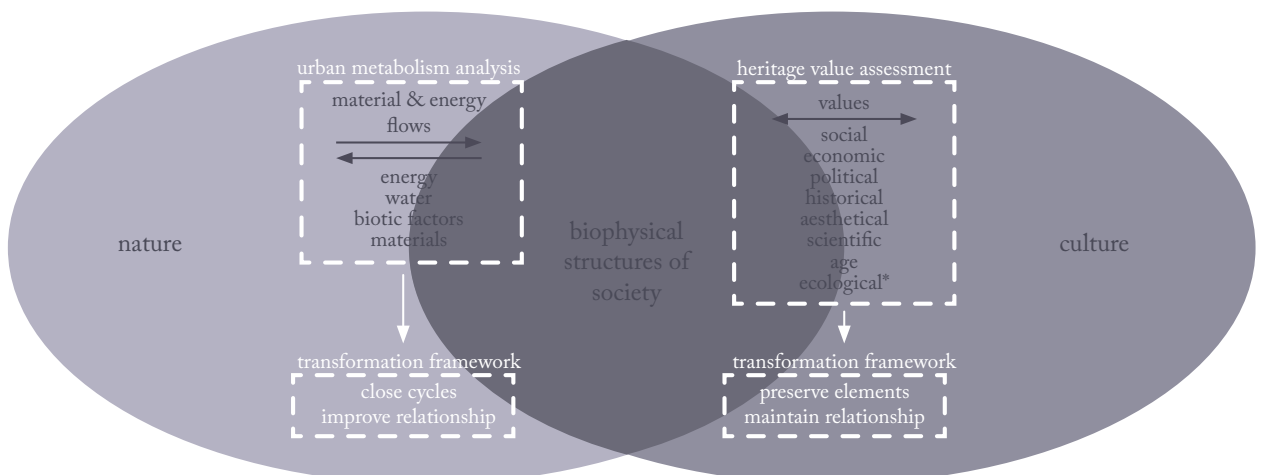

Figure 1: Relation between urban metabolism analysis and heritage value assessment

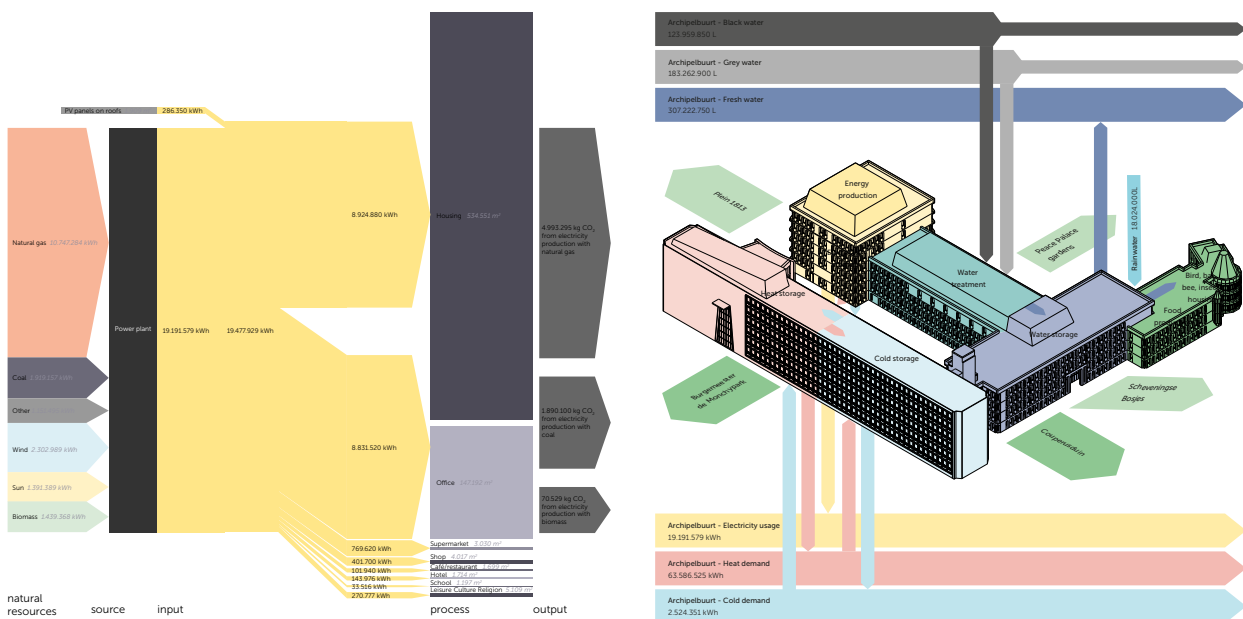

Figure 2: Urban metabolism analysis of the Archipelbuurt, focussing on the aspects of energy, water, materials, and biotic factors

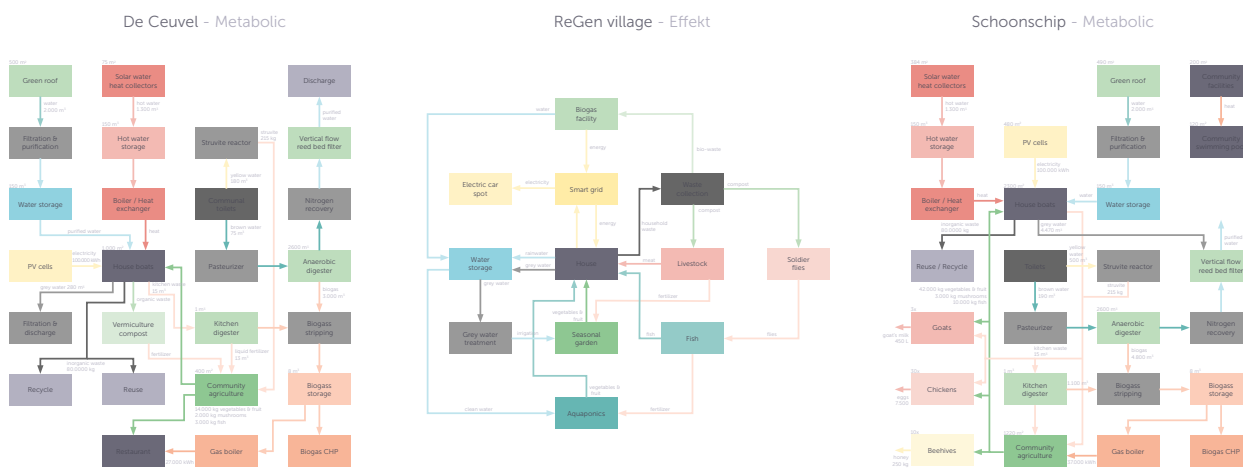

Figure 3: Case study research of the closed cycles of different circular projects

This transformation framework determines the amount of change that is possible with the re-design. Elements that have a high value should be preserved as much as possible, while elements with low value are opportunities for change, in this way maintaining the important cultural values of the building.

Combined transformation framework

These two transformation frameworks each react on a different relationship that the biophysical structures of society has with nature and culture. The frameworks guide the design in different ways, as the urban

metabolism framework determines functions that are needed to close the cycles in the neighborhood, while the heritage value framework determines which elements have opportunities for change and which elements should be preserved in order to maintain the values.

The research will be used to create criteria to reflect and develop the design, changes in the design will also develop this criteria, in this way performing design by research and research by design.

STORY-BASED ADAPTIVE REUSE OF COUNTRY HOUSES

How can the architect integrate the stories behind the layers of time in Huis 't Velde in Warnsveld in the adaptive re-design process in order to make these stories experienceable for future users?

Keywords: time layers, adaptive reuse, country houses, heritage, analysis, documentation tool, heritage as vector, biography

Introduction

Heritage buildings, such as the police buildings discussed in this book, usually have been changed several times during their lifespan. Therefore, in these buildings are traces of all these different changes; the time layers of these buildings. But the meaning of these time layers is more than just their physical existence. They can tell us something about the previous uses and users of the building, and about architectural history and historic building technology. The question how to deal with these time layers is therefore important in contemporary architectural practice and theory. Integrating them in the design, and making them experienceable for the future users of an building, might make it possible to create awareness about the value of heritage buildings.

Research







The individual research consists of three parts. First, the time layers present in the main topic for the design, Huis 't Velde, are described. Second, three case studies are analysed; Hofwijck in Voorburg, Oud Amelisweerd in Bunnik and Duin en Kruidberg in Santpoort. For the analysis of these case studies and Huis 't Velde, a matrix is being developed. This matrix will be further discussed here, because it could possibly also be applied in future research or in (design) practice. Based on the analysis, a few different strategy's were found and described. These strategies were applied to Huis 't Velde to create possible scenario's for the adaptive reuse process of this building, and to find out which impact each strategy would have on the timelayers present in this building.

Matrix

The matrix is based on the Shearing Layer smodel described by Steward Brand in his book *How Buildings Learn: What Happens After they're Built* (Brand, 1995). The six scale levels described in this book, that, according to Brand each have a different lifespan, are placed on the horizontal axis. On the vertical axis are the time layers, the different moments that changes were made to the building. An overview can then be created in the matrix of the impact of the changes on each scale level, using drawings, texts and images.

Aim

The aim of using this matrix was twofold; in the first place, it was used to answer questions concerning the design for Huis 't Velde, and in the second place, it was aimed to find out whether the matrix could function as a new research and documentation tool for architects and researchers in the field of Heritage and Architecture. It could be an addition to the existing biographical research methods and the heritage as vector approach, specifically useful for those involved in the design process (Janssen et al, 2017. Hermans, Kolen, Renes, 2015). The existing documentation methods are usually very textually oriented, whereas most designers are more visually oriented. Besides this, the existing methods do not always involve information on all the different scales. The timelayers matrix helps to get a clear, visual overview of all time layers and could functions as a starting point for assessing the values of the different time layers. It could be a more efficient way of communicating research, and

Timelayers	Stuff	Space plan	Services	Skin	Structure	Site
1824	Stucco in entrance hall			Stucco facades, 'empire vensters' 		Walls around the forecourt replaced with slopes. Design for the garden by Hendrik van Lunteren in an English landscape garden style. 
1897				Facades covered in vegetation		
1962	Changes in the interior. Spaces painted in the colors of different police forces. New furniture in many rooms	Room at the first floor split up. New meeting rooms created at the attic.		Restoration of the exterior. 'Schuilramen' brought back. Stucco replaced with a layer of chalk paint		Three farms that were part of the estate sold separately
1987						New garden design for part of the park 
2005						Memorial garden for police officers who died during their work 

No longer visible
Still visible

Image of part of the timelayers scheme of Huis 't Velde (own image, check TU-Delft Repository for full research and scheme)



Figure 2: Drawing of Huis 't Velde in 1671 (Gelders Archief)



Figure 3: Image of Huis 't Velde in 2021 (own image)

makes it easier for designers to quickly get an idea of what they are dealing with. It also forces the compiler to at least check whether information on all scales is available.

Experience

In general, we can conclude that the matrix turned out to be quite useful for analysing the time layers of the different buildings. It helps to get an visual overview of what has happened. Nevertheless, there are also some points in which the matrix could potentially be improved, based on the first experiences. The first one is the fact that it became clear that the (changes in) owners of the estate were quite important for the changes in the buildings. But, the matrices didn't provide a logical place

to include these owners, although this could be valuable. So it might be good to experiment with including them in the scheme as well. Furthermore, also the changes in the context, in case of Huis 't Velde the surrounding park, could potentially be included better in the matrices. The scheme only has one column, site, in which information about the park could be included, while a park also has different scale levels. Last but not least is the fact that matrix sometimes tends to be an overview of information, instead of an overview of changes. It's important to be aware of this while using the scheme; the fact that certain fields are empty, doesn't per se mean that nothing changed on this scale. Sometimes there simply isn't any information available about a specific topic.

Brand, S. (1995). *How Buildings Learn*. Van Haren Publishing.

Gelders Archief: Haen (II), 1551 Topografisch-historische Atlas Gelderland, 1671 Huis 't Velde, 1726 A. de - (Abraham), Public Domain Mark 1.0 licentie.

Hermans, D. R., Kolen, J. D. R., & Renes, H. (2015). *Landscape Biographies: Geographical, Historical and Archaeological Perspectives on the Production and Transmission of Landscapes*. Amsterdam University Press.

Janssen, J., Luiten, E., Renes, H., & Stegmeijer, E. (2017). Heritage as sector, factor and vector: conceptualizing the shifting relationship between heritage management and spatial planning. *European Planning Studies*, 25(9), 1654–1672.

ARCHITECTURAL YOUNG CLASSICS

How can the spatial characteristics of Dutch administrative office buildings from the late 1970s and 1980s be implemented into a sustainable adaptive reuse strategy, on the example of the Mathildelaan Police department in Eindhoven?

Keywords: 1970/1980s Architecture, Modern Heritage, Sustainability, Brutalism, Post Modernism, Flexibility, Prefabrication

General Problem Statement

Young architecture from the 1970s and 80s is still rarely listed. After almost fifty years, however, the question is whether they have to be demolished or renovated and can be used for other purposes. Considerations of monument protection are seldom considered as relevant due to the numbers of existing buildings, but often economic interests alone decide on the future of those buildings.

Especially in view of the current situation with regard to sustainability, however, it is worth examining whether the buildings should not be better preserved for several reasons. Both emissions and money could be saved in this way. But also the authenticity of cities through preserving more recent time layers can be worthwhile. The extent to which the buildings may be changed in its appearance in the case of adaptive reuse or renovation should therefore already to a certain amount be assessed in the light of later monument protection aspects. In this way, no architectural heritage would be destroyed simply because it is not yet considered worthy of protection. This is particularly important in view of the fact that the current perception of buildings tends to be negative, but this is often mainly results from their condition of maintenance. To simplify a designprocess which takes those characteristics into account the question arises what

special characteristics of the time there are and to what extent these might even correlate with the idea of sustainability.

The research investigated into the SBT police buildings of the respective time (Groningen, Den Haag and Eindhoven), furthermore added by case studies, literature and interviews. Consequently a broader investigation could be done and also reasons for and advantages of certain aspects can be identified.

Buildings from the 1970s and 80s make up almost 30% of the stock of office buildings in the Netherlands (BAK, 2001). Due to the urgent need for renovation or the threat of demolition, interest is currently growing in the entire so-called Post 65 era as can be seen in publications of the 'Rijksdienst voor het Cultureel Erfgoed'.

Building features

A key element is the buildings load-bearing structure. They are often constructed using a grid based load-bearing system with lightweight partition walls. Overall, prefabrication also plays a major role, as does the choice of materials such as concrete, steel and large glass panels, but also wood in the interior. These materials add to the strength and longevity of the buildings.

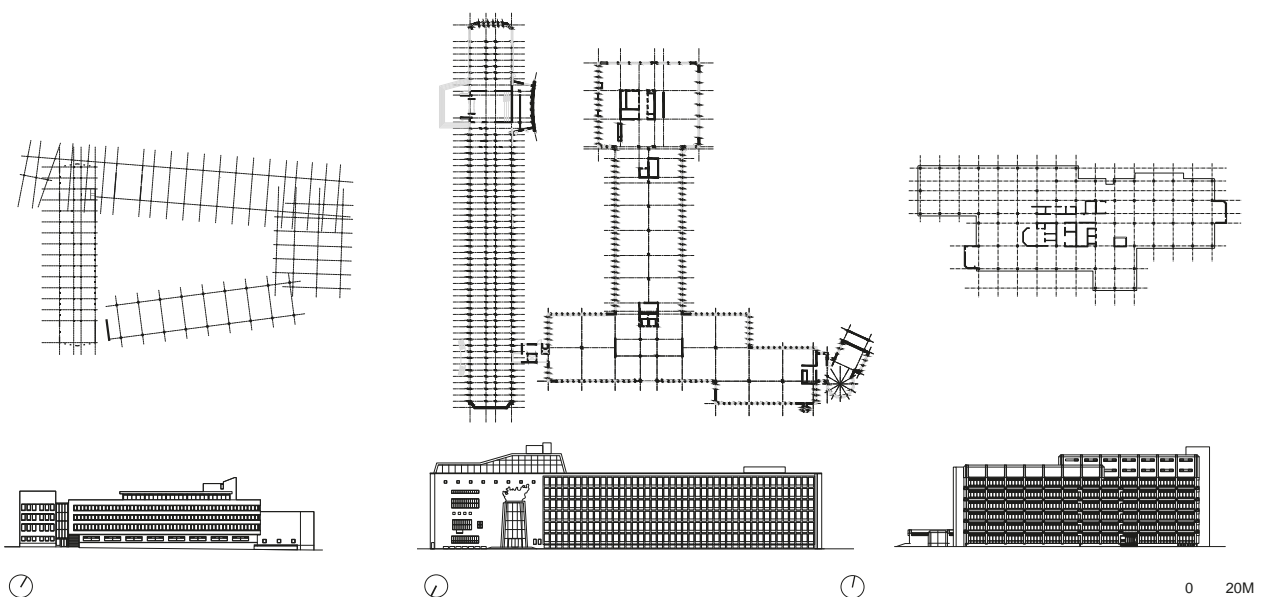

Figure 1: SBT Case Studies (Groningen 1971, Den Haag 1985, Eindhoven 1981)

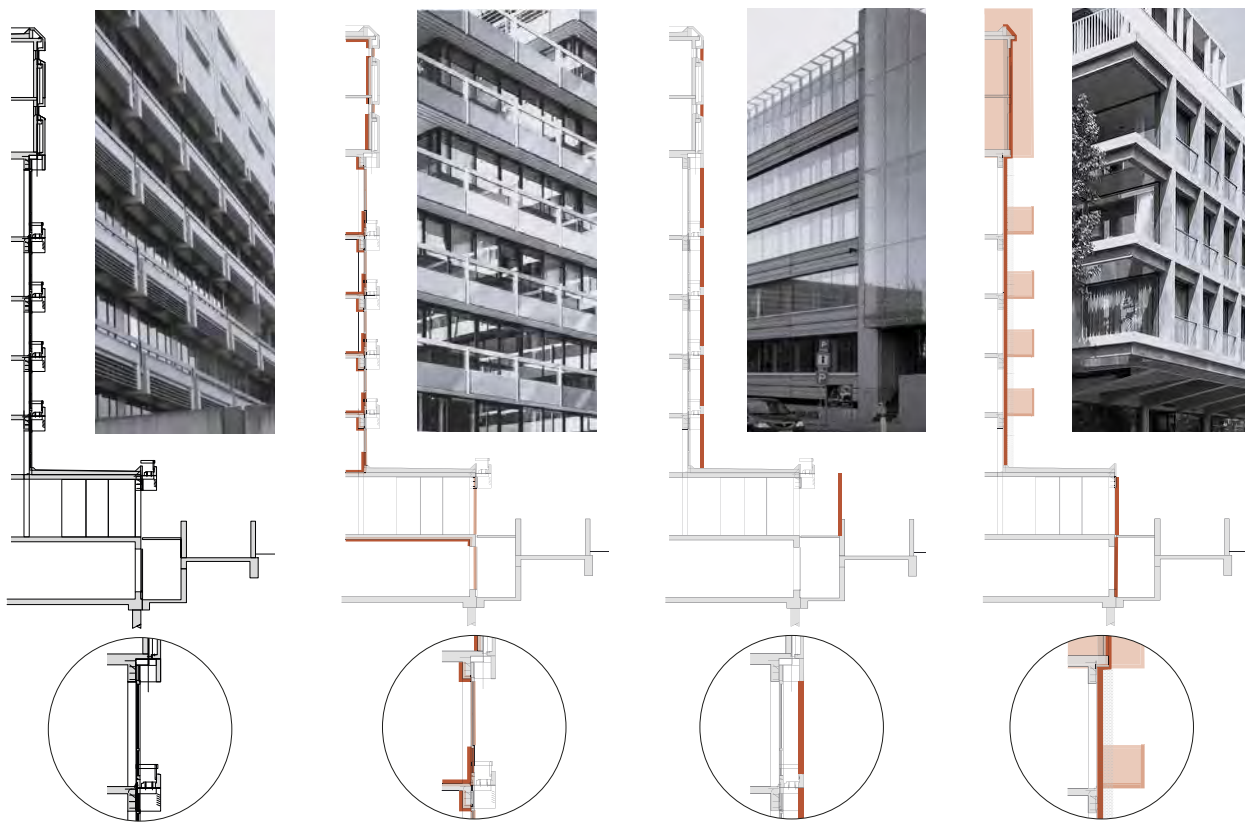

Figure 2: Original and 3 ways of transforming a façade from the 1970s/ 80s (1. Original, 2. Preserving, 3. Additional glass façade, 4. New Façade)

Building design

With regard to the building design, there are first approaches to energy saving through better insulation and accessibility, but also an easily adaptable basic structure. However, it is not only important to identify the design features, but also to investigate the reasons for these developments. These resulted from a situation that is to a certain amount comparable to today's. Because of the oil crisis, people tried to save energy and resources. This also led to the idea of constructing buildings in such a way that they could be adapted to new circumstances at a later date. This was a break with functionalist ideals, which saw a specific function as the goal of design. Further developments such as post-modernistic ideas questioned to a certain amount the puristic absence of decoration of the early post-war architecture.

Re-Use and Re-Design

For the re-design the façade is a particular challenge. Often the insulation and thinner windows don't meet today's requirements. Concrete parts often suffer from external

impacts and the design doesn't correspond much to the current aesthetics. On the other hand the design shown in the façades is often particularly includes characteristic of the 1970s and 80s design ideas. Therefore, a precise balance must be found between monument preservation aspects and quality of use and sustainability.

Use for sustainability

Some characteristics can be used in particular for a sustainable conversion of the buildings. In particular, the durable core construction of the buildings is still suitable for further use. A flexible floor plan and thus adaptability to today's uses is not only possible but often expressly intended in the design. The usability in terms of room heights, accessibility and technology are not meeting current standards entirely but are at least existent to a certain amount that can be updated. However, the façade is a challenge, because on the one hand it is often a special design statement, but with regard to insulation, many new and better possibilities have emerged in recent years.

Figure 2:

1. Police Station Mathildelaan: Lucca Fischer (own image)

2. Estel Residence, Norbert van Onna (n.d.), <https://www.teakebouma.nl/>

3. Ministry of Finance, Imre Csany (2013), CC0, https://commons.wikimedia.org/wiki/File:Ministerie_van_Financi%C3%ABn_wintertuin1.jpg

4. Schubertsingel, Den Bosch Building, René de Wit (2019), <https://www.archdaily.com/919869>

SUSTAINABLE RE-DESIGN OF ESTATE HUIS 'T VELDE IN WARNSVELD

How can design approaches help in a contemporary reuse and re-design of a Dutch estate where both building, and nature, contribute to a sustainable design and in particular for Huis 't Velde in Warnsveld?

Keywords: landgoed, buitenplaats, estate, sustainability, heritage, nature, design attitude, design approach, green energy

As seen in part 1 and 2 of the SBT research the estate Huis 't Velde is different than the other police buildings. The biggest difference is the large amount of space and nature surrounding the buildings. With a building footprint ratio of less than 0.5% and a total size of approximately 326,000 square meters, lies a big opportunity in the reuse of the land. Reusing and re-designing an estate is not only about the design of a building, but moreover about a spatial design of the whole area. This research is about the contribution of monumental buildings, space and nature to sustainable resources and the effect they can have on the monumental value of the whole estate. This is worked out by analysing the next four case studies: Kasteel Twickel, Landgoed Singraven, Kasteel Wijlre, and Kasteel Ruurlo.

Design attitudes

In recent decades, the attention of architects in the heritage sector has been on design attitudes. Designers and tutors in the architectural field were questioning how to deal with heritage? This former 'hot topic' was about the aesthetic design of old and new architecture and the integration of those new parts and elements into the existing. In 2006 former TU Delft R-MIT professor Jo Coenen distinguished five attitudes in dealing with the re-design of a heritage building: *continuity, polarity, dialogue, congruence and blending* (Coenen, 2006).

Six years later in 2012 distinguished American architect Charles Bloszies three equivalent approaches: *extreme, restrained, and referential* (Bloszies, 2012).

Both authors have in common that they were criticize and questioning the instant urge of making a striking image in every (re-)design. Both stated that it is more important to investigate the effect and impact of interventions on the existing building and to create a symbiosis by well-considered design choices.

The urge of sustainability

Nowadays the urge in the architectural field is shifted to sustainability. Every designer is questioning how he or she can re-design a heritage building as energy neutral as possible. But this is not so easy with monuments. In the Dutch built environment sector are monuments seen as hopeless cases that consume energy and are impossible to insulate properly (Meurs, 2021). In his essay for the Dutch Restoration Platform (NRP), Paul Meurs wrote that a general misjudgement is that sustainability interventions will lead to a loss of heritage values and architectural quality (Meurs, 2021).

The integration of technological facilities can have a major impact on the monumental values of a building. For example, solar panels can change the appearance of a roof. Insulation on the inside of the façade can affect the interior finishes and dimensions of rooms. Moreover, this also has an effect on the material due to the altered building physical performance. However, these technological interventions are inevitable, and an integral solution must be sought.

That is why it is important to question what the influence of sustainability is on the design and values of a building.

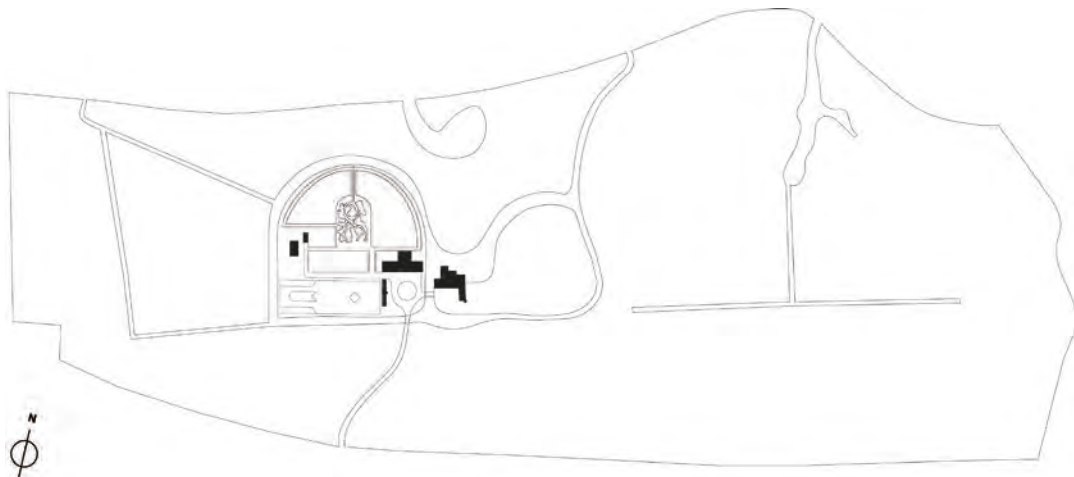

Figure 1: plan of estate Huis 't Velde. The island with house, coach house and aviary is only a small part of the total estate.

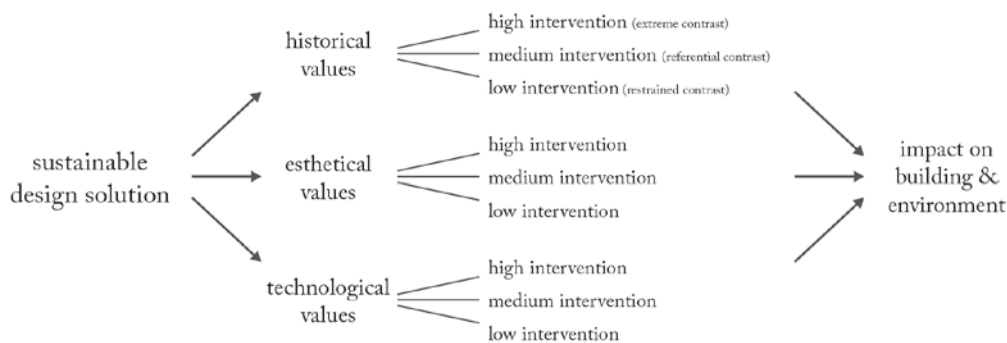

Figure 2: the three values concerning a sustainability intervention.

According to Birgit Dulski (Meurs, 2021), sustainability starts by analysing the existing building and investigating what could be done better. Can a certain solution really be implemented without negative impact or is a different solution necessary? That is where the theories of Coenen and Bloszies become interesting again.

Intervention in historical, aesthetical, and technological values

After the first part of the research, it was concluded that the theories of Coenen and Bloszies can be combined. Combined, they represent three degrees of intervention; with a high, medium, or low impact on the design and values of the building. Sustainability design solutions can be measured by their degree of intervention. But then the question arises; where do they have effect on?

Case study research resulted in three categories on which sustainability interventions in monuments can affect. These three are: historical, aesthetic, and technological interventions. For example, an owner or designer can either choose between historical justified changes or accept contrast. For instance, by introducing a new felling cycle for trees, which are used as fuel for a wood fired boiler, as can be seen by Estate Twickel. In this example, the historical intervention is low, because trees have always been felled according to the Twickel gardening traditions. Nevertheless, the aesthetic intervention is high because it is visible that trees have been felled. Finally, the wood fired boiler requires major interventions in the existing building technology. In this case, that has been accepted and fitted into the existing structure.

Design process

During a design process, the design attitudes can help to choose which elements of sustainability solutions are suitable for that specific re-design. By valuing parts of the

estate, buildings, interiors, etc., in grades of possibilities in low, medium, or high interventions, it can be made clear which design attitude or combination of attitudes and elements will fit on that certain part of the building.

Moreover, this shows how a sustainability goal can be integrated in the re-design. The goal should always be that an adjustment or addition should be an optimization of what is already present. Not a solitary addition as a patch-up (Meurs, 2021).

According to Margret Brons (Meurs, 2021), this involves four steps. It starts with an examination of the existing, and then you have to look at the actual needs. Thirdly, all interventions have to be tested for their specific situation. Finally, a degree of flexibility for the future will have to be taken into account. Because that too, is sustainability.

Research is key

The research has shown that making monuments more sustainable is custom work. Various interventions are possible, but it is important for each intervention to investigate what impact they have on the values of a monument. It should be clear that efforts should only be made to optimize the existing building. It is then up to the architect to choose a design attitude and to choose which interventions are permitted and which are not. It is likely that different parts of an estate require different attitudes, but in all cases a choice will have to be substantiated with research.

For examples of sustainability resources and measures for Dutch estates I would like to refer to my research report. This can be found in the TU Delft Architecture repository. Finally, the results of the research will be used in the re-design of estate Huis 't Velde in Warnsveld.

Bloszies, C. (2012). *Old Buildings, New Design*. Princeton Architectural Press.

Coenen, J. (2006). *Art of Blending*. Vssd & TU Delft R-Mit

Meurs, P. (2021). *Niets is zo duurzaam als een monument*. Nationaal Restauratie Platform Nederland.

STRUCTURE & ADAPTABILITY

What is the transformation potential of the load-bearing structures in the case of former Dutch police stations?

Keywords: structure, grid, load-bearing, adaptability, materiality, construction method

Topic introduction

A total of 700.000m² of Dutch police real estate will become vacant in the foreseeable future, due to the organizational reformation, which took place in 2013. This problem has societal, architectural and heritage associations, which need to be considered during the re-design of these buildings. The individual research aims to address the transformation potential of the load-bearing structure as a means of enriching the architectural qualities of former Dutch police station and improving their adaptability.

The research

The individual research builds directly upon the SBT, as an extended structural typology research, which sets structure in a wider context, aiming to find appropriate strategies that can be applicable to spatially identical projects. Thus, the research poses the following question: To what extent does the load-bearing structure in 20th-century Dutch police stations, influence their re-design options?

The examined fields that are researched, are the structural characteristics of these buildings and the exploration of modern strategies employed by architects in similar projects. Setting the theoretical framework that the research is based on, was the starting point, which was followed by case study analysis, where examined aspects of the literature were researched further. To that end, the focus shifted from a broader to a narrower scale regarding structure, space and adaptability.

Testing

The research showcased that the transformation potential of structure, highly influences the architectural form, exterior, daylight and the spatial flexibility, as explained by Charleson (2005). On top of that, the research uses former Dutch offices as case-studies, found in Van der Voordt's (2007) book, and examines five physical characteristics: structural grid, bay-width, depth & daylight, circulation, and core-location. This resulted in a production of a series of diagrams and reduction drawings of the examined aspects. Certain observations could be made afterwards, such as the spatial implications of a central colonnade in comparison to a double colonnade corridor. Configuring circulation alternatives, daylight improvements and core-relocation, contributed with a substantial output in the individual research and design assignment.

The sectional variation that relates to the existing structure and its transformative dimension, was further explored by reduction drawings, using examples of Lewis et al. (2016) book. The conclusion derived was that deep buildings, arranged in a stack section, need a central space that is often in the form of an atrium, which enables for spatial enrichment and visual connections.

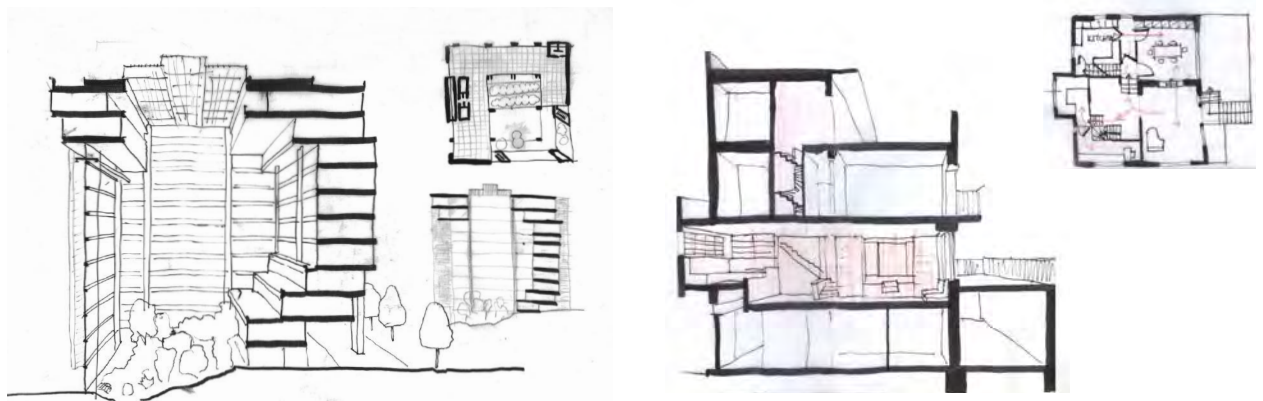

Figure 1: Sectional case studies - Ford Foundation Headquarters & Villa Moller, based on Lewis et al. (2016)

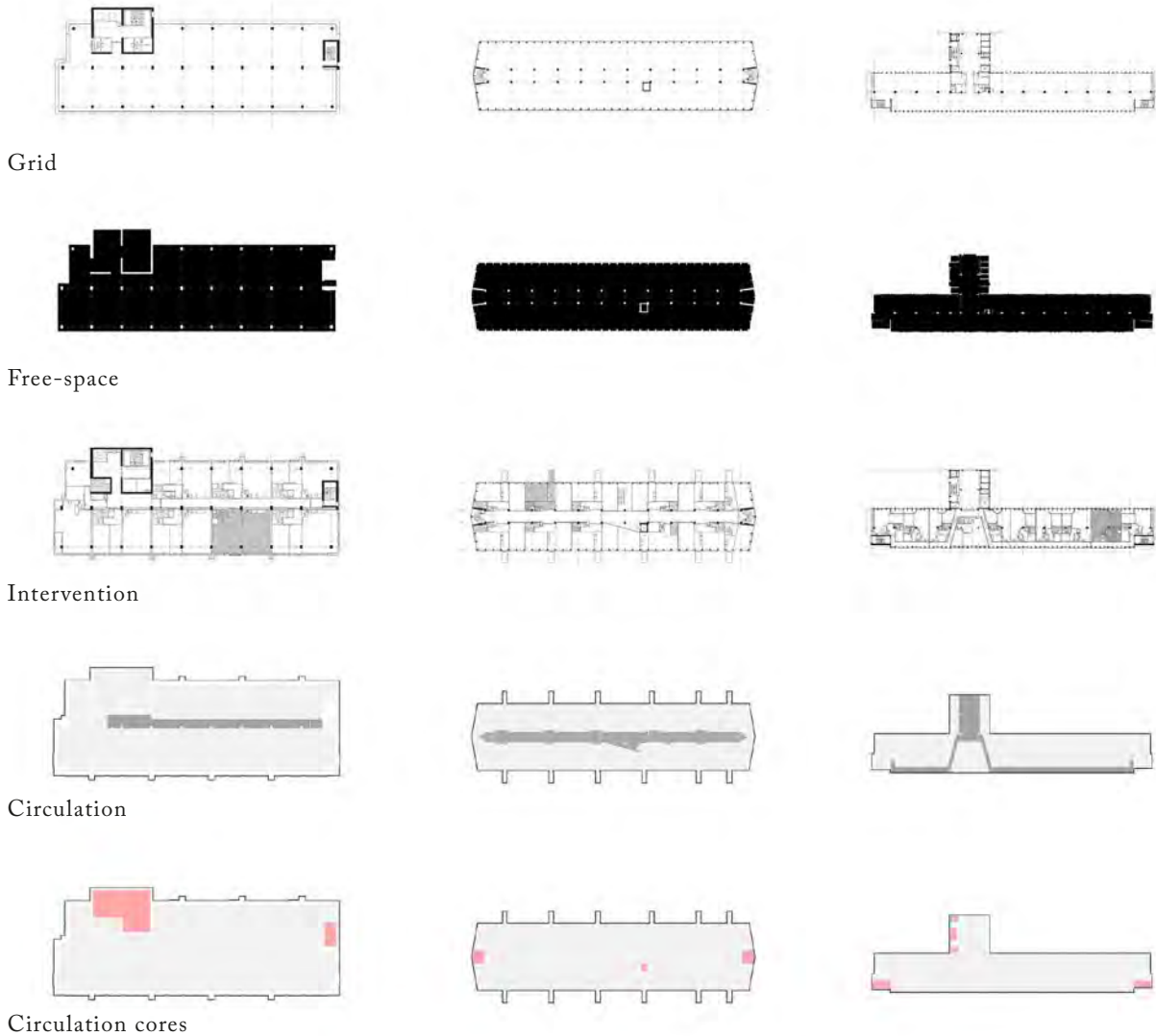

Figure 2: Case-study analysis diagrams for Den Haag police station

Conclusions

Throughout the various stages of the literature and case-study research, certain conclusions were derived, that gave direction towards re-design options. With the police stations, being spatially similar to office buildings, it is concluded that this typology is rather limited in terms of re-design options, due to high cost and the construction methods employed (Remøy, 2010). Additionally, a stack section, when combined with a dense structure, has equally limited opportunities. On the other hand, the structural capacity and structural layout is often suitable for residential projects. All things considered, certain design guidelines are formulated; improvement of

spatial conditions through the addition of voids, could be an effective strategy that enhances visual relations too. Introducing new circulation systems and maintaining large open-plan spaces could be another effective approach. On the other hand, more cost-demanding approaches, including façade alternations and core-relocation (Remøy, 2010), constitute re-design options too. Overall, once the structural potential of the former police stations is identified, clear directions can be given towards their re-design opportunities.

Azizi M. & Torabi, Z. (2015). *The Role of Structure in Creating Architectural Space*. Current World Environment.
 Charleson, A. (2005). *Structure as Architecture: A Source Book for Architects and Structural Engineers*. Architectural Press.
 Ebbert T., (2010). *Refurbishment strategies for the technical improvement of office façades*. RWTH Aachen University of Technology.
 Lewis, P., & Tsurumaki, D., & Lewis, J. (2016). *Manual of Section*. Princeton Architectural Press.
 Remøy H., (2010). *Out of Office: A Study on the Cause of Office Vacancy and Transformation as a Means to Cope and Prevent*. IOS Press.

CENTRAL SPACES // PUBLIC PLACES

How can the courtyard typology be characterized and what re-design opportunities does it provide for the re-design of the Koudenhorn police station in Haarlem?

Keywords: Courtyard, typology, public building, central space, spatial organization, entrances, routing, daylight

This research has been conducted in order to create a better understanding of the courtyard building typology. The conclusions drawn from this research will be used to inform the re-design proposal of the Koudenhorn police building in Haarlem. The construction of the building was concluded in 1771. The building consists of four wings enclosing a central courtyard. In the early 1970's an extension was added to the building. The building will potentially lose its current function, and the re-design will explore the possibilities for future use.

Methods

Through analytical drawings in plan and section, six case study buildings have been analyzed on five aspects: central space, spatial organization, entrances, routing and daylight. The analysis of these aspects is related to the central space rather than the complete building. Per aspect different typologies have been defined. These typologies will be the starting points for the spatial organization of the re-design proposal. In order to extract conclusions that are relevant and implementable to the design assignment the case studies have been selected based on the following criteria: The building has a central space, is a public building and is located in an urban context.

Aspect typologies

Central space

1. Open central space: These buildings were originally constructed with a central space open to the sky. Their use is dependent on weather conditions.
2. Covered central space: The covered central space allows for use year-round. This leads to more permanent layouts and use of the central space.



Figure 1: Central space typologies (left to right: 1, 2)

Spatial organization

1. Cloister: An interior traffic zone is located around the central space. From there, the central space and the programmatic spaces can be accessed. The traffic zone effectively functions as a barrier between the program of the central space and the programmatic spaces.
2. Arcade: A traffic zone is located around the central space. From there, the central space and the programmatic spaces can be accessed. The traffic zone is an arcade. Therefore there is a more direct connection to the central

space, as it can be accessed from everywhere in the traffic zone without the need for doors.

3. Hall: The central space is directly accessible from (some of the) adjacent programmatic spaces. The flow of traffic happens through the programmatic spaces and the central space. The relation between the programmatic spaces and the central space is reinforced through proximity and the possibility of the program to bleed into the central space.
4. Semi-open Hall: A variation on the Hall typology where the central space is not completely enclosed by the building, but is directly connected to the exterior of the building on one side.

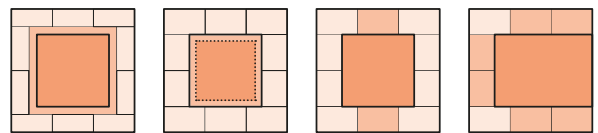

Figure 2: Spatial organization typologies (left to right: 1, 2, 3, 4)

Entrances

Concerning the entrances, no distinct typologies can be derived from the case studies. The buildings largely follow the same principles. The location of the one or two main entrances have a direct and important relation to the surroundings. Multiple secondary entrances are located around the building for logistical purposes.

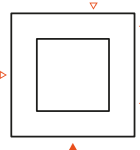

Figure 3: Entrances typology

Routing

1. A traffic zone is located around the central space. The vertical access points are located in the building.
2. A traffic zone is located around the central space. The vertical access points are located in the central space.
3. Traffic in the building happens through the programmatic spaces. The vertical access points are located in the building.
4. Traffic in the building happens through the programmatic spaces. The vertical access points are located in the central space.

Placement of the vertical access points in the central space leads to an increased use of the central space.

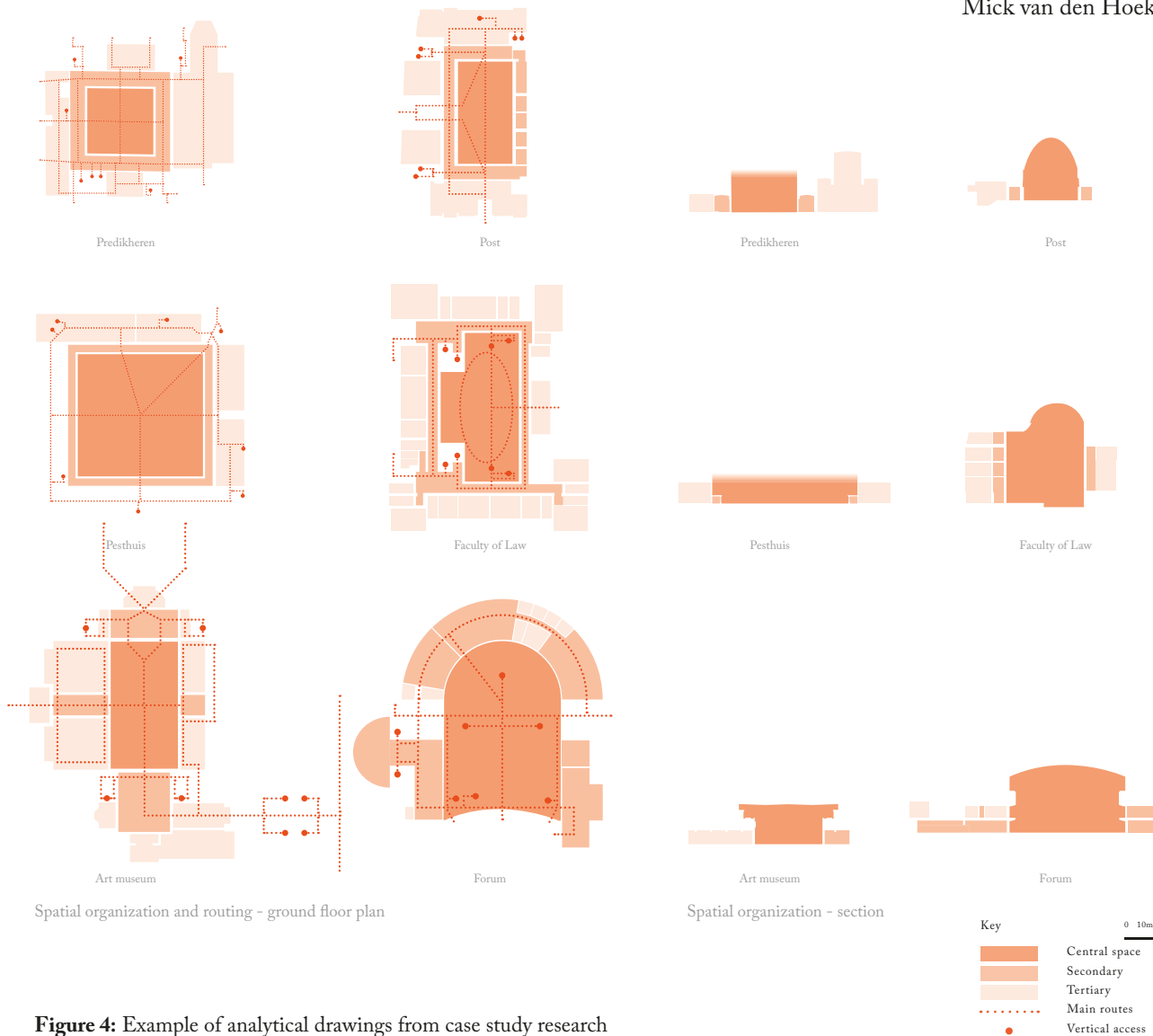

Figure 4: Example of analytical drawings from case study research

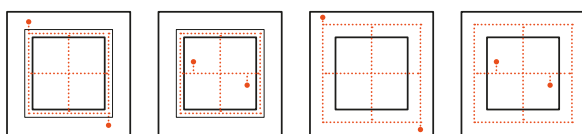

Figure 5: Routing typologies (left to right: 1, 2, 3, 4)

Daylight

1. A traffic zone is located around the central space. Direct daylight enters the traffic zone. Indirect and insufficient daylight reaches the programmatic spaces through the traffic zone.
2. The programmatic spaces are located directly adjacent to the central space. Direct daylight enters the programmatic spaces through the central space.



Figure 6: daylight typologies (left to right: 1, 2)

Conclusions

The case study research has led to the definition of distinct typologies for the five analysed aspects. There are three typologies which are expected to have the most significant impact on the use of central spaces: The covered central space (2) due to the possibility for year-round use, spatial organization with programmatic spaces adjacent to the central space (3,4) due to functions spilling into the central space and routing with vertical access points located in the central space (3,4) due to the flow of traffic through the central space. The actual impact of the typologies defined in this research will be tested through their implementation into the design process. The typologies will be used as optional scenarios during the development of the design proposal. When the final design is completed, reflection on the impact of the typologies will be conducted and final conclusions will be drawn.

Case studies: Predikheren library, Mechelen / Pesthuis, Leiden / Post library, Utrecht / Faculty of Law, Zürich / Municipal art museum, Den Haag / Forum cultural & recreational centre, Norwich

EXPERIENCING THE BUILDING TYPOLOGY OF A HAVEZATE

How can fourteenth-century havezaten from Het Kwartier van Zutphen be characterized to formulate a building typology and how can this be made experienceable to the public in the re-design of Huis 't Velde?

Keywords: building typology, havezate, fourteenth-century, Het Kwartier van Zutphen, Huis 't Velde, experienceability

Relevance and problem statement

“The conservation of historical estates and manors cannot be taken for granted” (Witteveen+Bos, 2012a, 1). On this day, Gelderland is still rich in historical estates and manors. While most of them are in use today, they may become vacant in the future. Since they have great social value, the search for suitable (re-)use is an issue that is increasingly emerging (Witteveen+Bos, 2012b). More and more, preservation of heritage buildings is linked with economic considerations (Vogelzang, 2016). The task of conservation is complex, especially with castles and estates, due to the many interests and high costs. Therefore, revenue models have become necessary in order to cover the costs of maintenance and renovation. Over time, these models have led to various changes in use and function, and as a result, castles have sometimes been radically adapted to new architectural fashions and more luxurious lifestyles (Vogelzang, 2016). Consequently, cultural-historical value and various other specific characteristics got (unintendedly) lost. Decision models are needed in which proposals for new functions of castles and estates can be weighed up against various cultural-historical values and their visibility in the future.

Havezaten

Het Kwartier van Zutphen is the pre-eminent castle region of Gelderland (Harenberg, 1987). This area in the east of the Netherlands, nowadays referred to as the ‘Achterhoek’, is rich in estates and manors, of which many date from the Middle Ages. The area consists of 36 acknowledged havezaten. These types of buildings are often called castles, manors or homesteads, but do actually have a different meaning.

Originally a havezate was a large home with land, but in the seventeenth century it became a knightly property. The possession of a havezate was a condition for membership of a Knighthood. In Het Kwartier van Zutphen it also had to be of certain size and defensible, which mostly resulted in a moated building (Straatsma, 2018). 23 of those 36 havezaten are still (partially) intact today. Since this typology is unique and its preservation comes with various challenges, it is relevant to identify the characteristics and thereby its values in order to make proper decisions for preservation in the future.

	Hackfort	Vorden	Ruurlo	Verwolde	Dorth	De Voorst	't Velde
Started as a moated site (a residential tower, or 'spieker', surrounded by water)	X	X	X	X	X	X	X
Originally built as fortified house (to gain access to the knightlyhood)	X	X	X	X	X	X	X
Long history of owners	X	X	X	X	X	X	X
Large estate with main building and some side buildings (like a coach house, orangery, stable and farms)	X	X	X	X	X	X	X
Historically developed building(s) (developed in different stages with many adjustments over time)	X	X	X	X	X	X	X
Historically developed estate and garden design (often classicist style and/or English landscape style)	X	X	X	X	X	X	X
Strong relation between buildings and estate	X	X	X	X	X	X	X
Rich materialization and finish of the interior (often representative for the habitation history)	X			X	?		X
Brickwork façade and construction	X	X	X	X	X		X
Windows with rod division (muntins)	X	X	X	X	X	X	X
Hipped roofs with dormers	X	X	X	X	X	X	X
Clear entrance	X	X	X	X	X	X	X
Chimney(s)	X	X	X	X	X	X	X
Detailed roofedge	X	X	X	X	X	X	X
Shutters	X	X		X	X		

Figure 1:
Characteristics that form the building typology of a fourteenth-century havezate from Het Kwartier van Zutphen

Key
 x = characteristic noticed during the research
 ? = interior of Huis Dorth is not known, due to its protection as being a private residence

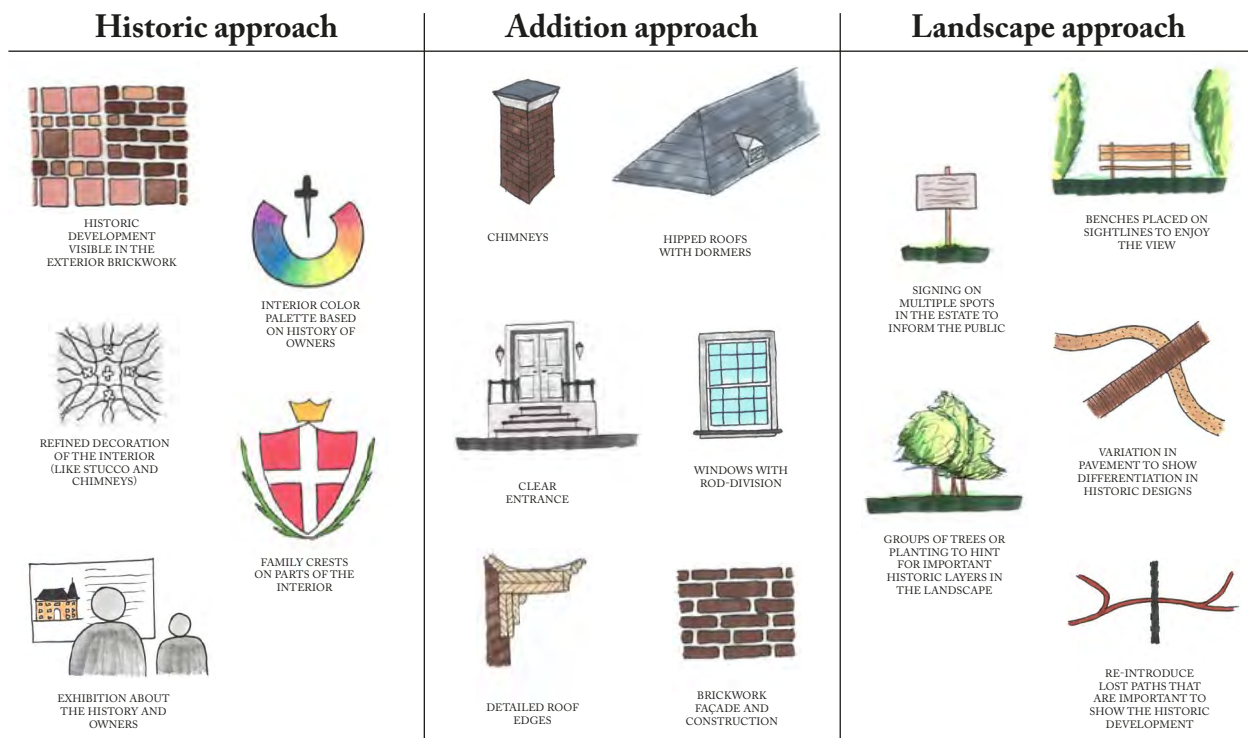

Figure 2: Design approaches for making the characteristics of the building typology of a havezate (more) experienceable

Aim of the research

The aim of this research is to find ways to make the building typology of a havezate experienceable to the public. In order to identify the characteristics of the buildings and to formulate a typology, six case studies are researched and compared. Next to 't Velde, the chosen case studies are Hackfort, Vorden, Ruurlo, Verwolde, Dorth and De Voorst. All those buildings are acknowledged havezaten, first mentioned in the fourteenth century and from the same area, namely located in Het Kwartier van Zutphen.

The analysis of those buildings eventually leads to a series of possible interventions, combined in a design toolbox, that can be used to alter and/or strengthen the experienceability of the typology. Three main approaches are derived from this design toolbox and tested on Huis 't Velde.

Analysis

The first part of the research consists of a literary and archival study on the history of the typology as a whole. This forms the base and contextualization and defines the criteria for the rest of the research.

The second part of the research is the analysis of the case studies. 't Velde and the six other havezaten are researched on owners, historic development of estate and building, materiality and detailing and use and function.

Comparison

The third part of the research is the comparison of the results of the analysis. The identified characteristics are bundled into a matrix, see *figure 1*. This matrix shows the building typology of fourteenth-century havezaten from Het Kwartier van Zutphen.

The results of this matrix are used to identify the experienceability of the characteristics of the building typology in the case studies. Each case study is analysed separately and the results are combined into a new matrix, the design toolbox. From this toolbox, three approaches are derived that formulate design interventions for making the building typology experienceable. The approaches are historic, addition and landscape, as is visualized in *figure 2*. These three approaches are finally tested on Huis 't Velde to show how they could be applied. For the full research and tests on Huis 't Velde, see the TU Delft Repository.

Harenberg, J. (1987). *Kastelen rond Zutphen I*. De Walburg Pers.

Straatsma, P. (2018, June 2). Mijn streek. *Dagblad van het Noorden*, 36-37.

Vogelzang, F. (2016). *Nieuwe functies voor kastelen en buitenplaatsen. Een eeuw herbestemming*. NKS.

Witteveen+Bos. (2012a). Economische betekenis van historische buitenplaatsen en landgoederen in de provincies Utrecht, Overijssel en Gelderland.

Vereniging Particuliere Historische Buitenplaatsen.

Witteveen+Bos. (2012b). Historische buitenplaatsen en landgoederen: In stand houden loont! Wageningen University & Research.

THE NATURE-INCLUSIVE Re-design

How can monumental buildings in an urban context be re-designed to be more nature-inclusive?

Nature-inclusivity, nature, biodiversity, possibilities, toolbox, decision trees, re-design & monumental buildings

Introduction of the topic

The biodiversity is under great pressure. It forms the basis of our food chain, maintains the quality of the soil, and filters the air (Wageningen University & Research, n.d.). Landscape coordinator Koen Helling (2020) concludes in his research that several fauna species depend on the buildings and vegetation in the city. The buildings and their outdoor spaces serve as accommodations, give shelter, and can also provide food. He therefore recommends that buildings should be built as nature-inclusive as possible (Helling, 2020). Thereby the biodiversity will be greatly enhanced.

Nature-inclusive building means creating more space for flora and fauna in built objects and the surrounding environment (IVN Natuureducatie, n.d.). This may involve adding vegetation, water, and accommodations for fauna, but also include aspects to reduce nuisance.

Nature-inclusive buildings bring many other benefits, such as for the city and the users of nature-inclusive buildings. Also, it is fascinating to integrate nature into the built environment to improve both the lives of humans and animals.

Problem

There is a wide range of nature-inclusive options that can be applied to make a building more nature-inclusive (Arcadis, 2018; Gemeente Amsterdam, 2018). The application of nature-inclusive aspects in monumental buildings is hard, because of the multiple constraints that have to be considered. For monumental buildings,

it is currently unclear if and if possible what should be considered in order to make this group of buildings more nature-inclusive.

Goal

The purpose of this study is to gain insight into the possibilities for nature-inclusive design in monumental buildings. Furthermore, to get a better perspective on what must be considered when applying this to a urban monumental building. To create a toolbox for designers and building owners of these buildings and to test it on a case study of the Koudenhorn building in Haarlem. The goal is to use the toolbox to make the case study, and in the future other monumental buildings, more nature-inclusive through a re-design. The implementation of nature-inclusive design will help nature and increase biodiversity.

The research

The research showed that nature-inclusive buildings have many advantages for its human and animal users. For example, nature-inclusive buildings improve: activities, health, the immune system, the mental state, the quality of the living environment, social connections, biodiversity and can be food or produce food.

Some of the animal species found in the Netherlands depend entirely (1.6%) or to a large extent (8.7%) on the city. This is mainly due to the favourable living conditions in the city, which makes them eager to forage there. The study focuses on birds, mammals, and insects (butterflies and bees).



Figure 1: The nature-inclusive possibilities regarding flora, water, and fauna



Figure 2: Some of the researched nature-inclusive possibilities: brown roof, blue roof, floatland & fauna residences

Twenty nature-inclusive options were discussed, with some of them being further subdivided. The possibilities are divided into three categories: flora, water, and fauna. The possibilities that could be applied to the façades and the immediate surroundings of a building are adressed, see figures. A sketch has been made of each possibility and a description has been given. Several design options are described for the various possibilities. In addition, there is a description of what should be taken into account when applying it to a monumental building. Subsequently, three decision trees were created on the basis of the points of attention. By filling in the questions

in these decision trees, designers and building owners of urban monumental buildings can see which nature-inclusive options they could apply in a re-design to make their building more nature-inclusive. It also gives them insight into which aspects need to be adapted to make the application of a nature-inclusive possibility possible.

Next, the created decision trees were tested using a case study of the Koudenhorn building. The results show which nature-inclusive options can be applied to the building. The results will be tried out in a nature-inclusive re-design of the case study of the Koudenhorn Building.

Arcadis. (2018, September). Puntensysteem voor groen- en natuurinclusief bouwen.
 Gemeente Amsterdam. (2018). Natuurinclusief bouwen en ontwerpen: in twintig ideeën. Retrieved 27-09-2021, from <https://www.amsterdam.nl/wonen-leefomgeving/duurzaam-amsterdam/duurzaam-ontwikkelen/amsterdams-beleid-betrekking/natuurinclusief-bouwen/>
 Helling, K. (2020, March). Ruimtelijke Koers: Onderzoekresultaten werkgroep natuur, landschap en recreatie. Retrieved at 20-09-2021, from https://www.houten.nl/fileadmin/user_upload/Burgers/Wonen_en_leefomgeving/Ruimtelijke_koers/20200929/1.4_-_5._Natuur_landschap_en_recreatie.pdf
 IVN Natuureducatie. (n.d.). Wat is Natuurinclusief bouwen eigenlijk? Retrieved 27-09-2021, from <https://www.ivn.nl/natuurinclusief-bouwen/wat-is-natuurinclusief-bouwen-eigenlijk?>
 Wageningen University & Research. (n.d.). Biodiversiteit. Retrieved 20-09-2021, from <https://www.wur.nl/nl/show-longread/Biodiversiteit-longread.htm>

PUBLICIZING VACANT HERITAGE

How could the Koudenhorn building in Haarlem be transformed into a building that will be perceived as a public accessible space by future users?

Keywords: heritage, transformation, reuse, public interior, accessibility, public space, opening-up

Meeting is part of the *raison d'être* of cities. The city exists by the need for interaction between people, encounters with known and unknown persons and discovering new things, products, places, knowledge and culture.

Problem statement

During the analysis of this SBT research part 1 into the spatial aspects of the buildings part of the police real estate and the related location visits, the disconnections of several of the buildings with their surrounding public space caught the attention. This observation raised questions on how such buildings could function if they would have a public use.

This research aims to discover the architectural aspects that influence the public perception of interior or enclosed spaces. Researching the discovered aspects in physical examples in the form of a case study research, results in strategies for each aspect that can be tested and applied during the transformation of a closed building into a building with a public accessible use.

Public interiors

Public interiors are covered or in another way enclosed spaces that are public accessible and thereby play a role in the urban tissue of a city (Boer, 2012). This concept is nothing new and already originates in the historic architectural discourse on public space. The map of Rome by Giambattista Nolli of 1748 shows an irregularity in

the coloring of the plan. Nolli used white in this plan to indicate the public spaces and a shaded pattern for the private areas (Poot, van Acker, & de Vos, 2016). In addition to the streets and squares, Nolli represented the important public buildings in the city with white as well. This already indicates that public accessible buildings, so interior spaces where considered part of the public realm.

Porosity

With the abstraction of interior private spaces of buildings in such a way that they become impenetrable, Nolli was also focusing on the porous aspects of cities (W. Maas, et al., 2018). By representing buildings as solids, Nolli revealed the city's permeability as structured both by the sequence of squares and courtyards and by the continuity of public accessible interiors and the city's public realm. In the book 'PoroCity', (W. Maas, et al., 2018) eight aspects of porous buildings are discussed which are; the ingress of natural daylight, creating views, open space for encounter, cooling, green, accessibility, half open and half closed and hybrid.

The use of public space

According to Jan Gehl (2011), the activities happening in public spaces can be categorized in three main groups. The three categories are necessary activities, optional activities and social activities. All three have their own interrelation with the environment and therefore have

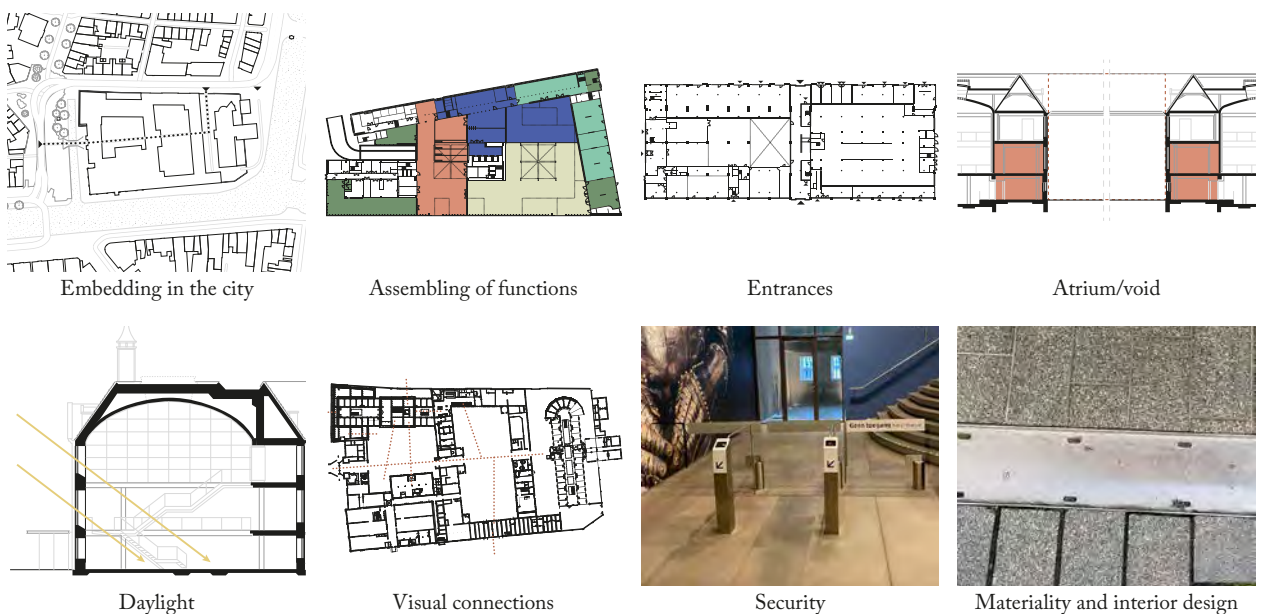

Figure 1: Analysis of focus points in case study research

different demands of the physical surrounding.

Besides the quality of the public space for activities happening, they are also related to the context. The physical surrounding can influence the use of public space by integrating functions, assembling activities, creating an inviting public space and opening up.

Focus points

The three theories on public interiors, porosity and the use of public space show commonalities in the physical architectural aspects. Therefore, the aspects are combined into eight focus points that influence the public perception of interior spaces.

- Embedding in the city

The location in the city and especially the connection with the pedestrian network are important. Public interiors and other urban facilities could benefit from each other's existence and the connection between them. The accessibility is also determined by the location and number of entrances.

- Assembling of functions

By assembling people and activities, it is possible for events to stimulate each other and for people to interact. Important for the assembling of functions on the level of a building is not specifically the distance between the various functions, but the possibility of groups of people to make use of the same public space. Therefore, the location of entrances to the various functions matters as well.

- Entrances

Also the design of entrances is an indication for the public status of an interior space. Entrances can be designed in a monumental and clear way or very subtle and small that one enters the interior space gradually.

- Atrium/void

On the interior, the use of a central open space has the possibility to create connections between various parts of the building

- Daylight

The concept of daylight relates to the atria and voids and has an influence on the porosity of buildings and the public feeling of interior spaces.

- Visual connections

Visual connections deals with the contact between the public accessible space with other parts of the building, with the exterior and the connection between other functions and thereby other groups of people using the building.

- Security

The amount and way of security influences the public character of a space. Also the location of for example a ticket check matters. The further a security element is located from the entrance, the more public an interior space feels.

- Materiality and interior design

The materiality and design of interior elements has an influence on the public character of an interior space. If the paving of exterior public space continues on the interior, the public feeling improves. Similar hard materials such as stone or tiles have a higher influence on the public feeling than a slightly softer appearing material such as polished concrete. Carpet and textile works in an opposite way and gives a more private feeling.

An analysis of those focus points in case studies results in strategies, of which the second diagrams show an example for the embedding in the city aspect, that can be used during the design process and as a way to reflect on the design decisions.

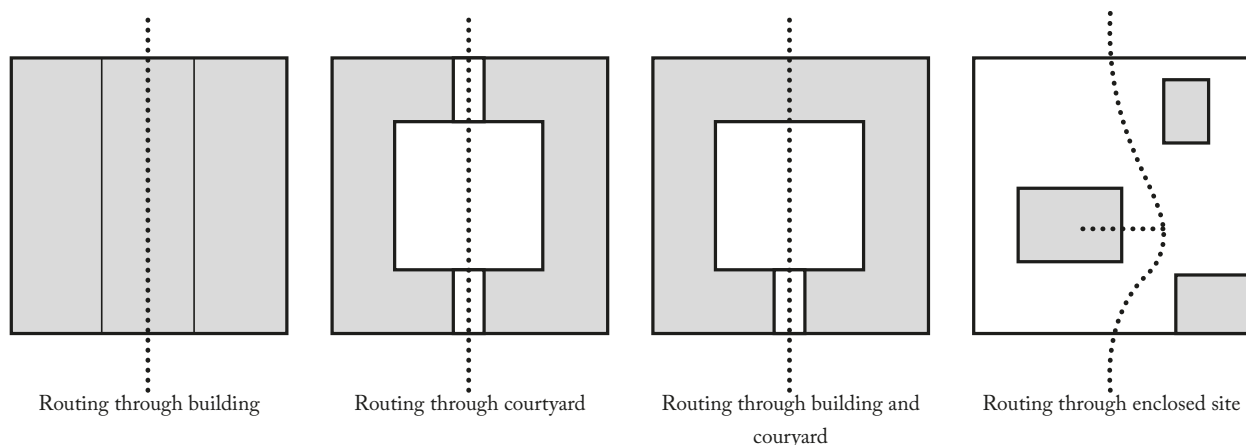

Figure 2: Example of strategies resulting from case study research on embedding in the city focus point

PART 4
RE-DESIGN OPTIONS

PERMANENT SPACE // CHANGEABLE USE

Haarlem

How could the space plan of a monument like the Koudenhorn in Haarlem be re-designed to accommodate changes in use over time?

Keywords: heritage, transformation, reuse, permanent frameworks, generic space, adaptability, user.

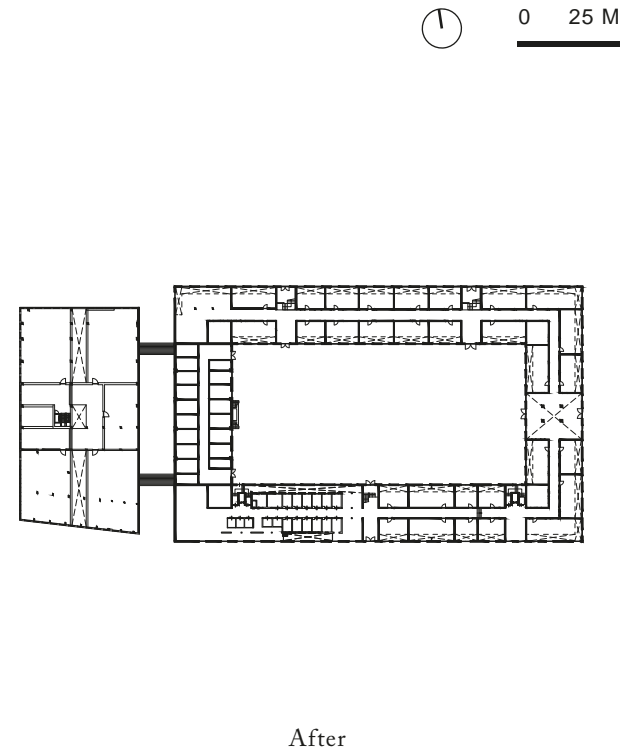
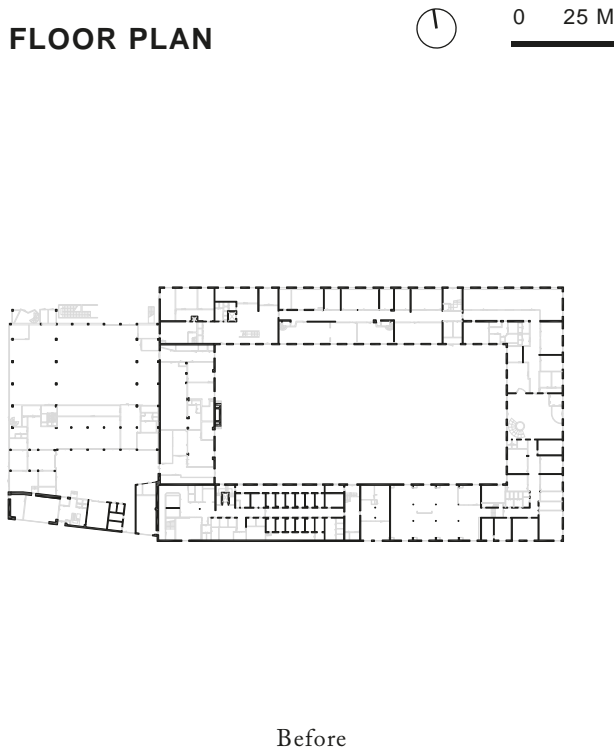
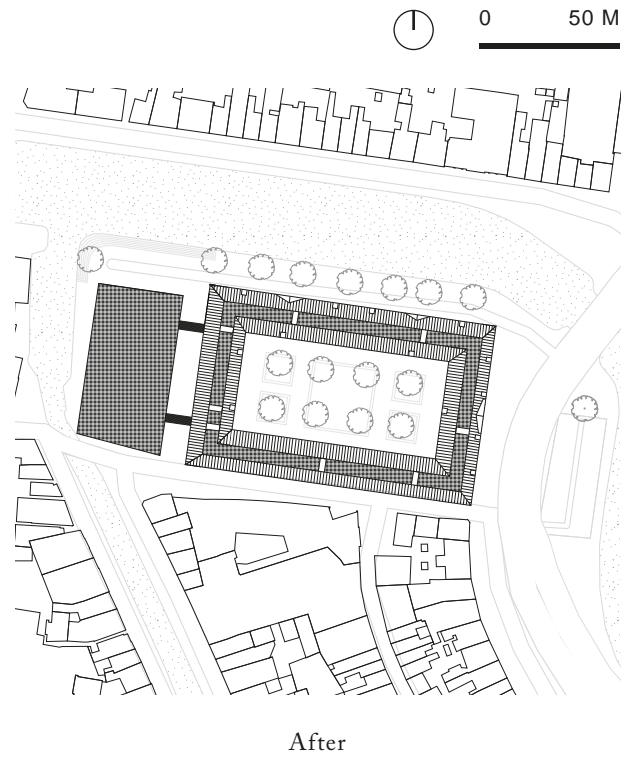
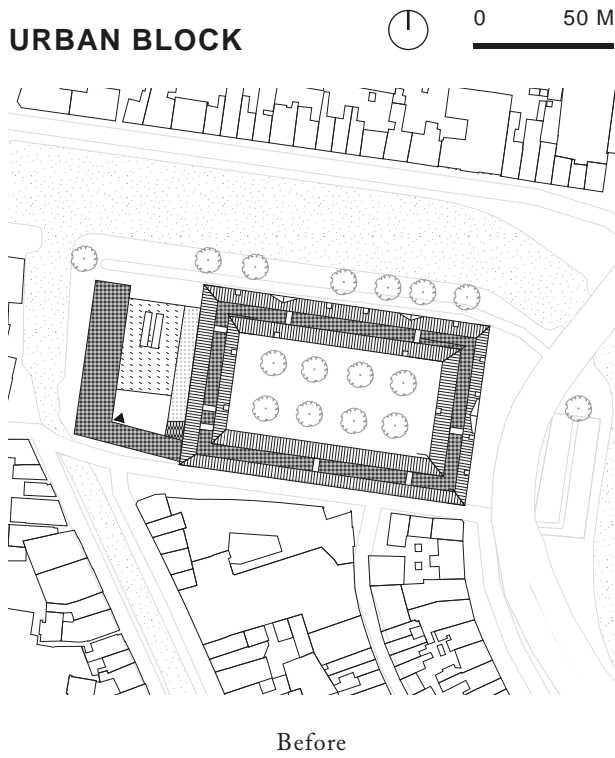

Vacant Heritage - Police Real Estate | The Netherlands

SECTION

0 10 M

0 10 M

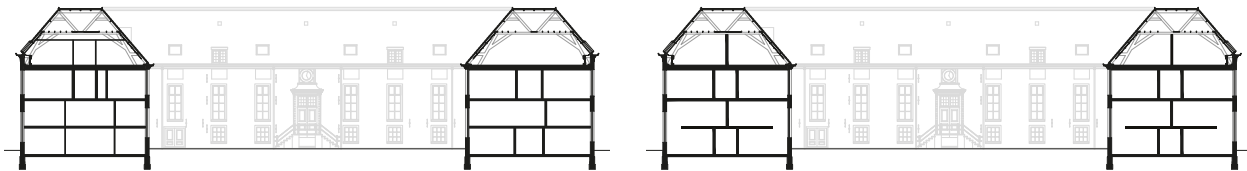

Before

After

FAÇADE

0 25 M



Before



After



BEFORE - Relation new and old

(Braunius, 2021)

The monumental Koudenhorn, completed in 1771 was designed as a Deaconry The care of the poor and the deprived in Haarlem dates back to the end of the 14th century. At that time, Haarlem was already a trading centre and in this small society, poverty arose as well. The care for this population of the city resulted in the many hospices and hofjes Haarlem is known for. In 1810 the building was put into use as barracks, and the residents had to be relocated to another place in the city. The Koudenhorn maintained this function until 1960 and in 1971 (200 years after it was completed) the building was transformed into a police building and a new volume was added on the side. Once the building was completed, everyone loved the newer volume and no one understood why the existing building was transformed, because they thought of the building as ugly and they would rather see it destroyed.

During the transformation, the internal structure of the Koudenhorn has been changed in such a way that the new function defined the form of the new design in

1971. Because of this, the current building has a lot of differences in the floor plan, even though the building was originally designed having a clear floor plan. Since we cannot permit it anymore to demolish buildings from our existing building stock, eventhough buildings can be perceived as 'ugly', a re-design strategy for both buildings on this location needs to be made. To re-design the buildings in such a way that it can be variously used and interpreted over time, was the starting point for this research. A re-design within the permanent in which the users need to become more adaptable since the use of a building is never definitive and will always be organic and changeable.

Combining the individual research and the analysis of the building, different design starting points have been conducted. On an urban scale, the building should relate to its neighborhood by creating a cluster for the social connection. A renewed relationship between the new and old volumes should be established, and the existing structure from both volumes should be kept.

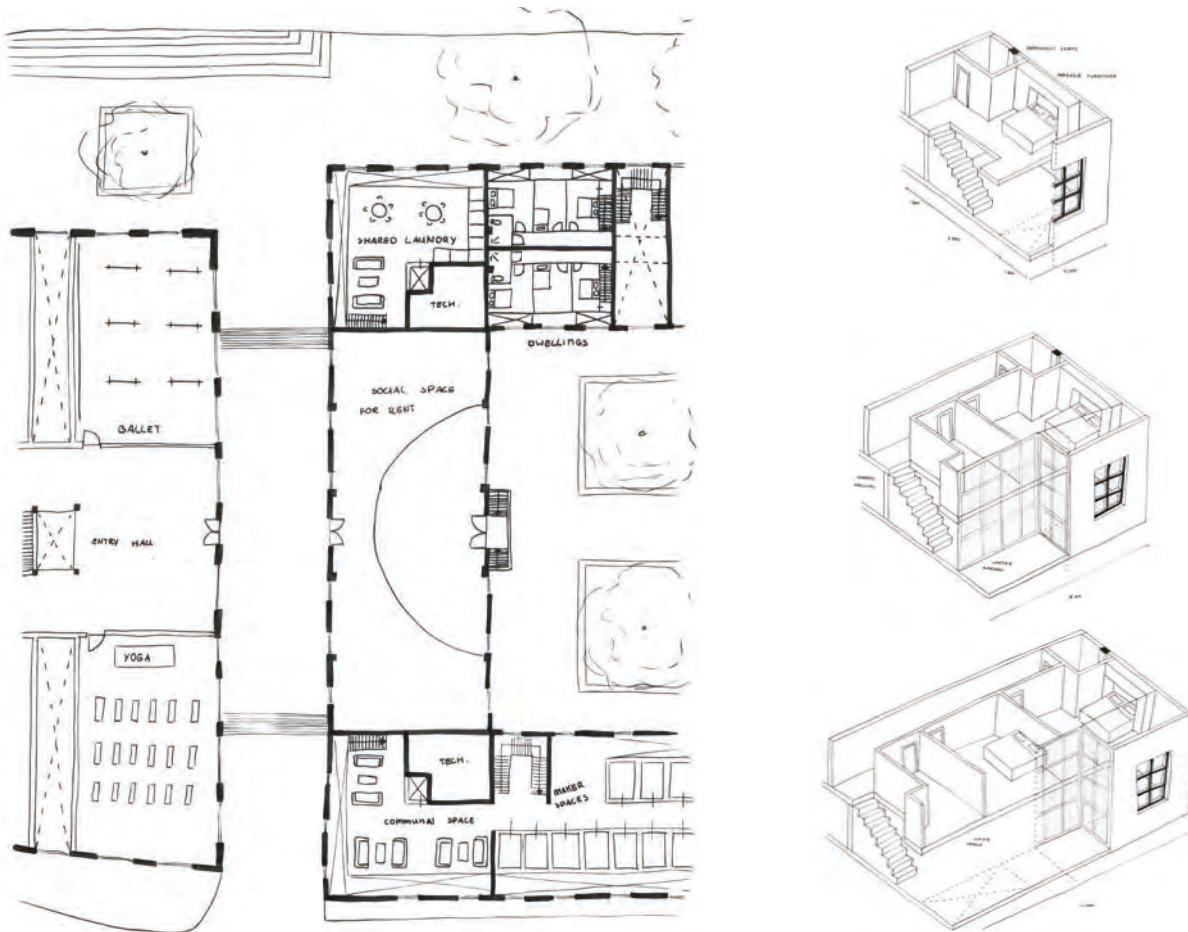

AFTER - Relation new and old

For this design, co-living and culture will be added to the Koudenhorn in order to enhance the social support of a community. Something that is related to why this building was originally built. In the Koudenhorn a combination of dwellings, communal spaces and food and beverage (F&B) will be added to the building. The newer volume will be a culture hub; a collective place for music, dance and theatre. The dwellings will house different types of target groups like starters, young couples and families and they will share the private courtyard together. The communal spaces and F&B will be clustered on one side of the building. This semi-public side of the Koudenhorn building relates to the public functions that the newer volume houses.

The design approach will take the heritage values of the buildings into account. During the re-design process, it will be important to re-design the space plan in such a way that it can be used in a different way over time. With this concept, the building could be kept alive indefinitely.

Within the Koudenhorn, the 8 dwellings for starters (40 m²), 36 dwellings for young couples (80 m²) and 24 dwellings for families (120 m²) are organized around a central corridor, which are connected to the halls located behind the monumental entrances. All dwellings have 2 storeys and are designed as a loft. With this design, the existing façade openings could be used in an optimal way and the dwellings could be easily transformed into office spaces, or spaces that can be used for start-ups or for organizing events. The newer volume houses 13 rooms that can be used in various ways, in this design for cultural purposes, but it could also be used for events, conferences or for rent.

However, because the Koudenhorn building has changed so many times over the years and every proposed function has their own specific requirements, it is difficult to come up with a proposal for a building that it is able to accommodate changes in use over time, and therefore hard to give a clear answer to the research question.

ACTIVATING THE “GLASS BOX”

Rotterdam, Witte de With

How can the building at Witte de Withstraat 25 contribute to the future challenges of the city centre of Rotterdam (in the context of densification)?

Keywords: post-war reconstruction, authenticity, open plan, densification, adaptability for future uses, active plinth, urban agriculture, Open Building.

Vacant Heritage - Police Real Estate | The Netherlands

URBAN BLOCK

0 50 M

0 50 M

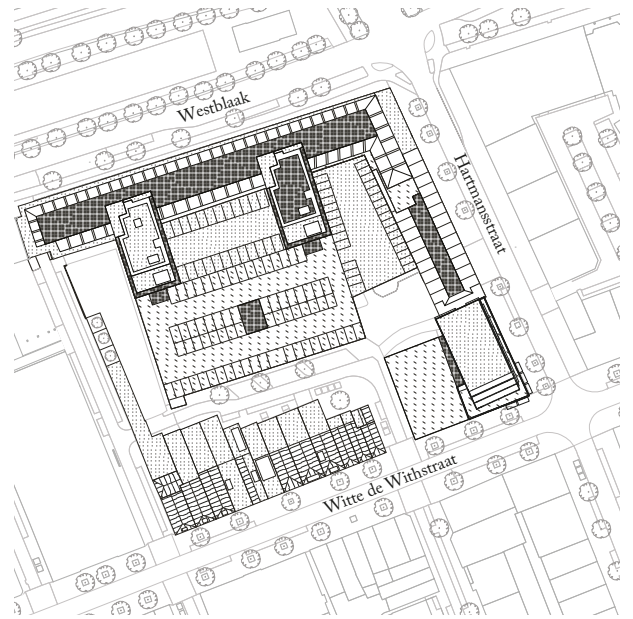
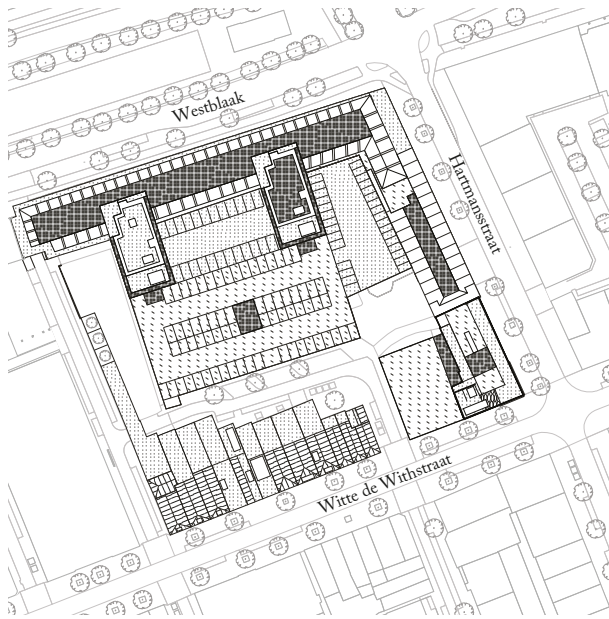

Before

After

FLOOR PLAN

0 5 M

0 5 M

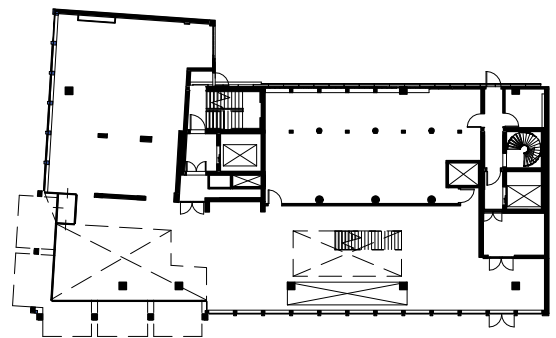
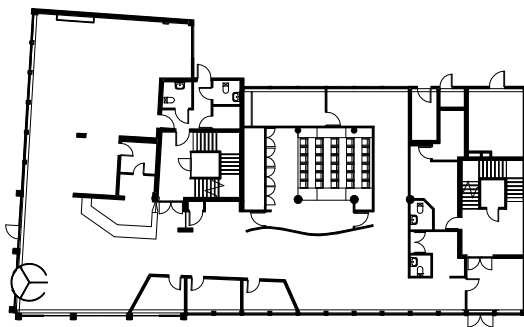

Before

After

SECTION

0 10 M

0 10 M

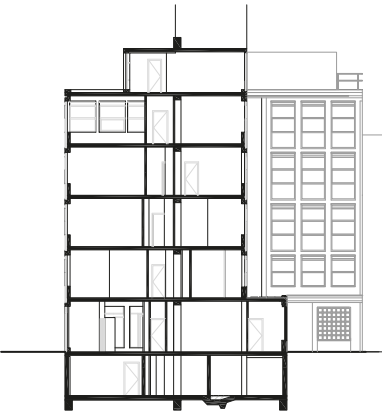

Before

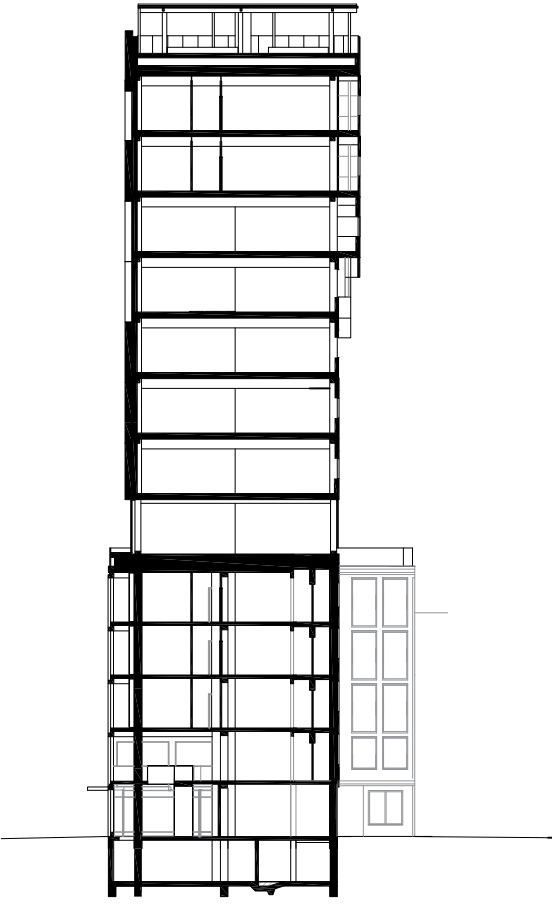

After

FAÇADE

0 10 M

0 10 M

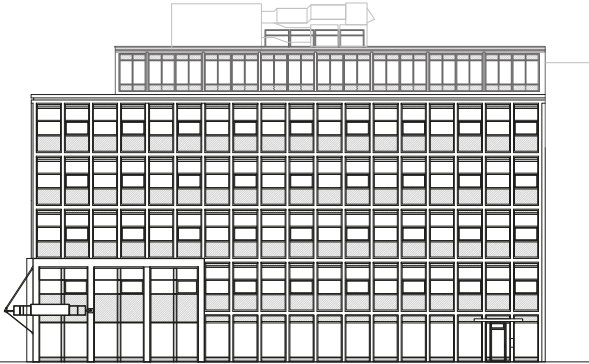

Before

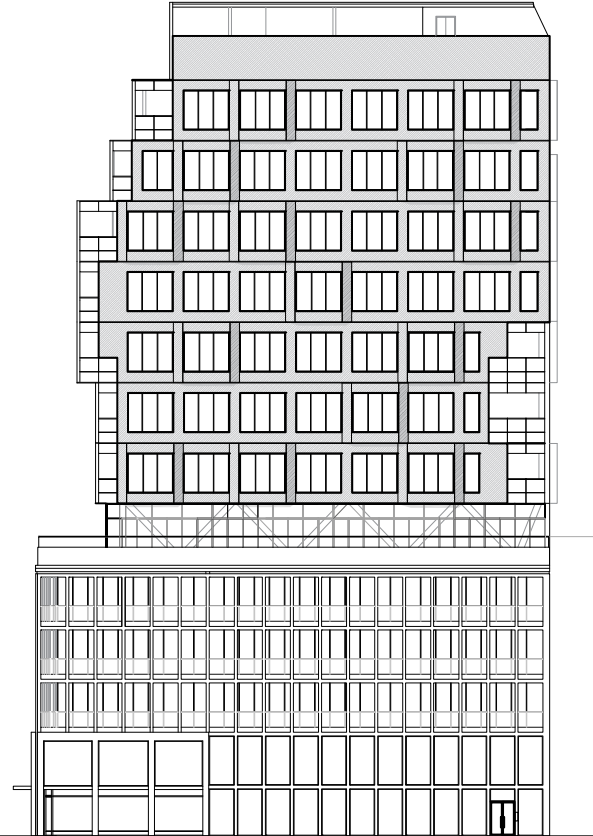

After

Re-design Options



BEFORE - South-east elevations

(Mankutè, 2021)

The site analysis have revealed that the police building at Witte de Withstraat 25, plays an important role in terms of the spatial configuration of the block - it forms a block corner between two important streets – Witte de Withstraat and Hartmansstraat. The Hartmansstraat – a connecting street between the small-scale old town cityscape of Witte de Withstraat and the larger-scale architecture of Westblaak street – is very interesting in terms of this contrast, which reflects Rotterdam’s architectural identity. While the 9-story parking garage takes up a lot of space in the urban block, it can also be an interesting opportunity for the re-design of the urban block - for instance, it could be repurposed as a biowaste energy plant or loft apartments.

With the research, I was looking for ways this building could contribute to the future challenges of densification in Rotterdam. From the study of a fairly wide range of topics and methods in my research, I have eventually distilled four scales of impact this building could have: urban, architectural/heritage, social, and technical. The strategy of each scale developed for this building is an outcome of the research.

In order to come up with the principles for architecture, with the design question based on the 4 scales mentioned, I am asking: how can the building at Witte de Withstraat 25 contribute to the urban setting, maintain authenticity, improve the neighbourhood socially, and be adaptable to changes over time?

On the urban scale, the building is to become a landmark for the street and have an active and inviting plinth. Regarding the architectural/heritage scale, the majority of the original building is reused, recreating the original double-height entrance space, and a new extension on top is introduced. New functions - restaurant, cooking school, shop (two plinth floors), urban farm (6-10th floors, basement), social housing (2-5th, 11-12th floors) and roof terrace with rentable bar for celebrations - will have a positive socio-cultural impact, providing locals with fresh food, education, job opportunities and making the neighbourhood more inclusive. Adaptability for different users over time will be introduced on the technical scale of the building by using Open Building principles: the long-lasting timber structure called “shell” with easily adjustable “infill” – the things that change with

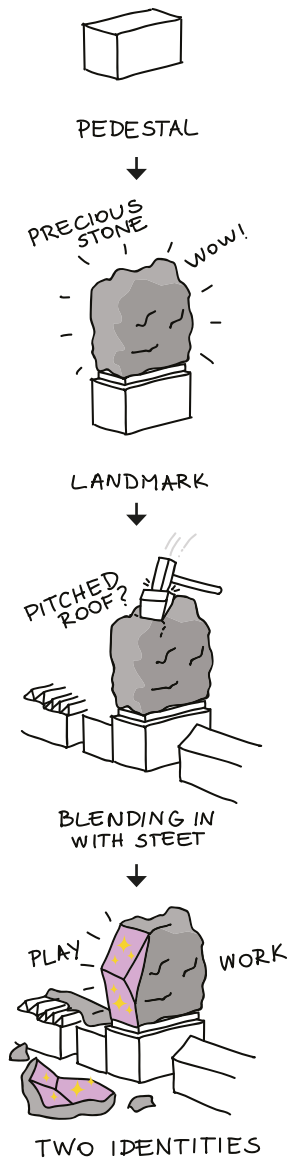

Architectural concept AFTER - South-east elevations

every new owner, introducing new, more spacious vertical circulation cores in the same places as the existing ones, and raised modular floors that guarantee easy adaptability of installations for the future functions.

The architectural expression of the existing building is defined by the original façade grid that will gain depth and outside space by the recessed new glazing on the 2nd–4th floors. The original entrance will be recreated to make the plinth more approachable. The architectural idea for the new façades renders the existing building as a pedestal for the “precious stone”, which becomes a landmark for the Witte de Withstraat. The “stone” tries to blend in with the street of pitched roofs, therefore it is broken and the different “extrovert” inside is exposed. The stone-like “introvert” façade reflects the serious modern city centre and the “extrovert” one - the playful street of bars and restaurants. The 5th floor, a transition between the old and new building parts, is expressed by a more

open façade with the wooden diagonal structure seen through. The new façades continue the existing building’s idea with today’s tools by using modular façade elements, visible structure, and flexibility.

To conclude, this adaptive reuse project introduces the abovementioned solutions as a strategy that addresses impact on the urban, architectural/heritage, social, and technical scales. The design’s goal is to activate the building by re-connecting it with the street, introducing environmentally and socially impactful functions and adaptability for various future uses, all while creating an architectural landmark.

To quickly reflect on the research, even though it was challenging to have the design and the research as parallel interwoven processes, this journey led me to fruitful and exciting conclusions and results.

ISOLATED ISLAND IN THE CENTRE OF GRONINGEN

Groningen

How could the interaction between buildings and residents influence the livability of the former police station in Groningen?

Keywords: Community, connection, isolated block, vibrant spaces, liveliness.

Vacant Heritage - Police Real Estate | The Netherlands

URBAN BLOCK



Before

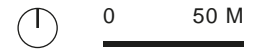

After

FLOOR PLAN

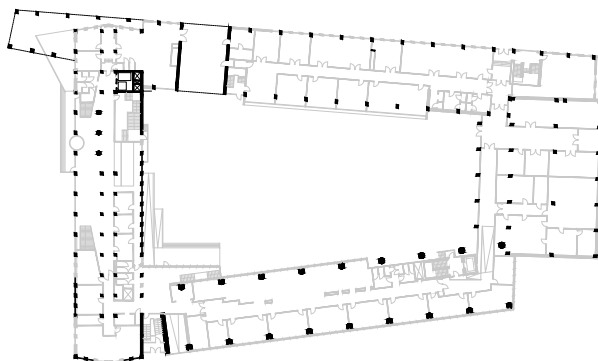

Before

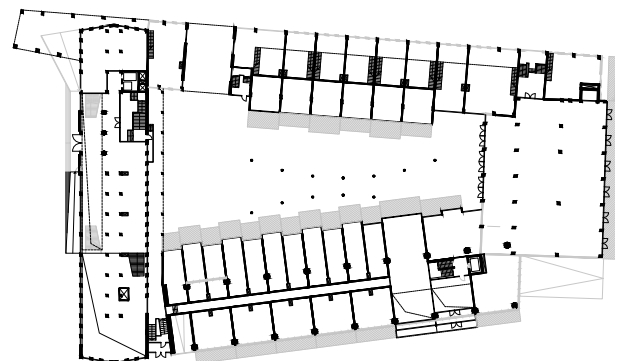

After

SECTION

0 10 M

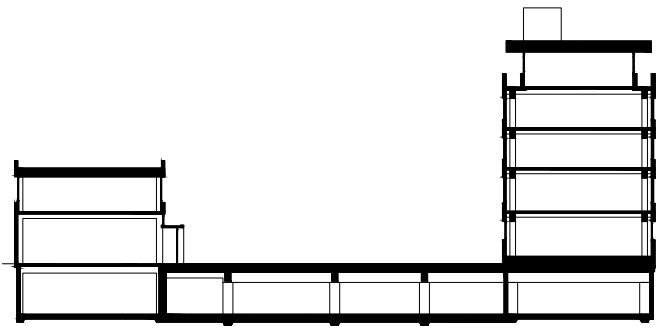

Before

FAÇADE

0 20 M

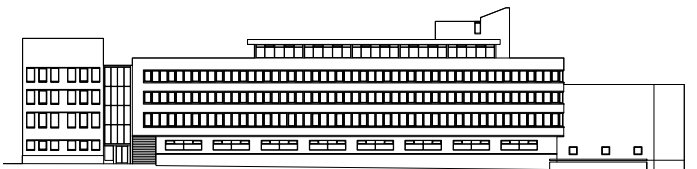

Before

0 10 M

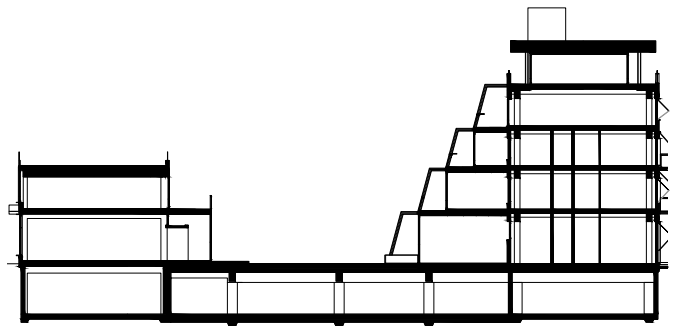

After

0 20 M

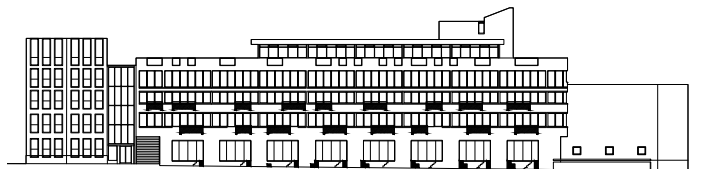

After

Re-design Options

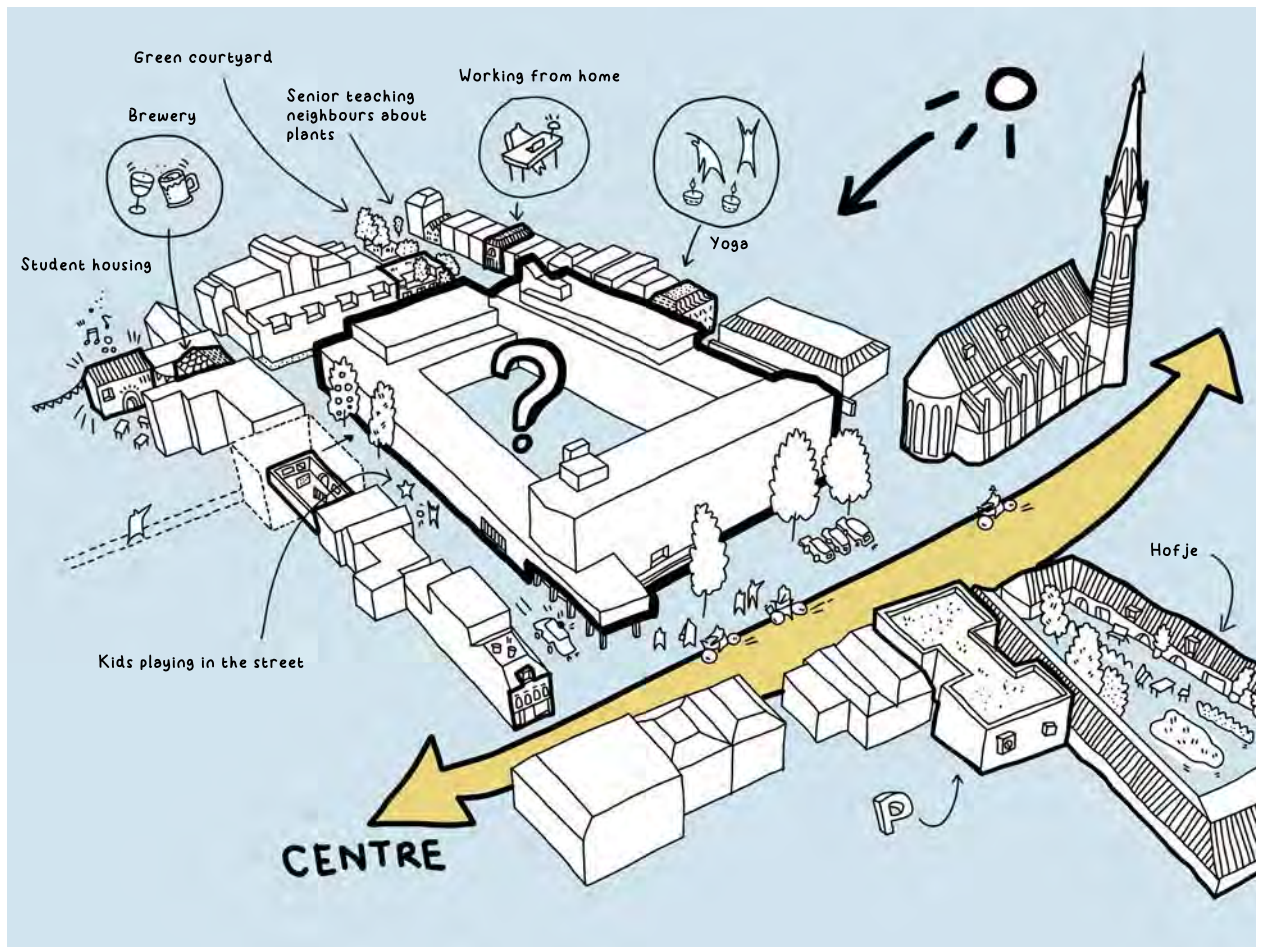

BEFORE - Site plan

Building more houses is one of the ways to tackle the housing crisis, but it is crucial to understand that there is a possibility to transform an existing building into housing instead of only building new ones. The design proposal for Vacant Police Heritage in Groningen city aims to cope with social and economic problems. It is crucial to understand that adaptive reuse of the building can significantly influence life in Groningen.

The idea of the proposal is to make a space around the police station livable and usable by people living in the block and around it. By opening the plinth and courtyard and creating inhabited spaces, the proposal seeks to bring the lost space back to the city life and develop social relationships.

Adaptive reuse of the Groningen police station focuses mainly on topics of the housing crisis. Moreover, while doing research and working on the design proposal, I realized that the Groningen police station has a lot of

valuable aspects that could be reused by changing as little as possible but at the same time achieving as much as possible.

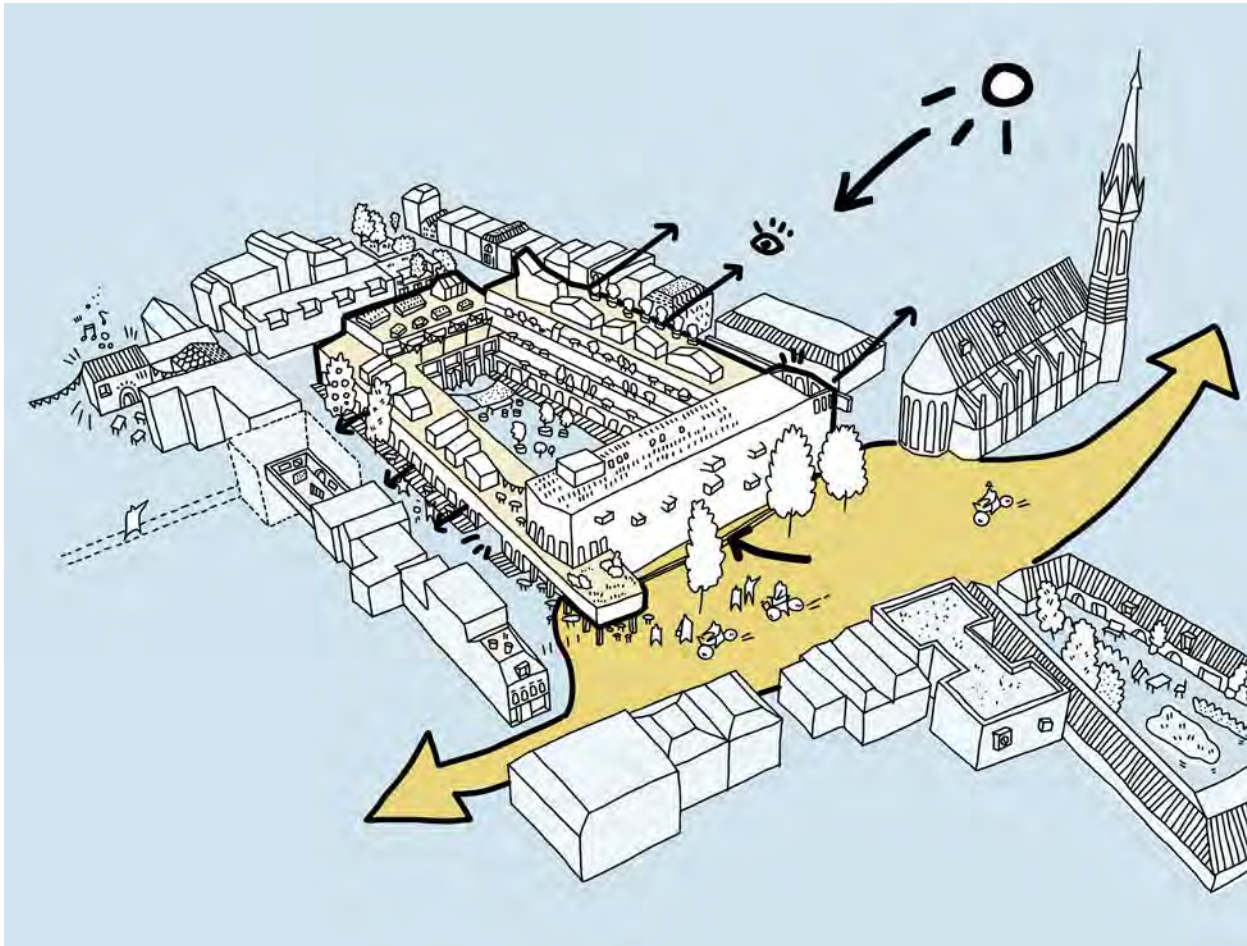

AFTER - Site plan

It was decided to transform Groningen police station into housing with mixed-use functions as an art gallery, office spaces, communal spaces, and student hostel. Due to the existing structure's possibilities and values, the office building can be transformed into a living function without any structural changes. One of the most significant functional changes is combining several social groups such as students, young entrepreneurs, couples and families into one building block. Part of the research was to understand how those groups can benefit from one another and engage with each other while also proposing the idea of keeping the privacy of each household by offering specific design strategies. Also, due to the housing crisis, there is a need to create flexible and as small m² housing units as possible.

Next to this approach, the design proposal of the police station focuses on material reuse. Due to the global problem of material crisis, there is a need to

reinvent how we should use materials in architectural design proposals. Since there are no major demolishing processes in the Groningen police station, there is an idea to get materials from other police stations that are being transformed or partially demolished in Vacant Heritage studio. The material reuse proposal focuses on collecting materials from my fellow groupmates' projects and reusing them on the Groningen police station. There collected material mainly would be used for newly added parts of the Groningen building and façades.

HOW WILL WE LIVE TOGETHER?

Den Haag

How can an architect transform the Eenheidsbureau in Den Haag in order to create a symbiotic urban metabolism in the neighborhood?

Keywords: ecology, heritage, community, urban metabolism, symbiosis, wellbeing

Vacant Heritage - Police Real Estate | The Netherlands

URBAN BLOCK



0 50 M

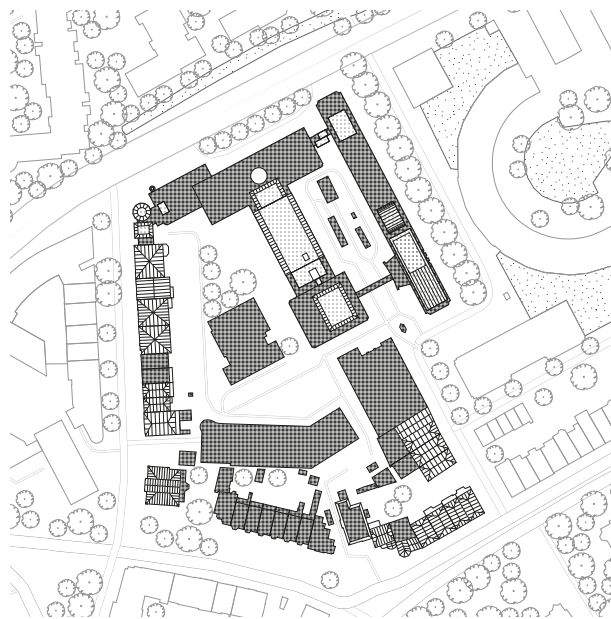

Before



0 50 M

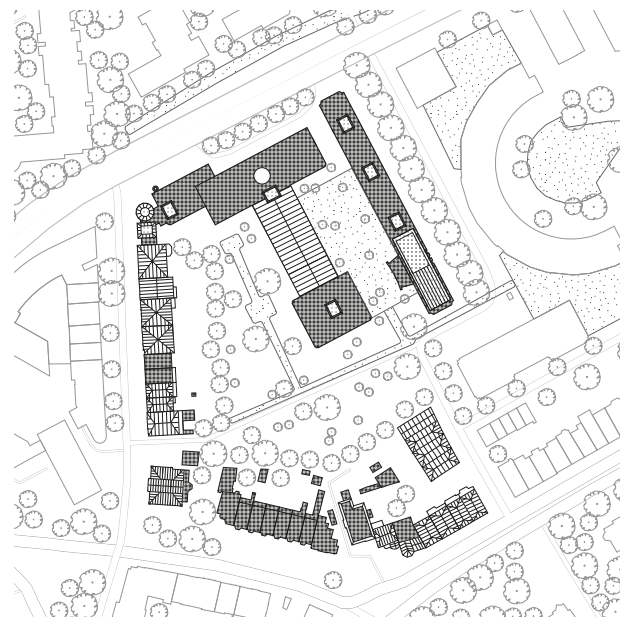

After

FLOOR PLAN



0 20 M

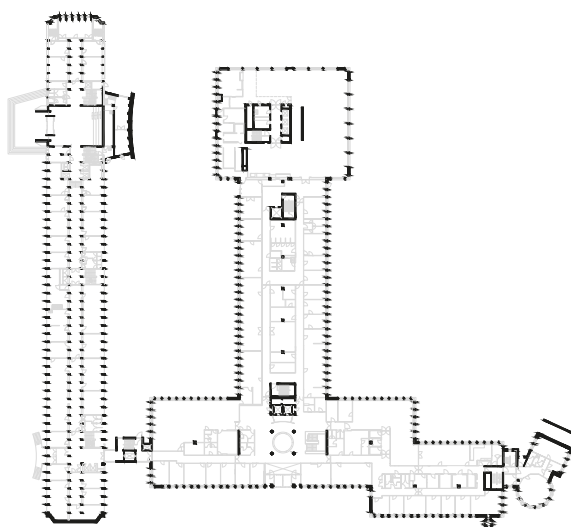

Before



0 20 M

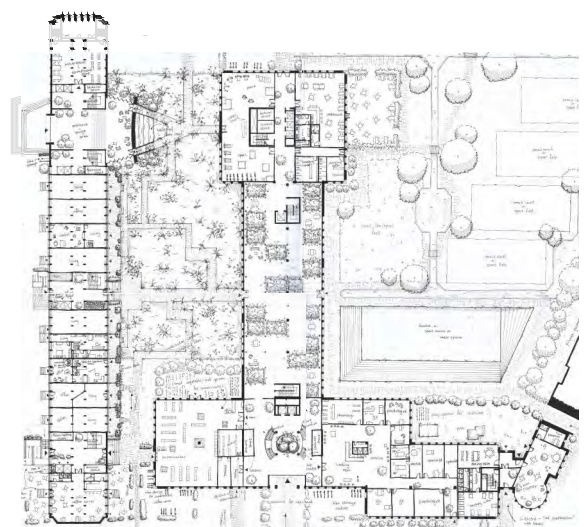

After

SECTION

0 20 M

0 20 M

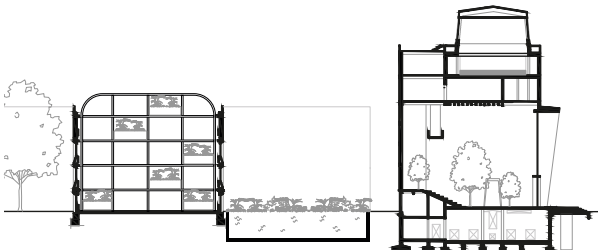
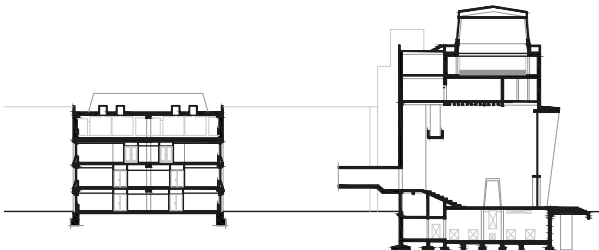

Before

After

FAÇADE

0 20 M

0 20 M

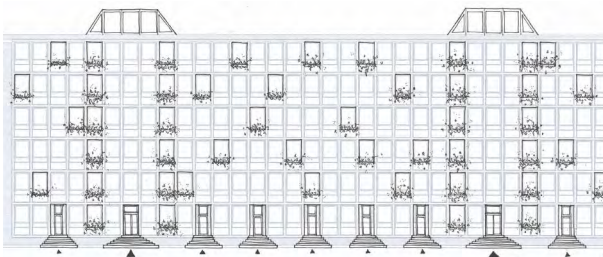
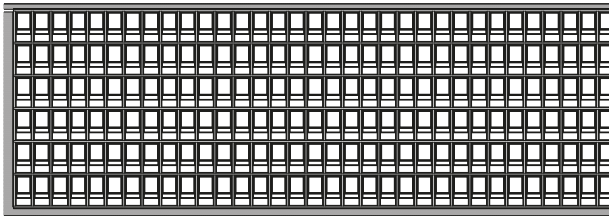

Before

After

Re-design Options



BEFORE - North-east elevations

(Mexis, 2021)

The Eenheidsbureau in Den Haag is a police station formed by two buildings both designed by Van de Erve and built respectively in 1959 and 1981. The rectangular building from 1959 is a municipal monument with a high value Schokbeton façade. The 1981 building is an ensemble of volumes, representing a fortress. The building is located in the Archipelbuurt, a rich neighborhood in the northern part of Den Haag, which mainly consists of rowhouses built before 1900. The neighborhood is analysed with an urban metabolism analysis, looking at the water, energy and biotic flows in the neighborhood.

The goal of the research is to create a transformation framework to guide the re-design from both an ecological perspective and a social cultural perspective. Therefore, two transformation frameworks are created, one based on the urban metabolism analysis of the neighborhood, and one based on the heritage value assessment. The frameworks guide the design in different ways, as the urban metabolism framework determines functions that

are needed to close the cycles in the neighborhood, while the heritage value framework determines which elements have opportunities for change and which elements should be preserved in order to maintain the values.

The starting points of the design are formulated with the research, creating criteria to reflect and develop the design. This includes which functions to add such as water treatment and storage, energy production and storage, food production, and habitat for plants and animals. Another starting point is to include a variety of housing types to react to the current housing crisis.

The design question is: How can an architect transform the Eenheidsbureau in Den Haag in order to create a symbiotic urban metabolism in the neighborhood? The goal of this re-design is therefore to find a new way of living together, improving the wellbeing of its users, the surrounding neighbors and nature, by creating closed cycles and symbiotic relationships.

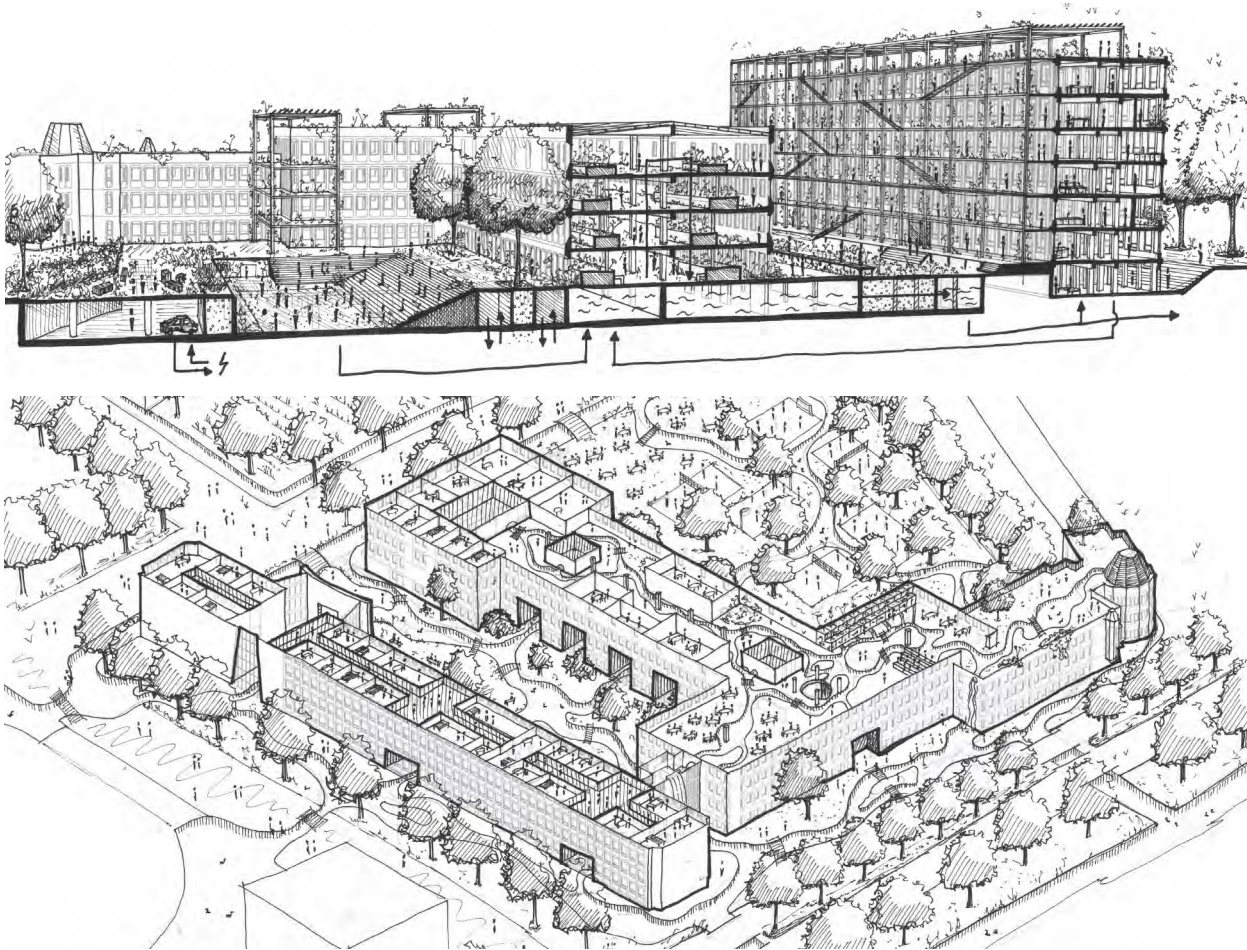

AFTER - Isometrics

The program of the design reacts to the research and consists of three parts. The social part exists of retail, work, leisure, and care facilities. The ecological part consists of a water treatment, food production, and habitat for plants and animals. The housing is divided into 1,2,3-bedroom apartments, work-living apartments, and co-housing.

The concept of the design is to utilize the qualities of the existing building. The social functions are placed on the ground floor, activating the street and creating interaction with the surroundings. The housing is organized based on the characteristics of the structure. The work-living apartments utilize the split-level basement. The dense structure of the 1959 building houses the 1,2,3-bedroom apartments, while the large open structure of the 1981 building is used for the co-housing. The living machine as water treatment will form the heart of the building placed in the centre. One of the courtyards is an artificial wetland, while the other courtyard is used for outdoor sports facilities. Circulation cores will be created on

strategic places in the building, creating clear vertical connections that house social and ecological spaces. A gallery and balconies are added for accessibility, social interaction, and habitats for plants and animals. The roof will be used for the production of energy as well as social space and ecological habitat.

The building is used by a wide range of inhabitants itself from starters to families to elderly, but will also become a community centre for the entire neighborhood. Flora and fauna are utilized for water treatment and food production. In this way, the building does not only connect the water and energy cycles in the neighborhood, but also connects people with each other.

This design is an exploration of the research and design question, as it researches a possible way of living together where the transformation of a building encourages a social community, while an attempt is made to close cycles on a neighborhood level, contributing to the energy transition.

STORY-BASED ADAPTIVE REUSE OF COUNTRY HOUSES

Warnsveld

How can the architect integrate the stories behind the layers of time in Huis 't Velde in Warnsveld in the adaptive re-design process in order to make these stories experienceable for future users?

Keywords: time layers, adaptive reuse, country houses, heritage, analysis, documentation tool, heritage as vector biography

URBAN BLOCK

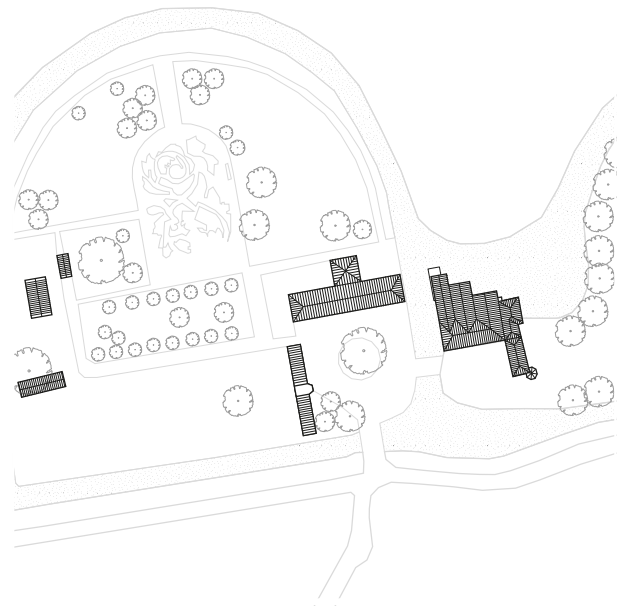
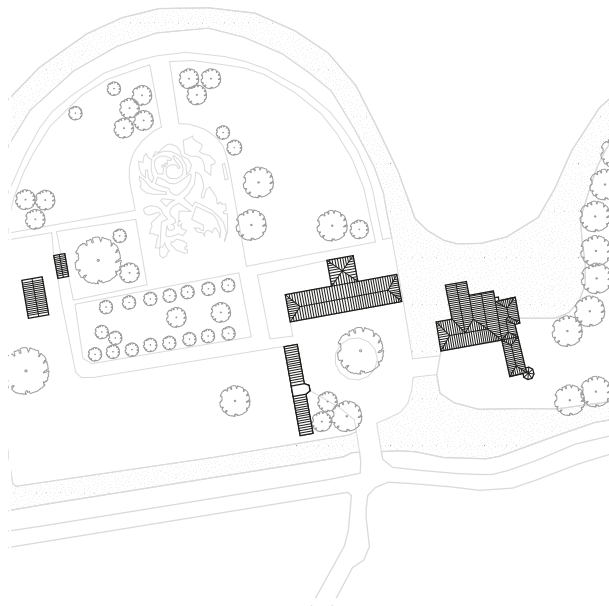

Before

After

FLOOR PLAN

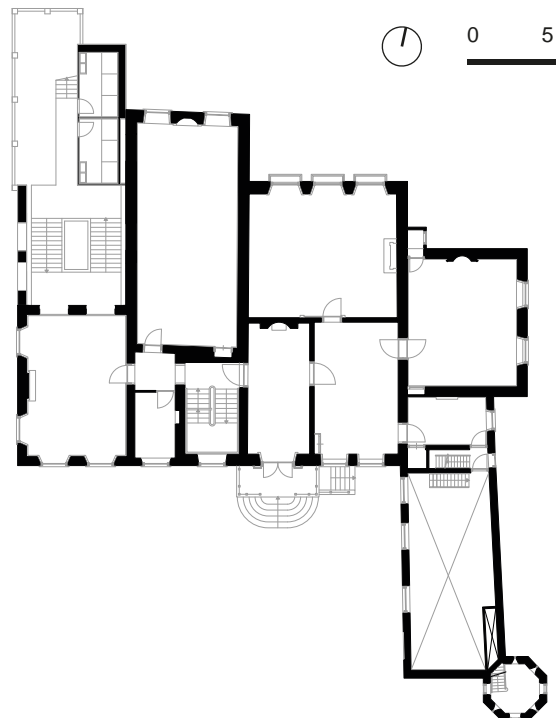
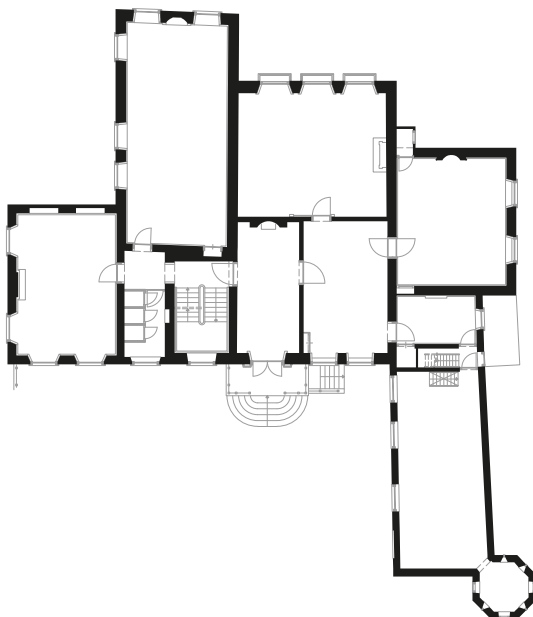

Before

After

SECTION

0 10 M

0 10 M



Before

After

FAÇADE

0 10 M

0 10 M

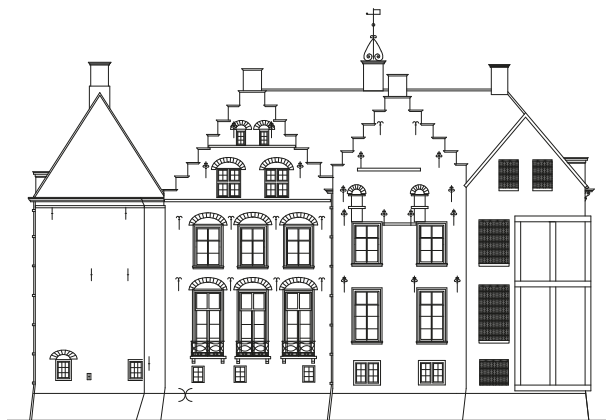

Before

After



BEFORE - South-east elevations

(Van Asselt, 2021)

Huis 't Velde is located on a large plot. The house is surrounded with a large garden and meadows. The house has been built in several stages, starting with a small, towerlike building. This building was extended with several new wings over time, and also the architectural expression changed quite a lot due to changes in the volumes, façade finishing and the windowframes.

In my research, several ways of dealing with these time layers in country houses were found and discussed. In order to find these different approaches and understand the time layers that were present, a matrix was introduced. In each of the case studies, the designers dealt with these time layers in a different way, namely by adding a new time layer, by conserving the existing or by reconstruction. In my re-design for Huis 't Velde, these strategies were combined.

The main design question throughout the process was how to deal with time layers present in Huis 't Velde in such a way that their stories are experientable for future users of the building.

The first starting point for the re-design was the conservation of the relevant time layers that were still present in the building, and enhanced experience of these layers. The second starting point is the addition of a new time layer, in the form of among others an extension to the building. The last starting point was maintaining/enhancing the unity of the house garden and landscape.



AFTER - South-east elevations

For the adaptive reuse of Huis 't Velde, a mix of functions has been selected. These functions were based on the existing spatial characteristics of the building and the plot.

The main house and the surrounding island are going to be used as a event and meeting/conference centre. This suits to the more public character of the main house of the complex. The rooms for events are located on the ground floor, in the spaces that were used by the former inhabitants to invent quests and organise parties. The first and second floor, which used to be more private, will be used for meetings and conferences, which do also have a more public character than the events on the ground floor. The basement will be used as a restaurant, in line with its functional character. The new addition, which is also visible in the image above, forms the connections between all the different floors, and symbolises in this way the change in function of the building; from private

to public. It introduces a new staircase and elevator to the building, making to building also more accessible. The large windows in the addition creates spectacular view over the surrounding garde and meadows, and creates a stronger connection between the house and its surroundings.

The coach house will be used as a retraite hotel, fitting to the more private character of this building, and appropriate because of the memorial garden for police officers who died during their job behind it. On the ground floor are the shared spaces for the quests, on the first floor the individual rooms. The dove cote will function as information centre for tourists, because of its location near the entrance to the estate.

ARCHITECTURAL YOUNG CLASSICS

Eindhoven

How can the spatial characteristics of Dutch administrative office buildings from the late 1970s and 1980s be implemented into a sustainable adaptive reuse strategy, on the example of the Mathildelaan Police department in Eindhoven?

1970/1980s Architecture, Modern Heritage, Sustainability, Brutalism, Post Modernism, Flexibility, Prefabrication

Vacant Heritage - Police Real Estate | The Netherlands

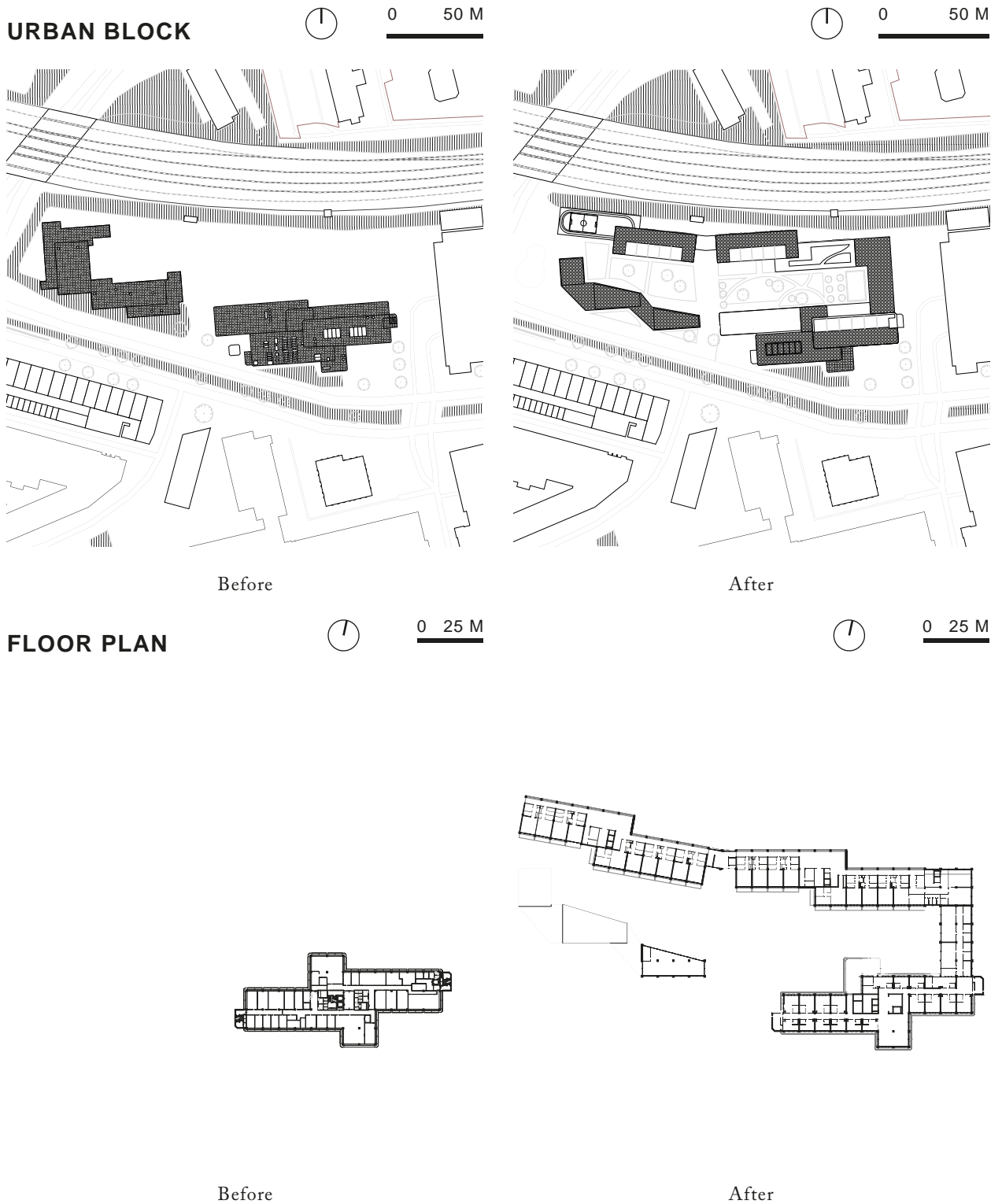

SECTION

0 20 M

0 20 M

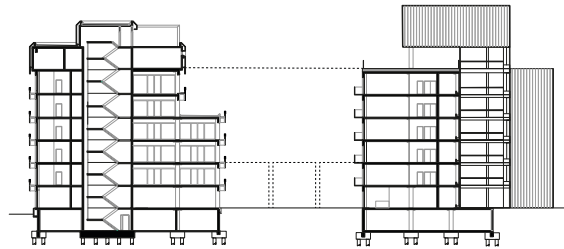
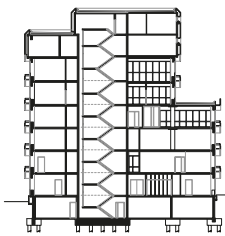

Before

After

FAÇADE

0 20 M

0 20 M

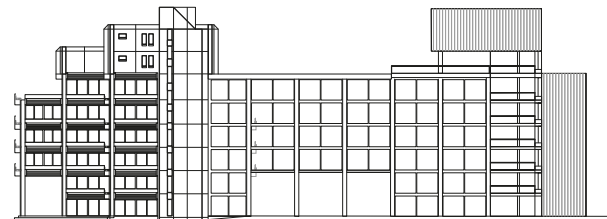
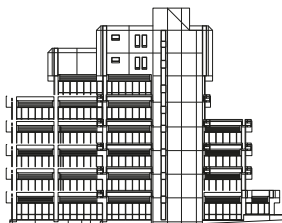

Before

After

Re-design Options



BEFORE - South-east elevation

(Fischer, 2021)

The Eindhoven Police building site is located in an area that is intended to become a lively, international city district in the future. Compared to its surroundings, however, it is rarely developed, but a large part of it is sealed for parking purposes. Greening is still very restrained and the choice of materials seems rather uninviting due to the current corporate use.

This is leading to the question how spatial characteristics of Dutch administrative office buildings from the late 1970s and 1980s can be implemented into a sustainable adaptive reuse strategy, on the example of the Mathildelaan Police department in Eindhoven?

Many aspects of typical 70-80s buildings such as the police building in Eindhoven support their continued use: the strict design grid of the load-bearing structure, for instance, offers possibilities for a flexible re-design of the interior. The use of a high amount of concrete is long-lasting and therefore advantageous in terms of load-bearing capacity. In this respect, the continued use of the supporting structure can be considered sustainable. On the

other hand, it is vulnerable to weathering in exposed areas and requires renovation after a few decades. The choice of colour and the use of large precast concrete elements for façade design are not always considered aesthetically pleasing, but they are particularly characteristic of the period.

The relief of the façade and the overall shape of the building are also a typical feature of a type of ornamentation in the architecture of the 1970s and 1980s. In terms of urban planning, as in this case, the plots are sparsely developed and greened and need to be redensified in terms of construction and landscaping.

The New Design of the Eindhoven Police aims to turn the police building into a sustainable residential block based on the idea of the city in the city, which opens up to the urban context and at the same time interweaves the historical characteristics of the 1970s and 1980s architecture with the new requirements.



AFTER - South-east elevation and west elevation

The concept includes a coexistence of public, semi-public or shared and private space. The ground floor provides infrastructure to supply the residents. The upper floors contain private living spaces and communal spaces to promote interaction and relocate disturbing activities to noise-protected parts of the building. In addition to the semi-open courtyard, the building façades and roofs offer opportunities for vertical greening of the block.

The localisation of all areas is oriented to given visible urban axes and grids, movement structures, the urban green space as well as the orientation to light and noise sources. Thus the inner courtyard, enclosed on all sides by buildings or greenery, forms the quiet gem and heart of the complex, while the open areas of the site present themselves as a lively square.

As with the large-scale archetype, the residents are also to be mixed. Through the presence of places of retreat on the one hand and an extended range of living facilities for

communal use on the other, interaction between residents of different ages and life situations is to be encouraged not by necessity but by self-interest and initiative.

This mixture is also reflected in the juxtaposition of architectural history and modernity. By making the new architecture lean from the old building, a harmonious interplay is sought, which does not deny but rather appreciates particularly characteristic periods and enables the people of Eindhoven to identify with the building. In order to achieve a more inviting character, the building envelope is changed, especially at the openings, by replacing the glass and metal curtain wall through a wooden. This increases an inviting appearance but also requirements to insulation. The new openness of the building is further reinforced by a number of purposefully placed break throughs.

SUSTAINABLE RE-DESIGN OF ESTATE HUIS 'T VELDE

Warnsveld

How can design approaches help in a contemporary reuse and re-design of a Dutch estate where both building, and nature, contribute to a sustainable design and in particular for Huis 't Velde in Warnsveld?

Keywords: *landgoed, buitenplaats, estate, sustainability, heritage, nature, design attitude, design approach, green energy*

Vacant Heritage - Police Real Estate | The Netherlands

URBAN BLOCK

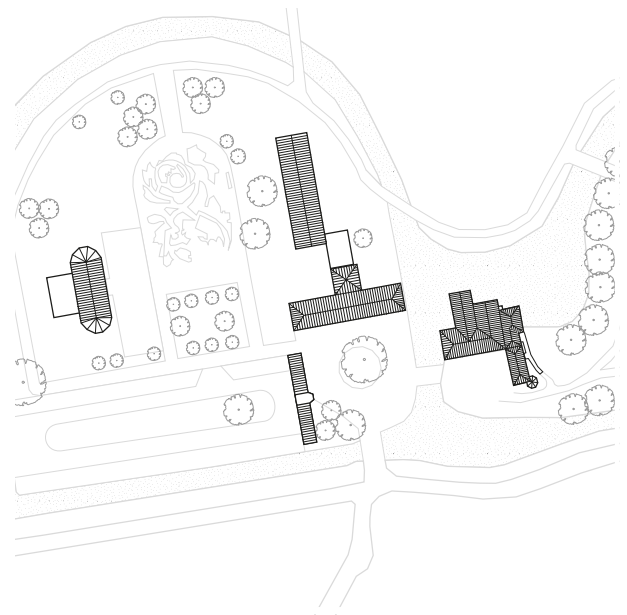
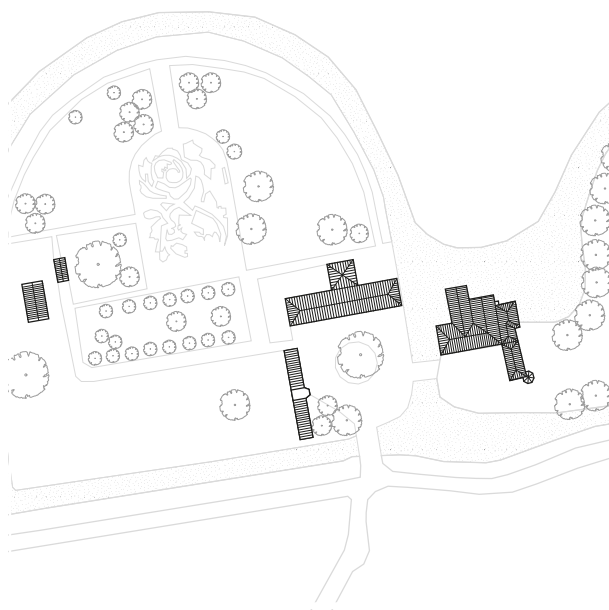

Before

After

FLOOR PLAN

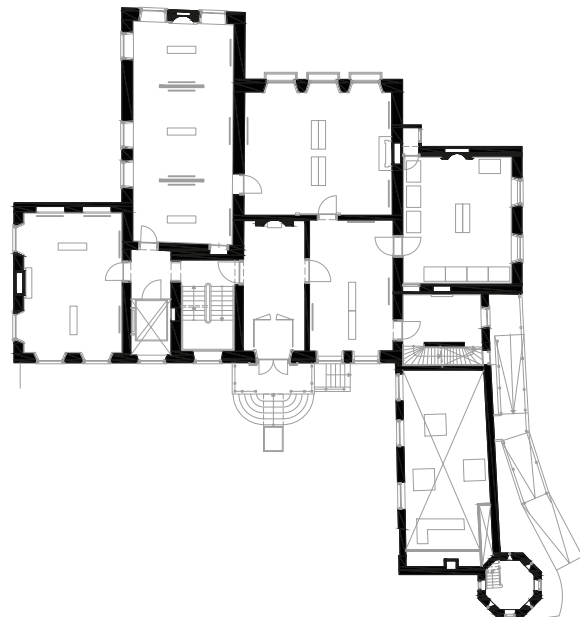
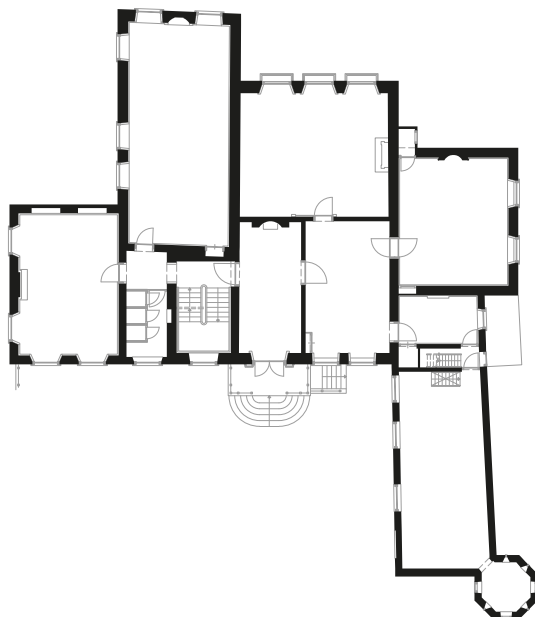

Before

After

SECTION

0 10 M

0 10 M



Before

After

FAÇADE

0 10 M

0 10 M



Before

After

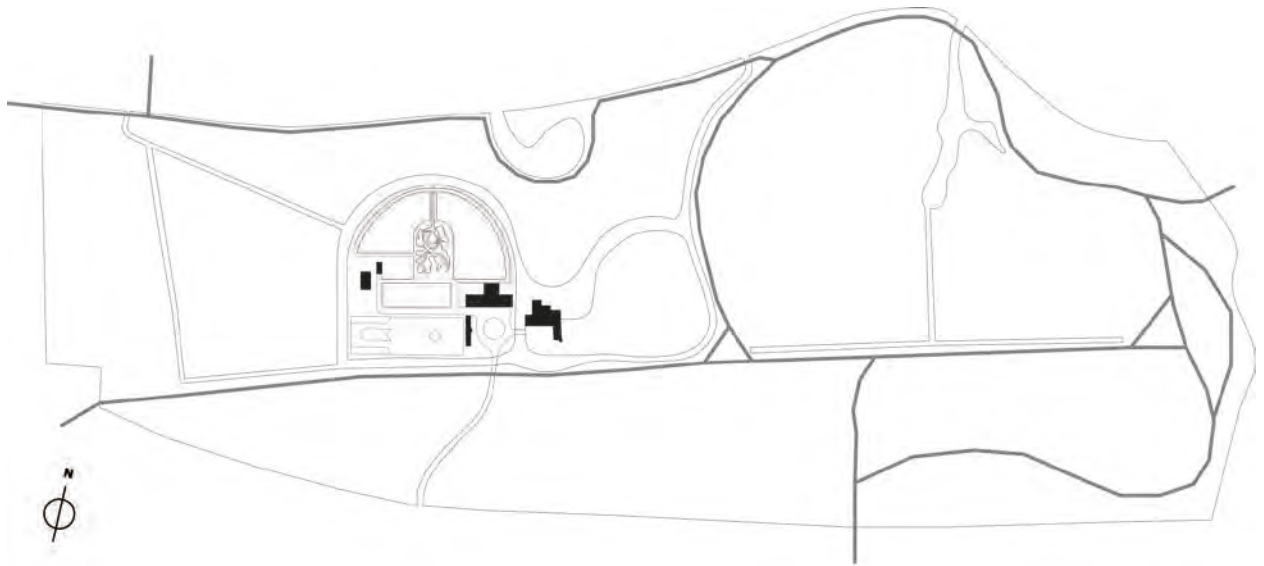

BEFORE - plan overview of the existing estate. The size of the area is 328.479 m².

The main quality of Huis 't Velde in Warnsveld is its large area. At the same time this is also a weakness. Because what do you have to do with so much land? In the analysis came up that there are various places on the estate that are suitable to change without threatening the historical context. In addition, there is plenty of green and free space on the land that can contribute to make the monuments more sustainable. Finally, it emerged from the value assessment that the monumental value focusses on the main residence and that the other buildings contribute to that monumental experience.

The research concluded that technical interventions always have an impact on the built heritage. When making a building more sustainable or modernizing the services, the influence of these interventions on the values of the building(s) must therefore be evaluated (see SBT part 3). In the case of Huis 't Velde it emerged that a restrained attitude towards the residence was appropriate. There was more room for adjustments in the side buildings and space for new buildings that can both contribute to the sustainability aim of the building services of the main residence.

With this in mind I elaborated a reuse design for the estate. The idea of the design is not to make only use of the buildings but also to make use of the 'natural' parts of the estate to make an integral reuse proposal. The design focusses on four points: firstly, to open the

estate for cultural visitors, secondly to present the time layers from the monument, thirdly to use the estate's lands to contribute to use and sustainability, and finally to modernise the outdated building technology with 'green' energy resources. The goal is to pursue a balanced and stable user function mix to guarantee a long term usage and stable income and to ensure and continue the existence and maintenance of the monumental estate.

The new program of the new reuse design consists of a number of different functions. The most important and largest part concerns a new museum in both monumental buildings that will function as the beating heart of the estate. There is much to experience here with the monumental house itself, a permanent exhibition in the museum house and temporary exhibitions in new rooms near the coach house. On the large island, the 'Tuin van Bezinning' has been respected and preserved. I changed the layout of the island to make space available for an orangery with a restaurant. The orangery functions independently, but can also support the coffee bar in the museum and the annual commemoration ceremonies from the Dutch national police.

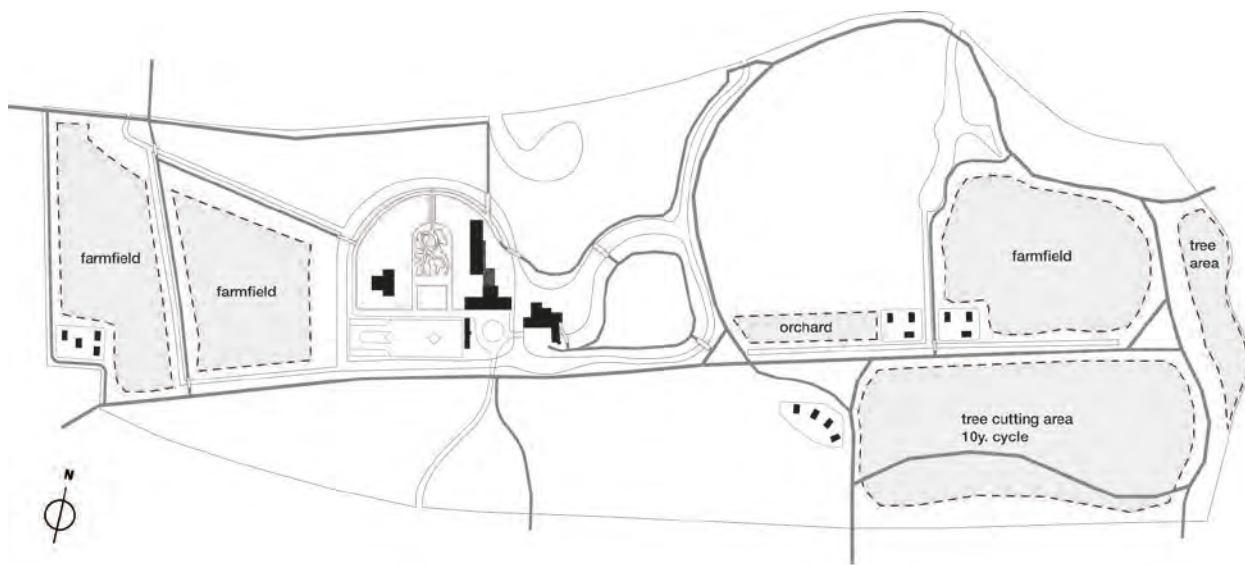

AFTER - plan overview of the re-designed estate. New development areas are selected and the routing is improved.

The routing has been adjusted to improve the experience of the estate. In the past it was only possible to walk around the outer edges, and now there are integral hiking trails through the entire estate. Hikers are tempted to discover the two inner islands as well. New small introverted residential areas have been designed in some places between the woods and meadows. This ensures a variety in user functions, but the rent money also ensures a continuous and stable income for the maintenance and preservation of the estate.

All new buildings have to be built energy neutral. This reduces the energy demand as much as possible. In addition, solar panels for solar energy will be placed onto the new houses, museum rooms and orangery. It is important that these must have an overcapacity in their energy generation. In this way, these buildings can support the main building which is left free of major sustainability adjustments due to its monumental character and values. A central geothermal heat exchanger will be installed on the estate that will provide all buildings with heat. Each building gets its own heat pump that is connected to the network. In addition there is a possibility to place a wood-fired boiler to gain more heat capacity during the winter. The wood comes from trees that are cut annually on the estate. The most important aspect of the sustainability plan is its integral and centralized implementation.

The design shows that an integrated design can make a monument more sustainable on an energetic and economic level. In SBT part 3 is more explained about the design attitudes of Jo Coenen and Charles Bloszies. At the start of the design, the attitude continuity was chosen. Research and analysis showed that a reserved attitude towards the monument was best here, but that other areas on the estate allowed more freedom in style of continuity. This is the benefit of the presence of a large plot.

Other than expected in the beginning, during the design process it turned out that one attitude was not always sufficient. The different design approaches show that customization is necessary and that even within one project, one attitude is not always enough. In this way, all parts of the estate were assessed and adapted according to what is necessary and appropriate within their value for the monumental ensemble. It turned out that the most important aspect of making a monument more sustainable is to determine the values of the building parts and to test the impact of design choices on this, instead of focussing on one attitude. Every scale level and even every building part of a design requires its own assessment and interpretation. The design attitude can vary here. It turned out that a design attitude can help to support and direct design choices, but in itself it can never be a goal to achieve.

STRUCTURE & ADAPTABILITY

Den Haag

What is the transformation potential of the load-bearing structures in the case of former Dutch police stations?

Keywords: structure, grid, load-bearing, adaptability, materiality, construction method

Vacant Heritage - Police Real Estate | The Netherlands

URBAN BLOCK



0 50 M

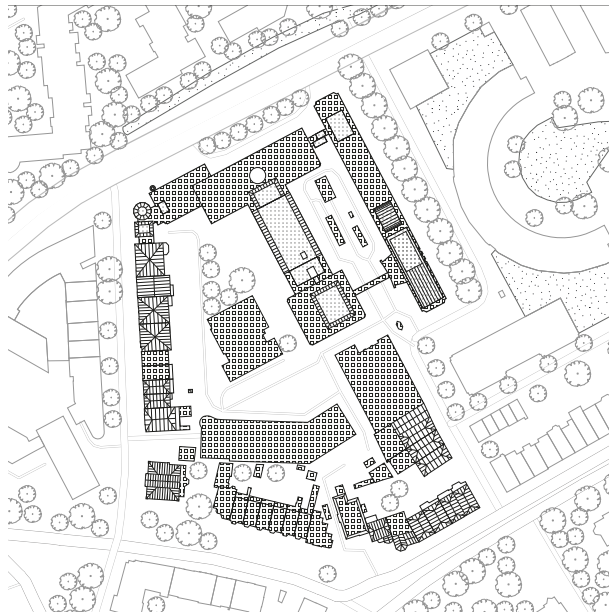

Before



0 50 M



After

FLOOR PLAN



0 20 M

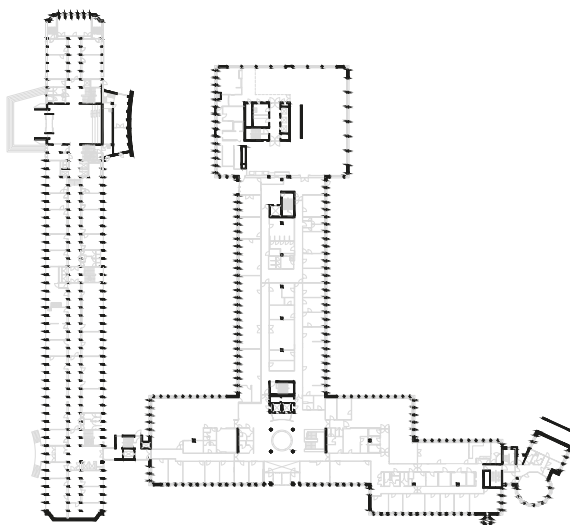

Before



0 20 M

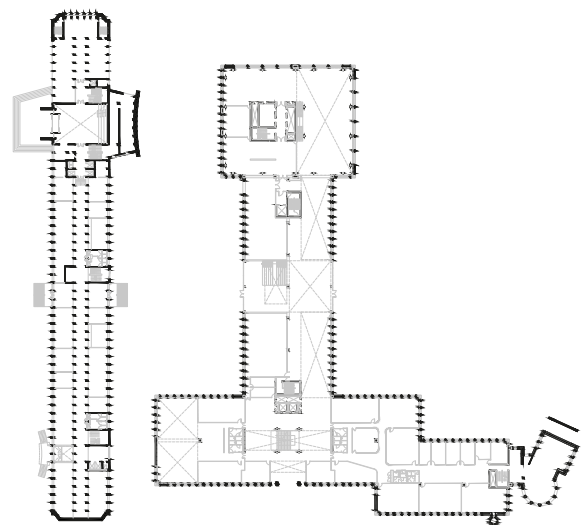

After

SECTION

0 20 M

0 20 M

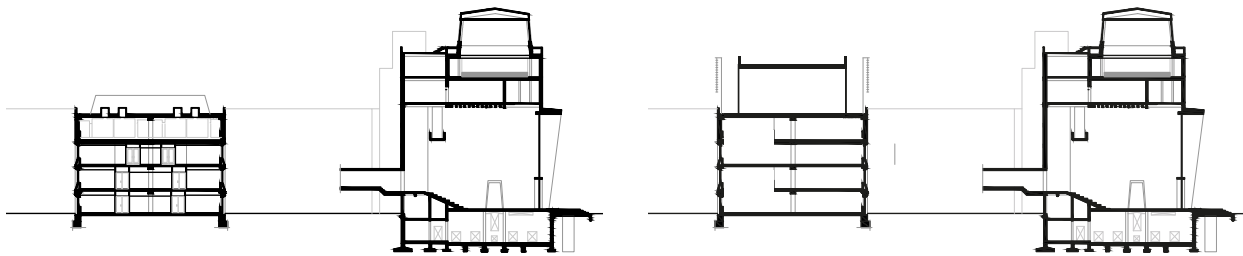

Before

After

FAÇADE

0 20 M

0 20 M

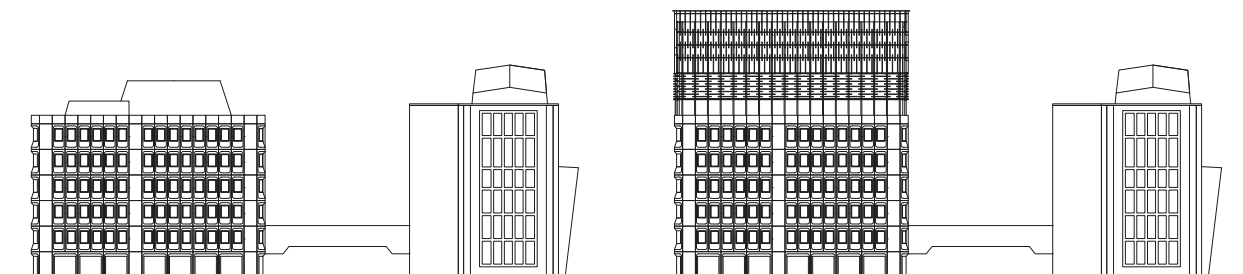

Before

After



BEFORE - North-east elevations

(Mexis, 2021)

The site analysis of the former police station in the Hague, laid the foundations for the design process, during which rational design decisions were taken, based on the findings of the analysis. The four scale levels of the analysis, showcased important aspects, from the location, to the composition, values and materiality of the building. Certain traits of the building, such as its massive scale, became central, that served as starting points. The area of the building, indicated as substantial programmatic potential, and the possibility of enriching the urban space of this region.

Being fascinated by the structure of the building, which is reflected in elevations of the structure, either as a rhythm, or as a repetitive element, I posed the following design question for my graduation studio:

“How can the role of load-bearing structure, improve the spatial qualities and adaptability in the Hague’s police station?”

Exploring this possibility, became a design principle and the purpose of my graduation project.

Through the carefully study of relevant literature, I was able to distinguish five spatial elements that stem from the load-bearing structure, and can be manipulated to increase the space’s adaptability, as well as the enrichment of the space. To that end, each of those spatial elements (grid, bay width, daylight, circulation, core-positioning) was tested and altered according to the ultimate goal of increasing its spatial impact. Given that the case study is an existing building, certain limitations were identified, and design decision were then taken.

The final proposal aims to showcase the spatial enrichment of an existing concrete prefabricated structure, and the extent that transformations can reach, in the broader domain of existing prefabricated structures.

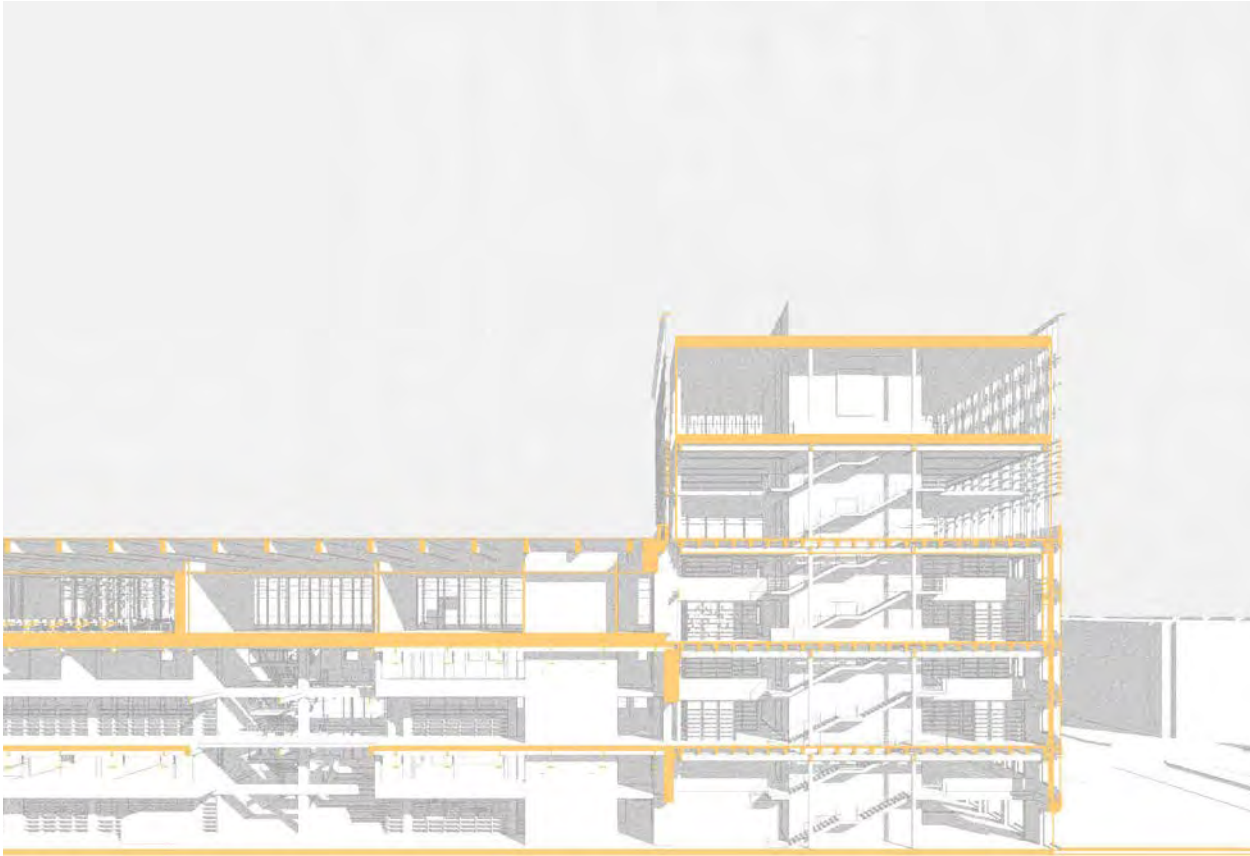

AFTER - Longitudinal section through extension

For the programmatic choice, a deep research was conducted, looking into the Hague's city plans, where the ambition for its future was expressed. Based on this research, and the conclusions of the site analysis, that indicated the police station, as an austere, introvert and secure building, expressing the strict regime of the police, this character of the building was found suitable for one of the biggest needs of the Hague; that of expanding its educational facilities. Specifically, an IT, cyber security university, takes advantage of the existing representation of the building and adds a transparent layer, on top of the existing, resembling the new public function of the former police station.

Both students and locals, as well as companies are invited to the program, which follows a careful separation between the private and public spaces, and converts the tower volume of the ensemble as the meeting point between the different users, promoting innovative knowledge clusters.

Key design principle, that influenced the concept was the idea of prefabrication and materiality. Structural prefabricated load-bearing elements are used, making the design more cost-effective and sustainable through the use of timber and steel. In terms of the façade articulation, the extension creates a strong link with the existing, through the prefabricated timber louver element, that creates a pattern on the envelope and serves as a climate façade.

Finally, the design revealed the significant contribution of the research to the design, and the extent to which the load-bearing structure, may improve the spatial qualities and the adaptability of the existing. Although the initial ambition was to utilize only the existing structure, certain constraints were revealed during the design process, when new structural elements were added, in such a way, that the spatial qualities of the existing were revealed and highlighted.

CENTRAL SPACES // PUBLIC PLACES

Haarlem

RQ: How can the courtyard typology be characterized and what opportunities does it provide for the re-design of the Koudenhorn police station in Haarlem?

DQ: How can Koudenhorn police station be re-designed into a public library and dwellings?

Keywords: *Courtyard, typology, public building, central space, public library, dwelling*

Vacant Heritage - Police Real Estate | The Netherlands

URBAN BLOCK

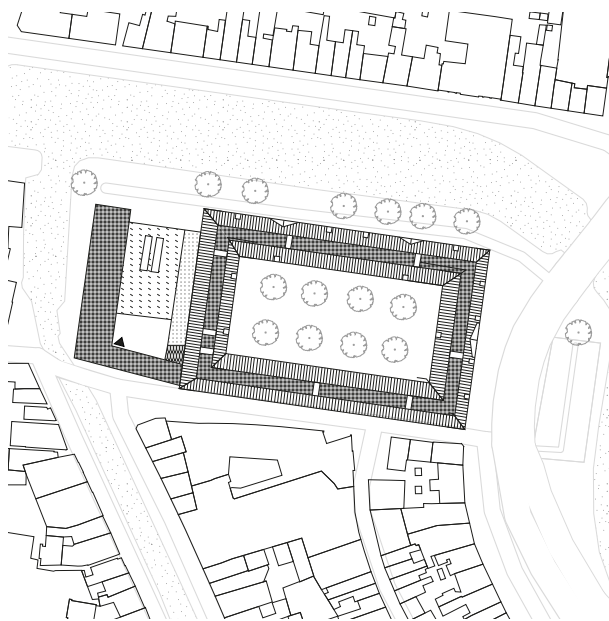

Before

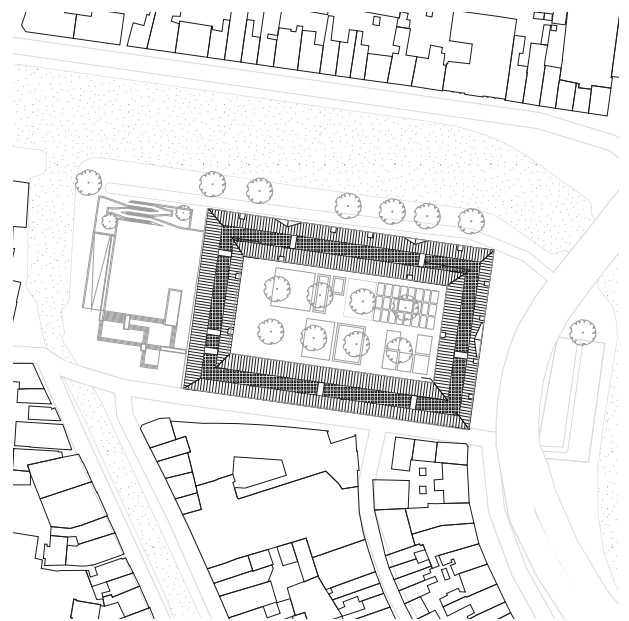

After

FLOOR PLAN

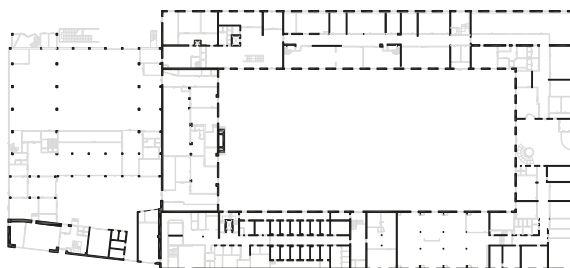

Before

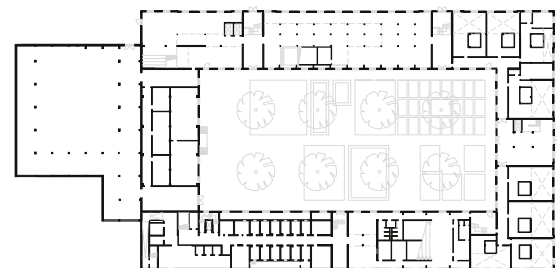

After

SECTION

0 10 M

0 10 M

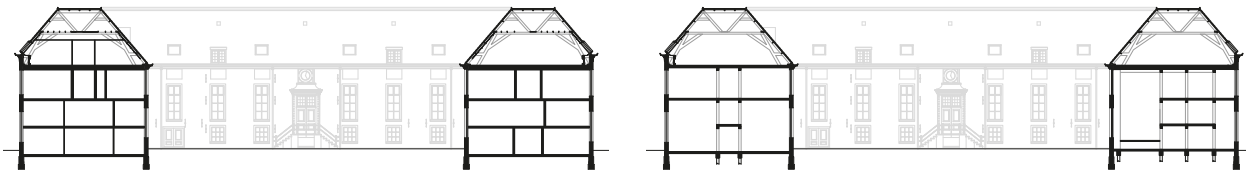

Before

After

FAÇADE

0 25 M



Before

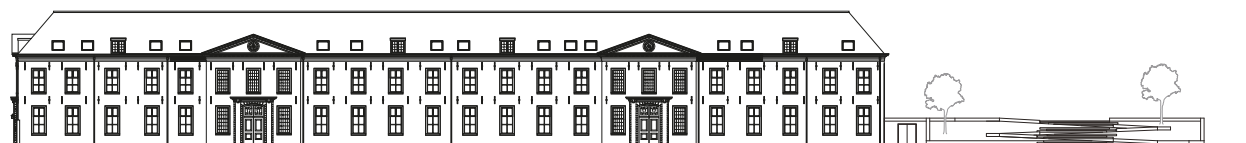

After



BEFORE - Single level corridor organization

(Van den Hoek, 2022)

The Koudenhorn police building is located in the historic inner city of Haarlem. It sits on the western bank of the Spaarne river, along which runs one of the main traffic arteries of the city. The northern side of the plot is defined by the wide canal of the Nieuwe Gracht. The narrow Zakstraat runs along the southern side. The building consists of two major volumes. The original three-storey rectangular volume consists of four wings enclosing a central courtyard. A later addition on the west side consist of a double-height L-shaped volume. The size of the building contrasts with the smaller grain size of the surrounding urban context. Due to its current function, accessibility to the public is very limited and the courtyard is scarcely utilized. The Haarlem central library is struggling with overdue maintenance, poor energy efficiency, an outdated spatial layout and a lack of space to make major changes. Relocating to the Koudenhorn building provides the space to create the desired future-proof library.

The Koudenhorn building is large enough to house more than a library. In order to alleviate some pressure from the the housing market, additional dwellings will be realised. The design question is therefore: How can Koudenhorn police station be re-designed into a public library and dwellings?

Concluding from case study research, buildings with a courtyard or central space can be defined using different typologies for the aspects of central space, spatial organization, entrances, routing and daylight. These typologies are the leading principles in understanding and redeveloping the Koudenhorn building.

The design aims to create an accessible, inclusive library offering multiple different spatial experiences, focussing on connection over collection. An urban living room facilitating the needs of various users, with the courtyard as a connector between the two programmes.

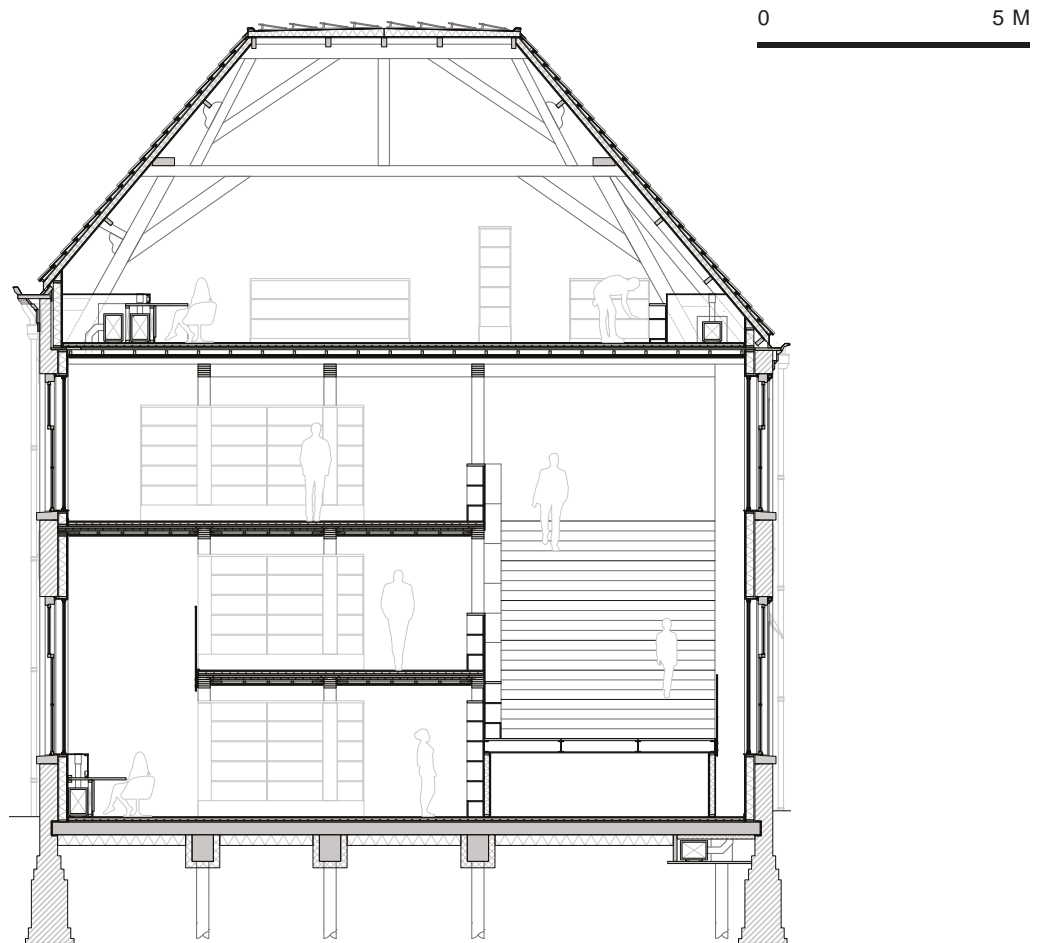

AFTER - Multi-level landscape organization

The Koudenhorn police building will be transformed in order to house the city's central library, in addition to several dwellings.

Utilizing the individual research, the spatial organizations of the two programmes can be defined using different typologies. The hall typology is apparent in the library, whereas the dwellings make use of the cloister typology.

The eastern side of the building contains dwellings for starters and seniors. They are connected to the library through programme and the courtyard, which offers spaces for appropriation by visitors and residents alike.

The new central library is organized around four vertical access points. Three of these are situated between original structural walls, effectively creating circulation cores. In between are the areas housing the library's core programme, as well as additional public facilities such as the cafe and auditorium. The repetition of small

compartments remaining from the use as a police station are maintained and used for closed stacks. Structurally, two important interventions are done to be able to carry the load of the library collection. Within the central space of the north wing, the interior load-bearing structure is replaced up to the second floor. This allows for the creation of vertical connections through voids and a landscape of stairs. A new load-bearing structure is added on top of the existing structure of small compartments in order to support the library floors above.

The entrance to the library will be situated in the original main hall. A new entrance plaza will lead up to the level of the entrance hall. Bicycle and car parking is situated in the existing basement and ground floor structure of the building extension underneath. The plaza acts as a transitional space, extending the library's sphere of influence and allowing for a more gradual approach to the building.

EXPERIENCING THE BUILDING TYPOLOGY OF A HAVEZATE

Warnsveld

How can fourteenth-century havezaten from Het Kwartier van Zutphen be characterized to formulate a building typology and how can this be made experienceable to the public in the re-design of Huis 't Velde?

Keywords: building typology, havezate, fourteenth-century, Het Kwartier van Zutphen, Huis 't Velde, experienceability

Vacant Heritage - Police Real Estate | The Netherlands

URBAN BLOCK

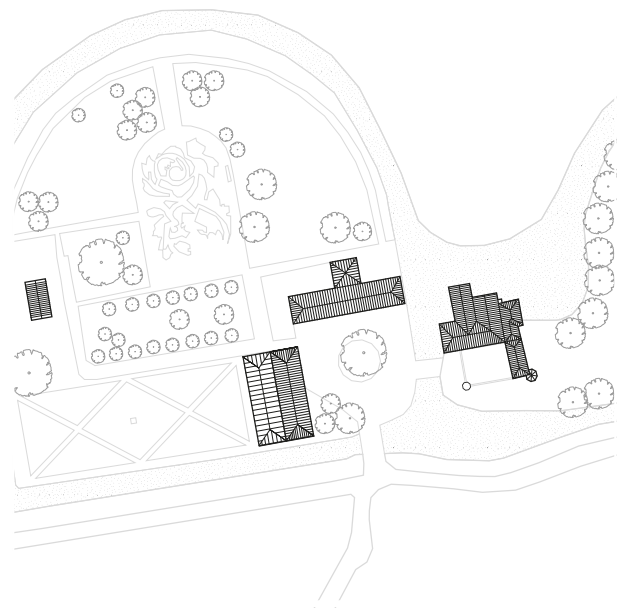

Before

After

FLOOR PLAN

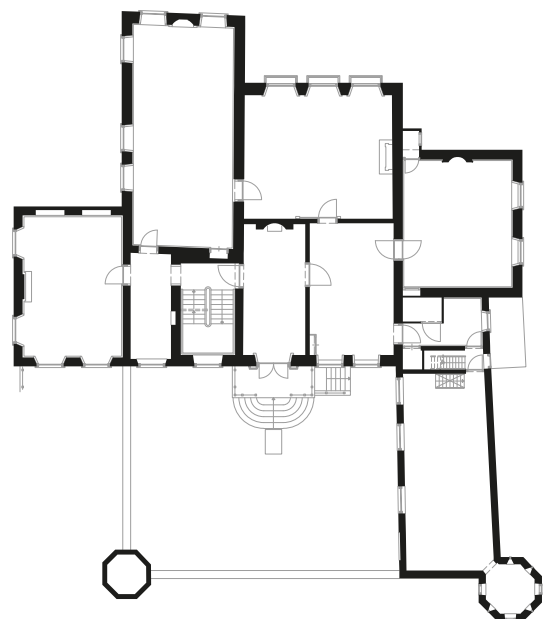
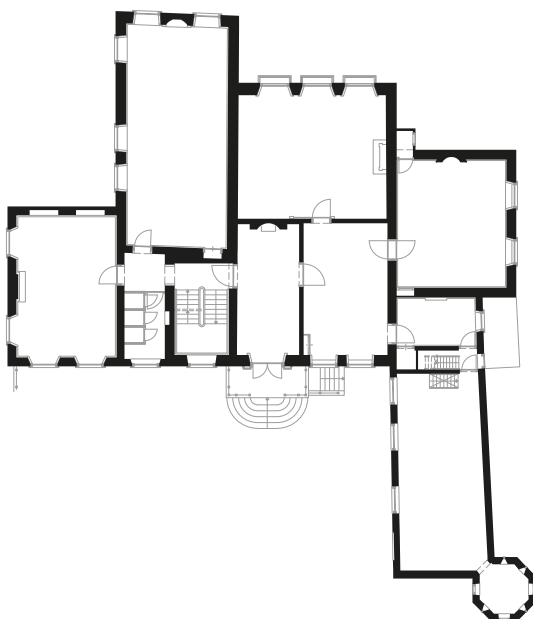

Before

After

SECTION

0 10 M

0 10 M



Before

After

FAÇADE

0 10 M

0 10 M



Before

After

Re-design Options



BEFORE - South-east elevations

(Van Asselt, 2021)

Huis 't Velde is a building first mentioned in 1326 and located in Warnsveld, in the east of the Netherlands. During the analysis of the building and site it became clear that it fell under a particular typology. Huis 't Velde was known as 'havezate', a specific type of castle which provided privileges and political rights. It was an ensemble of estate and buildings that evolved over time and was used as fortified house. Many similar buildings are seen across the region and seemed to have various similarities. Often, those havezaten were not publicly accessible, resulting in nescience of the typology among many people. The term 'havezate' was often even replaced by 'kasteel' or 'landhuis', while the definition was not identical.

These analysis resulted in the following research- and design question:

How can fourteenth-century havezaten from Het Kwartier van Zutphen be characterized to formulate a building typology and how can this be made experienceable to the public in the re-design of Huis 't Velde?

Since the current use of Huis 't Velde does not make the typology experienceable, the building will be made publicly accessible. By attracting people and allowing them on the estate and inside the buildings they can become acquainted with the characteristics of the typology and take in the atmosphere that makes it so special.

The majority of the (spatial) interventions are based on the previously conducted research. The design toolbox with interventions is used as guiding principle the make decisions in making the typology more experienceable.



AFTER - South-east elevations

(Van Asselt, 2022)

The main building will host a restaurant on the ground floor, wine tasting area in the basement and hotel rooms on the upper floors. The coach house will also consist of multiple hotel rooms, of which two are wheelchair accessible. The bird's house will be moved elsewhere on the estate and on its original location a new building is placed. This includes a shop, toilet facilities and event space for rental on the east side and an orangery with space for workshops on the west side.

Attached to the new building a flower garden is located, on place of the current car parking. The parking of both cars and bikes is erased from the central islands to make it an attractive and bustling place for pedestrians. The bird's house forms the centre of the vegetable garden and functions as storage and home for chicken.

The central part of the estate can with this new use provide the starting-, rest- and/or endpoint for bikers and

hikers. People can pass by, have a drink, use the bathroom and buy something in the shop. They can choose to picnic somewhere on the estate or have lunch/diner in the restaurant. In the afternoon there is the possibility to do a wine tasting and for a complete experience one can book a hotel room in either the main- or the coach house.

The biggest changes are made on the interior- and exterior finishing. The exterior paint is removed to show the historic building development, variation in brickwork and to bring back the allure and wealth the building was known for. The interior is dedicated to the long history of owners, with each room having their finishing based on one of the many family crests. The hotel rooms are large, luxurious rooms with their own chimney, to give the atmosphere of how people used to live there. Everything based on the concept of making the characteristics of the typology of a havezate more experienceable to the public.

THE NATURE-INCLUSIVE Re-design

Haarlem

How can monumental buildings in an urban context be re-designed to be more nature-inclusive?

Keywords: Nature-inclusivity, nature, biodiversity, possibilities, toolbox, decision trees, re-design & monumental buildings

Vacant Heritage - Police Real Estate | The Netherlands

URBAN BLOCK

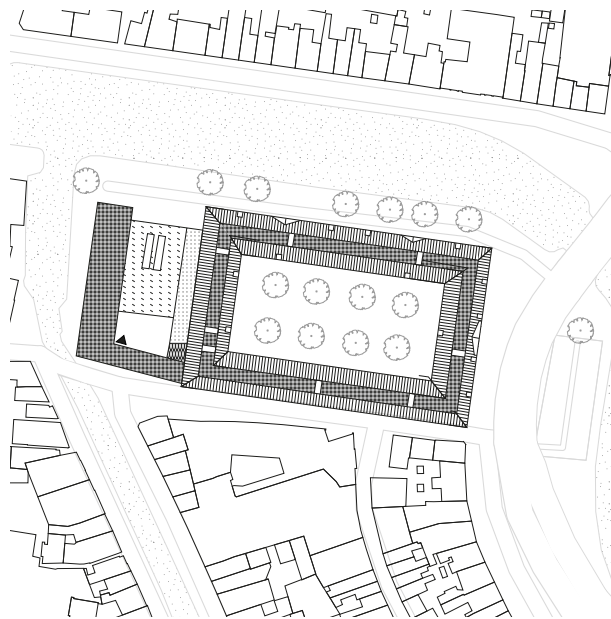

Before

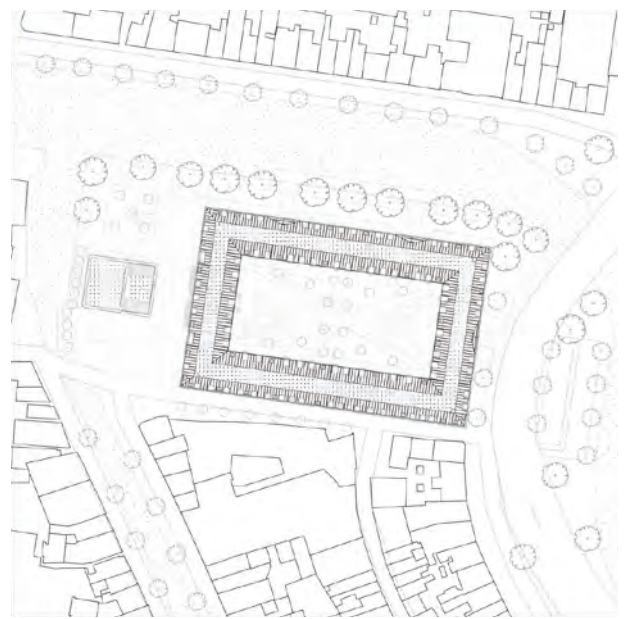

After

FLOOR PLAN

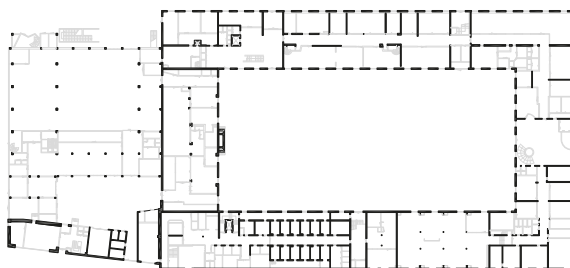

Before

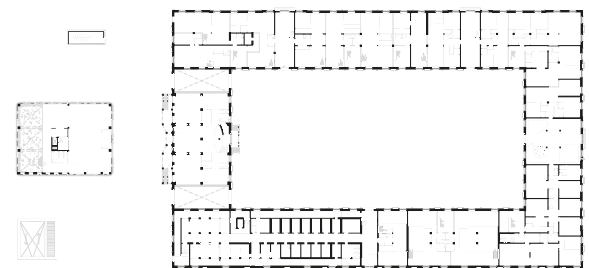

After

SECTION

0 10 M

0 10 M

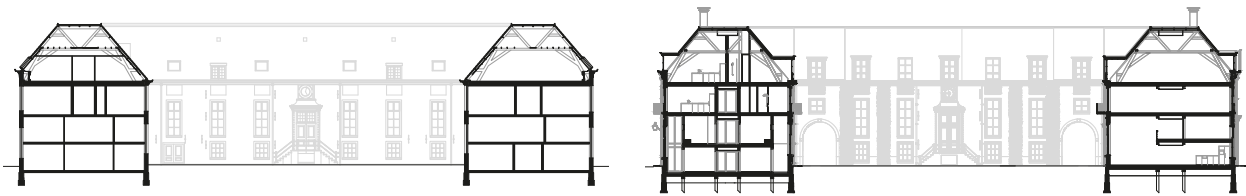

Before

After

FAÇADE

0 25 M

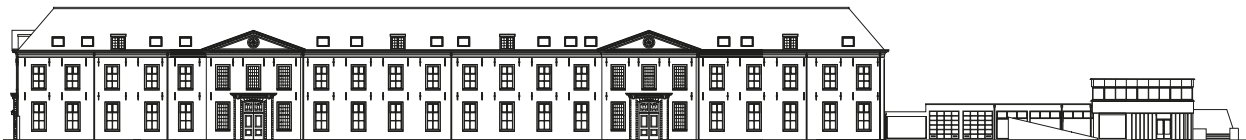

Before



After



BEFORE - Courtyard

(Braunius, 2021)

The monumental Koudenhorn building on the edge of Haarlem's old town centre was built in 1771 as a deaconry house. The extension is not monumental and was built in 1968. Many functions changed over the years. The monumental building consists of four sides surrounding a large courtyard, which originally contained an ornamental garden, but which is currently lacking in nature-inclusivity. This is also the case in the façades of the building. The original building had a spacious layout, which has changed significantly over the years. Some of the old spaces, such as the old entrances and the dining hall, are still present. The building is built in the neoclassical style. However, the South and West façades do not follow these style principles and can therefore be adapted. The current routing of the building is unclear and unpleasant and consists of a long central corridor with rooms on both sides. The extension is in stark contrast to the monument, blocking the view to and from the monument and detracting from its clear volume. One quality of the plot is that it is surrounded by water on three sides, but a connection is hardly made with it. The water is part of the ecological

structure of the city. The tree structure is interrupted locally on the plot. There are also a number of blocking and disruptive elements for fauna on the plot

My research discusses twenty nature-inclusive options. The possibilities that could be applied to the façades and the immediate surroundings of a building are addressed. Subsequently, three decision trees were created on the basis of the applicability of the nature-inclusive option on a monumental building. By filling in the decision trees for the monumental part of the Koudenhorn building, it emerged that 19 nature-inclusive possibilities can be applied to the plot and the façade of the building. The research resulted in the following design question: How can the monumental building Koudenhorn in the urban context of Haarlem be re-designed to be more nature-inclusive? The aim of the design is to create harmony between humans and animals in a nature-inclusive built environment, in which a strong connection with the courtyard and surrounding increases the quality of living and working.



AFTER - Courtyard

In the re-design, a mix of functions was chosen that results in a more vibrant place with the main function being that of housing, referring to the original function. A variety of spacious maisonettes, apartments, lofts and studios for young couples, families and elderly people have been designed in the monumental building. A community centre has been placed in the old dining hall. It is intended for the residents of the building and local residents. In the heavy concrete rhythmic spaces on the ground floor and entresol, art studios have been designed for artists and craftsman. A botanical café-restaurant has been added to the extension. The various dwellings are accessible through 11 porches and two corridors. These porches are connected to the highly valued courtyard and use is made of the old entrances, through which these elements will be experienced.

The first concept is to create unity, and restore sight and the clear volume of the monument. This is done by removing a part of the extension and adjusting the façades. The second concept is to enhance the connection with the water. The courtyard is connected to

a jetty on the water by means of two blue axes and the public space by means of two large stairs in the quay that lead to two terrace boats.

In addition, connections are made with the existing ecological structure. In addition, the structure is strengthened by the realization of a nature-inclusive building and plot. This is done by dividing the plot into different zones, in which the ideal living space for the various animal species is created. The nature-inclusive possibilities that emerged from the research were used here. In the end, 17 of the 19 suitable possibilities were applied. In the western wing, two fauna passages have been created, through which two green axes enter the courtyard.

Finally, a connection to the nature-inclusive oasis around the plot has been realised. This is achieved by having almost all the residences oriented on two sides and connected to the courtyard. Also by applying new façade elements and indoor gardens.

This results in a re-design where people and animals live together in harmony in a vibrant nature-inclusive built environment.

PUBLICIZING VACANT HERITAGE

Haarlem

How could the Koudenhorn building in Haarlem be transformed into a building that will be perceived as a public accessible space by future users?

Keywords: heritage, transformation, reuse, public interior, accessibility, public space, opening-up

Vacant Heritage - Police Real Estate | The Netherlands

URBAN BLOCK

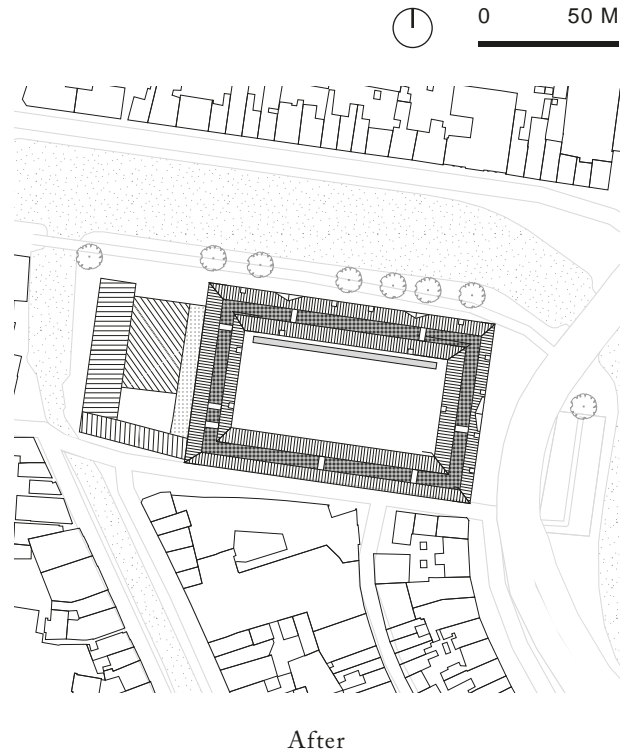
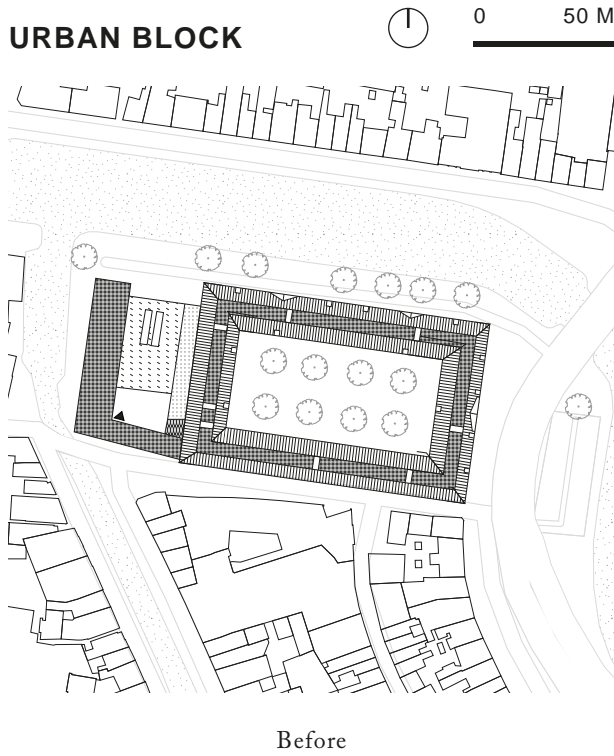

FLOOR PLAN

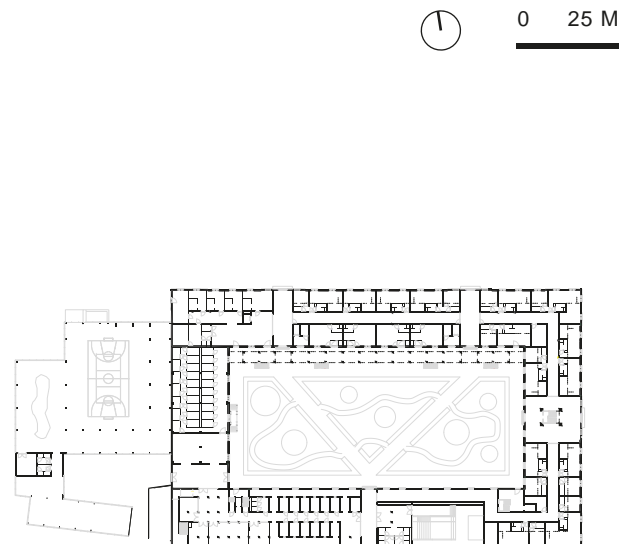
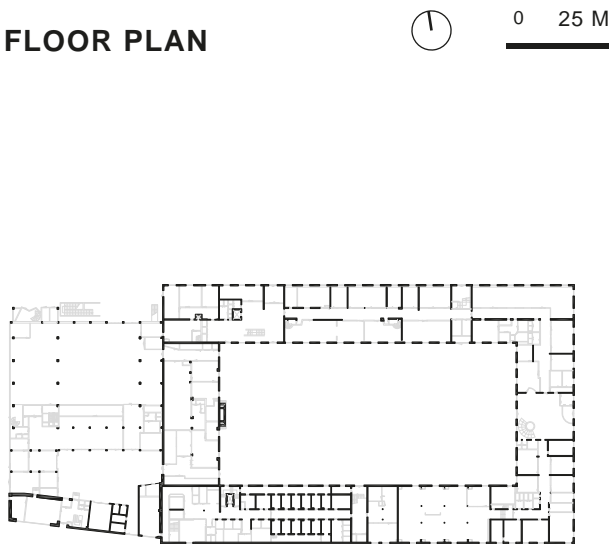

SECTION

0 10 M

0 10 M

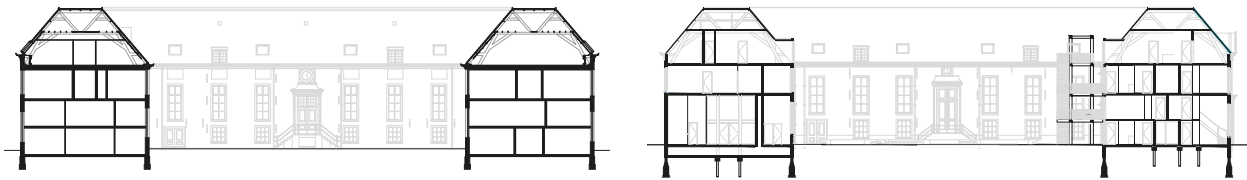

Before

After

FAÇADE

0 25 M



Before

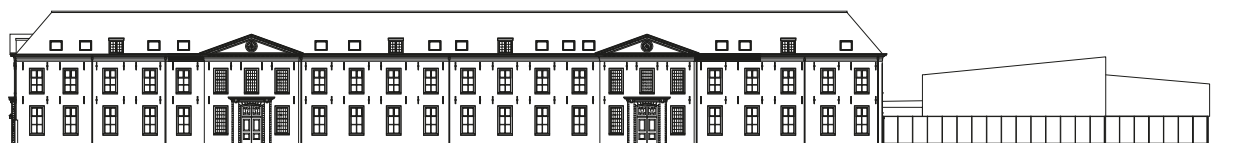

After



BEFORE - Courtyard

(Braunius, 2022)

The need for housing is still a relevant problem. Part of this problem is assigned to elderly, while they often only move out of their current dwelling when they are in need for housing combined with care. However, the actual problem, which is also visible in Haarlem, is a shortage of suitable elderly housing. Also elderly housing is often experienced as not appealing enough to move to before people are in need of care. This led to the following design question: How could the Koudenhorn in Haarlem be transformed into attractive elderly housing that includes public accessible functions to stimulate social interaction both amongst the inhabitants and with the neighborhood.

The literature research into public interiors, porosity and theories of Jan Gehl about the use of public spaces led to focus points for a case study research to see which architectural elements have an influence on the public

character of an interior or enclosed space. The case study research resulted in strategies for each focus points and those strategies led to various starting points for the re-design of the Koudenhorn. Those starting points are; the addition of the courtyard to the pedestrian network of the city and using the existing monumental entrances as passages. so people enter the enclosed space of the building without entering the building. Mixing functions in both a horizontal and vertical way and the assembling of entrances on the courtyard and passages leads to an assembling of functions and people of various groups making use of the same public space. In this way, the courtyard functions as a central open space, especially if the circulation space in the building is located along the courtyard façades. The design of borders and boundaries and the materialization of it is a last important starting point, while this influences the feeling of how accessible certain spaces are.



AFTER - Courtyard

(De Gouw, 2022)

The design goal contains two important concepts which are the public accessibility and the social interaction. Those concepts led to the following additional design starting points. Mixing public, collective and private functions throughout the building. Using the existing spatial qualities for public functions. Adding a gallery to stimulate social interaction. And replacing the façade of the newer volume to create a more appealing and open volume.

The last two starting points have the most influence on the expression of the building. The gallery is added to stimulate social interaction. It not only serves as circulation space for the dwellings, but it also connects to collective spaces such as music or art studios and creates spaces for social interaction for the inhabitants of the building.

The newer volume should become the largest public accessible use in the form of a mixed use volume that can function for the inhabitants of the building, people in

the neighborhood or schools and child care facilities with various user scenarios throughout the day. While this volume has lower values compared to the older volume, it allows for larger interventions to open up this building. The new volume will make use of the existing structure where possible.

The main function in the re-design is housing for elderly. Multiple typologies of dwellings are implemented with the idea that people can move within the building when they are in need for additional care and can even spend their time in the building until their last days in the hospice. The housing is combined with collective functions, such as a library, cooking studio, art and music studio and restaurant. A makerspace and exhibition area is located in the cell wing and a restaurant is located in the former dining hall of the Koudenhorn. Combining those functions in the design should create an appealing housing situation for elderly with functions that benefit them and the surroundings.

PART 5
REFLECTION ON DESIGN SOLUTIONS

PART 5: REFLECTION ON DESIGN SOLUTIONS

by Hielkje Zijlstra and Lidy Meijers

Architecture, however—the world of objects created by architecture—is not only described by types, it is also produced through them. If this notion can be accepted, it can be understood why and how the architect identifies his work with a precise type. He is initially trapped by the type because it is the way he knows. Later he can act on it; he can destroy it, transform it, respect it. But he starts from the type. The design process is a way of bringing the elements of a typology – the idea of a formal structure – into the precise state that characterizes the single work’. (Rafael Moneo 1978)¹

The comparative study of this graduation studio deals with the Spatial Building Typology (SBT) of buildings used by the Dutch Police in the Netherlands. First, the

analysis of eight locations was made at four scale levels on twelve aspects. The Dutch Police plans to divest 30% of its real estate in the coming years. Through the study in the HA studio, possibilities for re-design were explored. Of the eight buildings examined, five were originally built for the police and three were built for a different function and were still used by the police at the time of study.

Because the eight buildings are very diverse in size and type, based on the location analysis in PART 1 of this study, the buildings have been classified according to the spatial main shape and the complexity (See Figure 1). For Haarlem, both the situation without and with the volume from 1971 has been taken into account.

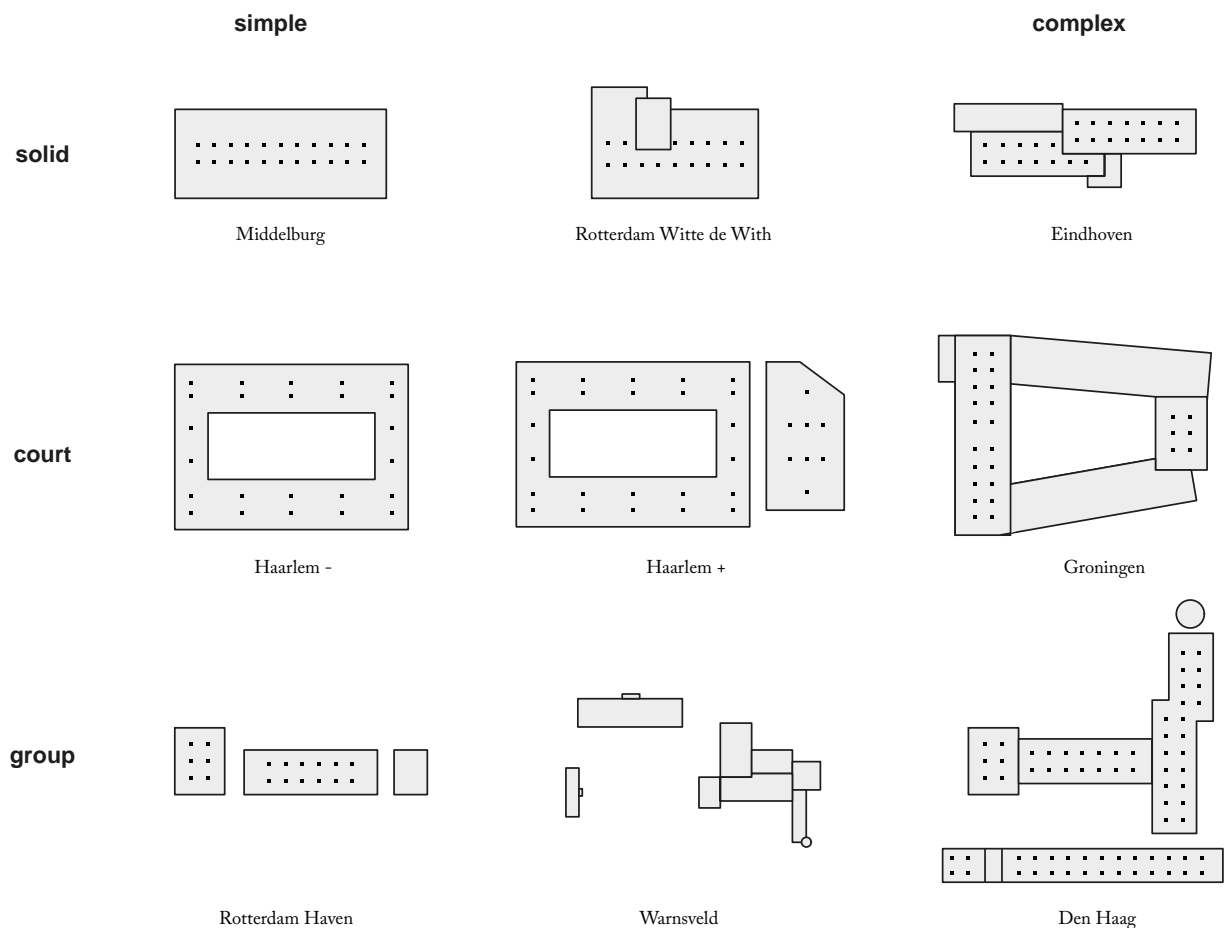

Figure 1: Matrix of division of the buildings according to main shape and degree of complexity (based on floor plans).

¹Moneo, R. (1978). On Typology. In: Oppositions, MIT press 13 (1978) 22-45

City and building block

The sites of all the analysed police real estate are within the urban fabric of 1900 and are connected with the primary network or nearby as shown in PART 1 and PART 2. The buildings of the Harbour police are at the main waterway in Rotterdam, and also the 'reused' buildings for police stations like Haarlem and Warnsveld are connected to water. But for the police itself it is not used in both cases. The building complexes and spaces of Groningen, Haarlem, Harbour police Rotterdam and Eindhoven form a building block itself and are visible from all sides in the context. The Hague, Witte de With, Middelburg are present in a building block in the urban fabric and not visible from all sides. Warnsveld is a complex of buildings in the landscape instead of in a city. The position of the buildings was near or in the centre of the city to be quick at the site and provide easy public access and they need to be visible to be recognised.

Building block and building

From Middelburg and Rotterdam Witte de Withstraat the main form is relatively simple. However, they are part of a building block and are connected on two sides to other buildings in the block (see part 1 – Building Block). Also Eindhoven appears as one volume.

The hollowed-out volumes Haarlem and Groningen, form building blocks on their own, but are part of the urban fabric. The Haarlem building was extended in 1971 replacing another volume.

The building in The Hague is also part of a building block of which the buildings around the main volumes are also used by the police. Over time the main volume doubled and other volumes were added to the program. Rotterdam Haven forms islands in the urban context. It developed in three stages. Every stage has its one building volume. Warnsveld, which was originally an estate, is light as an enclave in the rural area and was extended with different volumes over time as well. Some are connected to main house and some are not.

Time and function

The development over time also plays a role in the typological classification. The buildings that have been expanded over time have a higher degree of complexity, but are not the most complex ones. Three buildings: Rotterdam Witte de With, Haarlem + and Warnsveld have been adapted to the various functions over time, but this did not lead to a high degree of complexity. If that is the case, the users will look for another location. The buildings with the highest degree of complexity are the three large unified 'offices + police facilities' types (based on their original function): Eindhoven, Groningen and The Hague. The last one is placed in the matrix (Figure 1) are at the bottom right because it has also been expanded for the police itself with a more complex building volume in itself. Before the extension, it fell into the top category: a simple monolithic building. The Rotterdam Haven building was originally built for the police and was expanded twice with a separate volume, resulting in an unambiguous design, but still very clear overview of volumes related to the time they were realized. After the WO II most of the buildings are realised or extended because of the reorganisation of the Dutch police.

Base Types

Ultimately, this ordering leads to three basic types that can be seen in Figure 2: 1 Solid, 2 Court and 3 Group. For type 2 Court an extra type is introduced because the Haarlem building was extended with an extra volume in 1971 and doesn't fit in clearly in type 2. Based on this typology, the design proposals made by the students are analysed and compared. Based on these analyses a re-design typology could be developed. Re-designs were made for six locations by the students dealing with the SBT research: Rotterdam Witte de With, Eindhoven, Groningen, Haarlem + extension, Warnsveld and The Hague (indicated in bold in Figure 2).

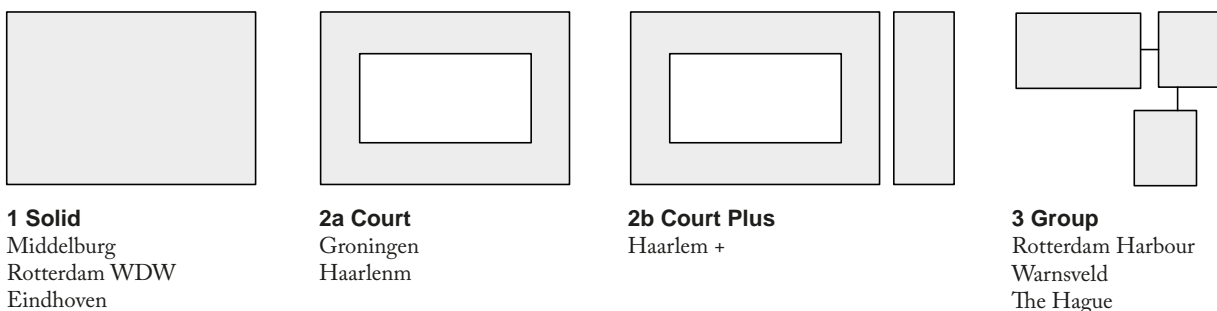

Figure 2: Base Types of the buildings according to main shape and degree of complexity based on the top view: 1 Solid, 2a Court, 2b Court Plus and 3 Group.

A Fill In applied 3x



B1 Add Supplement 1x applied



B2 Add Expand 3x applied



B3 Add Top Up 3x applied

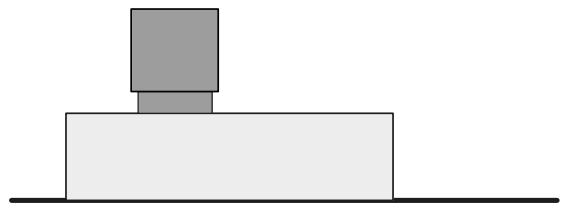

C Redistribute 2x applied

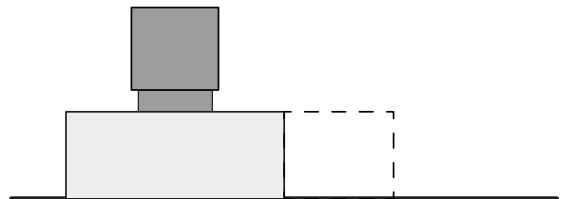

D Shrink



Figure 3: Re-design typology – drawn from a front view perspective – applied by the twelve students

RE-DESIGN TYPOLOGY

In the design proposals we can distinguish to four main types: A Fill In, B Add, C Redistribute and D Shrink. Type B Add has been worked out in three different ways: B1 Add Supplement – addition separated from the main volume; B2 Add Expand – addition connected to the main volume; and B3 Add Top Up – addition on top of the main volume.

Type A Fill In can be seen in the design for The Hague by Arne and in Groningen by Aiste R. In parts we also see A Fill In in the designs for the main house in Warnsveld by Mathyn and Noah, but here volumes have also been added to the collection of buildings on the site, which falls under type B2 Add Expand. For Warnsveld, Hilko only extends the main house and so falls under B1 Add Supplement. B1 Add Expand by Lucca was chosen for Eindhoven by adding several buildings at the location.

The designs by Tjeu and Annemiek for Haarlem are also of type B3 Add Top Up with a relatively small extension on top of the volume of the extension from 1971. Aiste M opts for B3 Add Top Up with a large volume on top of the existing building on the Witte de Withstraat in Rotterdam. Michail has chosen in The Hague for C Redistribute by removing parts and adding volume elsewhere. Robin and Mick opted for Haarlem for D Shrink by removing more volume from the 1971 parts than they add.

All types are listed in the table in Figure 4. If we put the base types of the locations next to the re-design types, we see the re-design options based on the combination of a base types and re-design types in Figure 5.

Re-design Type	Base Type	Location	Student
A Fill In	2a Court	Groningen	Aiste R
	3 Group	Den Haag	Arne
B1 Add Supplement	3 Group	Warnsveld	Hilko
B2 Add Expand	1 Solid	Eindhoven	Lucca
	3 Group	Warnsveld	Noah
	3 Group	Warnsveld	Mathyn
B3 Add Top Up	1 Solid	Rotterdam Witte de With	Aiste M
	2b Court Plus	Haarlem	Annemiek
C Redistribute	2b Court Plus	Haarlem	Robin
	3 Group	Den Haag	Michail
D Shrink	2b Court Plus	Haarlem	Mick
	2b Court Plus	Haarlem	Tjeu

Figure 4: Overview of Re-design Types, Locations, Base Type and Student

Top view



1 Solid



B2 Add Expand 1x

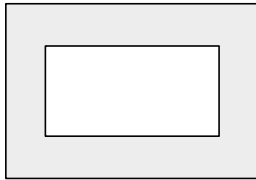

2a Court



A Fill In 1x

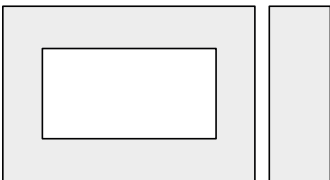

2b Court Plus

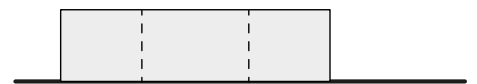

A Fill In applied 1x

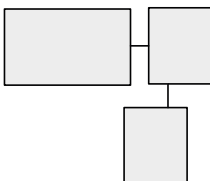

3 Group



A Fill In applied 1x

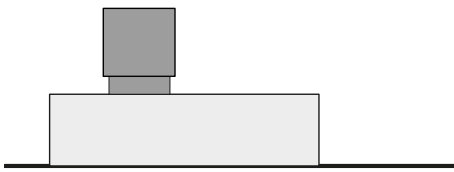

B3 Add Top Up 1x

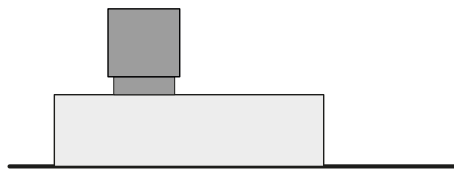

B3 Add Top Up 1x



D Shrink 2x



B1 Add Supplement 1x applied



B2 Add Expand 2x applied

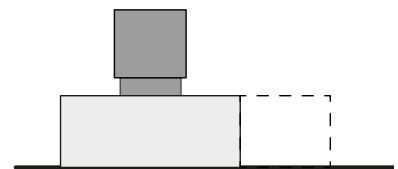

C Redistribute 1x applied

Figure 5: Combination of Base Types and Re-design Types

PART 6
FINAL CONCLUSIONS

PART 6: CONCLUSIONS

In the Spatial Building Typology study Volume 2, eight locations of buildings owned by the national police in the Netherlands were investigated in order to analyse the spatial characteristics in order to arrive at a typology. Compared to the SBT Volume 1 Department Stores | V&Ds, the study was more complex to reach general conclusions. All buildings except the one in Warnsveld are located in an urban context within the inner-city ring. All are well connected via primary and secondary roads with the city centre and the hinterland. Of the eight buildings, three were not originally designed as police stations: Haarlem, Warnsveld and Rotterdam Witte de Withstraat. To make it suitable for the police functions in Haarlem a volume next to the courtyard was replaced in 1971. For Rotterdam Witte de Withstraat and Warnsveld the functions of the police could be accommodated with adjustments within the existing volumes. At the Rotterdam Harbour and The Hague locations, we see significant expansions in volume over time. In Groningen, the office has been radically adapted within the existing volume. In Eindhoven and Middelburg, the police were also able to continue to carry out their activities within the existing volume.

Spatial Typology

The urban context of the buildings made possible that they could expand or shrink. New volumes could be added or more public space could be realised on ground level. In all designs the students wanted the buildings to be opened to the public and become even a public interior. More interaction in the urban fabric was realized or even whole blocks were made public accessible and more volumes have been added. The spirit of place, the historical values and layers of time helped to define the characteristics of the sites and buildings and ideas for new use and programs.

In essence, the larger office buildings are characterized by an elongated volume with a central corridor with smaller rooms on two sides that are used. In some places, larger hall-shaped spaces are realized that are suitable to use with many people at the same time, like lecture halls, restaurant and meeting rooms. There are also concentrations of smaller rooms for one person in the form of a cell blocks. Outside at the site there are always parking and storage facilities placed that are closed off from the public domain by a fence or gate. In Warnsveld, which is used as a training institute, we see less smaller spaces, but the entire building, which was originally a country house, is more like a collection of interconnected medium-sized spaces.

If we then look at a spatial typology at the building level (based on the floor plan), we see 3 Base Types: 1 Solid; 2 Court and 3 Group.

Individual research themes:

Twelve students made re-designs for six locations. In addition to the Spatial Building Typology research, they formulated an individual research question based on spatial characteristics and personal fascination. This resulted in the following research subjects (see PART 2) that guided their designs:

- Noah van Asselt: Experiencing the building typology of a *havezate*.

The Warnsveld location is positioned in the historical typology and development of *havezates* in this region of the Netherlands. A typology matrix is worked out. The identified intervention options will be tested in the re-design for Huis 'T Velde.

- Arne Boenders: How will we live together?

This Venice Biennale theme inspired Arne for his research. The symbiose between urban metabolism and the re-design of a particular building are investigated. All cycles in the neighbourhood Archipelbuurt in Den Haag have been worked out. The former *eenheidsbureau* of the police will contribute to this symbiose and tested if cycles can be closed and the building can contribute to a circular habitat on the scale of the neighbourhood.

- Annemiek Braunius: Permanent Space / Changeable Use.

The Haarlem Koudenhorn building from the 18th century will be transformed for a new future use including housing. Is it possible to apply an open building method on an existing (1st grade listed) building? The re-design will show the answer.

- Lucca Fischer: Architectural Young Classics.

The police building at the Mathildelaan in Eindhoven built in the 1980's is not listed, but it has characteristics that are valued to take into account in a re-design. In a more sustainable world, carbon emissions can be limited through a long-life cycle of buildings while 1970-80s buildings make up almost 30 % of the Dutch office stock. Lucca examines characteristics of this building period that provide opportunities for sustainable re-design. She outlines a strategy on the example of the Eindhoven police, which has so far been considered critical for further development by the police.

- Tjeu de Gouw:

Publicizing Vacant Heritage. The Koudenhorn building in Haarlem is a closed of courtyard building. To connect it more with the city and open it up to the public and form a new public interior is the topic of this research. Based on theories of Gehl and De Boer the next focus points are defined: Embedding in the city; Assembling of functions; Entrances; Atrium / void; Daylight; Visual connections; Security; Materiality and Interior design. Based on an analysis of six case studies and tested in the Koudenhorn building in Haarlem with housing and facilities for elderly.

- Mick van den Hoek: Central Spaces / Public Spaces.

Based on a throughout case study research of six locations a typology of courtyard buildings has been defined. The concluded design intervention strategies will be tested on the Koudenhorn building in Haarlem including a library and housing.

- Mathyn Klein: Sustainable re-design of estate Huis 't Velde in Warnsveld.

Based on theories of Bloszies and Coenen nine strategies on designing with heritage have been defined. The impact on the building and environment will lead to different design options for the case in Warnsveld. Also, the approach on sustainability will draw guidelines for the approach Mathyn will apply this on Huis 't Velde and the whole area of the original estate.

- Aiste Mankute: Activating the 'Glass Box'.

The building in Rotterdam Witte de Withstraat 25 in Rotterdam was original designed for a newspaper. The building changed overtime. It is a modern style historical building, but not listed (yet). The city of Rotterdam wants to densify and connect the Witte de Withstraat to the highstreets of the inner-city. So, this building and location have potential. By adding extra volume and new functions both will be combined at this location.

- Michael Mexis: Structure & adaptability.

All buildings will change, but how does the load-bearing structure effects the intervention options? By comparing three cases from the eight police cases general conclusions can be drawn based on a theoretical framework derived from Remøy, Van der Voordt et al., Ebbert, Azizi and Charleson. The two buildings in The Hague with a different structural scheme will serve as test location for the final approach including a university.

- Aiste Rakauskaite: Isolated Island in the inner city of Groningen.

After an analysis of the building in Groningen and a lot of interviews with neighbours the program for a building that serves the neighbourhood started to develop. The program definition from 'NO students' to 'YES PLEASE students' is the challenge in that will be proofed in the re-design.

- Hilko Riepema: Story-based adaptive reuse of country houses.

Huis 't Velde in Warnsveld was rented by the police for some time. They will pass by like many others. All leave traces and stories behind. Hilko tries to find the characteristics from every time and adds a new layer, but also articulate the existing ones that disappeared.

- Robin Simons: The Nature-Inclusive Re-design.

All built locations could be improved to include more natural aspects from the start. But what about listed monuments that will be redeveloped? Is it possible to include nature here as well? Robin designed a toolbox / decision tree to make clear what is possible or not. His conclusions will be tested at the Koudenhorn building in Haarlem.

FINAL CONCLUSIONS

The definition for a typology of these analyses of Police real estate is divided in three as before mentioned.

Finally, it remains the task of answering the research questions formulated at the start of the study.

- First: Can the analysis of 12 characteristics on four scale levels lead to a spatial typology of the buildings of the Dutch Police?

Yes, a basic typology has been defined for the eight buildings based on the spatial characteristics: 1. Solid; 2. Court; 3. Group.

- Second: Can this spatial building typology provide guidance for the possibilities for the re-design of these buildings?

We do see that the simpler basic types 1 Solid and 2 Court lend themselves to a simpler solution direction: A Fill in or B Add or D Shrink. In the more complex existing configurations 3 Group we see more different re-design options and combinations are made of removing and adding that even lead to C Redistribute.

- Third: Can a re-design typology be derived for the buildings of the Dutch Police more in general based on the design options from the design projects from the students?

Yes, a series of re-design types has been defined: A Fill In; B Add; C Redistribute; and D Shrink.

Ultimately, it can be concluded that the eight locations that were subject for the Spatial Building Typology research have various options for re-design. It does not depend on the degree of complexity of the base types which re-design types are applied. The number of designs is too small to draw any generic conclusions, but the re-design proposals indicate that there are various options for repurposing police real estate for other functions and uses in the future.

We conclude overall that this Heritage & Architecture | Vacant Heritage graduation studio led to series of inspiring re-designs. Thanks to the students and the supervisors from the Politie Bouwmeester, TU Delft MBE and H&A.

This book is Volume 2 in the book series Spatial Building Typology. It is the result of ten months of work within the Heritage & Architecture graduation studio Vacant Heritage (2021-2022) at the Faculty of Architecture in the Built Environment of the Delft University of Technology. A group of fourteen students investigated the spatial qualities of eight buildings currently used by the police in the Netherlands and probably becoming vacant in the near future. In the HA studio we are looking for options and solution for the re-design of those buildings with new uses. Spatial building types could be derived from the level of the inner city, the building block, the building object and the building envelope. In addition to the joint research, they elaborated on individual themes. Subsequently, re-designs were made at six locations. Those designs generated several spatial re-design types.

We thank the Nationale Politie and colleagues from the department MBE for this fruitful collaboration.

Hielkje Zijlstra & Lidy Meijers

ISBN: 978-94-6366-533-9

