



Team time trial strategy optimization

Model development and
optimization for the team time
trial in road cycling

W. Tel

Team Time Trial strategy optimization

Model development and optimization for the
team time trial in road cycling

by

W. Tel

to obtain the degree of Master of Science
at the Delft University of Technology,
to be defended publicly on Wednesday April 22, 2020 at 10:00 AM.

Student number: 4245245
Project duration: February 4, 2019 – April 22, 2020
Thesis committee: Dr. ir. A. L. Schwab, TU Delft, supervisor
Dr. D. H. Plettenburg, TU Delft
J. P. Meijaard, TU Delft

This thesis is confidential and cannot be made public until April 22, 2022.

An electronic version of this thesis is available at <http://repository.tudelft.nl/>.

Cover image: Team Sunweb | Cor Vos

Preface

This report contains my thesis work, which I have been working on for the past eight months. It concerns finding the optimal strategy for a team time trial in road cycling. As a keen cyclist, this subject is not only fascinating to me from professional point of view, but also on personal level. Being able to work together with the people at team Sunweb and getting a small glimpse into the world of professional cycling has been amazing. I'm proud of the work that lays before you and I'd like to thank everybody who helped me over the past months. First of all dr. Schwab from the TU Delft and Teun and Harm from team Sunweb for their help and guidance. My friends and family for supporting me throughout my studies and finally 'het 16e' and my girlfriend, Maaïke, for scrutinizing every word in this report to make sure it was up to par. Every word except the ones written here, these mistakes will be completely my own and the last mistakes I will ever make as a student at the TU Delft.

W. Tel
Delft, April 2020

Contents

List of symbols	1
1 Introduction	3
1.1 Previous work and background	3
2 Modelling	5
2.1 Mechanical model	5
2.2 Drag reduction model.	7
2.3 Physiological model.	8
2.4 Modelling of the changing maneuver	9
2.4.1 Analysis	10
2.4.2 Curve fitting	10
2.4.3 Modeling.	12
2.4.4 Evaluation	14
2.5 Model overview	14
2.5.1 Setting the strategy.	14
2.5.2 Simulation	16
3 Optimization	17
3.1 Method	17
3.1.1 Riders	17
3.1.2 Courses	18
3.1.3 Optimization function	18
3.1.4 Algorithm selection	19
3.1.5 Genetic algorithm explanation.	20
3.2 Optimization results	21
3.2.1 Results of two segment optimization.	22
3.2.2 Results of four segment optimization	24
3.2.3 Results of two segment optimization with turn skipping.	26
3.2.4 Results of four segment optimization with turn skipping.	27
3.3 Discussion	28
3.4 Conclusions.	29
4 Sensitivity analysis	33
4.1 Method	33
4.2 Sensitivity analysis results.	33
4.2.1 Conclusion.	34
5 Practical use of research results	37
5.1 Matlab application	37
5.2 Strategy guidelines and scenarios	38
5.2.1 Guidelines	38
5.2.2 Fictional time trial scenarios.	38
5.3 Validation.	39
5.3.1 Course	40
5.3.2 Rider parameters.	40
5.3.3 Original strategy	41
5.3.4 Strategy using new guidelines	41
5.3.5 Optimization algorithm strategy	44
5.3.6 Strategy comparison	44
5.3.7 Conclusion.	45

6 Recommendations	47
6.1 Team time trial model	47
6.1.1 Drag reduction model	47
6.1.2 Rider exertion	47
6.1.3 Model reliability	47
6.2 Optimization algorithm	48
6.3 Strategy optimization	48
A Appendix	49
A.1 Results of optimizations with and without head times	49
A.2 Results of optimizations for guidelines	52
Bibliography	53

List of symbols

Symbol	Unit	Description
η	-	Coefficient describing drive-train efficiency
ρ	kg/m^3	Air density
ϕ	deg	Gradient of a slope
A	m^2	Frontal area
a	m/s^2	Acceleration
C_d	-	Aerodynamic drag coefficient
C_{dr}	-	Aerodynamic drag reduction coefficient
$C_d A$	m^2	Aerodynamic drag coefficient and frontal area
C_r	-	Rolling resistance coefficient
F_d	N	Aerodynamic drag force
F_g	N	Gravitational drag force
F_p	N	Propelling force produced by the rider
F_r	N	Rolling resistance force
m	kg	mass
v	m/s	Velocity
τ	s	Constant describing recovery speed in critical power model
CP	W	Critical power
P	W	Power
W'	J	Size of a riders energy reserve
W_{bal}	J	Current state of a riders energy reserve
x_c	m or deg	Course parameters for optimization algorithm
x_{ht}	s	Head time variables for optimization algorithm
x_p	W	Power variables for optimization algorithm
x_r	W, J, kg or none	Rider parameters for optimization algorithm



Introduction

The team time trial is a discipline in road cycling in which all riders of a team ride together to cover a course in the least amount of time. It is often included as a stage of grand tours like the Tour de France. By riding in an echelon the riders can take advantage of a reduction in aerodynamic drag. By alternating turns on the front the riders can ride far above their threshold on the front after which they can recover while drafting behind their teammates allowing them to ride much faster than a solitary cyclist would be able to. A whole team riding a team time trial can consist of up to eight riders with the time of the fourth rider counting as the teams final time. This means that the team can lose four riders over the course of the time trial. A team usually consists of riders with different specialties like climbing, time-trialing, sprinting or riding for the general classification. All these different riders with different attributes make for a lot of different parameters, which makes creating a strategy very complex. Having the right strategy can not only mean winning or losing the stage, but, in the case of a multi stage race, also the entire race. In this thesis we will look into the optimization of strategies for the team time trial.

1.1. Previous work and background

This thesis project builds on the work done by Overtoom [14]. In Overtoom's thesis project he built a model for the team time trial and ran several optimizations to investigate certain properties of the team time trial strategy. This resulted in some interesting findings that are now being used by team Sunweb. However, the work by Overtoom was limited to flat time trials and did not feature any changes in gradient. Apart from this, not a lot of research has been done on this specific subject. Wolf [20] researched two riders working together in a breakaway situation, using an optimization algorithm to find the most efficient strategy. These optimizations were only done for a flat course of 5 km. One of the main findings of the work by Wolf was the most efficient way to perform a position change. However, the objective of this research is not to improve current team time trial technique, but to simulate. The most interesting finding from the research by Wolf, for our research, is the head times resulting from the optimization algorithm. Head times that are much longer than the ones currently used by most cycling teams turned out to be much more efficient. Individual rider parameters also have an influence on the head times. When critical power is increased, the head times get smaller, when anaerobic capacity is increased the head times get longer. There has also been quite some research done into the team pursuit in track cycling like the research by Wagner [19]. The problem with these researches is that the team pursuit in track cycling is a relatively short event, only 4 kilometers for men and 3 kilometers for women. This is much shorter than most team time trials in road cycling which are often between 20 and 50 kilometers. Also, since it is held on a velodrome there is no elevation gain and changing maneuvers are performed in a very different way than we would see on the road.

2

Modelling

To be able to simulate and optimize the strategies for the team time trial a good model is required. The goal of the team time trial is to ride the fastest possible time given the riders we have at our disposal. This means the model will have to tell us two things: the final time, to see whether one strategy is better than the other, and the impact of this strategy on the riders' physiological state, to see whether we can more efficiently distribute the workload. To be able to calculate this final time and physiological impact on the riders we have four main inputs: the physiological parameters of the riders, the parameters describing the course these riders have to complete, the head times, which describe the time each rider has to spend at the front of the group, and lastly the power they have to produce. Figure 2.1 gives a visual representation of the team time trial model. The team time trial model has three main building blocks: The mechanical model, the drag reduction model and the physiological model. The mechanical model describes what kind of speed a rider will ride at when producing a certain amount of power. The drag reduction model describes the benefit a rider has from riding at a specific place in the group. Lastly, the physiological model tells us the impact the race strategy has on the rider's physiological state. In this chapter all these different elements of the model will be introduced and a short overview will be given as to how the complete team time trial model works. Also, the modelling of the changing maneuver will be discussed. The entire model, as described in this chapter, is made using Matlab 2018.

2.1. Mechanical model

The mechanical model describes the forces acting on each of the cyclists in the team. Using these forces, it can calculate the amount of power a rider needs to produce to ride at a certain speed. The mechanical model consists of a single equation which is the equation of motion for a single cyclist. Already in 1979, this equation of motion was described by Prampero [7]. Many papers have been written about the equation of motion for a cyclist since. These are all based on the the same principle, but differ in the amount of detail. Overtoom already made a good overview of several different papers describing the equation of motion of a cyclist for his master thesis [14], hence we will not go into to much detail here. The equation of motion can be described according to Newton's second law (equation 2.1), where the sum of all forces consists of four main forces of which three resistance forces and one force produced by the cyclist that propels the rider forward (figure 2.2). The resistance forces are air drag, F_d , rolling resistance, F_r , and gravitational resistance, F_g . The force produced by the rider is indicated with F_p , which gives us equation 2.2. Since resistance forces from bearings and the chain drive are incredibly small compared to the other forces acting on the cyclist and bicycle we assume them to be negligible.

$$\sum F = m \cdot a \quad (2.1)$$

$$F_p - F_d - F_r - F_g = m \cdot a \quad (2.2)$$

The foremost force acting on the cyclist during the team time trial is the aerodynamic drag force which is described by equation 2.3.

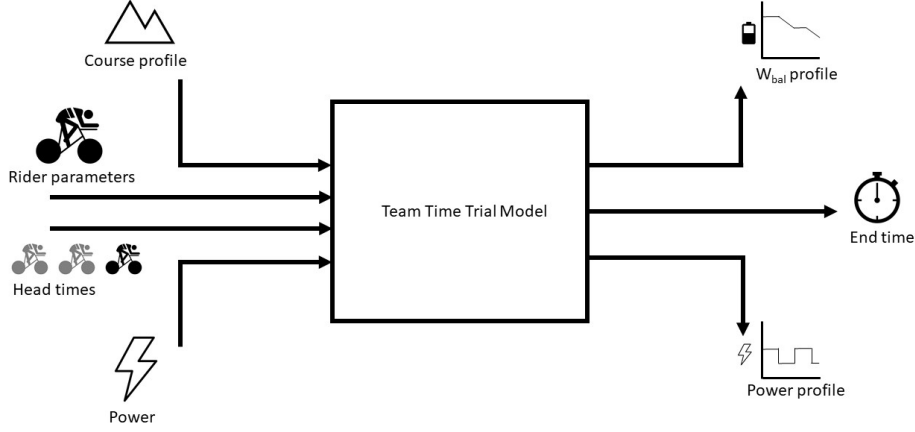

Figure 2.1: Visual representation of the team time trial model.

$$F_d = \frac{1}{2} \rho \cdot C_d A \cdot C_{dr} \cdot v^2 \quad (2.3)$$

Where C_d is the aerodynamic drag coefficient, A the frontal area of the rider, ρ the air density, and C_{dr} , a drag reduction factor that describes the rider's benefit from his position in the group. Although drag coefficient C_d and frontal area A are two separate parameters, we do not use two separate values. Instead, the combined $C_d A$ parameter is used which can be measured in a wind tunnel or with a test in a controlled environment like a velodrome. The drag reduction factor will be further elaborated upon in section 2.2. The rolling resistance is described by equation 2.4.

$$F_r = m \cdot g \cdot C_r \quad (2.4)$$

Where m is the mass of the cyclist, including his bicycle, g is the gravitational constant and C_r is the rolling resistance coefficient. Lastly, we have the gravitational resistance that a rider experiences when riding up a slope. This is given by equation 2.5

$$F_g = m \cdot g \cdot \sin(\phi) \quad (2.5)$$

Where ϕ is the angle of the slope the rider is riding on and m and g are once again the mass of the cyclist and the gravitational constant respectively.

The rider produces force through the pedals to propel himself forward. However, since every rider has a power meter on his bike, we can measure power in real life, hence we would like to express the equation of motion in terms of power. Most modern power meters have a deviation of +/- 1%, which is believed to be precise enough for use in this model. Also, the data from power meters has always been precise enough for use in team Sunweb's individual time trial model. Therefore, we describe the force propelling the rider forward according to 2.6. Where P is the power the rider produces and v the speed the rider is riding at. The power is measured with a power meter based in the cranks. This means the power that is measured is not the power directly propelling the rider forward which calls for an efficiency factor η . However, since we assume the losses in the drive-train are negligible, for our purposes we assume $\eta = 1$.

$$F_p = \frac{P\eta}{v} \quad (2.6)$$

Substituting equations 2.3, 2.4, 2.5 and 2.6 into equation 2.2 gives us the complete equation of motion 2.7.

$$\frac{P\eta}{v} - \frac{1}{2} \rho \cdot C_d A \cdot C_{dr} \cdot v^2 - m \cdot g \cdot C_r - m \cdot g \cdot \sin(\phi) = m \cdot a \quad (2.7)$$

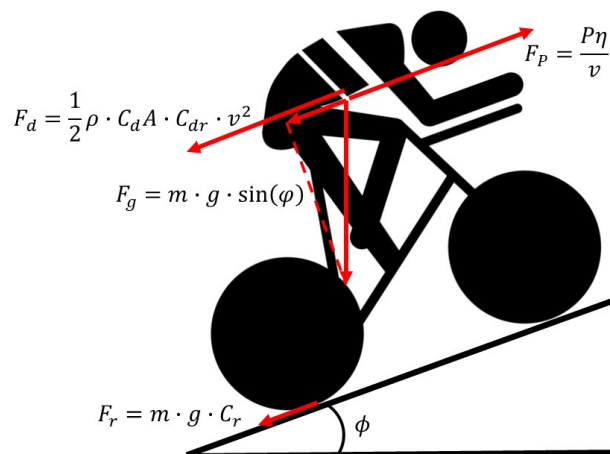

Figure 2.2: Visual representation of the forces acting on the cyclist.

2.2. Drag reduction model

The drag reduction model describes the reduction in aerodynamic drag that a rider experiences riding behind another rider. This is expressed in equation 2.3 as the drag reduction coefficient C_{dr} . This coefficient differs for each positions in the group and also between group sizes. A lot of research has been done on drag reduction in wind tunnels [4] [3] [1], track tests [6] [8] [10] as well as with CFD analysis[4] [11]. Overtoom compared different aerodynamic models in his thesis [14]. The model by Blocken, from 2013, [3] turned out to give the best results when simulating a team time trial. Since then a new paper by Blocken, from 2018, looked into larger groups of cyclists with CFD simulation. [4] This research found much larger drag reduction coefficients than the earlier work by Blocken. We compared simulations using both the drag reduction coefficients from Blocken's 2013 [3] and 2018 [4] research, but found that the larger drag reduction coefficients in the 2018 research resulted in unrealistically high power numbers when used in an optimization. Therefore, we used the drag reduction coefficients from Blocken's 2013 work [3] which can be seen in table 2.1.

Group size	Drag reduction coefficient C_{dr}								
1	1								
2	0.97	0.86							
3	0.97	0.83	0.78						
4	0.97	0.82	0.75	0.73					
5	0.96	0.82	0.75	0.70	0.69				
6	0.97	0.82	0.75	0.69	0.67	0.68			
7	0.96	0.82	0.75	0.70	0.66	0.66	0.66		
8	0.97	0.82	0.75	0.65	0.66	0.65	0.64	0.65	

Table 2.1: Drag reduction coefficients for cyclists in a group as reported by Blocken. [3]

The fact that the C_{dr} values found in the most recent study by Blocken [4] found unrealistically high power numbers may be because the study was done using CFD analysis, which means the riders are always riding with a fixed distance between the rear wheel of the leading cyclist and the front wheel of the trailing cyclist. Also, no lateral deviation between the cyclists can occur, which means the leading rider's rear wheel and the trailing rider's front wheel are always perfectly in line. In real life team time trials this is not the case. There are some other problems with the current drag reduction model. The model we are currently using does not account for the effect that riders of different sizes may have when trailing behind each other. Some research has been done into the influence of different size cyclists [10] [6] [8]. However, these do not provide equations describing the aerodynamic interaction between riders of different sizes, which can be incorporated in a simulation model. Also, since all research has been done either in a wind tunnel a velodrome or using CFD analysis, we only have knowledge of wind that hits the riders head on. Wind under a certain yaw an-

gle might drastically change the drag reduction factor, but for now we simply do not know if this is the case. Therefore, in this research we will always assume zero wind conditions, which means the relative air speed, as experienced by the cyclist, will always be equal to the speed the cyclist is travelling at and the cyclist will only experience air flow under a zero degree yaw angle (i.e. the cyclist will never feel any wind from the side). Although using the drag reduction coefficients in table 2.1 seems to give a realistic representation of the team time trial, the aerodynamic model is far from perfect. A lot is still unclear in this particular field of aerodynamics, especially concerning what happens with respect to the aerodynamics when riding on the open road, with varying wind conditions, corners, flawed riders etc. There is a lot of interesting research currently being done in this field, amongst others, by the TU Delft and team Sunweb. Research using the 'Ring of fire' as well as research using pitot-tube sensors will hopefully give us better insight into the aerodynamics of a team time trial, which will allow us to improve the drag reduction model in the near future.

2.3. Physiological model

With the mechanical and drag reduction model we can calculate the power needed for a certain speed on a certain course. When we know that power, the physiological model can tell us the duration for which the rider can sustain that effort. There are two main physiological models to describe a cyclist. The first one is the Margaria-Morton model [12], which is based on the three energy systems through which humans are able to produce energy: the aerobic, the anaerobic a-lactic and the anaerobic lactic system. The second one is the Critical power model [13] (CP-model), which is based on the functional threshold power, or critical power, of a cyclist. The critical power is the largest amount of power that a cyclist can sustain for a longer amount of time while keeping a constant blood lactate concentration, which is also described as the maximum lactate steady state[17]. More simply put: as long as a cyclist rides with a power less than his critical power he can theoretically cycle for an infinite amount of time, however, when the cyclist surpasses his critical power, the time he can sustain his effort is limited. From these two models the Margaria-Morton model is more detailed, however, it is more cumbersome to implement. Sundström compared the two models for simulating an individual time trial[16]. It was concluded that the Margaria-Morton model gives a more realistic representation of the riders physiology and, therefore, a more realistic optimal pacing strategy. However, tests with real riders should be done to validate these results. Overtoom compared both these models in a team time trial simulation and concluded that there was no advantage to using the Margaria-Morton model[14]. Therefore, since the Critical power model is easier to implement and it is easier to find the parameters necessary to describe a specific cyclist using this model, we chose to implement the Critical power model.

Critical power model The critical power model keeps track of the rider's energy stores on the basis of the power the rider produces. The critical power (or *CP* for short) of the rider is the power threshold below which the rider could, theoretically, ride for an infinite amount of time. When the rider produces more power than his critical power he starts to deplete his energy store. This store can be seen as the rider's battery and is indicated with W_{bal} . The size of this battery varies per rider and is indicated with W' . When a rider produces less power than his critical power he is able to recover and his W_{bal} will be replenished.

This process of depletion and recovery is described by two equations. When the rider rides above his critical power, the depletion of his W_{bal} is described by equation 2.8.

$$\frac{dW_{bal}^-}{dt} = CP - P, \quad P > CP \quad (2.8)$$

Where *CP* is the critical power of the cyclist and *P* the power the rider is producing. When a rider produces less power than his critical power the energy store W_{bal} is replenished. This process is described by equation 2.9.

$$\frac{dW_{bal}^+}{dt} = \frac{W' - W_{bal}}{\tau}, \quad P < CP \quad (2.9)$$

The rate at which W_{bal} is replenished is determined by two factors. Firstly, it depends on the difference between the capacity of the riders energy stores, W' , and the current state of his energy stores, W_{bal} . This means a rider will recuperate faster if his W_{bal} is further drained. Secondly, it depends on a parameter τ . This parameter τ is dependant on the critical power, *CP*, of the rider and the power the rider is producing, *P*. The less power the rider produces the faster the rider will recover. However, it seems that this does not

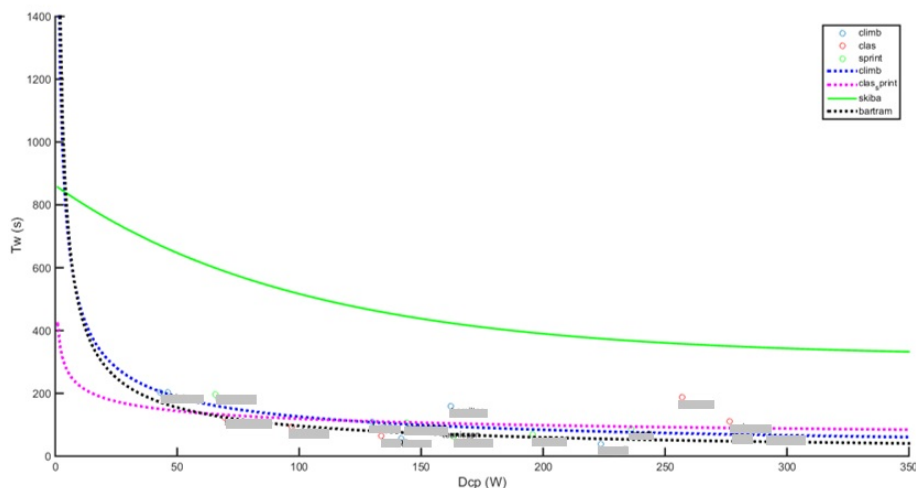

Figure 2.3: Recovery models by Skiba[15] and Bartram [2] compared to data from Team Sunweb riders. T_w stands for the τ in equation 2.9. A lower value indicates faster recovery. Dcp is the difference between the critical power of the rider and the power they had to produce during the recovery interval. To protect the riders' privacy and the interests of team Sunweb, the riders' names have been made unreadable.

happen in a linear fashion as with the depletion modelled by equation 2.8. There are two different research efforts that described the recovery part of the critical power model. Both use the description as shown in equation 2.9, but use a different description for τ . The first research was done by Skiba [15] and the second by Bartram [2]. Skiba used normal healthy male athletes for his research whereas Bartram used elite level cyclists. It is expected that elite level cyclists have a faster recovery than normal individuals. In a previous internal research effort team Sunweb ran tests on their own riders to see what recovery model would best describe their own riders. During the tests the riders were asked to do repeated efforts at a certain power above their critical power. These efforts were alternated with recovery periods during which the riders would ride at a power below their critical power. By repeating these intervals to failure, the recovery parameter τ can be calculated. The data from these tests can be seen in figure 2.3 where the value of τ is plotted against the difference between the critical power and the power a rider is producing during the recovery period, here called Dcp . τ as described by the Skiba model [15] is plotted in green while the Bartram model [2] is shown in black. The test data from the individual Sunweb riders are shown as dots. As can be seen from the graph, they all fit the Bartram model really well. Therefore, we will use the Bartram recovery model where τ is described according to equation 2.10.

$$\tau = 2287.2 \cdot (CP - P)^{-0.688} \quad (2.10)$$

2.4. Modelling of the changing maneuver

One thing that is not yet incorporated in the previous model by Overtoom [14] is a realistic description of the changing maneuver. During the team time trial, the riders take turns riding on the front. When a rider's turn on the front is over, he performs a changing maneuver. The rider peels of the front of the group and slows down to let the rest of the group overtake. The rider then accelerates to join back at the back of the group. In the previous model by Overtoom [14] it was assumed that a rider performing a changing maneuver would ride with a constant speed difference to the group for the time of the changing maneuver. In reality, the front rider peels off and decelerates to a certain point after which he starts accelerating again till the speed matches that of the group. The way these changing maneuvers are performed has an interesting impact on the energy stores, W_{bal} , of the rider. When the front rider peels off, his power drops allowing the rider to recover very slightly. However, to be able to catch back on at the back of the group requires a surge in power which will quickly drain the W_{bal} of the rider. This phenomenon can have a big effect when the rider's W_{bal} is almost empty and might mean the difference between catching back on or being dropped from the group. Hence we believe a correct modelling of the changing maneuver would enhance the reliability of the team time trial simulation. Figure 2.4 shows the power and W_{bal} of two riders riding a flat 5 kilometer time trial alternating

head turns every 30 seconds. The figure illustrates the drop and surge in power and the influence on the W_{bal} of the rider when using the changing maneuver model described in this section.

Nowadays, all riders ride with a bike computer and a power meter on their bicycle. The bike computer saves all data it measures like the speed the rider is travelling at, his pedaling cadence, power, altitude, travelled distance and much more. This data provides us with everything we need to build a decent model of the changing maneuver. The data from actual changing maneuvers is isolated and ordered after which a curve fit is performed. Using the polynomials that result from this curve fit we can then make a model for the changing maneuver for different group sizes.

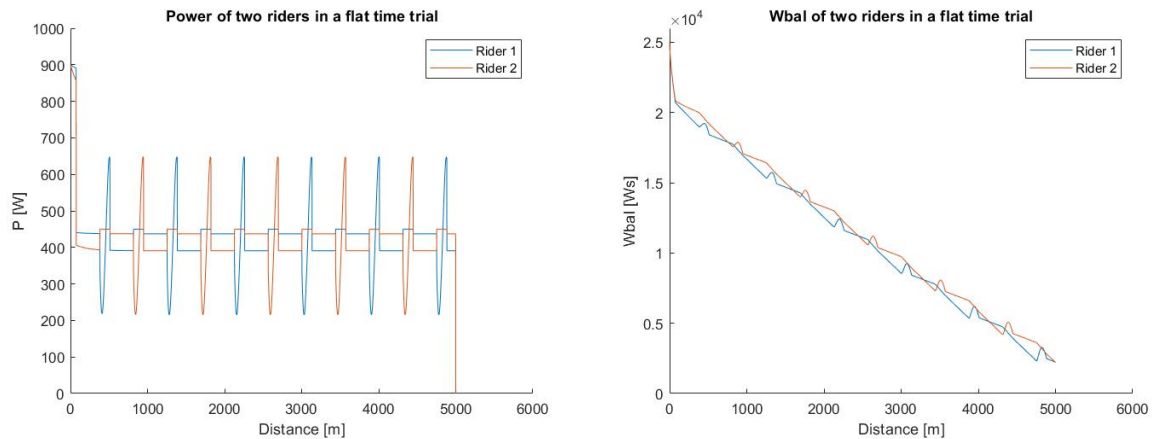

Figure 2.4: Example of the influence of a changing maneuver on the energy stores of a rider. The left picture shows the power of two riders riding a 5 km flat time trial. There is a pronounced dip and spike in the power curve while performing a changing maneuver, which translates into a slight rise and then sharp drop in W_{bal} as can be seen in the right picture.

2.4.1. Analysis

To make a more realistic model of the changing maneuver, real team time trial data is analyzed. Team Sunweb provided data from six team time trials, giving us data of 226 changing maneuvers from 16 unique riders. The data consists of power and speed with a measurement interval of one second.

Since the input for the mechanical model is speed, the easiest way to incorporate the changing dynamics into the model is to describe a speed profile for the rider that is performing the changing maneuver and let the model calculate the required power. Therefore, the speed data of the actual time trials is taken, the changing maneuvers are isolated and the speed difference between the rider performing the changing maneuver and the group is calculated. An example of this speed data for a certain time trial with five different riders can be seen in figure 2.5. You can clearly see the points where a rider performs a changing maneuver. Here, the riders speed drops below the speed of the other riders in the group momentarily. Figure 2.6 shows the speed difference between a rider performing a changing maneuver and the group. The figure shows all changing maneuvers of a single rider during a team time trial. The data of all these changing maneuvers is then sorted by duration of the maneuver in seconds and number of cyclists in the group. When a rider is at the back skipping a turn, the rider performing the changing maneuver has to let one less rider pass by before joining back. Therefore, the group size is defined as the amount of team mates the rider performing the changing maneuver has to let pass before joining back.

2.4.2. Curve fitting

With all the data sorted into subsets with the same length, the average of every subset is taken and a curve fit is performed. When looking at the raw data we see that the acceleration is almost never a linear function. Most of the time it has some kind of curve and sometimes it will have a kind of wave shape characteristic of a third order polynomial. Our goal is to have a model that is as accurate as possible without adding to much computing time. This means writing a function that has the speed of the group and the time that has passed since the rider started the changing maneuver as an input and the speed of the rider performing the changing maneuver as an output. This can be a continuous function but, since the time span of a changing is limited, could also take the form of a look-up table. In this case using a higher order polynomial will therefore not add any significant computing time and we will simply use the polynomial that seems to fit best to our raw data.

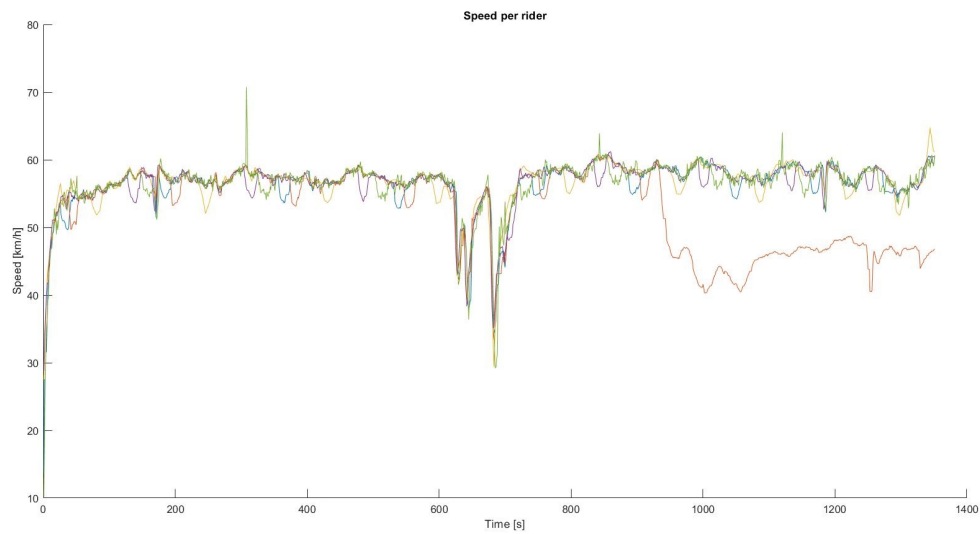

Figure 2.5: Speed data from five different riders in an actual team time trial. You can clearly see the places where a rider performs a changing maneuver. Here one line dips beneath the rest of the lines indicating the speed of one rider temporarily drops to let the other riders pass. One of the riders drops around the 900 second mark.

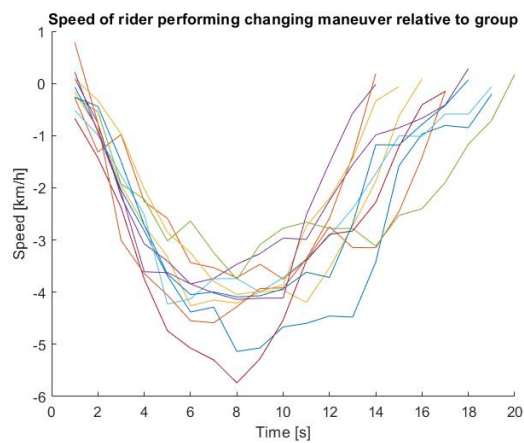

Figure 2.6: Speed of a rider performing a changing maneuver relative to the group. Data from one rider in one team time trial.

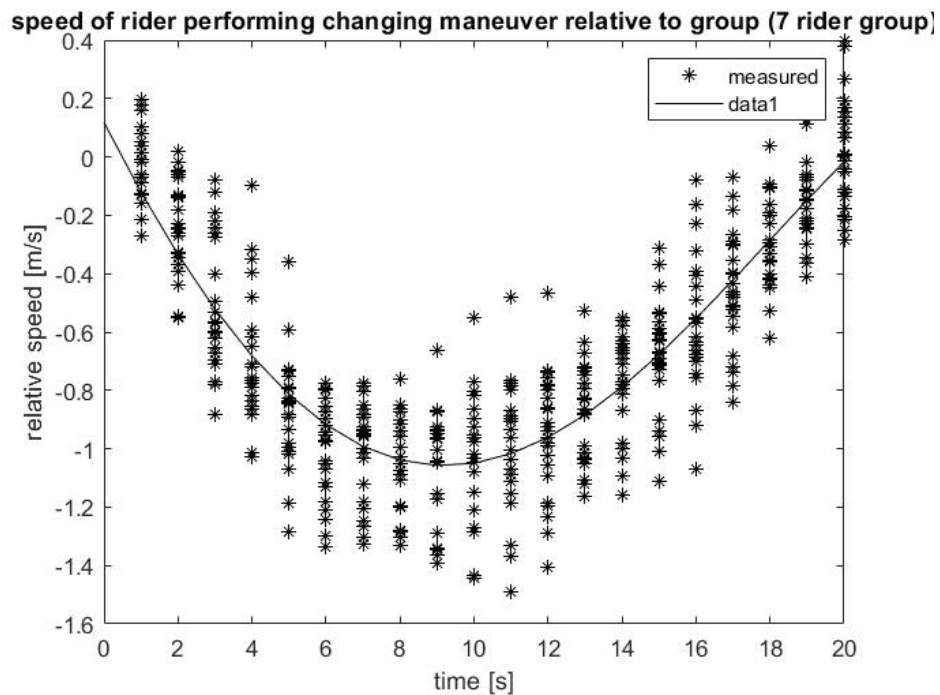

Figure 2.7: Raw data from changing maneuvers all lasting 19 seconds with the fitted curve.

Since the acceleration seems to be of the third order, a fourth order polynomial is used to fit to the velocity data. We have a subset of data for changing maneuvers of varying time length and group sizes. (One subset for a maneuver taking 19 seconds in a seven rider group, one subset for a maneuver taking 20 seconds in a seven rider group, one for a 19 second maneuver in a six rider group etc.) The Matlab function 'fit' is used to fit the polynomial to the data of each subset. The results of the fit of one such subset can be seen in figure 2.7. Figure 2.8 shows the resulting polynomials for all changing maneuvers, of different time lengths, with a seven rider group.

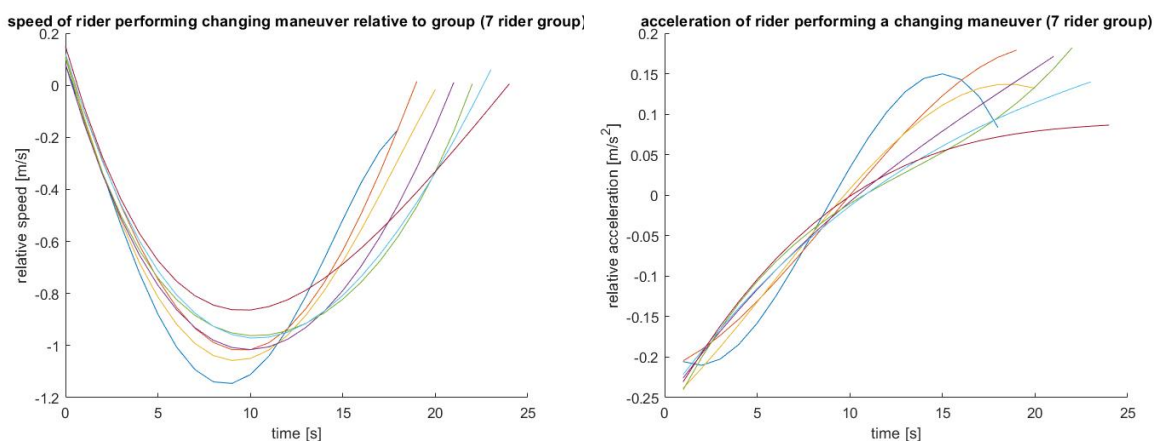

Figure 2.8: Results from the curve fitting. The speed of the rider performing a changing maneuver relative to the group and the acceleration of that rider.

2.4.3. Modeling

We would like to have a function description of the speed of the rider relative to the group that we can use in the model. The function descriptions that resulted from the curve fitting are not yet suitable for this purpose. Since the data only had one data point per second, the speed at the start and endpoint of the changing ma-

neuers is never perfectly zero, hence the functions resulting from the curve fitting are also not exactly zero at the start and end point. However, we will use the findings from the curve fitting to construct a function that describes an average changing maneuver. Just like for the curve fitting we will use a fourth order polynomial of the form of equation 2.11.

$$f(x) = ax^4 + bx^3 + cx^2 + dx + e \quad (2.11)$$

Because we have five unknowns, we need five boundary conditions. We can take all these boundary conditions from the curves that resulted from the curve fitting. This is done for a six and seven rider team since almost all of the data we have concerns either six or seven rider teams. For the model we assume the changing maneuver to last 17 seconds for a six rider group and 19 seconds for a seven rider group since these are the most often occurring changing maneuver lengths that we found in the data. However, to give a more accurate representation, the data of all curve fits is used to make the model description. For team smaller then six or larger then seven riders, we do not have enough data to perform a decent analysis. Therefore, the parameter values for the polynomial 2.11 are extrapolated for groups larger than seven or smaller than six riders. The area under the curve gives the distance that the rider has to drop back (or the additional distance the group has to cover relative to the rider) which is called $S_{echelon}$. The derivative of the velocity function gives the deceleration at the beginning of the changing maneuver, a_0 . The derivative also gives the peak of the function, where the acceleration is zero, which is called t_{max} . Lastly, the speed at the beginning and the end of the maneuver, relative to the group, should be zero, meaning $v(0) = 0$ and $v(end) = 0$.

The resulting boundary conditions from the curve fitting are shown in tables 2.2 and 2.3. For traveled distance we see an average of 13.336 meters for a group of a seven rider team and 11.377 meters for a six rider team, which comes down to 1.905 and 1.896 meters per rider respectively. Therefore, we take a distance of 1.9 meters per rider in the team as a boundary condition for all team sizes. For acceleration at $t=0$, there is a discrepancy between the results from the seven rider team and the six rider team. Therefore, this value will be linearly extrapolated across all team sizes. The same goes for the function peak, where the acceleration is zero. For both these boundary conditions the average values are taken as shown in tables 2.2 and 2.3.

With these boundary conditions we can now fill in the parameters in equation 2.11. First of all we know that $f(0) = 0$ which means $e = 0$. Second we know that $f(t_{end}) = 0$ which gives us equation 2.12. The derivative of $f(x)$ is known for $t = 0$ and $t = t_{max}$ which gives equations 2.13 and 2.14. Lastly, we know that the integral of $f(x)$ between $t = 0$ and $t = t_{end}$ is equal to the length of the echelon, which gives us equation 2.15. By solving this system of equations we can describe a function for the changing maneuver for each group size. The boundary conditions and polynomial parameters for each group size are shown in table 2.4.

$$f(t_{end}) = at_{end}^4 + bt_{end}^3 + ct_{end}^2 + dt_{end} = 0 \quad (2.12)$$

$$\frac{df(t_0)}{dt} = d = a_0 \quad (2.13)$$

$$\frac{df(t_{max})}{dt} = 4at_{max}^3 + 3bt_{max}^2 + 2ct_{max} + d = 0 \quad (2.14)$$

$$\int_0^{t_{end}} f(t)dt = \frac{1}{5}at_{end}^5 + \frac{1}{4}bt_{end}^4 + \frac{1}{3}ct_{end}^3 + \frac{1}{2}dt_{end}^2 = S_{echelon} \quad (2.15)$$

Maneuver duration [s]	17	18	19	20	21	22	23	avg.
Distance traveled [m]	12.71	12.12	13.21	13.92	14.32	14.14	12.93	13.336
Acceleration at t=0 [m/s ²]	-0.210	-0.198	-0.226	-0.211	-0.220	-0.207	-0.212	-0.212
t_{max} [s]	7.646	8.507	8.203	8.928	9.257	9.296	8.577	8.630

Table 2.2: Boundary conditions resulting from curve fitting with data from 7 rider team. The length of changing maneuver most often seen in the data is printed bolt.

Maneuver duration [s]	13	14	15	16	17	18	19	20	21	avg.
Distance traveled [m]	10.31	10.39	11.14	11.37	12.12	12.19	11.98	11.39	11.51	11.377
Acceleration at $t=0$ [m/s^2]	-0.247	-0.185	-0.196	-0.184	-0.19	-0.185	-0.186	-0.172	-0.162	-0.189
t_{max} [s]	6.031	7.163	7.121	7.721	7.902	8.234	9.134	8.753	8.809	7.875

Table 2.3: Boundary conditions resulting from curve fitting with data from 6 rider team. The length of changing maneuver most often seen in the data is printed bolt.

# riders	2	3	4	5	6	7	8
<i>Sechelon</i>	3.8	5.7	7.6	9.5	11.4	13.3	15.2
t_{max}	4.855	5.61	6.365	7.12	7.875	8.65	9.385
a_0	-0.097	-0.12	-0.143	-0.166	-0.189	-0.212	-0.235
t_{end}	9	11	13	15	17	19	21
a	$-7.709 \cdot 10^{-4}$	$-5.263 \cdot 10^{-4}$	$-3.351 \cdot 10^{-4}$	$-1.979 \cdot 10^{-4}$	$-1.087 \cdot 10^{-4}$	$-5.107 \cdot 10^{-5}$	$-1.378 \cdot 10^{-5}$
b	0.0157	0.0121	0.0085	0.0055	0.0033	0.0016	$3.35 \cdot 10^{-4}$
c	-0.0677	-0.0576	-0.0425	-0.0273	-0.0133	$-8.56 \cdot 10^{-4}$	0.0102
d	-0.097	-0.12	-0.143	-0.166	-0.189	-0.212	-0.235

Table 2.4: Boundary conditions and resulting coefficients for equation 2.11 for all team sizes. The values for six and seven rider groups are calculated. The rest of the values is extrapolated.

2.4.4. Evaluation

Now that we have a description of the relative speed between the rider and the group during the changing maneuver, we can put this description into the team time trial model. The mechanical model then gives us the power the rider needs to produce during the changing maneuver. To see whether the power from the model is a realistic estimate we compared it to data from real time trials. In most cases, the data from these time trials matches the model quite well. However, it is notable that at the end of the changing maneuver the power is usually a lot lower than the model predicts. This is probably the result of the rider already experiencing some aerodynamic drag reduction from the group. We played around with the drag reduction coefficient. Having the drag reduction coefficient linearly decline over the last five seconds of the changing maneuver, from 1 till the value that corresponds to riding at the back of the echelon, seems to give the best fit. Since the performance of changing maneuvers varies a lot, between riders but also between different maneuvers of the same rider, the model does not fit every changing maneuver from the data equally well. Figure 2.9 and 2.10 show two changing maneuvers with a very good and very bad fit respectively. However, the goal of the model is not to perfectly fit every changing maneuver possible, but to describe an average changing maneuver. Most importantly it should accurately describe the influence of the changing maneuver on the physiological state of a rider. It is believed that the model presented in this section meets these requirements. We hope that from the tests team Sunweb is currently performing with pitot-tube-sensors we can get a better insight into the drag reduction the rider may experience during the changing maneuver.

2.5. Model overview

The team time trial model has four inputs: course data, rider parameters, head times and power. The output of the model is the final time as well as physiological data from the riders that will help evaluate the strategy. The course data consists of the length, gradient and heading of each section of the course. The rider parameters consist of the riders' mass, $C_d A$ value, critical power and W' . The output data consists of the W_{bal} values of the riders, the velocity and the power that each individual rider produced for every time step of the simulation. Figure 2.1 gives a visual representation of the model.

2.5.1. Setting the strategy

Before a simulation can be carried out we first require a strategy. The model needs to know how long each rider should ride on the front of the group. This is done by filling in the head times for each rider. These can

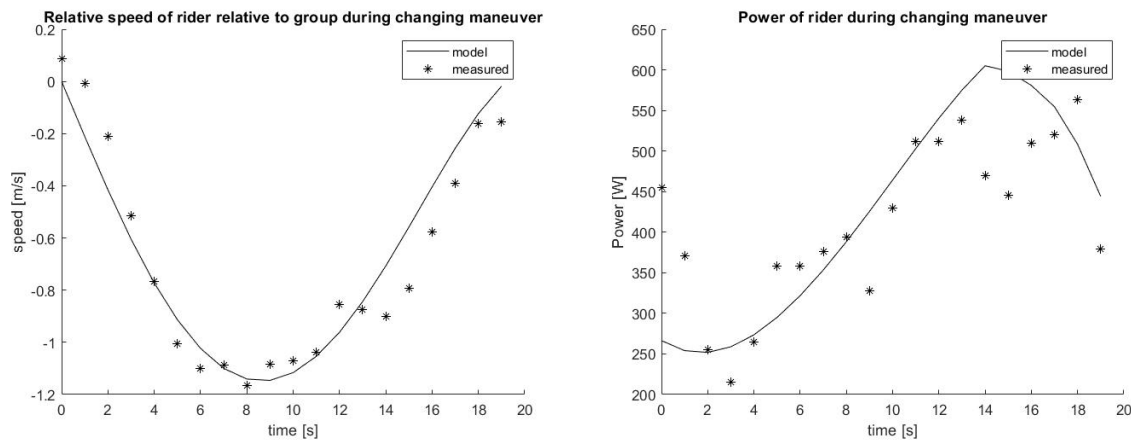

Figure 2.9: Measured speed and power data from actual time trials that has a good fit with the modeled speed and resulting power curves.

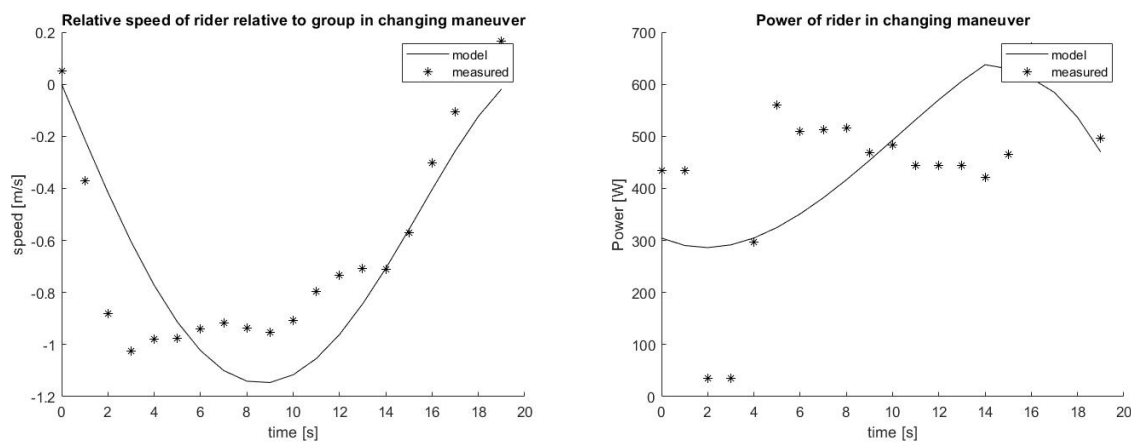

Figure 2.10: Measured speed and power data from actual time trials that has a bad fit with the modeled speed and resulting power curves.

differ for different parts of the course. Secondly, the model needs to know how much power each rider has to deliver on each section of the course. Because not all riders are the same size and build, their aerodynamic drag coefficient, $C_d A$, and their mass can be different. This means that to keep a constant speed a bigger rider will have to deliver more power when on the front than a smaller rider. Conventional wisdom is to keep a constant speed on a section of course with a constant slope. A study by Wagner [19] optimizing power strategies for the track cycling team pursuit also yielded strategies with a constant velocity profile. This turned out to be more efficient than a strategy with constant power. Therefore, the model always uses a strategy that keeps a constant velocity for a certain section of course with a constant slope. This is convenient from an optimization point of view, because we only need one power variable for each section of the course. In our case this is the power that the team leader will produce when riding on the front, from which the power numbers of all other riders can be calculated. One of the riders is selected to be team leader. In real world applications, which will be discussed in chapter 5, this will most likely be the rider that will be competing for the general classification. However, any rider can be selected as team leader. Which rider is selected as team leader has no influence on the outcome of the optimizations that will be discussed in chapter 3. Using the power that the team leader will produce, the corresponding speed is calculated for each section of the course. Because we want to adhere to this speed, we can then calculate the power that each rider should produce when riding on the front to keep that speed constant. This gives a power strategy consisting of a power number for each rider, for each section of the course. Even though the input of the model only has a single power variable for each section of the course. When not riding on the front the rider will simply produce the power needed to follow the lead rider. This is calculated at each time step by the mechanical model described in section 2.1. Hence, we only need to know the power that each rider will have to produce when riding on the front. The corresponding speed for each segment is also saved, the use of which will be

explained in the next section.

2.5.2. Simulation

When the strategy is set the model will run the simulation of the team time trial. Each time step the simulation looks roughly as follows.

- Check the traveled distance, if the traveled distance is equal to or larger than the length of the time trial the riders will have finished and the simulation can stop.
- Check which section of the course the riders are on and what the set velocity and power of the front rider is on that section.
- Check whether the team is moving at the set velocity and calculate acceleration accordingly as follows:
 - Velocity is equal to set velocity: the acceleration at this time step is zero.
 - Velocity is lower than set velocity: acceleration at this time step is calculated according to the power the front rider is producing. If the velocity is lower than 90% of the set velocity the front rider will produce twice the set power until the velocity passes 90% of the set velocity at which point the rider will continue at the set power for this section. This is done to better simulate the start of the race, where the front rider will usually produce much more power in the first few seconds to quickly get up to speed.
 - Velocity is higher than the set velocity: front rider produces set power at this time step and acceleration is calculated accordingly.
- Power is calculated for the trailing riders according to the rider parameters, gradient, velocity and place of the rider in the group.
- W_{bal} is updated. When a riders W_{bal} is empty and the rider still has to produce more power than his critical power the rider can not recover and is subsequently dropped. If a rider is dropped:
 - Check whether the team still has enough riders to finish the race. (For all optimizations the rules of the international governing body for cycling, the UCI, are assumed [18]. These stipulate that the time of the fourth rider counts as the final time of the group. This means at least four riders will always have to stay together.)
 - Check whether the team leader is still in the group.
- Amount of time the front rider has spent on the front is checked. If the front rider has done his time on the front, the rider performs a changing maneuver and the order of the riders in the group is updated.
- Traveled distance and velocity are updated for the next time step.

The model will repeat this process until the riders have completed the course or until too many riders are dropped or the team leader is dropped. When either too many riders are dropped or the team leader is dropped the simulation is stopped and the model will give an error message.

3

Optimization

The goal of the team time trial is to finish the course in the least amount of time. In an individual time trial it is relatively easy to find the optimal strategy. As long as the course is flat and there is no wind the optimal strategy is to produce so much power that the rider's energy stores are completely depleted by the time he arrives at the finish line. When introducing wind, climbs and descents the problem becomes a little more complicated, but again the only variable we can adjust is the power the rider produces. For the team time trial, we can also adjust the time that the riders are spending on the front, the head times. This means that even for a flat time trial, where we assume the riders ride with a constant velocity (like explained in section 2.5.1) and the head times remain constant for each rider during the entire race, we still have nine variables that can be adjusted: one head time for each of the riders in the eight rider group, and one power number. We can of course change our tactics according to the profile of the course. Say we have a course like the one in figure 3.1 consisting of four distinct segments. We can adjust our power and head times for each segment, which gives us four different head times for each rider and four power numbers giving us a total of 36 variables we can adjust. We can also have riders skip turns. For instance, if we have a rider that is a very good climber but not so strong riding on the flat, we might want to have this rider skip his turns on the first flat segment so he can do more work on the climb. This adds yet more variables to our optimization problem. We chose to have the head times and power numbers constant within each segment of the course. It would also be a possibility to have more dynamic head times and power numbers, meaning they could change within a segment of the course. However, this would make the the resulting strategy much more complicated and, with that, not practically applicable for team Sunweb. Also, the amount of variables for the optimization algorithm would drastically increase, which would cause very long run times.

Optimizations are carried out on a selection of different courses, using different teams of riders. The course is broken up into different segments with a constant gradient and a certain length. As mentioned above, each segment has its own set of head time and power variables. The optimization will always try to minimize the time it takes the team to finish the course while using the head times and power as free variables. The goal is to get an insight into the optimal strategy for the team time trial. Using different courses and different team compositions will hopefully enable us to understand the influence of these factors on the optimal strategy.

3.1. Method

3.1.1. Riders

In a professional cycling team there are a lot of riders with different specialties. In order to keep the results clear and easy to compare, we defined only four different cyclists: The General classification contender (Dutch: klassements renner), the Time trial specialist (Dutch: tijdrijder), the Climber (Dutch: klimmer) and the Domestique (Dutch: knecht). The General classification contender (or GC-contender) is both a strong time trial rider and a strong climber. The time trial specialist (or TT-specialist) is a strong time trial rider, but a lot heavier then the GC-contender and hence not a very good climber. The Climber is smaller than the previous two riders and can produce less power making him a bad time trial rider, but since he is light he is a good climber. Finally, the Domestique who is average at both time trialing and climbing. The rider parameters of all these riders can be seen in table 3.1. The C_dA and W' values are equal for all riders. When

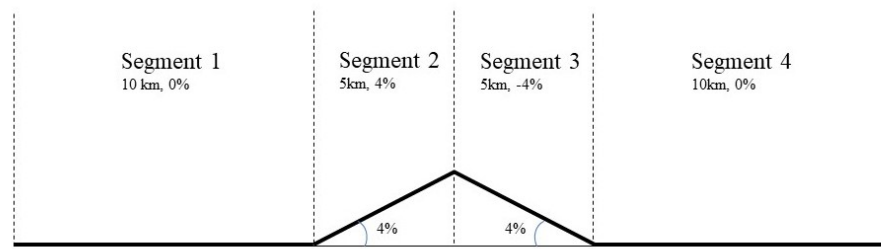

Figure 3.1: Example of a course used for optimization, consisting of 4 segments.

reviewing the data from Sunwebs own riders there was no real trend to be seen in the size of the W' between different riders. The W' of a larger or stronger rider is not necessarily larger than that of a smaller or weaker rider. Hence the W' of each rider is kept equal. There is often a correlation between the mass and the C_dA value of a rider since a smaller posture usually means a smaller mass and also a smaller frontal area. However, this is not true in all cases. Also a weaker time trial rider is not necessarily characterized by a larger C_dA or a lower critical power, but more by the combination of the two. A rider with a lower critical power can still be equally good at riding a time trial as a rider with a higher critical power as long as the weaker rider has a lower C_dA value. Therefore, the C_dA values of the riders for the optimization are all kept equal. This means the only identifier for time trial performance on flat roads is the critical power of each rider, which makes comparing riders and the optimization results more clear.

Rider	CP [W]	m [kg]	C_dA [m^2]	W' [J]
GC-contender	420	70	0.22	$25 \cdot 10^3$
TT-specialist	420	80	0.22	$25 \cdot 10^3$
Domestique	390	70	0.22	$25 \cdot 10^3$
Climber	360	60	0.22	$25 \cdot 10^3$

Table 3.1: Physiological parameters for the CP-model for the four different cyclists used in the optimizations.

Different team compositions are used for several optimizations. In some cases the team consists of just one type of rider and for some a mixed team was used. In the following optimizations, a mixed team always consists of two GC-contenders, two TT-specialists, two Domestiques and two Climbers. The starting order used is derived from the work by Overtoom [14] and is used to good effect by team Sunweb. This means that as the strongest rider rides on the front, the weakest rider rides at the most beneficial position to recover. We expect the strongest rider to have to do the largest amount of time on the front, meaning the weakest rider gets to spend the most time in the most beneficial position. Therefore, the GC-contenders will start at the front, followed by the TT-specialists, the Domestiques and finally the Climbers.

3.1.2. Courses

The courses used for the different optimizations all consist of either two or four different segments. A separate simulation is run for each segment of the course using the physiological states of the riders from the first simulation as an input for the second simulation. This allows us to optimize head times and power numbers for each segment of the course separately. The course segments all have a specific length and gradient that do not vary within the segment. An example of one of the courses used for the optimizations can be seen in figure 3.1.

3.1.3. Optimization function

The function to be optimized is the team time trial model as described in chapter 2. The goal of the optimization is to minimize the final time. The variables used to optimize the final time are:

- The power specified for each segment (x_p)
- The head times specified for each rider on each segment (x_{ht})

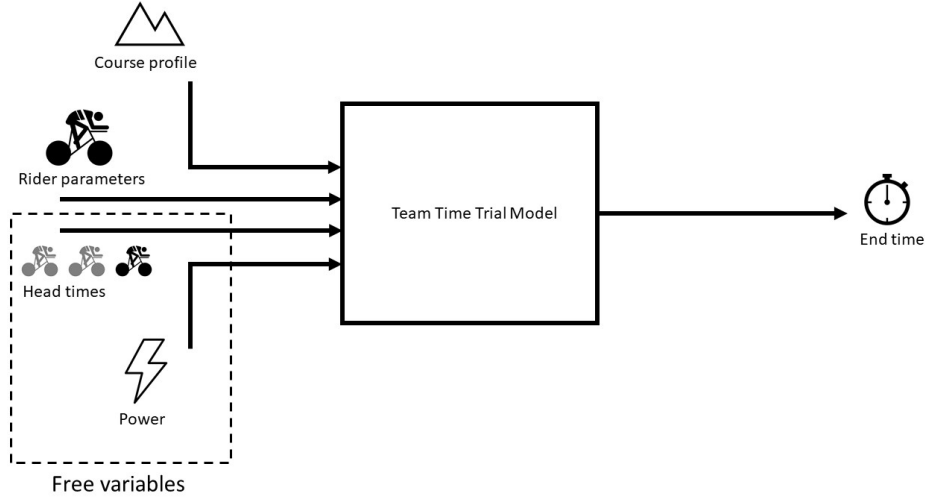

Figure 3.2: Visual representation of the optimization function.

Besides the variables used by the optimization algorithm, the model has two other input parameters which are kept constant:

- The course parameters which consists of the lengths and gradients of the different segments (x_C)
- The rider parameters consisting of the critical power (CP), energy stores (W'), mass (m) and drag coefficient ($C_d A$) of all the riders (x_R)

To make the results of the optimization more practically applicable for team Sunweb the head times and power are both taken as integers. The head times and power are altered in increments of five seconds and five Watts respectively to reduce the possible values for each variable and thus reducing optimization time. Also, when we look at the head times the riders actually use during a race, compared to the head times they are given by the coaches, there is often a discrepancy of a few seconds. This happens because the riders have to keep track of their own head times. Therefore, having more specific head times would not make any sense. The lower and upper bounds for the Power are 350 and 800 Watts respectively. since they are altered in five Watt increments the upper and lower bound supplied to the optimization function are 70 and 160. The team time trial model converts this to 350 and 800 Watts. For the head times the lower and upper bounds are 5 and 120 seconds respectively, which means they are supplied to the optimization function as 1 and 24. This means the optimization function takes the form of equation 3.1.

$$\begin{aligned}
 \min_{(x_P, x_{ht}) \in \mathbb{Z}} \quad & f(x_P, x_{ht}, x_R, x_C) \\
 \text{s.t.} \quad & 70 \leq x_{P,i} \leq 160 \quad (i \in 1, 2, \dots, nr.segments) \\
 & 1 \leq x_{ht,q} \leq 24 \quad (q \in 1, 2, \dots, 8 \cdot nr.segments)
 \end{aligned} \tag{3.1}$$

3.1.4. Algorithm selection

All optimizations are done in Matlab 2018. The function we are optimizing is highly non-linear and we expect there to be many local minimums. Therefore, we opted for the use of a genetic algorithm.[5] An added benefit of the genetic algorithm is that it allows the variables to be integers. This will not only make the results easier applicable for team Sunweb, but it also means we can use steps of a few seconds or Watts, as described in section 3.1.3, allowing us to make the free space of each variable a lot smaller and reducing run times. A short explanation of the genetic algorithm as well as the settings for the algorithm can be found in section 3.1.5.

3.1.5. Genetic algorithm explanation

General workings A genetic algorithm is based on the evolutionary process that we see in nature. The algorithm creates several individuals that form a generation. Each individual is basically an evaluation of the function that is being optimized. In our case this means each individual is a team time trial simulation. Each individual has different variable values as input for the function, meaning that in our case each individual can use different head times and power numbers. The values of the variables of each individual are like its genes. Based on result of the function evaluation each individual gets a fitness score. In our case this means that an individual whose variable values yield a faster time in the team time trial simulation will have a higher fitness score. To produce the next generation, individuals will have to reproduce to form offspring. Individuals with a higher fitness score are stronger and will have a larger change of reproduction, just like in nature. When two individuals reproduce their genes mix. This means that the offspring of these individuals will share some variable values with its father and some with its mother. However, there is also a change that these genes will mutate. This will cause a variable to have a value that was not present in either of the parents.

Genes Each individual has a chromosome that contains its genetic code. The chromosome is a string of genes, which are a 1 or a 0. The genes describe, in binary code, the values of the variables for the individual.

Creating the next generation There are a few ways that an individual in a new generation can be conceived. Either it is the product of reproduction, also known in this case as cross-over, the product of mutation or the individual can be passed down directly from the previous generation.

- **Elite children:** The elite count is the top of the generation with the highest fitness score. In our case this is the top five percent of the population. These individuals will move on to the next generation automatically and are called elite children.
- **Crossover** Reproduction between two individuals in the genetic algorithm is called crossover. It is called this way because the genes of both parents will swap places (or cross over) at a certain point in the gene to form two offspring. The point at which this crossover happens is called the crossover point and is selected at random. Figure 3.3 shows a visual representation of this process. The number of new individuals created by crossover is the crossover fraction which is 80 percent in our case.
- **Mutation:** Mutation can occur after cross over but it can also form a new individual just by mutating this individual's genes. Each gene of an individual has a certain chance to mutate. If the gene mutates it changes from a zero to a one or from a one to a zero and in doing so change the value of one of the variables. Figure 3.4 gives a visual representation.

Stopping criteria When a new generation is created, through crossover, mutation and elite children, the function that is being optimized has to be evaluated for each individual and fitness scores have to be calculated in order to start the process over again. The algorithm will only stop creating new generations when one of the following three stopping criteria is met:

- The maximum computing time is reached.
- The maximum number of generations is reached.
- The algorithm has found an acceptable minimum for the function.

The maximum computing time, in our case, is infinite, since we do not expect the optimizations to take longer than a few hours to a few days. The maximum number of generations is 100 times the number of variable. For a course consisting of two segments the optimization has 18 variables (eight head time variables and one power variable per segment), which means the maximum number of generations is 1800. Whether the algorithm finds the minimum to be acceptable is defined by the 'Maximum stall generations' and the 'Function tolerance'. The 'Function tolerance' in our case is 10^{-6} and the 'Max stall generations' is 50. If the relative change in the best function evaluation over the last 50 generations is smaller than the function tolerance, 10^{-6} , the algorithm will stop. This means that if we use the variables of the very best individual of every of the last 50 generations and the average change in the final time between these individuals is smaller than 10^{-6} the algorithm will accept the variables of the best individual of the last generation as the optimal strategy for the team time trial simulation. Table 3.2 provides an overview of the settings used for the genetic algorithm.

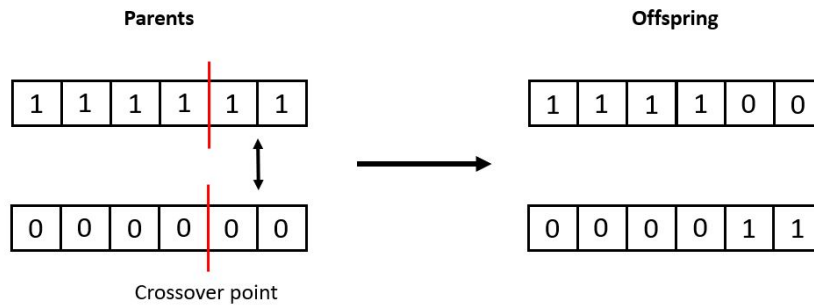

Figure 3.3: Visual representation of the crossover of genes. Each digit represents a gene. The crossover point, shown by the red line, is chosen at random. All the genes after the red line will cross over with the corresponding genes of the other parent. The two resulting individuals will be part of the next generation.

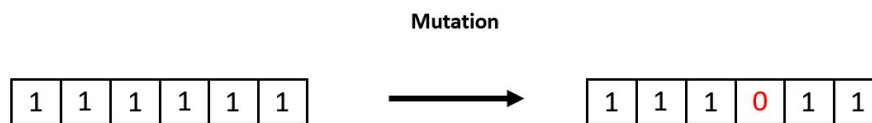

Figure 3.4: Visual representation of the mutation process. A chromosome containing six genes is shown. In this case, one gene has mutated, making it switch from a 1 to a 0.

Option	Setting
Function tolerance	$1 \cdot 10^{-6} s$
Maximum stall generations	50
Maximum number of generations	100 · number of variables
Maximum time	inf
Generation size	200
Crossover fraction	0.8
Elite count	5%

Table 3.2: Overview of the settings used for genetic algorithm.

3.2. Optimization results

For the optimizations a course consisting of two segments is used. The course consists of a flat segment with a length of 10 kilometers and a climb which varies in length and gradient. The climbs are 1, 2.5 and 5 kilometers long and have a gradient of 4%, 6% and 8%. These three different lengths and three different gradients of climbs give us a total of nine courses. First the strategy is optimized, for every course, using a mixed team. The goal of this first optimization is primarily to look at the distribution of power between the flat segment and the climb. We expect that it is more efficient to produce a higher power on the flats than on the climbs. Which is contrary to the ideal strategy for an individual time trial, where it is more efficient to produce a higher power on the climbs than on the flats [9]. This is hypothesized because of the influence of gravitational resistance on the climbs. Due to the increase in gravitational resistance on a climb the speed for a given power will be lower than on a flat segment. The lower speed on the climb, also means a decrease in air drag. When the gravitational resistance increases and the air drag decreases, the riders profit less from the drag reduction caused by their team mates as can be seen from the equation of motion 2.7. Because of this, the riders can not recover as well as on the flats, when riding at the back of the group. This, in turn, means the riders can not sustain the same kind of power, when riding on the front, as they would on the flats. These first optimizations are then repeated using different teams. These teams consist of all GC-contenders,

all TT-specialists and all Climbers to see if the individual capacities of the riders would have an effect on the optimal strategy. Since this does not yield a clear result, more optimizations are done using different lengths of climbs. Next, optimizations are carried out with longer courses consisting of four segments to see if the optimal power distribution is the same as in the case of the two segment courses. For these four segment courses, only a mixed team of riders is used. Finally, we look at whether having riders skip turns on a certain segment of the course might have a positive effect on the final time. This is done for both the courses consisting of two segments as well as the longer four segment courses. The optimizations are all done assuming the rules set by the international governing body for cycling, the UCI [18]. These rules stipulate that the time of the fourth riders counts as the teams finishing time. Since we are using an eight rider team, this means that four riders may be dropped during the race.

3.2.1. Results of two segment optimization

For the first optimizations we look at a two segment course consisting of a flat 10 km long segment followed by a climb varying in length between 1, 2.5 and 5 kilometers, and in gradient between 4, 6 and 8 percent. The results of these optimizations are given in table 3.3. It is clear from these results that, as expected, it is more efficient to produce less power on the climbs compared to the flats. The only exception being very short climbs. On the flat segment riders can recuperate riding behind their team mates, while on the climbs it is impossible to do so. This is clearly seen in figure 3.5 which shows the W_{bal} values of a team of riders performing a team time trial consisting of a 10 km flat segment followed by a 5 km climb at a 4 percent gradient. The team executes the time trial according to the head times and power numbers that resulted from the optimization. The climb starts at 10000 meters, after which the riders' W_{bal} values only increase very slightly when they start their changing maneuver. Apart from that the W_{bal} never increases even if they are riding at the back of the line and even though the power of the front rider is much lower than on the flat. The riders are still performing changing maneuvers on the climb. This is seen in figure 3.5 as the slight rise in W_{bal} brought about by the decrease in power while dropping back, followed by a sudden steep drop, brought about by the surge in power needed to increase the riders speed and catch back on at the back of the group. When the climb is very short the riders produce more power on the climb than on the flat segment. What is interesting, is that the riders no longer perform any changing maneuvers during the climb as can be seen in figure 3.6. This figure shows the W_{bal} of a team performing a time trial consisting of a 10 km flat segment followed by a 1 km climb at an 8% gradient. The team arrives at the foot of the climb with seven riders. Three of these riders perform what is known as a 'suicide pull', where the rider rides on the front until he is completely drained and unable to catch back on at the back of the group.

Different team compositions After reviewing the results from the first optimizations we are mainly interested in two things. Firstly we want to know whether the individual properties of the riders have an impact on the distribution of power between the flats and the climbs. Secondly, from the first optimization we see that for longer climbs it is more efficient to produce less power on the climbs than on the flats. While for shorter climbs the opposite is true. This means there must be a turn over point (a combination of length and gradient of the climb) where producing the same power on the climbs as on the flats is the most optimal strategy. Basically, we want to find the point where $P_{climb}/P_{flat} = 1$. We would also like to know if the individual properties of the riders have an influence on the location of this turn over point. Therefore, the same optimizations, using the two segment courses, are done using different team composition. The teams consist of only GC-contenders, only TT-specialists or only Climbers. The results are shown in table 3.4. It seems as though the riders divide their power towards their stronger attribute. This would mean the team of Climbers would have a larger ratio of power on the climb to power on the flat, P_{climb}/P_{flat} , compared to the team consisting of GC-contenders which in its turn would have a larger P_{climb}/P_{flat} ratio than the team consisting of only TT-specialists. This seems to hold quite well for most combinations, however, there are some inconsistencies and the differences are relatively small. Therefore, it is impossible to come to any real conclusions on this topic.

Zooming in on the turn over point The point at which it becomes more efficient to produce more power on the climb than on the flat is impossible to see from the results in the previous section. All teams produce more power on the climb than on the flat, when the climb was only 1 km in length. Also, they all produce less power on the climb than on the flat when the climb was 2.5 or 5 km in length. Therefore, more optimizations, using a two segment course, are performed. For these optimizations the length of the climbs is altered in smaller increments around the turn over point. This will hopefully allow us to identify the turn over point

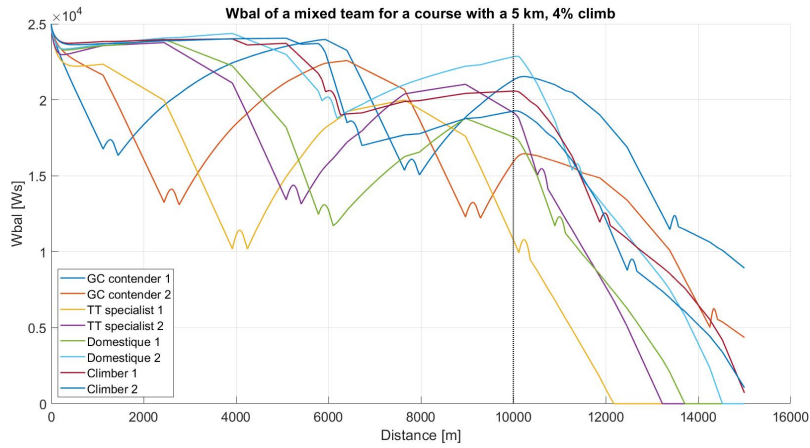

Figure 3.5: The W_{bal} values of a mixed team of riders riding a time trial consisting of a 10 km flat segment followed by a 5 km, 4 percent gradient climb using the head times and power numbers resulting from the optimization algorithm.

where having equal power on the climbs as on the flats is the optimal strategy (i.e. $P_{climb}/P_{flat} = 1$). This can then also tell us whether the individual properties of the riders have an influence on the location of this turn over point. The same teams are used as before: A mixed team, a teams consisting of only GC-contenders, only TT-specialists and only Climbers. We also used a team consisting of only Domesticques. Since we are only interested in the power distribution in this particular case the head times are not used as a free variable during these optimizations, since this will drastically reduce the computing time. The climbs have a length of 2, 1.75, 1.5 and 1,25 km with gradients of 4, 5, 6, 7 and 8 percent. All head times are 30 seconds for all riders.

What is interesting to see is that the riders indeed shift their power distribution towards the segment of the course that suits them best. If this is true we would expect the ratio of power on the climb to power on the flat, P_{climb}/P_{flat} , of the team consisting of only Climbers to be the highest, followed by the team of GC-contenders and lastly the team of TT-specialists. We would expect a team consisting of only Domesticques to have about the same P_{climb}/P_{flat} ratio as the GC-contenders. When we look at the results these statements all seem to hold true, as can be seen in table A.1.

Not using the head times as free variables seems to have a large influence on the distribution of power. The only course where it was more efficient for all teams to produce less power on the climbs than on the flats was the course with a 2 km, 8 percent gradient climb. When we ran the optimization again with head times as a free variable the power distribution became very different as can be seen from the results in table A.2. When all riders have the same head times the riders will all stay together until the foot of the climb. Also, the power on the flat is the same for all course profiles. This holds for all different teams. When the head times are also being optimized, the team is able to adopt different strategies. For instance, in the case of a 2 km, 4 percent gradient climb with a mixed team, the riders do not stay together until the climb. The Climbers and Domesticques both do a suicide pull on the flat segment and the GC-contenders and TT-specialists are the only riders that make it to the foot of the climb, as can be seen in the W_{bal} plot in figure 3.7. This allows the team to ride a much higher power on the flat segment, and even though the power on the climb is lower, the final time is still faster.

Climb length	5km	5km	5km	2.5km	2.5km	2.5km	1km	1km	1km
Inclination	4%	6%	8%	4%	6%	8%	4%	6%	8%
Power Flat [W]	535	530	535	550	545	525	570	560	555
Power Climb [W]	490	475	460	525	495	510	635	615	590
P_{Climb}/P_{Flat}	0.92	0.90	0.86	0.95	0.91	0.97	1.11	1.10	1.06
Time [s]	1107.5	1211.2	1335.7	861.1	913.7	966.1	712.3	729.3	748.6

Table 3.3: Results of optimizations for courses consisting of a flat segment and a climb with no turn skipping and a mixed team of riders.

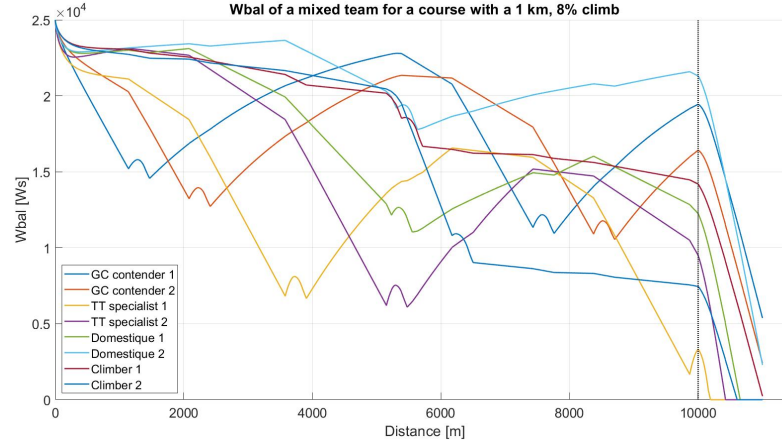

Figure 3.6: The W_{bal} values of a mixed team of riders riding a time trial consisting of a 10 km flat segment followed by a 1 km, 8 percent gradient climb using the head times and power numbers resulting from the optimization algorithm.

Climb length	5km	5km	5km	2.5km	2.5km	2.5km	1km	1km	1km
Inclination	4%	6%	8%	4%	6%	8%	4%	6%	8%
Team	General classification contenders								
Power Flat [W]	585	590	585	595	575	575	600	590	580
Power Climb [W]	505	475	465	545	535	505	675	680	665
P_{Climb}/P_{Flat}	0.86	0.81	0.79	0.92	0.93	0.88	1.13	1.15	1.15
Time [s]	1079.0	1186.5	1310.3	838.8	887.9	947.4	698.9	712.6	730.5
Team	Time Trial specialists								
Power Flat [W]	585	585	575	590	580	580	590	590	585
Power Climb [W]	495	470	460	540	515	490	725	655	605
P_{Climb}/P_{Flat}	0.85	0.80	0.80	0.92	0.89	0.85	1.23	1.11	1.03
Time [s]	1111.6	1242.0	1396.6	855.0	915.2	988.4	705.5	722.2	746.5
Team	Climbers								
Power Flat [W]	505	505	505	510	505	500	520	510	505
Power Climb [W]	440	415	405	490	460	440	615	615	585
P_{Climb}/P_{Flat}	0.87	0.82	0.80	0.96	0.91	0.88	1.18	1.21	1.16
Time [s]	1120.6	1224.7	1346.0	872.7	921.0	978.0	728.8	742.8	759.7

Table 3.4: Results of optimizations for courses consisting of a flat segment and a climb with no turn skipping with a team consisting of only GC-contenders, only TT-specialists or only Climbers.

3.2.2. Results of four segment optimization

From the optimization using only two segment courses we move on to courses containing more segments, to see whether the results from the first optimizations also hold in more complicated cases. The courses used in these optimizations consist once again of a flat segment of 10 km, followed by a climb with varying length and gradient. The length of the climb is varied between 5, 2.5 and 1 km. The gradient is varied between 4%, 6% and 8%, just like in for the two segment courses. The climb is followed by a corresponding descent (meaning a 5 km climb with a 6% gradient is followed by a 5 km descent with a 6% gradient) and finishes with another 10 km flat segment, just like in the course example in figure 3.1. For these optimizations, only a mixed team is used. The results are shown in table 3.5.

The distribution of power for the four segment course is still roughly the same as for the two segment course. Meaning that the riders will still produce less power on the climb than on the flat when the climb is 2.5 or 5 kilometers long. The riders will also still produce more power on the climbs than on the flat when the climb is only 1 kilometer long. However, the ratio of power on the climbs to power on the flats, P_{climb}/P_{flat} , for this four segment course is larger than for a two segment course. Meaning the riders are producing relatively less power on the climbs than on the flats, on the courses with a 2.5 or 5 km climbs, compared to the two segment course. They are also producing more power on the climbs compared to the flats, on the courses with a 1 km climb, compared to the two segment course. In short, on the four segment courses P_{climb}/P_{flat}

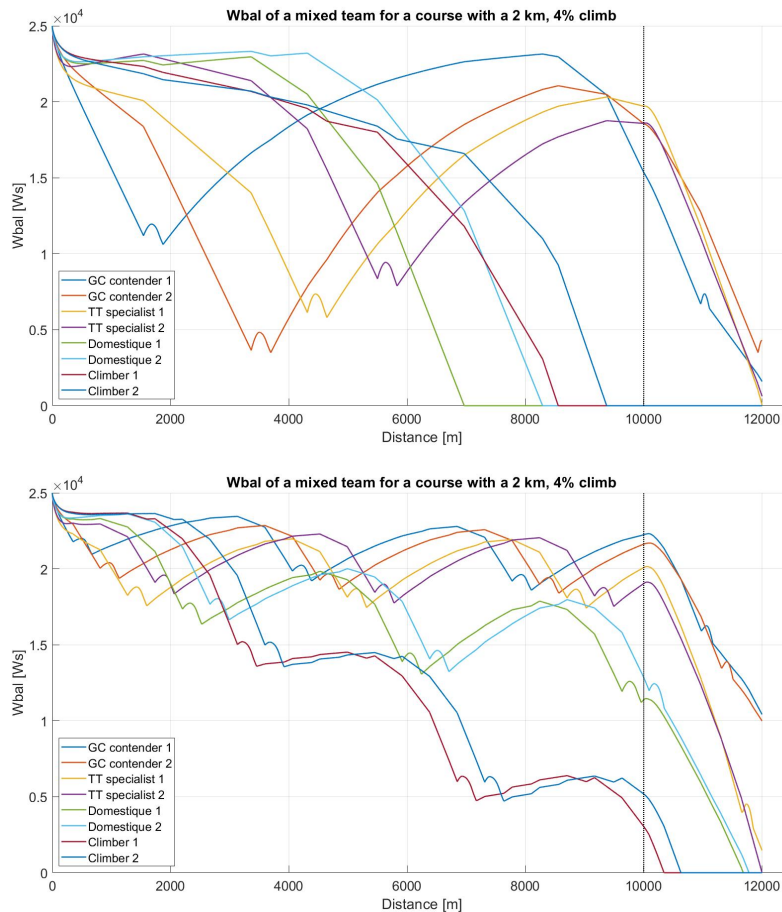

Figure 3.7: The W_{bal} values of a mixed team of riders riding a time trial consisting of a 10 km flat segment followed by a 2 km, 4 percent gradient climb with head times as optimization variable (top) vs without head times as optimization variable (bottom)

is smaller than on the two segment courses, when a 2.5 or 5 km climb is used. P_{climb}/P_{flat} is larger than on the two segment courses, when a 1 km climb is used. There is also a clear change of strategy between the shorter two segment courses and the longer four segment courses. On the two segment course with the 5 km climb, regardless of gradient, the TT-specialists gets dropped either on the flat segment or the beginning of the climb. On the four segment course, with a 4 or 6 percent gradient, the TT-specialists don't get dropped, but get carried over the climb. They are able to recover in the descent and help out on the second flat segment where the climbers get dropped. This explains the lower ratio of P_{climb}/P_{flat} . The TT-specialists have to be carried over the climb, meaning the power on the climb can not be as high, because the TT-specialists are a limiting factor. This can be clearly seen from the W_{bal} plot in figure 3.8. The TT-specialists start the climb with a much higher W_{bal} than the rest of the team, yet they are nearly empty at the top of the climb. However, they can easily recover in the descent. This means they can deliver enough work on the front to make it more efficient to keep them in the group, even though this means having to slow down on the climb. For the four segment course with a 5km, 8 percent gradient climb, the TT-specialist do get dropped on the climb. In this scenario the Climbers also get dropped on the second flat segment, meaning the GC-contenders and Domestiques finish the race. The Domestiques are weaker on the flats than the TT-specialists and weaker on the climbs than the Climbers. Therefore, they get dropped in almost all scenarios. It is interesting to see that in this particular scenario being average in both climbs and flats allows a rider to contribute more to the team. The course with the 5 km, 8% climb is also the only course where the power on the second flat segment is lower than on the first one. Also, the ratio P_{climb}/P_{flat} is higher than for the 5 km, 6 percent gradient climb. This shows that the power distribution, head times and consequently which riders are getting dropped are all very much interlinked. For the 1 km climbs we still see that it is more efficient to produce more power on the climbs than on the flats. There are still almost no changing maneuvers performed on the climb. The GC-contenders ride on the front for the entire climb. The climbers are dropped either on the flat or at the

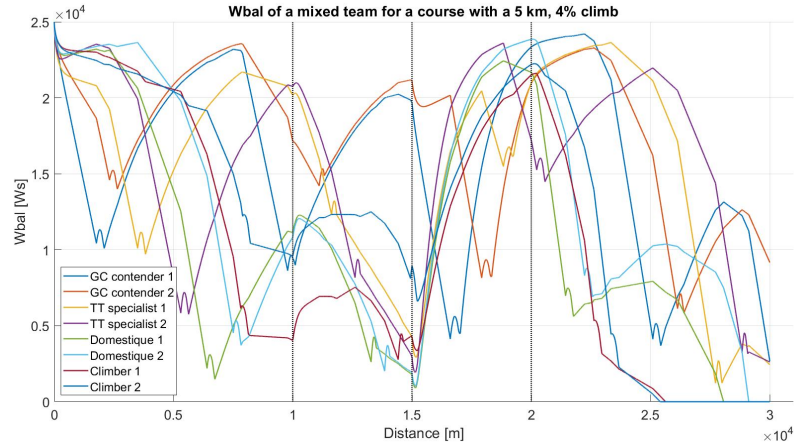

Figure 3.8: The W_{bal} values of a mixed team of riders riding a time trial consisting of a 10 km flat segment followed by a 5 km, 4 percent gradient climb, a 5 km, 4 percent gradient descent and another 10 km flat segment using the head times and power numbers resulting from the optimization.

beginning of the climb.

Climb length	5km	5km	5km	2.5km	2.5km	2.5km	1km	1km	1km
Inclination	4%	6%	8%	4%	6%	8%	4%	6%	8%
Power Flat [W]	555	550	535	540	540	540	550	525	540
Power Climb [W]	455	425	430	500	470	440	695	645	575
Power Descent [W]	605	645	635	560	590	610	435	455	555
Power Flat [W]	575	580	530	560	560	575	555	555	550
P_{Climb}/P_{Flat}	0.82	0.77	0.80	0.93	0.87	0.81	1.26	1.23	1.06
Time [s]	1996.4	2099.5	2228.8	1633.6	1674.5	1732.4	1407.6	1427.5	1438.0

Table 3.5: Results of optimizations for courses consisting of a flat segment, a climb, a descent and another flat segment with no turn skipping and a mixed team of riders.

3.2.3. Results of two segment optimization with turn skipping

The current strategy used by team Sunweb, and most other professional cycling teams, is to have all riders do turns on the front at the beginning of the race. Only when a rider feels he can not do another turn on the front, because he is too fatigued, the rider can skip a turn. The rider will stay at the back of the group and let his team mates piece in before him, giving the rider extra time to recover. The rider will stay at the back until the group has done a full rotation. If the rider then feels fresh enough to participate again he will join in again. He will do so behind the rider he was originally trailing to ensure the order of the riders stays the same.

When we look at the strategy that resulted from the optimizations for a course with only two segments, the Climbers usually do a lot of work on the climb. The limiting factor for how much work these riders can do on the climbs, however, is the state of their W_{bal} at the beginning of the climb. It can be seen from figures 3.5 and 3.6 that the Climbers can not recover on the flat segment even if they are riding at the back of the group. Therefore, we might be able to improve the resulting time by having the Climbers skip turns on the flat, even though their W_{bal} is still full. This way they can start the climb with a higher W_{bal} , which means they can do more work on the climb. In turn, this will hopefully provide the TT-specialists the chance to produce more work on the flat segment, since they can not contribute as much on the climbs, which will better utilize the strengths of every rider.

To see whether this strategy has a positive effect on the final time more optimizations are performed, first using two segment courses. Because we want to see whether we can use skipping to better utilize the strengths of different riders a mixed team is used. Only the courses with a 5 km climb are used, since the Climbers have a very prominent role on the climb and we expect this strategy to have a positive effect in

these scenarios. When a rider skips turns, he will skip all turns on the first segment. The rider will then join the rotation on the climb as soon as the team mate he was originally trailing pieces in. This way the order of the team is kept the same. For the first optimizations only the last Climber is exempt from riding on the front during the entire flat segment. Secondly, optimizations are done where both Climbers are exempt from riding on the front on the flat. The results of these optimizations are shown in table 3.6

In both the case where one Climber skips turns, as well as the case where both Climbers skip turns, an improvement in the final time is visible. However, when only one Climber gets to skip turns the other Climber has a tougher time on the flats. For the course with a 4 percent gradient climb this causes him to drop on the climb which means a Domestique has to take its place and finish. This is reflected in the power distribution. The riders produce more power on the flat than when no riders skipped turns. However, they produce less power on the climb. When both Climbers skip their turns on the flat, the improvements are much larger. The strategy differs somewhat between the different courses. For the 6 percent gradient climb the riders don't produce more power on the climb, but they are able to produce a lot more power on the flat segment. Figure 3.9 shows the W_{bal} plots for this course for both the no turn skipping case as well as the case where both Climbers skip turns on the flat segment. The W_{bal} plots show that, even though the riders produce more power on the flat when the Climbers are skipping turns, the Climbers and GC-specialists start the climb with approximately the same W_{bal} as in the case where no rider skips turns.

Optimization	Reference			Last rider skips			Last two riders skip		
	Inclination	4%	6%	8%	4%	6 %	8%	4%	6%
Power Flat [W]	535	530	535	550	535	535	545	550	545
Power Climb [W]	490	475	460	485	475	465	500	475	470
Time [s]	1107.5	1211.2	1335.7	1103.6	1209.9	1330.5	1096.6	1201.3	1323.5
Improvement [s]	0	0	0	3.9	1.2	5.2	10.9	9.9	12.2

Table 3.6: Results of optimizations for courses consisting of a flat part and a climb of 5 km with turn skipping and a mixed team of riders.

3.2.4. Results of four segment optimization with turn skipping

The same strategy involving turn skipping is used for a longer course consisting of four segments. Again, only the longer climbs are used, since here the Climbers can contribute the most. A mixed team is used and the strategy is optimized using the genetic algorithm. Since the Climbers have a less prominent role in this scenario it is expected that the turn skipping will have a less positive effect then in the two segment case. The results are shown in table 3.7.

The results from the optimizations show that for most cases the turn skipping on the first flat segment has a negative influence on the outcome of the race. The only exception is the scenario where both Climbers are skipping turns on a course with an 8% gradient climb. Here, the TT-specialists get dropped before the descent, hence the group produces much less lower power in the descent. However, the extra power on the climb is enough to offset this loss and the final time is still faster than in the case where no rider skips turns.

We only looked at a scenario where the Climbers skip turns. This seems to be a logical strategy since the Climbers are not so strong on the flats, but very strong on the climbs. We expect that riders who are stronger in a flat time trial will have to hold back on the flat in order to save the Climbers for the climb where they can be of most use. However, this does not mean that the Climbers are a limiting factor on the flat, as can be seen in figure 3.10 and table 3.7. When there is no turn skipping the TT-specialists begin the climb with a high W_{bal} . This is possible because they are able to recover better on the flats. The Climbers on the other hand begin the climb with an almost drained W_{bal} , but are able to recover during the climb. If we compare this with the case where the Climbers skip their turns during the flat segment (right image in figure 3.10) the TT-specialists begin the climb with a much lower W_{bal} . This is because the TT-specialists can spend less time recovering further down the group in a place where they experience a bigger drag reduction and thus can not recuperate as well. It is still a more optimal strategy to get the TT-specialists over the climb, making them the limiting factor. Therefore, in the case where the Climbers are skipping turns, the team produces less power on the first flat segment and less power on the climb. They are able to compensate during the descent but not enough to make up the difference.

Since it is not always clear what team member might be a limiting factor it might be interesting to look at whether it is beneficial to have other riders skip turns. During all optimizations we have used the same order

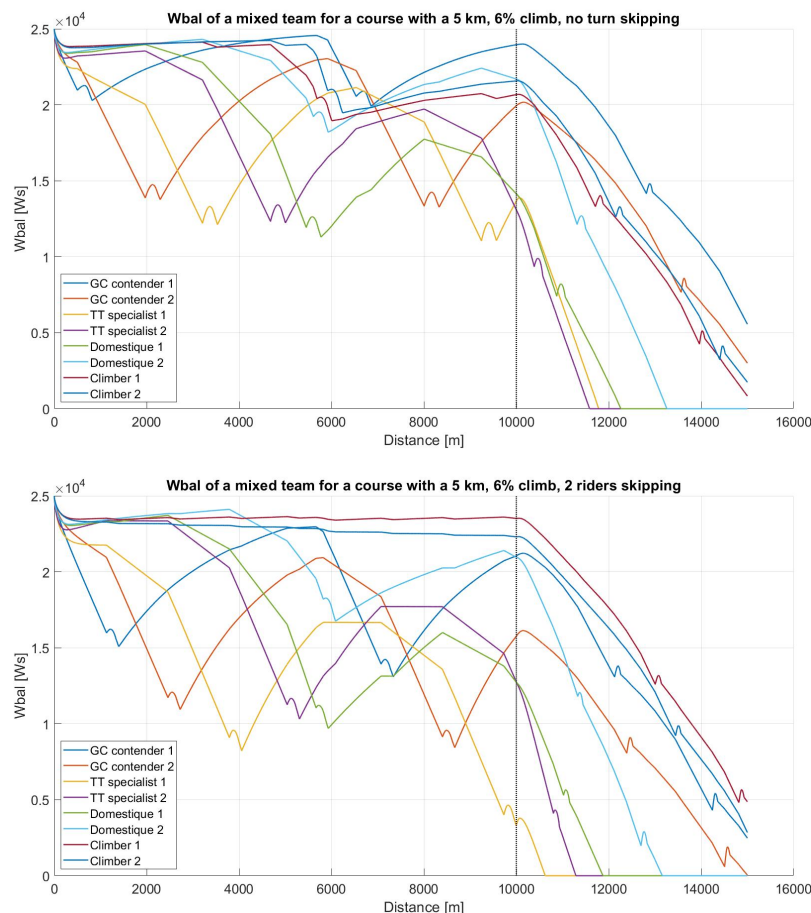

Figure 3.9: W_{bal} plots for a mixed team riding a course with a 5 km, 6 percent gradient climb with no turn skipping (top) vs. both Climbers skipping turns on the flat segment (bottom).

for the riders in the mixed team. This came from the results of the study by Overtoom [14]. Although these results hold very well for a flat course and are used to good effect by team Sunweb, it is unknown whether they hold true on different terrain. Changing the order will also allow other riders to skip turns on the first flat segment. Therefore, it might be interesting to include the order of the team and whether or not the riders are exempt from riding on the front on certain segments in the optimization variables. This will be further discussed in chapter 6.

3.3. Discussion

When we review the results of the optimizations in this chapter it becomes clear that each specific course requires a specific strategy. This makes it difficult to compose a set of clear rules that describes the perfect strategy, yet there are still some very interesting conclusions to be drawn from the results presented in this chapter.

Something that is seen in all optimization results where head times were a free variable, is that head times resulting from these optimizations are often much longer than the ones currently used by team Sunweb. These usually range from about 10 to 40 seconds. A head turn of 60 seconds will currently almost never be performed by a rider. However, in the optimization results head times often range from 60 to 100 seconds.

As expressed in the beginning of section 3.2, we expected it to be more efficient to produce less power on the climbs than on the flats. It is clear from the results of both the optimizations using two and four segment courses that this is true for longer climbs. However, as the climb becomes shorter, there will be a turn over point at which it becomes more efficient to produce more power on the climbs. Where this point is, however, is hard to say.

It can be seen from the results in section 3.2.1 that the individual capabilities of the riders have an in-

Optimization Inclination	Reference			Last rider skips			Last two riders skip		
	4%	6%	8%	4%	6 %	8%	4%	6%	8%
Power Flat [W]	555	550	535	540	545	535	550	545	540
Power Climb [W]	455	425	430	460	420	430	450	420	465
Power Descent [W]	605	645	635	630	640	610	650	665	425
Power Flat [W]	575	580	530	560	560	530	570	570	480
Time [s]	1996.4	2099.5	2228.8	2002.8	2115.5	2230.5	2000.0	2110.5	2215.7
Improvement [s]	0	0	0	-6.2	-16.0	-1.7	-3.6	-11.0	13.1

Table 3.7: Results of optimizations for courses consisting of a flat segment, a climb and descent of 5 km and another flat segment with turn skipping and a mixed team of riders.

fluence on the distribution of power between the flats and the climbs. It seems that it is best for a rider to produce relatively more power on the segments that favor his individual capabilities. This means a Climber will have a higher P_{climb}/P_{flat} ratio than a Time trial specialist when riding the same course, because the Climber is strong on the climbs and not on the flats, while the TT-specialist is strong on the flats but not on the climbs.

The head times also have a big influence on distribution of power. When not using head times as a free variable, like in section 3.2.1, the ratio P_{climb}/P_{flat} differs vastly from the optimization results using the same team on the same course, but with head times as a free variable. From the results in section 3.2.2 we can see that the distribution of power is also influenced by the rest of the course. The P_{climb}/P_{flat} ratio differs between the two segment and four segment courses with the exact same climbs, meaning the fact that whether the climb is followed by another segment influences the power distribution.

For the optimizations in this chapter we only used the head times and power as free variables, however, this does not guarantee the most optimal strategy. We used the starting order as was found by Overtoom [14] in his thesis for a flat time trial. This means having the riders which are stronger on the flat start at the front with the weakest rider at the back of the group. The stronger riders will, in an optimized pacing plan, do longer turns on the front, which means the weaker riders can spend a longer time further to the back of the group where they profit from a larger aerodynamic drag reduction. This means they can recover for longer in a more favorable position. In our case, this means that the order, when riding with a mixed team, is always to start with the GC-contenders on the front, followed by the TT-specialists, then the Domestiques and finally the Climbers. However, for courses with longer, steeper climbs it is not a given that the Climbers are the weakest riders in the group. Therefore, to find a true optimum, the order of the group should also be a free variable in the optimization. When we introduced skipping in sections 3.2.3 and 3.2.4 we only looked at the last one or two riders skipping turns. In some cases this caused an improvement in the final time of the time trial. Thus, to complete the strategy optimization, a variable should be added that describes whether a rider will skip turns. This could be done in a more complete way by using the same method that Overtoom [14] used for a flat time trial. He did not define whether certain riders should skip turns, but instead kept the place where the riders would cut back into the group at the end of their changing maneuver as a free variable. This is a more complete and flexible way to find the optimal strategy, but it would drastically increase optimization times, since this method would require more variables to describe the changing scheme. Also the order of the riders in the group may change during the time trial using this method. This could be a benefit with changing terrain, because as mentioned before, the weakest rider on the flat may not be the weakest rider on a climb or in a descent. Changing the order of the team throughout the race could, therefore, be potentially beneficial. To find the theoretically optimal strategy for a team time trial, not only the head times and power, but also the starting order of the riders and some kind of variable describing the changing scheme of the riders should be used as free variables. However, this would be a very costly optimization and could result in a very complicated strategy.

3.4. Conclusions

- Optimal head times can be much longer than the ones currently used by team Sunweb. These range from a short 10 second head turn to a long 40 second head turn. Head turns resulting from the optimizations can span the entire range defined for the optimizations from 5 up to 120 seconds, but usually range from about 60 to 100 seconds.

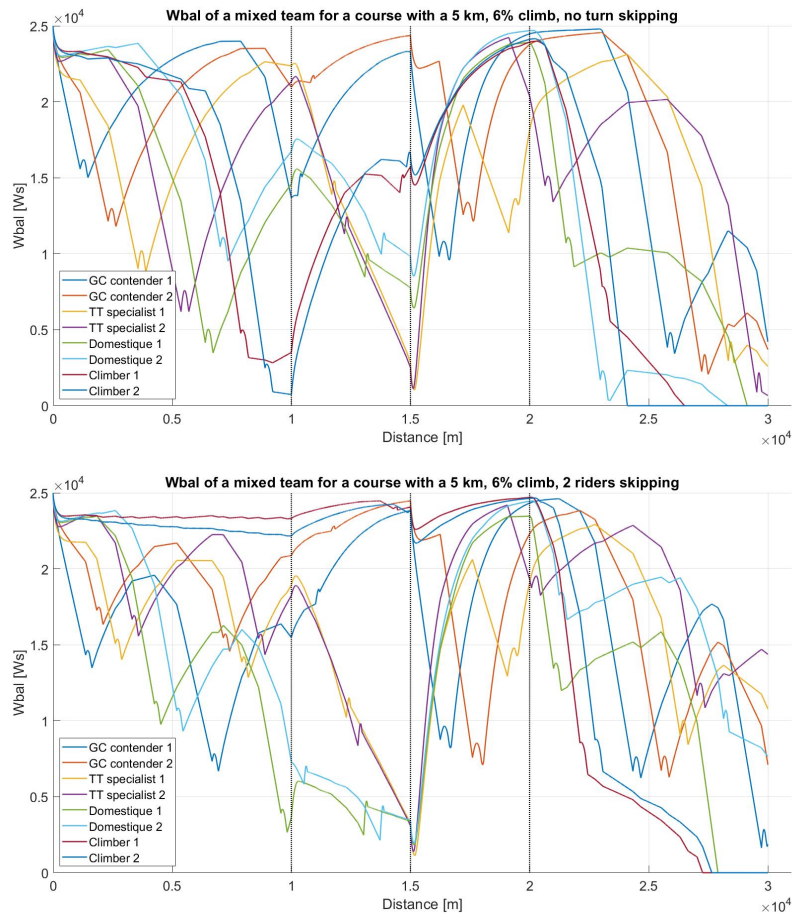

Figure 3.10: W_{bal} plots for a mixed team of riders on a course with a 5 km, 6 percent gradient climb and descent with no turn skipping (top) vs. both Climbers skipping turns on the flat segment (bottom).

- In most cases, it is beneficial to produce less power on the climbs than on the flats. The lower speeds on the climbs mean the riders do not experience the same aerodynamic benefits, which means they can hardly recover during the climb.
- For short climbs it might be beneficial to produce more power on the climbs. The point where it starts to be more efficient to produce more power on the climb than on the flat is hard to pinpoint since it depends on the rest of the course as well as on the selected riders. However, it seems that the climb should not be longer than about three minutes. This way either one or two very strong riders can ride on the front for the whole climb, or certain riders can perform a suicide pull.
- The individual strong points of a rider influence the distribution of power between flats and climbs. For instance, for a team of Climbers it will be more efficient to produce more power on the climbs relative to the flats than for a team of time trial specialists. In other words: in an optimal strategy a team of Climbers will have a higher ratio of P_{climb}/P_{flat} than a team of TT-specialists. This means that when developing a strategy, it is important to assess the qualities of all the riders in your team and adapt the power distribution accordingly.
- Having the head times of the riders as a free variable has a big impact on the distribution of power between the climbs and the flats. When all the riders have the same head times, even if all the riders have the same individual characteristics, P_{climb}/P_{flat} is much larger than with a more optimized head time distribution.
- Having riders skip turns even though they are not yet fatigued, may have a positive effect on the final time of the time trial. However, when the rider is not a limiting factor on the particular segment of the

course it may also have a negative effect. The rider may be a limiting factor when he is relatively strong compared to his team mates on a certain segment of the course, but relatively weak compared to its team mates on another segment. For instance, having a climber skip his turns on a flat segment while a long climb is coming up, delivering the climber to the bottom of the climb in a more rested state, can be beneficial.

- In order to get a true optimal strategy not only power and head times should be optimization parameters, but also the order of the riders and whether or not the riders are allowed to skip turns on certain segments of the course or when their W_{bal} becomes too low.

4

Sensitivity analysis

The strategies resulting from the optimization algorithm discussed in chapter 3 depend strongly on the individual characteristics of the rider. Naturally, a team of stronger riders will be able to ride a faster team time trial than a team of weaker riders, but as discussed in section 3.2, the relative strengths of riders can also have an influence on the power distribution over different segments of the course. Therefore, the rider parameters mass, critical power, aerodynamic drag coefficient and W' are critical in the development of a good strategy. Although some parameters are easy to measure, like mass, others are much more susceptible to measuring mistakes, like critical power. Critical power may also be affected if a rider starts the race fatigued from prior stages in a multi stage race. $C_d A$ may also be affected by fatigue during the race. Time trial positions are often hard to maintain and fatigue may make it harder for the riders to keep their perfect position. To analyse the influence of these small perturbations in the rider parameters a sensitivity study is performed. For this sensitivity study we will run a number of optimizations, like the ones described in chapter 3. Each optimization will use the same course and the same team of riders starting in the same order. Each simulation, however, one rider parameter will be either increased or decreased. By comparing the resulting time and variables we can see the influence that small measurement errors in the rider parameters can have on the outcome of the optimization, and thus whether these have a significant impact on the optimal strategy.

4.1. Method

A course consisting of two segments is used: a 10 kilometer flat segment, followed by a 5 km climb with a 6% gradient. The results from section 3.2.1 are used as a baseline. The mixed team is used, consisting of two GC-contenders, two TT-specialists, two Domestiques and two Climbers, starting in that order.

The parameters used in this sensitivity study are all rider parameters: critical power, $C_d A$, mass and W' . Each run one parameter is altered for one type of rider keeping all other parameters equal to the ones shown in table 3.1. This means for the first run the critical power for both GC-contenders is altered, for the second run the critical power of both TT-specialists is altered, and so on. A parameter alteration of 10 percent is used. This means in total we will increase and decrease four variables for four different types of riders which will result in a total of 32 optimizations.

4.2. Sensitivity analysis results

The result of the sensitivity analysis are shown in tables 4.1, 4.2, 4.3 and 4.4. Each table shows the results of the adaptation of one parameter. Each column shows the results for the case where a parameter was either increased or decreased for that particular rider type. Since we are only changing one parameter with 10 percent for two riders out of the eight rider team, we do not expect to see a very large change in the final time. However, it might be interesting to see what the influence of this change is on the strategy that is used. We can see, what appears to be, an inconsistency in table 4.1, where the CP is decreased by 10% for the Domestiques. The power does not change but the time is marginally slower. This happens because, in the model, every time the riders perform a changing maneuver, the distance the team has covered is set back the length of one rider. This means that if more changing maneuvers are performed the team can be marginally slower while they produced the same power.

As expected, the influence of the 10% change in parameter values does not have a big impact on the final time. The maximum increase in the final time is only 1.84% over the baseline case and is found for a 10% decrease in critical power of the GC-contenders (table 4.1). However, the distribution of power alters much more significantly due to the alteration of rider parameter values. The maximum difference in power produced on the flat segment compared to the baseline is -8.49%, which is seen for a 10% decrease in C_dA for the GC-contenders 4.2. The maximum difference in power on the climb is seen in table 4.3 for a 10% decrease in mass for the GC-contenders and is -7.37%. The ratio of power on the climb to power on the flat, P_{climb}/P_{flat} , was 0.90 for the baseline case and ranges between 0.81 for a 10% decrease in mass for a GC-contender (table 4.3 and 0.98 for a 10% decrease in C_dA for a GC-contender (table 4.2. These are differences of -9.08% and 9.28% respectively in P_{climb}/P_{flat} .

The main thing we can interpret from this sensitivity study is that the result of changing a certain variable value on the optimal strategy is highly non-linear and very unpredictable. For instance, a 10% increase in CP for the TT-specialist and GC-contender both give about a 0.7% improvement in the final time (table 4.1). However, a 10% decrease in CP gives a 1.8% increase in the final time for the GC-contender while it only gives a 0.25% increase in the final time for the TT-specialist. When the critical power is decreased by 10% for the GC-contender, the power distribution shifts more towards the flats. However, if the critical power of the TT-specialists is decreased with 10% the power distribution shifts more towards the climb. Furthermore, from the results presented in chapter 3, we would expect a decrease in mass to cause a shift in the power distribution towards the climbs. However, if we look at the results in table 4.3 we see the exact opposite happening. It can become even more unpredictable when a change in parameter would change the optimal strategy in such a way that different riders are getting dropped. In the baseline scenario it was most efficient to drop the Domestiques and TT-specialists at the bottom of the climb and have the GC-contenders and Climbers finish the race. However, a change in mass or critical power for one of the riders might mean that a strategy where the Climbers are being dropped instead of the TT-specialists might be more optimal. We have not seen this phenomenon in this sensitivity but for other courses or teams this could be an issue.

A second problem we see is that in some cases a change in a certain variable value for one rider only has a small impact on the final time or strategy while the same change for another rider can cause a drastic change in the final time. The change in mass shown in table 4.3 is a good example. In the baseline strategy the TT-specialist and Domestiques don't do much work on the climb and are dropped almost immediately as the climb starts. Since they are not contributing a lot on the climb and mass has little influence on the flat segment of the course, we would expect a change in mass to have little effect. Indeed, a 10 percent increase in mass for either the TT-specialist or the Domestique has little influence on the final time or strategy. However, this same 10 percent increase in mass for the GC-contender or Climber causes a much larger difference in the final time as well as a larger difference in the strategy.

One positive thing that we can interpret from the results of this study is that the a small change in W' , shown in table 4.4, has only a small effect on the strategy or final time. A 10% change in W' only caused a maximum of 0.45% change in the final time. Also, the change in power, due to the change in W' , is mostly between 0% and 3% with a maximum of 4.2%. This is a positive thing because W' is a difficult parameter to measure accurately and may differ from day to day due to the effects of fatigue. Mass and C_dA have a much larger influence but are much easier to measure and will most likely never deviate from the measurement data with anything even near 10%. The method for calculating CP can also be very accurate, but, as with W' , this value might differ somewhat from day to day due to fatigue. Also, CP is not measured very often by team Sunweb even though it can also change over the course of a season.

4.2.1. Conclusion

This sensitivity analysis has shown that small measurement mistakes in rider parameters will not cause a large deviation in potential final time, however, it can have a big influence on the optimal strategy. Therefore, having accurate parameter values is essential when developing the strategy for a team time trial. Some parameters are relatively easy to measure accurately, like mass. C_dA is also easy to measure accurately, although it is expensive and time consuming because of the need of a wind tunnel or a velodrome. The biggest problems are caused by CP and W' . The values of these parameters can not only be influenced by fatigue, causing them to change from day to day, but they also change over a longer period of time. At the moment CP and W' are not measured very often, which means long term changes in these parameters might not be noticed very quickly. Luckily the influence of a small perturbation in the value of W' seems to be limited, but an accurate CP value is very important. Since it is not always possible to have a very accurate value for all parameters for all riders it is sensible to develop a strategy with some margin for error.

Critical power +10%					
Case	Baseline	GC	TT	Dom.	Climb.
Time [s]	1211.2	1202.7	1203.0	1192.8	1194.3
Difference with baseline		-0.70%	-0.68%	-1.52%	-1.40%
Power Flat [W]	530	540	550	565	560
Difference with baseline		1.89%	3.77%	6.60%	5.66%
Power Climb [W]	475	480	475	480	480
Difference with baseline		1.05%	0%	1.05%	1.05%
P_{Climb}/P_{Flat}	0.90	0.89	0.86	0.85	0.86
Difference with baseline		-0.82%	-3.64%	-5.21%	-4.36%
Critical power -10%					
Case	Baseline	GC	TT	Dom.	Climb.
Time [s]	1211.2	1233.5	1214.2	1212.6	1230.7
Difference with baseline		1.84%	0.25%	0.12%	1.61%
Power Flat [W]	530	530	515	530	545
Difference with baseline		0%	-2.83%	0%	2.83%
Power Climb [W]	475	450	480	475	450
Difference with baseline		-5.26%	1.05%	0%	-5.26%
P_{Climb}/P_{Flat}	0.90	0.85	0.93	0.90	0.83
Difference with baseline		-5.26%	4.00%	0%	-7.87%

Table 4.1: Results of sensitivity analysis altering critical power.

C_dA +10%					
Case	Baseline	GC	TT	Dom.	Climb.
Time [s]	1211.2	1218.0	1213.5	1213.4	1231.0
Difference with baseline		0.56%	0.19%	0.18%	1.63%
Power Flat [W]	530	570	525	535	545
Difference with baseline		7.55%	-0.94%	0.94%	2.83%
Power Climb [W]	475	480	475	470	450
Difference with baseline		1.05%	0%	-1.05%	-5.26%
P_{Climb}/P_{Flat}	0.90	0.84	0.90	0.88	0.83
Difference with baseline		-6.03%	0.95%	-1.98%	-7.87%
C_dA -10%					
Case	Baseline	GC	TT	Dom.	Climb.
Time [s]	1211.2	1202.6	1208.2	1209.3	1195.5
Difference with baseline		-0.71%	-0.25%	-0.16%	-1.30%
Power Flat [W]	530	485	545	565	565
Difference with baseline		-8.49%	2.83%	6.60%	6.60%
Power Climb [W]	475	475	470	460	475
Difference with baseline		0%	-1.05%	-3.16%	0%
P_{Climb}/P_{Flat}	0.90	0.98	0.86	0.81	0.84
Difference with baseline		9.28%	-3.78%	-9.16%	-6.19%

Table 4.2: Results of sensitivity analysis altering C_dA .

Mass +10%					
Case	Baseline	GC	TT	Dom.	Climb.
Time [s]	1211.2	1232.0	1209.2	1208.3	1228.5
Difference with baseline		1.72%	-0.17%	-0.24%	1.43%
Power Flat [W]	530	550	545	545	550
Difference with baseline		3.77%	2.83%	2.83%	3.77%
Power Climb [W]	475	480	470	475	445
Difference with baseline		1.05%	-1.05%	0%	-6.32%
P_{Climb}/P_{Flat}	0.90	0.87	0.86	0.87	0.81
Difference with baseline		-2.62%	-3.78%	-2.75%	-9.72%
Mass -10%					
Case	Baseline	GC	TT	Dom.	Climb.
Time [s]	1211.2	1202.5	1205.1	1199.9	1195.1
Difference with baseline		-0.72%	-0.50%	-0.93%	-1.33%
Power Flat [W]	530	540	545	560	550
Difference with baseline		1.89%	2.83%	5.66%	3.77%
Power Climb [W]	475	440	475	475	485
Difference with baseline		-7.37%	0%	0%	2.11%
P_{Climb}/P_{Flat}	0.90	0.81	0.87	0.85	0.88
Difference with baseline		-9.08%	-2.75%	-5.35%	-1.61%

Table 4.3: Results of sensitivity analysis altering mass.

$W' +10%$					
Case	Baseline	GC	TT	Dom.	Climb.
Time [s]	1211.2	1206.4	1209.5	1207.8	1205.4
Difference with baseline		-0.40%	-0.14%	-0.28%	-0.48%
Power Flat [W]	530	540	545	530	535
Difference with baseline		1.89%	2.83%	0%	0.94%
Power Climb [W]	475	475	475	480	480
Difference with baseline		0%	0%	1.05%	1.05%
P_{Climb}/P_{Flat}	0.90	0.88	0.87	0.91	0.90
Difference with baseline		1.85%	-2.75%	1.05%	0.11%
$W' -10%$					
Case	Baseline	GC	TT	Dom.	Climb.
Time [s]	1211.2	1212.7	1209.6	1207.1	1213.1
Difference with baseline		0.12%	-0.13%	-0.33%	0.16%
Power Flat [W]	530	545	545	530	545
Difference with baseline		2.83%	2.83%	0%	2.83%
Power Climb [W]	475	470	475	480	455
Difference with baseline		-1.05%	0%	1.05%	-4.21%
P_{Climb}/P_{Flat}	0.90	0.86	0.87	0.91	0.83
Difference with baseline		-3.78%	-2.75%	1.05%	-6.85%

Table 4.4: Results of sensitivity analysis altering W' .

5

Practical use of research results

The goal of this research is to gather new knowledge on the strategy of the team time trial that will allow team Sunweb to better develop strategies for team time trials in the future. Therefore, an important part of the project was to make the knowledge that was gathered in this project, as well as the previous research efforts by Overtoom [14], practically applicable. The strategies resulting from the optimizations are very precise. Meaning that a little deviation in head time or power could cause riders to drop too early. Also, the model can not be assumed to be a perfect reflection of reality, which will be further discussed in chapter 6. Hence, we do not wish to use the optimization algorithm to develop the actual strategies for future time trials. Instead, it would be better to use the knowledge we gathered from these optimizations to build a strategy by hand. In this way we are able to build in some margin for error so riders will not be dropped too soon. Also, we can build strategies that are not overly complicated. To allow team Sunweb to do this a Matlab application is developed around the team time trial model. Also, a few guidelines are created for developing strategies for different scenarios. To see whether the application and the guidelines work in a satisfactory manner a validation is performed. The team time trial of the 2018 Tour de France is analyzed. Using the guidelines and the Matlab application a strategy is developed. Also, a strategy is made using the optimization algorithm. These two strategies are compared to each other and then to the strategy that was used by team Sunweb in the actual time trial to see whether the strategy developed with the application was satisfactory and to see what kind of time gains can be made by applying the knowledge gathered in the previous chapters.

5.1. Matlab application

In order to allow team Sunweb to use the team time trial model developed during this project, a Matlab application is developed. The application has two different options. The first option is to load a course using a gpx file. Which is a file containing coordinates and elevation from which the length and gradient of the course segments is calculated. The user can then select riders from a drop-down menu or create new riders if necessary. The user specifies a head time for all riders and selects a team leader. The power is then specified for the team leader and the minimum number of cyclists that should finish the race is also specified. When using the gpx option, the team will use the same tactics for the entire course. The user has the option to let the team produce more or less power depending on the gradient, but the head times stay the same over the entire course. The application can either use the power specified by the user or optimize the power to find the highest achievable power for the specified riders and head times. The application will increase the power that the riders produce until too many riders drop and select the highest power at which enough riders make it to the finish line as the optimal power for the current head time strategy. We also want to be able to use different head times on different segments of the course, hence the application has the additional option to create your own course. The user specifies length and gradient of all the different segments in a vector. The head times for every rider as well as the power can then also be specified for each individual segment. Here, the user will also have the option of optimizing the power. In this case, the power is optimized using the optimization algorithm described in chapter 3. The only difference is in this case the head times that the user provided, will be fixed, meaning only power is used as a free variable. For both these functionalities the app calculates the final time of the time trial and can display the W_{bal} , power and speed for all the riders plotted against the traveled distance. This way, the user can adjust the head times according to the W_{bal} plots of the

riders to optimize the strategy. The user can also specify whether riders are allowed to skip turns, either as a preventive measure or when they are tired. They can also specify whether the riders are allowed to perform a suicide pull when their W_{bal} is too low when they hit the front. Finally, the air resistance can be influenced by adding wind and by altering the air density.

5.2. Strategy guidelines and scenarios

In order to give the user of the Matlab application a starting point from which to begin developing the team time trial strategy, a few guidelines are set up, based on the results of the optimizations from chapter 3 as well as some additional optimizations. The guidelines consist of a few general conclusions from the optimization results as well as a few strategies for fictional time trial scenarios that were provided by team Sunweb. Each of these scenarios consists of a 20 km time trial that is ridden by a team consisting of four time trial specialists and four climbers as defined in chapter 3. There are six scenarios that consist of the following courses:

- **scenario 1:** 18 km flat segment followed by a 2 km climb at 6%.
- **scenario 2:** 18 km flat segment followed by a 2 km climb at 10%.
- **scenario 3:** 2 km flat segment followed by a 1 km climb at 6% and a 17 km flat segment.
- **scenario 4:** 2 km flat segment followed by a 3 km climb at 6% and a 15 km flat segment.
- **scenario 5:** 10 km flat segment followed by a 1 km climb at 6% and a 9 km flat segment.
- **scenario 6:** 10 km flat segment followed by a 3 km climb at 6% and a 7 km flat segment.

5.2.1. Guidelines

From the results of the optimizations described in chapter 3 we can draw a few general conclusions that will help develop team time trial strategies.

- Longer head times than the ones currently used by team Sunweb, which often range between 10 and 40 seconds, are more efficient. Head times should range from about 40 to 100 seconds if riders are relatively equally matched. Shorter head times can be used for riders that are a lot weaker than their team mates.
- When there is a big difference in rider capabilities within the team it is often best to have the weaker rider do very short turns on the front instead of one long turn and then have the rider drop. Keeping the rider in the team longer allows other riders more time to recover in a more favourable position.
- For longer climbs (approximately > 3 minutes), it is more efficient to produce a lower power on the climb than on the flat and a higher power in the descent than on the flat.
- For shorter climbs (approximately < 3 minutes) it is more efficient to produce more power on the climb than on the flats which in turn means producing less power in the descents than on the flats.
- When the course finishes with a flat segment, it is almost always favourable to keep time trial specialists in the group even if this means reducing the power on the climbs.
- When the course features a long climb, it may be favourable to have a weaker time trial rider start at the back and skip turns until the foot of the climb if the rider is a very capable climber.
- If a rider needs more rest, it is best to increase the head time of the riders following this rider so that the rider can spend a longer time in a more favourable position in the group.

5.2.2. Fictional time trial scenarios

In this section, a few strategies are presented for fictional team time trial courses. These courses were provided by team Sunweb. In all cases the team consists of four time trial specialists and four climbers, which was also specified by team Sunweb. In all cases, it is found to be most efficient to start with the four TT-specialists in front and the Climbers at the back, as was also concluded in the thesis of Overtoom [14]. All head times and powers presented are merely an indication to give a starting point from which a user of the Matlab application is able to develop a strategy. The optimization results for these scenarios can be found in table A.3 in the appendix.

Scenario 1 & 2 These scenarios consist of an 18 km flat segment followed by a 2 km climb at 6% or 10%. The strategy for both these scenarios will be similar. On the flat segment the TT-specialists will do long head turns (80-120 seconds) while the climbers will do very short head turns (10-25 seconds). The power on the flat should be high enough to drop the climbers before or at the foot of the climb, but not so high as to drop them immediately, which will allow the TT-specialists to start the climb relatively fresh. On the climb the TT-specialists will do shorter turns (25-75 seconds). The power will be higher on the climb than on the flats (about 10 to 20 percent higher). Be aware that this climb is around the turnover point when it comes to power distribution. This means that if the climb were to be slightly longer than 2 kilometers or slightly steeper than 10% it might be more efficient to deliver more power on the flats than on the climb.

Scenario 3 This scenario consists of a 2 km flat segment, followed by a 1 km climb with a 6% gradient which is subsequently followed by a 17 km flat segment. This scenario is a bit strange in the fact that the run into the climb is relatively short. If the first flat segment would be longer, it would be more efficient to produce more power on the climb when it is only 1 km in length, like we will see in scenarios 5. However, due to the short run in the strategy is somewhat different. The first flat segment is done by two or three TT-specialists riding a relatively high power. The climb will then be covered by the remaining TT-specialists at a relatively easy pace. On the second flat segment the Climbers will do the first pulls on the front to get back up to speed, allowing the TT riders to recover. TT-specialists will then do long turns on the front (80-100 seconds) while the climbers may do shorter turns if they have not yet been dropped (40-80 seconds). The power on the second flat segment will be higher than on the climb but lower than on the first flat segment (approximate distribution 65-45-55). It might be good to have one Climber skip the first round of turns. This will not allow the Climber to contribute more, but will give the TT-specialists some more rest in a more optimal position when the other Climbers are already dropped.

Scenario 4 This scenario consists of a 2 km flat segment, followed by a 3 km climb with a 6% gradient, which is subsequently followed by a 15 km or flat segment. Once again, the strategy differs from scenario 6, which has the same climb, due to the fact that the run in is much shorter. The power distribution for this scenario is approximately 60-50-50, which means the power on the first segment is relatively high and on the climb as well as on the flat it is comparable. Again, the first flat segment is done by two or three TT-specialists. Head turns on the climbs are 60-100 seconds for both the Climbers and the TT-specialists. On the second flat segment the head times are a bit shorter than in scenario 3 while the TT-specialists start the flat segment more drained than with a shorter climb. Head times on the flat will be around 60 seconds. Again Climbers will drop quite fast on the flat segment. It might be good to have one Climber skip the first round of turns in order to give the TT-specialists a bit more rest in a more favorable position later on in the race.

Scenario 5 This scenario consists of a 10 km flat segment followed by a 1 km climb at a 6% gradient and another 9 km flat segment. On the first flat segment the TT-specialists will do long 80-120 second turns while the Climbers will do 20-80 second turns. Since the climb is very short, one or two riders will do the whole climb. Head turns on the second flat segment stay the same. It might be good to have two Climbers skip turns on the first flat segment. This will allow the TT-specialists a bit more rest after the climb. The power on the climb will be slightly higher than on the flats.

Scenario 6 This scenario consists of a 10 km flat segment followed by a 3 km climb at 6% and another 7 km flat segment. The TT-specialists do longer turns on the first flat segment (60-120 seconds) while the Climbers do shorter turns (15-35 seconds). This allows the Climbers to stay with the group until the climb where they are able to do long efforts (70-110 seconds) until they drop. The power on the climb is slightly lower than on the flats. It might again be good to have one Climber skip turns on the first segment in order to have him survive the climb and enable the TT-specialists a bit more rest on the second flat segment.

5.3. Validation

To check whether the Matlab application and the guidelines presented in this chapter work in a satisfactory manner, a validation is performed using the 2018 Tour de France team time trial as a test case. The strategy used by team Sunweb in the actual time trial will be compared to a strategy developed using the Matlab application according to the guidelines presented above as well as to the strategy that results from the optimization algorithm as presented in chapter 3. This will show us the kind of gains we are able to make when

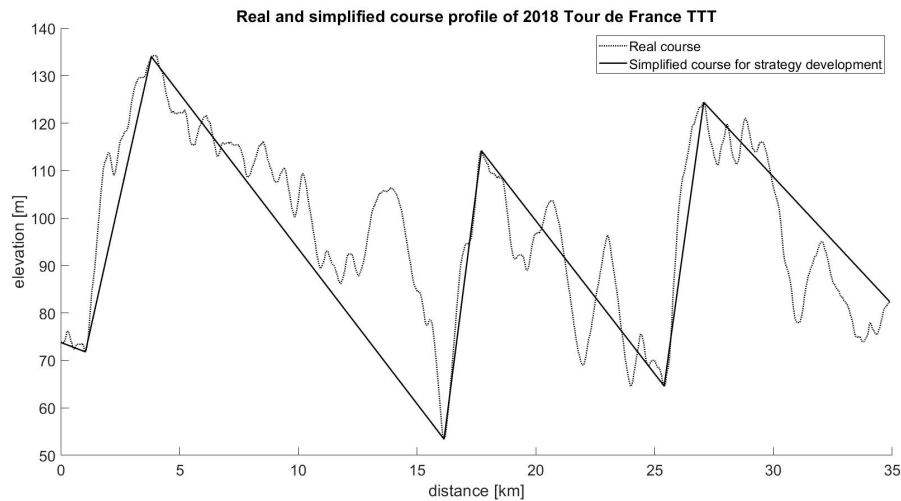

Figure 5.1: The actual course profile and simplified course profile of the 2018 Tour de France team time trial.

using these new strategy guidelines as well as whether we can come close to the theoretical optimal strategy when using the Matlab application. The goal is not to validate the team time trial model. This means that, when we simulate the strategy that was actually used in the 2018 Tour de France team time trial by team Sunweb, we do not expect a perfect prediction of the final time. We do, however, expect to see a final time in the correct order of magnitude.

5.3.1. Course

The course of the 2018 Tour de France team time trial was 35 km long and consisted of a few short climbs and long undulating descents. To allow a strategy to be developed using the Matlab application the course is split up into seven segments as can be seen in figure 5.1. The details of each segment are given in table 5.1.

Segment	type	length [m]	gradient
Segment 1	flat	1040	-0.19%
Segment 2	climb	2773	2.24%
Segment 3	descent	12320	-0.65%
Segment 4	climb	1571	3.87%
Segment 5	descent	7693	-0.64%
Segment 6	climb	1665	3.59%
Segment 7	descent	7823	-0.54%

Table 5.1: Details of the simplified 2018 Tour de France team time trial course.

5.3.2. Rider parameters

To be able to compare the strategy developed using the Matlab application and the strategy resulting from the optimization algorithm to that of the actual time trial the physiological parameters of the actual riders will be used. To protect the privacy of the riders and the interests of team, the riders will be simply called Rider 1 unto Rider 8 and their physiological parameters will not be presented in this thesis. Instead, the climbing and time trial qualities of the riders will simply be indicated as weak, average, strong or super strong as can be seen in table 5.2. Since we did not focus on the order of the riders in this research and since including the order of the riders in the optimization would drastically increase the run time, the starting order is kept the same as in the original time trial. The rider starting on the front is called Rider 1, which is followed by Rider 2, etc.

Rider	climbs	flats
Rider 1	average	weak
Rider 2	weak	weak
Rider 3	average	strong
Rider 4	super strong	super strong
Rider 5	strong	strong
Rider 6	strong	average
Rider 7	weak	weak
Rider 8	strong	weak

Table 5.2: Riders used in the 2018 Tour de France team time trial

5.3.3. Original strategy

Firstly, we will analyse and simulate the strategy that team Sunweb used in the actual 2018 Tour de France team time trial. Because we do not expect a perfect prediction of the final time, we want the resulting time from the simulation as a benchmark to see what kind of improvement we can make when we use a different strategy. By analysing the data from 2018 Tour de France team time trial we can deduct the original strategy that the riders used. Of course, there was a predetermined strategy set by the coaches. However, we chose to deduct the strategy from the data in case there are big discrepancies between the strategy set by the coaches and what the riders actually did. In the original strategy the riders seemed to use constant head times over the entire course. However, the riders keep track of the length of their head turns themselves, which causes quite some variation between the actual head times of each rider. Therefore, for this analysis we will use the average of the head times, for each rider, over the entire race. These averages are shown in table 5.3. To determine the power strategy used by the riders, we will look at the average power for each segment which is shown in figure 5.2. The average powers are low compared to the power that the lead rider is producing since it also includes the power of the trailing riders. However, it does give a good indication of the power distribution between the different segments of the course. The average power for each segment of the course is shown in table 5.4. For the simulation, the power distribution is kept the same. The power for each segment is multiplied by the same factor. This factor is increased until too many riders drop before the finish is reached. That way, the ratio between the power on each segment of the course is kept same. This results in the power strategy shown in the right most column of table 5.4. When we use these power numbers together with the head times from table 5.3 to run the simulation of the 2018 Tour de France team time trial course described in table 5.1 with the riders from table 5.2 we get a final time of 38:52. The actual result from this race for team Sunweb was a time of 38:57. Although it is not the goal to perfectly predict the final time, the fact that the final time is of the correct order of magnitude suggests that the strategy is well simulated. We will use this time as a benchmark to see what kind of gains we can make by adapting our strategy.

Rider	Average head time [s]
Rider 1	19.6
Rider 2	17.0
Rider 3	32.9
Rider 4	29.3
Rider 5	27.1
Rider 6	24.9
Rider 7	22.3
Rider 8	13.6

Table 5.3: Average head times of all riders from the 2018 Tour de France team time trial

5.3.4. Strategy using new guidelines

Now that we have our benchmark, we can work on a new strategy using the guidelines from section 5.2.1 and the scenarios from section 5.2.2. The course starts with a short flat segment followed by a relatively long climb and a long very shallow descent, which is comparable to scenario 4 in section 5.2.2. We therefore expect the best strategy to be a higher power on the first flat segment than on the climb. We also expect the power on the descent to be slightly higher than on the climb. After the long descent the course consists of two short climbs

Segment	type	Average power [W]	Power used in simulation [W]
Segment 1	flat	309	414
Segment 2	climb	417	559
Segment 3	descent	349	468
Segment 4	climb	465	624
Segment 5	descent	343	460
Segment 6	climb	428	574
Segment 7	descent	380	510

Table 5.4: Average power of each course segment from the 2018 Tour de France team time trial and power used in the simulation of the original strategy.

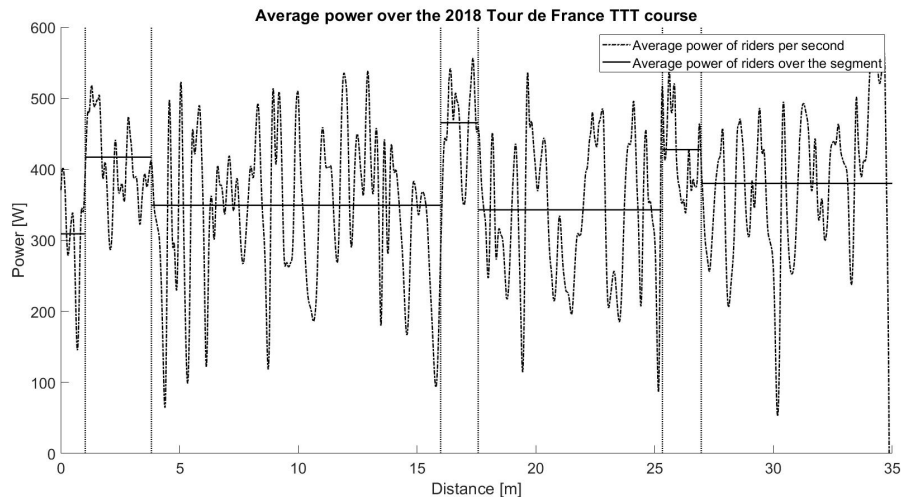

Figure 5.2: Power plot showing the average power of the riders per second and the average for each segment of the course.

each followed by a longer descent. This bears resemblance to scenario 5 in section 5.2.2. Therefore, we expect it to be favorable that the power on the climbs is higher than in the descents. Rider 4 is our strongest rider and will therefore be our team leader. Rider 3, Rider 5 and Rider 6 are also relatively strong and will finish the race. Rider 2 and Rider 7 are the weakest riders and will be dropped first, while Rider 1 and Rider 8 can contribute a bit more. The first two riders are not great at flat time trials, but since we are keeping the order the same as in the actual time trial, they will both be doing about 40 second turns on the first segment. This should cover the first segment of the course. The next riders in line are all strong climbers. They will do about 80 second head turns which will probably be enough to cover the whole climb. This will leave Rider 7 and Rider 8 to do the first part of the descent, but they will only do short turns of about 20 seconds while the stronger time trial riders will do 80 second turns on the front. Rider 2 and Rider 7 might have been dropped by the end of the descent. In the next climbs, we want two strong climbers to do the whole climb, probably doing 60 to 80 second turns on the front while in the descent the head times will be again 80 seconds. We expect Rider 1 and Rider 8 to drop somewhere in the second half of the course. With all this in mind, we can start to fill in all the necessary fields in the Matlab application. We will use the values in table 5.5 as a starting point.

Since this application is new, there is no real tried and tested method to use it. Therefore, we will try two different methods. First, we will be using the optimization function in the application after which we will adjust the variables further by hand. For the second method, we will only iterate by hand and not use the optimization function.

For the first method, we will use the head times and initial power shown in table 5.5 and use the optimization algorithm in the application to optimize the power variables. This optimization function only uses the power as free variables keeping the head times constant. Using this optimization function resulted in a strategy with a final time of 38:10. It turns out that iterating by hand from this point on is very difficult since a small alteration in head times usually results in too many riders getting dropped. However, we can adjust head times and once again use the optimization function. From the W_{bal} plots that resulted we suspected

that having Rider 1 ride on the front for the complete first segment of the course would allow for a more optimal strategy. Therefore, we increase the head time of the first rider on the first segment to 100 seconds and once again used the optimization function to optimize the power. The resulting strategy now gives a final time of 38:05. This procedure could be repeated more often, however, the run time of the optimization function in the Matlab application is still a few hours which makes it unpractical to use repeatedly. The power and head times of the resulting strategy are shown in table 5.6. Since not all riders do a head turn on every segment of the course the head times of riders that do not do a head turn on a certain segment are omitted.

Secondly, we will develop a strategy without using the optimization function. This is done by building up the course segment by segment trying to match the head times and power in such a way that the desired riders do their head turn on the desired segments as described above. Then, the power and head times are adjusted by hand to most effectively use the energy stores of all riders. This results in a strategy with a final time of 38:08. This strategy is shown in table 5.7. Once again only the head times of riders that actually do a head turn on a specific segment are shown.

The process using the second method is much faster and yields a result that is not much slower than using the first method. The advantage of doing this whole process without using the optimization function is that we can build in a bit of slack. Meaning, that when a rider is not as fresh as expected or the riders do not execute the strategy as well as expected, this will not be an immediate problem. Using the optimization function often yields a strategy where margins are really thin. This makes it potentially risky in a race situation, but it also makes it difficult to adapt the strategy any further. In the end, a combination of these two methods might be most practical, but this will have to become apparent from more elaborate use and experience.

For the comparison below, we will use the fastest strategy developed using the application which is the strategy shown in table 5.6.

	Head times [s]						
Rider	segment 1	segment 2	segment 3	segment 4	segment 5	segment 6	segment 7
Rider 1	40	10	25	10	20	10	20
Rider 2	40	10	10	10	10	10	10
Rider 3	5	70	80	70	80	70	80
Rider 4	5	70	80	70	80	70	80
Rider 5	5	70	80	70	80	70	80
Rider 6	5	70	80	70	80	70	80
Rider 7	5	10	25	10	10	10	10
Rider 8	5	10	25	10	25	10	25
	Power [W]						
Rider	segment 1	segment 2	segment 3	segment 4	segment 5	segment 6	segment 7
Rider 4	550	500	500	530	500	530	550

Table 5.5: Initial variables for strategy development using the Matlab application.

	Head times [s]						
Rider	segment 1	segment 2	segment 3	segment 4	segment 5	segment 6	segment 7
Rider 1	100		25		20		20
Rider 2		10	10		10		10
Rider 3		70	80		80		80
Rider 4		70	80		80	70	80
Rider 5		70	80	70	80	70	80
Rider 6			80	70			
Rider 7			25	10			
Rider 8			25	10	25		
	Power [W]						
Rider	segment 1	segment 2	segment 3	segment 4	segment 5	segment 6	segment 7
Rider 4	600	475	540	505	535	535	540

Table 5.6: Optimized power and actual head times following the first method, using the optimization function in the Matlab application. Initial values from table 5.5 where used. This strategy resulted in a final time of 38:05.

	Head times [s]						
Rider	segment 1	segment 2	segment 3	segment 4	segment 5	segment 6	segment 7
Rider 1	100						
Rider 2		20	20		20		50
Rider 3		70	80		80		30
Rider 4		70	80	70	80		30
Rider 5		70	20	70	50	70	35
Rider 6			40				
Rider 7			20				
Rider 8			30		50	70	15
	Power [W]						
Rider	segment 1	segment 2	segment 3	segment 4	segment 5	segment 6	segment 7
Rider 4	550	500	550	530	500	530	530

Table 5.7: Strategy developed by hand using the Matlab application and the guidelines from section 5.2. Once again the values from table 5.5 where used as initial values. This strategy resulted in a final time of 38:08.

5.3.5. Optimization algorithm strategy

Lastly, a strategy is developed using the optimization algorithm described in chapter 3. Again, the power and head times are used as free variables. The strategy resulting from the optimization algorithm can be seen in table 5.8. Not all riders do a front turn on each segment of the course, hence only the head times of riders doing a front turn on a certain segment are shown. The final time using this tactic is 37:58.

	Head times [s]						
Rider	segment 1	segment 2	segment 3	segment 4	segment 5	segment 6	segment 7
Rider 1	75						
Rider 2		75	115				
Rider 3		25	80	40	85		30
Rider 4			100	15	100		65
Rider 5			105		40	35	100
Rider 6			20		55	20	30
Rider 7			55		40	60	60
Rider 8			50		25		70
	Power [W]						
Rider	segment 1	segment 2	segment 3	segment 4	segment 5	segment 6	segment 7
Rider 4	595	490	550	535	515	485	565

Table 5.8: Strategy following from the optimization algorithm. This strategy resulted in a final time of 37:58.

5.3.6. Strategy comparison

With the original strategy as a baseline, we can now see what kind of gains we can make by adapting the strategy according to the guidelines and scenarios presented in this chapter and whether we can come close to the strategy resulting from the optimization algorithm. The final time using the original strategy was 38:52, the optimization algorithm yielded a final time of 37:58 and the Matlab application strategy gave a final time of 38:05. The difference between the Matlab application strategy and the optimization algorithm strategy is still 7 seconds, which is a lot in a team time trial (In the 2018 Tour de France team Sunweb came in third, 11 seconds behind the winner). However, there is still a very large improvement over the original strategy. Longer head times are used in the strategy developed using the Matlab application than are traditionally used. However, the strategy resulting from the optimization uses even longer head times, indicating that we might have been a bit too conservative in this respect. There is a big difference in the power distribution between the original strategy and the strategy developed using the Matlab application. Our initial input, shown in table 5.5, was not far off from the eventual power distribution shown in table 5.6, the only difference being that the power on the last descent is higher than on the last climb. Although the actual power numbers differ somewhat, the distribution of power in both the strategy made using the Matlab application and the one resulting from the optimization algorithm is remarkably similar. What is interesting when comparing

a strategy from the optimization algorithm, or the one developed with the Matlab application, to a more traditional strategy, is that there is a much bigger difference in exertion between the riders at any point in the race. This can be seen from the W_{bal} plots of all three strategies in figure 5.3. As can be seen from these plots, the sum of the W_{bal} of the riders at the finish line is much lower for the strategy made with the Matlab application than for the original strategy, indicating that the energy stores of the individual riders are used more efficiently. Whether this big difference in W_{bal} between riders at any given point is desirable will be further discussed in chapter 6.

5.3.7. Conclusion

When using the guidelines and scenarios presented in this chapter to develop a team time trial strategy, a big improvement can be made in the resulting time when compared to a strategy that was traditionally used. Using these guidelines will enable a better use of each riders' strong points and a more efficient use of the energy stores of each rider as can be seen from figure 5.3. Care should be taken when using the optimization function in the Matlab application. Using this function will often yield a strategy with very little room for error. A small error by the riders might cause a rider being dropped too soon which might mean the group will have to wait or the strategy will have to be changed. If a rider were to have a mechanical, like a flat tire, this could also mean having to hold back or change the strategy. When the strategy is made with a bit more room for error riders can always push a bit harder in the last segments of the course if they have energy to spare. This might not result in an optimal time, but could prevent much larger time losses. As mentioned in section 5.3.4 there is not yet a tried and tested way to use this Matlab application. The way the application is used, might have an impact on the margins for error in the strategy. It is of course up to the riders and coaches to decide how much risk they are willing to take in a certain race.

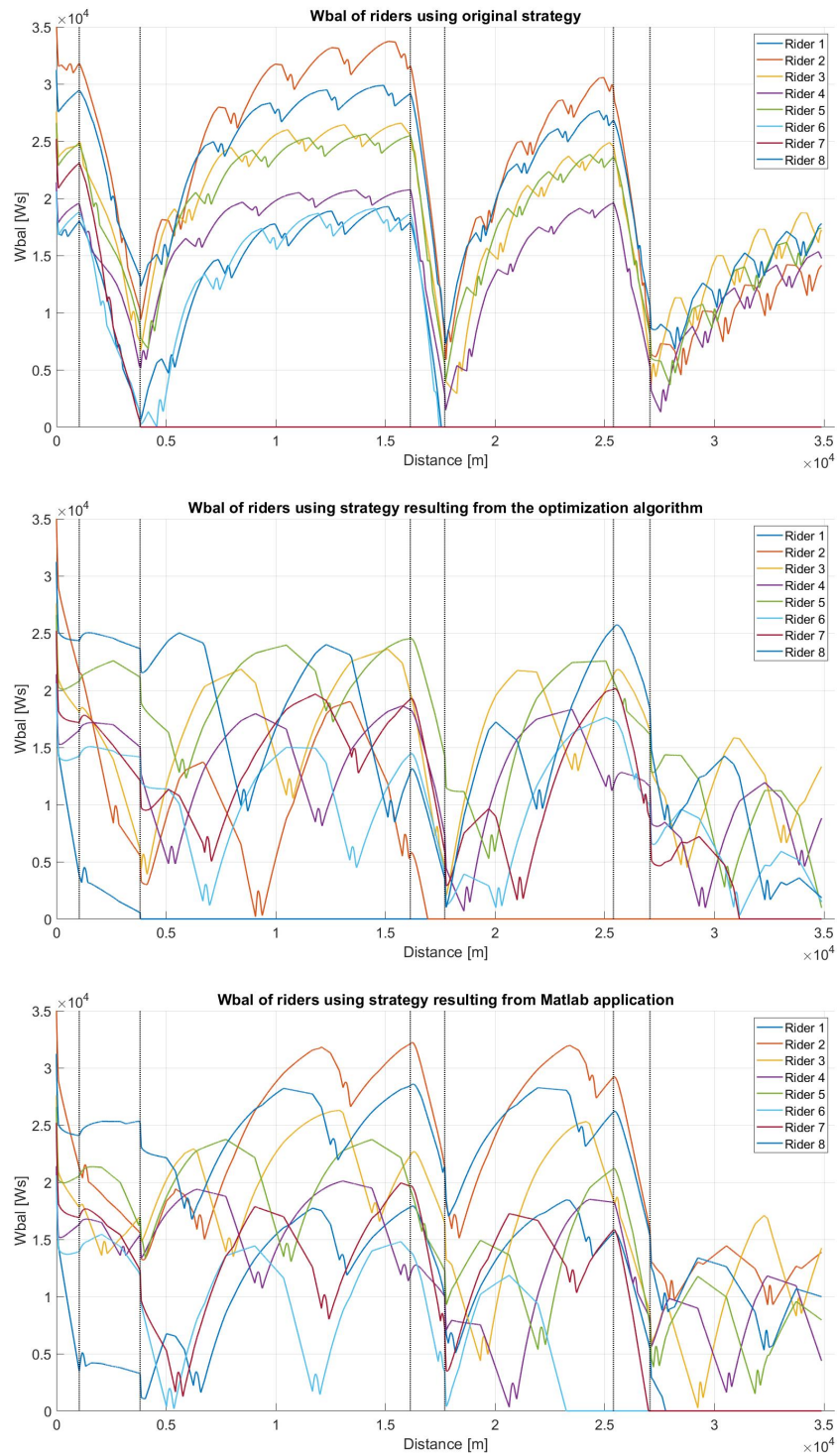

Figure 5.3: W_{bal} of riders riding the 2018 Tour de France team time trial course using the original strategy (top), the strategy from the optimization algorithm (middle) and the strategy from the Matlab application (bottom).

6

Recommendations

6.1. Team time trial model

6.1.1. Drag reduction model

The biggest gain to be made in improving the team time trial model is improving the drag reduction model. As already discussed in chapter 2 the drag reduction model used in the current team time trial model is far from perfect. The model assumes perfect riding without lateral or longitudinal deviation and assumes all riders are of equal size. Also, the aerodynamic influence of a rider riding next to the group when performing a changing maneuver is modelled in a very crude way. To make the model more realistic the aerodynamic model should be updated to include the influence of different size riders on the aerodynamics in the group and the influence of the group on a rider performing a changing maneuver and vice versa. Current research carried out by team Sunweb in collaboration with the TU Delft, will hopefully give better insight which will allow improvements to be made to the team time trial model in the future.

6.1.2. Rider exertion

All optimizations done in this research result in longer head times than are currently used. A similar research effort by Wolf [20] that looked at two riders working together in the breakaway of a road race found similar results. However, Wolf also used a penalty function on the exertion of the riders, limiting the difference in exertion that the riders were allowed to have. When this penalty function was used, the head times became smaller. In a road race this is important, because two riders working together in the breakaway will still have to sprint for the win at the end of the race. A big difference in exertion at that point will give an advantage to one of the riders, therefore, riders will avoid doing long turns on the front. In a team time trial riders do not have to account for this, because the riders are all part of the same team. However, we did not make any distinction between mild and severe exertion. According to the model a rider with an almost empty W_{bal} is just as capable as a rider with an almost full W_{bal} . In reality exertion might have an important effect on, for instance, the efficiency with which a rider performs his changing maneuvers or the way he holds his time trial position. This can have an effect on the performance of the rider and the team as a whole. Also, when a rider is severely exerted by doing a long turn on the front and starts his changing maneuver while a well rested team member takes the front, the well rested team member might unintentionally increase the tempo. A difference of a few Watts can make a big difference to the exerted rider when trying to join back at the back of the group, but is hard to notice for the fresh rider that just started his turn on the front. To the rider who just finished his turn on the front, this might mean the difference between getting dropped or not. As can be seen from figure 5.3 in chapter 5, a strategy resulting from the optimization algorithm (or the guidelines from section 5.2) can result in a much larger difference in exertion between the riders than in a more traditional strategy. Since these strategies have not yet been tested in real life it is difficult to say whether this would cause problems. If so, for future research, a penalty function like the one used by Wolf [20] to limit difference in exertion between riders might be a good addition to the team time trial model.

6.1.3. Model reliability

Finally, the aim of this model is not to reliably predict the final time of a team time trial, but to aid in the development of strategies. Although the predicted and actual final time of the Tour de France time trial used

in section 5.3 are really close, this is not a guarantee that this will be the case for all team time trials. It is very difficult to recreate the sterile computer simulation in a real life team time trial. Conversely, it is also very difficult to replicate a real life team time trial in a computer model. Not all changing maneuvers are made at exactly the right time in exactly the right manner, not every rider rides in the correct place without lateral or longitudinal deviation and not all riders ride at exactly the right power without any deviation. These small differences may have a large impact on the overall performance of the group. Although the final time from the Tour de France Team time trial simulation in chapter 5 was really close to the actual time of this team time trial, this is not yet a guarantee that this will be the case for all team time trials. If the model should give a reliable time estimate a lot more factors should have to be incorporated into the model like cornering, a more realistic wind model and a better drag reduction model. Also, a more elaborate validation should be performed. To do this, however, would surpass the goal of the current model.

6.2. Optimization algorithm

The optimizations done in this research used the standard settings for the Matlab genetic algorithm. To improve convergence a sensitivity study should have been performed using the optimization parameters. However, since this was not the focus of this study, the approach to optimization was very pragmatic. Also, since most optimizations were performed on the cluster at the faculty of mechanical, materials and maritime engineering of the TU Delft, computing time was less of an issue. Therefore, convergence speed could probably be increased. This could also be an improvement for the application developed for team Sunweb.

6.3. Strategy optimization

For this research we always used the starting order that followed from the research of Overtoom [14]. This means the starting order goes from strongest time trial rider on the front to weakest time trial rider in the back. This starting order was determined for a flat course. However, it is not necessarily the best starting order for any course. For the optimizations we did for the scenarios in section 5.2.2, a few different starting orders were used. As the results in table A.3 show, the starting order that was used in the rest of this research still turned out to be the most efficient. This is most likely because in these scenarios the biggest part of the race still favors the time trial specialists, as do most real life team time trial courses. However, it might still be interesting to look at different starting orders specifically for courses that have longer or steeper climbs. This would also allow other riders to skip turns on the first segments of the course. In sections 3.2.3 and 3.2.4 we only looked at having Climbers skip turns. In the scenarios used in these sections having other riders skip turns did not seem to make sense, but this might be different for other courses or team compositions.

Furthermore, the way in which the model is structured might have an influence on the strategies resulting from the optimization algorithm. When the speed of the riders is much lower than the speed dictated by the strategy, the riders will produce a much higher power (twice the power dictated by the strategy) until they reach 90 percent of the speed dictated by the strategy. This happens at the start or when riders crest the top of a climb. When the first part of the course is really short like scenarios 3 and 4 in section 5.2.2 or the course in section 5.3, the power on this first segment, resulting from the optimization algorithm, is usually really high. This means the riders get up to speed faster. Although their W_{bal} drops quite severely due to the surge in power, it is apparently still more efficient to use this strategy. However, since the power is fixed over a whole segment, this strategy can't be used when the first segment is longer since this would drain the riders' W_{bal} . This means that the strategy following from the optimization algorithm is dependent on the way the course is subdivided, which should ideally not be the case. More accurately modelling the way the riders get up to speed at the start of the race or when transitioning from a climb to a descent might help making this behaviour more realistic.

Lastly, We wanted the strategies that resulted from the optimizations in this research to still be practically applicable for team Sunweb, hence we only allowed the power and head times to differ for each segment of the course and not within the segment. For this particular research, it is still believed that this is the best choice. However, it might be interesting to see what the potential gains are if practicality of the strategy is not an issue. This could also mean adding extra optimization variables to describe, for instance, starting orders or changing schemes.

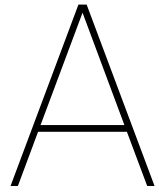

Appendix

A.1. Results of optimizations with and without head times

Climb length [km]	2	2	2	2	2	1.75	1.75	1.75	1.75	1.75	1.75	1.5	1.5	1.5	1.5	1.5	1.5	1.25	1.25	1.25	1.25	1.25	1.25																							
Inclination	4%	5%	6%	7%	8%	4%	5%	6%	7%	8%	4%	5%	6%	7%	8%	4%	5%	6%	7%	8%	4%	5%	6%	7%	8%																					
Team	Mixed																																													
Power Flat [W]	535	535	535	535	535	535	535	535	535	535	535	535	535	535	535	535	535	535	535	535	535	535	535	535	535																					
Power Climb [W]	575	560	550	535	525	605	585	570	555	545	640	625	605	590	570	700	675	655	635	615	1.07	1.05	1.03	1.00	0.98	1.13	1.09	1.07	1.04	1.02	1.20	1.17	1.13	1.10	1.07	1.31	1.26	1.22	1.19	1.15						
P_{Climb}/P_{Flat}	1.07	1.05	1.03	1.00	0.98	1.13	1.09	1.07	1.04	1.02	1.20	1.17	1.13	1.10	1.07	1.31	1.26	1.22	1.19	1.15																										
Team	TT specialists																																													
Power Flat [W]	540	540	540	540	540	540	540	540	540	540	540	540	540	540	540	540	540	540	540	540	540	540	540	540	540	540	540	540	540	540	540	540	540	540	540	540	540	540	540	540	540					
Power Climb [W]	610	585	560	540	525	645	610	585	565	545	685	650	620	595	570	750	710	675	640	610	1.13	1.08	1.04	1.00	0.97	1.19	1.13	1.08	1.05	1.01	1.27	1.20	1.15	1.10	1.06	1.39	1.31	1.25	1.19	1.13						
P_{Climb}/P_{Flat}	1.13	1.08	1.04	1.00	0.97	1.19	1.13	1.08	1.05	1.01	1.27	1.20	1.15	1.10	1.06	1.39	1.31	1.25	1.19	1.13																										
Team	GC contenders																																													
Power Flat [W]	545	545	545	545	545	545	545	545	545	545	545	545	545	545	545	545	545	545	545	545	545	545	545	545	545	545	545	545	545	545	545	545	545	545	545	545	545	545	545	545	545	545				
Power Climb [W]	625	600	580	560	540	660	630	605	580	560	705	670	645	615	590	770	735	700	670	635	1.15	1.10	1.06	1.03	0.99	1.21	1.16	1.11	1.06	1.03	1.29	1.23	1.18	1.13	1.08	1.41	1.35	1.28	1.23	1.17	1.16	1.16	1.16	1.16	1.16	
P_{Climb}/P_{Flat}	1.15	1.10	1.06	1.03	0.99	1.21	1.16	1.11	1.06	1.03	1.29	1.23	1.18	1.13	1.08	1.41	1.35	1.28	1.23	1.17																										
Team	Domestiques																																													
Power Flat [W]	510	510	510	510	510	510	510	510	510	510	510	510	510	510	510	510	510	510	510	510	510	510	510	510	510	510	510	510	510	510	510	510	510	510	510	510	510	510	510	510	510	510	510	510		
Power Climb [W]	585	560	535	520	500	615	585	565	540	520	660	625	600	575	545	725	685	655	620	590	1.15	1.10	1.05	1.02	0.98	1.21	1.15	1.11	1.06	1.02	1.29	1.23	1.18	1.13	1.07	1.42	1.34	1.28	1.22	1.16	1.16	1.16	1.16	1.16	1.16	1.16
P_{Climb}/P_{Flat}	1.15	1.10	1.05	1.02	0.98	1.21	1.15	1.11	1.06	1.02	1.29	1.23	1.18	1.13	1.07	1.42	1.34	1.28	1.22	1.16																										
Team	Climbers																																													
Power Flat [W]	480	480	480	480	480	480	480	475	480	480	480	480	480	480	480	480	480	480	480	480	480	480	480	480	480	480	480	480	480	480	480	480	480	480	480	480	480	480	480	480	480	480	480	480	480	
Power Climb [W]	550	530	510	490	475	580	555	535	515	500	625	595	570	545	520	685	655	625	590	560	1.15	1.10	1.06	1.02	0.99	1.21	1.16	1.11	1.07	1.05	1.30	1.24	1.19	1.14	1.08	1.43	1.36	1.30	1.30	1.23	1.23	1.23	1.23	1.23	1.23	1.23
P_{Climb}/P_{Flat}	1.15	1.10	1.06	1.02	0.99	1.21	1.16	1.11	1.07	1.05	1.30	1.24	1.19	1.14	1.08	1.43	1.36	1.30	1.23	1.17																										

Table A.1: Results of optimization looking into the turn-over point between more power on the climb than on the flat vs. less power on the climb than on the flat. Using power and head times as optimization variable for a two segment course with different team compositions.

Climb length [km]	2	2	2	2	2	2	2	2	2	2	2	2	2	2	2	2	2	2	2	2	2
Inclination	4%	5%	6%	7%	8%	8%	8%	8%	8%	8%	8%	8%	8%	8%	8%	8%	8%	8%	8%	8%	8%
Team	Mixed with fixed head times																				
Power Flat [W]	535	535	535	535	535	535	535	535	535	535	535	535	535	535	535	535	535	535	535	535	535
Power Climb [W]	575	560	550	535	525	585	570	555	545	640	625	605	590	570	700	675	655	635	615	635	615
P_{Climb}/P_{Flat}	1.07	1.05	1.03	1.00	0.98	1.13	1.09	1.07	1.04	1.02	1.17	1.13	1.10	1.07	1.31	1.26	1.22	1.19	1.15	1.19	1.15
Team	Mixed with head times																				
Power Flat [W]	560	555	550	550	535	555	560	550	540	555	560	560	555	540	560	560	560	545	550	545	550
Power Climb [W]	545	520	495	525	580	535	525	530	500	585	565	535	520	565	655	610	570	585	565	585	565
P_{Climb}/P_{Flat}	0.97	0.94	0.95	0.90	0.98	1.05	0.96	0.95	0.98	0.90	1.04	1.01	0.96	0.94	1.05	1.17	1.09	1.02	1.07	1.03	1.03
Team	GC contenders with fixed head times																				
Power Flat [W]	545	545	545	545	545	545	545	545	545	545	545	545	545	545	545	545	545	545	545	545	545
Power Climb [W]	625	600	580	560	540	660	630	605	580	560	705	670	645	615	590	770	735	700	670	635	635
P_{Climb}/P_{Flat}	1.15	1.10	1.06	1.03	0.99	1.21	1.16	1.11	1.06	1.03	1.29	1.23	1.18	1.13	1.08	1.41	1.35	1.28	1.23	1.17	1.17
Team	GC contenders with head times																				
Power Flat [W]	580	595	590	585	580	590	590	585	590	580	585	590	590	590	585	595	585	590	585	580	580
Power Climb [W]	575	555	545	535	525	605	580	565	545	545	620	605	590	565	555	670	625	605	600	600	600
P_{Climb}/P_{Flat}	0.99	0.93	0.92	0.91	0.91	1.03	0.98	0.97	0.92	0.94	1.06	1.03	1.00	0.96	0.95	1.13	1.15	1.06	1.03	1.03	1.03

Table A.2: Results of optimization looking into the turn-over point between more power on the climb than on the flat vs. less power on the climb than on the flat. Using power and head times as optimization variable for a two segment course with different team compositions.

A.2. Results of optimizations for guidelines

Course	scenario 1	scenario 2	scenario 3	scenario 4	scenario 5	scenario 6
Starting order	TT,TT,TT,TT,Climber,Climber,Climber,Climber					
Power 1st flat [W]	545	540	650	630	545	545
Power climb [W]	630	680	455	520	560	520
Power 2nd flat [W]	N/A	N/A	540	545	555	570
End time [s]	1286.9	1288.1	1290.7	1289.3	1287.8	1289.2
Starting order	Climber,Climber,Climber,Climber,TT,TT,TT,TT					
Power 1st flat [W]	525	525	515	575	525	525
Power climb [W]	670	655	680	525	700	510
Power 2nd flat [W]	N/A	N/A	525	525	520	540
End time [s]	1292.1	1294.2	1297.1	1297.6	1297.3	1299.7
Starting order	TT,Climber,TT,Climber,TT,Climber,TT,Climber					
Power 1st flat [W]	545	540	600	560	560	545
Power climb [W]	560	595	620	595	475	605
Power 2nd flat [W]	N/A	N/A	535	545	540	540
End time [s]	1291.2	1293.2	1291.5	1292.1	1291.2	1292.2

Table A.3: Results of optimizations for guidelines. Scenarios are as defined in chapter 5.2

Bibliography

- [1] Nathan Barry, David Burton, John Sheridan, Mark Thompson, and Nicholas AT Brown. Aerodynamic drag interactions between cyclists in a team pursuit. *Sports Engineering*, 18(2):93–103, 2015.
- [2] Jason C Bartram, Dominic Thewlis, David T Martin, and Kevin I Norton. Accuracy of w recovery kinetics in high performance cyclists—modeling intermittent work capacity. *International journal of sports physiology and performance*, 13(6):724–728, 2018.
- [3] Bert Blocken, Thijs Defraeye, Erwin Koninckx, Jan Carmeliet, and Peter Hespel. Surprises in cycling aerodynamics. *Europhysics News*, 44(1):20–23, 2013.
- [4] Bert Blocken, Yasin Toparlar, Thijs van Druenen, and Thomas Andrienne. Aerodynamic drag in cycling team time trials. *Journal of Wind Engineering and Industrial Aerodynamics*, 182:128–145, 2018.
- [5] AJ Chipperfield, PJ Fleming, H Pohlheim, and CM Fonseca. A genetic algorithm toolbox for matlab. In *Proc. International Conference on Systems Engineering, Coventry, UK*, volume 6, 1994.
- [6] Thijs Defraeye, Bert Blocken, Erwin Koninckx, Peter Hespel, Pieter Verboven, Bart Nicolai, and Jan Carmeliet. Cyclist drag in team pursuit: influence of cyclist sequence, stature, and arm spacing. *Journal of biomechanical engineering*, 136(1):011005, 2014.
- [7] PE Di Prampero, G Cortili, P Mognoni, and F Saibene. Equation of motion of a cyclist. *Journal of Applied Physiology*, 47(1):201–206, 1979.
- [8] Billy Fitton, Oliver Caddy, and Digby Symons. The impact of relative athlete characteristics on the drag reductions caused by drafting when cycling in a velodrome. *Proceedings of the Institution of Mechanical Engineers, Part P: Journal of Sports Engineering and Technology*, 232(1):39–49, 2018.
- [9] Scott Gordon. Optimising distribution of power during a cycling time trial. *Sports Engineering*, 8(2):81–90, 2005.
- [10] Levi Heimans, Wouter R Dijkshoorn, Marco JM Hoozemans, and Jos J de Koning. Optimizing the team for required power during track-cycling team pursuit. *International journal of sports physiology and performance*, 12(10):1385–1391, 2017.
- [11] A Iniguez-de-la Torre and J Iniguez. Aerodynamics of a cycling team in a time trial: does the cyclist at the front benefit? *European Journal of Physics*, 30(6):1365, 2009.
- [12] R Hugh Morton. A three component model of human bioenergetics. *Journal of mathematical biology*, 24(4):451–466, 1986.
- [13] R Hugh Morton and L Veronique Billat. The critical power model for intermittent exercise. *European journal of applied physiology*, 91(2-3):303–307, 2004.
- [14] M.W.B. Overtoom. Optimal team time trial strategy in road cycling. 2019.
- [15] PHILIP FRIERE Skiba, Weerapong Chidnok, Anni Vanhatalo, and Andrew M Jones. Modeling the expenditure and reconstitution of work capacity above critical power. *Medicine and science in sports and exercise*, 44(8):1526–1532, 2012.
- [16] David Sundström, Peter Carlsson, and Mats Tinnsten. Comparing bioenergetic models for the optimisation of pacing strategy in road cycling. *Sports engineering*, 17(4):207–215, 2014.
- [17] Anthony Turner and Paul Comfort. *Advanced Strength and Conditioning: An Evidence-based Approach*. Routledge, 2017.

-
- [18] Union Cycliste international. Uci cycling regulations, 2018. URL https://www.uci.org/docs/default-source/rules-and-regulations/part-i--general-organisation-of-cycling-as-a-sport.pdf?sfvrsn=b6f5c2e4_46.
- [19] Markus Wagner, Jareth Day, Dora Jordan, Trent Kroeger, and Frank Neumann. Evolving pacing strategies for team pursuit track cycling. In *Advances in Metaheuristics*, pages 61–76. Springer, 2013.
- [20] Stefan Wolf and Dietmar Saupe. How to stay ahead of the pack: optimal road cycling strategies for two cooperating riders. *International Journal of Computer Science in Sport*, 16(2):88–100, 2017.