

## Optical microlever assisted DNA stretching

ANDREW, PHILIPPA KATE; RAUDSEPP, ALLAN; FAN, DANIEL; STAUFER, URS; WILLIAMS, MARTIN A.K.; AVCI, EBUBEKIR

**DOI**

[10.1364/OE.430465](https://doi.org/10.1364/OE.430465)

**Publication date**

2021

**Document Version**

Final published version

**Published in**

Optics Express

**Citation (APA)**

ANDREW, PHILIPPA. KATE., RAUDSEPP, ALLAN., FAN, DANIEL., STAUFER, URS., WILLIAMS, MARTIN. A. K., & AVCI, EBUBEKIR. (2021). Optical microlever assisted DNA stretching. *Optics Express*, 29(16), 25836-25847. <https://doi.org/10.1364/OE.430465>

**Important note**

To cite this publication, please use the final published version (if applicable).  
Please check the document version above.

**Copyright**

Other than for strictly personal use, it is not permitted to download, forward or distribute the text or part of it, without the consent of the author(s) and/or copyright holder(s), unless the work is under an open content license such as Creative Commons.

**Takedown policy**

Please contact us and provide details if you believe this document breaches copyrights.  
We will remove access to the work immediately and investigate your claim.



# Optical microlever assisted DNA stretching

PHILIPPA-KATE ANDREW,<sup>1</sup>  ALLAN RAUDSEPP,<sup>2</sup> DANIEL FAN,<sup>3</sup>  
URS STAUFER,<sup>3</sup> MARTIN A. K. WILLIAMS,<sup>2,4</sup> AND EBUBEKIR  
AVCI<sup>1,4,\*</sup> 

<sup>1</sup>*Department of Mechanical and Electrical Engineering, Massey University, Palmerston North, New Zealand*

<sup>2</sup>*School of Fundamental Sciences, Massey University, Palmerston North, New Zealand*

<sup>3</sup>*Department of Precision and Micro Engineering, 3ME, Technische Universiteit Delft, Delft, The Netherlands*

<sup>4</sup>*MacDiarmid Institute for Advanced Materials and Nanotechnology, Wellington, New Zealand*

\**e.avci@massey.ac.nz*

**Abstract:** Optical microrobotics is an emerging field that has the potential to improve upon current optical tweezer studies through avenues such as limiting the exposure of biological molecules of interest to laser radiation and overcoming the current limitations of low forces and unwanted interactions between nearby optical traps. However, optical microrobotics has been historically limited to rigid, single-body end-effectors rather than even simple machines, limiting the tasks that can be performed. Additionally, while multi-body machines such as microlevers exist in the literature, they have not yet been successfully demonstrated as tools for biological studies, such as molecule stretching. In this work we have taken a step towards moving the field forward by developing two types of microlever, produced using two-photon absorption polymerisation, to perform the first lever-assisted stretches of double-stranded DNA. The aim of the work is to provide a proof of concept for using optical micromachines for single molecule studies. Both styles of microlevers were successfully used to stretch single duplexes of DNA, and the results were analysed with the worm-like chain model to show that they were in good agreement.

© 2021 Optical Society of America under the terms of the [OSA Open Access Publishing Agreement](#)

## 1. Introduction

Optical tweezers (OT) have been used to perform biological studies since 1987, when Ashkin and Dziedzic performed optical trapping of bacteria and viruses [1]. This experiment also exposed an enduring problem with the use of optical tweezers for biological studies: the damage the intense laser light can cause. The mechanisms for this damage have been the subject of several papers [2], with local heating [3,4], photobleaching [5] and oxidation due to photogenerated free radicals [6] all being considered. As a result, several different approaches to reducing damage have been suggested, including minimising laser power, using lasers of specific wavelength [7], and performing experiments in an anaerobic environment. However, each of these is subject to limitations. For example, the maximum force that can be applied with optical tweezers is related to the power of the laser [8]. Therefore, limiting laser power effectively prevents researchers from investigating phenomena at high forces. Restricting experiments to anaerobic environments is likewise limiting in terms of the scope of research that can be performed. The suggested use of certain wavelengths necessitates the build of an entirely new set-up, in cases where the original laser is inappropriate, which is inconvenient and expensive. Therefore, all of these potential solutions can be described as either limiting experiments, or requiring a full overhaul of the system. However, an alternative solution- indirect manipulation of biological material using optical microtools- has been recently proposed [9]. The great advantage of using optical microtools, when compared with the other suggested strategies, is that they can theoretically

be introduced into any OT set-up. Indirect optical manipulation has been demonstrated using single-body optical microtools made through two-photon absorption polymerisation (TPAP) [10], and examples can be found in the literature for yeast cells [11,12], and for rotating and translating filamentous cells [13]. Additionally, researchers have recently used a single-body optical microtool made using TPAP to measure the elasticity of human microvascular cerebral endothelial cells (hCMEC/D3) [14], further validating the use of microtools for biological studies at a cellular level. However, the potential of optical micromachines for single molecule studies—such as DNA stretching—is yet to be realised. This paper introduces a modified version of the well-known "dumbbell assay" for DNA stretching that uses a microlever made through TPAP to facilitate a stretch. The comparison between the conventional assay and the microlever-assisted method can be seen in Fig. 1.

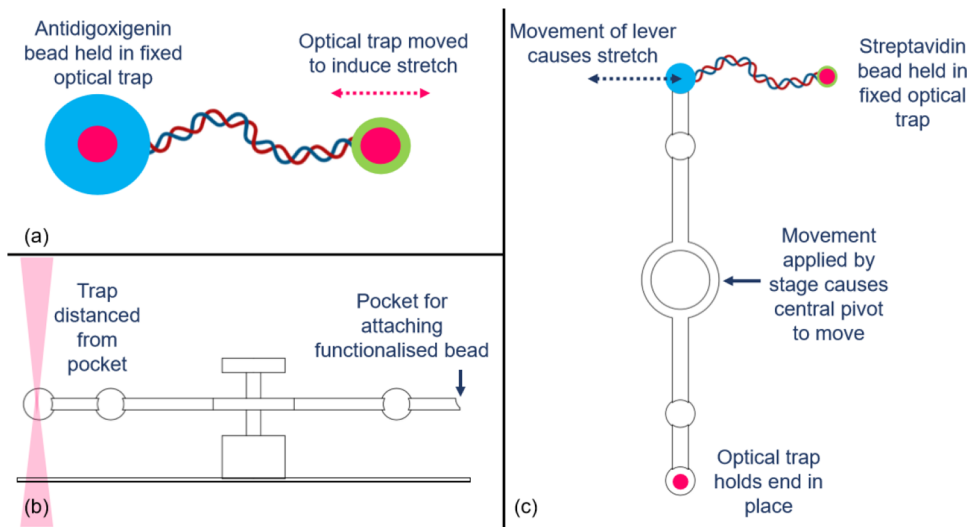

**Fig. 1.** (a) The familiar dumbbell assay moves functionalised microbeads apart, using optical tweezers to stretch DNA. (b) The microlevers used for this work have a pocket for attaching a microbead, and offer a simple mechanism for distancing the trap from the target. (c) The modified assay, using a microlever to distance one of the traps.

Working optical microlevers have been demonstrated in the literature [15–17], and great interest has recently been shown in developing strategies for successfully using optical tools in biologically relevant environments, [17,18]. However, there is still a lack of work demonstrating the successful use of multi-body optical micromachines as tools, meaning that the field is largely limited to single-body microtools. The few multi-body tools in the literature have been demonstrated to be able to perform tasks such as controlled out-of-plane rotation [19], which is typically extremely challenging for optical microrobotics. Stretching double stranded (ds) DNA, which has a well-characterised force-extension curve, using a simple experimental setup, presents an ideal starting point for proof-of-concept of the potential uses of optical micromachines. In this work we describe the adaptation of the dumbbell assay to include a microlever.

## 2. Design of microlevers

The microlevers were designed specifically with the task of molecule stretching in mind. Therefore, the starting point for the design was a fixed pivot point, known as the centre pin, about which a lever arm would rotate. The idea behind this was that a centred lever arm would allow for force transfer from the optical trap to the DNA. The next key consideration was the attachment of

DNA to the levers. The dumbbell assay being adapted uses  $1.25\ \mu\text{m}$  diameter streptavidin coated beads and  $2.12\ \mu\text{m}$  diameter antidigoxigenin coated beads, which attach to biotin and digoxigenin handles on the termini of the DNA, respectively, creating handles that can be manipulated with optical tweezers. Therefore, a pocket was printed at one end of the lever arm, to allow for the attachment of the antidigoxigenin microbead. The other end of the arm featured a spherical "handle" for trapping, in order to replace the direct trap on the antidigoxigenin bead with a distanced trap, with the motivation of limiting the exposure of the DNA to laser radiation. Two other spherical handles were also printed partway down the lever and these were previously also used as trapping handles [17]. However, in this work they served as a way to easily check whether the lever was in focus, and to track the movement of the lever, rather than being used as a trap handle. Following our previous work, two variations of the lever design were used, one which was supported by conical posts and the other which was unsupported. The supported levers also featured a thin ridge on the lever arm, where it encircled the centre pin, in order to reduce the overlapping area between the two components. Dimensions of the basic lever design can be seen in Fig. 2, and diagrams and SEM images of the supported and unsupported levers can be seen in Fig. 3.

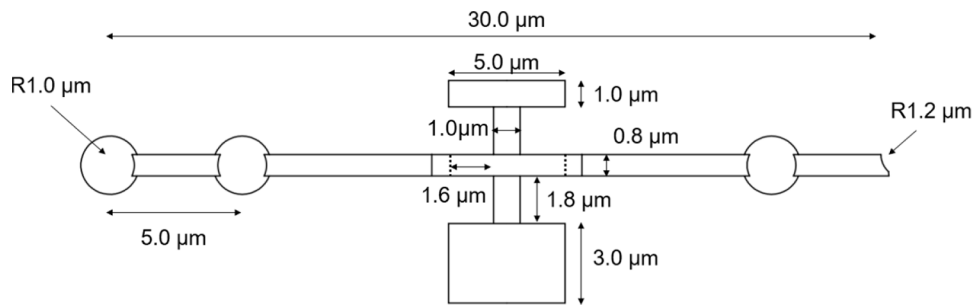

**Fig. 2.** The levers used for the DNA stretching were made with the dimensions shown.

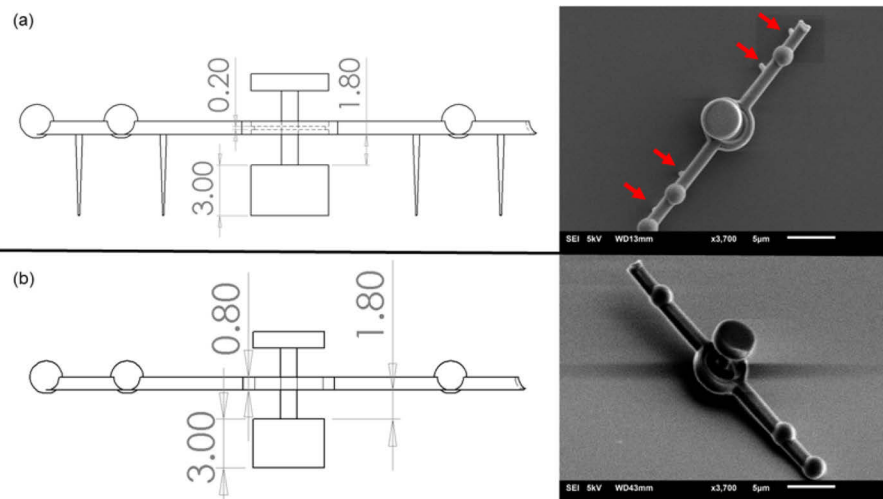
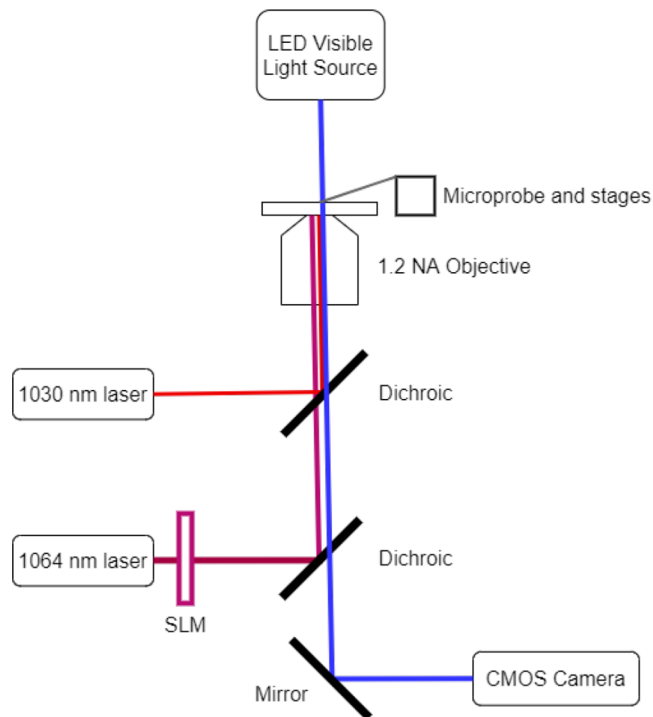

**Fig. 3.** (a) The supported levers used for DNA stretching had tapered supports that narrowed at the bottom, but otherwise shared the same dimensions as the unsupported levers shown in (b). The supports in the SEM image are pointed out by red arrows in the diagram.

### 3. Experimental method and materials

#### 3.1. Optical tweezer setup

A Nikon Eclipse TE2000-U inverted microscope was used as the major component of both the imaging and trapping setup. A 2W 1064 nm laser and a 5W 1030 nm laser were routed through a 60x, 1.2 NA plan apo water immersion objective (Nikon) to create two separate optical traps. A Boulder Nonlinear Systems spatial light modulator (SLM) was used in conjunction with the Red Tweezers software [20] and the 1064 nm laser in order to create a steerable trap, while the 1030 nm trap was treated as fixed, and aligned with the centre of the microscope's field of view. Rather than manoeuvring the 1030 nm trap, a piezomotor stage (Physik Instrumente) was used to finely position the substrate on the microscope. Experiments were conducted in bright field conditions and were imaged using a high speed CMOS camera (Andor Neo). The microscope and associated peripherals were mounted on a vibration isolation table in order to reduce the effects of mechanical noise. A diagram of the setup can be seen in Fig. 4.



**Fig. 4.** The optical tweezers setup used for this study consisted of two separate lasers, with dichroic mirrors used to reflect the beams into the objective.

As the experiment relies on the levers being free to rotate, a borosilicate microprobe was used to free the levers before experiments; separating the lever arm from the centre pin. The microprobe had a tip radius of  $<1 \mu\text{m}$  and was mounted on three stepper motor stages (TAMM40-10C and OSMS60-5ZF, Sigma-Koki), which were in turn mounted to the isolation table. This set-up allowed the microprobe to be controlled with three degrees of freedom, with a resolution of  $1 \mu\text{m}$  in the  $x$  and  $y$  directions and  $0.5 \mu\text{m}$  in the  $z$  direction.

#### 3.2. Lever printing and preparation

The levers were printed directly onto  $170 \mu\text{m}$  thick coverslips, using the conventional oil-immersion writing method, and remained on this substrate throughout the experiment. The

coverslips were cleaned with isopropanol and a brief oxygen plasma was performed to improve adhesion of the microlever devices to the coverslips before printing. The levers were printed using the Nanoscribe GmbH Photonic Professional set at 14 mW laser power and the proprietary IP-L 780 resist. Levers were developed in PGMEA for 30 minutes, followed by a five minute rinse with isopropanol. The sample was then blow-dried using compressed air. Printing the levers to the coverslip meant that the levers had a fixed rotating point, and so only the relative position of the lever arm needed to be controlled, rather than the pose of the entire microlever. The relatively close proximity of the microlever arm to the substrate also meant that there was little chance of additional beads being trapped during the experiment, as can sometimes happen in dual-trap experiments when beads "fly-in" to the trap from below.

After printing and developing, the levers were inspected in dry conditions, using the borosilicate microprobe to rotate them 360°. This step was performed to ensure that the levers were printed correctly, and were capable of rotating, as this is difficult to ascertain through visual observation under microscope alone.

### 3.3. Sample preparation

The double-stranded DNA used for the experiment was 10 kilobase-pairs (kbp) long and synthesized using PCR and modified primers to have biotin and digoxigenin present at the end of each strand. Anti-digoxigenin and streptavidin coated microbeads could then be attached to the DNA termini, forming a tether. In traditional dumbbell assays, the microbeads are then used as trap handles for stretching, as previously explained. However, in this work, the anti-digoxigenin beads were attached to the levers, using the pockets printed for this purpose. In order to do this the anti-digoxigenin beads were kept in a tris-saline buffer (TSB, 50 mM Tris, 150 mM NaCl, 1 mM EDTA) at a concentration of 0.01% w/v, and then added to filtered milliQ water on the lever substrate in order to produce a droplet of dilute microbead suspension containing approximately 10% TSB (approximately 5 mM Tris, 15 mM NaCl, 100  $\mu$ M EDTA). The quantities used for this study were 20  $\mu$ l of the microbead suspension into 180  $\mu$ l mQ water. The anti-digoxigenin beads were then guided into the lever pockets using the 1064 nm SLM trap, and held in place until the beads were firmly adhered. Images of this can be seen in Fig. 5(a) and (b). A suspension of streptavidin beads was prepared concurrently, at a concentration of 0.04% w/v, and 1  $\mu$ l 1/10 diluted biotin-digoxigenin functionalised DNA ( $\lambda$  DNA, 10kbp) was added to the suspension. The streptavidin-DNA suspension was then incubated for an hour at 25°C, while being stirred at 400 rpm, after which 1  $\mu$ l of the incubated mixture was introduced to the lever substrate. Later, a sample of 1/100 diluted DNA was used, in response to results that showed multiple DNA strands tethering when using the higher concentration of DNA. The concentration of DNA in the 1/10 dilution was 120 ng/ $\mu$ l and the concentration of the 1/100 dilution was 12 ng/ $\mu$ l. Other than changing the DNA dilution, the sample preparation method remained the same.

### 3.4. DNA stretching protocol

Once the microbeads were introduced to the trapping medium, a target lever was selected and manoeuvred using the piezo-electric microscope stage so that its trapping end was in the path of the fixed optical trap. The lever was then turned with the borosilicate microprobe in order to release any adhesion between the centre pin and the lever arm, meaning that the lever arm would be free to rotate when moved relative to the trap. Figure 5(c) shows the microprobe setup on the microscope, and Fig. 5(d) shows the probe being used to turn the lever. Turning the lever in this way also tested the adhesion between the anti-digoxigenin bead and the lever, as a weakly adhered bead would be lost during the turning process. A streptavidin-DNA bead was then trapped using the SLM-based optical tweezers, set at 2 W (full power), and brought near the anti-digoxigenin coated microbead positioned in the pocket of the microlever. The streptavidin bead was held in this position, almost touching the anti-digoxigenin bead, for a few seconds



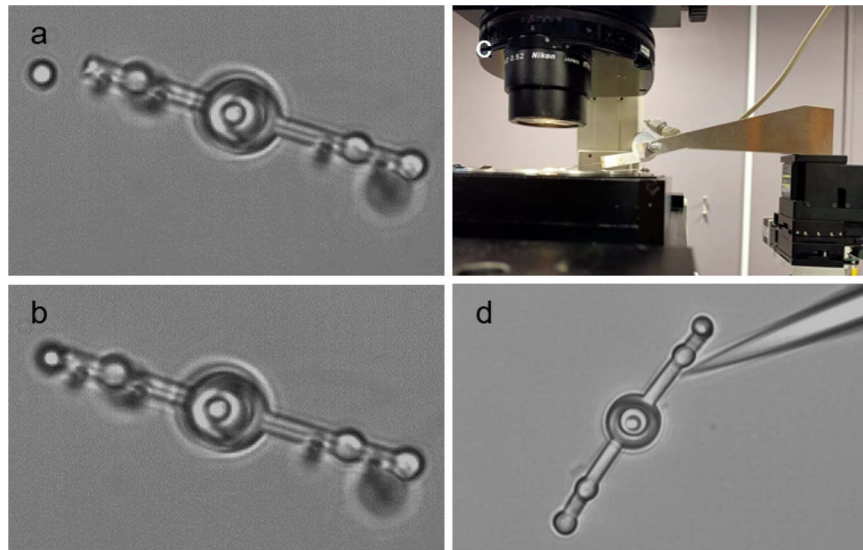

**Fig. 5.** (a) and (b) show an anti-digoxigenin coated bead being guided into the pocket of a lever. (c) shows the borosilicate microprobe setup on the microscope, and (d) shows the borosilicate probe being used to turn a microlever with a bead in its pocket. This process was useful for testing how firmly the beads were attached, as well as freeing seized levers.

to allow for a DNA tether to form between the two microbeads. A triangular waveform then was applied using the microscope stage, creating a rotation of the lever due to its trapped end, and consequently stretching the DNA tethered between the two microbeads. The frequency and amplitude of the triangular wave was varied during the experiment, but it became clear that the amplitude had to be limited to  $2.0\ \mu\text{m}$  to keep the stretch within the limits of the SLM trap and the contour length of the DNA (estimated at  $3.35\ \mu\text{m}$ ), due to the lever amplifying the motion applied. The amplitude also had to be kept above  $1.2\ \mu\text{m}$  to create a clear stretch. Therefore, the majority of the stretches reported in this work were performed with  $2.0\ \mu\text{m}$ ,  $0.1\ \text{Hz}$  triangle waves. Stretching was repeated with the same lever for as long as the streptavidin bead remained in the SLM trap, and the extension of the DNA was inferred from the displacement of the bead from the trap centre. This method was used to perform DNA stretches with several different levers—both supported and unsupported. The process of anti-digoxigenin attachment, lever turning and DNA stretching can be seen in [Visualization 1](#).

## 4. Results and discussion

### 4.1. Lever assisted stretches

Lever-assisted DNA stretches were successfully performed with both supported and unsupported lever types. Ten supported levers were used to perform 42 DNA stretches and nine unsupported levers were used to perform 26 DNA stretches. The forces applied were calculated using the stiffness constant of the SLM trap and the displacement of the streptavidin bead from the centre of the trap. The trap stiffness was calculated using Eq. (1), where  $k_x$  is the trap stiffness,  $k_B$  is Boltzmann's constant,  $T$  is the room temperature in Kelvin (293 K) and  $\langle X^2 \rangle$  is the variance of a streptavidin bead's restricted Brownian motion in the trap. This calculation produced a stiffness of  $8.14\ \text{pN}/\mu\text{m}$  in the x direction, sufficient for performing low force stretches.

$$k_x = \frac{k_B T}{\langle X^2 \rangle} \quad (1)$$

The force-extension data was then fitted to the worm-like chain (WLC) model [21], which is parameterised to produce  $l_c$ , the contour length of the DNA, and  $l_p$ , the persistence length. The WLC is given by Eq. (2), where  $d$  is the distance between the two microbeads tethered by the DNA.

$$F = \frac{k_B T}{l_p} \left( \frac{1}{4} \left( 1 - \frac{d}{l_c} \right)^{-2} + \frac{d}{l_c} - \frac{1}{4} \right) \quad (2)$$

The supported levers were tested first, as it was expected that the supports on the design would assist in keeping the levers plane, which is key to facilitating the straightforward analysis of a stretch. However, when the levers were positioned in the 1030 nm optical trap, there was a chance that scattering due to "folded" supports that had been damaged during sample preparation would cause the lever to be "pushed up" out of the plane, as in Fig. 6(a). In several cases this caused the supports to stick to the substrate, stopping the lever from turning. Even when the lever remained able to turn, the unfocused trapped end meant that the motion of the lever could not be reliably tracked. As a result, the DNA stretches reported in Fig. 7 were all carried out with levers that had their supports purposefully bent sideways, so as not to impede lever rotation. Additionally, as is shown in Fig. 6(b), some levers would spontaneously rotate slightly in the trap, which resulted in the entire lever being slightly angled, and leaving the supports completely visible.

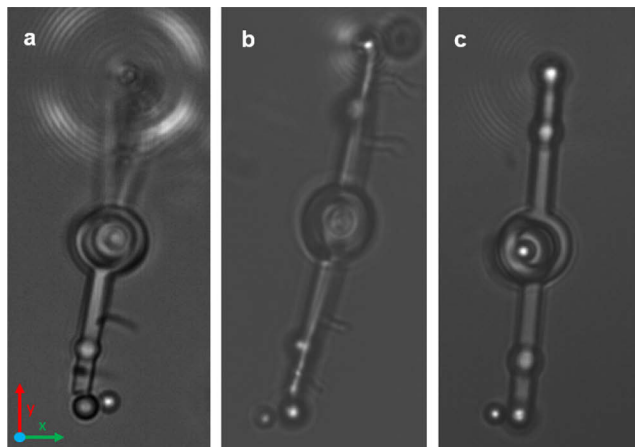
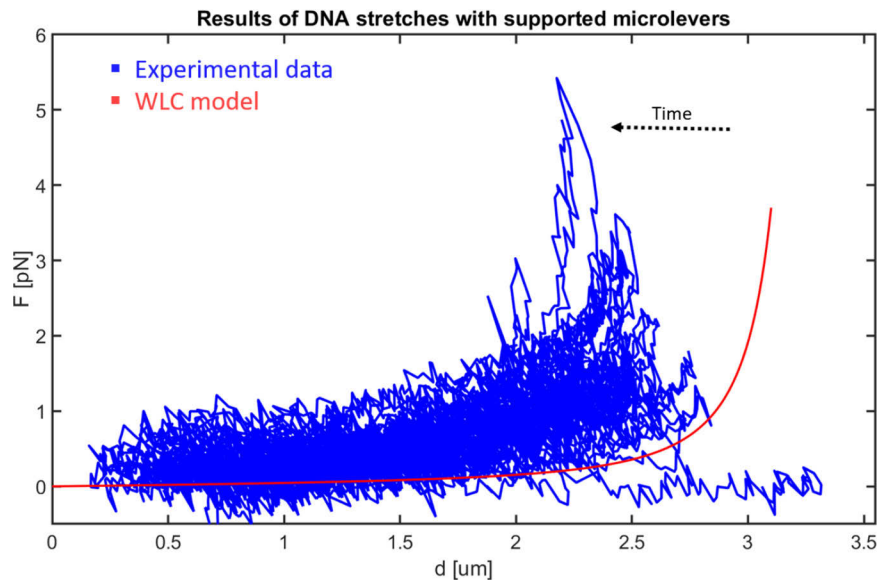

**Fig. 6.** Scattering interactions of bent supports occasionally led to levers being "pushed up" out of the plane, as in (a). (b) shows a supported lever spontaneously reorientating in the optical trap, resulting in the entire lever being slightly angled around the y (long) axis, rather than being flat in the x-y plane. (c) shows an unsupported lever, appearing to be well focused and flat in plane. Comparisons such as this validated the use of unsupported levers for this work.

In both the supported and unsupported cases the main challenge in the experiments was to continue stretching only a single duplex over many stretches, as more DNA tethers could be formed between the streptavidin and anti-digoxigenin beads as the lever rotated and the beads came into close contact. Several DNA strands building up over multiple repetitions can be seen in Fig. 7.

The concentration of DNA used in the supported-lever experiments was a 1/10 dilution. This meant that it was highly likely that each streptavidin bead had several attached DNA duplexes, and as the lever swung back and forth, repeatedly bringing the microbeads close together, more DNA became tethered. This effect can be seen in Fig. 7, with the force-extension data appearing to curl up and away from the curve with repeated stretches. Traditionally, researchers discard



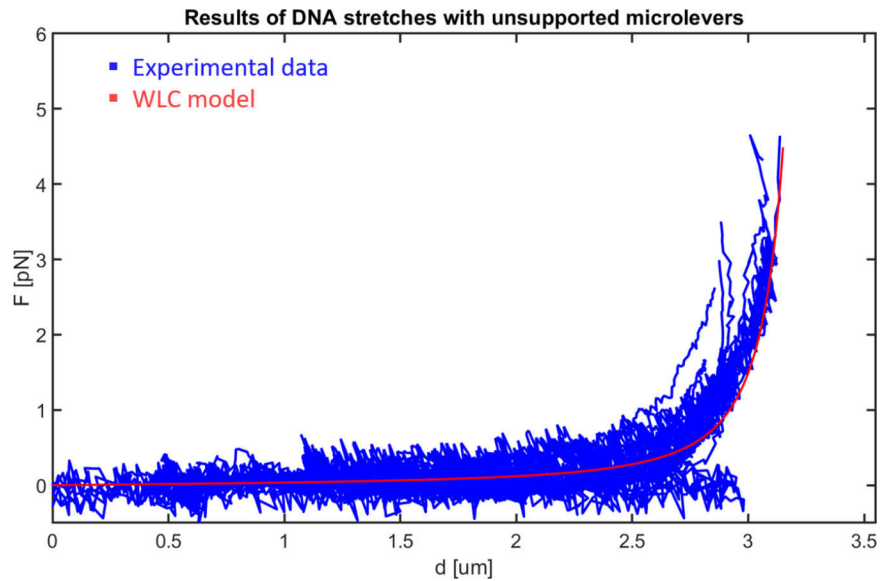

**Fig. 7.** Compilation of stretches performed using supported levers. These stretches demonstrated the difficulty of repeating a stretch with a single DNA duplex, as often over the course of the experiment more DNA attaches, leading to a narrowing of the force-extension curve.

the stretches involving multiple duplexes as in the AFM data reported in this Ref. [22], but they have been presented here as they dominate the stretches performed with the supported levers at the DNA concentration used. It is plain to see that once the concentration of DNA was reduced sufficiently, as it was for the unsupported levers, it becomes much easier to perform stretches with single duplexes. This can be seen in Fig. 8, where the vast majority of the data conforms well to the worm-like chain (WLC) model. Using the WLC to fit the stretches produced a persistence length value of 63.8 nm ( $\pm 1.3$  nm) and a contour length of 3.35  $\mu\text{m}$  ( $\pm 0.01$   $\mu\text{m}$ ). This persistence length is longer than the 59.1 nm previously reported for this DNA [23] but is in agreement with the higher electrostatic repulsion between DNA segments, due to the lower ionic strength of the trapping medium [24]. Specifically, in the 2015 study TSB was used, whereas in this study the ionic strength of the trapping medium was approximately 10x lower. The low ionic strength medium was used to reduce the likelihood of levers seizing during the experiment, which is related to the screening of electrostatic forces in high ionic strength environments [17]. While direct comparison of the lever-assisted stretches cannot be performed, due to the different DNA concentrations used, the fact that the supports added no discernible improvement to the levers' ability to stay in plane during stretches means that unsupported levers should be used for future work.

#### 4.2. Tracking lever movement

The movement of levers was tracked during several of the DNA stretches, as well as in several cases where no DNA was present. In the latter case, it was far easier to track lever movement for multiple cycles, as during DNA stretches large movement of the lever would often entirely displace the streptavidin bead from the SLM trap during the stretches, meaning that experiments were often stopped early, or even after a single stretch. However, the results of tracking one of the levers used in a particularly successful stretching run are shown in Fig. 9, for the sake of interest. Tracking the spheres on the levers during the experiments revealed subtle differences in how



**Fig. 8.** Compilation of stretches performed using unsupported levers. These stretches were performed with a 10x lower concentration of DNA, indicating that the problem of multiple strands attaching could be overcome for DNA-assisted stretches.

some of the levers were trapped, with fluctuations in the position of the trapped handle possibly due to slight differences in printing or inexact positioning of the lever, an example of this can be seen in [Supplement 1](#). However, in each case the movement of the trapped end was minor compared to the amplitude of the waveform applied, which is given by the movement of the fixed centre pin. When the lever was free to rotate clear amplification of motion was demonstrated.

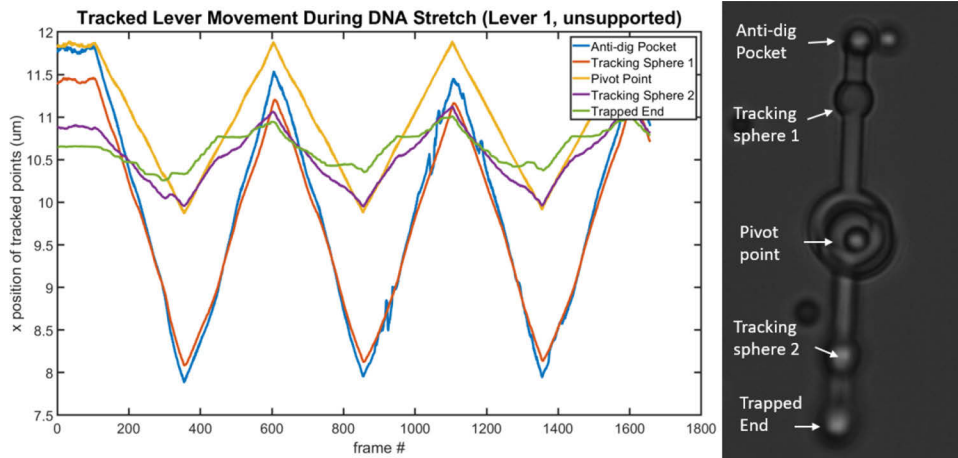

**Fig. 9.** It was difficult to perform multiple stretch repetitions with the levers, due to the difficulty of restricting the stretches to a regime that would not pull the streptavidin bead out of the trap, and the possibility of the lever seizing during the stretch. Here a particularly successful lever was tracked, which resulted in three stretch repetitions. A 2.0  $\mu\text{m}$ , 0.1 Hz triangle wave was applied and data were recorded at 50 fps.

### 4.3. Stretches using two beads

In order to evaluate the general performance of the lever-assisted method, we used the same dsDNA to perform traditional microbead-based DNA stretches. This was done by fixing a large microbead to a coverslip and performing stretches by applying a waveform and measuring displacement from the SLM trap, with the laser once again set to 2 W. Much larger ( $4.37\ \mu\text{m}$  diameter) anti-digoxigenin beads were used to perform these stretches, to reduce the chance of DNA strands becoming mechanically tethered to the substrate rather than attaching via the digoxigenin on the termini. The results of these stretches can be seen in Fig. 10. In these stretches, just as in the lever-assisted stretches, multiple strands of DNA appear to build up over the course of several repetitions. Applying the WLC model to the data gathered from the fixed-bead stretches resulted in a persistence length value of  $63.0\ \text{nm}$  ( $\pm 2.1\ \text{nm}$ ) and a contour length of  $3.35\ \mu\text{m}$  ( $\pm 0.02\ \mu\text{m}$ ), which is in agreement with the results from the lever-assisted stretches.

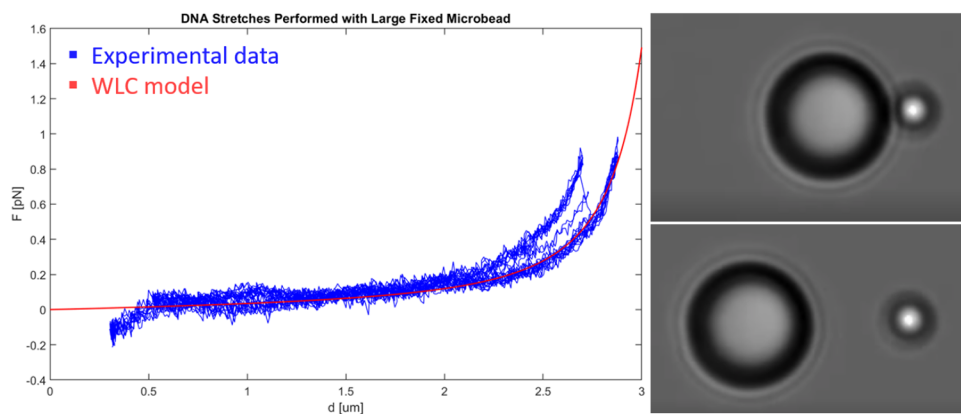

**Fig. 10.** Performing DNA stretches with microbeads allowed for a comparison of lever-assisted stretches with a more traditional method, here results are shown for 12 stretches performed using the fixed bead method. The stretches performed using this method show the same kind of multiple-strand behaviour seen in the supported lever results.

### 4.4. Discussion of the lever-assisted method

While this work represents a step forward in the use of micromachines in biological studies there are currently still some limitations and drawbacks to be overcome. Primary among these is that the method is relatively complex and involves multiple steps. This makes the lever-assisted method currently more difficult than single-trap methods. However, the distinct shape of the lever offers multiple tracking points for image analysis and makes this method a good candidate for automation, which would eliminate a good deal of the set-up difficulty. The simplicity of conventional single-trap stretching methods, such as surface tethering and using micropipettes to actuate stretching are also not without cost, as they mean that the experiment is vulnerable to mechanical drift and noise [25]. However, dual trap methods have been implicated in increasing the risk of damage to the sample, due to the proximity of two traps to the DNA [6,25]. Our lever-assisted method retains the ability to separate the DNA from the surface, and likewise to isolate it from some of the noise of the mechanical assembly. The end of the dsDNA that is distanced from the trap is also the handle that relies on the weaker antidigoxigenin-digoxigenin (antidig-dig) bond [26], while the microbead that provides the stronger streptavidin-biotin handle remains directly trapped. This could help to mitigate a mechanism for damage based on the irradiation of the antidig-dig bond, although this has not been investigated further.

Like most tools generally used for optical tweezer assays of DNA, the levers are currently one-shot devices. While the microbeads can be removed through sonication, the likelihood of contamination of the lever surface is considered too high for them to be used multiple times for different experiments. However, the small size of the lever, along with the capabilities of the Nanoscribe Photonic Professional, means that several hundred levers can be printed on a single substrate, and these could be pre-functionalised ahead of time, potentially following a process similar to that performed in Aekbote et al. [27]. Functionalisation during manufacture would make them specialised for a certain task rather than the general device that we have presented here, but it would reduce set-up time and researcher effort.

Stretches performed with dsDNA and the protocols used here do also have a limited experimental lifetime. In common with conventional dual-trap assays it is well known that after several hours, it becomes progressively harder to successfully stretch the DNA. However, by introducing the microlevers, another time window during which the experiments have to be completed, also of the order of hours is introduced, during which the levers turn freely before seizing. At the low ionic strengths used in this paper this is not a grievous problem, but the seizing time becomes more problematic at higher salt concentrations.

## 5. Conclusions

In this work we have developed functional microlevers and demonstrated that microlevers have the potential to become a key tool in the development of complex optical microrobotics systems. We developed both supported and unsupported levers for the task, and both types were successfully used to stretch dsDNA strands. The results were analysed and fit to the WLC, indicating that multi-body micromachines can be used to remotely apply forces with a high degree of sensitivity. Levers are a fundamental machine, and as limiting the exposure of biological subjects to laser light is a key concern, they represent an opportunity to address such concerns in a way that can theoretically be adapted to any optical tweezer setup. Both supported and unsupported levers were used to stretch DNA, but supports carried the risk of producing undesirable scattering effects, leading to less stable trapping and more out of plane movement, while unsupported levers had the advantage of a simpler shape. Additionally, it was shown that the problem of multiple DNA stretches building up could be simply dealt with by lowering the concentration of DNA used, meaning that the potential for this to occur is not a serious drawback of the method. When the results of more traditional microbead stretches were analysed, it became clear that the build up of multiple strands is also present when one of the beads is fixed to the substrate, meaning that it is not unique to the lever-based method. This work can serve as a proof-of-concept for more complex optical microrobotics studies, such as fully-remote, lever-assisted DNA stretches, as well as studies involving force amplification.

**Funding.** Royal Society Te Apārangi (MAU1714).

**Acknowledgements.** We are grateful to Lisa M. Kent for synthesising the DNA used for these experiments.

**Disclosures.** The authors declare no conflict of interest.

**Data availability.** Data underlying the results presented in this paper are not publicly available at this time but may be obtained from the authors upon reasonable request.

**Supplemental document.** See [Supplement 1](#) for supporting content.

## References

1. A. Ashkin and J. Dziedzic, "Optical trapping and manipulation of viruses and bacteria," *Science* **235**(4795), 1517–1520 (1987).
2. A. Blázquez-Castro, "Optical tweezers: Phototoxicity and thermal stress in cells and biomolecules," *Micromachines* **10**(8), 507 (2019).
3. A. Chowdhury, D. Waghmare, R. Dasgupta, and S. K. Majumder, "Red blood cell membrane damage by light-induced thermal gradient under optical trap," *J. Biophotonics* **11**(8), e201700222 (2018).

4. I. Krasnikov, A. Seteikin, and I. Bernhardt, "Thermal processes in red blood cells exposed to infrared laser tweezers ( $\lambda = 1064$  nm)," *J. Biophotonics* **4**(3), 206–212 (2011).
5. G. D. M. Jeffries, J. S. Edgar, Y. Zhao, P. J. Shelby, C. Fong, and D. T. Chiu, "Using polarization-shaped optical vortex traps for single-cell nanosurgery," *Nano Lett.* **7**(2), 415–420 (2007).
6. M. P. Landry, P. M. McCall, Z. Qi, and Y. R. Chemla, "Characterization of photoactivated singlet oxygen damage in single-molecule optical trap experiments," *Biophys. J.* **97**(8), 2128–2136 (2009).
7. A. Ashkin, J. M. Dziedzic, and T. Yamane, "Optical trapping and manipulation of single cells using infrared laser beams," *Nature* **330**(6150), 769–771 (1987).
8. M. Sarshar, W. Wong, and B. Anvari, "Comparative study of methods to calibrate the stiffness of a single-beam gradient-force optical tweezers over various laser trapping powers," *J. Biomed. Opt.* **19**(11), 115001 (2014).
9. P.-K. Andrew, M. A. K. Williams, and E. Avci, "Optical micromachines for biological studies," *Micromachines* **11**(2), 192 (2020).
10. S. Wu, J. Serbin, and M. Gu, "Two-photon polymerisation for three-dimensional micro-fabrication," *J. Photochem. Photobiol., A* **181**(1), 1–11 (2006).
11. S. Hu, H. Xie, T. Wei, S. Chen, and D. Sun, "Automated indirect transportation of biological cells with optical tweezers and a 3d printed microtool," *Appl. Sci.* **9**(14), 2883 (2019).
12. I. Shishkin, H. Markovich, Y. Roichman, and P. Ginzburg, "Auxiliary optomechanical tools for 3d cell manipulation," *Micromachines* **11**(1), 90 (2020).
13. S. Hu, R. Hu, X. Dong, T. Wei, S. Chen, and D. Sun, "Translational and rotational manipulation of filamentous cells using optically driven microrobots," *Opt. Express* **27**(12), 16475–16482 (2019).
14. I. Grexa, T. Fekete, J. Molnár, K. Molnár, G. Vizsnyiczai, P. Ormos, and L. Kelemen, "Single-cell elasticity measurement with an optically actuated microrobot," *Micromachines* **11**(9), 882 (2020).
15. C.-L. Lin, Y.-H. Lee, C.-T. Lin, Y.-J. Liu, J.-L. Hwang, T.-T. Chung, and P. L. Baldeck, "Multiplying optical tweezers force using a micro-lever," *Opt. Express* **19**(21), 20604–20609 (2011).
16. Y. J. Jeong, T. W. Lim, Y. Son, D.-Y. Yang, H.-J. Kong, and K.-S. Lee, "Proportional enlargement of movement by using an optically driven multi-link system with an elastic joint," *Opt. Express* **18**(13), 13745–13753 (2010).
17. P. K. Andrew, D. Fan, A. Raudsepp, M. Lofroth, U. Staufer, M. A. K. Williams, and E. Avci, "Design of optical micromachines for use in biologically relevant environments\*" in *2020 IEEE/ASME International Conference on Advanced Intelligent Mechatronics (AIM)*, (2020), pp. 2039–2045.
18. A.-I. Bunea and J. Glückstad, "Strategies for optical trapping in biological samples: Aiming at microrobotic surgeons," *Laser Photonics Rev.* **13**(4), 1800227 (2019).
19. E. Avci, M. Grammatikopoulou, and G.-Z. Yang, "Laser-printing and 3d optical-control of untethered microrobots," *Adv. Opt. Mater.* **5**(19), 1700031 (2017).
20. R. W. Bowman, G. M. Gibson, A. Linnenberger, D. B. Phillips, J. A. Grieve, D. M. Carberry, S. Serati, M. J. Miles, and M. J. Padgett, "'red tweezers': Fast, customisable hologram generation for optical tweezers," *Comput. Phys. Commun.* **185**(1), 268–273 (2014).
21. C. Bouchiat, M. Wang, J.-F. Allemand, T. Strick, S. Block, and V. Croquette, "Estimating the persistence length of a worm-like chain molecule from force-extension measurements," *Biophys. J.* **76**(1), 409–413 (1999).
22. H.-C. Chiu, K. D. Koh, M. Evich, A. L. Lesiak, M. W. Germann, A. Bongiorno, E. Riedo, and F. Storici, "Rna intrusions change dna elastic properties and structure," *Nanoscale* **6**(17), 10009–10017 (2014).
23. S. Succi, A. Raudsepp, L. M. Kent, S. A. Keen, V. V. Filichev, and M. A. Williams, "Dna visualization in single molecule studies carried out with optical tweezers: Covalent versus non-covalent attachment of fluorophores," *Biochem. Biophys. Res. Commun.* **466**(2), 226–231 (2015).
24. H. Chen, S. P. Meisburger, S. A. Pabit, J. L. Sutton, W. W. Webb, and L. Pollack, "Ionic strength-dependent persistence lengths of single-stranded rna and dna," *Proc. Natl. Acad. Sci.* **109**(3), 799–804 (2012).
25. I. Heller, T. P. Hoekstra, G. A. King, E. J. G. Peterman, and G. J. L. Wuite, "Optical tweezers analysis of dna-protein complexes," *Chem. Rev.* **114**(6), 3087–3119 (2014).
26. G. Neuert, C. Albrecht, E. Pamir, and H. Gaub, "Dynamic force spectroscopy of the digoxigenin-antibody complex," *FEBS Lett.* **580**(2), 505–509 (2006).
27. B. L. Aekbote, T. Fekete, J. Jacak, G. Vizsnyiczai, P. Ormos, and L. Kelemen, "Surface-modified complex su-8 microstructures for indirect optical manipulation of single cells," *Biomed. Opt. Express* **7**(1), 45–56 (2016).