

Final results alternative energy and propulsion technology literature study

van Muijden, Jaap; Stepchuk, I.; de Boer, A.I.; Kogehop, O.; Rademaker, E.R.; van der Sman, E.S.; Kos, J.; Posada Duque, J.A.; Palmeros Parada, M.D.M.

Publication date

2021

Document Version

Final published version

Citation (APA)

van Muijden, J., Stepchuk, I., de Boer, A. I., Kogehop, O., Rademaker, E. R., van der Sman, E. S., Kos, J., Posada Duque, J. A., & Palmeros Parada, M. D. M. (2021). *Final results alternative energy and propulsion technology literature study*. NLR. <https://cordis.europa.eu/project/id/864089/results>

Important note

To cite this publication, please use the final published version (if applicable).
Please check the document version above.

Copyright

Other than for strictly personal use, it is not permitted to download, forward or distribute the text or part of it, without the consent of the author(s) and/or copyright holder(s), unless the work is under an open content license such as Creative Commons.

Takedown policy

Please contact us and provide details if you believe this document breaches copyrights.
We will remove access to the work immediately and investigate your claim.



Dedicated to innovation in aerospace

Ref. Ares(2021)2297539 - 02/04/2021

NLR-CR-2020-026 | March 2021

Final results alternative energy and propulsion technology literature study

Deliverable D1.1 of the TRANSCEND project

CUSTOMER: Clean Sky 2 JU



NLR – Royal Netherlands Aerospace Centre

Final results alternative energy and propulsion technology literature study

Deliverable D1.1 of the TRANSCEND project

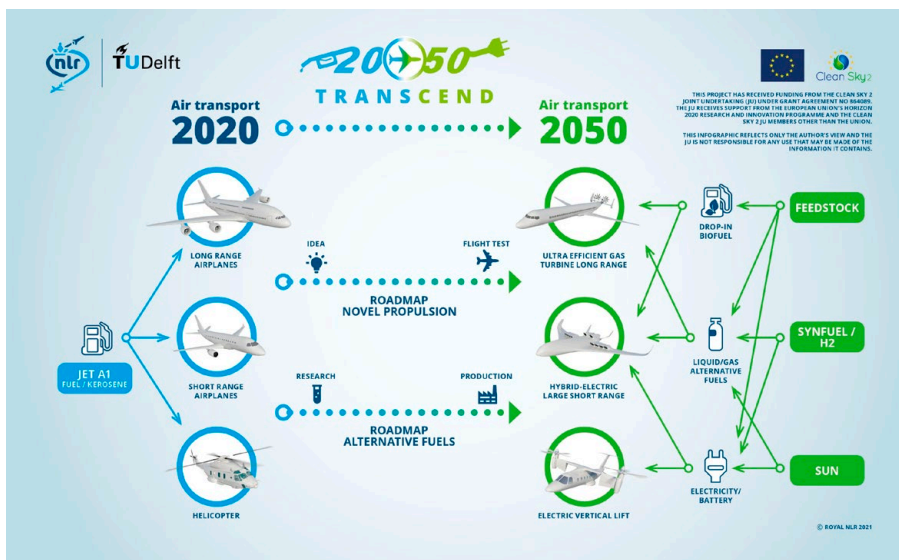

Problem area

Mitigation of climate change and other environmental impacts is increasingly globally pursued by governments, international bodies, and industry. Already in 2011, Europe set aviation goals in FlightPath2050 to protect the environment. Propulsion technologies and alternative energy sources are key to achieve this. In the timeframe 2014-2023 the European Clean Sky 2 (CS2) programme is taking major steps in novel propulsion and its integration into aircraft, which are evaluated on their environmental impact towards 2050 by CS2's Technology Evaluator instrument. Developments in alternative energy sources for propulsion and parallel and subsequent (after 2023) developments in novel propulsion give rise to the questions: what can these developments contribute to achieving the FlightPath2050 goals? How could the most promising technological developments actually take place?

REPORT NUMBER

NLR-CR-2020-026

AUTHOR(S)

J. van Muijden
I. Stepchuk
A.I. de Boer
O. Kogenhop
E.R. Rademaker
E.S. van der Sman
J. Kos
J.A. Posada Duque
M.D.M. Palmeros Parada

REPORT CLASSIFICATION

UNCLASSIFIED

DATE

March 2021

KNOWLEDGE AREA(S)

Aerospace Collaborative
Engineering and Design
Gasturbine Technology
Computational Physics and
Theoretical Aerodynamics
Air Transport Emissions

DESCRIPTOR(S)

alternative fuels
electric propulsion
hybrid-electric drive trains
CO2 emissions reduction
disruptive technologies

Description of work

As Coordination and Support Action for the Clean Sky 2 Technology Evaluator, TRANSCEND has carried out a literature study of alternative energy sources and novel propulsion. This study focuses on the reductions in CO₂ and NO_x emissions that can be obtained for large passenger aircraft (100+-seats) along the full life cycle from production of the alternative energy sources to their use as propellant in 2050 flights with the novel propulsion.

Technological, economic, and environmental and social performances of alternative energy sources have been investigated in the three classes of alternative energy sources studied: bio-based drop-in sustainable aviation fuels (SAFs), e-fuels as drop-in SAFs, and non-drop-in energy sources. Propulsion technologies have been investigated on their contribution to reduction of environmental impact in four categories of propulsion concepts: gas-turbine based propulsion (both for drop-in and for non-drop-in energy sources), electric propulsion, and hybrid-electric propulsion. Bottlenecks (technological, economic, environmental, and social) and key technological enablers have been identified for both alternative energy sources and novel propulsion.

Results and conclusions

An overview of alternative energy sources and their performances is presented. Five promising alternative energy sources and production routes are selected for further evaluation: hydroprocessed esters and fatty acids (HEFA) to produce bio-jet fuel, Fisher-Tropsch process (FT) to produce bio-jet fuel, fast pyrolysis (FP) to produce bio-jet fuel, power-to-liquid (PtL) for e-fuel production via the Fisher-Tropsch process, and alkaline electrolysis (AE) to produce hydrogen.

Seven classes of propulsion concepts with numerous underlying novel propulsion technologies are identified for potential aircraft application before 2050, allocated to aircraft seat classes. These propulsion concepts are: disruptive gas turbine based propulsion using drop-in SAF, hydrogen-combustion gas turbine based propulsion, electric battery, electric fuel cell using hydrogen, hybrid-electric turbo-electric propulsion based on drop-in SAF, other hybrid-electric propulsion using drop-in SAF, hybrid-electric propulsion using hydrogen as energy source.

Applicability

This literature study is the basis for selecting the to-be-evaluated aircraft concepts that are complementary to the Clean Sky 2 technologies. TRANSCEND will evaluate the environmental impact of the selected energy sources and propulsion, as a complementary contribution to the second assessment by the Technology Evaluator. TRANSCEND supports research policy making for climate neutral aviation in 2050 for the European Green Deal.

NLR

Anthony Fokkerweg 2

1059 CM Amsterdam, The Netherlands

p) +31 88 511 3113

e) info@nlr.nl i) www.nlr.nl



Dedicated to innovation in aerospace

NLR-CR-2020-026 | March 2021

Final results alternative energy and propulsion technology literature study

Deliverable D1.1 of the TRANSCEND project



CUSTOMER: Clean Sky 2 JU

AUTHOR(S):

J. van Muijden	NLR
I. Stepchuk	TUD
A.I. de Boer	NLR
O. Kogehop	NLR
E.R. Rademaker	NLR
E.S. van der Sman	NLR
J. Kos	NLR
J.A. Posada Duque	TUD
M.D.M. Palmeros Parada	TUD

No part of this report may be reproduced and/or disclosed, in any form or by any means without the prior written permission of the owner and/or contractor.

CUSTOMER	Clean Sky 2 JU
CONTRACT NUMBER	864089
OWNER	NLR + partner(s)
DIVISION NLR	Aerospace Vehicles
DISTRIBUTION	Limited
CLASSIFICATION OF TITLE	UNCLASSIFIED

APPROVED BY :		
AUTHOR	REVIEWER	MANAGING DEPARTMENT
 Jaap van Muijden 2021.03.31 15:58:25 +02'00'	 Vankan W.J. 2021.03.31 16:03:19 +02'00'	 A.A. ten Dam 2021.03.31 16:14:39 +02'00'

Summary

Mitigation of climate change and environmental impact are increasingly addressed globally by governments, international bodies, and industry. Already in 2011, Europe set aviation goals in FlightPath 2050 (FP2050, 2011) to protect the environment and to be a centre of excellence in sustainable fuels, including those for aviation. The Clean Sky 2 technical programme (2014-2023), building upon the first Clean Sky programme (2008-2017), is accelerating the progress towards the FlightPath 2050 with high level objectives for CO₂, NO_x, and noise reductions to be obtained through development of new aircraft and propulsion technologies. The progress of each demonstration platform (ITDs and IADPs in Clean Sky 2) towards these high level objectives will be monitored by the Technology Evaluator (TE) of Clean Sky 2.

Both propulsion and energy sources are key technologies for reducing the environmental impact of aviation. Therefore, the TRANSCEND project investigates novel propulsion technologies and alternative energy sources for aviation in the period 2035-2050. To be complementary to the TE, the scope for propulsion in TRANSCEND is technologies that are developed in parallel to or after Clean Sky 2. Within this scope the primary focus is on future large passenger aircraft (100+ seats in this study, since the large passenger aircraft contributed to 96% of the CO₂ emissions of commercial aviation during flight in Europe in 2018).

Technological, economic, and environmental and social performances of alternative energy sources have been investigated in the three classes of alternative energy sources studied: bio-based drop-in sustainable aviation fuels (SAFs), e-fuels as drop-in SAFs, and non-drop-in energy sources. Propulsion technologies have been investigated on their contribution to reduction of environmental impact in four categories of propulsion concepts: gas-turbine based propulsion (both for drop-in and for non-drop-in energy sources), electric propulsion, and hybrid-electric propulsion. Bottlenecks (technological, economical, and social) and key technological enablers have been identified for both alternative energy sources and novel propulsion.

An overview of alternative energy sources and their performances is presented. Five promising alternative energy sources and production routes are preselected for further evaluation: hydroprocessed esters and fatty acids (HEFA) to produce bio-jet fuel, Fisher-Tropsch process (FT) to produce bio-jet fuel, fast pyrolysis (FP) to produce bio-jet fuel, power-to-liquid (PtL) for e-fuel production via the Fisher-Tropsch process, and alkaline electrolysis (AE) to produce hydrogen.

Seven classes of propulsion concepts with numerous underlying novel propulsion technologies are identified for potential aircraft application before 2050, allocated to aircraft seat classes. These propulsion concepts are: disruptive gas turbine based propulsion using drop-in SAF, hydrogen-combustion gas turbine based propulsion, electric battery, electric fuel cell using hydrogen, hybrid-electric turbo-electric propulsion based on drop-in SAF, other hybrid-electric propulsion using drop-in SAF, hybrid-electric propulsion using hydrogen as energy source.

This literature study is the basis for selecting the to-be-evaluated aircraft concepts that are complementary to the Clean Sky 2 technologies. TRANSCEND will evaluate the environmental impact of the preselected energy sources and propulsion, as a complementary contribution to the second assessment by the Technology Evaluator. TRANSCEND supports research policy making for climate neutral aviation in 2050 for the European Green Deal.

Contents

Abbreviations	7
1 Introduction	13
1.1 TRANSCEND project summary	13
1.2 Scope and focus of the literature study	14
1.3 Organisation of the literature study	15
1.4 Complementarity with the Clean Sky 2 Technology Evaluator	16
2 Sustainable Aviation Fuels (SAFs)	17
2.1 Short technical description	17
2.2 Technology development	18
2.2.1 American Society for Testing and Materials (ASTM)	18
2.2.2 Technology Readiness Level (TRL)	19
2.2.3 Measuring readiness level of SAFs	20
2.3 Sustainability aspects of SAFs	20
2.3.1 Economic performance	21
2.3.2 Environmental and social aspects	21
2.4 Methodology	25
2.4.1 Literature Review	25
2.4.2 Workshop 1	27
2.4.3 Preselection of SAFs	28
3 Sustainable drop-in fuels	29
3.1 Short technical description	29
3.2 Biobased SAFs	30
3.2.1 Biomass feedstock	30
3.2.2 ASTM certified pathways to produce biobased SAFs	33
3.3 Non-biobased SAFs (e-fuels)	36
3.3.1 Eligible pathways to produce non-biobased SAFs	37
3.4 Technological Readiness Level (TRL) of pathways for drop-in SAF production	38
3.4.1 TRL comparison of drop-in production routes	38
3.5 Economic assessment of biobased SAFs production	41
3.6 Environmental assessment of biobased SAFs production	43
3.7 Other sustainability and social aspects of drop-in SAFs production routes	45
3.7.1 Biomass availability for SAFs production	45
3.7.2 LUC issue: Palm oil exception	47
3.7.3 Food-energy dilemma	47
3.7.4 Renewable energy availability for non-biobased SAFs production	47
3.8 Relevant projects	48
3.9 Comparative studies and roadmaps	49
3.9.1 Potential developments in the horizon – 100% SPK SAFs	50
3.9.2 Availability and economic viability resources for SAFs production routes towards 2050	50
3.10 Bottlenecks	52
3.11 Key technology enablers	53

4	Sustainable non-drop-in fuels and on-board storage	55
4.1	Short technical description	55
4.2	Biobased production routes	56
4.2.1	Biomass gasification (BG) production routes	56
4.2.2	Dark fermentation (DF) production routes	56
4.2.3	Photofermentation (PF) production routes	57
4.2.4	Photolysis (PhL) production routes	57
4.3	Renewable energy-based production routes	58
4.3.1	Alkaline electrolysis (AE) production routes	58
4.3.2	Proton exchange membrane (PEM) electrolysis production routes	58
4.3.3	High-temperature solid oxide electrolyzer cell (SOEC) production routes	58
4.3.4	Microbial Electrolysis Cell (MEC) production routes	59
4.3.5	Thermochemical Water Splitting (TWS) production routes	59
4.3.6	PEC/Photoelectrolysis production routes	59
4.4	Technological Readiness Level (TRL) of pathways for non-drop-in SAF production	60
4.4.1	TRL comparison of non-drop-in production routes	60
4.5	Economic assessment of hydrogen production routes	61
4.6	Environmental assessment of hydrogen production routes	63
4.7	Other sustainability and social aspects of hydrogen production routes	65
4.7.1	RES availability for non-drop-in SAFs production	65
4.8	On-board storage requirements for hydrogen	65
4.9	Relevant projects	67
4.10	Comparative studies and roadmaps	68
4.10.1	Potential developments in the horizon – Rolls Royce SMR for hydrogen	68
4.10.2	Availability and economic viability resources for SAFs production routes towards 2050	69
4.11	Bottlenecks	70
4.12	Key technology enablers	71
5	Comparison of drop-in and non-drop-in production routes	73
5.1	Technical development overview	73
5.2	Sustainability performance overview	73
5.2.1	Economic performance overview	74
5.2.2	GHG performance overview	76
5.3	Preselection of 5 SAFs production routes proposed for further study	77
5.3.1	Drop-in production routes preselection	78
5.3.2	Non-drop-in production routes preselection	78
5.4	Conclusions	79
6	Novel propulsion based on gas turbine with drop-in fuels	82
6.1	Concise technical description	82
6.2	Projects and open calls	88
6.3	Comparative studies and roadmaps	89
6.4	Bottlenecks	89
6.5	Key technology enablers	90

7	Propulsion based on tailored gas turbine with non-drop-in fuels	91
7.1	Concise technical description	91
7.2	Projects and open calls	93
7.3	Comparative studies and roadmaps	93
7.4	Bottlenecks	93
7.5	Key technology enablers	94
8	Full-electric propulsion with non-drop-in energy sources	95
8.1	Concise technical description	95
8.1.1	Electric propulsion architecture	95
8.1.2	Electric machine technology	96
8.1.3	Inverter and motor control	97
8.1.4	Electric power distribution and wiring	98
8.1.5	Batteries	98
8.1.6	Energy conversion / fuel cells	100
8.2	Projects and open calls	101
8.3	Comparative studies and roadmaps	102
8.4	Bottlenecks	102
8.5	Key technology enablers	103
9	Hybrid-electric propulsion	104
9.1	Concise technical description	104
9.2	Projects and open calls	106
9.3	Comparative studies and roadmaps	108
9.4	Bottlenecks	109
9.5	Key technology enablers	109
10	Aircraft-level / powertrain-level synergies	110
11	Conclusions and recommendations	114
11.1	Alternative energy sources	114
11.2	Novel propulsion for aircraft using alternative energy sources	117
11.3	Recommendation	120
12	Acknowledgement and disclaimer	121
13	References	122

Abbreviations

ACRONYM	DESCRIPTION
1.5LIFE scenario	Scenario for maximum 1.5 degrees Celsius global warming by changing consumer preferences and lifestyles
1.5TECH scenario	Scenario for maximum 1.5 degrees Celsius global warming by technological measures
2BSvs	Biomass Biofuels voluntary scheme
ACARE	Advisory Council for Aviation Research and innovation in Europe
AC	Alternating Current
AE	Alkaline Electrolysis
AMSL	Above Mean Sea Level
APR	Aqueous Phase Reforming
APU	Auxiliary Power Unit
ARA	Applied Research Associates
ASTM	American Society for Testing and Materials
ATAG	Air Transport Action Group
ATJ	Alcohol To Jet
BG	Biomass Gasification
BLI	Boundary Layer Ingestion
BPR	Bypass Ratio
BTEX	Benzene, Toluene, Ethylbenzene and Xylene
BWB	Blended Wing Body
C	Celsius
CAAFI	Commercial Aviation Alternative Fuels Initiative
CAPEX	Capital Expenditures
CCS	Carbon Capture and Storage
CH	Catalytic Hydrothermolysis
CHJ	Catalytic Hydrothermolysis Jet fuel
CO	Carbon Monoxide
CO ₂	Carbon Dioxide
CORSIA	Carbon Offsetting and Reduction Scheme for International Aviation
CQ	Certification and Qualification
CROR	Counter-Rotating Open Rotor
CRP	Counter-Rotating Propulsor/Propeller
CS2	Clean Sky 2
DAC	Direct Air Capture
dB	decibel
DC	Direct Current

ACRONYM	DESCRIPTION
DEP	Distributed Electrical Propulsion
DF	Dark Fermentation
DLR	German Aerospace Centre
DLUC	Direct Land Use Change
DOM	Dissolved Organic Matter
DSHC	Direct Sugar to Hydrocarbon
DWR	Detonative Wave Rotor
E	Energy
EASA	European union Aviation Safety Agency
EC	European Commission
EEA	Epoch-Era Analysis
e.g.	for example
EIS	Entry Into Service
EJ	Exajoule, 10^{18} Joule
ERF	Effective Radiation Forcing
ETS	Emissions Trading Scheme
EU	European Union
F	Fermentation
Fdox	Ferredoxin
f.e.	for example
FFA	Free Fatty Acid
FOGs	Fats, Oils, and Greases
FP	Fast Pyrolysis
FPR	Fan Pressure Ratio
FQD	Fuel Quality Directive
FRL	Fuel Readiness Level
FSRL	Feedstock Readiness Level
FT	Fischer-Tropsch
g	gram
g CO _{2-eq} /MJ	gram CO ₂ -equivalent per Megajoule
GaN	Gallium Nitride
GHG	Greenhouse Gas
GJ	Giga Joule, 10^9 Joule
GO	Guarantee of Origin
GTF	Geared Turbofan
h	hour
H ⁺	Hydrogen ion, proton

ACRONYM	DESCRIPTION
H ₂	Hydrogen
H ₂ O	Water
H ₂ S	Hydrogen Sulfide
H2020	Horizon 2020
HCl	Hydrogen Chloride
HCU	Hydrothermal Cleanup
HDCJ	Hydrotreated Depolymerized Cellulosic Jet
HDO	Hydro-deoxygenation
HEFA	Hydro-processed Esters and Fatty Acids
HEDP	Hybrid Electric Distributed Propulsion
H _E	Hybridization degree based on Energy
HEP	Hybrid Electric Propulsion
HER	Hydrogen Evolution Reaction
HFP	High Freeze Point
HFS	Hydro-processed Fermented Sugar
HHV	Higher Heating Value
HLFC	Hybrid Laminar Flow Control
H _P	Hybridization degree based on Power
HRJ	Hydro-processed Renewable Jet
HS/CN	Harmonized System/Combined Nomenclature (customs systems)
HT	High Temperature
HTL	Hydrothermal Liquefaction
HTS	High Temperature Superconducting
HVO	Hydrotreated Vegetable Oil
ICAO	International Civil Aviation Organization
ICCT	International Council on Clean Transportation
i.e.	that is
IEA	International Energy Agency
IGBT	Insulated-Gate Bipolar Transistor
IH ²	Integrated Hydrolysis and Hydroconversion
ILUC	Indirect Land Use Change
IPCC	Intergovernmental Panel on Climate Change
IRENA	International Renewable Energy Agency
IRR	Internal Rate of Return
ISCC	International Sustainability and Carbon Certification
ITSE	Intermediate Temperature Steam Electrolysis
IUCN	International Union for Conservation of Nature

ACRONYM	DESCRIPTION
K	Kelvin
kg	kilogram
kN	Kilo Newton, 1000 Newton
kV	Kilo Volt
kW	Kilo Watt
kWh	Kilo Watt-hour
KZR INiG	Global certification system for biofuels and bioliquids developed by the Polish Instytut Nafty i Gazy
LCA	Life Cycle Analysis
LH ₂	Liquid Hydrogen
LPA	Large Passenger Aircraft
LT	Low Temperature
LUC	Land Use Change
M	Mach number, the ratio of velocity to speed of sound
m ³	cubic meter
MALE	Medium Altitude Long Endurance
MATE	Multi-Attribute Tradespace Exploration
MDAO	Multi-Disciplinary Analysis and Design
MeOH	Methanol
MEC	Microbial Electrolysis Cell
Mha	Million hectares
mil.	million
MJ	Mega Joule
MJFSP	Minimum Jet Fuel Selling Price
MOSFET	Metal-Oxide Semiconductor Field Effect Transistor
MSW	Municipal Solid Waste
Mt	Megaton, a million ton
MW	Mega Watt
NASA	National Aeronautics and Space Administration
NaBH ₄	Sodium Borohydride
NCA	Nickel Cobalt Aluminium
NH ₃	Ammonia
NLR	Royal Netherlands Aerospace Centre
NM	Nautical Mile
NMC	Nickel Manganese Cobalt
NO _x	Nitrogen Oxides
NRDC	Natural Resources Defence Council
O ₂	Oxygen

ACRONYM	DESCRIPTION
OEM	Original Equipment Manufacturer
OER	Oxygen Evolution Reaction
OH ⁻	Hydroxide ion
OPEX	Operating Expenditures
OPR	Overall Pressure Ratio
P	Power
PAX	passengers
PC	Production Cost
PDE	Pulse Detonation Engine
PEC	Photoelectrochemical
PEM	Proton Exchange Membrane
PWh	Peta Watt-hour, 10 ¹⁵ Wh or 3.6*10 ¹⁸ Joule
PF	Photofermentation
PhL	Photolysis
PJ	Petajoule, 10 ¹⁵ Joule
PNS	Purple Non-Sulfur
PtL	Power to Liquid
PtX	Power to Gas/Liquid/Fuel
PV	Photovoltaic
R&D	Research and Development
RED	Renewable Energy Directive
RES	Renewable Energy Sources
RF	Radiation Forcing
RSB	Roundtable on Sustainable Biofuels
RSPO	Roundtable on Sustainable Palm Oil
RTRS	Round Table on Responsible Soy
s	second
SAF	Sustainable Aviation Fuel
SAJF	Sustainable Aviation Jet Fuel
SAK	Synthesized Aromatic Kerosene
SDG	Sustainable Development Goal
SiC	Silicon Carbide
SIP	Synthetic Isoparaffin
SK	Synthetic Kerosene
SkyNRG	Production and trader company in SAFs
SOA	State-of-the-Art
SOEC	Solid Oxide Electrolyzer Cell

ACRONYM	DESCRIPTION
SOFC	Solid Oxide Fuel Cell
SMR	Small Modular Reactor
SMR	Small-to-Medium Range
SO _x	Sulphur Oxides
SPK(/A)	Synthetic Paraffinic Kerosene (with Aromatics)
SRIA	Strategic Research and Innovation Agenda
SROR	Single Rotating Open Rotor
SRP	Single Rotating Propulsor/Propeller
SSAP	Soybean Sustainability Assurance Protocol
STARC-ABL	Single-aisle Turboelectric AiRCraft with Aft fuselage Boundary-Layer propulsor
SUGAR	Subsonic Ultra Green Aircraft Research
T	Absolute temperature
TBD	To Be Defined
TCT	Tail Cone Thruster
TUD	Technical University of Delft
TE	Technology Evaluator
TJ	Tera Joule, 10 ¹² Joule
TLAR	Top-Level Aircraft Requirement
TRANSCEND	Technology Review of Alternative and Novel Sources of Clean Energy with Next-generation Drivetrains
TRL	Technology Readiness Level
TRU	Transformer-Rectifier Unit
TSFC	Thrust-Specific Fuel Consumption
TW	Tera Watt, 10 ¹² Watt
TWS	Thermochemical Water Splitting
UAV	Unmanned Aerial Vehicle
UCO	Used Cooking Oil
UHBR	Ultra-High Bypass Ratio
UK	United Kingdom
US, USA	United States of America
USD	United States Dollar
USDA	United States Department of Agriculture
VFAs	Volatile Fatty Acids
VSS	Voluntary Sustainability Standard
VTOL	Vertical Take Off and Landing
WWF	World Wildlife Fund
y	year
ZEROe	Zero emission

1 Introduction

1.1 TRANSCEND project summary

Mitigation of climate change and environmental impact are increasingly addressed globally by governments, international bodies, and industry. Already in 2011, Europe set aviation goals in FlightPath 2050 (FP2050, 2011) to protect the environment and to be a centre of excellence in sustainable fuels, including those for aviation. The Clean Sky 2 technical programme (2014-2023), building upon the first Clean Sky programme (2008-2017), is accelerating the progress towards the FlightPath 2050 with high level objectives for CO₂, NO_x, and noise reductions to be obtained through development of new aircraft and propulsion technologies. The progress of each demonstration platform (ITDs and IADPs in Clean Sky 2) towards these high-level objectives will be monitored by the Technology Evaluator (TE) of Clean Sky 2.

Both propulsion and energy sources are key technologies for reducing the environmental impact of aviation. Therefore, the TRANSCEND project investigates novel propulsion technologies and alternative energy sources for aviation in the period 2035-2050. To be complementary to the TE, the focus for propulsion in TRANSCEND is on technologies that are developed in parallel to or after Clean Sky 2.

TRANSCEND identifies, analyses, selects and further evaluates alternative energy sources, based on environmental performance (greenhouse gas (GHG) emissions) and economics, through literature review and rounds of discussions with experts. These alternative energy sources are investigated as such and in combination with novel propulsion technologies. The novel propulsion technologies are investigated on their integration in aircraft and on CO₂ and NO_x emissions, through literature study and interactions with experts.

The high-level objectives of TRANSCEND are:

- To evaluate the environmental impacts of novel propulsion technologies and alternative energy sources in 2035-2050 based on the state-of-the-art knowledge, complementary to the TE Core evaluation of the environmental impact of innovations that are developed in Clean Sky 2;
- To shape the future of green aviation propulsion in 2050, by preparing roadmaps for a technologies programme on novel propulsion technology and for availability and viability of alternative energy sources in order to reduce the environmental impact of aviation in the time frame 2035-2050.

Shortly after the kick-off of TRANSCEND, the European Commission has published the European Green Deal – a roadmap with actions for making the EU’s economy sustainable. The actions include a proposal on a European “Climate Law”, scheduled for March 2020, enshrining the 2050 climate neutrality objective (The European Green Deal, 2019). Recently, five aviation associations (A4E, ACI, ASD, ERA, and CANSO) have planned a route to achieve this objective for aviation based on a scientific study (van der Sman, Peerlings, Kos, Lieshout, & Boonekamp, 2021)).

The TRANSCEND project is carried out by the Royal Netherlands Aerospace Centre (NLR) and Delft University of Technology (TUD).

The high-level objectives of TRANSCEND are depicted in its infographic in Figure 1-1.

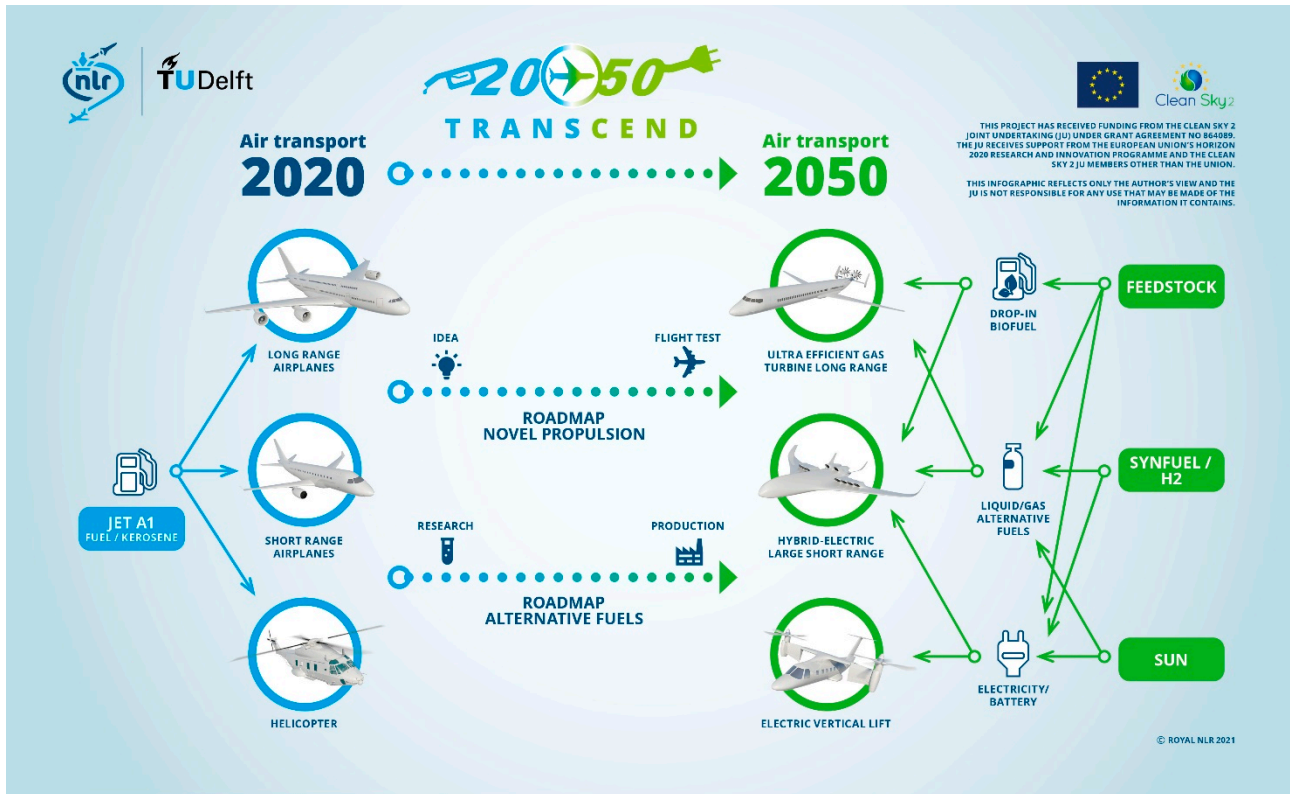

Figure 1-1: TRANSCEND infographic

1.2 Scope and focus of the literature study

The scope for this literature study is both alternative energy sources for aviation and novel aircraft propulsion concepts that potentially contribute to the reduction of the environmental impact and climate impact of aviation in 2050 in terms of CO₂ and NO_x emissions. Within this scope the primary focus is on future large passenger aircraft (100+-seats in this study), since the large passenger aircraft contributed to 96% of the CO₂ emissions of commercial aviation during flight in Europe in 2018. This scope and primary focus is further explained as follows.

Energy source mainly refers to the on-board energy source that is stored on-board the aircraft for use as propellant during flight. In addition, energy sources during production of these on-board energy sources are considered, such as renewable energy. The adjective "alternative" refers to any energy source that is other than Jet A-1 fuel, which is not considered as sustainable. Therefore other fossil hydrocarbon energy sources such as (liquefied or compressed) natural gas are not within the primary focus of the study. In this study, the on-board energy source for propulsion will also be referred to as "fuel", though in a strict sense (Merriam-Webster, 2020) fuel is related only to combustion (burning) processes.

The adjective "novel" refers to any propulsion technology that is neither used in large passenger aircraft that are presently on the market, nor is in aircraft programmes with entry-into-service (EIS) within 7 years (upcoming aircraft). Novel propulsion technologies that are evaluated in the Clean Sky 2 Technology Evaluator (TE) are mainly out of focus for TRANSCEND, since their evaluation and roadmapping is already taken place in the TE. In the class of large passenger aircraft all existing and upcoming aircraft use gas turbine engines as combustion engines. Hence for combustion engines

the primary focus is on gas turbine based propulsion. This includes hybrid propulsion technologies involving electric engines as well.

TRANSCEND contributes to climate neutrality. Aviation has a notable impact on the global climate through both CO₂ and non-CO₂ (NO_x, water vapour, contrail cirrus formation, SO_x, aerosols and soot) emissions. This influence is measured as radiative forcing (RF) or effective radiative forcing (ERF). Whereas the CO₂ contribution to RF is well-understood, substantial uncertainty exists about other sources – such as contrail formation and induced cirrus cloudiness. While the climate impact of CO₂ is independent of emission time and location, the effect of non-CO₂ is not. This also depends on aircraft performance characteristics (e.g. combustion temperature and efficiency), weather-related variables (such as humidity, temperature, wind), background concentration of different chemical species, time and location (longitude, latitude, altitude). The various emission species have various lifetimes and impact timelines (hours, days, years, decades). Although the level of scientific understanding of the formation and effect of aviation-induced cloudiness is still limited, its current contribution is estimated to be up to two times as large (66% of total) as the effect of CO₂ (33% of total) (Lee, et al., 2021). The focus of the TRANSCEND study lies on both CO₂ and NO_x emissions.

TRANSCEND focuses on the sustainability of the alternative energy sources for aviation along their life-cycle. TRANSCEND does not address the sustainability of the life-cycle of the propulsion technology. This sustainability is addressed in other projects in Clean Sky, see for example the THT-13 topic on the sustainability of hybrid-electric aircraft system architectures (Clean Sky 2 Governing Board, 2019).

A number of alternative energy sources and propulsion concepts are considered out of scope:

- Nuclear power as on-board energy source has been investigated in the first decades after 1945, see for example the movie (The Nuclear Airplane, 2015). Nuclear power for civil aircraft is considered out of scope to concerns about safety and health and the problems of shielding and weight that have not been overcome in military aircraft programmes (Ruhl, 2019).
- Solar power for propulsion is free and available during day-time flight, but conversion efficiency of photovoltaic cells is very low. It could be an energy harvesting device, however with low yields, also due to the low energy flux of sun light (1.36 kW/m², (Kopp & Lean, 2011)). Possible application in gliders and high-altitude airships, but even then, improvements in efficiency are needed. Hence solar power for propulsion is not expected to be feasible for large passenger aircraft for 2050.

1.3 Organisation of the literature study

The main alternative energy sources are drop-in fuels and non-drop-in energy sources. Drop-in fuels are any fuel that can replace Jet A-1 fuel without any changes to the aircraft, engine or on-board systems. Non-drop-in energy sources are all other energy sources other than Jet A-1 and drop-in fuels, such as hydrogen. The use of non-drop-in fuels for propulsion will require changes to the aircraft, engines, and on-board systems.

Propulsion technologies are studied as building blocks for propulsion concepts of aircraft. Therefore the study of propulsion technologies is split into different propulsion concepts. Propulsion technologies that contribute to multiple concepts are described in detail in a single concept (namely the first concept in the order of appearance in this document) with references to this description at the other concepts.

Propulsion concepts are distinguished according to the engines and motors that are used as part of the propulsion concept. Current large passenger aircraft have only gas turbines as engines. In addition, electric motors are considered for potential future aircraft propulsion. In TRANSCEND the following propulsion concepts are considered:

- Propulsion concepts based on novel gas turbines for drop-in fuels and Jet A-1 fuel
- Propulsion concepts based on novel gas turbines for non-drop-in fuels
- Propulsion concepts based on electric motors
- Hybrid-electric propulsion concepts with novel gas turbines and electric motors

Each of the categories of alternative energy sources and propulsion technologies is described in a separate chapter. The chapter is organised as follows:

- Concise technical description, including assessment results from literature
- Projects and open calls
- Comparative studies and roadmaps
- Bottlenecks (technical, economical and business-wise, social and environmental)
- Technology enablers

The concise technical descriptions in the chapters are split over several sections (chapters about alternative energy sources) or included in a single section with subsections (chapters about propulsion concepts).

Separate chapters are included on common topics for alternative energy sources, the comparison of the production routes of drop-in and non-drop-in energy sources, and on synergies at power train and aircraft levels.

1.4 Complementarity with the Clean Sky 2 Technology Evaluator

The conference paper (Flüthmann, et al., 2020) describes the Clean Sky 2 Technology Evaluator scenarios for 2035-2050 and the development of vehicle-specific scenarios to the Clean Sky 2 vehicle types. Two scenarios (high and low) are introduced for every Clean Sky 2 vehicle type (mainliner, regional aircraft, business jet, small air transport, rotorcraft). In its aviation technology scenario “high” the following assumptions for mainliners are mentioned:

- very high fuel efficiency improvements
- sustainable drop-in fuel (referred to as “SAJF” (sustainable aviation jet fuels) in (Flüthmann, et al., 2020)),
- hydrogen powered aircraft, and
- hybrid-electric aircraft with increasing ranges.

In the high scenario the share of sustainable drop-in fuel will increase from 10 percent in 2030 to 70-90% in 2050. Hybrid-electric aircraft enter into service from 2040 on short- and medium-haul routes and in 2050 even on long-haul routes. In addition, hydrogen-powered aircraft will be available from 2045 onwards. In the low scenario only a 30-50% SAJF share will be achieved in 2050.

The focus of TRANSCEND thus aligns well with the high scenario for mainliners in the Clean Sky 2 Technology Evaluator.

2 Sustainable Aviation Fuels (SAFs)

2.1 Short technical description

Sustainable aviation fuels (SAF) are aviation fuels developed with the aim to avoid adverse sustainability impacts when compared to conventional fossil jet fuels (ICAO, Sustainable Aviation Fuels Guide, 2018). SAFs can be divided into two groups: *i)* “drop-in” fuels, which are compatible with current aircraft infrastructure and can be blended with conventional jet fuel; and *ii)* “non-drop-in” fuels, which could be used only after special changes in the structure of aircrafts or with new infrastructure (e.g. liquid hydrogen LH₂, liquid ammonia, hydrogen fuel cells, etc.) (ICAO, Sustainable Aviation Fuels Guide, 2018). Although further aircraft developments are needed for implementation of non-drop-in fuels, major emissions reduction are expected from these fuels which makes them a promising alternative for the aviation sector (McKinsey, 2020).

In the last 15 years, the aviation industry has focused on developing alternative “drop-in” fuels to reduce the environmental impact of aviation. Drop-in SAF is a type of novel aviation fuel, which could be blended with conventional fossil jet fuel and therefore directly applicable to the aircraft infrastructure without special changes on it or supportive equipment (EASN, 2020). Drop-in SAFs have been acknowledged as a promising option to replace conventional fossil-based fuels for aviation, however for their actual implementation they should be certified by the American Society for Testing and Materials (ASTM) for use in existing fleet with no need for changes to the aircraft, engine or fuelling infrastructure (ICAO, Sustainable Aviation Fuels Guide, 2018). Drop-in SAFs can be produced from biobased sources like vegetable (used) oils, biomass, and captured CO₂ with hydrogen (Figure 2-1). Some of those technologies being already ASTM certified for use in the current fleet (M. Voráček, 2013). By 2050, it is expected that the mix of feedstocks for biobased drop-in SAFs (or bio-jet fuels) will diversify together with the introduction of e-fuels (EASA, Sustainable Aviation Fuels, n.d.), which are produced by using renewable energy sources in combination with hydrogen production and CO₂ capture (EASA, EEA, & EUROCONTROL, European Aviation Environmental Report 2019, 2019).

Non-drop-in fuels, such as hydrogen or ammonia, still require significant adaptations in the aircraft infrastructure as well as the development of novel technologies and advancements for production, distribution and storage of fuel, and also on the motive power system of the aircraft (M. Voráček, 2013). The recently published McKinsey’s report on hydrogen-powered aviation states that new propulsion technologies will come up to the aviation sector shortly including battery and turbo-electric technologies, as well as hydrogen for combustion applications and hydrogen fuel cells to power electric motors (McKinsey, 2020). Moreover, hydrogen could also be used on-board as a compressed liquid fuel to power the aircraft, but it still requires significant changes to the current aircrafts design and infrastructure (McKinsey, 2020).

This report focuses on drop-in SAFs (biobased and CO₂-based) and non-drop-in SAF (Figure 2-1), i.e., hydrogen, by covering key technical aspects of their production and their use for a more sustainable aviation sector in the 2021–2050-time horizon of TRANSCEND. The report aims to review/collect information on technologies (i.e. technologies, their development status), process performance (i.e. costs associated with the production of SAFs), environmental impacts, and other sustainability criteria (included in, for example, certification schemes, safety aspects) that would provide the inputs for discussion with experts during the Workshop session. Workshops are dedicated to the validation of the results with the aim of subsequent decision-making process. The outcome of the literature study and Workshops is reported with the focus on the representing and comparing existing SAF production routes and preselection of 5 promising SAFs in terms of 2021-2050-time frame horizon.

To address the key technical aspects of production and use of sustainable fuels, this literature study is composed of three sub-chapters. Chapter 2 focuses on the analysis of existing technology development indicators, technology/fuel certification schemes and sustainability criteria for both drop-in and non-drop-in fuels as this is a key element for selecting promising fuels in the project and presents the methodology for this literature review. Chapter 3 focuses particularly on already ASTM approved drop-in biofuels and on e-fuels still under technological development. The Sub-Chapter 4 focuses on non-drop-in fuels which are still at an early-technological development stage and that are far from being ASTM approved, such as hydrogen for on-board use. Chapter 5 provides a complex comparison of drop-in and non-drop in fuels with identification of the most promising ones in the 2021-2050 time-frame-horizon for sustainable usage in aviation.

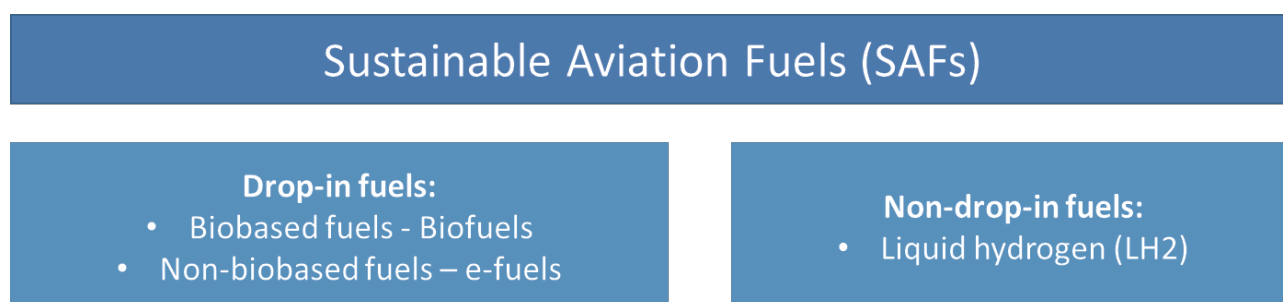

Figure 2-1: SAFs division in the context of the report

2.2 Technology development

Sustainable aviation fuels fall under the category of the high interest among aviation industry stakeholders intending to reduce the impact on climate change. Novel drop-in fuels should meet the ASTM testing requirements, which has a focus on comparison of the properties of new, alternative jet fuels to petroleum-derived jet fuel to determine whether a fuel can be considered as “drop-in” to facilitate their wide production and commercialization (CAAFI, Fuel Qualification, 2020). The aviation industry has developed testing standards to compare novel alternative jet fuels in comparison to traditional fossil-derived jet fuel and to determine whether they can be considered as “drop-in”. The testing protocols of novel alternative aviation fuels is regulated by the ASTM International’s Committee D02.J0.06 (Emerging Turbine Fuels) (CAAFI, Fuel Qualification, 2020). ASTM has developed several standards to streamline the approval process and permit the new fuel (or additive) into field use in a cost-effective and timely manner (U. Yildirima, 2012). However, ASTM certification does not characterize the level of commercialization for different production routes in a full manner. Therefore, for the purpose of the report, other indicators such as Technology Readiness Level (TRL), Fuel Readiness Level and Feedstock Readiness Level (FSRL) are considered during evaluation of the technological development of bio-jet production routes (CAAFI, Fuel Qualification, 2020). Technology development of hydrogen production routes is characterized by the synergy of indicators: green electricity generation technologies and TRL of production routes coupled with TRL of hydrogen storage facilities onboard (IEA, Energy Technology Perspectives Special Report on Clean Energy Innovation 2020, 2019).

2.2.1 American Society for Testing and Materials (ASTM)

The American Society for Testing and Materials (ASTM), and particularly its International Committee D02.J0.06 (Emerging Turbine Fuels), performs the certification process for determining if novel fuels can be used in the same way

as conventional aviation fuels for the current aircraft fleet. The bio-jet fuels go under ASTM D4054 Evaluation Process for getting a fuel approved for commercial use includes the following three phases (CAAFI, Fuel Qualification, 2020) (CAAFI, Commercial Aviation Alternative Fuels Initiative, 2019). A reidentification provision within the ASTM D7566 states that air jet fuel blends meeting all the requirements of the D7566 also meet the requirements of the ASTM D1655 “Standard Specification for Aviation Turbine Fuels” and can be regarded as conventional fuels (ASTM, 2020). Therefore, a novel SAF, at the blend levels specified in each fuel’s D7566 Annex, is considered a drop-in alternative jet fuel. Nonetheless, ASTM certification can be a barrier for novel fuels, as it requires almost 900,000 litres of new jet fuels to be tested, which is a large amount of a novel fuel being produced mostly through small-scale experimental set-ups from R&D steps (Janina Scheelhaasea, 2019).

Commercial Aviation Alternative Fuels Initiative (CAAFI) Certification and Qualification (CQ) team regularly updates the certification status and testing phase of the drop-in fuels production pathways.

The ASTM approval process for SAFs includes three phases: Initial Screening, Follow-on Testing and Balloting and Approval; and four tiers: Specification properties, Fit-for-Purpose Properties, Component/Rig Testing and Engine/APU Testing (Figure 2-2). To be approved and added in D7566 Drop-In Fuel Specification (Figure 2-2, Phase 4), as new conventional jet fuel, SAFs should meet all of the technical and performance specifications and pass all phases of the approval process (CSAFI, 2020) (Erik C. Wormslev, 2020).

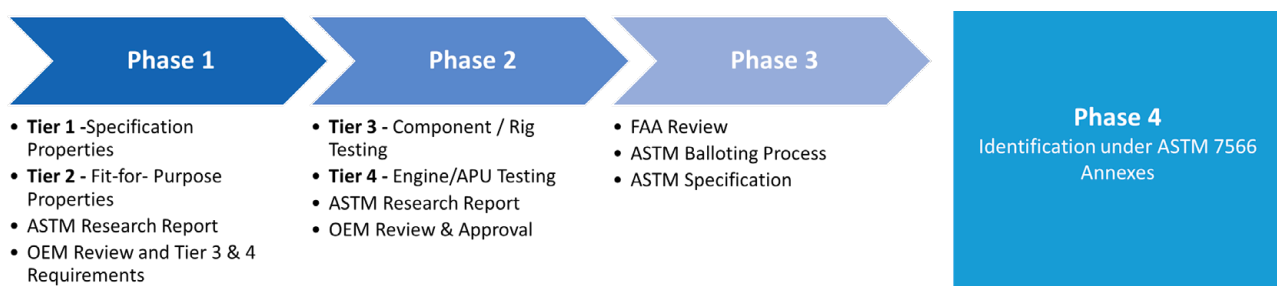

Figure 2-2: ASTM D4054 linkage to D7566. Adapted from: (Erik C. Wormslev, 2020), (CAAFI, Commercial Aviation Alternative Fuels Initiative, 2019), (ASTM, 2020) ASTM – American Society for Testing and Materials OEM - Original Equipment Manufacturers APU - Engine and Auxiliary Power Unit Testing FFA- Federal Aviation Administration

2.2.2 Technology Readiness Level (TRL)

In 2014, as a part of the Horizon 2020 framework program, the TRL scale was introduced into the EU funded projects arena to evaluate and measure the progress of the project in a scope of a Horizon 2020 (TRL Scale in Horizon 2020 and ERC, 2020). TRL plays an important role in other sectors of industry, where it can be applied as a tool/ measurement system used to assess the development level of technology. There are nine technology readiness levels from TRL 1, which is the lowest to TRL 9 - is the highest (Mai, 2012), see Figure 2-3.

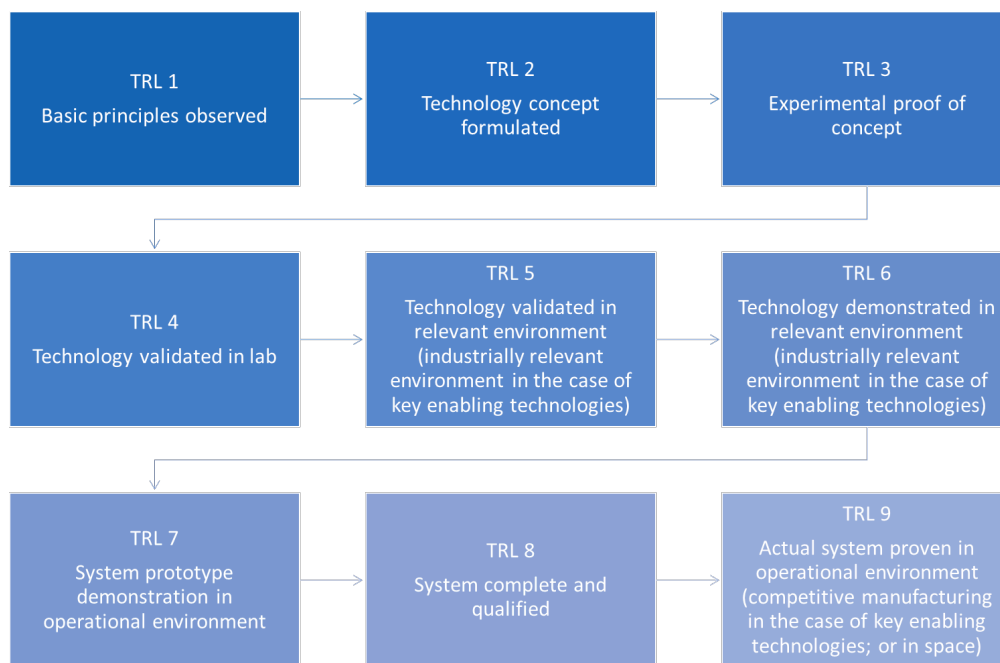

Figure 2-3: Technology Readiness Levels. Based on: (EC, HORIZON 2020 – WORK PROGRAMME 2014-2015, 2014-2015)

2.2.3 Measuring readiness level of SAFs

Fuel Readiness Level (FRL) and Feedstock Readiness Level (FSRL) are two alternative readiness level scales based on the TRL framework, which intends to provide a descriptive hierarchy indicating the progress of a technology towards commercialization (TRL Scale in Horizon 2020 and ERC, 2020). Additionally, there is an overall preferability of FRL over TRL since it is accepted as the best-practice tool to represent fuel technology maturity within the aviation industry (Becky Mawhood, 2016), (CAAFI, Fuel Qualification, 2020). However, FSRL, FRL and TRL are complementary and interlinked tools that can help to best understand level of development for SAFs production routes and their commercialisation readiness.

2.3 Sustainability aspects of SAFs

According to the European Aviation Environmental Report 2019 (EASA, EEA, & EUROCONTROL, European Aviation Environmental Report 2019, 2019), SAFs are defined as “biobased aviation fuels that reduce GHG emissions relative to conventional aviation fuel, while avoiding other adverse sustainability impacts.” The definition of sustainability in the context of SAFs is defined by the Air Transport Action Group (ATAG) as “something that can be continuously and repeatedly resourced in a consistent manner with economic, social and environmental aims, specifically something that conserves an ecological balance by avoiding depletion of natural resources and does not contribute to climate change” (ATAG, Beginner’s Guide to Sustainable Aviation Fuel, 2017). Therefore, the overall multidimensionality of sustainability should be taken into consideration for the continuous commercialization of SAFs’ for the aviation sector, which includes current and future development status of the technology, the economic performance of the production processes to obtain these fuels, as well as the environmental impacts (including others than only carbon footprint) and social aspects depending on the source of the fuel (e.g. land-use change is a prominent topic for some biobased fuels) (EASA, Sustainable Aviation Fuels, n.d.) (SkyNRG, n.d.).

2.3.1 Economic performance

Literature presents the economic performance and profitability of these technologies in different ways. Profitability for biobased production is mostly presented as Minimum Jet Fuel Selling Price (MJFSP) (i.e. the minimum price of the fuel to cover production expenses at a given internal rate of return), while for e-fuels and hydrogen it is mostly presented as Production Costs (PC) (i.e. costs incurred by a business from manufacturing a product: to the overall plant efficiency (technology selection), the feedstock cost, the processing scale, the total installed capital cost, etc.).

The report compiles these metrics as reported in literature, but they are converted to an energy basis (USD/MJ) to allow a comparative analysis. However, it is acknowledged that direct comparisons are limited due to conceptual and methodological differences across the literature sources considered for each of these metrics as indicated where relevant. The economic performance of SAF production routes was here reviewed from published techno-economic analyses of the relevant technologies.

2.3.2 Environmental and social aspects

SAFs must meet strict certification requirements for use in commercial aircraft to be acceptable by Civil Aviation Authorities (ATAG, Beginner's Guide to Sustainable Aviation Fuel, 2017). However, lots of certification schemes and initiatives has been launched for the recent years to facilitate sustainable production of SAFs (IATA, 2015). Majority of them cover other relevant sustainability issues, f.e. societal aspects, land-use change, biomass availability, etc. All these issues are relevant and should be taken into consideration during the life-cycle assessment of SAFs production.

Sections below highlight main documents and standards for identifying criteria for sustainability assessment. They represent an overview of how sustainability is addressed in the aviation sector, in EU policy, and in certification schemes in the scope of this project. The section will provide an overview of the existing certification standards, EU related policies and standards for SAFs.

2.3.2.1 Global and EU market based measures

2.3.2.1.1 ICAO CORSIA

In 2016, the International Civil Aviation Organization (ICAO) agreed on a Resolution for a global market-based measure to address CO₂ emissions from international aviation as of 2021. The Resolution sets the objective and key design elements of the global scheme, as well as a roadmap for the completion of the work on implementing modalities.

The Carbon Offsetting and Reduction Scheme for International Aviation (CORSIA) aims to stabilize CO₂ emissions at 2020 levels by requiring airlines after 2020 (EU-Climate Action, 2020):

- monitor emissions on all international routes;
- offset emissions from routes included in the scheme by purchasing eligible emission units generated by projects that reduce emissions in other sectors (e.g. renewable energy).

It is expected to offset approximately 80% of the emissions above 2020 levels in the period between 2021-2035 (EU-Climate Action, 2020). Additionally, in 2019, ICAO published the analysis and methodology to calculate the life cycle GHG emissions for CORSIA eligible fuels. ICAO's approach includes the effects of indirect land-use change. The core the life cycle GHG emissions are calculated from well-to-pump activities and well-to-wake fuel combustion. ILUC emissions,

related to changes in vegetative living biomass carbon stock and soil carbon stock, are calculated separately by using economic equilibrium models (ICAO, CORSIA Eligible Fuels, 2019).

2.3.2.1.2 European Union Emission Trading Scheme (EU-ETS)

The EU emissions trading system (EU ETS) is a key tool for reducing greenhouse gas emissions cost-effectively. It is the world's first major carbon market and remains the biggest one (EU Emissions Trading System (EU ETS), n.d.). Since 2012, all airlines operating in Europe, European and non-European alike, are required to monitor, report, and verify their emissions, and to surrender allowances against those emissions. They receive tradeable allowances covering a certain level of emissions from their flights per year (EU-Climate Action, 2020) (ICAO, Sustainable Aviation Guide, 2018):

- 2012 - 85% of the allowances were allocated for free, based on benchmarks.
- 2012-2020 -15% of allowances are to be auctioned and 82 per cent allocated for free, based on benchmarks; 3% constitutes a special reserve for new entrants and fast-growing airlines.

On 3 July 2020, the EU Commission published the Roadmap for the legislative initiative aimed at amending the EU ETS regarding aviation. It is planned for the second quarter of 2021 and it will (EU-Climate Action, 2020) (Roadmap for legislative initiative, 2020):

- implement the carbon offsetting and reduction scheme for international aviation (CORSIA) in a way that is consistent with the EU's 2030 climate objectives.
- increase the share of allowances auctioned under the system for aircraft operators to further contribute to reducing GHG emissions.

2.3.2.2 EU policies and certification standards

The EU continues to launch different policies and standards to reduce GHG emissions and at the same time to maintain economic growth. In December 2019, EC has set the Green Deal Communication, which is a roadmap for making the EU's economy sustainable. By this deal, the EU aims to be climate neutral in 2050. The European Green Deal covers all sectors of the economy (EC, A European Green Deal, 2020). The aim to be the first climate-neutral continent will be supported by the first European Climate Law, Biodiversity Strategy for 2030, the new Industrial Strategy and Circular Economy Action Plan, the Farm to Fork Strategy for sustainable food and proposals for pollution-free Europe. EC would like to accelerate the application of the strategies and will immediately start for upping Europe's 2030 emissions targets to reach the 2050 goal (EC, The European Green Deal sets out how to make Europe the first climate-neutral continent by 2050, boosting the economy, improving people's health and quality of life, caring for nature, and leaving no one behind, 2020). Although it is expected that EU Green Deal will come in force in the nearest future, other existing policies and standards already work on the sustainable development of the SAFs.

2.3.2.2.1 EU Renewable Energy Directive

The policy framework in the EU for the production and promotion of energy from renewable sources is the Renewable Energy Directive (RED) 2009/28/EC (EC Directive 2009/28/EC, 2009). The RED and its recast towards 2030 (Renewable Energy Directive II (RED II) (2018/2001/EU (RED II))) define the sustainability criteria for the fuels (Erik C. Wormslev, 2020). Table 2-1 below represents a comparison of RED and RED II.

Table 2-1: Comparison of RED and RED II targets

	Renewable Energy Directive (RED)	Renewable Energy Directive II (RED II)
Code	2009/28/EC	(RED II) 2018/2001/EU
Operational date	April 2009	December 2018
Time limit	By 2020	By 2030
Final energy consumption from renewable sources	20%	32%
Transport fuels come from renewable sources	10%	14%*
Minimum GHG emission savings	<ul style="list-style-type: none"> ▪ of 35% for old installations (in operation in 2008), 50% reduction in 2017, ▪ up to 60% GHG reduction in 2018 for new installations. 	The same
Additional crucial points	<ul style="list-style-type: none"> ▪ Areas of high carbon stock (wetland, forest, and peatland) should not be used for biofuel production. ▪ Land with high biodiversity should not be used for biofuels production. 	Fuel producers must deliver SAFs: <ul style="list-style-type: none"> ▪ at least 0.2 % in 2022, ▪ at least 1 % in 2025, ▪ at least 3.5 % by 2030".

*Fuels used in the aviation and maritime sectors can opt in to contribute to the 14% transport target but are not subject to an obligation.

More voluntary standards have been developed to assess the sustainability of SAFs. The EU has approved the following schemes, which follow and reflect principles of EU RED II, and therefore RED II will be taken as the main standard to refer for in the report (European Commission, Voluntary schemes, 2020):

- ISCC (International Sustainability and Carbon Certification)
- Bonsucro EU
- RTRS EU RED (Round Table on Responsible Soy EU RED)
- RSB EU RED (Roundtable of Sustainable Biofuels EU RED)
- 2BSvs (Biomass Biofuels voluntary scheme)
- Red Tractor (Red Tractor Farm Assurance Combinable Crops & Sugar Beet Scheme)
- Red Cert
- Better Biomass
- RSPO RED (Roundtable on Sustainable Palm Oil RED)
- KZR INIG System
- U.S. Soybean Sustainability Assurance Protocol EU (SSAP EU)

2.3.2.2.2 Roundtable on Sustainable Biomaterials (RSB)

The Roundtable on Sustainable Biomaterials (RSB) Standard developed a standard for sustainable biofuel production covering the entire chain of production of the biofuel, from feedstock production to final biofuel blending, which is based on 12 Principles & Criteria that ensure lasting solutions without creating social and environmental challenges (RSB, Demonstrate your commitment to a sustainable bioeconomy with RSB certification, 2020). The RSB Standard is built around the following principles: legality; planning, monitoring and continuous improvement; greenhouse gas emissions; human and labour rights; rural and social development; local food security; conservation; soil; water; air; use of technology, inputs, and management of waste; and land rights (RSB, RSB Principles & Criteria for Sustainable Biofuel Production, 2011) (RSB, Trusted Solutions for a New World, 2017). This RSB standard is recognised internationally by the World Wildlife Fund (WWF), the International Union for Conservation of Nature (IUCN), and the Natural Resources Defence Council (NRDC) (ICAO, 2019 Environmental Report, 2019). Moreover, it was recognized by the European Commission to be following the requirements of the EU Renewable Energy Directive (RED) in 2010. The RSB RED-compliant standard is termed the "RSB-EU RED Standard" and it includes its implementation of the EU RED GHG calculation methodology for biofuels (Guittet, 2016).

2.3.2.2.3 International Sustainability & Carbon Certification (ISCC)

Started in 2006, the International Sustainability and Carbon Certification (ISCC) certification system focuses on sustainability and the reduction of greenhouse gas emissions, within the food, feed, chemicals, and energy sectors. The ISCC was recognized by the European Union in 2011 as one of the first VSSs to comply with the EU RED. The global scheme that certifies a broad range of biomass covers entire supply chains from field to consumer and offers full traceability (ISCC, Sustainability Requirements, 2016).

The objectives of the International Sustainability and Carbon Certification (ISCC) system are to establish an international, practically viable, and transparent system for certifying biomass and bioenergy. With proper certification (ISCC, Sustainability Requirements, 2016) (ISCC, Guidance for the certification of co-processing, 2017), ISCC can

- Contribute to a reduction in greenhouse gas (GHG) emissions.
- Promote sustainable use of land.
- Promote traceability.
- Protect natural biospheres.
- Ensure social sustainability.

2.3.2.2.4 CertifHy GO Scheme

Hydrogen is a novel type of non-drop-in fuel, which is under high interest among the aviation community. R&D still goes on for the efficient application of the fuel for aircraft propulsion technologies, since liquid hydrogen requires considerable large storage facilities within aircraft (McKinsey, 2020). However, the study on the potential certification techniques, methodologies and standards have been launched to facilitate the possibility of hydrogen entering the market by 2021. In 2014, JU FCH has launched CertifHy GO¹ guarantees project to develop a European Framework for Guarantees of Origin for Green and Low-carbon Hydrogen. Even though several years have passed, CertifHy is still in a project phase and it is expected that the project will finalize Guarantees of Origin for Green and Low-carbon Hydrogen by the end of 2021. The project forecasts to provide outcomes from the next phase with a focus on (FCH, 2019):

- Establishment of the CertifHy stakeholder platform;
- Expanding the pilot scheme concerning new plants with different hydrogen production pathways and use cases other than the ones already covered;
- Development of an EU Voluntary Scheme for demonstrating compliance with targets via the so-called Supply Certificates (FCH, 2019).

2.3.2.3 Biomass Availability

Since the production of biofuels, in general, is so strongly related to agricultural activities, the European production follows the EU Common Agricultural Policy that governs all environmental standards of agricultural production. Therefore, the sustainability of European SAFs is guaranteed by the Cross-compliance rules followed by the European Farmers and by all social and economic standards of developed economies. As a result, the European Production of biofuels does not contribute to deforestation or land degradation due to existing management practices and stringent national environmental legislation in the European Member States (PUB, 2010). According to the EU policies and requirements, the major concern about the usage of biomass for SAFs production appear to reduce severe negative impacts on biodiversity, and therefore will directly affect the level of biomass availability (Agency, 2012). Consequently, the biomass availability issue should betoken explicitly under the scope of the report.

¹ A Guarantee of Origin (GO) is an electronic document informing the final consumers on the origin of a product.

2.4 Methodology

2.4.1 Literature Review

A literature review of drop-in and LH₂ as potential SAF was conducted with a focus on the technical development status for their production and expected sustainability performance (both economic and GHG performance). Publications types considered are primarily scientific papers (either peer-reviewed or not), policy publications and datasheets of state-of-the-art technology. The literature study was carried out with a research question: what are promising SAF and their production routes for the aviation sector in the 2021 – 2050-time horizon, and what is their sustainability performance?

The objective of the literature study was to provide a state-of-the-art overview of production options that have been published for SAF in a way that:

- provides an overview of technical and sustainability aspects to consider for the evaluation of SAF production alternatives;
- identifies the development status, economic feasibility, and sustainability performance of SAFs;
- allows comparison between production alternatives for drop-in and hydrogen as a SAF;
- serves as a basis for the subsequent selection of promising SAF production routes within the TRANSCEND project.

The methodology of the study is based on the understanding the most relevant criteria for the assessing overall sustainability of SAFs production routes by conducting in-depth literature review from the primary sources and validate it with the Workshop 1 expert's opinion (

Workshop details – Box 2-1). The criteria used in the project can be divided into two parts representing technical development and sustainability criteria (Figure 2-4). Other environmental and social aspects (i.e. biomass availability, LUC, other social issues, etc.) were not a part of literature review, but were discussed during the workshops, or when advised by experts. Technical development criteria are directly linked to technology certification and process maturity. Sustainability criteria cover economic performance, environmental and social aspects. Economic performance is linked to technical constraints, economic potential, and market potential. Environmental performance is linked to the ACARE goals for CO₂ and NO_x emission reduction. Social aspects, land-use change, and biomass availability issues are linked to workshop outcomes and expert's opinion. The TRANSCEND evaluation criteria thus do not concern only environmental impact but also any criterion that could suggest a risk for the entry-into-service of the aircraft with alternative energy source and novel propulsion technology. Environmental criteria include related air pollution factors, local land, and food security aspects (Kos, 2019). All criteria have been discussed during the Workshop 1, results from which are presented in the boxes after each section of main discussions.

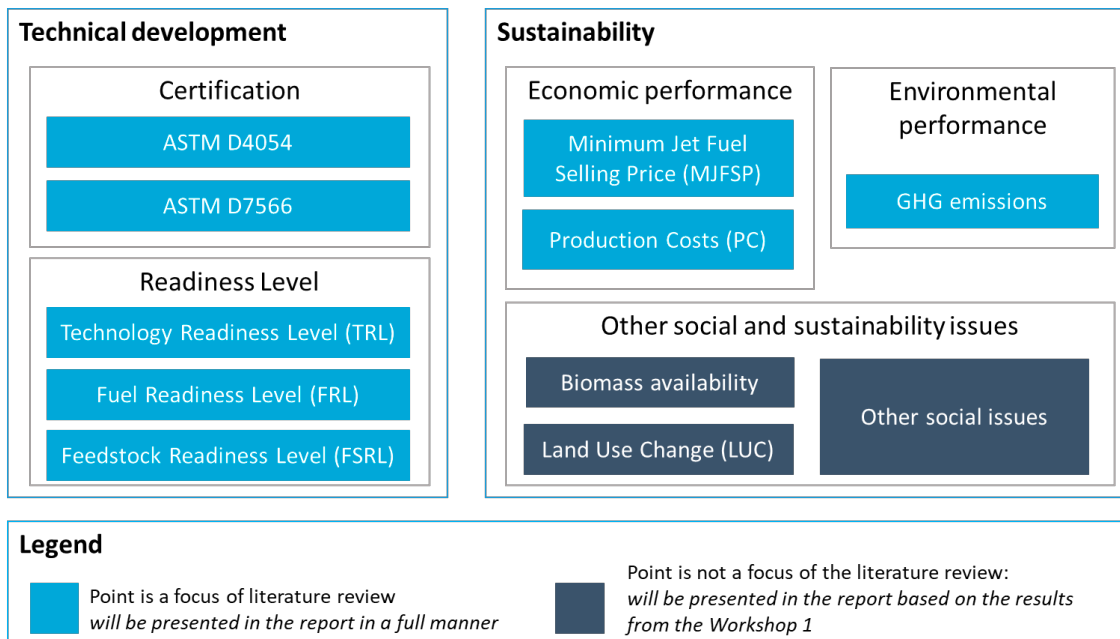

Figure 2-4: Methodological approach for reviewing the sustainability performance of SAFs

To evaluate the development status and technical aspects relevant in the development of SAF we identified the TRL and ASTM certification status from academic literature and reports from organizations related to the aviation sector. ASTM status is presented per approved fuel based on specific technologies (HEFA-SPK and HFP-HEFA-SK). However, given the diversity and limited availability of data in the literature review for all technologies and their derivatives, for the review of TRL and sustainability performance, the results are presented per technology group as presented in the Table 3-1.

The TRL scale mostly reflects technology risk of the new technologies entering the market but it does not cover issues related to the commercial uncertainty and risk remaining in the demonstration and deployment phase. FRL and FSRL, by contrast, are developed to reflect the overall range of risks affecting the development of fuels and disclosure of feedstocks respectively (Becky Mawhood, 2016). According to the Section 2.2.3, TRL has strong linkages to FRL and FSRL. Therefore, our analysis has focused on the review of all indicators in a synergy metric. For FSRL there are few feedstocks recognised and evaluated according to CAAFI and USDA Agricultural Research Service (CAAFI, Feedstock List (as of 3/2018), 2018), (CAAFI, Feedstock Readiness Level, 2020). However, all of them were assessed in terms of USA location, and therefore should be qualified for the EU scope of this work. Accordingly, we have decided to qualify FSRL in terms of the existence of EU-based biomass production coupled with possibility to trade biomass inside EU (eurostat, 2020) (European Union, 2018). Additionally, SAFs FRL also has been collected for different SAFs to recognize the status of certification and the prospect to enter the aviation market from the legal perspective according to ASTM certification (CAAFI, Fuel Qualification, 2020).

Although FSRL is usually focused on biobased feedstocks, in this report we consider a FSRL also for the feedstocks of non-biobased SAF. E-fuel SAFs production routes use direct/indirect CO₂ capture from the air coupled with electricity produced from the renewable energy sources, while hydrogen SAFs production routes use only the last one. Due to the specifics of the e-fuels and hydrogen production routes, FSRL has been represented as TRL of technologies for direct/indirect CO₂ capture from the air and with electricity produced from renewable energy sources. Therefore, FSRL for e-fuels production routes represents the synergy of TRL for both technologies used in the production, while FSRL for hydrogen refers to the TRL level of technologies to produce renewable electricity for the production.

To evaluate the sustainability performance of drop-in and non-drop-in production routes we have focused on economic performance (represented by MJFSP and PC) and GHG emissions related to each production route in separate. Study on

the production routes analysis was focused on understanding the connection between the performance of the process and price /cost of the final product delivered: summarizing studies, the results of which are of value for process modelling and development, evaluation, and control. Additionally, production routes for both drop-in and non-drop in fuels should be compared among each other to quantify economically feasible sustainable production routes for the mid-long-term horizon.

Economic performance has been investigated through economic indicators as reported in the literature for the respective production routes: Minimum Jet Fuel Selling Price (MJFSP) and Production Costs (PC). While MJFSP and PC reflect production costs, it should be taken into consideration that there is a difference between the two: MJFSP includes IRR, typically around 10-15%. While these indicators are usually presented in terms of monetary currency over mass or volume of product (e.g. USD/ton), in this report economic performance is presented in USD/MJ for all production routes for comparability.

According to different sustainability certification schemes and initiatives under Section 2.3.2.1, greenhouse gas emissions (GHG) reduction is one of the major aspects in the ongoing race for the development of the sustainable aviation sector, with focus on GHG reduction related to life cycle GHG emissions of SAFs, which are commonly presented as carbon equivalents (g CO₂ eq/MJ). Generally, life cycle GHG emissions refer to the emissions produced during feedstock production (e.g. biomass or vegetable oil) and transport, conversion to fuel, fuel transport and distribution, up to the final use in the aircraft engine. The emissions from combustion of biobased fuels are often not accounted for in literature since that they are considered as biogenic emissions, meaning that those come from carbon absorbed during the biomass production (e.g. bio CO₂ residues after combustion are present in the atmosphere until it is absorbed by replacement biomass (Samantha Eleanor Tanzer, 2019)). However, other sustainability criteria should be considered for the assessment of the whole picture of the SAFs, including but not limiting the following: carbon stock, land-use change, biomass availability, resources availability, indirect and direct effects on the resources, etc. In relation to biomass availability, further references about availability and economic viability resources for SAFs production routes towards 2050 will be discussed, including possible factors affecting the conditions in 2050, and the effects of these factors on availability and economic viability in 2050. This will be presented as a general vision for SAFs production routes development (based on the literature review findings on TRL, economic and environmental performance), and supported by a high-level perspective on availability of biomass and economic viability of renewable electricity from consulted literature.

2.4.2 Workshop 1

Additionally, a workshop has been held to gather updated information about the evaluated technologies from experts. Because it was clear from the literature review that other aspects to sustainability besides economics and GHG emissions were relevant, part of the workshop was dedicated to the identification and discussion with experts on other sustainability issues aligned with social aspects.

Workshop details – Box 2-1

Workshop practicalities

On October 15th, 2020, the Delft University of Technology (TU Delft) in collaboration with the Netherlands Aerospace Centre (NLR) hosted the “Workshop on Sustainable Aviation Fuels (SAF) for Aircraft Propulsion”. 30 experts have

gathered virtually to share their visions and expectations about SAF production technologies, availability, environmental impacts, and their sustainability for the aviation sector in the 2050-time horizon.

Experts background:

- **Countries:** Netherlands, Germany, France, Ireland, Switzerland, Belgium, Spain, Canada, United States.
- **Sectors:** Governmental agencies and international policy organizations, aircraft and engine manufacturers, airport groups, technology R&D experts, sustainability research and certification experts, Sustainable aviation fuels producers and distributors, hydrogen international experts and producers.

In total, the 30 experts with an expertise in the different sectors discussed different sustainability criteria. Experts agreed upon the methodological approach presented in section 2.4.1, gave research directions to finalize the literature review considering the criteria under Section 2.4, and suggested other sustainability topics for future research.

Also, during the Workshop on Potential Sustainable Aviation Fuels for Aircraft Propulsion, the TRANSCEND team has collected expert's comments and expectations about SAF production technologies, availability, economics, environmental impacts, and some sustainability aspects for the aviation sector in the 2050-time horizon, which were consolidated and summarized into the online survey.

An online survey has been distributed among experts to validate the main findings from the Workshop's discussions. The results of the online survey will be presented after each section, inside the Workshop outcomes boxes. They will be presented in % merit to show off most expert's opinions.

2.4.3 Preselection of SAFs

Preselection of SAFs production routes was based on the proposed three criteria and gathered information regarding them. For the better visual analysis and selection, all criteria presented in the table to highlight the overall performance of the production route. As per the scope of the report, 5 SAFs production routes are needed to be selected among the existing number. However, some of the routes have shown similar techno-economic and environmental performance, which made the selection process more difficult. Therefore, for the preselection of SAFs production routes the compatibility of technology/production route with existing supply chains and the potential product flexibility with the respective production routes were also considered for the preselection. Additionally, all the routes will be analysed with additional comments from Workshop 1 and expert's opinion to make a preselection of the 5 most promising SAF production routes.

3 Sustainable drop-in fuels

3.1 Short technical description

For the analysis, the section of the report will have a focus on both drop-in biobased and non-biobased liquid fuels (e-fuels), which could be used and produced in a safe and sustainable way for aviation purposes (Figure 3-1). The figure below summarizes, groups, and represents the most common pathways for biofuels, e-fuels and hydrogen production, reviewed in the report. Sections below will focus in detail on production routes, their technological development, sustainability performance and other social aspects.

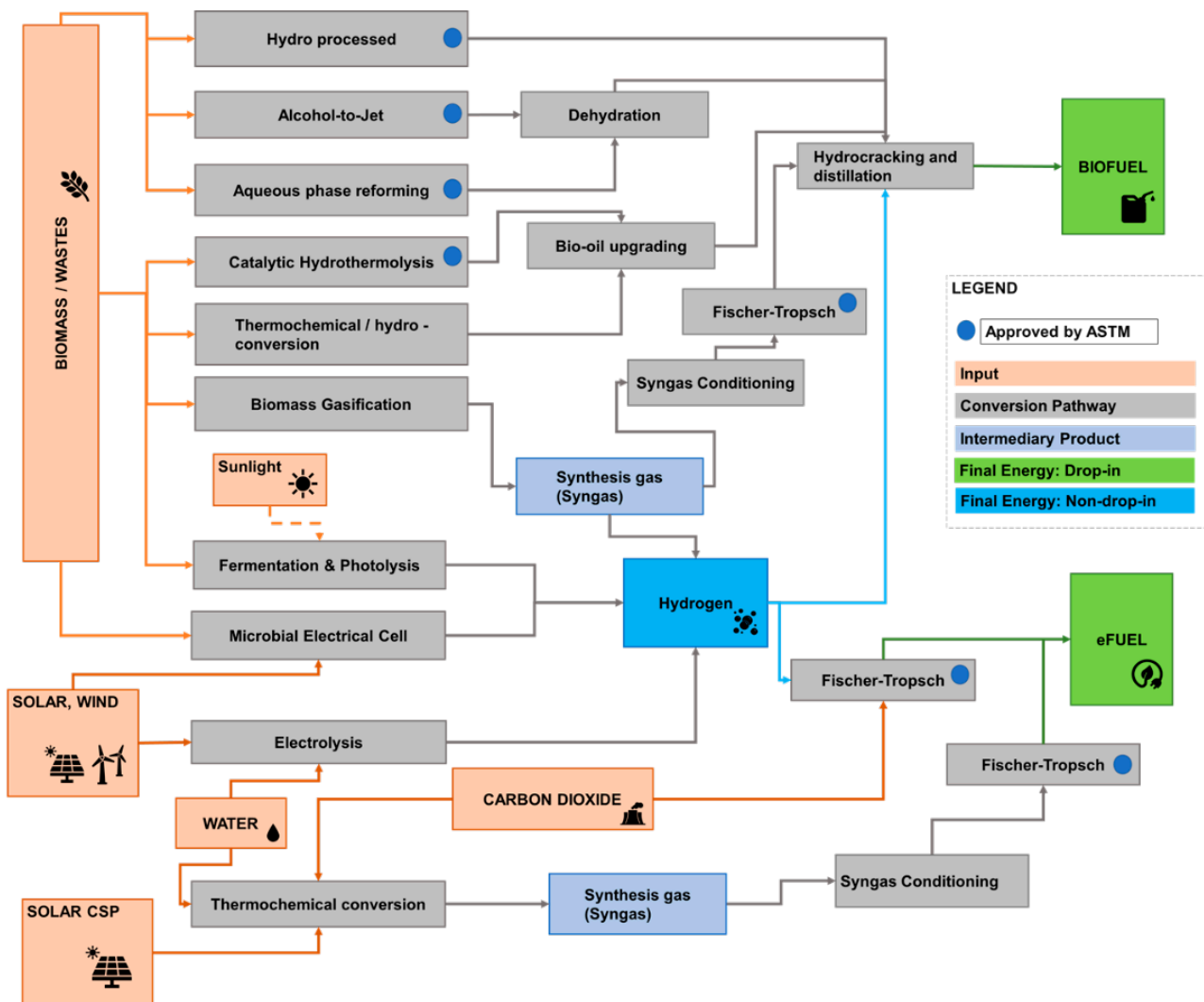

Figure 3-1: General scheme of conversion pathways for SAFs production

This chapter will describe in more detail the available biobased and non-biobased primary energy sources for drop-in SAFs production, conversion pathways, including techno-economic and environmental assessment of the available technologies and essential storage requirements for SAFs on board.

3.2 Biobased SAFs

Biobased aviation fuels are obtained from biobased feedstocks, such as woody biomass, hydrogenated fats and oils, recycled waste. To be ‘drop-in’ SAF, all biomass-derived fuels must decrease their oxygen content to meet the physiochemical properties of petroleum-derived fuels. The oxygen reduces SAFs energy density, increases storage requirements, as well as oxygenated functional groups of bioethanol and biodiesel, can react with refinery and pipeline metallurgy to form gums acids and other impurities. Hydrodeoxygenation (HDO) is a high-pressure and moderate-temperature process in which oxygen is rejected by a catalytic reaction with hydrogen (Ed de Jong, 2014). Up to the date, HDO is one of the most promising technologies to remove the oxygen from biomass-derived and therefore will be represented under the discussion of different SAF conversion pathways (Karatzos et al., 2014).

Hydrogen will be presented under the section of biobased fuels as an intermediary product for the Hydrodeoxygenation (HDO) process. Hydrogen production routes will not be covered under the section and will be presented under the section for non-drop-in fuels production.

3.2.1 Biomass feedstock

Production processes used to produce SAFs certified under ASTM’s D7566 Drop-In Fuel Specification can use various kinds of feedstocks (CAAFI, Feedstocks, 2020) (CAAFI, Feedstock List (as of 3/2018), 2018). Therefore, feedstocks have been divided into different feedstock categories that could be used in SAFs production (Figure 3-2).

Fats, oils, and greases (FOGs)	Cellulose	Carbohydrates/Sugars	Industrial Waste Streams	Fossil/Hydrocarbon /Other*
<ul style="list-style-type: none"> Oilseeds (e.g., camelina, rapeseed) Wastes/Industrial (e.g., tallow/lard) Algae/Aquatic Species (cyanobacteria) 	<ul style="list-style-type: none"> Woody (e.g., sawdust) Grasses (e.g., switchgrass) Residues (e.g., corn stover, grain hulls) Other (e.g., Brassicaceae, fungi) 	<ul style="list-style-type: none"> Crop Sugars (e.g., sugar beet, sugar cane) Industrial (e.g., food processing, whey) 	<ul style="list-style-type: none"> (e.g., food waste, municipal solid waste) 	<ul style="list-style-type: none"> (e.g., carbon dioxide, coal)

Figure 3-2: Common feedstock categories as per CAAFI. Adapted from: (CAAFI, Feedstocks, 2020) *Fossil/hydrocarbon/other category will not be considered for further research due to its initial CO₂ intensity and therefore will not be presented in the report

The section will be followed by a brief explanation of each type of feedstock for bio-jet production with the focus at EU prerogative towards preferred feedstock. The subsections below will represent a brief overview of one of the most common feedstocks in each of the categories.

3.2.1.1 FOGs

Oilseeds: Rapeseed

Rapeseed is one of the most widely distributed oilseeds crops due to its capacity to grow under temperate climate, into a variety of soils, resistant to droughts and has good recovery after droughts. However, it has a low tolerance for floods (Grau Baquero, 2011). Rapeseed provides more than 13% of the global supply of vegetable oil (L.-F. Li, 2016). Rapeseed is the main crop in the EU used for biofuels production representing about 56% of the total EU biofuel cropland (about

2 Mha) (Ecofys, 2019). From 2016, the rapeseed shares account for 38-39% in the total production of biofuels in the EU (Bob Flach, 2019). Into comparison, biofuel production from used cooking oil (UCO) accounts for 13%, animal fat (8%) and tall oil (2.5%). It is expected that rapeseed oil will take a further dip due to continued competition from lower-cost feedstock and biodiesels (Ecofys, 2019). It has been reported that the EU has been planted around 10.6 million ha with oilseeds in 2020. At the same time rapeseed accounts for around 5.3 million ha (Rapeseed and soy production expands in the EU-27, 2020).

Algae / Aquatic Species

Algae, microalgae, and cyanobacteria represent a highly specialized group of micro-organisms that live in diverse ecological habitats such as freshwater, brackish, marine, and hypersaline, with a range of temperatures and pH, and unique nutrient availabilities. Algae can survive and multiply under various environmental conditions (Hu et al., 2008). The most common ways for the algae cultivation are open ponds or photobioreactors. The last ones have higher efficiency and biomass concentration (2–5 g/L), shorter harvest time (2–4 weeks), and higher surface-to-volume ratio (25–125/m) than open ponds (Demirbas, 2010). Harvesting is quite a costly part in the growing process of algae and accounts for 20–30% to the total cost of algal biomass (Demirbas, 2010; Molina Grima et al., 2003; Pimentel et al., 2004). Algae is still developing as a potential feedstock for biofuels production, but has attracted researchers and entrepreneurs for several reasons (Wei-Cheng Wang, 2016) (Demirbas, 2010; Hu et al., 2008; Kandaramath Hari et al., 2015):

- has high productivity per acre and year-round production (e.g. 1–3 duplications per day);
- algal cultivation requires less freshwater than terrestrial crops and can use a variety of water sources including fresh, brackish, saline, and wastewater;
- algae can be cultivated on non-arable land;
- algae have rapid growth potential and high oil content (20%–50% dry cell weight);
- nutrients such as nitrogen and phosphorus for growth can be obtained from wastewater;
- various valuable co-products, such as proteins and residual biomass left after oil extraction potentially can be used as feed or fertilizer;
- hydrogen can be produced photobiologically from microalgae;
- the potential GHG reduction relative to other plant oils;
- algae do not affect crop cultivation;
- the biomass left after the extraction of algal oil can be used as animal feed.

Wastes/Industrial: Used Cooking Oil (UCO)

The used cooking oil (UCO) is a term for vegetable oil used in food production and cannot be longer used for its internal purposes. It comes from different sources, including domestic, commercial, and industrial. Waste vegetable oil is a potentially problematic waste stream which requires to be properly disposed (Refaat, 2010). In 2018, UCO was the second most common feedstock for biofuels production with the share up to 22% in the total biofuel production (Bob Flach, 2019). An estimated 90 per cent of the currently collected EU supply of used cooking oil (UCO) is used for biofuel or bioenergy production (Ecofys, 2019). UCO has started to be widely used after some ministries have allowed double-counting for biofuels (Austria, Belgium, Croatia, France, Hungary, Ireland, the Netherlands, Poland, Portugal, Slovenia, and the United Kingdom) and others introduced a GHG reduction component to their use mandates (Germany, Sweden, and the Czech Republic) (Bob Flach, 2019). UCO usage does not affect crop cultivation and therefore it is an attractive solution for the fuel scarcity issues. Between May 2014 and January 2015, 18 flights took place and used an average of 23% of UCO-based bio-jet fuel (a HEFA fuel from Used Cooking Oil) supplied via SkyNRG (Itaka, 2016).

3.2.1.2 Cellulose

Residues: Corn Stover

Corn stover is the most studied lignocellulosic feedstock for advanced ethanol production, which is also the most abundant crop residue readily available today (C.Yang, 2016). It consists of the stalks, leaves, and husks that remain in the field after corn harvest (Zhenhua Ruan, 2019) (Sophie Parsons, 2018). Corn residue plays an important part in the cropping system. Therefore, according to a sustainable corn stover harvest program, it is necessary only to remove a portion of the total corn stover, leaving a sufficient amount behind to meet critical needs (erosion control, fertility, soil carbon, etc.) (Mark Jeschke, 2020). In 2016, bioethanol consumed in the EU accounted for around 65% of EU feedstock, including wheat (25%), corn (22%) and sugar beet (17%). In 2019, it was estimated that EU global potential for corn stover will reach 9-18 Mt/year in the upcoming years (Ecofys, 2019) (Bob Flach, 2019)

3.2.1.3 Carbohydrates/ Sugars

Crop Sugars: Sugar Cane

Sugar cane or starch is commonly used for bioethanol processes, hence it contains a high amount of sugar. For this reason, it can be used as a source of energy and fuel, as well as raw feed for various materials in production (Mazuchi, 2018) (Hanshu Ding, 2014). Sugarcane, along with other biofuels, represents a promising future for biodiesels. According to recent studies, it has been found that using engineered sugarcane creates more than 2,500 liters of biofuel per acre of land² (Rogers, 2017).

3.2.1.4 Industrial Waste Streams: Municipal Solid Waste (MSW)

Wastes of plant origin and animal origins, such as foodstuffs, wood products, paper, forest residues, industrial and agricultural residues, household wastes, bagasse, animal wastes and municipal wastes can be processed and either burned directly or converted by chemical processes to make a high-quality jet and diesel fuels. The planning and designing of biofuel plants using waste sources are already underway. These plants may provide feedstock sources to complement the specially grown biofuel supply and could also prevent several hundred million tons of waste from entering landfill sites annually (Air Transport Action Group, 2011; Kandaramath Hari et al., 2015).

One example of another advantage municipal waste as biofuel source brings can be seen in London, California, Australia and Italy. Here, the plants will process municipal waste using the biomass to liquid process, gasification and then FT process to annually convert municipal waste into some 16 million gallons of jet fuel per plant. In addition to the jet fuel, they will produce electricity (which can be used to run the plant and also feed excess into the national grid) and bio-diesel for use in cars (Air Transport Action Group, 2011). Another example, a project that takes advantage of local conditions is project Solaris, a joint effort between Boeing and South African Airways, which is beginning to produce SAF using nicotine-free tobacco, allowing local farmers with specialized skills to continue production of tobacco without it being used for smoking (Air Transport Action Group, 2017).

² A Boeing 747 could fly for just over 10 hours on biofuel from 54 acres of land.

3.2.2 ASTM certified pathways to produce biobased SAFs

By April 2020, there are currently 8 ASTM Approved Technological Pathways for SAFs to be blended with Jet-A/Jet-A1 (Table 3-1). The list of 8 ASTM approved production routes contains the co-processing production route, which represents the simultaneous conversion of biomass residues and intermediate petroleum distillates in existing petroleum refineries to produce bio-jet fuels (Co-processing in refineries, 2020). Since the process uses petroleum subproducts, co-processing is outside of the scope of this work and will not be further considered in this review. Furthermore, multiple processes are currently in the approval process following ASTM D4054 as indicated in Table 3-1.

SAF may be blended with conventional jet fuel. The blending limit is specified in the certification process depending on the fuel characteristics (often up to 50% by volume). The blending limit ensures the appropriate levels of safety and performance for all systems. The blending limit is likely to increase in the future (Bhupendra Khandelwal, 2014). The main reason for this limit is the level of aromatics in the fuel. For a larger deployment of SAFs (and therefore a larger scale on reduced environmental impacts) new ASTM pathways could be investigated, developed, and approved for jet fuels with blends up to 100% of SAFs (Table 3-1).

Table 3-1: Biofuel production pathways and ASTM status : Approved and on application

ASTM Certification	Status	Pathway	Feedstocks	Blending limit by volume
ASTM D7566	Approved	Fischer-Tropsch Synthetic Paraffinic Kerosene (FT-SPK)	Municipal solid waste (MSW), agricultural and forest wastes, and wood and energy crops and non-renewable feedstocks (coal and natural gas).	50%
ASTM D7566	Approved	Hydro-processed Esters and Fatty Acids Synthetic Paraffinic Kerosene (HEFA-SPK)	Plant and animal fats, oils and greases (FOGs)	50%
ASTM D7566	Approved	Hydro-processed Hydrocarbons, Esters and Fatty Acids Synthetic Paraffinic Kerosene (HHC-SPK or HC-HEFA-SPK)	Hydrocarbon-rich algae oil	10%
ASTM D7566	Approved	Hydro-processed Fermented Sugars to Synthetic Isoparaffins (HFS-SIP)	Sugars	10%
ASTM D7566	Approved	Fischer-Tropsch Synthetic Paraffinic Kerosene with Aromatics (FT-SPK/A)	Municipal solid waste (MSW), agricultural and forest wastes, and wood and energy crops and non-renewable feedstocks (coal and natural gas).	50%
ASTM D7566	Approved	Alcohol to Jet Synthetic Paraffinic Kerosene (ATJ-SPK)	Starches, sugars, cellulosic biomass	50%
ASTM D1655	Approved	Co-processing	Renewable lipids (plant and animal fats)	5%
ASTM D7566	Approved	Catalytic Hydrothermolysis Synthetic Kerosene (CH-SK)	Renewable fats, oils and grease (FOG)	TBD*
ASTM D4054	Phase 2 Testing	Hydro-deoxygenation Synthetic Kerosene (HDO-SK)	Sugars and cellulotics	TBD
ASTM D4054	Phase 2 Testing	Hydro-deoxygenation Synthetic Aromatic Kerosene (HDO-SAK)	Sugars and cellulotics	TBD
ASTM D4054	Phase 1 OEM Review	High Freeze Point Hydroprocessed Esters and Fatty Acids Synthetic Kerosene (HFP HEFA-SK)	Renewable FOGs	TBD
ASTM D4054	Phase 1 Testing	Alcohol-to-Jet Synthetic Kerosene with Aromatics (ATJ-SKA)	Sugars and lignocellulosics	TBD
ASTM D4054	Phase 1 OEM Review	Integrated Hydropyrolysis and Hydroconversion (IH ²)	Lignocellulosics	TBD

ASTM Certification	Status	Pathway	Feedstocks	Blending limit by volume
ASTM D4054	Phase 2 Testing	Fast Pyrolysis + upgrading, HDCJ hydrotreated depolymerized cellulosic jet	Lignocellulosics	TBD
ASTM D4054	N/A	Hydrothermal Liquefaction	Sugars and cellulosics	TBD

Based on the source: (CAAFI, Fuel Qualification, 2020)

* To be determined further

3.2.2.1 HEFA group – Hydro-processed esters and fatty acids

Hydro-processed Esters and Fatty Acids (HEFA) or Hydroprocessed Renewable Jet Fuels (HRJ) fuels are considered as leading alternative replacements for conventional jet fuel. HEFA production routes involve feedstocks such as vegetable oils, used cooking oils, and oil-bearing crops and algae, which undergo a deoxygenation reaction followed by the addition of hydrogen to break down the compounds into hydrocarbons, followed by further refining steps to obtain a mix of fuels (Pavlenko, Searle, & Christensen, 2019)(CAAFI, 2020). HEFA-SPK production routes involve the chemical transformation of the fatty compounds (the FOGs) to hydrocarbons by catalytic deoxygenation of either triglyceride or secondary esters produced by the transesterification of triglycerides with inexpensive alcohol (Robota et al., 2013) (CAAFI, 2020).

3.2.2.2 HFS group – Hydroprocessed Fermented Sugar production routes

Hydro-processed Fermented Sugar-Synthetic Isoparaffins (HFS-SIP) formerly known as direct-sugar-to-hydrocarbon (DSHC) fuel is a drop-in SAF made by microbial conversion of sugars to hydrocarbons (CAAFI, 2020). The HFS-SIP process utilizes genetically modified microorganisms to convert sugar into hydrocarbons or lipids. In one of these cases, these microorganisms, instead of producing ethanol, produce substances such as farnesene (synthetic iso-paraffin (SIP)) that can be converted into a product with as good characteristics as aviation fuel (ICAO, Sustainable Aviation Fuels Guide, 2018). In this process, no by-products from the main conversion process are formed: farnesane is the only product. Farnesane derived from hydro-processed fermented sugars has been certified for use in commercial engines (Pavlenko et al., 2019).

3.2.2.3 FT group – Fischer-Tropsch production routes

Fischer-Tropsch (FT) is a process by which synthesis gas (or syngas, a mixture of carbon monoxide and hydrogen) can be converted into ultra-clean fuels and value-added chemicals. FT-SPK combines biomass gasification (or co-gasification with coal) with FT synthesis and catalytic cracking to produce synthetic paraffinic kerosene (SPK) from the usage of feedstocks such as lignocellulosic biomass and municipal solid wastes (Mawhood et al., 2016) (Pavlenko, Searle, & Christensen, 2019) (Michailos & Bridgwater, 2019). The FT-SPK route incorporates three major process blocks: the production of syngas by steam reforming/gasification; the conversion of syngas to aliphatic hydrocarbons and water (the FT synthesis process) by CO polymerization and hydrogenation follows; the product of FT (Speight, 2014)(van Dyk & Saddler, 2017). The production of FT-SPK/A is like the FT process but also produces synthetic aromatics along with paraffin and introduces the migration toward fuels that offer a full spectrum of molecules found in petroleum-based jet fuel, rather than just paraffin (CAAFI, 2020).

3.2.2.4 HTL group – Hydrothermal Liquefaction production routes

Hydrothermal liquefaction (HTL) is a thermal depolymerization process used to convert wet biomass into bio-oil or biocrude under moderate temperature and high pressure to produce bio-crude which can be upgraded to jet fuel (Ltd, 2019). Just like Fast Pyrolysis production route, it is not certified or in the process of being so by ASTM, either as freestanding upgrading - or as a coprocessing strategy (ASTM, 2020)(CAAFI, 2020). However, HTL production route shows promising economic and environmental data in the published source and has been used for multiple reviews, and therefore it comes under the report discussions and was included in the sustainability performance Section 3.5 and 3.6.

3.2.2.5 FP or HDCJ group – Fast Pyrolysis or Hydrotreated Depolymerized Cellulosic Jet production routes

Fast pyrolysis (FP) is a process in which organic materials are rapidly heated to 450 – 600 °C in the absence of air, which facilitates the production of organic vapours, pyrolysis gases and charcoal. After that, the organic vapours from FP are condensed to bio-oil (Venderbosch, 2010). FP is not approved by ASTM, either as freestanding upgrading - or as a coprocessing strategy (and no application is currently under review) (ASTM, 2020)(CAAFI, 2020). FP or HDCJ production route, however, has been economically and environmentally assessed under different published sources, and therefore it comes under the report discussions and was included in the sustainability performance Sections 3.5 and 3.6.

3.2.2.6 ATJ group – Alcohol-to-Jet production routes

Alcohol-to-jet (ATJ) fuel, also called alcohol oligomerization, is fuel converted from alcohols, such as methanol, ethanol, butanol, and long-chain fatty alcohols. The two primary alcohol sources used for ATJ fuel are ethanol and butanol, which can be obtained by the fermentation of sugary, starchy, and lignocellulosic biomass, such as sugarcane, corn grain and switchgrass (Yao et al., 2017) (Pavlenko, Searle, & Christensen, 2019).

ATJ processes extract polymer sugars from a biomass feedstock via mechanical, chemical or biological means. The polymer sugars are then decomposed to monomer sugars and metabolized (or fermented) by an engineered microorganism to an alcohol platform molecule (ethanol or isobutanol) (Yao et al., 2017). A typical three-step ATJ process that converts alcohols to jet fuel includes alcohol dehydration, oligomerization and hydrogenation-and-fractionation to yield a fuel product slate which includes some proportion of drop-in jet fuel or blendstock (Wang & Tao, 2016)(CAAFI, 2020).

3.2.2.7 IH² group – Integrated hydropyrolysis and hydroconversion

Integrated hydropyrolysis and hydroconversion (IH²) is currently at phase 1 research report under ASTM D4054. The technology is an alternative thermochemical biomass conversion technology to fast pyrolysis plus hydroconversion or catalytic pyrolysis plus hydroconversion, to produce hydrocarbon fuels from biomass (Marker T. L.-T., 2014). IH² offers a direct route for producing hydrocarbon gasoline and diesel fuels or blending components. These components allow inherent infrastructure compatibility, have an established large market and can be easily transported. The process integrates hydropyrolysis and hydroconversion. The exothermic nature of hydropyrolysis eliminates the need for recirculation of the solid heat carrier which is required for conventional endothermic pyrolysis (Marker T. L., 2012). IH²

production route, however, has been economically and environmentally assessed under different published sources, and therefore it comes under the report discussions and was included in the sustainability performance Sections 3.5 and 3.6.

3.2.2.8 HDO group – Hydro-deoxygenation production routes or Aqueous Phase Reforming (APR)

Hydro-deoxygenation (HDO) production route, also known as Aqueous Phase Reforming (APR), is a technology that has been commercialized to produce renewable diesel, and HDO bio-jet fuels are used in demonstration/commercial flights and testing phases for approval by ASTM, nowadays. Due to its technological maturity, it is expected that this pathway will play a major role in producing low carbon intensity jet fuels (Chu, 2017). The production process includes hydrogenation, (hydro-)deoxygenation, isomerization and hydrocracking stages. HDO process is quite similar to the HEFA-processes, however, HDO production routes use sugars and cellulosic feedstock as material for bio-oil production, while the HEFA processes directly use oil-based feedstocks (Chu, 2017).

Hydro-deoxygenation Synthetic Kerosene (HDO-SK) is molecularly similar to their petroleum counterparts, with the notable difference being a lack of aromatic content (CAAFI, 2020) (Chu, 2017). Hydrodeoxygenated Synthesized Aromatic Kerosene (HDO-SAK) is produced similar so HDO-SK, but it however composed of approximately 95% mono-aromatic compounds (CAAFI, 2020) (Canteenwalla, 2016). HDO production route was not covered in the published sources and multiple reviews, and therefore it was not included under the report discussions.

3.2.2.9 CH group – Catalytic Hydrothermolysis production routes

Catalytic Hydrothermolysis Synthetic Kerosene (CH-SK), also known as catalytic hydrothermolysis jet fuel (CHJ) has been approved by ASTM in D7566 in February 2020 (CAAFI, 2020). The production process as, consists of four main steps: a cleanup step, called hydrothermal cleanup (HCU); the actual conversion step, called catalytic hydrothermolysis (CH); a mild hydrotreating step; and a final distillation step (ARA, 2020). During the CH process, clean free fatty acid (FFA) oil from the HCU process is combined with preheated feed water and then passed to the CH reactor. In the CH reactor, under very high temperature and pressure conditions, a single-phase is formed consisting of FFA and supercritical water where the FFAs are cracked, isomerized, and cyclized into paraffin, isoparaffin, cycloparaffin, and aromatic compounds, a product called “CH crude” oil. The CH crude oil produced by the CH conversion process contains thousands of isomers distributed over the entire boiling range of jet and diesel fuels. The Biofuels isoconversion process was developed by ARA in partnership with Chevron Lummus Global, Euglena Co Ltd is another producer (ARA, 2020). CH production route was not covered in the published sources and multiple reviews, and therefore it was not included under the report discussions.

3.3 Non-biobased SAFs (e-fuels)

The Power-to-Gas/Liquids/Fuels (PtX) is a novel concept of sustainable aviation fuels production named e-fuels or synthetic fuels. E-fuels are produced from the synergy of hydrogen and captured carbon dioxide (CO₂) using electricity as the principal power source. Figure 3-1 provided a schematic showing the production of e-fuels. The principal advantages of e-fuels are that they have a relatively high energy density, they use the existing energy infrastructure and are compatible with existing internal combustion engines, albeit with slight modifications (FCH, 2019).

The capture of carbon dioxide from high concentration carbon dioxide industrial processes (e.g. steelworks, cement or ammonia production, etc.) or power generation is one of the possible cheap sources of carbon (Carbon Capture and Storage, CCS), but it can also be obtained from the air through direct air capture (DAC). However, DAC technologies are currently under development and testing phase (Society, 2019). For the e-fuels section, hydrogen will be presented as an intermediate product used for e-fuels production. Hydrogen production routes will not be covered under the section and will be presented under the section for non-drop-in fuels production.

3.3.1 Eligible pathways to produce non-biobased SAFs

According to the report from the German Environmental Agency (Schmidt & Weindorf, 2016), there are two main production PtL production routes: the Fischer-Tropsch (FT) and the methanol (MeOH) production route (Table 3-2). In terms of energy efficiency, both PtL production routes require an almost equal amount of energy to produce e-fuel. In terms of the sensitivity, both are highly sensitive to the point of how well waste heat from syntheses can be recuperated and used in, e.g., electrolysis or CO₂ provision. Table 3-2 below represents the ASTM certification status of the e-fuels production routes.

Table 3-2: E-fuel production pathways and ASTM status: Approved and on application

Certification	Status	Pathway	Blending limit by volume
ASTM D7566	Approved	Fischer-Tropsch (FT) synthesis and upgrading	50%
ASTM D7566	Pending	Methanol (MeOH) synthesis and conversion	TBD**

Based on the source: (Schmidt & Weindorf, 2016) (Malins, 2017) (Karl Hauptmeier, Electrofuel / e-Fuel, Production Pathways and Costs, 2018)

(ICAO, 2019) (ICAO, Power-to-Liquid (PtL) for Aviation, 2020)

*Oxymethylene Ether

** To be determined further

3.3.1.1 PtL group – Power to Liquid production routes

Power-to-Liquids (PtL) is a production pathway for liquid hydrocarbons based on electric energy, water, and CO₂. This process creates synthesis gas by using hydrogen produced with electrolysis of renewable electricity and CO₂ either from industrial facilities or captured from the air. Renewable electricity can be supplied by a connection to the grid or by directly connecting to renewable electricity installations. To obtain potentially 100% CO₂ reductions over the life cycle, CO₂ can be captured from the air by using Direct Air Capture (DAC) technology.

To produce jet fuel two possible pathways can be used (FCH, 2019):

- Fischer-Tropsch (FT) synthesis and upgrading.
- Methanol (MeOH) synthesis and conversion coupled with renewable energy sources (e.g. solar, wind, hydro, etc.)

The potential for PtL-kerosene grows if the technology to capture CO₂ from the air matures. This technology is essential to make the process fully sustainable in the long term. Factors that influence the economic viability of the project are the process efficiency, the scale-up possibilities and the capital investment costs. Furthermore, the availability of renewable electricity needs to be scaled-up worldwide to provide PtL with renewable electricity input (Schmidt & Weindorf, 2016).

3.4 Technological Readiness Level (TRL) of pathways for drop-in SAF production

Currently there are 7 ASTM approved production pathways for biofuels and 1 ASTM approved e-fuel conversion pathway for blending with Jet-A/Jet-A1 (see Table 3-1, EAER, 2019), which will be described in the sections below. Table 3-3 below presents a grouping of the production routes, which was developed with the aim to facilitate an efficient analysis, representation, and discussion of the ASTM approved production routes.

Table 3-3: Grouping of the production routes for the report analysis

Group	Pathway	Final product
HEFA	Hydroprocessed Esters and Fatty Acids Synthetic Paraffinic Kerosene (HEFA-SPK)	Bio-jet fuel
	Hydroprocessed Hydrocarbons, Esters and Fatty Acids Synthetic Paraffinic Kerosene (HHC-SPK or HC-HEFA-SPK)	Bio-jet fuel
	High Freeze Point Hydroprocessed Esters and Fatty Acids Synthetic Kerosene (HFP HEFA-SK)	Bio-jet fuel
HFS	Hydroprocessed Fermented Sugars to Synthetic Isoparaffins (HFS-SIP)	Bio-jet fuel
FT	Fischer-Tropsch Synthetic Paraffinic Kerosene (FT-SPK)	Bio-jet fuel
	Fischer-Tropsch Synthetic Paraffinic Kerosene with Aromatics (FT-SPK/A)	Bio-jet fuel
HTL	Hydrothermal Liquefaction	Bio-jet fuel
FP or HDCJ	Fast Pyrolysis + upgrading	Bio-jet fuel
ATJ	Alcohol to Jet Synthetic Paraffinic Kerosene (ATJ-SPK)	Bio-jet fuel
	Alcohol-to-Jet Synthetic Kerosene with Aromatics (ATJ-SKA)	Bio-jet fuel
IH ²	Integrated Hydropyrolysis and Hydroconversion (IH ²)	Bio-jet fuel
HDO	Hydro-deoxygenation Synthetic Kerosene (HDO-SK)	Bio-jet fuel
	Hydro-deoxygenation Synthetic Aromatic Kerosene (HDO-SAK)	Bio-jet fuel
CH	Catalytic Hydrothermolysis Synthetic Kerosene (CH-SK)	Bio-jet fuel
PtL	Fischer-Tropsch (FT) synthesis and upgrading	E-fuel
	Methanol (MeOH) synthesis and conversion	E-fuel

Based on the source: (CAAFI, Fuel Qualification, 2020) (Schmidt & Weindorf, 2016) (Malins, 2017) (Karl Hauptmeier, Electrofuel / e-Fuel, Production Pathways and Costs, 2018)

3.4.1 TRL comparison of drop-in production routes

As per the methodological approach presented under Section 2.4, Technology Readiness Level was reviewed in synergy with Feedstock Readiness Level and Fuel Readiness Level.

3.4.1.1 FSRL

For bio-jet production routes, Feedstock Readiness Level has been considered as per methodological approach represented under the Sections 2.2.3 and 2.4 and represented under Table 3-4³. According to the Table 3-4, SAF production chains based on canola, corn and its residues, and switchgrass have a relatively high readiness level, while of the reviewed feedstocks show low scores or are still under FSRL certification procedures (USDA, 2020), (Commission,

³ However, EU biomass availability is still a significant indicator to focus at. Therefore Table 3-4 includes the possibility of international trading of biomass to qualify FSRL.

2019), (CAAFI, Feedstock List (as of 3/2018), 2018). It must be considered, however, that these assessments are based on specific locations, and that most of the crops are available in the EU or could be traded.

Table 3-4: Feedstock Readiness Level for the feedstock presented in the literature review

Feedstock	Feedstock type	FSRL	EU availability
Agro residues	Cellulosics	5.4	Available
Bagasse	Cellulosics	Under FSRL evaluation	Available
Beef tallow	Wastes/Industrial	N/A	Available
Camelina	Oilseeds	4.2	Internationally traded
Canola	Oilseeds	6.2-9	Internationally traded
Carinata	Oilseeds	1	Internationally traded
Corn grain	Cellulosics	6.2	Internationally traded
Corn stover	Cellulosics	6.2	Internationally traded
Eucalyptus	Cellulosics	2.4	Internationally traded
Jatropha	Cellulosics	Under FSRL evaluation	Internationally traded
Macauba	Oilseeds	N/A	Internationally traded
Manure	Wastes/Industrial	Under FSRL evaluation	Available
Microalgae oil	Algae	Under FSRL evaluation	Available
MSW	Wastes/Industrial	Under FSRL evaluation	Available
Palm oil	Oilseeds	Under FSRL evaluation	Internationally traded
Pennycress	Oilseeds	Under FSRL evaluation	Available
Pinus	Cellulosics	Under FSRL evaluation	Available
Poplar	Cellulosics	2.4-5.1	Available
Soybean oil	Oilseeds	Under FSRL evaluation	Available
Sugar cane	Sugars	3.2	Available
Sunflower	Oilseeds	Under FSRL evaluation	Available
Switchgrass	Cellulosics	5.4-6.2	Internationally traded
Used cooking oil	Wastes/Industrial	Under FSRL evaluation	Available
Willow	Cellulosics	Under FSRL evaluation	Internationally traded
Wheat straw	Cellulosics	5.4	Available
Woody biomass	Cellulosics	2.4-5.1	Available

Based on the source: (CAAFI, Fuel Qualification, 2020) (USDA, 2020), (Commission, 2019), (CAAFI, Feedstock List (as of 3/2018), 2018), (European Union, 2018)

PtL production routes require renewable energy for CO₂ capture and electricity generation for the production. Therefore, their FSRL represented as TRL of renewable energy and CO₂ capture technologies involved into the e-fuel production routes and is presented under the separate Table 3-5.

Table 3-5: Feedstock Readiness Level for the RES presented in the literature review

Feedstock type	Industry	TRL (FSRL)
Renewable electricity	Solar PV	8-9
Renewable electricity	Solar thermal	8-9
Renewable electricity	Wind	8-9
CO ₂ captured	Different	6-7

Based on the source: (IEA, Energy Technology Perspectives 2020, 2019)

3.4.1.2 FRL and TRL

Comparability of production routes for bio-jet fuel and e-fuel production is presented under the *Table 3-6* below, which presents a condensed summary of different FSRL, FRL and TRL as per production routes. The FSRL range is based upon Table 3-4 and Table 3-5.

Table 3-6: Detailed overview of technological maturity of bio-jet fuels and e-fuels production routes

Group	Pathway	Feedstock in the published sources	Final product	FSRL	FRL	TRL
HEFA	HEFA-SPK	Jatropha, Palm oil, Soybean oil, Used cooking oil, Woody biomass, beef tallow, camelina, canola, carinata, macauba, microalgae oil, pennycress, rapeseed oil, waste oils, animal fat, sunflower	Bio-jet fuel	3.2-9	6-9	8-9
	HHC-SPK or HC-HEFA-SPK		Bio-jet fuel	3.2-9	6-9	N/A
	HFP HEFA-SK		Bio-jet fuel	3.2-9	6	N/A
HFS	HFS-SIP	Bagasse, sugar cane	Bio-jet fuel	3.2-9	4.5-7	6-8
FT	FT-SPK	Agro residues, Corn stover, MSW, Manure, Poplar, Sugar cane, Wheat straw, Willow, Woody biomass	Bio-jet fuel	3.2-6.2	6.5-8.5	7-8
	FT-SPK/A		Bio-jet fuel	3.2-6.2	6.5-8.5	6-7
HTL	Hydrothermal Liquefaction	Woody biomass	Bio-jet fuel	2.4-5.1	N/A	5-6
FP or HDCJ	Fast Pyrolysis + upgrading	Woody biomass, Corn stover	Bio-jet fuel	5.1-6.2	4.5-6.5	4-6
ATJ	ATJ-SPK	Agro residues, Corn grain, Corn stover, Poplar, Sugar cane, Switchgrass, Wheat, Woody biomass	Bio-jet fuel	3.2-6.2	6-7	6-7
	ATJ-SKA		Bio-jet fuel	3.2-6.2	4.5-6.5	5-6
IH ²	IH ²	Corn stover, Woody biomass	Bio-jet fuel	5.1-6.2	N/A	6
HDO	HDO-SK	N/A	Bio-jet fuel	N/A	4.5-6.5	4-6
	HDO-SAK		Bio-jet fuel	N/A	4.5-6.5	4-6
CH	CH-SK	N/A	Bio-jet fuel	N/A	6	5-6
PtL	FT	Captured CO ₂	E-fuel	7-8	8	6-7
	MeOH		E-fuel	7-8	8	6-7

Based on the source: (CAAFI, Fuel Qualification, 2020) (USDA, 2020), (Anders Winther Mortensen, 2019), (Ltd, 2019), (Karl Hauptmeier, Electrofuel / e-Fuel, Production Pathways and Costs, 2018), (Gielen, 2019), (EASA, TRL and FRL of the six production pathways certified by ASTM for use in commercial flights, 2020).

Looking at TRL level, groups HEFA, HFS, FT and ATJ are the most developed. However, looking at the overall picture that includes the development and availability of feedstock, and the certification status of each group, the most promising pathways in the nearest horizon are HEFA, HFS, FT, ATJ and PtL. Other production routes, such as FP and CH are at the same level and could be expected to reach their technological maturity level in the midterm horizon. The groups HTL, HDO and IH² have the lack of ASTM certification or low TRL. According to (CAAFI, 2020) and TU Delft analysis under *Table 3-6*, the least mature technologies are HTL and HDO, which still under research and development stages. These technologies will need some time to reach technological maturity and enter the market, expected to be in the long-term horizon, by 2050.

Workshop outcomes – Box 3-1 highlights outcomes from the experts' discussion during Workshop.

Workshop outcomes – Box 3-1

TRL of biobased SAFs and e-fuels - Experts points during Workshop discussion*:

1. Technology Readiness Level (TRL) and American Society for Testing and Materials (ASTM) certification are not only indicators to focus at for the assessment of technological development of biofuels production

- routes and their commercialization status, but other indicators also/factors, such as Fuel or Biomass/Feedstock Readiness Level (FRL or FSRL), should be taken into consideration.
2. ASTM certification becomes faster for the novel technologies due to gained experience and development of testing tools and procedures.
 3. Production routes with technologies like Fast Pyrolysis (FP) and Hydrothermal Liquefaction (HTL) have the challenge to pass ASTM certification due to the complexity of their intermediate bio-oil composition and its upgrading.
 4. Hydrothermal Liquefaction (HTL) and Catalytic Hydrothermolysis (CH) production routes have different feedstock, oily and solid biomass respectively, and therefore cannot be assessed as one production routes and should be examined separately.
 5. Power-to-Liquid (PtL) production route is one of the promising options for hydrogen and e-fuel production and should be developed further to meet an increase in the demand for aviation needs.

*** Detailed information regarding the percentage of experts who have agreed upon the presented points in the online survey will be presented in the TRANSCEND report D2.1. Outcomes of the online survey have been considered during preselection.**

3.5 Economic assessment of biobased SAFs production

Aside from being investigated on the technological aspect, the described SAF production pathways have been economically assessed. Regarding Sections 3.2.2, the economic feasibility of production routes will be assessed based upon MJFSP for bio-jet fuel production and PC for e-fuel production routes.

It is imperative to keep in mind that there are limitations to the comprehensiveness and accuracy of techno-economic assessments for SAF production processes. Firstly, recent analyses are limited to conversion pathways that have already received the mandatory technical certification from the ASTM, omitting the technologies that are expected to receive certification in the coming years. Secondly, a fair comparison of techno-economic studies is a sensitive exercise due to different input assumptions (feedstock prices, hydrogen production, tax rate, etc.), economic evaluation metrics, temporal scales, and geographical locations. Thirdly, there is a variation in the date of articles which provides costs ranges as per particular article and has been not adjusted as per technology development upgrades (de Jong et al., 2015).

Figure 3-3 represents MJFSP and PC values for the different SAF technologies available in the literature. Almost all technologies do not come within price parity of conventional jet fuel without some sort of price support or subsidy. It should be noted that neither the fast pyrolysis (FP) nor the hydrothermal liquefaction (HTL) pathway is currently certified under ASTM for producing bio-jet fuel, either as freestanding upgrading - or as a coprocessing strategy (and no application is currently under review). HTL is a thermal depolymerization process used to convert wet biomass into bio-oil or biocrude under moderate temperature and high pressure (ASTM, 2020; CAAFI, 2020).

- Main findings as per the literature review are (Figure 3-3):
- HEFA, ATJ, FT have approximately the same range of MJFSP from 0.02-0.06 USD/MJ (equivalent to 0.9 to 2.1 USD/L).
- FP, IH², HTL have shown the lowest prices in the range of 0.01-0.021 USD/MJ (equivalent to 0.5 - 1.15 USD/L).
- The feedstock price is the predominant contributor to the MJFSP for HEFA.
- The CAPEX contributes significantly to MJFSP for FT processes.
- HFS-SIP, ATJ, HTL and FP are CAPEX intensive as well as yield dependent.
- IH² prices are feedstock and CAPEX intensive due to the hydrogen plant and equipment contingency.

- PtL has high price range due to the involvement of novel technologies and low technology maturity level, compared to other biobased SAFs.

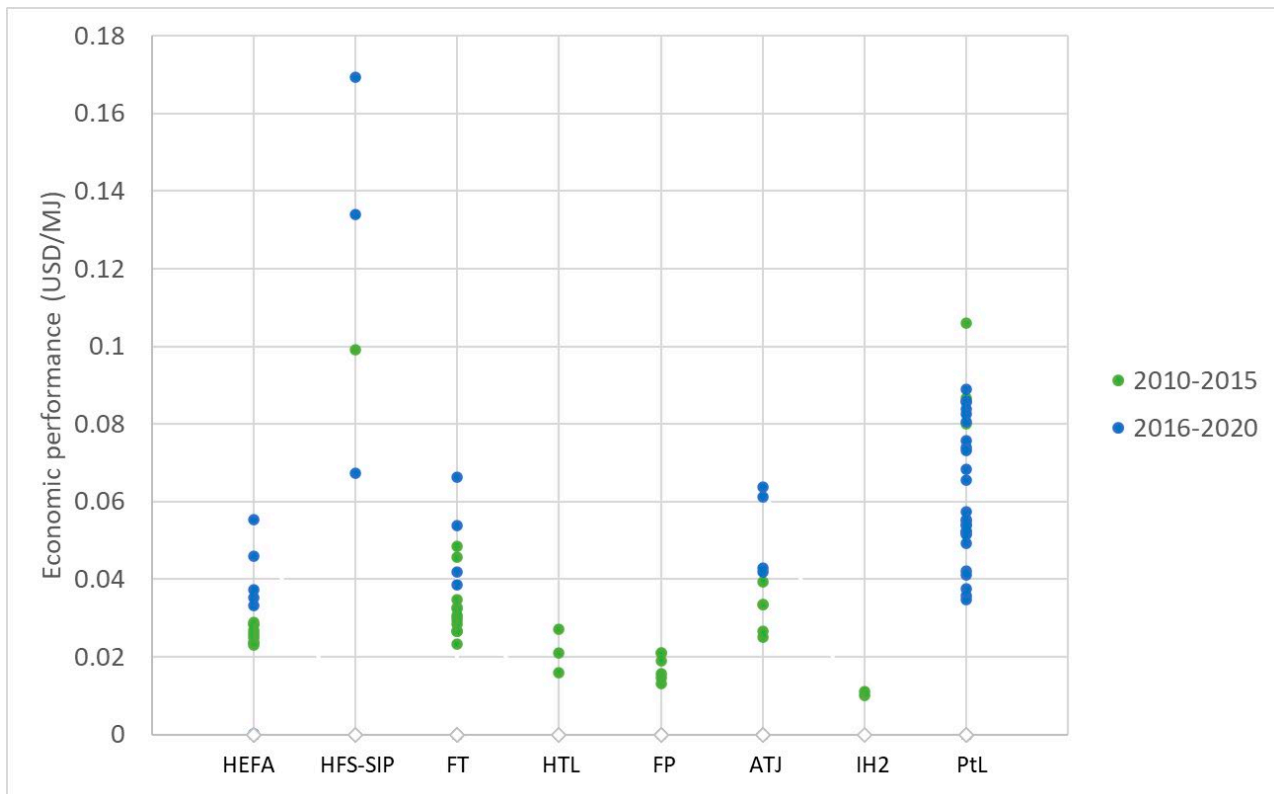

Figure 3-3: Economic performance of biofuels and e-fuels production routes found in the literature with the conventional fuel price as reference. Based on the source: (Atsonios et al., 2015; da Silva, 2016; de Jong et al., 2015; Michailos & Bridgwater, 2019; Pavlenko et al., 2019; Pearlson et al., 2013; Wang, 2016; Wang & Tao, 2016), (Friedemann G. Albrecht, 2017), (Stavros Michailos, 2019) (Maximilian Decker, 2019), (Patrick Schmidt W. W., 2016)

For most bio-jet production processes, the feedstock is usually the most significant portion of the total fuel cost. Aside of that, facility size, yield (overall, carbon, oil, etc.), financing, location, hydrogen source, ramp-up schedule of a plant (i.e. an increase of production ahead of anticipated increases in product demand) and capacity utilization also influence production costs (Michailos & Bridgwater, 2019; Pearlson et al., 2013). For HEFA, the feedstock price is the predominant contributor to the MJFSP. For FT processes, the CAPEX contributes significantly. For HFS-SIP and ATJ this is also true, but the effect of the yield plays a role, and the CAPEX is not negligible either. HTL and FP are CAPEX intensive as well as yield dependent. IH² seems feedstock and CAPEX intensive due to the hydrogen plant and equipment contingency, however, not enough research has been done for an adequate comparison. Only speculative arguments concerning the economics have been given for co-processing and HDO.

For new bio-jet fuel production processes, production costs are expected to be higher for first-of-a-kind facilities, which is rarely taken into account in the literature evaluations of economic performance. However, through technological learning and upscaling of production, the costs are expected to decrease over time. Nevertheless, there is a lot of uncertainty in the price development of the different fuels as the demand for sustainable feedstocks may rise in the future. The economic feasibility will also be influenced in the future by the carbon emissions cost. Higher CO₂ prices help to reduce the difference between the production costs of drop-in fuels concerning that of fossil fuel (Pavlenko, Searle, & Christensen, 2019). There is also uncertainty in terms of carbon tax involvement. Most of the production routes as evaluated in the literature do not include a carbon tax in the calculation of their MJFSP.

PC of PtL production routes depends on the electricity costs, which still play the major role since renewable energy sources, such as wind, solar, etc. are undergoing of the process to enter the market. While production costs are usually presented in terms of monetary currency over mass or volume of product (e.g. USD/ton), in this report economic performance is presented in USD/MJ for all production routes for comparability. PTL technologies have high TRL but still, experience in parallel technological development and improvement nowadays. As a result, reduction in CAPEX and OPEX could be expected in the nearest future, which will result in the reduction of e-fuel production costs in the nearest term (IEA, Energy Technology Perspectives Special Report on Clean Energy Innovation 2020, 2019). However, PtL production routes also involve low mature technologies and are at a low-scale production. Nonetheless, it is still a promising way to produce SAFs and it could be expected to be expanded in the nearest future.

Workshop outcomes – Box 3-2 highlights outcomes from the experts' discussion during Workshop.

Workshop outcomes – Box 3-2

Economic Performance of biobased SAFs and e-fuels - Experts points during Workshop discussion*:

1. The approach of integrating biofuels production routes into existing refineries to reorganize them into biorefineries and dedicated facilities based on regional supply chains will also result in the lower production costs of SAFs.
2. The valorization of side-streams or a fraction of the feedstock into higher value-added products can have a significant positive effect on the economic performance of SAF production. The challenge, however, is on finding partners for valorizing these streams.
3. Due to the rapid development of the renewable energy technologies around the world, which experience a decrease in their electricity costs (e.g. solar, wind, hydro, etc.), one can predict that production costs of e-fuel and hydrogen production routes will also decrease accordingly in mid- and long-term.

**** Detailed information regarding the percentage of experts, who have agreed upon the presented points in the online survey will be presented in the TRANSCEND report D2.1. Outcomes of the online survey have been considered during preselection.***

3.6 Environmental assessment of biobased SAFs production

Life-cycle GHG emission data (in g CO₂ eq/MJ) collected from several references helps to understand the environmental impact of SAF production pathways. There are different assumptions possible when calculating the life cycle GHG emissions. Two imperative variations in these assumptions are the inclusion of (co-product) allocation and the inclusion of land-use change (LUC). The LUC reflects the direct change of the land, say creating new cropland for agriculture, or the indirect LUC (ILUC) where existing cropland is converted; forest to cropland or grassland to cropland (forcing food, feed, and materials to be produced on new cropland elsewhere). The GHG emissions effects of creating cropland or agriculture expansion form part of the life cycle GHG emissions of the total SAF production process. To quantify the cumulative impacts of the SAFs production on the environment other environmental metrics should be modelled and considered for a more comprehensive indication of the environmental impact. These metrics could include reduction of fossil depletion (specific calculation); terrestrial acidification; eutrophication; human/environmental toxicity; particle matter formation; photochemical oxidant formation; etc. (Capaz et al., 2020). PtL production routes also have different assumptions in regard to the g CO₂ eq/MJ allocation: accounting for the emissions from the infrastructure (e.g. RES production, electrolyzers production, etc.) (Soler, 2019).

Figure 3-4 depicts all data found for life cycle GHG emissions for SAF pathways. The first clear observation is that nearly all emission values for SAF pathways have lower emissions than conventional jet fuel. And clearly could be seen that PtL is among cleanest production routes. Only some feedstocks for the HEFA pathway led to higher emissions than conventional jet fuel, due to the fact of including results from the literature review, which contain palm oil. FT is the process with the lowest (negative) emission value of -3 g CO₂ eq/MJ, because of the allocation of emissions. Negative emissions could arise due to the different allocation of g CO₂ eq/MJ inside the same production routes. Some of the methodologies allocate majority of g CO₂ eq/MJ to by-products routes, and therefore reduce overall level of g CO₂ eq/MJ from the main biofuel production route. Such allocation includes HTL and FP show encouragingly low emission values as well, but the LUC was not considered for either of these processes.

Main findings as per the literature review are (Figure 3-4):

- HEFA, HFS-SIP, ATJ have the highest range of the emissions reported, which was mainly due to the choice of including (I)LUC and the allocation of the chosen feedstocks. Moreover, this range is related to the type of feedstock these processes can take (f.e. oil feedstocks are associated to higher LUC).
- HTL and FP show low emission values as well, but the LUC was not considered for either of these processes.
- For all processes, the inclusion of LUC and allocation are of importance for the emission estimations as well as the yields of the conversion process and natural gas usage.
- In almost all processes hydrogen is an important contributor to the overall product supply chain g CO₂ eq/MJ.
- On-site hydrogen production led to lower emissions than purchasing off-site produced hydrogen.
- Among all the processes PtL has the lowest range of g CO₂ eq/MJ since production routes involve usage of RES.

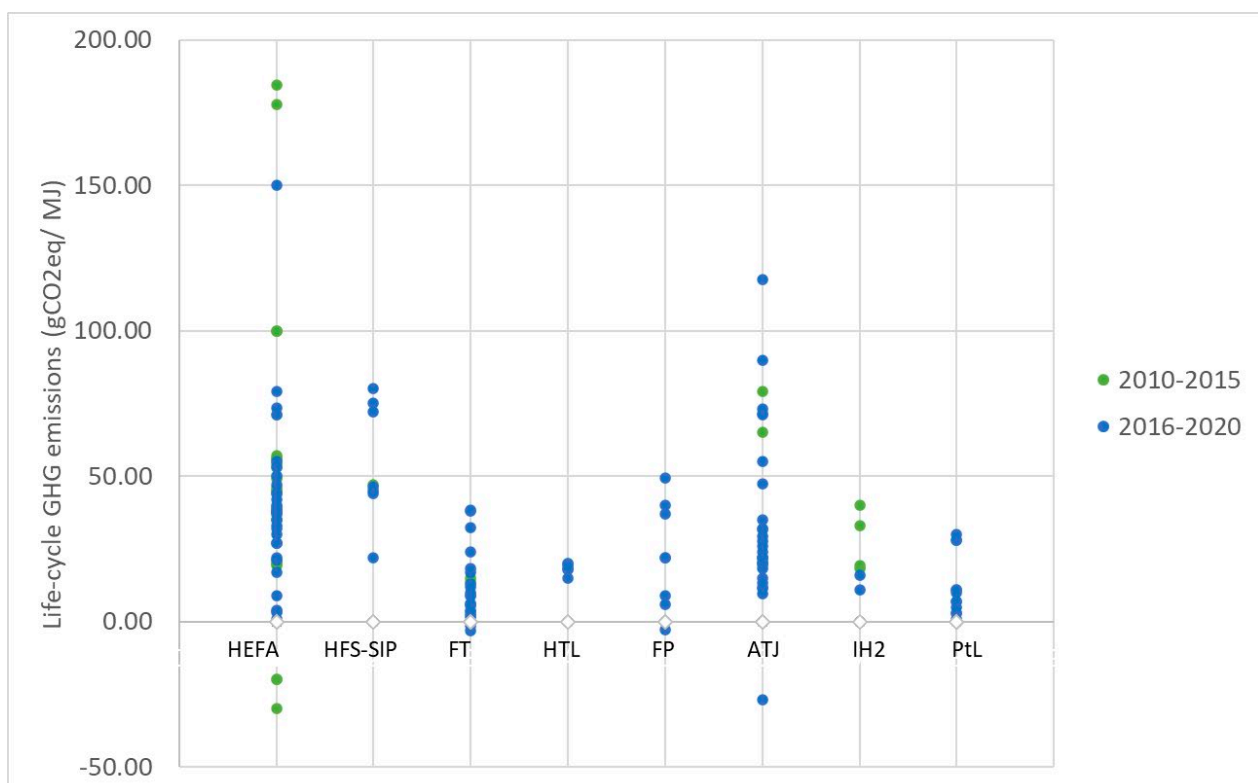

Figure 3-4 Life-cycle GHG emissions for biobased and e-fuel production routes found in the literature with the conventional fuel life-cycle emission as reference. Based on the source: (Capaz et al., 2020; da Silva, 2016; De Jong et al., 2017; O'Connell et al., 2019; Pavlenko et al., 2019; Zemanek et al., 2020), (Patrick Schmidt V. B., 2018), (Lehmann, 2018), (Karl Hauptmeier, *Electrofuel / e-Fuel, Production Pathways and Costs*, 2018), (Soler, 2019).

Workshop outcomes – Box 3-3 highlights outcomes from the experts’ discussion during Workshop.

Workshop outcomes – Box 3-3

GHG emissions of biobased SAFs and e-fuels - Experts points during Workshop discussion*:

1. The decision-making for sustainable production of SAF should take into consideration the feedstock production stage for the decision making about SAF production, due to the fact that it is the main contributor to the GHG emissions from SAFs production routes.

**** Detailed information regarding the percentage of experts, who have agreed upon the presented points in the online survey will be presented in the TRANSCEND report D2.1. Outcomes of the online survey have been considered during preselection.***

3.7 Other sustainability and social aspects of drop-in SAFs production routes

The chapter represents other sustainability and social aspects related to the drop-in SAFs production routes. It also highlights major issues and experts’ opinions as gathered in Workshop 1 held on X date.

3.7.1 Biomass availability for SAFs production

3.7.1.1 Availability of biomass Worldwide

A key concern is the availability of sustainable biomass for all sectors of the economy. The worldwide biomass potential in 2050 is estimated between 67-160 EJ per year by different energy transition scenarios (IRENA, Global energy transformation: The REmap transition pathway (Background report to 2019 edition), 2019). Not all biomass is, however, suitable to produce biofuels. Some feedstocks are easier to convert to fuels while others need more processing steps. Furthermore, many sectors of the economy rely on biomass to move away from fossil energy sources. Biomass can be used in heat, power, plastics, road, and maritime sectors (CAAFI, Feedstocks, 2020). The International Council on Clean Transportation (ICCT) expects 9% of the available biomass being delivered to the aviation sector in 2050 while the majority of biomass (83%) will be used by heat, power, plastics, and road vehicles. A different view is given in the Mission Possible report published by the Energy Transitions Committee which considers aviation a priority sector in the allocation of biomass. It therefore assumes that 45% to 60% of worldwide biomass potential will be used to meet the energy demand from aviation in 2050 (Energy Transitions Commission, 2019).

Another recent report from the collaboration of WWF and Boeing, “Taking off: Understanding the sustainable aviation biofuel potential in sub-Saharan Africa”, highlights, that there is a small, but not insignificant, potential for the production of alternative aviation fuels in sub-Saharan Africa in compliance with the robust sustainability requirements of the Roundtable on Sustainable Biomaterials (RSB). As per the report, it has been quantified that Sub-Saharan Africa could contribute around 30 - 90 per cent by 2050 in the form of RSB-compliant SAF produced from energy crops on

approximately 241 million ha of both prime, good quality (84 million ha) and moderately suitable land (157 million ha) (Günther Fischer, 2019).

3.7.1.2 Availability of biomass in the EU and the Netherlands

In 2016, the EU has been used around 3.6 Mha of cropland to produce agricultural raw materials for biofuels, which equals 3.1% of the EU total cropland of 115 Mha. In 2015, the ILUC Directive (Directive 2015/2013) came into force, amending Directive 2009/29/EC, which introduced a 7% cap on the share of food crop-based biofuels. However, some EU states have already reached or were near this 7% limit and these countries did not further raise their demand for these crop-based biofuels (Ecofys, 2019). In 2018, biofuels accounted for 7.1 % of energy use in transport and a further increase is expected to be in 2019, up to 7.3% mainly supported by elevated imports (considering double-counting) (Bob Flach, 2019).

The report on biomass availability for the Netherlands in 2020 highlights the overall global availability of sustainable biomass from agriculture and forestry will total 129 EJ per year, by 2030. As per the report, the requirement of the Netherlands will be 1,760 PJ per year (1.76 EJ per year), which will cover up to 1.4% of global biomass availability or 80% of the projected biomass availability in the EU. As a result, the Netherlands is not able to satisfy its own future biomass needs under any of the perspectives, and therefore, in all cases, the country needs imports from the rest of the world, even to meet the lower limit of its needs. (Bart Strengers, 2020).

3.7.1.3 EU and the Netherlands imports of biomass

In 2018, most biodiesel, about 3.3 billion litres, was imported under HS/CN code 3826.00.10 containing at least 96.5 % of biodiesel and the dominant suppliers of biodiesel to the EU were Argentina and Indonesia, with 42 and 27 % of EU biodiesel imports, respectively. The majority of biodiesel imports occur through the Netherlands and Spain (Bob Flach, 2019) (Bioeconomy, 2019).

The EU trade of feedstocks for biofuels is driven by the EU blending targets for biofuels. In 2017, the production capacity of Hydrotreated Vegetable Oils (HVO) has increased the demand for imports of vegetable oils in Europe. Demand was 1.5 Mtoe mainly covered by the use of palm oil and waste oils (EC, Sustainable and optimal use of biomass for energy in the EU beyond 2020, 2017).

However, in 2019, EC launched an assessment of indirect land-use changes (iLUC) where has identified that 45% of palm oil plantation expansion took place in high carbon stock areas over the period 2008-2015 (Section 3.7.2). Therefore, it has been classified palm oil as high iLUC, meaning that it cannot be counted towards EU green targets and that it will be gradually phased out by 2030 (Fortuna, 2019). In regard to that fact, palm oil should be phased out by 2030, but soybeans from the U.S. could be employed further as feedstock for EU biofuel. Therefore, the EU expects that soybean exports from the U.S. will increase from 2,439 Mt in 2018 to 5,182 Mt in 2019 (Gardner, 2019).

3.7.2 LUC issue: Palm oil exception

Land is both a source and a sink of greenhouse gases (GHGs) and plays a major role in the exchange of energy, water and aerosols between the land surface and atmosphere (IPCC, 2019). Land-use change issue covers emissions and removals of GHG as a result from direct and indirect human-induced land use and forestry activities. LUC impact the global carbon cycle by adding or removing CO₂ or other carbon compounds from the atmosphere (EMISSIONS REPORTING, 2018).

Biofuel production involves feedstock production compound which can lead to direct and indirect LUC (DLUC and ILUC). Direct LUC is responsible for the change from a previous land use to biofuel feedstock production. Indirect LUC is a change in land use elsewhere because the direct LUC results in either (i) displaced production of agricultural food, feed and fibres to continue to meet the demand, or (ii) more land being taken into agricultural production because of increased food prices (Sarah J. Gerssen-Gondelach, 2017). According to the recent EU measurements in the line with Intergovernmental Panel on Climate Change (IPCC) methods, EU's GHG emissions are highly affected by the LUC component (EC, Guidance to report on land use, land-use change and forestry emissions, 2016).

In 2019, the European Committee launched the EU's Renewable Energy Directive related to the targets for food-based biofuels after 2020. It states high iLUC risk biofuels, which cannot be cultivated above each country's 2019 consumption levels and should gradually decrease from 2023 until 0 per cent target in 2030 (Muzi, 2019). After the Commission assessment, palm oil is the only biofuel feedstock crop to be classified as high iLUC, meaning that it cannot be counted towards EU green targets and that it will be gradually phased out by 2030 (Fortuna, 2019) (Gardner, 2019).

3.7.3 Food-energy dilemma

Biobased SAFs are produced from the different types of biomass, which need a land to be produced. Land requirement for biofuels rises significantly, and therefore it may cause issues to food supply and to the environment. Since arable lands are used for biofuels production, it reduces possibility for food crops production. Therefore, some major interconnected challenges occur in delivering food security (Thom Achterbosch, 2013). On another hand, humanity has increased the demand for the use of biomass to provide additional renewables, energy for heat, power and fuel, pharmaceuticals and green chemical feedstocks (J. Popp, 2014). Therefore, an issue of the food-energy dilemma should be taken as one of other sustainability issues and be discussed during experts' workshops to quantify its impact.

3.7.4 Renewable energy availability for non-biobased SAFs production

According to the European Commission's strategy "A Clean Planet for all", by 2050 the share of electricity in final energy demand in Europe will be 53 per cent. From which, around 80% of electricity will be coming from renewable energy sources to achieve a carbon-free system (European Commission, A Clean Planet for all, 2018). Given a massive scale-up of renewable electricity production in the EU, e-fuels can play an important role in decarbonizing aviation and other sectors such as ships and heavy transport vehicles. The 1.5LIFE and 1.5TECH scenarios, developed by the EC, estimate that the supply of e-fuels to the aviation sector will not cover the entire fuel consumption in 2050 but will remain limited to 10-35% (European Commission, A Clean Planet for all, 2018).

The section highlights outcomes from the experts' discussion during Workshop regarding social and other sustainability aspects of hydrogen production routes (Workshop outcomes – Box 3-4).

Workshop outcomes – Box 3-4

Other social and sustainability issues of biobased SAFs and e-fuels - Experts points during Workshop discussion*:

1. Because there is not enough waste biomass to power the aircraft fleet or produce SAFs, energy crops take a leading position and should be used for SAF production. As a result, the food-energy dilemma is a major issue that should be addressed in decision making for SAF production. Therefore, food feedstocks should not be taken into account.
2. Sustainability issues raised from the biofuels production routes, such as use, re-use and recovery of resources, social level, land-use changes and biodiversity, are crucial to be considered for sustainability assessment of the Biofuels production routes.
3. Sustainability issues raised from the combustion of biofuels from the operation, such as local air quality, the effect on contrails and clouds, are crucial to be considered for sustainability assessment of the combustion of biofuels during aircraft operation.
4. A Power-to-Liquid production route is a promising option for e-fuels production when it is coupled with carbon capture from the air. Therefore, this option is expected to be scaled-up in the mid-term horizon.

**** Detailed information regarding the percentage of experts, who have agreed upon the presented points in the online survey will be presented in the TRANSCEND report D2.1. Outcomes of the online survey have been considered during preselection.***

3.8 Relevant projects

2019-onwards RENJET 3 (Renewable Jet Fuel Supply Chain and Flight Operations), continuation of Renjet 2.0 (2017-2018).

2018-2022 Bio4A – project has an aim to enable the large-scale pre-commercial production of ASTM-certified sustainable aviation fuel in the EU.

2018-2021 REWOFUEL – project has an aim the goal to demonstrate the transformation of residual soft-wood into hydrolysate (RWH), conversion of RWH into bio-Isobutene (bio-IBN) by fermentation and further conversion to biofuels.

2018-2021 FlexJET - provides clear technical and economic validation, by building a demonstration plant at pre-commercial scale to deliver high quality SAF.

2017-2021 HyFlexFuel - focuses on advancing hydrothermal liquefaction as key technology for truly sustainable and economically competitive production of drop-in fuels from a broad range of biomass feedstocks.

2017-2020 JETSCREEN - aims to reduce the gap between candidate fuel producers and stakeholders in the approval process. It will develop a screening and optimization platform for alternative fuels.

2016-2019 SUN-to-LIQUID - demonstration of solar thermochemical production. The ambition of the project is to advance solar fuels well beyond the state of the art and to guide the further scale-up towards a reliable basis for competitive industrial exploitation.

2013-2016 CORE-JETFUEL - supported the European Commission in its implementation of a programmatic research and innovation agenda in the field of sustainable alternative fuels. Furthermore, it aimed to connect initiatives and projects at European and Member State level and to serve as a focal point to all public and private stakeholders.

2012-2016 ITAKA (Initiative Towards Sustainable Kerosene for Aviation) - focused on biofuels and in particular the HEFA pathway to develop a full value-chain in Europe to allow testing its use in existing logistic systems and in normal flight operations in the EU.

2011-2015 SOLAR-JET (Solar chemical reactor demonstration and Optimization for Long-term Availability of Renewable JET) - fuel lab-scale proof of concept of solar thermochemical production that combines concentrated sunlight with CO₂ captured from air and H₂O to produce kerosene.

2008-2012 ALFA-BIRD (Alternative Fuels and Biofuels for Aircraft Development) - was an R&D project aiming at viable technical solutions. It looked at the technical feasibility of the few SAFs known at the time and further potential candidates as well as the economics and environmental impact.

2009-2011 SWAFEA (Sustainable Way for Alternative Fuels and Energy in Aviation) - developed a comparative analysis of different fuels and energy-carrier options for aviation. This analysis included technical, environmental, and economic assessments. The project also investigated a possible vision and roadmap for their deployment in order to facilitate and support future policy decisions.

3.9 Comparative studies and roadmaps

Drop-in fuels in general:

- 2020 UK Sustainable fuels roadmap
Latest industry publication which specifies the role of SAF in fully decarbonizing UK aviation. The report covers both the technical and economic aspects.
- 2019 ICCT Long term aviation fuel decarbonisation: highlights the bottlenecks over the entire value chain and specifies which policies and actions can be taken on the short, medium and long term.
- 2019 Mission Possible: visionary work to show the potential to fully decarbonize hard to abate sectors like aviation. The report indicates that aviation should be treated as a priority sector for allocating sustainable feedstocks for the production of SAF.
- 2019 ICAO Environmental Report: shows the pathway that was followed by ICAO to promote the use of SAF in aviation. Many stakeholders share their vision in the report and the steps they expect to take or believe are necessary for a successful deployment of SAF worldwide.
- 2018 EC vision “A clean planet for all”: EC decarbonisation strategy towards 2050 including transport and in particular aviation. It shows multiple scenarios with respective SAF uptake.
- 2015 IATA sustainable aviation fuel roadmap: industry roadmap showing the steps that have been taken and the bottlenecks that the industry faces in upscaling production to commercial scale.

Biofuels specifically:

- 2011 IEA Biofuels roadmap: international roadmap for the deployment of biofuels in multiple sectors of the economy.

Power-to-Liquid:

- 2019 Role of e-fuels in the European transport system. Literature review.
- 2018 International Aspects of a Power-to-X Roadmap.
- 2016 Power-to-Liquids Potentials and Perspectives for the Future Supply of Renewable Aviation Fuel.

3.9.1 Potential developments in the horizon – 100% SPK SAFs

At present there is a significant range of SAFs as per ASTM certification. As per certification, different SAFs has different blending % as well as % of aromatic content. It has been shown that there is a good potential for 100% SPK fuels without aromatics to be used in aviation. However, such fuel poses several other problems related to lubricity and seal swells which are engineering challenges which needs further development (Bhupendra Khandelwal, 2014). Moreover, 100% SPK fuels can face a problem with ASTM certification procedure. According to the ASTM D7566, the minimum aromatic content of 8 vol% should apply. Therefore, aromatic content is of particular importance when blending SAFs (Alexander Zschocke, 2012).

3.9.2 Availability and economic viability resources for SAFs production routes towards 2050

The section below provides further references about availability and economic viability resources for SAFs production routes towards 2050, possible factors affecting the conditions in 2050, and the effects of these factors on availability and economic viability in 2050. This information is presented as a general vision for SAFs production routes development (based on the literature review findings on TRL, economic and environmental performance), and supported by a high-level perspective on availability of biomass and economic viability of renewable electricity from consulted literature. Sections 0 and 3.11 provide a more detailed overview of SAFs production routes bottleneck and technology enablers, which could limit or facilitate the disclosure of SAFs production routes in the 2021–2050-time frame horizon based on literature review under the scope of the report.

3.9.2.1 Availability

The legislation is one of the pillars to facilitate rapid technical development and economic performance of different production routes. Recently, the EU has adopted several ambitious climate and energy strategies and frameworks to meet the long-term 2050 GHG reduction target. The synergy of the Paris Agreement, RED II, European Fuel Quality Directive (FQD), EU ETS and CORSIA measures, facilitate the aviation sector to contribute to the reduction of fossil fuels supplied. Nonetheless, players in aviation still need to put lots of efforts towards the achievement of those targets through energy transition measures (e.g., SAFs applications) (Adrian O’Connell, 2019).

Biobased SAFs production routes are highly dependent on feedstock availability. However, feedstock availability should be investigated not only from the side of the availability towards 2050 but also regarding the potential to meet aviation fuel demand. The literature review shows that there will be enough feedstock to support SAFs production in the next 30 years as well as the possibility to meet aviation needs (Section 3.7.1) (IEA, Energy Technology Perspectives 2020, 2019). By 2020, the EU has expected to have around 2 Mt of SAFs in use for aviation needs (Adrian O’Connell, 2019). And due to the recent projections, it could be assumed to have between 150 to 285 Mt/year of SAFs will be used in the 2050-2060 horizon, which will give an emission reduction factor of 77% (B2DS scenario) (Sustainable Aviation, 2020).

E-fuels could be a promising option for aviation purposes in the 2021-2050 horizon. However, e-fuels production routes strongly depend on the technological development of direct CO₂ capture and renewable energy electricity generation technologies. Currently, only 15 direct air capture plants operating worldwide (around 9 000 tCO₂/year), with a 1 MtCO₂/year capture plant in advanced development in the USA. According to the IEA projections it could be expected to reach direct air capture at almost 10 MtCO₂/year by 2030 (IEA, Direct Air Capture, 2020). Another requirement for e-

fuel production is stable renewable electricity supply. Since 2000, it has been observed a continuous decrease in the CAPEX for solar and wind installations due to their rapid technical development and support from the policies perspectives (ATAG, Balancing growth in connectivity with a comprehensive global air climate emergency., 2020). However, the competition for resources with other industries and their effects on feedstock prices and production costs need to be further investigated.

3.9.2.2 Economic viability

According to the report (Sustainable Aviation, 2020), the majority of SAFs production plants in target are still under construction or planned to be built. This gap in production capacity could be linked to the currently limited demand for sustainable aviation fuels from the aviation sector due to the high SAFs costs. It is expected, as mentioned in previous sections, that increased production capacities will lead to a decrease in cost. Although there are a few initiatives aimed to encourage SAF production and use, with a low economic performance, extra-measures are needed to drive an increase in capacity. Additionally, for e-fuels, the possibility to scale up production also requires significant investments in renewable energy capacities, which is being favoured by the current decline of the cost of electricity from renewable energy sources (proportional to the increase in capacities).

MJFSP of biobased fuels is predominantly dependent on the price of the feedstock used (around 75–80 % of the total operation cost), while production costs of e-fuels depend on two main components: CO₂ capture and renewable energy electricity generation (Carlotta Panzone, 2020). Due to the deployment of SAFs in different sectors, it can be expected that competition for biomass resources will occur, which can lead to an escalation of biomass prices and result in higher MJFSP (i.e. HEFA). However, such an occasion will have a less significant effect on CAPEX intensive technologies (i.e. FT). Furthermore, for technologies that are in development, it could be expected that the effect on biomass price increase can be somewhat attenuated by CAPEX reduction with technology learning and scale-up. E-fuels production costs are based on more than 60% of electricity generation costs and 20% of CO₂ capture costs (direct capture considered). Due to the development of electrolysis and CO₂ capture technologies it could be expected to achieve around 63% of efficiency by 2050, which will result in the e-fuels price reduction (Carlotta Panzone, 2020).

With regards to GHG, one of the advantages of SAFs production routes is that they have already taken CO₂ out of the atmosphere at the initial stage of production. In terms of biobased fuels - biomass captures CO₂ during its cultivation. The LUC issue is, however, prominent for some biomass feedstocks, and will be a limiting factor when considering potential biomass sources for SAF production. Promising alternatives are then PtL routes, which could provide an almost 100% reduction from the SAFs production based on the technologies used (renewable energy and carbon capture) (ATAG, Balancing growth in connectivity with a comprehensive global air climate emergency., 2020). As well as, PTL production line has low land demand and the land used for the PtL process can still be used for other purposes (Carlotta Panzone, 2020). However, the technology is still under the phase of continuous research and development to scale up production volumes by the usage of renewable energy as an electricity source. Moreover, renewable energy electricity still has low shares and cannot be fully applied only for the SAFs production (ATAG, Balancing growth in connectivity with a comprehensive global air climate emergency., 2020).

3.10 Bottlenecks

The section below summarises technological, economic, social, and environmental bottlenecks of the discussed technologies as per literature review and Workshop outcomes.

Technological

- Technological development and commercialization status of SAFs production routes depends on the production technology itself (measured through TRL), but also on its certification status by the ASTM as well as the availability or readiness of feedstock supply chains (discussed in this report through FRL and FSRL indicators).
- ASTM certification limitations are:
 - additional financial investments to support fuel certification procedures,
 - existing frameworks to support fuel approvals,
 - the complexity of the production route.

Biofuel production routes

- Production routes with technologies like Fast Pyrolysis (FP) and Hydrothermal Liquefaction (HTL) have the challenge to pass ASTM certification due to:
 - the complexity of their intermediate bio-oil composition,
 - its upgrading,
 - the wide variety of molecules that end up in the fuel and the high aromatic content of many of these fuels.
- 100% SPK fuels can face a problem with ASTM certification procedure:
 - Based on the ASTM D7566, the minimum aromatic content of 8 vol% should apply.

Power-to-Liquid

- Power-to-Liquid (path: Methanol-to-Jet) is not approved and has not even entered the fuel approval process.

Economical and business-wise

- Current policy frameworks offer limited financial support especially for advanced feedstocks and new production processes.
- Current production levels of SAFs are very low, coupled with a high difference in prices with fossil fuel, which directly affects airline competitiveness.
- SAFs production routes require high investment for the:
 - certification and testing procedures, CAPEX.

Biofuel production routes

- SAFs prices limitations:
 - HEFA - the feedstock price is the predominant contributor to the MJFSP.
 - HFS-SIP, ATJ, HTL and FP are CAPEX intensive as well as yield dependent.
 - IH² prices are feedstock and CAPEX intensive due to the hydrogen plant and equipment contingency.
- The approach of integrating biofuels production routes into existing refineries is likely applicable to a small share of SAF, but it is not likely to contribute significantly to aviation decarbonization.

Power-to-Liquid

- Power-to-Liquid has high price range due to:
 - the involvement of novel technologies and low technology maturity level compared to other biobased SAFs.
 - the electricity costs, which still play a major role since renewable energy sources, such as wind, solar, etc, are undergoing the process to enter the market.
- One can expect that due to the enormous demand for electrification, price reduction on electricity is not expected.

Social and environmental, including sustainability

- Current policy frameworks are not fully consistent in terms of GHG allocation methodology.

Biofuel production routes

- GHG emissions from SAFs production routes very much dependent on the pathway, the inclusion of LUC and GHG allocation and yields of the conversion process:
 - HEFA, HFS-SIP, ATJ have the highest range of the emissions reported, which was mainly due to the consideration of (I)LUC impacts and the allocation of some of the considered feedstocks (f.e. oil feedstocks are associated to higher LUC).
 - HTL and FP show low emission values as these feedstocks are usually evaluated for the conversion of SAF from biomass residues (i.e. with little or no GHG emissions associated to biomass production).
 - In almost all biofuels production routes hydrogen is an important contributor to the overall product supply chain CO₂ emissions:
 - On-site hydrogen production led to lower emissions than purchasing off-site produced hydrogen because Hydrogen in the market is typically produced from fossil resources.
- Other sustainability issues occur and should be taken seriously into consideration for each pathway:
 - from the biofuels production routes: use, re-use and recovery of resources, social level, food-energy dilemma, land-use changes, and biodiversity:
 - f.e. energy crops can be used provided there are protections to ensure that they do not compete with food for scarce cropland and to ensure that they deliver strong GHG reductions.
 - from the combustion of biofuels from the operation: changes in local air quality, the effect on contrails and clouds.

Power-to-Liquid

Now, CO₂ capture for Power-to-Liquid pathway can occur from point sources but in the longer term, it will need to utilize direct air capture.

3.11 Key technology enablers

The section below summarises technological, economic, social, and environmental enablers of the discussed technologies as per literature review and Workshop outcomes.

Technological

- ASTM certification becomes faster for the novel technologies due to gained experience and development of testing tools and procedures.

Biofuel production routes

- Biobased SAFs and e-fuels can be used with the existing infrastructure and not be limited by the time it takes for new propulsion technologies to be taken up by an aviation fleet.

Power-to-Liquid

- Power-to-Liquid production route coupled with direct carbon capture from the air is one of the promising options for hydrogen and e-fuel production and should be developed further to meet an increase in the demand for aviation. The option is expected to be scaled-up in the mid-term horizon.

Economical and business-wise

- Higher carbon prices can improve the business case for SAF, in other words can create competitiveness with higher carbon prices.

Biofuel production routes

- The approach of integrating biofuels production routes into existing refineries to reorganize them into biorefineries and dedicated facilities based on regional supply chains can result in the lower production costs of SAFs.
- The valorisation of side-streams or a fraction of the feedstock into higher value-added products can have a significant positive effect on the economic performance of SAF production.

Power-to-Liquid

- Due to the rapid development of the renewable energy technologies around the world, which experience a decrease in their electricity costs (e.g. solar, wind, hydro, etc.), one can predict that production costs of e-fuel and hydrogen production routes will also decrease accordingly in mid-and long-term.

Social and environmental, including sustainability

- Recently initiated EU policies facilitated SAFs production and usage by direct effect scaling up of the production in the 2021-2050 time-frame horizon.
 - Scaling up SAFs production creates CO₂ emission reductions associated with the aviation sector: less fine particle emissions will lead to better air quality around the airport and different contrail properties with lower climate impact.

4 Sustainable non-drop-in fuels and on-board storage

4.1 Short technical description

Potentially sustainable energy sources for on-board aircraft include batteries, supercapacitors, solar power, hydrogen, and other non-drop-in fuels such as ammonia, n-octane, methanol, methane (Goldman, 2018), and formic acid (BBC, 2017). Ammonia (liquid at -33 °C, 1 bar) and formic acid (liquid at standard sea-level conditions) provide a simple means of carrying hydrogen without the need for either very high-pressures or cryogenic temperatures. However, a catalyst is needed to free the hydrogen from the carrier substance.

Non-drop-in fuels typically require significant changes in infrastructures at many airports for the supply of these fuels. This may align with the use of these fuels for other applications than aircraft propulsion. According to the hydrogen-powered aviation report (McKinsey, 2020), long-range aircraft designs still need to be developed for hydrogen energy applications. Fuel efficiency during transport is low for liquid hydrogen⁴ (F. Troeltsch, 2020). However, the latest studies show that hydrogen applications could account for 40 % of all aircraft by 2050, with a continuous increase in shares after 2050. It is predicted that by 2050, aviation's demand for LH₂ would grow to 40 mil. tons/year and medium-range H₂ aircraft would be introduced and important adjustments for the hydrogen technology application are possible within 5-10 years (e.g. lighter tanks, fuel cell configuration, distribution- systems of the liquid hydrogen (LH₂) within the aircraft, turbines, and efficient refuelling technologies) and hydrogen will enter the commercial aircraft market before 2035 (McKinsey, 2020).

Hydrogen has several obvious advantages compared to other alternative aviation fuels, such as elimination of the CO₂ and non- CO₂ emissions in the flight, and that it could be produced from renewable energy. According to the hydrogen-powered aviation report (McKinsey, 2020), application of the hydrogen fuel cell systems can reduce climate impact by 75 - 90 % and NO_x emissions can be reduced by 50 - 80 % with lean-mixture technology. The second-best alternative is aircraft with H₂ combustion, 50 – 75% reduction (McKinsey, 2020) (CleanHydrogen, 2020).

Hydrogen can be produced using a range of energy sources and technologies. There are several raw materials to produce hydrogen, including: fossil fuels, renewable energy sources (RES), biomass, water, or from a mix of both (Seyed Ehsan Hosseini, 2016). Fossil fuels are predominant fuel for global hydrogen production nowadays (IEA, The Future of Hydrogen: Seizing today's opportunities, 2019). Although fossil fuels are a predominant energy source for hydrogen production, the report will have a focus on low-energy and carbon technologies. Sustainable processes to produce hydrogen are in development and partly available on small scale, mainly heavily based on the use of green electricity (Schrope, 2001) (Jo De Vrieze, 2020) (S. Cotterill, 2016). Because of the availability of green electricity, energetic efficiency of the alternative fuels from production to exhaust should be considered as well (Europe, 2020). Green or renewable electricity is produced from renewable energy sources, such as biomass, wind, hydro, solar, etc.

The Figure 3-1 under the Section 3.1 provides an overview of the existing pathways for hydrogen production as a non-drop-in fuel and incorporated in the other SAFs production routes.

Hydrogen is a very promising fuel for aviation as it can be produced fully carbon free. Nowadays, the development of hydrogen as SAF is under very active investigation, with much focus on hydrogen storage and conversion. However, the sustainability of hydrogen is also quantified by the maturity of the production process and sustainability aspects involved. There are two different production categories for hydrogen production, as per Figure 4-1 below.

⁴ Only 2% of LH₂ is used for 9000 km maritime transport + 1000 km truck

Hydrogen production routes

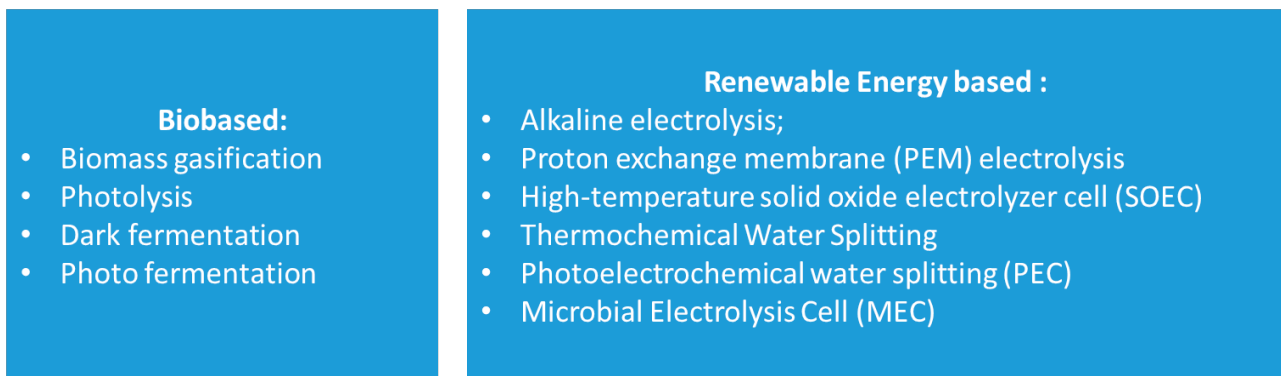

Figure 4-1: Hydrogen production routes overview

4.2 Biobased production routes

Biobased hydrogen production pathways focus on the conversion of the biomass to hydrogen. It could potentially be done by application number of different microbial routes that are under active investigation (Emrah Sağır, 2019). The chapter will develop a discussion on the hydrogen production routes from biobased sources.

4.2.1 Biomass gasification (BG) production routes

Biomass gasification process has high potential and level of maturity due to various gasification technologies commercialized and available for biomass. Biomass gasification is the thermochemical conversion process of hydrogen production, which converts organic or fossil-based carbonaceous materials at high temperatures (>700°C), without combustion, with a controlled amount of oxygen and/or steam into carbon monoxide, hydrogen, and carbon dioxide (E. Shayan, 2018). As a result of the reaction between the carbon monoxide and water, the gas stream of carbon dioxide is formed coupled with hydrogen. Hydrogen is separated from the gas stream by adsorbers or membranes. Gas cleaning and upgrading are necessary to remove bulk CO and CO₂ as well as trace components like H₂S, NH₃, HCl, and tar. Separating benzene, toluene, ethylbenzene, and xylene (BTEX) is not necessary as it is usually removed with the H₂ separation equipment (Matthias Binder, 2018).

4.2.2 Dark fermentation (DF) production routes

Dark fermentation is a process of hydrogen production, which takes place under anaerobic conditions or in the absence of oxygen. Dark fermentative differs from the other processes because it utilizes carbohydrate-rich substrates as the sole source of energy and electrons (F.Dalena, 2017). The carbohydrate-rich substrates are broken by bacteria (e.g. Clostridia sp., Enterobacter sp.) or microalgae (e.g. green algae) to H₂ and other intermediate products such as volatile fatty acids (VFA's) and alcohols (Dahbia Akroum-Amrouche, 2013). The process can be done by in the range of 30–80°C (25–40°C - mesophilic, 40–65°C - thermophilic, >80°C - hyperthermophilic conditions), especially in dark condition. The products of dark fermentation are hydrogen and carbon dioxide combined with VFAs (F.Dalena, 2017). Dark

fermentation is considered as the most practical and efficient among the various bio-production methods for hydrogen production, but the process is under the development stage (You-KwanOh, 2013).

4.2.3 Photofermentation (PF) production routes

Photofermentation (also called photoheterotrophic H₂ production) is a process for hydrogen production, which is done with the use of solar light under an anaerobic condition, where electrons scavenged from organic acids are transferred to oxidized ferredoxin (Fdox) through a series of membrane-bound, electron transport carrier molecules (You-KwanOh, 2013), (Emrah Sağır, 2019). Photofermentation converts volatile fatty acids (VFA) (such as acetic acid) in H₂ and CO₂ using photosynthetic nonculture (PNS) bacteria under anaerobic conditions. The process of hydrogen production has several advantages, such as high hydrogen production rate, moderate reaction conditions, the path to convert organic waste to H₂ and CO₂ (F.Dalena, 2017). Photofermentation is a very promising process, however, it is still under the development phase and has some disadvantages (Sathyanarayanan Sevilimedu Veeravalli, 2019), (F.Dalena, 2017): using nitrogenase enzyme coupled with its high-energy demand; low solar energy conversion efficiencies, low volumetric production rates (light conversion efficiencies 0.2% and 9.3%); large land areas are needed for anaerobic photobioreactors.

4.2.4 Photolysis (PhL) production routes

Biophotolysis is a natural bioprocess due to the effect of sunlight on microorganisms giving rise to water dissociation into molecular oxygen and hydrogen. The light-dependent bio-photolysis can be distinguished in two distinct metabolic pathways, namely direct biophotolysis and indirect biophotolysis (Kuan-Yeow Show Y. Y.-J., 2019).

4.2.4.1 Direct Photolysis

Direct photolysis is photolysis based on the photosynthetic capability of microalgae and cyanobacteria to split water into O₂ and H₂. Algae has developed the capability of harnessing solar energy in extracting protons and electrons out of water. The water-splitting reactions take place under anaerobic environment via absorption of sunlight energy and electron being transferred to hydrogenases and nitrogenases. As a result, a hydrogenase enzyme leads to conversion of hydrogen ions to hydrogen gas. However, the following process is facing prodigious challenges, such as an excessive surface area for collection of sufficient light is required and an issue of impossibility to produce hydrogen continuously under aerobic conditions (Kuan-Yeow Show D.-J. L., 2013).

4.2.4.2 Indirect Photolysis

Indirect photolysis is a process, where degradation occurs via reaction of the compound with a reactive species generated by photosensitisers. Biohydrogen can be produced by using some microorganisms (algae) that can directly produce hydrogen under certain conditions, with energy derived from sunlight. At the moment, around 10% of the algae photosynthetic capacity was utilized for hydrogen production (Kuan-Yeow Show D.-J. L., 2013). Dissolved organic matter (DOM) and nitrate are two wastewater components which have been recognised as important photosensitisers and play key roles during the indirect photolysis (Yufei Wang, 2017). Biohydrogen production with indirect photolysis may

be feasible if the efficiency of photon conversion can be enhanced through large-scale bioreactors (Kuan-Yeow Show D.-J. L., 2013).

4.3 Renewable energy-based production routes

RES based production routes for hydrogen production have a high level of perspective and could become a competitor for the conventional hydrogen production pathways. RES based production routes focus on the hydrogen production from electrolysis process conversion of the water to hydrogen. The chapter will develop a discussion on the hydrogen production from RES electrolysis.

4.3.1 Alkaline electrolysis (AE) production routes

Alkaline-based systems remain the most used water electrolysis systems, which utilize the principles of alkaline water electrolysis. The main principle behind the hydrogen production is the transfer of hydroxide ions (OH^-) through the electrolyte from the cathode to the anode with hydrogen being generated on the cathode side. Electrolyzers using a liquid alkaline solution of sodium or potassium hydroxide as the electrolyte have been commercially available for many years (Energy, 2020). Alkaline electrolyzers have an advantage compared with other hydrogen electrolysis production pathways, which is technological maturity coupled with relatively low production cost. However, they have several technological disadvantages as well: low current density, limited ability to operate at low loads, and the inability to operate at high pressure (Greig Chisholm, 2016).

4.3.2 Proton exchange membrane (PEM) electrolysis production routes

Proton exchange membrane electrolysis or PEM electrolysis is based on the operating principle of polymer membrane allowing only protons to pass. PEM electrolyzers reactions occur on anode and cathode catalyst layers, where the water taken into the cell through the anode inlet dissociates into a hydrogen ion (H^+ , Proton) and oxygen gas in the anode catalyst layer. As one of the disadvantages of PEM electrolysis is the fact that extra voltage (overvoltage) is required because of the realization of anode and cathode reactions and losses. These losses occur due to the configuration of the anode in which the oxygen-induced reaction occurs. To increase performance PEM electrolyzer, the catalysts should be used to keep the overvoltage losses to a minimum (Ali Kecebaş, 2019) (Greig Chisholm, 2016). However, PEM electrolyzers have major advantage compared to alkaline electrolyzers to respond to power changing demand, which is one reason why they could be considered in future studies despite their emerging status (IRENA, HYDROGEN: A RENEWABLE ENERGY PERSPECTIVE, 2019)

4.3.3 High-temperature solid oxide electrolyzer cell (SOEC) production routes

Electrolysis process inside solid oxide electrolyzer cell or SOEC differs from both alkaline and PEM systems. The operating temperature is typically an order of magnitude greater inside SOEC and could reach the range 800–1000 °C. The following temperatures put a restriction to use water as a feed, but rather provide the best option to use steam. Inside

the SOEC, the high-pressure steam is reduced at the cathode to give hydrogen gas and oxygen anions, which after migrate through the solid oxide electrolyte, where they are oxidized on the anode to produce oxygen gas and generate electrons for the external circuit (Energy, 2020). High thermal energy demand is compensated by the decrease in the electrical energy demand and the overall energy demand of the system is largely insensitive to increasing the temperature (Greig Chisholm, 2016).

4.3.4 Microbial Electrolysis Cell (MEC) production routes

Microbial Electrolysis Cell (MEC) is a system for hydrogen generation, which was developed with the aim for sustainable biohydrogen production. MECs are fully anaerobic and works with the same principle as a fuel cell. The structure of MEC has anode and cathode. A MEC is an electrolyzer that oxidizes organic matter at the anode, while the cathode carries out the abiotic reduction of water in the usual way (Elitsa Chorbadzhiyska, 2011). In a MEC, electrochemically active microbes growing on the surface of the anode break down organic matter into CO₂, electrons, and protons. The electrons and protons pass through the external electric circuit and the electrolyte, respectively, and combine at the cathode to generate hydrogen (Tahereh Jafary, 2019) (Elitsa Chorbadzhiyska, 2011).

In a MEC, an additional voltage supplementary to that produced by the bacteria is needed to generate hydrogen. As overpotentials increase with mem-brane fouling or as temperatures decline (i.e., during winter), the voltage can be increased to maintain the same potential (S. Cotterill, 2016). The combined voltage is sufficient to reduce protons, producing hydrogen gas. The efficiency of hydrogen production depends on which organic substances are used. Lactic and acetic acid achieve 82% efficiency, while the values for unpretreated cellulose or glucose are close to 63% (Elitsa Chorbadzhiyska, 2011).

4.3.5 Thermochemical Water Splitting (TWS) production routes

Thermochemical water splitting (TWS) production route is a hybrid process involving both thermal energy and electricity to decompose water for hydrogen production. The highest temperature for the cycle is about 550 °C. (Ibrahim Dincer, 2020). The process is based on water decomposition through a repetitive series of chemical reactions. TWS is not very catalyst dependent and the only consumed substance in the cycle is water, which is the source of hydrogen production (F.Safari, 2020). The interest of such a cycle is the separate production of O₂ and H₂, and the high purity of hydrogen for its direct utilization in fuel cells. The synthesis of metallic compounds with high energy content enables the storage of solar energy. For some specific oxides, the solar step can be realized with reducing compounds to decrease the reaction temperature (Stéphane ABANADES, 2020). Currently, TWS production route is an attractive technique for the conversion of renewable energy to hydrogen (M.Harada, 2016).

4.3.6 PEC/Photoelectrolysis production routes

Photoelectrochemical (PEC) water splitting production routes offers an approach for solar energy conversion into hydrogen fuel. Photovoltaic-powered water splitting (PV-electrolysis) systems couple photovoltaic and water electrolysis technologies have found a broad application for hydrogen production (Avigail Landman, 2019). In the PEC water splitting process, photons are first absorbed by the photoelectrode producing electrons and holes, which are then separated and participated in the hydrogen evolution reaction (HER) on the cathode and the oxygen evolution reaction

(OER) on the anode, possibly with the assistance of a bias voltage (Kai-Hang Ye, 2019). PEC electrolysis is one of the promising options for the future of hydrogen production, however, it is still on the start of its development and research is undergoing.

4.4 Technological Readiness Level (TRL) of pathways for non-drop-in SAF production

4.4.1 TRL comparison of non-drop-in production routes

As per the methodological approach presented under the Sections 2.4 and 2.2.2, Technology Readiness Level should be reviewed in synergy with Feedstock Readiness Level and/or Fuel Readiness Level. Due to the specifics of the hydrogen renewable energy-based production routes, FSRL has been mostly represented as TRL of technologies to produce renewable electricity for the production. Feedstock Readiness Level has been considered as per reviewed published sources and represented under Table 3-5. However, for biobased production routes EU biomass availability is still a significant indicator to focus at, including the possibility of international trading, which has been addressed under Section 2.3 and Section 3.4.1 (Table 3-4). *Table 4-1* summarises findings from the literature review regarding the TRL for non-drop-in production routes and presents a condensed summary of different FSRL and TRL as per production routes. Hydrogen, as a fuel, does not have certification scheme and therefore FRL is not applicable for the analysis.

Table 4-1: Detailed overview of technological maturity of hydrogen production routes

Group	Route	Feedstock	Efficiency, %	FSRL	FRL	TRL
Biobased	Biomass gasification (BG)	Biomass	35-50	5.1-6.2	N/A	6-7
	Dark fermentation (DF)	Biomass	60-80	N/A	N/A	4
	Photo fermentation (PF)	Biomass+Sunlight	1.9	N/A	N/A	3
	Photolysis (PhL)	Water+Sunlight	0.5-16	8-9	N/A	3
Renewable energy based	Microbial Electrolysis Cell (MEC)	Biomass +RES	78	8-9	N/A	1-3
	Alkaline electrolysis (AE)	Water+RES	62-82	8-9	N/A	9
	PEM electrolysis (PEM)	Water+RES	67-82	8-9	N/A	6-7
	High-temperature solid oxide electrolyzer cell (SOEC)	Water+RES+Heat	<110*	8-9	N/A	5
	Thermochemical Water Splitting (TWS)	Water+Heat	20-45	8-9	N/A	3-5
	PEC/Photoelectrolysis (PEC)	Water+Sunlight	12.4	8-9	N/A	3-4

*Voltage efficiency (%) based on HHV of hydrogen (may be greater than 100%)

Based on the source: (CAAFI, Fuel Qualification, 2020), (Roxanne Pinsky, Comparative review of hydrogen production technologies for nuclear hybrid energy systems, 2020), (Mostafa Ibrahim El-Shafie, 2019), (The Royal Society, 2018), (Carina Faber, 2019), (Jorg Gigler, 2018), (EC, Thermochemical Hydrogen Production from Concentrated Sunlight, 2018), (EC, Innovative Photoelectrochemical Cells for Solar Hydrogen Production, 2018), (Uwe Albrecht, 2015), (IEA, Energy Technology Perspectives 2020, 2019)

Workshop outcomes – Box 4-1 highlights outcomes from the experts’ discussion during Workshop.

Workshop outcomes – Box 4-1

TRL of Hydrogen - Experts points during Workshop discussion*:

1. Technology Readiness Level (TRL) is not only one indicator to focus at for the assessment of technological development hydrogen production routes and their commercialization status, but other indicators also/factors, such as the development of the certification scheme for hydrogen production and TRL of storage facilities onboard, should be taken into consideration.
2. At the moment, production routes, such as alkaline electrolysis (AE), proton exchange membrane (PEM) and high-temperature solid oxide electrolyze cell (SOEC) are the most promising routes for hydrogen production in the nearest and middle-term.
3. Photoelectrochemical (PEC), Dark fermentation (DF), Fermentation(F), Photolysis (PhL) are small scale production technologies, which will not be able to contribute to meeting future demands of the hydrogen production for aviation.
4. Even though Biomass gasification technology has high TRL 8-9, the biomass gasification route to produce hydrogen has only TRL 3-5, due to the fact that currently there are no commercial projects producing hydrogen from biomass gasification and its integration is a challenge.

**** Detailed information regarding the percentage of experts, who have agreed upon the presented points in the online survey will be presented in the TRANSCEND report D2.1. Outcomes of the online survey have been considered during preselection.***

4.5 Economic assessment of hydrogen production routes

The section provides an overview of the economic performance for different hydrogen production routes as per published sources review. The Figure 4-2 represents a condensed summary of the price ranges for the different production routes. The review contains information about different technologies coupled with “green” electricity supply or electricity from the grid. A prominent source of data is a literature review from author (Jeffrey R.Bartels, 2010), which compiles economic performance data from articles in a range of 1998-2009. This literature review is prominent in the field and is often cited in recent literature, however it has to be noted that the compiled data from these studies was not adjusted for inflation or harmonized in terms of assumptions for cost estimations. This highlights an emerging issue in the review of published economic performance, when gathering data from independent studies. Overall, hydrogen production costs are quite high, even when compared to biobased SAFs. However, they are strongly dependent on the electricity cost from RES and electrolyzers cost, which is the main contributor of most of the reviewed routes. According to the different sources hydrogen production from RES expects to increase due to the continuous technological improvement of the RES and their scale-up (IEA, The Future of Hydrogen: Seizing today’s opportunities, 2019), (Ilker Yilmaz, 2012), (Janic, 2014), (Roxanne Pinsky, Comparative review of hydrogen production technologies for nuclear hybrid, 2020).

As per the Figure 4-2, Alkaline electrolysis has the broadest range of production cost, which is due to two main points. Firstly, the gathered data corresponds to different electricity sources, from grid or RES. Secondly, obtained data comes from published studies performed at different times and locations, for which electricity prices can vary greatly. Overall, Biomass Gasification provides the lowest price range since the hydrogen production costs are based on the feedstock costs, which are in some cases lower than CAPEX costs of electrolyzers for other production routes. Thermal Water Splitting, PEM, SOEC, MEC have almost the same range of the prices.

Main findings as per literature review are (Figure 4-2):

- AE and TWS have high production costs because of high capital requirements.
- BG production costs are driven by feedstock price.
- Other technologies have almost the same production costs range – around 0.025-0.07 USD/MJ (equivalent to 2-10 USD/kg H₂).

RES production routes have one major drawback in common – the inflexibility of the system demand-side. This drawback makes technologies used more expensive and increases CAPEX due to the storage facilities or costly electrolyzers, which can add to the system demand-side flexibility by sloping production up and down on a time scale of minutes or even seconds. Therefore, reduction of the production costs should be considered and addressed through the production of a very large volume of hydrogen from renewable power in combination with proper hydrogen storage. Moreover, this synergy can help provide long-term seasonal flexibility to the system (IRENA, HYDROGEN: A RENEWABLE ENERGY PERSPECTIVE, 2019).

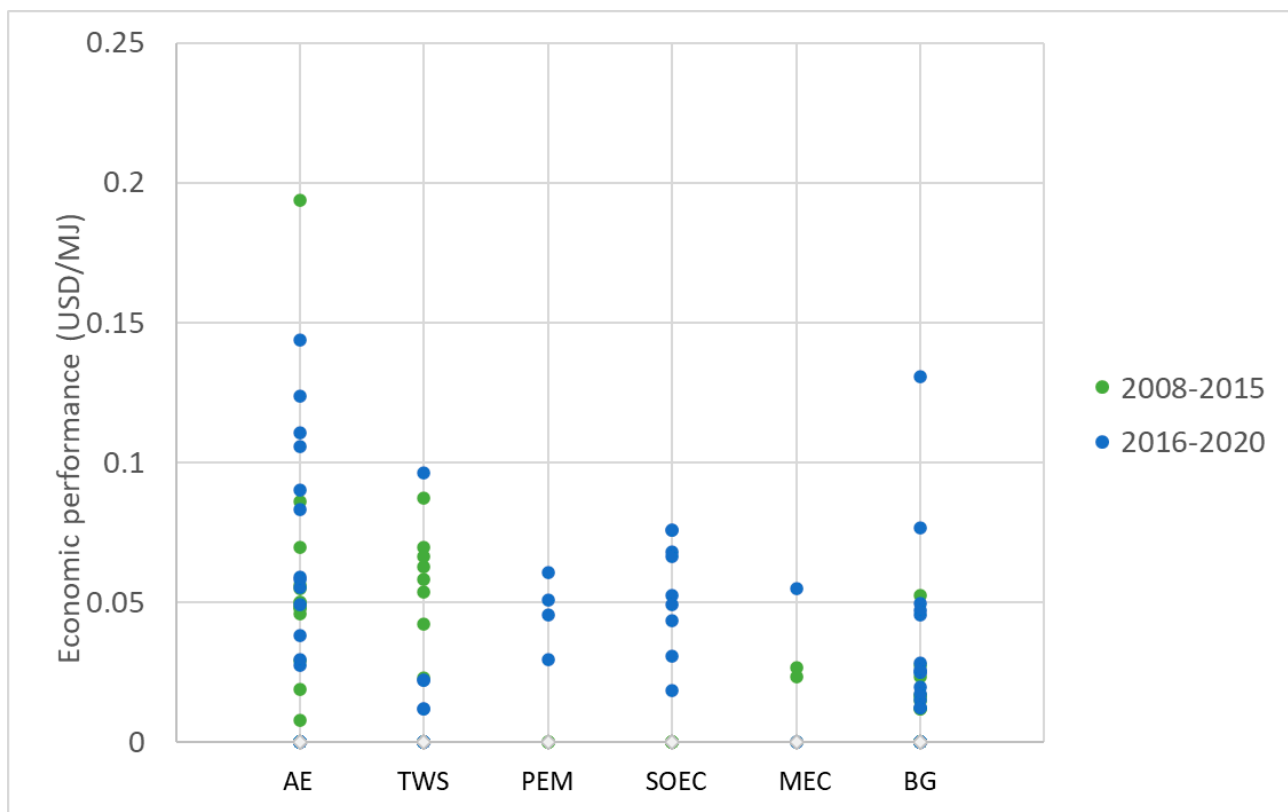

Figure 4-2: Economic performance of hydrogen production routes found in the literature with the conventional fuel price as reference. Based on the source: (Jeffrey R. Bartels, 2010), (Pavlos Nikolaidis, 2017), (Amin Mohammadi, 2018), (Luca Mastropasqua, 2020), (Meng Lin, 2017), (Matthew R. Shaner, 2016), (Monforti Ferrario Andrea, 2018), (B. Parkinson, 2019), (M. Shahabuddin, 2020), (Mayank Kumar, 2019), (Shayan Sadeghi, 2020), (Daniel C. Aiken, 2019), (Muhammad Hassan, 2018)

Workshop outcomes – Box 4-2 highlights outcomes from the experts' discussion during Workshop.

Workshop outcomes – Box 4-2

Economic Performance of Hydrogen - Experts points during Workshop discussion*:

1. EU Hydrogen policy and Green hydrogen certification scheme will promote more subsidies for hydrogen production, as a fuel, and will facilitate the rise of the production volumes which will, in turn, decrease CAPEX

(e.g. electrolysers prices), and increase EU renewable energy transition (as a "green electricity" option for hydrogen production).

2. Due to the rapid development of the renewable energy technologies around the world, which experience a decrease in their electricity costs (e.g. solar, wind, hydro, etc.), one can predict that production costs of e-fuel and hydrogen production routes will also decrease accordingly in mid- and long-term.
3. Once low TRL hydrogen production technologies (f.e. PEM, SOEC), as well as hydrogen storage facilities onboard, will reach market maturity level, it could be expected effect in the reduction of hydrogen production costs.

*** Detailed information regarding the percentage of experts, who have agreed upon the presented points in the online survey will be presented in the TRANSCEND report D2.1. Outcomes of the online survey have been considered during preselection.**

4.6 Environmental assessment of hydrogen production routes

Figure 4-3 presents the GHG emissions related to the different hydrogen production alternatives gathered from the reviewed literature. Most of the data comes from the up-to-date sources, which allows to have state-of-the-art picture regarding the emissions from hydrogen production routes. Under the scope of the report, hydrogen production routes do not include direct use of fossil fuels but can include electricity from grid as in the respective studies, RES and biomass. The first clear observation is that nearly all hydrogen pathways have lower emission values than conventional Jet A-1 fuel.

Main findings as per literature review are (Figure 4-3):

- AE, SOEC, PEM and MEC have a very high range of emissions based on the electricity from the grid, which is produced by the application of fossil fuels.
- AE, SOEC, PEM have almost five times lower g CO₂eq/MJ emissions once they are coupled with electricity from renewable energy (i.e. wind, photo-voltaic, and thermal).
- The major contributor to the GHG emissions from renewable electricity production is GHG emissions from RES installation.
- The emission range with TWS is the lowest, with reported emissions based on the use of nuclear/solar energy.
- For MEC, electricity from the grid is the main contributor to the emission range. Data for CO₂ emissions from renewable energy is missing.
- The literature review has observed extensive differences between hydrogen production routes for the calculation of emissions as per LCA borders assumed for emission assessment.
- Often electrolysers are partly run with energy from the grid (fossil resources) to cover fluctuations in RES supply. By keeping a constant utilization of the equipment, this mode of operation prevents CAPEX per amount of product from rising, but it also results in higher GHG emissions.

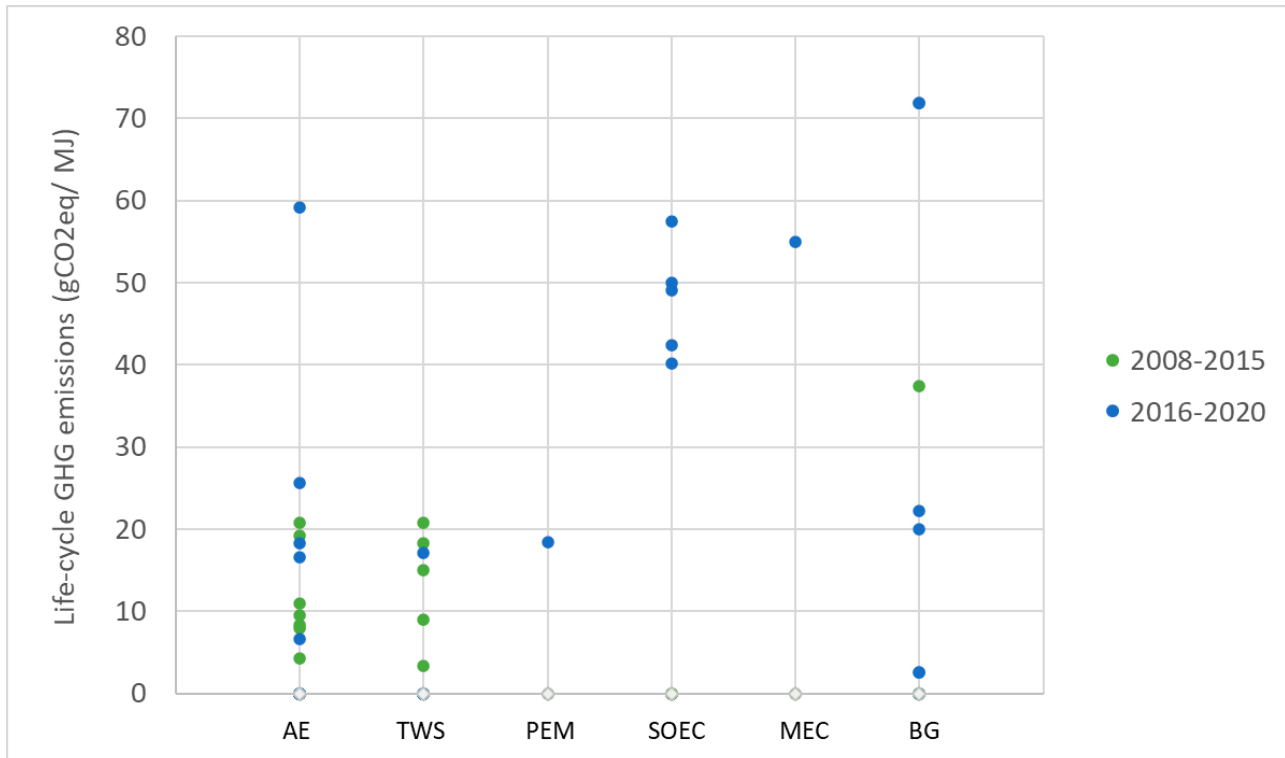

Figure 4-3: Life-cycle GHG emissions for hydrogen production routes found in the literature with the conventional fuel life-cycle emission as reference. Based on the source: (B. Parkinson, 2019), (Andi Mehmeti, 2018), (Ramchandra Bhandari, 2014), (Shayan Sadeghi, 2020), (Luca Mastropasqua, 2020), (Amin Mohammadi, 2018), (M.Shahabuddin, 2020), (Jingwei Chen, 2019), (Ministerie van Waterstaat, 2019), (IRENA, HYDROGEN: A RENEWABLE ENERGY PERSPECTIVE, 2019).

Workshop outcomes – Box 4-3 highlights outcomes from the experts' discussion during Workshop.

Workshop outcomes – Box 4-3

GHG emissions of Hydrogen - Experts points during Workshop discussion*:

1. It is important to establish a certification scheme for Green hydrogen production in the nearest future, which will be a tool to verify and quantify the positive effects of hydrogen production in comparison with SAFs and will give a legislative basis for hydrogen to be an a priori better and cleaner option than other SAF.
2. The only acceptable option for "green" hydrogen production will be from renewable energy sources, other options, such as electricity from fossil fuels or nuclear are out of scope for hydrogen production and should not be taken for future analysis.

*** Detailed information regarding the percentage of experts, who have agreed upon the presented points in the online survey will be presented in the TRANSCEND report D2.1. Outcomes of the online survey have been considered during preselection.**

4.7 Other sustainability and social aspects of hydrogen production routes

The chapter represents other sustainability and social aspects related to the non-drop-in SAFs production routes. It also highlights major issues and experts' opinions.

4.7.1 RES availability for non-drop-in SAFs production

According to the IRENA hydrogen report, it is predicted that demand for renewable electricity to power electrolysis processes for hydrogen production will reach up to 30-120 EJ or 8-30 Peta-Wh (4-16TW) by 2050. The predominant share of renewable electricity to produce hydrogen and hydrogen-based products will be generated from solar and wind installations. In total, IRENA sees a global economic potential for 19 EJ of hydrogen from renewable electricity in total final energy consumption by 2050. In IRENA's REmap scenario for 2050, 19 EJ of hydrogen from renewable power translates into 5% of total final energy consumption and 16% of all electricity generation being dedicated to hydrogen production in 2050 (IRENA, HYDROGEN: A RENEWABLE ENERGY PERSPECTIVE, 2019).

Producing low-carbon hydrogen through the electrolysis of water will become more commercially viable as the price of renewable electricity falls and the electrolyzers become more efficient. Research is underway to improve the costs of electrolysis and is already starting to yield benefits. For example, ThyssenKrupp claims their advanced electrolyser technology can make large scale hydrogen production from renewable electricity economically attractive by achieving high efficiencies of around 69% (FCH, 2019).

The section highlights outcomes from the experts' discussion during Workshop regarding social and other sustainability aspects of hydrogen production routes (Workshop outcomes – Box 4-4).

Workshop outcomes – Box 4-4

Other social and sustainability issues of Hydrogen - Experts points during Workshop discussion*:

1. Water availability and RES acceptance will not be a problem in terms of the Netherlands and EU and will not negatively affect the development of the hydrogen production routes/technologies.

**** Detailed information regarding the percentage of experts, who have agreed upon the presented points in the online survey will be presented in the TRANSCEND report D2.1. Outcomes of the online survey have been considered during preselection.***

4.8 On-board storage requirements for hydrogen

Hydrogen requires special storage and fuel system technologies to be used in typical aircraft operating conditions. There is a variety for hydrogen storage technologies, which can be further split into groups: high-pressure compressed, low-temperature liquid or cryo-compressed liquid, storage in solids (metal-hydrides), and in chemical storage (in liquids or solids) which require a reforming step (e.g. NaBH₄) (CleanAviation, 2020).

However, with or without special storage technologies the gravimetric and volumetric energy density of non-drop-in fuels may be quite different from Jet-A1 fuel, which transfers to other (take-off) weight and volume requirements for aircraft than usual (CleanAviation, 2020). According to the European Commission’s 2017 Staff Working Document on energy storage, hydrogen energy storage has not yet been developed to its full potential (FCH JU, 2017). Therefore, research and development still need to be done to identify new materials and to address a host of associated performance and system issues. No material available today comes close to meeting all the requirements for onboard storage of hydrogen for fuelling a fuel cell/electric vehicle (Hydrogen basics-storage, 2014). The size and weight of H₂ tanks pose major limitations for high energy demand on long-range flights – potentially reducing economics significantly for long-range aircraft (McKinsey, 2020).

According to the hydrogen quality standards, some storage technologies may produce contaminants for which effects are unknown and not addressed by the published standards. Therefore, hydrogen storage systems must be able to deliver hydrogen that meets acceptable hydrogen quality standards for fuel cell vehicles (DOE Technical Targets for Onboard Hydrogen Storage for Light-Duty Vehicles, 2020). As per Air Liquide Research and Development, the Aircraft type and the foreseen system integration induce certain constraints (Bensadoun, 2015) such as H₂ leakages due to the unpressurized area installation, security toward hydrogen access, etc. All of them should be addressed to meet proper working conditions as well as hydrogen quality standards.

Hydrogen on-board storage facilities have a significant impact on the costs of hydrogen as well, by considered in assessing storage system performance relative to program goals. For instance, the cost to compress, store, and dispense (including pre-cooling) hydrogen for 700 bar hydrogen storage systems is estimated to be from USD6.50-USD8.00/kg for a low capacity (300 kg/day) station. However, it is also projected, that it will be reduced to USD1/kg at high capacity / high-volume component stations of the future.

It is expected that low-temperature storage technology would lower costs and minimize the capital investment required for compression and heat transfer soon. At the same time, cold / cryo-compressed and adsorbent systems currently under development, which observes the need for liquid hydrogen delivery or the need to cool hydrogen well below ambient temperature. This point will affect the cost of hydrogen production. Majority of chemical storage systems have quite high fuel costs due to the complexity of dehydrogenation of the hydrogen carrier materials (U.S. DRIVE, 2017). Table 4-2 below summaries the current TRL of storage types for hydrogen represented in the literature.

Table 4-2: TRL of storage facilities for hydrogen on-board

Storage type	TRL
High-pressure compressed	8-9
Low-temperature liquid or cryo-compressed liquid	6-8
Storage in solids (metal-hydrides)	6-8
Chemical storage (in liquids or solids)	9

Based on the source: (Michael Beckmann, 2019), (EC, Hydrogen storage standardisation and components optimization for mass production, 2015), (IEA Hydrogen, 2018), (White, 2020)

4.9 Relevant projects

2020 – onwards ANIONE (Anion Exchange Membrane Electrolysis for Renewable Hydrogen Production on a Wide-Scale) - overall objective of the ANIONE project is to develop a high-performance, cost-effective, and durable anion exchange membrane water electrolysis technology.

2018-2021 ENABLEH2 (H2020): cryogenic hydrogen-based propulsion with development and test of fuel system heat management; safety audit; impact analysis on aircraft, airports, and operation; and roadmap.

2013-onwards CERTIFHY - Developing a European Framework for the generation of guarantees of origin for green hydrogen. The objectives of the CertifHy project are to assess the necessary market and regulatory conditions, develop the complete design and initiate a unique European framework for green hydrogen guarantees of origin. The project will be carried out in consultation with a broad range of relevant stakeholders from all over Europe, including hydrogen producers, traders and customers. Ultimately the CertifHy guarantee of origin scheme will facilitate the penetration of green hydrogen throughout Europe.

2019 MultiPLHY - Multimewatt high-temperature electrolyser to generate green hydrogen for the production of high-quality chemical products (H2020). MULTIPLHY offers the unique opportunity to demonstrate the technological and industrial leadership of the EU in Solid Oxide Electrolyser Cell (SOEC) technology.

2019 SWITCH - Smart Ways for In-Situ Totally Integrated and Continuous Multisource Generation of Hydrogen (H2020). Switch focuses on the development of this specific solution and realizes a mostly green and always secured production of hydrogen, heat, and power.

2019 CHANNEL - Development of the most Cost-efficient Hydrogen production unit based on AnioN exchange membrane Electrolysis (H2020). The main objective of CHANNEL is to develop a low cost and efficient electrolyser stack and balance of plant (BoP) that will become a game-changer for the electrolyser industry.

2017 EVERYWHERE - Making hydrogen affordable to sustainably operate Everywhere in European cities (H2020).

2017 REMOTE - Remote area Energy supply with Multiple Options for integrated hydrogen-based Technologies (H2020).

2016 PECSYS - Technology demonstration of the large-scale photo-electrochemical system for solar hydrogen production (H2020). The objective of the project PECSYS is the demonstration of a system for the solar-driven electrochemical hydrogen generation with an area >10 m².

2015 GrInHy - Green Industrial Hydrogen via Reversible High-Temperature Electrolysis (H2020).

2015 ECo (Efficient Co-Electrolyser for Efficient Renewable Energy Storage (H2020)) - The overall goal of ECo is to develop and validate a highly efficient co-electrolysis process for conversion of excess renewable electricity into distributable and storable hydrocarbons via simultaneous electrolysis of steam and CO₂ through SOEC (Solid Oxide Electrolysis Cells) thus moving the technology from technology readiness level (TRL) 3 to 5.

2015 ELY4OFF (PEM ElectroLYsers FOR operation with OFFgrid renewable installations (H2020)) – aims to develop and demonstrate of an autonomous off-grid electrolysis system linked to renewable energy sources, including the essential overarching communication and control system for optimizing the overall efficiency when integrated into a real installation.

2014 BIONICO (Biogas membrane reformer for decentralized hydrogen production)- aims to develop, build and demonstrate at a real biogas plant (TRL6) a novel reactor concept integrating H₂ production and separation in a single vessel.

2012 SOL2HY2 - Solar to Hydrogen Hybrid Cycles.

2011 ARTIPHYCTION - Fully artificial photo-electrochemical device for low-temperature hydrogen production.

2011 Don Quichote - Demonstration of a new qualitative innovative concept of hydrogen out of wind turbine electricity - aims at the long-term demonstration of the readiness of the technology of the combination of renewable electricity and hydrogen; facts-based data generated in this project is the base for analysis for further deployment and implementation of combined systems “renewable electricity – hydrogen”.

2009 ADEL (Advanced Electrolyser for Hydrogen Production with Renewable Energy Sources project) proposes to develop a new steam electrolyser concept named Intermediate Temperature Steam Electrolysis (ITSE) aiming at optimizing the electrolyser lifetime by decreasing its operating temperature while maintaining satisfactory performance

level and high energy efficiency at the level of the complete system including the heat and power source and the electrolyser unit.

4.10 Comparative studies and roadmaps

Hydrogen application in general:

- 2020 EC "A hydrogen strategy for a climate-neutral Europe": the communication paper on the point that hydrogen is essential to support the EU's commitment to reach carbon neutrality by 2050 and for the global effort to implement the Paris Agreement while working towards zero pollution.
- 2020 McKinsey "Hydrogen-powered aviation: A fact-based study of hydrogen technology, economics, and climate impact by 2050."
- 2019 IEA "The Future of Hydrogen": the study provides an extensive and independent assessment of hydrogen that lays out where things stand now; the ways in which hydrogen can help to achieve a clean, secure and affordable energy future; and how we can go about realizing its potential.
- 2018 Roland Berger "Study on Development of Business Cases for Fuel Cells and Hydrogen Applications for European Regions and Cities".
- 2015 IEA "Hydrogen and Fuel Cells: Technology Roadmap": the study focuses on Cross-cutting opportunities offered by hydrogen and fuel cells.
- 2015 LBST and Hincio "Study on Hydrogen from Renewable Resources in the EU".
- 2006 IEA "HYDROGEN PRODUCTION AND STORAGE": The review of priorities and gaps in hydrogen production and storage R&D.

4.10.1 Potential developments in the horizon – Rolls Royce SMR for hydrogen

Nuclear energy is a type of energy generated from the fossil fuel resources (e.g. uranium). It gives different advantages for aircraft development, such as low CO₂ emission output and enormously high-power density, which will allow the vehicle to cover long distances with a small amount of fuel. The research studies focus on the development of the nuclear propulsion systems for spacecraft rather than for commercial airlines application, due to the enormous power characteristics of the nuclear fuel (e.g. energy stored in nuclear propellants is 10⁷-10⁹ times higher than in chemical propellants) (Tajmar, 2003) (Bruno, 2012). The development of the nuclear energy applications for commercial aircraft usage has begun from the 1960s, due to which have been launched several prototypes and has been made a proof of the possibility of such application (Todreas, 2015) (Wendorf, 2019). However, till nowadays nuclear energy for aircraft did not found its commercial pathways due to several factors, such as waste residues issue, supplemental heat and radioactivity and acceptance from the society (Associations, 2009).

According to Rolls-Royce Holdings, nuclear reactors, or small modular reactors (SMRs) is the most effective way of powering the production of carbon-neutral synthetic aviation fuel (SAFs) without draining global electricity grids. As a solution to it, SMRs could be applied into individual plants to generate the large amounts of electricity needed to secure the hydrogen used in the process, as SAF. Electricity costs would be 30% lower than for a large nuclear facility, matching wind power, with the modular approach allowing parts to be made on a factory production line. The plants, costing 1.8 billion pounds (USD2.4 billion) apiece, would feed the national grid and come online from the 2030s, with all complete by 2050 (Jasper, 2019) (Day, 2019).

4.10.2 Availability and economic viability resources for SAFs production routes towards 2050

The section below provides further references about availability and economic viability resources for SAFs production routes towards 2050, possible factors affecting the conditions in 2050, and the effects of these factors on availability and economic viability in 2050. This information is presented as a general vision for SAFs production routes development (based on the literature review findings on TRL, economic and environmental performance), and supported by a high-level perspective on availability of biomass and economic viability of renewable electricity from consulted literature. Sections 4.11 and 4.12 provide a more detailed overview of SAFs production routes bottleneck and technology enablers, which could limit or facilitate the disclosure of SAFs production routes in the 2021–2050-time frame horizon based on literature review under the scope of the report.

4.10.2.1 Availability

Currently, hydrogen does not have lots of applications in the aviation sector as a fuel and its demand mostly comes from oil refinery and chemical production facilities (equal to 70 Mt/y). However, it could be expected to apply hydrogen in the transport sector, especially in aviation, once LH₂ aircraft and conventional reference aircraft will be designed for entry into service between 2024-2050 (Penke C., 2021) (Carlotta Panzone, 2020) (JU, 2019). By 2030, as synthetic fuel, hydrogen could replace about 4% of the EU's fuel supply for aeroplanes and freighters (JU, 2019). Between 2040 and 2050, it is expected to have demand from the aviation sector for hydrogen from 10 Mt/year to 40 Mt/year due to the possibility of medium-range aircraft appearance in the market. Accordingly, it will result in the need to increase renewable energy supply to meet the expected demand for hydrogen production (McKinsey, 2020).

At the moment, most production facilities are based on fossil fuels, with only a small amount of hydrogen production from green electricity, which makes hydrogen production a huge contributor to CO₂ emissions. To be able to use renewable energy for the electrolysis process, it should be assured to have a stable electricity supply. Currently, renewable energy technologies experience fast technological development. According to the IEA Hydrogen report 2019, it could be expected to achieve almost 8Mt/y of hydrogen produced from low-carbon technologies by 2030 (SD scenario) (IEA, Hydrogen, 2020).

4.10.2.2 Economic viability

According to the report (McKinsey, 2020), hydrogen could be a major option used in the aviation sector to fuel aircrafts (with the share to power aircraft around 40% by 2050). Both e-fuel and hydrogen production strongly interlinked with the changes in electricity prices coming from renewables market development and state-of-art of electrolyser technologies (IRENA, 2016). Electrolyser is the main contributor to the CAPEX of hydrogen production. Currently, high-temperature electrolysers are under development stage, but the literature review shows that investment cost reduction, as well as lower fuel costs can be obtained by 2050 (Carlotta Panzone, 2020). Another contributor to high CAPEX is renewable energy technologies applied in the production. Hydrogen production is still costly, due to the inflexibility of renewable energy system demand-side, which requires additional investments resulting in higher CAPEX (IRENA, 2016). It could be expected to have production costs reduction in the 2021-2050 time-frame horizon due to continuous decrease in renewable electricity production costs coupled with technological development of electrolysers (McKinsey, 2020) (Carlotta Panzone, 2020).

With regards to GHG, one of the advantages of hydrogen, that it does not produce CO₂ emissions from the combustion and therefore hydrogen usage coupled with the usage of biobased fuels and e-fuels will significantly reduce climate impact by 2050 (McKinsey, 2020) (Carlotta Panzone, 2020).

4.11 Bottlenecks

The section below summarises technological, economic, social, and environmental bottlenecks of the discussed technologies as per literature review and Workshop outcomes.

Technological

Hydrogen production

- Small scale production technologies, which will not be able to contribute to meeting future demands of the hydrogen production for aviation.
- Even though Biomass gasification technology has high TRL 8-9, the biomass gasification route to produce hydrogen has only TRL 3-5, and its integration is a challenge.
- Currently, the availability of renewable power is limited, therefore focus should preferably be on the development of more energy-efficient routes.

Hydrogen storage

- Hydrogen requires special storage and fuel system technologies that have not been yet developed and used in typical aircraft operating conditions due to its gravimetric and volumetric energy density.
- R&D for storage still needs to be done to identify new materials and to address a host of associated performance and system issues.
- The size and weight of H₂ tanks pose major limitations for high energy demand on long-range flights – potentially reducing economics significantly for long-range aircraft.

Economical and business-wise

Hydrogen

- Hydrogen requires special redevelopment of the aircraft infrastructure: research & development undergoing.
- Issue of the flexibility of RES demand-side facilitates the development of mature electrolyser and storage technologies. Nowadays, those technologies are more expensive and increases CAPEX of SAFs production route, which affects production cost of hydrogen.
- R&D needs to be done to facilitate an increase of hydrogen production from renewable power in combination with adjusted flexibility of the system and hydrogen storage.

Storage

- Hydrogen storage and distribution facilities are not available at airports.

Social and environmental, including sustainability

- Current policy frameworks are not fully consistent in terms of GHG allocation methodology.

Hydrogen

- GHG emissions from SAFs production routes are very much dependent on the pathway:
 - Industrialized hydrogen production is mostly done using steam methane reforming or by the usage of the electricity from the grid. Greener options like electrolysis have not yet matured to the industrial scale needed.

- AE, SOEC, PEM and MEC have a very high range of emissions based on the electricity from the grid, which is produced by the application of fossil fuels.
- No certification scheme is available for green hydrogen production and usage, as equivalent to ASTM scheme.
- The only acceptable option for hydrogen production will be produced from renewable energy sources.
- EU energy transition is a crucial factor to facilitate scaling up of “green” hydrogen production.
- Now, CO₂ capture for Power-to-Liquid pathway can occur from point sources but in the longer term, it will need to utilize direct air capture.
- Now, average range of electrolyzers requires continuous supply of electricity, which could be achieved only through usage of grid electricity, which results in the higher GHG emissions.

Storage

- Since hydrogen can be considered as “not safe” fuel, security issues should be considered for the development of the storage facilities.

4.12 Key technology enablers

The section below summarises technological, economic, social, and environmental enablers of the discussed technologies as per literature review and Workshop outcomes.

Technological

- Now, production routes, such as alkaline electrolysis (AE), proton exchange membrane (PEM) and high-temperature solid oxide electrolyze cell (SOEC) are the most promising routes for hydrogen production in the nearest and middle-term, but they need to include RES for electricity production.

Economical and business-wise

Hydrogen

- Current work on the EU Hydrogen policy and Green hydrogen certification scheme will promote more subsidies for hydrogen production, as a fuel, and will facilitate the rise of the production volumes which will, in turn, decrease CAPEX (e.g. electrolyzers prices), and increase EU renewable energy transition (as a “green electricity” option for hydrogen production).
- Due to the rapid development of the renewable energy technologies around the world, which experience a decrease in their electricity costs (e.g. solar, wind, hydro, etc.), one can predict that production costs of e-fuel and hydrogen production routes will also decrease accordingly in mid-and long-term.
- Once low TRL hydrogen production technologies (f.e. PEM, SOEC), as well as hydrogen storage facilities onboard, will reach market maturity level, it could be expected effect in the reduction of hydrogen production costs.
- Small Modular Reactors could be a promising option for stable and cheap electricity supply for hydrogen production.

Social and environmental, including sustainability

- AE, SOEC, PEM have almost five times lower g CO₂eq/MJ emissions once they are coupled with electricity from renewable energy (i.e. wind, photo-voltaic, and thermal).
- It is not expected that water availability and RES acceptance will be a problem in terms of the Netherlands and generally over the EU, and will not negatively affect the development of the hydrogen production routes/technologies.

- Current work on the EU Hydrogen policy and Green hydrogen certification scheme will promote a tool to verify and quantify the positive effects of hydrogen production in comparison with SAFs and will give a legislative basis for hydrogen to be an a priori better and cleaner option than other SAF.

5 Comparison of drop-in and non-drop-in production routes

The section represents the condensed summary of the findings from the research and Workshop outcomes. Drop-in and non-drop-in SAFs will be compared between each other to find out the most promising SAFs in the nearest (2021-2025), mid-(2025-2035) and long-term (2035-2050) horizon.

5.1 Technical development overview

In the TRANSCEND project, technical development data for SAFs production routes has been collected from a review of the literature and a workshop with experts. The technical development of the considered production routes has been assessed through the qualitative indicator “Expected timeframe to come to the market”, which is based on reported Technology Readiness Level (TRL), Feedstock Readiness Level (FSRL), ASTM certification / Fuel Readiness Level (FRL) and the existence of supply chains. Table 5-1 represents the comparability of TRL for both drop-in and non-drop-in sources.

Table 5-1: Comparison of TRL of drop-in and non-drop-in SAFs production routes

Abbreviation	Group of SAFs production routes	Product	Timeframe to come to market*
HEFA	Hydro-processed Esters and Fatty Acids	Bio-jet fuel	near-
HFS	Hydro-processed Fermented Sugars	Bio-jet fuel	near-
FT	Fischer-Tropsch	Bio-jet fuel	near-
HTL	Hydrothermal Liquefaction	Bio-jet fuel	medium-
FP	Fast Pyrolysis	Bio-jet fuel	medium-
ATJ	Alcohol to Jet	Bio-jet fuel	medium-
IH ²	Integrated Hydropyrolysis and Hydroconversion	Bio-jet fuel	long-
HFS	Power-to-Liquid (Fischer-Tropsch)	E-fuel	near-
BG	Biomass gasification	LH2	long-
MEC	Microbial Electrolysis Cell	LH2	medium-
AE	Alkaline electrolysis	LH2	medium-
PEM	Proton exchange membrane electrolysis	LH2	medium-
SOEC	High-temperature solid oxide electrolyzer cell	LH2	medium-
TWS	Thermochemical Water Splitting	LH2	medium-

*near- (years: from 2021 until 2025); medium- (years: from 2025 until 2035); long- (years: from 2035 until 2050). Based on the Sections 3.4 and 4.4

Note: The possibility of the hydrogen production routes to be disclosed also is based upon the supply/demand issue. The issue should be considered as such technologies DF, PtL, PF have small production rates, which will not be able to contribute to existing high production rates production routes, such as AE, PEM, SOEC, etc. Therefore, and based on the Table 5-1 low-production range technologies will enter the market in the mid-long-term horizon but will not be able to contribute to the hydrogen production on the high level.

5.2 Sustainability performance overview

Under the report, sustainability performance has been identified as a synergy of economic performance, environmental and social aspects. Economic performance has been linked to technical constraints, economic potential, and market potential. Environmental performance has been linked to the ACARE goals for CO₂ and NO_x emission reduction. Social

aspects, land-use change, and biomass availability issues were summarized from workshop outcomes and expert's opinion. The section below, summarizes and provides main findings from literature review and workshop outcomes.

5.2.1 Economic performance overview

Economic performance has been investigated through economic indicators as reported in the literature for the respective production routes: (MJFSP) and (PC). The main difference between them is that MJFSP includes IRR, typically around 10-15%, while PC does not. Report presents these indicators in terms of monetary currency over energy content (e.g. USD/MJ), for all production routes for comparability.

Figure 5-1 and Figure 5-2 show comparison of drop-in and non-drop in SAFs production routes in terms of production costs and emissions during production, respectively. As per the Figure 5-1, in general, biobased drop-in SAFs have shown lower production costs compared to e-fuels and hydrogen production routes. It could be explained through a high technological maturity level, which biobased drop-in fuels have. That is, some biobased drop-in fuels, especially those that already have ASTM certification, have gone through technological learning coupled with a continuous biofuel policy support, which resulted in a decrease of the price ranges. Figure 5-1 shows the difference between production costs of ASTM approved and pending biobased SAFs, which is due to different approaches for assessing the production costs as per published sources as well as the difference in the maturity level of technologies used resulting in smaller CAPEX and feedstock costs.

On another hand, e-fuels and hydrogen production routes are novel technologies, which have recently entered the market and still going under major changes in terms of technological upgrade and development. Therefore, they are expected to enter the market in the mid-term. Both e-fuel and hydrogen production strongly interlinked with the changes in electricity prices coming from renewables market development (IRENA, 2016). As consequence, renewables' levelized cost of energy is going down and the proportion of renewables on many grids is growing (IEA, Renewable energy market update: Outlook for 2020 and 2021, 2020), (Deign, 2020). Therefore, production costs for e-fuels are expected to drop in the 2050 timeframe, correspondingly to the renewable electricity prices decrease. However, it is not the case for bio-based routes: as the feedstocks for biofuels are limited and demand is expected to grow, it is likely that feedstock prices will even rise in the future (Section 3.9.2).

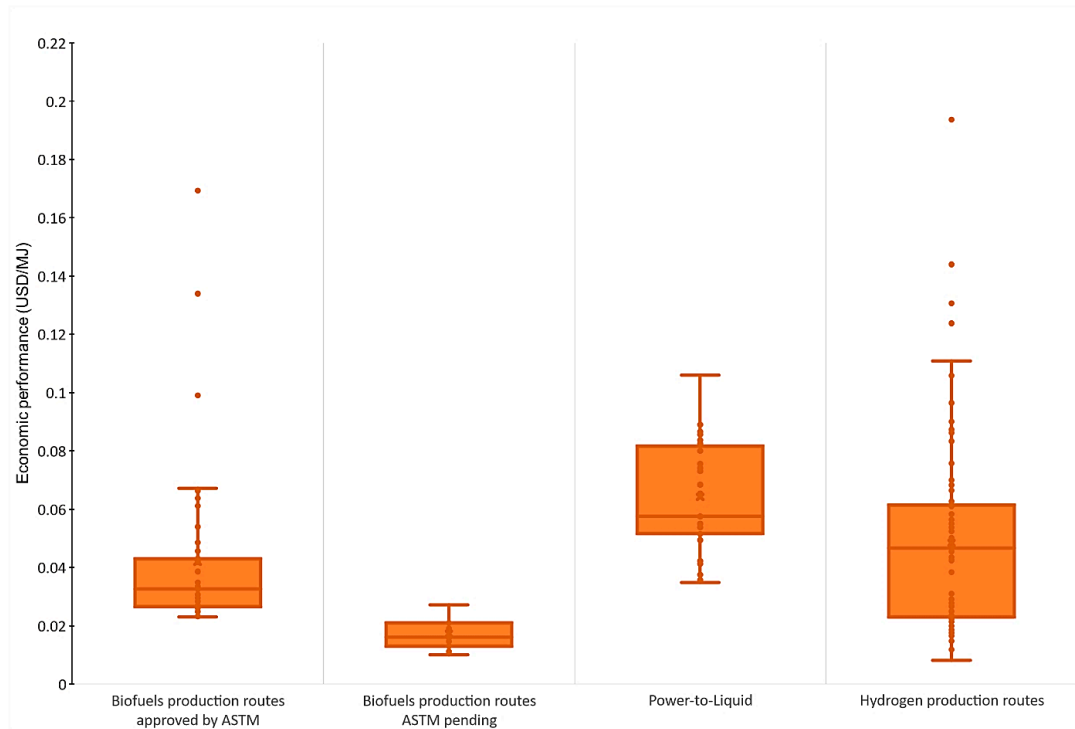

Figure 5-1: Comparison of the economic performance of drop-in and non-drop-in production routes

Based on the Sections 3.5 and 0

Note: Economic performance has been investigated through economic indicators as reported in the literature for the respective production routes: for biofuels - Minimum Jet Fuel Selling Price (MJFSP); for e-fuels & Hydrogen -Production Costs (PC). Section 2.4.1 provides more detailed information regarding the difference between MJFSP and PC.

Workshop outcomes – Box 5-1 highlights as outcomes from the experts’ discussion during Workshop.

Workshop outcomes – Box 5-1

Economic Performance of SAFs- Experts points during Workshop discussion*:

1. The technology-related costs become less important when policies and initiatives come into perspective, which are defining factors for the current economic viability, and future price development.
2. Due to the synergy of policies, initiatives and technological development (e.g. technology learning, optimization and upgrading on CAPEX/OPEX reduction, etc.), one could expect to achieve a reduction in the overall production costs of SAFs in the range of approximately 40-50% by 2050 (f.e. Nth plant methodology/approach). However, further research and development actions are needed.
3. Published estimations of the economic performance of SAF production routes consider an Nth plant methodology and do not consider the higher costs associated with the first plants for a given technology, as well as there is present difference between simulations and real data cost, which should be made explicit and taken into account for decision making.

* Detailed information regarding the percentage of experts, who have agreed upon the presented points in the online survey will be presented in the TRANSCEND report D2.1. Outcomes of the online survey have been considered during preselection.

5.2.2 GHG performance overview

GHG performance has been assessed through GHG emissions as $\text{gCO}_2 \text{ eq/MJ}$. Figure 5-2 provides an overview of the CO_2 emissions, generated from different SAFs production routes. Most of the data points for all the SAF production routes are below the Jet A-1, which is roughly equal to $83.8 \text{ gCO}_{2\text{eq}}/\text{MJ}$ as per EU RED II (EC Directive 2009/28/EC, 2009). Outstanding single emission points are from the ASTM approved biobased SAFs production routes related to the HEFA process, which was discussed in details under Section 3.6. Those high emission points come from the HEFA processes with high LUC crops (e.g. soy bean). In general, the majority of points are at the same level (between 10 and 50 $\text{gCO}_{2\text{eq}}/\text{MJ}$). Power-to-Liquid pathways have the lowest range of CO_2 emissions since they involve renewable energy for green electricity production. However, PtL production routes also use captured CO_2 as an additional input for e-fuel production. This input proportionally reduces the total GHG emissions range, therefore PtL production routes have lower total GHG emissions compared to the hydrogen production routes. Hydrogen production routes have a low range of CO_2 emissions as well, due to the involvement of RES technologies into the production lines.

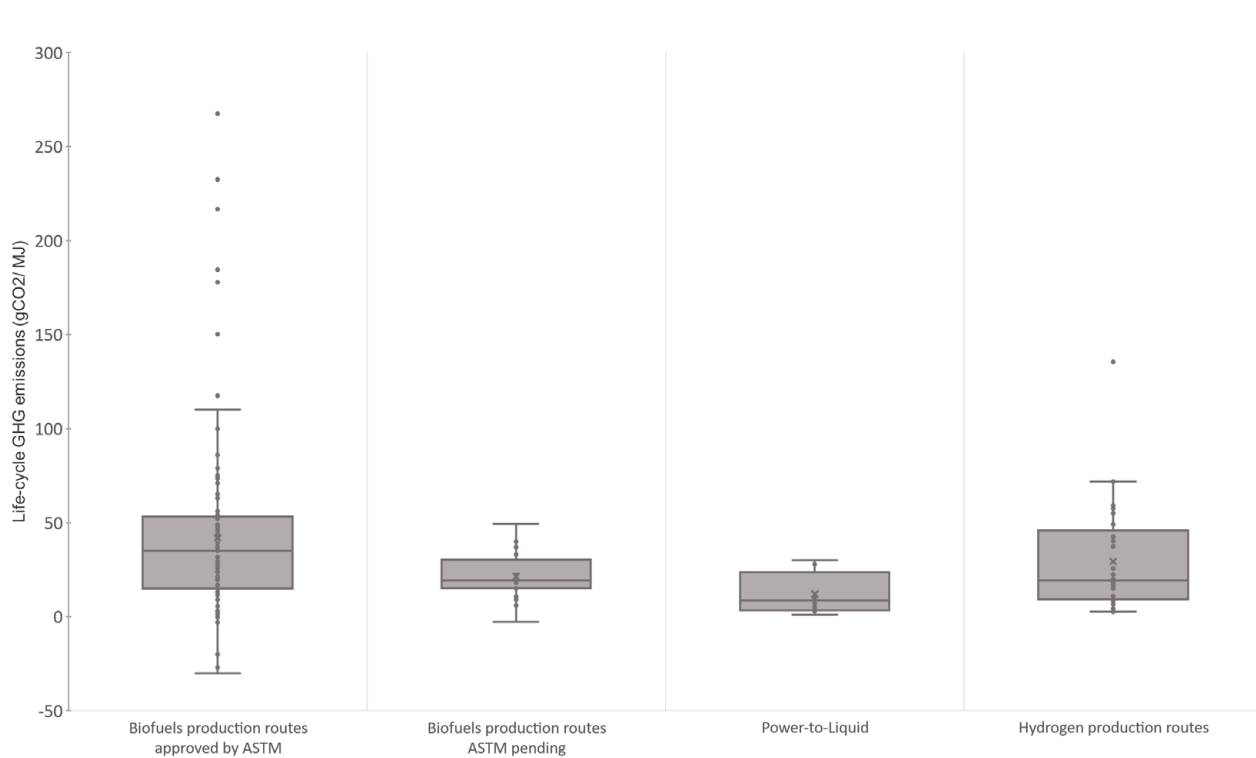

Figure 5-2: Comparison of ranges of emissions from drop-in and non-drop-in production routes. Based on the Sections 3.6 and 4.6

To conclude everything stated above, it could be clearly seen that drop-in fuels have higher TRL, which results in the possibility for them to enter the market of SAFs in the nearest future or consolidate their positions. At the same time, they have lower production costs, due to their high TRL level and technological upgrade. On another side, PtL and hydrogen production routes have shown low ranges of CO_2 emissions, coupled with high TRL level, which could facilitate their enter to the market in the nearest future and provide base for competitiveness with biobased SAFs. High price ranges of both technologies could be expected to decrease due to the continuous technological improvement of the technologies involve in production processes and scale-up of the production facilities (Sections 3.9.2 and 4.10.2).

Workshop outcomes – Box 5-2 and Workshop outcomes – Box 5-3 highlight outcomes from the experts' discussion during Workshop.

*Workshop outcomes – Box 5-2****GHG emissions of SAFs- Experts points during Workshop discussion*:***

1. Sustainability assessment of SAFs' benefits should be proportionally based on proven benefits of climate change policies and initiatives on a case-by-case basis, and not generic for technologies or feedstocks (f.e. employed technology, production chain or specific locations, resource availability, water and soil issues, rural development, etc.).
2. SDGs-related calculations are complex, and they may even be questioned on their objectivity for impacts and assessment indicators. Therefore, they are not an effective framework to assess the sustainability of SAFs.
3. High-level decisions and users' decisions on decarbonization initiatives or technologies are not always science-based or data-based, sometimes emotions or market-based aspects may also have an impact on decision-making.

**** Detailed information regarding the percentage of experts, who have agreed upon the presented points in the online survey will be presented in the TRANSCEND report D2.1. Outcomes of the online survey have been considered during preselection.***

*Workshop outcomes – Box 5-3****Other social and sustainability issues of SAFs- Experts points during Workshop discussion*:***

1. Sustainability plays an important point for SAFs production routes, and therefore emerging sustainability concerns should be identified over the entire production chain: including feedstock availability, the economics of higher value products (intermediates), etc.
2. International policies, initiatives and certification schemes, that have been or will be implemented (e.g. EU Green Deal, CORSIA, RED, REDII, etc.), as well as regional schemes will facilitate the development of SAFs production routes and speed up their certification and commercialization.

**** Detailed information regarding the percentage of experts, who have agreed upon the presented points in the online survey will be presented in the TRANSCEND report D2.1. Outcomes of the online survey have been considered during preselection.***

5.3 Preselection of 5 SAFs production routes proposed for further study

Based on the analysis represented under Sections 5.1 and 5.2, it has been decided to proceed with all of the proposed SAFs: biobased fuel or bio-jet fuel, e-fuel and hydrogen. All of them in equal could be the options for the energy transition in aviation due to their high performance both technologically, economically and on sustainability level. Sub-sections below will discuss the preselection of the SAFs production routes for each type of fuel with the start from drop-in fuels, as the most promising option for SAFs in the nearest future. The results of the preselection are presented in Table 5-2 below.

5.3.1 Drop-in production routes preselection

Bio-jet fuel production routes preselection

The literature review has shown that biobased fuels are the most promising option in the short term for the energy transition in aviation due to their applicability with aircraft infrastructure. As per the scope of the project, it has been decided to limit the preselection of bio-jet production routes to three in the final number of SAFs production routes.

Production routes for bio-jet production have shown different techno-economic and environmental performances. IH₂, HDO, CH production routes are under technological research and development now and still require technological adjustments as well as certification. HFS has a high production cost and high GHG range, compared to other SAFs production routes. All stated indicators make HFS production route out of the preselection. ATJ and FT production routes have similar technical and economic performance. However, ATJ process has broader range of the GHG emissions compared to the FT production routes due to the feedstock they can process while both FT and ATJ can process lignocellulosic material, ATJ is also used to produce SAF from sugar-rich feedstocks (i.e. sugarcane juice) associated to higher GHG emissions. However, ATJ production routes do not have much advancement in the technical development recently (especially with regards to cellulosic feedstocks that are of most interest due to their lower GHG emissions). Since FT has a narrower range towards lower GHG emissions compared to ATJ, it has been decided to exclude ATJ from the preselection process. Therefore, HFS, HDO, CH and ATJ have not been preselected for further research purposes.

Among all the bio-jet routes HEFA is the one with the highest technological maturity, and relatively good economic and environmental performance (excluding high LUC corps), which could be also adjusted based on the choice of the feedstock. According to Table 5-2, thermochemical routes (e.g. FP, HTL) have shown the best economic and environmental performance. The literature review has shown uncertainty in the data collected and low technological maturity of these production routes. Both processes employ the same kind of feedstock and are thermochemical in principle. . TRANSCEND could endorse continuing with both of them due to their good economic and GHG performances, as well as similarities. However, TRANSCEND would recommend for the further road mapping to proceed with FP, due to more data available in the literature which makes the further roadmapping easier. Therefore, has been decided to choose for the future discussion FP.

E-fuel production routes preselection

E-fuels are complementary and quite promising SAFs to enter fuels market in the nearest future. They still have higher fuels price range, compared to biobased fuels, due to their technology immaturity and continuous development. However, they have a low range of emissions compare to biobased fuels, since they involve renewable energy sources and one can expect their significant contribution to the CO₂ reduction once they will enter the market. Among two production routes presented, MeOH does not have a lot of data available regarding economic and GHG performance in the literature as well as PtL MEOH is still under ASTM certification procedure (Table 3-2), which takes it out of scope for the further study. Therefore, for the next steps of the research and validation have been proposed to take FT production route for e-fuels production, because of the positive points in all the sustainability criteria presented.

5.3.2 Non-drop-in production routes preselection

According to the recent reports and studies (McKinsey, 2020), hydrogen production has found support from the energy communities and European governments and hydrogen usage in transport as a fuel could be one of the most promising options to reduce CO₂ emissions from the transport sector. However, hydrogen still requires changes in the aircraft infrastructure, which are coupled with significant adjustments in terms of storage facilities, safety, and logistics.

Currently, plenty of R&D goes in this direction. Therefore, due to its properties and low-carbon effects at the climate, hydrogen has been chosen as one of the SAFs with the perspective to use in the mid and long-term horizon.

At present, many of the hydrogen production routes are under development, such as Biomass Gasification, Fermentation, Photolysis or Photo electrolysis. All of them still require more technological adjustments and modification and have been taken out of the preselection process since they have very low production scale, which make them almost impossible to contribute to the expected demand for hydrogen production in the mid- and long-term horizon. The most promising routes for hydrogen production are routes based on the electrolysis technologies coupled with RES electricity, such as PEM, MEC, SOEC, Thermolysis and Alkaline electrolysis. From the literature review, alkaline electrolysis is available now and has continued technology development, therefore it could be assumed that it will be the first available at the market. PEM and SOEC electrolysis are the second most developed technologies and will be able to come to the market in the mid-long-term horizon. However, for further study, alkaline electrolysis will be the one preselected.

Table 5-2: Preselection of SAFs production routes

Abbreviation	Group of SAFs production routes	Product	TRANSCEND TU Delft team preselection*
HEFA	Hydro-processed Esters and Fatty Acids	Bio-jet fuel	✓
HFS	Hydro-processed Fermented Sugars	Bio-jet fuel	✗
FT	Fischer-Tropsch	Bio-jet fuel	✓
HTL	Hydrothermal Liquefaction	Bio-jet fuel	!
FP	Fast Pyrolysis	Bio-jet fuel	✓
ATJ	Alcohol to Jet	Bio-jet fuel	!
IH ²	Integrated Hydropyrolysis and Hydroconversion	Bio-jet fuel	✗
PtL	Power-to-Liquid (Fischer-Tropsch)	E-fuel	✓
BG	Biomass gasification	LH2	✗
MEC	Microbial Electrolysis Cell	LH2	✗
AE	Alkaline electrolysis	LH2	✓
PEM	Proton exchange membrane electrolysis	LH2	!
SOEC	High-temperature solid oxide electrolyzer cell	LH2	✗
TWS	Thermochemical Water Splitting	LH2	!

Legend: ✓ - selected; ! - some of the performance indicators could be improved ; ✗ - not selected

5.4 Conclusions

The world is on track to meet the target of reducing the amount of GHG emissions. One of the major sectors for GHG contribution is the transport sector including aviation, which contributes around 2% to the global GHG emission pool (D.S. Lee, 2021). EU has set several targets regarding limit and reduce CO₂ emissions from the transport sector and aviation especially (e.g., Green deal, Climate strategy 2030). The target is to make all the industries carbon neutral by 2050. Therefore, the aviation sector has been pushed to find novel alternative energy sources for its needs. Drop-in and non-drop-in SAFs are potential options to reduce GHG emissions in mid-and long-term horizon.

The study aimed to identify potential SAFs for aviation in 2021-2050 time-horizon and the most sustainable production routes based on their techno-economic and environmental performance, Section 2. SAFs have been divided into two groups based on their possibility to be directly used for the aircraft propulsion: drop-in (bio-jet fuels and e-fuels or PtL) and non-drop-in (hydrogen). The methodology, Section 2.4, was developed to determine sustainability criteria presented in the EU initiative, policies, and sustainability certification schemes. According to the documents, three major criteria for sustainability evaluation have been taken for the further assessment of SAFs production routes:

technological maturity or TRL level, economic (production price) and environmental performance (GHG emissions). The technological maturity level of biobased production routes has been analysed through the synergy of Feedstock Readiness Level, Fuels Readiness Level, Technology Readiness Level of production route itself coupled with the compatibility of technology/supply chain with existing supply chains in the industry presented now. Hydrogen as a fuel for aviation purposes does not have an existing certification scheme for FRL, as well as production route, do not need FSRL. However, it is crucially depending on the electricity from renewable energy sources, therefore for the hydrogen production routes, FSRL was taken as TRL of potential RES technologies, which could be applied to produce electricity to supply production process coupled with the compatibility of technology/supply chain with existing supply chains in the industry presented now. Economic performance has been analysed based on the MJFSP for biobased production routes and PC for e-fuels and PC for hydrogen. Biobased SAFs production routes performance highly dependent on the type of the feedstock or energy source used, therefore it was assumed that economic performance, as well as GHG emissions, could be adjusted by selection of the feedstock. As an addition, products' flexibility can play a major role in GHG allocation and thus depends on the chosen methodology. Therefore, the same production route can give different ranges in emissions based on the chosen allocation methodology and feedstock.

The analysis of SAFs production routes sustainability has been done through collecting and evaluating existing data regarding three criteria. Data collection was done by a literature review of published sources (e.g., articles, reports, conference proceedings, etc.). Analysis of results has been presented under Sections 3.4, 3.5 and 3.6 for biobased production routes and under Sections 4.4, 0 and 4.6. Several issues have occurred during literature review and analysis, such as uncertainty in the data due to different time ranges of articles presented and applied methodologies to quantify economic or environmental performance. They have been discussed throughout the report and comments have been made for further studies. Other relevant sustainability and social issues have been discussed under Sections 3.7 and 4.7.

Developed methodology of literature study and obtained results have been presented at online-workshop on October 15th, 2020. The workshop aimed to align the results of the literature study with an expert's opinion and collect controversial comments from experts to adjust existing study results. As an outcome of the expert's workshop, TRANSCEND TU Delft team has gathered ideas and expertise. The discussion has been developed over new perspectives of the GHG reduction for the aviation sector linked to the European Green Deal (EC, A European Green Deal, 2020) presented at the end of last year. Experts have pointed out their attention about the complexity and the lack of methodological consistency of the GHG reductions and related calculations - due to emission allocation per technology, which should be considered during finalization of the potential alternative aviation fuels and production technologies lists for the 2021-2050-time horizon. Participants used this opportunity to bring to the discussion the issues of energy and resource intensity of the production routes, land-use change, food-energy dilemma, biomass availability in case of biofuels, the potential for renewable energy systems to supply electrolysis processes, sustainability certification schemes for hydrogen, and the potential role of the United Nations Sustainable Development Goals (UN-SDGs, 2020) in the large scale development and implementation of SAFs. Participants highlighted Power to Liquid (PtL) as a good option for hydrogen and e-fuel production but pinched that the actual extent of carbon emissions reduction with this approach is not clear yet, as it depends on its coupling with renewable energy systems.

Based on the points collected from expert's has been created an online survey with the purpose to validate experts' comments. The results of the survey have been analysed, combined, and presented in the report inside boxes with per cent ratio to quantify each statement. Experts also had a chance to add some comments, which have been analysed as well and presented in the report.

Workshop discussions and online survey outcomes were in the line with the methodological approach presented, which allowed to proceed with the preselection of the sustainable SAFs production routes. Figure 5-3 summarises preselected 5 SAFs production routes for the further evaluation and roadmapping (Section 5.3).

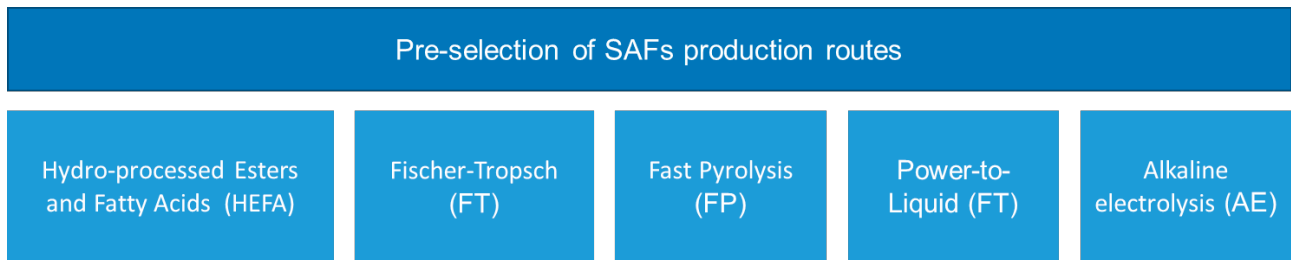

Figure 5-3: Preselection of SAFs production routes

6 Novel propulsion based on gas turbine with drop-in fuels

6.1 Concise technical description

Advances in propulsion fuel efficiency are being explored. A two-fold design perspective is used to work to this objective. The first perspective is the further development of ultra-efficient low pressure system propulsion technology as characterized by the (further) development of geared and open rotor concepts. The second perspective is characterized by the development of ultra-efficient core technology design concepts which include radical changes to the gas turbine cycle including intercooling, heat recuperation and alternative compression/combustion techniques. Novel propulsion technologies may improve gas turbines beyond improvements that have been investigated in Clean Sky 2. These propulsion technologies that will be evaluated by the CS2 TE include, amongst others, advanced geared engine architectures, very high bypass ratio turbofan demonstrators as well as various individual nacelle, compressor, combustion and turbine technologies.

Examples to improve fuel efficiency are variable gas turbine engine cycles (by adaption of the flow path), improved heat exchange by recuperation and inter-cooling, and semi-closed support gas turbine cycles (as addition of Rankine cycles to deliver additional power to the engine shafts (Ref.)). Alternative combustion processes such as constant volume/pressure gain combustion, flameless combustion, inter turbine combustion or closed volume combustion (composite engine and wave rotor combustion) (DLR, 2020).

The overall efficiency of a gas turbine constitutes of the thermal efficiency (thermodynamic cycle efficiency) and the propulsive and transmission efficiency.

The thermodynamic efficiency is addressed by the development of novel technologies. For the distribution of lost work in a state-of-the-art turbofan engine, the individual contributions to the gas turbine cycle should be investigated to understand future technologies that advance the efficiency of future turbofan/open rotor engines. The figure below (Grönstedt & et. al., 2016) shows that the turbomachinery components (fan, compressors and turbines) account for less than a quarter of the irreversibility of the gas turbine cycle. The gas turbine efficiency improvements have resulted from a combination of technology efforts, e.g.:

- improved materials with better high temperature capability (allowing higher compressor pressures and turbine inlet temperatures),
- improved cooling,
- the development of thermal barrier coatings,
- more advanced aerodynamic design for blades, and
- reduction of losses (e.g., by better sealing capability).

However, large/dominating contributors to the irreversibility originate from the combustor, the core exhaust and the bypass flow (Figure 6-1). The focus should be averted to the more dominant loss sources from the combustor and the core exhaust.

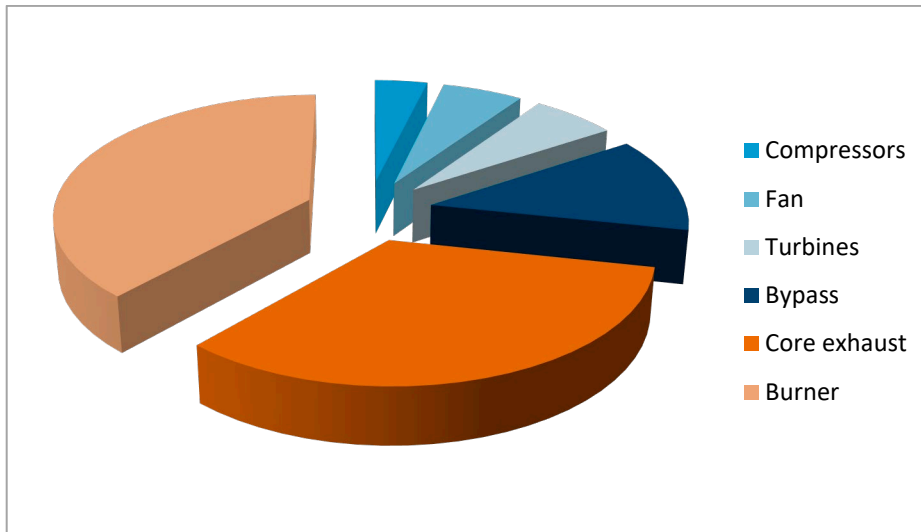

Figure 6-1: Lost work potential of a state-of-the-art turbofan engine design from 2015 (Grönstedt & et. al., 2016)

The propulsive and transmission efficiency are addressed by ultra-efficient low pressure and geared propulsor solutions in the form of large fans or open rotors, BLI concepts and distributed propulsion. Current technology advances are focussing on the radical increase of propulsion efficiency by introduction of (geared) fan solutions with increased diameter (UHBR, Ultra high Bypass Ratio engines) and open rotor solutions (e.g. CROR, Counter Rotating Open Rotor engines). Note that increasing fan diameters and lowering fan pressure ratios allow for higher propulsive efficiencies, it is limited (Cumpsty, 2009) to the point that fan pressure ratio becomes so low that it requires to use variable pitch fan blades (Rolls-Royce Ultrafan) like used in turboprop engines or a variable fan exhaust area to have a decent overall efficiency for all off-design fan power settings. Furthermore the engine airframe (or wing) integration requires substantial attention.

Alternative cycles

Much research in the past has been carried out to lower aero-engine thrust specific fuel consumption by the introduction of alternative thermodynamic cycles. Examples of such cycles are intercooled, recuperated, combined (intercooled and recuperative, see Figure 6-2) and combustion at nearly constant volume by the application of wave rotor technology.

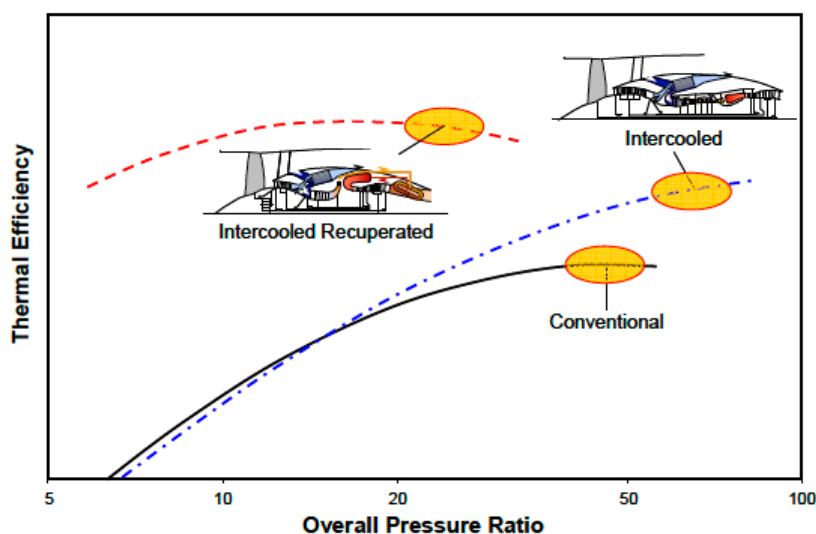

Figure 6-2: Investigated alternative thermodynamic cycles (from the NEWAC project, (Rolt, 2009))

Thrust specific fuel consumption (TSFC) gain for the combined cycle at an OPR of about 25 is 20% compared to the Brayton cycle engine (NEWAC project). Intercooled and recuperated techniques require the application of large and heavy heat exchangers (Figure 6-3), which have to be integrated into the engines. Main problems are that the air residence times are small, the amounts of transmitted power are large and the temperature differences in the heat exchangers lead to thermal stresses, which may reduce component life.

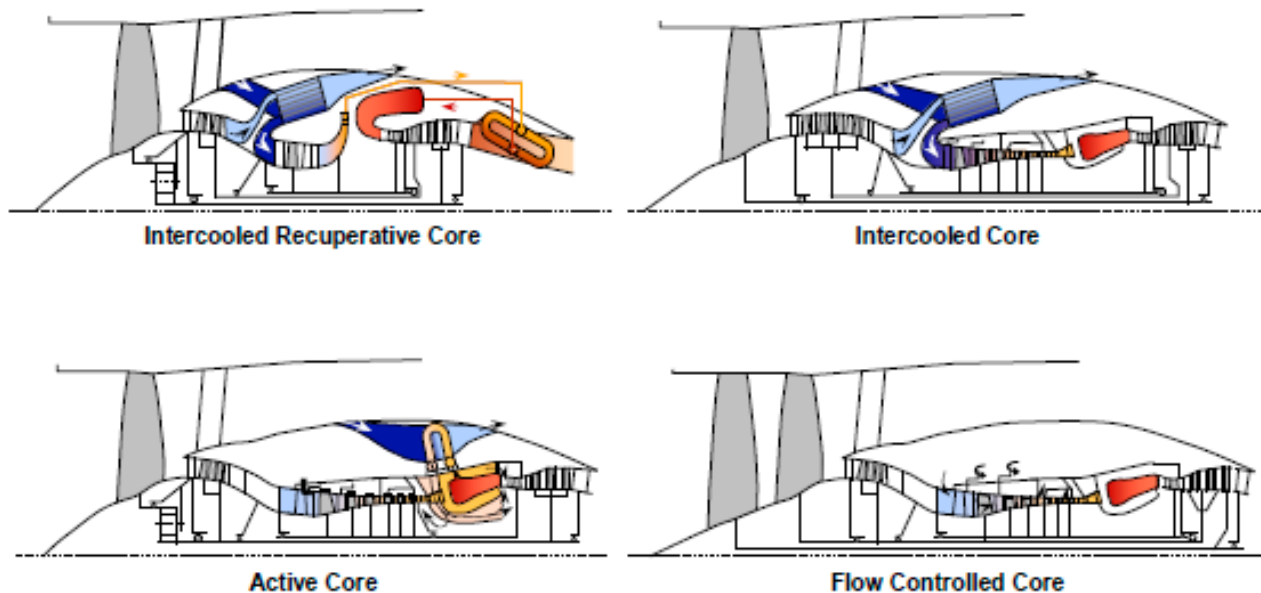

Figure 6-3: Engine lay-outs for alternative cycles (from the NEWAC project, (Rolt, 2009))

Inlet

Boundary layer ingestion may reduce fuel consumption. The difference in Thrust Specific Fuel consumption for a modern engines at Take-off and Cruise is about a factor 2 (at Take-off half of the fuel consumption compared to cruise conditions). However fans continuously will experience circumferentially varying flow with structural integrity risks on high cycle fatigue. Fan distortion is a major concern to engine manufacturers. If propulsors (fan and propellers) are operating in unsteady in-flow conditions strong adverse noise effects are to be expected (Michel, 2011). For embedded engines, the additional noise generated by turbulence interacting with the fan will by far exceed the benefits of shielding (+20 dB, see Figure 6-4).



Figure 6-4: Airplane with embedded engines (distorted flow causes much additional noise and is a threat to fan structural integrity expected (Michel, 2011))

Fan

Wide-chord variable pitch fan blades at low fan pressure ratio may, compared to current large engines, improve fuel efficiency by a few percent. Furthermore variable pitch fan blades have the capability (as a propeller) to generate reversed thrust saving the nacelle thrust reverser. The flow pattern of a fan in reversed thrust is very complex:

1. The engine operates at high power, which requires high core mass flows,
2. The roles of the fan leading and trailing edges are exchanged and
3. The supply air to the fan in the outer region is sucked from the exhaust duct (reverse flow). The supply air near the hub is normally delivered from the front.

The UHBR fans will be preferably geared (CleanAviation, 2020), action area 3.1. Gears currently used in geared turbofans transfer a fan power of about 25 MW. For large turbofans powering wide body aircraft, the transferred power has to be increased to maximum value of about 75 MW, which requires substantial research in gear technology (design, materials, cooling, reliability and safety aspects).

Compressor

Active core concepts (NEWAC project, (Wilfert)) were studied: active cooling control in the high pressure turbine and active clearance control and active surge control in the high pressure compressor. Active clearance control is used to minimise blade tip clearances, which lead to less aerodynamic losses. Active surge control is used to locally re-energize the flow in the tip region, so that the compressor can operate close to the surge line, where the isentropic compressor efficiencies have their highest values.

Combustor

The entropy of a gas is a measure of the amount of energy which is able or unable to perform work. The higher the entropy, the larger the measure for the losses of the system expressed in the thermodynamic quantity exergy (Grönstedt, Irannezhad, Lei, Thulin, & Lundbladh, November 2013). Exergy is defined as the minimal amount of work to bring a gas from ambient conditions to the actual thermodynamic conditions and is by definition also equal to the maximum amount of work that the gas can perform in ambient environment. For the combustor, primary losses are caused by the nature of the thermodynamic process.

Thermodynamically heating of gas is ideal by an isentropic process (isentropic compression), which preserves exergy. Heating the gas at constant pressure or volume causes the entropy to increase, which causes exergy losses compared to the heat input. Only a fraction of the heat input is reserved as exergy and can therefore be applied for delivering mechanical work. Exergy losses are larger for constant pressure combustion in comparison with constant volume combustion. Furthermore in a combustor there are pressure, thermal and kinetic losses. State-of-the-art "constant pressure" combustors do have a 2-4 % pressure loss associated to the fuel combustion. This pressure loss is caused by diffusion, friction and momentum and reduces the engine's thermodynamic efficiency by an equal percentage amount. Alternative combustion at constant volume would give a pressure increase. This can potentially reduce the increase in entropy for a specified temperature increase. Examples of such systems that use a constant volume and/or detonative combustion are (Detonative Wave Rotors) (DWR) and Pulse Detonation Engine (PDE) combustion units and the use of piston combustion (composite cycles).

As stated earlier an aero-engine could thermodynamically operate much more efficient when the combustion would take place under constant volume. The TSFC gain is dependent on engine size (17 % and 7 % for respectively small and large engines (Welch, 1995)). The device which could make this possible is called a wave rotor (Figure 6-5). A wave rotor consist of a rotating drum with multiple, axially orientated gas channels around the circumference. The drum rotates

between two stationary end plates, each of which has ports or manifolds at different pressures, controlling the flow through the channels. Two configurations are possible:

- (1) a pressure-exchange wave rotor with external combustor (a topping unit into the gas turbine cycle) and
- (2) a wave rotor with internal combustion in the axial channels.

In both cases a dynamic system of compression and expansion waves guarantees the in-flow from the compressor and out-flow to the turbine. Main advantage of this technique is that the high pressure turbine at the same thrust or power can operate at lower turbine entry temperatures due to the higher pressure.

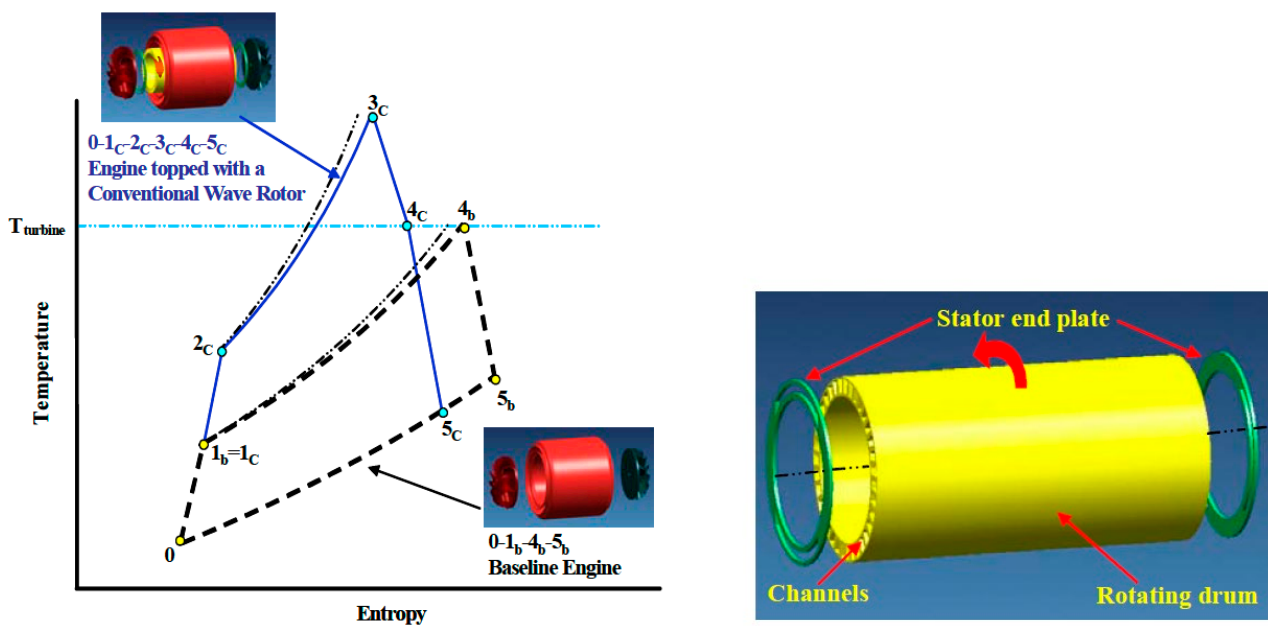

Figure 6-5: Wave rotor technology, left the cycle and right the implementation (from (Akbari, 2007))

For completeness it is noted that constant volume combustion may lead to cooling problems in the high pressure turbine, since the compressor delivery pressure may be (much) lower than the turbine inlet pressure. Normally in a gas turbine, the amount of cooling flows is passively regulated on basis of pressure differences between cooling supply pressure (compressor delivery conditions) and static pressure in the turbine. When due to the application of wave rotor technology the turbine delivery pressure is too high, active measures (additional compression for turbine cooling) might be required.

Core Exhaust

The primary core exhaust loss is accounted for by the loss of thermal and kinetic energy that exists the exhaust. It is not uncommon that the gas turbine cycle rejects heat in excess of 600 K over the ambient temperature. This leaves a potential to reuse the heat (recuperation) to heat the airflow prior to the combustion process. This would lead to a decrease in fuel flow to maintain a similar exit temperature without reuse. Reusing the energy from the exhaust is challenging as the pressure difference is the largest (burner pressure on the cold side, low pressure on the hot side) and the speed of the hot air is very high which would require a large surface area to exchange the heat. The larger the surface area the more weight needs to be added which is detrimental for the aircraft performance (would require more thrust). An alternative is to use a Rankine bottoming cycle to recuperate the energy using a super-critical CO_2 cycle to generate electrical power.

Bypass

The bypass exhaust losses include pressure losses from the bypass duct and from the nozzle as well as residual thermal and kinetic losses in the bypass exhaust flow. To counteract these losses, the velocity of the jet needs to be decreased and the mass flow increased.

Open rotors

The ultimate large UHBR fan with a bypass-ratio BPR of about 15, an overall pressure ratio OPR of about 60 and a fan pressure ratio FPR of about 1.3 will be reasonably fuel efficient at cruise conditions (with a cruise TSFC between 14 and 15 g/kN/s). Thermodynamic efficiency of the engine will be 55 % and propulsion efficiency will be 72 %. To increase fuel efficiency further, open rotors (Counter Rotating Open Rotors (CROR) or Single Rotating Open Rotors (SROR), also named advanced propellers) can be applied. For CROR's on large aircraft at current cruise conditions, the propulsion efficiency will increase to a maximum of about 78 % (Epstein A. , 2013). However, it is expected that the thermal efficiency will be lower due to the much smaller OPR. The fuel efficiency gain of large CROR's dependent on flight cruise speed is expected to be 5-7 % compared to the ultimate UHBR fan at the expense of:

1. Large impact on aircraft geometry,
2. Severe safety risks
 - a. Unproven technology (aviation community is rather conservative) and
 - b. The absence of a propeller/fan containment ring and
3. Uncertainties in operating and maintenance costs.

Currently, Airbus has chosen for the use of proven technology with turbofans (and/or turboprops) at the expense of a relatively small decrease (5-7 % compared to the ultimate UHBR fan) in fuel efficiency. A comparison between propulsive efficiencies dependent on cruise Mach numbers of open rotors and turbofans is shown in Figure 6-6 (Epstein A. , 2013). The small differences in propulsive efficiencies between CROR's and ultimate UHBR fans (cruise FPR is about 1.30) at a typical flight Mach number equal to 0.8 give reasoning to the choice of Airbus for "an ultimate UHBR fan". It is not sure whether Airbus will reconsider their current choice (and give CROR's credits).

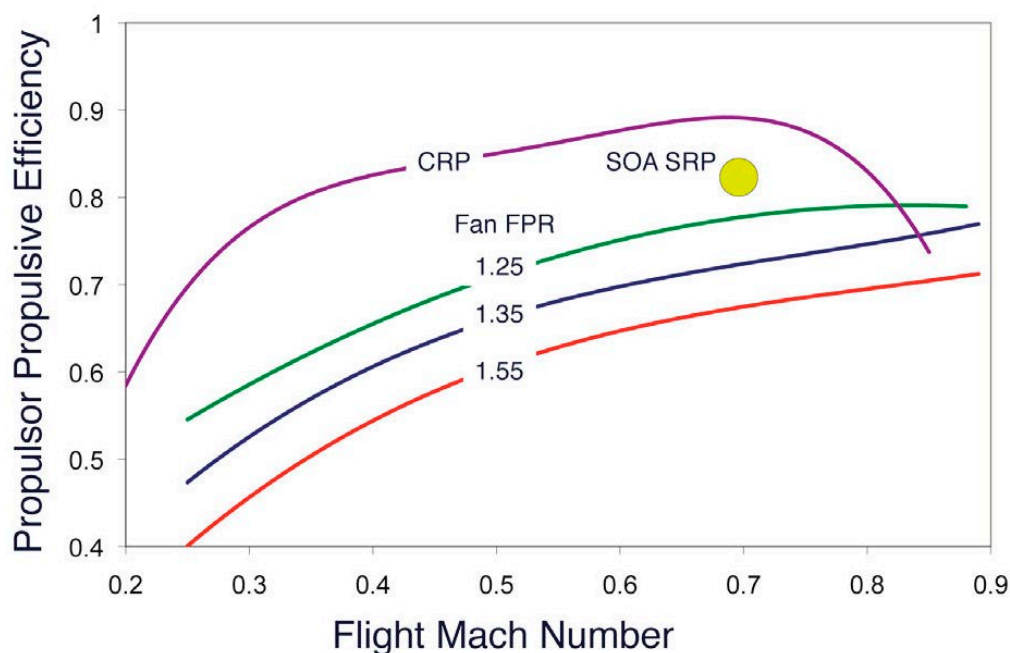

Figure 6-6: Comparison between propulsive efficiencies of open rotors and turbofans (from (Epstein A. , 2013))

SROR's or turboprops with advanced propellers may be used for regional aircraft. One advantage is the higher propulsion efficiency (can even be higher than 0.8) at the expense of a lower maximum cruise speed (M=0.7 versus M=0.85 for current aircraft, see also Figure 6-6 on SOA SRP (State of the art single rotating propulsor/propeller) propulsive efficiency) and the effects mentioned earlier (advanced propellers are more proven technology compared to SROR (scimitar-shaped), have less impact on aircraft design and the non-containment issue is equal to that of current turboprops). A further fuel efficiency gain can be realised by lowering the flight Mach number to a value around M=0.6.

General remarks

Engine manufacturers are rather conservative applying new technologies and have very high safety and reliability standards. Technical solutions for altering the Brayton cycle up to the present day have not led to mature technology for current aero-engines. Heat exchangers are large and heavy (short gas residence times and large energy transfers needed for substantial efficiency gains) may have short life due to thermal stresses. The introduction of wave rotor technology is at the expense of much additional complexity in the engine.

6.2 Projects and open calls

VITAL (FP6, 2005-2010, Figure 6-7): EnVironmenTALLY Friendly Aero Engine, provides a breakthrough in low noise and low emission engine architecture by developing and validating novel low weight and low noise technologies. Design, manufacturing and rig testing of the critical technologies are part of the project.

NEWAC (FP6, 2006-2011): new aero engines core concepts by developing and validating new core configurations using heat management (intercooler, cooling air cooler, recuperator), improved combustion, active systems and improved core components. Design and manufacturing of innovative components and model, rig and core tests have been performed to validate the critical technologies.

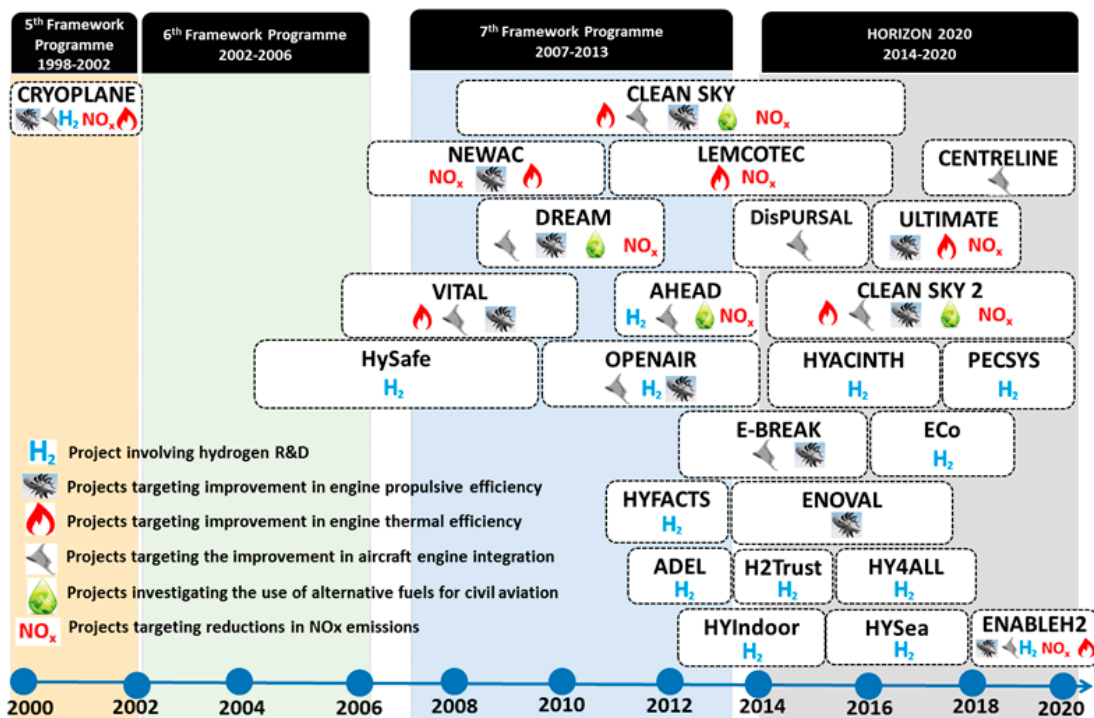

Figure 6-7: Overview of EU research projects [courtesy of Cranfield University and ENABLEH2 consortium]

6.3 Comparative studies and roadmaps

NACOR (Clean Sky 2 Airframe ITD) study comparing different fuselage BLI concepts with different analysis methods tries to quantify the distortion effects on fan stability and integrity.

Clean Aviation aims for low and zero emissions technologies that will allow fuel efficiency gains of one-third to one-half in 2050, compared to today's fleet. Furthermore, usage of low or zero carbon fuels (e.g. hydrogen) should accelerate the transition towards climate-neutrality.

6.4 Bottlenecks

Technological

Current large turbofans with conventional Brayton cycle (no intercooling or recuperation and combustion at constant pressure) have limited potential for further improvement by enlarging OPR and BPR and lowering FPR as shown in figure for UHBR fans (Figure 6-8, (Rademaker, 2019)). Alan Epstein suggests to bring the class of smaller engines (powering A320 and B737) to the large engine standards (Epstein A. , 2013). To some extent, a technical bottleneck will be the scaling problem (large engines are more efficient than small engines). Furthermore, the economic viability of the addition of must complexity in smaller engines may hamper the introduction.

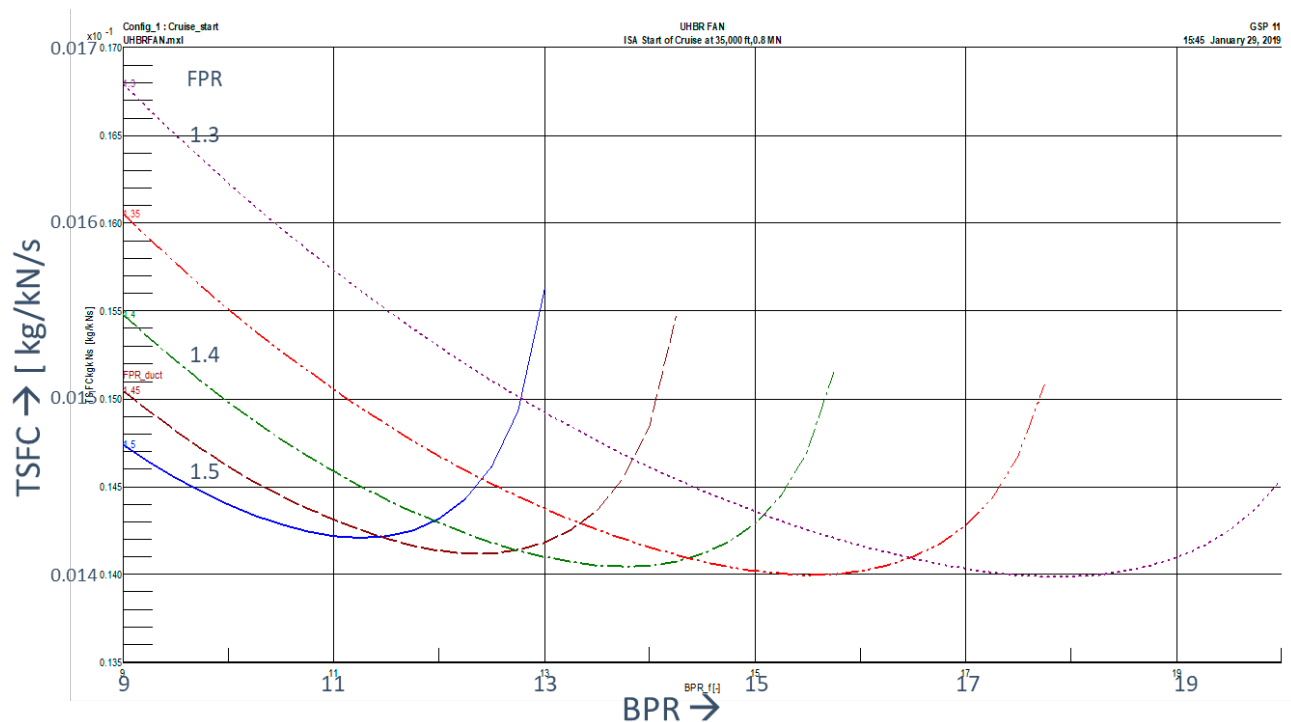

Figure 6-8: Design exploration for UHBR fans compared to state-of-the-art technology (blue line = current large turbofan) derived from (Cumpsty, 2009)

Bottlenecks are:

- Radical innovations require a large amount of time, experiments and costs to mature these technologies. Examples of such technologies are: pulse detonation, wave rotors, composite cycles, recuperation and intercooling.

- Engine certification is very expensive. Furthermore radical innovations (mentioned in the previous bullet) have high risks to problems and failure in the certification process.
- The application of these new technologies have great uncertainty in safety, reliability and sustainment costs.

Economical and business-wise

New technologies require substantial financial investments and a dedicated team to develop, model and test these technologies. Furthermore it is questionable whether the civil aviation community (especially the airliners) can be convinced of the added values of these radical solutions, in other words: the market driven request of operators is lacking.

Social and environmental, including sustainability

A recent investigation of EASA (EASA/EU, 2020) concluded that the radiative forcing of air transport is enhanced by a factor 1.7 (compared to solely CO₂ emissions) due to non-CO₂ related radiative forcing components: contrails, soot and NO_x (the latter has complex interactions with the atmosphere (ozone)). Research on this subject is still in progress to come to a final judgement of all radiative forcing components and their relative and quantitative contribution.

6.5 Key technology enablers

Possible technology enablers are listed in the sequel. It is emphasized that is speculative which technologies will become mature and end up as a product:

Category conventional turbofan with Brayton Cycle

- Geared UHBR fan without and with variable geometry
- Improved combustors (lean combustion) to lower NO_x emissions

Category alternative cycles

- Constant volume combustion (wave rotor or PDE)
- Bottoming Organic Rankine Cycle (e.g. super critical CO₂)
- Intercooling and recuperation
- Composite cycles (piston engine integration)

Category open rotor and advanced propellers

- The application of CROR's (attractive with respect to the increase of the propulsive efficiency)
- Advanced propellers for turboprops (regional aircraft at lower flight Mach numbers $0.6 \leq M \leq 0.7$)

7 Propulsion based on tailored gas turbine with non-drop-in fuels

7.1 Concise technical description

Gas turbines are relatively fuel flexible engines, which have to be tailored for use of non-drop-in fuels rather than Jet-A1 fuel. The turbo-components (compressors and turbines) are relatively unaffected by the use of alternative or non-drop in fuels. Gas turbine to be tailored can be either an advanced turbofan evaluated by the Clean Sky 2 Technology Evaluator for 2035 or novel gas turbine from the preceding Chapter 6. Generally, a gas turbine with relatively small modifications to the fuel injection system and combustor can be operated with various fuels as long as the thermodynamic conditions at the exit of the combustor (mass and volumetric flows, fire temperature and pressure) don't deviate from those obtained from Jet-A1 fuel. The combustor (certainly the lean one to prevent large NO_x emissions) however requires special attention on main issues as stability, flash back and altitude relight. The combustor design has to meet a long list of detailed requirements to be valid at various engine operating conditions (take-off, climb, cruise, approach and idle):

- Combustion stability (crucial for lean combustion),
- Combustion efficiency,
- Altitude relight,
- Lean blow out characteristics depending on fuel-air ratio,
- Ignition fuel-air ratio,
- Pattern temperature factors (circumferential and radial),
- Pressure drops (system and liner),
- Structural lifing aspects (maximum wall temperatures) and
- Smoke and gaseous emissions (to be lower than the certification standards).

The advantage of some of these non-drop-in fuels (hydrogen, liquid natural gas or ammonia) is that they do not contain any carbon atoms and hence the carbon emission from flight is zero and there is an absence of soot. Depending on the fuel composition and engine operating temperature there may be an increase in emission of other greenhouse gases such H₂O (vapour and/or contrails). The related emission of NO_x will depend on the trade-off between combustor stability and low NO_x emissions by (very) lean combustion. (McKinsey, 2020) claims that there are indications that turbine combustion of hydrogen leads to (50-80)% reduction in NO_x emissions. An important role is reserved in (Clean Aviation, 2020) for alternative or non-drop-in fuels.

For completeness it is mentioned that DLR is carrying out research on synthetic aromatics-free-near-drop-in fuels with favourable properties compared to kerosene (Henke, 2020). An additional problem is that there is no approval for the use of such fuels in civil aviation.

Fuel injection system

Current aero-engines are certified for the consumption of Jet A1 fuel or for blended (Jet A1 & synthetic kerosene) fuels up to a maximum of 50% of synthetic components. Main reason for this restriction is the limited amount of aromatic contents in synthetic kerosene. The fuel system (sealings to prevent leakages and pumps) for higher mixing rates require some modifications to cope with the differences in fuel composition.

Alternative fuels as hydrogen, which is regarded as a highly potential candidate (Clean Aviation, 2020) and (McKinsey, 2020) require a complete different fuel injection system (from storage tank to injection in the combustor). NASA in the sixties/seventies has flown with liquid hydrogen and designed an outline for a hydrogen fuel system (Figure 7-1).

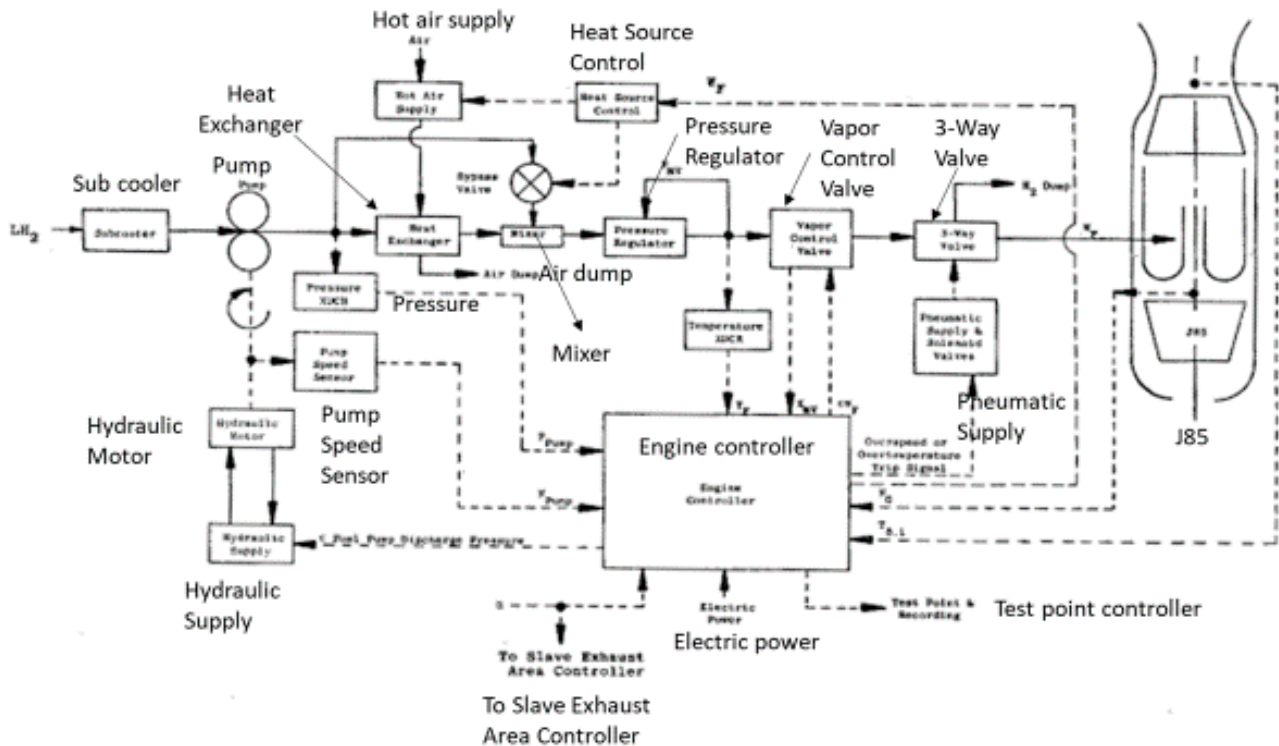

Figure 1. Schematic Diagram of Hydrogen Fuel System.
Schematic Diagram of Hyrdogen Fuel System

Figure 7-1: NASA outline of a hydrogen fuel system (Goldsmith, 1974), ©US Gov, 1973

Main components of the hydrogen fuel system are: (1) cryogenic pump, (2) heater (active) and/or recuperator (passive) and (3) pressure regulator valves (including safety valve to prevent high boiling pressures).

As example for a large aircraft at Take-Off 3 kg/s of liquid hydrogen is required. Bringing that amount to ambient temperature ($T=288.15$ K) an heating energy of 12 MW is required. One could ask him- or herself the question if this heat is externally generated or partly generated by the combustion of a small amount of hydrogen. The implications for both cases on safety risks should be investigated. This example shows that still a lot of development work related to the hydrogen fuel storage and injection systems has to be carried out.

For general aviation powered by fuel-cells with relatively small hydrogen fuel flows raises the question whether all elements of the NASA fuel system are necessary. It might be that no high vapor or gas pressure is required for which the cryogenic fuel pump can be omitted (only passive (recuperation) or active heating is required).

Liquid hydrogen storage

For large aircraft liquid hydrogen storage is the most preferred option. The alternatives (hydrogen storage under large pressures ranging from 350 to 700 bar) require heavy storage vessels at a volume of about three times the volume occupied by liquid hydrogen. Liquid hydrogen itself requires also much more storage volume than kerosene at equal heat content (about a factor of 4). Furthermore, the liquid hydrogen probably cannot be stored in the wing, because storage means have to be heavy isolated (or maybe additionally actively cooled) to prevent boiling and rise hydrogen

pressure to threatening levels to the aircraft. A quantitative and illustrative example of the problems related to the storage of low volumetric energy density fuel is given for the A380 as example: fuel capacity A380 is 250 tons or about 312 cubic meters in the wing volume. An isolated cylindrical fuel tank for liquid hydrogen with the same heat content would require a vessel of dimensions of $3 \times 3 \times 138 \text{ m}^3$ (containing 90 tons of hydrogen). It's evident that for large aircraft additional volumetric storage capacity is required leading to modified airframe geometries and structures (i.e. flying V of the TU-Delft or blended wing body configurations, see also (McKinsey, 2020), page 6). Furthermore, it is questionable whether for large wide body aircraft (with current fuselage / wing configuration due to limited storage capacity) liquid hydrogen compared to synthetic kerosene is the preferred fuel option (Rolls-Royce presentation (Morvan, 2021)). A cautious conclusion also supported by (McKinsey, 2020) that due to storage limitations hydrogen is more suitable for commuter to medium-range aircraft.

7.2 Projects and open calls

ENABLEH2 (H2020, 2018-2021): cryogenic hydrogen based propulsion with development and test of ultra-low NO_x hydrogen micromix combustion; and roadmap.

7.3 Comparative studies and roadmaps

Thermodynamic performances and therefor efficiencies between GTF on Jet A-1 and tailored GTF and hydrogen will not differ much at nearly equal thermodynamic cycles. NO_x emissions will be strongly dependent on the equivalence ratio in the combustor flame and primary zones. Low NO_x emissions require low equivalence ratio's in the fore mentioned zones, but these can conflict with combustion stability requirements (flash back, lean burn out and altitude relight). Hydrogen for example has a high flammability, which possibly enables low equivalence ratios. However high flammability may go along with large risks on flash back.

For general aviation aircraft hydrogen storage at high pressure is the most obvious choice avoiding the complexity related to cryogenic storage. Also for these aircraft the low volumetric energy density of pressurized hydrogen (about factor 9 lower than the value of kerosene) will require attention, although it's regarded as a minor problem due to the limited range of these aircraft.

7.4 Bottlenecks

Technological

Generally, gas turbines are well suited for the use of non-drop-in fuels, especially if they are designed for these fuels. Also, conventionally fired gas turbines are fuel-flexible machines. However, gas turbines with low NO_x or lean (pre-vaporized and pre-mixed) combustors are rather fuel inflexible due to their propensity to flame instability and flash back. Alternative fuel projects aimed at trying alternative fuels in an existing gas turbine require profound reparation. Compatibility of fuel and gas turbine as well as environmental and safety compliance must be verified before testing the fuel in a gas turbine. (Brink, 2011).

- Large technological efforts on aircraft level are required (fuel storage, fuel injection system and thermal peripherals for cooling/heating the liquified fuel).
- The long- and mid-range aircraft geometries have to be adapted to the differences in specific volume density compared to kerosene.
- Large investments are needed on land-based production facilities and infrastructure (airfields).

Economical and business-wise

Switching to non-drop-in fuels will have a large technological and economical impact on aircraft, fuel system (storage, fuel injection system and combustor design) and infrastructure.

Social and environmental, including sustainability

As oil reserves are depleted, alternative non-drop-in fuels will become inescapable. Liquid hydrogen in the far future may fill the gap. The application of non-drop in fuels will require enormous investments and depreciations of current equipment.

7.5 Key technology enablers

The future UHBR turbofan will be geared. Adapted combustors must be designed to meet the extensive list of requirements for these devices. Success will be highly dependent on the availability of true sustainable non-drop-in fuels. At the moment it is not clear whether CROR's will become feasible again. Regional aircraft are well fitted for alternative fuels powered by turboprop engines.

Main enablers are:

- Sufficient production capabilities of sustainable fuels (see for details (Körner, 2015)),
- The availability of fuel supply chains and land-based infrastructure
- Solutions to fuel storage:
 - Small aircraft (high pressure tanks),
 - Large aircraft (liquid fuel vessels) and
- Development of certification and safety standards.

8 Full-electric propulsion with non-drop-in energy sources

This chapter addresses propulsion technologies with only electric engines. Hybrid-electric propulsion technologies, containing both electric motors and non-electric fuel-powered engines, are addressed in Chapter 9. This chapter includes a section on batteries as electric energy storage means. In addition, a section on fuel cells to convert hydrogen fuel to electricity, is included in this chapter.

8.1 Concise technical description

8.1.1 Electric propulsion architecture

Figure 8-1 shows a generic high-level battery-electric propulsion architecture. The battery pack contains the energy required for the aircraft's mission, is charged through a charge port, and delivers DC power to a distribution and protection system, which provides a motor controller (inverter) with electric power at the battery pack's voltage level. Other aircraft electric loads (not shown) are also powered through the distribution system. The motor controller produces alternating current waveforms for the electric motor, generally for three motor phase windings. The current waveform's frequency and amplitude are specifically tailored for the motor's instantaneous operating condition (rotor position, speed, torque). The motor's shaft drives the propulsor.

A thermal control system keeps the equipment operating within thermal limits and tries to maintain conditions for maximum lifetime of the components, which both are especially important for batteries.

Redundancy concepts are not shown in Figure 8-1. The number of battery packs can be increased for redundancy, weight distribution and physical integration constraints. Depending on the aircraft concept, the number of propulsors varies. Each electric motor has a dedicated controller. The electric power distribution system handles distribution between multiple sources and multiple users, and ensures fault isolation and prioritisation of loads in critical conditions through load shedding (i.e. disabling of least important loads).

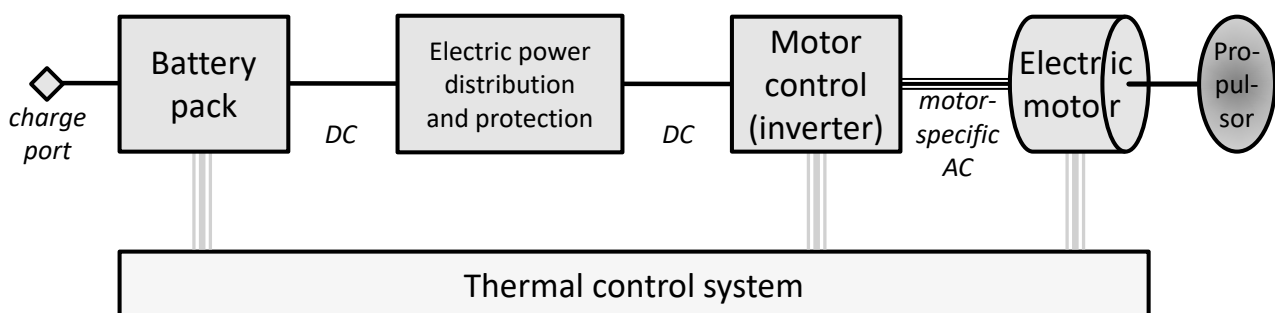

Figure 8-1: Battery-electric propulsion architecture. Redundancy provisions not shown

Figure 8-2 shows a generic high-level fuel-cell electric propulsion architecture, using liquid or gaseous hydrogen as energy source. A venting provision (applicable for liquid hydrogen only) such as a valve prevents excessive tank pressure in case of hydrogen evaporation through tank heat influx exceeds hydrogen consumption. The fuel cell produces electricity using gaseous hydrogen and oxygen from ambient, possibly compressed, air. A battery is generally required

to smoothen fast load changes that the fuel cells cannot handle. The rest of the drivetrain is identical to the battery-electric architecture.

The main task of the thermal control system is to remove the (relatively large) thermal losses from the fuel cell. In addition, it prevents overheating of motor and control, and heats liquid hydrogen in the tank (for controlled evaporation) and before feeding to the fuel cell (heating to levels acceptable to the fuel cell). Cooling of the hydrogen in the tank is normally not performed due to the large weight impact of the cryogenic cooling system.

Redundancy concepts are not shown in Figure 8-2. The number of tanks, number of fuel cells, number of batteries and the number of motors can all be individually varied.

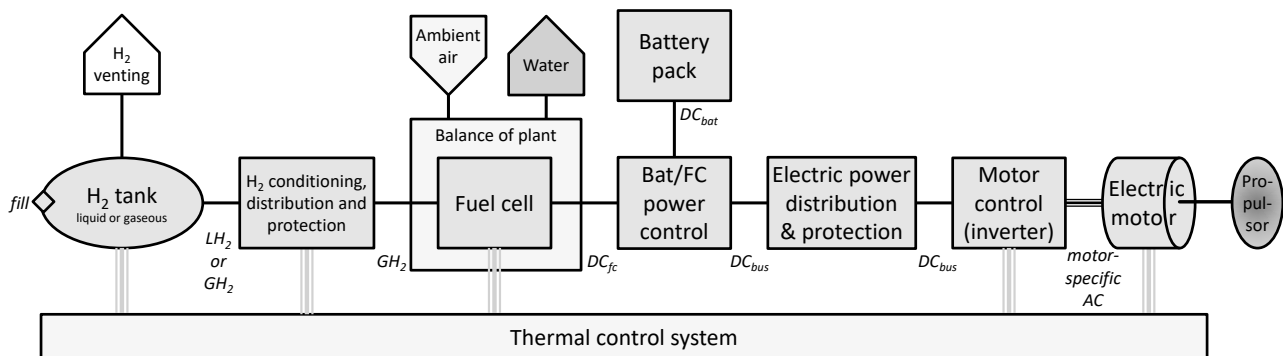

Figure 8-2: Hydrogen fuel cell electric propulsion. Redundancy provisions not shown

8.1.2 Electric machine technology

The regular means of electric propulsion are an electric motor to convert electricity in angular motion and a propeller or fan for conversion to thrust. State-of-the-art motors are invariably of the brushless AC type, i.e. without physical electric contact between stator and rotor. The prominent type is the permanent-magnet machine due to its superior specific power and/or efficiency (Anderson, 2018) (SANABRIA von WALTER, 2016) although reluctance, induction and wound-field machines are also under study (Jansen, 2017) (Thalin, 2019). Electric current flows through coils in the stator, causing the rotor to move. The current to each coil needs a specific waveform, dependant on the momentary position of the rotor, i.e. a specific alternating current, which is provided by the inverter.

As the inverse of electric motors, electric generators are machines that convert angular motion into electric energy. Although the functions of motor and generator differ, the machines are technically identical, and one machine can even perform both functions (starter/generator). The generic term covering both machine types is electric machine.



Figure 8-3: Rolls Royce prototype RRP260D electric aircraft motor, 260kW, 5.2kW/kg, used in the Extra 330LE aerobic flying testbed. Picture © Rolls Royce

An important distinction between types of electric machines is by cooling method, either air-cooled or liquid-cooled. Liquid-cooled machines are lighter and smaller than air-cooled machines, but require a cooling loop, liquid, pump and heat exchanger. For both types weight and drag need to be taken into account at aircraft level.

A state-of-the-art electric machine is shown in Figure 8-3, which is a 260 kW 95% efficient oil-cooled electric motor with a weight of 50 kg (5.2 kW/kg) (Anton, 2019), developed by Siemens/Rolls Royce.

In comparison to conventional aircraft engines, energetic efficiencies of electric machines are high, generally above 95%, even at MW-level (Jansen, 2017). Main loss components are resistive losses in the conductors (“copper losses”), induced eddy current losses in the stator (“iron losses”), induced eddy current losses in the rotor due to space harmonics, air resistance losses (“windage losses”) and mechanical losses such as bearing losses.

Improving machine efficiency leads to little benefit from an energy consumption perspective, but helps to significantly reduce machine cooling requirements, leading to lighter and smaller cooling systems, and also to lighter and smaller electric machines.

Superconducting electric machines are under study, for example in the EU project ASuMED (ASuMED - Advanced Superconducting Motor Experimental Demonstrator, 2021). Superconducting stator coils allow much higher current densities than copper and prevent resistive conduction losses, and superconductive magnets may replace rotor magnets. This comes at the cost of complex cryogenic cooling systems and their power consumption. In (Grilli, 2019), the ASuMED project team describes a 1 MW motor design with high-temperature superconducting compound $GdBa_2Cu_3O_7$ wiring in both stator and rotor that requires a 200 kg 50 kW cryocooler. The project aims a motor specific power 20 kW/kg, but no weight estimate of the design is given in the publication. In general, technology readiness level is currently low. The combination of liquid hydrogen as energy carrier and superconducting powertrain components is potentially a powerful concept.

A fundamentally different means of electric propulsion is by ionic wind, requiring no moving parts. The concept has been demonstrated experimentally in academic context (Xu, 2018). However, efficiency (<3 %) and specific power (0.25 kW/kg) are very low. The concept is not further investigated in this study.

8.1.3 Inverter and motor control

Modern electric machines are driven by an inverter, which converts DC electric power to the specific three-phase AC current waveform required to move the rotor. The algorithms to calculate the waveforms (space vector modulation; field-oriented control) are complex and require dedicated computing power as part of the inverter, but allow fine control of motor speed and torque. The high-power current waveforms are generated through pulse-width modulation of the DC input voltage, using a half-bridge switch. The power switching elements are advanced semiconductor devices, for example insulated-gate bipolar transistors (IGBTs) or metal-oxide semiconductor field-effect transistors (MOSFETs). Conventional devices are based on silicon; advanced devices are based on silicon-carbide or gallium-nitride (so-called wide band gap devices).

To operate an inverter with AC power, a conversion to DC is required, e.g. with a transformer-rectifier unit (TRU).

Similar to electric machines, an important distinction for inverters is by cooling method, either air-cooled or liquid-cooled.

Reported values of specific power for inverters should be regarded with care because their scope varies. Sometimes only the power-electronic elements are included, which constitutes only a fraction of the inverter weight. A complete

inverter consists of power electronics, cooling provisions, electromagnetic interference filters, internal wiring / bus bars, controller, internal power supply, housing and connectors.

8.1.4 Electric power distribution and wiring

Transferring high levels of electric power requires advanced distribution (switching, protecting) and wiring, with a balance between weight, cable losses (for energy loss and more importantly heating) and redundancy to ensure aircraft safety. To reduce conductor weight, high-voltage solutions are under study, for example 3 kV DC.

Generators inherently produce AC power, batteries and fuel cells produce DC power, and electric motor drives require DC power. Conventional aircraft distribution architectures are based mainly on AC power, with only a small proportion of low-voltage DC (28V); currently high-voltage DC power distribution architectures are under study.

8.1.5 Batteries

Batteries are a convenient form of electrical energy storage, requiring no moving parts, but suffer from low specific energy. The dominant technology is lithium ion, with the subtypes lithium nickel manganese cobalt oxide (NMC) and lithium nickel cobalt aluminium oxide (NCA), which currently achieve specific energy ratings of about 250 Wh/kg at cell level. Lithium-ion cell voltages are 3.0-4.2V. Packs are assembled from multiple cells in series and in parallel to achieve the desired pack voltage, power and energy. In addition, packs typically contain a battery management system and thermal management provisions. For automotive packs, pack overhead is typically about 40% of the pack weight. In addition, packs should not be fully discharged for safety or lifetime reasons, leading to a usable capacity that is about 20% lower than nominal capacity.

Specific energy is a major limiting aspect of batteries for main energy storage in electric aircraft. Current state-of-art specific energies are 200-250 Wh/kg at cell level (Bauhaus Luftfahrt, 2021), current industrial improvement developments such as the Tesla 4680 battery indicate that 300 Wh/kg (Kharinta, 2020) at cell level is likely to be achieved soon. This approaches the theoretical maximum specific energy of Li-ion chemistry of 387 Wh/kg (Bruce, 2012).

Promising alternative lithium technologies include: (Lopez, 2020) (Bruce, 2012) (Lvovich, 2018)

- lithium-sulfur (Li-S) has a theoretical maximum specific energy of 2.6 kWh/kg and foreseen practical capacity (i.e. not laboratory but commercial product conditions) of 370 Wh/kg. Apart from specific energy, other advantages are cost (sulphur is cheaper than cobalt, however metallic lithium for anodes is more expensive), environmental (sulphur is more abundant and more easily obtainable than cobalt) and recyclability aspects. Disadvantageous aspects are safety (presence of highly reactive metallic lithium and risk of lithium dendrite formation), lifespan (severely less than lithium cobalt types), self-discharge (high), environmental tolerance (large performance impact at low temperatures), and volumetric energy density (slightly worse than lithium cobalt types – i.e. the weight benefits do not extend to volume benefits). (Li, 2018)
- lithium-air (Li-O₂) has a theoretical maximum specific energy of 3.5 kWh/kg and foreseen practical capacity of 1.7 kWh/kg. Two variants exist, an open or “air-breathing” type, in which design features of conventional batteries and fuel cells are combined, and a closed type, that contains the oxygen instead of taking it in. The open type gains weight during discharge as atmospheric oxygen is bound to lithium. Disadvantages of the open type are its sensitivity to nitrogen and water (causes cathode damage). Disadvantages of both types are a large difference between charge and discharge voltage leading to low charge efficiency (about 65%), long recharge times, low discharge efficiency at high discharge rates and low lifespan. (Kraytsberg, 2011)

Compared to kerosene (12 kWh/kg), current-technology batteries are 40 to 60 times heavier for the same energy. However, this does not mean battery energy performance needs to improve 40-60 fold before battery-electric propulsion becomes feasible. Important advantages such as the inherently zero in-flight emissions, low acoustic noise, high drive efficiency, small motor weight and size (compared to general aviation engines), good scalability of motors (enabling advanced integration concepts such as distributed propulsion), high reliability and low maintenance cost (due to low component count), and low energy cost (Moore, 2014) enable certain applications where the advantages outweigh the battery specific energy disadvantages, such as trainer and air taxi applications. Predictions vary about the critical specific energy where battery-electric flight becomes feasible. (Lvovich, 2018) reports 400-500 Wh/kg for general aviation and 750 Wh/kg for regional jets.

Safety of battery installations requires specific attention, as with all high-energy storage. Already for relatively small packs this has led to in-flight issues such as with the Boeing 787 (National Transportation Safety Board, 2014), and for much larger packs it needs thorough attention to avoid, mitigate and isolate the effects of cell failures such as thermal run-away.

Battery lifetime is an important criterion for economic viability of battery packs. Over time, the capacity of the ageing battery will shrink and the electric resistance will grow. Pipistrel Velis, a commercially available certified two-occupants single-engine aircraft with battery-electric propulsion, shown in Figure 8-4, requires its two 12 kWh batteries to be replaced after 500 hours of use (Pipistrel, 2021), which translates to about 1000 cycles because of the short duration of this aircraft type's typical flights. 1000 cycles is also foreseen for the 900 kWh battery pack of the Eviation Alice conceptual aircraft. (Warwick, 2018)

Research performed on automotive batteries (Harlow, 2019) indicates promising developments, with capacity degradations of 1% and resistance increases of 2-3% per 1000 cycles (at 20°C, with 100% depth of discharge) currently being shown in laboratory conditions.



Figure 8-4: Example of certified and commercially available battery-electric aircraft: Pipistrel Velis Electro (NLR research aircraft). Photo © NLR

8.1.6 Energy conversion / fuel cells

Instead of using relatively heavy batteries, electricity for electric propulsion may be converted from other energy sources. Most prominent is conversion from hydrogen to electricity through an electro-chemical reaction in a fuel cell, using oxygen from ambient air and producing pure water as the reaction product. The most prominent and mature type is low-temperature proton-exchange membrane (LT-PEM, <math><100^{\circ}\text{C}</math>). Alternative and less mature technologies are high-temperature proton-exchange membrane (HT-PEM, 120-200°C) and solid-oxide fuel cells (SOFC, up to 1000°C).

Fuel cell efficiencies are around 50-60% (based on the H_2 lower heating value), yielding 40-50% conversion losses that are release as heat. This means that for high-power installations substantial cooling provisions need to be in place. Loss components are resistive losses in the internal current-carrying components, electrode activation losses (output voltage decrease due to electrochemical reaction kinetics) and concentration losses (reactant depletion at the electrodes under high loads). In addition, some hydrogen is lost due to permeation from one electrode to the other through the non-ideal electrolyte (fuel crossover) – note that this loss component reduces efficiency but does not lead to waste heat.

Fuel cells use ambient air for oxygen, requiring an air compressor at higher altitudes. In addition, a humidifier system may be required to maintain proper membrane humidity. Components external to the core fuel cell are called “balance of plant” components.

Typical fuel cell specific power is currently around 0.75 kW/kg including the ‘balance of plant’ components (McKinsey, 2020).

Other fuel cell concepts employ a reformer to generate the hydrogen for the fuel cell from another fuel (e.g., a methanol reformer in Antares E2 (UAS Vision, n.d.)), in order to have higher specific energy for fuel storage + hydrogen generation. Reformers are additional equipment and require a start-up procedure before being operational at the right working temperature.



Figure 8-5: One of Airbus ZEROe hydrogen aircraft configuration concepts. In this concept, each propulsion pod contains an LH_2 tank, fuel cell and electric drivetrain. (Airbus, 2021)

8.2 Projects and open calls

- The Rolls-Royce **ACCEL** (Accelerating the Electrification of Flight) is an electric aircraft demonstrator developed by Rolls-Royce plc. Rolls Royce intends to fly ACCEL in 2020 to gain the all-electric air speed record. The aircraft is a single-person aircraft with 750kW YASA motor and should reach 480 km/h with a 320 km range (Rolls Royce, 2019).
- [Airbus Electric Flight \(2010 - present\)](#). Roadmap including CriCri , E-Fan, Vahana, CityAirbus and E-Fan X flight test demonstrators.
- [ASuMED \(2017-2020\)](#) – Advanced Superconducting Motor Experimental Demonstrator (H2020). Main objective of ASuMED is to develop a fully superconducting motor prototype with the power densities and efficiency needed for hybrid-electric distributed propulsion (HEDP) of future large civil aircrafts, as an enabler to achieve the targets of Flightpath 2050. Currently a system topology report, giving an overview of super conducting motor types, and a rotor cooling concept are published on <http://asumed.oswald.de/index.php/media-centre>. In addition, paper (Grilli, 2019) was published.
- [ELICA - Electric Innovative Commuter Aircraft](#) (H2020, 2019-2022). The ELICA research project activities are focused on the conceptual design of a 19 passengers commuter aircraft based on alternative propulsion concepts, targeting near-zero CO₂ emissions.
- [ENABLEH2 \(2018-2021\)](#) – ENABLING cryogEnic Hydrogen based CO₂ free air transport (H2020). ENABLEH2 is revitalising the enthusiasm for liquid hydrogen (LH₂) for civil aviation. With the ambitious long-term environmental and sustainability targets for civil aviation in mind, the project will demonstrate that switching to LH₂ is feasible and must be a complement to the research and development (R&D) of advanced airframes, propulsion systems and air transport operations.
- [EPICEA](#) (2016-2019) – Electromagnetic Platform for lightweight Integration/Installation of electrical systems in Composite Electrical Aircraft (H2020). The EPICEA project aims to release, validate and verify a unique computer environment, the EPICEA platform, assimilating a complete understanding of electromagnetic issues on a composite electric aircraft (CEA). Project results are available on <http://epicea-env714.eu/news-and-events>. The platform was developed and demonstrated. Technology readiness is level 4. Further maturation and functionality extension is planned for a follow-up project, with the goal of entering an aircraft programme in 2023.
- [HyFlyer \(2019-2021\)](#) will demonstrate a phased approach from battery power to hydrogen power, integrating the new technology aboard a Piper M-class six-seater aircraft. The aircraft will perform initial test flights out of Cranfield and culminate in a 250 – 300 nautical mile (NM) demonstration flight out of an airfield in Orkney.
- [I²MPECT \(2015-2018\)](#) – Integrated, Intelligent modular power electronic converter (H2020). Cordis result web site: <https://cordis.europa.eu/project/id/636170/results>, project web site: https://www.i2mpect.eu/i2mpect/html_76/achievements.htm. Description: Modular power electronic converters are the key technology enabling a 'more electric' aviation. The I²MPECT project will demonstrate important advances in power converters for harsh environments. The project published results on modelling, cooling and health monitoring of power module temperature monitoring and on a method and test bench for silicon carbide module health monitoring. Two power module demonstrators were developed. Converter efficiency of 99% and power density of 13.7 kW/kg are reported. The project web site gives a good overview of the achievements.
- [MAHEPA](#) (2017-2021) - Modular Approach to Hybrid Electric Propulsion Architecture. (H2020). The MAHEPA project is developing two new hybrid electric powertrains to enable cleaner, quieter and more efficient aircraft propulsion. The first variant is a serial hybrid-electric architecture (see section 9), where a fuel-driven generator is used to charge the batteries and power the electric motor. The Pipistrel Panthera aircraft is used as the flight demonstrator. The second variant relies on fuel cells to produce power enabling zero-emission flight. The fuel-cell demonstrator is a single-propeller four-person aircraft Hy4, which performed its first flight on 6 November 2020. Project progress and results site: <https://mahepa.eu/>. [A recent publication is \(Trainelli, 2020\)](#).

- [NASA EAP - Electrified Aircraft Propulsion \(2010-present\)](#). Electrified Aircraft Propulsion (EAP) is the use of propulsors (propellers or fans) driven by electric motors to propel aircraft ranging from air taxis to subsonic transports. NASA is developing technology, aircraft concepts, test aircraft, and ground test facilities to turn this idea from science fiction to reality.

8.3 Comparative studies and roadmaps

- The **Clean Aviation strategic research and innovation agenda** (SRIA, ((CS3PG), 2020)) identifies the need for smart motors with integrated power electronic modules and targets 5 kW/kg and 95% efficiency, for 0.5-2 MW electric engines, and for ducted electric propulsors. High-voltage distribution and high specific power and energy batteries (targets: 1.75-2.5 kW/kg and 410 Wh/kg at pack level in 2035).
- **Hydrogen-powered aviation** (McKinsey, 2020) describes liquid hydrogen fuel cell powered aircraft for the commuter (19 passengers, 500km range) and regional (80 passengers, 1000km range) segments, and a hybrid hydrogen combustion and fuel-cell powered short-range (165 passengers, 2000km range) segment, where the fuel cell system provides cruise power. For fuel cells, low-temperature PEM is identified as most suitable today. Key technological developments required include liquid hydrogen tanks with 50% reduced mass, safe and reliable fuel distribution and low-NO_x hydrogen-combusting gas turbines
- **Airbus' ZEROe** roadmap targets a hydrogen-powered aircraft for entry into service in 2035. Various concepts were disclosed in 2020 and 2021, including hydrogen combustion concepts with fuel cells for APU functions, and a concept with multiple propulsion pods containing liquid-hydrogen tank, fuel cell, electric motor and propulsor (see §8.1.6, Figure 8-5).
- The **Clean Hydrogen for Europe strategic research and innovation agenda** (SRIA, (CleanHydrogen, 2020)) contains a section with the aviation roadmap. Hydrogen has a strong potential, in fuel cells and turbines. For short to medium range aircraft: high-power fuel cells using either gaseous or liquid hydrogen storage. For short to medium and long-range: gas turbine with liquid hydrogen storage. A leading role is seen for EU in the hydrogen transformation.

8.4 Bottlenecks

The bottlenecks listed below are shown in arbitrary order, not implying a severity ranking.

Technological

- Upscaling to MW range. Many components are not available in the power range needed for full-electric propulsion of larger aircraft, or are intended for ground operations. Upscaling aerospace-compatible equipment may bring considerable technological challenges.
- Component efficiencies
 - Fuel cell efficiency is currently typically 50-60%, high fuel cell losses lead to a) large thermal losses which are difficult to shed, and b) the need to carry additional onboard hydrogen.
 - Other components: energetic efficiencies of electric components are generally high, but because of very high, multi-MW, power levels, the bottleneck is the cooling rather than the energy loss
- Components cooling. For large powers, even at high efficiencies, there is a major heat dissipation problem requiring heavy, complex and costly cooling provisions. Many components are limited to relatively low temperatures (e.g.

silicon electronics 150°C, electric machines 200°C, low-temperature PEM fuel cells <100°C) which leads to complex cooling solutions. Weight and reliability optimised systems need to be developed.

- Component weight. Improvements are always strongly desirable to reduce aircraft weight. The most prominent components that need improvement are batteries to achieve higher specific energy and fuel cells to achieve higher specific power.
- Wiring, switching and protection of high power electric distribution architectures:
 - High currents lead to heavy conductors
 - Risks at higher voltages are corona discharge effects, requiring improved insulation and monitoring.
- Airworthiness certification

Economical and business-wise

- Lifetime of all components, and energy storage systems in particular.
- Cost of high quality motors, power electronics, fuel cells. Component optimisation often leads to use of highly costly materials and processes.

Social and environmental, including sustainability

- Recyclability (e.g. rare-earth metals in magnets, fuel cell catalysts)
- Responsible material use (e.g. responsible mining of cobalt, lithium, copper)
- Regulatory limitations

8.5 Key technology enablers

- Superconducting technology for components in the propulsion chain ($\text{YBa}_2\text{Cu}_3\text{O}_7/\text{Bi}_2\text{Sr}_2\text{Ca}_x\text{Cu}_y\text{O}_z$, MgB_2 , $\text{Nb}_3\text{Sn}/\text{NbTi}$), in particular in combination with liquid hydrogen.
- Advanced power electric components and technologies (SiC, GaN)
- Fuel cell components for aerospace use
- Advanced two-phase cooling systems.
- High-cycle energy storage development.

9 Hybrid-electric propulsion

9.1 Concise technical description

Hybrid-electric propulsion (HEP) includes any combination of electrically driven propulsion (see Chapter 8) and combustion engine driven propulsion (see Chapters 6 and 7). It should be noted that, in this definition, the combustion engine propulsion part is not necessarily based on fossil fuels. One could very well imagine a hybrid-electric propulsion system employing hydrogen-based gas turbines. A commonly used classification of HEP has been proposed by (Felder, 2015) of which the most important types apart from all-electric (see Chapter 8) are:

- Parallel-hybrid: it comprises a fan driven by a combustion engine and by electric motor(s) fed by batteries, where the electric motor is typically used during high power demand flight phases (e.g. take-off and climb). In this case the combustion engine may be downsized for better cruise performance.
- Series-hybrid: it comprises a combustion engine that drives an electric generator that feeds batteries that supply power to electric motor(s) driving fan(s). The batteries decouple the electric motor instantaneous power demand from the combustion engine instantaneous power generation.
- Turbo-electric: as series-hybrid, but without the batteries. This type requires the gas turbine to operate continuously to generate the electric power.

Slightly other naming conventions can be found, e.g. in (DLR, 2020; Zill et. al., 2020; Jansen, 2017) to be more to-the-point for certain specific implementations, but in general the above three main forms cover all of the hybrid-electric propulsion options. The degree of hybridization is sometimes used to indicate the extent of hybridization. This can be done for both power sources and energy sources (Brelje & Martins, 2019). The ratio of the power coming from electric motors divided by the total power is the hybridization degree of power, the ratio of energy from batteries divided by the total energy is the hybridization degree of energy. In both cases, this would imply that zero hybridization equals the conventional aircraft with full propulsive power coming from the combustion engine, and 100 percent of hybridization equals all-electric flight. A further classification of electric propulsion architectures then results in the following table:

Table 9-1: Classification of hybrid-electric propulsion architectures using a distinction based on electric power and electric energy (from (Brelje & Martins, 2019))

Architecture	$H_P = P_{\text{motor}}/P_{\text{total}}$	$H_E = E_{\text{battery}} / E_{\text{total}}$
Conventional	0	0
All-electric	1	1
Turbo-electric	>0	0
Series-hybrid	1	<1
Parallel-hybrid	<1	<1

Elements of the HEP drive train, in addition to the classical components of a fuel-based propulsion drive train, can comprise motors, fans and ducts, power cables, controllers and control wiring, buses and power electronics, batteries, fuel cells, generators, hydrogen tanks, and gearboxes. Depending on the specific form of the selected hybrid-electric propulsion option, some or all of them could be present.

Propulsor placement on the aircraft is much more flexible when driven electrically. In this respect, a limited number of underwing engines like in conventional large aircraft is less likely to be an energetically and cost optimized configuration. A larger number of fans could be envisaged, and placement of distributed propulsors over the wing and fuselage opens up a plethora of configurational options. Some studies include a tail cone thruster, other options involve

distributed electric propulsion by a (large) series of fans. A key component is a high voltage generator, which has been described in Section 8.1.2 about electric machines.

The additional electrical systems add weight to the aircraft and impact the empty weight mass fraction and range. Even in the case of highly efficient components with high specific energy and power, the impact of the additional weight needs to be counterbalanced by the advantages of a HEP propulsion system. The main advantages of HEP are:

1. Smaller and lighter combustion engine(s);
2. Less fuel for a specific mission;
3. Higher energy efficiency, also in off-design flight phases like take-off, climb, descent.

HEP could be combined with other fuel consumption reduction measures like electric taxiing and very efficient generators. Also, other, more aerodynamically efficient configuration types come to mind when HEP is envisaged for the future, like blended wing bodies (BWB) with embedded advances of modern materials (lightweight structures) and boosted propulsion efficiency (e.g. by boundary layer ingestion and distributed electric propulsion). For efficient power distribution of large amounts of electric power, high-temperature superconducting (HTS) cables may need to be considered in the near future.

Two main issues with hybrid-electric propulsion are the energy storage on board and the thermal management challenges involved, see for instance (Hepperle, 2012) and (Sahoo, Zhao, & Kyprianides, 2020). The inclusion of (new) energy carriers on-board will impact the overall design of the aircraft, not only in terms of configurational shape but also in terms of stability and control. Furthermore, there is a serious thermal issue with HEP electrical components as they are not automatically located in or near a cool air stream. The electrical components have an efficiency less than unity, indicating that part of the power will be transformed into heat that needs to be cooled. It depends on the overall drive train set-up and the efficiency of the individual components to what extent the on-board power will be transformed into heat. To cope with the distributed heat dissipation inside the aircraft, the inclusion of appropriately sized thermal management control and margins, already in an early stage of aircraft predesign, requires new procedures and tools. In order to assess these design procedures and tools, ground and flight testing will be needed on a variety of legacy and newly developed designs to generate the necessary experimental verification and validation data.

The expectations of benefits from the above referred technologies are diverse: based on specific configurations, baseline configuration, methods of estimation (low-fidelity versus high-fidelity) as well as best guesses, references come up with a wide and nonuniform range of benefits. Some of these assumed benefits are significantly downsized at a later stage when high-fidelity analysis has been performed. Therefore, it is likely that a true step forward will be based on the smart combination of many advanced technologies, both in propulsion and aerodynamics as well as in systems and structure. The following fuel burn reduction estimates, obtained from the indicated referenced studies, may give some cautious indications of potential improvement benefits relative to conventional aircraft of 2016 to be expected from hybrid-electric propulsion, provided a well-developed and matured design is made.

- Turboelectric drive train propulsion efficiency optimization (Sahoo, Zhao, & Kyprianides, 2020): 4-8 percent fuel burn reduction.
- BLI fuel burn reduction (Plas, 2006): 3-4 percent.
- BLI using tail cone thruster (TCT) (Farokhi, 2020): 3-4 percent fuel burn reduction.
- Distributed Electric Propulsion (DEP) using 40 percent of boundary layer ingestion (Farokhi, 2020; Uranga et.al., 2017): 8.5-9 percent of fuel burn reduction.

In case the hybrid-electric propulsion benefits are combined with other, configuration-dependent benefits like improved aerodynamic efficiency as is the case for blended wing bodies (BWB) and flying wings, (hybrid) laminar flow control

(HLFC) and higher wing aspect ratios for lowering viscous and induced drag, significantly larger fuel burn reductions could be envisaged as shown by the following studies:

- STARC-ABL BLI using TCT study fuel burn reduction: about 7-12 percent (Jansen, 2017).
- SUGAR Volt hybrid electric fuel burn reduction: about 10-20 percent (Brelje & Martins, 2019).
- CS2 LPA HEP block fuel reduction: up to 10 percent for 2035 EIS aircraft, however dependent on many aspects (Zill et. al., 2020).
- (Hybrid) laminar flow control, HLFC (Farokhi, 2020): 12 percent fuel burn reduction.
- BWB with HLFC (Farokhi, 2020): 32 percent savings in fuel burn.
- Percentage of aviation CO₂-exhaust reduction by 2050 (Sustainable Aviation, 2020): 17 percent for improved conventional aircraft, 24 percent for future aircraft using HEP (relative to state-of-the-art of 2016, and assuming likely fleet penetration by that date).

9.2 Projects and open calls

European projects:

- CS2-WP1.6 (2018-2024): demonstration of radical aircraft configurations, especially with HEP-concepts (Zill et. al., 2020).
- IMOTHEP (H2020, 2020-2023): achieve a key step forward in assessing the potential of HEP by an integrated end-to-end investigation of hybrid-electric power trains for commercial aircraft (IMOTHEP, 2020).
- FutPrint50 (H2020, 2020-2022): identify and drive forward technologies that will enable the commercial use of a hybrid-electric aircraft with up to 50 seats by 2035/40. (Futprint50, 2021).
- UNIFIER 19 (CS2, 2019-2022): design of 19 seater with modular hybrid-electric architecture based on different propellers, different combinations of battery and range-extending technologies. (Unifier19, 2021)
- HECARRUS (H2020, 2019-2022): Develop and integrate the conceptual design of a 19-passenger commuter aircraft based on hybrid-electric propulsion configurations. (HECARRUS, 2021)
- MAHEPA (H2020, 2017-2021): developing turbo-electric propeller propulsion with flight demonstration in single propeller Panthera (4-seater) scheduled for July 2020 and methodology for conceptual design of serial (hybrid-) electric propulsion (MAHEPA, 2021).
- HASTECS (H2020, 2016-2021): serial hybrid-electric powertrain with focus on high specific power electric machines (Touhami et.al., 2020) and converters. The HASTECS project aims at supporting the demonstration of radical aircraft configurations (CS-2/WP1.6) by means of models and tools development that can help the designers in assessing main benefits of architectures and power management of hybrid electric propulsion (HASTECS, 2016).
- EU H2020 CENTRELINE project (2017-2020): investigation of HEP with a fuselage BLI tail fan (CENTRELINE, 2017).
- EU 7th framework DisPURSAL project (2013-2015): to study the practical implementation of distributed propulsion as a realistic system solution and examine overall aircraft performance benefits (DisPURSAL, 2013).
- EU H2020 ULTIMATE project (2015-2018): Investigation of variable geometry inlet to counteract distortion effects on fans (ULTIMATE, 2015).
- EU PARE project (October 2017 – December 2020): Perspectives for Aeronautical Research in Europe. The objective of PARE is to consider the progress made towards the achievement of each of the 23 FlightPath 2050 goals defined by ACARE and make recommendations on how to close the remaining gap (PARE, 2017).

American projects:

- NASA's STARC-ABL (2016-present): single-aisle turboelectric aircraft with tail cone thruster (Welstead & Felder, 2016).
- Boeing's SUGAR project (2008-2015): Subsonic Ultra Green Aircraft Research. Phases 1 and 2 of investigations under Boeing leadership were employed to identify and evaluate technologies for disruptive fuel consumption reductions. (Bradley et.al., 2011; Bradley et.al., 2012; Bradley et.al., 2015; Bradley et.al., 2015-2).
- FAA's CLEEN program (2019-present): continuous lower energy, emissions, and noise. CLEEN is the FAA's principal environmental effort to accelerate development of new aircraft and engine technologies and advance alternative jet fuels (CLEEN, 2019).
- NASA's CAS-project (Convergent Aeronautics Solutions): an overarching project with the objective to rapidly assess the feasibility of novel concepts with potential to transform civil aeronautics and determine whether additional investment is warranted. Concepts that prove feasible are expected to transition into more focused technology development projects to mature and apply the enabling technologies. Multiple novel concepts are corroborated in separate projects under the CAS-umbrella (CAS, 2020).
- HEATheR: High-Efficiency Electrified Aircraft Thermal Research is part of NASA's CAS-project and explores the feasibility of managing the waste heat on a megawatt-level electric aircraft propulsion system while achieving performance and operational cost benefits (HEATheR, 2020).
- NASA's ULI (University Leadership Initiative): provides an opportunity for the U.S. university community to receive NASA funding and take the lead in building their own teams and setting their own research agenda with goals that support and complement the agency's Aeronautics Research Mission Directorate and its Strategic Implementation Plan. It is an umbrella-project like CAS. (ULI, 2020).

Demonstrator projects:

- E-fan-X (expected flight in 2021): BAe-146-based serial hybrid-electric demonstrator with 2-2.5 MW generator (project cancelled in 2020) (Airbus, 2020).
- UTC Project 804 (flight in 2022): 2MW hybrid-electric propulsion system with new battery technology on mid-sized regional turboprop using existing airframe, systems, and propellers. (UTC project 804, 2019).
- Electric Aviation Group's (EAG) HERA project (July 2020-present): Hybrid-Electric Regional Aircraft. Defining and designing a hybrid-electric regional aircraft for 70+ passengers with ATR-72-like performance, aiming for EIS-date in 2028. Based on battery-electric take-off employing electric taxiing and electric acceleration using electric motors in wheels, and turboelectric cruise including battery recharging (HERA, 2020).
- EcoPulse (2019-2022): distributed propulsion hybrid aircraft demonstrator (EcoPulse, 2020).

Other projects:

- IATA's TERESA project (2008-present): technology roadmap for environmentally sustainable aviation (Nolte et.al., 2011).
- Fokker/GKN's e-Volution project (2016-2018): turboelectric single aisle demo pre-study, electric system and fan design (e-Volution, 2016).
- German national project SynergIE (2018-2021): study into the benefits of DEP on improved aerodynamics, wing loading distribution rearrangement, reduction of wing weight, propulsion system benefits, aircraft noise (SynergIE, 2018).

9.3 Comparative studies and roadmaps

Section 9.2 shows an impressive list of completed and active projects in the field of HEP. In addition to these projects, the following studies and roadmaps have also been used to identify bottlenecks, key technology enablers, and comparative data. Many roadmaps on (hybrid-)electrical propulsion have been written at different moments and from different focal points: therefore, the following list is not exhaustive but has proven to be useful.

For concise but useful technological background information on electric and hybrid-electric flight, see (Hepperle, 2012).

The **Clean Aviation Strategic Research and Innovation Agenda** (SRIA, ((CS3PG), 2020)) identifies the need for disruptive technologies for hybrid-electric regional aircraft by 2035, including key areas of research and development to arrive at the target. This involves hybrid-electric drive chains, energy storage, power management, aircraft integration, and many more aspects.

The **DLR White Paper** defines the path to climate-neutral aviation and identifies a strong need for radical technologies in all areas, including the role of hybrid-electrical propulsion for future commercial aircraft (DLR, 2020).

Flüthmann represents the vision on technological developments from the Clean Sky 2 programme from the viewpoint of the Technology Evaluator (TE). The Technology Evaluator is Clean Sky's instrument for critical self-reflection, assessing the expected environmental, societal and economic benefits of technology advancements being developed in Clean Sky 2 and the related longer-term impact on the air transport system (Flüthmann, et al., 2020).

Sustainable Aviation provides the UK-roadmap to decarbonisation. It is based on a thorough review of the opportunities to cut aviation carbon emissions through smarter flight operations, new aircraft and engine technology, modernizing airspace, the use of sustainable aviation fuels and significant investment in carbon reductions through effective market-based policy measures (Sustainable Aviation, 2020).

The Air Transport Action Group (ATAG) provides a global industrial view on the climate challenge in relation to air transport growth and the associated need for technological developments (ATAG, 2020).

Roland Berger 2019 provides an overview of progress made, highlights key technological trends, addresses the implications of the revolutions, and showcases industrial perspectives on the role of electrical propulsion (Roland Berger, 2019).

Roland Berger 2017 defines the status of 2017, already showing increased developments at settled industries but also at a large number of start-ups, with outlook for cleaner, greener, cheaper and potentially safer flight (Roland Berger, 2017).

The **Clean Sky 2 Joint Undertaking Development Plan** defines the Clean Sky 2 Programme's main objectives and key performance targets towards environmental impact and energy efficiency, industrial leadership and Europe's need for sustainable and competitive air transport. As such, it provides the direction of technological research and demonstration activities within Clean Sky 2. The main objectives are to accelerate the progress towards the ACARE SRIA goals for 2020-2050, to enable a technological leap in the face of emerging competitors, and to justify the early replacement of aircraft that have yet to enter service and accelerate the adoption of new technology into the global fleet (Clean Sky, 2017).

The **Strategic Transport Research and Innovation Agenda (STRIA) Roadmap for Transport Electrification**, one of the European Commission initiated roadmaps, aims to bring forward the developments carried out in the framework of the European Green Vehicle Initiative and encourage multi-sectorial and multi-disciplinary research and innovation activities on new materials, advanced propulsion systems and information computer technology. It compares the status quo of different modes of transportation (road, rail, waterborne, and aviation) and identifies strength, weaknesses, opportunities and threats for each of them (STRIA Electrification, 2016).

NASA's Aeronautics Strategic Implementation Plan outlines the NASA Aeronautics Research Mission Directorate (ARMD) vision for aeronautical research aimed at the next 25 years and beyond. It comprises a broad range of

technologies to meet future needs of the aviation community for safe, efficient, flexible, and environmentally sustainable air transportation. The plan is laid down in six strategic thrusts: safe efficient growth, innovation in commercial supersonic aircraft, ultra-efficient commercial vehicles, transition to low-carbon propulsion, safety assurance, assured autonomy for aviation transition (NASA, 2015).

9.4 Bottlenecks

Technological

Additional weight of added electrical systems: compensation is necessary to avoid an increase in energy needs.

Standardization of HEP-technology is missing: design, development and manufacturing methodology needs to be matured.

Heat dissipation in electrical components is of a different, larger order: integral thermal management becomes of paramount importance.

Economical and business-wise

Challenging certification processes of high-power HEP-systems, see e.g. (ASTM (2), 2020).

Additional costs due to extra on-board systems: the operations business case needs to take this into account.

Social and environmental, including sustainability

Recyclability aspects for ecological acceptability.

Regulatory immaturity: the certification regulations for future HEP aircraft need maturization.

9.5 Key technology enablers

Fundamental improvements in vehicle modelling, design, test and evaluation: intended to design efficiently for performance, energy efficiency as well as recyclability.

Propulsion improvements: e.g. BLI, DEP to reduce CO₂ emissions.

Improvements in components performance: high specific energy motors, batteries, fuel cells, capacitors, high-voltage power distribution, gas turbines for improved energy efficiency.

Regulatory progress for HEP-systems in aircraft to pave the way for efficient certification.

Advanced system integration design addressing multi-disciplinary aspects in an early stage of development.

Thermal, energy and power management integration in early design loops.

10 Aircraft-level / powertrain-level synergies

This chapter deals with:

1. the necessity of synergy of innovations treated in the chapters 2 through 9 for future aircraft developments;
2. new ways to analyze and compare non-conventional aircraft concepts based on multiple technological innovations;
3. notable results;
4. candidate configurations.

Necessity of synergy

The individual aspects of alternative fuels, combustion engine improvements and (hybrid) electric propulsion approaches have been addressed in the previous chapters. The potential of each of the innovations, the expected benefits in carbon emission reduction, and the estimated maturity of the concepts has been summarized. However, in order to meet stringent ACARE objectives for 2050 (ACARE, 2011), a future viable configuration will not be based on just one or a combination of these subsystem innovations, it will also be based on innovations of the aircraft configuration such as high aerodynamic efficiency, lightweight structures, new materials, active load alleviation, adaptive wing technology, laminar flow technology, turbulent drag reduction using riblets, and active flow control. A new optimized future aircraft configuration will combine innovations in such a way that the combined improvements provide an optimal result at aircraft level.



Figure 10-1: Airbus MAVERIC concept of blended wing body (BWB) design, an example of a future aircraft configuration with higher aerodynamic efficiency than conventional tube-and-wings (courtesy Airbus)

New ways of analysis and comparison

The design of optimized future aircraft configurations requires appropriate design methodologies and sufficiently detailed knowledge on all of the engineering aspects involved, see e.g. (Aigner et.al., 2020). Examples of interesting studies from recent years touching the integration aspects at aircraft level are now briefly indicated, with the objective to open up several ways of comparative efficiency analysis for different aircraft types in terms of payload and range.

(Hepperle, 2012) compares the overall efficiencies of typical on-board powertrain systems for several propulsion concepts – turboprop, turbofan, battery electric, and fuel cell electric – using state-of-the-art component efficiencies. Although the assumed component efficiencies reflect year 2012 technological level, the approach provides an interesting comparison of and insight into overall efficiencies of energy conversion in typical on-board powertrains. The overall efficiencies of powertrains can be used to prioritize the selection of best powertrain for a future aircraft, e.g. depending on the range and payload. Such an analysis could be updated to current state-of-the-art component efficiencies and to several main forms of hybrid-electric propulsion powertrains to determine the current baseline of possibilities for future configurations.

Furthermore, (Hepperle, 2012) takes an existing regional aircraft (Dornier Do328) and performs several configuration and propulsion updates to assess the impact on range and performance of these innovations, and subsequently identifies ways to restore the original payload and range characteristics. The initial change is to alter the conventional propulsion system with a battery electric system of the same weight. As the effective range then drops dramatically, configuration changes are then attempted to restore the range, as shown in Figure 10-2. Such a comparative study shows what is needed in terms of efficiency improvements for a specific existing type of airplane and what is likely to become feasible.

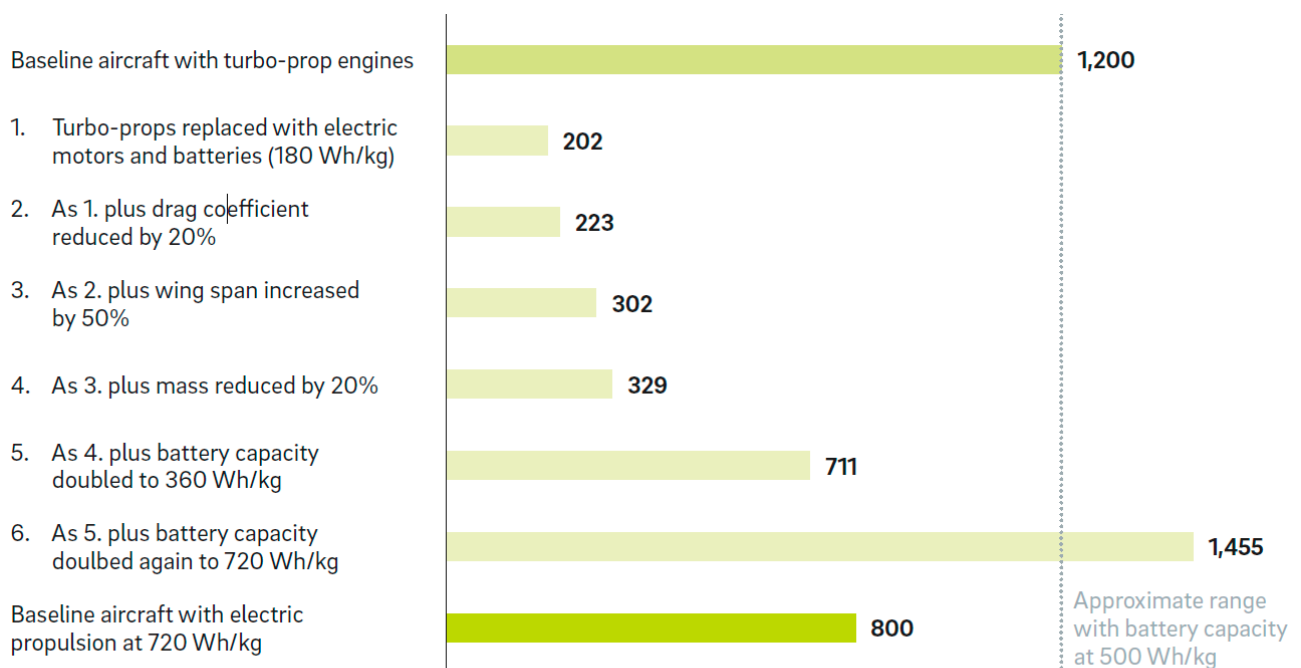

Source: DLR, Roland Berger

Figure 10-2: Visualisation by Roland Berger of the Dornier Do-328 analysis by DLR (Roland Berger, 2017)

Another comparative study on the inclusion of a parallel hybrid-electric powertrain in four different aircraft types – general aviation aircraft, regional transport aircraft, VTOL air taxi, and MALE UAV – for different types of missions is found in (Finger et.al, 2020). Hybridization, both for power and energy, is assumed to have a value between 0 (conventional propulsion) and 1 (fully electric). The applied optimization routine determines the hybridization ratio as part of the solution for a typical set of top-level aircraft requirements and mission type, using different levels of technological state-of-the-art. The aircraft are analyzed based on their take-off mass and primary energy consumption. It is found that hybridization makes sense if the propulsion system is sized by short-duration power constraints. If the

propulsion system is sized by a continuous power requirement, hybridization offers hardly any benefit according to this study.

A thorough comparative analysis study based on the physical principles of exergy is given by (Affonso et.al, 2019). Exergy is the maximum useful work which can be extracted from a system as it reversibly comes into equilibrium with its environment. The need for such a design and analysis approach is, according to the authors, based on (Brelje & Martins, 2019) who reviewed concepts, models and design approaches for fixed wing aircraft propelled in part or in whole by electricity, concluding that this problem introduces a new coupling between previously distinct disciplines, for example between aerodynamics and propulsion, or between propulsion, electrical systems and thermal management. Therefore, a high fidelity multidisciplinary analysis and optimization (MDAO) is required. The exergy analysis is particularly appropriate to perform this type of MDAO analysis. The methodology allows for an exergy efficiency comparison between different powertrains.

A completely different way to compare hybrid-electric aircraft during the design process is proposed by (Tanimura et.al, 2021). They propose an application of Epoch-Era Analysis (EEA) and Multi-Attribute Tradespace Exploration (MATE) to consider future evolvability during the conceptual design process of hybrid electric aircraft. By considering the TLARs, a utility function is defined – e.g. fuel weight –, and in order to compare designs over iterations, commonality is evaluated. Utility conformation can be traded for commonality and vice versa between design iterations. From the tradespace of utility and commonality, the designed aircraft are visualized in terms of conformity to the requirements and complexity of developments involved. In a way, the proposed approach resembles a formalization of the Do328-variants exercise of (Hepperle, 2012).

At the integration level of aircraft and propulsion, (Abolmoali et.al., 2020) address the need for integrated propulsive and thermal management system design. The energy benefits of hybrid-electric architectures may be offset by new thermal management challenges introduced by multiple heat sources formed by components in the hybrid-electric powertrain. Their approach consists of using integrated simulations of propulsive, thermal and flight dynamics models to account for interactions between these subsystems in order to arrive at optimal vehicle performance in the light of the prescribed TLARs. Variations in hybrid flight phases, e.g. when battery power will be used, has been examined to determine the optimum.

A more holistic approach towards the environmental assessment of a hybrid-electric aircraft design, taking other-than-CO₂ pollutants in-flight and on the ground into account as well as the expected fleet adoption, is described in (Scholz et.al, 2021). Taking into account production capacity and air traffic growth scenarios, an integrated methodology is developed to determine the climate impact of a given hybrid-electric aircraft concept on a fleet-wide scale. The methodology shows that the climate impact benefits of developing hybrid-electric aircraft strongly depend on achievable future technology levels, e.g. in battery technology. The methodology might be a good way to compare the environmental impact of different disruptive aircraft developments against those of hybrid-electric propulsion.

Notable results

An example of a matrix of advantages and disadvantages and best application of various propulsive powertrain types for different purposes is provided in (DLR, 2020). This matrix may serve as initial guideline for the selection of a drivetrain for a specific application. However, for each new application, further literature research, detailed analysis of drivetrain performance as well as design space exploration will be necessary to make sure that the appropriate choice is made and an optimum selection is achieved, given the contemporary state-of-the-art in (hybrid) electric aerospace technology.

Some roadmaps state that long-range aircraft require completely new configurational designs in order to be ready for hydrogen, see e.g. (McKinsey, 2020). This opens up the exploration of new aircraft configurations including BWB and involving a mix of propulsive and aircraft innovations.

Integrated thermal, energy and power management is a key aspect in (hybrid) electric aircraft configurations and needs to be entered in a sufficiently early design phase, see e.g. (Abolmoali et.al., 2020), (Kratz et.al., 2019).

Candidate configurations

Based on recent studies and plans for fixed-wing aircraft, a number of potential and recurring candidate configurations and propulsion systems emerge for current and future consideration and for different operational payloads and ranges, including:

- Airbus ZEROe liquid hydrogen-based concepts (Airbus, 2020):
 - Regional hybrid-hydrogen turboprop aircraft, up to 100 passengers, cruise Mach number $M_{cr}=0.5$.
 - Small to medium range (SMR) hybrid-hydrogen turbofan aircraft, up to 200 passengers, $M_{cr}=0.78$.
 - SMR hybrid-hydrogen turbofan-driven blended wing body (BWB), up to 200 passengers, $M_{cr}=0.78$. Due to the inherently higher aerodynamic efficiency of a BWB over a conventional tube-and-wing aircraft, the range of a BWB is larger for similar payload.
 - A low-speed electric propeller commuter aircraft for short range with “pods”, containing propeller, motor, fuel cells, LH2 tank and auxiliary systems.
- Boeing Subsonic Ultra Green Aircraft Research (SUGAR) studies relative to a reference aircraft denoted SUGAR free which is a 737-sized aircraft configuration (Bradley et.al., Subsonic Ultra Green Aircraft Research: Phase I Final Report, 2011):
 - Refined SUGAR, a conventional configuration using 2030 technology status.
 - SUGAR High, a configurations with high-mounted slender wing, extended span width, strut-braced for strength, conventional optimized turbofan propulsion.
 - SUGAR Volt, similar to SUGAR High, however with electrical propulsion options (several have been studied: battery all-electric, fuel-cell gas turbine hybrid, battery electric gas turbine hybrid).
 - SUGAR Ray, a BWB with propulsion similar to SUGAR High. Primary design emphasis is on noise reduction.
- NASA studies (Brelje & Martins, 2019):
 - X-57 Maxwell, a 2-seat flying testbed for distributed electric propulsion using battery power.
 - STARC-ABL, a 154 passenger single-aisle turbo-electric aircraft with aft fuselage boundary layer ingestion propulsor.
 - N3-X, a 300 passenger BWB with turbo-electric propulsion employing superconducting technology, similar in payload and range as a Boeing 777.
- Other developments:
 - Heart Aerospace ES-19 Hero commuter class propeller aircraft, 19 passengers, fully electric, battery power (HEART Aerospace, 2020).
 - Zunum Aero ZA10, 12 passengers, series hybrid electric propulsion using two ducted fans.
 - Wright Electric Wright 1, 186 passengers, fully electric, distributed propulsion using about 10-14 motors, battery power, range 300 nm.
 - Eviation Alice, 9 passengers, fully electric, battery power.

This list is not exhaustive and further promising configurational changes can be envisaged, based on new mixes of concepts and progress in state-of-the-art of power sources and propulsion systems. Expectations regarding future scenarios and cost developments may influence the viability of choices.

11 Conclusions and recommendations

This literature study has been executed with the objective to identify

1. sustainable alternative energy sources to be used on-board aircraft for propulsion, with their production routes, and
2. associated novel propulsion technology

with the objective to contribute to the stringent Flightpath 2050 goals for gaseous emissions of aviation: 75% CO₂ emissions reduction and 90% NO_x emissions reduction (with respect to capabilities of typical new aircraft in 2000) complementary to Clean Sky 2 and to contribute to climate neutrality for aviation in line with the European Green Deal.

In Section 11.1 the conclusions on alternative energy sources are given. In Section 11.2 the conclusions are presented on novel propulsion technology for aircraft using the alternative on-board energy sources. These conclusions also address the impact on air transport. Finally, a recommendation for further evaluation is given in Section 11.3.

11.1 Alternative energy sources

The study aimed to identify potential SAFs for aviation in the 2021-2050 time-horizon and the most sustainable production routes based on their techno-economic and environmental performance, see Chapter 2. SAFs have been divided into two groups based on their possibility to be directly used for the aircraft propulsion: drop-in (bio-jet fuels and e-fuels or PtL) and non-drop-in (hydrogen). The revision methodology was developed to identify and select sustainability criteria presented in EU initiatives, policies, and sustainability certification schemes, Section 2.4. According to the reviewed literature, three major criteria for sustainability evaluation have been taken for the further assessment of SAFs production routes: technological maturity or TRL level, economic (production cost) and environmental performance (GHG emissions). The sustainability analysis of SAFs production routes has been done through collecting and evaluating existing data regarding three criteria. Data collection was done by a literature review of published sources (e.g., articles, reports, conference proceedings, etc.). The developed methodology of literature study and obtained results have been presented at the online workshop on October 15th, 2020. The workshop aimed to align the results of the literature study with expert opinions and collect controversial comments from experts to adjust the existing study results. As an outcome of the experts' workshop, the TRANSCEND TU Delft team has gathered ideas and expertise, which were integrated into decision-making process of preselection of SAFs.

The literature review showed that the most developed production routes are biobased. PtL has taken a second position and could be expected to enter market rather sooner than later (Table 11-1). However, hydrogen production routes still require significant research and development and could be expected to enter market only in long-term perspective. Experts were highly positive for biobased SAFs production routes to find acceptance in the market as soon as possible, because of recent policy developments in aviation field and on EU level. Regarding PtL and hydrogen, experts questioned the rapid deployment of routes due to availability of renewable electricity to supply production facilities as well supply/demand issue of the final product. The issue should be considered as such technologies DF, PhL, PF have small production rate, which will not be able to contribute to existing high production scales production routes, such as AE, PEM, SOEC, etc.

As additional criteria, economic performance also showed that biobased SAFs are more likely to be a competitive and sustainable alternative option for existing jet fuels, especially those that already have ASTM certification (Table 11-1).

They have gone through technological learning coupled with a continuous biofuel policy support, which resulted in a low production cost. On another hand, e-fuels and hydrogen production routes are novel technologies, which have recently entered the market and are still going under major changes in terms of technological upgrade and development. Therefore, they are expected to enter the market in the mid-term. Both e-fuel and hydrogen production are strongly interlinked with the changes in electricity prices coming from renewables market development (IRENA, 2016).

GHG performance shows that most SAF production routes have lower emissions than those from Jet A-1, which is roughly equal to 83.8 gCO_{2eq}/MJ as per EU RED II (EC DIRECTIVE, 2009). Outstanding-high single emission points are from the ASTM approved biobased SAFs production routes related to the HEFA process, which was discussed in details under Section 3.6. Those high emission points come from the HEFA processes with high LUC crops (e.g. soy bean). Power-to-Liquid pathways have the lowest range of CO₂ emissions since they use renewable energy for green electricity production. However, PtL production routes also use captured CO₂ as an additional input for e-fuel production. This input proportionally reduces the total GHG emissions range, therefore PtL production routes have lower total GHG emissions compared to the hydrogen production routes. Hydrogen production routes have a low range of CO₂ emissions as well, due to the involvement of RES technologies into the production lines (Table 11-1).

As a general trend, drop-in fuels have higher TRL and lower production costs. However, PtL and hydrogen production routes are promising ones in a long term due to their outstanding GHG performance, and they could be expected to decrease production costs of fuels due to the continuous technological improvement of the technologies (Sections 3.9.2 and 4.10.2).

Table 11-1: Comparison technical, economic and GHG performances of drop-in and non-drop-in SAFs production routes based on literature study and Workshop outcomes

Abbreviation	Group of SAFs production routes	Product	Timeframe to come to market*	Economic Performance, USD/MJ	GHG performance, gCO ₂ /MJ
HEFA	Hydro-processed Esters and Fatty Acids	Bio-jet fuel	near-	average	low
HFS	Hydro-processed Fermented Sugars	Bio-jet fuel	near-	low	low
FT	Fischer-Tropsch	Bio-jet fuel	near-	average	high
HTL	Hydrothermal Liquefaction	Bio-jet fuel	medium-	high	average
FP	Fast Pyrolysis	Bio-jet fuel	medium-	high	average
ATJ	Alcohol to Jet	Bio-jet fuel	medium-	average	average
IH ²	Integrated Hydropyrolysis and Hydroconversion	Bio-jet fuel	long-	high	average
PTL	Power-to-Liquid (Fischer-Tropsch)	E-fuel	near-	low	high
BG	Biomass gasification	LH2	long-	average	average
MEC	Microbial Electrolysis Cell	LH2	medium-	average	low
AE	Alkaline electrolysis	LH2	medium-	low	high
PEM	Proton exchange membrane electrolysis	LH2	medium-	low	high
SOEC	High-temperature solid oxide electrolyzer cell	LH2	medium-	low	low
TWS	Thermochemical Water Splitting	LH2	medium-	high	high

*near- (years: from 2021 until 2025); medium- (years: from 2025 until 2035); long- (years: from 2035 until 2050)

The aim of the literature review and Workshop outcomes was to identify potential 5 SAFs for aviation in 2021-2050 time-horizon and the most sustainable production routes based on their techno-economic and environmental performance. In both cases biobased fuels are found to be the most promising option in the short term for the energy transition in aviation due to their applicability with the current aircraft infrastructure. However, since IH², HDO, and CH production routes are currently under technological research and development, they still require technological

adjustments as well as certification. HFS has a high production cost range and high GHG range compared to other SAFs production routes. ATJ and FT production routes have similar economic and GHG performance. However, ATJ process does not have much advancement in the technical development recently and has a broader range of the GHG emissions compared to the FT production routes (ATJ uses sugar-rich feedstocks (i.e. sugarcane juice), which are associated with higher GHG emissions). Among all the bio-jet routes, HEFA is the one with the highest technological maturity, and relatively good economic and environmental performance (excluding high LUC crops), which could also be adjusted based on the choice of the feedstock. FP and HTL are both thermochemical routes in principle, employ the same kind of feedstocks and have shown the best economic and environmental performance. TRANSCEND could endorse continuing with both of them due to their good economic and GHG performances, as well as similarities. However, FP production routes have been more widely studied leading to more data available in the literature on it. Therefore, TRANSCEND has decided to exclude HFS, HDO, CH and ATJ from the pre-selected list, and decided to continue with three bio-jet production routes: HEFA, FT and FP (Table 11-2).

E-fuels are complementary and quite promising SAFs to enter fuels market in the near future due to its good GHG performance, usage of renewable energy and CO₂ capture. However, MeOH does not have a lot of data available regarding economic and GHG performance in the literature as well as PtL MEOH is still under ASTM certification procedure (Table 3-2), which makes it out of the scope for the further study (Table 11-2).

In the case of hydrogen as SAF, although it would require significant changes in the aircraft infrastructure, it has found support from the energy communities and European governments to be used as a fuel (McKinsey, 2020). At present, many of the hydrogen production routes are under development, such as Biomass Gasification, Fermentation, Photolysis or Photo electrolysis. All of them still require more technological adjustments and modification and have been taken out of the preselection process since they have very low production scale, which make them almost impossible to contribute to the expected demand for hydrogen production in the mid- and long-term horizon. The most promising routes for hydrogen production are routes based on the electrolysis technologies coupled with RES electricity, such as PEM, MEC, SOEC, Thermolysis and Alkaline electrolysis. From the literature review, alkaline electrolysis is available now and has continued technology development, therefore it could be assumed that it will be the first available at the market. PEM and SOEC electrolysis are the second most developed technologies and will be able to come to the market in the mid-long-term horizon (Table 11-2).

Table 11-2: Preselection of SAFs production routes

Abbreviation	Group of SAFs production routes	Product	TRANSCEND TU Delft team preselection*
HEFA	Hydro-processed Esters and Fatty Acids	Bio-jet fuel	✓
HFS	Hydro-processed Fermented Sugars	Bio-jet fuel	✗
FT	Fischer-Tropsch	Bio-jet fuel	✓
HTL	Hydrothermal Liquefaction	Bio-jet fuel	!
FP	Fast Pyrolysis	Bio-jet fuel	✓
ATJ	Alcohol to Jet	Bio-jet fuel	!
IH ²	Integrated Hydropyrolysis and Hydroconversion	Bio-jet fuel	✗
PtL	Power-to-Liquid (Fischer-Tropsch)	E-fuel	✓
BG	Biomass gasification	LH2	✗
MEC	Microbial Electrolysis Cell	LH2	✗
AE	Alkaline electrolysis	LH2	✓
PEM	Proton exchange membrane electrolysis	LH2	!
SOEC	High-temperature solid oxide electrolyzer cell	LH2	✗
TWS	Thermochemical Water Splitting	LH2	!

Based on the points collected from the literature review, Workshop, and online survey the following 5 preselected SAF production routes have been chosen (Table 11-2):

- Hydro-processed Esters and Fatty Acids (HEFA)
- Fischer-Tropsch (FT)
- Fast Pyrolysis (FP)
- Power-to-Liquid (FT)
- Alkaline electrolysis (AE)

The experts' Workshop was useful to collect their ideas and additional suggestions for further research and developments of the study. They pointed out that ASTM certification will become faster from a technological perspective, but limitations can occur, such as additional financial investments to support fuel certification procedures and existing frameworks to support fuel approvals, technological complexity of the production routes. As well as GHG performance strongly depends upon the choice of the feedstocks and local conditions. Moreover, the availability of renewable power is limited for PtL and hydrogen production, therefore the short-term focus should preferably be on the development of more energy-efficient routes, i.e. bio-jet ones. Additionally, the approach of integrating biofuels production routes into existing refineries is likely applicable to a small share of SAF options that is not likely to contribute significantly to aviation decarbonization. This approach does little to facilitate the rapid deployment of advanced lignocellulosic SAFs.

11.2 Novel propulsion for aircraft using alternative energy sources

The main classes of novel propulsion concepts identified in the document are shown in Table 11-3.

The novel propulsion concepts have been described in more detail in the preceding chapters. The descriptions also include the integration of the propulsion concept in aircraft.

The aircraft integration aspects are shown in Table 11-4. The integration into aircraft provides in some cases further opportunities to increase energy efficiency (as for propulsion concepts that may be involve distributed propulsion using electromotors with boundary layer ingestion, which is denoted by x in Table 11-4). In other cases adaptations need to be made to the aircraft for integration of the propulsion concept, such as the integration of potentially large LH₂ tanks for hydrogen-powered aircraft. Typically most novel propulsion concepts add weight, but also additional energy efficiency improvement of the airframe and aircraft systems is needed. Moreover, scarcity and cost of SAFs urge for energy efficiency improvements at aircraft level.

To distinguish between the application of the propulsion technology in the fleet, the negative environmental impact on the novel propulsion technology due to weight and volume increases is estimated roughly and relatively in Table 11-4. Boundaries between low, medium, and high are not defined, since there can be quite some variation in volume and weight impact within a class; in a class depicted with low negative impact some propulsion technologies may actually have some positive impact (e.g., replacing a component of a drop-in SAF gas turbine by a similar component made of a novel, lighter material).

Table 11-3: Overview of the main classes of novel propulsion concepts for large passenger aircraft (100+-seats) with entry-into-service 2035-2050, as described in the report. These include propulsion concepts for other aircraft that are building blocks for large passenger aircraft. The propulsion concepts are distinguished by their energy sources, shaft driving devices, and other means for conversion of on-board propulsive energy. HE stands for hybrid-electric, i.e., involving both gas turbines and electromotors

Chapter	Propulsion concept (class)	On-board energy source	drop-in SAF	LH2	electricity from battery	Shaft driving devices	gas turbine	electromotor	On-board energy conversion	generator	fuel cell
6	drop-in SAF gas turbine		x				x				
7	H2 combustion gas turbine			x			x				
8	electric battery				x			x			
8	electric fuel cell			x				x			x
9	HE turbo-electric		x				x	x		x	
9	HE drop-in SAF		x		x		x	x		x	
9	HE hydrogen			x			x	x		x	x

An overview of resulting CO₂ and NO_x emissions from flight is shown in Table 11-4. All novel propulsion technologies have potential to reduce CO₂ and NO_x emissions during flight, even down to zero. The impact of other emissions on climate, like water vapor from hydrogen-powered aircraft, requires further detailed study in order to appropriately implement the use of hydrogen in aviation, e.g. by flight altitude limitations and restrictions, which impact air transport.

The novel propulsion concepts listed in

Table 11-4 are already addressed in roadmaps. Some first preliminary conceptual studies, comparing different conceptual options, have appeared, mostly for kerosene (or drop-in SAF) based propulsion. Roadmaps, comparative studies, and aircraft level evaluation have been indicated in the preceding chapters.

Based on the literature, bottlenecks (technological, economical, and social (including environmental)) and technological enablers for the novel propulsion concepts have been summarised as well in the preceding chapters.

Roadmaps show that, within the time frame 2030-2050, most novel propulsion technologies are likely to enter into service in tube-and-wing aircraft configurations. Potential diversification of novel propulsion technologies in seat classes for tube-and-wing configurations is indicated by x in Table 11-4. The large passenger aircraft category (100+-seats) has been split in two subcategories with the boundary at 350 seats. The impact of novel propulsion concepts on weight and volume may reduce the payload and/or range of these tube-and-wing configurations for all propulsion concepts with “H” or “M” in Table 11-4. Research on alternative aircraft configurations such as blended wing body is therefore needed well before 2030. Such configurations require major changes in methods, tools, regulations, and means of compliance on aircraft level.

Table 11-4: Novel propulsion concepts and related aircraft configuration changes, aircraft emissions during flight, and diffusion of propulsion concepts into aircraft seat classes for tube-and-wing configurations. Aircraft configuration changes concern propulsion concepts for which distributed propulsion with boundary layer ingestion may contribute to additional benefits at aircraft level, impact at aircraft level in terms of increased volume and weight due to novel propulsion concepts (H = high, M = medium, L = low), and the need for additional energy efficiency increase at aircraft level. Aircraft emissions during flight indicate the reduction potential for CO₂ and NO_x emissions (x: denotes potential for reduction, 0 denotes zero emission). The diffusion into aircraft seat classes distinguishes between large passenger aircraft and other aircraft categories

Chapter	Propulsion concept (class)	A/c configuration changes	distributed propulsion/BLI	volume impact	weight impact	energy efficiency increase needed	Emissions during flight	CO ₂ emissions	NO _x emissions	A/c seat classes (tube-wing configs)	small, including rotorcraft	regional	large a/c: single aisle, small twin aisle	large a/c: large twin aisle
6	drop-in SAF gas turbine			L	L	x		x	x			x	x	x
7	H ₂ combustion gas turbine			H	L	x		0	x				x	
8	electric battery		x	M	H	x		0	0		x			
8	electric fuel cell		x	H	M	x		0	0		x	x		
9	HE turbo-electric		x	L	L	x		x	x			x	x	x
9	HE drop-in SAF		x	L	M	x		x	x			x	x	x
9	HE hydrogen		x	H	L	x		0	x			x	x	

Disruptive aircraft and propulsion design, testing and certification requires not only new technologies but also the availability of appropriate methods, tools, and regulations, and means of compliance.

The introduction of novel propulsion technologies and alternative energy sources may have impact beyond the fleet level. If the number of passengers and the range per flight needs to be adjusted to contemporary technological standards, the impact of the increased number of stops due to shorter legs per energy charge has impact on air transport level.

The introduction of liquid hydrogen as an aviation fuel has a significant impact on airport infrastructure, facilities and logistics. Hydrogen liquefaction, its associated additional energy needs, storage and handling, and aircraft turn-around times for refueling impact the airport operations, safety and security, whereby aircraft turn-around time has also an impact on air transport level.

Policy measures are needed to achieve the Flightpath 2050 objectives and/or climate neutrality in 2050. This is typically addressed in roadmaps such as the recent Destination 2050 in which five aviation associations (A4E, ACI, ASD, ERA, and CANSO) have planned a route to achieve this for aviation based on a scientific study (van der Sman, Peerlings, Kos, Lieshout, & Boonekamp, 2021)).

11.3 Recommendation

The TRANSCEND project continues with further evaluation of alternative energy sources and novel propulsion. It is recommended to focus on the introduction of novel propulsion (e.g., high-level comparison of hydrogen combustion versus drop-in SAF based propulsion) at aircraft level and air transport level. This shall be considered in terms of environmental benefits of the novel propulsion during operation and in terms of ecological balance, economic viability, and availability of the energy sources. The evaluation of economic viability and availability should address not only the feedstock needed for production, but also renewable energy needed during production, taking into account the amount of energy that is needed for propulsion.

12 Acknowledgement and disclaimer

This project has received funding from the Clean Sky 2 Joint Undertaking (JU) under grant agreement No 864089. The JU receives support from the European Union's Horizon 2020 research and innovation programme and the Clean Sky 2 JU members other than the Union.

The document reflects only the author's views and the JU is not responsible for any use that may be made of the information it contains.



13 References

- (CS3PG), C. s. (2020). *Strategic research and innovation agenda - The proposed European partnership for Clean Aviation (draft version July 2020)*. Retrieved from <https://clean-aviation.eu>
- Abolmoali et.al., P. (2020). Integrated Propulsive and Thermal Management System Design for Optimal Hybrid Electric Aircraft Performance. *AIAA paper 2020-3557*.
- ACARE. (2011). *Flightpath 2050, Europe's Vision for Aviation*. Luxembourg: EC.
- Adrian O'Connell, M. K. (2019). Considerations on GHG emissions and energy balances of promising aviation. *Renewable and Sustainable Energy Reviews*, 504–515.
- Affonso et.al, W. (2019). Exergy and Exergoeconomic Comparative Analysis Between Conventional and Hybrid Electric Propulsion Systems for a Regional Aircraft. *AIAA paper 2019-3682*.
- Agency, N. (2012). *Sustainability certification for biomass*. NL Agency.
- Aigner et.al., B. (2020). An Integrated Design Framework for Aircraft with Hybrid Electric Propulsion. *AIAA paper 2020-1501*.
- Airbus. (2020, February 9). *E-FAN X*. Retrieved from <https://www.airbus.com/innovation/zero-emission/electric-flight/e-fan-x.html>
- Airbus. (2020). *ZEROe*. Retrieved from <https://www.airbus.com/innovation/zero-emission/hydrogen/zeroe.html>
- Airbus. (2021, 01 20). *These pods could provide a blueprint for future hydrogen aircraft*. Retrieved from <https://www.airbus.com/newsroom/stories/hydrogen-pod-configuration.html>
- Akbari, P. S. (2007). Recent Developments in Wave Rotor Combustion Technology and Future Perspectives: A Progress Review. *AIAA 2007-5055*.
- Alexander Zschocke, S. S. (2012). *High Biofuel Blends in Aviation (HBBA)*. Wehrwissenschaftliches Institut für Werk- und Betriebsstoffe.
- Ali Kecebaş, M. K. (2019). Electrochemical hydrogen generation. In *Solar Hydrogen Production* (pp. 299-317). Academic Press.
- Amin Mohammadi, M. M. (2018). Techno-economic analysis of hydrogen production by solid oxide electrolyzer coupled with dish collector. *Energy Conversion and Management*, 167-178.
- Anders Winther Mortensen, H. W. (2019). *Nordic GTL – a pre-feasibility study on sustainable aviation fuel from biogas, hydrogen and CO2*. NISA.
- Anderson, A. D. (2018). System Weight Comparison of Electric Machine Topologies for Electric Aircraft Propulsion. *AIAA Propulsion and Energy Forum*. Cincinnati.
- Andi Mehmeti, A. A.-D. (2018). Life Cycle Assessment and Water Footprint of Hydrogen Production Methods: From Conventional to Emerging Technologies. *Environments*.
- Anton, F. (2019). eAircraft: Hybrid-elektrische Antriebe für Luftfahrzeuge. *Technology14. Tag der Deutschen Luft- und Raumfahrtregionen*. Potsdam. Retrieved from Siemens corporate.
- ARA. (2020). *ARA-CH Technology*. Retrieved from Applied Research Associates: <http://www.readifuels.com/ARA-CH-technology.html>
- Associations, I. C. (2009). NON-DROP IN FUELS AND ADVANCED AIRCRAFT SYSTEM POWER TECHNOLOGIES. *CONFERENCE ON AVIATION AND ALTERNATIVE FUELS* (p. 6). Rio de Janeiro, Brazil: ICAO.
- ASTM (2). (2020). *F2490-20 Standard Guide for Aircraft Electrical Load and Power Source Capacity Analysis*. West Conshohocken, PA: ASTM International. Retrieved from www.astm.org
- ASTM. (2020). *ASTM, About Us*. Retrieved from ASTM : <https://www.astm.org/ABOUT/overview.html>
- ASuMED - *Advanced Superconducting Motor Experimental Demonstrator*. (2021, 01 20). Retrieved from <http://www.asumed.oswald.de/index.php>
- ATAG. (2017, November 3). *Beginner's Guide to Sustainable Aviation Fuel*.

- ATAG. (2020). *Balancing growth in connectivity with a comprehensive global air climate emergency*. ATAG.
- ATAG. (2020). *Waypoint 2050: Balancing Growth in Connectivity with a Comprehensive Global Air Transport Response to the Climate Emergency*.
- Avigail Landman, R. H. (2019). Decoupled Photoelectrochemical Water Splitting System for Centralized Hydrogen Production. *Joule*, 448–471.
- B. Parkinson, P. B. (2019). Levelized cost of CO₂ mitigation from hydrogen production routes. *Energy & Environmental Science*, 19-40.
- Bart Strengers, H. E. (2020). *AVAILABILITY AND APPLICATIONS OF SUSTAINABLE BIOMASS*. The Hague: PBL.
- Bauhaus Luftfahrt. (2021, 01 20). *Exploring the frontiers of battery technology*. Retrieved from <https://www.bauhaus-luftfahrt.net/en/research/energy-technologies-power-systems/exploring-the-frontiers-of-battery-technology/>
- BBC. (2017, June 27). *Ant power: Take a ride on a bus that runs on formic acid*. Retrieved from BBC news: <https://www.bbc.com/news/business-40403351>
- Becky Mawhood, E. G. (2016). Production pathways for renewable jet fuel: A review of commercialization status and future prospects. *Biofuels Bioproducts and Biorefining Advance online publication*.
- Bensadoun, E. (2015). *Hydrogen Storage on board aeronef and ground infrastructure*. Air Liquide.
- Bhupendra Khandelwal, S. R. (2014). Comparison of Vibrations and Emissions of Conventional Jet Fuel with Stressed 100% SPK and Fully Formulated Synthetic Jet Fuel. *aerospace*, 52-66.
- Bioeconomy, T. E. (2019). *Brief on biomass for energy in the European Union*. European Union.
- Bob Flach, S. L. (2019). *EU Biofuels Annual 2019*. USDA Foreign Agricultural Service.
- Bradley et.al., M. (2011). *Subsonic Ultra Green Aircraft Research: Phase I Final Report*. NASA/CR-2011-216847.
- Bradley et.al., M. (2012). *Subsonic Ultra Green Aircraft Research Phase II: N+4 Advanced Concept Development*. NASA/CR-2012-217556.
- Bradley et.al., M. (2015). *Subsonic Ultra Green Aircraft Research: Phase II - Volume I - Truss Braced Wing Design Exploration*. NASA/CR-2015-218704/Volume I.
- Bradley et.al., M. (2015-2). *Subsonic Ultra Green Aircraft Research: Phase II - Volume II - Hybrid Electric Design Exploration*. NASA/CR-2015-218704/Volume II.
- Brelje, B., & Martins, J. (2019). Electric, Hybrid, and Turboelectric Fixed-Wing Aircraft: a Review of Concepts, Models, and Design Approaches. *Progress in Aerospace Sciences* 104, 1-19.
- Brink, R. (2011). *Fuel Flexibility of Gas Turbines*. NLR-TR-2011-114.
- Bruce, P. G. (2012, December 15). Li-O₂ and Li-S batteries with high energy storage. *Nature Materials*, pp. 19-29.
- Bruno, C. (2012). Nuclear Propulsion. In *Fluid Dynamics, Computational Modeling and Applications*. Roma: ResearchGate.
- C.Yang, R. B. (2016). 5 - Biomass harvesting and collection. *Biomass Supply Chains for Bioenergy and Biorefining*, 103-125.
- CAAFI. (2018, March). *Feedstock List (as of 3/2018)*. Retrieved from CAAFI: http://www.caafi.org/focus_areas/docs/CAAFI_Feedstock_List_02_2018.pdf
- CAAFI. (2018). *Feedstock List (as of 3/2018)*. Retrieved from CAAFI: http://www.caafi.org/focus_areas/docs/CAAFI_Feedstock_List_02_2018.pdf
- CAAFI. (2019, January 11). *Commercial Aviation Alternative Fuels Initiative*. Retrieved from Fuel Qualification: http://caafi.org/focus_areas/fuel_qualification.html#approved
- CAAFI. (2020). *Feedstock Readiness Level*. Retrieved from CAAFI: [http://www.caafi.org/tools/Feedstock_Readiness_Level.html#:~:text=The%20Feedstock%20Readiness%20Level%20\(FSRL,to%20make%20alternative%20jet%20fuels](http://www.caafi.org/tools/Feedstock_Readiness_Level.html#:~:text=The%20Feedstock%20Readiness%20Level%20(FSRL,to%20make%20alternative%20jet%20fuels)
- CAAFI. (2020). *Feedstocks*. Retrieved from CAAFI: http://www.caafi.org/focus_areas/feedstocks.html
- CAAFI. (2020). *Fuel Qualification*. Retrieved from CAAFI: http://www.caafi.org/focus_areas/fuel_qualification.html

- CAAFI. (2020). *Fuel Qualification*. Retrieved October 12, 2020, from http://www.caafi.org/focus_areas/fuel_qualification.html
- Canteenwalla, P. D. (2016). Testing of Synthesized Aromatic Kerosene (SAK) Aviation Fuel Blends at Simulated Altitudes. *ASME Turbo Expo*.
- Carina Faber, Y. A.-R. (2019). *Technological Roadmap*. Sunrise.
- Carlotta Panzone, R. P. (2020). Power-to-Liquid catalytic CO₂ valorization into fuels and chemicals: focus on the Fischer-Tropsch route. *Journal of CO₂ Utilization*, 314–347.
- CAS. (2020). Retrieved from <https://www.nasa.gov/aeroresearch/programs/tacp/cas/activities>
- CENTRELINE. (2017). Retrieved from <https://www.centreline.eu/innovation/>
- Chu, P. L. (2017). Process modeling of hydrodeoxygenation to produce renewable jet fuel and other hydrocarbon fuels. *Fuel*.
- Clean Aviation. (2020). *Strategic Research and Innovation Agenda - The Proposed European Partnership on Clean Aviation*.
- Clean Sky 2 Governing Board. (2019). *Decision of the Governing Board adopting the Bi-annual Work Plan and Budget 2020-2021*. JU Clean Sky.
- Clean Sky. (2017). *Clean Sky 2 Joint Undertaking Development Plan*.
- CleanAviation. (2020). *Strategic research and innovation agenda*. DLR.
- CleanHydrogen. (2020). *Draft proposal for a European Partnership under Horizon Europe Clean Hydrogen for Europe*. European Commission. Retrieved from https://ec.europa.eu/info/sites/info/files/ec_rtd_he-partnerships-clean-hydrogen_0.pdf
- CLEEN. (2019). Retrieved from https://www.faa.gov/about/office_org/headquarters_offices/apl/research/aircraft_technology/cleen/
- Commission, E. (2019, March 13). *Report on the status of production expansion of relevant food and feed crops worldwide*. Retrieved from European Commission: <https://eur-lex.europa.eu/legal-content/EN/TXT/?qid=1558977620744&uri=CELEX:52019DC0142>
- Co-processing in refineries. (2020, November). Retrieved from ETIP Bioenergy: <https://www.etipbioenergy.eu/value-chains/conversion-technologies/advanced-technologies/co-processing-in-refineries#:~:text=Definition,production%20of%20renewable%20hydrocarbon%20fuels.>
- Cumpsty, N. (2009). Preparing for the future: reducing gas turbine environmental impact. *ASME Turbo Expo 2009 GT2009-60367*.
- D.S. Lee, D. A. (2021). The contribution of global aviation to anthropogenic climate forcing for 2000 to 2018. *Atmospheric Environment*. Retrieved from <https://www.sciencedirect.com/science/article/pii/S1352231020305689>
- Dahbia Akroum-Amrouche, N. A. (2013). Biohydrogen production by dark and photofermentation processes. *IEEE*.
- Daniel C.Aiken, T. P. (2019). Avenues to the financial viability of microbialelectrolysis cells [MEC] for domestic wastewatertreatment and hydrogen production. *International Journal of Hydrogen Energy*, 2426-2434.
- Day, R. (2019, December 6). *Jet Engine Makers Cast an Eye on Nuclear Power for Help Making Cleaner Fuel*. Retrieved July 16, 2020, from Karma: <https://karmaimpact.com/jet-engine-makers-cast-an-eye-on-nuclear-power-for-help-making-cleaner-fuel/>
- Deign, J. (2020, November 2). *Why Aren't Falling Renewables Costs Cutting European Energy Market Prices?* Retrieved from gtm:: <https://www.greentechmedia.com/articles/read/why-arent-lower-renewable-costs-cutting-european-energy-market-prices>
- DisPURSAL. (2013). Retrieved from <http://www.dispursal.eu/>
- DLR. (2020). *Zero Emission Aviation - German Aviation Research White Paper*. Cologne: DLR.

- DOE Technical Targets for Onboard Hydrogen Storage for Light-Duty Vehicles. (2020). Retrieved from Energy efficiency and Renewable Energy: <https://www.energy.gov/eere/fuelcells/doe-technical-targets-onboard-hydrogen-storage-light-duty-vehicles>
- E. Shayan, V. Z. (2018). Hydrogen production from biomass gasification; a theoretical comparison of using different gasification agents. *Energy Conversion and Management*, 30-41.
- EASA. (2020). *TRL and FRL of the six production pathways certified by ASTM for use in commercial flights*. Retrieved from EASA: <https://www.easa.europa.eu/eaer/figures-tables/trl-and-frl-six-production-pathways-certified-astm-use-commercial-flights>
- EASA. (n.d.). *Sustainable Aviation Fuels*. Retrieved July 16, 2020, from European Union Aviation Safety Agency : <https://www.easa.europa.eu/eaer/climate-change/sustainable-aviation-fuels>
- EASA, EEA, & EUROCONTROL. (2019). *European Aviation Environmental Report 2019*.
- EASA/EU. (2020). *Updated analysis of the non-CO2 climate impacts of aviation and potential policy measures pursuant to EU Emissions Trading System Directive Article 30(4)*.
- EASN. (2020, April). FutPrint50. *EASN news letter*.
- EC. (2014-2015). *HORIZON 2020 – WORK PROGRAMME 2014-2015*. EC.
- EC. (2015). *Hydrogen storage standardisation and components optimization for mass production*. Retrieved from EC: https://cordis.europa.eu/programme/id/H2020_FCH-01.4-2014/it
- EC. (2016, August 9). *Guidance to report on land use, land-use change and forestry emissions*. Retrieved from EU SCIENCE HUB: <https://ec.europa.eu/jrc/en/news/guidance-report-land-use-land-use-change-and-forestry-emissions>
- EC. (2017). *Sustainable and optimal use of biomass for energy in the EU beyond 2020*. European Commission.
- EC. (2018, January 1). *Innovative Photoelectrochemical Cells for Solar Hydrogen Production*. Retrieved October 12, 2020, from <https://cordis.europa.eu/project/id/760930>
- EC. (2018, November 7). *Thermochemical Hydrogen Production from Concentrated Sunlight*. Retrieved October 12, 2020, from https://cordis.europa.eu/programme/id/H2020_FCH-02-4-2018
- EC. (2020, December 11). *A European Green Deal*. Retrieved from European Commission: https://ec.europa.eu/info/strategy/priorities-2019-2024/european-green-deal_en
- EC. (2020, December 11). *The European Green Deal sets out how to make Europe the first climate-neutral continent by 2050, boosting the economy, improving people's health and quality of life, caring for nature, and leaving no one behind*. Retrieved from European Commission: https://ec.europa.eu/commission/presscorner/detail/en/ip_19_6691
- EC DIRECTIVE. (2009). *DIRECTIVE 2009/28/EC*. European Commission. Official Journal of the European Union. doi:<https://eur-lex.europa.eu/LexUriServ/LexUriServ.do?uri=OJ:L:2009:140:0016:0062:EN:PDF>
- EC Directive 2009/28/EC. (2009). *DIRECTIVE 2009/28/EC*. European Commission. Official Journal of the European Union. doi:<https://eur-lex.europa.eu/LexUriServ/LexUriServ.do?uri=OJ:L:2009:140:0016:0062:EN:PDF>
- Ecofys. (2019). *Technical assistance in realisation of the 2018 report on biofuels sustainability*. Ecofys.
- EcoPulse. (2020). Retrieved from <https://www.safran-group.com/media/ecopulsetm-hybrid-aircraft-demonstrator-achieves-its-first-key-milestone-success-20201210>
- Ed de Jong, R. J. (2014). Lignocellulose-Based Chemical Products. *Bioenergy Research: Advances and Applications*.
- Elitsa Chorbadzhiyska, Y. H. (2011). Microbial electrolysis cells as innovative. *Workshop: "Renewable Energy Technologies"*, (pp. 422-427).
- EMISSIONS REPORTING. (2018, Decemebr 8). Retrieved from Climate Change Connection: <https://climatechangeconnection.org/emissions/ghgdatareporting/>
- Emrah Sağır, P. C. (2019). Photofermentative Hydrogen Production. In *Biohydrogen (Second Edition): Biomass, Biofuels, Biochemicals* (pp. 141-157). Elsevier.
- Energy Transitions Commission. (2019). *Mission Possible - Sectoral Focus: Aviation*.

- Energy, U. D. (2020). *Hydrogen Production: Electrolysis*. Retrieved from Energy Efficiency and Renewable Energy: <https://www.energy.gov/eere/fuelcells/hydrogen-production-electrolysis>
- Epstein, A. (2013). *Aeropropulsion for Commercial Aviation in the 21st Century. 51st AIAA Aerospace Sciences Meeting AIAA 2013-0001*.
- Epstein, A. (2013). *Aeropropulsion for Commercial Aviation in the 21st Century and Research Directions Needed*. AIAA 2013-0001.
- Erik C. Wormslev, M. K. (2020). *Sustainable Jet Fuel for Aviation*. Nordic Energy Research. Retrieved from <https://www.nordicenergy.org/wp-content/uploads/2020/02/Sustainable-Jet-Fuel-Update-FinalNER.pdf>
- EU Emissions Trading System (EU ETS)*. (n.d.). Retrieved from EU-Climate Action: https://ec.europa.eu/clima/policies/ets_en
- EU-Climate Action. (2020, July 3). *Revision of the EU ETS Directive concerning aviation*. Retrieved from EU-Climate Action: https://ec.europa.eu/clima/policies/transport/aviation_en#:~:text=Revision%20of%20the%20EU%20ETS%20Directive%20concerning%20aviation&text=This%20initiative%2C%20planned%20for%20the,the%20EU's%202030%20climate%20objectives.
- Europe, H. (2020). *Strategic Research and Innovation Agenda - Final Draft*. Hydrogen Europe.
- European Commission. (2018, November 28). *A Clean Planet for all. A European strategic long-term vision for a prosperous, modern, competitive and climate neutral economy*. Brussels: European Commission.
- European Commission. (2020, March 19). *Voluntary schemes*. Retrieved from Biofuels: https://ec.europa.eu/energy/topics/renewable-energy/biofuels/voluntary-schemes_en?redir=1
- European Union. (2018). *Economy-wide material flow accounts: Hand book*. European Union.
- eurostat. (2020, November 18). Retrieved from <https://ec.europa.eu/eurostat/web/main/home>
- e-Volution*. (2016). Retrieved from <https://nag.aero/wp-content/uploads/2018/05/e-volution-Program-AERO-ENGINE-ROUND-TABLE-ELECTIFICATION-IN-PROPULSION-Introduction-20MAY2018v01.pdf>
- F. Troeltsch, V. B. (2020). *Re-Thinking the Long-Haul Air Transport Segment*. Bordeaux: Bauhaus Luftfahrt e. V.
- F. Dalena, A. A. (2017). 17 - Bioenergy production from second- and third-generation feedstocks. In *Bioenergy Systems for the future* (pp. 559-599). WP.
- F. Safari, I. (2020). A review and comparative evaluation of thermochemical watersplitting cycles for hydrogen production. *Energy Conversion and Management*.
- Farokhi, S. (2020). *Future Propulsion Systems and Energy Sources in Sustainable Aviation*. Wiley.
- FCH JU. (2017). *FUEL CELL AND HYDROGEN TECHNOLOGY: EUROPE'S JOURNEY TO A GREENER WORLD*. FCH JU.
- FCH, J. (2019). *Towards a Dual Hydrogen Certification System for Guarantees of Origin and for the Certification of Renewable Hydrogen in Transport and for Heating & Cooling*. JU FCH.
- Felder, J. (2015). NASA Electric Propulsion System Studies. *EnergyTech 2015*. Cleveland, OH.
- Finger et.al, D. (2020). Comparative Assessment of Parallel-Hybrid-Electric Propulsion Systems for Four Different Aircraft. *Journal of Aircraft, Vol. 57, No. 5*.
- Flüthmann, N., Junior, A., Leipold, A., Grimme, W., Gelhausen, M., & Zill, T. (2020). Clean Sky 2 Technology Evaluator. Aerospace Europe Conference 2020, paper 155.
- Fortuna, G. (2019, February 12). *Biofuels: Commission blacklists palm oil, throws soybeans lifeline*. Retrieved from Euroactiv: <https://www.euractiv.com/section/agriculture-food/news/biofuels-commission-blacklists-palm-oil-throws-soybeans-lifeline/>
- Friedemann G. Albrecht, D. H.-U. (2017). A standardized methodology for the techno-economic evaluation of alternative fuels – A case study. *Fuel*, 511-526.
- Futprint50*. (2021). Retrieved from <https://futprint50.eu/>

- Gardner, S. (2019, January 23). *Palm Oil's Loss May Be U.S. Soybean Gain in EU Biofuel Rule (1)*. Retrieved August 20, 2020, from Bloomberg: <https://news.bloomberglaw.com/environment-and-energy/palm-oils-loss-may-be-u-s-soybean-gain-in-eu-biofuel-rule-1>
- Gielen, D. (2019, May 28). *Where will we get our biojet?* Retrieved from IRENA: <https://www.irena.org/-/media/Files/IRENA/Agency/Events/2019/May/biojet-EUBCE/0-DolfGielen.pdf?la=en&hash=1FA1D387B23EA8DF00635733670D8CC1B0519DD2>
- Goldman. (2018). A study on electrofuels in aviation. *Energies, Vol. 11, No. 392*.
- Goldsmith, J. a. (1974). *Hydrogen-methane fuel control systems for turbojet engines*. NASA-CR-121247.
- Grau Baquero, B. E.-R. (2011). Use of Rapeseed Straight Vegetable Oil as Fuel Produced in Small-Scale Exploitations. *Biofuel's Engineering Process Technology*.
- Greig Chisholm, L. C. (2016). Chapter 16 - Hydrogen From Water Electrolysis. In *Storing Energy* (pp. 315-343). Elsevier.
- Grilli, F. e. (2019). Superconducting motors for aircraft propulsion: the Advanced Superconducting Motor Experimental Demonstrator project. *32nd International Symposium on Superconductivity*.
- Grönstedt, T., & et. al. (2016). Ultra low emission technology innovations for mid-century aircraft turbine engines. *ASME Turbo Expo 2016 GT2016-56123*.
- Grönstedt, T., Irannezhad, M., Lei, X., Thulin, O., & Lundbladh, A. (November 2013). First and second law analysis of future aircraft engines. *Journal of Engineering for Gas Turbines and Power*.
- Guittet, M. (2016). SUSTAINABILITY AND CERTIFICATION FOR AVIATION BIOFUELS. *ResearchGate*. Retrieved from <https://www.researchgate.net/publication/310376820>
- Günther Fischer, S. T.-R. (2019, January 24). *Sustainable Aviation Biofuel Feedstock Potential in sub-Saharan Africa*. INTERNATIONAL INSITUTE FOR APPLIED SYSTEMS ANALYSIS: WORLD WILDLIFE FUND FOR NATURE - SOUTH AFRICA. Retrieved from RSB: https://dtnac4dfluyw8.cloudfront.net/downloads/sustainable_biofuel_potential_ssaf_full_report.pdf
- Hanshu Ding, F. X. (2014). Production of Phytochemicals, Dyes and Pigments as Coproducts in Bioenergy Processes. *Bioenergy Research: Advances and Applications*.
- Harlow, E. J. (2019). A Wide Range of Testing Results on an Excellent Lithium-Ion Cell Chemistry to be used as Benchmarks for New Battery Technologies. *J. Electrochem. Soc.*, A3031-A3044.
- HASTECS. (2016). Retrieved from <https://cordis.europa.eu/project/id/715483/fr>
- HEART Aerospace. (2020). Retrieved from <https://heartaerospace.com/>
- HEATheR. (2020). Retrieved from https://www.nasa.gov/sites/default/files/atoms/files/heather_cas_fact_sheet_508.pdf
- HECARRUS. (2021). Retrieved from <https://www.hecarrus.eu/>
- Henke, R. a. (2020). *Zero emission aviation*.
- Hepperle. (2012). *Electric flight - potential and limitations*.
- HERA. (2020). Retrieved from <https://www.electricaviationgroup.com/electric-flight/>
- Hydrogen basics-storage*. (2014). Retrieved from Florida solar Energy Center: <http://www.fsec.ucf.edu/en/consumer/hydrogen/basics/storage.htm>
- IATA. (2015). *IATA Sustainable Aviation Fuel Roadmap*. IATA.
- Ibrahim Dincer, Y. B. (2020). Integration of nuclear energy systems for multigeneration. *Integrated Energy Systems for Multigeneration*.
- ICAO. (2018). *Sustainable Aviation Fuels Guide*. ICAO.
- ICAO. (2018). *Sustainable Aviation Guide*. ICAO.
- ICAO. (2019). *2019 Environmental Report*. Montréal: ICAO.
- ICAO. (2019, June). *CORSIA Eligible Fuels*. Retrieved from CORSIA supporting document — Life cycle assessment methodology: <https://www.icao.int/environmental->

protection/CORSIA/Documents/CORSIA%20Supporting%20Document_CORSIA%20Eligible%20Fuels_LCA%20Methodology.pdf

- ICAO. (2019). POWER-TO-LIQUIDS (PTL): SUSTAINABLE FUELS FOR AVIATION. *ASSEMBLY — 40TH SESSION - Agenda Item 16: Environmental Protection – International Aviation and Climate Change — Policy* (p. 5). International Civil Aviation Organization. Retrieved from https://www.icao.int/Meetings/a40/Documents/WP/wp_526_en.pdf
- ICAO. (2020). *Power-to-Liquid (PtL) for Aviation*. Retrieved from ICAO: <https://www.icao.int/environmental-protection/GFAAF/Pages/Project.aspx?ProjectID=46>
- IEA. (2019). *Energy Technology Perspectives 2020*. Paris: IEA.
- IEA. (2019). *Energy Technology Perspectives Special Report on Clean Energy Innovation 2020*. Paris: IEA.
- IEA. (2019). *The Future of Hydrogen: Seizing today's opportunities*. Paris: IEA. Retrieved from <https://webstore.iea.org/download/direct/2803>
- IEA. (2020). *Direct Air Capture*. Paris: IEA.
- IEA. (2020). *Hydrogen*. Paris: IEA.
- IEA. (2020). *Renewable energy market update: Outlook for 2020 and 2021*. Paris: IEA. Retrieved from <https://www.iea.org/reports/renewable-energy-market-update/covid-19-impact-on-renewable-energy-growth#abstract>
- IEA Hydrogen. (2018). *IEA-HIA Task 32 "Hydrogen-based Energy Storage", Hydrogen storage in porous materials*. Stuttgart: IEA Hydrogen.
- Ilker Yilmaz, M. I. (2012). Investigation of hydrogen usage in aviation industry. *Energy Conversion and Management*, 63-69. doi:<https://doi.org/10.1016/j.enconman.2011.12.032>
- IMOTHEP. (2020, February 9). Retrieved from <https://www.imothep-project.eu/>
- IPCC. (2019). *Climate Change and Land*. IPCC.
- IRENA. (2016). *THE POWER TO CHANGE: SOLAR AND WIND COST REDUCTION POTENTIAL TO 2025*. Abu Dhabi: IRENA.
- IRENA. (2019). *Global energy transformation: The REmap transition pathway (Background report to 2019 edition)*. Abu Dhabi: Renewable Energy Agency International.
- IRENA. (2019). *HYDROGEN: A RENEWABLE ENERGY PERSPECTIVE*. Abu Dhabi: International Renewable Energy Agency. Retrieved from https://www.irena.org/-/media/Files/IRENA/Agency/Publication/2019/Sep/IRENA_Hydrogen_2019.pdf
- ISCC. (2016). *Sustainability Requirements*. ISCC System GmbH.
- ISCC. (2017). *Guidance for the certification of co-processing*. ISCC System GmbH.
- Itaka. (2016). *INITIATIVE TOWARDS SUSTAINABLE KEROSENE FOR AVIATION*. Madrid: EC.
- J. Popp, Z. L.-R. (2014). The effect of bioenergy expansion: Food, energy, and environment. *Renewable and Sustainable Energy Reviews*, 559-578.
- Janic, M. (2014). Greening commercial air transportation by using liquid hydrogen (LH2) as a fuel. *International journal of Hydrogen energy*, 16426-16441. doi:<https://doi.org/10.1016/j.ijhydene.2014.08.011>
- Janina Scheelhaase, S. M. (2019). Synthetic fuels in aviation – Current barriers and potential political measures. *Transportation Research Procedia*, 21–30.
- Jansen, R. H. (2017). Overview of NASA Electrified Aircraft Propulsion Research for Large Subsonic Transports. *AIAA Propulsion and Energy 2017 Forum*. Atlanta, US: AIAA.
- Jasper, C. (2019, December 6). *Rolls-Royce Touts Nuclear Reactors as Key to Clean Jet Fuel*. Retrieved July 16, 2020, from Bloomberg: <https://www.bloomberg.com/news/articles/2019-12-06/rolls-royce-pitches-nuclear-reactors-as-key-to-clean-jet-fuel>
- Jeffrey R. Bartels, M. B. (2010). An economic survey of hydrogen production from conventional and alternative energy sources. *International Journal of Hydrogen Energy*, 8371-8384.

- Jingwei Chen, W. X. (2019). System development and environmental performance analysis of a pilotscale microbial electrolysis cell for hydrogen production using urbanwastewater. *Energy Conversion and Management*, 52-63.
- Jo De Vrieze, K. V. (2020). The hydrogen gas bio-based economy and the production of renewable building block chemicals, food and energy. *New Biotechnology*, 12-18.
- Jorg Gigler, M. W. (2018). *Outlines of a Hydrogen Roadmap*. TKI NIEUW GAS.
- JU, F. (2019). *A SUSTAINABLE PATHWAY FOR THE EUROPEAN ENERGY TRANSITION*. Fuel Cells and Hydrogen 2 Joint Undertaking.
- Kai-Hang Ye, H. L. (2019). Enhancing photoelectrochemical water splitting by combining work function tuning and heterojunction engineering. *nature communications*.
- Karl Hauptmeier, N. A. (2018). *Electrofuel / e-Fuel, Production Pathways and Costs*. sunfire. Retrieved from <https://iea.blob.core.windows.net/assets/imports/events/244/4KarlHauptmeier.pdf>
- Kharinta, M. (2020, 12 03). *A Closer Look at Tesla's New 4680 Cell Battery Pack*. Retrieved from FutureCar: <https://www.futurecar.com/4282/A-Closer-Look-at-Teslas-New-4680-Cell-Battery-Pack>
- Kopp, G., & Lean, J. L. (2011). A new, lower value of total solar irradiance: Evidence and climate significance. *Geophysical Research Letters*, 38. doi:10.1029/2010GL045777
- Körner, A. (2015). *Technology Roadmap Hydrogen and Fuel Cells*.
- Kos, J. (2019). *Transcend project: proposal*. NLR.
- Kratz et.al., J. (2019). Evaluation of Electrical System Requirements for Implementing Turbine Electrified Energy Management. *AIAA paper 2019-4502*.
- Kraytsberg, A. e. (2011). Review on Li-air batteries—Opportunities, limitations and perspective. *Journal of Power Sources*, 886-893.
- Kuan-Yeow Show, D.-J. L. (2013). Chapter 13 - Bioreactor and Bioprocess Design for Biohydrogen Production. In *Biohydrogen* (pp. 317-337). Elsevier.
- Kuan-Yeow Show, Y. Y.-J. (2019). Chapter 16 - Bioreactor and Bioprocess Design for Biohydrogen Production. In *Biohydrogen (second Edition)* (pp. 391-411). Elsevier.
- L.-F. Li, K. O. (2016). Genes and Evolution. *Current Topics in Developmental Biology*.
- Lee, D., Fahey, D., Skowron, A., Allen, M., Burkhardt, U., Chen, Q., . . . Wilcox, R. (2021). The contribution of global aviation to anthropogenic climate forcing for 2000 to 2018. *Atmospheric Environment*, 244. Retrieved from <https://doi.org/10.1016/j.atmosenv.2020.117834>
- Lehmann, H. (2018). *Power-to-Liquids – Potentials and Perspectives*. Energie wende.
- Li, G. e. (2018). Lithium-Sulfur Batteries for Commercial Applications. *Chem*, 4(1), 3-7.
- Lopez, C. V. (2020). Lithium-Sulfur Batteries: Advances and Trends. *Electrochem*, 1, 226-259.
- Ltd, E. (. (2019). *Study on the potential effectiveness of a renewable energy obligation for aviation in the Netherlands*. London: E4tech (UK) Ltd.
- Luca Mastropasqua, I. P. (2020). Solar hydrogen production: Techno-economic analysis of a parabolic dish-supported high-temperature electrolysis system. *Applied Energy*, 114392.
- Lvovich, V. (2018). Integrated Computational-Experimental Development of Lithium-Air Batteries for Electric Aircraft. *Annual Meeting of International Society of Electrochemistry*. Bologna: NASA.
- M. Voráček, J. K. (2013, May 02). Production and properties of alternative aviation fuels. *Magazine of Aviation Development (MAD)*, pp. 7-10. doi:HTTPS://DOI.ORG/10.14311/MAD.2013.05.02
- M.Harada, T. H. (2016). Building a hydrogen infrastructure in Japan. *Woodhead Publishing Series in Energy*, 321-335.
- M.Shahabuddin, B. B. (2020). Advances in the thermo-chemical production of hydrogen from biomass and residual wastes: Summary of recent techno-economic analyses. *Bioresource Technology*, 122557.
- MAHEPA. (2021). Retrieved from www.mahepa.eu

- Mai, T. (2012, October 28). *Technology Readiness Level*. Retrieved from NASA:
https://www.nasa.gov/directorates/heo/scan/engineering/technology/txt_accordion1.html
- Malins, C. (2017). *What role is there for electrofuel technologies in European transport's low carbon future?* Cerology.
- Mark Jeschke, A. H. (2020). *Sustainable Corn Stover Harvest for Biofuel Production*. Retrieved from Pioneer:
https://www.pioneer.com/us/agronomy/stover_harvest_biofuels.html
- Marker, T. L. (2012). Integrated hydrolysis and hydroconversion (IH 2) for the direct production of gasoline and diesel fuels or blending components from biomass, part 1: Proof of principle testing. *Environmental Progress and Sustainable Energy*.
- Marker, T. L.-T. (2014). Integrated hydrolysis and hydroconversion (IH2[®]) for the direct production of gasoline and diesel fuels or blending components from biomass, Part 2: Continuous testing. *Environmental Progress and Sustainable Energy*.
- Matthew R. Shaner, H. A. (2016). A comparative technoeconomic analysis of renewable hydrogen production using solar energy. *Energy & Environmental Science*, 2354-2371.
- Matthias Binder, M. K. (2018). *Hydrogen from biomass gasification*. IEA Bioenergy.
- Maximilian Decker, F. S. (2019). Off-grid power-to-fuel systems for a market launch scenario – A techno-economic assessment. *Applied Energy*, 1099-1109.
- Mayank Kumar, A. O. (2019). A comparative analysis of hydrogen production from the thermochemical conversion of algal biomass. *International Journal of Hydrogen Energy*, 10384-10397.
- Mazuchi, M. (2018). Life Cycle Assessment of Sugarcane Biorefinery. *Advances in Sugarcane Biorefinery*.
- McKinsey. (2020). *Hydrogen-powered aviation: A fact-based study of hydrogen technology, economics, and climate impact by 2050*. Belgium: The Print Agency. Retrieved May 21, 2020, from
https://www.fch.europa.eu/sites/default/files/FCH%20Docs/20200507_Hydrogen%20Powered%20Aviation%20report_FINAL%20web%20%28ID%208706035%29.pdf
- Meng Lin, S. H. (2017). Techno-economic modeling and optimization of solar-driven high-temperature electrolysis systems. *Solar Energy*, 1389-1402.
- Merriam-Webster. (2020). Retrieved from Merriam-Webster Dictionary: <https://www.merriam-webster.com/>
- Michael Beckmann, C. P. (2019). Readiness level of technologies for the “Energiewende”: Results from VGB Scientific Advisory Board. VGB.
- Michel, U. (2011). The benefits of variable area fan nozzles on turbofan engines. *49th AIAA Aerospace Sciences Meeting AIAA 2011-226*.
- Ministerie van Waterstaat. (2019). *Study on the potential effectiveness of a renewable energy obligation for aviation in the Netherlands*. E4tech (UK) Ltd and studio Gear Up.
- Monforti Ferrario Andrea, R. H. (2018). Techno-economic analysis of in-situ production by electrolysis, biomass gasification and delivery systems for Hydrogen Refuelling Stations: Rome case study. *Energy Procedia*, 82-89.
- Moore, M. D. (2014). Misconceptions of Electric Propulsion Aircraft and their Emergent Aviation Markets. *AIAA SciTech Forum*. National Harbor.
- Morvan, H. (2021). *Hydrogen tier 1*.
- Mostafa Ibrahim El-Shafie, S. K. (2019). Hydrogen Production Technologies Overview. *Power and Energy Engineering*, 107-154.
- Muhammad Hassan, A. S. (2018). Hydrogen evolution in microbial electrolysis cell treating landfill leachate: Dynamics of anodic biofilm. *International Journal of Hydrogen Energy*, 13051-13063.
- Muzi, N. (2019, January 24). *Palm oil and soy oil for biofuels linked to high rates of deforestation - new study*. Retrieved from Transport&Environment: <https://www.transportenvironment.org/press/palm-oil-and-soy-oil-biofuels-linked-high-rates-deforestation-new-study>
- NASA. (2015). *NASA Aeronautics Strategic Implementation Plan*.

- National Transportation Safety Board. (2014). *Aircraft Incident Report - Auxiliary Power Unit Battery Fire, Japan Airlines Boeing 787-8, JA829J, Boston, Massachusetts, January 7, 2013*. NTSB/AIR-14/01.
- Nolte et al., P. (2011). Technology Screening, Selection and Modelling for an Environmentally Sustainable Aviation. *11th AIAA Aviation Technology, Integration, and Operations (ATIO) conference*. Virginia Beach, VA: AIAA.
- PARE. (2017). Retrieved from <https://www.pareproject.eu>
- Patrick Schmidt, V. B. (2018). Power-to-Liquids as Renewable Fuel Option for Aviation: A Review. *Chemie Ingenieur Technik*.
- Patrick Schmidt, W. W. (2016). *Power-to-Liquids Potentials and Perspectives for the Future Supply of Renewable Aviation Fuel*. GEA.
- Pavlenko, N., Searle, S., & Christensen, A. (2019, March). The cost of supporting alternative jet fuels in the European Union. ICCT.
- Pavlos Nikolaidis, A. P. (2017). A comparative overview of hydrogen production processes. *Renewable and Sustainable Energy Review*, 597-611.
- Penke C., F. C. (2021). Pathways and Environmental Assessment for the Introduction of Renewable Hydrogen into the Aviation Sector. In S. Albrecht, *Sustainable Production, Life Cycle Engineering and Management* (pp. 41-52). Springer, Cham. doi:https://doi.org/10.1007/978-3-030-50519-6_4
- Pipistrel. (2021). Airworthiness Limitations. In *Aircraft maintenance manual Velis Electro AMM-128-00-60-001 revision A08* (pp. chapter 04-00).
- Plas, A. (2006). *Performance of a boundary layer ingesting propulsion system*. MIT.
- PUB. (2010). *CLASSIFICATION, CERTIFICATION AND STANDARDIZATION INCLUDING*. PUB.
- Rademaker, E. a. (2019). *Environmental aspects with emphasis on noise related to the electrification of civil aviation*. NLR-TR-2019-187.
- Ramchandra Bhandari, C. A. (2014). Life cycle assessment of hydrogen production via electrolysis – a review. *Journal of Cleaner Production*, 151-163.
- Rapeseed and soy production expands in the EU-27*. (2020, May 7). Retrieved from biofuels international: <https://biofuels-news.com/news/rapeseed-and-soy-production-expands-in-the-eu-27/>
- Refaat, A. A. (2010). Different techniques for the production of biodiesel from waste. *Environ. Sci. Tech.*, 183-213.
- Roadmap for legislative initiative*. (2020, July 3). Retrieved from EU-Climate Action: <https://ec.europa.eu/info/law/better-regulation/have-your-say/initiatives/12494-Revision-of-the-EU-Emission-Trading-System-Directive-concerning-aviation->
- Rogers, S. (2017, November 29). *Sugarcane Can Be Engineered into Jet Fuel to Reduce Airlines' Carbon Emissions*. Retrieved from Interesting Engineering: <https://interestingengineering.com/sugarcane-can-be-engineered-into-jet-fuel-to-reduce-airlines-carbon-emissions>
- Roland Berger. (2017). *Aircraft Electrical Propulsion - The Next Chapter of Aviation?* London.
- Roland Berger. (2019). *Aircraft Electrical Propulsion - Onwards and Upwards*. London.
- Rolls Royce. (2019, 3). *ACCEL: entering the era of zero-emissions aviation*. Retrieved from <https://www.rolls-royce.com/innovation/key-demonstrators/accel.aspx>
- Rolt, A. a. (2009). *Intercooled Turbofan Engine Design and Technology Research in the EU Framework 6 NEWAC Programme*. ISABE 2009-1278.
- Roxanne Pinsky, P. S. (2020). Comparative review of hydrogen production technologies for nuclear hybrid. *Progress in Nuclear Energy*.
- Roxanne Pinsky, P. S. (2020). Comparative review of hydrogen production technologies for nuclear hybrid energy systems. *Progress in Nuclear Energy*, 103317.
- RSB. (2011, March 23). RSB Principles & Criteria for Sustainable Biofuel Production.
- RSB. (2017). *Trusted Solutions for a New World*. Geneva: RSB.

- RSB. (2020). *Demonstrate your commitment to a sustainable bioeconomy with RSB certification*. Retrieved from RSB: <https://rsb.org/certification/about-certification/>
- Ruhl, C. (2019, January 20). *Why There Are No Nuclear Airplanes*. Retrieved from The Atlantic: <https://www.theatlantic.com/technology/archive/2019/01/elderly-pilots-who-could-have-flown-nuclear-airplanes/580780/>
- S. Cotterill, E. H. (2016). Microbial electrolysis cells for hydrogen production. In *Microbial Electrochemical and Fuel Cells* (pp. 287-319). Woodhead publishing.
- Sahoo, S., Zhao, X., & Kyprianides, K. (2020). A Review of Concepts, Benefits, and Challenges for Future Electrical Propulsion-Based Aircraft. *Aerospace*.
- Samantha Eleanor Tanzer, J. P. (2019). Lignocellulosic marine biofuel: Technoeconomic and environmental assessment for production in Brazil and Sweden. *Journal of Cleaner Production*.
- SANABRIA von WALTER, C. D. (2016). *Design of High-Torque-Density Synchronous Drives for Propulsion of Rotary-Wing Aircraft*. TU Delft, PhD thesis.
- Sarah J. Gerssen-Gondelach, B. W. (2017). GHG emissions and other environmental impacts of indirect land use change mitigation. *Bioenergy*, 725–742.
- Sathyanarayanan Sevilimedu Veeravalli, S. R. (2019). Chapter 15 - Biohydrogen Production From Renewable Resources. In *Advanced Bioprocessing for Alternative Fuels, Biobased Chemicals, and Bioproducts* (pp. 289-312). Woodhead Publishing Series in Energy.
- Schmidt, P., & Weindorf, W. (2016). *Power-to-Liquids Potentials and Perspectives for the Future Supply of Renewable Aviation Fuel*. German Environment Agency.
- Scholz et.al, A. (2021). Design, Operational and Environmental Assessment of a Hybrid-Electric Aircraft. *AIAA paper 2021-0259*.
- Seyed Ehsan Hosseini, M. A. (2016). Hydrogen production from renewable and sustainable energy. *Renewable and Sustainable Energy Reviews*, 57, 850-866. doi:<http://dx.doi.org/10.1016/j.rser.2015.12.112>
- Shayan Sadeghi, S. G. (2020). Comparative economic and life cycle assessment of solar-based hydrogen production for oil and gas industries. *Energy*, 118347.
- SkyNRG. (n.d.). *Sustainable Aviation Fuel*. Retrieved July 16, 2020, from SkyNRG: <https://skynrg.com/sustainable-aviation-fuel/saf/>
- Society, T. R. (2019). *Sustainable synthetic carbon based fuels for transport*. The Royal Society.
- Soler, A. (2019). *Role of e-fuels in the European transport system - Literature review*. Concawe.
- Sophie Parsons, M. C. (2018). Chapter 13 - Second-Generation Ethanol from Lignocellulose. *Greenhouse Gas Balances of Bioenergy Systems*, 193-206.
- Stavros Michailos, S. M. (2019). Dimethyl ether synthesis via captured CO₂ hydrogenation within the power to liquids concept: A techno-economic assessment. *Energy Conversion and Management*, 262-276.
- Stéphane ABANADES, G. F. (2020). *THERMOCHEMICAL WATER-SPLITTING CYCLES*. Retrieved from cnrs: <https://www.promes.cnrs.fr/index.php?page=thermochemical-water-splitting-cycles>
- STRIA Electrification. (2016). Retrieved from https://trimis.ec.europa.eu/sites/default/files/stria_roadmap_-_transport_electrification_0.pdf
- Sustainable Aviation. (2020). *Decarbonisation road-map: a path to net zero - a plan to decarbonise UK aviation*.
- Sustainable Aviation. (2020). *SUSTAINABLE AVIATION FUELS ROAD-MAP: Fueling the future of UK aviation*. Sustainable Aviation.
- SynergIE. (2018). Retrieved from https://www.dlr.de/as/desktopdefault.aspx/tabid-15870/25719_read-66107/
- Tahereh Jafary, W. R.-M. (2019). Clean hydrogen production in a full biological microbial electrolysis cell. *International Journal of Hydrogen Energy*, 30524-30531.
- Tajmar, M. (2003). Nuclear propulsion Systems. In M. Tajmar, *Advanced Space Propulsion Systems* (pp. 57-72). Vienna: Springer-Verlag.

- Tanimura et.al, T. (2021). Consideration of Future Development of Hybrid Electric Aircraft using Epoch-Era Analysis. *AIAA paper 2021-1639*.
- Thalin, P. (2019). *Fundamentals of Electric Aircraft*. SAE.
- The European Green Deal. (2019, December). *Annex to the Communication from the Commission to the European Parliament, the European Council, the Council, the European Economic and Social Committee and the Committee of the Regions*. The European Green Deal.
- The Nuclear Airplane. (2015, June 28). Discovery Channel. Retrieved from https://www.youtube.com/watch?v=fLK9hYXWZw4&t=2538&ab_channel=TheOhioVeritasProject
- The Royal Society. (2018). *Options for producing low-carbon hydrogen at scale: Policy Briefing*. The Royal Society.
- Thom Achterbosch, G. M. (2013). *Sustainable Biomass*. Utrecht: NL Agency.
- Todreas, N. (2015). Small modular reactors (SMRs) for producing nuclear energy: an introduction. In *Handbook of Small Modular Nuclear Reactors*. (pp. 1-26). MA, USA: Elsevier Ltd.
- Touhami et.al., S. (2020). Electrothermal Models and Design Approach for High Specific Power Electric Motor for Hybrid Aircraft. *Aerospace Europe Conference*. Bordeaux.
- Trainelli, L. e. (2020). A general preliminary sizing procedure for pure-electric and hybrid-electric airplanes. *Aerospace Europe Conference 2020*. Bordeaux.
- TRL Scale in Horizon 2020 and ERC*. (2020). Retrieved from Enspire.science: <https://enspire.science/trl-scale-horizon-2020-erc-explained/>
- U. Yildirima, S. A. (2012). Manufacture, qualification and approval of new aviation turbine fuels. *Procedia Engineering*, 310 – 315 .
- U.S. DRIVE. (2017). *Hydrogen Storage Tech Team Roadmap*. U.S. DRIVE.
- UAS Vision. (n.d.). *Antares E2 Fuel Cell Technology at INTERGEO*. Retrieved March 16, 2020, from <https://www.uasvision.com/2018/09/20/antares-e2-fuel-cell-technology-at-intergeo/>
- ULI. (2020). Retrieved from <https://www.nasa.gov/aeroresearch/programs/tacp/uli/>
- ULTIMATE. (2015). Retrieved from <http://www.ultimate.aero/>
- Unifier19. (2021). Retrieved from <https://www.unifier19.eu>
- UN-SDGs. (2020). Retrieved from UN: <https://sdgs.un.org/en/goals>
- Uranga et.al., S. (2017). Boundary Layer Ingestion Benefit of the D8 Transport Aircraft. *AIAA Journal, Vol. 55, No. 11*.
- USDA. (2020). *Feedstock Readiness Level Evaluations Summary Table v4.0 - Q1&2*. Retrieved from U.S. DEPARTMENT OF AGRICULTURE: <https://data.nal.usda.gov/dataset/feedstock-readiness-level-evaluations-summary-table-v40/resource/65c3497c-3bc5-4285-916f-ef534a45d6a4#{view-graph:{graphOptions:{hooks:{processOffset:{},bindEvents:{}}},graphOptions:{hooks:{processOffset:{},bindEvents:{}}}}>
- UTC project 804*. (2019). Retrieved from <http://sustainableskies.org/project-804-dash-8-hybrid/>
- Uwe Albrecht, M. A.-C.-S. (2015, July 8). *Study on hydrogen from renewable resources in the EU*. Retrieved October 12, 2020, from https://www.fch.europa.eu/sites/default/files/GHyP-Final-Report_2015-07-08_5%20%28ID%202849171%29.pdf
- van der Sman, E., Peerlings, B., Kos, J., Lieshout, R., & Boonekamp, T. (2021). *Destination 2050: A Route to Net Zero European Aviation*. Amsterdam: NLR.
- Venderbosch, R. H. (2010). Fast pyrolysis technology development. *Biofuels*.
- Warwick, G. (2018, March 12-25). Batteries Ready To Power Electric Regional Aircraft, Says Aviation. *Aviation Week & Space Technology*, p. 47.
- Wei-Cheng Wang, L. T. (2016). *Review of Biojet Fuel Conversion Technologies*. National Renewable Energy Laboratory. Retrieved from <https://www.nrel.gov/docs/fy16osti/66291.pdf>
- Welch, G. J. (1995). *Wave rotor-enhanced gas turbine engines*. NASA TM-166998.

- Welstead, J., & Felder, J. (2016). Conceptual design of a single-aisle turboelectric commercial transport with fuselage boundary layer ingestion. *AIAA 2016-1027*.
- Wendorf, M. (2019, November 17). *Both U.S. and Soviet Attempts at Developing a Nuclear-Powered Aircraft Ended in Failure*. Retrieved July 20, 2020, from <https://interestingengineering.com/both-us-and-soviet-attempts-at-developing-a-nuclear-powered-aircraft-ended-in-failure>
- White, B. (2020). *Energy Storage: America's New R&D Priority to Secure the Grid*. Retrieved from Power: <https://www.powermag.com/energy-storage-americas-new-rd-priority-to-secure-the-grid/>
- Wilfert, G. S. (n.d.). New Environmental Friendly Aero Engine Core Concepts. *ISABE – 2007 – 1120*.
- Xu, H. (2018). Flight of an aeroplane with solid-state propulsion. *Nature vol 563*, 532-535.
- You-KwanOh, S. M. (2013). Chapter 3 - Metabolic Engineering of Microorganisms for Biohydrogen Production. In *Biohydrogen* (pp. 45-65). Elsevier.
- Yufei Wang, F. A. (2017). Direct and indirect photolysis of seven micropollutants in secondary. *Chemosphere*, 297-308.
- Zhenhua Ruan, X. W. (2019). Chapter 3 - Corn. *Integrated Processing Technologies for Food and Agricultural By-Products*, 59-72.
- Zill et. al., T. (2020). An Overview of the Conceptual Design Studies of Hybrid Electric Propulsion Air Vehicles in the Frame of Clean Sky 2 Large Passenger Aircraft. *Aerospace Europe*. Bordeaux.



Dedicated to innovation in aerospace

NLR - Royal Netherlands Aerospace Centre

Royal NLR operates as an unaffiliated research centre, working with its partners towards a better world tomorrow. As part of that, Royal NLR offers innovative solutions and technical expertise, creating a strong competitive position for the commercial sector.

Royal NLR has been a centre of expertise for over a century now, with a deep-seated desire to keep innovating. It is an organisation that works to achieve sustainable, safe, efficient and effective aerospace operations.

The combination of in-depth insights into customers' needs, multidisciplinary expertise and state-of-the-art research facilities makes rapid innovation possible. Both domestically and abroad, Royal NLR plays a pivotal role between science, the commercial sector and governmental authorities, bridging the gap between fundamental research and practical applications. Additionally, Royal NLR is one of the large technological institutes (GTIs) that have been collaborating since 2010 in the Netherlands on applied research as part of the TO2 federation.

From its main offices in Amsterdam and Marknesse plus two satellite offices, Royal NLR helps to create a safe and sustainable society. It works with partners on numerous (defence) programmes, including work on complex composite structures for commercial aircraft and on goal-oriented use of the F-35 fighter. Additionally, Royal NLR helps to achieve both Dutch and European goals and climate objectives in line with the Luchtvaartnota (Aviation Policy Document), the European Green Deal and Flightpath 2050, and by participating in programs such as Clean Sky and SESAR.

For more information visit: www.nlr.org

Postal address

PO Box 90502
1006 BM Amsterdam, The Netherlands
e) info@nlr.nl i) www.nlr.org

NLR Amsterdam

Anthony Fokkerweg 2
1059 CM Amsterdam, The Netherlands
p) +31 88 511 3113

NLR Marknesse

Voorsterweg 31
8316 PR Marknesse, The Netherlands
p) +31 88 511 4444