

Assessment of the Suitability of NB-IoT Technology for ORM in Smart Grids

Nair, Varun; Litjens, Remco; Zhang, Haibin

DOI

[10.1109/EuCNC.2018.8443186](https://doi.org/10.1109/EuCNC.2018.8443186)

Publication date

2018

Document Version

Accepted author manuscript

Published in

2018 European Conference on Networks and Communications, EuCNC 2018

Citation (APA)

Nair, V., Litjens, R., & Zhang, H. (2018). Assessment of the Suitability of NB-IoT Technology for ORM in Smart Grids. In *2018 European Conference on Networks and Communications, EuCNC 2018* (pp. 418-423). Article 8443186 IEEE. <https://doi.org/10.1109/EuCNC.2018.8443186>

Important note

To cite this publication, please use the final published version (if applicable). Please check the document version above.

Copyright

Other than for strictly personal use, it is not permitted to download, forward or distribute the text or part of it, without the consent of the author(s) and/or copyright holder(s), unless the work is under an open content license such as Creative Commons.

Takedown policy

Please contact us and provide details if you believe this document breaches copyrights. We will remove access to the work immediately and investigate your claim.

Assessment of the Suitability of NB-IoT Technology for ORM in Smart Grids

Varun Nair

Department of Network
Architectures & Services, TU Delft
Delft, The Netherlands
v.nair@student.tudelft.nl

Remco Litjens

Department of Networks, TNO
The Hague, The Netherlands
Department of Network
Architectures & Services, TU Delft
Delft, The Netherlands
remco.litjens@tno.nl

Haibin Zhang

Department of Networks, TNO
The Hague, The Netherlands
haibin.zhang@tno.nl

Abstract—In this paper, we assess the suitability of NB-IoT (Narrowband Internet of Things) cellular technology for smart grid applications, concentrating on the reliable and timely delivery of Outage Restoration & Management (ORM) messages at the event of a local or regional power outage. Using system-level simulations modelling of both the cellular NB-IoT and the energy distribution networks for different environments, we present an extensive sensitivity analysis of the ORM service performance w.r.t. various radio network configurations. In particular, we propose and analyze different packet schedulers, an essential mechanism in optimizing the service performance. A key outcome of the study is the conclusion that indeed NB-IoT is a suitable technology for supporting ORM services in smart grids, accompanied with a proposed near-optimal radio network configuration to best do so.

Keywords—NB-IoT, cellular networks, smart grids, Outage Restoration & Management, reliability, performance assessment.

I. INTRODUCTION

The upcoming years will see a huge growth in the number of connected devices on the internet with Internet of Things (IoT) devices accounting for about 15 billion out of the totally 28 billion connected devices by 2021 [1]. In view of this, the 3rd Generation Partnership Project (3GPP) introduced a radio access technology known as Narrowband Internet of Things (NB-IoT) as part of its Release 13 specifications [2]. NB-IoT is specifically targeted at low-cost and low-data rate applications involving a large number of devices. Additionally, there is support for a long battery life (> 10 years) and improved coverage (20 dB higher link budget than in GPRS (General Packet Radio Service)).

One of the most important application areas for IoT applications is the domain of smart grids, which utilize available two-way communication between the utility and monitoring/control devices in order to monitor and control the efficient and effective generation, distribution and usage of energy, e.g. utilizing fast and automated responses to changes in the energy demand and supply [3]. NB-IoT is potentially suitable for smart grids in providing low-cost connectivity to smart meters in every household, enabling use cases such as automated meter readings and Outage Restoration and Management (ORM) [4][5]. ORM enables utilities to efficiently and quickly detect, localize and restore power outages, using notifications received from smart meter devices upon the detection of a loss or restoration of power. However, it may involve a ‘near-simultaneous’ network

access from a large number of devices at e.g. the event of a power outage. This may lead to congestion of the network resources, particularly of the random access channel, consequently resulting in failures and unwanted delays in the transmission. Ultimately, this impacts the reliability performance, i.e. the percentage of notifications successfully delivered within a certain transfer delay target and, consequently, the accuracy of the power outage localization [4].

Most of the existing work on NB-IoT focusses on the analysis and development of enhancements to technology elements such as paging mechanisms and data transmission protocols [6][7], but do not address the performance impact for specific use cases. In [8], a capacity analysis is presented for NB-IoT in (sub)urban environments for smart metering applications. The results are based on analytical calculations with rather optimistic data rate assumptions. In [9], a new concept of control channel load balancing for NB-IoT is introduced, aimed at a dynamic allocation of control channel resources during sudden traffic spikes. The proposed methodology is however based on pre-standard specifications and needs to be adapted.

The objective of this study is to assess the suitability of NB-IoT technology for the ORM use case in smart grids, while in the process tuning radio network configurations for optimized reliability performance. Another key contribution is the design of a suitable packet scheduler that achieves (near-)optimal performance. The simulation-based assessment considers all relevant scenario aspects of smart grids and a detailed technological modelling of the NB-IoT network.

The rest of the paper is organized as follows. In Section II, a brief description is given of the key smart grid use cases and their traffic modelling. The modelling of the NB-IoT cellular network and the proposed schedulers are discussed in Section III. Section IV presents and analyze the simulation results. Key conclusions and recommendations are drawn in Section V.

II. SMART GRID MODEL

Smart grid use cases can be classified by the associated grid segment: energy generation/transmission, energy distribution or customer usage. Use cases in the distribution segment, including (on demand or periodic) remote meter reading, Real-Time Pricing (RTP) and ORM [4][5], require communication with large numbers of devices at potentially challenging locations (deep indoor: poor radio channel). Further, since the latency

requirements of such services are in the order of seconds, minutes or even hours, a cellular technology like NB-IoT seems particularly suitable to handle these services.

Table I non-exhaustively summarizes the typical traffic aspects and requirements on latency and reliability [4] for key use cases in the distribution segment.

TABLE I. USE CASES: TRAFFIC ASPECTS AND REQUIREMENTS.

USE CASE	TRAFFIC ASPECTS (UL = Uplink / DL = Downlink)	REQUIREMENTS
Meter reading (scheduled)	4-6 messages/residential meter/day; 1600-2400 Bytes (UL)	≤ 4 hours, $\geq 98\%$
	12-24 messages/industrial meter/day; 200-1600 Bytes (DL)	≤ 2 hours, $\geq 98\%$
RTP	60/1000 meters: 1 message/day 100 Bytes (DL) + 25 Bytes (UL)	≤ 5 seconds, $\geq 99\%$
ORM	1 message/meter/event 25 Bytes (UL)	≤ 20 seconds, $\geq 30\%$ ¹
Firmware updates	2×/meter/year 400-2000 kB (DL)	≤ 4 hours, $\geq 98\%$

Considering the relatively stringent latency requirement in combination with a large number of involved meters, we select ORM as the most demanding use case for the presented suitability assessment of NB-IoT technology in smart grids, while we consider meter reading as background traffic. In the ORM use case, the smart meters identify any occurring power outage and near-immediately report this to the utility operator, who then gathers all these reports and performs detection, localization and restoration of a power outage. More specifically, upon an outage event, each affected meter initiates its reporting after a beta (3,4)-distributed amount of time with an adapted range of [0,10] seconds [10].

Besides the use case traffic aspects and requirements in Table I, we need to specify the layout and nodal density of the energy distribution network. The network comprises three distinct components, as also visualized in Fig. 1 [11]. The network generally consists of a ring of substations (converting medium to low voltage), from where distribution feeders originate in a radial topology towards multiple households, each with a smart meter installed. Typical energy distribution network parameters in The Netherlands are given in Table II [11], wherein ‘HH’ refers to ‘household’.

In our simulation-based assessment study, we will model the energy distribution network in a hexagonal layout, using the parameters of Table II. Each hexagon models the service area of a given substation with uniformly spread households. The hexagon radius is equal to the approximated feeder length given in the rightmost column of the table. The feeder lengths are chosen such that the number of households per hexagon (model) is same as that for a substation area (in reality). In the next section, the cellular NB-IoT network is modelled. As will be explained and visualized in Section III, the overall model thus consists of two distinct and independently planned networks, viz. an energy distribution network including

households with smart meters, and a cellular network used to convey the ORM messages transmitted by modem-equipped smart meters at the event of a power outage.

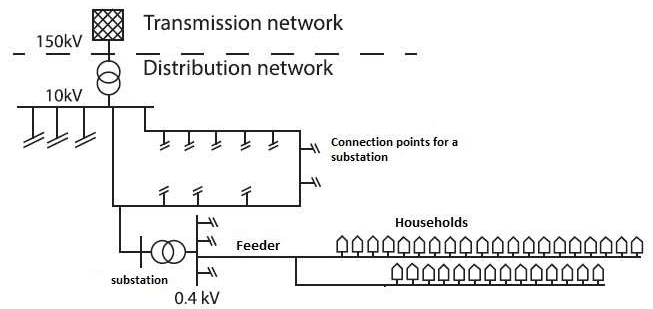

Fig. 1. Energy distribution network topology [11].

TABLE II. TYPICAL ENERGY DISTRIBUTION NETWORK PARAMETERS.

ENVIRONMENT	HH DENSITY	#HHs / SUBSTATION	FEEDER LENGTH
Dense Urban (DU)	2272 HHs/km ²	693	0.35 km
Urban (U)	1500 HHs/km ²	480	0.35 km
Suburban (SU)	350 HHs/km ²	165	0.43 km
Rural (RU)	50 HHs/km ²	24	0.43 km

III. CELLULAR NETWORK MODEL

NB-IoT may be deployed in three different modes: *in-band* mode, where the NB-IoT carrier is deployed within the bandwidth of an LTE (Long-Term Evolution) carrier; *guard-band* mode, where the NB-IoT carrier is deployed within the guard band of an LTE carrier; or *stand-alone* mode, where the NB-IoT carrier is deployed independently of any LTE carrier, e.g. in a re-farmed GSM band. Mobile operators generally tend to deploy the first NB-IoT networks in the in-band mode for the sake of low cost and deployment complexity [12]. We therefore also assume the in-band deployment mode, noting that the obtained results may be extended to the other modes with some modest adjustments.

The NB-IoT radio network is modelled as a hexagonal grid comprising nineteen sectorized sites. The considered frequency carrier is assumed to be in the 800 MHz and planned with contiguous reuse. Each sector is served with a directional antenna with a main lobe gain of 18 dBi and a 3D antenna pattern taken from [13]. The User Equipment (UE) is equipped with an omnidirectional antenna with a gain of 0 dBi, installed at an assumed height of 1.5 m. The environment-specific inter-site distances (ISDs) are taken from [14][15], assuming that an NB-IoT network is typically deployed on an existing 2/3/4G site grid.

Table III shows the ISDs and propagation models considered for the different environments. In general, the models chosen in this study, reflect realistic scenario aspects in the best possible way. Although, different modelling choices may influence results to some degree, key qualitative outcomes are expected to be the same, irrespective of the different choices.

¹ For large outages. No reliability requirement is specified for small outages, nor is the distinction between what is a ‘large’ and what is a ‘small’ outage clearly defined [4].

Fig. 2 shows overlapping NB-IoT and energy distribution networks, modelled with a hexagonal layout of cell sites and substation areas, respectively, as discussed above. The red, green and yellow colored markers represent UEs served by the three cells of the central site, while the grey colored UEs are served by other cells. In the analysis, a single cell will be explicitly simulated, while all other cells are statically configured to establish realistic interference levels.

TABLE III. ENVIRONMENT-SPECIFIC NETWORK AND PROPAGATION ASPECTS.

ENVIRONMENT	ISD (km)	PATH LOSS (dB)	SHADOWING ²	PENETRATION LOSS	CHANNEL MODEL
DU	0.5	$119.8 + 37.6 \times \log_{10}(d_{\text{km}})$	10 dB	Based on adapted COST231 NLOS model [2]	Typical Urban (TU), 20 taps, 0 Hz Doppler
U	1.732				
SU	3.2	$103.8 + 33.6 \times \log_{10}(d_{\text{km}})$	8 dB		
RU	7.5	$94.6 + 34.1 \times \log_{10}(d_{\text{km}})$	6 dB		

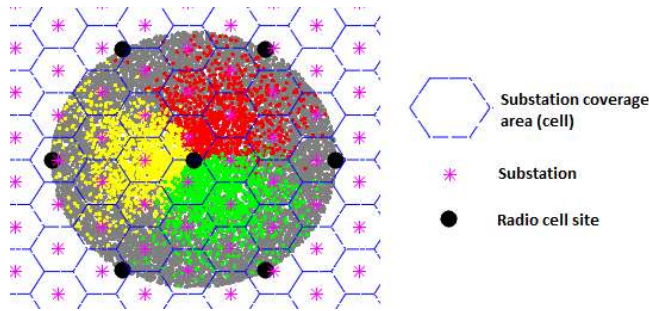

Fig. 2. Overlapping NB-IoT and energy distribution networks for a region around the central site, shown for an urban environment.

An NB-IoT UE has a communication bandwidth of 180 kHz and uses Half Duplex – Frequency Division Duplexing (HD-FDD), which helps to keep the device cost and complexity low. To speed up development and deployment efforts, some of the LTE air interface features have been reused in NB-IoT, e.g. the general radio resource grid structure and the multiple access schemes in the up- and downlink. Certain optimizations have been standardized on top of this, such as the option of 3.75 kHz (besides the default 15 kHz) UL subcarrier spacing and the use of transmission repetitions, in support of specific application requirements, e.g. good coverage and long battery life [16].

Fig. 3 illustrates the modeling of the random access and uplink data transmission procedures as relevant for the ORM use case. Note that the uplink data is transmitted via the control plane during the RRC connection setup phase [16]. Upon the generation of an ORM message, the UE in the smart meter attempts a preamble transmission via the so-called Narrowband Physical Random Access Channel (NPRACH). Due to the possibility of collision when the same preamble is used simultaneously by multiple devices, the preamble detection success probability might vary depending on the NPRACH

configuration (discussed in Section IV) and the traffic load. The successful reception of a preamble is followed by the exchange of certain signaling messages between the base station and the device, followed by the UL data transmission. Any failure during this whole procedure, including the failure of preamble detection and time-out of the signaling messages, will trigger the device to re-attempt a preamble transmission. A backoff time is used to detect/assume failure and initiate such re-attempts. In case of persistent failure even after a maximum allowed number of attempts, the random access process fails.

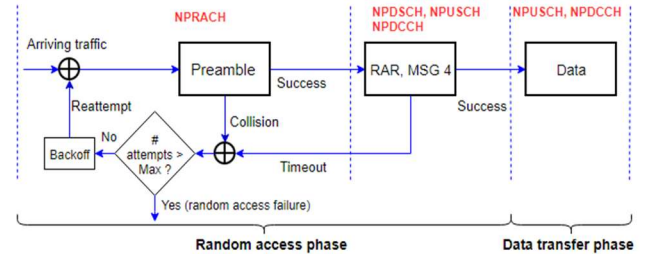

Fig. 3. Random access and uplink transmission procedures in NB-IoT.

Scheduling plays a significant role in the overall data transmission process and is required for the transmission of the so-called Random Access Response (RAR) message (DL), MSG3 (UL), MSG4 (DL), the corresponding ACK/NACK (UL), and the actual data transmission (UL). These messages and data are delivered using the so-called Narrowband Physical Downlink Shared Channel (NPDSCH) and Narrowband Physical Uplink Shared Channel (NPUSCH), for DL and UL, respectively. The scheduling message itself is delivered on the Narrowband Downlink Control Channel (NPDCCH). We aim to design a scheduler which maximizes the reliability performance of the transmission of ORM messages. Two major tasks are foreseen for such a scheduler:

- The *UE prioritization* scheme determines the priority order in which to serve the queued UEs. We consider three different options of prioritization with their respective metrics: (i) Earliest Due Date First (EDDF), with prioritization metric W / t_d , where W and t_d denote the waiting time and the time until the due date, respectively; (ii) Shortest Processing Time First (SPTF) with prioritization metric $1 / T$, where T denotes the expected transmission time; and (iii) EDDF-SPTF, with prioritization metric $W / (t_d \times T)$. EDDF prioritizes UEs with low remaining delay budget, while SPTF prioritizes UEs with a relatively short expected transmission time. EDDF-SPTF aims to strike an optimal compromise between the two other schemes.
- The *subcarrier allocation scheme* determines how many subcarriers are allocated to each of the UEs. We consider three options: (i) Least Granularity Allocation (LGA), which assigns the configured maximum possible number (1, 3, 6 or 12) of 15 kHz subcarriers to a scheduled UE in order to maximize its bit rate; (ii) Min-Max Allocation (MMA), which assigns the minimum number of 15 kHz subcarriers that is needed to provide

² Inter- and intra-site correlations of 0.5 and 1 are assumed, respectively.

the maximum attainable bit rate, targeting the most resource-efficient bit rate maximization; and (iii) Maximum Granularity Allocation (MGA), which assigns a single 3.75 kHz subcarrier per UE, allowing the concurrent scheduling of multiple UEs.

IV. SIMULATION RESULTS AND ANALYSIS

This section presents the results of an extensive performance analysis. Given the range of relevant network configuration aspects, incl. the NPRACH configuration and the scheduler, the analysis assumes a given baseline configuration and performs a sensitivity analysis considering unilateral variations for each configuration aspect. In the end we then derive a near-optimal configuration by combining the unilaterally identified optimal settings for each configuration aspect. The assumed baseline configuration itself is derived in a pre-study, applying a similar approach of combining unilaterally optimized settings starting from an arbitrary ‘pre-baseline’ configuration. Table IV shows the baseline network configuration and general scenario settings. The coupling loss thresholds of three distinct coverage levels (CLs) are set to reflect the typical distribution of UEs across these coverage levels [17]. Refer to [18] for detailed descriptions of the NPDCCH and NPRACH configuration parameters.

TABLE IV. BASELINE NETWORK CONFIGURATION AND SCENARIO SETTINGS.

PARAMETER	SETTINGS			
# substations / radio cell	RU	SU	U	DU
Mean	96	32	18	4
Standard deviation	3	1	1	1
# smart meters / substation	RU	SU	U	DU
Mean	8	29	67	48
Standard deviation	1	1	4	8
Carrier operation	single carrier			
Scheduler	EDDF-SPTF with MGA			
Coupling loss ranges per CL (dB)	CL1 [0,130]	CL2 (130,140]	CL3 (140, ∞)	
NPDCCH CONFIGURATION		SETTINGS		
Maximum # repetitions (R_{max})	8			
Offset (α)	0			
Periodicity parameter (G)	1.5			
Period (T)	12 ms			
NPRACH CONFIGURATION		SETTINGS		
Maximum # RA attempts	CL1 19	CL2 5	CL3 7	
Period	80 ms	160 ms	320 ms	
Resource configuration	# preamble repetitions	2	4	32
	# preambles	24	12	12
Starting subframe	8 ms	8 ms	8 ms	
Backoff interval	[0, 1024] ms			
RAR window size	$10 \times T$ ms			
MSG 4 window size	$64 \times T$ ms			

Fig. 4 shows the simulation results obtained for the four considered environments under the baseline configuration, presenting the impact of the so-called ‘outage percentage’ on three key performance indicators: (i) the *success rate*, i.e. the fraction of ORM messages that is transferred successfully; (ii) the *95th transfer delay percentile* of the successfully transferred

ORM messages; and (iii) the *reliability*, defined as the fraction of ORM messages that is successfully transferred within the assumed deadline of 20 seconds. The *outage percentage* is the fraction of substations in the simulated radio cell that are modelled to be in a power outage and will consequently initiate the transmission of an ORM message. For each value, the 95% confidence interval is indicated. For all outage percentages, the worst reliability performance is observed for the urban environment. This is because, for a given outage percentage, the network load in terms of the number of power outage-affected smart meters per radio cell is highest in the urban environment, as can be derived from the first two rows of Table IV. A higher network load leads to more preamble collisions and timeouts, and causes a drop in the success rate and reliability.

Based on this insight, the sensitivity analyses focusses on the urban environment, unilaterally deriving the performance impact of the following configuration aspects: (i) scheduler; (ii) NPRACH resource configuration; (iii) the maximum number of Random Access (RA) attempts; and (iv) NPDCCH resource configuration. In all cases, where applicable, the change of configuration is performed for CL1. The scenarios are detailed in Table V, while the obtained results are presented in the several rows of Fig. 5, denoted Fig 5. I through Fig 5. IV.

Fig. 5.I shows a comparison of the different candidate schedulers discussed in Section III. The scheduler combining EDDF-SPTF prioritization with MGA subcarrier allocation achieves the highest reliability for nearly all outage percentages. We see a performance degradation as the granularity of the UL subcarrier allocation decreases (from MGA to LGA). Thus, due to the small packet sizes involved, increasing the granularity helps to decrease the waiting time of UEs which improves both the success rate and the 95th transfer delay percentile.

Fig. 5.II compares the different NPRACH configurations in terms of the number of Random Access Opportunities (RAOs) per second (the number of preambles/period; see Table IV). In this analysis, only the length of the period T, the time interval between consecutive RAOs for a UE, is varied. Since the NPRACH and NPUSCH share the same UL resources, the aim is to find a configuration that optimally balances the occurrence of preamble collisions and timeouts, influenced by the distribution of the resources over the respective channels. We see that configurations A1 and A2 show nearly similar optimal performance. The performance achieved by configurations A3 and A4 is significantly lower, with the NPRACH resources so limited that it causes a high preamble collision probability.

Assessing the performance sensitivity w.r.t. to the maximum number of RA attempts, Fig. 5.III shows an improvement in reliability if the maximum number of RA attempts is increased from 15 (A1) to 19 (baseline), but decreases for higher settings (A2, A3). As is intuitively clear, an increase in the allowed number of RA attempts improves the success rate at the cost of increased transfer delays. For configurations A2 and A3, a significant proportion of the successful attempts lead to transfer delays exceeding the 20-second target, reducing the reliability performance. Apparently, the baseline configuration achieves the optimal tradeoff between success rate and transfer delay.

Fig. 5.IV shows the performance sensitivity w.r.t. the NPDCCH resource configuration, in terms of the ratio R_{max} / T ,

where R_{\max} denotes the maximum number of repetitions. The higher this ratio for a given coverage level, the more resources are available for scheduling. However, this reduces the resource availability and the performance of the UEs at the other coverage levels. At high loads, the waiting time until scheduling for UEs in CL1 is expected to be more dominant w.r.t. those of the UEs of CL2 and CL3, compared to low-load scenarios. We see indeed that the baseline configuration with the maximum ratio performs best at high loads, whereas configuration A3, with a slightly lower ratio, performs better at low loads.

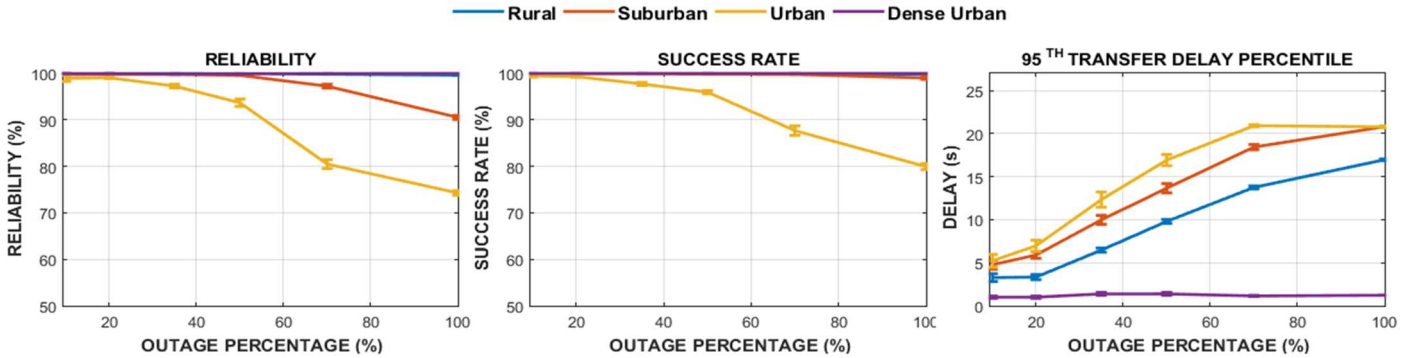

Fig. 4. Comparison of the baseline reliability, success rate and 95th transfer delay percentile versus the outage percentage for all four environments.

TABLE V. CONFIGURATION SETTINGS FOR SENSITIVITY ANALYSES (FIG. 5.I-IV) AND DERIVATION OF NEAR-OPTIMAL CONFIGURATION (FIG. 5.V).

CONFIGURATION	FIG. 5.I		FIG. 5.II	FIG. 5.III	FIG. 5.IV	FIG. 5.V	
	SCHEDULER		#RAOs / SECOND	MAX # RA ATTEMPTS	NPDCCH R_{\max} / T	#RAOs / SECOND	NPDCCH R_{\max} / T
Baseline	EDDF-SPTF	MGA	300	19	8/12	-	-
A1	EDDF	MGA	600	15	1/8	300 (Baseline)	4/8
A2	SPTF	MGA	150	23	2/8	600	8/12 (Baseline)
A3	EDDF-SPTF	MMA	75	27	4/8	600	4/8
A4	EDDF-SPTF	LGA	-	-	-	-	-

V. CONCLUDING REMARKS

We presented an assessment of the suitability of the recently standardized NB-IoT technology for smart energy grids, with a focus on the reliable collection of ORM messages in the event of a local or regional power outage. To this end, we have developed realistically tuned models for both the energy distribution and the cellular NB-IoT networks and conducted a thorough sensitivity analysis of the performance (latency, reliability) impact of a wide range of NB-IoT configurations. From this analysis, we conclude that indeed the NB-IoT technology, when appropriately tuned, is suitable to adequately support ORM and other smart grid services with similar or milder performance requirements. Among the assessed packet schedulers, we recommend the scheduler combining EDDF-SPTF prioritization with MGA subcarrier allocation to optimize performance, achieving reliability levels for example in the range of 98-100% for power outage percentage up to about 50%.

As a future work, we recommend to assess the suitability of NB-IoT for a mix of diverse smart grid (or other) services and devise a self-optimization scheme for the adaptation of radio network configurations in response to e.g. spatio-temporal variations in environment aspects, traffic loads, service mix and the associated performance requirements.

The sensitivity analysis results in Fig. 5.I-IV show that few alternative configurations perform on a par with (A1) or better (A2) than the baseline configuration, though only for a subset of loads. To investigate whether a ‘robust’ configuration exists which is near-optimal for all loads, a candidate configuration A3 is created for the final analysis in Fig. 5.V, combining the above alternative configurations (see Table V). As shown in Fig. 5.V, configuration A3 indeed performs near-optimally at all loads, with an achieved reliability performance close to 100% for the majority of the considered outage percentages.

REFERENCES

- [1] Ericsson AB, ‘Cellular networks for massive IoT’, see https://www.ericsson.com/res/docs/whitepapers/wp_iot.pdf, 2016.
- [2] 3GPP, ‘Cellular system support for ultra-low complexity and low throughput Internet of Things (CIoT)’, *TR 45.820*, v13.1.0, see www.3gpp.org, 2015.
- [3] U.S. Department of Energy, ‘Smart grid: an introduction’, see <https://energy.gov/oe/downloads/smart-grid-introduction-0>, 2004.
- [4] Open Smart Grid SG-Network task force, ‘Shared Documents – SG Communications (NIST PAP’s)’, see <http://osgug.ucauiug.org/>, 2012.
- [5] M. Kuzlu, M. Pipattanasomporn and S. Rahman, ‘Communication network requirements for major smart grid applications in HAN, NAN and WAN’, *Computer Networks*, vol. 67, 2014.
- [6] Y. Shi, W. Xi and H. Zhou, ‘Efficient paging message design based on a binary tree in NB-IoT system’, *CSCN '16*, Berlin, Germany, 2016.
- [7] S.-M. Oh and J. Shin, ‘An efficient small data transmission scheme in the 3GPP NB-IoT system’, *IEEE Communication Letters*, vol. 7798, 2016.
- [8] S. Persia and L. Rea, ‘Next generation M2M cellular networks: LTE-MTC and NB-IoT capacity analysis for smart grids applications’, *Proceedings of AEIT '16*, Capri, Italy, 2016.
- [9] J.W. Shin et al., ‘Control channel load balancing in narrow band cellular IoT systems supporting coverage class’, *Proceedings of ISMS '16*, Bangkok, Thailand, 2016.
- [10] 3GPP, ‘Study on RAN improvements for machine-type communications’, *TR 37.868*, see www.3gpp.org, 2011.
- [11] M. Nijhuis et al., ‘Demand response: social welfare maximisation in an unbundled energy market case study for the low-voltage networks of a

distribution network operator in The Netherlands', *IEEE Transactions on Industry Applications*, vol.53, no. 1, 2017.

- [12] Analysys Mason, 'Successful deployment of NB-IoT will depend on spectrum choices', see <http://www.analysismason.com/AboutUs/News/Newsletter/successful-deployment-of-nb-iot-jan17/>, 2017.
- [13] F. Gunnarsson et al., 'Downtilted base station antennas – a simulation model proposal and impact on HSPA and LTE performance', *Proceedings of VTC '08*, Calgary, Canada, 2008.
- [14] 3GPP, 'Radio Frequency (RF) system scenarios', *TR 25.942*, Release 13, see www.3gpp.org, 2016.

- [15] 3GPP, 'UMTS 900 MHz Work Item technical report', *TR 25.816*, Release 7, see www.3gpp.org, 2012.
- [16] J. Schliez and D. Raddino, 'NB-IoT white paper', Rohde & Schwarz, see https://cdn.rohdeschwarz.com/pws/dl_downloads/dl_application/application_notes/1ma266/1MA266_0e_NB_IoT.pdf, 2016.
- [17] S.H. Khan, 'Capacity study for LTE release 13 eMTC with coverage enhanced RACH', *MSc Thesis*, TU Eindhoven, see <https://pure.tue.nl/ws/files/46944860/855330-1.pdf>, 2016.
- [18] 3GPP, 'Radio Resource Control (RRC); protocol specification', *TS 36.331*, v13.3.0, see www.3gpp.org, 2016.

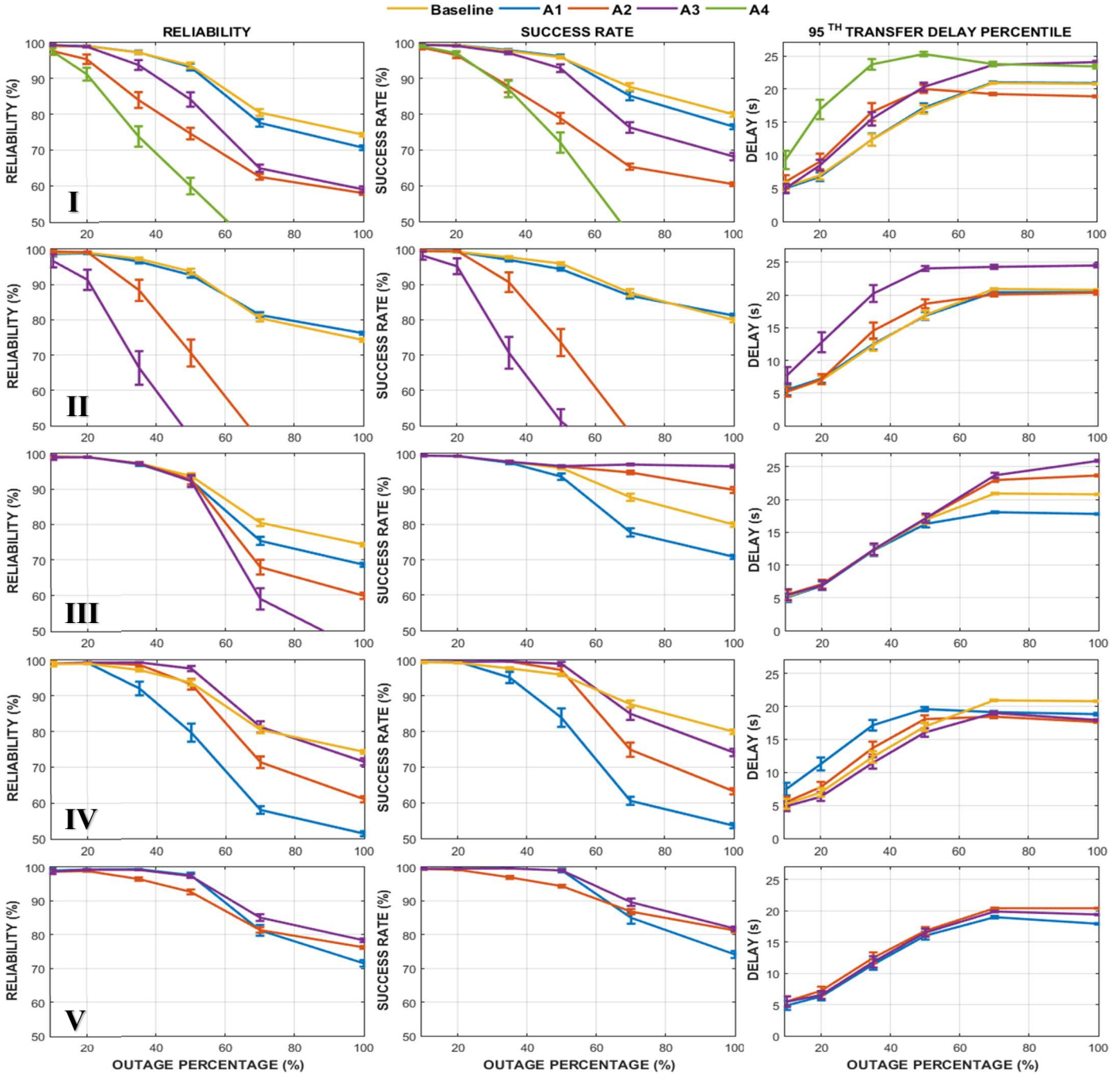

Fig. 5. Comparison of the reliability, success rate and 95th transfer delay percentile versus the outage percentage, considering the urban environment and either the baseline versus a set of alternative configurations (rows I-IV), or set of potential near-optimal configurations (row V)