

Dwelling in Spaces of Movement

Dwelling in Spaces of Movement

Theme Research

Delft University of Technology,
Architecture & Dwelling Graduation Studio:
At Home in the City

Authors:

Inwha Paik
Maciej Jan Abramczyk
Ramazan Dogan

Supervision:

Birgit Jürgehake
Paul Kuitenbrouwer

Delft, May 2014

Contents

05 Introduction

- 06 Van Der Kunbuurt
- 07 Spaces of Movement
- 08 Dwelling
- 09 Problem Statement
- 09 Research Question

11 Method

- 12 Introduction
- 13 Tools for Analysis: Literature
- 14 Tools for Analysis
- 16 Tools for Performance Assessment
- 18 Case Selection: Conditions
- 18 Case Selection: Criteria

21 Case Studies

23 Zuidpoort, Delft

- 24 Introduction
- 28 Programme Distribution
- 30 Routes & Access
- 32 Access Points
- 34 Public, Collective & Private Space
- 36 Perspective: Public Space
- 37 Perspective: Collective Space
- 48 Materials: Public Space
- 39 Materials: Collective Space
- 40 Open Space Scale & Proportions
- 44 Visual Connections
- 48 Performance Assessment

51 Monnikhof, Groningen

- 52 Introduction
- 56 Programme Distribution
- 58 Routes & Access
- 60 Access Points
- 62 Public, Collective & Private Space
- 64 Perspective: Public Space
- 65 Perspective: Collective Space
- 66 Materials: Public Space
- 67 Materials: Collective Space
- 68 Open Space Scale & Proportions
- 72 Visual Connections
- 76 Performance Assessment

79 Grenelle, 35 Logements, Paris

- 80 Introduction
- 84 Programme Distribution
- 86 Routes & Access
- 88 Public, Collective & Private Space
- 90 Perspective: Public Space
- 91 Perspective: Collective Space
- 92 Materials: Public Space
- 93 Materials: Collective Space
- 94 Open Space Scale & Proportions
- 98 Visual Connections
- 102 Performance Assessment

105 Django Building, Amsterdam

- 106 Introduction
- 110 Programme Distribution
- 112 Routes & Access
- 114 Access Points
- 116 Public, Collective & Private Space
- 118 Perspective: Public Space
- 119 Perspective: Collective Space
- 120 Materials: Public Space
- 121 Materials: Collective Space
- 122 Open Space Scale & Proportions
- 126 Visual Connections
- 130 Performance Assessment

133 Case Comparison

- 134 Introduction
- 135 Programme
- 138 Routes & Access
- 144 Public, Collective & Private Space
- 150 Materials
- 152 Scale & Proportions
- 153 Visual Connections

155 Conclusions

- 156 General Conclusions
- 158 Summary: Design Recommendations

160 Bibliography

Introduction

Van Der Kunbuurt



1 Public programming in the vicinity of Van Der Kunbuurt



2 Main routes surrounding Van Der Kunbuurt based on observation of the site

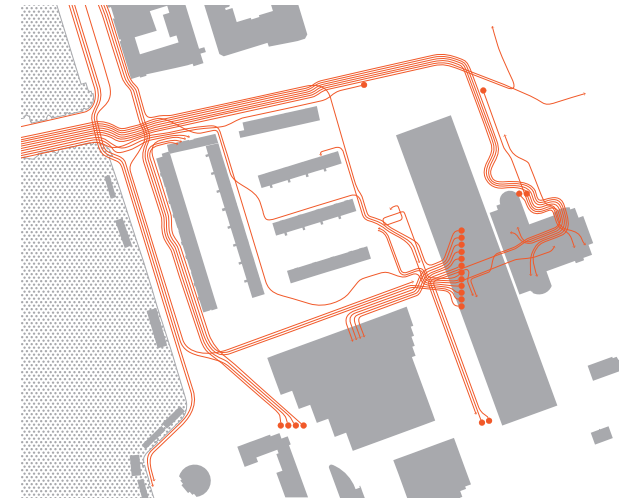

3 Case scenario of pedestrian routing in the area based on site analysis

Location

The site is located on the knot of diverse neighbourhoods, each displaying different urban and programmatic qualities.

To the North lies an area of expensive single or double-family attached houses, facing waterfront of Amstel. The buildings were mostly developed during second part of the 19th century, having individual entrances located at the street and the ground floor is often dedicated for small retail programme. The waterfront is a pleasant recreation area, intensively used by both the inhabitants and outsiders.

To the South a business district of skyscrapers and highrise buildings is located, being a destination of numerous day-to-day commuters.

To the West there is Berlage Brug, a busy connection with 'IJsselbuurt' area.

To the East the site is bordered by railroad, performing as an effective spatial and visual separator. Most importantly however, the site is adjacent to station Amsterdam Amstel, which is the main destination for most of the trespassers in the area and a generator of intense pedestrian traffic.

In the direct vicinity of the site there are only buildings dedicated for public use, rendering Van Der Kunbuurt a sole island of dwelling within public programme (fig.1). Furthermore, due to its location at Amsterdam Amstel station, Berlage Brug and the crossing with Wespertzijde waterfront route, the site is indisputably located at a large communication node (fig.2). As a result an intense traffic of users of public facilities engulfs the site - the users that only use the area periodically, anonymously, without strong personal relation with the area.

Performance

The site was developed as part of Van Eesteren plan in 1960's, basing on the idea of functional organisation of the city. The urban planning leitmotifs of the time: programme and routing segregation, as well as purely functional disposition of buildings in accordance to sunlight exposition benefits were applied to the site's design.

Due to its Van Eesterenian origin, architecture of Van Der Kunbuurt responds solely to the functional or parametric aspects of living in the city, offering its inhabitants a due amount of green areas, square meters of dwelling space and access to sunlight. It is destined for what Jaap Bakema

referred to as a nuclear family - an independent family unit, capable of freely entering chosen relations with others, which finds its expression in architecture of independent dwelling units situated in an ultimately open environment. Van Der Kunbuurt was not intended to support or respond to social activities other than those internal to a single dwelling unit. It is incapable of accommodating a community space, nor a performing private outdoor space. Simultaneously the site remains oblivious about its lively neighbourhood, not offering any facilities, public spaces, or services - with an exception of a cafeteria, which success demonstrates the area's potential as a public domain.

As a result the outdoor space of the site remains vacant, which leads to its neglect and deterioration. The inhabitants of the site are dissatisfied with absence of dwellers community, or they take their social activities to other parts of the city. The periodical users of the area avoid the site, taking a detour, rather than passing through it, partly due to Kunbuurt's bad reputation of a criminal hideout, partly due to its apparent spatial and visual unattractiveness (fig.3).

Van Der Kunbuurt is therefore a no-man's land, an empty open space surrounded by thousands of day-to-day trespassers.

Spaces of Movement



- 1 Social activities are depending on the presence of others.
- Children at play
 - Greetings and conversations
 - Communal activities
 - Passive contacts: seeing and hearing others

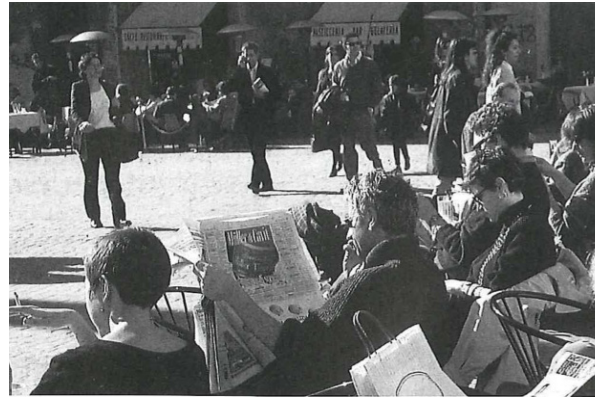

- 2 Optional activities are depending on personal wish and possibilities offered by the surroundings.
- Taking a walk
 - Standing around
 - Sitting / Sunbathing
 - etc.

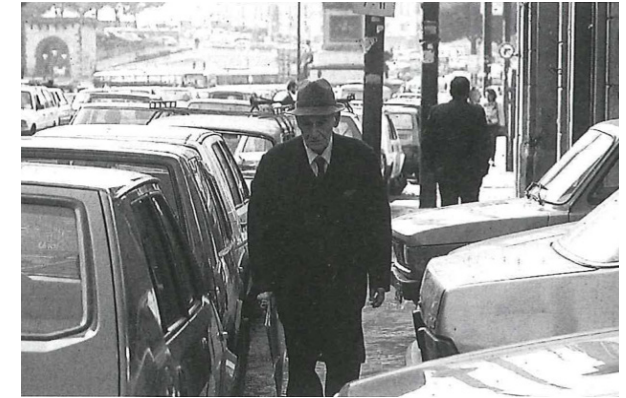

- 3 Necessary activities are more or less compulsory.
- Going to school or work
 - Waiting for public transport
 - etc.

Three types of outdoor activities

Three side of Van der Kunbuurt faces the busy communication movement. And the open space is incapable of accommodating neither any community space nor the private outdoor space. To assess precisely about the quality of the open space it is important to notice what kind of activities are taken place.

According to Jan Gehl, outdoor activities in public spaces can be divided into three by greatly simplification, which is social activities, optional activities, and necessary activities.

Social activities occur with the presence of others such as children at play, greetings and conversation, communal activities and also seeing and hearing other people. It is resultant activity that is linked and supported to the other two activities when it is in better conditions in outdoor spaces (fig1).

Optional activities happen only under favorable exterior conditions, which include taking a walk to get fresh air, standing around, sitting and sunbathing (fig2).

Necessary activities are compulsory activities, which involve lesser degree of participation of others. Commuting, shopping, waiting for a bus or a person and etc. can be included in this category (fig3).

Interwoven of these three patterns creates the whole outdoor activities. While in Van der Kunbuurt outdoor activity is extremely limited to only necessary activities that don't lead to other social or optional activities. Except the cafeteria, even the passive contacts- seeing and hearing a great number of unknown people- doesn't occurs. The activity between the buildings is missing due to the sharp boundary between the isolation and contact.

Dwelling



1 Low level of public space anonymity. The usage of public space is restricted to a narrow group of fellow inhabitants. In response the private space of dwelling freely extends into public domain.



2 Intermediate level of public space anonymity. The street is accessible to anyone, however its relatively small scale limits the traffic intensity. Private domain retreats to the upper floors, leaving the ground floor to retail functions.



3 High level of public space anonymity. The users are complete strangers, perceived rather as traffic, then persons. The only remaining connection between public space and dwelling is purely visual. Dwelling is in defense.

Anonymity and Personality

One of characteristics of public space is its relative anonymity. The users of public domain are alien to one another and to the surroundings. The broader the admittance of users into particular space, the higher the level of anonymity. Likewise, with an increase of access restrictions, the number of users decreases, and with it the anonymity of space. Therefore, the anonymity of public space can be seen as function of amount of its users, of the traffic intensity.

The same dependence is true also for dwelling ensembles. However there, a strive is in general to suppress anonymity and create a personalised environment, to which inhabitants can relate to as their own part of the city. And the level of anonymity is in relation to the how the layout of the space is dedicating the different kind of activities. The way on how space is organised will determine the increased anonymity in the personalised environment, to be an obstacle or contribution in creating social or optional activities.

By necessity, dwelling - in one way, or another - is always located within public space. The balance between public anonymity and dwelling personality is what constitutes the character of city spaces. Dwelling responds to the pressure of public space's anonymity by means of spatial language, striving to achieve the desired equilibrium - and vice versa.

Therefore, the confrontation of two opposing tendencies of anonymity of public space and the personality of dwelling, is what gives birth to a scope of dwelling typologies (fig.1-2). An extreme case of such confrontation occurs when dwelling has to respond to the pressure of public space dedicated to movement. As it was explained beforehand, such spaces display perhaps the highest degree of anonymity, for they lack any access restrictions and therefore they host a constant flow of countless strangers (fig.3).

This is exactly the case of Van Der Kunbuurt, as it is located in the middle of a busy communication node - at the entrance to Amsterdam Amstel station and at the crossing of two transit routes.

However the spatial language of the site does not respond to the challenging pressure of its environment. Due to that the anonymity of the surrounding public space has overcome and dominated the space of the dwelling ensemble.

Perhaps the architecture of Van Der Kunbuurt would be capable of hosting a community, if the ensemble would have been placed in a different context, relieved from an external pressure of anonymous space, like for instance a remote rural area, where the inhabitants would have been free to engage with one another and their surroundings.

This is however never going to happen, and therefore the task of transformation of Van Der Kunbuurt has to deal with the problem of dwelling located within the space of movement, the problem of spatial mediation between two contradicting influences.

Problem Statement

Research Question

Due to a reciprocal contradiction of interests and atmospheres between spaces of movement and dwelling, their spatial form is interrelated.

How can a dwelling project respond spatially to exposure to spaces of movement?

Method

Introduction

Comparative analysis of selected dwelling ensembles and buildings is to be performed. The preparation of analysis consists of four steps:

- ❶ Definition of uniform conditions that each analysed case has to meet. The conditions ensure the comparability of cases.
- ❷ Definition of case selection criteria ensuring heterogeneity of case's performance and therefore heterogeneous results of analysis.
- ❸ Definition of uniform tools for analysis including uniform subject and layout, ensuring comparability of analysis results.
- ❹ Definition of a uniform performance assesment tool of each analysed building or ensemble, allowing for correlation of analysis results with the adequacy of design solutions.

The analysis of each selected project consist of four steps:

- ❶ Analysis of spatial relation of project and the surrounding public space, as defined by selected parameters.
- ❷ Analysis of architectural qualities and expression
- ❸ Assessment of project performance
- ❹ Conclusions

Subject of Analysis

The subject of analysis will be the spatial relation of different dwelling buildings or ensembles (in accordance to defined selection criteria) with the adjacent public space (under the defined, uniform conditions).

The spatial and performative properties of interest are those, which constitute the relation between public domain and dwelling, further discussed in chapter "Tools for Analysis" (see page 13).

Aim of Analysis

The retrieved results will serve to answer the research question by displaying morphological and semiotic characteristics of case study projects constituting their spatial response to expoure to intense pedestrian traffic in public spaces dominated by neccessary activities. The analysis aim to provide an insight to *what* are the proposed solutions under the examined circumstances, *how* they perform and *why*.

The far-reaching aim of analysis is to relate and implement the analysis results into the design task at Van Der Kunbuurt, to broaden the perspectives and awareness of the designers. The theme research is designed to respond to the problems observed at Van Der Kunbuurt and to aid the designers with tools for more responsible design reaction.

Tools for Analysis: Literature

Public, Collective, Private & Space Usage

The analysis is on focus of the movement in the space, divided into public, collective and private. According to Manuel de Sola Morales, 'collective space is that is neither public nor private but both things simultaneously.'¹⁾ Especially in residential building collective spaces are formed naturally that are mostly used by the dweller. By extracting only the routes and access on diagram can clearly show how the general routes are taken by different purpose.

Jane Jacobs says that 'To understand cities, we have to deal outright with combinations or mixtures of uses, not separate uses, as the essential phenomena.'²⁾ As the research is dealing with a movement in space in cities the program distribution in the building contributes to the movement. Access points are illustrated to compare the difference of public, collective and private access.

References

1. Manuel de Sola-Morales, *Public Spaces, Collective Spaces* In *Architectural Positions*, Amsterdam: SUN Publishers, 2009, p.89.
2. Jane Jacobs, *The Death and Life of Great American Cities*, Vinatage Books, New York, 1961, p.144.

Human dimension and Visual Relationship

According to Jan Gehl who gave a strong recognition of people and events than the building claimed that 'the design of buildings in relation to relevant human dimension is crucial.'

¹⁾ The each foot of street and each square foot of space are important, as 'intensity of experience is increase in reduced sizes'.²⁾ The small dimension is necessary as it allows to see and to hear other people.

He points out that 'history of human settlement, streets and square have been the basic elements around which all cities were organized.'³⁾ And streets that are formed along the building are the elements that are 'based on the linear patten of human movement'⁴⁾ and squares are 'based on the eye's ability to survey an area.'⁵⁾ By visualizing the section of the building ensemble in consequence, the linear movement and sensory orientation can be revealed.

The research will try to express how the residential building is dealing with the scale and proportion and also the visual relationship in open space. A sightline is important, because space will be in use when people can see the space.⁶⁾ Herman Hertzberger gives importance of 'in influencing visual

relationship and possibilities for encountering or avoiding others.'⁷⁾ The visual relationship between the public and collective space in private dwelling has to be considered as it encounter the space of movement with anonymity.

Alexander Christopher states, window is an device that gives streets to have liveliness as they provides 'a unique kind of connection between the life inside buildings and the street.'⁸⁾ Also the views from individual dwelling to outside area according to different function can be discovered in modest sensory range.

References

- 1 Jan Gehl, *Life Between Buildings Using Public Space*, The Danish Architecture Press, Copenhagen, 1986, p.85.
- 2 *ibid.*, p.93
- 3 *ibid.*, p.91
- 4 *ibid.*, p.93
- 5 *ibid.*, p.93
- 6 *ibid.*, p.99
- 7 Herman Hertzberger. "'Collective Space, Social Use'." In *Architectural Positions*, Amsterdam: SUN Publishers, 2009, p.98
- 8 Alexander Christopher, *A Pattern Language*, Oxford University Press, New York, 1977, p.770

Tools for Analysis

Routes and Access

- 1 **Spatial distribution of public, collective and private routes in and around the building or ensemble.**

[Exploded axonometry drawing]

- 2 **Amount of public, collective and private access points and their spatial distribution.**

[Percentage diagrams: overall amount in the building or ensemble, amount on the ground level, amount on the other levels]

- 3 **Semiotic expression of access points.**

[Perspective drawings reduced from photographs]

Programme Distribution

- 1 **Spatial distribution of dwelling, retail, public, cafeteria / restaurant and parking functions in and around the building or ensemble.**

[Exploded axonometry drawing]

- 2 **Amount of square meters per programme included in the building or ensemble.**

[Percentage diagrams: overall amount in the building or ensemble, amount on the ground level, amount on the other levels]

Public, Collective & Private Space

- 1 **Spatial distribution of public, collective and private outdoor / access space in and around the building or ensemble.**

[Exploded axonometry drawing]

- 2 **Amount of square meters per space type included in the building or ensemble.**

[Percentage diagrams: overall amount in the building or ensemble, amount on the ground level, amount on the other levels]

- 3 **Expression of representative public & collective / private space.**

[Perspective drawings reduced from photographs]

- 4 **Facade & paving materials representative to public & collective / private space.**

[Photographs]

Open Space Scale & Proportions

- 1 **Dimensions and proportions of public and collective space in and around the building or ensemble.**

[Axonometry sections representative to the building or ensemble]

- 2 **Width and height of public and collective space within and around the building or ensemble.**

[Linear diagrams: dimensions extracted from a 3D model of the building or ensemble, including the model of surroundings // Measuring points located in constant distance from one another // Extraction of average values]

- 3 **Relation to human scale of representative public & collective / private space.**

[Perspective drawings reduced from photographs]

Visual Connections

- 1 **Visual relation of living / kitchen area and private rooms with the outdoor public and collective spaces.**

[Exploded axonometry drawing]

- 2 **Visual connections from living / kitchen area and private rooms into the outdoor public and collective spaces.**

[Axonometry sections representative to the building or ensemble]

- 3 **Facade openings of representative public & collective / private space.**

[Perspective drawings reduced from photographs]

Tools for Performance Assessment

A uniform performance assessment tool for each analysed building or ensemble is aimed to correlate the analysis results with the adequacy of design solutions. For that purpose a questionnaire has been developed with questions related to the analysed properties of the studied cases: the relation with public space, the performance of collective and private outdoor spaces and the relation of dwelling interior with the outdoor spaces.

The assessment will base on the level of respondent's satisfaction:

Very Dissatisfied: **0%**
Dissatisfied: **25%**
Neutral: **50%**
Satisfied: **75%**
Very Satisfied: **100%**

Based on the number of responses and satisfaction level of each respondent, an average satisfaction level will be calculated for each question.

Assesment of the Relation with Public Space

In order to assess the performance of relation between the public domain and community spaces provided in the project a series of questions has been asked to the inhabitants related to use public spaces and facilities:

1 How satisfied are you with the location of the building where you live, in the context of the city?

Very Dissatisfied Dissatisfied Neutral Satisfied Very Satisfied

2 How satisfied are you with the public facilities provided in the building where you live?

Very Dissatisfied Dissatisfied Neutral Satisfied Very Satisfied

3 How satisfied are you with the public facilities provided in the area in the vicinity of the building where you live?

Very Dissatisfied Dissatisfied Neutral Satisfied Very Satisfied

4 How satisfied are you with the level of disturbances (such as noise, intrusions) coming from the public space surrounding the building you live in?

Very Dissatisfied Dissatisfied Neutral Satisfied Very Satisfied

Assesment of the Private Space Performance

In order to assess the performance of private outdoor spaces provided in the project a series of questions has been asked to the inhabitants related to use of the aforementioned spaces:

1 How satisfied are you with the quality and amount of private outdoor spaces (such as terraces, balconies) provided in the building you live in?

Very Dissatisfied Dissatisfied Neutral Satisfied Very Satisfied

2 How satisfied are you with the view from your private outdoor space?

Very Dissatisfied Dissatisfied Neutral Satisfied Very Satisfied

Assesment of the Common Space Performance

In order to assess the performance of common and community spaces provided in the project a series of questions has been asked to the inhabitants related to use of the aforementioned spaces:

1 How satisfied are you with the level of interaction with your neighbours?

Very Dissatisfied Dissatisfied Neutral Satisfied Very Satisfied

2 How satisfied are you with the amount and quality of common spaces provided in the building you live in?

Very Dissatisfied Dissatisfied Neutral Satisfied Very Satisfied

Assesment of the Private Interior Space Performance

In order to assess the performance of dwelling spaces a series of questions has been asked to the inhabitants related to use of their apartments:

1 How satisfied are you with the view from your apartment?

Very Dissatisfied Dissatisfied Neutral Satisfied Very Satisfied

2 How satisfied are you with the level of disturbances (such as noise, intrusions) coming from the spaces surrounding your house or apartment?

Very Dissatisfied Dissatisfied Neutral Satisfied Very Satisfied

Case Selection: Conditions

Case Selection: Criteria

Primary Conditions

In accordance to the problem statement, a set of case study selection conditions has been defined, in order to ensure relevance of the investigated cases of dwelling buildings or ensembles. The primary conditions has been defined as follows:

- 1 **At least one facade of analysed building or ensemble is in direct contact with public space dominated by necessary activities.**

Domination by necessary activities is understood as an absence of spaces destined for optional and social activities, as defined by Jan Gehl¹.

- 2 **The aforementioned public space includes a major pedestrian communication node, or is a commuting route with perceivably intense pedestrian traffic.**

The condition ensures a pressure of necessary activities as described in the introduction chapter (see page ...).

Auxiliary Conditions

Additional conditions has been outlined to further narrow down the scope of investigated cases, to those that are relevant to the design task at Van Der Kunbuurt:

- 1 **The analysed building or ensemble has been designed posteriorly to the domination by necessary activities of the location's public space.**
- 2 **The analysed building or ensemble is of recent origin (has been designed not earlier than year 2000).**

The above conditions ensure that the design of analysed building or ensemble is responsive to the predefined primary conditions and a modern form of necessary activities.

- 3 **The analysed building or ensemble has a mixed programme.**

The above condition ensures that the analysed building or ensemble strives to engage the public domain and therefore addresses not solely the issues of dwelling.

The subject of analysis is the spatial relation of dwelling ensemble or building with the adjacent public space. Invariably, each analysed case is exposed to public spaces similar in character, as defined in the previous chapter by the primary conditions of case selection.

The spatial relation of dwelling and public space can be classified and constituted by the type of access to a single dwelling unit, which can be described as permutation of connections between public space, outdoor community space, indoor community space and the dwelling unit itself.

In order to retrieve inhomogeneous results of spatial relation from the performed analysis, case selection criteria has been developed: Each analysed case should have a different access type for inhabitants. (fig. 1-4).

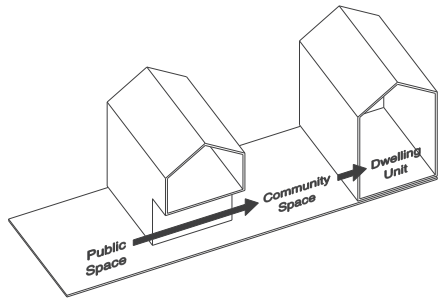

1 Direct Access from Community Space

A single house or apartment is accessible directly from an outdoor community space. An entrance to each house or apartment is located on the same level as the community space, or accessible via outdoor stairs or ramp.

Alternatively, a single house or apartment is accessible directly from public space, with a corresponding disposition of an entrance. An outdoor community space is provided, accessible via interior of house or apartment.

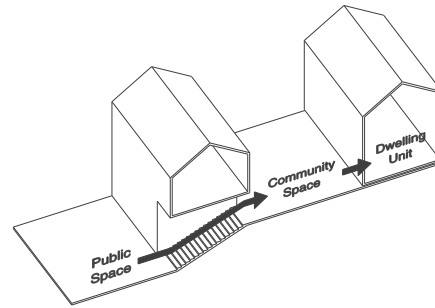

2 Direct Access from Elevated Community Space

A single house or apartment is accessible directly from an elevated outdoor community space. An entrance to each house or apartment is located on the same level as the community space, or accessible via outdoor stairs or ramp. The community space is accessible from public space via an outdoor stairs or ramp.

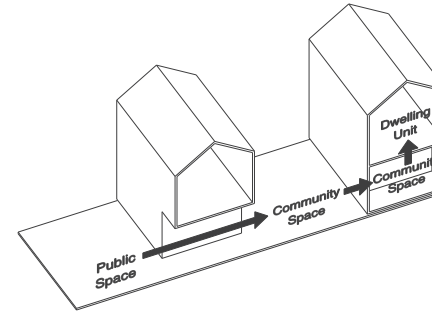

3 Access from Outdoor Community Space Through Interior Community Space

A single apartment is accessible from an outdoor community space through an indoor community space (corridor, staircase, a combination of the afore mentioned, or otherwise). An entrance to each apartment is located in the interior of the building, or at the gallery.

Alternatively, a single apartment is accessible from public space through an indoor community space (as described above). An outdoor community space is provided

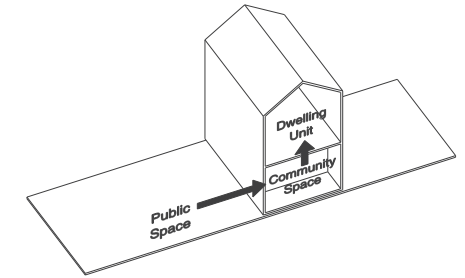

4 Access Through Interior Community Space

A single Apartment is accessible from public space through an indoor community space (corridor, staircase, a combination of the afore mentioned, or otherwise). An entrance to each apartment is located in the interior of the building, or at the gallery.

Case Studies

Zuidpoort Delft

Architect: O'Donnel & Tuomey

Location: Delft, Nederlands

Design: 1998 - 2001

Completion Date: 2002 - 2003

Programme: Housing, Cinema, Retail

Area: 10.000m²

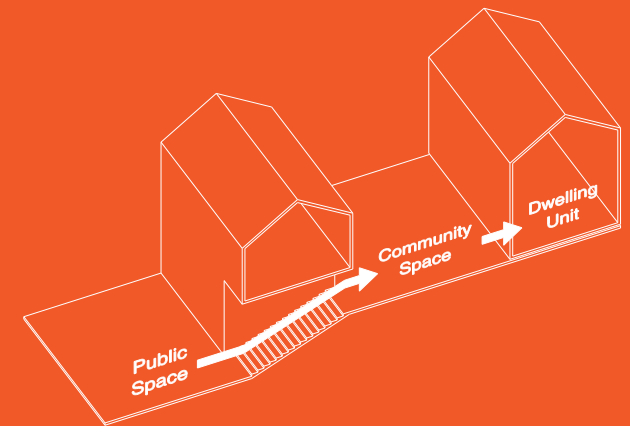



Zuidpoort Delft

Architect: O'Donnel & Tuomey

Location: Delft, Nederlands

Design: 1998 - 2001

Completion Date: 2002 - 2003

Programme: Housing, Cinema, Retail

Area: 10.000m²

Location

The Building by O'Donnel & Tuomey Architects is part of master plan developed for the Zuidpoort area in 90's. Together with a twin development by AWG Architects the project designates a public square - Bastiaansplein - serving the city as a shopping plaza abundant with retail and commercial functions. That, together with a public parking garage situated underneath the square, which has replaced the prior surface parking lot, and the location at the busy Zuidwal street leading to Delft Campus and southern districts of the city renders the site an intensively attended place, yet - a place for trespassing, a space of movement.

Project

In order to blend with the surrounding cityscape, the building facilitates commercial and public programme, including retail shops, caffeterias and a cinema. It is also integrated with the underground parking space. As for the dwelling program, architects have chosen to provide an elevated community space encompassed by 20 dwelling units, from among which 16 were intended as a variation of a row house type, characteristic to Delft's dwelling tradition, and 4 - stacked apartments.

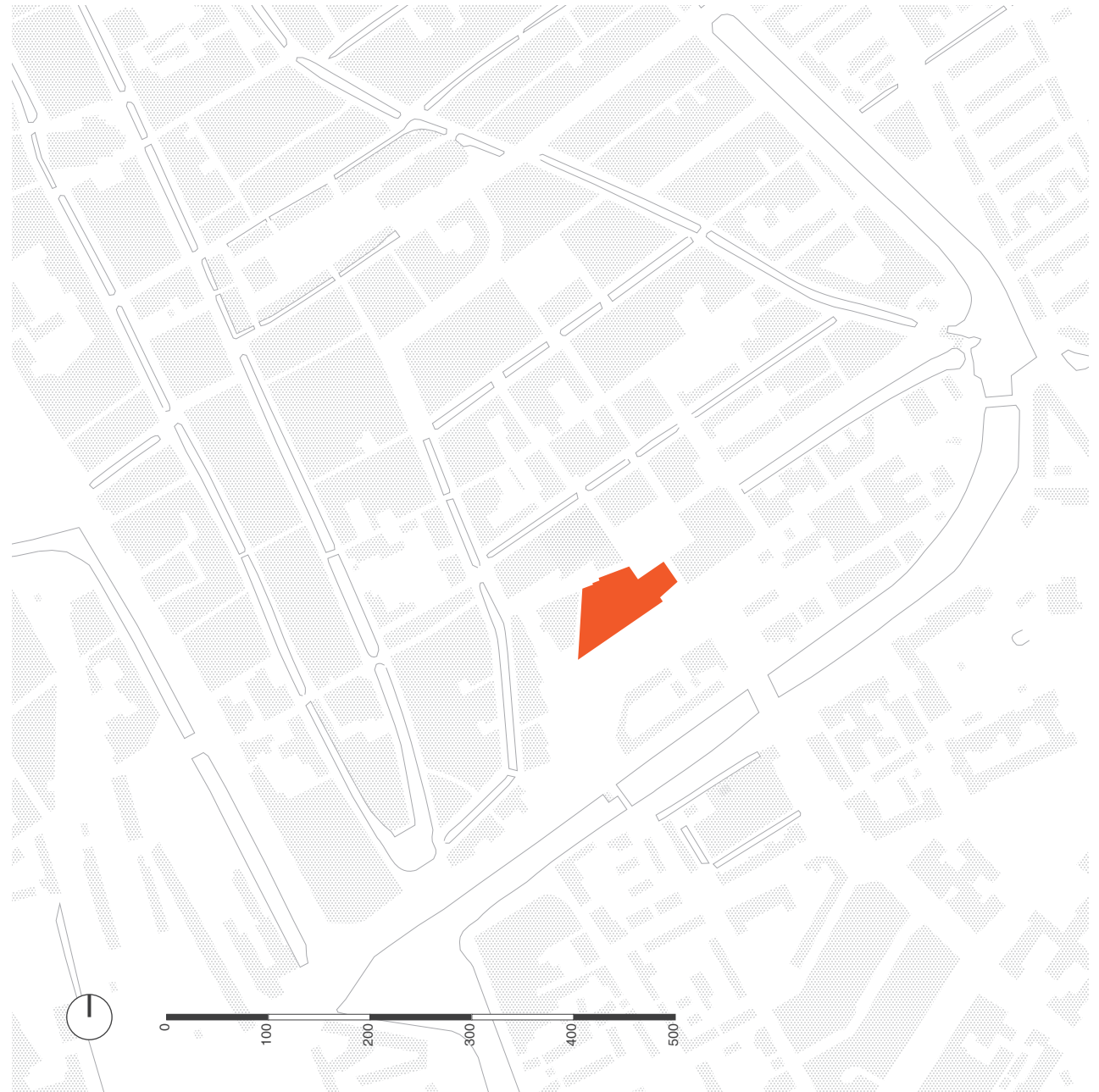

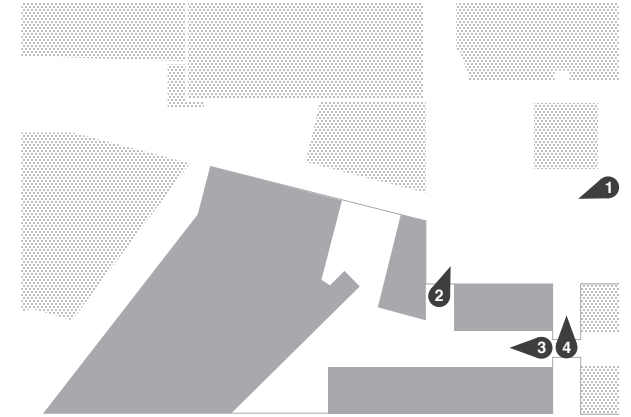

- 1 View from Bastiaansplein**
The building demarcates a concave, pronounced shopping plaza with numerous retail programme users.
- 2 View of Bastiaansplein from the community space**
- 3 Community space seen from an access bridge**
The community space characteristics are at first glance in great contrast with the surrounding public space.
- 4 Bastiaansplein seen from the access bridge**
There are numerous visual connections with public space from the area dedicated to dwellers.

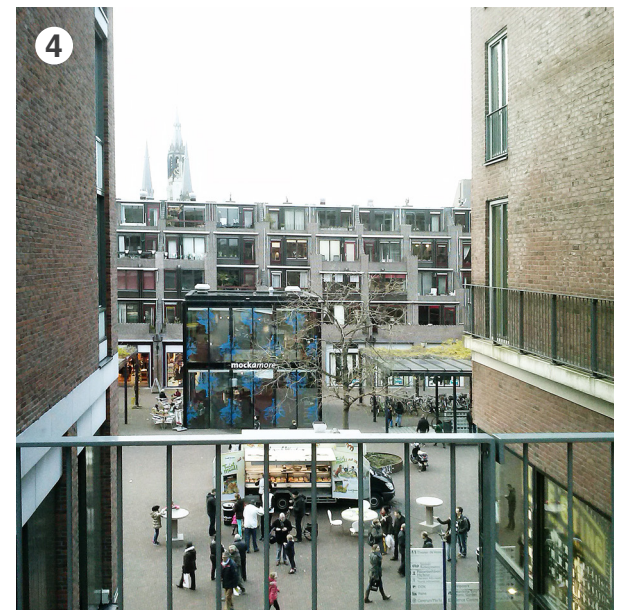

Programme Distribution

The diagrams to the right depict programme distribution in the analysed project as well as in its immediate vicinity. The circular diagrams refer to areas included only within the analysed building.

There is a clear stratification of programme around Bastiaansplein area. The first two levels are almost solely dedicated to retail, commercial and public programme, while dwelling occupies the levels above. Noteworthy, the function mix within the building is quite evenly distributed between dwelling, retail and public functions, with retail being slightly dominant.

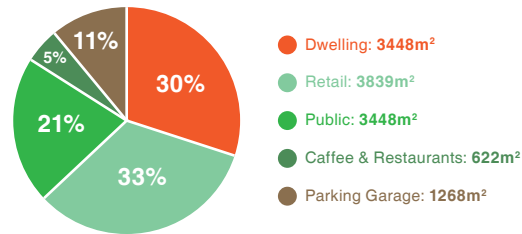

A Programme Distribution: Overall Amounts in the Ensemble

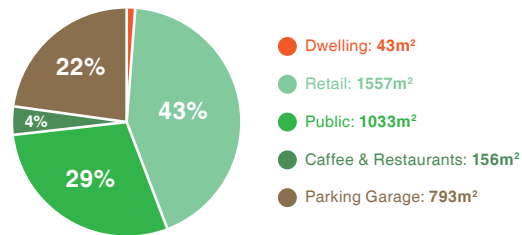

B Programme Distribution: Ground Floor

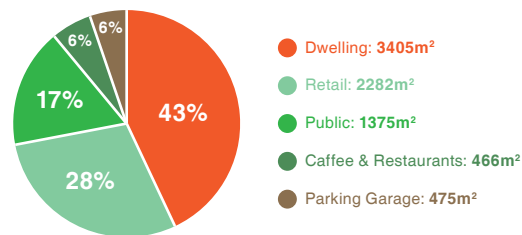

C Programme Distribution: Other Levels

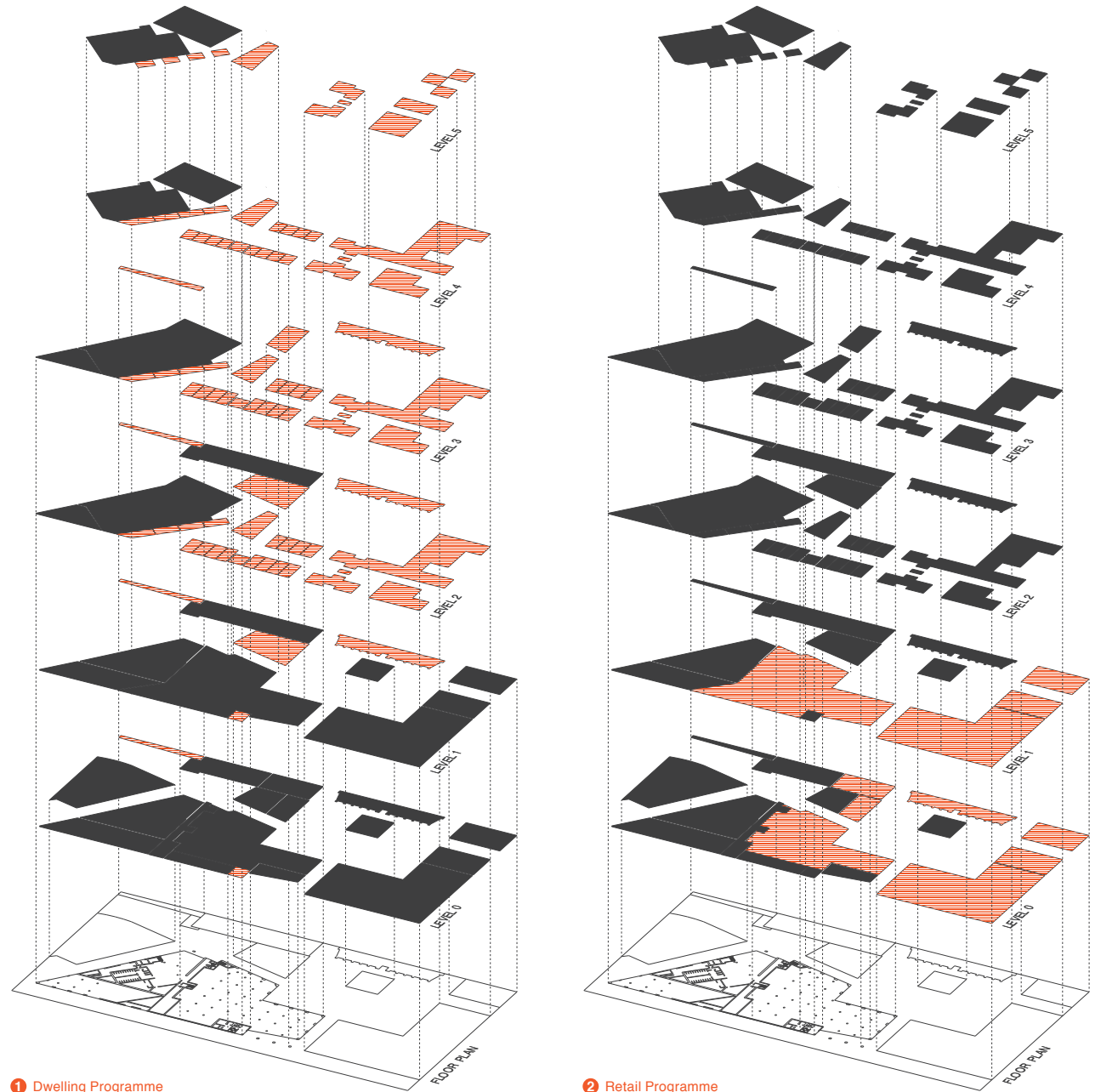

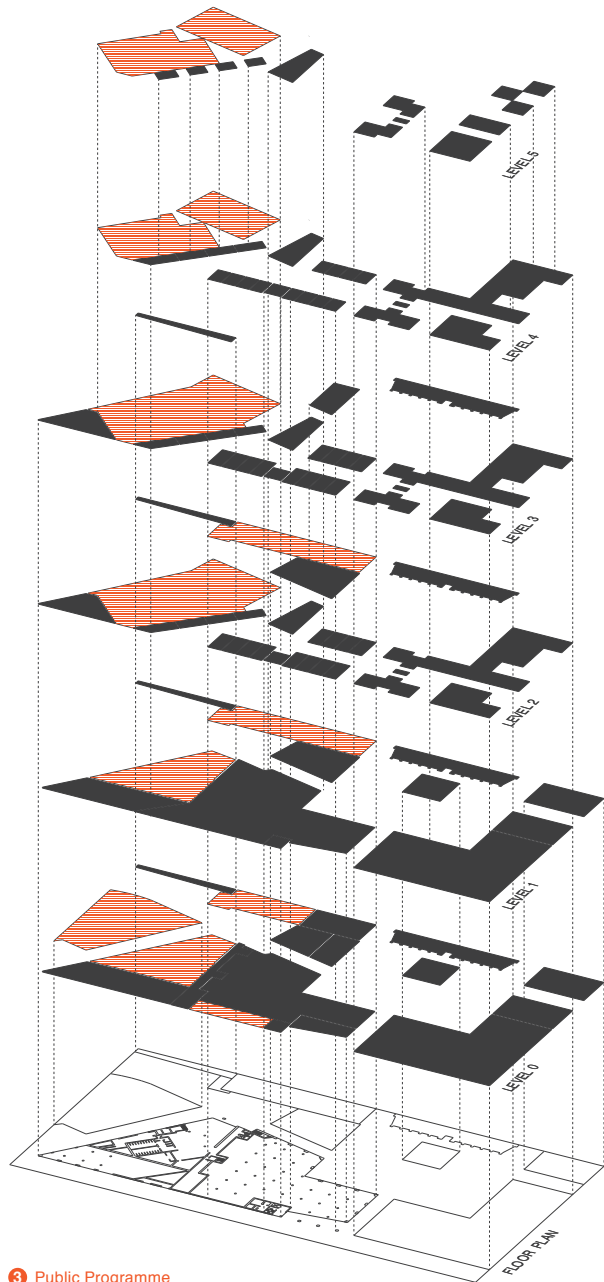

3 Public Programme

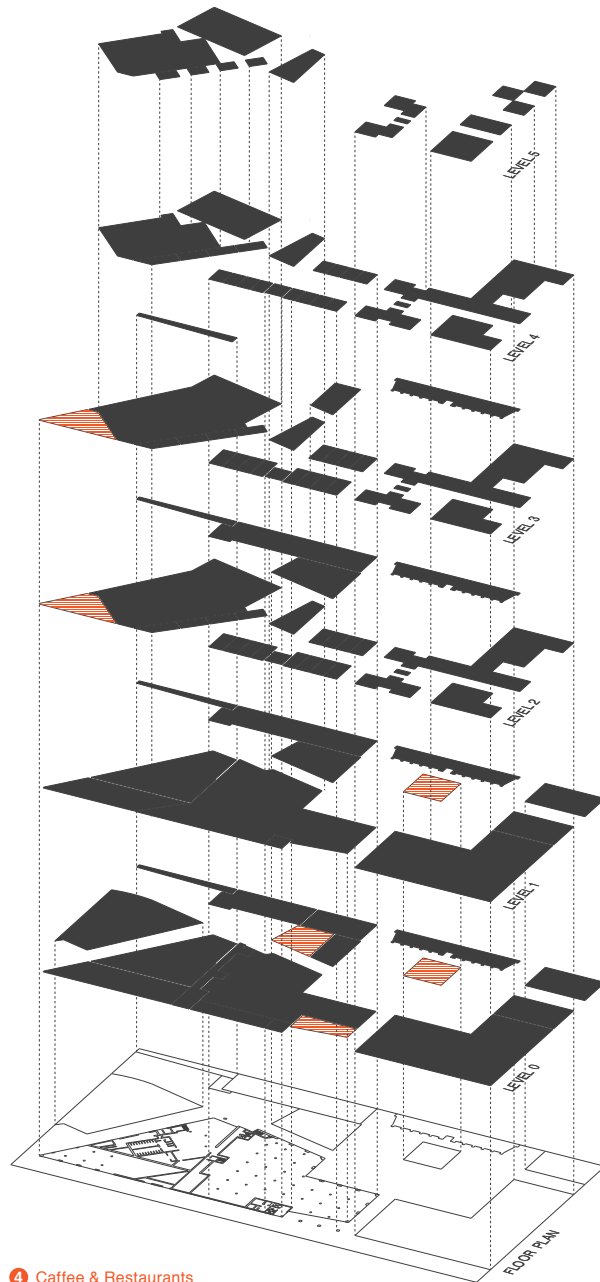

4 Caffee & Restaurants

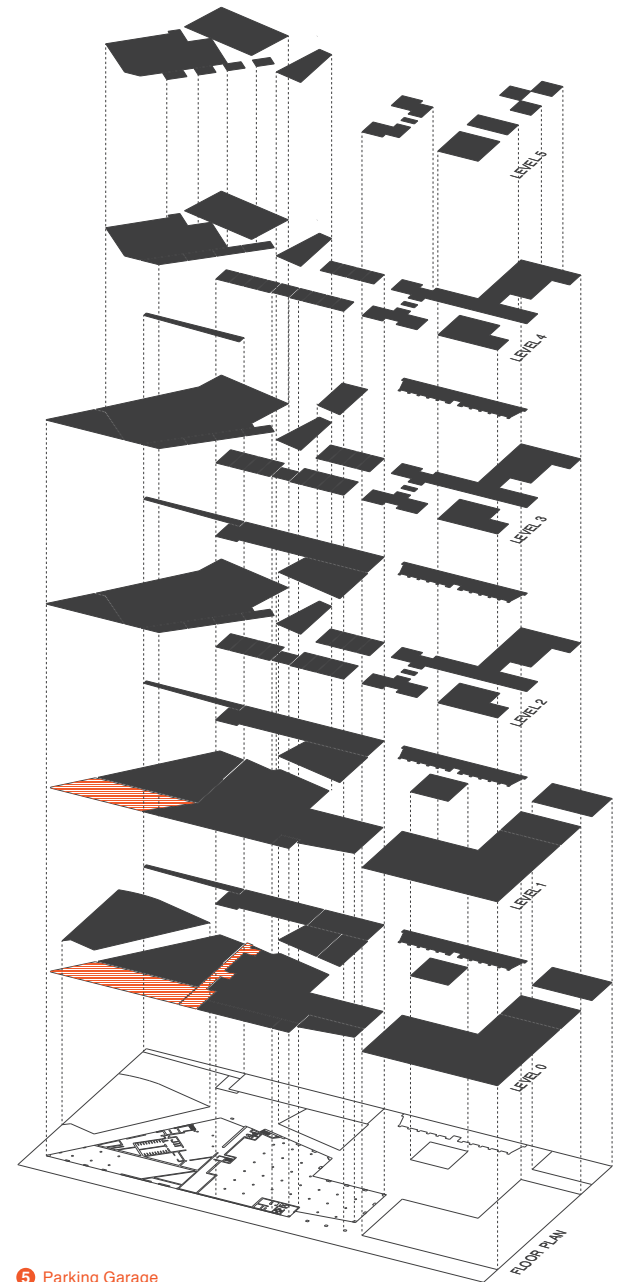

5 Parking Garage

Routes and Access

Disposition

The routing system is clearly stratified: The ground level is solely dedicated to the public users, with an exception of two access points to the community area. The community routes occupy the second level of the ensemble and are protected from public space with walls of dwelling. The private routes are situated in the building's interior on levels 2 to 5.

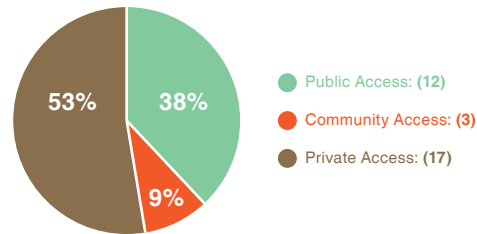

A Public, Community & Private Access: Overall Amounts in the Ensemble

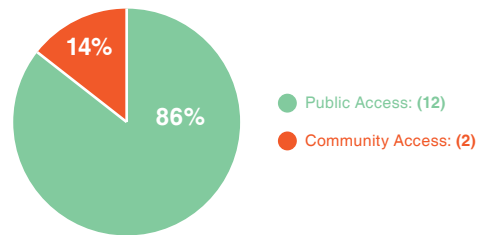

B Public, Community & Private Access: Ground Floor

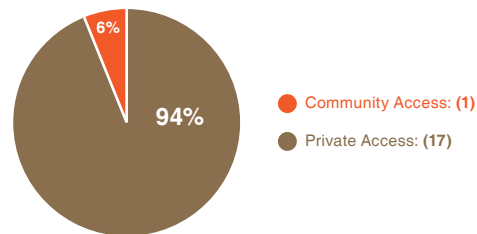

C Public, Community & Private Access: Other Levels

Access Point Frequency: Public Route

The average access point frequency along the public route is 0.34 per 7 meters distance. The Access points are distributed unevenly: alongside Zuidwal, there are hardly any access points - the access frequency drops down to almost 0.1 there, meaning the entrances are almost as far as 70 meters from one another. Zuidwal is clearly treated as a backside of the building. There are however two peaks in frequency of access points distribution: One situated around an entrance to the cinema, second allocated along Bastiaansplein facade.

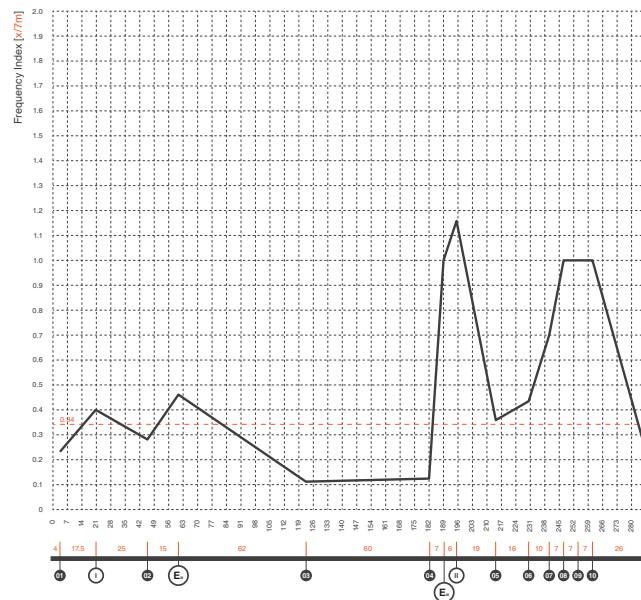
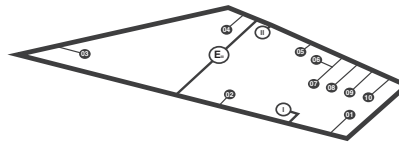

1 Access Point Frequency: Public Route

Access Point Frequency: Community Route

The average access point frequency along the community route is significantly higher than in public route's case and equals 0.85. This means, that almost every 7 meters there is an entrance. As one proceeds north-east along the route, the access point frequency rises due to duplication of entrances on both sides of the route. On approach to exit from community space, where the spatial connection with surrounding public domain is the strongest, the frequency decreases.

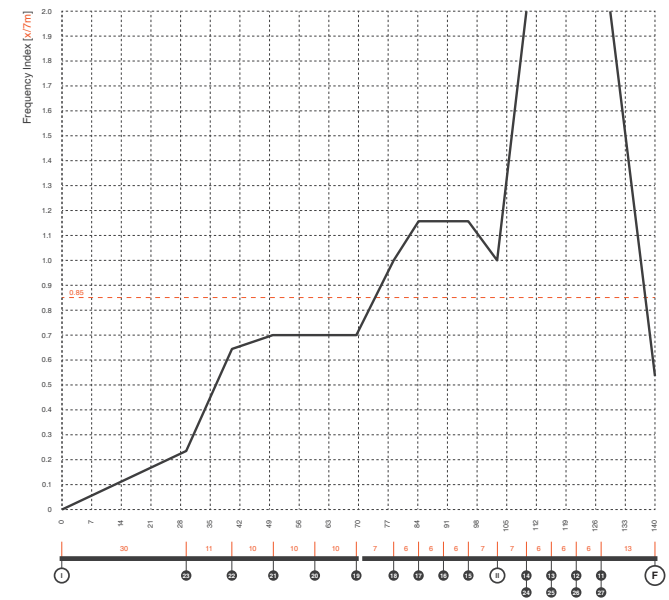
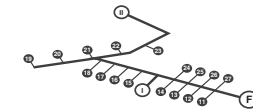

2 Access Point Frequency: Community Route

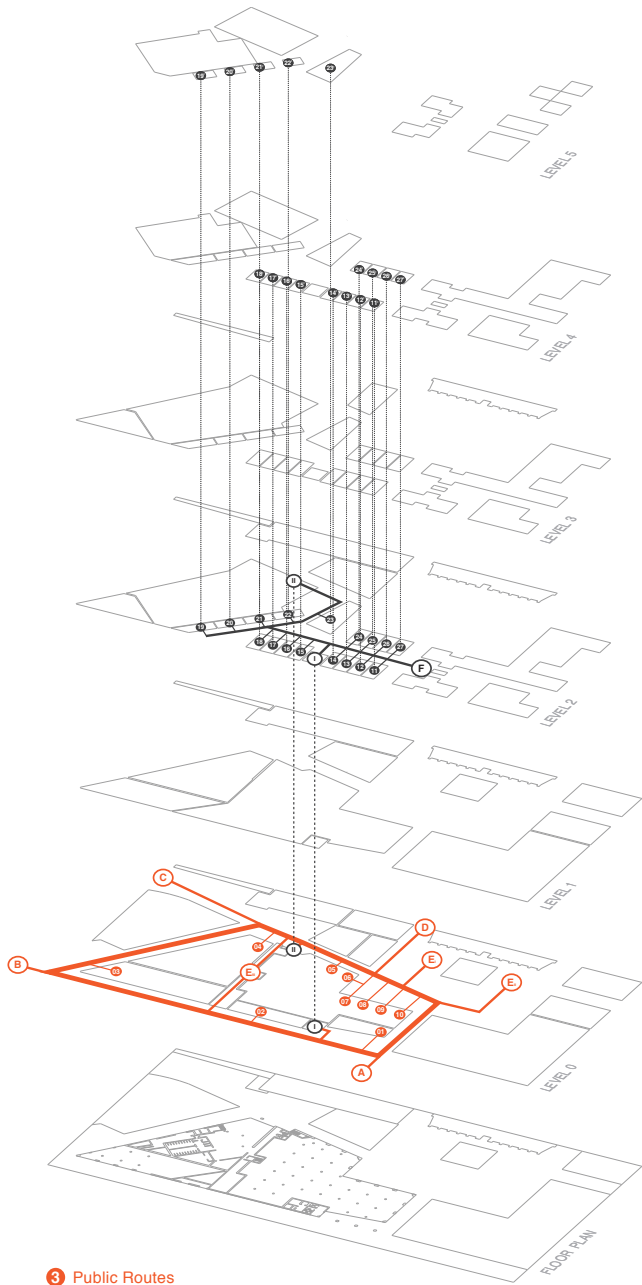

3 Public Routes

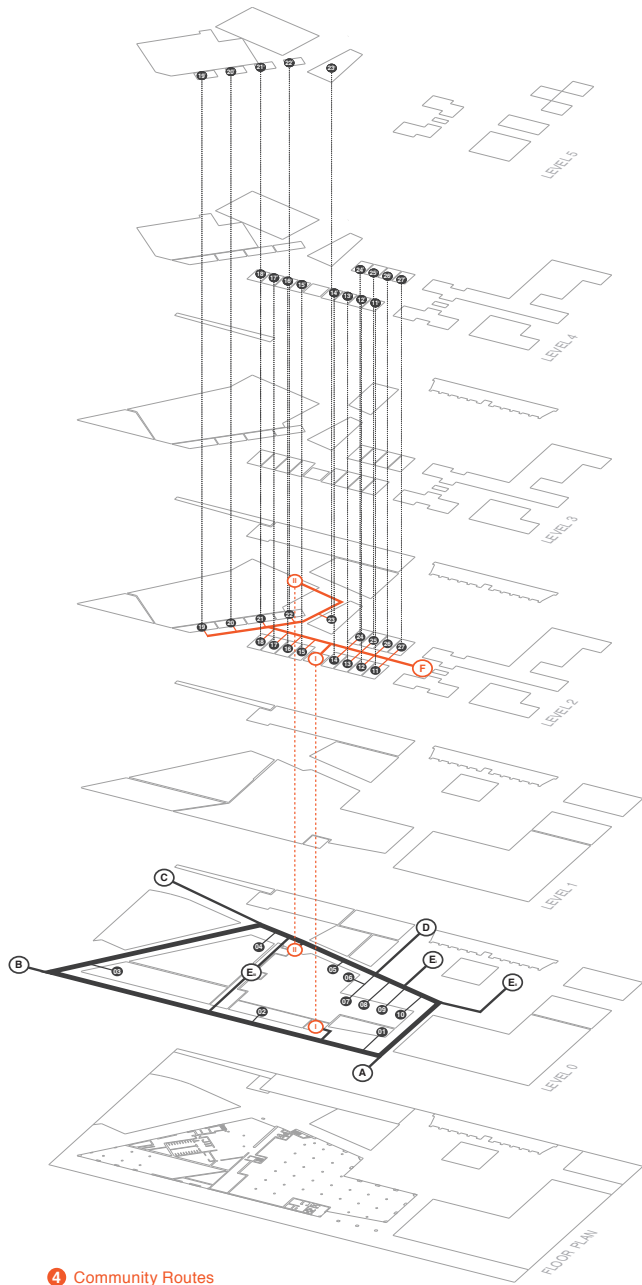

4 Community Routes

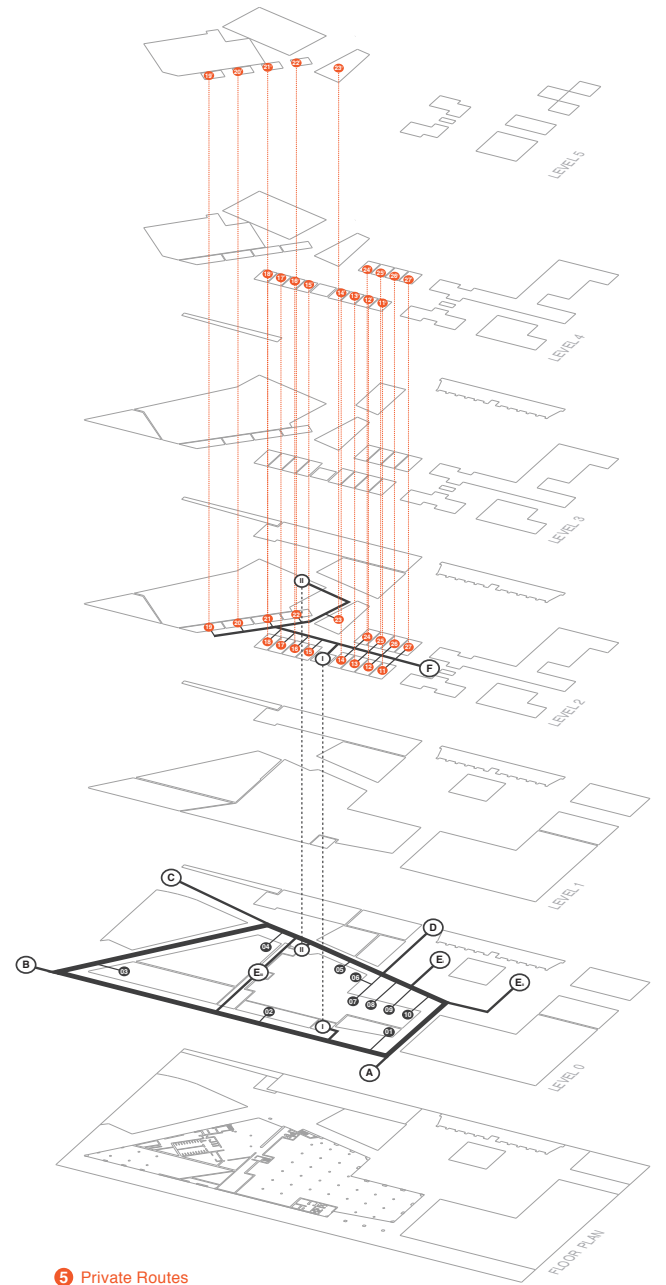

5 Private Routes

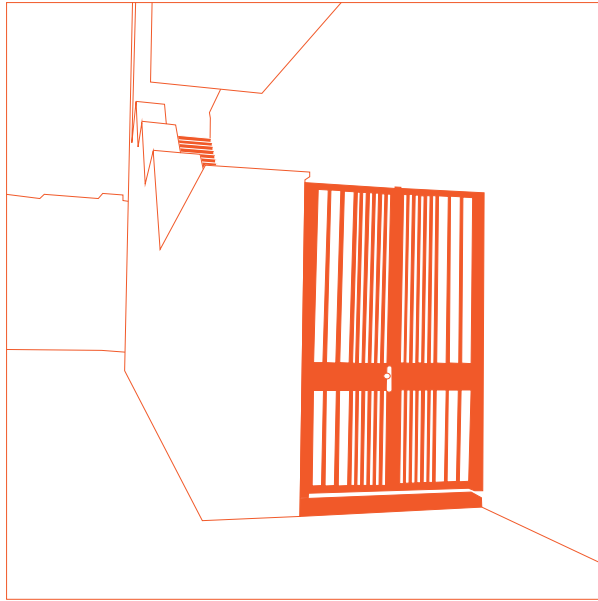

Access Point II

An entrance to the elevated community space resembles a fortification: Deprived of any non-functional details, even intercom it is a gray-painted, steel gate only operable for those in possession of a key. In the background, a glimpse of stairs leading upwards is all that is presented of the community space to a trespasser. An intriguing, yet discouraging spatial element.

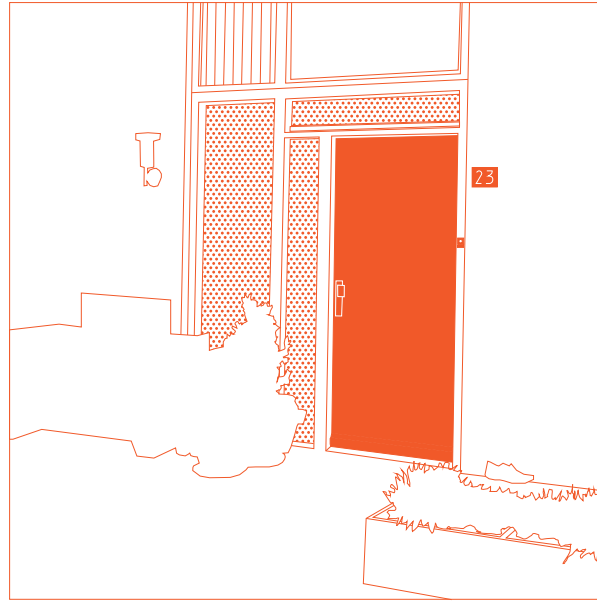
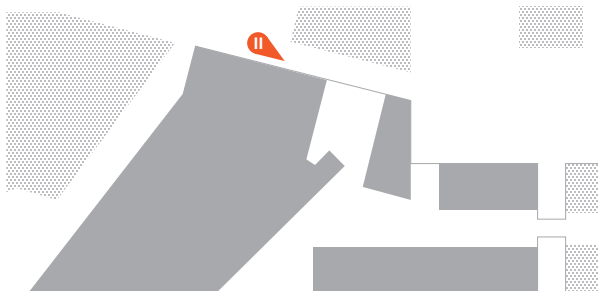

Access Point 21

An entrance to one of row houses located along the community space stands in high contrast with the preceding community space access: The doors are engulfed by transparent surfaces of windows revealing interior of private space. The entrance is accompanied by multiple private objects scattered around, like plants, pet cages, even shoes, diffusing the collective-private boundary. Elements such as lanterns and house number plate further identify the entrance as belonging to a private individual.

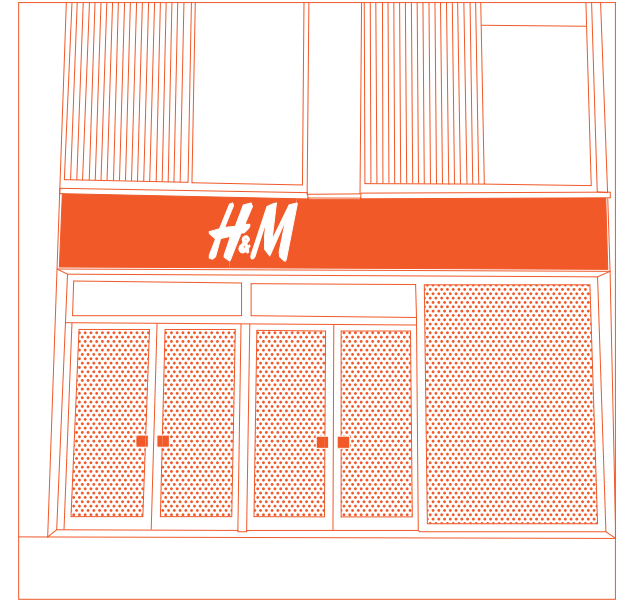
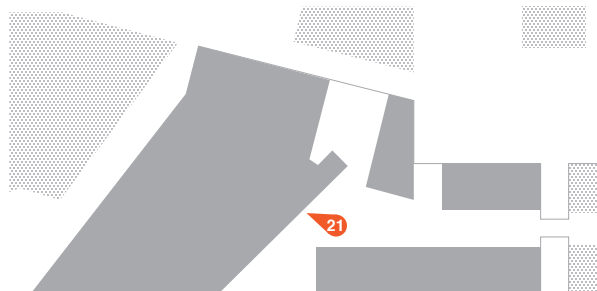

Access Point 06

An access point to one of the biggest shops located within the building provides high degree of transparency and communicativeness. The door handles are big and inviting. As opposed to the dwelling entrance, an official expression is maintained by tidiness of front space resulting in a clear boundary between inside and outside.

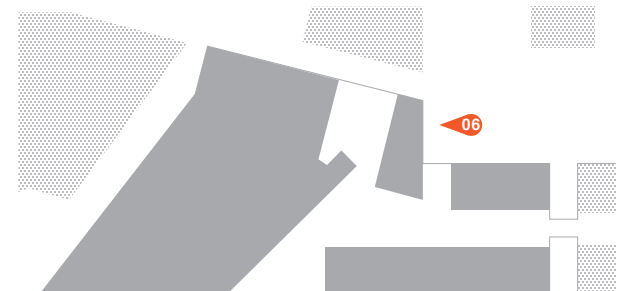



Access Point 04

An entrance to the cinema strives to be inviting by means of multiple signals: Ever-open doors with custom, playful door handles and big welcoming signs encourage trespassers to enter; High transparency of facade provides a good insight to the interior. An entrance zone is created by a separating line on the pavement, and an additional layer of facade, created by support of an overhanging movie hall.

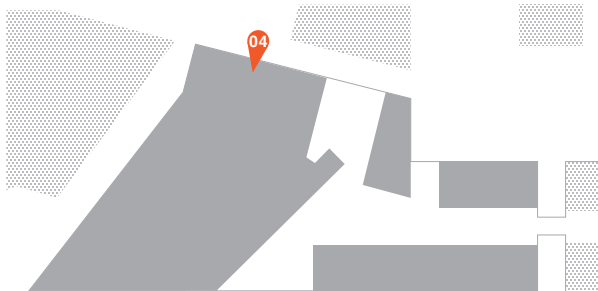

Access Point 01

As in the case of access to dwelling, an entrance to cafeteria has an informal character due to numerous objects diffusing the space boundaries. However the objects are quite generic and impersonal and so presents itself the cafeteria.

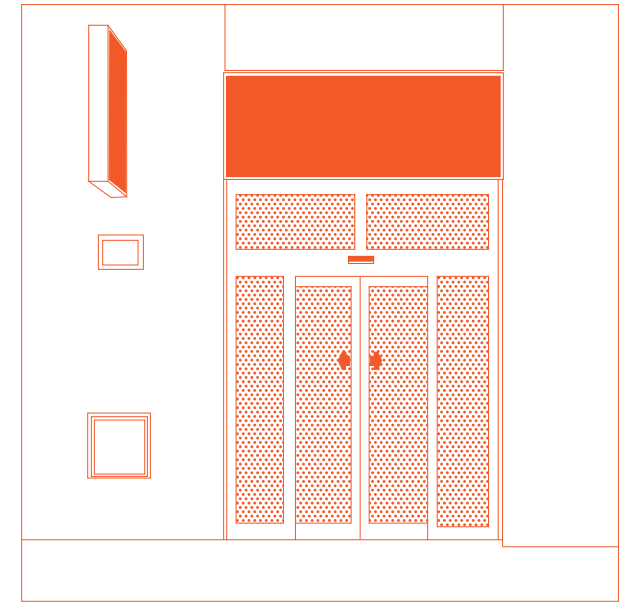
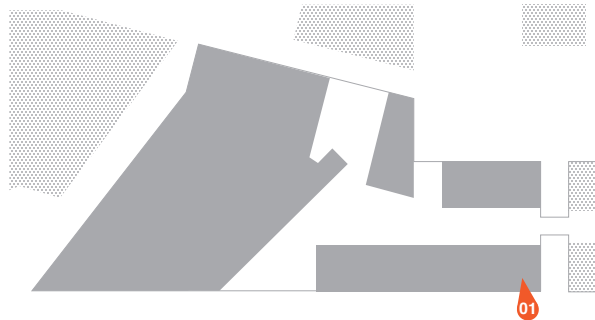

Access Point E_{III}

An entrance to the public parking garage is purely communicative. Automatically-opening doors are indicated by system of clearly visible and legible signs visible from all sides. The expression is impersonal.

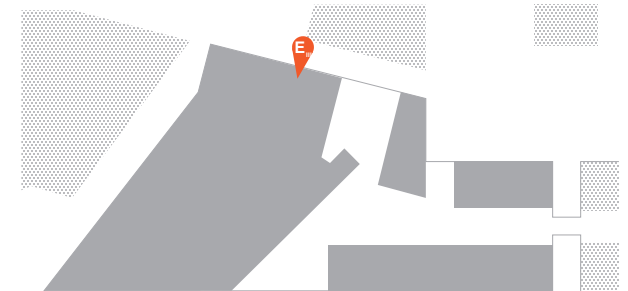

Public, Collective & Private Space

Once more a clear stratification is apparent in project's spatial organisation. Public space - analogous to routing and access - only belongs to the ground level and surrounds the building from all sides.

Community space elevated to the second level is quite generously provided - about 1100m² - is almost one third of the area provided for dwelling programme (3448m² - see programme distribution, p. 30). It is flat and undivided. Since all dwelling entrances are in the community space, it is a compulsory meeting place for neighbours.

Private outdoor spaces are all located on the top levels, distancing themselves from public bustle. They are quite small, but noteworthy, they are all protected from public space and all face the community space, encouraging interaction with neighbours.

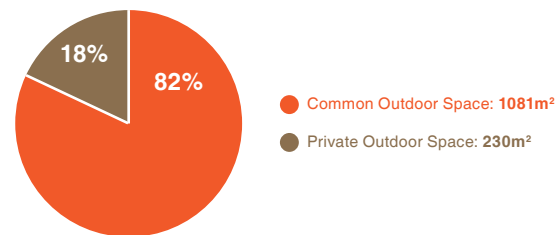

Public, Common & Private Outdoor Space Facilitated in the Project

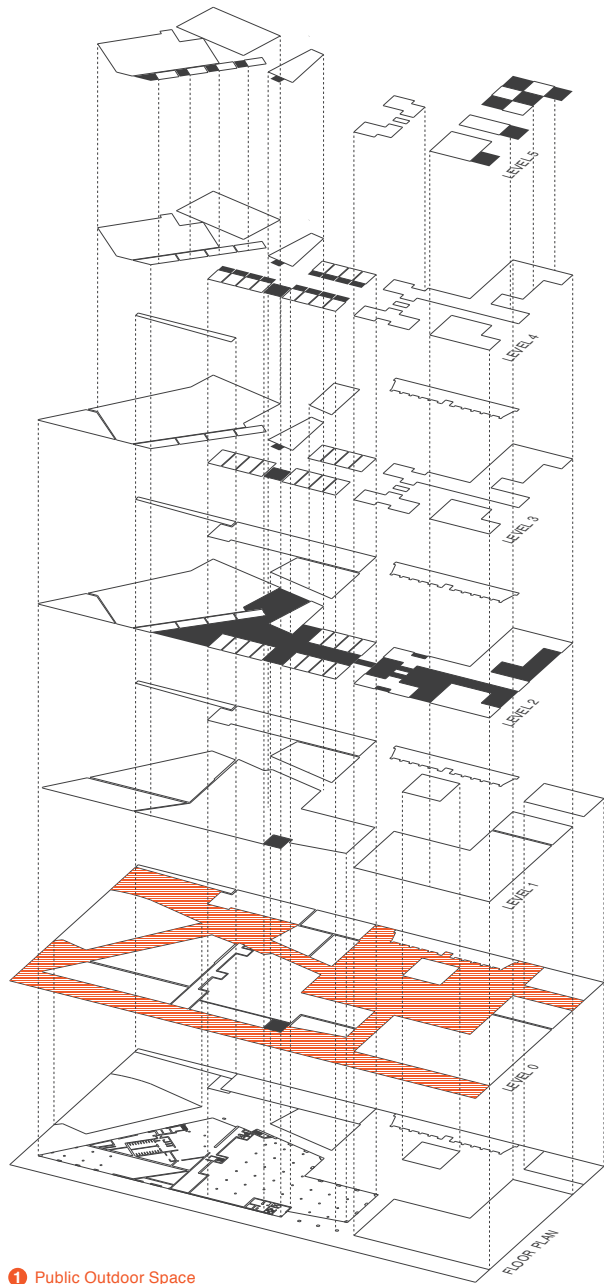

1 Public Outdoor Space

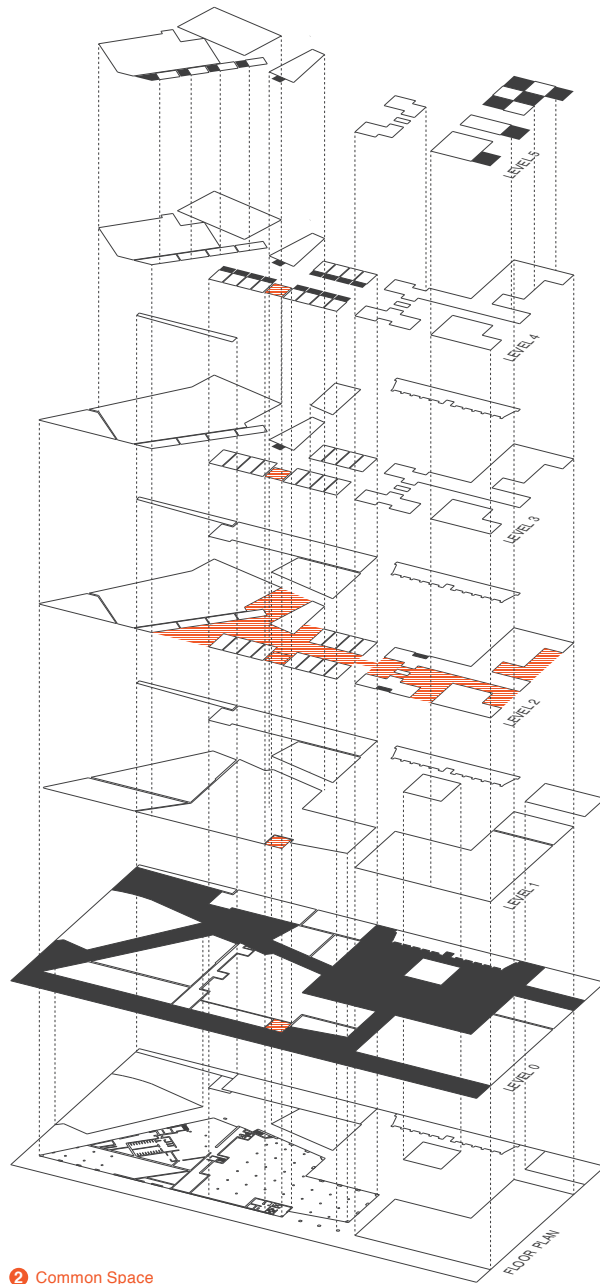

2 Common Space

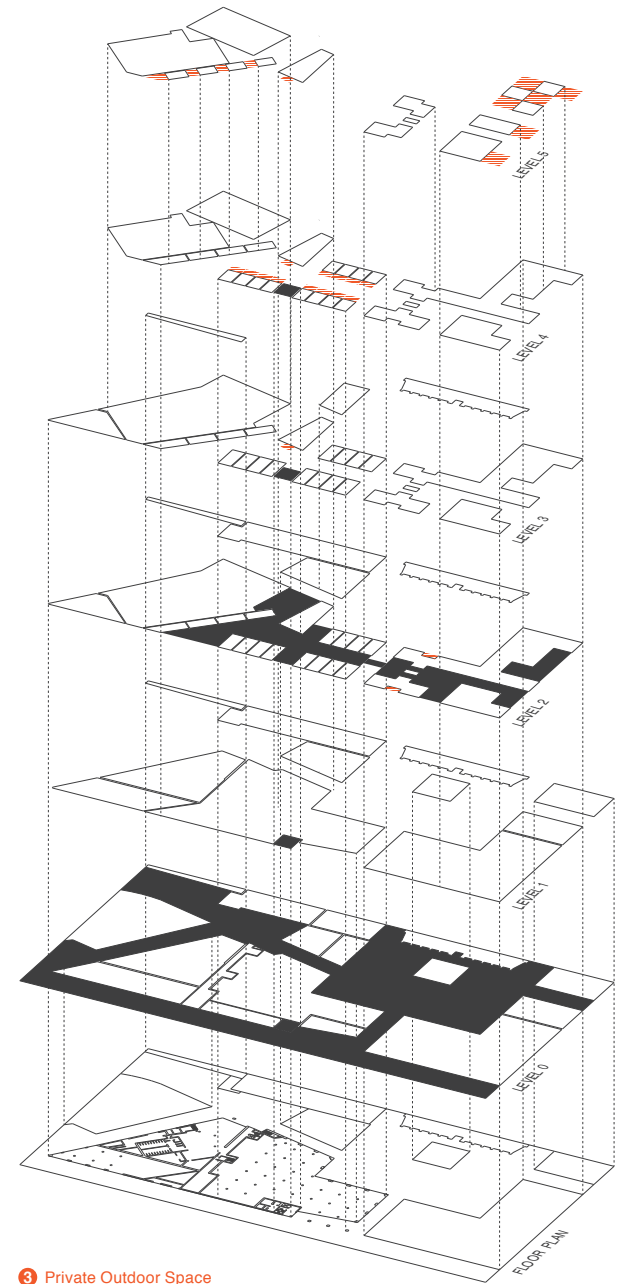

3 Private Outdoor Space

Perspective: Public Space

The boundaries of public space are clearly defined by the outline of the building. Hardly any object interferes with the sight lines.

The skyline has a uniform height and windows are positioned on a rigid grid, enhancing an impression of an organised space. There is a distinction in facade rhythm of lower two levels dedicated for retail programme and upper levels containing dwelling.

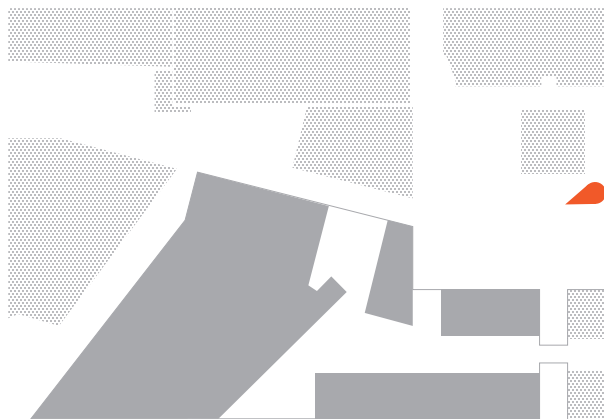



Perspective: Collective Space

The boundaries of collective space are diffused by numerous objects placed within it and along its edges, contributing to inofficial atmosphere.

The skyline and building volumes are irregular, with setbacks and protrusions. Window rythms are often displaced.

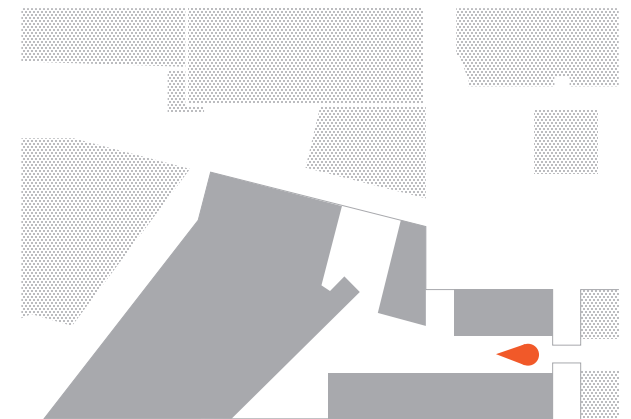

Materials: Public Space

Three major types of materials appear in public space: brick, glass and steel or aluminum details. Both facades and paving are mainly made of bricks, creating fairly warm atmosphere, which is cooled down by large glass surfaces of shop expositions.

The materials are slightly worn out and deteriorated (note the graffiti and chewing gums stuck to the pavement) confirming absence of personal relation between users and space.



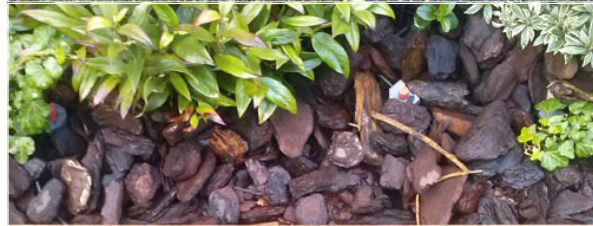
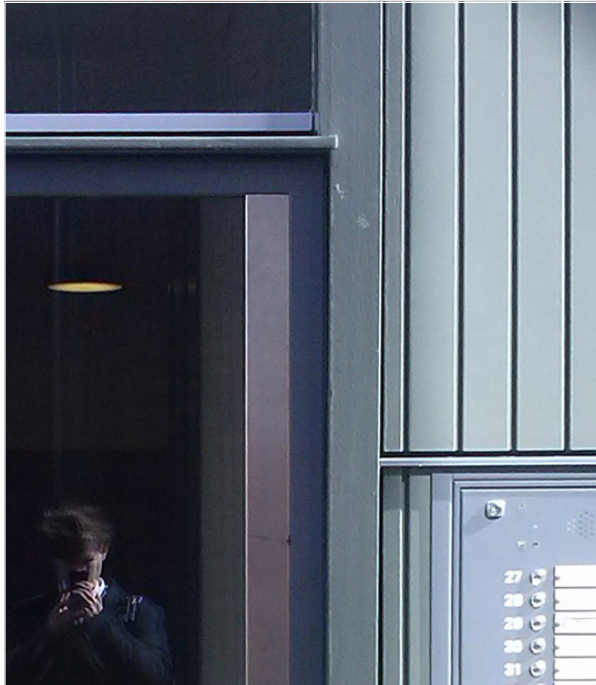
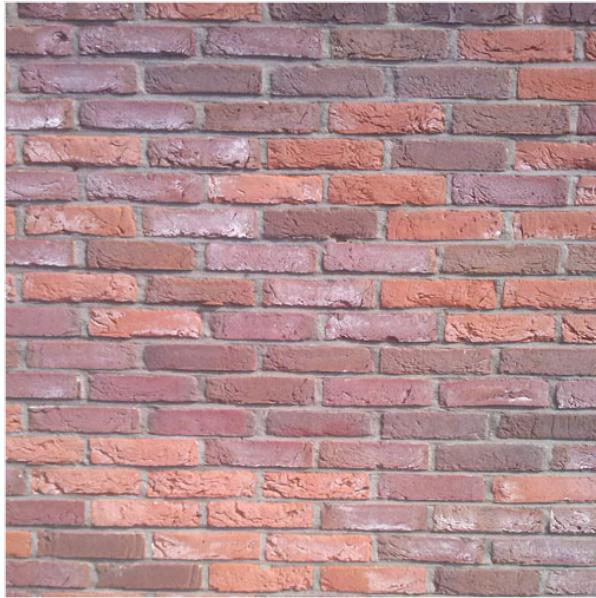

Materials: Collective Space

Materials of collective space facades are similar to those used in public space: brick, glass and aluminum details. There is however significantly less glazing.

The space is paved with concrete tiles, less durable than the brick paving of public space. The concrete is softened by additional materials used for objects placed within the space, such as wooden pots and benches. There is plenty of low vegetation arranged within the space.

The materials are noticeably tidier and better maintained than in the public space - due to less intense usage and personal care of inhabitants.



Open Space Scale & Proportions

Public Space

The height of public space remains more or less constant as one proceeds around the building - it ranges from about 20 to 10 meters (thick black line on the diagram 1). Average height equals 15.46 meters. The height of the building itself however is even more constant and ranges from 22 to 15 meters with an exception of measurement points 04 and 05 facing Zuidwal where it decreases to about 10 meters.

The width of public space is however highly diversified around the building (green line on diagram 1), ranging from about 65 to 5 meters, offering a wide scope of spatial experiences. An average ratio of height to width (15.46 to 33.48) equals 0.46.

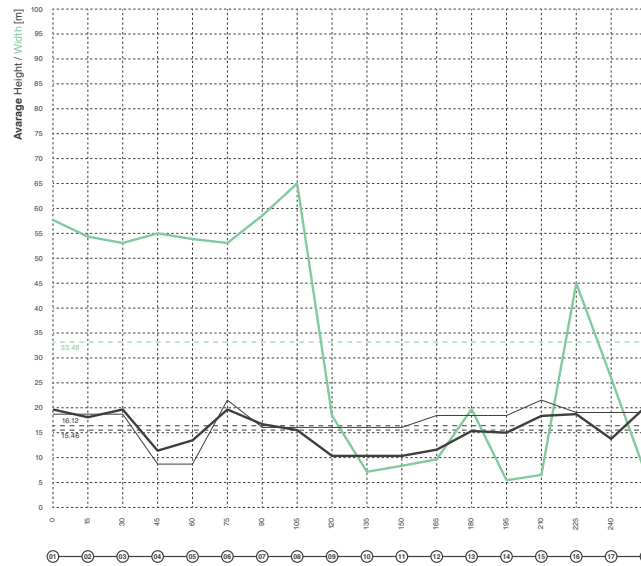
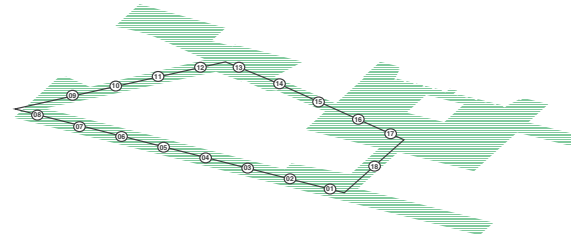

1 Public Space Proportions

Collective Space

The height of collective space is close to constant, oscillating around 10 meters, with resulting average dimension of 9.90 meters. The width of space is more diverse and ranges from about 22 to only 6 meters with an average width of 12.86 meters. Along the route however, the space retains a constant width most of the time resulting in space experienced as square in proportion: the average ratio of height to width (9.90 to 12.86 meters) is close to 0.8.

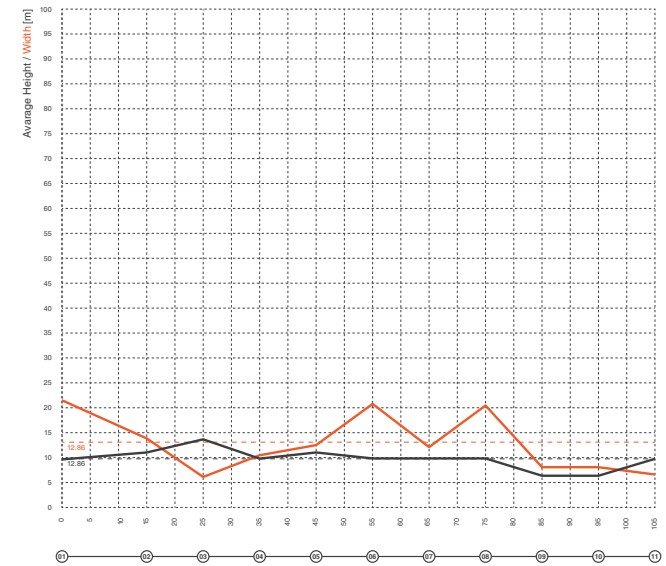
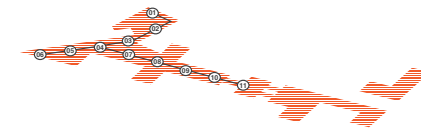

2 Community Space Proportions

Section Overview

The sections below demonstrate the diversified proportions of public space surrounding the building. The width varies from 58 to only 3.28 meters, while the height is more or less constant - about 20 meters.

The collective space retains an approximate proportion of a square, varying slightly in dimensions from 12 to about 10 meters, with ratio of height to width almost equal 1.

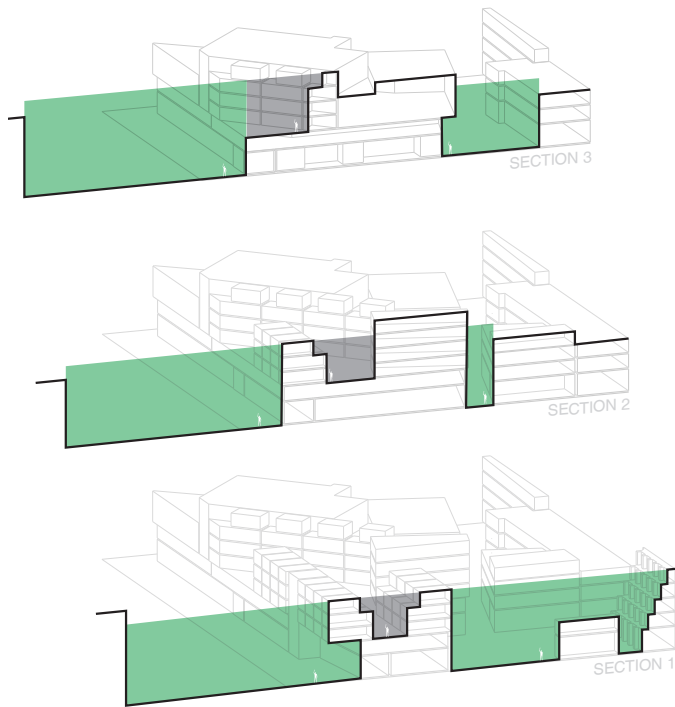

3 Public Space Scale & Shape

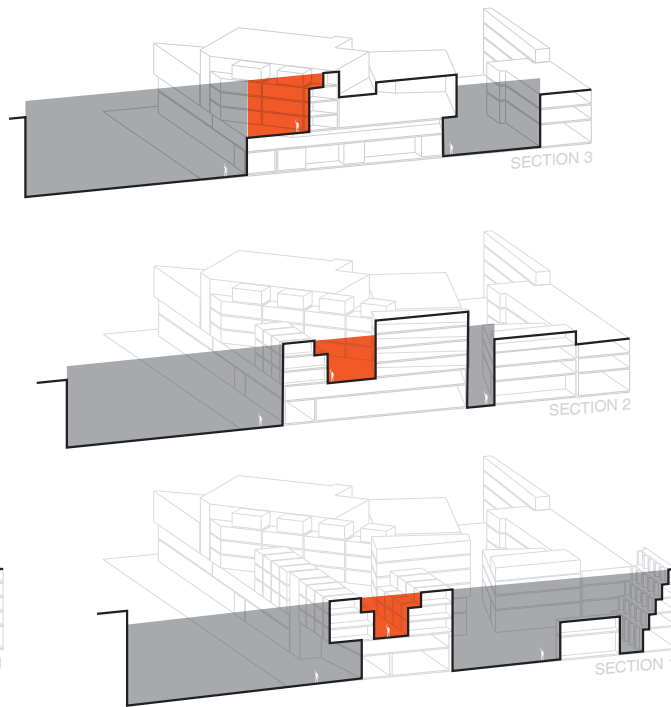

4 Collective Space Scale & Shape

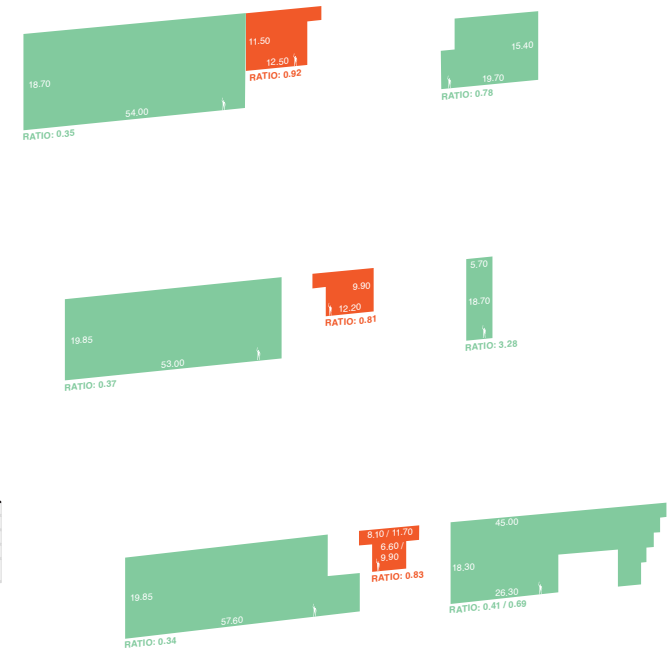

5 Public & Community Space: Scale, Dimensions & Proportions

Scale: Public Space

The elements relating to human scale are scarce at Bastiaansplein. Most of them are other humans passing through the space. Otherwise, one can relate to the scale of dwelling windows and clearly defined line of building's plinth - about 4 meters high - signifying public character of space.

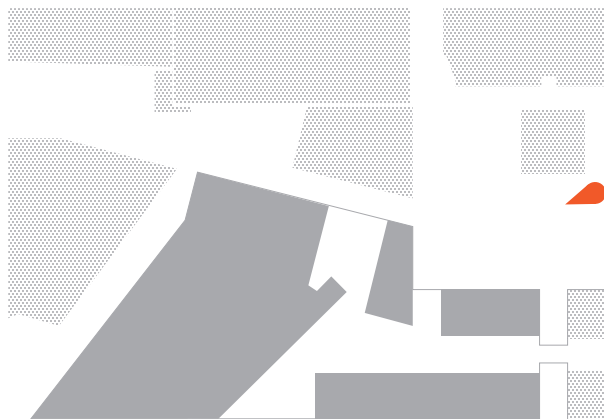



Scale: Collective Space

Within the collective space there is an abundance of human-scale elements, such as lanterns, vegetation, pots and personal belongings placed in front of entrances. The surrounding buildings are noticeably lower and the volumes are shattered and more irregular than it is experienced in the public space around the ensemble.

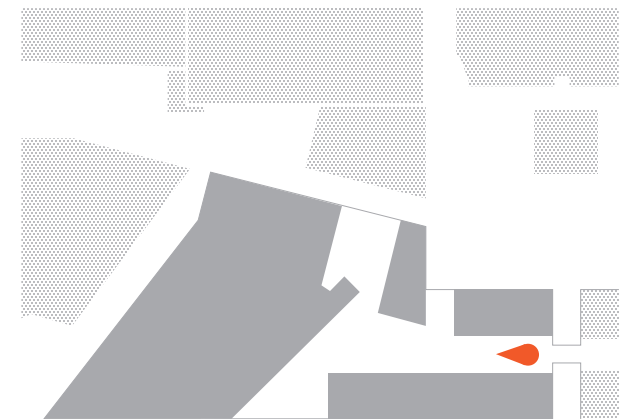

Visual Connections

Majority of dwelling spaces have a visual connection both with public and collective space. This is due to a distribution of interior programme on separate levels. Only a few interior spaces have an immediate connection only with the collective space, however even those can overlook the public areas through the collective space.

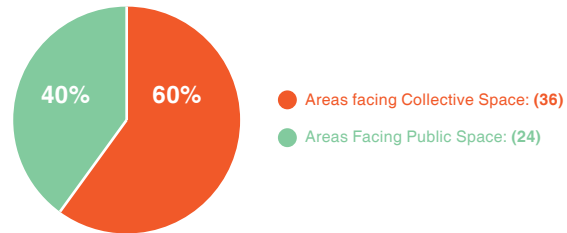

A Visual Connections: Private Living Areas

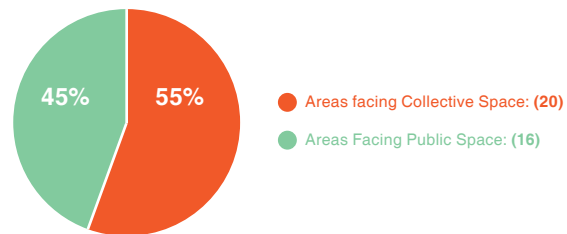

B Visual Connections: Living Room & Kitchen Areas

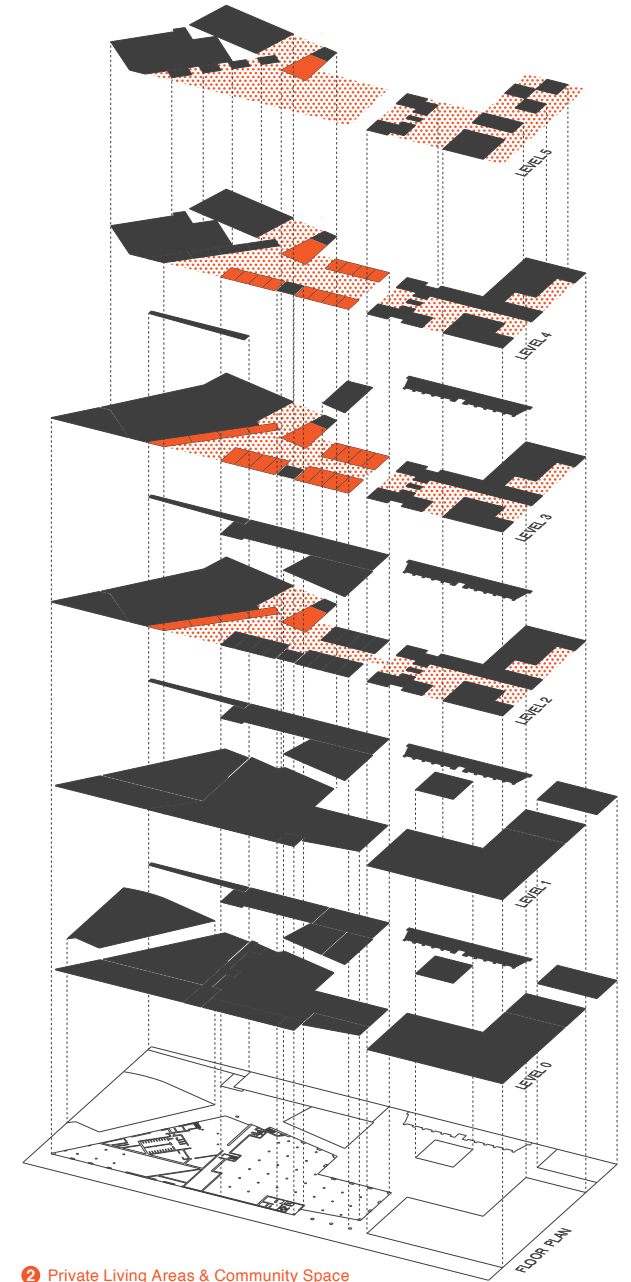
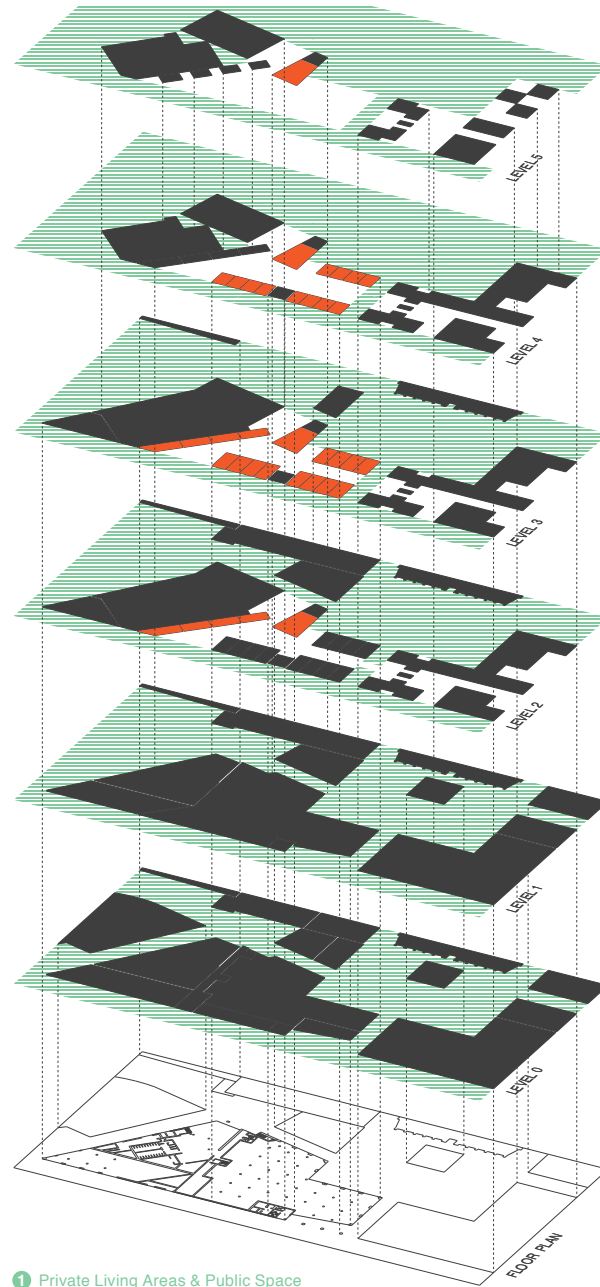

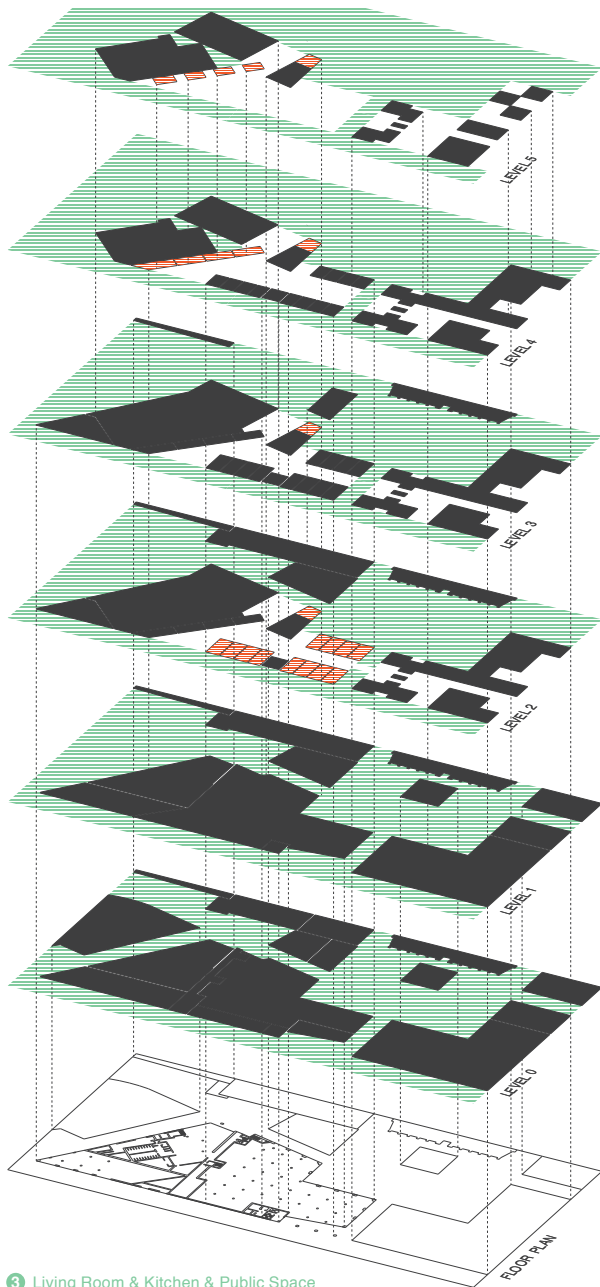

3 Living Room & Kitchen & Public Space

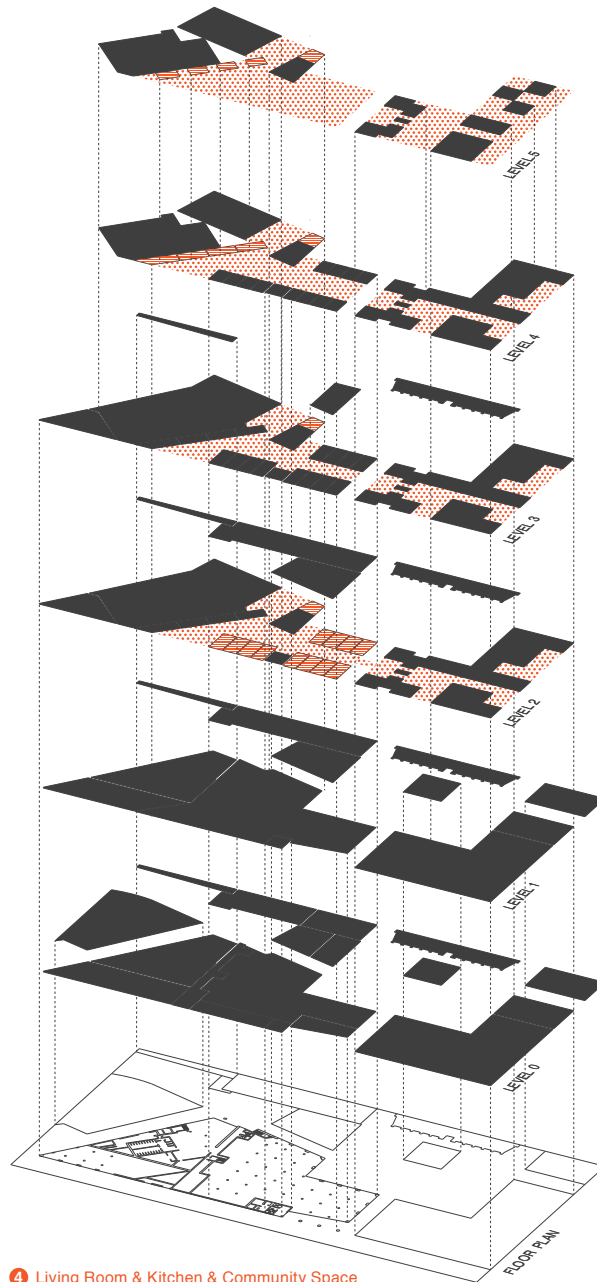

4 Living Room & Kitchen & Community Space

Section Overview

Due to being elevated, dwellings have a far-reaching view, overlooking the city from the top floors. An additional asset is that each house is distributed on three or four levels, resulting in view diversity. Each dwelling has visual connection with both collective and public space, further enhancing the diversity.

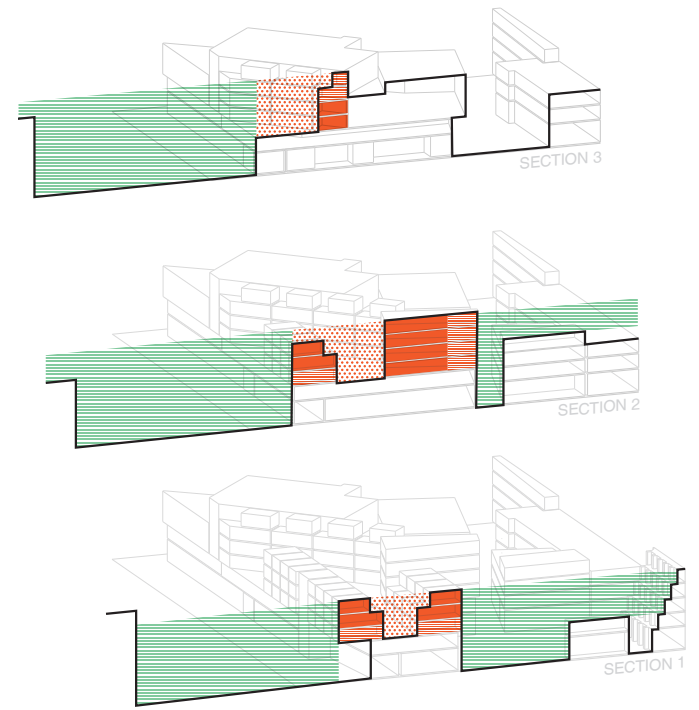

5 Visual Connections: Private Living Areas, Living Room & Kitchen Areas

Visual Connections: Public Space

The ground level of retail plinth at Bastiaansplein is the most open part of building's facade, offering a strong visual connection with the interior. First level on the contrary, has the most closed facade, behind which the retail spaces of shops are located.

The facades of upper levels dedicated for dwelling with regular grid of windows are semi-closed and don't provide a good visual connection with the interior due to a sharp viewing angle from the ground level.

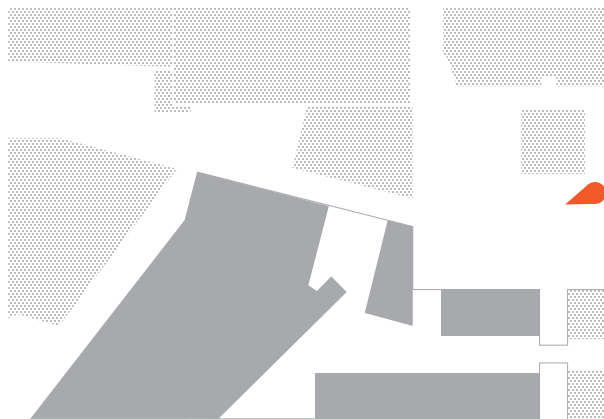



Visual Connections: Collective Space

Ground level of the collective area is dedicated for dwelling entrances, providing limited glimpses of interior through narrow windows located next to the doors. Upper floors' facades are more open, providing a good view from the interior, but restricting the insight from the ground, increasing the privacy.

The private outdoor spaces overlook the collective area, offering a possibility to interact with community, but are high enough to provide privacy.

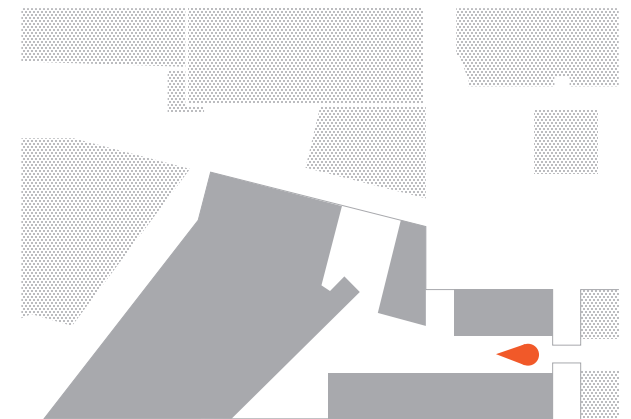

Performance Assessment

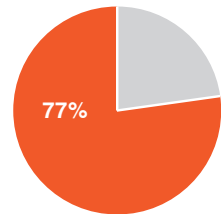

● Average Satisfaction

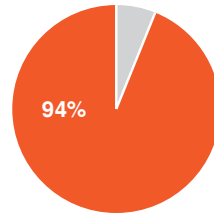

1 How satisfied are you with the location of the building where you live, in the context of the city?

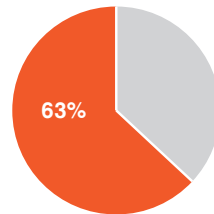

2 How satisfied are you with the public facilities provided in the building where you live?

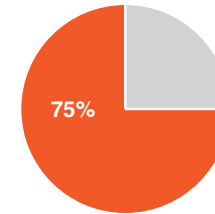

3 How satisfied are you with the public facilities provided in the area in the vicinity of the building where you live?

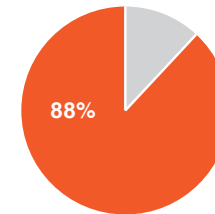

4 How satisfied are you with the level of disturbances (such as noise, intrusions) coming from the public space surrounding the building you live in?

Three families of inhabitants were interviewed using a priorly developed questionnaire: an old lady, a mid-age couple, and a mid-age man with three children. Inhabitants dwell in three different parts of the ensemble.

The assessment results are based on the level of respondent's satisfaction in accordance to their answers:

- Very Dissatisfied: 0%
- Dissatisfied: 25%
- Neutral: 50%
- Satisfied: 75%
- Very Satisfied: 100%

Based on the number of responses and satisfaction level of each respondent, an average satisfaction level has been calculated for each question.

Relation with Public Space Performance

Inhabitants point out, that it is very convinient for them to live on top of a shopping plaza. The facility used most frequently is a nearby supermarket.

There seems to be however a certain amount of dissatisfaction with the availability of places proper for mid-age people to go out in the evening, as the nearby bars are overrun by students.

The collective space is strongly disconnected from the public space below. There are no intrusions, and the noise level coming from the public space is surprisingly low. Inhabitants frequently repeated that they are very happy with that kind of setup.

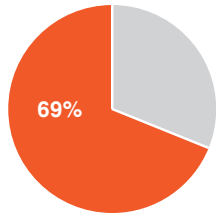

1 How satisfied are you with the interactions with your neighbours?

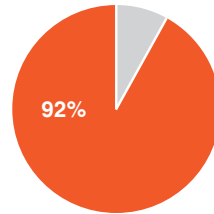

1 How satisfied are you with the quality and amount of private outdoor spaces (such as terraces, balconies) provided in the building you live in?

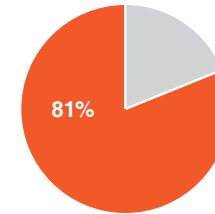

1 How satisfied are you with the view from your apartment?

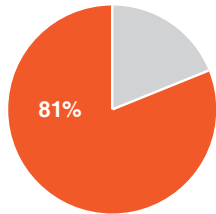

2 How satisfied are you with the amount and quality of common spaces provided in the building you live in?

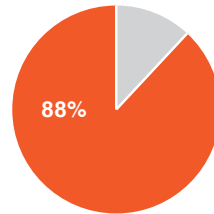

2 How satisfied are you with the view from your private outdoor space?

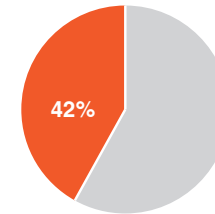

2 How satisfied are you with the level of disturbances (such as noise, intrusions) coming from the spaces surrounding your house or apartment?

Collective Space Performance

It was stressed by inhabitants that they are pleased with the spatial quality of community space provided in the building. They described it as living in a village in a city. The level of interaction between neighbours varies from case to case, however they are all satisfied with the possibilities the space provides.

Private Space Performance

Private outdoor spaces are quite limited, however each dwelling has a roof terrace provided, facing the collective area, extending the possibilities of its usage.

Private Interior Space Performance

All dwellings have a view into public space, which seems to please the inhabitants. Perhaps the biggest flaw of the design are the concrete tiles used to pave the collective space, for they generate a lot of noise when children are playing. Brick facades of collective space cause additional sound reflections. Therefore some inhabitants are dissatisfied with the disturbances coming from collective space, while some accept it as a natural part of living with children.

Monnikhof

Architect: S333 Architecture + Urbanism

Location: Groningen, Nederlands

Design: 1998

Completion Date: 2002

Programme: Housing, Retail

Area: 8.000m²

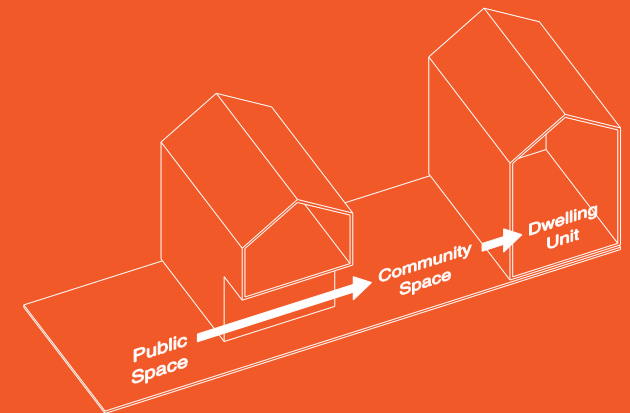



Monnikhof

Architect: S333 Architecture + Urbanism

Location: Groningen, Netherlands

Design: 1998

Completion Date: 2002

Programme: Housing, Retail

Area: 8.000m²

Location

The project is located north from Groningen city center, a 14ha post-industrial site that was badly contaminated by the gas factory. S333 won the European 3 and was commissioned to design a master plan for the entire Circus, Boden and Gasfabriek site. In 1998 S333 started designing the first phase of the new development in schotsen 1 and 2. The urban blocks were shaped by traffic flow and views towards the city centre. The space between schots 1 (De Beren) and schots 2 (Monnikhof) is perceived as space of movement dedicated for necessary activities.

Project

The project includes 41 single-family dwellings and retail programme facing the passage between schotsen 1 and 2 on ground level. The soil polluted by factory was excavated and now the space is used for car parking. The supermarkets and smaller shops create shopping street - dwelling units are located on top. The internal collective space is accessible to the public despite the fact that most of entrances to the dwellings are located there. The courtyard space becomes an outdoor space for the dwellings situated on top of retail programme. Despite a limited number of dwelling types, diverse orientation and access possibilities as well as the split-level courtyard result in spatial diversity within the ensemble.



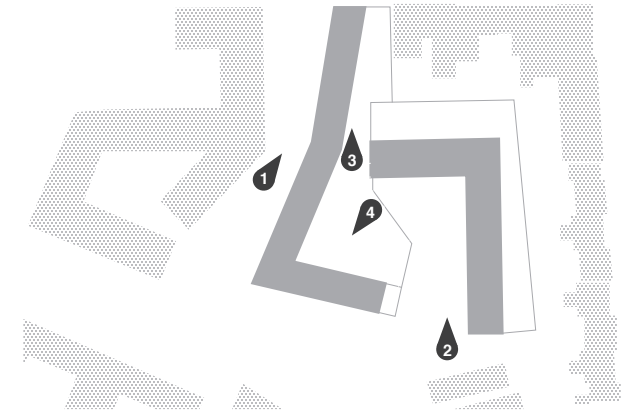

1 View from Beren

The shopping street 'Beren' is created by using ground level that is facing the street as retail.

2 View of the Inner Courtyard

In the inner courtyard, there is no strong demarcation between private and collective outdoorspace

3 View of the dead-end in courtyard

It becomes more private as the courtyard is in distance from the public

4 View from the inner courtyard



Programme Distribution

The diagrams to the right depict programme distribution in the analysed project as well as in its immediate building. The circular diagrams refer to areas included only within the analysed building.

The ground level is dedicated to retail, cafes and office, which faces street Beren. But the project is creating the inner courtyard on the same level; the usage of ground floor is quite diverse. There is only dwelling facing the courtyard side. Underground I used for parking and storage is placed under the stairs of the courtyard.

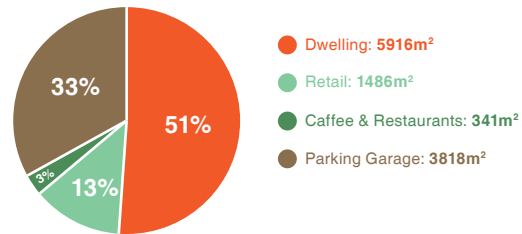

A Programme Distribution: Overall Amounts in the Ensemble

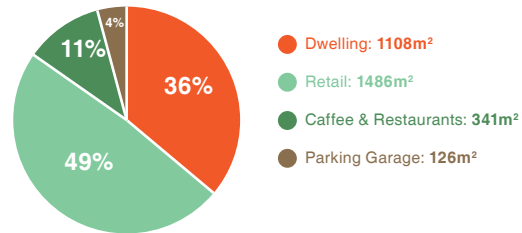

B Programme Distribution: Ground Floor

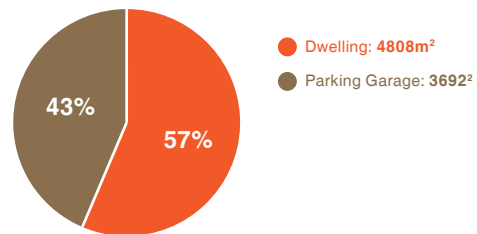

C Programme Distribution: Other Levels

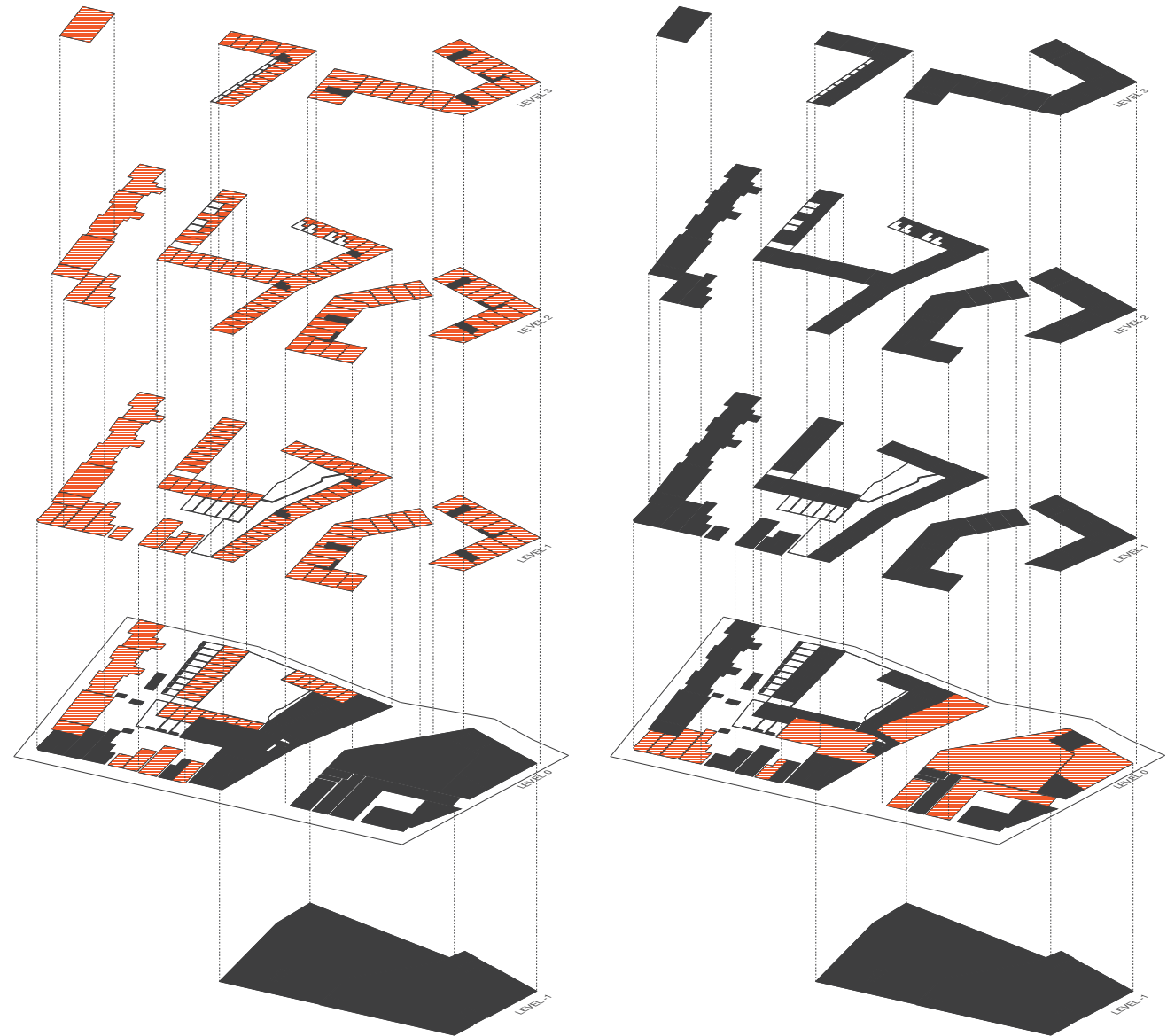

1 Dwelling Programme

2 Retail Programme

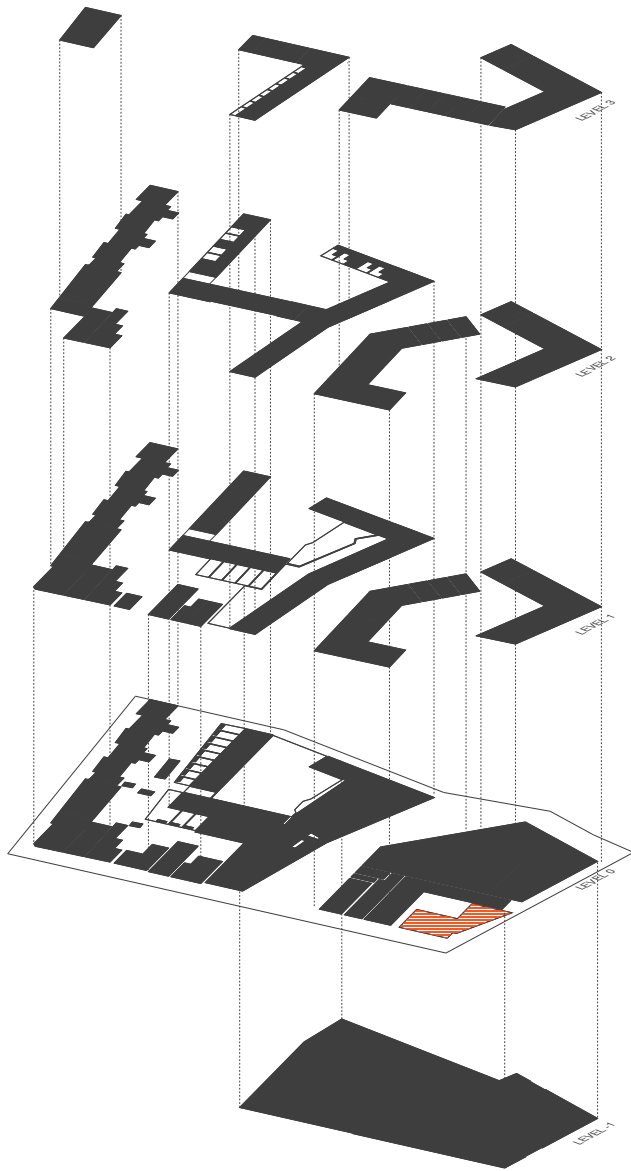

3 Public Programme

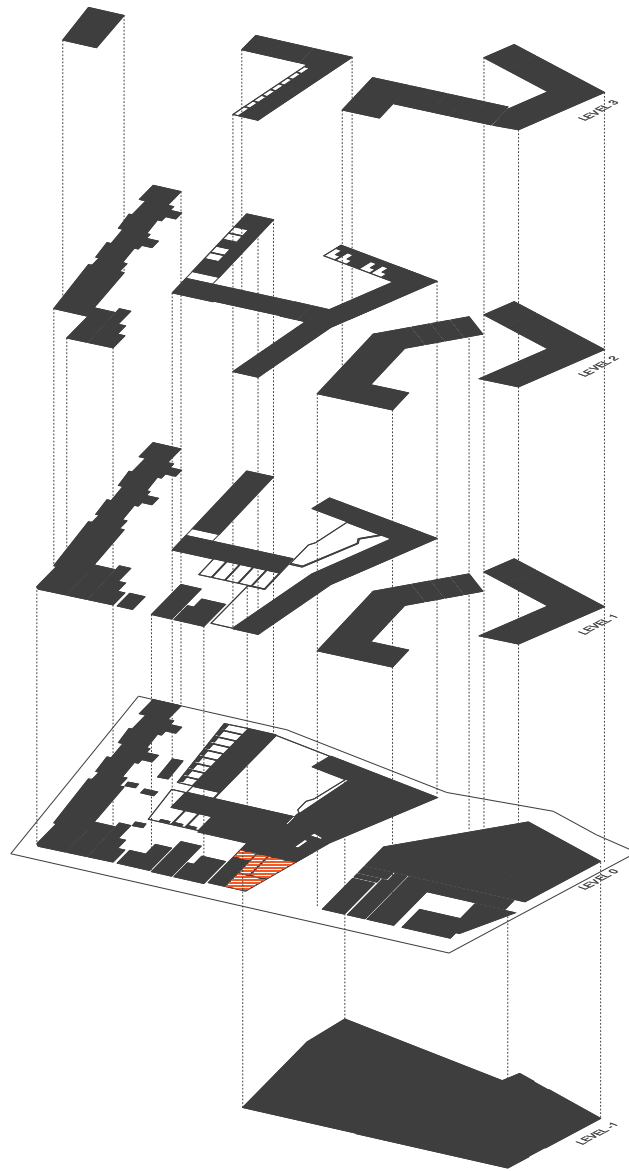

4 Caffee & Restaurants

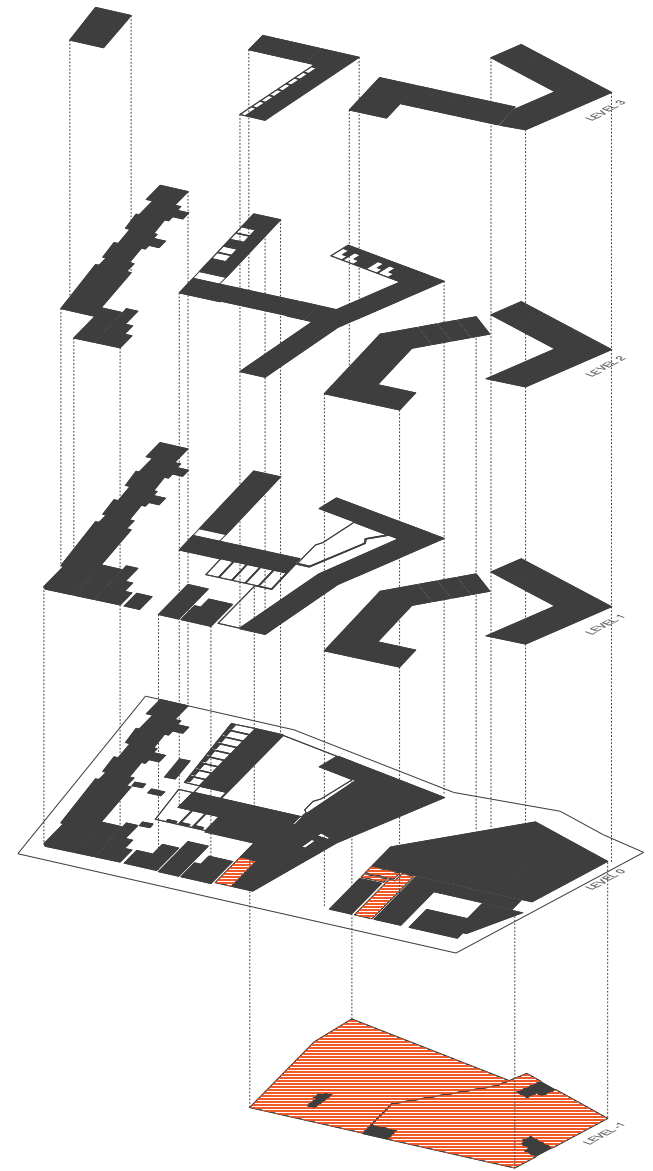

5 Parking Garage

Routes and Access

Public can access retail area on ground level and also the inner courtyard is accessible. The vertical collective core is in the center of mass that faces Beren. The private routes are situated in the building's interior on level 0 to 2 and levels 1 to 3.

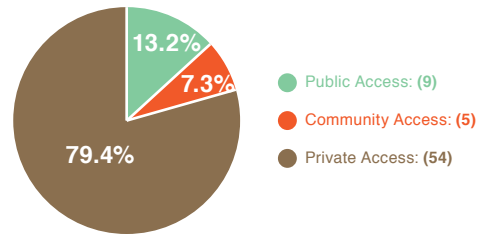

A Public, Community & Private Access: Overall Amounts in the Ensemble

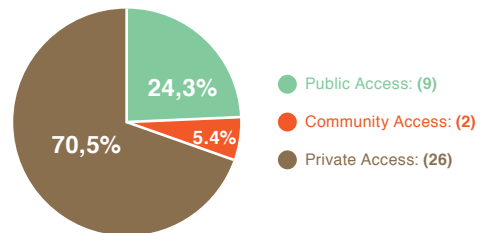

B Public, Community & Private Access: Ground Floor

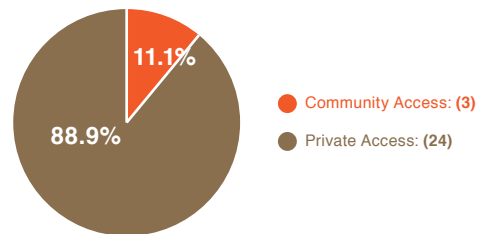

C Public, Community & Private Access: Other Levels

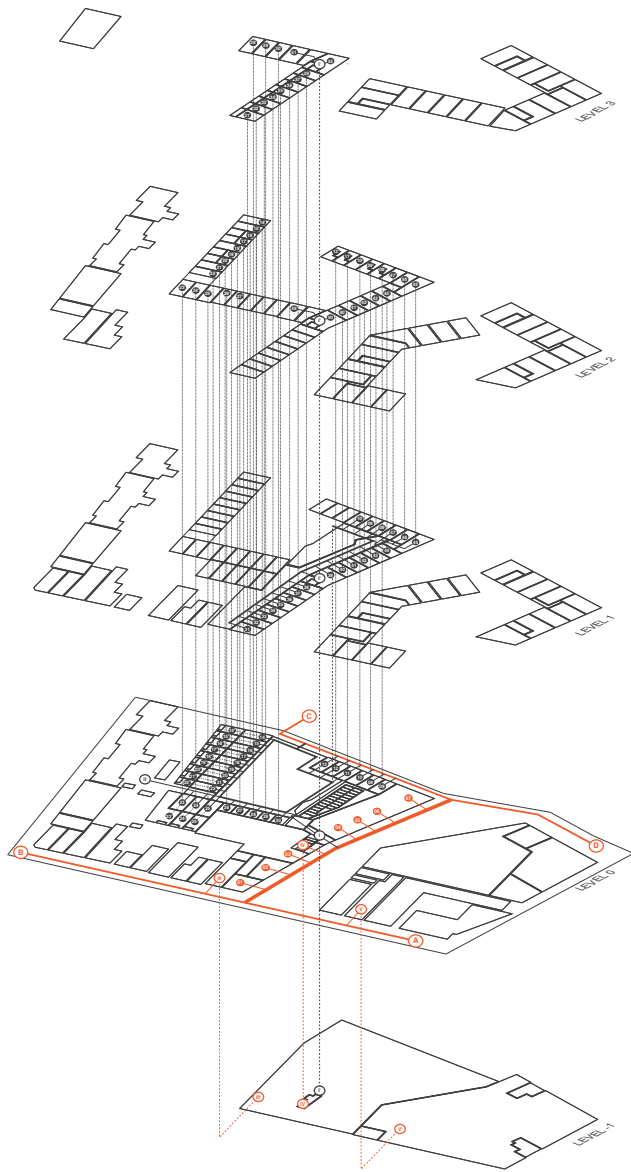

3 Public Routes

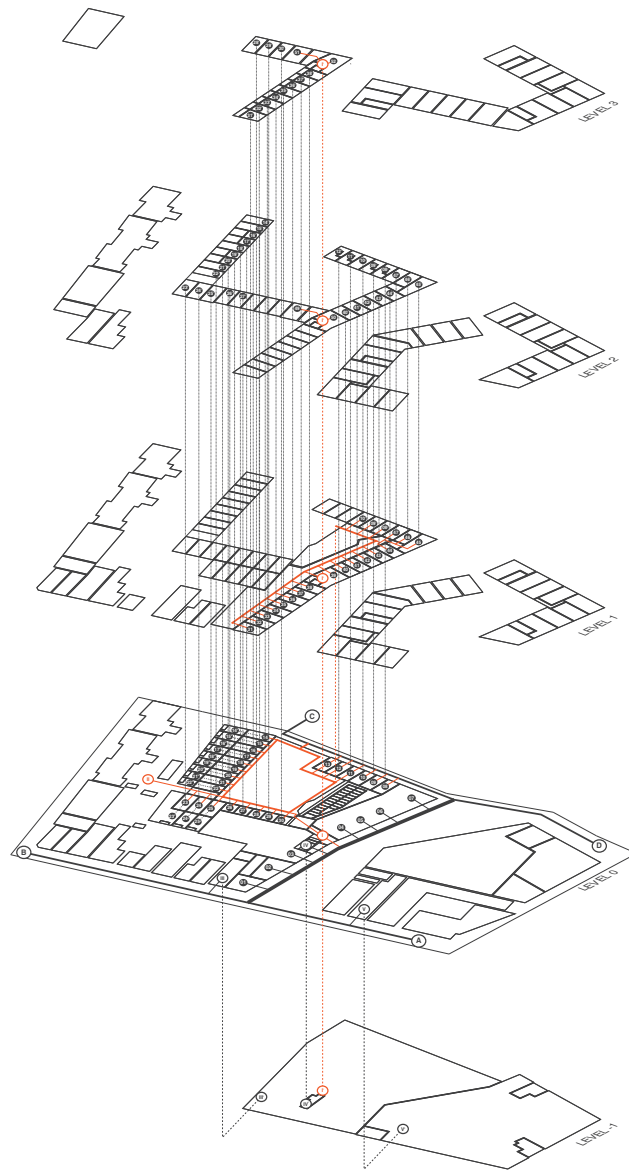

4 Community Routes

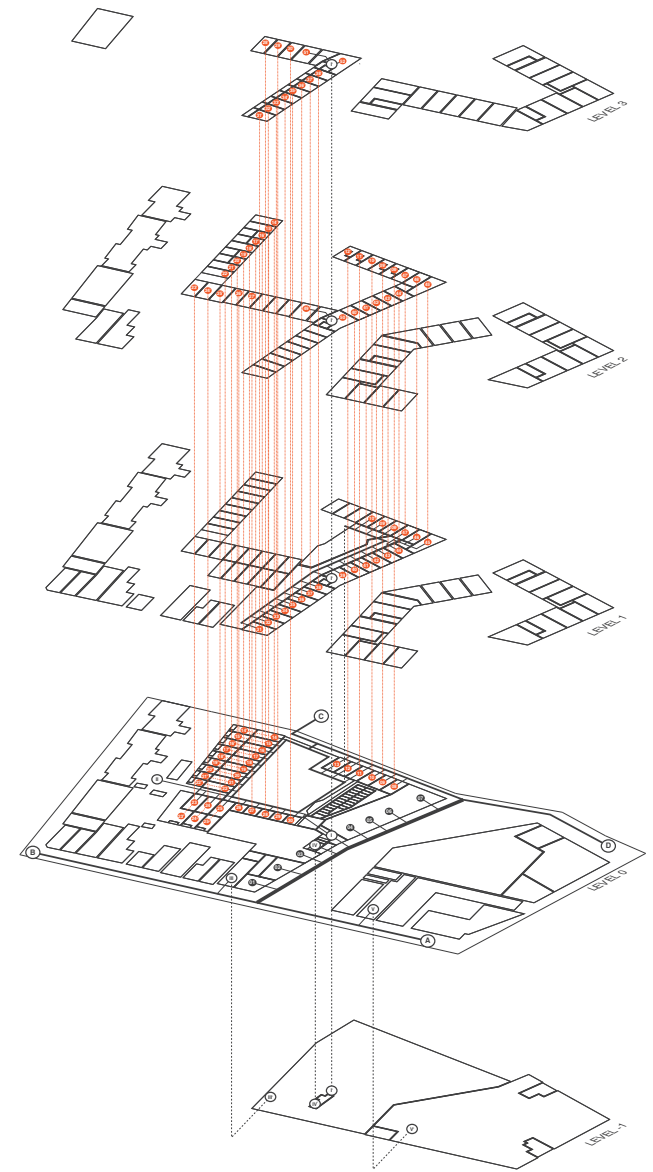

5 Private Routes

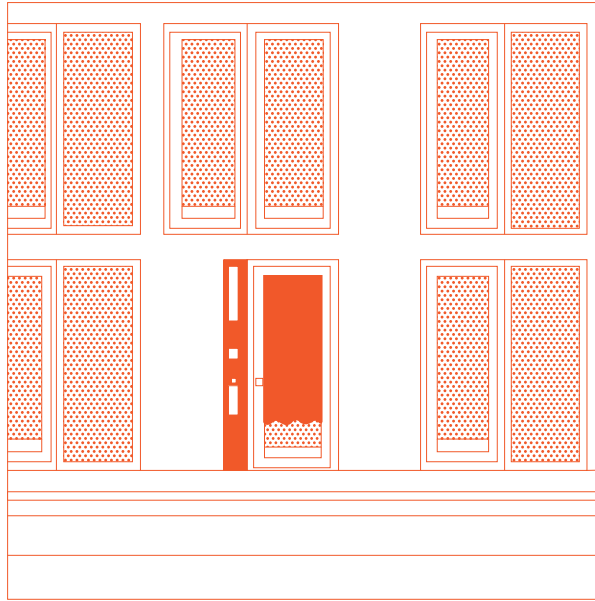

Access Point 11

A dwelling entrance in the south part of building is located where public can access easily. The dark steel panel with house number and lightning on top indicates the entrance. All the doors and windows are using the same transparent glass. Any object that is indicating private possession is not placed in front of any dwelling on this side.

Access Point 20

A dwelling entrance from collective area shows difference in using front space of individual housing. There is demarcation of public to collective or collective to private only in the paving. But as the entrance is facing the collective, residents are more willing to place their individual belongings such as pots.

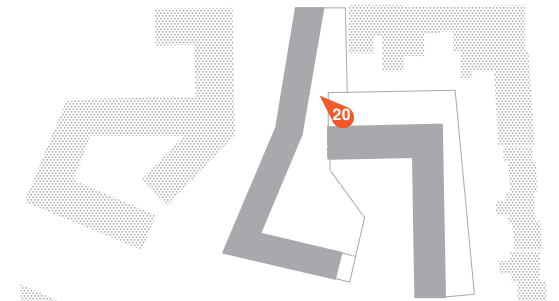
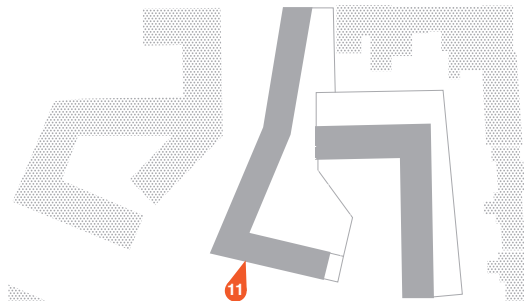

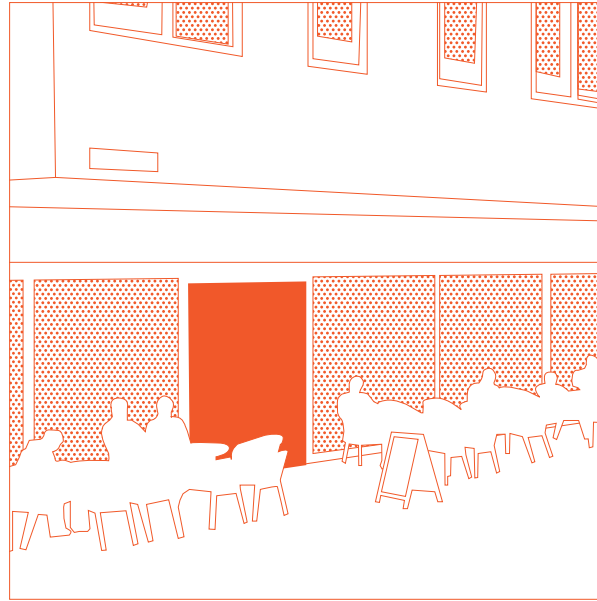

Access Point 05

The entrance (colored as red) to retail on the ground floor has an informal character due to numerous objects diffusing the space boundaries. The building provides various scales of retail shops creating intimate character improving the opportunities for stopping.

Access Point 31

The Cafeteria is located in the corner of the building also provides opportunity to stay in outdoor space. Slight different angle of façade on the ground and the above level establish good connections between indoor and outdoor combined with good resting places in front of the buildings.¹⁾

Access Point III

The entrance to the parking garage is hardly noticeable and the similar material is used in façade and the door. As the retail street is not accessible by cars not putting the any importance in car seems appropriate.

1. Jan Gehl, *Life Between Buildings Using Public Space*, The Danish Architecture Press, Copenhagen, 1986, p. 85.

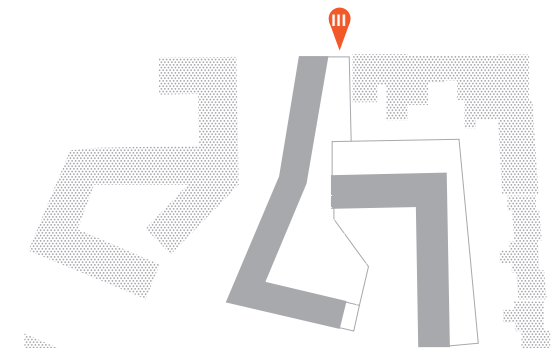
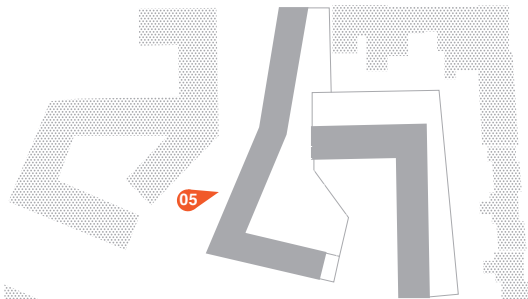

Public, Collective & Private Space

The collective space of this project is not only access by residents but also the public. The colored area for collective outdoor space has gradual gradient between publicity and collectiveness. The common outdoor space occupies the most of the area among all outdoor space. Some private outdoor space is on the opposite side of courtyard on ground level. And some are placed on the top floor.

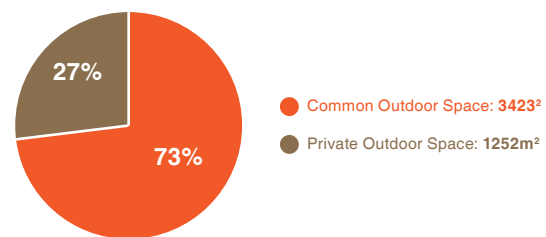

Public, Common & Private Outdoor Space Facilitated in the Project

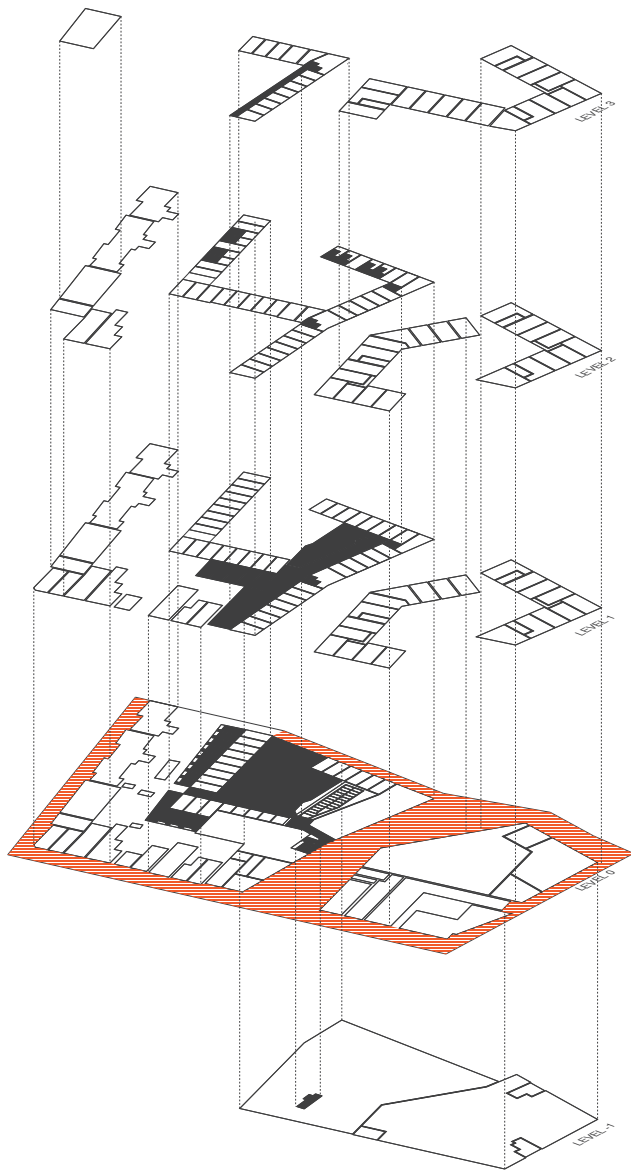

1 Public Outdoor Space

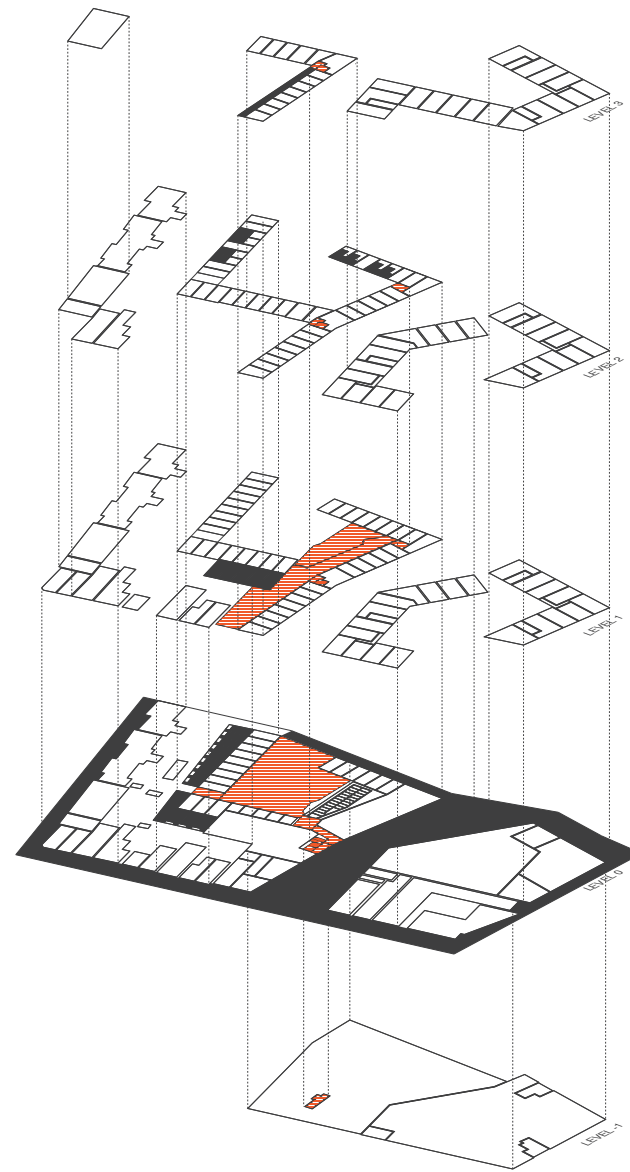

2 Common Space

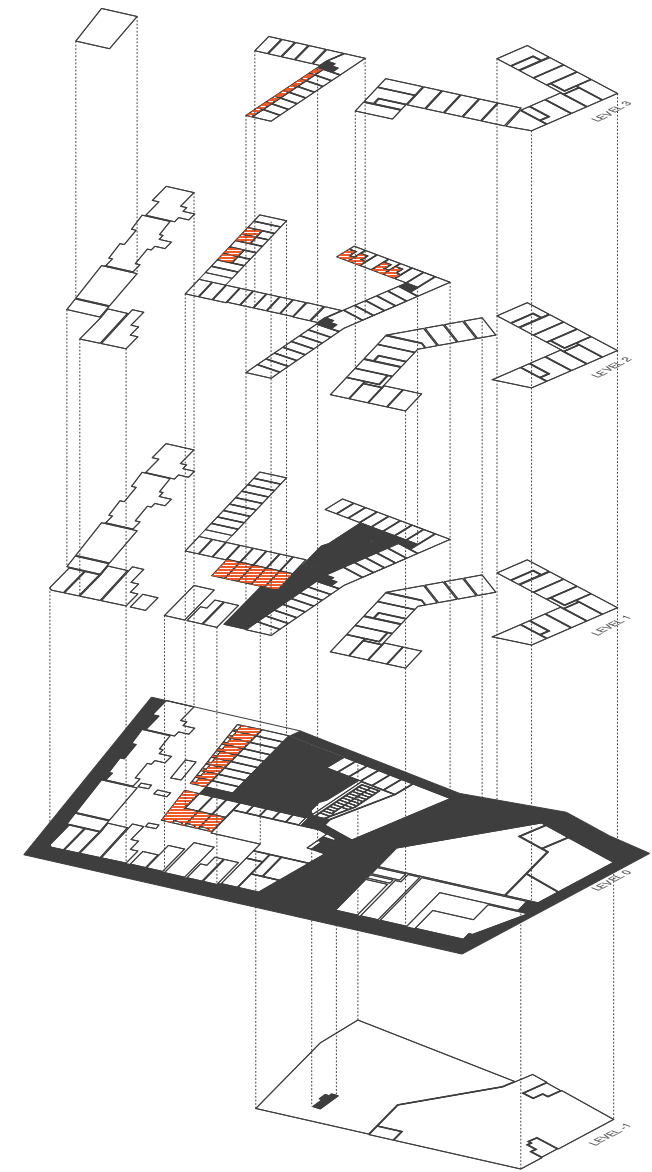

3 Private Outdoor Space

Perspective: Public Space

The bicycle parking area is placed on the middle of wider street creates informal atmosphere of Public space. Transparent glass façade on the ground and the irregular window positionon above dwelling exposes the different function of the building.

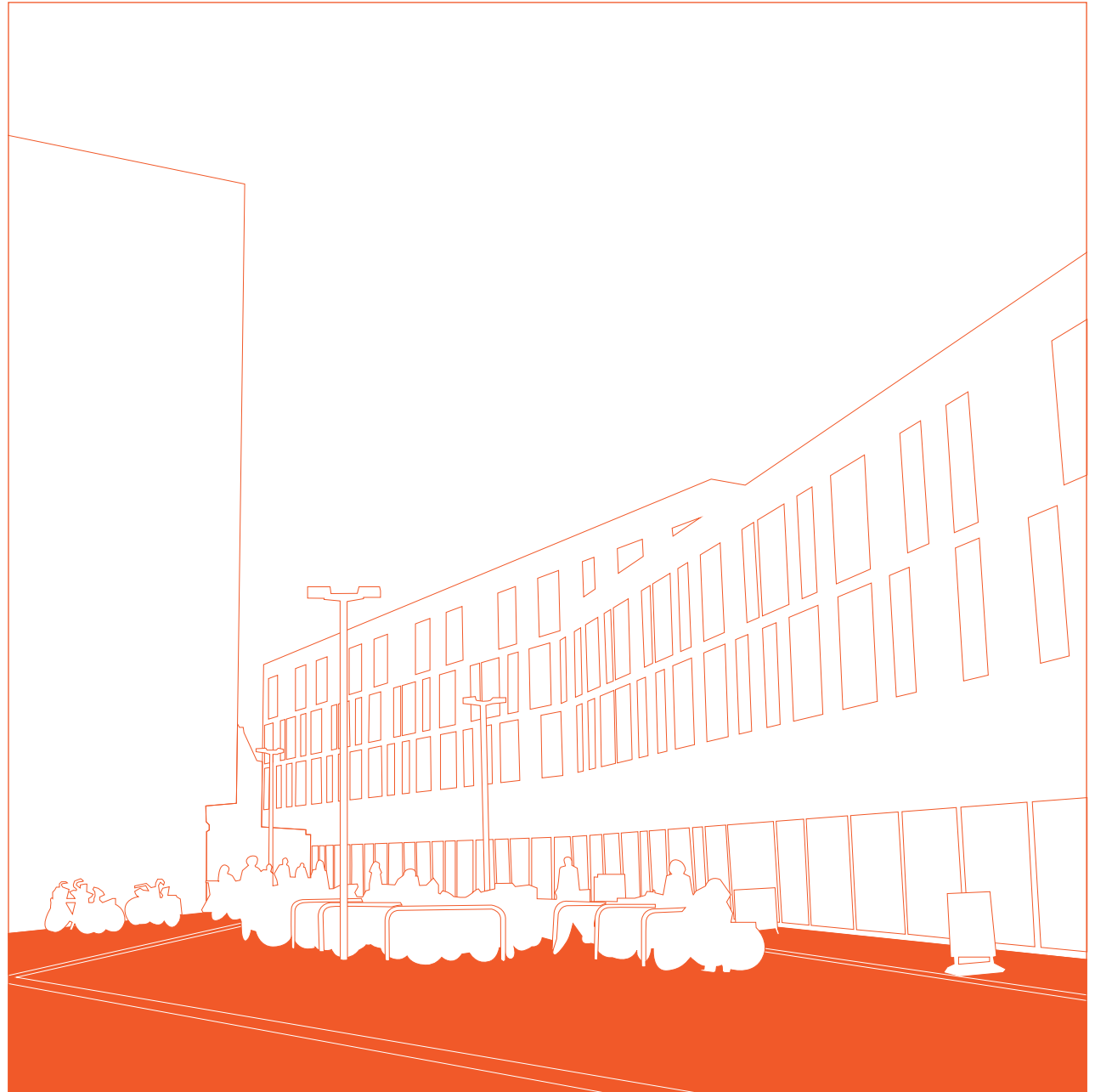
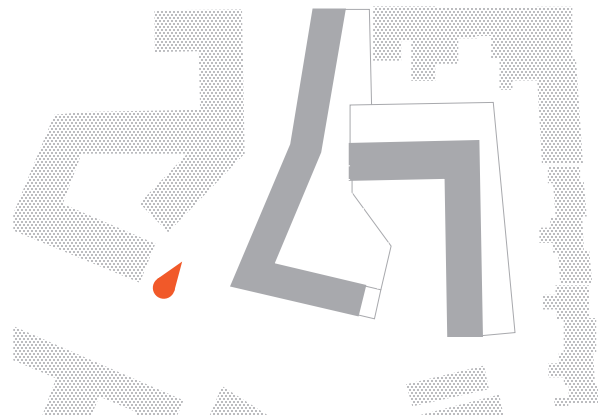

Perspective: Collective Space

The courtyard is formed like a hill above the retail shop. A gatehouse made on the end collective stairs extending the route to the behind collective area.

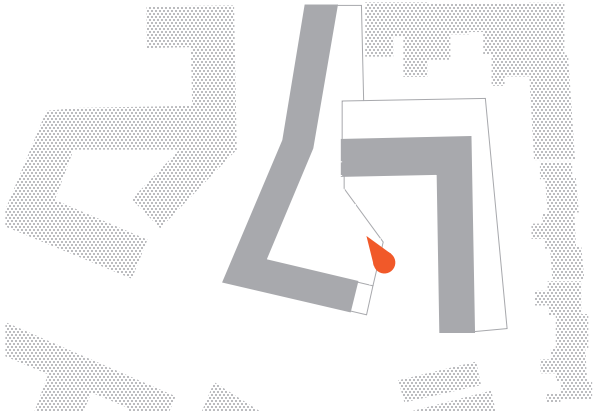

Materials: Public Space

The wood panel and white window frame with glass balustrade is used. Different dimension of wood panel is cladded according to position of openings. Bicycle parking pavement is colored purple to demarcate its position. Due to public movement cement pavement is deteriorated.

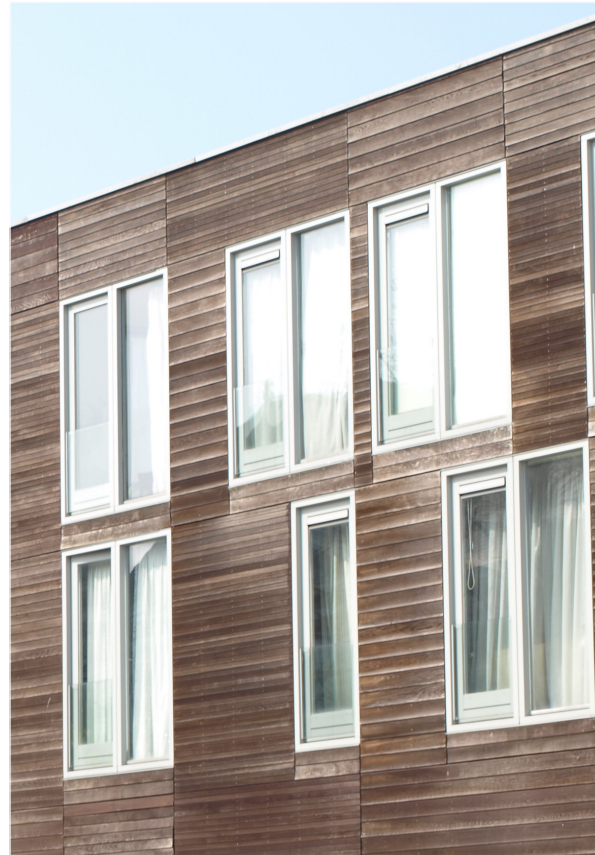



Materials: Collective Space

Exactly same material is used for the façade in collective area only the difference appears in the pavement. Gravel with cement is used for the general collective area. And in front of the dwelling concrete tile is used for transition to private



Open Space Scale & Proportions

Section Overview

The sections below demonstrate the proportions of public space surrounding the building. On the public space, height and width are relatively diverse. The width varies 19m to 32m and the height varies 10m to 32m.

On collective space, the width and height is more or less consistent about ratio of height to width 0.3. Only the narrow entrance has 0.7. But the stairs provides variant on height. The building gets higher on east side providing sunny out door space.

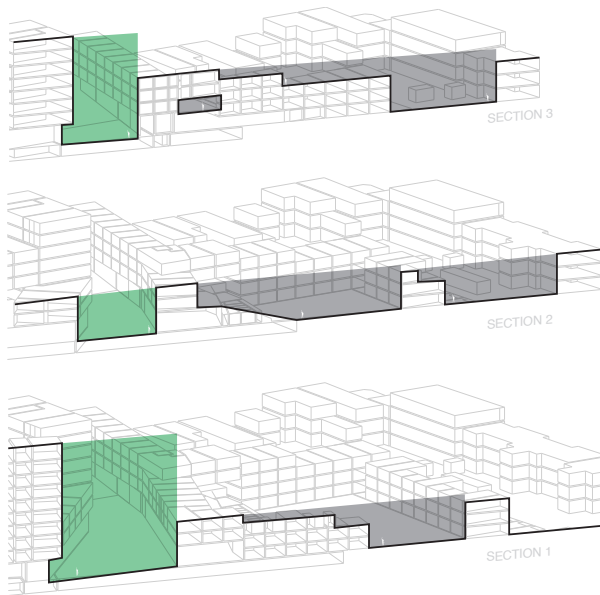

3 Public Space Scale & Shape

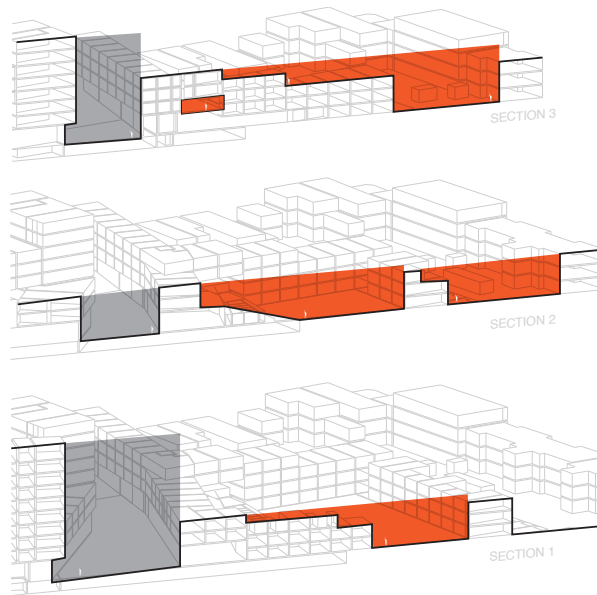

4 Community Space Scale & Shape

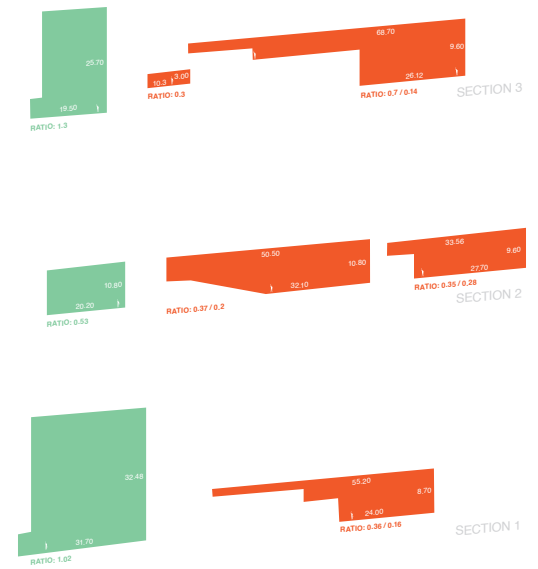

5 Public & Community Space: Scale, Dimensions & Proportions

Scale: Public Space

The difference in height on left and right side of the street, and the variant on width of street shows inconsistency. Overall elements don't seem to obstruct the human scale.

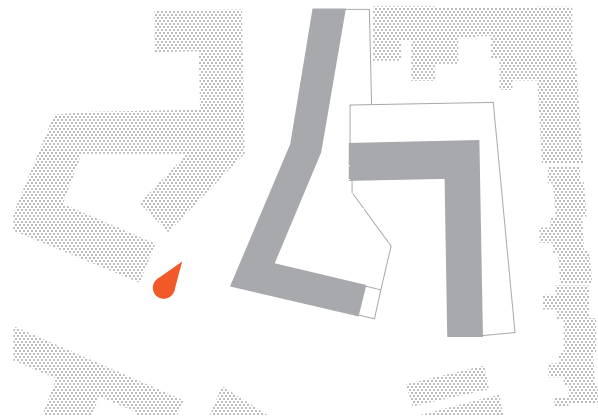

Scale: Collective Space

The height of the stairs, the gate seen on the top and the irregularly positioned windows can be seen as an element related human scale. The form of the outdoor collective space is not uniformed providing various dimensions on width and height.

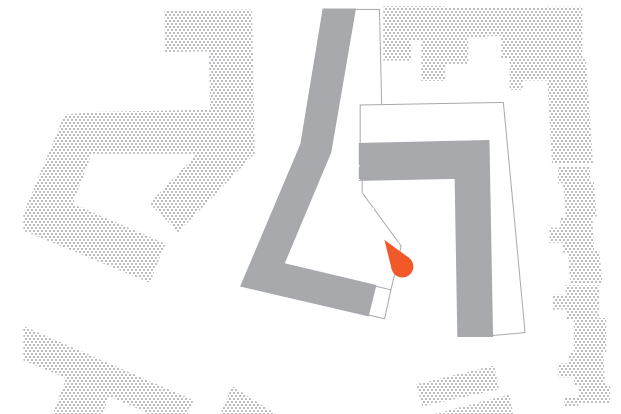

Visual Connections

According to the location of the dwelling some have a visual connection both with public and collective spaces while the other have visual connection only to collective space. Private living area are mostly positioned in the same level of collective area that reaches to dwelling.

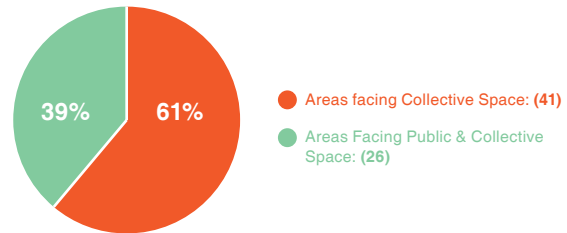

A Visual Connections: Private Living Areas

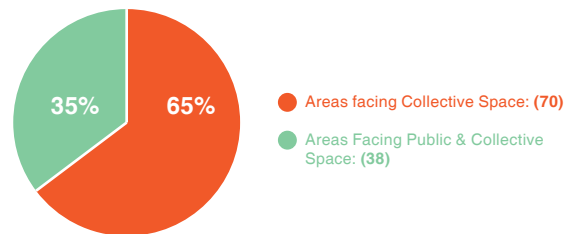

B Visual Connections: Living Room & Kitchen Areas

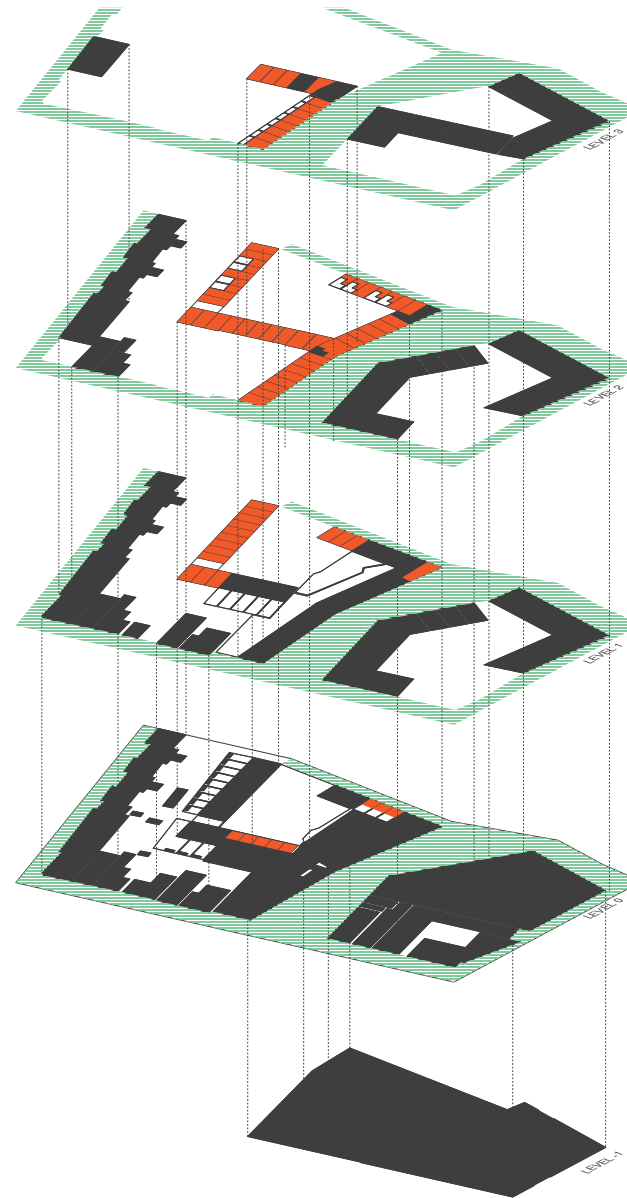

1 Private Living Areas & Public Space

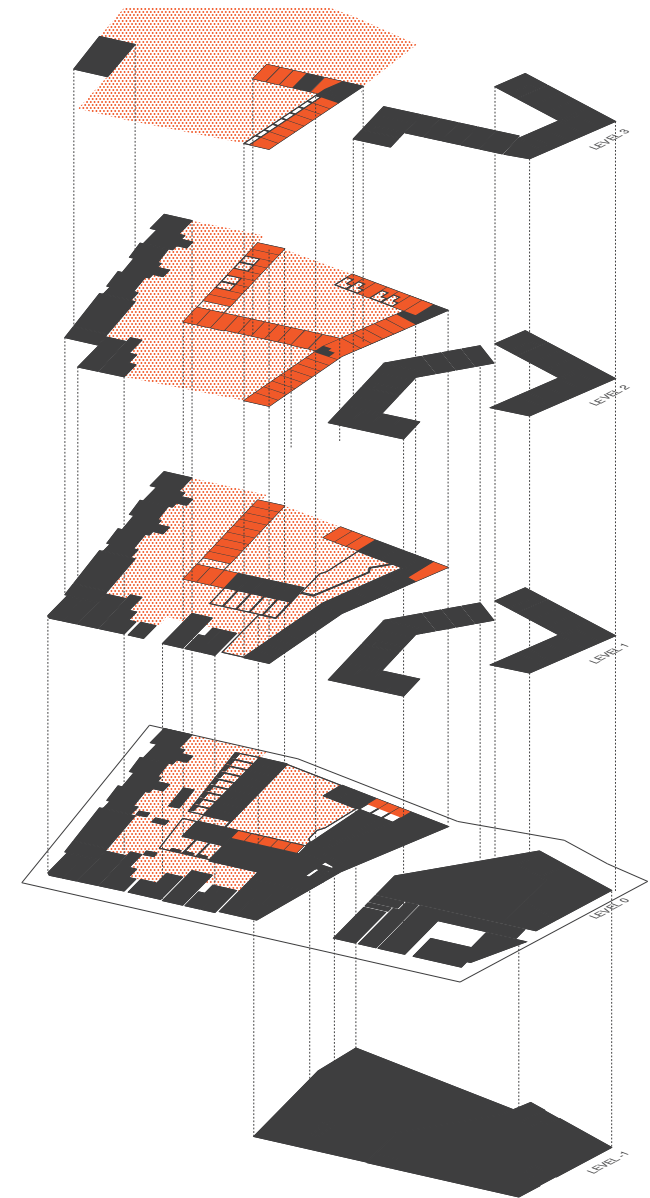

2 Private Living Areas & Community Space

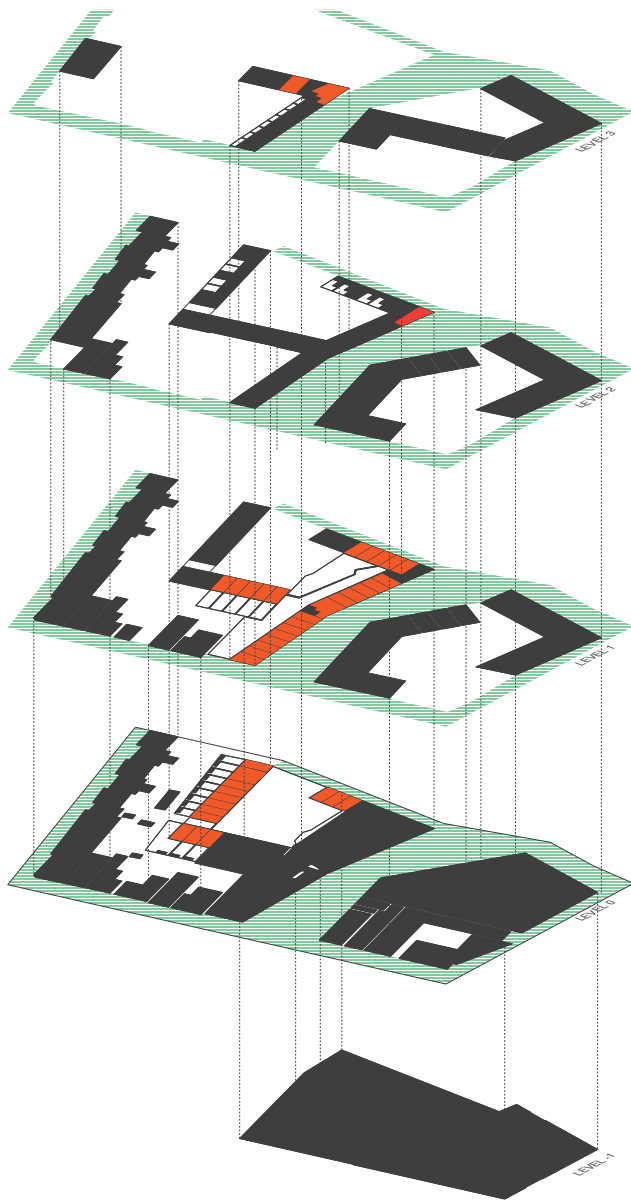

3 Living Room & Kitchen & Public Space

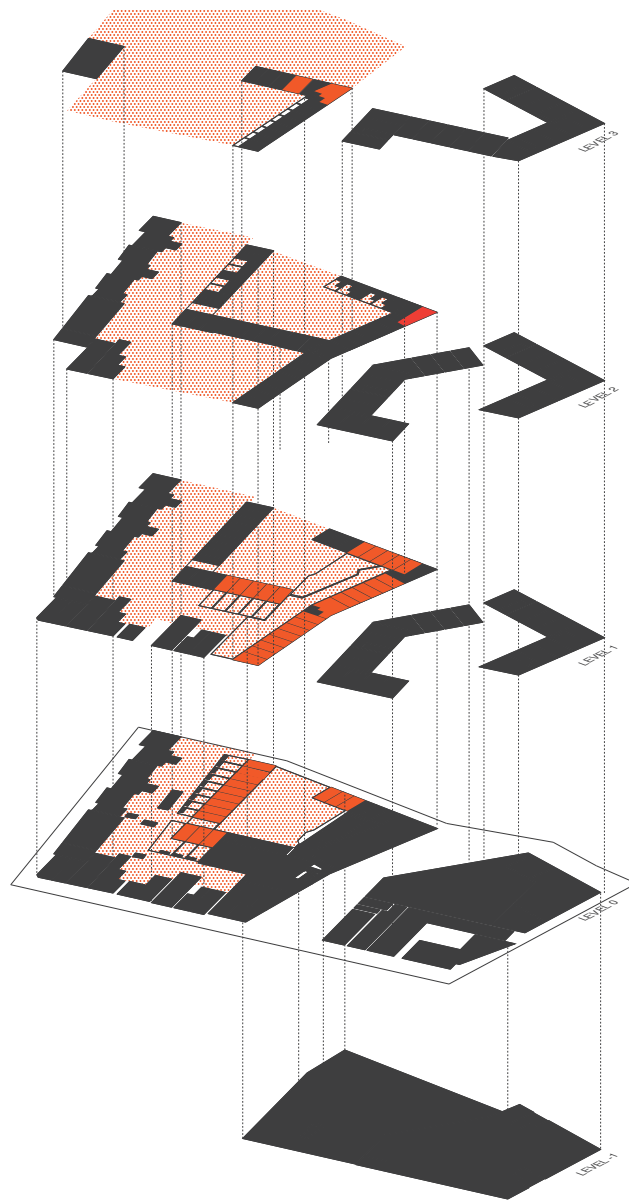

4 Living Room & Kitchen & Community Space

Section Overview

View towards the public is always limited by the front building while the top floor of dwelling can have far-reaching views on collective area. Most of dwelling has the private living area on top and the living & kitchen area on the bottom.

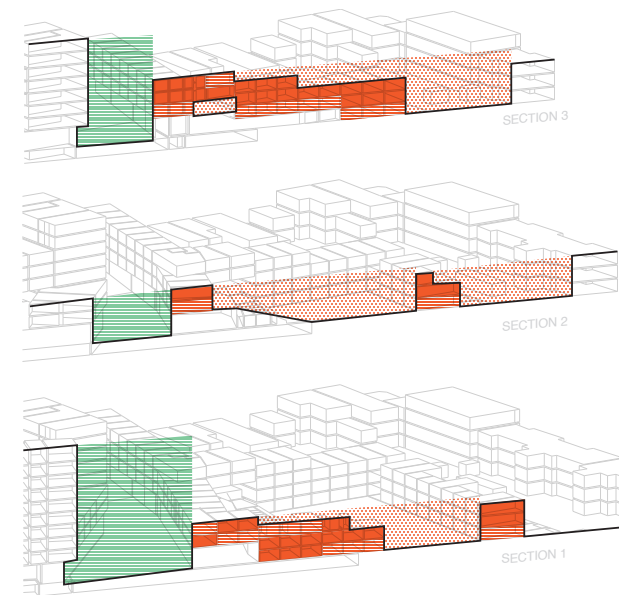

5 Visual Connections: Private Living Areas, Living Room & Kitchen Areas

Visual Connections: Public Space

The ground level of retail plinth at Baren is the most open part of building's facade, offering a strong visual connection with the interior. The facades of upper levels dedicated for dwelling will have view towards public space but cannot be overlooked.

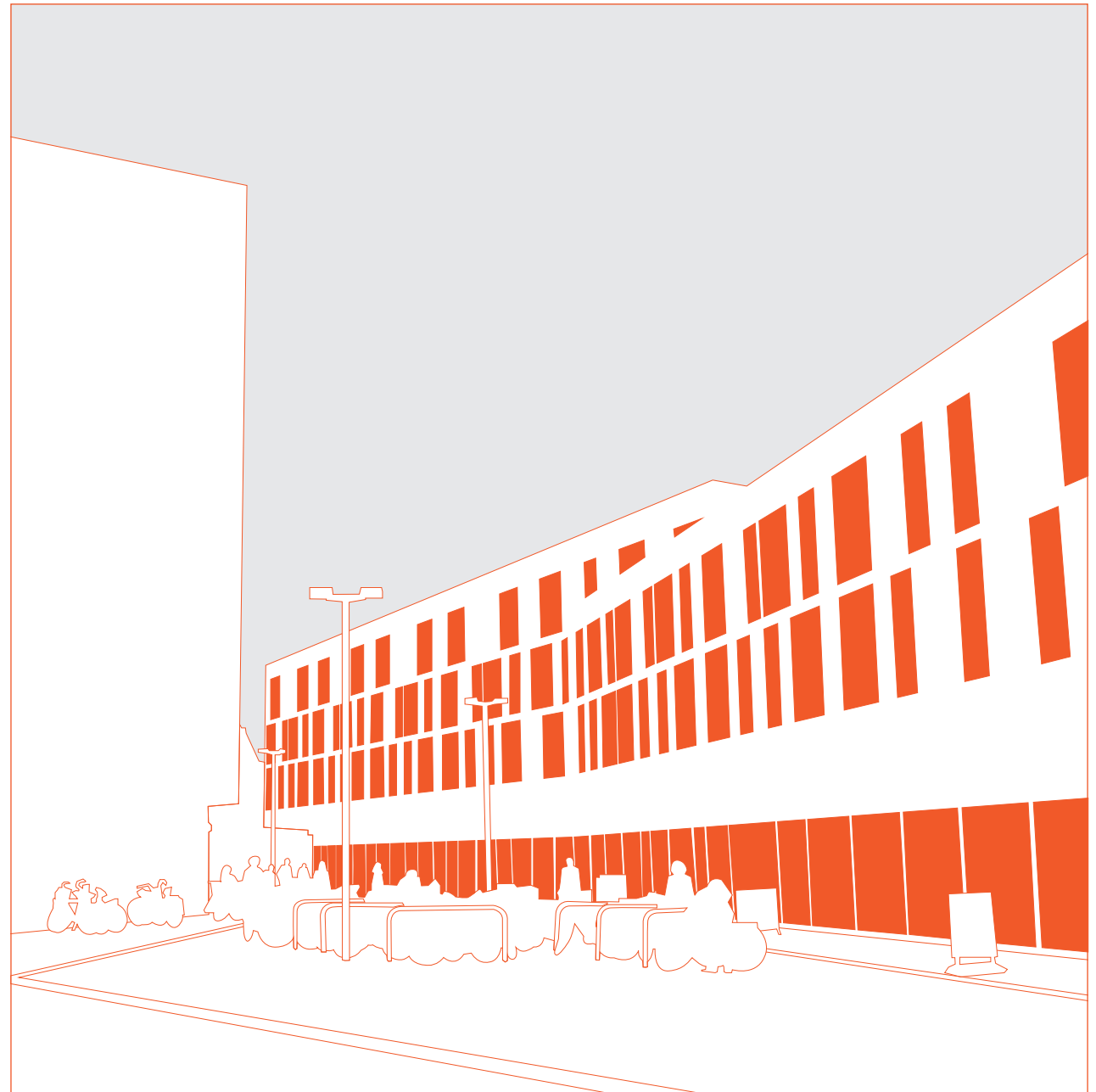
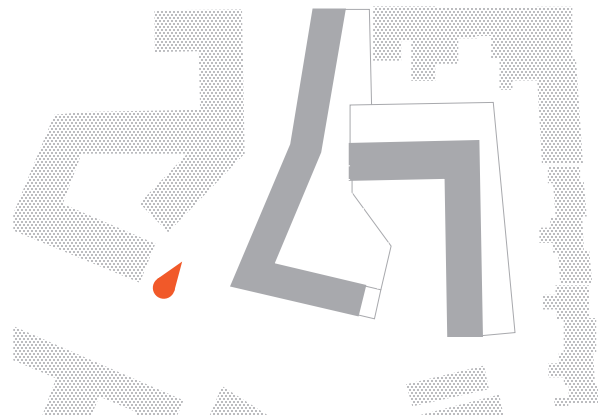

Visual Connections: Collective Space

The surrounding building mass of collective area provides pleasant view of communal space. Something that could happen in the collective area can have more attention than the facing dwelling as it is far enough from one another.

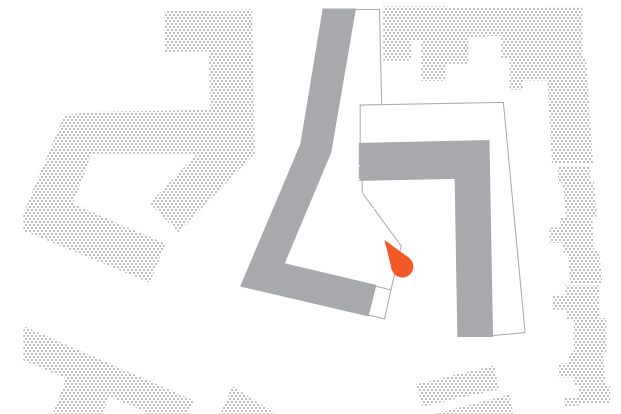
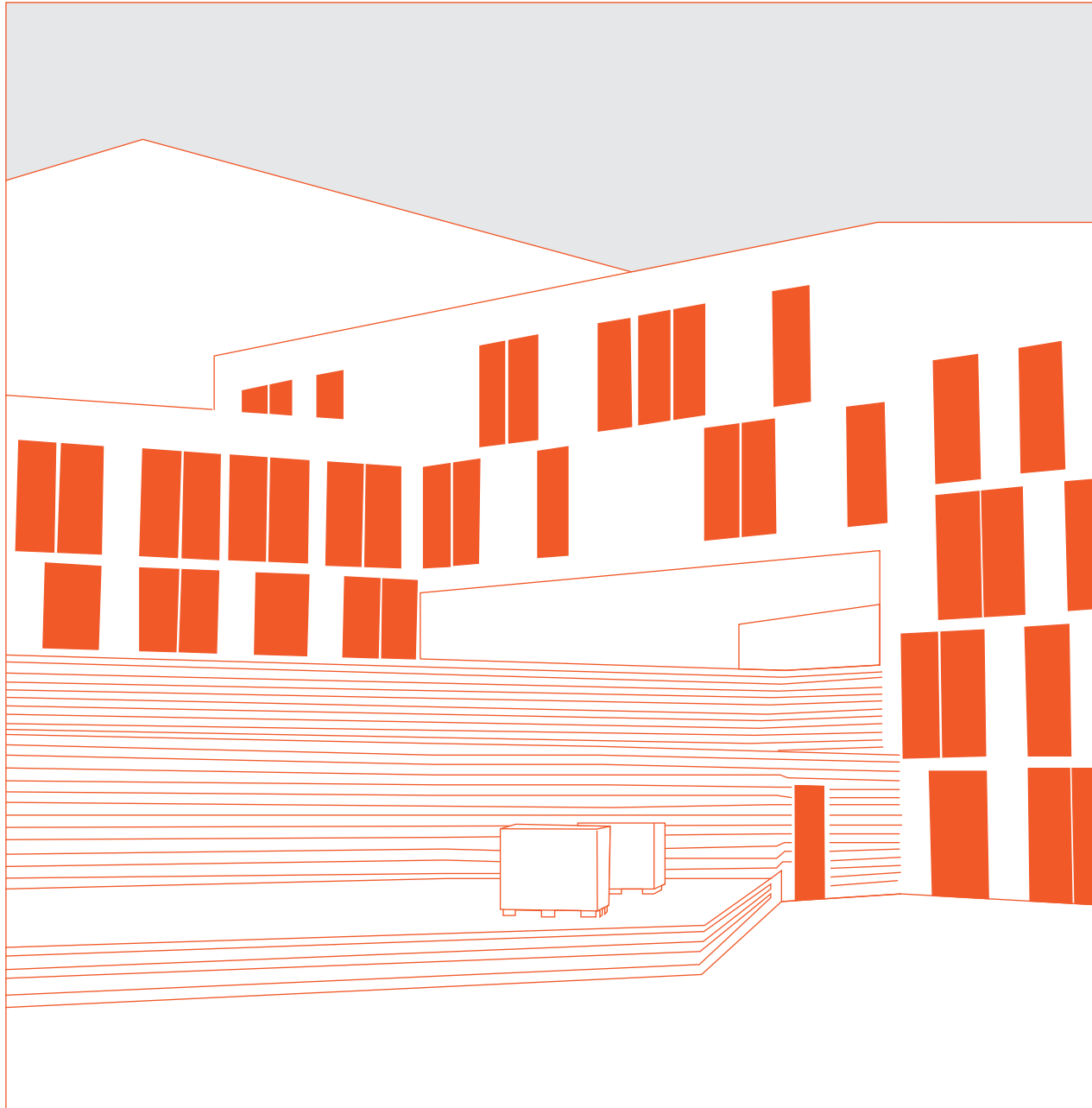

Performance Assessment

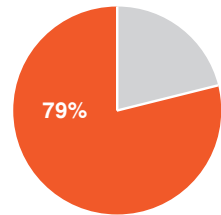

● Average Satisfaction

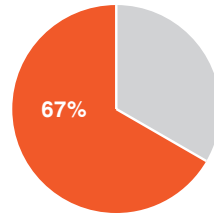

1 How satisfied are you with the location of the building where you live, in the context of the city?

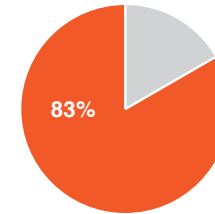

3 How satisfied are you with the public facilities provided in the area in the vicinity of the building where you live?

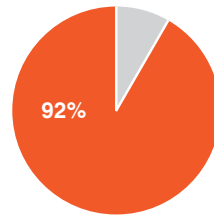

2 How satisfied are you with the public facilities provided in the building where you live?

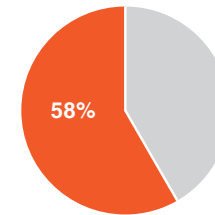

4 How satisfied are you with the level of disturbances (such as noise, intrusions) coming from the public space surrounding the building you live in?

The assessment results are based on the level of respondent's satisfaction in accordance to their answers:

- Very Dissatisfied: 0%
- Dissatisfied: 25%
- Neutral: 50%
- Satisfied: 75%
- Very Satisfied: 100%

Based on the number of responses and satisfaction level of each respondent, an average satisfaction level has been calculated for each question.

Relation with Public Space Performance

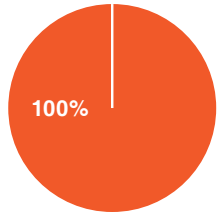

① How satisfied are you with the interactions with your neighbours?

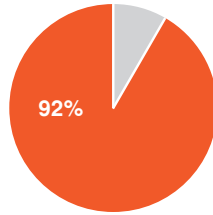

① How satisfied are you with the quality and amount of private outdoor spaces (such as terraces, balconies) provided in the building you live in?

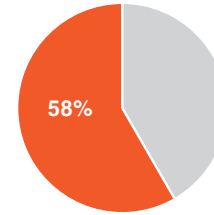

① How satisfied are you with the view from your apartment?

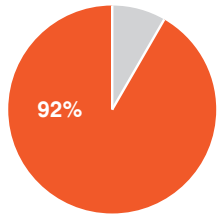

② How satisfied are you with the amount and quality of common spaces provided in the building you live in?

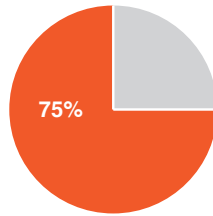

② How satisfied are you with the view from your private outdoor space?

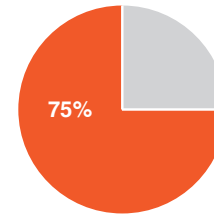

② How satisfied are you with the level of disturbances (such as noise, intrusions) coming from the spaces surrounding your house or apartment?

Collective Space Performance

Private Space Performance

Private Interior Space Performance

Grenelle, 35 Logements

Architect: Peripheriques Architectes

Location: Paris, France

Design: 2007 - 2011

Completion Date: 2013

Programme: Housing, Retail

Area: 2.800m²

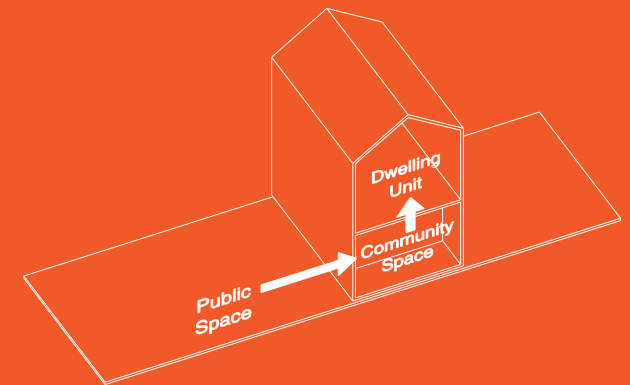



Grenelle, 35 Logements

Architect: Peripheriques Architectes

Location: Paris, France

Design: 2007 - 2011

Completion Date: 2013

Programme: Housing, Retail

Area: 2.800m²

Location

The project is located in between Fremicourt street and Boulevard de Grenelle in Paris. The residential housing *Grenelle, Immeuble de 35 logements* was developed together with social housing *Fremicout, Immeuble de 54 logements* and the nursery *Creche, 30 Berceaux*. The metro station La Motte-Picquet-Grenelle is situated only 50 meters away from the site, generating commuters' traffic on the adjacent Boulevard de Grenelle.

Project

10 different types of housing varying from single unit to 3-bed room family unit are included in the project. The building is 9 levels high conforming to the height of surrounding buildings. Loggia spaces were provided on the south facade overlooking an inner courtyard. Only the top dwellings have more private outdoor space, occupying roof terraces facing Boulevard de Grenelle on the north side of the building. The nursery *Creche, 30 Berceaux* is located on the west side of the inner courtyard. It has strong visual characteristics due to usage of colorful terracotta elements on façade.

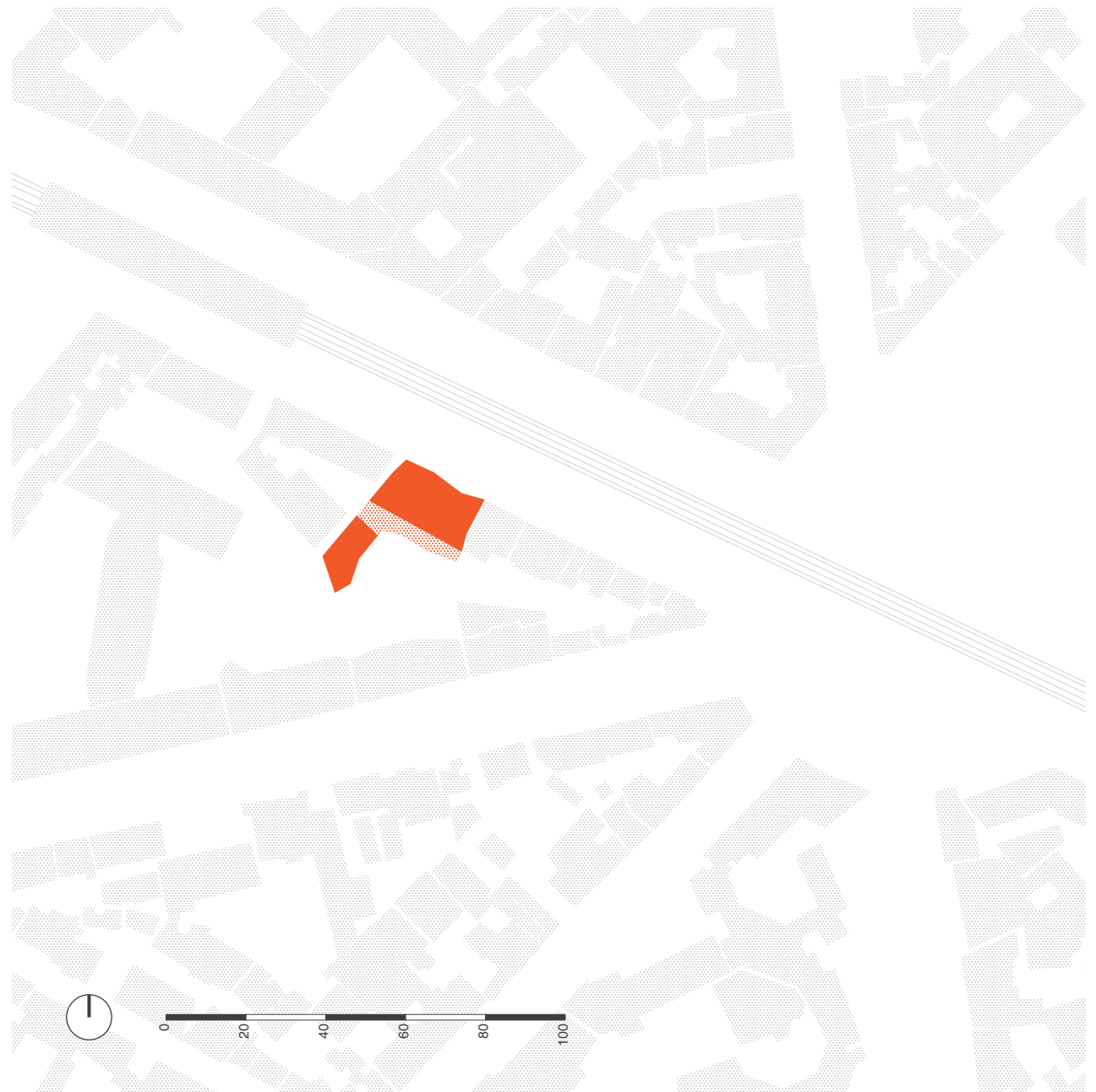

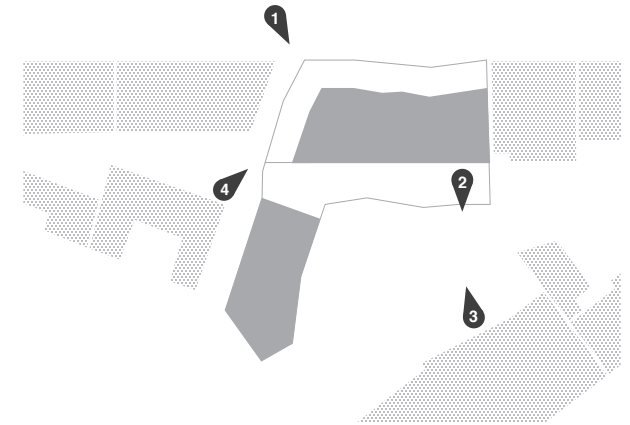

1 View from Grenelle Boulevard

The Metro runs right in front of the residential building.

2 View of the Inner Courtyard

In the inner courtyard fences and a hedge shrub demarcate boundaries of ownership.

3 View from the Inner Courtyard

Uniquely shaped loggias and balconies diversify the inner facade of apartment building.

4 View from Kindergarten Access Path

The nursery is accessed from Boulevard de Grenelle, through small alley.

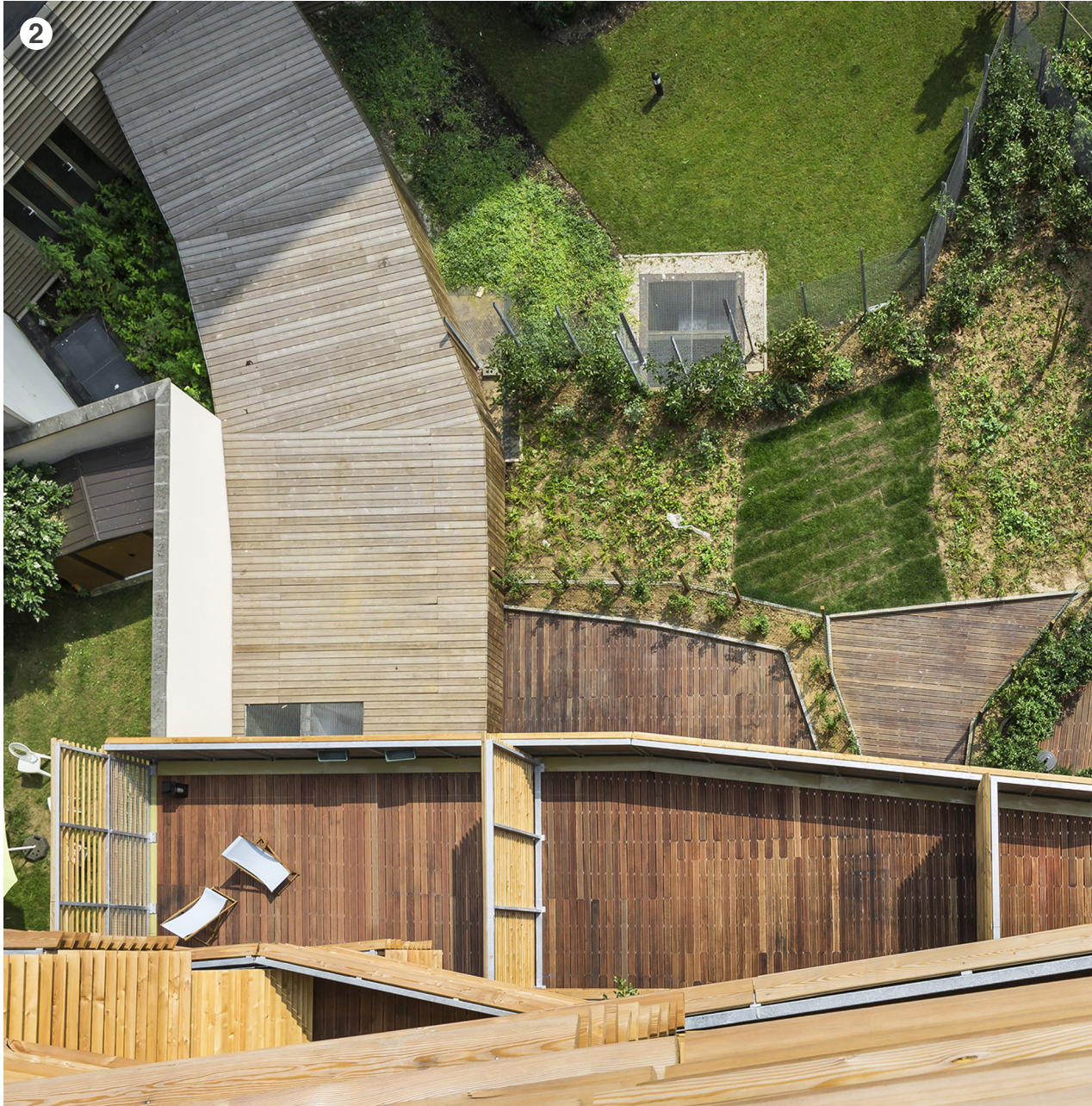

Programme Distribution

The diagrams to the right depict programme distribution in the analysed project as well as in its immediate building. The circular diagrams refer to areas included only within the analysed building.

The ground level is mostly dedicated to retail, which faces Boulevard de Grenelle. But the project is creating the inner courtyard on the same level; the usage of ground floor is diverse. In the courtyard side 2 different types of dwelling are located next to the nursery. The bicycle parking is placed closed to the elevator on ground level and the car parking area is provided in two levels on the basement.

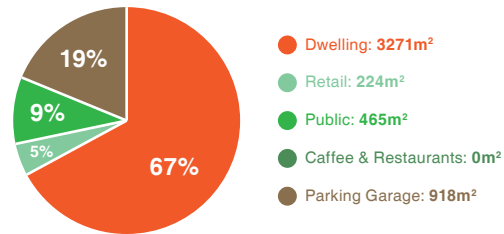

A Programme Distribution: Overall Amounts in the Ensemble

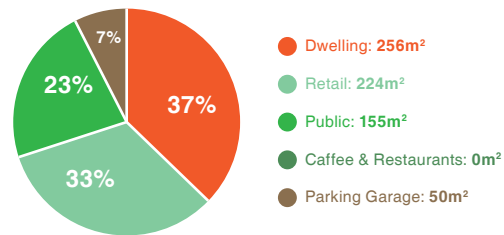

B Programme Distribution: Ground Floor

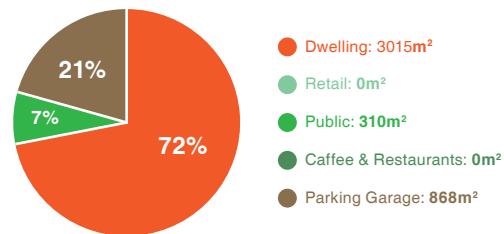

C Programme Distribution: Other Levels

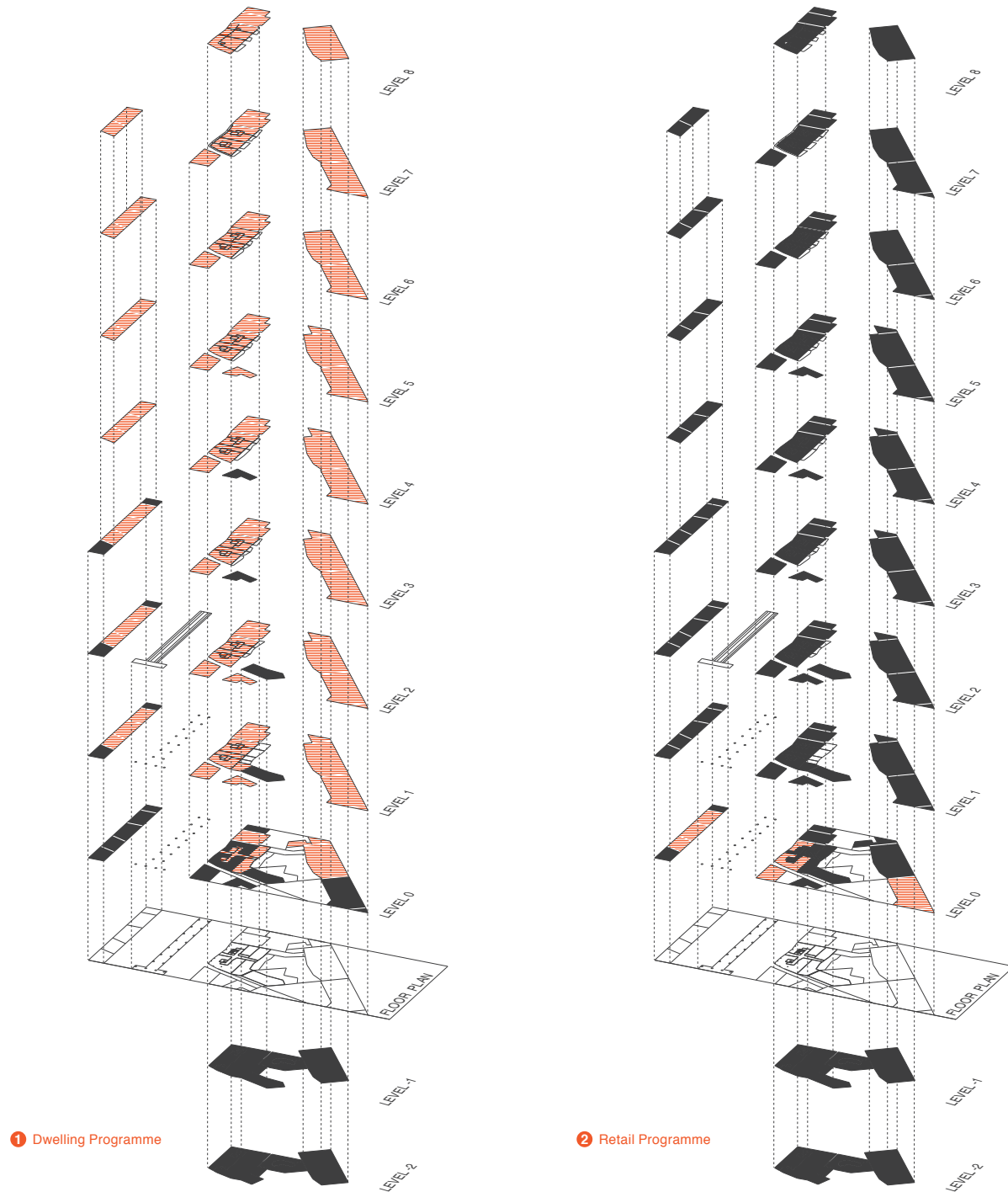

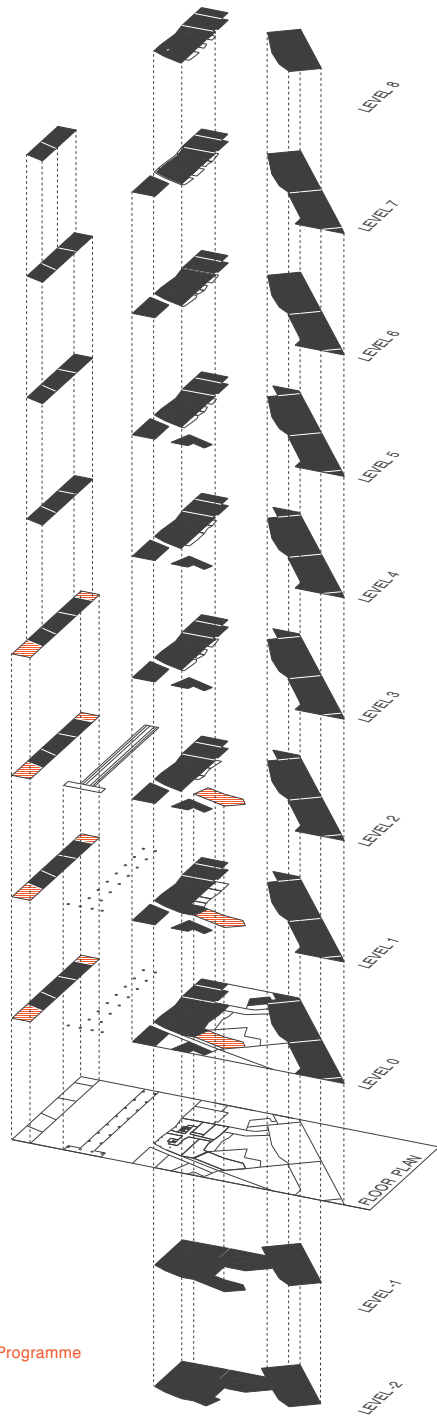

3 Public Programme

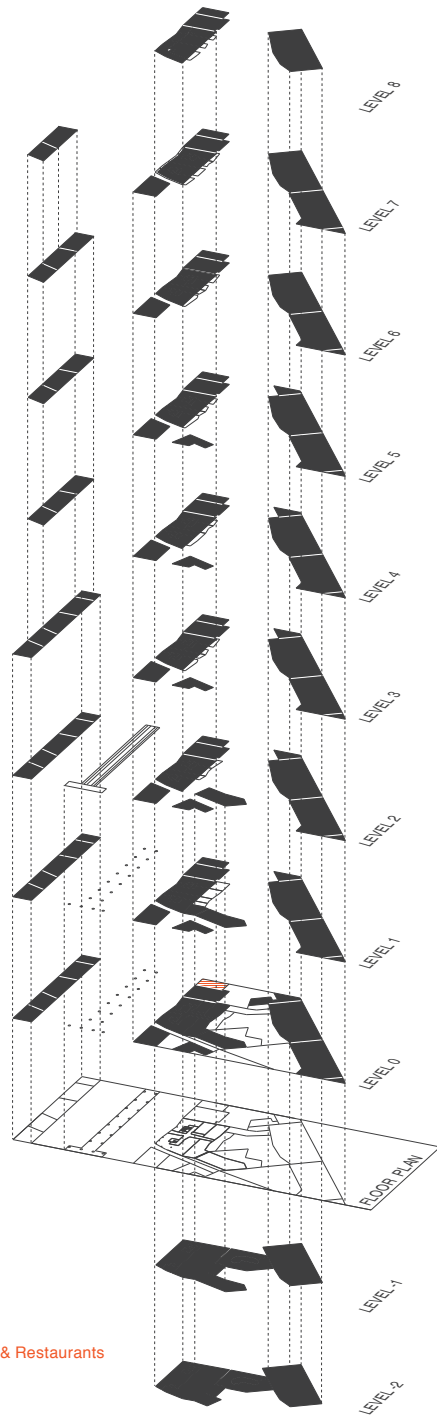

4 Caffee & Restaurants

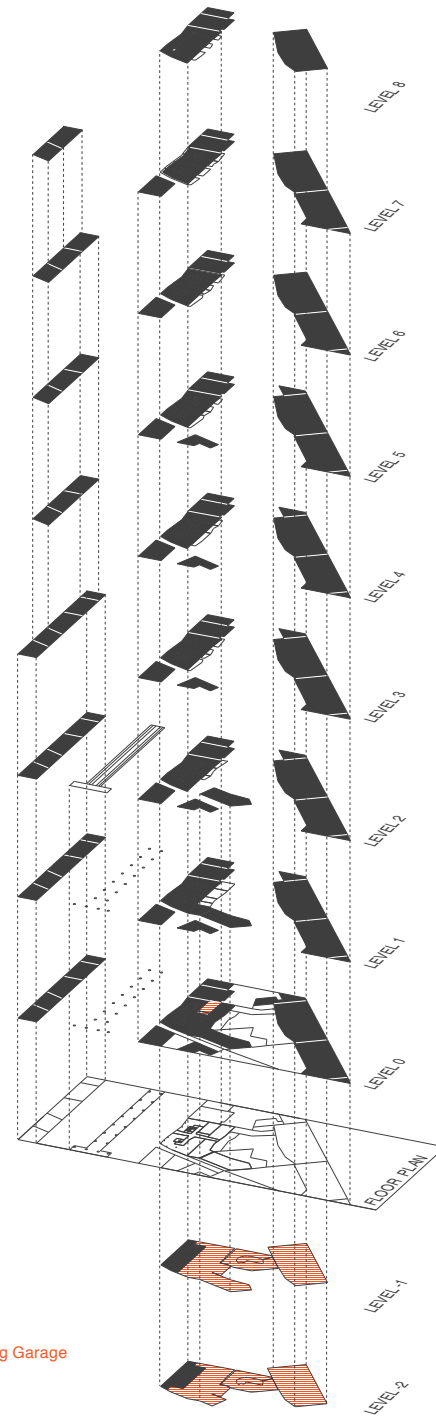

5 Parking Garage

Routes and Access

Public can access retail area on ground level and the alley to nursery from Boulevard de Grenelle. The vertical collective movement is dominant by two elevators. The private routes are situated in the building's interior on level 0 to 1 and levels 7 to 8.

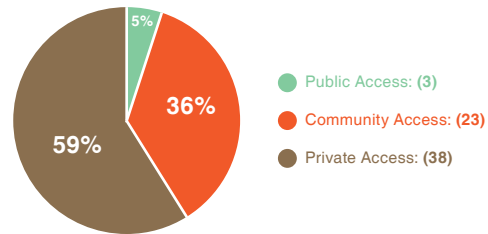

A Public, Community & Private Access: Overall Amounts in the Ensemble

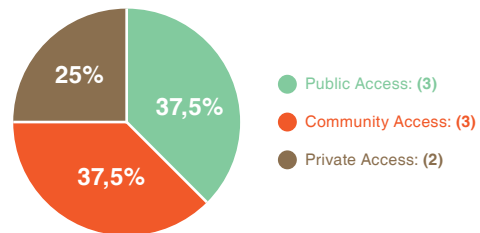

B Public, Community & Private Access: Ground Floor

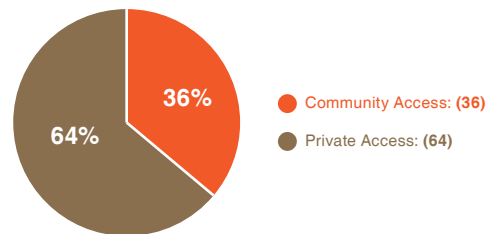

C Public, Community & Private Access: Other Levels

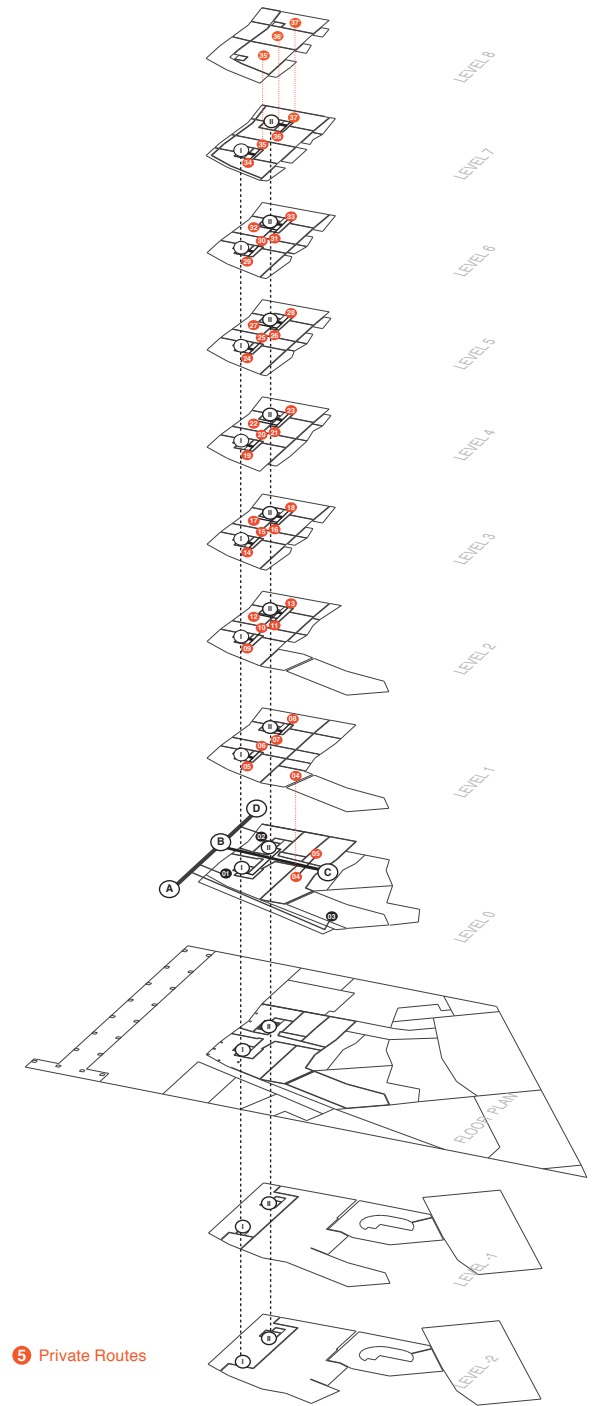
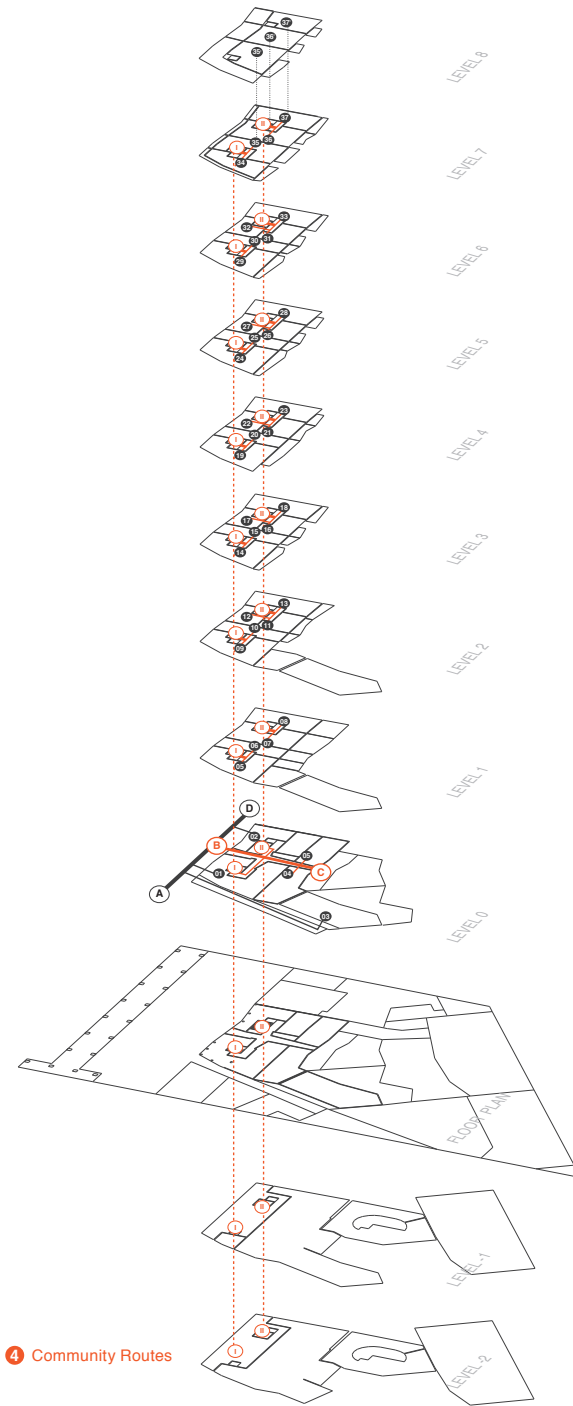
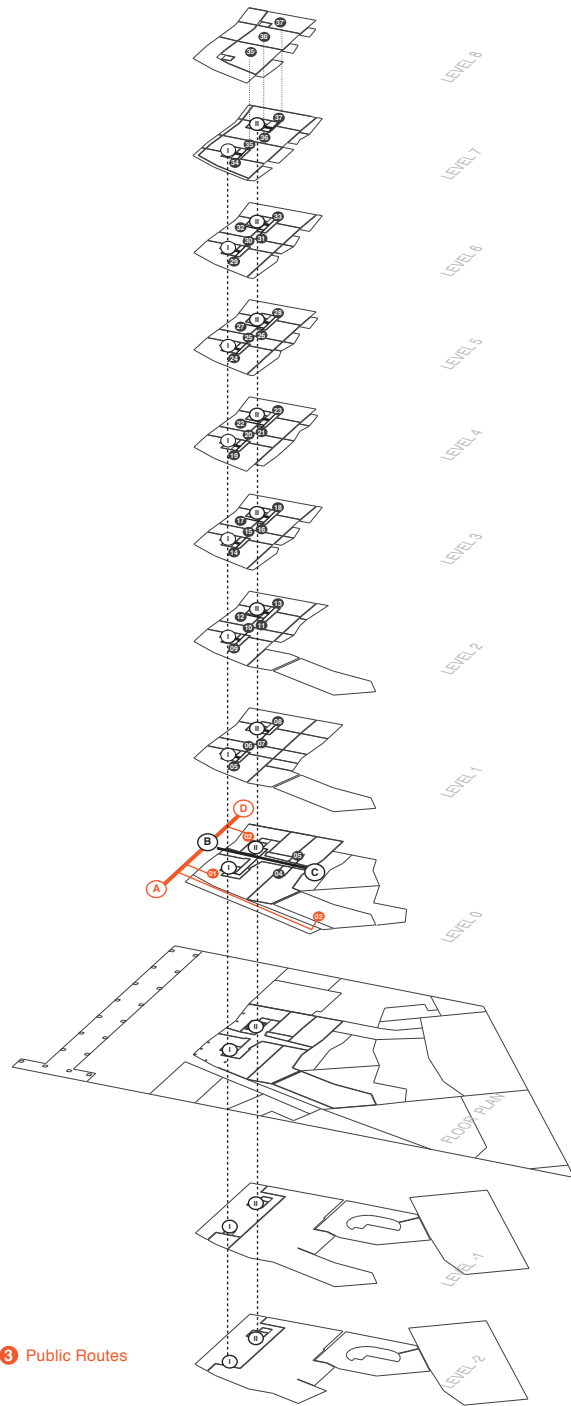

Public, Collective & Private Space

Public outdoor space on Boulevard de Grenelle is arranged for the public parking area and street for cars and pedestrians. In inner courtyard outdoor space is separated for nursery and collective garden. Collective garden can be seen from every private outdoor space on south side but it is not a place for communal events. As every dwelling has its own private outdoor space; it occupies the most of the area among all outdoor space. Especially on the highest floor large outdoor space is provided along all the edge of building.

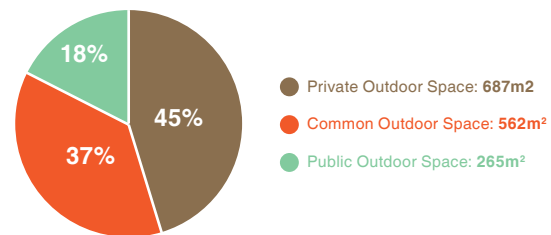

A Public, Common & Private Outdoor Space Facilitated in the Project

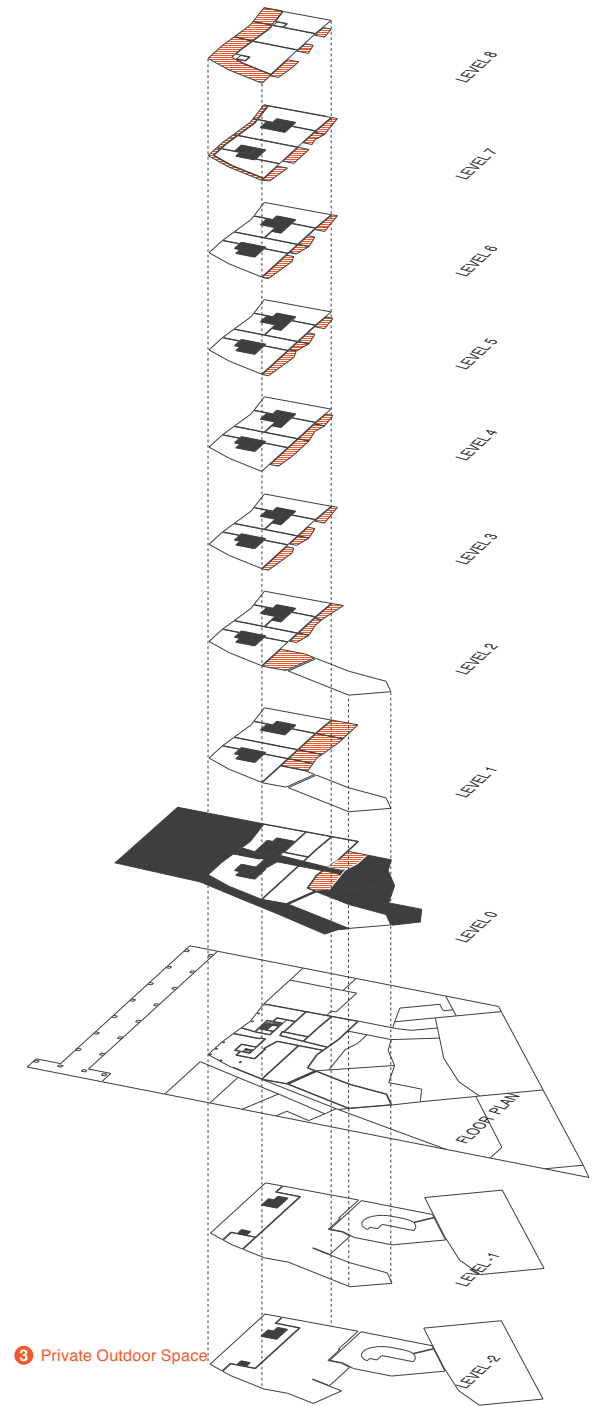
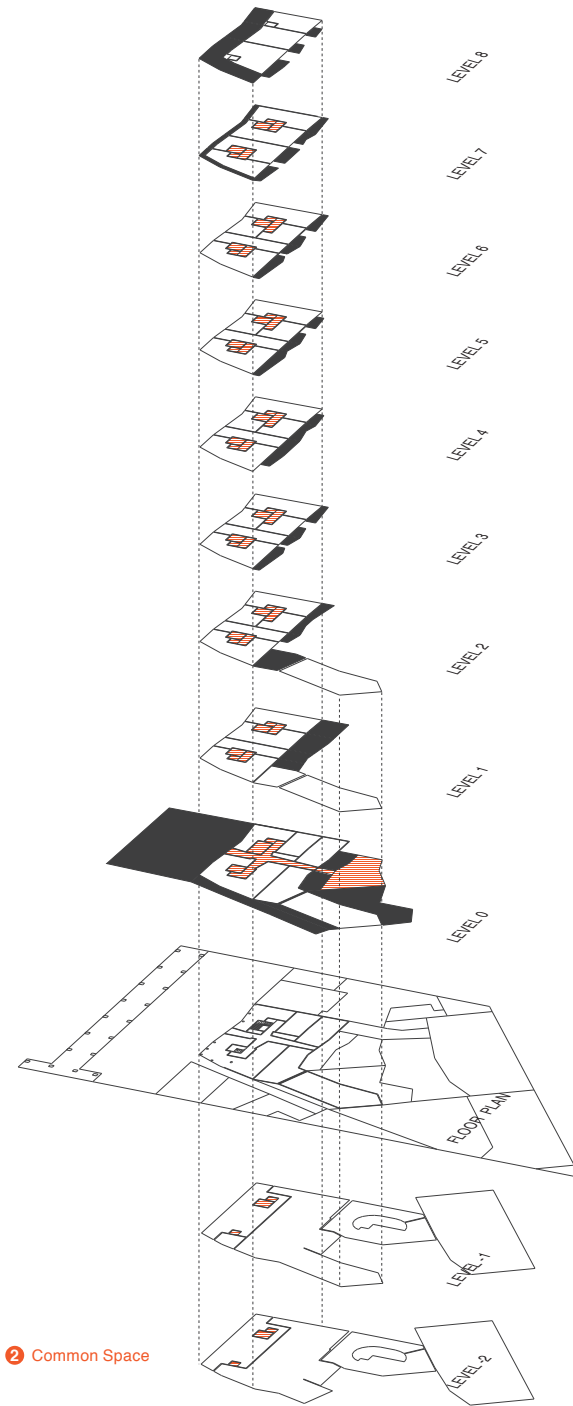
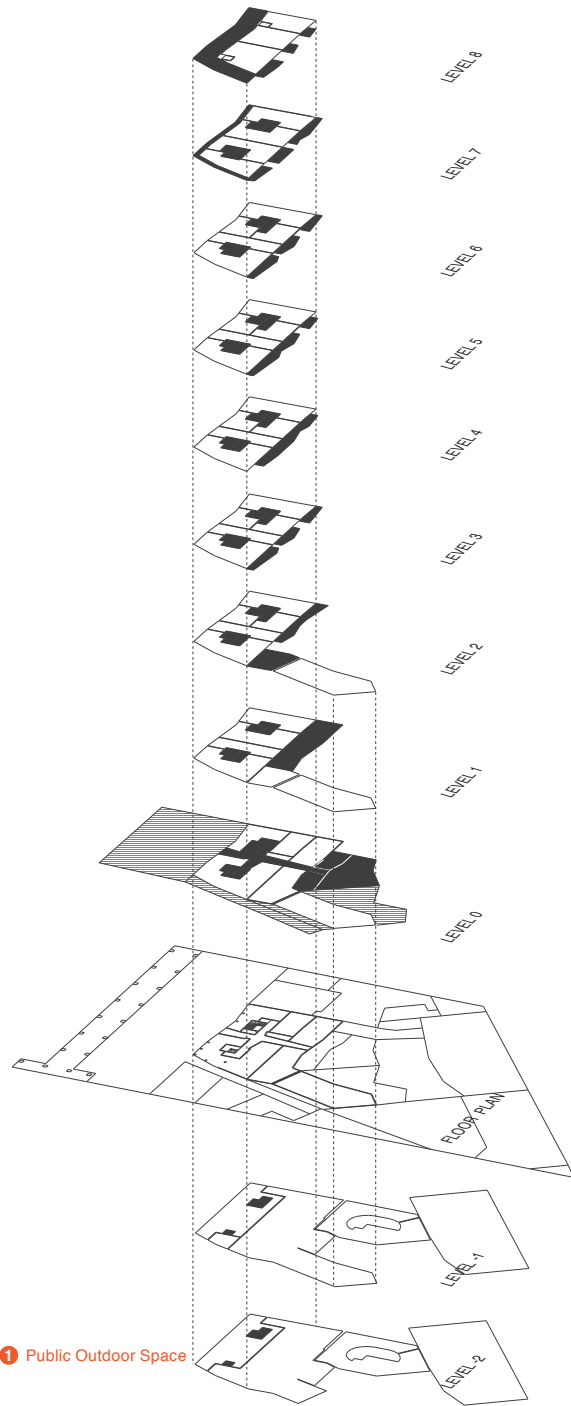

Perspective: Public Space

The boundaries of public space are clearly defined by the outline of the building. Transparent glass façade on the ground and the different level exposes the different function of the building. Façade has its own rhythm by irregularly positioned windows. On low angle windows are hidden due to railing.

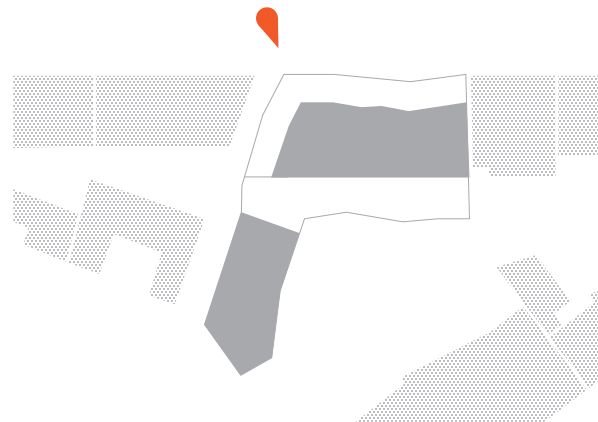

Perspective: Collective Space

The boundaries of collective space are diffused by plantation on ground level. Windows are hidden behind the wooden railing creating extensive private outdoor space. Also the irregular form of the balconies creates diffused atmosphere of collective space

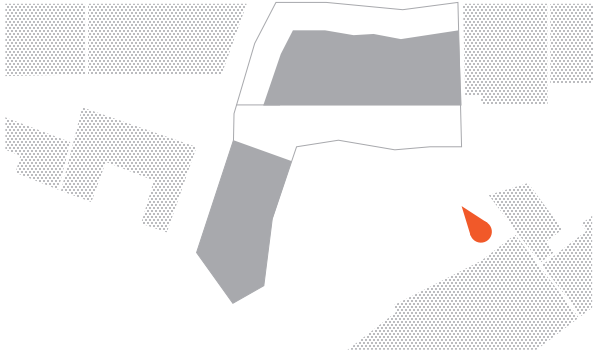
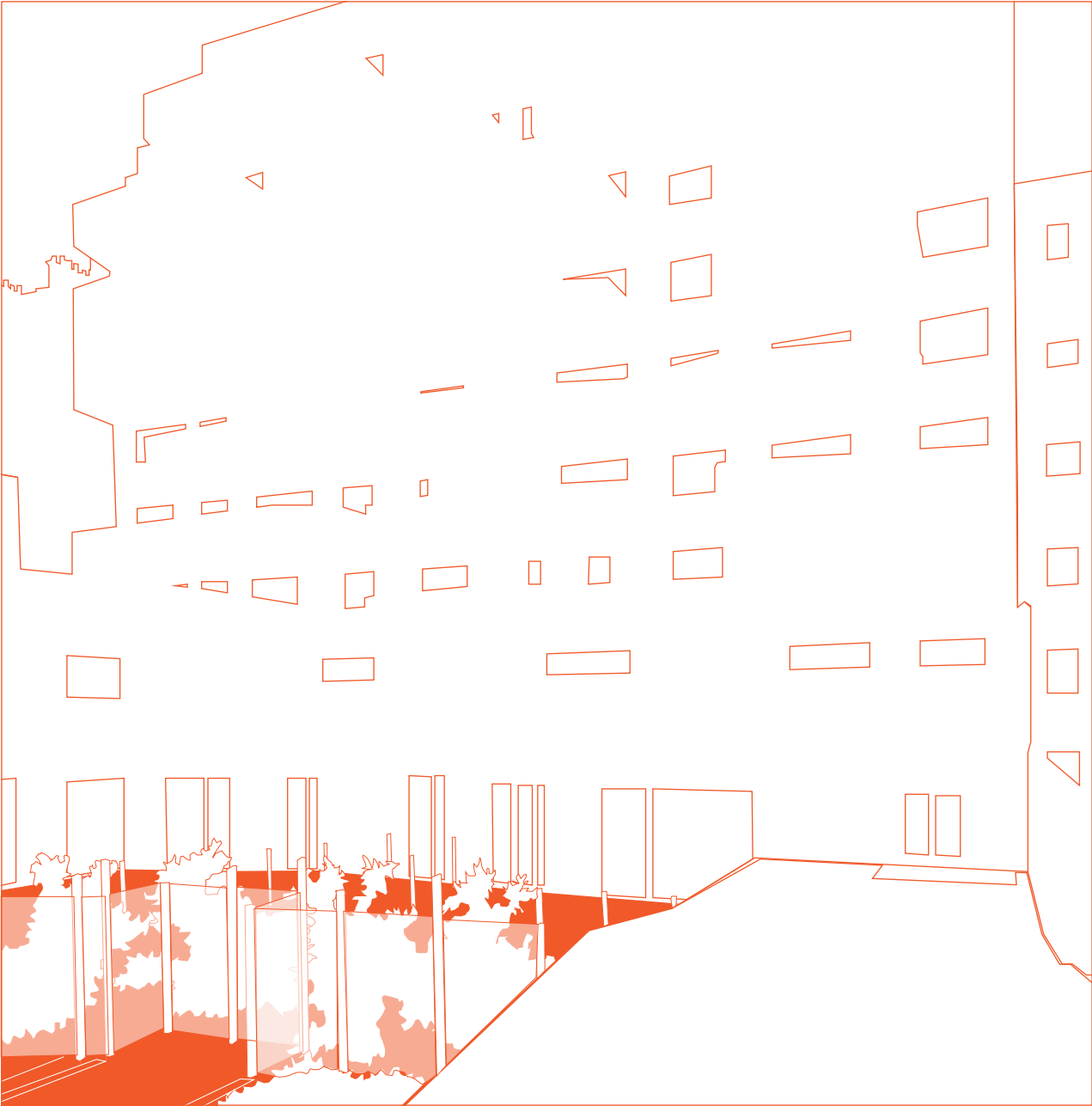

Materials: Public Space

The façade on northeast side facing the Boulevard de Grenelle is clad with enameled terracotta panels, creating an iridescent effect. Large glass surfaces are provided for the retail on ground level. Noteworthy architects seem to have taken into account the presence of adjacent metro line when materialising the building: The facade cladding colours are complementary with the characteristic colouring of Paris' metro trains.

For nursery terracotta blocks enameled in various shades of pink, green, yellow, red and white is used. Some of these blocks are used for louver. Cement pavement was there ever since.

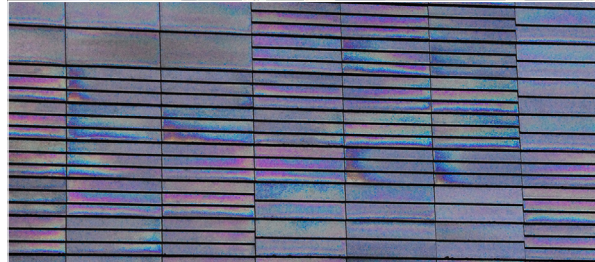
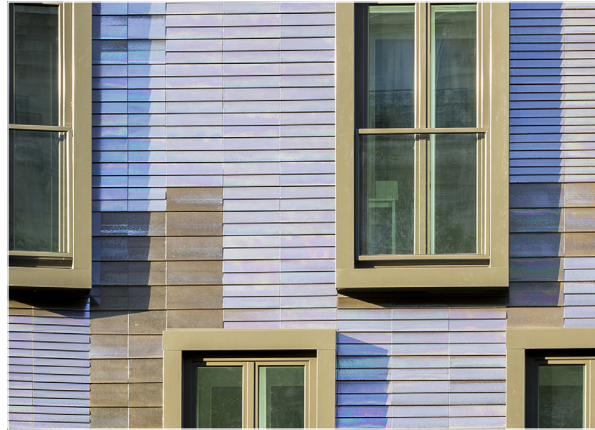

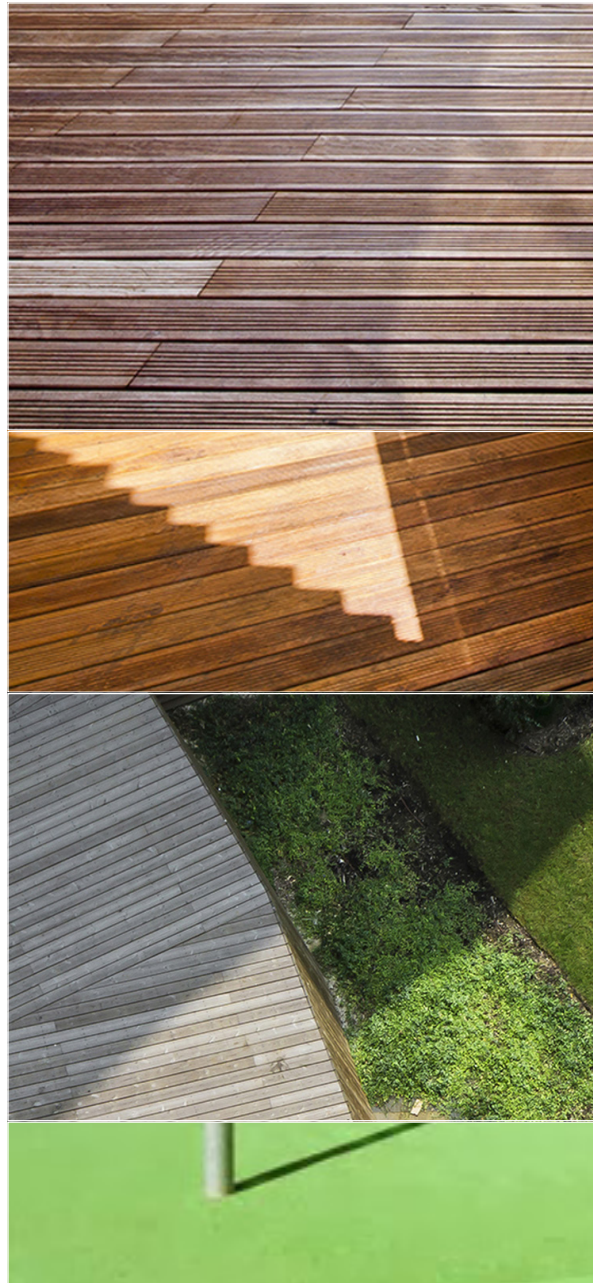

Materials: Collective Space

The façade of residential building facing collective garden is clad with timber slats whilst the nursery uses playful terracotta blocks, indicating a differentiation in use of the building parts. Timber cladding contributes to an unofficial atmosphere of the collective courtyard and improves the acoustics.

A lot of planting is done on communal garden and wooden decks demarcate private outdoor spaces.

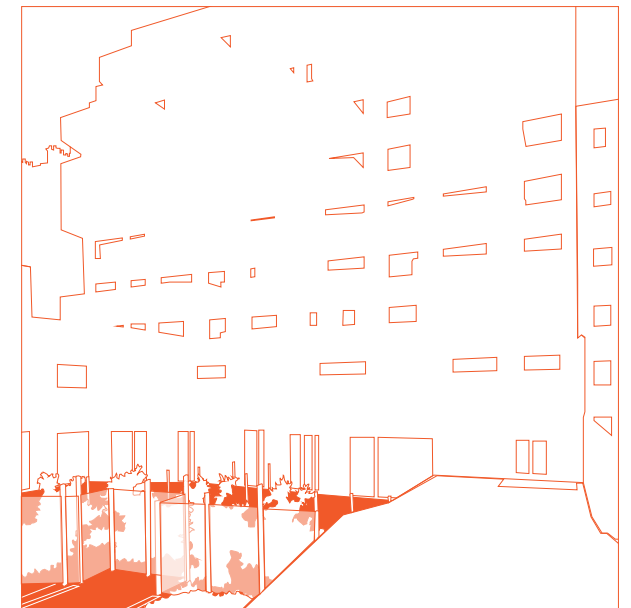

Open Space Scale & Proportions

Section Overview

The sections demonstrate the proportions of public space surrounding the building. The width and height is more or less consistent about ratio of height to width 0.6.

The collective space shows varying in proportion, due to differences in dimensions, from 20 to about 33 meters, with ratio of height to width close to 1.

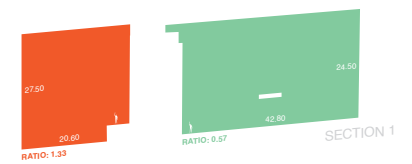
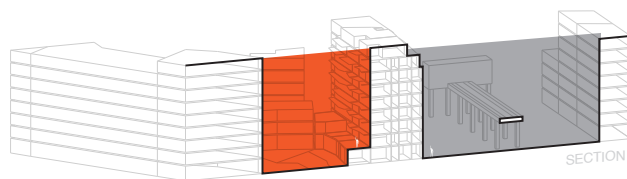
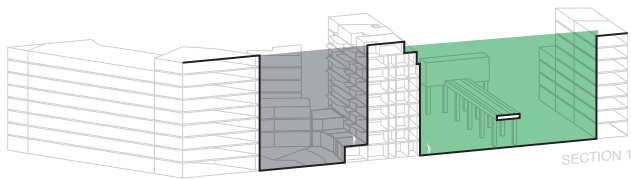
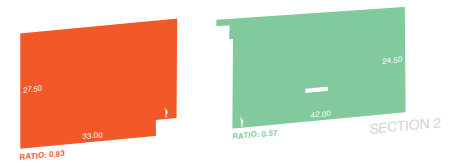
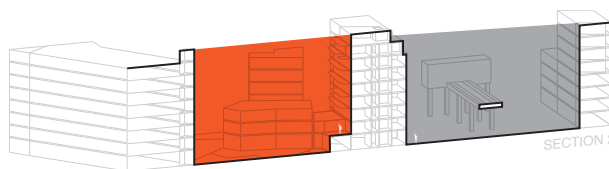
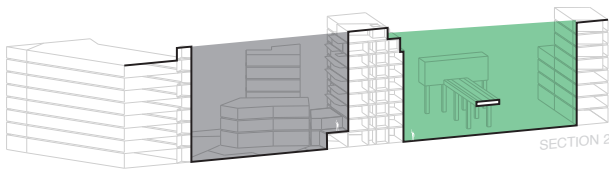
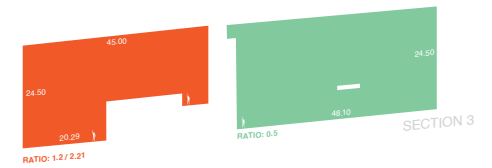
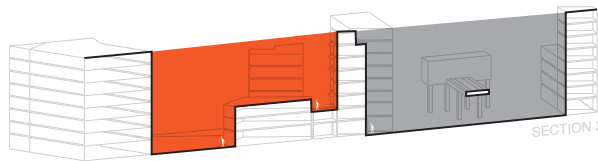
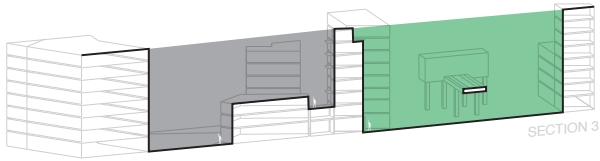

3 Public Space Scale & Shape

4 Community Space Scale & Shape

5 Public & Community Space: Scale, Dimensions & Proportions

Scale: Public Space

The elements relating to human scale are scarce at Boulevard de Grenelle. But the glass façade with different width provides irregularity. And the above window is relatively narrow. As the mass gets smaller when it gets higher on upper two levels, overall building height can be hidden from the ground level.

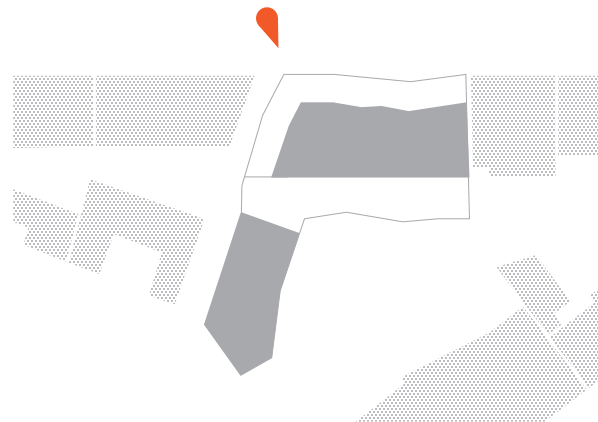



Scale: Collective Space

The Large irregular extruded balconies shatters the façade looking at collective area. Due to balconies irregularity is outstanding and it is difficult to figure out what is happening on above ground level.

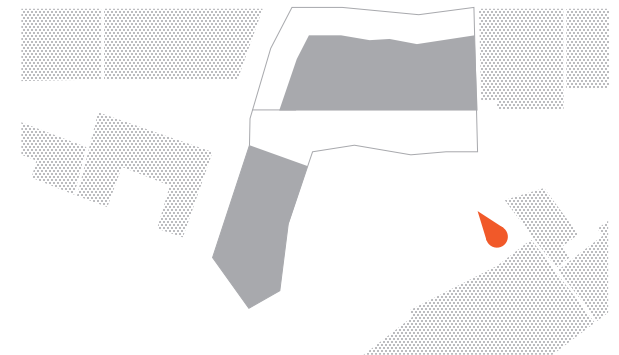

Visual Connections

Majority of dwelling spaces have a visual connection both with public and collective space. And the irregular extruded balcony facing the community space is in relation to the private living areas allowing the view into the calm enclave while bedrooms are mostly located on the north, facing public space.

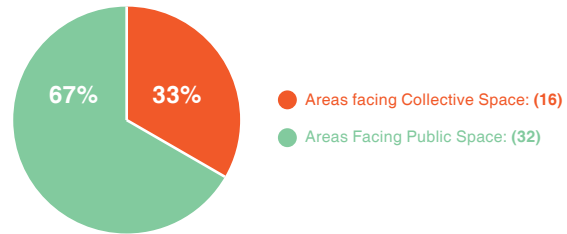

A Visual Connections: Private Living Areas

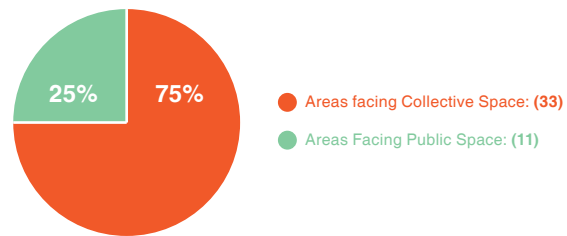

B Visual Connections: Living Room & Kitchen Areas

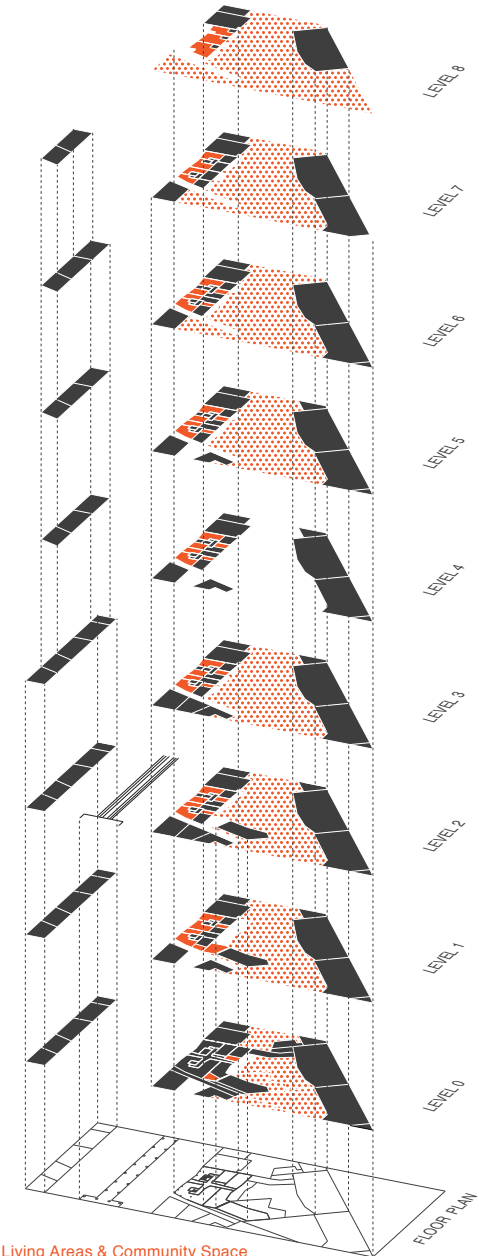
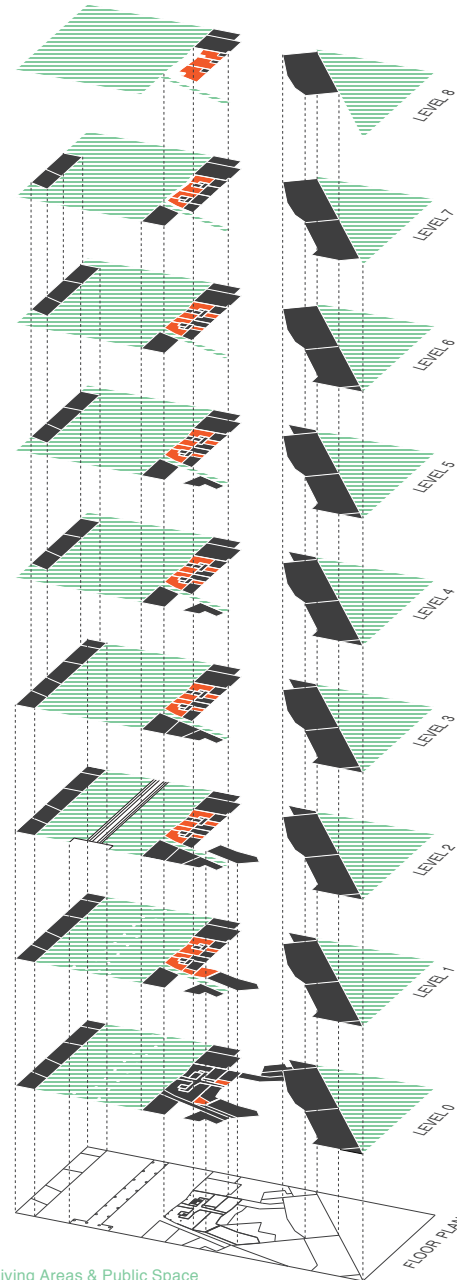

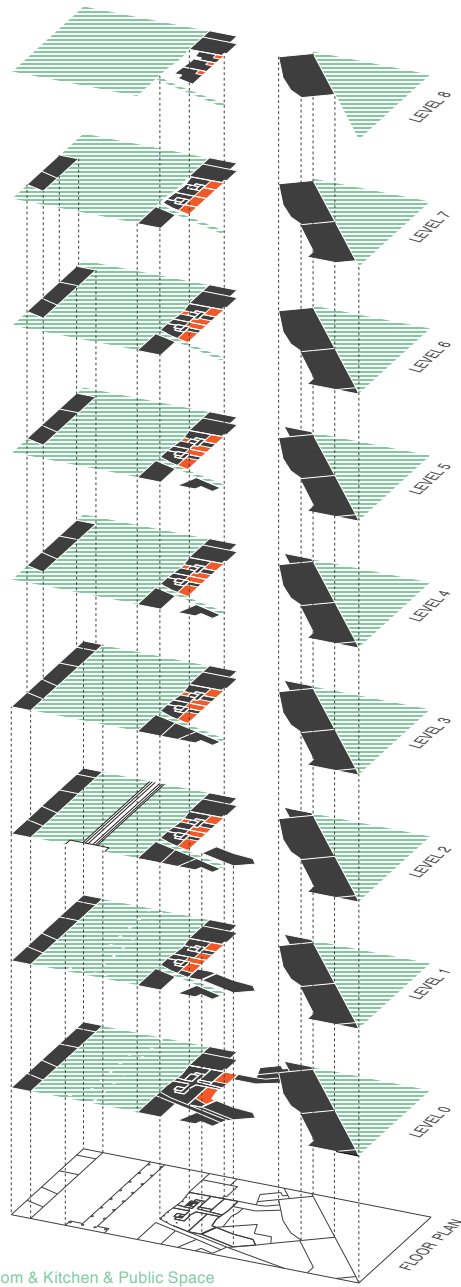

3 Living Room & Kitchen & Public Space

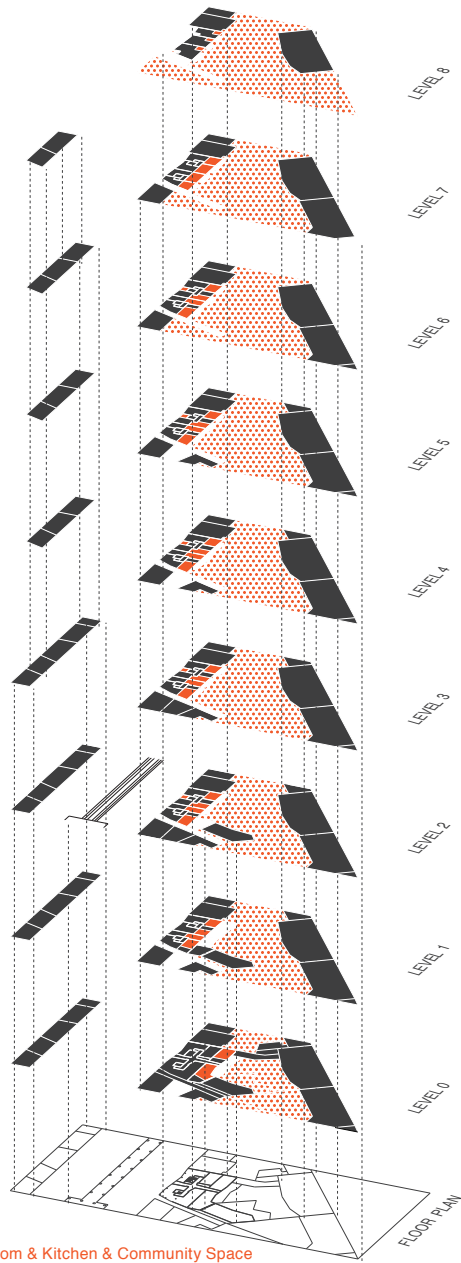

4 Living Room & Kitchen & Community Space

Section Overview

Upper part of dwellings has a far-reaching view in totally different atmosphere of dense city and the quite neighborhood. Even the alley part of facade has an opening providing different views.

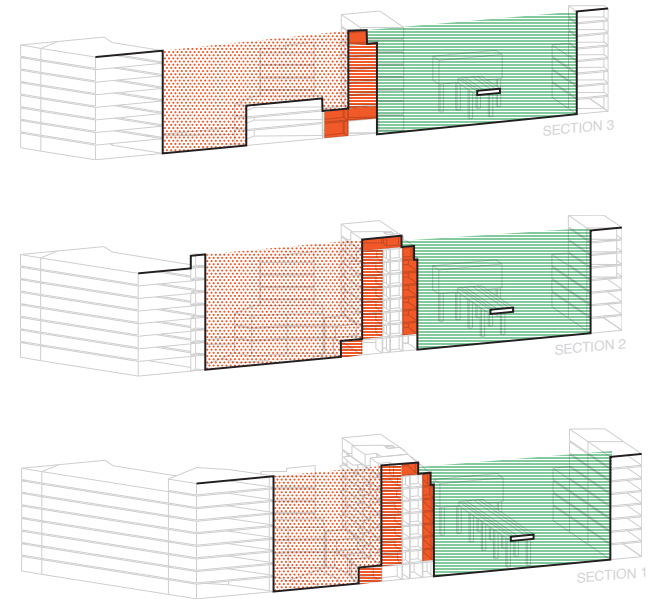

5 Visual Connections: Private Living Areas, Living Room & Kitchen Areas

Visual Connections: Public Space

The ground level of retail plinth at Boulevard de Grenelle is the most open part of building's facade, offering a strong visual connection with the interior. The facades of upper levels dedicated for dwelling provides rhythm using two different kinds of positioned window in a row repeated one by one.

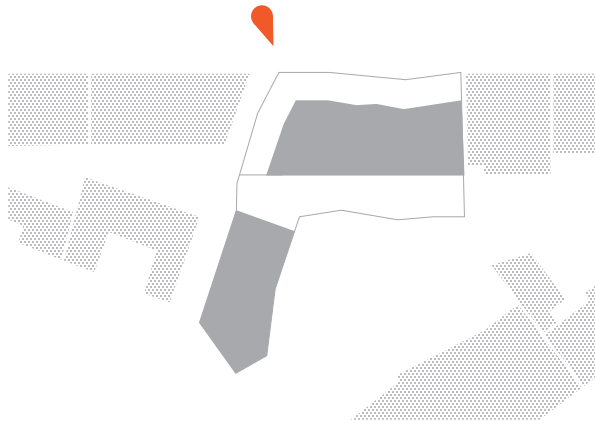



Visual Connections: Collective Space

Ground level of the collective area has wide view towards collective area even though the different functions behind. Due to the railing direct view from ground level to upper housing is limited increasing the privacy. Private comfort was much more considered than to interact with community.

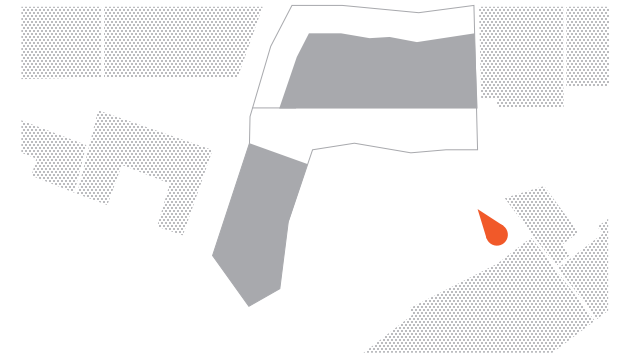

Performance Assessment

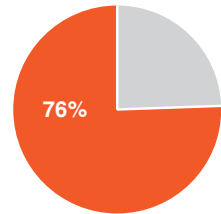

● Average Satisfaction

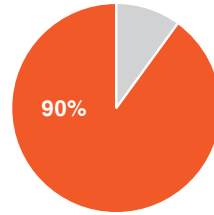

1 How satisfied are you with the location of the building where you live, in the context of the city?

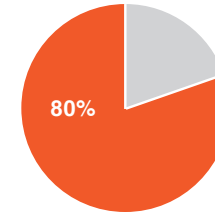

3 How satisfied are you with the public facilities provided in the area in the vicinity of the building where you live?

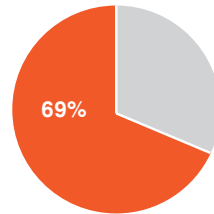

2 How satisfied are you with the public facilities provided in the building where you live?

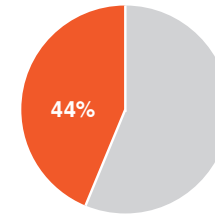

4 How satisfied are you with the level of disturbances (such as noise, intrusions) coming from the public space surrounding the building you live in?

The assessment results are based on the level of respondent's satisfaction in accordance to their answers:

Very Dissatisfied: 0%
 Dissatisfied: 25%
 Neutral: 50%
 Satisfied: 75%
 Very Satisfied: 100%

Based on the number of responses and satisfaction level of each respondent, an average satisfaction level has been calculated for each question.

Relation with Public Space Performance

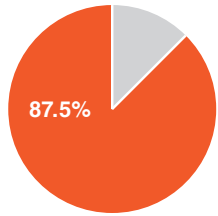

① How satisfied are you with the interactions with your neighbours?

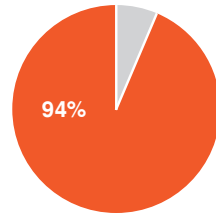

① How satisfied are you with the quality and amount of private outdoor spaces (such as terraces, balconies) provided in the building you live in?

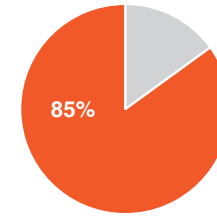

① How satisfied are you with the view from your apartment?

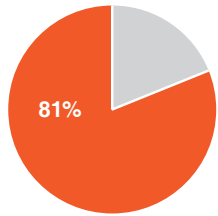

② How satisfied are you with the amount and quality of common spaces provided in the building you live in?

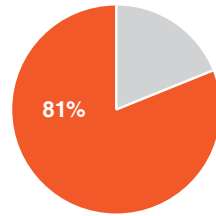

② How satisfied are you with the view from your private outdoor space?

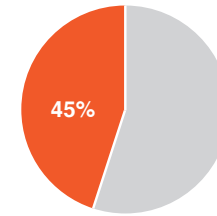

② How satisfied are you with the level of disturbances (such as noise, intrusions) coming from the spaces surrounding your house or apartment?

Collective Space Performance

Private Space Performance

Private Interior Space Performance

Django Building

Architect: KCAP Architects & Planners

Location: Amsterdam, Nederlands

Design: 2002 - 2010

Completion Date: 2010

Programme: Housing, Retail

Area: 15.000m²

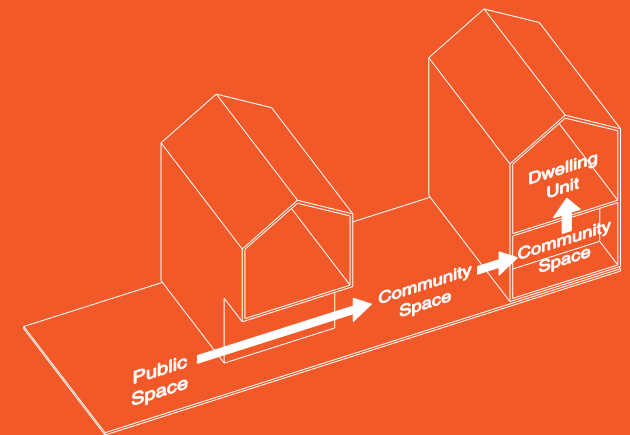



DIANCO

FOR RENT

THE ZUIDAS

YOU

BUSINESS

THE WORLD

WALKING ZONE
WALKING ONLY
NO MOTOR VEHICLES
→

DIANCO

Django Building

Architect: KCAP Architects & Planners

Location: Amsterdam, Nederlands

Design: 2002 - 2010

Completion Date: 2010

Programme: Housing, Retail

Area: 15.000m²

Location

'Django Building' is an apartment complex in Amsterdam's Zuidas development area. The building occupies lot 8 of Zuidas' Gershwin, cluster III, district for which KCAP previously completed a mass study. Gershwin is a living center, it should be a district with as wide a variety of housing types. With its 9 storeys, the Django building is the lowest city block between the highest building in the area, the 29-storey twin tower Amsterdam Symphony designed by the Architecten Cie, and the 20-storey Duke Tower designed by Ateliers Lion.

Project

The Django Building comprises of 108 rental apartments, commercial spaces and a one-storey underground parking garage by Inbo architects. The lower floors, with mainly commercial spaces, are defined by a printed glass facade. Above, black brickwork and a repetitive but slightly shifted pattern of anodized window frames and balconies dominate the building's appearance. The all-sidedness of the facade enhances the sculptural character of the stone volumes on the glass plinth. Constructively, the application of a load bearing facade allows for large window openings on all sides. All living areas are oriented in two directions and glazed from floor to ceiling. Innovative cold and warmth storage, with a closed source system, is employed to ensure sustainable cooling and heating in the apartments.



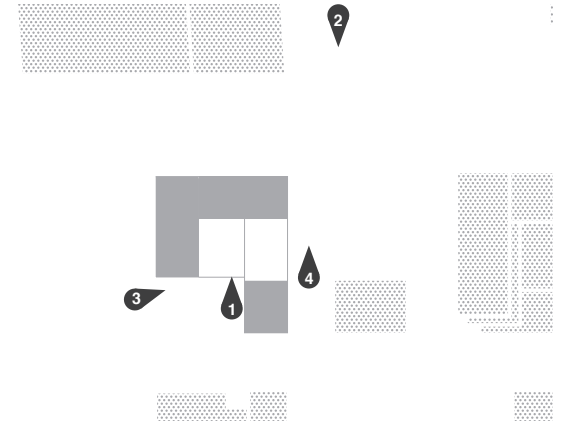

① View from the South

The sunken garden of the two story high child care is visible with a room on the roof. Staggered balconies are oriented towards south and west.

② View from plaza of railway station Amsterdam-Zuid

The Django building draws no attention because of the big towers in front of it with striking colours. The route is towards the building exists of different zones with many pedestrians.

③ View from the West

The enormous difference in height between the buildings is clearly shown. In contrast to the towers, the Django building has staggered windows and balconies of different sizes.

④ View towards railway station Amsterdam-Zuid

The cafe on the ground floor is shown with parked bikes on the car-free zone. The route coming from the railway station is a wide open route.



Programme Distribution

The diagrams to the right depict programme distribution in the analysed project as well as in its immediate vicinity. The circular diagrams refer to areas included only within the analysed building.

It is clearly visible that the upper floors are for dwellers only, strangers can only enter the public functions on the ground floor such as the cafe. There are also no dwellings on the ground floor, except for the entrances to the dwellings. The circular diagrams show that the floor area is almost three-fourths of the whole building.

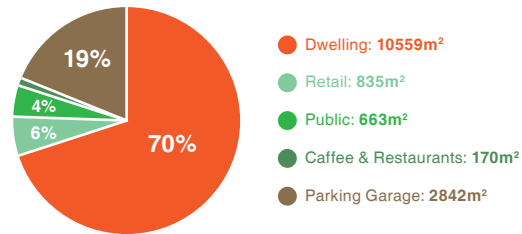

A Programme Distribution: Overall Amounts in the Ensemble

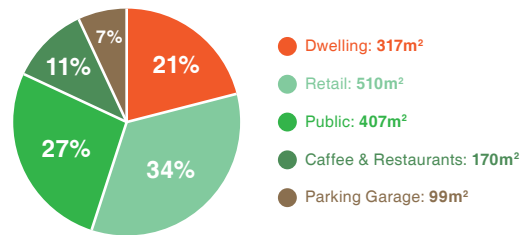

B Programme Distribution: Ground Floor

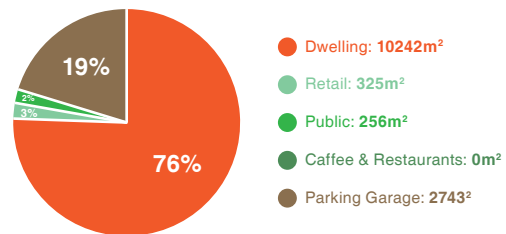

C Programme Distribution: Other Levels

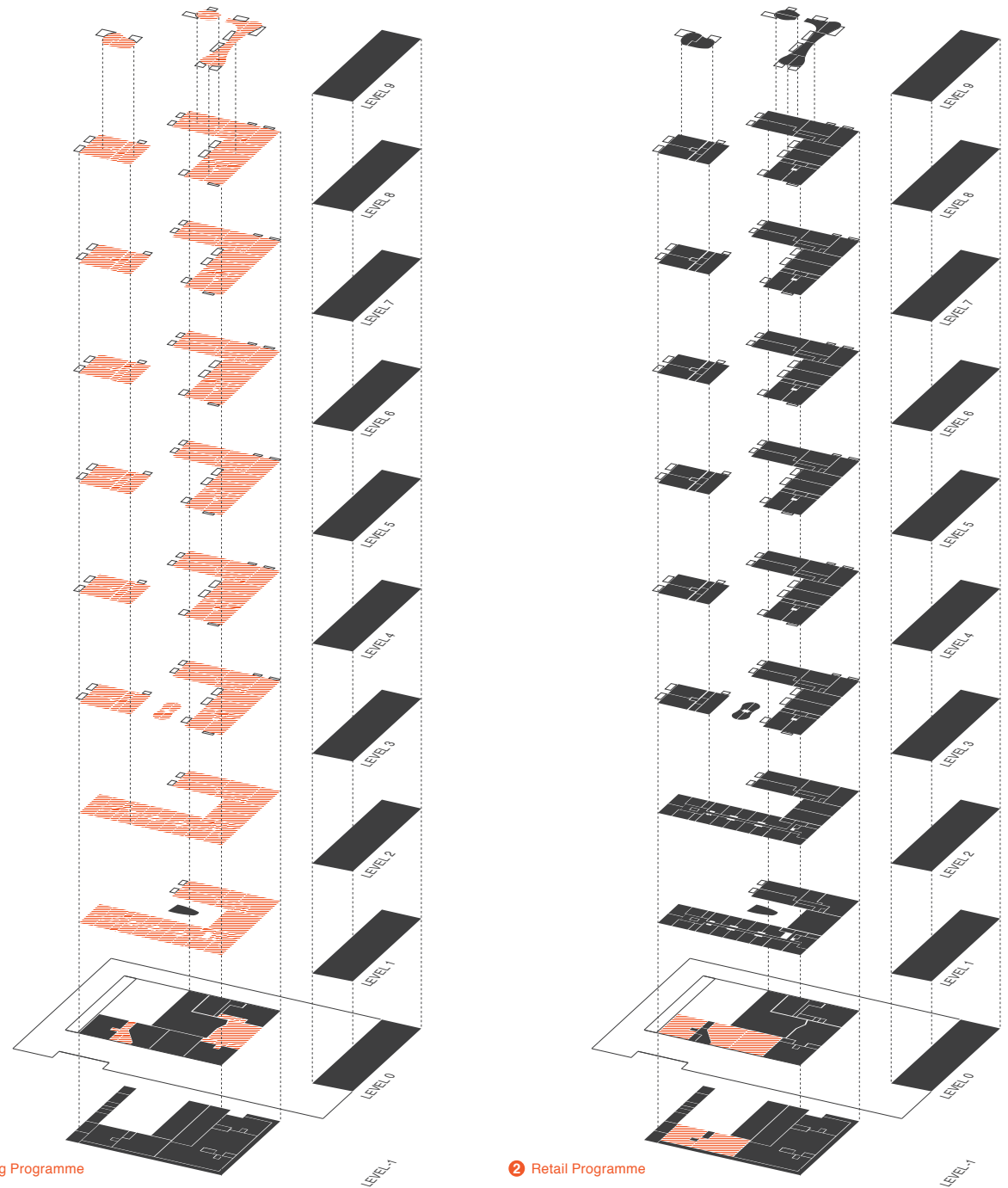

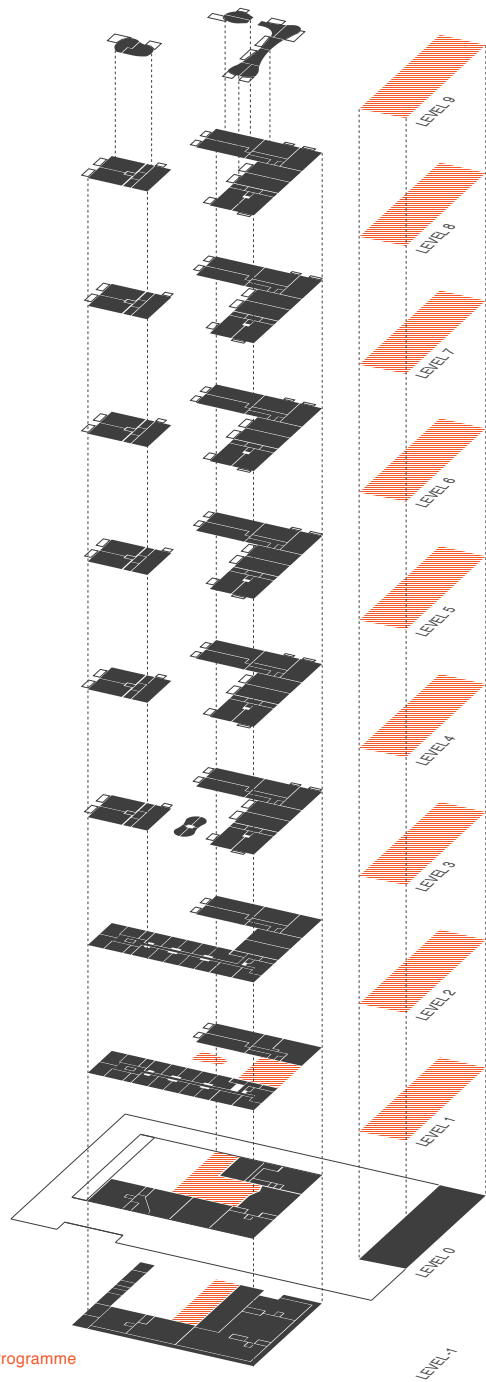

3 Public Programme

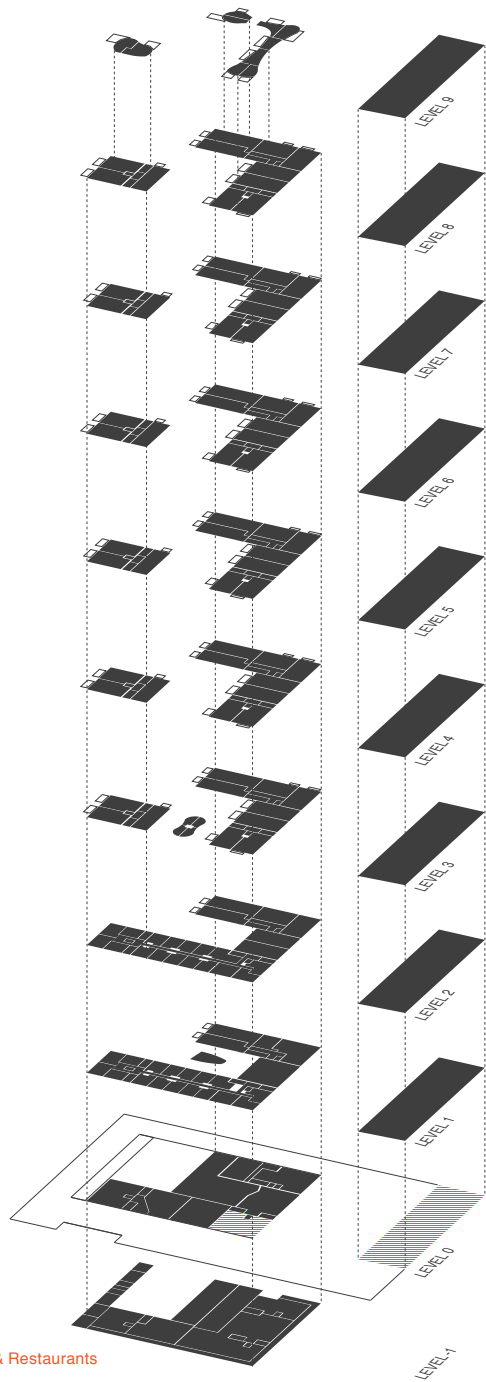

4 Cafees & Restaurants

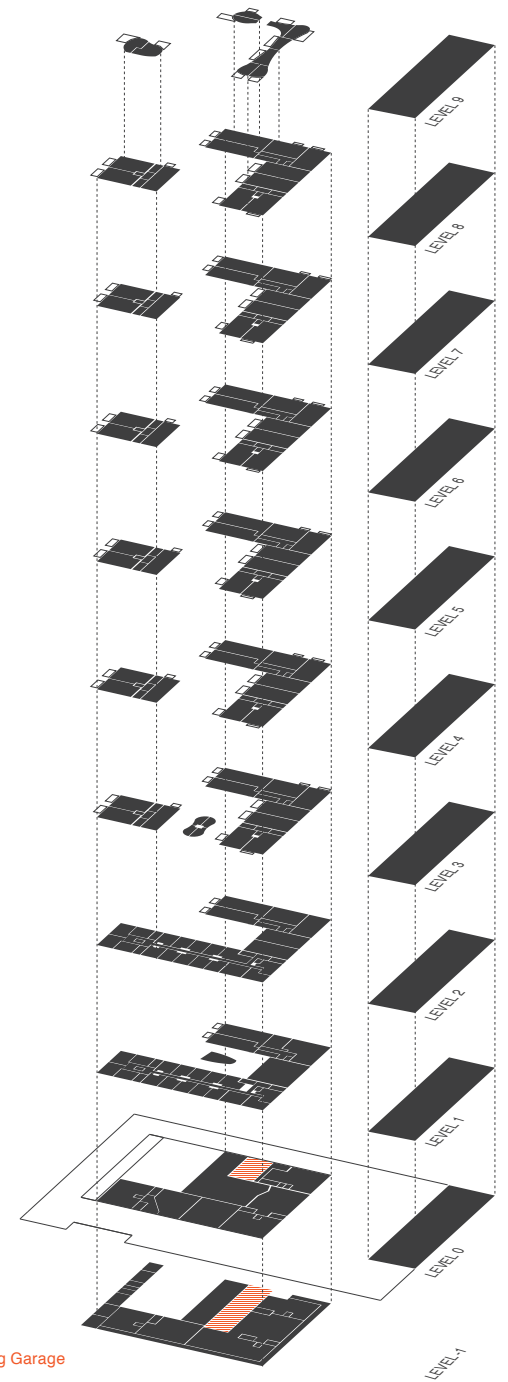

5 Parking Garage

Routes and Access

The route A-C in figure 3 is the busiest path for pedestrians. Most of the public functions are accessed via this route on the ground floor. Some of the public functions exist of two floors, which means that one of the floors is directly accessible from the ground floor, from this floor, the other floor is accessible via stairs. The main entrance for dwellers however is on the route B-D, which is also a busy road, but with cars. There are two other access points for the dwellings on the ground floor, but are used less. The routing of the dwellings exist of stairs and elevators in the halls, which are connected with narrow corridors that lead to the dwellings.

The access points for the dwellings are located inside corridors with very little views to the outside world. As strangers it was very hard to get inside, once we got in, there was nothing to see, except for doors in corridors. In the diagrams it is visible how close the access points are to each other. The organisation of corridors and the doors makes the dwellings very anonymous and makes it hard to have any relation with the neighbours. This is exactly what the users wanted. They are foreigners who do not stay for a long period and they demand a dwelling with high privacy. This also explains why the dwellings are only for rent. The access points on the ground floor are more spread and facing the public space.

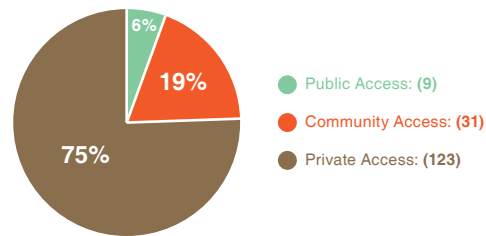

A Public, Community & Private Access: Overall Amounts in the Ensemble

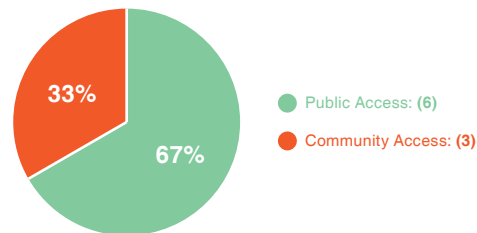

B Public, Community & Private Access: Ground Floor

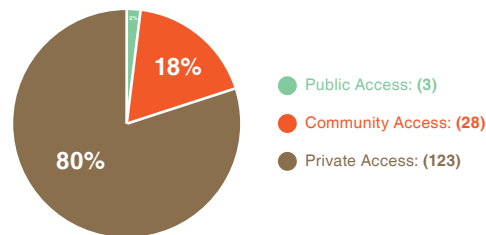

C Public, Community & Private Access: Other Levels

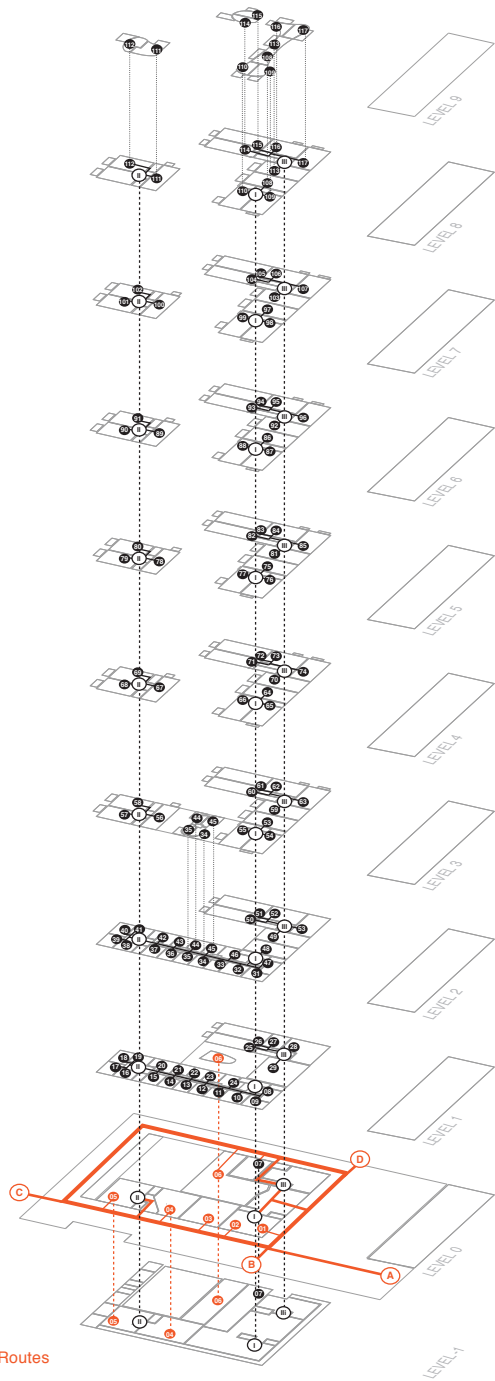

3 Public Routes

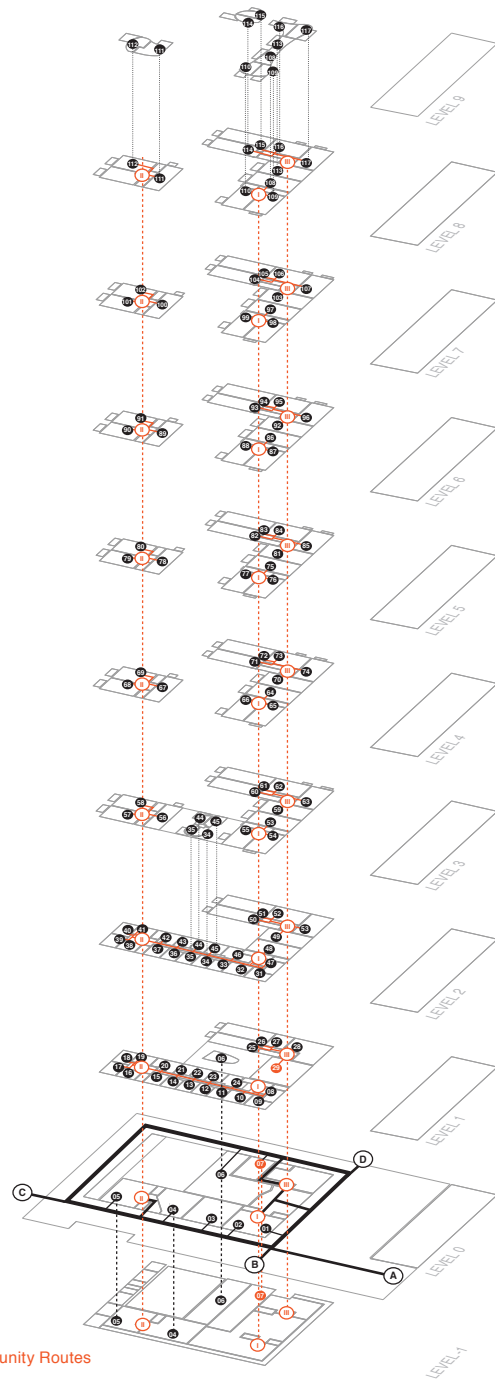

4 Community Routes

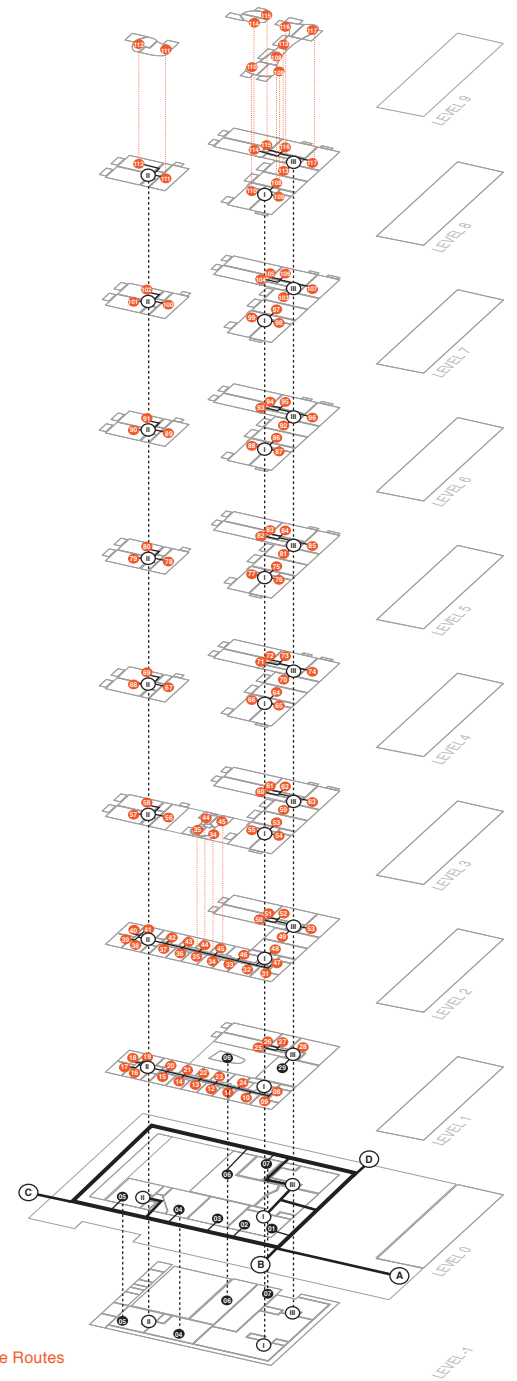

5 Private Routes

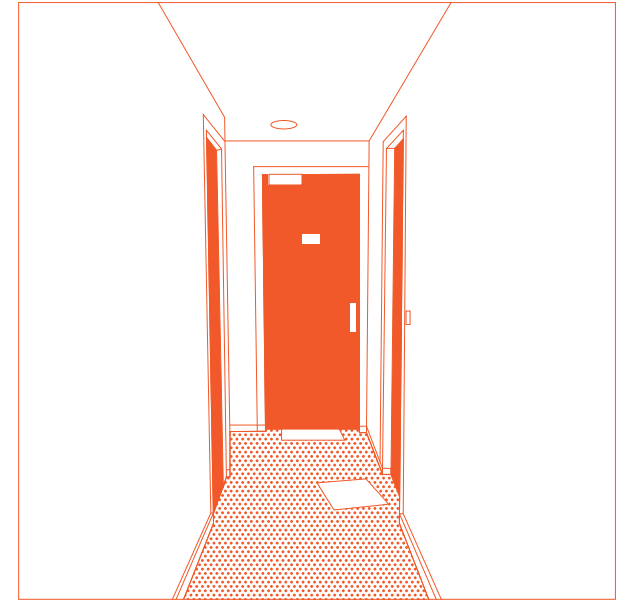

Main entrance to dwellings on Gustav Mahlerlaan

The main entrance is easy to find because of its contrast with the rest of the plinth. It makes no use of the printed colours like the rest, it instead uses normal transparent glass. Also by making this plane of facade two storeys high, it is easy to find. The entrance is symmetrical which makes it formal. The big signs with the house numbers above the sliding doors and the mailboxes mark the entrance even more.

Corridor with access to the dwellings

The corridor with no openings to the outside world is shown. The doors to the dwellings are yellow and the doors to the storages are white. Also the walls and the suspended ceiling are white. The design of the corridor does not give you the feeling that you are in a residential building. There is nothing to be found in the corridors except for a couple of doormats.

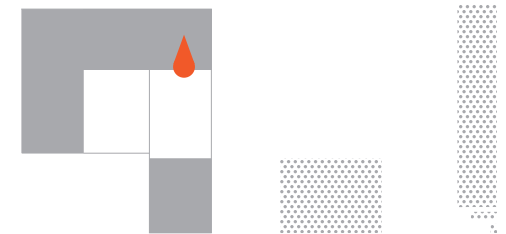
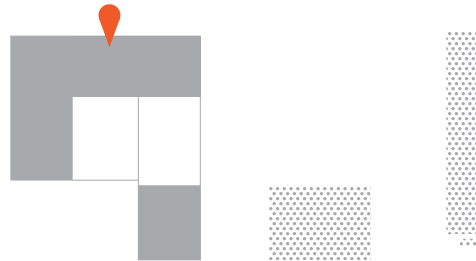

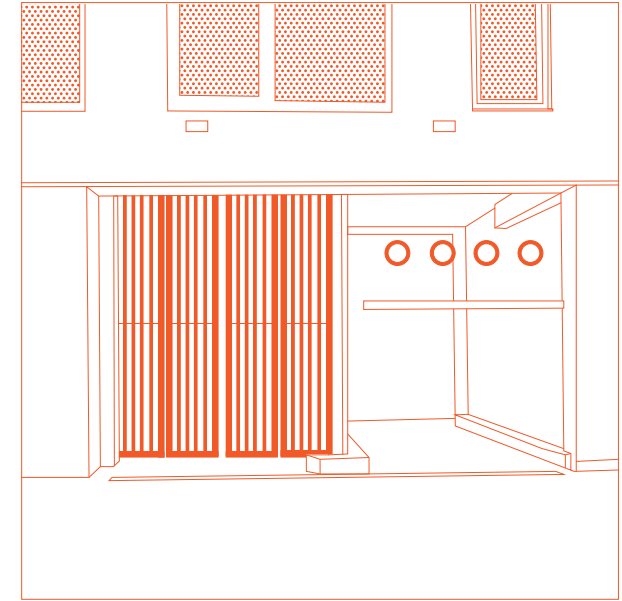
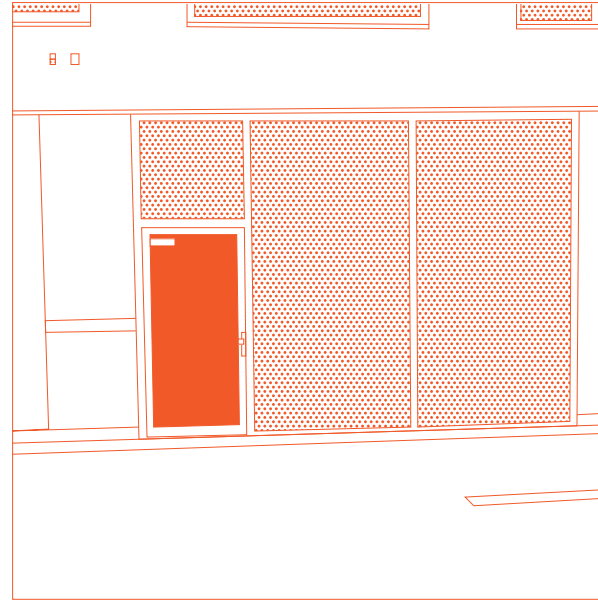
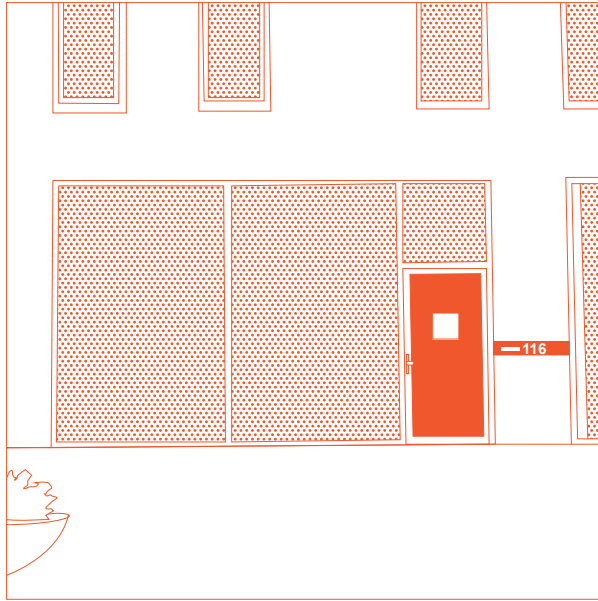

Care taker of the building

The facade design for the location of the care taker is interesting. As it is placed on the ground floor, it uses the big glass openings like the other functions on the ground floor. It is different however, because the black bricks are coming down from the upper levels and go around the glass openings. It is inviting for people from outside and nice to stay inside because of the light and views.

Regular function on the ground floor

In contrast with the design of the care taker's facade, this facade makes no use of the black bricks which is assigned to the dwellings above. It instead uses the printed colours on glass panels, which make it obvious that there are public functions. The big openings show how the atmosphere is inside.

Entrance parking garage

The entrance to the parking garage is obviously different than the rest of the ground floor. It has signs which have been hung on the first floor. It makes use of horizontally sliding doors. The entrance and the exit have their own doors. It is positioned towards the area that has not been built yet. This side functions as the backside.

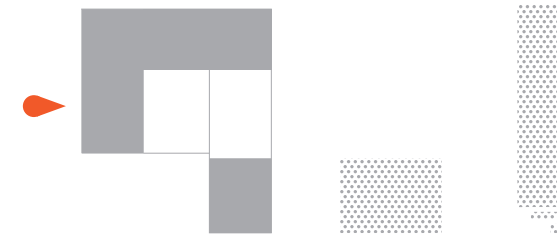
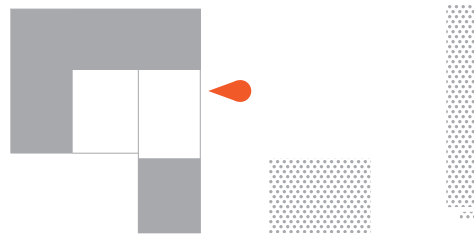
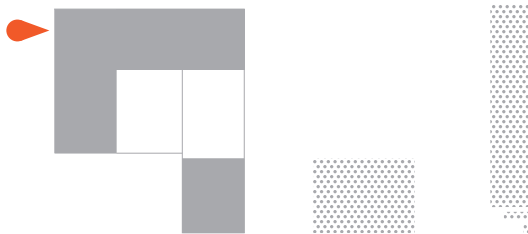

Public, Collective & Private Space

As said earlier, there is no access for strangers to the upper floors, leaving all the public space on the ground floor. The public space on the ground floor is quite large in the whole area. It is used by many pedestrians. The public functions are mainly placed along the public routes.

The building also has no collective space except for the corridors and staircases/elevators. The corridors are closed and anonymous, combined with the materials it is an unpleasant place to be.

The private outdoor spaces are staggered and are facing the south and the east. It looks like the balconies are used well because of the furniture placed inside them. The organization of the balconies seem to improve the interaction between the dwellers. Also on top of the building there are terraces for the penthouses.

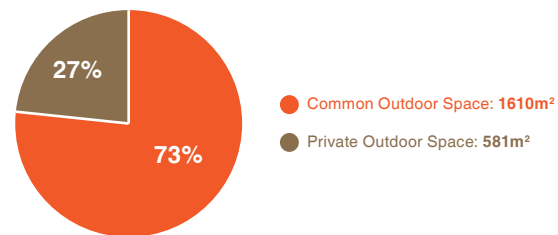

Public, Common & Private Outdoor Space Facilitated in the Project

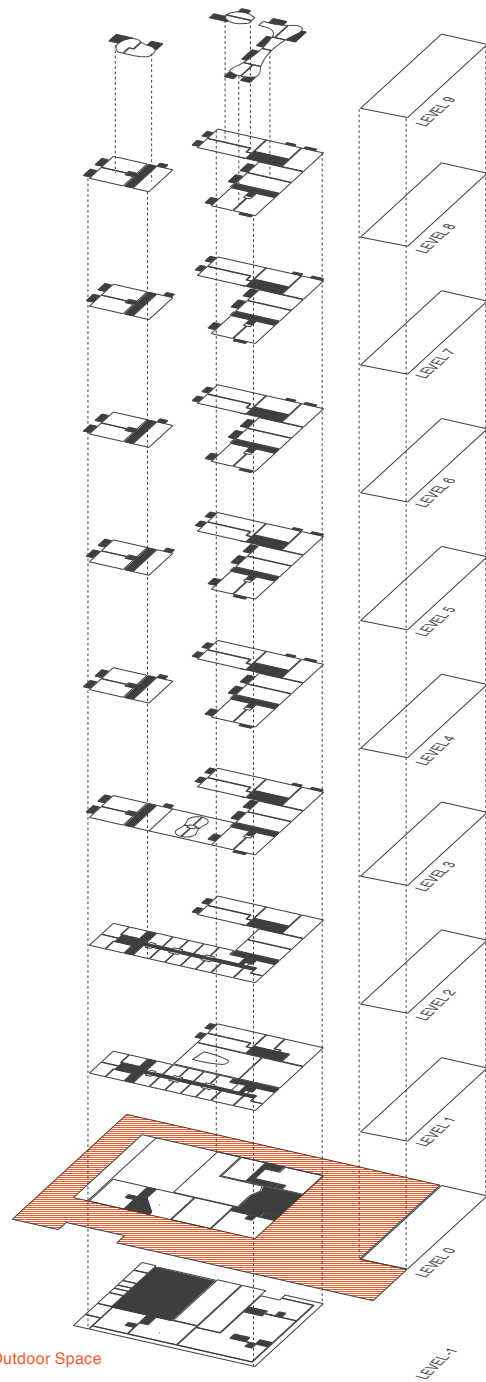

1 Public Outdoor Space

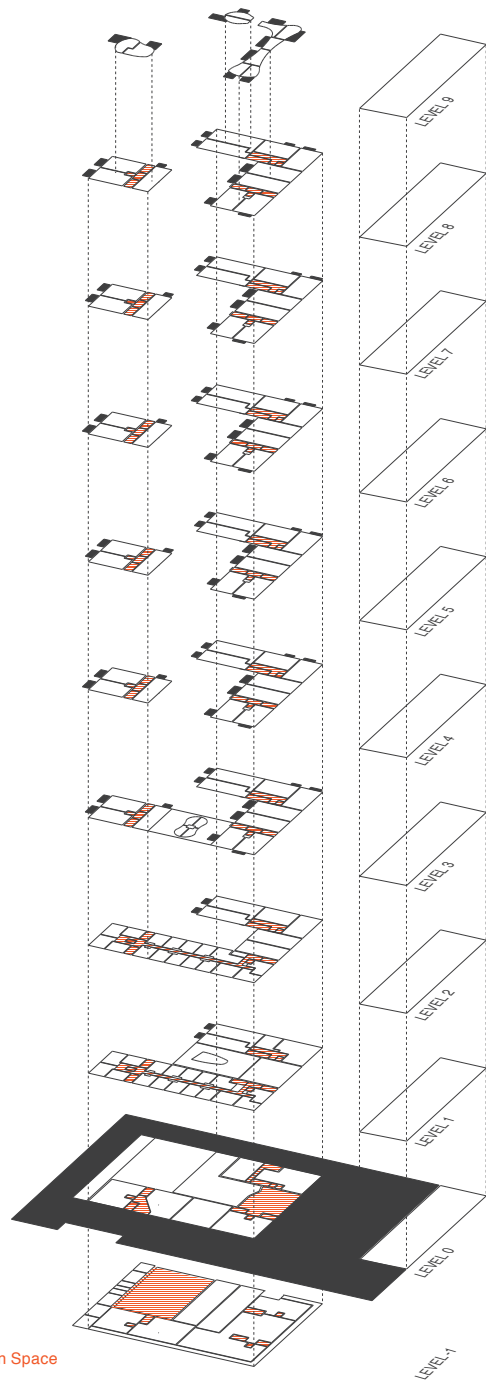

2 Common Space

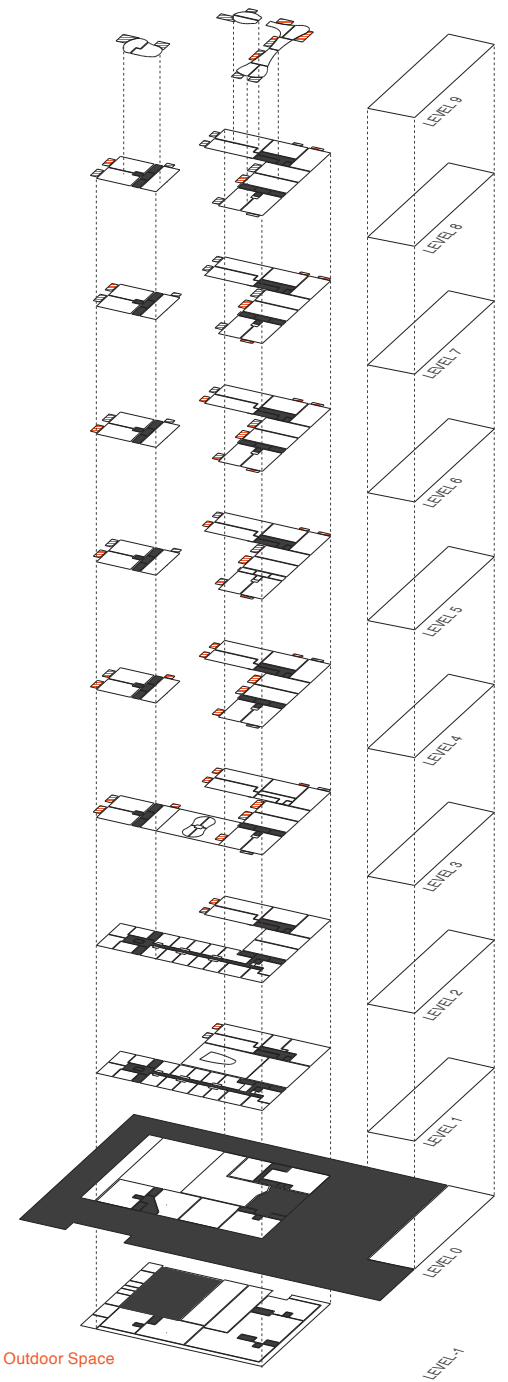

3 Private Outdoor Space

Perspective: Public Space

The footprint of the building with no setbacks or whatsoever marks the boundaries of the public space. However, the terrace of the cafe is an exception which is surrounded with fences. The picture shows the different zones which are strengthened by the poles. There are places made where bikes can be parked in between lampposts.

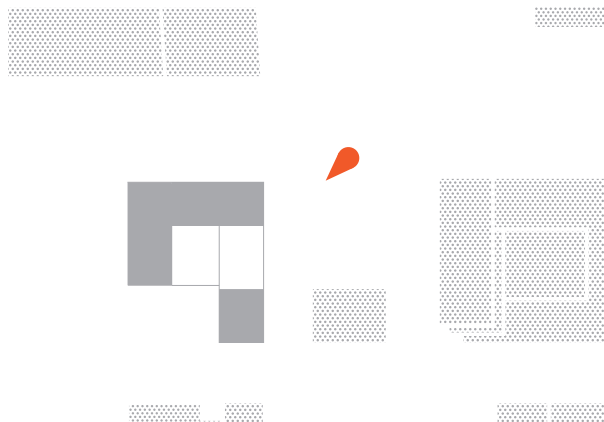

Perspective: Collective Space

A Courtyard is placed in one level below the ground level. As there is no dwelling function on the basement floor, this space is more dedicated to the day care center. Collective space becomes a totally for visual and not for the direct use for residents.

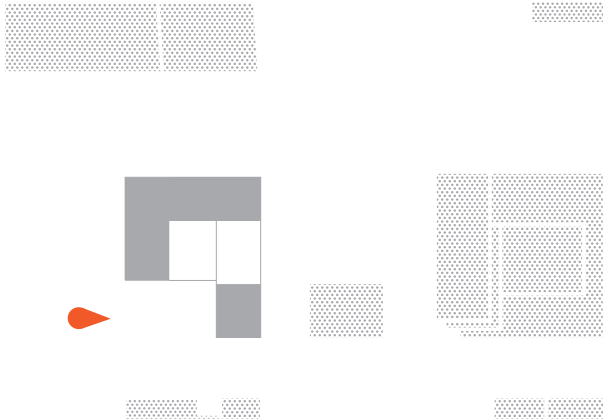
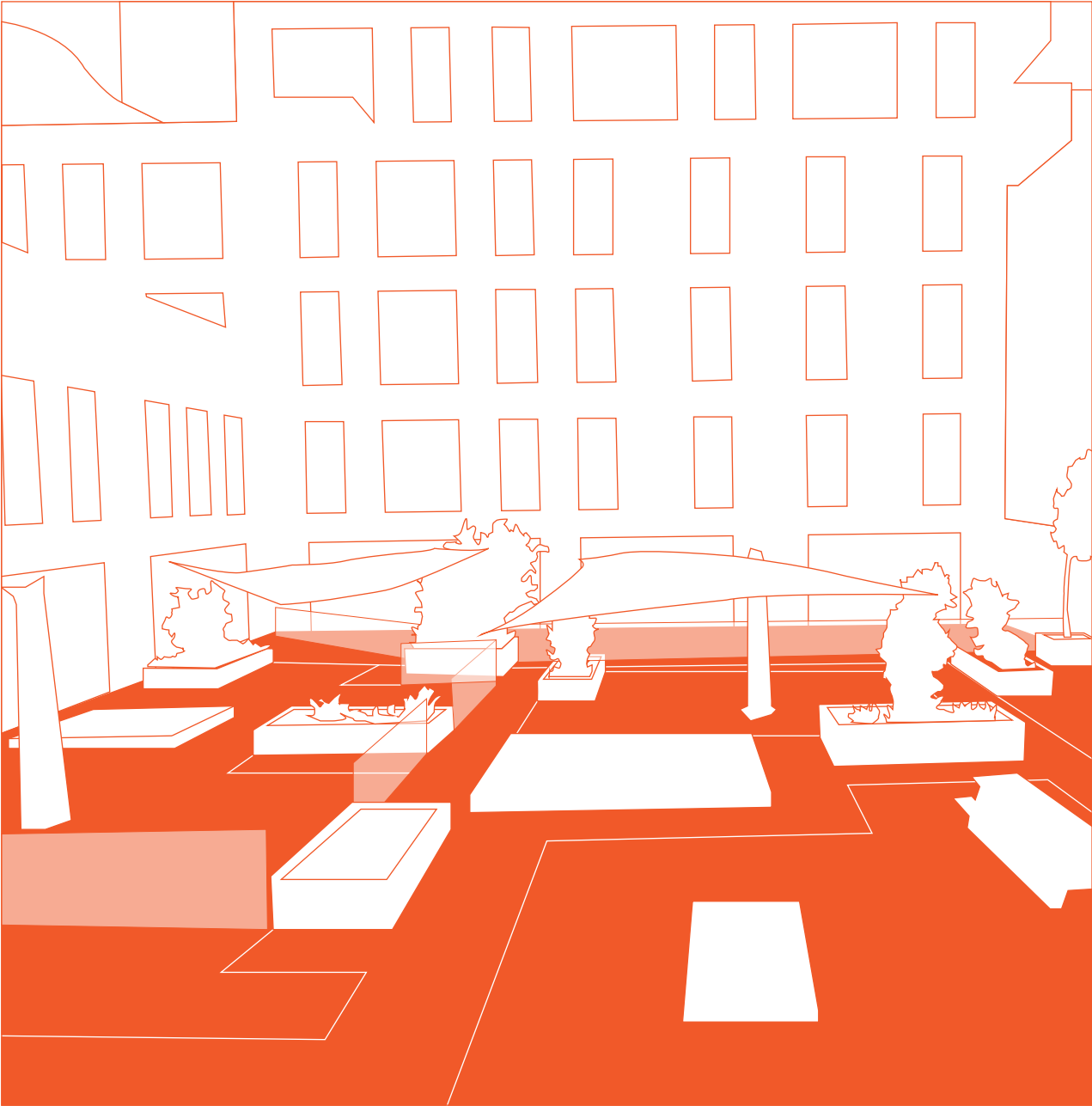

Materials: Public Space

The plinth makes use of glass with printed colors on it to mark closed parts. In contrast with the plinth, the upper floors use black bricks. This has been done to show the difference in function, however the first and second floor are dwellings, yet the architect still decided to materialize it as the public functions.

The materials of the streets are grey and they have been used to create different zones.

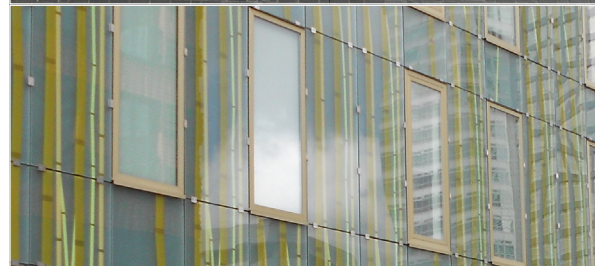



Materials: Collective Space

The materials of the facade of the inside are the same as the outside, the printed colors on glass have been used for the plinth and black bricks have been used for the upper floors. The window profiles of big openings have different colors than the window profiles of small openings

The materials of the child care are totally different than the materials used in the public areas. The tiles are bigger and colored, combined with sand over it, it implies that children are making use of it. Fences of wood combined with artificial turf is used. We also see that boxes have been used to create zones.

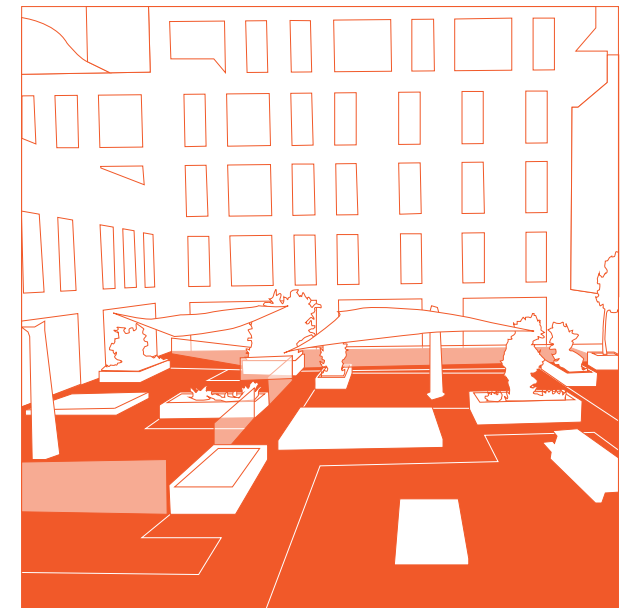

Open Space Scale & Proportions

Section overview

In the sections below we see that the public space is very large, because the scales of the buildings are large. The building is lower than the surrounding buildings, which limits the views of the top levels.

The scale of the community space is much smaller and more enclosed, which increases the relation with the neighbors. The distances allow interaction from one side to another. The inside space is also more fragmented than the public space.

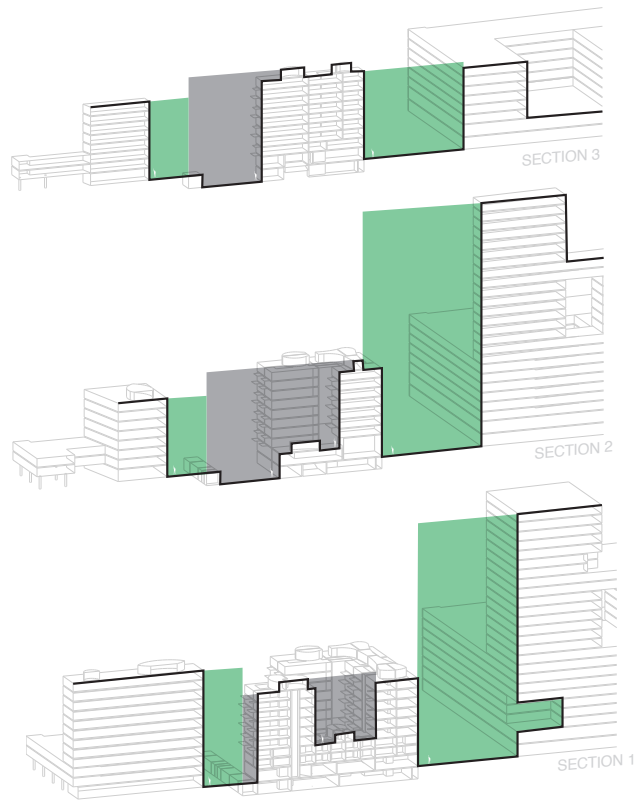

3 Public Space Scale & Shape

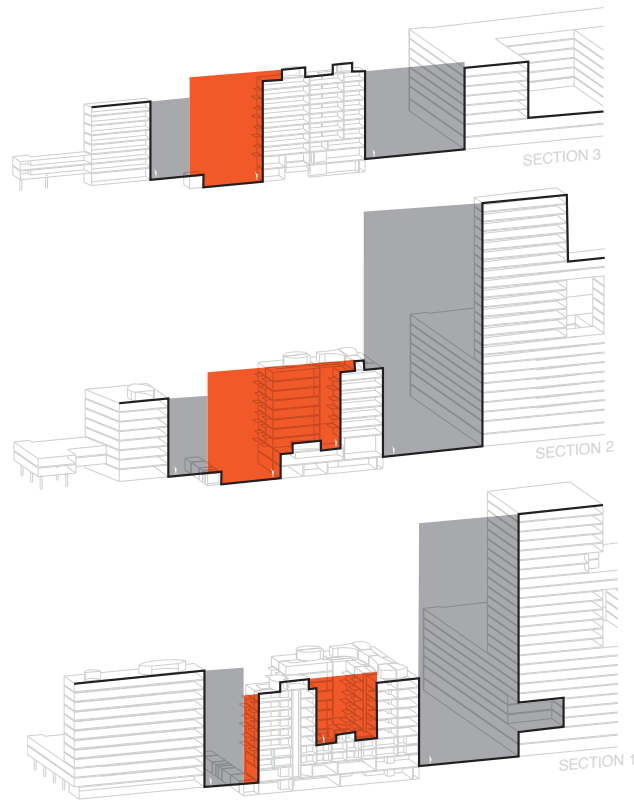

4 Community Space Scale & Shape

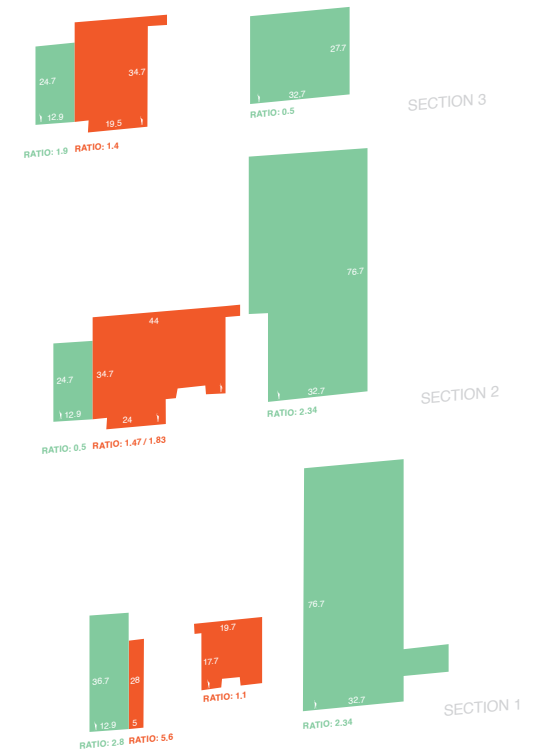

5 Public & Community Space: Scale, Dimensions & Proportions

Scale: Public Space

As said earlier, the public space is very large scale, except for the terrace of the cafe and the lampposts. The public space has no other objects which can relate with the people. The big amount of people passing makes the public space more relatable to the human scale.

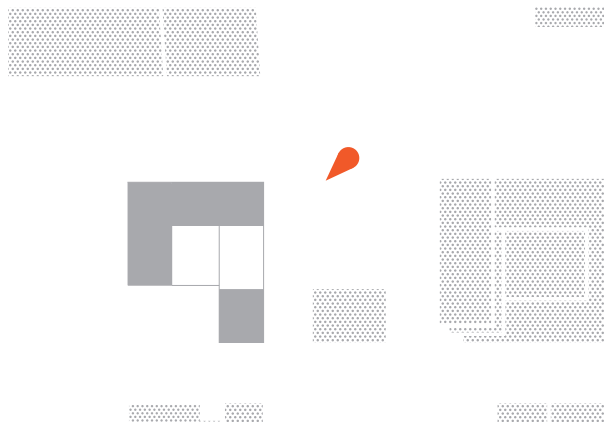

Scale: Collective Space

Various elements are placed and only these elements such as pots, vegetation and shades are in relation to the human scale. The higher part of the building becomes much higher than the public street because it is sunken.

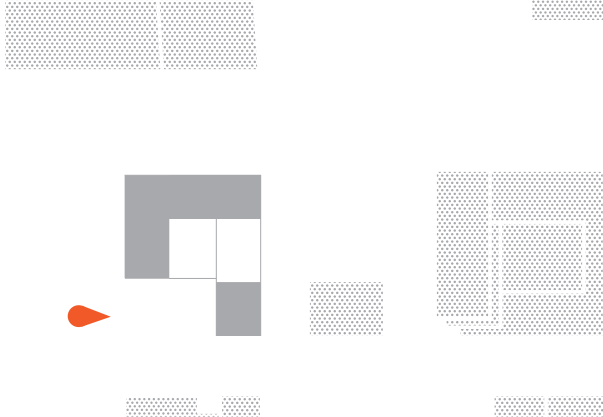

Visual Connections

Most of the dwellings are located along the corridors, this has resulted in dwellings with very different views to the outside world. Basically, one has a view over the public space and the other has a view over the collective space. The larger dwellings have views over both the public space and the collective space.

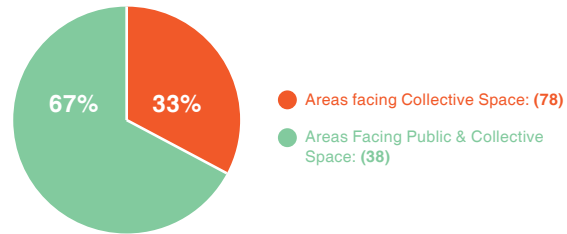

A Visual Connections: Private Living Areas

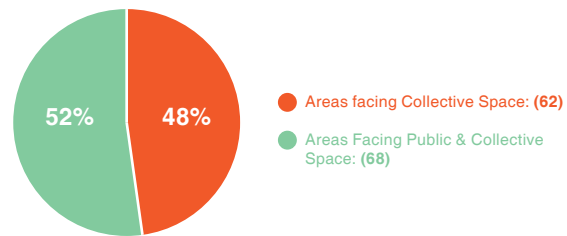

B Visual Connections: Living Room & Kitchen Areas

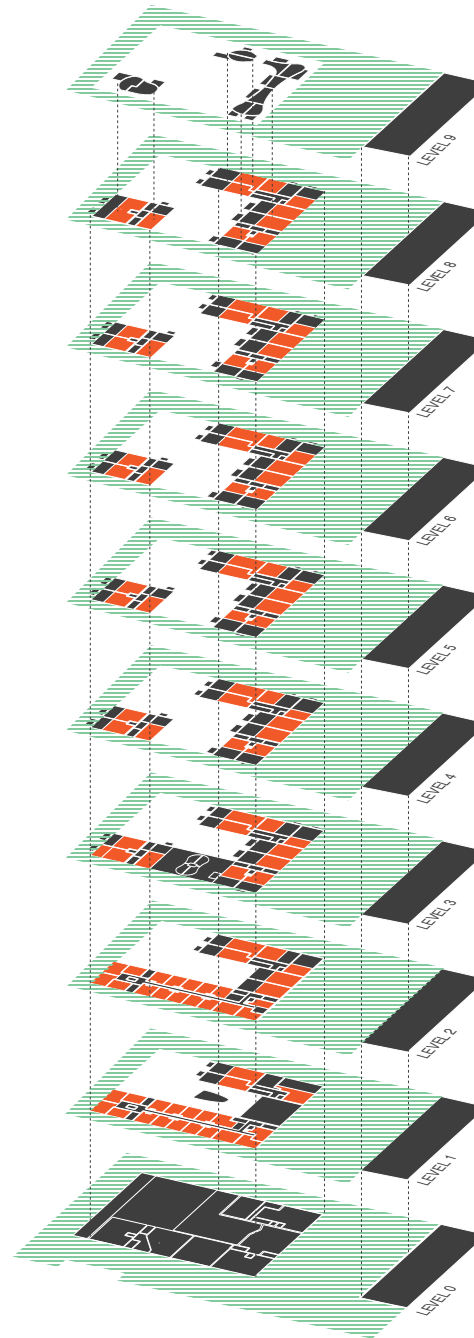

1 Private Living Areas & Public Space

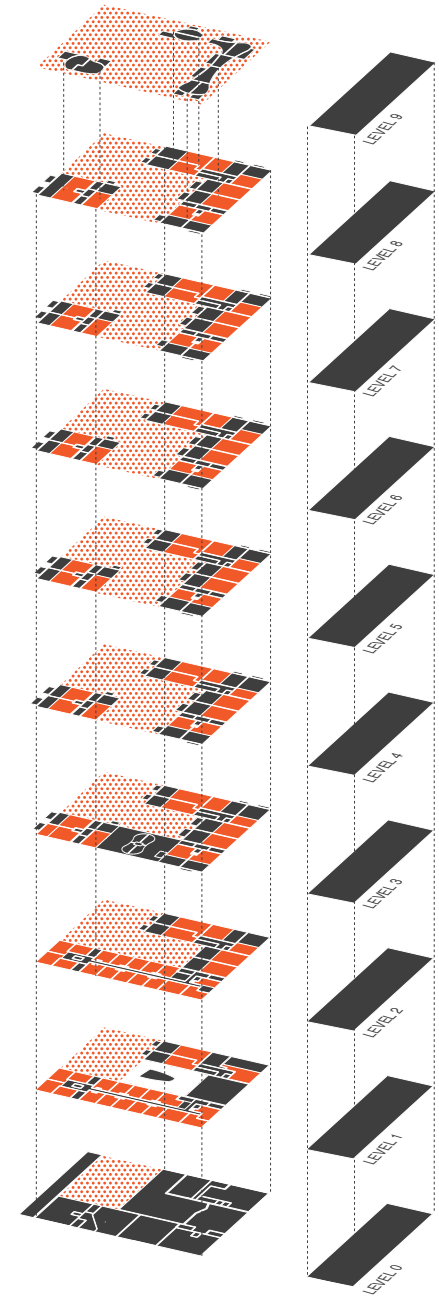

2 Private Living Areas & Community Space

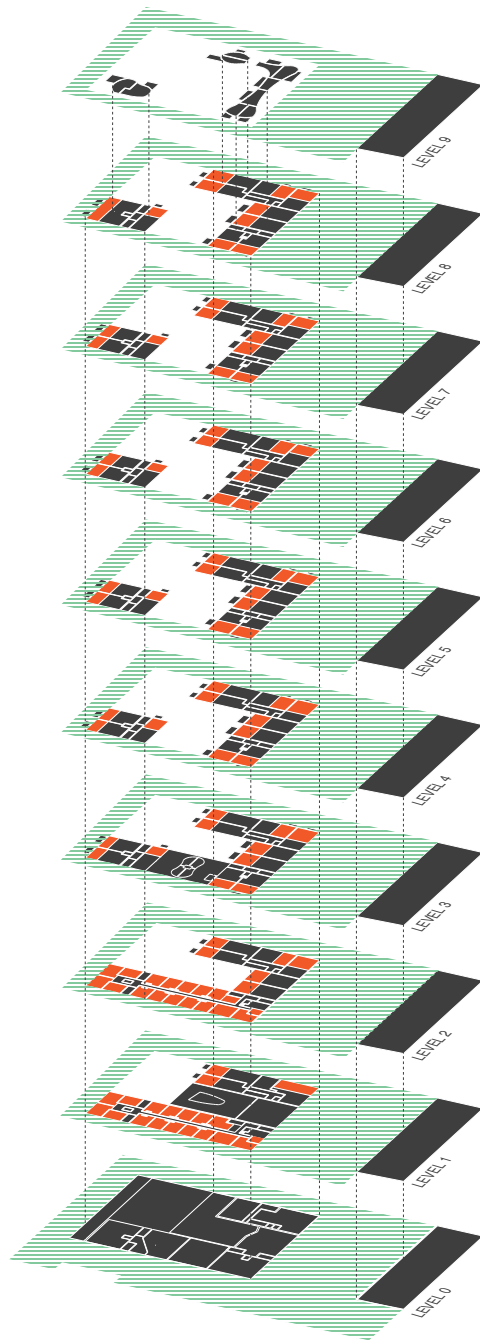

3 Living Room & Kitchen & Public Space

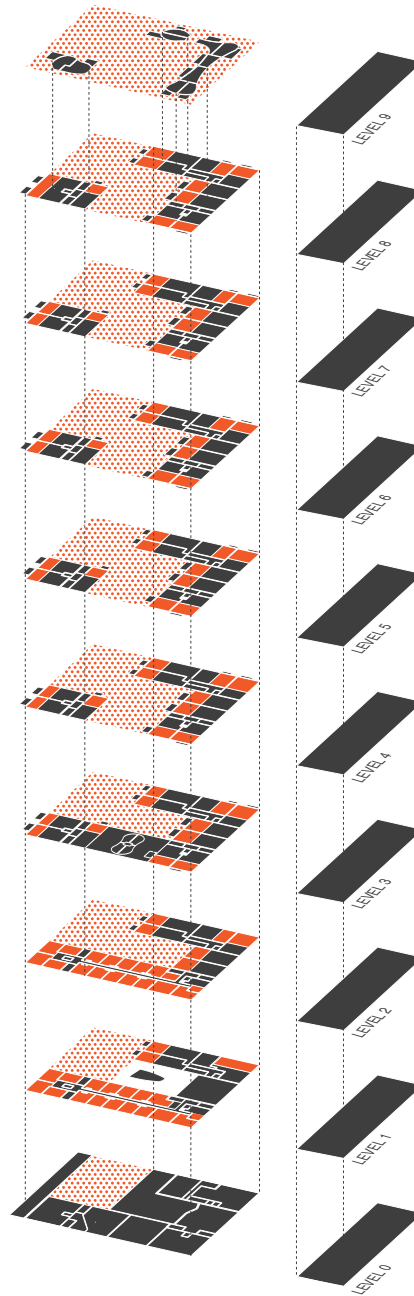

4 Living Room & Kitchen & Community Space

Section Overview

Because of the fact that the building is not a regular closed block, the views are rather interesting. From the same window, some of the users can both see the collective space and the public space as shown in the section overview.

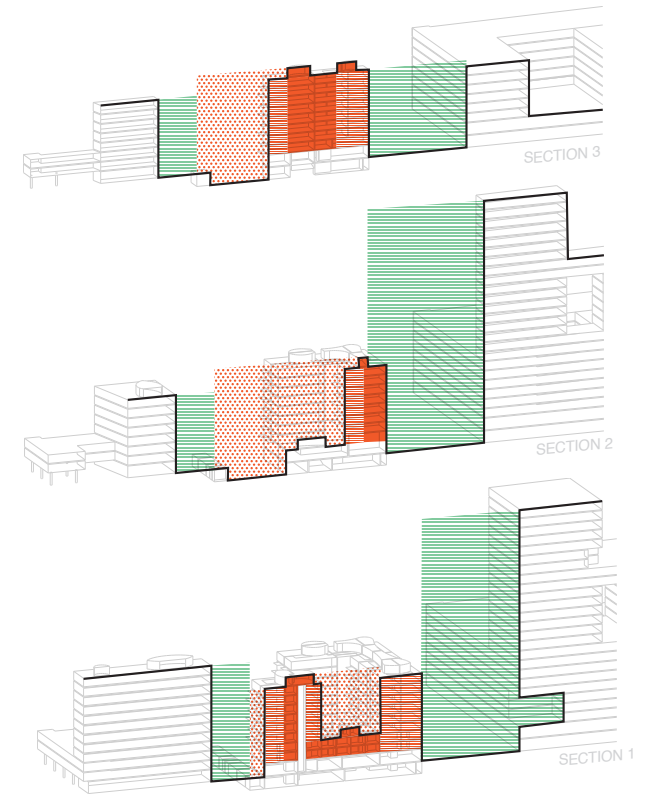

5 Visual Connections: Private Living Areas, Living Room & Kitchen Areas

Visual Connections: Public Space

In the drawing we can clearly see that the building has three zones with different windows. The ground floor with the public spaces has large glass areas which allows interaction between the inside and the outside. The windows are aligned with the windows of the first and second floor, yet these windows are much smaller and makes it hard to see what is happening inside. The windows of the upper floors are a mix of bigger and smaller windows. The big windows make the interiors nice and bright. These windows are staggered and are not aligned with the windows of the lower floors, which indicate a different function. The functions of the upper floors and the first and second floor are actually both dwellings, yet they have different windows. The reason behind this could be that the dwellings of the first and second floor are mostly studios (1 room).

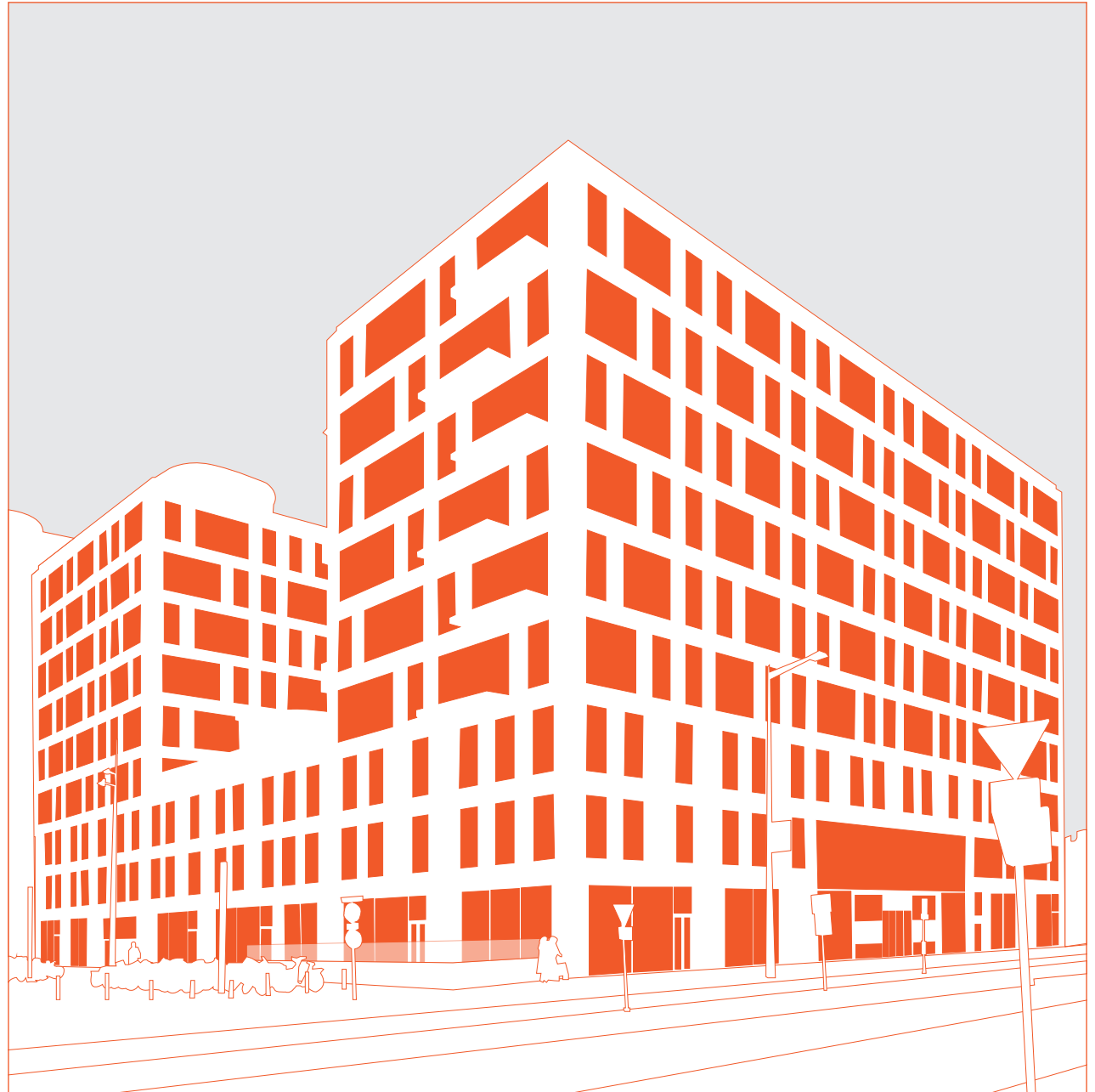
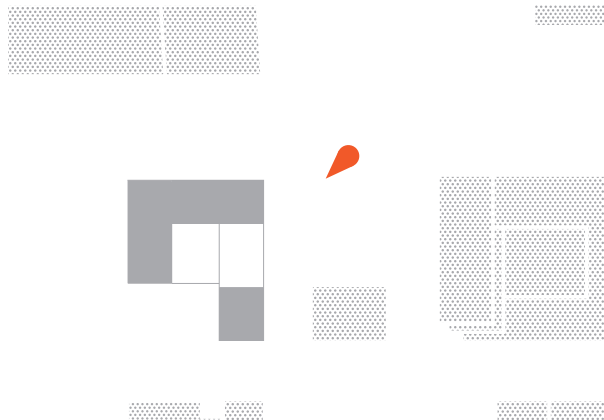

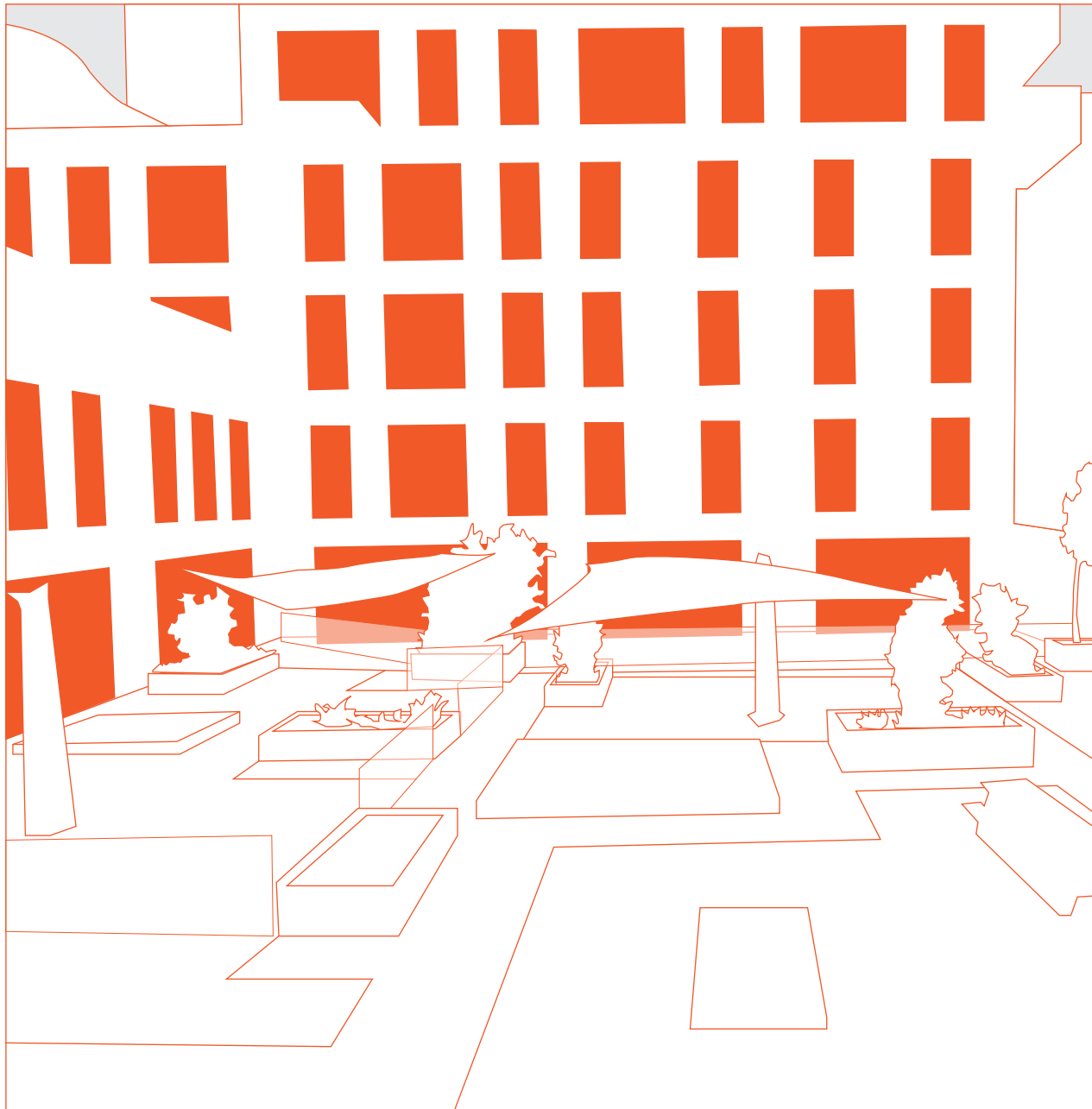

Visual Connections: Collective Space

Similar manner; using windows with a difference in width was done in collective space. The larger opening is made on the lowest level allowing wider view towards the courtyard. The privacy was in priority than the relation between the individual dwelling.

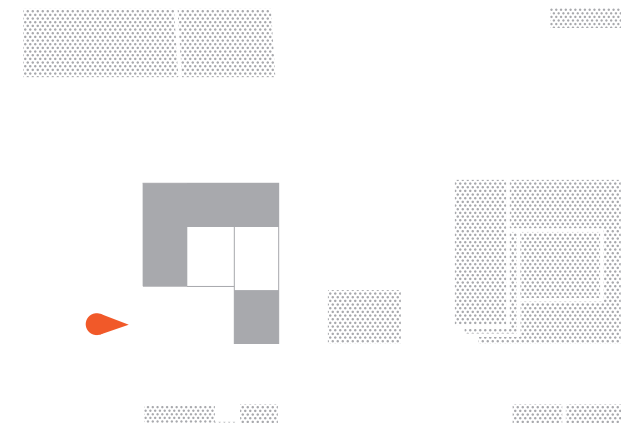

Performance Assessment

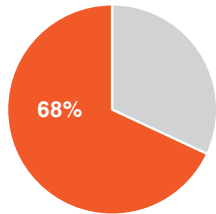

● Average Satisfaction

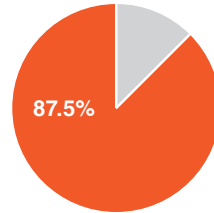

1 How satisfied are you with the location of the building where you live, in the context of the city?

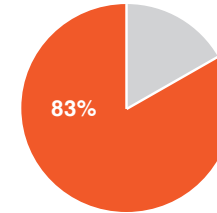

3 How satisfied are you with the public facilities provided in the area in the vicinity of the building where you live?

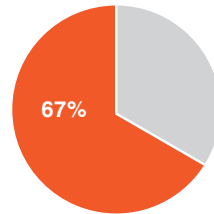

2 How satisfied are you with the public facilities provided in the building where you live?

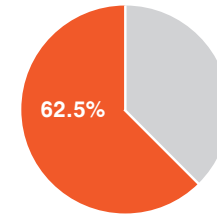

4 How satisfied are you with the level of disturbances (such as noise, intrusions) coming from the public space surrounding the building you live in?

The assessment results are based on the level of respondent's satisfaction in accordance to their answers:

Very Dissatisfied: 0%
Dissatisfied: 25%
Neutral: 50%
Satisfied: 75%
Very Satisfied: 100%

Based on the number of responses and satisfaction level of each respondent, an average satisfaction level has been calculated for each question.

Relation with Public Space Performance

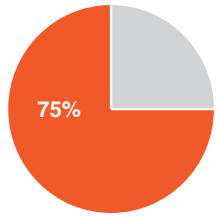

① How satisfied are you with the interactions with your neighbours?

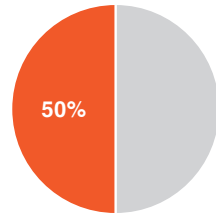

① How satisfied are you with the quality and amount of private outdoor spaces (such as terraces, balconies) provided in the building you live in?

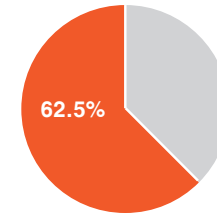

① How satisfied are you with the view from your apartment?

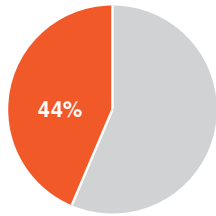

② How satisfied are you with the amount and quality of common spaces provided in the building you live in?

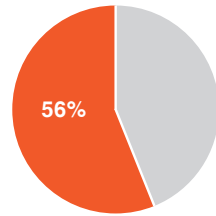

② How satisfied are you with the view from your private outdoor space?

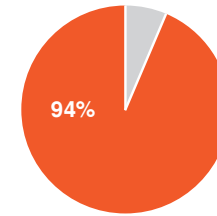

② How satisfied are you with the level of disturbances (such as noise, intrusions) coming from the spaces surrounding your house or apartment?

Collective Space Performance

Private Space Performance

Private Interior Space Performance

Case Comparison

Case Comparison



1 Zuidpoort, Delft



2 Monnikhof, Groningen

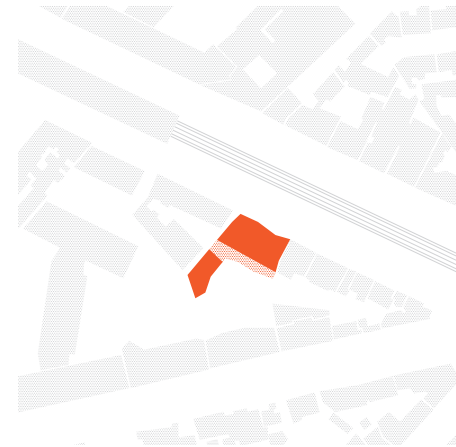

3 35 Logements, Paris



4 Django Building, Amsterdam

The following chapter will serve to correlate the collected data on spatial properties of dwelling buildings and ensembles exposed to spaces of movement. The cross-referenced data will establish a base for conclusions and recommendations for design task at Van Der Kunbuurt.

The cases will be compared per theme analysed in the *Case Study* chapters:

- 1 Programme
- 2 Routes & Access
- 3 Public, Collective & Private Space
- 4 Materials
- 5 Scale & Proportions
- 6 Visual Connections

The correlation of data aims to reveal the prevailing tendencies in dwelling complexes exposed to spaces of movement, but also to confront and assess the performance of facilitated solutions:

Programme

- Function mix and relative areas per function
- Spatial distribution of programme
- Functional & spatial implications

Routes & Access

- Distribution of public, collective & private routes
- Distribution of Access points per user group
- Functional & spatial implications

Public, Collective & Private Space

- Distribution of outdoor space per user group (including indoor collective spaces)
- Functional & spatial implications

Materials

- Functionality of materials in public & collective spaces
- Expression of materials in public & collective spaces

Scale & Proportions

- Shape, size and ratio of public & collective spaces
- Spatial diversity
- Functional & expression implications

Visual Connections

- Distribution of living rooms and private rooms in relation to public & collective spaces
- Functional & spatial implications

Programme

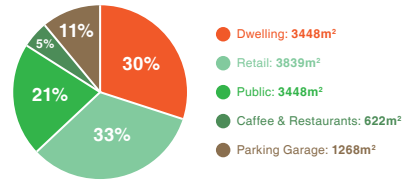

1 Zuidpoort Programme: All Levels

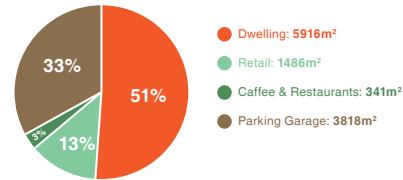

2 Monnikhof Programme: All Levels

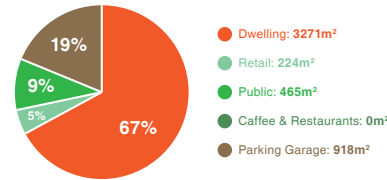

3 35 Logements Programme: All Levels

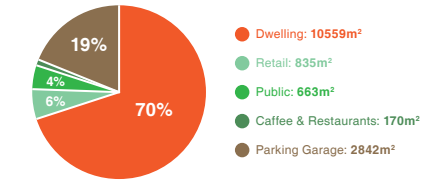

4 Django Building Programme: All Levels

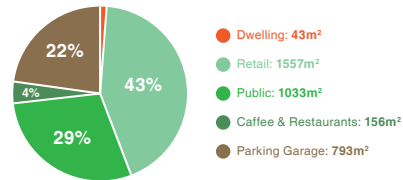

5 Zuidpoort Programme: Gound Level

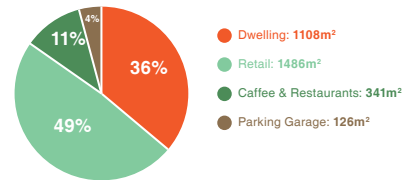

6 Monnikhof Programme: Gound Level

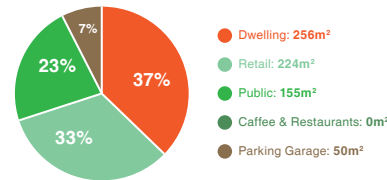

7 35 Logements Programme: Gound Level

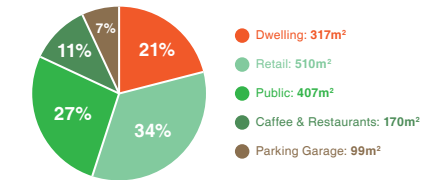

8 Django Building Programme: Gound Level

Function Mix

Overall amount of programme other than dwelling is significant in every analysed case, ranging from quite surprising 70% (!) in case of Zuidpoort to 30% of overall programme included in Django Building (fig. 1-4).

The additional function mix consists of:

- Retail programme (all analysed cases, from 33% to 5% of overall project area)
- Public programme (three of four analysed cases, from 21% to 4% of overall project area)
- Food consumption programme (three of four analysed cases, from 5% to 1% of overall project area)
- Parking (all analysed cases, from 33% to 11% of overall project area)

Programme Distribution

One of the most commonly observed features of the analysed projects is the superposed segregation of programme. In every analysed case, whenever a facade is facing spaces of movement, the ground floor programme is almost exclusively dedicated to retail and public functions (fig. 5-8, 13-16).

Dwelling Programme

The majority of dwelling programme is invariably situated on the upper levels of analysed cases, disconnected from the ground level (fig. 9-12). In case of Monnikhof numerous dwellings have access from the ground level, however only from on the sides of the ensemble, which are not in contact with space of movement, but with low traffic density space or limited accessibility for public users (fig. 10).

Retail Programme

Ground level in all cases is mostly dedicated to retail functions (fig. 13-16). In case of Zuidpoort and Monnikhof, the functions provided are

large, impersonal shops, such as supermarkets and department stores, enhancing the level of necessary activities on analysed sites. In 35 Logements and Django Building, the programme provided is more local, however also there it is not personally related to the inhabitants, resulting in a relatively low level of satisfaction of inhabitants with the public facilities provided in the projects.

Public Programme

Relatively a lot of commercial and public service functions is included in all cases except for Monnikhof. In Zuidpoort: a cinema and a post office; both in 35 Logements and Django Building - a nursery.

Restaurants & Cafeterias

Quite surprisingly there is not a lot of consumption-related programme in neither of analysed cases. If provided, the cafeterias and bars are quite generic and impersonal, which may be related to their perceivable lack of success or popularity.

Parking Garages

All analysed cases facilitate underground parking spaces. In case of Zuidpoort and Monnikhof, the garage is accessible for public users. In 35 Logements and Django Building, the garage serves only the inhabitants. The location of parking spaces underground releases the ground floor facade for other, more representative functions

Functional & Spatial Implications

A clear separation between publicly accessible facilities and dwelling programme prevents intermingling of user groups. Thus dwelling areas in all analysed cases function as independent units, despite their location within the spaces of movement, preventing the collision between contradictory interests and characters of space.

The spatial character of spaces for dwelling is preserved, while the ground level gains a quality of public domain due to retail and public functions distributed there.

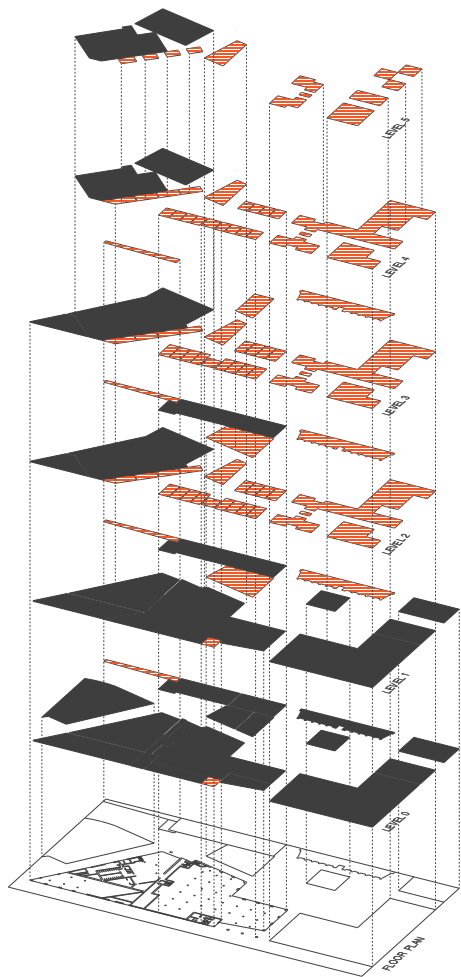

9 Zuidpoort: Dwelling Programme Distribution

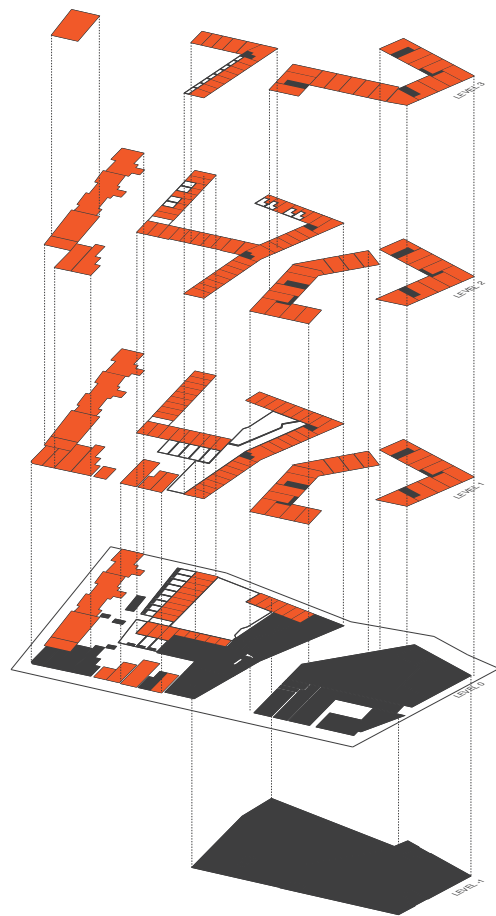

10 Monnikhof: Dwelling Programme Distribution

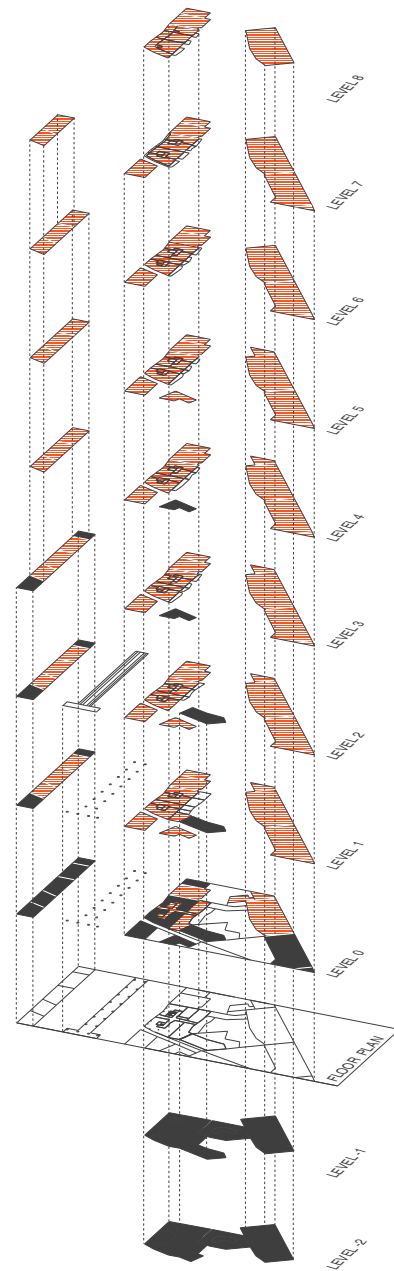

11 35 Logements: Dwelling Programme Distribution

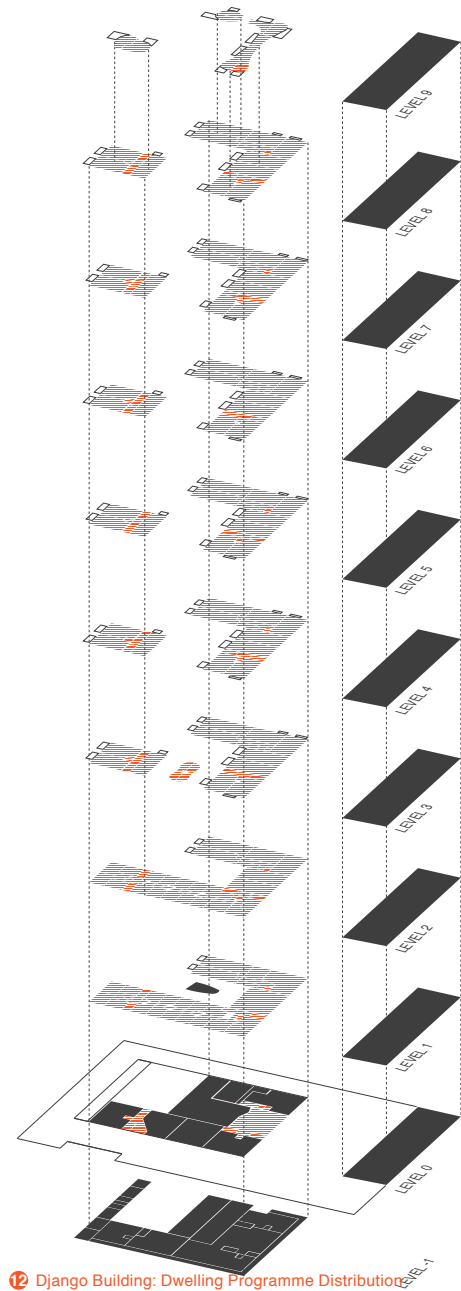

12 Django Building: Dwelling Programme Distribution

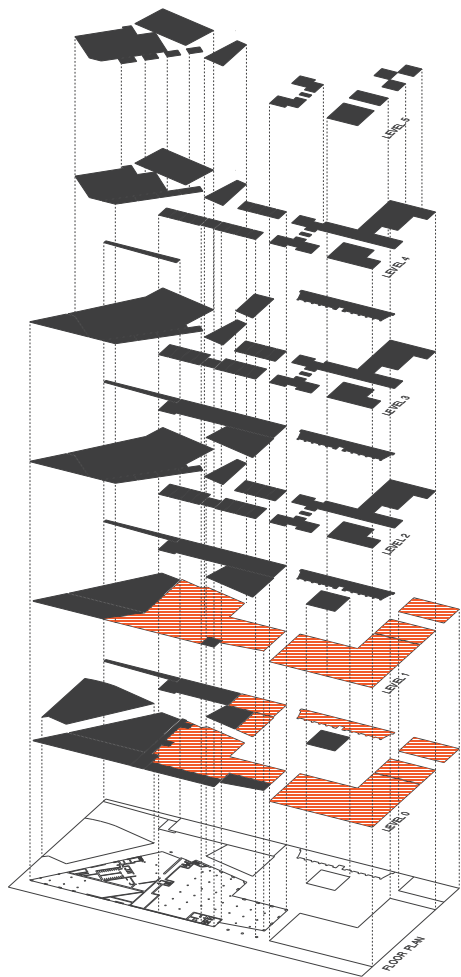

13 Zuidpoort: Retail Programme Distribution

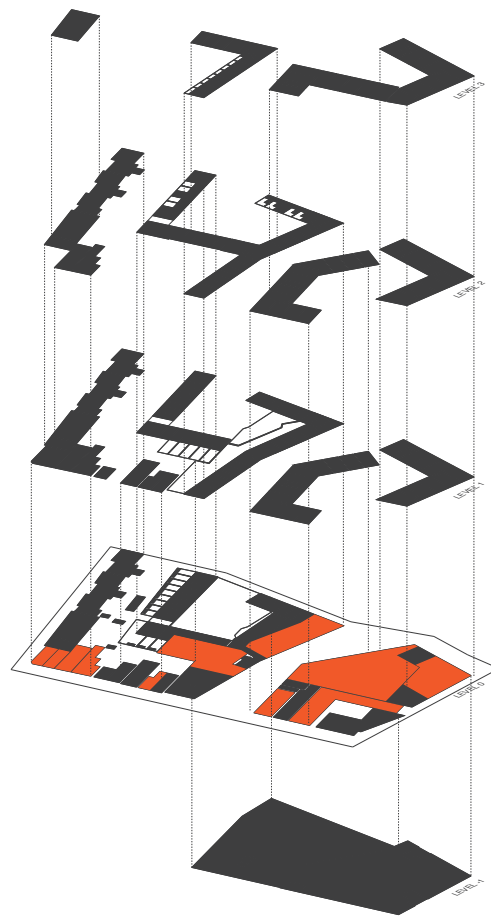

14 Monnikhof: Retail Programme Distribution

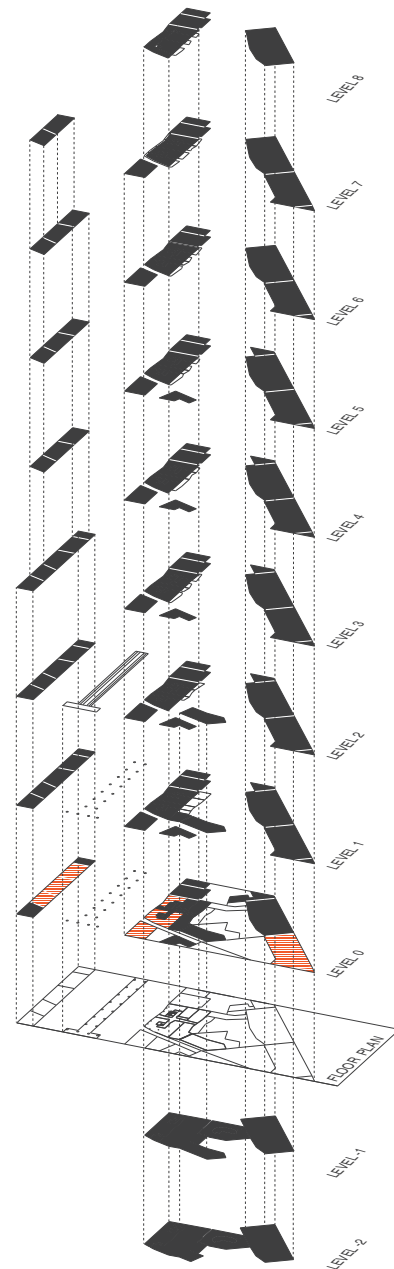

15 35 Logements: Retail Programme Distribution

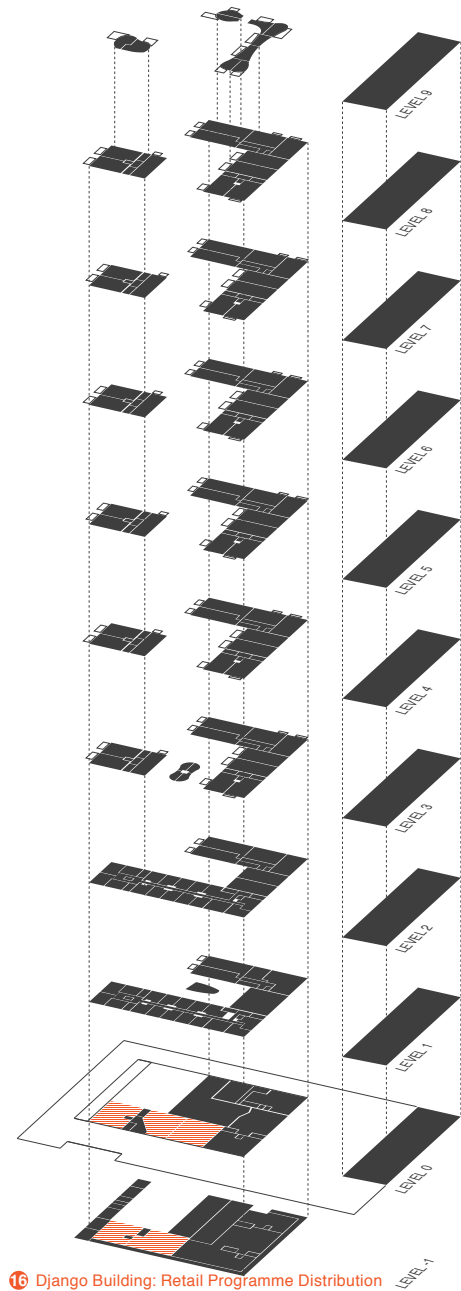

16 Django Building: Retail Programme Distribution

Routes & Access

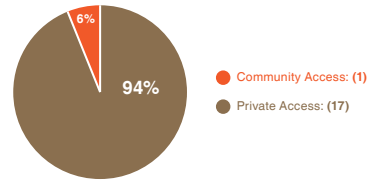

1 Zuidpoort Access: Excluding Ground Level

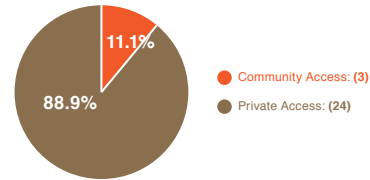

2 Monnikhof Access: Excluding Ground Level

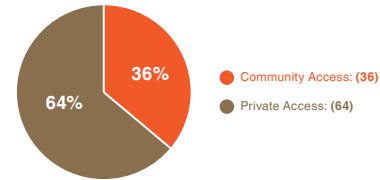

3 35 Logements Access: Excluding Ground Level

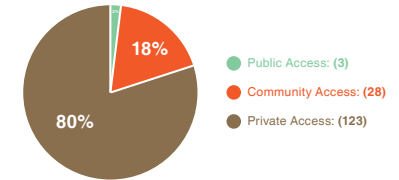

4 Django Building Access: Excluding Ground Level

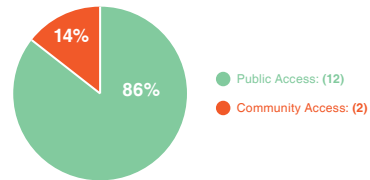

5 Zuidpoort Ground Level Access

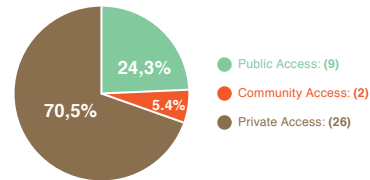

6 Monnikhof Ground Level Access

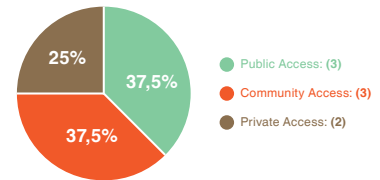

7 35 Logements Ground Level Access

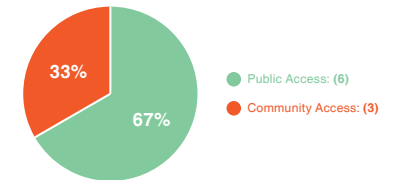

8 Django Building Ground Level Access

Distribution of Routing System

In three of four analysed cases public, collective and private routes are segregated: not interfering, nor overlapping with one another. In Monnikhof however, routing system is very diversified, due to a comparatively complex situation of the project (fig. 9-16).

Public Routes

In case of Zuidpoort and Django Building the public routes located in spaces of movement encompass the projects. Projects at Grenelle and Monnikhof are facing the spaces of movement with only one facade.

Collective Routes

In Case of Zuidpoort and Monnikhof the collective routes are situated mostly in the outdoor space. Interior collective routes play only an auxiliary role. Collective routes in 35 Logements and Django Building are located in the buildings' interior facilitating system of staircase and corridor access with hardly any relation with exterior.

A common characteristic of collective routes in all analysed cases is high degree of spatial disconnection from the public routes. (fig. 13-16)

Private Routes

With an exception of Monnikhof, private routes are limited to the interior of private dwelling and sometimes roof terraces. Monnikhof is the only case in which architects have managed to provide a large outdoor private space to some of the dwellings, which contributes to diversification of private routing in this project (fig. 18).

Access Points Distribution

Accordingly to distribution of the routing system, the access points for respective groups of users are segregated: All public access points are situated on the ground floor (fig. 9-12). Access to collective routes is scarce. Private access is provided mostly on the upper levels of all analysed cases, in great majority - directly from the collective routes (fig. 17-20).

Public Access

Frequency of distribution of public access points along the route is in close relation with exposure to spaces of movement, which is clearly visible in all analysed cases (fig. 9-12). Invariably public access is only provided on the ground floor, and the highest access point frequency occurs along the most busy sections of public routes.

Collective Access

The access to collective routing is invariably very restrictive, when approaching from the public spaces dominated by necessary

activities. In all analysed cases these access points have an official and uninvitive expression, with an intercome signalling change of domain.

Whenever a collective space is approached from a less busy area (such as an access via bridge from an adjacent collective area of gemini building at Zuidpoort, or a scarcely attended public space located south of Monnikhof ensemble) the access is far less restrictive, or even invitive.

Private Access

Monnikhof is the only analysed project in which access to part of the dwellings is provided directly from public space, which was apparently possible due to some of the surrounding public spaces not displaying characteristics of spaces of movement. Other than that in all other three cases private access is strictly connected only to collective routes - outdoor and interior.

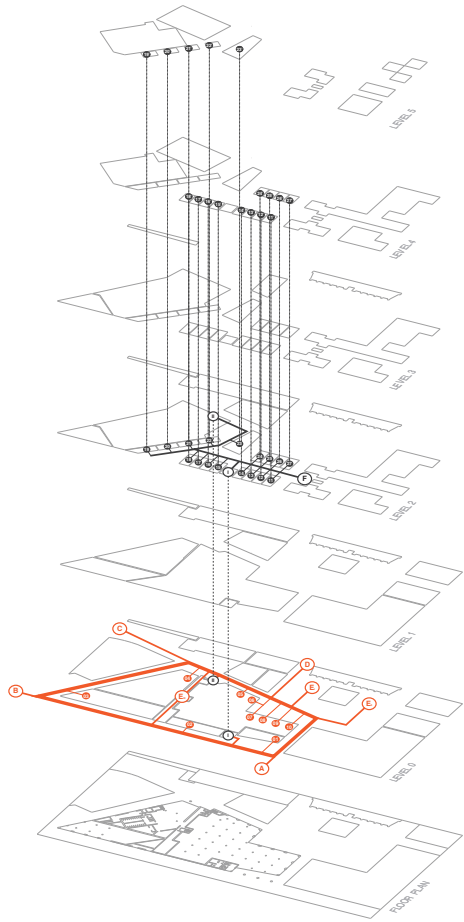

9 Public Route: Zuidpoort

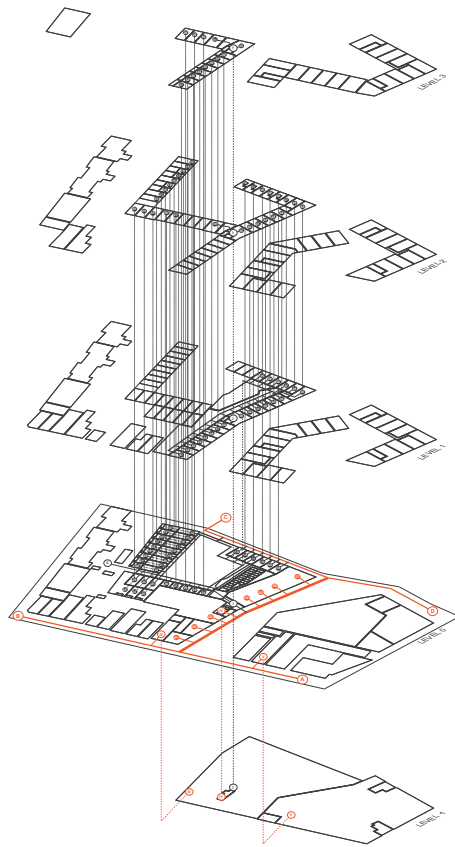

10 Public Route: Monnikhof

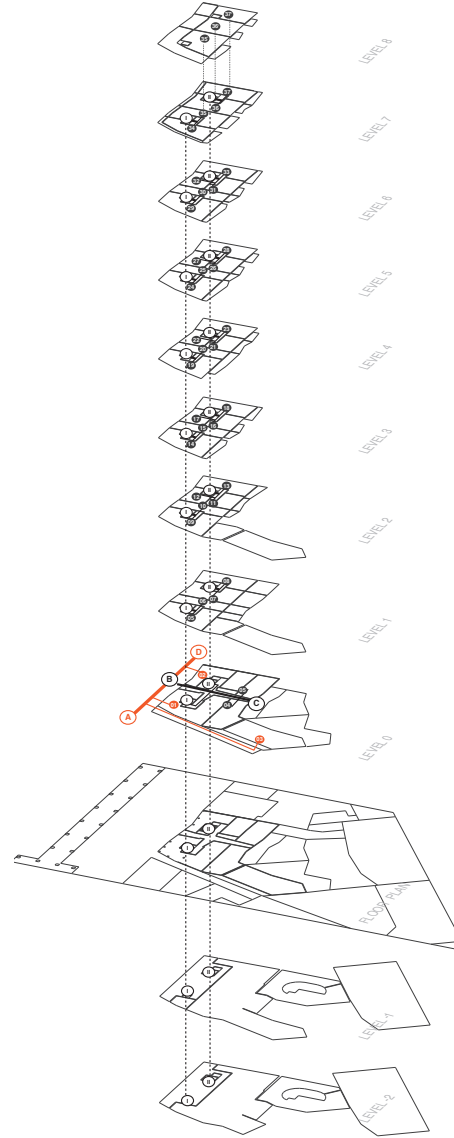

11 Public Route: 35 Logements

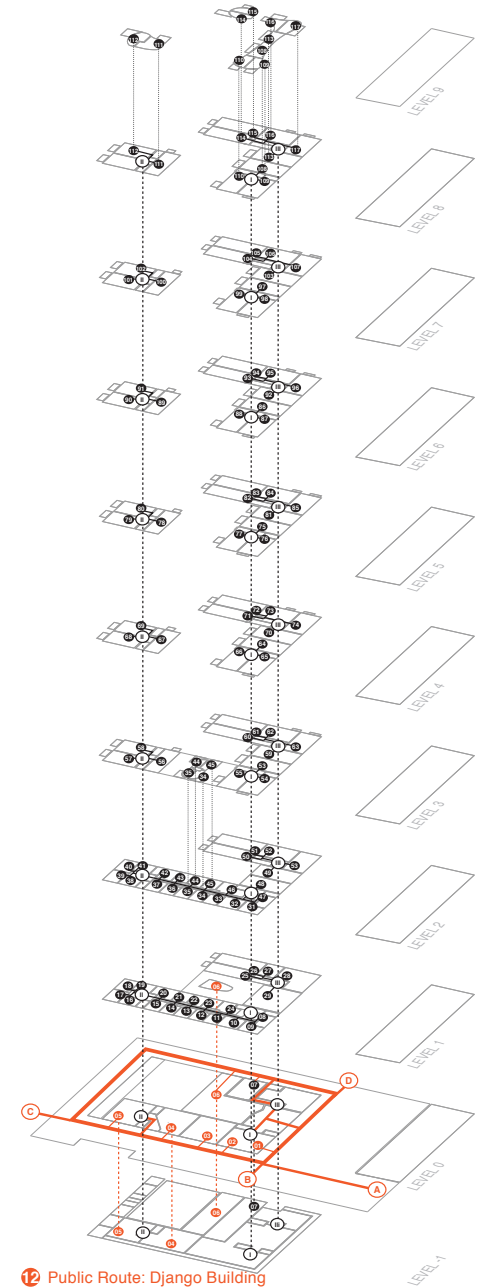

12 Public Route: Django Building

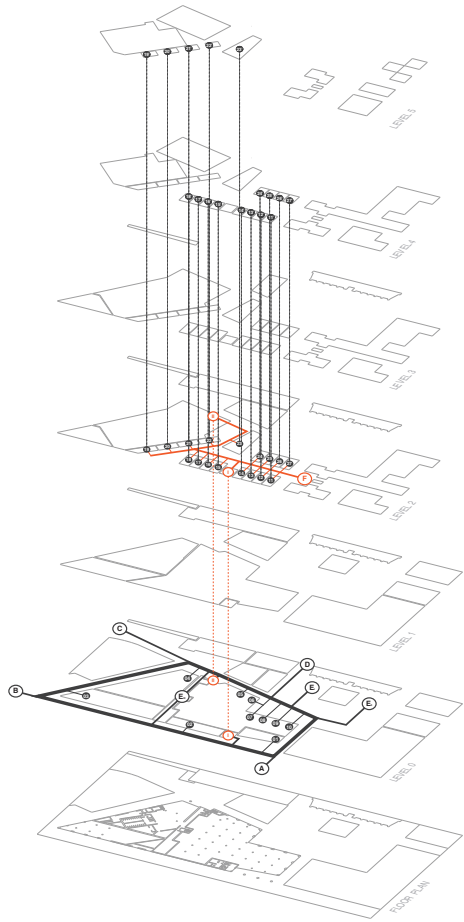

13 Collective Route: Zuidpoort

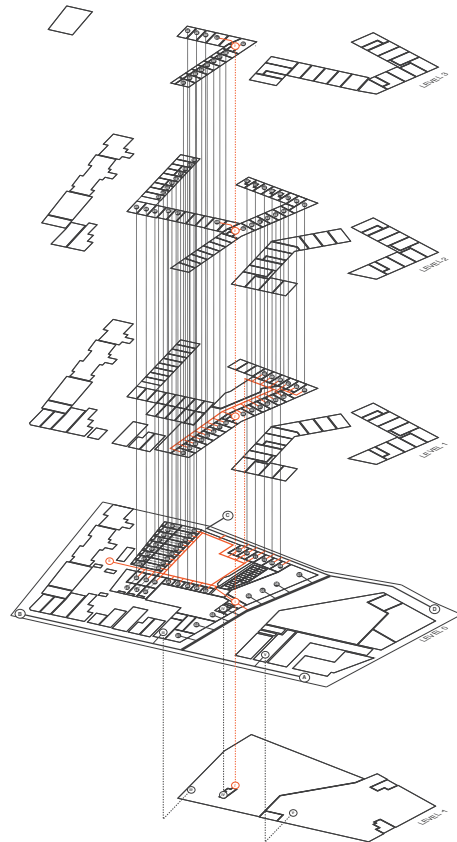

14 Collective Route: Monnikhof

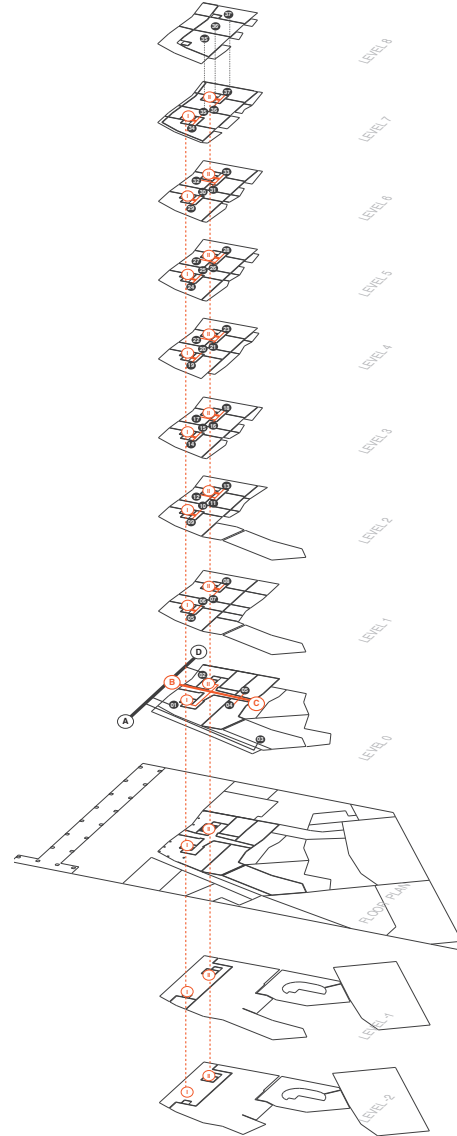

15 Collective Route: 35 Logements

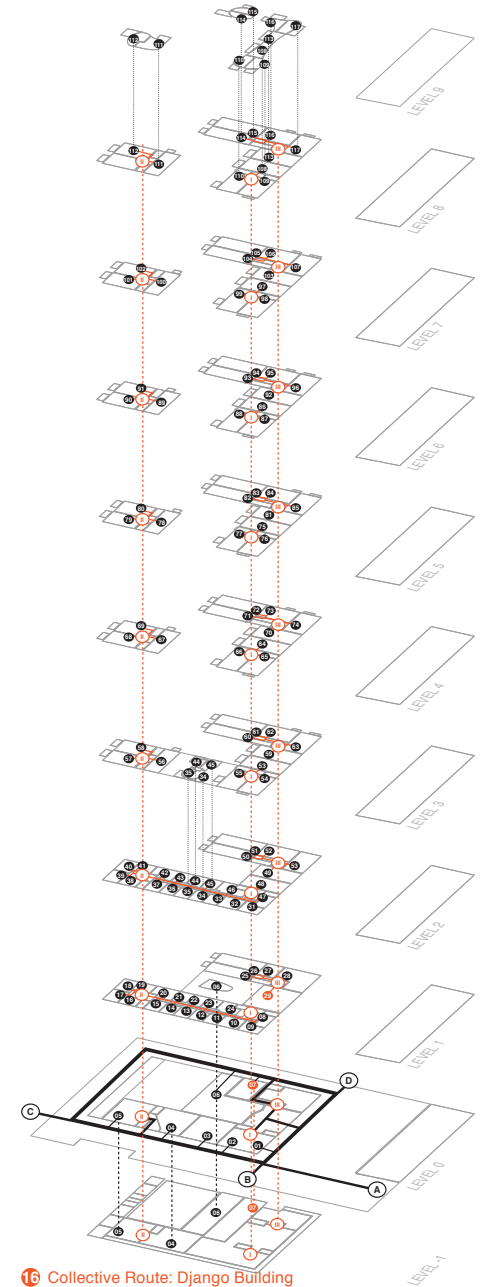

16 Collective Route: Django Building

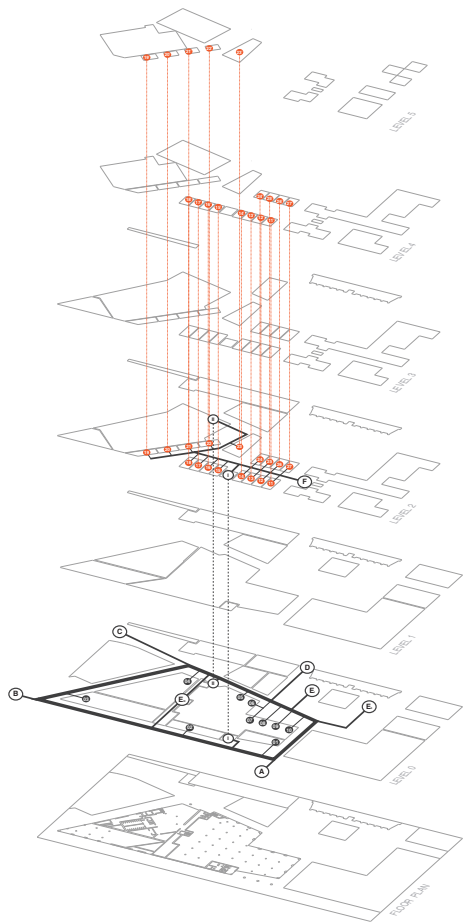

17 Private Route: Zuidpoort

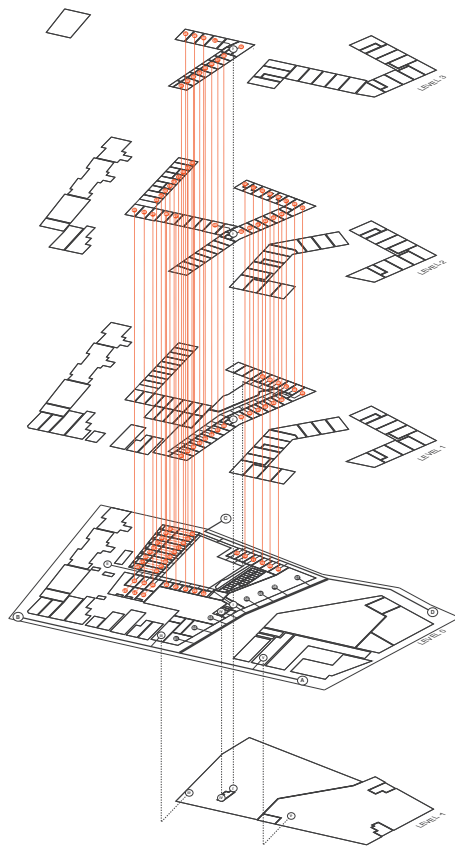

18 Private Route: Monnikhof

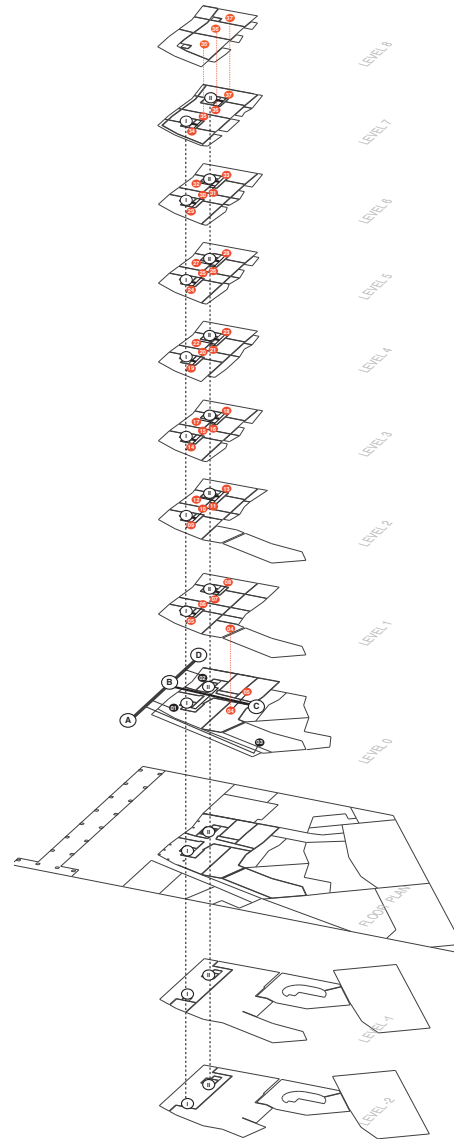

19 Private Route: 35 Logements

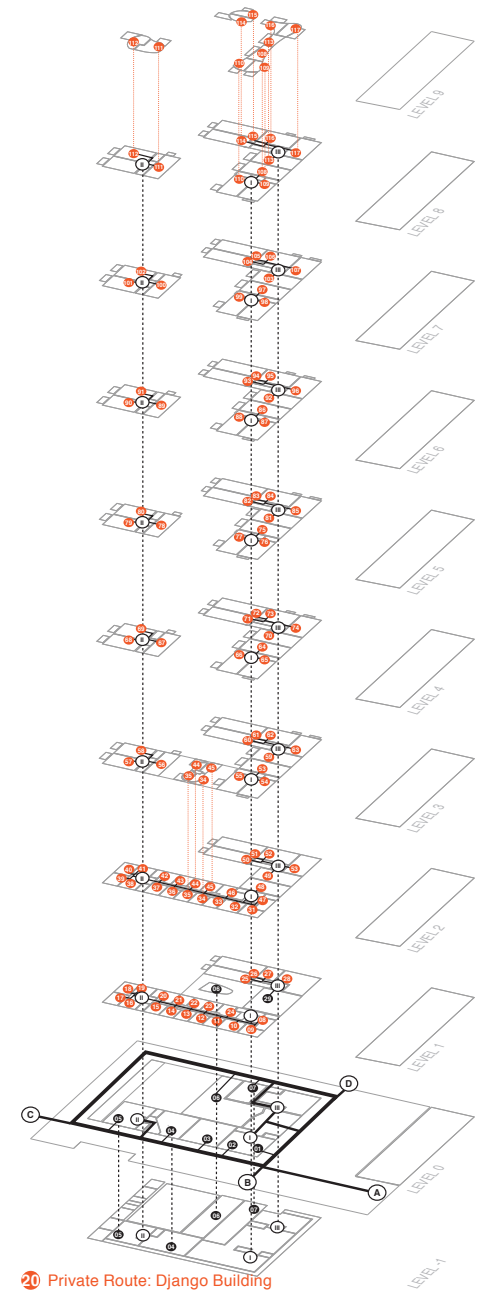

20 Private Route: Django Building



21 Zuidpoort: Public Space Facade Expression

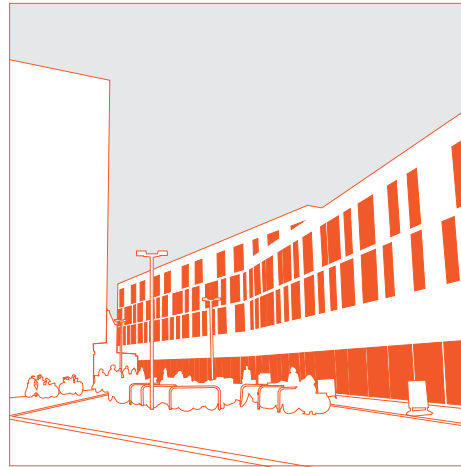

22 Monnikhof: Public Space Facade Expression



23 35 Logements: Public Space Facade Expression

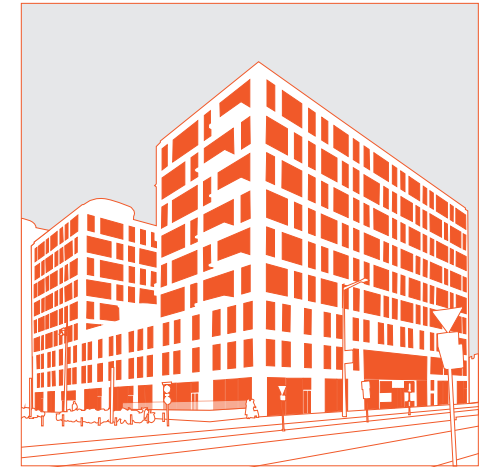

24 Django Building: Public Space Facade Expression

**Functional & Spatial Implications:
Public Domain**

The above perspective drawings depict public spaces of all four analysed cases from the side where public traffic intensity is the highest (fig. 21-24). A dependency can be observed, that simultaneously in the depicted areas the majority of public access points is located (fig. 9-12).

Especially in Zuidpoort, Monnikhof and 35 Logements, such density of public access points create a distinctive public plinth exhibiting high level of transparency and connecting outdoor public space with interior of the buildings. The plinth created via densification of public access points has such a strong spatial expression, that it very well constitutes the public domain in the depicted areas, since the access points are anchors of public activities. On absence of the public

plinth, neither public domain, nor dwelling could have functioned properly - location of dwelling programme on the ground level would result in a dead facade, which could not be facilitated by inhabitants nor public users - very much as it is happening at Van Der Kunbuurt.

The tandem of private access from a disconnected collective routes facilitated in all analysed cases results in dwelling programme overlooking the public domain, safe from intrusions due to its elevation. The dwelling facades are more closed and rhythmic, attracting far less attention than the public plinth.

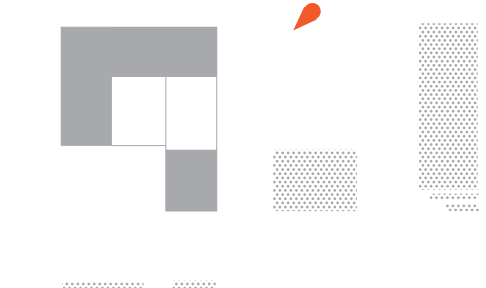
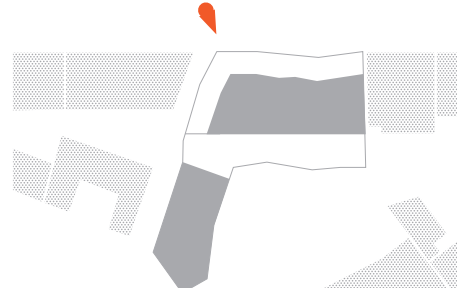
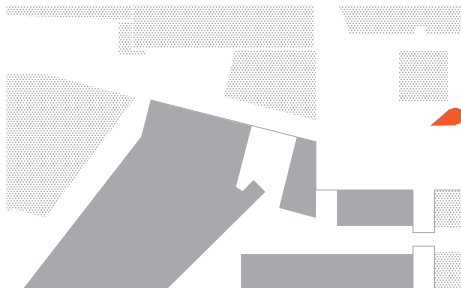



25 Zuidpoort: Private Dwelling Entrance in Collective Space

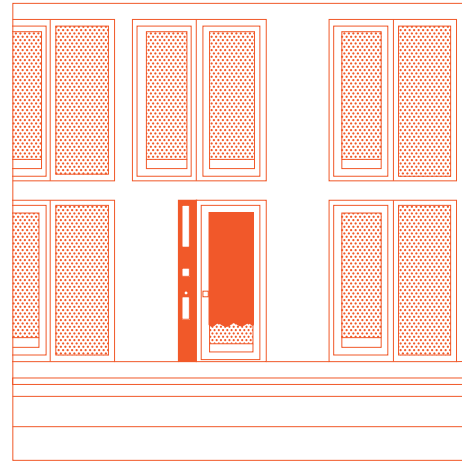

26 Monnikhof: Private Dwelling Entrance Facing Public Space

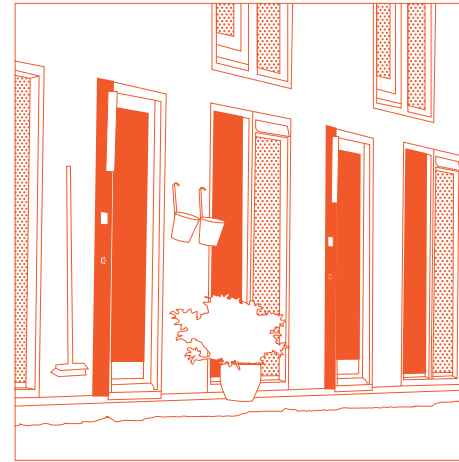

27 Monnikhof: Private Dwelling Entrance in Collective Space

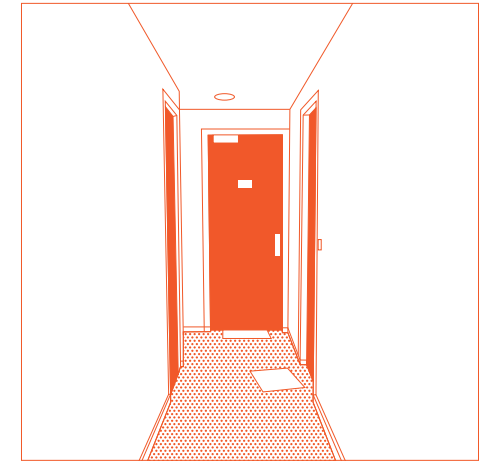

28 Django Building: Private Dwelling Entrance in Interior Collective Space

**Functional & Spatial Implications:
Collective & Private Domain**

The presented selection of representative access points to private dwellings from analysed projects displays some regular dependencies. In general three different types of dwelling access has been observed:

1. Access from outdoor collective space
2. Access from public space
3. Access from interior collective space

The dwelling access types appears to have a profound influence on the atmosphere of collective space and the ensembles altogether, directly affecting the use of provided outdoor spaces: Direct access to a house from collective space allows for appropriation of the space in front of one's entrance, perceivably increasing the level of interaction between neighbours (regardless of the level of satisfaction with such interactions expressed by inhabitants). The projects which facilitate

such entrance solution display the highest level of satisfaction with the quality and performance of collective spaces (fig. 25, 27).

On the contrary, in projects where a direct access to collective space is not provided, a personal atmosphere is absent, resulting in an unpleasant dwelling environment (fig. 28). In case of Django Building such solution was intentional, due to an intended target group of the project. Nonetheless the difference of

expression of collective spaces in conjunction with implemented entrance solution is striking.

An illustrative example of interrelation of dwelling space spatial expression and the pressure of public spaces is an entrance to a private dwelling at Monnikhof, located directly in public space (fig. 26). As opposed to a similar entrance located in the collective space (fig. 27) there are no private belongings exposed, nor there is a sign of private activity.

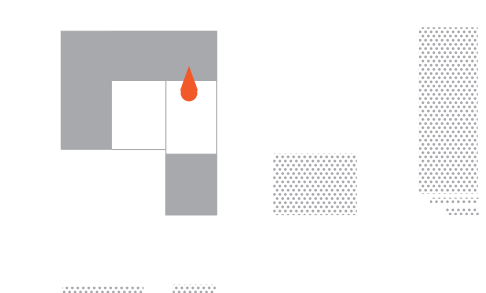
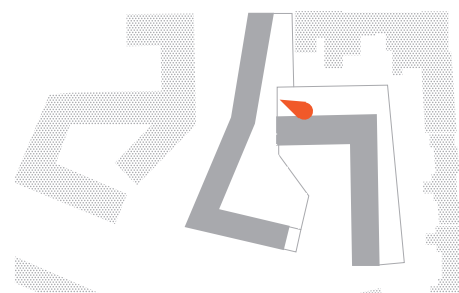
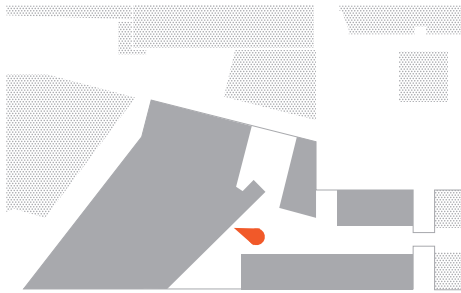

Public, Collective & Private Space

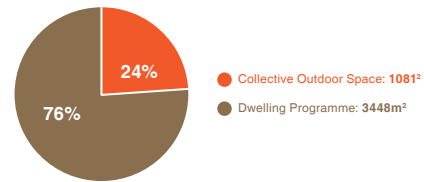

1 Zuidpoort: Dwelling to Collective Space Area Ratio

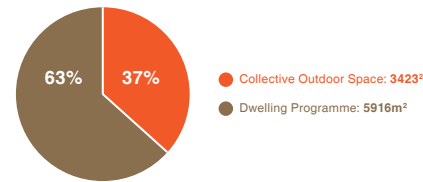

2 Monnikhof: Dwelling to Collective Space Area Ratio

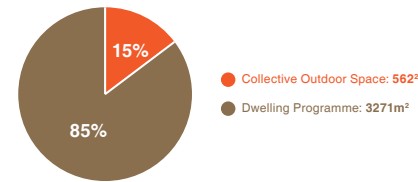

3 35 Logements: Dwelling to Collective Space Area Ratio

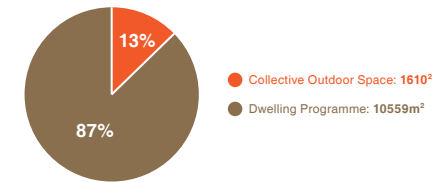

4 Django Building: Dwelling to Collective Space Area Ratio

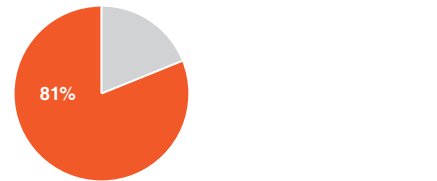

5 Zuidpoort: Collective Space Performance Satisfaction

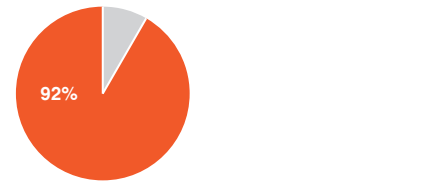

6 Monnikhof: Collective Space Performance Satisfaction

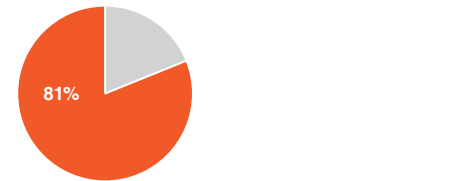

7 35 Logements: Collective Space Performance Satisfaction



8 Django: Collective Space Performance Satisfaction

Distribution of Public, Collective & Private Space

A regularity has been observed that in all analysed cases public domain is clearly separated from collective and private spaces. The separation is achieved via demarcation of space allegiance boundary by the perimeter of building or distribution of public and collective space on different levels (fig. 9-12).

Simultaneously another regularity emerges: a correlation between ratio of provided collective space area and amount of dwelling programme, and the overall satisfaction of inhabitants with performance and quality of collective spaces (fig. 1-8). The differences in results according to diagrams are not big, however the difference in atmosphere of each project is strongly perceivable depending on the amount of collective space provided. The more collective spaces is implemented in a project proportionally to the amount of dwelling programme, the more personal and lively is the atmosphere. It has to be noted, that if it was not

for the poor acoustics of Zuidpoort's collective space (due to unfortunate materialisation), it's average satisfaction level with the performance of collective space would have been much higher. As for 35 Logements, the scarcity of available collective space is compensated by very thoughtful and high quality solutions.

Public Space Distribution

Public Spaces are invariably distributed on the ground level adjacent to the analysed projects. The public domain is not allowed inside the perimeter of the buildings and is seldom in direct contact with either collective or private outdoor spaces (fig. 9-20).

Collective Space Distribution

Throughout the analysed cases collective spaces are distributed diversely:

In Zuidpoort the collective space is situated on the second level of the ensemble, with two restricted connections with the public space, and one open connection to collective space of adjacent building (fig. 13).

In Monnikhof it is distributed on two levels, split into half by terrain steps. The outdoor access to the space is provided unrestrictedly from public space, however only in the area which is not exposed to intense public traffic. There is also a connection via an interior collective staircase directly from public space, the access however is only allowed for inhabitants (fig. 14).

In 35 Logements and Django Building, the collective space is distributed in the interior on all levels of the building, with 1 (35 Logements) and 3 (Django Building) restricted access points (fig. 15, 16).

Private Space Distribution

The private spaces provided vary from case to case: Roof terraces are included in all four projects, however only in Zuidpoort and Monnikhof they are a common feature to most of the dwelling units. In other cases, roof terraces are exclusive for selected apartments. The most common type of private outdoor space encountered in the projects are balconies, which appear in all case projects, except for Monnikhof. There however a private gardens were provided for significant amount of dwellings.

All private outdoor spaces have one thing in common - vast majority of them faces the collective space, regardless of geographic orientation of the buildings (fig. 17-20).

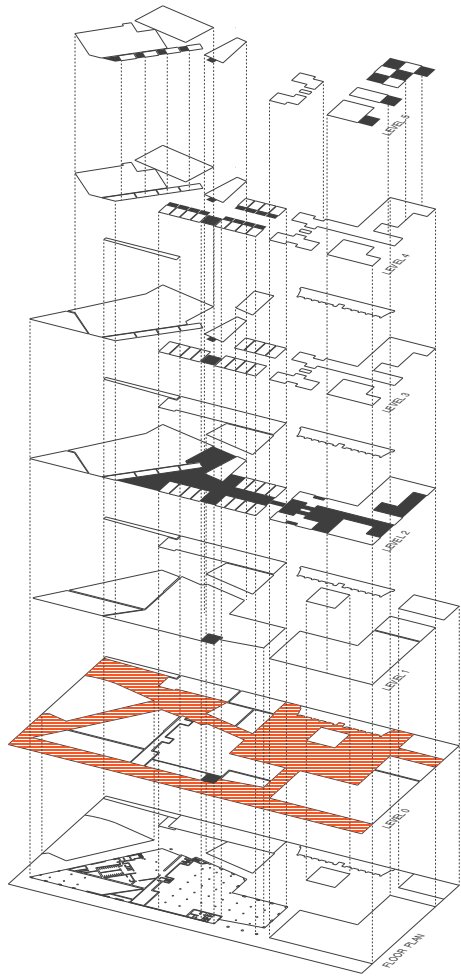

9 Collective Space Distribution: Zuidpoort

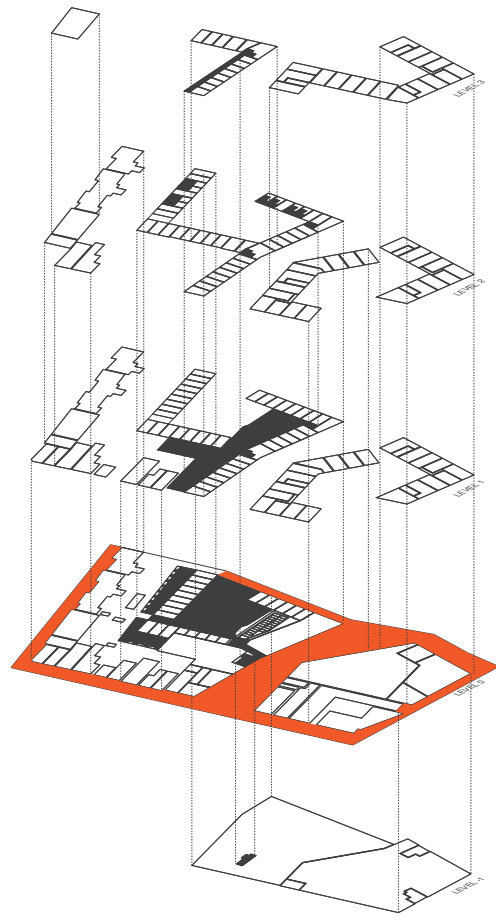

10 Collective Space Distribution: Monnikhof

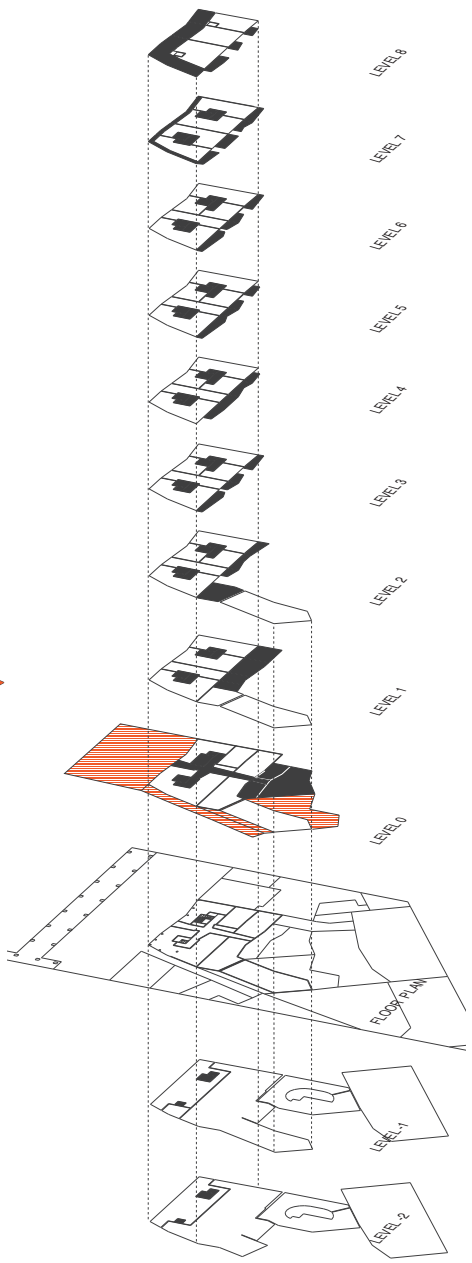

11 Collective Space Distribution: 35 Logements

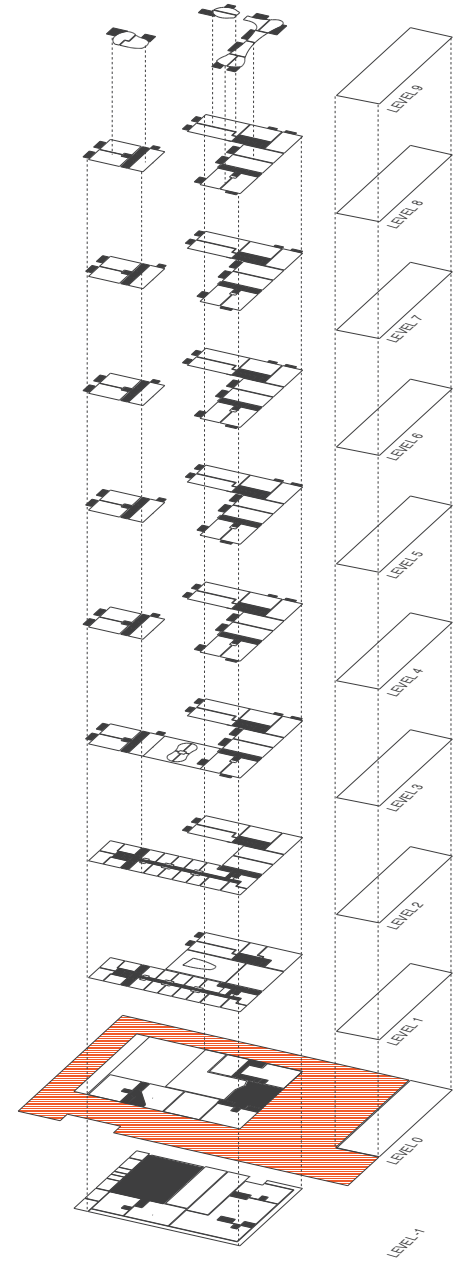

12 Collective Space Distribution: Django Building

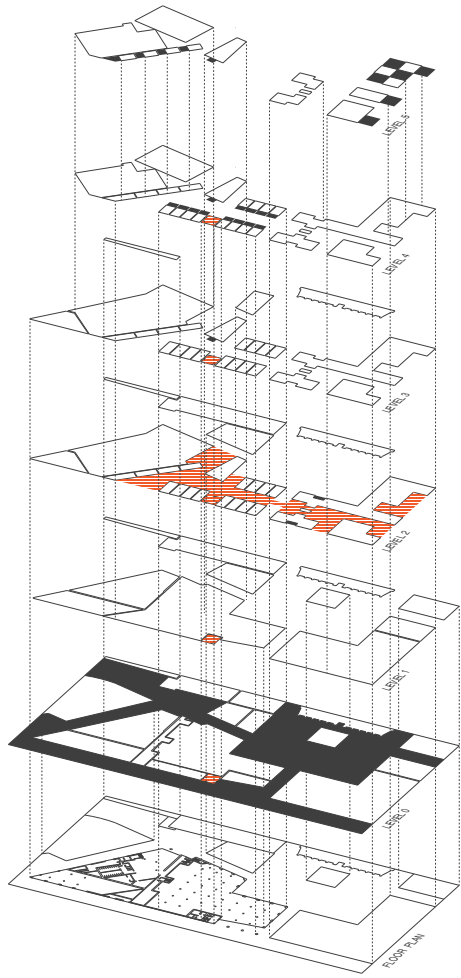

13 Collective Space Distribution: Zuidpoort

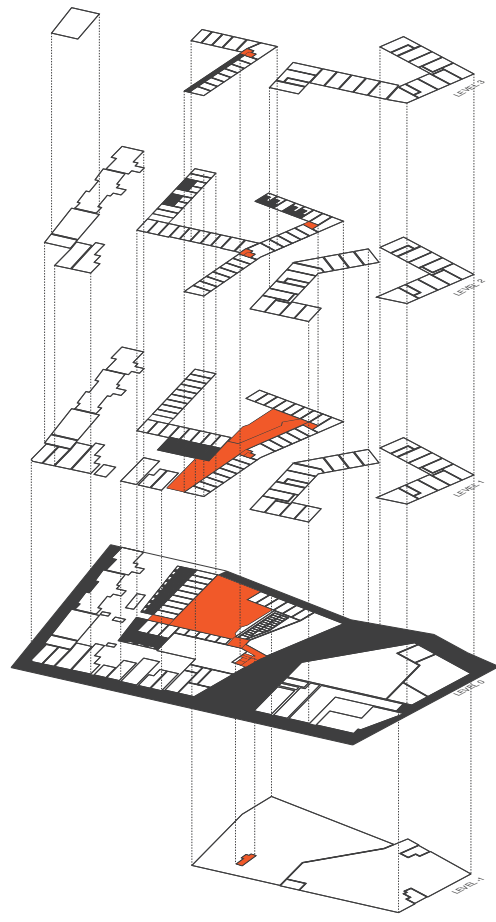

14 Collective Space Distribution: Monnikhof

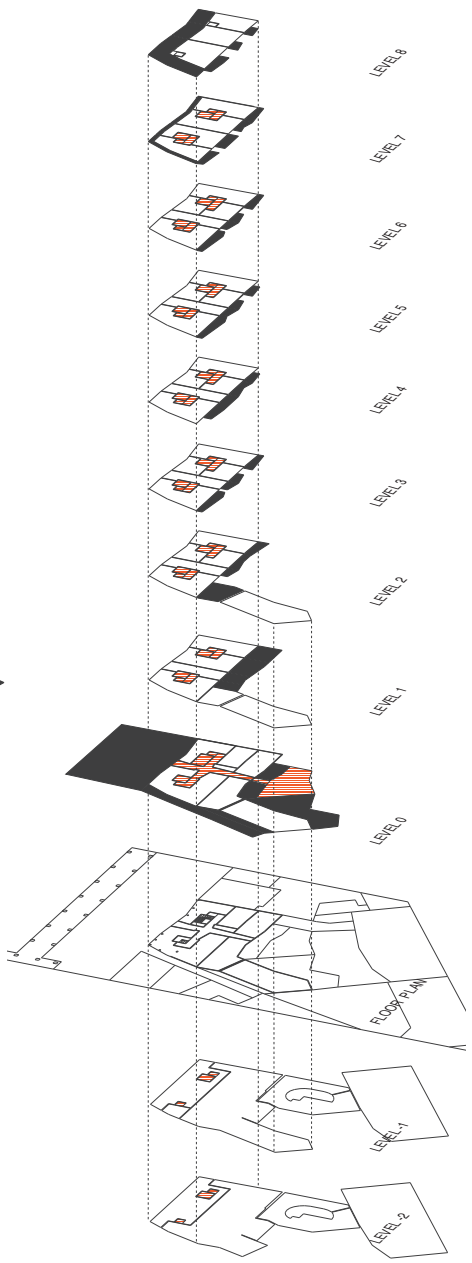

15 Collective Space Distribution: 35 Logements

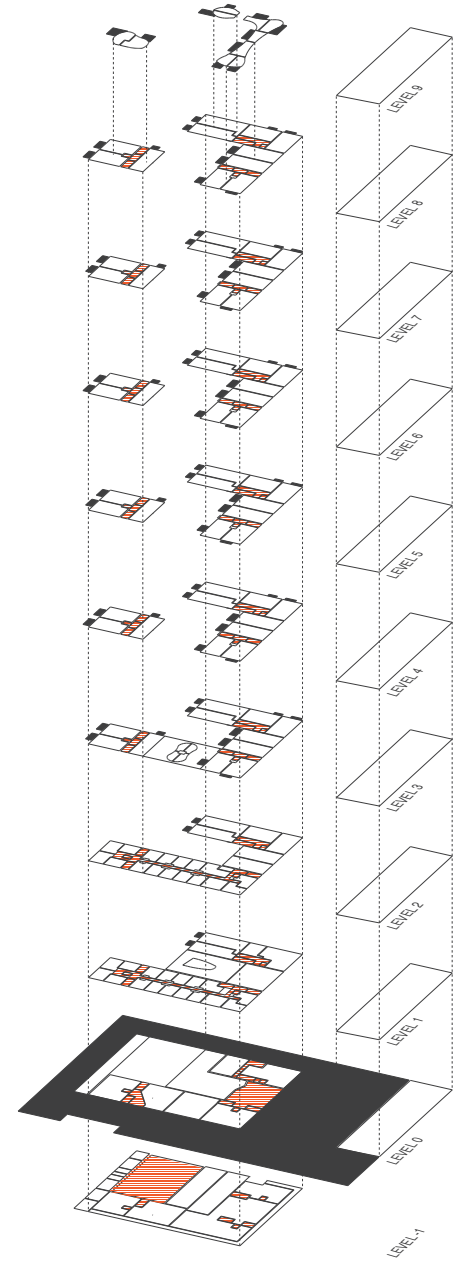

16 Collective Space Distribution: Django Building

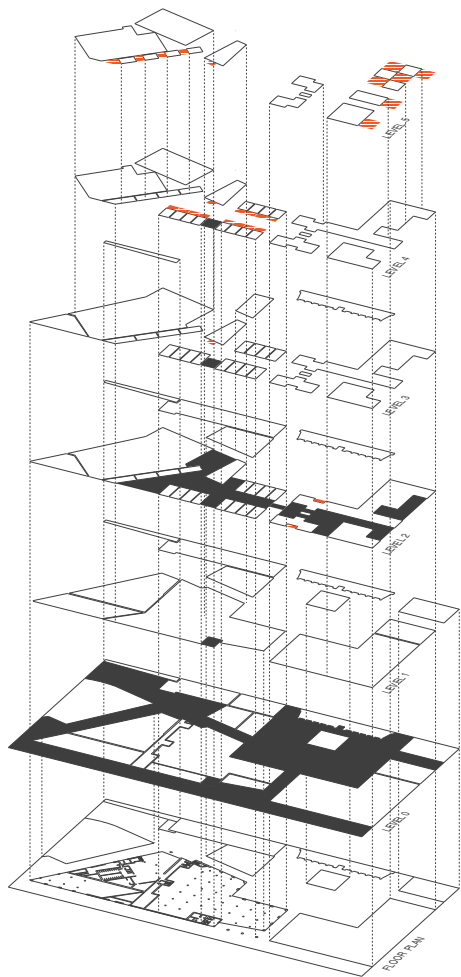

17 Private Outdoor Space Distribution: Zuidpoort

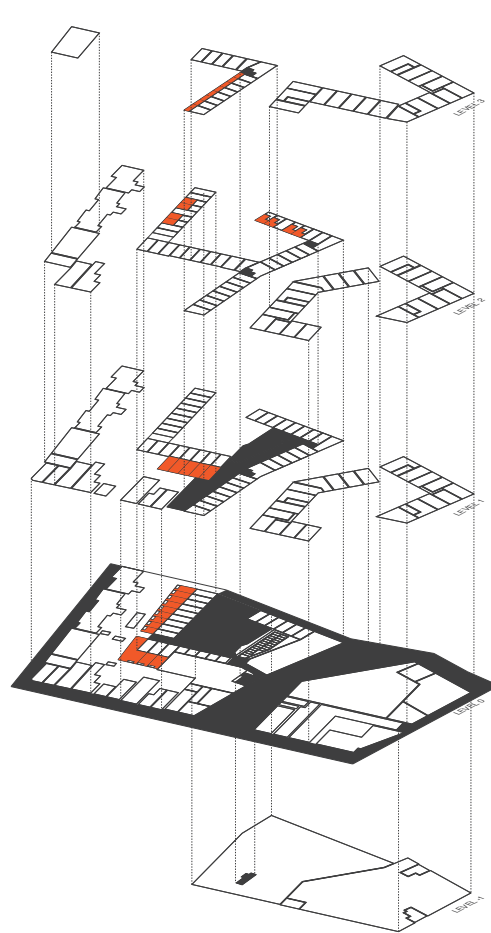

18 Private Outdoor Space Distribution: Monnikhof

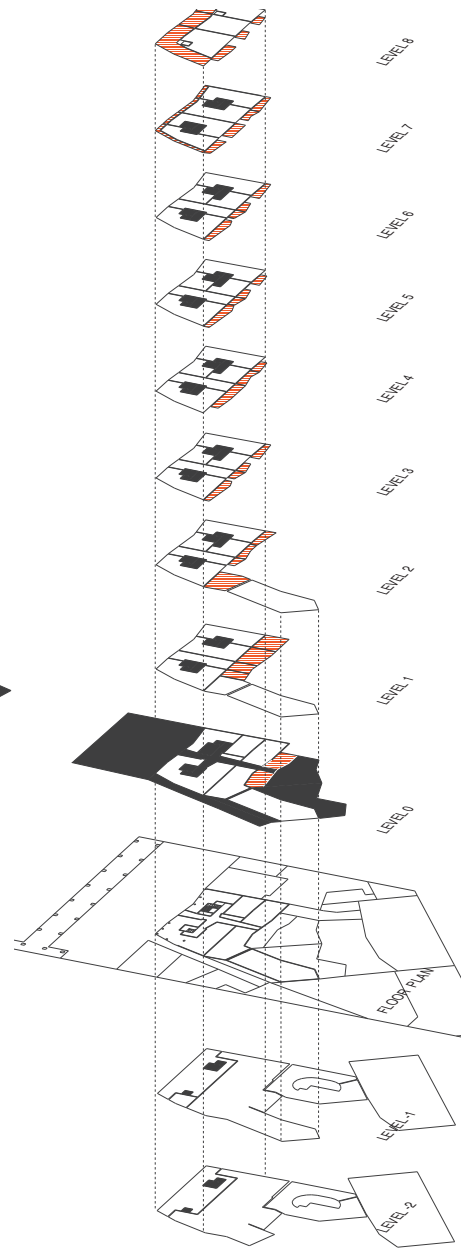

19 Private Outdoor Distribution: 35 Logements

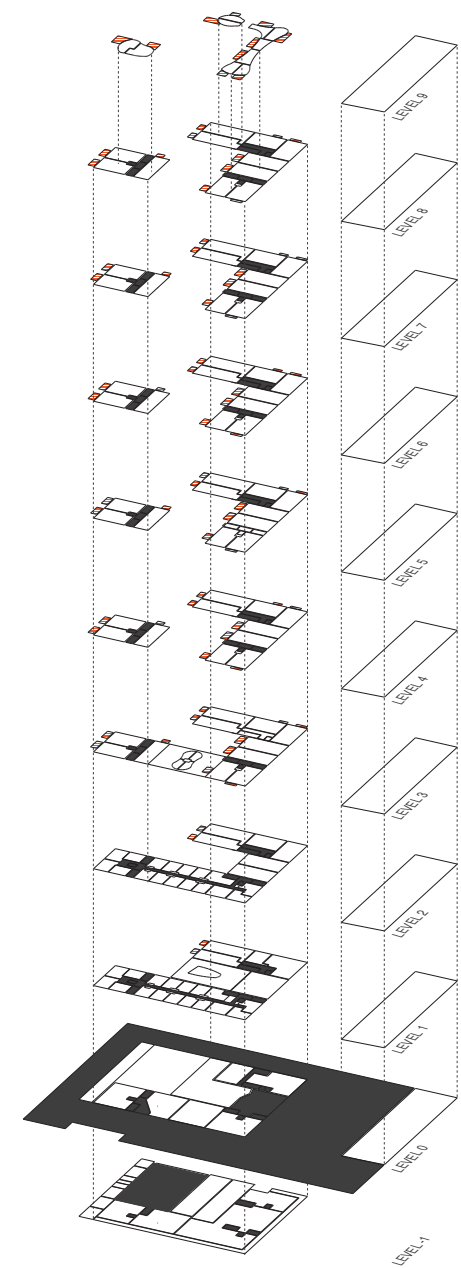

20 Private Outdoor Space Distribution: Django Building



21 Zuidpoort: Public Space Overview



22 Monnikhof: Public Space Overview



23 35 Logements: Public Space Overview



24 Django Building: Public Space Overview

**Functional & Spatial Implications:
Public Domain**

The clear separation of public domain from collective and private spaces finds in expression in clear spatial boundaries delineated along the perimeter of buildings (fig. 21-24). Nothing invites the public user to explore the dwelling areas.

Simultaneously, the dwelling facades are formed in a way distinguishing them from the public plinth, and highlight their inaccessibility via elevation and disconnectedness from the ground level.

Compared to Collective space's expression, the public facades are much more clearly pronounced as uniform, solid volumes, protecting the collective interior of perimeter.

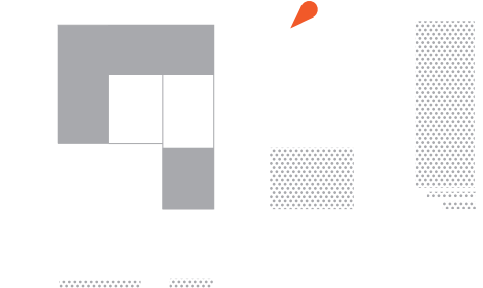
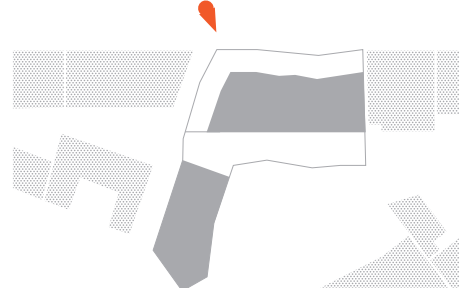
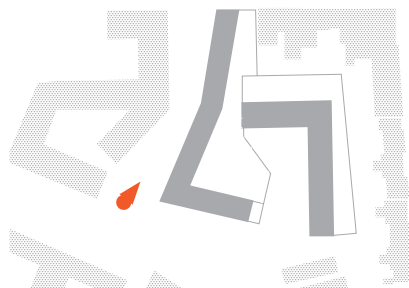
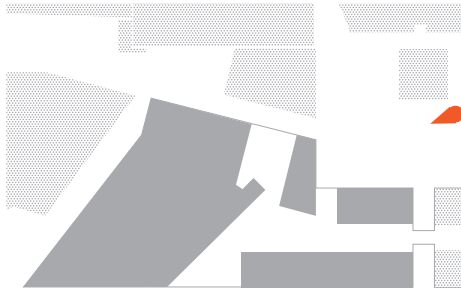



25 Zuidpoort: Collective Space Overview

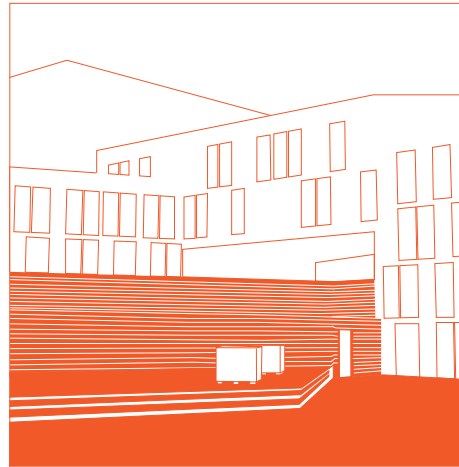

26 Monnikhof: Collective Space Overview

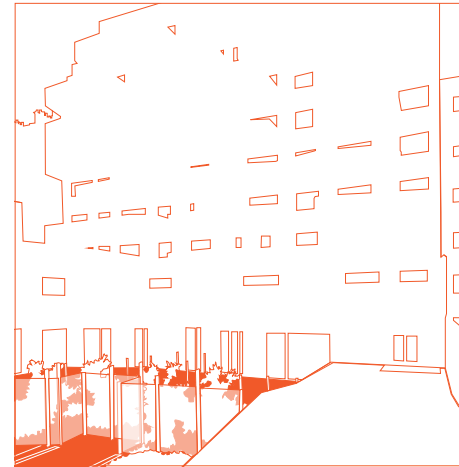

27 35 Logements: Collective Space Overview

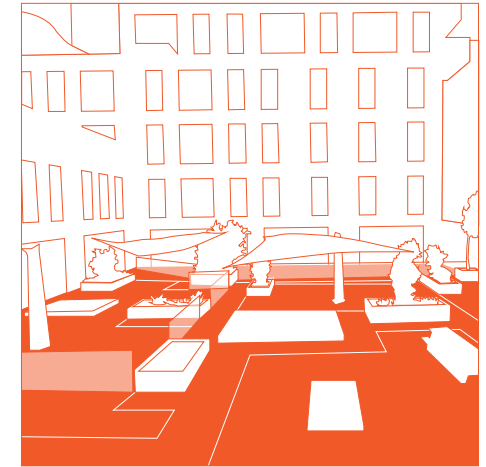

28 Django Building: Collective Space Overview

**Functional & Spatial Implications:
Collective & Private Domain**

It has been observed, that the distribution of private outdoor spaces facing the collective space, as well as direct access to dwellings are reciprocally enhancing the functionality and performance of the mentioned components. The analysed dwelling compounds exposed to spaces of movement display function as pleasant dwelling environment as long as the life of inhabitants is concentrated around the

collective space. Direct access to houses extends the private domain and improves the interactions with neighbours, whilst situation of outdoor private spaces around the collective space protects inhabitants from public disturbances and offers spatial and visual connection with neighbours (fig. 25-27).

In Zuidpoort and 35 Logements, there is particularly strong unofficial reception of space, followed by high level of satisfaction with

space's performance. This may be prescribed to high level of space boundaries diffusion, an important factor in reception of space, as explained by Jan Gehl.

A counter example is Django Building, where the majority of outdoor collective space is situated on level -1 and is accessible only via collective nursery (fig. 28). As a result, the private activities are not focused around the collective space, instead they are taken

inside the apartments, reducing the level of interaction between neighbours. Nonetheless, inhabitants of Django Building seem to be satisfied with that situation, since the target group doesn't desire interaction.

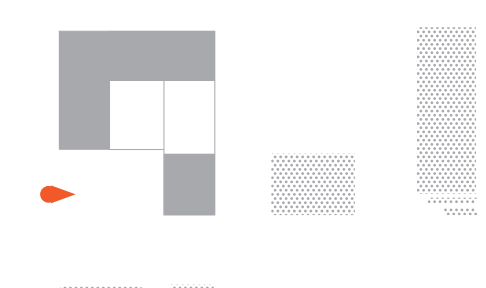
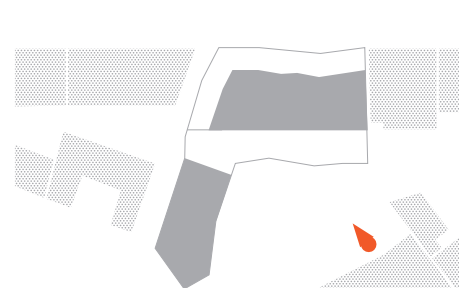
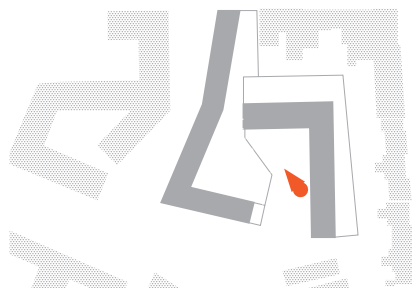
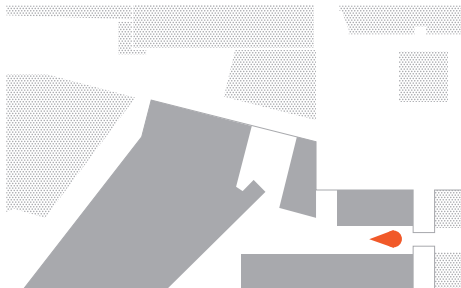

Materials: Public Space



1 Zuidpoort: Public Space Facade & Paving Materials



2 Monnikhof: Public Space Facade & Paving Materials

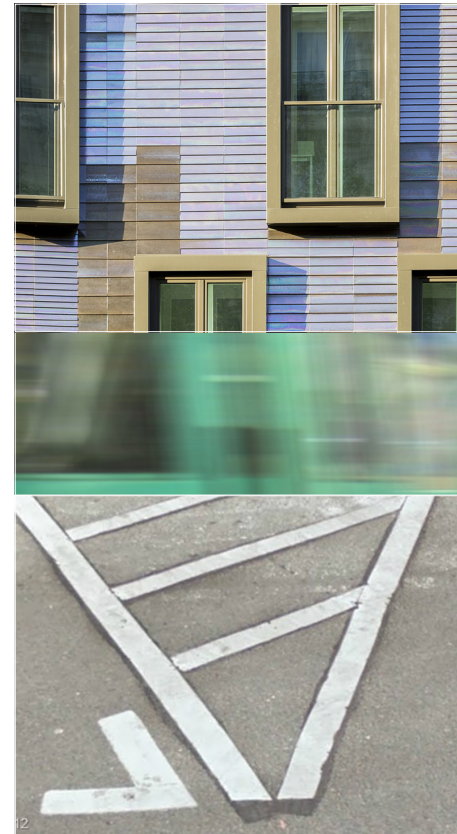

3 35 Logements: Public Space Facade & Paving Materials



4 Django Building: Public Space Facade & Paving Materials

Functionality of Materials in Public Space

Materials used for public creates the general impression about the space towards the public. Materials in public space should be considering deterioration, as it will be not taken care in personal, especially the paving and ground level facade is exposed to a lot of users (fig.1).

Expression of Materials in Public Space

Façade material used in public space provides fairly warm atmosphere and public can easily recognize that the upper level is dedicated for dwelling. Not only providing residential impression by using brick and wood (fig.1, 2, 4), but also there is a possibility to respond on adjacent environment. For example, in 35 Logement using terracotta creates great

harmony with a metro that runs in front of the building, reflecting the various color (fig.3). All of the cases on ground level façade, uses large glass surface to interact trespassers. In case of Django, printed glass is used in the plinth contrasting with dark brick on upper part of the façade (fig.4).

Materials: Collective Space

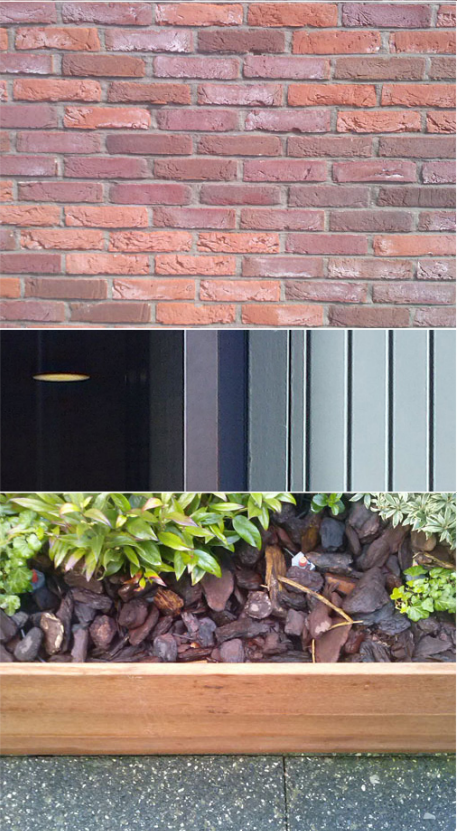

5 Zuidpoort: Collective Space Facade & Paving Materials



6 Monnikhof: Collective Space Facade & Paving Materials



7 35 Logements: Collective Space Facade & Paving Materials



8 Django Building: Collective Space Facade & Paving Materials

Functionality of Materials in Collective Space

On collective space material and the elements placed in collective are much personal and well maintained. Concrete tile (fig.5) used in Zuidpoort were complained a lot by residents due to pragmatic acoustic performance.

Expression of Materials in Collective Space

The same material is used in collective space that is used in the public for the façade in three analysed cases. Only 35 Logements made a contrast by using light colored wood (fig.7). But all of the analysed cases used different material for the pavement creating much more intimate atmosphere such as in Monnikhof using the gravel (fig.6) with cement

and in Grenelle wooden deck was placed with greenery (fig.7). Bright color materials can reflect lights to dwelling. More collective greenery (fig.8) was provided and personal plants can be easily placed in front of the entrance in collective space.

Open Space Scale & Proportions

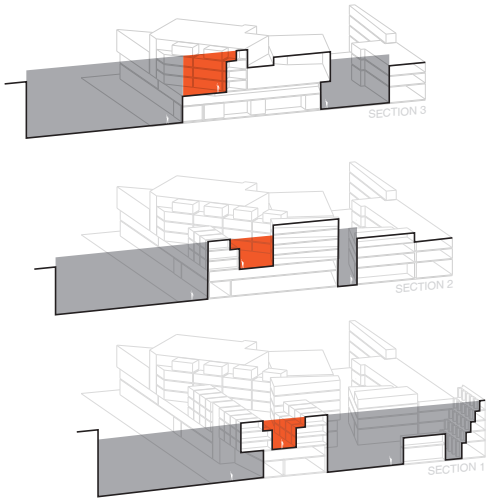

1 Zuidpoort: Public & Collective Space Section

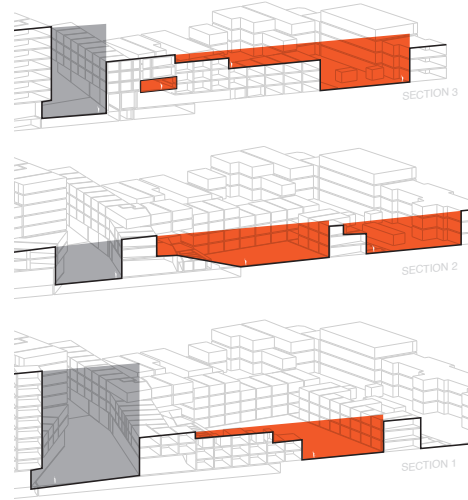

2 Monnikhof: Public & Collective Space Section

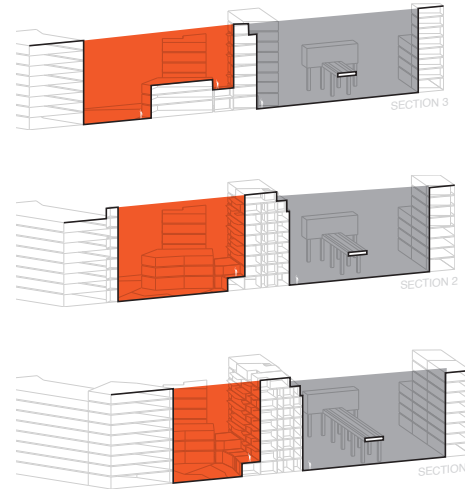

3 35 Logements: Public & Collective Space Section

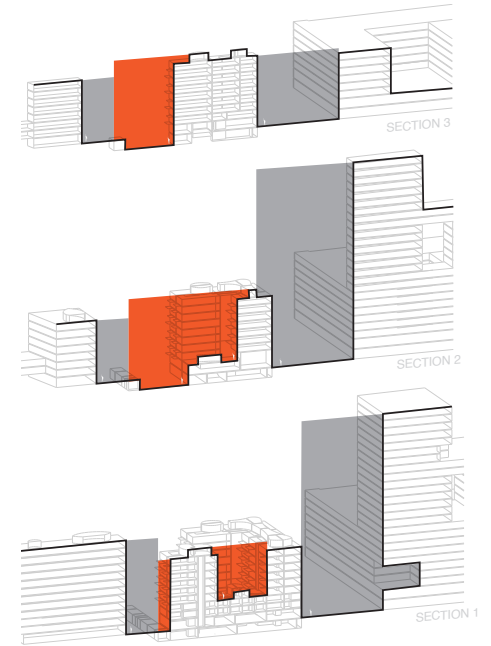

4 Django Building: Public & Collective Space Section

Public Open Space

In case of the right side in Zuidpoort (fig.1) and Monikhof (fig.2), public open space is purely dedicated to pedestrian. And the width and the height vary in the sequence; wider open space becomes a square naturally intermingling the necessary activities with optional and social activities. And in a certain part of the façade on ground level, is set back, providing the intermediate space between outside and inside. Design tries to provide various proportion of the open space enhancing the relation between the public.

Public open space in Grenelle (fig. 3) will not be perceived as the outer form of the building as the metro line runs in between. And also the similar goes for the left side of Zuidpoort (fig.1) due to bus station and the traffic. But in Grenelle as the mass gets smaller when it gets higher on upper two levels (fig. 3), overall building height can be hidden from the ground level.

The Django building (fig.4) is dealing with massive office building in front without many differences in proportion, human scale can be lost easily. Still using different expressive material on plinth provides smaller scale perception than the whole.

Collective Open Space

Collective open space is providing much more intimate space in width and height in Zuidpoort (fig.1), and height in Monnikhof (fig.2). Two projects even though the proportion is different create collective area in relation to neighbor, works well without much disturbance of public atmosphere. Providing quite large scale of collective open space creates diverse activities in front of private dwelling. And this increases chance of communication between neighbors.

The proportion and scale in the 35 Logements (fig. 3) and Django (fig.4) has similarity also with the disturbance by nursery. As it is not in direct use from private space scale and proportion is similar to one's in public.

In collective open space general scale should be more in accordance with human dimension when it is intentionally expecting highly in use by dwellers. Much smaller detail will allow interaction between the residents as they can hear and see each other.

Visual Connections

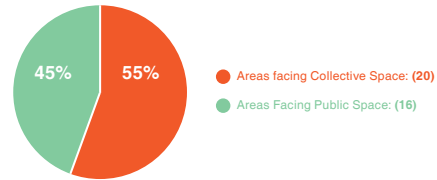

1 Zuidpoort: Living Rooms and Kitchen Areas

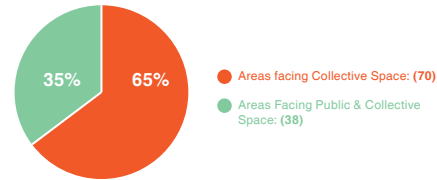

2 Monnikhof: Living Rooms and Kitchen Areas

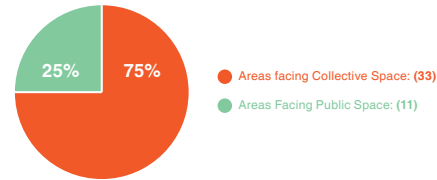

3 35 Logements: Living Rooms and Kitchen Areas

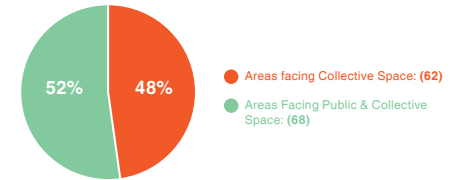

4 Django: Living Rooms and Kitchen Areas

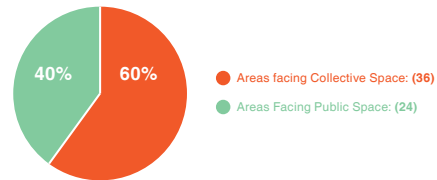

5 Zuidpoort: Private Rooms

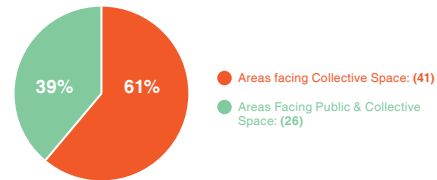

6 Monnikhof: Private Rooms

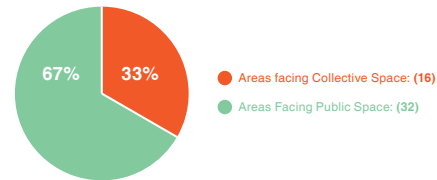

7 35 Logements: Private Rooms

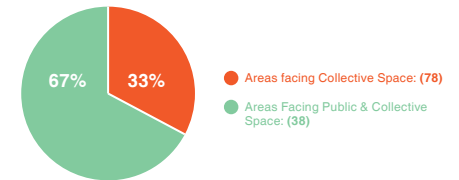

8 Django Building: Private Rooms

View Facing Public Space

Reading from the circular diagrams above, we can see that Zuidpoort and Monnikhof are comparable and 35 Logements and Django Building have in common except for the ratios of the visual connections from the living room and kitchen areas. Both the living rooms as the private areas of the Zuidpoort (fig.1, 5) and Monnikhof (fig.2, 6) have more visual connections with the collective spaces than with public spaces.

These two projects have in common that they are located in shopping areas with anonymous movement, which form the public spaces. But still only limited private dwelling is facing directly to the space of movement and the rest of the dwelling is located along the courtyard.

In the 35 Logements we clearly see a difference between living room areas and private living areas. The private living areas have a view over the public space (fig.7), which

means that they are more separated from the collective space. The bedroom will be in use when there is less pressure on public at night-time.

The Django building on the other hand (fig.4, 8), is more oriented towards the public space. The public spaces are much larger and more interesting to look at than collective space, as they are more vibrant.

View Facing Collective Space

In general, the collective space is used by people living in the buildings, and often by children. Parents want to have a view over their children when they are playing outside (fig.1, 2). This is possible on Zuidpoort and Monnikhof. Also the relations among the dwellers were positive, this makes it more interesting to have visual connections with the collective spaces. The interiors of collective spaces have been designed in such a way that they are more interesting to have a look at as well. The materials, proportions of space and buildings, the plants and so on make the collective space a nicer place to have a view on.

In the 35 Logements a lot of percentage in living rooms and kitchen areas are facing the collective area (fig.3). As they were combined with a huge extruded balconies people can relax casually during daytime when public space is highly in use. The collective space is only accessible in Django for children that are

using the nursery. The dwellers have almost no relation with each other, as they are mostly expats, making it more logical to have views over the public spaces (fig.4, 8).

Conclusions

General Conclusions

Analysis Outcome

The case study of dwelling ensembles and buildings at Bastiaansplein, Monnikhof, Boulevard de Grennelle and Zuidas, all exposed to similar conditions in accordance to case selection criteria, has revealed numerous analogies in solutions developed within the projects, but also - many differences.

The analysed aspects of projects, all striving to grasp the spatial relation with surrounding public space, were reduced to a common denominator of comparable data, by means of a uniform research and notation method.

The analysis are composed in triad: *what?* - *how?* - *why?*
The *objective data* analysis answers to question *why*, by aiming to establish the characteristics of analysed solutions. The *performance assessment* part strives to reveal *how* the analysed solution is performing. The *subjective semiotic observations* provide possible answers to *why* a certain solution is performing in a particular manner.

Objective Data

Part of retrieved data is presentable in form of raw numbers and ratios describing objectively (however in somewhat limited manner) the solutions facilitated within the analysed projects. The *performance assessment* part of analysis enables to evaluate the success and relevance of these solutions, altogether offering a reliable data set to work with when dealing with the design task at Van Der Kunbuurt.

The aspects of projects reduced to the aforementioned raw data are - among others - programme and access points distribution and amounts, which can be regarded as a partial indicator of how strongly the project is responding to the public domain and how accessible it is for different groups of users. Furthermore, a distribution of public, collective and private spaces within and around the project has been analysed in a similar manner.

Last, part of analysis of visual connections and scale and proportions of open spaces was presented in form of ratios of spatial dimensions, and amounts of living areas and private rooms facing respectively collective and public open space.

Subjective Observations

In order to complement the objective data retrieved from the analysis, scale, shape and materials of public and collective spaces as well as openness of public and collective facades were analysed in terms of their architectural expression and communicativeness, using a semiotic approach. Respectively, the communicativeness and expression of access points to different parts of buildings has been analysed by means of series of reduced perspective drawings, supplementing the priorly retrieved statistic data.

Unlike in case of the objective part of analysis, these subjective observations do not constitute a coherent data set, however they provide an important insight which - undoubtedly - will prove to be informative when designing dwelling unit at Van Der Kunbuurt.

Relevance to Problem Statement

Due to a reciprocal contradiction of interests and atmospheres between spaces of movement and dwelling, their spatial form is interrelated.

The research has confirmed that there is an interrelation between spaces of movement, defined by the accommodated type of activities and intensity of traffic, and the spatial form of dwelling situated in direct contact with those spaces.

Numerous examples of spatial organisation of analysed cases being responsive to immediate presence of spaces of movement have been retrieved. The summary of analysis outcome is presented in the following chapter: *Summary: Design Recommendations*.

Response to Research Question

How can a dwelling project respond spatially to exposure to spaces of movement?

The analysis have provided an answer to the research question by displaying a scope of spatial solutions facilitated in the case study projects in response to exposure to spaces of movement. These can be divided into morphological and semiotic responses:

Morphological responses:

- Programme distribution
- Routes and access distribution
- Public, collective and private space distribution

Semiotic responses:

- Expression of public and collective space facades
- Expression of access points for respective groups of users
- Relation to human scale of public and collective spaces
- Visual connections with the interior
- Paving and facade materials

In accordance to performed analysis, the successful, or well-performing spatial solutions for coexistence of dwelling and spaces of movement have been listed in the following chapter. Those can be seen as recommendations for designing at Van Der Kunbuurt.

Summary: Design Recommendations

Programme

- 1 Dwelling function should be only part of implemented programme. Basing on the analysed cases at least 30% of programme should be dedicated for other, publicly accessible functions. The solution is mutually beneficial for public domain and dwellers: at the cost of accommodating publicly accessible programme, dwelling can be situated in otherwise inaccessible location within the city context. The location attractiveness is further increased by the implemented public programme.
- 2 Dwelling function should be located on the levels disconnected from public domain. If dwelling function is to be located in direct contact with public domain, the adjacent public space should be formed so, that it is not dominated by necessary activities.
- 3 The additional, publicly accessible functions should be distributed on levels with direct access to public domain. If the publicly accessible functions are to be distributed on other levels, they should be accessible only from public domain in order to avoid functional collision with dwelling programme.

- 4 It is advisable, that the publicly accessible programme should be related to the local community of inhabitants in order to soften the dominance of necessary activities and to raise inhabitant's satisfaction with available public facilities. Generic, impersonal public programme, as facilitated in the analysed cases should be avoided, for it enhances the dominance of necessary activities and atmosphere of anonymity.
- 5 Parking garage should be provided and located below ground level in order to reduce the presence of cars in public domain and preserve building's facades for other functions.
- 6 Depending on additional functions provided, parking garage may be accessible for public users. This improved access capacity is another way of reciprocal benefits of dwelling and spaces of movement.

Routing & Access

- 1 Access to collective areas from spaces of movement should be restricted for users of public domain in order to prevent the pressure of anonymity on dwelling. A non-restrictive access to collective areas is possible from sections of public routes which are not dominated by necessary activities.
- 2 Distribution of access points to public and retail functions should be densified along sections of public routes displaying the highest intensity of pedestrian traffic in order to constitute and sustain the public dimension of space.
- 3 Ideally, private access to dwellings should be provided directly from outdoor collective spaces. This has proven to be an efficient countermeasure for anonymity pressure of spaces of movement, for it is capable of introducing dwellers personality into outdoor spaces, improves the functionality of dwelling and collective space. Direct access from public space is only possible when the necessary activities are not dominant.

Public, Collective & Private Space

- 1 Collective spaces should be provided in dwelling ensembles situated within spaces of movement. On absence of public space capable of accommodating inhabitant's social and optional interactions, collective space is the only available substitute for it, a carrier of personal character of dwelling environment.
- 2 It is advisable, that the collective space is situated on levels other than ground floor: Firstly, to ensure spatial disconnectedness of public and collective domains by introducing level difference between them; Secondly, to maximize the ground level area available for publicly accessible programme, releasing the footprint of a building for use by public domain.
- 3 Private outdoor spaces should be facing the collective area in order to organise inhabitant's activity around it and reciprocally improve the functionality and performance of both types of spaces: enhance the visual and spatial connectivity of dwelling community, and protect the private outdoor spaces from disturbances coming from spaces of movement.

Materials

- 1 Materialisation of public and collective spaces should be differentiated to help to shape the character of spaces. Failure to do so may result in prevailing of official public, atmosphere in the dwelling environment.
- 2 Paving materials in public areas should be personalized to constitute distinct character of space, as a recognizable part of the city, relating public users to surroundings and thus decreasing the anonymity of space. The implementation of dwelling ensemble offers a chance to improve the quality of public domain.
- 3 A special care should be taken that functional properties of materials used in collective areas should provide appropriate acoustics, reducing sound reflections. Materials such as lawns, greenery, wooden cladding and paving not only provide good acoustic performance of space, but also encourage direct contact with users, when using the collective or private outdoor spaces.

Scale & Proportions

- 1 Human scale can be organised in public open space in creating diverse proportion so that the experiences can be enriched.
- 2 When scale and proportion is in accordance with human dimension in collective open space, it can be expected to be highly in use by dwellers.

Visual Connections

- 1 Living rooms should have a visual connection with collective areas in order to reciprocally improve the performance of dwelling and collective spaces.
- 2 Bed rooms and other private rooms should have a visual connection with public domain, to provide seclusion from comparatively intimate collective areas.

Bibliography

Books

Alexander Christopher, *A Pattern Language*, Oxford University Press, New York, 1977.

Herman Hertzberger, "Collective Space, Social Use.", In *Architectural Positions*, Amsterdam: SUN Publishers, 2009.

Jane Jacobs, *The Death and Life of Great American Cities*, Vinatage Books, New York, 1961.

Jan Gehl, *Life Between Buildings Using Public Space*, The Danish Architecture Press, Copenhagen, 1986.

Manuel de Sola-Morales, "Public Spaces, Collective Spaces.", In *Architectural Positions*, Amsterdam: SUN Publishers, 2009.

