

Document Version

Accepted author manuscript

Licence

CC BY-NC-SA

Citation (APA)

Post, J. A. B., Pothof, I. W. M., Dirksen, J., Baars, E. J., Langeveld, J. G., & Clemens, F. H. L. R. (2016). Monitoring and statistical modelling of sedimentation in gully pots. *Water Research, 88*, 245-256.
<https://doi.org/10.1016/j.watres.2015.10.021>

Important note

To cite this publication, please use the final published version (if applicable).
Please check the document version above.

Copyright

In case the licence states "Dutch Copyright Act (Article 25fa)", this publication was made available Green Open Access via the TU Delft Institutional Repository pursuant to Dutch Copyright Act (Article 25fa, the Taverne amendment). This provision does not affect copyright ownership.
Unless copyright is transferred by contract or statute, it remains with the copyright holder.

Sharing and reuse

Other than for strictly personal use, it is not permitted to download, forward or distribute the text or part of it, without the consent of the author(s) and/or copyright holder(s), unless the work is under an open content license such as Creative Commons.

Takedown policy

Please contact us and provide details if you believe this document breaches copyrights.
We will remove access to the work immediately and investigate your claim.

1 Monitoring and statistical modelling of 2 sedimentation in gully pots

3 Post, J.A.B.^{1*}, Pothof, I.W.M.^{1,2}, Dirksen, J.³, Baars, E.J.³, Langeveld, J.G.^{1,4}, Clemens, F.H.L.R.^{1,2}

4 ¹Section Sanitary Engineering, Faculty of Civil Engineering and Geosciences, Delft University of Technology, PO Box 5048,
5 2600 GA, Delft, The Netherlands

6 ²Deltares, PO Box 177, 2600 MH, Delft, The Netherlands

7 ³Waternet Foundation, PO Box 94370, 1090 GJ, Amsterdam, The Netherlands

8 ⁴Partners4urbanwater, Javastraat 104A, 6524 MJ, Nijmegen, The Netherlands

9 **Abstract**

10 Gully pots are essential assets designed to relief the downstream system by trapping solids and
11 attached pollutants suspended in runoff. This study applied a methodology to develop a quantitative
12 gully pot sedimentation and blockage model. To this end, sediment bed level time series from 300
13 gully pots, spanning 15 months, were collected. A generalised linear mixed modelling (GLMM)
14 approach was applied to model and quantify the accumulation of solids in gully pots and to identify
15 relevant physical and catchment properties that influence the complex trapping processes. Results
16 show that the retaining efficiency decreases as sediment bed levels increase. Two typical silting
17 evolutions were identified. Approximately 5% of all gully pots experienced progressive silting,
18 eventually resulting in a blockage. The other gully pots show stabilising sediment bed levels. The
19 depth of the sand trap, elapsed time since cleaning and the road type were identified to be the main
20 properties discriminating progressive accumulation from stabilising sediment bed levels.
21 Furthermore, sediment bed levels exhibit no residual spatial correlation, indicating that the
22 vulnerability to a blockage is reduced as adjacent gully pots provide a form of redundancy. The

* Corresponding author e-mail: j.a.b.post@tudelft.nl

23 findings may aid to improve maintenance strategies in order to safeguard the performance of gully
24 pots.

25 **Keywords:** sediment accumulation; gully pot blockage; Bayesian inference; generalised linear mixed
26 modelling

27 **Nomenclature**

28 t observation number

29 i gully pot identity

30 p the probability of 'success'

31 ε random part of the generalised linear model

32 η Linear predictor containing the deterministic part of the generalised linear model

33 d available sump depth

34 y measured sediment bed level

35 v normalised sediment bed level with respect to the sump depth

36 x quantitative explanatory variable

37 β model weight assigned to explanatory variable x

38 ϕ autocorrelation strength

39 ω noise term

40 a shape parameter for the beta distribution

41 b shape parameter for the beta distribution

42 θ over-dispersion parameter

43 \mathbf{z} row incidence vector for the random effects

44 **1 Introduction**

45 Street inlets are essential sewer assets responsible for collecting and conveying excess water from
46 the urban surface. These structures are commonly designed as gully pots, referring to the presence

47 of a sand trap. By capturing suspended particles in runoff, silting and wear of downstream sewer
48 components are reduced. In addition, the impact on the pollutant wash-off to the sewer system is
49 considerable (Ashley et al. 2004, Butler et al. 1995). Therefore, gully pots decrease the pollution load
50 to receiving water bodies, especially for storm sewers. Depending on the retaining efficiency of the
51 sand trap, the supply of solids induces progressive silting over time. When the trap capacity of is
52 exceeded, the hydraulic performance of the gully pot is impaired. In the absence of alternative flow
53 routes, water will pond and spread over adjacent areas causing potential health risks (De Man et al.
54 2014, Ten Veldhuis et al. 2010) and tangible damage (Arthur et al. 2009). The role of gully pot
55 blockages as main contributor to sewer flooding events has been recognised by several studies (e.g.
56 Ten Veldhuis et al. (2011) and Caradot et al. (2011)).

57 Unlike most sewer system components, gully pots are generally maintained with a proactive
58 preventive approach (Butler and Davies 2004, Karlsson and Viklander 2008). It comprises of cleaning
59 activities that are undertaken after a fixed period of time. Currently, the cleaning frequency is based
60 on either the available budget (Fenner 2000), expert judgment, or vulnerability of the urban
61 environment. The effectiveness of this type of management depends on the number of a blockages
62 in a system within the specified interval (Swanson 2001). Yet, authorities lack quantitative data to
63 support observed blockages. If data on the operational condition of gully pots are utilised to
64 determine the maintenance interval, it is possible to balance the effectiveness of strategies and the
65 associated resources to provide cost-effective service provision.

66 Adopting a condition-based approach for maintenance requires prediction tools and field data (Van
67 Riel et al. 2014). Prediction models for solids transport in gully pots are described by e.g. Fulcher
68 (1994) Butler and Karunaratne (1995) and Deletic et al. (2000). These models are based on dense
69 time series with a duration varying from one to several storm events or artificial events for a limited
70 (1 – 60) number of gully pots. Although this duration is adequate to simulate transport processes
71 during individual events, the characteristic time scale of the solids induced blockage process in gully

72 pots calls for time series covering a period of at least one year. Considering the complex transport
73 processes and the corresponding parameter uncertainty, Rodríguez et al. (2012) and Pratt et al.
74 (1987) opted for a probabilistic approach. This study modelled the long term accumulation of solids
75 that leads to blockages by applying a generalised linear mixed modelling (GLMM) approach to time
76 series of multiple gully pots. This approach allows for the identification of catchment and physical
77 properties of gully pots that affect the accumulation of solids. Sufficient monitoring locations are
78 essential for probabilistic modelling, as the potential correlation between successive measurements
79 over time results in less unique information. To this end, sediment bed levels of 300 gully pots were
80 measured monthly for over a year. Findings from this study may support overall maintenance
81 strategies on a system scale and improve gully pot design. Furthermore, this work complements
82 previous research on sediment accumulation and water quality aspects (e.g. Ellis and Harrop (1984),
83 Memon and Butler (2002) and Butler and Karunaratne (1995)). This paper first presents an overview
84 of literature on the relevant processes to identify the main explanatory variables that influence the
85 occurrence of gully pot blockages. Second, the collection of sediment bed level data is discussed.
86 Subsequently, a procedure for modelling is introduced and applied to these data.

87 **2 Relevant transport processes and parameters**

88 Various processes govern sediment accumulation. The following review identifies properties that are
89 relevant for modelling sedimentation in gully pots.

90 **2.1 Supply to gully pots**

91 Particles present in the urban environment are predominately inorganic, comparable to sand and silt
92 (Lager 1977, Sartor and Boyd 1972). These particles originate from different sources, such as local
93 traffic (Deletic et al. 2000), construction activities (Ashley and Crabtree 1992), weathering of
94 buildings (Jartun et al. 2008), animal wastes, litter, and de-icing materials (Brinkmann 1985). Particles
95 that are transported to gully pots during storm events are generally not well removed by street

96 sweeping (Brinkmann 1985, Sartor and Boyd 1972). Material available for wash-off to gully pots may
97 vary spatially, as the presence of potential sources is subject to local circumstances. Pratt and Adams
98 (1984) reported a relation between characteristics of the contributing area (e.g. size, drainage path
99 length) and the mean mass of the measured sediment wash-off in the field. These data did, however,
100 originate from the same gully pots, indicating a potential dependence between successive
101 measurements over time. In addition to spatial variation, the supply to gully pots may also vary
102 temporally. Grottker (1990b) analysed the organic content of sediment samples and found a higher
103 organic loading (5 – 10%) in autumn. Peaks in the material supply in June, autumn and after
104 snowmelt were mentioned by Pratt et al. (1987), indicating seasonal variation. On a shorter
105 timescale, flow characteristics dominate the temporal variation. Ellis and Harrop (1984) found that
106 the antecedent dry period was only weakly correlated with the sediment loading to gully pots.
107 Rainfall intensity was, however, strongly correlated. Similar results lead Pratt and Adams (1984) to
108 the conclusion that the shear force required to suspend material is limiting, rather than the
109 availability of material. The overall variation in particle loading results in models that typically calls
110 for several site specific calibration parameters (Memon and Butler 2002).

111 **2.2 Retaining efficiency**

112 The fraction of solids captured by gully pots has been studied extensively. Field studies reported
113 retaining efficiencies ranging from 20 – 50% (Deletic et al. 2000, Pitt and Field 2004). Both Butler and
114 Karunaratne (1995) and Grottker (1990a) conducted lab experiments where the solids supply to gully
115 pots was varied. They found that the retaining efficiency was independent from the solids
116 concentration, which support model results from Butler and Memon (1999). Butler and Clark (1995)
117 found the build-up rate to vary between 14 – 24 mm / month for urban areas. This variation may well
118 be related to the substantial variation in grain size distributions of samples from different gully pots
119 (Jartun et al. 2008), as solids with a smaller diameter are captured less efficiently (Butler and
120 Karunaratne 1995, Lager 1977).

121 Laboratory tests by Butler and Karunaratne (1995) with varying sediment bed levels up to the level of
122 the outlet pipe of a gully pot show a marginal increase in the retaining efficiency with increasing
123 sediment depths. This is contradictory with experimental results reported by Lager (1977), who
124 found that solids removal efficiencies decreased when a threshold of 40% of the gully pot storage
125 was exceeded. The latter is supported by the increase in the retaining efficiency with an increasing
126 cleaning frequency (Memon and Butler 2002, Mineart and Singh 2000). Field measurements from
127 Butler and Clark (1995) indicate that equilibrium sediment bed levels were reached at the level of the
128 outlet pipe. Conradin (1990) reported similar results for 63 gully pots monitored for 16 months;
129 sediment bed levels did not exceed the level of the outlet pipes and equilibrium depths were
130 generally reached in 6 months.

131 **2.3 Re-suspension of sediments**

132 There is a general consensus that the sedimentation rate is inversely proportional to the rainfall
133 intensity (e.g. Morrison et al. (1988), Deletic et al. (2000) and Ciccarello et al. (2012)). Depending on
134 the particle size, the jetting effect induces erosion of the gully pot sediment bed (Butler and Memon
135 1999). Sartor and Boyd (1972) applied flushing tests equivalent to heavy storms and found only 1% of
136 the sediment bed to be re-suspended. This confirms earlier results reported by Fletcher and Pratt
137 (1981), who mentioned that the majority of solids discharged from gully pots are due to a lack of
138 sedimentation rather than re-suspension. As the top layer of the sediment bed is more unstable,
139 these solids may be eroded (Pitt and Field 2004). However, bed erosion decreases substantially as
140 these particles are depleted and the bed becomes graded (Butler and Karunaratne 1995).

141 **2.4 Summary of relevant transport parameters**

142 A statistical approach calls for data on gully pots properties that may influence solids accumulation in
143 a sand trap. Gully pots are subject to successive storm events over time, where sediment bed levels
144 increase or decrease depending on the rainfall regime. As the height of the bed increases over time
145 the trapping efficiency reduces, indicating the relevance of the gully pot sump depth as an

146 explanatory variable. In addition, the transient trapping efficiency implies interaction terms between
147 the physical properties and the elapsed time since last maintenance. Catchment properties govern
148 both the flow rate and the supply of solids. As such, these properties are potential explanatory
149 variables. An overview of the explanatory variables included in the model is presented in Table 4-1.
150 Model residuals are potentially correlated, as the availability of particles from the urban surface
151 varies both spatially and temporally.

152 **3 Materials**

153 Sediment bed levels of gully pots in a residential urban area in Amsterdam, the Netherlands were
154 been monitored. The catchment area has 10.5 ha of surfaces that contribute to the runoff into the
155 separate sewer system.

156 **Figure 3.1: Schematisation of a roadside gully pot, with the outlet pipe positioned at the back**

157 A sample size of 300 gully pots was selected from the catchment with 801 gully pots to allow for valid
158 inferences given the spatial variation of the process measured. Data on the properties of gully pots in
159 the study area was inventoried prior to the measurements. This includes geometrical data describing
160 the physical properties of each gully pot (depth of the sand trap, surface area, manufacturer,
161 presence of a water seal, position of the outlet pipe with respect to the grating) and catchment
162 properties (contributing area, slope, road type). Based on the spatial distribution of the physical
163 properties of the gully pots (see Figure 3.1), a stratified sampling design was applied. This sampling
164 technique improves estimates of both the population and the sub-groups by taking a proportional
165 sample from each sub-group. Stratification distinguished between the presence of a water seal, the
166 position of the outlet pipe and the depth of the sand trap. Table 3-1 shows the frequency distribution
167 over the different strata.

168 **Table 3-1: Frequency distribution of the different strata**

Water seal	Depth trap (cm)	Position outlet pipe		
		Back	Front	Side
No	[0 - 20]	11	23	14

	(20 - 40]	5	9	12
Yes	[0 - 20]	13	37	75
	(20 - 40]	11	21	79

169

170 The associated costs and spatial spread render continuous monitoring for this sample size
 171 impractical. Instead, an apparatus able to rapidly measure the height of the bed has been
 172 constructed. The principle is illustrated in Figure 3.2. It consists of a punctured disk attached to a
 173 shaft, with a retractable rod in the middle. The disk rests on the sediment bed, while the rod is driven
 174 through until the bottom of the gully pot is reached. The rod is equipped with a sequence of marks at
 175 $5 \cdot 10^{-3}$ m intervals enabling the operator to determine the height of the bed. Tests with repeated
 176 measurements from the same gully pot indicate the error to be smaller than the increment of the
 177 instrument scale.

178 **Figure 3.2: Schematisation of the device used to measure sediment bed levels in gully pots.**

179 Three weeks prior to the first measurement, all gully pots were emptied and lateral connections
 180 cleaned. In addition, the hydraulic capacity of the lateral connections was tested by means of a
 181 vehicle mounted sewer jetting installation capable of providing a flow of 100 l/min, equivalent to 60
 182 mm/hr on 100 m², assuming the design standard applied in the Netherlands (Ganzevles and Oomens
 183 2008). In case of a defect, the gully pot was removed from the dataset. This excluded the influence of
 184 external failure mechanisms not related to the sedimentation mechanism, such as collapse or
 185 deformation of the geometry. Gully pots were removed from the monitoring set when more than
 186 one measurement was missing, e.g. due to accessibility, or in case of signs of tampering. In addition,
 187 gully pots presumed blocked due to the accumulation of sediment during the monitoring period
 188 were tested by means of a vehicle mounted sewer jetting installation to validate this observation.
 189 The duration of the campaign was chosen to be longer than the standard preventive cleaning interval
 190 of once or twice per year and to include all four seasons.

191 **3.1 Catchment properties**

192 The contributing area and average slope for each gully pot was determined by means of the eight-
193 direction flow approach described in Jenson and Domingue (1988). The digital elevation model (DEM)
194 used to deduct these flow patterns is based on high-resolution altimetry data obtained by airborne
195 laser scanning (Van der Zon 2011) and has a spatial resolution of $0.5 \cdot 0.5$ m. The vertical stochastic
196 error for the grid is $2.5 \cdot 10^{-3}$ m. Confounding objects (e.g. cars and trees) were filtered from the DEM
197 and were interpolated from the surrounding data. Both Kriging with an external drift (KED) based on
198 land use and Ordinary Kriging (OK) were considered as interpolation methods. However, analysis of
199 the variogram of the regression residuals showed no substantial improvement (1.5%) of the
200 semivariance. Hence, Ordinary Kriging was applied to interpolate the DEM.

201 The area has two road types, being main roads and local roads (see preview photos in Figure 3.3).
202 The former has a continuous traffic flow (2000 – 6000 vehicles/day) and a road surface consisting of
203 asphalt pavement. The latter is characterized by brick paving (< 2000 vehicles/day) and parking lots.
204 The area is considered to be a dense urban environment, developed as a residential area with some
205 commercial properties concentrated around the main roads. An overview of the monitoring area is
206 given in Figure 3.3.

207 **Figure 3.3: Measurement area in Amsterdam, the Netherlands. Gully pots are marked by circles.**

208 **4 Methods for data analysis**

209 As the processes associated with the transport and subsequent sedimentation of solids are complex
210 and not fully understood, deterministic storm water quality modelling is associated with various
211 difficulties (Deletic et al. 2000, Freni et al. 2009). Moreover, a deterministic approach requires the
212 estimation of various site specific parameters, which are subject to uncertainty (David and Matos
213 2002). Based on these considerations, this study applies a probabilistic approach. Sediment bed level
214 data were analysed by applying a Generalised Linear Mixed Model (GLMM) from a Bayesian
215 perspective. The four components that compose this model are discussed in chapter's 4.1 - 4.4.

216 Selection of the structure of these components follows the protocol suggested by (Zuur et al. 2009),
 217 which is summarised in Figure 4.1. First, the data exploration procedure outlined in chapter 4.5 was
 218 applied. Subsequently, the random part and the distribution of the response variable were
 219 determined with the complete deterministic part including interactions between the physical
 220 properties and the elapsed time since cleaning. After validation, model selection was applied to
 221 identify relevant explanatory variables in the deterministic part.

222 **Figure 4.1: procedure for the selection of the components of a GLMM. References to the corresponding paragraphs**
 223 **where the results are presented have been added.**

224 4.1 Structure of the deterministic part

225 The linear predictor η contains the deterministic part of the model, which is a linear function of k
 226 explanatory variables and is given by

$$227 \eta_{t,i} = \beta_0 + \beta_1 x_{t,i,1} + \dots + \beta_k x_{t,i,k} \quad (4.1)$$

228 where t represents the observation number and i the gully pot. β refers to the weights assigned to
 229 the respective explanatory variables x , summarised in Table 4-1. β_0 is the intercept.

230 **Table 4-1: Explanatory variables and their characteristics**

Variable	Index	Type	Unit	Range
Depth sand trap	x_1	continuous	(cm)	[9 - 44]
Catchment slope	x_2	continuous	(%)	[1.3 - 4.3]
Time since cleaning	x_3	continuous	(days)	[21 - 420]
Contributing area	x_4	continuous	(m ²)	[5 - 1380]
Cum. Rainfall depth	x_5	continuous	(mm)	[115 - 1160]
Water seal	x_6	categorical	-	yes / no
Position outlet pipe	x_7	categorical	-	front / back
Position outlet pipe	x_8	categorical	-	side / back
Road type	x_9	categorical	-	main / local

232 4.2 Structure of the random part

233 The model assumption of independence is not guaranteed, as successive observations from the same
 234 gully pot can be expected to be more similar compared to observations from other gully pots. This
 235 violation of independence was resolved by extending the deterministic part η with a correlation
 236 structure to model inter-gully pot variation and the correlation caused by this variation. Two

237 extensions were considered. The first candidate was a random intercept, which implies that all pairs
 238 of observations from the same subject gully pot are equally correlated (i.e. compound symmetry
 239 correlation) and defines the random part as

$$240 \quad \varepsilon_{t,i} = N(0, \sigma_i^2) \quad (4.2)$$

241 Alternatively, an auto-regressive process of order 1 (AR-1) model was considered. It is a special case
 242 of the autoregressive–moving-average model family. This structure has correlations, between
 243 observations from the same gully pot, that decline exponentially with time and is given by

$$244 \quad \begin{aligned} \varepsilon_{t,i} &= \phi \varepsilon_{t-1,i} + \omega_{t,i} \\ \omega_{t,i} &= N(0, \sigma^2) \end{aligned} \quad (4.3)$$

245 where the estimated parameter ϕ is the strength of the autocorrelation and ω the noise term.

246 **4.3 Distribution of the response variable**

247 Each outcome of the response variable is assumed to be generated from a particular distribution.
 248 This study analyses the normalised sediment bed level v , which is defined as the sediment bed level y
 249 normalised with respect to the available sump depth d . Two distributions were considered, the first
 250 being the binomial distribution, with probability p , specified by

$$251 \quad \begin{aligned} y_{t,i} &\square \text{Binomial}(p_{t,i}, d_{t,i}) \\ E(y_{t,i}) &= p_{t,i} \cdot d_{t,i} \quad \text{and} \quad \text{var}(y_{t,i}) = p_{t,i} \cdot d_{t,i} \cdot (1 - p_{t,i}) \end{aligned} \quad (4.4)$$

252 However, when the variation of the data is inflated compared to the theoretical expected variance
 253 according to the binomial model (i.e. over-dispersion), a more general model is required.
 254 Alternatively the response variable can be described by a beta-binomial distribution. This mixed
 255 distribution permits heterogeneity by modelling the probability of success as a beta distribution.
 256 Parameters a and b describe the beta distribution. The expected value of the beta-binomial is similar
 257 to the expected value of the binomial distribution in eq. 4.4. Yet, the variance is given by

$$258 \quad \text{var}(y_{t,i}) = p_{t,i} \cdot d_{t,i} \cdot (1 - p_{t,i}) \cdot \left(1 + \frac{d_{t,i}}{\theta + 1}\right) \quad (4.5)$$

259 Where the parameter $\theta = a + b$ accounts for over-dispersion. For large values of theta, the variance
260 converges to that of the binomial distribution.

261 **4.4 Link function**

262 Subsequently, the link function describes the relationship between the expectation of the response
263 variable and the extended deterministic part. The logistic link is such a function and is given by

$$264 \quad p_{i,j} = \frac{e^{\eta_{i,j} + \varepsilon_{i,j}}}{1 + e^{\eta_{i,j} + \varepsilon_{i,j}}} \quad (4.6)$$

265 Introduced by (Berkson 1944), it approximates the inverse cumulative distribution function of the
266 Gaussian distribution and is able to model binomial data effectively (Hardin and Hilbe 2007).

267 **4.5 Data exploration and model validation**

268 The process of exploration and validation provides information about eligible model structures and
269 explanatory variables. Outliers may influence the statistical analysis and cause over-dispersion (Hilbe
270 2007). In addition, an abundance of zero measurements may result in biased parameter estimates
271 and incorrect standard errors (Zuur et al. 2010). Graphical exploration of the explanatory variables
272 and the response variable allowed for the identification of both zero abundances and outliers.

273 Strong collinearity between explanatory variables may result in unreliable parameter estimates, as
274 the estimates may respond erratically to small changes in the data (Zuur et al. 2013). Collinearity was
275 assessed by inspecting pair-plots and computing Variance Inflation Factors (VIF) for high-dimension
276 relations.

277 Following the model specification, the influence of individual observations was analysed by
278 computing Cook's distance (Cook 1977). This statistic represents the normalised change in fitted
279 values when one observation is removed. Pearson residuals were extracted from the model to verify
280 the assumptions inherent to GLMM's. Homogeneity of variance was verified by graphical techniques,
281 as statistical tests are sensitive to non-normality (Sokal and Rohlf 1995). Non-linear patterns in the

282 residuals may indicate that the model needs to be extended with quadratic terms (Zuur et al. 2013).
 283 Mantel correlograms of the residuals were analysed to determine whether there is any inherent
 284 spatial or temporal dependency.

285 4.6 Bayesian Inference

286 In recent years, Bayesian inference has gained an increasing amount of attention in the field of
 287 environmental engineering (e.g. Kanso et al. (2006), Liu et al. (2008), Korving et al. (2006) and Egger
 288 et al. (2013)). The Bayesian framework considers unknown parameters as random variables. The
 289 uncertainty about these parameters is expressed by the posterior density function. This approach is
 290 not hindered by the potential inaccurate penalized quasi-likelihood generally applied to GLMM's in a
 291 frequentist framework (Zhao et al. 2006). Bayes' theorem evaluates the posterior density by
 292 updating prior information when new observations are available and is given by,

$$293 \quad P(\boldsymbol{\beta} | \mathbf{y}) = \frac{P(\mathbf{y} | \boldsymbol{\beta})P(\boldsymbol{\beta})}{P(\mathbf{y})} = \frac{P(\mathbf{y} | \boldsymbol{\beta})P(\boldsymbol{\beta})}{\int P(\mathbf{y} | \boldsymbol{\beta})P(\boldsymbol{\beta})d\boldsymbol{\beta}} \quad (4.7)$$

294 where $P(\boldsymbol{\beta} | \mathbf{y})$ is the joint posterior density of parameter vector $\boldsymbol{\beta}$ based on prior information and
 295 observations $\mathbf{y} (y_{1,1}, y_{1,2}, \dots, y_{n,t})$ from n different gully pots on t occasions. The prior probability density
 296 $P(\boldsymbol{\beta})$ represents expert information or historical observations before new data are involved. The
 297 marginal likelihood is denoted by $P(\mathbf{y})$ and is a fixed normalising factor, scaling the sum of the
 298 posterior likelihood to one. $P(\mathbf{y} | \boldsymbol{\beta})$ is referred to as the likelihood function, which for a binomial
 299 generalised linear mixed model can be expressed as,

$$300 \quad P(\mathbf{y} | \boldsymbol{\beta}, \boldsymbol{\varepsilon}) = \prod_{n=1}^N \prod_{t=1}^T \binom{d_{n,t}}{y_{n,t}} \left[P_{n,t}(\boldsymbol{\beta}_{n,t}, \boldsymbol{\varepsilon}_n) \right]^{y_{n,t}} \left[1 - P_{n,t}(\boldsymbol{\beta}_{n,t}, \boldsymbol{\varepsilon}_n) \right]^{d_{n,t} - y_{n,t}} \quad (4.8)$$

301 where,

$$302 \quad p_{n,t}(\boldsymbol{\beta}_{n,t}, \boldsymbol{\varepsilon}) = \left[1 + e^{\mathbf{x}_{n,t}^T \boldsymbol{\beta}_{n,t} + \mathbf{z}_n^T \boldsymbol{\varepsilon}} \right]^{-1} \quad (4.9)$$

303 includes both the deterministic and random part. \mathbf{z} is a row incidence vector for the random part.

304 Non-informative priors were used for the regression parameters, representing the lack of knowledge

305 about the parameters. These distributions have a negligible influence on the posterior distribution. A
306 half-Cauchy(25) prior was used for the standard deviation parameter, as recommended by Gelman
307 (2006) and Marley and Wand (2010). This prior expresses the belief that the random intercepts are
308 concentrated close to the common intercept.

309 Integration over the denominator of eq. 4.7 is considered to be infeasible for most practical
310 applications due to high-dimensionality of β (Qian et al. 2003). Markov Chain Monte Carlo (MCMC)
311 algorithms do not require evaluation of the marginal likelihood, since the posterior distribution is
312 sampled directly. This study applied the Gibbs sampler (Geman and Geman 1984) as MCMC
313 algorithm. It is referred to as an alternating conditional sampler, as it samples from the conditional
314 distribution of each parameter with respect to the remaining parameters. The Gibbs sampler has
315 been found to be particularly suited for multidimensional problems (Gelman et al. 2003) and is
316 implemented in the open source software JAGS (Plummer 2003), which was called from the R
317 software environment (R Core Team 2014).

318 Convergence of the MCMC algorithm is essential for a correct estimation of the posterior distribution
319 for the parameters of interest. To this end, the Gelman-Rubin diagnostic (Gelman and Rubin 1992)
320 was used. This diagnostic compares the variance of the independent Markov chains to the variance
321 between the chains.

322 **5 Results and discussion**

323 4500 sediment bed level measurements spanning 15 months (Sept. 2013 – Nov. 2014) were available
324 at the end of the monitoring campaign introduced in chapter 3. 2% of the locations were removed
325 from the set due to missing measurements or suspected tampering. A total rainfall depth of 1160
326 mm was recorded. Section 5.1 presents the results of this campaign. The remainder of this chapter is
327 dedicated to applying the procedures introduced in chapter 4. This involves applying a generalised

328 linear mixed modelling (GLMM) approach to the field data in order determine how the properties of
329 gully pots affect their operational condition over time.

330 5.1 Field measurements

331 The distribution of measured sediment bed levels for each measurement day are presented in the
332 respective violin plots in Figure 5.1. This figure shows a main cluster, consisting of a majority of the
333 gully pots, which experienced stable bed levels several months after cleaning. In contrast, a fraction
334 of all measured gully pots experienced progressive accumulation, eventually resulting in a blockage.
335 The latter group covers approximately 5% of all gully pots at the end of the campaign. Based on the
336 measured sediment levels, gully pots in this group were distinctly separated from the main cluster.

337 Analysis of the median sediment bed levels over time indicates that more sediment was retained in
338 the first weeks after cleaning, compared to subsequent measurements. Since the measurement
339 campaign lasted more than one year the increased retention of sediments cannot be attributed to
340 seasonal variation, as later measurements in the same season do not display similar patterns. This
341 implies a reduction in the retaining efficiency over time, under the assumption of a stationary solids
342 load from the urban surface. Increased skewness of the distribution over time indicates dispersion of
343 the main cluster, characterising the long term accumulation of solids.

344 **Figure 5.1: Box-violin plot of the measured sediment bed levels over time. The symmetrical density plot shows the**
345 **distribution of sediment bed levels for each day of measurement. The box plot presents quartiles and individual points**
346 **representing outliers. Vertical jitter was added to the outliers to aid visual interpretation.**

347 5.2 Data exploration

348 Graphical exploration of the data revealed no clear signs of outliers or zero-inflation. Analysis of the
349 Cook's distance statistic discussed in section 4.5 showed no particular influential observation. A pair-
350 plot of the normalised sediment bed levels v , and all explanatory variables is depicted in Figure 5.2.
351 All explanatory variables were standardised to improving mixing of the MCMC chains. This pair-plot
352 shows that the elapsed time since cleaning x_3 and the cumulative rainfall depth x_5 are strongly
353 correlated, demonstrating that these variables cannot be identified separately. This is confirmed by

354 the corresponding variance inflation factor of 64.16, which is larger than the cut-off range of 5 - 10
 355 suggested by Montgomery and Peck (1992). Therefore it was decided to exclude the cumulative
 356 rainfall x_5 as explanatory variable.

357 **Figure 5.2: Pair-plot of the response variable and all continuous standardised (dimensionless) explanatory variables x .**
 358 **The lower left part contains pair-wise correlations, whereas the upper right part contains scatterplots with a locally**
 359 **weighted polynomial (LOESS) added to reveal patterns in the scatter.**

360 Subsequently, the Bayesian approach presented in section 4.6 was applied to the collected sediment
 361 bed data in order to determine which physical and catchment properties distinguish progressive
 362 accumulation from stabilizing sediment bed levels.

363 5.3 Random part and probability distribution of the response variable

364 Estimations of the relative quality of the proposed probability distributions and random parts in
 365 section 4.2 - 4.3 was obtained by means of the Akaike information criterion (AIC) (Akaike 1973),
 366 which is a penalized likelihood method. Each model included the complete set of explanatory
 367 variables and interactions for the physical properties. The AIC values given in Table 5-1 reveal that
 368 the models with an autoregressive component outperform their counterparts. The binomial GLMM
 369 with AR-1 correlation structure has the best relative performance. The Akaike weights (w_i) in this
 370 table represents the probability that this model has the best performance, given the data and the
 371 other proposed models.

372 **Table 5-1: AIC analysis for four competing model structures**

Model	AIC	w_i AIC
Binomial GLMM with AR-1	19416.24	1.00E+00
Binomial GLMM	30597.16	0.00E+00
Beta-binomial GLMM with AR-1	19474.30	2.47E-13
Beta-binomial GLMM	20566.96	1.33E-250

373

374 Analysis of the Pearson residuals revealed that the binomial GLMM is subject to an over-dispersion of
 375 2.92. The beta-binomial GLMM allows for this extra dispersion through θ in eq. 4.5. A comparison of

376 the mean values for θ derived from the beta-binomial GLMM with and without an AR-1 correlation
 377 structure, $4.32 \cdot 10^4$ versus 20.03 respectively, demonstrates the effectiveness of this component to
 378 capture the over-dispersion. Since $4.32 \cdot 10^4 \ll d_{t,i}$ (available sump depth), the variance of the beta-
 379 binomial distribution in eq. 4.5 converges to the variance of the binomial distribution.

380 5.4 Deterministic structure

381 The optimal deterministic structure was obtained by applying backwards selection based on the
 382 95% highest probability density interval (HPDI). None of the interaction terms for the physical
 383 properties were significant. In addition, the explanatory variables: x_6 “presence of a water seal” and
 384 x_2 “catchment slope” are not significant from 0 at a 5% level and were excluded from the model.
 385 Exclusion of the interaction terms implies that the effect of the physical properties on the retaining
 386 efficiency does not change as the sand trap progressively silts. Figure 5.3 presents the marginal
 387 posterior distributions of the weights β_k for each explanatory variable x_k of the optimal model.

388 **Figure 5.3: Marginal posterior distributions of the weights β_k for each explanatory variable x_k . The horizontal line shows**
 389 **the 95% credible interval for 800 MCMC samples. The vertical line depicts the intersection with the y-axis, indicating**
 390 **whether the credible interval contains zero.**

391 The variables x_8 “position of the outflow pipe (side)” and x_4 “contributing area” have the largest p-
 392 values, 0.001 and 0.005 respectively. The deterministic component of the estimated GLMM with
 393 standardised (dimensionless) covariates and mean weight values from Figure 5.3 can be written as:

$$394 \eta_{t,i} = -2.490 - 0.415 \cdot Depth_{t,i} + 0.261 \cdot Time_{t,i} + 0.084 \cdot Area_{t,i} + 0.710 \cdot PipeOut_{t,i} \text{ (front)} + 0.503 \cdot PipeOut_{t,i}$$

$$395 \text{ (side)} + 0.481 \cdot Road_{t,i} \text{ (main)} \quad (5.1)$$

396 The predicted mean values for the normalised sediment bed level v , without the random component,
 397 for the different levels of the categorical explanatory variables are visualised in Figure 5.4. Credible
 398 intervals provide a region that contains the mean fitted values with a 95% probability, based on the
 399 marginal posterior distribution of the explanatory variables. The positive weight for β_9 “road type
 400 (Main Road)” compared to the baseline, corresponds to a higher sediment bed level for the gully
 401 pots located in main roads. Similar inferences hold for the weights β_7 and β_8 corresponding to the

402 side of the outlet pipe. The higher sediment bed levels for main roads are in accordance with the
403 statements in chapter 2, which ascribe the difference to the increased solids supply associated with
404 the traffic intensity. It is possible that the position of the outlet pipe influences the rolling motion of
405 flows in the sump reported by Faram and Harwood (2003), which results in high velocities near the
406 sediment–water interface.

407 **Figure 5.4: Fitted normalised sediment bed levels v for the entire population (without the random component) based on**
408 **the marginal posterior distribution of categorical explanatory variables x_9 “road type” and $x_7 - x_8$ “position of the outlet**
409 **pipe”, with 95% credible intervals**

410 Memon and Butler (2002) found that the depth of the sand trap is an important parameter, having a
411 considerable impact on the reduction of the suspended solids load to downstream sewer
412 components. The negative weight β_9 in eq. (5.1) corresponding to the depth of the sand trap
413 demonstrates that in addition to improving the water quality, increasing the depth of the sand trap
414 also reduces the probability of a blockage. Evidently, a reduction in the ability to retain sediment
415 does not compensate for the smaller volume of the sand trap under similar solids loading conditions.

416 The contributing area to each gully pot x_4 is positively correlated with the normalised sediment bed
417 level. Therefore it seems that, for the range of values for the contributing area in this study (5 – 1380
418 m^2), the impact of a higher solids supply associated with a larger contributing area predominates the
419 scouring effect of an increased flow rate.

420 **Figure 5.5: Model results of the Binomial GLMM with AR-1 correlation for the normalised sediment bed level v over time,**
421 **including a prediction interval containing 95% of the observed data. Horizontal jitter was added to visualise overlaying**
422 **points.**

423 Estimated normalised sediment bed levels including the random part are presented in Figure 5.5.
424 This figure illustrates that the proposed modelling approach is able to reproduce the dense cluster of
425 gully pots in a near equilibrium state perceived in Figure 5.1, as well as the blocked gully pots. Figure
426 5.6 shows the propagation of the estimated blockage rate for the area, given the parameter
427 uncertainty. The threshold where the monitored gully pots become susceptible to blockages was
428 found to be 100 days.

429 **Figure 5.6: The mean estimated cumulative blockage probability over time, including 95% credible intervals.**

430 Further analysis of the model estimates for the last day of measurement is presented in Figure 5.7.
431 The measured normalised sediment bed levels are within the 95% credible intervals for each bin,
432 suggesting agreement between model estimates and field observations over the entire range. This
433 confirms that the model is able to discriminate progressive accumulation from stabilizing sediment
434 bed levels, given the estimated model parameters.

435 **Figure 5.7: Kernel density plot of the distribution of the measured sediment bed levels for the final day of measurement,**
436 **expressing the variability of the sediment bed levels over a gully pot population of 298 individuals. In addition, a**
437 **histogram of the corresponding model estimate including 95% credible intervals is added.**

438 **5.5 Model validation**

439 Analysis of the model residuals is provided in Appendix B. The Mantel correlogram in Figure 5.8
440 shows that there is no significant spatial correlation present in the model residuals at distances of
441 more than 5 meters. The corresponding density graph presents the distribution of the Euclidean
442 distances between each gully pot. This graph reveals that although there was some spatial
443 dependence present at small distances, this concerns only a small fraction ($2 \cdot 10^{-4}$) of the total sample
444 of gully pots. As such, this figure demonstrates that there are no spatially correlated variables (e.g.
445 trees, local construction activities) missing in the model. The absence of a residual spatial
446 dependence demonstrates that there are no clusters of gully pots with higher normalised sediment
447 bed levels. This implies that maintenance strategies can be optimised when taking into account the
448 explanatory variables x_k of the deterministic structure. Moreover, in the presence of a gully pot
449 blockage there is no evidence of an increased blockage probability for adjacent gully pots. Therefore,
450 the vulnerability to an event is reduced, as alternative flow routes may compensate for the
451 occurrence of a blockage. With respect to the design of the public space, this entails that increasing
452 the gully pot density directly adds to redundancy.

453 **Figure 5.8: Spatial correlation of the model residuals, including 95% confidence bounds, plotted together with the**
454 **empirical density function of gully pots interdistances.**

455 **Figure 5.9: Autocorrelation of the rejected binomial GLMM with compound correlation and the chosen binomial GLMM**
456 **with AR-1 correlation structure. 95% confidence bounds were added.**

457 The effectiveness of the AR-1 model to catch the temporal dependence in the residuals was
458 illustrated in Figure 5.9. This figure shows the difference between the rejected binomial GLMM with

459 a compound correlation structure and the selected binomial GLMM with AR-1 correlation structure.
460 The former model structure was positively autocorrelated for several orders, as successive residual
461 values tend to persist on one side of the mean. It exhibits a slow meandering pattern, in which
462 residuals were consistently overestimated at the start of the time series and underestimated at the
463 end. A clear seasonal pattern was, however, not present. Furthermore, the low-lag positive
464 autocorrelation confirms that the sampling density of the monitoring campaign was sufficient to
465 reconstruct the long term sedimentation process in gully pots.

466 **5.6 Generalisation**

467 The results presented in Figure 5.5 - Figure 5.7 are case specific due to the set of properties for gully
468 pots in the study area. Under the assumption of sample representativeness, the marginal posterior
469 distributions of the model parameters in Figure 5.3 can be generalised and applied to similar
470 designed gully pots beyond the frame of the study area, e.g. to improve gully pot design. Results
471 found in this study are generally consistent with the literature in Chapter 2. In addition, the proposed
472 method for modelling sedimentation in gully pots can be applied to measurements from other study
473 areas.

474 **6 Conclusions**

475 This study provides a procedure to model the long term accumulation of solids that leads to
476 blockages. To this end, field measurements from 300 gully pots were analysed by means of a
477 generalised linear mixed model (GLMM). Analysis of the measurements revealed a majority of the
478 gully pots to have stable sediment bed levels after several months. However, a fraction (5%)
479 experienced a blockage due to the progressive accumulation of sediment.

480 From the model results it can be concluded that the depth of the sand trap and the position of the
481 outlet pipe are physical properties that distinguish progressive accumulation from stabilising
482 sediment levels. The latter was believed to influence the velocity profile at the sediment-water

483 interface. The former demonstrates that requirements concerning hydraulic efficiency and pollutant
484 retention for water quality purposes are not necessarily conflicting; both benefit from deeper sand
485 traps. No interaction between the physical properties and the elapsed time since cleaning was found
486 to be significant. This entails that the effect of these physical properties do not change as the
487 sediment bed level increases. The road type and the area contributing to runoff were found to be
488 relevant catchment properties. As the parameter estimate for the latter is positive, this indicates that
489 the higher solids supply predominates the scouring effect associated with an increased flowrate.

490 The absence of residual spatial correlation indicates that there are no clusters of gully pots with
491 higher normalised sediment bed levels. Since the blockage probability is spatially independent,
492 alternative drainage paths through adjacent gully pots may be available. As this limits the exposure
493 to flood events, the vulnerability of the public space to blockages reduces.

494 Findings from this study may aid to support maintenance strategies on a system scale and to improve
495 gully pot design. Knowledge of properties that contribute to progressive accumulation and eventually
496 blockages, may justify investments during the design phase in order to minimise future maintenance
497 and blockages. That is, decision makers should consider the physical and catchment properties that
498 prevent progressive accumulation of solids, when aiming to prevent gully pot blockages. In addition,
499 the absence of a residual spatial dependence allows for directing preventive maintenance, taking
500 these properties into account.

501 **7 Acknowledgements**

502 The authors would like to thank Wietse Dijkstra for his effort during the monitoring campaign. The
503 research is performed within the Dutch 'Kennisprogramma Urban Drainage' (Knowledge Programme
504 Urban Drainage). The involved parties are: ARCADIS, Deltares, Gemeente Almere, Gemeente Breda,
505 Gemeente 's-Gravenhage, Gemeentewerken Rotterdam, Gemeente Utrecht, GMB
506 Rioleringsstechniek, Grontmij, KWR Watercycle Research Institute, Royal HaskoningDHV, Stichting

507 RIONED, STOWA, Tauw, vandervalk+degroot, Waterboard De Dommel, Waternet and
508 Witteveen+Bos.

509 **Appendix A. Supplementary data**

510 **Appendix B**

511 Fitted values from the Binomial GLMM model with AR-1 correlation structure versus the Pearson
512 residuals are depicted in Figure B.1. Values on the right side of this graph represent gully pots which
513 are blocked according to the model. The change in variation for larger fitted values is not substantial,
514 taking into consideration the increase in point density for lower fitted values. The model does,
515 however, seem to underestimate values for nearly blocked gully pots to some extent. This is
516 attributed to the delineation of the upper asymptote of the applied link function, which cannot
517 return a probability of 1. Therefore, model estimations can only approximate the top full sand traps
518 associated with perceived blockages.

519 **Figure B.1: Fitted values from the model versus the Pearson residuals**

520 **8 References**

- 521 Akaike, H. (1973) Information theory and an extension of the maximum likelihood principle, pp. 267 -
522 281, Akadémia Kiado, Budapest, Hungary.
- 523 Arthur, S., Crow, H., Pedezert, L. and Karikas, N. (2009) The holistic prioritisation of proactive sewer
524 maintenance. *Water Science & Technology* 59(7), 1385 -
525 1396, <http://dx.doi.org/10.2166/wst.2009.134>.
- 526 Ashley, R.M., Bertrand-Krajewski, J.-L., Hvitved-Jacobsen, T. and Verbanck, M. (2004) Solids in
527 Sewers: characteristics, effects and control of sewer solids and associated pollutants., IWA Publishing
528 Company.
- 529 Ashley, R.M. and Crabtree, R.W. (1992) Sediment origins, deposition and build-up in combined sewer
530 systems. *Water Science & Technology* 25(8), 1-12
- 531 Berkson, J. (1944) Application of the logistic function to bio-assay. *Journal of the American Statistical*
532 *Association* 39(227), 357-365, <http://dx.doi.org/10.1080/01621459.1944.10500699>.
- 533 Brinkmann, W.L.F. (1985) Urban stormwater pollutants: sources and loadings. *GeoJournal* 11(3), 277-
534 283
- 535 Butler, D. and Clark, P. (1995) Sediment management in urban drainage catchments, p. 93.
- 536 Butler, D. and Davies, J. (2004) *Urban drainage*, CRC Press.
- 537 Butler, D. and Karunaratne, S.H.P.G. (1995) The suspended solids trap efficiency of the roadside gully
538 pot. *Water research* 29(2), 719-729, [http://dx.doi.org/10.1016/0043-1354\(94\)00149-2](http://dx.doi.org/10.1016/0043-1354(94)00149-2)

539 Butler, D. and Memon, F.A. (1999) Dynamic modelling of roadside gully pots during wet weather.
540 Water research 33(15), 3364-3372, [http://dx.doi.org/10.1016/S0043-1354\(99\)00050-0](http://dx.doi.org/10.1016/S0043-1354(99)00050-0)

541 Butler, D., Xiao, Y., Karunaratne, S.H.P.G. and Thedchanamoorthy, S. (1995) The gully pot as a
542 physical, chemical and biological reactor. Water Science and Technology 31(7), 219-
543 228, [http://dx.doi.org/10.1016/0273-1223\(95\)00339-0](http://dx.doi.org/10.1016/0273-1223(95)00339-0).

544 Caradot, N., Granger, D., Chappier, J., Cherqui, F. and Chocat, B. (2011) Urban flood risk assessment
545 using sewer flooding databases. Water Science & Technology 64(4), 832-
546 840, <http://dx.doi.org/10.2166/wst.2011.611>

547 Ciccarello, A., Bolognesi, A., Maglionico, M. and Artina, S. (2012) The role of settling velocity
548 formulation in the determination of gully pot trapping efficiency: Comparison between analytical and
549 experimental data. Water Science and Technology 65(1), 15-
550 21, <http://dx.doi.org/10.2166/wst.2011.775>.

551 Conradin, F. (1990) Study on catch basins in Switzerland, pp. 199-214, ASCE.

552 Cook, R.D. (1977) Detection of influential observation in linear regression. Technometrics 19, 15-18

553 David, L.M. and Matos, R.S. (2002) Wet weather water quality modelling of a Portuguese urban
554 catchment: difficulties and benefits. Water Science & Technology 45(3), 131-140

555 De Man, H., van den Berg, H.H.J.L., Leenen, E.J.T.M., Schijven, J.F., Schets, F.M., Van der Vliet, J.C.,
556 van Knapen, F. and de Roda Husman, A.M. (2014) Quantitative assessment of infection risk from
557 exposure to waterborne pathogens in urban floodwater. Water research 48, 90-
558 99, <http://dx.doi.org/10.1016/j.watres.2013.09.022>.

559 Deletic, A., Ashley, R.M. and Rest, D. (2000) Modelling input of fine granular sediment into drainage
560 systems via gully-pots. Water research 34(15), 3836-3844, [http://dx.doi.org/10.1016/S0043-1354\(00\)00133-0](http://dx.doi.org/10.1016/S0043-1354(00)00133-0).

562 Egger, C., Scheidegger, A., Reichert, P. and Maurer, M. (2013) Sewer deterioration modeling with
563 condition data lacking historical records. Water research 47(17), 6762-
564 6779, <http://dx.doi.org/10.1016/j.watres.2013.09.010>.

565 Ellis, J.B. and Harrop, D.O. (1984) Variations in solids loadings to roadside gully pots. Science of the
566 total environment 33(1), 203-211, [http://dx.doi.org/10.1016/0048-9697\(84\)90394-2](http://dx.doi.org/10.1016/0048-9697(84)90394-2).

567 Faram, M.G. and Harwood, R. (2003) A method for the numerical assessment of sediment
568 interceptors. Water Science & Technology 47(4), 167-174

569 Fenner, R.A. (2000) Approaches to sewer maintenance: a review. Urban water 2(4), 343-
570 356, [http://dx.doi.org/10.1016/S1462-0758\(00\)00065-0](http://dx.doi.org/10.1016/S1462-0758(00)00065-0).

571 Fletcher, I.J. and Pratt, C.J. (1981) Urban Stormwater Quality, Management and Planning, pp. 116-
572 124, Water Resources Publications Colo.

573 Freni, G., Mannina, G. and Viviani, G. (2009) Urban runoff modelling uncertainty: Comparison among
574 Bayesian and pseudo-Bayesian methods. Environmental modelling & software 24(9), 1100-
575 1111, <http://dx.doi.org/10.1016/j.envsoft.2009.03.003>

576 Fulcher, G.A. (1994) Urban stormwater quality from a residential catchment. Science of the total
577 environment 146, 535-542, [http://dx.doi.org/10.1016/0048-9697\(94\)90279-8](http://dx.doi.org/10.1016/0048-9697(94)90279-8)

578 Ganzevles, P. and Oomens, A. (2008) Leidraad B3000: Detaillering en aanleg van stelselonderdelen,
579 Rioned Foundation.

580 Gelman, A. (2006) Prior distributions for variance parameters in hierarchical models (comment on
581 article by Browne and Draper). Bayesian analysis 1(3), 515-534, <http://dx.doi.org/10.1214/06-ba117a>.

582 Gelman, A., Carlin, J.B., Stern, H.S. and Rubin, D.B. (2003) Bayesian Data Analysis, Chapman and
583 Hall/CRC.

584 Gelman, A. and Rubin, D.B. (1992) Inference from iterative simulation using multiple sequences.
585 Statistical science, 457-472, <http://dx.doi.org/10.1214/ss%2F1177011136>

586 Geman, S. and Geman, D. (1984) Stochastic relaxation, Gibbs distributions, and the Bayesian
587 restoration of images. IEEE Transactions on Pattern Analysis and Machine Intelligence (6), 721-
588 741, <http://dx.doi.org/10.1109/TPAMI.1984.4767596>

589 Grottker, M. (1990a) Pollutant Removal by Catch Basins in West Germany State of the Art—New
590 Design. Torno, H.C. (ed), pp. 215-244, ASCE, Davos Platz, Switzerland.

591 Grottker, M. (1990b) Pollutant removal by gully pots in different catchment areas. *Science of the*
592 *total environment* 93, 515-522, [http://dx.doi.org/10.1016/0048-9697\(90\)90142-H](http://dx.doi.org/10.1016/0048-9697(90)90142-H)

593 Hardin, J.W. and Hilbe, J.M. (2007) *Generalized linear models and extensions*, Stata Press.

594 Hilbe, J.M. (2007) *Negative binomial regression*, Cambridge University Press.

595 Jartun, M., Ottesen, R.T., Steinnes, E. and Volden, T. (2008) Runoff of particle bound pollutants from
596 urban impervious surfaces studied by analysis of sediments from stormwater traps. *Science of the*
597 *total environment* 396(2), 147-163, <http://dx.doi.org/10.1016/j.scitotenv.2008.02.002>.

598 Jenson, S.K. and Domingue, J.O. (1988) Extracting topographic structure from digital elevation data
599 for geographic information system analysis. *Photogrammetric engineering and remote sensing*
600 54(11), 1593-1600

601 Kanso, A., Chebbo, G. and Tassin, B. (2006) Application of MCMC–GSA model calibration method to
602 urban runoff quality modeling. *Reliability engineering & system safety* 91(10), 1398-
603 1405, <http://dx.doi.org/10.1016/j.res.2005.11.051>.

604 Karlsson, K. and Viklander, M. (2008) Trace metal composition in water and sediment from catch
605 basins. *Journal of Environmental Engineering* 134(10), 870-
606 878, [http://dx.doi.org/10.1061/\(ASCE\)0733-9372\(2008\)134:10\(870\)](http://dx.doi.org/10.1061/(ASCE)0733-9372(2008)134:10(870)).

607 Korving, J.L., Clemens, F.H.L.R. and van Noordwijk, J.M. (2006) Statistical modeling of the
608 serviceability of sewage pumps. *Journal of Hydraulic Engineering* 132(10), 1076-
609 1085, [http://dx.doi.org/10.1061/\(ASCE\)0733-9429\(2006\)132:10\(1076\)](http://dx.doi.org/10.1061/(ASCE)0733-9429(2006)132:10(1076)).

610 Lager, J. (1977) *Catchbasin technology overview and assessment*, U.S. Environmental Protection
611 Agency, USA.

612 Liu, Y., Yang, P., Hu, C. and Guo, H. (2008) Water quality modeling for load reduction under
613 uncertainty: a Bayesian approach. *Water research* 42(13), 3305-
614 3314, <http://dx.doi.org/10.1016/j.watres.2008.04.007>.

615 Marley, J. and Wand, M. (2010) Non-standard semiparametric regression via BRugs. *Journal of*
616 *Statistical Software* 37(5), 1 - 30

617 Memon, F.A. and Butler, D. (2002) Assessment of gully pot management strategies for runoff quality
618 control using a dynamic model. *Science of the total environment* 295(1), 115-
619 129, [http://dx.doi.org/10.1016/S0048-9697\(02\)00056-6](http://dx.doi.org/10.1016/S0048-9697(02)00056-6).

620 Mineart, P. and Singh, S. (2000) The value of more frequent cleanouts of storm drain inlets.
621 *Watershed Protection Techniques* 1(3), 129 - 130

622 Montgomery, D.C. and Peck, E.A. (1992) *Introduction to linear regression analysis*, Wiley-
623 Interscience.

624 Morrison, G.M., Revitt, D.M., Ellis, J.B., Svensson, G. and Balmer, P. (1988) Transport mechanisms
625 and processes for metal species in a gullypot system. *Water research* 22(11), 1417-
626 1427, [http://dx.doi.org/10.1016/0043-1354\(88\)90099-1](http://dx.doi.org/10.1016/0043-1354(88)90099-1).

627 Pitt, R. and Field, R. (2004) *Catchbasins and Inserts for the Control of Gross Solids and Conventional*
628 *Stormwater Pollutants*, pp. 1-21.

629 Plummer, M. (2003) JAGS: A program for analysis of Bayesian graphical models using Gibbs sampling,
630 p. 125, Vienna.

631 Pratt, C.J. and Adams, J.R.W. (1984) Sediment supply and transmission via roadside gully pots.
632 *Science of the total environment* 33(1), 213-224, [http://dx.doi.org/10.1016/0048-9697\(84\)90395-4](http://dx.doi.org/10.1016/0048-9697(84)90395-4).

633 Pratt, C.J., Elliott, G.E.P. and Fulcher, G.A. (1987) Suspended solids discharge from highway gully pots
634 in a residential catchment. *Science of the total environment* 59, 355-
635 364, [http://dx.doi.org/10.1016/0048-9697\(87\)90459-1](http://dx.doi.org/10.1016/0048-9697(87)90459-1)

636 Qian, S.S., Stow, C.A. and Borsuk, M.E. (2003) On monte carlo methods for Bayesian inference.
637 *Ecological Modelling* 159(2), 269-277, [http://dx.doi.org/10.1016/S0304-3800\(02\)00299-5](http://dx.doi.org/10.1016/S0304-3800(02)00299-5).

638 R Core Team (2014) *R: A language and environment for statistical computing.*, R Foundation for
639 *Statistical Computing*, Vienna, Austria.

640 Rodríguez, J.P., McIntyre, N., Díaz-Granados, M. and Maksimović, Č. (2012) A database and model to
641 support proactive management of sediment-related sewer blockages. *Water research* 46(15), 4571-
642 4586, <http://dx.doi.org/10.1016/j.watres.2012.06.037>.

643 Sartor, J.D. and Boyd, G.B. (1972) Water pollution aspects of street surface contaminants,, U.S.
644 Environmental Protection Agency, USA.

645 Sokal, R.R. and Rohlf, F.J. (1995) Biometry: The Principles and Practices of Statistics in Biological
646 Research, W. H. Freeman.

647 Swanson, L. (2001) Linking maintenance strategies to performance. International Journal of
648 Production Economics 70(3), 237-244,[http://dx.doi.org/10.1016/S0925-5273\(00\)00067-0](http://dx.doi.org/10.1016/S0925-5273(00)00067-0).

649 Ten Veldhuis, J.A.E., Clemens, F.H.L.R., Sterk, G. and Berends, B.R. (2010) Microbial risks associated
650 with exposure to pathogens in contaminated urban flood water. Water research 44(9), 2910-
651 2918,<http://dx.doi.org/10.1016/j.watres.2010.02.009>.

652 Ten Veldhuis, J.A.E., Clemens, F.H.L.R. and Van Gelder, P.H.A.J.M. (2011) Quantitative fault tree
653 analysis for urban water infrastructure flooding. Structure and Infrastructure Engineering 7(11), 809-
654 821,<http://dx.doi.org/10.1080/15732470902985876>.

655 Van der Zon, N. (2011) Kwaliteitsdocument AHN-2, p. 31, Rijkswaterstaat & Waterschappen.

656 Van Riel, W., Langeveld, J.G., Herder, P.M. and Clemens, F.H.L.R. (2014) Intuition and information in
657 decision-making for sewer asset management. Urban Water Journal 11(6), 506-
658 518,<http://dx.doi.org/10.1080/1573062X.2014.904903>.

659 Zhao, Y., Staudenmayer, J., Coull, B.A. and Wand, M.P. (2006) General design Bayesian generalized
660 linear mixed models. Statistical science, 35-51,<http://dx.doi.org/10.1214/088342306000000015>.

661 Zuur, A.F., Hilbe, J.M. and Ieno, E.N. (2013) A Beginner's Guide to GLM and GLMM with R: A
662 Frequentist and Bayesian Perspective for Ecologists, Highland Statistics.

663 Zuur, A.F., Ieno, E.N. and Elphick, C.S. (2010) A protocol for data exploration to avoid common
664 statistical problems. Methods in Ecology and Evolution 1(1), 3-14,[http://dx.doi.org/10.1111/j.2041-
665 210X.2009.00001.x](http://dx.doi.org/10.1111/j.2041-210X.2009.00001.x).

666 Zuur, A.F., Ieno, E.N., Walker, N., Saveliev, A.A. and Smith, G.M. (2009) Mixed effects models and
667 extensions in ecology with R, Springer Science & Business Media.

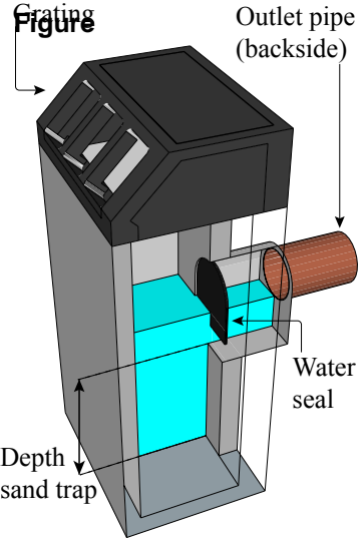

Figure

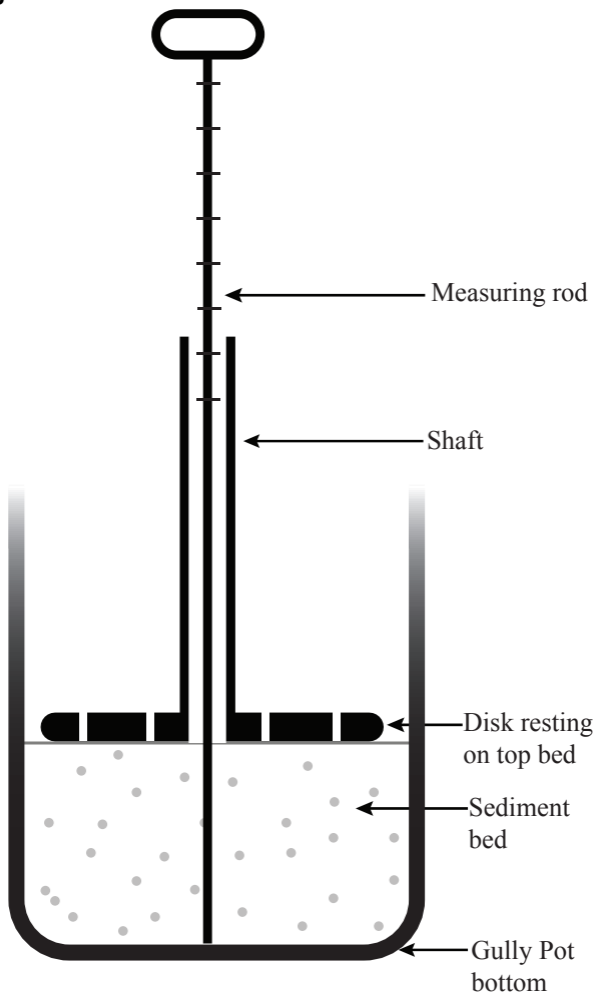

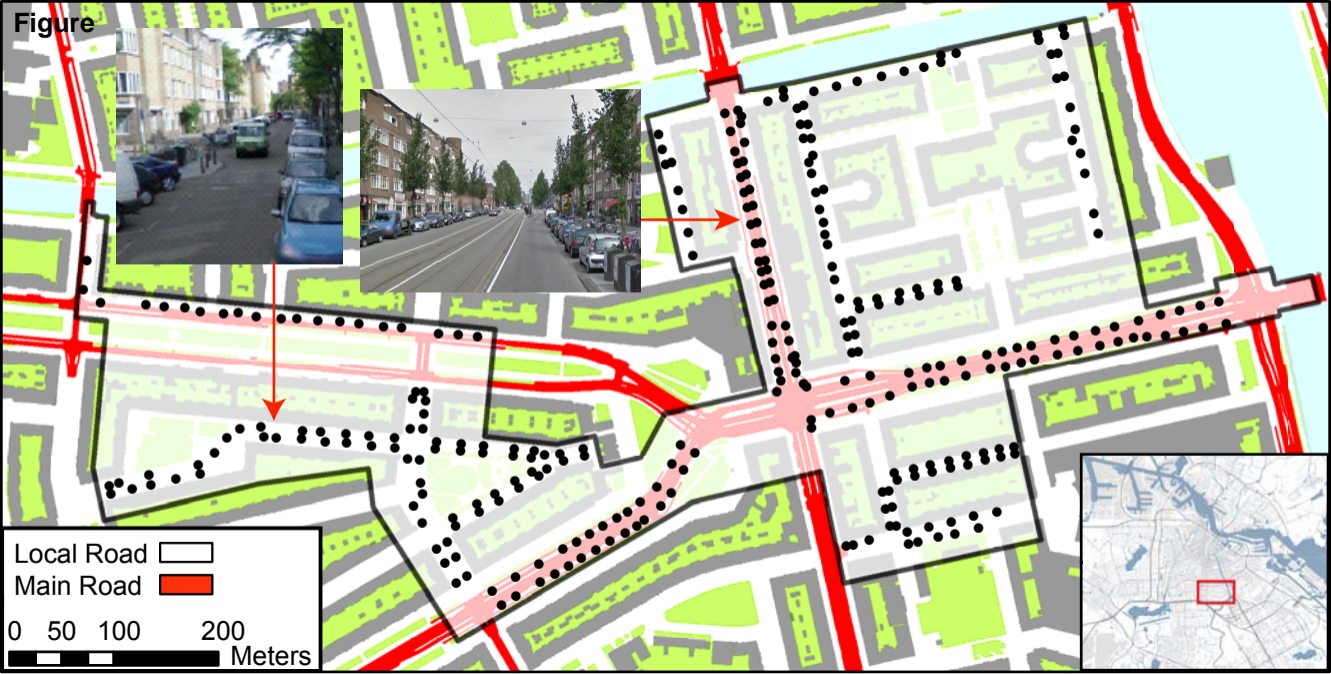

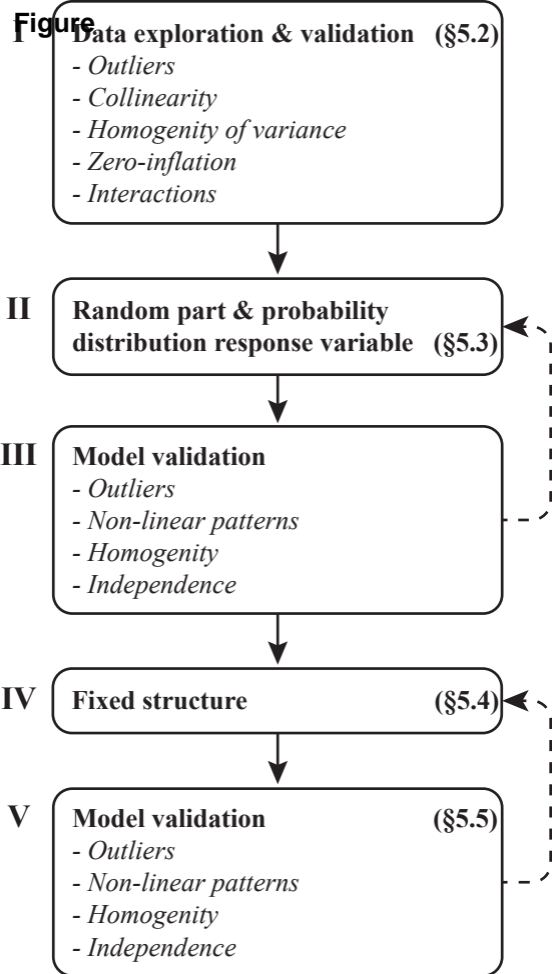

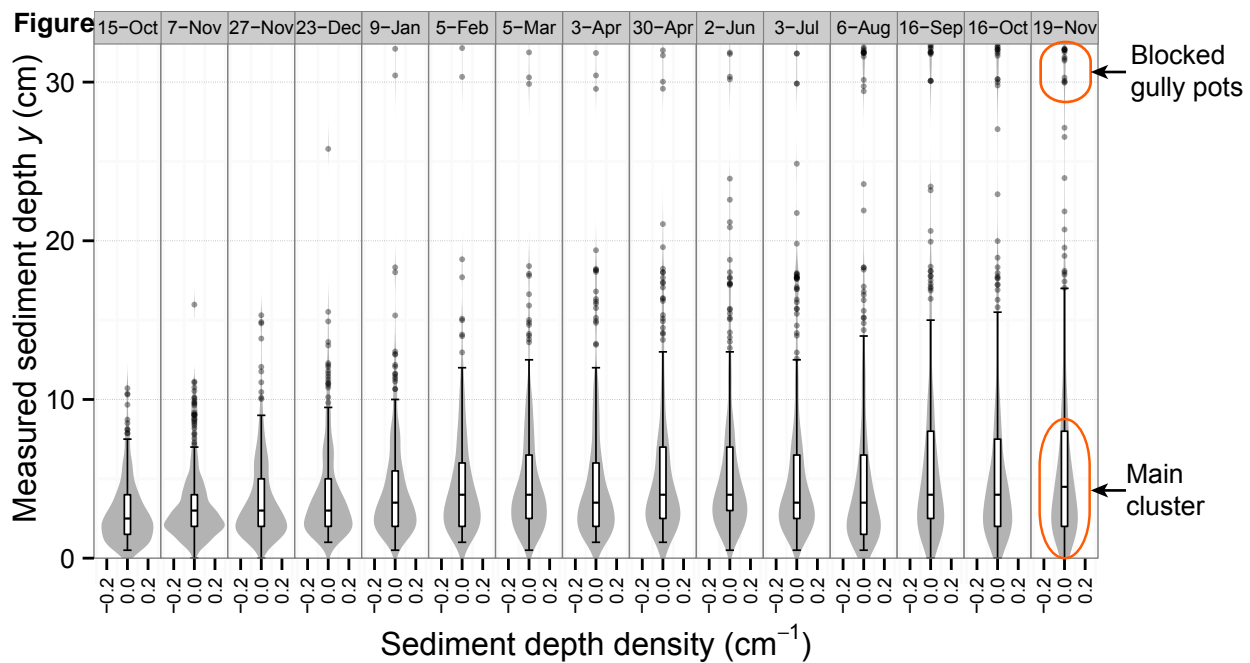

Figure

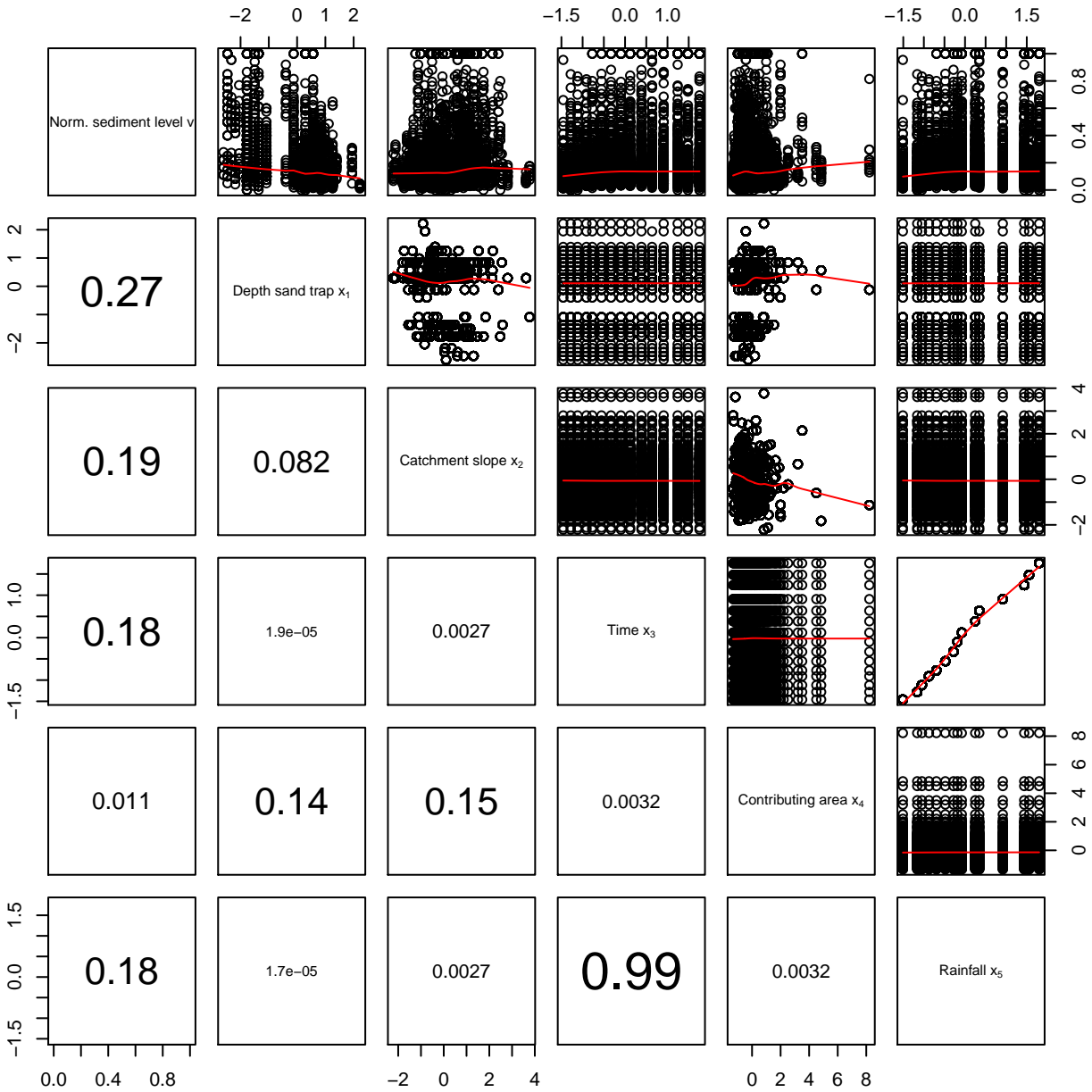

Figure

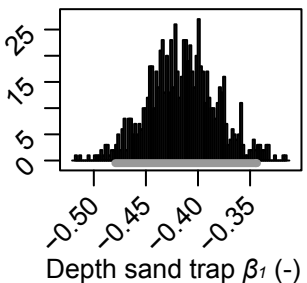
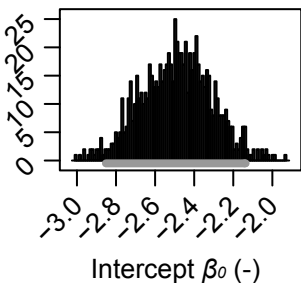
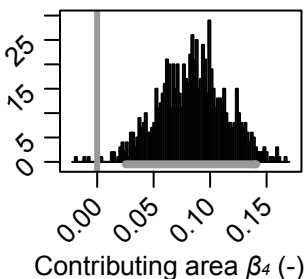
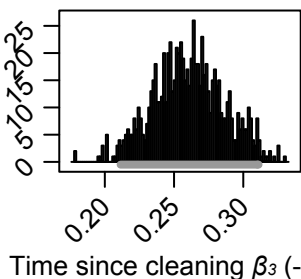
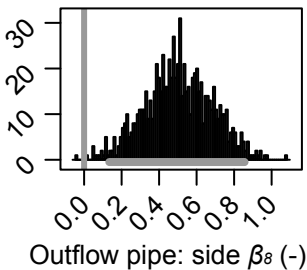
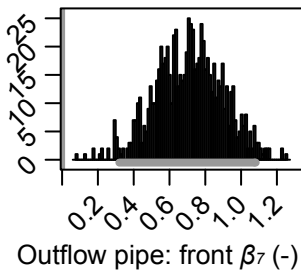
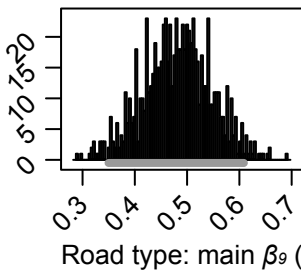

Posterior marginal distribution of weights β_k

Figure

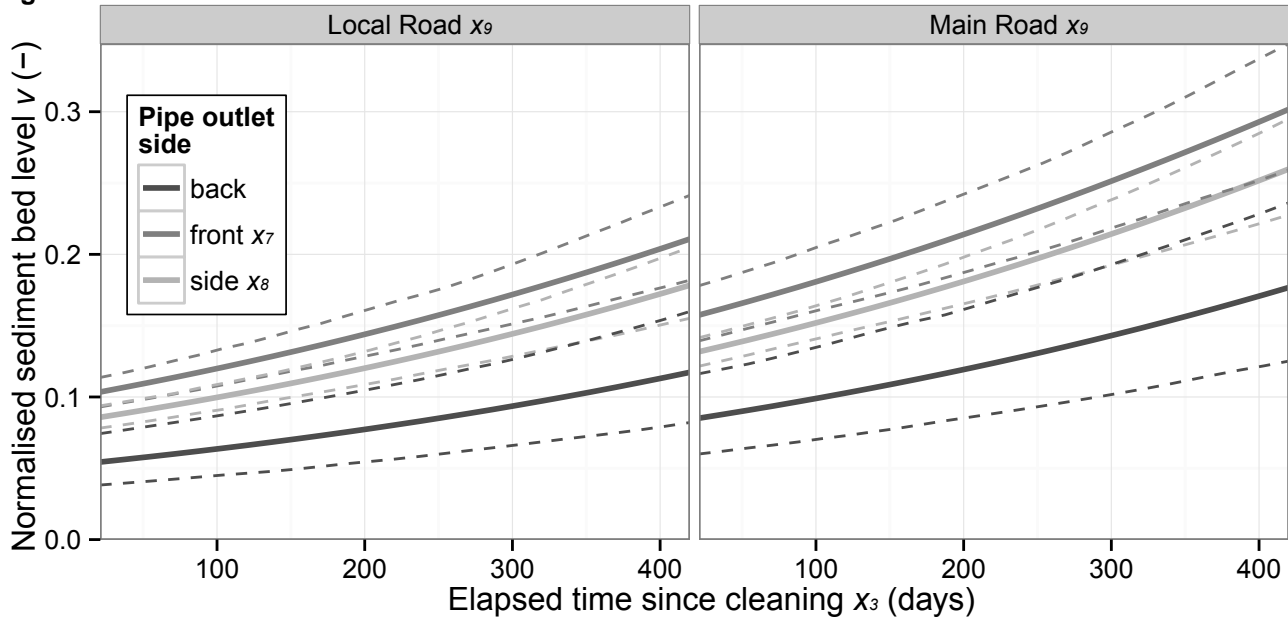

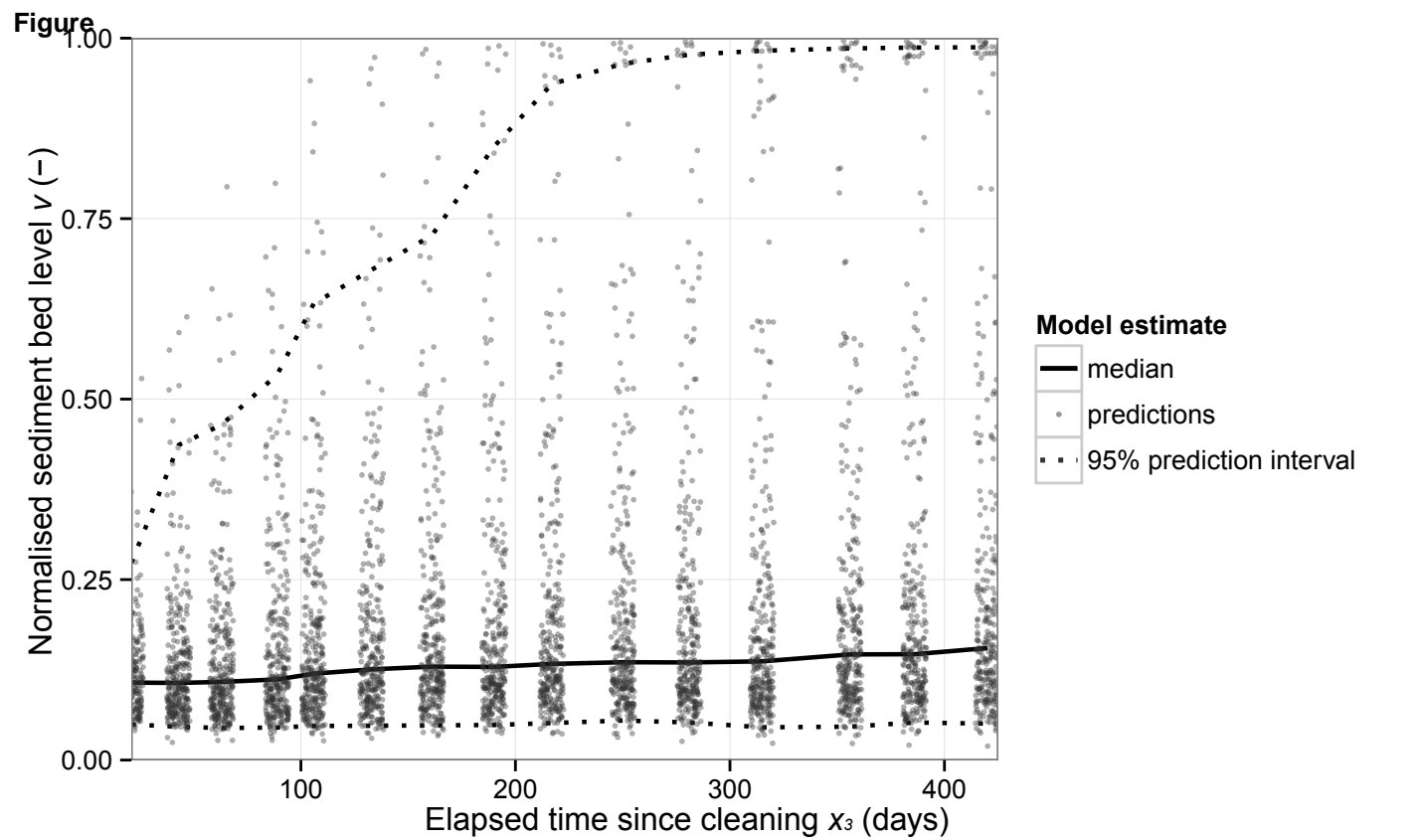

Figure

Figure 4



Figure

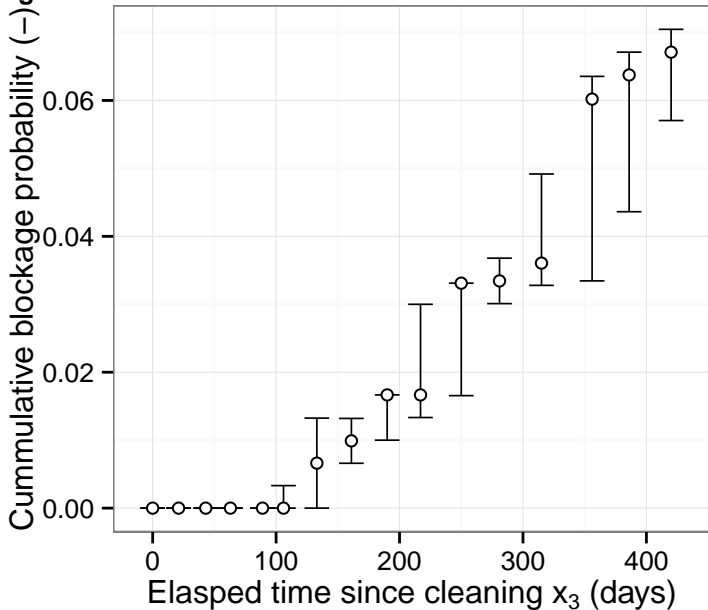
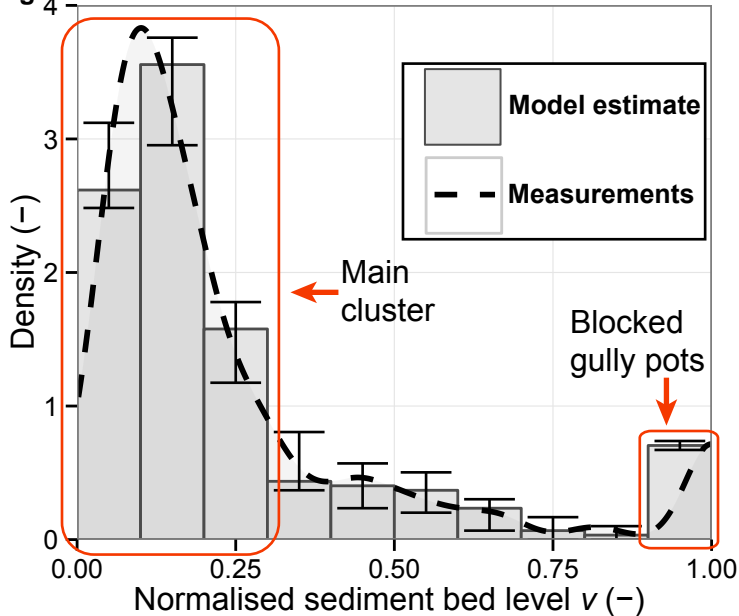
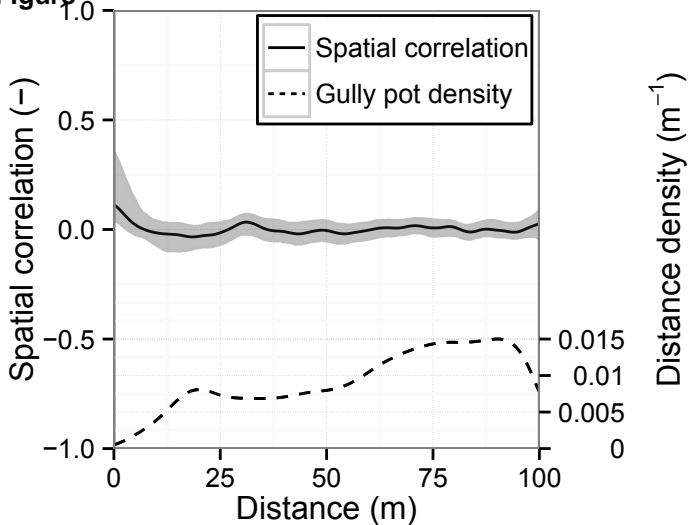

Figure

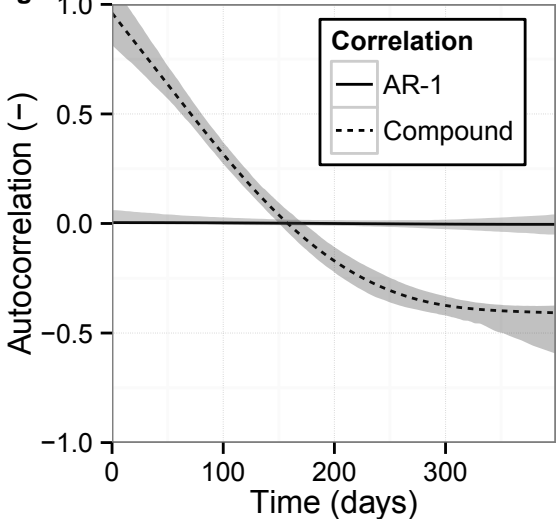

Figure

