

## Modelling of large-sized electrolyzers for realtime simulation and study of the possibility of frequency support by electrolyzers

Tuinema, Bart W.; Adabi , Ebrahim; Ayivor, Patrick K.S.; Garcia Suarez, Victor; Liu, Lian; Perilla , Arcadio; Ahmad, Zameer; Rueda Torres, José Luis; van der Meijden, Mart; Palensky, Peter

**DOI**

[10.1049/iet-gtd.2019.1364](https://doi.org/10.1049/iet-gtd.2019.1364)

**Publication date**

2020

**Document Version**

Accepted author manuscript

**Published in**

IET Generation, Transmission and Distribution

**Citation (APA)**

Tuinema, B. W., Adabi , E., Ayivor, P. K. S., Garcia Suarez, V., Liu, L., Perilla , A., Ahmad, Z., Rueda Torres, J. L., van der Meijden, M., & Palensky, P. (2020). Modelling of large-sized electrolyzers for realtime simulation and study of the possibility of frequency support by electrolyzers. *IET Generation, Transmission and Distribution*, 14(10), 1985-1992. <https://doi.org/10.1049/iet-gtd.2019.1364>

**Important note**

To cite this publication, please use the final published version (if applicable).  
Please check the document version above.

**Copyright**

Other than for strictly personal use, it is not permitted to download, forward or distribute the text or part of it, without the consent of the author(s) and/or copyright holder(s), unless the work is under an open content license such as Creative Commons.

**Takedown policy**

Please contact us and provide details if you believe this document breaches copyrights.  
We will remove access to the work immediately and investigate your claim.

# Modelling of Large-Size Electrolysers for Real-Time Simulation and Study of the Possibility of Frequency Support by Electrolysers

Bart W. Tuinema<sup>1\*</sup>, M. Ebrahim Adabi<sup>1</sup>, Patrick K. S. Ayivor<sup>2</sup>, Víctor García Suárez<sup>3</sup>, Lian Liu<sup>1</sup>, Arcadio Perilla<sup>1</sup>, Zameer Ahmad<sup>1</sup>, José L. Rueda Torres<sup>1\*</sup>, Mart A.M.M. van der Meijden<sup>12</sup>, Peter Palensky<sup>1</sup>

<sup>1</sup>Dept. of ESE, faculty of EEMCS, Delft University of Technology, Mekelweg 4, 2628CD, the Netherlands

<sup>2</sup>TenneT TSO B.V., Utrechtseweg 310, 6812AR, Arnhem, the Netherlands

<sup>3</sup>DNV-GL, Utrechtseweg 310, 6812AR, Arnhem, the Netherlands

\*b.w.tuinema@tudelft.nl; j.l.ruedatorres@tudelft.nl

**Abstract: Hydrogen as an energy carrier holds promising potential for future power systems. An excess of electrical power from renewables can be stored as hydrogen, which can be used at a later moment by industries, households or the transportation system. The stability of the power system could also benefit from electrolysers as these have the potential to participate in frequency and voltage support. Although some electrical models of small electrolysers exist, practical models of large electrolysers have not been described in literature yet. In this publication, a generic electrolyser model is developed in RSCAD, to be used in real-time simulations on the Real-Time Digital Simulator (RTDS). This model has been validated against field measurements of a 1-MW pilot electrolyser installed in the northern part of the Netherlands. To study the impact of electrolysers on power system stability, various simulations have been performed. These simulations show that electrolysers have a positive effect on frequency stability, as electrolysers are able to respond faster to frequency deviations than conventional generators.**

## Abbreviations

AEM	Anion Exchange Membrane
aFRR	Automatic Frequency Restoration Reserve
BoP	Balance of Plant
RoCoF	Rate-of-Change-of-Frequency
FCR	Frequency Containment Reserve
PEM	Polymer Electrolyte Membrane
PEM	(Proton Exchange Membrane)
RTDS	Real-Time Digital Simulator
SOE	Solid Oxide Electrolyser

## 1. Introduction

In the future energy system, the share of renewable energy sources is expected to increase continuously. The intermittent and variable nature of these renewable energy sources lead to various challenges regarding the operation of the power system. One challenge is the decrease of the total inertia and the resulting vulnerability to disturbances that can cause frequency instability. As renewable energy sources slowly replace conventional generation and conventional generators traditionally support frequency stability by their inertia and frequency controls, alternative possibilities of power system stability support are being searched for. A promising solution can be found in hydrogen technology. An abundance of electricity generated by renewable energy sources can be converted into hydrogen by electrolysers and stored for a relatively long period. The hydrogen can then be used by final consumers like the transportation system or industries. Hydrogen can also be converted back into electricity by fuel cells, thereby helping to solve the issue of long-term electricity storage. The flexibility of electrolysers (and fuel cells) offers promising opportunities for electrical grid support by the provision of ancillary services like frequency and voltage

support. For this purpose, appropriate controllers need to be developed and the potential of ancillary services support by electrolysers must be analysed and demonstrated in studies.

Currently, a 1-MW pilot electrolyser is installed in the northern part of the Netherlands. A larger electrolysis plant of 300 MW is planned to be installed in this area later on. The feasibility of the installation of this large-scale plant, its impact on the stability of the electrical transmission network covering the northern part of the Netherlands, and the possibilities for ancillary services provision have been studied in the project TSO2020 [1], [2]. Various literature describes the development of electrolyser models, as discussed in the thorough literature review presented in Section 2.2. Nevertheless, the challenge is that electrical models of large-scale (>1 MW) electrolysers for the purpose of grid studies have not been described in existing literature yet. Therefore, a generic electrolyser model has been developed specifically for this project.

Initial studies on the impact of hydrogen technology on the operation of the power system have been presented in some publications. For example, the impact of hydrogen technology on electricity and gas networks has been investigated in [3]. The impact of electrolysers on distribution networks considering operational limitation and electricity cost scenarios has been described in [4]. The results show that electrolysers have the capability to provide effective performance under different scenarios. In [5], a PEM fuel cell based power system is analysed in order to provide insight into PEM operating parameters and impacts. The use of alkaline electrolysers to enhance frequency stability of power system has been investigated in [6], where an electrical power system combined of steam turbine generation units, electrolysers, conventional loads and wind farms has been implemented in Matlab/Simulink to study the effect of alkaline electrolysers on frequency stability of

power system considering high integration of wind parks. An initial generic electrical model of a PEM electrolyser and fuel cell to study the provision of ancillary services via these technologies was presented in [7]. Nevertheless, the development of a generic model of large-scale (>1 MW) electrolysers, the design of appropriate controllers for ancillary services provision and the study on the impact on the frequency stability of interconnected power systems has not been described in literature yet.

This publication describes the development of a model of the 1-MW pilot electrolyser in RSCAD, to be used in real-time simulations on the Real-Time Digital Simulator (RTDS). The developed model has been extended with a control system that enables the electrolyser to respond to grid and market conditions in order to participate in ancillary services provision like frequency support. The developed model has been validated against field measurements from the pilot electrolyser and has been tuned accordingly. Then, the developed model has been used to study the impact of smaller and larger electrolysers on the stability of power systems and to analyse the possibilities to participate in the provision of ancillary services. In this analysis, it is studied whether large-scale electrolysers could be utilised to support power system frequency and how effective this is in comparison with frequency support by conventional generators.

This paper is organised as follows. First, Section 2 describes the modelling of the electrolyser. The validation of the model against field measurements of the 1-MW pilot electrolyser is discussed in Section 3. Section 4 describes several simulations in which the contribution of electrolysers to frequency support is analysed. Finally, general conclusions and future work are discussed in Section 5.

## 2. Modelling of the Electrolyser

This section describes the modelling of the electrolyser. After introducing the various electrolyser technologies in Section 2.1, a detailed literature review is given in Section 2.2. The electrolyser model which will be used in this research is then presented in Section 2.3.

### 2.1. Electrolyser Technologies

Four main types of electrolysers exist at the moment: Polymer Electrolyte Membrane (PEM) electrolysers, alkaline electrolysers, Anion Exchange Membrane (AEM) electrolysers and Solid Oxide Electrolysers (SOE) [8]. Presently, PEM and alkaline electrolysers are available for commercial purposes. The number of applications of AEM electrolysis is limited, while SOE electrolysers are still in their first development stage. Of these four electrolyser technologies, the most developed one is alkaline electrolysis, while PEM is in its initial commercial phase. Although alkaline technology is well suited for smaller applications, PEM electrolysis is a promising technology for future, large-scale applications [9], [10]. It is expected that this technology has the lowest capital cost, a higher power density, a smaller electrolyser size, a scalable design and a larger dynamic range. Therefore, the models described in this paper are developed for PEM electrolysers in particular.

An electrolyser plant basically consists of three parts: (i) the electrolyser stack, in which the electrolysis takes place; (ii) the Balance of Plant (BoP), supporting the stack operation (e.g. circulation/feedwater pumps); and (iii) the power conversion system, which connects the stack to the electric power system (e.g. rectifier, DC/DC converter and transformer).

### 2.2. Electrolyser Models in Literature

Although several models of small electrolysers exist, practical models of large (>1 MW) electrolysers are not existent in literature yet [11]. Research on PEM electrolysis during the last ten years has resulted in models that are increasingly detailed and complicated [12]. Important studies have been performed to improve the reliability and efficiency of PEM electrolysers, for example, and this has resulted in models that improve the electrolyser and its integration with other components. The developed models also differ depending on the physical parameters of interest. As an example, electrical models concentrate on voltages and currents in the system, whereas temperature and entropy flow are considered in thermal models. Some existing models focus on variables like pressure, temperature and thermal energy on performance of the PEM stack, whereas other models consider all phenomena that occur [13]. Nevertheless, simplifications of these electrical and thermal models are often used in practice [14]. Simplification of electrolyser models often includes the omission of losses in the model. The losses of a single cell PEM electrolyser have been considered in [15], whereas an equivalent electrical circuit model for PEM electrolysers to study the electrochemical effects has been presented in [16].

A linear dynamic thermal model and a steady-state electrical model have been presented in [14]. The parameters of the electrical model have been determined using a non-linear least square method, while the parameters of the thermal model have been determined based on the characteristics of a first-order linear model. This study concentrated on the design of a model to support monitoring of PEM cells, such that this model considers the electrolyser at the PEM stack layer. Of course, this model does not include the power conversion and other parts of the electrolyser, such that this model is less suitable for studies of the interaction with the power system. The electrolyser model developed in [17] was created following a similar approach, and this model can represent various sizes of PEM electrolysers and also series/parallel cell combinations. The developed model can be used to study the electrical response of PEM electrolysers. However, because it models the electrolyser at the stack layer, the possible applications of this model are limited.

Electrochemical Impedance Spectroscopy has been applied in the creation of an electrical equivalent of a PEM electrolyser in [18]. Although it models the PEM stack layer of the electrolyser in high level of detail, this model excludes the power conversion. Reference [12] presents a PEM cell model created in SIMULINK. This model consists of modules that reflect the response of the cathode, anode, membrane and cell voltage in terms of physical parameters of the construction materials. The study concentrated on enhancing the PEM electrolyser cell, while components like the BoP and power conversion were omitted. Energetic

Macroscopic Representation, which is a graphical modelling strategy that aims to model phenomena in various domains, was used for the creation of the model presented in [13]. The output of this model approximates real data well, but the modelling of power conversion in this model is not detailed enough. The power conversion system is of particular interest for analysis of the interactions with power systems and controllers, and this was modelled as an energy source following a black box approach. Therefore, the application of this model for analysis of the electrolyser behaviour regarding the provision of ancillary services in power systems is limited. Regarding the power conversion system, a literature review about the topology of interfaced converters for PEM electrolysers can be found in [19], [20].

The coupling to renewable sources is considered in some of the electrolyser models, but the scale is still small (i.e. <1 MW). As an example, a model describing atmospheric or low-pressure PEM electrolysers, consisting of three sub-models, has been presented in [21]. Also this model considers the electrolyser at the PEM stack layer. A model of a 500-kW electrolyser created in PSCAD is described in [22]. This model has been developed to show the capabilities of electrolysers in the support of voltage stability. Although this model represents an electrolyser smaller than 1 MW, this model probably is the nearest to a large-scale model available in literature.

The different electrolyser models described above focus on various layers of the electrolyser, based on the objectives of the study, and mainly represent electrolysers with a capacity smaller than 1 MW. The largest part of these models can be used within the limited scope for which they are designed. However, to understand the interactions of large-scale electrolysers with the power system, more is required. Therefore, a generic model needs to be developed that considers the PEM stack together with key subsystems like power conversion and BoP representing electrolysers with a capacity of several megawatts. Such a model should be equipped with a control system which is able to control the active power consumption of the electrolyser based on the grid and market conditions. This is currently missing in the existing literature models.

### 2.3. Electrolyser Model Development

For this study, a model of the 1-MW pilot electrolyser has been specifically developed in RSCAD (i.e. the simulation software of the RTDS) [23]-[25], based on existing literature describing the working principles of electrolysers. Fig.1 shows the components of the electrolyser system, as modelled in this study. There are various implementations of the DC-DC and AC-DC converters possible, which depends on the specific application. In this paper, AC-DC conversion is done with a 3-phase active rectifier in series with a DC-DC converter. The DC-DC converter is implemented as an interleaved buck converter. The BoP components are modelled by a constant load, as it can be assumed that most of these have a fixed power consumption.

Fig. 2 shows the electrical equivalent of the PEM electrolyser stack. Electrolysis requires a DC source that must overcome a reversible voltage that leads to the chemical reaction of water splitting into oxygen and hydrogen. Losses within the PEM stack increase the

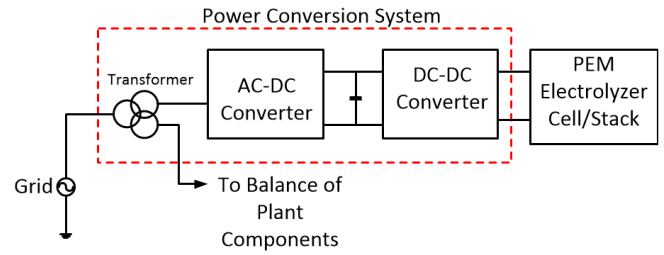

Fig. 1. Electrolyser system components.

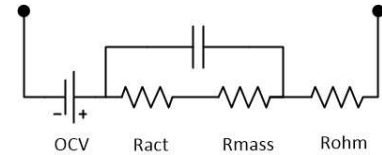

Fig. 2. PEM stack equivalent.

required voltage and are modelled as overpotentials. The representation by the electrical equivalent is widely used in current literature [26]. The reversible voltage is represented by a fixed DC voltage, the open cell voltage (OCV in Fig. 2).  $R_{act}$ ,  $R_{mass}$  and  $R_{ohm}$  represent the activation, mass transport and ohmic losses, respectively. The double layer capacitance of the cell is represented by a capacitor.

Simplification of the PEM stack model is mainly dependent on the decision which losses are included and based on several assumptions:

- The mass transfer losses are not significant for low and moderate current densities if the flow field is appropriate for gas removal. Thus, the mass transfer overpotentials can be neglected for up to 3 A/cm<sup>2</sup>.
- Activation losses are dominant at low current densities, while the ohmic overpotential becomes dominant at medium current densities.
- Pressure and temperature are assumed constant.

Based on these assumptions, a further simplification of the model can be made by neglecting the activation and mass transport losses and the double layer capacitance. The electrical model then becomes a series connection of the open cell voltage and ohmic losses, which can be determined from the gradient of the current-voltage curve between the upper and lower operating boundaries for a given cell area. A possible impact of this simplification could be a small error in the conversion efficiency (i.e. ratio of energy used in the hydrogen process to total energy consumed by the whole system). Also, the model assumes that interactions between units due to delays in the control system or the chemical process are negligible. As the model developed in this work is intended to be used for grid studies, it does not model the electrochemical reactions and thermal phenomena in detail and the aforementioned simplification is expected to be sufficiently accurate. This will be verified against field measurements in Section 3.

The electrolyser model developed in this project has been equipped with a control system [23], [25], which is based on an architecture discussed in [27]. Control systems in commercial electrolysers are mainly designed to support plant automation for the production of hydrogen. To optimise the electrolyser to support additional objectives such as ancillary services provision, an additional control

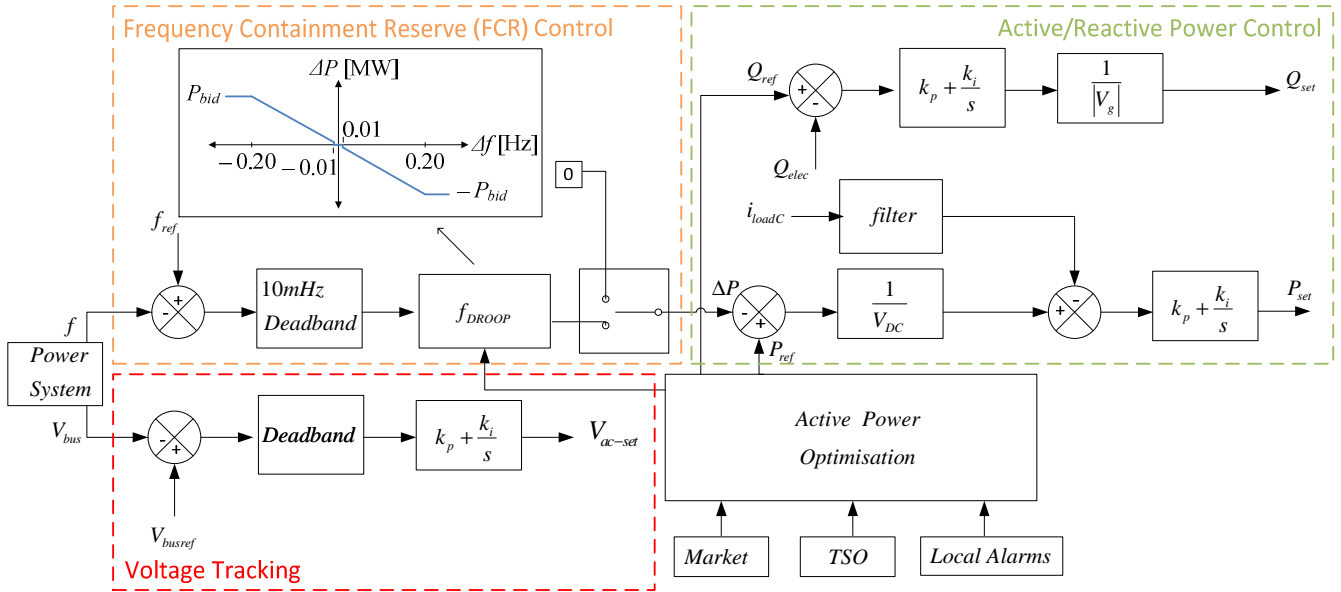

Fig. 3. Structure of the high-level control (Front End Controller).

system is required. The Front End Controller is this control system and communicates with low-level controls to form a hierarchical controller with extended capabilities, such as the capability to simultaneously respond to market price signals, the condition of the power system and internal signals like electrolysis process alarms. Fig. 3 shows the structure of the high-level control. A detailed description of the high- and low-level controls of the electrolyser can be found in [23], [25].

### 3. Validation of the Developed Model against Field Measurements

The developed electrolyser model has been validated against field measurements of the 1-MW pilot electrolyser installed in the northern part of the Netherlands in Veendam-Zuidwending. The parameters of the electrolyser model have been adjusted to the field measurements, such that the model is able to replicate the behaviour of a real electrolyser. This section discusses the network configuration and measurement setup (Section 3.1), the measurement procedure (Section 3.2), the measurement results (Section 3.3), and the adjustment of the developed electrolyser model to the measurements (Section 3.4).

#### 3.1. Network Configuration and Measurement Setup

The simplified network configuration at Veendam-Zuidwending is illustrated in Fig. 4. A 5-km (double circuit) cable connects the 33-kV substation Veendam-Zuidwending to the 110-kV substation Meeden. At Veendam-Zuidwending, two 110/33-kV transformers are installed. The substation contains two busbars and several bays, to which the compressors and other systems of the natural gas storage facility at this location are connected. The electrolyser has its own bay and is connected by a three-winding transformer. The electrolyser itself is linked to the secondary winding of the transformer, while auxiliary systems are connected to the tertiary winding.

Measurements have been performed at all three windings of the transformer, i.e. points 3, 4 and 5 in Fig. 4.

The measurements at 33 kV were performed within the substation. The current was measured in the secondary circuit of the 33-kV installation with a current clamp of 1A/1V. The secondary current comes from a (200/1A, 5p20, 10VA) current transformer. The voltage was measured at the secondary side with a  $(33\text{kV}/\sqrt{3}/100\text{V}/\sqrt{3})$  voltage transformer. The 33-kV measurements were performed using a Dewetron measurement system, equipped with a DAQP-VB measurement card for the current measurements and a DAQP-HV measurement card for the voltage measurements. The current measurements were performed using Universal Technic M1.UB 1A/1V and Chauvin Arnoux 20-200A/2V MN 38 current clamps.

The measurements at 450 V and 400 V were performed directly at the secondary and tertiary windings of the transformer, respectively. For these measurements, Fluke 435 series 2 power quality and energy analysers were used. For the current measurements, I430-FLEXI-TF-II Ragowski coils were used, while the voltages were measured directly.

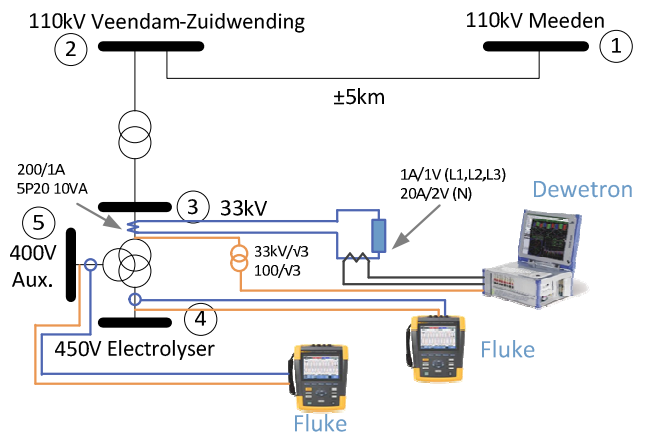

Fig. 4. Measurement setup at Veendam-Zuidwending.

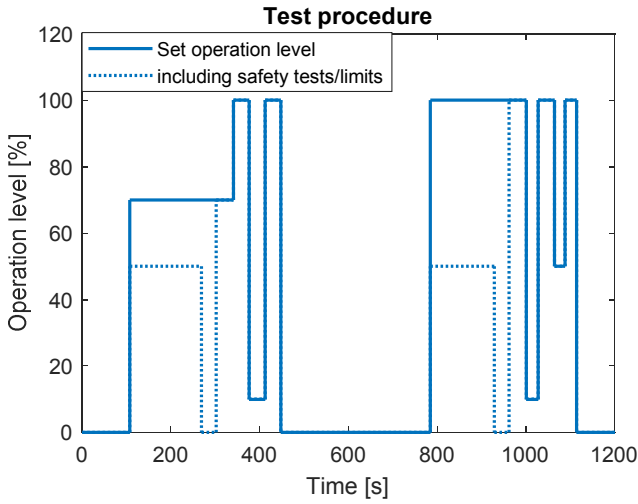

Fig. 5. Operation cycles during the electrolyser test.

### 3.2. Description of the Measurement Procedure

During the test, the operation of the electrolyser was tested in two cycles, as illustrated in Fig. 5. These cycles consisted of starting up the unit, varying its operation setpoint between various levels (i.e. 10/50/70/100%), and shutting down the unit. As the electrolyser needs to build up pressure and perform some safety checks first, the operation level is limited to 50% directly after starting up the unit. After a certain time, the operation level goes to the desired setpoint. This is indicated in the graph by the dashed lines. During the test, measurements were recorded at the three mentioned voltage levels, where the main quantities of interest were: the voltage and current magnitudes, the total active power and the total harmonic distortion of the voltage and current.

### 3.3. Experimental Measurement Results

The active power consumed by the electrolyser, measured at the 450-V side of the transformer, is illustrated in Fig. 6. It can be seen that the active power consumption clearly follows the test cycles shown in Fig. 5, apart from the inrush currents when starting up the unit. As the active power consumed deviates from the operation level setpoints (i.e. 50/70/100% of 1 MW), it can be concluded that the setpoints of the pilot electrolyser are not very accurate.

The graphs shown in Figs. 7 and 8 zoom in on the active power ramps during the setpoint changes, which are aligned at  $t = 0$ . For this graph, the measurements at 33 kV were used, as the Dewetron device has a higher resolution than the Flukes. The graphs show that the active power ramps are linear and quite similar during normal operation (i.e. between 10 and 100%). It can therefore be concluded that the response of the electrolyser is determined by its converter and its controls. The active power ramps after starting up the unit are typically slower. From these graphs, the average ramp rate of the electrolyser can be estimated. It can be seen that the average ramp up rate is about 0.5 MW/s (0.5 pu/s) during normal operation, while it is about 0.2 MW/s (0.2 pu/s) during startup of the electrolyser. The average ramp down rate is about 0.4 MW/s (0.4 pu/s).

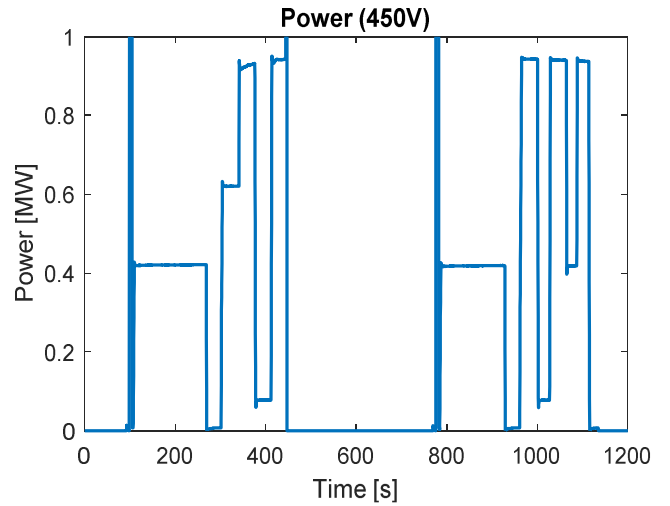

Fig. 6. Active power of the electrolyser measured at the 450-V bus.

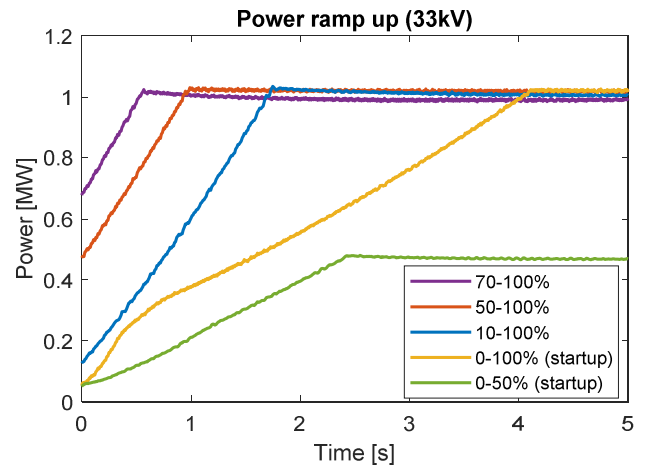

Fig. 7. Response of the pilot electrolyser to operation level setpoint changes (ramp up).

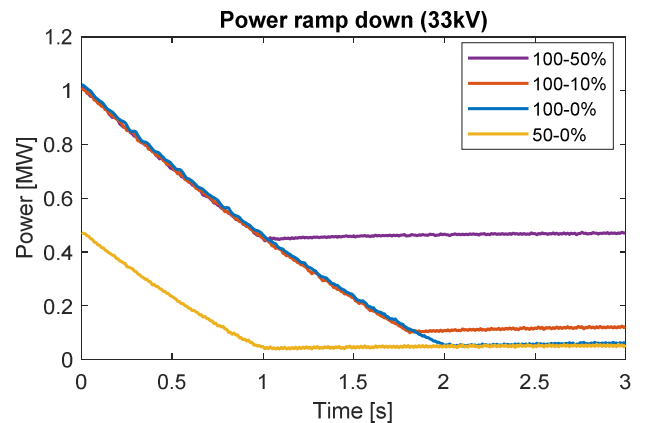

Fig. 8. Response of the pilot electrolyser to operation level setpoint changes (ramp down).

### 3.4. Comparison of the Developed Model with the Field Measurements

Based on the field measurements, it is possible to estimate the ramp rate of a larger electrolyser unit. It was found that the 1-MW pilot electrolyser shows a linear response to setpoint changes, and has a ramp rate of about 0.5 MW/s (0.5 pu/s). Large electrolyser facilities consist of

many small electrolyzers in parallel. This means that a 300-MW electrolyser plant consisting of 300 units of 1 MW can reach a ramp rate of 150 MW/s (0.5 pu/s). This result can, roughly, be compared with data available in literature. In [28], the response of a 40-kW PEM electrolyser was tested. It was found that this electrolyser shows a non-linear behaviour, where the dependence of the response time on the size of the setpoint change is only small. Ramping up or down is generally completed within 0.2 s. A capacity change of 50% within 0.2 s gives a ramp rate of  $20\text{kW}/0.2\text{s} = 0.1\text{ MW/s}$  (2.5 pu/s). Under the assumption that the response time does not increase significantly for electrolyser capacities in the range up to a MW and the fact that a 300-MW electrolyser plant consists of many smaller units, this would lead to a ramp rate of 750 MW/s (2.5 pu/s) for a 300-MW electrolyser plant. Although this comparison is based on rough assumptions, it still gives an indication of the range of ramp rate to consider in further studies, i.e. 150–750 MW/s (0.5–2.5 pu/s).

The parameters of the developed electrolyser model have been adjusted, such that the electrolyser model is able to follow the response of a real electrolyser. The difficulty here is that the control parameters of the pilot electrolyser are not known because of confidentiality. It was therefore decided to extend the electrolyser model with a ramp rate limiter, which has been empirically tuned to follow the desired response. Figs. 9 and 10 show the response of the 1-MW electrolyser model. It can be seen that the developed model is able to replicate the electrical behaviour of a real electrolyser. There are however some differences in the power ramps, because the control parameters of the real electrolyser were unknown. Furthermore, there are some differences in the initial and final values of the active power. This is because the power setpoints of the pilot electrolyser are not very accurate, whereas it was decided to have more accurate power setpoints in the developed model. Nevertheless, the behaviour of the developed electrolyser model is accurate enough for the purpose of stability analysis of power systems.

The response of a second, simplified and scaled-up, version of the electrolyser model (without DC/DC converter) is shown in Figs. 11 and 12. This scaled-up model assumes stacking many smaller (i.e. around 1 MW) electrolyser units to a large (i.e. 300 MW) electrolysis plant. It can be seen that this scaled-up model is able to follow the measurements as well. As the response of this simplified version was already inherently linear, this scaled-up model follows the measurements more accurately than the detailed model.

Since different electrolyser manufacturers have their own parameters of electrolyser controls, it is expected that the developed generic model needs to be tuned for each specific electrolyser application. As shown in this section, tuning of the parameters is practically possible, such that the response of a specific electrolyser can be replicated.

#### 4. Simulation of the Impact of Electrolysers on Power System Frequency Stability

The developed electrolyser model is used to study the impact of smaller and larger electrolysers on the stability of the power system. This section discusses the considered network topology and two study cases, namely the loss of generation capacity and the loss of demand.

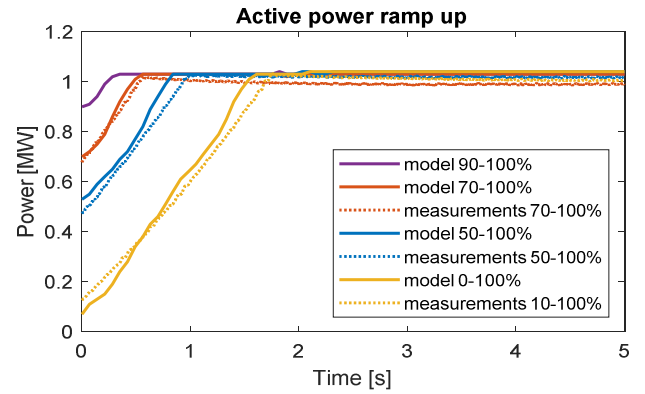

Fig. 9. Comparison between the detailed electrolyser model and the field measurements (ramp up).

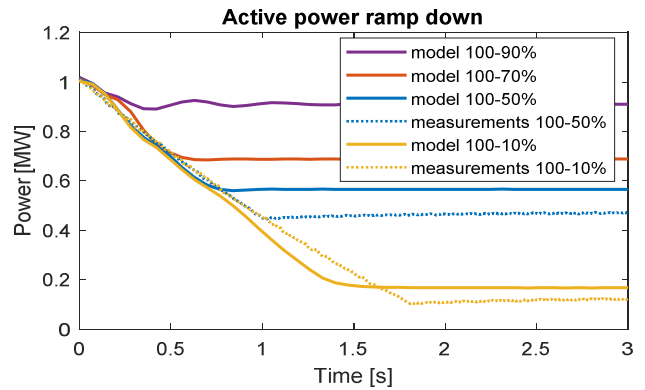

Fig. 10. Comparison between the detailed electrolyser model and the field measurements (ramp down).

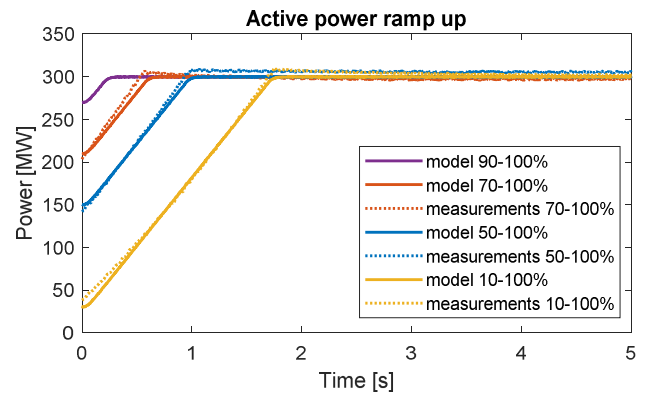

Fig. 11. Comparison between the simplified, scaled-up electrolyser model and the field measurements (ramp up).

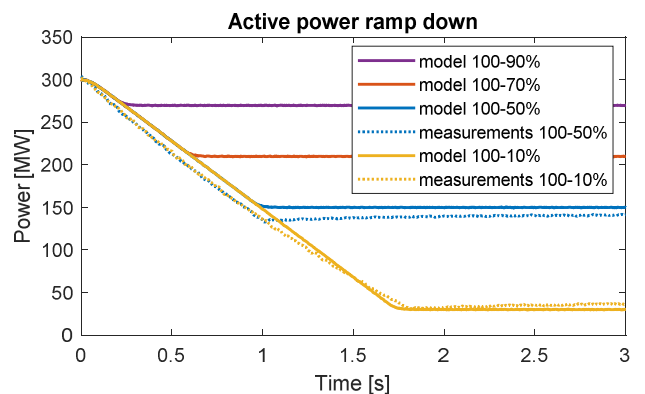
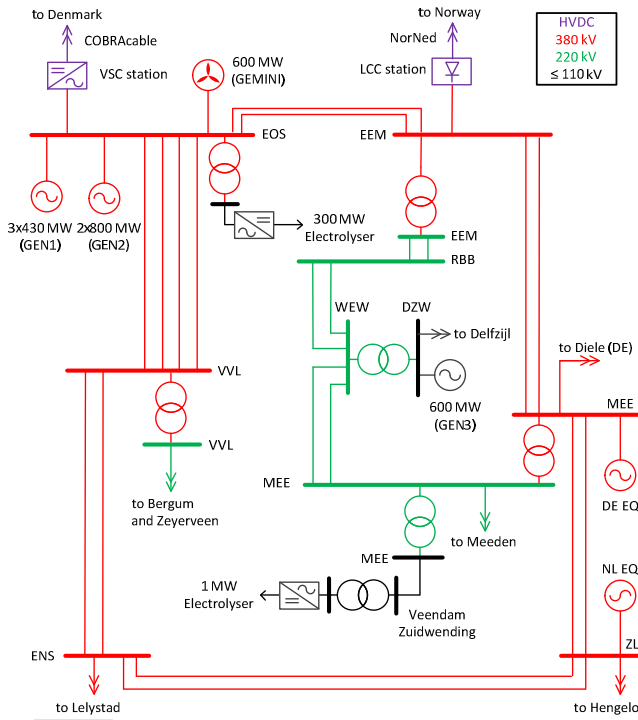

Fig. 12. Comparison between the simplified, scaled-up electrolyser model and the field measurements (ramp down).



**Fig. 13.** Considered network topologies for this study.

**Table 1** Operational scenarios considered in this study

Generator/HVDC link/electrolyser	Case 1: loss of generation [MW]	Case 2: loss of load [MW]
GEMINI wind farm(EOS)	450	450
GEN1 (EOS)	3×430	3×430
GEN2 (EOS)	2×800	2×650
GEN3 (DZW)	233	233
NorNed import (EEM)	700	700
COBRACable import(EOS)	-700	-500
Electrolyser demand (EOS)	300	190

#### 4.1. Network Topology and Operational Scenarios

For this study, a model of the northern part of the Dutch transmission network has been developed in RSCAD. This part of the transmission network contains several large-scale facilities which interact with electrolyzers, namely: the 700-MW HVDC NorNed connection (to Norway), the 700-MW HVDC COBRACable (to Denmark), the 600-MW GEMINI offshore wind farm, and almost 3 GW conventional generation. The network topology considered in this study is illustrated in Fig. 13. The two operational scenarios considered here are shown in Table 1. The total electricity demand of this area is 2075 MW for the considered scenarios. The demand is divided over the three provinces within this area: Groningen-Drenthe (875 MW), Overijssel (800 MW) and Friesland (400 MW), and distributed over the substations within the network. The demand has been projected based on the demand of 2018 [29], while considering the estimated growth proportion and distribution over the substations.

#### 4.2. Simulation of Case 1: Loss of Generation Capacity

In the first study case, a loss of generation capacity is considered. For this purpose, the generation at EOS substation is reduced by 200 or 50 MW by decreasing the power generated by GEMINI wind farm. The impact on frequency stability of the system is studied considering Frequency Containment Reserve (FCR) support by generators. In this study, there is a total of 300 MW FCR support in the system, divided over the generators in the system (i.e. 190 MW DE EQ, 30 MW for each other generator and NL EQ). To study the impact of electrolyzers, the participation of electrolyzers in FCR is varied from 0 to 100% by replacing the FCR support of some generators with FCR support by the electrolyser. As the total amount of FCR reserve in the system remains the same, it is expected that the steady-state frequency after a disturbance remains the same, but electrolyzers will influence the dynamic frequency response after a disturbance.

The results of these simulations are shown in Fig. 14 (for a loss of 200 MW generation capacity) and Fig. 15 (for a loss of 50 MW generation capacity). An overview of the frequency nadirs is given in Table 2. It can be seen that the replacement of FCR support by the electrolyser has a positive effect on the frequency response of the system, as the electrolyser has the ability to react faster to deviations of the frequency. The oscillation of the frequency completely

**Response for different shares of electrolyser FCR capacity**

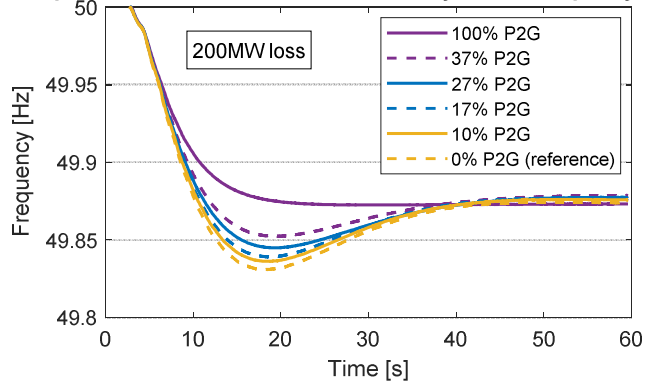

**Fig. 14.** Frequency response of the system with different shares of electrolyser FCR capacity for a loss of 200 MW generation capacity.

**Response for different shares of electrolyser FCR capacity**

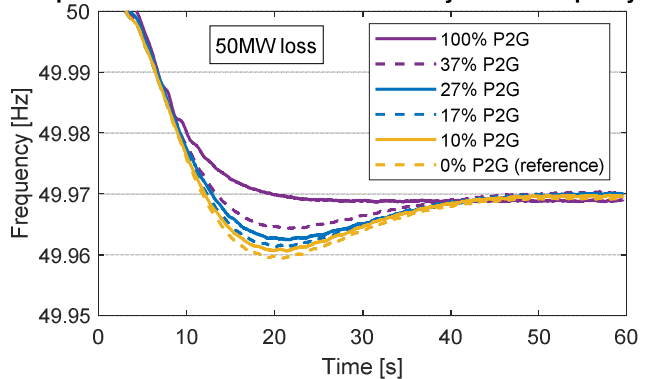

**Fig. 15.** Frequency response of the system with different shares of electrolyser FCR capacity for a loss of 50 MW generation capacity.



**Table 2** Frequency nadirs for case 1: loss of generation

Share of electrolyser FCR capacity	Loss of 200 MW		Loss of 50 MW	
	nadir [Hz]	difference [mHz]	nadir [Hz]	difference [mHz]
0%	49.831	0	49.959	0
10%	49.836	5	49.961	1
17%	49.839	8	49.961	2
27%	49.845	14	49.963	3
37%	49.852	21	49.964	5
100%	49.872	41	49.969	9

disappears when the electrolyser takes over the full FCR support, as electro-mechanic oscillations of the generators do not occur then. Simulations with different electrolyser ramp rates (i.e. 150 and 750 MW/s; 0.5 and 2.5 pu/s) have been performed, but this did not result in significantly differently results as the Rate-of-Change-of-Frequency (RoCoF) is slow in comparison to the minimum ramp rate of the electrolyser.

### 4.3. Simulation of Case 2: Loss of Load

In the second study case, a loss of load is considered. For this purpose, the operational scenario has been changed according to Table 1. The electrolyser operational setpoint has been reduced to 190 MW, to enable upwards regulation

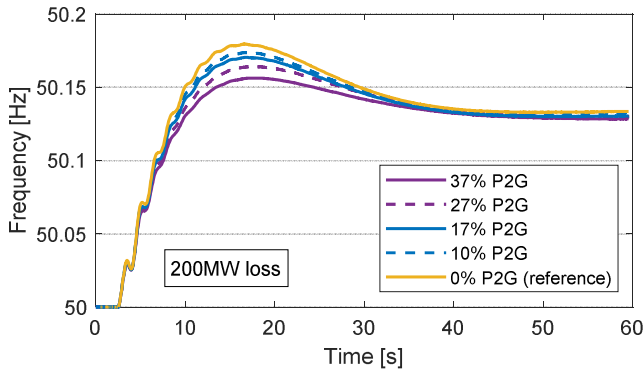
**Response for different shares of electrolyser FCR capacity**

**Fig. 16.** Frequency response of the system with different shares of electrolyser FCR capacity for a loss of 200 MW demand.

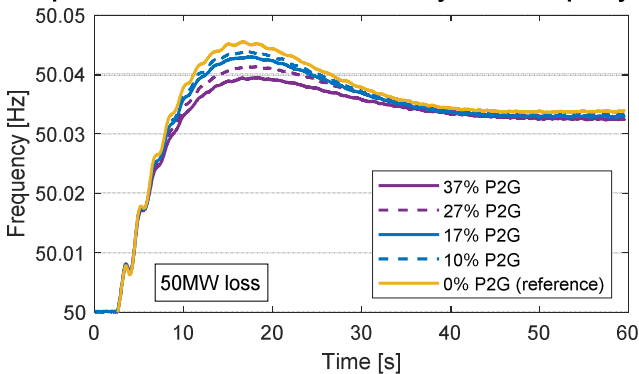
**Response for different shares of electrolyser FCR capacity**

**Fig. 17.** Frequency response of the system with different shares of electrolyser FCR capacity for a loss of 50 MW demand.

**Table 3** Frequency nadirs for case 2: loss of load

Share of electrolyser FCR capacity	Loss of 200 MW		Loss of 50 MW	
	nadir [Hz]	difference [mHz]	nadir [Hz]	difference [mHz]
0%	50.180	0	50.046	0
10%	50.174	6	50.044	2
17%	50.171	9	50.043	3
27%	50.164	15	50.041	4
37%	50.156	23	50.040	6

of the electrolyser consumption and 37% of electrolyser FCR support. In this case, the loss of load is simulated by reducing the load at MEE380 substation by 200 or 50 MW. The results of these simulations are shown in Figs. 16 and 17. An overview of the frequency nadirs is shown in Table 3. Similar to the loss of generation capacity, it can be concluded that electrolysers have a positive effect on the frequency stability as electrolysers are able to respond faster than generators to deviations of the frequency.

## 5. Conclusions and Future Work

In this paper, a generic electrolyser model was developed in RSCAD, to be used in real-time simulations on the Real-Time Digital Simulator (RTDS). In order to provide frequency support, the electrolyser model has been equipped with a Front End Controller that responds to grid and market signals like frequency deviations. The electrolyser has been validated against field measurements of a 1-MW pilot electrolyser installed in the northern part of the Netherlands. After adjustment of the model, it is able to replicate the behaviour of a real electrolyser. Frequency support by electrolysers was then studied in several real-time simulations, considering the northern part of the Dutch transmission network. It was found that electrolysers have a positive effect on frequency stability after losing generation capacity or load, as electrolysers are able to respond faster to frequency deviations than conventional generators. This work is part of a larger project in which the technical and economic viability of power-to-gas solutions is investigated. For the electrical studies, various scenarios for 2030 and 2040 are considered. The contribution of electrolysers to Automatic Frequency Restoration Reserve (aFRR) and voltage support are considered in the studies as well. Generally, the simulations show that electrolysers have the potential to support frequency stability more effectively than conventional generators.

## 6. Acknowledgments

The authors thank the colleagues from EnergyStock and Qirion for supporting and performing the field measurements at Veendam-Zuidwending.

This work has received funding from the European Union's Connecting Europe Facility (CEF) programme under the grant agreement No INEA/CEF/SYN/A2016/1336043 – TSO2020 Project (Electric “Transmission and Storage Options” along TEN-E and TEN-T corridors for 2020).

This paper reflects only the authors' views and the European Commission is not responsible for any use that may be made of the information it contains.

## 7. References

- [1] 'TSO2020: Electric "Transmission and Storage Options" along TEN-E and TEN-T corridors for 2020', <http://tso2020.eu/>, accessed 31 July 2019
- [2] TSO2020 Consortium, 'TSO2020 Grant Agreement' (TSO2020 Consortium, 2014)
- [3] Clegg, S., Mancarella, P.: 'Integrated modelling and assessment of the operational impact of power-to-gas (P2G) on electrical and gas transmission networks', *IEEE Transactions on Sustainable Energy*, 2015, 6, (4), pp. 1234-1244
- [4] Xu, H., Kockar, I., Schnittger, S., Rose, J.: 'Influences of a hydrogen electrolyser demand on distribution network under different operational constraints and electricity pricing scenarios', *CIREN Workshop*, Helsinki, Finland, June 2016
- [5] Alrewq, M., Albarbar, A.: 'Investigation into the characteristics of proton exchange membrane fuel cell-based power system', *IET Science, Measurement & Technology*, 2016, 10, (3), pp. 200–206
- [6] Kiaee, M., Cruden, A., Infield, D., Chladek, P.: 'Utilisation of alkaline electrolysers to improve power system frequency stability with a high penetration of wind power', *IET Renewable Power Generation*, 2014, 8, (5), pp. 529–536
- [7] Alshehri, F., García Suarez, V., Rueda Torres, J.L., Perilla, A., van der Meijden, M.A.M.M.: 'Modelling and evaluation of PEM hydrogen technologies for frequency ancillary services in future multi-energy sustainable power systems', *Heliyon*, 2019, 5, (e01396), pp. 1-24
- [8] Smolinka, T., Ojong, E.T., and Lickert, T.: 'Fundamentals of PEM water electrolysis', in 'PEM Electrolysis for Hydrogen Production: Principles and Applications' (CRC Press, 2017), pp. 11–33
- [9] Harvey, R., Abouattallah, R., and Cargnelli, J.: 'Large-scale water electrolysis for power-to-gas', in *PEM Electrolysis for Hydrogen Production: Principles and Applications* (CRC Press, 2017), pp. 303–313
- [10] Schmidt, O., Gambhir, A., Staffell, I., et al.: 'Future cost and performance of water electrolysis: An expert elicitation study', *International Journal of Hydrogen Energy*, 2017, 42, (52), pp. 30470–30492
- [11] Ruuskanen, V., Koponen, J., Huoman, K., et al.: 'PEM water electrolyzer model for a power-hardware-in-loop simulator', *International Journal of Hydrogen Energy*, 2017, 42, (16), pp. 10775–10784
- [12] Abdin, Z., Webb, C., and Gray, E.M.: 'Modelling and simulation of a proton exchange membrane (pem) electrolyser cell', *International Journal of Hydrogen Energy*, 2015, 40, pp. 13243
- [13] Agbli, K., Péra, M., Hissel, D., et al.: 'Multiphysics simulation of a pem electrolyser: Energetic macroscopic representation approach', *International journal of hydrogen energy*, 2011, 36, pp. 1382
- [14] Lebbal, M., and Lecoche, S.: 'Identification and monitoring of a pem electrolyser based on dynamical modelling', *International journal of hydrogen energy*, 2009, 34, pp. 5992
- [15] Van der Merwe, J., Uren, K., Bessarabov, D.: 'A study of the loss characteristics of a single cell PEM electrolyser for pure hydrogen production', *IEEE International Conference on Industrial Technology (ICIT)*, Cape Town, South Africa, February 2013
- [16] Martinson, C., Van Schoor, G., Uren, K., Bessarabov, D.: 'Equivalent electrical circuit modelling of a proton exchange membrane electrolyser based on current Interruption ', *IEEE International Conference on Industrial Technology (ICIT)*, Cape Town, South Africa, February 2013
- [17] Atlam, O., and Kolhe, M.: 'Equivalent electrical model for a proton exchange membrane (pem) electrolyser', *Energy Conversion and management*, 2011, 52, pp. 2952
- [18] der Merwe, V., and Petrus, J.H.: 'Characterisation of a proton exchange membrane electrolyser using electrochemical impedance spectroscopy', PhD thesis, North-West University, 2012
- [19] Guida, V., Guilbert, D., Douine, B.: 'Literature survey of interleaved DC-DC step-down converters for proton exchange membrane electrolyzer applications', *Transactions on Environment and Electrical Engineering*, 2019, 3, (1), pp. 1-11
- [20] Guilbert, D., Maria Collura, S., Scipioni, A.: 'DC/DC converter topologies for electrolyzers: State-of-the-art and remaining key issues', *International Journal of Hydrogen Energy*, 2017, 42, (38), pp. 23966-23985
- [21] García-Valverde, R., Espinosa, N., and Urbina, A.: 'Simple pem water electrolyser model and experimental validation', *International journal of hydrogen energy*, 2012, 37, pp. 1927
- [22] Chiesa, N., Korpås, M., Kongstein, O., and Ødegård, A.: 'Dynamic control of an electrolyser for voltage quality enhancement', *Proc. Int. Conf. on Power System Transients (IPST2011)*, London, UK, 2011
- [23] Ayivor, P.K.S.: 'Feasibility of Demand Side Response from Electrolysers to support Power System Stability', MSc thesis, Delft University of Technology, Delft, the Netherlands, Available: [repository.tudelft.nl](https://repository.tudelft.nl)
- [24] Ayivor, P., Torres, J., van der Meijden, M.A.M.M., et al.: 'Modelling of Large Size Electrolyzer for Electrical Grid Stability Studies in Real Time Digital Simulation', *Proc. Energynautics 3rd Int. Hybrid Power Systems Workshop*, Tenerife, Spain, May 2018
- [25] Ayivor, P., Rueda Torres, J.L., and Meijden, M.A.M.M. van der: 'Modelling of Large Size Electrolyser for Electrical Grid Stability Studies - A Hierarchical Control,' *Proc. 17th Wind Integration Workshop*, Stockholm, Sweden, October 2018
- [26] da Costa Lopes, F., and Watanabe, E.H.: 'Experimental and theoretical development of a pem electrolyzer model applied to energy storage systems', *Proc. Power Electronics Conference, (COBEP'09)*, Brazil, 2009, pp. 775–782
- [27] Mohanpurkar, M., Luo, Y., Terlip, D., et al.: 'Electrolyzers enhancing flexibility in electric grids', *Energies*, 2017, 10, pp. 1836
- [28] Eichmann, J., Harrison, K., and Peters, M.: 'Novel Electrolyser Applications: Providing More Than Just Hydrogen – Technical Report NREL/TP-5400-61758', (National Renewable Energy Laboratory, Denver CO, 2014)
- [29] TenneT TSO B.V. 'Kwaliteits- en Capaciteitsdocument 2017 (KCD2017)' (TenneT TSO B.V., Arnhem, the Netherlands, 2017) Available: [https://www.tennet.eu/fileadmin/user\\_upload/Company/Publications/Technical\\_Publications/Dutch/TenneT\\_KCD2017\\_Deel\\_I\\_web.pdf](https://www.tennet.eu/fileadmin/user_upload/Company/Publications/Technical_Publications/Dutch/TenneT_KCD2017_Deel_I_web.pdf)