

RESEARCH & ANALYSIS REPORT - TECHNICAL ANALYSIS

Manutenção Militar Complex - Lisbon, Portugal



Images
1. Interior of the milling (photo by Hielkje
Zijlstra, 04-09-2016)

PREFACE

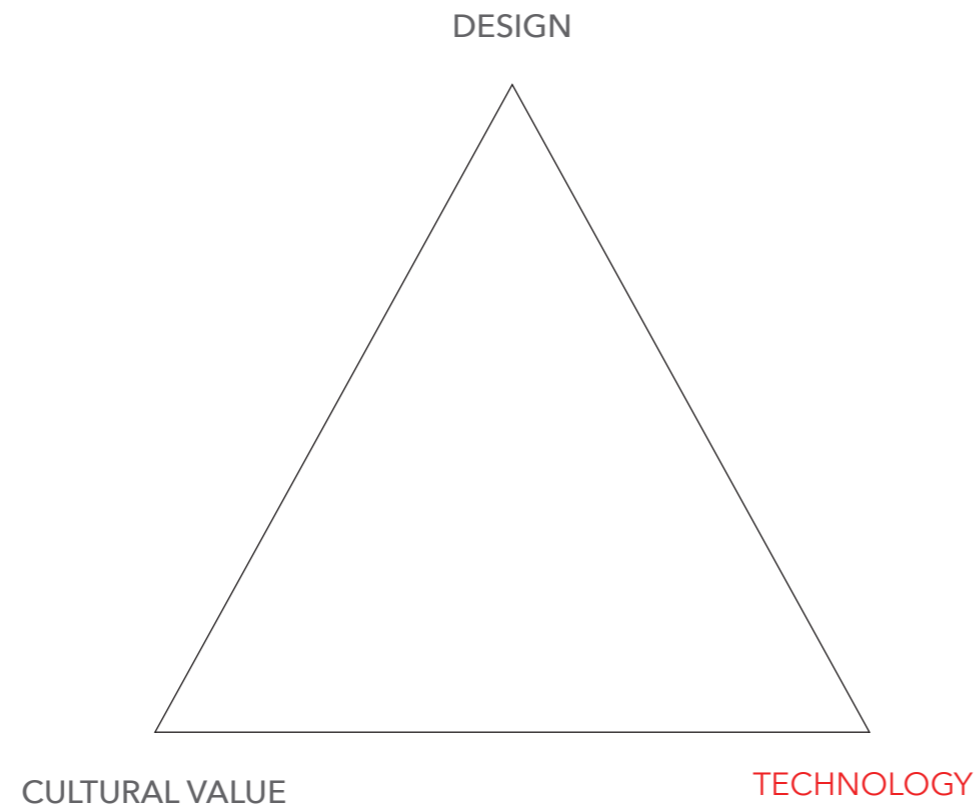

Before you lies the *Research and Analysis Report* of the Manutenção Militar Complex. The Research and Analysis is part of the graduation studio *Disclosing the Military City Lisbon* Autumn 2016 - 2017. The graduation studio is organized by the chair of Heritage and Architecture at the Faculty of Architecture at the TUDelft. The Research and Analysis Report will form the basis for our later design approach and answering the research question.

The Research and Analysis Report is constructed by three integrated (but separately presented) parts: Architectural Analysis, Technical Analysis and the Cultural Value.

The research is not complete, due to the language barrier and inaccessible information. But conducting extensive investigation has allowed us to answer the questions that we identified. The process was guided by Job Roos (architecture), Hielkje Zijlstra (architecture), Wido Quist (technology) and Marieke Kuipers (Cultural Value).

Images:
Triangle Heritage and Architecture
(Graduation Studio Manual Heritage and Architecture, own editing)



The Manutenção Militar Complex (MMC) is located in the city of Lisbon, the capital of Portugal. The MMC was an industrial facility that produced food, uniforms and other goods for the Portuguese Army. Especially the southern part of the complex had an industrial function, where the northern part had a rather social function. In this Research and Analysis Report we will focus mainly on the southern part of the complex due to the industrial heritage present in this area.

The MMC was accommodated in a former Convent, *Convento das Grilas*, by the end of the 19th Century. During the 20th Century, due to the needs during the First World War and the Portuguese Colonial War in the 1960s, the complex was expanded multiple times. The industrial capacity became superfluous due to reduction of the army, the production stopped in 2010. The MMC was finally substituted by a public enterprise MM-Gestão Partilhada in 2015.

In the heart of the (southern) complex an ensemble of two objects is highlighted: The Milling Factory and The Bakery. Our group of students was chosen to analyse these objects in the built environment.

We hope you enjoy your reading.

*Noëlle Dooper
Ruben Klinkenberg
Guido Martin
Amela Rašidkadić*

Images
1. Birds-eye view MMC (photo by Carla Goncalves)

INDEX

INTRODUCTION	9
OVERVIEW BUILDING COMPONENTS	11
Bakery and cookie factory	12
Milling	14
DRAWINGS	17
Bakery and cookie factory	18
Milling	19
MEASUREMENTS	21
Bakery and cookie factory	22
Milling	23
HISTORICAL DEVELOPMENT ENSEMBLE	25
Stage 1	26
Stage 2	27
Stage 3	28
Stage 4	29
Stage 5	30
Stage 6	31
Conclusion	32
CONSTRUCTION BUILDING COMPONENTS	35
Building 16 - bakery	37
Building 16A - silo	51
Building 16B - storage	57
Building 17 - cookie factory	63
Building 18 - milling	73
Building 19 - silo	95
Building 20 - storage	103
CONCLUSION	113
STATE OF CONSERVATION	123
CLIMATE	131
LITERATURE	135

INTRODUCTION

Within the graduation studio the buildings of the Manutenção Militar Complex are divided into four ensembles: riverside, middle, weird corner and streetside. This report is made to get a better understanding of the technical aspects of the buildings which are part of our ensemble; the middle. This ensemble consists of the bakery, cookie factory and milling. The knowledge obtained in this report will form the technical basis for the new design. During the site visit a lot of different construction typologies were found in our ensemble. The analysis has shown that over time, for various reasons, changes have occurred in the separate buildings. On this basis the following research question was drawn up:

How did the buildings become as they are right now and what are the technical characteristics of this development?

The report starts with some general information about the ensemble: overview of building components, available digital drawings and measurements. Then an overview will be given of the historical development of the ensemble: it will answer the first part of the research question. After this, the technical analysis of the different building components is presented. This information, combined with the historical development, will answer the second part of the research question. The report ends with information about the state of conservation and climate.

For the research photos, documents provided by DOCOMOMO, like historical photos and drawings, old maps from the internet and our own technical knowledge are used. The images in this report are all own images unless otherwise stated.

OVERVIEW BUILDING COMPONENTS

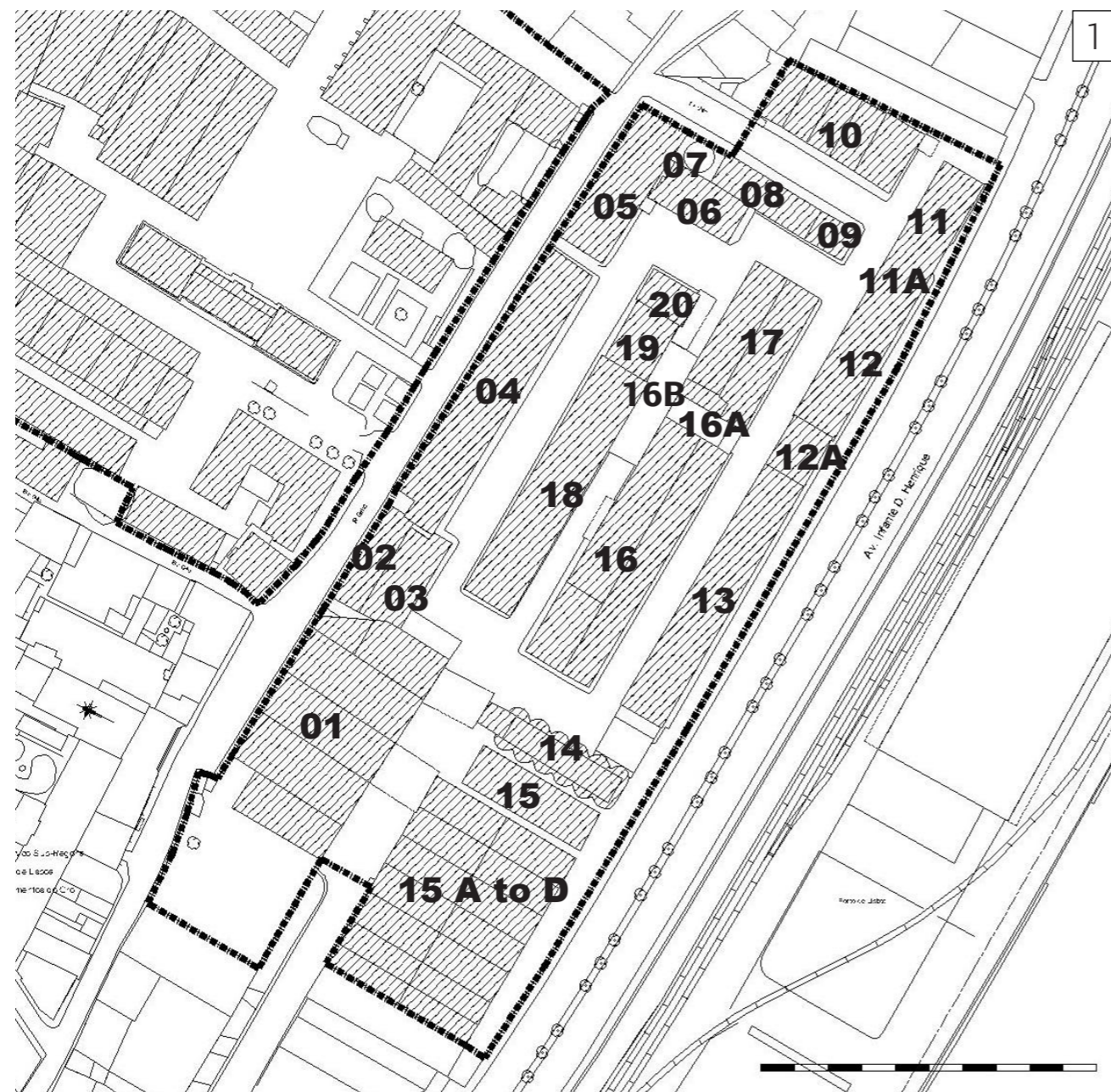

As explained in the introduction, the ensemble which is addressed in this report consists of the bakery, cookie factory and milling. The ensemble is divided into building components, which are listed below and illustrated on the next pages. Since the ensemble contains only a few buildings of the entire complex, each building component has been given its own number. These numbers were already set by DOCOMOMO.

- 16 - Bakery
- 16A - Silo
- 16B - Storage*
- 17 - Cookie factory
- 18 - Milling
- 19 - Silo
- 20 - Storage

* We've added this number ourselves. The storage is the volumetric connection between the bakery and milling. This building component is not visible on the drawings on the next pages.

Images
1. MMC South area plan (drawing provided by Docomomo)

BAKERY AND COOKIE FACTORY

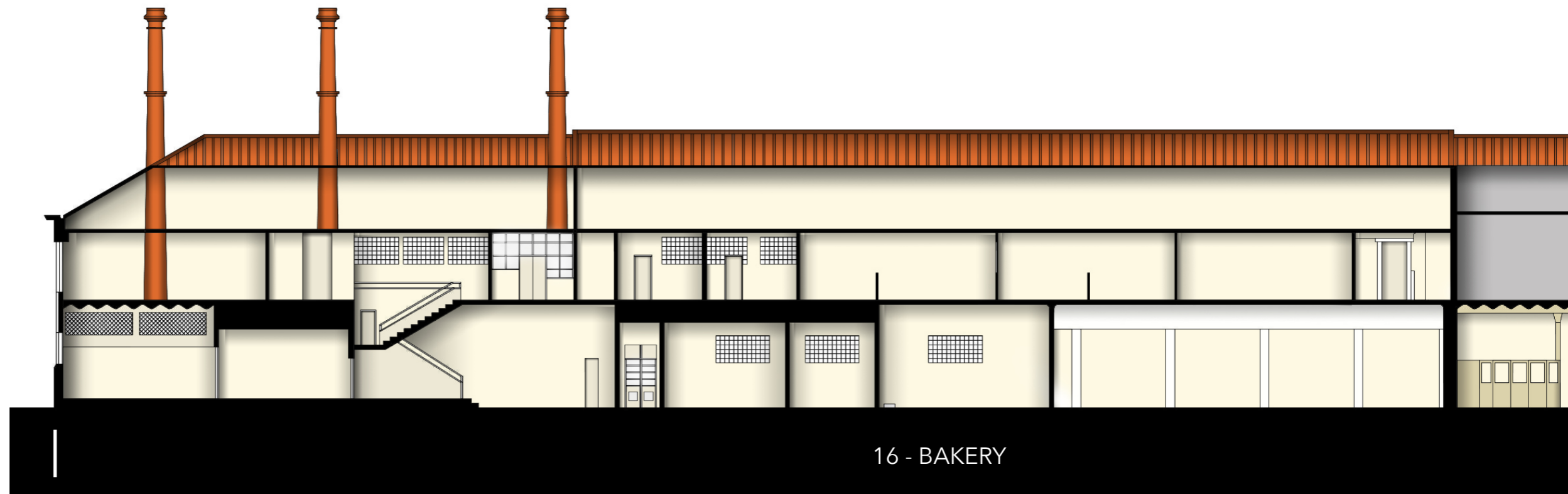

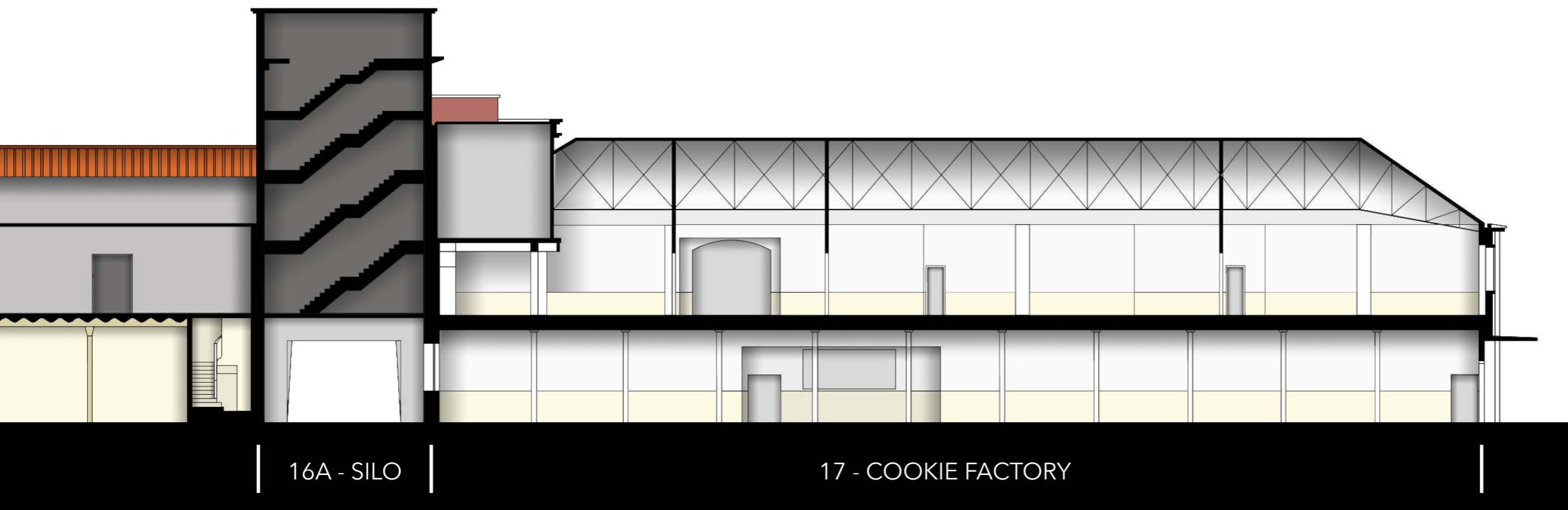

MILLING



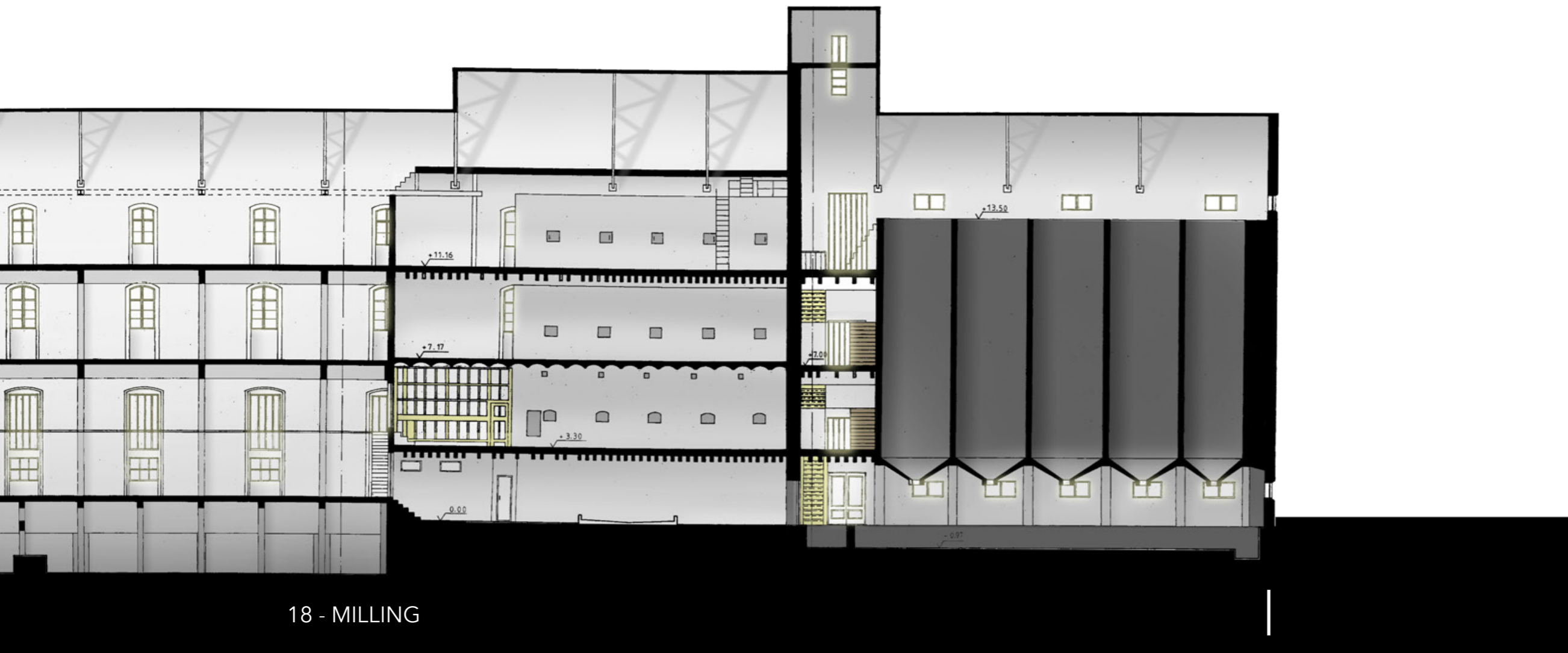

18 - MILLING

DRAWINGS

The groups, which all analyse an ensemble of buildings of the Manutenção Militar complex, have agreed to produce digital drawings of all the building components that are part of their ensemble. The drawings on the following pages are available in DWG.

BAKERY AND COOKIE FACTORY

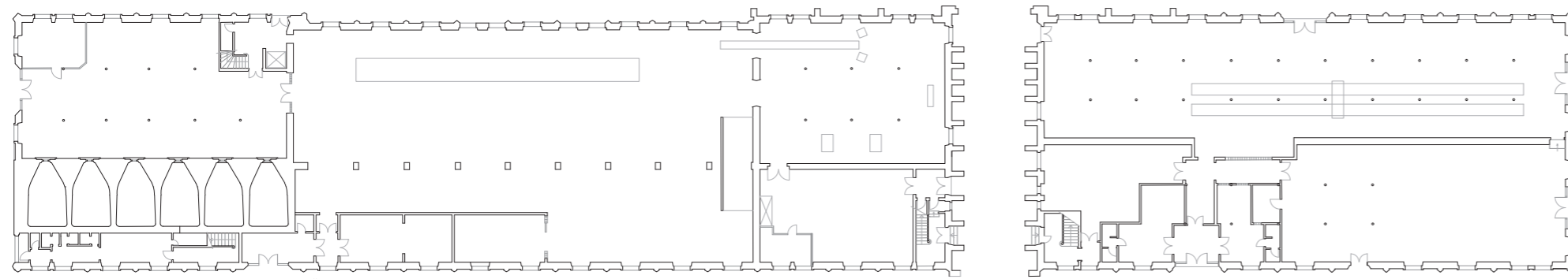

GROUND FLOOR 1:500

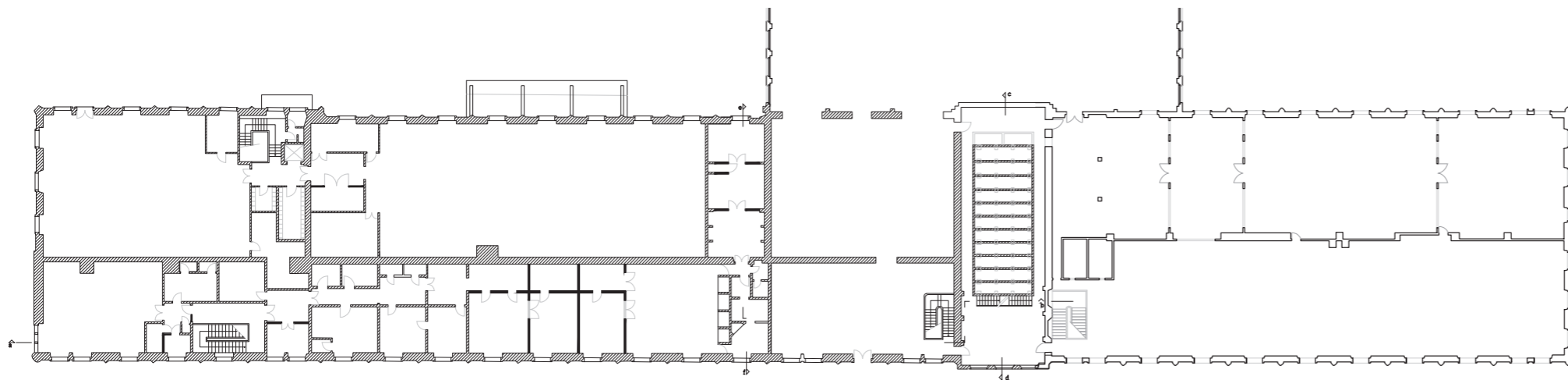

FIRST FLOOR 1:500

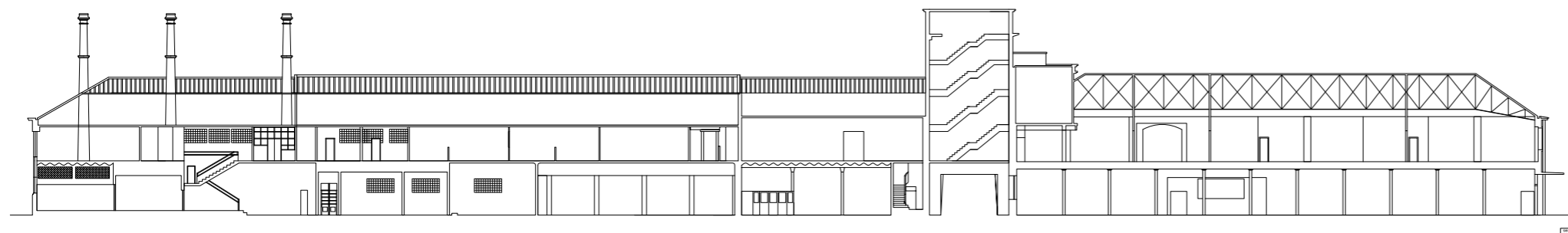

SECTION A-A 1:500

MILLING

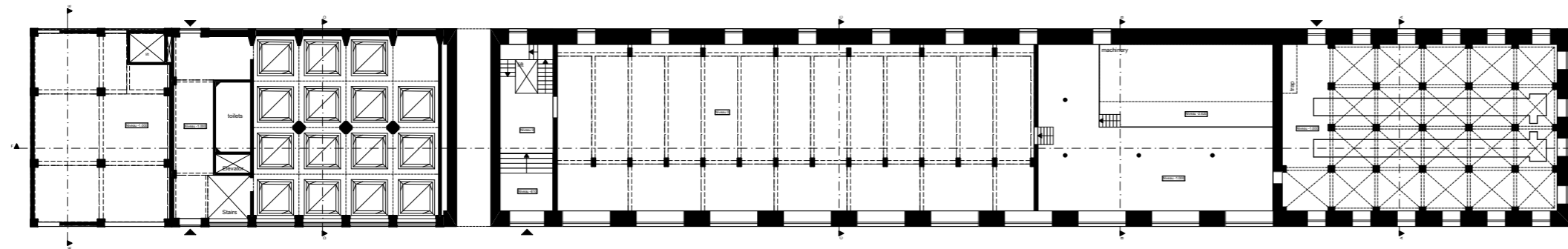

GROUND FLOOR 1:400

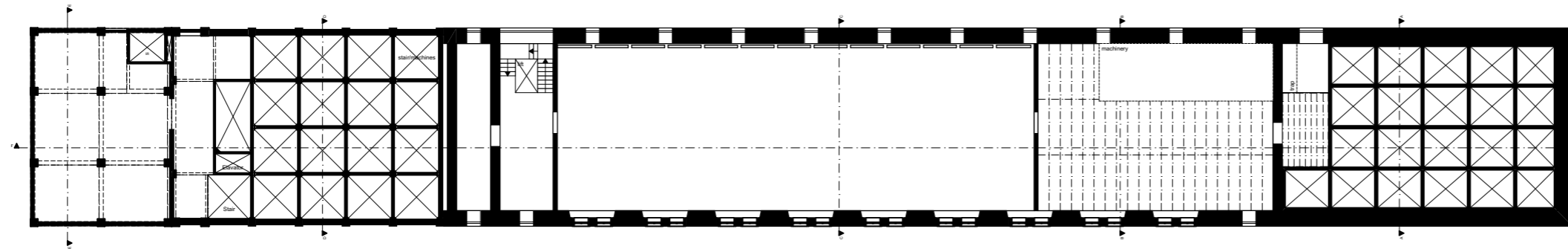

THIRD FLOOR 1:400

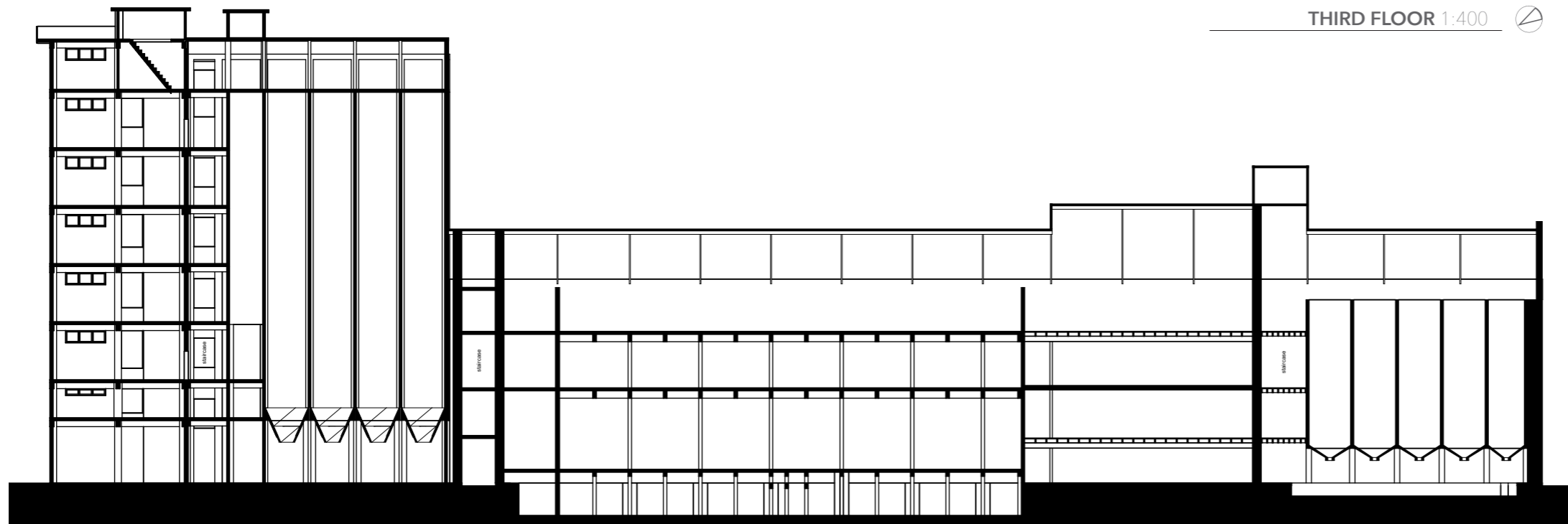

SECTION A-A 1:400

In addition to these drawings, there are also cross sections available in DWG of each building part.

MEASUREMENTS

The total surface area of the ensemble is calculated to get a grip on the size of the buildings. This chapter shows the surface area of different spaces of the ensemble and the total surface area of it. In addition, a comparison is made with other projects to create awareness regarding the size (and future possibilities).

The surface areas are based on internal measures according to drawings provided by Docomomo. The silos are not included in the total surface area, since there are no floors in it.

BAKERY AND COOKIE FACTORY



Total surface area bakery and cookie factory
5004,20m²

Total surface area building 16B
370,00m²

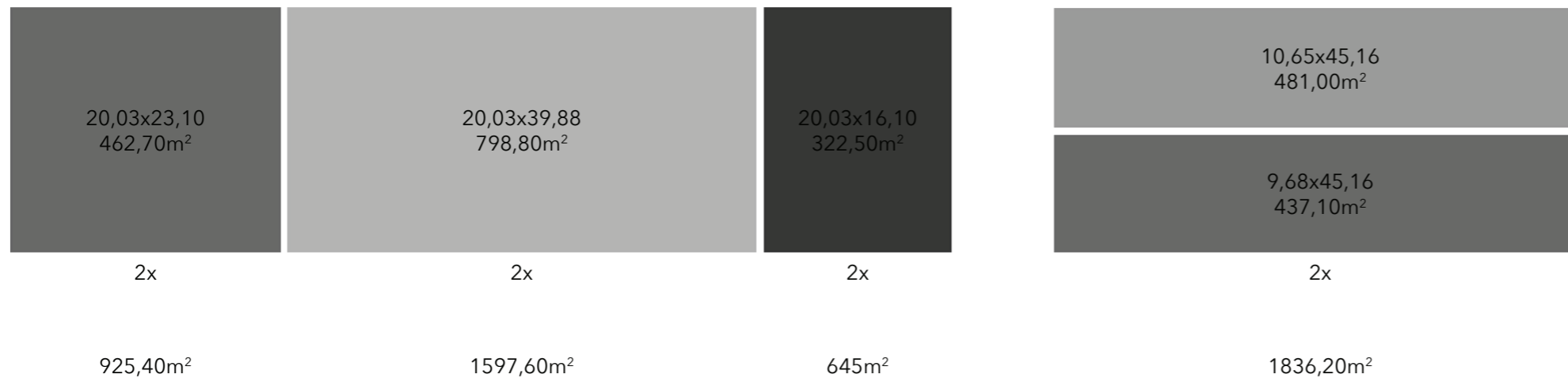
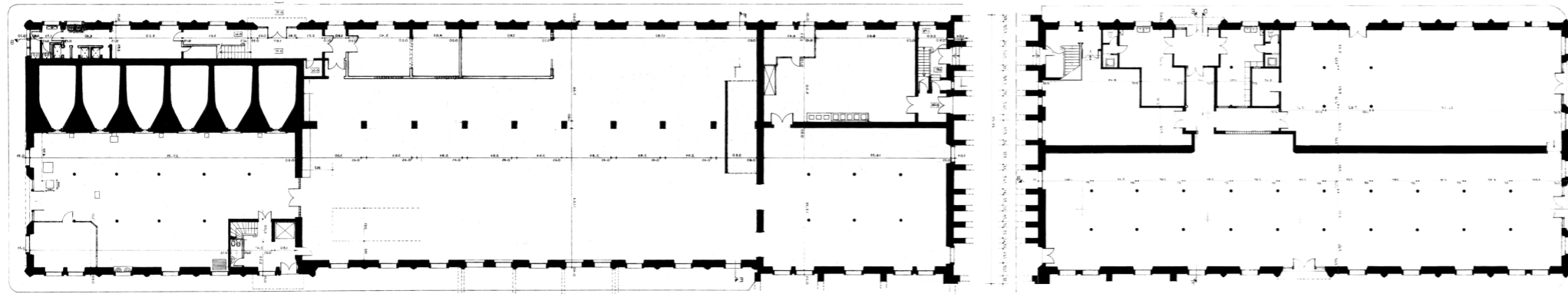

MILLING

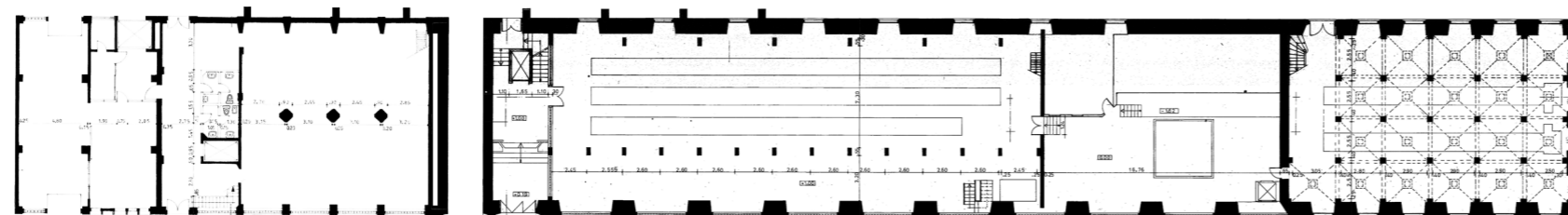
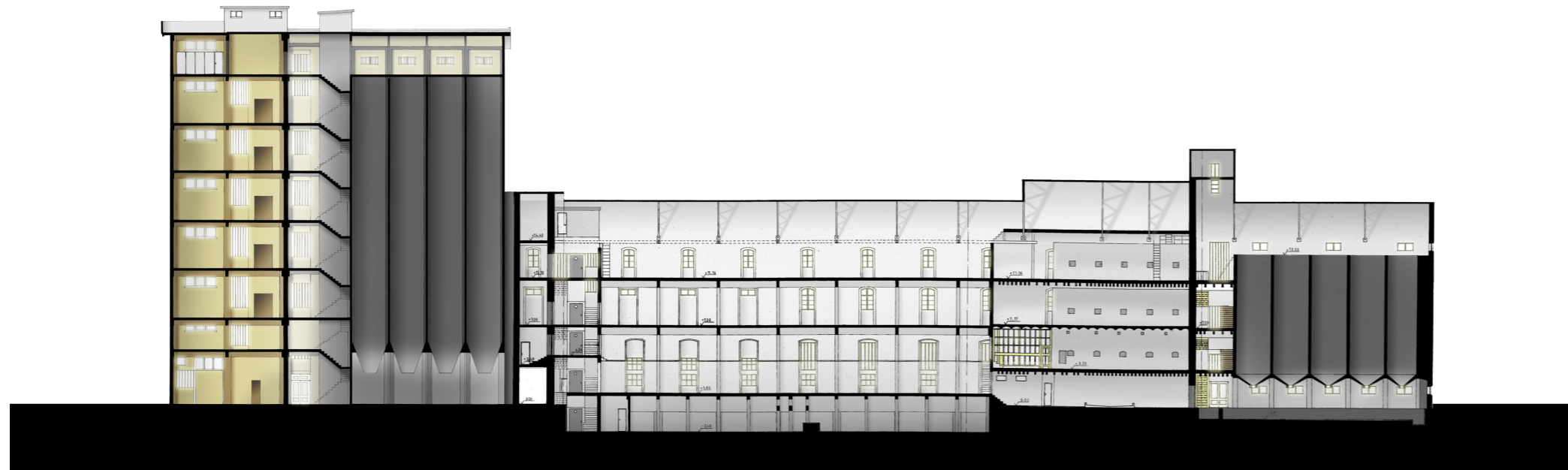

9,65x13,15 126,90m ²	5,40x13,15 71,00m ²	13,15x13,15 172,90m ²	29,20m ²	3,85x11,90 45,80m ²	33,95x11,90 404,00m ²	16,70x11,90 198,70m ²	39,30m ²	16,30x11,90 194,00m ²
8x	8x	2x	4x	5x	4x	4x	4x	1x
1015,20m ²	568,00m ²	345,80m ²	116,80m ²	229,00m ²	1616,00m ²	794,80m ²	157,20m ²	194,00m ²

Total surface area milling
5036,80m²

Total surface area ensemble
10411,00m²

BK-City¹
Total surface area: 36.400m²

Library TU Delft²
Total surface area: 15.000m²

Text
1. From: <http://www.braaksma-roos.nl/projecten/herbestemming/bkcity/>
2. From: <http://www.mecanoo.nl/Projects/project/27/Library-Delft-University-of-Technology?t=0>

HISTORICAL DEVELOPMENT ENSEMBLE

As explained in the introduction, the research question of the technical analyses is: how did the buildings become as they are right now and what are the technical characteristics of this development? In this chapter the focus lies on the first part of the question; how did the buildings become as they are right now? The reasons for the modifications of the ensemble will be explained in six stages. Each stage is illustrated with a historical map of the complex, which shows the buildings that have been added in that particular stage, and (historical) photos and drawings. This chapter is also included in the Architectural Analysis.

STAGE 1



LEGEND (MAP)

- Existing buildings
- Added buildings

Ministerio da Guerra takes possession of the site.¹ The former convent is converted to Manutenção Militar to provide the Portuguese army with all kinds of products. In this stage no building of our ensemble was built yet.

34 years earlier, in 1862, an experiment was carried out to manufacture and supply bread to the army. A military bakery was created on a site now known as Rocha do Conde de Obidas named "Padaria Militar".¹

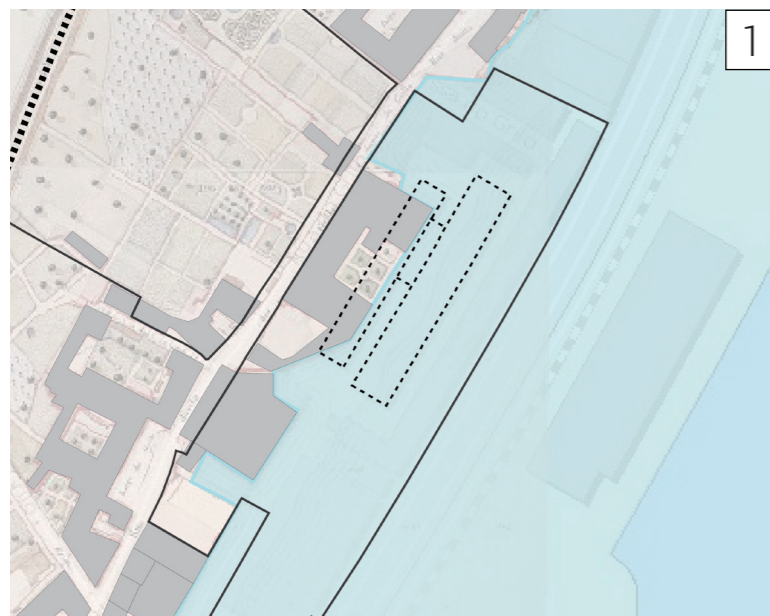

Text

1. Folgado, D., & Custódio, J. (1999). *Caminho do Oriente - Guia do Património Industrial*. Lisboa: Livros Horizonte.

Images

1. Map of 1956-58 by Filepe Folque (own editing)

STAGE 2



LEGEND (MAP)

- Existing buildings
- Added buildings

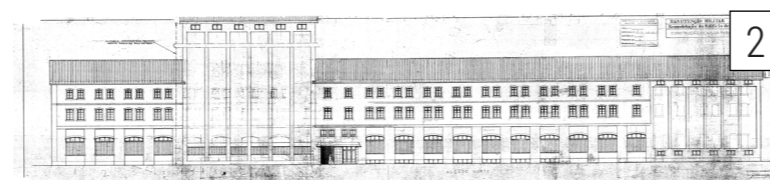
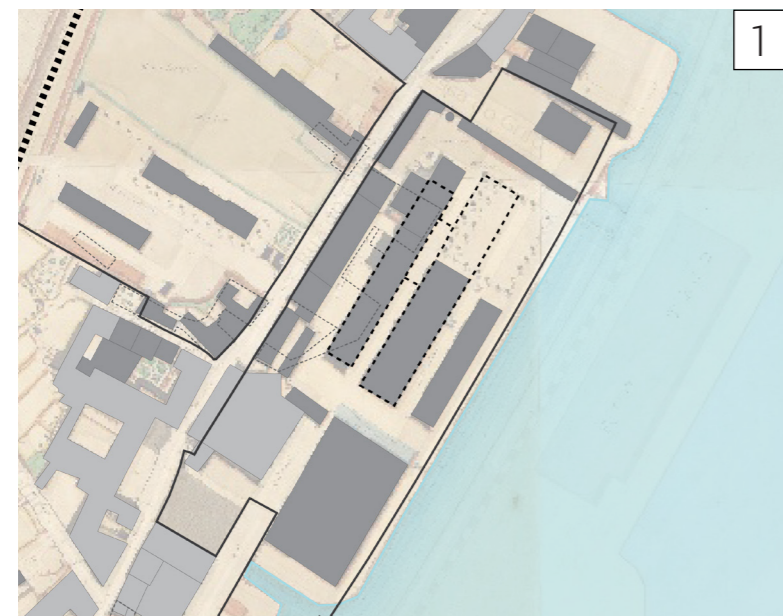
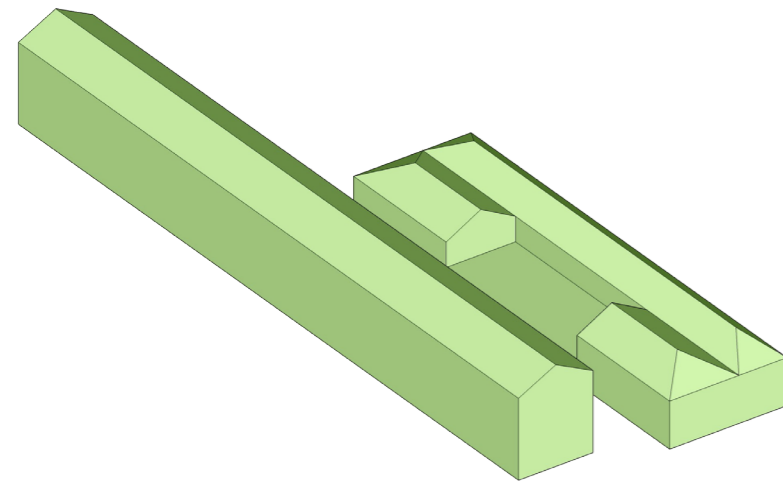

Between 1898 and 1910 construction of several factories, including the mill building and bakery.¹The bakery is a volume with two roofs, in which a clear exception is visible: the middle part of the left roof is flat and lower. The milling is one elongated volume, as can be seen in a drawing that was made for its extension with a silo.

Text

1. Folgado, D., & Custódio, J. (1999). *Caminho do Oriente - Guia do Património Industrial*. Lisboa: Livros Horizonte.

Images

- 1. Map of 1911 by Silva Pinto (own editing)
- 2. Drawing 'Remodeling of the mill building' (provided by Docomomo)
- 3. Ground floor bakery (photo by Hielkje Zijlstra, 04-09-2016)
- 4. Bakery 1917 (photo Facebook MMC)

STAGE 3

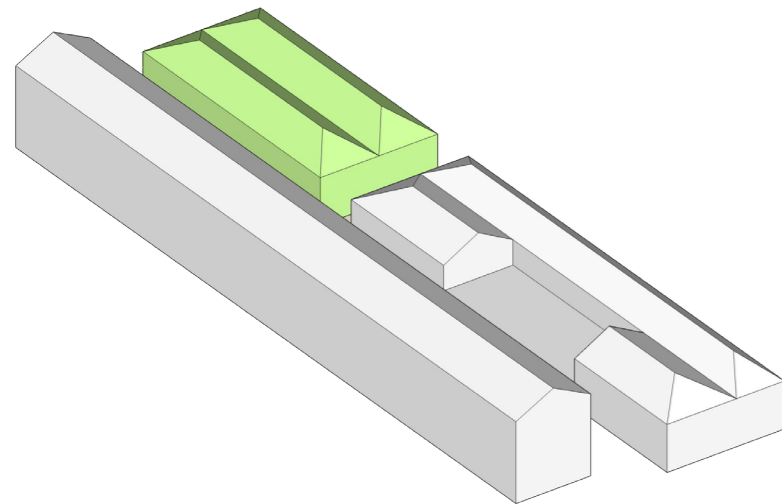
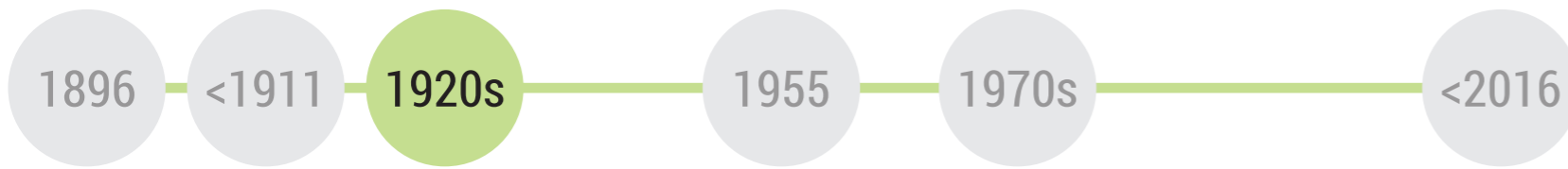

LEGEND (MAP)

- Existing buildings
- Added buildings

The period between 1920 and 1935 can be indicated as a period of industrialization. A lot of industrial (infra) structures have been developed or built. For example, the baker system was implemented in the bakery (image 3), the cookie factory has been built and the milling was distributed over three floors (image 4).¹ The sweets factory had a connection with both the bakery and mill building (image 1 and 2).

Text

1. Folgado, D., & Custódio, J. (1999). *Caminho do Oriente - Guia do Património Industrial*. Lisboa: Livros Horizonte.

Images

- 1. Connection bakery and sweets factory (screenshot video of 1927 from www.cinemateca.pt)
- 2. Connection sweets factory and mill building (screenshot video of 1927 from www.cinemateca.pt)
- 3. Baker system bakery (photo 1930s, provided by Docomomo)
- 4. First floor mill building with 22 mills (photo 1930s, provided by Docomomo)

STAGE 4

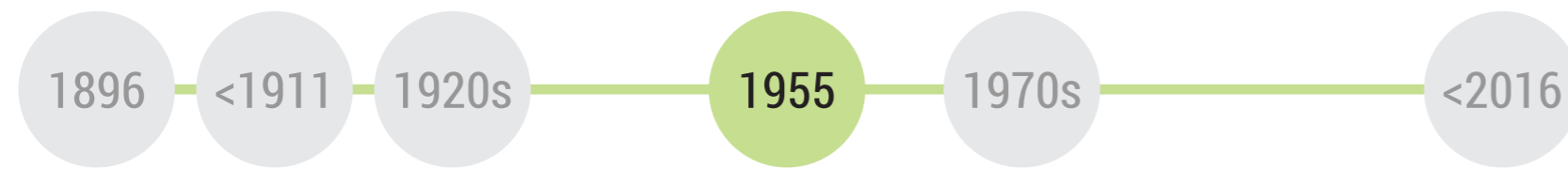

LEGEND (MAP)

- Existing buildings
- Added buildings

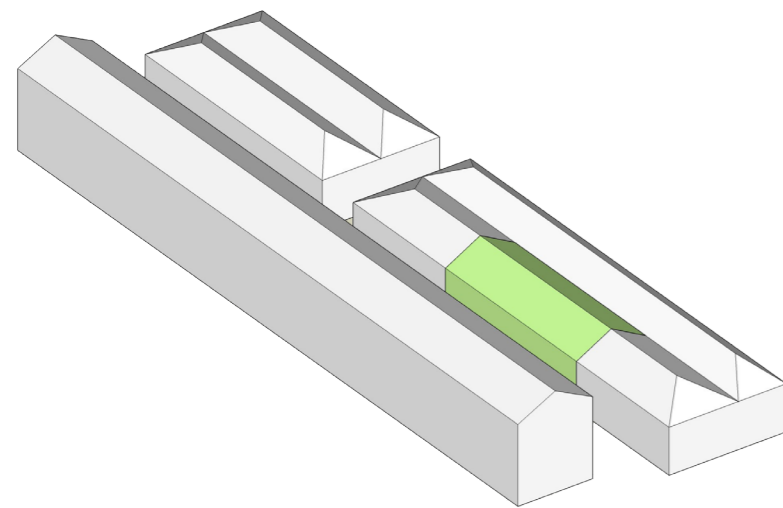

In the bakery the baker system has been replaced in 1955 by two automatic ovens.¹ Because of the need for a column-free space and the addition of a floor, which 'completes' the volume, they chose for a monolithic concrete structure. For this reason the old ovens in the middle part have been removed.



Text
 1. Texts exhibited at Manutenção Militar Complex by Lisbon Municipality

Images
 1. Map of 1950 by unknown (own editing)
 2. Automatic ovens bakery (photo provided by Docomomo)

STAGE 5

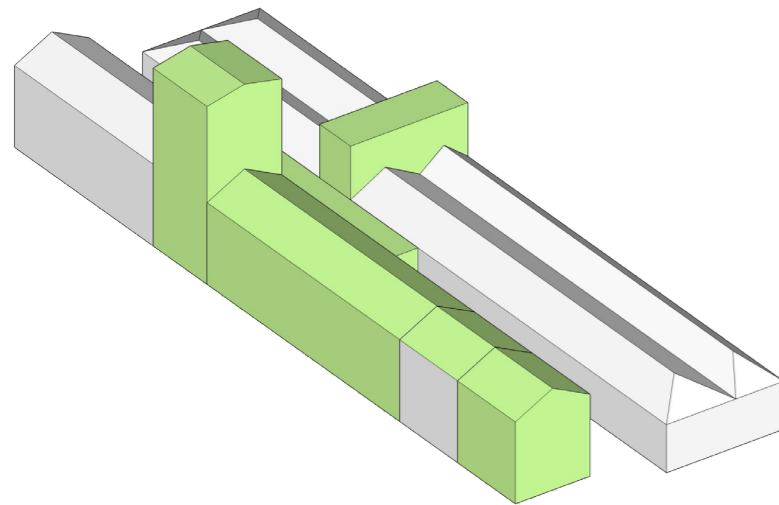

LEGEND (MAP)

- Existing buildings
- Added buildings

During the Ultramar War, Manutenção Militar (MM) is very active in the provision of food for the troops. In this period the MM reached its maximum level of production: silos were built and the production process was modernized, especially in the mill building.¹ The new machines asked for a specific concrete structure, for that reason most of the original floors were removed.



Text

1. Texts exhibited at Manutenção Militar Complex by Lisbon Municipality

Images

- 1. Map of 1970-1983 by ART 91 - PDM (own editing)
- 2. New mills and concrete structure milling (photo by Hielkje Zijlstra, 01-09-2016)

STAGE 6



LEGEND (MAP)

- Existing buildings
- Added buildings

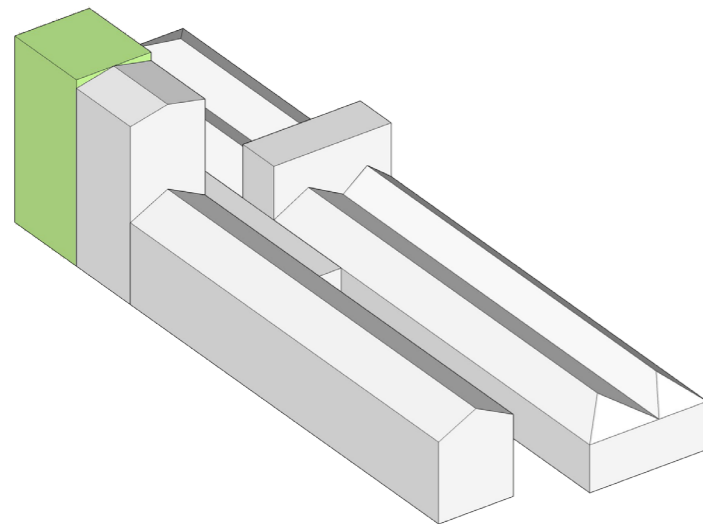

In 1975 independence of the former colonies: MM had to reduce the production. However, in the 1980s a warehouse has been added to the ensemble. This is probably done because the products were not shipped directly anymore, but stored and spread inland. In 2011 the complex officially closed most of the factories, of which the bakery was the last.¹

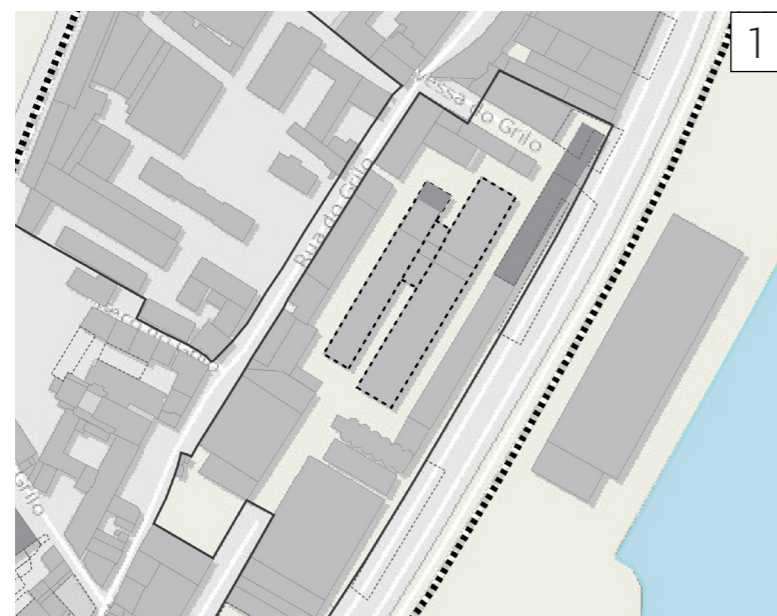

Text
1. Texts exhibited at Manutenção Militar Complex by Lisbon Municipality

Images
1. Map of 2015 by LXI (own editing)
2. Overview complex (photo mid-term presentation workshop group 6)

CONCLUSION

<1911

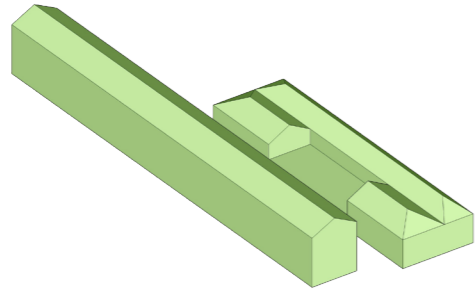

1920s

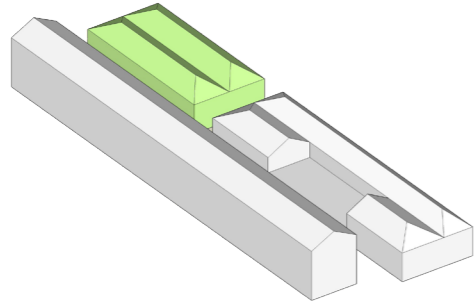

1955

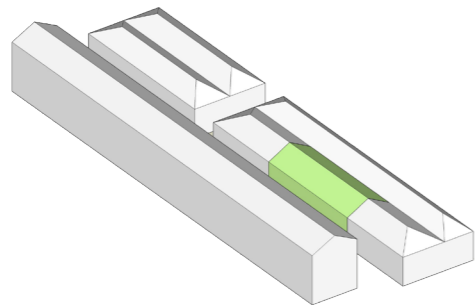

1970s

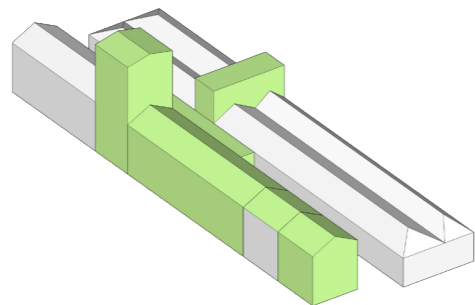

<2016

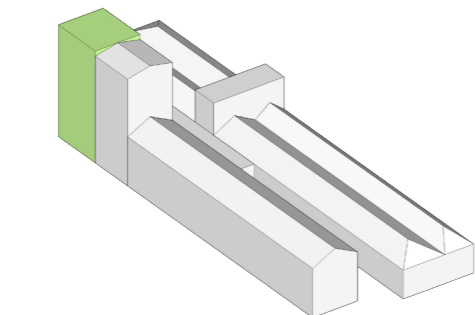

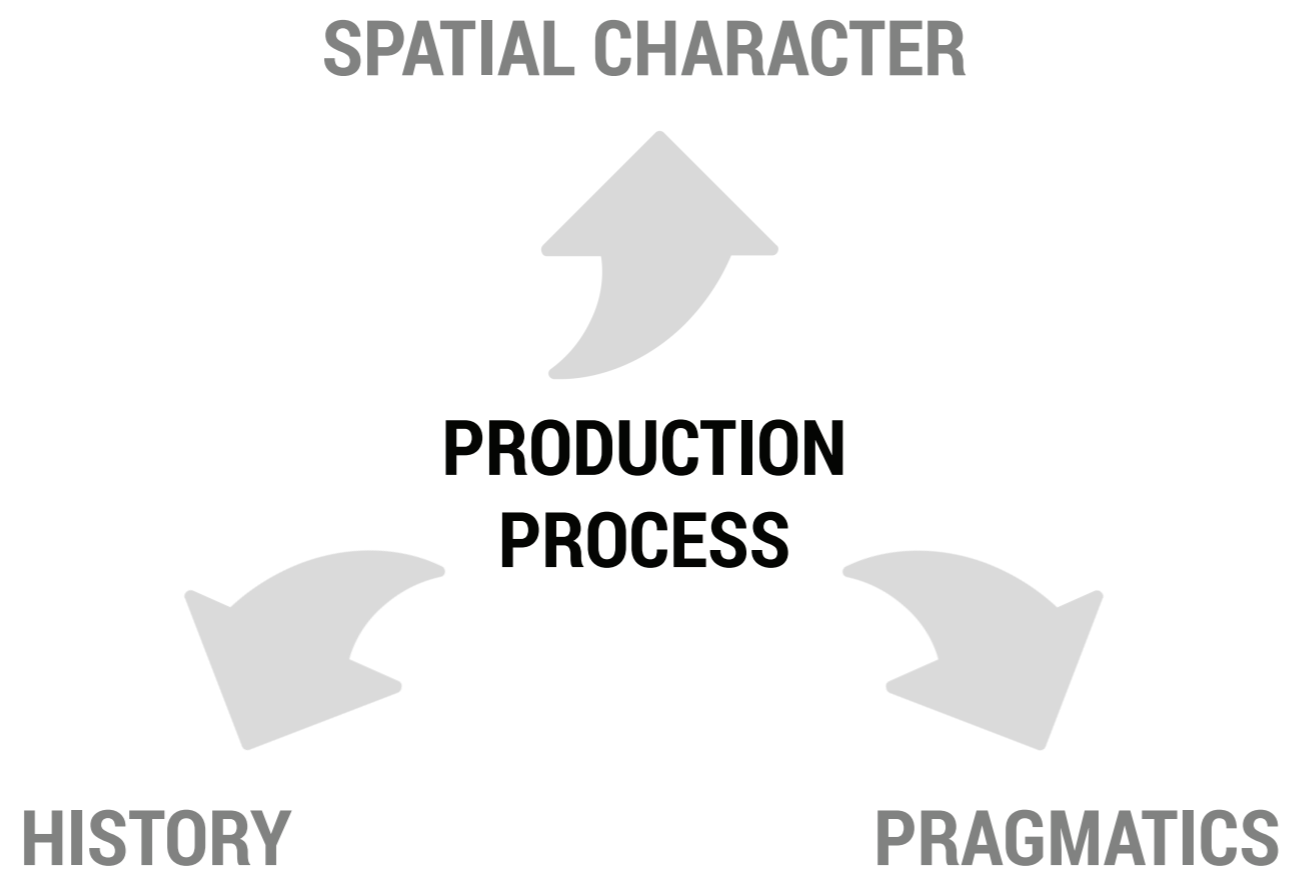

Modernization of the production process played a significant role in how the buildings became as they are right now. The production process is hereby strongly related to the military history, the spatial character of the buildings and site and it reflects the pragmatic attitude. The spatial character will not be discussed in this report, but will be explicitly addressed in the Architectural Analysis.

To be able to answer the second part of the research question, the construction of the different building components have been analysed separately. For each building greater or lesser attention is paid to the following aspects:

- Construction materials
- Structural scheme
- Dimensions
- Interior materials
- Details

Concerning the details we focused on the milling (building 18), silo (building 19) and storage (building 20). This is done because none of the students has chosen the bakery as main building in their graduation project.

In the analysis we established a relationship with the historical development of the ensemble as presented before (p. 25-33). This is done by adding a button of the specific stage on the right top of the page to each relevant drawing, which is mainly the case with the details. For the designation of materials the term 'steel' is used as a common name for non-casted ferrous materials, since it was impossible to define all the exact materials.



The bakery is built between 1898 and 1910. In the period between 1920 and 1935, a period of industrialization, the baker system was implemented. This system was placed next to the original ovens. About twenty years later, in 1955, the baker system has already been replaced by two automatic ovens. For this reason a monolithic concrete construction has been implemented in the building and the old ovens were removed. In 2011 the bakery officially closed.^{1,2}

Text

1. Folgado, D., & Custódio, J. (1999). *Caminho do Oriente - Guia do Património Industrial*. Lisboa: Livros Horizonte.
2. Texts exhibited at Manutenção Militar Complex by Lisbon Municipality

Images

1. Bakery (photo by Noëlle Dooper, 06-09-2016)

BUILDING 16 - BAKERY

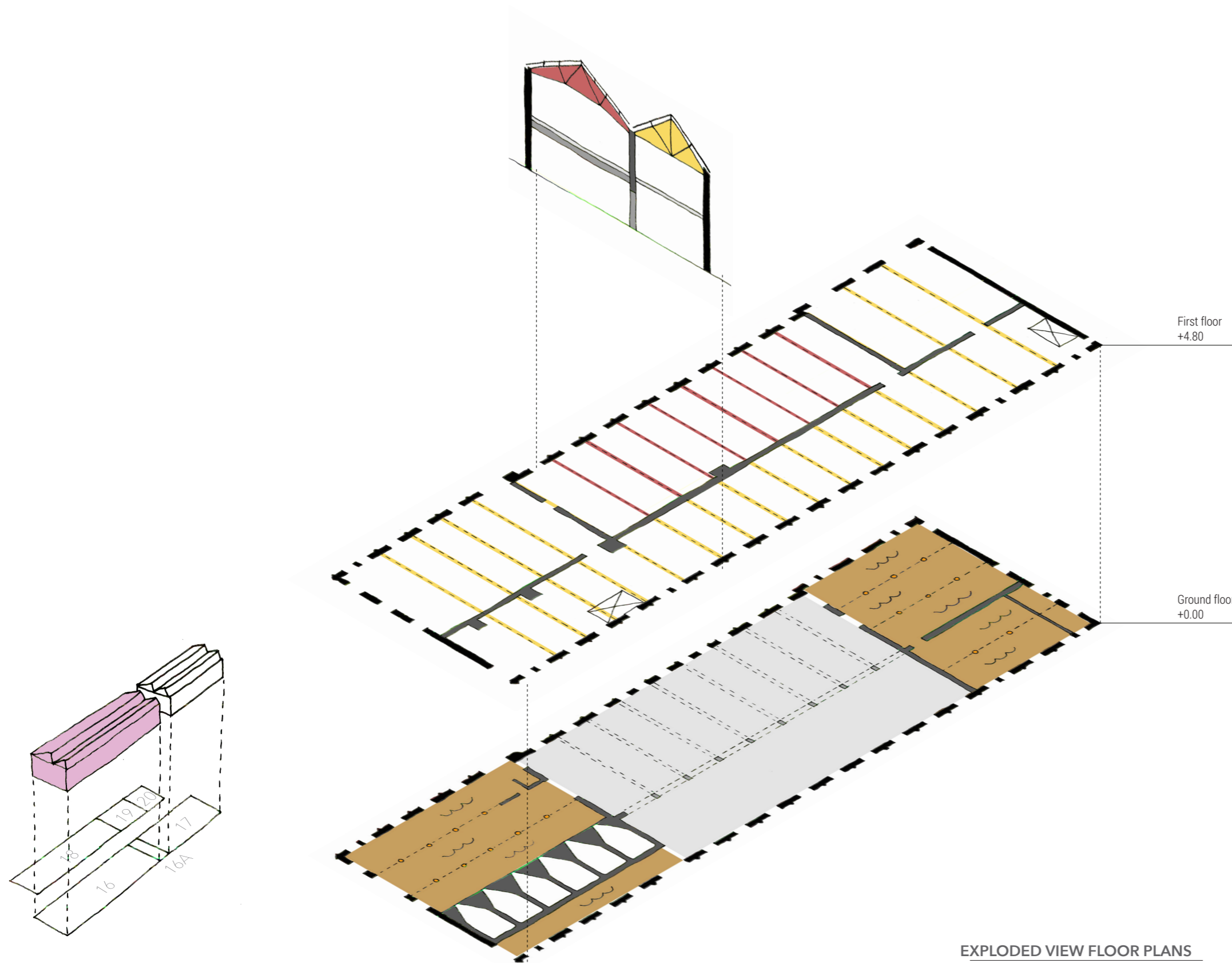

LEGEND

- Load-bearing facade
- Load-bearing interior wall
- Floor concrete
- Floor wood (incl. beams)
- Floor brick vaults
- Column / beam concrete
- Column cast iron
- Steel truss
- Wooden truss

CONSTRUCTION MATERIALS*

In the bakery one can distinguish two different ways of constructing. The interesting thing is that the middle part seems to be built much more recently. The front and back off the building are constructed with cast iron columns, brick vaults and wooden trusses, while the middle part is completely made of concrete.

Overview materials

Front and back part

- Cast iron columns and beams
- Brick vaults
- Wooden trusses
- Brick facade
- Brick interior wall

Middle part (monolithic structure)

- Concrete columns
- Concrete beams
- Concrete floor
- Steel trusses
- Wooden trusses
- Brick facade
- Brick interior wall

* The construction elements which are drawn in the floor plan relates to the floor/roof above it.

EXPLODED VIEW FLOOR PLANS

BUILDING 16 - BAKERY

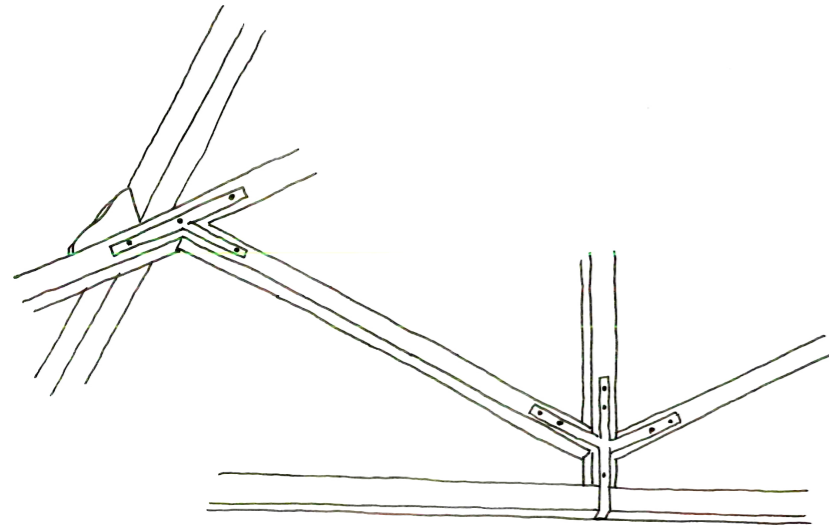

Wooden truss - elements connected with steel strips

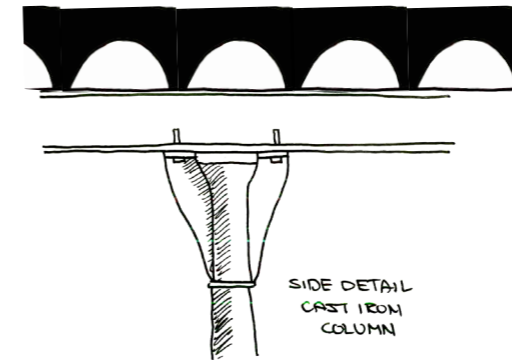
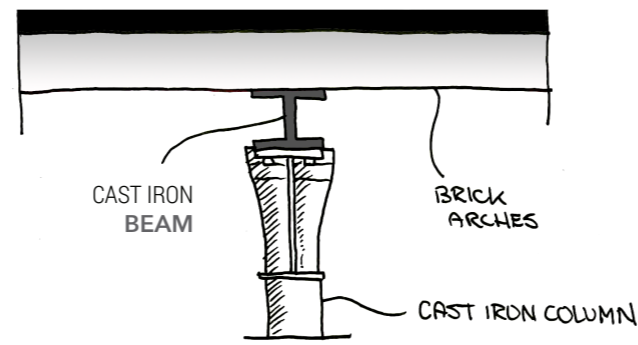

Cast iron columns (two views of same column)

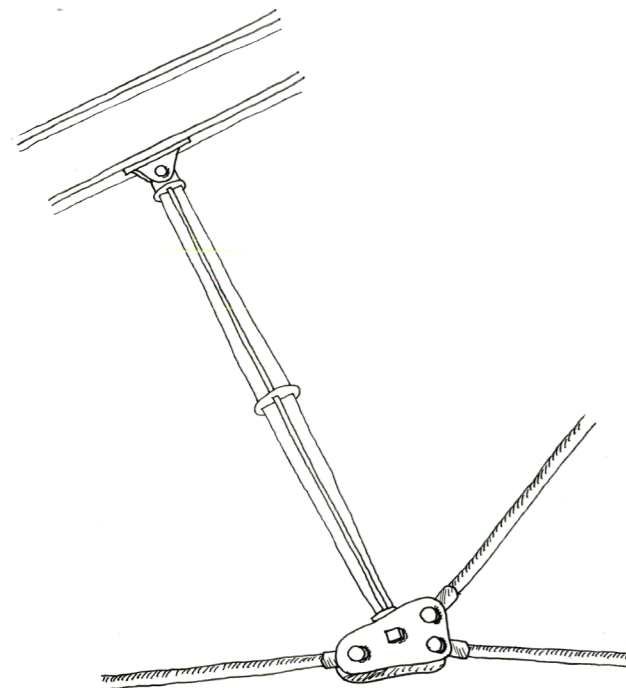

Steel truss - elements connected with screw bolts

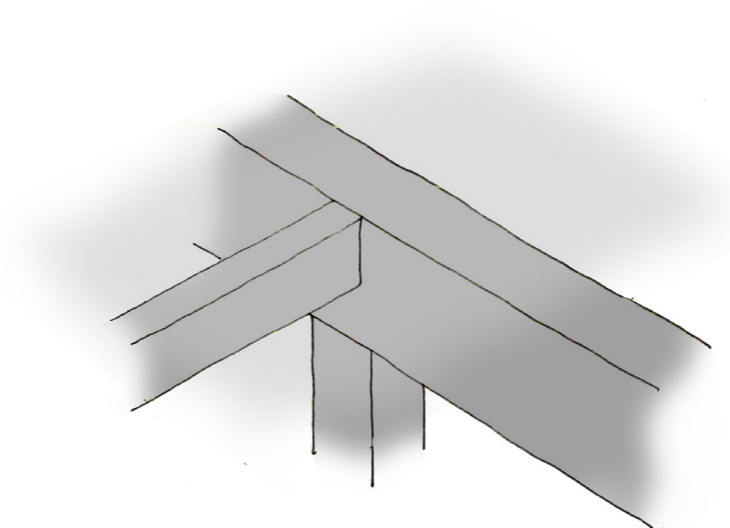

Monolithic concrete structure

CONSTRUCTION MATERIALS

This are some details of characteristic construction elements of the bakery. In this way it is possible to relate the construction parts to the historical development of the building. The cast iron beams are not integrated in the brick vaults (image 1 & 3), as is the case in the milling (p. 76). The reason for this difference is unknown. In the detail of the concrete structure it is clear that the beams have totally different dimensions (image 2). The difference in type of roof construction is probably the consequence of the modernization of the production process in 1955: when the automatic ovens were implemented a floor was added. The roof of the original building is made with wooden trusses (image 5), while the new added floor is covered with trusses made out of steel elements that are connected with cast iron fittings and screw bolts (image 6). These bolts are widely used in the 19th century to make hinge connections. The dimensions of the bolts were tailored to the forces that had to be transmitted. That's why such a truss structure is characterized by a few bolts with a relatively large diameter. The type of truss that is used in the new part of the bakery is called a Polonceau-truss.¹

Text

1. Oosterhoff, J., Arends, G.J., Van Eldik, C.H., & Nieuwmeijer, G.G. (1988). *Bouwtechniek in Nederland. Constructie van ijzer en beton*. Delft: Delftse Universitaire Pers



1



2



3



4



5

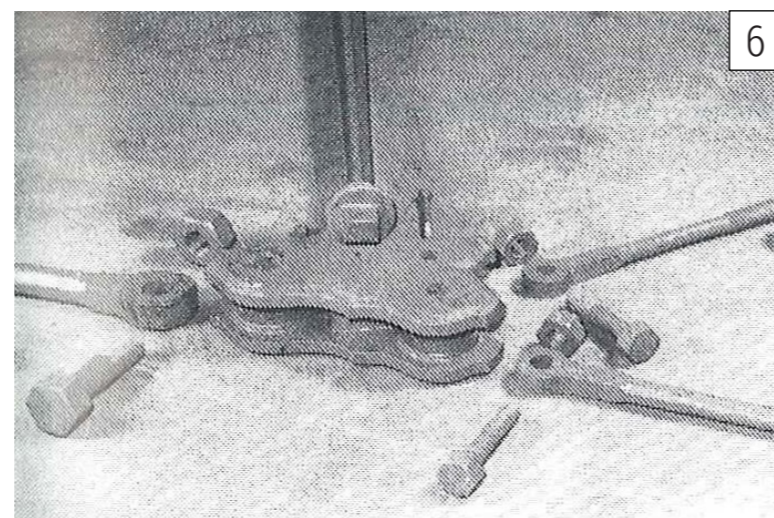

6

CONSTRUCTION MATERIALS

The pictures give an impression of the different construction typologies of the bakery (see facing page).

Images

1. Ground floor - left part (photo by Hielkje Zijlstra, 01-09-2016, own editing)
2. Ground floor - central part (photo by Hielkje Zijlstra, 04-09-2016, own editing)
3. Ground floor - right part (photo by Alessandro Scalisi, 02-09-2016, own editing)
4. First floor - central part (photo Alessandro Scalisi, 02-09-2016, own editing)
5. First floor - central part (photo by Hielkje Zijlstra, 01-09-2016)
6. Bolted connection with cast iron fittings (from: Oosterhoff, J., Arends, G.J., Van Eldik, C.H., & Nieuwmeijer, G.G. (1988). *Bouwtechniek in Nederland. Constructie van ijzer en beton*. Delft: Delftse Universitaire Pers)

BUILDING 16 - BAKERY

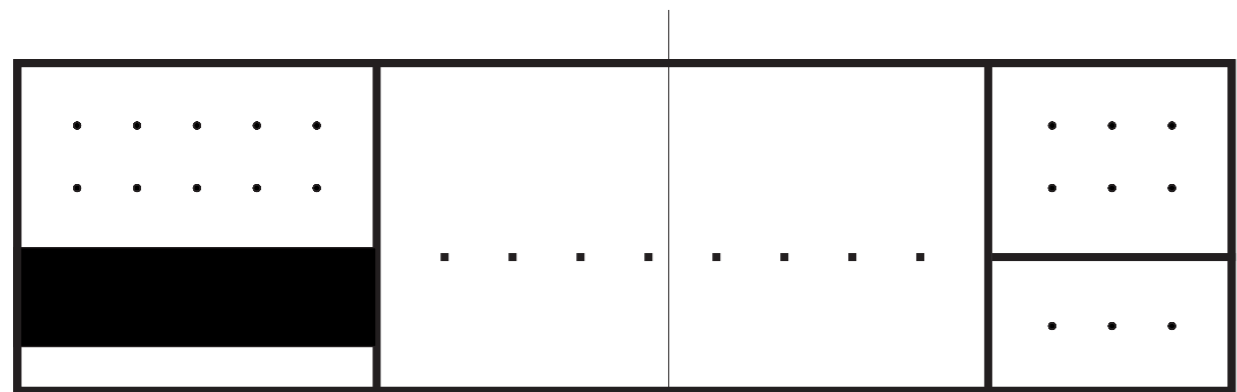

GROUND FLOOR 1:500

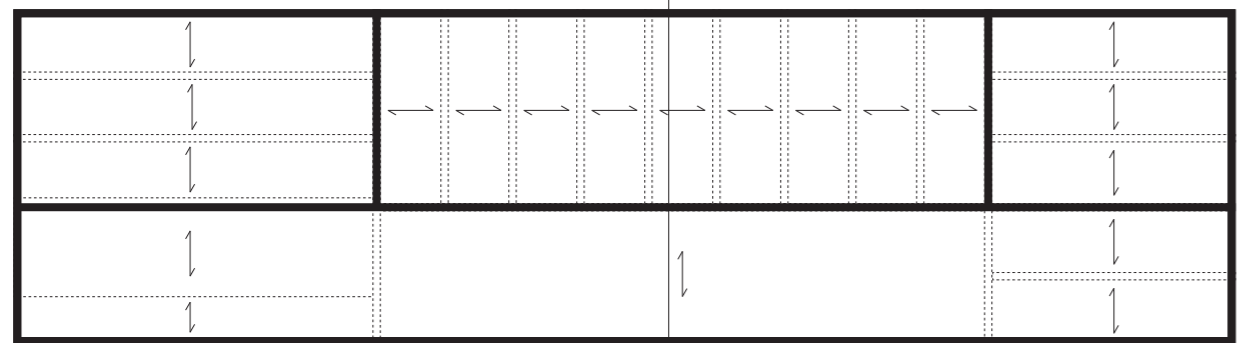

FIRST FLOOR 1:500

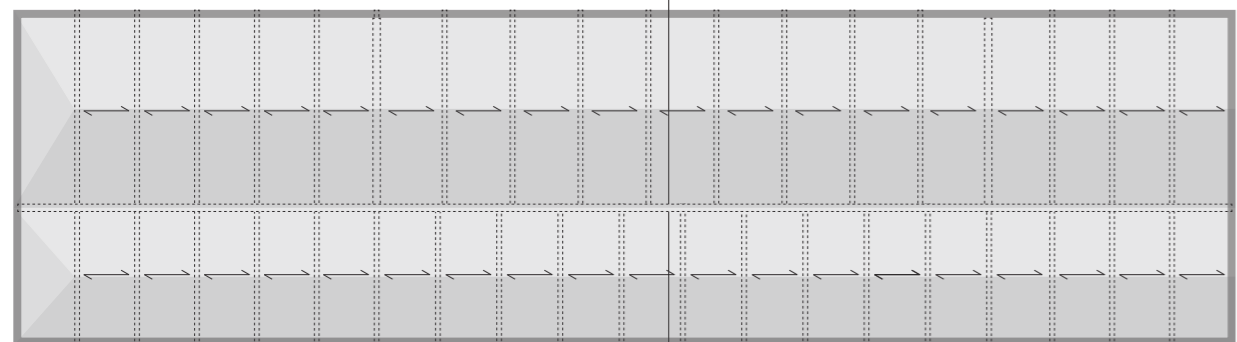

ROOF 1:500

SECTION A-A 1:500

LEGEND

Front	Middle	Back
-------	--------	------



STRUCTURAL SCHEME

The facade and some of the interior walls are load-bearing. This ensures the stability of the building as well. Within these load-bearing walls there is a column structure with beams. The span directions are indicated in the drawings. It should be noted that the old ovens in the front part of the bakery are load-bearing as well. For this reason it is impossible to remove them without severe impact on the building. The difference between the ground floor and first floor is the central wall in the longitudinal direction of the building: on the ground floor there is an open structure in the middle part of the building, while on the first floor there is a clear division between spaces.

As explained on page 40, the truss that is used in the new part of the bakery (left part section) is called a Polonceau-truss. Because it has just two fields per supporting leg it is called a single Polonceau-truss. In the Netherlands, these trusses are mainly used between 1850 and 1940.¹

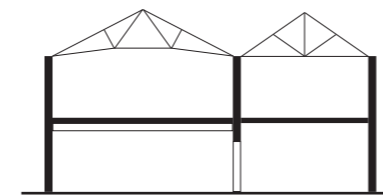

SECTION A-A 1:500

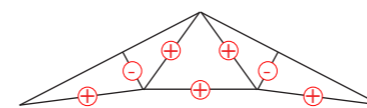

PRINCIPLE POLONCEAU-TRUSS

Text

1. Oosterhoff, J., Arends, G.J., Van Eldik, C.H., & Nieuwmeijer, G.G. (1988). *Bouwtechniek in Nederland. Constructie van ijzer en beton*. Delft: Delftse Universitaire Pers

LEGEND



DIMENSIONS

There's not only a clear difference in construction materials, but also in the pattern of the different parts of the building. In the top picture the (probable) original pattern, before 1911, is drawn: if you extend the pattern of the cast iron columns it exactly fits in the size of the building. We think thus that until the 1920s, when the baker system was implemented, the construction of the bakery consisted completely of cast iron. Due to the implementation of the baker system the cast iron columns have been removed because of the need for a column-free space.

The grid size of the middle part is bigger, probably due to the load-bearing capacities of concrete compared to the cast iron columns. This can be seen as evidence that internal changes have occurred, probably around 1955. In this year the baker system was replaced by two automatic ovens and an extra floor was added (see historical development ensemble, p. 25-33).

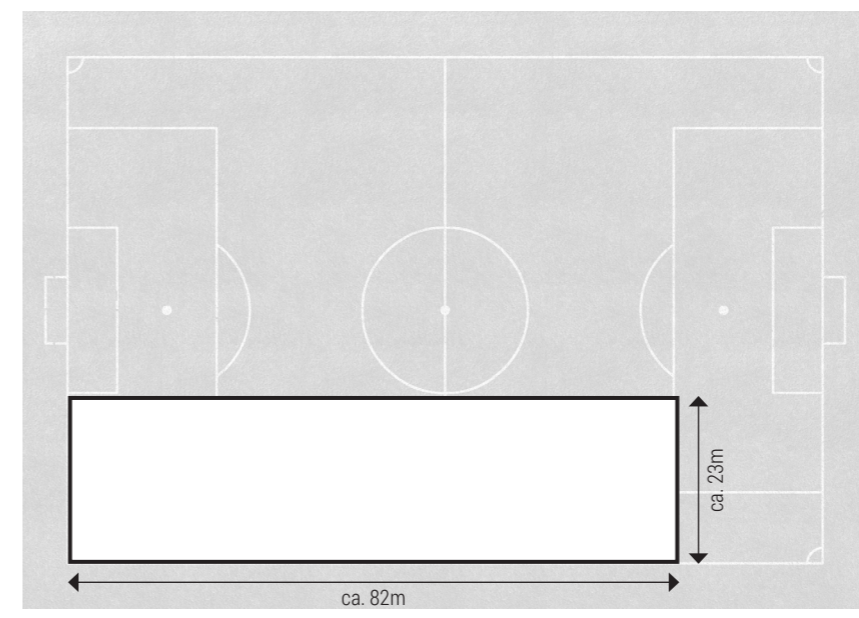
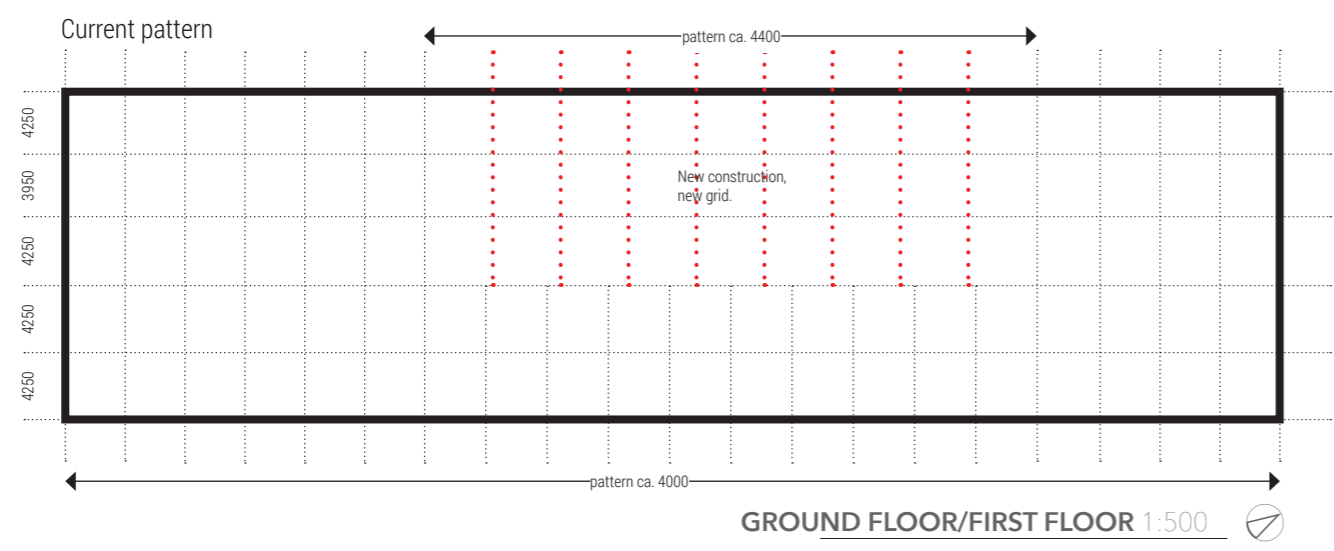
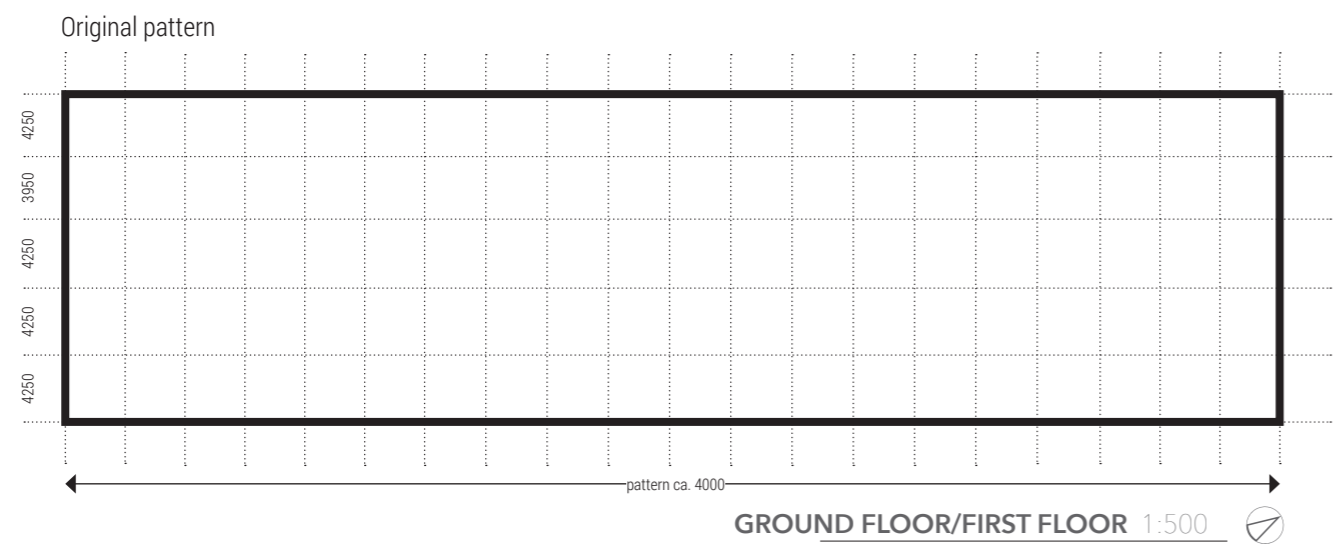

BUILDING SIZE 1:1000



1

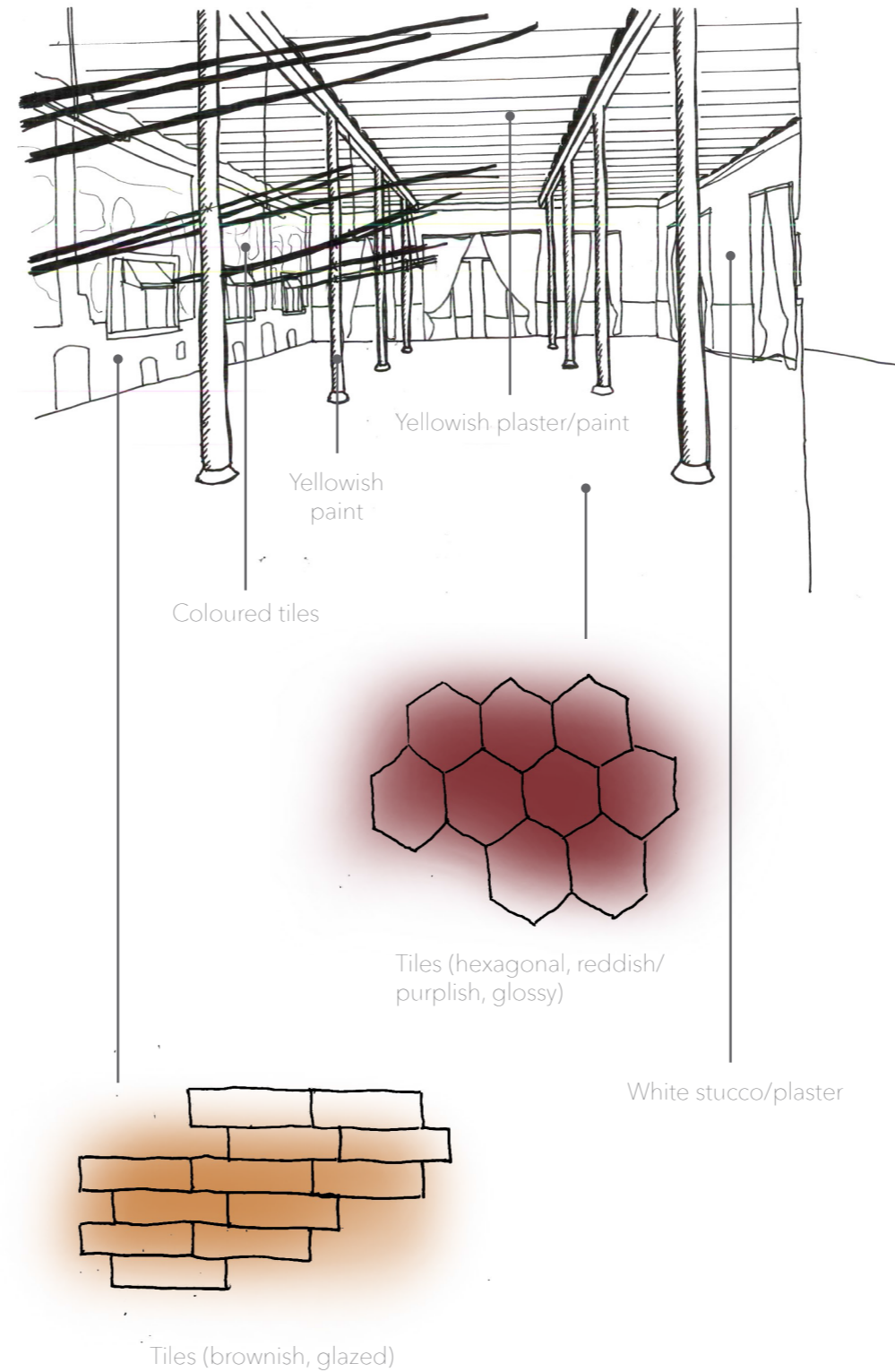

LEGEND

Front	Middle	Back
-------	--------	------



INTERIOR MATERIALS

Nowadays, the front part of the bakery is a representative room. This is probably done because the MMC originally started with just a bakery (p. 26). For this reason one can assume that the Portuguese are proud of MMC's history. The floor and part of the walls are clad with glossy/glazed and coloured tiles. Especially the tiles on the old ovens, which tell the story of the production process of bread, have artistic value. Furthermore, the walls and ceiling are finished with plaster or paint, even the cast iron columns and beams are painted. This means that no bare construction material is visible anymore. This can be done for two reasons: in order to make the space representative or for hygienic purposes. As regards the first, the bakery is one the oldest buildings on the complex and it was closed as last. After the implementation of the two automatic ovens in 1955 (p. 29) this part of the bakery was probably out of use. It is plausible to state that in this period the room was given more meaning.

Images

1. Ground floor - left part (photo by Hielkje Zijlstra, 04-09-2016)

BUILDING 16 - BAKERY



1

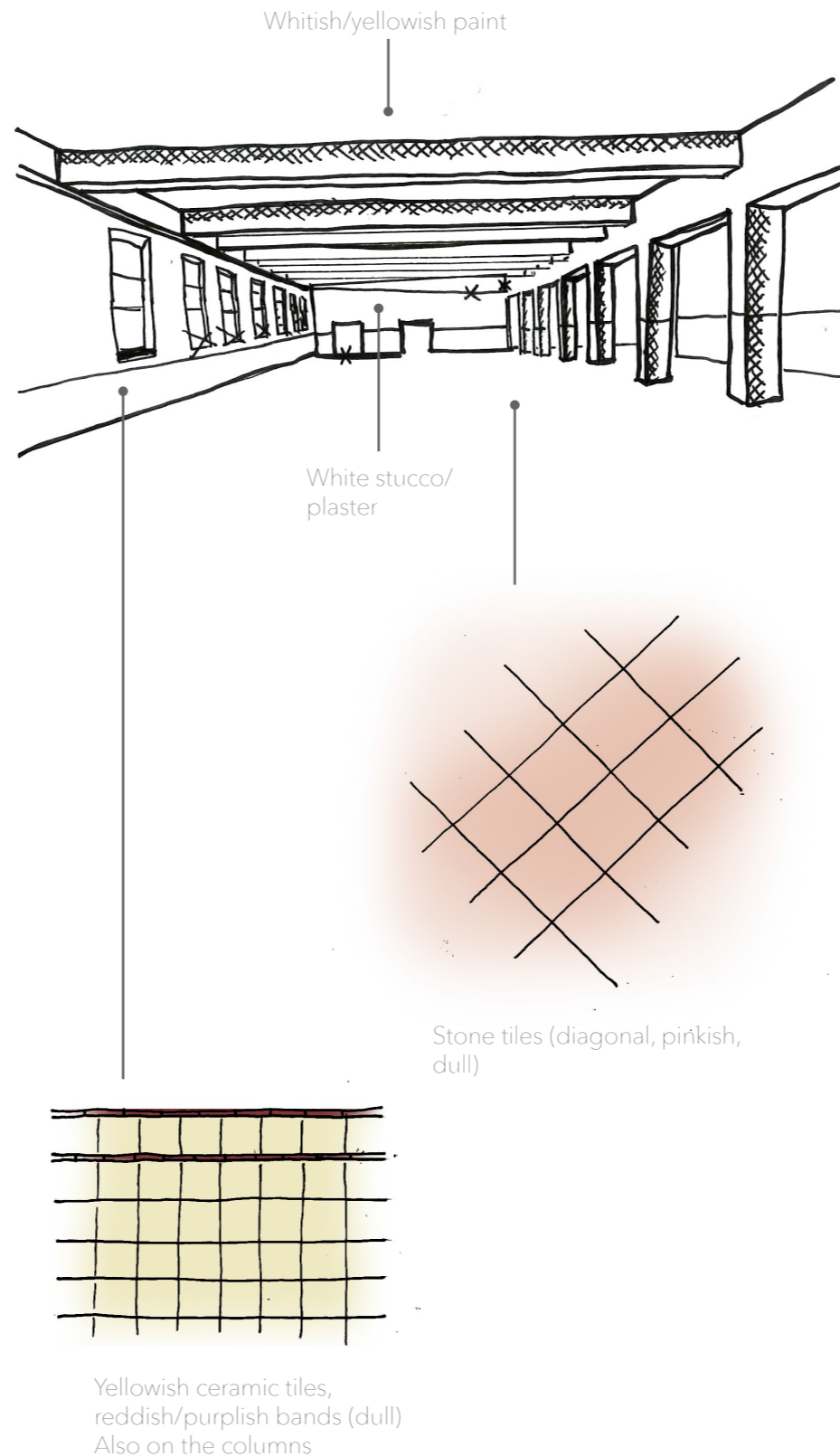

LEGEND

Front	Middle	Back
-------	--------	------



INTERIOR MATERIALS

Also in the middle part of the bakery the floor (stone) and part of the walls (ceramic) are clad with tiles. The tiles in this space are more sober in comparison with the front part (colour, glossy, form), so it feels more like a working area. Like in the bakery, the rest of the walls and ceiling are finished with plaster or paint so none of the bare construction materials is directly visible. It is plausible to suggest that all this is done because of hygienic purposes. The tiles are not original, since they do not match with the tiles that are on the photo of the baker system (image 3, p. 28). The tiles are probably put on the wall around 1955, when the automatic ovens were implemented (p. 29).

If you compare this space with the front part of the bakery, you can say that the colour and gloss really influence the spatial character (working vs. representative area).

Images

1. Ground floor - central part (photo by Hielkje Zijlstra, 01-09-2016)



1

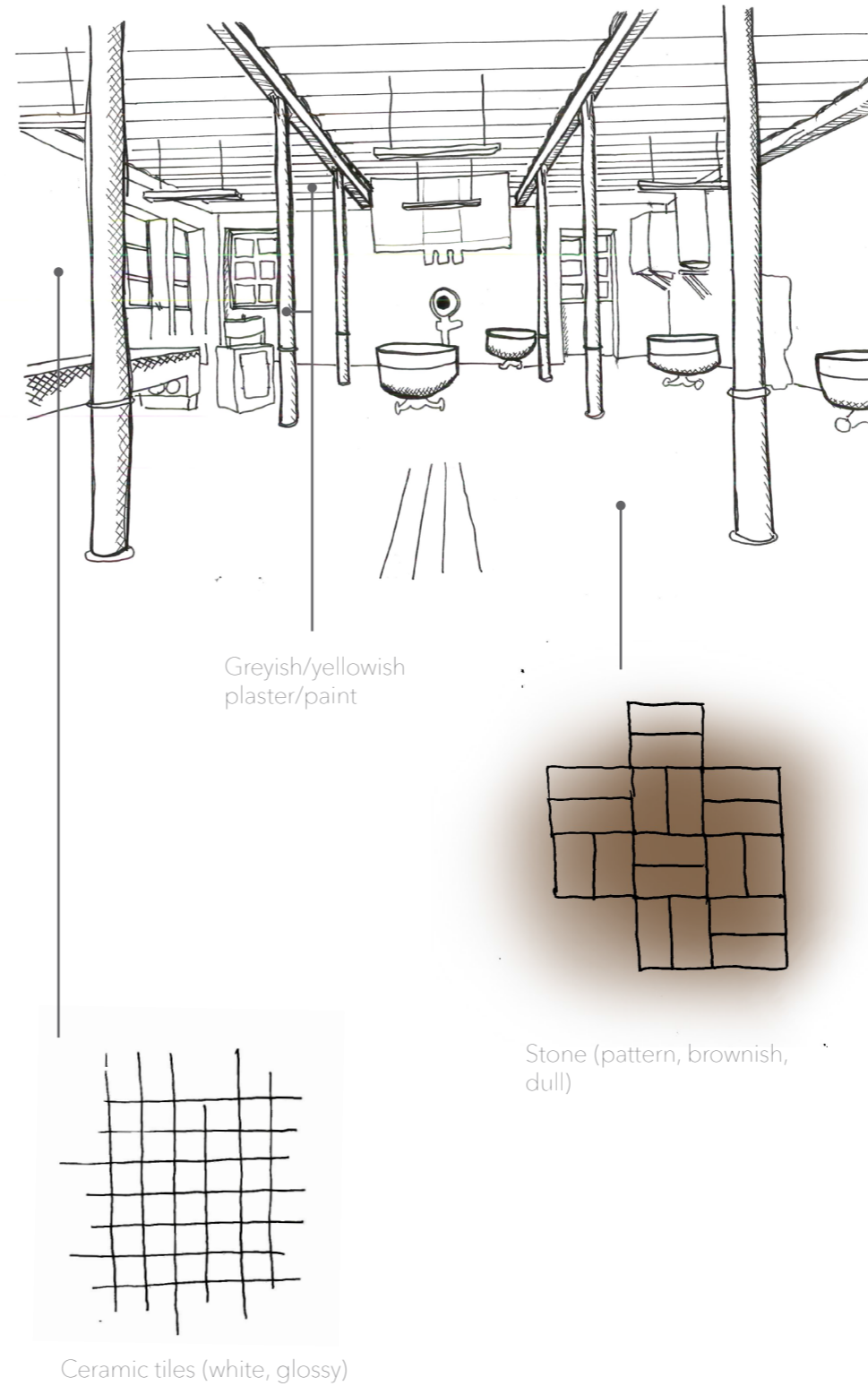

LEGEND

Front	Middle	Back
-------	--------	------



INTERIOR MATERIALS

This part of the bakery feels like a working environment, as is also the case in the middle part. The floor is clad with stones in a kind of a weave pattern and the ceiling has been plastered and/or painted. The walls are completely covered with ceramic tiles, probably of hygienic reasons: easy to clean. The tiles don't seem to be that old, twenty or thirty years at max. This could mean that the function of this part of the bakery has changed recently or that it has been refurbished.

Images
 1. Ground floor - right part (photo by Noëlle Dooper, 01-09-2016)

BUILDING 16 - BAKERY

1955 1920s <1911

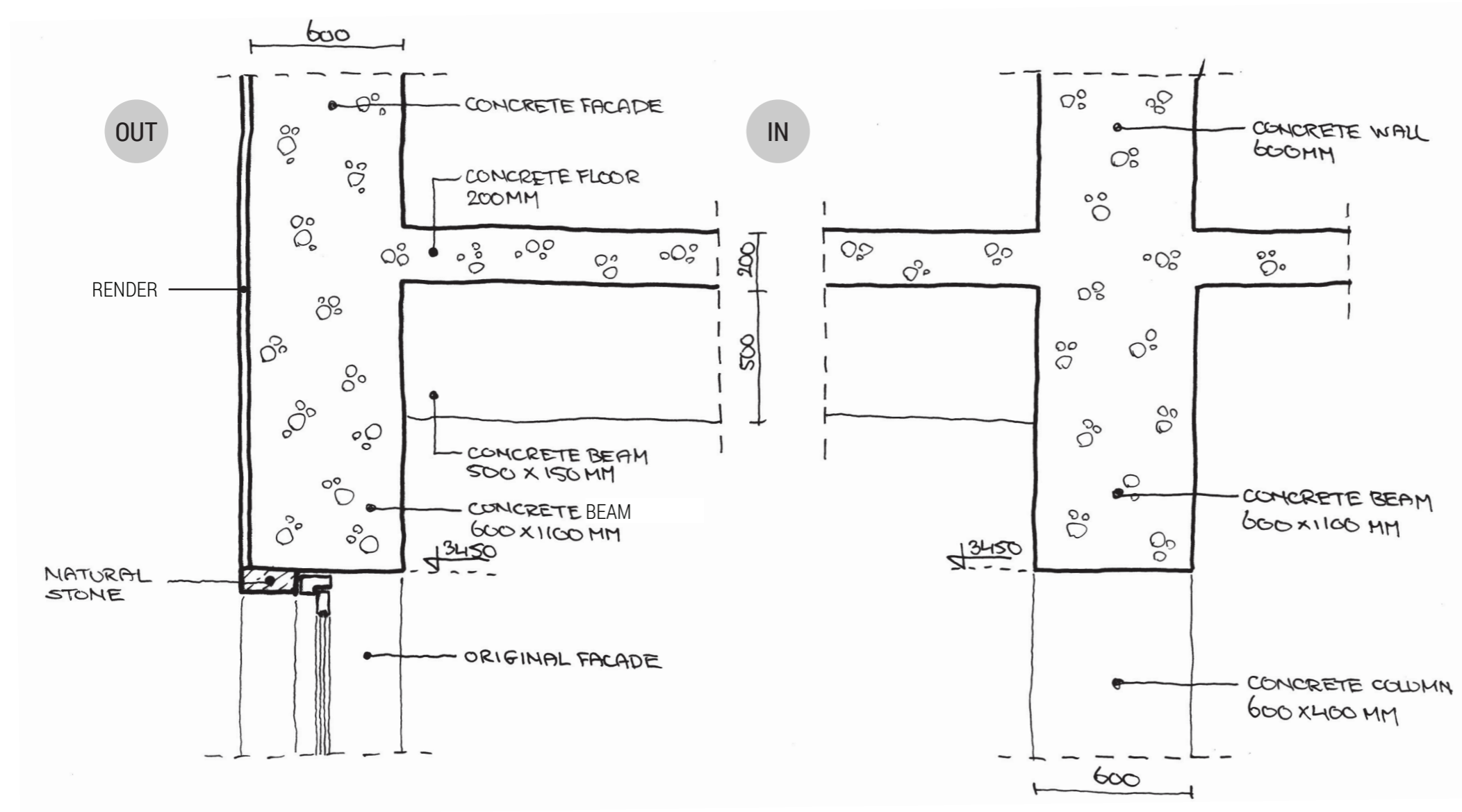

LEGEND

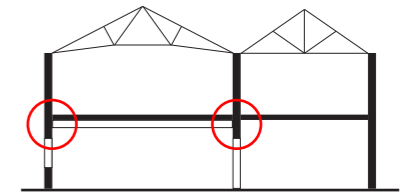

DETAILS

The fact that the windows of the bakery are right-angled at the top suggests that there is a kind of lintel, like bricked shelves or a concrete or stone lintel. Since the rest of the structure is made out of concrete we assume that it is a concrete lintel. When you compare the windows in the screenshot of a movie of 1927 (image 1) with the ones in the photo of the baker system (image 2) you can conclude that the windows have been replaced. The baker system, implemented around 1934, was of such dimensions that possibly the existing roof had to be removed. Other possibilities were the on-site building of the machine or replacing of (part of) the facade. We consider the first assumption as most realistic. For the installation of the machine the likely existing structure of cast iron columns, see pattern analysis p. 43, has been removed and replaced by concrete floors to create a column-free space. For this it is possible that a concrete edge-beam is poured on top of the original facade. It is also possible that this is done during the installation of the automatic ovens in 1955. The fact that the 'beam' in the facade is of the same height as the one inside the bakery, constructed in 1955, advocates this. Since there is unity in the façades of the individual buildings it is possible that they decided to replace all the arched windows for rectangular windows.



Images

1. Arched windows bakery - front - and milling building - back (screenshot video of 1927 from www.cinamateca.pt)
2. Facade bakery (photo by Hielkje Zijlstra, 01-09-2016)
3. Baker system bakery (photo 1930s, provided by Docomomo)
4. Concrete beam inside bakery (photo by Ruben Klinkenberg, 01-09-2016)



During the Ultramar War the MMC reached its maximum level of production. Therefore, the silo between the bakery and cookie factory was built in 1972.¹

Text
1. Texts exhibited at Manutenção Militar Complex by Lisbon Municipality

Images
1. Silo (photo by Hielkje Zijlstra, 01-09-2016)

BUILDING 16A - SILO

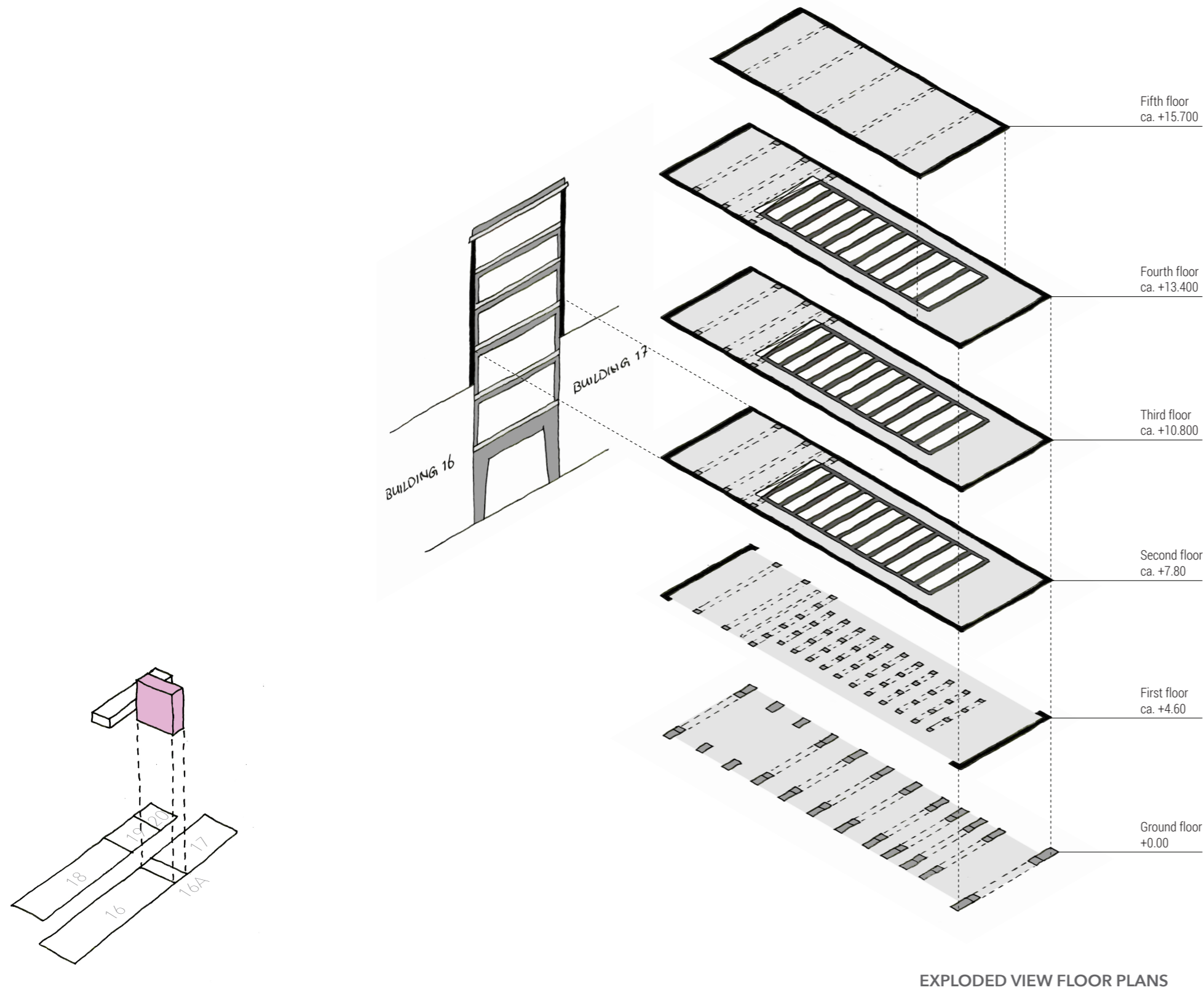

EXPLODED VIEW FLOOR PLANS

LEGEND

- Load-bearing facade
- Load-bearing interior wall
- Floor concrete
- Floor wood (incl. beams)
- Floor brick vaults
- Column / beam concrete
- Column cast iron
- Steel truss
- Wooden truss

CONSTRUCTION MATERIALS*

The silo has been constructed completely out of concrete. In the beginning of this report (p. 25-33) it became evident that the silo of the milling (building 19) is constructed in 1972, which is completely made out of concrete as well. That's part of the reason why we assume that this silo is built in the same period. In contrast to the adjacent buildings the load-bearing facade is also of concrete. Because of the weight of the silos, when completely filled with wheat (80kg/hl) or flour (50kg/hl), the structure of the columns and beams on the ground floor and first floor is really dense (image 1 and 2). What is interesting to see is that the building doesn't have an own facade on the ground floor and first floor: it makes use of the façades of building 16 and 17. This is an evidence that the silo has been built in a later stage.

Overview materials (monolithic structure)

- Concrete facade
- Concrete interior walls
- Concrete columns
- Concrete beams
- Concrete floor
- Concrete roof

The approximate volume of one silo is:
 $5,0 \times 1,0 \times 9,0 = 45\text{m}^3 = 450\text{hl}$

If we assume that the silo are completely filled with wheat, the total weight of the contents is:
 $450 \times 11 \times 80 = 396000\text{kg} = 396 \text{ ton}$

* The construction elements which are drawn in the floor plan relates to the floor/roof above it.

CONSTRUCTION MATERIALS

The pictures give an impression of the construction of the silo.



Images
1. Ground floor (photo by Hielkje Zijlstra, 01-09-2016, own editing)
2. First floor (photo by Alessandro Scalisi, 02-09-2016, own editing)

BUILDING 16A - SILO

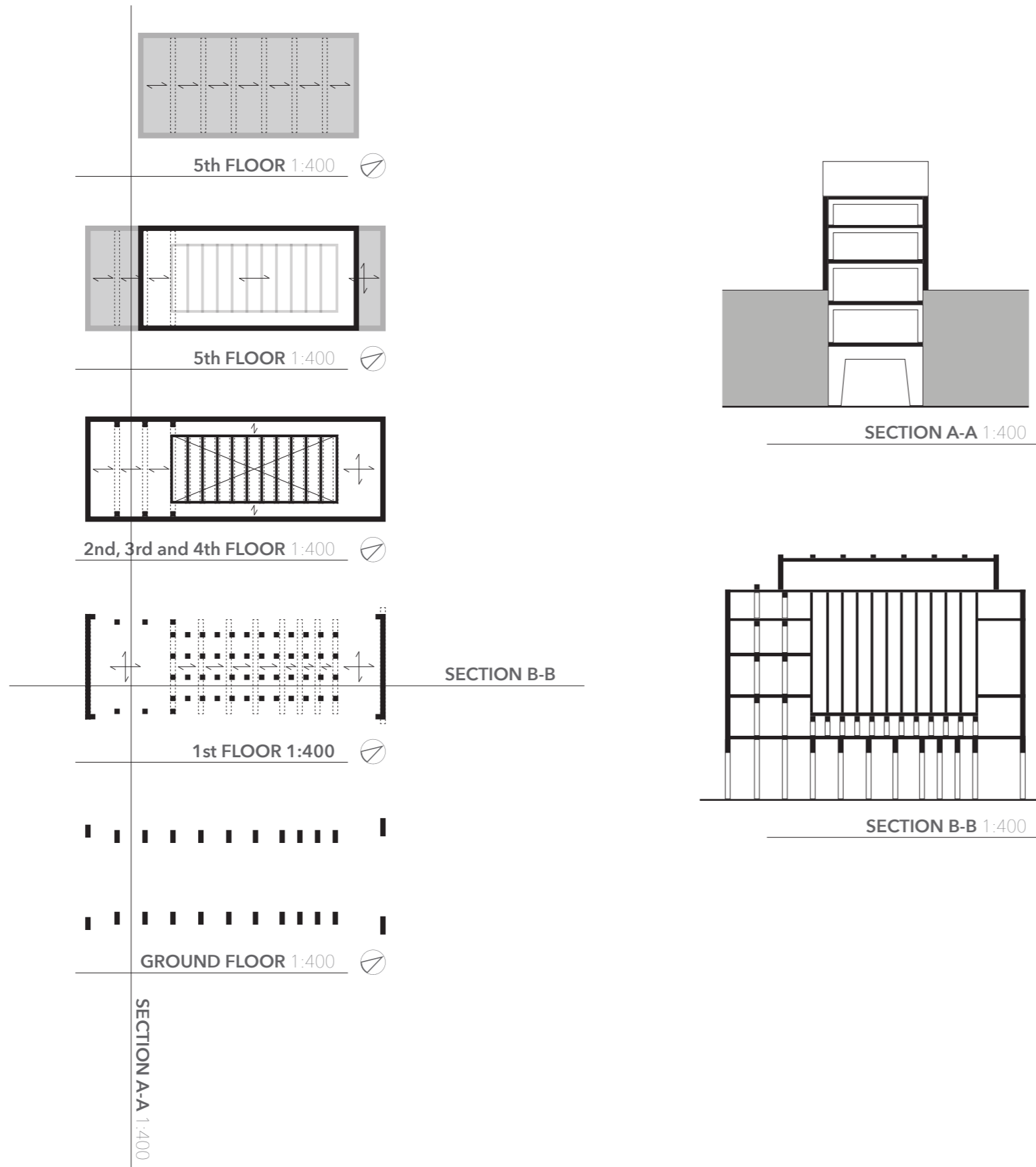

STRUCTURAL SCHEME

It's a monolithic concrete structure, for this reason the stability of the building is ensured as well. Next to this it is also possible that the adjacent buildings, the bakery and the cookie factory, contribute to the stability of the building as well. It is also possible that it is the other way around, that the silo contributes to the stability of the cookie factory and bakery, but since it is plausible that the silo is built in a later stage we don't expect this. What stands out in the floor plan is the shape of the silo: they are long and narrow instead of square or round. The reason for this is unclear.

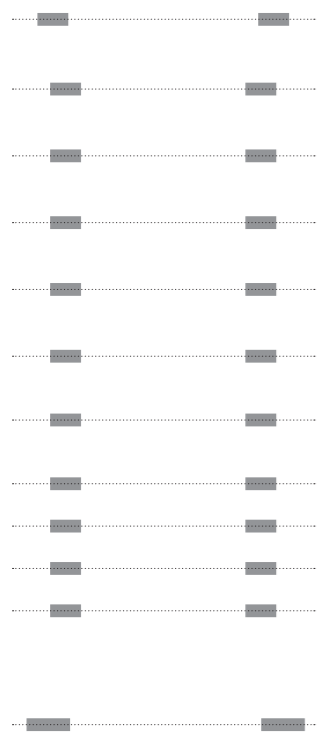

1. Irregular pattern columns

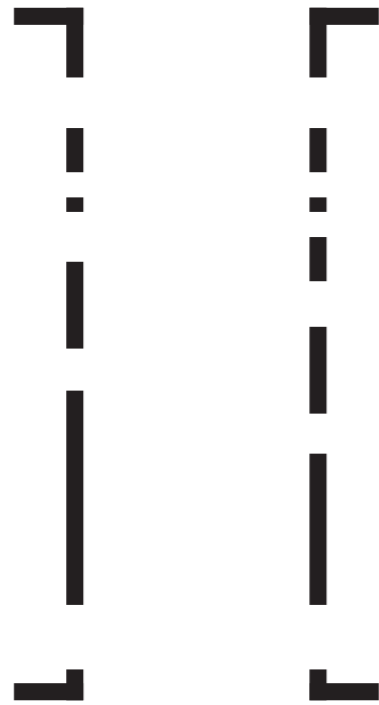

2. Existing opening facade building 16 ad 17

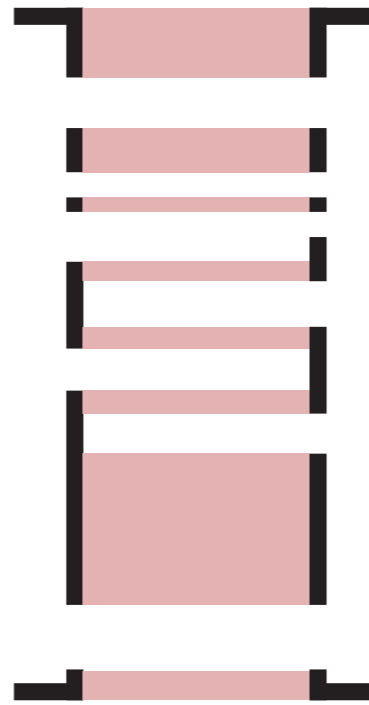

3. Possible positions columns

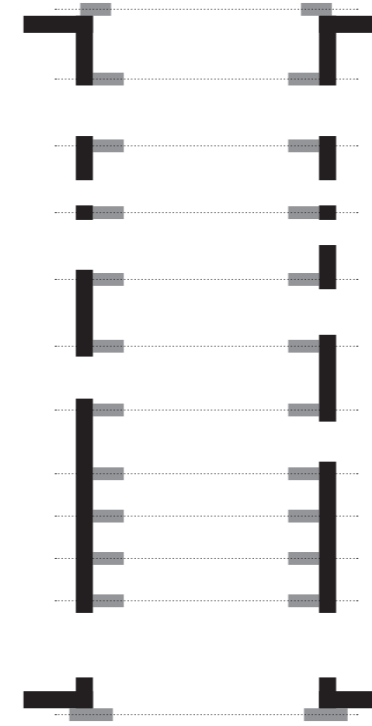

4. Current situation

DIMENSIONS

The pattern of the silo is tuned to the existing openings in the façades of the bakery and cookie factory. This is the explanation for the irregular pattern of the columns of the silo on the ground floor and thus can be stated that the silo has been built afterwards. Second evidence for this is the fact that the yellow plaster of the bakery is still visible between the columns on the ground floor. This conclusion corresponds to the assumptions made on the previous pages.

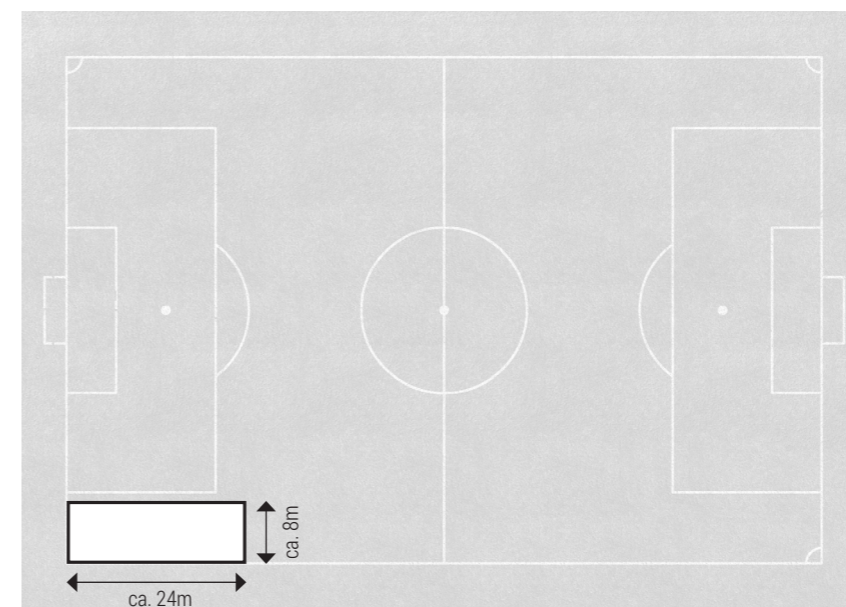
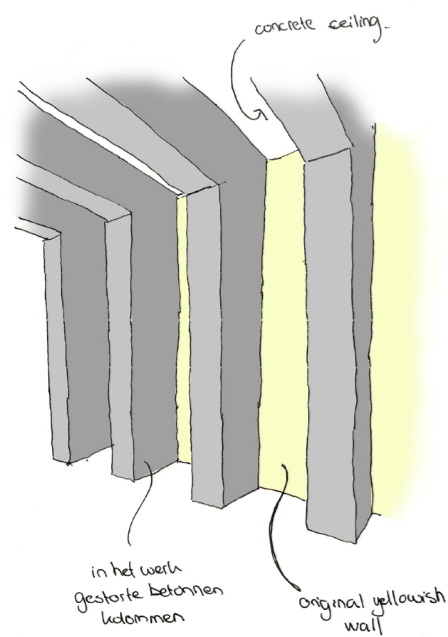

BUILDING SIZE 1:1000



During the Ultramar War the MMC reached its maximum level of production. Therefore, the storage between the bakery and milling was built in 1972.¹ The storage is the volumetric connection between the milling, bakery and cookie factory.

Text
1. Texts exhibited at Manutenção Militar Complex by Lisbon Municipality

Images
1. Storage (photo by Hielkje Zijlstra, 01-09-2016)

BUILDING 16B - STORAGE

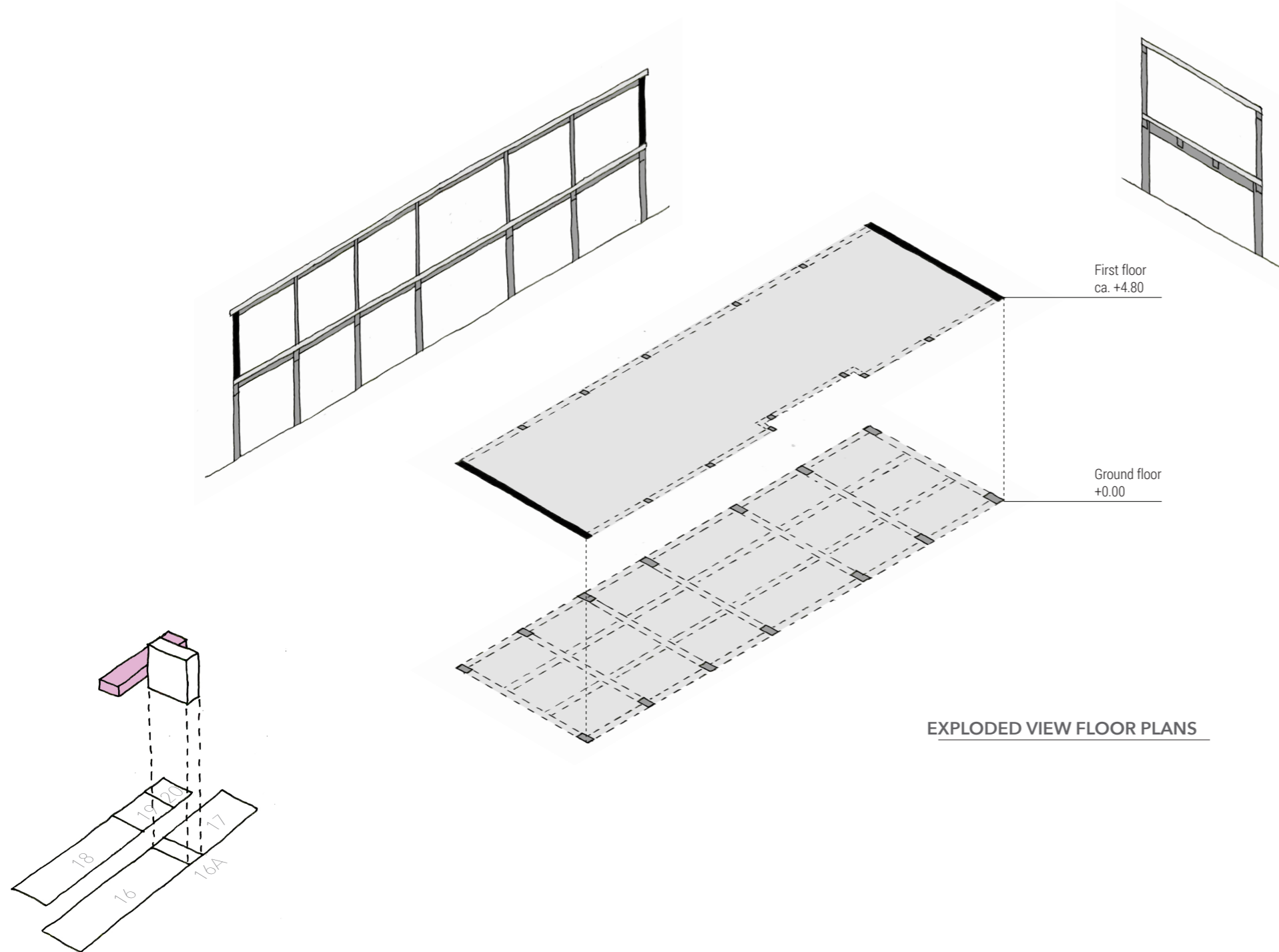

EXPLODED VIEW FLOOR PLANS

LEGEND

- Load-bearing facade
- Load-bearing interior wall
- Floor concrete
- Floor wood (incl. beams)
- Floor brick vaults
- Column / beam concrete
- Column cast iron
- Steel truss
- Wooden truss

CONSTRUCTION MATERIALS*

Like building 16A, the structure is completely made of concrete, including the roof (image 1 and 2). Since this is a monolithic structure, the stability of the building is ensured as well. The façades that do not coincide with the adjacent buildings are solid, load-bearing walls. The roof has a minimal slope to these sides.

Overview materials (monolithic structure)

- Concrete facade
- Concrete columns
- Concrete beams
- Concrete floor
- Concrete roof

* The construction elements which are drawn in the floor plan relates to the floor/roof above it.



CONSTRUCTION MATERIALS

The pictures give an impression of the construction of the storage.

Images
1. Ground floor (photo by Hielkje Zijlstra, 01-09-2016, own editing)
2. First floor (photo by Alessandro Scalisi, 02-09-2016, own editing)

BUILDING 16B - STORAGE

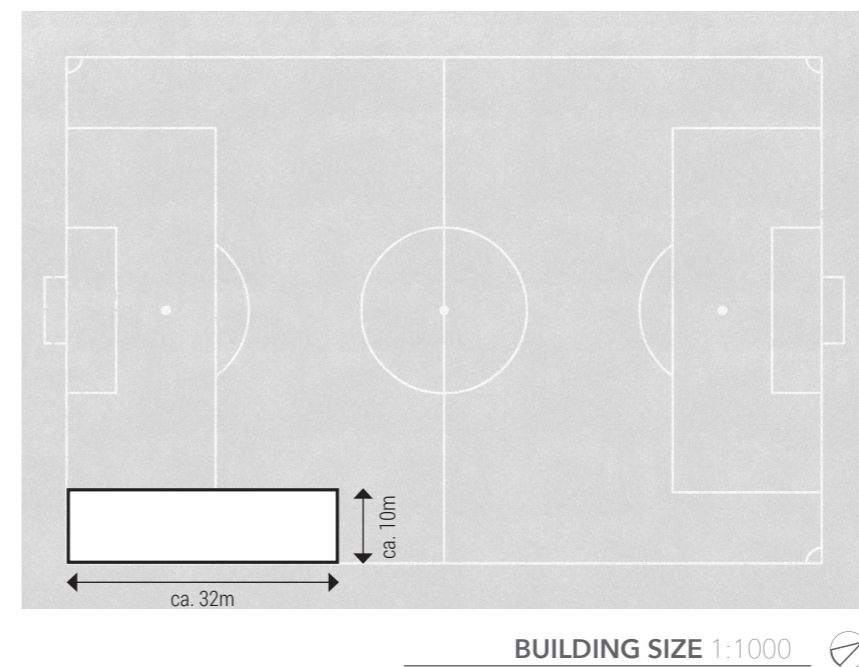
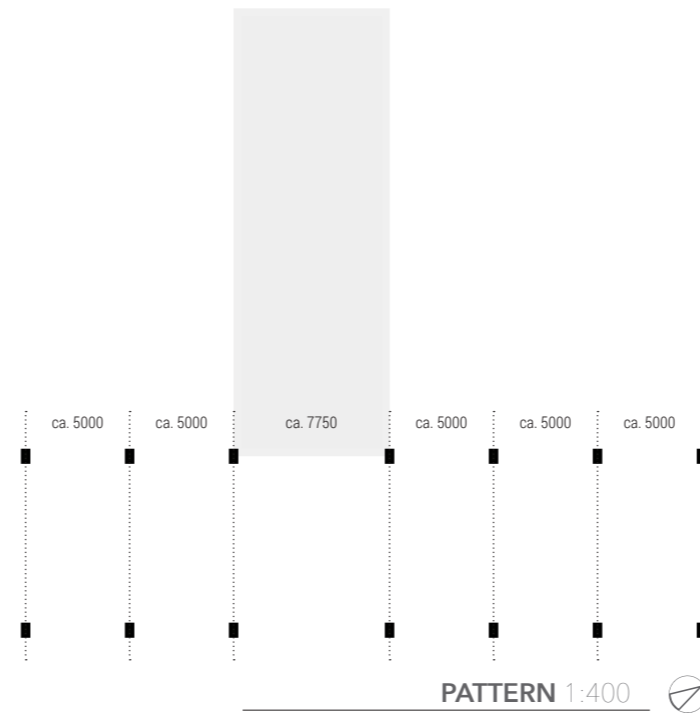
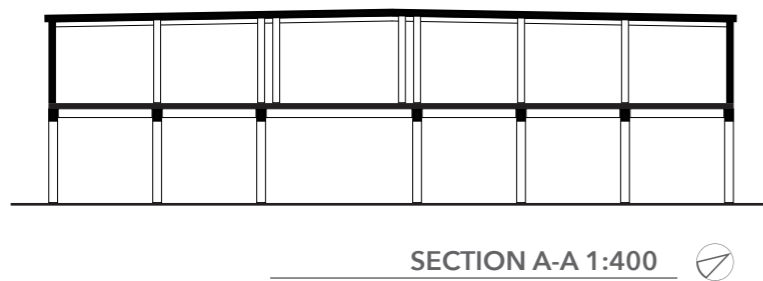
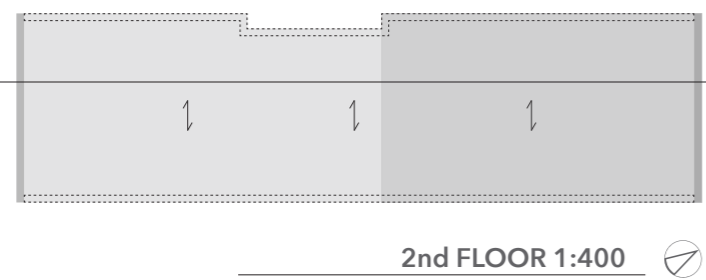
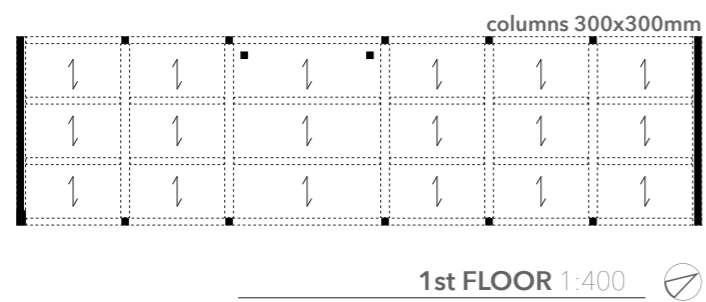
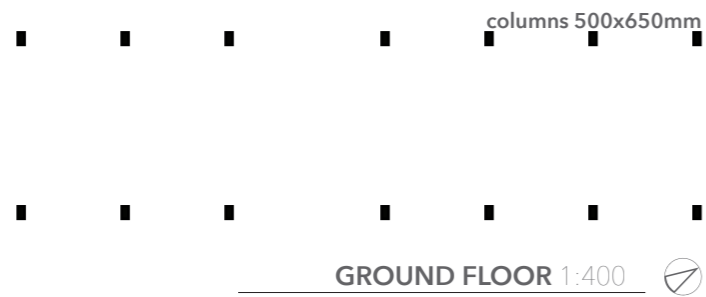

STRUCTURAL SCHEME AND DIMENSIONS

In the pattern there's one clear exception: the wide grid in the middle. This grid is tuned to the width of the silo. Rest of the grid has no relation with the ones of the bakery, cookie factory or milling. This could mean that the storage is built at the same time as the silo. This assumption corresponds with the historical development as presented before (p. 25-33).

BUILDING 17 - COOKIE FACTORY

1920s



The cookie factory has been built between 1920 and 1935.¹

Text
1. Folgado, D., & Custódio, J. (1999). *Caminho do Oriente - Guia do Património Industrial*. Lisboa: Livros Horizonte.

Images
1. Cookie factory (photo by Hielkje Zijlstra, 01-09-2016)

BUILDING 17 - COOKIE FACTORY

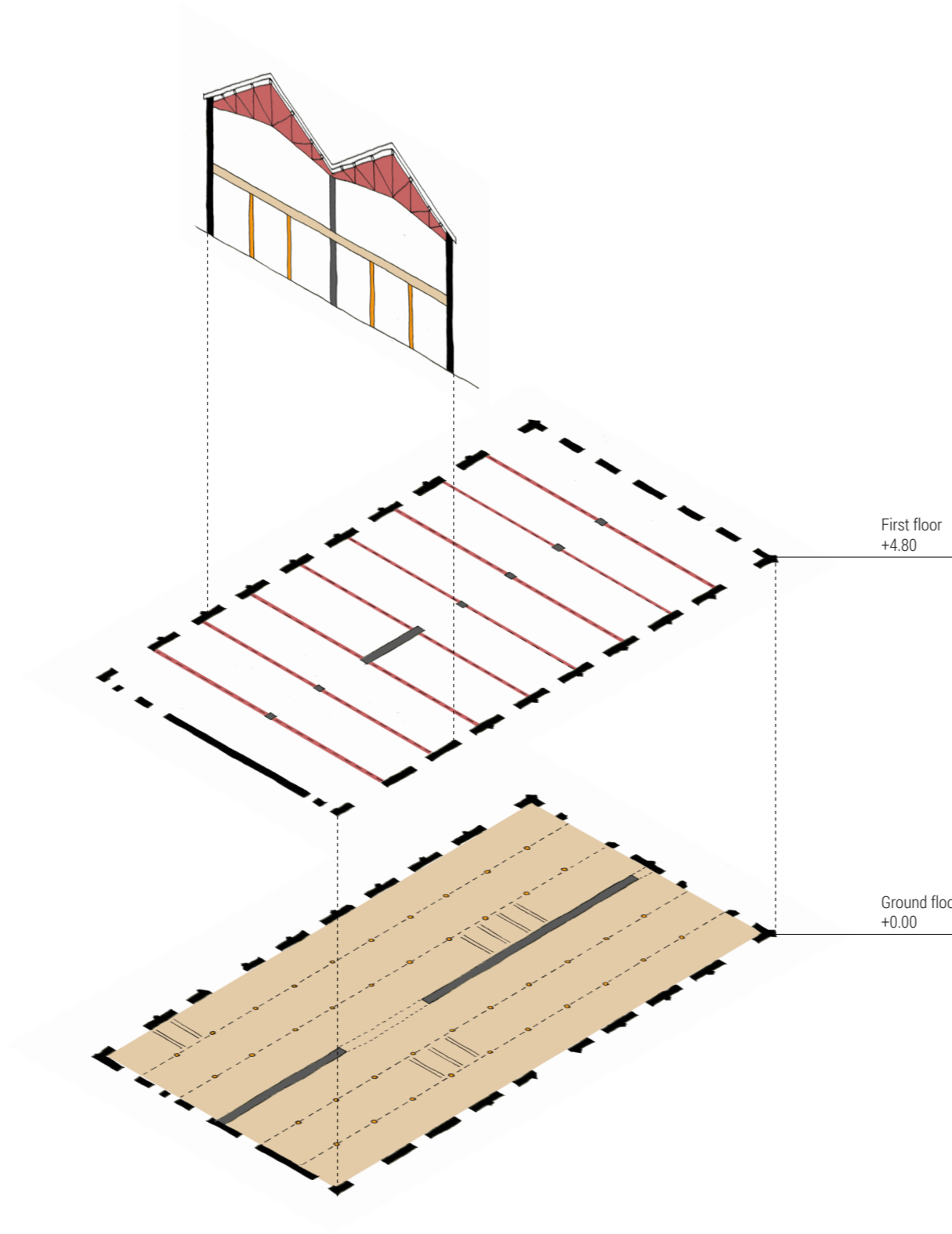
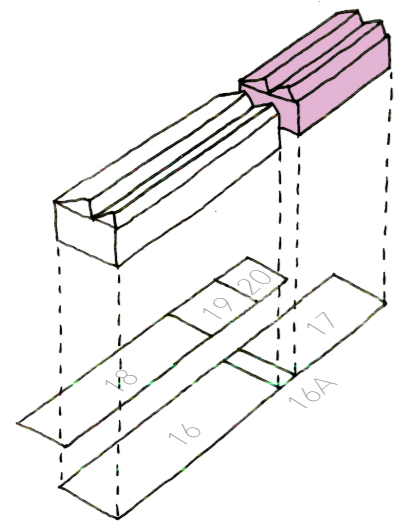

EXPLODED VIEW FLOOR PLANS

LEGEND

- Load-bearing facade
- Load-bearing interior wall
- Floor concrete
- Floor wood (incl. beams)
- Floor brick vaults
- Column / beam concrete
- Column cast iron
- Steel truss
- Wooden truss

CONSTRUCTION MATERIALS*

At first sight the construction of the cookie factory is similar to that of the front and back part of the bakery: load-bearing façades, cast iron columns and a central load-bearing interior wall (p. 39). However the floor is made out of wood and the trusses are made of steel.

- Overview materials
- Cast iron columns and beams
 - Wooden floor
 - Steel rafters
 - Brick facade
 - Brick interior wall

* The construction elements which are drawn in the floor plan relates to the floor/roof above it.

BUILDING 17 - COOKIE FACTORY

LEGEND

left
right

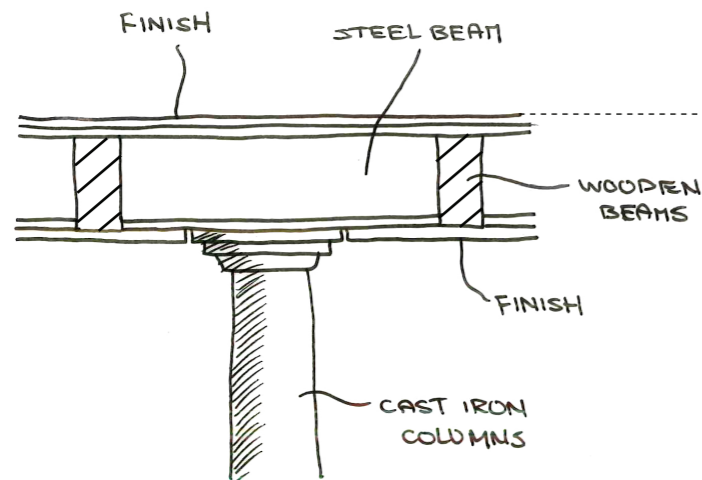

Detail A - floor construction

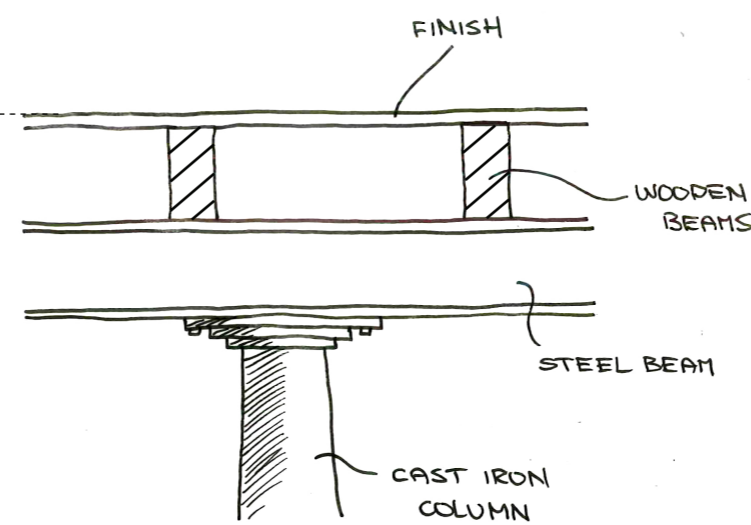

Detail B - floor construction

CONSTRUCTION MATERIALS

There is a difference between the details of the first floor in the two parts of the building. The wooden beams in the left part lie in the cast iron beams, while the wooden beams in the right part lie on the cast iron beams (image 1 and 2). The exact reason for this is not clear, but it is possible that the floor in the left part has been replaced, for example because of damage to the original floor, and that it was easier to lay the wooden beams on top of the cast iron beams.

If we take into account the detailing of some elements, differences between the cookie factory and bakery become clear. For example, the top of the cast iron columns in the cookie factory are less ornamented than the ones in the bakery (p. 40). The assumption is that because of technical development the columns became more sober. The second example is the roof construction of the buildings. In the cookie factory they made use of steel profiles that are connected with rivets (image 3), while in the bakery the rafters are made of wood and steel elements that are connected with cast iron fittings and screw bolts (p. 40). As explained, the latter trusses are characterized by a few bolts with a relatively large diameter. Later there was a desire for connections with smaller bolts: this resulted in a larger number of bolts and gusset plates. Such connections were hardly made with bolts, but later they were made with rivets according to the same principle.¹ Despite the fact that the trusses in the middle part of the bakery are placed around 1955 (p. 40), this would mean that they are older than the ones in the cookie factory. The only plausible explanation for this is that the trusses in the middle part of the bakery are re-used from a building on the complex that had been demolished.

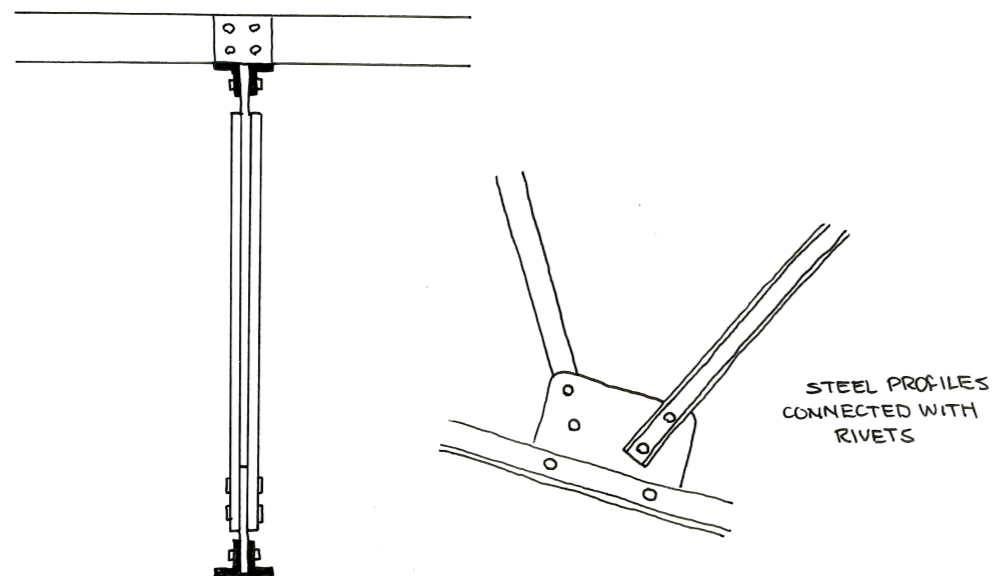

Detail C - truss (profiles connected with rivets)

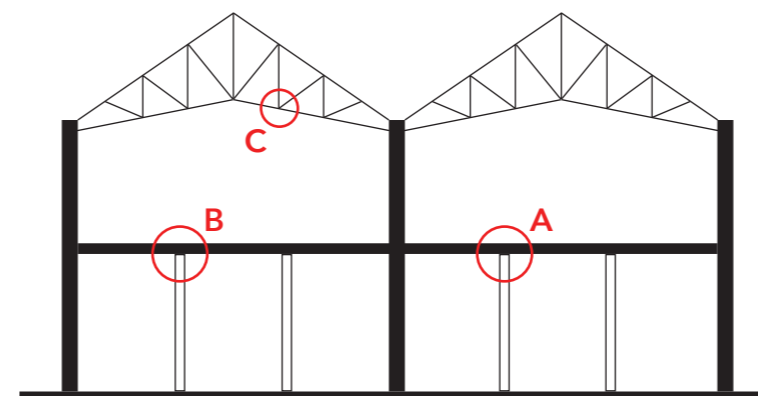

Position details

Text

1. Oosterhoff, J., Arends, G.J., Van Eldik, C.H., & Nieuwmeijer, G.G. (1988). *Bouwtechniek in Nederland. Constructie van ijzer en beton*. Delft: Delftse Universitaire Pers



CONSTRUCTION MATERIALS

The pictures give an impression of the construction of the cookie factory.

Images

1. Ground floor (actual photographic survey Docomomo)
2. Ground floor (actual photographic survey Docomomo, own editing)
3. First floor (photo by Alessandro Scalisi, 02-09-2016)

BUILDING 17 - COOKIE FACTORY

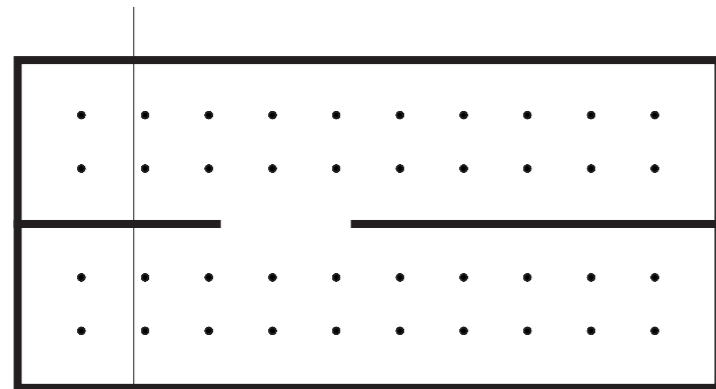

GROUND FLOOR 1:500

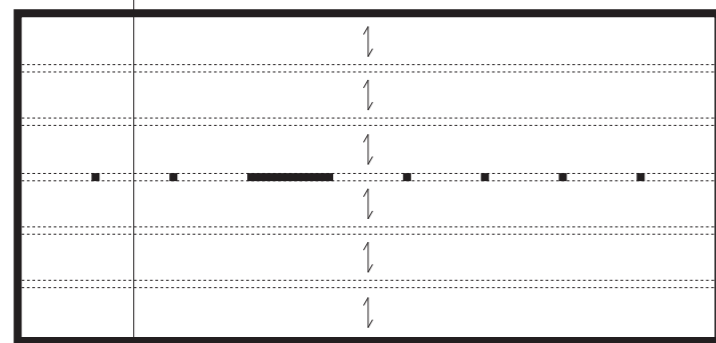

FIRST FLOOR 1:500

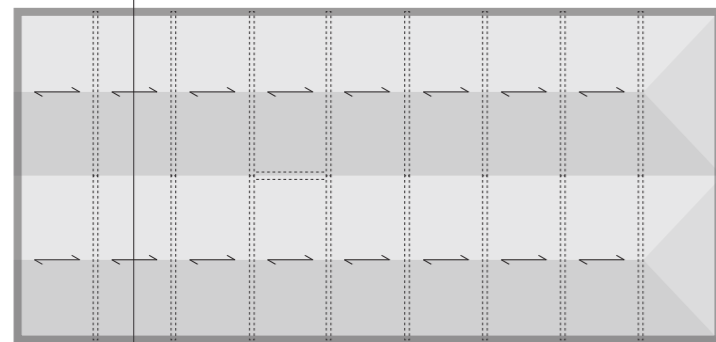

ROOF 1:500

SECTION AA' 1:500

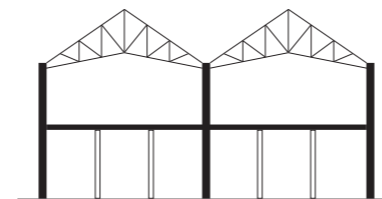

SECTION A-A 1:500

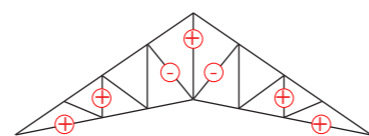

PRINCIPLE POLONCEAU-TRUSS

STRUCTURAL SCHEME

The facade of this building is load-bearing. On ground floor the central interior wall is load-bearing as well, while on the first floor there are columns. These elements ensure the stability of the building. The span directions are indicated in the drawings. The structural scheme is quite similar to that of the bakery (p. 42): a volume with a double roof and cast iron columns on the ground floor, but spatially seen it is opposite to the bakery: on ground floor there is a clear division of spaces, while on the first floor there is an open structure.

Looking closer to the trusses, a conclusion can be drawn that they differ from the Polonceau-trusses in the bakery (p. 42). The trusses in the cookie factory are called English trusses. In the Netherlands, these trusses are used between 1870 and 1920. Differently than one would expect, the diagonal bars are subjected to compressive forces and the vertical bars to tensile forces.¹ The difference in trusses is probably the consequence of the fact that the building components are built in different stages (p. 25-33).

Text

1. Oosterhoff, J., Arends, G.J., Van Eldik, C.H., & Nieuwmeijer, G.G. (1988). *Bouwtechniek in Nederland. Constructie van ijzer en beton*. Delft: Delftse Universitaire Pers

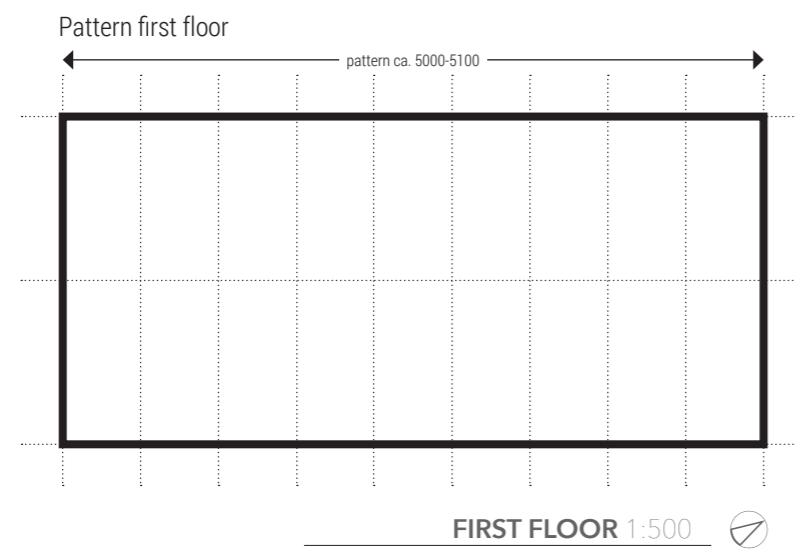
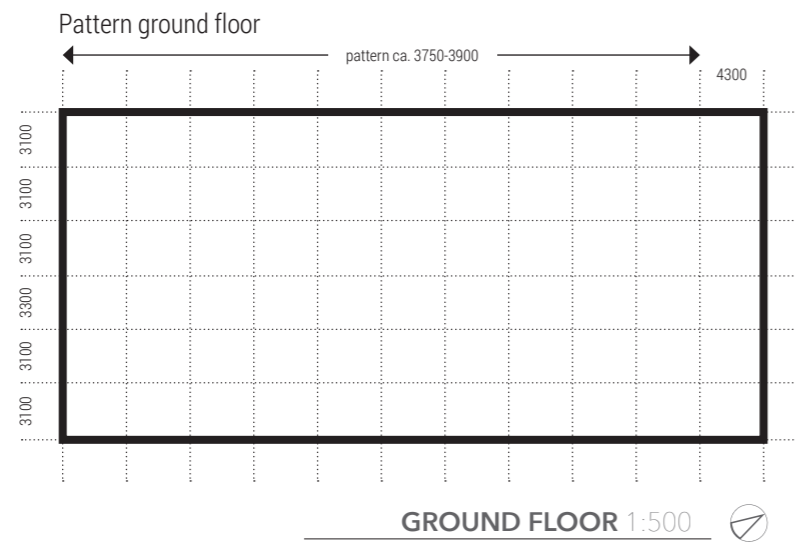

PATTERN AND DIMENSIONS

There is clearly no connection between the pattern of the ground floor, which is also irregular, and the first floor. Since the first floor is subjected to higher forces than the roof, this difference is not remarkable. The irregular pattern of the ground floor can be the result of inaccurate building or the difference in size of building materials that were available.

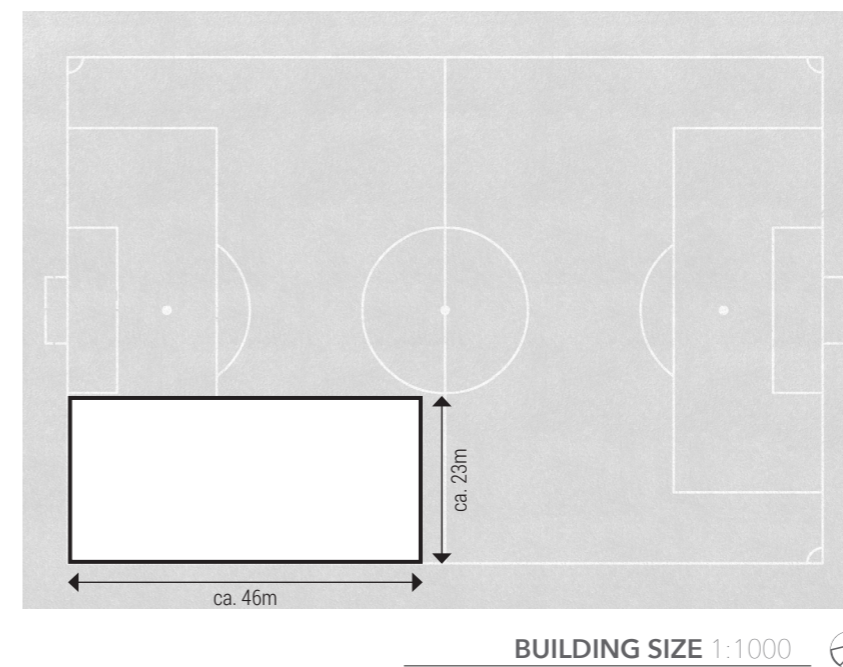

BUILDING 17 - COOKIE FACTORY

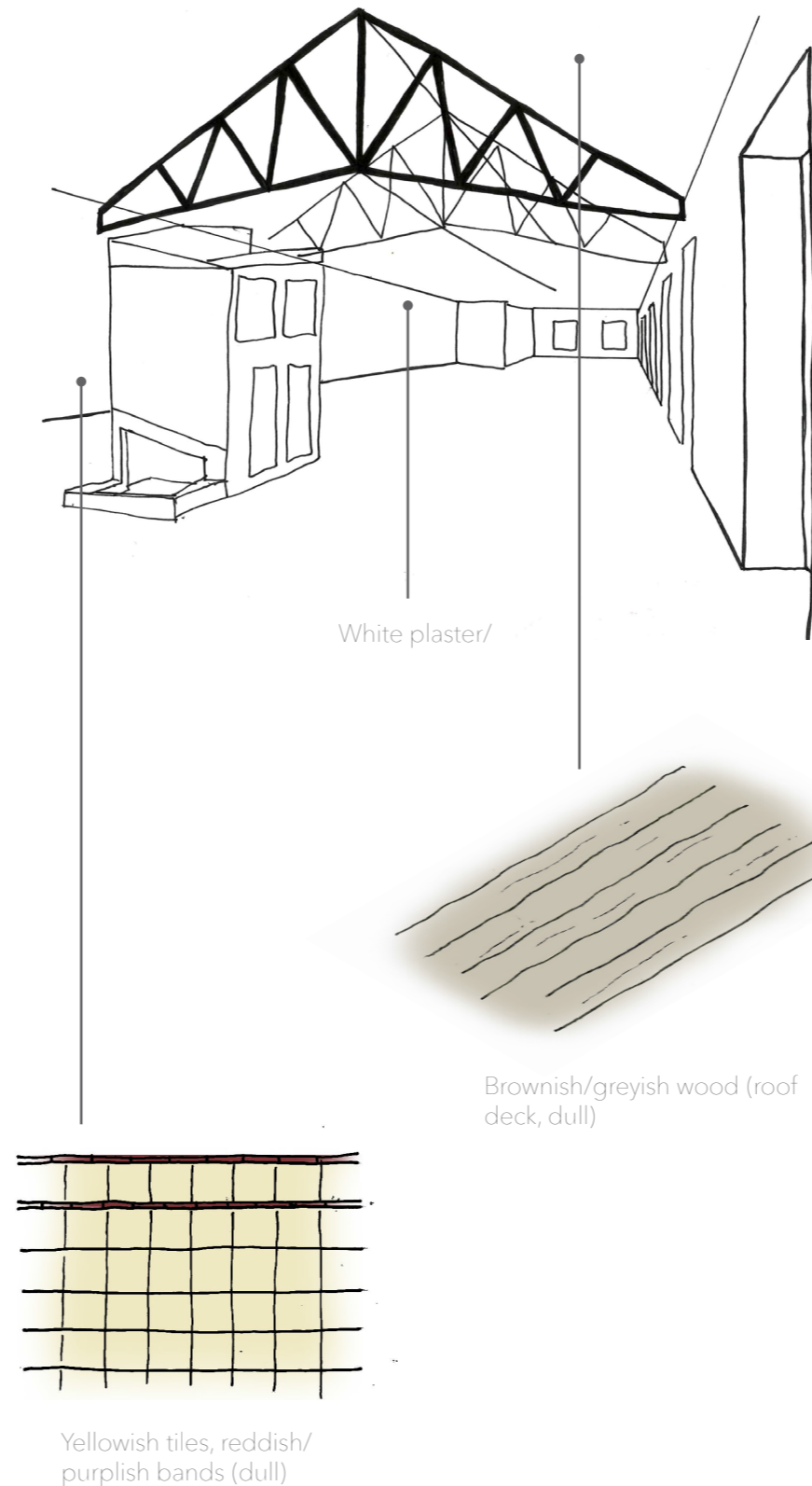

INTERIOR MATERIALS

Due to all the dirt it is hardly visible what finishing the floor has. From an archive picture (image 2) it is clear that there used to be a wooden finish in a herringbone pattern. During the next site visit we have to determine the current finish. Only part of the walls are clad with tiles. These are the same tiles as in the bakery, which are probably put on the wall around 1955 (p. 46). For this reason we think that the tiles on the first floor of the bakery are also not original. It's obvious to state that these tiles are put on the walls around 1955 as well. We expect that the roof deck is original, because there is no reason to state differently.

- Images
1. First floor (photo by Noëlle Dooper, 02-09-2016)
 2. First floor (Archive photographic survey Docomomo, no date)



1

The milling is built between 1898 and 1910. During the Ultramar War the MMC reached its maximum level of production. Therefore the production process was modernized, especially in the milling.^{1,2} The new machines asked for a specific concrete structure, for that reason most of the original floors were removed.

Text
1. Folgado, D., & Custódio, J. (1999). *Caminho do Oriente - Guia do Património Industrial*. Lisboa: Livros Horizonte.
2. Texts exhibited at Manutenção Militar Complex by Lisbon Municipality

Images
1. Milling (photo by Hielkje Zijlstra, 04-09-2016)

BUILDING 18 - MILLING

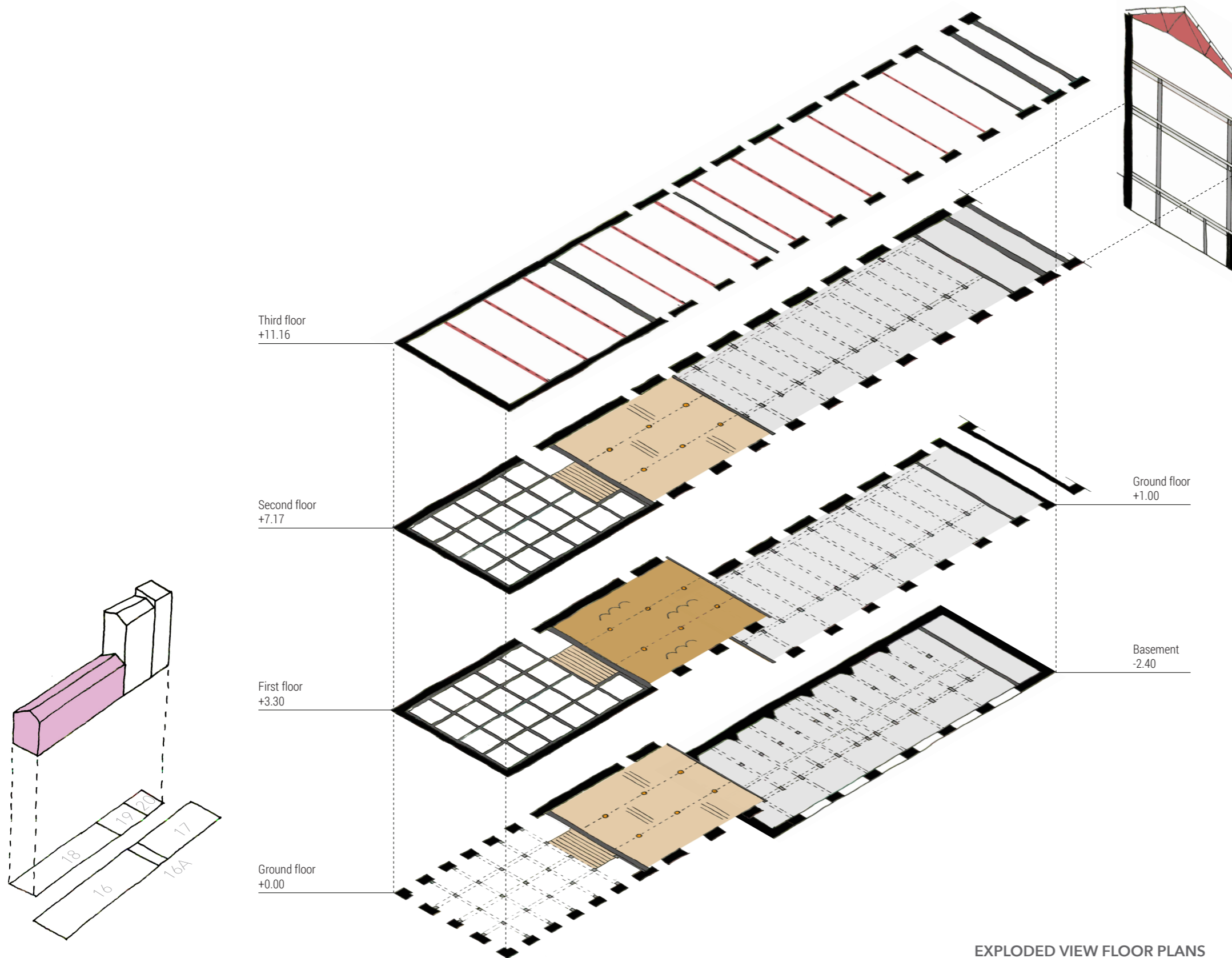

LEGEND

- Load-bearing facade
- Load-bearing interior wall
- Floor concrete
- Floor wood (incl. beams)
- Floor brick vaults
- Column / beam concrete
- Column cast iron
- Steel truss
- Wooden truss

CONSTRUCTION MATERIALS*

In the milling one can distinguish different construction typologies: cast iron columns, brick vaults, wooden floors and a monolithic concrete structure. The interesting thing is that the load-bearing facade show no difference in the separate building parts. The same applies to the roof construction. This suggests that over time mainly interior changes have taken place.

The approximate volume of one silo is:
 $3,0 \times 2,9 \times 10,0 = 87\text{m}^3 = 870\text{hl}$

If we assume that the silo are completely filled with wheat (80kg/hl), the total weight of the contents is:
 $870 \times 21 \times 80 = 1461600\text{kg} = 1461,6 \text{ ton}$

* The construction elements which are drawn in the floor plan relates to the floor/roof above it.

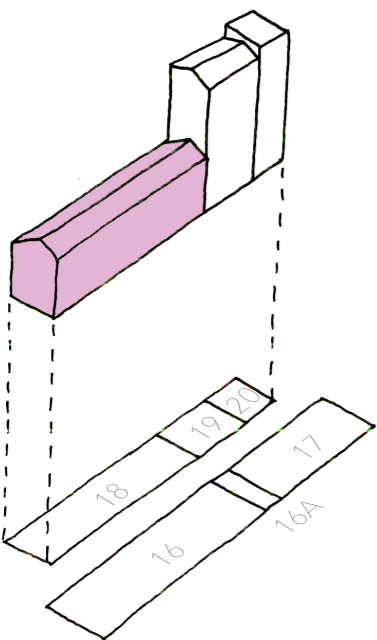

BUILDING 18 - MILLING

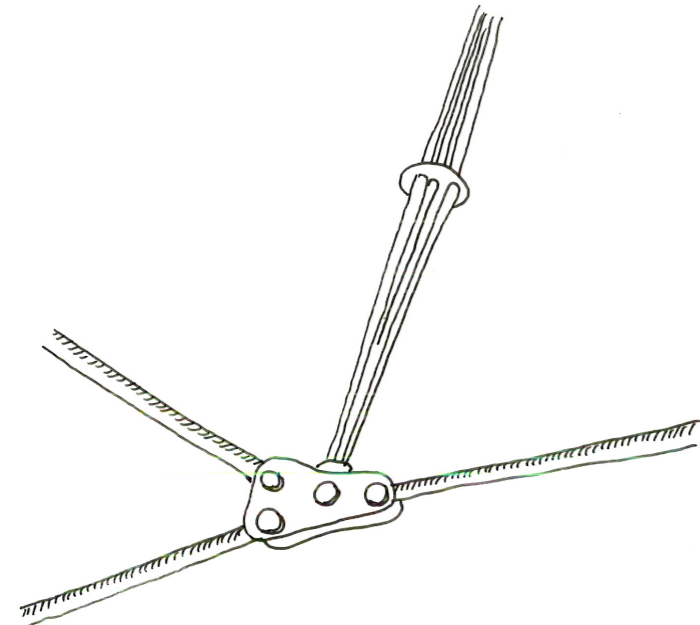

Steel truss - elements connected with screw bolts

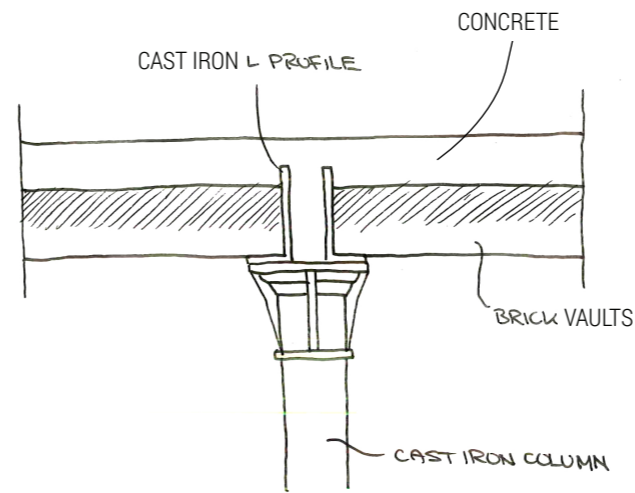

Detail cast iron column and brick vaults

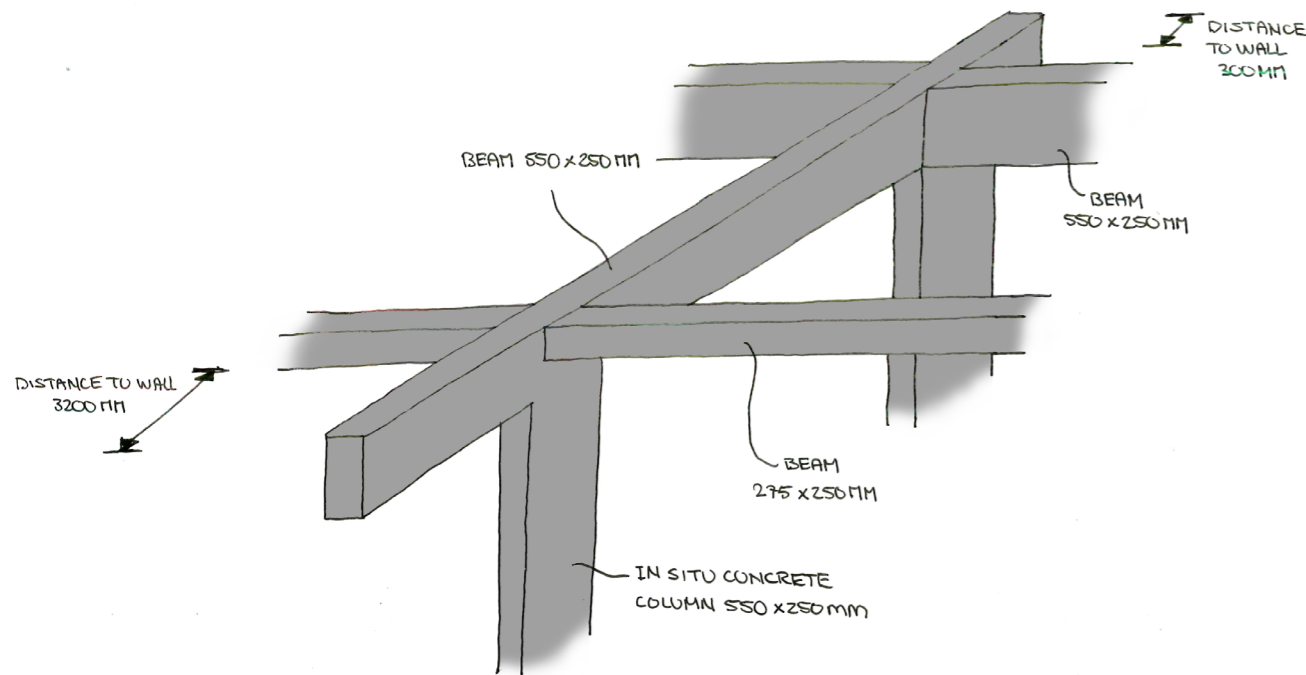

Reinforced concrete structure ground floor

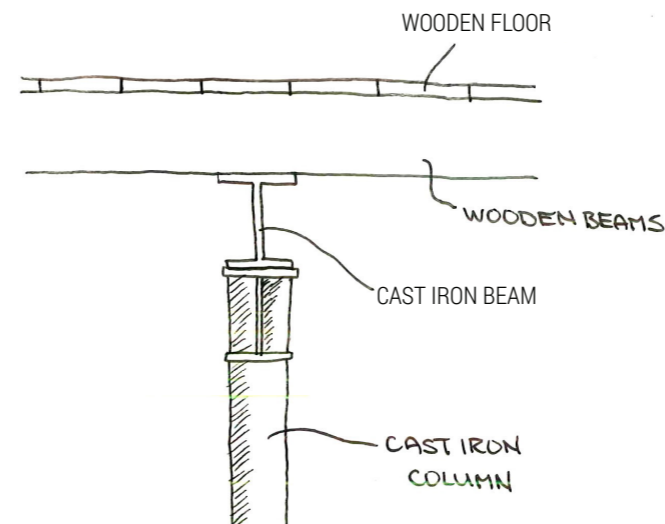

Detail cast iron column and wooden floor

CONSTRUCTION MATERIALS

This are some details of characteristic construction elements of the bakery. In this way it is possible to relate the construction parts to the historical development of the building. The cast iron beams are integrated in the brick vaults (second floor, image 3). The wooden beams of the first and third floor lie on the cast iron beams and in the facade (image 4). For the roof construction the same trusses are used as in the middle part of the bakery: Polonceau-trusses (image 6). According to the historical development of the ensemble (p. 25-33), the milling is built before 1911. With the knowledge presented on page 66 we assume that these trusses are original. On the other hand, the concrete construction is implemented in the 1970s when the production process in the milling has been modernized (image 5).



CONSTRUCTION MATERIALS

The pictures give an impression of the different construction typologies of the mill building.

Images

1. Ground floor left part (photo by Hielkje Zijlstra, 04-09-2016)
2. Ground floor left part (photo by Hielkje Zijlstra, 04-09-2016)
3. First floor central part (photo by Hielkje Zijlstra, 04-09-2016)
4. Second floor central part (photo by Hielkje Zijlstra, 04-09-2016)
5. Second floor right part (photo by Hielkje Zijlstra, 04-09-2016)
6. Steel trusses right part (photo by Hielkje Zijlstra, 04-09-2016)

BUILDING 18 - MILLING

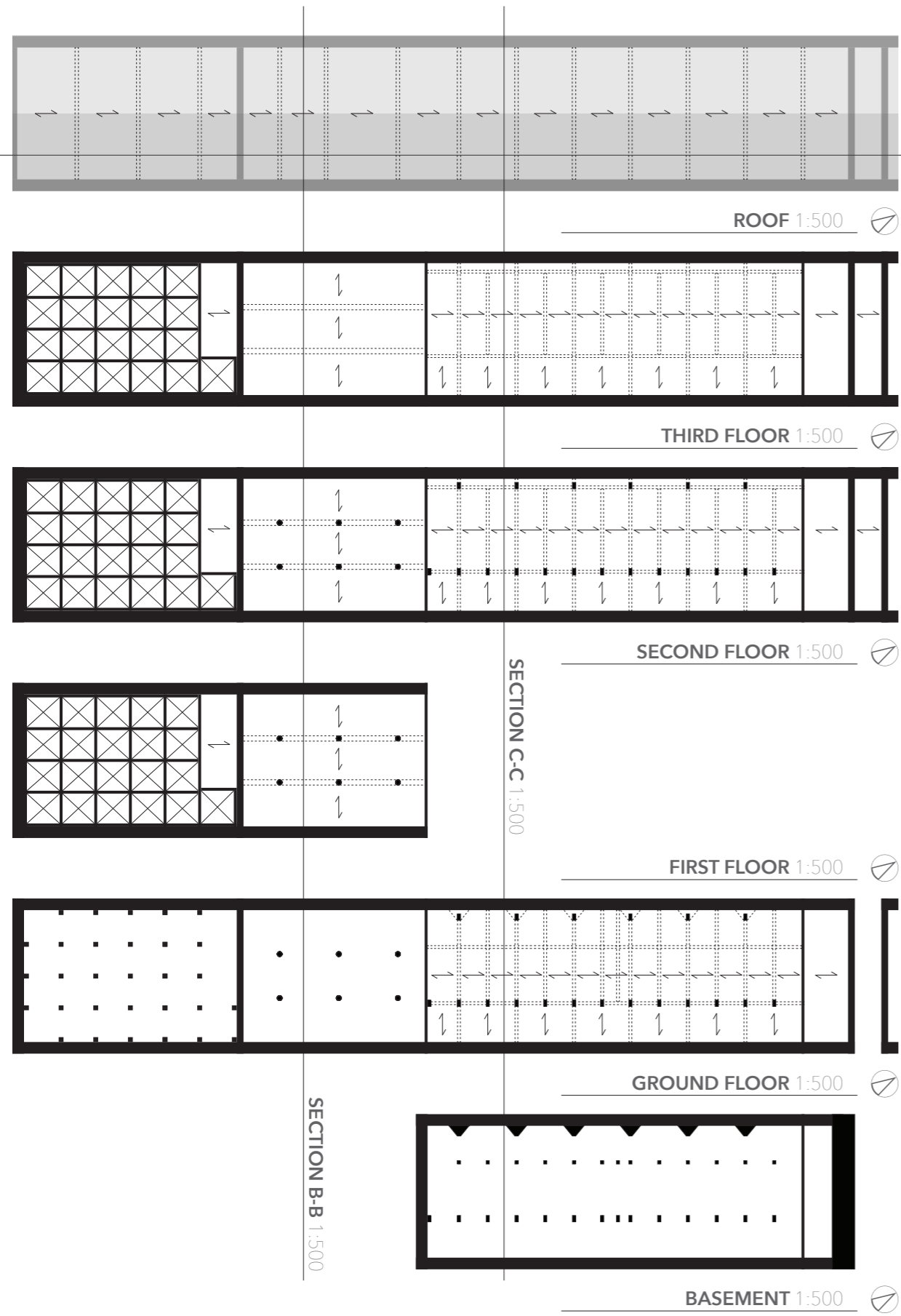

SECTION A-A 1:500

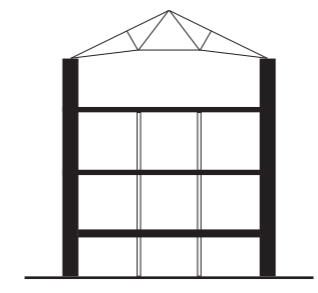

SECTION B-B 1:500

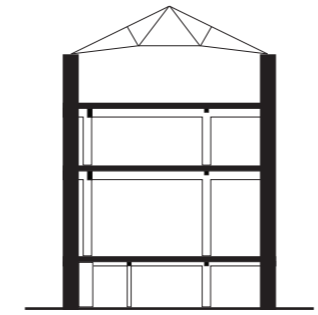

SECTION C-C 1:500

STRUCTURAL SCHEME

The facade of this building, constructed with stone blocks, is load-bearing and plays an important role in the stability of the building. The concrete interior load-bearing walls divide the different construction typologies, like cast iron columns with brick vaults and a monolithic concrete structure. The walls of the silos are constructed with concrete as well, as becomes clear on page 82. For the roof construction Polonceau-trusses are used (p. 76).

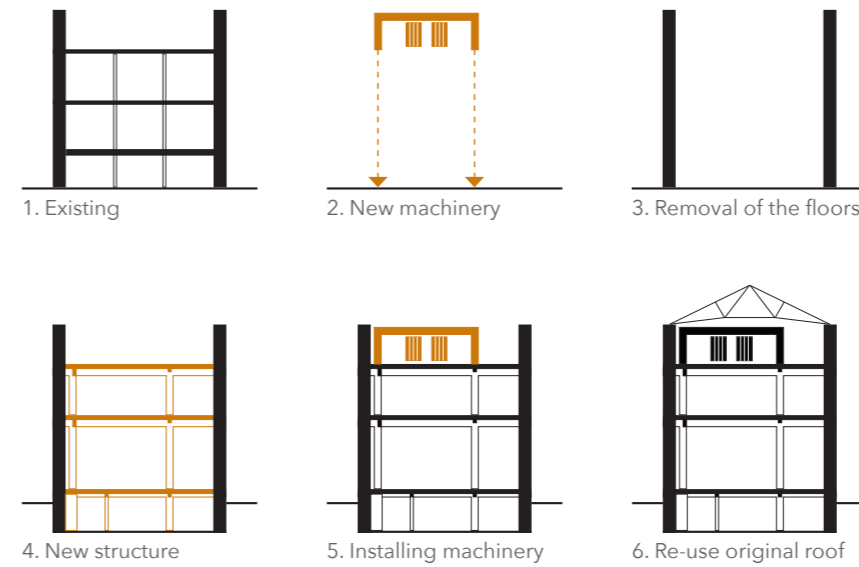
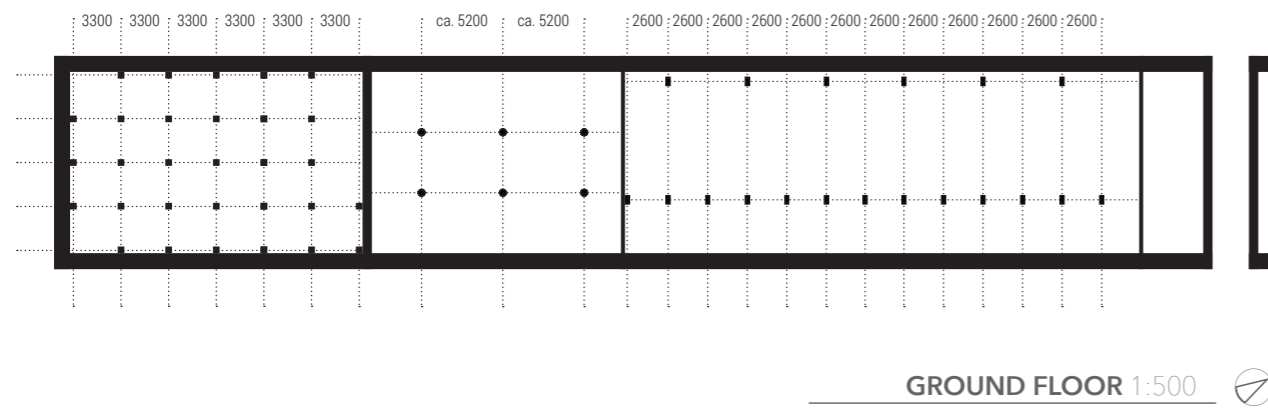
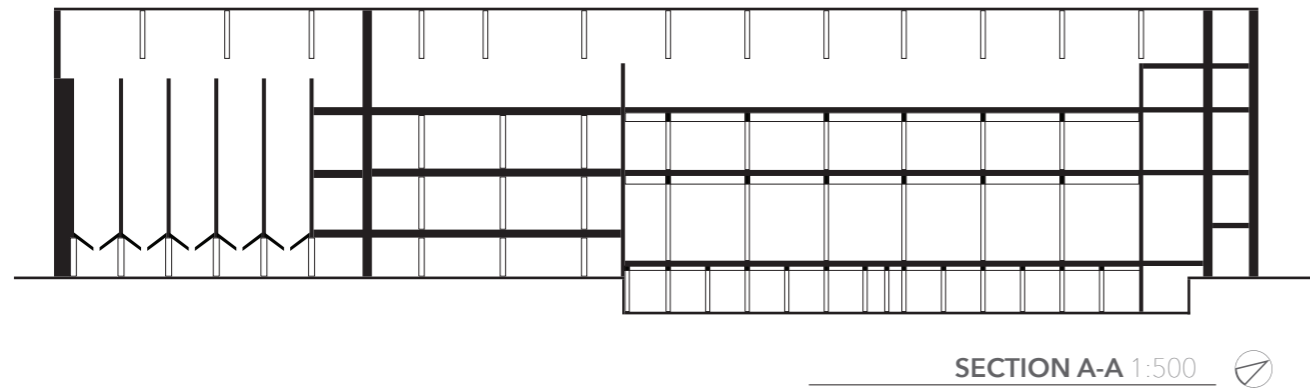

STRUCTURAL SCHEME AND DIMENSIONS

To the way the interior walls connect to the windows, one can assume that internal changes have occurred (image 1). Besides that, the construction materials and pattern of the different construction typologies are totally different. As explained on page 30, the MMC reached its maximum level of production during the Ultramar War. For that reason, in the 1970s, silos were built and the production process was modernized, especially in the milling. The new machinery asked for a specific concrete structure, that's why the structure is not placed symmetrical in the building.

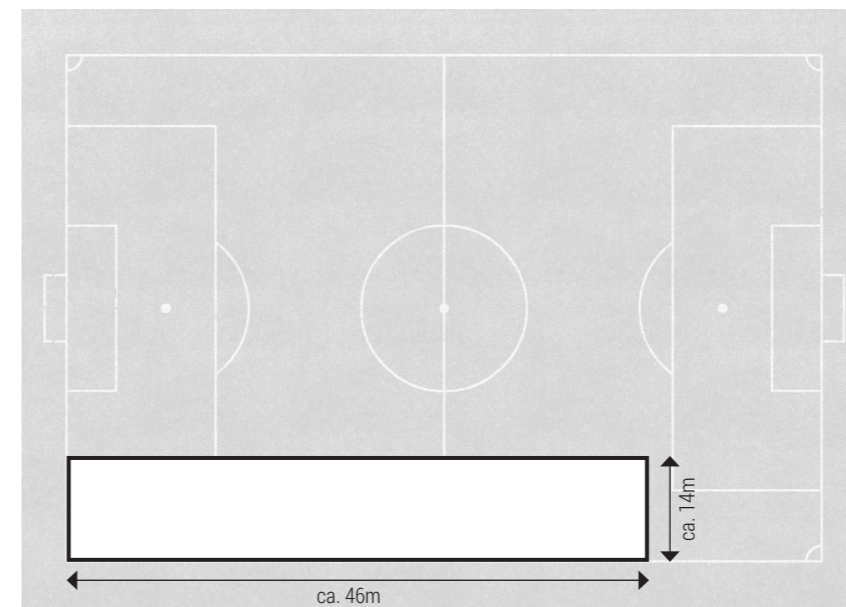

Images
1. Connection window and interior wall (photo by Ruben Klinkenberg, 01-09-2016)

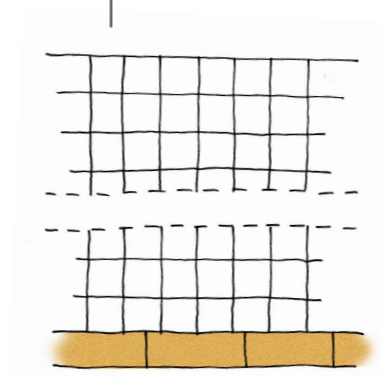
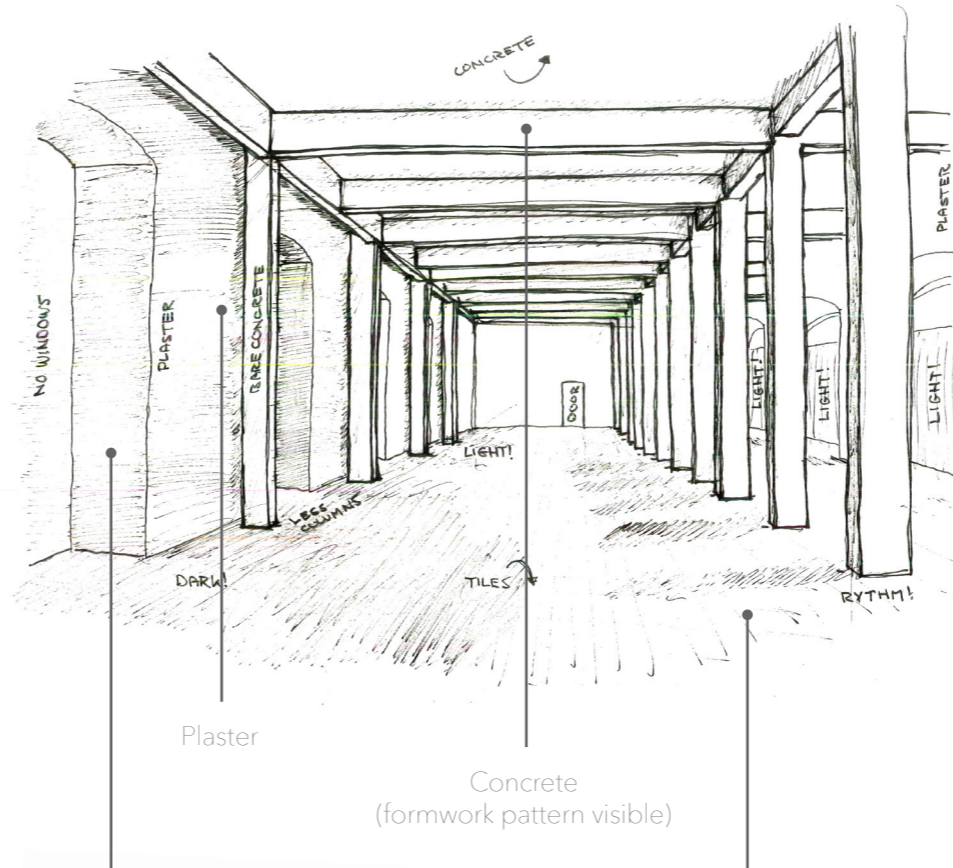

Whitish/yellowish ceramic tiles (glossy) with a brownish/orangish stone plinth (dull)

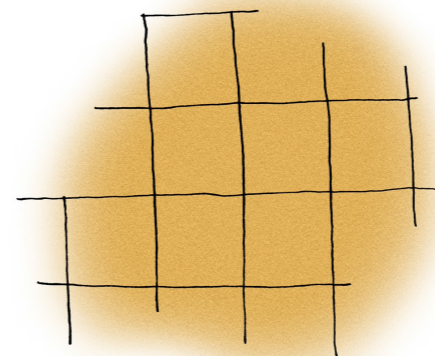

Brownish/orangish stone tiles (dull)

LEGEND



INTERIOR MATERIALS

As explained (p. 45-47), no bare construction material in the bakery is visible anymore because they're all finished with paint, plaster or tiles. In the milling it is different: the concrete structure and the stone sills are not cladded or painted (image 1 and 2). These are materials that have been added in the 1970s, as will become clear later in this report (p. 83-93). This phenomenon is not only the case in the milling, but also in the interior of the other buildings that have been added to the ensemble in the 1970s and 1980s (building 16A, 16B, 19 and 20). The interior materials of these buildings will not be further discussed, because only concrete is visible. The floors (stone) and part of the walls (ceramic) in this part of the milling are cladded with tiles: this is easy to clean.

Images

1. Ground floor (photo by Hielkje Zijlstra, 04-09-2016)
2. Ground floor (photo by Hielkje Zijlstra, 01-09-2016)

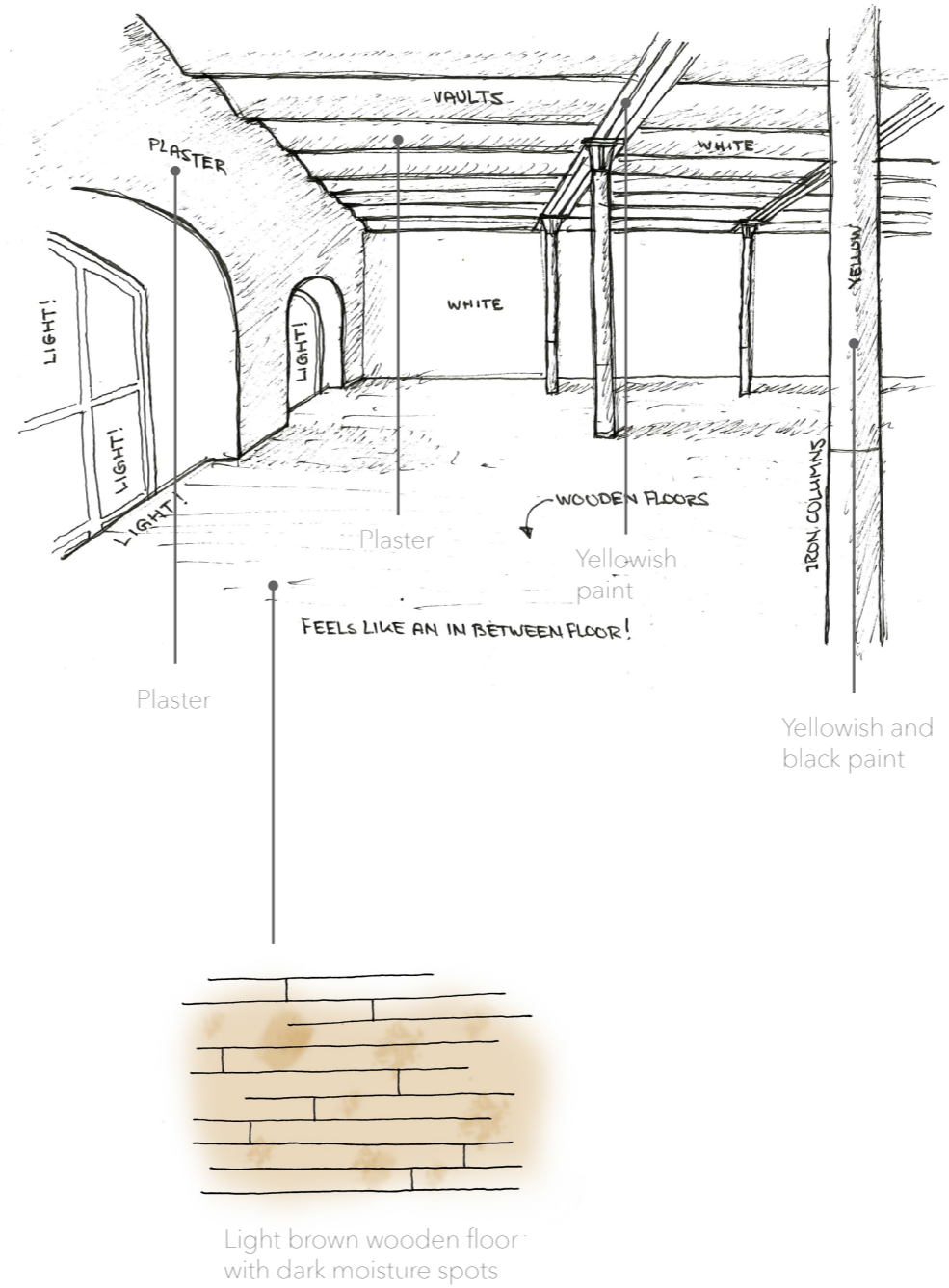

LEGEND



INTERIOR MATERIALS

In this part of the milling there's a totally different atmosphere, partly because of the different materials and finishes. The reason for this can be explained on the basis of the historical development of the ensemble (p. 25-33): this part of the milling is original, while the part discussed on the previous page is radically changed in the 1970s. Since the plaster is in a very good state, it is likely that it is restored or replaced over time. Also the wooden floor is not original, as will be explained on page 89. Like in the bakery (p. 45-47), all the bare construction materials in this part are not visible anymore, except from the wooden floor.

Images
1. First floor (photo by Hielkje Zijlstra, 04-09-2016)

BUILDING 18 - MILLING

1970s <1911

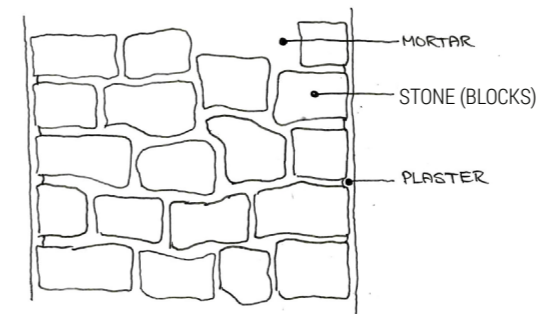
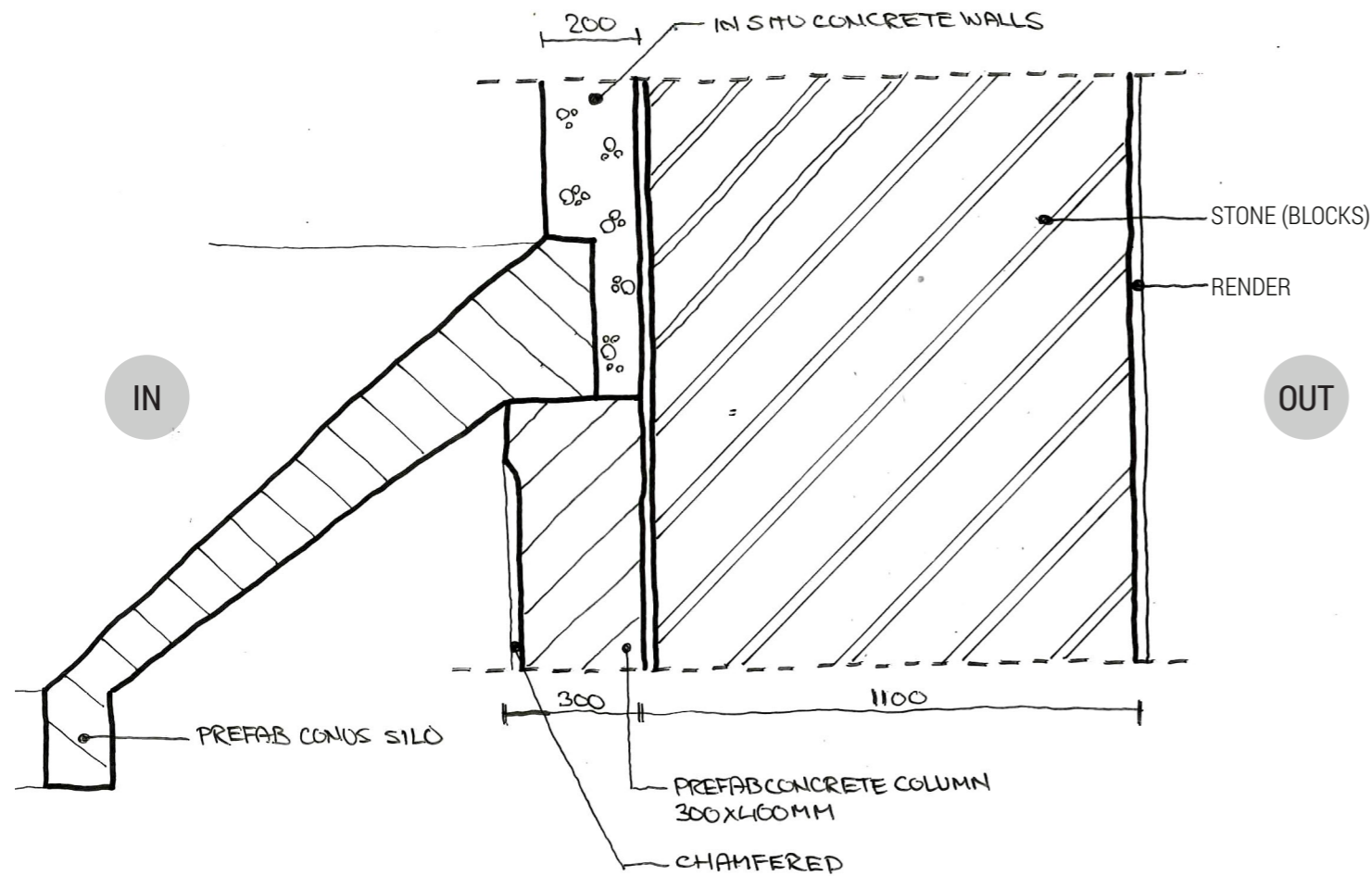

LEGEND



DETAILS

From the historical development (p. 25-33) it became clear that internal changes have occurred. The windows that used to be in the facade of the silo (image 1) are not there anymore. For that reason we assume that the silos have been built around the 1970s within the original load-bearing facade. Because of the chamfered corners of the columns and the constant shape and quality of the silos we think that these are prefab elements. The walls are made in situ, making it a monolithic structure.

We assume that the facade is constructed out of stone blocks. The blocks on the outside have a more or less straight side, while the blocks on the inside are more irregular. The wall is finished with a thick layer of plaster to hide the irregularities.

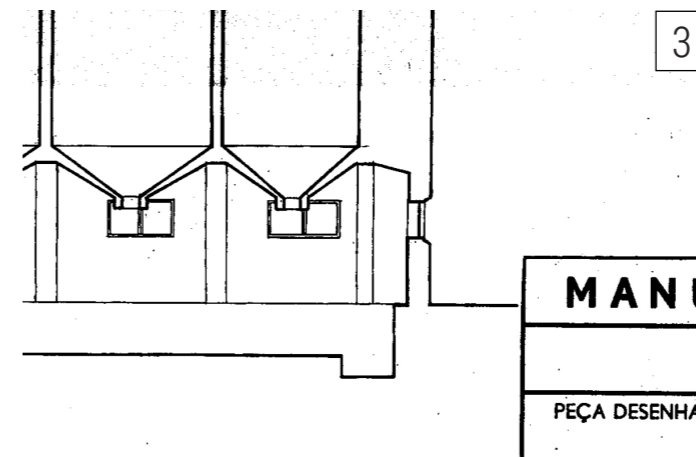

MANU

PEÇA DESENHADA

- Images
1. Front facade milling (screenshot video of 1927 from www.cinematca.pt)
 2. Ground floor silos mill building (photo by Hielkje Zijlstra, 04-09-2016)
 3. Detail section mill building (drawing provided by Docomomo)

BUILDING 18 - MILLING

<1911

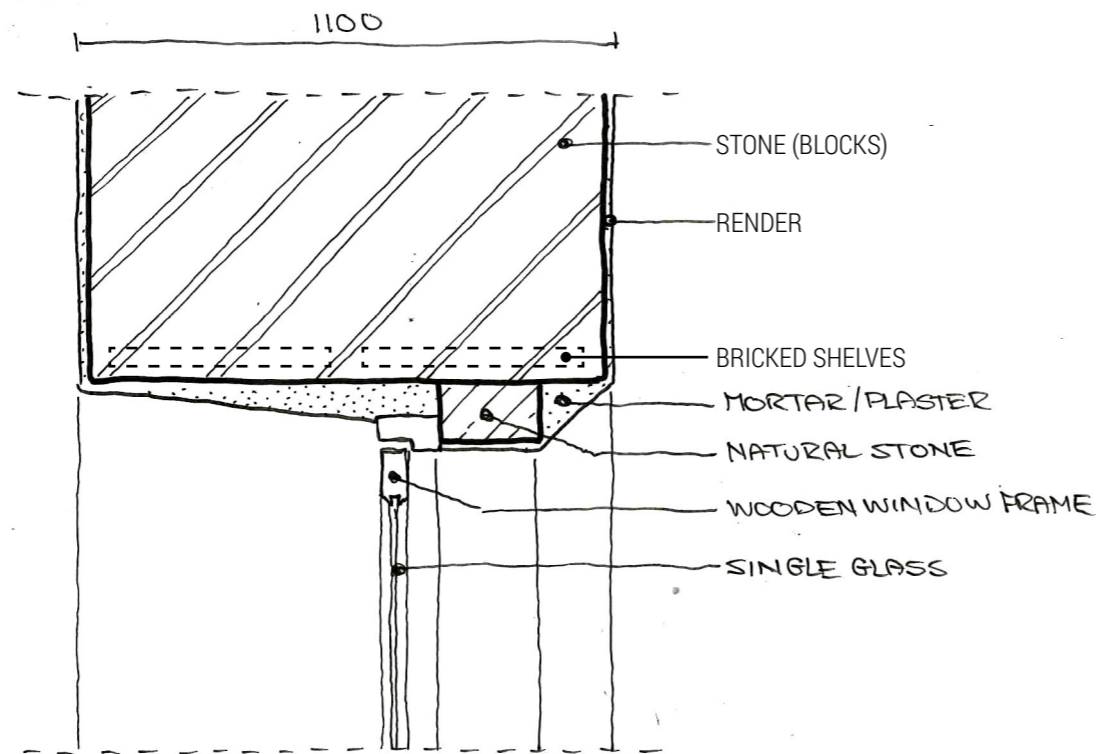

IN

OUT

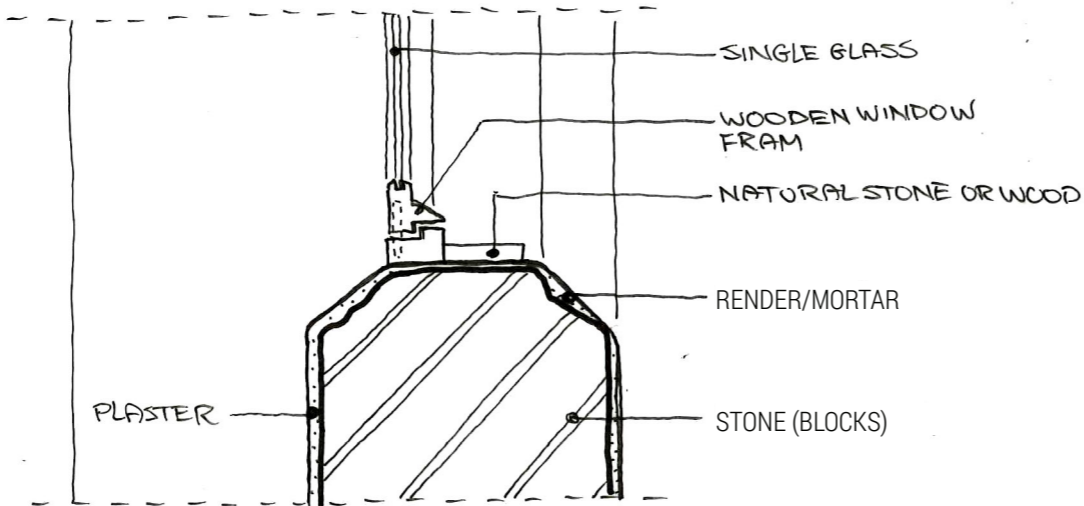

LEGEND



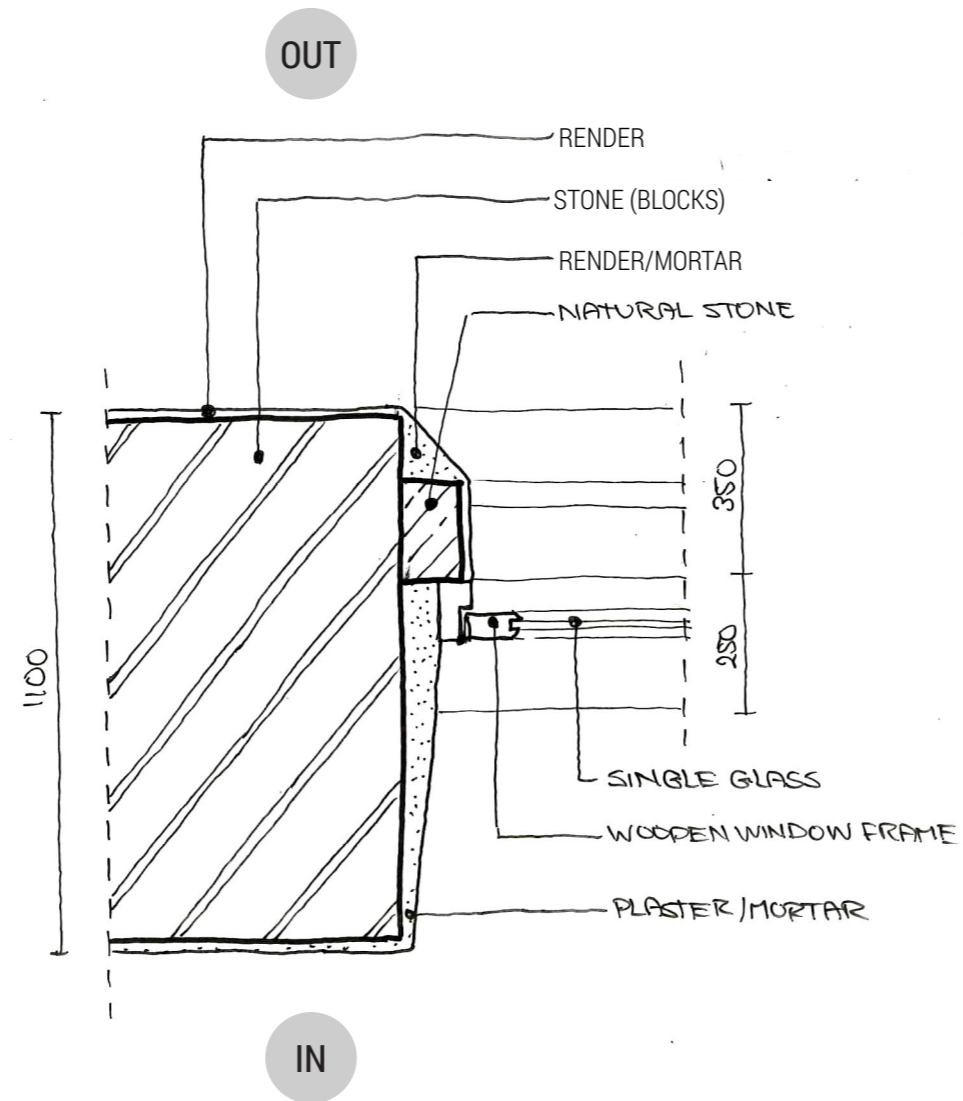
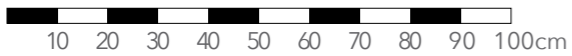

LEGEND



DETAILS

This are the vertical and horizontal details of the wooden window frames on the ground floor of the silos in the milling. The side and top sill of the wooden window frames are not visible from the outside. For this reason it can be concluded that it is inside glazing. We assume that (local) natural stone is used as a mounting frame, because this material has been used extensively in the buildings at the MM complex for framing of the windows, for example on the first and second floor of the milling, as will be illustrated on page 86 and 87. The bevels have been created with mortar or plaster and we think that bricked shelves have been used to create a lintel.

The wooden window frames need to be maintained, because the paint starts to peel and the wood begins to rot. It is plausible that this are the original frames, since there's no reason to think differently.



Images
 1. Ground floor silos milling (photo by Hielkje Zijlstra, 04-09-2016)
 2. Exterior silos milling (photo by Ruben Klinkenberg, 01-09-2016)

BUILDING 18 - MILLING

<1911

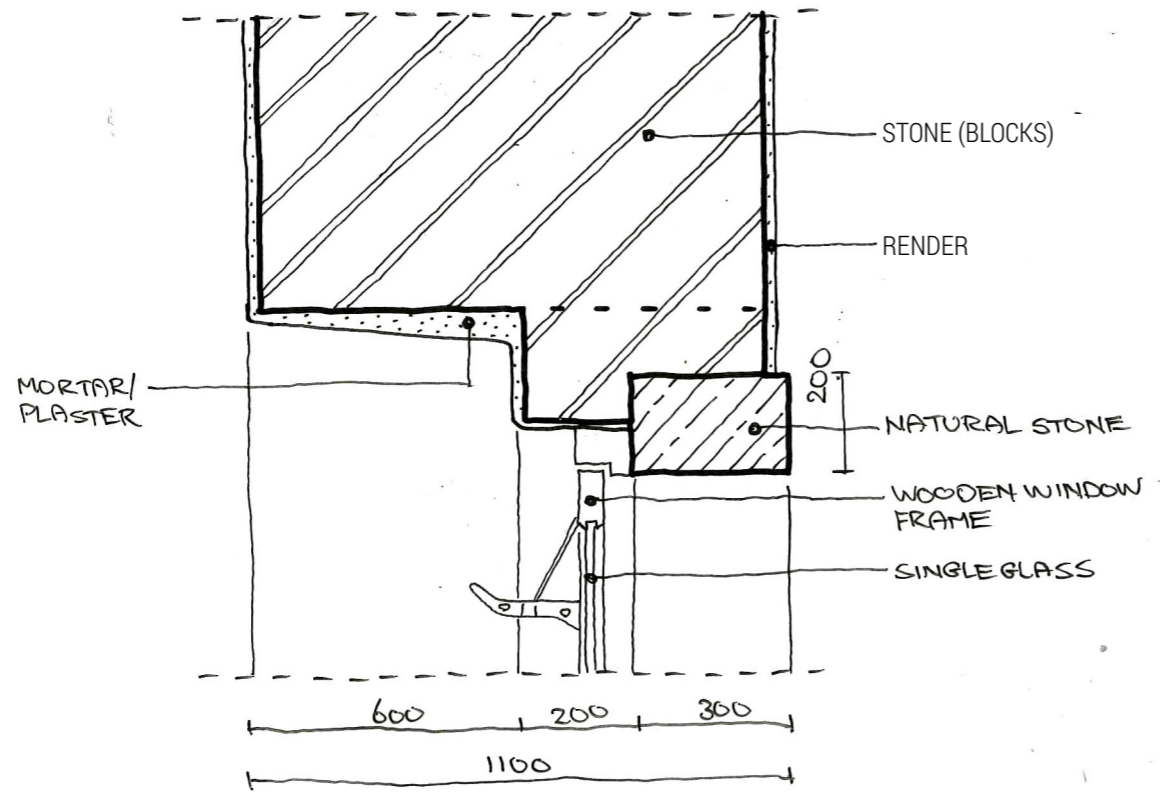

IN

OUT

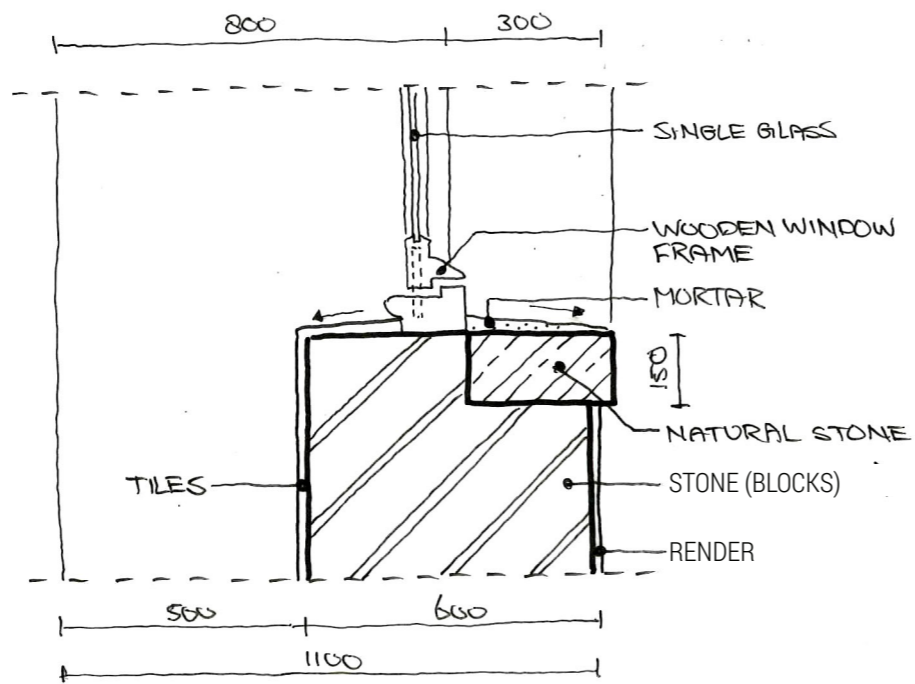

LEGEND

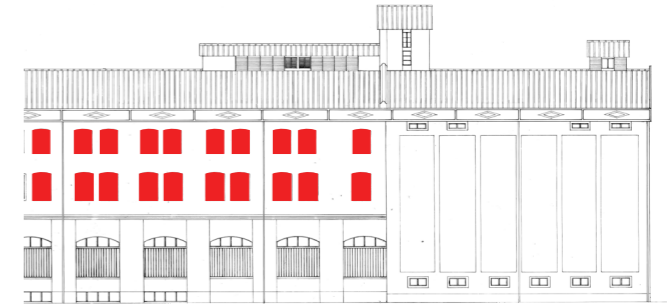

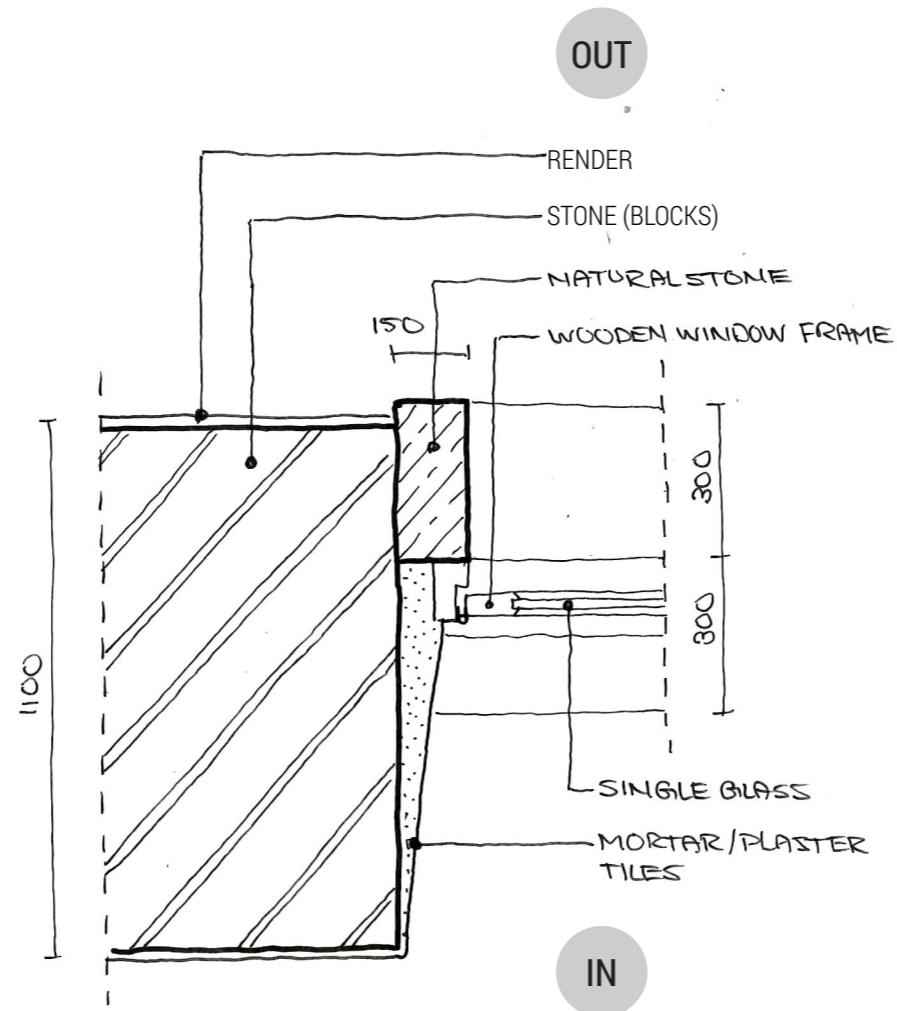
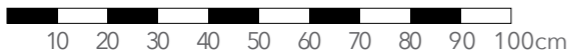

LEGEND

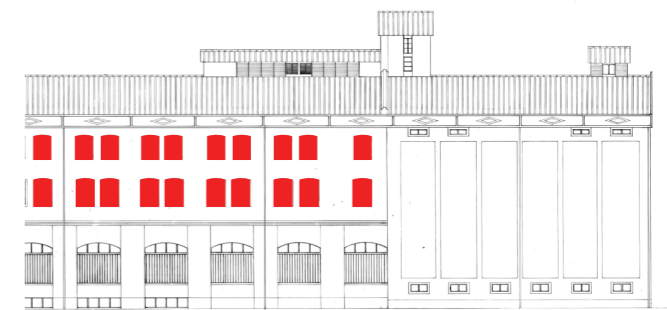

DETAILS

This are the vertical and horizontal details of the wooden window frames on the first and second floor of the milling. The side and top sill of the wooden window frames are not visible from the outside. For this reason we can conclude that it is inside glazing. Local natural stone, which is visible from the outside, is used as a mounting frame. Because the frame protrudes on the outside and the slope of the bottom sill is minimal, a lot of dirt accumulates around the windows (image 3). The bevels have been created with mortar or plaster.

The wooden window frames need to be maintained, because the paint starts to peel and the wood begins to rot. Despite the internal changes in this part of the building during the 1970s, we assume that this are the original window frames: the detailing of it is comparable to the window frames on the ground of the silos in the mill building. Only the tiles on the inside date from the 1970s (p. 80).



Images
 1. First floor milling (photo by Hielkje Zijlstra, 04-09-2016)
 2. First floor milling (photo by Hielkje Zijlstra, 04-09-2016)
 3. Exterior milling first floor (photo by Jeroen van Lier, 06-09-2016)

BUILDING 18 - MILLING

1970s <1911

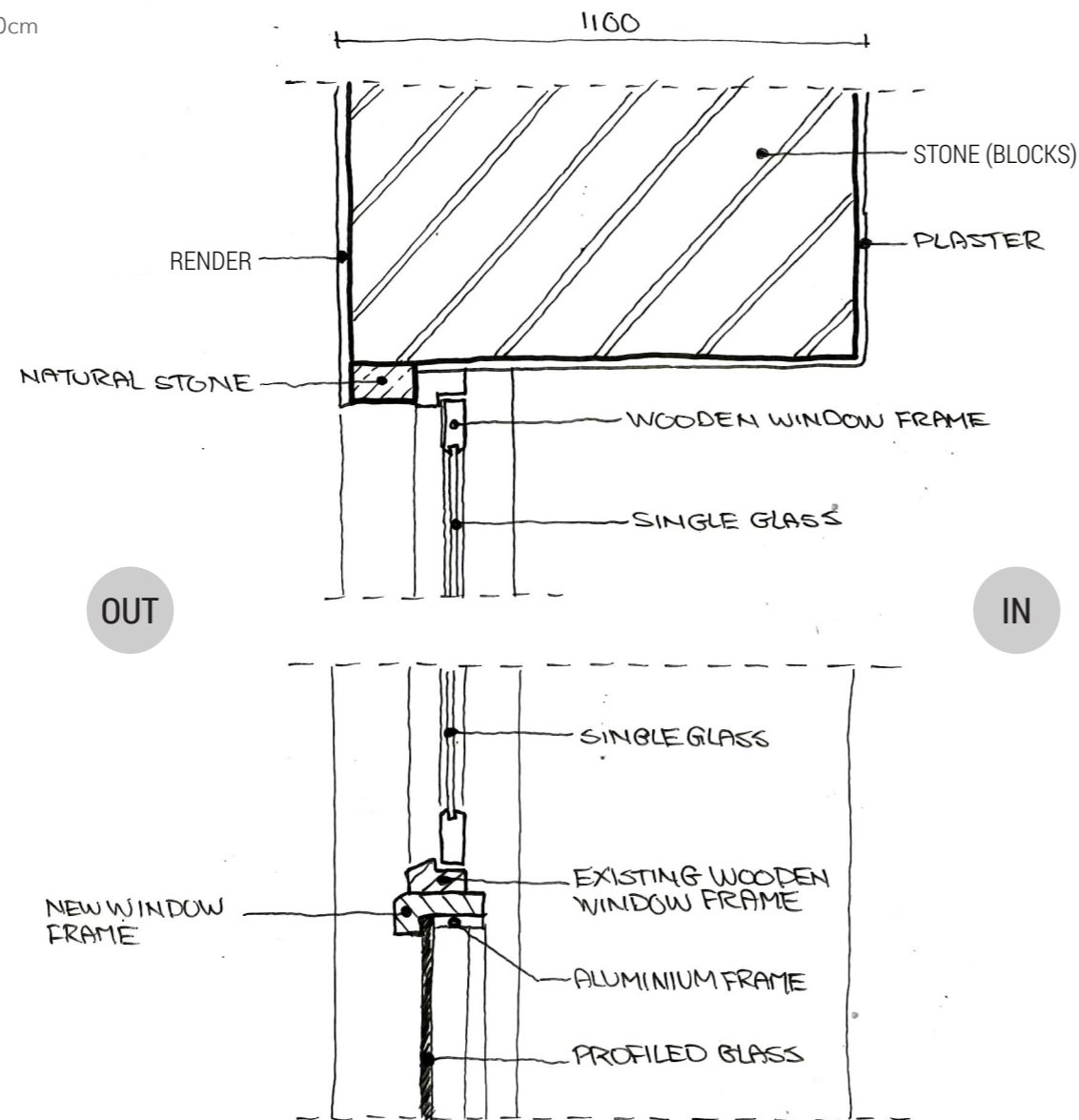

LEGEND

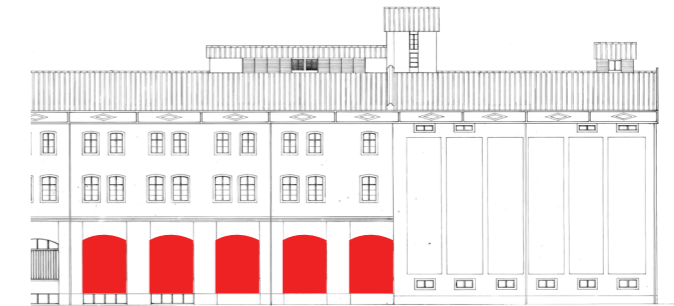

DETAILS

This are the vertical details of the upper part of the wooden window frames on the ground floor of the milling. The side and top sill of the wooden window frame are not visible from the outside. Unlike the windows discussed on the previous pages this is outside glazing, as will become apparent on page 90. Also for this window local natural stone is used as a mounting frame. This frame is finished with a render on the outside. We think that the wooden window frames are original, like all the wooden window frames in the milling, and that the profiled glass is an addition of the 1970s (see facing page).

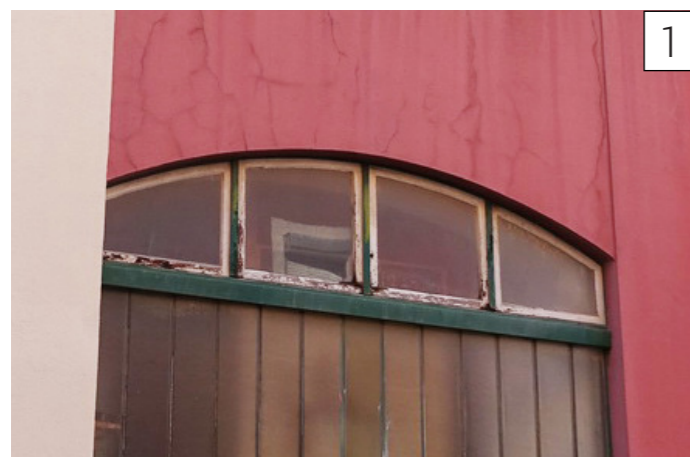

Images

1. Exterior milling ground floor (photo by Hielkje Zijlstra, 04-09-2016)
2. Ground floor milling (photo by Jeroen van Lier, 01-09-2016)
3. First floor milling (photo by Hielkje Zijlstra, 04-09-2016)

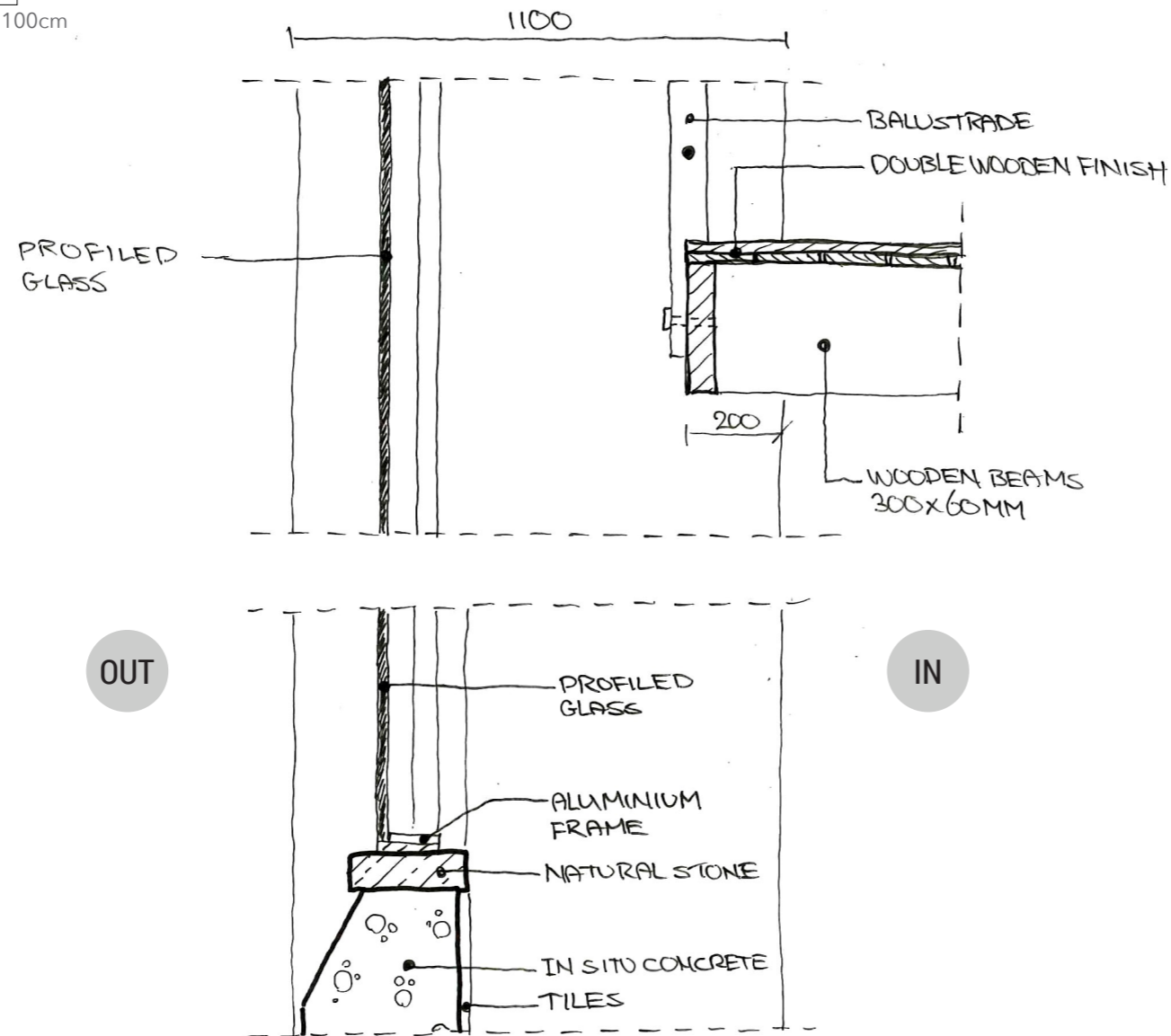

LEGEND

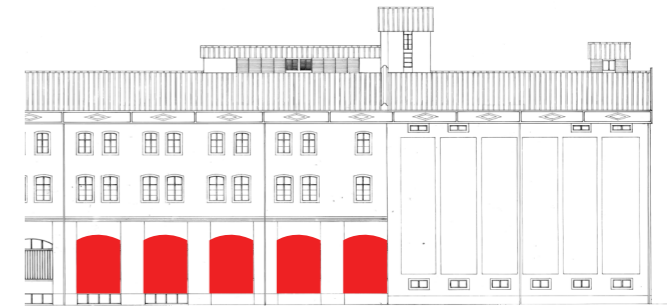

DETAILS

This are the vertical details of the lower part of the wooden window frames on the ground floor of the milling. The profiled glass that is used is a typical material of the 1970s. This can be seen as a characteristic of the internal changes during the 1970s due to the modernization of the production process (p. 25-33). For the same reason the ground floor became a double height space (p. 90). We also believe that the sill and the concrete wall beneath the window are from the 1970s.

Another interesting observation is the double wooden floor on top of the wooden beams: the direction of the wooden parts at the bottom differs from the ones on top. The assumption is made that only the bottom layer is original, since the direction of the wooden parts of the top layer does not correspond with the ones in image 4 on page 28. The upper layer is probably added because of the holes that were made for the machinery (maybe the mills) that once stood there. They 'repaired' this by adding a new layer of wood. It can be assumed that this is done in the 1970's as well.



Images
 1. First floor milling (photo by Hielkje Zijlstra, 04-09-2016)
 2. Exterior milling ground floor (photo by Hielkje Zijlstra, 04-09-2016)
 3. Detail profiled glass milling (photo by Noëlle Dooper, 01-09-2016)

BUILDING 18 - MILLING

1970s <1911

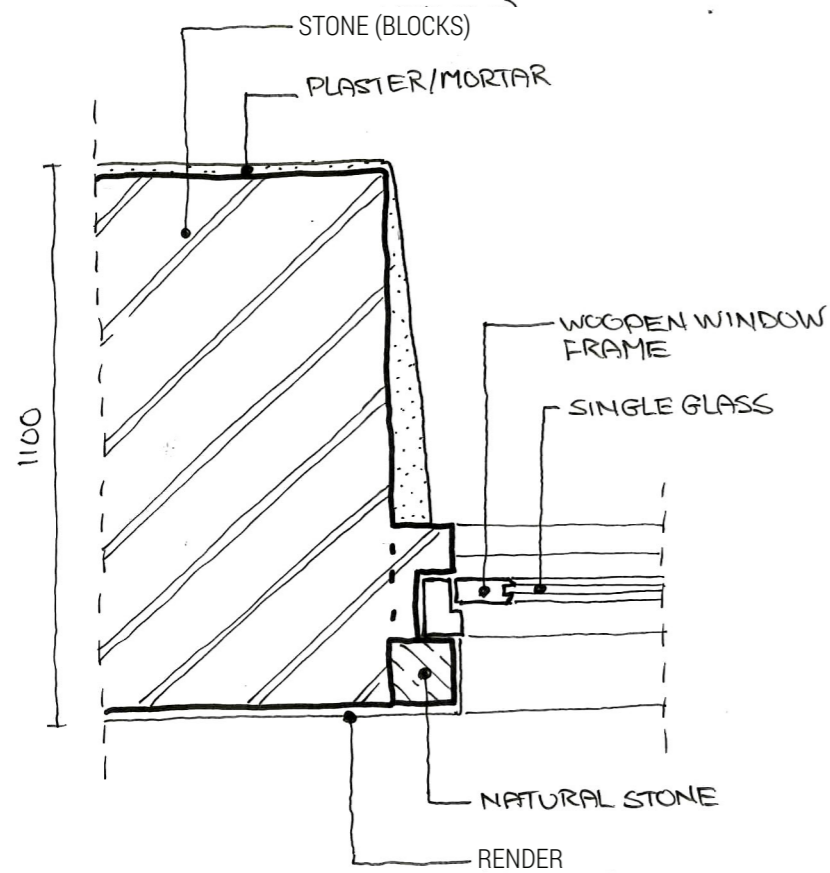

IN

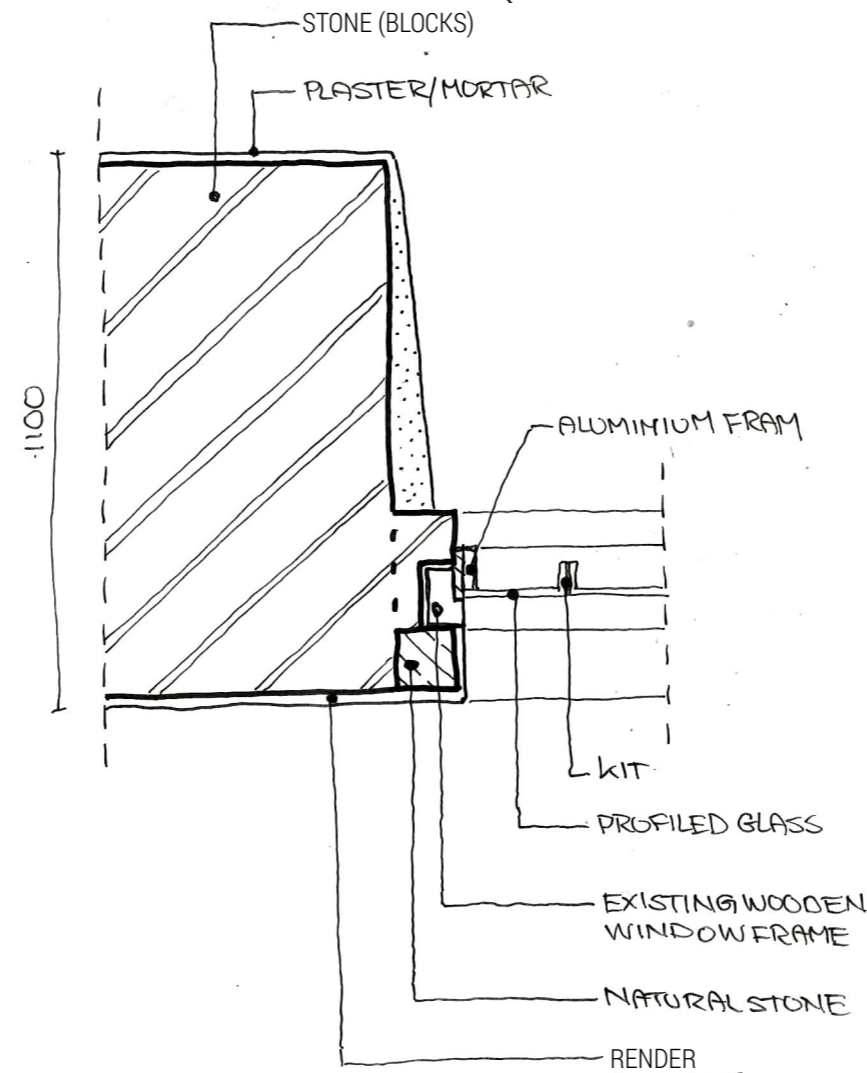

OUT

LEGEND

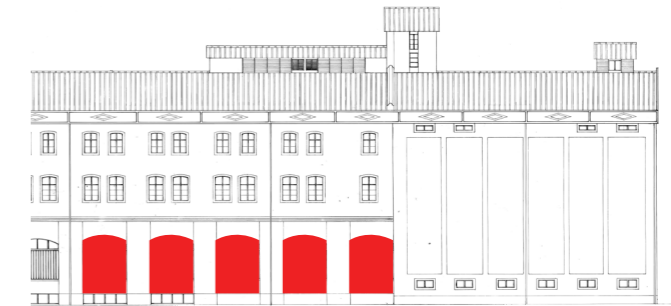

DETAILS

This are the horizontal details of both the upper (left detail) and lower (right detail) part of the wooden window frames on the ground floor of the milling. In the current situation the ground floor has a double height because the new machinery asked for this. We think that originally there used to be an extra floor, which is still the case in part of the milling (p. 81). In contrast to the windows on the upper floors (p. 86-87), outside glazing is used on the ground floor: they could not place the big windows from the inside because of the originally 'extra' floor. On the ground floor, during the 1970's, they've changed the single glass for profiled glass. For this, they re-used the original wooden window frames (right detail), because it was impossible to remove the frame without demolishing part of the exterior wall.

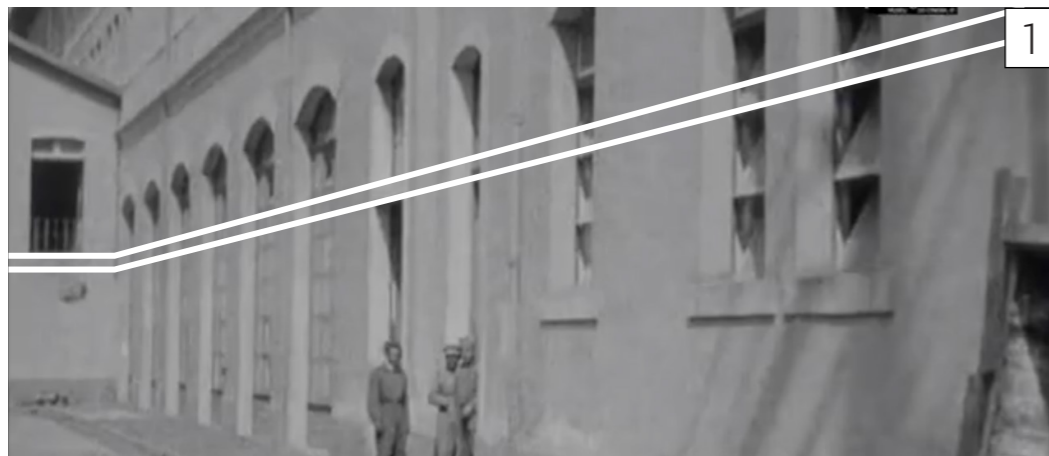

Images
1. Facade ground floor milling (screenshot video of 1927 from www.cinamateca.pt, own editing)

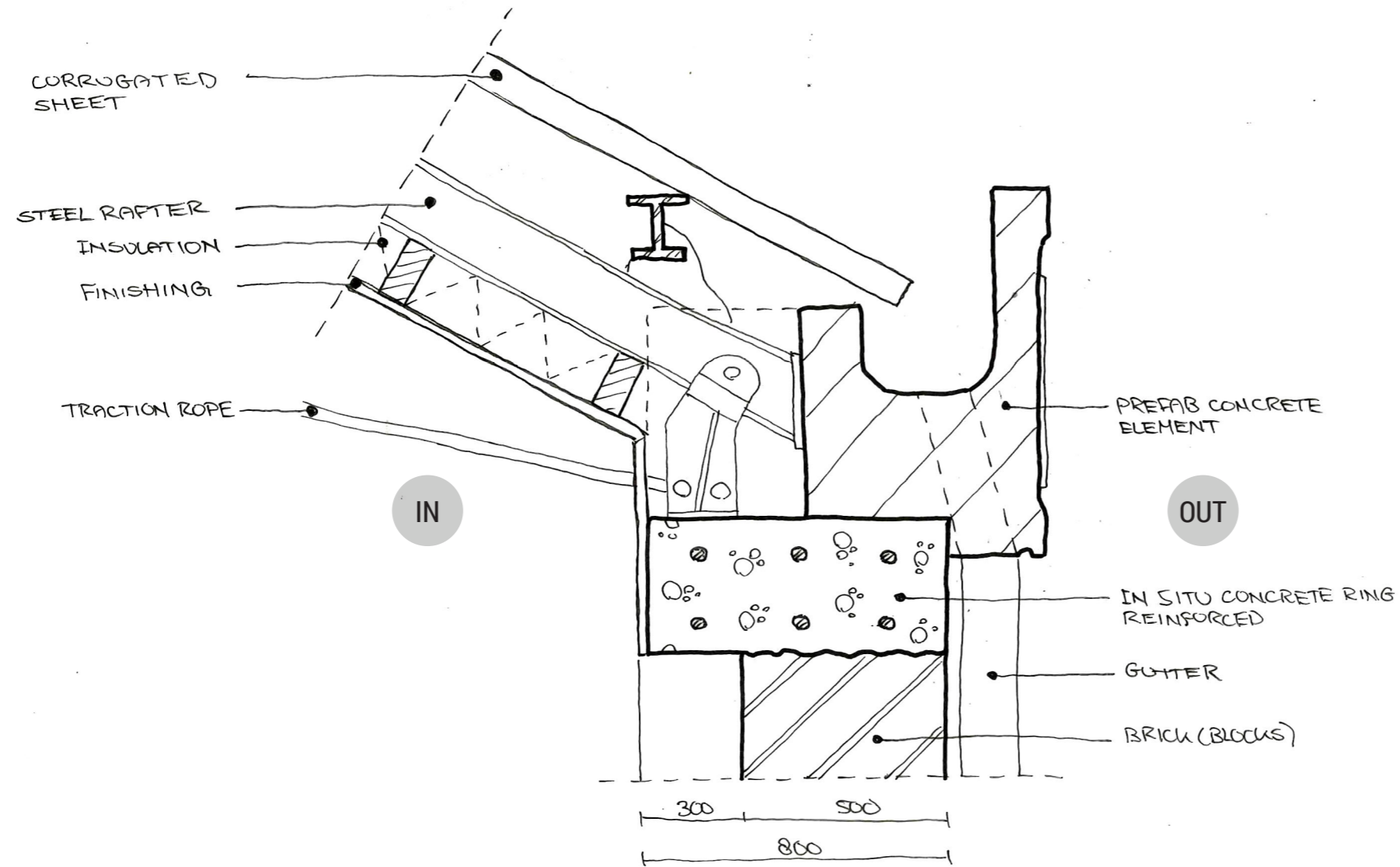

LEGEND

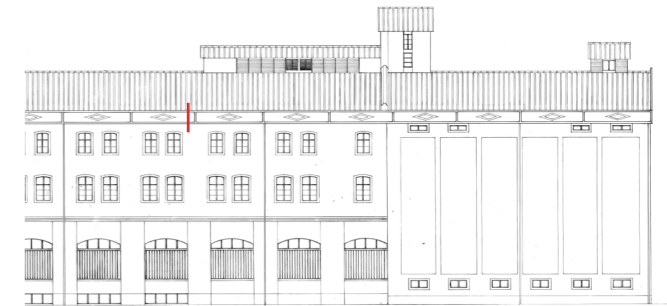

DETAILS

In the 1970s a lot of things changed in the milling because of the modernization of the production process (p. 30). Because of the new machinery and concrete structure, almost the complete roof had to be removed. Because the lintel is too big to be made out of stone blocks (image 2), and based on the drawings (image 3), we think that a concrete ring has been mounted on top of the original load-bearing facade to hand over the forces and to increase the stability of the building. This latter was necessary because of the vibrations of the new machinery. The trusses in the milling are called Polonceau-trusses, as explained on page 76. These are the same ones as in the renewed part of the bakery, of which we had assumed that they have been re-used. That's the reason why we think that the trusses in the milling have been re-used as well, illustrated on page 79.

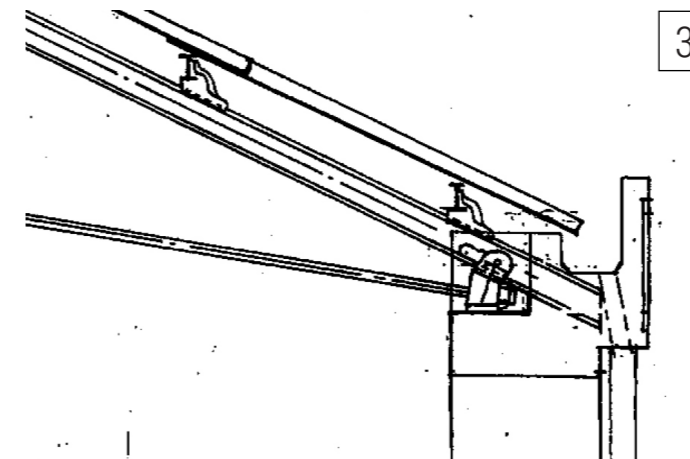
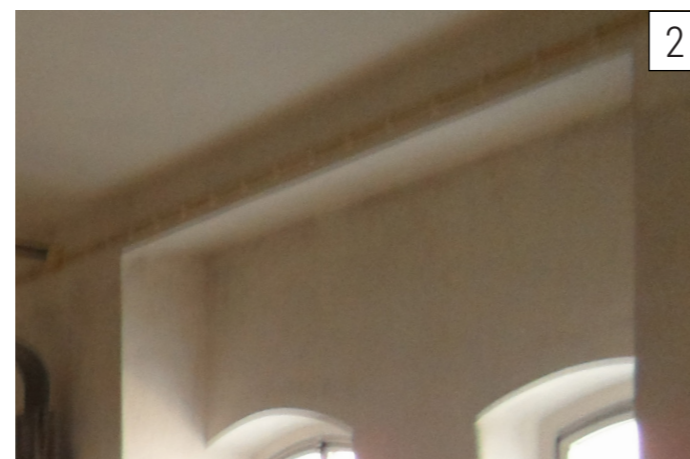

Images
 1. Exterior milling second floor (photo by Jeroen van Lier, 06-09-2016)
 2. Second floor milling (photo by Ruben Klinkenberg, 01-09-2016)
 3. Detail section milling (drawing received from Docomomo)

BUILDING 18 - MILLING

<1911

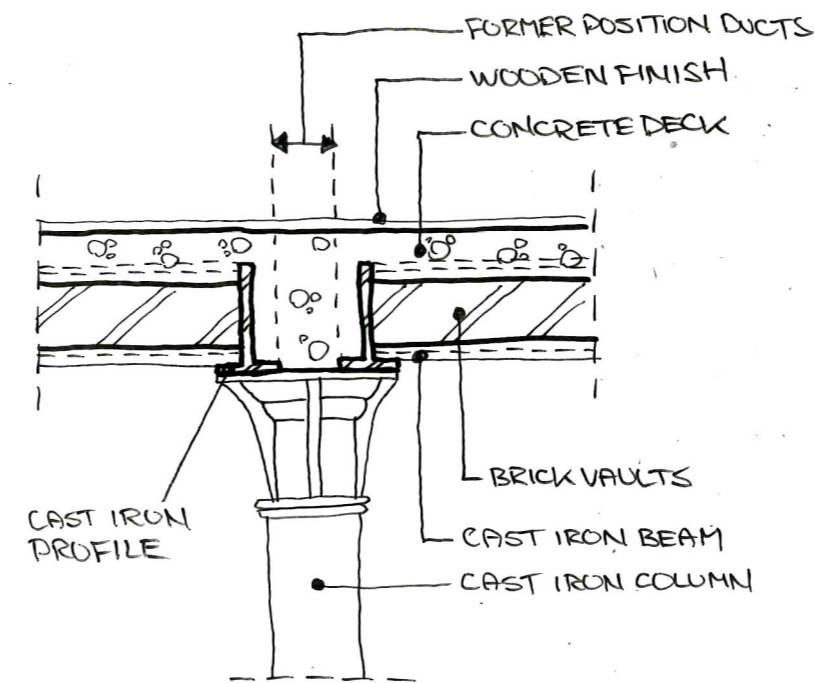
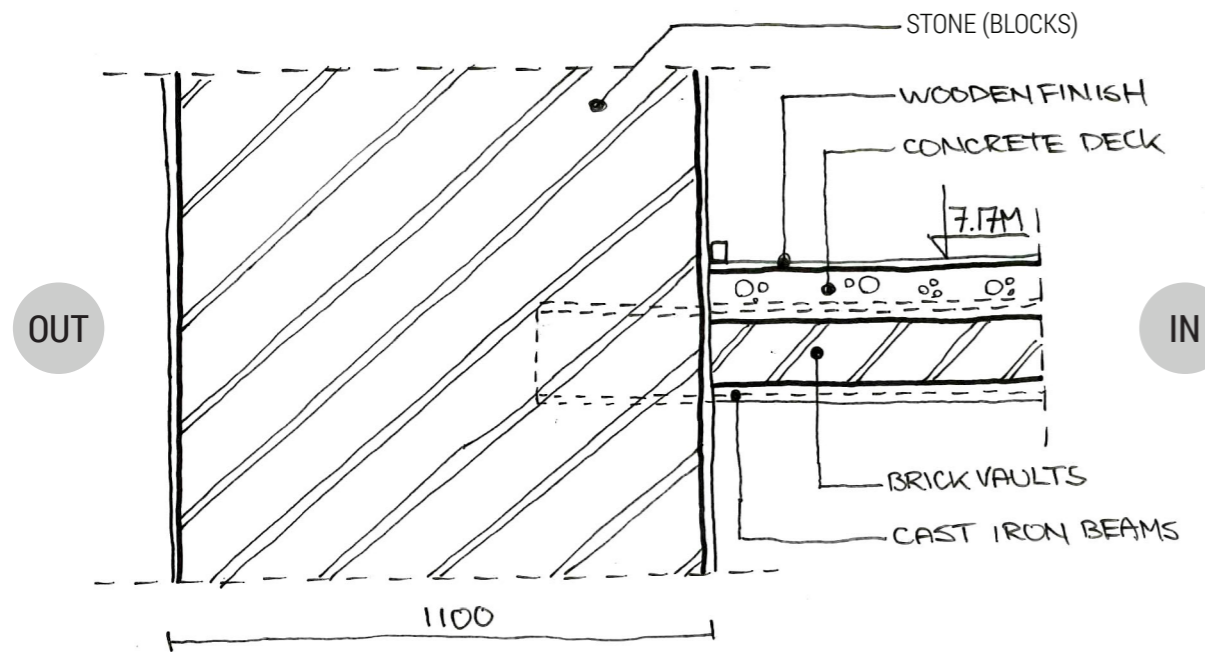

LEGEND

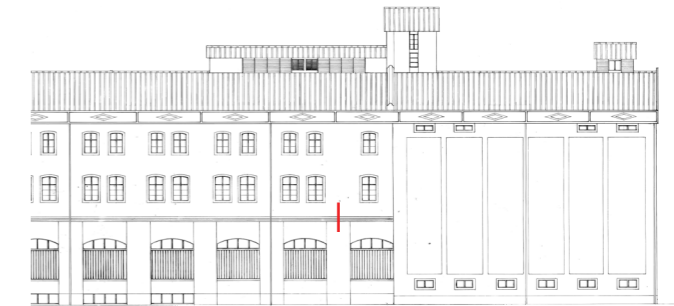

DETAILS

This are the horizontal details of the floor in the original part of the milling. It is composed of cast iron columns and beams, brick vaults, a concrete deck and wooden finish. The beams are integrated in the brick vaults, as is illustrated in image 3. On the right detail it is visible that two beams are used to hand over the forces to the column. In this way, the beams could have smaller dimensions (as well as the floor).

During the 19th century the definition of fireproof construction was all-masonry construction of walls and partitions, iron beams and columns and arch floors. The selling point of cast iron beams and columns were its fire resistance, slender proportions and light appearance. The common mode of filling-in between the cast iron beams was the brick arch, which was seen as almost indestructible. Arches were used relatively more frequently in industrial buildings, were the higher live loads were more efficiently resisted by the strong segmental form and were a scalloped ceiling was not an aesthetic problem.¹ This latter, combined with the conclusion on the facing page, proves the pragmatic attitude that was adopted in relation to the (development of the) buildings.

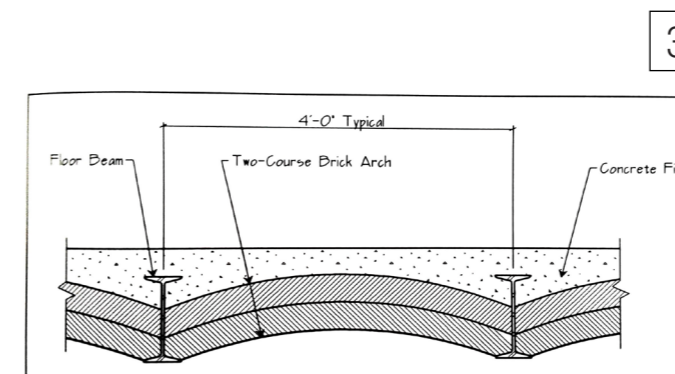

Text

1. Friedman, D. (1995). *Historical building construction. Design, materials and technology*. London: W.W. Norton & Company

Images

1, 2. Floor construction mill building (photos by Hielkje Zijlstra, 04-09-2016)
 3. Principle build-up floor, image from: Friedman, D. (1995). *Historical building construction. Design, materials and technology*. London: W.W. Norton & Company

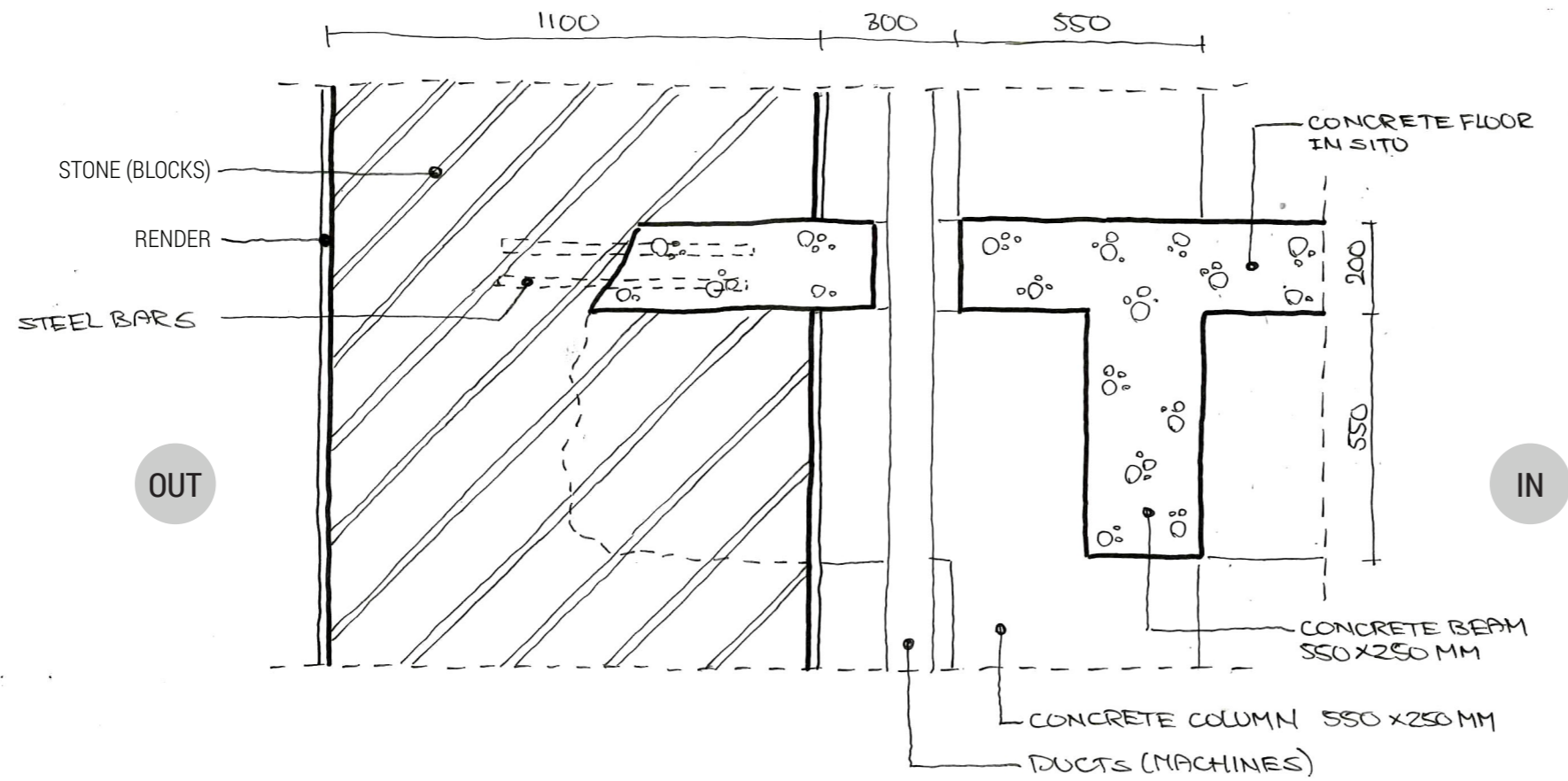

LEGEND

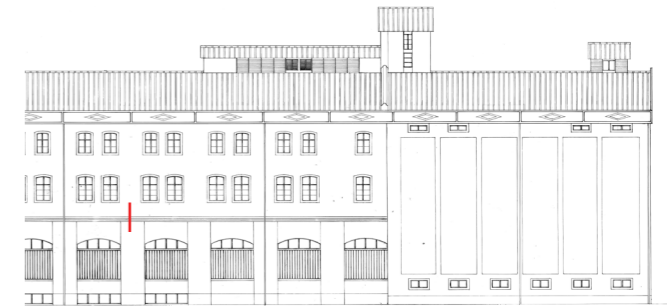

DETAILS

This is a horizontal detail of the connection of the concrete structure from the 1970s and the original facade of the milling. After 1900 reinforced concrete was rapidly adopted for industrial buildings of one or several stories. Reinforced concrete buildings could be built quickly, were fireproof and could resist vibrations from heavy machinery.¹ The concrete structure that has been implemented in the 1970s, because of the modernization of the production process, is placed within the original, massive load-bearing facade (re-use). For a good connection between the two structures, part of the facade was removed and steel bars were integrated. After the concrete structure was poured, the wall has been replenished and finished with a plaster.

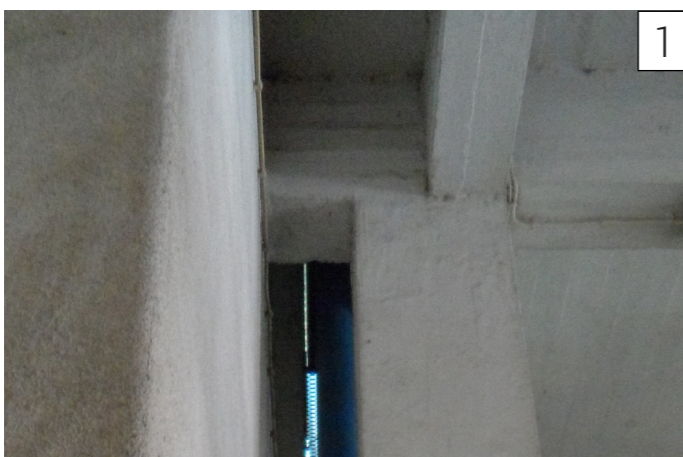

Text

1. Jester, T.C. (1995). *Twentieth-century building materials. History and conservation*. Washington: Archetype Press

Images

1. Detail concrete structure milling (photo by Ruben Klinkenberg, 01-09-2016)



During the Ultramar War the MMC reached its maximum level of production. Therefore, this silo was added to the milling in 1972.¹

Text
1. Texts exhibited at Manutenção Militar Complex by Lisbon Municipality

Images
1. Silo (photo by Hielkje Zijlstra, 01-09-2016)

BUILDING 19 - SILO

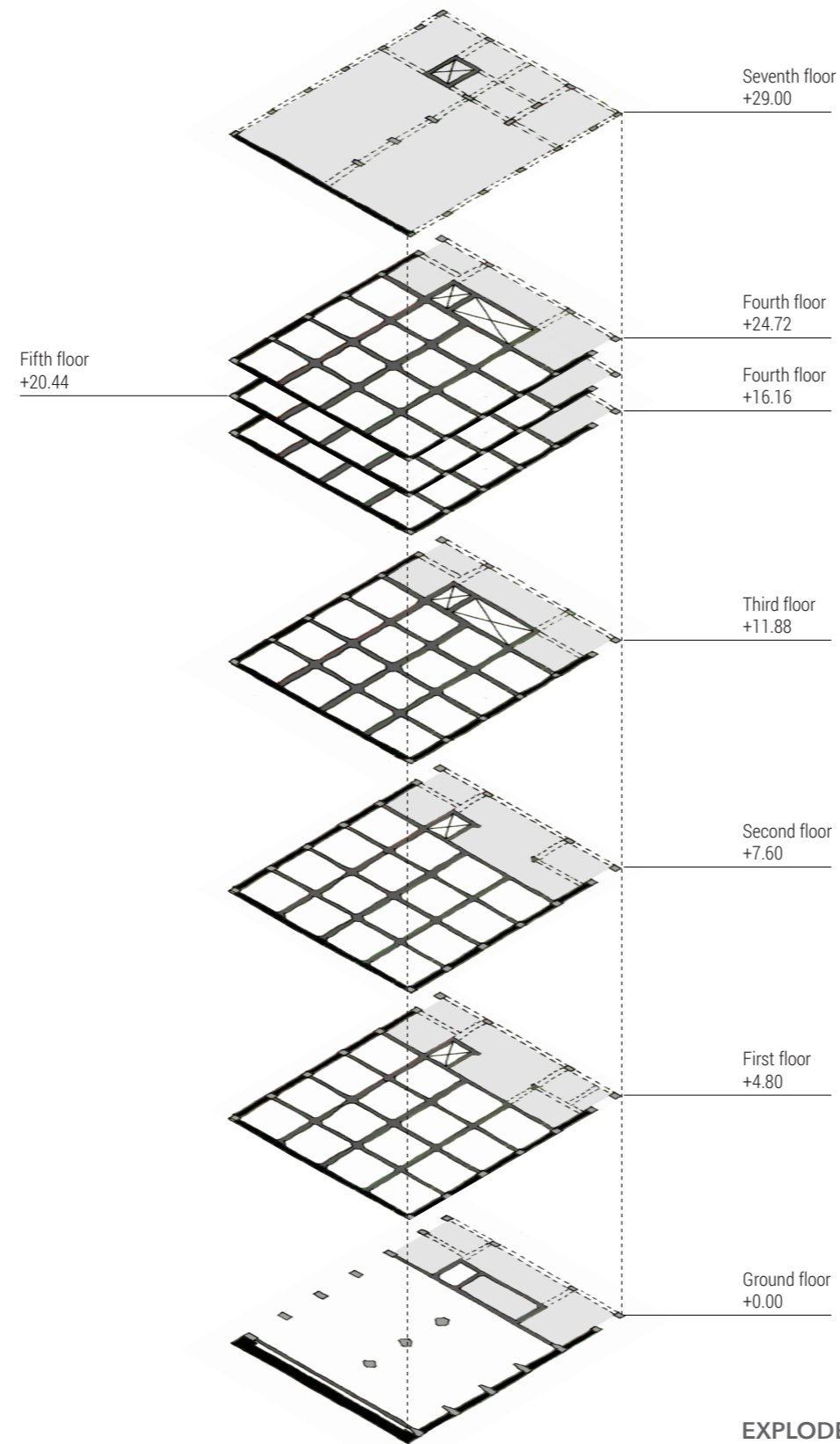
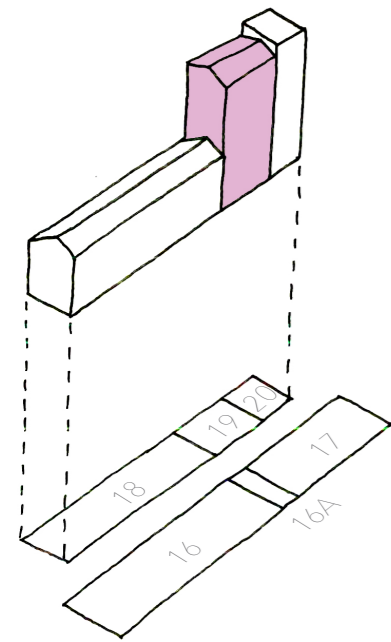

EXPLODED VIEW FLOOR PLANS

LEGEND

- Load-bearing facade
- Load-bearing interior wall
- Floor concrete
- Floor wood (incl. beams)
- Floor brick vaults
- Column / beam concrete
- Column cast iron
- Steel truss
- Wooden truss

CONSTRUCTION MATERIALS*

Like building 16 and 16A, the structure consists completely of concrete, including the roof (image 1-4). Since this is a monolithic structure, the stability of the building is ensured as well. The walls of the silos are also constructed with concrete.

Overview materials (monolithic structure)

- Concrete facade
- Concrete columns
- Concrete beams
- Concrete floor
- Concrete roof

The approximate volume of one silo is:
 $3,1 \times 3,1 \times 24,0 = 230,6\text{m}^3 = 2306\text{hl}$

If we assume that the silo are completely filled with wheat (80kg/hl), the total weight of the contents is:
 $2306 \times 16 \times 80 = 2951680\text{kg} = 2951,7 \text{ ton}$

* The construction elements which are drawn in the floor plan relates to the floor/roof above it.



CONSTRUCTION MATERIALS

The adjacent pictures give an impression of different construction typologies.

Images

- 1. Staircase (photo by Daan Masmeijer, 06-09-2016)
- 2. Second floor (photo by Daan Masmeijer, 06-09-2016)
- 3. Third floor (photo by Daan Masmeijer, 06-09-2016)
- 4. Top floor (photo by Daan Masmeijer, 06-09-2016)

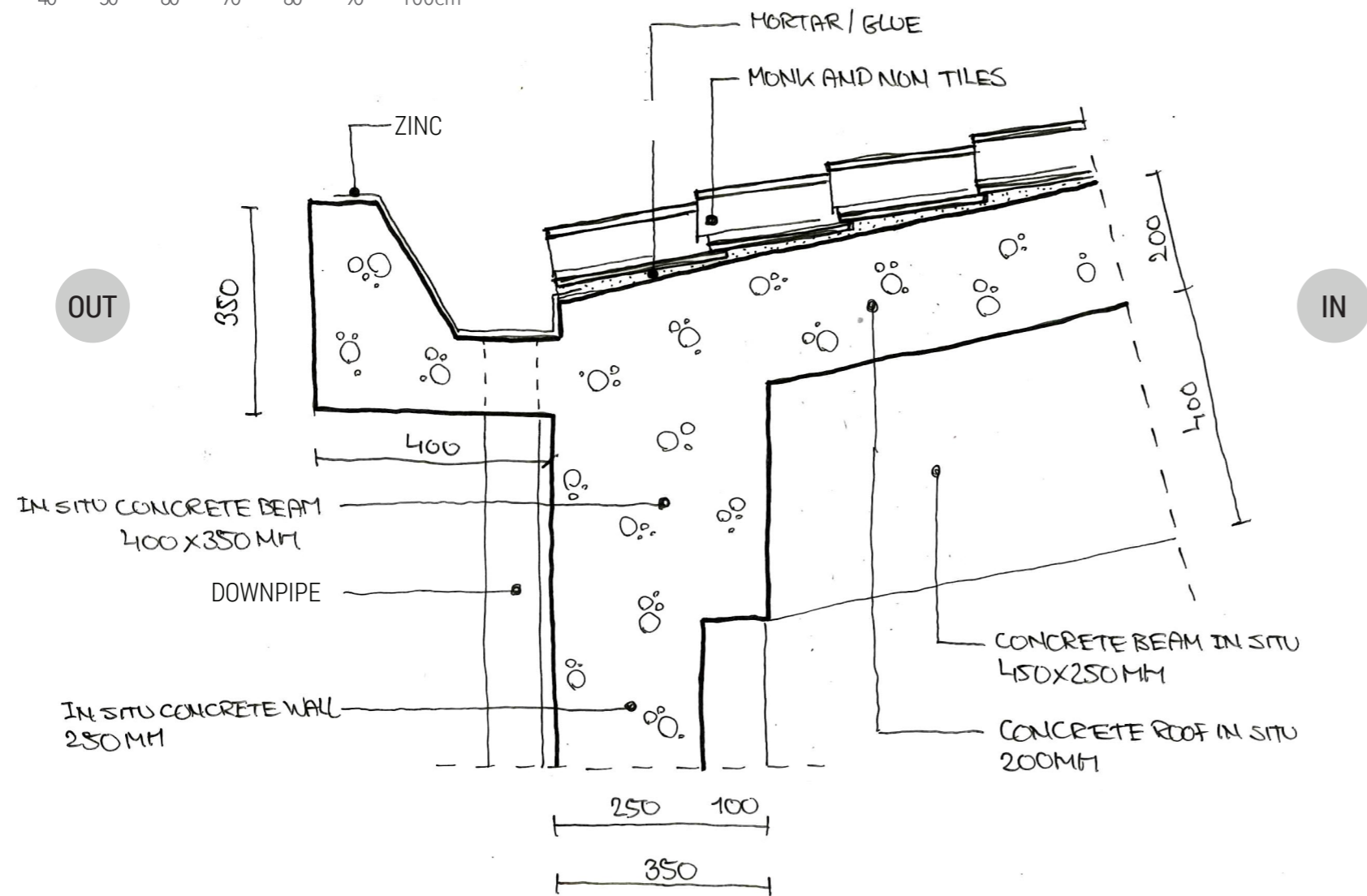

LEGEND

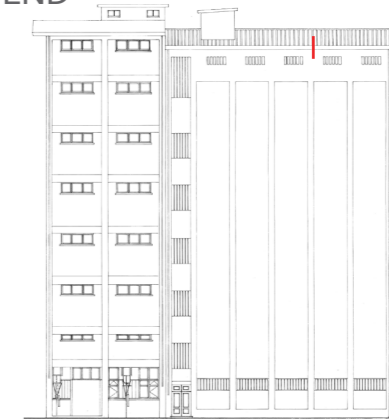

DETAILS

This is the detail of the eaves of the silo. As already mentioned, the construction is made entirely of concrete. Also the gutter, which is probably cladded with zinc, is part of the monolithic structure. The filling-in of the structure is done with concrete as well and contributes to the stability of the whole. In image 1 you can see that the roof is cladded with monk and nun tiles. We assume that these are fixed with mortar on the concrete roof, but we are not sure about this. With regard to the drainage it's probably not necessary to have tiles on the roof. It could be done for aesthetic reasons, since the roofscape plays an important role in a 'sloping city' as Lisbon.



Images

1. Eaves silo (photo by Noëlle Dooper, 01-09-2016)
2. Top floor (photo by Daan Masmeyer, 06-09-2016)
3. Monk and nun tiles (image from <http://www.kroonkeramiek.nl/en/rooftiles/monk-nun>)

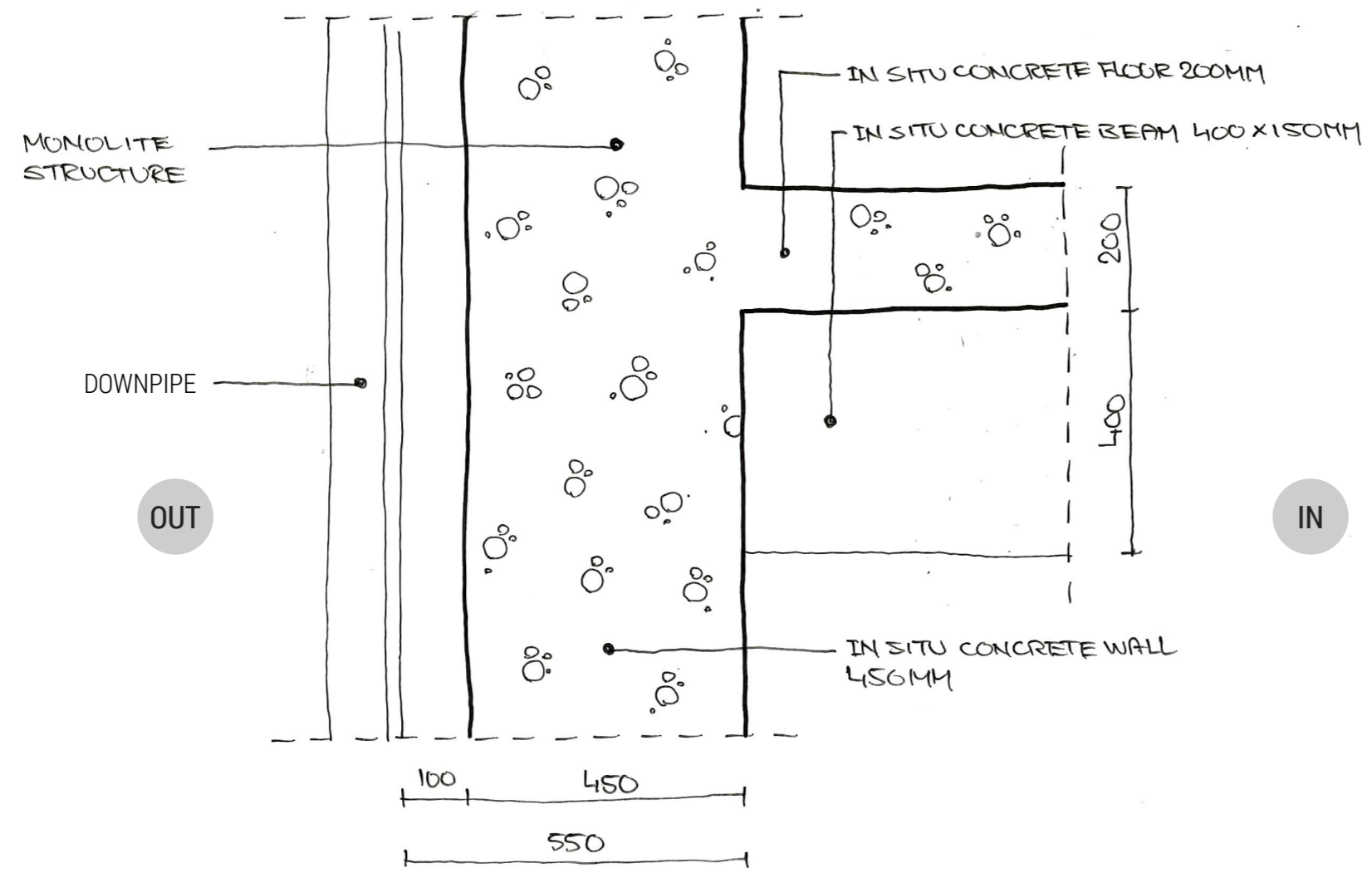

LEGEND

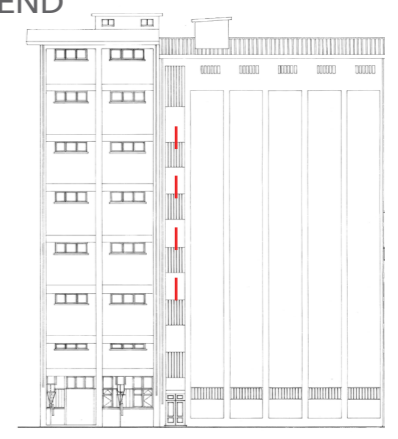

DETAILS

This is a vertical detail of the connection of a floor to the facade at the location of the stairwell: it's monolithic. The exterior concrete wall has a thickness of 45cm, which is also the case with the exterior walls of the silos. The walls that divide the different silos have a thickness of approximately 25cm.



Images
 1. Fourth floor (photo by Daan Masmeyer, 06-09-2016)

BUILDING 19 - SILO

1970s

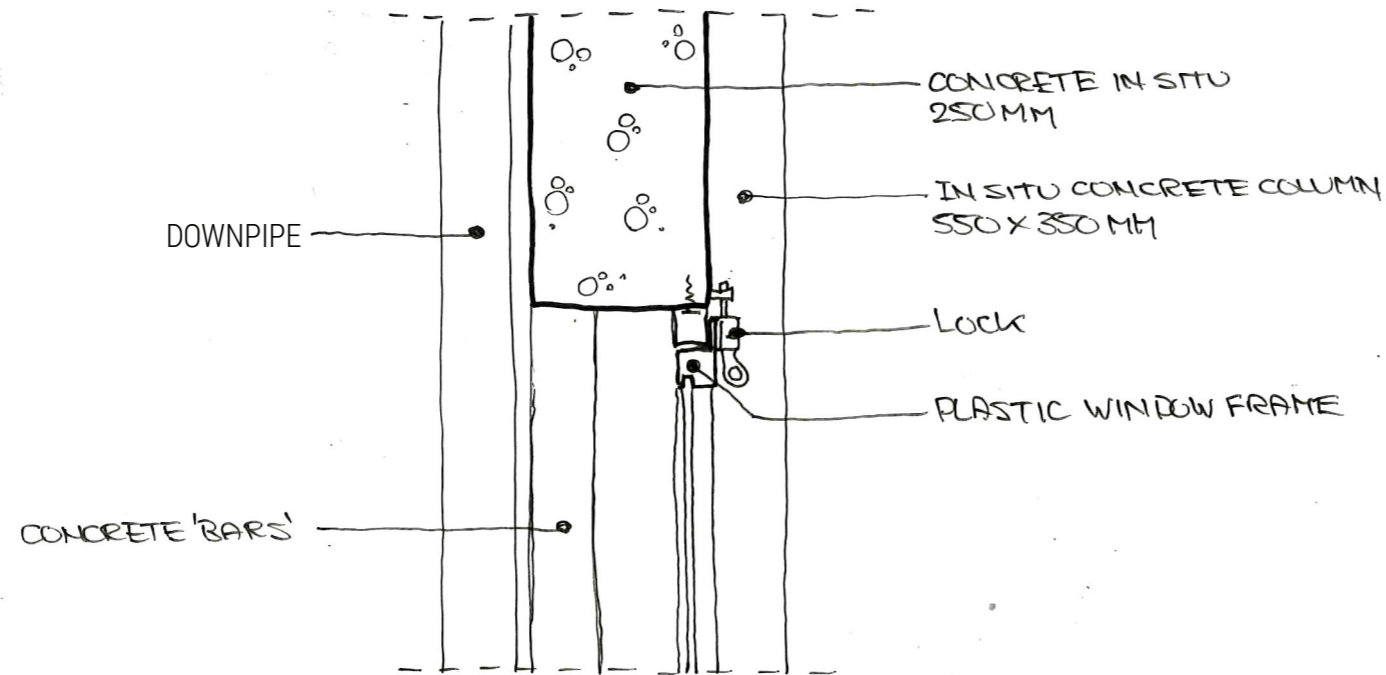

OUT

IN

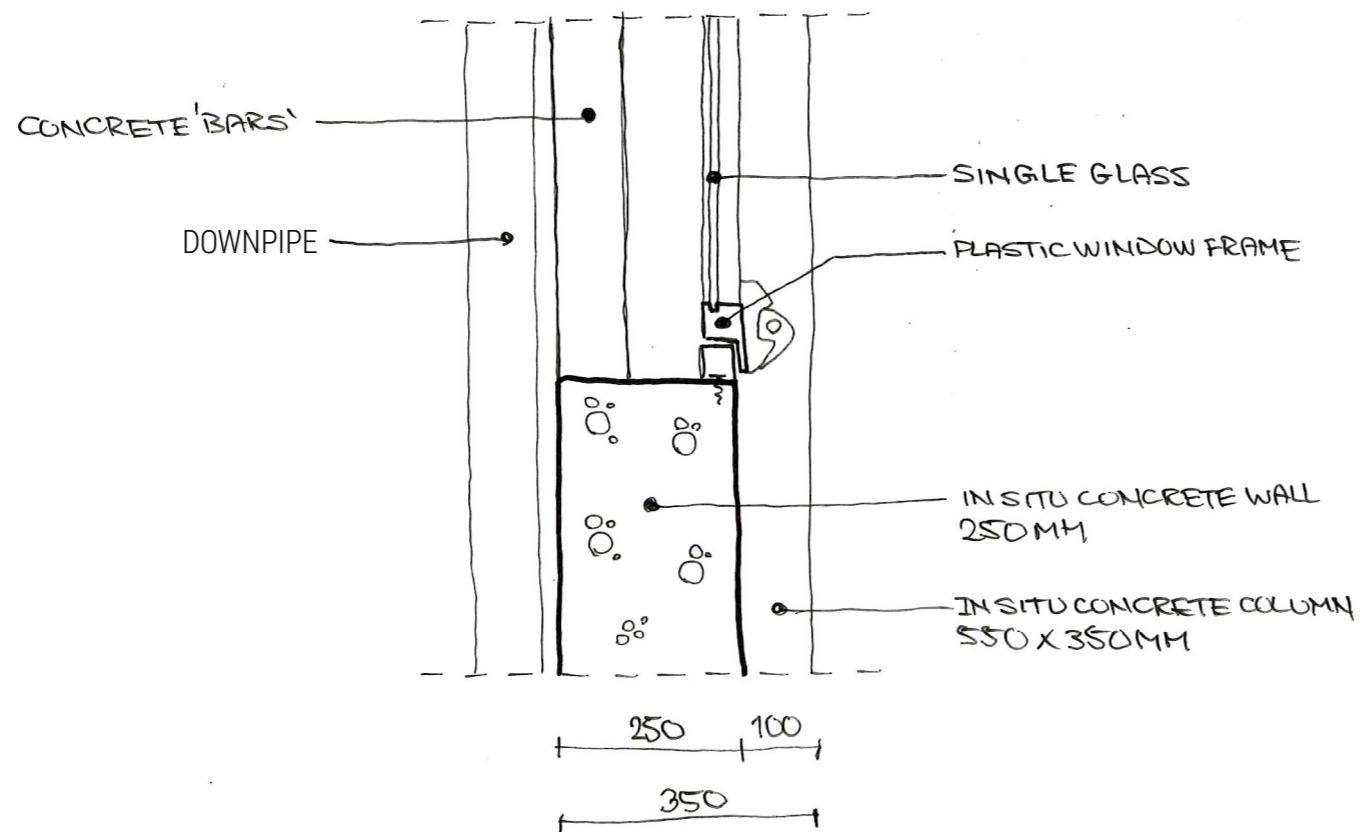

LEGEND

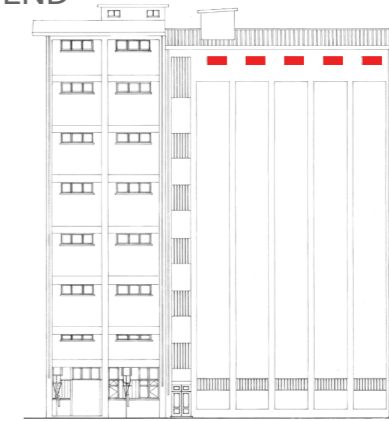

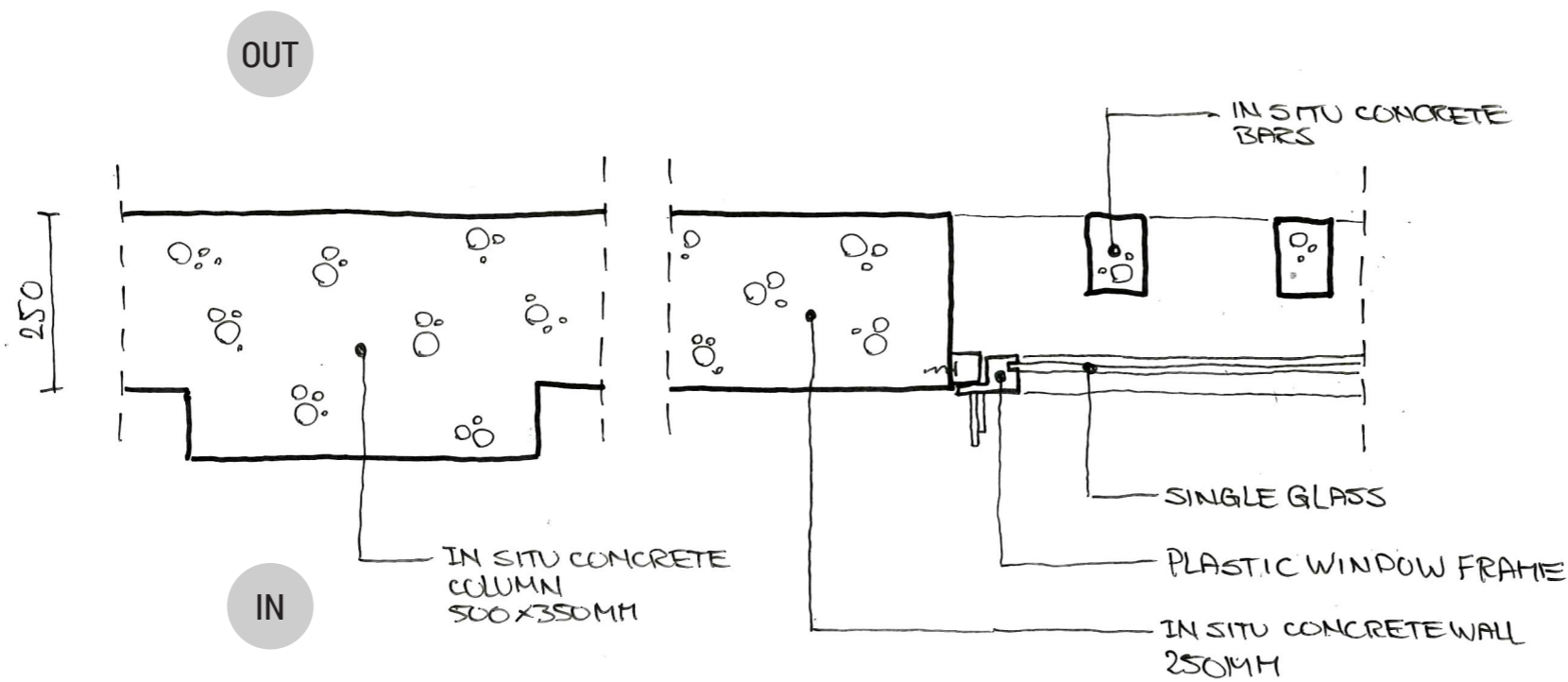
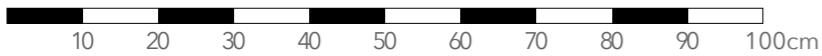

LEGEND

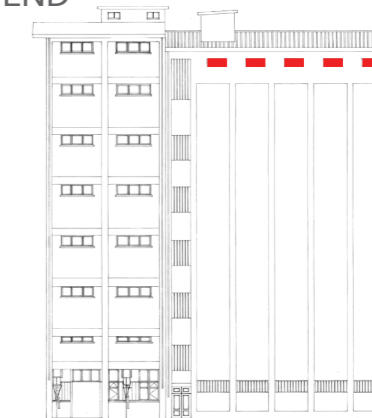

DETAILS

This are the horizontal and vertical details of the windows of the top floor of the silo. The window frames are made out of plastic and probably connected to the concrete facade with screws. This facade is thinner compared to those of the silos and stairwell: less lateral forces are the reason for this. Also the columns have smaller dimensions. As can be seen in image 1 and 2 there are concrete 'bars' in front of the windows. The reason why they are here is not clear. Since the building is built quite recently, in the 1970s (p. 30), we think that everything is original, including the windows.

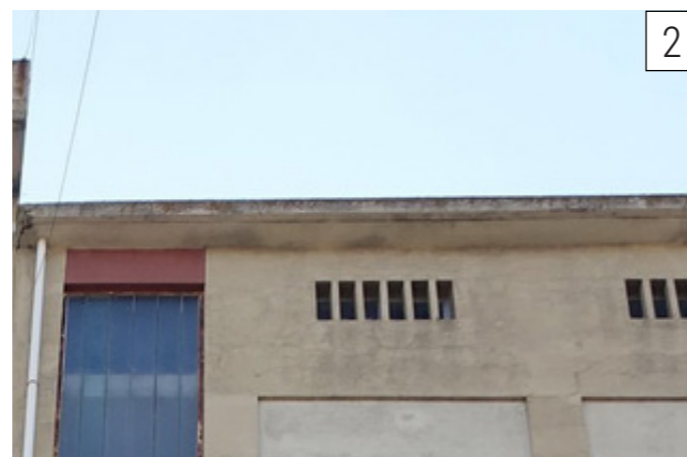

Images
 1. Top floor window (photo by Daan Masmeijer, 06-09-2016)
 2. Top floor window (photo by Hielkje Zijlstra, 04-09-2016)
 3. Top floor (photo by Daan Masmeijer, 06-09-2016)



In the 1980s a warehouse has been added to the ensemble.¹ Because of independence of the former colonies in 1975, MMC had to reduce the production: the products were not shipped directly anymore, but stored and spread inland.

Text
1. Texts exhibited at Manutenção Militar Complex by Lisbon Municipality

Images
1. Warehouse (photo by Hielkje Zijlstra, 04-09-2016)

BUILDING 20 - STORAGE

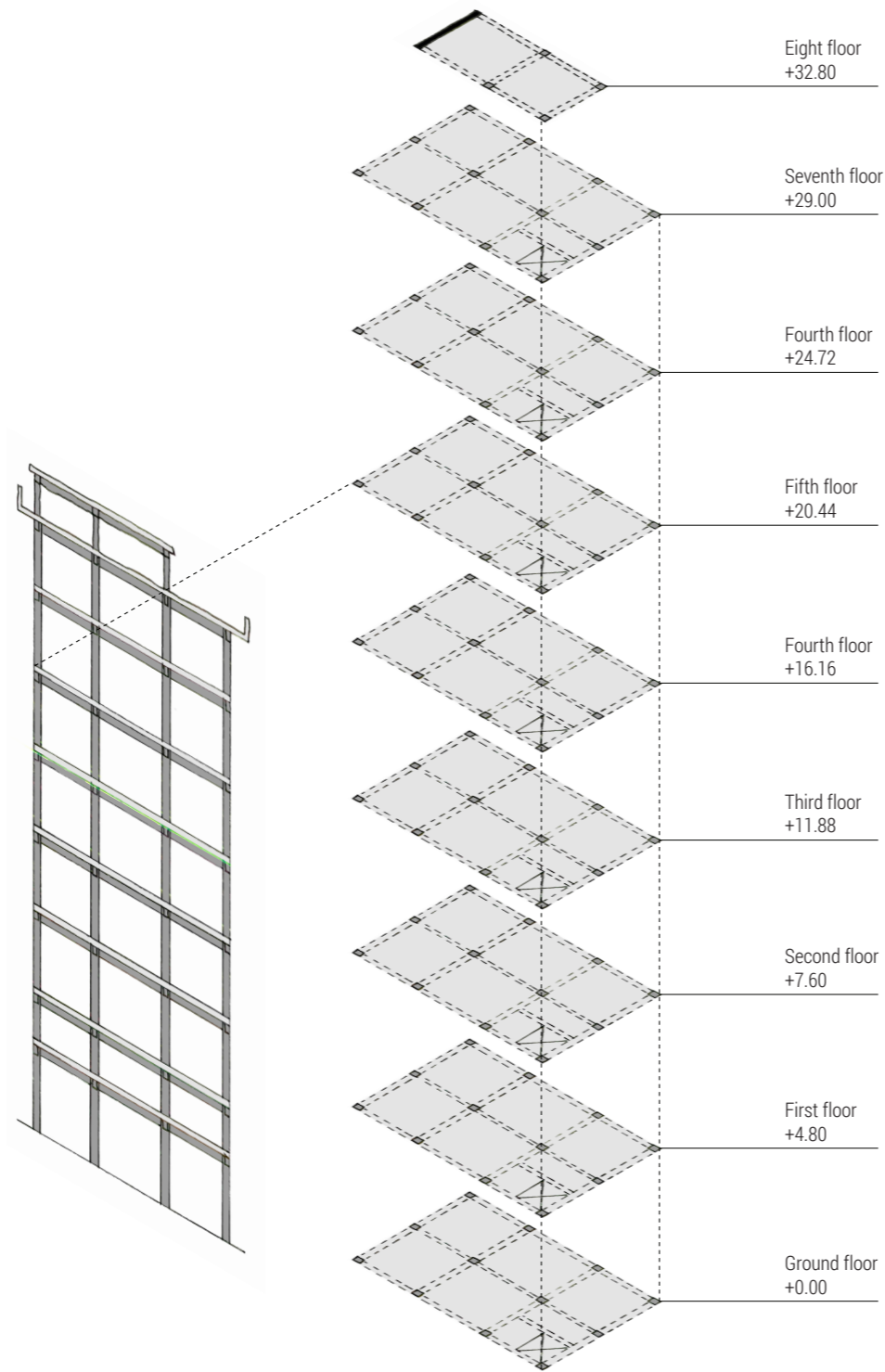
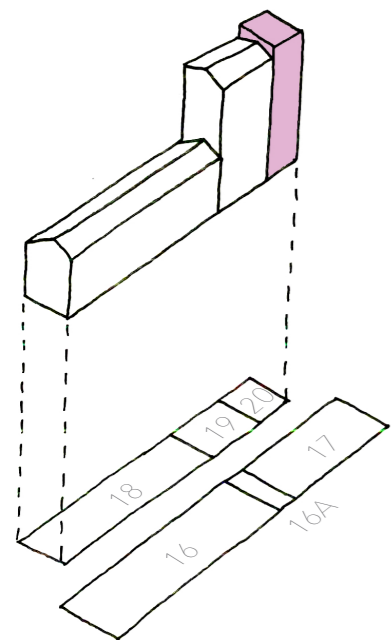

EXPLODED VIEW FLOOR PLANS

LEGEND

- Load-bearing facade
- Load-bearing interior wall
- Floor concrete
- Floor wood (incl. beams)
- Floor brick vaults
- Column / beam concrete
- Column cast iron
- Steel truss
- Wooden truss

CONSTRUCTION MATERIALS*

Like building 16, 16A and 19, the structure consists completely of concrete (image 1-3). Since this is a monolithic structure, the stability of the building is ensured as well.

Overview materials (monolithic structure)

- Concrete facade
- Concrete columns
- Concrete beams
- Concrete floor
- Concrete roof

* The construction elements which are drawn in the floor plan relates to the floor/roof above it.



CONSTRUCTION MATERIALS

The adjacent pictures give an impression of the monolithic concrete structure of the storage.

Images

1. Detail concrete structure (photo by Daan Masmeijer, 06-09-2016)
2. Monolithic concrete structure (photo by Daan Masmeijer, 06-09-2016)
3. Overview concrete structure (photo by Daan Masmeijer, 06-09-2016)

BUILDING 20 - STORAGE

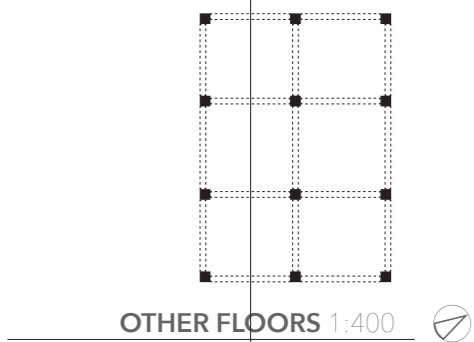

SECTION A-A 1:400

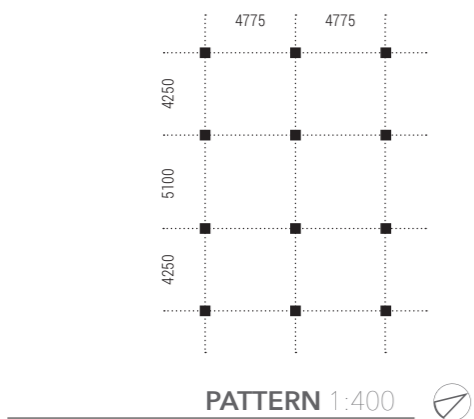
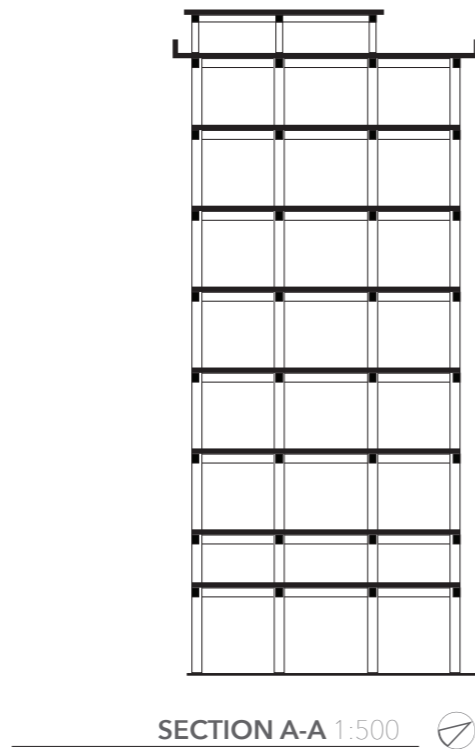

STRUCTURAL SCHEME AND DIMENSIONS

The construction of the storage is very simple. The two columns in the centre of the building are 600x600mm, while the columns in the facade are 500x500mm. This is probably done because more weight rested on the centre columns when the storage was in use. All the beams have the same dimensions: 450x300mm. The first floor stands out regarding the height: while the other floors have a height of around 4m, the first floor has a height of less than 3m. The floor height is probably adjusted to the stairwell of the silo, since the storage has been added in a later stage (p. 25-33).

BUILDING 20 - STORAGE

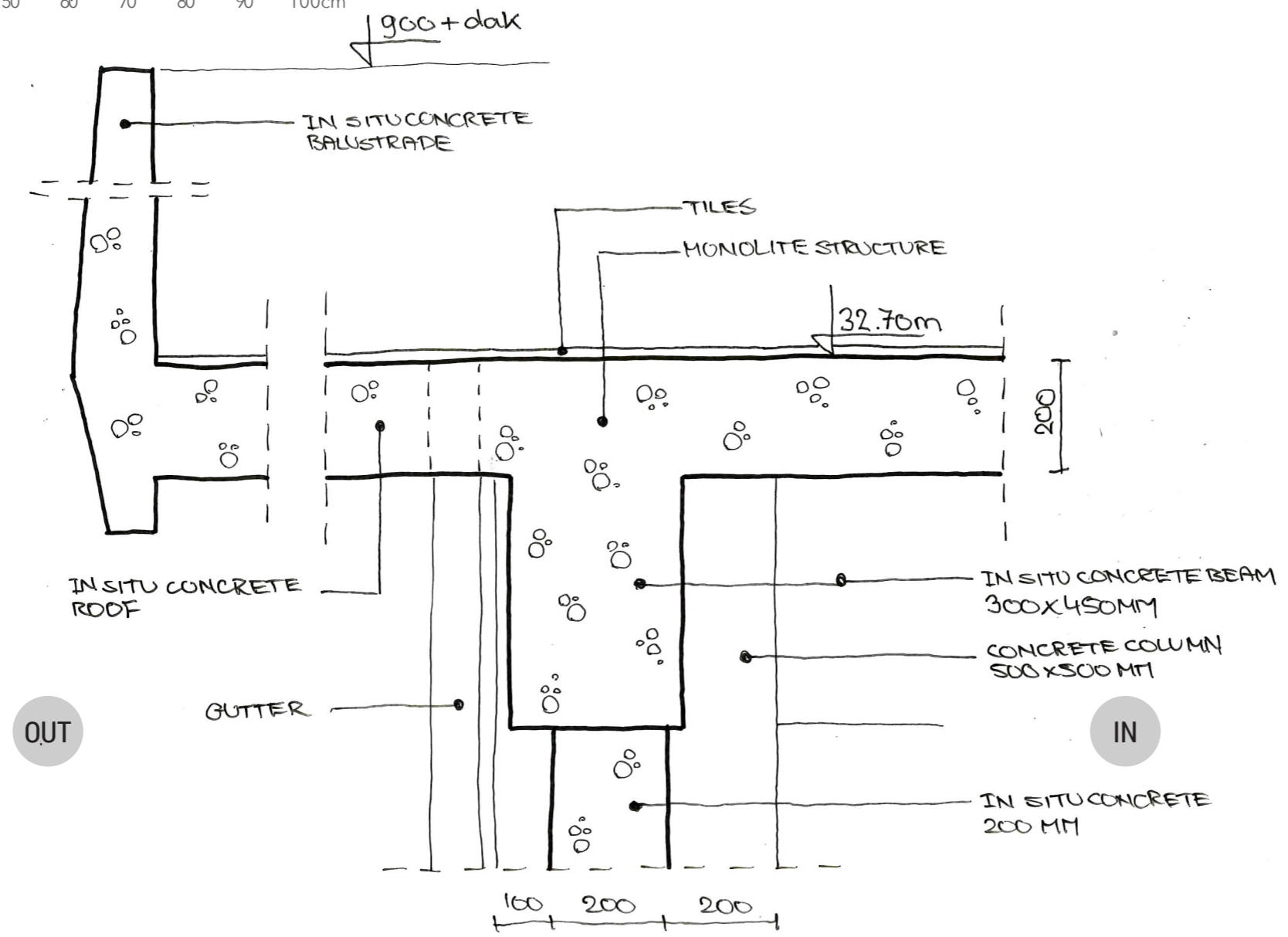

LEGEND

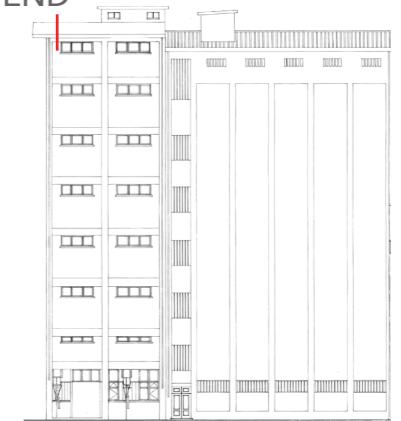

DETAILS

This is the detail of the 'eaves' of the storage. There is a balustrade because the roof, which is clad with tiles (image 3), is accessible. As already mentioned, the construction is made entirely of concrete. Also the balustrade is part of the monolithic structure. The filling-in of the structure, which is visible from the outside, is done with concrete as well and has a thickness of around 20cm. The filling-in can be done with in situ concrete, but also with stone/concrete blocks. We think that in both cases it is possible to remove the filling-in without losing stability, because the columns have such dimensions that no problems are expected (p. 107).



Images
 1. Exterior silo (photo by Hielkje Zijlstra, 04-09-2016)
 2. Exterior silo (photo by Hielkje Zijlstra, 04-09-2016)
 3. Roofsilo (Screenshot video by Noëlle Dooper, 06-09-2016)

BUILDING 20 - STORAGE

<2016

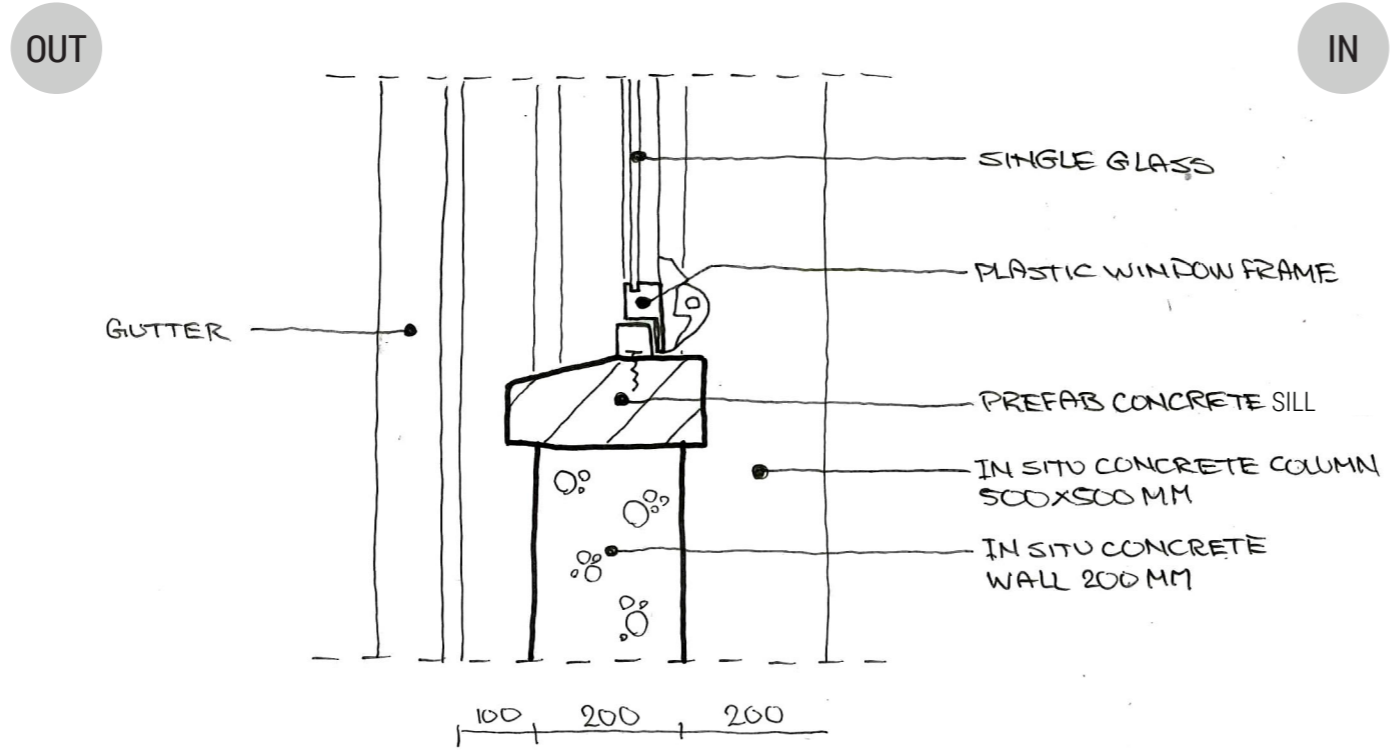
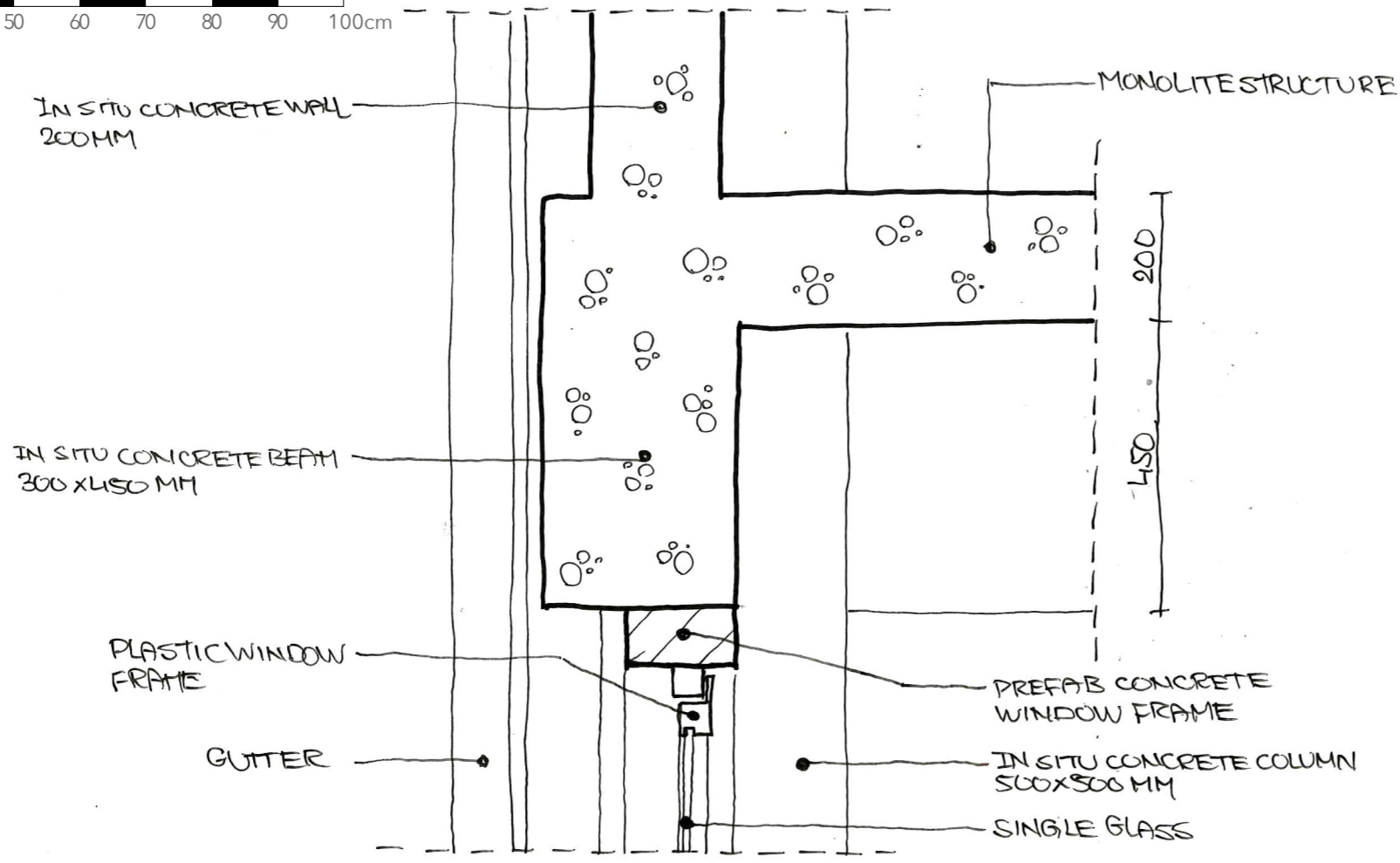

LEGEND

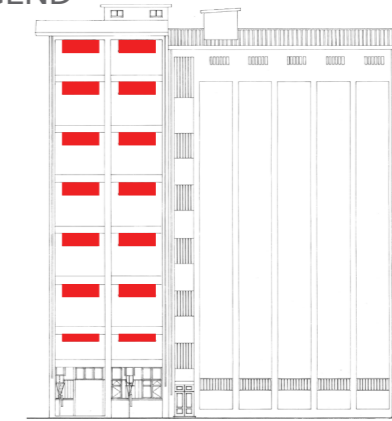

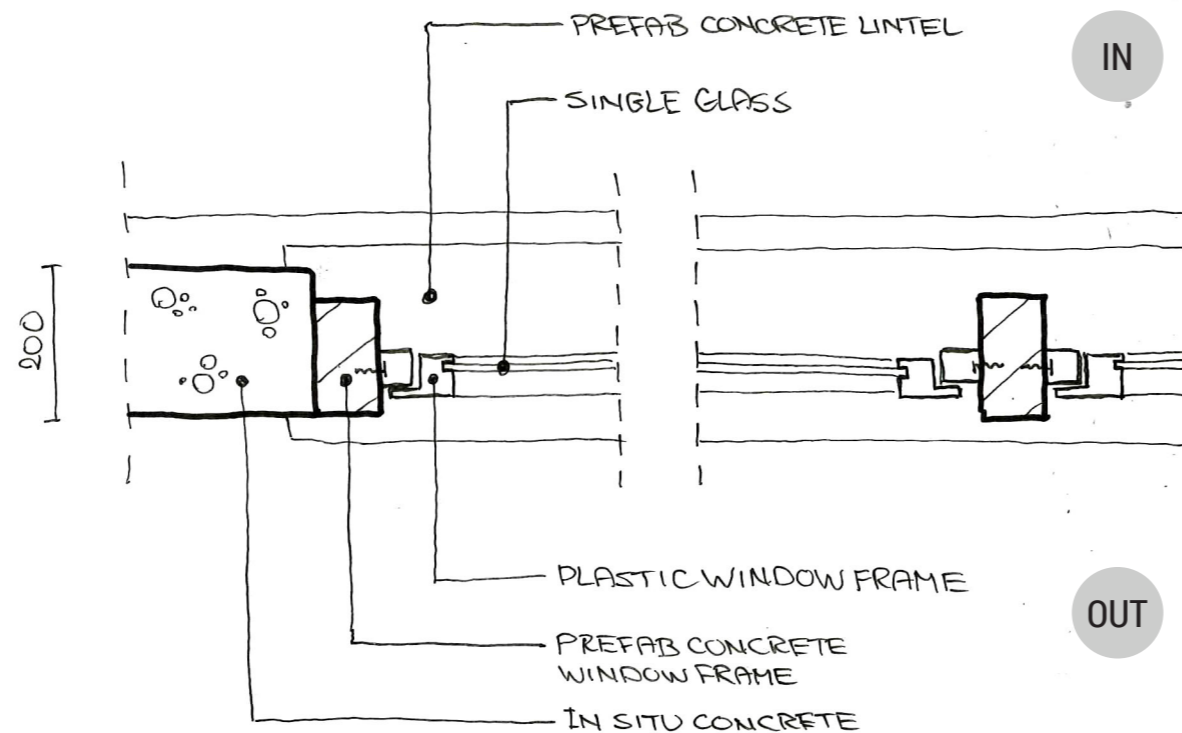
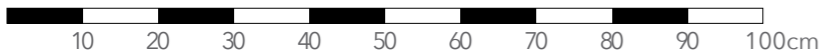

LEGEND

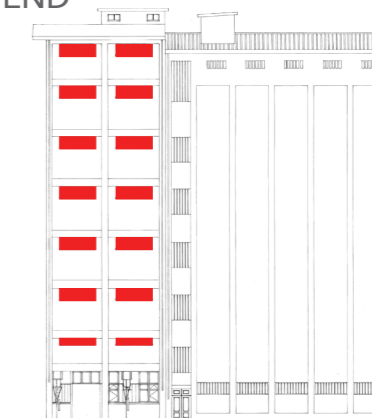

DETAILS

This are the horizontal and vertical details of the windows of the storage. The window frames are made out of plastic and connected to the concrete frame with screws. The connection between the concrete and plastic frame is not always sufficient causing condensation on the inside (p. 124). This prefab concrete frame, including the bottom sill, is probably used as a formwork: this ensured the easy placing of the standard plastic window frames. Since the building is built quite recently, in the 1980s (p. 31), we think that everything is original, including the window frames.



Images
 1. Windowsilo (photo by Daan Masmeijer, 06-09-2016)
 2. Exterior silo (photo by Hielkje Zijlstra, 04-09-2016)

CONCLUSION

As concluded on page 33, the modernization of the production process played a significant role in how the buildings became as they are right now. We divided the development of the ensemble in six stages (p. 25-33). These stages can be recognized by the different construction typologies and materials. In this chapter an overview will be given of the technical characteristics of each stage. The first stage (1896) is excluded since no building of our ensemble was built yet. By doing so, an answer is given to the research question: how did the buildings become as they are right now and what are the technical characteristics of this development?

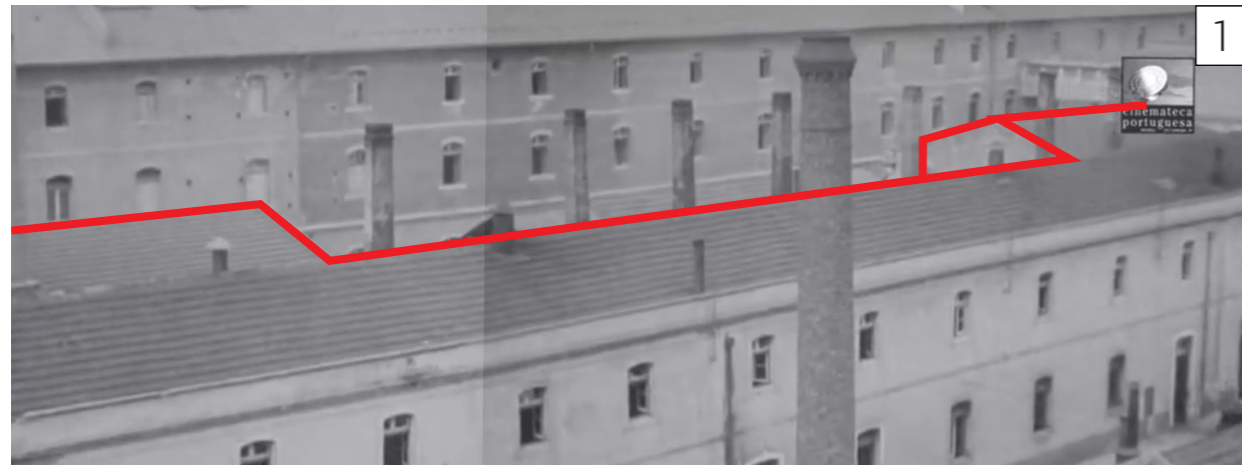

Original volume of the bakery

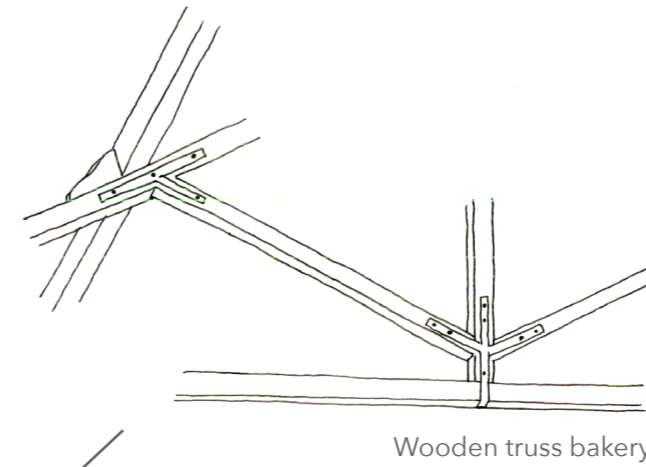

Wooden truss bakery

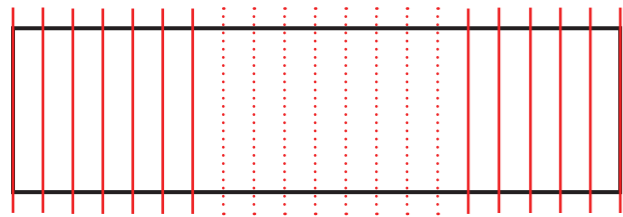
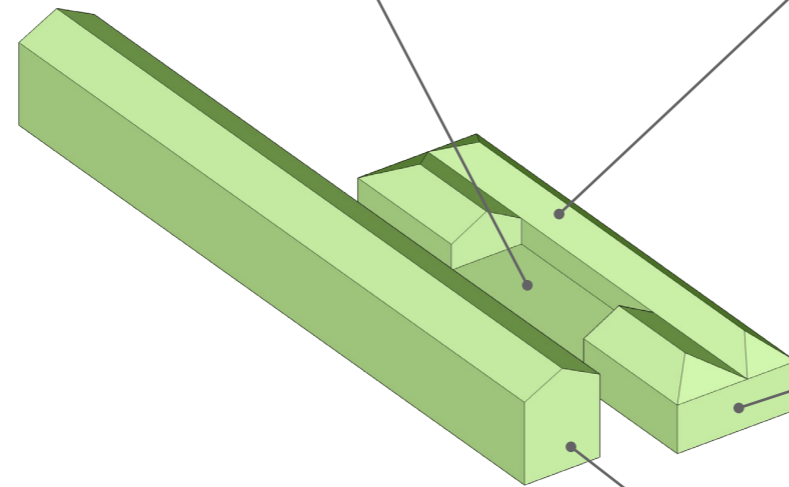

Original pattern cast iron columns bakery

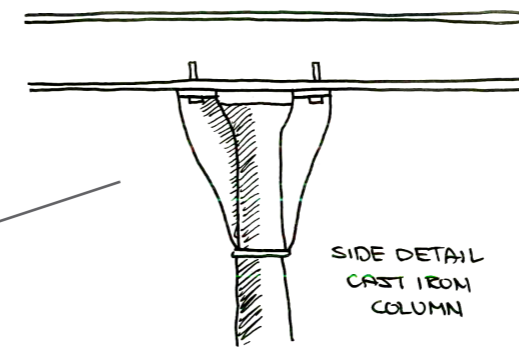

Cast iron column bakery

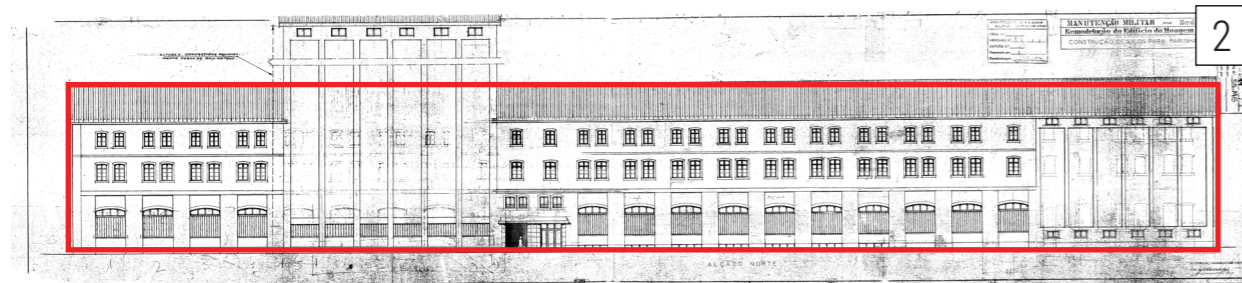

Original volume milling

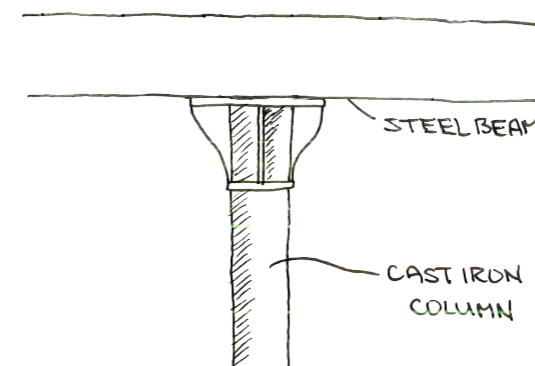

Cast iron column milling

The second stage, built before 1911, consists of the bakery and the milling. The bakery is a volume with two roofs, in which a clear exception is visible: the middle part of the left roof is flat and lower (image 1). The construction of the bakery on the ground floor consisted completely of cast iron columns and beams, since the pattern of the existing cast iron columns fits exactly in the building. The trusses are made out of wood.

The milling is one elongated volume, as can be seen in a drawing that was made for its extension with a silo (image 2). The construction consists of massive load-bearing façades, wooden floors, brick vaults and cast iron columns. The roof is constructed with Polonceau-trusses (p. 76).

The detailing of the columns in the bakery and milling is comparable.

- Images
1. Original volume bakery (screenshot video of 1927 from www.cinamateca.pt, own editing)
 2. Drawing 'Remodeling of the mill building' (provided by Docomomo)

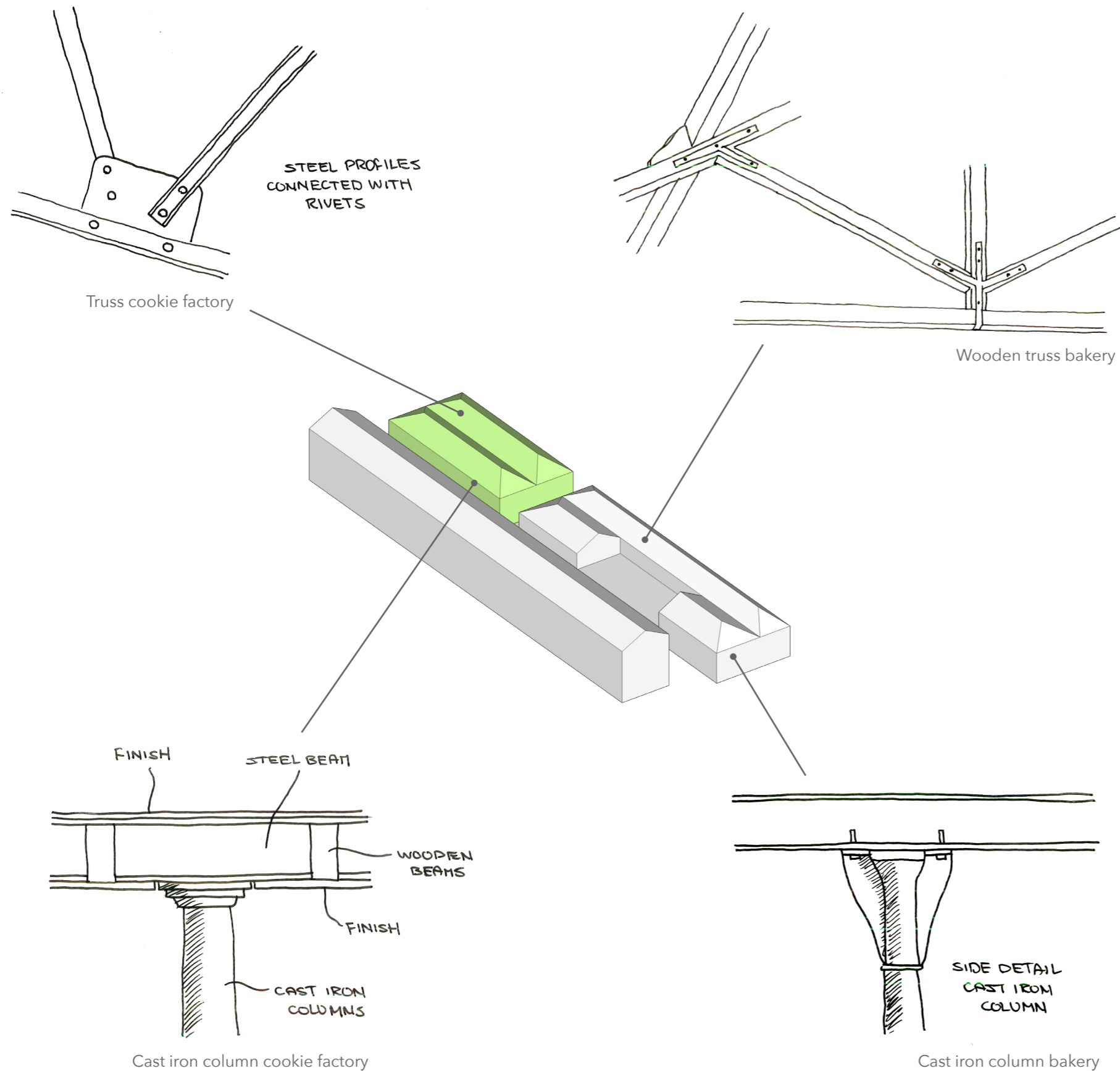

Between 1920 and 1930 the cookie factory has been added to the ensemble. The structural scheme of it is quite similar to that of the bakery: a volume with a double roof and cast iron columns on the ground floor. Though, differences become visible when we take into account the detailing of some elements. For example, the top of the cast iron columns in the cookie factory is less ornamented than the ones in the bakery. We think that because of technical development the columns became more sober. The second example is the roof construction of the buildings. In the cookie factory they made use of steel profiles that are connected with rivets, while in the bakery the trusses are made of wood. The trusses in the cookie factory are called English trusses (p. 68).

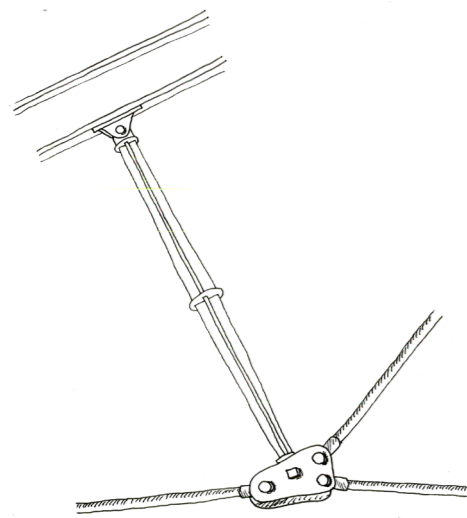

Steel truss bakery

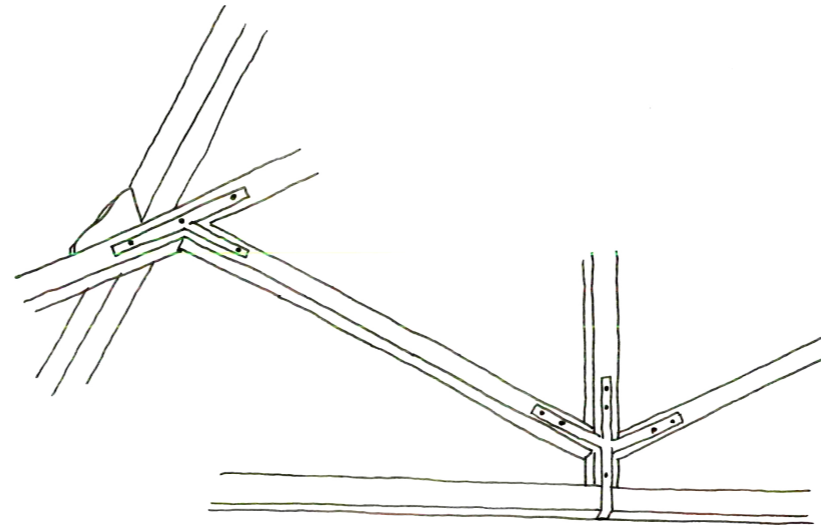

Wooden truss bakery

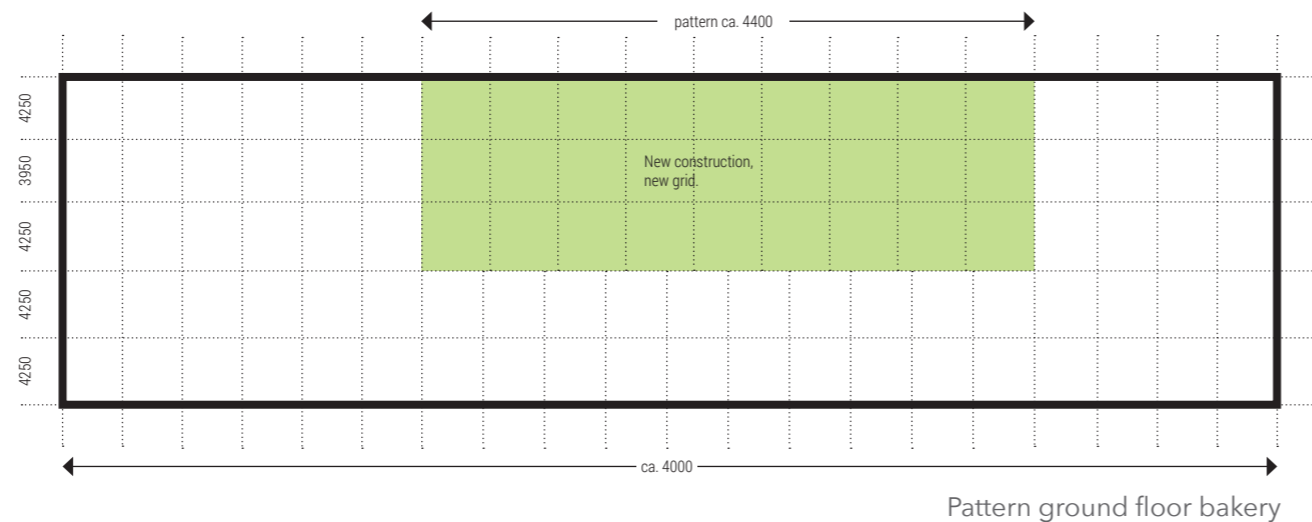
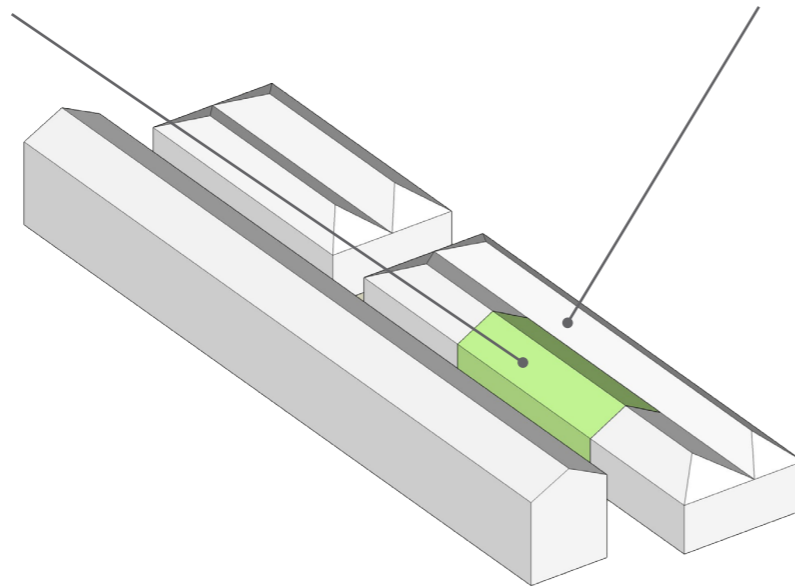

In 1955 part of the bakery has been changed because of the modernization of the production process. Therefore the cast iron columns have been replaced by a monolithic concrete structure and also a floor has been added that 'completes' the volume. Except from a different construction material, concrete instead of cast iron, a different pattern is used. The difference also becomes clear in the roof construction. The trusses, called Polonceau-trusses, are made out of steel elements that are connected with cast iron fittings and screw bolts. These bolts were widely used in the 19th century: despite the fact that the trusses are placed around 1955, we think that they are older than the ones in the cookie factory. An explanation could be that the trusses in this part of the bakery are re-used from a building on the complex that had been demolished.



Pattern of the silo is tuned to the opening in the facade of the adjacent buildings

Eaves detail silo

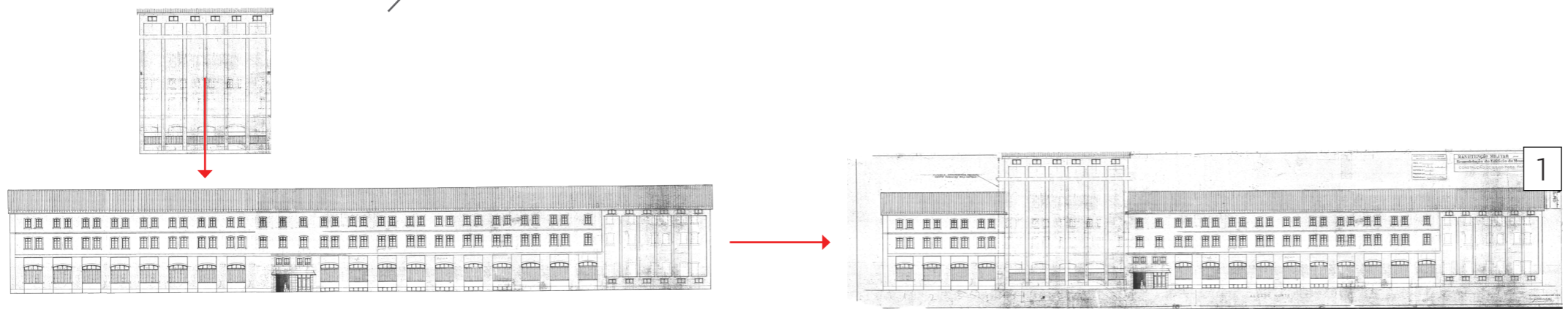
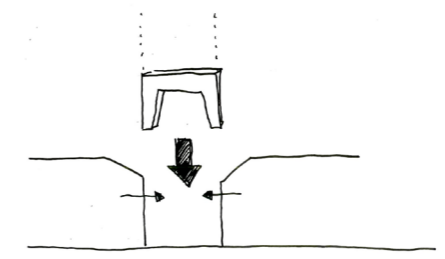
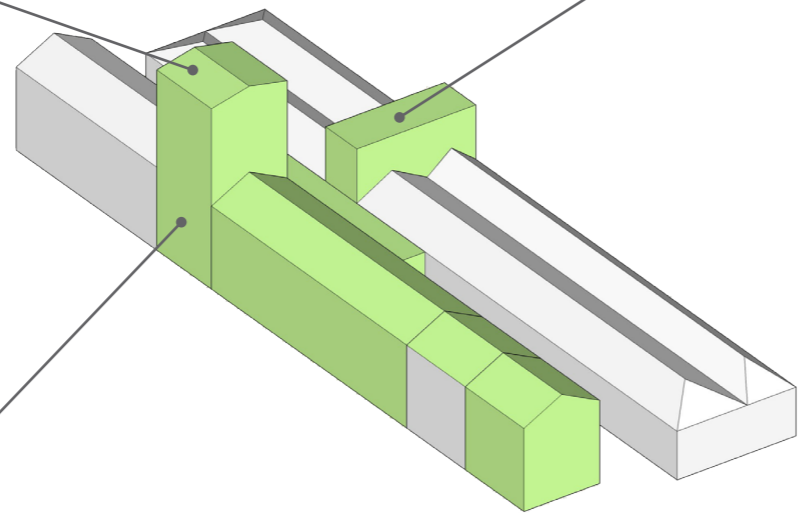

The silos (building 16A and 19) and storage (building 16B) are part of a radical development at the beginning of the 1970s: the MMC reached its maximum level of production. These building components are added later to the ensemble, as becomes evident in several things. First, the big silo (building 19), completely made out of concrete, has replaced part of the original building. The profiled glass that is used in this building is a typical material of the 1970s. Also building 16A and 16B are entirely constructed of concrete. Secondly, as explained on page 55, the pattern of building 16A is tuned to the existing openings in the facade of the bakery and cookie factory.

Images
1. Drawing 'Remodeling of the mill building' (provided by Docomomo, own editing)

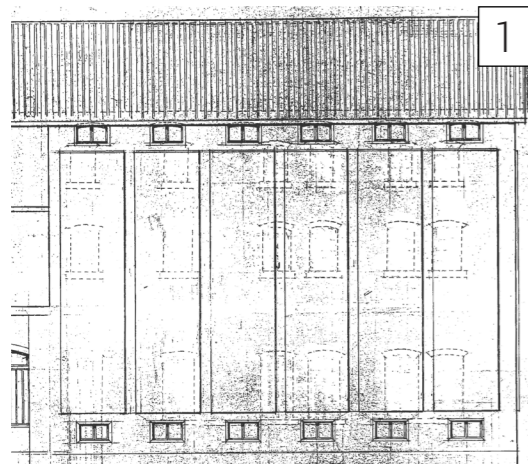

Dotted lines show position former windows

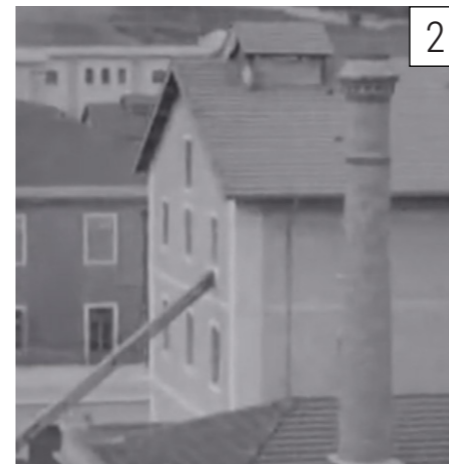

Windows front facade mill building

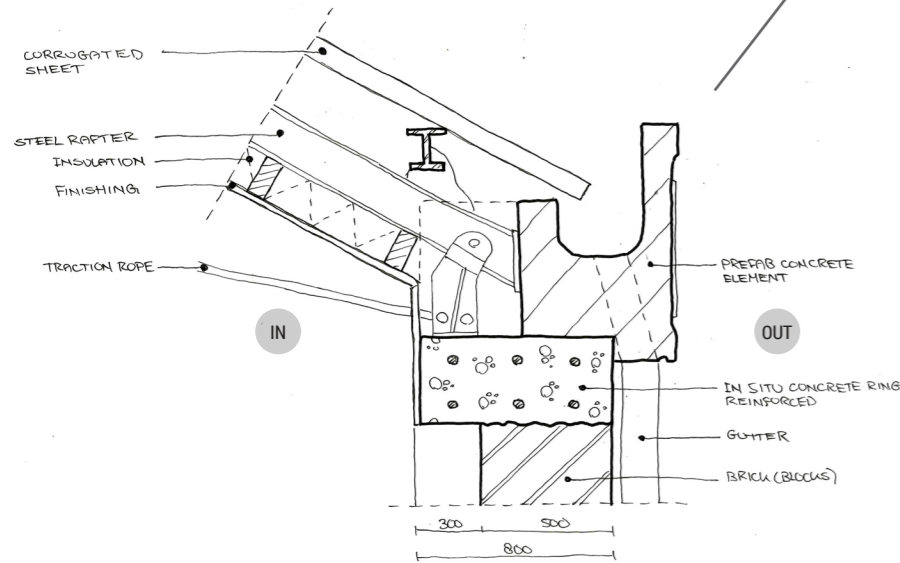
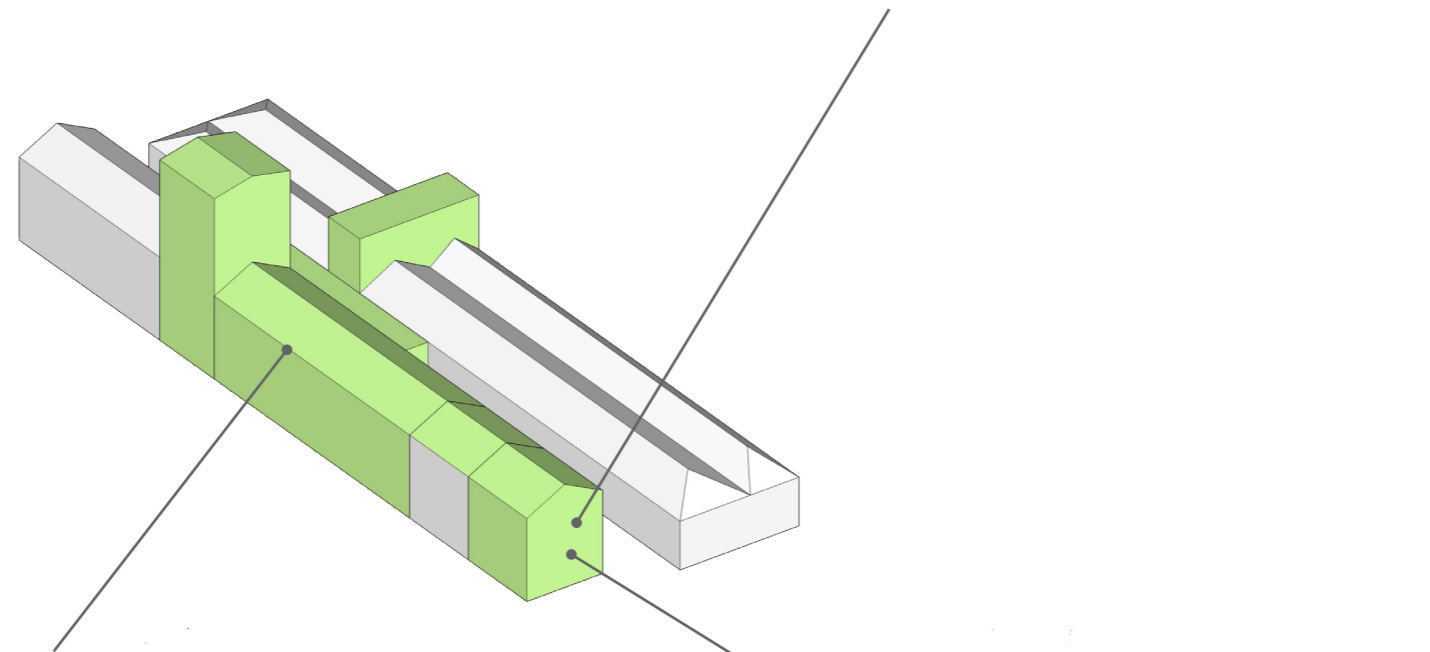

New concrete ring on top of the original load-bearing facade

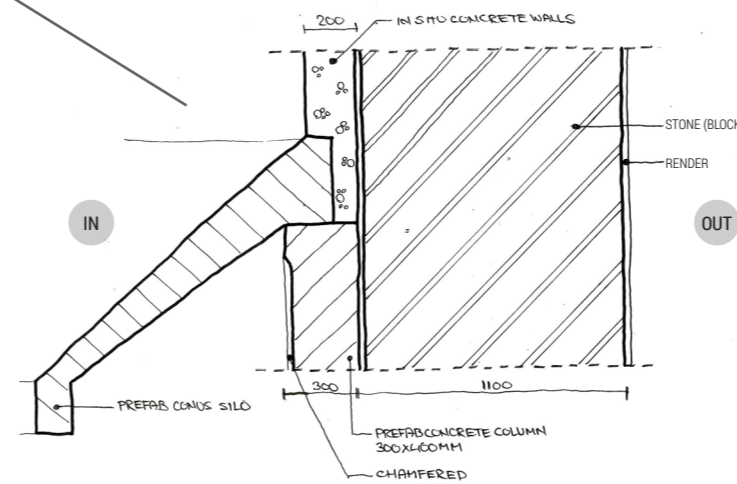

Concrete structure within load-bearing facade

In the 1970s almost the entire roof of the original milling had to be removed because of the implementation of new machinery, a concrete structure and new silos in the first part of the milling. A concrete ring is mounted on top of the original load-bearing facade to hand over the forces and to increase the stability of the building. This latter was necessary because of the vibrations of the new machinery. The original Polonceau trusses have been re-used. The windows that used to be in the in the facade of the current silos (image 2) are not there anymore. The dotted windows in the drawing named 'remodelling of the mill building' (image 1) also indicates the position of former windows. For that reason we assume that the silo have been built within the original load-bearing facade.

- Images
 1. Detail drawing 'Remodeling of the mill building' (provided by Docomomo)
 2. Front facade milling (screenshot video of 1927 from www.cinamateca.pt)

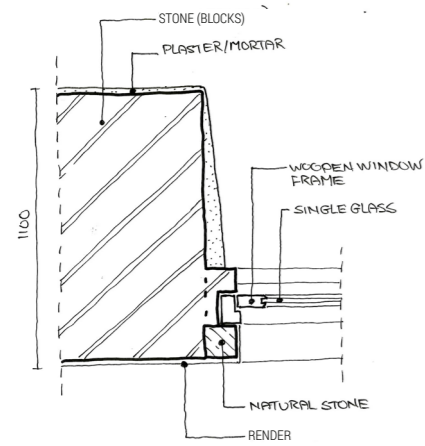

Ground floor milling outside glazing

IN

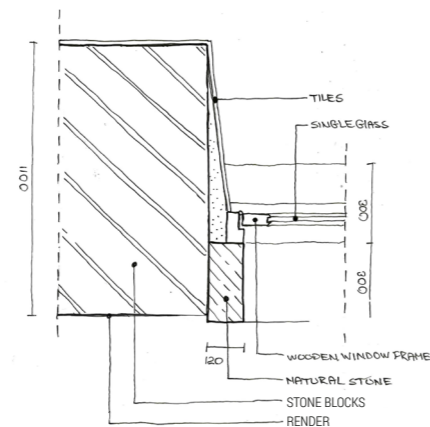

1st and 2nd floor milling inside glazing

OUT

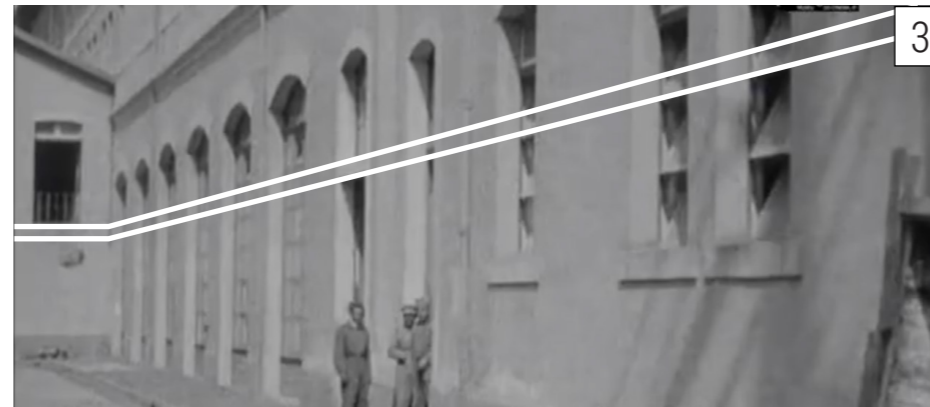

3



Profiled glass

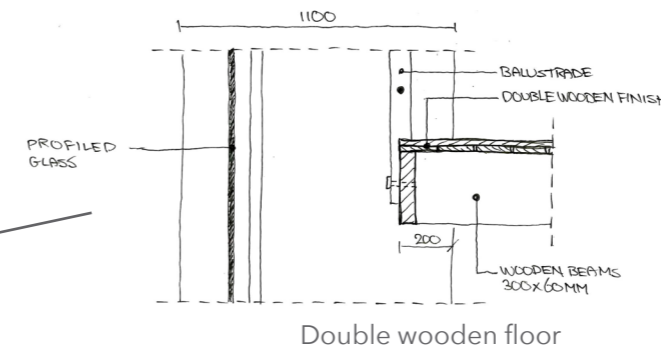
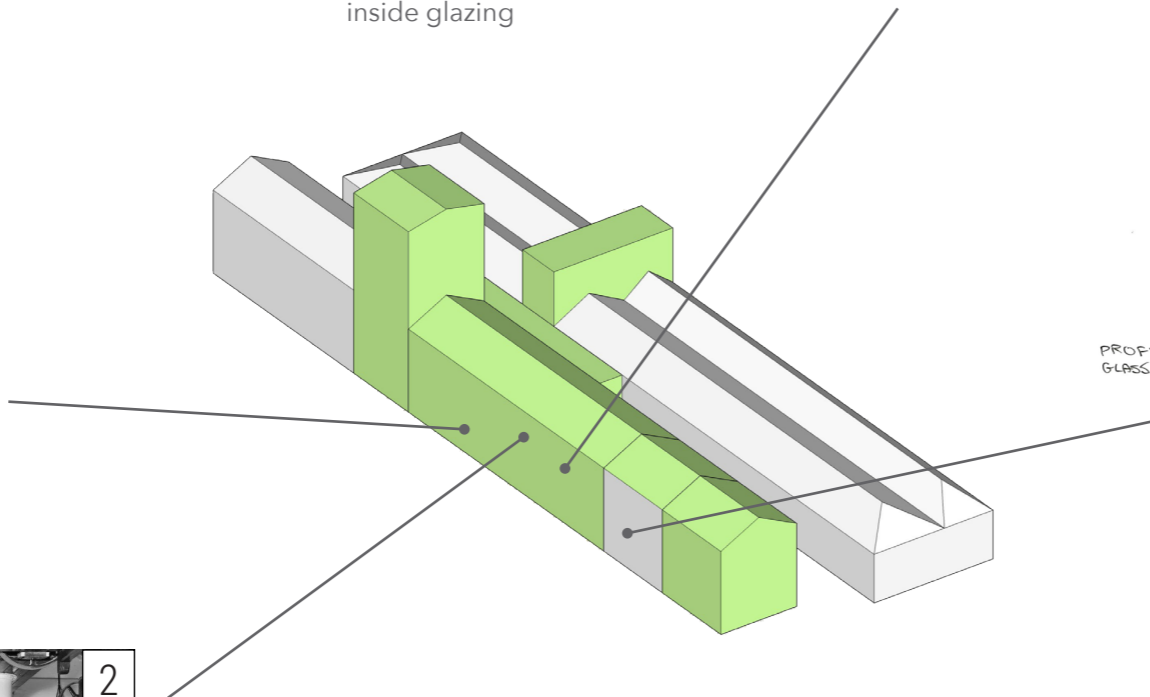

Former interior milling

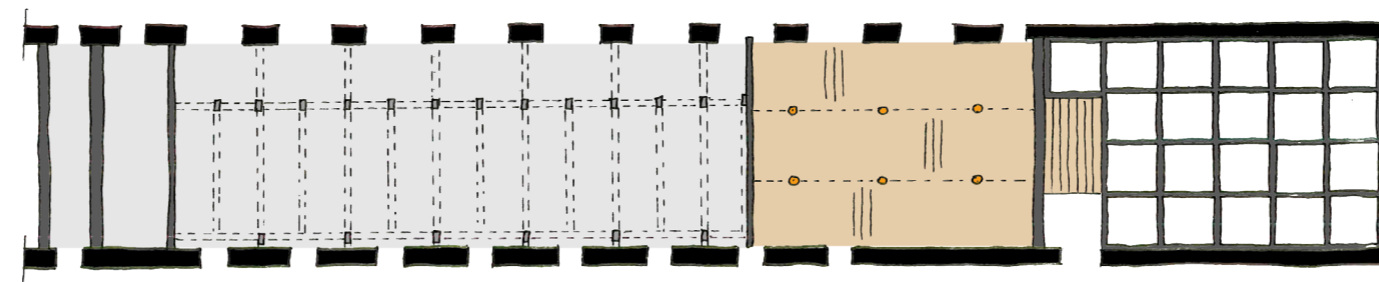

Different construction typologies milling

Another radical change at the beginning of 1970s was the implementation of a concrete structure within the massive load-bearing façades. This change was necessary because of the modernization of the production process. In the current situation the ground floor in this part of the building has a double height, because the new machinery asked for this. We think that originally there used to be an extra floor (image 3), which is still the case in part of the building (p. 81). In contrast to the windows on the upper floors, outside glazing is used on the ground floor: they could not place the big windows from the inside because of the originally 'extra' floor. On the ground floor, during the 1970's, they've changed the single glass for profiled glass (image 1). For this, they re-used the original wooden window frames, because it was impossible to remove the frame without demolishing part of the exterior wall. Another interesting fact is the double wooden floor in the almost original part of the milling. This is probably done because the machines that once stood there (image 2) left behind holes in the floor. They 'repaired' this by adding a new layer of wood.

Images

1. Profiled glass ground floor milling (photo by Hielkje Zijlstra, 04-09-2016)
2. First floor milling with 22 mills (photo 1930s, provided by Docomomo)
3. Facade ground floor milling (screenshot video of 1927 from www.cinematica.pt, own editing)

COOKIE FACTORY

LEGEND

- High value
- High value (in view)
- Average value
- Average value (in view)
- Low value
- Low value (in view)

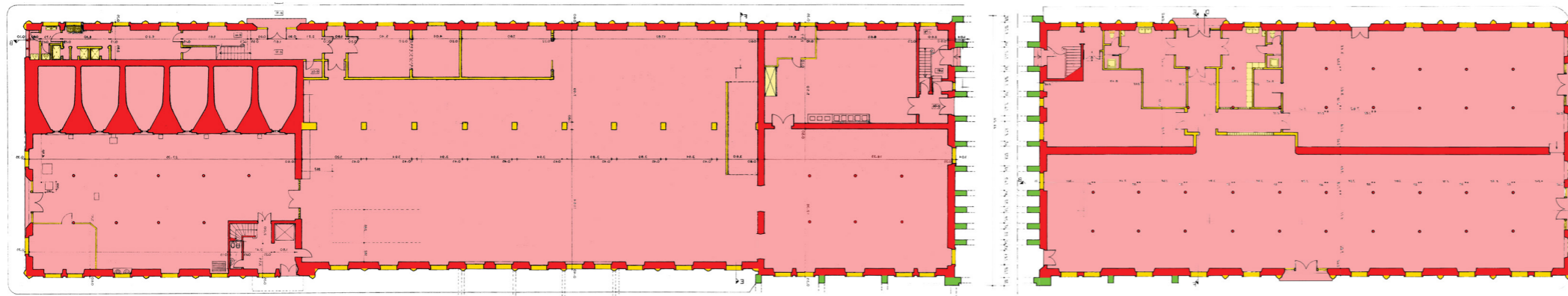
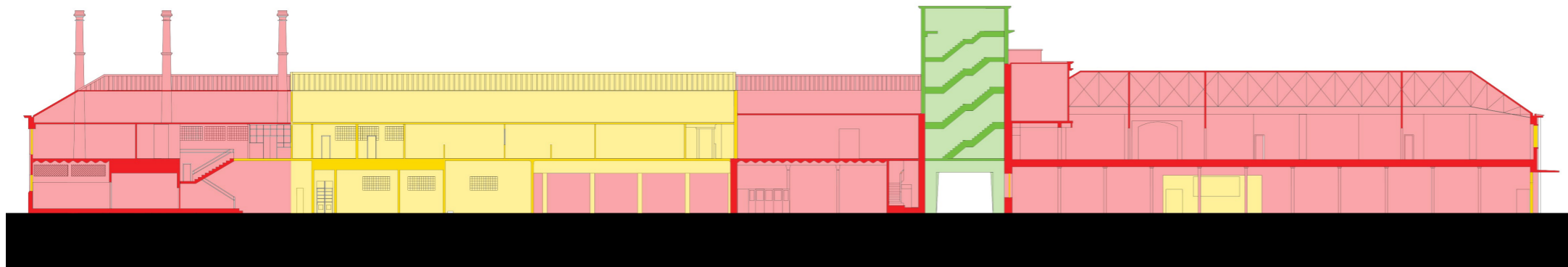

MILLING



LEGEND

- High value
- High value (in view)
- Average value
- Average value (in view)
- Low value
- Low value (in view)

These drawings are based on the drawings which Suzanne Fischer made for the former Unilever building in Rotterdam. They show the age value of the construction of both the bakery and milling. The values are based on the following criteria:

Bakery

- <1911 : high value
- 1920s ● 1955 : average value
- 1970s ● <2016 : low value

Milling

- <1911 : high value
- 1955 ● 1970s : average value
- <2016 : low value

It can be said that the cookie factory (building 17) is almost original and that a lot of time layers are visible in the milling (building 18). These conclusion drawings do not mean that the components with average value and low value can be simply removed, because we value the layering of the different construction typologies and materials high!

STATE OF CONSERVATION



The overall state of conservation of the ensemble is very good, which suggests that there was regular maintenance of the buildings while functioning for the army. The lack of maintenance of the last couple of years resulted in the first signs of damage caused by dirt, water and overall neglect.

The damages of the buildings which need attention when redeveloping the ensemble are divided into seven categories:

- Water damage
- Thermal bridges
- Asbestos
- Corrosion
- Scaling
- Lichens and algae
- Machines

Images

1. Street between bakery and milling (photo by Noëlle Dooper, 01-09-2016)

STATE OF CONSERVATION



Building 20: part of the water pipe is missing causing leakage.



Building 16B: this building part causes water damage around the drainage system.



Building 18: the eaves are in a bad condition due to water damage (relief).



Building 16: the bakery has some drainage issues, resulting in leakages which are causing local water damage.



Water damage

Most of the damages that are present in the ensemble are caused by water. This water damage is the consequence of leakages in the drainage system or because of the storage added in the 1970s (building 16B): the faulty connection of it with the older building components of the ensemble, like the milling and bakery, forces the water to penetrate into the interior of it. The water damage causes mould, lichens and scaling.

On the left some examples of the water damage on both the exterior (image 1-5) and interior (image 6-10) of the ensemble are shown. When redeveloping the buildings it is important to think about the drainage system, especially between the different building components.



Building 16 and 16A: drainage problems at the connections between the buildings resulting in water damage on the inside of building 16, 16A and building 17.



Building 18 and 19: water damage caused by leakages and badly detailed windows.



Images
1, 3, 4, 8. Photos by Hielkje Zijlstra, 04-09-2016
2, 5, 9, 10. Photos by Noëlle Dooper, 01-09-2016
6, 7. Photos by Alessandro Scalisi, 02-09-2016

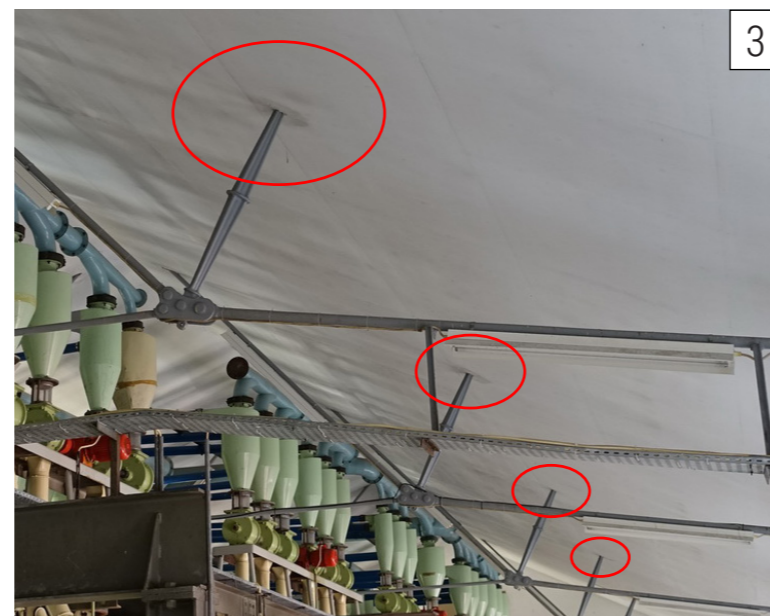

Thermal bridges

The milling (building 18) has some problems related to thermal bridges. As shown in the details, the walls of the milling are very thick (1100mm). This increases the risk of condensation near the window frames and the roof construction. Most of the wooden window frames are damaged (peeling of paint, rotting of wood, etc.) and the thermal bridges in the roofing show some condensation damages on the interior (image 3).

Images

1. Building 18: damaged wooden window frame (photo by Hielkje Zijlstra, 04-09-2016)
 2, 3. Building 18: the trusses of the milling goes through the insulation causing a thermal bridge resulting in condensation (photos by Hielkje Zijlstra, 04-09-2016)



Asbestos

The roofing of the milling is covered with asbestos corrugated sheets, causing a serious health hazard when not removed. There are still a lot of buildings with asbestos in Portugal, even though a law on the removal of asbestos was pronounced in 2011 and the European Commission kept pressuring.¹ Despite the fact that the government couldn't finance the removal yet, the municipality of Lisbon wants to have asbestos removed from 42 municipal buildings before 2017.² When redeveloping the MMC, all the asbestos that is present have to be removed to secure a healthy living environment.

Text

1. Portugal Press (2014). *Brussels cranks-up pressure on Portuguese government to act over asbestos*. Retrieved on 16 November from <http://portugalresident.com/brussels-cranks-up-pressure-on-portuguese-government-to-act-over-asbestos>

2. The Portugal News Online (2015). *Scores of Lisbon buildings cleared of asbestos by 2017*. Retrieved on 16 November from <http://theportugalnews.com/news/scores-of-lisbon-buildings-cleared-of-asbestos-by-2017/36614>

Images

1. Building 18: the roofing is covered with asbestos corrugated sheets (photo by Noëlle Dooper, 01-09-2016)



Corrosion

The ensemble show damages of corrosion, especially in the concrete building component of the 1980s (image 2) and the canopies of the cookie factory (image 1). The corrosion of the reinforcement is probably due to the thin concrete cover. Because the reinforced concrete is exposed to the weather, the majority of deterioration is caused by moisture. The issue is whether the existing material can be repaired or not. For this, the material must be investigated to determine their condition. Laboratory analysis of the concrete to be repaired is an important part of this investigation.¹ Since it is hardly impossible to do laboratory research during the graduation project, an assumption have to be made. Based on visual inspection we assume that the concrete structure of the storage (building 20) can be simply repaired. This does not apply to the canopies of the bakery, these are too badly damaged.

Text

1. Jester, T.C. (1995). *Twentieth-century building materials. History and conservation*. Washington: Archetype Press

Images

1. Building 17: corrosion of reinforcement of the thin concrete canopy (photo by Hielkje Zijlstra, 01-09-2016)
 2. Building 20: corrosion of reinforcement of the concrete (photo by Hielkje Zijlstra, 04-09-2016)

STATE OF CONSERVATION



Scaling

A lot of damages are visible in the plaster and paint of the buildings, sometimes due to water damage but also because of a lack of maintenance.

Lichen and algae

The façades of the ensemble show a lot of dirt and the formation of lichen and algae. The formations are not causing any harm right now, but the façades need to be cleaned to prevent future damage.

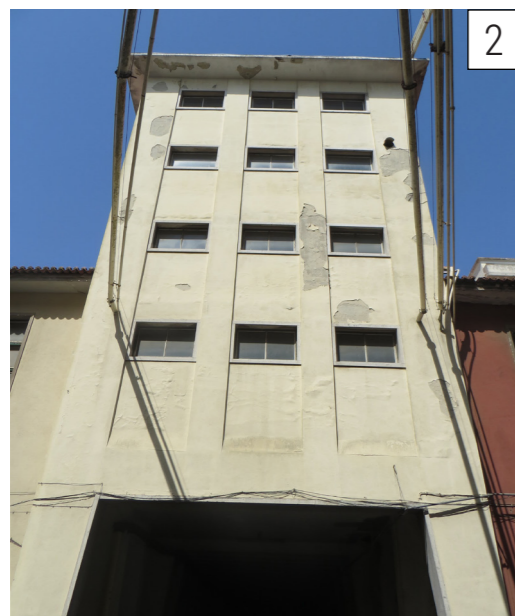

Images

1. Building 18: forming of lichen, algae and dirt (photo by Hielkje Zijlstra, 04-09-2016)
2. Building 16A: detachment of render (photo by Noëlle Dooper, 01-09-2016)
3. Building 19: detachment of plaster (photo by Noëlle Dooper, 01-09-2016)
4. Building 17: peeling of paint (photo by Noëlle Dooper, 01-09-2016)



Machinery

A lot of machinery is still present in the ensemble. The machines themselves are in a very good condition, but they are usually connected with each other through the flooring and/or outside walls. These connections are actually holes in the floor and exterior walls. When transforming the buildings, and probably removing the machines, it should thus be considered that a lot of holes will be left in the walls and flooring. These holes can cause future problems when not sealed.

Images

1. Building 16: hole in the floor for transporting the bread (photo by Hielkje Zijlstra, 01-09-2016)
2. Building 16: holes in the exterior wall for transporting bread (photo by Hielkje Zijlstra, 01-09-2016)
3. Building 20: hole in the floor (photo by Noëlle Dooper, 01-09-2016)
4. Building 18: holes in the floor (photo by Noëlle Dooper, 01-09-2016)

CLIMATE

Some of the problems that have been addressed in the previous chapter are the result of condensation. For that reason we wanted to take a closer look to the climate in the buildings of our ensemble, especially that of the milling.

CLIMATE

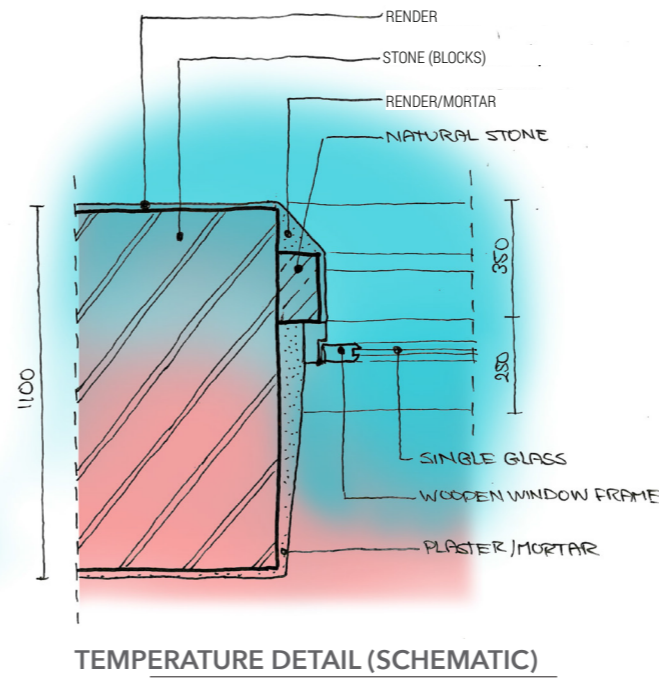
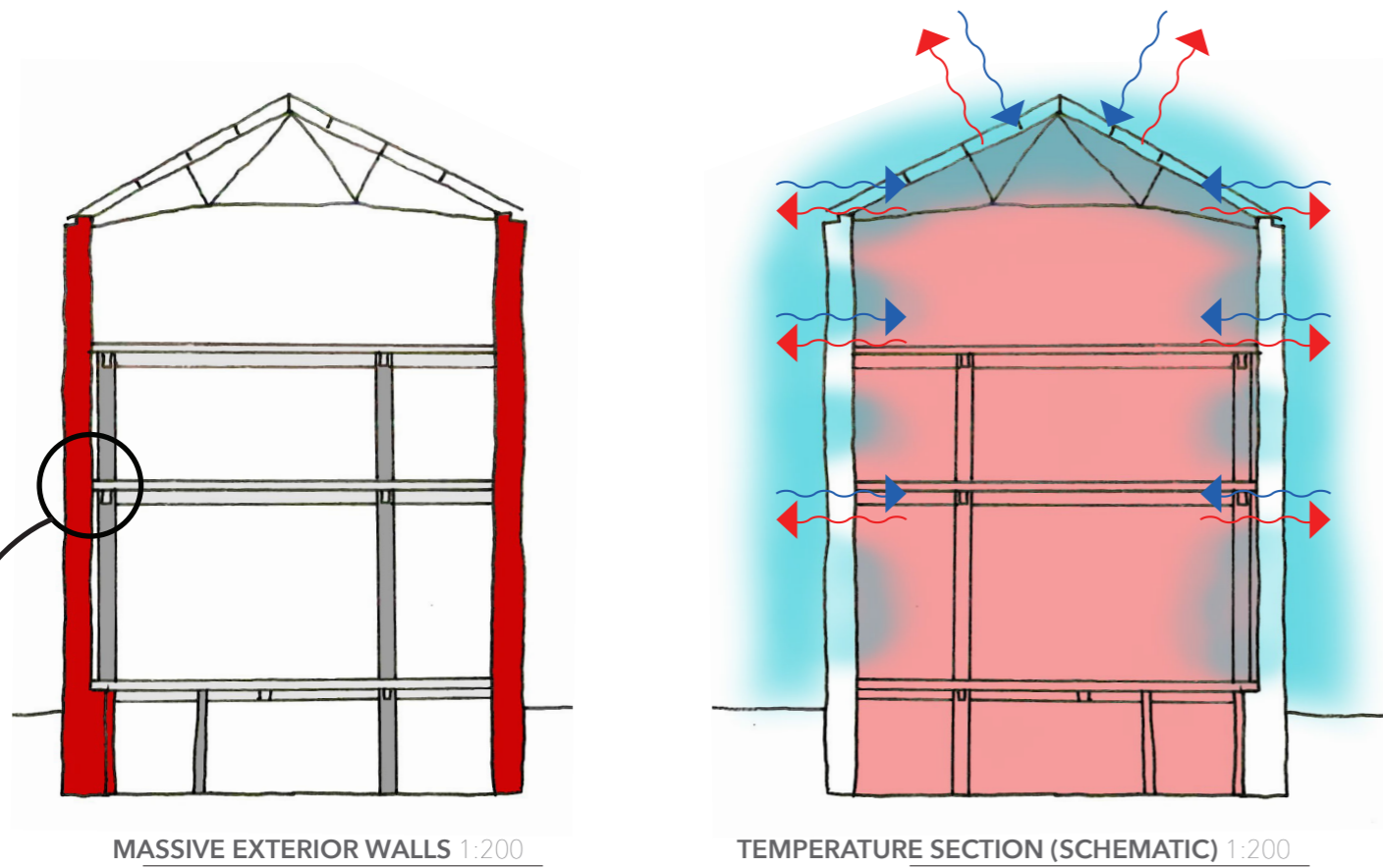

CLIMATE

The first thing that came into mind in relation to the climate are the massive load-bearing façades of the milling. These walls have a high accumulating capacity which contributes to a constant internal temperature. The walls are of such dimensions (1100mm) that you can hardly speak of a thermal bridge: it has a relatively high Rc-value. On the other, this increases the risk of condensation near the wooden window frames and the roof construction, since the Rc-value of these elements is lower. Partly for this reason most of the wooden window frames are damaged (p. 125).

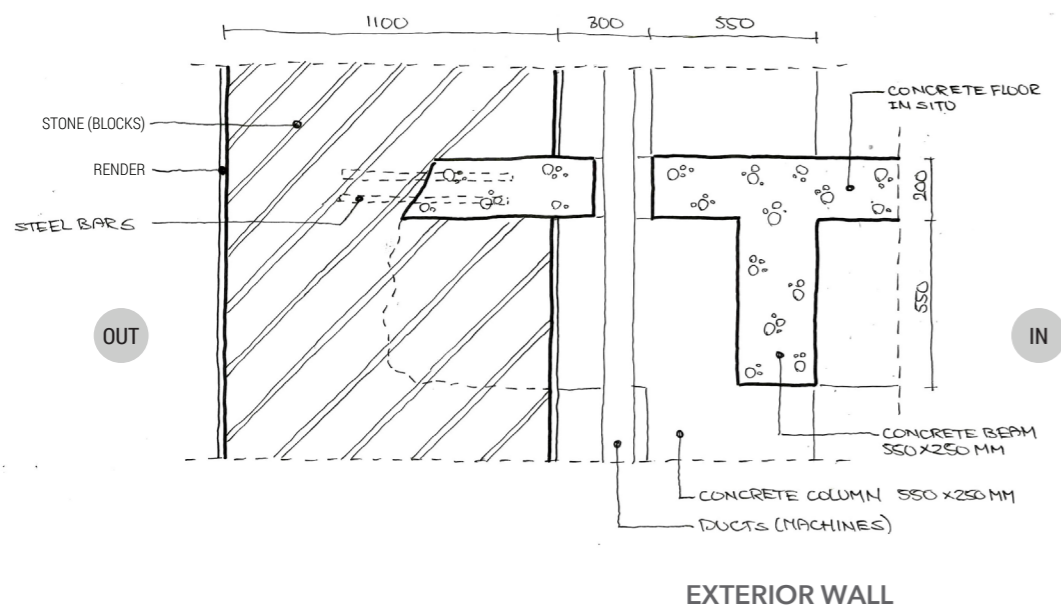

Images

1. Damaged window frames ground floor silos milling (photo by Hielkje Zijlstra, 04-09-2016)

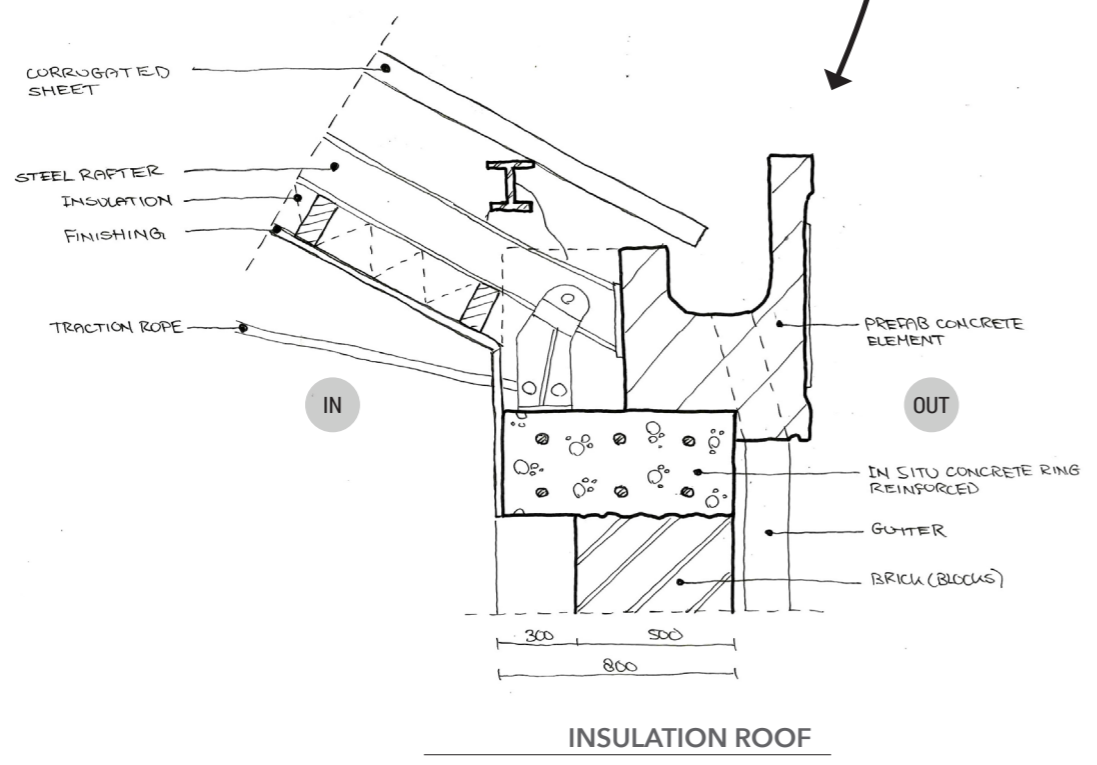
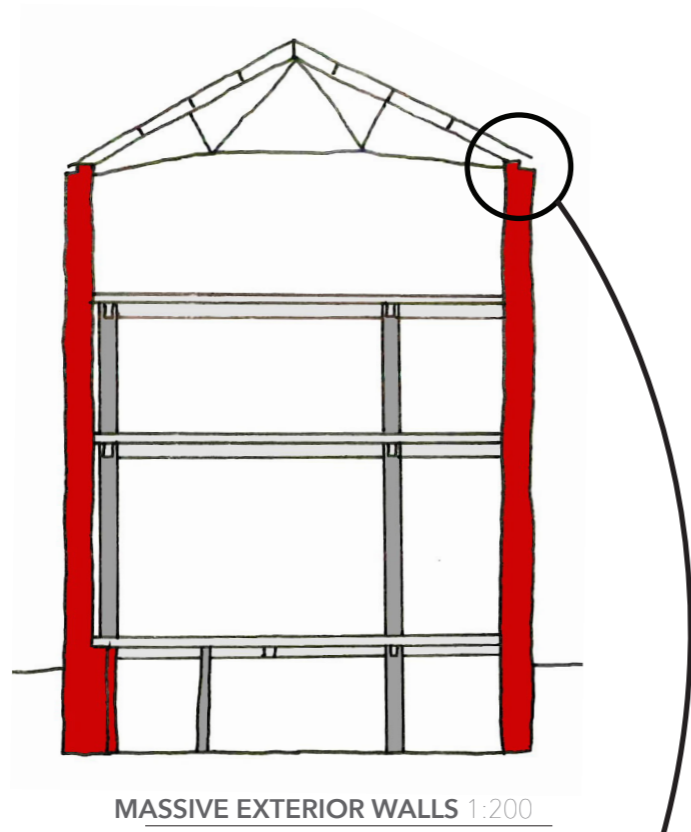

CLIMATE

The roofing of the milling is covered with asbestos corrugated sheets (p. 126). Originally the roof was not isolated. We think that because of condensation problems the roof has been isolated afterwards (see detail). Since warm air rises the biggest difference between indoor and outdoor temperature appears at the roof. When redeveloping the MMC, attention should be paid to this risk of condensation.

The same risk applies to the bakery. However, the façades of this building have a thickness of 'just' 60cm, so the difference between the Rc-value of the facade and roof is lower. For that reason the risk of condensation problems near the roof of the bakery is less, but at some points moisture problems are clearly visible as well.

Images
 1. Detail roof milling (photo by Hielkje Zijlstra, 04-09-2016)
 2. Roof bakery (photo by Hielkje Zijlstra, 04-09-2016)

LITERATURE

Literature

Folgado, D., & Custódio, J. (1999). *Caminho do Oriente - Guia do Património Industrial*. Lisboa: Livros Horizonte.

Friedman, D. (1995). *Historical building construction. Design, materials and technology*. London: W.W. Norton & Company

Jester, T.C. (1995). *Twentieth-century building materials. History and conservation*. Washington: Archetype Press

Oosterhoff, J., Arends, G.J., Van Eldik, C.H., & Nieuwmeijer, G.G. (1988). *Bouwtechniek in Nederland. Constructie van ijzer en beton*. Delft: Delftse Universitaire Pers

Portugal Press (2014). *Brussels cranks-up pressure on Portuguese government to act over as-bestos*. Retrieved on 16 November from <http://portugalresident.com/brussels-cranks-up-pressure-on-portuguese-government-to-act-over-asbestos>

The Portugal News Online (2015). *Scores of Lisbon buildings cleared of asbestos by 2017*. Retrieved on 16 November from <http://theportugalnews.com/news/scores-of-lisbon-buildings-cleared-of-asbestos-by-2017/36614>

Other sources

Texts exhibited at Manutenção Militar Complex by Lisbon Municipality

<http://www.braaksma-roos.nl/projecten/herbestemming/bkcity/>

<http://www.mecanoo.nl/Projects/project/27/Library-Delft-University-of-Technology?t=0>

