

# Asphaltic Concrete Cores for Embankment Dams

KAARE HÖEG

*Sept. 1993*



Montauban

Asphaltic Concrete Cores  
for  
Embankment Dams



# Asphaltic Concrete Cores for Embankment Dams

*Experience and Practice*

KAARE HÖEG

*Statkraft  
Veidekke  
Norwegian Geotechnical Institute  
1993*

Printed i Norway  
by StikkaTrykk,  
Asker og Bærums Budstikke,  
Billingstad 1993.

*Cover photo: Berdalsvatn Dam.*

ISBN 82-546-0163-1.

# P r e f a c e

This book describes Norwegian and international experience and practice with the use of asphaltic concrete cores for embankment dams.

The properties of asphaltic concrete can, within fairly wide limits, be tailored to satisfy specific dam design requirements. This is an important aspect and advantage of using bituminous cores in embankment dams. The additional costs of achieving special core properties, by for instance increasing the bitumen and/or filler content, must in each case be compared with the potential benefits in terms of safety and reliability.

Bituminous cores may be built by different construction procedures, for instance by the "stone-bitumen" method or "flowable asphaltic concrete" utilizing formwork and hand placement (Chapter 2). However, the most common procedure used so far is compacted dense concrete employing special machinery but no formwork. The central core with the filter/transition zones on either side are placed simultaneously in one operation. It is the latter method which is emphasized in this book.

Chapter 4 describes modern construction equipment and procedures, and Chapter 6 presents design recommendations for embankment dams with asphaltic concrete core. Chapter 7 discusses contract and work specifications using as a case study the Storglomvatn Dam, 125 m high and presently under construction in Norway.

The book is a result of a research and development project which summarized and evaluated available experience and expanded the know-how through experimental and analytical studies. The sponsors of the project have been:

The Research Council of Norway (NFR)  
A/S VEIDEKKE  
STATKRAFT SF (The Norwegian Energy Corporation)  
The Norwegian Geotechnical Institute (NGI)

Their financial support and permission to publish the results are gratefully acknowledged.

Chapter 4 is authored by Helge Saxegaard, Leif E. Karlsen wrote the section on contract specifications in Chapter 7, and the NGI dam engineering group contributed throughout the study.

Oslo, September 1993  
Steering Committee for R & D Project:  
Svein Huse, Chairman  
Kaare Høeg  
Leif E. Karlsen  
Helge Saxegaard

# Contents

Preface	5
Chapter 1 Norwegian Dam Building - Historic Review	9
Chapter 2 Merits of the Asphaltic Concrete Core Design	13
2.1 Introduction	13
2.2 General merits of the asphaltic concrete core	14
2.3 Core construction procedure	15
Chapter 3 Norwegian Dams with Asphaltic Concrete Core	17
Chapter 4 Norwegian Construction Equipment and Practice	29
4.1 Asphaltic concrete plant	29
4.2 Core paving equipment	30
4.3 Placing and compaction procedures	33
4.4 Quality assurance and control	36
Chapter 5 Case Study - The Storvatn Dam	37
5.1 Dam design	37
5.2 Construction and control of the asphaltic concrete core	42
5.3 Predicted and observed dam performance	44
5.4 Predicted seismic response	49
Chapter 6 Design - Principles and Requirements	55
6.1 Design analyses	55
6.1.1 Typical core design	56
6.1.2 Filter/transition zone	58
6.1.3 Supporting shell	59
6.2 Asphaltic concrete mix design and properties	60
6.2.1 Aggregates and filler	61
6.2.2 Effect of bitumen content and viscosity	65
6.3 Laboratory testing of asphaltic concrete	67
6.3.1 Marshall method of mix design	67
6.3.2 Triaxial testing	67
6.3.3 Permeability testing	68
6.3.4 Resistance to cracking under flexure	69

<b>Chapter 7</b>	<b>Construction - Contract and Work Specifications . . . . .</b>	<b>71</b>
7.1	Contractual aspects . . . . .	71
7.1.1	Basic contract considerations . . . . .	71
7.1.2	Prequalification, quality assurance and control . . . . .	72
7.1.3	Price adjustment . . . . .	72
7.2	Work and material specifications - a case study . . . . .	73
7.2.1	Asphaltic concrete mix design assumed when preparing tender . . . . .	73
7.2.2	Modifications to basic mix design proposed by contractor . . . . .	74
7.2.3	Prequalification of contractor . . . . .	75
7.2.4	Test production and placing of asphaltic concrete on site . . . . .	75
7.2.5	Requirements to plant and equipment . . . . .	75
7.2.6	QA/QC and reporting during construction . . . . .	76
7.2.7	Requirements to core placing and compaction procedures . . . . .	78
7.2.8	Requirements to filter/transition zone . . . . .	80
7.2.9	Unit prices . . . . .	80
<b>References</b>	. . . . .	<b>82</b>
<b>Index</b>	. . . . .	<b>85</b>

# Chapter 1

## Norwegian Dam Building - Historic Review

Hydropower is one of Norway's major natural resources and has come to mean more to Norway than to possibly any other country in the world (Hveding, 1992). When the technologies for producing and using electricity on a large scale emerged in the second half of the 19th century, Norway was in a process of rapid industrialization. With no coal of its own, except at the arctic island of Svalbard, it took quickly to harnessing the power of its rivers. What got Norway off to a strong and early start was, more than anything else, the favourable distribution of its hydropower resources. There were sites suitable for development throughout the country.

Even in overall terms, this country of little over 4 million people ranks with the world's top hydropower producers. In contrast to most industrialized countries, Norway still has hydropower resources yet to be tapped, enough for another 20 - 30 years of development. Technologies need therefore to be maintained and constantly updated.

To create high heads for hydropower, most dams are sited in regions where long winters and poor accessibility must be dealt with (Fig. 1.1). As a result, climatic conditions and logistics have significantly influenced their design and construction.



Fig. 1.1 The Blåsjø reservoir in mountainous West Norway



The first large dams in Norway date back to the 1890s, and now (1993) there are 290 dams exceeding 15 m in height. Mass concrete or masonry were the main materials used during the first 30 to 40 years. Then, with the advance of reinforced concrete, gravity dams were succeeded by slab-buttress dams of the Ambursen type, and later by reinforced arch dams. These types of dam were predominant during the period 1930 to 1960.

Systematic construction of embankment dams, mainly rockfill dams, began in 1924, and now 174 of the 290 are embankment dams of various types (see Table 1.1). Moraine or glacial till, a broadly graded mixture of stones, gravel, sand, silt and clay, is to be found in the vicinity of most dam sites in Norway. This was therefore the first choice for impervious core material, and the zoned rockfill dam with moraine core dominated the period between 1960 to 1980 (Fig. 1.2).

**Table 1.1 Norwegian embankment dams higher than 15 m per September 1993 - statistical summary**

Dam type	Impervious material and element	Number of dams	Height above lowest core foundation (m)		Length of crest (m)		Volume of dam (1000 m <sup>3</sup> )		Comple- tion year
			mean	max	mean	max	mean	max	<u>first dam</u> last dam
Rockfill	Moraine core	111	40	145	361	3400	578	5750	<u>1956</u> 1993
	Crushed soft-rock core	1	-	17	-	100	-	23	1966
	Concrete core	9	21	31	154	400	46	135	<u>1930</u> 1974
	Asphaltic concrete core	7*	51	90	641	1472	1884	9515	<u>1980</u> 1990
	Stone-bitumen core	4	24	34	199	339	151	280	<u>1981</u> 1984
	Wooden deck	3	41	52	643	970	448	860	<u>1956</u> 1959
	Concrete deck	25	25	55	184	460	87	495	<u>1924</u> 1986
	Asphaltic concrete deck	1	-	64	-	240	-	357	1963
Earthfill	Clay or silt core	2	16	17	408	640	168	212	<u>1964</u> 1970
	Moraine core	11	27	43	389	820	218	731	<u>1959</u> 1974

\* Plus two under construction (see Table 3.1)

This dominance lasted until around 1980 when asphaltic concrete core walls were adopted for three rockfill dams in the Aurland scheme. These dams were built very high up in the western mountains, in locations where only scarce deposits of moraine could be found, and where severe weather conditions and deep frost (approaching permafrost) would have hampered the construction of earth cores. Furthermore, for environmental reasons, the planners wanted to avoid scars in the landscape caused by earth borrow pits.



**Fig. 1.2** The Svartevatn Dam (129 m high) with moraine core under construction

The highest embankment dam in Norway was completed in 1987: the 145 m high Oddatjørn Dam with a moraine core. The Storvatn Dam (90 m high, 9.5 mill. m<sup>3</sup>) with an asphaltic concrete core was finished the same year. Norway's highest arch dam, the Virdnejavre Dam (145 m high) on the Alta river, was also recently completed (Fig. 1.3). However, since 1965, four out of five new dams have been embankment dams. Presently two rockfill dams are under construction, Storglom-

vatn (125 m high) and Holmvatn (56 m high), both with vertical asphaltic concrete core.

The design and construction of rockfill dams, primarily based on Norwegian experience and practice, was recently presented in the book by Kjærnsli et al. (1992). The performance of these dams has, in general, been very satisfactory.



**Fig. 1.3** The Virdejavre Arch Dam on the Alta River, under construction in 1987

# Chapter 2

## Merits of the Asphaltic Concrete Core Design

### 2.1 Introduction

ICOLD Bulletin 84 (1992) presents, in chronological order from 1948 to 1991, the existing embankment dams built with bituminous cores of different types, hand placed and machine placed.

A construction procedure which has been successfully applied in Norway on several dams, is the stone-bitumen method. The core consists of uniformly graded, crushed stones or pebbles impregnated to void saturation with bitumen. Metal sheet shuttering is used along the sides of the core wall, which is built in consecutive horizontal layers 0.2 - 0.3 m thick. The layer form is first filled with clean and dry stone material which must be accurately levelled over the entire length of the layer before hot bitumen is pumped in from a heated tank. To avoid entrapment of water or air, the filling of bitumen starts from one end. The hot bitumen flows forward as an advancing slope, and the hose nozzle is moved in small steps to ensure that the voids are filled to saturation.

With a stone-bitumen core the adjacent filter zones become of special importance as they must be impervious to bitumen. The filter must be of such consistent fineness and compactness that bitumen cannot be squeezed out at any point by the water pressure (Haas, 1983).

The reverse procedure is to vibrate gravel into a bituminous mastic filled in between shutters along the sides of the core wall. This method is considered to be less reliable and has therefore not been practiced in Norway.

The first embankment dam with a machine-compacted dense asphaltic concrete core, was built in Germany in 1962, and since 1970 almost only such cores, compacted in thin layers, have been used in large dams. The procedure does not require the use of shutters. It is this method, with a bitumen content in the vicinity of 6% by weight, that is the focus of attention in this book.

As a variation on the methods mentioned above, a different technique is presently being used in Russia for three large embankment dams under construction (Moiseev et al., 1988). The dams all rest on deep, compressible, alluvial deposits, which may cause large differential settlements and distortions in the dam body. The asphaltic concrete mix, with a bitumen content of 10 - 12%, is poured into 1 m high steel shutters positioned on top of the previous layer. The shutters are removed as soon as the asphaltic concrete has cooled down to approx. 45°C, and then the gravel filter/transition zones are placed. The asphaltic concrete, which is supersaturated with bitumen (termed "flowable" concrete), cannot be effectively compacted. The main reasons for using this technique rather than leaner, compacted asphaltic concrete, are the extremely cold climate and the extra core ductility required at these

sites. Furthermore, the technique does not require any specialized placing and compaction equipment for building the core.

## **2.2 General merits of the asphaltic concrete core**

In about 70% of the 174 large Norwegian embankment dams, a core of morainic material has been chosen (Table 1.1). However, a core wall of asphaltic concrete has been found to be a very attractive option, and in the past decade this method has come increasingly into use with excellent results. As opposed to earth materials, asphaltic concrete is man-made, and its controlled properties can be tailored to satisfy specific design requirements.

Since 1978, when the machine-compacted, asphaltic concrete method was first used in Norway, the equipment and placing and compaction techniques for the core and adjacent filter/transition zones have been greatly improved. The unit costs have also steadily decreased, which now makes this a competitive alternative even when moraine material is locally available. Furthermore, potential scars in the landscape from large earth borrow pits are avoided.

Compared with an earth core, the placement and compaction of asphaltic concrete is much less susceptible to adverse weather conditions. This enables the contractor to extend the working season and to conduct an almost continuous operation, keeping the construction on schedule. While rainy weather rarely causes difficulties for asphaltic core construction, snow and sub-zero weather limits the construction season to about 5 months in the Norwegian mountains. This is approximately one month longer than that available for moraine core construction

Asphaltic concrete is virtually impervious, flexible, resistant to erosion and aging, workable and compactable, and offers jointless core construction. When the asphaltic concrete mix is properly designed, its viscoelastic-plastic and ductile properties provide a "self-healing" (self-sealing) ability, should cracks develop in the core wall. Asphaltic cores are therefore very well suited for dams in earthquake regions, as discussed in Chapter 5.

Chapter 3 presents summaries of important data for Norwegian dams recently completed or under construction with asphaltic concrete core. The maximum core thickness so far required is 0.9 m (Storglomvatn Dam, 125 m high), and the specified minimum thickness is 0.5 m. The central core is vertical, except in one case, the Storvatn Dam to be presented in detail in Chapter 5.

The thin asphaltic concrete core has to follow and adjust to the movements and deformations imposed by the embankment as a whole. These deformations must be accommodated by the asphaltic concrete without cracking or significant shear dilation (volume expansion) which may lead to increased permeability. To reduce the probability of core cracking due to excessive static and/or dynamic embankment deformations and distortions, the embankments have all been well compacted.

Almost all have so far been rockfill dams resting on firm ground or bedrock. However, based on acquired experience, that is no longer considered a requirement. For future situations with embankments placed on top of compressible river deposits, extra core flexibility and ductility may be provided by designing a richer asphaltic concrete mix (Chapter 6). Mixes with a bitumen content 2 - 3% points above the 5 - 6% which gives optimum density, may still be compacted and controlled by the procedures described below. Furthermore, one has also started with the use of softer less viscous bitumen, which increases the crack "self-healing" ability and allows lower operating temperatures during core placement. Thus, through further development, one may extend the applicability of the asphaltic concrete core design method to other site conditions than it so far has been used for.

### 2.3 Core construction procedure

Details of the core construction procedure and equipment are presented in Chapter 4 and only a very brief overview is given here (Fig. 2.1).



**Fig. 2.1 Asphaltic concrete core construction for Riskallvatn Dam**

The asphaltic concrete is compacted at a temperature around 160°C depending on the type of bitumen used, and is given immediate lateral support from the adjacent zones in the embankment. Placement of the core wall and filter/transition zones proceed simultaneously, with equal layer thickness, usually limited to 0.2 m, and compaction is achieved by vibratory rollers which follow the placing unit. The

rollers operate in a coordinated manner, side by side, to avoid lateral displacement of the hot asphaltic concrete.

The asphaltic concrete is produced in accordance with specifications for grain size distribution of the concrete aggregates, filler and bitumen content in the mix, any admixtures, and temperature constraints at the various stages of the process (Chapters 6 and 7).

# Chapter 3

## Norwegian Dams with Asphaltic Concrete Core

Table 3.1 below gives key figures for seven Norwegian rockfill dams with compacted, asphaltic concrete core built since 1978. In addition, two more are under construction. The Storglomvatn Dam, 125 m high, will be the highest so far built with an asphaltic concrete core.

**Table 3.1 Norwegian rockfill dams with asphaltic concrete core**

Name	Height above lowest core foundation (m)	Core thickness (m) Top/bottom	Core inclination (v:h)	Vertical projection area of core (m <sup>2</sup> )	Volume of asphaltic concrete (m <sup>3</sup> )	Construction period	Main contractor/ Asphalt contractor	Main dam owner
Vestredalstjern	32	0.5	1:0	6000	3100	1978-80	Selmer <sup>1)</sup> /Strabag	Oslo Energy
Katlavatn	35	0.5	1:0	4600	2300	1979-81	Selmer/Strabag	Oslo Energy
Langavatn	22	0.5	1:0	3800	1900	1979-81	Selmer/Strabag	Oslo Energy
Storvatn	90	0.5/0.8	1:0.2	76000	49000	1981-87	Statkraft/ Veidekke <sup>2)</sup>	Norwegian Energy Corporation
Riskallvatn	45	0.5	1:0	14600	8000	1983-86	Veidekke/ Korsbrekke and Lorck	Nyset-Steggje Kraft A/S
Berdalsvatn	62	0.5	1:0	13000	6800	1986-88	Veidekke/ Korsbrekke and Lorck	Nyset-Steggje Kraft A/S
Styggevatn	52	0.5	1:0	30400	15300	1986-90	Statkraft/ Korsbrekke and Lorck	Norwegian Energy Corporation
Storglomvatn (under construction)	125	0.5/0.9	1:0	44000	22500	1993-	Statkraft/ Korsbrekke and Lorck-Veidekke	Norwegian Energy Corporation
Holmvatn (under construction)	56	0.5	1:0	12000	6200	1993-	Statkraft/ Korsbrekke and Lorck-Veidekke	Norwegian Energy Corporation

<sup>1)</sup> At the time the company name was Furuholmen

<sup>2)</sup> At the time the company name was Hesselberg

In the following some key information about the dams listed in Table 3.1, ranked according to height, is presented. Table 3.2 gives details about the asphaltic concrete core mix used for the different dams, and Table 3.3 presents material properties and compaction procedures for the various embankment zones referred to on the



cross sections in Figs 3.1 - 3.8. (Note: The thick crown cap protection is a requirement imposed by the Norwegian civil defense authorities as a safeguard against acts of war.)

**Table 3.2 Asphaltic concrete mix design for the dams listed in Table 3.1**

Name	Dam height (m)	Core thickness (m) Top/ bottom	Aggregate			Filler			Bitumen	
			Type	Impact value	Flakiness index	Total content (%)	Crushed from aggregate (%)	Added (%)	Content (%)	Type
			Grain size							
Storglomvatn	125	0.5/ 0.9	Natural gravel + 50% crushed 0-18 mm	34 to 45	1.29 to 1.43	13	max. 6.5	min. 6.5 crushed limestone	6.3	B180
Storvatn	90	0.5/ 0.8	Crushed gneiss 0-16 mm	34 to 45	1.29 to 1.43	12	4-5	7-8 crushed limestone	6.2	B60
Berdalsvatn	62	0.5	Natural gravel + 20% crushed 0-20 mm	20 to 46	1.29 to 1.45	11	6-8	4-6 crushed limestone	6.1	B60
Styggevatn	52	0.5	Crushed granitic gneiss 0-16 mm	43 to 45	1.33 to 1.43	12	5-7	5-7 crushed limestone	6.3	B60
Riskallvatn	45	0.5	Natural gravel + 20% crushed 0-20 mm	35 to 44	1.28 to 1.35	11	1-5	6-10 crushed limestone	6.3	B60
Katlavatn	35	0.5	Natural gravel 0-16 mm	40 to 48	1.39 to 1.55	12.5	6.5	6 crushed limestone	6.3	B65*
Vestredalstjern	32	0.5	Natural gravel 0-16 mm	40 to 48	1.39 to 1.55	12.5	6.5	6 crushed limestone	6.3	B65
Langavatn	26	0.5	Natural gravel 0-16 mm	40 to 48	1.39 to 1.55	12.5	6.5	6 crushed limestone	6.3	B65

\* The top 7 m of core was built by the stone-bitumen method with bitumen type B180 (see Section 2.1)

- Remarks:**
- Chapter 6 gives the principles, procedures and terminology concerning asphaltic concrete mix design and required properties.
  - The grain size distribution for the aggregate with filler satisfies the Fuller design curve (Section 6.2).

- Asphaltic concrete with bitumen types B60 and B65 is compacted at a temperature of 160°- 180°C and with type B180 at 140°- 155°C.

**Table 3.3 Description of embankment zones for the dams listed in Table 3.1**

Zone	Material	Layer thickness (m)	Compaction <sup>1)</sup>	
			Vibratory roller, min. weight (tons)	Number of passes
(1) Asphaltic concrete core	See Table 3.2	0.2	Trials on site, approx. 0.25 - 0.50 <sup>2)</sup>	Until void content < 3%
(2) Filter/transition	Natural gravel or crushed rock, 0-60 mm	0.2	1.5	3 - 6 <sup>3)</sup>
(3) Transition	Crushed rock, 0-200 mm	0.4	15 + water sluicing	4
(4a) Shoulder (shell)	Quarried rock, 0-400 mm	0.8	15 + water sluicing	8
(4b) Shoulder (shell)	Quarried rock, 0-800 mm	1.6	15	6
(5) Slope protection	Selected, large blocks > 0.5 m <sup>3</sup>	Individually placed by backhoe	-	-
(6) Crown cap	Selected, large blocks > 1.0 m <sup>3</sup>	Individually placed by backhoe	-	-
(7) Toe drain	Selected, large blocks > 0.5 m <sup>3</sup>	Dumped in lifts up to 4 m	-	-

<sup>1)</sup> The specifications under compaction of fill materials are for the Storglomvatn Dam (Fig. 3.1). For the other dams (Figs 3.2 - 3.8) the requirements may have been specified somewhat differently.

<sup>2)</sup> In general, the optimum vibratory roller depends on properties of asphaltic concrete mix and core width.

<sup>3)</sup> Number of passes has to be adjusted on site as it depends on properties of filter material.

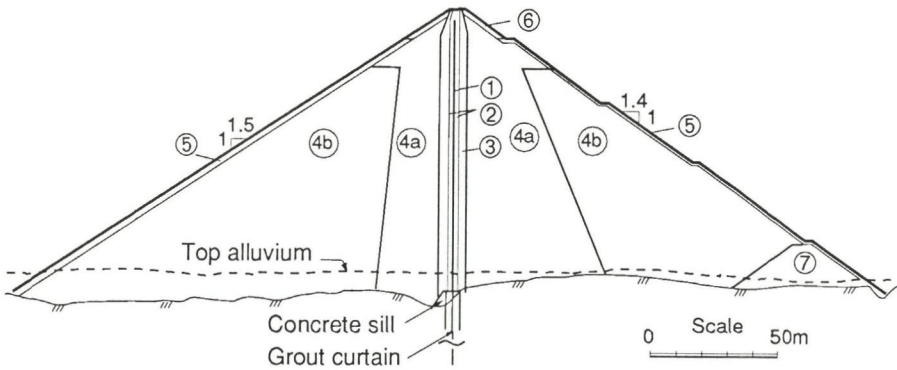

**Fig. 3.1 Site and cross section of Storglomvatn Dam**

*Maximum height: 125 m Crest length: 825 m Total embankment volume: 5.3 mill. m<sup>3</sup>*

The dam is currently under construction (1993). The alluvial overburden to bedrock (maximum depth 20 m) has been excavated. The rock foundation grouting will take place partly from the surface and partly from a tunnel 20 m deep under the right half of the dam which rests on a complex karstic rock formation.

Storglomvatn is located at the latitude of the Arctic Circle, where the effective embankment construction season is from about 1 July - 1 November. The site is inaccessible due to snow during the rest of the year.

The detailed work specifications for the core (zone 1) and filter/transition (zone 2) are presented in Section 7.2.

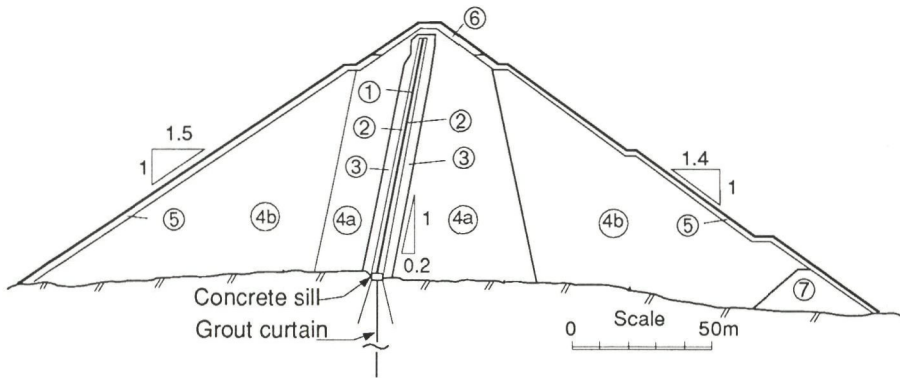

**Fig. 3.2 Storvatn Dam**

*Maximum height: 90 m Crest length: 1472 m Total volume: 9.5 mill. m<sup>3</sup>*

Chapter 5 presents details about design, construction and performance of the Storvatn Dam.

### **Performance**

The total seepage registered at maximum reservoir level is only 10 l/s. However, part of this comes from underseepage and from the abutments, so the leakage through the core is even smaller.

The measured maximum settlement at the top of the core is 165 mm, or 0.18% of the dam height, 5 years after end of construction. The maximum embankment displacement is registered inside the downstream shell at mid-height and is 580 mm (520 mm vertically and 206 mm horizontally).

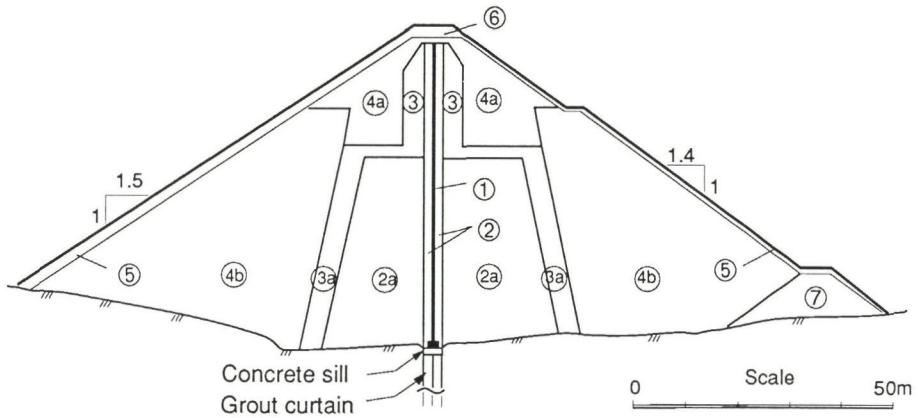

**Fig. 3.3 Berdalsvatn Dam**

*Maximum height: 65 m Crest length: 465 m Total volume: 1.0 mill. m<sup>3</sup>*

The unusual zoning in Berdalsvatn as compared to Storglomvatn (Fig. 3.1) and Styggevatn (Fig. 3.4), is because more suitable natural gravel than originally anticipated, was found in the borrow area. Therefore zone 2 was expanded with zone 2a, which reduced the extent of zone 4a and thus the total cost. Core placement and compaction were achieved by the equipment and procedures described in Chapter 4.

### **Performance**

The total seepage is very small and less than 2.5 l/s.

Only movements of points on the dam surface and top of core are monitored. Maximum measured settlement at the top of the core is 70 mm, or 0.1% of the dam height, 3 years after end of construction.

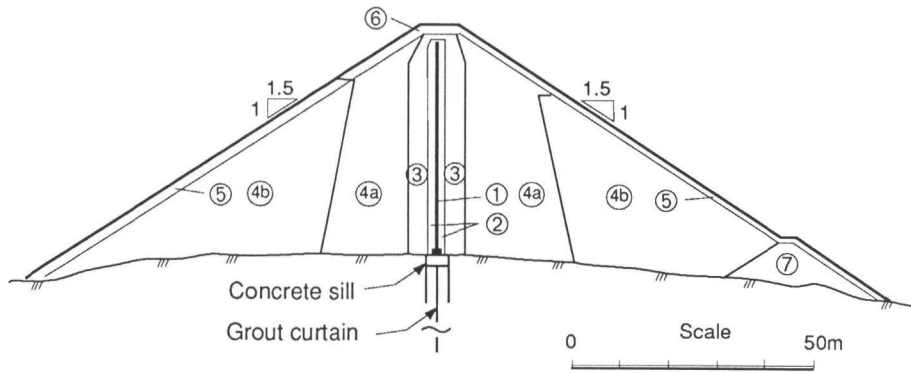
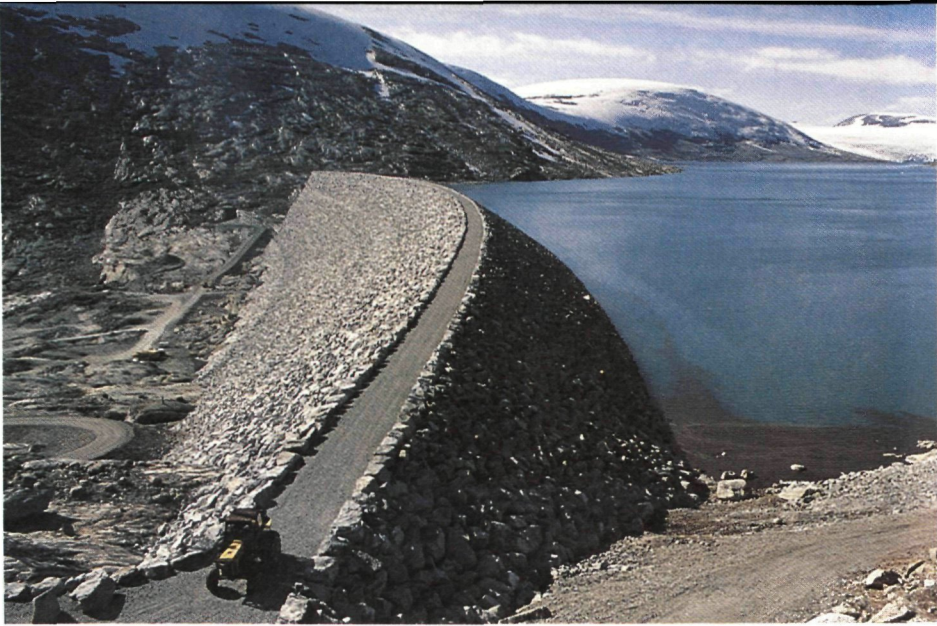

**Fig. 3.4 Styggevatn Dam**

*Maximum height: 52 m Crest length: 880 m Total volume: 2.5 mill. m<sup>3</sup>*

Core placement and compaction were achieved by the equipment and procedures described in Chapter 4.

### *Performance*

The total seepage registered at maximum reservoir level is 20 l/s. A significant part of this does not come from the reservoir through the core but from underseepage and from the abutments.

Only movements of points on the dam surface and top of core are monitored. The maximum settlement at top of the core is 35 mm one year after end of construction. The maximum displacements are 67 mm vertically and 68 mm horizontally at about midheight of the downstream slope.

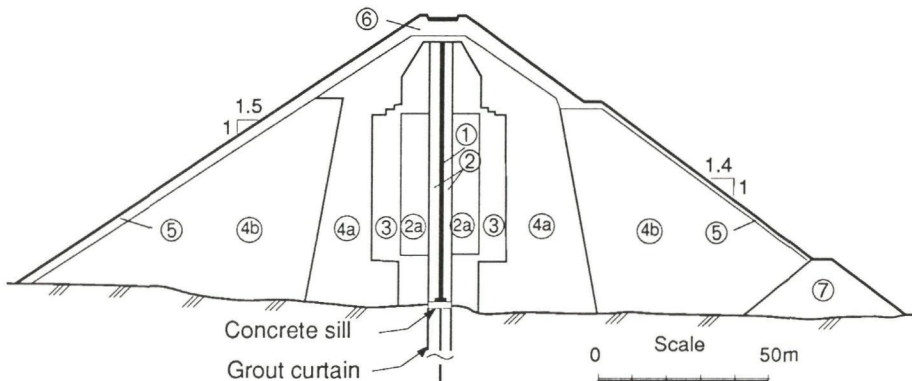

**Fig. 3.5 Riskallvatn Dam**

*Maximum height: 45 m Crest length: 600 m Total volume: 1.1 mill. m<sup>3</sup>*

The unusual zoning in Riskallvatn Dam is because more suitable natural gravel than originally anticipated, was found in the borrow area. Zone 2 was therefore expanded with zone 2a, which reduced the width of zone 4a and thus the total cost. Core placement and compaction were achieved by the equipment and procedures described in Chapter 4.

### ***Performance***

The total seepage increased rapidly when the filling of the reservoir started in August 1986. When reaching elevation 971 m, the leakage was 106 l/s. The seepage, which primarily took place beneath the foundation sill, is now, 6 years after first reservoir filling, 20 l/s at the highest regulated water level (980.3 m). No remedial grouting has been carried out. The significant reduction is due to a gradual clogging and sealing of cracks in the rock foundation.

Only movements of points on the dam surface and top of core are monitored. The maximum vertical settlement recorded at the top of the core is 45 mm 6 years after end of construction. This is 0.1% of the dam height.

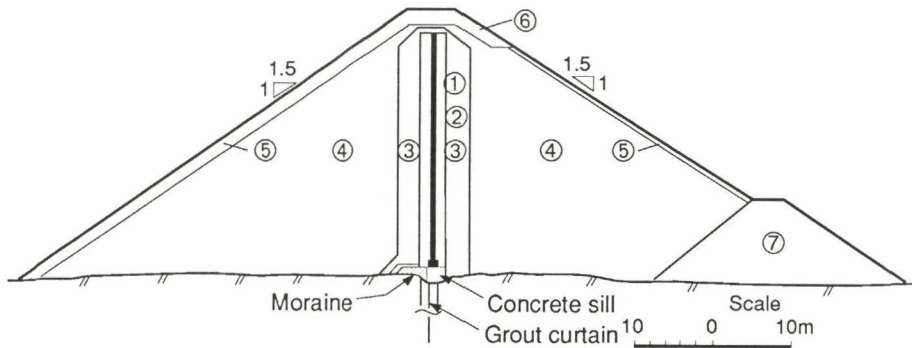

**Fig. 3.6 Katlavatn Dam**

*Maximum height: 35 m Crest length: 265 m Total volume: 0.2 mill. m<sup>3</sup>*

The width of the core sill (plinth) is 1.5 m, and upstream along the sill there is a 3 m wide strip of moraine to reduce any potential leakage at the core base.

During the 1980-season the construction of the compacted asphaltic core was very much behind schedule. It was therefore decided, as no extra placing machine was available, to construct the top 7 m of the core by the stone-bitumen method described in Section 2.1. Crushed rock (uniformly graded) and bitumen B180, which has considerably lower viscosity than B65, were used for this purpose.

### ***Performance***

The total seepage registered is stable at 0.4 l/s at maximum reservoir level.

Only movements of points on the dam surface and top of core are monitored. The maximum vertical settlement at top of core, 12 years after embankment construction, is 35 mm, i.e. 0.1% of the dam height.



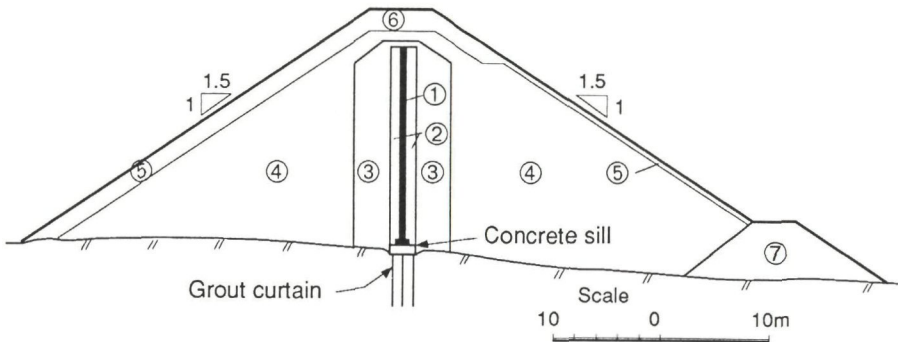

**Fig. 3.7 Vestredalstjern Dam**

*Maximum height: 32 m Crest length: 500 m Total volume: 0.4 mill. m<sup>3</sup>*

***Performance***

The total seepage registered is stable at 0.2 l/s at maximum reservoir level.

Only movements of points on the dam surface and top of core are measured. The vertical settlement of the top of the core, 12 years after embankment construction, is 44 mm, i.e. 0.14% of the dam height.

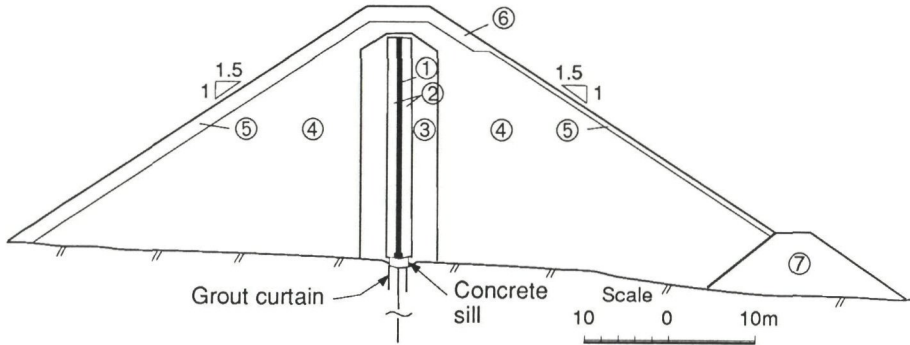

**Fig. 3.8 Langavatn Dam**

*Maximum height: 26 m Crest length: 290 m Total volume: 0.3 mill. m<sup>3</sup>*

***Performance***

The total seepage registered is stable at 0.4 l/s at maximum reservoir level.

Only movements of points on the dam surface and top of core are measured. The vertical settlement of the top of the core, 12 years after embankment construction, is less than 0.1% of the dam height.

# Chapter 4

## Norwegian Construction Equipment and Practice

After the three first dams were completed (Table 3.1), new and improved equipment for placing the asphaltic concrete core was designed and built for the construction of the Styggevatn Dam in 1981. Since then, further improvements have taken place to increase the mobility of the paver, reduce extent of hand placement required, and to simplify transportation and loading of asphaltic concrete into the paver.

The present Norwegian equipment, shown in Figs 4.1 and 4.3 has been used on three dams in Norway (1987 - 1991) and one in Jersey, U.K. (1990 - 1991). In the Norwegian mountains, the paving season is short due to severe winters with much snow. However, the paving equipment has proved itself and shown that core building can be performed within strict specifications even under very wet and cold conditions.



**Fig. 4.1** The Norwegian asphaltic concrete paver at work on Styggevatn Dam

### 4.1 Asphaltic concrete plant

A reliable batch plant with a capacity of 50 - 60 tons an hour is normally sufficient (Fig. 4.2). The plant should have a minimum of 4 hot aggregate storage bins, and a data printout of all weights per batch is recommended (Section 7.2).

As daily output is moderate and production often somewhat discontinuous, special care is put on temperature controls. An airbag filter is used to regain all the aggregate fines from the crushing process. With the high content of filler required in the mix (approximately 12% smaller than 0.075 mm), added filler in the form of Portland cement or crushed limestone is normally specified to give a mix good working characteristics. Two storage silos are therefore required, one with the added material, and the filler is composed of a prescribed mixture which depends on the acidity of the crushed aggregate fines.

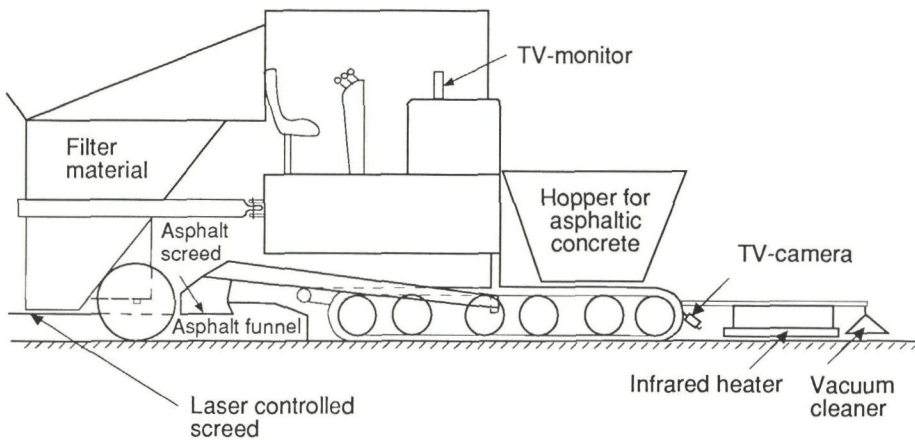

**Fig. 4.2** The batch plant erected close to the downstream toe of Riskallvatn Dam

## **4.2 Core paving equipment**

The paving equipment shown in principle on Fig. 4.3 places asphaltic concrete and filter simultaneously in 20 cm horizontal layers (after compaction). The machine is a hydraulically driven crawler paver, and the widths of the core and filter screeds are adjusted according to the design specifications. The level of the filter screed is automatically controlled by a rotating laser which ensures a horizontal base for the next layer.

The precise center line is marked for each layer and fixed by a thin metal string. A video camera mounted in front of the machine and a television monitor inside the cab enable the operator to steer the machine with precision following the course of the string.



**Fig. 4.3 Working principle for core paver**

In front, the machine is equipped with a gas fired, infrared heater and a heavy duty vacuum cleaner which removes dust and moisture. The heater dries and heats the surface before the next layer is placed. No tack coat is applied between the asphaltic concrete layers as core sampling has proved that the joint is tight and hardly detectable.

Asphaltic concrete and filter are compacted by three vibrating rollers as shown in Fig. 4.4. The center roller should be somewhat wider than the asphaltic core. As

the mix is soft, the roller must not be too heavy, but the compaction energy must be sufficient to give an in-situ void content which satisfies the design requirements (Chapter 6).



**Fig. 4.4** Simultaneous compaction of core and filters



**Fig. 4.5** Loading of asphalitic concrete and filter material into paver

Compaction of the filter is achieved by two 1.5 - 2.5 tons vibrating rollers working in parallel (see Table 3.3). The sequence and amount of compaction have to be adjusted on site and depends on the asphaltic concrete mix and the filter material being used.

Transportation and loading of asphalt has been simplified after introducing wheel-loaders with specially designed insulated buckets to maintain the strict temperature control. The asphalt plant must be erected close to the dam if transport with wheel-loaders alone shall be sufficient. Fast and reliable supply of asphaltic concrete and filter material is essential. The filter material is transported in heavy duty trucks and loaded into the machine by an excavator. A storage bin pulled by the same excavator has in most places proved advantageous (Fig. 4.5).

### 4.3 Placing and compaction procedures

The concrete base (foundation sill) for the core should be planned and designed in order to minimize required hand placement of asphaltic concrete. Hand placement inside formwork (shutters) with the filter outside, is time-consuming and expensive, but usually necessary, to establish a horizontal base for the core paver (Fig. 4.6).



Fig. 4.6 Hand placement of asphaltic concrete

The accumulation of water in the low points of the foundation is a problem, and the use of water pumps is normally required. As the concrete surface has to be dry and

clean before the layer of asphalt mastic can be placed, the concrete base (sill) should be made with a slight cross elevation. When the concrete sill is within a deep ditch, this has to be wide enough to accommodate the machinery.

The concrete surface should be rough but even. Any spoils from injection grouting must be removed. In order to secure good adhesion between the concrete and the asphalt mastic, the concrete is either sand-blown or washed with hydrochloric acid. Stearin acid is added to the asphalt mastic in order to secure good adhesion (Fig. 4.7).



**Fig. 4.7** Placement of asphalt mastic on the foundation sill

The asphalt mastic surface must be cleaned and heated before asphaltic concrete is placed on top.

Hand placed asphaltic concrete and filter, levelling, removing of formwork and compaction have all to be done in quick succession in order to meet the specifications for temperature and maximum allowable air void content (porosity).

Having established a horizontal core base (minimum 30 m long), one may commence using the paving machinery. However, some hand work will always be required at each abutment. Progress should be continuously adjusted in accordance with the plant and transport facilities, normally 1 to 3 meters per minute. If stops exceed 10 to 15 minutes, proper construction joints must be made before proceeding.



Filter is placed with an extra height above the asphaltic concrete level corresponding to the difference in compressibility. As filter and asphalt mix vary from project to project, compaction routines are established for each new project to achieve the specified in-situ density.

The asphaltic concrete surface will curve somewhat (convex) after layer compaction, and fine cracks will occur in the middle. These fine cracks are of no concern as they will disappear when the next layer is placed.

The cross section of the core wall has to be controlled periodically to check for lateral deformations due to uneven compaction. This is achieved by excavating down on each side of a short section of the core.

As the dam construction progresses, the various zones are raised simultaneously. Where rain or snow or seasonal stoppages can cause delays, it is advisable that the core and filter level at all times in any cross section is higher than that of the adjacent fill upstream and downstream.

Transport across the asphalt core is normally a necessity for construction purposes. Light steel bridges, which easily can be removed, are required for this purpose, and no vehicle is permitted to cross the core except over a bridge (Fig. 4.8).



**Fig. 4.8** Light steel bridge across the core

## 4.4 Quality assurance and control

There are rigorous specifications for the construction of watertight asphaltic concrete cores. Quality assurance and control (QA/QC) are required to comply with these specifications. An example of contract specifications is presented in Chapter 7, and only a few special points are mentioned here.

Fully automatic batch plants with computer printout for each batch are used on Norwegian dams. Statistics indicate that the plant computer controls the bitumen content and aggregate weights more accurately than the control laboratory tests can measure. Table 4.1 shows an example from Storvatn Dam (Chapter 5) of the weekly recorded standard deviation of mix parameters in per cent.

The computer alerts the operator if the proportion of any material deviates from the preset limits. Scales and screens in the asphalt plant must be checked regularly as errors in these are not detected by the computer. Mechanical properties of the aggregates including grain size distribution must be determined daily during production, and settings for the crusher openings and sieves must be adjusted to compensate for natural wear.

Removal of unacceptable asphaltic concrete placed in the core is expensive, time-consuming and difficult, and the number one rule is therefore never to gamble on the quality of any asphaltic concrete delivered for placement (Section 7.2).

Drilling in order to obtain control specimens from the core, can only be performed when the asphalt has cooled down. This normally takes several days, and core drilling can accordingly not be performed as a daily control. New control methods measuring the density (void content) by means of non-destructive, isotope methods have proved promising. However, these methods require further development to improve accuracy and reliability and do not yet eliminate the need for periodic core drilling.

**Table 4.1** Weekly standard deviation of mix parameters from design values at Storvatn Dam (given in per cent)

Bitumen content	Filler content	Content of < 2 mm	Content of < 4 mm	Content of < 8 mm
0.0587	0.0089	0.184	0.213	0.140
0.0622	0.103	0.233	0.270	0.146
0.0380	0.133	0.195	0.286	0.201
0.0611	0.122	0.409	0.576	0.262
0.0544	0.095	0.300	0.254	0.151
0.0500	0.086	0.220	0.141	0.123
0.0843	0.102	0.392	0.263	9.177
0.0585	0.068	0.220	0.221	0.226
0.0692	0.122	0.454	0.619	0.266
0.0597	0.165	0.409	0.326	0.203
0.0717	0.132	0.433	0.492	0.284

# Chapter 5

## Case Study - The Storvatn Dam

The Storvatn Dam and 3 other large and 9 small dams of various types form the Blåsjø Reservoir which is part of the Ulla-Førre scheme. The location is in South West Norway, about 60 km east of the city of Stavanger. Two power stations, two pumped power stations and one pump station account for a net production of approximately 4500 GWh in an average year. The Blåsjø Reservoir, with a capacity of  $3.1 \times 10^9 \text{ m}^3$ , is situated on a mountain plateau, and the maximum storage level is 1055.0 m a.s.l. (see Fig. 1.1). The Storvatn Dam, which is presented below, was completed in 1987.

### 5.1 Dam design

At the early planning stage in the late 1960's, Storvatn Dam, as well as the other large embankment dams around the Blåsjø Reservoir, were designed as rockfill dams with central core of moraine. The design volume of Storvatn Dam was then  $10 \times 10^6 \text{ m}^3$  with a maximum height of 90 m. Rockfill could be quarried at the site, but the hauling distance of morainic material and filter material was 42 km and 28 km, respectively, which was greater than for the other dams in the scheme. The large cost of transportation including extra cost to build mountain roads to allow the heavy transport, called for an alternative design. This request was also supported by the fact that the total volume of borrow material was limited. Therefore, if Storvatn could leave the moraine to be used in the other dams, their thin cores could be widened and made safer.

Four alternative impervious elements were examined:

- Upstream facing of Portland cement concrete or asphaltic concrete
- Central core of asphaltic concrete
- Central core of crushed rock with grain size distribution similar to that of moraine

To decide among these alternatives the following points of consideration were evaluated:

- Construction cost
- Value of water stored during construction
- Sensitivity to severe weather conditions during construction
- Performance of previously completed dams

It would take three years of average precipitation to fill the reservoir, and the economic value of water which could be stored during construction was significant. A rockfill dam with an upstream facing cannot store water during construction to the same degree as a dam with a central core, and an estimate of total cost and benefit

favoured the latter type. The final decision was therefore whether the central core should consist of asphaltic concrete or crushed rock.

The rock at the site consists mainly of granitic gneiss, and test results showed that quarried rock could be crushed down to a grain size distribution similar to moraine. The crushed rock was sufficiently impervious and behaved in laboratory testing very much like a coarse grained moraine. It was therefore considered suitable as core material.

Cost estimates showed that at equal cost the maximum gradient through the core of crushed rock would be 3 compared to the maximum gradient through the asphaltic core of about 100. However, the crushing of  $0.75 \times 10^6 \text{ m}^3$  of rock down to the grain size of a moraine has no precedence in Norway, whereas the production of  $50,000 \text{ m}^3$  of asphaltic concrete over several years could be handled with well-known equipment. Furthermore, the construction of the core of asphaltic concrete would be much less sensitive to bad weather conditions than the core of crushed rock.

In the late 1970's the choice was made. The Storvatn Dam should be a rockfill dam with a central core of asphaltic concrete. When that overall decision was made, the further design involved location of the dam axis, foundation preparation, cross section geometry and zoning of the dam embankment.

### **Location and alignment of the dam axis**

Generally the dam axis should be located in such a way that the volume of the dam is a minimum, and if no significant additional volume is required, the dam axis should be curved convex to the reservoir.

At the site of Storvatn the axis giving the minimum volume is partly straight, partly curved concave and partly convex to the reservoir (see Figs 5.1 and 5.2). A straight axis all across the natural lake gave a maximum height of dam approximately 10 m higher and the corresponding volume about  $10^6 \text{ m}^3$  larger. For a dam everywhere curved convex to the reservoir the difference would be even larger. Avoiding the local concave curvature of the dam required an extra cost of approximately 10%.

The question was therefore how large negative effects a concave curvature would have on the dam behaviour. It is well known that an internal core in a rockfill dam usually displaces a little upstream during the early stages of filling, but is subsequently pushed downstream as impounding proceeds. This displacement would create extensional strains in the core of concave curvature and could, depending on the extent of straining, lead to transverse cracks. Finite element analyses showed, however, that the extensional strains to be expected would be very small and acceptable. They would be smaller than those predicted at the steep right abutment. The alignment of the dam as shown on Fig. 5.2 was therefore decided upon in spite of the undesirable curvature over a portion of the embankment.



Fig. 5.1 Photo of Storvatn Dam showing the unusual alignment

### Foundation

The asphaltic core should be founded on a concrete structure in a rock trench, and a grout curtain should be constructed underneath. A main question was, however, whether this concrete structure could be a simple concrete sill or should be a complete gallery.

The extra cost of erecting a gallery was estimated to approximately 10% of the total cost of the dam. Furthermore, erecting a gallery would possibly extend the period of construction by one year. Would the advantages of a gallery be worth the extra construction and time costs?

A concrete gallery may serve as a grouting gallery as well as an inspection gallery. However, the advantage of carrying out the primary construction grouting from a gallery was looked upon as minor or nil. The advantage of a grouting gallery therefore depended on the potential need for supplementary grouting during the lifetime of the dam. Based on the results of ten exploratory diamond drilled holes to depths greater than 50 m, the likelihood that the planned grout curtain would need future repair was judged to be very small. In any case, a potential future increase in permeability of the rock foundation, which in this formation would have to be moderate, was evaluated to be of relatively little economic significance. If essential, leakage at a later stage could be reduced by grouting from adits (tunnels) driven under the dam, at a cost corresponding to that of a gallery.

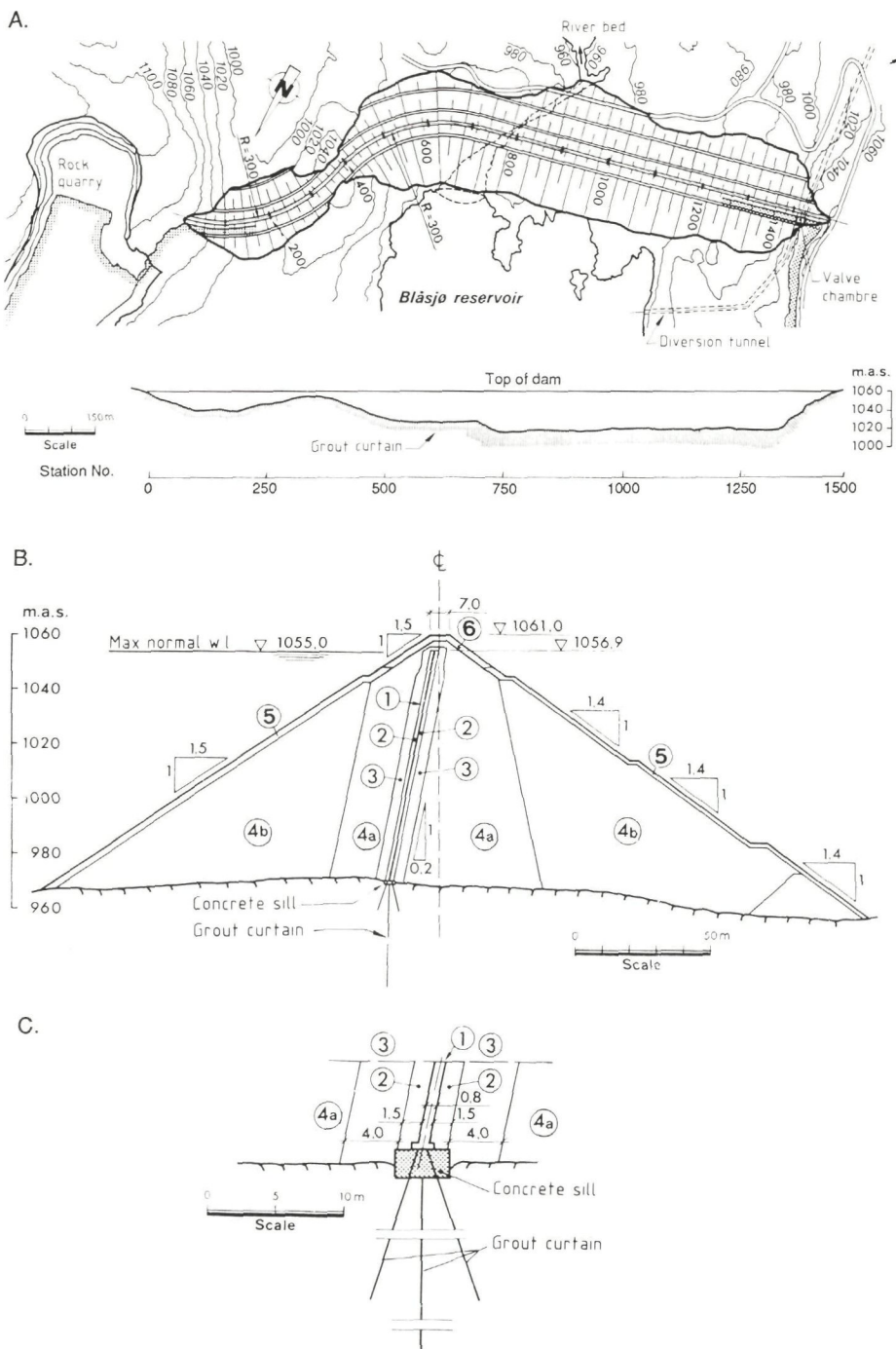

**Fig. 5.2 Design of Storvatn Dam**  
**A. Plan and cross-valley profile**  
**B. Principal cross section**  
**C. Core base and foundation sill**

The grouting work subsequently carried out involved 2080 boreholes, three rows, c/c 1.5 m, to a maximum depth of 75 m, making up 32,140 m and a grout take of 180 tonnes. The cost of this work corresponds to approximately 15% of the cost difference between a concrete gallery and a simple concrete sill. Therefore, when the foundation consists of good rock, as is the case for the Storvatn Dam, the cost of a grouting gallery seems to be an unreasonably high insurance premium.

On the advice of the consulting engineer, the owner decided to omit the concrete gallery and let the asphaltic core rest on a concrete sill. This sill was to be cast in a rock trench, reinforced and anchored. The width of the sill varies between 4 and 5 m. The minimum depth of the trench was set at 0.5 m, the minimum thickness of the sill to 0.75 m, and the sill should not anywhere protrude more than 1.5 m above the adjacent rock surface. Some chemical grouting was used to seal cracks in the concrete sill after construction. (It may be noted that for the Storglomvatn Dam currently under construction on a karstic foundation, a grouting tunnel at approximately 20 m depth is included as described in Chapter 3).

Omitting the concrete gallery at Storvatn Dam, made it necessary to collect and measure the seepage downstream of the core where it was recorded within eight separate segments along the dam.

### **Cross section and specified compaction**

The cross section of the dam was designed and built with the aim to minimize the embankment displacements and deformations as much as possible within practical and economical constraints. Final zoning, material and compaction specifications are presented in Fig. 5.2 and Table 3.3.

The thin core wall is inclined, producing a favourable transfer of the water load to the downstream rockfill and foundation. Even the top of the core wall is situated upstream of the centre line of the dam, leaving a large proportion of the rock fill as a support for the water load.

The thickness of the core wall decreases in steps of 0.1 m from 0.8 m at the base to 0.5 m at the top. The core rests on a slab of asphaltic concrete 0.4 m thick and 1.5 m wide, placed on top of the concrete sill. The interface between the asphaltic slab and the concrete sill was cleaned by sand blasting, primed and coated with asphaltic mastic with a special additive to enhance interface bonding.

The asphaltic concrete in the core wall was specified to be placed in layers of 0.2 m thickness. Each layer is displaced 50 mm downstream in relation to the foregoing layer to obtain the prescribed inclination of the core. The thickness of the wall is defined as the width of the interface between successive layers. Adjacent to the core, a zone 1.5 m wide, consisting of crushed rock 0 - 60 mm, is placed in layers of 0.2 m and compacted by vibratory rollers simultaneously with the asphaltic concrete.

Between zone 2 and the supporting fill of blasted rock (granitic gneiss) is placed a transition zone (zone 3) of processed rock 0 - 200 mm. This zone, 4 m wide, is placed in layers of 0.4 m and compacted by vibratory rollers. Zone 4a is placed in layers of 0.8 m, sluiced and compacted by vibration, whereas the rock in zone 4b is placed in layers of 1.6 m and compacted by vibration without sluicing. The slope protection upstream and downstream consists of blocks weighing approximately 1.5 tonnes each, individually placed by backhoe.

The design analyses included use of the finite element method for computing embankment displacements and deformations to assure that the strains imposed on the core were acceptable (Section 5.3). Furthermore, special earthquake analyses were performed as described in Section 5.4.

### **Mix design of asphaltic concrete**

The asphaltic concrete mix design specified:

- Quality and grain size distribution of aggregates
- Quality and content of bitumen
- Temperature at which the aggregates and bitumen should be mixed and compacted
- Upper limit of allowable air void content (porosity) of compacted asphaltic concrete in core

Based on laboratory prepared specimens with aggregates from the borrow pit, the owner specified the preliminary mix design in the tender documents. In these documents it was required that the contractor carry out additional testing on asphaltic concrete produced by his plant at the site. The contractor had the right and obligation to propose suitable adjustments to the specified mix before starting the construction of the asphaltic concrete core (see work specifications presented in Section 7.2).

## **5.2 Construction and control of the asphaltic concrete core**

### **Construction**

Up to-date Norwegian construction equipment and procedures are presented in Chapter 4.

The construction season at Storvatn was limited to between mid-May and mid-October. Snowdrifts up to 15 m prevented the access road to the dam from being opened before the first part of May. In the summer, heavy rain was prevailing, and the annual precipitation in the area is between 2500 mm and 3000 mm.

The plant for the production of the asphaltic concrete for the core was erected downstream the eastern part of the dam, giving transport distances in the range 1-3 km. The zone 2 material was produced in a crushing plant located on the same site as the



asphalt plant, and the aggregates for the asphaltic concrete were produced by the same plant.

The core placing equipment was designed and constructed especially for this job, taking advantage of the experience from the three first Norwegian dams built with compacted asphaltic concrete core (Table 3.1). Some special considerations at Storvatn were:

- construction should take place unhampered by wind and rain;
- very small tolerances were allowed regarding deviation from the centre line, as the dam core was not vertical but sloping 5:1;
- there was a requirement that the surface of the previous layer could be inspected immediately before the next layer was to be placed.

The construction took place with one asphaltic concrete placing machine during the first two construction seasons, but as the crest length increased, a second unit was brought into use as well. The actual production rate had to be adapted to the placing of the embankment and varied between 1 and 3 layers per day. The placing equipment was fitted with a two-stage vibrating screed for initial compaction of the asphaltic concrete, while the zone 2 material was initially compacted by a static roller and vibratory plate, connected to the back part of the machine. Both zones were then compacted by vibratory rollers to the specified density. (This equipment developed in 1981 for Storvatn Dam was not quite as advanced and convenient as today's version presented in Chapter 4).

### **Quality assurance and control (QA/QC)**

Quality control was exercised at every stage of the production, from monitoring the mixing plant and placing operations to sampling of raw materials as well as the finished core. To ensure high quality in the mixing process, a computer controlled asphalt plant was installed. Reports from the computer were displayed on the operator's screen and compared with the specified grain size distribution (Fig. 5.3).

For further details concerning QA/QC, reference is given to Chapters 4 and 7, and only a few points are mentioned here.

The properties of the asphaltic concrete mix were determined daily. The results had to be presented quickly in order to stop the work if some irregularity should occur. For every fifth layer and every 200 m section of the dam, vertical cores of 0.1 m diameter and 0.4 m length were taken. Additional cores were drilled on spots where visual control gave reason for concern. All cores were subject to tests for air void content which was required to be less than 3%.

The core length of approximately 0.4 m made it possible to go through two layers. All inspected layers proved to be properly bonded to each other with joints as tight as the layer itself.

The density (porosity) was also determined by means of a nuclear frequency counter. This equipment has the great advantage that it provides an estimate of the void volume within ten minutes after core compaction. However, on Storvatn Dam these results proved to be unreliable, and further development of the technique would have been required to make it useful in the quality control programme. (Entirely satisfactory equipment and techniques still do not exist today, 1993.)

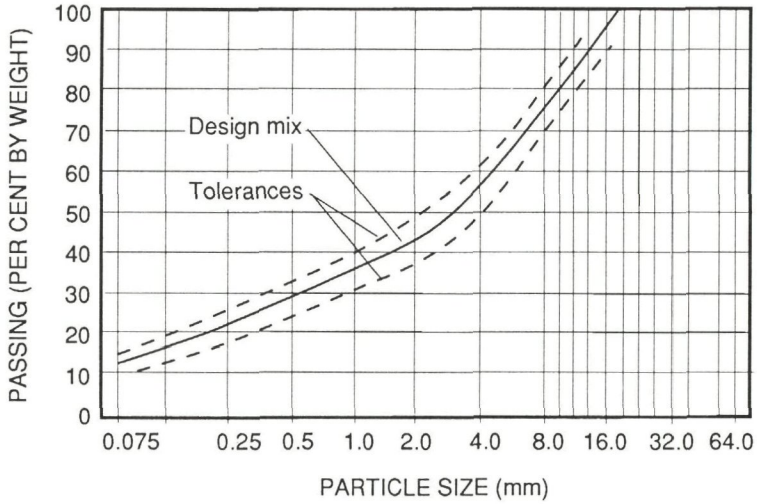

Fig. 5.3 Specified grain size distribution for aggregates in asphaltic concrete (Fuller's curve)

### 5.3 Predicted and observed dam performance

#### Field instrumentation programme

The extensive field instrumentation for Storvatn Dam, concentrated in three cross sections at stations 610, 730 and 940 (Fig. 5.2), included 12 inclined, vertical or horizontal inclinometer casings to measure deformations in the embankment and 28 extensometers for strain measurements in the asphaltic concrete core. Additionally, 284 survey monuments were located at regular intervals and at various levels along the embankment to measure surface displacements.

The leakage water is collected between the core foundation and walls erected 10-20 m further downstream. Within this area the leakage is registered for eight separate segments along the dam to localize any source of leakage. The registration is automatic and remotely recorded.

#### Leakage measurements

The measured total leakage is very small considering the height and length of dam. The highest total leakage is recorded at 10.2 l/s. However, some of the registered leakage water does not originate from the reservoir. A cross valley groundwater

flow was observed within section B (see Table 5.1 below) before raising the water level, and the measurements show that the total leakage decreased by up to 2 l/s during the cold winter months despite the constant reservoir level. Several months with temperature well below freezing will most certainly reduce a possible ground water flow and therefore explains the recorded reduction in leakage.

**Table 5.1 Registered leakage at Storvatn Dam**

Date	Storage level, m.a.s.l.	Registered leakage, l/s			
		Segment (Distance in m along the dam)			Total (25-1450)
		A (25-350)	B (350-1155)	C (1155-1450)	
850425	1004.7		6.7	0.2	6.9
860406	1025.2	0.2	8.0	1.5	9.7
870412	1041.1	0.1	7.8	2.2	10.1
871115	1050.5	0.2	8.0	2.0	10.2
881021	1052.2	0.1	8.0	1.9	10.0
890815	1055.3	0.1	7.0	1.9	9.0
901001	1054.6	0.1	6.6	0.9	7.6
911008	1052.2	0.1	6.2	0.8	7.1
920722	1052.6	0.3	6.8	0.4	7.5

The very small leakage recorded at Storvatn Dam is consistent with corresponding leakage measurements at for instance Finstertal Dam (Austria) and Meget Dam (Scotland), when the vertical projection area of the corresponding cores are considered. The conclusion is that a properly designed and constructed asphaltic concrete core is virtually impervious.

### **Prediction of embankment deformations**

Both linear and non-linear two-dimensional finite element analyses were performed, applying the sequential loading method described by Clough and Woodward (1967). The procedure used for approximating the material stress-strain behaviour is by successive load increments, within which the material behaviour is assumed to be linear. After each increment the deformation properties are re-evaluated in accordance with the stresses in the element. Three-dimensional, linear analyses were also performed to evaluate the accuracy of the two-dimensional idealizations.

The stress-strain properties of the rockfill were determined both through laboratory tests and field plate loading tests. The laboratory test programme consisted of fourteen triaxial tests and six oedometer tests. Five of the triaxial tests were carried out in NGI's large vacuum triaxial cell with specimen diameter 625 mm and height

1250 mm (Fig. 5.4). Conventional triaxial equipment with specimen diameter 102 mm and height 200 mm was used for the remaining nine triaxial tests. The six oedometer tests were performed in a fixed ring oedometer with specimen diameter 500 mm and height 250 mm.

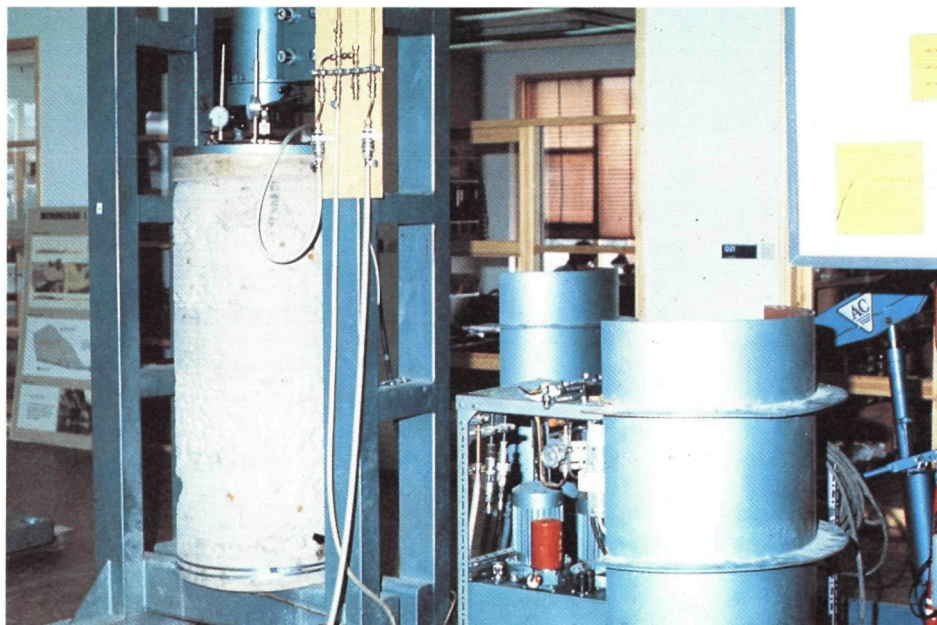

**Fig. 5.4** NGI's large vacuum triaxial test

The derivation of material parameters for use in the finite element analyses was carried out in two stages. In the first stage, the results of the laboratory tests were used directly in the analyses, and the calculated movements were compared with measurements taken during the early construction stages. Based on such comparisons, a final set of material parameters was selected for the subsequent analyses of the completion of the embankment and the raising of the water to full reservoir level.

The magnitude and distribution of the vertical and horizontal displacements predicted by the finite element analyses, are shown in Fig. 5.5 for the maximum cross section (station 940 in Fig. 5.2). No attempts were made to use the finite element model to predict the time-dependent creep deformations after end of construction and reservoir filling, and empirical relationships from earlier dams were applied for this purpose (Kjærnsli et al., 1992).

### **Deformation measurements**

The first set of complete deformation measurements was taken in October 1986 when the embankment was virtually completed (2 m from crest), and the water level was 17 m below full reservoir level. The registered displacements at that stage are shown in Fig. 5.6.

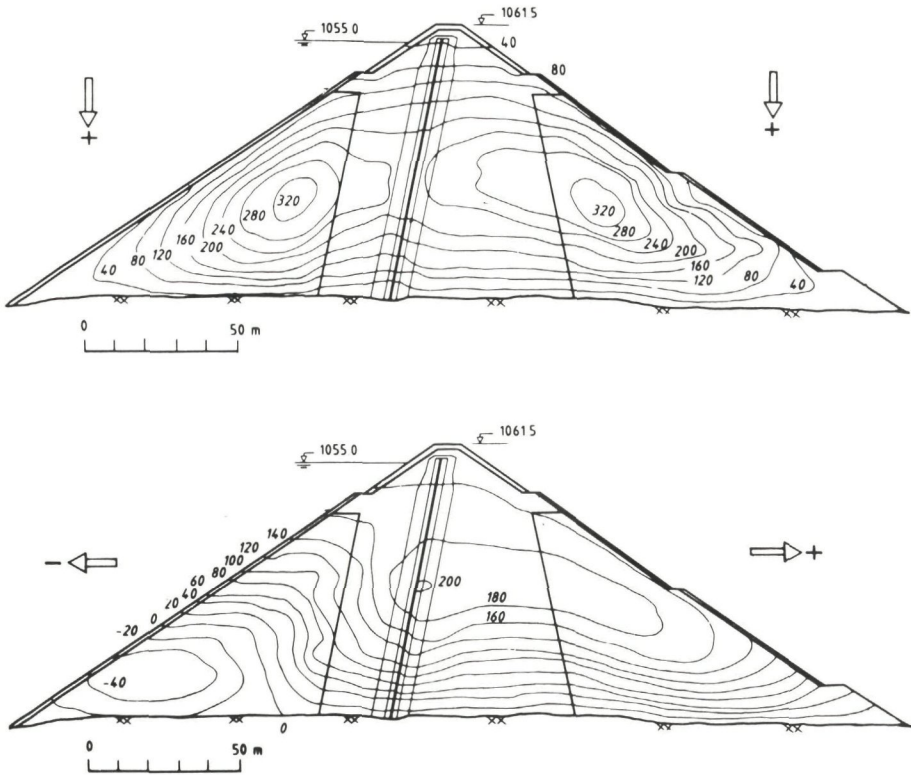

Fig. 5.5 Computed vertical and horizontal displacements in mm for the maximum cross section at full reservoir level

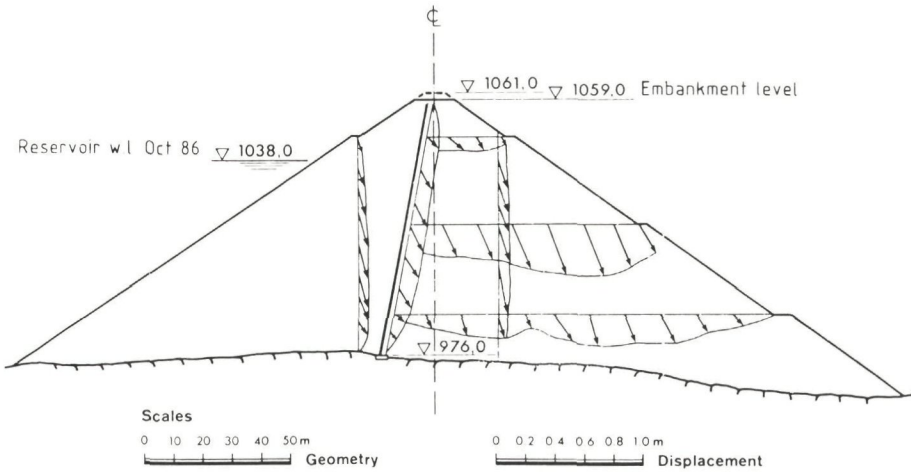

Fig. 5.6 Recorded displacements for the maximum cross section in October 1986

Due to the heavy compaction and good rockfill materials, the displacements are small. In general, they are in fair agreement with those computed by the finite element analyses described above. The displacements originally estimated, using directly the deformation parameters from the laboratory tests, were somewhat larger as the in-situ material behaviour was stiffer than the laboratory tests indicated. The displacements are of similar magnitude to those measured at Finstertal Dam in Austria, an asphaltic sloping core dam 100 m high (Pircher and Schwab, 1988). Further comparisons between computed and measured displacements are presented in the article by Adikari et al. (1988).

The maximum core displacements, which took place at about midheight, were 0.18 m vertically and 0.12 m horizontally in Oct. 1986. The maximum vertical settlement in the embankment at that time was 0.35 m, at a point located about mid-height 40 m downstream of the dam axis. The maximum horizontal displacement was measured near the same location, 10 m further downstream, and was 0.14 m.

Since October 1986 deformation measurements have been taken approximately every year. However, since 1990 the inclinometer readings inside the embankment have not been recorded and only the surface movements and settlements of the top of the core. The reservoir was full for the first time in September 1989. At that time the maximum vertical and horizontal displacements inside the downstream embankment were 0.50 m and 0.20 m, respectively, at the same locations as described above.

The recorded settlement vs time for the measuring point at the top of the core since end of construction is shown in Fig. 5.7. The settlement is primarily caused by creep, but there are also some contributions from the 17 m increase in reservoir level between 1986-89 and the load cycles from the slight lowering and raising of the reservoir level between 1989 and 1992.

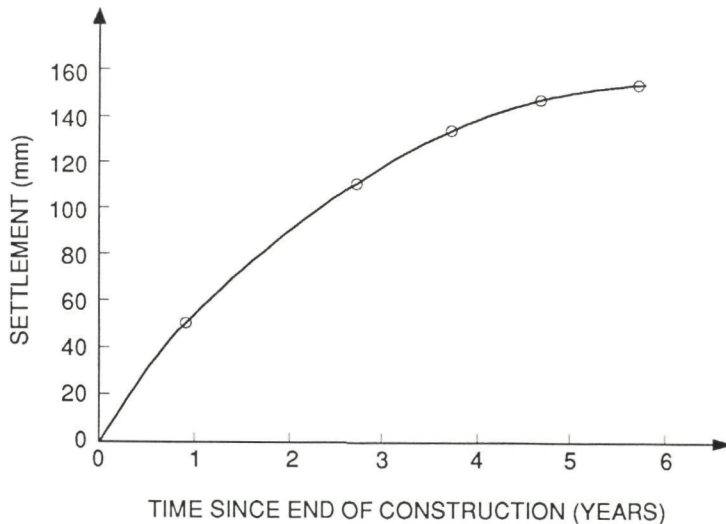

**Fig. 5.7** Recorded top-of-core settlement with time after end of embankment construction (close to maximum cross section at bolt No. XIX)

## 5.4 Predicted seismic response

### Design earthquake

The Storvatn Dam is located in an area of moderate seismic activity, and a study was conducted to evaluate the integrity of the dam under earthquake loading. Analyses were also performed for significantly more severe earthquakes (high seismicity) than can ever be expected at that site. This was done to study the ultimate earthquake resistance of this type of dam and to estimate the permanent (residual) deformations which could be induced during severe shaking.

The criteria adopted for the selection of the design earthquake loads were in accordance with the recommendations of the US Committee on Safety Criteria for Dams (1985). Two levels of earthquake loading were considered:

- *Operational safe earthquake (OSE)*: an earthquake event that is likely to occur during the economic life of the dam. The dam should withstand the OSE without any significant damage and be fully operational afterwards. The OSE was defined as ground shaking with a probability of occurrence of  $5 \times 10^{-3}$  per year (return period 200 years). The OSE corresponds to earthquake Richter magnitudes of 6.5 in the Storvatn area (moderate seismicity), and 7.5 in an area of high seismicity.
- *Maximum credible earthquake (MCE)*: the maximum earthquake event likely to occur at the dam site. The dam should survive the MCE without any sudden, uncontrolled release of the reservoir, but damage to the dam and any appurtenant structures would be tolerated. The MCE was defined as ground shaking with a probability of occurrence of  $10^{-4}$  per year (return period 10 000 years). The MCE corresponds to earthquake magnitudes of 7.5 in the Storvatn area, and 8.25 in an area of high seismicity.

### Pseudo-static stability analysis

In a conventional pseudo-static, limiting equilibrium, earthquake stability analysis, a horizontal earthquake force is applied to the sliding body in addition to the static forces. The additional horizontal force is proportional to the total mass of the sliding body, and the factor of proportionality is denoted "earthquake coefficient". This type of analysis is applicable only for dams constructed of materials that do not experience a significant reduction in strength during cyclic loading. The dense rock-fill, which makes up the bulk of Storvatn Dam, and the asphaltic concrete core are of this type. The permeability of the rockfill and the transition zones is so great that the excess pore pressures generated during cyclic loading dissipate quickly, and no significant accumulation of pore pressures takes place during an earthquake.

According to Seed (1979), the acceptable design criterion for a rockfill embankment dam exposed to earthquakes, is a pseudo-static factor of safety greater than 1.15 for an earthquake coefficient of 0.1 for a magnitude 6.5 event, and an earthquake coefficient of 0.15 for a magnitude 8.25 event.

Using the infinite slope method, considering the equilibrium of a shallow mass in the direction parallel to the slope, one may evaluate the pseudo-static factors of safety for the submerged upstream and the dry downstream slopes in closed-form. Stability analyses were also carried out by the circular arc method. The friction angle of the rockfill was specified as function of effective stress level and was conservatively taken as  $43^\circ$ -  $45^\circ$  on the upstream slope, and  $45^\circ$ -  $47^\circ$  on the downstream slope.

The results are presented in Fig. 5.8 which shows the variation of the computed factors of safety as function of the earthquake coefficient. The down-stream slope satisfies the stability criterion (factor of safety  $> 1.15$ ) for a magnitude 6.5 earthquake (earthquake coefficient = 0.1), and the upstream slope fails to satisfy this criterion by a very small margin. Should a dam like Storvatn be constructed in an area of high seismic risk, the gradient of the outer slopes of the dam would have to be decreased to satisfy the pseudo-static stability criterion. For an earthquake of magnitude 8.25, the upstream slope would need to be flattened from 1:1.5 to 1:1.85 and the downstream slope from 1:1.4 to 1:1.5.

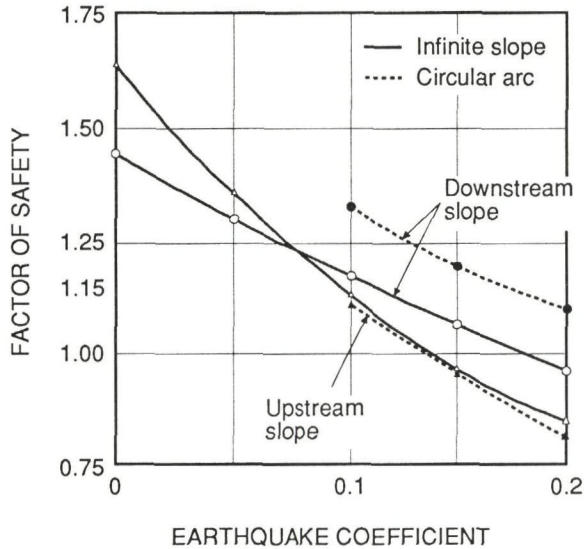

**Fig. 5.8 Results of pseudo-static stability analysis**

#### Dynamic analysis to compute induced permanent displacements

Additional analyses were performed to study the dynamic response of the dam and to estimate the permanent deformations which could be induced by a severe earthquake (Gazetas and Dakoulas, 1992).

Newmark (1965) suggested as a useful approximation that the potential failure mass in an embankment can be modelled as a rigid block sliding along a potential slip sur-



face. The yield acceleration is defined as the horizontal acceleration required to initiate sliding. This model does not account for the variations in ground motion along the potential failure surface caused by the dynamic response of the structure. Makdisi and Seed (1978) therefore proposed an equivalent linear earthquake response analysis to evaluate an average, effective base motion for estimating the permanent block displacements. In the study for Storvatn Dam, the acceleration time histories for the effective motion along the potential failure surface were obtained from simulations with the finite element computer program FLUSH (Lysmer et al., 1975).

The Taft earthquake in 1952, which had a magnitude of 7.6 was selected as the input bedrock motion for the analyses. The horizontal component of that earthquake was scaled to a peak acceleration of 0.5 g, and the vertical component to a peak acceleration of 0.32 g. Two sets of analyses were carried out. In the first one, only the horizontal component of the earthquake motion was applied; in the second, both the horizontal and the vertical components were applied simultaneously. Figure 5.9 shows the contours of the computed maximum horizontal accelerations for the first case and Fig. 5.10 the maximum horizontal and vertical accelerations at selected points for the second. Contours of the computed maximum cyclic shear strains are also shown in Fig. 5.10.

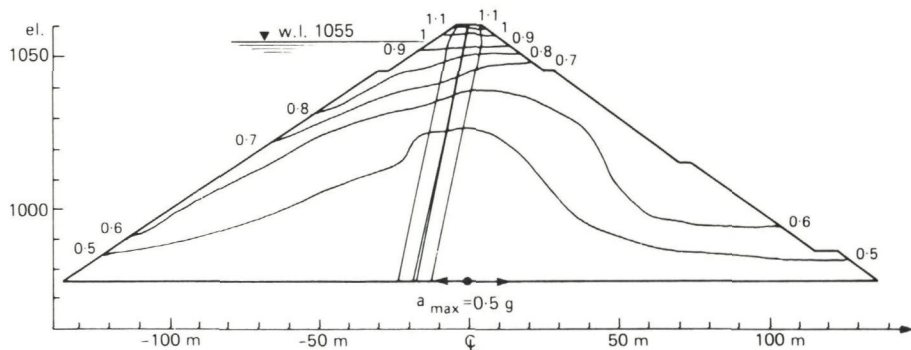

**Fig. 5.9 Computed maximum horizontal accelerations caused by horizontal base motion**

Valstad et al. (1991) provide details of the analyses and discuss the case where the permanent shear displacements due to severe shaking of the dam, are so great that the thin core may be sheared off in the top portion. In their computations they conservatively assume that the permanent shear displacements are all concentrated along a single shear surface through the core. In reality the shear distortion may be distributed vertically over a shear zone and thus be less likely to open a gap between the top and lower part of the impervious core.

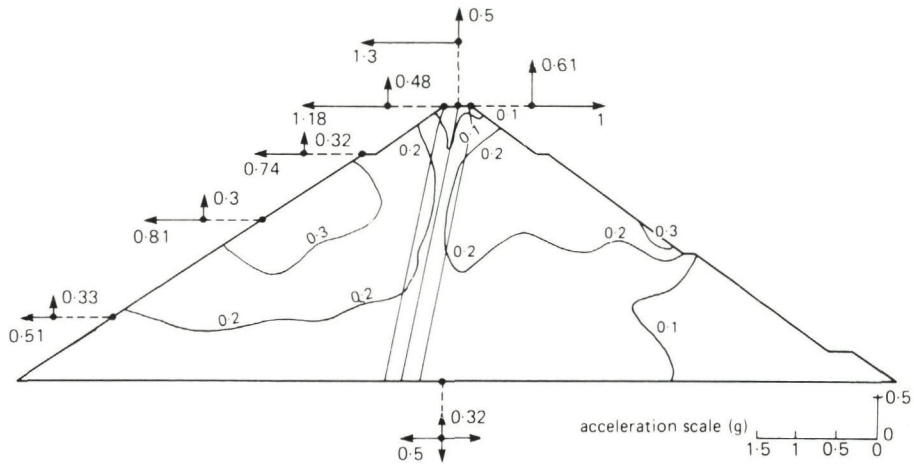

**Fig. 5.10** Computed maximum accelerations and cyclic shear strains caused by combined horizontal and vertical base motions

### Summary of seismic response analysis

The analyses demonstrate that the Storvatn Dam has an ample margin of safety for earthquakes in the region. The design would enable the dam to function adequately even in an area of high seismicity if the inclination of the outer slopes were decreased from 1:1.5 to 1:1.85 upstream and from 1:1.4 to 1:1.5 downstream. The same core assembly (core and filter/transition zones) could be used.

During an extreme earthquake, the induced permanent shear displacements for an embankment dam, may become so large that a narrow core is sheared off and a gap opens. Then it will be the depth of the gap beneath the water level and the permeability of the filter/transition zones that will govern the magnitude of the leakage rate until the reservoir is lowered. For such an eventuality it would be advisable to have a relatively fine-grained material next to the asphaltic core. In any case, it is essential that the downstream shell and toe is designed with adequate drainage capacity to handle accidental leakage and prevent dam failure even if the temporary water loss is dramatic (Kjærnsli et al., 1992).

The main reasons for the favourable seismic behaviour of a rockfill dam with an asphaltic concrete core are as follows:

- The dam is built with core and embankment materials that do not experience any significant reduction in strength during cyclic loading. The permeability of the dense rockfill which makes up the bulk of the dam is so great that the excess pore pressures generated during cyclic loading dissipate quickly, and no significant accumulation of pore pressures takes place during the earthquake.

- The dam can tolerate large permanent shear deformations without experiencing an uncontrolled release of the reservoir water. This type of behaviour is likely to prevent failure even in the event of an extreme earthquake.

## **Acknowledgment**

The information presented in this Chapter is primarily extracted from the articles by Arnevik et al. (1988), Adikari et al. (1988), Valstad et al. (1991) and recent field performance observation reports (see list of references in the back). Most of the work behind these articles has been sponsored by STATKRAFT (The Norwegian Energy Corporation), and their support and permission to publish the data are gratefully acknowledged.

# Chapter 6

## Design - Principles and Requirements

ICOLD Bulletin 84 (1992) presents recommendations related to the use of bituminous cores in embankment dams. This bulletin supplements Bulletin 42 (1982) with experience gained through recent developments in construction methods and field performance monitoring for dams with asphaltic concrete core.

A summary of requirements to design analyses, materials and material testing is presented below with particular emphasis on results from Norwegian research and field practice. The requirements to construction equipment and procedures and the accompanying work specifications and quality assurance are presented in Chapters 4 and 7.

### 6.1 Design analyses

The thin asphaltic concrete core has to adjust to the deformations in the embankment and to differential displacements in the dam foundation (Fig. 6.1). Displacements accumulate during embankment construction, filling of reservoir, time-dependent consolidation and creep, fluctuations in reservoir level and any earthquake shaking or fault movements. The essential function of the core is to remain impervious without any significant increase in permeability due to shear dilatancy or cracking. Furthermore, should cracks occur, the asphaltic concrete mix design should be such that viscous creep and plastic flow will gradually close these cracks (self-healing ability).

For a dam founded on bedrock the key to limiting the embankment deformations lies in the material properties and in the compaction of the transition zones and supporting shells (shoulders). If the embankment is founded on compressible soil overburden, differential distortions due to unequal settlements under the embankment are likely to occur both across and along the valley.

Comparison with and evaluation of field measurements from existing dams combined with finite element analyses, is the best way to predict the deformations and distortions in new structures (Kjærnsli et al., 1992). The probable ranges for important parameters should be included in the analyses to study the sensitivity of the numerical predictions to uncertainties in the embankment and foundation properties.

The stress and strain levels in the core, estimated from finite element design analyses, are used when modelling the behaviour of the asphaltic concrete in the laboratory. The laboratory specimens are subject to conditions approximating those that will exist in the field, and the behaviour is studied with respect to degree of dilatancy and increase in permeability, ductility and cracking resistance, stiffness and strength, and self-healing ability after a crack has formed.



**Fig. 6.1** The thin asphaltic concrete core adjusts to the deformations in the embankment (from the construction of Storvatn Dam)

The fact that the properties of asphaltic concrete can, within fairly wide limits, be tailored to satisfy specific design requirements, is an important aspect and advantage of the method of using bituminous cores in embankment dams.

In finite element stress-strain analyses, which do not properly model the time-dependent, viscous behaviour, it is difficult to assign appropriate, equivalent deformation moduli for asphaltic concrete. The values strongly depend on temperature and strain rate during loading. However, a non-linear analysis approximated by linear steps simulating the embankment construction sequence, is still very useful in design and in interpreting field deformation observations. When one uses a formulation based on concepts from the theory of elasticity, Young's modulus ( $E$ ) and Poisson's ratio are commonly specified for the different materials in and under the embankment. Asphaltic concrete may then, depending on the mix, be assigned a fairly low  $E$ -value to partly account for the viscous creep behaviour. However, the bulk (volumetric) and one-dimensional moduli for asphaltic concrete are high, as there is very little air in the pores which are virtually filled (saturated) with bitumen. Thus, the analysis requires that Poisson's ratio be specified close to 0.5 or the bulk modulus be given explicitly as an input parameter. Failure to recognize this may lead to significant underestimation of stresses in the core.

### **6.1.1 Typical core design**

As described in Chapters 4 and 7, the core and adjacent filter/transition zones are placed in approximately 0.2 m thick layers and compacted simultaneously during

construction. This construction procedure gives the hot asphaltic concrete immediate lateral support and close interlocking along the core-filter interface. The contour of that interface is not smooth but jagged as observed in situ after placement and compaction (Fig. 6.2). This is caused by the slight squeezing of the hot asphalt at the base of the layer and bulging at the top.

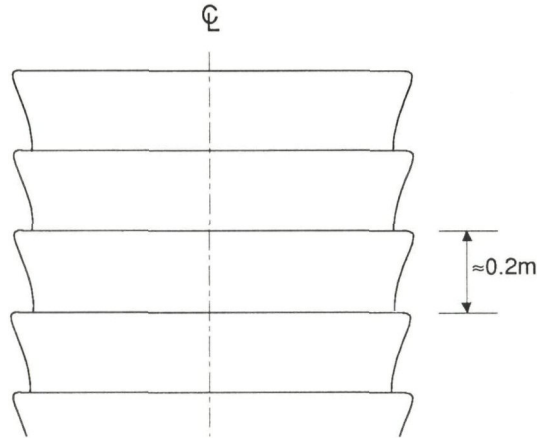

**Fig. 6.2 Core cross section after placement and compaction**

The core thickness may be decreased from core base to top, usually in steps of 0.1 m. For the Storvatn Dam described in Chapter 5, the base width was 0.8 m and the top width 0.5 m. Modern construction equipment may produce a gradual tapering, not stepped, if that modification in procedure is found economical.

Among the existing large dams with compacted asphaltic concrete core, the minimum core width, in the top portion of the embankment, is 0.4 m. The maximum thickness so far used is in a 105 m high dam in Hong Kong where the bottom portion is 1.2 m wide. An undocumented rule-of-thumb has evolved which calls for a core thickness at any level of at least 1% of the head difference between the upstream and downstream sides of the core at that level. With modern construction procedures and quality control this seems an unduly conservative practice for high dams. Norwegian experience suggests a minimum core thickness of 0.5 m, and no more than 1.0 m should be necessary, unless there are very special circumstances, for instance in extreme earthquake regions or for embankments on compressible, erratic foundations.

ICOLD Bulletin 84 (1992) states that an upward tapering of the core, as so often practised, cannot be recommended "due to the multiple stressing to which the impervious element is subjected". In high dams, and where the cost of bitumen and asphaltic concrete production is significant, this practice would lead to an unreasonable additional cost not warranted from a safety point of view.

The core is given a central position in the embankment. The core in Storvatn Dam (Chapter 5) has a downstream slope 5:1, but the highest dam now under construction, the Storglomvatn Dam (Chapter 3), has been given a vertical core. The additional construction and material costs of using a sloping core do not seem warranted. Although a sloping core gives the advantage of producing a favourable transfer of the water load to the downstream shell, a vertical, central core is subject to smaller shear stresses. A vertical core is also somewhat easier to repair by grouting than an inclined core, in the unlikely event that cracks should occur and repair be required. Boreholes may then be drilled in the upstream filter zone and grout injected to seal the leakage once it is located.

It does not seem necessary or advantageous to incline the top portion of vertical asphaltic concrete cores in high dam as so often practised.

In a narrow V-shaped valley with steep flanks, and especially if the embankment is resting on a compressible soil overburden, cross-valley arching will be significant and should be analyzed. In the design analyses one should check the stresses in the plane of the core and evaluate the shear distortions, dilation and potential cracking that may occur.

### 6.1.2 Filter/transition zone

There is a practical limit to the combined width of core and filter/transition zones that may be placed simultaneously by the asphaltic concrete placing machine. The outer parts of the transition zones may therefore have to be placed independently by other equipment. The minimum width of the filter/transition zone placed simultaneously with the core should be no less than 1.0 m.

The filter/transition zone should preferably consist of crushed hard rock with maximum grain size 60 mm,  $d_{50} > 10$  mm and  $d_{15} < 10$  mm. Crushed, angular rock usually gives somewhat more stable support to the core and placing machine than naturally rounded gravel. The transition material should have stretched gradation curve, and one must regularly monitor and control the grain size distribution. The difference in grain size between aggregates in core, in filter/transition and adjacent supporting shell must not be too great. ICOLD (1992) gives the following guideline:

$$d_{100}^{\text{core}} \geq d_{10}^{\text{trans.}} \quad \text{and} \quad d_{100}^{\text{trans.}} \geq \frac{1}{4}d_{100}^{\text{shell}}$$

Some designers recommend the addition of fine grain materials to the upstream filter/transition zone. The reasoning is that if a defect exists or a crack opens in the core, the transport of fine particles into the defect will reduce the leakage until the viscous, plastic flow of the asphaltic concrete causes self-healing. However, it may also be argued that the migration of fine particles into the crack will impair the healing and be detrimental in the long run.

During extreme earthquake shaking, the core may be partly sheared off due to large displacements in the top portion of the embankment (Section 5.4). The leakage rate through the core will then depend on the width of the sheared zone, its depth below

reservoir level, and the permeability of the filter/transition zones next to the core. For such an extreme event, it would be beneficial to have added fine-grained material to the filter zones to reduce the leakage rate until the reservoir level can be lowered and repairs executed.

### 6.1.3 Supporting shell

For an embankment dam resting on a stiff foundation, the materials in the transition zones and supporting shells, the degree of compaction and uniformity, and the steepness of the dam slopes govern the deformations and distortions imposed on the thin core. For dams on compressible foundations additional displacements and differential movements are imposed and must be estimated and accounted for.

Kjærnsli et al. (1992) present field deformation measurements for a number of embankment dams and point out the effects of compaction equipment and energy input, construction layer thickness, water content for earth materials and rock size and water sluicing for rock materials, to reduce embankment deformations during and after construction. A slow and gradual reservoir filling gives the core time to adjust to this change in loading and any unpredicted, non-uniform deformations that might arise. Thus, the simultaneous embankment construction and filling of the reservoir, which the central asphaltic core method allows, is beneficial from a technical as well as economical point of view.

It is recommended to place an especially well compacted zone on either side of the filter zones, as done for Storvatn Dam (Zone 4a in Fig. 5.2) and the other dams presented in Chapter 3. Water sluicing, in addition to vibratory compaction of layers with moderate thickness, is usually specified for these zones to increase the deformation modulus.

For a well compacted embankment of good rockfill resting on bedrock, the dam slopes may be as steep as 1:1.3 to 1:1.4 as demonstrated by for instance the Finstertal (Pircher and Schwab, 1988) and Storvatn Dam (Chapter 5). Even so, the measured maximum displacements inside these two approx. 100 m high dams are very small (of the order 0.5 m) and the strains in the core far below allowable levels. The measurements agree quite well with the deformations computed by corresponding idealized finite element analyses.

For a given situation the designer may, to accommodate potentially large core distortions, have decided to use a particularly soft asphaltic concrete mix, super-saturated with a high bitumen content (see Section 6.2). The shear resistance of the asphaltic concrete will then be low. This must be considered when analysing the stability of the slopes of the supporting shells, especially if the embankment is founded on a soil foundation (overburden) which may develop excess pore pressures and reduced effective stresses and strength during potential earthquake shaking.



## 6.2 Asphaltic concrete mix design and properties

Standard asphaltic concrete core mix design criteria have been developed and, with relatively small variations, used for most of the recently built dams of this type (ICOLD, 1992). The aggregate composition complies with Fuller's gradation curve (Fig. 6.3) improved with a fine grain component smaller than 0.075 mm (filler material). Thereby the grain sizes from filler, sand and crushed rock or natural gravel usually lie between 0 - 16 or 18 mm. In order to increase the workability and compactibility, naturally rounded sand is often added with a gradation which complies with the Fuller curve approximated by the equation:

$$p_i = \left( \frac{d_i}{d_{\max}} \right)^{0.41} 100\%$$

where  $p_i$  is the percent by weight smaller than the equivalent grain size dimension,  $d_i$ .

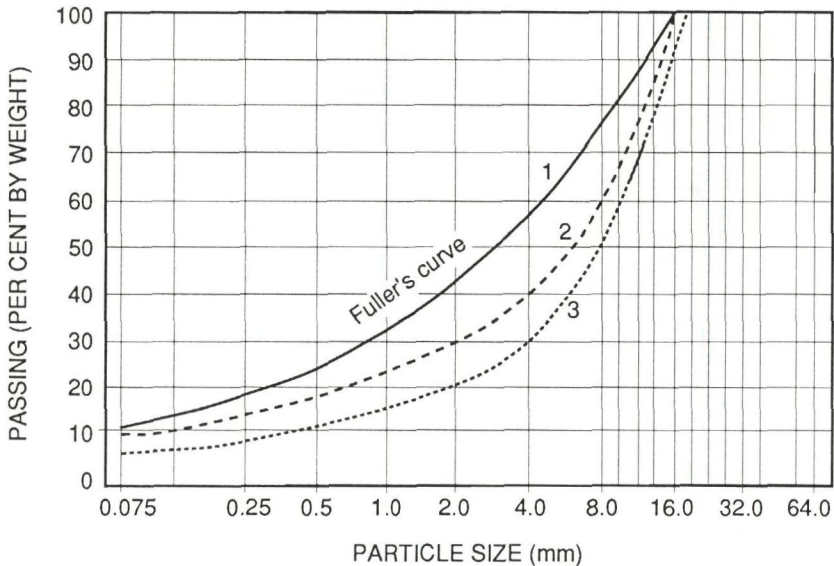
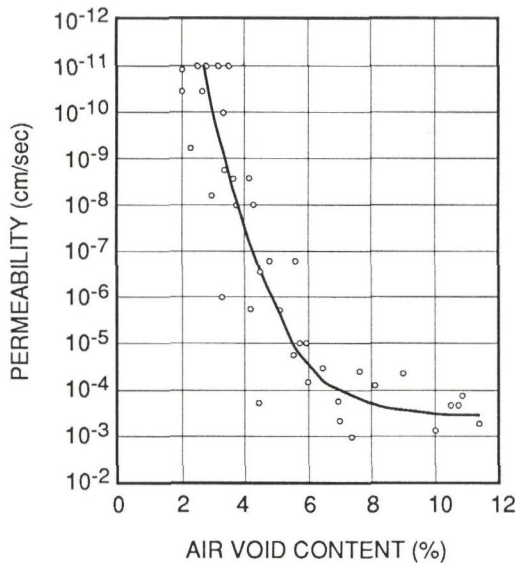

Fig. 6.3 Fuller's gradation curve for asphaltic concrete aggregates

The bitumen content is usually a little higher than just sufficient to theoretically fill the voids between the aggregates, and thus a close to maximum density is achieved during compaction. This would typically correspond to a bitumen content of 5.5 - 6% (of total weight), and the mix is then easy to place and compact to the required air void content of 3% (of total volume) or less. At this void content (porosity) the asphaltic concrete has been found, through extensive laboratory testing, to be practically impervious even under high water pressures (Kjærnsli et al., 1966; Bikar and Haas, 1973; Breth and Schwab, 1979). Above 3% the permeability increases fairly rapidly, and at 6% the permeability coefficient is about  $10^{-6}$  m/s (Fig. 6.4). Labora-

tory Marshall tests on the specified design mix should be required to show a volume of air voids less than 2% to account for the difference in degree of compaction achieved in the laboratory and in the field, respectively (see Section 6.3.1).

Laboratory tests on asphaltic concrete with the same bitumen content, 6.2%, and aggregates, but of different grain size distributions, show the importance of satisfying the Fuller curve criteria within reasonable margins. Figure 6.3 presents two grain size curves beneath the Fuller curve. Asphaltic concrete using curve 3-material could not be compacted to an air void content < 3%, it was relatively pervious, exhibited brittle behaviour and had the lowest strength of the three mixes. Asphaltic concrete using the Fuller curve and the same bitumen content was practically impervious, had the highest strength, was ductile and showed the greatest ability to sustain tensile and shear strains before cracking. In order to make an impervious asphaltic concrete with curve 3-material, a significantly higher bitumen content would have to be used.



**Fig. 6.4 Permeability of asphaltic concrete as function of air void content (after Kjærnsli et al., 1966)**

### 6.2.1 Aggregates and filler

The quality of aggregates is classified using standard testing procedures (e.g. Asphalt Institute, 1979; Statens Vegvesen, 1983) to determine flakiness and brittleness indices. The indices are measures of aggregate particle shape and mechanical resistance when subjected to a falling mass from a prescribed height. Only the aggregate grain sizes between 8 -16 mm are used for this purpose (Fig. 6.5). A high flakiness index indicates elongated particle shape, and high impact value indicates a brittle crushable aggregate.

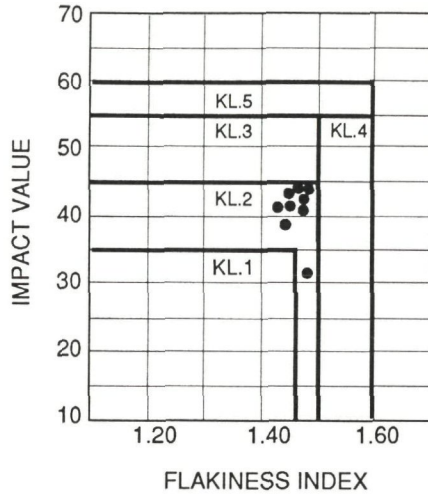

**Fig. 6.5** Quality testing of aggregates where KL.1 (Class 1) indicates highest quality (after Statens Vegvesen, 1983)

The acceptance criteria are adopted from road pavement engineering and may in some respects be unnecessarily strict. Once in place, the aggregates in a dam core are not exposed to abrasion, weathering and significant temperature changes as are road pavements.

On the other hand, the asphaltic concrete in the core for a high dam may be exposed to very high stresses. In a relatively dry asphaltic concrete mix, say bitumen content less than 5%, the contact stresses between aggregates of low strength (quality) may cause cracking and create flow paths for the water and increased permeability through the core. This may put requirements on the aggregate quality as discussed below. In a supersaturated mix, say bitumen content above 7%, there will be less contact between aggregate grains, and aggregate quality and increase in permeability may not be of concern.

The effects of aggregate quality on the stress-strain behaviour of asphaltic concrete at stress levels corresponding to those in very high embankment dams, were recently studied (NGI, 1992). Triaxial, strain-controlled, compression tests were performed on cylindrical specimens 100 x 200 mm. The lateral stress,  $\sigma_3$ , was kept constant while the axial stress,  $\sigma_1$ , was increased such that the axial strain rate was constant at 2%/hour. The temperature was held constant at 5°C throughout the test, and three different levels of  $\sigma_3$  (confining stress) were used 0.5, 1.0 and 2.0 MPa.

Three different types of aggregates were used, classified as very good to poor: crushed gabbro, crushed gneiss and crushed limestone (shale). These aggregates correspond to quality classes 2, 3 - 4 and 5 in Fig. 6.5, which shows results for the crushed gabbro.

Table 6.1 presents three asphaltic concrete mixes, which were all designed with a bitumen content corresponding to maximum dry density, following the Marshall laboratory compaction procedure, plus 0.1% (Tests 1 - 9). The aggregate grain size distribution satisfied Fuller's criteria. The differences in bitumen content in the mixes are due to small differences in the grain size distribution curves, grain shapes and the affinity of the aggregate surface to bitumen. The table also presents key results from the triaxial testing.

**Table 6.1 Different asphaltic concrete mixes tested in triaxial compression (axial strain rate 2%/h, testing temperature 5°C)**

Test No.	Aggregate type	Bitumen type	Bitumen content (%)	Confining stress, $\sigma_3$ (MPa)	Axial stress at failure, $\sigma_1$ (MPa)	$\frac{\sigma_1 - \sigma_3}{2}$ at failure (MPa)	$\frac{\sigma_1}{\sigma_3}$ at failure	Young's modulus (secant value at 1% axial strain) (MPa)
1	Crushed gabbro (very good)	B60	5.6	0.5	4.7	2.10	9.4	280
2		B60	5.6	1.0	6	2.50	6.0	290
3		B60	5.6	2.0	8.6	3.30	4.3	290
4	Crushed gneiss (good)	B60	5.9	0.5	4.6	2.05	9.2	290
5		B60	5.9	1.0	6	2.50	6.0	300
6		B60	5.9	2.0	8.7	3.35	4.3	300
7	Crushed limestone (poor)	B60	6.0	0.5	4.2	1.90	8.4	250
8		B60	6.0	1.0	5.5	2.25	5.5	270
9		B60	6.0	2.0	8.5	3.25	4.3	260
10	Crushed gneiss (good)	B60	8.0	1.0	4.4	1.70	4.4	110
11		B60	8.0	2.0	6.0	2.00	3.0	110
12	Crushed gneiss (good)	B180	5.9	1.0	4.3	1.65	4.3	140
13		B180	5.9	2.0	6.0	2.00	3.0	90

The resulting stress-strain curves at corresponding levels of confining stress show little difference among the three asphaltic concrete mixes. All curves showed plastic yielding behaviour after the maximum shear stress was reached, without any strain-softening. This is due to the relatively high confining stresses used compared to those in earlier tests reported in the literature. At an axial strain of 1%, the secant value of Young's modulus for  $\sigma_3 = 2.0$  MPa, was 290 MPa for the mix with the best aggregate and 260 MPa for the mix with the poorest aggregate. There was

somewhat more volume expansion (dilatancy) for the former as the shear stresses increased and failure was approaching.

Young's modulus for asphaltic concrete shows little increase with increasing confining stress. This is in contrast with results from triaxial samples of the aggregate alone, which show a modulus increasing markedly with increasing  $\sigma_3$ .

The compressive strength values for the three mixes differed very little. The strength of the mix with the poor aggregate (Tests 7 - 9) was only slightly lower than for the very good aggregate mix (Tests 1 - 3) as shown in Table 6.1 and Fig. 6.6.

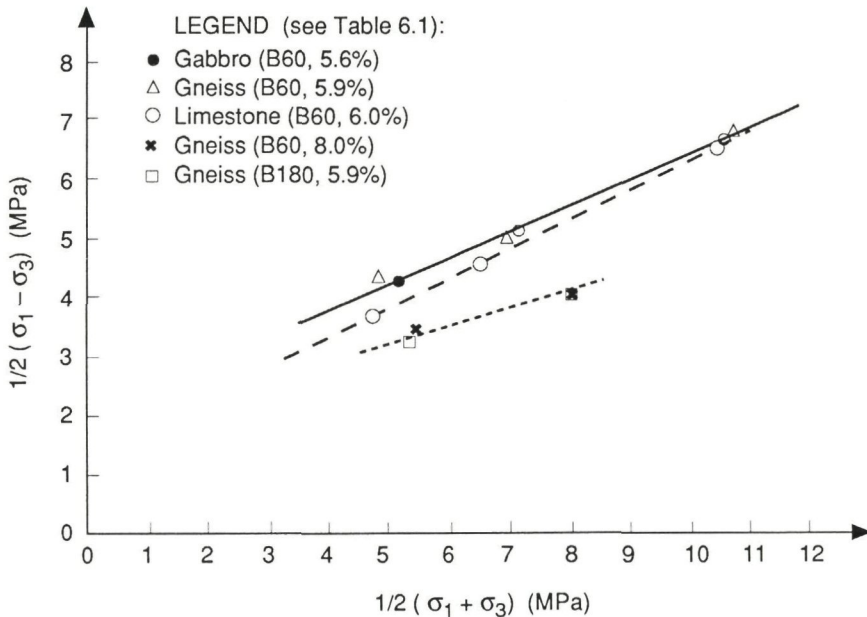

**Fig. 6.6** Strength of different asphaltic concrete mixes determined from tri-axial compression tests

In conclusion, the difference in quality of the aggregates tested in this study had little effect on the asphaltic concrete stress-strain-strength behaviour.

However, aggregate flakiness has effect on the content of bitumen required in a mix to obtain the specified low porosity and hence permeability. The series of Marshall tests performed to determine the optimum design mixes with the three aggregate types clearly demonstrated this. At a bitumen content of 5.5%, the mix with the gabbro aggregate had a significantly lower porosity than the mix with the limestone aggregate with higher flakiness index.

Typically the total weight of fine-grained material smaller than 0.075 mm (filler) constitutes 12% (Fig. 6.3). Of this about half may be added fines in the form of

Portland cement or crushed limestone to supplement the fines recovered from the mechanical crushing of aggregates. The maximum allowable quantity of fines taken from the crushed aggregates themselves, depends on the acidity of the aggregates and must be evaluated in each case (Section 7.2.6).

### 6.2.2 Effect of bitumen content and viscosity

In most dams so far built with compacted asphaltic concrete core, the bitumen content has been somewhat higher than that required for optimum density achieved in Marshall compaction tests. The aggregate grain size distribution has in all recent dams satisfied the Fuller curve within reasonable margins. Depending on the type of aggregate, flakiness, mineral composition and surface characteristics, exact grain size distribution and viscosity of bitumen, this will commonly lead to a bitumen content in the range 5.5 - 6.5% by total weight of asphaltic concrete mix.

A lower bitumen content leads to an asphaltic concrete mix which is less workable, more difficult to place and compact, and it will be more pervious. A higher bitumen content makes for a softer mix which has more pronounced viscoelastic-plastic properties, has lower stiffness and strength but is less pervious.

High shear stresses imposed on asphaltic concrete may lead to shear dilatancy and volume expansion. Figure 6.7 shows the degree of dilatancy as a function of bitumen content (type B80) and axial strain in triaxial compression tests as described in Section 6.2.1. The results are plotted for two different confining stress levels and clearly show the reduced dilatancy with increasing bitumen content. Furthermore, as is reasonable, the dilatancy is reduced when the confining stress is increased. For a bitumen content of 8% there is virtually no volume change for the test with low confining stress and actually a volume reduction for the higher confining stress.

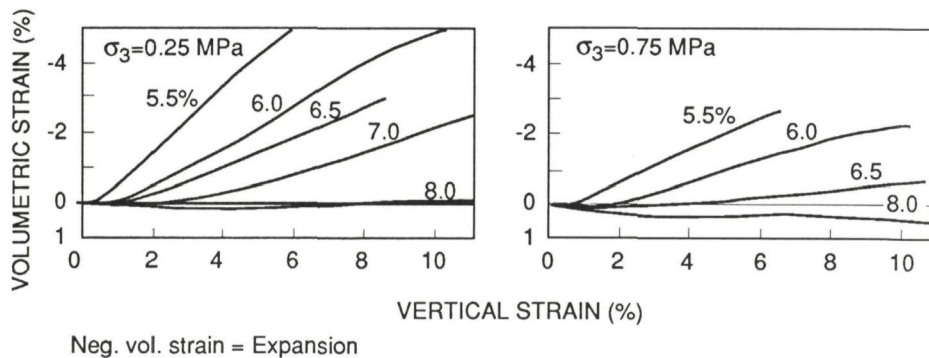

Fig. 6.7 Degree of dilatancy as function of bitumen content (after Breth and Schwab, 1979)

The dilation causes an increase in permeability due to the opening of small fissures, although no visible cracks may appear. Therefore, the increase in permeability may become much larger than the increase in volume would indicate, because the shear strains and resulting dilatancy may have caused fissures that interconnect.

This has been demonstrated by permeability tests on specimens first tested in triaxial compression (NGI, 1985). In the regions of high shear strains along the failure plane, smaller samples were cut out of the triaxial specimens. These small samples were in turn tested in a permeameter. Although the volumetric strain during dilation only amounted to 1 - 2% expansion, the permeability coefficient showed an increase by a factor of  $10^3 - 10^5$ . This increase can only be explained by a set of communicating fissures (cracks). However, the increase in permeability only occurred as fissures opened for shear deformations close to the failure level (strength) for the asphaltic concrete. No significant increase was detectable until about 80% of the strength was mobilized.

To study the effect of increasing the bitumen content on deformation modulus and strength, additional triaxial tests were run on asphaltic concrete specimens with the crushed gneiss aggregate in Table 6.1. The bitumen content was increased from 5.9% to 8% in Tests 10 and 11. The same strain rate (2%/h) and temperature (5°C) were specified as for the previous tests. The secant deformation modulus at 1% axial strain and  $\sigma_3 = 2$  MPa was reduced from 300 MPa to 110 MPa, and the shear strength was reduced from 3.35 MPa to 2.00 MPa (Fig. 6.6). Furthermore, a small volume contraction rather than dilation occurred, in agreement with the results presented in Fig. 6.7.

To study the effects of reducing bitumen viscosity, but keeping the bitumen content at 5.9%, supplementary triaxial tests were performed (Table 6.1). Bitumen type B180 was used rather than B60. The results from these tests (Tests 12 and 13) with 5.9% B180 were very similar (by coincidence almost identical) to those obtained for 8% B60 both with respect to stress-strain behaviour and strength (Fig. 6.6 and Table 6.1).

These new laboratory tests, and others reported in the literature, demonstrate that the properties of the asphaltic concrete mix may be designed to satisfy specific engineering requirements for a given situation. The potential extra costs of achieving special properties, for instance by increasing the bitumen content, must in each case be compared with the benefits in terms of safety and reliability.

Recent field tests in Norway demonstrated that even with a low-viscosity soft bitumen (B180) and a content as high as 8%, the placing equipment and procedures described in Chapter 4 could be successfully applied. However, when the bitumen content exceeds 10%, one gets a supersaturated "flowable" asphaltic concrete which cannot be effectively compacted. Section 2.1 briefly discussed hand-placement procedures and use of shutters for such high bitumen contents.

## 6.3 Laboratory testing of asphaltic concrete

The asphaltic concrete mix design is based upon experience from extensive surface pavement research and engineering. In addition to the standardized Marshall method (see below), supplementary tests have been and are being used to evaluate and document the suitability of an asphaltic concrete mix for use in a dam core. This is particularly important where the engineering properties of the asphaltic concrete are tailored to satisfy specific core design requirements.

### 6.3.1 Marshall method of mix design

The Marshall method (Asphalt Institute, 1979) uses standard shaped specimens 64 mm (2½ in) high and 102 mm (4 in) in diameter, prepared using a specified procedure for heating, mixing, and compacting the bitumen-aggregate mix in a mold. The two principal features of the Marshall method of mix design are a density-voids (porosity) analysis and a stability-flow test of the compacted test specimen.

The density-voids analysis corresponds to the Proctor procedures for determining optimum water content for earth core materials in embankment dams.

The Marshall stability-flow test is performed by radially loading the disc shaped specimen at 60°C. The load is applied through semi-circular testing heads at a constant displacement rate of 51 mm/min until failure occurs. The stability number is the maximum load resistance recorded in units of force (N). The flow value is the total radial deformation that occurred in the specimen between no load and maximum resistance.

Typical results from applying the Marshall method plotted as function of the bitumen content, are presented in Fig. 6.8. These are the results from the asphaltic concrete mix with the high quality gabbro aggregate described in Table 6.1.

### 6.3.2 Triaxial testing

The use of triaxial tests to determine properties of asphaltic concrete is illustrated in Section 6.2.1.

Norwegian practice has been to use samples 100 mm in diameter and 200 mm high. The aggregates for the mix are first preheated for 4 hours at 160°C and the bitumen for 2 hours at 145°C. At a temperature between 150 - 160°C the mix is placed in 5 cm thick layers in a preheated triaxial mould with inside diameter 100 mm. Each layer is compacted for ½ min. by a method similar to the one used for Marshall specimens. The indicated temperatures are for use with bitumen type B60. For bitumens with lower viscosity (like B180) somewhat lower temperatures are used.

The tests are usually run strain-controlled at a specified strain rate and temperature. Common reference values used are 2%/h and 5°C. Most tests have been run as axial compression tests, but different stress paths may be followed to best model field conditions for representative elements in the core. Results obtained are stress-



strain behaviour, dilatancy as function of imposed shear stress and strain, shear strength as function of confining stress, shear strain when the strength level is reached, and whether the sample exhibits ductile or brittle behaviour.

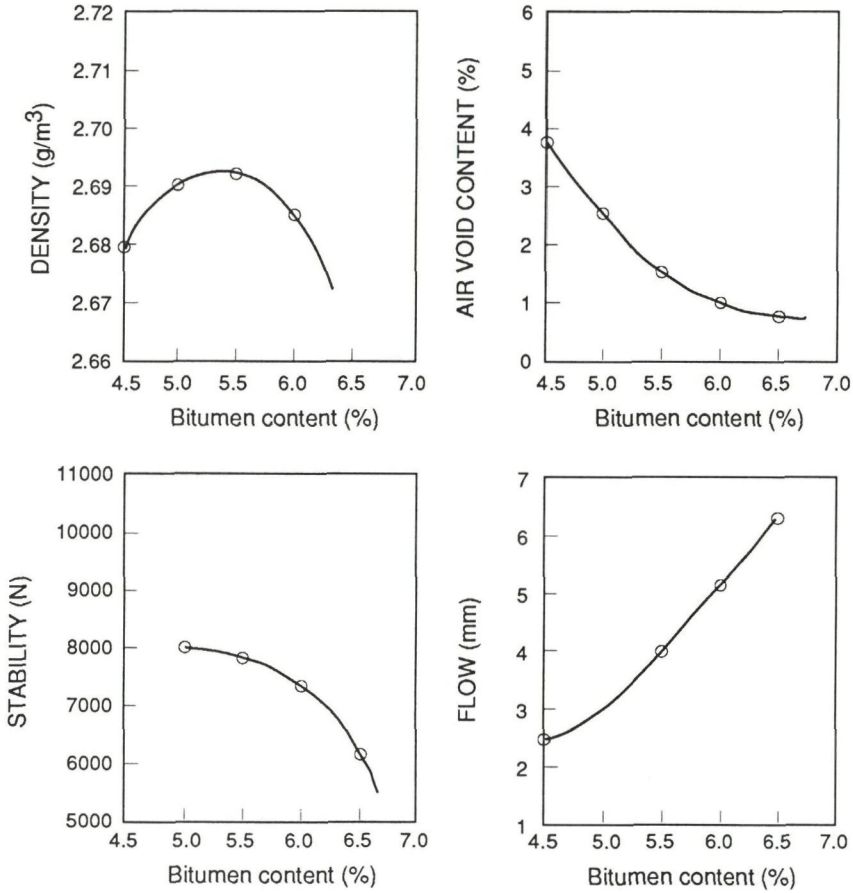

Fig. 6.8 Typical results from the Marshall method of testing

### 6.3.3 Permeability testing

Typical results from permeability testing are shown in Fig. 6.4.

In principle the permeameter may look like the one illustrated in Fig. 6.9, where the specimen is sealed against the sides of the container by a bitumen layer and rests on a porous base. More elaborate test set-ups, where the sample is subjected to known horizontal and vertical stresses like in a triaxial test, may also be used.

As described in Section 6.2, specimens may be cut from triaxial samples subjected to significant shear distortions, to measure the permeability as function of dilation and internal fissuring (cracking). The degree and rate of self-healing and permeabi-

lity reduction with time, due to viscous, plastic flow, may be studied as function of bitumen content and type.

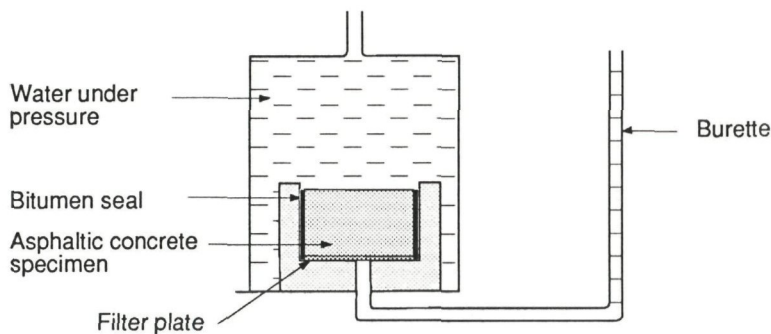

Fig. 6.9 Permeability testing

#### 6.3.4 Resistance to cracking under flexure

In pavement design, small test beams are being used to study the behaviour in flexure and the ability of the asphaltic concrete to undergo extensional strains without cracking.

In Norway a simple plate bending test has been developed to study the suitability of different asphaltic concrete mixes for use in a dam core (Fig. 6.10). The situation "simulates" in a way local bending in the core due to differential deformations in the embankment or locally reduced support from the downstream filter/transition zone. A disc shaped specimen 300 mm in diameter and 60 mm thick is supported inside the walls of a cylindrical pressure chamber. The specimen is sealed with bitumen around the edges to prevent any leakage between the upper and lower part of the chamber. The upper part is filled with water, and the pressure under the plate may also be controlled.

The test is usually run by applying an overpressure in the upper chamber, for instance 500 kPa, which is kept constant, and the central deflection of the plate is measured as a function of time. The gradual opening of fissures increases the permeability and the leakage through the sample, and a sudden increase in leakage occurs when cracks penetrate the plate. As for the triaxial tests described in Section 6.3.2, the tests are commonly run at 5°C.

The behaviour of different mix compositions is compared by looking at the deflection-time curves and the magnitude of central deflection tolerated before water break-through. Typical results for the asphaltic concrete mixes described in Table 6.1 are shown in Fig. 6.11. There is only one test for each mix, so the available data set does not justify general conclusions. However, the results show significant differences in deflection rate and magnitude of break-through deflection for mixes with bitumen types B60 and B180, respectively.

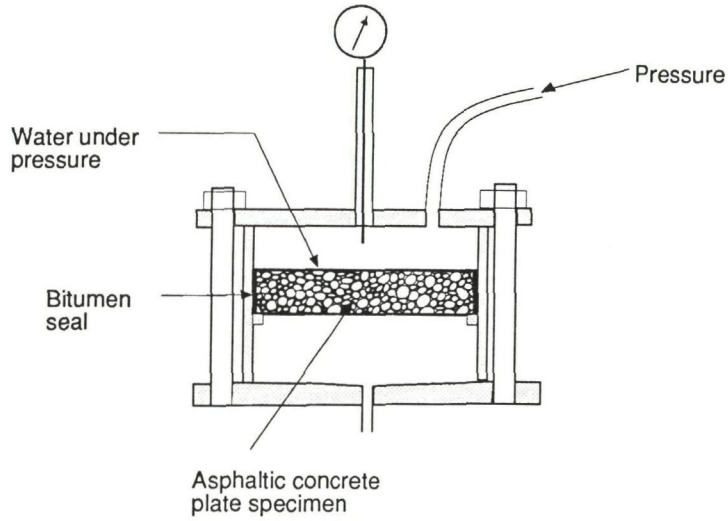

**Fig. 6.10 Sketch of the NGI plate permeameter**

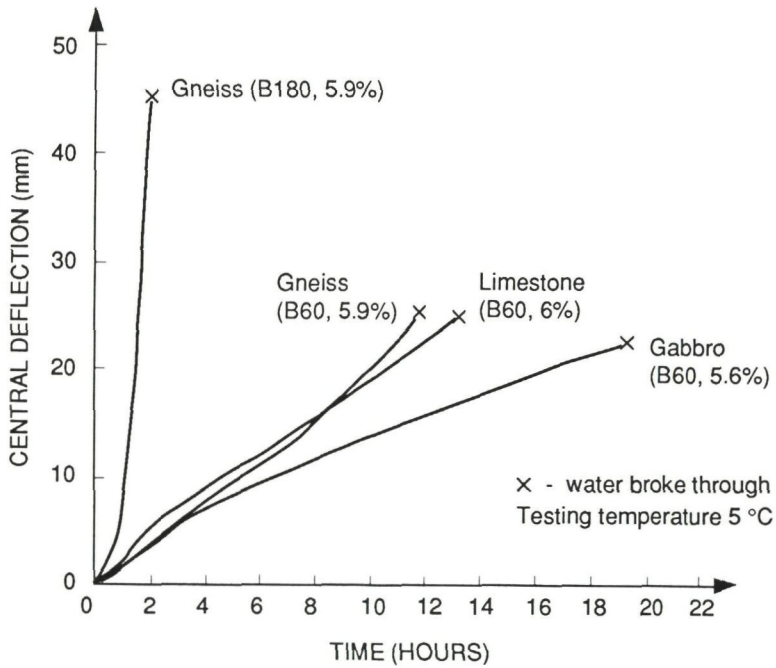

**Fig. 6.11 Results from plate permeameter tests**

Alternatively, the plate permeameter experiments may be run deformation-controlled by controlling the plate deflection rate with time.

# Chapter 7

## Construction - Contract and Work Specifications

### 7.1 Contractual aspects

The general contractual terms presented by Fédération Internationale des Ingénieurs Conseils (FIDIC, 1992) are recommended, and ICOLD's Bulletin 85 (1992) contains very useful guidelines concerning contracts for dam construction work.

#### 7.1.1 Basic contract considerations

Norwegian practice favours the use of a flexible type of contract based on risk sharing between owner (client) and contractor as illustrated in principle in Fig. 7.1. Furthermore, the contract is based on unit prices, where the quantity listed for each item of work is estimated at the tender stage and is calculated when the work is finished.

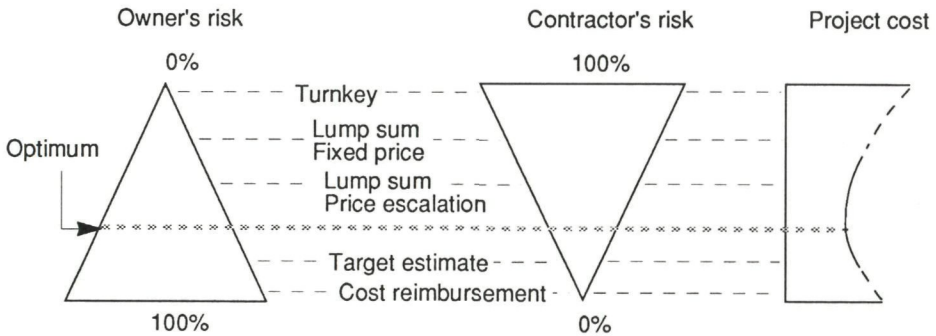

Fig. 7.1 Risk sharing according to type of contract and assumed influence on project cost (after Kleivan, 1988).

There are in principle two philosophies for the preparation of tender documents: the result-oriented and the operation-oriented contract type. In the result-oriented model, the documents specify the requirements which must be fulfilled by the end product. In the operation-oriented contract model, the client specifies the work operations which have to be performed, and the contractor calculates the unit prices based on those specifications.

With the result-oriented type of contract one may encounter difficulties in reaching agreement on change in price if the client should want to alter the design during construction. This is because the various work operations chosen by the contractor to achieve the results required in the tender documents may be different from the ones best suited to satisfy the altered design, and the differences may not have been defined in advance.

In the operation-oriented model a formal work procedure must be specified to achieve satisfactory field control of the materials which are placed and compacted in a continuous process. In case of alterations in design or operation, both owner and contractor must have experienced representatives present who can make binding decisions at the site, without causing undue delays in the progress of other aspects of the dam construction.

The discussion presented below presumes that the contract considered herein comprises only the asphaltic concrete core and the adjacent filter zones. Thus, the contractor for these works has either a subcontract with the general dam contractor or a contract with the owner as one of many coordinated contracts for the dam construction. As illustrated by the case study in Section 7.2, Norwegian practice for the construction of asphaltic concrete cores is a contract which in effect uses elements of both the result-oriented and operation-oriented model.

### **7.1.2 Prequalification, quality assurance and control**

The critical importance of the thin core in a zoned embankment dam, where all the different construction processes are so interdependent, requires an experienced and resourceful contractor. It is therefore necessary to practice stringent prequalification. If a contractor cannot refer to earlier asphaltic concrete works on embankment dams, he will only have the opportunity to participate in the competition by demonstrating through field tests his ability to produce, place and compact the asphaltic concrete in a prescribed manner. He must document that his field personnel is experienced, knowledgeable and prepared to cope with problems should they arise during construction.

To ensure the intended quality at all times, it is necessary to have a comprehensive and coordinated quality assurance and control system (QA/QC). This applies to the client as well as the contractor. Since regular reporting is a comprehensive task for the contractor, it is recommended to include this as a cost item in the Bill of Quantities.

With strict quality control during production, transportation and compaction, it is rare that asphaltic concrete actually built into the core does not meet the requirements. If so happens, the unacceptable material has to be removed and replaced unless the contractor can execute other acceptable remedial measures without damaging any other parts of the dam. The contractor should describe potential methods of repair in his tender bid.

### **7.1.3 Price adjustment**

In accordance with the contractual spirit of risk sharing between owner and contractor, the unit prices should be adjustable in conformance with the general changes of the price level. This is especially relevant for contracts lasting over several years, which is common in the case of embankment dams.

The work with the core is subject to the same price adjustment procedures as those used for other parts of the embankment. In Norway, a price index for rockfill dams has been practised for several years, and that has been found very convenient. Prior to this practice the price adjustment procedure in heavy construction was an onerous task because of its complexity and the many factors to be taken into account. The escalation of the price was greatly influenced by the way the items of reference were specified in the bid and how each factor was credited. In order to simplify and standardize the procedure, the hydroelectric power industry therefore took steps to establish price indices applicable to each of the following: rock tunnels, underground power stations, concrete dams, and rockfill dams. It was not found possible to arrive at one index common to all these structures.

For the bitumen in the asphaltic concrete mix and for the heating oil used for drying aggregates, the prices will not vary according to the domestic, but to the international market. Therefore, there may be special price adjustment clauses for bitumen and heating oil.

### 7.2 Work and material specifications - a case study

As an example of how work and material specifications are formulated in practice, elements of the specifications for the asphaltic concrete core and filter zone for the 125 m high Storglomvatn Dam (Fig. 7.2) are presented below.

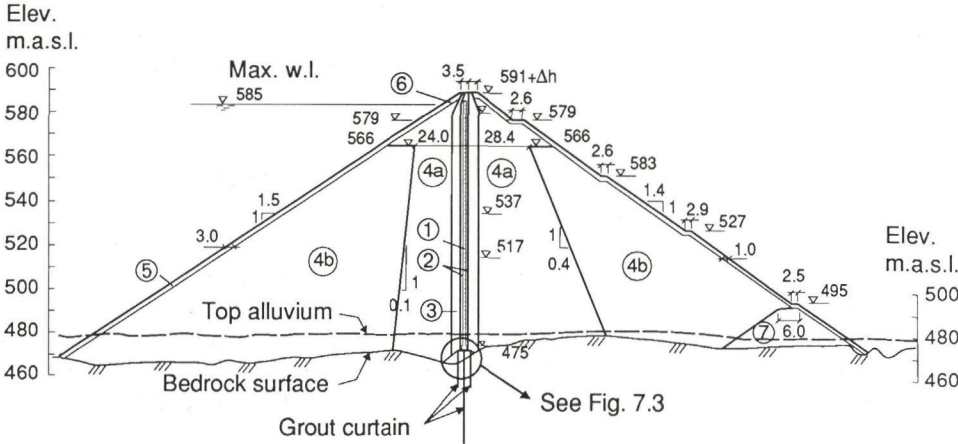

**Fig. 7.2 Storglomvatn Dam**

#### 7.2.1 Asphaltic concrete mix design assumed when preparing tender

A fairly soft and rich asphaltic concrete mix is specified to achieve the desired engineering properties and core behaviour. The bitumen type is B180, and the content

is 6.3% (of total weight). The bitumen content of random samples must not deviate more than  $\pm 0.3$  percentage points from this specified value.

Gravel taken from the specified location at Holmvatn should be used as aggregates. The grain size distribution must satisfy the Fuller criteria within the margins specified below:

<i>Grain Size (mm)</i>	<i>Weight (%)</i>
8 - 18	28
4 - 8	18
2 - 4	13
0.075 - 2	28
0 - 0.075 (filler)	13

The grain size distribution for random samples of the asphaltic concrete mix must lie within the following margins from the mean values presented above:

- $\pm 6\%$  for grain size  $> 2$  mm
- $\pm 4\%$  for  $0.25$  mm  $\leq$  grain size  $\leq 1$  mm
- $\pm 3\%$  for grain size =  $0.125$  mm
- $\pm 2\%$  for grain size =  $0.075$

50% of the aggregates should consist of crushed Holmvatn gravel.

The filler material ( $< 0.075$  mm) may consist of a combination of fines from the crushing of aggregates and added fines from other sources. The added fines must consist of either crushed limestone, cement or other material accepted by the client. The maximum allowable quantity of fines taken from the crushed Holmvatn aggregates, depends on the acidity of the gravel and is subject to clients's approval, but should not exceed 50% of the total filler mass.

### **7.2.2 Modifications to basic mix design proposed by contractor**

The mix design specified in Section 7.2.1 is documented in the report from the Norwegian Geotechnical Institute (NGI, 1993). This design is based on gravel materials from the Holmvatn location available at the time of laboratory testing. The laboratory asphaltic concrete mix contained aggregates of natural gravel mixed with 50% crushed material from gravel sizes larger than 18 mm. The filler material consisted of 1/13 crushed Holmvatn gravel and 12/13 crushed limestone.

The contractor is required to perform his own tests using the aggregates, crushing and mixing equipment at the site. The results from these tests may be somewhat different from those obtained by NGI in the laboratory due to differences in aggregate properties, scale of operation, crushing techniques and asphaltic concrete mixing processes. The results must be documented and reported with the contractor's proposal for modifications to the mix design presented in Section 7.2.1. Any modifications are subject to the client's approval. Any subsequent changes in mix design during core construction, including the filler used, are subject to the client's approval.

### **7.2.3 Prequalification of contractor**

Prior to contract agreement, the client may require that a contractor, with no satisfactory references from earlier similar work, demonstrate his ability to simultaneously place core and filter materials with the equipment he plans to use on the dam. The demonstration includes the placing of two layers, each 0.20 m thick, with the width of core equal to 0.5 m. The costs for this demonstration must be included in the tender bid.

### **7.2.4 Test production and placing of asphaltic concrete on site**

Test production and test placing of asphaltic concrete on site is required prior to start of construction. The asphaltic concrete used must be according to approved mix design, and the production and placing equipment the same as that to be used during subsequent construction. The core (zone 1) and filter (zone 2) should be placed in the same way and widths as in the dam.

The results of the test production and placing must be reported by the contractor and approved by the client before construction can start. The report must include the results of the material investigations specified in Section 7.2.6.

### **7.2.5 Requirements to plant and equipment**

The asphaltic concrete mixing plant must have the capacity to produce the volume required for two layers placed within 24 hrs. The plant production should be continuous while the placing machine (crawler paver) operates.

A fully automatic batch plant must be used with a computer printout to show the proportioning for each batch. The computer alerts the operator if the proportions are outside the preset limits, and the plant must then stop automatically. At all times the temperatures of the aggregates, bitumen and final mix must be automatically controlled.

A production flow diagram must accompany the tender bid. The contractor must control all scales and production equipment at least once a month and always before the start of a new construction season.

The placing machine must be of such design that the placing process may be observed visually. In front the machine must be equipped with a vacuum cleaner to soak up any water and dirt on the existing asphaltic concrete surface. Behind the vacuum cleaner a heater must be mounted to heat the existing layer immediately before a new layer is placed. However, the asphaltic concrete surface must not be exposed to open flames. All parts of the placing machine in contact with the asphaltic concrete must be preheated prior to start of placing. A principle sketch of the machine must accompany the tender bid.

Three self-propelled, smooth, vibratory rollers, must be used to simultaneously compact the core and the adjacent filter/transition zones. The roller for the asphaltic



concrete must have a width equal to or no more than 0.10 m wider than the core. The minimum weight of the rollers used for filter compaction is 1.5 t. The core is compacted by light rollers to achieve the required in-situ void content  $\leq 3\%$ .

The contractor is required to establish a field testing laboratory of sufficient capacity to do all the routine testing (Section 7.2.6) within specified reporting deadlines. The laboratory investigations must satisfy the guidelines presented by Statens Vegvesen (1983). Subject to prior agreement between contractor and client, the tests on the bitumen itself may be done and reported by the supplier.

The contractor must present a QA/QC-plan for the production specifying the names of persons responsible for the different control routines. The plan is subject to approval by the client.

### 7.2.6 QA/QC and reporting during construction

#### *Bitumen*

- The bitumen type is specified as B180. The penetration value must be between 145 and 210 at 25°C for a penetrating mass of 100 g in 5 s.
- For each new delivery of bitumen supply to the plant, the following properties must be reported:

#### *Standard required*

- penetration	ASTM D5-73
- viscosity	ASTM D2171-66/72
- failure point (Fraas)	DIN 1995/1960
- ductility	ASTM 113-76
- density	ASTM D70-72

#### *Aggregates*

- The aggregates for the asphaltic concrete must satisfy the grain size requirements specified in Section 7.2.1.
- The impact value and flakiness index for the aggregates must be less than 60 and 1.45, respectively. Tests on the Holmvatn gravel have shown these criteria to be satisfied, but the contractor is required to run independent tests at regular intervals during construction to document the quality of the aggregates.
- Special tests have shown that the adhesion between bitumen and Holmvatn gravel is good (Riedel value 8 - 9). However, the contractor is required to run independent tests once a month during construction to document that the adhesion is satisfactory. The test method must be acceptable to the client.
- The requirements to the filler material ( $< 0.075$  mm) are presented in Section 7.2.1. The organic content of the fines resulting from the crushing of aggregates, must be controlled weekly before the fines may be accepted for use

as filler material. The "colour intensity" must be  $\leq 2$  when tested by the NaOH-method (Statens Vegvesen, 1983) The aggregates must be stored and protected against contamination.

#### *Asphaltic concrete production*

- Aggregates must be dry but have temperature not exceeding 200°C.
- Temperature of asphaltic concrete mix must not exceed 160°C.
- The client's QC representative must be informed when scales or temperature controls on the automatic plant are adjusted.
- Asphaltic concrete produced with incorrect proportions or outside specified temperature limits must not be transported to the dam core.

#### *Asphaltic concrete from plant*

- Extraction analyses must be performed on four asphaltic concrete samples per day to determine the bitumen content and the grain size distribution of aggregates. The sampling must take place at roughly regular intervals during the production day.
- Compaction of Marshall test specimens for daily control of consistency and air voids content.

#### *Asphaltic concrete compacted in core*

- Core drill samples must be taken as soon as the asphaltic concrete temperature allows sampling. One core sample must be taken for each four layers placed, or at least one per week of production. Each core must be drilled through two layers (i.e. 0.40 m). The core is cut into approx. 50 mm long pieces, and the following properties must be determined:
  - specific density of asphaltic concrete
  - specific density of aggregates
  - grain size distribution of aggregates
  - bitumen content
  - air voids content

The core drill boreholes must be filled with hot asphaltic concrete and compacted immediately after sampling.

- In addition<sup>1</sup>, the contractor is required to continuously control the air voids content for each layer placed by means of a non-destructive test method (e.g. use

---

<sup>1</sup> A requirement on this particular project, as the owner (The Norwegian Energy Corporation) wants to further develop the non-destructive control method for subsequent projects.

of isotopes). The contractor must in his tender bid describe the non-destructive test method and procedures which are subject to approval by the client.

In case irregularities appear in the data from any of the control tests, they must immediately be reported to the client's QC representative, who may require additional tests, at no cost to the client.

### **7.2.7 Requirements to core placing and compaction procedures**

Transportation, placing and compaction of the asphaltic concrete require special equipment. The field work must satisfy the guidelines presented by Norwegian Asphalt Association (1980) unless stated otherwise in these work specifications.

During compaction the temperature of the asphaltic concrete must be between 140°-155°C.

If the temperature during placing exceeds 155°C, the mass must be allowed to cool before compaction can start.

The asphaltic concrete is to be placed and compacted in 0.20 m ( $\pm$  0.03 m) horizontal layers. The air void content must be less than 3% (of total volume) after compaction. Requirements to compaction equipment are presented in Section 7.2.5.

Zones 1 and 2 must be placed simultaneously, with zone 1 slightly ahead of zone 2. During compaction the two zones must be of approximately the same height and be compacted with three vibratory rollers run in parallel<sup>2</sup>.

No more than two layers of asphaltic concrete (i.e. 0.40 m) may be placed in 24 hrs. A third layer may be placed if the contractor can document the in-situ quality also of this third layer after compaction.

Zones 1 and 2 must at no time be built up to a height more than 0.40 m above the level of zone 3 (see Fig. 3.1), which, on the other hand, must not be more than 0.40 m above zone 2.

The interface between concrete sill (plinth) and base of asphaltic core should be covered with a 10 mm thick layer of mastic. The concrete surface must be clean and dry and may have to be sandblasted and/or washed with hydrochloric acid to promote good adhesion (bond) between concrete and mastic. The concrete surface must be heated prior to the application of mastic at a temperature of 150°C. The width of the mastic strip along the sill must be at least 0.50 m wider than the base of the asphaltic core, and mastic must fill the space around the special construction joints in the concrete sill. The waterstop must be made of material that can stand the heat from the hot mastic.

---

<sup>2</sup> See Fig. 4.4

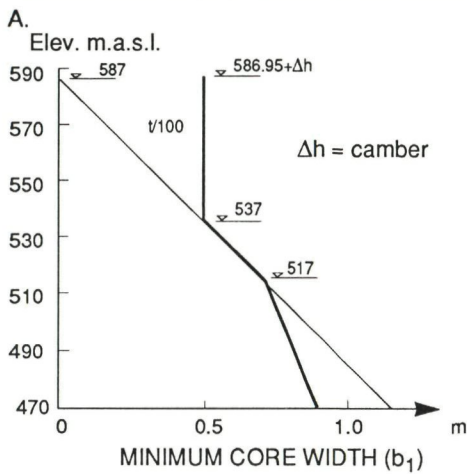

Minimum width of core and filter

m.a.s.l.	Core $b_1$ (m)	Core base $b_2$ (m)	Zone 2 (m)
above 537	0.5	1.0	1.50
537-517	$0.5 + \frac{537 - \text{elev}}{100}$	$b_1 + 0.5$	$\frac{3.5 - b_1}{2}$
below 517	$0.7 + \frac{537 - \text{elev.}}{250}$	$b_1 + 0.5$	$\frac{3.5 - b_1}{2}$

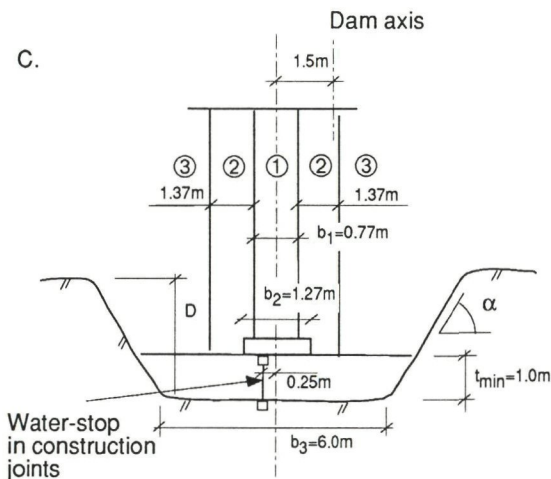
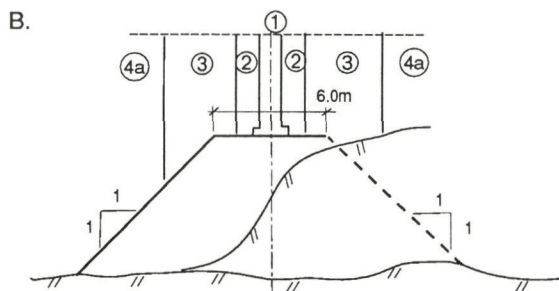

D (m)	$\alpha$ ( $^\circ$ )
0 - 1.5	$\leq 90$
1.5 - 3.0	$\leq 60$
> 3.0	$\leq 45$

m.a.s.l.	Min. sill width, $b_3$ (m)	Min. sill thickness, $t$ (m)
above 537	4.0	0.50
537 - 505	5.0	0.75
below 505	6.0	1.00

Dimensions of concrete foundation sill

Fig. 7.3 Details of core and foundation sill design

The two first layers of asphaltic concrete on top of the mastic strip must have the width shown in Fig. 7.3. At locations along the valley floor and at the abutments inaccessible to the placing machine, hand placement procedures must be used. For this purpose shutters must be employed, and the requirements to temperature control and maximum allowable air voids content after compaction are the same as for machine placing.

During construction the width of the core in place must be checked by direct measurements when required by the clients's QC-representative. Effective horizontal width on the interface between two subsequent layers must be equal to or larger than the minimum width specified on Fig. 7.3. Furthermore, the distance from the theoretical centerline to the upstream or downstream side is required to be at least half the specified width at that elevation.

To ensure proper bonding between subsequent layers, the interfaces must be clean, dry and preheated prior to placement of the next layer. Temporary bridges must be built for vehicles to cross the core during construction.

If the weather conditions are such that the placing and compaction procedures do not meet the requirements, the construction process must be discontinued. The client's QC-representative can require work stoppage.

If any asphaltic concrete as placed and compacted does not meet the specified requirements outlined above, it must be removed without causing any harm to other parts of the core already built. Such removal and repair work is not reimbursed for.

#### **7.2.8 Requirements to filter/transition zone**

Natural gravel from the Holmvatn borrow area should be used for zone 2, which must consist of well graded masses with grain size 0 - 60 mm,  $d_{50} > 10$  mm and  $d_{15} < 10$  mm. This zone must be placed and compacted simultaneously with the core to provide immediate lateral support to the hot asphaltic concrete. Zone 2 is placed in its full design width (Fig. 7.2) and compacted as described in Section 7.2.7 with 3 - 6 passes of a roller of minimum weight 1.5 t. The amount of compaction has to be adjusted on site as it depends on the properties of the filter material.

The contractor is required to control the grain size distribution of zone 2 by sampling at least once a day. A report must be submitted to the client's QC-representative once a week.

#### **7.2.9 Unit prices**

The tender bid must be expressed in terms of unit prices for zones 1 and 2, respectively.

##### *Core*

Specify price per  $m^3$  of asphaltic concrete placed and compacted in core. The price must include the costs of all operations and materials related to production, transport-

ation, placement and compaction, laboratory testing, quality control and reporting. It must include the laying of mastic and special hand placement required. The reimbursement is based on theoretical (design) core width and the measured contour profile of the top of the concrete foundation sill across the valley.

*Filter*

Specify price per m<sup>3</sup> of Holmvatn gravel placed and compacted in zone 2. The price must include the costs of all operations such as work in the borrow area, crushing, screening, transportation, laboratory testing, quality control and reporting.

## References

- Adikari, G.S.N., T. Valstad, B. Kjærnsli, and K. Høeg (1988)  
Behaviour of Storvatn Dam, Norway. A case of prediction versus performance.  
Proceedings 5th Australia - New Zealand Conference on Geomechanics, Sydney,  
Australia. (Also presented in Norwegian Geotechnical Institute Publication No. 173,  
Oslo).
- Arnevik, A., B. Kjærnsli, and S. Walbø (1988)  
The Storvatn Dam. A rockfill dam with a central core of asphaltic concrete.  
16. International Congress on Large Dams, San Francisco, R.9-Q.61. (Also  
presented in Norwegian Geotechnical Institute Publication No. 173, Oslo).
- Asphalt Institute (1979)  
Mix design methods for asphalt concrete and other hot-mix types.  
Manual Series No. 2, The Asphalt Institute, College Park, Maryland.
- Bikar, R. and H. Haas (1973)  
Untersuchungen über den Einfluss der Dichte auf Wasserdurchlässigkeit von  
Asphaltbetonen.  
Strabag, Schriftenreihe Nr. 9, Cologne.
- Breth, H. and H.H. Schwab (1979)  
Zur Eignung des Asphaltbetons für die Innendichtung von Staudämmen.  
Wasserwirtschaft 69, Heft 11, pp. 348-351, Stuttgart.
- Clough, R.W. and R.J. Woodward III (1967)  
Analysis of embankment stresses and deformations.  
Journal of Soil Mechanics and Foundation Engineering, ASCE, Vol. 93, SM4,  
pp. 529-549.
- FIDIC (1992)  
Conditions of contract for works of civil engineering construction.  
Fédération Internationale des Ingénieurs-Conseils, 4. edition, Paris.
- Gazetas, G. and P. Dakoulas (1992)  
Seismic analysis and design of rockfill dams: state of the art.  
Journal of Soil Dynamics and Earthquake Engineering, Vol. 11, pp. 27-61.
- Haas, H. (1983)  
Zur Eignung und Optimierung von Asphaltbeton für Kerndichtungen in Staudämmen.  
Bitumen, Heft 3, pp. 97-106, Hamburg.
- Hveding, V. (1992)  
**Hydropower Development in Norway.**  
Norwegian Institute of Technology, ISBN 82-75598-012-7, Tapir, Trondheim.

ICOLD (1992)

Owners, consultants and contractors.

International Commission on Large Dams, Bulletin 85, Paris.

ICOLD (1992)

Bituminous cores for fill dams.

International Commission on Large Dams, Bulletin 84, Paris.

ICOLD (1982)

Bituminous cores for earth and rockfill dams.

International Commission on Large Dams, Bulletin 42, Paris.

Kjærnsli, B., T. Valstad, and K. Høeg (1992)

**Rockfill Dams - Design and Construction.**

Norwegian Institute of Technology, ISBN 82-75598-012-11, Tapir, Trondheim.

Kjærnsli, B., J. Moum and I. Torblaa (1966)

Laboratory tests on asphaltic concrete for an impervious membrane on the Venemo rockfill dam.

Norwegian Geotechnical Institute Publication No. 69, pp. 17-26, Oslo.

Kleivan, E. (1988)

Norwegian tunnelling contract system.

Norwegian Soil and Rock Eng. Assoc., Publication No. 5, pp. 67-72.

Lysmer, J., T. Udaka, C.F. Tsai, and H.B. Seed (1975)

FLUSH - A computer program for approximate 3-D analysis of soil-structure interaction problems.

Earthquake Engineering Research Center, Report EERC 75-30, University of California, Berkeley.

Makdisi, F.I. and H.B. Seed (1978)

Simplified procedures for estimating dam and embankment earthquake-induced deformations.

Journal of Geotechnical Engineering, ASCE, Vol. 104, No. GT7, pp. 849-867.

Moiseev, I.S., N.N. Yakovlev, A.L. Goldin, L.V. Gorelik and V.G. Radchenko (1988)

Rockfill dams with asphalt concrete diaphragms.

16. International Congress on Large Dams, San Francisco, R.62-Q.61.

Newmark, N.M. (1965)

Effects of earthquakes on dams and embankments.

Geotechnique, Vol. 15, No. 2, pp. 139-160.

Norwegian Asphalt Association (1980)

Guidelines for design and construction of bituminous pavements (in Norwegian).

Ingeniørforlaget, Oslo.



Norwegian Geotechnical Institute (1992)

Asphaltic concrete cores for embankment dams - laboratory triaxial tests.  
NGI Report 530106, Oslo.

Norwegian Geotechnical Institute (1993)

Storglomvatn Dam - asphaltic concrete mix design (in Norwegian).  
NGI Report 736013-076, March 10, Oslo.

Norwegian Geotechnical Institute (1980)

Laboratory investigations of asphaltic concrete.  
NGI Report 68601, Oslo.

Pircher, W. and H. Schwab (1988)

Design, construction and behaviour of the asphaltic concrete core wall of the Finstertal Dam.

16. International Congress on Large Dams, San Francisco, R.49-Q.61, pp. 901-924.

Seed, H.B. (1979)

Considerations in the earthquake-resistant design of earth and rockfill dams.  
Geotechnique, Vol 29, No. 3, pp. 215-263.

Statens Vegvesen (1983)

Laboratory investigations, Design Manual 014, Oslo (in Norwegian).

US Committee on Safety Criteria for Dams (1985)

Safety of dams: Flood and earthquake criteria.

National Research Council, National Academy Press, Washington DC.

Valstad, T., P.B. Selnes, F. Nadim and B. Aspen (1991)

Seismic response of a rockfill dam with an asphaltic concrete core.

Water Power and Dam Construction, April, pp. 1-6. (Also presented in Norwegian Geotechnical Institute Publication No. 184, Oslo).

# Index

## A

Abutment 21, 38, 80  
Acceleration 51, 52  
Acceptance criteria 43, 62, 73, 76  
Accidental leakage 52  
Acidity (acidic) 30, 65  
Added filler 64  
Adhesion 34, 76, 78  
Adit 39, 41  
Admixture (additive) 34, 41, 76, 78  
Aggregate 61-65, 74, 76  
Aging 14  
Air void content (porosity) 34, 42, 43, 60, 61, 68, 77, 78  
Alluvial deposit 13, 15, 59  
Alignment 38, 39  
Alta River 12  
Ambursen type 10  
Appurtenant structure 49  
Arching 56, 58  
Arch dam 10, 12  
Arctic Circle 20  
Asphaltic concrete mix 18, 42, 60-66  
Asphalt mastic 34, 78  
Aurland scheme 11

## B

Backhoe 19, 42  
Batch plant 29-30, 42, 75  
Berdalsvatn Dam 22  
Bitumen,  
  content 13, 15, 18, 36, 61, 63, 65-66, 74, 77  
  density 76  
  ductility 76  
  penetration 76  
  seal 68-69  
  type 18, 66  
  viscosity 14-15, 65-66, 76  
Blåsjø reservoir 9, 37  
Blocks 19, 42  
Bonding 78, 80  
Boreholes 39, 41, 58  
Borrow pit 11, 14, 37, 80  
Brittle behaviour 68  
Bulk modulus 56

## C

Cement (Portland) 37

Clay core 10  
Climate 11, 14, 29, 42-43, 80  
Colour intensity test 77  
Compaction 13, 14, 19, 33, 41-42, 55, 59, 75-80

Concrete,  
  deck 10, 37  
  gallery 39  
  sill 20-27, 33-34, 39-41, 78-79

Confining stress 62, 64

Construction,  
  equipment 15, 29-30  
  joint 78-79  
  procedure 15, 33-35  
  season 11, 14, 20, 42

Contamination 77

Content,

  air voids 19, 32, 43, 60-61, 77-78  
  bitumen 13, 15, 18, 36, 61, 63, 65-66, 74, 77  
  filler 18, 30, 36, 60, 74, 76

Contract specifications, 71

  operation oriented 71-72

  result oriented 71-72

Contractor 71

Core,

  base (slab) 41, 80  
  bituminous 13  
  bridge 35, 80  
  clay 10  
  concrete 10  
  concave 38  
  convex 35, 38  
  drilling 36, 43, 77  
  inclination 21, 41, 57  
  silt 10  
  sloping 21, 41, 57  
  thickness (width) 14, 17, 18  
  width (thickness) 14, 17, 18

Cost,

  construction 37, 41, 71

  project 37, 41, 71

  reimbursement 71, 80

  total 71

Cracking 14, 51, 55, 59, 68-70

Cross section 20-27, 40-42, 73

Crushed,

  gravel 18

  limestone 18, 30, 63, 65, 74

rock 10, 19, 37-38  
soft rock 10  
Crushing plant 30, 36, 42, 75  
Cyclic,  
loading 49-52  
strains 52

## D

Dam,  
alignment 38, 39  
crest 10, 20-27  
height 10-12, 17-18, 20-27  
volume 20-27  
Deformations 14, 20-27, 45-48, 51-52, 55-56,  
59  
Density 60, 67-68, 77  
Design,  
analyses 37-42, 49-53, 55-59  
conditions 9, 13-14, 37-42, 49  
earthquake 14, 49  
mix 18, 42, 60-70  
Differential settlement 13, 15, 55, 66  
Dilatancy (volumetric expansion) 14, 64-66  
Displacement 20-27, 45-48, 51, 55, 59  
Distortion 14, 45-48, 64-66  
Ditch (trench) 34, 39, 79  
Drainage capacity 52  
Ductility 14, 61, 66, 68, 76  
Dynamic analysis 49-53

## E

Earthquake,  
acceleration 51, 52  
coefficient 49-50  
region 14, 57  
resistance 14, 49  
shaking 49, 59  
Taft 51  
Elasticity theory 45, 50, 56  
Embankment dam 10  
Equipment,  
compaction 33, 75, 78-79  
construction 15, 29-33, 75  
Extensional strain 38

## F

Factor of safety 49-50  
Field measurements 20-27, 44-48, 55  
Filler 16, 18, 30, 61, 64-65, 74  
Filter (transition) 15, 19, 32, 58, 78-81  
Fines (filler) 16, 18, 30, 61, 64-65, 74

Finite elements 45, 51, 55-56  
Finstertal Dam 45, 48  
Fissures (cracks) 14, 68-70  
Flakiness index 61-62  
Flexure 69-70  
Flow value 67  
Flowable concrete 13, 66  
Foundation,  
compressibility 13-15, 20, 55, 57, 59  
grouting (injection) 20-27, 34, 39, 41  
stability 13-15, 55, 59  
Fuller's curve 18, 44, 60

## G

Gabbro 62-64, 67, 70  
Gallery (adit, tunnel) 20, 39, 41  
Glacial till (moraine) 10-11, 14, 25, 37-38  
Gneiss 38, 62-64, 70  
Gradation 18, 44, 52, 58, 60, 74, 77, 80  
Grain size 16, 18-19, 44, 52, 58, 60, 74, 77, 80  
Granite 38  
Gravel 18-19, 58, 74, 80  
Grout,  
curtain 20-27, 39  
grouting 20-27, 34, 41

## H

Hand placement 13, 33-34  
Hauling distance 33, 37, 42  
Heater 31, 73, 75  
Holmvatn Dam 12, 17  
Hydrochloric acid 34, 78  
Hydropower 9

## I

Impact index 61-62  
Impervious element 10, 37  
Inclined core 21, 41, 57  
Inclinometer 44  
Infrared heater 31  
Instrumentation (field) 44  
Inspection (quality) 36, 43, 72  
Isotope 36, 44, 77

## J

Jersey, U.K. 29  
Joint,  
construction 78-79  
rock 34, 41

## K

Karst 20, 41  
Katlavatn Dam 17, 18, 25

## L

Landscape (environment) 11, 14  
Langavatn Dam 17, 18, 27  
Laser 31  
Layer thickness (lift) 13, 15, 19, 43, 78  
Leakage 14, 44-45, 52, 60-61  
Limestone 18, 30, 62-63, 65, 70, 74  
Lump sum, 71  
    fixed price 71  
    price escalation 71, 72-73

## M

Marshall test 64-65, 67-68, 77  
Mastic (asphalt) 34, 78  
Material specification, 73-78  
    admixture 34, 78  
    aggregate 74, 77  
    bitumen 76  
    filler (fines) 74  
Max. credible earthquake (MCE) 49  
Measurements (field) 21-27, 44-48  
Mix,  
    design 18, 42, 60-66  
    parameters 18, 42, 60-66  
Modulus,  
    bulk 56  
    one-dimensional 56  
    secant 63  
    Young's 56, 63, 66  
Mold (Marshall) 67  
Monitoring (field) 21-27, 44-48  
Moraine core 10-11, 14, 25, 37-38  
Movements 44-48, 55-56, 59

## N

Natural gravel 18-19  
Non-destructive test 36, 44, 77

## O

Observed behaviour 12, 21-27, 44-48  
Oddatjørn Dam 11  
Oedometer 45-46  
Operation-oriented contract 71-72  
Operational safe earthquake (OSE) 49  
Organic content 77

## P

Parameters,  
    design 18, 42, 55, 60-66  
    mix 18, 42, 60-66  
Particle size 16, 18-19, 44, 52, 58, 60, 74, 77,  
    80  
Paver (placing machine) 13, 15, 29-32  
Penetration (bitumen) 76  
Permafrost 11  
Permanent displacement 50-51  
Permeability,  
    coefficient 45, 60-61, 66  
    increase 14, 60, 62, 66  
    permeameter 68-69  
Placing machine 13, 15, 29-32  
Plant 29-30, 42, 75, 77  
Plastic flow 14-15, 65, 66  
Plate permeameter 69-70  
Plinth (sill) 20-27, 33-34, 39-40, 78-79  
Poisson's ratio 56  
Porosity (air void content) 34, 42, 43, 60,  
    61, 68, 77, 78  
Prediction 44-53  
Prequalification (contractor) 72  
Price,  
    adjustment 71-72  
    fixed 71  
Principal stresses 62-63  
Pseudo-static analysis 49-50

## Q

Quality,  
    assurance 36, 43, 72  
    control 36, 43, 72  
Quarried rock 19, 38

## R

Rainfall (precipitation) 14, 29, 42  
Repair 58, 80  
Result-oriented contract 71-72  
Requirements (specifications) 71, 73-81  
Richter magnitude 49, 51  
Riedel value 76  
Risk sharing 71-72  
Riskallvatn dam 15, 17, 18, 24, 30  
Rockfill 10, 12, 15, 17, 19, 20-27, 37, 45, 52,  
    73

## S

Safety factor 49-50  
Sand blasting 34, 41, 78  
Scar 11, 14

- Screed 30-31  
 Screening 36, 43, 74  
 Seismic,  
   acceleration 51, 52  
   analysis 49-53  
   coefficient 49-50  
   response 14, 49-53  
 Seepage 44-45  
 Self-healing (sealing) 14, 55, 58, 68  
 Shear deformation 63-66  
 Shear strength 59, 62-64, 66  
 Shutters 13, 33, 66  
 Sill (plinth) 20-27, 33-34, 39-40, 78-79  
 Silt core 10  
 Sluicing (water) 19, 42, 59  
 Snow 14, 42  
 Specifications 71, 73-81  
 Stability,  
   analysis 55, 59  
   number 67  
 Stability-flow test 67  
 Standard deviation 36  
 Stearin acid 34  
 Stone-bitumen method 13, 18  
 Storglomvatn Dam 12, 17, 18, 19, 20, 73-81  
 Storvatn Dam 11, 14, 17, 18, 36, 39, 56  
 Strain,  
   -controlled 62, 70  
   rate 62, 66  
 Strength,  
   compression 59, 62-64, 66  
   shear 59, 62-64, 66  
 Stress ratio 63  
 Styggevatn Dam 17, 18, 29  
 Sub-zero weather 11, 14, 29  
 Supersaturated 59, 62, 65-66  
 Supporting shell (shoulder) 19, 55, 59  
 Svartevatn Dam 11
- T**  
 Tack coat 31  
 Tapering (of core) 17, 41, 57  
 Television monitor 31  
 Temperature,  
   constraint 15, 16, 19, 69, 77-78  
   control 15, 16, 19, 33, 34, 42, 63, 67, 69, 77-78  
 Tender documents 42, 71  
 Test,  
   aggregates 61-62, 76  
   bitumen 65-66, 76  
   flexure 69-70  
   Marshall 64, 67  
   oedometer 45-46  
   permeability 68-69  
   plate 69-70  
   Proctor 67  
   triaxial 45-46, 62-68  
 Transition zone 15, 19, 35, 41-42, 52, 58, 78-81  
 Triaxial test 45-46, 62-67  
 Toe drain 19, 20-27, 52, 73  
 Tolerances 44, 74  
 Tunnel (grouting) 20, 39, 41
- U**  
 Underseepage 20-27, 39-41  
 Unit price 72, 80-81  
 Upstream facing 10, 37-38
- V**  
 Vacuum triaxial test 46  
 Vesterdalstjern Dam 17, 18, 26  
 Vibratory,  
   compaction 13, 14, 19, 33, 41-42, 55, 59, 75-80  
   rollers 19, 75-80  
 Virdnejavre Dam 12  
 Volume,  
   dam 20-27  
   expansion (dilatancy) 55, 58, 64-66  
 Viscosity 14-15, 65-66, 76  
 Viscoelastic-plastic 14, 55, 56, 65
- W**  
 Water sluicing 19, 42, 59  
 Waterstop 78-79  
 Weather conditions 11, 14, 29, 42-43, 80  
 Workability 14, 65  
 Work specifications 73-81
- Y**  
 Yield acceleration 51, 63-64  
 Young's modulus (E) 56, 63, 66
- Z**  
 zone (embankment) 10, 19, 20-27, 41-42, 59, 73