

EASTERN SCHELDT STORM SURGE BARRIER

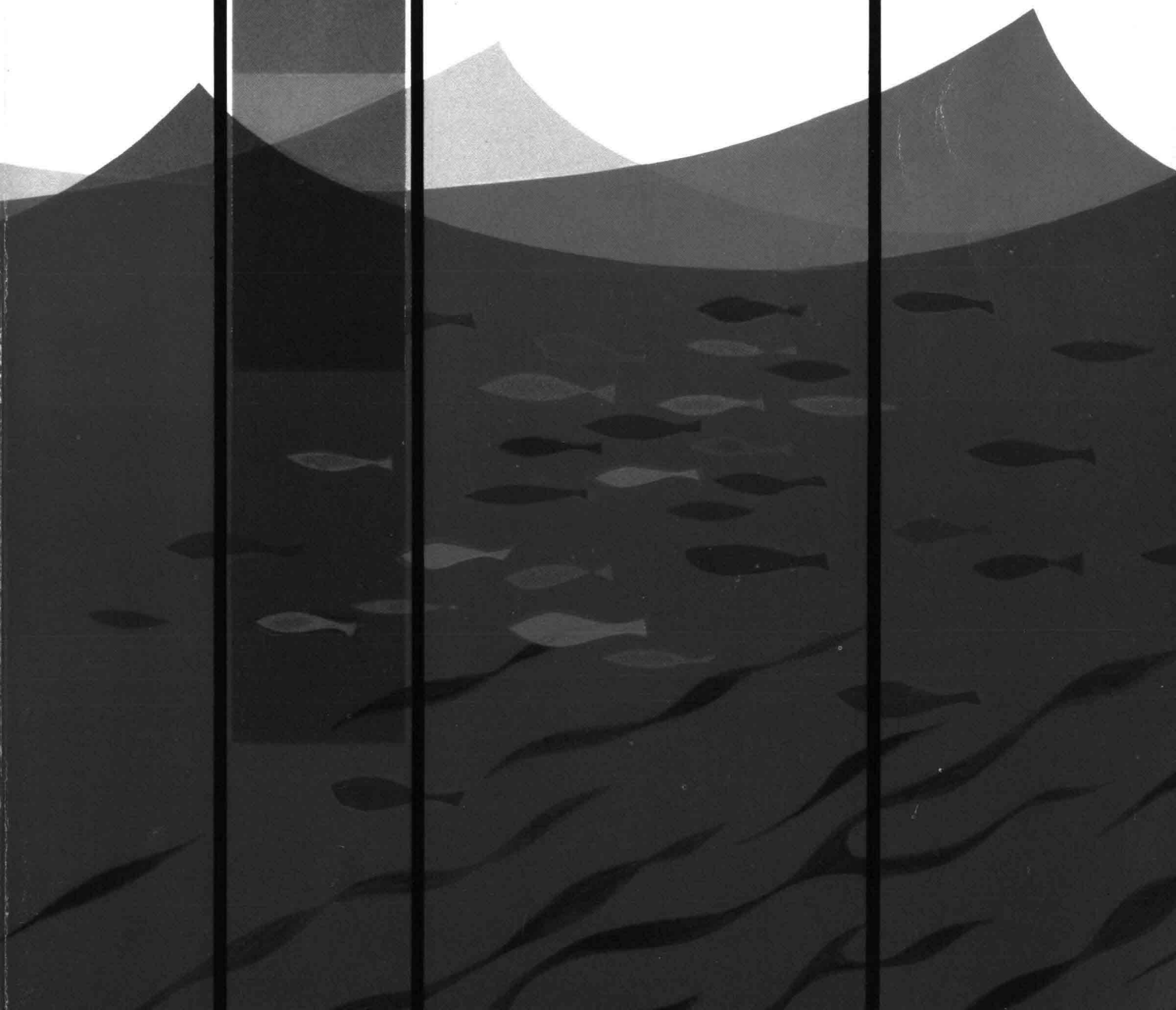

**EASTERN
SCHELDT
STORM
SURGE
BARRIER**

*Proceedings of the Delta Barrier Symposium
Rotterdam, 13 - 15 October 1982*

These proceedings have been compiled by the Organization of the Symposium, in co-operation with the editorial staff of the magazine CEMENT.

editorial adress:

Magazine CEMENT

P.O.Box 3011

5203 DA 's-HERTOGENBOSCH

The Netherlands

cover design: Otto Treumann, Weesp

printing: Drukkerij Waalwijk b.v., Waalwijk (N-B)

No part of these proceedings may be reproduced in any form by print, photoprint, microfilm or any other means, without written permission from the above-mentioned publisher.

Table of Contents

| | |
|-----|--|
| 3 | Introduction by J. van Dixhoorn |
| 6 | 30 Years of development of the design criteria for flood protection and water-control works by prof.J.F.Agema |
| 14 | The joint evaluation of design construction of large scale concrete coastal structures by J.C.Slagter |
| 20 | 500,000 Cubic metres of prefabricated, prestressed concrete by A.A.H. van Dam |
| 28 | Special equipment as a result of integrated design and construction by J.M.Schetters |
| 40 | The Eastern Scheldt barrier in the family of ever growing use of prestressed concrete for offshore applications by Ben C.Gerwick Jr <i>'Design of concrete structures'</i> |
| 44 | Probability design method by J.K.Vrijling |
| 50 | Durability and corrosion by H. van Schaik <i>'Design of gate structures'</i> |
| 56 | Gates by E.Ypey |
| 64 | Operating machinery for the gates in the barrier by J.F.Remery <i>'Construction aspects'</i> |
| 69 | Methods and tools used in construction by G.Offringa |
| 78 | Labour and social aspects of the barrier construction by J.Brants <i>'Operations'</i> |
| 83 | Assembly by Tj.Visser |
| 89 | Transport and placing of 18,000 tons piers by R. de Leeuw <i>'Research on concrete'</i> |
| 98 | Durability testing by T.Monnier |
| 106 | Investigation of the mechanical properties of fresh and hardened concrete used in the Eastern Scheldt storm surge barrier by Prof.H.W.Reinhardt, P. van den Berg, K.M.Postma and D.W. de Haan <i>'Surveying'</i> |
| 115 | Dimensional deviations and tolerances in the assembling of the construction elements by F.F.M. de Graaf |
| 120 | Surveying systems by R.Jellema |
| 124 | Colophon |

Introduction



1
The Netherlands in Europe

A large part of the Netherlands lies below the mean sea level; it is protected by dikes and dunes. In the twentieth century impressive civil engineering works have been carried out to increase the safety of the low lands against storm floods. Flood disasters are part of Holland's history and have occurred as often as three times in a century. In former ages the defence consisted of building up dikes. Only this century, great plans have been executed to shorten the coast-line. This began with the closing off of the Zuiderzee in 1932, because of severe flooding in 1916, and more recently, the Delta Plan, inspired by the disastrous flood of February 1953 (figure 2 and 3).

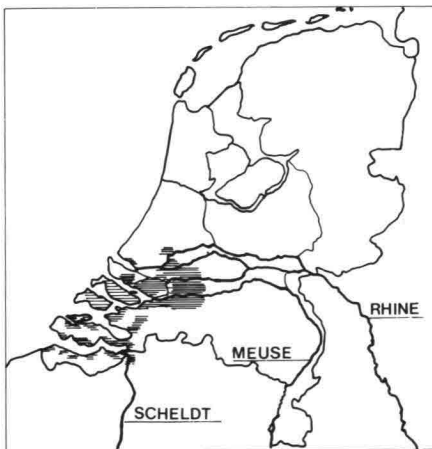

2
Situation flood 1953; flooded area are shaded

The Delta in the south-western part of the Netherlands is formed by the rivers Rhine, Meuse and Scheldt; by its very nature such an area is flat and low. In the past the Delta was flooded several times with considerable loss of human lives and economic damage. The most recent, and one of the most catastrophic disasters happened on February 1, 1953, when 150,000 hectares were flooded and more than 1800 people lost their lives. It was clear that a disaster on such a scale must be prevented in the future and for ever.

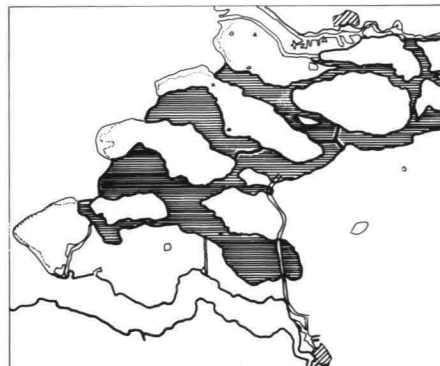

3
Delta Plan

Immediately after restraining the situation had been stabilized, the Delta Plan was drawn up: a plan in which the tidal waters in the south-western part of the Netherlands were intended to be cut off from the sea by dams. Only the Western Scheldt, which forms the access to the harbour of Antwerp, and the Rotterdam Waterway, which forms the access to the harbour of Rotterdam, would remain open. These estuaries should be protected by higher dikes.

The Delta Plan was approved by the Dutch Parliament in 1958. It not only offered a better protection against the sea, but it also provided advantages for fresh-water management and it would connect the isles in the south-western with the mainland. The period in which the 1953 disaster occurred, was favourable for the undertaking of great improvements. The reconstruction after the Second World War came to an end; owing to the increase of the population and the expanding industrialization questions concerning our environment were raised. Questions not only on how to protect the country against the storm surges from the North Sea, but also questions on how to use the water of the Rhine and the water of the archipelago in the south-west. The Delta Plan, conceived in the first place to provide safety for the Dutch people, brought more than protection alone. In the 'fifties and 'sixties' the main secondary benefits of the Delta Plan besides protection, were seen in the field of water management. The total plan seemed challenging enough and logically the execution started with the defence of the most vulnerable spots of the country around Rotterdam and with the closure on the smallest scale. Thus the Delta Plan was started in 1958 with the completion of a movable

flood barrier in the river Hollandsche IJssel, near Rotterdam (*figure 4*). In this solution the circumstances for navigation and the shipbuilding industry behind the barrier remained practically unaltered. For those periods during which the barrier is closed, navigation can pass through a lock next to the barrier. At the same time work was started on the closure of the smaller estuaries in the south-western Delta area. An important construction within the Deltaplan is formed by the big discharging sluices complex in the Haringvliet which was finished in the midsixties (*figure 5*).

4
Movable flood barrier in the Hollandsche IJssel

The original time schedule was closely followed and the development of new methods for bottom protection, for dike construction and for closing operations seemed to indicate that the biggest estuary, the Eastern Scheldt should be closed in 1978 by an impervious dam. Behind that dam a brackish lake turning gradually into a fresh water lake would benefit agriculture in the surrounding areas. People became more interested in the environment including the preservation of the landscape and the more or less natural areas.

The Eastern Scheldt basin with a relatively great tidal range, large tidal flats and shoals became more and more interesting not only for the oyster and mussel fisheries, but also for the biologists who found in it an area where very interesting and unique ecological processes take place. It proved to be an estuary with a great biomass production and one of

the nurseries of the marine life in the North Sea. Re-evaluation of the Eastern Scheldt closure seemed necessary. A long period of political disputes, demonstrations by action groups and scientific confrontations passed before the Government announced a new study, regarding the closure of the Eastern Scheldt. Rijkswaterstaat, as a part of the Ministry of Transport and Public Works, was ordered to take the study in hand. On base of this feasibility study the Government took the decision in June 1976, to build a storm surge barrier across the mouth of the Eastern Scheldt. The barrier can be closed when storm floods are predicted. Under normal conditions the barrier will be open, so that for the most of the time the basin will remain under the influence of the tide of the North Sea. In principle, the construction of the barrier is comparable with the flood barrier in the Hollandsche IJssel near





5
*Dischargingsluices complex in the
 Haringvliet*

Rotterdam. Only the considerations that brought about this solution are partly different: the main goal of both barriers is protection against floods, a secondary goal is maintaining navigation and the shipbuilding industry for the Hollandsche IJssel barrier and the environment for the Eastern Scheldt barrier.

The Delta Barrier Symposium will give detailed information on the conditions and results of the Rijkswaterstaat study, as well as on

the design and execution of the storm surge barrier.

For a comprehensive and ambitious plan, like the Eastern Scheldt project, the effort of all civil engineering disciplines is needed. Therefore, from the beginning, the Rijkswaterstaat (Public Works Department), contractors, consultants and research-institutes such as the Delft Hydraulics Laboratory and the Delft Soil Mechanics Laboratory, have been working closely together.

Three Rijkswaterstaat divisions are chiefly involved in the building of the storm surge barrier:

- 'Deltadienst' (Delta Division), coordinator and general designer for all projects in the Delta area;
- 'Directie Bruggen' (Bridges Division), which designs all steel structures;
- 'Directie Sluizen en Stuwen' (Locks and Weirs Division), which designs all concrete structures.

Usually a project is designed by Rijkswaterstaat and subsequently offered for tender. Supervision during the construction phase remains the responsibility of Rijkswaterstaat. Because of the complexity and the time needed for the main closures in the Delta Plan, a different method is used.

In an early stage a consortium of Dutch contractors named 'Dobouw' was invited to take part in negotiations according to general criteria concerning their ability, the costs of their equipment, the overheads, etc. As a result an overall project contract has been drawn up which defines the criteria for the sub-contracts; these are being detailed at a later stage. As the project takes several years of construction, new techniques are developed in cooperation with the contractor. The form of contract makes it possible that both contractor and Government profit by these new developments.

30 Years of development of the design criteria for flood protection and water-control works

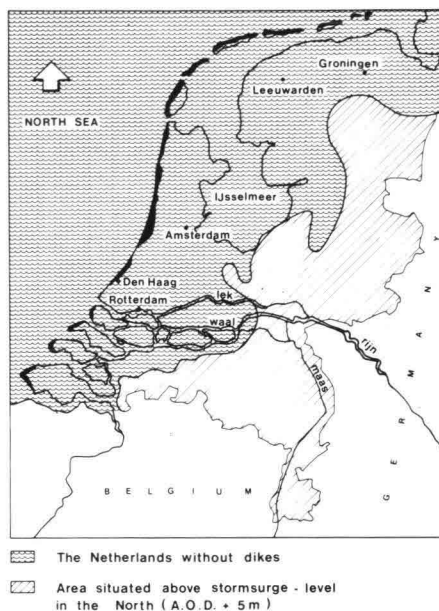

1
Dikes protect a major part of the Netherlands

1. Introduction

More than 50% of the Netherlands is lying below storm surge level. This means that the protection of this densely populated area of 'polder'land, by dunes, dikes and other 'hydraulic structures' is of paramount importance. For more than 1000 years the dike design was heavily based on experiences in practice. After the storm surge disaster in 1953, which hit the south west of the country, a major improvement was achieved by introducing the boundary conditions and derived loads as stochastic phenomena. A better design of the geometry became possible.

A complete probabilistic design taking into account load, geometry and strength is not yet possible, due to lack of knowledge mainly related to ultimate limit states of strength. After a brief discussion of geography, history of protection, storm surges and their effects and polders, the above mentioned design aspects will be considered.

2. Geography

Geographically the Netherlands belong to the alluvial coastal region of the North Sea. More than half the country, viz. the western and north-western part, is alluvial deposits. These areas lie mainly below storm surge level and are protected from the hydraulic effects (high waterlevels, waves and currents) of the North Sea by dunes and dikes (figure 1).

About 60% of the total population lives in these parts. The eastern part of the country is of pleistocene origin and dates back to one of the glacial periods. The low-lying part consists of series of large and small areas that are kept dry both naturally by drainage sluices at low tide and artificially by means of pumping sta-

tions. These areas are called polders, which possess a considerable degree of technical and administrative independence. The rivers Rhine, Meuse and Scheldt all run into the North Sea in the south west part of the country. The estuarial region of these rivers is known as the Delta area. A branch of the river Rhine, called Yssel, runs out into the former Zuyder Sea, now Yssel Lake.

3. History of protection

Geology

To understand the historical development of the protection by dikes in the Netherlands, it is essential to know the aspect of the gradual rise of the sealevel with respect to the land and also the deposits of soil by the North Sea and the rivers.

From geological studies it has learned that the sealevel has been rising for several thousands of years. There have been times of accelerated rise and times of slow development and occasionally the trend has been reversed. About 5000 BC the level of the sea was 16-18 m below the present level. Before that time the North Sea was land.

During one of the geological periods the coastal barrier (dunes) along the North Sea was formed. Between this barrier and the higher pleistocene area in the eastern part of the country, sand and silt were deposited. The rivers Rhine, Meuse and Scheldt added river silt, building and shaping the land by means of regular inundations. As a result the geological profile of the western Netherlands shows sand, silt en peat layers (figure 2).

During storm surges the North Sea penetrated low areas by means of the estuaries and through breaks in the dune barrier. This involved erosion of land and coming into existence of

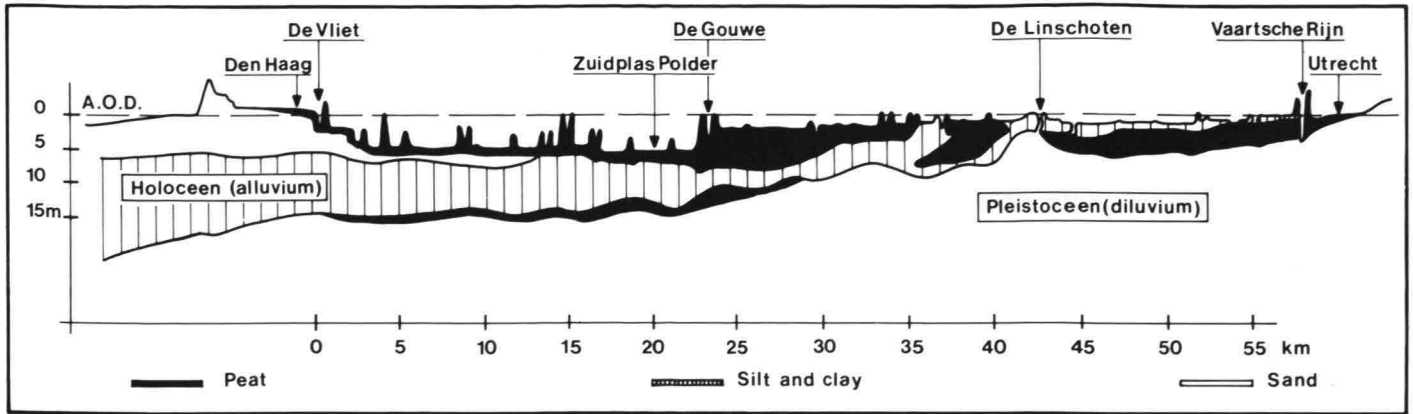

2 Geological profile of the western Netherlands

3 Wadden Sea and Zuyder Sea divided by the barrier dam ('Afsluitdijk')

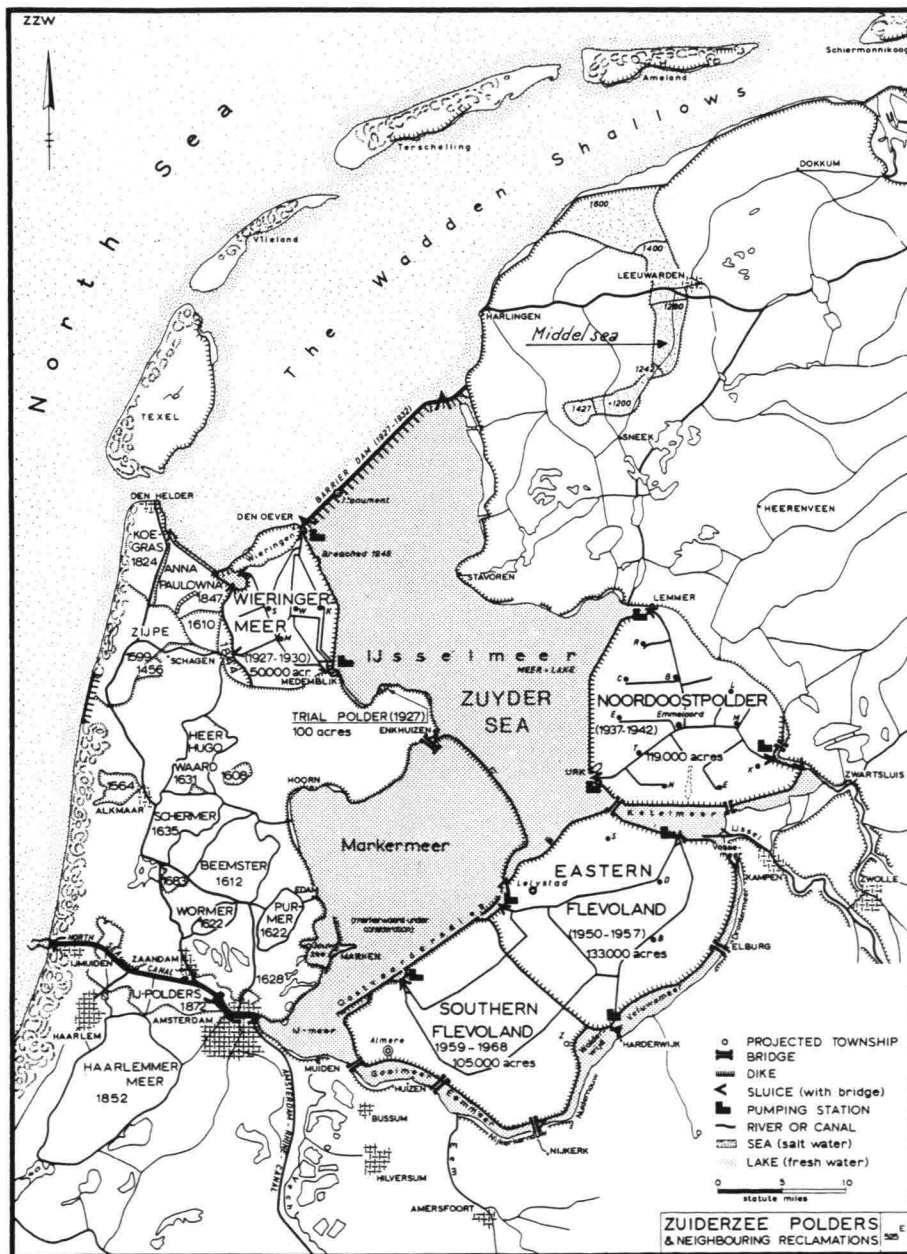

new inlets. Two of the major effects were the forming of the Zuyder Sea in the center and more to the north of the country the transformation from land into sea, which became the Wadden Sea (figure 3).

Early settlements

Long before the Christian era people must have lived in the unprotected lower parts of the Netherlands. Mainly in the first centuries people learned to protect themselves and their stock against stormtides in natural higher parts of the land and artificial mounds of clay (terps) on which their homes and barns were built. Many of such early settlements became a nucleus of existing villages and towns.

Considering the simple tools available at that time for the digging and transportation of soil and the construction of the terps, one is impressed by the tremendous task these early settlers carried out. Several of these 'terps' were namely more voluminous than the famous pyramids of Cheops. An important step was made towards improving the living conditions and safety by building dikes.

Protection by dikes

In the ninth century the first dikes were built. This developed in such a way that in the thirteenth century one can speak of a more organized way of dikebuilding. An area protected against high waterlevels by surrounding dikes is called a 'polder'. Dikebuilding at that time was organized and realized by the people who had faced the elements of nature. At first the aim of dikebuilding was defensive; people protected the land where they lived. In a later phase the construction of dikes was used in an offensive way viz. reclaiming land from the sea. In this way, from the



4a
Dikebuilding: the both dam sections are approaching



4b
On the place where the 'Afsluitdijk' was closed in 1932, a monument has been built

middle of the thirteenth century in total about 550,000 ha of land was reclaimed. However, during the centuries much of the previous reclaimed land was loosed by attack of the sea mainly due to storm surges which many times caused destruction of the dikes.

An other phenomena was the occurrence of landslides along tidal channels, whereby dikes disappeared; then during high (storm) tides the sea took also this land. Nevertheless every time there was the spirit of the people to push back the sea. So most of the lost land was reclaimed again, despite the ever occurring storm surges.

4. Storm surges and their effects

The history of the Netherlands is

marked by storm surge disasters. The oldest known occurred in the year 1287 and hit the whole country; in the north 50,000 people drowned. About 380,000 ha of land was inundated during a storm surge in 1825, mainly around the (former) Zuyder Sea. Also in 1916 a serious storm caused damage to large areas around this sea. This gave the impulse of shortening the length of dikes with 300 km by constructing a 32 km long barrierdam, which closed-off the Zuyder Sea from the North Sea. This dam, with discharge sluices and navigation locks at two locations (Den Oever and Kornwerderzand), was completed in 1932 (figure 4).

The most recent disaster took place at the first day of February 1953 when a north westerly storm struck the south western part of the Netherlands (Delta area). The storm surge level reached 3 to 3.5 m above normal high water and exceeded storm surge levels about 0.5 m at some places. The dikes could not withstand these levels, so that at several hundreds of places the dikes were damaged and broken, over a total length of 190 km. Through nearly 90 breaches 150,000 ha of polderland inundated. This caused the death of 1800 people and 100,000 persons had to be evacuated. Moreover a lot of live-stock drowned and thousands of buildings were damaged or destroyed.

This disaster gave a new impulse to improve the whole seadefence system of the Netherlands. The resulting Delta plan included the strengthening of existing dikes and dunes and shortening the length of protection in the Delta area by closing-off estuaries and a tidal river. The Rotterdam Waterway through which the rivers Rhine and Meuse flow into the North Sea, and the Western Scheldt, both important fairways for the harbours of Rotterdam/ Europoort respectively Antwerp, should remain open.

The original planned barrier dam of the Eastern Scheldt has been changed into a storm surge barrier, now under construction. The other estuaries (Haringvliet, Brouwershavense Gat, Grevelingen and Veerse Gat) and the tidal river Hollandse IJssel are separated from the North Sea mainly by barrierdams. In the north of the mentioned river a storm surge barrier has been built. A significant part of the Haringvliet barrier consists of a discharge sluice,

which acts mainly during the high floods from the river Rhine. The strengthenings of the existing seadefences of the Netherlands is nearly completed. Together with the Deltaworks the low lying 'polderland' of the Netherlands has reached already a relative high degree of safety against storm surges. To understand the system of dikes in relation to polders in the next paragraph, the two ways of creating polders are discribed.

5. Polders

Polders are reclaimed low lands protected by dikes against high waterlevels and waves.

Two types of polders can be defined:

- a. impoldering of marshlands in tidal waters, with a height of mean high water;
- b. reclaiming (parts of) the bottom of lakes with a depth of several meters below mean sea level.

Impoldering of marshlands (figure 5a)

In areas where hydraulic conditions of tidal waters are appropriate (small currents, quiet wave climate etc.) sand and silt will deposit. This process accelerates in the phase that the level of deposits is rising and grasses are starting to grow. Finally the level of deposits equals the mean high water mark and marshlands are formed.

These marshlands are located along the coast, at the end of estuaries, bays etc. and sometimes as islands. After surrounding an area of marshland by a dike and so protecting the land against highwater and storm surges, a polder is created. Draining water is discharged by gravity through sluices in the dike. In course of time the soil of the polder settles due to decreasing the watertable as a consequence of draining. This means that the level of the polderland and -dikes may settle in the order of 1 to 1.5 m.

A process of impoldering one after another developed in such a way that large areas of tidal waters and in many cases whole estuaries or bays were gained from the sea. An example is the former Middel Sea (figure 3). As a consequence dikes of polders behind new reclaimed land (polder) became 'dry' dikes (inner dikes) creating a system of safety. This was important because before the 13th and 14th century dike technology was not developed and maintenance was of poor quality.

5
Impoldering of marshlands and reclamation of lakes

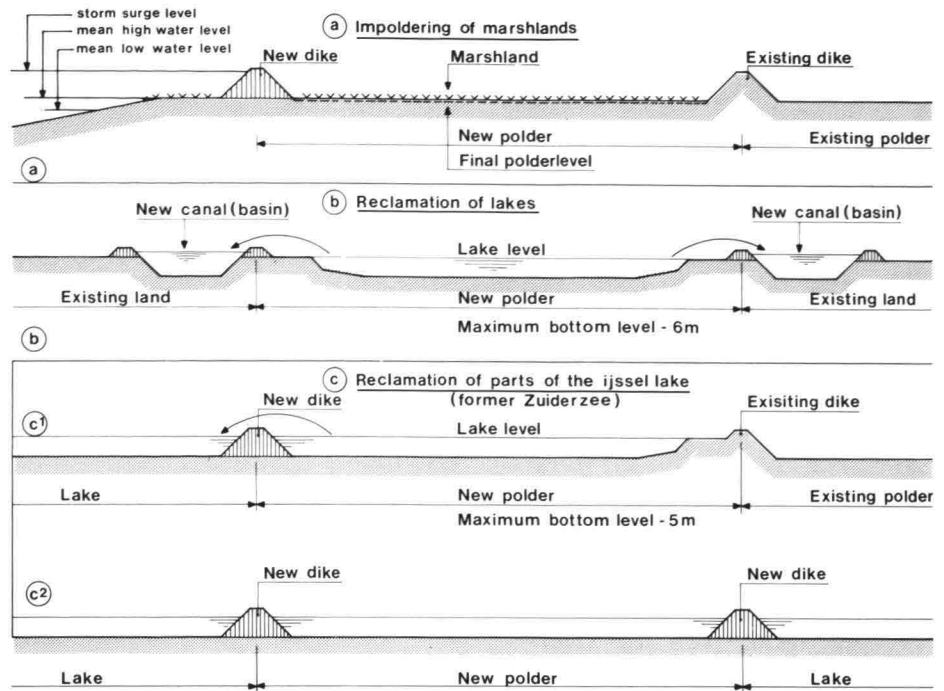

During storm surges, frequently dike breaches occurred, causing inundation of polders. However, in the mentioned period it was a bad custom to remove dry dikes. This is the reason that at several locations in the country large polder areas exist without inner dikes. From the year 1452 it was forbidden to remove inner dikes. Together with the dikes which before this year were not removed, now low lying areas in the country are comparted by a system of inner dikes.

Reclaiming land from lakes (fig. 5b)
 Several lakes in the west of the Netherlands have become polders in the following way. First on the land around the lake a canal with a dike on each side was constructed and 'pumping' stations were built. Then the water in the lake was pumped into this canal, acting as a basin, and finally discharged via a system of canals to the sea. The dikes are also acting as inner dikes. This way of reclamation started in 1542, when 'pumping' became possible with paddle wheels driven by windmills. Later (1787) also steam engines were applied. These 'pumping' stations are also used to drain the polder. An example of this type of reclamation is the Haarlemmermeer (18,000 ha) with a bottom depth of 4.5



6
Outer berm of a dike protected by polygone concrete blocks

m below A.O.D., wherein is located the international airport Amsterdam-Schiphol. Another one is the Prins Alexanderpolder (depth: A.O.D. - 6 m), with new residential areas of the city of Rotterdam. In the Yssel Lake, formed after closing off the Zuyder Sea by a barrier-dam (1932), four polders (depth: to 4.5 m below A.O.D. have been reclaimed viz. Wieringermeer, Noordoostpolder, Eastern- and Western Flevoland. In the last mentioned polder, a new city 'Almere' (250,000 inhabitants) is under construction. In these cases the polders are realized by building a dike with some pumping stations on the Yssel Lake bottom around the to be reclaimed parts of the lake (figure 5c). The enclosed area of water is simply pumped into the remaining part of the lake and discharged through sluices in the barrier dam. This dam is protecting the polders against storm surges of the Nort Sea. The polder dikes have to resist all the time the water of the Yssel Lake; they can also acts as a secondary protection against storm surges in case the barrier dam fails.

6. Design of dikes, period 1000 — 1953/58

The design of dikes and hydraulic structures as drainage sluices etc. in this period was mainly based on experience in practice. Dikes were generally constructed with clay and showed a trapezoidal cross section with the steep slope at the inner side.

In more recent times also a dike with a wave energy absorbing outer berm was developed (figure 6) and sand was applied as cone material. The height and strength of dikes and structures had to be related to a certain storm surge level and wave action, specially a value of the wave run-up. This run-up is increasing with steepness of the outer slope. Occurred storm surge levels were sometimes marked in stones of buildings. For more than a century waterlevels are continuously recorded. Wave characteristics and wave run-up were only observed by eye so that reliable data were not available. Only the swag marks on the slope of dikes, after a storm gave an indication of the level of wave run up. Later these swag marks were levelled. Taking into account the (still) waterlevel a rough value of wave run-up could be derived. With this data it was possible to improve the design to a certain extend. In general it can be said that the design was based on the highest observed storm surge level and an estimate of wave characteristics (height and period) and wave run-up.

Experiences

The experience during centuries was that again and again higher storm surge levels and extremer wave action occurred than those which were imaged. Overflow and/or overtopping of dikes, caused in most cases instability of the steep innerslopes, which in many cases induced a

breach and consequently led to inundation (figure 7). Depending on the storage capacity of the polder(s) (depth and area) and the composition of the soil under and in the vicinity of the dike, deep and wide tidal channels can develop in these breaches. This mode of failure occurred also in the dikes around the Zuyder Sea during the storm surge of 1916. Amongst others this was the reason that in 1920 in the Netherlands soil mechanical investigations started in order to improve dike safety.

Also due to other modes of failure, for example erosion of the outer slope, collapse of drainage sluices, coupures in dikes etc. breaches followed by inundations occurred. The increase of storm surge levels was not only due to nature but also impoldering of relatively large tidal areas that decreased the storage capacity, originated by higher water levels.

As a consequence and moreover due to erosion of the wave-reducing foreland of dikes, caused by tidal currents and wave action, wave attack and -run-up became more severe. The more severe wave attack necessitated an improvement of the grass protection of the outer slope of dikes. Seaweed, rows of wooden piles and in more recent years boulders, rockstone, concrete blocks etc. were applied.

First calculations of storm surge levels and investigations of wave run-up

The first calculations of the influence on waterlevels, in case of decreasing the storage capacity of tidal waters, have been done for the barrierdam of the Zuyder Sea. The physicist Prof. Lorentz developed a mathematical tidal model and calculated water levels and currents before, during and after closing off the Zuyder Sea. The results were as later was experienced quite accurate. The calculated design storm surge level was based on the storm surge of 1894, which at that time caused the highest water levels. This design level was about 1 m higher than in 1894, which until now is not exceeded. However nearly the same level was reached in 1953 and 1954.

Design waves and related wave run-



up were also investigated in the frame work of the Zuyder Sea enclosure. It has been proved that these results were inaccurate.

Probability of storm surge levels

The possibility that higher storm surge levels may occur than has been observed or recorded, was considered during the design of the Zuyder Sea barrier dam. However, this has not resulted in a new design philosophy. This philosophy was introduced by the Dutch hydraulic engineer Wemelsfelder, who published in 1949 an article about probability of exceedance of storm surge levels along the coast of the Netherlands. He presented probability exceedance lines, using a linear scale for the water levels and a logarithmic scale for frequencies of occurrence.

From this time in principle it was possible to establish a design water level which has a beforehand determined acceptable probability of exceedance.

7. Design philosophy from 1953/1958

Recommendations of the Deltacommittee, who advised the government about the measures to be taken after the disaster of 1953, proposed a new design philosophy for the sea-defences. This committee reached the conclusion that for the entire coast of the country inadequate protection was provided by the existing defences and that strengthening of the main sea defence structures was necessary. The measures laid down in the Deltaplan have been described briefly in paragraph 3.

The strengthening should be related to a storm surge level which will ensure an acceptable and economically sound protection for the future. So the first task was to determine design water levels along the coast. An economic approach and a simple reasoning based on safety considerations have been performed.

Economic approach

Prof.dr.D. van Dantzig (1956) has treated the question of the optimal strength of the dikes protecting central Holland as an economic decision problem. For simplification a polder surrounded by a dike has been considered. It is assumed that the cost K (D.fl.) of constructing the dike is partly a function of the crest height H (m) of the dike:

$K = C_0 + C_1 H$ wherein
 C_0 = initial cost of the dike (D.fl.)
 C_1 = cost per unit height of the dike (D.fl. m^{-1})

both over the total length.

This means that by rising the crest height of the dike the cost (K) is increasing. On the other hand the probability (p) of inundation of the polder is decreasing so $p = P_r(H > H) = F(H)$ whereas $F(H)$ is a mathematical expression for exceedance curve of storm surge levels. Inundation is causing death of lives and damage or loss of goods (S). Only the latter has been taken into account. So the total cost that has to be taken into account is the sum of construction (K) and the present value (W_e) of the expectation of the damage caused by inundation. In

Table 1

| <i>m</i> number per year | maximum storm surge levels |
|-----------------------------|-------------------------------|
| 5 - 1 | low |
| 1 - 0,1 | normal |
| 0,1 - 0,01 | high |
| 0,01 - 0,001 | very high |
| 0,001 - 0,0001 | extreme |

case of a dike with a very low crest the amount of money related to the construction cost (*K*) is limited but will reach a high value. In contrast a high crested dike shows a limited value of W_e due to its low probability of exceedance *P* but relatively high construction costs. It can be shown that the sum $K + W_e$ must have a minimum, in other words there is an optimal dike height ($H_{optimum}$) which can be derived from $\frac{d(K + W_e)}{dH} = 0$.

As risk (*R*) is defined as the mathematical expected value of damage caused by inundation (*S*) this results in: $R = p.S$ (D.fl. year⁻¹). The risk can also be considered as the insurance premium which should be paid each year in case one had an insurance cover against inundation. The present value of the insurance premium paid during the lifetime of the dike is equal to:

$$W_e = \sum_{n=1}^N \frac{R}{(1+i)^n} \text{ (D.fl.)}$$

i = interest base in percent
N = lifetime in years
n = number of years

The minimum of the cost can be calculated by differentiation of the total cost function. Subsequently the optimal dike height is found by solving:

$$\frac{d(K + W_e)}{dH} =$$

$$\frac{d}{dH} (C_0 + C_1 H + \sum_{n=1}^N \frac{F(H)S}{(1+i)^n}) = 0$$

Prof. Van Dantzig calculated with a rather low estimate for damage or losses of goods an optimum dike height related to a storm surge level (station Hook of Holland) of A.O.D. + 6 m. This water level has a probability exceedance of 8.10^{-6} or nearly 10^{-7} .

Safety considerations

Mr. Wemelsfelder (1949) performed safety approaches to arrive at an acceptable frequency of exceedance of a storm surge level.

Table 2

| character of safety | duration <i>T</i> (years) | frequency of exceedance | | remarks |
|---------------------|---------------------------|--|------------------------------------|--------------------------------------|
| | | material interest, accepted threat 10% | vital interest, accepted threat 1% | |
| Lifetime | 50 | 2.10^{-3} | 2.10^{-4} | solid design of hydraulic structures |
| Country | 1000 | 10^{-5} | 10^{-6} | |
| and people | 1000 | 10^{-4} | 10^{-5} | |

A frequency of exceedance of 10^{-4} seems to be acceptable which corresponds with a water level of A.O.D. + 5 m at Hook of Holland.

The design frequency of exceedance is defined as $N = \frac{m}{T}$ wherein
N = number of exceedance per year
T = planning period (duration in years that a potential storm surge threat can occur)
m = the acceptable number of storm surges that lead to inundation during *T*

Maximum storm surge levels were classified as in table 1.

First the safety for a lifetime has been considered. A lifetime of 50 years has been stated as the duration wherein a certain protection against severe damage or a complete disaster caused by a storm surge is considered. If an object has to be safe against 'normal' storm surges *m* = 10% should be chosen which means $N = \frac{0,1}{50} = 2.10^{-3}$. Are also lifes and livelihood threatened a limitation to 1% (high storm surge levels) or even less must be considered, so $N = \frac{0,01}{50} = 2.10^{-4}$.

Next attention was paid to the safety for the country and the people. Here the duration of the planning period is much longer than 50 years and has been arbitrarily fixed on 1000 years. Taking into account the safety of the lifes of hundreds of people and the livelihood of millions it is not unreasonable to decrease the accepted threat with a factor 10, which means 0.1% (very high storm surge levels) or $N = \frac{10^{-3}}{1000} = 10^{-6}$.

In case only objects of material interest play a part

$$N = \frac{10^{-2}}{1000} = 10^{-5}$$

Expertly designed and well maintained, a failure will only take place when the design water level is exceeded by a couple of dm. This means that the design water level can be fixed lower, say $N = 10^{-4}$. As a result of the safety considerations the frequencies of exceedance are listed in table 2.

Design waterlevel advised by the Deltacommittee

The Deltacommittee, taking into account the various approaches, came to the conclusion that the economic optimum design water level for central Holland, is about A.O.D. + 5 m (station Hook of Holland). The corresponding probability of exceedance is 10^{-4} .

This level is 1 m lower than the economic optimum design failure water level (probability x 10), calculated by Prof. Van Dantzig. In relation to this it should be remarked that the Deltacommittee is considering the design water level in such a way that an exceedance of this level extent, leads not to a failure so the committee required that at the design water level complete safety against breaches must be guaranteed.

Depending on the economic importance of protected polder areas along the coast north and south of central Holland, reduced design water levels are advised. For example in the Deltaregion these levels are corresponding with a probability of 2.5×10^{-4} .

Up till now only the storm surge (still) water level has been considered. Other phenomena related to storm surge tides such as seiches and gust bumbs have been taken into account separately. Finally wave action and wave run-up have significant influence on the design of hydraulic structures.

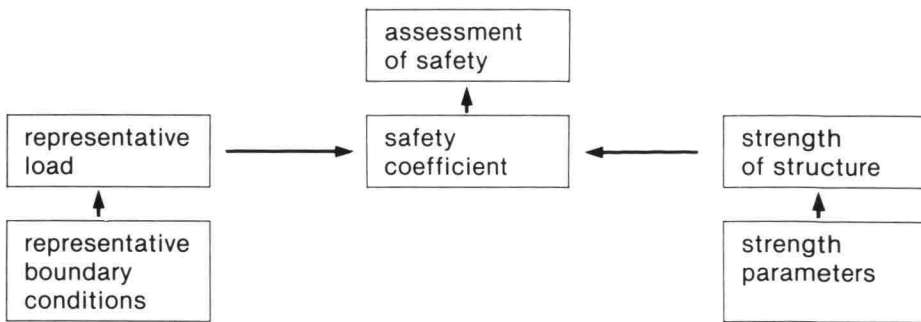

Figure 8

8. Possibilities of probabilistic design

The design of the seadeffence in the Netherlands till 1953 was based on the highest recorded storm surge waterlevel and observed wave run-up and -attack. Height, geometry and strength were mainly a matter of practice and simple calculations. During centuries it appeared that the occurring storm conditions were more severe, seadeffence crests too low and strengths too weak. These aspects caused numbers of inundations with the bitterest consequences. This way of designing based on recorded waterlevels and run-ups only is referred to as 'deterministic design'.

After the storm surge disaster in 1953, according to an advise of the Deltacommittee, the design water level is based on extrapolation of the frequency curve of occurred storm surge levels, and a selected frequency of exceedance. As previously described waves are taken into account as a stochastic phenomena and wave amounts has the same probability of exceedance as the design water level.

The geometry and strength of the seadeffence is now determined on physical (hydraulic) models and more sophisticated calculations. However practical experience plays an important part.

The currently used design method contains probabilistic aspects as far as the boundary conditions are considered.

A next and final step in improving the design of seadeffences is the complete probabilistic design method. Before describing this method it is useful to consider the deterministic design first.

The representative load is derived from (representative) boundary conditions as water levels, waves, during storms etc., which are based on existing knowledge. Generally they are arbitrary chosen.

The permissible load (normally lower than the failure load) and the strength of this structure and its parts, which is determined by investigations, are compared with the representative load (figure 8). If this load appeared to be higher than the strength of the structure, the safety is considered to be insufficient.

The probabilistic method in principle takes into account all causes of a possible inundation. These are analysed in their relations to each other and from the corresponding separate probabilities of occurrence, the total probability of failure calculated. Distinguished are all imaginable causes of inundation as human failure, sabotage, acts of God, etc.

In order to get insight of the mentioned causes of inundation a faulttree of a complete seadeffence of a polder is a good tool.

For a probabilistic calculation of a structure it is necessary to calculate the probability of failure for each ultimate limit state.

First the fundamental parameters which are involved on a mechanism are gathered. These basic variables concern two main categories: load and strength. In the category strength material properties and geometry are involved. The type of probability distribution of these parameters as well as the expected value and related standard deviations have to be specified.

The category loads are containing basic variables which are to be conceived as boundary conditions (wave action, water levels, etc). Also the stochastic character has to be taken into account.

It should be remarked that material properties as well as geometry of the structure may influence loads and stresses.

From the basic variables, respectively the strength and load are determined by means of a theoretical model. A theoretical relation used for deriving load from boundary conditions of nature (water levels, waves etc) is also called a transfer function. Uncertainties in these models ought to be quantified by employing theoretical solutions with results of a sufficient number of model tests. Moreover, the probability density function of the relation between the actual and the theoretical predicted behaviour of the structure has to be determined.

If for one mechanism the probability density function of the load ($f_R(r)$) and of the strength ($f_S(s)$) is determined, the last step is to establish the probability of failure of the considered part of the structure, by solving the convolution integral (Freudenthal, 1966).

$$P_f = \iint f_S(s) \cdot f_R(r) \, ds \, dr$$

$f_S(s)$ = probability density function of the load (p.d.f. load);
 $f_R(r)$ = probability density function of the strength (p.d.f. strength).

As the probability density functions are independent stochastics, the joint probability is $f_R(r) \cdot f_S(s)$. This is represented by a mountain with equal contours referred to a horizontal plain. Also is indicated the unsafe space between lines $z=0$ and S . It can be seen that the probability P_f is equal to the content of the mountain in the unsafe space. This probability of failure is to be attached to the element in the faulttree that symbolizes the considered failure mechanism. In this way the failure probability of all mechanisms is calculated and after considering all technical aspects in their relation one to another, the total probability of failure can be determined.

As far as now is assumed, theoretical models are available to derive the load (or potential threat) from the nature boundary conditions and from the basic variables of material properties the strength. From a certain number of problems related to hydraulic structures these theoretical models are not available. This can be loosened by applying a physical model of the structure for a number of discovered combinations of boundary conditions.

Integration of the joint p.d.f. of boundary conditions in the area in which severe damage occurs, gives an impression of the probability of failure. In repeating series of model tests by changing the value of one of the basic variables of strength, the p.d.f. of strength is determined.

9. State of the art of probabilistic design

In principle it is possible to arrive at a value of the probability of failure of a dike on an other structure, using the probabilistic method. Probabilistic calculations of the height of the dike taking amongst others into account the combination of occurrence of storm surge levels and wave run-up, can lead already to a more accurate dimensioning.

This has been done by W.T.Bakker and J.K.Vrijling (1980) considering, under several assumptions a dike along the coast of Schouwen in the vicinity of the storm surge barrier in the Eastern Scheldt. They compared the results of the probabilistic calculations with those derived from the philosophy of the Delta Committee.

Table 3 presents the calculation according to the philosophy of the Delta Committee, taking into account all phenomena. It is a demonstration; only the results of the comparison are given in table 4.

Table 3 contains the dike heights calculated by probabilistic method without taking into account uncertainties of dike height. Further the results derived from the philosophy of the Delta Committee both with and without uncertainties of dike height (b1 and b2) are presented (table 4). Wave run-up is a function of the slope; namely the steeper the slope the higher the dike. The values of probability of failure related to b2 show that by flattening the dike from 1 : 6 to 1 : 8 the change of overtopping or failure is increased by a factor 4.

The dike facing SE is not exposed to waves. So the potential threat is only the still storm surge level. The probability of failure of this dike is 1000 times likelier than the dikes exposed to waves.

It is clear that under simplifying assumptions designs of dike height according to the advice of the Delta Committee, specially considering dikes exposed to waves and those which are located on the leeside, show significant differences in safety. Applying the probabilistic method

Table 3

| Exposed to waves | | Yes | No | |
|---------------------------------|---|-----------|-----------|----------|
| Orientation | | NW | SE | |
| Slope | | 1 : 6 | 1 : 8 | 1 : n |
| phenomena and transfer function | Storm surge level (A.O.D.) | + 5.50 m | + 5.50 m | + 5.50 m |
| | Wave run-up $< 2\% = 0,7 T_p \sqrt{gH_s} \text{ tga}$ | 9.90 m | 7.42 m | 0.50 m |
| | Seiches S | 0.24 m | 0.24 m | 0.24 m |
| | Cust bump $\frac{\beta}{\beta + a 2\%} \cdot \beta$ | 0.03 m | 0.04 m | 0.18 m |
| Design water level (A.O.D.) | | + 15.67 m | + 13.20 m | + 6.42 m |
| uncertainties | Change of chart datum | 0.15 m | 0.15 m | 0.15 m |
| | Settlement of dike | 0.10 m | 0.10 m | 0.10 m |
| | Settlement of subsoil | 0.50 m | 0.50 m | 0.50 m |
| Dike height (A.O.D.) | | + 16.42 m | + 13.95 m | + 7.17 m |

Table 4

| Exposed to waves | | Yes | No | |
|--------------------------------------|--|----------------------|----------------------|----------------------|
| Orientation | | NW | SE | |
| Slope | | 1 : 6 | 1 : 8 | 1 : n |
| Height of dike in m above A.O.D. | a. probabilistic without uncertainties of dike height | 12.21 | 10.50 | 5.95 |
| | b1. philosophy Delta Committee without uncertainties of dike height | 15.67 | 13.20 | 6.42 |
| | b2. idem, taking into account uncertainties of dike height (probabilistic) | 15.90 | 13.43 | 6.65 |
| Probability of failure related to b2 | | 5.8×10^{-8} | 2.2×10^{-7} | 4.1×10^{-5} |

in determining the dike height a more balanced and defined safety will be achieved. Also more economical designs will result.

Considering the possibilities which the probabilistic design offers in calculations the probability of failure of the structure as a whole, there are problems to solve. From all ultimate limit states which play a part, only the u.l.s. overflow and overtopping can be calculated in a probabilistic way. All other u.l.s. do not offer this possibility. Moreover the interactions between various limit states are unknown.

For each u.l.s. are relations to define, which give the connection between the parameters strength and load and another per strength and load parameter the probability density functions are to be determined. Also the fault tree must be completed, not only regarding the dike sections but also structures like drainage sluices, pumpstations etc. which are forming together the seadefence.

Investigations and studies are underway to gather the knowledge step by step in order to arrive in the future in a stage that calculations of the probability of failure of a seadefence system is possible.

Regarding the storm surge barrier in the Eastern Scheldt, consisting of several materials as soil, gravel, rockstone, concrete and steel, existing knowledge and intensive studies with investigations have made it possible to apply, with certain limitations, a probabilistic calculation.

Literature

- W.T.Bakker, J.K.Vrijling, Probabilistic design of seadefences; Conf. Coastal Engin. Sydney 1980
D. van Dantzig, Economic Decision Problems for Flood Prevention; *Econometrica* 24, 276-287, New Haven 1956
P.J.Wemelsfelder, Wetmatigheden in het optreden van stormvloeden; *De Ingenieur* nr. 9, 's-Gravenhage 1949.

The joint evaluation of design and construction of large scale concrete coastal structures

1. Introduction

Anywhere in the world one observes concentrations of populations wherever important sea shipping lanes and major inland shipping routes meet. The Netherlands is a country exactly in that position. The Netherlands, the delta area of three rivers of which the Rhine is the most important one, is situated on the North Sea coast. This is the positive influence of its location by the sea. Harbours and port installations, industry, transport, trade and employment develop in such an area. This creates an international atmosphere. Delta areas are formed by material carried along by rivers. Usually they are low-lying areas built up of sand and clay. Living in such areas therefore gives rise to problems, too. Buildings must be erected on poor subsoil. Thus expensive foundations have to be provided resulting in additional building costs. However, at the other end of the scale, the constraint of having to build in these difficult circumstances has provided Dutch civil engineers with very expensive knowledge and experience. There was a further problem to be solved. Under the influence of westerly storms the originally rather shallow water level of the North Sea is raised by several meters whenever this occurs. This piling up of the water together with tidal floods could inundate sixty per cent of the land if there were no protective dikes. These, then are the negative influences of living in Delta areas close to the sea. It is therefore understandable that the struggle against the sea has been going on for centuries past. It has marked the Dutch. Skill in hydraulic engineering was a necessity. Our country had experienced major floods in the course of history. Land has been lost to the sea. However, we have always succeeded in

beating back the attacker. After the flood disaster of 1953 The Delta Plan was developed and put into operation. It will have to provide the definitive protection of the Netherlands against the sea.

2. The Delta Plan

The original Delta Plan was aimed at improving the safety of the inhabitants. This is understandable in the light of the 1953 disaster. The plan envisaged a raising of the dikes, and in particular, a shortening of the protective dikes by closing off the mouths of the estuaries in the south-west. The total shortening of the sea defences was 700 km. The plan which was adopted by Parliament in 1958, should have been completed by 1978. At the end of the 'sixties' when the implementation of the Delta Plan was in full swing, a discussion — albeit rather reluctantly at first — was started on the assumptions on which the project was based. Many people expressed the fear that the implementation of the project would adversely affect the environment, if the estuaries, rich in wild-life, were to be closed off.

This is a discussion which takes place anywhere in the world where infrastructural works bring about major changes in the environment concerned.

Subsequent to fierce political strife, the Delta Plan was reconsidered in 1972 that is to say, that part of it which had yet to be constructed, i.e. the closing-off of the Eastern Scheldt estuary. In 1974, Rijkswaterstaat was commissioned with the study concerning the feasibility of building a storm surge barrier in the tidal channels of the Eastern Scheldt estuary. This barrier would be open in normal circumstances in order to grant free access to the tidal currents to the estuary behind the river mouth.



1
The Netherlands

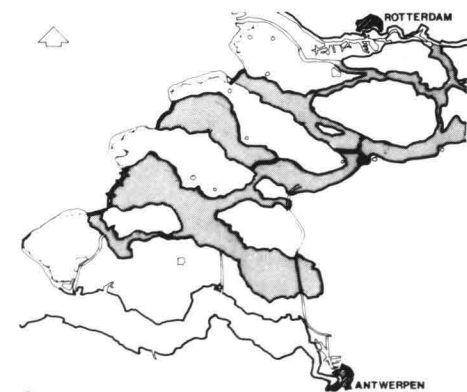

2
Original Delta project

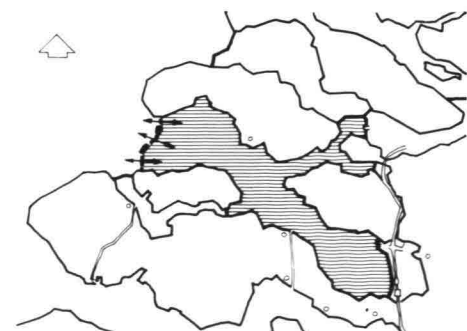

3
Modified Delta project

A barrier which, however, would have to be closed during a storm in order to stem the floods. There would be an interplay between environment and safety, a balance between the two. Rijkswaterstaat, assisted by Dutch laboratories, contracting firms and consultant engineers provided a positive answer, after 18 months, to the questions raised. A storm surge barrier could be built in the mouth of the Eastern Scheldt, completed by 1985 within the maximum earmarked budget i.e. three thousand million guilders. In 1976 the political decision was taken to go ahead with the construction of the storm surge barrier. In the light of the affirmative reply 'yes, indeed, we are able to implement this difficult project' the accumulated hydraulic engineering knowledge of the engineers from the groups quoted above proved to be of vital importance. It took a great deal of confidence and perseverance to even start thinking about this most advanced project. Both these qualities proved absolutely necessary.

To build a storm surge barrier in the mouth of the Eastern Scheldt is enormously difficult. The tidal volume amounts to over one thousand million m^3 . The channels are almost 40 m deep, the bottom consists of loosely packed, and sometimes polluted, sand. The site constitutes, partly because of these problems, a fascinating challenge giving an impetus to hydraulic engineering in Delta regions.

3. Storm surge barrier in the Eastern Scheldt

The Eastern Scheldt storm surge barrier cannot be built in situ within a temporary ring dike as was done earlier in the construction of the 'Haringvliet' sluices since otherwise the ecological circumstances might change during the construction. The barrier must be built in the river at the site of the three tidal channels. Of the 9 km wide river mouth the total width of the channels thus also of the barrier, is almost 3 km. In between there are sand banks on which a dam will be built. To maintain the present-day environment in the Eastern Scheldt implies the maintaining of the present tides in the river. It was clear, however, from the outset that maintaining the present tides would not be feasible from an economic viewpoint. For, movable steel gates are about five times as expensive per surface unit than fixed

structures built of concrete. Hence the feasibility of a flood barrier with a reduced tidal profile was made the subject of a study. At the present-day tidal profile of approximately 80,000 m^2 , the head is a maximum of about 4 m. A reduction in the tidal profile to 40,000 m^2 implies a reduction in the tidal head of only 5%; a further reduction to 15,000 m^2 brings about a reduction in tidal head of 30%. It was demonstrated that a storm surge barrier with a tidal profile of 15,000 m^2 remained just within the allowable maximum budget.

When the study was begun it became clear that all knowledge and experience in the field of hydraulic engineering had to be combined. Holland United arose. A number of major Dutch contracting firms jointly set up the design office STUCOS in order to assist Rijkswaterstaat. Laboratories everywhere assisted and where necessary reinforced their ranks with foreign specialists. Consulting Engineers' Offices furnished their best people. Many designs were produced. Caissons were given a great deal of attention. In the many years during which work on the Delta Plan had been ongoing, much experience was obtained with caissons.

Following evaluation of these designs from the 'brainstorming' period, three designs were selected: a. caissons on shallow foundations; b. caissons founded on piles; c. piers founded on open caissons. The design envisaging piers founded on open caissons came out as a favourite. Following the parliamentary decision of 1976 much work went into perfecting this design. In this optimization attention had to be given to the hydraulic boundary conditions in particular, the foundation aspects, the sill construction and the risks inherent in construction.

a. Hydraulic boundary conditions

The foregoing article has already dealt with the hydraulic boundary conditions at length.

b. Foundations

The design comprising 'piers on open caissons' is characterized by the great depth at which these foundations are installed in the harder Pleistocene sand strata, the location and condition of which were investigated with the aid of a large number of exploratory borings and tests.

Exploration of the bottom led to modification of the proposed levels of the foundations. A greater

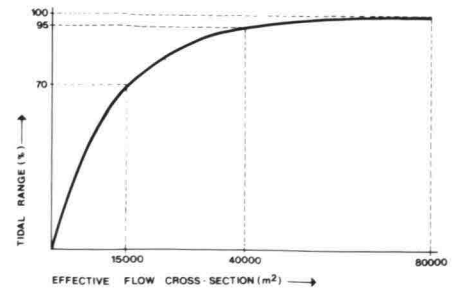

4 Relationship between tidal range and flow cross section

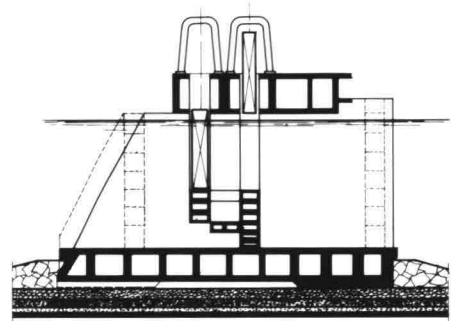

5 Gated caisson on a rubble base

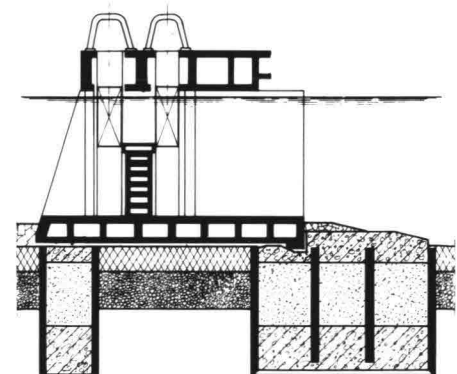

6 Gated caissons on a pile foundation

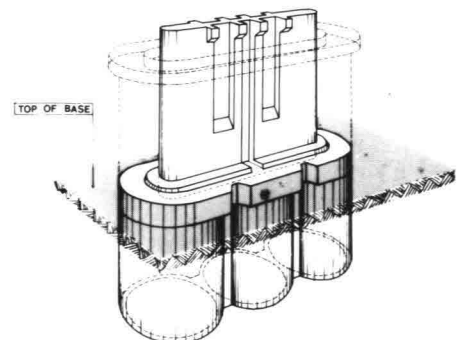

7 Piers on open caissons

understanding of the way in which the foundations are likely to behave has been obtained by carrying out a great many tests on scaled models and numerous calculations. More particularly, additional information has been gained concerning the stability of the structure and on the changes it will undergo when it is exposed to storms of the anticipated ferocity. A detailed analysis has revealed that there are two kinds of ways in which the barrier is likely to be affected: the open caissons may undergo horizontal displacement and they may overturn. The deeper these caissons are installed into the sea bed the more likely they will be to overturn rather than to be displaced. The soil around and underneath the caisson foundations has to have the necessary qualities to enable it to resist overturning or displacement. Since the soil under the caisson is structurally better than the soil next to it, the caisson derives most of its stability from its base. However, the deeper the caisson is installed in the ground, which increases the risk of overturning, the greater the pressure on the base. To compensate for this, the caisson has to rely more and more on the lateral support provided by the relatively weaker soil strata. Contrary to what might be supposed, it emerges that the risks do not progressively decrease as the caisson is installed deeper in the ground. From an embedded depth of about 10-12 m onwards, the positive effect of lateral support is cancelled by the negative effect of the larger risk of overturning.

For depths of less than 10-12 m, on the other hand, the caisson has a greater tendency to shift horizontally than to overturn. In the light of these facts the maximum height of the caissons — originally envisaged as 26 m — was reduced to 16 m. In addition

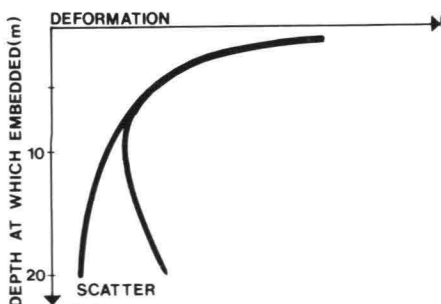

8 Embedded depth of less than 10 - 12 m increases the tendency of the caisson to shift rather than overturn

tion to the depth to which the caisson is embedded, the area of its base has a considerable affect on stability which increases as the area of the base increases.

With a larger base, requirements regarding the strength of the subsoil can also be relaxed slightly which is especially important for less deeply embedded caissons in less densely packed upper strata.

On the basis of these considerations the diameter of the open caissons was increased from 16 m to 18 m. The original design of a caisson foundation system embedded at a relatively great depth in Pleistocene strata had evolved into a system comprising caissons with a larger base area and installed at lesser depth.

c. Sill

The function of the sill i.e. the substructure in which the foundation caissons are lodged, is to protect the sandy sea bed in the vicinity of the caissons from erosion by currents. It also counteracts the undesirable flow of water under the barrier. The underflow will tend to concentrate under the closed gates when there is a danger of an abnormally high tide. In order to distribute the underflow over a greater distance, the first design provided for a watertight layer of stonefilled asphalt between the caissons and against the caisson walls, the purpose of which was to reduce the steepness of the hydraulic gradient.

When it came to detailing the structure, however, it was found difficult to ensure permanent water-sealing contact between the asphalt layer and the caisson wall. In fact, the caissons may shift or tilt in a storm, creating a gap a few centimetres wide and a risk of scouring of the material underneath. For this reason the design has been so modified that the sealing layer is not applied between the caissons but extends over the top of them and up to the piers themselves.

d. Construction risks

The risks are bound up with the final closure of the openings in the main flow channels an important part of which is the construction of the open caissons and piers within the protection of a cofferdam. The work involves a gang of men at a mean depth of - 25 m in the pumped-out area who will take about three months to construct one complete caisson/pier combination. Much of the work at this stage is at

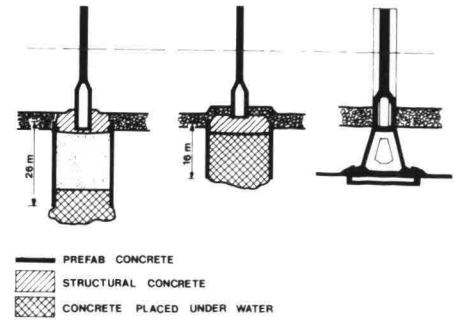

9 Evolution of the design of the foundation

the mercy of the weather, so that particularly in the winter months progress is likely to be irregular and difficult to plan.

4. Optimization of the caisson/pier in accordance with (monolithic) pier design

As a result of the evaluation of the caisson/pier design an entirely new design of the storm surge barrier eventually emerged; the risks in construction determined the direction in which optimization of the scheme was sought.

An important improvement was achieved by deciding not to assemble the piers and caissons in situ in the openings but to construct complete caisson-cum-pier units, each constituting a prefabricated whole or monolithic pier, on a safe construction site protected from the weather. Installing the piers in their final positions by means of this method is still a sensitive operation requiring good weather but it takes only two to three days. Finishing everything off then occupies a period of one to two weeks and is much less vulnerable to adverse weather conditions.

The piers are transported from the construction site to their ultimate destination at the mouth of the Eastern Scheldt by means of a special lifting vessel. Each pier is lowered into a trench previously dredged in the sea bed in which a layer of supporting material has been put down.

The technique therefore differs from the method originally envisaged of positioning open caissons by sinking them into the ground by means of suction excavation. When in position, the base of the pier is completely covered with coarse-grained fill material of high grade which is strengthened further by compaction.

In the absence of a cofferdam which

is not needed in this modified scheme the load on these units is about 75% less than that envisaged in the original design for 'piers on open caissons'. As a result, the risks during construction are less and the work is much safer, because now men do not have to work in a coffer-dam at 25 m below water level.

On account of their great size the piers will be prefabricated in dry construction docks.

The storm surge barrier is formed by 66 heavy piers of prestressed concrete with a distance of 45 m between them.

Between the piers there are movable steel lifting gates. In most instances, in normal conditions, the gates will be up in order to maintain the tidal currents in the Eastern Scheldt; only when a storm is predicted the gates will be lowered. As opposed to other flood barriers in the Netherlands, only one set of gates is applied in view of the fact that if one of the gates might be stuck and would not move, the stability of the barrier is not endangered and moreover the water level in the Eastern Scheldt remains within acceptable limits.

The foundation underneath the piers is formed by a prefabricated foundation mattress filled with sand and gravel as filtering agents.

One of the most important functions of the foundation mattress is the keeping in place of the surrounding Eastern Scheldt bottom sand under the influence of the static and dynamic hydraulic forces, caused by the difference in water level on either side of the barrier.

The reduction in the flow profile (down to 15,000 m²) is effected by heavy concrete sill beams between the piers.

Lastly there is a sill of rocky material which serves to protect the foundation mattress and so, indirectly the bottom soil by preventing erosion, caused by currents and waves, from occurring. The sill is built up from layers of rocky material of varying weight; the top layer is formed by basalt blocks weighing between 6 to 10 t.

The development of the design is largely influenced by the construction conditions at the site. The mouth of the Eastern Scheldt may almost be regarded to be the 'open sea', that is to say, having tidal movements and frequently subject to bad working conditions. Implementation is clearly

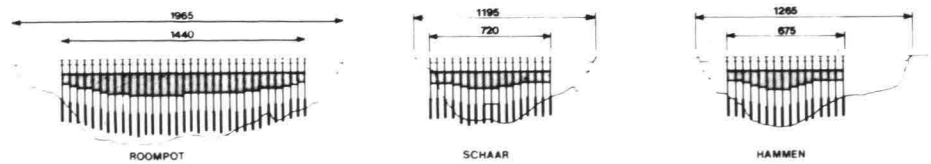

10
Longitudinal profile of flow channels

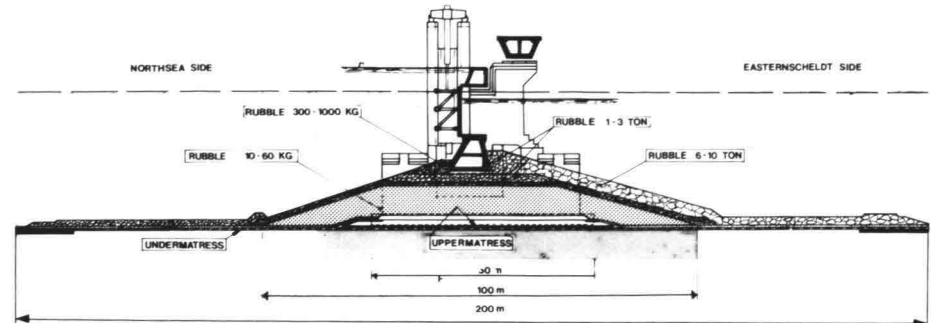

11
Cross section of the barrier

aimed at limiting work at the site to a minimum, comparable with the installation of concrete oil platforms in the North Sea. Prefabrication is applied on a large scale in the construction of the storm surge barrier; also, extensive use is made of newly designed working vessels in the placing of the parts.

In the implementation, a number of phases can be distinguished: Prefabrication of the 66 concrete piers (dry weight 18,000 t max.) in a building dock. The building dock (surface approx. 1,000,000 m²) is subdivided into four building compartments. If all the piers were to be built in one very large building dock, this would imply that the last pier would have to be finished before the dock could be filled with water. Such a procedure is too time-consuming.

Once the piers in a compartment have been completed, the compartment is flooded and an opening is dredged in the encircling dike. The piers are then going to be removed one by one from the compartment by a purpose-built lifting vessel and transported to their final destination in one of the channels to be closed. The lifting vessel 'Ostrea' (Latin for oyster) is a U-shaped pontoon, measuring 90 m by 50 m, equipped with two lifting installations with a combined capacity of 10,000 t. In the meantime the foundation level in the channels to be closed is brought to the correct height, on the one hand by filling up, on the other hand by dredging (below the banks). Since the subsoil consists of rather

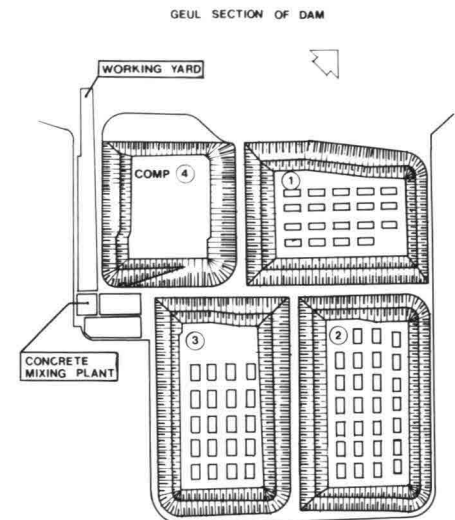

12
Subdivision of construction dock into four compartments

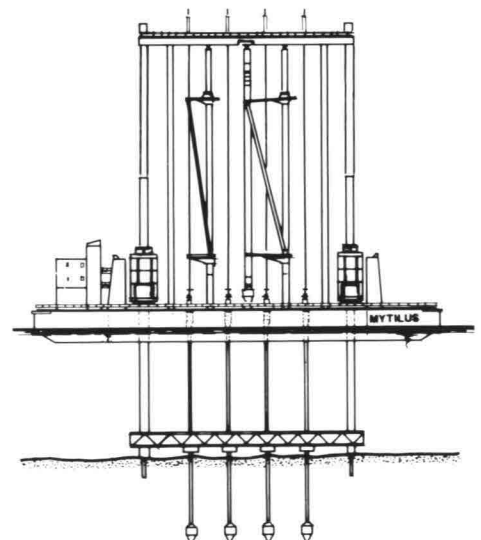

13
Compacting barge

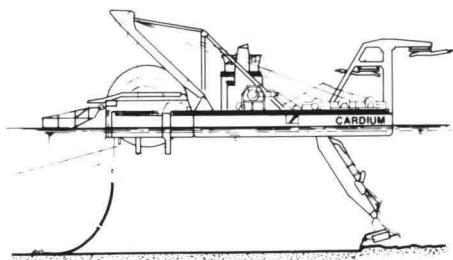

14
Mattress-laying vessel

loosely packed sand, there is the danger of liquefaction resulting from cylindrical wave loads. In order to achieve the required bearing capacity, the sandy soil will have to be compacted by vibration. Vibration compaction is being performed by a purpose-built compaction vessel 'Mytilus' (Latin for mussel) equipped with four poker vibrators which can compact the soil down to a depth of 15 m (maximum).

After compaction, the soil, consisting of small sand grains, must be kept in place and protected from the scouring action of the current. Grains of sand smaller than 1/2 mm are rapidly carried away whereas the velocity in the channels increases at the rate at which construction progresses. Protection is afforded by a filter construction build-up, beginning with fine gravel and ending with dumping stones of 10 t each. The lowest part of this filter which at the same time forms the pier foundation, is wrapped in mattress fabric, is prefabricated in a factory situated in the building dock; the filter is thereafter wound round a drum and subsequently unwound at the correct location in the tidal channels: it is 35 cm thick, 200 m long, 43 m wide and weights 5,500 t. For this operation, too, a vessel was purpose-built, the 'Cardium' (Latin for cockle). The Cardium consists of a pontoon measuring 90 m by 60 m, equipped with a very wide suction mouth in front, measuring 45 m, and with a large drum (diameter 16 m) at the rear round which the foundation mattress is wound. In the gap this vessel brings the foundation level to the correct height in front and simultaneously places the prefabricated filter construction in the rear.

Lastly, the pier is placed on the foundation mattress by the lifting vessel.

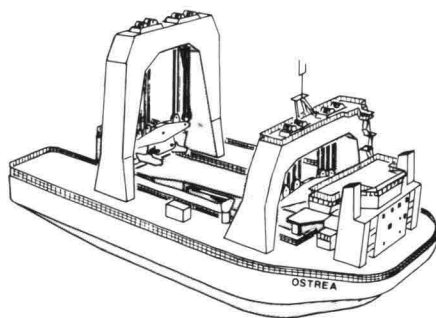

15
Pier-lifting vessel

In the operation the lifting vessel is coupled to a 'mooring pontoon' which has been anchored at the correct location several hours earlier. In this way time is gained for the positioning of the Ostrea carrying the pier, and more time is available for placing the latter. In view of the severe tolerance constraints, placing must be effected very accurately at the turn of the tide. Once the sill has been built up round the piers, the space between pier base and foundation mattress is filled with a mixture of cement and sand.

After the piers have been placed, their respective positions are measured very accurately. The results of these measurements are used to prefabricate and install subsequent parts at the correct length: the concrete sill beams (in order to reduce the flow profile to 15,000 m²) weighing approx. 2,500 t; the concrete upper beams, weighing approx. 1,200 t, the steel gates weighing between 400 and 800 t, and the concrete box girders for traffic weighing approx. 1,250 t. The assembling of these elements is planned to begin in 1983 and will be effected by a floating crane. In order to limit the weight to be lifted by the crane, the sill beams (dry weight 2,500 t) are floated to the site so that the 'apparent weight' will be reduced to 1,500 t.

Enormously difficult technical and organizational problems had to be solved and certainly there will be a confrontation with all sorts of problems yet in the coming years. There has also been a delay of nearly one year owing to some mishaps. However, we'll pull through. The final result we hope to achieve will constitute good harmony between the safety of the population living upstream of the flood barrier and the unique environment of the estuary.

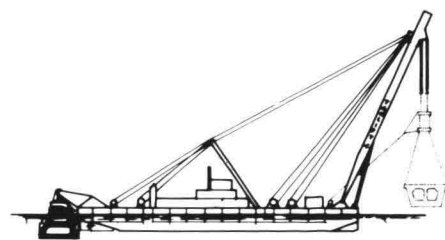

16
Lifting vessel

The political will was present to spend thousands of millions on the project.

5. Influence of the project on hydraulic engineering

When projects situated outside the usual field of knowledge are being implemented, that knowledge will develop. It is not a matter of scale enlargement but of a jump ahead. It possibly needs the assistance of a combination of existing knowledge and experience, research, and a good deal of daring to start such an advanced project. The construction of the storm surge barrier certainly constitutes a jump ahead in hydraulic engineering. This progress is based on both technology and management.

a. It has become clear as early as the study phase that the design and implementation phases would lead to a favourable result only if all available knowledge in the field of hydraulic engineering in the Netherlands were combined. Hundreds of staff would be involved in the project: Staff of the respective departments of Rijkswaterstaat, many laboratories, Delft University of Technology, a large number of contracting firms, consulting engineers and industrial enterprises. The total manpower varying between 500 and 1,000 persons, was grouped in a project organization of a matrix-type structure. One of the most important lessons learned was that the top management had to delegate a great many decision-making responsibilities to lower levels. The selection of staff, planning, and budget control must be given as much care as technology. It is vital to adhere to the time schedules agreed upon. It is possible to make do with a very brief study period but this calls for a

very broad-based research program. This again is costly. Decisions must be taken within the project organization. Therefore a difference must be made between decision-makers and advisers. This matter calls for a great deal of attention from top management. A very positive experience, partly based on projects jointly carried out in the past, is that a concentration of design activities with the principal (Rijkswaterstaat) and the contractor 'Dosbouw' (a consortium of Dutch contractors) yields remarkable performances. The respective roles of principal and contractor are not endangered, on the contrary: This is a concentration of strength.

- b. The knowledge in the field of hydraulics and soil mechanics in the Netherlands has considerably advanced by work on the storm surge barrier. Among the important elements we find: the probabilistic approach of the boundary conditions and the influence of cylindrical wave loads. Research into filters built up from granular materials equally constitutes an important feature. This knowledge is relevant for all types of constructions in hydraulic engineering and offshore technology. The close relationship between hydraulic designers and specialists of the shipbuilding laboratory is certainly worth mentioning. The large-scale use of specially designed vessels rendered this necessary. New developments in soil mechanics and hydraulic research are likewise noteworthy.
- c. The designed concrete- and steel structures are exposed to major forces and must be not only rugged but also durable. An additional problem is the necessity of having to move, i.e. to close, part of the structure at the very moment at which a storm is rising. In the design sphere, progress has been made in mechanics. The implementation of the calculations to be carried out was possible only by using computer calculations of schematized models. As regards details, a subdivision into finer elements was applied in the computations. In the steel construction of the gates, particularly noteworthy aspects are the vibration investigation and the development of the movement-performing machinery.

In the execution of the concrete structures, a very high-quality type of concrete was required for reasons of durability and loading. New developments are to be noted in the field of prestressing while progress in concrete technology can be reported, too.

- d. The building of large-scale works in the sea such as the storm surge barrier is only possible by assembling the components of such a structure on the site. The time of assembling will have to be brief. It calls for the prefabrication of the largest possible size of elements and the use of purpose-built vessels for placing. This applies not only to concrete- and steel constructions but also to the fine filter constructions. At the design stage a study must be performed of all occurring dimensional deviations. Any mistakes or belittling causes almost insoluble problems at the execution stage. The design philosophy acquires a new dimension, as it were. Placing the elements in a brief period of time presupposes good knowledge of local conditions. Data concerning the prevailing weather, waves, and currents must be known beforehand. Determining the exact location of the working vessels is of great relevance. Here, too, new developments are to be noted.
- e. As stated above, the contractors' consortium Dosbouw co-operated very intensively with the respective divisions of Rijkswaterstaat in designing the storm surge barrier. For the implementation, however, there should be a contract drawn up between principal and contractor. Because of the enormous scope of the work in hand this cannot be settled in one move. Implementation of the construction has been arranged between the two parties as follows:
A framework contract was drawn up for the entire work. This contract which has been the subject of intensive negotiations, settles General Affairs. It indicates which components are to be built by the Dosbouw consortium, how the equipment is to be used and paid for and how the method of determining prices is elaborated. It furthermore states the fixed percentages for overheads and profits and settles price disputes. Contracts were passed in their hundreds for various components of the work, the Framework Contract

- remaining the general basis, however. This manner of inviting tenders is not new to the Netherlands, but the large-scale character of the projects provides one more confirmation of the correctness of the system applied. This, too, is of major relevance. It asserts that co-operation during the design state, and separation of the parties during the implementation phase is very well possible.
- f. All developments that took place in the Eastern Scheldt during the past ten years arose because of growing concern for the environment. It is safely to state that this result is of world-wide significance.

500,000 Cubic metres of prefabricated, prestressed concrete

Holland is geographically situated in a delta area, bordered by a hinterland that stretches far into Europe. That this fact may have determined the economic development of the country in general, as well as the specific technical expertise of Dutch civil engineers in particular is, to a large extent quite an acceptable point of view.

In wartime many sacrifices are made in order to manufacture weapons considered necessary for the preservation of all that one values most highly. This is equally true of the constant war against our everlasting enemy, the sea. We are now, however, in a position to take advantage of the sea as long as it contributes to those values we do not wish to lose. Dutch civil engineers are an integral part of this ecological system, and we consider ourselves very fortunate that the world is our oyster. It is not only a duty but also a great privilege to share our experiences.

The pros and cons of prefabrication

Although arguments in favour of using the prefabrication method for constructions are wellknown it might be useful to highlight a few important factors which have played a part in recently completed constructions.

1. One of the most straightforward and crucial criteria is, the practical and physical impossibility of building a concrete structure in any other way. A few examples of this are the Andoc/Dunlin platform, submersed tunnels and the piers of the Eastern Scheldt storm-surge barrier. In this context the term 'prefabrication' could even be misleading. We are talking about constructions which have been built with professional skill and can be moved in its entirety. Of

the piers only the roof elements of the caissons section, should be referred to as prefabricated concrete units. The piers themselves are prefabricated components of the storm surge barrier. A finished product is supplied, as in the case of a ship, and no-one would think of referring to a ship as being prefabricated.

It is preferable to apply the term 'prefabricated' only in those cases where, although construction in situ may be feasible, the appropriate structure is not erected in the definitive location for reasons other than a physical impossibility to do so.

2. When there is a choice, technical considerations, related to production and quality, often play a role.
3. Finally, time and/or money may be decisive factors.

Production and quality

The advantages as far as production and quality are concerned, are:

- the influence of shrinkage can be limited and there is better control of temperature conditions;
- the effects of unequal subsidence can be counteracted;
- production in a plant allows for more favourable conditions and offers the possibility of taking advantage of serial building;
- heat and vacuum treatment can be applied;
- better quality control as well as a greater degree of accuracy can be achieved;
- less storage space is needed on the building site.

1

Large and small prefabricated caissons, Ouwerkerk 1953



The time factor

The construction time is limited to the time needed to assemble the components. Moreover, these elements can be produced in different places simultaneously.

Cost aspects

- Higher productivity;
- concentration of labour resulting in reduction of travelling time.

Apart from these wellknown advantages, some disadvantages can be mentioned:

- fitting problems;

- joints and connections are often very complex;
- the use of equipment to transport the components both horizontally and vertically is expensive.

The actual savings effected by the prefabrication of building components are seldom of any decisive importance. However, this changes as soon as there is a wider market for the products. For example, piles, bridge girders, pipes, etc. meet with this criterion.

Examples of prefabrication

Some significant examples of

prefabricated constructions in the Netherlands are:

Bridges

Zeeland bridge 1965

Quays/jetties

Eems Harbour Rotterdam 1965-75

Caissons

Brouwersdam caissons 1972

Sluices/dams

Haringvliet - nabla girders 1965

Tunnels

Drecht tunnel (widest components) 1978

Offshore constructions

Lighting-pylon, Europort 1973

Dunlin platform 1976

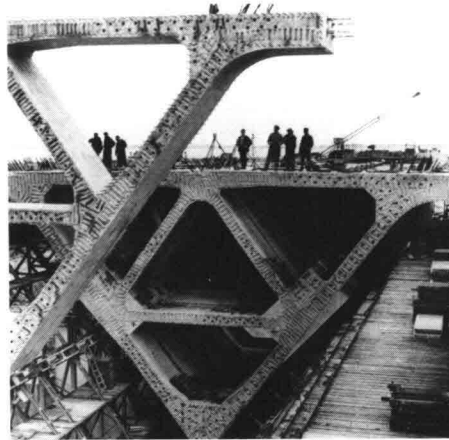

| | |
|----|----|
| 2 | 3a |
| 3b | |
| 4b | 4a |

2

Zeeland bridge 1965

3a

Elements of the nabla girder

3b

Haringvliet sluices under construction

4b

Widest elements used for Drecht-tunnel (on the left side)

4a

Longest floating elements for Hem-tunnel



5a
Segments of lighting-pylon

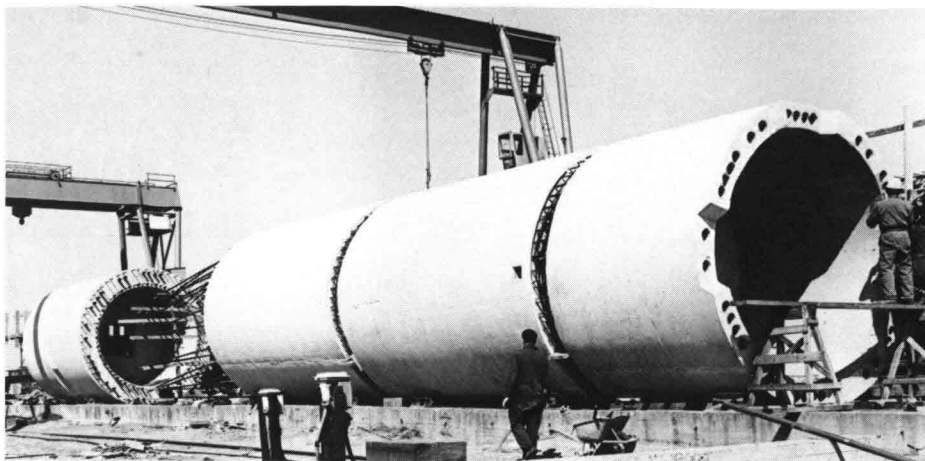

5b
Lighting-pylon Europort on location



6
Dunlin platform 1976

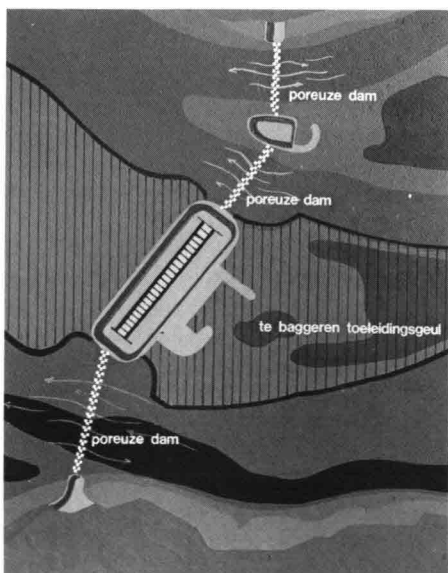

7
Study of building the storm surge barrier in a construction dock

The Eastern Scheldt storm surge barrier

Unlike the Haringvliet sluices, the whole of the storm surge barrier could not be constructed in situ in a construction dock. To do so would have violated the underlying principle which was to preserve and maintain the natural environment as far as possible.

The gate openings in the barrier had to be designed in such a way that the cross-section features of the existing tidal flow channels were maintained. Optimisation of the plans has led to gate openings in the barrier with a clear width of approximately 40 metres. These are relatively small in proportion to the width of the channels, particularly from an aesthetic point of view.

It has now been established that if the clear width of the gate openings had been made any larger, the construction of the barrier would have

posed tremendous problems. Take, for instance, the gradual adjustment to the contours of the sea bed, the need to enlarge the size of vital components, such as the foundation mattresses, and, last but not least, the exponential extrapolation of plant and equipment.

Above all, it would have proved almost impossible to control operations in the circumstances prevailing in the Eastern Scheldt.

Prefab concrete components used in the construction of the storm surge barrier

The 500,000 m³ of concrete are used in the following way:

- 440,000 m³ for the piers, 66 in number;
- 4,000 m³ for the abutments, 6 in number;
- 35,000 m³ for the road bridge box girders, 69 in number;

8
Storm surge barrier components

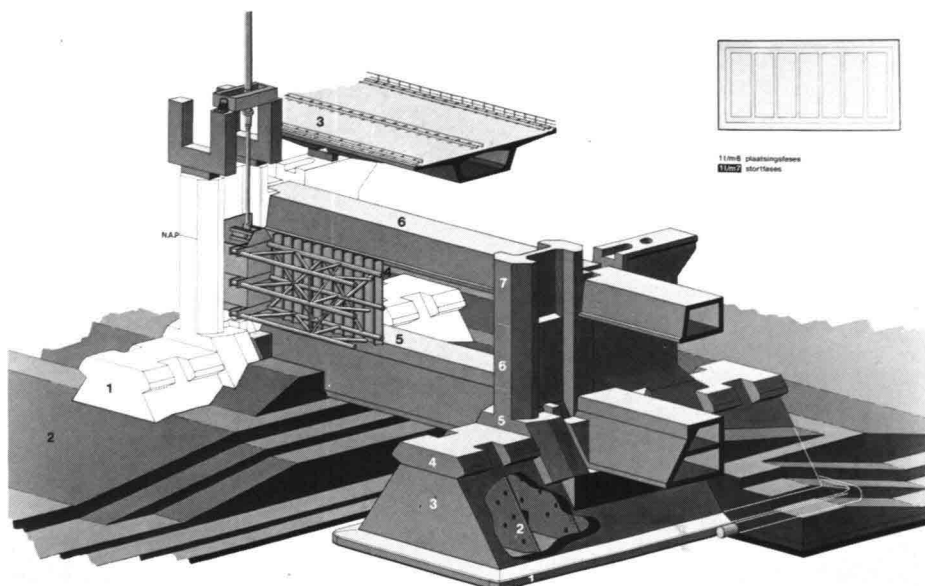

9
Foundation rings for the abutment construction



Table 1

| | max. weight in air | weight submerged |
|----------------------------|--------------------|------------------|
| 1. piers | 18,000 tons | 9,500 tons |
| 2. road bridge box girders | 1,200/1,600 tons | |
| 3. capping units | 250 tons | |
| 4. steel gates | 600 tons | |
| 5. sill beams | 2,800 tons | 1,500 tons |
| 6. upper beams | 1,200 tons | |
| 7. abutment rings | 230 tons | |

30,000 m³ for the upper beams, 63 in number;
9,000 m³ for the capping units, 132 in number;
63,000 m³ for the sill beams, 63 in number.
This covers all concrete components. They will be placed in position in the following order (table 1).

In the production planning account must be taken of the fact that the construction of the road bridge box girders, the sill beams and upper beams can be completed only after the corresponding piers have been installed and actual measurements taken.

Initially, the road bridge box girders are made in two sections and afterwards an appropriate middle section is fitted between them. The bodies of the sill beams are constructed first and both end parts are added later. In the 440,000 m³ of concrete 45 kg of prestressing steel as well as 65 kg of support and reinforcing steel are used per m³.

10
Overall relation between production and placing of the piers

Construction of the piers

Construction of the piers immediately gives rise to the question of how, at what rate, and where, the piers should be built. The second part of the question has to be answered first as the rate at which the piers are to be supplied depends entirely on the rate at which they can be installed.

Within the overall planning the timing curve of the installing operations looks like figure 10. It is necessary that the installing operations should not be delayed by a shortage of components. In such circumstances the rule is therefore that production should be somewhat in excess of the customer's needs, but without unac-

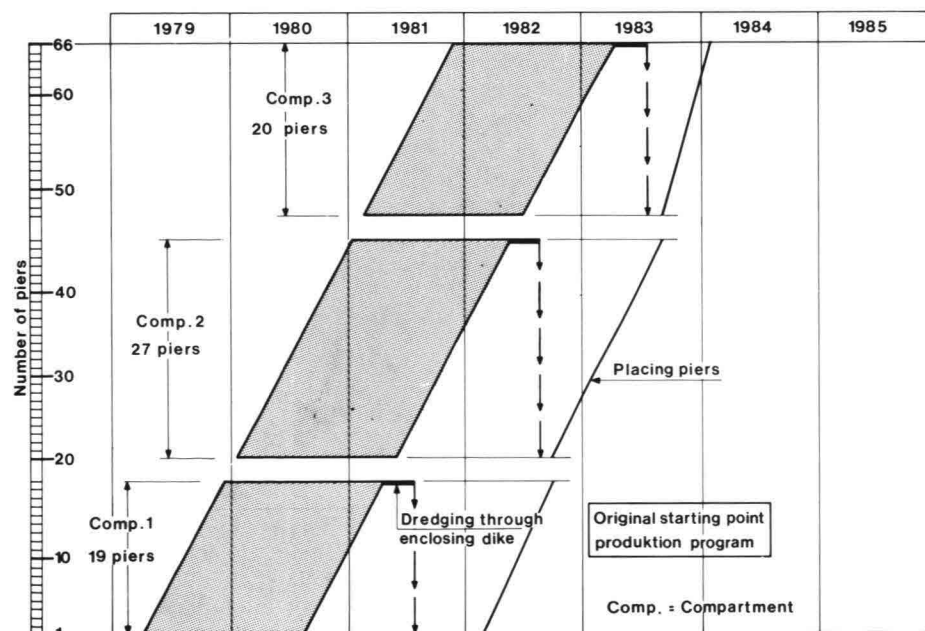

11

Construction dock divided in four compartments

ceptable stock piling, particularly if this were followed by higher expenditure.

The timing of the installing operations therefore determined the production curve. The number of elements being constructed simultaneously at any given time was dependent on the production period needed to construct one unit. To specify this production time an analysis of the production process as well as the plant involved was required. In consultation with the designer pier construction has been divided into various phases. The physical processes applied can be influenced within certain parameters. Once we have determined

- a. how many piers are to be constructed simultaneously;
- b. in which order the piers are to be supplied as well as what special provisions are dictated by the movements of the transport vessel;
- c. how many piers should be kept in store;
- d. how much space is needed for equipment, plant and other means of production, such as building huts, roads, etc.,

12

Construction yard; one compartment flooded



then the acreage required for the construction dock and the construction yard can be calculated.

The construction dock occupies 35 ha.

The construction yard covers 12 ha.

The use of a construction dock is not strictly necessary, but it does pose the least possible problems as far as transport of the completed piers is concerned. This well-known construction dock method, in which part of the pier weight can be eliminated by water displacement, was favoured from the moment the present design was adopted. Moreover, a number of circular dikes had already been built prior to the pending construction of the storm surge barrier.

Because of social implications other locations were also investigated. They all involved either time-consuming draining operations or less favourable planning aspects. So we returned to the idea of using the Schaar construction dock on the Geul dam section, isolated though it is. When phasing production in accordance with the timing of the installing operations, the various external and internal factors which may have some bearing on the duration of the process have to be taken in account. Constructing concrete elements of this size and nature near the coast and under Dutch weather conditions does not, in itself, present any problems for the contractors. The construction period is of such duration



13

Construction system of the sill beams

that, on the basis of meteorological statistics, allowances can be made for inclement weather conditions. The installation of the piers is, however, quite a different matter. Attaching the hoisting gear and lifting the pier, preparing it for transport and actually moving it, mooring and positioning the pier precisely in the correct location, is a long and complicated operation. Only with the aid of computer simulation programmes we are able to approach real conditions as closely as possible. Uncertainty, however, is caused by the long term unpredictability of extreme sea- and weather conditions. On the other hand it must be admitted that the repetitive nature of the operation will, undoubtedly, be an element in our favour.

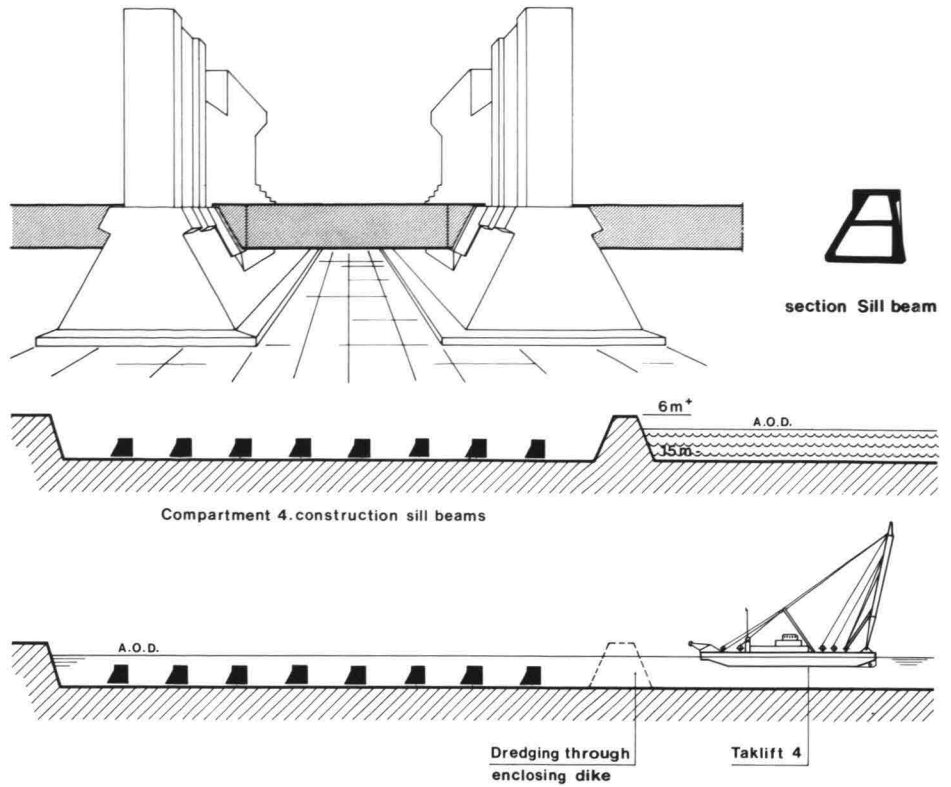

Construction of the other components

Construction of the other components, such as the road bridge box girders, capping units, sill beams and upper beams, presents no specific problems. As mentioned before, the definitive size of the road box girders, sill beams and upper beams can be determined only after the corresponding piers have been installed and correct measurements taken. Both the production process of the other components and the required production site have also been mapped out within the frame work of the overall planning. One of the four compartments of the construction dock has been reserved for the sill beams, the biggest and heaviest elements, so that full advantage can be taken of their apparent weight reduction through submersion.

Some of the partners of Dosbouw have at their disposal a construction site suitable equipped for the production of concrete units. It is favourable situated and it is not much further away from the storm surge barrier than the Schaar construction dock. Dosbouw will use this site for the construction of the somewhat lighter, but still rather bulky elements. The components will be installed with the aid of a 2,000 tons floating sheerlegs.

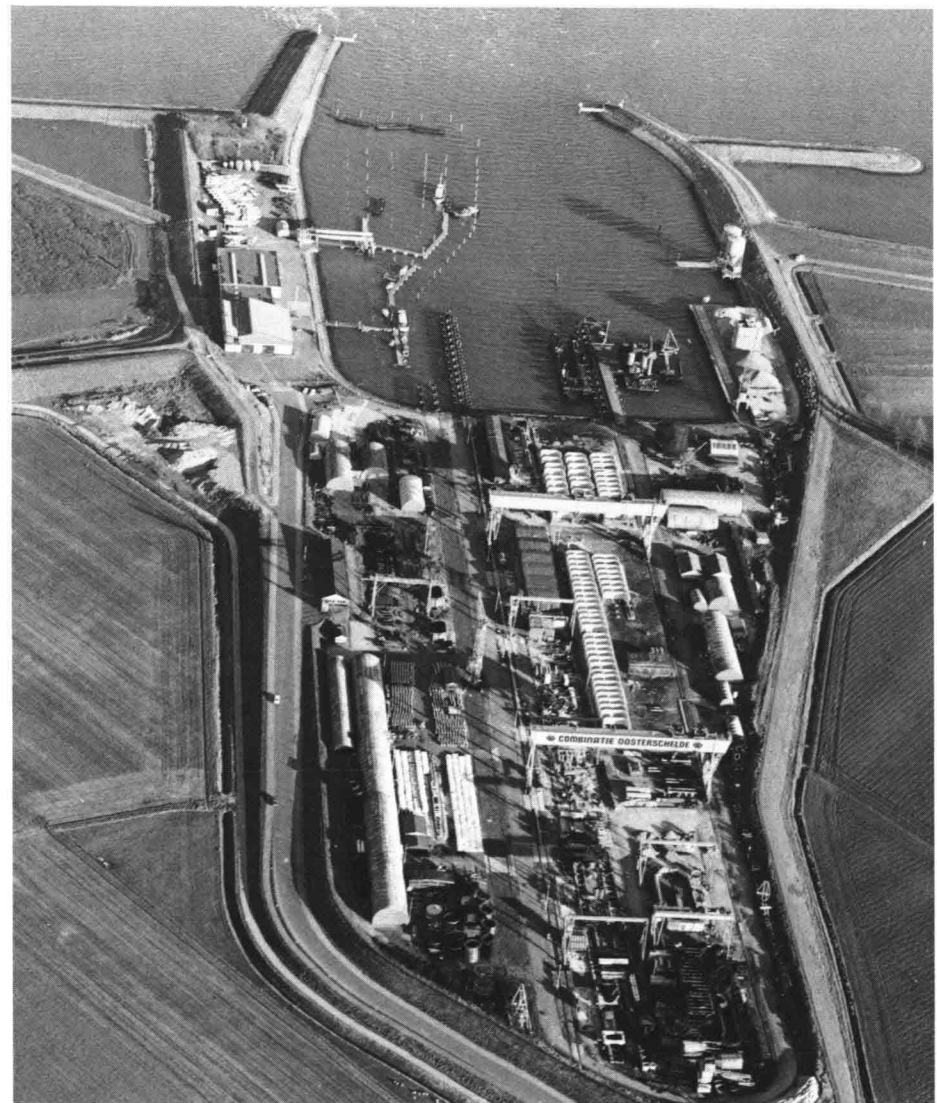

14

Eastern Scheldt construction yard at Kats near the barrier

Transport and placing equipment for sill beams

Static load curve : 1600 tons
 Salvage capacity : 2000 tons
 i.e. 1200 tons in main blocks
 800 tons over bow rollers

Length : 83.03 m
 Breadth extreme : 28.25 m

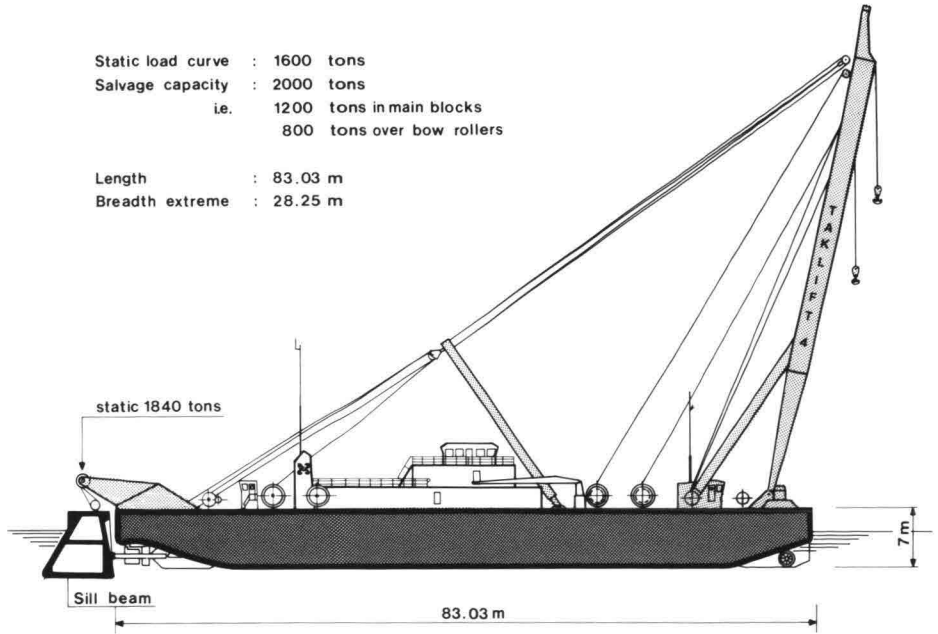

Lifting and transporting them, will likely present no special problems.

Operations involving the installation of components at high level are strongly affected by the movements of the pontoon, and this has repercussions on the operating ratio. The low-lying sill beams demand a very precise installation plan, as the process has to be carried out under difficult current conditions and within very narrow tolerances.

Integration of design process and study of construction methods

The design process can be divided broadly into:

1. specification of requirements;
2. design (sketch plan - draft plan

- final plan), parallel research, tests, calculations;
3. specification of construction methods;
4. specifications of building schedule and costs.

If the whole programme of requirements can be met within the specified conditions of time and money, the design is considered acceptable in a technical-commercial sense. If this cannot be achieved the whole cycle will have to be re-appraised, and even if the outcome is satisfactory the question still remains as to whether the optimum solution has been arrived at. In the case of the storm-surge barrier we had to go through this cycle several times because, as regards

design and construction methods, no previous experiences existed which could be drawn upon. Many new and unknown factors had to be taken into account. Obviously, in circumstances such as these it is more than ever essential that researchers, designers and contractors work as team. That the project is the result of a co-operative effort can be seen in many respects.

Some interfaces, in both figurative and literal sense, are:

- a. the supporting ribs: the foundation bed cannot be made sufficiently flat to allow the base slab of the piers to fit tightly onto the foundation bed and to be fully supported by it. The bottom slab, therefore,

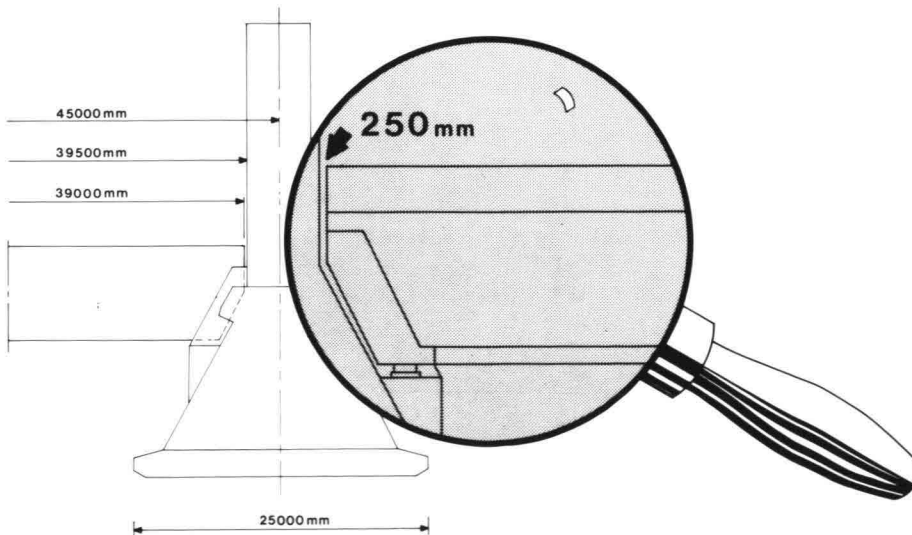

Small tolerances between huge elements

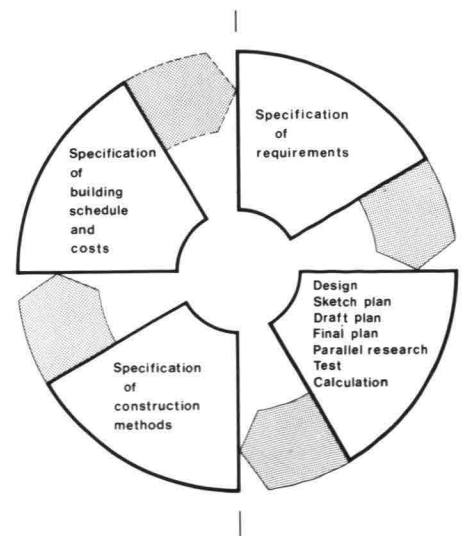

Integration of the design process

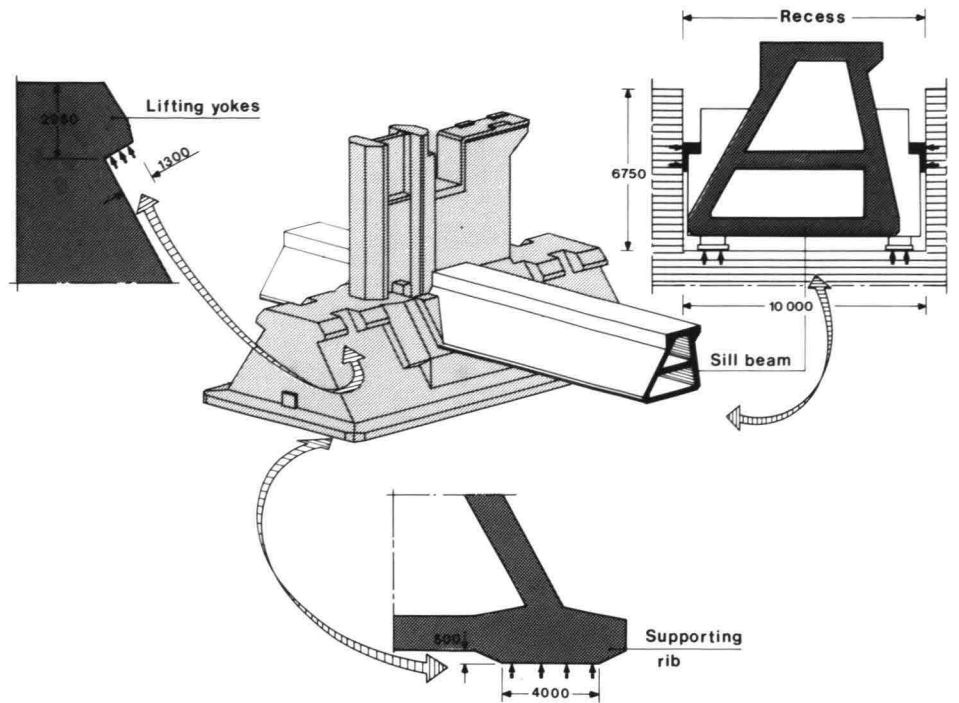

- has two strengthening ribs on which the pier is supported during the construction period of the barrier.
- b. the lifting yokes: it is a fact practically unlimited weights can be lifted. The biggest problem turning up time and again is posed by the intermediate construction between the hoisting equipment and the (concrete) object to be lifted.
- c. the sill beams recesses: the question is which are the minimum inside measurements required that, at the same time, are adequate enough to present no problems when the beams are installed.

This, obviously, does not present an comprehensive picture of all interfaces, on the contrary, these are not even the most important ones, but they stand out so clearly that it is evident to highlight them.

In order to prevent any misunderstanding it should be pointed out that, in spite of a closely integrated co-operation between designer and contractors, the responsibility for the design is and remains with the designer, whereas its proper execution is and remains the responsibility of the contractors.

Fitting problems

When a construction consists of a number of components and when the required precision is not unnecessarily high, work can be carried out effectively and quickly, which means a saving of time and money. Not only does a high degree of precision intrinsically require more time and money, but it also carries with it the risk of rejection because only very small tolerances are permissible. If rejection leads to a lengthening of the critical path operating costs can often grow into a multiple of the costs involved in correcting the rejected item. Should one of the primary requirements be affected, e.g. the movement of the steel gates, the designer will, undoubtedly, lay down certain limits. The extent of these limits and how they are allocated to the various com-

ponents or phases are subjects outside the framework of this article. Discrepancies in measurements of the successive concrete components do not present the biggest problem. However, where the installation of the piers or the improvement of the subsoil are concerned, this is a different matter.

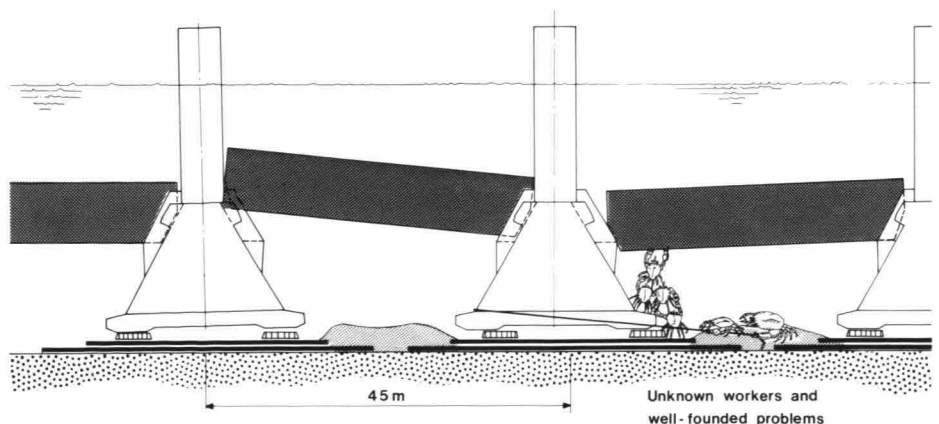

Special equipment as a result of integrated design and construction

1. Introduction

1.1. The special equipment, as developed and built for the construction of the Eastern Scheldt storm surge barrier has to be seen in the perspective of the development in civil engineering, not only during the last decades, but during centuries past.

Developments in civil engineering have always resulted from an interaction between the need for better or more daring structures, and the capability of building equipment to realize such designs.

Although in ancient history spectacular constructions were realized like the pyramids, aqueducts, cathedrals, etc., at the time it was chiefly a result of human ingenuity coupled with a surplus of cheap manpower. It was not till the 19th century that concrete and steel as construction materials, and mechanical inventions, extended the possibilities in civil engineering, and with that, the limits to which designs could go.

1.2. Equipment used in hydraulic engineering (fig. 1-3)

A major example in this development is the dredging industry. As early as the 15th century the Dutch started developing techniques to protect and reclaim land and to keep their ports accessible to increasing traffic. The 19th century, however, with the arrival of steel ships and mechanical power led to the development of various dredging equipment like bucket- and hopper dredgers which made larger port projects possible.

Not only in Holland, but also in England and the USA, dredging techniques were developed further. In the USA, where often hard soil had to be removed, the cutter-suction dredger was developed.

The basis for a world-wide Dutch dredging industry was laid at the end

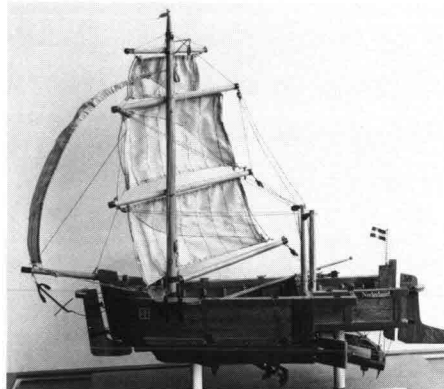

1
15th century dredger — Zeeland

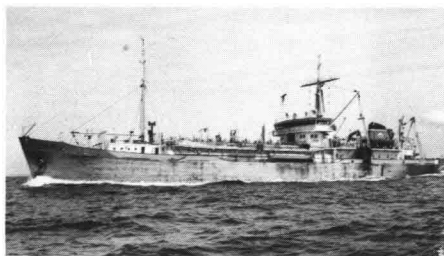

2
Hopper dredger

3
Cutter suction dredger



4
Modern offshore construction crane

of the 19th century, with the construction of the two important access channels to Amsterdam and Rotterdam. From that time on, design of ports, port entrances, land reclamation and -protection went hand in hand with the development of new and more powerful equipment.

1.3. Equipment for offshore construction (fig. 4)

Quite another civil engineering area where the development of design and equipment is strongly integrated is the offshore oil industry.

It is only 60 years ago that on the

5
 Stone dumping barge at Rotterdam
 harbour entrance



6
 Cable railway for dike construction
 7
 Laying modern, prefabricated erosion
 protection mattress (Dos I)
 8
 Erosion protection with asphalt (Jan
 Heijmans)

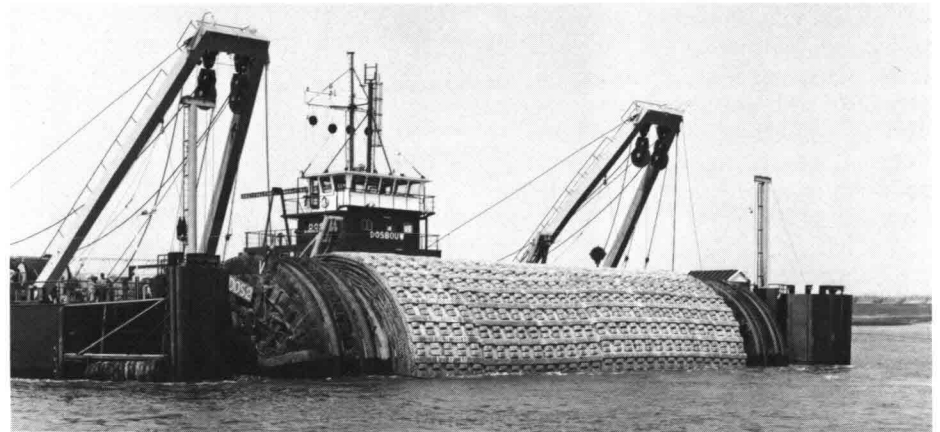

shore of lake Maracaibo oil companies were competing in looking for oil at only meters of distance from each other. The difference being that the one worked on land and the other in water, although this was only a few feet deep.

However, this gave rise to the off-shore oil industry as it is known now, and of which the end of the development has yet to be seen. Ever more daring designs are realized, such as drilling and production platforms, pipelines, etc., in ever deeper waters.

The equipment developed simultaneously, and it is hard to say when the design is ahead of the equipment, or when new equipment spurs on new design. Underwater techniques and electronics take part in this development as well.

1.4. Recent development in Holland (fig. 5-8)

In Holland the post-war period was marked by the port extension at Amsterdam and Rotterdam and the acceleration of the Delta Works,

caused by the disastrous flooding in 1953. Both gave a strong impetus to further development of designs, construction methods and, consequently, equipment for hydraulic and coastal engineering.

Examples are, inter alia, the ever more powerful dredging equipment, and the stone dumping barges for the breakwater at Europoort Rotterdam. The Delta Works were marked by the sophisticated use of caissons and a cable railway for dumping stones. Erosion protection, once traditionally

Delta Works area with two major, but basically different, barriers

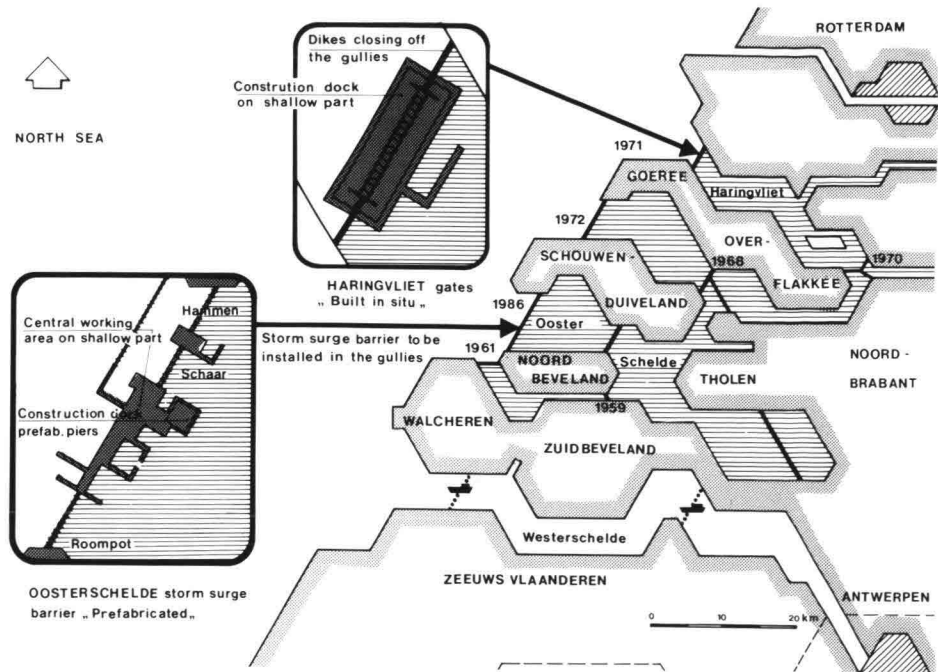

made of woven twig mattresses sunk by ballasting with stones, was replaced by laying large size prefabricated block mattresses and underwater asphalt layers. For the building of the 5 km long Zeeland Bridge across the Eastern Scheldt a special 500 tons floating crane was built to install the prefabricated parts.

1.5. Eastern Scheldt project (fig. 9)

It was at this time, in the early 70's, that it was decided to construct the Eastern Scheldt storm surge barrier. It had always been intended to build a dike and make it the last and glorious part of the Delta Works, in which experience obtained would show the Dutch art in holding back the sea, however, the scene changed at once.

In stead of a dike, a structure unique in concept and size would have to be built within strict limits of time and money and in one of the most exposed areas along the Dutch coast. Forced by these conditions, government and contractors had to fall back on the tradition of centuries; to think great, be innovative, and have capable designers, contractors, consultants and wharves at hand. In 1976 a start was made on simultaneously working out the design of the storm surge barrier, its construction methods and equipment.

As compared to another major work of the Delta Works: the sluices of the Haringvliet, the point of departure was completely different. There, the sluices were built in situ in a construction dock on the shallow part of the estuary, with later on the closure of the tidal channels by dikes. At the storm surge barrier it had to be the other way round: the shallow part was built-up as a dike and the sluice structure had to be installed right in

the tidal channels. Prefabrication therefore became the leading idea. As it worked out, the result was a fleet of unique equipment. Lack of space does not permit to explain all of these items, nor to go into much detail. Emphasis will therefore be given to equipment used in two major operations: the placing of the 18,000 tons prefabricated concrete piers and the preparation of the foundation in water 30 m deep, prior to installing these piers.

2. Technical description of special equipment

2.1. Transport and installation of the concrete piers (fig. 10-14)

The concrete piers are to be considered as the backbone of the storm surge barrier, supporting the superstructure, guiding the gates for

closing the Eastern Scheldt and transferring the forces exerted by a superstorm to the foundation. Three major items are involved in what is called 'the installation of the concrete piers':

- the Ostrea: for transport and installation of the piers;
- the Macoma: as a dredging pontoon for cleaning up and a mooring pontoon for the Ostrea and Dos I;
- the Dos I: for laying the block mattress and so as to give the foundation the required flatness before the piers are placed.

10
Lifting vessel Ostrea



11
Ostrea/Macoma combination for installing the piers and dredging sand deposits

12
Mooring and dredging pontoon Macoma



The lifting vessel Ostrea, is the most spectacular item of the fleet of special equipment and can be considered as its flag-ship. It has a lifting capacity of 10,000 tons, sufficient to lift the heaviest pier (18,000 tons) in a partly submerged condition. Even in the offshore industry cranes with such lifting capacity do not yet exist!

With its U-shaped pontoon of 87.25 x 47.00 m, the Ostrea wraps itself around the pier and lifting tackles from the portals perform the actual lift. In loaded condition the combination of Ostrea and the pier has a draught of 12 m. The Ostrea has its own propulsion: 4 Schottels (propellers moving in the horizontal plane) with in total 9000 HP, sufficient to manoeuvre itself in the drydock and around the piers. For the transport from the construction dock to the site, it will be assisted by several powerful tugs. Like other floating equipments, the basic design was made by 'Bureau voor Scheepvaart' at Bloemendaal.

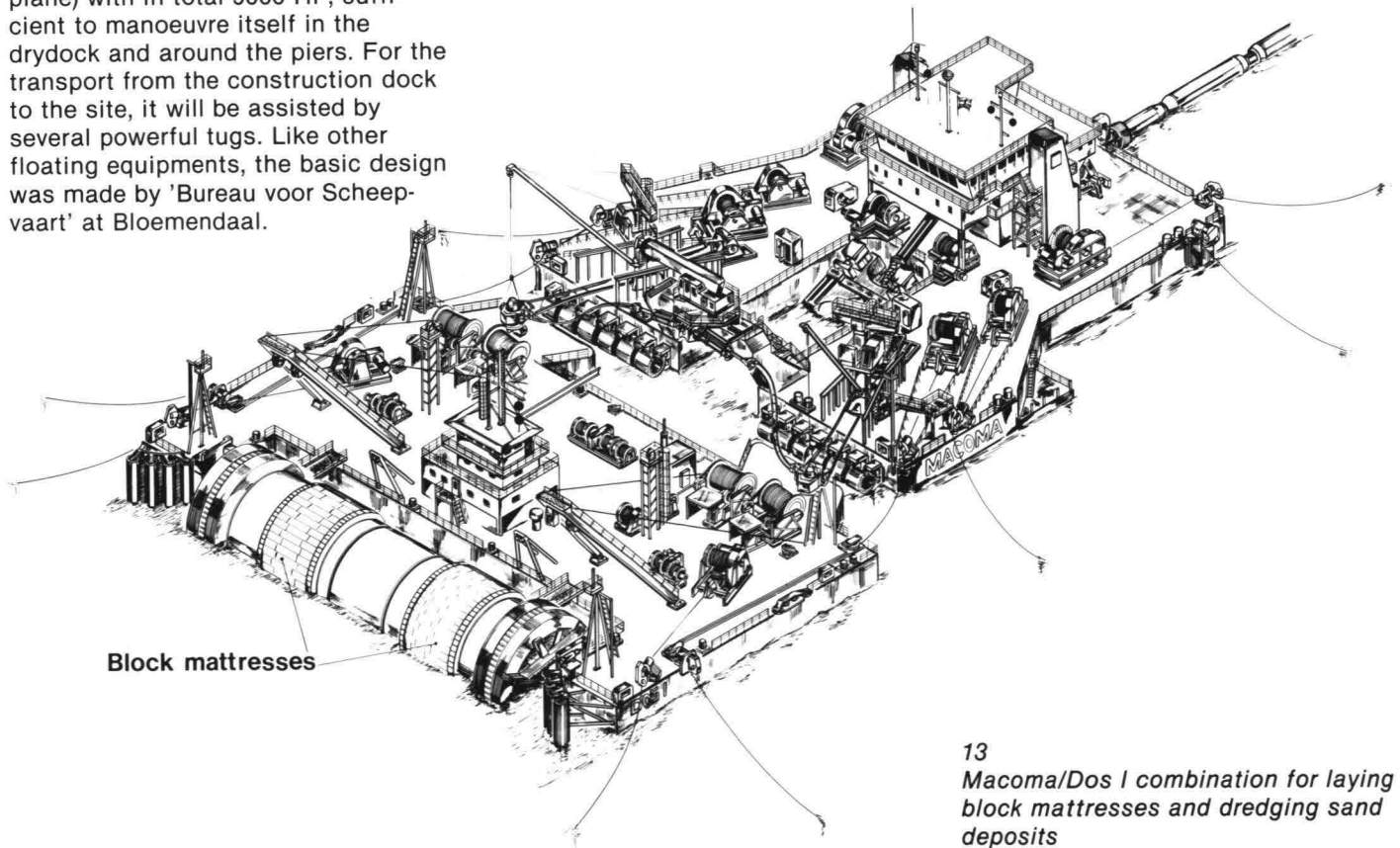

13
Macoma/Dos I combination for laying block mattresses and dredging sand deposits

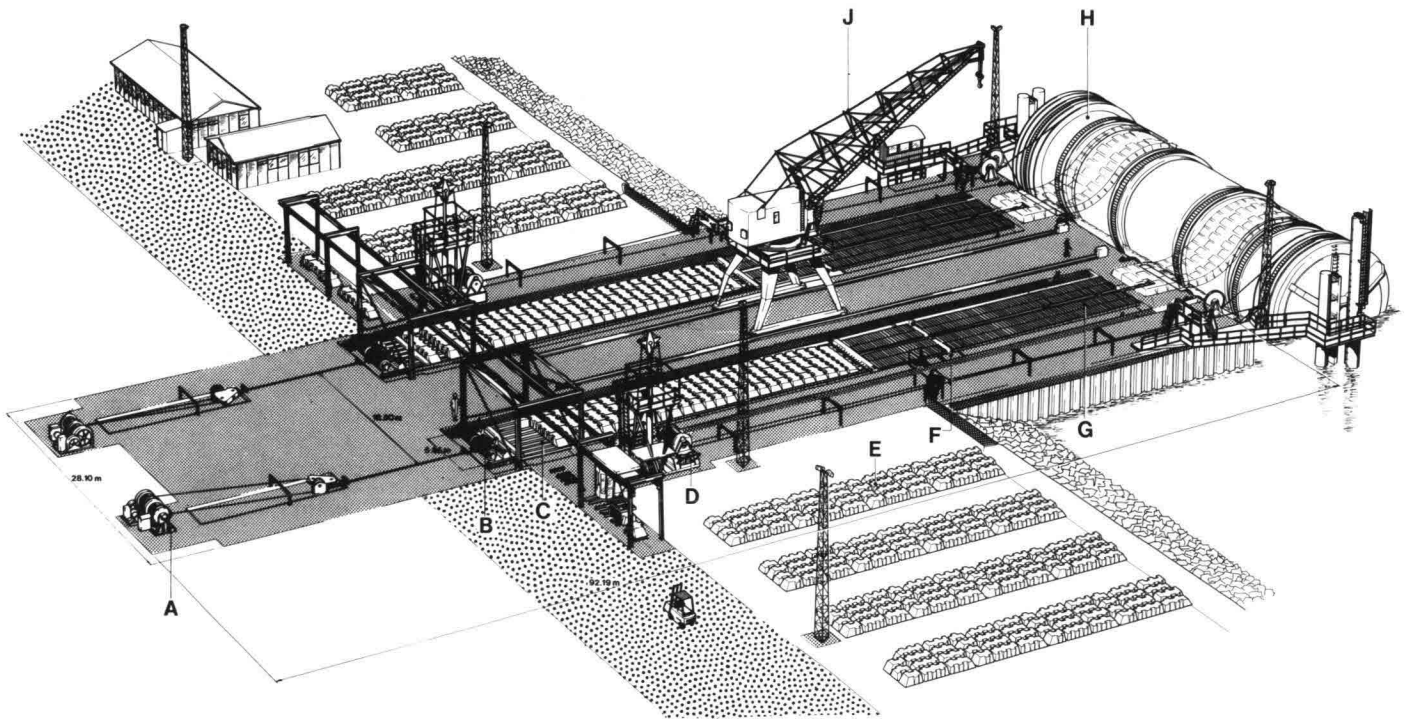

14
Block mattress factory

- A: Winchsystem for moving block mattresses
- B: Coils for block mattress wires
- C: Room for connecting blocks with wires (assembling room)
- D: Winchsystem for turning transport cylinder
- E: Storage (of blocks)
- F: Inspection room
- G: Roller-conveyor
- H: Crain for handling front- and end parts
- J: Transport cylinder

15
Sequence of soil improvement and foundation mattresses

Arriving at its final location, the Ostrea will meet and tie-up against the Macoma. This vessel is considerably smaller but is at least as complex because its dual function as a mooring and dredging pontoon.

As a dredging pontoon it has to remove sand deposited since the laying of the foundation mattress, the last layer only a few hours before placing the pier. The Macoma is fitted out with a 30 m wide dustpan dredger for that purpose.

As a mooring pontoon the Macoma has a powerful 8-anchor line system. The Ostrea ties up at the Macoma by

means of a special connecting device and the combined unit can then either be operated from the Ostrea, or from the Macoma. The Macoma serves as well as a mooring pontoon to the Dos I, for laying the block mattresses.

The Dos I is a converted erosion mattress laying barge as shown in an earlier figure. Its function is to lay prefabricated block mattresses of variable thickness in the contact area between pier and foundation. By varying the thickness of the mattress, the supposedly always somewhat irregular surface of the foundation will be flattened and an even surface for

Soil improvement

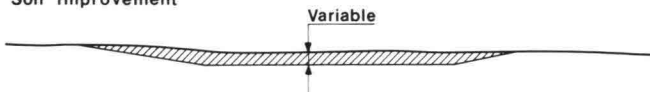

Deep-compaction

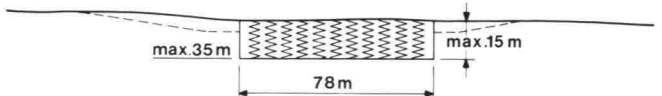

Upper mattress

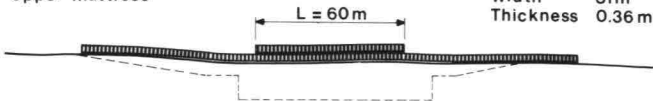

Block mattress

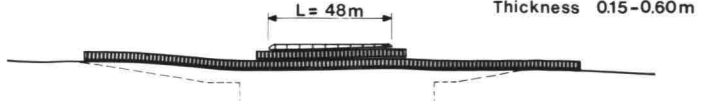

Lower mattress

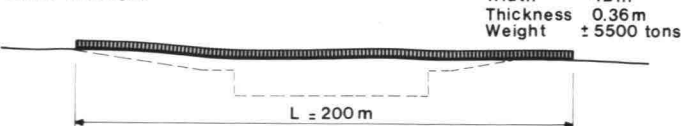

Pier foundation

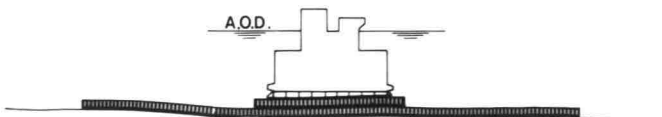

placing the piers will be obtained. The factory for the prefabrication of these mattresses is the same installation where former erosion mattresses were made, but it was drastically modified.

For the transport of the block mattresses one of the existing floating cylinders is used, which was modified as well.

2.2. Preparation of the foundation

2.2.1. Introduction (fig. 15)

The foundation on which the concrete piers are to be placed is rather complicated although this does not appear from a cross section of the barrier. For a proper understanding, a short explanation is necessary. First of all the original bottom of the Eastern Scheldt, although mainly consisting of sand, has interalia a relatively low bearing capacity. The quality of the soil therefore has to be improved. Furthermore some parts of the sandy bottom contain too much lime and have to be replaced by 'clean' sand before improving the sandy bottom anyway. Thirdly, the profile of the cross-section is too irregular: close to the shore a trench has to be dredged to a depth below the installation depth of the concrete piers, whereas in the middle the tidal channels are too deep, and sand has to be added to achieve the foundation level of the piers. Because of the currents, this sand has to be protected against erosion by being covered with a layer of gravel. Dredging the trench or raising the height of the bottom is done simultaneously with changing the bad parts of the sandy soil.

Later on, the bottom has to be very evenly dredged by a special process (dustpan dredging) to its exact required depth, according to the height of the pier, and the sand should be covered at the same time by a foundation mattress which has a double function:

- to protect the sand bottom from erosion and to maintain the even surface obtained by dredging;
- to form a cover which would keep the sand particles of the original Eastern Scheldt bottom in place even if they would be subjected, during a superstorm, to the rapid

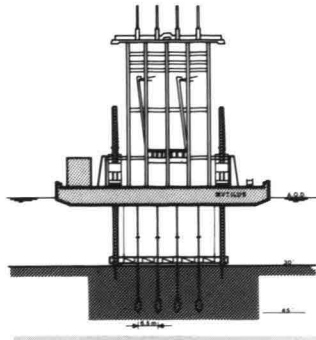

changes in pore water pressure. The mattress therefore is of a filter construction gradually built up from coarse sand, to fine gravel, to coarse gravel. The concrete pier is placed on this layer of coarse gravel. In order to give the top layer of coarse gravel under the pier more 'body', it was decided to install a smaller, but similar mattress under the pier, filled with 3 layers of coarse gravel.

The concrete piers are spaced at distances of 45 m and the lower mattresses measures 200 x 42 m. The opening in between of 3 m has to be sealed with marine gravel, through which the sand of the Eastern Scheldt bottom will not pass. To protect this seal against corrosion, the sea gravel is covered by a layer of coarse gravel 30-60 mm and a layer of small stones 40-250 mm.

2.2.2. Resulting special equipment (fig. 16-20)

To construct the foundation, as explained above, several pieces of equipment are used of which the most important had to be especially built.

- For the dredging and filling operations use was made of an existing dredger, and existing hopper barges. The dredger, of the cutter suction type, was modified and provided with a 10 m wide 'dustpan' suction mouth. Experience with this dredger was used while designing the super dustpan dredger for laying the

foundation mattress. Also the trailing suction hopper barges had to be adjusted, so as to use their suction pipes as discharge pipes. In both cases considerable experience was obtained in dredging and discharging sand at great depths (38 m).

- To improve the bearing capacity and density of the soil a deep compaction method was used and a special barge, the 'Mytilus' was built to handle 4 deep-vibration needles simultaneously. The vibration method consists of inserting a vibrating tube into the bottom, the tube having a vibrator at its top and a resonator at the end. The vibrator generates vertical vibrations which are transmitted to the soil by the resonator. As a result the sand grains are set in motion and this leads to compaction of the soil. The Mytilus is designed to penetrate and compact layers of max. 15 m thickness to a depth of 35 m. If necessary, the needles can be extended, and a depth of 42 m can be reached.
- After compaction, the bottom has to be dredged to an exact level at one haul over a width of 46 m and a length of 200 m; simultaneously a filter foundation mattress has to be laid. For this complicated task a special barge was developed: the Cardium.

The Cardium has multiple functions and is the most complicated item floating in the Eastern Scheldt. If the Ostrea is considered to be the flag-

17

Mattress laying barge Cardium

18

Isometric view of Cardium and components

ship, the Cardium should be considered the master piece. The functions of the Cardium are:

- a. Dredging the Eastern Scheldt bottom at an exact elevation, over a width of 46 m in one haul of 200 m, with criterias for flatness not set before in the dredging industry. The material to be dredged is the compacted sand and its protection layer of marine gravel or coarse gravel (30-60 mm) or sand deposits accumulated since the trench had been dredged. A variety of materials therefore to be expected at the same time but at different places over the width of the dustpan dredger.
- b. Laying the 42 m wide, 200 m long, foundation mattress. This has to be done simultaneously with dredging the last 1,50 m sand so as to prevent the tidal current from disturbing the evenly dredged surface.

Basically it is this combined operation of dredging and laying the mattress, which determines whether or not the concrete piers can be installed within the given tolerances.

For laying the mattress, the back end of the Cardium is fitted out to receive the floating cylinder, loaded with the mattress, and unroll it in a controlled operation. As a matter of fact, at the rear end, the Cardium is a complete different ship compared to the front end.

- c. On the top of the lower mattress, the smaller gravel-filled top mattress has to be laid. As far as mattress laying is concerned, this is nearly an identical operation. However, the dredging part has by then a complete different function: to remove by vertical suction all sand deposits on the lower mattress. For vertical suction, the dustpan dredger, as used when

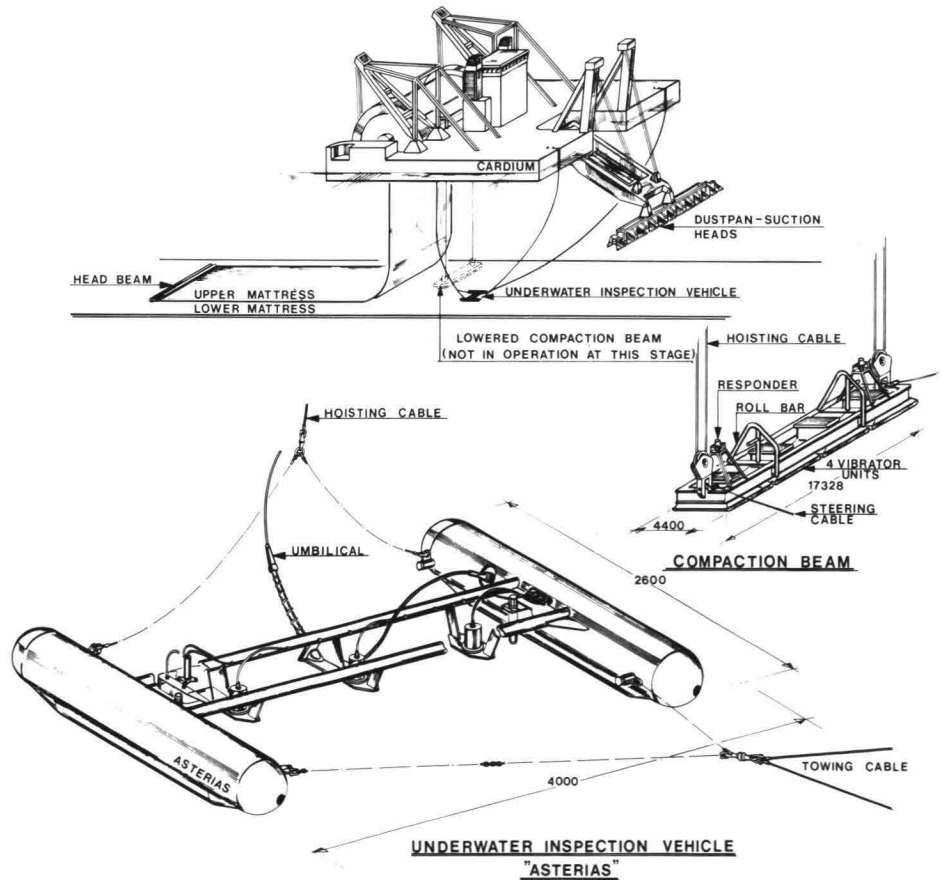
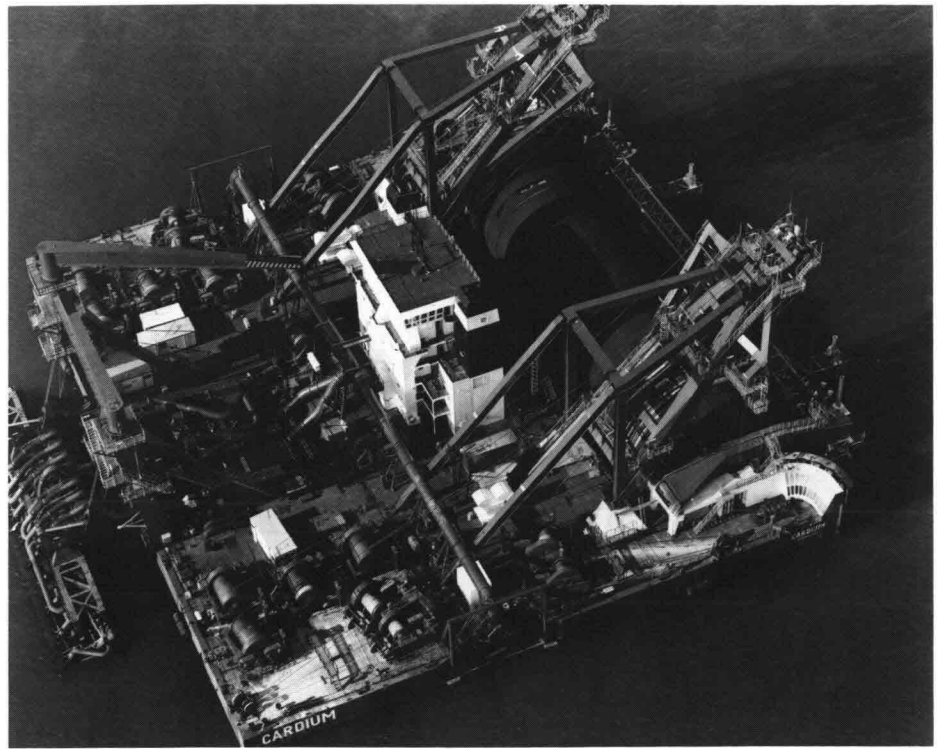

laying the lower mattress, has to be turned by approx. 30°. Actually, the dredging part of the Cardium consists of two dredgers combined in one!

- d. The mattresses once laid have to be compacted against the underlying

bottom. The Cardium is therefore equipped with a 'compaction-beam' of 18 x 4 m.

- e. In order to inspect whether sand remained on the lower mattress after cleaning up by vertical suction, an underwater vehicle is in-

- 19 Foundation filter mattress factory
- 20 Converted barge Jan Heijmans
- 21 Stone depositing barge

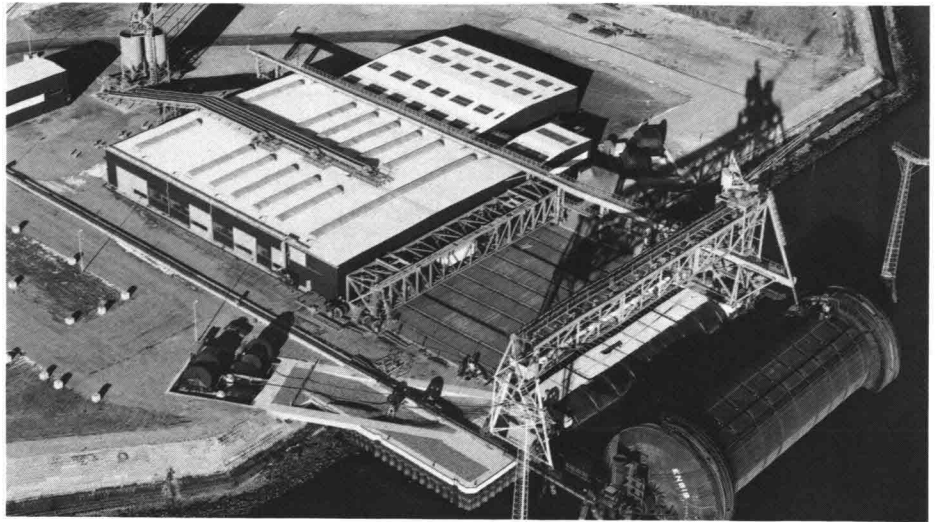

stalled on the Cardium, which slides over the lower mattress between the ladder and the top mattress which is being laid.

4. To prefabricate the foundation mattress, a complete factory had to be built; a very unusual installation in the civil engineering industry. Knowing that the problems would be numerous, a strong engineering team was set up from the start, consisting of members of Rijkswaterstaat, Dosbouw, Tebodin as consultant, and suppliers of key-parts of the factory, selected at a very early stage. In front of the factory a floating cylinder can be moored to store the mattress and transport it after fabrication to the Cardium.
5. To seal the joint between two mattresses, the existing asphalt laying barge Jan Heijmans was converted into a gravel depositing barge. Gravel and stones of selected sizes can be deposited very accurately by means of a ladder and special distribution devices. Prior to this, sand deposits can be removed by jetting. The Jan Heijmans works in close cooperation with the Cardium.

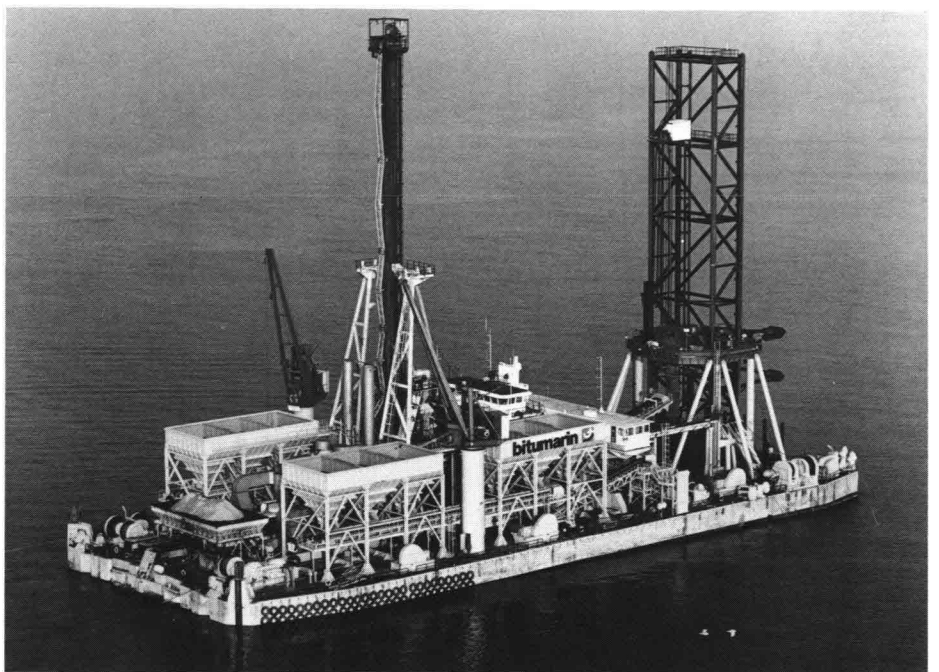

2.3. Underwater sill and superstructure (fig. 21-22)

2.3.1. The piers will be embedded in an underwater sill of selected quarry stones gradually becoming larger and larger. The toplayer at the Eastern Scheldt side consists of stones of 6-10 tons, so as to make this sill resistant to currents even when a gate fails to go down. To place these stones close to the then relatively light and vulnerable concrete piers, a special stone depositing barge has been developed.

2.3.2. To install the prefabricated beams between and on the piers and

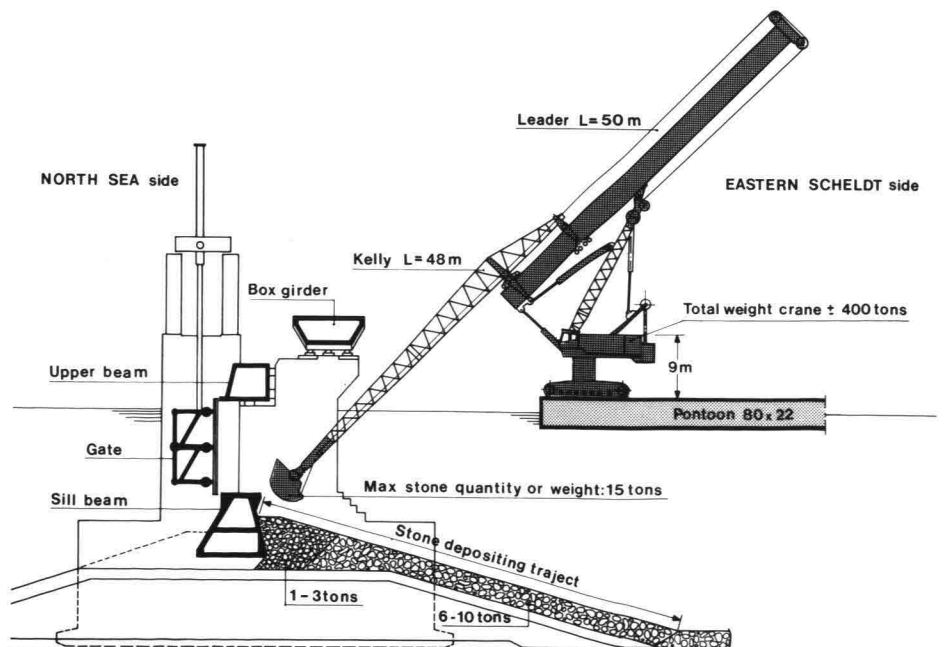

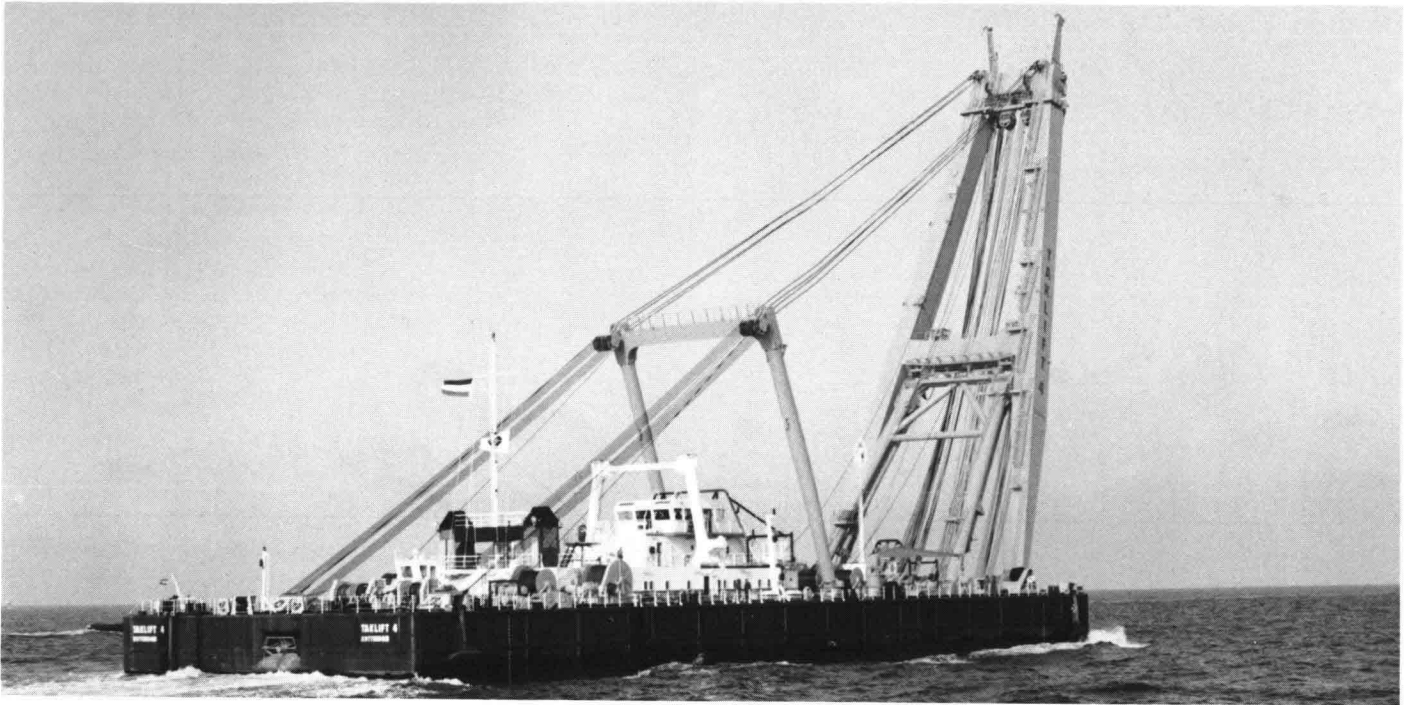

22
2000 tons floating crane Taklift IV

to install the gates, a 2000 tons floating crane was built. Although tailor-made for this work, it can be and is used for other jobs as well.

2.4. Investigation and inspection equipment (fig. 23-24)

The equipment mentioned earlier has to be very reliable, so that one can rely on it performing its task properly. Nevertheless, to make sure that the results aimed at are indeed achieved, several special investigation and inspection devices had to be built.

2.4.1. First of all it was necessary to perform soil investigations before and after improving the sandy bottom. This led to the design of a geophysical survey pontoon Johan V, equipped at one side with a conventional drilling and sounding rig, and

at the other side with a central well from which a 70 ton diving bell can be lowered, designed to work down to a depth of 200 m.

From the bell, soundings and density measurements can be made under atmospheric conditions, which is of great advantage. For borings, the diving bell has to be open at the underside and a hydrostatic counter pressure is needed; divers have to work in the bell in saturated diving conditions, and the Johan V is therefore equipped with a decompression-chamber. Operating costs and time for soil investigations were strongly reduced by the use of the diving bell.

2.4.2. Besides, the soil improvement, the laid mattresses, their joints, and

23
Geophysical survey pontoon Johan V



Remote operated bottom crawler Portunus with mother-ship Wijker Rib

the installed piers have to be checked for possible damage.

A remote operated bottom crawler (ROB), the 'Portunus', has for that purpose been developed and built. It is assisted by the 'Wijker Rib', a converted surveying-ship. The Portunus is equipped with a variety of sensors like sand detectors, camera's (photo and T.V.) and side looking- and obstacle avoiding sonars. It is the result of a worldwide investigation of available systems.

2.5. Electronics

Modern equipment is unthinkable without electronics. Starting from a very sophisticated system for positioning, electronics at the Eastern Scheldt works are named 'survey'. But this name is erratic because it includes much more:

- the latest developments on continuous automatic positioning with an accuracy of 5 cm at 2 km from the coast;
- newly developed sounding techniques for positioning under water, bottom flatness measurements, and sand detection of layers of less than a few cm thickness;
- the use of rate-gyros and accelerometers
- computer systems on board for real time reading, checking, processing, presentation, registration, storage and selection of information from hundreds of sensors.

In addition to what is called survey, a semi automatic hauling system is installed on the Cardium. This system will permit the Cardium, on its anchor lines, to be hauled nearly automatically over a distance of 200 m within an accuracy of plus or minus 50 cm, while dredging and laying a mattress at the same time. According to insiders, the problems to be solved were of a higher dimension as compared to the most sophisticated DP-system used in the deep sea offshore industry. In case this system were to fail, a somewhat simplified back-up system will be available.

3. Commercial aspects

In total approx. 400 million Dutch guilders were invested in special equipment for building the

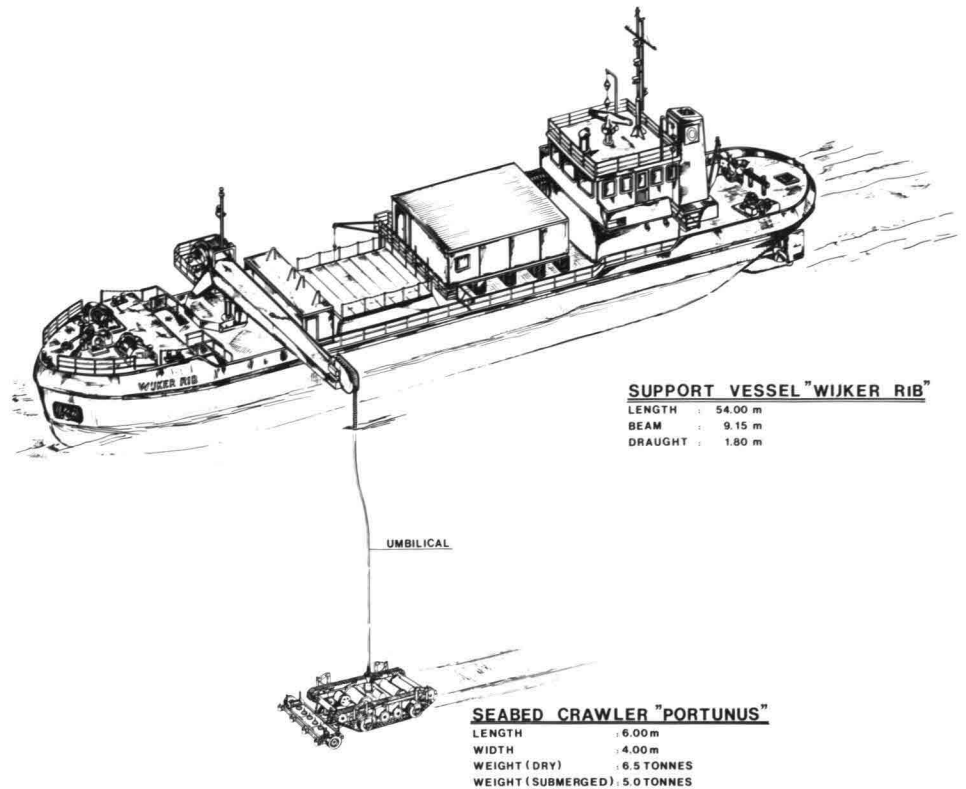

prefabricated storm surge barrier. Is this price too high?

Earlier studies always indicated that work on the site, that is to say in the tidal channels of the Eastern Scheldt, would be costly, apart from being dangerous. Time does not permit to make a complete evaluation between the prefabrication idea and building the storm surge barrier in situ. In that case a double final design would have to be made. Based on the earlier conceptual studies, however, one can safely state that the seemingly excessive amount, paid for equipment that might be useless after its job has been completed, is justified. However, the question of resale and re-use of this equipment remains open. Avoiding lengthy discussions between the government as principal and the contractor, it was decided that the very special and costly new equipment would be government owned. Therefore no major obstruction existed to having the equipment available at the right time.

At the end of the work, the contractor has the opportunity to buy the equipment; if not, it will be sold to third parties. Whatever the outcome may be: it will be an advantageous solution for the Eastern Scheldt project, because prefabrication has already paid itself.

4. Conclusion

It can be stated without exaggeration that the storm surge barrier is one of the best examples of any projects with special equipment as a result from integrating design and construction. However, as explained in the introduction, it is not the first and certainly will not be the last. As long as technology is developing, design and equipment will go hand in hand, the one sometimes leading the other. Sometimes the equipment appears to become too specialized in order to be used elsewhere and one has to consider the potential use of the special know-how and the experience gained. This is generally called the 'spin-off' and, undoubtedly, the Eastern Scheldt works will certainly have such spin-offs.

Finally it is worthwhile to pay attention to the human effort behind the Eastern Scheldt works. It is only by a nearly total dedication of government and company employees, that design, working methods and equipment could evolve simultaneously. Early preparation, world-wide research for techniques, experience and trials, innovation without disregarding the existing 'state of the art', were their tools. And one may be confident that this will result in a solidly built storm surge barrier.

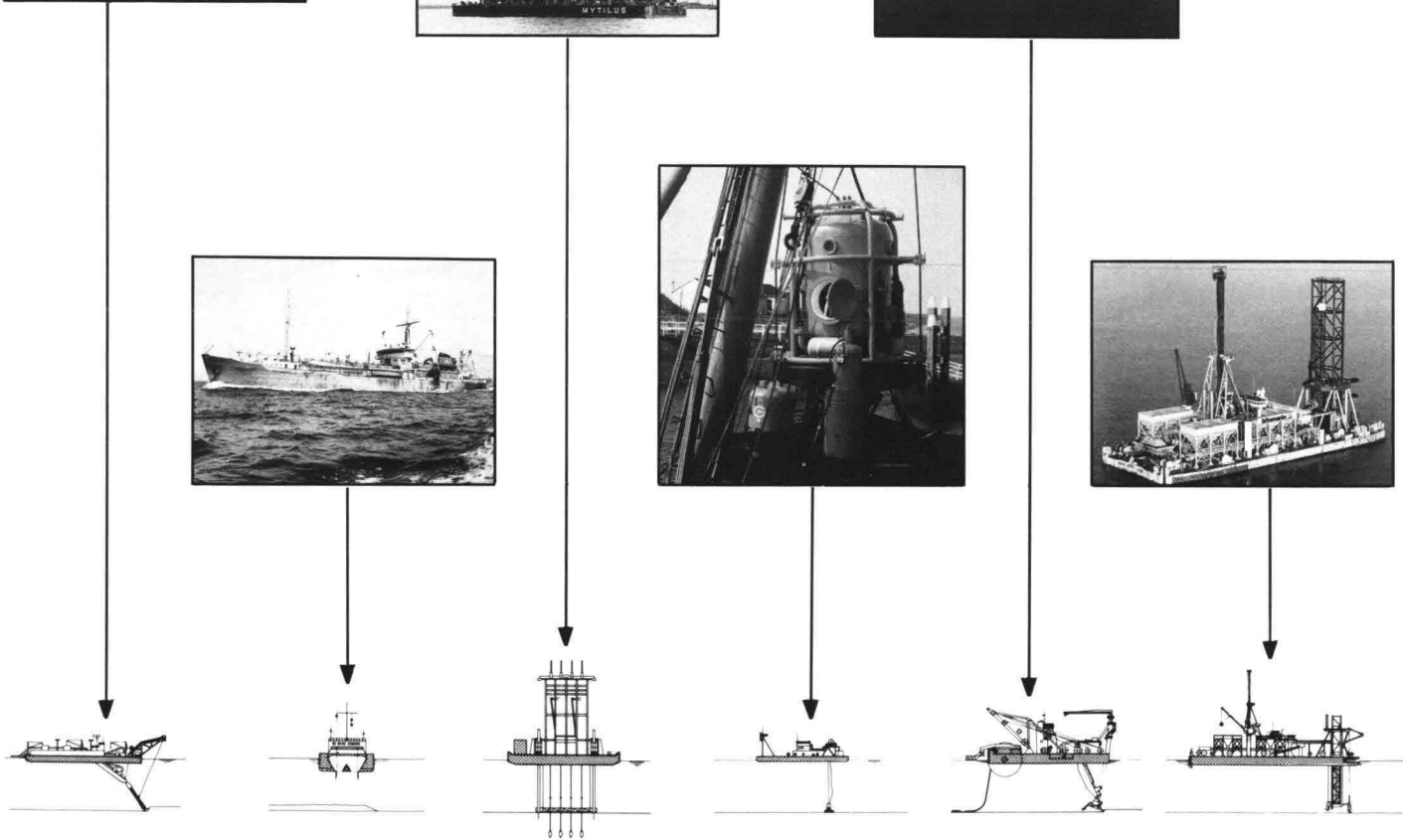
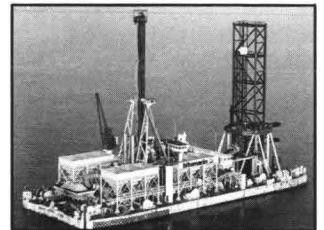
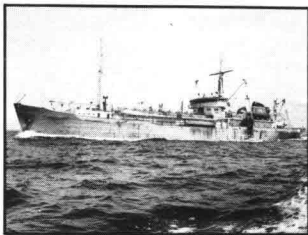
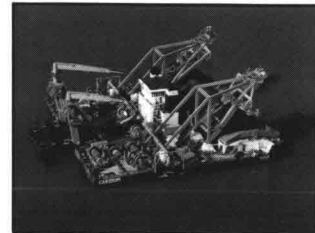
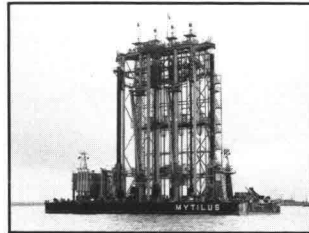
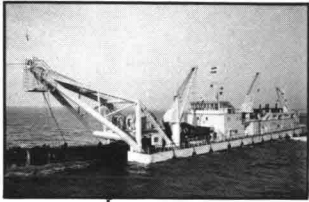

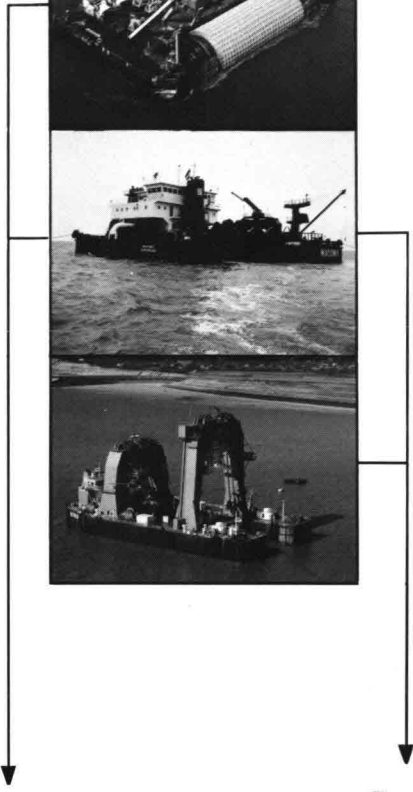
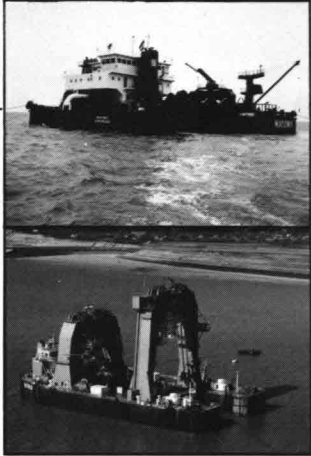
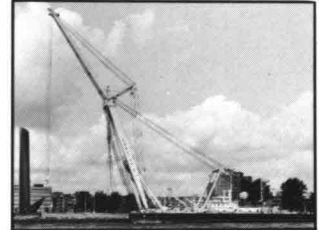
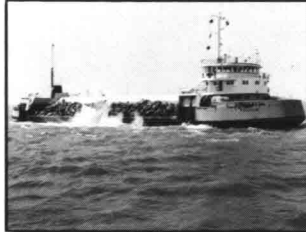
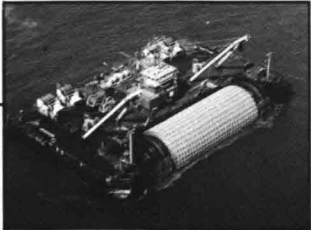

**Stone
depositing
barge**

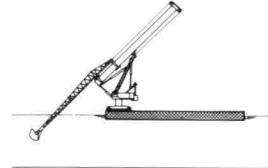
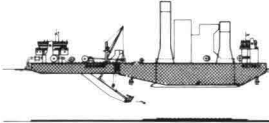
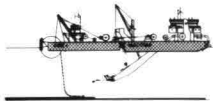

Ben C. Gerwick, Jr.
Professor of Civil Engineering,
University of California, Berkeley

The Eastern Scheldt barrier in the family of ever-growing use of prestressed concrete for offshore applications

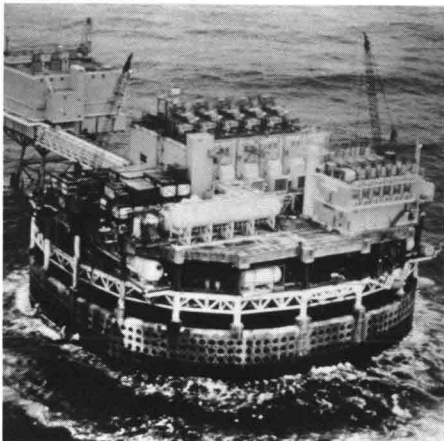

1a
Ekofisk offshore oil storage caisson

Concrete in the sea

The Eastern Scheldt storm surge barrier marks the culmination of a long history of the use of concrete in the sea. From the pozzolanic concrete of the Roman bridge piers and port construction to the Eddystone lighthouse, almost two millenia were required. In the last two centuries, a revolutionary growth has taken place in construction on the sea and concrete has played a leading role in meeting the challenge. Major milestones in this era have been the concrete antisubmarine net support structures and the concrete ships of World War I, the concrete lighthouses in the Baltic, and the breakwater armor units such as Tetrapod and Dolosse. It remained, however, for the advent of prestressing to enable a rational and effective design of major structures, so that endurance could be assured against fatigue under the millions of cycles of wave action that the structure will experience during its service life.

The Ekofisk Oil Storage Caisson ushered in a decade of explosive

growth that has been dominated by the great structures in the North Sea; the Andoc, the Sea Tanks, the Condeeps, and the Doris offshore oil drilling, production, and storage platforms.

Activity and development continued elsewhere during this decade, augmenting the reservoir of experience in coastal and offshore construction. A large offshore coal loading terminal was constructed in Queensland, Australia, proving the practicability of founding caissons in an area of weak seafloor soils, by the conceptually simple but technically and practically difficult task of foundation improvement. In this particular case, the soft clay overlying sediments were dredged and replaced by a crushed rock base on which the caissons were then founded.

In Japan, a great national project of similar scope to that of the Delta Plan was initiated during the decade of the 1970's. This was the unification of Honshu and Shikoku by means of three great bridges crossing the Island Sea. Major research

1b
Andoc, a platform under tow to a deep building site

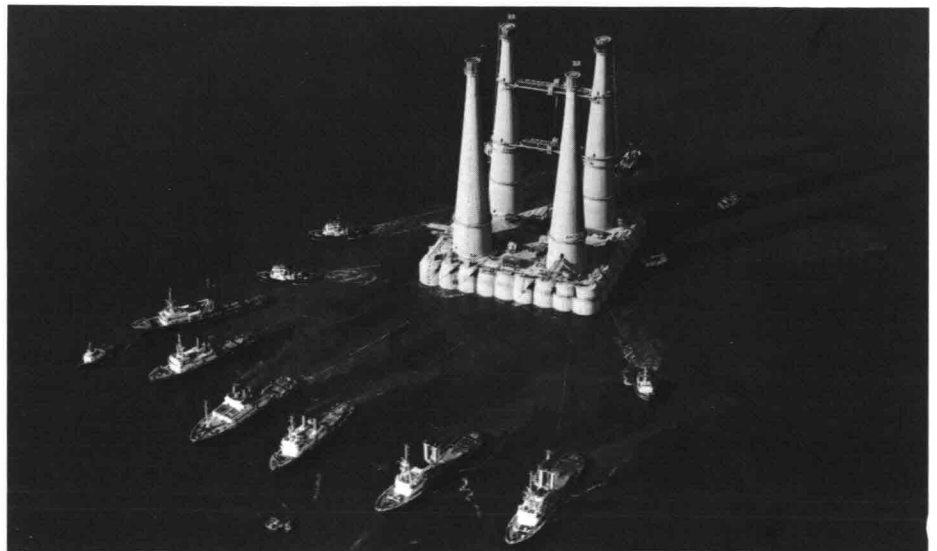



2a
Offshore coal loading terminal;
Queensland, Australia



2b
Concrete piers on caisson bases sup-
port huge shiploader gantry

3a
Beryl, a platform under construction
3b
Statfjord, a platform under tow to site

was carried out on large scale under-water concreting and specialized equipment was built to meet the demands of this unprecedented construction.

In the North Sea, the Statfjord A and B platforms have been installed and the Statfjord C platform construction is underway. The use of prestressed concrete has been extended to articulated single point moorings: a further extension of the application of prestressed concrete to highly dynamic structures.

Meanwhile, a highly significant pioneering venture has succeeded in constructing the Tarsiut caisson-retained island in the Beaufort Sea. Prestressed lightweight concrete caissons have been seated on an underwater embankment of dredged sand and gravel. The island must resist not only the open sea waves but the Arctic sea ice which builds rubble piles of ice to a height of 12 metres. It is notable that Dutch engineers have been heavily involved in many aspects of this project.

Concrete caissons have now been installed for offshore breakwaters and platforms at Tomokomai, Japan; Burnie, Tasmania, Australia; offshore in Brazil, Canada, South Africa, Algeria, France, Libya, and the Mideast, and in the Gulf of Mexico. A floating concrete container dock is under construction at Valdez, Alaska; a 62,000 ton displacement floating LNG terminal has been in service now for five years in the Java Sea of Indonesia, a floating prestressed concrete phosphate processing plant was built in Singapore and is now operating off the West Coast of Mexico, and floating bridges are under construction in the State of Washington, USA.

Underwater tunnels of prestressed concrete have been constructed in

many countries, based largely on the pioneering developments and techniques originated in Denmark and The Netherlands.

It is both fitting and significant that the successful contractor for one of the modern world's greatest bridges, the Saudi Arabia-Bahrain bridges and causeways, is a consortium led by Dutch enterprises, demonstrating the successful export of Dutch marine concrete technology to a remote and environmentally difficult part of the world.

Amidst this great activity, the Eastern Scheldt storm surge barrier stands out as a quantum leap forward in the technology for utilization of concrete in the sea. The scale of the project, the interactive considerations of environmental and the functional objectives in the conceptual development, the design life of 200 years, the constraints imposed during construction by the exposure to currents and waves, the complexities of having to found the structure in loosely consolidated sands and silts, and the close tolerances imposed by operating requirements: all these combine to make this a truly memorable undertaking. They have demanded nothing less than a full 'systems-approach' to the entire project, one which has pushed forward the state of art for large scale marine projects.

The Eastern Scheldt project could not have been attempted, however, without the full background of prior developments in materials, structural, geotechnical, hydraulic, mechanical, and construction engineering and technology. The heritage upon which this project drew includes not only prior concrete sea structures but long-span bridges, and nuclear power plant vessels and containments. It especially includes the research that has been undertaken in many laboratories around the world;



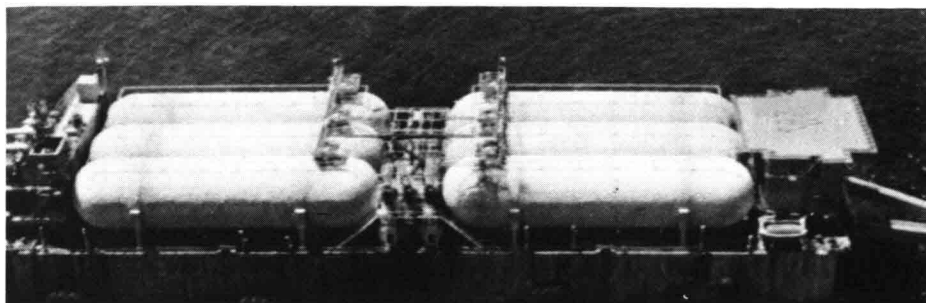

research in which Delft University has figured prominently. It includes such aspects as shear and multi-axial prestress, in prestressed concrete, advanced analytical and computational techniques, dynamic soil-structure and wave-structure interaction, and underwater consolidation of soils.

This project has also drawn heavily upon the long experience gained in The Netherlands in dredging, embankments, and anti-scour protection and on the other great projects of the Delta Plan.

Materials Technology

A notable aspect of this project is the very extensive research carried out in relation to the materials utilized and their application. This was entirely appropriate to the very large quantities of concrete and steel involved, each 5 times that of the largest North Sea platform so far constructed. It was also appropriate to the severe environmental conditions and the long term service performance required.

Of particular interest to the prestressing fraternity is the detailed evaluation that was made of the various available prestressing systems, which led to the selection of four different systems, each judged most suitable to its particular application.

Construction Methods

The extremely exposed conditions at the site have demanded the selection of construction procedures which can be carried out expeditiously and accurately during the available periods of minima currents and waves. Full recognition has been given to constructability as a major factor in the selection of appropriate methods and equipment.

While this is in keeping with the trend already developed on previous offshore concrete structures, the Eastern Scheldt project has gone far beyond past practice in conceiving, designing, and building specialized equipment. The deep compaction

barge Mytilus, the underwater trimming and protective mattress laying vessel Cardium and the caisson-setting vessel Ostrea are not only major technological achievements in themselves but essential components in an overall construction program. While the Eastern Scheldt storm surge barrier represents a culmination of a long history of development, it can also be considered as the progenitor of great projects for the future.

Some of these are even now in the planning stage. Offshore Eastern Canada, studies are being carried out for concrete caissons massive enough to withstand the impact of huge icebergs. A major consideration has been that of local concentrated impact loads from the ice, (punching shear), for which extensive use is being made of research carried out at Delft.

Further north and to the west, the arctic is becoming a focus for extensive development in order to produce the apparent large oil reserves there. The environment is unprecedentedly harsh for man yet at the same time, highly sensitive to man's impact. Similarly to the case of the Eastern Scheldt Barrier, the objectives of resource development and environmental protection must be melded. Prestressed concrete structures in a variety of forms, both fixed and floating, appear to have a major role to play in the Bering, Beaufort, and Chokchi Seas. Also as in the Eastern Scheldt, structure-foundation interaction looms as a critical consideration.

The recent USA sponsored studies for Ocean Thermal Energy Conversion were based on large concrete hulls. It is interesting to note that Dutch consultants were engaged to make the constructability analyses for these hulls and for the cold water pipes which are to be suspended beneath them. Although the project is in a holding stage now due to economic considerations, these reports and current review studies will undoubtedly

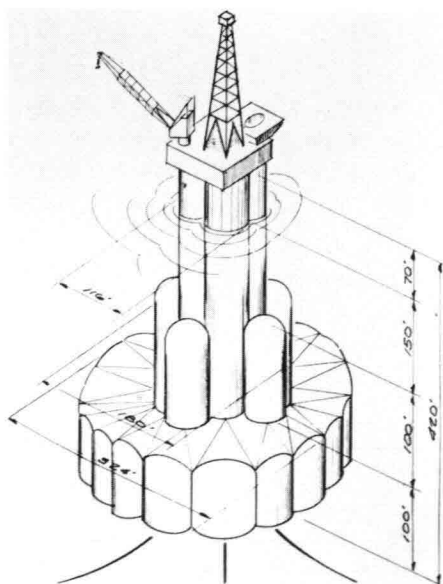

form a sound basis for other large-scale ocean developments. The Storebaelt (Great Belt) Bridge in Denmark was under design concurrently with the Eastern Scheldt barrier and very similar conceptual techniques were selected. Although that project also has been indefinitely delayed, should it be revived, the experience gained here will be invaluable to the constructors.

Extensive studies continue for the development of prestressed concrete vessels for storage and transport of LNG. The intensive research at Delft, augmented by successful experience in dry-land installations, by marine-oriented research at our University of California, and by studies for offshore LNG terminals in California, the Arabian Gulf, and the Canadian Arctic Islands, are all serving to move this concept towards ultimate realization.

What lies beyond? Precast concrete tidal barriers for power generation in Southwestern England, Eastern Canada, and the USSR? Precast concrete tunnel segments for a trench-type crossing of the English Channel? Submerged floating tunnels across deep fjords and channels in Norway, Greece, and Italy? Prestressed concrete floating semi-submersible production plants for crude oil production in deep water and for LNG liquefaction? Bridge piers in deep water, subjected to high currents and waves and possibly even ice? Floating power plants, industrial facilities, and waste disposal plants, moored offshore our large cities, in order to minimize hazards, minimize pollution, and utilize the abundant cooling water?

These and other dreams abound, being carried closer to reality by the advances in prestressed concrete in marine applications.

Research Needs

If the promise of the future widespread development of the seas through the use of concrete is to be fulfilled, then research must be not only continued but be intensified. Among the many areas with high need or potential are the following:

1. Investigation of failure modes under accident or overload. Ways to improve ductility and energy absorption so as to prevent sudden failure and progressive collapse.
2. Triaxial prestress as a means of enhancing ultimate strain and stress capacities.

3. The role of micro-cracking in corrosion and, if confirmed, means of minimizing micro-cracking
4. Composite construction using steel or other fibres. Sandwich construction of steel plate and concrete, using, for example, welded studs for shear connectors.
5. Prestressed concrete under cyclic shear while exposed to cryogenic temperatures, in order to further qualify concrete for maritime transport of LNG.
6. Fatigue of steel in cracked concrete in the marine environment.
7. Developing means for effective monitoring of in-service performance of prestressed concrete and its components. Improvement of methodology for reduction of data, interpretation, evaluation and dissemination of results.
8. Large scale tests of prestressed concrete shell elements under concentrated loadings. This could extend the work previously done at Delft to address the use of headed stirrups, and prestressed stirrups in thick-walled shells.

International Activity

The explosive development of concrete in the seas has been fostered to a great extent by the world-wide acquisition of information and data, and its dissemination through such organizations as FIP. Indeed FIP's early recognition of the potential role for prestressed concrete in the Oceans led to its promulgation of the first Recommended Practice and to its support of concrete platforms for the North Sea. Its commissions continue active in many areas having both direct and indirect implications for maritime utilization. It is indeed gratifying to recognize the leadership roles played by Dutch engineers in the FIP Commissions on Concrete Sea Structures and on Steels for Prestressing as well as important contributions in other commissions. FIP also serves to disseminate information on such great projects as this Eastern Scheldt Barrier to the rest of the world, both the developed countries and the developing nations. This is an important and constructive role. However, it seems perhaps not to be enough. As the world and its peoples become increasingly inter-related and dependent on each other, governments and organizations and individuals increasingly question our engineering decisions and demand to participate in the formulation of programs and concepts. This has occur-

red already on this great project and will continue on future projects. Society demands to be informed and involved. Therefore we must communicate more widely and more effectively with Society. You, the organizers of this symposium are doing this magnificently, but we need to intensify and extend this to the people in our own countries, so as to rebuild their confidence that we can and will build with safety for them and their environment.

This great storm surge barrier climaxes the epic struggle of the Netherlands against the North Sea and marks the completion of the Delta Plan. 'The proud waves have indeed been stayed and the sea girded with a rigid zone.' In a larger sense, this great achievement will take its place in history as a symbol of man's continuing struggle against the seas everywhere, not just a struggle for survival but a bold reach outward to challenge the seas and realize their promise for the benefit of mankind.

Design of concrete structures

Probability design method

1. Introduction

Probabilistic methods were introduced in the design of the storm surge barrier for two reasons. After the storm flood disaster of February 1st, 1953, The Netherlands Delta Committee stipulated that primary sea-retaining structures had to provide full protection against storm surge levels with an excess frequency of 2.5×10^{-4} time per year. In the case of conventional defences, such as dikes, an extreme water level may be used as a design criterion, because overtopping is considered to be the most important threat to dikes. In the preliminary design stage of the Eastern Scheldt storm surge barrier a design storm surge level was chosen in accordance with the report of the Delta Committee. This surge level was combined with a maximum extrapolated single wave and a low estimate of the inside water level to determine the hydraulic load (deterministic approach). In fact this approach is unsuitable for a storm surge barrier. The structure consists of concrete piers, steel gates, a sill, a bed protection and a foundation. These components have to be designed on the basis of load combinations, which will provide the most dangerous threat to the structural stability.

Secondly, the various components of the barrier were designed according to principles and rules prevailing in the fields of concrete, steel, coastal engineering and soilmechanics. As the rules and principles differ considerably between the abovementioned disciplines, a consistent approach to the structural safety of the barrier was not guaranteed.

The first problem is solved with a probabilistic approach classified as level III, by JCSS standards. The probability density function of the load is

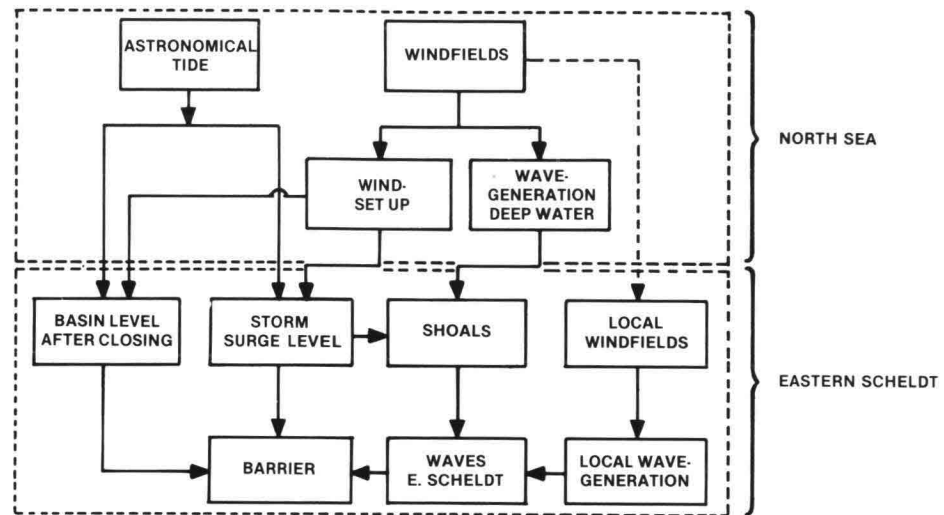

1
A schematic diagram of the physical relations used for the derivation of the three dimensional probability function of the storm surge level, wave energy and basin level

derived by integrating the multidimensional probability density function of wave spectra, storm surge levels and basin levels using the transfer function of the structure. For quasi probabilistic design calculations the threat or load with a probability of exceeding of 2.5×10^{-4} per annum was chosen as a criterion following the advise of the Delta Committee. To ensure consistent safety throughout the structure, probabilistic analyses taking into account the stochastic character of the loads and the structural resistance are performed for the main components. Using the advanced first-order second moment approach (level II) the main sections of the concrete components, the steel gate, the sill, and the foundation are designed to fulfill the failure criterion of 10^{-7} per annum. From these probabilistic

calculations safety factors were derived to guide the daily design activities that were conducted along semi-probabilistic lines (level I). To assess the safety of the barrier as a sea defence system, a risk analysis is performed using the fault tree technique. In this analysis attention is given not only to the probability of failure of the structural components but also to the consequences of mismanagement.

2. The hydraulic boundary conditions

The probabilistic load calculation, that was deemed necessary to bridge the gap between the Delta design criterion for dikes and the questions arising from the design of a complicated barrier requires knowledge of the three-dimensional probability density function of storm surge level, basin level and wave energy. Basically there are two ways of extrapolating the measured data of these parameters and their correlations into the regions of low probability of occurrence where measured data are not available:

1. a purely statistical extrapolation;
2. a statistical extrapolation sup-

plemented by mathematical models based on physical laws and checked with measured data. A combination of these methods has been used in finding the probability density function of the storm surge level and the conditional probability density functions of wave energy and basin level, from which the three-dimensional probability function is derived. A schematic diagram for the development of this three-dimensional function has been given in figure 1.

The probability density function of the storm surge level is based on 68 years of historical data; extremes are predicted by statistical extrapolation. The knowledge of the physical laws governing this phenomenon has been used to see whether predicted extremes could be reached. The conditional probability density function of the basin level depends at least partly on the closing strategy governing the barrier during storm surges. A simple model was

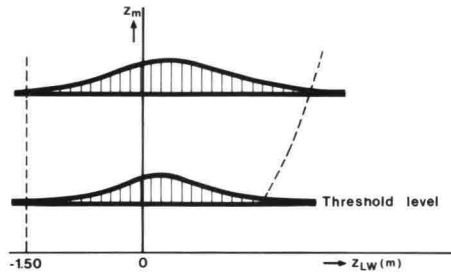

2 The two dimensional probability density function of maximum storm surge level and low water level at closing

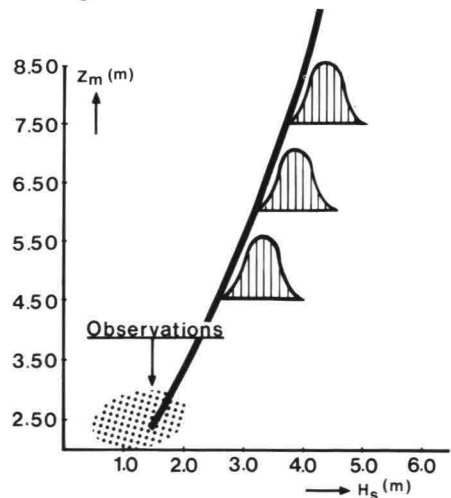

3 The relation between the storm surge level and the significant wave height; in the figure the conditional probability density function of H_s for a number of storm surge levels has been given

developed based on the fact that a storm surge is formed by a random combination of wind set up and astronomical tide. From this model the conditional probability density function of the basin level (conditional on storm surge level) could be derived for different closing strategies (figure 2). The basin level was found to be virtually statistically independent of the wave energy. It appeared from wave data that a loose correlation exists between the storm surge level and the energy of the wave spectrum. Lack of data, however, prevented a reliable extrapolation of this two-dimensional probability function by purely statistical methods. Therefore a mathematical model has been developed. It is based on the hypothesis that the typical double peaked form of the wave spectrum is caused by the fact that the wave energy originates from two sources. Waves, entering the estuary from deep water via the shoals are in-

fluenced by the processes of breaking, bottom dissipation and refraction by depth and current. The remaining wave energy reaching the barrier depends on the storm surge level. In addition, waves are generated by local windfields, showing a loose relation to the general storm intensity. The model, which incorporates all these effects is tested in a hindcast of several storms. Being in good agreement, the model is used in extrapolating the conditional twodimensional probability density of storm surge level and wave energy (figure 3).

The required three-dimensional probability density function of storm surge level, wave energy and basin level is derived as the product of the probability density functions referred to above. It has been used as an input in the calculations of the probability distribution of the hydrodynamic load on the storm surge barrier.

3. The probabilistic load determination

The basic parameters in the determination of the hydraulic load at the storm surge barrier are:

- maximum storm surge level at sea z_m;
- wave energy spectrum S_η;
- basin level at the Eastern Scheldt b.

The joint probability density function of these parameters f_{z_m, b, S_η}, derived in the previous paragraph has been used as an input for the calculation of the probability distribution of the hydraulic load on the storm surge barrier. To transfer the hydraulic parameters into the hydraulic loads, the static loads, and the wave loads, acting on the structure have to be written as functions of the respective parameters:

Static load S = G(z_m, b, geometry).....(1)
 Wave load spectrum S_w = H(z_m, S_η, geometry).....(2)

In the case of the static load this function can be easily determined from the hydrostatic pressure distribution on both sides of the barrier and a potential flow pattern in the sill around the base of the piers.

For the calculation of the wave loads a linear wave theory was adopted. The wave load is found by integrating the wave pressure distribution for waves partially reflected against a vertical wall over the height.

$$W(t) = \int_{\text{height}} p(x, z, t) dz$$

where $p(x, z, t) = \rho g a \frac{\cosh kz}{\cosh kd} \sqrt{1 + a^2 + 2a \cos kx} \sin(\omega t + \phi)$
 for $0 < x < d$

and $p(x, z, t) = \rho g \{ a - (z - d) \} \sqrt{1 + a^2 + 2a \cos kx} \sin(\omega t + \phi)$
 for $d \leq x \leq d + a$

- in which
- k = wave number
- a = reflection coefficient
- ω = angular frequency
- t = time
- φ = phase shift = $\text{arctg} \left\{ \left(\frac{1-a}{1+a} \right) \text{tg} kx \right\}$

The maximum of the wave load W(t) must be divided by the incoming wave amplitude to find the transfer value for the considered wave period. Repeating this procedure for a number of wave periods the transfer function is established.

Now assuming linearity, the transfer function $O(f)$ is used in the frequency domain to transfer the wave spectrum in the wave load spectrum.

$$S_w(f) = O^2(f) S_n(f)$$

As the wave load spectrum is narrow the individual wave load maxima follow a Rayleigh distribution. The traditional parameters W_s (significant wave load) and T_w (mean wave load period) can be obtained by the well-known relations.

$$W_s = 2\sqrt{m_0}$$

$$T_w = \sqrt{\frac{m_0}{m_2}}$$

$$m_n = \int f^n S_w(f) df$$

The assumption of linearity and the application of the spectral analysis have been extensively investigated in the facilities of the Delft Hydraulic Laboratory. Numerous tests with regular and irregular wave patterns were performed to prove the validity of the method described. Summarizing, we can conclude that the model tests support the mathematical models. Consequently the model for the static load and the model for the wave load have been used in the probabilistic calculation.

The result of the previous paragraph was the three-dimensional probability density function of the boundary conditions.

This density function is transformed into the two-dimensional probability density function of static load and significant wave load, using

$$f_{W_s, S}(W_s, S) = \int_0^\infty \frac{1}{\frac{\delta W_s}{\delta S_\eta} \frac{\delta S}{\delta b}} f_{z, b, S_\eta}(z, b, S_\eta) dz$$

Secondly, it is now possible to transfer $f_{W_s, S}(W_s, S)$ in a joint p.d.f. of the static load and the wave load peaks W , as follows:

$$f_{W, S}(W, S) = \int_0^\infty f_{W_s, S}(W_s, S) \frac{\delta P_{r_i}}{\delta W} dW_s$$

in which P_{r_i} represents a probability distribution which depends on the limit state considered. In the following, three kinds of limit states are discussed.

1. In cases, where all wave load peaks are in principle important, the Rayleigh distribution will be used

$$P_{r_1} = Pr(W > W | W_s) = \exp \left\{ -2 \left(\frac{W}{W_s} \right)^2 \right\}$$

In case of the storm surge barrier this distribution has been used for the increasing deformations of the subsoil.

2. If, however a model is considered in which a one-off exceeding of the load leads to a collapse, than the probability distribution of the wave loads which are exceeded at least once has to be used. Starting from N independent wave load peaks within the duration of a sea state, according to the Binomial distribution, the probability that none of the wave load peaks will exceed a level W , equals $\left\{ 1 - Pr(W > W | W_s) \right\}^N$

The probability Pr_2 that W is exceeded at least once, equals

$$Pr_2 = 1 - \left\{ 1 - Pr(W > W | W_s) \right\}^N$$

In case of the storm surge barrier this probability distribution has been used in the structural design of the pier, the beams, and the gate.

3. Finally, we can also look at another model, where collapse only occurs when a load level is exceeded several times (e.g. in case of failure of an element of the barrier due to fatigue). Based on the Binomial distribution we find for the probability Pr_3 that a load peak exceeds a given level W at least m times, out of N .

$$Pr_3 = 1 - \left\{ \sum_{h=0}^{h=m-1} \frac{N!}{h!(N-h)!} Pr(W > W | W_s)^h (1 - Pr(W > W | W_s))^{N-h} \right\}$$

To arrive at a probability distribution of a total load T for a specific limit state, based on the joint p.d.f. of the wave load peaks and the static load, it has to be known in which ratio the wave load and the static load contribute to this limit state.

In general this can be defined as follows:

$$T = \beta \cdot S + \gamma \cdot W$$

Now the probability of a specified total load $Pr\{T > T\}$ being exceeded, can be determined per limit state by integrating the bi-dimensional probability density function $f_{W, S}(W, S)$ over the area for which

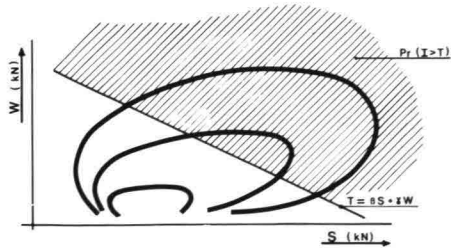

$$\beta S + \gamma W > T$$

$$Pr (T > T) = \int_{\beta S + \gamma W > T} f_{W,S}(W, S) dW dS \text{ (fig. 4.)}$$

The result of this integration is the probability of the total load T acting on a pier being exceeded. This probability distribution is well approximated by an extreme value distribution (fig. 5).

In comparison to the deterministic approach, the probabilistic approach resulted in a more realistic design load which was approximately 40% lower, as shown in table 1.

4 Calculation of the probability of exceedance of the total load T

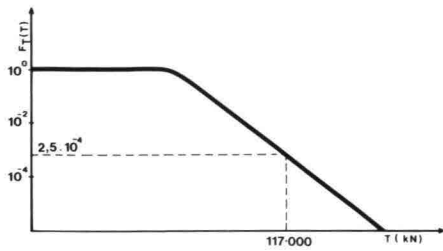

5 Probability of the exceedance line for the total load on pier R 17

4. Probabilistic design procedures

Probabilistic methods were introduced in the design of the storm surge barrier for two reasons. First, the design rules for dikes formulated by the Delta Committee had to be transformed into a set of a complicated structure. Secondly, a consistent approach to the structural safety of the barrier did not seem to be guaranteed if the component such as the foundation, the concrete pier, the sill, and the gates, were designed according to the rules and principles prevailing in the various fields.

The first problem is solved by using the result of the previous paragraph. In compliance with the Delta Committee, the total load with a probability of exceedance of $2.5 \cdot 10^{-4}$ p.a. was chosen as a design load.

The 'daily' design activities were guided by a quasi-probabilistic design method. The basis of the quasi probabilistic design method is that the parameters used in the structural design are not specified constants, but stochastic variables, whose exact magnitude is not known with certainty at the design stage and in case of the hydraulic parameters, not even after construction. Because the use of these stochastic elements is not practical for the normal design activities due to the lack of statistical information and of computer programs for mass-production,

| | deterministic approach | probabilistic approach |
|------------------------|--------------------------|--|
| storm surge level | AOD + 5.50 m | $P_r(z_m > z) = \exp\left(-\frac{z_m - 2.94}{0.3026}\right)$ |
| wave spectrum | $H = 10$ m $t = 12$ s | $P_{s_\eta}(S_\eta z_m)$ |
| basin level | AOD - 1.70 m | $P_b(b z_m)$ |
| total horizontal force | $T = 173,000$ kN | $P_r(T > 117,000) = 2.5 \cdot 10^{-4}$ |

Table 1

the concept 'characteristic value' has been introduced in the structural design. The safety margin had to be specified in a format of partial safety factors according to the ISO standard 2394. Although the Dutch building codes prescribe design safety factors for concrete and steel, no formal guide lines exist for foundation- and coastal engineering.

The lack of rules mentioned above

and the difficulties encountered in the design called for a special assessment of the appropriate safety factors in the various fields of engineering. The first guesses regarding the values of the safety factors were made on the basis of experience and engineering judgement. This approach however did not lead to a consistent approach as the building codes prescribed a higher safety factor for the concrete structure than the specialists advised for the foundation of the piers. Moreover in coastal engineering the use of

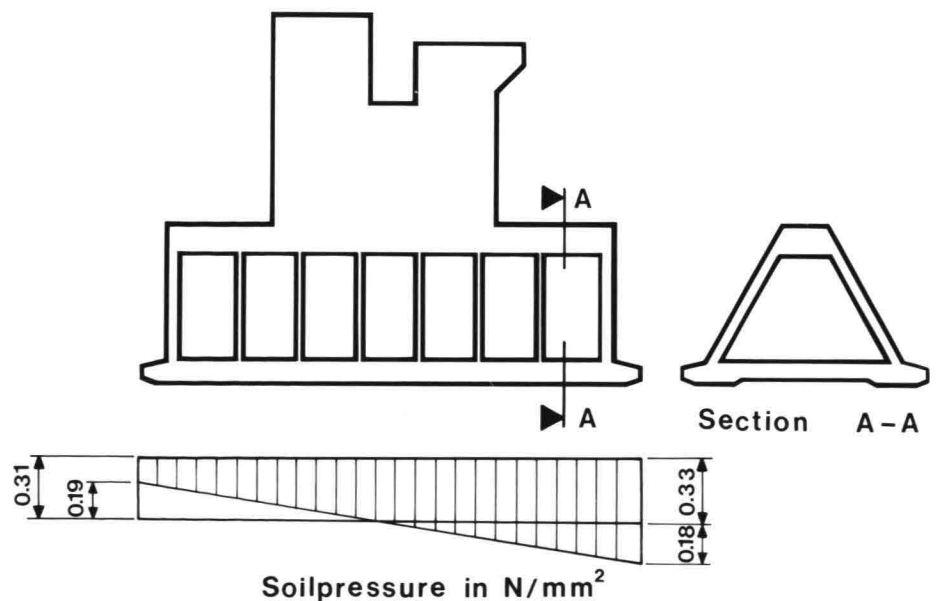

6 The cross-section subjected to probabilistic calculations

safety factors is unknown, which led to designs that fail under the $2.5 \cdot 10^{-4}$ p.a. design load.

To improve this state of affairs a search was started for objective methods to ensure consistent safety throughout the whole barrier system. A simple approach that met the standards of objectivity was found in the modern first order second moment probabilistic calculations (Level II).

The availability of the theoretically correct p.d.f. of the loading facilitated the application of the Level II methods. The problem of the specification of safety factors for the different parts of the structure was now transformed into the more general problem of formulating a single failure criterion, valid for all parts; concrete pier, steel gate, as well as foundation, and sill. The failure criterion that had to be fulfilled, was tentatively established at 10^{-7} per annum on the basis of the following simple reasoning. The fatality statistics point out that the average probability of death caused by a fatal accident is 10^{-4} p.a. On the other hand, previous experience has shown that a failure of the sea defence system may cost 10^3 casualties. So only if the probability of failure of the system is less than or equal to 10^{-7} per annum, a normal safety level can be guaranteed. The failure criterion provided the starting point for the probabilistic calculations according to the advanced first-order second moment method, which were consequently performed for all major parts of the barrier. An advantage of the method used is that the contribution of each basic variable to the probability of failure of the studied component is neatly specified. Thus the design and research efforts could be spent on the variables that contribute most to the probability of failure. In the field of concrete design, the cross-section of the pier base was subjected to probabilistic calculations performed in co-operation with TNO/IBBC.

The probabilistic model of the cross section is very simple and expressed in the form of a reliability function Z .
 $Z = M_{ult} - M_{W,S} - M_d$

Where:

M_{ult} = the ultimate moment of the section;

$M_{W,S}$ = the moment caused by the wave load and static load;

Table 2

| | expectation | standard deviation | type of p.d.f. | % of total variance |
|---|--------------|--------------------|----------------|---------------------|
| M_D moment due to dead load and post-tensioning | 0.3500 E + 1 | 0.300 E + 0 | normal | 70.6 |
| f_p yield strength tensioning steel | 0.1835 E + 4 | 0.400 E + 2 | normal | 0.9 |
| E_p Young's modulus tensioning steel | 0.2050 E + 6 | 0.500 E + 4 | normal | 0.0 |
| f_a yield strength mild steel | 0.5000 E + 3 | 0.500 E + 2 | normal | 0.1 |
| E_a Young's modulus mild steel | 0.2100 E + 6 | 0.500 E + 4 | normal | 0.8 |
| A error in dimensions | 0.1000 E + 1 | 0.500 E - 2 | normal | 10.7 |
| V_G degree of post-tensioning | 0.1060 E + 4 | 0.250 E + 2 | normal | 4.2 |
| V error in tensioning steel area | 0.100 E + 1 | 0.100 E - 1 | normal | 1.6 |
| B error in concrete dimensions | 0.1000 E + 1 | 0.200 E - 1 | normal | 0.4 |
| F'_p compression strength of concrete | 0.2000 E + 2 | 0.300 E + 1 | log-normal | 10.1 |
| $M_{w,s}$ wave load and static load | 0.1400 E + 4 | 0.105 E + 3 | special | 0.7 |

$$\beta = \frac{\mu_z}{\delta_z} = 6.0$$

$$P_{failure} = 8.7 E - 10$$

M_d = the moment caused by the dead weight of the pier and by post-tensioning.
 $Z < 0$ failure of the section.

Now the strength M_{ult} and the loading $M_{W,S} + M_d$ have to be written as functions of the basic variables whose p.d.f.'s are known. The loading side of the problem has been treated in the previous paragraph and the result, i.e. the p.d.f. of the total load is accepted here.

The M_{ult} -function is given by a standard computer program, that checks a post-tensioned concrete cross-section. The completed picture of the basic variables with their respective p.d.f.'s is given in table 2. The result of the calculation is a β -value of 6.0 and a probability of failure of $8.7 E-10$ which is clearly acceptable. From the contributions of the basic variables to the total variance of Z it appears that M_d is most likely to cause failure. M_d contains the extreme post-tensioning force, so to say, the force that nearly destroys the structure. This level of post-tensioning was chosen to prevent steel corrosion which was seen as the most dangerous threat to the structural integrity of the structure. The corrosion problem in fact determined by the concrete dimensions and the level of post-tensioning. More interesting use of the first order second moment methods was made

in the design of the foundation. There the choice of the safety factors was based on probabilistic calculations as reported elsewhere (3). Also the design of the sill and the transitional structure (4) between the first pier and the shore were intensively influenced by probabilistic methods. In fact the application of safety factors was introduced in coastal engineering as a result of the studies performed in this field.

5. The fault tree analysis

The simple reasoning of the previous paragraph that produced a failure criterion of 10^{-7} p.a. was applied to each component. However, the correct approach is to assess the safety of the total barrier as a sea defence system. From this point of view the failure of a single component still plays a part depending on its relative importance, but also the possibilities of mis-management, fire and ship-collisions play their part.

To analyse the relative importance of the various components in the total system, a faulttree was constructed. The most unwanted consequence, the inundation of parts of Zeeland is placed at the top of the fault tree. And the allowable probability of this catastrophic event occurring is 10^{-7} p.a. according to the simple philosophy. Next, the chain of intermediate events that leads from the

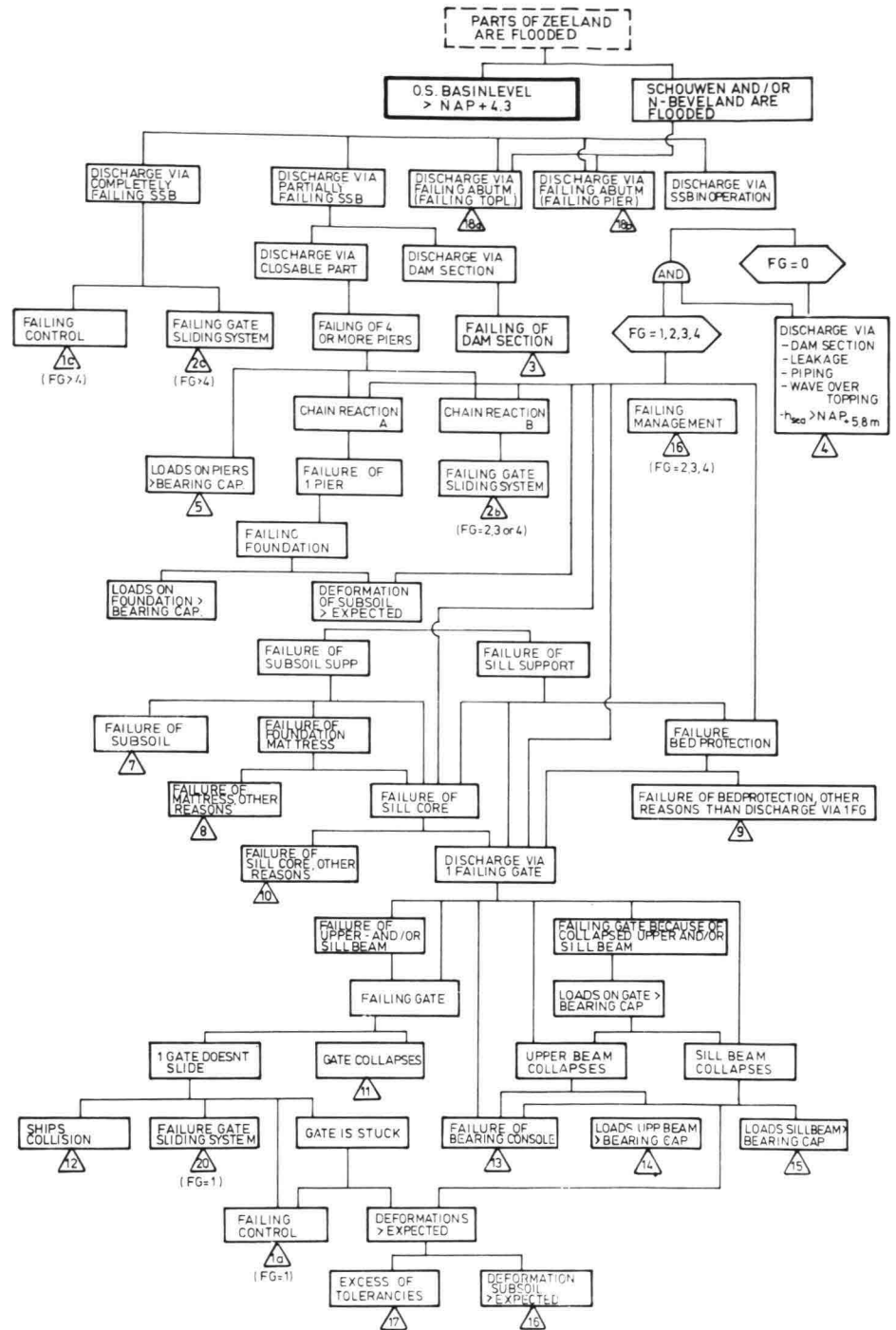

failure of a specific component to the extreme event is analysed. Besides the failure of components within the meaning of the previous paragraph, the malfunctioning of the hydraulic system in lowering the gates and mismanagement were also incorporated in the fault tree (fig. 7). The first assessment of the safety of the barrier by means of the fault tree yielded unsatisfactory results. The probability of failure was far too high due to the likelihood of malfunctioning of the hydraulic system to lower the gates. As a result a second independent hydraulic system was installed as a back-up. Further the possibility of serious consequences of mismanagement of the barrier (i.e. neglecting to close it) were minimised by providing a system that will close the gates automatically, if the storm surge exceeds a given extreme level. Thus, by using the fault tree as a tool, the design of the barrier was refined in every aspect while care was also taken to achieve the specified safety criterion of 10^{-7} in the most economical manner.

6. Conclusions

Probabilistic methods have greatly influenced the design of the Eastern Scheldt storm surge barrier. It proved possible to establish the joint probability density function of the storm surge level, the basin level and the wave energy, in the regions of very low probability by a combination of physical models and statistical methods. The probabilistic load determination provided more realistic loading combinations which were 40% lower than the deterministic values previously used. The advanced first order second moment method has proved to be a good tool in providing consistency between the designs of the concrete pier, the steel gate, the foundation and the sill. The criterion was specified as an allowable probability of failure for the overall structure. The safety of the total sea defence system was assessed by means of a fault tree analysis. This technique

enables the designers to relate the probabilities of failure of the various components to the overall safety of the structure. Further aspects such as the malfunctioning of the hydraulic system, mismanagement or a ship collision could be incorporated. Design changes resulted from this approach. Probabilistic methods were experienced to be very useful in the design of a fullscale structure such as the Eastern Scheldt storm surge barrier.

Literature

1. Th. Mulder, J.K.Vrijling, 'Pro-

babilistic load determination'; Hydraulic aspects of coastal structures, Delft University Press, 1980
 2. J.K.Vrijling, J.Bruinsma, 'Hydraulic boundary conditions'; Hydraulic aspects of coastal structures, Delft University Press, 1980
 3. D.Kooman e.a., 'Probabilistic approach to determine loads and safety factors'; Foundation aspects of coastal structures, Delft 1978
 4. J.P.Schellekens, J.Wouters, J.K.Vrijling, 'Transitional structures between barrier and dikes'; Hydraulic aspects of coastal structures, Delft University Press, 1980

Design of concrete structures

Durability and corrosion

1. Introduction

The lifetime of the flood barrier envisaged is 200 years. This is quite a stringent requirement for a concrete structure, especially in a aggressive sea water environment. There is lack of experience with regard to such a long period of time, while inspection and maintenance are virtually impossible, because vital parts of the structure are under deep water embedded in a 10 meter thick layer of rubble. Although there is lack of experience an attempt has been made to predict the expected lifetime by analysing the corrosion process. At the start of the design in 1976 the assumption was that corrosion of the reinforcement and durability were closely bound up with cracking in the concrete. The design therefore aims at achieving a structure that will be as crack-free as possible.

2. The corrosion process in time

2.1. Corrosion

Steel embedded in dense concrete obtains its resistance to corrosion from a passive surface layer, caused by the alkaline environment of the concrete (pH 12,5). This alkaline, non-corrosive environment can be transformed into a corrosive environment by several causes:

- a. carbonation of the concrete;
- b. influence of aggressive substances, among them chloride;

ad.a. Carbonation involves the interaction with the atmospheric CO_2 . The pH of the surface zone of the concrete becomes depressed to a value below pH 9. However, in the structure in question, with a cover of 7 cm concrete with a high quality, the carbonation front will not reach the reinforcing steel during the lifetime of 200 years. So there is no fear for depassivation of the steel due to carbonation.

ad.b. Chloride penetration appears to be the actual cause of depassivation and corrosion of the reinforcing steel. In both cases oxygen and moisture are necessary for the actual corrosion process.

2.2. Corrosion initiated by chloride penetration (see fig. 1)

The following phases can be distinguished in the corrosion process.

Phase 1. Chloride penetration.

In this phase chloride from water and air gradually penetrates the concrete in course of time. After some time the chloride reaches the reinforcement and finally after time 'To' reaches such a concentration (approximate 0,5% Cl^- on cement mass) that the corrosion process will start. The period 'To' depends on thickness and properties of the concrete cover. The choice of the kind of cement is very important. For blast furnace cement the chloride penetration is 5 times as slow as for Portland cement.

Phase 2. In this phase the corrosion of the reinforcement takes place when there is a sufficient offer of oxygen. This corrosion process is coupled with an increase of volume, so that finally the concrete cover is pressed from the reinforcement, or longitudinal cracks appear parallel to the reinforcement.

Phase 3. In this phase the cover has been damaged in such a way that the bare reinforcement freely corrodes under the influence of weather and wind or water. Now the corrosion process takes place faster than in the preceding phase, namely approximately 0,1 mm/year. Now, for outsiders a psychological limit state will have been reached, by which maintenance will have to be carried out. The resistance of the piers however is so big that they will not fail, partly because of the bigger cover on the prestressing cables.

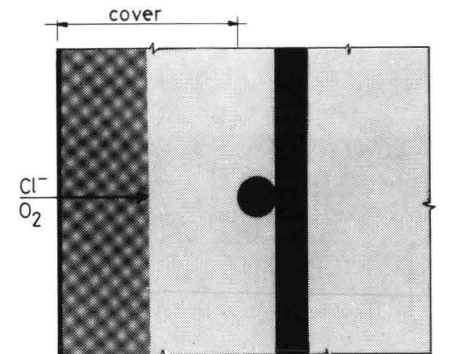

PHASE 1
 Cl^- penetration

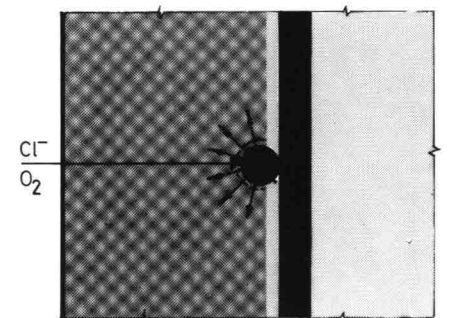

PHASE 2
 corrosion reinforcement

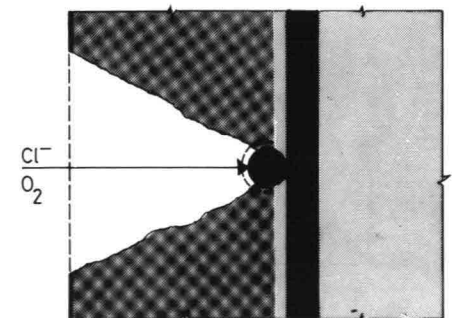

PHASE 3
 loss of cover (free corrosion)

1
 Phases in the corrosion due to chlorides

| ZONE | BASIC CORROSION SPEED (without cover) cm/year | O ₂ | | CL ⁻ # |
|----------------|---|---|---|---|
| | | OFFER grams/cm ³ | DIFFUSION CONSTANT D _b cm ² /year | DIFFUSION CONSTANT D _c cm ² /year |
| splash zone | 0,01 | $3,0 \times 10^{-4}$ | 3000 | 0,2 |
| tidal zone | 0,01 | $< 3,0 \times 10^{-4}$ $> 0,13 \times 10^{-4}$ | ≈ 100 | > 0,2 < 0,5 |
| submerged zone | 0,01 | $0,13 \times 10^{-4}$ | 100 | 0,5 |

the critical Cl⁻ content is assumed to be 0,5 % Cl⁻/cementmass

2.3. Corrosion environments.

In the corrosion process, initiated by chloride penetration three principally different corrosion environments can be distinguished, dependent on the offer of oxygen and chloride (see figure 2).

1. Splash Zone.

Here the offer of oxygen from the air is relatively high. The diffusion speed of oxygen is also high because the concrete is not saturated with water. The diffusion of chloride is relatively low.

2. Submerged zone.

The offer of oxygen from the water is relatively low, while the diffusion of oxygen through the concrete saturated with water is much lower than through concrete of a dryer consistency. On the other hand the diffusion of chloride is relatively high.

3. Tidal zone.

Lastly the tidal zone can be mentioned where a mixing of the above-mentioned circumstances takes place. The diffusion of oxygen will be lower than in the splashzone if the concrete is saturated with water.

3. The lifetime of the flood barrier

As mentioned in the introduction the required lifetime is 200 years. Because of lack of experience with regard to such a long period of time, there was a need to make a prediction of the durability. Theoretically it is possible to approach the corrosion process arithmetically. For this purpose a study of literature with regard to durability and corrosion reseach was carried out (lit. 1). On the basis of this study the required parameters such as diffusion constants for chloride and oxygen in concrete, critical chloride content, etc., were determined. With these parameters an analysis of the corrosion process in time was carried out. Because the results of short-term tests (10-50 year) were used, the prediction of the lifetime should be seen only as an indication. The corrosion process as a function of time is given in figure 3 for three corrosion environments: splash zone; submerged zone; tidal zone.

The corrosion process has been divided into the three phases mentioned above.

- Phase 1: chloride penetration
- Phase 2: corrosion in the presence of the cover
- Phase 3: free corrosion after loss of the cover.

Splash zone

After about 80 years the chloride will reach the reinforcement in such a concentration that the corrosion process might start. In the splash zone there is a lot of oxygen so that the corrosion process proceeds very quickly. After a couple of years already the cover spalls from the corroding bar.

Submerged zone.

In this zone the relatively quick chloride penetration caused by the high offer of chloride is striking. After that however, the corrosion process

proceeds very slowly due to the low offer of oxygen and a very low diffusion speed of the oxygen. Only after more than 200 years loss of cover takes place.

Tidal zone

In the tidal zone chloride penetration probably proceeds somewhat faster than in the splash zone. However, because the concrete is more saturated with water, the diffusion speed of the oxygen will be lower and also consequently the corrosion speed.

Conclusions regarding the corrosion process in time. In the design of the piers no difference has been made in the part of the piers which is situated under water and the part which is situated above water. It appears from the corrosion process that the submerged part has a much longer lifetime — about 200 years — than the part above water. This is a good point because under water repair on large scale is almost impossible. Above water on the other hand the necessity of repair of the cover after 80-100 years is not precluded and repair here is practicable. For the rest it can be noted that, even when the mild steel reinforcement has been lost, the barrier will have sufficient safety. The prestressing cables have got a larger concrete cover and therefore they will be attacked by corrosion in a later phase. However loss of cover will be a psychological limit state for many people, in each case for the administrator and maintenance will then be carried out.

4. Design (lit. 2)

4.1. General

At the beginning of the designstage in 1976 the assumption was that corrosion and thus durability depended to a great extent on the cracking of the concrete. Therefore the design aims at achieving a structure that will be as crack-free as possible. Besides

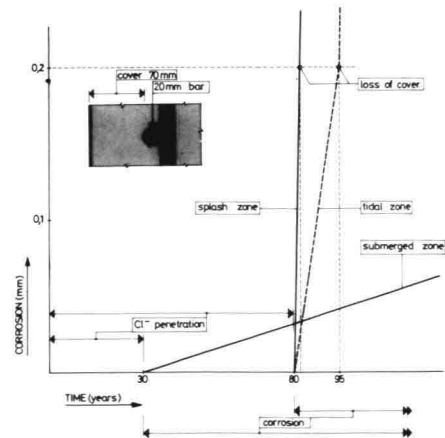

4
Semi probabilistic design method

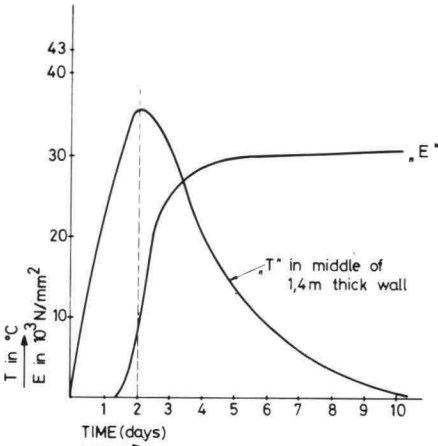
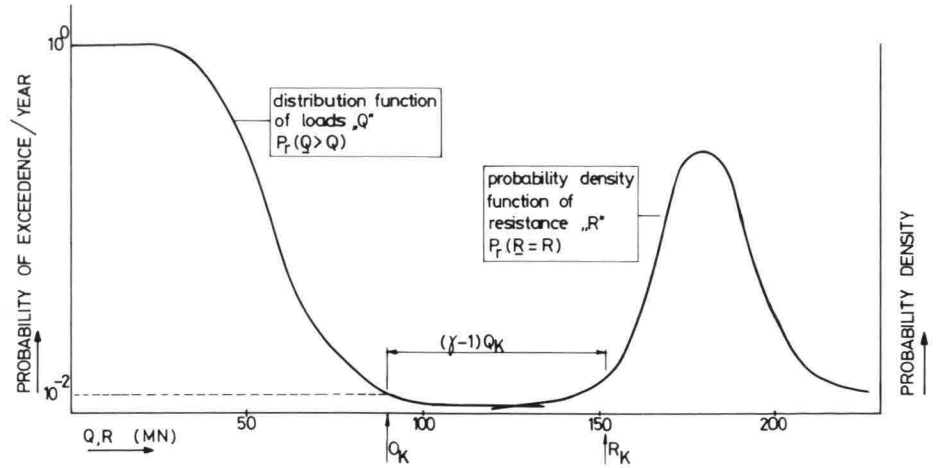

5
Development of:
— temperature 'T'
— modulus of elasticity 'E'

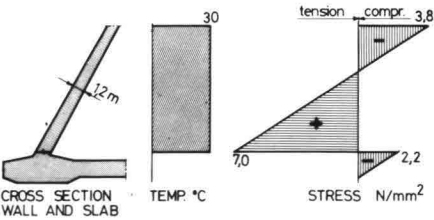

6a
Stresses due to hydration in wall and bottomslab (uncooled)

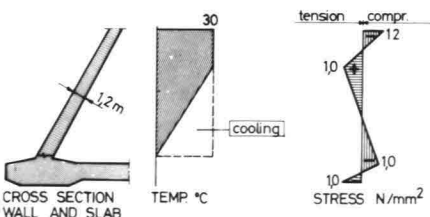

6b
Stresses due to hydration in wall and bottomslab (cooled)

other reasons, this was an important argument for choosing the prestressing method. At the same time a surface reinforcement is applied to limit cracking, which cannot be avoided completely.

4.2. Semi-probabilistic design method
The design is based on the semi-probabilistic method. Figure 4 shows the principle thereof. The one curve shows the probability density function of the strength 'R' of the material. The other curve gives the distribution function of the load 'Q'. The most important limit states on which the design is based are:
— the serviceability limit state;
— the ultimate limit state.
The requirements which arise from the serviceability limit state are in general governing. From figure 4 it can be seen that the probability of exceedance of the hydraulic loads applied to the serviceability state is 10^{-2} per year!

4.3. Prestressing
In the serviceability state under influence of dead load and hydraulic loads the following requirements are applied:
 $\sigma_b < 0$
 $\rho < 0,5 f_b$
 σ_b = bending tensile stress (concrete)
 ρ = principal tensile stress (concrete)
 f_b = design value of the tensile strength of concrete.

4.4. Reinforcement
It is an illusion to suppose that a concrete structure will remain uncracked, if tensile stresses due to serviceability loads are limited. Special influences as the hydration process, shrinkage and differences in temperature can be cause of tensile stresses which even exceed those

due to the serviceability loads! Later will be come back to these special influences. Reinforcement is applied now, to limit the cracking due to these special influences.

4.5. Cracking
In the design the crack width has been limited to:
< 0,4 mm for incidental cracks;
< 0,3 mm for permanent cracks;
< 0,15 mm for cracks at the place of the prestressing cables.

4.6. Special measures to limit cracking in the construction phase
4.6.1. Artificial cooling of concrete.
During the hydration process a considerable temperature rise occurs in the concrete, in thicker parts even up to about 40 °C. A major part of this temperature rise takes place in a phase in which concrete has practically no stiffness, while cooling takes place in a phase in which concrete has almost full stiffness (see figure 5). If now for instance a pier wall is poured on the pier slab, high tensile stresses develop in the wall after cooling, because the slab prevents the free deformation of the wall. Figure 6a shows that these stresses rise far above the tensile strength of concrete. For the piers these so-called hydration stresses are limited to the level of the tensile strength of the concrete obtained by artificial cooling of the concrete during approximately 4 days. Cooling is effected by a system of cooling-water ducts in the concrete, connected with cooling units. The cooling of the pier wall is shown in figure 6b. At the lower side of the wall the expected temperature rise is fully prevented by cooling, while at a height of 8 m there is no more cooling. Between these extremes there is a linear path. The average tensile stresses are now reduced from 7,0 to 1,0 N/mm². Figure

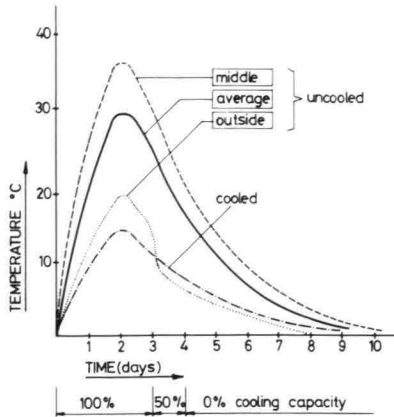

7
Development of temperature in wall 'cooled' and 'uncooled'

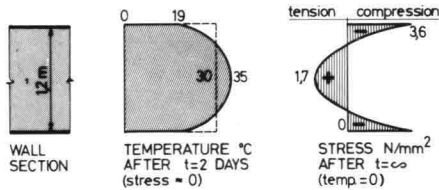

8
Temperature gradient and stresses in uncooled wall section

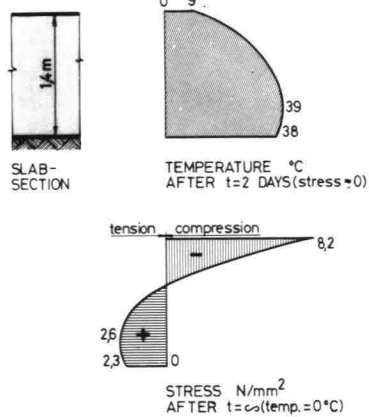

10
Development of temperature and stress in bottom slab (non-insulated)

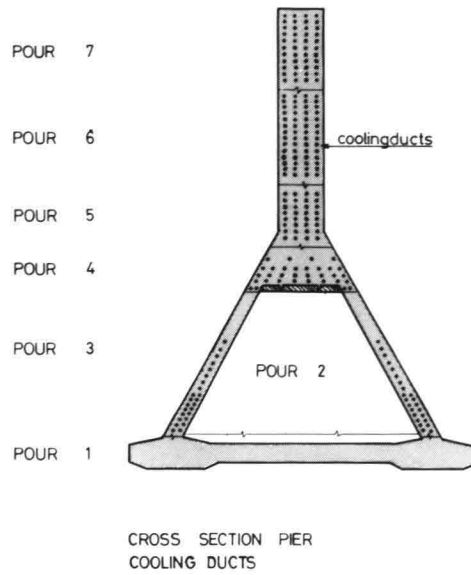

9
Artificial cooling concrete of piers

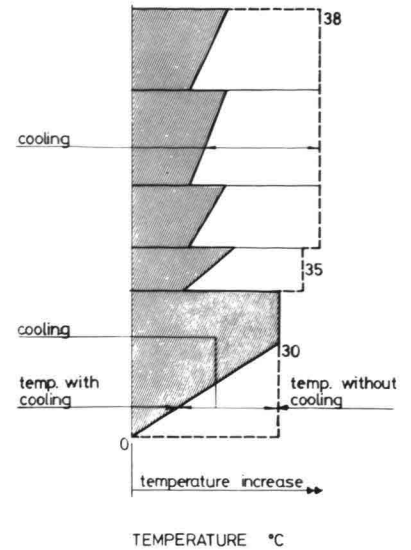

7 shows the development of the temperature in time for the non-cooled part of the wall and for a wall section, where half of the temperature rise has been cooled down. This artificial cooling is applied during approximately 3 days on full capacity and about 1 day on half the capacity. After approximately 4 days, depending on the outside temperature, cooling is stopped. It appears also from figure 7 that in the non-cooled wall section a temperature gradient develops due to faster cooling at the outside. The stresses belonging to this gradient are given in figure 8. Figure 9 gives an outline of the artificial cooling in the different pouring phases of the pier.

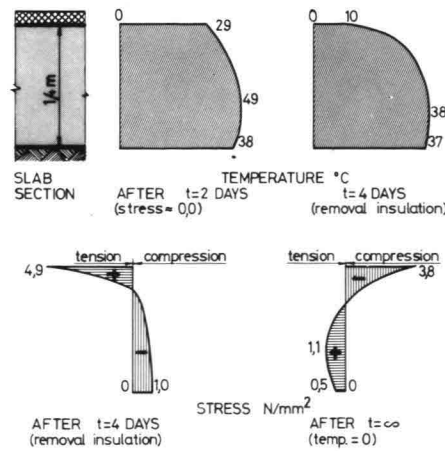

11
Development of temperature and stress in bottom slab (insulated)

4.6.2. Thermic insulation of the base slab of the pier.
In a non-insulated base slab the following phenomenon presents itself (see fig. 10).
In the lower part of the base slab an increase of temperature of about 39 °C occurs due to the hydration process. At the upper side this increase is limited to about 9 °C. Now a temperature gradient of about 30 °C arises. This gradient generates without stress during the first two days after pouring, because the concrete has almost no stiffness then (see figure 5). A later drop in temperature causes high tensile stresses at the bottom of the slab, through which risk of cracking occurs. Thermic insulation on the top of the slab during 4 days after pouring considerably depresses the gradient (see figure 11) and thus also the level of the tensile stresses. Temporary high tensile stresses occur after removal of the insulation.

12
Phases in horizontal prestressing of pier

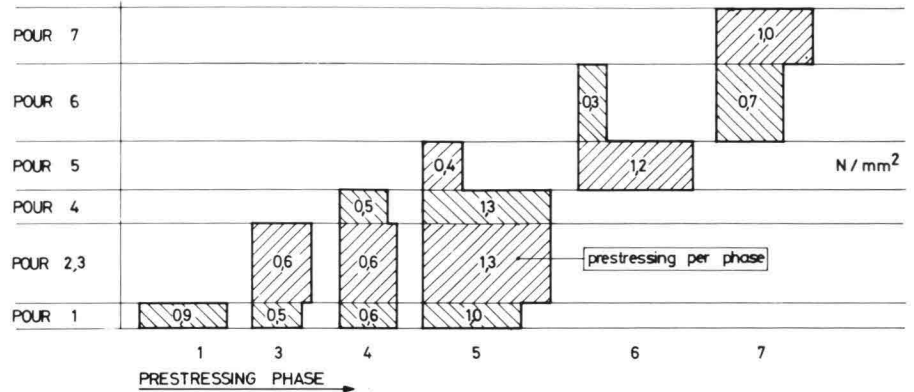
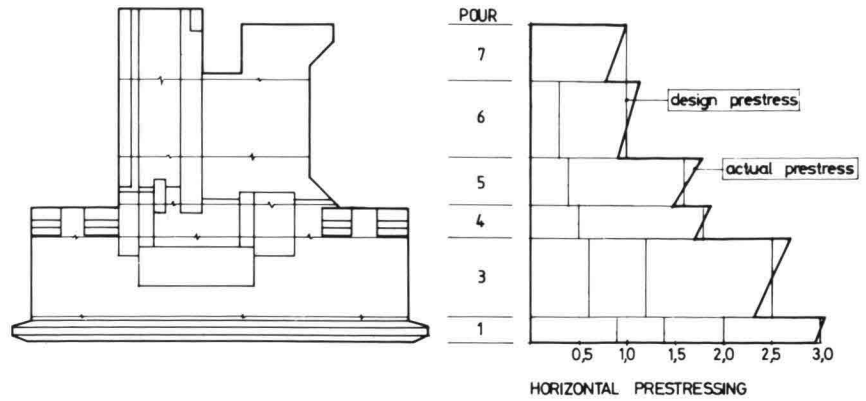

4.6.3. Shrinkage prestressing
An other measure which has been taken to prevent cracking is the so-called 'shrinkage prestressing'. The principle is to install a part of the total prestressing as soon as possible in each poured part of the structure. The advantage is that the acting tensile stresses, which arise in the course of time can be limited by the prestressing and so the risk of cracking can be depressed. Figure 12 shows an outline of the phases of the prestressing of the pier. The disadvantage of this measure is that it causes some problems in the organization of the implementation.

4.7. Durability in details

Up to now the most important design criteria with a view to durability have been dealt with. In practice it shows

up that damage cases in structures are frequently caused by insufficient detailing. This does not only apply to failure of structures but also to early maintenance. It will be shown in the following examples how durability has been taken care of in detailing, too.

The fill of the recesses for the anchorages of the prestressing cables (see fig. 13). The anchorages of the prestressing cables are finished with three layers of tar epoxy with a total thickness of 0.15 mm. The ends of the strands are provided with a plastic protection cap. The recesses are filled with spray concrete. Electric isolation of metal parts on the outside of the structure. If metal parts on the outside of the structure make electrical contact with the internal reinforcement,

13a
Grid-blasted tendon anchorage recess
13b
Filling the tendon anchorage recesses

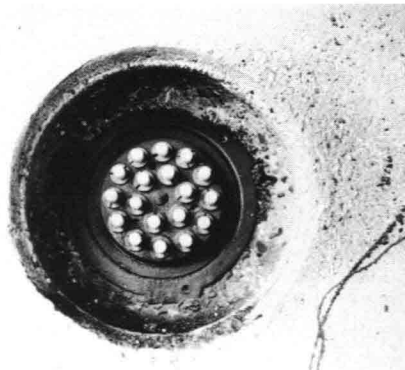

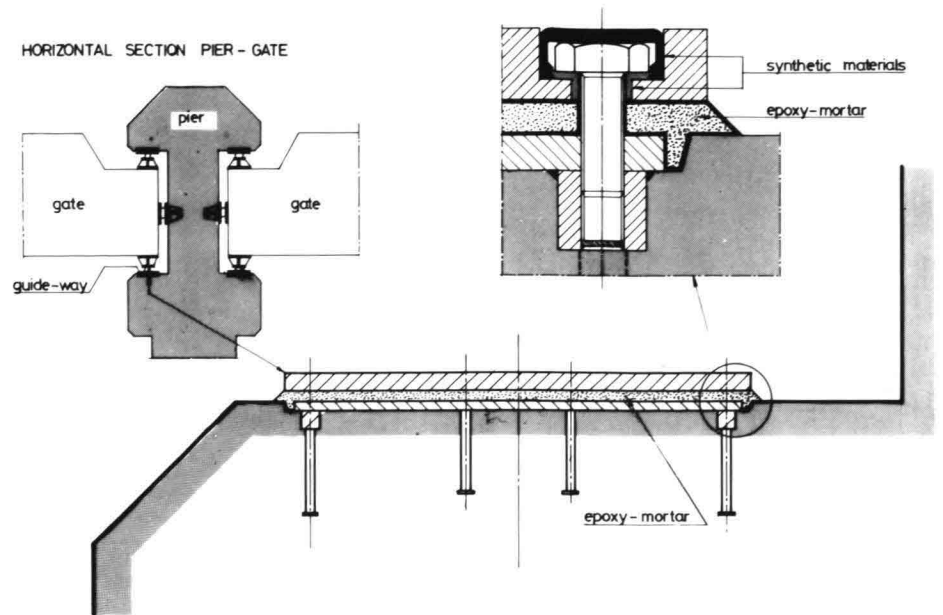

potential differences arise by which corrosion is initiated. In order to avoid this happenings metal parts on the outside of the structure and inserts are electrically isolated. Figure 14 shows an example for the guideway of the gate. The isolation has been established by means of grouting with an epoxy-mortar. The isolation of anchor bolts has been achieved by means of a plastic layer on the bolts. Figure 15 shows the control measurement of the electrical resistance of such an anchor bolt.

Literature

1. The lifetime of the Eastern Scheldt Barrier or An arithmetical approach of the corrosion process in reinforced concrete, by: J.G. Hageman
 2. *Cement* nr. 12, 1979
- Eastern Scheldt Storm Surge Barrier — Design criteria and design calculations for the concrete structure, by: F.F.M. de Graaf and H.H. van Schaik
- Probabilistic design method by H.H. van Schaik and D. Kooman

5. Quality control during execution

Up till now design criteria were discussed which are oriented towards getting a reliable and durable construction. However besides these theoretical assumptions, the quality of the execution is just as important. With a view to this requirement, a special staff division 'quality control' is incorporated into the organization. This division has at its disposal highly qualified personnel and a well utilized laboratory. Beside the normal control on pressure and split strength of the concrete, setting measure, water-cement ratio etc, critical details such as the filling of the centre-pen holes, the recesses of the anchorages of the prestressing cables a.s.o. are regularly controlled for permeability. Furthermore, the construction is inspected in detail for gravel nests and unacceptable cracking (> 0.15 mm). And so the staffdivision 'quality control' guarantees that the theoretical quality requirements are implemented in practice.



15
Control measurement electrical resistance anchor bolt

Design of gate structures

Gates

Introduction

As mentioned in other articles the barrier in the Eastern Scheldt is a composition of concrete, steel and stones. The apertures in the barrier are formed by the piers, the sill and the upper beam giving the desired effective flow opening of 14,000 m². The apertures can be closed by means of movable elements, the gates. Figure 1 illustrates the various members of the barrier. Because of the fact that the piers are placed 45 metres centre to centre, the span of a gate is 41.3 metres. The height of the gates varies from 5.9 metres to 11.9 metres since the top plane of the sill follows more or less the existing bottom line of the three gulleys of the Eastern Scheldt.

Requirements of the structure with regard to the strength

As mentioned above, the barrier must be capable of withstanding the forces and actions that have a probability of occurring 2.5×10^{-4} per year. Fixing these requirements in a deterministic way, this implies that the gates have to withstand forces resulting from:

Case I: water level sea side M.S.L. + 5.3 m;
water level land side M.S.L. - 1.7 m;
waves significant height 4.5 m;
period 12 seconds.

Case II: water level sea side M.S.L. - 1.5 m;
water level land side M.S.L. + 3.5 m.

In case I the maximum loading of the gate is approx. 140 kN/m². The effect of the waves can be illustrated in figure 3. Considering the wave height which has an occurrence of 2.5×10^{-4} per year and taking into account the rebound effect of the barrier the extreme wave height in front of the gates located at the deepest parts of the gulleys will be approx. 16 metres. Since the periods when the Eastern Scheldt is completely closed will be

as short as possible this implies that during the closing and the opening of the apertures, heavy loads will act on the gates.

The maximum load exerted on the gate at the end stage of the closing process will be as illustrated in figure 4. As can be noticed this is a heavily alternating loading with maximum values of approx. 80 kN/m². During the movement of the gate the loading will be as given in figure 5. The value at the beginning of the closing process may be approx. 30 kN/m². This loading acts on the lower part of the gates.

A load reduction is obtained when the loading cases are considered according to a probabilistic method. The method takes into account the possible coincidence of various occurrences such as:

- storm surge level;
- wave energy;
- water in Eastern Scheldt basin, etc.

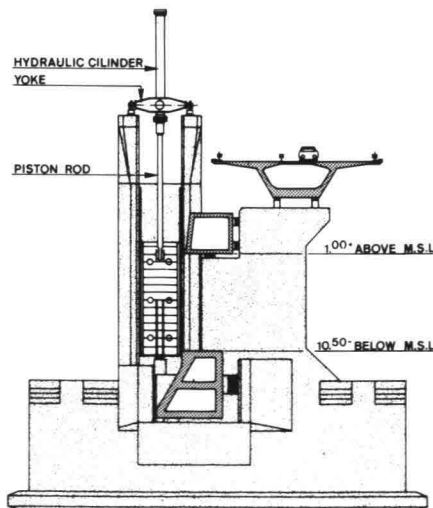

1
Cross section gate and concrete girders

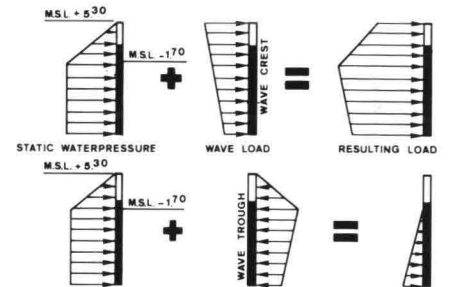

NORTH SEA LEVEL HIGHER THAN EASTERN SCHELDT LEVEL

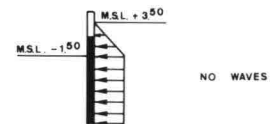

NORTH SEA LEVEL LOWER THAN EASTERN SCHELDT LEVEL

2 Loading of the gate in closed position

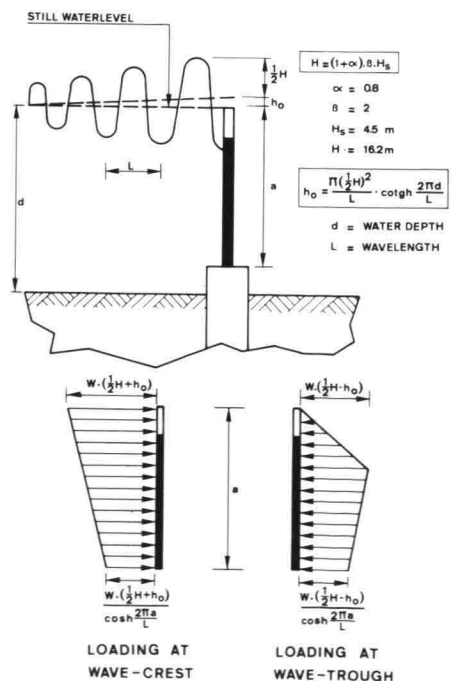

3
Wave loading of the gate

It has been found that the extreme loadings that have an occurrence of 2.5×10^{-4} per year are approx. 75% -80% of the loadings determined according to the deterministic method. In determining the probability of occurrences it is accepted that the operator of the barrier shall have every freedom in any operating activities regarding the gates. This requirement makes of course a heavy demand on the load-carrying capacity of the structures.

The design life of the barrier has been set at 200 years. In this period a certain amount of damage in the steel gates is accepted as it can be repaired. For the determination of the ultimate strength of the steel gates the following factors are taken into account:

material factor $\gamma_m = 1.05$

loading factor $\gamma_1 = 1.00$

calculation factor $\gamma_e = 1.10$

The material factor takes into account:

the difference in strength of the material in the completed construction and the test pieces.

The calculation factor takes into account:

- the inaccuracy in the schematisation of the construction with regard to the calculations;
- the inaccuracy in the calculation methods;
- the deviations in the completed construction.

The requirement of the gate design with regard to the building tolerances

Since the barrier is to be built in the open sea, consideration must be given to the tolerances in the dimensioning of the total construction.

The tolerances stem from:

- unevenness of the foundation bed;
- elevation of the foundation bed;
- placing tolerance of piers, a.s.o.

Furthermore consideration must be given to:

- unequal running of the ends of the gates during closing and opening procedures;
- settlement effects of the piers, sills etc. due to loading effects of the barrage, a.s.o.

In view of these tolerances, it has to be considered that the span of a gate varies between $41.3 \text{ m} + 0.55 \text{ m} > L > 41.3 \text{ m} - 0.55 \text{ m}$.

Furthermore each gate must be a torsional weak construction, as the rotation difference of two adjacent piers with regard to the axis of the barrier

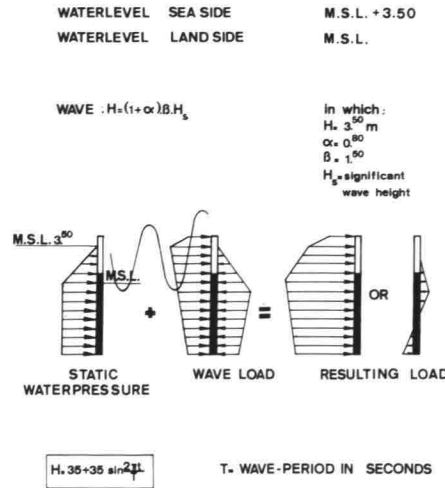

4 Loading of the gate at moment of closing

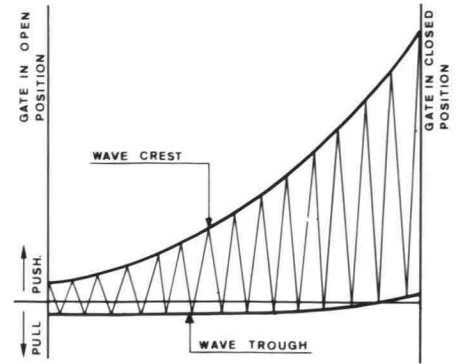

5 Forces required for closing the gate

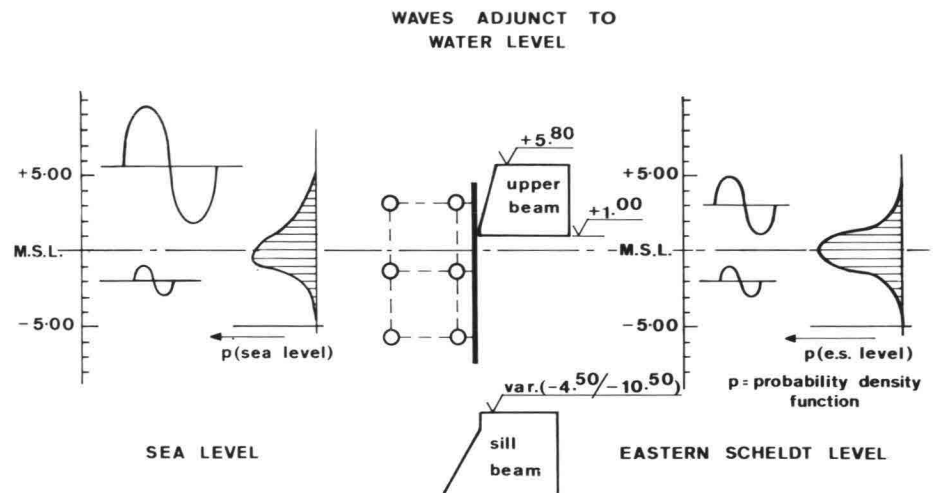

6 Natural conditions

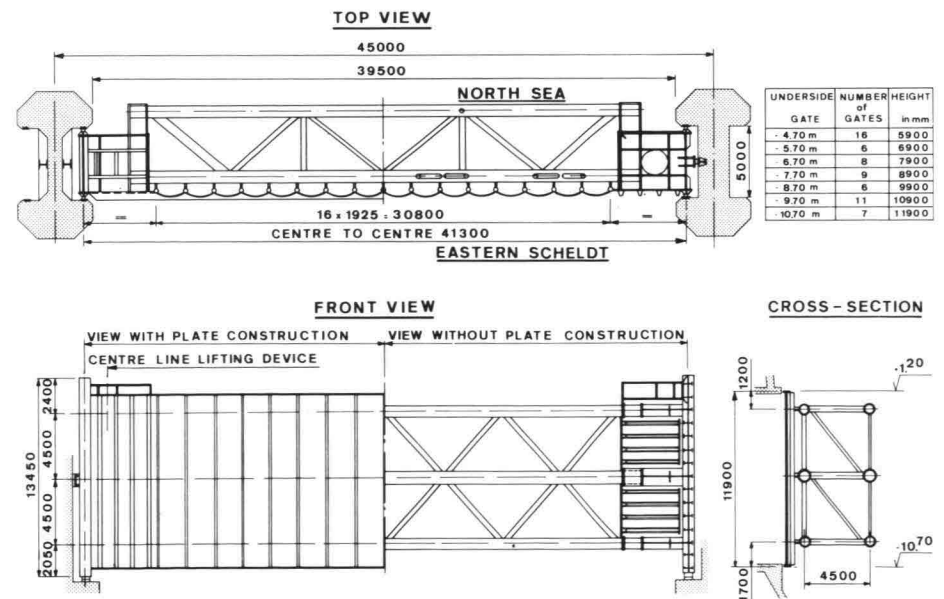

7 Construction of gates

can be 1 cm in 1 metre. To overcome the rotation effects of a pier along its longitudinal axis, the width of the rubbing faces in the piers must be determined in accordance with the tolerances.

Description of the steel structure

There are in total 63 gates in the barrier varying in height from 5.9 metres to 11.9 metres. The variation is in steps of 1 metre. The steel weights vary between 300 and 500 tons.

The gates are composed of the following parts:

- a vertical plate construction;
- a main girder system;
- a vertical girder system.

For the vertical plate construction cylindrical segments were chosen that are located at the Eastern Scheldt side. Within the segments the stresses are primarily tensile, but in the case where the water level of the Eastern Scheldt is higher than that of the North Sea the occurring compressive stresses are permissible. The loads are transmitted to the main supporting system via the vertical beams.

The advantages of cylindrical segments compared to flat plate constructions are:

- no stiffening of the plates is required;
- large openings exist between the segments and the main girders.

The latter advantage makes it possible for water to flow in the vertical direction through the gates, resulting in a damping effect on gate oscillations and a reducing effect on the underpressure. The main support system is composed of 2 or 3 horizontal truss type girders, depending on the gate height. The truss members are tubes, hence they are less sensitive to wave impact effects. The main girders are coupled by vertical bracing and supporting

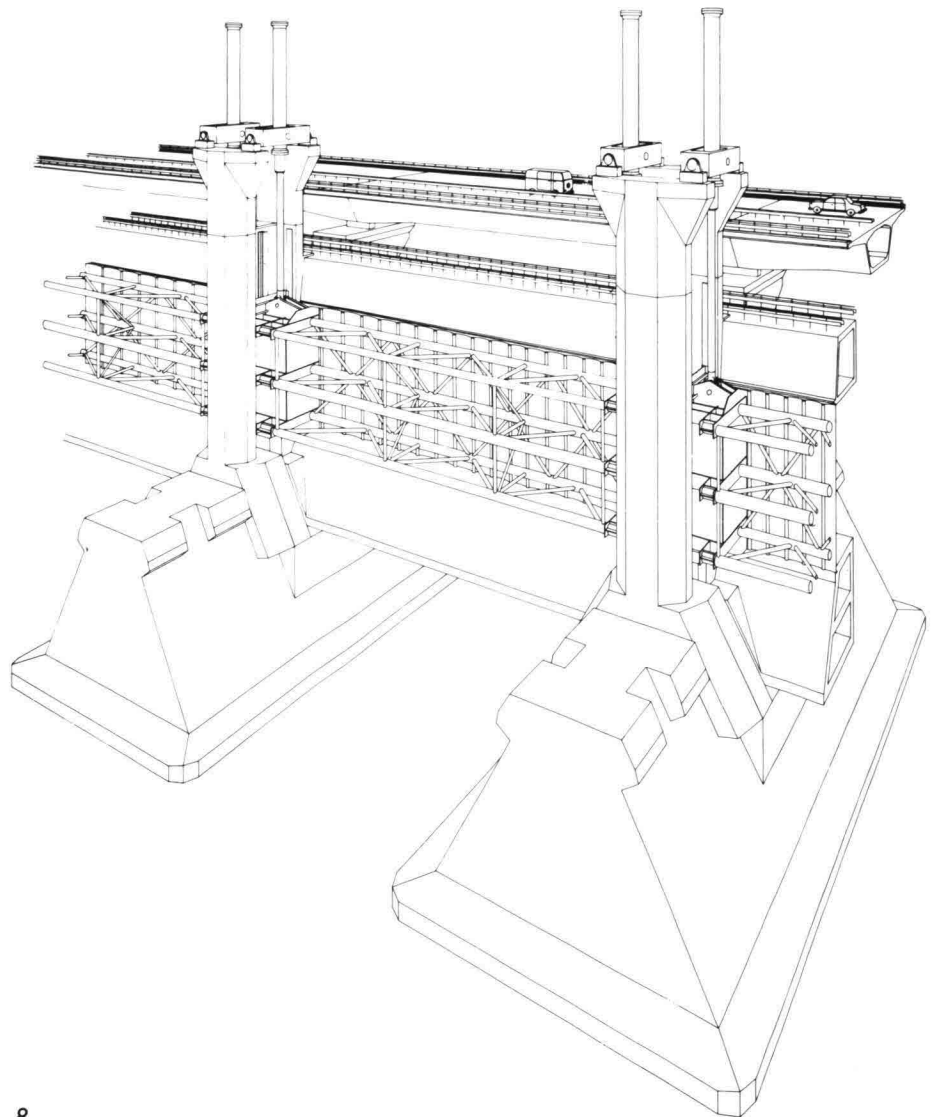

8
View of gates

members. The positioning of the vertical members of the gate construction is such that the torsional rigidity of the gate is as low as possible and acceptable. The horizontal forces acting on the gates are transmitted to the piers by vertical end beams located in the recesses of the piers. Given the fact that the gates are designed as slide gates, special 'low friction' material will be mounted throughout the entire height of the end beams to keep the forces, necessary to open and close the gate, as low as possible. In order to prevent oscillation during gate movement (stick-slip), the difference between the static and dynamic coefficient of friction must moreover be as small as possible.

The gates will be positioned in the recesses of the piers in such a way that horizontal movements of the end beams in relation to the piers is reduced to a minimum.

SECTION PIER NEAR GATE

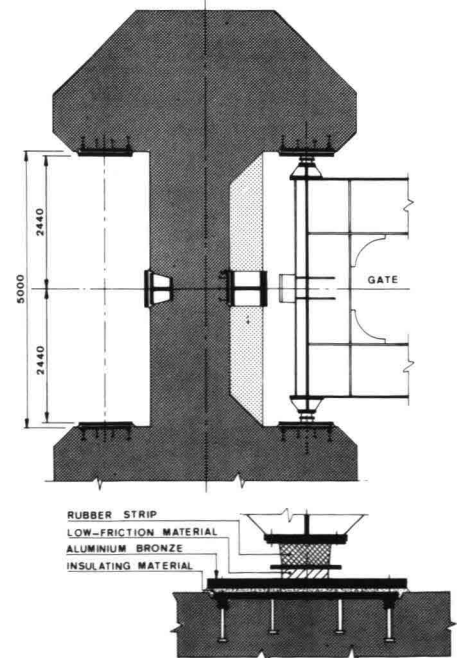

9
Rubbing faces in the piers

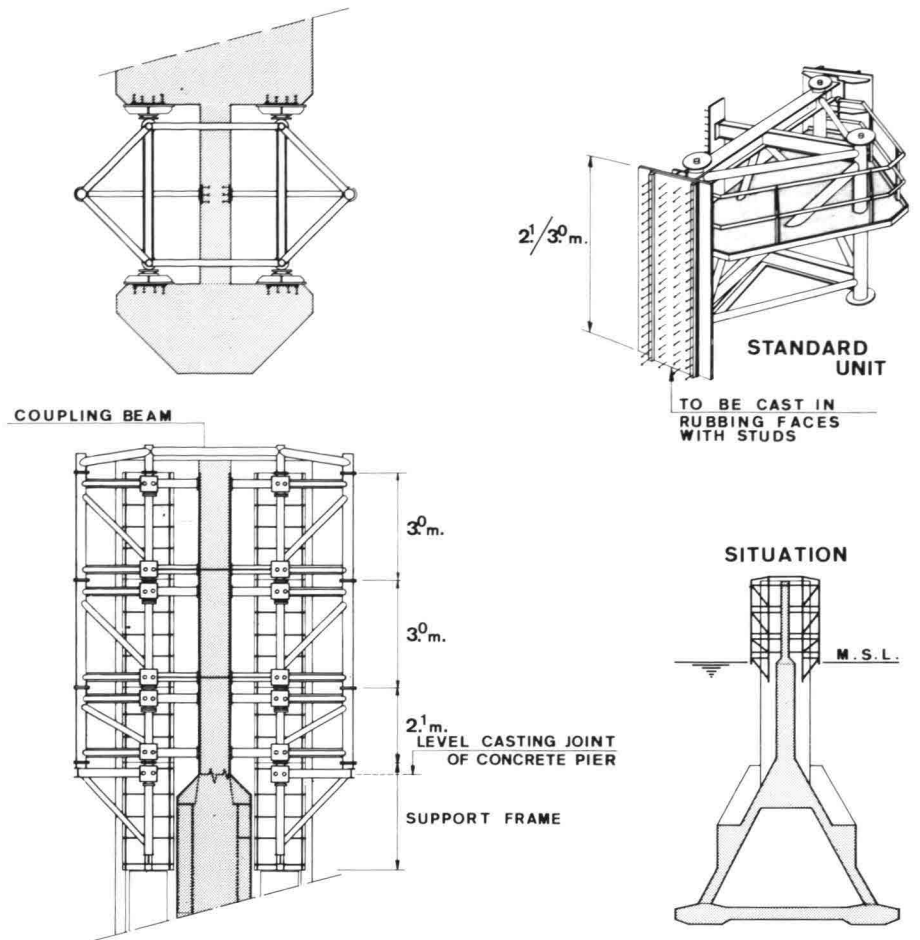

This precaution is essential since the wave loadings are very large as compared to the static loadings. The reduction will be obtained by creating sufficient high prestressing forces in the rubber strips at both sides of the end beam.

Great care must be given to the correct positioning of the rubbing faces in the piers. For that purpose adjusting frames are employed as are shown in figure 10.

Figure 11 gives an impression of the completed rubbing faces. Between the rubbing face plates and the concrete of the piers an epoxy-resin consisting of two components was used. A difficulty in this application is the effect of the vertical height of the rubbing faces being 10 metres – 24 metres, especially with regard to the mixing and pumping of the epoxy-resin.

The positioning of the vertical plate construction

In the over-all design of the barrier concrete upper beams above mean sea level have been adopted, giving a reduction in the total surface of the steel plates. Without upper beams this surface would be 35,000 m², whilst with the use of the beams the total surface is 22,500 m², giving a reduction of more than 50% with regard to the last figure.

Location of the upper beams at the seaward side of the gates as shown in figure 13 has the disadvantage of heavy wave impacts against the underside of the beam when the water level is in the neighbourhood of M.S.L. + 1.0 m. These impact forces can be as high as 200 - 300 kN/m², which means that the dead weight of the beams is insufficient to withstand the up-lift forces. Secondly, during closure of the gates unfavourable flow effects will be imparted to the

10
Adjusting frame for positioning rubbing faces

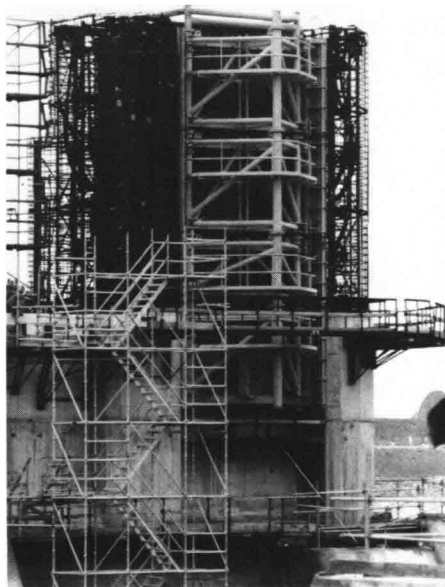

11
Adjusting frame (construction phase)

gates resulting in heavy vibrations, a.s.o. Thirdly, the sides of the piers protrude to the seaward side with regard to the vertical plate of the

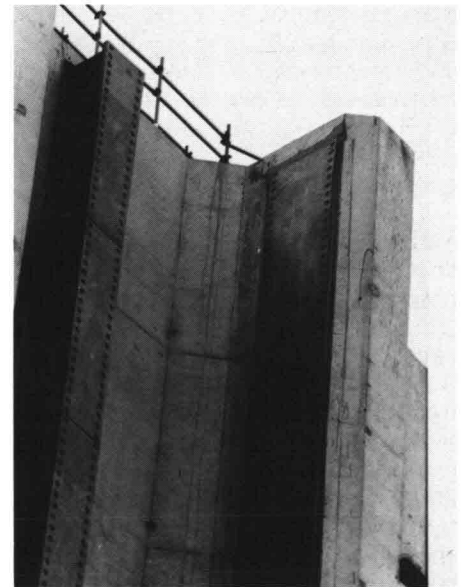

12
Alu-bronze rubbing faces mounted on the pier

gates which will result in heavy wave impacts in the corners formed by the side of the piers and the vertical plate of the gate. For these reasons

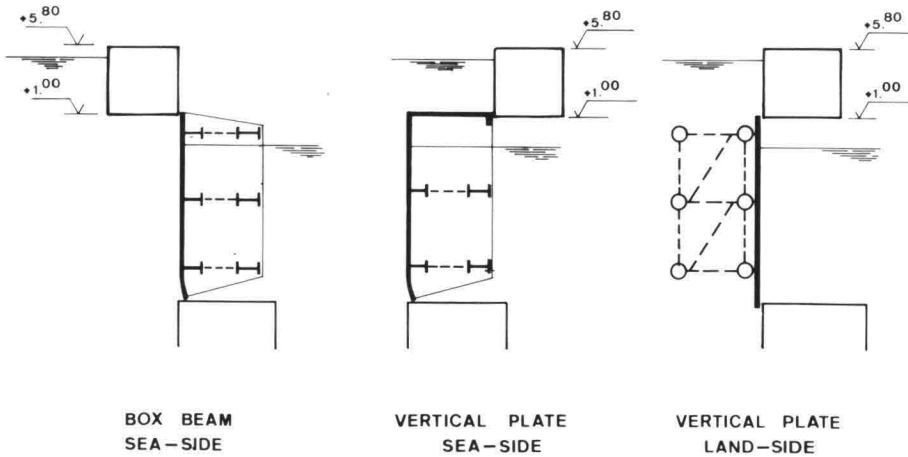

13 Positioning of the vertical plate construction

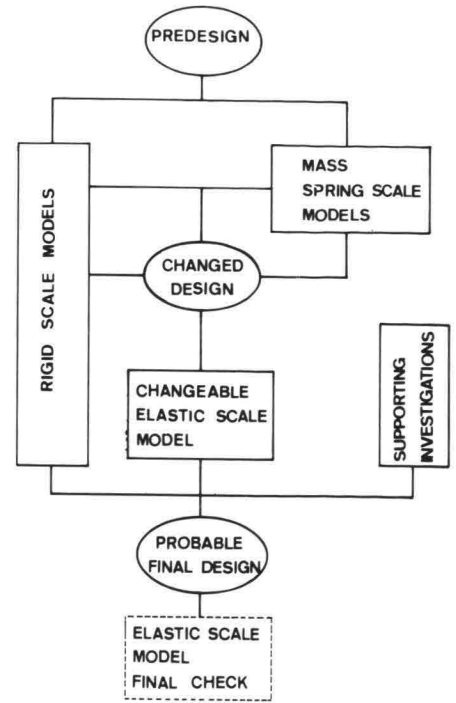

14 Scheme of hydraulic model investigations

the location of the upper beam on the seaward side of the gate is unacceptable. With regards to the location of the vertical plate on the seaward side, the following remarks apply: *firstly*, the force required for the lifting of the gate is increased by the dead weight of the water volume above the gate; *secondly*, unfavourable forces will act on the web of the top beam of the gate due to wave impacts a.s.o.; *thirdly*, during the closing of the gates vibration problems will arise with regard to the lowest main girder and the total gate construction. The latter as a result of the unfavourable ratio of height to thickness of the gate, this being approximately 1 to 1 for the lower gates and 1 to 3 for the higher gates. For these reasons the location of the vertical plate on the seaward side is unacceptable. Therefore the location of the plate construction at the Eastern Scheldt side must be accepted.

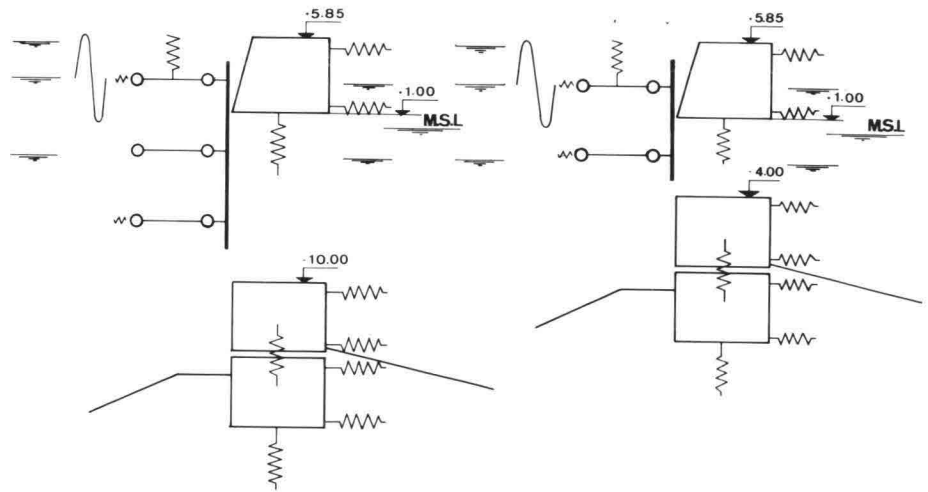

15 Investigated sections with elastic beam and gate supports

Vibration effects and wave impact
In the design period of the barrier great attention is being given to the possible vibration- and wave impact effects. In general, it can be said that the greatest attention will be given to a design by close co-operation between designer and researcher. Each one has his own expert knowledge; together they can cover more than the simple sum of this individual knowledge. In figure 14 an impression is conveyed of the general scheme of the research with regard to vibrations.

- The rigid model provides the possibility of measuring the loads acting on the gate
- The spring scale model indicates the response of the construction
- Minor changes had to be made to the pre-design.

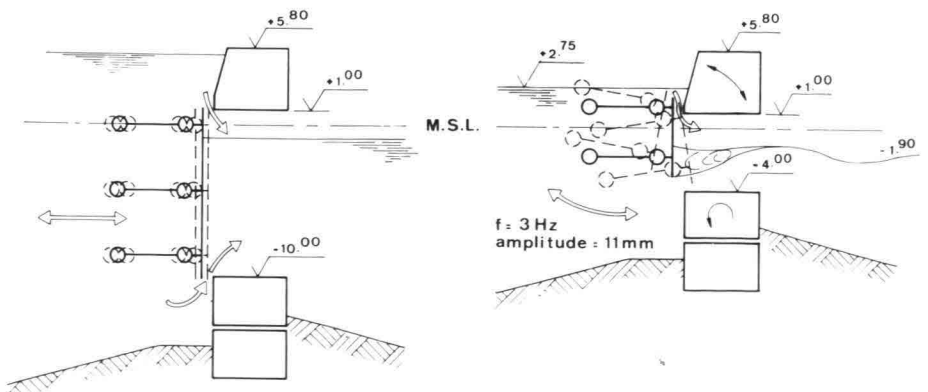

16 Vibrations due to gap flow at lowered gate and to gap flow at partially raised gate

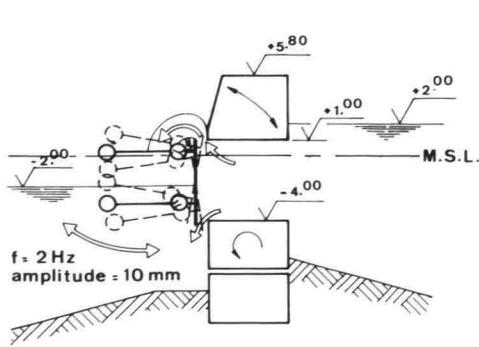

17
Vibrations due to nappe phenomena and fluid oscillations

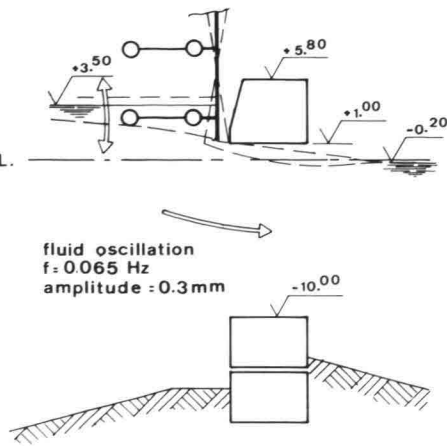

18
Nose construction upper beam for suppressing vibrations

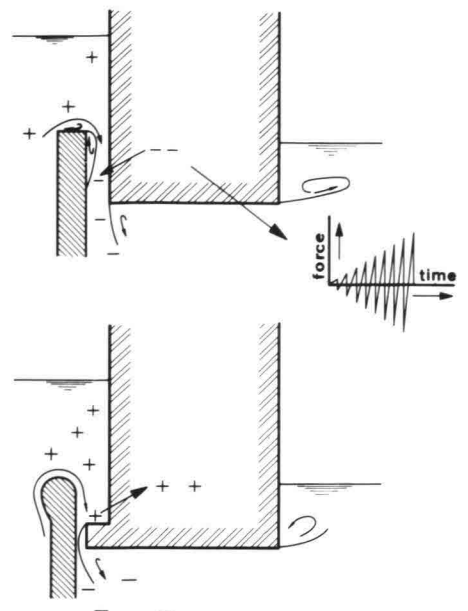

- After that, more detailed information was obtained by using an elastic scale model.
- The final check was made testing the elastic scale model made in accordance with the final design of the gate.

During the testing period a constant exchange took place between designer and researcher in order to obtain the most acceptable design. As can be seen in figure 15 the barrier consists of a number of elastic beams affecting the vibration behaviour of the gate.

Figure 16 gives an illustration of the vibrations due to gap flow at lowered position of the gate and partially raised gate. Figure 17 illustrates the vibration due to nappe phenomena; this can occur when the water level in the Eastern Scheldt is higher than sea level, at a lowered gate position. Also shown in this figure is the possible fluid oscillation at fully raised gate position.

The effect of adopting a so called nose construction to the concrete upper beam is illustrated in figure 18. At the bottom side of the gate the shape of the cylindrical segments against the straight face of the sill construction yielded a positive effect in suppressing the magnitude of the vibrating amplitudes of the lower members of the gate.

Another investigation is the study of the effects of wave impact. Figure 19 shows the calculation procedure of the wave impact on the gate members. The maximum effect of the wave impact occurs when horizontal members of the gate are in the neighbourhood of the mean water level, more precisely within an area

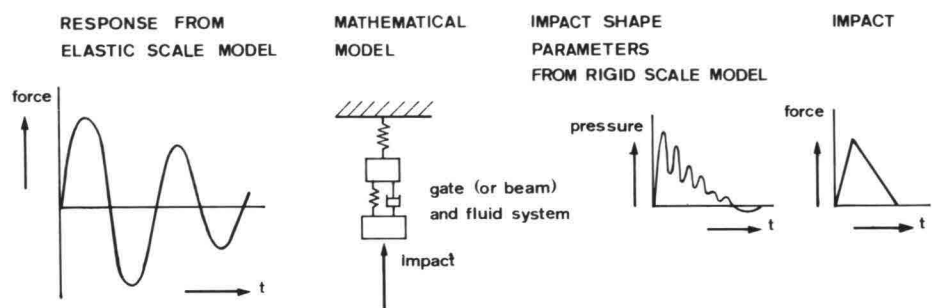

19
Calculation of wave impact

of between plus 50 cms and minus 50 cms of that water level. In the raised position of the gates this occurs when the water level is in the neighbourhood of M.S.L. + 3.0 m. The other possible occurrence of wave impact is during the lowering or raising procedure of the gate, see figure 20.

As mentioned above, heavy wave impact on gate members will occur when these members are in the area of between plus 50 cms and minus 50 cms of the water level. Since the lowering or raising speed of a gate is approximately 3 mm per second, this implies that the member of a gate is in this area for approximately 5 minutes. At lowered position the members of the gate will not receive heavy impact forces, since they are deep below the mean water level. Figure 21 gives an impression of the wave impact on horizontal members of the gate. The pressures caused by wave impact against horizontal members of plate constructions may be as high as 280 kN/m², whilst these pressures against tubular members may be 85 kN/m².

Other investigations

A number of studies and investigations were required for the design of the gates. Next to the investigations regarding the vibration problems and the effects resulting from wave impact, the following studies and investigations were carried out among others:

- the determination of the friction coefficient when various material combinations for the rubbing faces in the piers and the sliding surfaces of the gates are adopted;
- the effect of marine growth to the friction coefficient and the wear of the surfaces;
- the stickslip effect to the oscillations of the gates;
- the response of the gate structures to wave loads etc.;
- the stress and strain concentrations in the tubular connections.

Fatigue and inspection

Since the gates are above water level under normal conditions, inspection of the various members of the gate is possible. The access to the members will be made by using a special inspection car. This car will run over the bridges of the barrier and carries an inspection platform. The platform can be brought to the required posi-

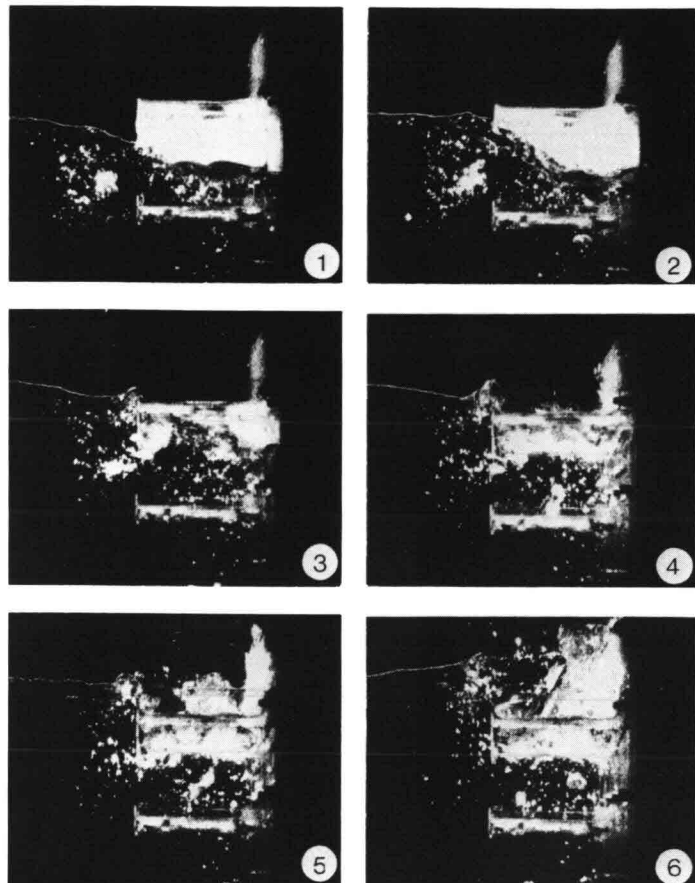
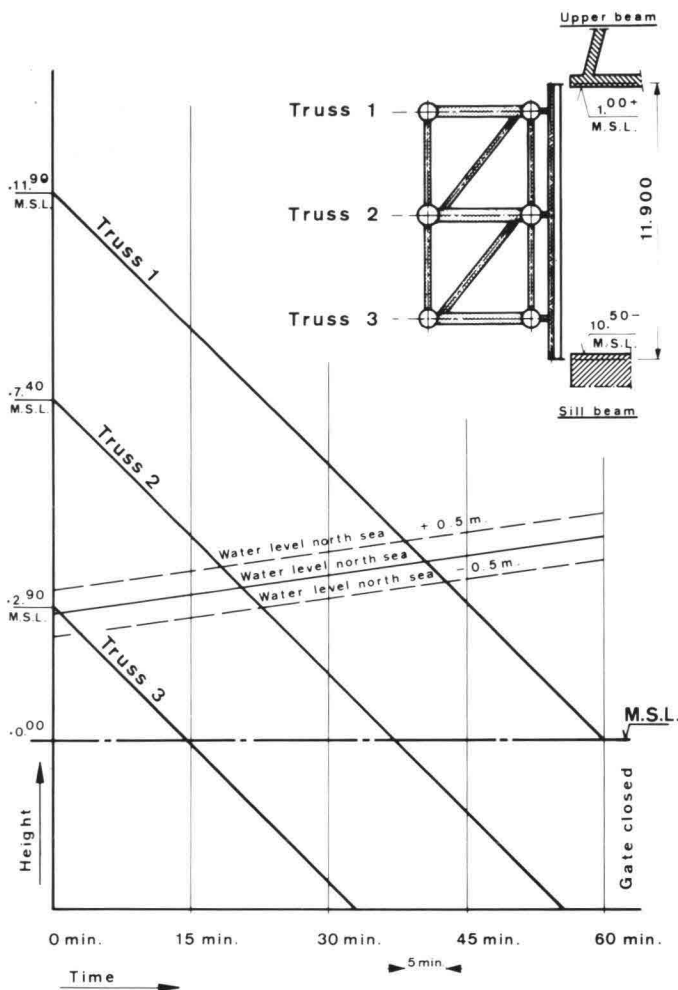

20
Position trusses during enclosure gate

tion with the use of a number of hydraulic operated lever-arms. The effects of the wave loads are cyclic with periods of 6 to 10 seconds, resulting in approximately 15,000 load cycles during a 24-hours storm.

In the design philosophy it is accepted that during the lifetime of a gate cracks may occur in the most heavily loaded tubular connections. From tests it has been found that the ratio between the number of cycles after which the crack has completely gone through the wall of the tube and the number of cycles required for the first visible cracks to appear is greater than 1.5. For the most heavily loaded gate, this being the gate in the centre of the Roompot gulley, this implies that approximately 10 heavy storms are required after occurrence of the first crack before complete failure of the tubular connection is reached.

In order to detect the cracks at an early stage the principle has been

adopted as an inspection policy that after each heavy storm in which the gates were closed, the most heavily loaded members would be inspected. In doing so it will be possible to repair the crack in its initial stage. From fatigue tests on repaired tubular joints it has been shown that the fatigue strength is equal or even better than the fatigue strength of the original specimen.

Construction, assembly and placing of the gates

In total 63 gates have to be manufactured and placed in the storm surge barrier. In order to obtain a kind of quantity production the gates have been split up in members that are more or less identical to each other. Figure 23 gives an impression of this splitting up. The major members are:

- the horizontal tubular trusses;
- the vertical tube members;
- the cylindrical segments;
- the end wall constructions.

Since the manufacture of the various items will be started before the piers are placed in their final position, certain precautions are being taken in order to overcome the consequences

21
Wave impact on horizontal girder

of placing tolerances etc. These precautions are:

- the horizontal tubular trusses have an excess length of 850 mm's;
- the vertical plates connecting the cylindrical segments to the end walls have an excess length of 850 mm's.

The assembly of the gates will be effected in the sequence in which they have to be placed. The effects of the tolerances in the positioning of the piers will be taken into account during the assembly of the gates. The placing of the gates will be carried out with the floating derrick that is also used for placing the bridge girders, the upper beams a.s.o. of the barrier.

In order to place the gates in the recesses of the piers in which they are more or less in a prestressed position, funnel type temporary constructions will be placed on top of the piers. The bottom sides of the gate will be placed in these funnels and by being lowered the gates will slide in between the rubbing faces of the piers.

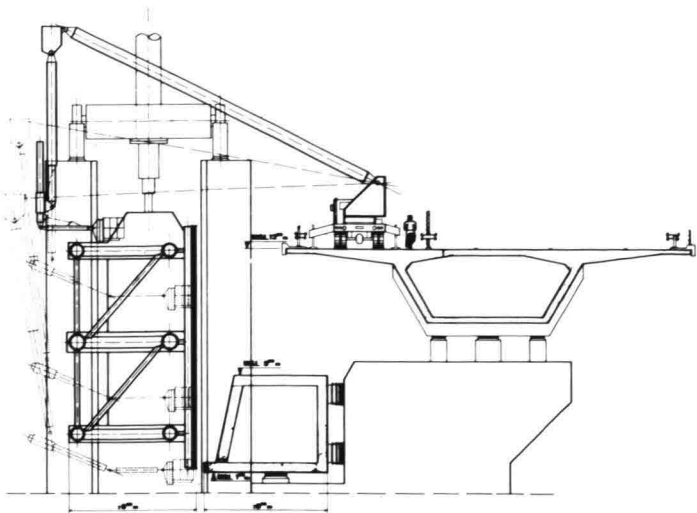

22
Inspection car

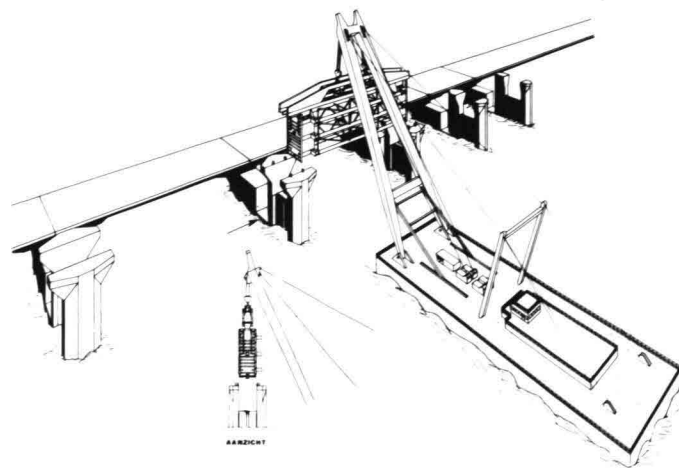

24
Placing gate with floating derrick

23
Exploded view of gate

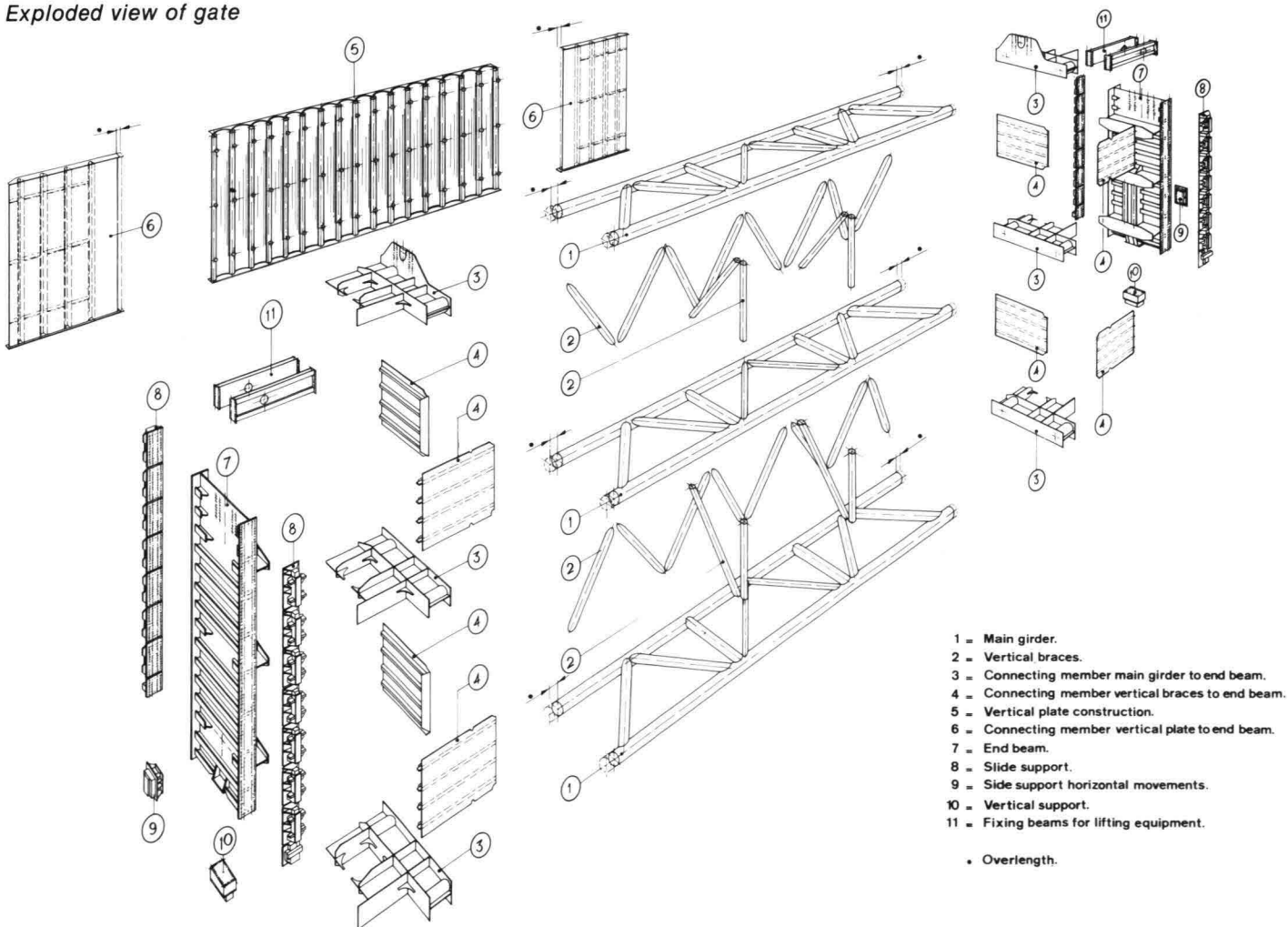

Design of gate structures

Operating machinery for the gates in the barrier

1. Choice of the type of machinery for the storm surge barrier.

The choice of the type of operating mechanisms for gates in barriers depends highly on the type of gates to be operated and the forces to be exerted. We knew from experience that hydraulic cylinders offer the cheapest solution when big forces and low velocities are to be achieved. Nevertheless, considering the importance of this project it was worthwhile examining all possibilities for the construction of the operating machinery. Moreover, the shape of the barrier and the dimensions of the gates had been changed significantly during the design process, resulting in ever growing forces and dimensions of the machineries, especially as far as the stroke was concerned.

At last the gate dimensions were fixed, and it became clear that the gates should be driven from both extremities, resulting in two operating machineries for each gate. All gates have the same length of approx. 41.3 m, whereas the height ranges from 5.9 to 11.9 m in 7 steps, depending on the location of the gates in the barrier. In principle the stroke of the machinery is equal to the gate height, but in order to facilitate maintenance of the gates, it was decided to increase the stroke of the machinery by approx. 1.3 m, resulting in a total stroke of the machinery ranging from 7.2 to 13.2 m.

The question arises whether a hydraulic cylinder with a stroke of approx. 13 meters is still a good solution for a gate-operating machinery. Hence an alternative type of machinery was developed as well and we ended up with 2 types of machineries:

- a dual action hydraulic cylinder;
- a toothed rack, driven by a number of pinions operated in parallel.

Incidentally the latter type of machinery is used as a jack-up system for off-shore platforms. However, the demand for a reasonable lifetime of the system did not allow for rough constructions. So this type should also be highly sophisticated. Complete preliminary designs were made for both machineries and they were thoroughly evaluated regarding a series of aspects:

- design qualification;
- reliability / possibilities for monitoring;
- lifetime and maintenance;
- fabrication;
- costs and planning (complete offers were made);
- aesthetics.

In what could be called, to some extent, a neck-to-neck race, the hydraulic type of machinery was finally chosen (fig. 1). Decisive aspects were possibilities of monitoring, costs and aesthetics. The other aspects got more or less a comparable qualification.

2. Operating requirements for the machinery

In a policy analysis study for the storm surge barrier called BARCON (for 'barrier control') operation strategies (i.e. rules for closing and opening the barrier) were developed

1
The Eastern Scheldt gates

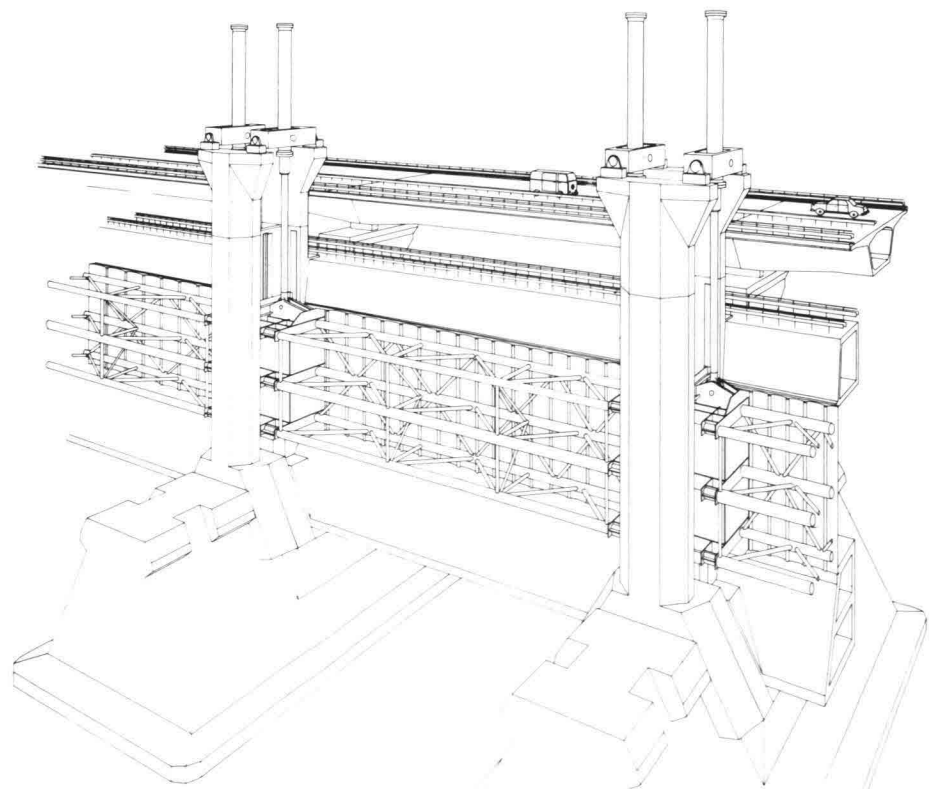

2
Comparison of two extreme closing strategies

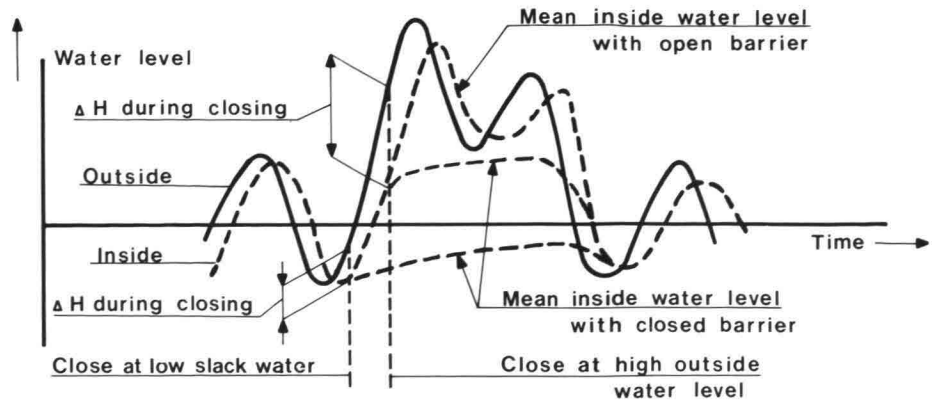

and their effects on the Eastern Scheldt basin (safety, ecology, water-management, shipping) analysed. Barcon studies revealed a.o. that the forces to be exerted by the machinery of the gates are largely influenced by the operation strategy chosen. This can be made clear in fig. 2 where two extreme closing strategies are represented for the same storm surge outside water levels.

If the barrier is closed at low slack water the head difference over the gates and hence the loading on the operating machinery during closing is low. On the other hand high loading on the machinery is to be expected if a relatively late moment of closing is chosen. From the very beginning it was decided that the choice of the moment of closing should be completely free.

A probabilistic approach was used to determine the resulting maximum head difference over the gates during closing with an excess frequency of 1/4000 per year taking into account at the same time a relatively high outside water level. The calculated head difference is 4.2 m and the corresponding wave loading with the same excess frequency is based upon a significant wave height of 3.7 m and a period of 5.7 sec. In all this it was assumed that the gates, once they started to close, would be closed without any interruption. In that case, the tallest gates need about one hour and the smallest about half an hour for the complete closing operation, the gate velocity being approx. 3 mm/sec.

Figure 3 indicates that entirely different closing strategies might be possible. They are called reductor strategies, since the barrier is not completely closed, thus working as a reductor. Their application is still subject of the BARCON-study.

The design of the machinery is based upon strait-on closing strategies. Reductor strategies and also the opening operation will be restricted by the capabilities of the machinery. In the opening sense a total equivalent head of 2.5 m is allowable. In actual practice these restrictions will probably not exert a major influence on the complete freedom of operation.

For the design of the machinery the following main forces are to be taken into account:

- head difference over the gates and horizontal wave loading in combination with the friction coefficient of the gate slides on the rubbing faces in the pier recesses;
- flow forces over and under the gate;
- vertical wave loading;
- prestressing of the gate slides between the rubbing faces in the pier recesses;
- (apparent) gate weight.

Head difference and wave heights are known from the probabilistic studies. Their effect in the form of flow forces and wave loading were determined by extensive tests in the hydraulic laboratory.

The friction coefficient was determined in an investigation which took the combination of the material of slides and rubbing faces into account (Hakorit L:L and aluminium bronze respectively). This investigation revealed that a static friction coefficient in the order of 0.4 is an upper limit and that after some years of operation a dynamic friction coefficient of 0.2 is to be expected. Such a difference between static and dynamic friction coefficient causes a stick-slip behaviour of the gate during movements which influences the hydraulic cylinders. This influence has been the subject of a dynamic analysis of the complete hydraulic system.

Because the gates are prestressed between the rubbing faces, the machinery has to overcome friction forces for each movement, even in the absence of any horizontal load. When the gates are partly submerged during the closing operation they are subjected to the alternating vertical wave forces and the machinery must be able to keep the gate tight in that situation. In the lowered position the gates have to be pressed on their seats. In the opening sense only pulling forces have to be exerted by the machinery.

3. Description of the actual design

In the actual design the gate operating mechanism comprises three main parts:

- 2 double acting hydraulic cylinders
 - one at each extremity of the gate — which are connected to the gate with a spherical bearing and to the piers via a complete cardan ring;
- 2 electrically driven and controlled pump sets — one for each hydraulic cylinder — which are housed in the interior of the box girder bridge;

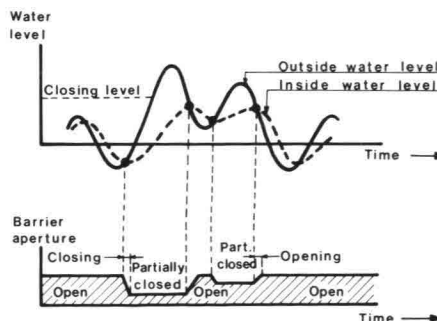

3
Reductor strategy

Table 1

| | smallest cylinder | biggest cylinder |
|----------------------------------|-------------------|-------------------|
| stroke | 5,900 + 1,300 mm | 11,900 + 1,300 mm |
| inside cylinder diameter | 635 mm | 830 mm |
| minimum wall thickness | 62.5 mm | 75 mm |
| piston rod diameter | 390 mm | 520 mm |
| total length when gate is closed | 20,575 mm | 33,290 mm |
| total mass of cylinder | 41,890 kg | 91,675 kg |

— piping between pump sets and hydraulic cylinders.

In order to get the gates moving, there is also an electrical installation subdivided into three parts as well:

- power generation- and distribution system;
- control system;
- monitoring system.

This installation will not be described in detail here, but it is just mentioned because of its close relationship with the operating mechanism.

The hydraulic cylinders.

As mentioned before, the hydraulic cylinders and appurtenant mechanical parts have various dimensions according to the location in the barrier (see table 1).

The cylinders are designed for a max. internal working pressure of 220 bar and a testing pressure of 270 bar.

A hydraulic cylinder is mainly composed of:

- cylinder cover with connections to the hydraulic system;
- cylindrical part with bearing block for the connection to the cardan ring;
- piston rod with piston, carrying lining and sealings;
- cylinder bottom with sealings lining and connections to the hydraulic system;
- conservation chamber;
- rod eye with plain spherical bearing for the connection to the gate.

The cylinder as such is a completely welded structure. For the two smaller types of cylinders the cylindrical parts are made of thick-walled pipe. For the 5 other types these parts will be made from steel plates, hot rolled into a cylindrical shape and welded by electro-slack welding.

The piston rod, forming a one-piece forging with the piston, will be nickel and chromium plated (100 μ mNi and 50 μ mCr). Because of the corrosive environment the top layer on the rod might be heavily attacked when the gates are down and the piston rod is out. For that reason tests were executed in order to find nickel and chromium layers with an improved

corrosion resistance. Galvanizing vats for the treatment of such long parts do not exist in Europe. Moreover, the complete handling of these relatively slender parts which bend considerably in horizontal position, requires utmost care during machining, assembling with the cylinder, store and transport. Extensive instructions for all stages of these operations will therefore accompany the design.

As a second protection aid against corrosion of the piston rod the lower end of the cylinder is equipped with a conservation chamber filled with slushing oil. When the piston rod moves downwards it will be covered by a thin film of slushing oil which by drying has such a consistence that it resists the influence of water sprays caused by wind and waves.

When re-entering the conservation chamber, the dried slushing oil will be dissolved by the oil in the chamber which is cleaned and refreshed at each movement of the gate.

The cardan ring is a completely welded structure, carrying the pins for the rotating connection with the hydraulic cylinder, and those for the bearings on the piers. Each cardan ring houses a levelling gear which continuously measures the position of the matching extremity of the gate. This installation does not only provide good information about the gate position as such (which is required for barrier operation) but it also creates the opportunity of controlling the horizontality of the gate during closing and opening procedures. This is necessary because the pier recess depth and the rubbing face width restrict the allowable deviation of the gates from the horizontal position. During movement of the gate the loading end will be stopped if the level difference between both ends exceeds a certain value (15 cm). The trailing end then has the opportunity to overtake the leading end and from that moment both ends continue moving. If — due to a fault — a se-

cond, wider limit is exceeded (50 cm) both machineries are stopped and a signal is flashed to the central control room, where corrective measures can be taken.

The hydraulic installation

The hydraulic installation of a cylinder is mainly composed of a pump set, hydraulic valves, filters, safety valves, pressure switches and so on. Together with the appurtenant electric control installation, these parts are housed in containers which are built into the interior of the box girder bridge.

The containers were chosen as a protection for the hydraulic and electric installation, both during the construction of the box girder bridge when these parts must already be present, and to ensure a reasonable lifetime of the installations after completion of the barrier. If necessary, internal heating is possible, whereas the noise from the hydraulic pumps is damped.

A container houses the complete hydraulic installations of the two cylinders on a pier. This creates the opportunity to use one of the installations as a back-up in case of failure of the other one. All switches and valves necessary for this switching operation are housed in the container as well.

The oil tank is located outside the container. It also services both hydraulic cylinders on a pier. The inside of the box girder bridge furthermore houses containers for the electric installations (power distribution, control and monitoring system), workshops, laboratories and measurement containers. All these containers are located at one side of the box girder, whereas the opposite side is completely filled with a continuous cable-rack for all high and low-tension cables, data transmission lines, piping and so on (fig. 4). Between cable-racks and containers a through corridor is available in a channel over the full length of the interior of the box girders. Therefore even under the worst weather condi-

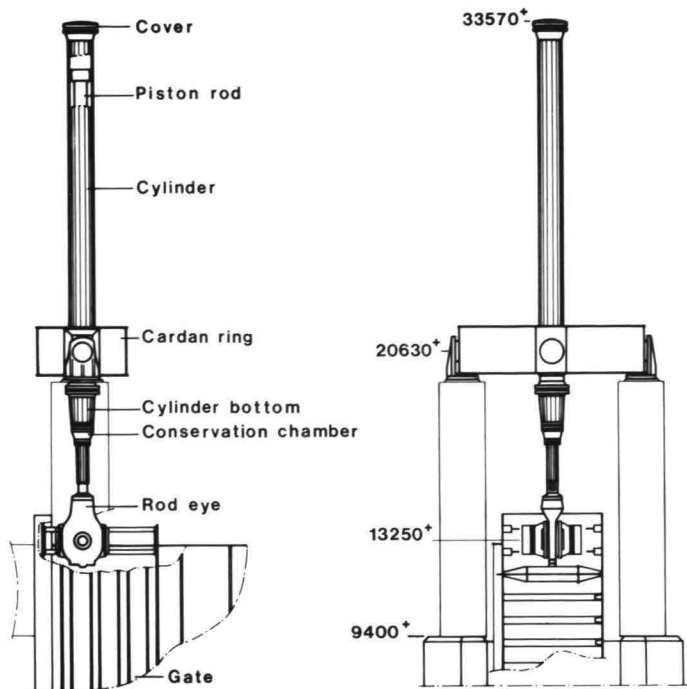

4 Operation machinery for gate
 $h = 11,900 \text{ mm}$

tions all hydraulic and electric installations can be easily reached. For transport in the corridor an electro-car is planned.

The hydraulic system of which fig. 5 gives a scheme feeds oil to a hydraulic cylinder via a piping system. During closing hydraulic oil is fed at the topside of the cylinder at constant pressure, whereas at the bottom of the cylinder the hydraulic oil leaves at a load-independent constant velocity via a constant flow device.

In this manner the hydraulic cylinder is internally prestressed by the oil columns under and above the piston in order to prevent the gate from changing its direction of moving under influence of the alternating wave loading.

In the opening sense oil is fed at the bottom of the cylinder, the pressure being determined by the external load, and the gate velocity by the discharge of the pumpset.

The piping system between pump sets and cylinders will be executed in stainless steel for the section in the open air and in carbon-steel for the section in the interior of the box girder bridge. Since the box girder bridge is supported on the piers via one fixed and one free bearing, the piping system leaves the box girder at the fixed end. Where movements

between pipe sections must be made possible, hose connections have been used.

4. Reliability

From the main fault tree for the storm surge barrier it follows that failure of the gateoperating machinery can lead to a failure of the bottom protection, followed by the foundation, causing the collapse of the pier. Hence the constructional strength of the bottom protection and the failure rate of the operating machineries are interrelated. Failing

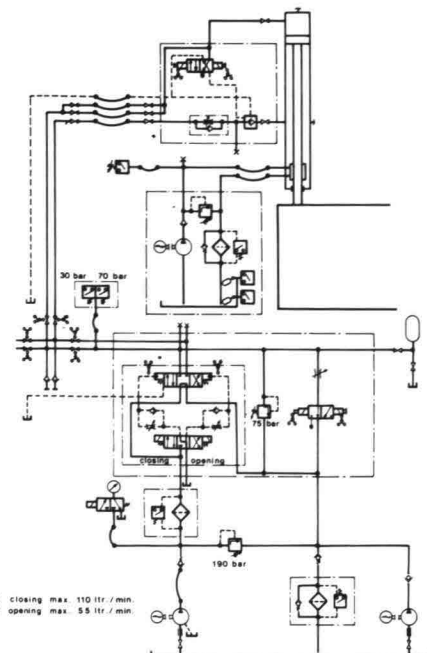

5 Hydraulic scheme for operation of a cylinder

of one machinery leads to a 'failing gate', i.e. a gate which cannot be properly closed within one hour after complete closure of the barrier.

Design harmonization put figures to the probability of all undesirable events, one of them being the failing gate. The figure actually was 2×10^{-3} per barrier closing operation, which — presuming a storm surge closure

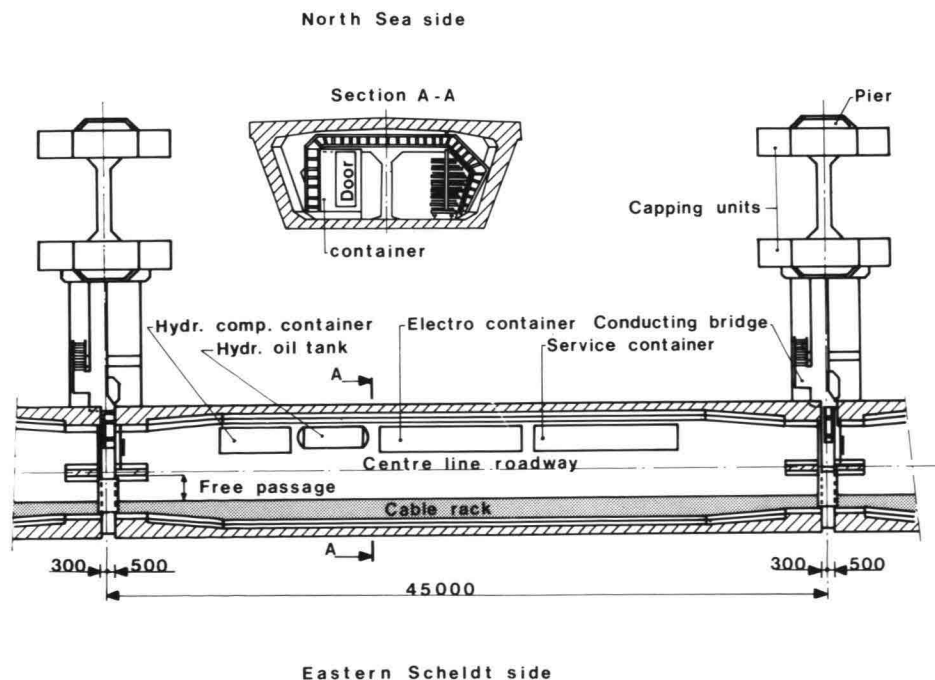

6 Components in box girders

of once a year — is equivalent to 2×10^{-3} per year. Therefore the failure rate of one out of 126 machineries should be in the order of 10^{-5} a year which is a very high demand. The probability of an operating machinery failing was estimated on the basis of extensive analysis carried out with the help of specialized institutions. Both the electrical system and the hydraulic system contribute to the failure rate. The main components to be taken into account were:

- power generation. The failure rate can be kept quite low by installation of a relatively great number of power generating sets and by subdividing the power station into 2 completely separate parts;
- power distribution. It was decided to have two completely separate high voltage distribution systems (both high voltage lines, transformers and switchgear), which can be connected to each other in case of failure of one of them;
- control system. Where possible, the control system is threefold, possibly with hand operation; local control and central control via separate systems. Cabling is of a fire-resisting type, well mounted and protected on cable racks in the box girder bridge;
- hydraulic system.

The major contribution to the total failure rate comes from the electro-hydraulic switching devices and the pressure hoses. The main design philosophy was to reduce the number of switching components in series as much as possible, whereas hose connections for the downward movement are executed with a back-up.

The most important contribution to reliability is formed by the choice to have two adjacent hydraulic pumping sets which are complete spares of each other. On the 6 boundary piers where only one hydraulic cylinder is present, the hydraulic installation has a complete spare installation just the same.

Monthly all gates of the barrier will be closed and opened in order to test the availability of the complete operation system. We trust this system will enable us to remain within the required failure rate and an earlier analysis has demonstrated that we were!

8
Central control room

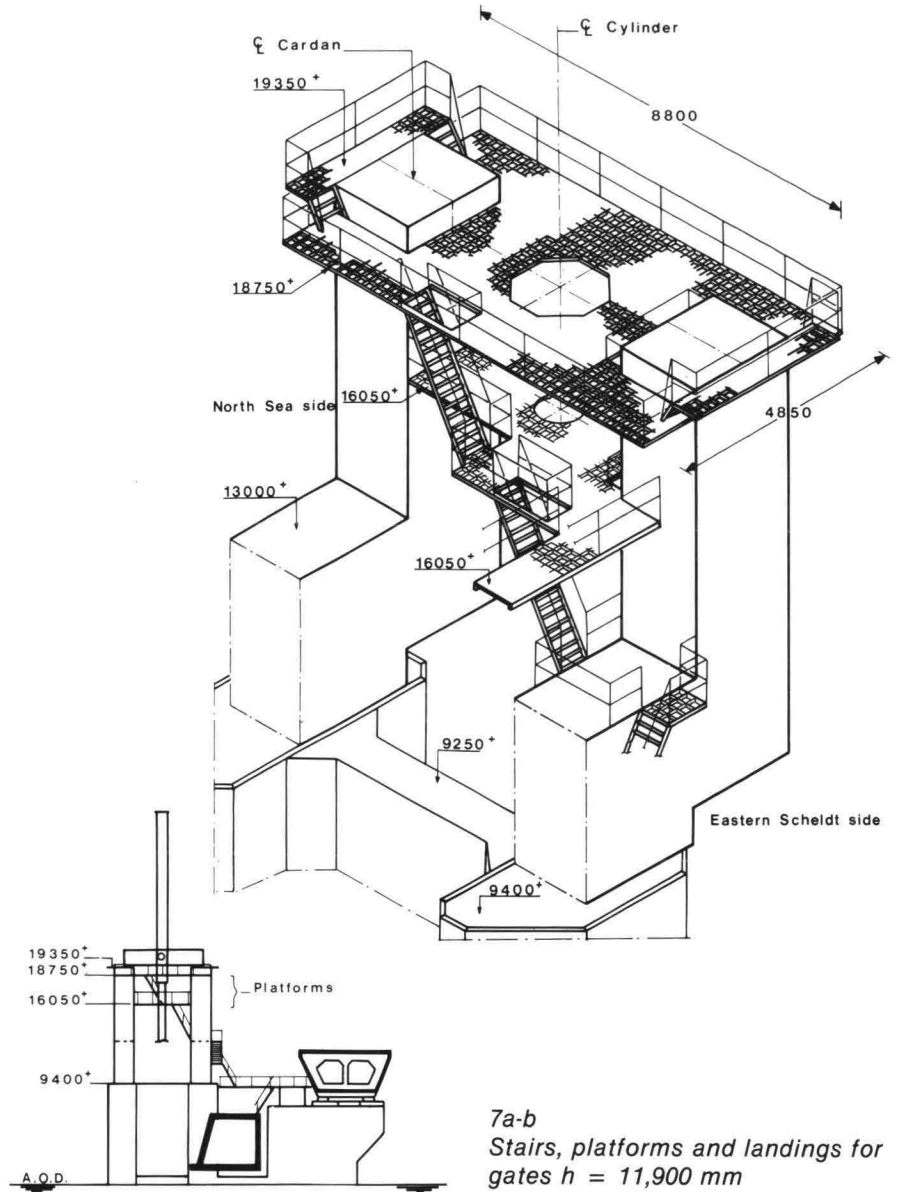

7a-b
Stairs, platforms and landings for gates $h = 11,900$ mm

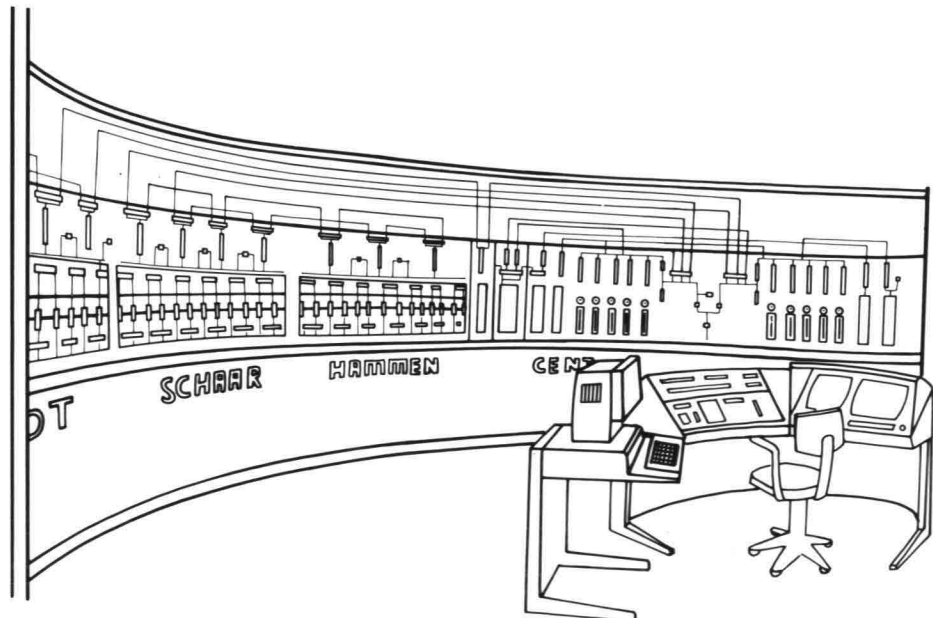

Construction aspects

Methods and tools used in construction

1. Introduction

The concrete piers (*fig. 1*) are very large prefabricated structures to be installed in the 3 gullies of the Eastern Scheldt with the main function of supporting the superstructure, consisting of steel gates and concrete beams, and of course, to transfer during a super storm the forces exerted against gates and beams to the foundation. Basically all piers are of the same type, measuring 25 x 50 m at the base and with a height varying between 30 and 40 m, depending on their final location. Some differences have led to 5 sub-types and, as a matter of fact, because of further minor differences, very few piers are completely identical. The average weight of a pier is approximately 17,000 tons. Approximately 7,000 m³ concrete per pier is used; in all for 66 piers: 450,000 m³.

The lower part of the pier is called the caisson-part, because it is hollow. The upper part is of massive concrete with two vertical holes, giving access to the caisson. The final shape of the pier became rather complex and this had considerable influence on especially formwork and prestressing. The most complicated parts are the lifting yokes ('Knuckles') at the outer end of the caisson for lifting the piers, the groove for the sill beam, and groove in the shaft for the steel gates with its sliding plates, to be installed with utmost precision. To organize the construction, the pier has been split up into 7 fabrication stages as is shown in figure 2. The total available construction time was determined by the start of the construction of the piers (01-03-1979), the date of opening the first and last dry dock compartments and the

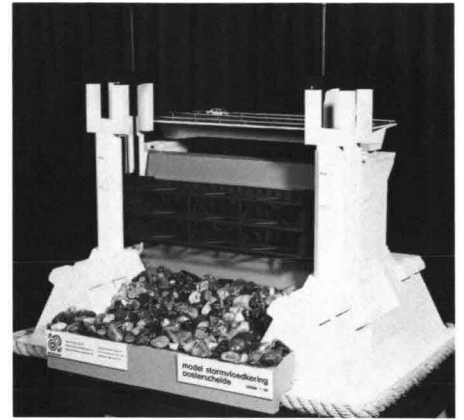

1 Model of storm surge barrier

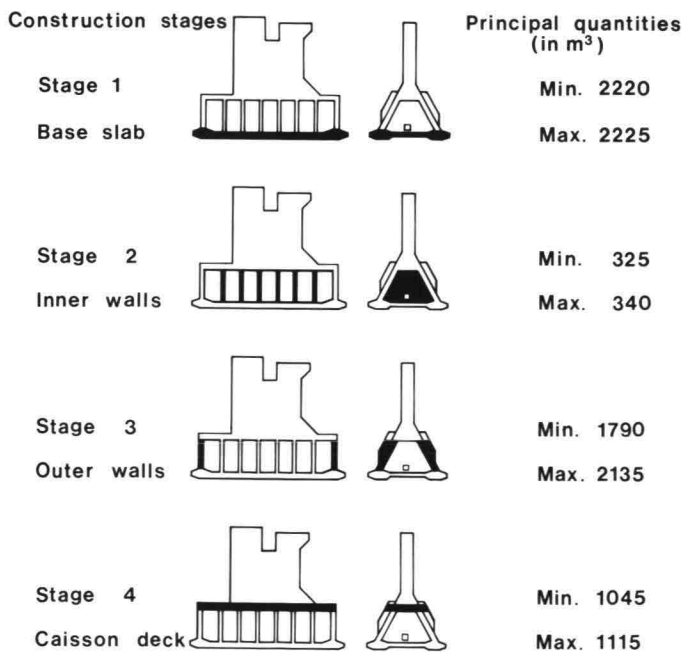

2 Construction stages during prefabrication

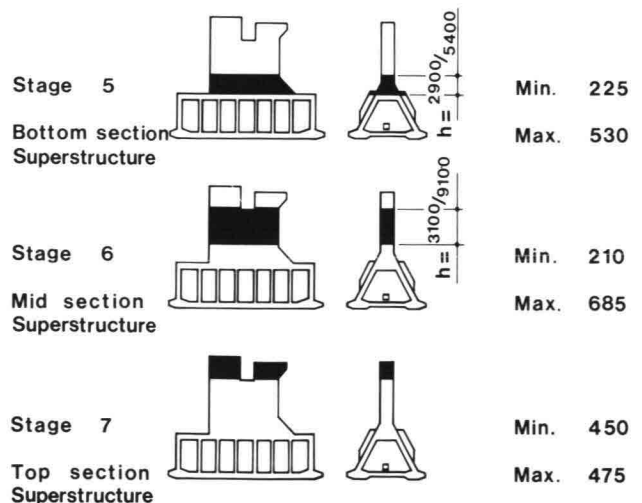

3
Overall-planning of prefabrication

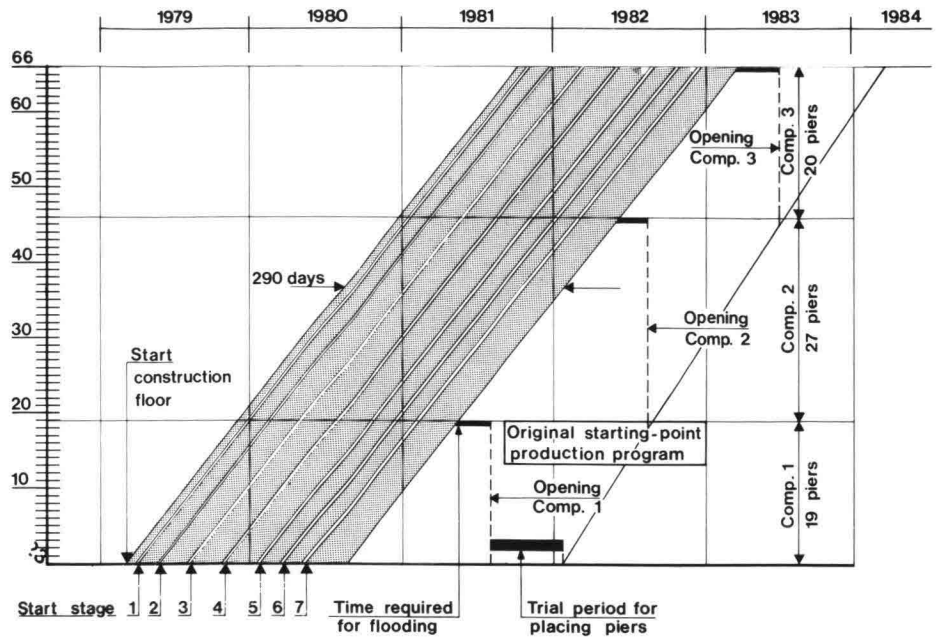

4
Central working area and construction dry dock

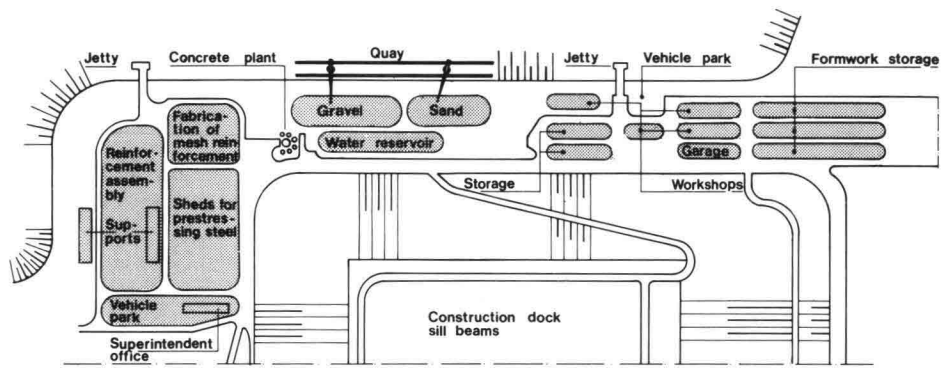
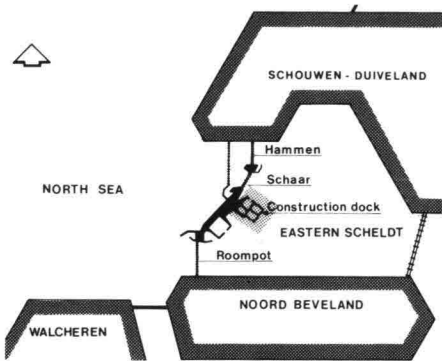

numbers of piers per dry dock compartment. By trial and error a suitable plan was established to meet these dates (fig. 3). The construction period of one pier was set at 290 days (approximately 1.5 year) including some time for solving initial problems. The fabrication was basically split up into 4 building streams. With 7 fabrication phases, this meant that approximately 30 piers were under construction simultaneously.

The fabrication site of the pier is to be considered as a very large open air factory, with a strict and well-maintained organization. Construction methods and tools of course had to fit this factory and considerable time was spent during the preparatory period to invent and study alternatives, and select the optimum solution.

2. Central working area (fig. 4)

As already stated, fabrication takes place in the dry dock compartments three of which are used for the piers and the last one for the sill beams.

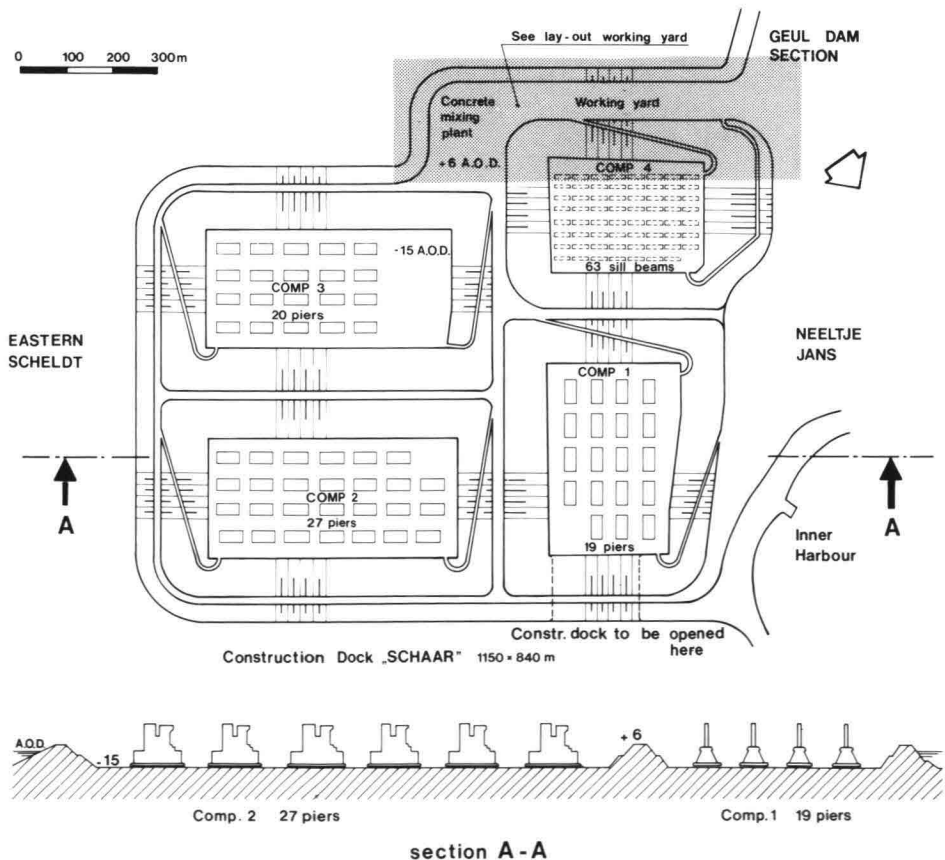

5
Prestressing systems

All compartments are served from a central working area where a concrete mixing plant has been installed, and formwork, prestressing and reinforcing steel are prepared. Auxiliary structural steel supporting frames are made as well, for pre-installing cable ducts, reinforcing steel, and all kinds of fixtures. A road circulation system has been designed and laid out between the central working area and the compartments of the dry dock, minimizing transport distances.

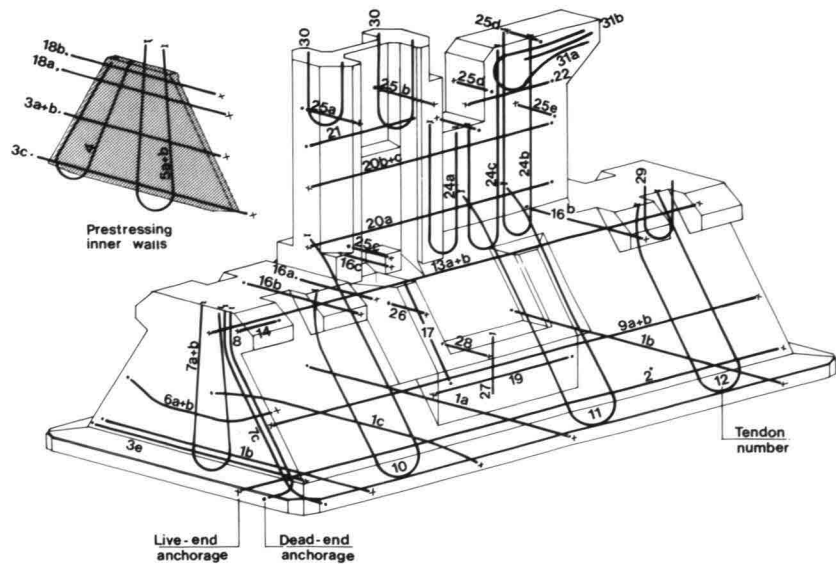

3. Post-tensioning of the pier (fig. 5)

The piers for the Eastern Scheldt are of prestressed concrete; although quite a lot of reinforced concrete is used as well. In both cases approximately 40 kg steel per m³ of concrete; it is little as far as reinforcing is concerned, but considerable for a prestressed concrete structure. Because of the number of the piers and the quantity of concrete involved, the construction of the piers is one of the largest prestressed concrete works ever undertaken.

As can be seen, the total prestressing consists of a variety of cables. After an extensive study, a selection was made from existing systems, based on costs and technical preferences. The following systems were finally chosen:

- Dywidag bars Ø 36 mm, ultimate load 124 t (for cable length up to 5 m);
- BBRV anchors with 50 wires of 7 mm, ultimate load 326 t (for cable length of 5 up to 10 m);
- Dywidag anchors with 8 x 15.7 mm strands, ultimate load 218 t;
- Dywidag anchors with 18 x 15.7 mm strands, ultimate load 490 t;
- Cona Multi anchors with 12 x 15.7 mm strands, ultimate load 326 t.

The Dywidag bar and strand systems were supplied by Dywidag. The BBRV wire and Cona Multi strand systems were supplied by Spanstaal.

The tendon ducts are formed from smooth-walled sheets with a wall-thickness of approximately 2 mm, offering a better protection than the normally used corrugated sheet metal ducts.

As the work progressed, considerable experience was obtained, for example:

- Being so close to the sea, proper corrosion protection of the

| CABLE NR | SYSTEM | NUMBER OF CABLES | WIRES | STRANDS | BAR | ULTIMATE LOAD IN MN | LENGTH IN M |
|----------|------------|------------------|--------|-----------|------|---------------------|----------------------------|
| 1a | DYWIDAG | 26 | | 18 x 15,7 | | 490 | 24,860 |
| 1b | " | 22 | | " | | " | " |
| 1c | " | 6 | | 8 x 15,7 | | 218 | 24,800 |
| 2 | " | 40 | | " | | 490 | 49,860 |
| 3a | " | 52 | | " | Ø 36 | 124 | 15,148 |
| 3b | " | 28 | | " | " | " | 12,800 |
| 3c | " | 12 | | " | " | " | 19,580 |
| 3e | " | 4 | | " | " | " | 19,360 |
| 4 | " | 12 | | 8 x 15,7 | | 218 | 24,800 |
| 5a | " | 12 | | " | | " | 33,610 |
| 5b | " | 12 | | " | | " | 33,210 |
| 6ab | " | 32 | | " | | " | 13,270 |
| 6ab | " | 10 | | 9 x 15,7 | | 245 | " |
| 7a | CONA MULTI | 8 | | 12 x 15,7 | | 326 | 27,230 |
| 7b | " | 16 | | " | | " | 33,320 |
| 7c | " | 4 | | " | | " | 21,700 |
| 8 | " | 12 | | " | | " | 20,760 |
| 9a | DYWIDAG | 12 | | 18 x 15,7 | | 490 | 44,860 |
| 9b | " | 24 | | 8 x 15,7 | | 218 | " |
| 10 | CONA MULTI | 12 | | 12 x 15,7 | | 326 | 41,180 |
| 11 | " | 26 | | " | | " | 45,500 |
| 12 | " | 34 | | " | | " | 37,050 |
| 13a | DYWIDAG | 10 | | 18 x 15,7 | | 490 | 44,860 |
| 13b | " | 2 | | 8 x 15,7 | | 218 | " |
| 14 | " | 48 | | " | Ø 36 | 124 | 39,80 |
| 16a | BBRV. | 39 | 50 Ø 7 | " | | 326 | 7,780 |
| 16b | " | 50 | " | " | | " | 9,070 |
| 16c | DYWIDAG | 3 | | " | Ø 36 | 124 | 5,330 |
| 17 | CONA MULTI | 40 | | 12 x 15,7 | | 326 | 9,460 |
| 18a | DYWIDAG | 8 | | " | Ø 36 | 124 | 15,250 |
| 18b | " | 6 | | 9 x 15,7 | | 224 | 13,880 |
| 19 | BBRV. | 14 OF 17 | 50 Ø 7 | " | | 326 | 15,000 |
| 20a | CONA MULTI | 8 | | 12 x 15,7 | | " | 22,360 |
| 20b | " | 4,6 OF 8 | | " | | " | " |
| 20c | DYWIDAG | 8 OF 10 | | 18 x 15,7 | | 490 | " |
| 21 | BBRV. | 6 | 50 Ø 7 | " | | 326 | 9,500 |
| 22 | " | 10 | " | " | | " | 9,730 |
| 24a | CONA MULTI | 4 | | 12 x 15,7 | | " | 18850 bij 30 26850 bij 70 |
| 24b | " | 18 | | " | | " | 33930 bij 310 41930 bij 70 |
| 24c | " | 8 | | " | | " | 26040 bij 310 34040 bij 70 |
| 25a | DYWIDAG | VAR 16-23 | | " | Ø 36 | 124 | 533 1 x 389 |
| 25b | " | VAR. 30-35 | | " | " | " | " |
| 25c | " | 0 OF 2 | | " | " | " | 3,580 |
| 25d | " | 18 | | " | " | " | 4130 |
| 25e | " | 5 | | " | " | " | 3330 |
| 26 | " | 5 OF 6 | | " | " | " | 3,480 |
| 27 | " | 16 | | " | " | " | 5880 |
| 28 | " | 16 | | " | " | " | 309 OF 358 |
| 29 | | | | | | | |
| 30 | EMPTY | | | | | | |
| 31a | DUCTS | | | | | | |
| 31b | | | | | | | |

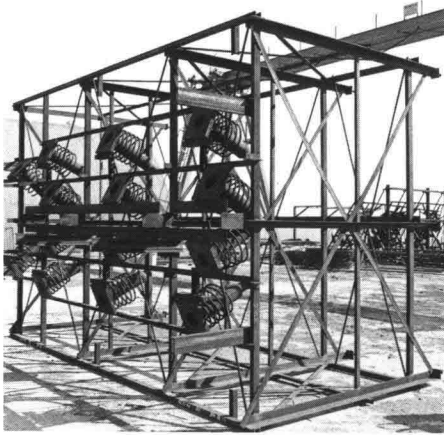

6
Internal support frames: stage 5



7
Formwork: upper part, stage 7

prestressing steel is very important. Storage time should be reduced to a minimum and the storage-sheds should be climate-controlled. The total time between the arrival of prestressing steel at site and injecting the ducts proved too long in the beginning (12 months). It could be reduced to less than 50%.

- The Dywidag bars are installed with their ducts before concreting. Installing supports, reinforcement, etc., required spot welding and this proved dangerous to these bars, causing some near-accidents when prestressing was applied. Utmost care was taken to prevent further accidents.

4. Internal support frames (fig. 6)

To install the ducts for the prestressing cables as accurately as possible, extensive use was made of auxiliary support frames of structural steel.

While the project was being elaborated, this support frame became of much more importance, because many other items had to be secured in place before the concrete was poured. Besides, a large frame, loaded with such fixtures, and prepared at the central working area saved a lot of work at the site of the pier. By carefully preparing all auxiliary support frames in drawings, one made sure that each item got its pro-

per place, and that sufficient space was kept in between, among others, to give concrete- and steel-workers access while cleaning, or pouring concrete.

And last but not least, because the frames were made very accurately, they could be used to position external formwork.

Approximately 15 kg structural steel per m³ concrete was used for the support frames.

5. Formwork (fig. 7)

With so many stages, each of them with a different character, selecting the type of formwork and its design was a major task.

For labour-saving purposes and quick installation, the formwork comprises large panels.

The construction consisted mainly of timber panels on timber battens supported by a backing frame of structural steel. For the relatively thin inner walls of the caisson, steel-forms are used. Tests have been performed on hydrostatic concrete pressure while pouring high walls of concrete. For the thin inner walls it proved that the formwork should be designed for a hydrostatic concrete pressure of 13 t/m², whereas often 4 t/m², is sufficient. Measurements during pouring showed that these design values were correct and not overestimated. The formwork is of rigid construction

so that it can be re-used several times: in general on average, 30 times.

6. Placing concrete

Concreting the piers is of course a major operation. The base plate alone, measuring 25 x 50 m and 2 m thick, contains more than 2,000 m³ of concrete, to be placed in one continuous operation, lasting more than 30 hours.

In the central area, a concrete plant has been erected with a maximum capacity of 200 m³/hour, sufficient if, for some reason, concrete has to be poured simultaneously at two, or more, places (fig. 8). Normally there is only one pour at a time so as to make a balanced use of the concrete pouring group. The organization of placing the concrete was such that throughout the normal working week (5 days) 2 shifts, working day and night, had continuously work.

The concrete batching plant is completely automated and requires very little attendance. Sand and gravel are supplied by conveyor belts from a storage area with a stock sufficient for 3 weeks. Sand, gravel and cement are brought in by ships to the storage area.

Normal potable water is used, brought in by pipeline from the mainland, and stocked in an olympic-sized-pool in case of water shortage. The concrete is transported by truck-



Composition of concrete

350 kg portland blastfurnace cement, class A, water-cement ratio 0.45, 0,75 l superplasticizer per 100 kg of cement aggregates:
 10% (± 185 kg) 'Meuse' sand 0-4 mm
 25% (± 465 kg) 'Rhine' sand 0-7 mm
 65% (± 1205 kg) gravel 5-30 mm

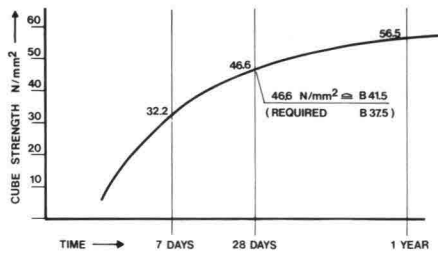

9 Composition and quality of concrete

mixers with a capacity of 9 m³ (14 cuy), the largest available, to the site. At the site the concrete is placed either by batch or pump. The first method generally has preference because it is less vulnerable and has fewer requirements of workability. However, in places where access is a problem, and for flexible use of capacities, the concrete pump has proven to be a successful tool. Through a balanced composition of two types of sand, gravel, water and additives the concrete can be placed by either means, although if it is known that it will be pumped, the amount of water is slightly increased. The pouring capacity varies between 40 and 50 m³/hour per pump or crane.

7. Concrete quality (fig. 9)

For this marine type of concrete, blast furnace cement is used. To arrive at the required strength, 350 kg cement per m³ of concrete is added

with a watercement ratio of 0.45. The required concrete quality is defined as B 37.5, which is a statistical value but means that the average cube strength is of about 400 kg/cm² + (or 40 N/mm² +, or 6000 psi). Concrete strength is measured by crushing cubes in a laboratory at different stages of curing. In general, the average strength obtained was higher than 40 N/mm² and the deviation less than assumed in the Dutch code. On the job, experiments have been carried out with the 'lok-test', which defines the strength of concrete locally by the force needed to pull out a certain type of bolt. Crushing cubes and the lok-test showed a good coincidence. Tests by rebound-hammer were not satisfactory.

8. Compacting the concrete

Compaction of concrete is mostly done by vibrating needles. External vibrators were only used on the steel formwork for the inner walls of the caissons. The use of 'torpedoes', horizontal vibrators being pulled up at the rate at which the concrete rises, was rejected because of the possibility of damage to the ducts. The needles of the vibrator had to be operated manually, and, as the pours for the walls were very high, these men had to work inside and climb up during the placing of the concrete. For determining minimum wall thickness, this factor had to be taken into consideration as well. Having support frames was certainly useful to the men working inside.

9. Curing of the concrete

Once placed, the concrete had to be cured, and the method depended on the part of the pier concerned. For example, to avoid cracks in the massive base plates, the formwork was left in place during a certain period and the

upper face of the base plate was covered with insulating panels. In addition, curing compound was used to prevent loss of water by evaporation. For the outer walls and following stages the concrete was cooled by pumping cooling water through ducts incorporated in the concrete; in all approximately 10 km of duct were installed per pier (fig. 10). The development of the temperature was recorded by thermo couples. In general the

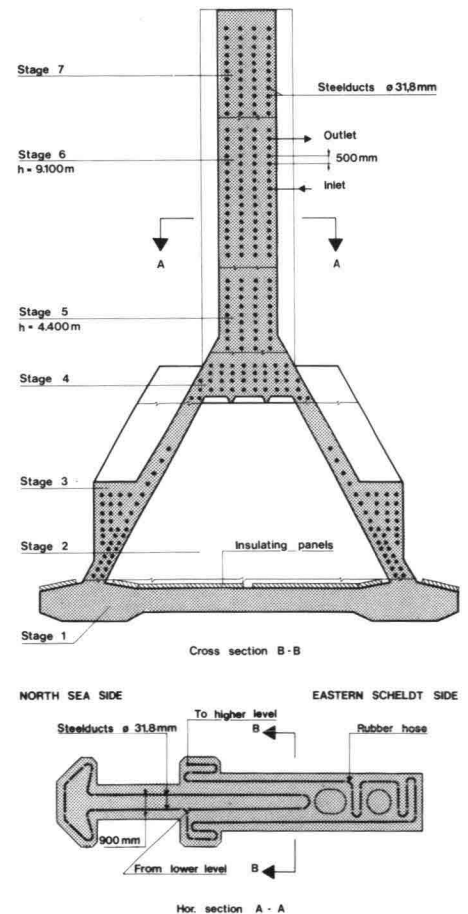

10
Cooling of concrete during curing

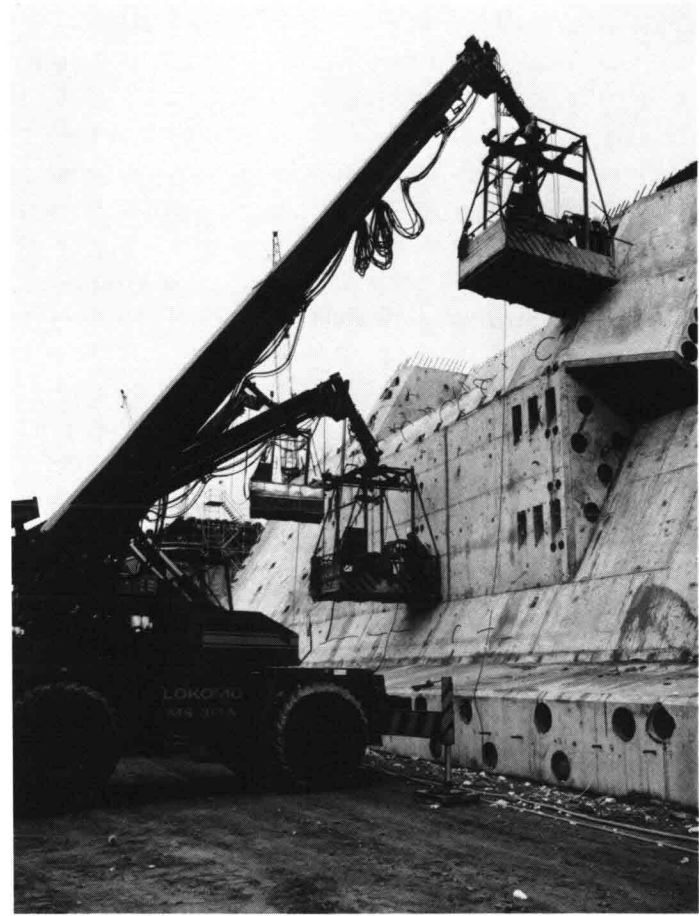
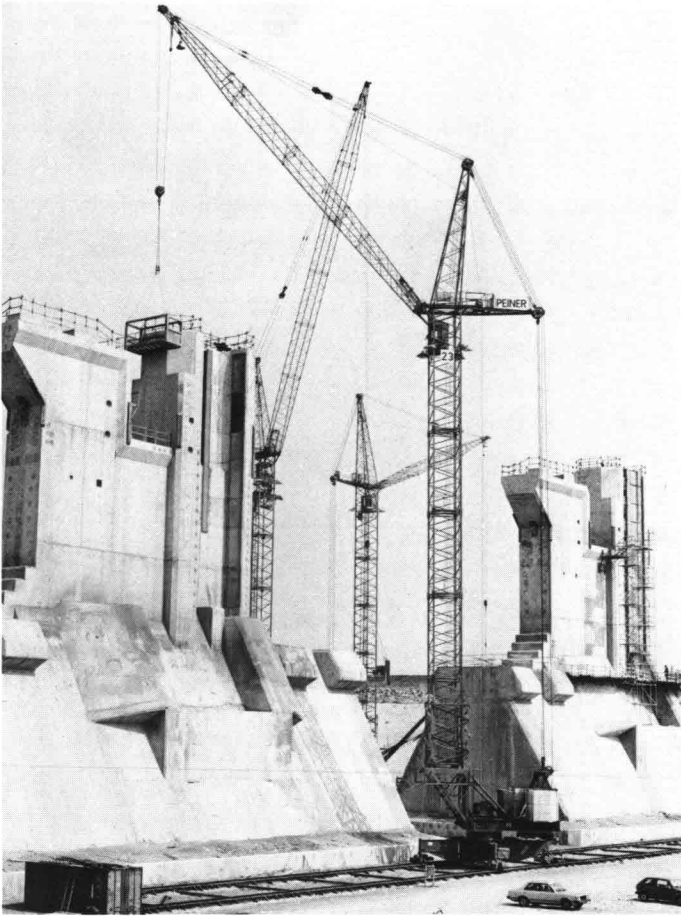

11
Use of cranes: Peiner crane TN 180
12
Locomo crane for prestressing

cooling system worked well, although the preliminary method for calculating the amount of cooling did not prove very accurate and is being reviewed. In the few cases when the cooling system did not work (e.g. when the ducts were blocked by concrete) cracks were the inevitable result!

Another means of preventing cracking was to tension some of the prestressing cables at an early stage, even before removal of the formwork.

10. Summer and winter precautions

Summer and winter had of course their influence on the mixing, placing and curing of concrete. The water for example can be cooled or heated between 10 and 22°C before being added; in cold weather, sand and gravel can be heated by steam. In winter, additives are used which have a less retarding effect than normal; cooling

water is mixed with antifrost, as is injection mortar. If cold weather is expected, fresh concrete is covered. In general, the placing of concrete is stopped at temperatures below zero and/or at an unfavourable forecast. It is not intended continue placing concrete during frost periods.

11. Use of cranes

After extensive studies, it was finally decided to install a crane on rails alongside of each pier. If necessary, two cranes could then work together on one pier. Although the various partners in the joint venture had cranes available, they were of different types, capacities and state of maintenance. Having 30 of these cranes in operation would have been asking for problems.

Therefore, after selecting the most suitable cranes, invitations were sent out to crane manufacturers or their representatives. This resulted in a lease-contract for 30 Peiner-cranes type TN 180 (fig. 11). The same company got also the maintenance contract, and the contract to move a crane from dry dock to dry dock. A special installation on tracks was invented to perform this move within hours and without dismantling the

crane. Of course other cranes were used as well; e.g. smaller pedestal cranes on top of the caisson and Locomo-cranes fitted out with cabs for prestressing activities (fig. 12).

12. Scaffolding (fig. 13)

The choice of scaffolding was again a result of studies. Numerous places had to be reached at different stages without a crane always being available. Access had to be provided to the caisson and the shaft. As the height of the pier was 30 - 40 m, consideration was of course given to the use of elevators; however, this proved to be complicated and costly, and it was decided to use staircases of scaffolding-material.

13. Construction organization

Considering 'tools for, and methods of construction', a proper, well-maintained and motivated organization is a most important tool without which quality, time and costs cannot be kept under control.

14. Quality control

As quality takes first place, quality control for this complicated prefabrication-job with a tight schedule was considered as a special

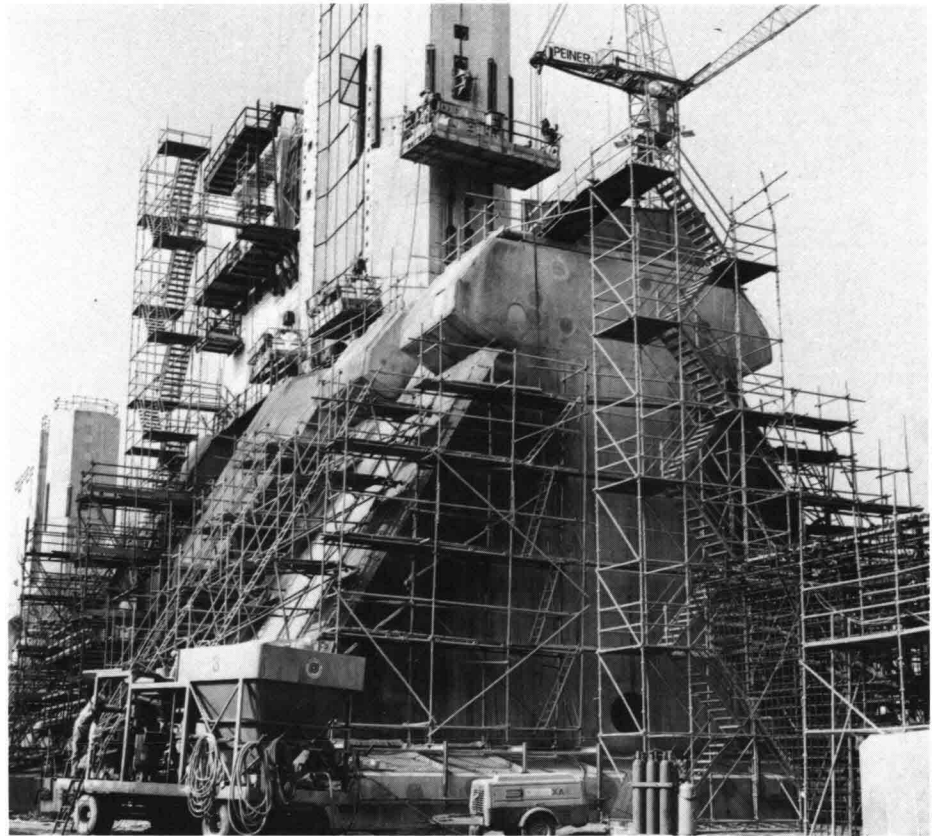

tool in itself. It was therefore decided to install a department where both parties, principal and contractor, could work together for achieving one goal: quality!

Although it was obvious that there would be certain moments of conflict of interests between the construction and quality department, both were sufficiently aware of each other's duties and goals that mutually acceptable solutions could always be found.

15. Special features

The concrete piers are fitted out with some special features which influenced the fabrication of the piers, and also of certain interest for off-shore construction. These features are:

- a. *Protection against falling stones*
Extensive tests showed that the larger stones of the underwater-sill, when dropped from the waterline, could easily damage the concrete piers. This problem was solved by deciding that the very large stones (> 3 tons) should not be dropped, but placed. To permit the dropping of medium-sized stones, the pier is protected at the most vulnerable places by increasing the concrete cover or adding an additional layer of gunnite (fig. 14). Furthermore, a temporary cover of metal sheet piling is installed to protect the place where the concrete sill beam is to be placed (fig. 15). Later on, a special curtain will be hung in the groove for the steel gates so as to protect the sliding plates.

- b. *Sealing-off a pier after installation in situ*
Once a pier is installed, the void between foundation and underside of the pier has to be sealed off from the Eastern Scheldt, the reason being that the growth of

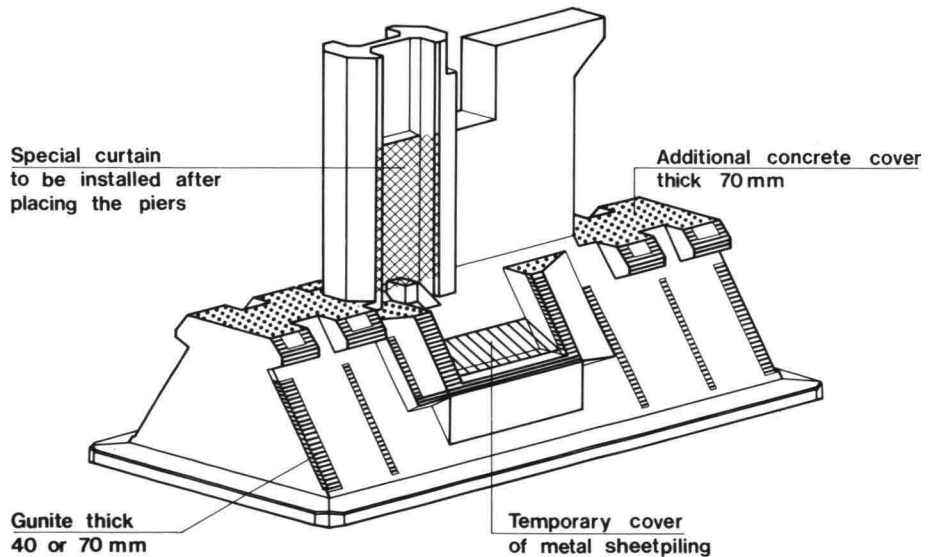

14
Protection against falling stones



15
Protection of pier by gunnite layer

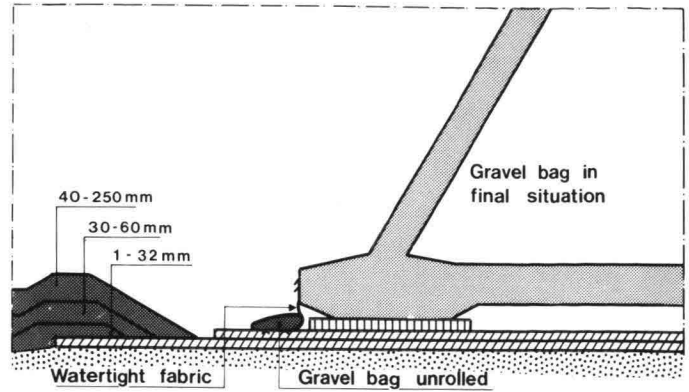
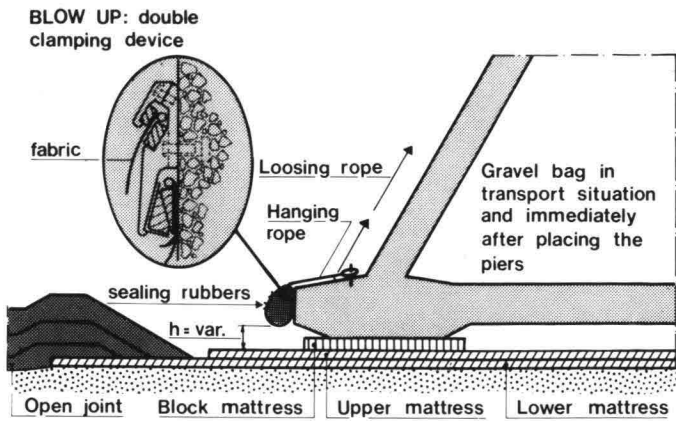

16
Sealing bag around the pier

mussels should be prevented as well as settlements of lime or sand. At a later stage, this void will have to be completely filled with grout.

It took a number of alternatives and experiments to arrive at the final solution: a sealing bag, flexible enough to close an opening of variable height (fig. 16). The bag can be easily loosened after the piers have been installed and is sufficiently robust of construction to withstand forces during installation, transportation and grouting.

- c. *Undergrouting after installation*
To have a complete connection with the foundation, the void between pier and foundation mattress will have to be filled with grout. It was of importance for the construction of the pier that the

grouting system be incorporated in the concrete base plate and lower part of the outer walls of the caisson, as shown in figure 17. One of the main problems was to make the connection between pipe and concrete pressure-resistant because grouting operations will take place inside the pier under atmospheric conditions at 30 m under water!

- d. *Sandballasting the pier (fig. 18)*
For final stability, the piers will be filled with sand. This is done by a circulating system of a sand/water mix, where the sand will settle inside the caisson, and the water is returned by pumping it out. Tests have shown that for a good distribution over the various compartments, the inner walls should be perforated with a number of smaller openings. In this 'remote controlled' way, the caisson will be filled for approximately 90%.

16. Conclusion
It should be clear that utmost care was taken to have high-quality piers available within the short time planned for their construction (general view, fig. 19). This quality should not only ensure the lifetime of the structure (200 years), but also the safety of the workers in the caisson when undergrouting at 20 - 30 m below sea level.

Although no piers have been placed yet, flooding the dry dock (fig. 20) showed that the piers are watertight. Trials with the lifting-vessel *Ostrea* have shown that lifting the pier with its sealing bag and transporting it to its final location is no problem either.

Therefore confidence is justifiable that the prefabricated piers will arrive safely at their final location and that, by installing them in one quick operation, they will have tremendously reduced the risky work at the site.

17
Details of undergrouting system

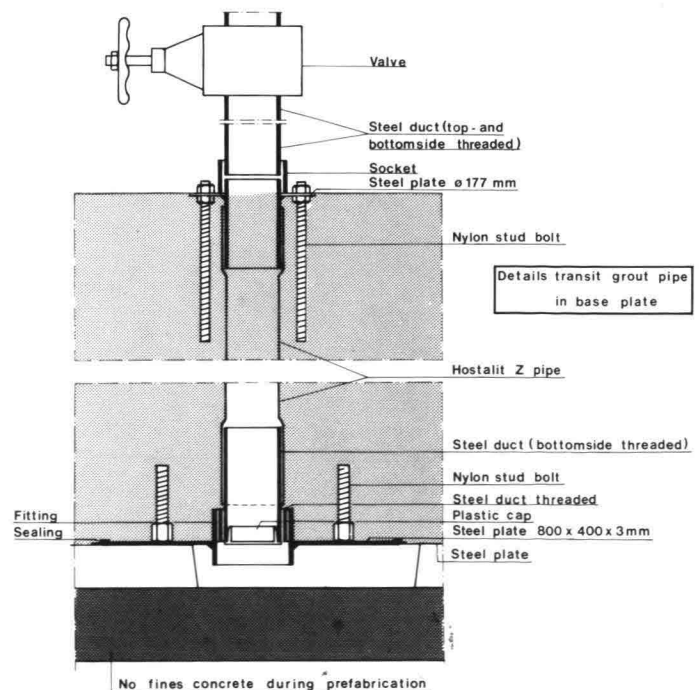
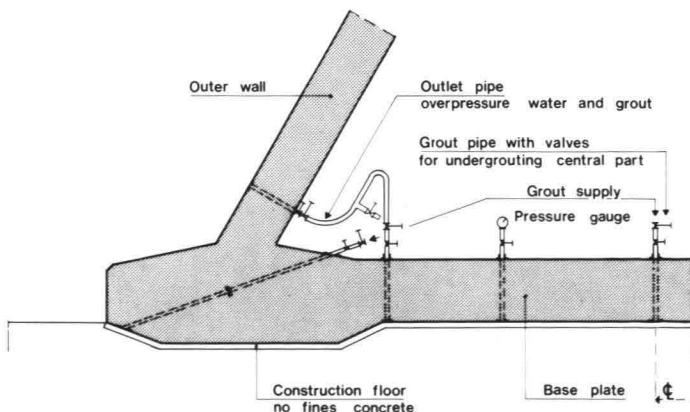

18
Sandballasting system

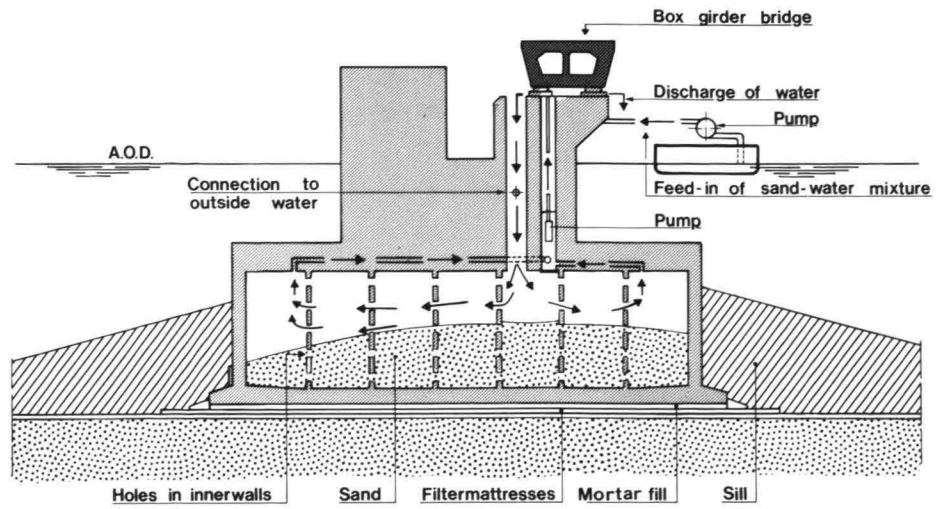

19
General view of prefabrication of piers



20
First prefabrication dry dock flooded



Construction aspects

Labour and social aspects of the barrier construction

Introduction

Labour aspects are very much related to the kind of work involved.

- Large- or small scaled;
- planning all or not tied - (normal 40 hours' work week possibly with overtime, double shift or continuous working day of 24 hours);
- smaller or larger repetition effect (partly retrained (un)skilled labourers can be employed).

The construction of the 66 prestressed concrete piers for the storm surge barrier presents a large scale project involving the planning of normal 40 hours' work week (except the large concrete pours) and a major repetition effect. A general view of the planning of, and labour force for each pier and an insight into the overall planning and organisation is necessary.

Schedules and labour

Construction stages

Each of the 66 piers is divided into 7 construction stages and one stage for final finishing activities (*figure 1*). The first studies for the construction of the piers in three dry docks in con-

nection with the seabed construction (filter mattress)-towing-placing including the sill construction indicated that for each pier a total of 290 working days was available with an interval of 8 working days between them.

Figure 2 shows the elaboration of this construction schedule divided into the construction- and prestressing stages. Next to each stage the labour force and their staff are shown.

It was decided to work according to a so called conveyor (assembling line) belt system which means: one shift and its staff will always remain at the same construction stage. To cope with downtimes in the conveyor system, slack time between construction stages is required to deal with delays in one stage in view of the next stage.

Delays may be caused by e.g.:

- break-downs and transport of equipment;
- strong wind force which affects only tower crane handling;
- unforeseen repair work on concrete structures;
- concrete pours and injectionwork

dependent on cold weather situation;

- in winter, a longer waiting time for the shrinkage of the prestressing system, a.s.o.

It is shown on figure 3 that the 290 days set aside for each pier would be maintained for the entire construction of the 66 piers while the gain in time obtained by the repetition effects could be used to get the above-mentioned required slack time. As can be seen the total working time for a pier could be reduced to 242 working days. Equipment and staff employed are based on this last figure for economical reasons.

Figure 4 shows the management structure of the construction team which proves to be the most effective one.

The graph indicating the average estimated and actual labour force is shown in figure 5. At the start we used more than the estimated figures while later on the repetition effect infers the graph more than we expected. Every newly started construction phase has its own problems

1
 Construction stages of a pier

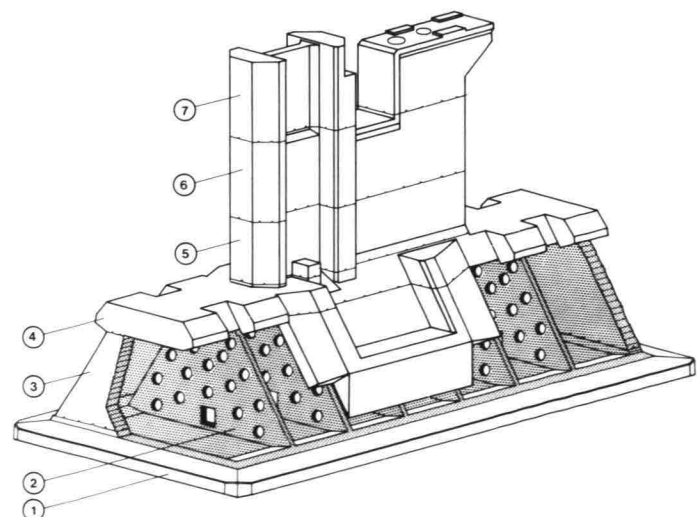
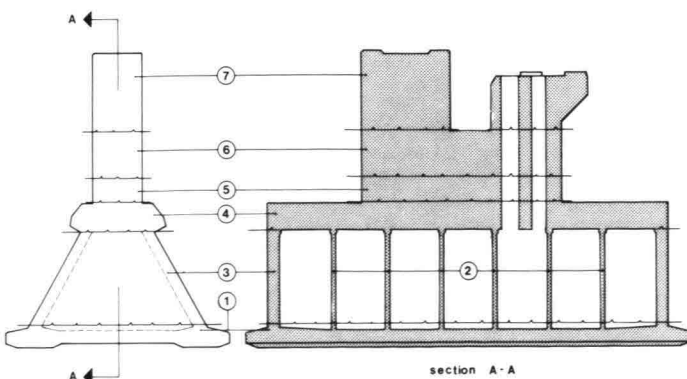

2
Planning of the construction stages

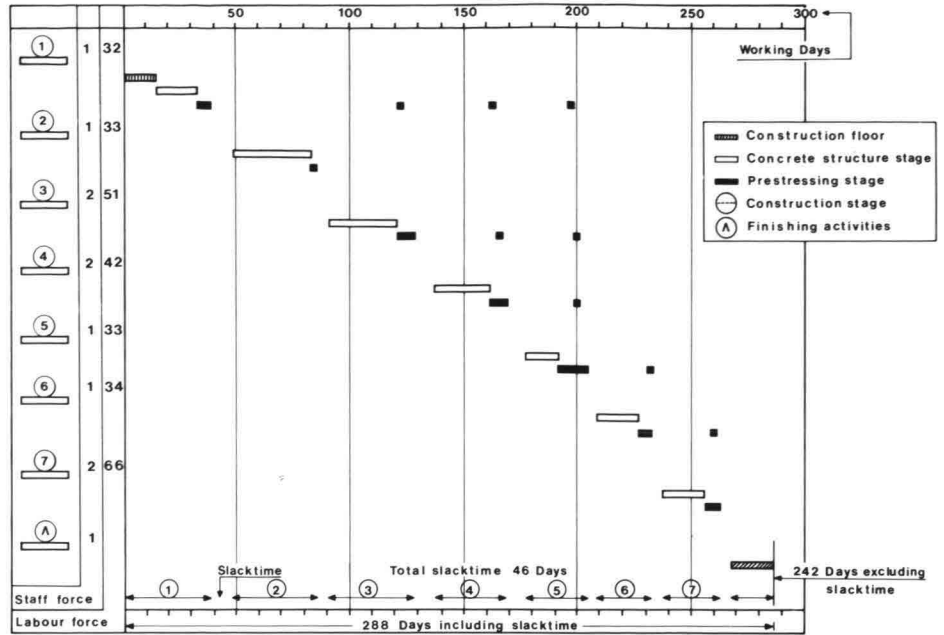

3
Planning of 66 piers

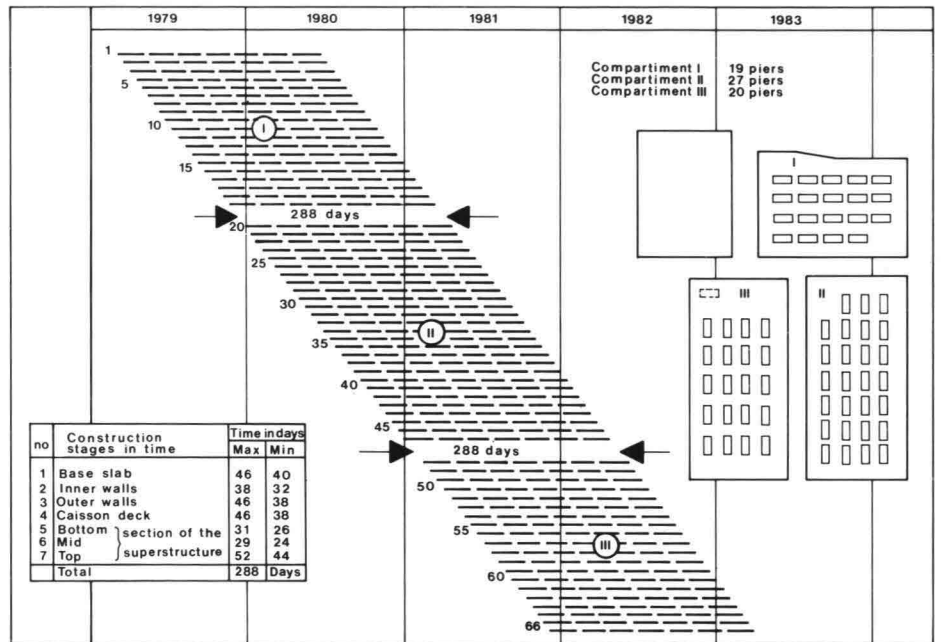

4
Organisation scheme of construction team

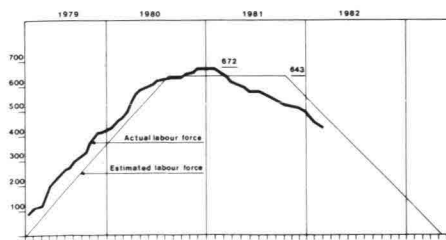

5
Graph of estimated and actual labour force

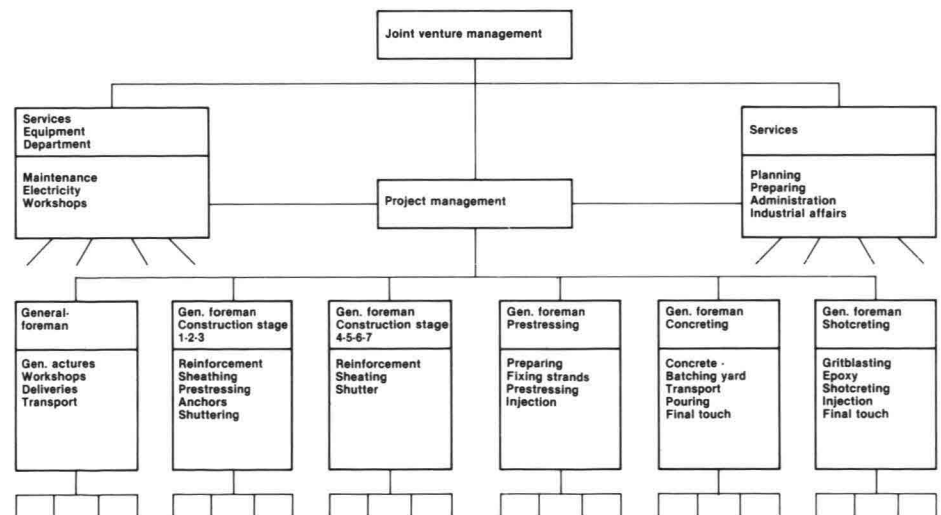

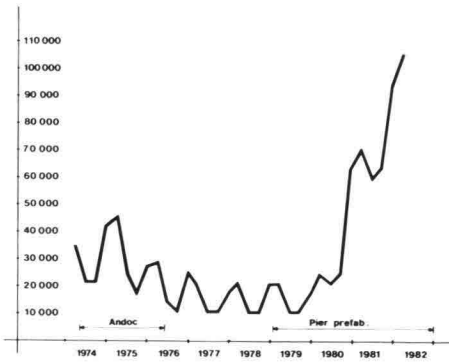

6
Unemployment figures 1974 - 1981

7
Map of Delta area with information

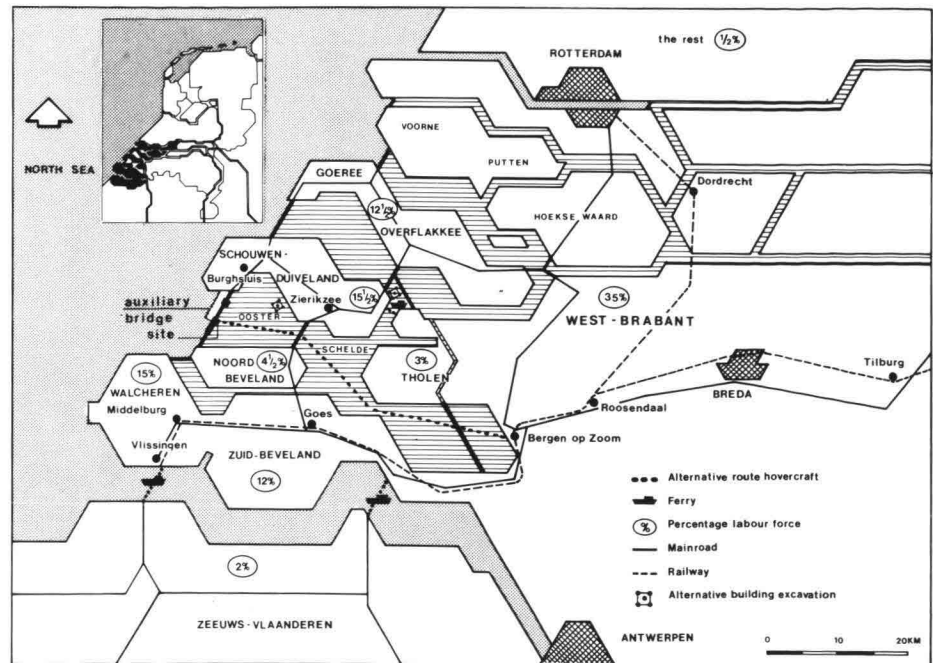

while a repetition effect continues to affect figures to a greater extent than expected.

Labour resources

The recruitment of the labour force was started towards the end of 1978 -beginning of 1979 at the very time when the national unemployment figures in Holland were at its lowest since years (figure 6). In the light of the experience of the past years obtained with other offshore concrete structures which are always more or less built in outlying areas, studies were made how and when the required labour force could be obtained with particular reference to the West Brabant area.

The working site is located on an artificial island which means transport by boat or over an auxiliary bridge of 3 km length (figure 7). Several studies for other construction sites nearer to populated areas were made but transport problems of the prefabricated piers forced us to maintain the original designated construction site.

To prevent difficulties with local contractors, arrangements were made with local authorities according to which no local labourers from the province of Zeeland should be recruited.

Studies were made for the transport from West Brabant by Hovercraft, busses and even by helicopters. Unfortunately railway connections were not available at a reasonable distance. In general the building

trade operative is used to travelling daily and his car is partly be financed by the employer in the form of travelling expenses. The worker is therefore quite willing to drive over a long distance. Solutions were searched in the form of transport by coach and to reduce travelling hours which normally will also be paid by the employer. The auxiliary bridge proved to be the most economic one. The longest travelling time is around 2x1½ hours and is still acceptable according to the collective labour agreement which concedes 11¼ hours away from the worker's residence.

Shift working

There remained the problem of a double shift (2x12 hours) for the concrete pour gang.

In general the Dutch building operative is used to living at home and shows no willingness to stay in labour camps. For the double shift work of the concrete pour gang a solution was found in consultation with the governmental labour inspectorate and the unions that within a 2 weeks period the working time should be 2x8 + 3x12 hours for the day shift and 3x12 hours for the night shift. The total for 2 weeks being 88 hours. These figures have to be reduced for meal breaks. The concrete pours within a period of 2 weeks were organized in such a way that each week a continuous pour of 3 days and 2 interrupted pours of 3 days and 2 interrupted pours of 8 hours are carried out. This solution agrees with a subsequent action to

reduce overtime in connection with the ever-growing unemployment figures of the past years and we were able to satisfy this aim in the manner described (figure 8).

The crews performing dredging activities — anchor handling, rubble placing (sill), in short, all those workers falling under the so-called Dredging Collective Labour Agreement are used to stay at work-camps. Most of them are working in shifts of 12 hours with a total of 44 hours a week. A work camp with a capacity of 250 occupants is therefore being established in the vicinity of the project.

The whole complex is divided into:

- one general service building with a common dining-day- and entertainment room (TV, reading, billiards, table-tennis/kitchen a.s.o.);
- five separate one-storey buildings with 50 bedrooms each (night- and day shifts do not mingle).

Each guest has at his disposal one bedroom with shower and toilet; each 16 bedrooms have their own day-room.

Training

Apart from a campaign for the recruitment of building labourers from different parts around the Delta area and in view of the above mentioned low unemployment figures investigations were carried out in consultation with the Ministry of Social Affairs about starting reconversion courses for the building trade.

8
Two weeks concrete pouring schedule

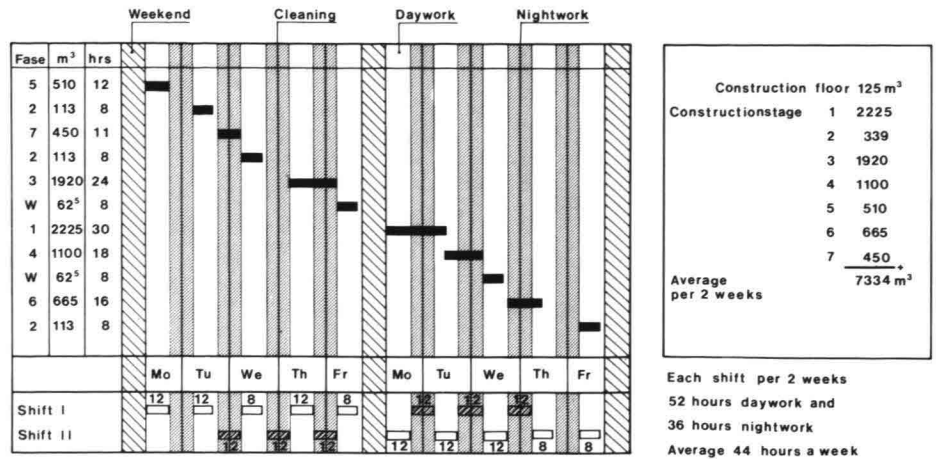

9
Carpenter training course program

Studies were made where as to how and for whom, the duration of a course and the number of trainees. It was advisable to install the school as near as possible to the working site to accustom the apprentices to the circumstances in which they would have to work later-on and to facilitate trips to the site for inspecting in actual practice what they had learned in class. The target and the contents of the course were based on a course which was already used for other retraining schools in parts of the country where industries that no longer proved viable had to shut down (textile and shoe industries).

| Weeks | 1 | 2 | 3 | 4 | 5 | 6 | 7 | 8 | 9 | 10 | 11 | 12 | 13 | 14 | 15 | |
|--|------------|---|---|---|--------------|---|---|---|---|----|----|--------------|----|----|----|--|
| A 4 Weeks Carpentry | 50% Theory | | | | 50% Practice | | | | | | | | | | | |
| B 7 Weeks Carpentry and Shuttering | | | | | 30% Theory | | | | | | | | | | | |
| | | | | | 70% Practice | | | | | | | | | | | |
| C 4 Weeks Carpentry and Complicated Shuttering | | | | | | | | | | | | 10% Theory | | | | |
| | | | | | | | | | | | | 90% Practice | | | | |

Each course consists of:

- 4 weeks carpentry; reading of drawings; preparing of machines; material and tool theory; codes.
- 7 weeks carpentry of shuttering; operating carpentry machines; practical measuring; maintenance of tools; theory of concrete; carpentry from drawings.
- 4 weeks carpentry of complicated shuttering; additional theory.

After the first course we learned that on a large-scale project like the Eastern Scheldt barrier the apprentices were very disappointed that they had not the chance of putting into practice what they had learned. The fact being that nearly all shuttering was prefabricated outside in workshops so that only very small quantity of carpentry work was available.

Only some minor items called for work in carpentry shops such as repair work on shuttering-recesses a.s.o. (However most of the prestressed recesses are made of steel and rubber). Since most of the construction items were prefabricated wherever possible e.g. supports for reinforcement steel in which prestressing items such as anchors and sheathing were fixed simultaneously, the apprentices in the second course were more prepared for these activities in steel work instead of only carpentry work. In total 87 apprentices attended a course, 75 of which with good results, 5 went to the site before finishing the course and 7 left the course. After two years 50% of the apprentices are still on the site. From the other half approximately 75% are still active in the building trade. With the ever growing unemployment figures prolongation of the course proved no longer necessary after two years.

The works council and the working condition act

Concerning the social aspects we mention
I the Works Council Act (WC act)
II the Working Conditions Act (Arbo act).
The purpose of the Works Council Act is the proper performance of the enterprise and representation of the interests of the employees of the enterprise. The Working Council Act is compulsory with 100 and more employees and the number of members of the Works Council Act are:
7 members elected by 100-200 employees
9 members elected by 200-400 employees
15 members elected by 1000-2000 employees.

Nomination of candidates by the trade unions and of employees who are not member of any trade unions. Works Councils consult with management at least 6 times annually.

For the first time since the Works Council Act was implemented the joint venture Dosbouw was obliged to install a Works Council: the main rights and duties are mentioned in figure 10. The marked subjects are largely not applicable to a Works Council of a joint venture.

A summary of the hierarchical communication in an enterprise or joint venture, the supplementary communication and the communication of the Working Council with all the branches of the enterprise is given in figure 11.

The Working Conditions Act (so-called Arbo act) became law and will be introduced gradually. It will take 8 to 10 years to be implemented. Basis principles:

safety;
health;
welfare.

The worksituation must be as safe and as healthy as possible. These requirements must be fulfilled as regards:

- production and working procedures;
- limitation of the effects of possible injury;
- use of machines, tools and materials;
- prevention at the 'source'.

Work must be adjusted to personal factors such as age, experience, physical and mental fitness; work must not harm the mental and physical health of employees; frequently recurring and monotonous work procedures must be avoided wherever possible; the work situation must help employees to develop their personality and skills.

Concerning this kind of career development opportunities have to be provided such as:

- initiative;
- organisation of work according to the workers' own insight;
- contact with fellow workers;
- information on purpose and results of the work.

Viewed in this light Work Councils require the provision of consultation facilities, by right so as to be informed by:

- the employer
- the Labour Inspectorate and
- specialized services.

It also compromises the right to talk with labour inspectorate officials privately and to accompany them dur-

ing inspection tours of the firm. There must be regular work consultations between management and (a delegation of) employees in divisions which may be regarded as working units.

Firms will be obliged to employ specialists in the areas of safety, health and welfare. Services may be set up by one or more firms together. The specialized services advise and assist employers, employees and Works Councils.

The Joint Venture Dosbouw tried to satisfy as many of these requirements as possible, though the Act has not yet been implemented, such as introducing:

- a safety officer;
- a safety committee to assist and advise the safety officer;
- a first aid officer with a clinic-sary on the site;
- a weekly consulting hour of a fully qualified physician for those who think that they have physical complaints resulting from work conditions;
- first aid course for labourers (for every 25 labourers there is a trained employee).

To prevent fraud regarding social liabilities of (sub) contractors, each employee on the working site has to prove his identity by means of a special identity card. In consultation with the Government Labour Inspectorate and unions the chief contractors furnish these cards with all kind of information regarding registration of the (sub) contractor.

A continuous guard during 24 hours per day at the entrance of the auxiliary bridge is installed for control purposes.

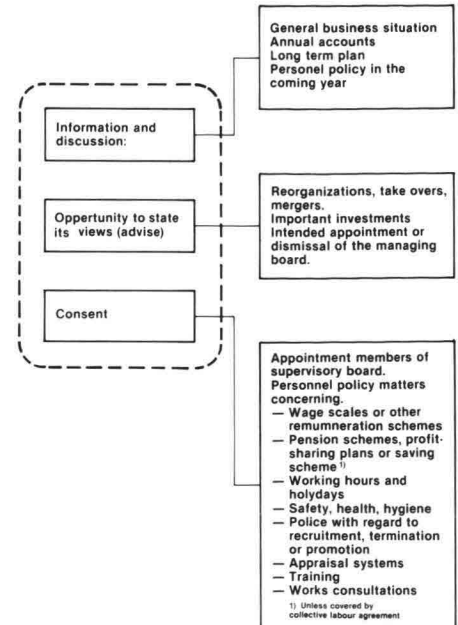

10
Survey of main rights and duties of works council

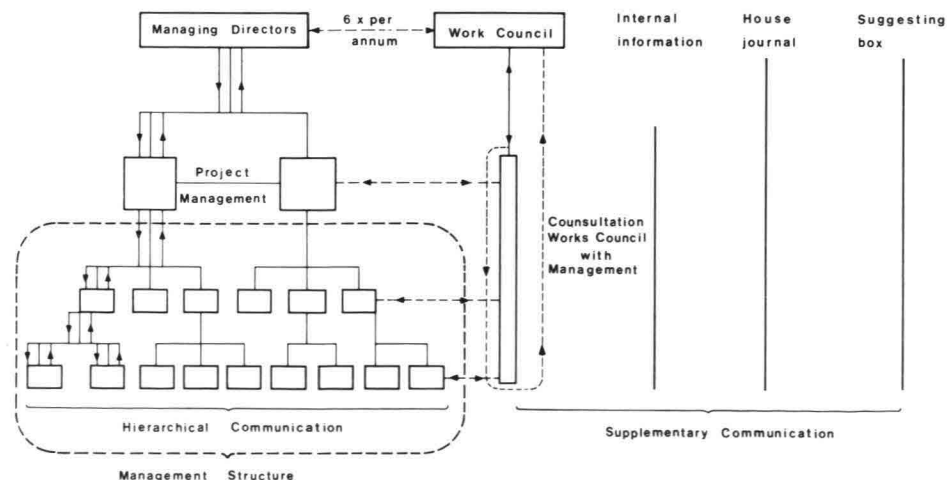

11
Summary of communication lines in an enterprise connected with the work council

Operations Assembly

A consequence of the requirement that the configuration of the Eastern Scheldt should remain unchanged was the decision to design a prefabricated barrier. The elements of which the barrier is composed are very large. The filter mattresses have the surface of a soccer pitch, the piers have the weight of a freight vessel, the sill beams have the size and dimensions of box girder bridges. These elements have to be placed under water in tidal channels at an exposed location. The superstructure elements like the capping units, the upper beams, the bridges, the gates and the hydraulic rams are also massive but can be placed above water.

The four subjects of this paper are:

1. planning the assembly;
2. decisionmaking in design and construction;
3. the supply of information on natural conditions;
4. a manual for future use.

1. Planning the assembly

The elements that eventually compose the barrier are in their order of placing

- the filter mattresses and intermediate seams;
- the protection mattress;
- the block mattress;
- the piers;
- the rip-rap;
- the capping units;
- the gates;
- the sill beam;
- the upper beam;
- the rock armouring.

The machines that have been built to place the prefabricated elements are large in comparison with the width of the three channels in which they will work. The working sequence is from North to South, from the narrowest channel to the widest, from Hammen to Schaar to Roompot. It became

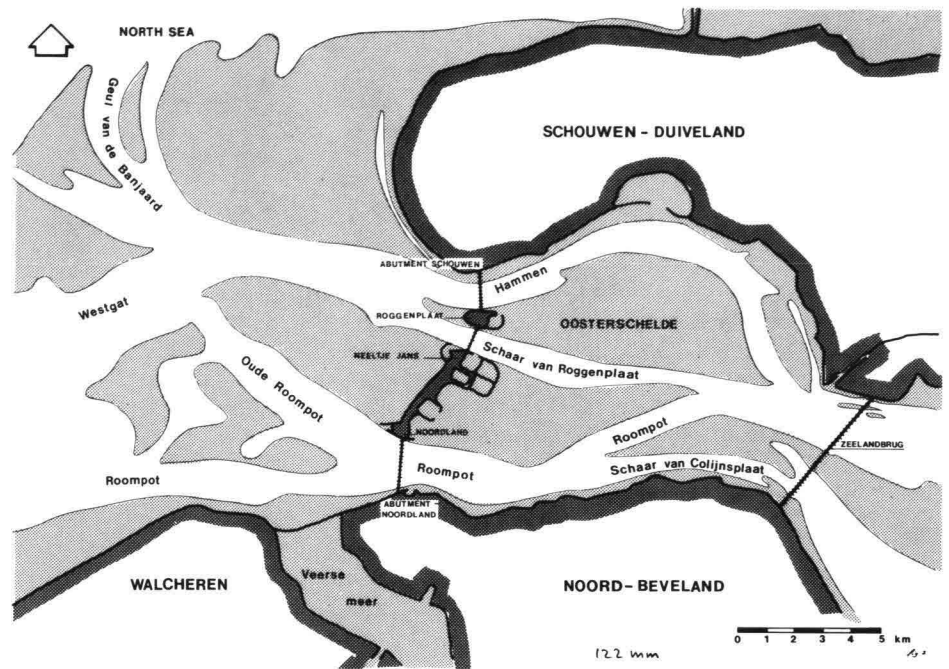

clear at a very early stage that the limitations imposed by the space the machines occupy would govern the assembly pace.

The mattress laying barge *Cardium* with its anchoring wires for instance cannot work closer than 1050 m' to the preceding soil compactor *Mytilus* and cannot be followed closer by the pier placing *Ostrea* than 1050 m'.

1
Eastern Scheldt estuary

2
Pier and congresscentre 'De Doelen'

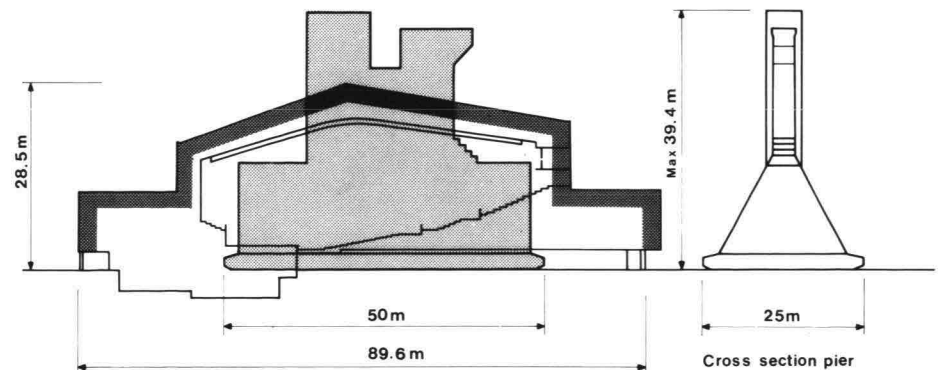

3
Pattern of anchoring cables

These limitations are due to the undesirability to cross anchor wires. Another determining factor for assembly planning is the velocity of the tidal currents that can be accepted with regard to scouring occurring in the narrowing channels. Therefore not all six abutments can be built prior to placing the filter mattresses. It became evident that the best way to represent the assembly plan was to put it down in the way of a road-time diagram, very much like railways and airlines do. Numerous variations were drawn up until in April 1982 Plan 600 was eventually declared the governing scheme. This plan is based on progress estimates of each assembly unit. The progress estimates are forecast after a study of each handling sequence and based on annual weather worse than average.

The consequences of deviations from the target progress are very complex and, as these are certain to happen, an effort has been made to computerize the road-time diagram in order to enable a quick assessment to be made of the effects on the other operations. The existence of a computerized road-time diagram enables the project management to implement in advance various progress rates in the plan. In this way the sensitivity of the plan can be tested and an eventual completion date can be forecast with a certain probability. Thus the probabilistic approach that was applied to the design of the barrier, is also applied to the time schedule.

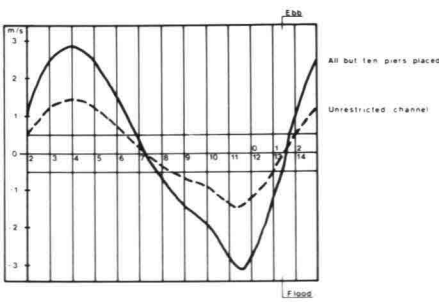
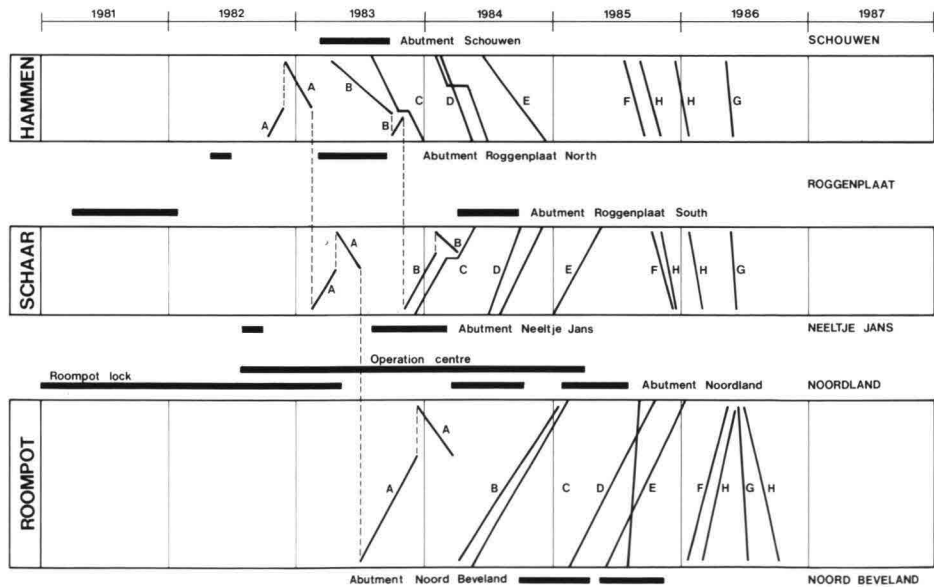
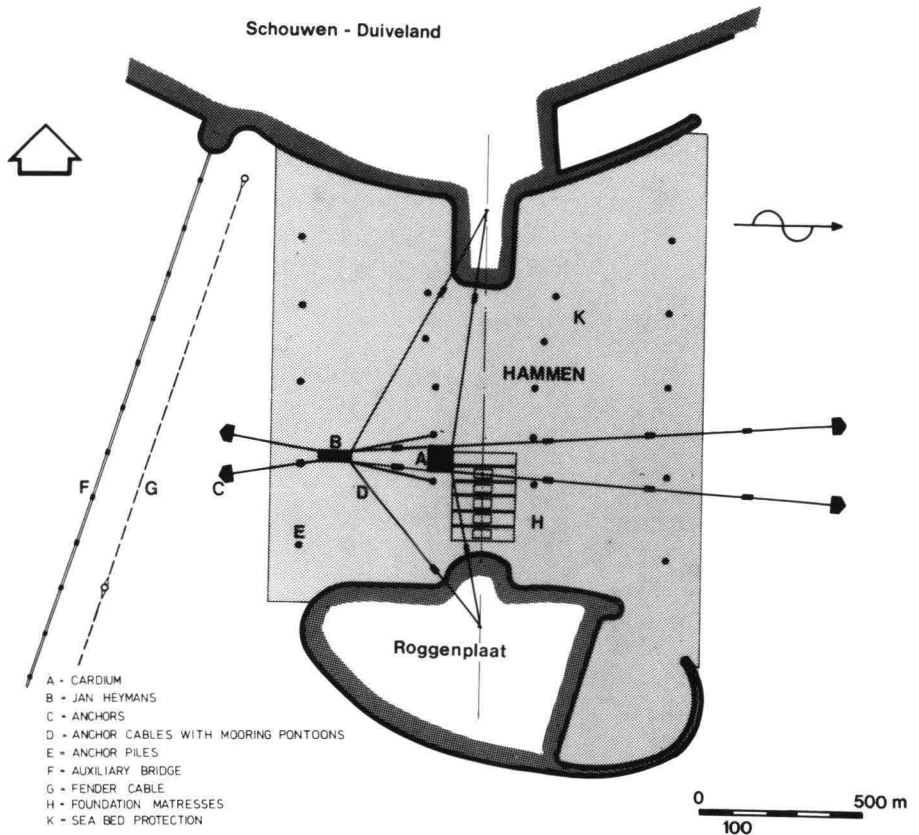

4
Velocity of tidal current in Roompot

5
Time-distance chart

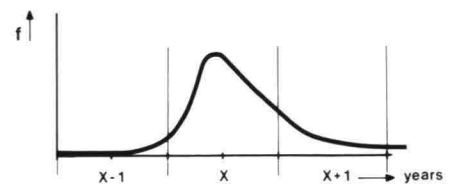

6
Probability of completion in time

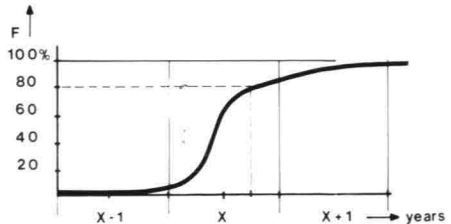

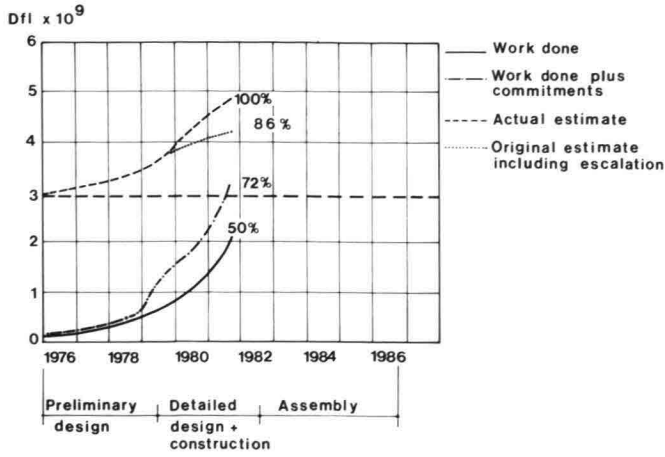

7
Development of cost estimate and expenditure

8
Development of cost estimates for some North Sea projects

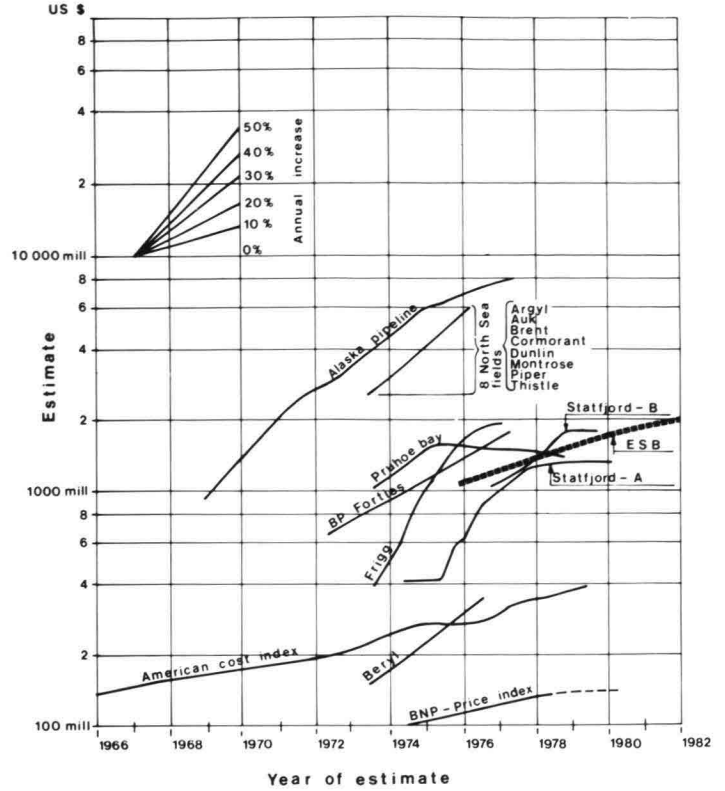

2. Decision-making in design and construction

In an earlier article it has been explained that a contract has been concluded with a consortium of civil engineering contractors. This contract fixes the terms under which prices are negotiated for design work and for construction. The implication is that the same group of engineers is involved first in the design and later in the construction. This was especially necessary because design work had to be done whilst construction was already under way, at first on the closed dam scheme, later on the barrier scheme. A second contract was placed with a consortium of construction contractors for the fabrication and placement of the steel gates and electro-mechanical equipment. This latter contract is a fixed price contract with variation clauses for adjustment to escalation. The design process takes place in mixed groups representing the civil engineering contractor and the employer. These groups report to a design board that sets out the main principles and checks the designs of the various groups for consistency with the main principles and for cost. Decisions are made at all levels of the design organizations by consensus of the different disciplines of engineering. This process of decision-making is time-consuming, but it has the enormous advantage that the

design is accepted by all participants. General acceptance of the design adds greatly to the motivation of the design managers that consecutively are in charge of constructing what they have designed. During construction however the roles of employer and contractor become more distinct. The contractor is given a fixed price contract for a portion of the job and his personnel is in charge of operations with the aim of profitable progress. The designers become inspectors and as such must not interfere with the construction line of command. They must be so informed at each decision level

so as to render them able to judge the soundness of the contractors' decision with regard to quality, time and cost. This requires a change in the employee's organization at the time when the construction progress is so fast that quick decisions must be made. Authority of a single man taking decisions must replace the group decision-making process of the design period.

9
Organization chart of contractor in relation to clients, design staff and supervisory staff

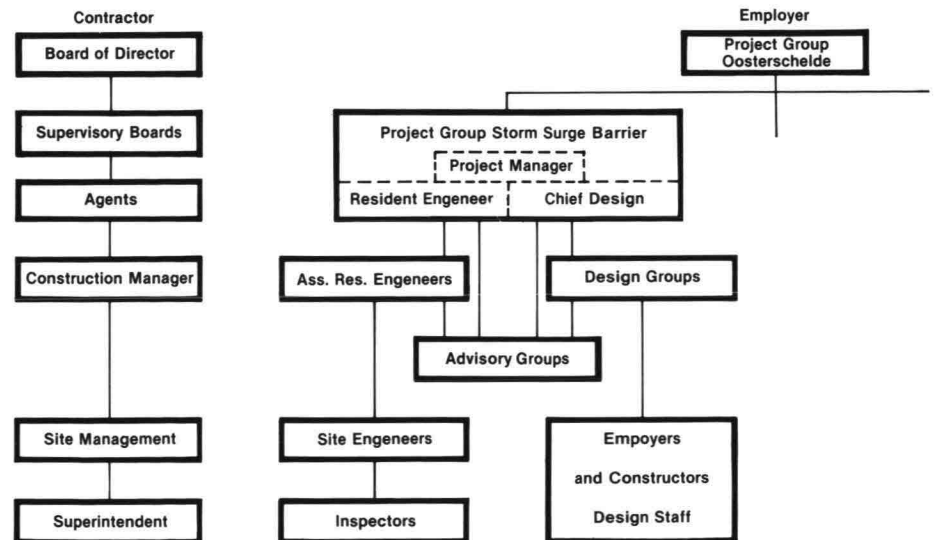

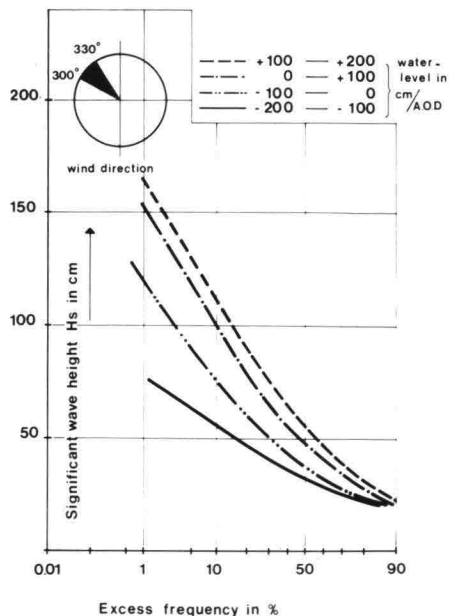

10a
Wave frequencies

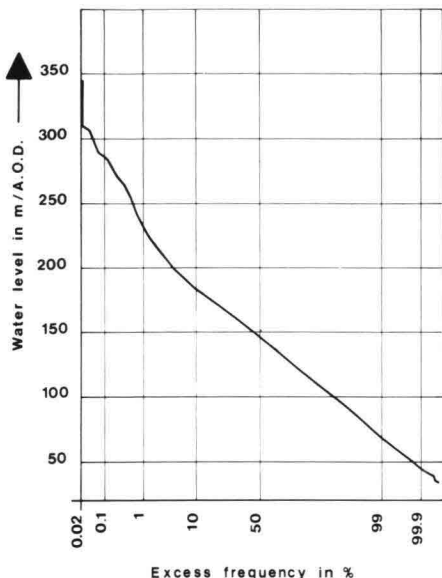

10b
Flood level frequency

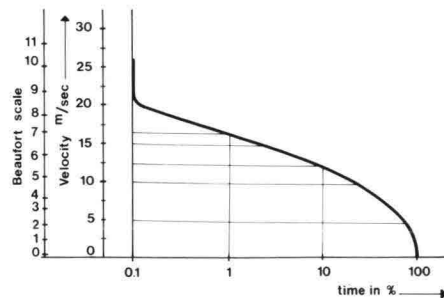

10c
Wind force frequency

The above process of changing the organization is a continuous activity, as some elements of the construction pass from the design to the construction stage earlier than others. Therefore during the past two years the organizations of both the employer and the contractor have gradually been changing from being design-oriented to construction-oriented.

The values of work done per annum is in the order of fl. 600/700 million under a multitude of contracts averaging fl. 20 million each. The assembly contracts are divided into five groups. The manager of each group is also in charge of supervising the prefabrication of the appurtenant elements.

The five groups are of similar relevance.

They are:

- soil improvement and abutments;
- mattress laying and rock placing;
- placing of piers and construction of special plant;
- placing of bridges, superstructure and capping units;
- placing of the steel gates and mechanical structures.

Each group has three decision levels. Decisions can be made autonomously by each group manager as long as the effects of his decisions do not affect the other groups. This is not often the case therefore many cross-references have to be made, controlled by the project management. The

decisions are governed by quality specifications and tolerance rules derived from an overall tolerance guideline. The five construction groups consist each of about 30 government employees. They are supported by just as many civil servants providing information, or furnishing support facilities to the construction groups.

The information and support functions are:

- survey and underwater inspection;
- risk analysis and tolerances
- research and natural conditions;
- architecture and landscaping
- administration and secretariat.

3. The supply of information

The storm surge barrier is situated on a most unfriendly coast. It is typified by shifting sands off unruly banks, storms generating incoherent waves and deforming the tidal curves to dangerous values, fogs that reduce the world to a few square meters. The prefabrication method reduces the opportunities of placing construction elements to less than two hours around the low water turn of the tide. There are only 10 such windows in a working week of 126 hours. Many of them will be useless due to bad weather. The remaining windows are precious and should be precisely forecast for optimum use. Therefore a unique facility has been created, called the hydro meteo centre, which makes special forecasts for the area not only as regards the weather, but also for the resulting waves, the tidal

set-up, and the tidal currents. Efforts are being made to also predict the transportation of sands by the tide and wave action.

The forecasts are put at the disposal of the contractor and the engineer to enable accurate planning of the operations in the channels at regular times. If ordered in advance, extra forecasts can be made for special occasions. The information thus available is accessible round the clock through an operator's counter on site, to which meteorologists, hydrologists and hydrographers supply their data. The operators have access to the information through written bulletins, radio broadcasts and telephone enquiries.

4. A manual for future use

Upon completion the barrier will be placed under the authority of Rijkswaterstaat (Ministry of Public Works). A complete set of revision documents must accompany the handing over. These documents consists in a written design bibliography plus drawings. The information contained in the revision documents must be so comprehensive that the control authority will be able to trace back every construction detail. During design and construction therefore the catalogue of data must be kept up to date. The time span of 10 years from concept to delivery is too long for the work to be allowed to be done at the end of construction period if for no other reason than staff rotations.

11
 Measuring instrument for sand in suspension

- LEGEND:
 A: INSTRUMENT CANISTER
 B: SOIL SAMPLING DEVICE
 C: TRANSDUCER CONFIGURATION
 D: ECHO SOUNDER

1. ABSORPTION RECEIVING TRANSDUCER
 2. TRANSMITTING TRANSDUCER
 3. TRANSMISSION TRANSDUCER

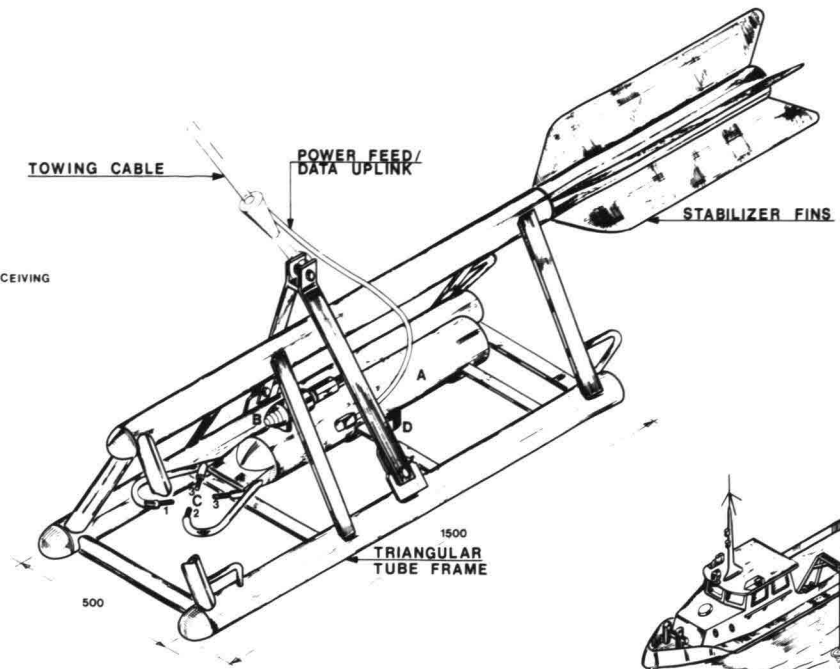

ACCOUSTIC DOPPLER SAMPLER
 WITH COMBINED ABSORPTION AND TRANSMISSION

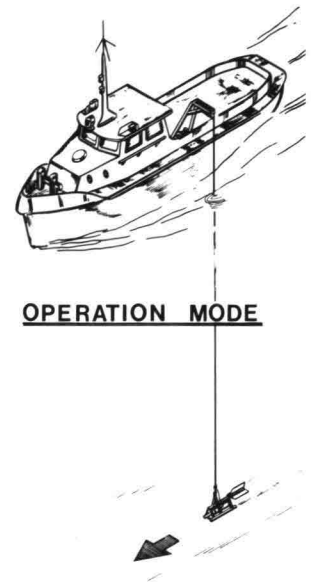

OPERATION MODE

Also the control unit must have a maintenance manual based on observations made and experience gained during construction. For that purpose some engineers of the operating department are already working on a draft maintenance manual within the project organization.

The decision whether to open or close the gates will have a wide effect on the environment of the Eastern Scheldt basin. The results will affect different interests in sometimes conflicting ways. For instance closure at low tide will negatively affect marine life on the mud flats that will remain uncovered during more than one ebb tide. The maintenance of the sea walls around the basin will however, be adversely affected if closure takes place during high tides.

A study is under way to define various strategies for closure and opening responding to possible approaching calamities such as storm surges or sea pollution. The result of the study will be that the barrier control unit will have at its disposal automated operating programs that can be run from the control tower. Emergency handling of each pair of gate pistons is an option that will be built into the box girder bridge. The operating strategies will be discussed prior to being laid down with all relevant parties in the area,

such as the fishing industry, the ecologists and the polder authorities responsible for the sea walls. During the construction period the four subjects discussed above form part of the daily concerns of the project management team.

The multifunctional purpose of the barrier enlarges the scope of experience gained by the builders beyond pure technicalities. It is our conviction that this kind of experience has a value that can not be expressed in money, but which will make the barrier construction profitable when put to use world-wide.

An other, more direct, source of income is the sale of the special plant that has been financed by the employer. Already, even before the vessels are at work, a world-wide campaign is advertising the capacities and the possible use of the equipment. The expertise in doing unusual things with unusual machines is also available through our contractors, who by the time our job is finished will be perfectly capable and willing to serve you.

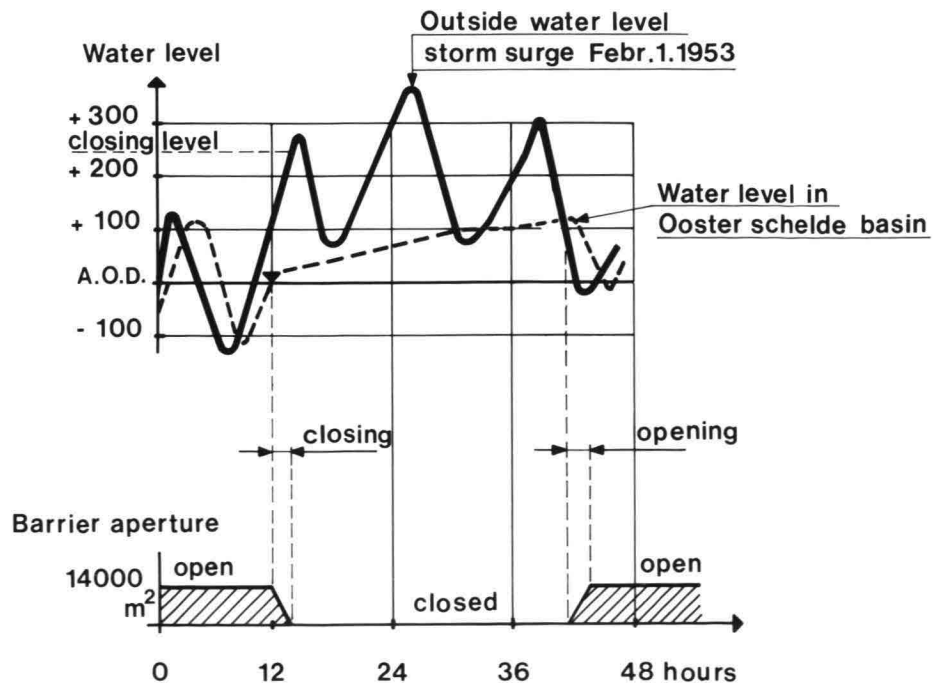
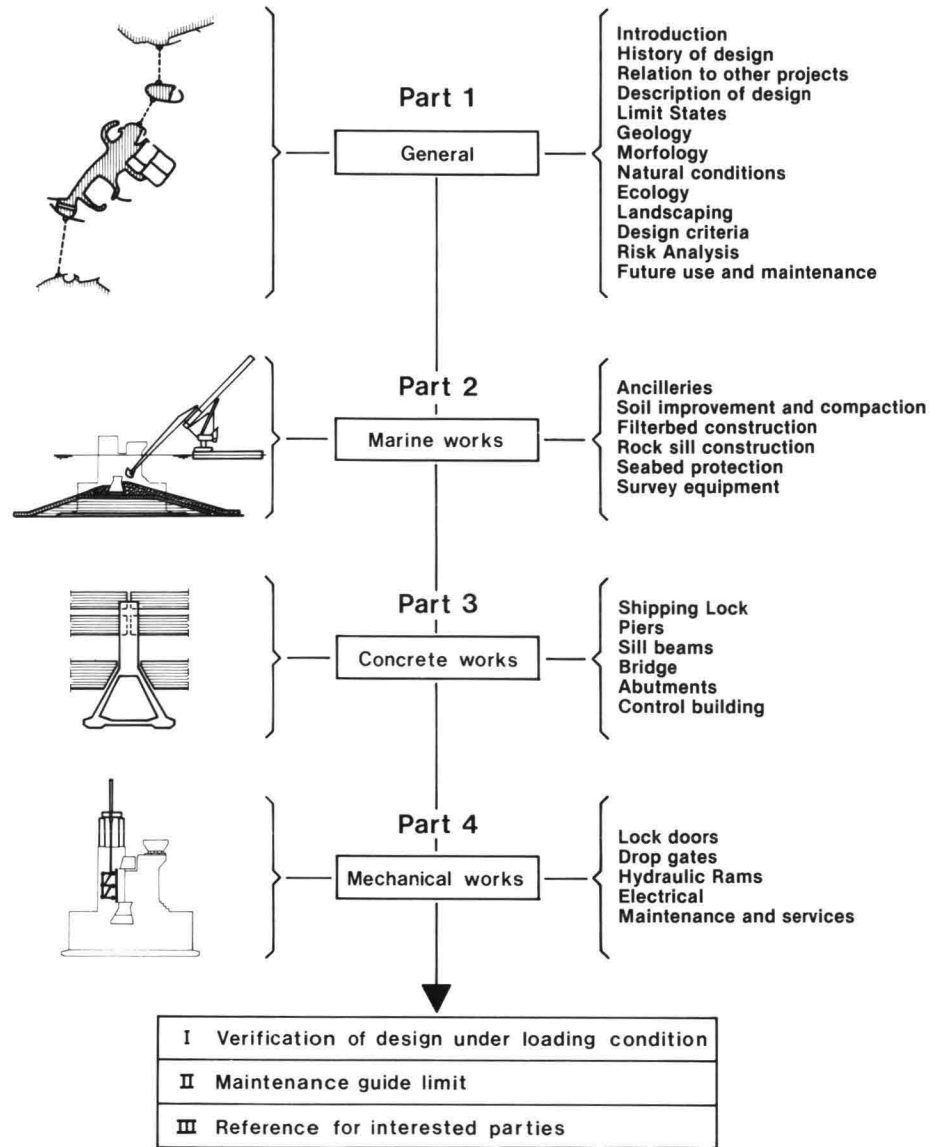

Operations

Transport and placing of 18,000 tons piers

Introduction

Building a storm surge barrier in the Eastern Scheldt surroundings poses many problems caused by prevailing natural conditions. The Eastern Scheldt, an inlet of the North Sea, although not subjected to offshore conditions, is still affected by rather strong wave movements. During operations waves may reach a significant height of one metre, and under extreme circumstances equipment and construction may have to withstand wave heights of up to 2.50 m. Another of the prevailing circumstances is the tide. In the present situation a maximum current velocity of 2.50 m/sec occurs at least once a year. As during construction the channel openings are reduced this velocity will increase to a maximum of 6 m/sec.

The third important natural condition is the constant movement of sand. The above mentioned tidal currents cause the sand to be swept up from the river bed when the current velocity increases and to be deposited again when velocity decreases. The total quantity of sand shifting across the axis of the barrier amounts to between $25 \cdot 10^6$ and $50 \cdot 10^6$ m³ per year. These natural conditions were decisive factors in the choice of a design and a corresponding method of construction based, as far as possible, on prefabricated elements. This plan reduces construction risks in the three channels. Now, a number of assembly operations of restricted duration can be carried out when prevailing conditions are most favourable.

The largest components are the 66 prefabricated concrete piers which are to be installed on a foundation bed, laid beforehand and itself also prefabricated. The piers themselves, with bottom slab dimensions of

25x50 m, a height of maximum 40 m and a maximum weight of 18,500 tons, will serve as a foundation for the other concrete components, such as the road bridge box girders, sill beams, upper beams and sliding steel gates.

History

Apart from various general quality aspects an important factor involved in the assembly of a prefabricated construction is to make everything fit. This is of particular relevance in the construction of the storm surge barrier.

In order to ensure that the road bridge box girders, the sill beams, upper beams and, in particular, the sliding steel gates will fit properly, tolerances in respect of translational displacements in x, y and z as well as rotations ϕ_x , ϕ_y and ϕ_z of the pier positions are of the utmost importance (fig. 3).

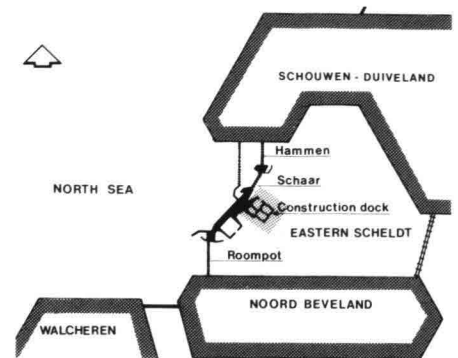

1 Eastern Scheldt area

2 Concrete pier

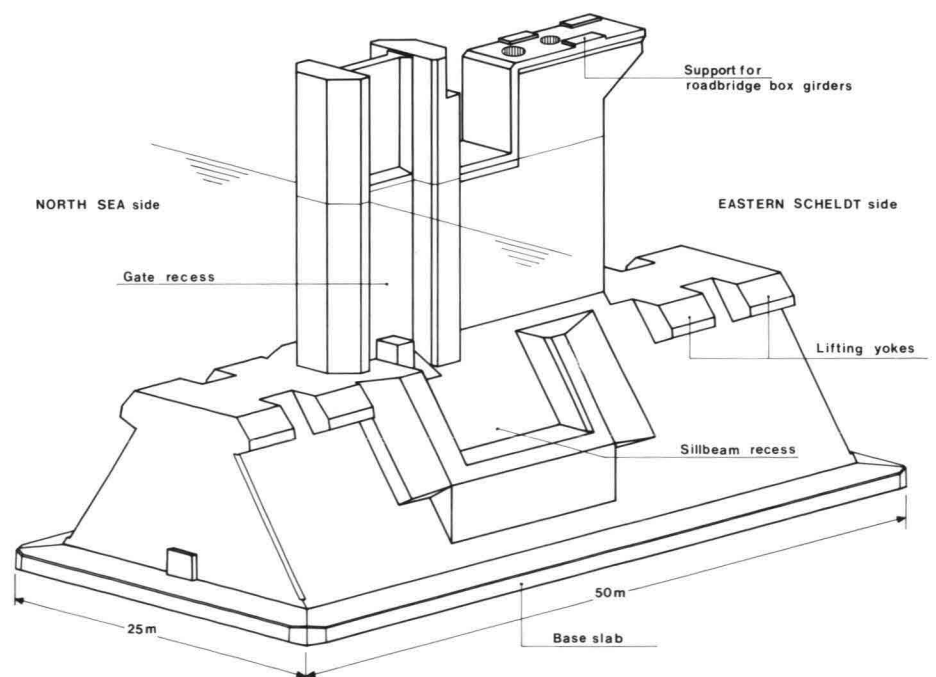

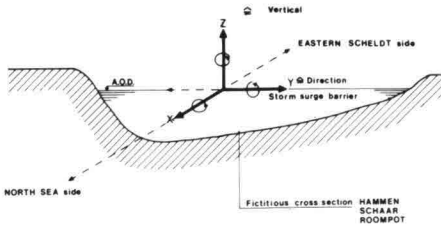

3 Local grid

Because of this tolerance problem a lifting vessel equipped with four legs was initially envisaged. This would lower the pier with great accuracy to just above the foundation bed which would already have been cleaned and levelled to tolerances of plus or minus 25 cm.

With the pier in this position the remaining space between the bottom slab of the pier and the foundation bed would then be filled with grout. An operation such as this would restrict all six variables of the pier within precise parameters. Although it would have been the ideal solution to the tolerance problem, it had to be abandoned for a number of reasons. The most important ones were:

- the vulnerability of the grouting operations;
- the duration of the operational cycle in the channel, particularly if account were to be taken of possible interferences, and the ensuing risk of extreme conditions which the equipment might not be able to withstand.

An alternative solution was based on the idea of a foundation bed, laid with the utmost precision, upon which the pier could be directly installed. Within this solution the variables in z and ϕ_x and ϕ_y would be determined by the foundation bed. The installing operation would then be subject only to certain requirements in respect of tolerances in the x and y -direction and in rotation about the z -axis. It was thought that the problem might possibly be resolved by using a lifting vessel equipped with spuds which would rest on the foundation bed. Then, with the aid of a guiding frame, the pier could be positioned between the legs of the vessel with the greatest accuracy in x and y as well as in ϕ_z -direction.

This proposal also caused a great deal of design problems which were related to:

- possible damage of the foundation bed by the spuds;
- too great a load on the legs in extreme conditions.

In the meantime, however, several other alternatives had been studied and developed both in theory and in the laboratory. On this basis of calculations and tests with the model the final choice was that of a lifting vessel without legs.

This lifting vessel, secured by an eight cable mooring system, will position the piers within tolerances of 30 cm in the x and y -direction and within 7 mm/m rotation about the z -axis. Together with tolerances for the foundation bed of plus or minus 15 cm in z -direction, of 8 mm/m in ϕ_x direction and of 4.50 mm/m in ϕ_y direction, these positioning tolerances result in an acceptable solution for the problem of fitting the other components. These tolerances, however, are related to deformations existing during the final stages of the operation and due only to deformations in the foundation. This means that sand must be prevented from being deposited on the foundation bed itself and between foundation bed and installed pier, as this could be swept away in the final stages and cause extra deformation. Consequently, the foundation bed has to be swept clear of sand just before the

positioning of the pier within the same turn of the tide period. This requirement and the fact that the lifting vessel has to be moored within the shortest possible time, have led to the design of a dual-purpose mooring and cleaning-up pontoon, equipped with a dustpan suction head, about 28.50 m in width.

The final decision, therefore, favoured the use of a lifting vessel, the *Ostrea*, to collect the pier in the construction dock, and to transport it to the designated location in one of the channels.

After arrival on site the vessel will be secured to the mooring and cleaning-up pontoon, the *Macoma*. Just before the turn of the tide lifting vessel and mooring pontoon together, secured by eight mooring cables, will be warped so that the pontoon, in passing over the foundation bed, can perform the final dredging operation. Around the turn of the tide the pier is then installed within the required tolerances.

Short description of equipment

Ostrea: measurements and output

The *Ostrea* (fig. 5) is a vessel with a U-shaped hull which can be positioned around a pier. The principal particulars are: length 87.25 m, width 47.00 m, depth 12.50 m, well width 22/16 m, well length 69.75 m, draught approx. 10.00 m, height above waterline when loaded 47.00 m, total machinery output 6,845 kW (9,300 hp).

4 Lifting vessel with legs

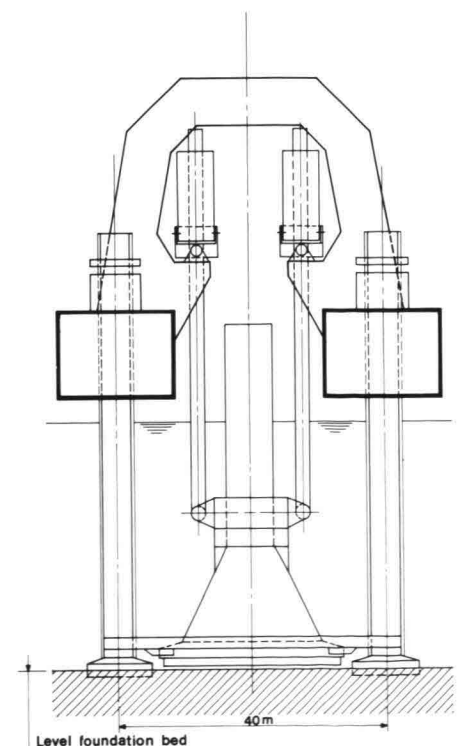
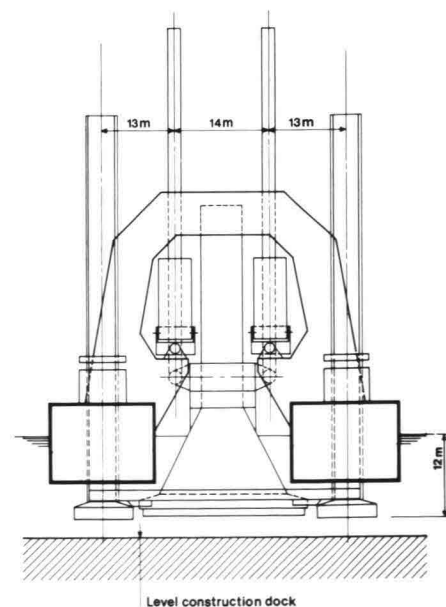

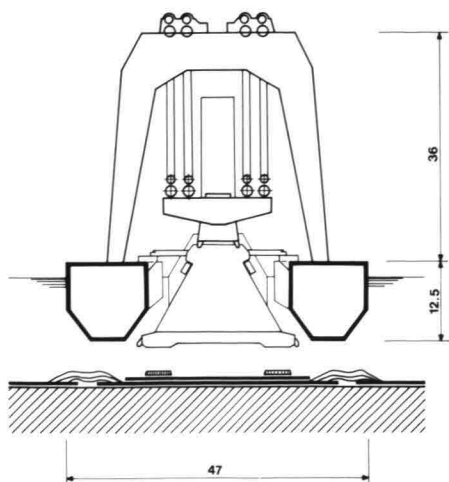

5
Lifting vessel Ostrea

After the hoisting tackles of the Ostrea have been attached to the pier the well is closed off for added strength with a heavy boom of 3.50 x 1.80 m.

Hoisting equipment: in order to lift the pier two gantry cranes, rising respectively 36 m and 24 m above deck level and equipped with multiple lifting systems with a lifting capacity of about 10,000 tons, have been mounted on the vessel. Each gantry crane has four tackles from which a heavy hoisting beam is suspended. Each tackle consists of two 28-sheave blocks and a cable of 64 mm diameter.

Each hoisting beam has two clam attachments which fit underneath the pier's lifting yokes.

The 315 kW winches, installed below deck, are of the continuous type, and consist of a separate hauling and a separate winding winch.

Pier buffers:

during transport the pier is kept in position aboard the vessel by ten buffers of which four are positioned lengthways, four sideways at deck level and two sideways in the lower gantry.

The buffers consist of heavy hydraulically operated rams with a nominal operating pressure of 220 bars.

Mooring:

for mooring purposes four 800 kN anchor winches, each with a pulling power of 1,400 kN, have been installed on board the Ostrea. In the ends of the U-shaped hull heavy coupling pins which can transfer a load of 8,000 kN have been mounted to connect the Ostrea to the Macoma.

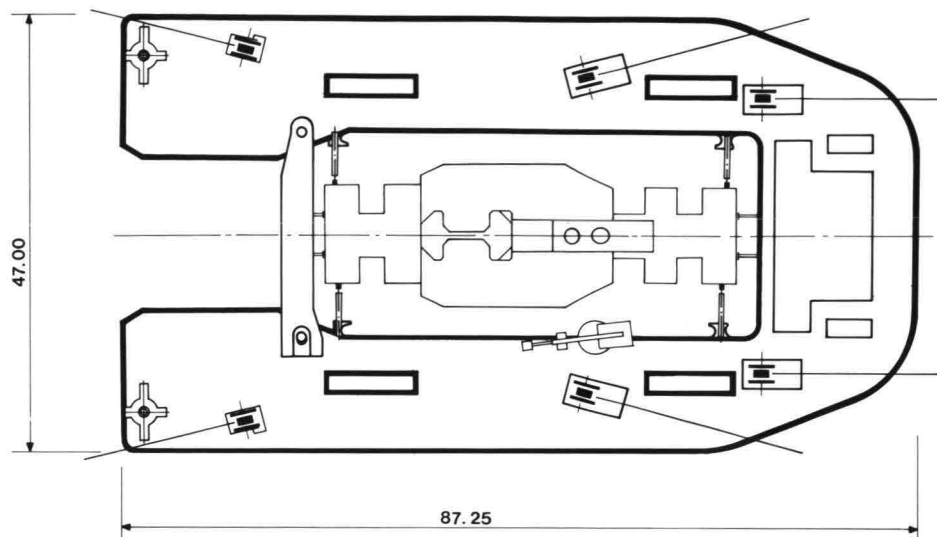
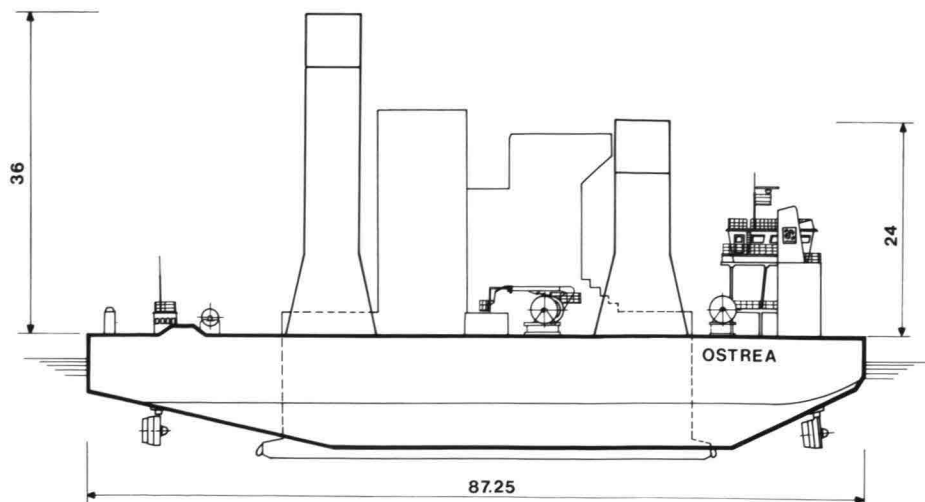

Furthermore, for mooring in the construction dock and to assist in the coupling operation the vessel is equipped with two ancillary winches of 300 kN, producing a pulling power of 750 kN.

Propulsion:

after detailed studies the vessel has been equipped with some propulsive power of its own to increase its manoeuvrability in the construction dock and during mooring operations in the channels.

At each of the four corners of the Ostrea a Schottel rudder propeller with an output of 1,335 kW (1,800 hp) has been installed.

Additional propulsive power during transport is provided by tugs.

Control:

all operations are controlled from a central control room equipped with a general control console and separate ones for mooring, lifting and navigating operations.

Macoma: measurements and output
The shape of the Macoma (fig. 6) is

such that it is tapered in width. The principal particulars are:

length of hull 45.00 m, length overall 67.10 m, width 33.60/47.50 m, depth 5.80 m, draught 2.25 m, freeboard 3.55 m, total machinery output 5,050 kW (6,860 hp).

Mooring: the mooring of the vessel is carried out with the aid of eight winches, i.e. four 1,000 kN, two 900 kN and two 600 kN winches. The vessel is connected to the Ostrea by means of the afore mentioned 8,000 kN coupling system.

For this operation the Macoma is equipped with four horizontally mounted hydraulic rams of which two are positioned lengthways and two sideways.

Each cylinder transfers the required pulling power via two steel cables to a steel ring fitted over the pin construction on board the Ostrea.

Dredging installation

The Macoma is equipped with a dredging ladder. Mounted on this ladder and supported by rollers are six dustpan suction heads designed to

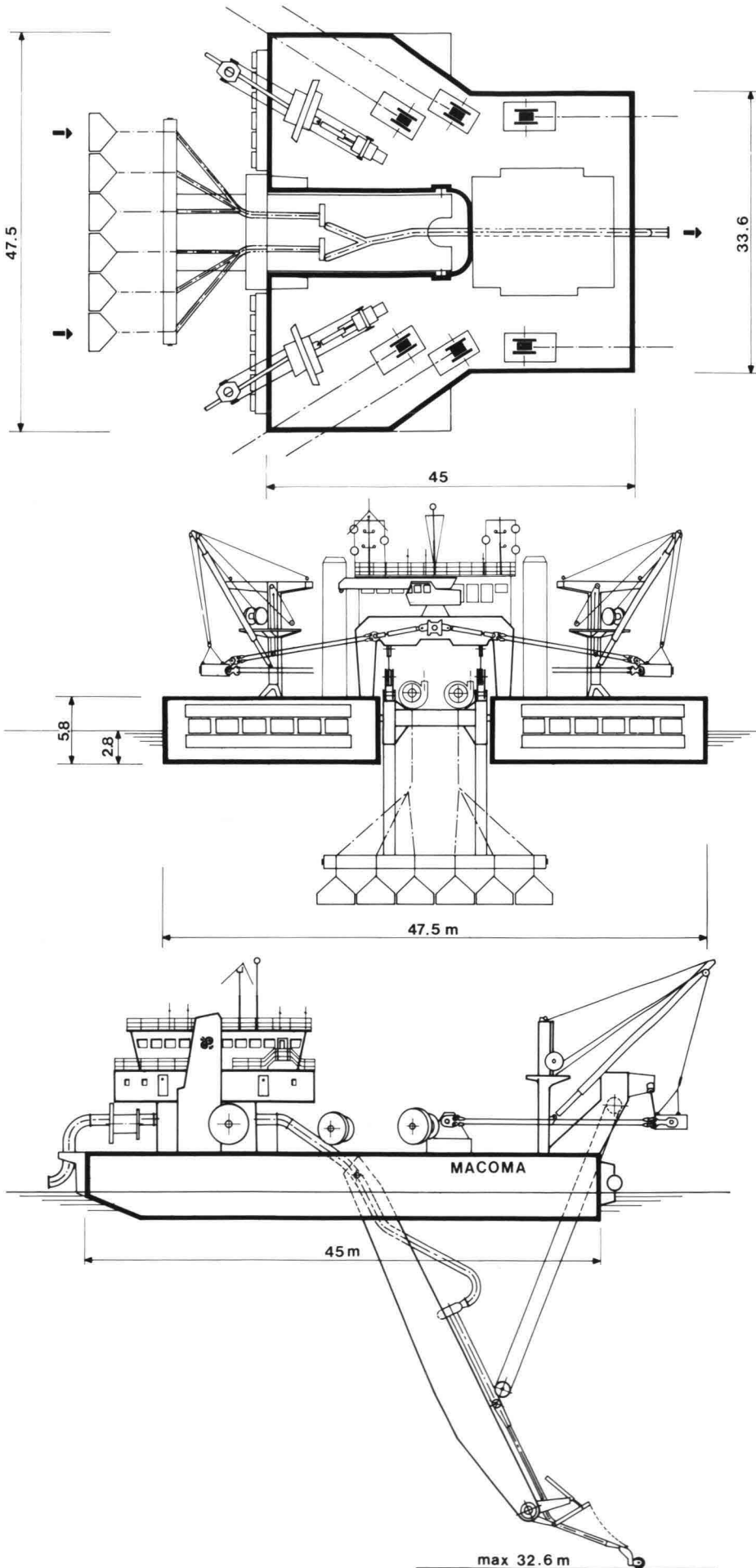

6
**Mooring and cleaning-up pontoon Ma-
 coma**

clean up the foundation bed. The heads are each 4.70 m wide and the overall width, inclusive of spaces between the heads, is 28.50 m.

For every three suction heads an underwater pump has been installed powered by an electric motor with an output of 800 kW and with nominal capacity of 2.30 m³ of sand/water mixture per second.

To bring the sand deposits into suspension a jet system consisting of three rows of jets with a total output of 0.04 m³/sec/m has been installed on top of the heads. Additionally, air can be pumped through the jets at a nominal amount of 2 m³/sec under a pressure of 4 bars. The shape and dimensions of the dustpan heads were decided upon after extensive tests with a model on a scale of 1 to 4.

Control:
 the Macoma also has a central control room equipped with a general control console and separate ones for dredging and warping operations.

Operating method

Mooring

The various craft used in the building of the storm surge barrier cannot be anchored in the conventional way as this could damage the extensive mattresses already laid to protect the seabed. To make mooring possible within the working site anchor piles have been installed. These anchor piles consist of tubular poles with a diameter of 1.40 m, driven 10 to 15 m into the seabed and protruding 1.50 m above it.

On top of each anchor pile a revolving head piece has been mounted to which, via a shaft and shackle, a mooring line of 84 mm is attached. The piles can withstand an operating load of 200 tons and have a breaking load of more than 300 tons. Whilst the anchor pile is not in use the

7

Block mattress on top of the filter mattresses

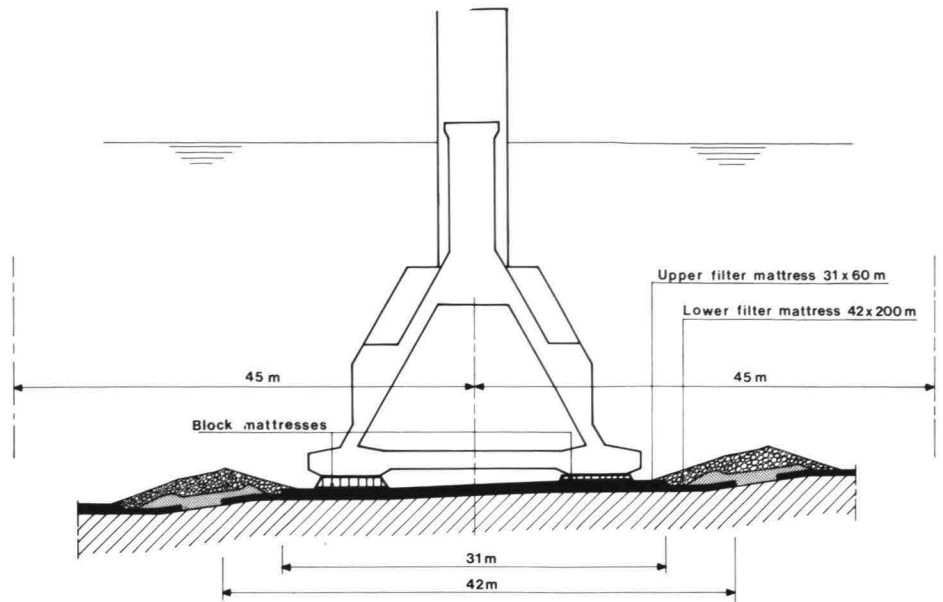

mooring line is attached to a buoy by means of a hauling wire. When a working vessel is to be moored to such an anchor pile the mooring line is hauled above water by means of the hauling wire and coupled onto the anchor cable of the vessel concerned.

Preparations along the barrier axis in the channels

The foundation bed consists of prefabricated filter mattresses laid by a specially developed rig (fig. 7). There are two mattresses the first of which measures 42 x 200 m and consists of three filter layers, containing respectively sand of 0.3-2.50 mm, gravel-sand of 2-8 mm and gravel of 8-40 mm.

The second mattress, measuring 31 x 60 m, consists of three layers of gravel of 8-40 mm and serves as a protective covering for the first underlying mattress immediately beneath the base of the pier.

As the filter mattresses are laid at a centre to centre distance of 45 m there is some space left between them which will be filled with loose filter material.

After the mattresses have been laid a very accurate profile of the foundation bed is made. On the basis of this profile two block mattresses with counter profiles are manufactured consisting of concrete blocks connected to each other by steel cables. These block mattresses will be positioned on top of the filter mattresses in order to obtain as flat a surface as possible.

The positioning of these block mattresses will be carried out by the pontoon DOS I which, for years, has been involved in seabed protection operations (fig. 8).

The block mattresses are manufactured on a loading quay and are

8

Laying the block mattress with the Dos I and Macoma

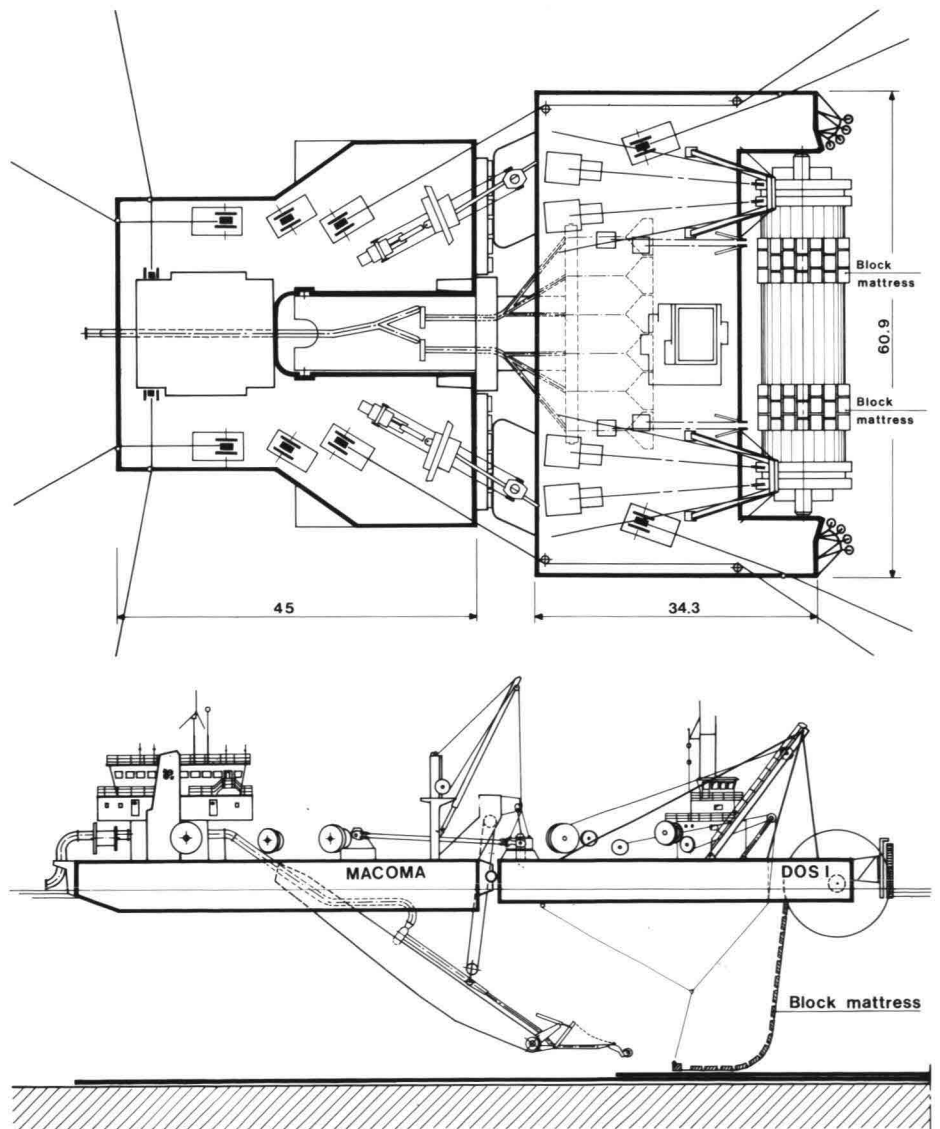

Anchoring system of the Dos I and Macoma

wound onto a floating cylinder which is then towed and attached to the DOS I.

Before these block mattresses can be laid, however, the foundation mattresses have to be cleaned up because of possible deformations affecting tolerance parameters, as has already been mentioned. These cleaning-up operations are carried out by the Macoma which, for anchoring reasons, will be working in the channel at least four pier locations ahead of the pier most recently installed. The vessel will be moored partly to anchor piles and partly to piles on shore or to piers already positioned, depending on the location (fig. 9).

The greater part of the sand deposits which, in some areas, may be many metres thick will be dredged by the Macoma and removed downstream via a 300 m long floating pipeline. After this 'preliminary' cleaning-up process DOS I will be moored to the Macoma at the turn of low tide. Then, at the turn of the next high tide, the cylinder with the block mattress will be towed to the DOS I. Again six hours later, at the next turn of low tide, the combined Macoma and DOS I will be warped first seawards for the final clean-up of the foundation bed by the Macoma, and then landwards for the block mattress to be laid. After this operation has been completed it will be decided whether the next block mattress is to be laid or the appropriate pier is to be installed. This decision depends on progress, location, weather conditions, the amount of sand deposits, mooring pattern and many other factors.

Activities of the Ostrea in the construction dock

After a pier has been installed the Ostrea will return to the construction dock. A decision is then to be made as to whether the vessel should be moored alongside the specially constructed jetty or around a pier, or whether it should lift the next pier. This decision will also depend on the progress of operations, weather conditions, sea conditions in the channel as well as on the actual day and time. The whole operational process is based on three shifts working a six day week. This means that, in view of

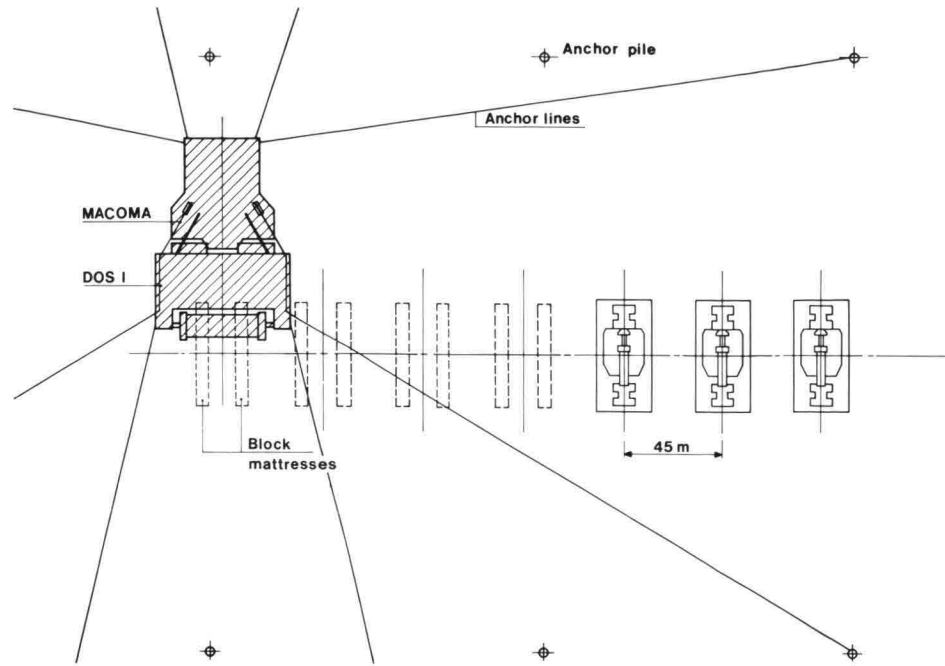

the time needed to position a pier, no installing operation will be started after 19.00 hours on Thursdays. When it has been decided to go ahead with the installation of the next pier the Ostrea, under its own propulsive power and using ancillary anchoring points on shore, will manoeuvre itself around the pier concerned. The hoisting tackles will then be paid out and the claw attachments fitted under the lifting yokes of the pier. After the claw attachments have been fastened onto the concrete lifting yokes the closing beam is fitted and secured across the open side of the well. The pier can now be lifted (fig. 10).

As the pier is hollow and contains no water, it develops its own buoyancy of 9,000 tons. The greatest load to be lifted by the Ostrea is, therefore, in the case of the heaviest pier about 9,500 tons (18,500 minus 9,000 tons). When the Ostrea lifts the pier from the bottom of the construction dock the draught of the vessel will increase by about 6.50 m to 9.50-10.00 m, depending on the weight of the pier to be lifted.

To keep the pier in place horizontally hydraulic buffers have been fitted around the well and along one of the gantries of the Ostrea. The draught of the suspended pier itself will be about 11 metres.

10 Lifting device of the Ostrea

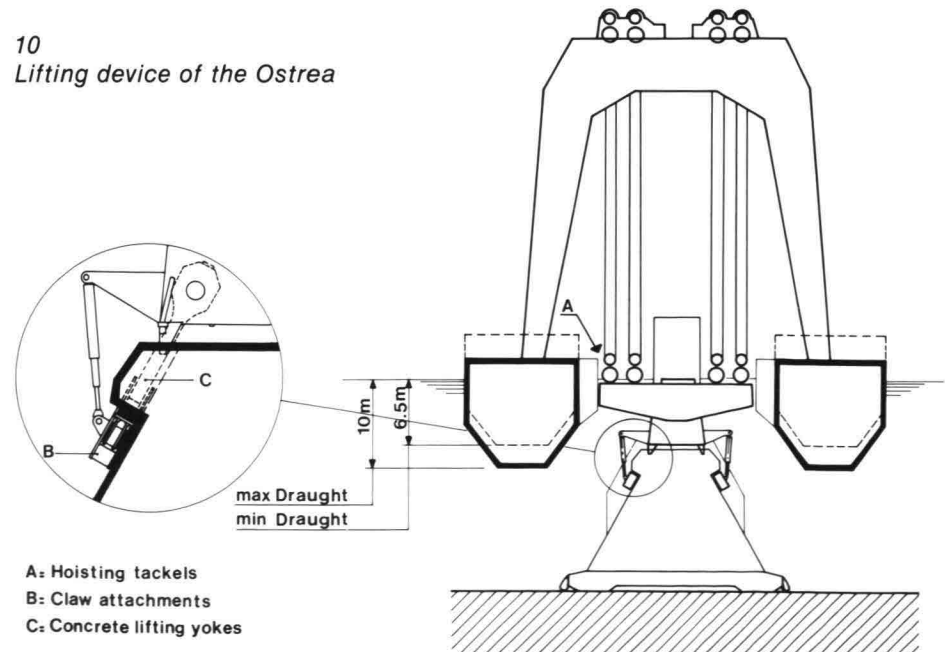

11
 Routes from construction dock to
 Hammen, Schaar and Roompot chan-
 nels

The lifting vessel with the pier will then manoeuvre out of the construction dock.

Transport:
 depending on where they are to be installed, the piers will have to be transported over distances of up to 23 km as only navigable channels between the existing sandbanks can be used.

The depth of the routes to be taken should be 15 m below Amsterdam Datum Point to allow for a low tide level of 2 m below Amsterdam Datum Point, a keel clearance of one metre and a tolerance of one metre to take into account possible sanding-up and sounding errors. The channels to be used should be 200 m wide at a level of minus 15 m, this being about twice the vessel's diagonal.

Transport is planned to take place with the flow of the current. The required power, however, is determined by the condition that the *Ostrea*, for reasons of safety, must be able to travel with a speed of 0.50 m/sec in relation to the seabed against the flow of the current which, along the transport routes, may reach a velocity of maximum 2 m/sec. It has been calculated that to achieve this an extra 4,500 kW will be needed in addition to the vessel's own propulsive power of 5,350 kW. This power will have to be provided by at least two easily manoeuvrable tugs.

The conditions which will allow the transport to take place and on which the design of the quipment has been based are:

- significant wave height 0.75 m;
- mean wave period 4 sec;
- maximum current velocity 2 m/sec;
- maximum wind velocity 15 m/sec;
- visibility 500 m.

An additional condition is that when the vessel leaves the construction dock the current velocity must not exceed 0.75 m/sec.

As transport takes place with the flow of the current, mooring facilities have been provided at the turning point in the estuary for the *Ostrea* to await the turn of the tide (fig. 11). The lifting vessel with the pier must arrive at the appropriate location in the channel when the current velocity is diminishing and is less than 1.25 m/sec.

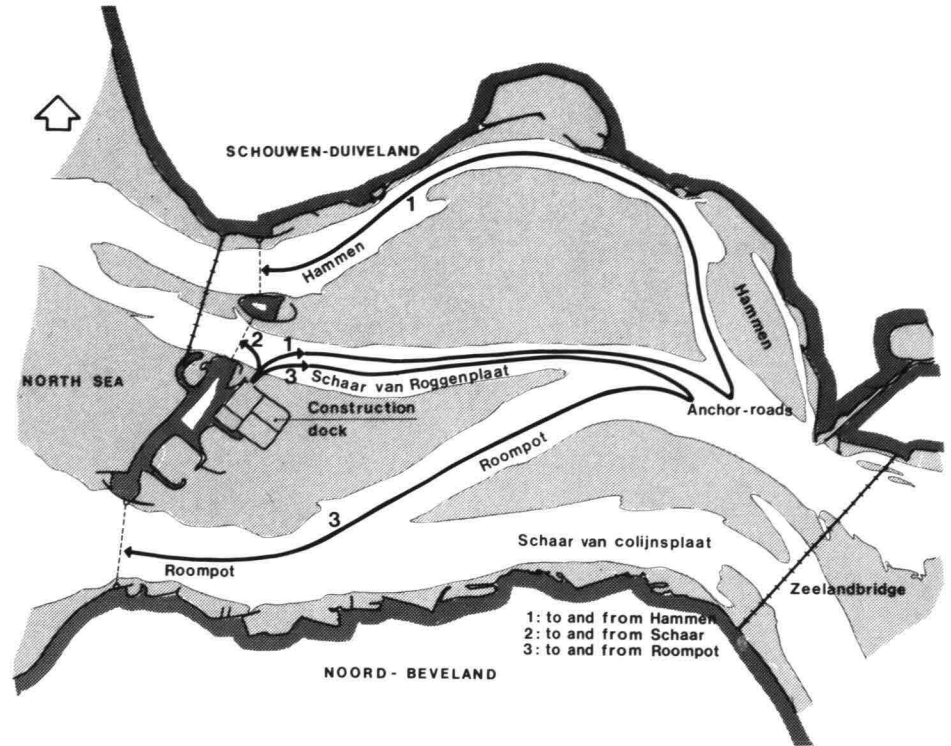

After arrival towards the turn of low tide the *Ostrea* will be moored to the *Macoma*. The combined vessels will be secured with an eight cable anchoring system (fig. 12).

Installing the pier

After the vessels have been moored at the turn of low tide the installing operations proper can commence. The foundation bed, consisting of two filter mattresses and complemented by the block mattress, will have been cleaned up previously by

the *Macoma*. During this cleaning-up operation certain complications occur. These are due, on the one hand, to dredging restrictions in a horizontal direction, caused by the presence of loose material between two foundation mattresses, and, on the other hand, to the change in distance between the dustpan heads and the foundation bed, when covered by block mattresses (fig. 13).

The horizontal restriction problems have been solved by accurate positioning of the loose material through a pipe lowered from the vessel *Jan Heijmans* and by careful adjustment of the dustpan heads of the *Macoma*, i.e. plus or minus 0.75 m.

12
 Anchoring system of the *Ostrea* and *Macoma*

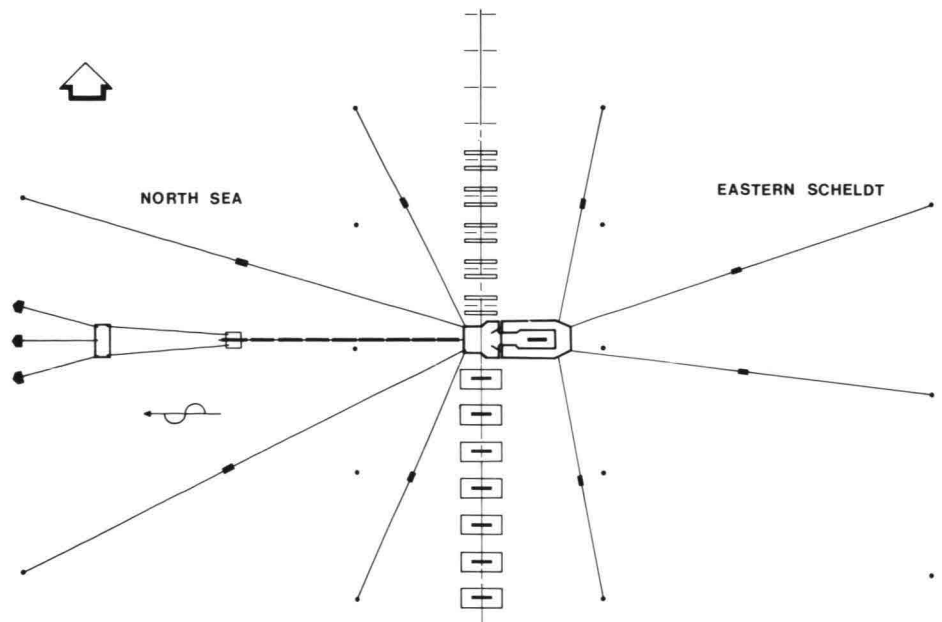

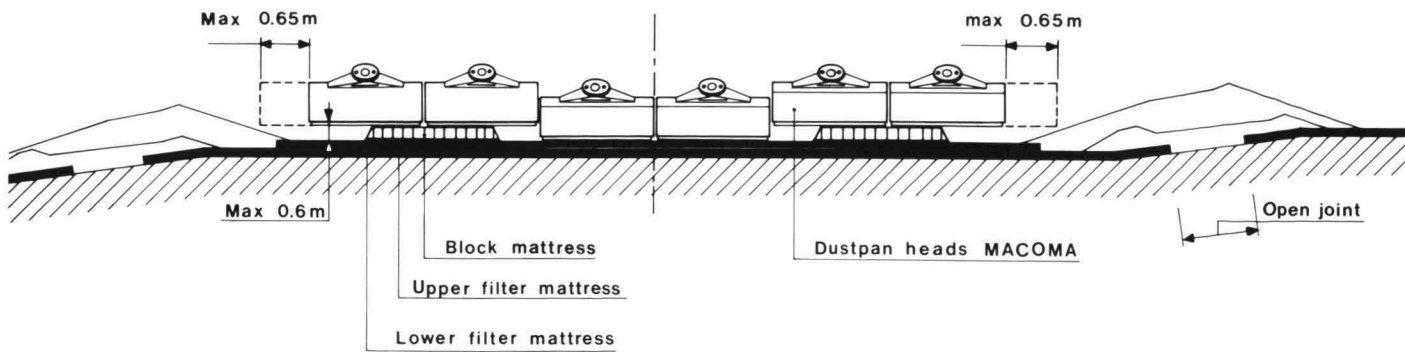

13
*Dustpan heads of the Macoma on
 and between the block mattresses*

The maximum 0.60 m vertical distance between the dustpan heads and the foundation bed is a result of extensive tests in the laboratory. An absolutely clean foundation bed can be achieved by the careful positioning of the jets, which is a decisive factor in ensuring the best results, and by the provision of a combined water/air system for the final cleaning-up operation. This operation will be carried out only just before the pier is installed at the turn of low tide, following the low tide at which the *Ostrea* has been moored.

The turn of low tide has been chosen as being the best time to install the pier for several reasons:

- movement of the pier during the installing operations is dependent on wave and current conditions. The turn of the tide is the most favourable period as the current significantly decreases. Wave conditions tend to be more favourable at the turn of low tide rather than at that of high tide;
- in the Eastern Scheldt the duration of the turn of low tide is much longer than that of high tide;
- cleaning-up operations combined with the mooring of the *Ostrea* on the Eastern Scheldt side can be accomplished much more easily in the current conditions prevailing at the turn of low tide.

As soon as the current of the outgoing tide decreases to 1 m/sec the combined Macoma/*Ostrea* will be warped over the foundation bed and the final cleaning-up operation will be carried out. In view of the fact that the cleaning-up operation is of vital importance the Macoma is equipped not only with the normal recording instruments used to monitor the dredging process, but also with a number of sand detectors mounted behind the suction heads and designed to

check the cleaning-up process. These detectors have been mounted in such a way that it is possible to check the angle between tile mat and foundation mattress, in particular. Simultaneously, the various locking devices and buffers between vessel and pier are retracted, and the lowering of the pier is started as soon as the current velocity reaches less than 1 m/sec.

At the turn of the tide, when current velocity is less than about 0.20 m/sec, the pier is installed onto the foundation bed within the prescribed tolerances of plus or minus 30 cm in the x and y-direction, and of 7 mm/m in the ϕ_z direction. It has been calculated that this operation can be carried out under the following wave conditions: $H_s = 0.75$ whilst $T = 3-4$ sec, and $H_s = 0.35$ m whilst $T = 7-8$ sec.

When 20 percent of the pier's weight has been transferred to the foundation bed the position is carefully checked.

After the required confirmation has been obtained the final stage of lowering the pier is completed. When the pier rests completely on the foundation bed the *Ostrea* will be disconnected. Next, gravel-filled bags, so-called 'sausages', attached to the pier's base, will be released to close off the cavity between the bottom slab of the pier and the foundation bed. The mooring lines will be detached and the *Ostrea* will be ready to return to the construction dock.

This whole operation will take about 45 hours (*fig. 14*). In order to carry out the operation a system of weather forecasts for periods of up to 6, 12, 24, 48 and 72 hours has been set up. On the basis of these forecasts subsequent decisions will have to be taken as to whether or not to proceed

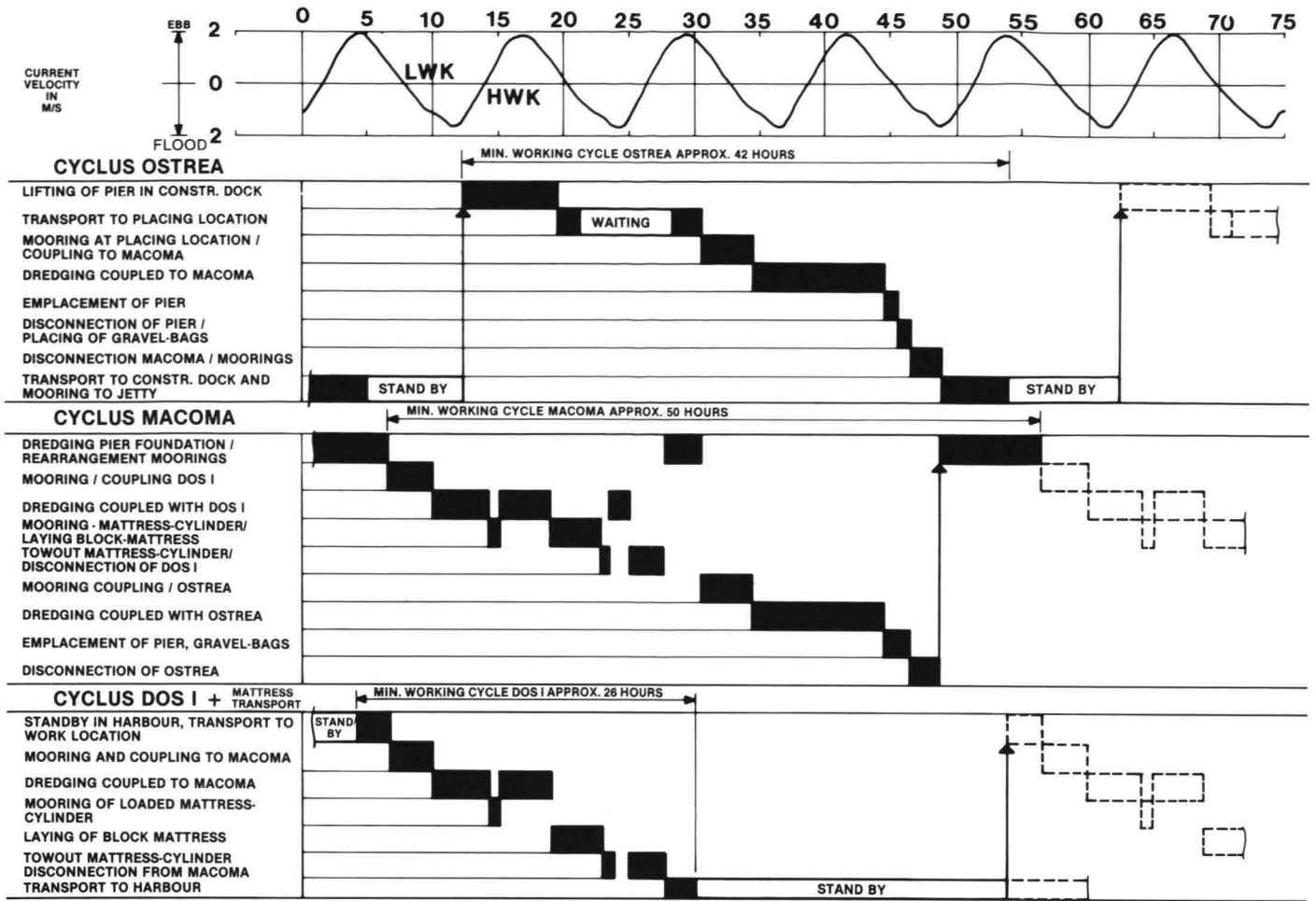

14 Working cycle of Ostrea, Macoma and Dos I

with the next stage of the operation. These decisions will have to be made at the moment the pier is on the point of leaving the construction dock, when the turning point half-way along the transport route is reached, at the moment of mooring and immediately before installation of the pier.

As the latter process has been delayed, the preparatory operations for the installation of the piers can be carried out at a steady pace. The schedule of the whole operational process is set out in the diagram of figure 15.

The most outstanding date is, undoubtedly, 1 April 1983, as by that time the first pier is to be installed.

Schedule

The schedule of the whole operational process is dependent on the building time and, therefore, completion dates of the various vessels involved, as well as on the progress of laying the foundation bed.

15 Time schedule

| | 1982 | | | | | | | | | | | | 1983 | | | | |
|----------------------|------|------|-------|-------|-----|------|------|-----|------|-----|-----|-----|------|------|-------|-------|-----|
| | Jan | Febr | March | April | May | June | July | Aug | Sept | Oct | Nov | Dec | Jan | Febr | March | April | May |
| OSTREA | | | | | | | | | | | | | | | | | |
| Construction | █ | █ | █ | █ | █ | █ | █ | █ | █ | █ | █ | █ | █ | █ | █ | █ | █ |
| Yard-trials | | | | | | | | | | | | | | | | | |
| Training and try-out | | | | | | | | | | | | | | | | | |
| Start production | | | | | | | | | | | | | | | | | |
| MACOMA | | | | | | | | | | | | | | | | | |
| Construction | █ | █ | █ | █ | █ | █ | █ | █ | █ | █ | █ | █ | █ | █ | █ | █ | █ |
| Yard-trials | | | | | | | | | | | | | | | | | |
| Training and try-out | | | | | | | | | | | | | | | | | |
| Start production | | | | | | | | | | | | | | | | | |
| DOS 1 | | | | | | | | | | | | | | | | | |
| Reconstr. and trials | | | | | | | | | | | | | | | | | |
| Training and try-out | | | | | | | | | | | | | | | | | |
| Start production | | | | | | | | | | | | | | | | | |

Research on concrete

Durability testing

1. Introduction

The Eastern Scheldt barrier must be safe and servicable in operation during a long life set at 200 years. Moreover, the barrier will exist in a continuously aggressive environment. Therefore the durability of the structure is an important aspect in design and construction. This contribution will give a survey of some of the investigations which were carried out with respect to the durability of concrete structural elements.

The strategy with regard to the durability in the design of the concrete structures was to aim at uncracked concrete. Therefore most of the structural concrete was designed as prestressed concrete. The concrete itself of course must be of good quality and density. For the proper protection of the reinforcement massive concrete covers were applied throughout the structures. Special attention has been paid to the protection of the prestressing tendons and the anchorages, including the injection of the cable-ducts. Finally, in the mass concrete of the pier structures mesh-reinforcement was applied with reasonable concrete cover underneath the full external surface of these structures. The so-called 'skin-reinforcement' must ensure that the unavoidable crack-formation or local damage will be of minor importance only which will not cause any reduction in the durability.

The concrete structures of the Eastern Scheldt barrier and especially the piers have vast dimensions. Rather big quantities of concrete are cast in situ in one pour. With regard to the aim of uncracked concrete, stresses in the mass concrete at early ages must be considered and reduced if necessary. Investigations

related to this problem-area of having no cracks in concrete at early age, will be explained in chapter 2. The prediction of the crack width in case of extensive concrete cover and big diameters of the reinforcing bars needed attention. The regular formulae do not always yield satisfactory results in these cases. Investigations carried out within this field are described in chapter 3.

2. Concrete at early ages

The hardening of concrete is the result of the hydration of the cement. The cement reaction is exothermic. The heat produced by hydration can cause a considerable rise in temperature in the interior of a concrete mass, since the conductivity of concrete is relatively low. Figure 1 shows examples of the temperature development recorded in the interior of concrete hardening under almost adiabatic conditions. The maximum temperature may reach high values up to over 70°C.

Cracks may arise if the concrete cannot deform freely and strain is imposed on it. Then tensile stresses may arise and crack formation is very probable, especially within the period when the concrete cools down again.

To judge whether cracks will arise as a consequence of hydration heat developing, the tensile stress occurring in the concrete σ_{ct} must be compared with the tensile strength f_{ct} of the concrete. Both are developing in time t . To prevent cracks, the requirement $\sigma_{ct} \leq f_{ct}$ must be fulfilled. This judgement is rather complicated. The scheme shown in figure 2 gives the factors and their relations, which are determining the crack formation under consideration. The temperature throughout the concrete mass is of great importance.

Assuming that some restraining will always exist, the temperature changes are directly responsible for the development of stresses. On the other hand the temperature rise plays an important part in the development of the concrete properties: stiffness and strength.

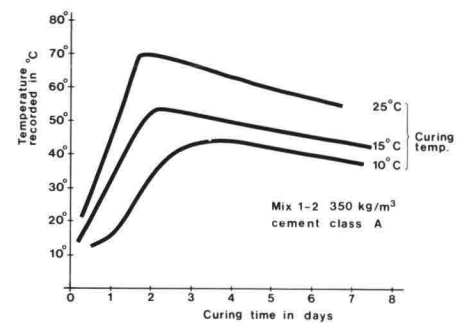

1 Typical curves for the average temperature in 1 m cubes (with 350 kg cement per m³ concrete) under almost adiabatic conditions

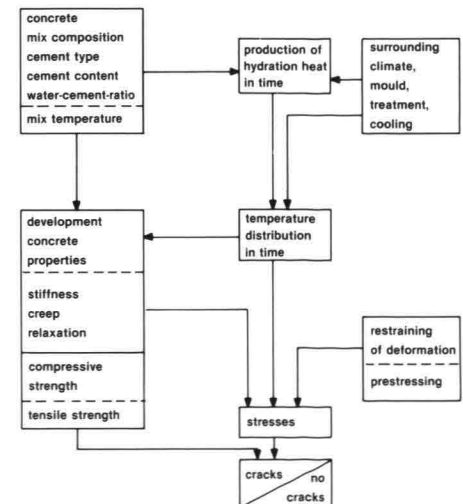

2 Factors determining the behaviour of concrete at early ages and the crack formation

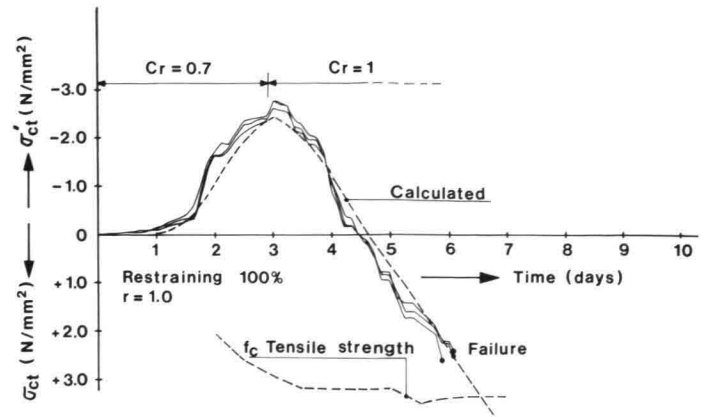
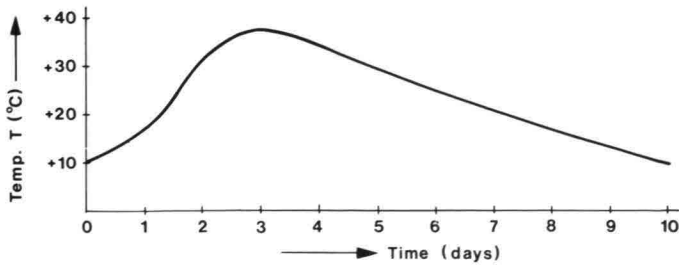

The problem may be clarified somewhat further by showing through figure 3 the stresses which may occur during the period of hardening. These stresses were obtained from experiments on concrete prisms measuring 150 x 150 x 700 mm. The prisms represent concrete from the interior of a concrete mass. The hardening of the prisms was stipulated by imposing a temperature development as might be expected in the concrete mass (fig. 3a).

Besides, the deformation of the prisms was restrained in the direction of their length. The stresses in the prism show a typical curve: during the increase of the temperature compressive stresses arise. After the temperature has reached the maximum value, the compression decreases gradually and changes relatively into tensile stress. Finally the prism breaks when the tensile stress σ_{ct} comes up to the minimum tensile strength f_{ct} .

Under the circumstances considered, the change of the concrete stress $\Delta\sigma_{ct}$ in a short period of time Δt equals the product of the restrained thermal expansion and the actual effective modulus of stiffness:

$$\Delta\sigma_t = -r \cdot \alpha \cdot \Delta T_t \cdot c_r \cdot E'_{ot}$$

in which:

$\Delta\sigma_t$ = change of the stress in Δt (- for compression);

r = restraining factor, $0 \leq r \leq 1$;

α = coefficient of thermal expansion;

ΔT_t = temperature change in Δt (+ for rise in temperature);

c_r = relaxation factor, $0 \leq c_r \leq 1$;

E'_{ot} = the actual modulus of elasticity in period Δt , being the tangent to the stress-strain curve at the origin.

After a specific time t_1 , the concrete stress σ_{ct} will be:

$$\sigma_{ct} = \sum_{t=0}^{t=t_1} -r \cdot \alpha \cdot \Delta T_t \cdot c_r \cdot E'_{ot} < f_{ct}$$

Note that the influence of sustained imposed deformation has been introduced by a simple coefficient c_r , called relaxation factor. Knowing that creep and relaxation reflect on identical phenomena and both could affect the stresses considered, only relaxation will be mentioned for simplicity's sake.

This simple model defines in fact the chief part of the objectives of the investigations to be performed, since the designer must be able to calculate the stresses by good approximation in order to find out if cracks will occur and to define the measures to be taken against them, if any.

2.1. The temperature course in concrete during the first days of hardening

Since the cement produces hydration heat, the amount of heat liberated in a concrete mass consequently depends on the type of cement, the cement content, the water-cement ratio and the temperature. The rate of heat development is mainly determined by the temperature and the hardening state in addition to the other factors mentioned. The influence of the various factors is well-known from cement chemistry and can be quantified for a specific type of cement by rather simple tests.

Therefore one could assume that by introducing the temperature capacity of the concrete, the rise in temperature may be calculated. It seemed however that the granular composition of the concrete mix, the water content and the use of admixtures may affect considerably the expectations based on that calculation.

3a

Temperature regime imposed to restrained prisms

3b

Typical stress development in a prism fully restrained ($p_v = 1.0$) for the temperature deformation at early age (according to temperature course shown in figure 3a)

Therefore it has been decided to record the rise in temperature direct within concrete of similar composition as the one to be used in the actual structure. For this purpose large cubes were cast with dimensions of 1 m. At several points in the interior of these cubes the temperature development was measured during the first day of hardening. The curing conditions were almost adiabatic. The cubes were wrapped up in a thick layer of insulation material. Moreover, the cubes were fabricated and cured in a specific room conditioned to a specific temperature. By these means the temperature of the materials used, the temperature at the beginning of the hydration was laid down and maintained during the recordings. Three temperature levels were investigated, namely 10°C, 15°C and 25°C. Each of the 12 mixes indicated in table 1 was treated at each of the three temperature levels. Including 3 duplicates per temperature, a total of 45 cubes were investigated. In table 1 the variables applied to the mixes are given. Two types of cement were used: low heat cement type A (ordinary portland blast-furnace cement) and type B (rapid hardening). The mixes 1-4 were especially composed for use in the Eastern Scheldt barrier. The required characteristic strengths for the various elements amount to 45 N/mm² and 37,5 N/mm² respectively.

| mix | cement content kg/m ³ | water-cement ratio | air content % | type cement | additional |
|-----|----------------------------------|--------------------|---------------|-------------|---|
| 1 | 350 | 0.48 | 1.0 | A or B | <ul style="list-style-type: none"> the aggregates contain 35% sand and 65% gravel in mix 2 and 4, 0.75 l superplasticizer per 100 kg cement was added in mix 6, 0.04 l air-entraining agent per 100 kg cement was added. |
| 2 | 350 | 0.42 | 3.0 | A or B | |
| 3 | 325 | 0.50 | 1.0 | A or B | |
| 4 | 300 | 0.48 | 3.0 | A or B | |
| 5 | 275 | 0.56 | 1.0 | A | |
| 6 | 275 | 0.53 | 4.0 | A | |
| 7 | 275 | 0.57 | 1.0 | A | |
| 8 | 275 | 0.58 | 1.0 | A | |

Table 1
Concrete mixes applied in adiabatic tests

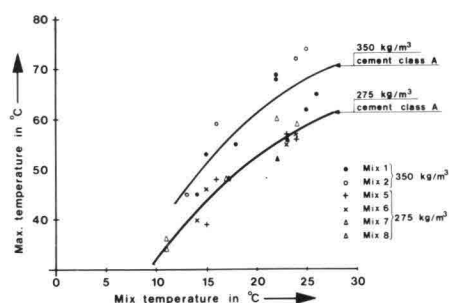

4
Maximum temperatures recorded in 1 m cubes cured under almost adiabatic conditions

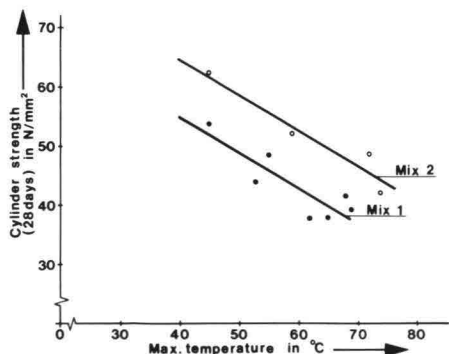

5
Reduction of compressive strength of the concrete due to high temperatures at hardening

Figure 1 shows typical graphs for the three temperature levels during casting and curing. These curves concern the recorded average temperatures in the 1 m cubes with respect to mixes 1 and 2 (350 kg cement A/m³).

The maximum temperature in the cubes clearly depends on the temperature of the mix at the beginning of hydration. Besides, the maximum

temperature occurs earlier in proportion at the rate of which the temperature level at the beginning is higher. The maximum temperature recorded in various test-cubes are also shown in figure 4. The lower curve in this figure concerns mixes 5-8, having a cement-content of 275 kg cement A/m³. The curves clearly illustrate the effect of the temperature at the beginning of hydration and the scatter that may sometimes be expected. However, most of the deviations are caused by irregularities in the temperature course in relative short periods of time.

Moreover, the accurate starting temperature recorded within the mix is in many cases somewhat unstable. The drawn curve represents the smoothed specific results very well. As appears also from figure 4 the temperature rise depends linearly on the cement content of the mix. The effects of the variables in the mixes, like water-cement ratio and the admixtures used were minor - the limited range in which they varied - and insufficient for any conclusion based on the recordings made. The use of cement type A or B appeared to show no significant difference with respect to the temperatures recorded. In addition to the measurements of the temperature developments, the investigations on the 1 m cubes were used to gain further information with regard to the mix, the workability and the strength. The most interesting conclusion from this additional information concerns the compressive strength of the concrete from cores taken out of the cubes. As illustrated in figure 5, the compressive strength of the concrete (measured after 28 days) decreases in proportion with the increase of the temperature during hydration. This result is a confirmation of the well-known effect from cement-chemistry.

2.2. Development of concrete properties

Another important item of the investigations deals with the development of the concrete properties during the first hardening period. Therefore test-specimens were made of more regular sizes and cured in a special testing chamber in which the temperature during the first 10 days' hardening varies according to the temperature development within mass concrete, as composed for the actual structure. Of course, the concrete mix belonging to that temperature development was applied. The investigations concern:

- cube strength using 150 mm cubes;
- tensile strength measured by splitting of 150 mm cubes;
- the modulus of stiffness or Young's modulus through prisms 150 x 150 x 600 mm;
- the coefficient of thermal expansion by recording the elongation of prisms 150 x 150 x 600 mm;
- the development of the stresses in prisms 150 x 150 x 700 mm, restrained for different percentages of the temperature deformation.

The testspecimens were wrapped up with tight foil to prevent drying shrinkage. Except the last ones, in fact all tests concerning the strength and the stiffness were regular short-term tests. The only special aspect was that the temperature during hardening was imposed on the specimen according to a certain course.

Special equipment was built for recording the development of the stresses. These frames allow the length of the test prism to be kept constant (= 100% restraining) or to adapt the specimen length in such a way that a chosen percentage of the 'free temperature deformation' of a dummy prism will be restrained. These tests concerning the stress variation were a practical solution also. The tests mentioned were all carried out for several concrete mixes and temperature regimes imposed. The results of the tests which will be mentioned here, all concern two concrete mixes designed for the Eastern Scheldt barrier and are identical to the mixes 2A and 2B from table 1 (A and B refer to the cement-type used). The imposed temperature-time relations were based on the adiabatic cube test mentioned above and concerned all three mixtemperatures of 10, 15, and 25°C respectively.

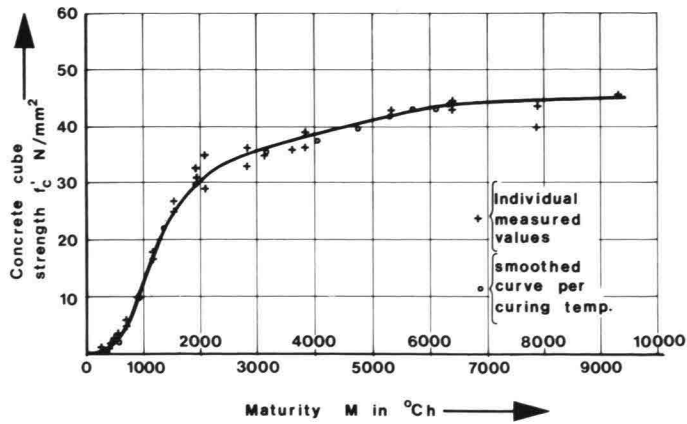

6a
Procedure for the determination of the maturity

6b
Maturity according to Papadakis/Bresson for mix 1 and 2 and three different curing temperature regimes

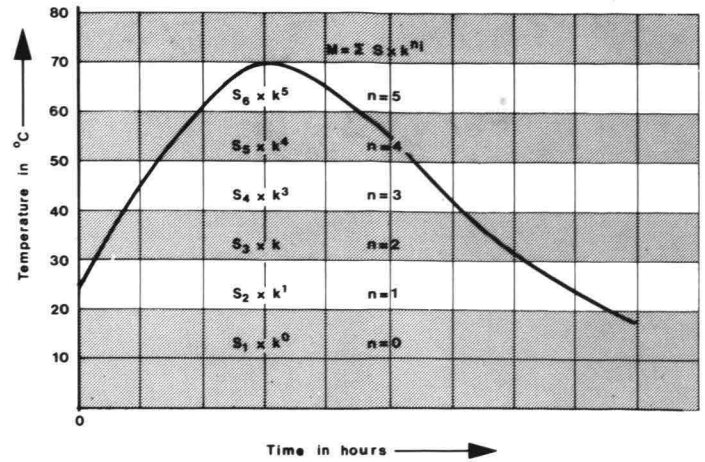

From the development of the *compressive cube strength* measured, direct relations appear between the specific curves and the curing temperatures. An important aspect with regard to the practical application is the definition of a method enabling the prediction of the cube strength, assuming a certain temperature development. Therefore the maturity has been considered. The idea, well-known from literature, is to relate on an empirical basis the strength of the concrete to the summation of (time x temperature), called the maturity.

Papadakis and Bresson (1) proposed to enlarge the influence of the higher temperature ranges in the maturity, because of their relatively favourable effect on the strength development. Following this proposal, the maturity M must be calculated as:

$$M = \sum t_i \cdot \Delta T_i \cdot k^{n_i}$$

In which t_i = the time during which the temperature interval ΔT_i is imposed on the concrete during hardening. The factor k is a material factor depending on the type of cement used. Moreover, n_i is related to specific temperature intervals (see figure 6a). Applying the maturity according to Papadakis and Bresson, the cube strength obtained during the several curing temperature regimes are rather well related to one curve, as shown in figure 6b.

From the *tensile splitting strength* tests it appeared that for the concrete at early age a regular empiric relation to the compressive strength holds, as is valid for hardened concrete. The tensile splitting strength f_{ct} then may be derived from:

$$f_{ct} = 0.28 \sqrt[3]{f'_{ct}{}^2} \text{ N/mm}^2$$

or from

$$f_{ct} = 1 + 1/20 f'_{ct} \text{ N/mm}^2 \text{ if } f'_{ct} > 15 \text{ N/mm}^2$$

in which f'_{ct} = compressive cube strength of the concrete. The approximation of measured values is rather good for all concrete mixes investigated.

The *modulus of elasticity* has been determined by measuring the stress-strain relation up to the crushing of the prisms. On a load level equal to half the estimated actual prism strength, unloading was performed to consider the permanent deformation. The development of the modulus of elasticity is very fast. From about 1/4 up to 3/4 of the final value, the stiffness develops in about one day. The higher the curing temperature, the more this speeds up.

The E'_0 -values concerned are determined as the tangent at the origin of the measured stress-strain diagram. A typical result of the measurements is laid down in figure 7. It appears also with regard to the modulus of elasticity that an empiric relation to the compressive cube strength, as applicable for hardened concrete, may be applied:

$$E'_{ot} = (1800 - 4 f'_{ct}) \sqrt{10 f'_{ct}} \text{ N/mm}^2$$

The *coefficient of thermal expansion* recorded on prisms appeared to be a constant factor by very good approximation during the complete hydration period. This coefficient shows slight variation depending on the concrete mix. The concrete considered here delivered $\alpha = 12 \cdot 10^{-6}$.

The *stresses in a prism restrained for thermal deformation* were recorded extensively. Several different levels of restraining were applied. It appeared that during one temperature development, two constant reduction factors for relaxation can be used. Those factors appear to be dependent on the mix used. But they are the same, in-

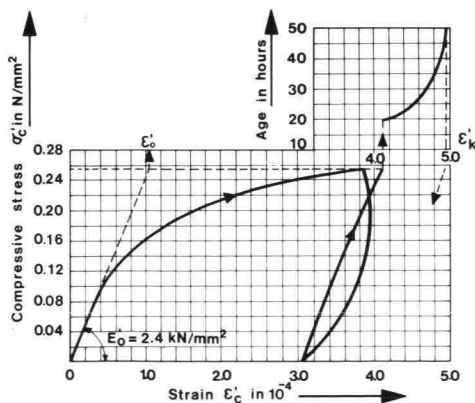

7
Typical stress-strain curve and creep of a prism with $f'_c = 0.735 \text{ N/mm}^2$ loaded after 19 hours hardening under warm curing conditions

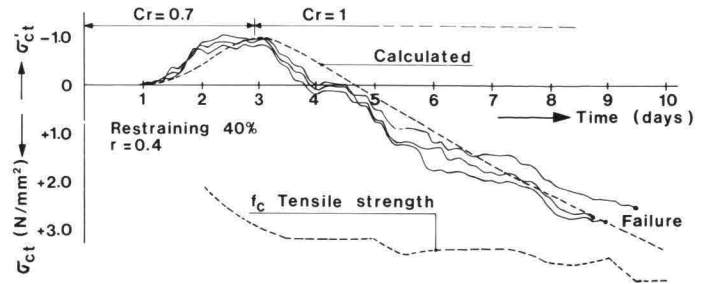
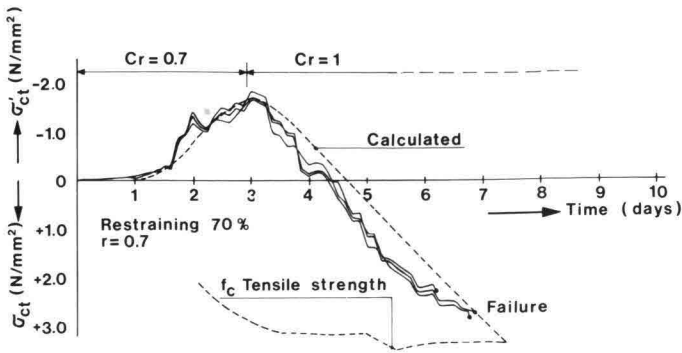

8 Comparison between recorded and calculated stress in a prism partly restrained for temperature deformation at early age

dependent of the temperature course and the measure of restraining. For the mix considered here, the relaxation factor amounts to 0.7 in the period of increasing temperatures and to 1.0 when the concrete cools down. Figure 8 shows the comparison for two examples, of recorded and calculated stresses determined according to the analysis shown. A calculated curve has been drawn in figure 3 also. Generally stated the agreement is satisfactorily. All test-specimens of the stress recording experiment finally broke on a stress level of about 75% of the recorded tensile strength. This difference can be explained. The specimen concerned failed in sections with about the minimum strength under sustained loading. The tensile strength reported before, however, concerns the mean value taken from short term tests. Both aspects bring about a reduction of the effective strength in the restrained prisms. The restraining of the concrete at hardening is evidently an important aspect.

Generally, two main types of restraining may be distinguished. One type is the restraining of deformations of concrete fibres in a cross-section. An other type concerns the restraining of the mean deformation of a structural element (e.g. a wall) cast in place on a hardened element (e.g. a slab). Both types will often occur in combination. Especially the latter type of restraining has been subject of investigation (2). Two important aspects in this matter can be mentioned. The stress distribution highly depends on the

possibility of the hardened element, the slab, to deform together with the early age wall. Piled-up structures are very unfavourable in this respect. During the hardening of the wall the stiffness will increase, which means that the stiffness ratio and the restraining factor will change during hardening. The second aspect is the fact that in the contact area of wall and slab, strain is imposed from point to point in principle. This prevents the occurrence of other than very small cracks, if any. At a certain distance from that contact area, a larger discontinuous deformation become possible and wider cracks may arise with greater spacing. Finally, investigations with regard to the measures against cracking of concrete at early ages have been considered. Tests were carried out to determine the effect of direct cooling by a flow of water through cooling pipes constructed within the concrete mass. Several big concrete blocks provided with such cooling were carefully recorded. A typical result is shown in figure 9. Theoretical study, including the composition of a computer program for the analysis of temperature distributions are carried out (3). Information obtained from the investigations mentioned have been successfully applied in combination with a lot of knowledge and experience obtained previously. It may be understood that a full explanation of all aspects of these matters is rather impossible within the scope of the present contribution to the symposium.

3. Cracks in large concrete structures

The durability of reinforced or prestressed concrete structures requires that excessive corrosion of the embedded steel will be prevented. Although no unique correlation can be shown between crack width and

the long term durability of the structures concerned, crack width limitations are generally used as one of the measures to ensure durability. The idea of limiting cracks widths has been applied here too, knowing that smaller cracks will reduce the probability of excessive corrosion unless other phenomena overrule their importance. The latter must be avoided otherwise. In large concrete structures, the sizes of the reinforcing bars and of the concrete cover may exceed by far the regular sizes. This holds especially when the structure must operate in an aggressive environment. Then the problem arises that most of the practical methods known for analyzing the crack width only apply to regular sizes of the parameters mentioned. The formulae concerned may overestimate the crack width considerably if the bars exceed 25 mm diameter and the concrete cover is

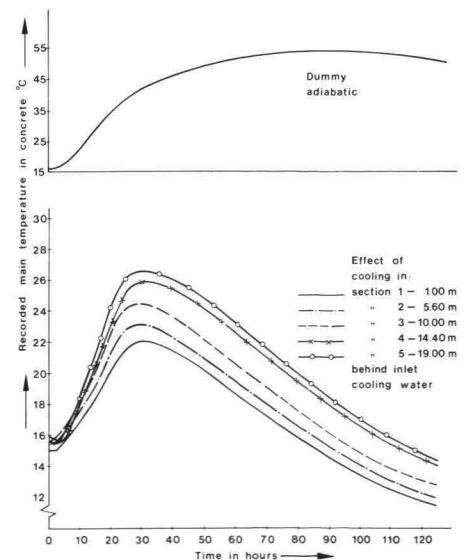

9 Effect of cooling in a concrete cross-section of 650 x 650 mm with 1" pipe in the centre, water flow 0,48 m³/hour of 5°C

greater than 50 mm. This of course reflects on the empiric character of these formulae and the limited but common range of variations in bar sizes and concrete covers applied for the purpose of their experimental verification.

Nevertheless there is a necessity to gain a realistic idea about the crack width in large concrete structures. In order to solve this problem to some extent, experiments were carried out on concrete elements reinforced with bars and provided with concrete covers beyond the regular sizes.

The test-specimen may be considered as sections out of large walls or slabs. The load cases applied represent situations in which these walls or slabs are subjected to axial tension or bending, investigated in two series respectively.

Before explaining these experiments further, the crack width analysis used for comparison will be mentioned. As the representative of a simple regular formula, the one applied in the former edition of the Dutch code for concrete structures (1974) has been used. This formula reads:

$$w_{\max} = \sigma_s \cdot \xi_1 (2c + \xi_2 \frac{\Phi}{\omega_o}) 10^{-5} \text{ mm} \quad (3.1)$$

in which:

- w_{\max} = maximum crack width;
- σ_s = steel stress in a cracked cross-section;
- c = concrete cover;
- Φ = bar diameter;
- ω_o = percentage of reinforcement with respect to the effective cross-section;

ξ = empiric coefficient depending on the bond characteristics of the reinforcement and the type of loading e.g. pure tension or bending.

This formula is obtained from the edition 1966 of the CEB-FIP Model Code and extensively evaluated in experiments. The calculated results concerning regular sizes are very satisfactory compared with recorded crack widths.

Specifically with respect to big concrete cover and big bar diameters, a formula has been developed. This formula reads:

$$w_{\max} = \sigma_s \cdot \left\{ 100 + 0.08 \frac{(2c + \Phi)a}{\Phi} \right\} \cdot 10^{-5} \text{ mm} \quad (3.2)$$

in which: $(2c + \Phi) \leq 0.5 h_t$

a = distance between reinforcing bars;

h_t = full depth of the cross-section.

This formula concerns pure tension in the first place, but will be applied also to bending.

Later on, the last 1978 edition of the CEB-FIP Model Code became available. The analysis for crack control contained therein has been considerably adapted. This analysis has also been used for comparison. The CEB-FIP method is rather complicated. Full account is taken of the favourable contribution of the concrete in tension between the cracks. For the description of the method, reference is made to the CEB-FIP Model Code (4).

The first series of tests performed concerned 6 specimens subjected to

pure tension. These specimens are drawn in figure 10. The main reinforcement consists of two 40 mm bars or four 28 mm bars. As shown in the figure, the test specimens were partly provided with reinforcing bars perpendicular to the main reinforcement. That reflects on a common situation in practice. The concrete cover in the various specimens varied within the limits from 25 mm to 150 mm.

The results of these tests confirmed the basic problem defined:

the crack widths recorded were far below the values according to the simple regular formula (3.1).

Figure 11a shows the maximum crack width recorded. All calculated results are drawn in this figure too. Note that the recorded crack widths refer to the maximum width after 1000 load cycles of the level concerned. The 1000 load cycles of a certain load level result in deformations and crack widths which are comparatively stable and approximately constant in further load cycles. These values will therefore be defined as the crack width at the load level concerned. They concern a fully developed crack pattern.

The results from the experiments related to pure tension with respect to the mean crack spacing and the mean crack width are shown in figure 11b and c.

The following conclusions have been drawn with regard to pure tension. The maximum crack width can be calculated rather well for steel stresses around 200 N/mm² by using

10
Measures (in mm) of the test-specimen loaded in pure tension

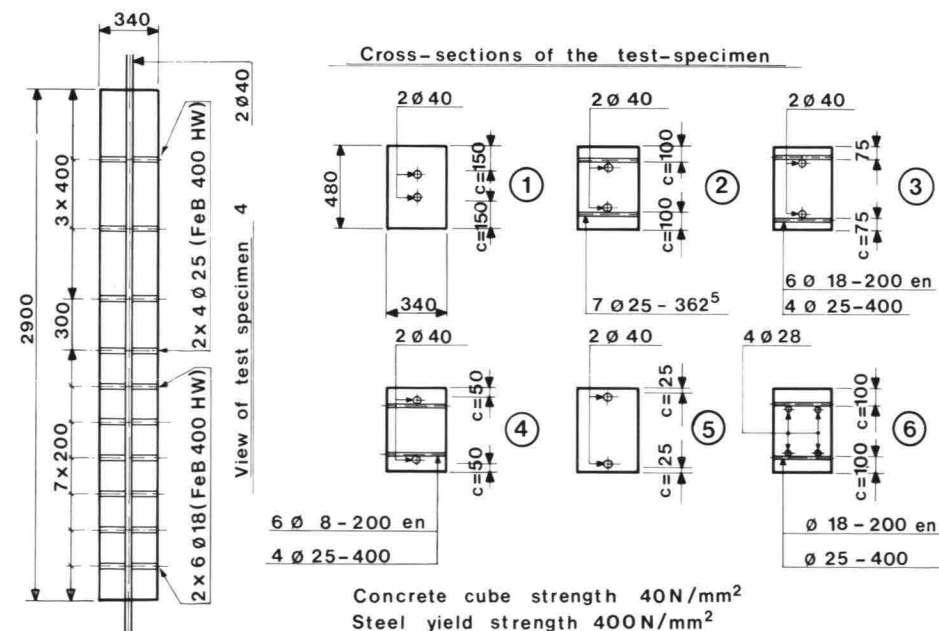

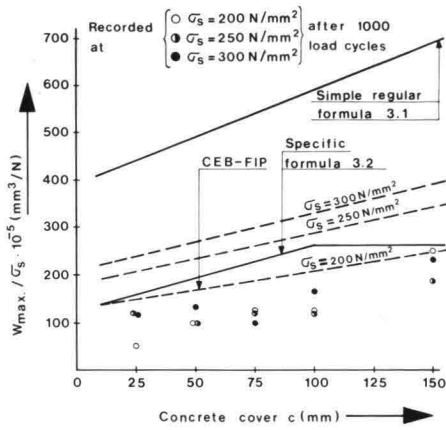

11a
Maximum crack width W_{max}

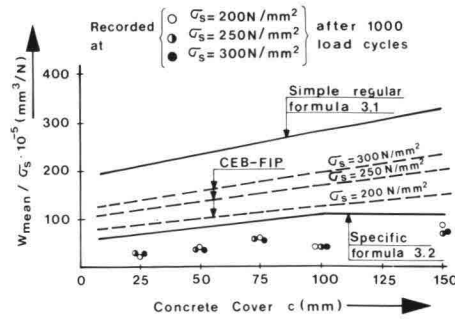

11b
Mean crack width W_{mean}

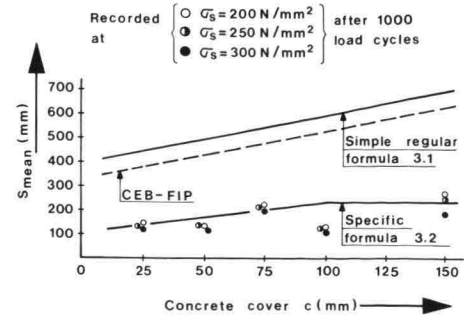

11c
Mean crack spacing S_{mean}

11
Comparison of recorded and measured values related to the crack width in reinforced concrete, loaded in pure tension

the CEB-FIP formula. However, the results are pessimistic. The difference increases with increasing steel stress which means also that the maximum crack width depends more strongly on the steel stress in the reinforcing bars than appears from the recordings. The CEB-FIP formula overestimates both the mean crack width and the mean crack spacing as well. The specific formula (3.2) shows satisfactory results regarding the mean values

$$(w_{mean} = \frac{W_{max}}{1.7 \times 1.4})$$

compared with the measured values. However, the maximum crack width is overestimated. The simple regular formula (3.1) in which $w_{mean} = W_{max}$ divided by 2.1, overestimates by far all measured values. This formula thus appeared too much connected

12
Measure (in mm) of the test-specimen loaded in bending

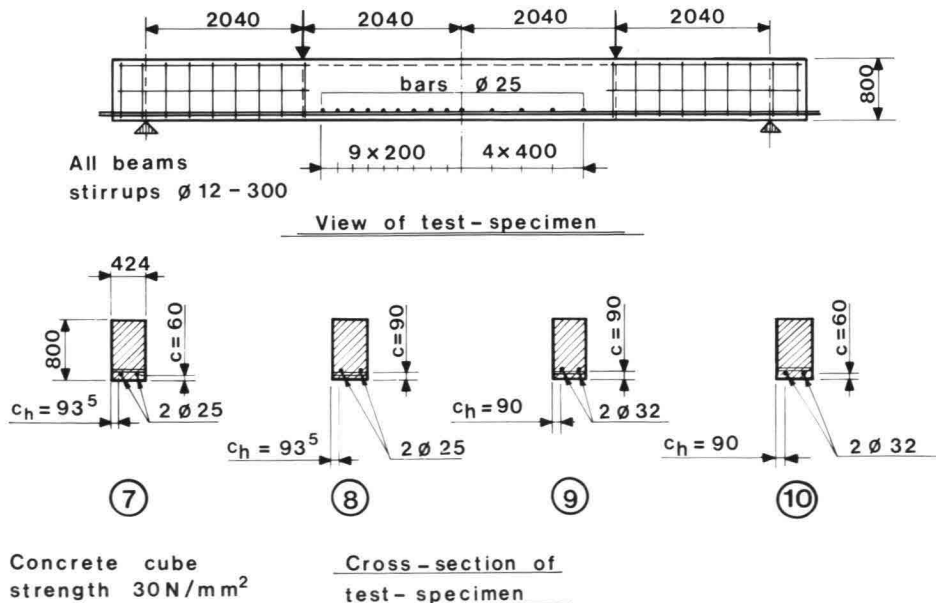

Concrete cube strength 30 N/mm^2
Steel yield strength 400 N/mm^2

to regular sizes for the bar diameter and the concrete cover. These conclusions of course cannot be stated too firmly because of the statistics and the scatter playing a part in the crack mechanism and the relative low number of experiments performed.

Remarkable phenomena in these experiments were the many cracks occurring along the main reinforcement. These longitudinal cracks already arise at rather low load levels. The widths of these cracks were generally smaller than the crack across the main reinforcement. However, it is clearly apparent that the bigger bar sizes cause longitudinal cracks in a much earlier stage of loading. These cracks affect bond, anchorage and corrosion of the bars concerned.

The second series of test specimen consists of 4 beams subjected to bending. Figure 12 shows the main dimensions. Reinforcing bars of 25 mm and 32 mm respectively were applied. The concrete cover on these bars is 60, or 90 mm. These specimen were also provided with reinforcing bars perpendicular to the main reinforcement.

The maximum crack widths recorded are indicated in figure 13a together with the calculated values from the formulae described before. Again the measured values refer to the maximum crack-width after 1000 load cycles at the load level concerned, but in this case to the steel stress $\sigma_s = 200 \text{ N/mm}^2$ only. In figure 13b and c the mean crack width and the mean crack spacing are given.

As will be clear from the figures, the simple regular formula results in crack widths which are too big compared to the recordings.

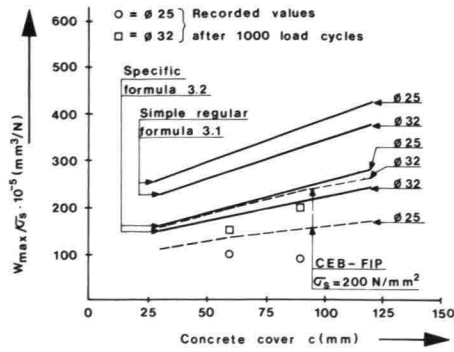

13a
Maximum crack width W_{max}

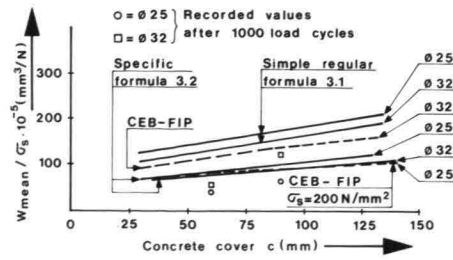

13b
Mean crack width W_{mean}

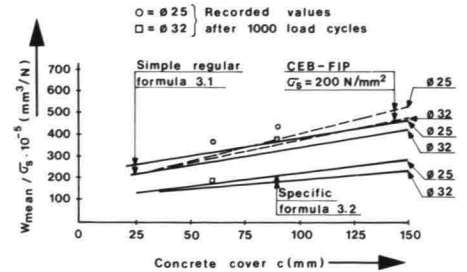

13c
Mean crack spacing S_{mean}

13
Comparison of recorded and measured values related to the crack width in reinforced concrete loaded in bending

Moreover, these calculated values are greater than the values from the two other formulae. The CEB-FIP formula shows in fact the best agreement with the experiments in bending. Especially the influence of the bar size works out very well. The specific formula developed for tension in the first place, appears less satisfactory in the bending situation. However, with regard to the scatter and the very limited information gained, one could conclude that the specific formula may be a useful approximation. Also in bending, the longitudinal cracks along the main bars were remarkable.

The general conclusion is that with regard to the validity of the crack width analysis for large concrete structures, the rather complicated formula described in the last edition of the CEB-FIP Model Code (4) shows satisfactory results in a wide range of bars sizes and concrete covers. This statement is to some extent related to a steel stress level of 200 N/mm². A specific formula (3.2) for big bar sizes and concrete covers, which is much simpler, may be applied as a useful approximation. The simple regular formula (3.1), well known from several concrete codes, appears too strongly calibrated to regular sizes. Such formulae cannot be applied to the analysis of crack widths in large concrete structures.

4. References

- The investigations described have been completely reported in a great number of TNO-IBBC reports and reports of Rijkswaterstaat, Locks and Weirs Division. No specific reference will be made to these reports, but further information could be obtained on request.
- (1.) Papadakis M and Bresson J, Contribution à l'étude du facteur de maturité des liants hydrauliques application à l'industrie du béton manufacturé; *Revue des Matériaux* No. 678, Mars 1973.
 - (2.) Stoffers, H. Cracking due to shrinkage and temperature variations in walls; *Heron* 1978, 23 (No. 3).
 - (3.) Reinhardt, H.W., Blaauwendraad, J. and Jongedijk, J., Temperature development in concrete structures taking account of state dependent properties; Contribution to RILEM-symposium 'Concrete at early ages' 1982, Paris.
 - (4.) CEB-FIP Model Code for Concrete Structures; International system of Unified Standard Codes of Practice for Structures, Volume II. CEB-FIP International recommendation 3rd edition 1978.

Research on concrete

Investigation of the mechanical properties of fresh and hardened concrete used in the Eastern Scheldt storm surge barrier

1. General introduction

This contribution to the symposium will treat three types of investigations which belong to concrete technology. The problems to be solved arise in connection with extraordinary loading conditions and in connection with the use of huge prefabricated concrete elements which have to be placed and fixed precisely and securely on the foundation. The three investigations concern firstly the mechanical behaviour and the workability of the filling concrete under the piers, secondly the forces exerted on and damage to concrete surfaces caused by impacting boulders, and thirdly the erosion of concrete in water carrying abrasive material.

Although the investigations have been carried out for the specific case of the Eastern Scheldt storm surge barrier, the results are more widely applicable. On the other hand some parts of the research were stopped while in progress because of little significance and utility for the structure in question or because the structural concept has been changed during the design process and the investigation was no longer relevant. Nevertheless, the authors believe that there are numerous aspects which are worthwhile reporting and which can help other engineers to avoid or to solve problems in future hydraulic structures.

2. Concrete filling under the piers

2.1. Introduction and requirements

The joint between pier and foundation mattress requires special attention within the design of the storm surge barrier. This joint has to be filled to prevent undesirable rotations and translations of the pier. The filling must also conform to strict conditions in order to avoid subsurface erosion.

To design the present shape of the pier base as well as to find the most suitable materials and method of filling, extensive technological investigations are being carried out. Requirements with regard to the underbase filling are:
durability: 200 years, equal to the barrier as a whole;
strength: 5-10 N/mm² (cube compressive strength);
stability: must be stable under an extreme hydraulic gradient (400-600%);
degree of filling: almost completely filled (90-100%).

2.2. Preliminary tests

Preliminary investigation took place to make an inventory of suitable materials. This has led to a sand-cement mortar. With this material an almost complete filling of 95-100% can be reached with cementing material under limited stream conditions: in this case a gradient of approx. 5%. The required strength can be realized easily. The space to be filled has to be limited in a coarse granular setting just as the sill. For this a permeable sand tight fabric is applied with positive effect. Local leakages in this application can be remedied without excessive losses. Alternative applications of materials were less attractive.

With a grout of cement-water and additives such as bentonite, the desirable strength is not easily attained, a very tight fabric is required and leakages are difficult to remedy. The guarantee of a sufficient degree of filling appeared not to be attainable with concrete. This also applies to asphalt mixtures. Underflowing with sand gives an unstable filling.

2.3. Experimental investigation

2.3.1. Underfilling caissons on coarse stone foundations

At first the necessary research was performed in a flow channel at Lith for the preliminary design of the storm surge barrier with caissons. The underbase filling of the caissons had to be started from a filling pipe of 35 m height. This meant an effective pressure of 5 bar from the mortar against the base. In view of the large forces in the fabric required and the great unevennesses of the foundation bed, nylon fabric with a tensile strength of 250 kN/m and a strain limit of 25% was chosen. This fabric gave very good results. Due to the strong current, cement was washed away under the construction, but within 15 to 20 minutes a complete sealing was obtained while no more than a few percent of the cement used were rinsed out.

The high pressure of approx. 5 bar accelerates the hardening process. Strengths of 20 N/mm² are being measured already after 48 hours when an alternating load has been applied with a period of 8 sec from the moment of completed filling. The filling layer appeared to be very homogenous.

Experiments in the test tank at Kats, which made it possible to exert vertical and horizontal loads upon a full-sized underfilling gave values for the H/V ratio from 0.5 (dynamic) to 1.0 (static).

The results of the tests with a sand-cement mortar in a fabric were so positive that these tests were also continued with the next designs.

2.3.2. Filling tests under high pressure

In a following design stage of the storm surge barrier the possibility of transferring horizontal loads from the pier to the foundation bed a few hours after casting was still being exerted. Because underfilling under high pressure effects a prestressed

1
Shear resistance on function of time

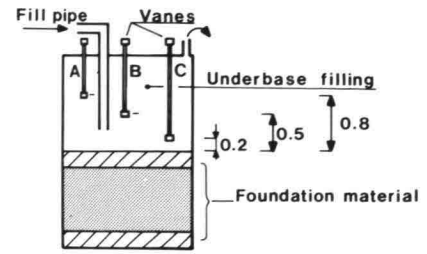
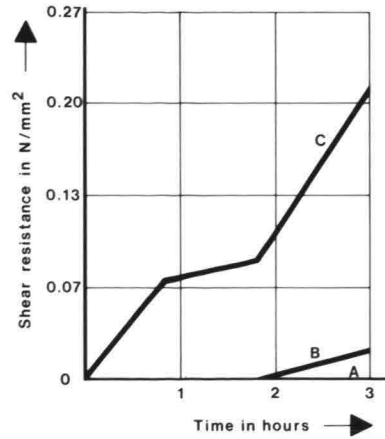

2
Testing arrangement for underbase filling

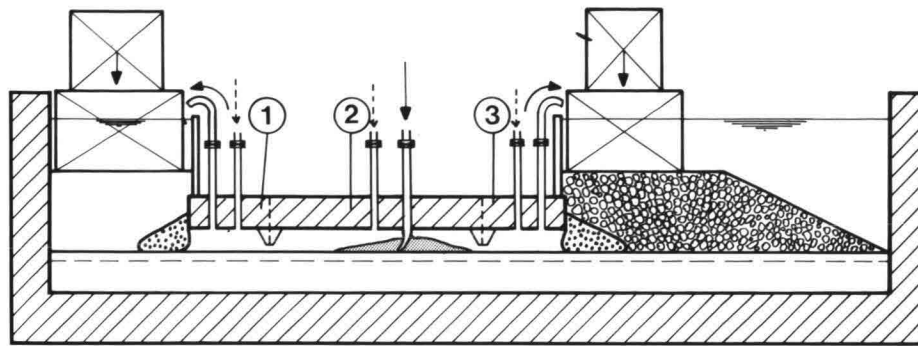

sand skeleton, the property of direct strength is available. The shear strength of the mortar has to be known. Therefore a pressure tank was made with vanes at different heights to determine the difference between the strength of the outer shield and of the core of the filling. An example with an overpressure of 2 bar is given in figure 1. Investigations are also carried out in the pressure tank how to prevent penetration of the foundation bed and thus any disturbance of the filter action during underfilling. Various stoney materials were tested. It was found out that materials with an identical granular build-up from 0.5-30 mm are not injected by a sand-cement mortar. This material however is not current-resistant. More coarse material did not appear to be mortar-tight, so that application of a sand-tight fabric was needed. This permeable fabric is intergrated in the filtermattress as a cover cloth.

2.3.3. Filling tests with limited pressure

a. Test method applied to underfill
In support of the elaboration of the underbase filling model for the operative design of the piers a full-sized run of tests is set up. Plans of the prototype are as such as possible brought into use such as the

gravel bag as edge sealing, a height of the underfilling space of 0.5 à 1.0 m, permeable fabric protection of the gravel layers of the foundation bed. The underfilling space is separated by dividing ribs of limited height. Each compartment is filled from a central sleeve in the base slab, the outlet being at the edges of each partition (fig. 2).

In the test special attention was given to:

- the behaviour of the mortar when transported over long distances and the appearance of signs of segregation and bleeding;
- the influence of the shape of the under-surface (flat or corrugated) on the possibility of obtaining a good water discharge and consequently a good rate of filling;
- the progress of the whole filling process under low overpressure to attain a sufficient degree of filling;
- the influence of the dividing ribs to transmission of the pressure to the adjacent compartments;
- the determination of the location of in- and outlet pipes;
- measure of the pressures against underside floor.

After the mortar had hardened for a few days, the entire set-up was dismantled and the mortar product examined, both visually and by means of core drillings. The tests

have shown that a homogenous composition is guaranteed when a rubber tube, mounted to the inlet, reaches the foundation bed.

Discharge of water takes place mainly through the foundation bed. Only at a late stage the outlets start discharging water. The completion of filling a compartment is then marked by the almost simultaneous overflowing of mortar through the four outlets. Until then, practically no increase in the pressure should be observable. During half-an-hour after the outlets have been closed a filling process takes place with limited overpressure of about 1 bar. To confine the influence of overpressure to only one compartment, the second inlet without a rubber tube under the pier slab is used. The pressure within one compartment shows in all cases an even level. The ribs prevented the transmission of pressure to an adjacent compartment (fig. 3). Application of pigment to a single charge has shown that the sand-cement mortar does not move over large areas but flows through

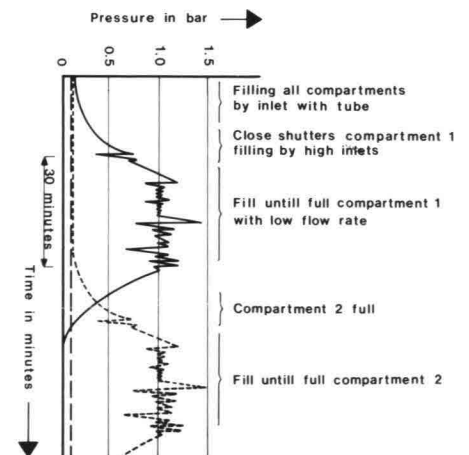

3
Pressure in the compartments as function of time, schematic

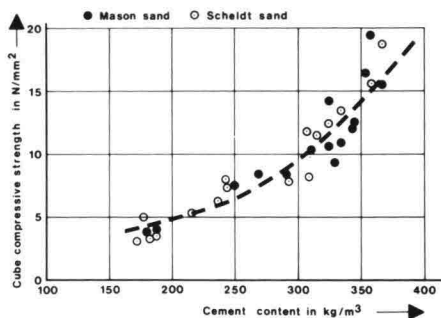

4 Mortar strength deriving from quantity of cement

| Mixture | A | B |
|------------------------|------|------|
| Blast furnace cement A | 235 | 245 |
| Mason sand | 1360 | 1420 |
| Bentonite | 40 | 20 |
| Water | 355L | 340L |

A and B in kg

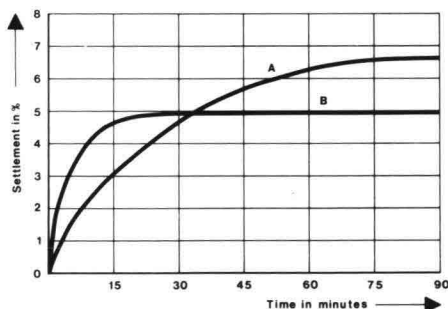

5 Settlement of fresh mortar

comparatively narrow channels. Full overflow of all outlets guarantees a good rate of filling, so corrugation of the underside floor does not appear to be needed. No test gave any bleeding or segregation which can be explained by discharge of water towards the latter part of the filling under overpressure.

Ground pressure boxes against the underside of the floor gave the same results as water pressure gauges mounted in cast-in pipes.

b. Optimization of the concrete mix. Therefore a test was carried out to check:

- the strength of the mortar;
- the pressing out of water as a function of pressure;
- the kind of aggregates;
- the kind of additive;
- appearance of bleeding and segregation.

On compiling mixtures, a roughly equal workability was taken as a standard. To meet the requirement of 5 to 10 N/mm² after 28 days, a quantity of cement up to 200 to 300 kg/m³ was required, as shown in figure 4. The grain size of sand largely determines the speed by which water is going to be pressed out. Concrete sand shows a quicker consolidation than Scheidt-sand ($d_{50} = 200 \mu$) (fig. 5). To prevent segregation and bleeding, plastifiers and bentonite were applied. In comparison with other additives it was found that the addition of bentonite gave clearly better

results in spite of its higher water-cement ratio.

The least segregation and/or bleeding of the mortar is obtained by addition of 40 kg bentonite per m³, but the press-out of water is much slower than when 20 kg bentonite per m³ is applied (see figure 5).

2.4. Conclusions for actual practice

The following conclusions concerning the shape of the piers and the process of underfilling are drawn from the results of the above tests:

- the intended compartmentalization is satisfactory;
- two inlets (with and without rubber tubes) and four outlets are desired per compartment. These outlets are inserted in the inside of the pier for observation purposes;
- the underside of the pier-base is corrugated to provide a satisfactory transmission of shear force from the base-slab to the filling material;
- water pressure gauges which are assembled in cast-in pipes will be used for measurement;
- to prevent an excess of the acceptable pressure against the floor the pumps were placed on the floor of the pier. As result, the pumps are acting as dosing — and reducing devices;
- with the outlined model with limited pressure, an almost complete filling is well attainable with a material of the desired quality. An indication of the procedure and the mechanical equipment which have definitely been chosen for the storm surge barrier are shown in figure 5.

6 Outline of filling procedure and equipment

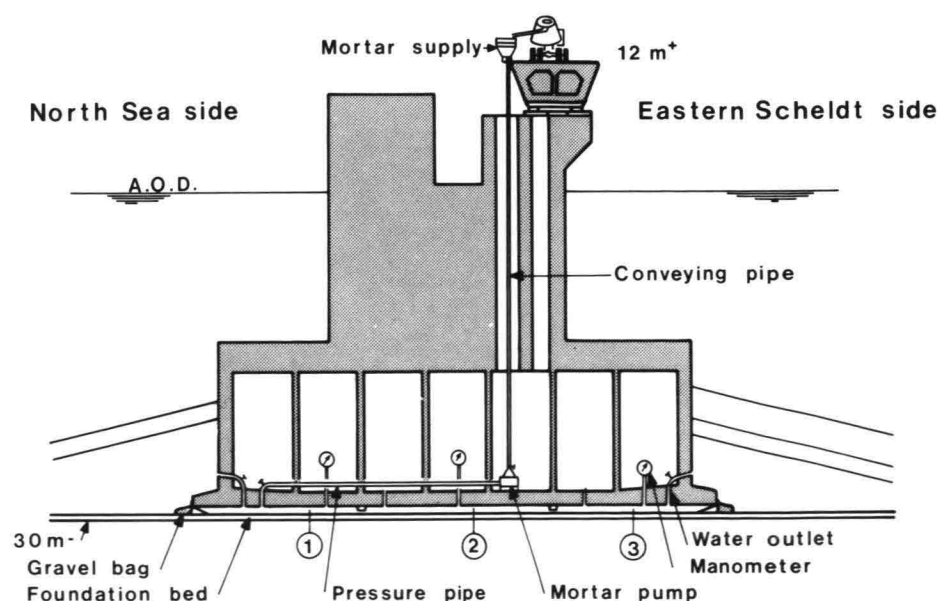

3. Impact of falling boulders

3.1. Introduction and scope of the investigation

One of the conditions of the pier-and sill beam design is that the current method of building the sill should be applied where boulders are dumped from the surface of the water. This would imply that stones falling free under water hit the concrete structures. It concerns diverging sizes from 10 to 10,000 kg. Two types of damage may occur; smashing of the concrete surface and overloading of the concrete structure. In 1978 a research project on 'falling boulders' was started to investigate the magnitude of the impact forces and the amount of damage inflicted. The theoretical and static approaches gave such doubtful and improbable

results, partly because of the number of proposals, that it was decided to continue the research as an experiment on a real scale.

3.2. Theoretical approach

The theoretical research is aimed to predict the expected damage. Therefore the hitting velocity has to be determined. It is permitted to start from the terminal velocity because of the great depths of water in which the threatened structural elements are located (fig. 8). Depending on the response of the structure to impact loading there is a

difference between an elastic and a non-elastic impact. The magnitude of an elastic impact is deduced from the equation of motion of a single mass spring system (formula a₁).

In case of a non-elastic response of the structure, the impact force is as given in formula a₂. At first, impact forces are computed in accordance with the formula of the elastic impact. Depending on the impact location on the piers (fig. 9) the spring stiffness *k* is determined in different ways:

- theory of the semi-circle-formula b₁ (location 1 and 3);

formulae for impact forces

a1 elastic impact $m\ddot{x} + kx = 0$

$F = v\sqrt{k \cdot m}$

a2 non-elastic impact $F = v \cdot \frac{E \cdot A}{c}$

$c = \frac{\sqrt{E \cdot c}}{Q}$

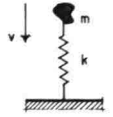

formulae for spring stiffness

b1 started from semi-circle $k = \frac{\pi \cdot E \cdot a}{1 - f}$

b2 started from depression of concrete $k = \frac{A \cdot E}{d}$

b3 started from plate bending $k = \frac{\alpha \cdot E \cdot I}{L^3}$

stone *v* = hitting velocity
m = mass

structure *k* = spring stiffness
E = young's modulus
f = E-modulus / G-modulus
Q = density
A = impact area
a = width of impact area
I = moment of inertia
L = length of plate
α = coefficient of fixation

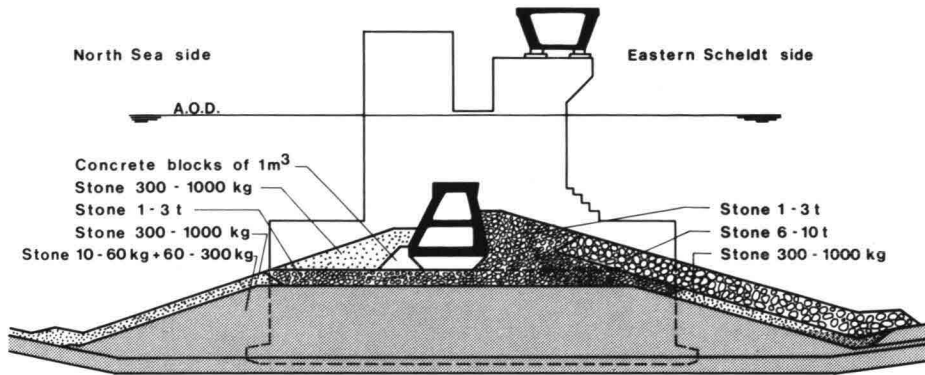

7 Sill construction

8 Underwater movement of the stones

9 Impact areas on the pier

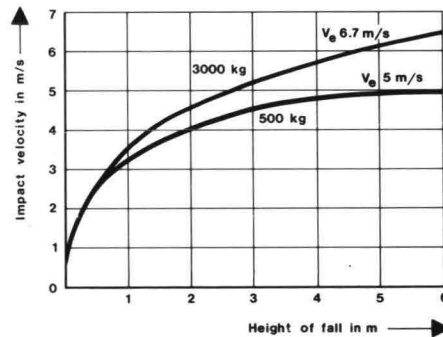

Impact forces

- depression effected on half of the concrete section — formula b₂ (location 2);
- bending of the plate — formula b₃ (location 4).

The impact forces thus computed are presented in table 1.

Treatment according to the formula of the non-elastic impact leads to even higher impact forces. The computed elastic impact forces are so high that the construction parts of the piers should collapse when hit by stones of 3,000 kg; a stone of 500 kg should cause considerable damage to the concrete surface. Related to actual practice, the computations appeared to lack credibility. The great number of fac-

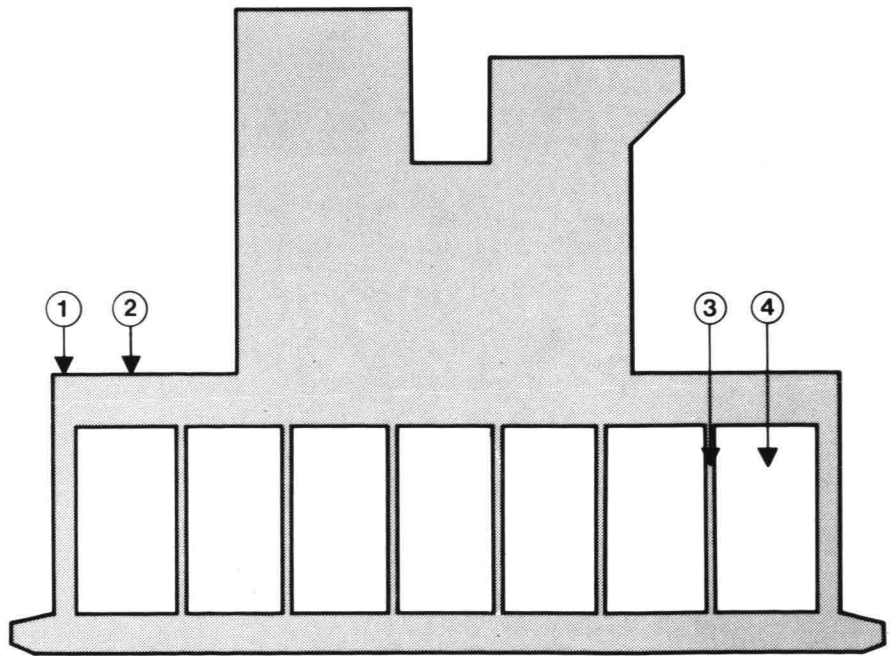
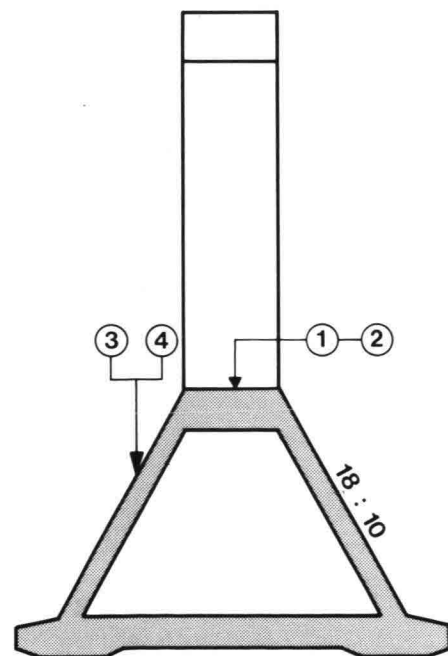

Table 1
Computed impact forces

| impact area | spring stiffness treatment | reduction factor | impact forces (kN) | |
|--------------|----------------------------|------------------|--------------------|--------------|
| | | | stone 3,000 kg | stone 500 kg |
| 1. (support) | b_1 | — | 89,000 | 27,000 |
| 2. | b_2 | — | 52,000 | 16,000 |
| 3. (support) | b_1 | 0.3 | 26,000 | 8,000 |
| 4. | b_3 | 0.3 | 12,000 | 3,000 |

Table 2
Measured impact forces

| weight of stones | impact forces (kN) | | | |
|------------------|--------------------|-------|---------------------------|-------|
| | horizontal square | | vertical square (18 : 10) | |
| | average | 5% | average | 5% |
| 3,000 kg | 3,700 | 7,400 | 600 | 1,050 |
| 500 kg | 1,000 | 1,800 | 150 | 300 |

Table 3
Measured damages

| weight of stone | damage in mm | | | |
|-----------------|-------------------|----|--------------------------|----|
| | horizontal square | | sloping square (18 : 10) | |
| | average | 5% | average | 5% |
| 3,000 kg | 36 | 56 | 29 | 44 |
| 500 kg | 29 | 29 | 18 | 26 |

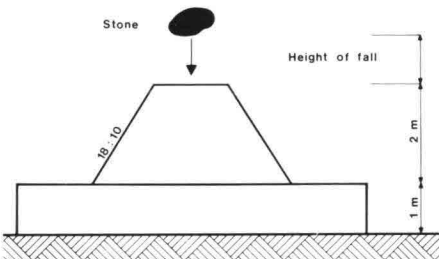

10
Testing arrangement

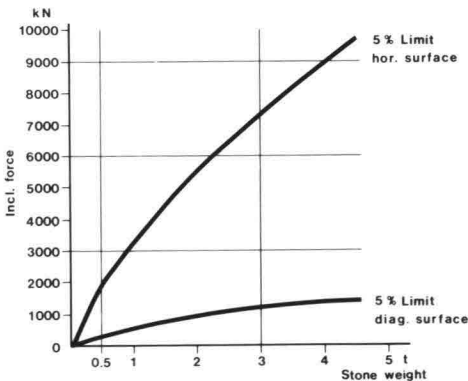

11
5% limit of impact forces

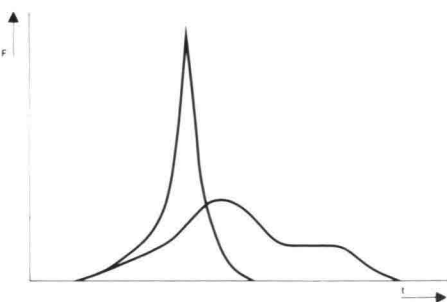

12
Impact registrations

tors for which proposals have to be made such as spring stiffness, impact area, effective mass and impact character obscured the issue. Therefore it was decided to perform experimental investigation.

3.3. Experimental investigation
3.3.1 General research

Aspects such as the smashing of the concrete surface, imitation of impact velocities and of the non-elastic character of impact as well as the practical possibilities of registering impact, have led to real-scale investigations. To imitate a non-elastic impact (the upper limit) and to neglect the influence of the subsoil, a testing arrangement with a mass of 150,000 kg with horizontal and vertical hitting areas was chosen (fig. 10).

The impact velocity of the stones under water is converted to the corresponding height of fall in the air. The impact force and impact time are registered by acceleration recorders glued into the stones. Measurements are also made with the help of pressure boxes, situated beneath the tested concrete plate. Both methods have given similar results. The measured impact times, ranging from 4 to 10 msec, indicated that the character of the non-elastic impact was imitated well.

3.3.2. Measured impact forces and damage of concrete

After the pilot research, a larger number of falling tests was executed

to attain a statistical compilation of measured impact forces and damage inflicted (table 2). The 5% limit-lines are composed for several stone weights on the basis of the measured impact forces (fig. 11).

The measured impact forces seemed to be reasonably lower (multiplier 10) than the theoretically computed values. Besides there appeared to be a large variation (multiplier 4) in impact forces exerted by identical stone weights. Moreover, the shape of the impact area of the stones and the momentary position of the impact area with respect to the centre of gravity of the stone (rotation after impact) proved to be of great relevance. A small impact area causes a short impact time and a high impact force, whereas larger impact area gives a longer impact time and a lower impact force. Compare figure 12, in which both figures have equal energy capacity (area $F-t$ -diagram).

Falling tests with concrete cubes of 2,500 kg, when compared to basalt stones of equal weight resulted in lower impact forces (multiplier 2 or 3). The extent of the smashing of the cubes, depending on whether they fall on a square, an edge or a point is of great relevance to the impact time and the impact force.

The measured damage is shown in table 3.

Here 5% limit lines are likewise composed for the measured damage (fig. 13).

Additionally to the measured damage the following was noted:

Table 4
Damage: conical-ended shape

| | | | | | | |
|---------------------|----------|------|------|---------|------|------|
| weight of stone (M) | 3,000 kg | | | 500 kg | | |
| impact velocity (v) | 6.7 m/s | | | 5.0 m/s | | |
| impact angle | 30° | 45° | 60° | 30° | 45° | 60° |
| d ₀ (m) | 0.20 | 0.24 | 0.28 | 0.09 | 0.10 | 0.13 |
| x ₀ (m) | 0.17 | 0.12 | 0.08 | 0.08 | 0.05 | 0.04 |

Table 5
Damage: spherical ended shape

| | | |
|----------------------------------|----------|---------|
| weight of stone | 3,000 kg | 500 kg |
| impact velocity | 6.7 m/s | 5.0 m/s |
| diameter stone | 1.24 m | 0.68 m |
| x ₀ (depth of damage) | 0.12 m | 0.025 m |

Table 6
Computed impact forces from measured impact time

| | | | | |
|------------------------|-----------|----------|----------|---------|
| weight of stone | 3,000 kg | | 500 kg | |
| impact velocity | 6.7 m/s | | 5.0 m/s | |
| impact time (measured) | 4 msec | 10 msec | 4 msec | 10 msec |
| impact force | 10,050 kN | 4,000 kN | 1,250 kN | 500 kN |

- damage going further than visible was not discovered (investigations on micro-flaws in drilled frozen cores);
- increasing the concrete cover did not lead to a greater depth of damage;
- the edges of the concrete areas are very vulnerable;
- damage to vertical areas is small (5-10 mm).

3.3.3. Explanation of measured impact forces and damage

A theoretical explanation of the measured impact forces and damage, particularly the mutual relation, is not, or hardly available. A prediction of the depth of damage is treated to some extent in the article, published after the above investigation had been completed: 'Impact of Falling Loads on Submerged Concrete Structures' presented by J.J. Jensen (3). A formula for the depth of damage is given for different shapes of the impact area of the falling object (formulae c₁ and c₂).

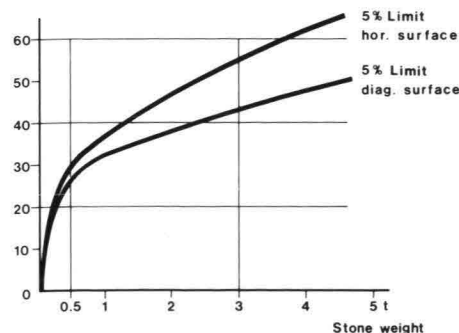

13
5% limit of damage depth on concrete

The different depths of damage are computed for two weights of stone as well as for different angles Q of a conical-ended shape as for a spherical-ended shape (tables 4-5). The depth of damage calculated in this way for 500 kg stones is nearer to the measured values than for 3,000 kg stones. The difference with the latter weight mentioned is still a multiplier 2 or 3. In the publication it is suggested to determine the impact time from $t = 2 \cdot x_0 / v$. The impact force is then computed from $F = 2 \cdot mv/t$. This treatment gives excessive values for the impact time and consequently too low values for the impact forces. A better approach of the measured impact forces is obtained by computation according to $F = 2 \cdot mv/t$, where t is the measured impact time.

formulae for damage depth

c1 for conical ended shape

$$x_0 = \beta^{1/3} \cdot v_e^{2/3}$$

$$\beta = \frac{15m}{y \cdot \pi \cdot \text{tg} \phi}$$

$$d_0 = 2 \cdot \text{tg} \phi \cdot x_0$$

y = yield strength (375 × 10⁶ N/m²)

c2 for spherical ended shape

$$x_0 = \left(\frac{m \cdot \pi \cdot D}{y} \right)^{1/2} \cdot v_e$$

$$D = \left(\frac{6V}{\pi} \right)^{1/3}$$

formula for impact time

$$d = F \cdot \frac{2 \cdot m \cdot v}{t}$$

for m = 3000 kg
x₀ = 0,12
t = 0,036
F = 1100 kN

Damage depth

Compare the values shown underneath with the measured values from table 2 (table 6).

3.3.4. Damage prevention

Referring to the investigations into impact forces and damage many protective possibilities are examined as to their ability both regarding the reduction of the impact forces and the prevention of damage. To attain the impact reduction, investigations were made to replace stones by bags filled with sand or concrete or by wire netting packets filled with asphalt. Reduction of the impact forces proved to be necessary because it appeared in the course of the investigation that dropping stones heavier than 3,000 kg should be excluded. Coverings of gravel mattresses, wooden screens, synthetic sheets and spray concrete were examined as protective devices. The solution with spray concrete proved to be the most favourable in effectiveness and cost-wise, especially on the slope areas. Sandbags and concrete mortar bags and bags with stoneasphalt as substitutes were tested. The former two were lost by the great percentage of tears. This was no disadvantage for the stoneasphalt because of the cementing of the material. The impact force reduction is large.

3.4. Practical measures derived from the test

In the system of sill design, sill execution and the protection of the piers, the investigation 'falling boulders' resulted in the measures and adjustments mentioned below: The sill design was adapted. In a

strip of 5 m width around the piers stone-asphalt loads of 20-30 tons were used instead of stones heavier than 3,000 kg. Free falling from the water surface is allowed in that case. Sill execution for stones ranging from 1,000-3,000 kg is subject to constraints, in such a way that the maximum height of fall amounts to 2 m, with the effect of achieving an impact reduction of 50%. To this end special equipment was designed. The protection of the piers consist of a combination of measures:

- an increase of the concrete cover from 70 to 100 mm so that the damage caused by free falling stones of 300-1000 kg is acceptable;
- all edges of the concrete construction will be chamfered;
- application of a protective layer of 70 mm spray concrete along the slope faces and an additional layer of 100 mm concrete along the horizontal faces of the part of the pier under water. Amoured netting of \varnothing 6-50 mm is supplied.

4. Erosion of concrete by water and abrasive material

4.1. Motive

According to calculations, the flow velocity in the openings between the piers of the barrier will range from 3 to 5 m/s, possibly attaining higher values at particularly unfavourable locations. The water carries abrasive material along with it, sand in particular. There were fears that the relatively high velocity of the water, together with its sand load, may cause substantial erosion of the concrete. These considerations were the motive for a detailed investigation of the phenomenon of erosion of concrete. Erosion attack may occur in two different forms: the first as the wear that a surface undergoes by the action of water and the sediments carried along in it, the second as a deterioration that is usually local and

characterized by circular cavities (cavitation). The present research is concerned with the first form whereas the second is thought not to be relevant. Cavitation usually occurs at higher velocities than those expected in the openings of the surge barrier.

4.2. Testing method

The testing method was designed to simulate the exposure of a structure in running water with abrasives. It is similar to that employed by Gardet and Dysli (4). For this purpose twelve segmentshaped specimens, each with a surface area of about 0.5 m² and provided with adjustable feet, were placed horizontally on the bottom of a circular flume (open channel) with an outside diameter of 4 m and a rectangular cross-section as shown in figure 14. At rest, the top surfaces of the specimens were 0.30 m below the surface. Vertical paddles mounted on a rotating assembly extended to a depth of 0.15 m below the water surface. The speed of rotation, and therefore the flow velocity of the water in the flume was subject to continuously variable control by means of an electric motor with a gearbox. The average speed of the paddles was 3,5 m/s. With this system the water performed a helical motion and carried along a total quantity of 50 kg of river gravel, which means a ratio of water to gravel of 87:1. After a certain number of revolutions measurements were taken of the abrasion of the surface. The abrasion was measured at 24 points on the concrete surface by means of LVDTs against three fixed points.

4.3. Material tested

Fifteen mixes of concrete have been designed to investigate the influence of cement type, cement content, water-cement ratio, maximum aggregate size, aggregate content, the

use of an admixture, and the way of curing on erosion behaviour. Table 7 gives a summary of the various types of concrete. The 28 days' cube compressive strength ranged from 22 to 48 N/mm². The specimens of mixes 1-6 and 10-15 were covered after casting so as to prevent drying of fresh concrete. After 2 days they were demoulded and stored in the fog room or under water until testing took place. Several specimens (indicated with N) of mixes were allowed to dry out at the surface until testing took place.

4.4. Test results

The total average erosion is calculated from 48 measuring points (two specimens with 24 points each). Figure 15 shows an example of the erosion vs. time. At first, it displays a non-linear behaviour which later, after about 40 hours, changes into a steady rate of increase. Table 7 summarizes the results of the flume tests. Column 13 indicates the total average wear after 240 hours and column 14 gives the abrasion rate for the steady rate behaviour.

4.5. Discussion of the results

The structure of concrete at the surface which had been in contact with the mould or formwork is different from that in the interior of the concrete mass: there will be more hardened cement paste and fine aggregate constituents according to the rate at which the distance to such a surface is lessened. The outer 'skin' of the concrete will consist chiefly of hardened paste and fine particles. The probability of the presence of small cracks due to shrinkage and cooling is greatest in this outer zone.

The progress of erosion in the course of time can be explained as follows: since the strength and density of the matrix (hardened cement paste plus fine particles) are inferior to those of

14

Section through flume apparatus

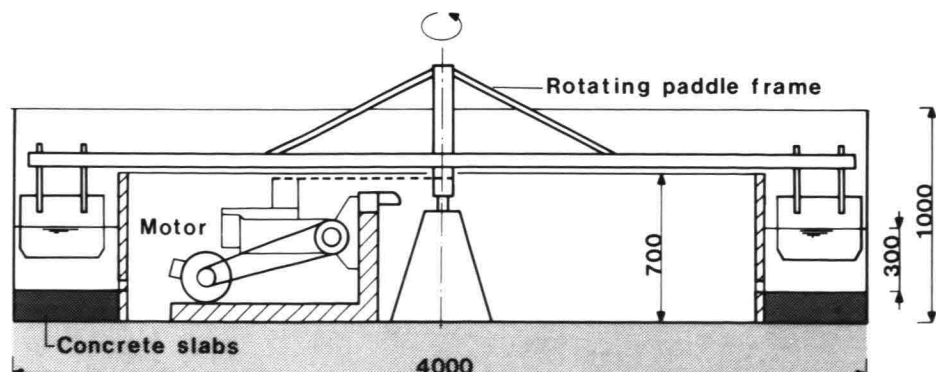

| 1 | 2 | 3 | 4 | 5 | 6 | 7 | 8 | 9 | 10 | 11 | 12 | 13 | 14 |
|-----|-------------------------------------|----------------|--------------------|---------------|--|---|------------|------------------|---------------|------------------------------------|------------------------|------------------------------------|----------------------------------|
| mix | cement content (kg/m ³) | type of cement | water-cement ratio | % plasticizer | quantity of aggregate (kg/m ³) | compressive strength (N/mm ²) | slump (mm) | compaction index | air content % | nominal maximum particle size (mm) | aggregate-cement ratio | total erosion (mm) after 240 hours | erosion increase (mm/1000 hours) |
| 1 | 281 | HA | 0.55 | — | 1935 | 37.2 | 0 | 1.14 | 0.8 | 32 | 6.89 | 2.75 | 4.38 |
| 2 | 296 | HA | 0.48 | 0.40 | 1926 | 37.9 | 45 | 1.10 | 1.4 | 32 | 6.51 | 2.81 | 5.57 |
| 3 | 307 | HB | 0.50 | — | 1918 | 43.1 | 5 | 1.08 | 0.8 | 32 | 6.25 | 3.38 | 8.39 |
| 4 | 303 | HB | 0.50 | 0.85 | 1897 | 41.3 | 190 | 1.00 | 1.7 | 32 | 6.26 | 3.00 | 7.24 |
| 5 | 308 | HA | 0.37 | 0.85 | 2014 | 48.0 | — | (1,25) | 1.2 | 80 | 6.58 | 3.38 | 6.85 |
| 6 | 368 | HB | 0.37 | 0.85 | 1826 | 47.7 | 100 | 1.08 | 3.2 | 32 | 4.96 | 2.86 | 6.36 |
| 7C | 266 | HA | 0.63 | — | 1938 | 31.2 | 80 | 1.08 | 1.2 | 32 | 7.27 | 3.49 | 6.91 |
| 7N | 266 | HA | 0.63 | — | 1933 | 24.1 | 150 | 1.11 | 1.1 | 32 | 7.27 | 5.36 | 10.45 |
| 8C | 335 | HA | 0.42 | 0.85 | 1825 | 39.2 | 120 | 1.05 | 4.0 | 32 | 5.43 | 2.81 | 7.56 |
| 8N | 335 | HA | 0.42 | 0.85 | 1813 | 40.1 | 100 | 1.08 | 3.8 | 32 | 5.43 | 2.57 | 7.10 |
| 9C | 384 | HA | 0.43 | 0.85 | 1782 | 44.4 | 140 | 1.04 | 3.2 | 32 | 4.63 | 2.07 | 4.41 |
| 9N | 384 | HA | 0.43 | 0.85 | 1776 | 39.1 | 200 | — | 3.6 | 32 | 4.63 | 2.23 | 4.88 |
| 10 | 303 | HA | 0.38 | 0.85 | 1999 | 46.3 | — | (1,21) | 1.2 | 80 | 6.60 | 3.27 | 10.98 |
| 11 | 263 | HA | 0.63 | — | 1948 | 22.7 | 100 | 1.11 | 1.0 | 32 | 7.41 | 3.60 | 10.33 |
| 12 | 334 | HA | 0.41 | 0.85 | 1850 | 40.5 | 120 | 1.07 | 3.2 | 32 | 5.54 | 3.44 | 10.30 |
| 13 | 380 | HA | 0.43 | 0.85 | 1790 | 35.4 | — | 1.01 | 3.1 | 32 | 4.71 | 3.49 | 11.50 |
| 14 | 266 | HA | 0.63 | — | 1922 | 21.0 | — | 1.01 | 1.3 | 32 | 7.23 | 3.97 | 7.90 |
| 15 | 225 | HA | 0.63 | — | 1999 | 21.9 | — | 1.13 | 1.7 | 32 | 8.88 | 5.66 | 18.95 |

HA = portland blastfurnace cement class A

HB = portland blastfurnace cement class B

Plasticizer = Cretoplast SL (superplasticizer)

Mixes Nos. 5 and 10 are so-called coars gravel mixes with nominal maximum aggregate particle size of 80 mm

The sand/gravel ratio was 35/65% for the mixes 8, 9, 12, 13 and 15 and was 38/62% for the mixes 1, 2, 3, 4, 6, 7, 11 and 14

The designation 'N' appended to a mix number indicates 'not cured' while 'C' indicates 'cured'

Table 7
Data of the various concrete qualities together with erosion test results

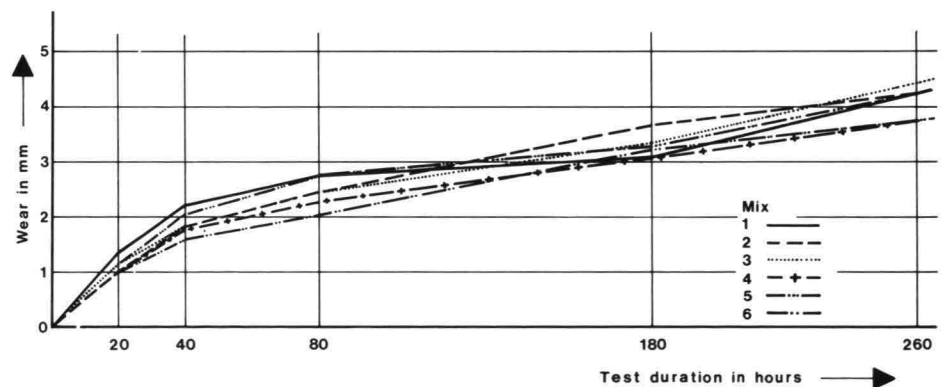

15
Total average erosive wear per mix

the aggregate, the outer skin wears away more rapidly than in specimens of concrete taken from the interior of a structural member and exposed to similar conditions. Once the outer skin has been removed, further erosion will (for constant conditions of erosion load), proceed at a constant rate.

From the statistical processing of the measurements, the following qualitative results emerged (a detailed treatment is given in (5,6)):

- The compressive strength of the concrete has a distinct effect. At the rate at which this strength becomes greater, the resistance to erosion also increases. A concrete of poor quality, even if this occurs only locally, will be quickly attacked by erosion.
- The curing treatment is of influence on erosion behaviour, especially in concrete having a low compressive strength. Good curing improves erosion

resistance, thus reducing the effect of compressive strength. On the other hand, in specimens made of high-strength concrete there was no demonstrable effect of curing.

- c. There was no ascertainable effect associated with the addition, or absence, of an admixture to the concrete mix, apart from the attendant variation in compressive strength.
- d. There was a slight relation between the quantity of aggregate and erosion resistance.

This trend was clearly manifest in concrete with a low cement content (so that the water-cement ratio was higher and the strength accordingly lower). For concrete made with coarse gravel aggregate the results are less clear. If the conclusions are confined to those types of concrete which have approximately equal strength, the effect of the quantity of aggregate on the erosion resistance is no longer detectable. Coarse gravel concrete then behaves no differently from concrete made with finer aggregate.

Before the test results can be reliably translated into reality as regards the magnitude and time-related behaviour of the phenomenon, it will be necessary to make a closer study of the erosion mechanisms. At the present time the results allow only a relative classification, assuming the mechanisms in the tests and in reality to be approximately similar.

5. General conclusion

Various aspects of concrete behaviour were the subject of this study. The use of large prefabricated concrete elements and the location of the structure in a rather aggressive environment have raised many questions about the workability of filling concrete, the impact of boulders and the erosion in water containing abrasive material. The investigation was carried out in a rather practical manner, i.e. problems arising in connection with the design of the storm surge barrier and questions arising at the building site were solved as quickly as possible with the emphasis on utility. Therefore the investigations were sometimes not as fundamental as the authors would have liked. On the other hand, many

problems have been touched upon and their solution and the discussion thereof will hopefully help the practical engineer to avoid similar problems in other hydraulic structures.

6. References

1. DOSBOUW: Research Report 561VAS-M-81010.
2. TNO-IBBC: Reports B-79-114/603/604.
3. Jensen, J.J.: Impact of falling loads on submerged concrete structures; RILEM Symposium 'Brasil Offshore', Rio de Janeiro 1979, vol.1, page 11.
4. Gardet, A, Dysli, M.: Essais à l'abrasion de revêtements d'ouvrages hydraulique; *Bulletin Technique de la Suisse Romande* 91 (1965), no. 4, pp. 45-49.
5. Pat, M.G.M. Fontijn, H.L. Reinhardt, H.W., Stroeven, P.: Erosie van beton; Stevin rapport 5-79-30, Delft University of Technology 1979.
6. Pat, M.G.M., Reinhardt, H.W.: Erosion of concrete; *Heron* 24 (1979), no. 3.



Surveying

Dimensional deviations and tolerances in the assembling of the construction elements

1. Introduction

When building under offshore conditions it is desirable to choose a high degree of prefabrication especially for those technical reasons pertaining to construction.

The structure considered here is the storm surge barrier which comprises 66 openings. Each opening is surrounded by a concrete frame (piers, sill beam and upper beam) and can be closed by a steel gate (*figure 1*). Roughly speaking there are two methods of dividing the barrier into precast elements (*figure 2*).

The first method is to precast all 66 concrete frames as monolithic units that are subsequently placed in position in the channel.

The second method divides each frame into smaller precast components (viz. piers, sill beam and upper beam), which will be assembled when placed in the channel.

Method 1 is attractive, because a dimensional deviation when placing the frame, and an unevenness of the foundation bed will have no influence on the tolerances between pier and gate. As a result the functioning of the gates is unaffected.

This in contrast to method 2 (*figure 3*) where dimensional deviations when placing the piers, and an unevenness of the foundation bed will influence the shape and the dimensions of the frame. If this is not controlled, difficulties may arise in the functioning of the gates.

Indeed in the pre-design stage method 1 was one of the alternatives. But this method calls for larger units. The corresponding foundation problems and costs were the most important reasons why this alternative was rejected.

However, the choice of method 2 implies that the composition and the function of the barrier strongly

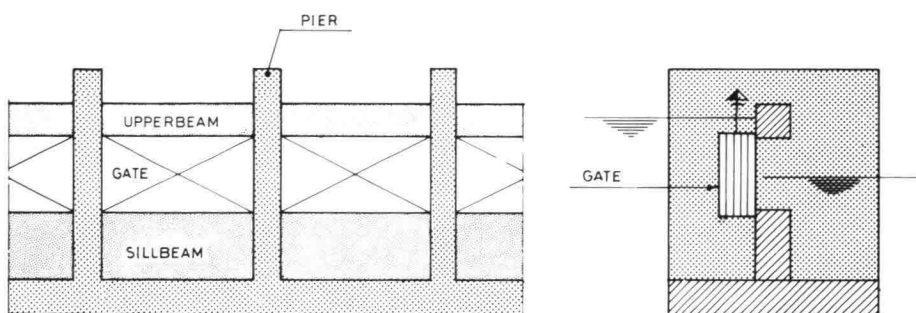

1
Schematization of the barrier

depends on the dimensional deviations initially agreed upon. An analysis of the inherent problems can be divided into:

- tracing of causes influencing the good fitting of the parts;
- determination of the assumptions required for the assembly and for assessing of any deviations;

- determination of the tolerances and deformations;
- examining the influence of the measuring procedures and of the order of implementation;
- determination of the inspection procedures during construction;
- stock-taking of the measurements that are available in the case of unfavourable results.

These points will be explained below.

2a
Method 1: joint at a pier

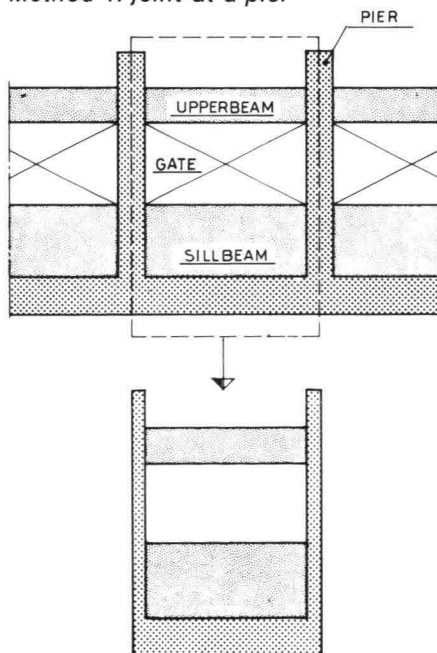

2b
Method 2: joint between piers upper beams and sill beam

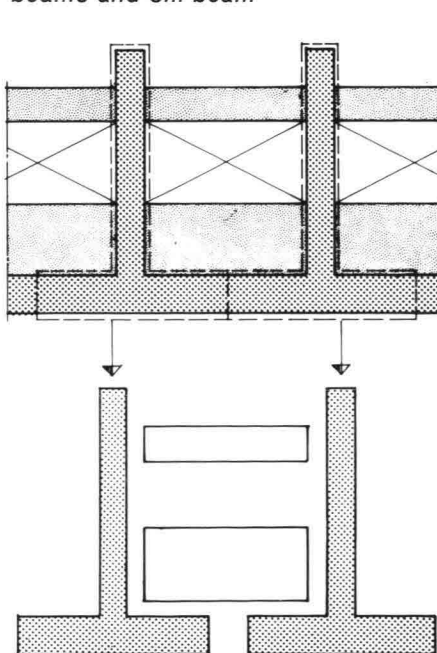

Influence of the unevenness of the bottom surface and placing the piers

2. Causes of dimensional deviations

The prefabricated parts of which the construction consists are:

foundation mattresses, piers, sill beams, upper beams, the box girder bridge, the capping units, and the movable gates (*figure 4.*) In the composition of these parts the following connections are critical:

- the position of the foundation mattresses with respect to the piers;
- the connection of the sill, upper beams and the traffic deck with the pier;
- the guideways for the gates let into the pier.

Because the gates have to fit in both closed and lifted position, the guideways for the gates on the piers appear to be the most critical factor in dimensioning. The fit is affected by the dimensional deviations of the pier and the gate with respect to their theoretical position.

The most important dimensional deviations appears in the y-z-plane (*figure 5*) and are caused by:

1. Deformations of the subsoil. These are dependent on the composition of the soil and the degree of compaction.
2. The unevenness of the foundation. For constructive and safety reasons two filter mattresses are needed. After these two mats are laid down, the upper side is in most instances not adequate. For this reason two block-mats made as a reverse moulding are fitted on the spot of the bearing plates. The remaining unevenness is mainly caused by the dimensional accuracy in the determination of the reverse moulding.
3. Washing out of enclosed sand layers. Despite the construction method it is not entirely excluded that sand will remain between, and on the filter mats. These sand layers can be washed out in a later stage and cause settlement and/or rotation of the piers.
4. Manufacturing errors in the piers. The shaft with the guideways has to be perpendicular to the mean plane through the underside of the bearing plates of the pier. In the determination of this plane inaccuracies may appear, caused by the usual construction errors (swelling up, adjustment and

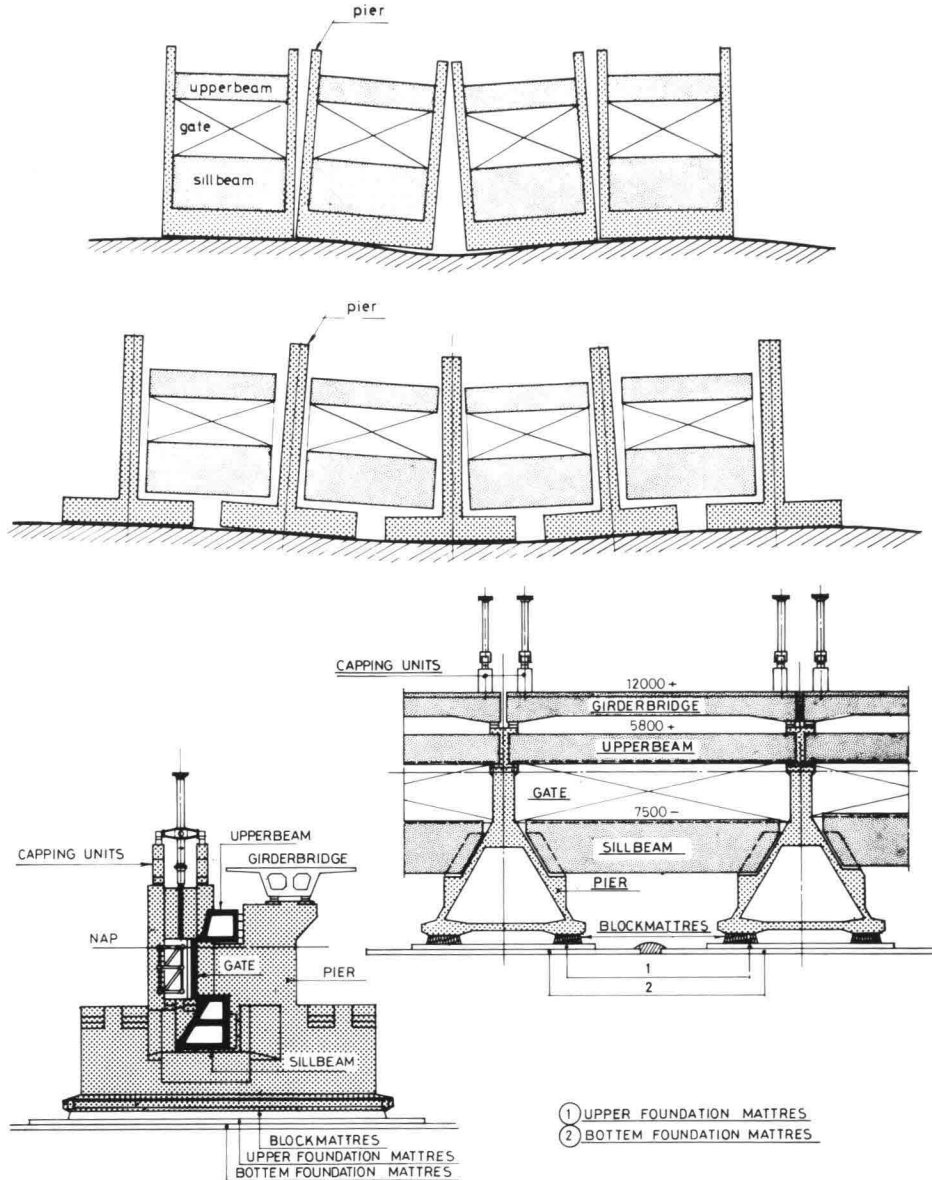

4
The prefabricated parts of the barrier

5
Most important causes of variation of dimension in z-y plane

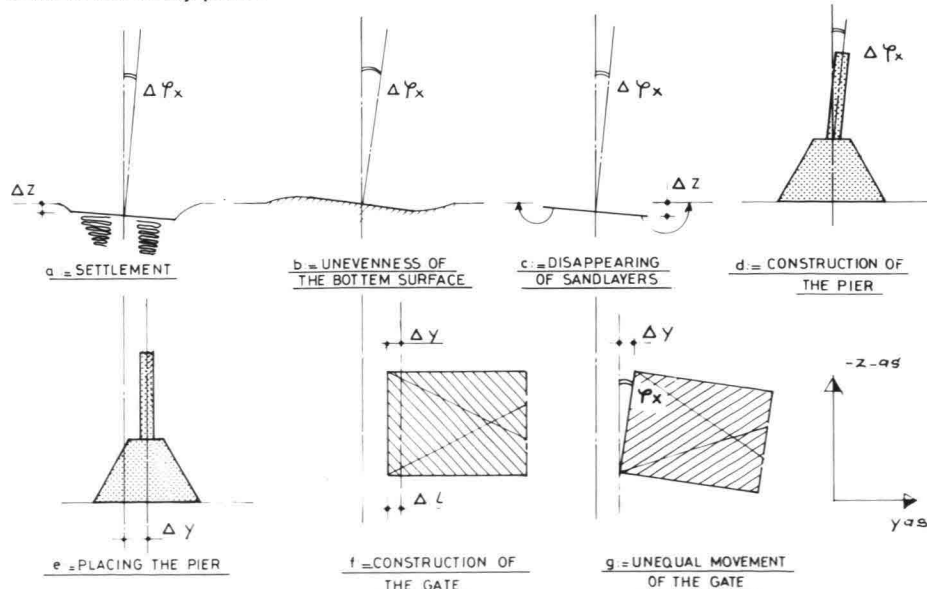

deformation of the formwork) during construction of the pier, and settlement of the subsoil.

5. Installing of the piers in the channel. The accuracy of placing is determined by any dimensional errors in fixing the pier, by any adjustment error of the anchorage system and by the motions of the piers consequent upon current and waves.
6. Manufacturing errors in the gates. These errors are in general relatively minor in nature and have hardly any influence on the fit.
7. Unequal movement of the gates. The gates are suspended on both sides and driven independently. Because of the hydraulic cylinder drive chosen it is not possible to move the suspension points synchronously.

3. Design assumptions for the composition and judgement of dimensional deviations

When designing a construction where dimensional deviation plays an important role it is necessary to determine a number of design assumptions:

- it is assumed that the occurring dimensional deviations follow a normal distribution, with the characteristic parameters μ and σ ;
- combination and assessment of the dimensional deviations takes place at 95% reliability boundaries that is to say $\mu + 2\sigma$ -values. In the following this will be referred to as tolerance boundaries;
- combination of dimensional deviations is effected according to the probability theory;
- the total tolerance for the gate bearing is divided into two parts. The first part is reserved for dimensional deviations that may occur in the building phase. The second part is reserved for the expected dimensional deviation that may occur in the operational phase, thus after delivery of the barrier. This subdivision is necessary if at moment of delivery of the barrier the requirement is expressed that every gate has to be able to move with a certain degree of reliability. This can be seen as a quality claim requirement at time when the completed barrier is handed over;
- in the elaboration of the design endeavours are made to render the tolerances in the gate bearing as large as possible, in order to restrict the tolerances as little as

possible for the processes still executing offshore. However, the widening of the tolerances in the gate bearing is limited for two reasons. On the one hand because of the technical limits set to the manufacturing of these high-quality bearings where very high demands of evenness obtain and on the other hand because of the dimensions of the pier. These dimensions are limited because of the admissible lifting weight of the pier and because of the minimum size of the cross-sectional area of the channels.

4. Tolerance boundaries of the dimensional deviations

The tolerance boundaries for the processes causing dimensional deviations are determined by the design assumptions, by the measuring procedures, and the adaptation to the implementation. To this end, the tolerance boundaries are optimally adjusted according to discipline, commensurate with what can be achieved from both the technical and the economic point of view.

This means that in an absolute sense there are big differences between the tolerance boundaries of the different processes. For the most important processes the tolerance boundaries are given in table 1. In this table the values are expressed in a frame of reference the origin of which is located in the bottom of the pier in the heart of the base slab. Hereby not only the tolerance boundaries are given that have influence on the fit of

the gate, but also those boundaries which influence other less critical fits, like those of the concrete elements between the piers, and the connection of the foundation mattresses with each other between the piers and the block mat. From this table one can see that the contribution of the offshore processes dominates the rest (for example laying mattresses and placing the piers).

To give an impression of what the tolerance boundaries of the individual partial processes mean to the fit of the gates, these tolerances are transposed to a point of reference on the pier. For this point of reference the heart of the gate guideways is taken at the OD-level for a pier with a construction depth of 30 m below mean sea level (figure 6). Only the most important tolerance boundaries in the y-z-plane were considered. Applied to the construction stage: in consequence of the unevenness of the foundation bed:

$$\Delta y_{OD} = 300 \text{ mm}$$

In the final stage:

in consequence of deformations:

$$\Delta y_{OD} = H \cdot \Delta \phi_x = 30 \cdot 1.2 = 36 \text{ mm}$$

In consequence of the washing out of the sand layers:

$$\Delta y_{OD} \cdot 30 \cdot 2.8 = 84 \text{ mm}$$

In consequence of uneven walk movement of the gates:

$$\Delta y_{OD} = 12 \cdot 3.7 = 44 \text{ mm.}$$

The contributions to the construction and the final stage may be collected and are assumed to be uncorrelated, except for the contribution to the uneven movement of the gates.

Hence in the construction stage a total displacement of $\Delta y_{OD} = \pm 338$ mm and in the final stage on $\Delta y_{OD} = \pm 135$ mm. Only for the tolerances mentioned above there has to be a width of the gate guideways of $2 \cdot (338 + 135) = 946$ mm.

Table 1
Tolerance boundaries for the most important partial processes in mm and mm/m

| | Δ_x | Δ_y | Δ_z | $\Delta \phi_x$ | $\Delta \phi_y$ | $\Delta \phi_z$ |
|----------------------------|------------|------------|------------|-----------------|-----------------|-----------------|
| implementation phase | ± 25 | ± 25 | ± 25 | $\pm .6$ | $\pm .3$ | — |
| construction of piers | — | ± 20 | ± 20 | $\pm .4$ | — | — |
| construction of gates | ± 1000 | ± 1000 | ± 95 | ± 9.3 | ± 3.7 | ± 20 |
| placing upper mattresses | ± 1000 | ± 650 | ± 200 | ± 5.2 | ± 2.6 | ± 14 |
| placing block mattresses | ± 300 | ± 300 | — | — | — | ± 4.2 |
| placing piers | | | | | | |
| operational phase | | | | | | |
| soil deformations | 0 | ± 45 | + 58 | ± 1.2 | ± 2.9 | $\pm .3$ |
| | + 92 | | + 95 | | | |
| washing out of sand layers | — | — | ± 50 | ± 2.8 | ± 1.4 | — |
| unequal movement of a gate | — | — | — | ± 3.7 | — | — |

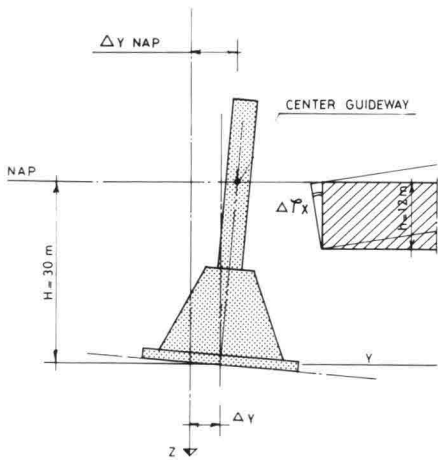

6
Variation of dimension at the center of guideway

The width has to be enlarged yet by the required constructive bearing width by the influences of tolerances that were neglected in consequence of the diagrammatizing of the problem to one point in the x-z-plane. Determination of the required width in this manner yields a result which is not realistic in a practical sense. It is therefore necessary to adapt the construction and dimensioning procedures to reduce the width of the guideways.

5. Construction procedures aimed at reducing tolerances

If the implementation is based on the assembling of prefabricated parts in a limited time set aside for this purpose, the measuring has to be done with respect to an absolute frame of reference. This implies that in prefabrication of the elements the

tolerance elements has to include deviations resulting from the placing of the piers. From the foregoing it is demonstrated that for the storm surge barrier this leads to an unacceptable width of the gate guideways, particularly as a result of the unevenness of the top of the foundation bed and also because of the deviation arising from placing of the pier.

However, the time required for the assembling of all parts of one location of the pier is relatively long. The numerous manoeuvres in the channel with vessels require long anchoring distances between each other. For this reason, i.e. the total construction time after placing the pier up to the finished work takes a number of years. This offers the opportunity of carrying out measuring procedures, so that a major part of the dimensional deviations in the length of the gates and the concrete elements can be corrected. In a construction sequence like placing the piers, measuring their position, building and placing the gates, the production process encompassing the gates is in direct dependence on the process of placing the piers. Because of the production time required for erecting the gates, it is impossible to start building them from scratch only after the dimensioning has been carried out. Hence a way of execution is chosen in which every gate is constructed from one middle section of constant length and two variable end sections. The determination of the definite length is effected after the placing of the piers and as briefly as possible before the assembly. For constructive reasons adaptations of the length are limited. The maximum variation has to be determined beforehand. The tolerance boundaries

chosen in this case are $\mu \pm 2\sigma$ from the expected dimensional deviations up to the measuring of the pier positions. In actual practice this means that the correction in the gate may have a maximum of ± 850 mm. For the same reason as applies to the gates it is necessary to determine the required length of the concrete elements after placing the piers. The concrete elements were prefabricated at different locations. The sill beams were built in construction dock 4. The bridge girders and upper beams will be made on a different construction site. Just like the gates the sill beams are prefabricated in sections. A middle section with constant length and prismatic cross-section is made independently of the placing of the piers. After the piers have been placed and secured the head sections are constructed. For the present the production of the bridge girders and upper beams is not planned to start until the required length has been measured. In all cases endeavours are made to carry out measuring as late as possible in order to eliminate the occurring deviations as much as possible. The remaining tolerances will be taken into account in the further details of the bearings and recesses in the way described above. In actual practice this implies that the measuring of the sill beams and the bridge girder will take place immediately after the placing of the piers and the upper beams and simultaneously with the gates.

6. Inspection procedures during construction

In the design stage some assumptions that were determining for the fit of the different parts are tied up (figure 3).

The most important assumption refers to what has been implemented,

7
Bearing of the gate and guideway on the piers

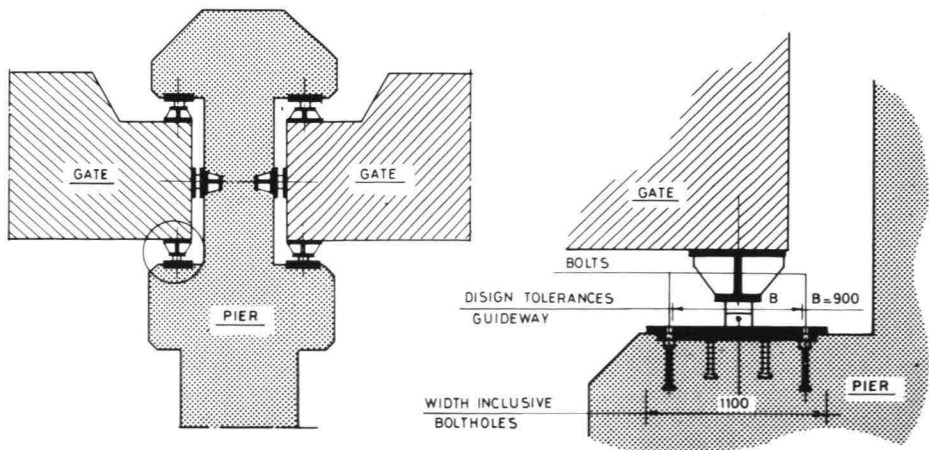

namely the assumption that the dimensional deviations which occur satisfy the normal distribution with the accepted mean values and standard deviations. During the implementation it is important to determine the distribution of the deviations that have actually been brought about and to compare these with the a priori expected values. In view of the minor number of realizations this has to be done with the aid of the theory of minor random inspections. A difference between the 'a posteriori' stated standard deviation, and the 'a priori' expected value may give rise to correction. From a statistical point of view the inspection of additional parameters to the mean values and the standard deviations is enough. If all values determined 'a posteriori', are equal to or less than the ones expected beforehand, their tolerance boundaries will be exceeded only in 5% of the piers.

However, there are a few reasons why it is desirable to have rejection limits fixed per action and per partial process.

- For given distributions of the partial processes the chance of the gates and the concrete elements not fitting is reduced.
- If the realized values satisfy a distribution with a much bigger standard deviation, this might be established too late with statistical methods (Bacean). In this case fixed rejection limits prevent such deviation from influencing the definite results (the fit) too strongly.
- Lastly, fixed rejection limits keep up the discipline.

Because every partial process can not be inspected apart (e.g. measuring processes) it is necessary to have an inspection in which a number of

partial processes are checked together. The fitting of the gate, including the expected dimensional deviations in the operational stage is a test for all foregoing execution processes.

7. Measures in cases where tolerance boundaries are exceeded

As regards the presented design assumptions and testing procedures it may be expected that the realization of partial processes will on occasion exceed the fixed rejection limits. If these limits are exceeded, implementation is as a matter of principle rejected and the process repeated. However during implementation it is also possible to test whether the design assumptions are satisfactory. Deviations with respects to these assumptions can give rise to measures being taken. These can be divided into measures taken during the implementation and during the operational stage.

Measures taken during the implementation

If the actual distribution of the realized values deviates from the previously estimated values, the following measures can be taken:

1. adjustment of the examined process;
2. adjustment of the following processes;
3. adaptation of the rejection limits of the examined process;
4. adaptation of the rejection limits of the following partial processes;
5. acceptance of the loss of quality during the implementation stage and taking measures in the operational stage after delivery.

If adjustment of the partial processes is at stake this implies in actual practice that one has to start from other working conditions or work pro-

cedures because adaptation of the special rejection limits is chosen then the chance of rejection increases for equal working conditions. Then the number of repetitions increases. Both adaptation of the working conditions and the additional repetition of the partial process have their consequences in planning and costs. A risk analysis has to decide which of the measures is the optimum.

Measures taken during the operational stage

The actual influence of some partial processes such as compaction of the foundation and washing out of the sand layers only will find expression in the operational stage after the first storms has appeared. If unfavourable results are obtained, the following measures can be considered. These have reference to the fitting problems of the gates.

1. Enlarging the tolerance field of the gate guideways width by permitting the gate bearing gliding over the bolt holes (*figure 6*). This means extra maintenance and a quicker replacing of the bearings.
2. If disassembly is still possible, adjusting the gate to the right length and/or adjusting the bearings to the slope of the piers.
3. If disassembly is not possible (the piers incline too much toward each other) then the gates have to be burned off, and replaced by new ones.

For the concrete elements constituting upper beam and bridge girder the following measures can be envisaged:

1. jacking up the beams which allows the rubber bearings to relax;
2. replacing or exchanging the elements.

Surveying

Surveying systems

Introduction

The organisation of the surveying for the construction of the storm surge barrier has three outstanding characteristics:

- intensive co-operation between the Government and the contractor;
- it provides for both sides the same control possibilities for every survey system;
- it meets the requirements of accuracy so that our engineers can optimize their work.

This intensive co-operation has achieved good problem solving as a result of research, trial, work experience and individual specialization. The decision not to duplicate all tasks has the great advantage that the costs are kept relatively low, that the available manpower is utilised at an optimum and that both parties, Government and contractor require the same good control system. Experimenting with concrete piers also requires special attention to the control of measurements.

The high accuracy demands which are to be ascribed chiefly to the use of prefabrication for so many elements are unique in hydraulic engineering projects. Whereas people have been used to metres or at most decimeters in horizontal projection and decimetres in vertical projection, this particular project calls for centimetric accuracy.

This accuracy together with the speed required have resulted in special instrumentation, a great deal of automation also with regard to pure geodetic aspects, (such as) good coordinate systems taking in piers, vessels and the channels. Furthermore the reduced time scale for the total operation necessitates back-up possibilities which should preferably work according to different principles.

Hence control activities are required to check measurements independently as well as back-up methods to obtain measurements by other means. The back-up devices can often be used in control procedures.

The demands made on organisation of the survey organisation and the complexity of the tasks have resulted in several projects. The organisation of the different projects is distributed over a number of working teams. An overall team is responsible for technique, planning and costs.

In the following pages two of our projects, 'Ostrea' and 'Underwater Inspection' are described in detail.

Ostrea surveying system

The operations commence with a feasibility study and a functional specification of the total process from building to placing the piers. Previous projects used for comparison were those concerning tunnel elements which had been made and placed regularly over the past ten years.

The work was sub-divided as follows:

- building and 'form detection';
- lifting and transport;
- coupling and cleaning;
- positioning and deformations;
- data registration.

The basic considerations were:

- every measurement is checked with a fault detection device;
- back-up is always possible, preferable by other devices;
- 2 computer systems are operating simultaneously;
- registration of all measurements;
- use of instruments is expected to provide up-date speed, movements and accuracy.

The main purpose of building and 'form detection' (pier dimensions) was to provide basic information as to tolerances and the theoretical

position in the channel. Obviously it was necessary to allocate the right dimensions to the pier, but in addition information was needed concerning volumes, weight, thickness, outline dimensions and rotations.

To furnish an idea about the requirements:

- flatness underside pier has a tolerance of approx. 10 millimetres;
- accuracy of the points from which the outlines are determined $x = y = z$ has a tolerance of 4 millimetres and 1 millimetre respectively;
- accuracy of the lifting yokes has a tolerance of between +3 and -3 mm.

The stringent requirements for all these measurements during construction have been met by special theodolite fittings, Electronic Distance Measurements (EDM) instruments, levels and optical plummets. For other purposes such as lifting, positioning, deformation, beams and stone dumping for the sill, the coordinates of the outlines of the piers are placed on magnetic tapes for computer use.

Lifting and transport of the piers states navigational requirements of the lifting vessel (Ostrea) in the construction yard, around a pier, for the lifting claws and in the pre-determined channels.

For the precision positioning an accuracy of + or - 5 centimetres in the x, y and z alignments is attained with electronic tachymeters. The instruments pointed at the prisms on board give horizontal-, vertical angle and distance in a real time.

The information is received on board by telemetry with the addition of gyro, and inclination angles of the ship and outline information of the pier, a computer is able to calculate

the required coordinates, distances a.s.o. All this information is then presented on graphic screens and printers. For transport in the predetermined channels sounding information on tape is used together with a radiographic positioning system called 'Trident 3'. It passes on 3 or more distances from the transceiver on board to beacons ashore whose coordinates are known. Once these distances are known, the position and the speed of the vessel is calculated and checked. Presentation of this information on a screen together with the channel outlines supplies the required information.

Coupling to the mooring pontoon (Macoma) and cleaning of the mattress with this pontoon calls for simultaneous positioning. Instruments specially required for positioning the piers, called 'Minilir' are also used for coupling. The Minilir placed ashore is pointed manually at an infrared light on board. Thereafter it stays automatically centered on the light and is able to do this by movements up to $36^\circ/\text{sec}$. Every tenth of a second it provides an output of horizontal or vertical angle with an accuracy of 4.5 arc seconds. An EDM instrument placed on top of it indicates the distance to the prisms above the light. Now the coupling of the pontoons is achieved by pointing two Minilir/EDM combinations at the Macoma and at the Ostrea. All the information is transmitted to the Ostrea computer system because it is moving and it is then possible to observe on the screens the position and rotation in relation to each other.

With regard to the cleaning process with the Macoma we mention only the existence of sensors behind the suction heads which are able to measure the sand thickness on the mattress after cleaning. These are sensors derived from the medical field operating as echo-sounders. When too much sand (1 or 2 centimetres) is still present on the bottom mattress and the next mattress is placed over it, there is a great danger of being rinsed out giving rise to deformations.

Positioning a pier in the Eastern Scheldt stipulates measuring requirements not only for the static translations and rotations but also for the dynamic movements of the pier base. Furthermore an update time of less than 3 seconds is need-

ed whereby no stagnation is permitted. For those purposes the three Minilir/EDM combinations are pointed at the top of the pier and a trim-and list measuring instrument is placed on it. All instruments are used in such a way that all necessary information is available from two sources and offer the possibility of controlling the positioning process but also of determining whether movements are too big for placing. With the trim- and list instrument we are able to measure the static angles (rate-gyro principle) with an accuracy of plus/minus 11 arc seconds, and the dynamic movements (accelerometer) with an accuracy of plus/minus 72 arc seconds.

A dual computer system is used on board to minimise the down-time. The systems are also used for all kinds of calculations and presentations (f.i. all anchor data) needed for controlling the processes.

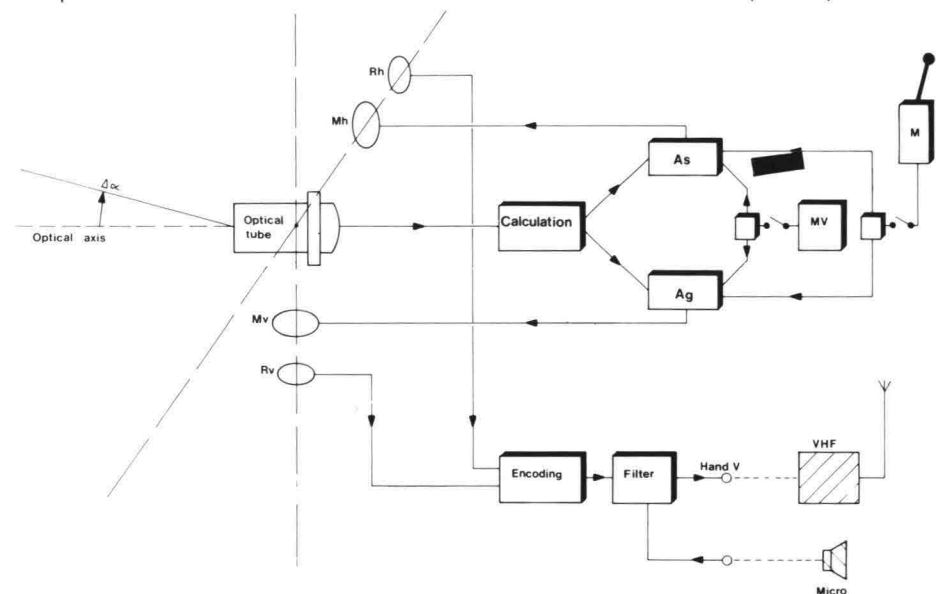

Data registration is obtained from almost every sensor and calculation. These registrations are used for tolerance calculations, process analyses and for further operations. Wherever possible common data carriers and code systems are therefore used so that an on-shore computer system can work with these data. The requirements are to collect, file and quickly present all data. A separate task is the combining and making available of data for subsequent processes. One of these processes is underwater inspection.

Underwater inspection

Underwater inspection is totally different from the Ostrea survey project. Because the design of the storm



1 Automatic theodolite (Minilir)

2 Schematic operation (Minilir)

surge barrier calls for stringent requirements as regards positioning; moreover the condition of foundation piers and sill makes an underwater inspection system (integrated in the several cycles) indispensable.

To quote an example, the inspections associated with the placing of a pier are:

- the tile mattress for missing tiles;
- the gravel bags, prior to lifting, for tears;
- the underside of the pier for concrete damage;
- the upper- and tile mattresses for sand;

— the gravel bag connection to the mattress for gaps.

The stringent requirements for these inspections have to be seen in the context of the strict allocation of time within the cycle, the strong water current, the restricted space and the low visibility conditions. We therefore use special equipment for this project. The systems were chosen in the light of feasibility studies and user specifications.

As a result of these a Bottom Crawler (BC) has been developed, built and put in operation; a support vessel, and divers for assistance and repair are also present. The BC is controlled from the support vessel through the umbilical cable which is used for the transmission of power and sensor information both up and down. On the crawler there are tracks for lateral motion up to 2,5 m/sec and wheels which can push the tracks from the mattress, for turning.

It also carries visual and acoustic inspection sensors like video- and still cameras, obstacle avoidance- and side scan sonar, a sand thickness sensor together with positioning equipment for dead reckoning or position calculation relative to the support vessel. Because of the low visibilities the black/white video cameras are placed in plastic cones so that with a dispersion lens larger areas (80 by 80 cm) can be observed from a height of 10 centimetres above the mattress. From the operations room it is possible to manoeuvre the BC either by manual or by semi- or fully-automatic control. In the operations room information is available on position, status and environmental conditions. The instrumentation part consists of video- and sonar displays, of positioning equipment like Trident, ultra short baseline acoustics and gyro systems. Digital computer hardware takes care of the I/O software, calculations, automatic control and presentations.

On the support vessel there are a hangar, a repair shop, power generators and evidently the wheel-house as well as accommodation. The vessel can rest on its anchors but is also capable of sailing along the line or holding position on a given spot by means of thrusters and propellers. A big revolving crane takes care of the launch and recovery procedures. The dry weight of the BC is 6.5 T, the jib length 10.5 metres. The total com-

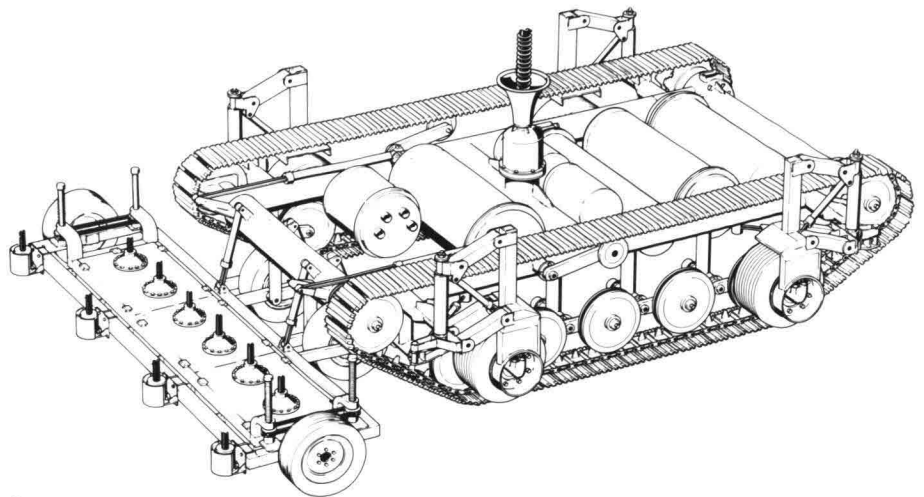

3
Seabed crawler 'Portunus'

ination of BC and vessel can work in currents up to 2 m/sec and at water visibility of above 10 cm. No damage is inflicted on the mattress and a good control of the BC offers a wide inspection area.

Because of the previously mentioned requirements pertaining to the measurement of sand thickness another vehicle was developed for use on board of the mattress-laying pontoon. When laying the second mattress on top of the first it is necessary to measure the sand thickness a few metres above the touch-down point of the second mattress. This is achieved with an inspection ledge which is lowered from the pontoon and is equipped with a camera and the special echosounders. Information is thus presented in real time on board of the pontoon.

The last but also important part of the underwater inspection system are the divers. They have been on this work for many years and their experience is very valuable. However, because of stronger currents the dive-time is becoming shorter. It is possible to dive at speeds of up to 25 cm/sec, however, nowadays this gives the divers only 30-45 minutes depending on the tide and the availability of a compression tank, to go down, inspect, and come on board again. They do have the up-to-date modern equipment but the diving-bell offers a real possibility for long time diving. This diving-bell is also used for effecting small repairs.

Conclusions

Because of the prefabricated constructions, the short tidal cycle and hence the need for rapid and highly accurate measurements, our survey-

ing systems have specially designed equipment, big computers and associated control- and back-up facilities.

Our automation projects (8), some of them worth up to 3 million dollars and ranging from 5 to 30 man-years have made us fully aware of the know-how and manpower required for their implementation. In those real-time systems with up to 300 sensors, fully updated presentations and registration you need:

- a company with experience in surveying and automation to assist in implementing such projects;
- a good description agreed by all parties of the requirements and purposes of the system in relation to the work to be done (a so-called functional specification);
- and furthermore a good system design, quality plan and project management.

Much attention must be given to:

- project management in automation, there are valuable rules;
- accurate accounts of every meeting and agreement of hard- and software;
- coupling of the sensors to the computer.

About positioning we have learned that with present-day technology it is possible to meet almost any requirement for measurement of translations (x, y and z) in air and rotations in static or dynamic movement.

In 50% of the cases problemsolving in the matter of positioning is a matter of money, trials and time. However positioning under water can be greatly improved.

To detect objects in the vicinity requires contact and/or use of energy.

Contact is often difficult because of the swift currents and swell in the Eastern Scheldt. As regards the use of energy, light waves have a short range, electromagnetic waves a bad resolution, electronic fields a short range and bad resolution, magnetic fields a moderate resolution so that only acoustic waves which have a reasonable range, resolution and fixed travel speed are practicable.

New development, as well as changes to existing products cost a disproportionate amount of time and money compared to existing products.

Our personnel is highly trained in the above-mentioned techniques and must be able to do most of the re-

quired system maintenance themselves. A survey project such as the Ostrea in combination with the Macoma equipment has a total of 25 men working in 3 shifts. Personnel on this kind of surveying projects should present in our opinion a combination of the following skills:

electrotechnician — for interfacing, trouble shooting, repair, and market knowledge;
automation technician — for systems development, design, and supervision;
surveyors — for contact with users and builders, formulae, statistics, measurement and calibrations.

Because of the implemented control and back-up facilities the risk of down-times is very low but this is

dependent on the speed of fault detection.

Planning aspects are:

- preparation 1 month (no trials or modifications);
- description 1 month (when work principles are known);
- internal agreements 1 month;
- company's assessment company finding 1-2 months;
- functional specification 2 months;
- system design and development 6-18 months (also hardware-dependent);
- in-house trials 1 month;
- installation 1-2 months;
- fields tests 1-3 months.

Thus the planning will vary from approximately 15 to 31 months.



Colophon

The drawings are made by Locks & Weirs Division Rijkswaterstaat, Bridges Division Rijkswaterstaat and Dosbouw, contractor.

Photographs are published from the under-mentioned photographers; the numbers refer to the pages and the number of the illustration.

- Aerocamera - Bart Hofmeester/Rotterdam: 5/5, 21/4a, 4b, 22/6, 24/11, 28/2, 29/5, 40/1b, 114, 123
- J. Berrevoets/Zierikzee: 75/15
- Jack van Bodegom/Spijkenisse: 21/5b, 22/7, 23/8, 28/1, 30/10, 31/11, 33/16, 69/1, 72/6, 77/20
- Delta-phot/Middelburg: 21/2, 24/12, 29/8, 31/12, 34/17, 35/19
- Dosbouw: 28/4, 29/7, 36/23
- Hoofddirectie Waterstaat, bureau Reprografie: 23/9, 29/6, 72/7, 73/8, 74/11, 12, 75/13
- KLM-Aerocarto/Schiphol: 4/4, 20/1, 21/3b
- Schaart/Rotterdam: 36/22
- Volder en De Mey/Rotterdam: 28/3

ERRATUM (provisional)

- Page 13, column 1, line 13: change "...on..." in "...or..."
- Page 14, column 1, line 28: change "...expensive knowledge..." in "...extensive knowledge..."
- Page 15, column 2, line 6: change "...head..." in "...tidal range..."
- Page 18, column 2, line 30: change "...1983..." in "...1984..."
- Page 19, column 1, line 29: change "...cylindrical wave loads" in "...cyclic wave loads"
- Page 32, figure 15: sequence must be:- soil improvement - deep compaction - lower mattress - upper mattress - block mattress - pier foundation.
- Page 66, column 1, line 48: change "...100 μm Mi" in "...100 μm Ni".
- Page 66, column 2, line 49: change "...loading end" in "leading end".
- Page 66, column 3, line 1: change "... (50cm) ..." in "... (25cm) ...".
- Page 66, column 3, line 50: change "... (fig. 4) ..." in "... (fig. 6) ...".
- Page 78, column 3, line 26: change "...inferences..." in "...interferes..."
- Page 80, column 2, line 38: delete "...and 2 interrupted pours of 3 days..."
- Page 81, column 2, line 4: change "...prestressed.." in "...prestressing..".
- Page 82, column 2, line 22: change "...clisnensary.." in "...clinical hospital..."
- Page 117, Table 1: Table 1 changes in following way:

Table 1
Tolerance boundaries for the most important partial processes in mm and mm/m

| | Δ_x | Δ_y | Δ_z | $\Delta\phi_x$ | $\Delta\phi_y$ | $\Delta\phi_z$ |
|-----------------------------|------------|------------|------------|----------------|----------------|----------------|
| <u>implementation phase</u> | | | | | | |
| construction of piers | ± 25 | ± 25 | ± 25 | ± .6 | ± .3 | — |
| construction of gates | — | ± 20 | ± 20 | ± .4 | — | — |
| placing upper mattresses | ± 1000 | ± 1000 | ± 95 | ± 9.3 | ± 3.7 | ± 20 |
| placing block mattresses | ± 1000 | ± 650 | ± 200 | ± 5.2 | ± 2.6 | ± 14 |
| placing piers | ± 300 | ± 300 | — | — | — | ± 4.2 |
| <u>operational phase</u> | | | | | | |
| soil deformations | 0 | ± 45 | + 58 | ± 1.2 | ± 2.9 | ± .3 |
| | + 92 | — | + 95 | — | — | — |
| washing out of sand layers | — | — | ± 50 | ± 2.8 | ± 1.4 | — |
| unequal movement of a gate | — | — | — | ± 3.7 | — | — |

Page 120, column 2, line 8, delete "organisation".

Page 120, column 3, last paragraph, change in "The information is received on board by telemetry and with the addition of gyro, inclination angles of the ship and outline information of the pier, a computer is able to calculate".

Page 121, column 1, line 5, change: "...channels sounding..." in "...channels pre-sounding...".

Page 121, column 1, line 38, change: "Macoma and at" in "Macoma and one at".

Page 121, column 3, line 14, change: "(rate-gyro principle)" in "(accelerometer)".

Page 121, column 3, line 17, change: "(accelerometer)" in "(rate-gyro)".

Page 122, column 1, line 63, change: "...6,5 T..." in "...9 T".

