

The storm surge barrier in the Eastern Scheldt

For safety and environment

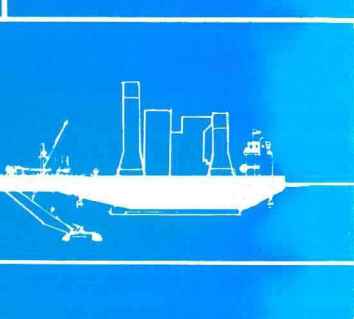

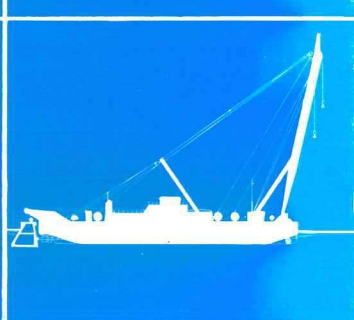
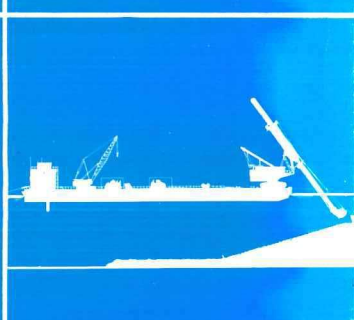
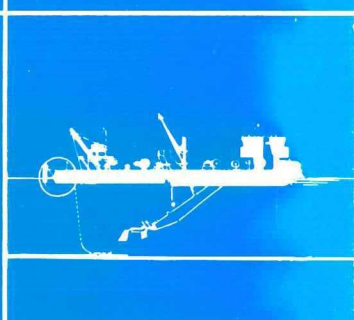
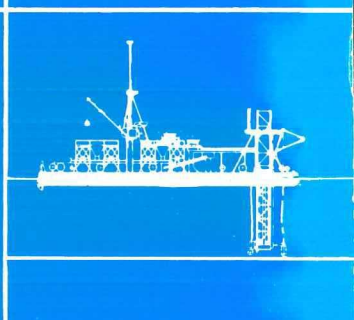
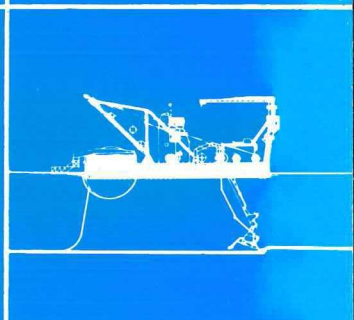
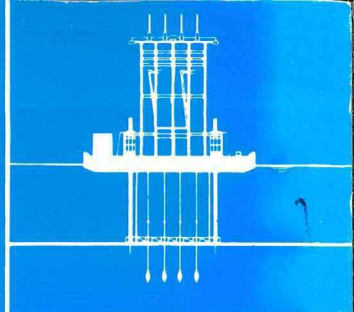
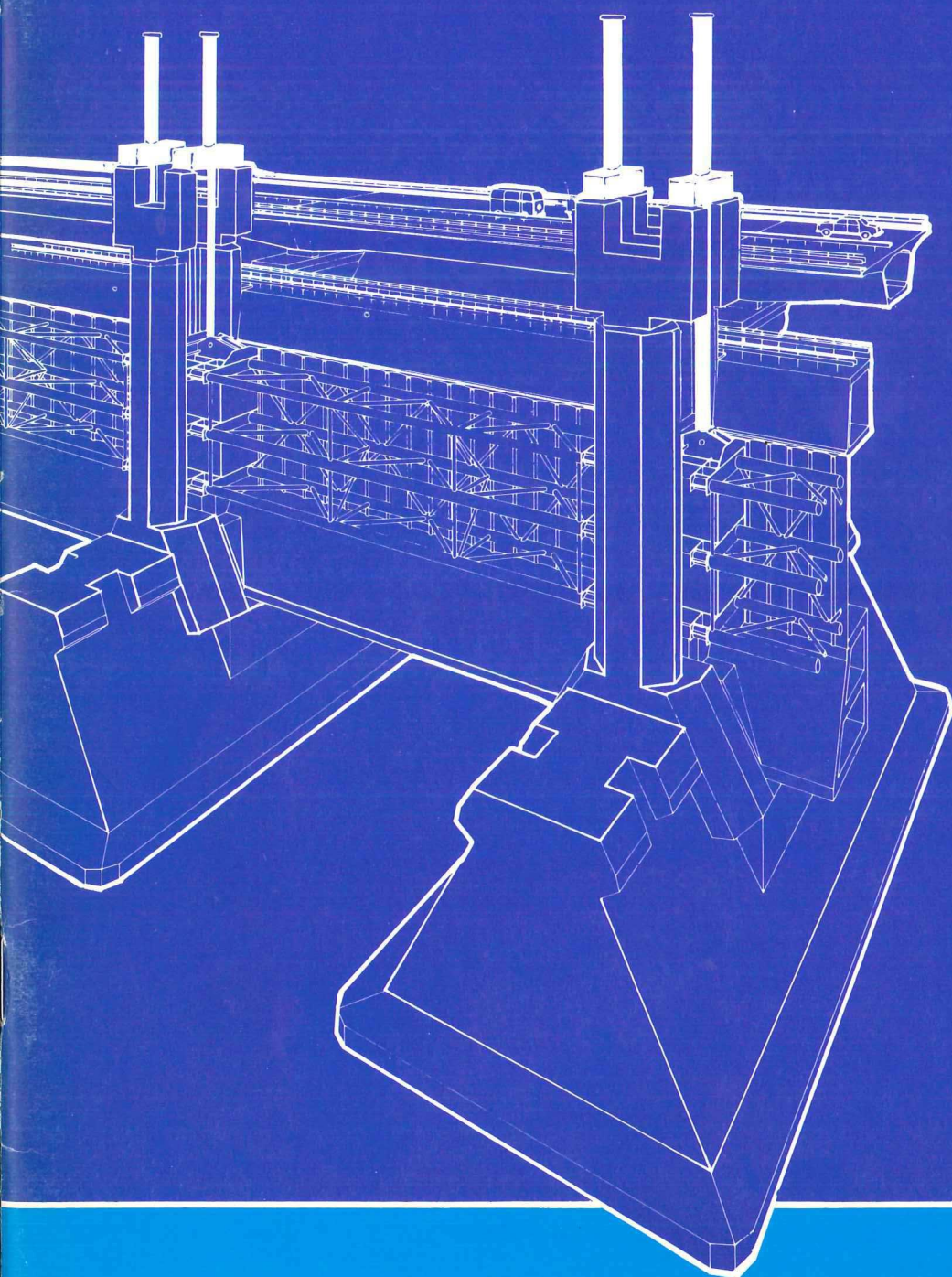
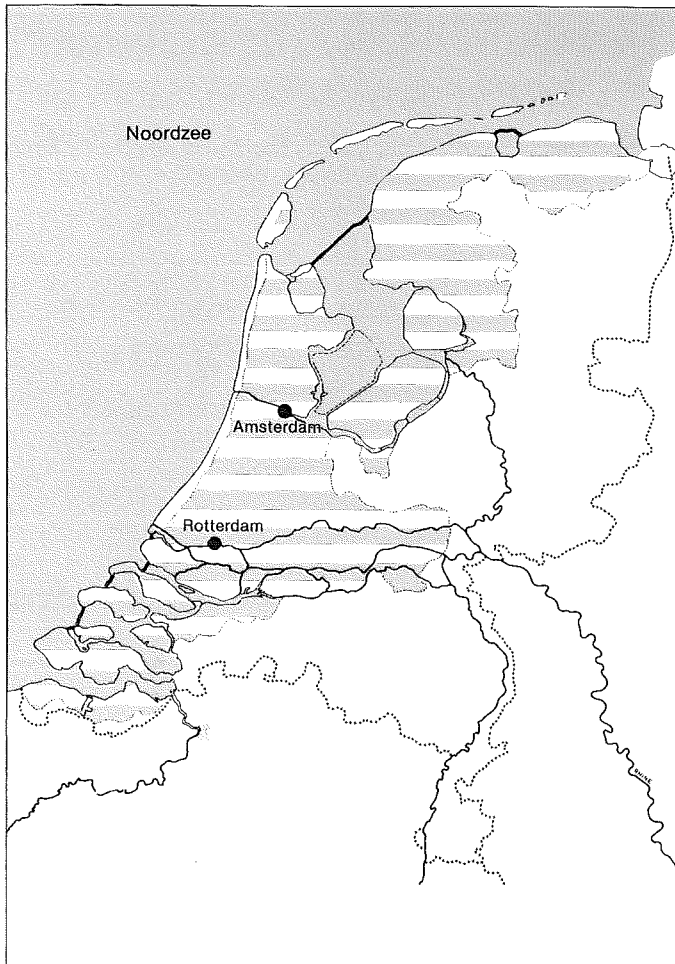

Areas which would be periodically flooded if the Netherlands was not protected by dykes.

Cover illustrations

Storm surge barrier pier and gate construction

Vessels, from top to bottom:

Mytilus

Cardium

Jan Heijmans

Donax I and Macoma

Trias

Taklift 4

Macoma and Ostrea

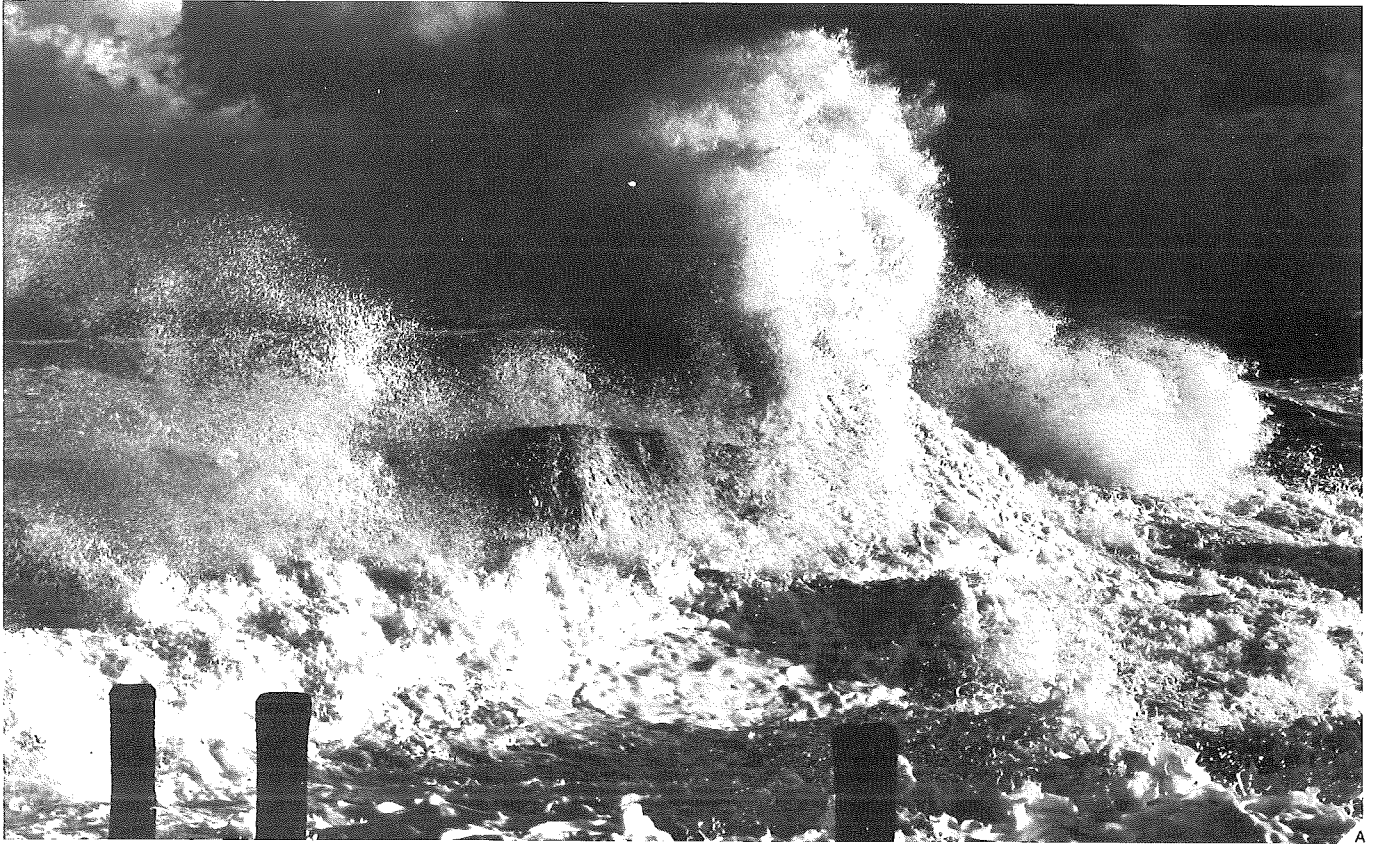

A

- A. The centuries old struggle against the sea
- B. Various stages in the development of the southwest of the Netherlands
- C. The Netherlands, the gateway to Europe, situated on the North Sea at the delta of three great rivers, the Rhine, the Maas and the Scheldt.

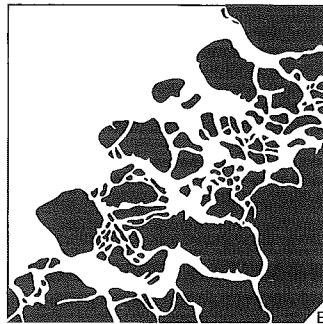

B



B

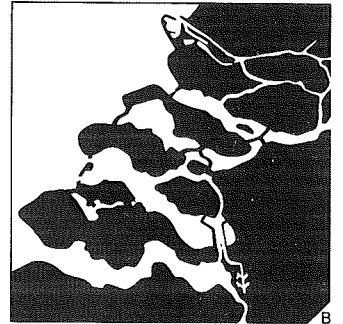

B

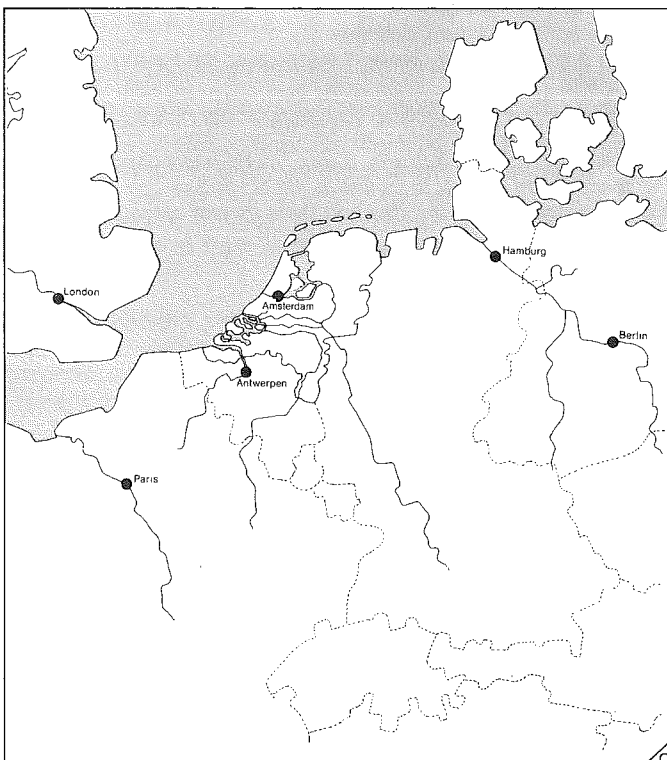

C

The Netherlands, a country wrested from the sea

In the Netherlands water is both friend and foe: the inhabitants have struggled against it down through the centuries, and have overcome it by turning water into dry land. Among the benefits which water has yielded is access for shipping, which has been responsible for the blossoming trade for which the Netherlands is famous, while the freshwater rivers together with adequate rainfall have ensured a successful agricultural industry on the fertile sea clay land.

The relationship between the Dutch and the water has always been and indeed remains a love-hate one; today it is expressed through the building and constant strengthening of dykes, the construction of important trading links such as the New Waterway and the North Sea Canal and the building of the Barrier Dam, which resulted not only in the reclamation of new tracts of land but also in increased safety and a freshwater lake.

The special relationship which the Netherlands has with the water is particularly noticeable in the province of Zeeland, where the battle with the sea is still continuing, though the province owes its fine trading centres to that same water, which has enabled it to remain a major pillar of trade, industry and agriculture.

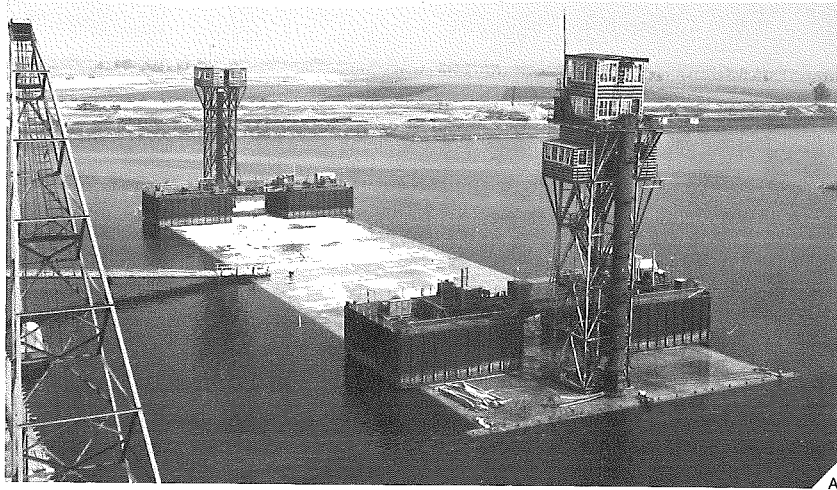

A

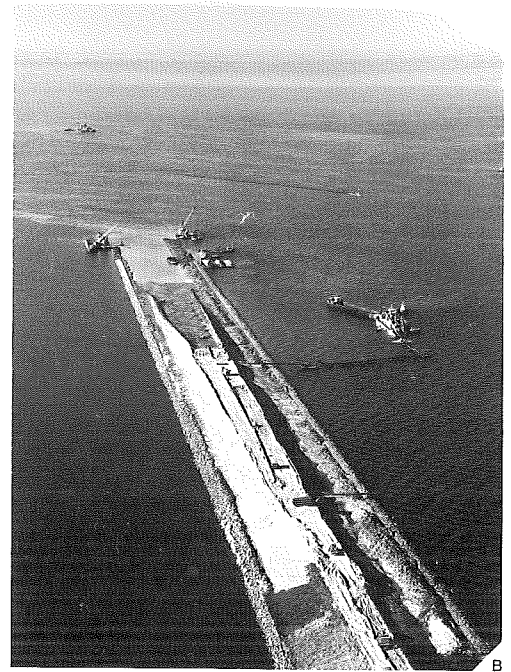

B

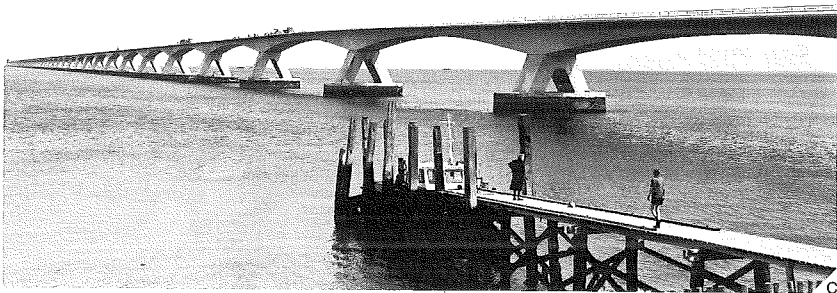

C

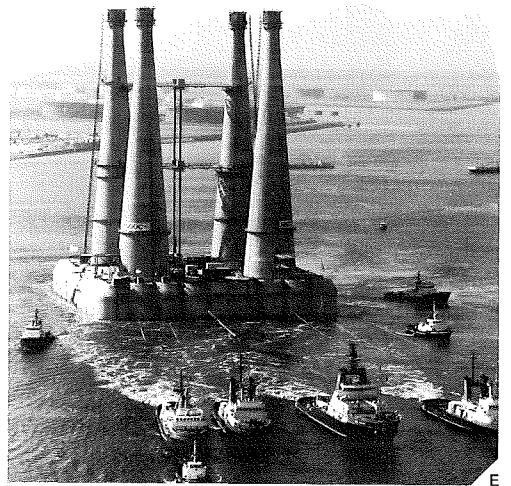

E

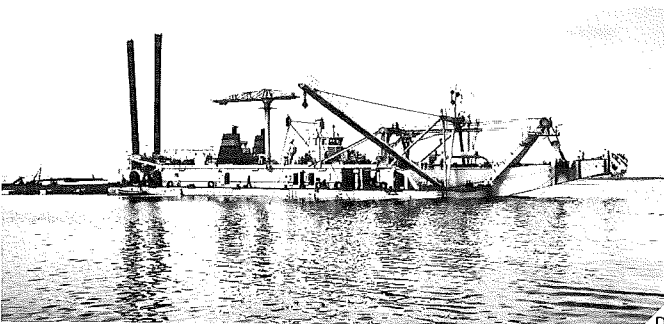

D

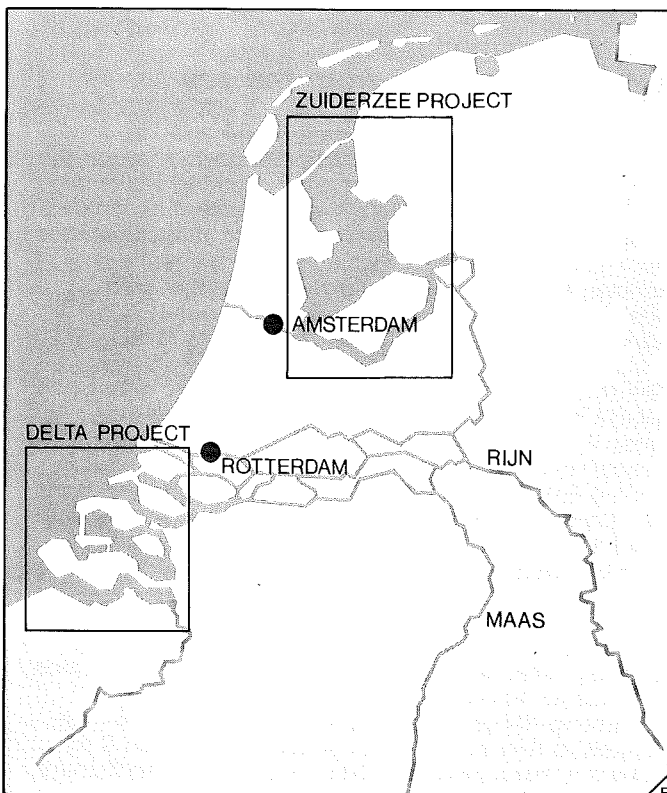

F

- A. Section of the Heinenoord road tunnel with equipment for sinking it into position
- B. Dam building in the IJsselmeer
- C. The 5 kilometre long Zeeland Bridge over the Eastern Scheldt
- D. The development of ever improved dredging and dustpan equipment goes on
- E. The oil production platform, Andoc, made largely from concrete, on its way to its site in the North Sea
- F. The location of Zuyder Zee and Delta Project operations

Dutch hydraulic engineering

The Netherlands has long and varied experience of hydraulic engineering, and particularly of constructing dykes, digging canals, draining polders and building locks, tunnels and ports. That experience is also put to use in the off-shore industries - in the construction of production platforms for example. Working in and with water has given the Dutch a world-wide reputation, and the Zuyder Zee project, which not only protected large areas of the country from flooding but also provided about 160,000 ha. of new land, and the Delta project, which is also to protect the Netherlands from the ravages of the sea, are outstanding examples of their expertise in this field.



A. The 200,000 hectares of land flooded in the 1953 storms
 B. The water pours through the holes in the dykes, sweeping all before it.



The Delta Project

This project proposed the closure of the main tidal estuaries and inlets in the southwestern part of the Netherlands with the exception of those giving access to the ports of Rotterdam and Antwerp. Not only would this shorten the country's coastline by hundreds of kilometres but, by forcing the saltwater further back towards the sea it would also provide significant improvements to freshwater management in the country.

After the floods of 1953, which engulfed large areas of this region, claiming 1,835 lives, it was decided to accelerate the implementation of plans already in existence.

In 1958 Parliament passed the Delta Act, which launched the Delta project, involving the closure of all tidal inlets except the New Waterway and the Western Scheldt, the shipping routes to Rotterdam and Antwerp.

The various parts of the project were undertaken, one after the other, without delay. All were challenging and interesting pieces of hydraulic engineering, each one more complicated than the last.

They were carried out in the following order:

- 1958: Storm surge barrier in the Hollandse IJssel
- 1960: Zandkreek Dam
- 1961: Veerse Dam
- 1965: Grevelingen Dam
- 1970: Volkerak Dam with lock complex
- 1971: Haringvliet Dam with discharge sluices
- 1972: Brouwers Dam



- A. Brouwers Dam
 - B. Haringvliet Dam
 - C. Volkerak Dam
 - D. Hollandse IJssel storm surge barrier
 - E. Zandkreek Dam
 - F. Veerse Dam
 - G. Grevelingen Dam
 - H. Locations of the dams in the Delta Project
 - I. Philips Dam } on map only
 - J. Oester Dam } on map only
- (See also map below)

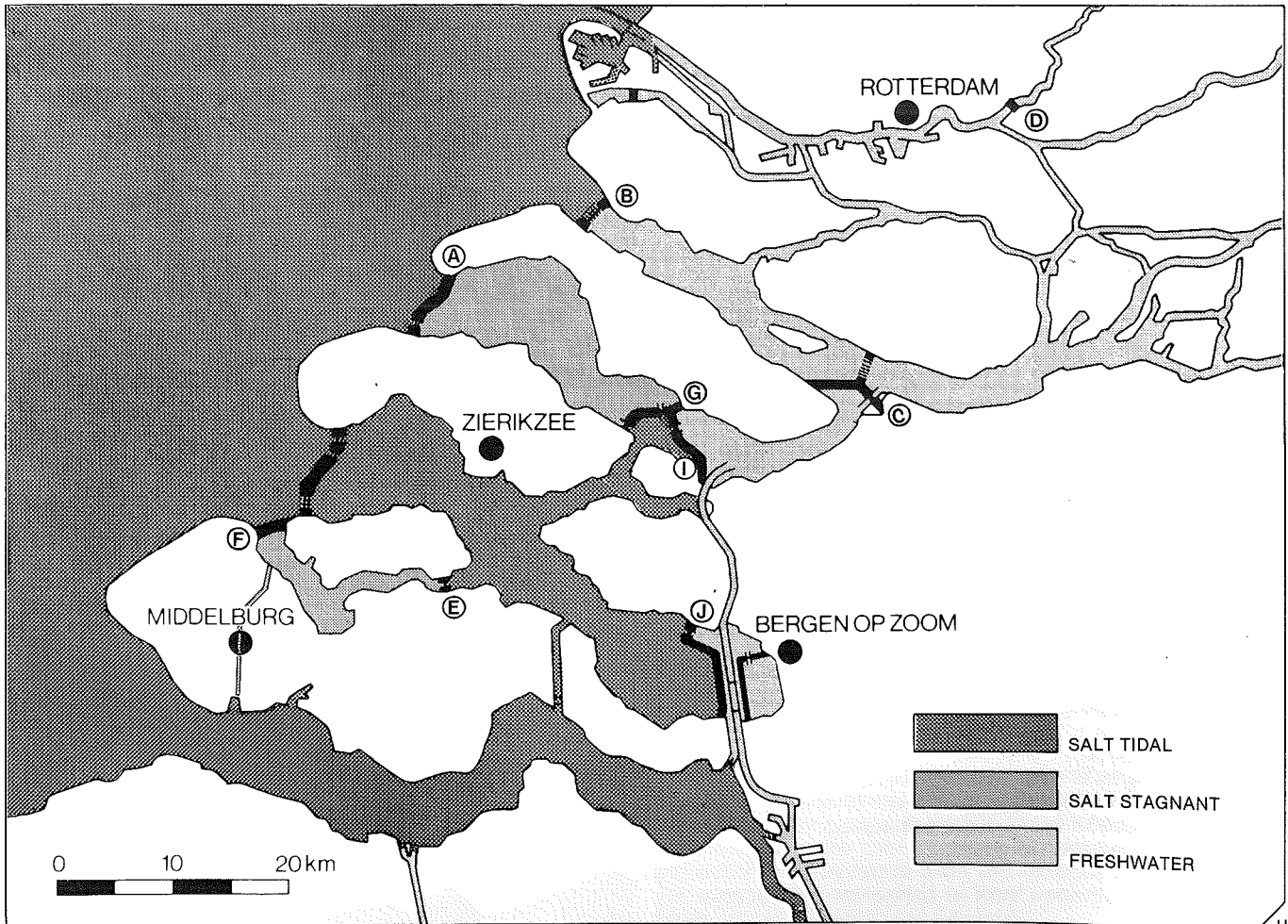
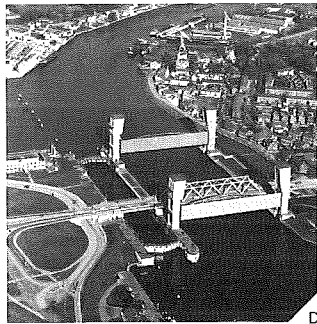

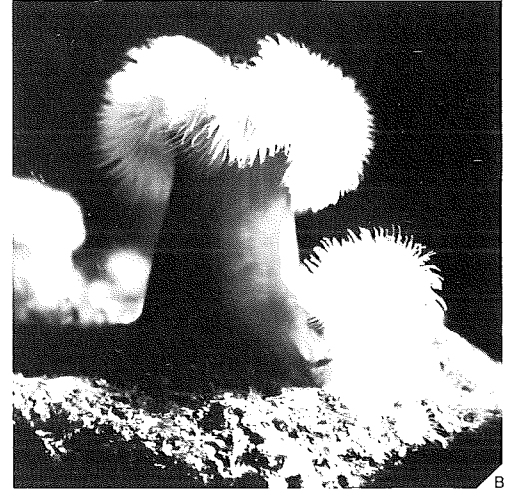

Keeping the Eastern Scheldt open to the sea means the preservation of:

- A. resting and feeding places for birds
- B/C. underwater life
- D. fishing

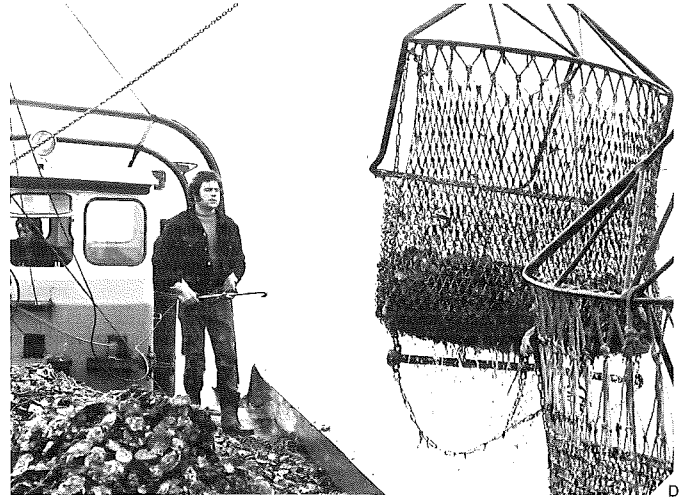
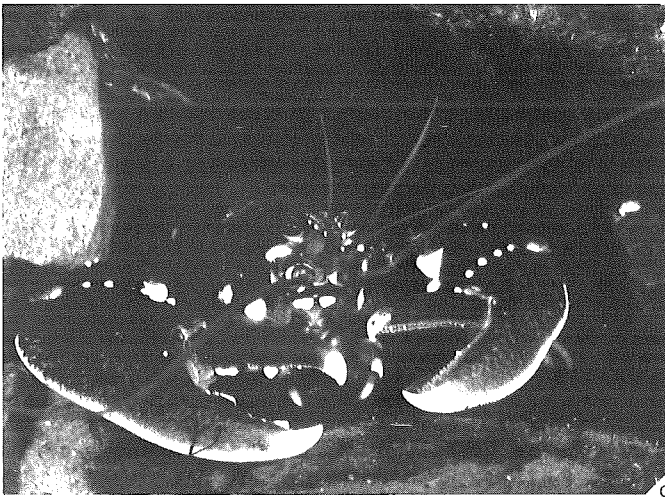

The Eastern Scheldt

The final part of the project was to be a dam closing off the Eastern Scheldt. This was considered to be the most complicated part of the whole Delta project. However, thanks to the experience gained during the earlier operations it was not regarded as a problem.

It was not long, however, before voices were raised in favour of keeping the Eastern Scheldt open and maintaining the tidal flow to preserve the original natural environment of the area. As public disquiet grew the Dutch Government ordered a new study to investigate whether it was technically feasible to keep the Eastern Scheldt open while not only ensuring the safety of the population at all times, but also maintaining the original natural environment as much as possible. The study proved positive and the decision was taken to build the storm surge barrier with steel gates. The alternative, to keep the estuary open and to raise approximately 150 kilometres of dykes along the islands to the required height, was rejected. Complete closure, for which contracts had already been awarded, ceased to be a possibility. The Eastern Scheldt was to be kept open in normal circumstances, but would be closed when storm surges were expected.

The decision to build a storm surge barrier also necessitated the construction of two auxiliary dams,

the Philips Dam and the Oester Dam. These dams have a twofold function. Firstly, they reduce the area of the tidal basin behind the storm surge barrier, thus maintaining a greater tidal range at Yerseke (3.00 metres) than would otherwise have been possible. Secondly, they create a tide-free shipping route between Antwerp and the Rhine.



The Eastern Scheldt storm surge barrier

The decision to build a storm surge barrier in one of the most formidable estuaries along the Dutch coast had considerable consequences. In order not to interfere with the channel configuration in the Eastern Scheldt the storm surge barrier had to be built in the three tidal channels, the deepest part of the estuary. Experience gained from previous projects now proved to be insufficient. The development of even more new techniques, never before tested, was called for. It was decided to prefabricate as many components as possible in advance as construction operations in situ would not only affect the tidal currents in the channels and cause environmental problems but could also prove hazardous to those working on them. They would then only have to be installed or assembled on the spot.

As the new storm surge barrier had to be operational by 1985 the design process and the study of construction methods were started simultaneously. From the outset the Public Works Department (Rijkswaterstaat) which commissioned the work, and the contractors, Doshouw, worked in close cooperation, assisted by advisers and consultants from a wide range of specialised areas. It soon became clear that completion of the storm surge barrier would have to be deferred till 1986.

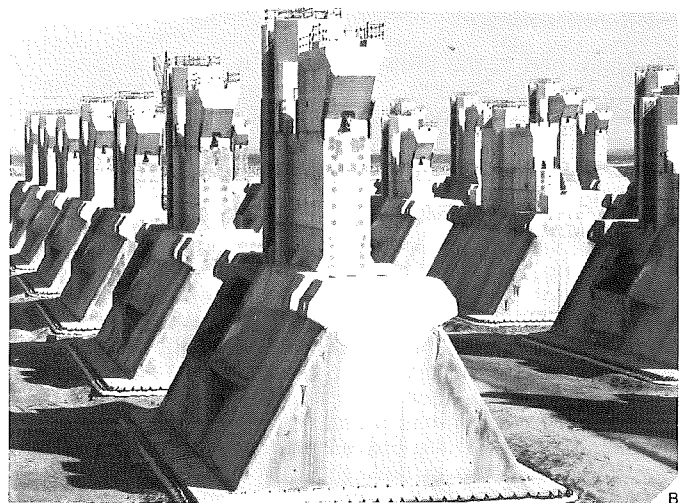

Various alternative plans were studied and developed, and within a few years a basic design was produced accompanied by suggestions as to construction methods and the equipment to be used. Although the details of design, techniques and materials had still to be worked out, the broad outline of the project was agreed.

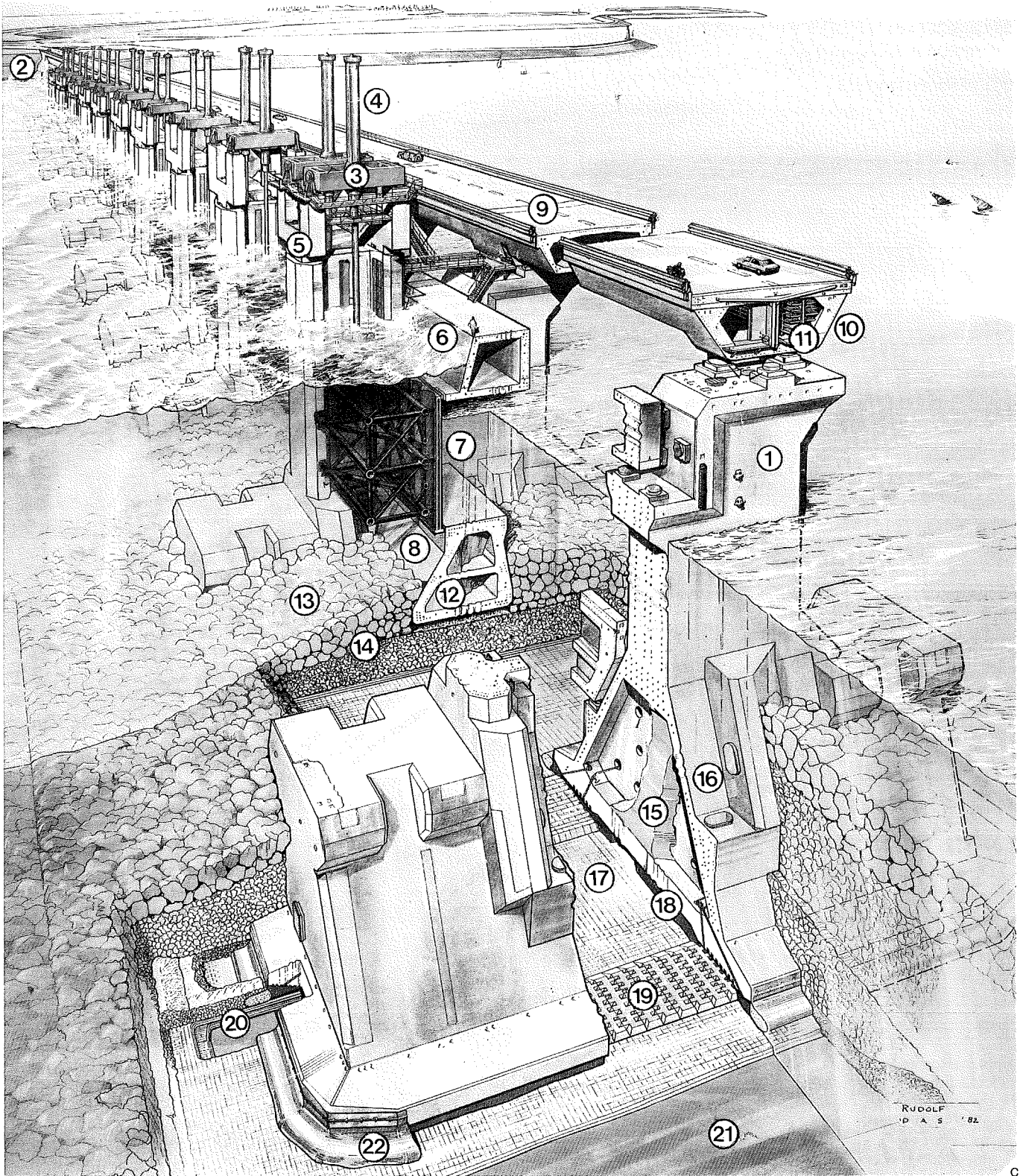

A. The mouth of the Eastern Scheldt

B. Piers in the construction dock

C. The storm surge barrier in detail

1 pier

2 quarry stone dam for land abutment construction

3 beam supporting operating equipment

4 hydraulic cylinders

5 capping unit

6 upper beam

7 gate

8 sill beam

9 road

10 road box girder and machinery for gate operation

11 power supply duct

12 sand filling of sill beam

13 top layer of sill

14 core of sill

15 sand filling of pier base slab

16 sill beam stops/bearings

17 upper mattress

18 grout filling

19 block mattress

20 bottom mattress

21 compacted sand under the bed of the Eastern Scheldt

22 gravel bag

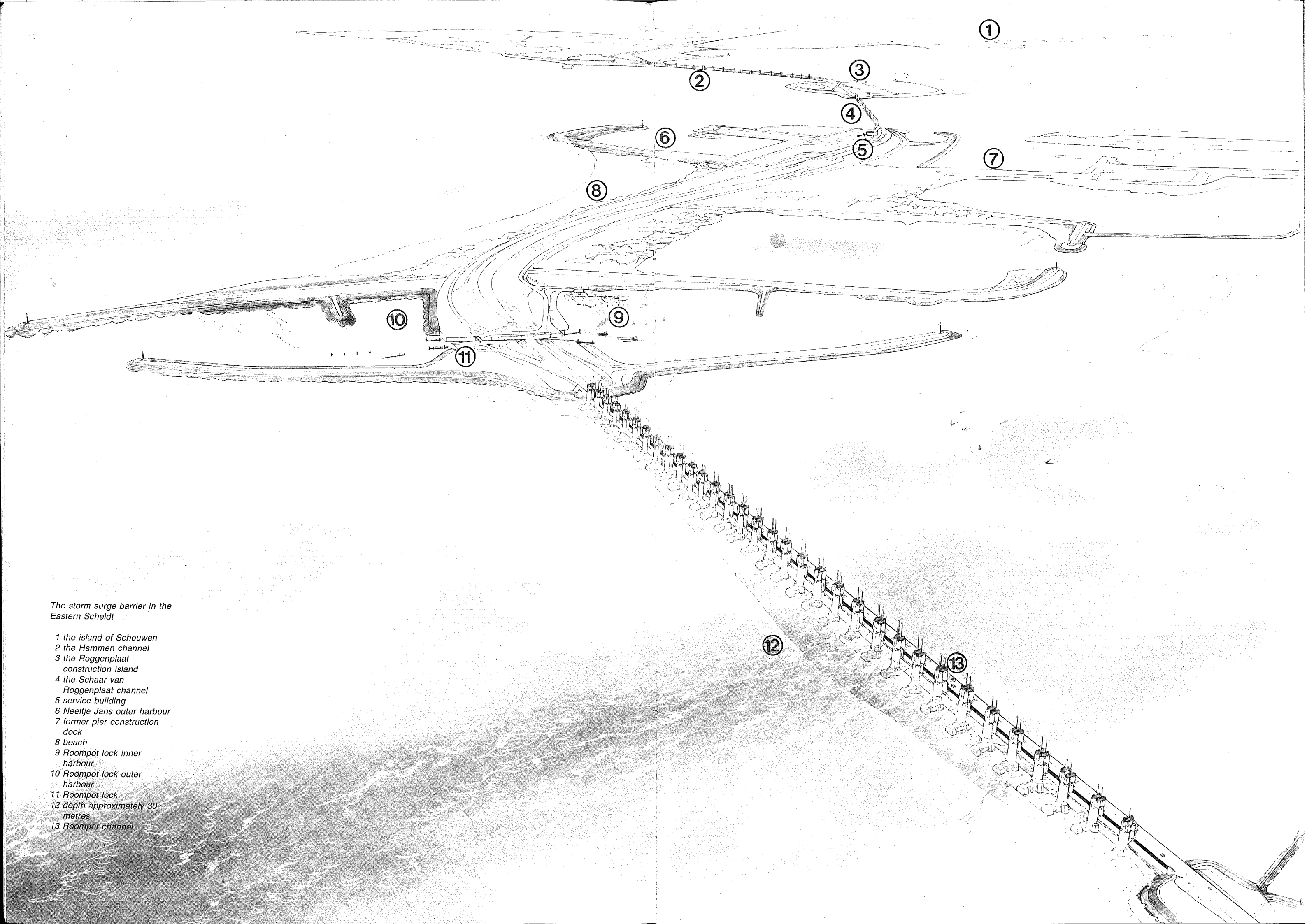

The storm surge barrier in the Eastern Scheldt

- 1 the island of Schouwen
- 2 the Hammen channel
- 3 the Roggenplaat construction island
- 4 the Schaar van Roggenplaat channel
- 5 service building
- 6 Neeltje Jans outer harbour
- 7 former pier construction dock
- 8 beach
- 9 Roompot lock inner harbour
- 10 Roompot lock outer harbour
- 11 Roompot lock
- 12 depth approximately 30 metres
- 13 Roompot channel

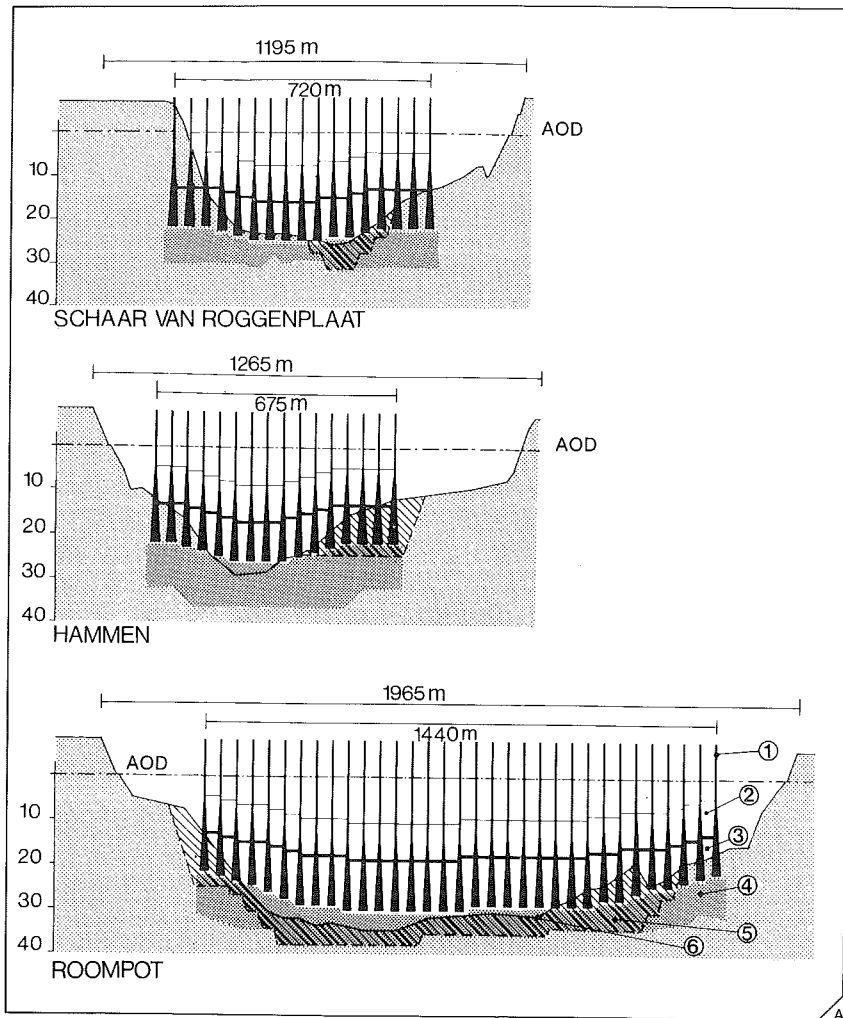

A. Cross-sections of the three tidal channels in which the piers are being positioned.
 1 piers
 2 sill beam
 3 underwater sill
 4 depth compaction
 5 seabed improvement
 6 original bed profile
 B. The Neeltje Jans construction island

The final plan for the construction of the storm surge barrier can be described as follows.

The storm surge barrier, in all 3,000 metres long, was to be built in the three tidal channels, Hammen, Schaar van Roggenplaat, and Roompot. It was to consist of 65 prefabricated concrete piers, between which 62 sliding steel gates were to be installed. With the gates in a raised position, the difference between the high and low tide behind the barrier would be maintained at least three-quarters of its original range, sufficient to preserve the natural environment of the Eastern Scheldt basin. When storms and dangerously high water levels are forecast the gates can be closed, thus safeguarding the population of the islands from the ravages of the North Sea.

In connection with the initial plans to build a dam across the Eastern Scheldt some islands (Roggenplaat and Geul) had already been constructed at shallow points in the estuary. The construction islands, Neeltje Jans and Noordland, are connected by Geul, which is in fact a section of dam. These raised parts will form the dam sections of the storm surge barrier.

In view of its convenient situation and the facilities which had already been constructed there, Neeltje Jans was turned into a construction island from where operations were conducted. The greater part of the prefabricated components were also built here - the

piers, the sill beams and upper beams, and the foundation mattresses. The stone to be dumped to form the underwater sill around the piers was stockpiled here too.

The following gives a brief description of the chief components of the storm surge barrier and other important related subjects.

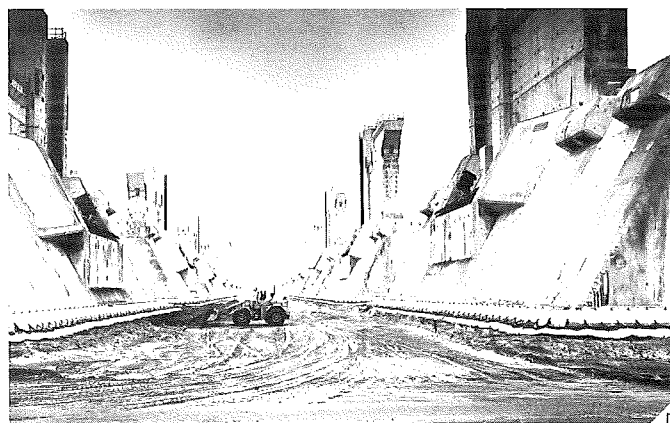
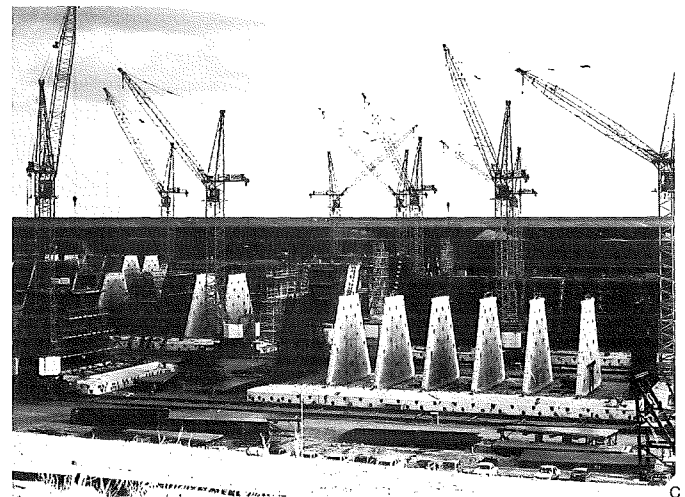
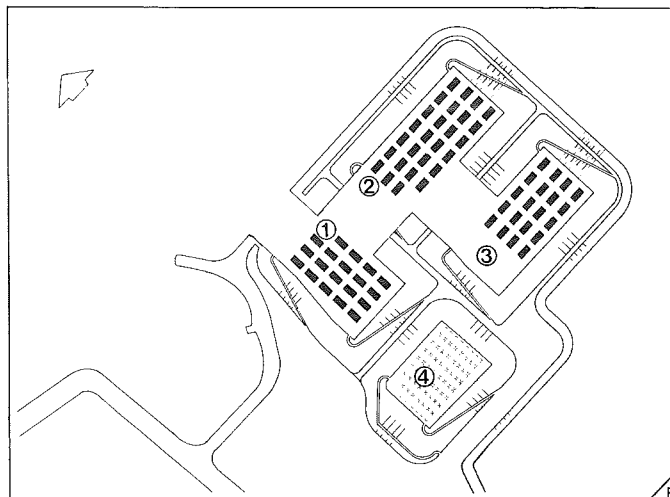

Pier construction

The prefabricated piers of prestressed concrete, with a dry weight of up to 18,000 tonnes, are built in the Schaar construction dock, a gigantic building dock, covering an area of one square kilometre. It was surrounded by a ring dyke and pumped dry; the base of the dock is 15.2 metres below sea level.

The construction dock is divided into four compartments by means of dykes. As soon as all piers in one compartment are ready an opening is made in the ring dyke, and the compartment is flooded. Depending on the tide the water in the flooded compartment reaches a depth of 13 to 17 metres, sufficient for the draught of the lifting vessel which lifts the piers and transports them, one by one, to their designated locations. They develop their own buoyancy of about 9,000 tonnes per pier and a hoisting capacity of 10,000 tonnes is therefore adequate to lift even the heaviest pier and transport it to its site.

To keep the construction dock dry a deep-well draining system has been installed consisting of a great number of wells sunk into the surrounding dyke. Any water seeping through from the outside collects there and can be pumped out.

- A/B. Schaar construction dock. The piers are built in compartments 1, 2 and 3 and the sill beams in compartment 4
 C. Piers being constructed
 D. Completed piers

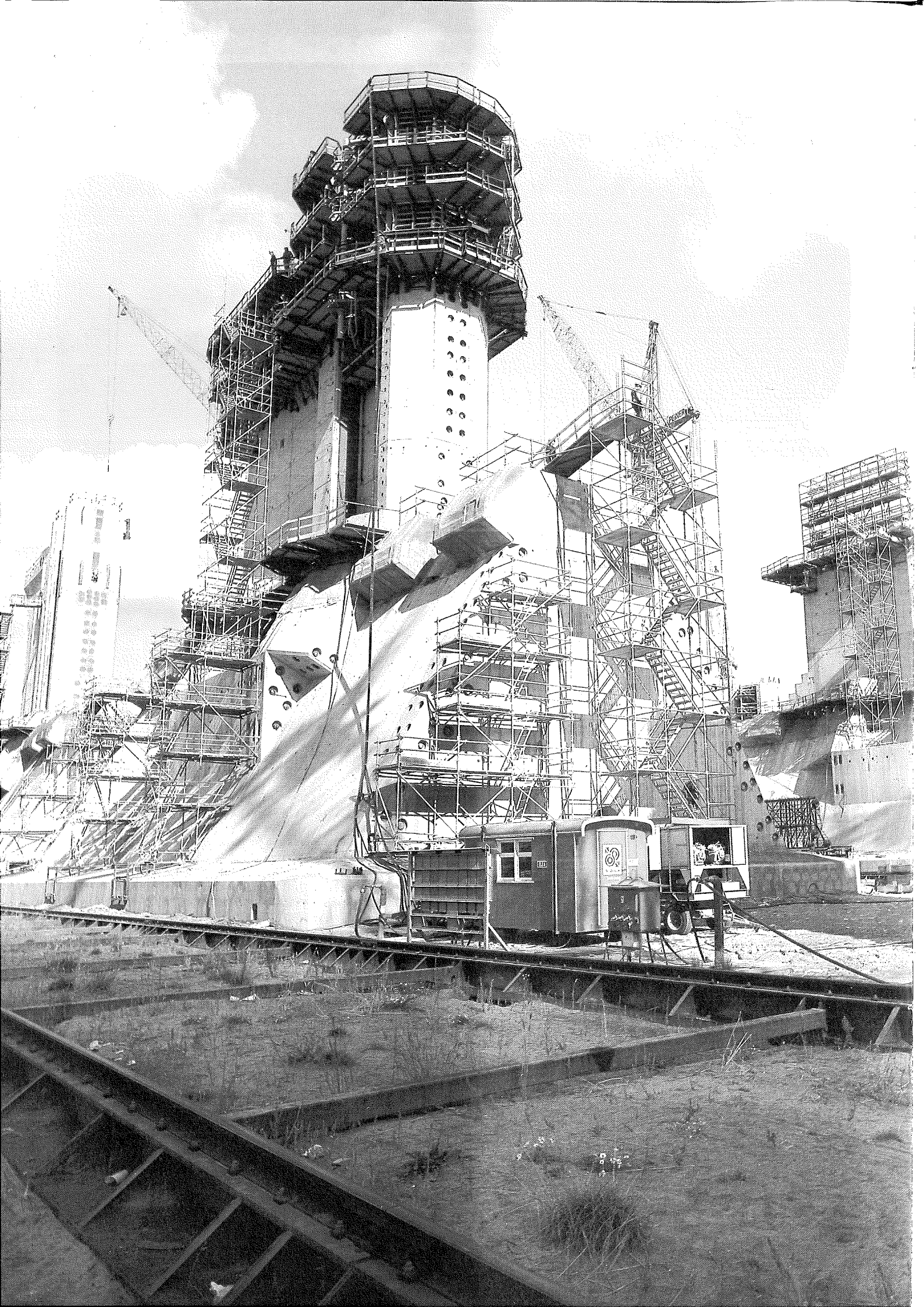

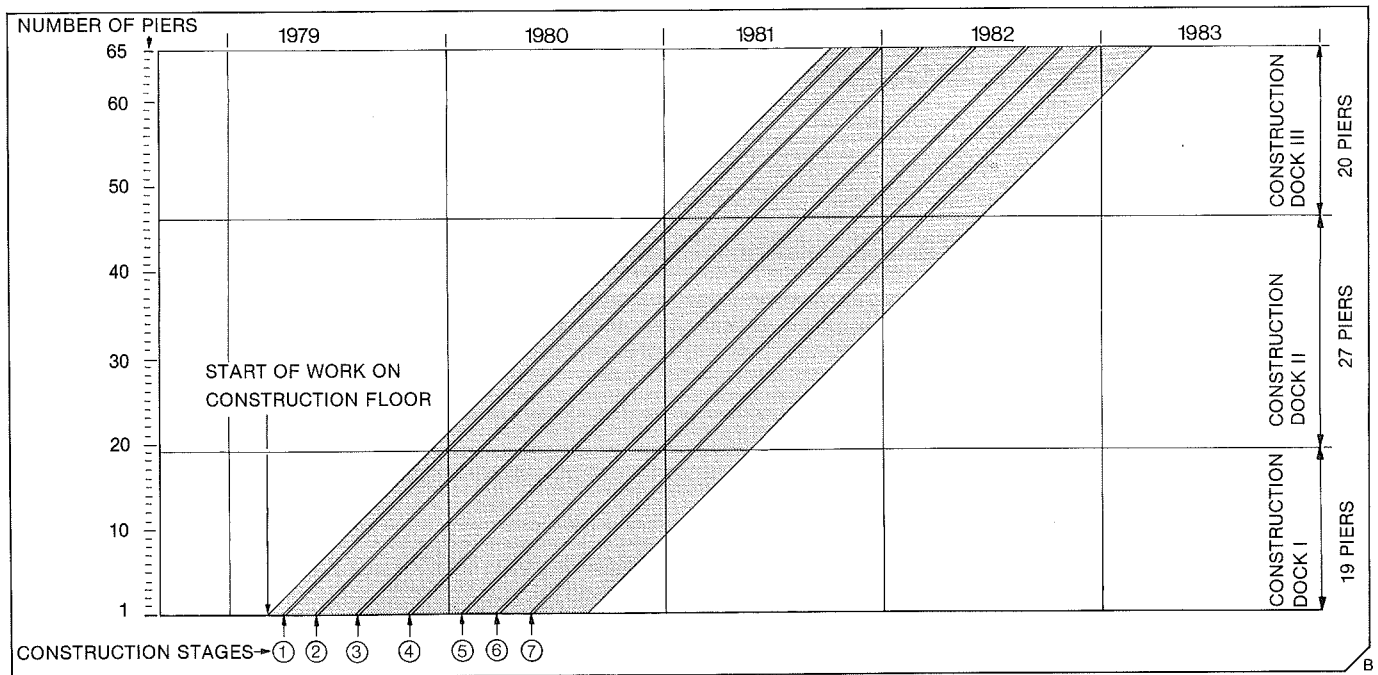
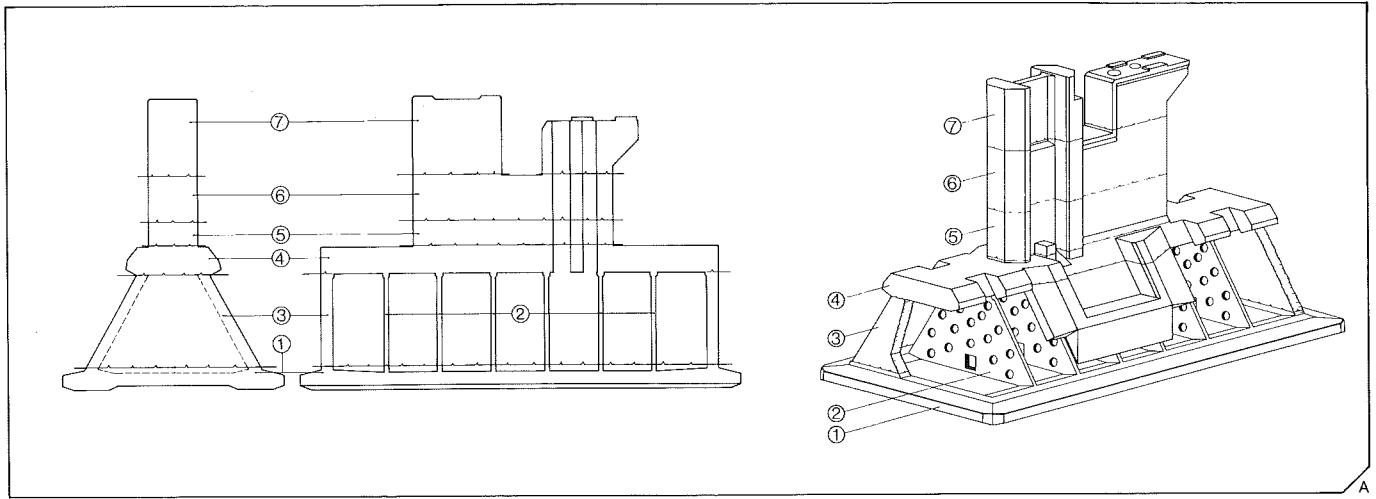

The construction of the piers is a story in itself. Each pier is a concrete building varying in height from 30.25 to 38.75 metres. The lower part, the caisson section, is hollow and will be filled with sand during the final construction phase of the barrier, once all the piers have been installed.

The construction period for one pier was almost a year and a half. Every two weeks work was started on a new pier so that at any given time, more than 30 piers were under construction, each in a different state of completion. A well-planned organisation was required to complete these extensive and complicated concrete construction operations within the time schedule. During the construction of the piers, the construction dock was in fact one huge open-air concrete factory, where a total of 450,000 cubic metres of concrete was processed between March 1979 and the beginning of 1983.

A. The stages in which a pier is constructed

- 1 base slab
- 2 interior walls
- 3 outer walls
- 4 roof of caisson section
- 5 connecting section
- 6 middle section
- 7 top section

B. Timetable of construction stages of the piers, as planned in 1979

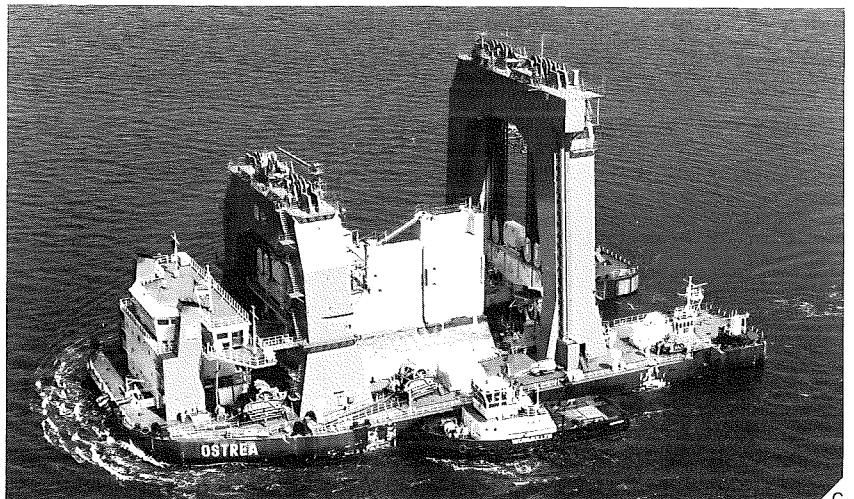
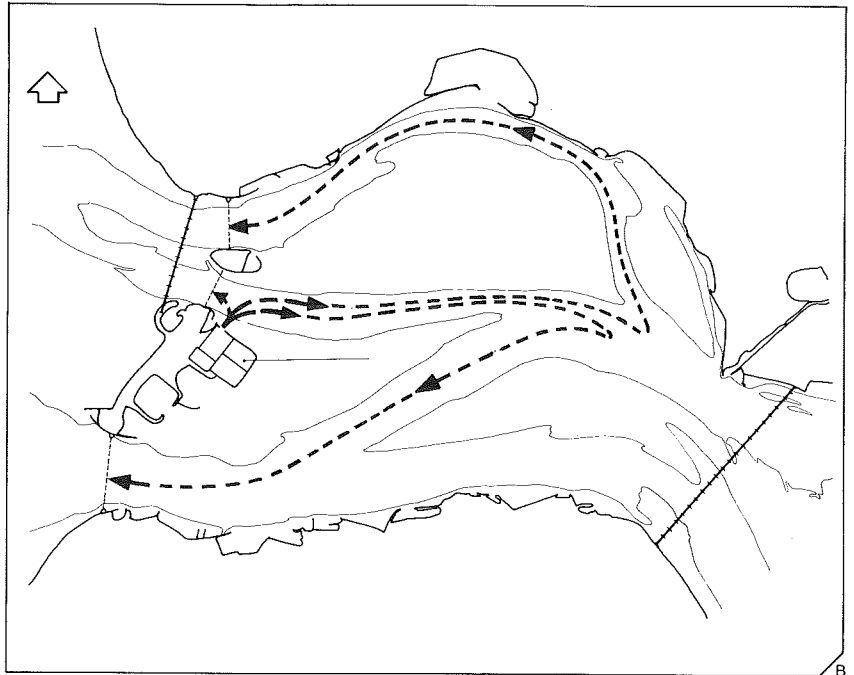
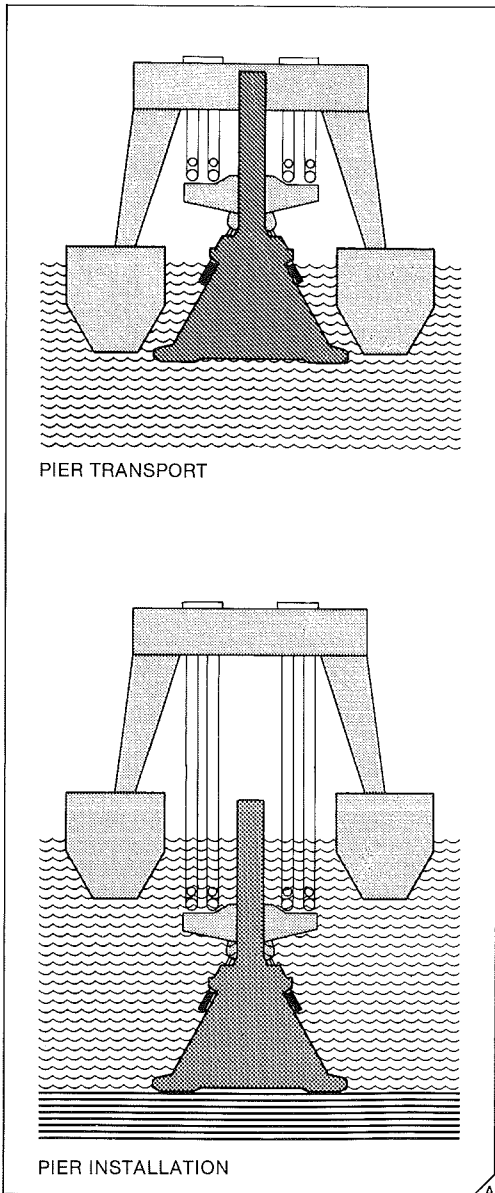

Installation of the piers

To transport these concrete giants, weighing 18,000 tonnes, and to position them accurately to within a few centimetres in 30 metres deep channels at a centre to centre distance of 45 metres is a far from simple job.

Two of the most important vessels involved are the Ostrea, the lifting, transport and installation vessel, and the Macoma which, apart from performing several other functions, acts as a mooring pontoon for the lifting vessel during the installation of the piers.

The Ostrea (Oyster) is shaped like a letter U and can therefore „embrace” a pier in the construction dock, lift it a few metres and transport it from the Schaar construction dock to the site in the Eastern Scheldt. With its load the Ostrea's draught is 12 metres and it therefore has to make a considerable detour when transporting a pier from the Schaar construction dock to any location in either the Hammen or the Roompot channel. As this involves extra time the operation is in principle only carried out when a somewhat longer period of reasonably good weather can be expected.

The Ostrea is equipped with a 9,000 hp engine of its own with four rudder propellers, two at the bow and two at the stern, enabling the vessel to manoeuvre itself in the construction dock. For longer journeys in the Eastern Scheldt itself it is assisted by tugs. With its

10,000 tonnes lifting capacity and its two towering gantry cranes, the Ostrea is undoubtedly the flagship of the fleet. On arrival with the pier at the appropriate location the Ostrea meets up with the Macoma.

The Macoma (the name of another mollusc found in the Eastern Scheldt) is equipped as a mooring pontoon for the Ostrea and the two vessels are secured to each other by means of a coupling device capable of withstanding a load of 600 tonnes. The role of the Macoma is to keep the Ostrea accurately positioned while the pier is being lowered onto the seabed. The exact positioning of the piers is of vital importance for the correct functioning of the storm surge barrier. As the Macoma runs out its mooring lines in advance the combined craft Ostrea/Macoma can be manoeuvred into position without delay, thus reducing installation time.

The Macoma also acts as a kind of vacuum cleaner. No sand can be allowed to collect between foundation bed and pier as it might be washed away at a later stage causing settlement of the pier and jamming of the gates. It is vital, therefore, that the sand be removed.

This is easier said than done. With each high tide great quantities of sand are shifted into the estuary to be swept back again at low tide, making it very difficult to keep a surface free from sand for any length of

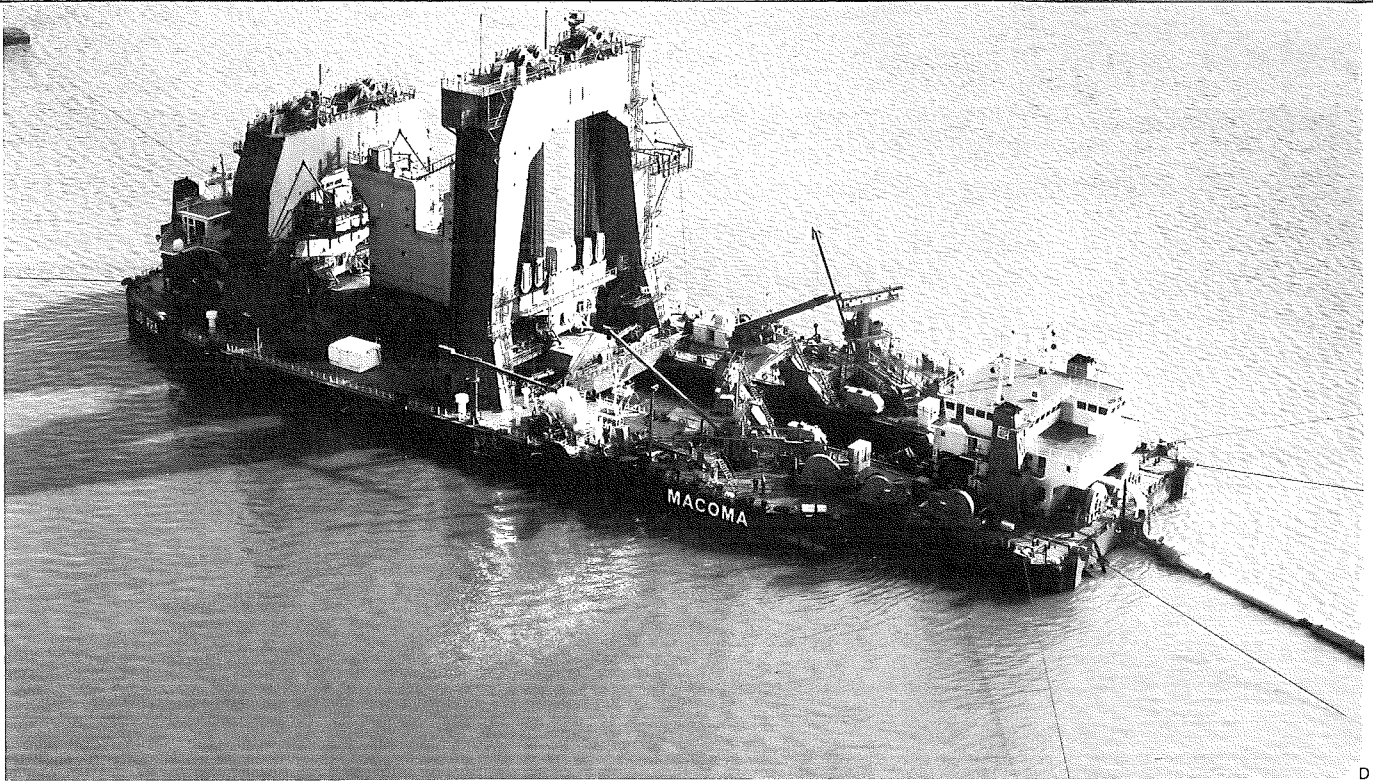

D

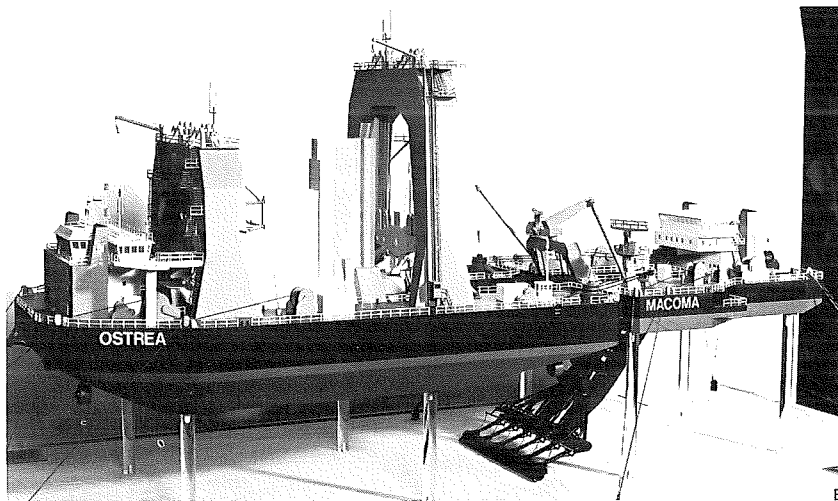

E

- A. Diagrammatic representation of the transportation and installation of a pier by the Ostrea
- B. The routes taken by the Ostrea
- C. The Ostrea transporting a pier
- D/E. The Ostrea moored to the Macoma during an installation operation
- F. Grouting and ballasting a pier
 - 1 grout supply
 - 2 grout pump
 - 3 layer of grout
 - 4 sand/water mixture
 - 5 sand ballast

time. Just before the pier is put in position the Macoma therefore removes any last traces of sand.

Both vessels have to perform such unique functions that no existing vessel or equipment would have been able to cope. The Ostrea and Macoma had to be specially designed and built for this part of the Eastern Scheldt project.

When the underwater sill (see later) has been partly raised to the required height the cavity between the base of the piers and the foundation bed is filled with grout, a mixture of sand, cement and water, thus providing uniform bearing conditions over the entire base slab area. Grouting is done through the hollow compartment inside the pier once it has been locked into position and pumped dry.

To give the piers added stability they are filled with sand during the final construction phase by pumping a sand/water mixture into the caisson section. After the sand has settled, the water is pumped out again. This system ensures that the caissons are 90 percent filled.

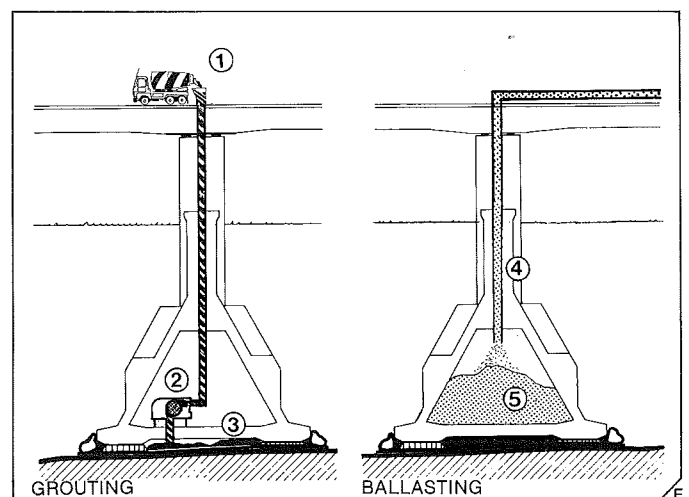

F

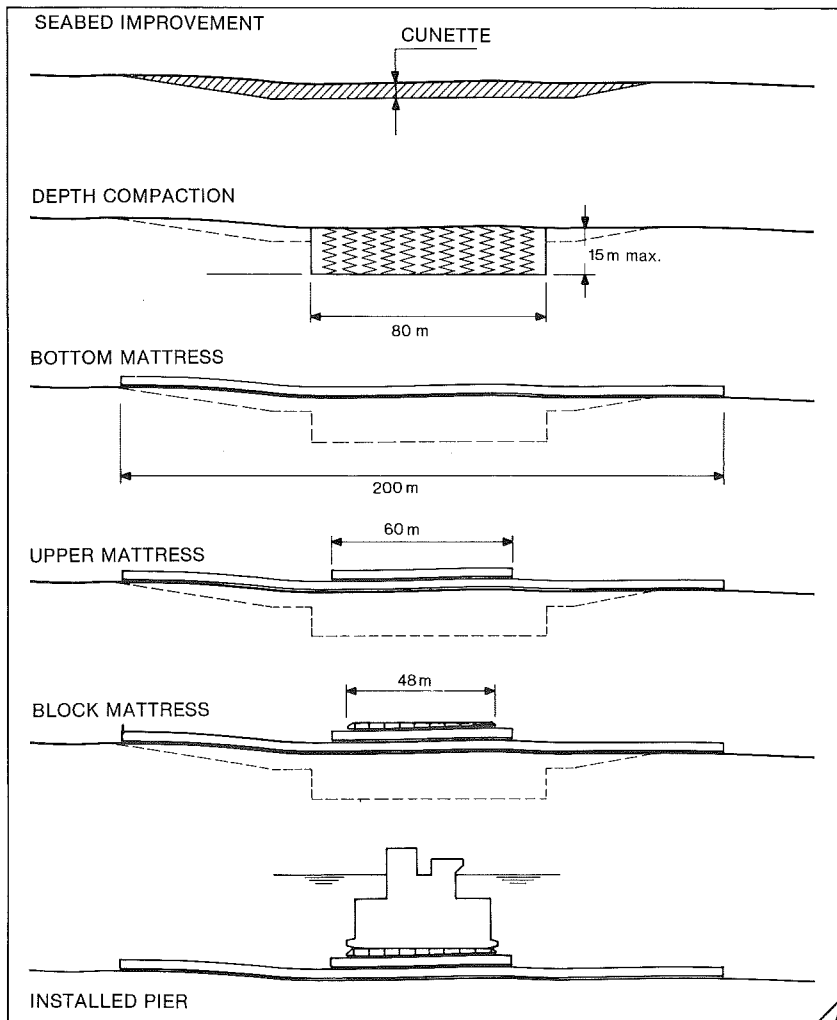

A. Construction of the foundations
 B. Diagrammatic representation of seabed compaction by the Mytilus

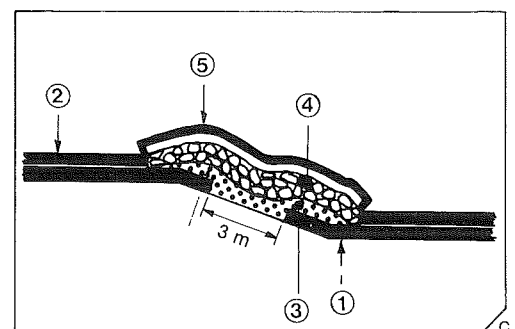
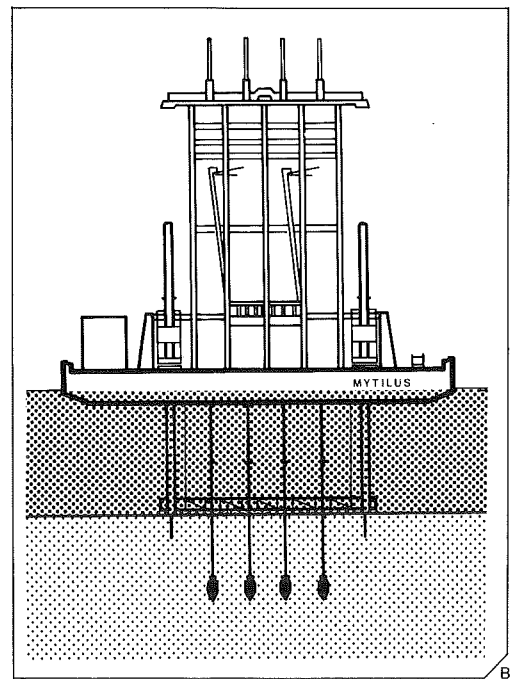

C. Sealing the joint between two sets of mattresses
 1 bottom mattress
 2 upper mattress
 3 sea gravel
 4 quarry stone
 5 gravel ballast mattress

Foundation bed

The piers are the backbone of the storm surge barrier, supporting the superstructure which consists of steel gates, a roadway and the beams. When storms occur and the gates are closed, the barrier will be subjected to enormous forces which the piers must transfer to the foundation bed. This bed must be constructed in such a way that it does not cause movement of the pier, which might result in jamming of the gates. It is, therefore, as in any construction, of vital importance.

The piers of the Eastern Scheldt storm surge barrier are positioned on the seabed without pile foundations. First, a cunette was excavated and, where necessary, unsuitable sand replaced by better quality sand. The deepest parts of the tidal channels were raised and covered with gravel to prevent erosion. To improve the bearing capacity of the seabed further and to prevent settlement of the piers, it was compacted over a distance of 80 metres around the piers. This work was carried out by the Mytilus (mussel), a compacting rig, specially designed and built for the purpose. By driving its four giant vibrating needles into the subsoil the rig can compact layers of up to 18 metres thick over an area of 6 x 25 metres. In this way it was possible to compact and strengthen the subsoil of all three tidal channels over a period of three years.

In order to survey the condition of the seabed before and after compaction the Johan V., a purpose-built

geotechnical survey pontoon, equipped with a conventional drilling rig and a diving bell, was used. With the aid of the diving bell soil sampling and density measurements can be carried out under water.

After compaction and inspection and before installation of the piers, the seabed has to be dredged and levelled off to the correct depth and covered with a prefabricated foundation mattress, measuring 200 x 42 metres x 36 centimetres laid under each pier. The simultaneous dredging of the seabed and positioning of the foundation mattresses are carried out by the Cardium (cockle), another special purpose-built rig, and the Jan Heijmans. The piers and the mattresses are positioned at a centre to centre distance of 45 metres leaving a gap of about three metres between the 42-metres wide mattresses.

Apart from assisting with the laying of the mattresses the Jan Heijmans is responsible for filling in the spaces between the mattresses with loose sea gravel topped by two layers of heavier stone. The Jan Heijmans, formerly an asphalt laying barge, underwent drastic conversion for this particular operation.

To reinforce the foundation structure, which does after all have to bear the weight of the pier, a second smaller mattress, measuring 60 x 29 metres and again 36 cm thick is then placed by the Cardium on

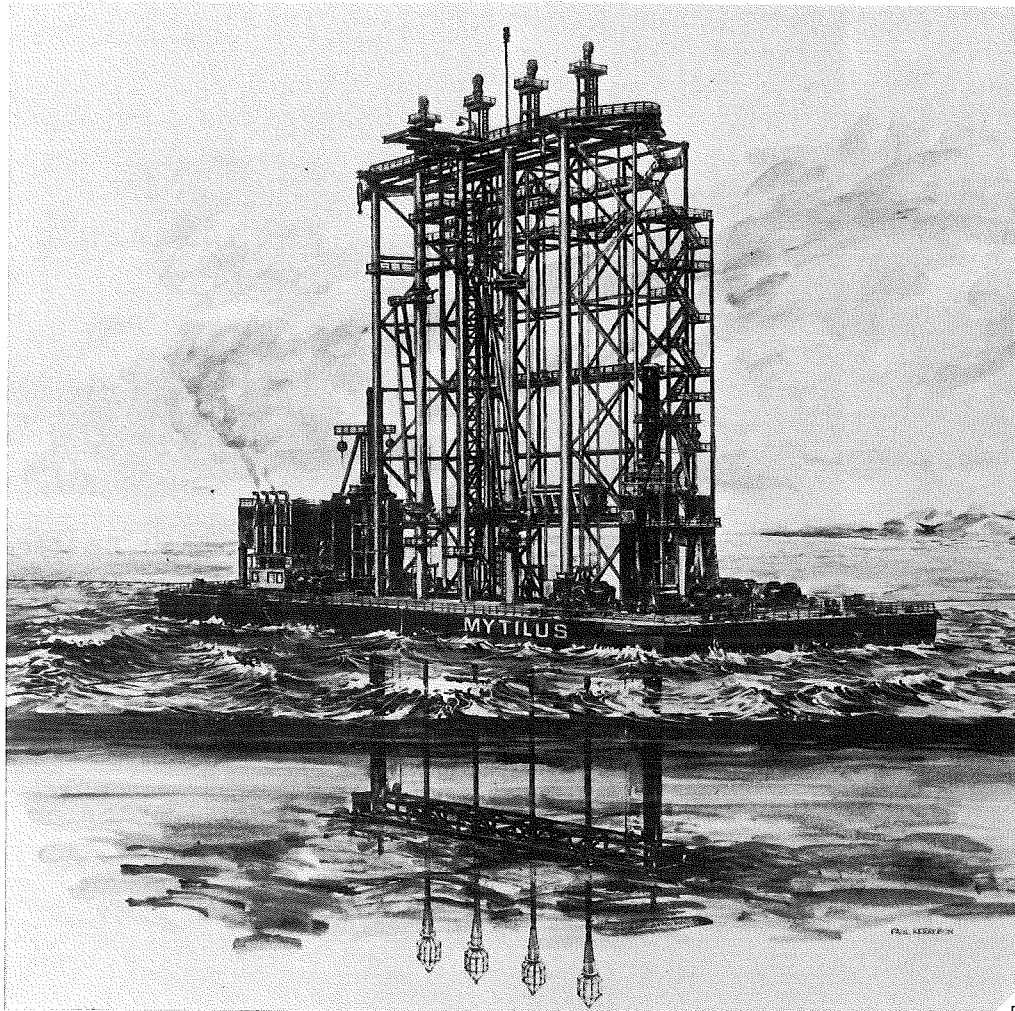

D. Mytilus
 E. Johan V.
 F. Diving bell with base plate
 G. Cardium
 1 foundation mat being unrolled
 2 beam at end of roll
 3 compacting unit
 4 adjustable dredger/ dust pan

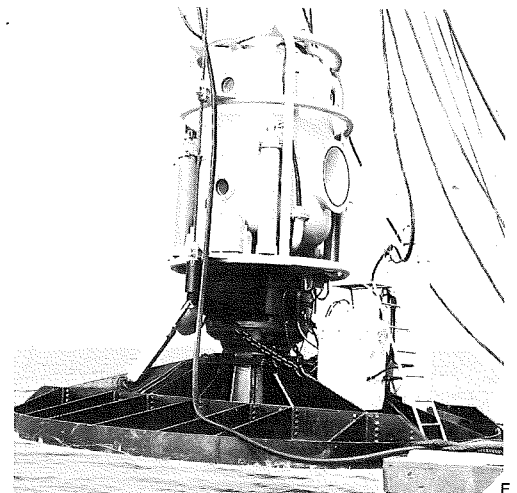

top of the first one. The foundation bed, therefore, consists of a lower and an upper mattress.

The placing of the lower mattress is the most crucial operation, because this is what ultimately determines the levelness of the foundation on which the piers are to be installed.

Both upper and lower mattresses are manufactured in the filter mattress plant, specially built for this purpose on the work island, Neeltje Jans. They are called filter mattresses because of the way in which they are constructed - in three layers of graded material (sand, fine gravel, coarse gravel). The function of the mattresses is to absorb the changing water pressure in the subsoil so that it does not weaken and to ensure that the fine sand on the seabed is not washed away. The filter mattresses are an essential part of the whole

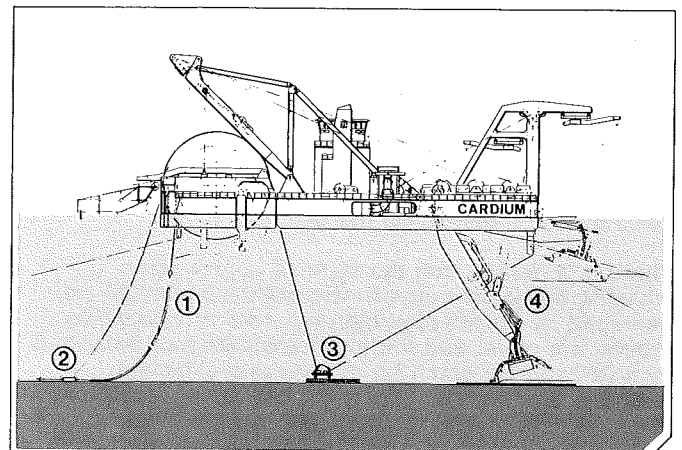

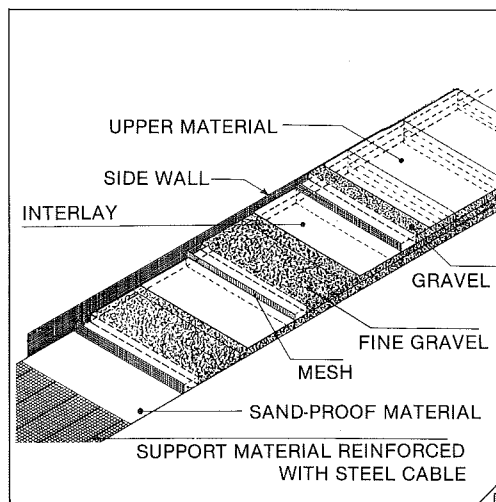
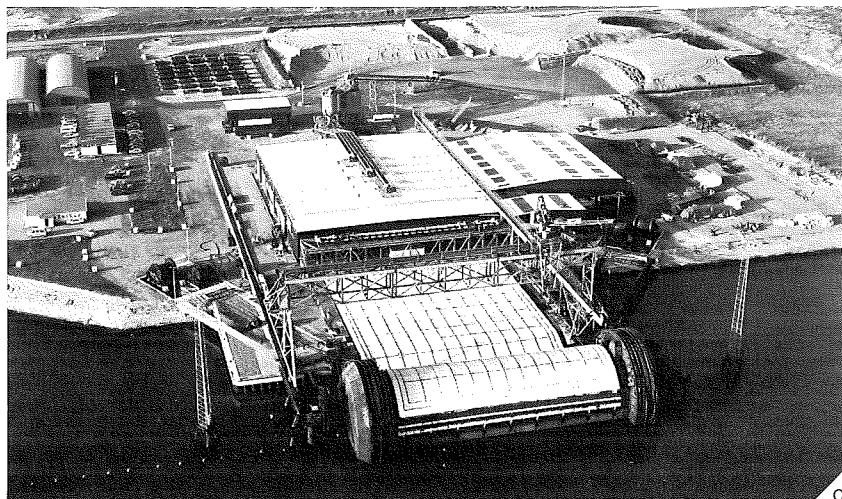
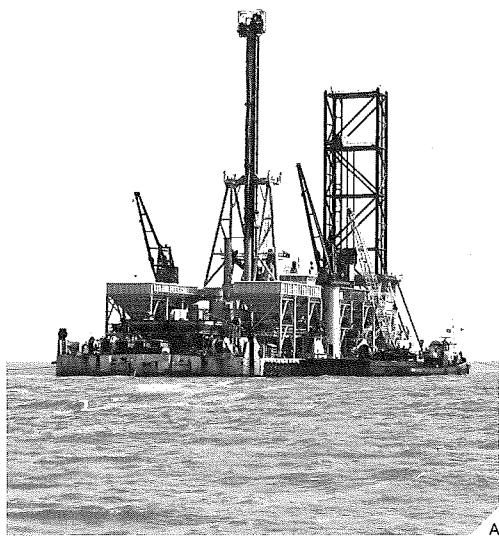

foundation structure which is designed to prevent settlement of the piers.

The levelling which can be achieved by the Cardium may still vary by some 30 centimetres however, whereas the ribs under the piers require an even more level surface. If surveys of the upper mattress indicate that the foundations are not sufficiently level, a block mattress can be positioned immediately under the pier. This consists of concrete blocks varying in thickness from 15 to 60 centimetres in order to smooth out any unevenness.

These block mattresses are manufactured in a plant at Sophia harbour, formerly used to make concrete weighted erosion mats (see later under Seabed Protection) and now converted for this purpose. They are wound onto a floating cylinder, the Donax II, (Donax is a kind of mollusc), towed to the converted pontoon, Donax I, and moored to the Macoma, which positions the mattress on the seabed.

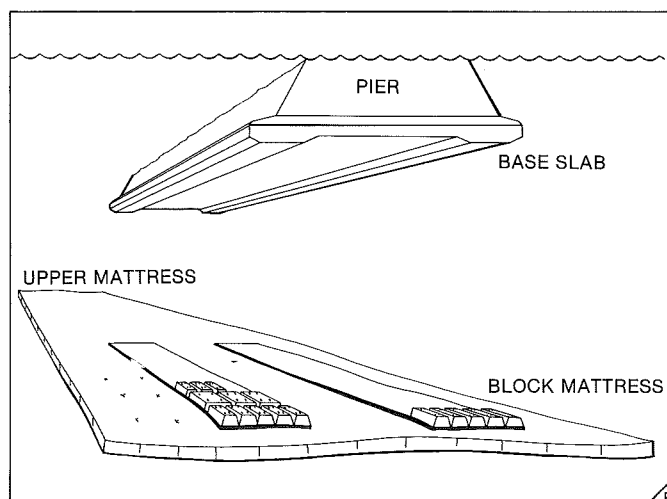

There is a danger that the layer of quarry stone covering the joints between the mattresses might be damaged by unexpected high currents or turbulence around the piers, and the joints are therefore protected by a 200 m long and 13,5 m wide gravel-ballast mattress which consists of a flexible steel woven mat to which rolls of quarry stone (ballast) packed in a wire mesh are attached diagonally. The number and weight

- A. Jan Heijmans
- B. Cardium
- C. Filter mattress factory on Neeltje Jans
- D. Composition of a filter mattress
- E. How a block mattress is used

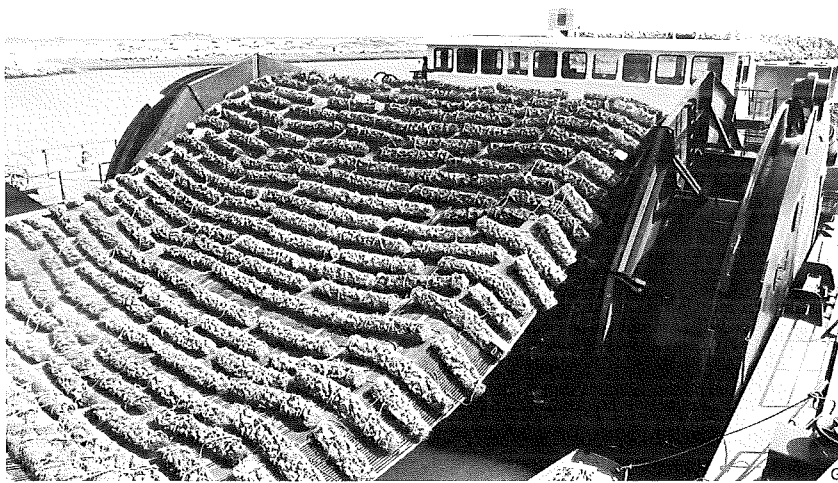
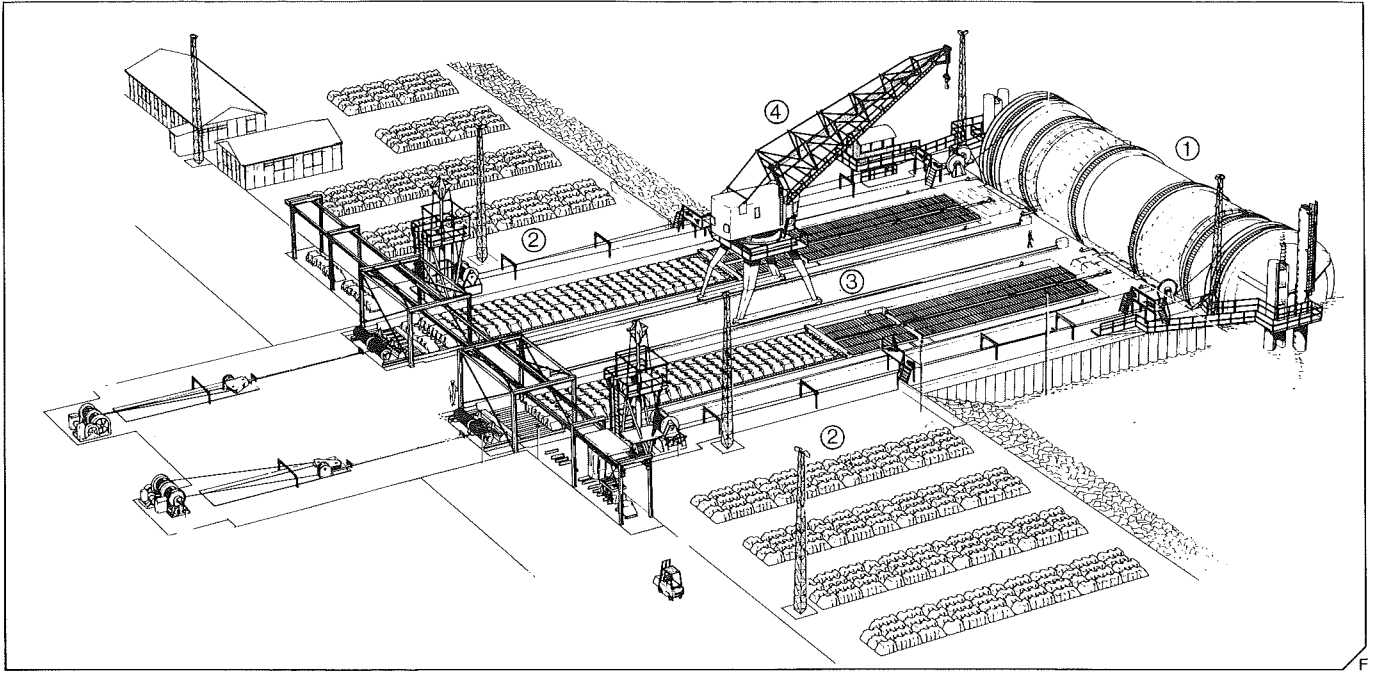

- F. Block mattress factory
 1 drum
 2 concrete blocks
 3 rolling track
 4 crane for transporting end beams
- G. Gravel ballast mattress
 H. The Macoma, the Donax I and the Sepia linked to lay a gravel ballast mattress

of the rolls are chosen so as to ensure that the mattress will be able to withstand the current in any circumstances.

This mattress is made on a special site with loading facilities at Sophia-haven. It is rolled up and transported on board the Sepia (a kind of octopus), an adapted pontoon with winding equipment which earlier belonged to the Jan Heijmans. The Sepia can be tied up to the Jan Heijmans or to the Donax I (with Macoma) and can, in this combination, unroll the ballast-mattress over the joints.

The foundation bed is then ready to receive the pier.

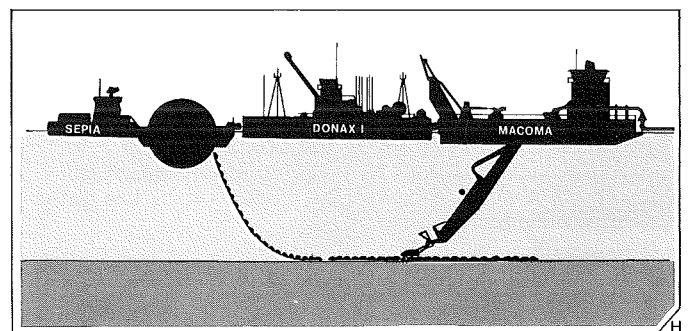

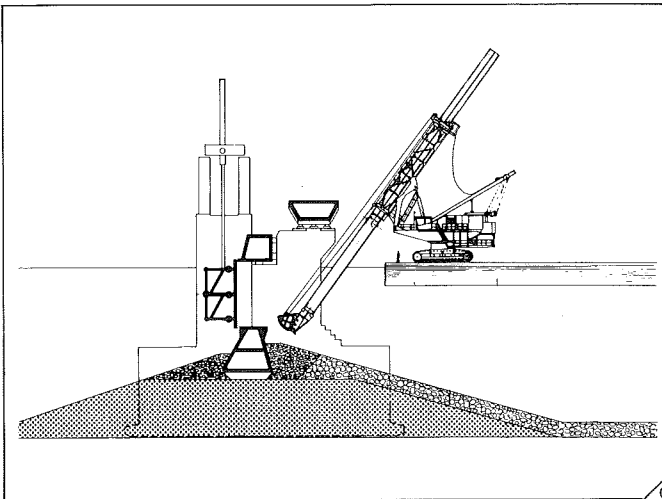
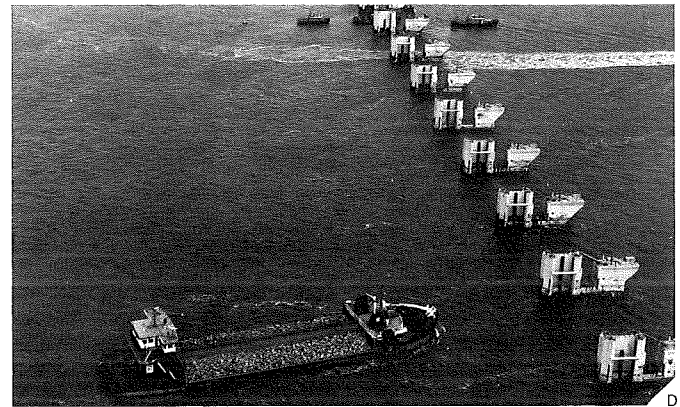
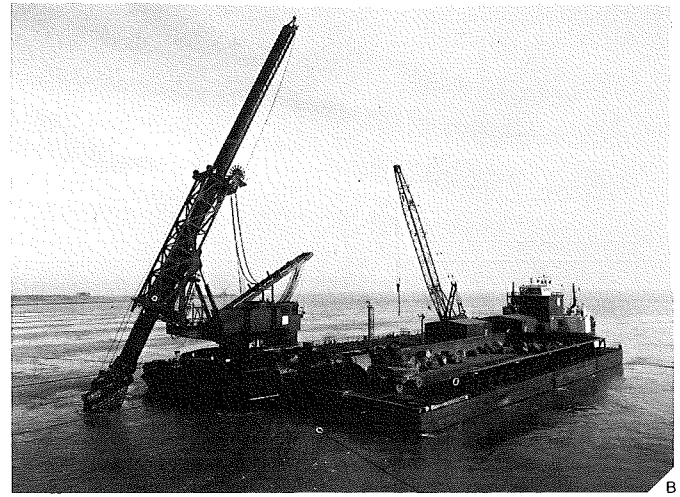

A. Stockpile of stone on the construction island
 B. Stone deposition barge Trias
 C. Diagrammatic representation of top-layer dumping
 D. Stone dumping pontoon Libra
 opposite: installation of a gate

Sill construction

To increase the stability of the piers once they have been installed, a sill, built up of graded layers of stone is constructed under water around the base of the piers. This also helps reduce the opening in the Eastern Scheldt estuary, as the ultimate intention is that only that part which can be closed off by the gates will remain open.

The stone used in the sill is graded, the stones in each layer becoming larger the nearer the top they are, so that the larger stones in the upper layers prevent the smaller stones in the lower layers from being swept away. The construction of the sill thus follows the same filter principle as that used in the foundation mattresses. The top layer on the Eastern Scheldt side consists of basalt blocks weighing 6-10 tonnes in order to ensure that, should a gate fail to close, the stone will not be carried away by the currents, thus endangering the barrier.

Pieces of stone like these cannot be dumped from the surface of the water as they would damage the concrete structure of the piers. They are therefore put in position by a pontoon equipped with a specially adapted crane, the stone depositing barge. Pieces of one tonne or less are dumped from stone dumpers fitted with a dynamic positioning system, which enables the ship to be kept in position or manoeuvred

slowly with the aid of movable thrusters and without the assistance of other vessels. Apart from the stone dumpers pontoons are also used to compact the dumped layers of stone, to remove excess sand and to survey the underwater operations.

The most vital parts of the piers, e.g. the anchorage sockets for the prestressing tendons, are specially protected against stones being dumped from the surface of the water. When very heavy pieces of stone (6 -10 tonnes) are being dumped a protective layer of asphalt is applied to the piers in order to prevent the concrete from being damaged or cracked if they are hit directly, thus endangering the life span of the barrier, which has been designed to last for 200 years.

Some five million tonnes of stone had to be put in position within the space of about two years. As it was practically impossible to tailor the supply of stone to the immediate need, the stone was brought in over a period of four years and stockpiled on the work island. It comes from Germany, Finland, Sweden and Belgium, and has a high density (2.8 - 3.0 tonnes/m³), which prevents it from being too easily swept away by the currents.



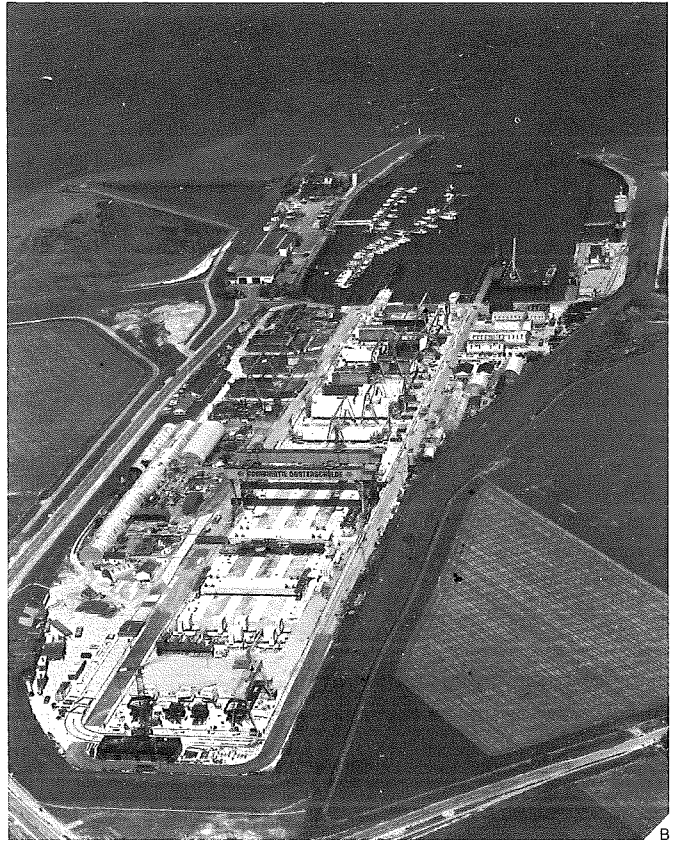
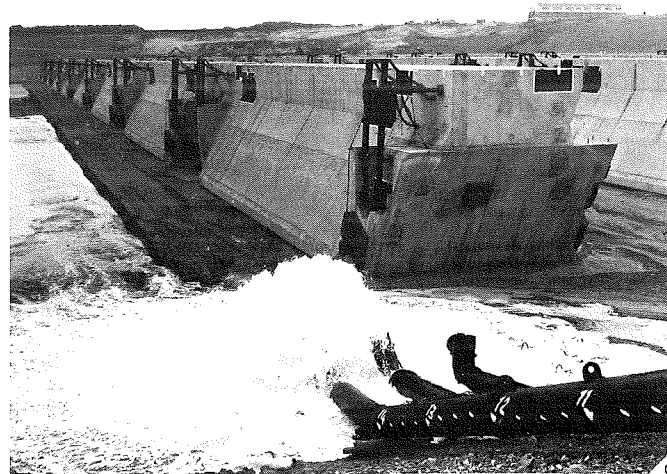
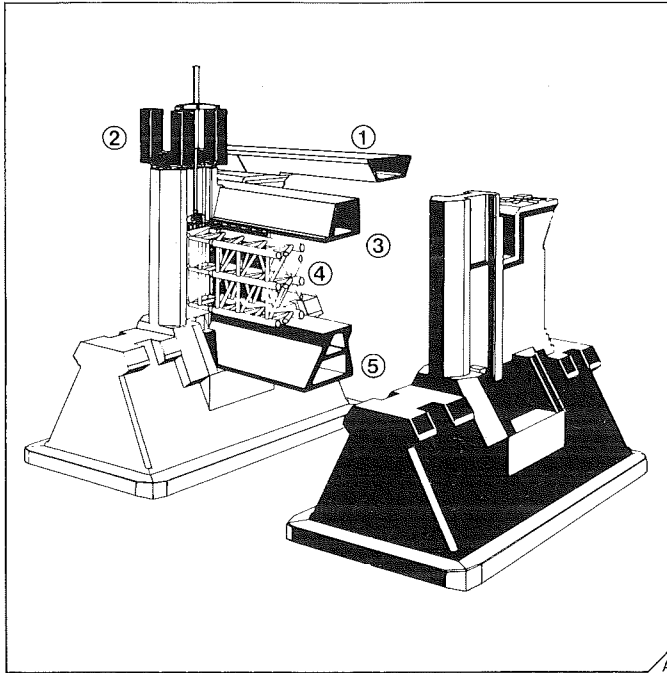

- A. Pier superstructure
 - 1 road box girder
 - 2 capping unit
 - 3 upper beam
 - 4 gate
 - 5 sill beam
- B. Kats' yard
- C. Sill beam in construction dock

Superstructure

Once the underwater sill has been completed the superstructure will be put in place. This consists in order of assembly, of road bridge box girders, pier capping units, gates, sill beams and upper beams. Each component has a specific function and presents its own problems of manufacture, and they are therefore all briefly described here.

The road bridge box girders, 45 metres long, made of prestressed concrete and each weighing 1,200 tonnes at the time of assembly, will be placed on the piers. The space within them houses the gate operating machinery and the road will be constructed on top of them, hence their name. Apart from the 62 box girders resting on the piers, there are six additional girders, which are especially long (80 metres) and will link the first pier in each section of the barrier with the land or island adjacent to it. These are made of lightweight concrete.

The capping units are prefabricated and also made of prestressed concrete and they increase the height of the piers so as to accommodate the gate structure. Each pier has two connected capping units, together weighing between 250 to 460 tonnes.

The sill beams, 39 metres long, 8 metres wide and 8 metres high, are hollow beams, each weighing 2,500

tonnes, which are installed between the piers on top of the underwater sill. Once the sill beams have been positioned, stone will be placed against them on both sides to improve the flow profile of the barrier. They are made of prestressed concrete and will be finished to their exact length only when the exact position of the piers, which may deviate from that planned, is known. After final construction they will be filled with sand.

The upper beams form the upper edge of the openings in the barrier which can be closed by the gates. They are hollow rectangular beams measuring 5 x 4 metres and are made of prestressed concrete; they weigh about 1,100 tonnes each.

The sill beams are manufactured in the fourth compartment of the Schaar construction dock, while the other concrete components are made at the former Zeeland bridge construction site at Kats. Production at this complex concrete factory must be continually tailored to the progress of construction at the barrier site.

The 62 steel gates will be installed between the piers. When the gates are raised the Eastern Scheldt will be open, i.e. the barrier will have an opening of 14,000 m², allowing sufficient water to pass through in order to maintain three-quarters of the original tidal range at Yerseke.

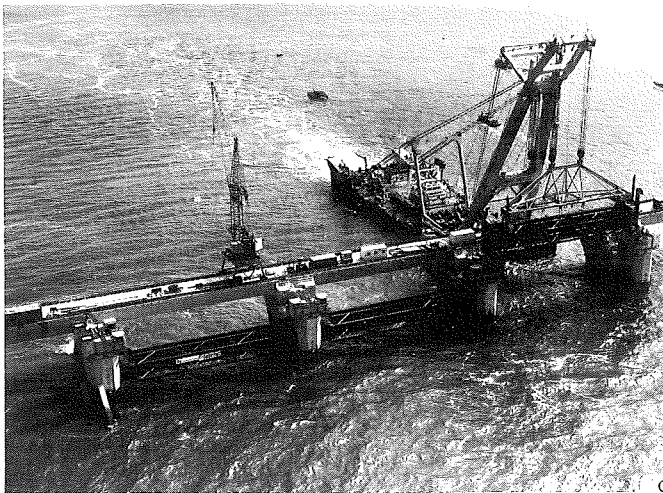
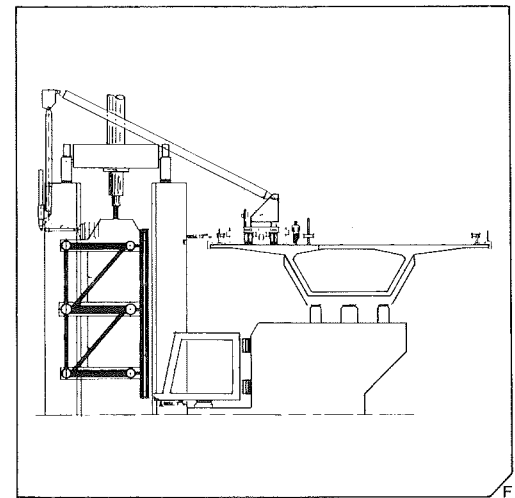
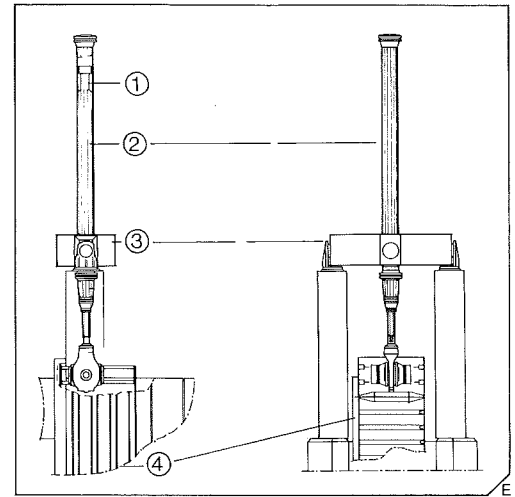
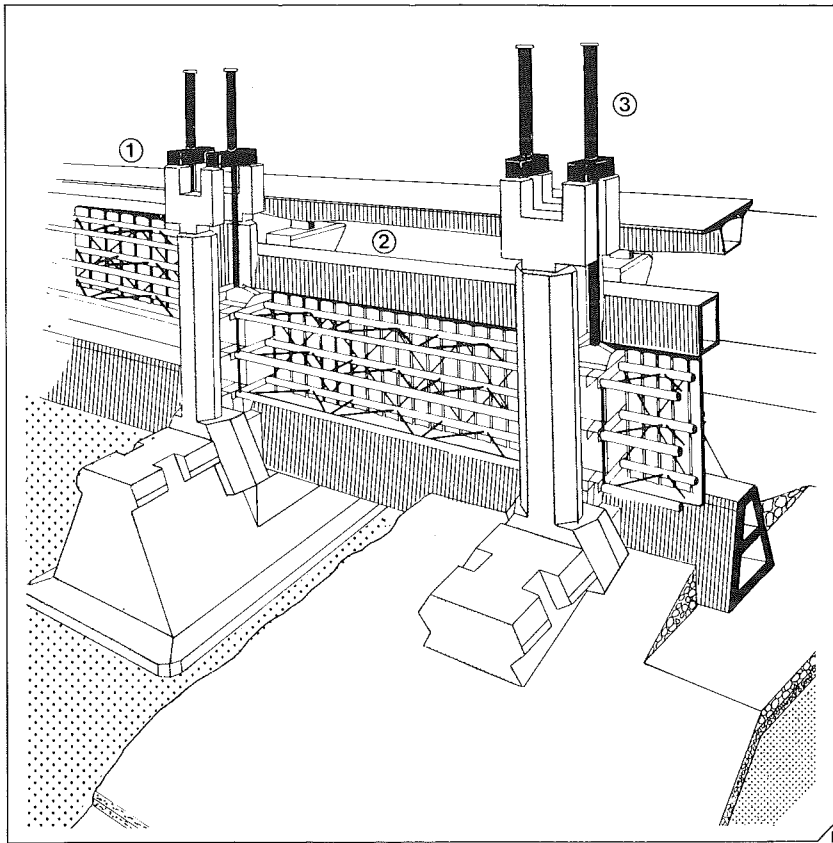

D. The gate system

- 1 gate raised, normal position
- 2 gate lowered, only in stormy conditions
- 3 cylinder in the hydraulic operating system

E. Diagrammatic representation of the hydraulic operating system

- 1 piston rod
- 2 cylinder
- 3 cardan ring
- 4 gate

F. To carry out maintenance work the gates will be raised another 1.30 m

G. Installation of a gate

The gates, made of steel, have a span of about 42 metres. The exact dimensions can only be determined only after the precise distance between the piers concerned is known. The height of the gates varies from 5.90 to 11.90 metres as the flow profile of the tidal barrier roughly follows the bottom profile of the tidal channels, which is deeper in the centre and shallower at the sides. The gates in the middle of the tidal channels are therefore much higher than those at the sides. Their weight varies from 300 to 500 tonnes.

The gate structure consists of a vertical plate on the Eastern Scheldt side, and of horizontal and vertical truss girders made of tubular steel on the North Sea side. The gates are designed to withstand the loads caused by the different water levels on either side, and can be closed and opened under even the most adverse conditions.

A hydraulic system has been chosen to operate the gates. Each gate is opened and closed with the aid of two hydraulic cylinders. All 124 cylinders are operated from the central control building.

The gates and the operating equipment are constructed, supplied and installed by OSTEM, a joint undertaking comprising Grootint BV of Zwijndrecht and Hollandia Kloos NV of Krimpen a/d IJssel, which was awarded the contract by Rijkswaterstaat, the Public Works Department.

All the parts of the superstructure mentioned above are being installed by the 1600 tonne floating crane Taklift 4.

After the installation of the sill beams stone and concrete blocks will be dumped on both sides.

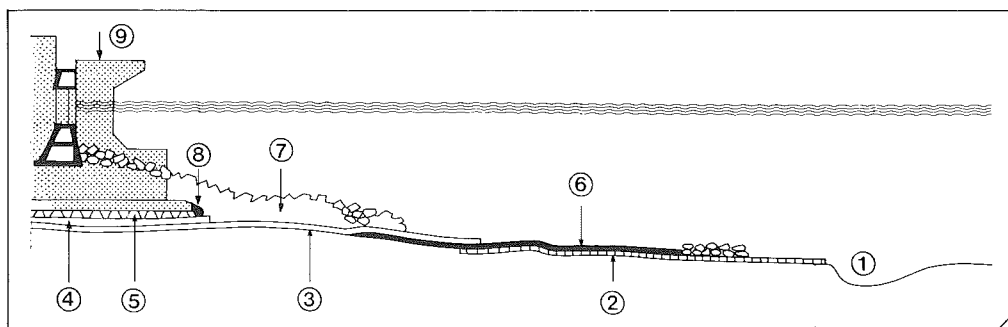
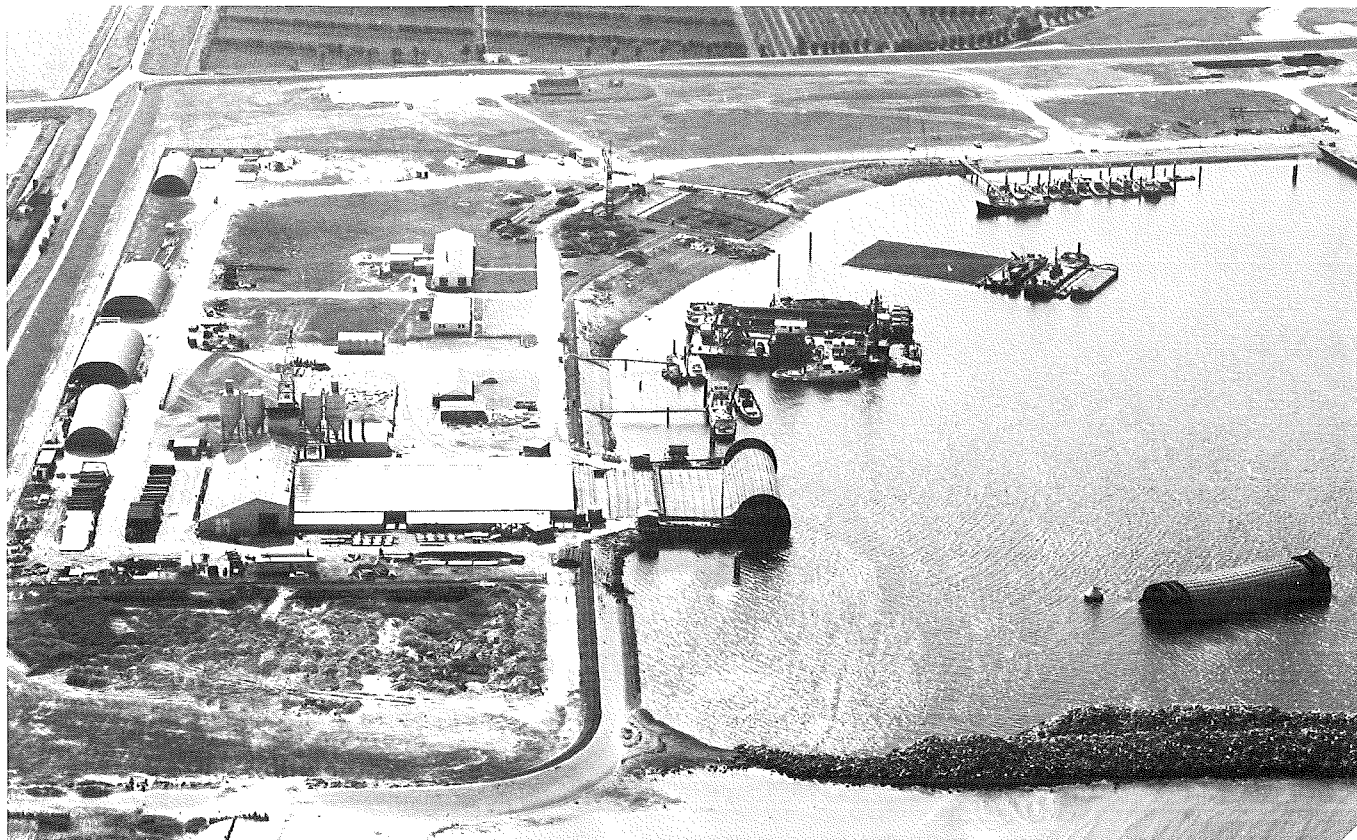

- A. Concrete weighted erosion mat factory at Sophiahaven near Kamperland
- B. Seabed protection
- 1 erosion gully
 - 2 concrete weighted erosion mat
 - 3 bottom foundation mattress
 - 4 upper foundation mattress
 - 5 block mattress
 - 6 mastic asphalt slabs
 - 7 sill
 - 8 gravel bag
 - 9 pier

Seabed protection and anchor piles

To protect the seabed from erosion caused by the increased speed of the currents a 500-600 metre wide area on either side of the barrier had to be covered. Had this not been done the channels might have eroded to such an extent that the barrier would be endangered. The protection consists of concrete weighted erosion mats, aprons of stone filled asphalt and stone weighted mastic asphalt slabs. Highly advanced techniques were developed especially for this operation. The concrete weighted erosion mats, manufactured in the factory at the Sophia harbour later used to make the block mattresses, were laid by Dos I, which was later converted into Donax I. The asphaltting operations were carried out by the Jan Heijmans, owned by Bitumarin BV, which has later been converted into a gravel/stone dumper to be used for filling in the space between the foundation filter mattresses.

As the anchors of the various craft used in the construction of the storm surge barrier would have damaged the seabed protection, anchor piles were driven into the seabed within the working area in accordance with a particular pattern. These piles can withstand a load of 200 tonnes and can be used for several anchoring lines simultaneously.

A special department has been set up to coordinate and handle all anchoring and transport operations. It has several tugs at its disposal, some hired and some owned by the Public Works Department, one of which is the Arca (a mollusc), which was specifically built as an auxiliary anchoring craft.

Temporary bridge

To facilitate the daily transport of more than a thousand employees to and from the construction site, a temporary bridge, nearly three kilometres long, was built between the work island, Neeltje Jans, and the island of Schouwen-Duiveland. The bridge is also used to transport materials not carried by ship. As soon as traffic across the barrier itself is possible the bridge will be dismantled.

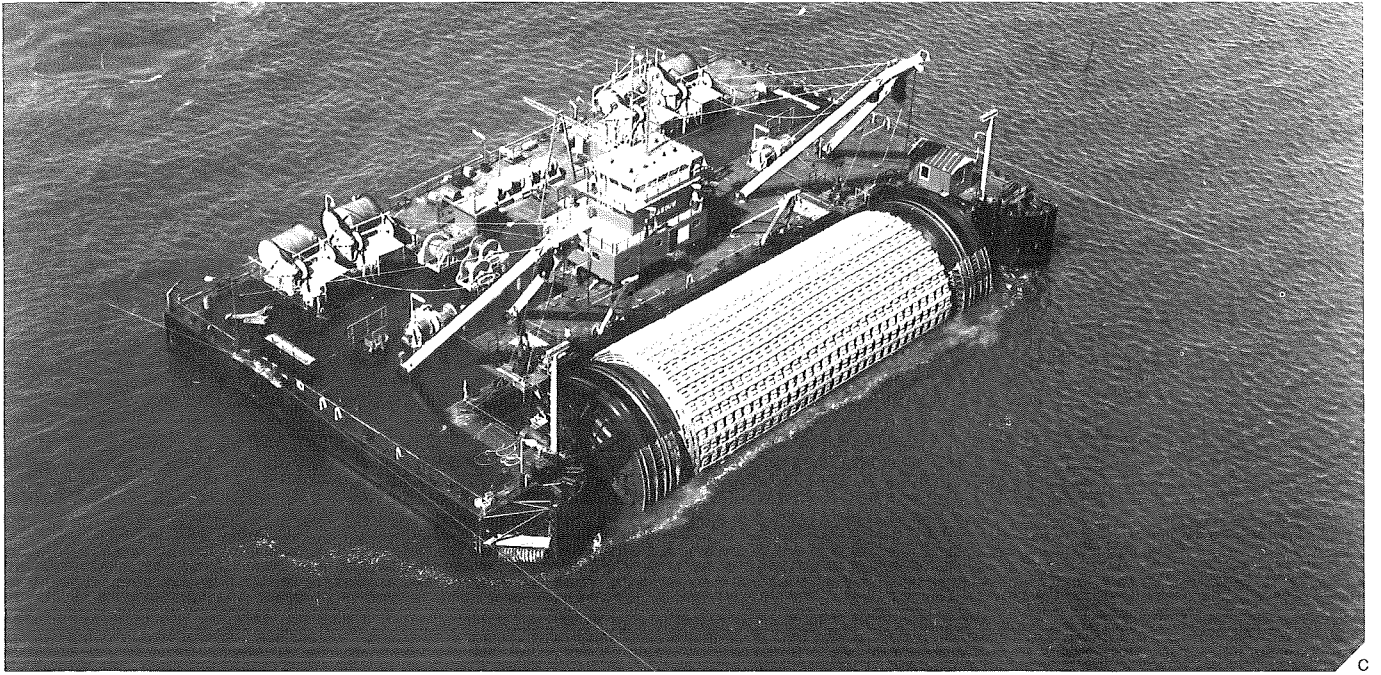

C

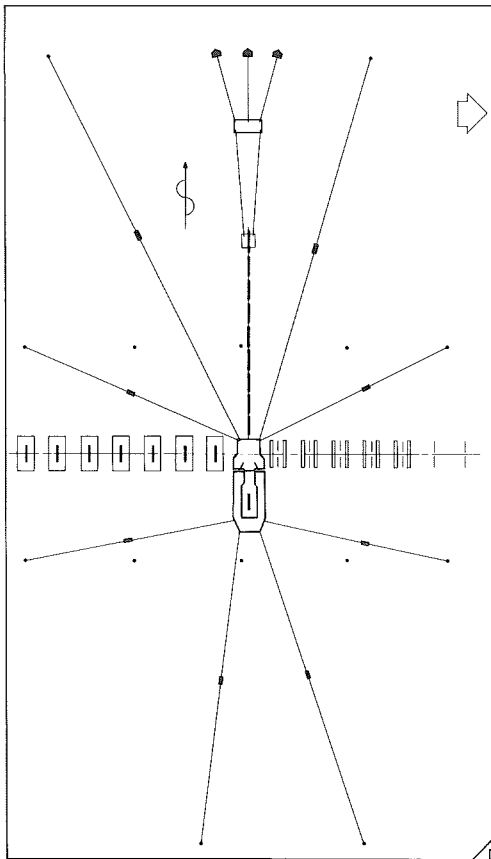

D

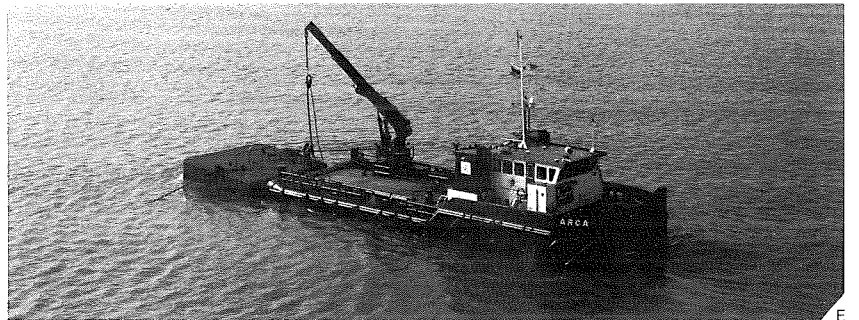

E

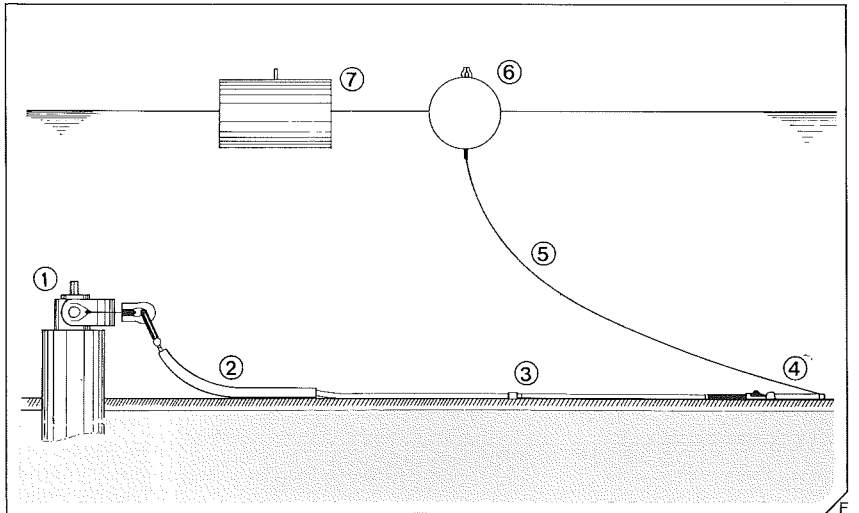

F



G

- C. Laying of concrete weighted erosion mat by the Dos I
- D. Position of anchor lines when the Ostrea is moored to the Macoma
- E. The Arca, an anchoring vessel
- F. The anchoring system
 - 1 anchor post
 - 2 protective rubber covering
 - 3 steel cable
 - 4 ballast block
 - 5 hauling cable
 - 6/7 buoy
- G. Temporary bridge

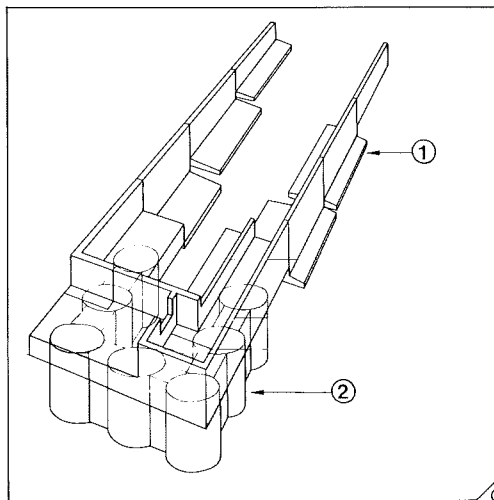
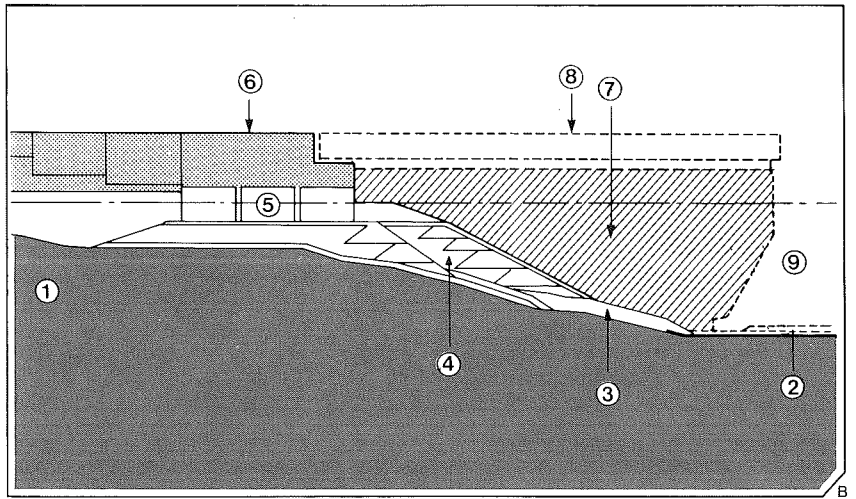
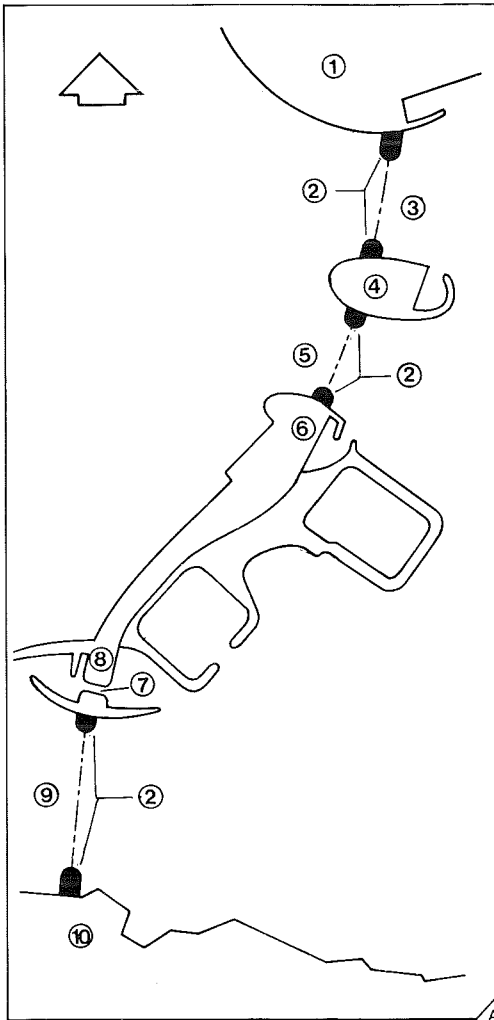

A. Diagram of mouth of Eastern Scheldt

- 1 Schouwen
- 2 dam extensions
- 3 Hammen
- 4 Roggenplaat
- 5 Schaar van Roggenplaat
- 6 Neeltje Jans
- 7 Roompot lock
- 8 Noordland
- 9 Roompot
- 10 Noord-Beveland

B. Dam extension and land abutment

- 1 dam extension
- 2 foundation mattress
- 3 quarry stone
- 4 rough quarry stone
- 5 cylindrical elements
- 6 land abutment
- 7 quarry stone dam
- 8 land abutment box road girder
- 9 pier

C. Land abutment construction

- 1 outer walls
- 2 cylindrical elements

D. Roompot lock

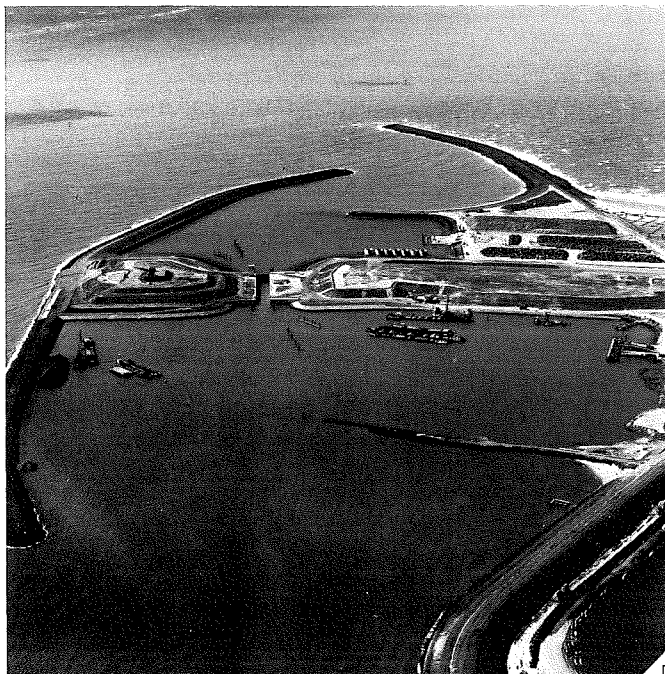

Roompot lock

In the southern part of Dam Section Geul, which is called Noordland, a lock has been built for the use of small vessels, fishing boats and leisure craft. The lock chamber measures 100 × 16.5 metres and its floor lies 6.5 metres below AOD. There is an inner harbour on the Eastern Scheldt side and an outer harbour on the North Sea side with fenders and mooring points.

Abutments

The spaces between the first pier in each section of the barrier and the adjacent bank or island have to be bridged. The constructions designed to do this comprise four sections: a foundation layer rising towards the land, which supports the land abutment, a quarry-stone dam between this and the first pier, and a bridge beam.

The substructure of the land abutment consists of 7 prefabricated cylindrical elements which are placed on the level foundation bed and immediately filled with concrete. The superstructure and the outer walls are constructed on site. The land abutment constitutes part of the barrier and links the land, the foundation layer and the quarry-stone dam, which in turn forms the barrier linking the land abutment and the first pier.

The quarry stone dam is constructed in much the same way as the sill between the piers in the storm surge barrier, the filter principle again being used, with layers of stone increasing in size and weight from the bottom upwards.



A

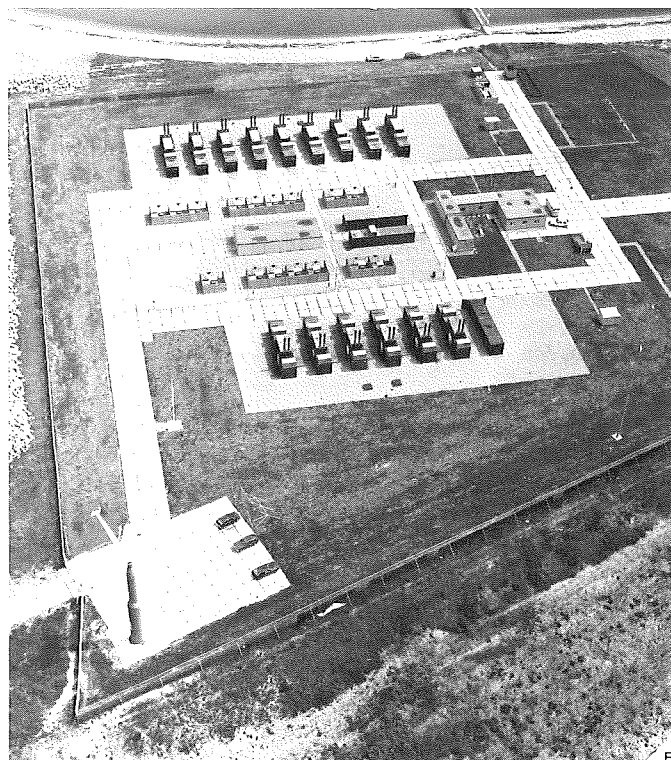

B

A. Construction cranes - heavy users of energy
 B. Power plant

Power supply

The power requirements during the construction operations, especially for the continuous deepwell draining system of the Schaar construction dock, are very heavy. In the early stages, therefore, a power plant was built on the work island which has a capacity of 12,000 kVA, sufficient to meet the electricity demands of a town with a population of about 45,000. The plant houses 15 diesel generators, ten of which were overhauled and installed in the service building.

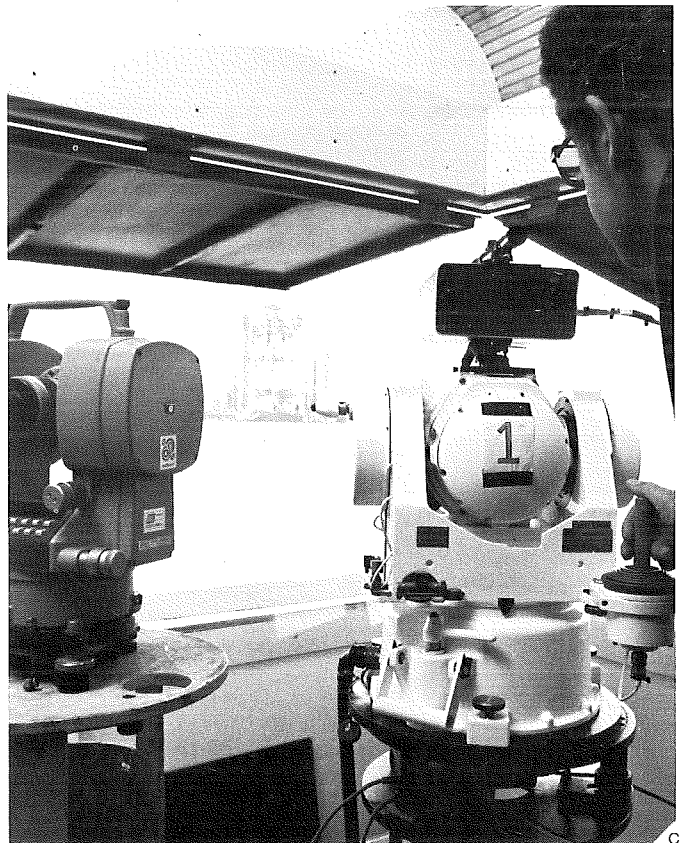
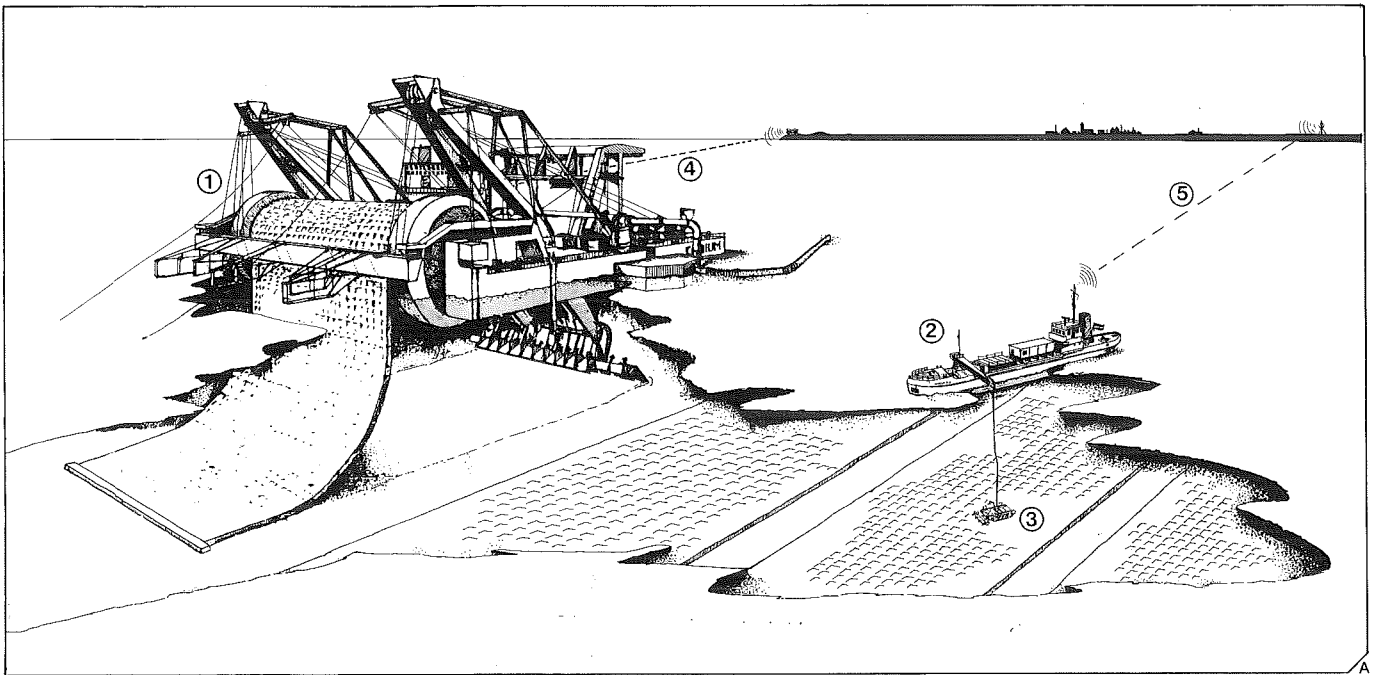

Electronics

It is nowadays virtually unthinkable for modern plant and equipment not to use applied electronics. Within the context of the Eastern Scheldt storm surge barrier operations such systems including a highly sophisticated position fixing system, are all classified as „survey”. This classification, however, is inaccurate because the equipment does much more than just survey. It includes, for example:

- the latest equipment for automatic continuous position fixing which is accurate to within 5 cm at a distance of 2 km offshore;
- newly developed sounding techniques enabling underwater position fixing and techniques for measuring the evenness of the seabed and detecting sand deposits less than a few centimetres thick;
- the use of gyroscopes and accelerometers;
- computer systems on board the various work vessels making it possible to read, check, process, present, record, store and retrieve information from hundreds of sensors.

The Cardium has been equipped not only with these 'survey' systems but also with a semi-automatic warping system. This enables the rig to be moved more or less automatically while attached to its anchor cables over a distance of 200 metres and within an accuracy of about 50 cm, while actually dredging and

- A. Position-finding and inspection
 1 Cardium
 2 Wijker Rib
 3 Portunus
 4 Infra-red position-finding
 5 Radio position-finding using the Trident III
- B. Steering the Portunus from the Wijker Rib
- C. Position-finding using the automatic tracking theodolite, Minilir, and the distance meter AGA 112.
- D. The Portunus on a test drive over a concrete weighted block mattress
- E. Trigla inspects the hollow gap under the pier

laying mattresses. Should this system fail, there is still a somewhat simpler warping system to fall back on.

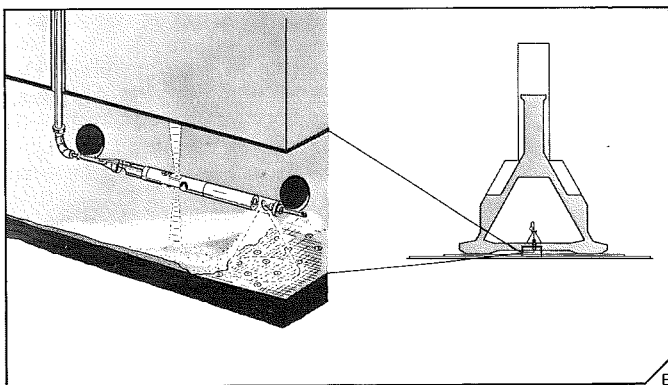

metres and weighs 6.5 tonnes on land and 5 under water. It comprises two parts: the vehicle itself, including the engine, and the inspection trawler, which is attached to the vehicle by a system of metal rods. The latter is equipped with three „Klar Sicht Vorsatz” blocks, each of which acts as light and wide angle lens for two black and white television cameras. The pictures taken by the cameras are transmitted to the Wijker Rib, a vessel positioned above, through the connecting cable. The inspection compartment is also fitted with sensors which measure the thickness of layers of sand. Under normal circumstances the Portunus moves on caterpillar tracks (0.5 m/sec.) but it has to use four castors to turn sharply in any direction. It can either be steered manually from the Wijker Rib or programmed in advance to follow a given course.

The connecting cable is 7 cm thick and 250 metres long and provides all the energy needed on board the Portunus, transmits measurements from the sensors and acts as a lifting cable.

The Trigla, a small self-propelled device which can be operated by remote control, has been developed to inspect the gap between the foundations and the installed pier. It is tubular (900 x 42.5 mm) and also has television cameras and sensors for measuring the thickness of layers of sand. It travels through the grot channels in the base of the pier in order to get under the pier.

Underwater inspection

Various craft have been developed for underwater inspection, including the Portunus (named after a type of crab), an unmanned vehicle which measures 6 x 4

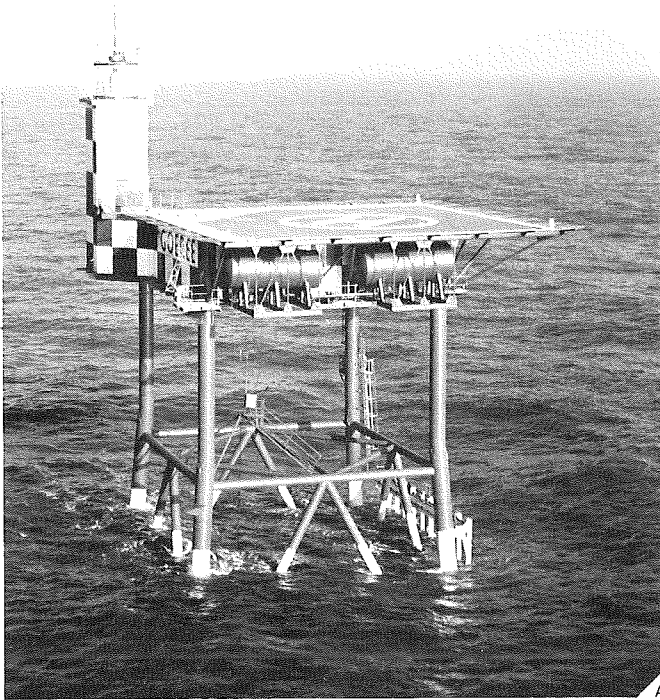

A. Measuring platform with sensors for obtaining information on the weather and sea conditions
 B. 'The Ir. J. W. Topshuis'
 C. The control panel in the service building

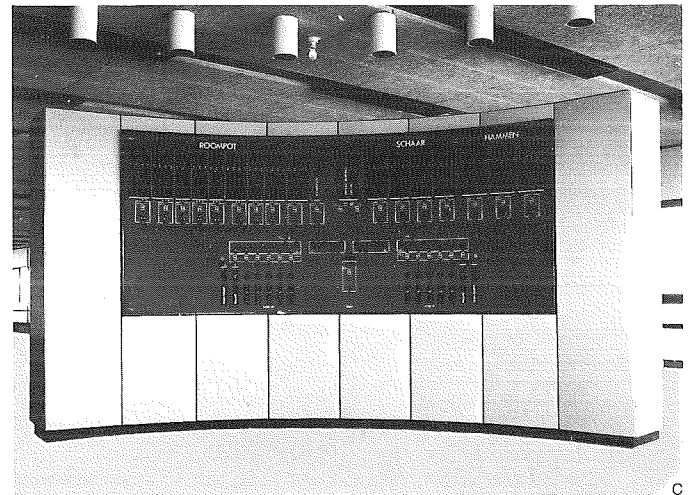
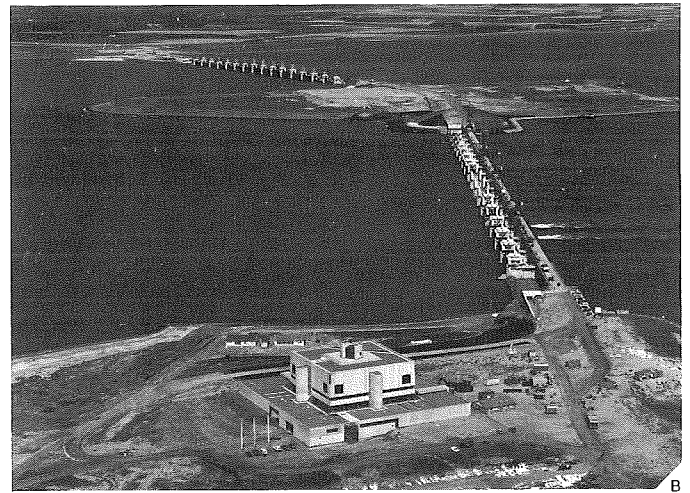

The Hydro-Meteo Centre

Most sections of the storm surge barrier are prefabricated and therefore have to be taken to their ultimate site and placed in position - for example, foundation mattresses have to be laid, the piers and sills have to be positioned, and so on. These operations can only be carried out in good weather and when the seas are suitable. This means that highly accurate forecasts have to be available for periods of several days at a time and in order to facilitate this a special meteorological and hydrological centre, the Hydro-Meteo Centre, has been set up, where experts process information from dozens of measuring points in the North Sea relating to water levels, the speed of the currents, wave fields, water temperatures, salinity and wind. It is particularly important to know when wave fields are approaching as they may cause a long swell in the estuary, something to which the special equipment involved in the project is particularly sensitive.

A direct link with the Royal Netherlands Meteorological Institute and a connection with the international meteorological network also provide some of the information on which forecasts are based, and frequent bulletins are issued to all concerned; during positioning operations these are updated minute by minute.

Service building

All 62 gates will be centrally operated from the service building on the construction island, Neeltje Jans, 'The Ir. J. W. Topshuis'. The top two floors of this building also houses a permanent exhibition on the Delta Project in general and the Eastern Scheldt barrier in particular.



A



B

A. Personnel facilities at Moermond
B. Moermond Castle

Personnel amenities - Moermond

About 60 per cent of all personnel come from the province of Zeeland. The remaining 40 per cent live in the rest of the country. For some the distance between home and work is too great to travel or shift work prevents them from going home each day.

Temporary living quarters were therefore built in the grounds of Moermond Castle in Renesse which can accommodate 260 people. They have their own kitchen, canteen and recreation rooms.

The castle itself is used by the Public Works Department and Dosbouw for meetings etc.

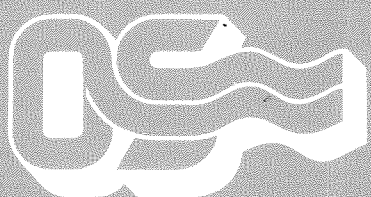

oosterschelde-project



dosbouw



OSTEM

