

*deviation.*

# ARCHITECTURE, CONTROL, AND THE BEURSTRAVERSE

# INTRODUCTION

# OBSERVATIONS



# INTRODUCTION

# OBSERVATIONS



# INTRODUCTION

# THE RESPONSE

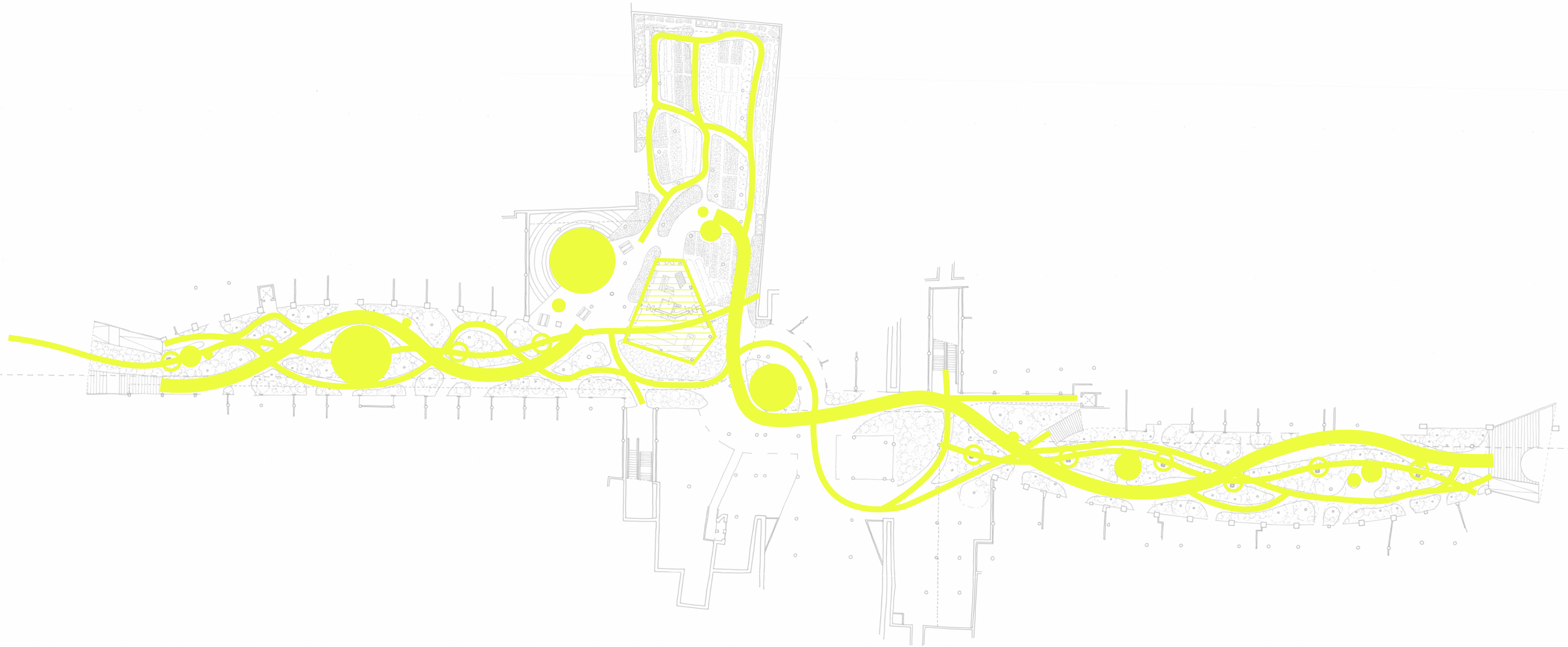

# THEORY

# DISCIPLINE AND CONTROL

discipline society

[visibility]

panopticon

[body]

confined

[access]

walls/gates

[deviation]

transgression

# THEORY

# DISCIPLINE AND CONTROL

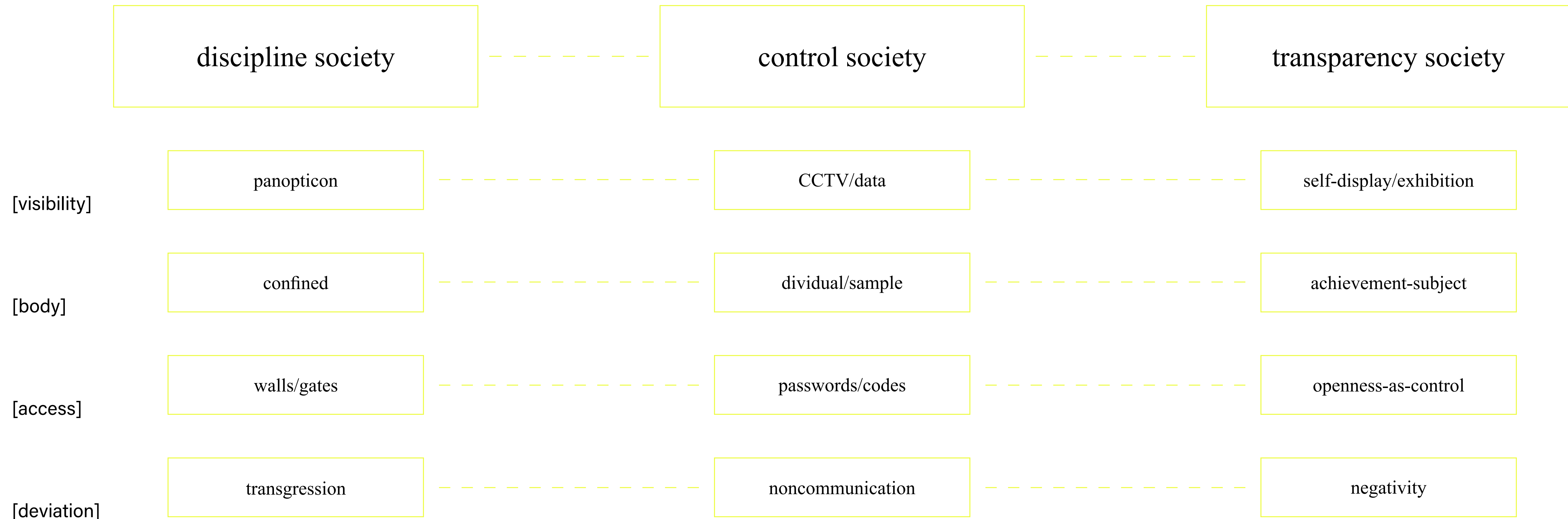

# THEORY

# THE QUESTION



How can architectural intervention design for deviation within the apparatus of control of a consumerist semi-public space?

CONDITION

THE TRENCH



# CONDITION

# THE TRENCH



CONDITION

THE TRENCH

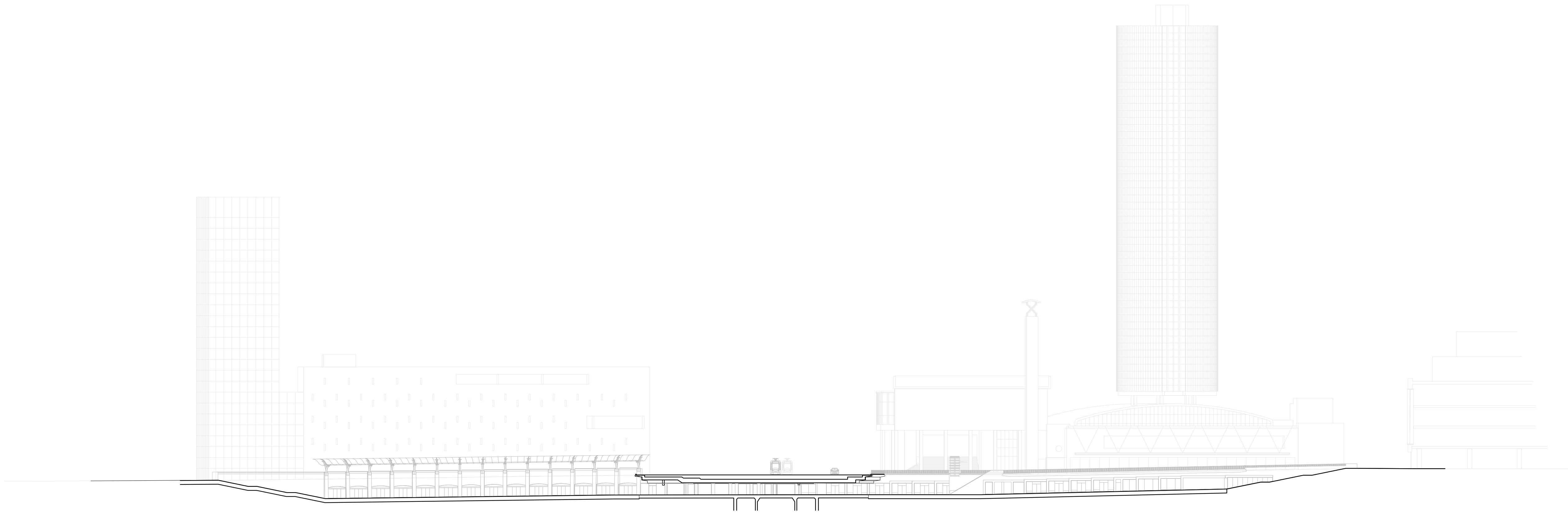

# CONDITION

# THE APPARATUS

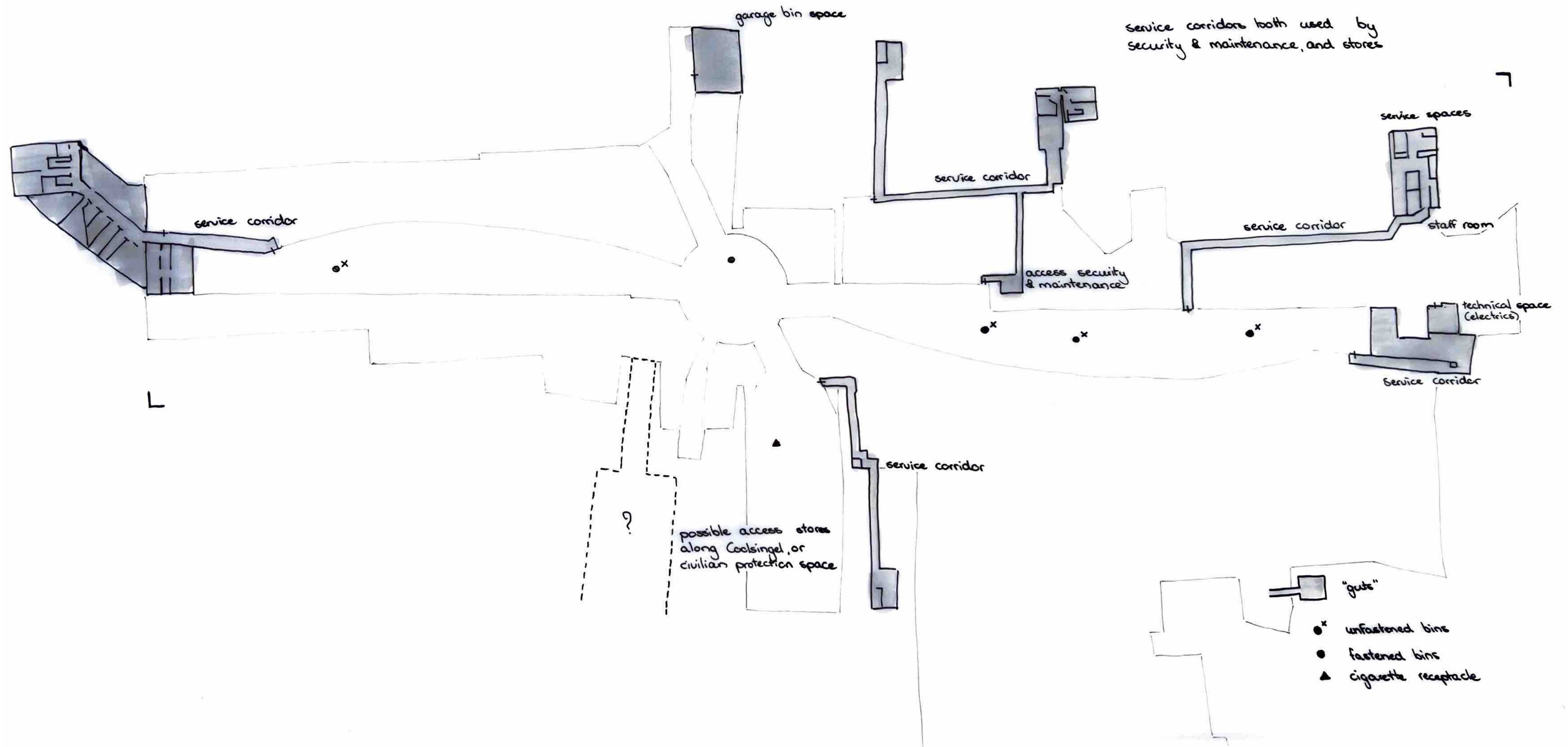

# CONDITION

# THE APPARATUS

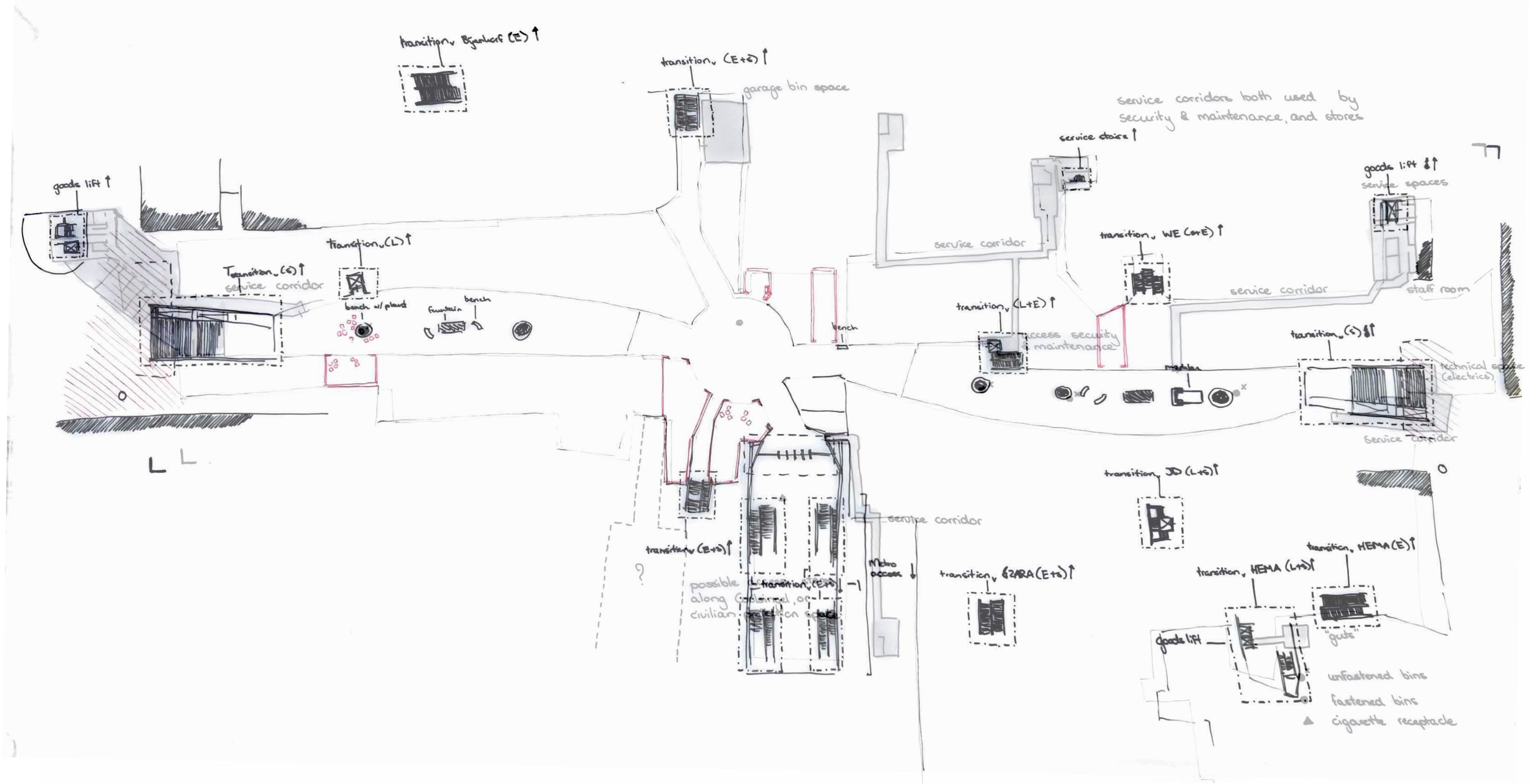



# CONDITION

# THE APPARATUS

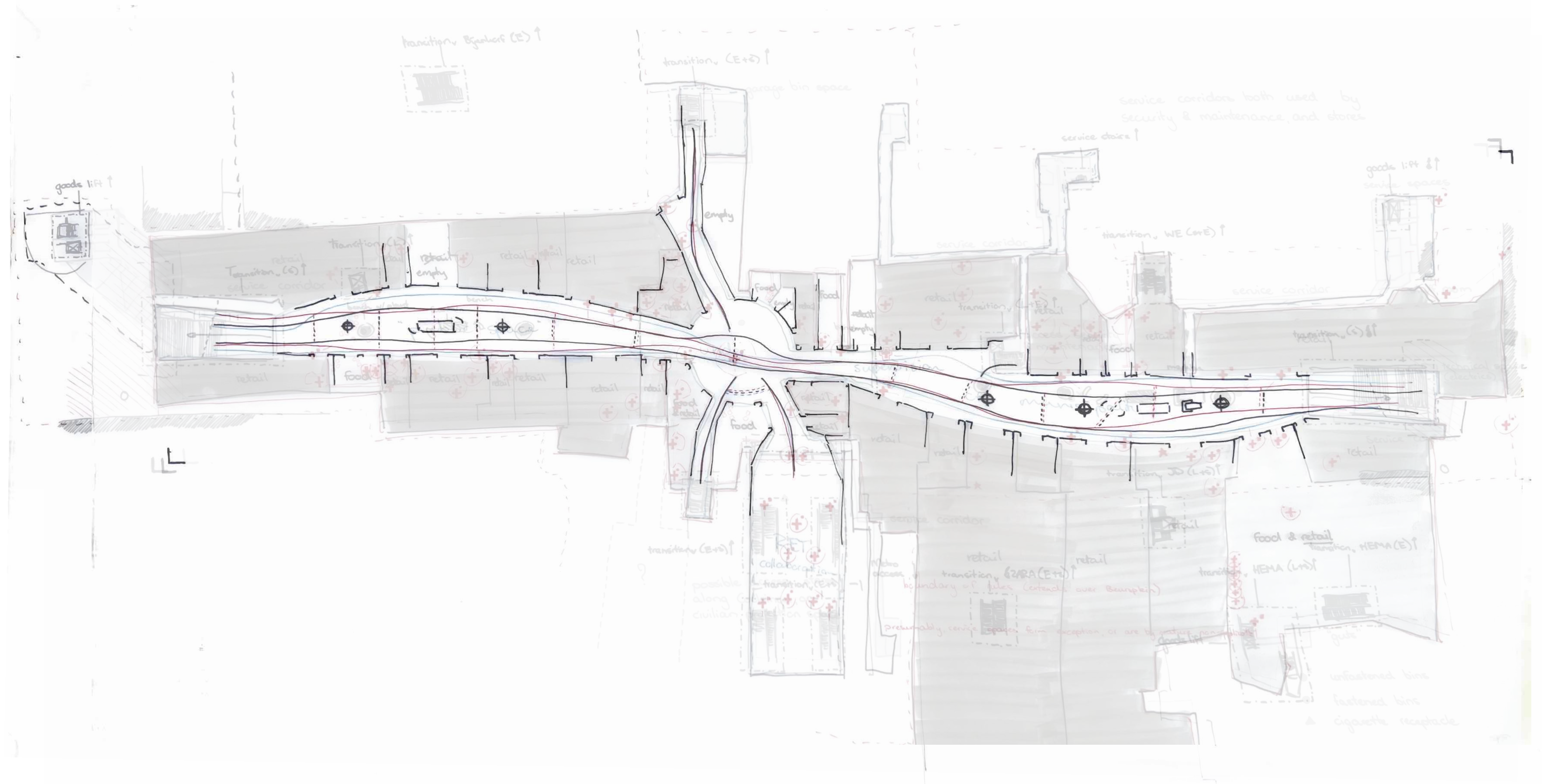

# CONDITION



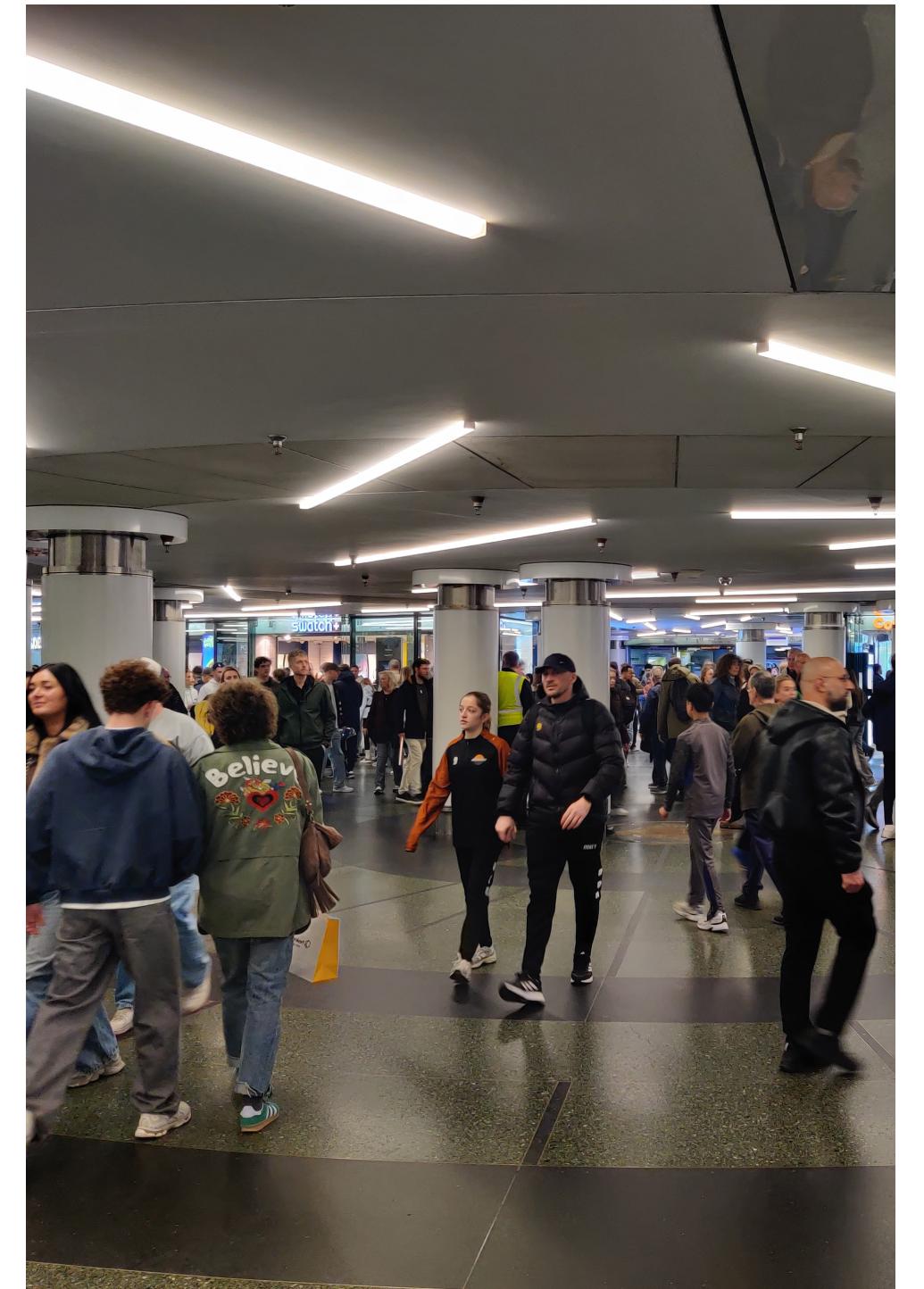

# THE EXPERIENCE

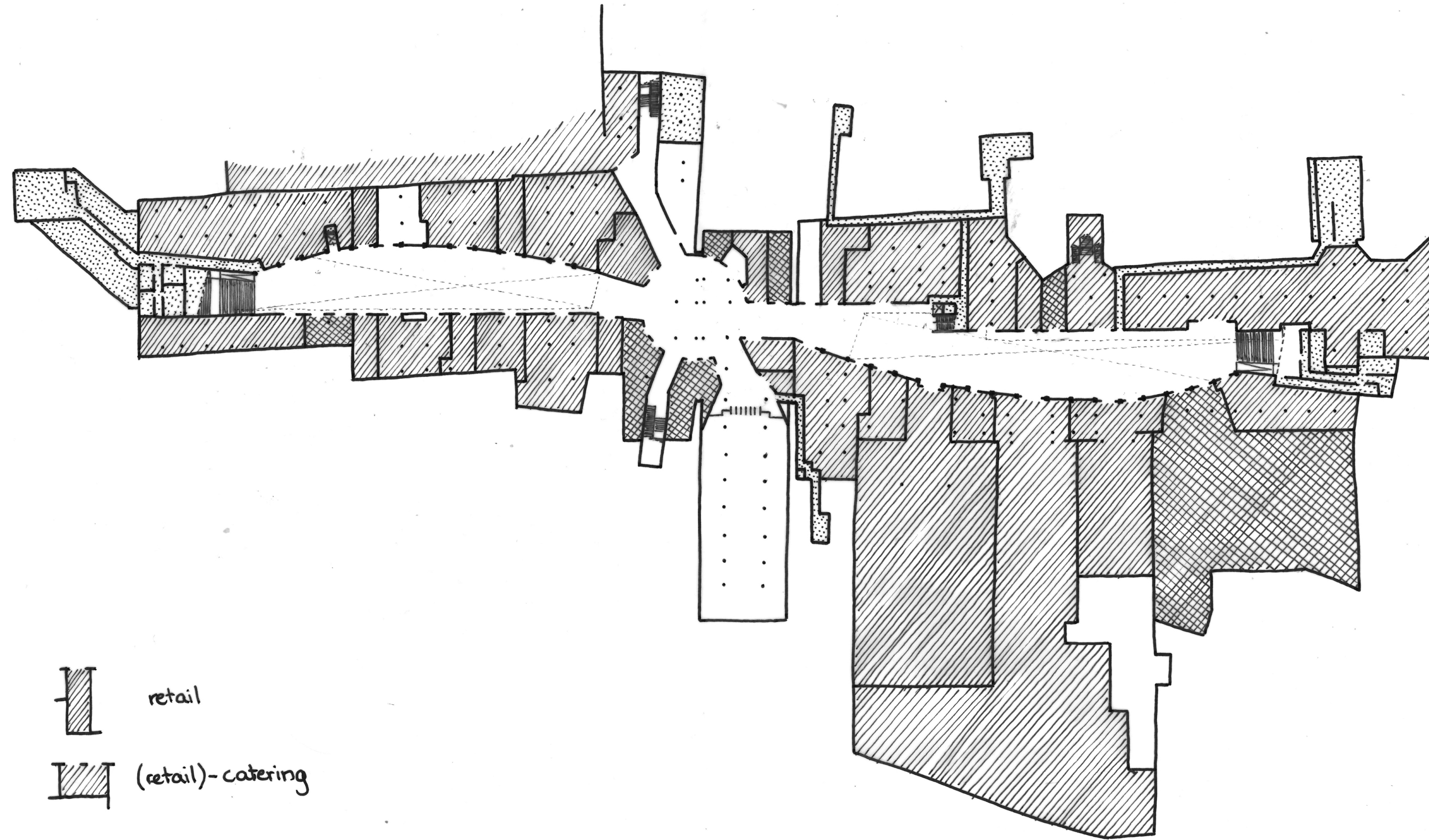

# CONDITION

# THE MACHINE



-  retail
-  (retail)-catering
-  services
-  vacant, as of now

# CONDITION

# THE MACHINE

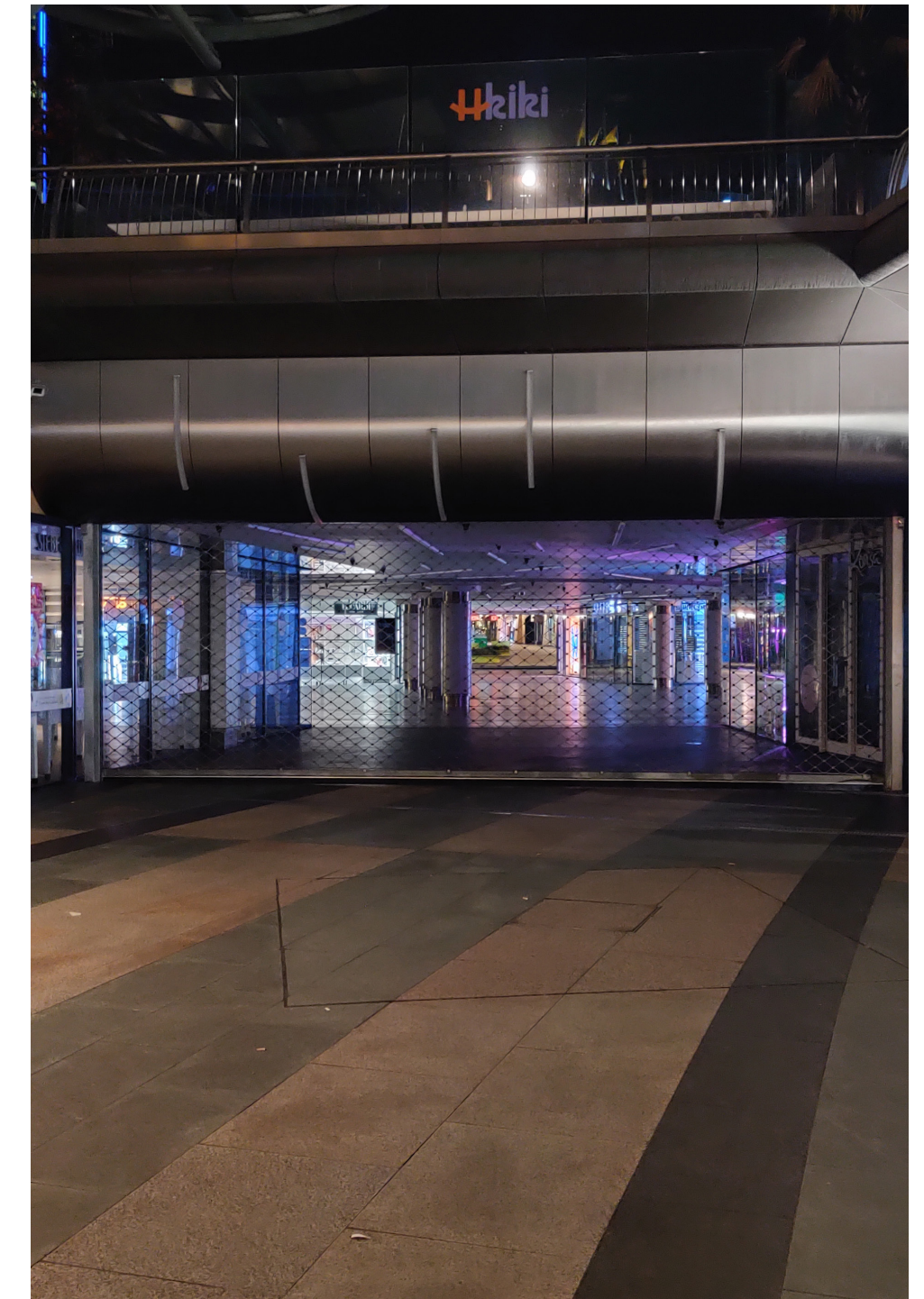
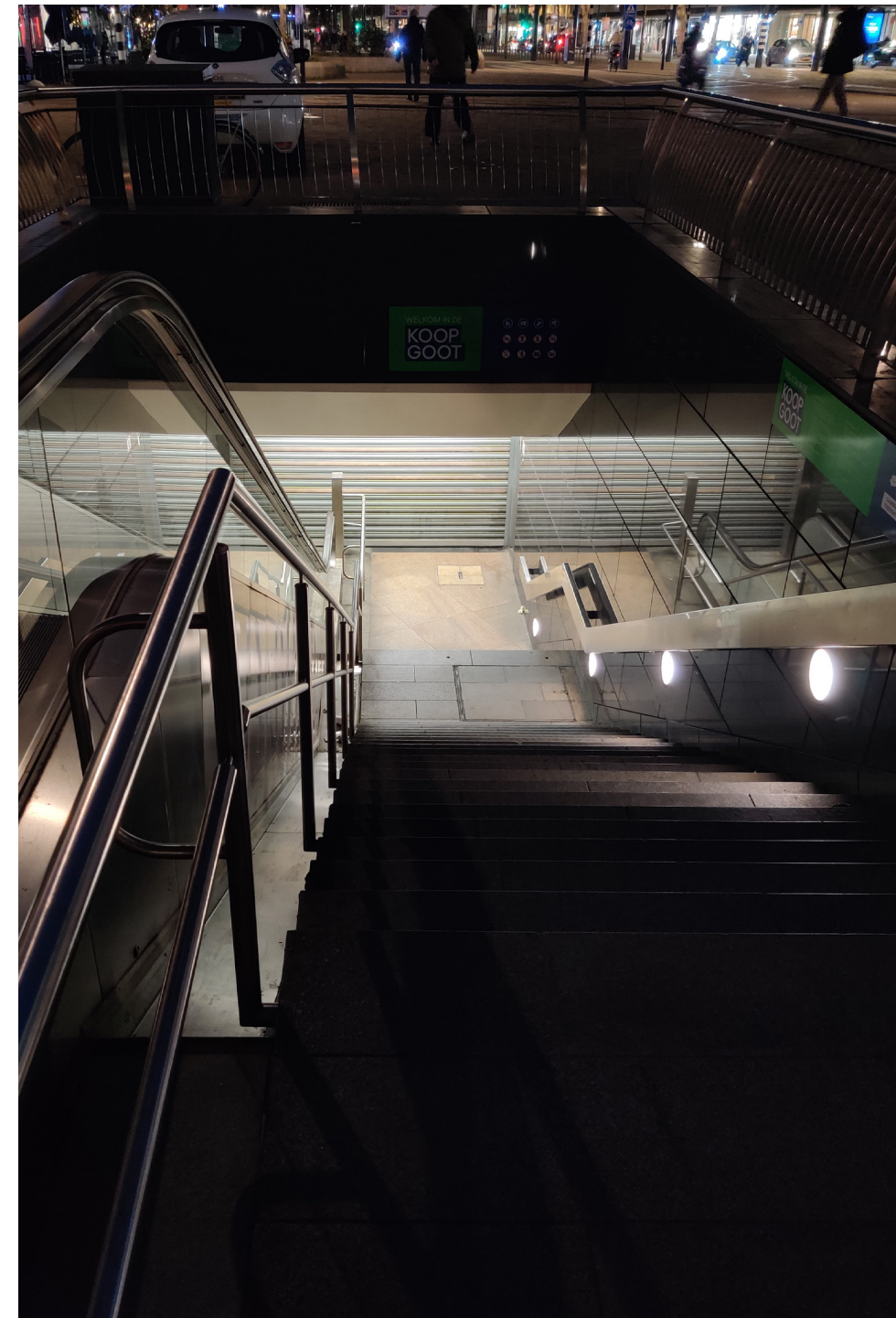
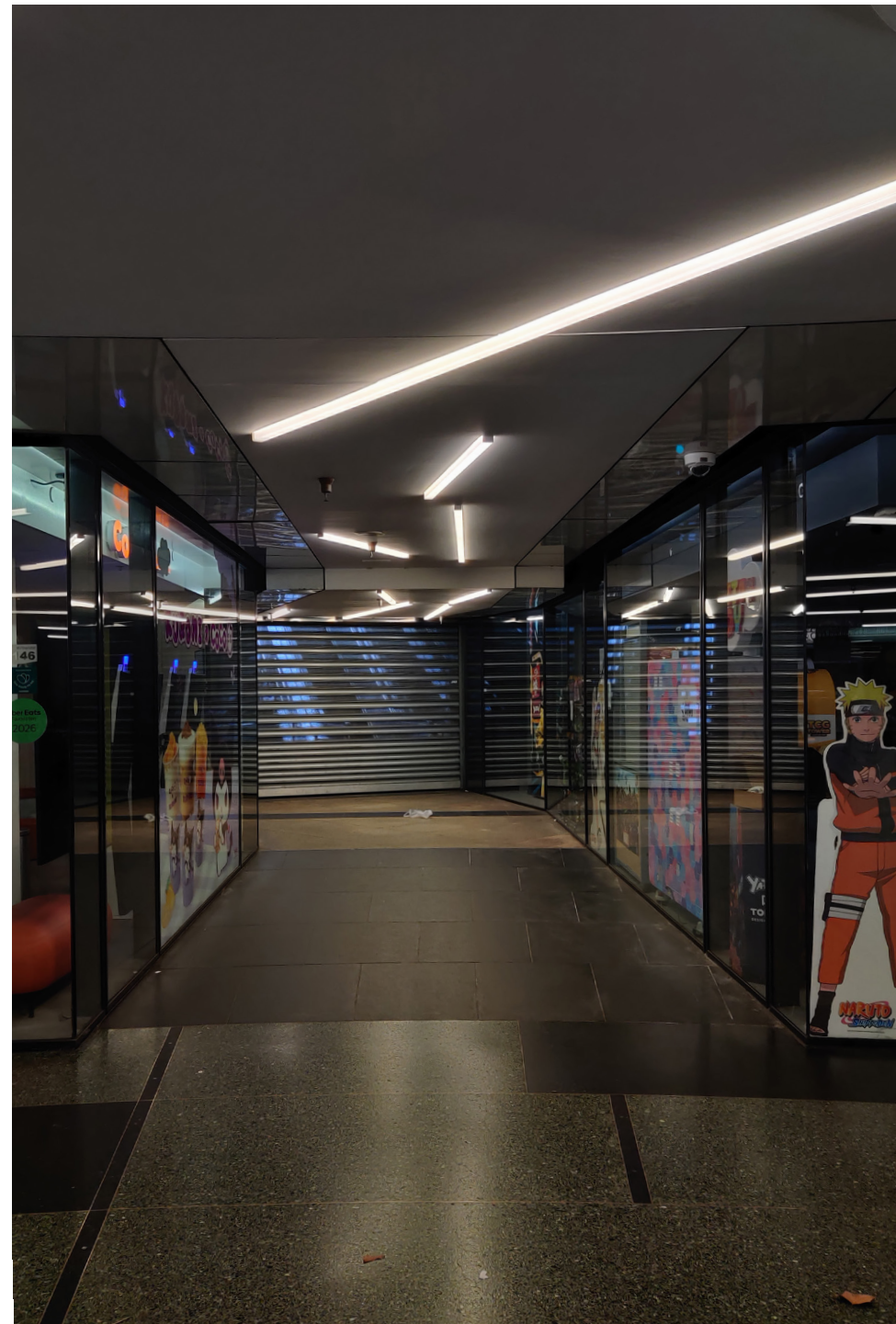

# CONDITION

# THE MACHINE

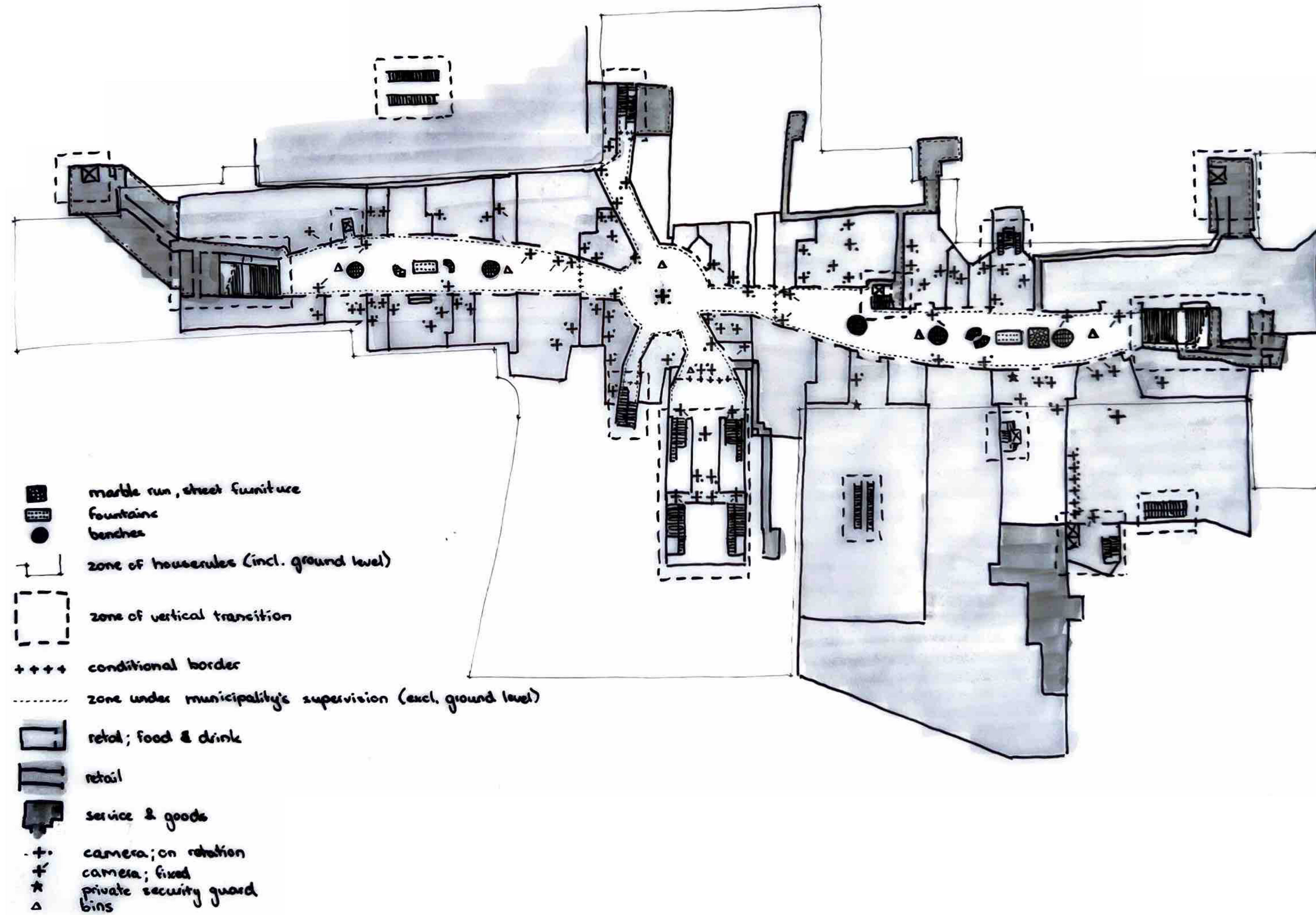

CONDITION

THE MACHINE



## CONDITION

## THE MACHINE



Welkom in de Koopgoot

Beursplein is a public promenade and shopping area. The entire area is covered by CCTV and surveillance instructions given by (security)staff and/or the police must be followed. The following is not permitted:

- Bringing (electric) bicycles and mopeds inside.
- Roller-skating, skateboarding, riding scooters and rollerblading.
- Smoking.
- Loitering in groups.
- Consuming drugs or alcoholic drinks.
- Holding surveys, distributing leaflets and selling goods without permission.
- Taking photographs, making film/video recordings or music.
- Pestering visitors.
- Begging

Thank you for your coöperation.

# CONDITION

# THE MACHINE



Welkom in de Koopgoot

Beursplein is a public promenade and shopping area. The entire area is covered by CCTV and surveillance instructions given by (security)staff and/or the police must be followed. The following is not permitted:

- Bringing (electric) bicycles and mopeds inside.
- Roller-skating, skateboarding, riding scooters and rollerblading.
- Smoking.
- Loitering in groups.
- Consuming drugs or alcoholic drinks.
- Holding surveys, distributing leaflets and selling goods without permission.
- Taking photographs, making film/video recordings or music.
- Pestering visitors.
- Begging

Thank you for your coöperation.



# CONDITION

# THE MACHINE



Welkom in de Koopgoot

Beursplein is a public promenade and shopping area. The entire area is covered by CCTV and surveillance instructions given by (security)staff and/or the police must be followed. The following is not permitted:

- Bringing (electric) bicycles and mopeds inside.
- Roller-skating, skateboarding, riding scooters and rollerblading.
- Smoking.
- Loitering in groups.
- Consuming drugs or alcoholic drinks.
- Holding surveys, distributing leaflets and selling goods without permission.
- Taking photographs, making film/video recordings or music.
- Pestering visitors.
- Begging

Thank you for your coöperation.

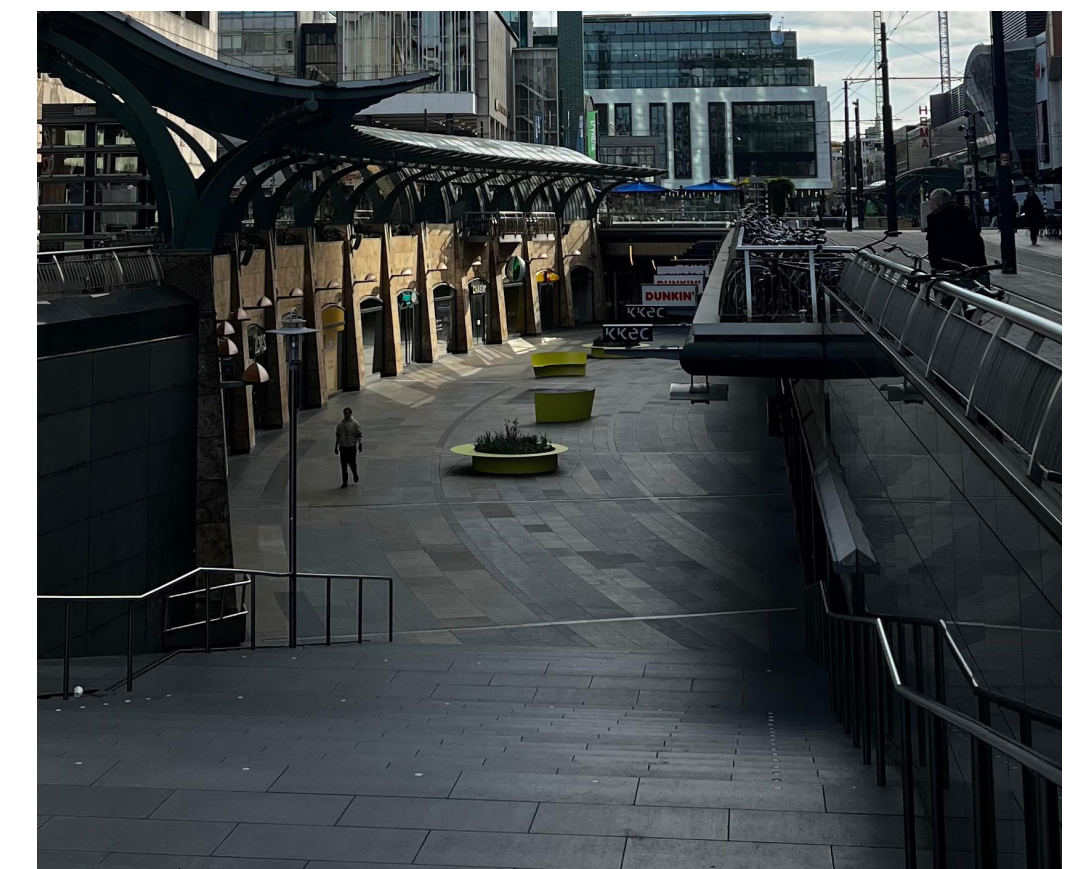

DESIGN

NON-PROFITABLE PRODUCTIVITY

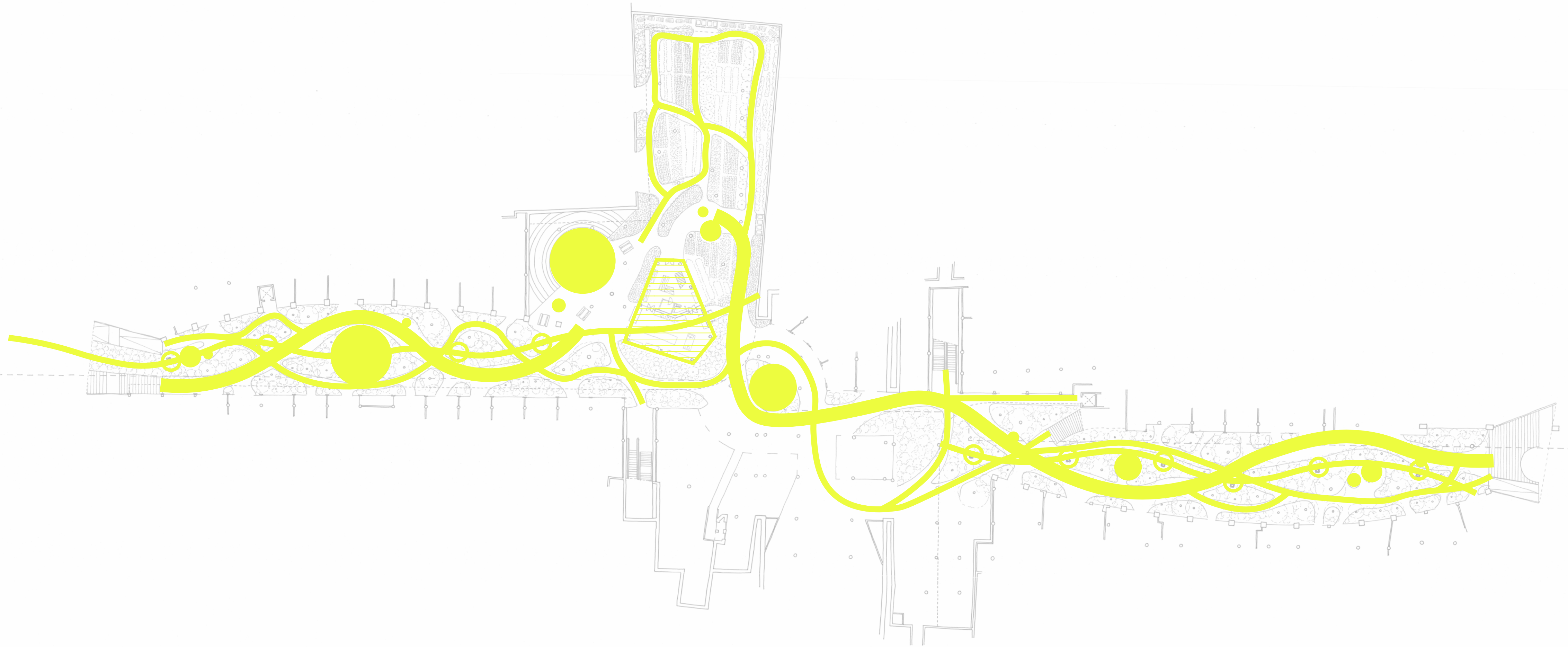

DESIGN

NON-PROFITABLE PRODUCTIVITY

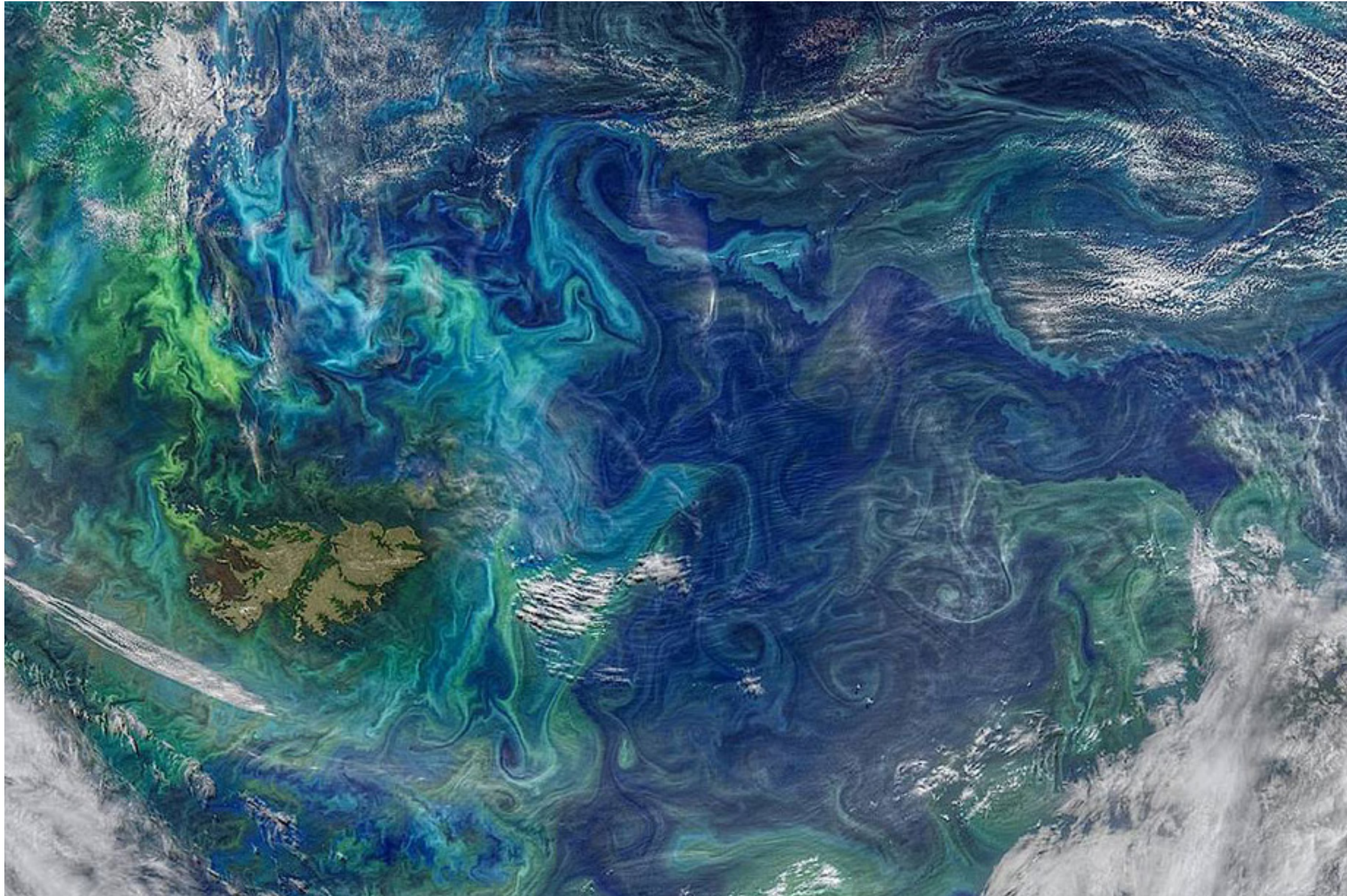

DESIGN

NON-PROFITABLE PRODUCTIVITY

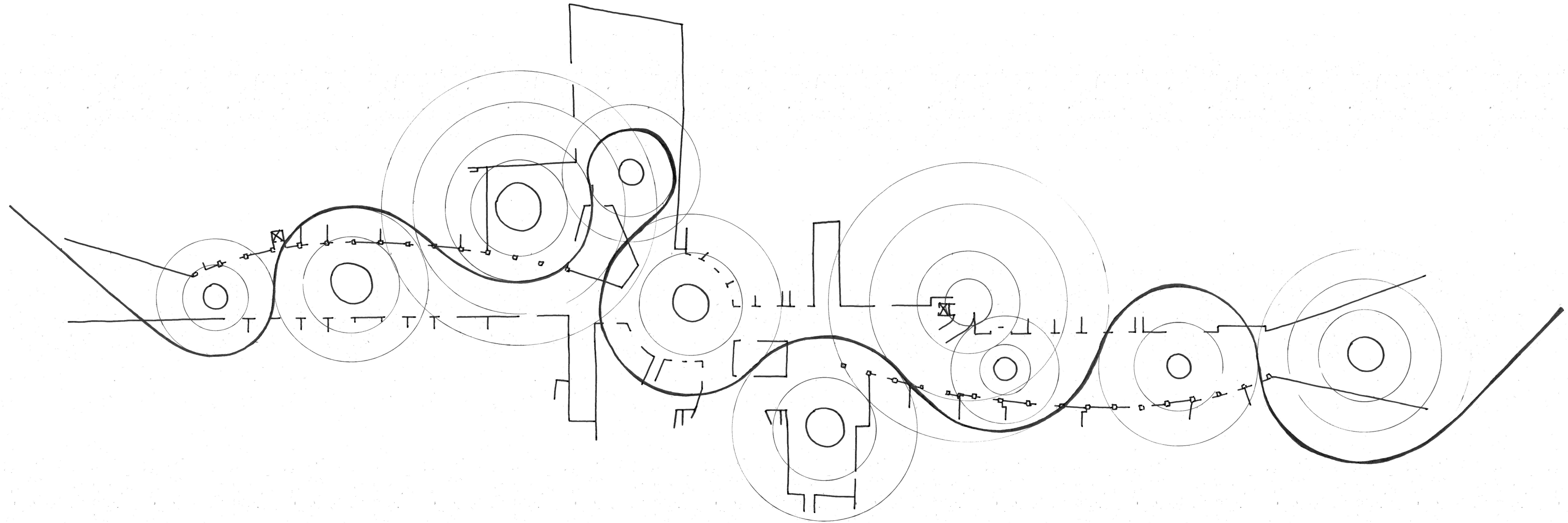

DESIGN

TO WANDER



# DESIGN

# TO WANDER

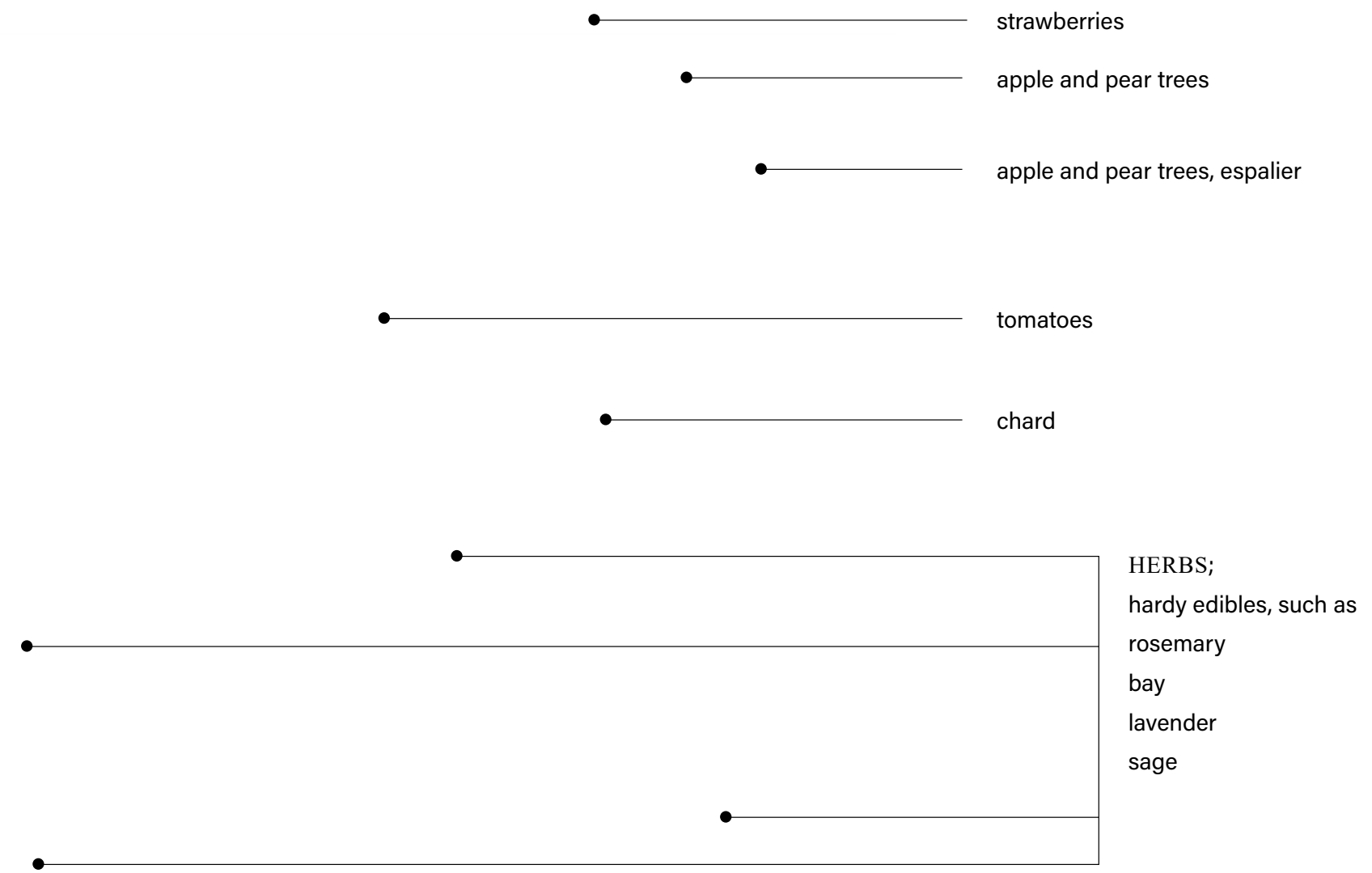

# DESIGN

# TO WANDER

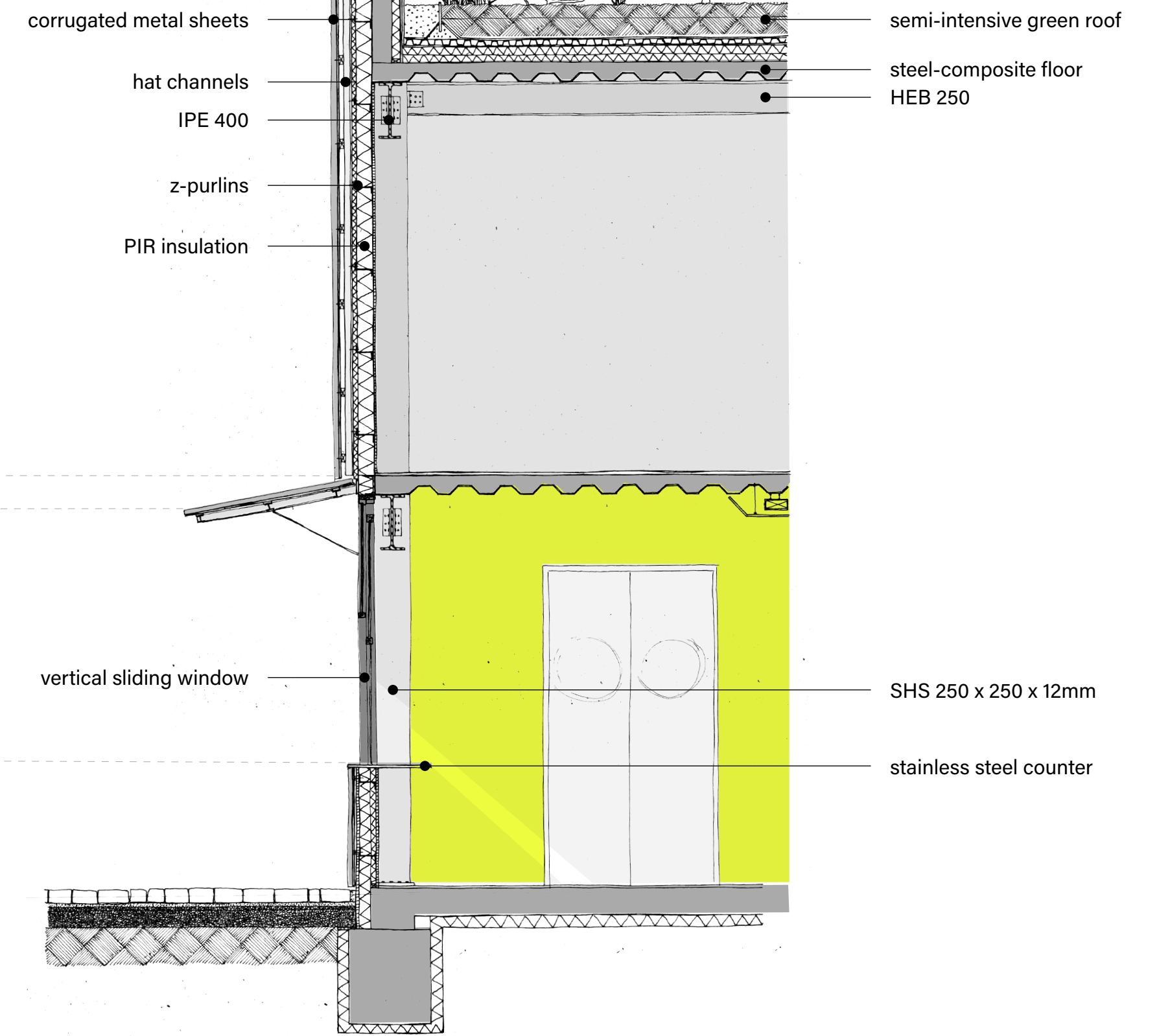
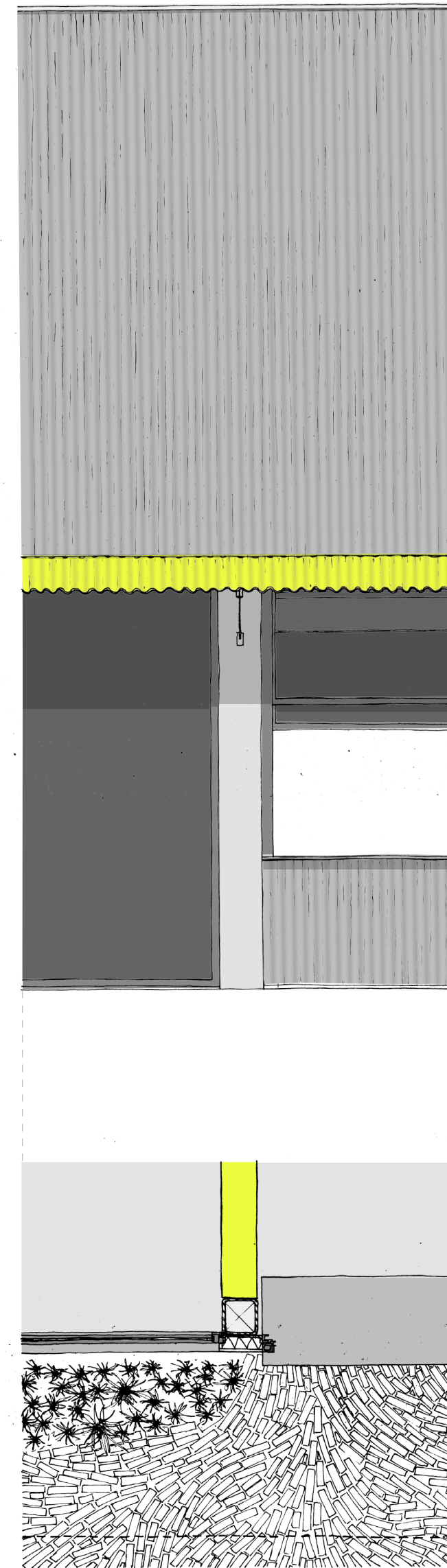
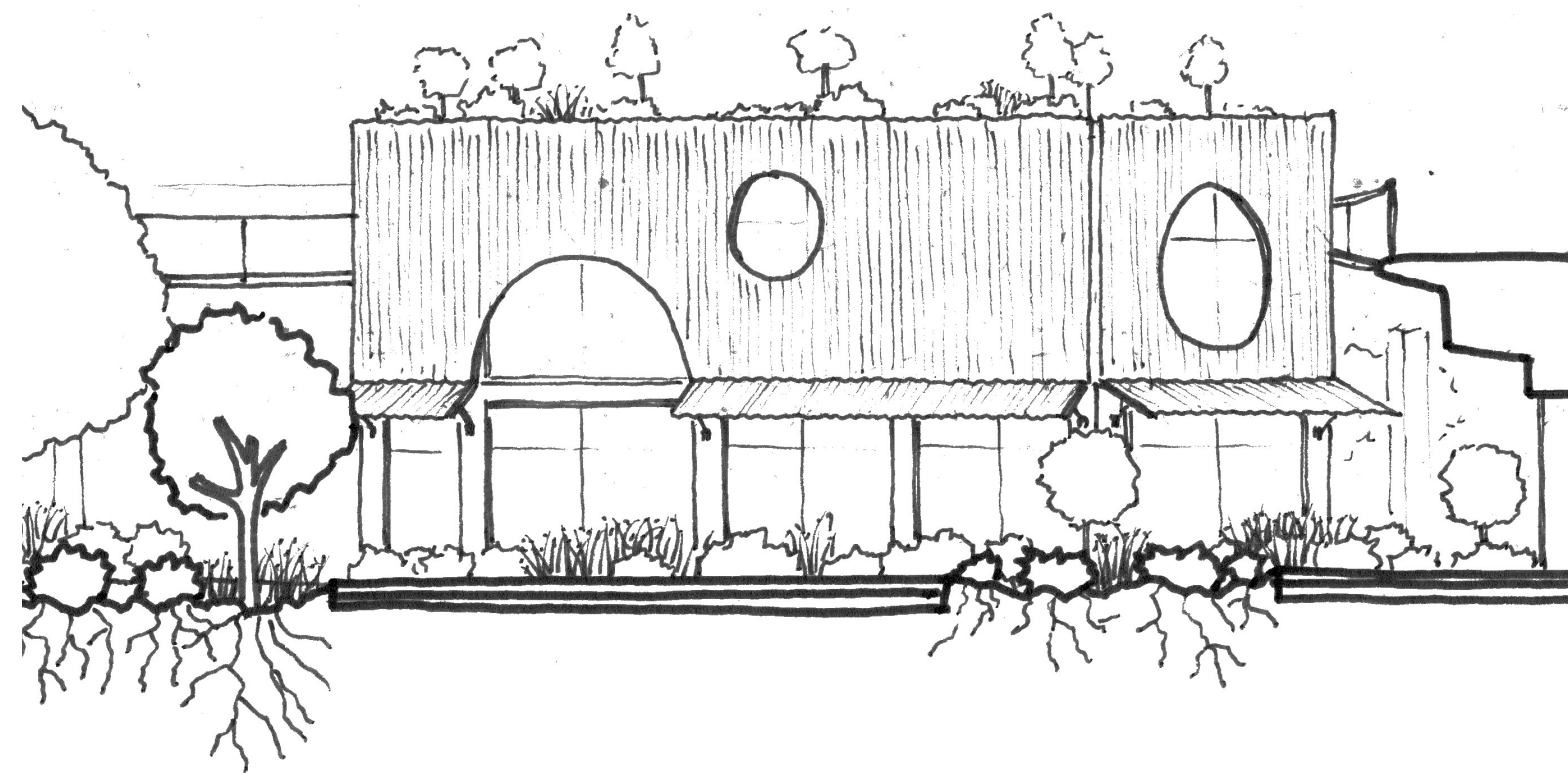

# DESIGN

# TO BYPASS

DAY

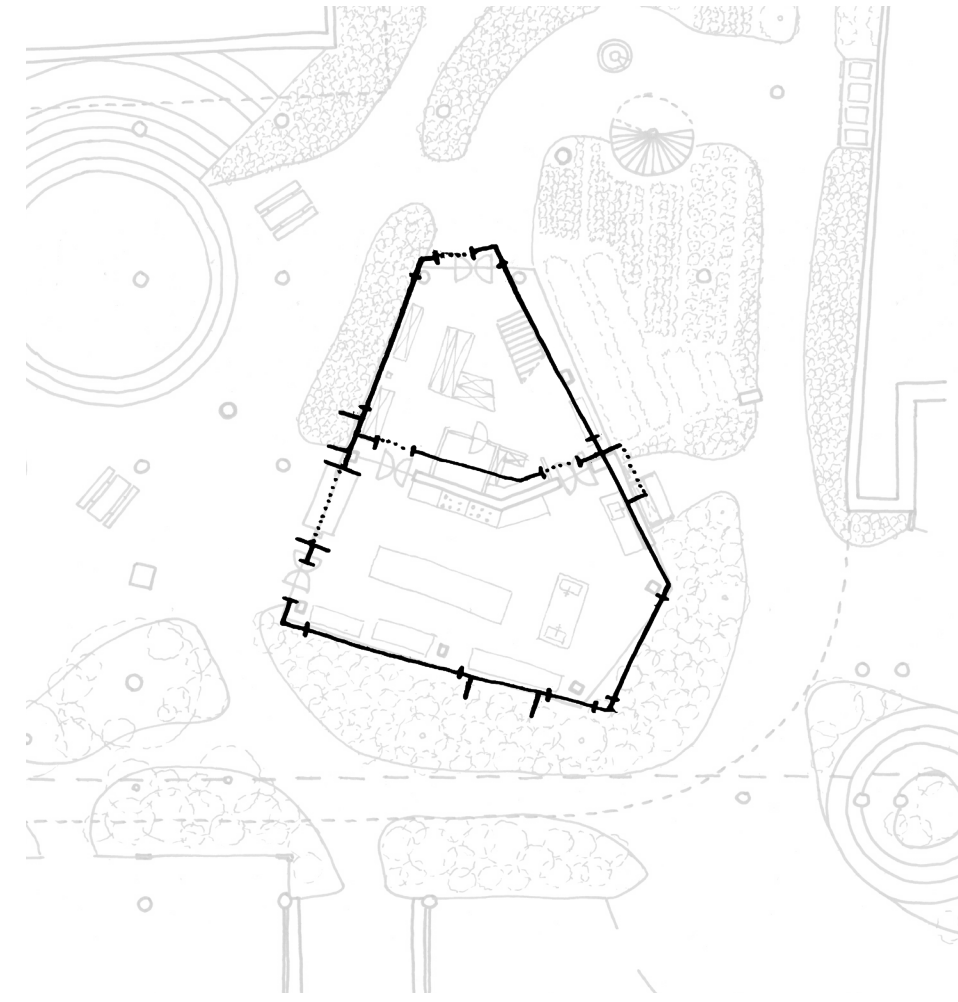

## FULL COMMONS

kitchen, and handout table accessible  
garden in use

EVENING

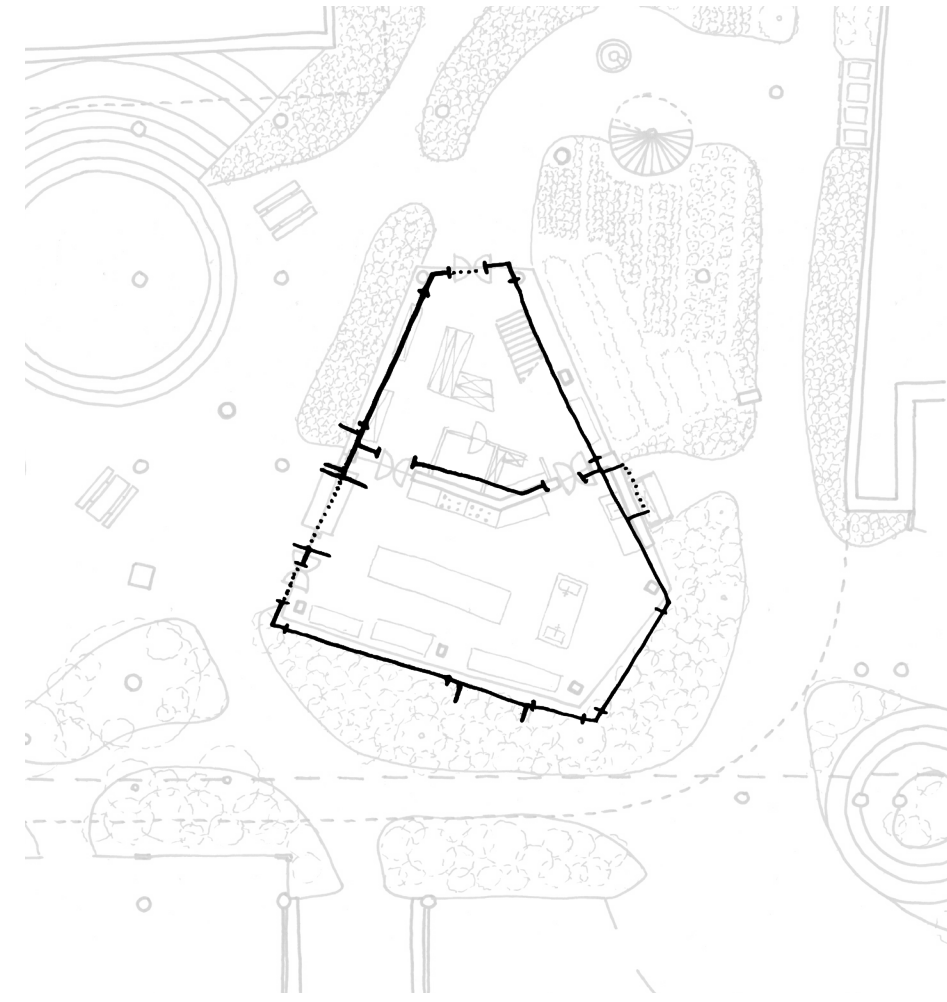

## REDUCED

kitchen semi-closed  
counter remains staffed for prepped meals,  
leftovers, tea, water, and information

NIGHT

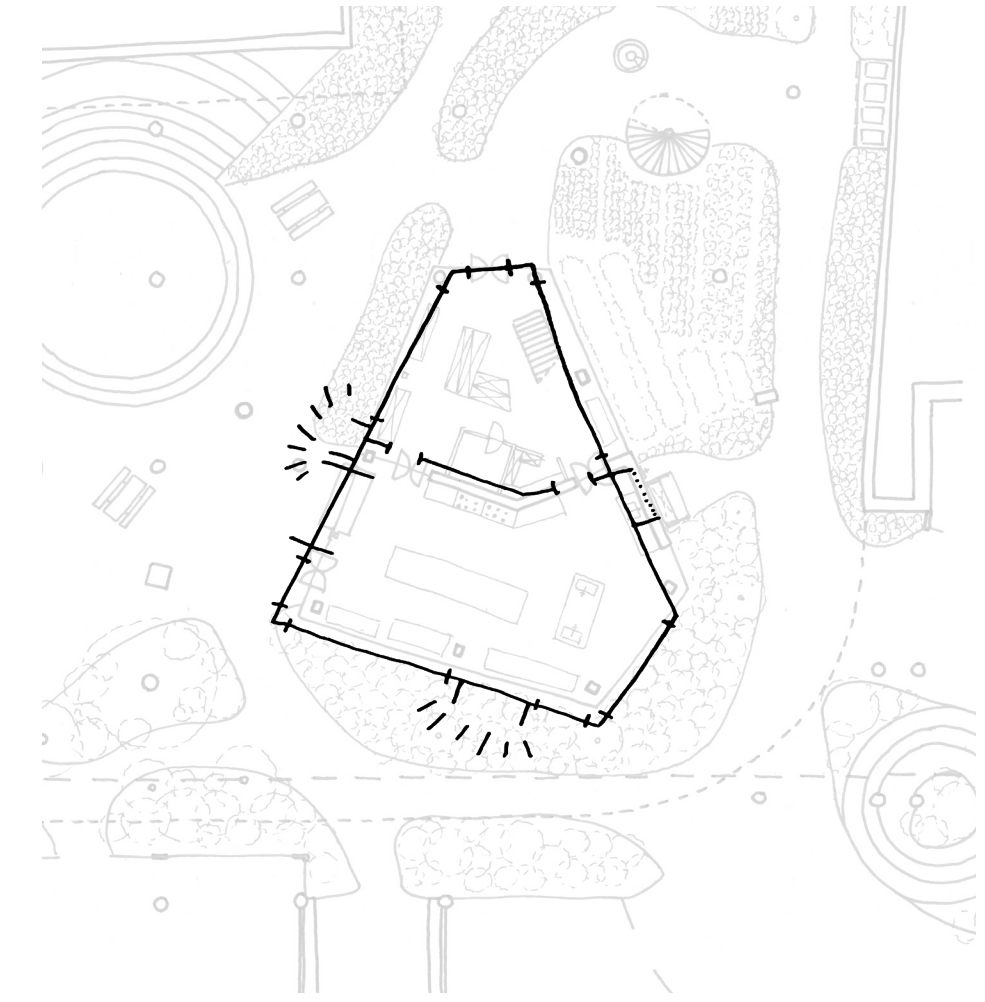

## 24/7

cover from rain  
tap  
information board  
public fridges

DESIGN

TO BYPASS

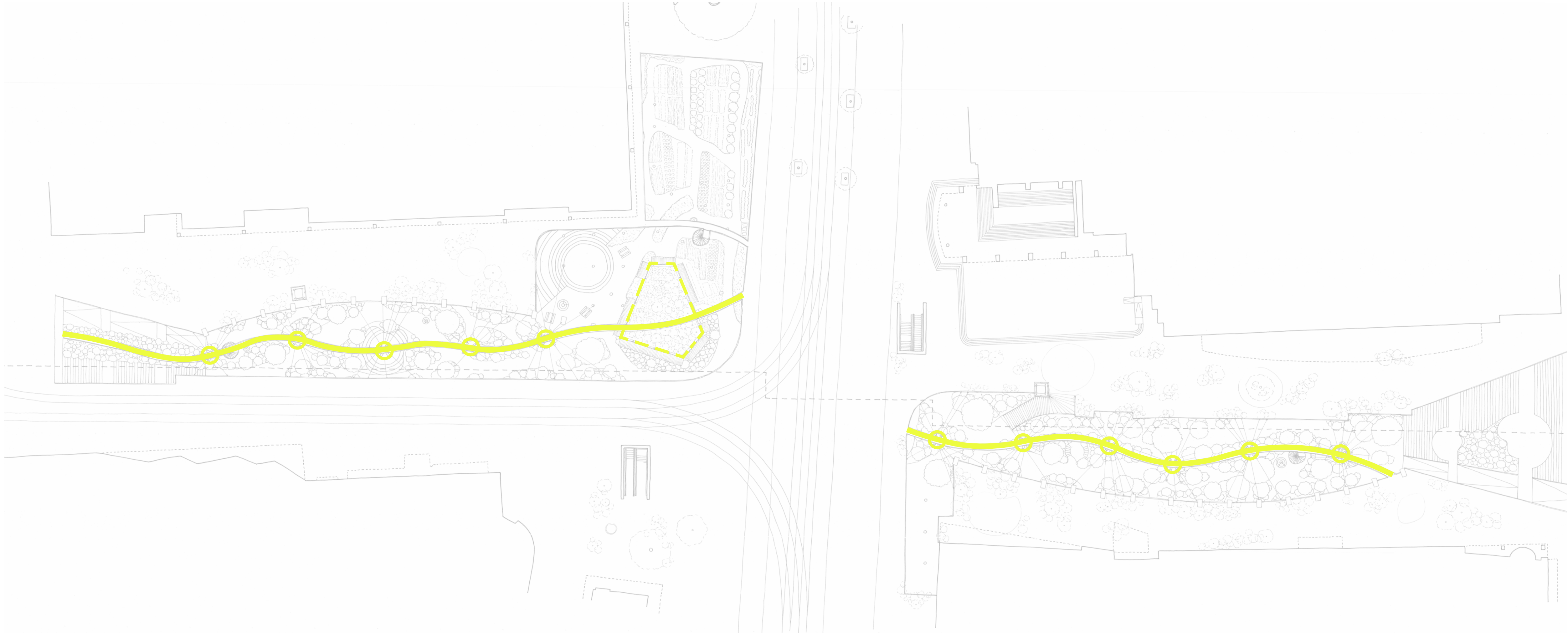

# DESIGN

# TO BYPASS

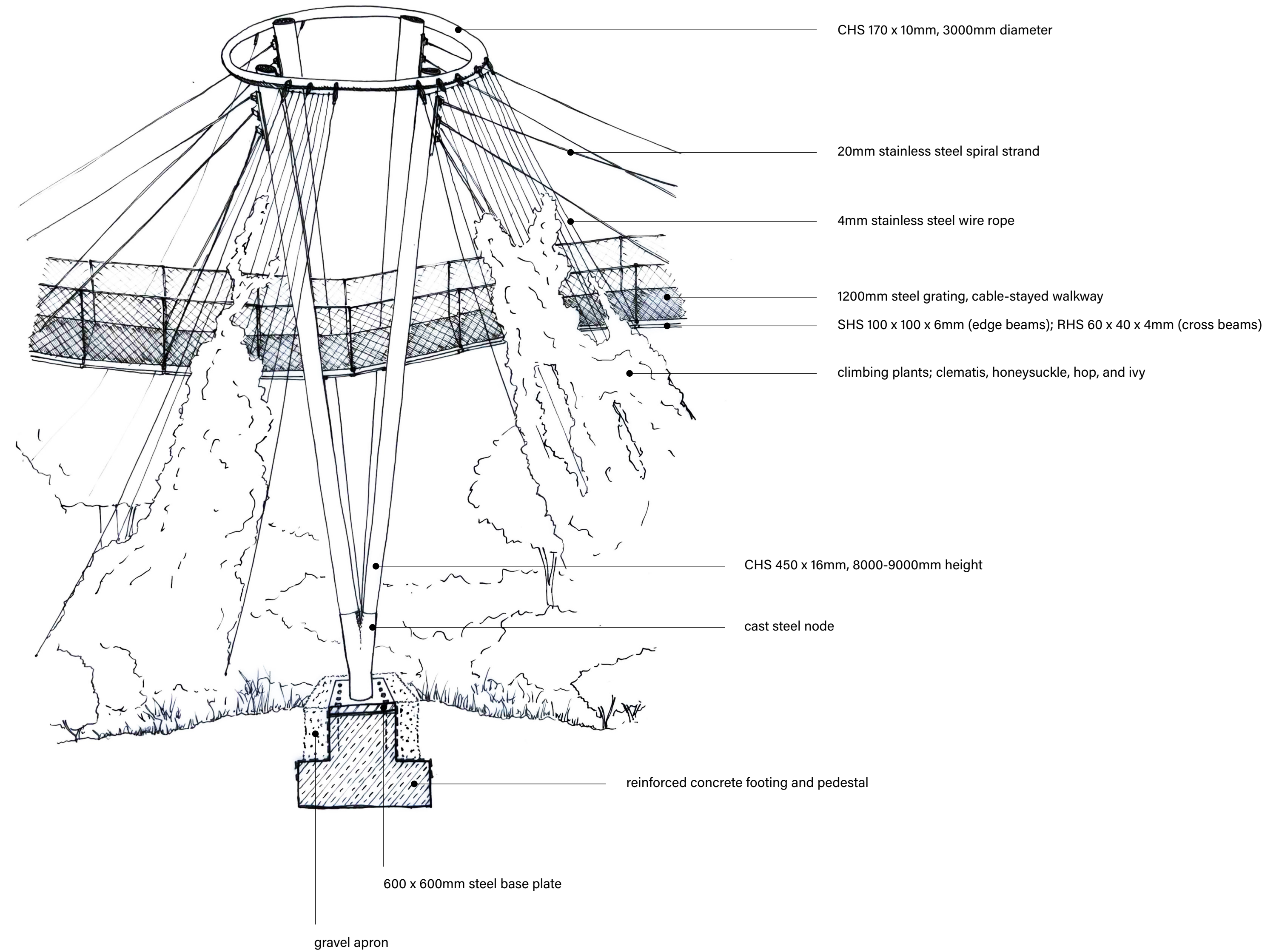

DESIGN

TO COLLIDE

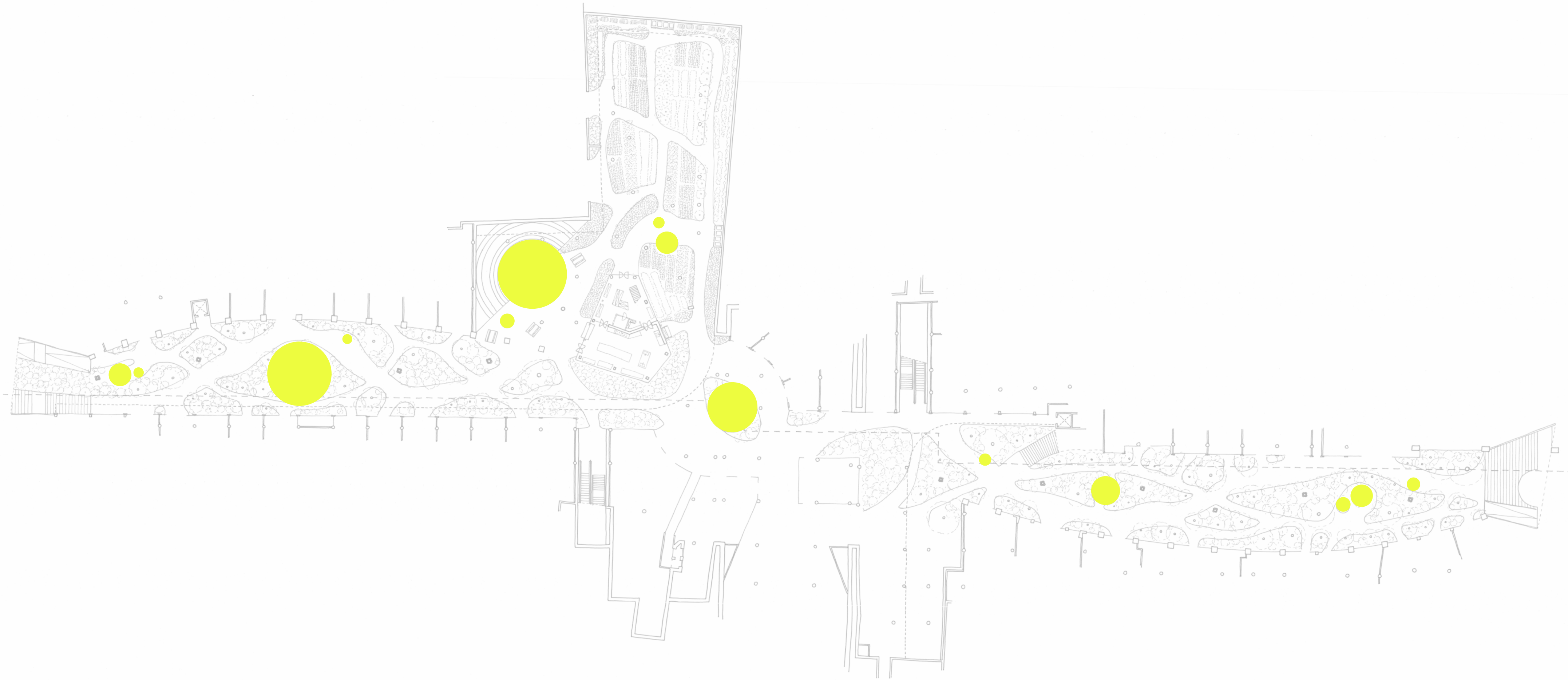

# DESIGN

# TO COLLIDE

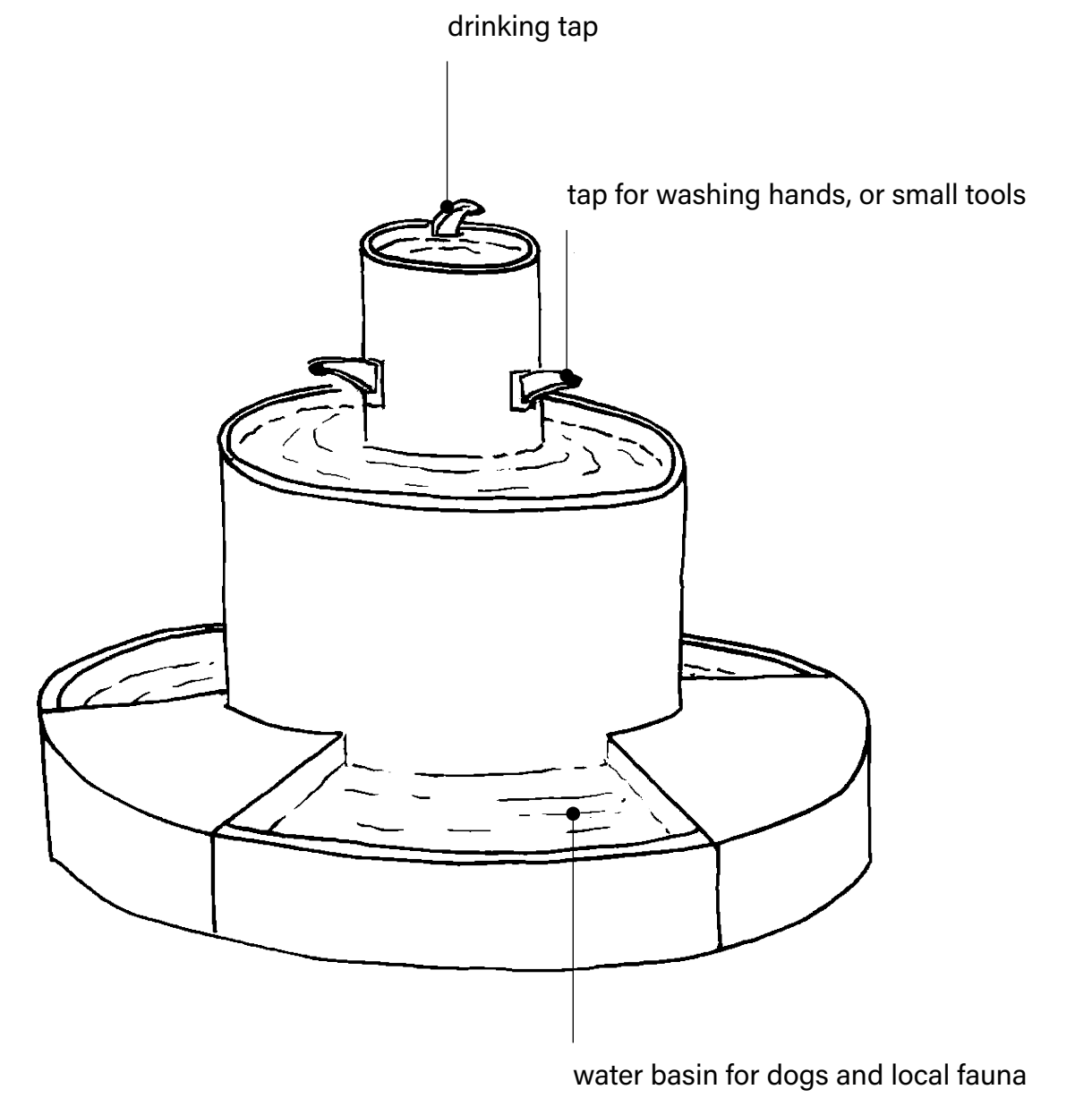
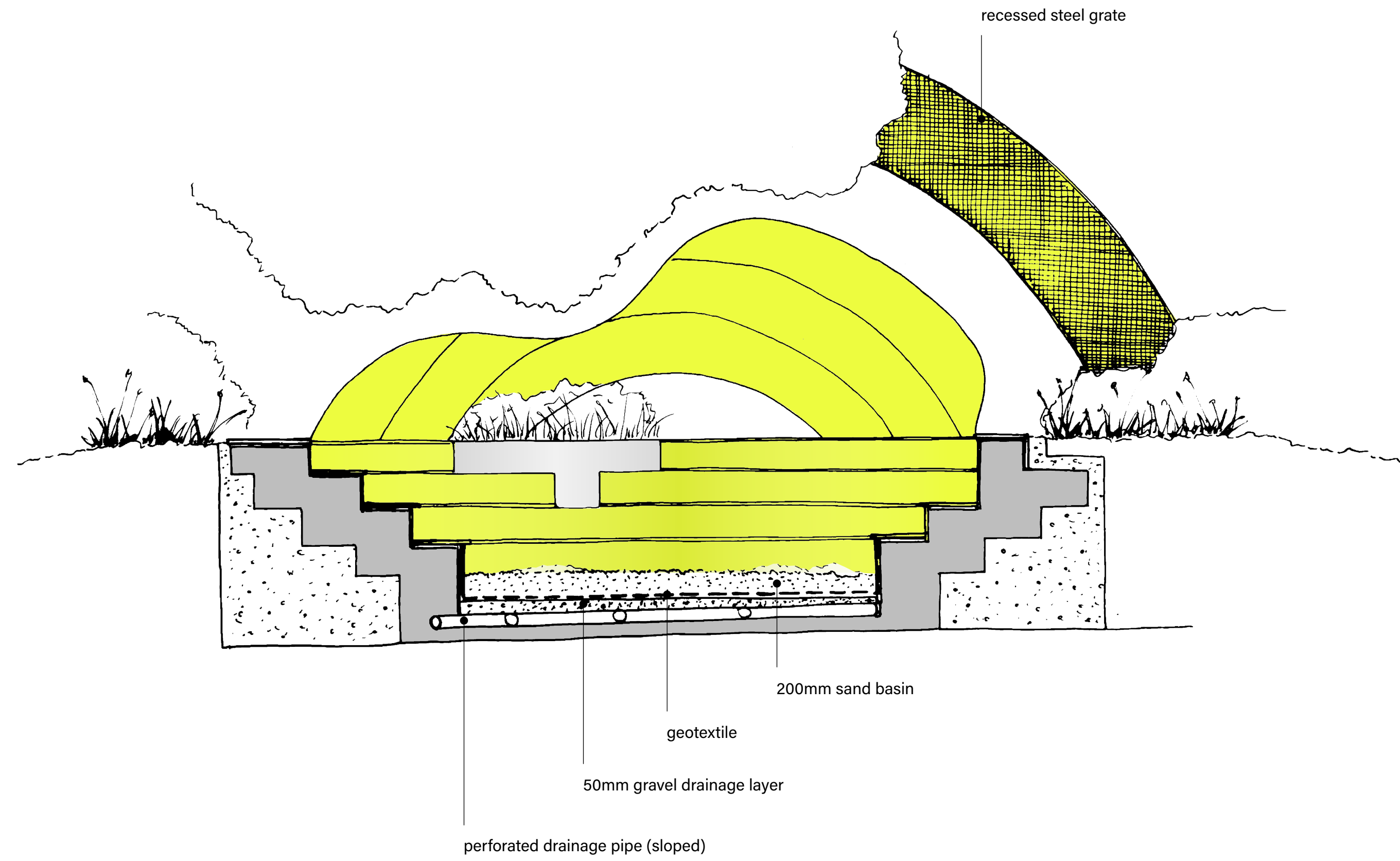

DESIGN

NEGOTIATIONS

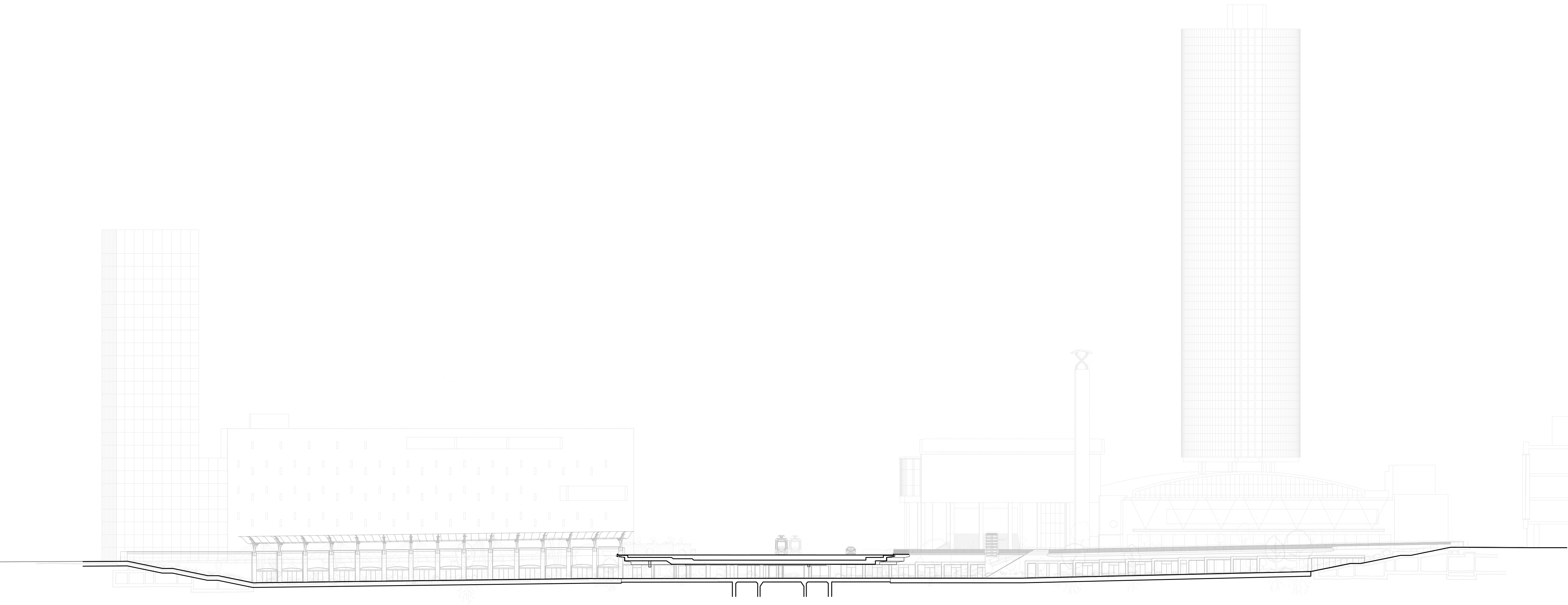

# DESIGN

# NEGOTIATIONS

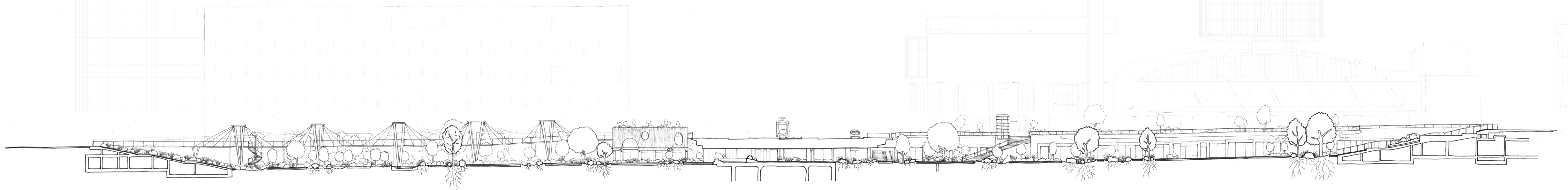
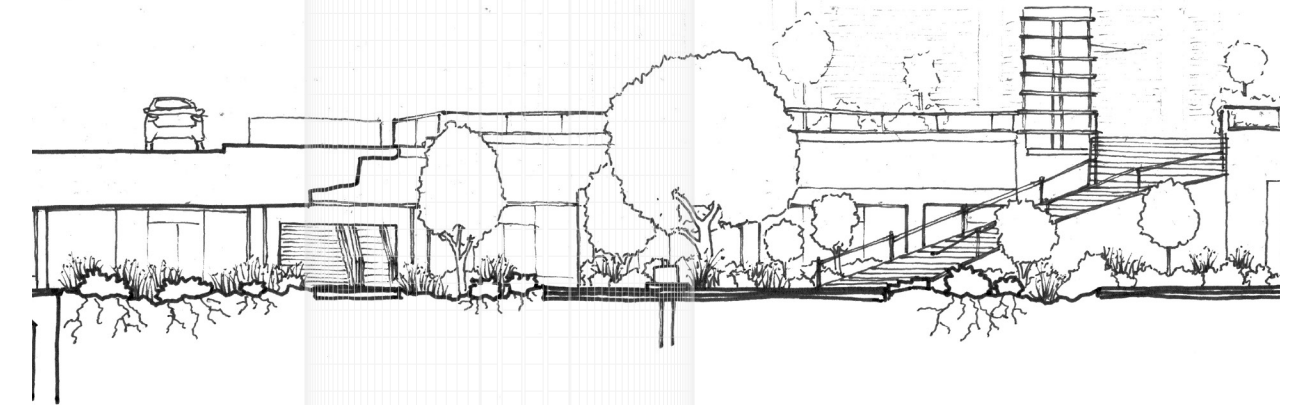
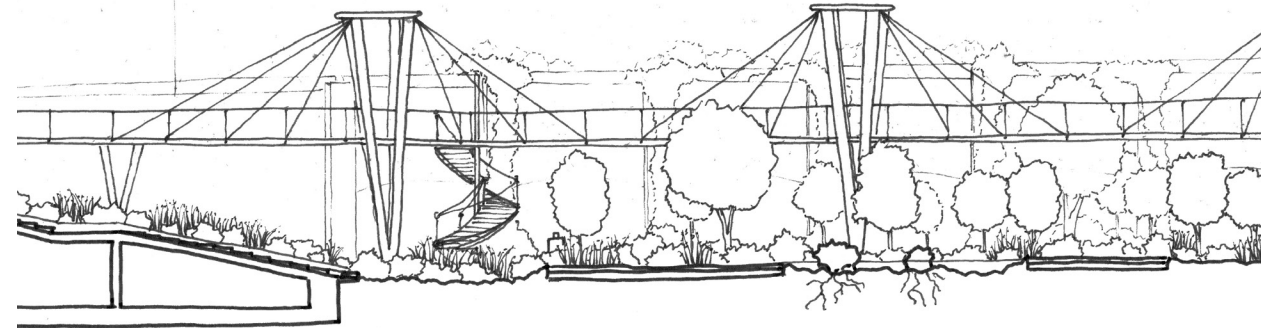
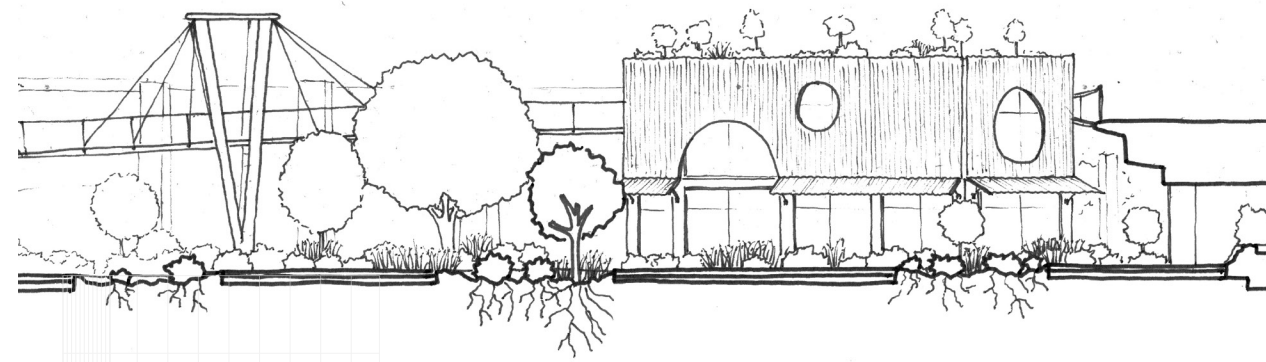

## CONCLUSION

## RETURNING TO THE QUESTION

How can architectural intervention design  
for deviation within the apparatus of control  
of a consumerist semi-public space?

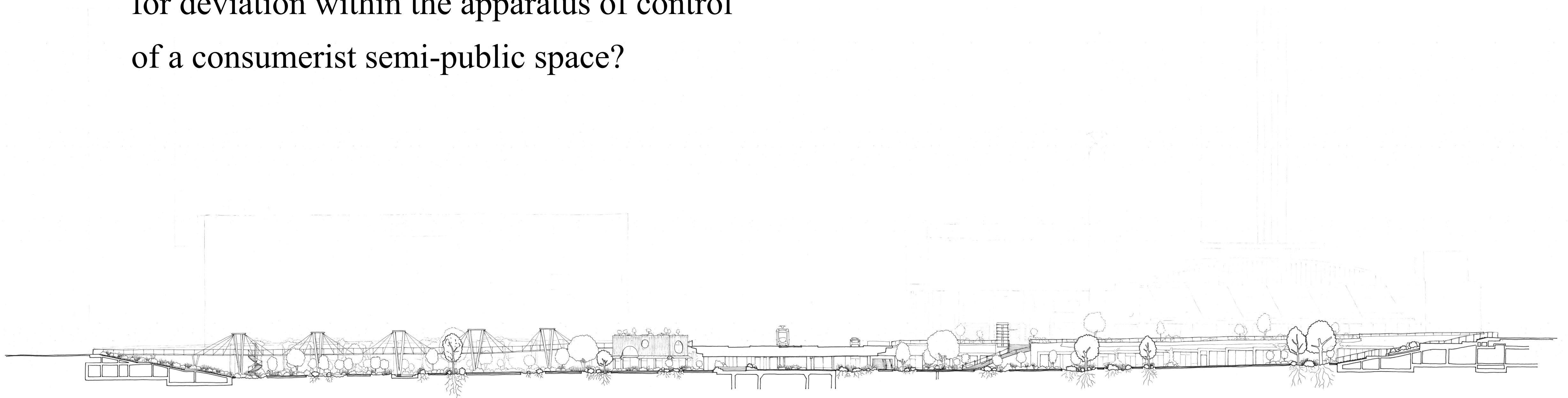

BEURSTRAVERSE, basement | 1:200  
section

*and then...*