

# DEMOCRATIC LEARNING LANDSCAPE

*VLEDDER AND SURROUNDING AREA, DRENTH*

*DESIGN AS POLITICS  
WE THE PEOPLE*

*SANNE BRANDER*

*1ST OF NOVEMBER 2013*

# LOCATION











# EDUCATIONAL LANDSCAPE



# DEMOCRATIZATION OF PRIMARY EDUCATION

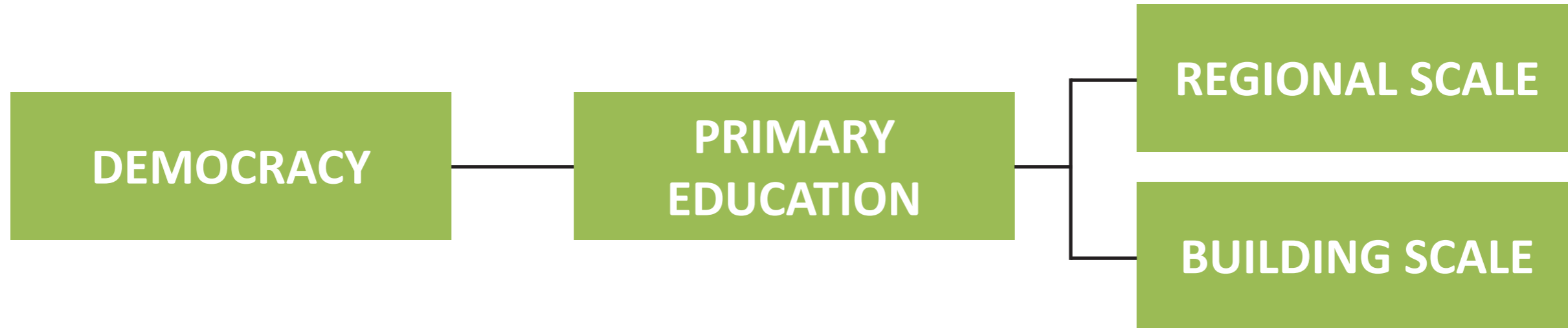





# SHRINKAGE

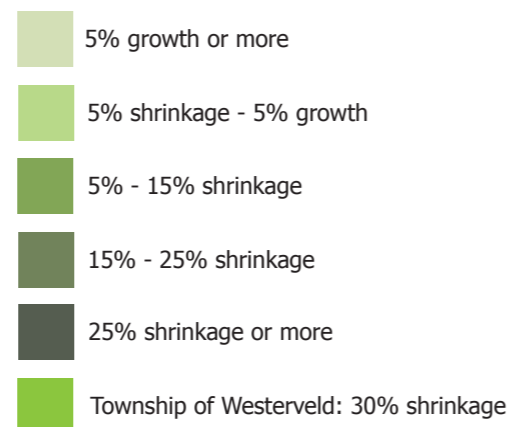
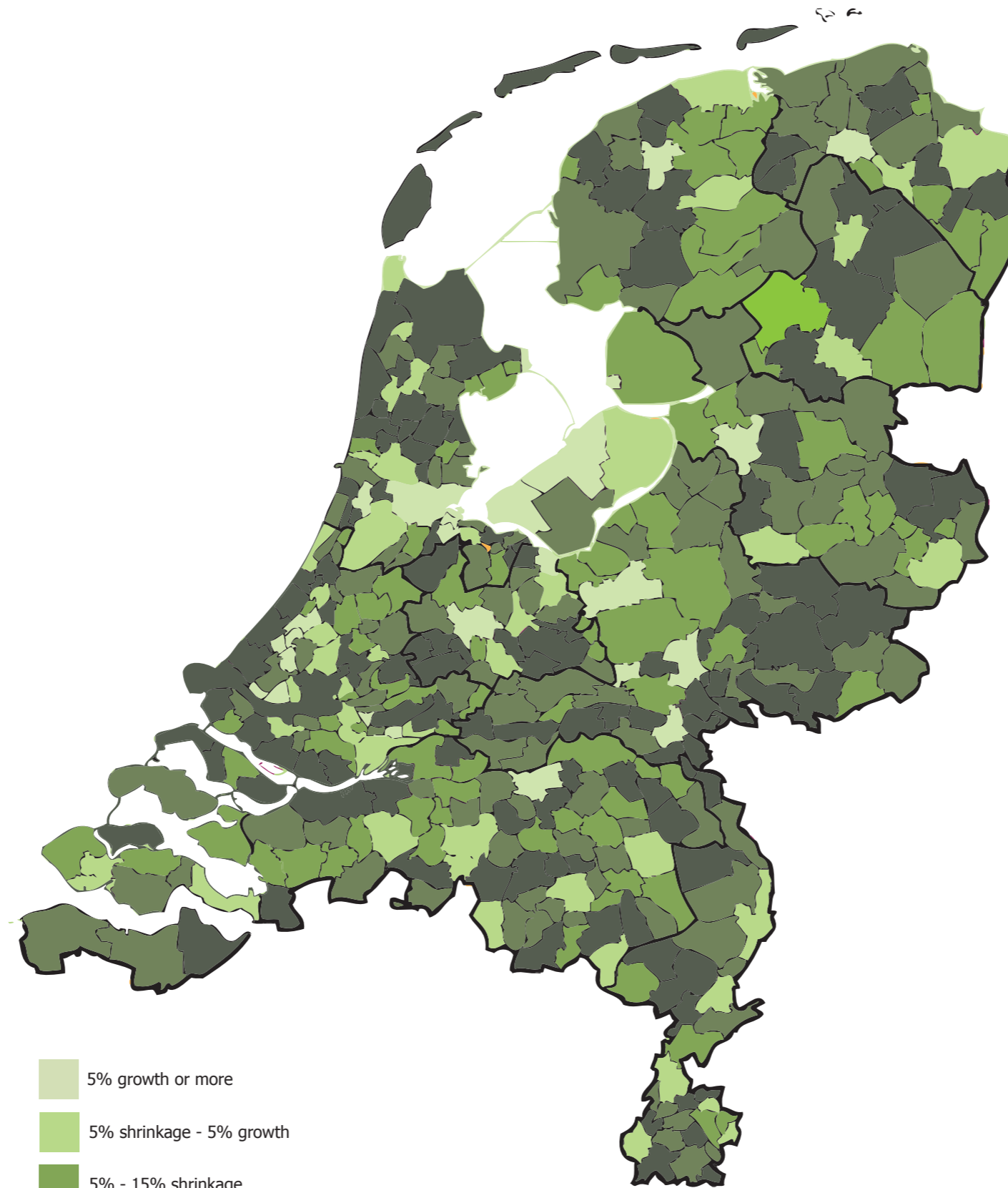

# FINANCIAL SITUATION

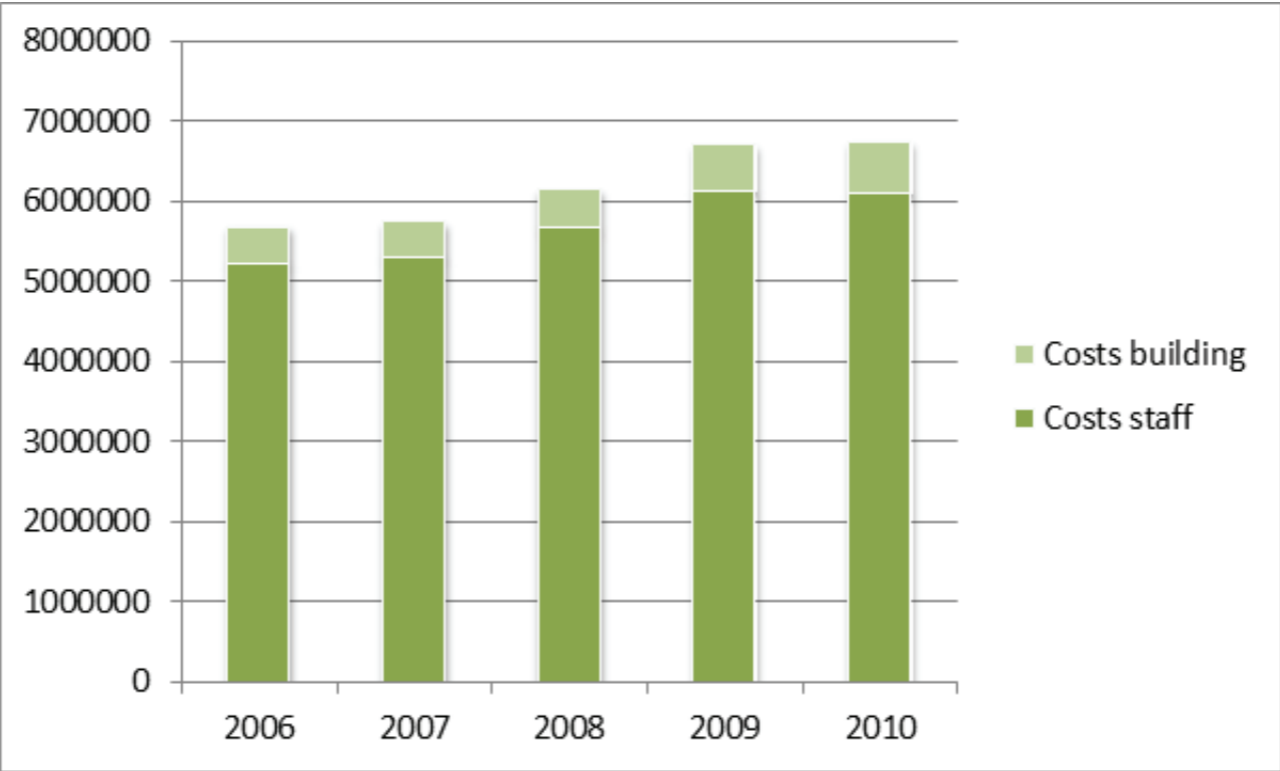

COSTS PER PUPIL IN RELATION TO SCHOOL SIZE

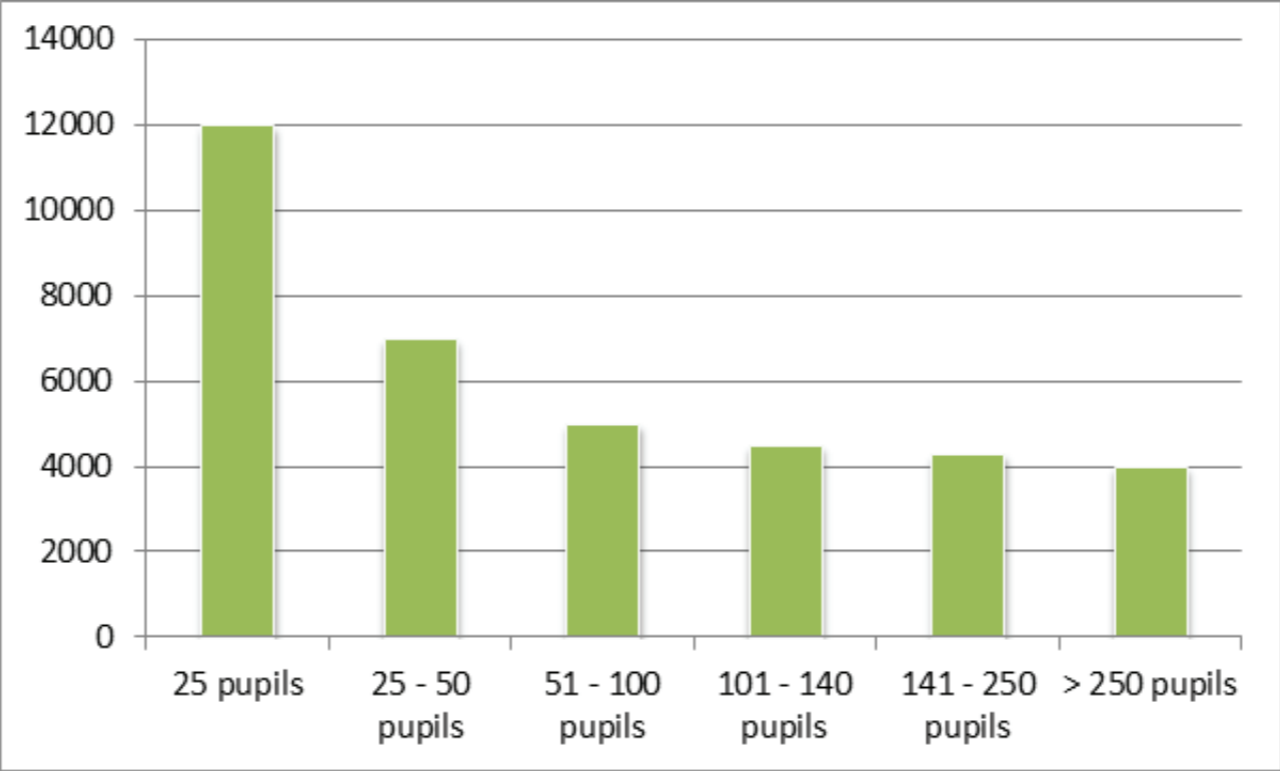

# CONFLICT



# PROBLEM STATEMENT

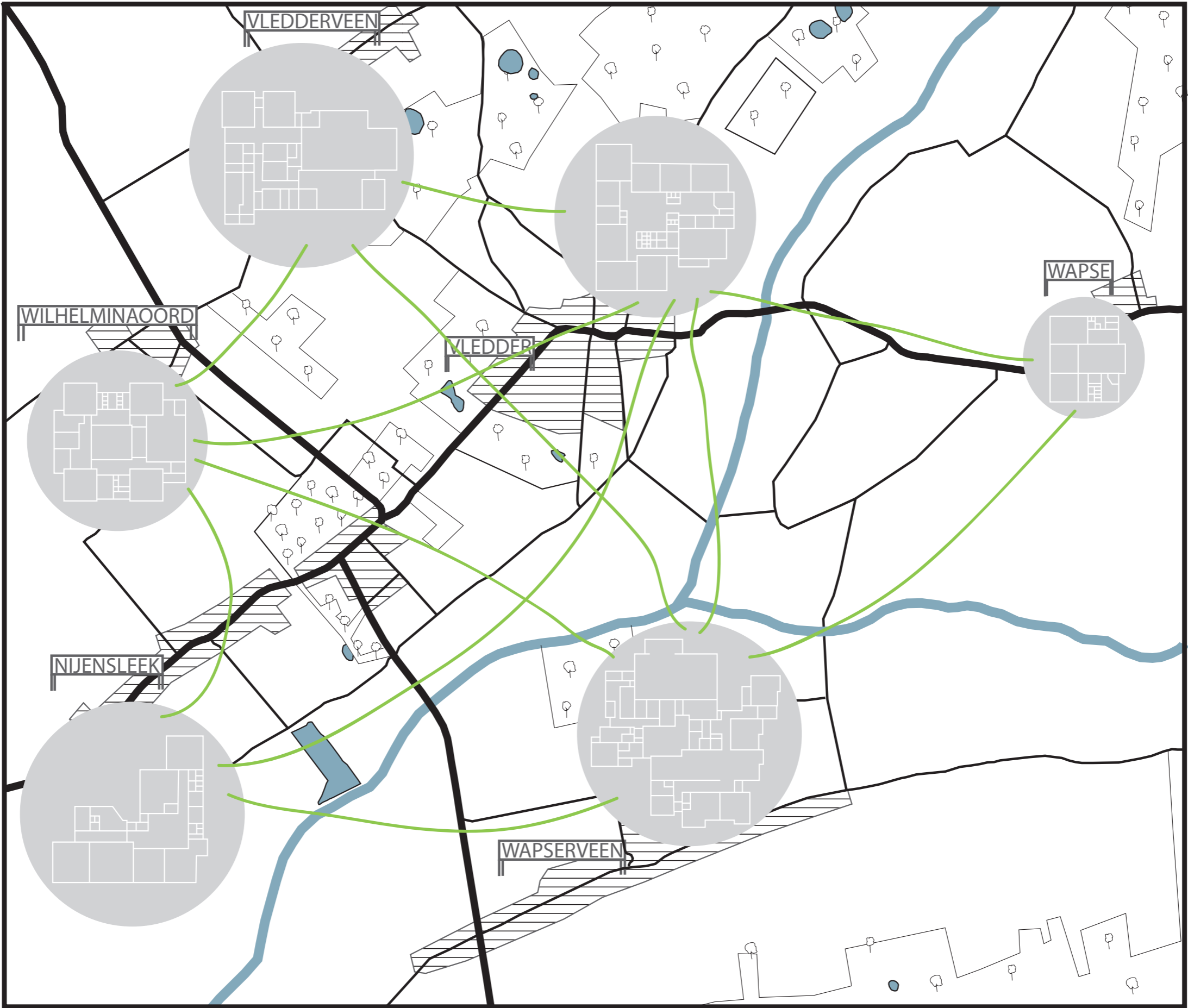



# CHANGING COMPOSITION OF THE POPULATION

SOCIAL CULTURAL CHANGE  
ECONOMIC CHANGE  
PLANNING



DEMOGRAPHICAL CHANGE

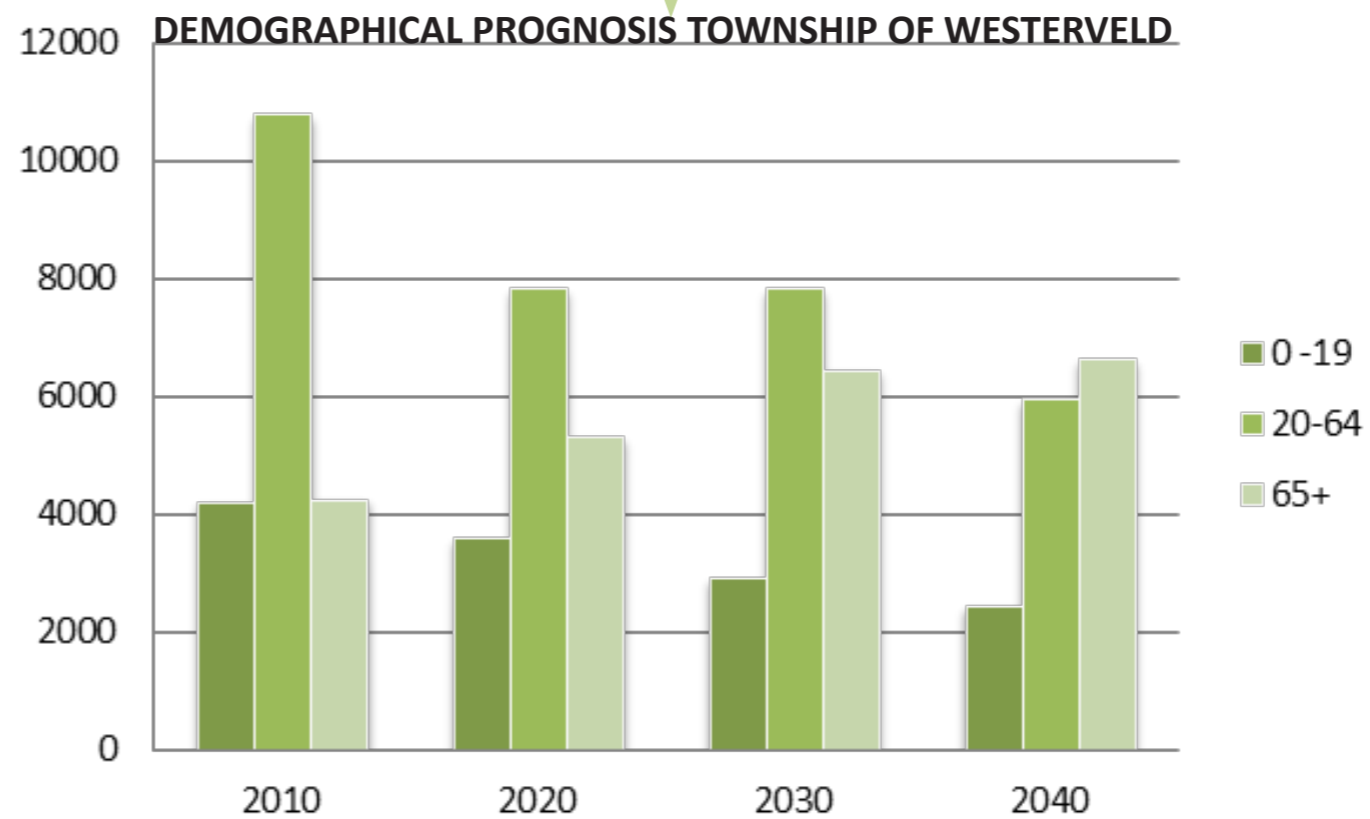

CHANGE IN AMOUNT & TYPES OF FACILITIES

SHRINKAGE AMOUNT OF YOUNG PEOPLE

LESS DEMAND FOR SCHOOLS, DAYCARE, SPORTS CENTRE, LIBRARY

SHRINKAGE WORKING POPULATION

LESS DEMAND FOR SUPERMARKET, BANK, SPORTS CENTRE, COMMUNITY CENTRE

GROWTH ELDERLY

MORE DEMAND FOR DOCTOR, PHARMACY, HOME FOR ELDERLY, COMMUNITY CENTRE, SUPERMARKET

# LIVEABILITY

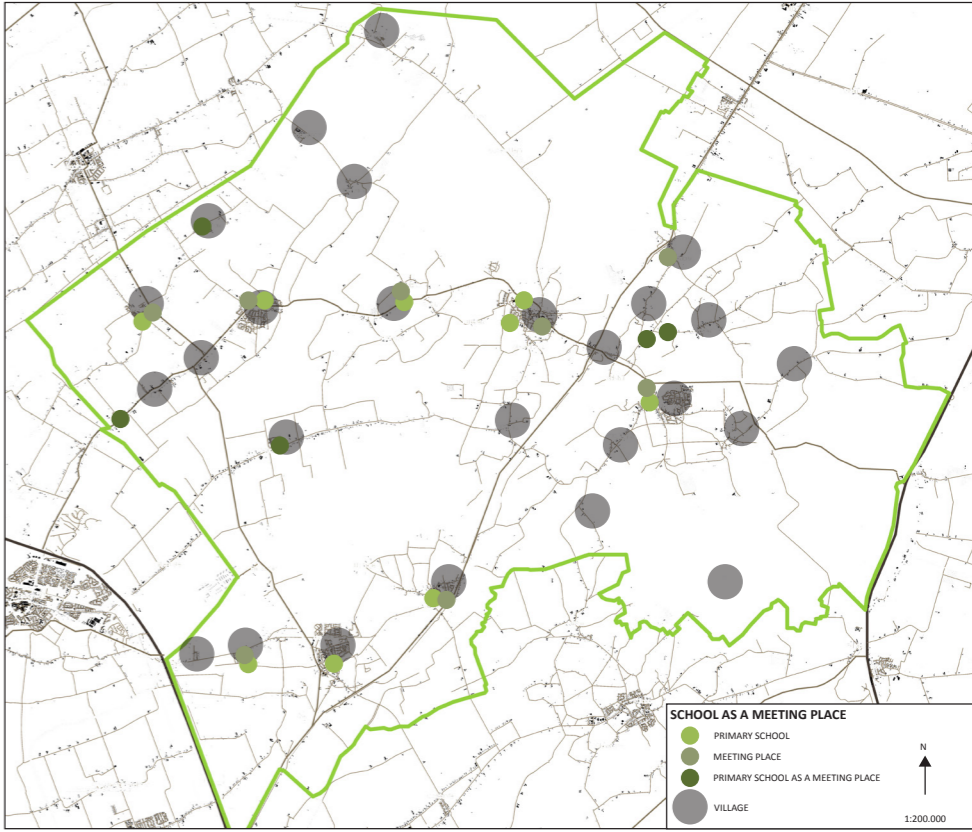
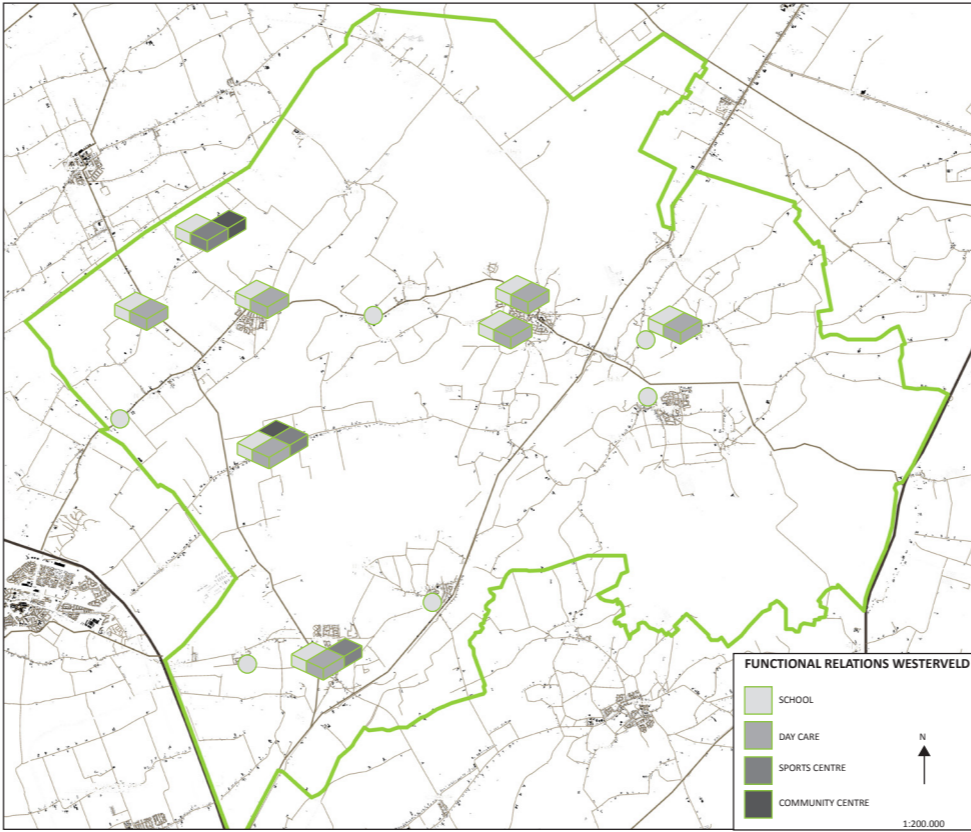
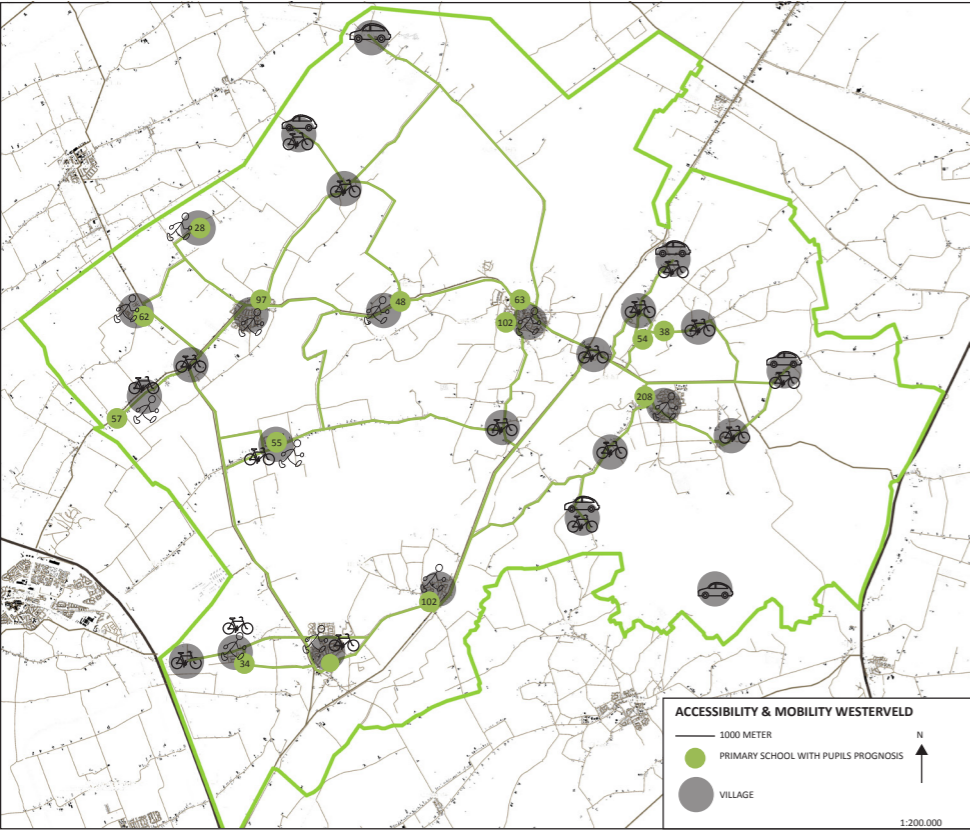



# STRATEGY

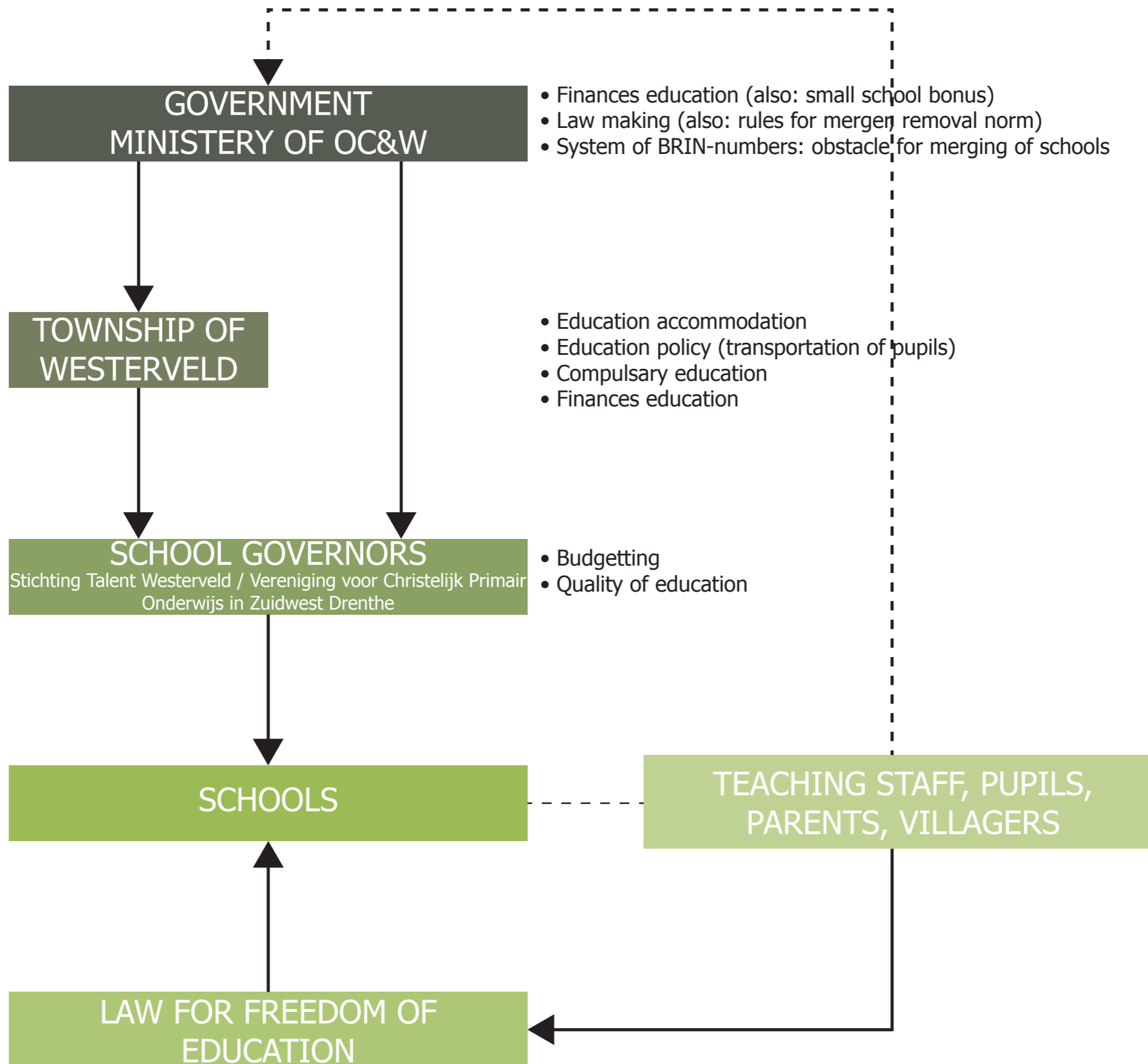



# NETWORK OF LEARNING

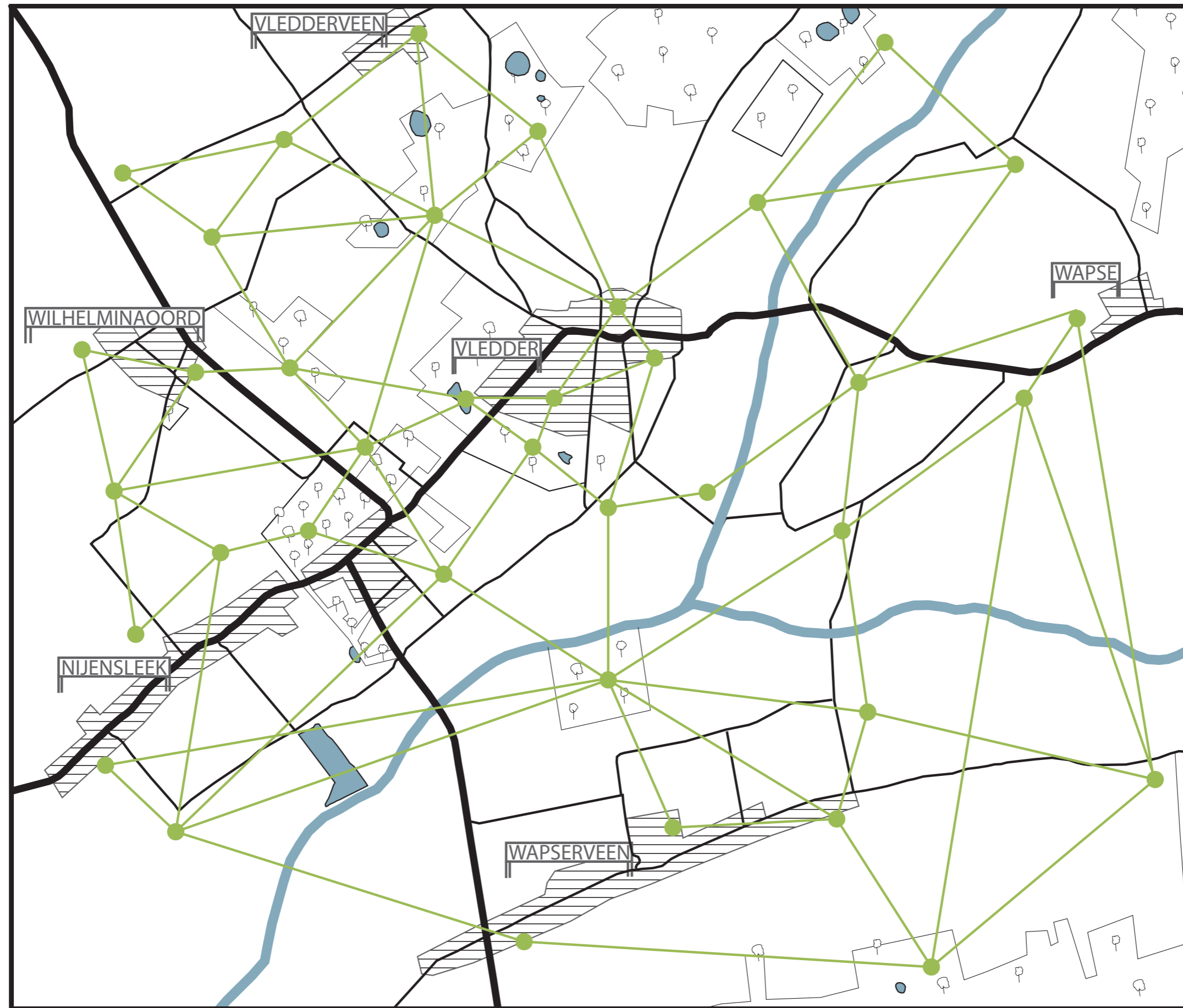

# 2 HOME BASES

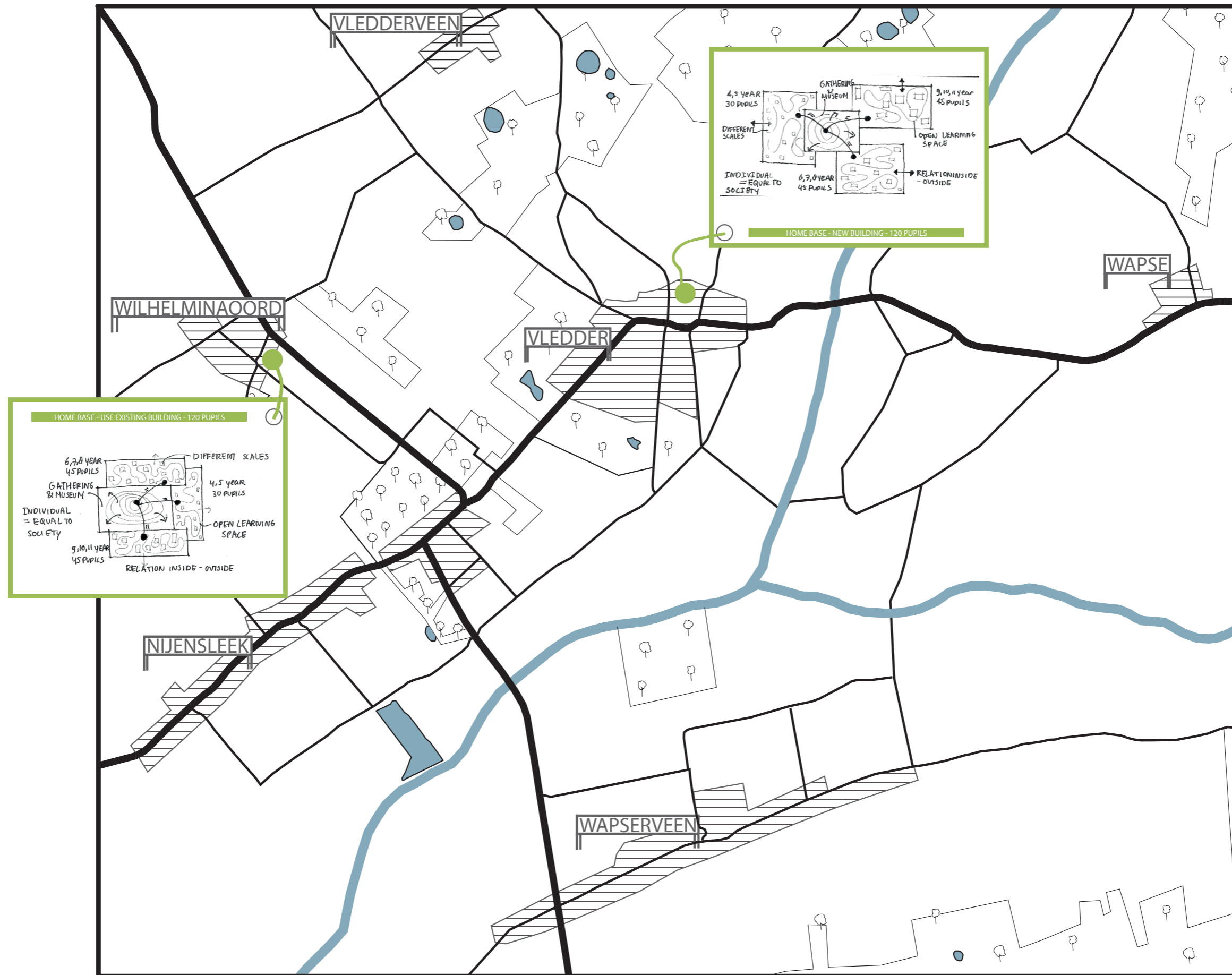

# SPECIFIC LEARNING CENTRES

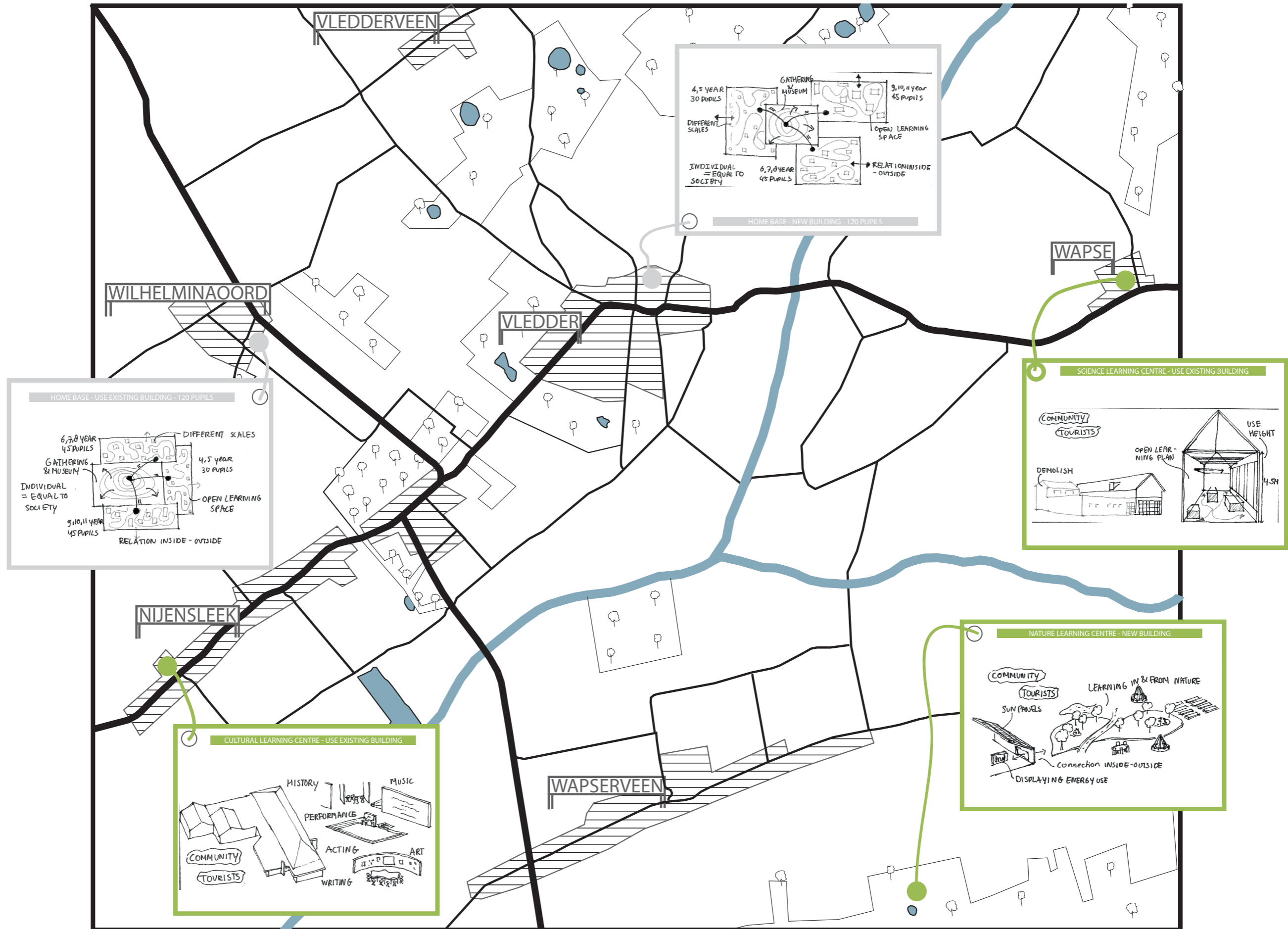

# ABRI

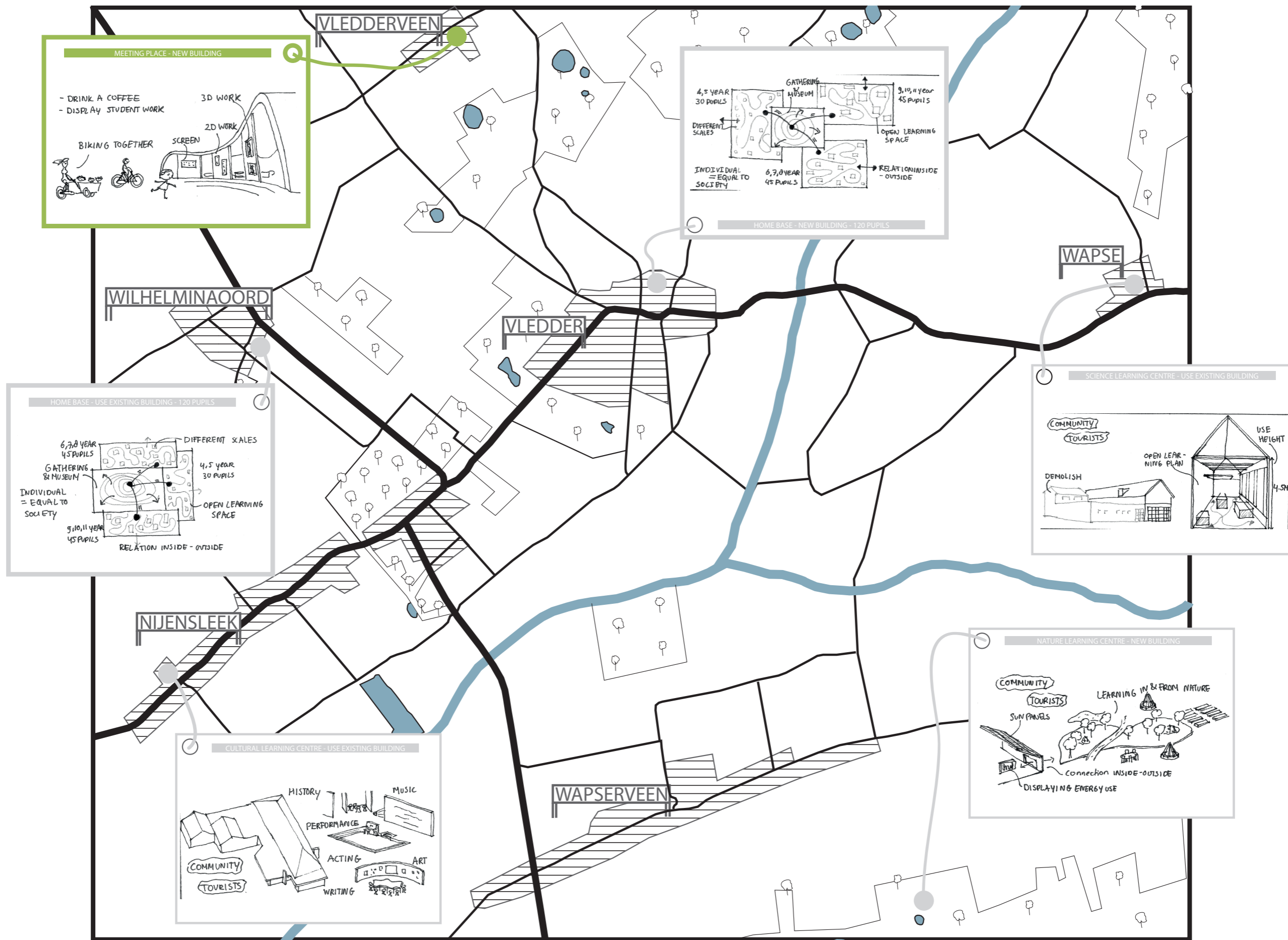

# EXISTING FACILITIES

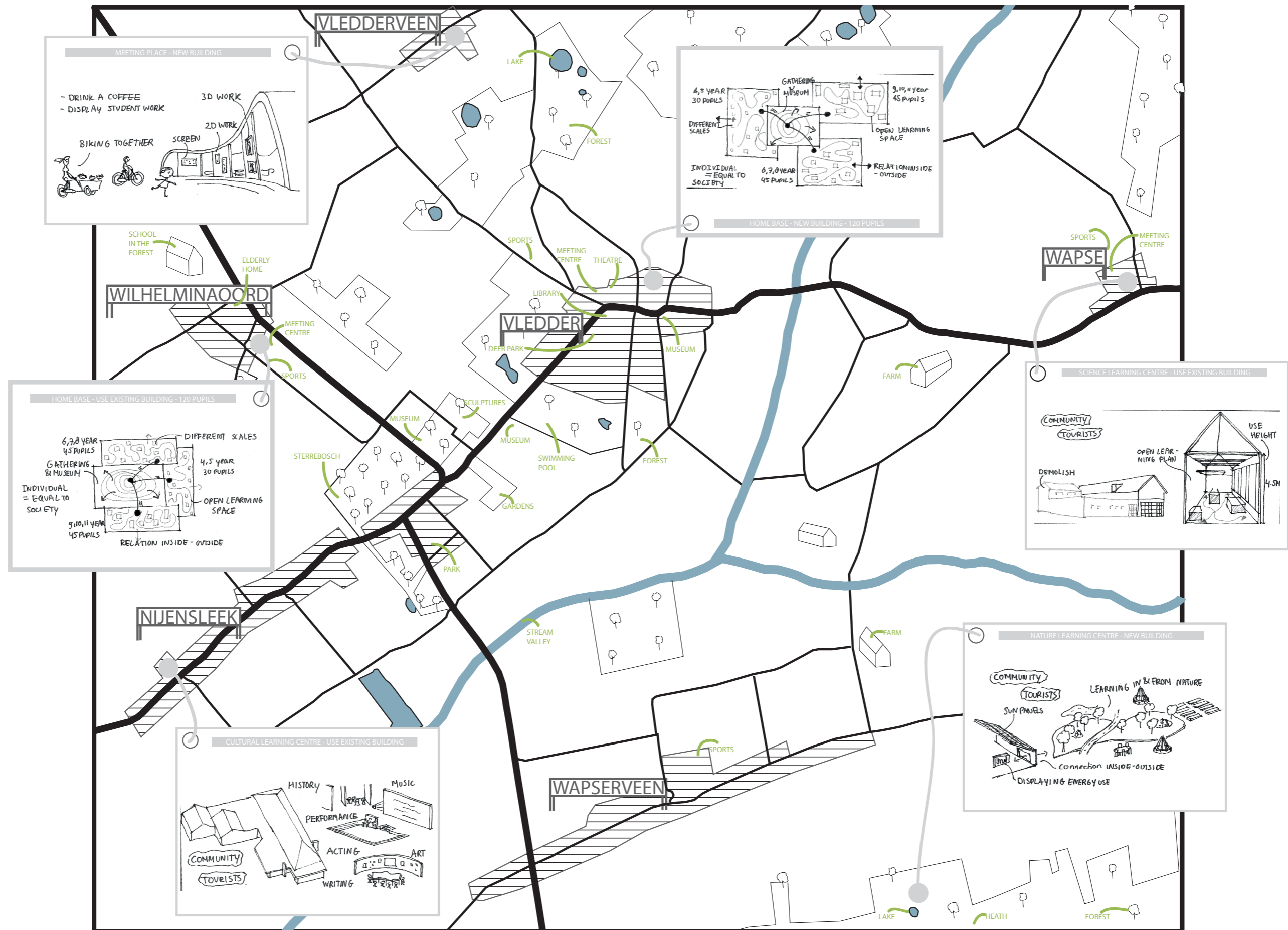





# JOHN DEWEY

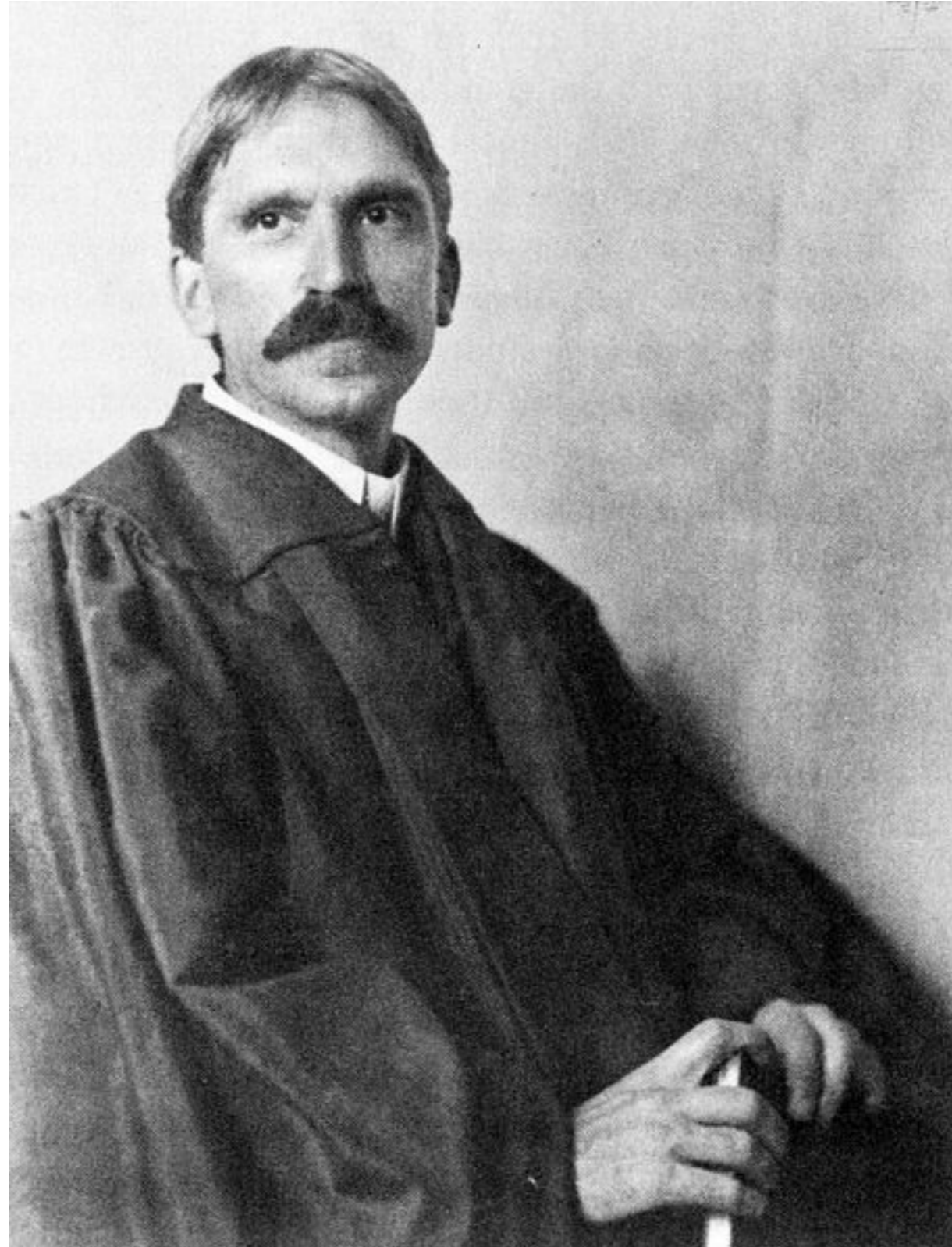

# CONFLICT OF THE CLASSROOM

**TODAY OUR CLASSROOM WILL  
BE THE LAKE!**

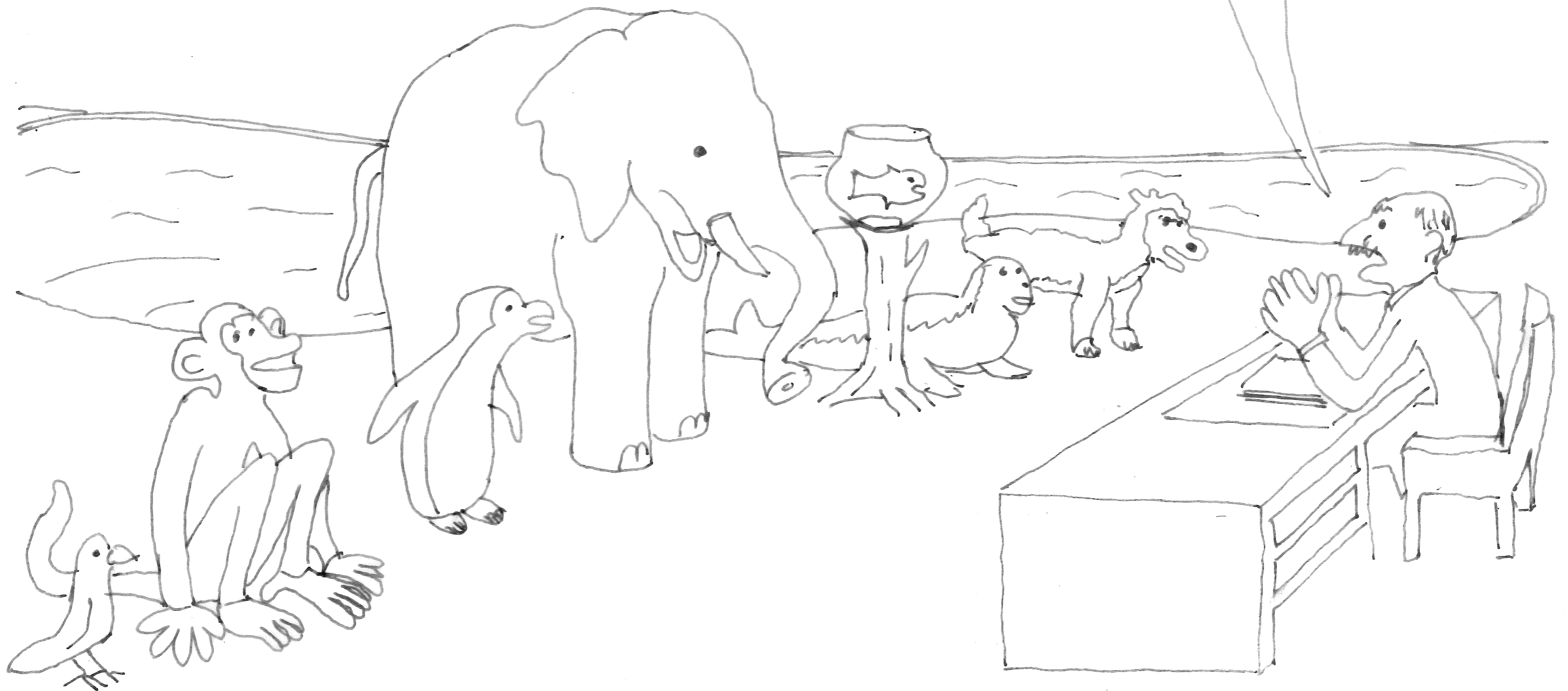

# PROBLEM STATEMENT

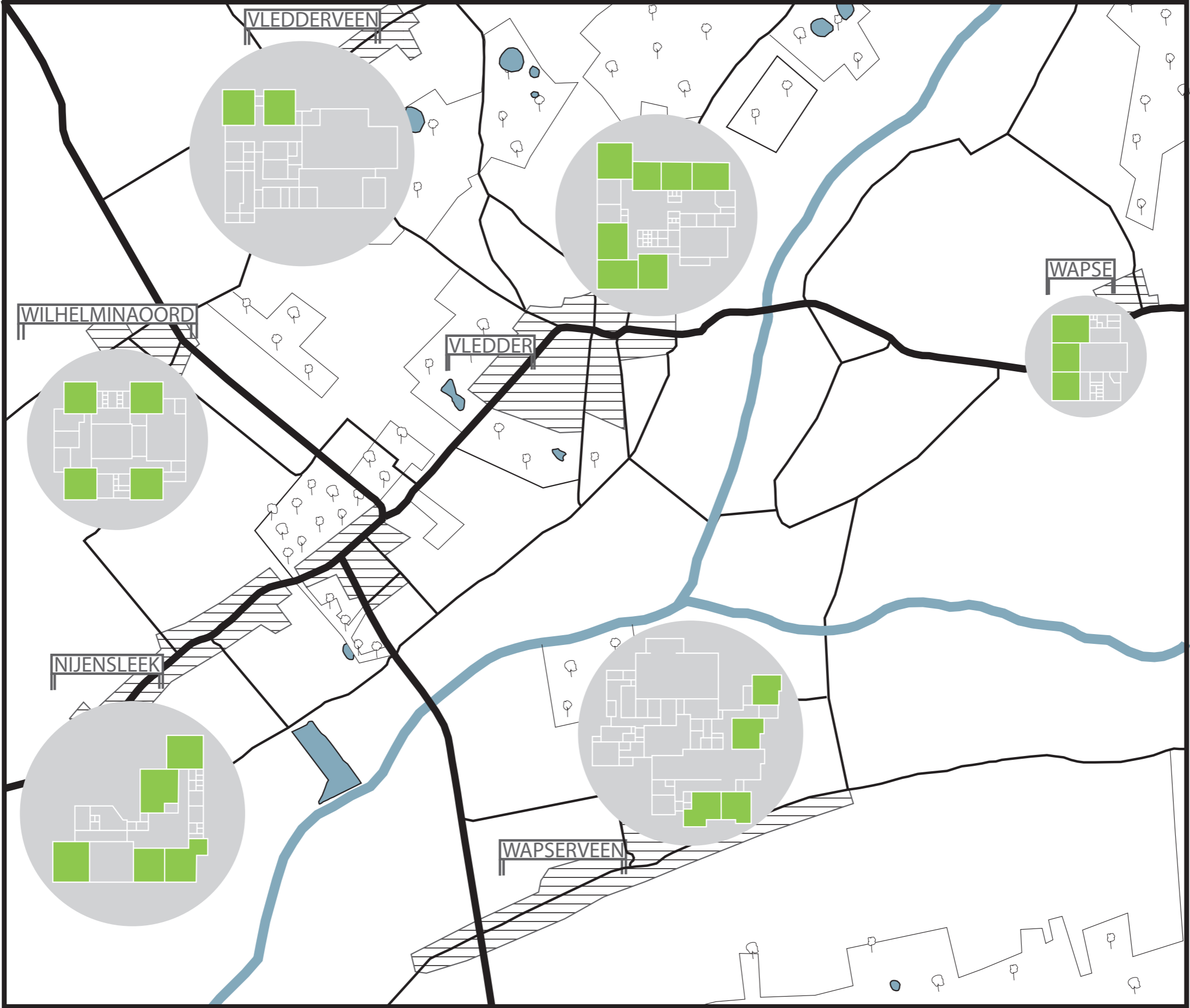



D  
R  
E  
A  
M  
E  
R

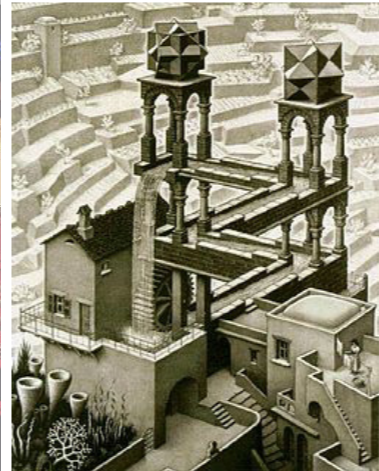
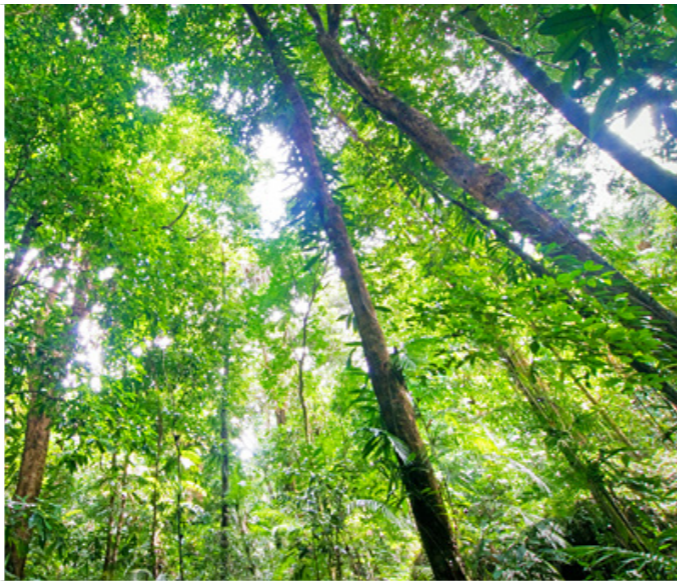
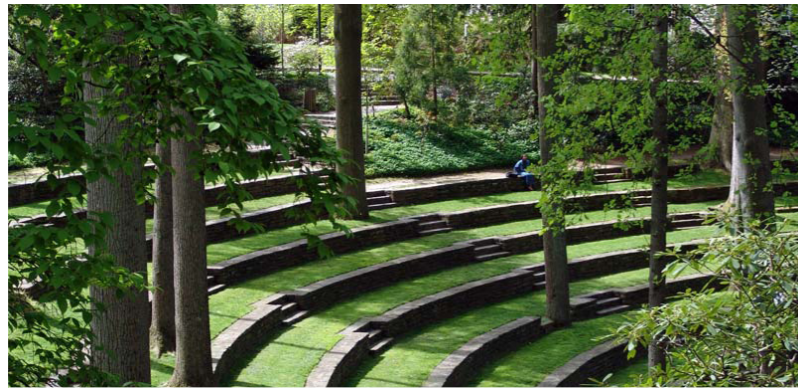

D E L I B E R A T O R

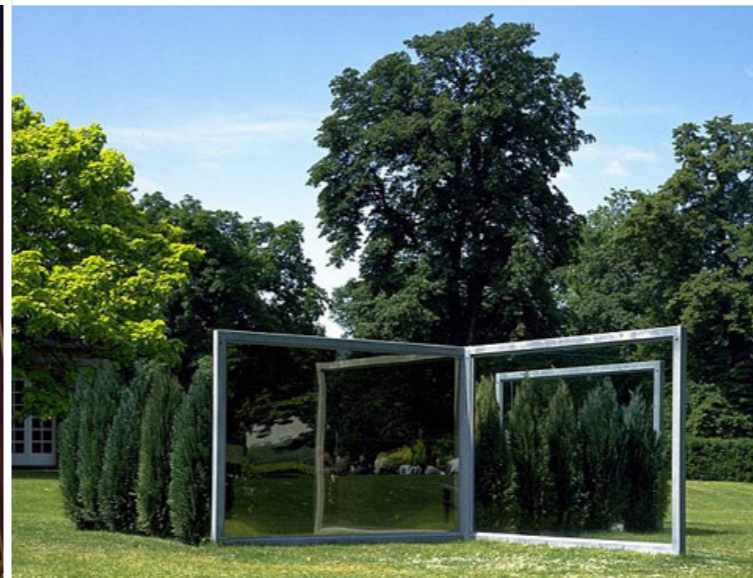

# DISPLAY LEARNING

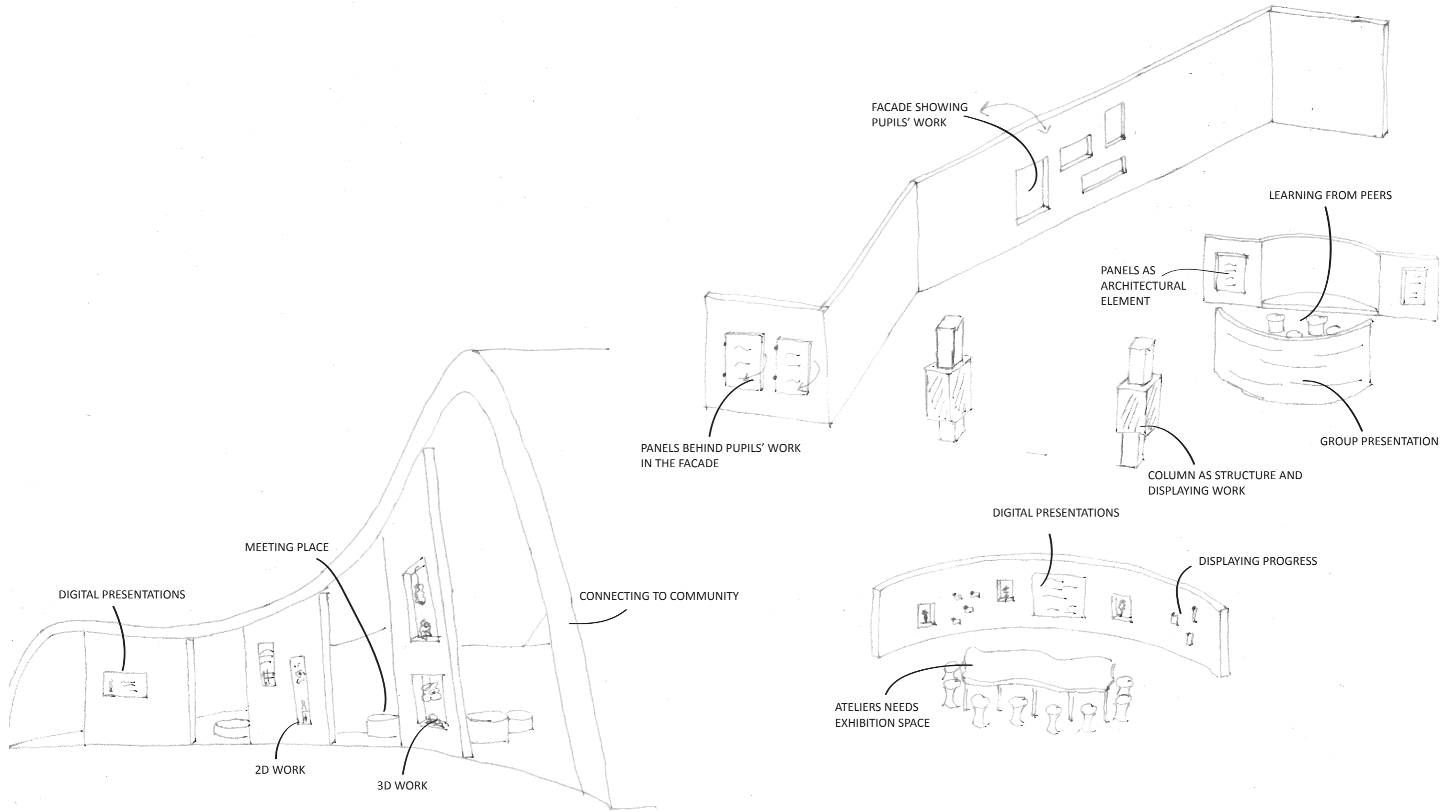

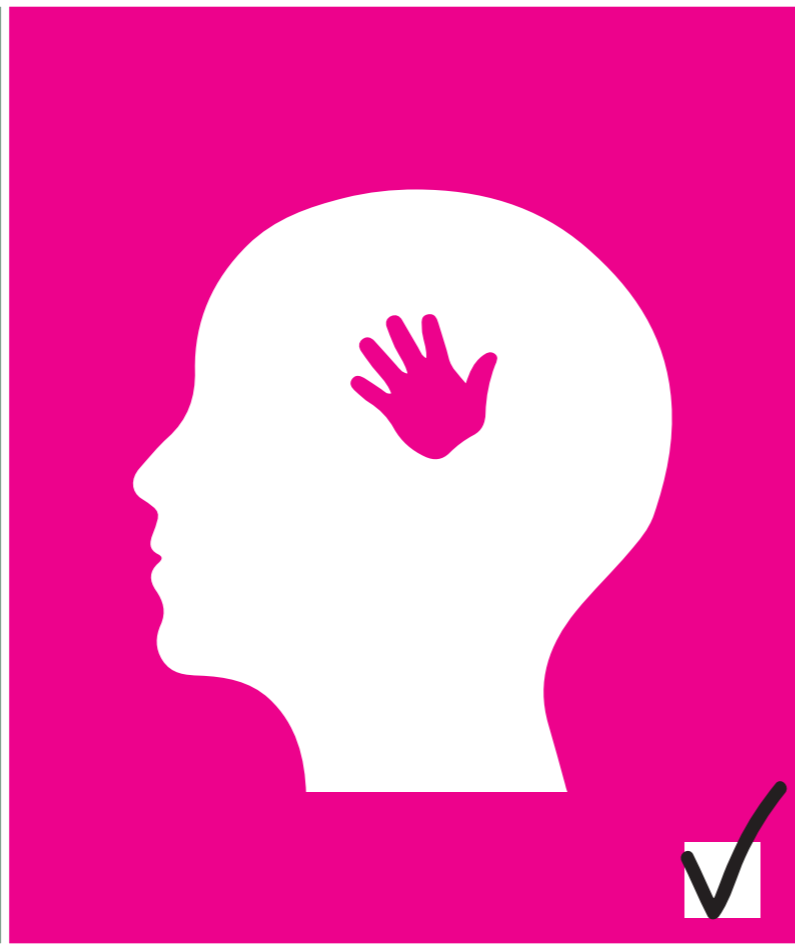

# HOW ARE YOU SMART?

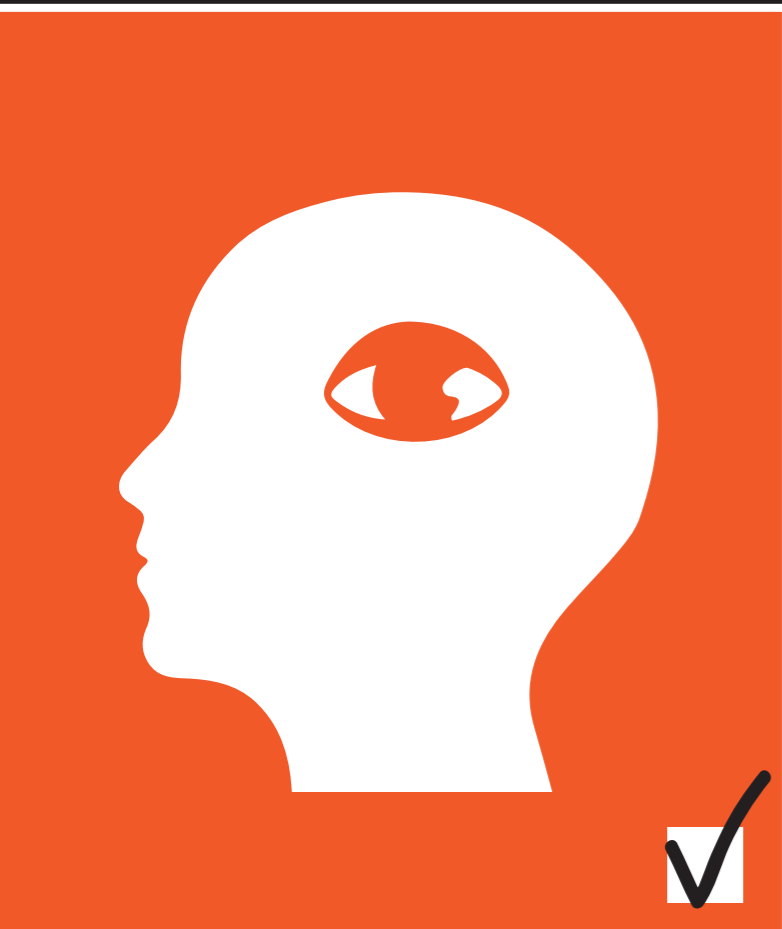



# INTRAPERSONAL INTELLIGENCE

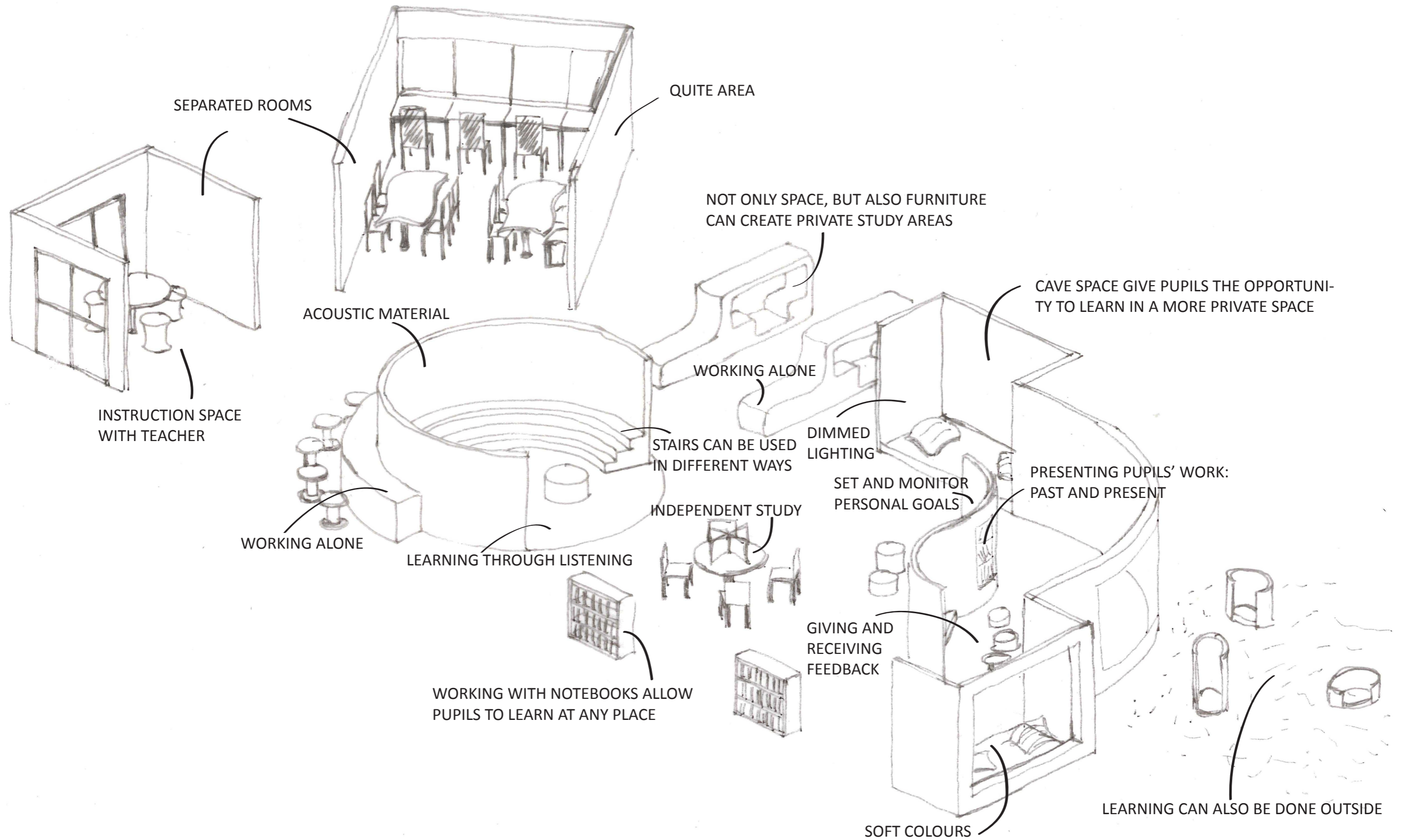

# INTERPERSONAL INTELLIGENCE

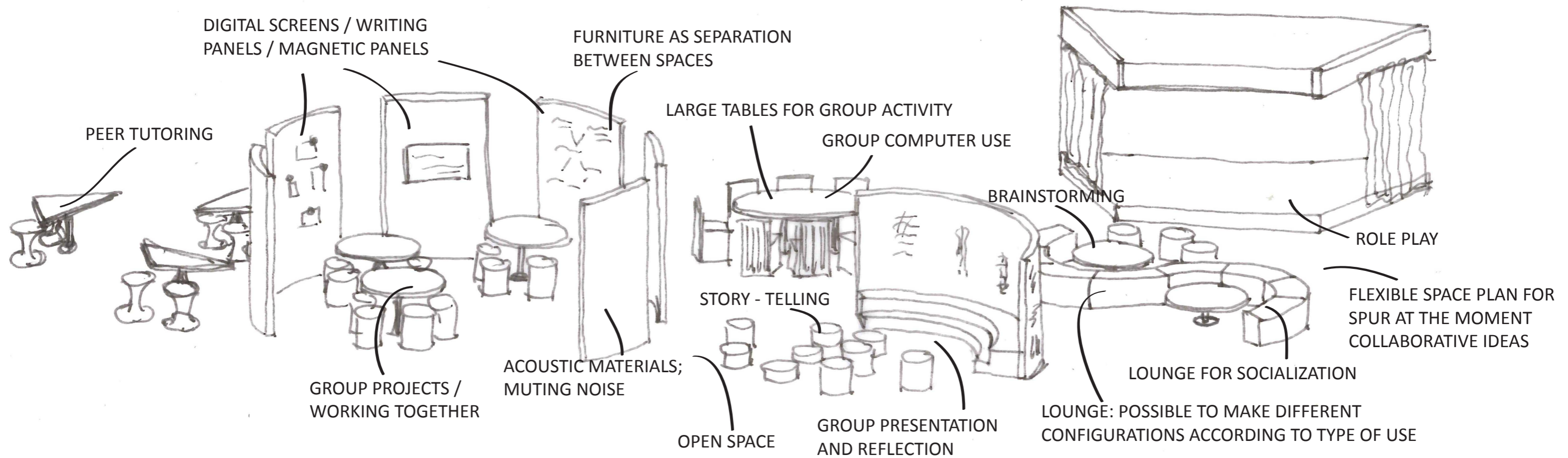

# DIFFERENT CENTRES OF ATTENTION

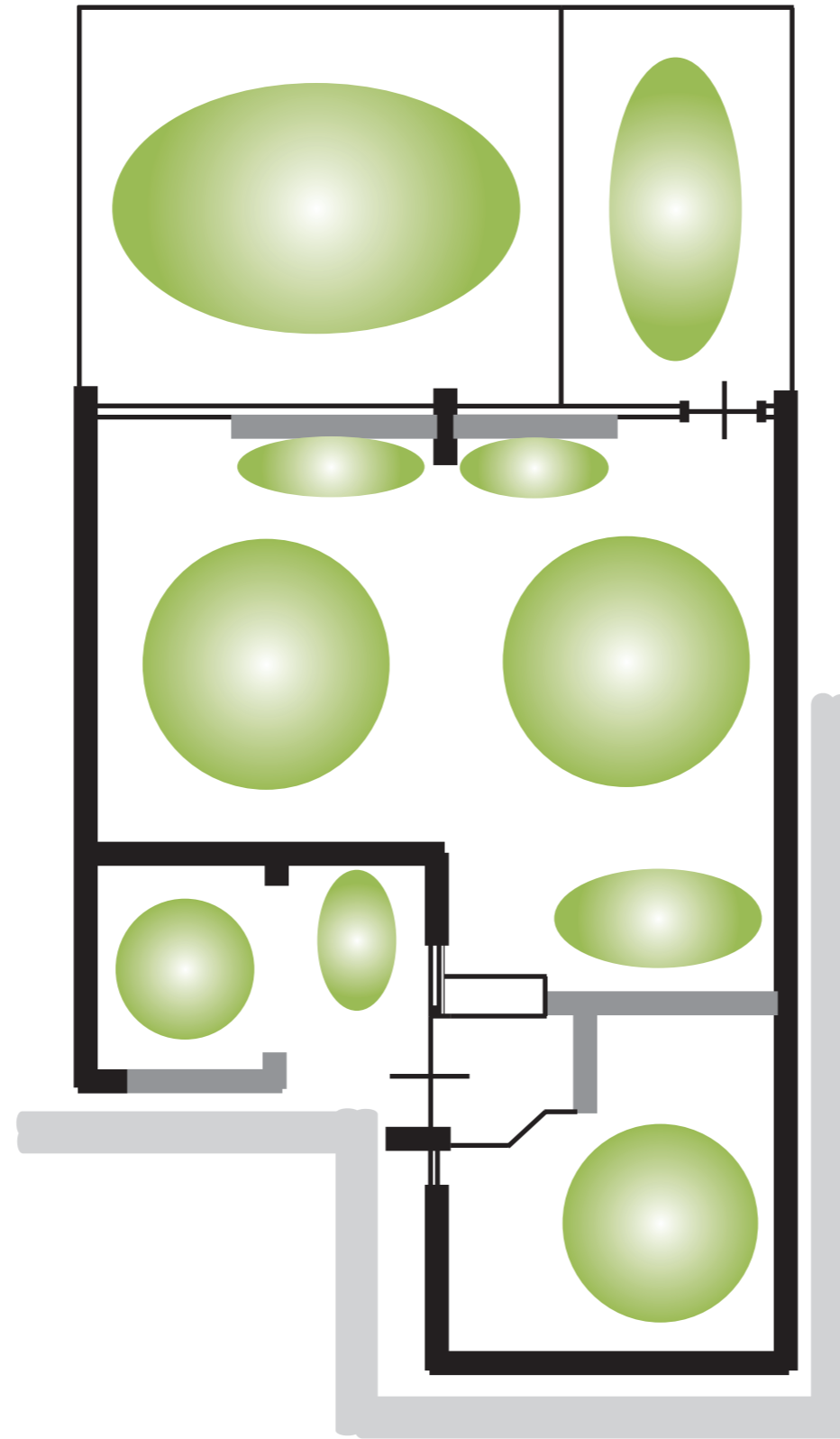

# AMOUNT OF INTIMACY

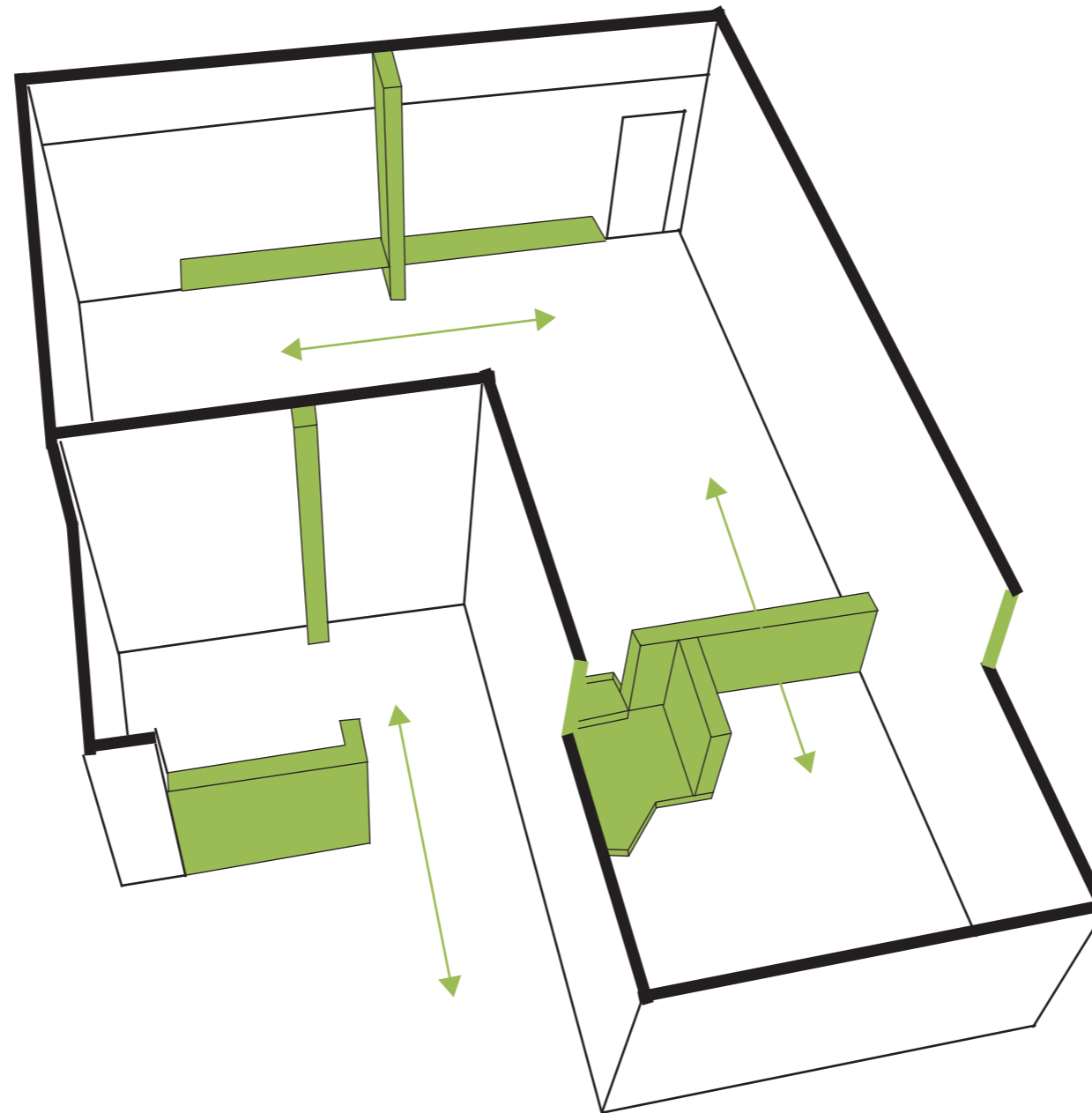



# THE TRADITIONAL CLASSROOM



# OPEN AIR CLASSROOM



# ARTICULATED CLASSROOM

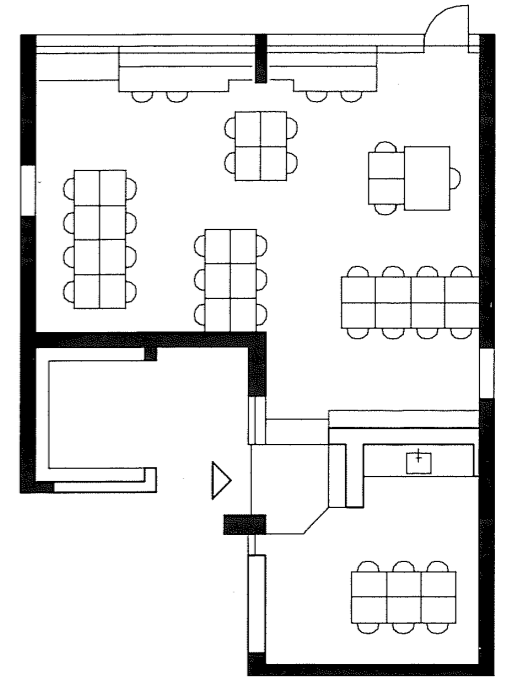
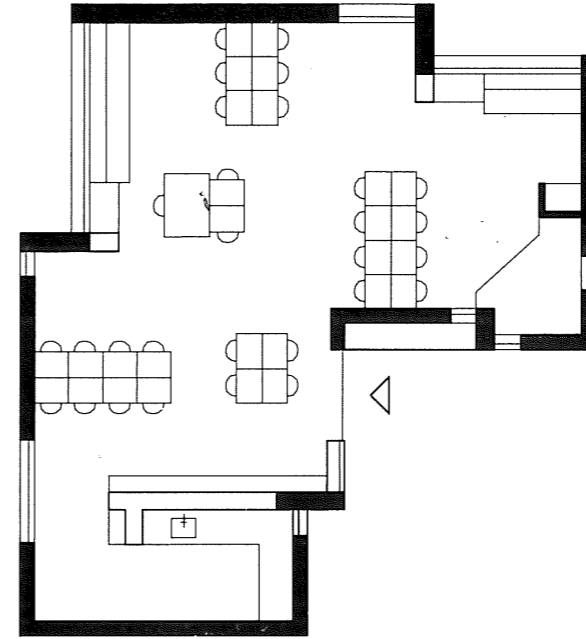
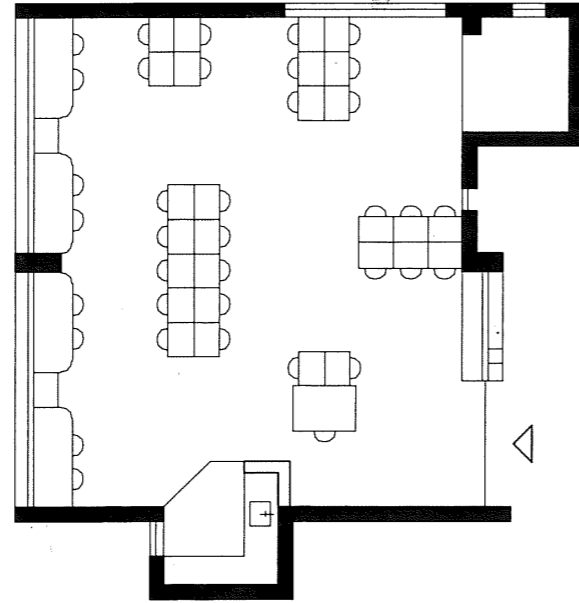
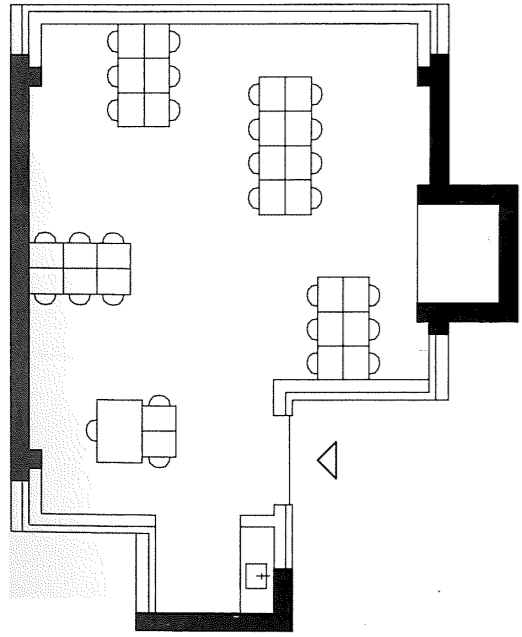



# LEARNING STREET



# LEARNING SQUARE

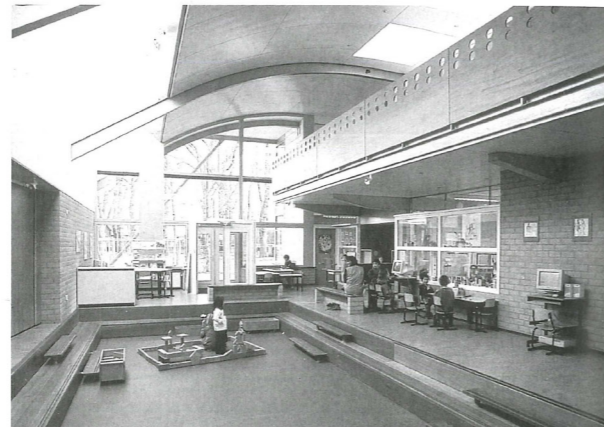
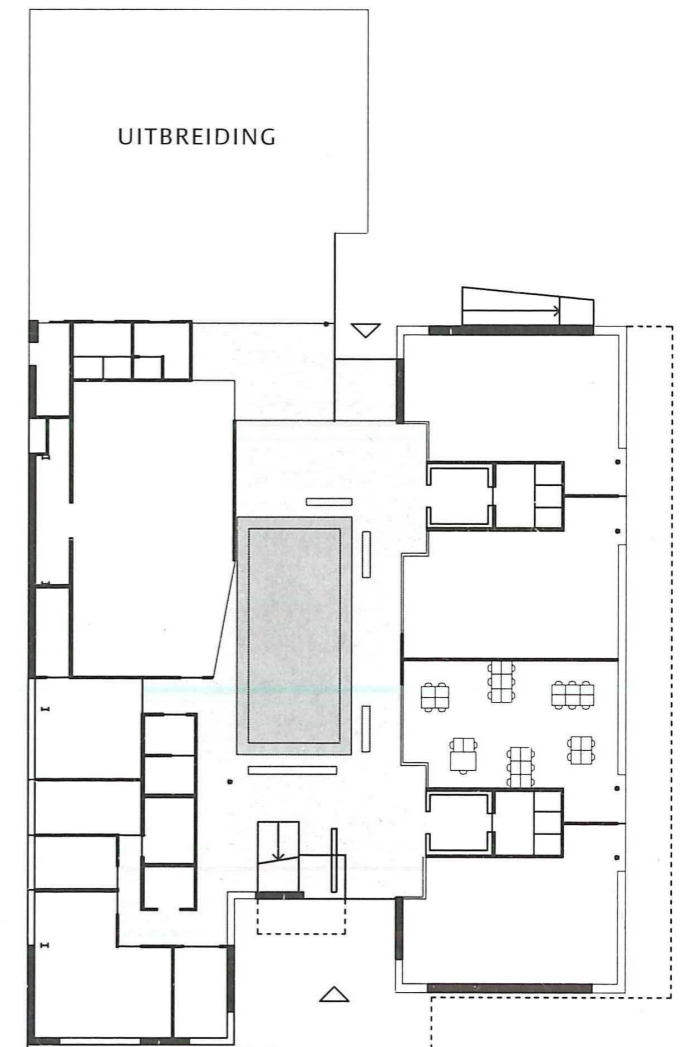

# SMALL LEARNING COMMUNITY

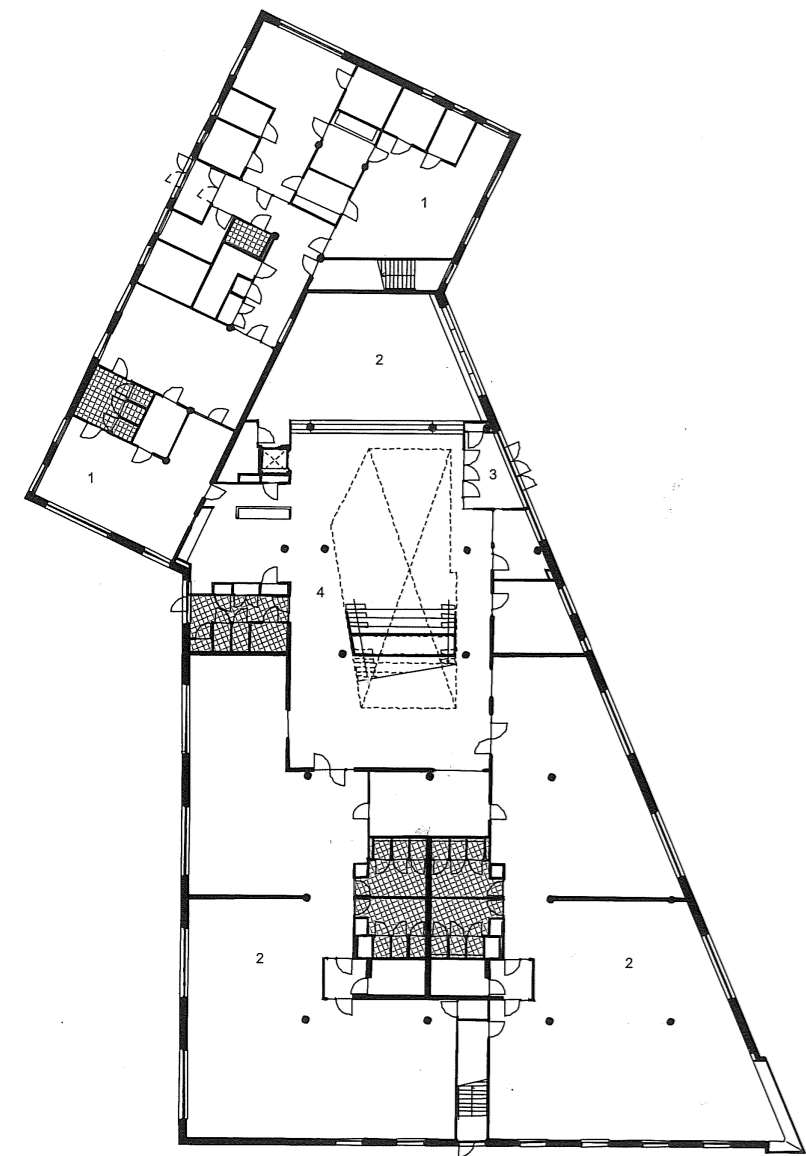

# STUBBORNLY CLASSROOM PATTERN

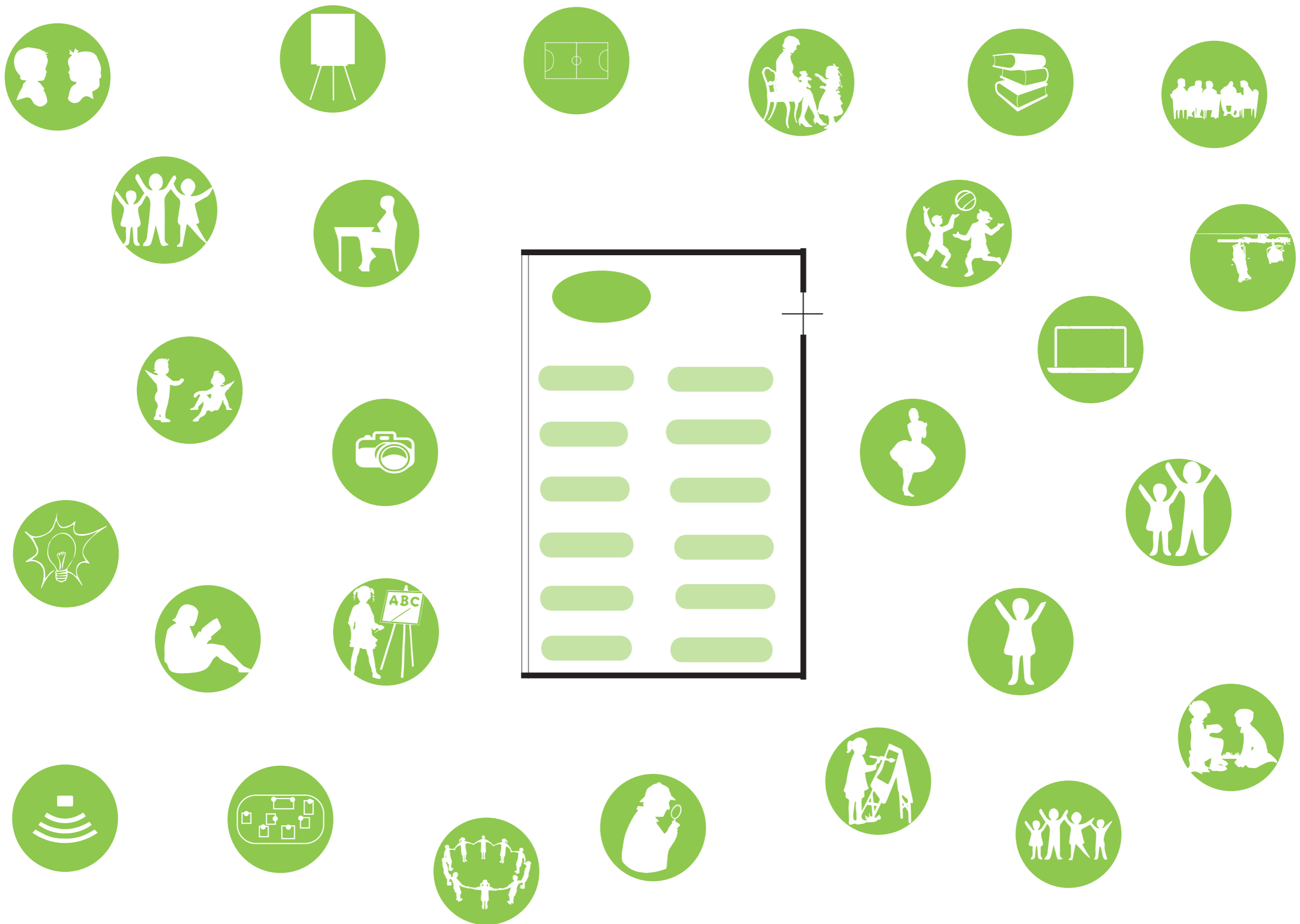

# THE CHALLENGE

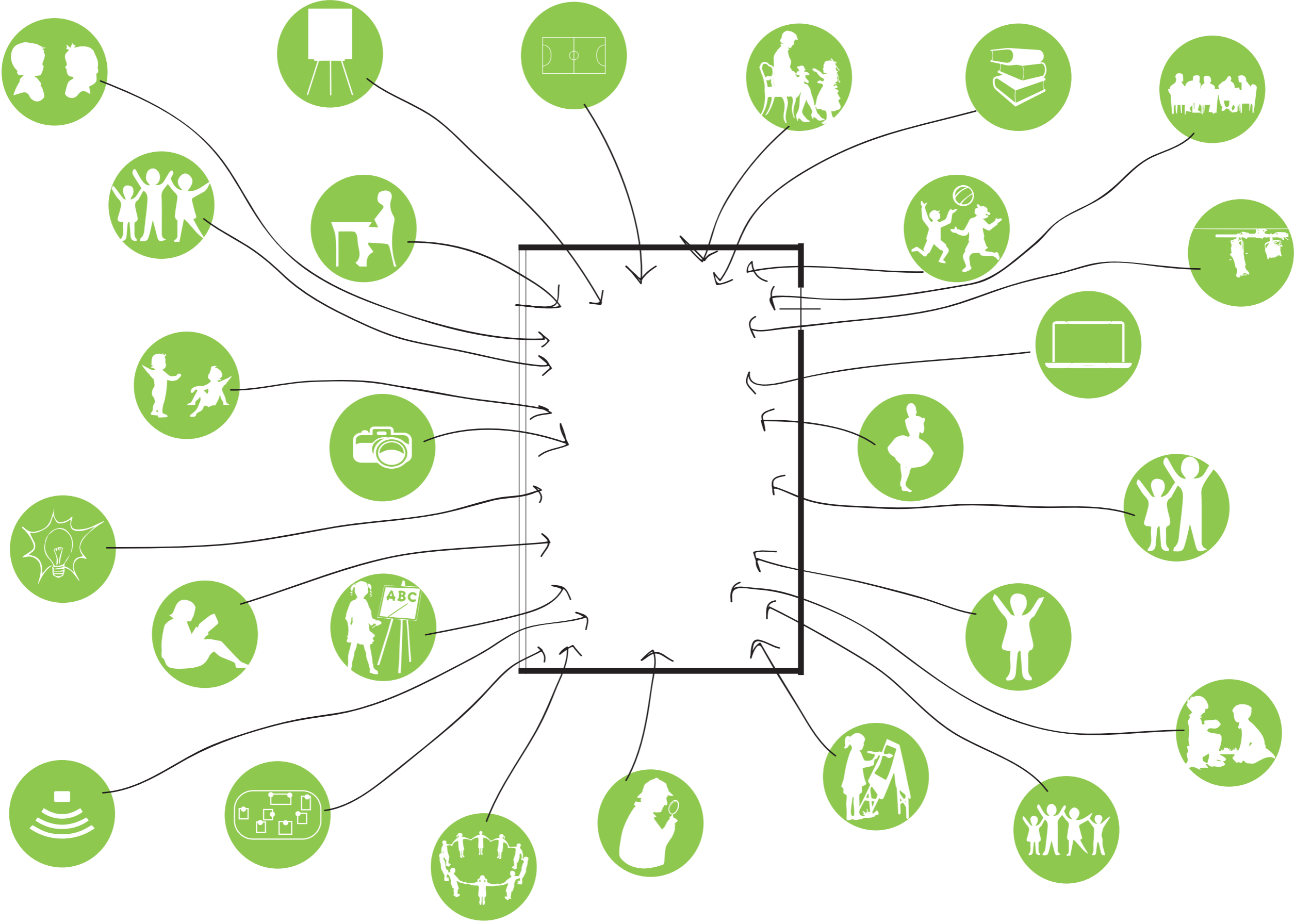



# TYPICAL BUILDING



# ABSTRACT SILHOUETTE OF A BARN

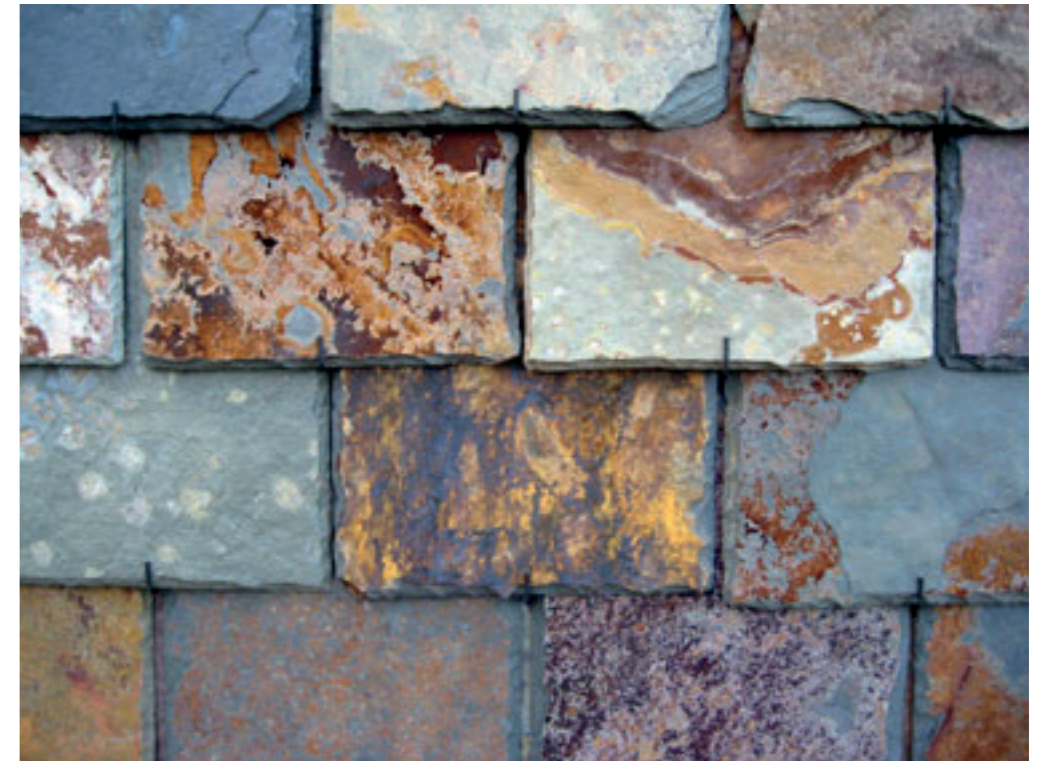
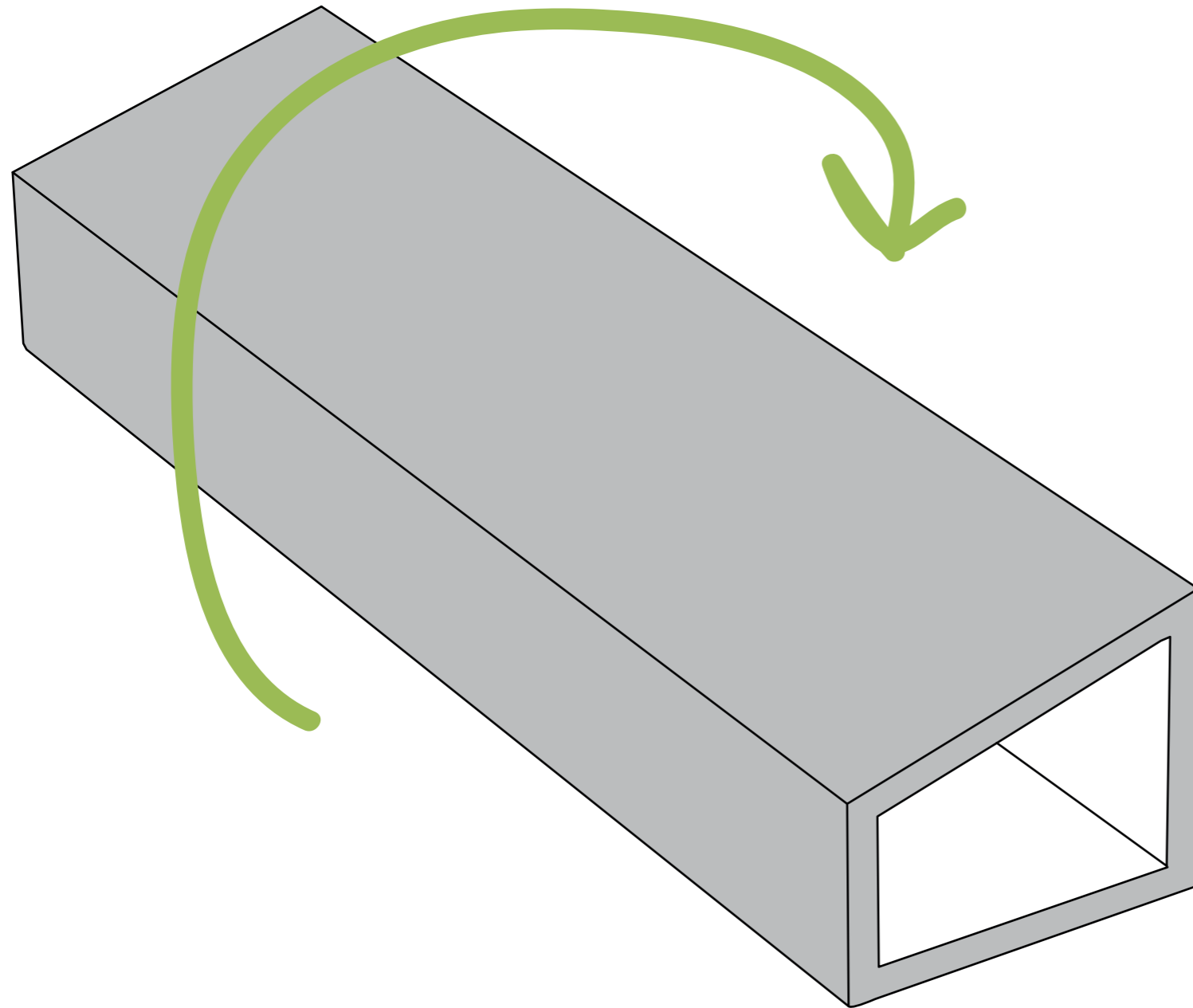



# ADDING

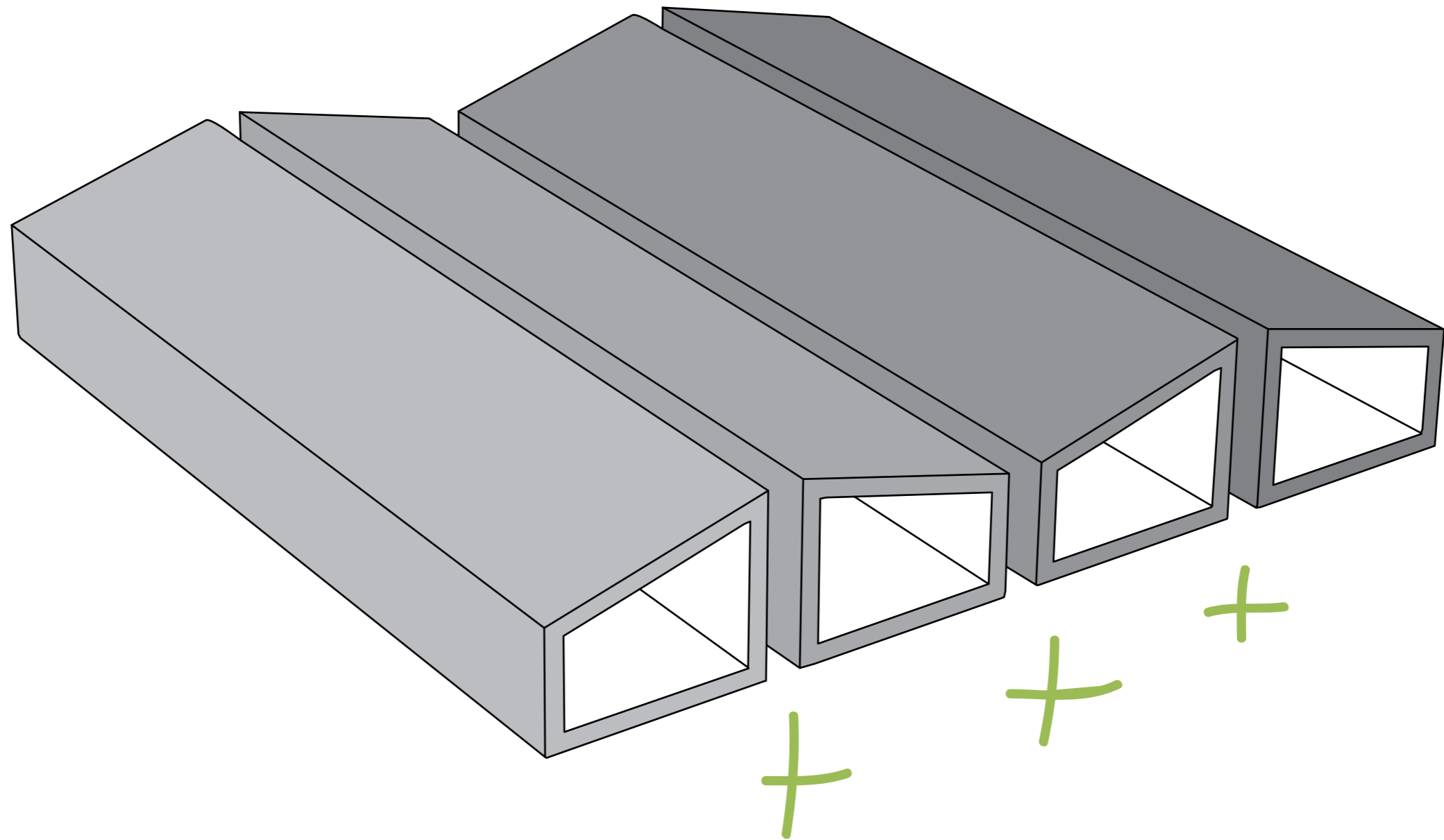

# ADJUSTING HEIGHT

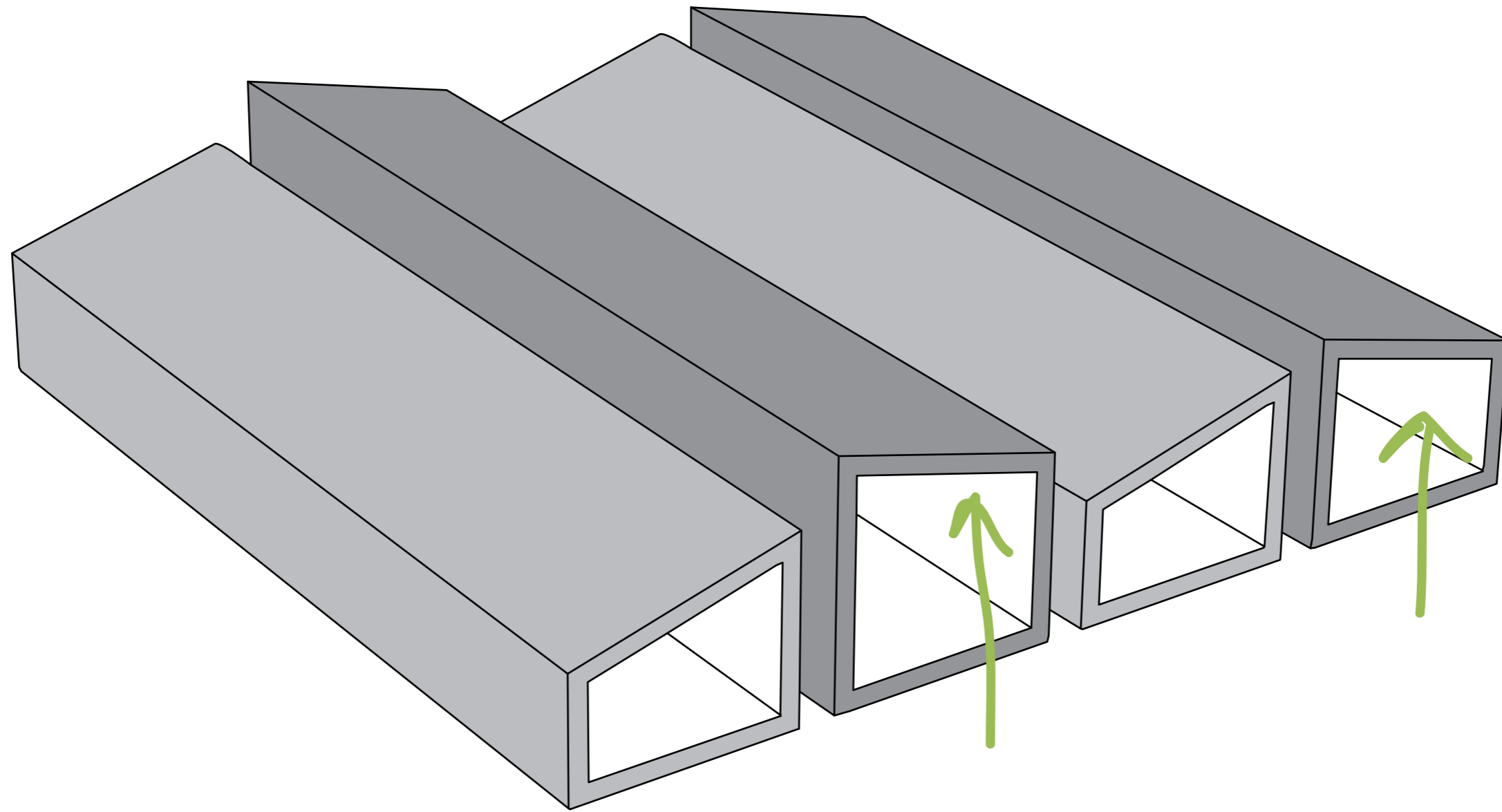

# ADJUSTING WIDTH

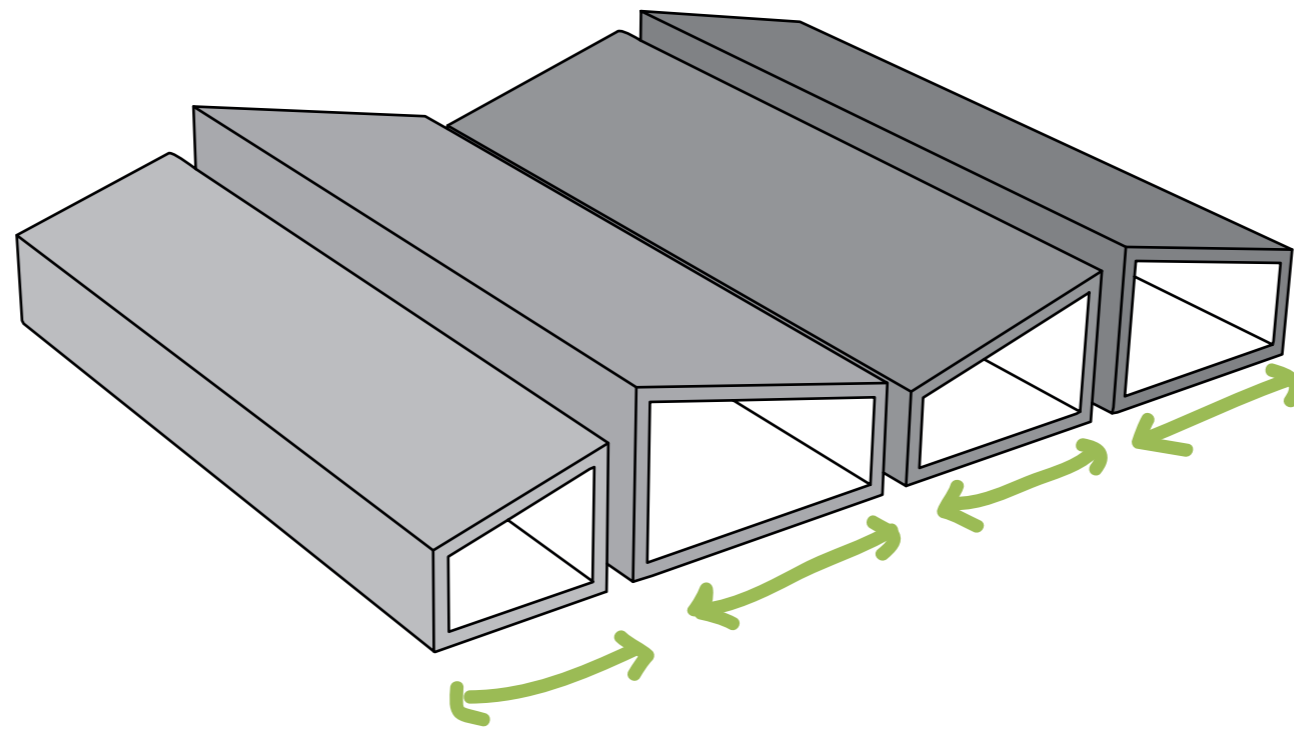

# SHIFTING LENGTHWISE

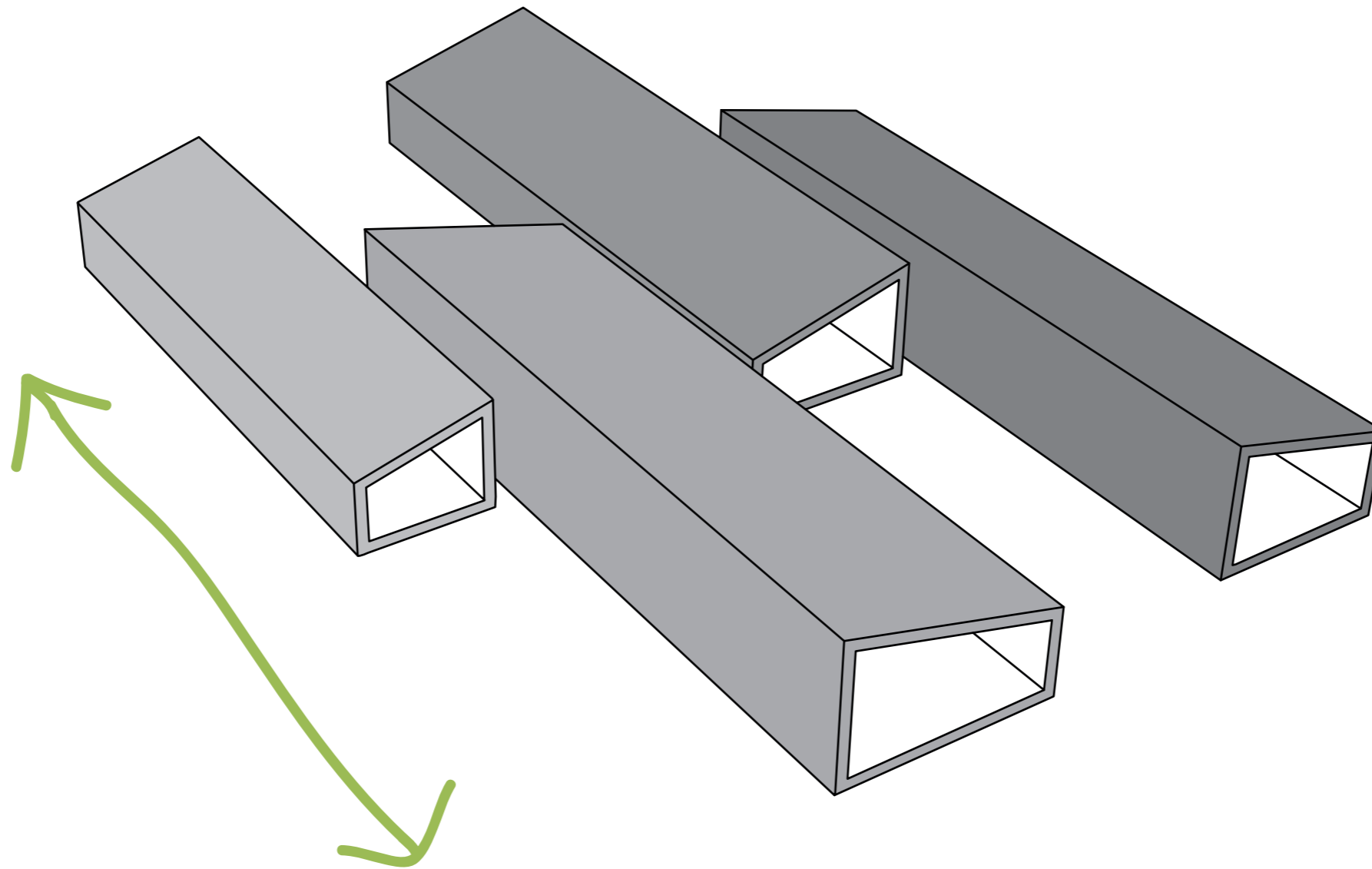

# SHIFTING CROSSWISE

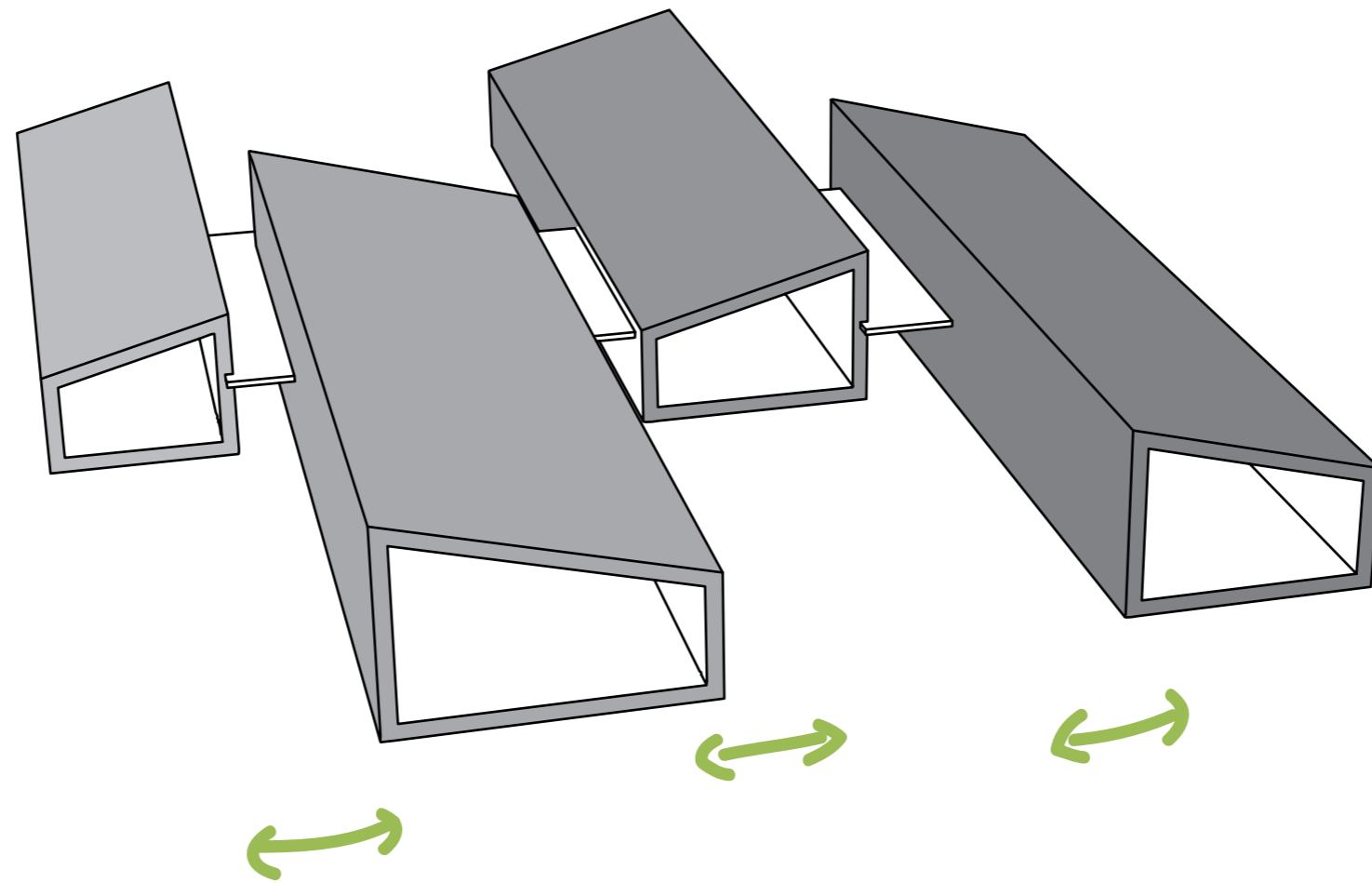

# TAKING MASS OUT

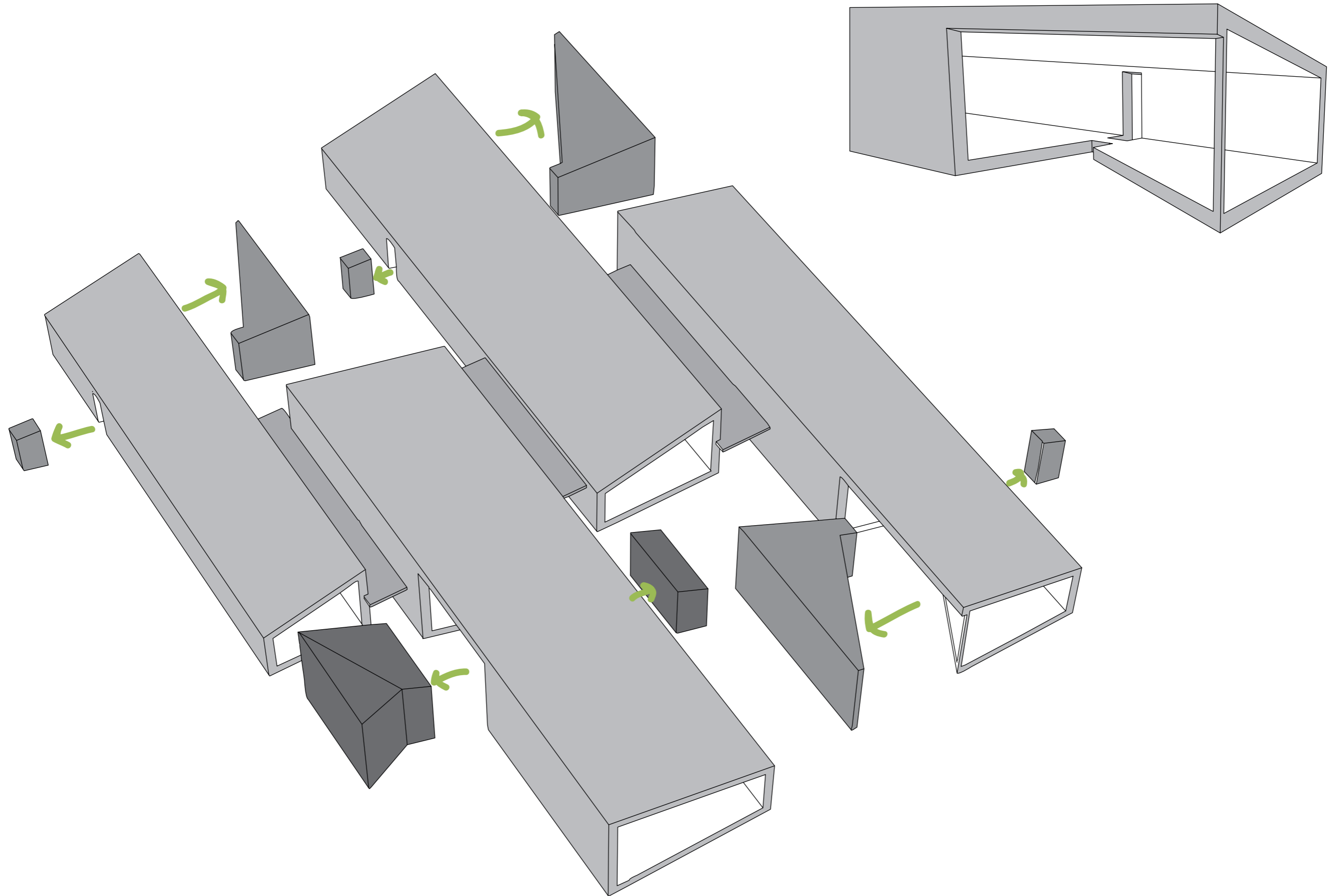

# LOAD BEARING STRUCTURE

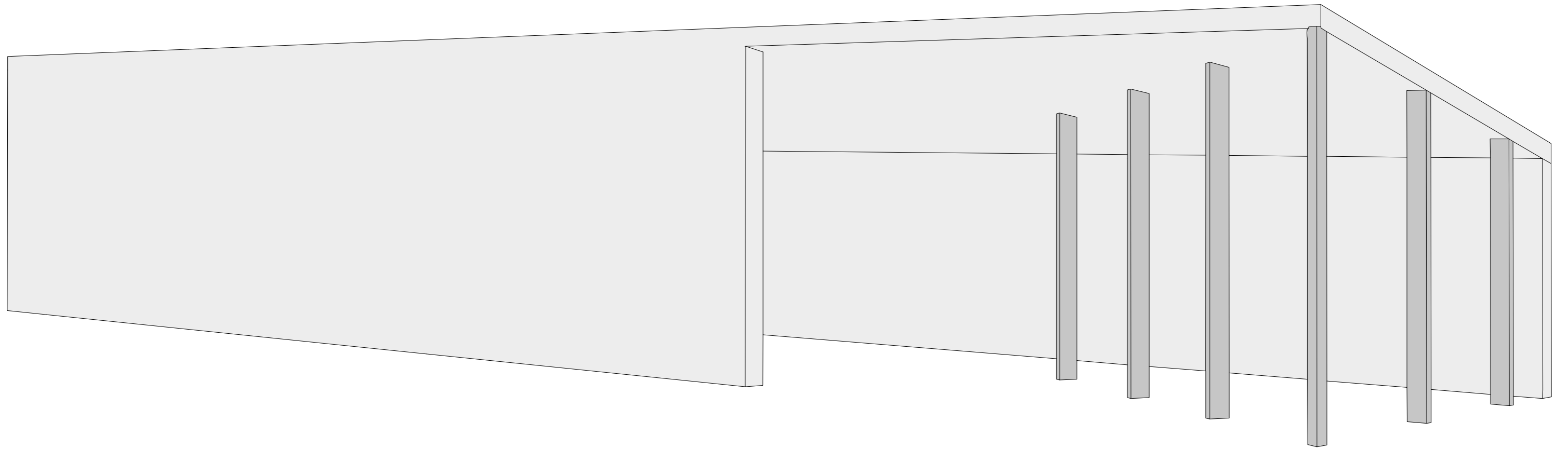

# ARTICULATION IN THE GARDEN DESIGN

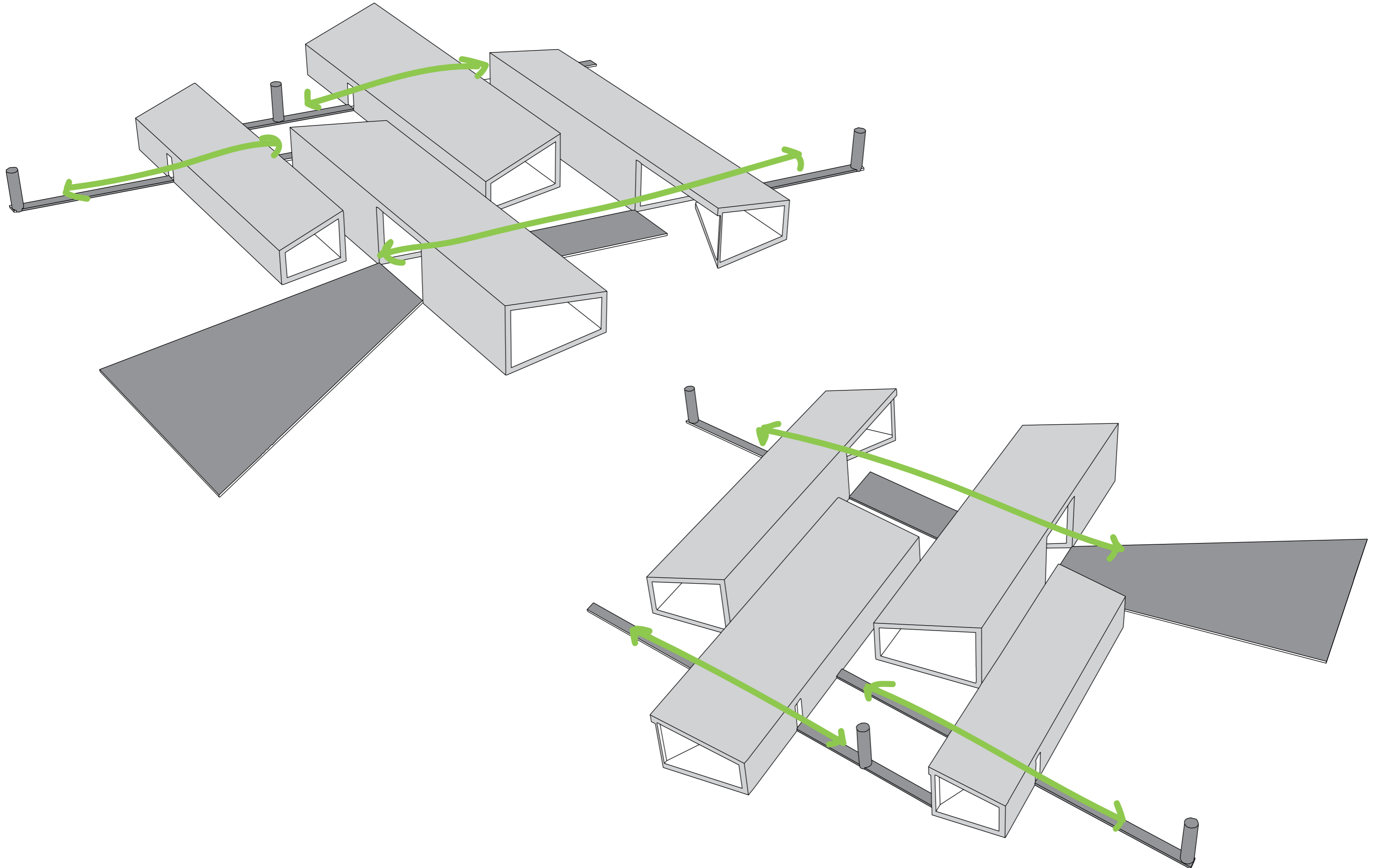



# SIGHTLINE



# ADDING BUILDING BLOCKS

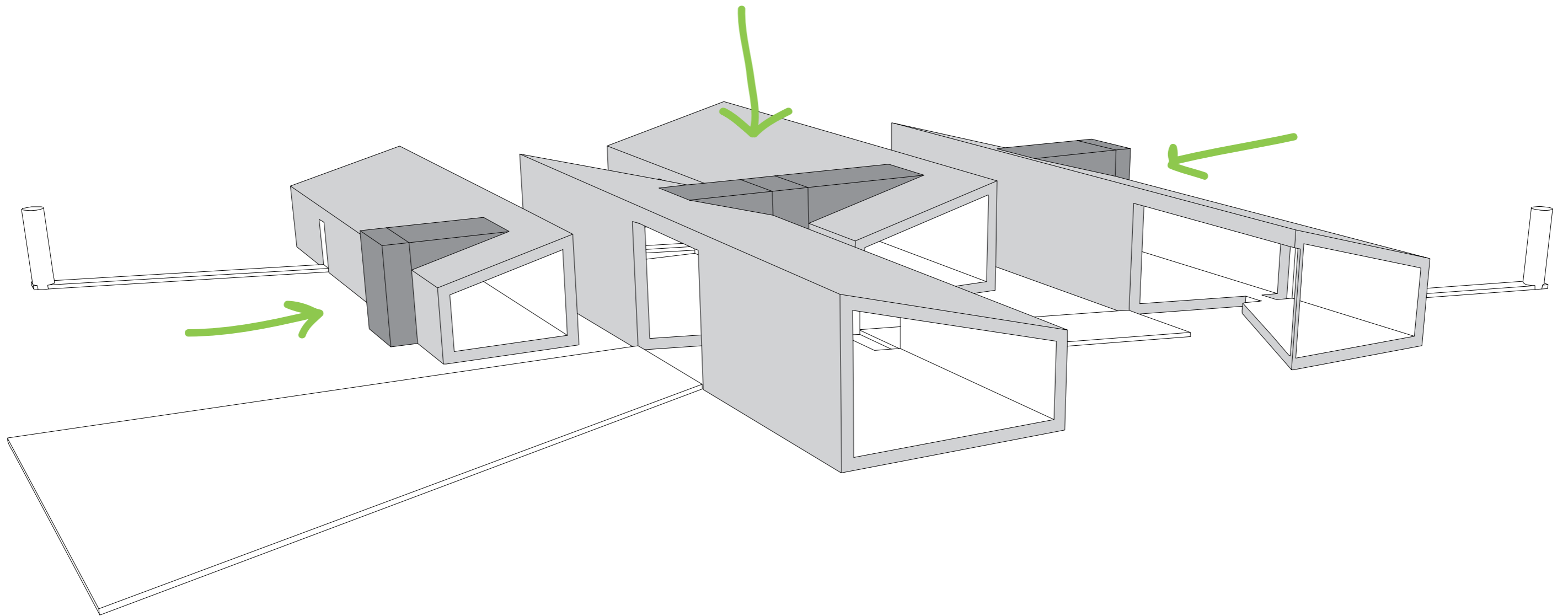

# AXIS SECTION

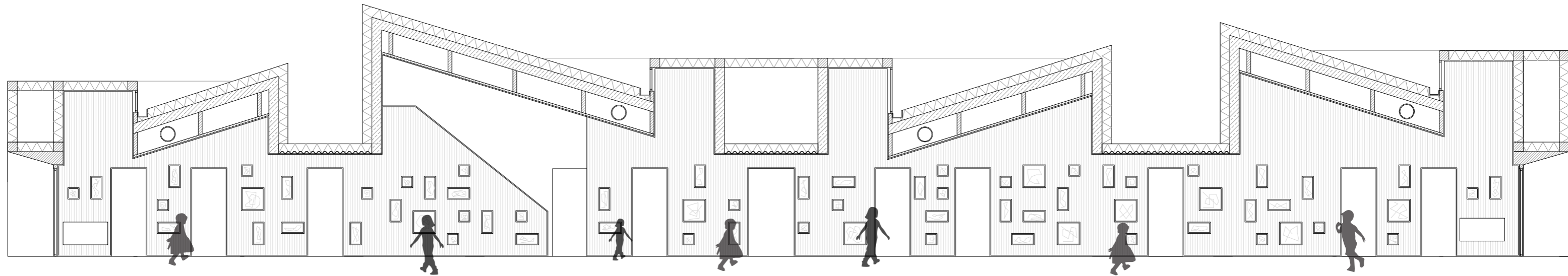

# AXIS PERSPECTIVE



# LAY OUT OF FLOOR PLAN: LEARNING SPACE AND AXIS



# LEARNING SPACE OPENS TO GARDEN



# THICKENING THE WALL

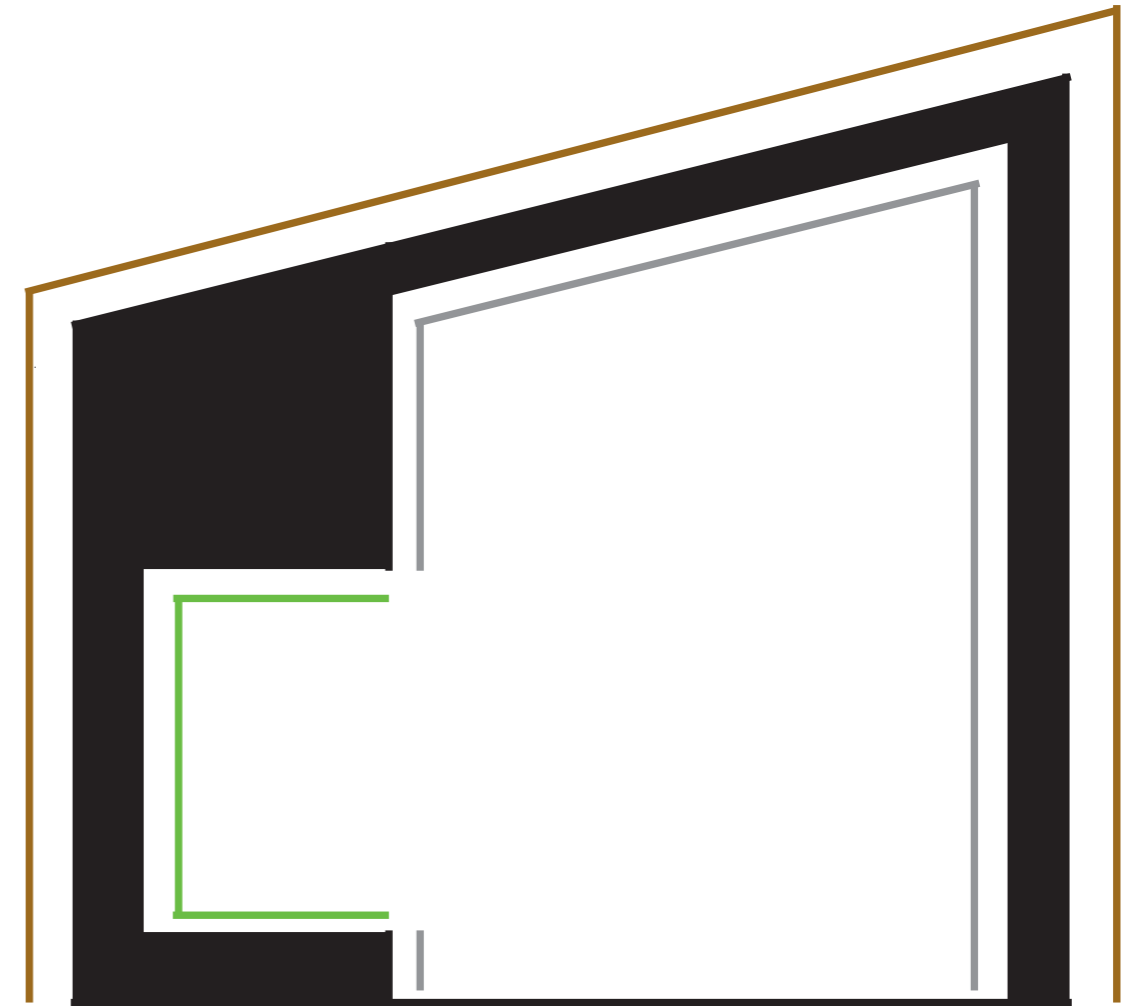
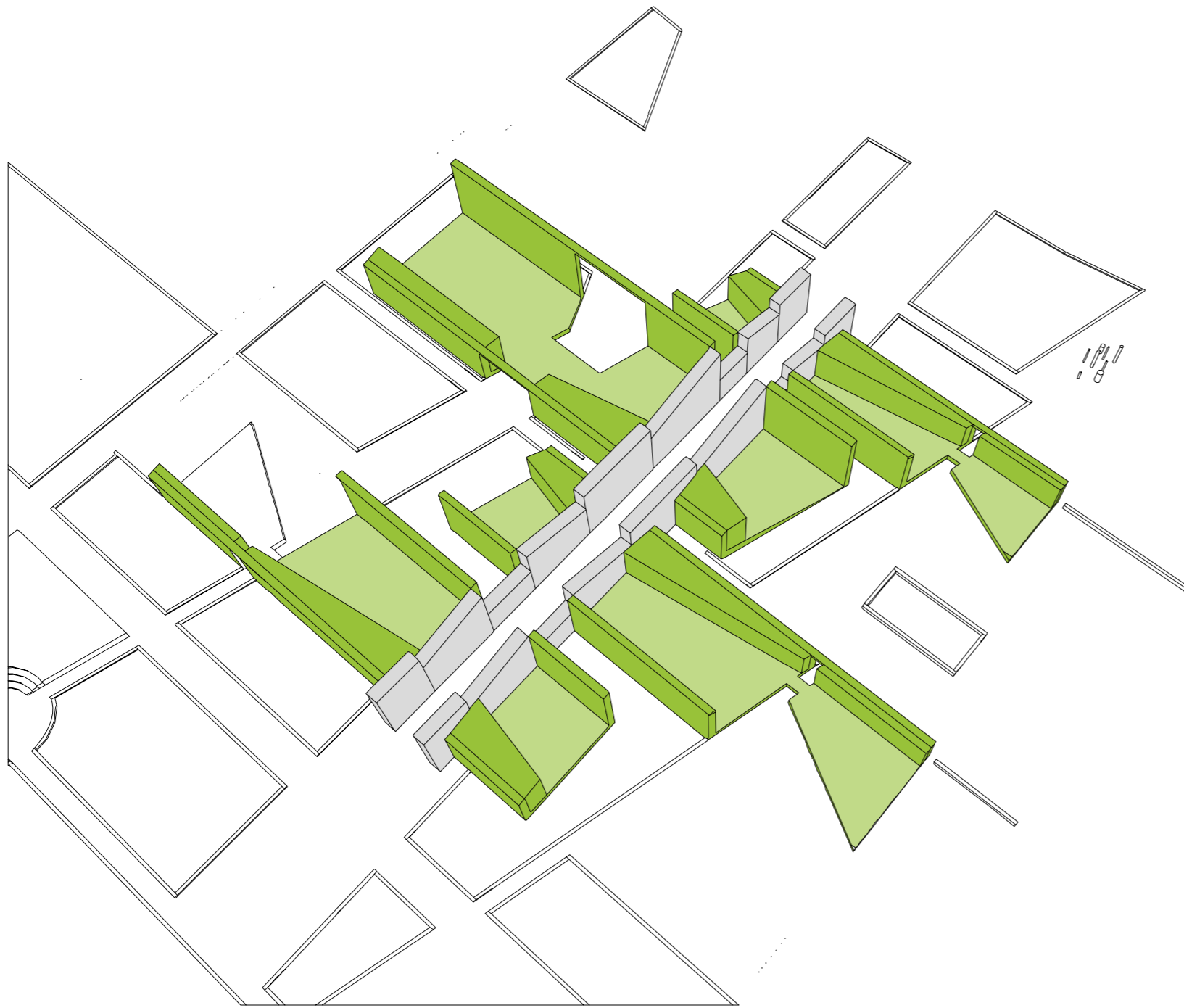

# ADDING MOVEABLE FURNITURE

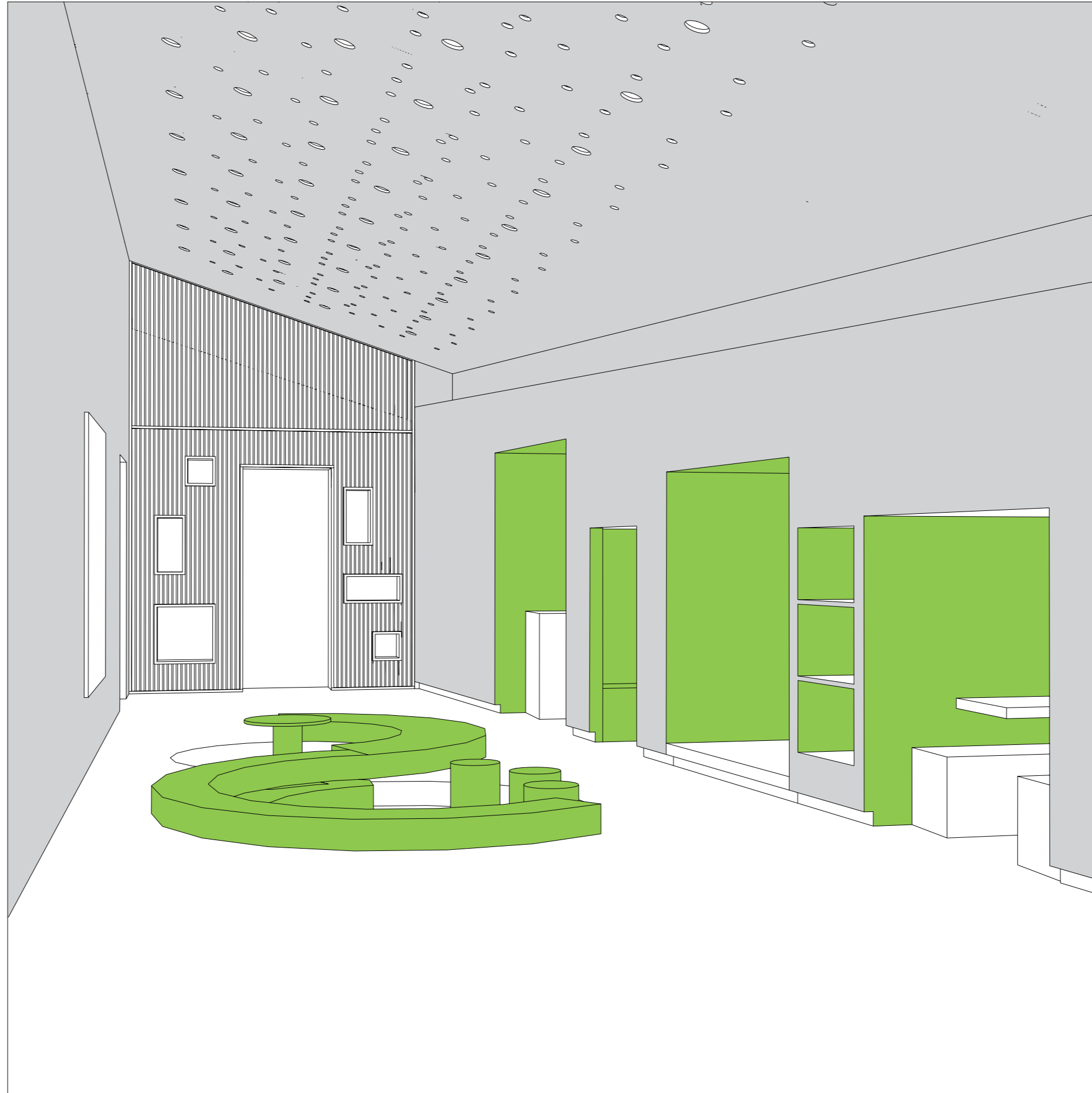



# LEARNING SPACE



# OVERVIEW OF DIFFERENT SPACES

- READING CORNER
- COOKING CORNER
- MULTIPLE PURPOSES
- STAGE
- PLAY CORNER
- INDIVIDUAL WORKING SPACE
- BRAINSTORMING
- STORAGE AREA
- EXHIBITION SPACE
- PUZZLE WALL
- STORY TELLING
- CAVE SPACE
- SCRABBLE WALL
- WINDOW PLACE OUTSIDE
- DEBATING SPACE
- ATELIER
- SCIENCE SPACE
- INSTRUCTION SPACE
- PEER TUTORING
- CONCENTRATION SPACE
- GROUP WORK
- PRESENTATION SPACE
- THEATRE SPACE
- MUSIC SPACE
- SAND BOX
- TOILETS
- OFFICE
- DEMONSTRATION SPACE
- GARDEROBE
- PARKING
- GATHERING SPACE
- LUNCH SPACE
- WRITING PANELS
- ENTRANCE AREA
- FRUIT TREES GARDEN
- BUILDING AREA
- FLOWER GARDEN
- GRASS FIELD
- OUTSIDE PLAY AREA
- WINDOW PLACE INSIDE
- VEGETABLE GARDEN
- SPORTS FIELD
- LEARNING SPACE / MOVING WHILE WORKING
- TERRACE
- AXIS

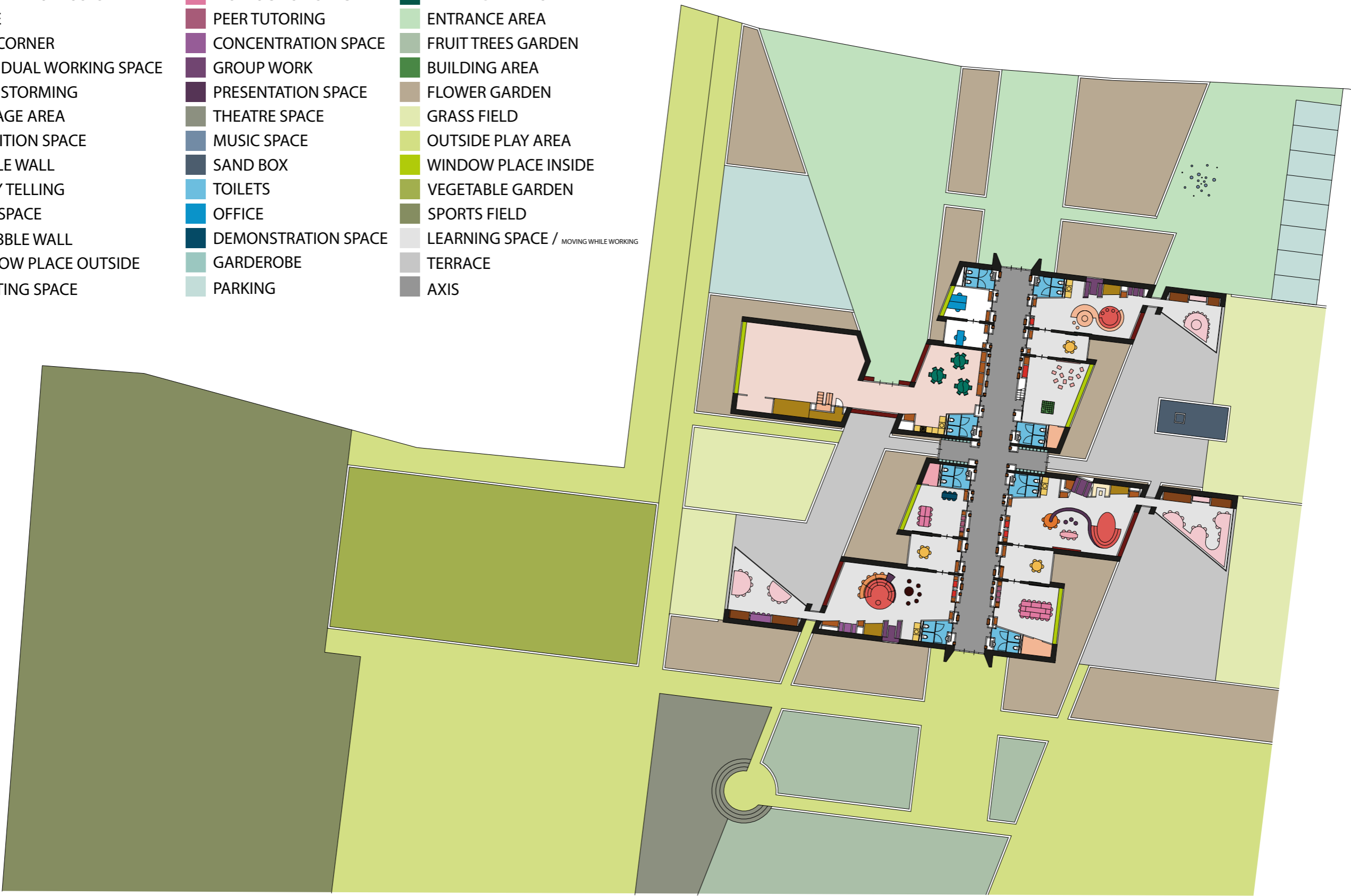

# DEMOCRATIC LEARNING LANDSCAPE

