

Secondary Cities in Polycentric Urban Region

by means of a comparative study
between SuzhouWuxiChangzhou Region and the Randstad



Living in the Netherlands especially in the Randstad, the territory of human activities is beyond to the city borders. City has different meaning to the people. For instance, people are travelling between cities in one day for different purposes, like working, visiting friends, shopping, etc. As a well-known emerging Polycentric Urban Region, “the Randstad” is already on the mental map of dutch people.

The same process is happening in China now. Recently, with the development of infrastructure (e.g high-speed train) and the growth of private cars, some parts of China, such as Yangtze River Delta, are facing a new challenge, which means interaction between cities will influence the development of different cities instead of only focusing on the city itself. Meanwhile, the high living pressure of big cities will be partly released by decentralization to the suburbs, new towns or small cities. In reality, this situation is happening in the latest years. Instead of struggling in the large cities like Shanghai or Beijing, many young people choose to move back to their hometowns - small cities or towns. Because some small cities can provide a good balance of job opportunities and living qualities, as well as social connections.

Referring back to the Randstad, a large amount of people prefer living in the small cities, besides four large cities (Amsterdam, Rotterdam, the Hague and Utrecht). The living quality of small cities is quite comparable with the large cities, because of good social facilities in the small cities and good accessibility to other cities. Therefore, I’m very interested in these small cities in the Randstad which play specific roles in the region. There is a challenge to learn from the Randstad, which is my original intention.



1. Introduction	
1.1 Polycentric Urban Region & Secondary Cities	P 4
1.2 Problem Statement	
1.3 Research Field	
<i>1.3.1 Yangtze River Delta and SWC Region</i>	
<i>1.3.2 Northwest Europe and the Randstad</i>	
<i>1.3.3 Why the Randstad relevant for SWC</i>	
1.4 Aim and Research Questions	
1.5 Theoretical Framework	
1.6 Societal and Scientific Relevance	
2. Comparative Research	P 18
2.1 Definition of Comparative Research	
2.2 Scale Large and Scale Small	
2.3 Three Indicators	
<i>2.3.1 Distribution & Polycentricity</i>	
<i>2.3.2 Diversity & Polycentricity</i>	
<i>2.3.3 Accessibility & Polycentricity</i>	
2.4 Polycentricity Measure Tools	
2.4.1 Polycentricity Matrix	
2.4.2 Polycentricity Triangle	
2.4.3 Moran's I	
3. Three Indicators: Distribution, Diversity and Accessibility	P26
3.1 Distribution – Analytical Dimension	P27
<i>3.1.1 Distribution of Live and Work</i>	
<i>3.1.1.a Mapping</i>	
<i>3.1.1.b Measuring</i>	
<i>3.1.1.c Conclusion</i>	
<i>3.1.2 Distribution of Three Economic Sectors</i>	
<i>3.1.2.a Mapping</i>	
<i>3.1.2.b Measuring</i>	
<i>3.1.2.c Conclusion</i>	
3.2 Diversity – Normative Dimension	P66
<i>3.2.a Mapping</i>	
<i>3.2.b Measuring</i>	
<i>3.2.c Conclusion</i>	
3.3 Accessibility - Normative Dimension	P80
<i>3.3.a Mapping</i>	
<i>3.3.b Measuring</i>	
<i>3.3.c Conclusion</i>	
4. From Indicators to Polycentricity	P94
4.1 Synergy of Three Indicators	
4.2 Final Conclusions	
5. Testing by Design	P102
5.1 Current Vision of SWC Region	
5.2 Evaluation of Current Vision of SWC Region	
5.3 Proposals	
6. Evaluation	P114
7. Reference	P115
8. Appendix	P117



1. Introduction

1.1 Polycentric Urban Region & Secondary Cities

1.2 Problem Statement

1.3 Research Field

1.3.1 Yangtze River Delta and SWC Region

1.3.2 Northwest Europe and the Randstad

1.3.3 Why the Randstad relevant for SWC

1.4 Aim and Research Questions

1.5 Theoretical Framework

1.6 Societal and Scientific Relevance

1.1 Polycentric Urban Region and Secondary Cities

Regionalisation is taking place over the world, because of the decentralization of economic activities, increasing mobility, fragmented spatial distribution of activities and changes of household structure (Davoudi, 2003). That's why the notion of Polycentricity, usually with regard to a regional system, becomes a highly popular term by urban planners and policy makers. There are a diversity of explanation about what Polycentric Urban Region (PUR) is by different authors (Hall, 1966; Davoudi, 2003; Kloosterman and Musterd, 2001; etc). Not only the definition of PUR, the more importance issue is to understand the Polycentric Urban Region development and even to use PUR as a design strategy.

Scale is a very crucial issue for Polycentric Urban Region. Hall (2003) supposed that "polycentricity can occur at multiple levels or spatial scales, and what is monocentric at one level can be polycentric at another- and vice versa". Therefore, Northwest Europe and Yangtze River Delta as Scale Large will be compared, so do the Randstad and SWC Region as Scale Small.

Moreover, Hall and Pain (2006) referred Polycentric Urban Region development as "a process is often associated with the outward diffusion of functions from major cities to smaller cities with in a regional setting", which means smaller cities are playing their roles to participate the development of the region. The importance of smaller cities has been promoted already in the European level. For instance, there is a project of ESPD from 2010 called SGPTD - Secondary Growth Poles and Territorial Development in Europe; Performance, Policies and Prospects (ESPON, 2010). Because smaller cities, as a part of network in the region, do benefit for and from Polycentricity as spatial planning strategy (Davoudi, 2003) by means of "reconciling the social and economic claims for spatial development with the area's ecological and cultural functions" in order to achieve "a sustainable, and balanced territorial development" (European Commission, 1999).

In principle, "large cities" and "smaller cities" are more referring to size-rank distribution. However, the notions of "Primary Cities" and "Secondary Cities" are more represented by the function importance. In respecting to functional PUR, "secondary cities" will be the research focus instead of "smaller cities". In fact, it is very difficult to precisely define secondary cities. There are several ways to define what secondary cities are. These criteria include "population density, physical size, the proportion of the labor force engaged in nonagricultural occupations, the mix and diversity of functions located within a city, its physical characteristics, and its relationships with other cities and towns" (Rondinelli, 1983a, p. 47). However, the city size and function complexity are positively correlated (Rondinelli, 1983a). Thus, Size-ranking of population (Hardoy and Satterthwaite, 1988; Rondinelli, 1983a; Van der Merwe, 1992) and employment (Anderson and Bogart, 2001) are main criteria to define secondary cities. Based on these Criteria, there are three primary cities (Suzhou, Wuxi, Changzhou) and nine secondary cities in SWC Region (Map 2), while the Randstads has four primary cities (Amsterdam, Rotterdam, the Hague, Utrecht) and twelve secondary cities (Map 1).

Map 1:
Four Primary cities and Secondary Cities in the Randstad

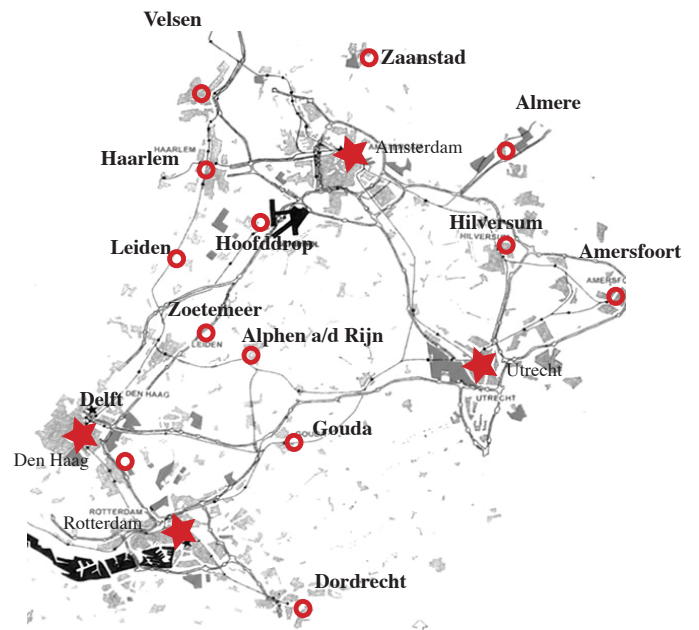

Map 2:
Four Primary cities and Secondary Cities in SWC



1.2 Problem Statement

After rapid expansion of large cities in China, now more and more attention is paid on these medium or small cities in order to understand how these cities function in the process of urbanization. The small cities in SuzhouChangzhouWuxi Region (SWC) are very representative cases in China, because there cities have very strong economic position, even with comparable GDP as large cities. For instance, Jiangyin as a county level city with one third population of Suzhou, created 70% GDP of Suzhou. These small cities in this region are famous for the high average income and high percentage of private sectors. SWC Region is famous because of these small cities rather than three big cities. Thus, SWC Region is a specific and interesting region in Yangtze River Delta.

is a problem for this region as well as an opportunity. It is a problem because most of development are taking place on the east, while the west area is lack of facilities and infrastructure. However, it could be an opportunity that the whole region will benefit from the development of the west part. In reality, the development on the west part is carrying on already, like high-speed train railway from Nanjing to Hangzhou is finished in 2012 to connect secondary cities on the west of SWC on the railway network.



Rapid Urban Sprawl

The last two decades, the cities (Map 3) in the SWC Region are expanding rapidly, including secondary cities. In addition, these secondary cities have experienced the process of switching from a county to a city. The urban sprawl was induced mainly by the development of industry rather than population growths, especially rapid expansion of industrial development zones and/or economic and technical development zones since 2000 (Ma et al, 2008). Because of rapid urban sprawl, there are many problems in these secondary cities, such as urban congestion, pollutions, high price of housing, shrinking open space, etc.

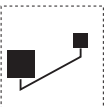

Disparity between East and West

Considering the size of population, built area or economic level, secondary cities on the east of three Primary cities are further developed than Secondary Cities on the west. Take population as an example, five out of six cities on the east has population between 1 and 2 million, while only one out of three cities on the west has comparable population. From the GDP rank of 2010 in SWC Region, most of secondary cities on the east have a GDP between 100 to 200 billion yuan, while GDP of each secondary city on the west is below 50 billion. This disparity

Map 3: Expansion of Building Area in Tai Lake Region

Source: Wu, 2008

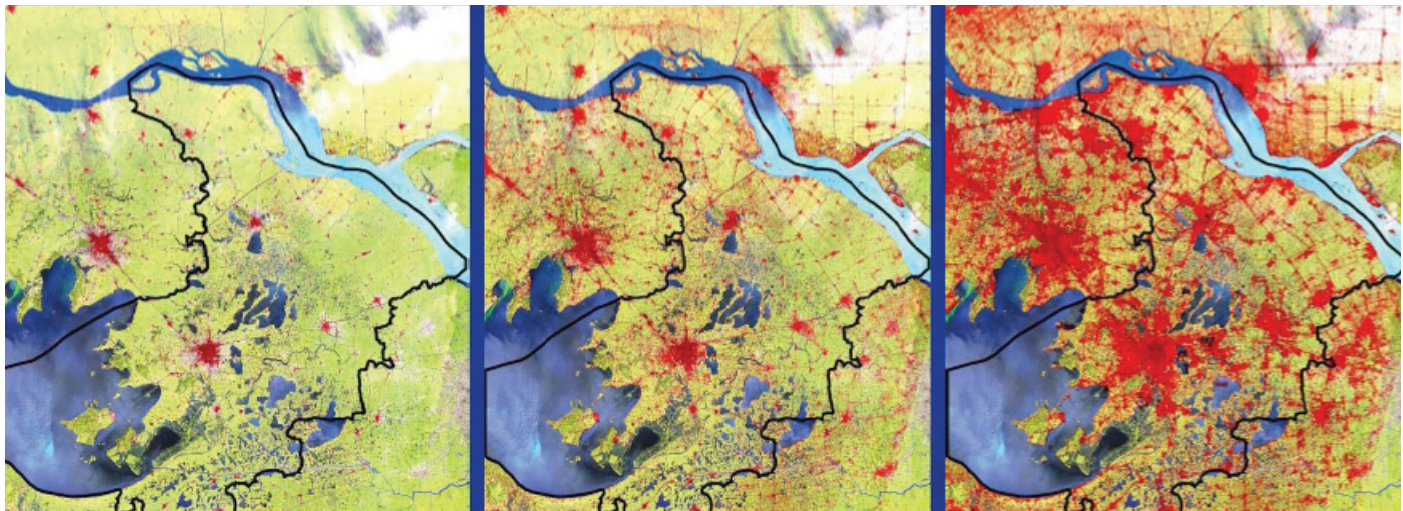



Lack of Identity

Due to globalisation and fast urbanization in SWC Region, many cities including primary cities and secondary cities becomes similar to each other. Most of them are only pursuing for large size instead of identifying city itself. There are not so many differences of city image between primary cities and secondary cities (Photo 4). “Regional Plan for Yangtze River Delta” (2010) points out that many cities do not clarify their specific roles and directions, which becomes a big barrier for the identity of a city spatially and functionally.

Photo 4: City Image of Primary Cities and Secondary Cities

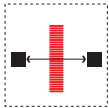

Difficulties of Inter-city Cooperation

In 2002, there was a regional plan for SWC (SWC Regional Plan 2001-2010, 2002) which is the first regional plan approved by the Chinese government. However, this plan has encountered various problems especially for the implementation of this plan. There are several causes that make this plan difficult to achieve inter-city cooperation. One reason is that the prefecture-level cities (three primary cities) have strong administrative and economic power due to the decentralisation from central and provincial government (Wu, 2008). Therefore, even the plan was made by provincial government and legalised by central government, the feasibility of the plan had many difficulties by unhealthy competitions instead of cooperation (Luo & Shen, 2008). For example, three primary cities have intention to upgrade its own airport to compete for the leading airport of SWC Region. Moreover, all secondary cities belong to its own primary cities administively, which means the competitions between primary cities definitely influence the development of secondary cities. Each primary cities defined their own city-region based on their own interests (Map 5). For instance, Suzhou would like to invite other two prefecture-level cities on the south to participate in the regional development, so it can be the centre to lead the whole region. Meanwhile, Wuxi government formulated totally different city-regions, where Wuxi functions as the leading city of Wuxi-Changzhou-Taizhou city-region, but Suzhou was pushed under the wing of Shanghai (Luo & Shen, 2008). Empirical experience proved that this kind of competition will obstruct the development of SWC, either in polices or urban development strategies(Xu, 2003).

Map 5: Region by different Municipalities

(Source: drawn based on Luo & Shen, 2008)

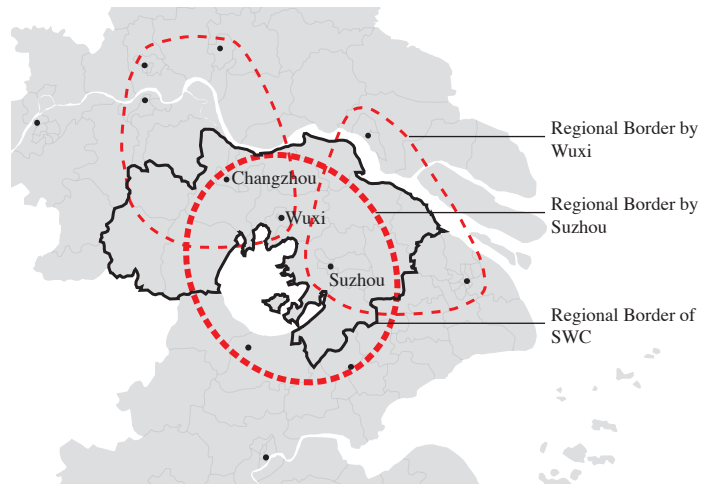

1.3 Research Field

1.3.1 Yangtze River Delta and SWC Region

Yangtze River Delta (YRD) is well-known as one of three economic powerhouses in China, while the other two refer to Bohai Economic Rim, Pearl River Delta. Originally, YRD contains three province-level municipalities – Shanghai, southern Jiangsu province and northern Zhejiang province, with 16 prefecture-level cities. Since 2008, due to the development of rest part of two province and the expansion of interaction area, three governments made an agreement to extend YRD to the entire two provinces together with Shanghai. Therefore, “Regional Plan for YRD 2009-2020” (2010) was the first cooperation between municipalities at provincial level, which was admitted and legalized by the national government of China.

In YRD, there are eight city regions on the agenda of government (Map 6). Among these eight city regions, Shanghai city region is much more on the international scale by a large amount of foreigner companies. Besides Shanghai city region, Nanjing city region and Hangzhou city region have priority for the development of YRD. That’s why the high-speed rail way were firstly built among these three city regions. SWC Region is located between Shanghai city region and Nanjing city region.

SWC stands for the names of three main cities in the region – Suzhou, Wuxi and Changzhou. This region is famous for Sunan Model, so that SWC Region has been on the mental map of Chinese people since 1970s. The orthodox Sunan Model means that the local state-directed township and village enterprises (TVEs) in the southern Jiangsu Province has been “conceptualized as local state corporatism and development/urbanization from below” (Wei et al, 2009) To some extent, the success of Sunan Model provided a good base for the development of SWC Region. Besides, due to the proximity to Shanghai as a global city, SWC Region benefits by attracting foreigner investment, especially manufacturing sector.

Map 6. Yangtze River Delta Border & City regions

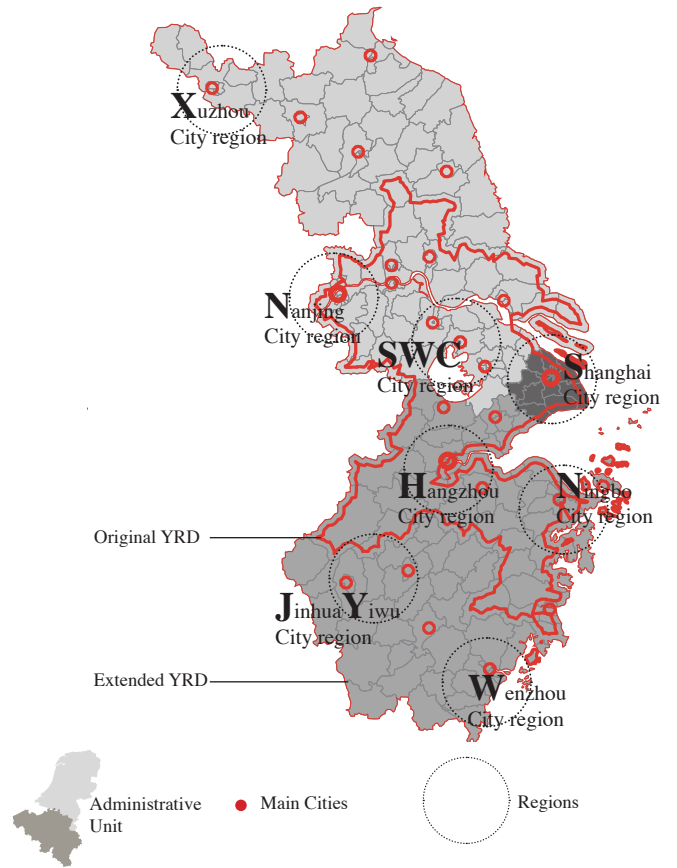

1.3.2 Northwest Europe and the Randstad

Northwest Europe (NWE) was chosen as the study area because of its comparable size with Yangtze River Delta and several interesting emerging urban regions, such as London and Paris region as Monocentric Urban Regions, the Randstad and Ruhr Area as Polycentric Urban Regions (Kloosterman and Musterd, 2001) (Map 7). In the Vision of Northwest Europe (2000), it is concluded as a small area concentrated by the great diversity and individuality, where 143 million people live with “standards of living and consumption patterns among the highest in the world”. As one important economic powerhouse of Europe, it contains economic cores at global scale like London and Paris, established industrial area with regeneration like Rhine-Ruhr, international trade and communications gateway like port of Rotterdam and airport of Frankfurt, as well as culture diversity.

Cities and regions in Northwest Europe are tend to be interdependent. Therefore, there are several programs organized by European Union to enhance the cooperation in NWE. The ANKE network (Arnhem, Nijmegen, Kleve, Emmerich) is an example for the marketing cooperation(Vision of North West Europe, 2000). Cities and towns are emerging into the network of NWE, aiming to achieve a sustainable and balanced development. The way how they cooperated and the impact of cooperation can be discussed with Yangtze River Delta.

In NWE, the Randstad, is one of the most densely populated region and with strong economic position as well. The Randstad contains four main cities (Amsterdam, the Hague, Rotterdam, Utrecht) which play complementary roles: Amsterdam as financial centre, the Hague as administrative centre, Rotterdam as harbor city with industry and Utrecht as national logistic centre.

Beside these four primary cities, there are a plenty of secondary cities around each primary city. In order to understand Polycentricity of the Randstad, there is an article “Vele Steden Maken Nog Geen Randstad” (Rck & Oort, 2006) analysing the company network, commuting pattern and travel for shopping (Map 8). They discovered that primary cities are still playing enormous important role as “magnet” (Rck & Oort, 2006), which means secondary cities are concentrating relation with the primary city that they belong to. Because most of flow are still within the city-region of Amsterdam, the Hague, Rotterdam and Utrecht. Polycentricity of the Randstad appears very differently for different issues.

Map 7. Northwest Europe Border & Regions
Source: Atlas ABC, 2011

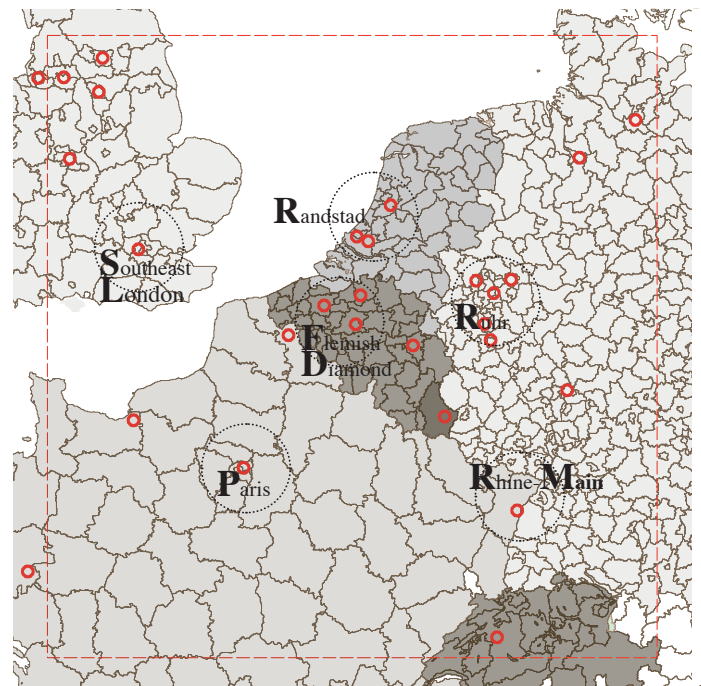

Map 8. Network by Different Issues
Source: Rck & Oort, 2006

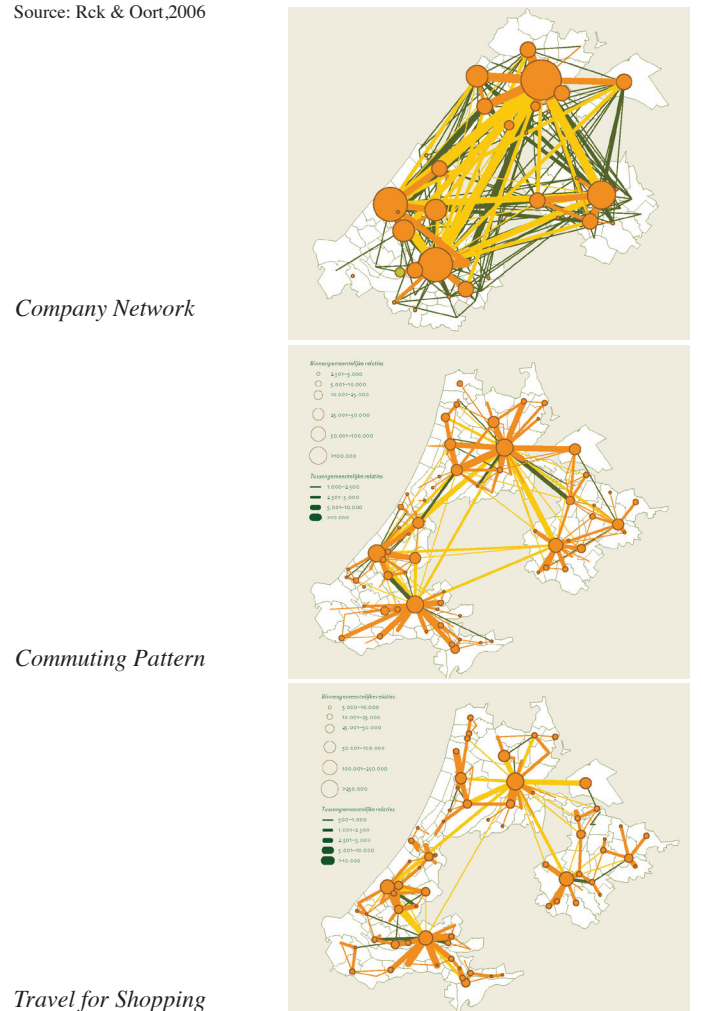

Company Network

Commuting Pattern

Travel for Shopping

1.3.3 Why the Randstad relevant for SWC

In order to do comparative research for two regions of the Randstad and SWC Region, It is very important to argue whether these two regions are relevant to be compared. The following part will explain why these two region can be compared from several aspects, like scale issue, economic position, regional planning aim and spatial planning system.

Scale Comparison

Scale is a very crucial issue for comparison of two regions. Comparable size is the prerequisite to this research. Thus, two scales are compared: Northwest Europe (NWE) with Yangtze River Delta (YRD), the Randstad with Suzhou-Wuxi-Changzhou Region (SWC). NWE contains several well-know regions like Southeast London, Paris, Flemish Diamond, Rhine-Ruhr region and the Randstad, while YRD with some important regions like Shanghai Metropolitan Region, Nanjing Region, Hangzhou Region and SWC in the middle (Map 9). The other scale is comparing the Randstad with SWC Region. There is a very important similarity that two regions contain more than one Primary cities (Map 9). It means SWC Region has possibility to develop a more polycentric configuration for which the Randstad is well-known in the world. Meanwhile, the Green Heart with cities around is comparable to Tai lake with most of cities on the one side in SWC Region (Map 9).

Map 9: Scale Comparison
NorthWest Europe

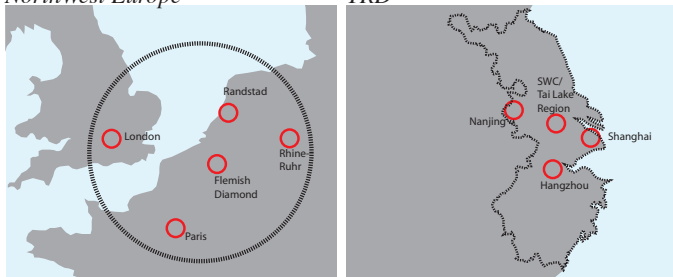

the Randstad

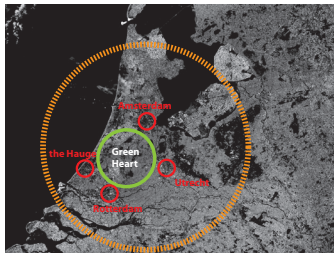

SWC

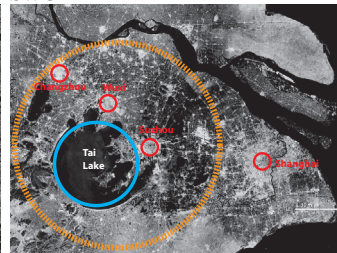

Economic Position

The Randstad is famous as the economic powerhouse of the Netherlands, with 20% of total land and 40% population producing half of GDP of the whole country. SWC has also very strong economic position, with 15% of total land and 20% population of Original YRD producing 30% GDP. GDP per capita (SWC: 163.5%, the Randstad: 122.9%) explains that both of region have concentration of economic activities . However, the difference is population density of the Randstad is twice as the average of the Netherlands which also leads higher total GDP, while SWC has comparable population density with Original YRD which means high productivity and concentration of economy (Figure 10).

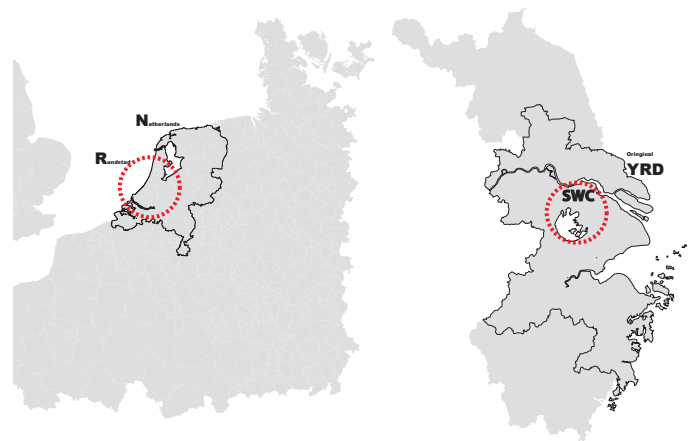

Area	Land Area (10,000 km2)	Population (millions)	GDP (billions of yuan)	GDP per Capita (yuan)
SWC	1.75(15,9%)	19.2(19,2%)	1463.5(31,4%)	76,225 (163,5%)
Original YRD	10.96(100%)	100.1(100%)	4667.2(100%)	46,625 (100%)
GDP: year of 2003				
the Randstad	0.83 (20%)	7.1(41,5%)	2712 (51%)	381,971 (122,9%)
the Netherlands	4.15 (100%)	16.8(100%)	5317 (100%)	310,798 (100%)

Figure 10: Economic Position Comparison

Spatial Planning System

In China, the administrative hierarchy is very dominant with more layers and more complicated administration departments than the Netherlands (Figure 11). For the spatial planning, there are two kinds of instruments. One is urban plan referring to vision or precise development of an area in different scale, the other is related to development control like “Detailed Development Control Plan” and “Parcel-Based Detailed Construction Plan” (Yeh & Wu, 1999). The relation between these five instruments and administration system is not so clear as spatial planning system in the Netherlands. The Netherlands has three administrative levels and each of them has one structure vision. And the only link among all three levels is Zoning Scheme (Bestemmingsplan). Thus, spatial planning hierarchy in the Netherlands is much more clear and simple than China. This also means that one spatial plan in China needs to be checked and legalized by multilevel governments. Another big difference between China and the Netherlands is that spatial planning instruments in China are about plan which were used in the Netherlands before 2008. Now the Netherlands prefers structural vision instead of plan (Figure 11).

Related to the administrative hierarchy of primary cities and secondary cities defined in SWC and the Randstad, the situation in both regions is very different. In the Randstad, all primary cities and secondary cities have equal position of government and belong to a province. However, in SWC, all secondary cities belong to their own primary cities, such as Kunshan is a part of Suzhou, and Jiangyin belongs to Wuxi. This kind of governance relation has big influence on the spatial planning of the whole region.

Referring to inter-city cooperation, there are some similarities and differences between YRD and Europe. Both conclude three models of cooperation from empirical implementation. In YRD, Hierarchical partnership, Hybrid partnership and Spontaneous partnership (Luo & Shen, 2009) have been implemented for spatial plan, infrastructure, environment, etc (Figure 12). Europe has more complicated situation by the different countries, regions and cities. Thus, they do not mention high-level government, which shows a sort of shift from government to governance. Therefore, they use authorities instead of government to define different cooperation models (Figure 12): The Comprehensive model, the Core Power model and the Agency/Voluntary model (Albrechts, 2011). By comparing cooperation in YRD and Europe, Spontaneous partnership in YRD is very similar to the Agency/Voluntary model, both of which have bottom-up approach. The Comprehensive model in Europe has some relation with Hierarchical and Hybrid partnership in YRD. The Comprehensive model requires authorities with comprehensive power that mainly refers to government, while Hierarchical and Hybrid partnership are mainly about cooperation between different levels of government. But the difference is that the Comprehensive model asks for restructure of local administrative arrangement, and in YRD they pay more attention about balanced control of high-level government to city government. The Core Power model in Europe requires authorities with power for specific issue, like transportation or environment, which involves public and private stakeholders. This model has relation with Hybrid partnership, with respect of combination of public and private stakeholders. But The Core Power model has more focus on

specific issue to develop in order to gather as many actors as possible. To sum up, the models of cooperation in Europe emphasize diverse stakeholders either public or private, while in China it is inevitable to make use of the power of government for cooperation.

Figure 11: Spatial Planning System Comparison

Source: Based on Yeh & Wu, 1999; MLIT

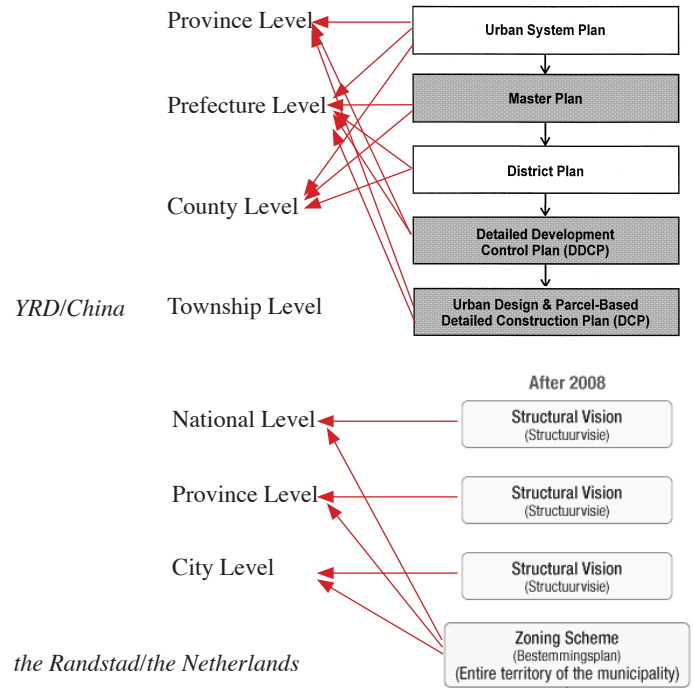
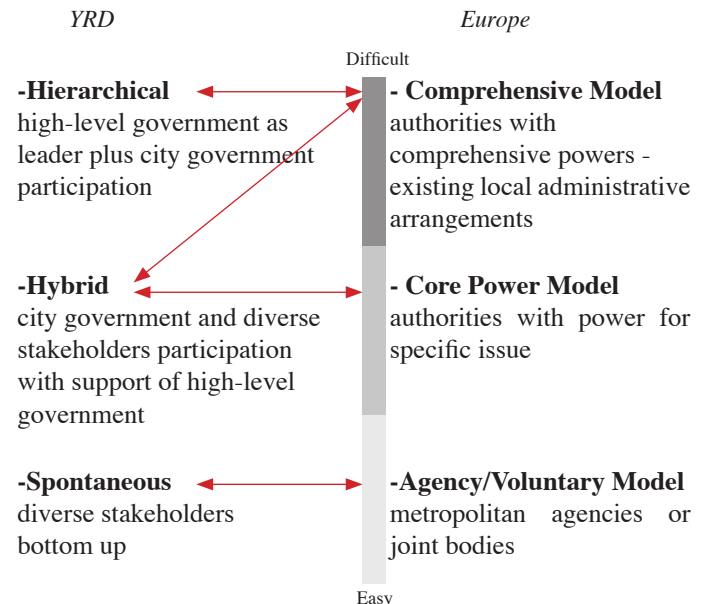

Figure 12: Mechanism of inter-city cooperation

Source: based on Luo & Shen, 2009; Albrechts, 2011



Regional Planning Aim

There are two regional plans that are relevant for SWC : Yangtze River Delta Regional Planning 2009-2020 and SWC Regional Planning 2001-2020 (Map 13). Yangtze River Delta Regional Planning 2009-2020 was published in 2010 which is more updated version, however, SWC Regional Planning was done in 2002 which will be an old version. At this moment, Jiangsu Institute of Urban Planning and Design is responsible for the new version of SWC Regional Planning, which is not public yet.

According to two regional plans above, there are three main aims for YRD as well for SWC (Figure 14). Firstly, YRD will become an important gateway to the Asia-Pacific region. This is also one aim for SWC, because cities in these area are trying to improve their positions on the global scale, such as building new international airport – Sunan International Airport. Second aim is about the changing type of economy. Cities in SWC already have good economic base, but most of economy is depending on manufacturing. The industrial level of manufacturing is relative low comparing with developed countries, which caused a lot of environmental problems. Thus, it is very helpful to improve the manufacturing level and to develop modern service industry. Meanwhile, SWC will concentrate on ecological agriculture, tourism and textile appliances (Map 13). In one word, SWC aims to develop its own specific economic sector to facilitate Shanghai Metropolitan Region complementarily. The last but the most important is to improve the urban network with all scales of cities to strengthen the regional competitiveness, which can be applied in different scales: YRD scale or SWC.

When comparing aims of regional planning for the Randstad and SWC, both of them emphasize the regional competitiveness, especially from the economic perspective. However, the economy development stage in two region is different, so that there are different focus on the economy. The Randstad 2040 (2008) mentions development of the Green Heart as one of these aims which is not very apparent in the aims of YRD and SWC. Fortunately, SWC contains a very important ecological area “Tai Lake”, which can play similar role as the Green Heart. To sum up, there are similarity and differences from the aims of two regional plans.

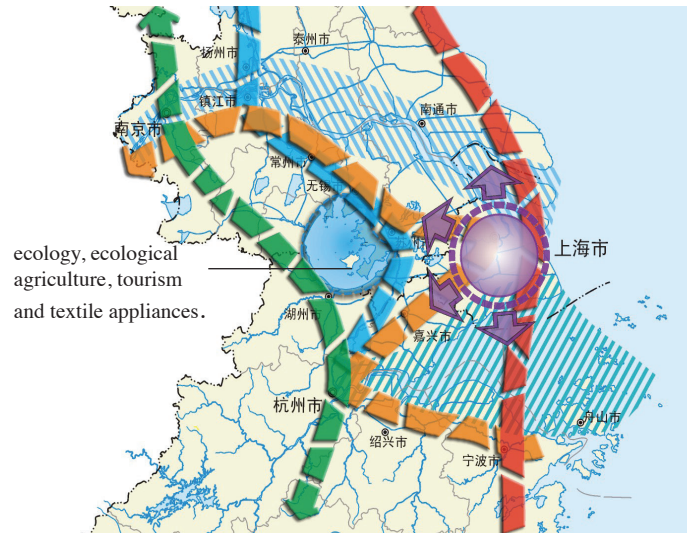

Map 13: Developing Concept of SWC in YRD
Source: Based on Regional Plan for Yangtze River Delta 2009-2020, 2010

SWC Regional Plan 2001-2020
/Regional Plan for Yangtze River Delta 2009-2020

- ▶ 1. Important international gateway to the Asia-Pacific region
- 2. International Modern Service Industry and Advance Manufacturing Center
- 3. Urban Region with Global Competitiveness ←
- network urban system with mega-city and large cities as main cores together with medium or small sized towns
-
- ▶ 1. Strengthen international competitive position ←
- 2. Boosting the economy ←
- 3. Increasing strength and dynamics of the cities ←
- 4. Developing unusual qualities of the Green Heart

The Randstad 2040

Figure 14: Aims of Regional Planning Comparison
Source: Based on Regional Plan for Yangtze River Delta 2009-2020, 2010; SWC Regional Plan 2001-2020, 2002; Randstad 2040, 2008

1.4 Aim and Research Questions

In the context of Northwest Europe, there are a set of emerging regions with interactions on the scale of intra-region and inter-region as well. The recognition of relationship between cities or regions has stimulated a variety of interactions already. In Yangtze River Delta, there are several regions are emerging and developing, including SWC.

Thus, the aim of this project is to understand Polycentricity Urban Region in the scale of SWC and YRD by a comparative research with the Randstad and Northwest Europe(NWE), in order to search a way to identify Polycentric Urban Region and discover the Role of Secondary Cities.

The research questions will be as follows:

- a. What is emerging polycentric urban region on the scale of SWC and YRD by comparing with the Randstad and NWE?
- b. What is the role of secondary cities in SWC Region by a comparison study with the Randstad?
- c. How can the development of secondary cities contribute to the emergence of Polycentric Urban Region?
- d. How do the results correspond to existing vision of SWC?

1.5 Theoretical Framework

This part of research is mainly going to use literature review to set up a theoretical framework (Figure 15) for the whole project. Based on the large amount of theory research about Polycentric Urban Region, how to identify Polycentric Urban Region and the role of secondary cities in PUR are the main focuses, particularly from the analytical and normative Dimension. Different from review paper, this part will mainly focus on the link through problem statement, theoretical framework and analysis orientation (Figure 16).

Analytical dimension is applied to observe existing spatial structure of PUR including morphology and functional interaction. Parr (2010) concludes that PUR is “consist of a cluster of similarly sized centres which are separated by open land (agriculture or simply vacant) with highly intensive interaction (especially economical interaction) and economic specialisation”, which emphasises the importance of the morphological and functional aspects for PUR.

From the morphological aspect, PUR in general is opposite to Monocentric Urban Region (MUR) and urban sprawl (ESPON, 2006). Because PUR is more spread and **decentralised** than MUR, and more **clustered** than urban sprawl. In addition, organized open space between cities makes PUR different from

Dispersed Urban Sprawl(DUS). Besides the distinguish among PUR, MUR and DUS, the history will explain why and how the morphology of the region was developed through alternative ways. Meanwhile, rank-size distribution is a tool to distinguish primary cities and secondary cities. Morphological aspect of PUR can tackle the problem of Urban Sprawl and Disparity in SWC Region, by means of exploring the existing spatial morphology of economic activities including distribution of labour force and employment.

Functional interaction is another important aspect, which means proximity is more referring to functional relationship rather than physical distance. Economic relationship and interaction is very crucial to evaluate the level of emerging PUR (level of Polycentricity), which means more intensive interaction more emerged PUR. Simin Davoudi (2003) has observed that “without the economic underpinning a PUR will simply represent a group of neighbouring cities of more or less similar size and economic weight, rather than a functional integrated region”. Travel pattern is one direct tool to measure functional interaction of PUR, such as journey to work, company network and travel for shopping, etc. By observing functional relationship of economic activities, the problem of identity and cooperation can be evaluated from analytical dimension.

Figure 15: Theoretical Framework

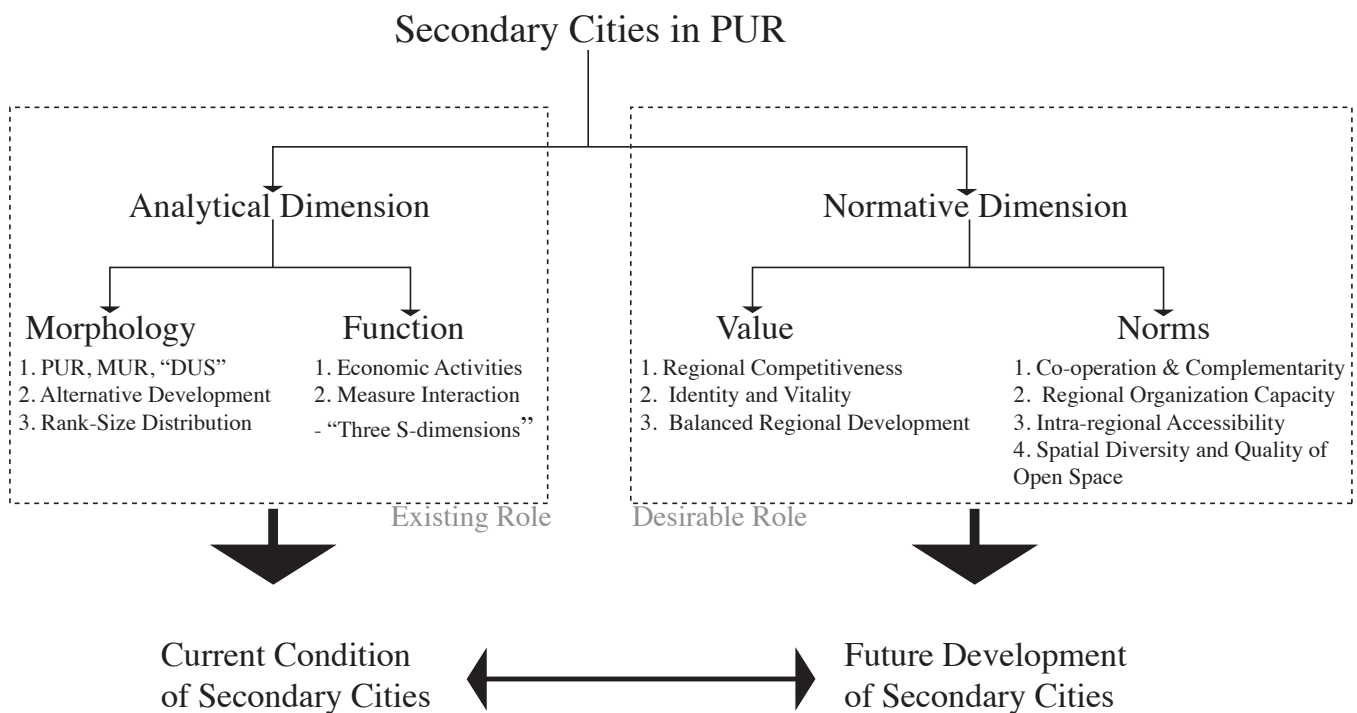

Normative dimension, including the value and norms of PUR, provides a strategy for secondary cities and the whole region. There are three main values of PUR: “Balanced Regional Development” referring to disparity in SWC, “Identity and Vitality” referring to lack of identity of cities in SWC, and “Regional Competitiveness” as the ultimate aim of PUR. Regional identity is very crucial for functional PUR which needs combination of difference norms, such as cooperation or complementarity, accessibility, spatial diversity and organization capacity. Kees Terlouw (2009) proposed to use thick and thin regional identity as a tool to analyse the trend of different region in terms of regional identity. Due to the globalisation and individualisation regional identity is shifting from thick to thin regional identity. It means traditional thick regional identity, which emphasises the culture and historical identity of a certain territorial, is decreasing. The thin regional identity are more network based and more economy and future oriented. Take Dune-Bollenstreek as an example, several secondary cities including Leiden and Haarlem could make use of culture and historical identity of cultivation of flower bulbs. In order to enhance the competitiveness of the region, these sort of cities could cooperate with one another to build up a specific network which is more **economical focus** rather than only culture and historical identity. These sorts of cities

are also trying to connect to primary cities (schipol airport city or Rotterdam harbour) as well, so that they could participate in the global network.

Norms of PUR actually function as concrete strategies to achieve all the values of PUR. “**Cooperation and Complementarity**” leads to two different types of PUR: “Club” type and “Web” type (Meijers, 2007). In the club type, cities “share a common objective, activity or service, while also having parallel interests and transaction chains” (Meijers, 2007), especially with similar economic sectors, like port cities or tourist cities. Web type is characterised by specialised activities of different cities. For instance, a city with a specific production needs to work with an international city with airport or harbour, and it also needs the support from a knowledge city with universities or research institutions. Thus, these two types of synergy can be existing at the same time (Meijers, 2007). In the club type of PUR, cooperative cities will face similar problems, like internal competition, a weak economic base, the same need for public transportation. Distinguished from club type, PUR with web type network means “the individual cities perform different economic roles and host complementary urban facilities, activities, residential and working environments” (Meijers, 2007). Although co-operation and complementarity both can

Figure 16: Theoretical Framework linking Problem Statement and Analysis Orientation

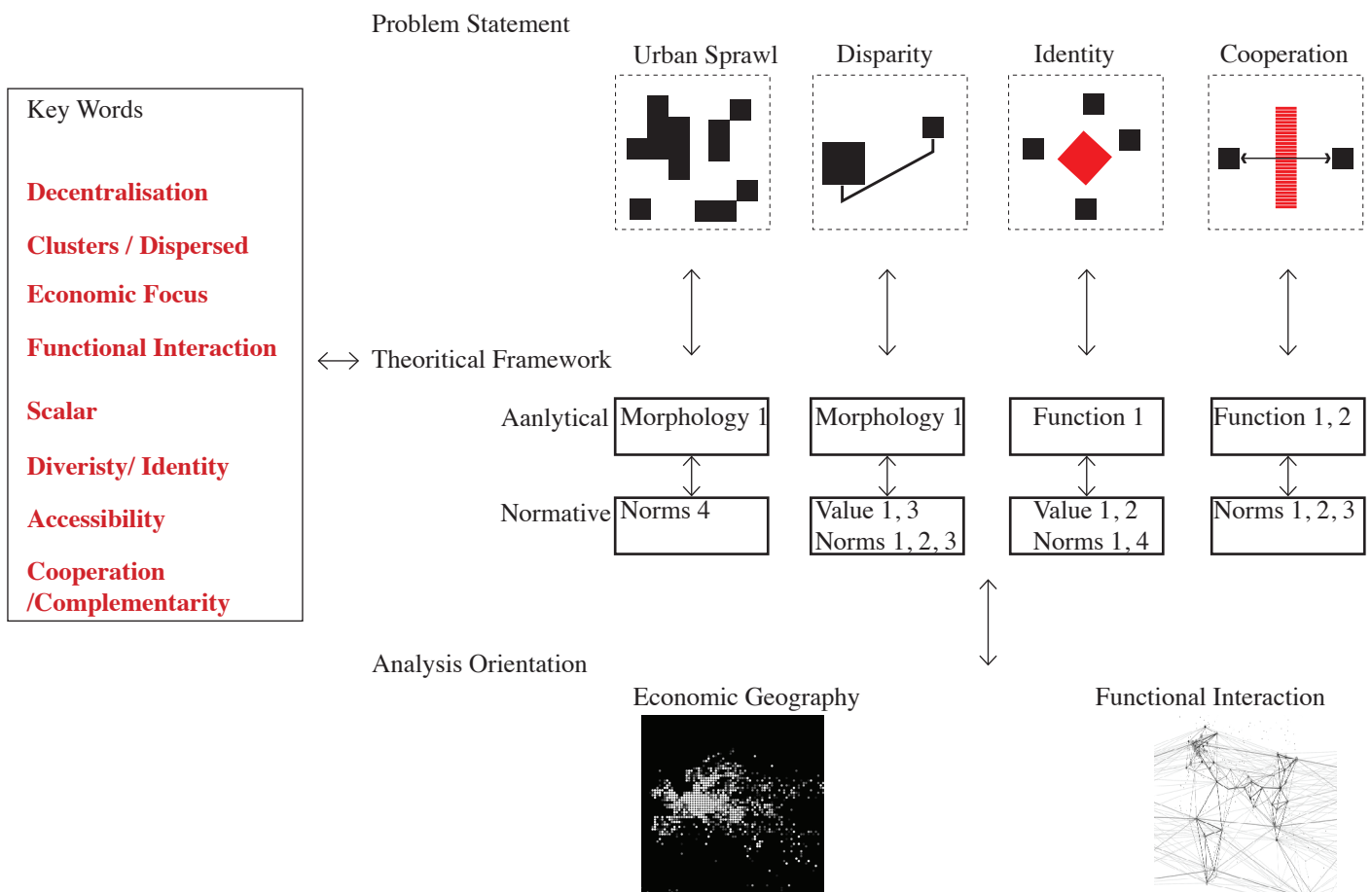

be applied in the PUR, the latter one –complementarity is more relevant of PUR. “Cooperation and Complementarity” will be a part of research to tackle the problem of identity and cooperation in SWC, because this norm will essentially lead to functional interaction and regional identity that contribute to emerging PUR.

Another norm “Intra-regional **Accessibility**” provides physical connection by infrastructure network for functional interaction, comparing with “Cooperation and Complementarity” as functional needs of interactions. That’s why many regions are improving their infrastructure network in order to attract investors, businessmen, visitors and local consumers (Romein, 2004). By improving intra-regional accessibility, the cooperation between cities in SWC can be stimulated informally. That’s why many countries are busy with infrastructure projects to strengthen private car transport and public transport as preference. “Stedenbaan Project in the south wing of the Randstad, MetroRapid in RheinRuhr and Regional Express Networks in the Flemish Diamond are three examples for public transport. Moreover, multi-**scalar** approach of transport planning is necessary for namely a integrated transport system in a PUR, which includes multi-model and multi-scalar transfer nodes (Romein, 2004), strategic transport links according to the functional position of cities, multi-layered stakeholders.

“Spatial **Diversity** and Quality of **Open Space**” can be a proper norm to solve the problem of urban sprawl and lack of identity in SWC. “Contour Policy” is widely used by different PUR. In the Randstad, “red and green contours” distinguish where the urban expansion can be implemented and where ecological or culture landscape must be protected. In Flemish Diamond, the “red and green contour” is replaced by “blue and green network”.

“Regional Organization Capacity” can provide a alternative solution for the cooperation of cities in SWC. By reviewing the different cooperation systems in Europe and Yangtze River Delta, there are many differences between them and many difficulties existing in both of them (discussed in 1.3.3).

In conclusion, four main problems of SWC can be reflected from theoretical framework of PUR, either analytical dimension or normative dimension. Based on the understand PUR and links with problem statement, there are several key words highlighted, such as clustered/dispersed, cooperation/complementarity, Diversity/Identity, Scalar, Economic Focus, Functional Interaction. Therefore, the analysis orientation will be Economic Geography and Functional Interaction. Economic Geographic is used to describe spatial morphology of economic activities, and to conclude some norms of PUR like cooperation or complementarity. Functional Interaction is used to measure polycentricity in analytical dimension, and meanwhile to discover potential interactions and development by combination of different norms like cooperation/complementarity and accessibility.

1.6 Societal and Scientific Relevance

Societal Relevance

SWC Region is one of the most developed region in China, and it has very large influence to Yangtze River Delta and the whole country as well. The development of SWC Region will contribute to the large scale in different ways, like environment improvement, economic switching, government cooperation and so on. Especially these secondary cities with strong economic position and active private sectors, they have good base to develop the clear and strong roles. Their experimental development will give a clear example to other cities in China. For instance, nowadays people in china pay more attention to the living environment after economic booming. Most of large cities don't have good urban environment, like enormous urban congestion, expansion eating the green area, etc. Thus, secondary cities with more space and green can face these as opportunities to develop their specialisation instead of only industry cities. Besides, interaction between cities is increasing rapidly due to the good transportation system in SWC Region or the new life style and requirement of chinese citizens, some secondary cities in SWC in reality have good accessibility to employment. They could improve their living environment by good facilities and spatial qualities, so that secondary cities in SWC could be preferred cities to live.

Scientific Relevance

Polycentric Urban Region is a still developing theory of urbanism. For the analytical dimension of PUR, the analysis of four regions (NWE & YRD, Randstad & SWC) will provide different empirical context of PUR in different scales. For example, spatial morphology can occur differently by the choice of criteria and scales. Normative dimension of PUR is not as developed as analytical tool. Norms of PUR will be concluded from the experience of NWE and the Randstad, in order to discover how these norms facilitate for PUR in different contexts and scales.



2. Comparative Research

2.1 Definition of Comparative Research

2.2 Scale Large and Scale Small

2.3 Three Indicators

2.3.1 *Distribution & Polycentricity*

2.3.2 *Diversity & Polycentricity*

2.3.3 *Accessibility & Polycentricity*

2.4 Polycentricity Measure Tools

2.4.1 Polycentricity Matrix

2.4.2 Polycentricity Triangle

2.4.3 Moran's I

2.1 Definition of Comparative Research

Comparative Research is a research methodology in the social sciences that aims to make comparisons across different countries or cultures. There are two crucial issues that need to be clear for comparative research.

One is referring to the method. The method of Comparative Research contains the definition of indicators, equivalence of indicators, hypotheses required to link indicators to constructs. Thus, the choice of the indicators will be very essential to support the research topic. The other issue is about data access and comparability, which is preliminary to compare (C.S. Yadav, 1968).

2.2 Scale Large and Scale Small

Scale Large includes two areas: Northwest Europe and Yangtze River Delta. Based on the comparable size of unit, Nuts 3 is the proper scale for the analysis of NWE, while for YRD, county-level has been applied. The Randstad and SWC Region belong to Scale Small. Municipality level of the Randstad and township-level of SWC Region have been chosen for the analysis (Map 17).

Map 17: Scale Large and Scale Small

Scale Large

NWE:NUT3

YRD: County

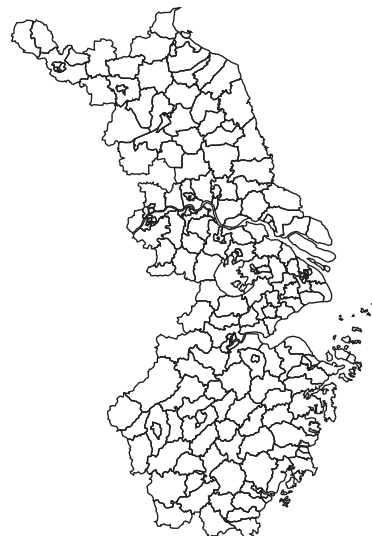

Scale Small

Randstad: Municipality

SWC: Township

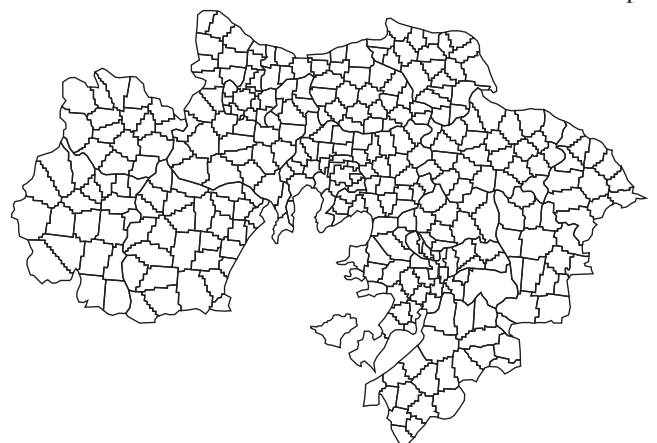

2.3 Three Indicators

“Without the economic underpinning a PUR will simply represent a group of neighbouring cities of more or less similar size and economic weight, rather than a functionally integrated region” (Davoudi, 2003), which means two levels of Polycentricity: Morphological Polycentricity and Functional Polycentricity. In order to understand both levels of Polycentricity, the relation between live and work is the main topic of this research. Morphological Polycentricity will be described by Economic Geography that includes “Geography of Residence” and “Geography of Economic Activities”, in order to discover the origins and the destination of “Journey to Work” travel pattern. That’s why “Distribution” is one indicator to represent the spatial pattern of activities by live and work. Zooming in activities of work, there are different sorts of economy, such as agriculture or industry or service. Not only use “Distribution” to understand different sort of economy, “Diversity” as another indicator is applied to analyse existing specialisation of different locations. In this sense, “Distribution” and “Diversity” are two indicators for analytical dimension of PUR.

Functional Polycentricity is even more important for PUR. Direct way to measure functional interaction is to use “journey to work” and “Company Network”. For the Randstad, “journey to work” and “Company Network” are available from many existing research papers and Central Statistics Bureau (CSB). However, these data are impossible to achieve for China. Instead

measuring existing interactions, it makes sense to discover the norms which generate interaction potentials Polycentric Urban Region. Thus, “Diversity”, as one of three indicators, functions in normative dimension referring to “Cooperation” and “Complementarity” which aims for the functional relationship. “Accessibility” is selected as another indicator for normative dimension. “Accessibility” mainly depends on the infrastructure network as well as distribution of activities. It is a common and efficient indicator to express potentials interactions including “journey to work”, company network, etc.

In conclusion, “Distribution”, “Diversity” and “Accessibility” as three indicators of my comparative research, will be applied to describe and measure morphology and functional interaction of Polycentricity Urban Region through analytical and normative dimension. Both two dimensions help each other to understand existing emerging regions and the role of secondary cities, and at the same time these two dimensions can underpin future development of the region including secondary cities for PUR.

Figure 17: Three Indicators

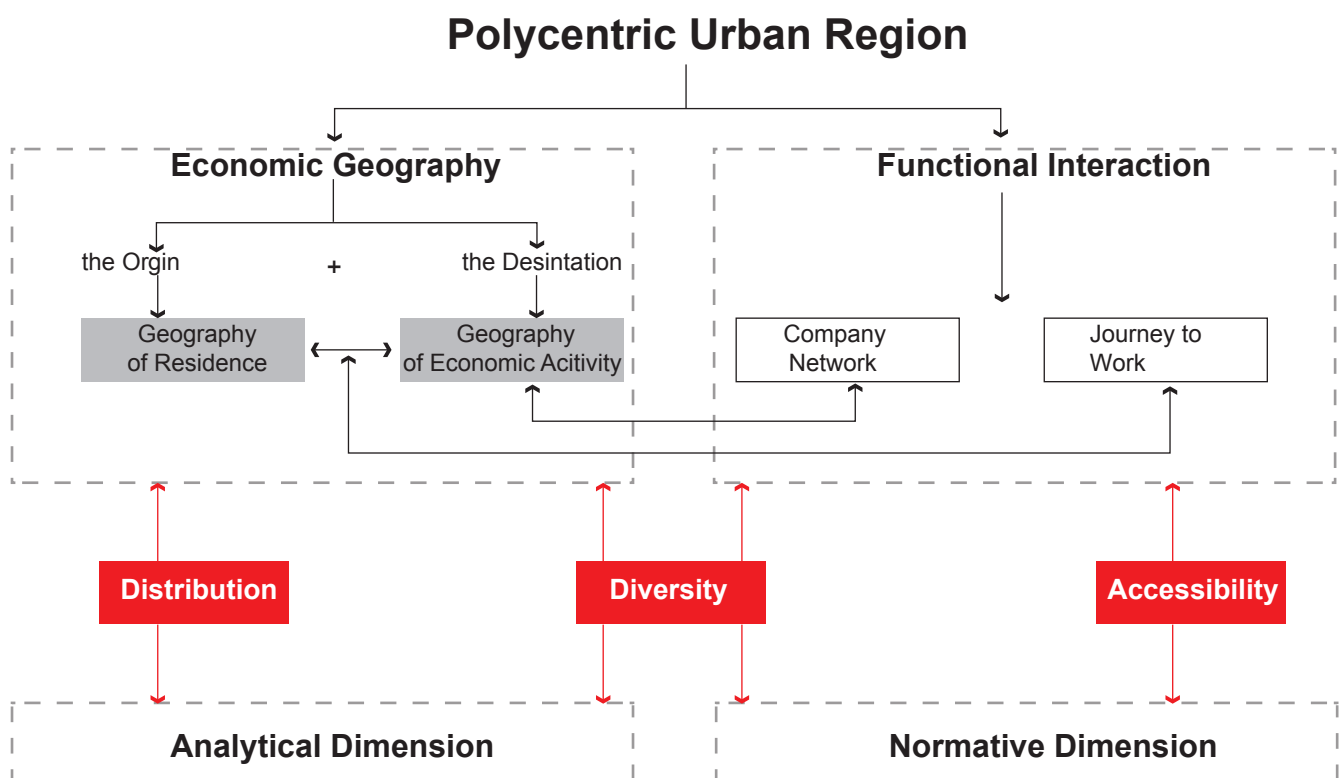

2.3.1 Distribution & Polycentricity

Spatial distribution of economic activities is mainly used to describe spatial pattern of a region, which could be polycentric, monocentric or decentralised urban sprawl (ESPON, 2006).

Rank-Size Distribution is a useful tool to measure polycentricity in the urban region, meanwhile, which are primary cities and which are secondary cities in a certain scale can be defined. Population rank as well as employment rank (Anderson & Borgart, 2001) are two main indicators. Thus, the distribution of population and employment will be analysed to highlight the position of secondary cities in the region.

Besides defining primary cities and secondary cities, the distribution of population and employment can be used to describe measure polycentricity, particularly morphological polycentricity. In referring to commuting pattern in the region, the relation between labour force (population between 15 to 64 years old in Europe; population between 15 to 59 years old in China) and employment are chosen as indicators in order to represent existing or potential journey to work.

Besides labour force and total employment distribution, it is meaningful to research the distribution of employment in different sectors of economy: primary sector (e.g. agriculture), secondary sector (e.g. manufacturing) and tertiary industry (e.g. commercial or service). Because the distribution of different sectors indicates various types of spatial structure of the region, which could be Monocentric or Polycentric or dispersed. Based on Bid Rent Curve, Clark (2000) has supposed a hypothesis of spatial structure (Monocentric or Polycentric) with different activities (CBD, manufacturing, residential, commercial, agriculture). Thus, the distribution analysis of economical activities by three main sectors can explore the regional spatial structures from empirical cases: Northwest Europe & Yangtze River Delta, the Randstad & SWC Region.

2.3.2 Diversity & Polycentricity

Due to the globalisation, economic decentralisation, the improvement of transport and communication etc, the formerly self-supporting cities are able to trade with other cities. Then cities were “stimulated to specialise and build on their specific strengths of natural endowments or economies of scale in particular activities” (Kloosterman and Lambregts, 2001). Because a specific milieu that specialised in particular products can not be copied, which can strengthen the competition of a city or a region. For example, lots of cities in the Randstad are making efforts to specialise themselves in the region, like media city Hilversum, bio-science centre Leiden. The specialisation process of different cities within the regional scales will increase the diversity of the region.

In addition, a specialised region with diversity could stimulate the interactions among cities. Based on the concept of synergy in Polycentric Urban Region by Evert Meijers, there are two types of network – Club network and Web network. The synergy in Club Network “derives from co-operation leading to economies of scale and so-called positive network externalities” (Meijers, 2007), which is called horizontal synergy. Horizontal synergy means each city could share and exchange facilities,

labour market, infrastructure, etc. The synergy in Web Network “results from a specialisation process, redistributing resources and activities among the participating actors according to their competence”. Vertical synergy is more relevant for the PUR, because each city could emphasize on its own specialisation so that there is an inevitable demands to interact with other specialised cities within the region.

“Scale” issue needs to be highlighted for this indicator “diversity”. “Specialised cities in a diverse region” refers to the Scale Small, and “specialised regions in the inter-regional scale” refers to Scale Large. Thus, indicator “diversity” aims to identify whether and at which scale (spatial level) specialisation of economic activities is taking place in the different contexts.

A diversity index is “a quantitative measure that increases when the number of types into which a set of entities has been classified increases, and obtains its maximum value for a given number of types when all types are represented by the same number of entities” (wiki, Diversity Index). It can be used to measure the balance of different functions within study unit (town, city or region).

There are a variety of equation of diversity index. Shannon Diversity is the most popular used equation as follows:

$$H = - \sum_{i=1}^N (P_i * \ln P_i)$$

where:

H = the Shannon diversity index

P_i = proportion of an individual in a category

N = numbers of individuals

∑ = sum from individual 1 to individual N

High value of H represents high diversities. If only one individual in this category, H will be zero. If all individuals are more equal to each other, H will be higher.

This Diversity Index will be applied in NWE, YRD, the Randstad and SWC, so that how specialisation and diversity react on the different scales will be observed.

2.3.3 Accessibility & Polycentricity

With the development of technology, especially transportation system, the spatial proximity is not as crucial as before. Interactions among cities or locations are partly depending on transport network. Therefore, there are a variety of study about travel pattern in order to describe the real interaction between cities or locations. Basically there are five measures of travel patterns: travel distance, travel time, journey frequency, model split, transport energy consumption (Stead & Marshall, 2001). This research is mainly focus on the existing or potentials commuting travel pattern, so travel time, corresponding with travel distance, is most crucial for people to choose their living and working location. Besides, within daily urban system, commuting within one hour is always an important parameter.

There are three main equations for accessibility: Cumulative Opportunity Measures, Gravity-based Measures and Utility-based Measures. The first one Cumulative Opportunity Measures is the most common equation, which measures a total opportunities within a given travel cost (e.g. travel time). For example (Figure 19), if S5 could achieve S2, S3, S5, S6, S7 and S8 within one hour, then the accessibility of S5 will be the sum of all the opportunities of all these locations contain.

Therefore, accessibility could represent potential areas with a certain purpose, which could promote functional interactions in the region.

Figure 18: Accessibility Equation
Source: Based on Handy & Niemeier, 1997

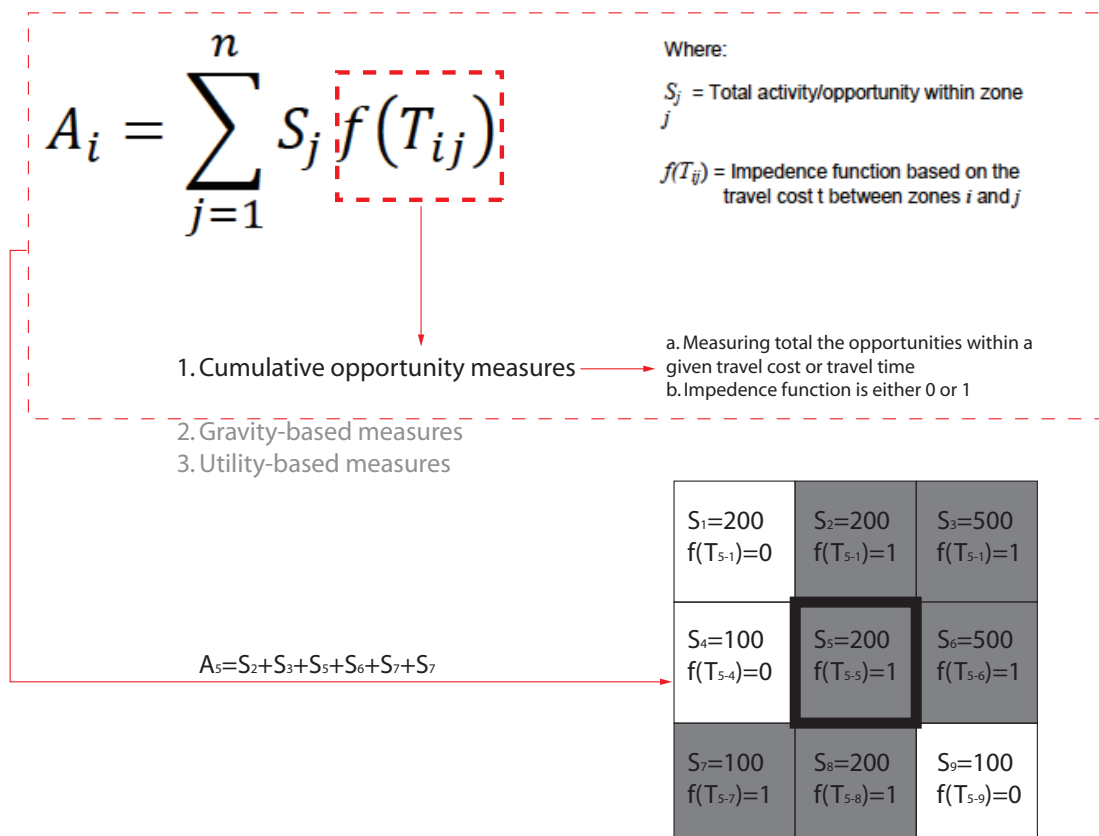

2.4 Polycentricity Measure Tools

“Distribution”, “Diversity” and “Accessibility” are three indicators in order to unpack Polycentric Urban Region and secondary cities from analytical dimension and normative dimension. Thus, besides geographic map of these three indicators, it is necessary to invent some tools which can measure Polycentricity efficiently for all the maps. These “Polycentricity Measure Tools” functions as the ruler for the length or the scale for the weight. There are three Polycentricity Measuring tools in terms of different research questions. One tool “Polycentricity Matrix” is mainly used to measure Polycentricity from the spatial configuration of the whole region. “Polycentricity Triangle” can describe the role of secondary cities in the region, especially by comparing with primary cities. “Moran’s I” will explain how Polycentricity varies by the scale. All these tools can provide direct and effective message about Polycentricity, so that it makes comparison study easier to represent the essentials of concept of Polycentric Urban Region.

2.4.1 Polycentricity Matrix

Polycentricity Matrix is a tool to measure the spatial configuration of the region, by distinguishing Polycentric with Monocentric and random dispersed. There are two dimensions of measures: centralisation and clustering (Anas et al., 1998). Centralisation describes the degree of concentration around a single centre: more centralised means more monocentric spatial distribution. Clustering represents the number and size of sub-centres, which means more clustering more important the sub-centres are. By combining these two dimensions, a sort matrix is figured out (Figure 20). “Centralised” and “Decentralised” are used to distinguish monocentric and polycentric spatial structure, while “Clustered” and “Dispersed” shows the level of emerging regions with the participation of sub-centres. Actually there is no exact border between “Centralised” and “Decentralised”, between “Clustered” and “Dispersed”. In this tool, there are four general categories: “Clustered Decentralised” refers to “High Polycentricity” and “Dispersed Decentralised” refers to “Low Polycentricity”, “Clustered Centralised” means “High Monocentric” and “Dispersed Centralised” means “Low Monocentric”. Therefore, to put analysed regions into these four categories aims to compare spatial structure of regions directly. For example, there is a map about Northwest Europe and Yangtze River Delta. Ruhr Area has a very clustered decentralised structure and SWC has more dispersed decentralised structure. Basically, the conclusion can be that Ruhr Area and SWC both have Polycentric spatial structure, but Ruhr Area is more clustered than SWC which means Polycentricity of Ruhr Area is higher than SWC. The comparative situation happens between Paris and Shanghai. Both of them are Monocentric Urban Regions, while Paris is more clustered than Shanghai.

Map 19: Polycentricity Matrix: Measure Regional Configuration

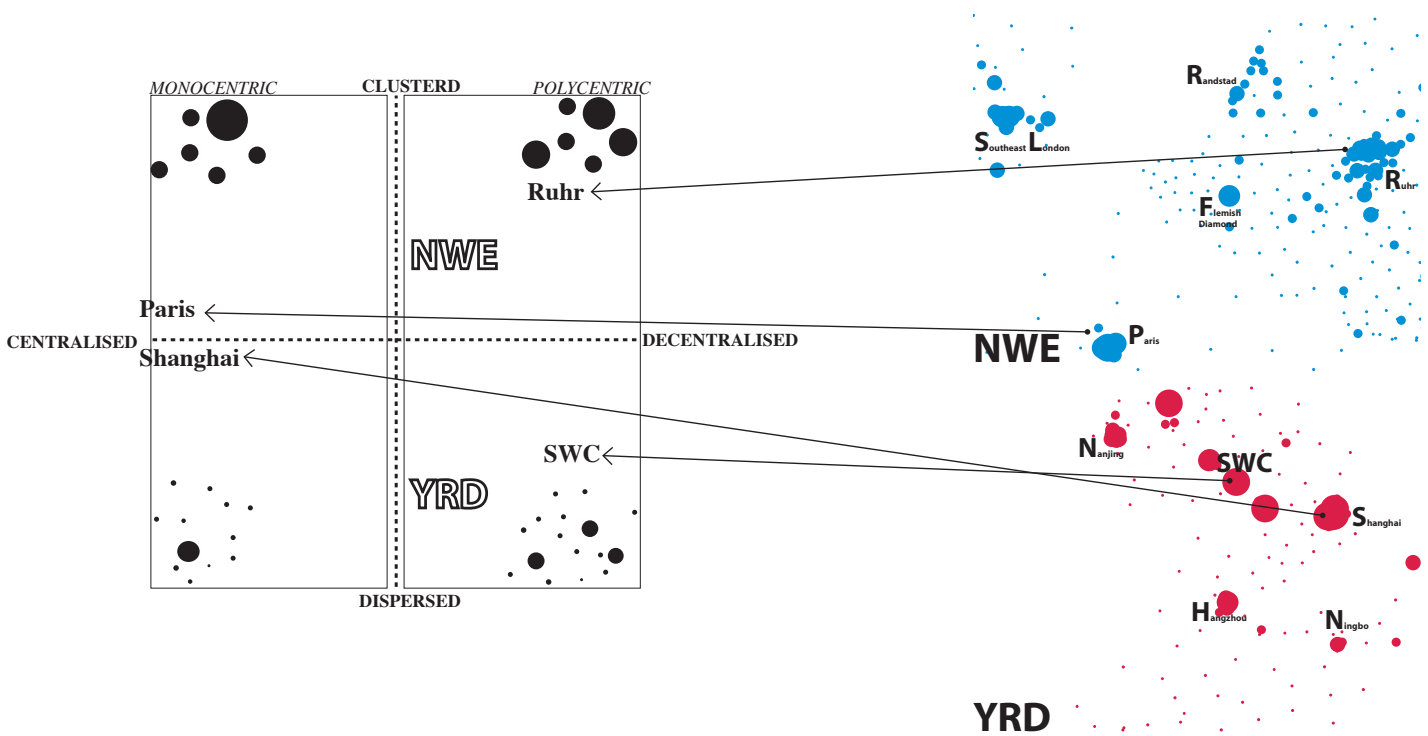

2.4.2 Polycentricity Triangle

Polycentricity Triangle is a tool to describe the role of secondary cities are playing in the region by comparing with primary cities. There are two dimensions within this tool as well. The half circle above is to compare the density of activities between primary cities and secondary cities. One point of “Polycentricity Triangle” is moving on this half circle. The point moving to the middle of circle means the equivalence of concentration between primary cities and secondary cities. The more to the left expresses more concentration on primary cities, while the more to the right means more concentration on secondary cities. The half circle below is about spatial configuration of primary cities or secondary cities with their neighbours, so there are other two points of “Polycentricity Triangle” referring to primary cities and secondary cities. If the spatial configuration is more clustered, the point on the circle will move to the middle, otherwise move to the sides. Moreover, different circles can stand for different issue to analyse the role of secondary cities in the region. Take SWC as one example (Figure 21). The map above shows unbalance of activities between primary cities and secondary cities, that’s why the point on the above half circle is on the side of primary cities. The primary cities have more clustered structures than secondary cities. Thus, the point in terms of primary cities is located almost the middle of the half circle below and the point in terms of secondary cities is much more to the side. Applied the same principle of this tool to the map below, a totally different triangle is created. This triangle is much more symmetry than the other one, which means a sort balanced concentration of activities in primary cities and secondary cities of SWC, and the spatial configurations of both are also comparable in terms of clustering.

Figure 21: Polycentricity Triangle: Measure Primary & Secondary Cities

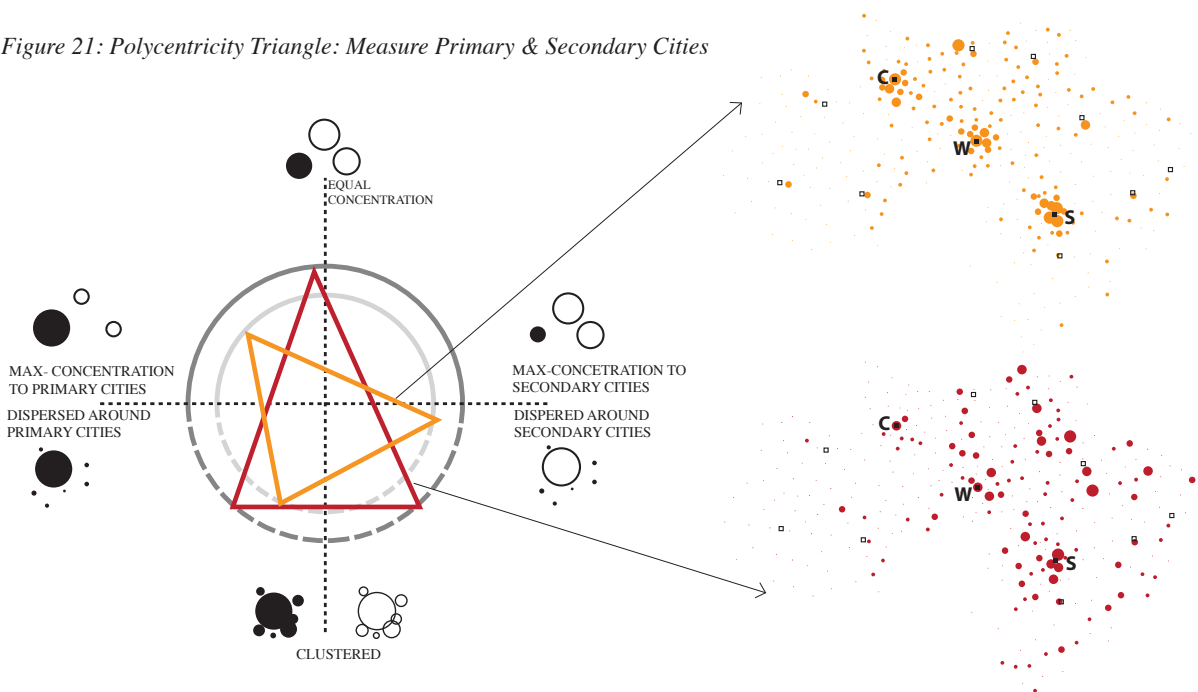

2.4.3 Moran's I

Measuring clustering of economic activities is an effective research in economic geography. On one hand, it can discover the edge of emerging regions with specific economic activities; on the other hand, to explore “at what level of spatial aggregation a kind of clustering of economic activities is taking place within a specific kind of advanced urbanised area, namely, a Polycentric Urban Region” (Kloosterman & Lambregts, 2001).

Global Moran's I is a very useful index to measure spatial autocorrelation. Global Moran's I is based on both spatial value and statistic value (e.g. employment), so it indicates if the pattern is clustered (positive spatial autocorrelation), dispersed (negative spatial autocorrelation) or random dispersed? The result will be five values: the Moran's I Index, Expected Index, Variance, z-score, and p-value.

The Conceptualization of Spatial Relationships analysis should be based on your understanding of spatial interaction among the features being analyzed.

For Inverse Distance conceptualization options: when zero is entered for the “Distance Band or Threshold Distance” parameter all features are considered neighbors of all other features; when this parameter is left blank, a default threshold distance will be applied.

This specific Moran's I combines different “Distance Band” (e.g. 100km for 1 hour travel, and 300km for 3 hours travel) into one line with all the dots. The figure of the line represents how spatial structure varies by scale in terms of clustered or dispersed.

The results of Moran's I could be simply interpreted by the example of Figure 22: the line moving up stands for more clustered spatial structure, and going down means more dispersed structure.

Figure 22: Moran's I: Accurate Measure Clustered or Dispersed

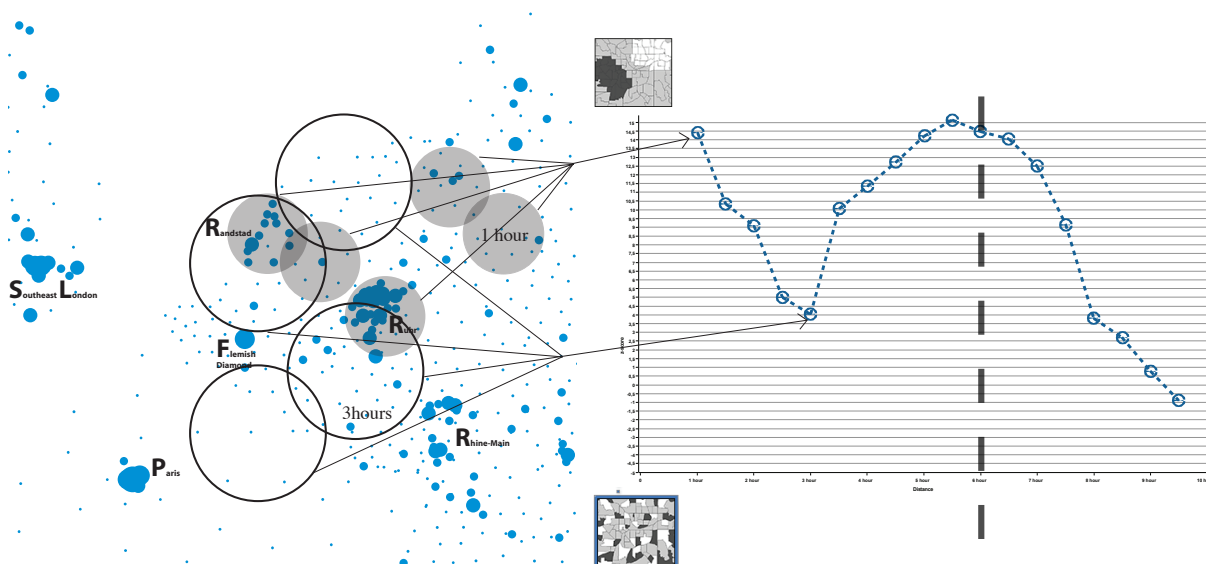



3. Three Indicators: Distribution, Diversity and Accessibility

3.1 Distribution – Analytical Dimension

3.1.1 *Distribution of Live and Work*

3.1.1.a *Mapping*

3.1.1.b *Measuring*

3.1.1.c *Conclusion*

3.1.2 *Distribution of Three Economic Sectors*

3.1.2.a *Mapping*

3.1.2.b *Measuring*

3.1.2.c *Conclusion*

3.2 Diversity – Normative Dimension

3.2.a *Mapping*

3.2.b *Measuring*

3.2.c *Conclusion*

3.3 Accessibility - Normative Dimension

3.3.a *Mapping*

3.3.b *Measuring*

3.3.c *Conclusion*

3. Distribution, Diversity and Accessibility

3.1 Distribution - Analytical Dimension



3. Distribution, Diversity and Accessibility

3.1 Distribution - Analytical Dimension

Distribution as one of three indicators will be applied to two issues: one is to analyse human activities distinguished by live and work, the other is about three main sectors of economic activities. All the analysis is about the density of activities, in order to understand spatial morphology by different functions and different scales. Therefore, the following analysis has been done at two scales, which has been introduced in Chapter 2: Scale Large refers to Northwest Europe (NWE) and Yangtze River Delta (YRD); Scale Small refers to the Randstad and Suzhou-Wuxi-Changzhou Region (SWC). Different issues includes labour force density (age between 15 and 65 in NWE and between 15 and 60 in YRD), employment density, employment density in three sectors of economy separately.

All the maps of Distribution are using circles with different sizes to represent activities density. The size of each circle stands for different categories of density rather than exact density. And the division of categories is done by Natural break method which minimizes the differences within each category and maximizes the differences between categories. In this way, a larger circle can indicate higher density within a certain context and scale. Thus, every two maps will be compared in the sense of spatial configuration, not the precise density.

There will be three steps analysis: mapping, measuring and concluding. Firstly, relevant data will be translated into geographic maps by Arcgis with the explanation of the technical application and data source. Afterwards, three Polycentricity Measure Tools are applied from three aspects: comparing PUR, PUR by Scale and the Role of secondary cities. Finally, conclusion maps will represent geographically the similarities and differences between two regions.

3.1.1 Distribution of Live and Work



3.1.1.a. Mapping of Distribution of Live and Work

Technical Application

Calculation of Labour Force Density and Employment density in Nuts 3 in NWE and in Country level in YRD using Natural Break. Calculation of NWE is based on the source in 2007, while calculation of YRD for labour force is based on the source in 2000 and employment in 2004. Different from other source, Employment of YRD is derived from the amount of business units with a rough number of employees (e.g. 200 business units with employees between 1-19).

Data Source

Labour Force and Employment data of NWE is from “Atlas ABC” and data of YRD is from the website “Urban and Regional Explorer”.

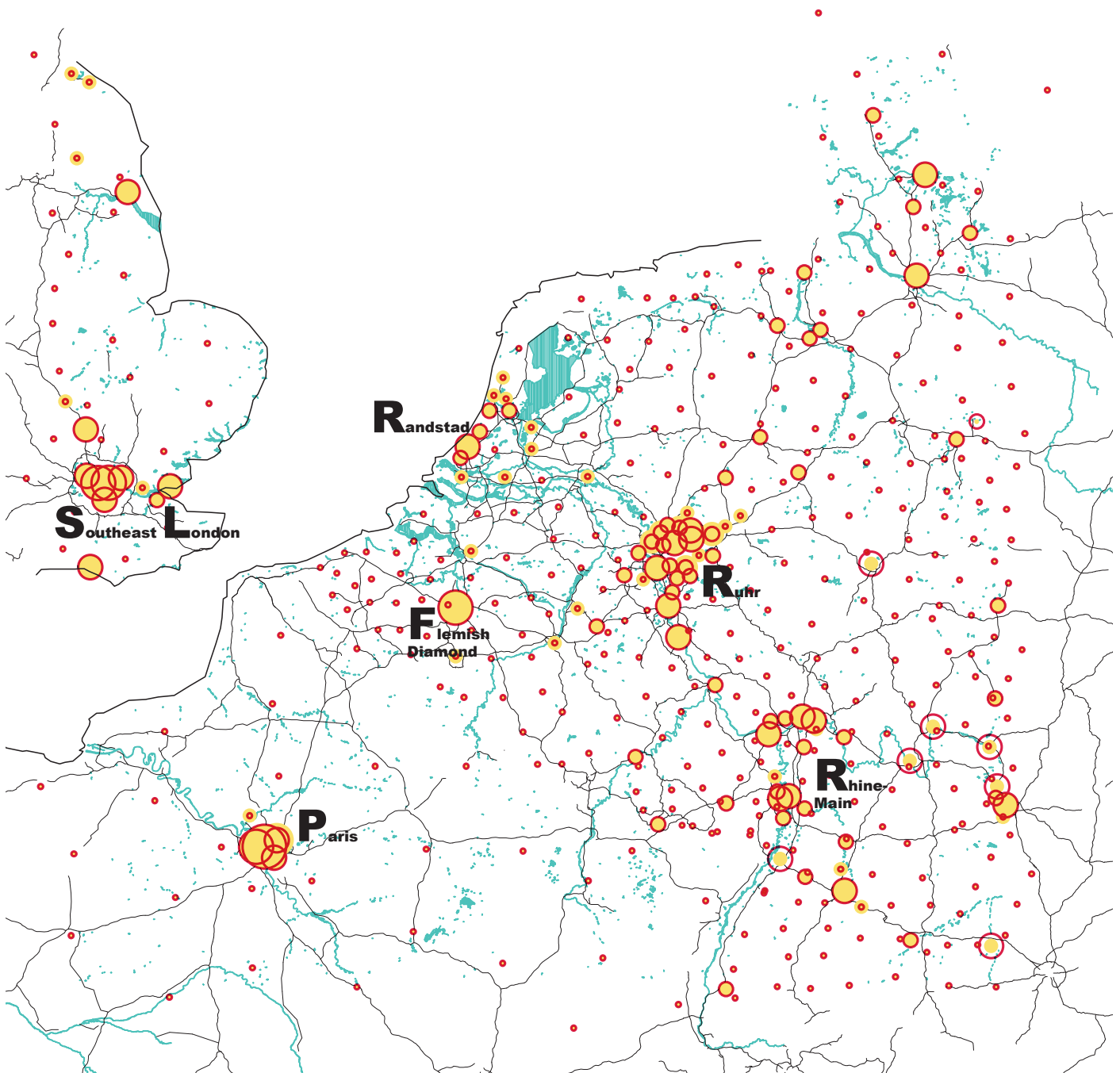

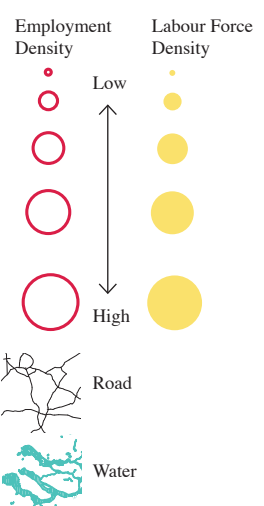
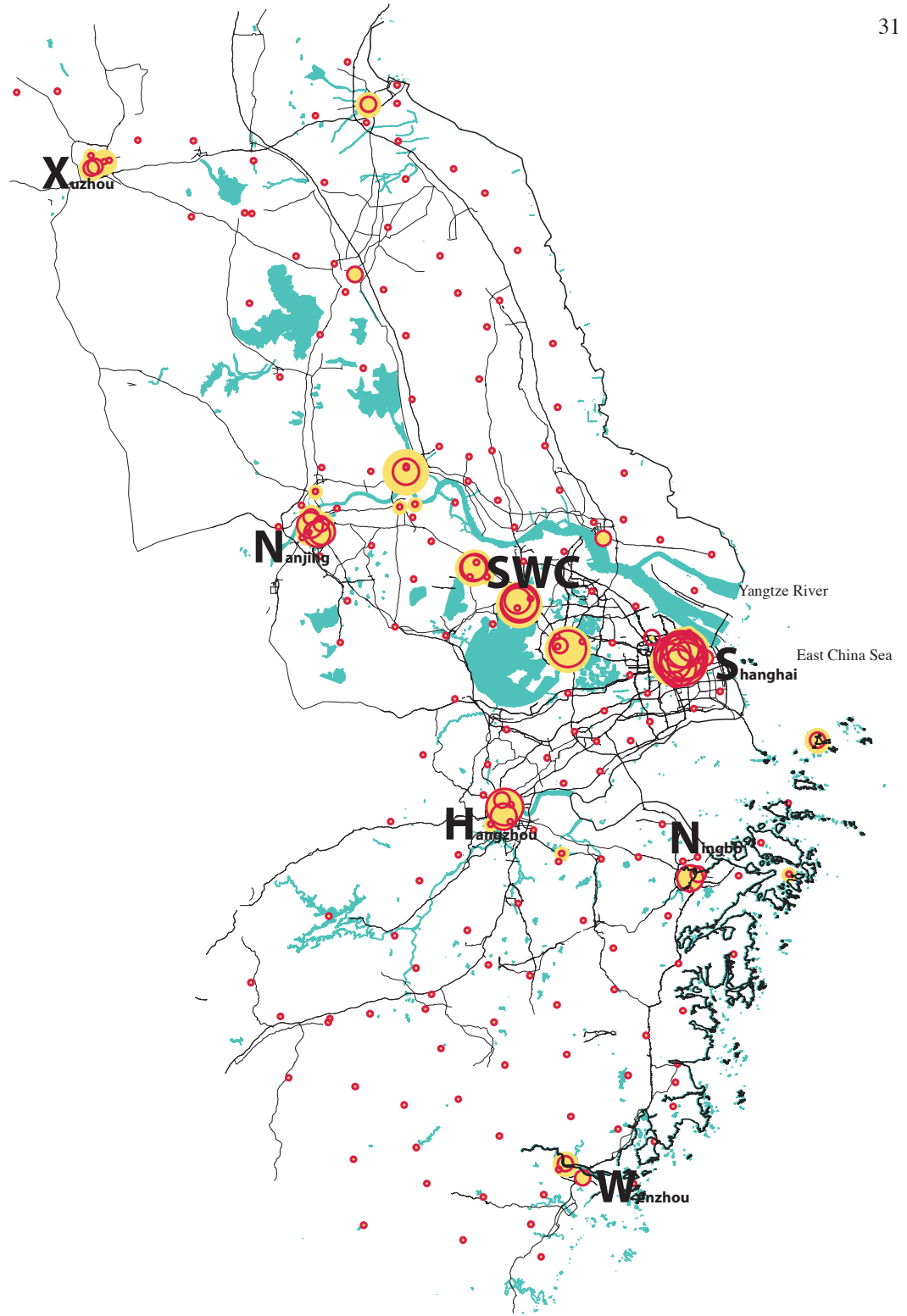

Scale Large- Live and Work

For NWE and YRD, there is almost no difference between labour force distribution and employment distribution (yellow circles and red circles). However, the spatial structure of NWE, referring to either labour force or employment, is totally different from YRD. In YRD, most of living and working activities are concentrated in the large cities, and the neighbour cities has much less density. All these large cities with high concentration area mainly the leading cities for the urban regions which are planned by Chinese government, such as three primary cities in SWC Region In terms of infrastructure like water way, road and railway network, most of regions in YRD are only connected to one of these three networks.

Different from concentration on the large cities in YRD, the regions in NWE have more clustered spatial structure, which means quite a few neighbour cities have comparable activities density, either large cities or small cities. The same as YRD, Waterway, road and railway network play important role for the regions in NWE. Infrastructure network is more equally distributed than YRD. Moreover, On the regional scale, most of regions of YRD has one leading city except SWC, but there are more regions in NWE with poly-centres except Flemish Diamond and Paris.

3.1.1.a. Mapping of Distribution of Live and Work

Technical Application

Calculation of Labour Force Density and Employment density in Municipality level in the Randstad and in Township level in SWC using Natural Break. Calculation of the Randstad is based on the source in 2005, while calculation of SWC for labour force is based on the source in 2000 and employment in 2004. Different from other source, Employment of SWC is derived from the amount of business units with a rough number of employees (e.g. 200 business units with employees between 1-19).

Data Source

Labour Force and Employment data of the Randstad is from the website “Centraal Bureau voor de Statistiek” and data of SWC is from the website “Urban and Regional Explorer”.

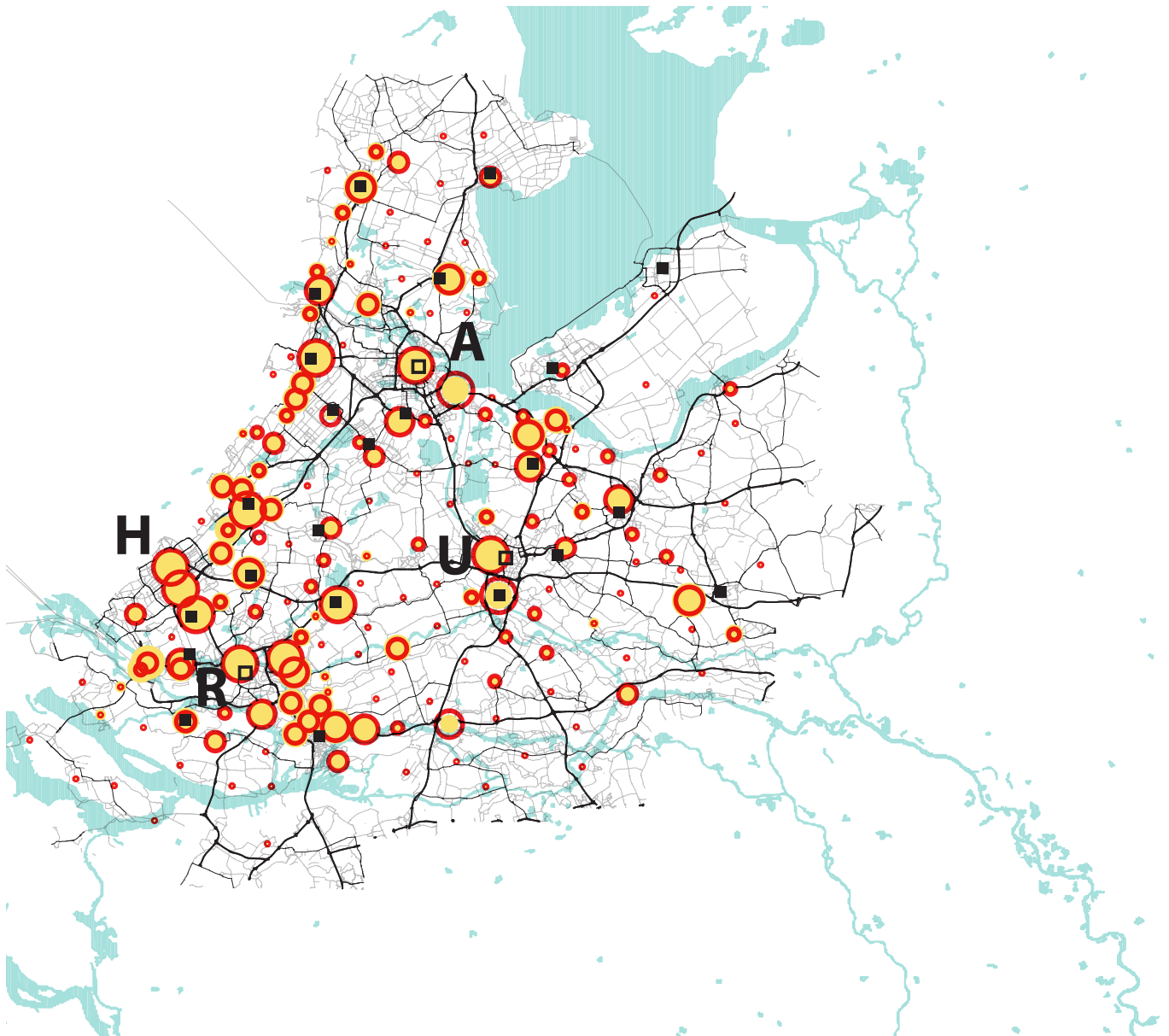

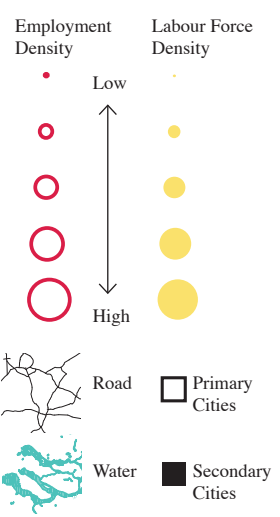
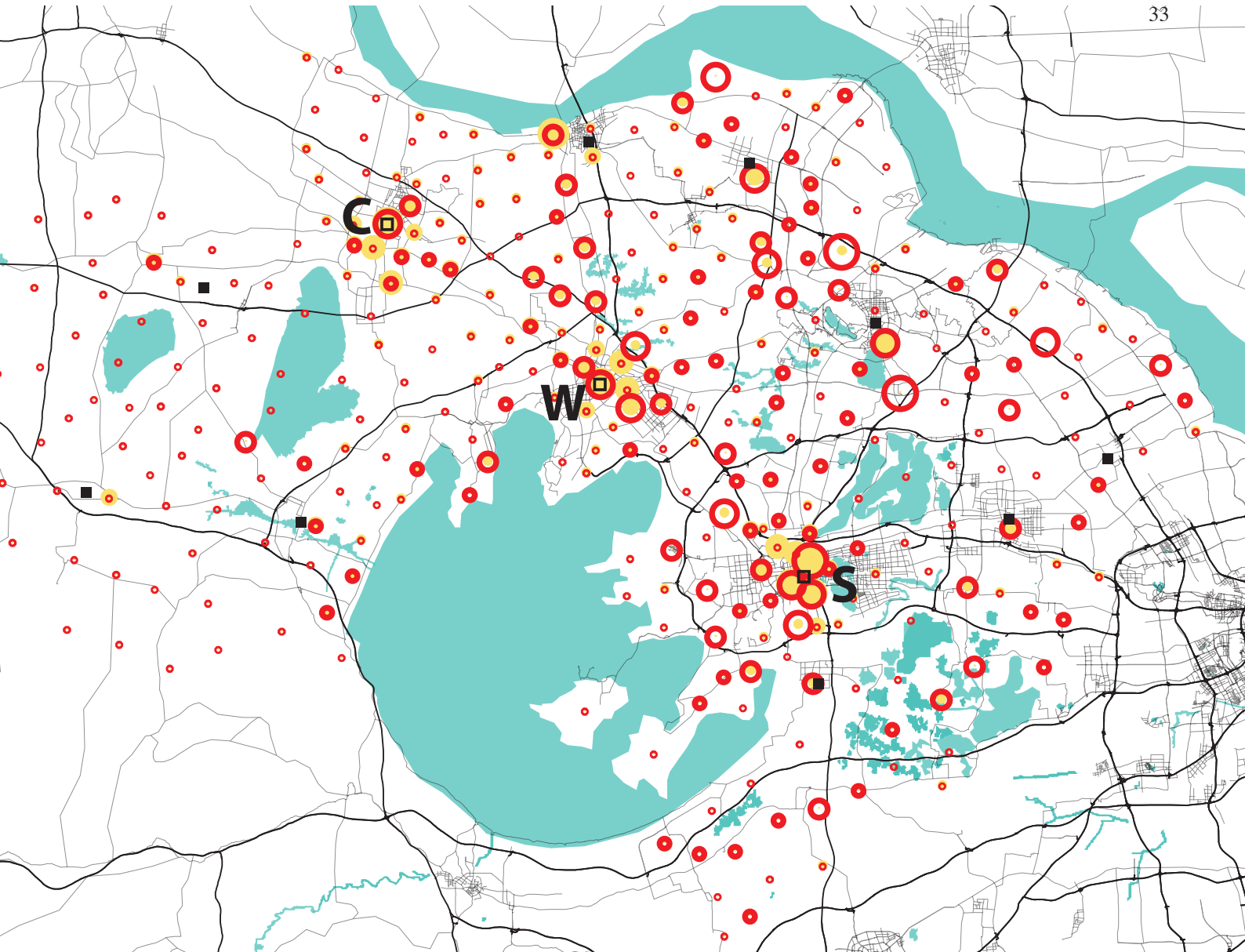

Scale Small- Live and Work

For the Randstad, Labour Force and Employment density have comparable spatial configuration: a ring around green heart. This configuration generally is caused by the location of four primary cities and the protection of “Green Heart”. The difference between primary and secondary cities in terms of activity density is quite small. The situation in SWC is different. Due to three primary cities on the north side of Lake Tai and big influence from Shanghai, the most activities are concentrated on the Northeast part of SWC. Labour Force mainly focuses on the primary cities, but Employment is decentralised to secondary cities. This difference between labour force and employment in SWC can be explained by two reasons. One is because of higher living quality of primary cities, such as facilities, transportation. The other reason could be the statistic process without counting floating people. Considering infrastructure, all secondary cities in the Randstad are well connected with primary cities by highway and railway. Secondary cities next to water make use of water to develop their specialisation, like Zaanstad for fishing. In SWC, the road network is well developed, but the railway network is not access to secondary cities. There are also several harbours along the river belonging to secondary cities which need to upgrade their roles for river transportation.

3.1.1.b. Measuring Distribution of Live and Work
Comparing Polycentric Urban Region

In order to measure Polycentric Urban Region relating to different scales, Polycentric Matrix tool is used by three scales: Macro, Meso and Micro Scale (Figure 23).

- Macro Scale: refers to NWE and YRD; based on Scale Large
- Meso Scale: regions in NWE and YRD, such as the Randstad, Shanghai Region; based on Scale Large
- Micro Scale: refers to the Randstad and SWC; based on Scale Small

NWE and YRD as the Macro scale both represent Polycentric spatial structure, however, Polycentricity of NWE is much more clustered than YRD (Figure 24). This means the activities of live and work in NWE is more decentralised to sub-centres instead of mainly concentration on the leading cities and dispersion into surroundings in YRD.

In the Meso Scale, three regions along the river Rhein in NWE are clustered polycentric, including the Randstad, Ruhr Area and Rhine-Main. Southeast London and Paris have monocentric structure from the map, but South East London is more clustered than Paris Region because of concentrations on multi sub-centres. Flemish Diamond had unexpected conclusion from literature review in which Flemish Diamond is often cited as archetypal examples of polycentric urban regions (Meijers, 2007b). From the urban fabric, Flemish Diamond contains three large cities: Brussels, Antwerp and Gent. However, the density of activities of live and work in Brussels is much higher than other two cities. Thus, in terms of activities density, Flemish Diamond is more dispersed monocentric. The situation of Yangtze River Delta in Meso Scale is much simpler than NWE. Most of regions represent dispersed monocentric spatial structure except SWC. SWC contains three primary cities that have comparable population and city size, while SWC is more dispersed than the Randstad and Ruhr Area as Polycentric Urban Region. Among all the Monocentric Urban Regions, Shanghai Region is more clustered than others, with participation of small cities or towns around.

The Randstad and SWC in Micro Scale both have polycentric structure, but polycentricity of the Randstad is more clustered than SWC. Especially around four primary cities of the Randstad as well as long the coast, there are many sub-centres with high activities density. SWC is almost twice big as the Randstad, with a bit more than doubled population. There are still a lot of areas with few activities.

To sum up, in all three scales, the spatial structures in NWE is much more clustered than that in YRD. It means NWE already has longer process of decentralisation, either for population or for employment. That's why there are many business areas moving to infrastructure nodes, or technology and research institutions are setting up in secondary cities. Yangtze River Delta is facing the process of decentralisation. Most of decentralisation happens that population moving to the suburbs of primary cities, and industry transferring to secondary cities, in order to relieve the pressure of primary cities for environment, facilities, energy, etc. It is very helpful to understand the spatial structures in NWE in different scales, which could give some inspirations for YRD or SWC or cities in SWC.

Figure 23: Macro, Meso and Micro Scale

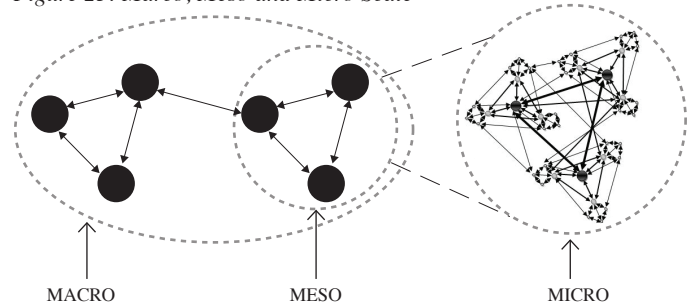
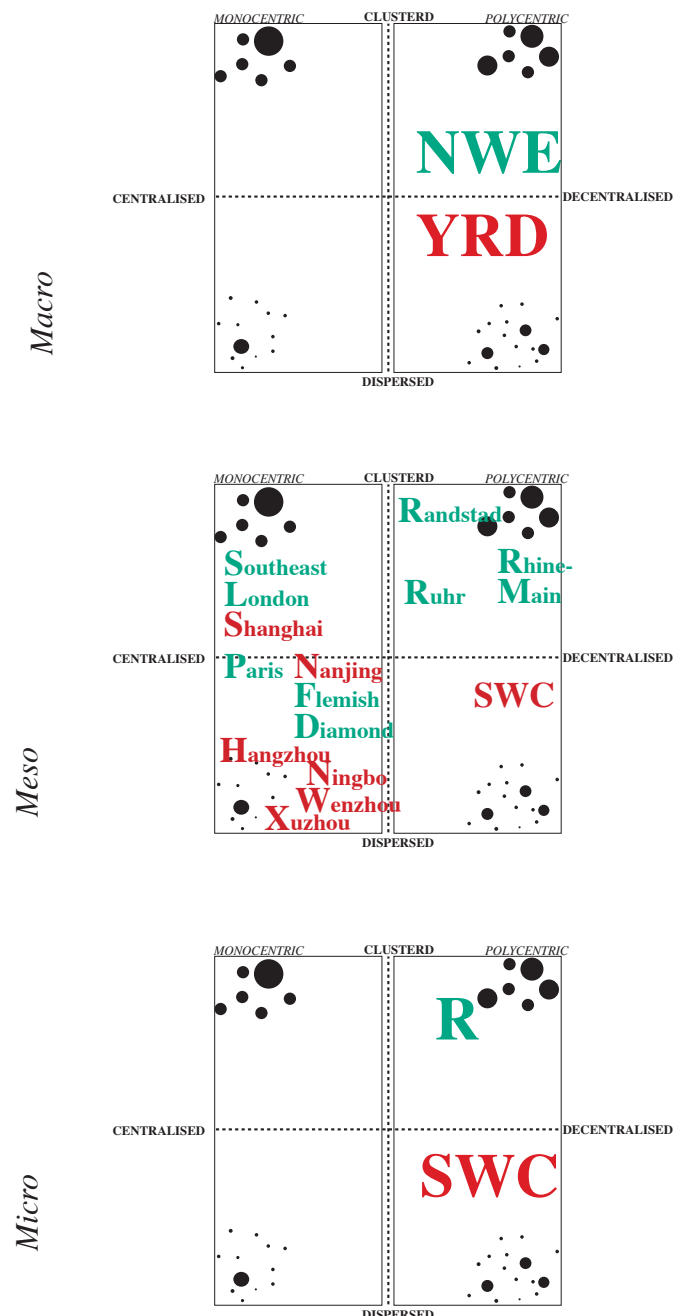

Figure 24: Comparing PUR



3.1.1.b. Measuring Distribution of Live and Work
Comparing Polycentricity by Scale

Moran'I is a tool to measure Polycentricity by varying scales. For example, new Moran's I can give different calculations by 100 km, 200 km, etc, which can be linked to travel time. Thus, in Scale Large the scale is progressively increased by 100 km (travel one hour by car), while in Scale Small increased progressively by 25km (travel between 15 minutes and half hour by car). In addition, "calculation blind" happens by Moran's I because of calculation methodology of this tool which has been explained in Chapter 2. That's why only from 100 km to 500 km (travel 1 hour to 5 hours by car) in Scale Large and from 25 km to 75 km (travel within one hour by car) will be sufficient data for analysis.

Scale Large: Daily Urban System (DUS) has been proved by Moran'I for distribution of live and work, which is the peak for both NWE and YRD. But afterwards, the extent of polycentricity varies differently in NWE and YRD. In NWE, clustering extent decreases until 300 km (3 hours travel by car), which is the scale of Activity Void as well as average distance between regions. Then it goes up to another peak, which is on the scale of 500 km (5 hours travel by car) indicating Inter-Regional Scale. However, in YRD clustering goes down until the scale of 500 km, which indicates monocentric urban structure of YRD. In other words, Shanghai Region is still definitely the centre of YRD, even there are several emerging regions.

Scale Small: In the Randstad, the extent of clustering goes down smoothly from 25 km (travel between 15 minutes and half hour by car) to 75 km (travel within one hour) for live and work, which indicates high-clustered structure there. In SWC, clustering of live is comparable with the Randstad, where most clustering takes places within 50 km (travel within 45 minutes by car). But economic activities has a totally different figure. It becomes more clustered by distance, which means average distance between concentrated activities is 45min travel distance.

Scale Small: In the Randstad, the extent of clustering goes down smoothly from 25 km (travel between 15 minutes and half hour by car) to 75 km (travel within one hour) for live and work, which indicates high-clustered structure there. In SWC, clustering of live is comparable with the Randstad, where most clustering takes places within 50 km (travel within 45 minutes by car). But economic activities has totally different figure. It becomes more clustered by distance, which means average distance between concentrated activities is 45min travel.

Figure 25: Moran'I of Scale Large and Scale Small

Scale L:
Sufficient Analysis- 1 hour to 6

Scale S:
Sufficient Analysis- 15min to 45 min

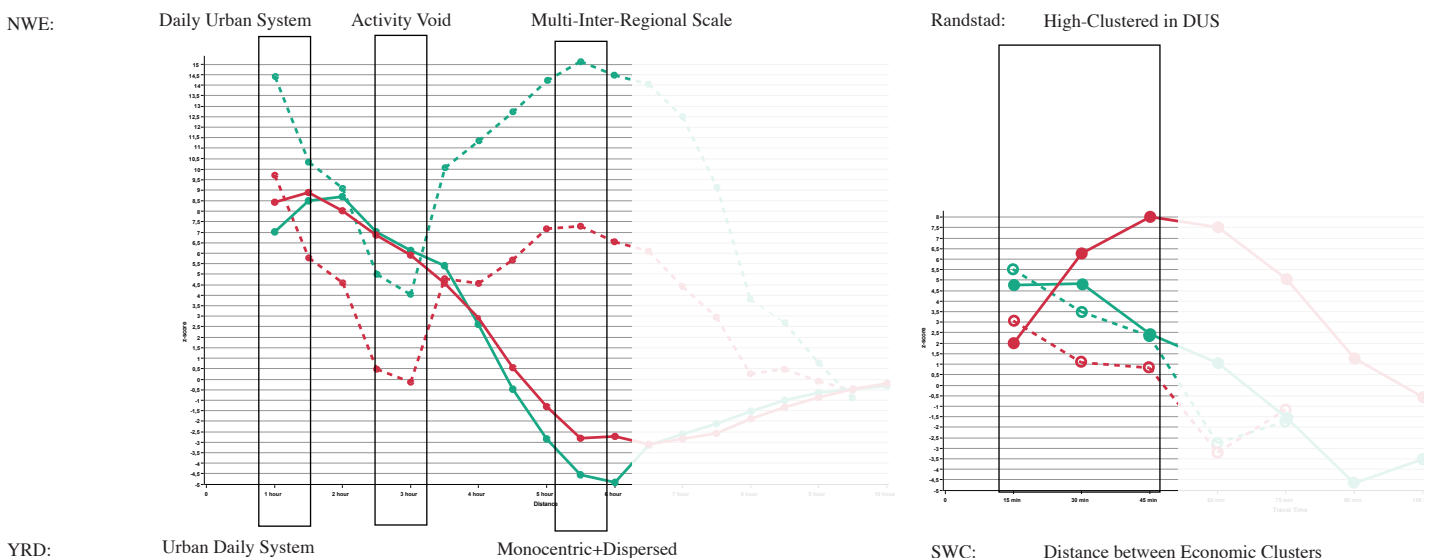

3.1.1.b. Measuring Distribution of Live and Work
Comparing Role of Secondary Cities

Distribution of Live and Work to primary cities and secondary cities in the Randstad is very similar to each other, with clustered spatial structure. That’s why two triangle standing for labour force density and employment density both have symmetric narrow shapes (Figure 26). It can be concluded that the activities density of live and work is more or less equally distributed to primary cities and secondary cities in the Randstad.

The situation in SWC is not the same (Figure 26). Labour force density is very unbalanced distributed between primary cities and secondary cities. Concentrations are mainly on the primary cities. Even there could be some ignorance of floating people, however, this unbalanced density of local people can still express that primary cities have more attractions than secondary cities in SWC. In addition, primary cities of SWC have much more clustered spatial structure than secondary cities. It means that the development of suburbs of primary cities attracted people settle down, however, only the centre of secondary cities with high density of residence. For Employment density, secondary cities of SWC stand up on the map equally with primary cities, so the triangle is also has symmetric shape but wider than the triangle of the Randstad. This more balanced distribution of employment density in SWC is caused by the success of “Sunan Mode” which has been mentioned before. “Sunan Model” starts with Township Village Enterprise in 1980s to create rural industry, and in the late of 1990s with privatization of this local government owned enterprise in order to participate in the market economy. This development of rural industry also attracted a lot of foreigner investment. All these enterprises activate the economy in the secondary cities in SWC. That’s why these secondary cities have strong economic power equally with primary cities.

In conclusion, the secondary cities in the Randstad are very equal to the primary cities in terms of labour force density and employment density. However, secondary cities in SWC are only equal to the primary cities in terms of employment density, and very unbalanced for labour force distribution. These similarities and differences explained that secondary cities in the Randstad attract enterprises and people to settle down, while secondary cities in SWC contains a large amount of enterprises but not attractive for people to live (at least for local people in the region). In addition, the spatial structure in both regions related to secondary cities is different. In the Randstad, secondary cities are participating clustered structure of activities of live and work. In SWC, spatial structure is more dispersed, especially for labour force density. SWC could learn from the Randstad to prevent dispersion of industry. Instead, SWC needs to create opportunities for clustering enterprises so that enterprises can benefit from sharing facilities, infrastructure and labour force, meanwhile, contribute to the improvement of environment.

Figure 26: Role of Secondary cities by Live and Work

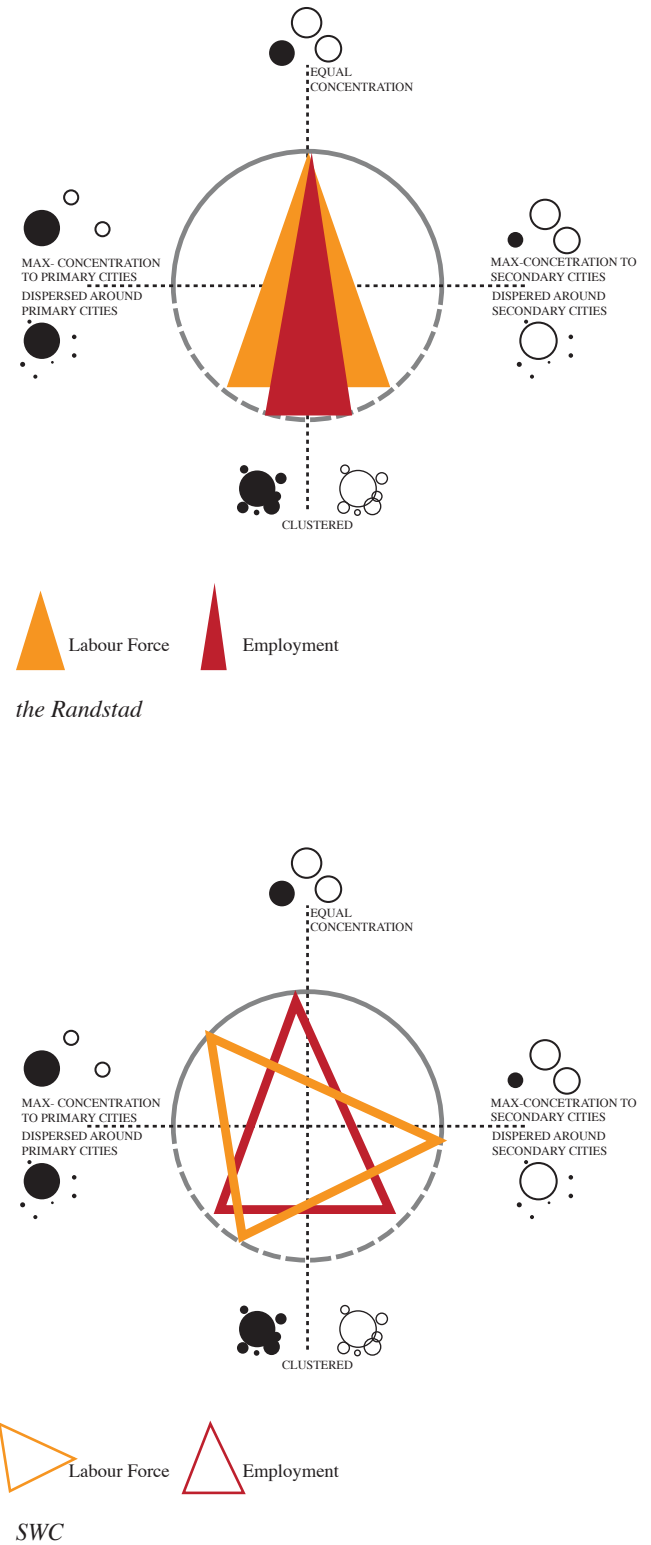

3.1.1.c. Conclusion of Distribution of Live and Work

After measuring and comparing distribution of live and work in different regions, it is necessary to represent all the results by measure tools (Polycentricity Matrix, Polycentricity Triangle, Moran's I) in the geographical maps. Because all these measure tools are very abstract to understand without the real maps. Therefore, this step will represent by conclusion maps in two scales to understand identification of Polycentricity and the role of secondary cities.

Scale Large (Map 27)

Conclusion map of Scale Large mainly focuses on the spatial structure of NWE and YRD as a whole, as well as the spatial structure of diverse regions in NWE and YRD, such as the Randstad and Paris region in NWE, SWC and Shanghai Metropolitan Region in YRD. In NWE, most of regions in NWE have clustered structure, with cooperation and participation of sub-centres. Particularly the three regions along River Rein have most clustered structure with multi-centres. Afterwards, Southeast London has less clustered polycentric structure. Flemish Diamond doesn't not really represent polycentric structure as its name, instead it has comparable situation as Paris which is typical monocentric region with extreme dispersion. As the description above, there is a hierarchy between these regions in NWE in terms of clustering or dispersion: Randstad, Rhur and Rhine-Main on the first level, South East London on the second level, Flemish Diamond and Paris on the third level. Regions in YRD are much simple to describe. All of them have dispersed monocentric structure except SWC that is dispersed polycentric region with three primary cities. This means there is no hierarchy between regions in terms of clustering and dispersion. Definitely there are still some differences between them. For example, the density of population and employment in Shanghai region is much higher than others. Comparing with three regions along River Rein in NWE, there are also three important regions along Yangtze River: Shanghai Region, SWC and Nanjing Region. These three regions are always the flourish areas in the history with high density of population and good economic base. That's why the first railway was built to connect these three regions along Yangtze River.

Inter-regional infrastructures including harbours, international airport and fast-speed train are marked on the map of NWE and YRD. Half of regions in NWE and YRD are located on the coast line so that harbour city in its region could have good connection on the network. All the regions in NWE have international airport, like Schipol Airport, Paris Airport, London Airport. In YRD, only four regions along the coast have international airport, as well as Nanjing Region which is a crucial node to connect YRD with others regions in China.

In the scale of NWE and YRD, Fast-speed train network is even more crucial for the regional development. In NWE, network of Fast-Speed train is well developed so that almost all the regions are connected with one another. The only missing link between the Randstad and Ruhr Area is very outstanding on the map. Comparatively, the network of fast-speed train in YRD is not as advanced as NWE, even it has been developed rapidly in the last decade. Now there is a triangle of fast-speed train network to connect Nanjing, Hangzhou, Shanghai Region

and SWC, where are the powerhouse of economy of YRD. It's very logic that the first fast-speed train was built along Yangtze River linking Shanghai Region, Nanjing Region and SWC, with the extension to Beijing. Afterwards, railway between Shanghai Region and Hangzhou Region was finished and the last fast-speed railway was done this year to finish this triangle network. In reality, the most current fast-speed railway between Nanjing Region and Hangzhou Region has big influence for the core of YRD. Because the other two links already exist with normal railway system, while there is no direct link between Nanjing Region and Hangzhou Region. That's why people need to pass by Shanghai in order to travel between Nanjing and Hangzhou if they choose to take a train, so it cost a lot of extra time. Now with the construction of this fast-speed railway, not only Nanjing Region and Hangzhou Region could benefit from this direct link, but also small cities between two regions will face a great challenge. Thus, a concrete triangle of fast-speed train will provide physical linkage among the regions in the middle of YRD. Besides this triangle, the rest of three regions in YRD are not connected to the fast-speed railway network at this moment. However, there is a plan to extend the fast-speed railway between Shanghai Region and Hangzhou Region along the coast to the south until Pearl River Delta, so that Ningbo and Wenzhou Region will be on this network as well.

After analysis of polycentricity of different regions and relationship among them, it is also relevant to understand distribution in NWE and YRD as a whole. By the comparing the extent of clustering in both region, we discovered that Urban Daily System (travel within one hour) is the scale with the most clustered distribution. It means Urban Daily System works in different contexts and can be improved as a proper scale for existing regions or emerging regions. With the growing scale, the clustering pattern of YRD is decreasing. However, the situation in NWE is different. The extent of clustering decreases from 1hour travel (Daily Urban System) to 3 hours travel, but it goes up again from 3 hours travel to 5 hours travel which is another peak. This differences of clustering pattern in scales for NWE and YRD explain very different distribution conditions. There are two main explanations about this difference. In YRD, the most activities of live and work are only concentrated on the daily urban systems, and space between them don't not have large population and employment. While in NWE, the area between regions still has some distribution of population and jobs, which will support next increase after 3 hours. The other explanation is about the disparity between regions. In YRD, Shanghai is definitely the most densely distributed region, while Xuzhou Region even with the support of the government is very week in reality. That's why it is very difficulty to achieve another peak of clustering by involvement of more regions. NWE contains relatively equal regions relating to distribution pattern. After 3 hours travel (300km's circle), the extent of clustering increase to involve more than one regions. 3 hours travel (300km's circle) is a good scale with most dispersion in NWE, so that this circle is named "Activity Void". 5 hours travel (500km's circle) is another peak for NWE, which is a scale containing most of important regions in NWE.

3.1.1.c. Conclusion of Distribution of Live and Work

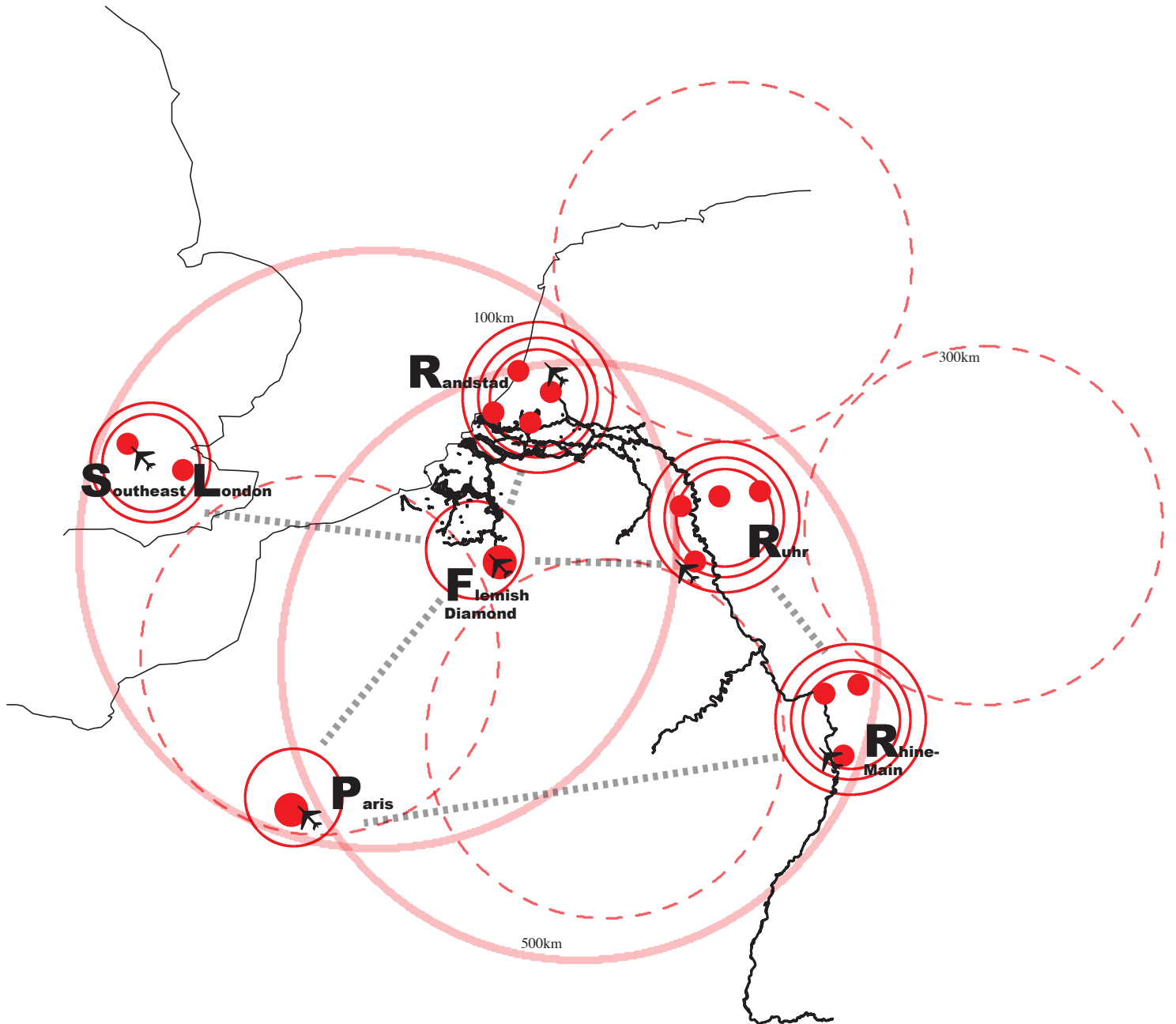

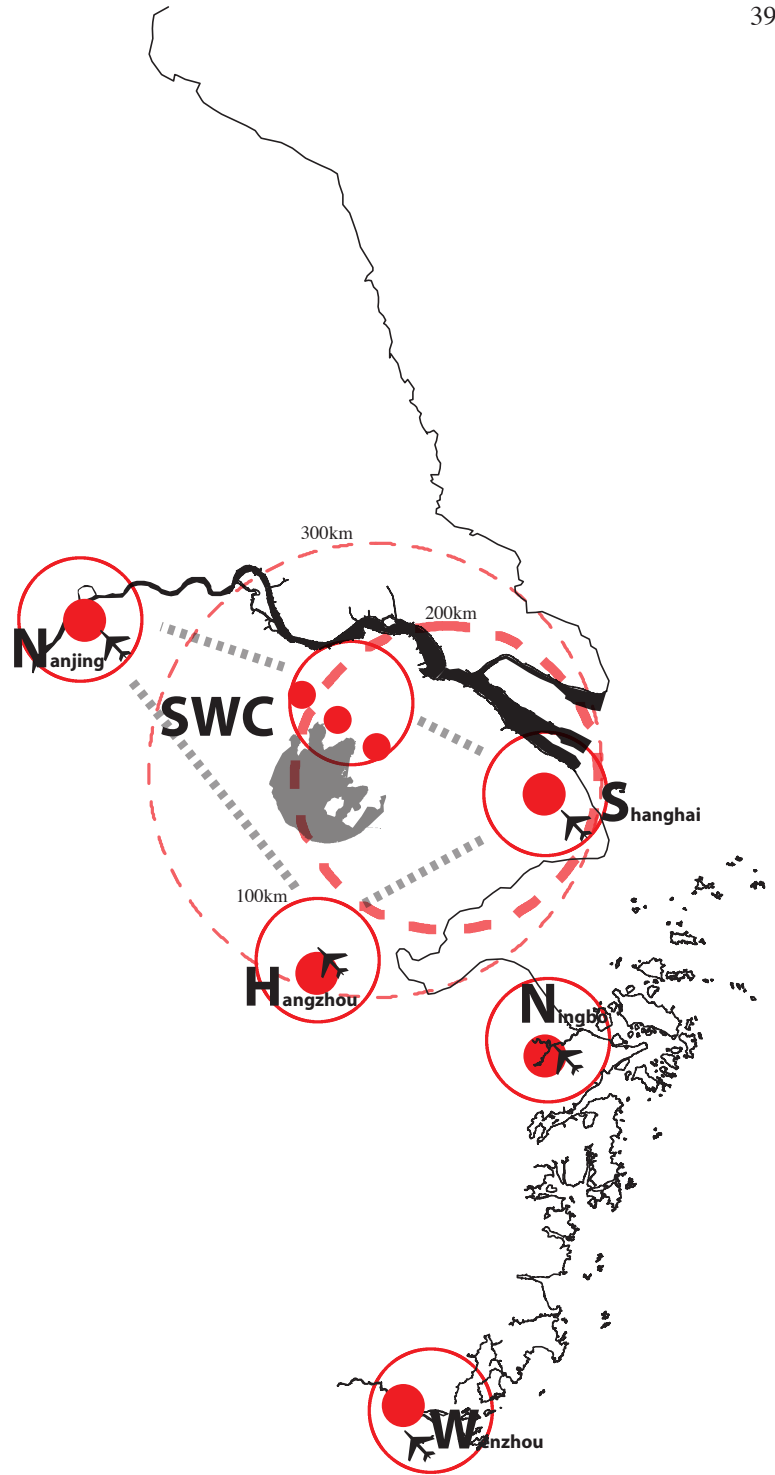

Map 27: Conclusion Map of Scale Large by Live of Work

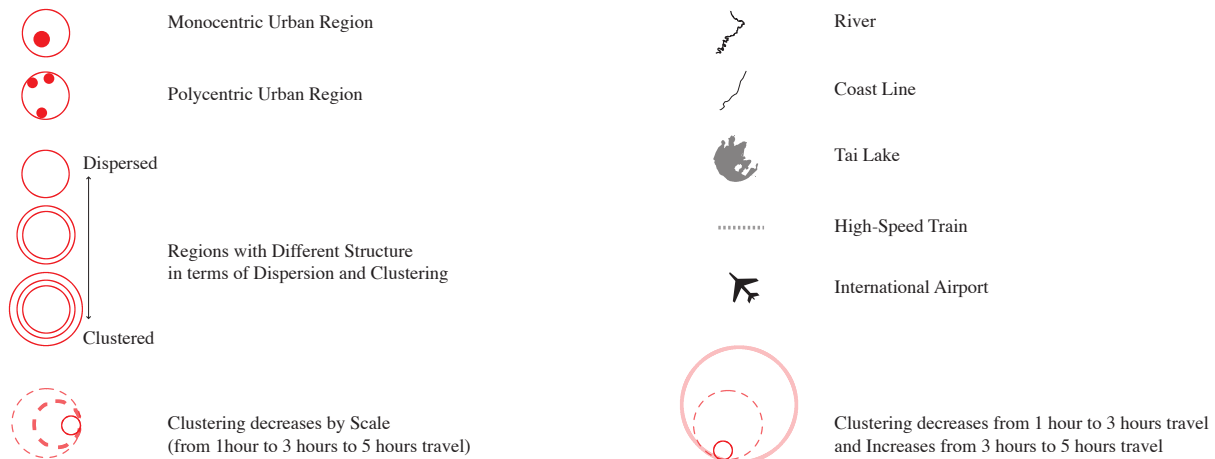

3.1.1.c. Conclusion of Distribution of Live and Work

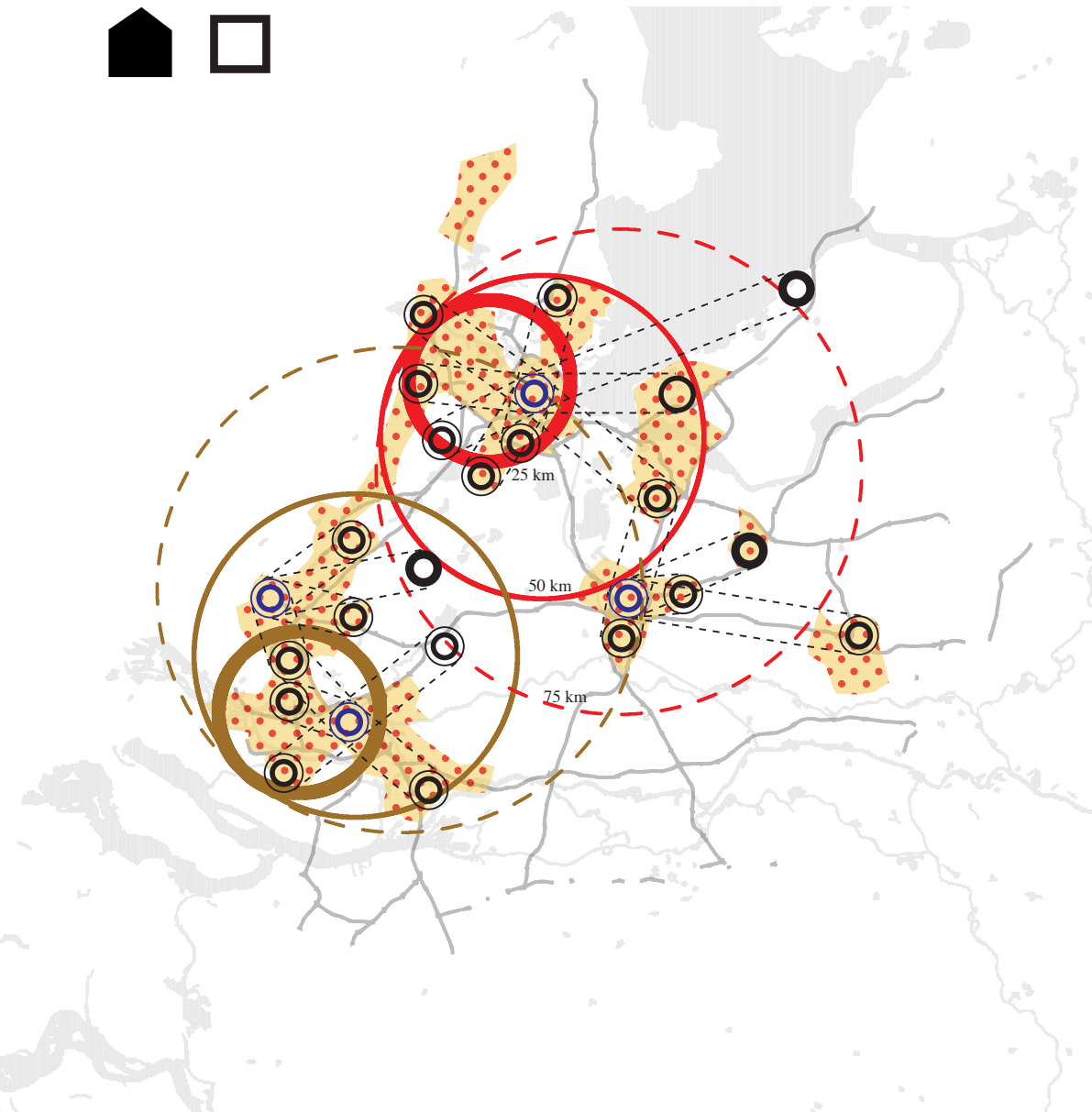

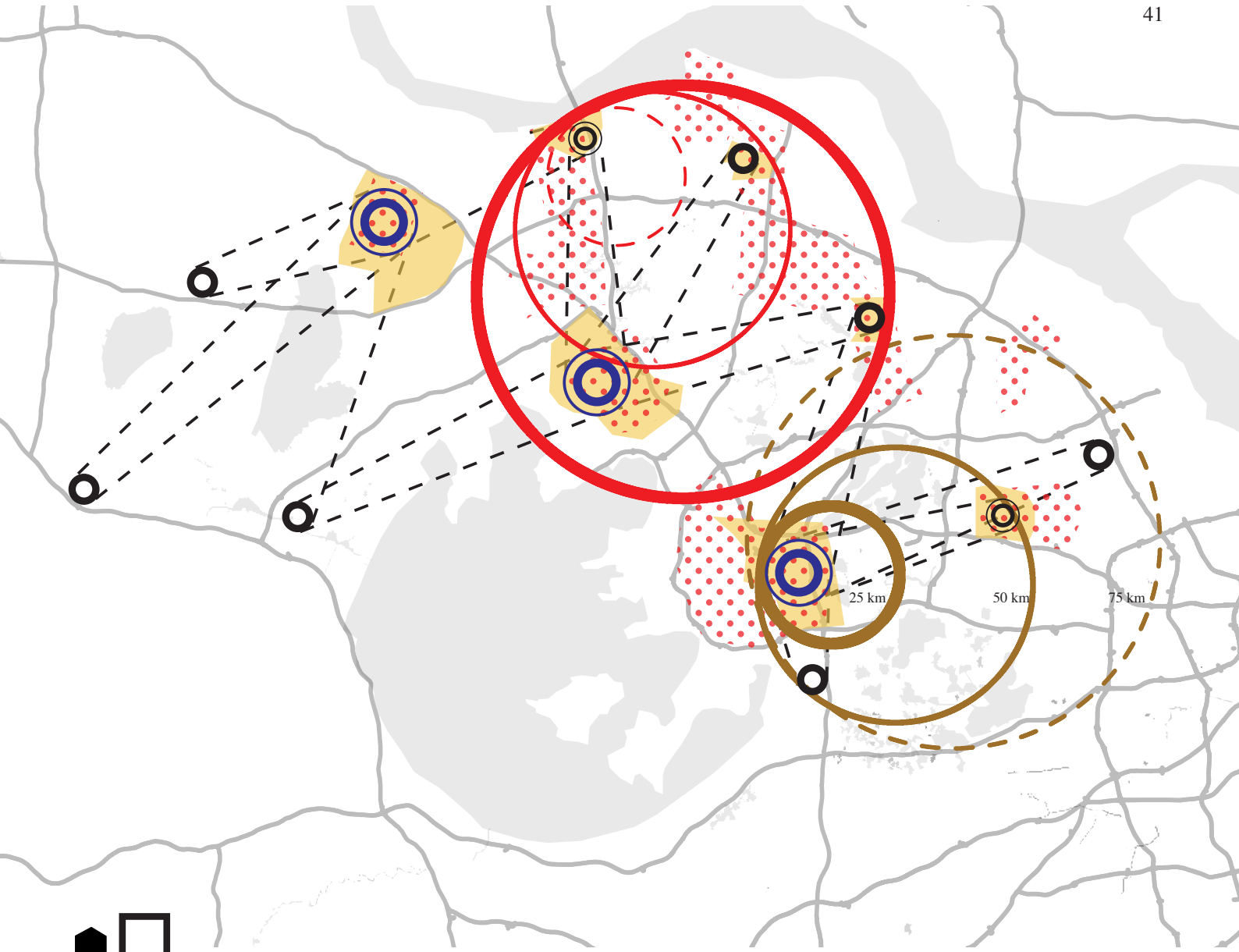

Map 28: Conclusion Map of Scale Small by Live of Work

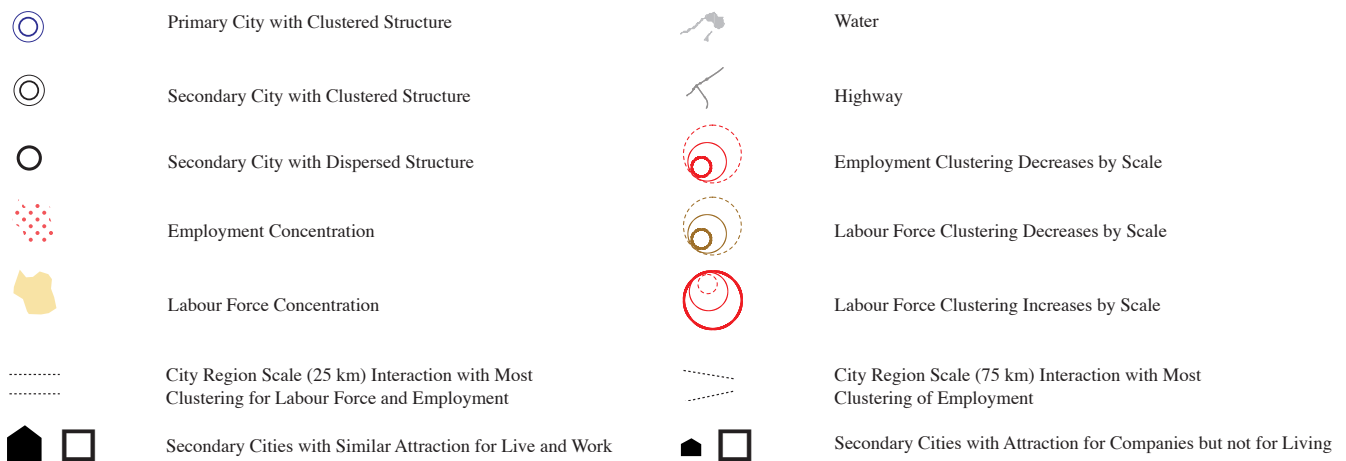

3.1.1.c. Conclusion of Distribution of Live and Work

Scale Small (Map 28)

Conclusion map of Scale Small focuses on the spatial structure of the Randstad and SWC, particularly relating to secondary cities and primary cities. In this way, it aims not only to understand the distributed pattern in two regions, as well as the role of secondary cities in the region.

All the cities in the Randstad is much smaller than that in SWC, while the distance between cities in the Randstad is smaller as well. Proximity plays an important role for the interaction between cities, so it makes sense to compare the size of the cities and distance among them. For example, many secondary cities in the Randstad can be achieved from primary cities between 15 minutes and half hour (25km circle), while for SWC it will be half hour to 45 minutes (50km's circle). Proximity gives opportunities for interaction between cities.

By looking at different scale of distribution of live and work, spatial structure can be discovered for both regions. Distribution of labour force and employment is the same for the Randstad. 25 km is the scale with most clustering pattern, which is also the scale of city-region for the Randstad. Afterwards, the extent of clustering goes down by larger scale. This result of distribution by scale explains that 25 km as city-region scale is still the most concentration of human activities. The area between city-regions is still much less populated and less companies located, and meanwhile, the disparity among city-regions is still quite large like Amsterdam Region with much more activities than Utrecht Region. That's why when the circle is growing to achieve other city-regions, the extent of clustering is still decreasing. For SWC, labour force distribution is comparable with the Randstad, which means the extent of clustering decreases with the growth of scale. This was led by the all the concentration of population on the three primary cities in SWC. The interesting thing is the distribution of employment in SWC exists differently from labour force. 25 km is not the most clustered scale, and the extent of clustering goes up by the increasing scale. One hour travel (75 km) is the peak with the most clustering pattern. This strange result can be explained by the dispersion of employment in this area. A large amount of companies in SWC were set up by the township government, which is famous as "Sunan Mode". That's why these companies are spread in different towns, instead of only the urban area of secondary cities and primary cities.

In addition, the role of secondary cities in the Randstad and SWC is different as well. It is very apparent that secondary cities of the Randstad has similar density of activities by live and work, while secondary cities of SWC has much lower population density and a bit lower employment density than primary cities. Thus, it can be concluded that secondary cities in the Randstad have comparable attraction for people to settle down and for companies to set up. However, secondary cities in SWC are not so attractive for people, at least for local people to live; but have more attraction for companies.

Conclusion

Finally, the total image of distribution of live and work in Scale Large and Scale Small for both regions is quite different. In Scale Large, there is hierarchy among regions for both, but disparity in NWE is much less than YRD where Shanghai Region is the dominating region. Moreover, participation of sub-centres of regions in NWE is much stronger than regions in China. Thus, the infrastructure network has connected all the regions in NWE, but there is only concentration of infrastructure development in the middle of YRD including Shanghai Region, SWC, Nanjing Region and Hangzhou Region. Even Chinese government has ambitious to develop YRD as a region, however the reality tells that only the middle part are starting to emerge as a whole, while the rest area still needs a long time to be stimulated to participate the development of YRD. In Scale Small, the involvement of secondary cities in the Randstad is much more active and sufficient than SWC. Secondary cities in the Randstad make use of their own advantages to attract a group of people like people prefer quiet and greenery environment as well as to attract specific companies like companies needs large cheap space. However, secondary cities in SWC is not so attractive as a living city, due to the lack of facilities, uncontrolled sprawl of factories, etc. At this moment, companies were located in the suburb of primary cities as well as secondary cities in SWC. This companies based on township government in secondary cities provides opportunities to develop secondary cities. It is crucial to reorganize spatial structures of these companies and at the same time to improve living environment, which is taking place recently.

3.1.2 Distribution of Three Economic Sectors



3.1.2.a. Mapping Distribution of Three Economic Sectors

Technical Application

Calculation of Employment density of three economic sectors in Nuts 3 in NWE and in Country level in YRD using Natural Break. Calculation of NWE is based on the source in 2007, while calculation of YRD is based on the source in 2004. Different from other source, Employment of YRD is derived from the amount of business units with a rough number of employees (e.g. 200 business units with employees between 1-19).

Data Source

Labour Force and Employment data of NWE is from “Atlas ABC” and data of YRD is from the website “Urban and Regional Explorer”.

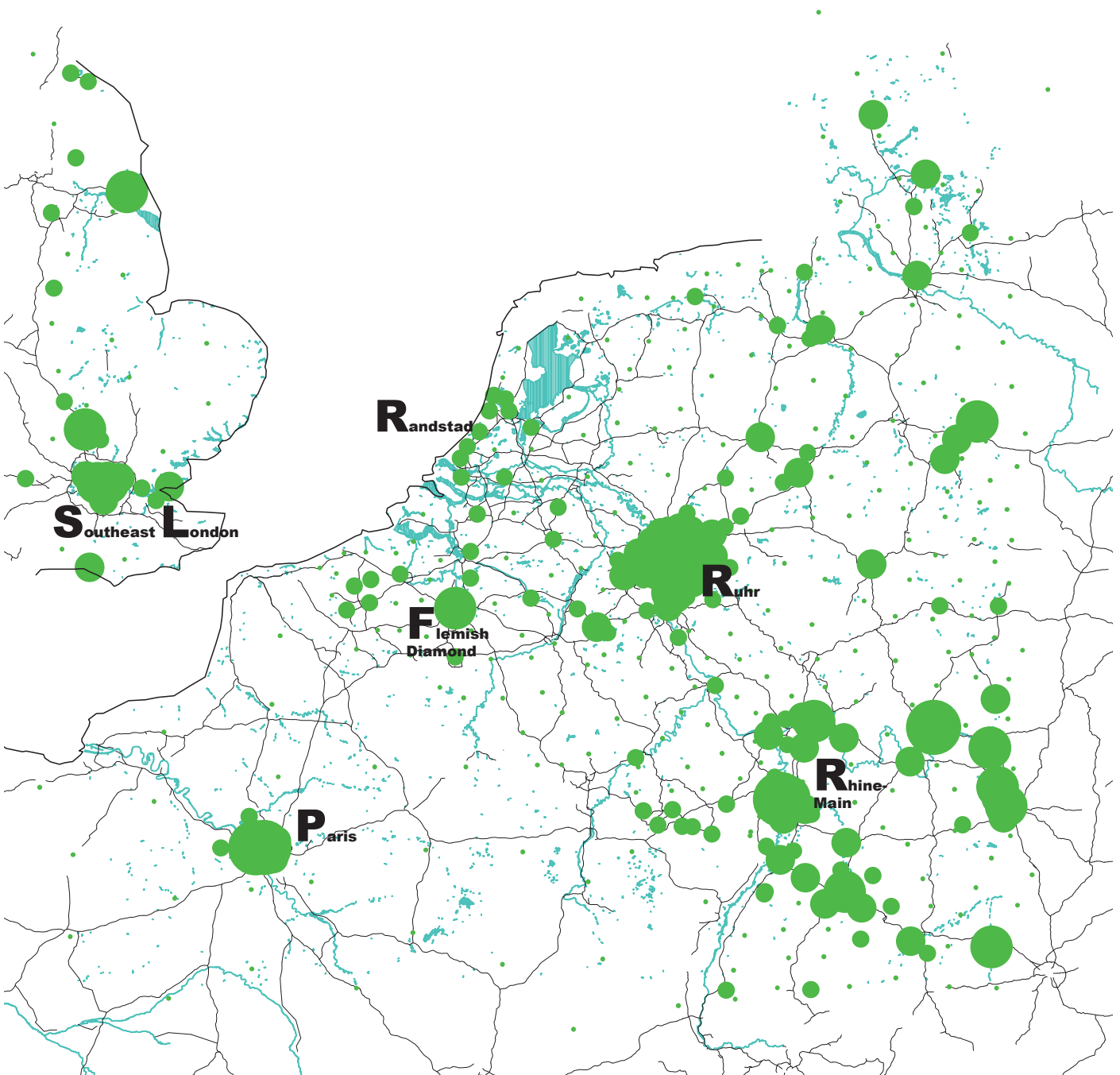

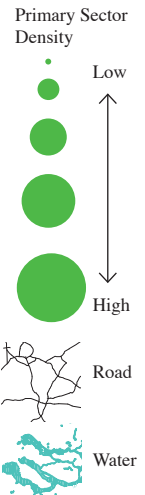
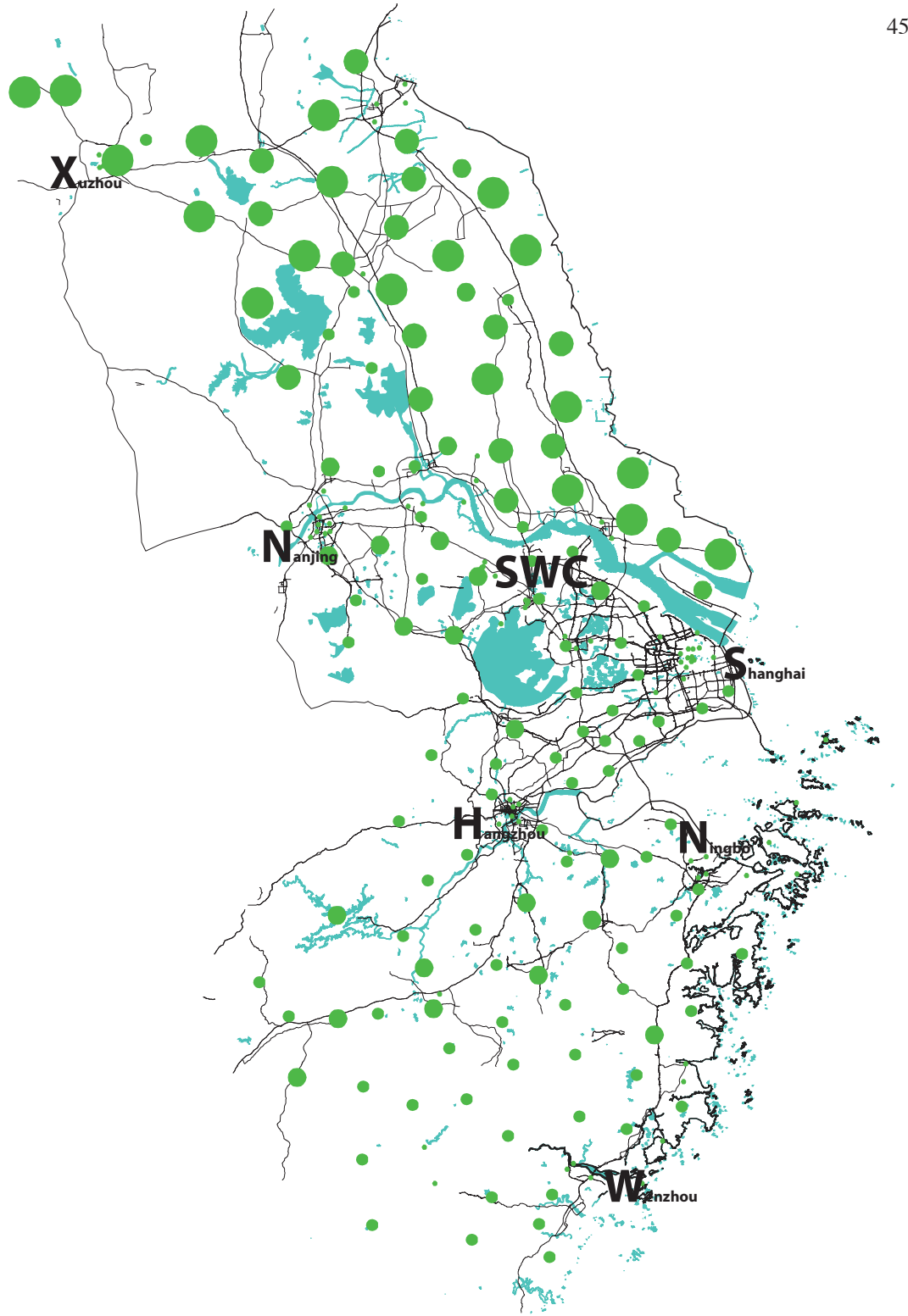

Scale Large- Primary Sector

The map of distribution of employment density in Primary sector, referring to agriculture and fishery, can only indicate primary sector activities with intensive labour instead of land use of agriculture. For instance, the area along the coast within the Randstad is famous for the flower production in the world, has been represented on the map.

In NWE, most of clusters of agriculture are located around all the urban regions or close to it. On the one side, these areas with intensive agriculture activities need good accessibility to the labour force and infrastructure which can be provided by the urban regions. On the other hand, proximity to these green open area add nature quality for the urban regions. However, there are some wrong indications on the map of NWE. Take Paris and London as an example, most of farmers are registered in the city of Paris and London, that's why there are big bubbles on these two cities. In YRD, activities of primary sector are very dispersed distributed, with higher density in the north. Agriculture there is still mainly traditional agriculture based on the land, that's why there is little requirement to become clusters to share facilities, infrastructure and labour force. By this comparison, the agriculture in YRD can reconsider relation with urban regions to develop high productive primary economy as well as contribution to the environment.

3.1.2.a. Mapping Distribution of Three Economic Sectors

Technical Application

Calculation of Employment density of three economic sectors in Municipality level in the Randstad and in Township level in SWC using Natural Break. Calculation of the Randstad is based on the source in 2005, while calculation of SWC is based on the source in 2004. Different from other source, Employment of SWC is derived from the amount of business units with a rough number of employees (e.g. 200 business units with employees between 1-19).

Data Source

Labour Force and Employment data of the Randstad is from the website “Centraal Bureau voor de Statistiek” and data of SWC is from the website “Urban and Regional Explorer”.

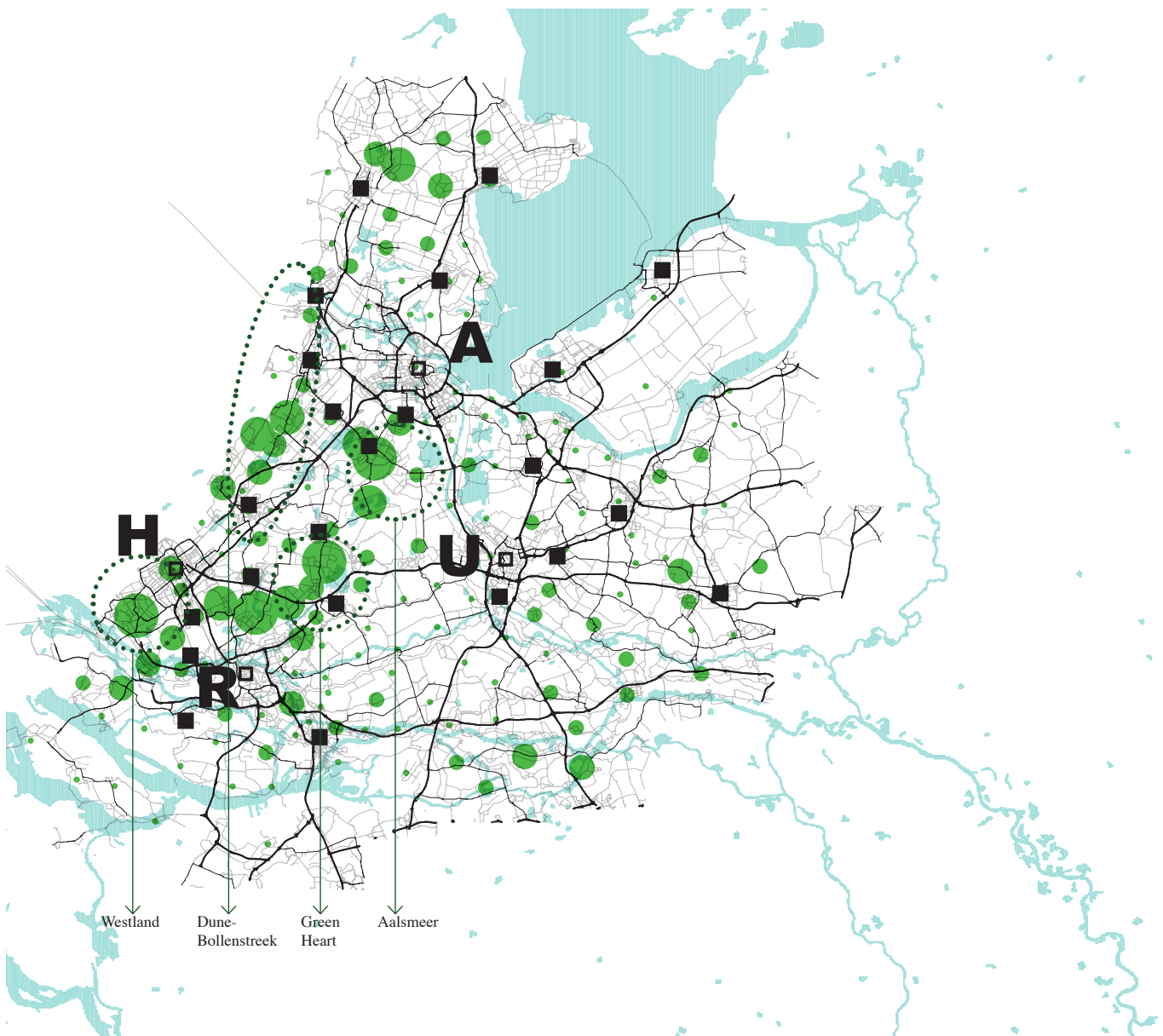

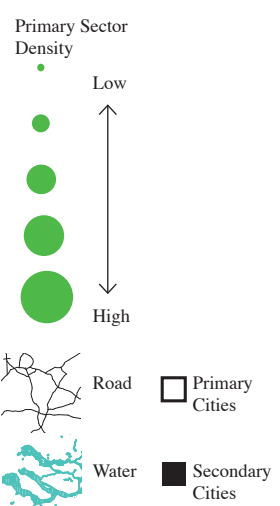
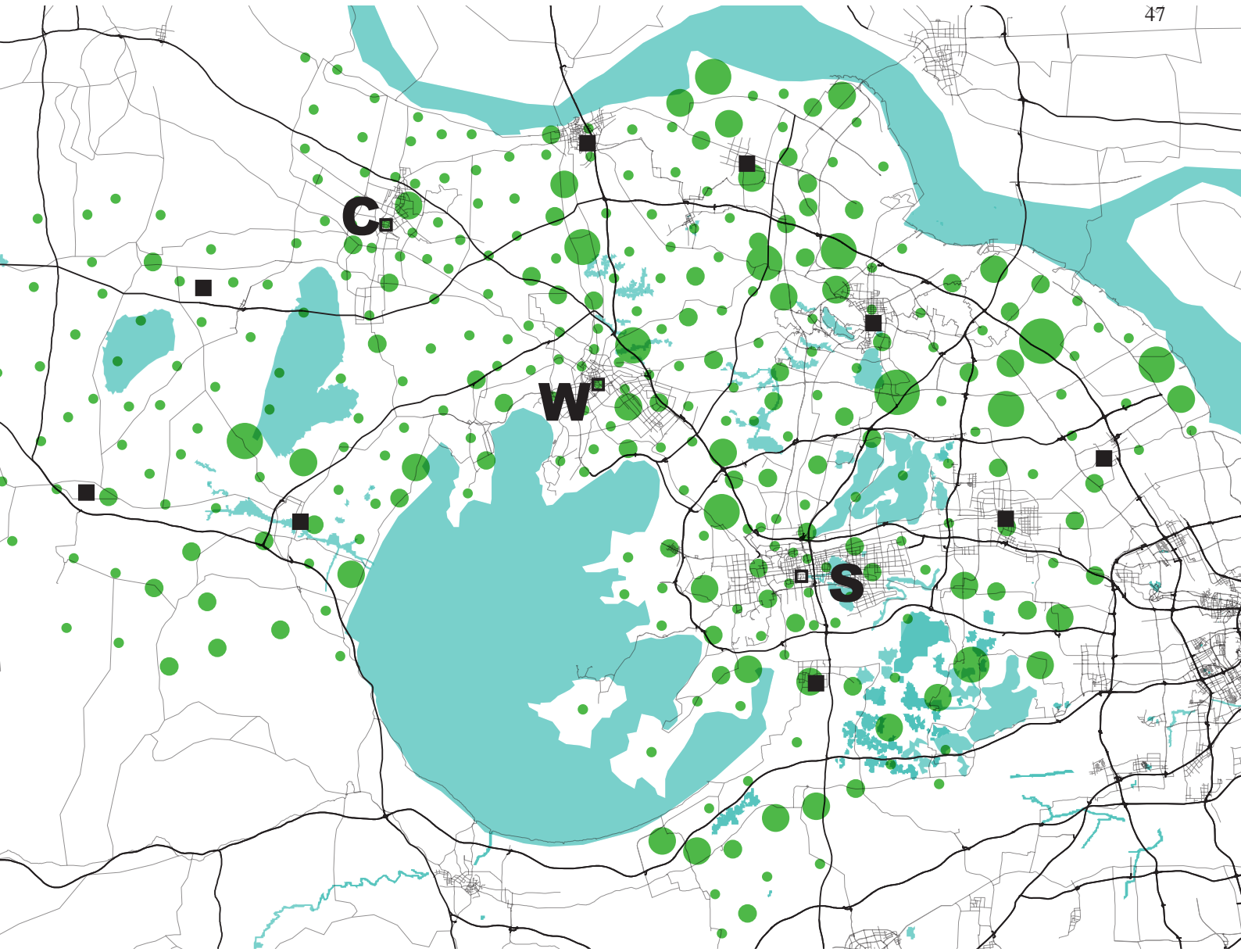

Scale Small- Primary Sector

The Netherlands economy has strong international orientation, including primary sector. In 2006, exported agriculture production was equivalent to 17% of total exportation value. Especially in the Randstad, the land is very scarce resource. Thus, the agriculture is pursuing intensity and productivity. There are clusters are represented on the map of the Randstad, such as Dune-Bollenstreek around Leiden, part of “green heart” among secondary cities, Aalsmeer next to Schiphol airport, Westland close to Rotterdam harbour. These clusters are located around these secondary cities which have cheaper land, plenty of labour force, close to knowledge centre (university or research institutions), and good connection to transportation network. SWC in history was a flourish area for agriculture and fishery, but unfortunately it was replaced mainly by industry economy. At present, agriculture land per capital in SWC is only 500 m², which is half of average of China. The map of SWC represents more dispersed structure of activities in primary sector, comparing with the Randstad. With high population density and decreasing agriculture land, SWC need to improve productivity and intensity of agriculture like the Randstad to create clusters on strategic locations. Clustered distribution of agriculture was one strategy in the SWC Regional Plan (SWC Regional Plan, 2002).

3.1.2.a. Mapping Distribution of Three Economic Sectors

Technical Application

Calculation of Employment density of three economic sectors in Nuts 3 in NWE and in Country level in YRD using Natural Break. Calculation of NWE is based on the source in 2007, while calculation of YRD is based on the source in 2004. Different from other source, Employment of YRD is derived from the amount of business units with a rough number of employees (e.g. 200 business units with employees between 1-19).

Data Source

Labour Force and Employment data of NWE is from “Atlas ABC” and data of YRD is from the website “Urban and Regional Explorer”.

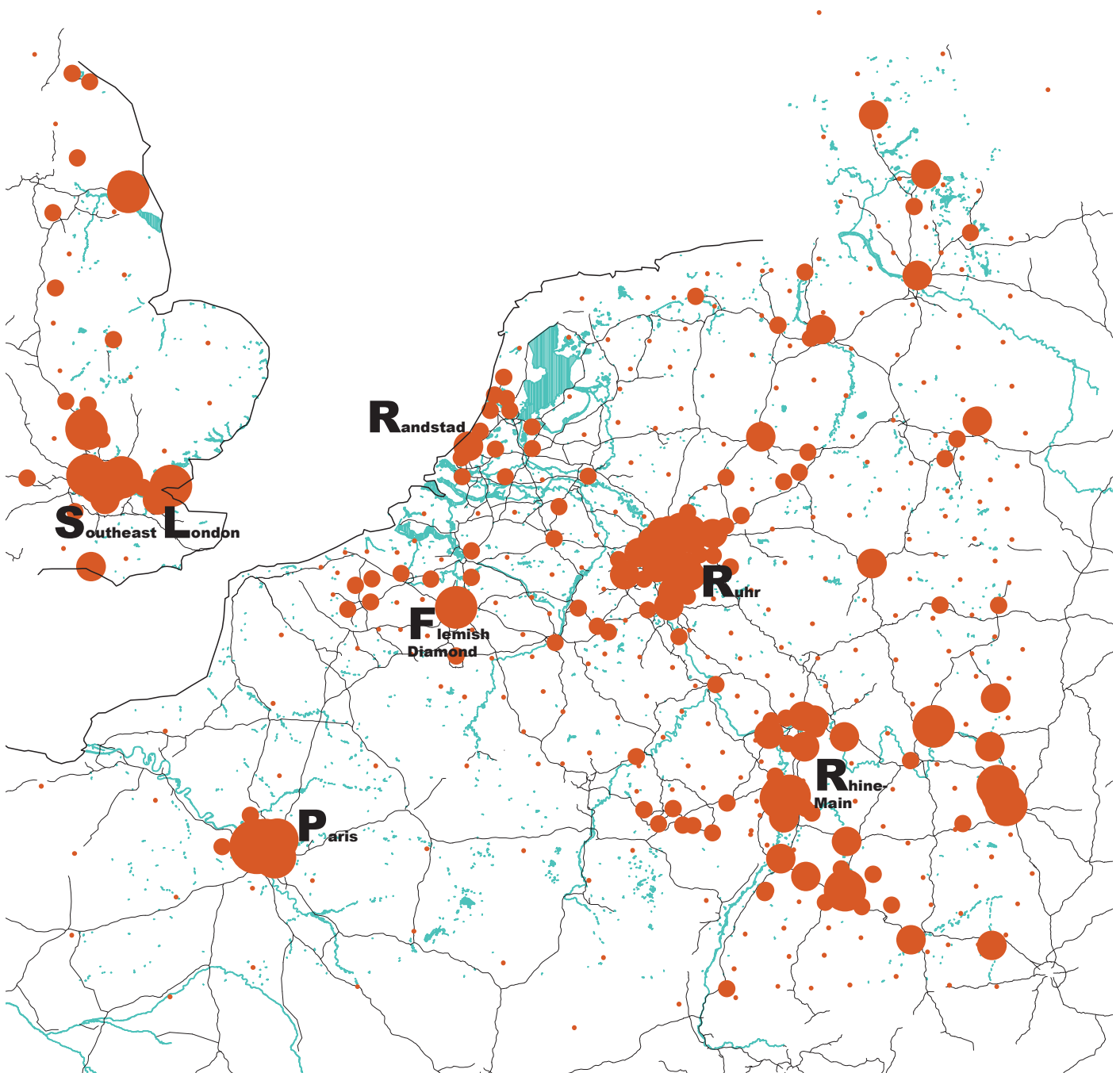

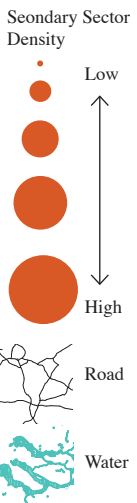
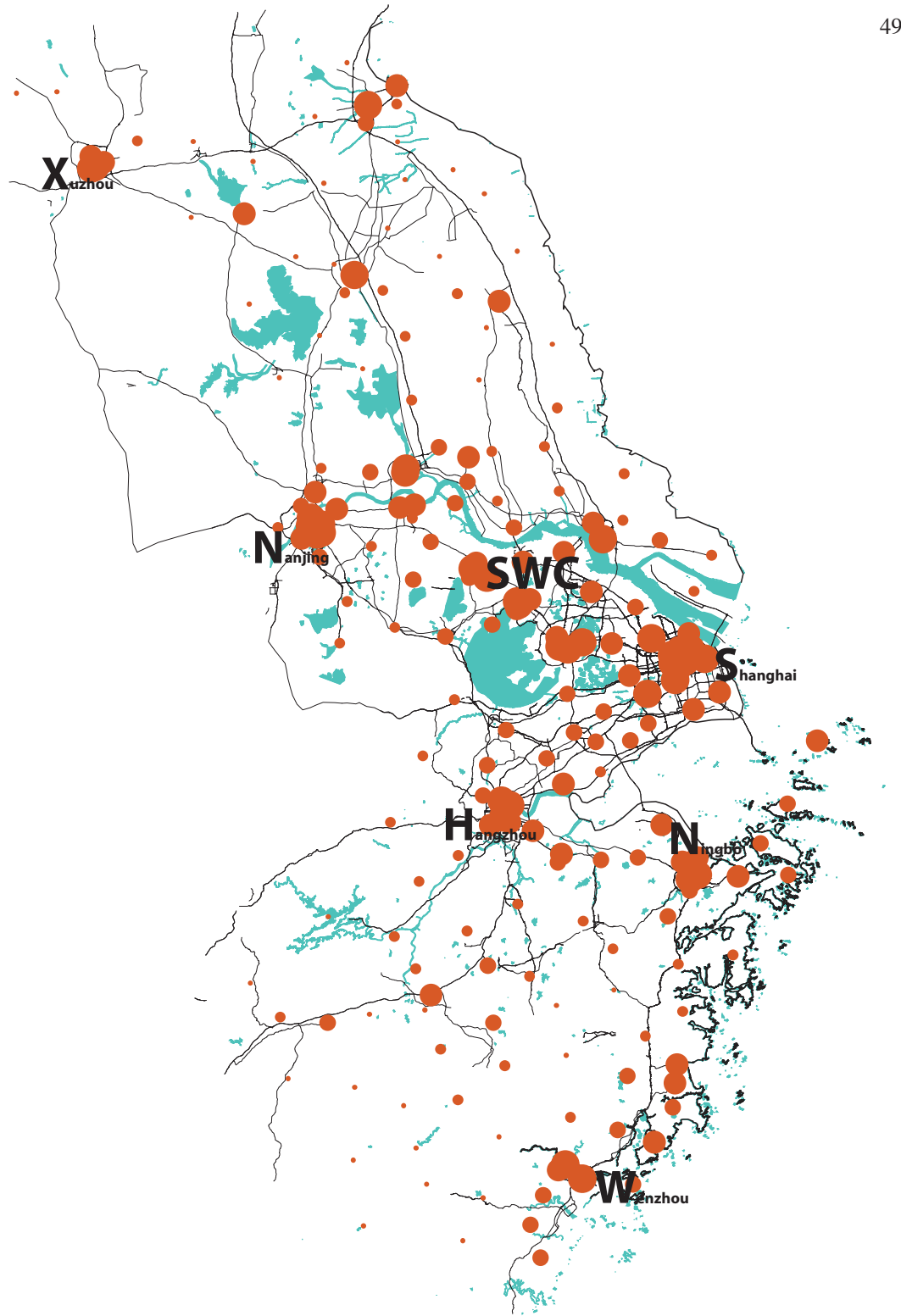

Scale Large- Secondary Sector

Activities of secondary sector still represent all the regions in NWE, however, they are more decentralised to the surroundings of these regions. For example, sub-centres in Flemish Diamond become apparent on the map, and new clusters on the east of Rhine-Main as well.

YRD has a very different structure for secondary sector. The middle of YRD with high clustered structure is the central area for industry, with the participation of primary cities and secondary cities. The rest area doesn't represent any clusters of industry, where only leading cities have attractions for industry. In this sense, YRD is a monocentric urban region for industry activities.

3.1.2.a. Mapping Distribution of Three Economic Sectors

Technical Application

Calculation of Employment density of three economic sectors in Municipality level in the Randstad and in Township level in SWC using Natural Break. Calculation of the Randstad is based on the source in 2005, while calculation of SWC is based on the source in 2004. Different from other source, Employment of SWC is derived from the amount of business units with a rough number of employees (e.g. 200 business units with employees between 1-19).

Data Source

Labour Force and Employment data of the Randstad is from the website “Centraal Bureau voor de Statistiek” and data of SWC is from the website “Urban and Regional Explorer”.

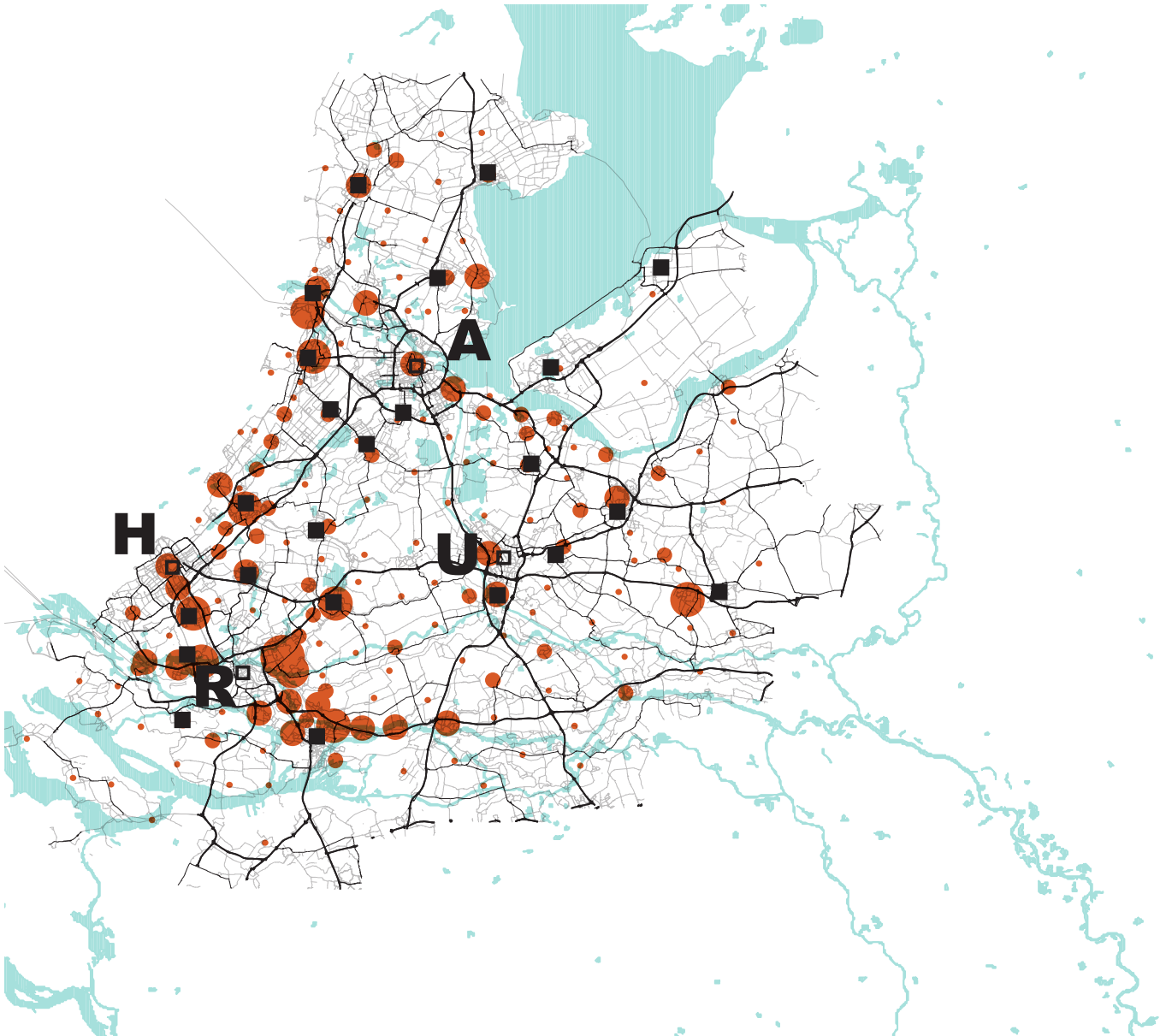

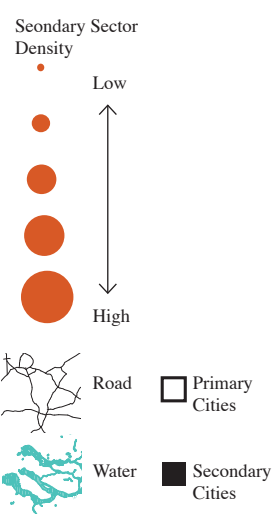
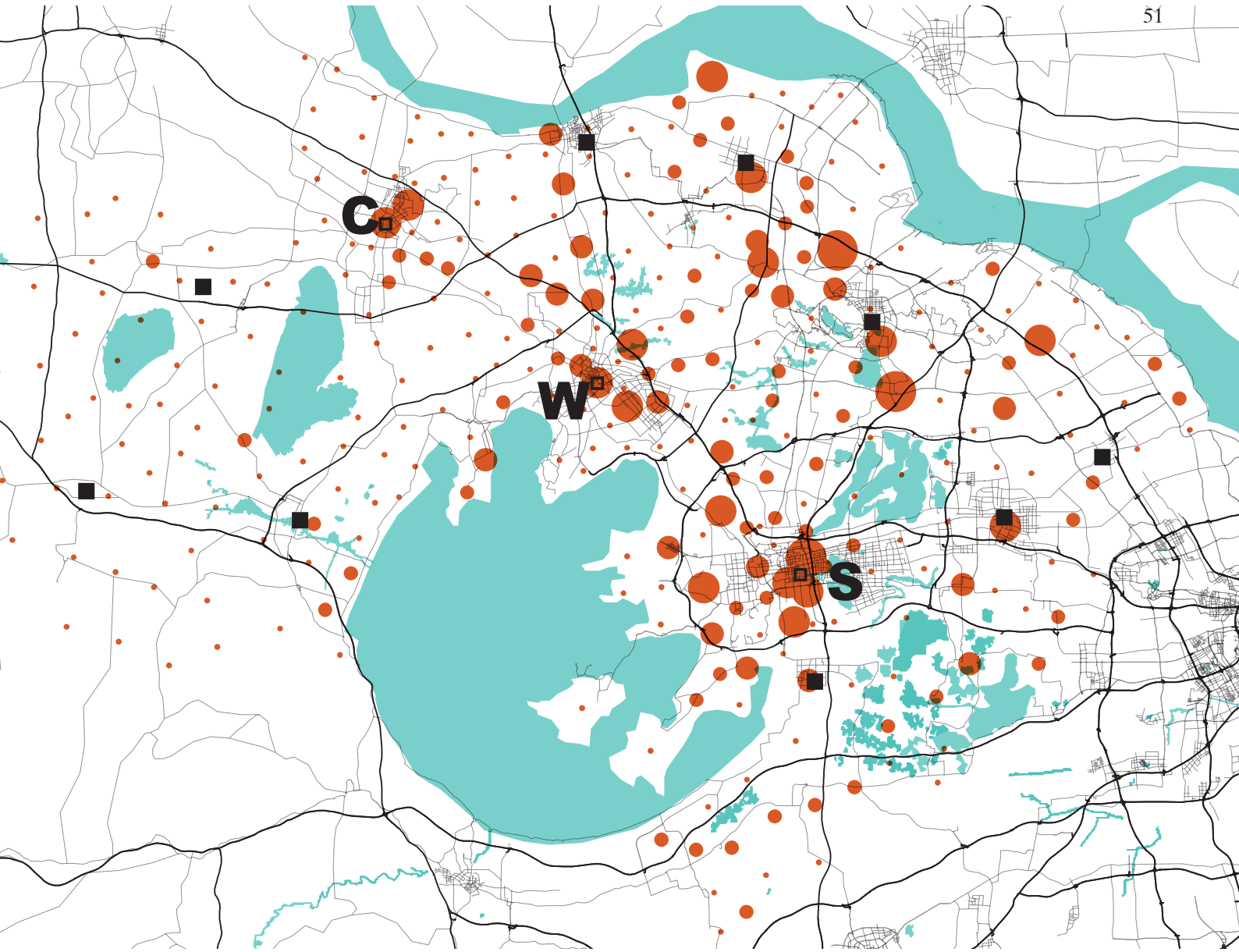

Scale Small- Secondary Sector

For the Randstad, Clusters of industry are main located on the secondary cities around Rotterdam. These secondary cities are either along the coast like Schiedam and Leiden, or along the River Rhein. Due to the decentralisation of industry to secondary cities, only secondary cities, which have good connection on the network of different infrastructure, water way, highway and railway, became ideal location for industry. Besides, it is very clear that South Wing of the Randstad has much more concentration of Industry than North Wing.

Although SWC has clustered polycentric structure for industry as well, the concentration of industry are on the suburb of primary cities and a few secondary cities on the Northeast of the region. Because suburb of primary cities has good accessibility by the railway and highway, and secondary cities on the Northeast has been linked to the highway and harbours along Yangtze River. This map represents the situation in 2000. Until now the secondary cities close to Shanghai have been developed rapidly, because of the movement of factories from Shanghai to SWC. This transition is still on the process. That's why it is very relevant to understand the structure of the Randstad which has much experience of decentralisation of industry from large cities.

3.1.2.a. Mapping Distribution of Three Economic Sectors

Technical Application

Calculation of Employment density of three economic sectors in Nuts 3 in NWE and in Country level in YRD using Natural Break. Calculation of NWE is based on the source in 2007, while calculation of YRD is based on the source in 2004. Different from other source, Employment of YRD is derived from the amount of business units with a rough number of employees (e.g. 200 business units with employees between 1-19).

Data Source

Labour Force and Employment data of NWE is from “Atlas ABC” and data of YRD is from the website “Urban and Regional Explorer”.

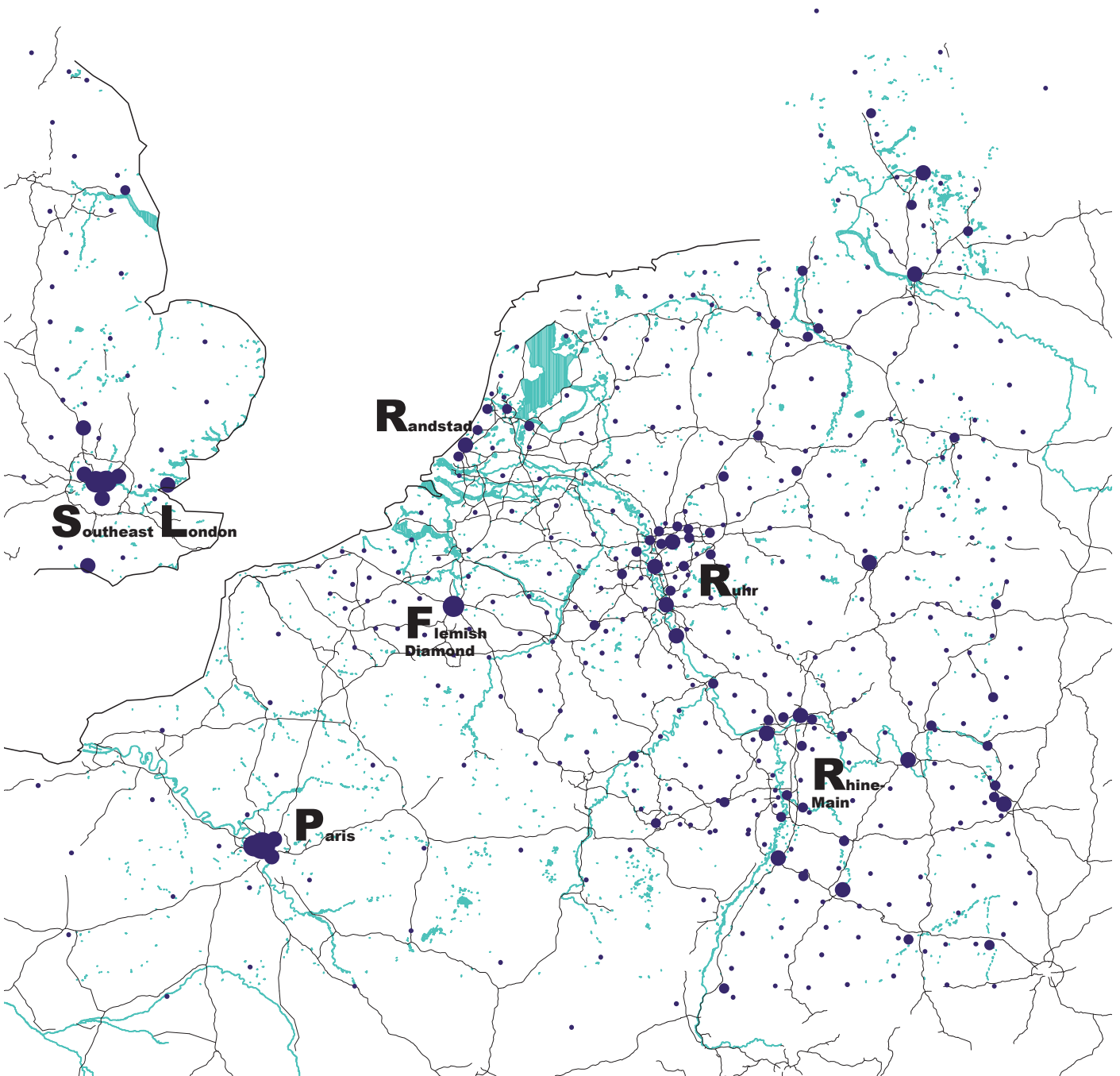

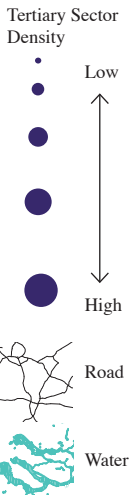
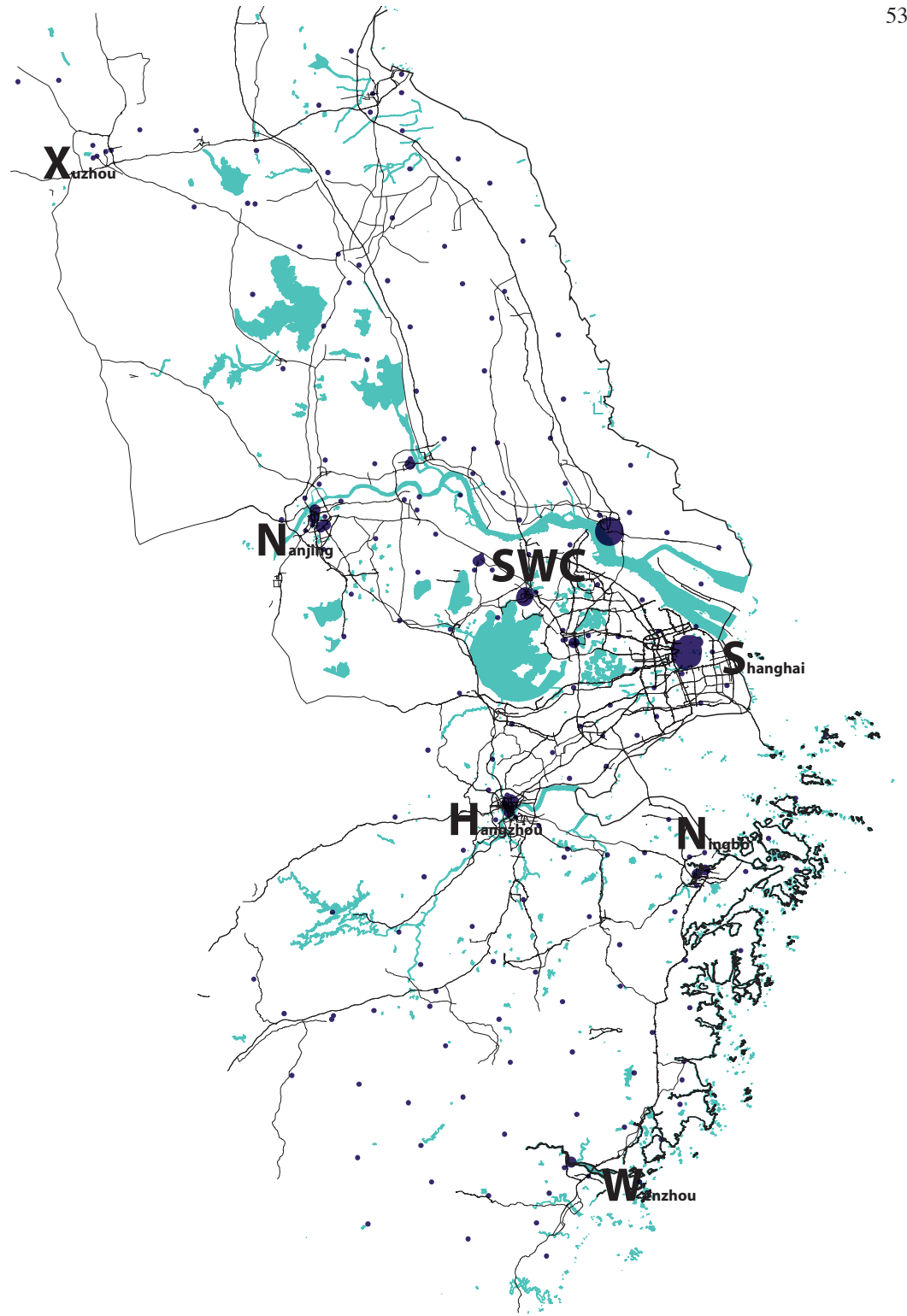

Scale Large- Tertiary Sector

Tertiary Sector (Service Sector), occupying the biggest proportion of the total employment, are mainly concentrated on the primary cities and a few secondary cities of all the regions. This map indicates that primary cities have much more attraction for Service Sector. Because these cities are mainly connected on the high level of network, like national scale or international scale.

In YRD, Tertiary Sector is developing rapidly. Only primary cities of all the regions have high density of Service economic activities. Among these primary cities, Shanghai plays an dominate role for Service economy in the entire region, particularly on the international scale, while there are a few Service economy centres in NWE, like London, Paris, Frankfurt Amsterdam and etc.

3.1.2.a. Mapping Distribution of Three Economic Sectors

Technical Application

Calculation of Employment density of three economic sectors in Municipality level in the Randstad and in Township level in SWC using Natural Break. Calculation of the Randstad is based on the source in 2005, while calculation of SWC is based on the source in 2004. Different from other source, Employment of SWC is derived from the amount of business units with a rough number of employees (e.g. 200 business units with employees between 1-19).

Data Source

Labour Force and Employment data of the Randstad is from the website “Centraal Bureau voor de Statistiek” and data of SWC is from the website “Urban and Regional Explorer”.

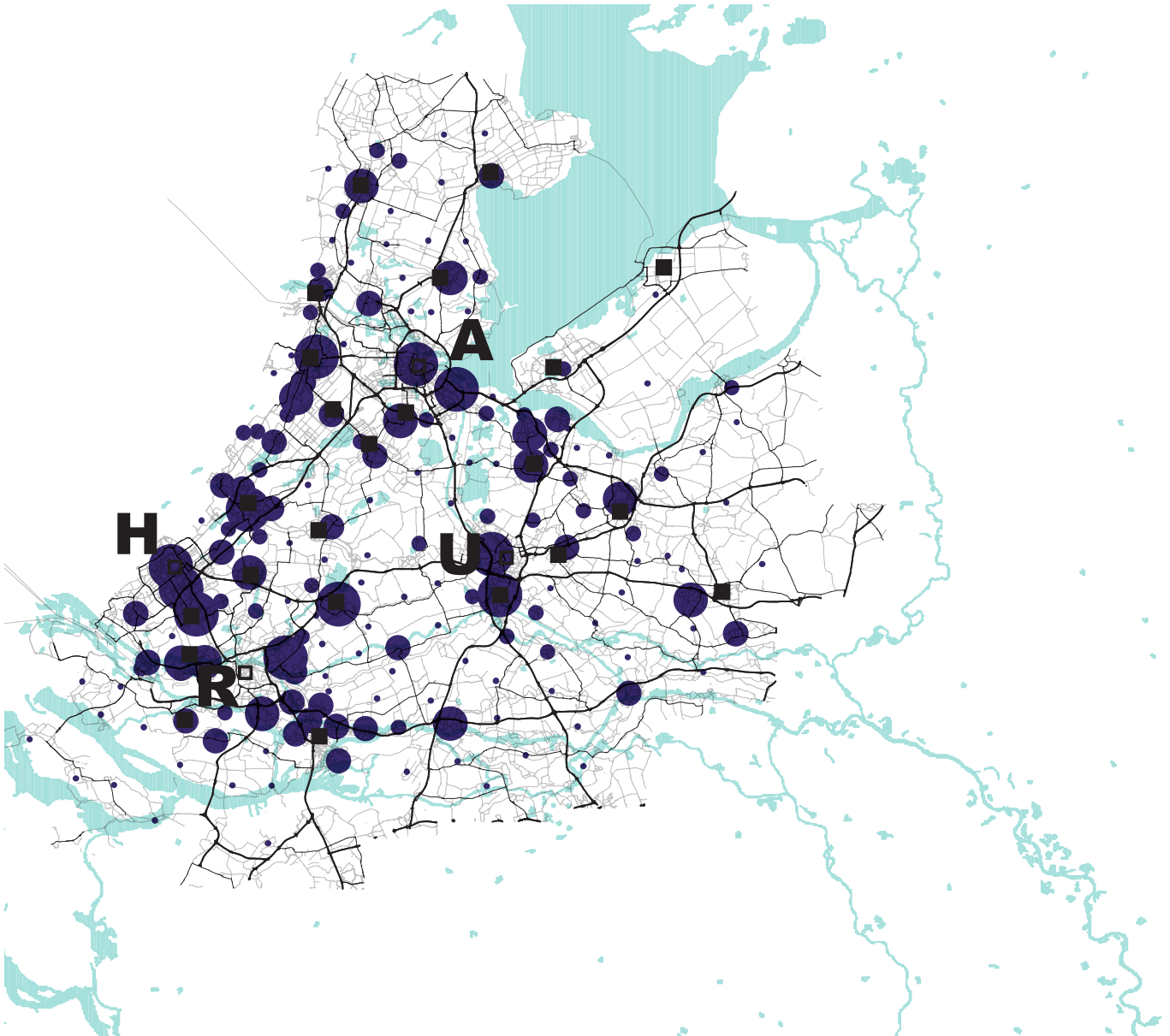

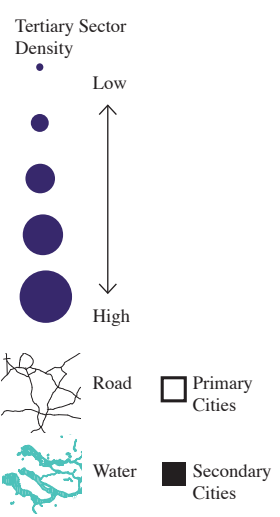
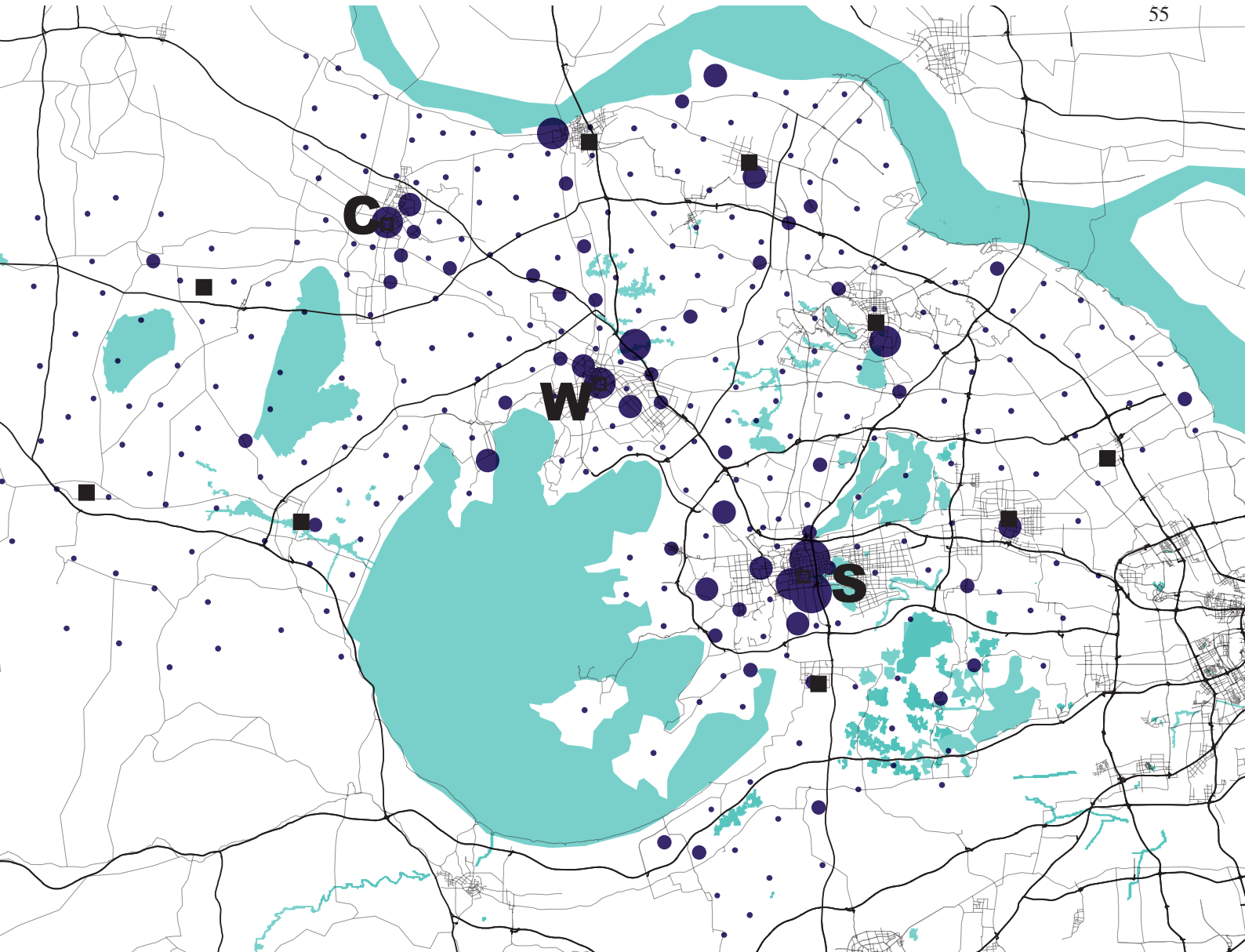

Scale Small- Tertiary Sector

It is very difficult to distinguish primary cities and secondary cities from the economical activities of Tertiary Sector in the Randstad, which means secondary cities can be attractive for Service economy as well. Because a plenty of secondary cities can be accessed easily by different transport network. However, what more important is that many secondary cities have been developed their specific service economy in order to distinguish with primary cities, which can be considered as complementarity in the region. For instance, Hilversum is a “media city” with most of important TV and Radio broadcast companies in the Netherlands. Delft is a “knowledge city” with universities and institutions, combination with tourism. Zoetermeer has ambitious to strengthen ICT sector as well as leisure activities (Masterplan Zoetermeer 2025, 2002).

The situation in SWC is totally different. Most of Service economy activities are concentrated on the primary cities, while service economy in secondary cities is very weak. There are several factors leading to this condition, such as transformation of industry, lack of high educated labour and living environment. Thus, secondary cities in SWC to search for a suitable way for the transformation development, which could be inspired by secondary cities in the Randstad.

3.1.2.b. Measuring Distribution of Three Economic Sectors
Comparing Polycentric Urban Region

In order to understand scalar PUR, the flowing will make use of “Polycentricity Matrix” tool to explain distribution of activities in three sectors separately by three scales: Macro, Meso and Micro.

Firstly, the distribution of employment in Primary sector has been measured by “Polycentricity Matrix” in order to understand spatial structure in different regions. In Macro Scale, North-West Europe has clustered polycentric structure, while very dispersed structure in Yangtze River Delta. There is almost no cluster in YRD, which means the lack of intensive and productive agriculture. That’s why YDR belongs to extreme dispersion on the north part of YRD. There is another difference between two regions. Activities density of agriculture in YRD are mainly located on the much less urbanised area. However,

agriculture clusters have close relationship with urbanised regions in NWE. This close relationship could benefit for both sides, either agriculture area or highly urbanised area. In Meso Scale, the regions in NWE and YRD have different spatial configuration as well. Most of regions in NWE belong to clustered Polycentric, except Paris as dispersed monocentric and Flemish Diamond as clustered monocentric regions. It needs to be noticed that some regions don’t represent reality by the map because of registration system, such as Paris and South East London. In Micro Scale, the Randstad has a much more clustered spatial structures than SWC, which means agriculture in the Randstad aims for productivity and intensity what can be achieved by clusters rather than random dispersion. Instead of agriculture in the less populated area in YRD, agriculture clusters in the Randstad have good accessibility to labour force,

Figure 29: Comparing PUR

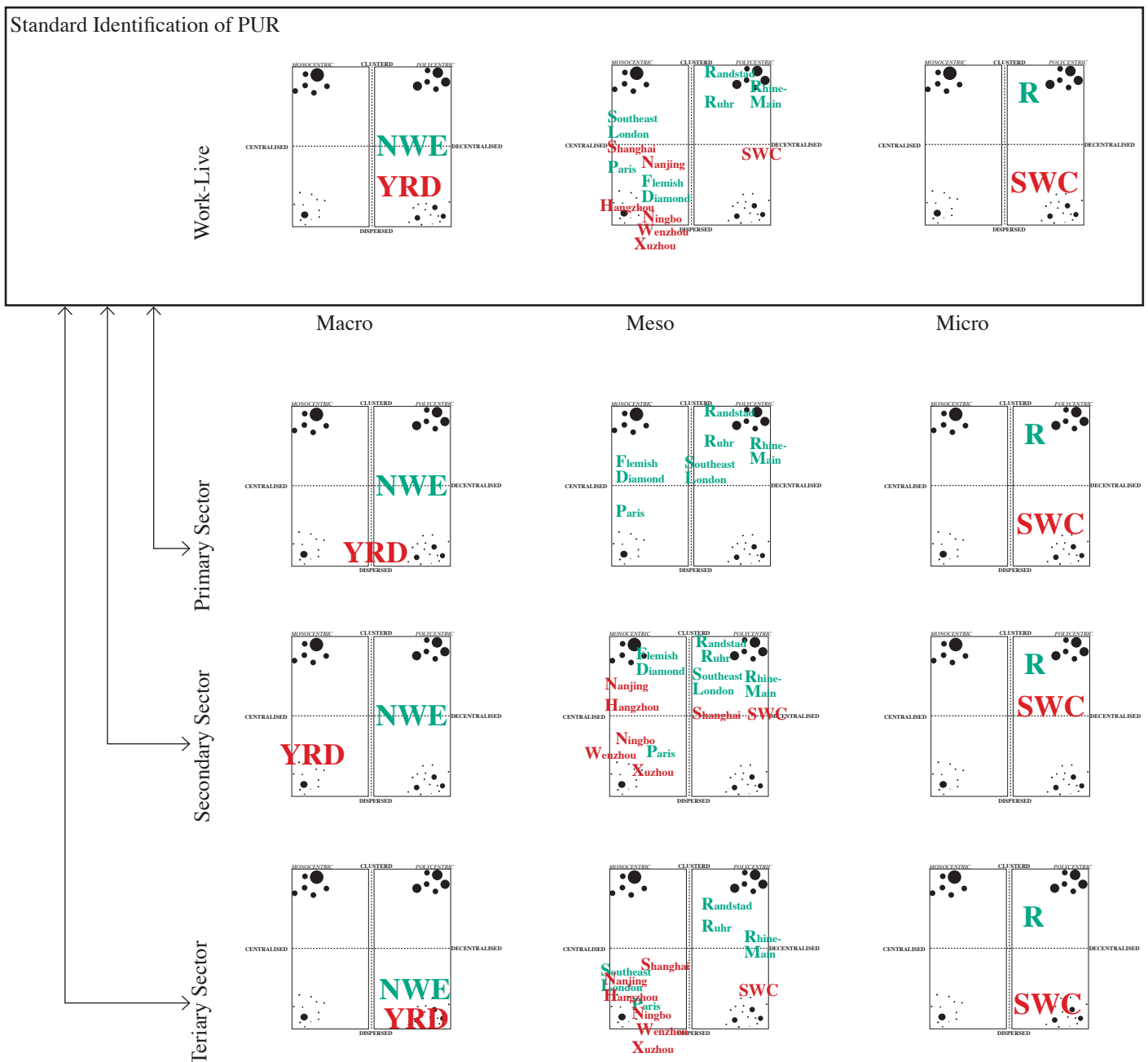

agriculture clusters have close relationship with urbanised regions in NWE. This close relationship could benefit for both sides, either agriculture area or highly urbanised area. In Meso Scale, the regions in NWE and YRD have different spatial configuration as well. Most of regions in NWE belong to clustered Polycentric, except Paris as dispersed monocentric and Flemish Diamond as clustered monocentric regions. It needs to be noticed that some regions don't represent reality by the map because of registration system, such as Paris and South East London. In Micro Scale, the Randstad has a much more clustered spatial structures than SWC, which means agriculture in the Randstad aims for productivity and intensity what can be achieved by clusters rather than random dispersion. Instead of agriculture in the less populated area in YRD, agriculture clusters in the Randstad have good accessibility to labour force, technical research institutions in order to combine agriculture with technology, such as Leiden Biological Park, Food Valley. Besides, connection on the global network makes agriculture in the Randstad more competitive for the region. With good base and history, agriculture in SWC is shrinking due to replacement of industry. Rethinking about development of agriculture is important for SWC, because it could strengthen the regional competitiveness as well as improving the ecological condition of the total region.

Secondly, the distribution of employment in Secondary Sector appeared differently as well by different scales. From "Polycentricity Matrix" of Macro Scale, NWE has more clustered spatial structure than YRD, which means all regions in NWE have outstanding privilege for industry economy than the rest area, and at the same time sub-centres are actively participating in the regions. The area including Nanjing Region, SWC and Shanghai regions have much more concentration of industry than other area, so in this sense the spatial structure of YRD has trend to mononcentricity. In Meso Scale, most of regions in NWE belong to "Clustered Polycentric" structure, except Paris and Flemish Diamond as "Clustered Monocentric" regions. Conversely, most of regions in YRD have monocentric structure. The exceptions are Shanghai Region and SWC belonging to "Clustered Polycentric" region, which was caused by the decentralisation of industry to small cities or new towns in the surroundings. The appearance of sub-centres in SWC and Shanghai Regions also proved that the industry economy of these areas is leading the development of industry for the entire YRD. In Micro Scale, the spatial structure of the Randstad is comparable with SWC, as "Clustered Polycentric" regions. For example, the area around Rotterdam in the Randstad has a very strong cluster for industry activities, and suburbs of Wuxi and Suzhou are full of industry.

Thirdly, the distribution of employment in Tertiary Sector is very similar to the distribution of live and work. In the Macro Scale, NWE still has more clustered spatial structure than YRD with a few small cities participation. However, this clustered structure of Tertiary Sector in NWE is not so clustered as other sectors, which means most of service economical activities are still taking place in the primary cities of regions. In YRD, this situation is even stronger. Primary cities have definitely priority for Service Industry. In Meso Scale, three regions along River

Rein in NWE belong to "Clustered Polycentric" urban region, and the rest have dispersed monocentric structure. All the regions in YRD have "Dispersed Monocentric" structure except SWC with multi-centres. In Micro Scale, the Randstad has much more clustered structure than SWC, with the involvement of primary cities and secondary cities. Tertiary Sector in SWC mainly focuses on the primary cities.

Finally, it is very clear that "Polycentricity" varies by scales and issues in terms of distributed spatial structure (Figure 29). In all this issues, distribution of live and work can represent spatial structure as the best way. That's why distribution of live and work is considered as a sort standard identification of Polycentric Urban Region. With this standard, it is very easy to find out how "Polycentricity" varies by other issues. The result is that "Polycentricity" doesn't vary so much for NWE and the Randstad, but appears very differently by issues for YRD and SWC. Thus, we can conclude that all economic sectors in NWE and the Randstad have close relationship with regionalisation process, but for YRD and SWC this relationship is not formulated yet.

3.1.2.b. Measuring Distribution of Three Economic Sectors Comparing Role of Secondary Cities

“Polycentricity Triangle” was used to express the role of secondary cities by comparing the balanced distribution between secondary cities and primary cities, as well as spatial clustering configuration around secondary cities and primary cities. This gives a direct comparison that the role of secondary cities are very different for the Randstad and SWC by different sectors. The following part will explain in details why these triangles are different (Figure 30).

Firstly, for the economic activities of primary sector (Agriculture), secondary cities of both regions have priority than primary cities due to cheap land and improved infrastructure. That’s why both triangles are asymmetric and incline to secondary cities. However, the difference is that activities of primary sectors around secondary cities in the Randstad is much more clustered than in SWC, which can be easily seen by the width of these triangles. The narrower the triangle is, the more clustered the structure is. The Randstad already gives a good example. Clustered agriculture in the Randstad explains that a sort of agriculture industry which is based on labour force rather than the land. It means productivity of agriculture within the limited land can be achieved in the reality, which is very relevant for SWC with scarce land. First of all, labour force density of secondary cities is very comparable with the primary cities in the Randstad. Plenty of labour force will support the high productivity of agriculture, conversely, the development of agriculture can provide job opportunities to attract people to live. Thus, in this sense, secondary cities of SWC could consider about how to attract people to settle down instead only in the primary cities, so that enough labour force will meet the need of agriculture industry with high productivity. In addition, agriculture technology is the trend all over the world. In the Randstad, many secondary cities contain universities or research institutions, such as Delft and Leiden. These secondary cities provide knowledge or technology for the development of agriculture within these secondary cities or other secondary cities close by. However, in SWC, the most universities and research institutions are still located on the primary cities. Moreover, agriculture activities in the Randstad are mostly located on the secondary cities which have good connection to the international port, such as Westland close to Rotterdam Harbour, Aslmeer next to Schipol airport. This is a good lesson for SWC that secondary cities with agriculture economy need good connection on national or even international scale, because this connection will not only be used for exportation of agriculture production, but also provide opportunities to exchange agriculture knowledge and experience. After all, agriculture economy in SWC is much more behind with very dispersed structure. However, agriculture can be a useful tool to develop secondary cities in SWC by many ways.

Secondly, the role of secondary cities in the Randstad and SWC in terms of Secondary Sector (Industry) is different. The situation in the Randstad for Industry is quite comparable with Agriculture, which means secondary cities are very attractive for Industry Enterprises as well. However, factories in SWC prefers to set up in secondary cities as well as primary cities. As we can see, there are a large amount of factories in the suburbs of three primary cities in SWC, as well as in the secondary

Figure 30: Role of Secondary cities by Three Economic Sectors

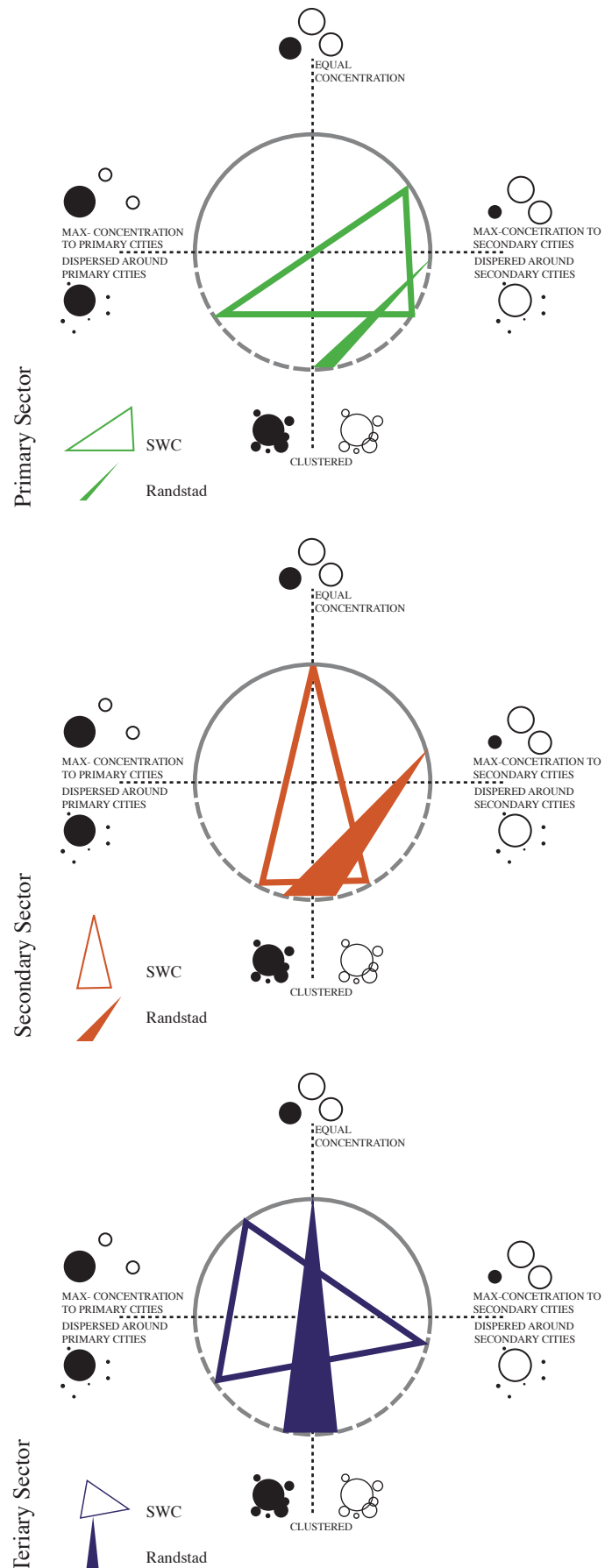

cities. Therefore, the triangle standing for Secondary Sector for SWC has symmetric figure. Why do primary cities in SWC have comparable attraction as secondary cities? There could be several reasons. From the industry development of SWC, the first amount of factory were located in the primary cities. Later on, especially in 1980s, the township owned factories were developed rapidly in the secondary cities. Thus, until 2004, the industry in primary cities are still very equal to secondary cities. Moreover, even the infrastructure network in SWC is very advanced in China, the connection of secondary cities is a bit behind. For this point of view, suburbs of primary cities are suitable for industry. In addition, all kinds of facilities in primary cities are much more complete than secondary cities, which is also an important factor for a factory to choose its location. Particularly, high-tech industry becomes more and more important, which is the trend for industry development of SWC. Due to a variety of necessary facilities (e.g. knowledge institutions), most of high-tech factories chose primary cities rather than secondary cities (Map 31). That's why primary cities and secondary cities in SWC have their own advantages and disadvantages for industry. This is opposite with the Randstad. Secondary cities in the Randstad have definite attraction for industry companies, because they have comparable amount of labour force, the support of knowledge institutions and universities, good connection with diverse infrastructure network and plenty of land with cheap price.

Thirdly, the comparison about Service economy between the Randstad and SWC indicates the different role of secondary cities play in the region. In the Randstad, secondary cities have comparable density of Service economy, which can be shown by a symmetric triangle. However, secondary cities in SWC contain much less Service economic activities, instead, most of Tertiary Sector focuses on the primary cities. Another differences about clustered structures of Tertiary Sector is that the Randstad has much more clustered structure than SWC. This means a sort of equality between cities for Service economy, no matter it is a primary city or a secondary city. Definitely Service economy in SWC is much behind the Randstad. Companies belonging to Tertiary Sector are mainly located on the centres of primary cities. However, with the economical development of SWC, especially switching to Service economy, secondary cities could play an important role to cooperate with primary cities. For example, primary cities will keep their priority to develop Service economy in national scale or even international scale, such as Amsterdam is the financial centre of the Netherlands or the Europe. But secondary cities can develop low scale of Service economy (Regional Scale), or find out specific Service economy. For Example, a secondary city Hilversum, has been mentioned before, is well-known as the Media City for the Netherlands, where almost all the dutch radio broadcasting organizations (followed by television broadcasters) have established their headquarters since 1950s. Therefore, secondary cities in SWC could make use of existing resource and potentials to develop their own Service economy, in order to distinguish with primary cities.

To sum up, the role of secondary cities in the Randstad is very different from SWC in terms of three economic sectors.

Secondary cities in the Randstad have more attraction for Agriculture and Industry than primary cities, but has equal employment density of Service economy as primary cities. In SWC, comparing with primary cities, secondary cities are only preference for agriculture, has similar concentration for Industry and no attraction for Service at all. On one side, this difference is caused by not so advanced economical level of SWC, where Industry mainly underpins the regional economy. On the other side, this difference can be lead by unclear development vision of different cities, especially secondary cities whose functions were under estimated. Secondary cities in SWC are not only the cities providing industrial production full of factories as now, but also could develop Primary sector or Service sector to find out their specific roles. Then secondary cities in SWC will not just remind people endless cold factory boxes, instead, they become more liveable cities with their specialisations.

Map 31: Distribution of High-tech Industry Enterprises

Source: Yuan & Song, 2012

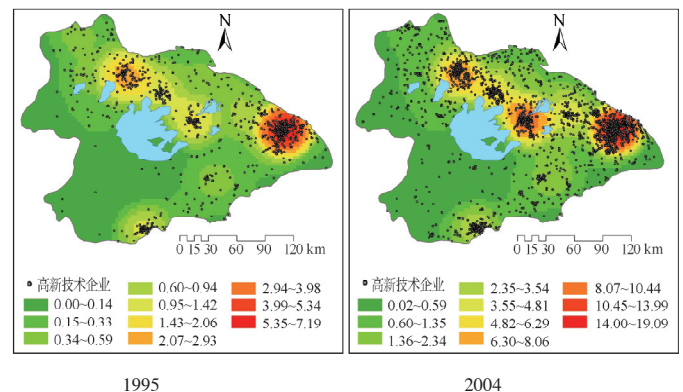

3.1.2.c. Conclusion of Distribution of Three Economic Sectors

The result of measuring polycentricity gives a direct comparison for two regions. But these abstract diagrams need to be reflected on the geographic map with real size and position. This part aims to represent similarities or differences simply and directly on the map for different regions at two scales.

Scale Large (Map 32)

The conclusion map of NWE tells that all clusters of three sectors have ultimate relationships with all the regions. Only the extent of clustering of different sectors is different from others. Service Sector mainly focuses on the primary cities of each region, with less participation of sub-centres. Industry has relatively clustered structures within or around the regions. Agriculture is switching to the outskirts of the regions, but there is still a lot of agriculture existing within the region. Therefore, all activities of different economic sectors are concentrated on the urban regions, because urban regions could provide most necessary and sufficient conditions for three sectors, such as labour force, facilities, infrastructure, etc. For example, agriculture traditionally is located in the area with low population density, but nowadays, agriculture has been combined with technology to pursue high productivity and sufficiency. This leads to the open land within or around the region becoming the preference for agriculture, where has plenty of high educated labour and easily transport production in different scales.

Distribution of three economic sectors in YRD represents a very different condition. Activities of Service economy only take place in the primary cities of each region, and Shanghai plays a dominating role for YRD. Industry sector starts clustering for most of the region in YRD, especially SWC and Shanghai Metropolitan Region has been integrated as a whole. That's why "SWC Regional Plan 2001-2020" addressed the relation between SWC and Shanghai, especially seeking a complementary industry to reduce unhealthy competitions. Agriculture in YRD is located on the north of Yangtze River, which has few relations with regions. This situation is caused by undeveloped agriculture depending on the land, as well as industry development and urbanization have eaten a lot of agriculture land. In the process of regionalisation in YRD, economic sectors will react and adjust correspondingly, so that allocation of different activities will help the formulation of the urban regions.

Scale Small (Map 33)

Activities of three sectors in the Randstad represent an extreme clustering structure around "Green Heart". Service sector is the best representative sector for the ring structure of the Randstad. Industry has been separated into North Wing and South Wing. And Agriculture is located between Amsterdam and Rotterdam along the coast. Moreover, Secondary cities, comparing with Primary cities, are strongly participating in all economic activities of the region. In order to understand which sector a secondary city focuses on, all secondary cities are categorized by three sectors. What has been discovered is that most of secondary cities containing all three sectors are located on the south of the Randstad ("South Wing"), which indicates the dominating role of Amsterdam is much stronger than Rotterdam or the Hague. In one word, the Randstad has a clustered structure for three sectors and there is a balance between secondary cities and primary cities in terms of economic activity density.

The structure of three economic sectors in SWC is not so clustered and clear as the Randstad. However, there are two lines with concentration of economic activities: one line is to link three primary cities, the other line is to connect five secondary cities to Shanghai on the west of the region. Service sector in SWC only focuses on the primary cities and city centres of some secondary cities, while service sector in the Randstad has the most clustering structure. Industry in SWC has most clustering structure, with participation of secondary cities with good connection of infrastructure. Agriculture is randomly distributed in SWC, mainly next to the lake or the river. In addition, this map represents the disparity of economy between the east part and the west part of the region. Secondary cities on the east attract different economic sectors, particularly industry. But secondary cities on the west contain few activities except agriculture.

Conclusion





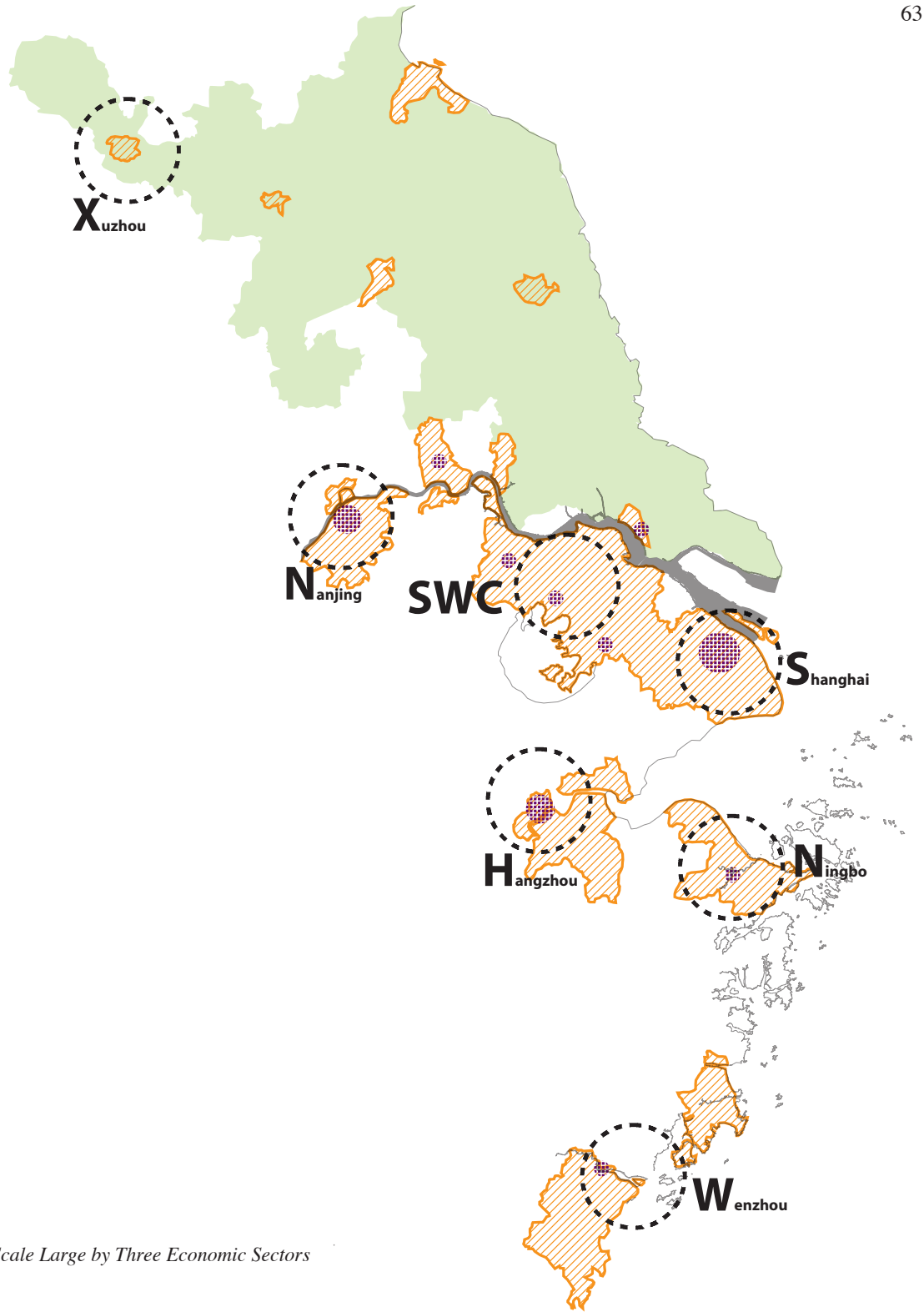

To sum up, the spatial structure of different regions in Scale Large and Scale Small is very different, in terms of three economic sectors. NWE has more clustered spatial configuration than YRD. And what more crucial is that economic activities in NWE mainly concentrate on the urban region, while there is very little relation between economic activities and urban regions in YRD. In Scale Small, the Randstad has more clustered ring structure than SWC, and the balance between primary cities and secondary cities in the Randstad is higher than SWC. It is very efficient to understand different regions and role of secondary cities by the comparative study.

3.1.2.c. Conclusion of Distribution of Three Economic Sectors





Map 32: Conclusion Map of Scale Large by Three Economic Sectors





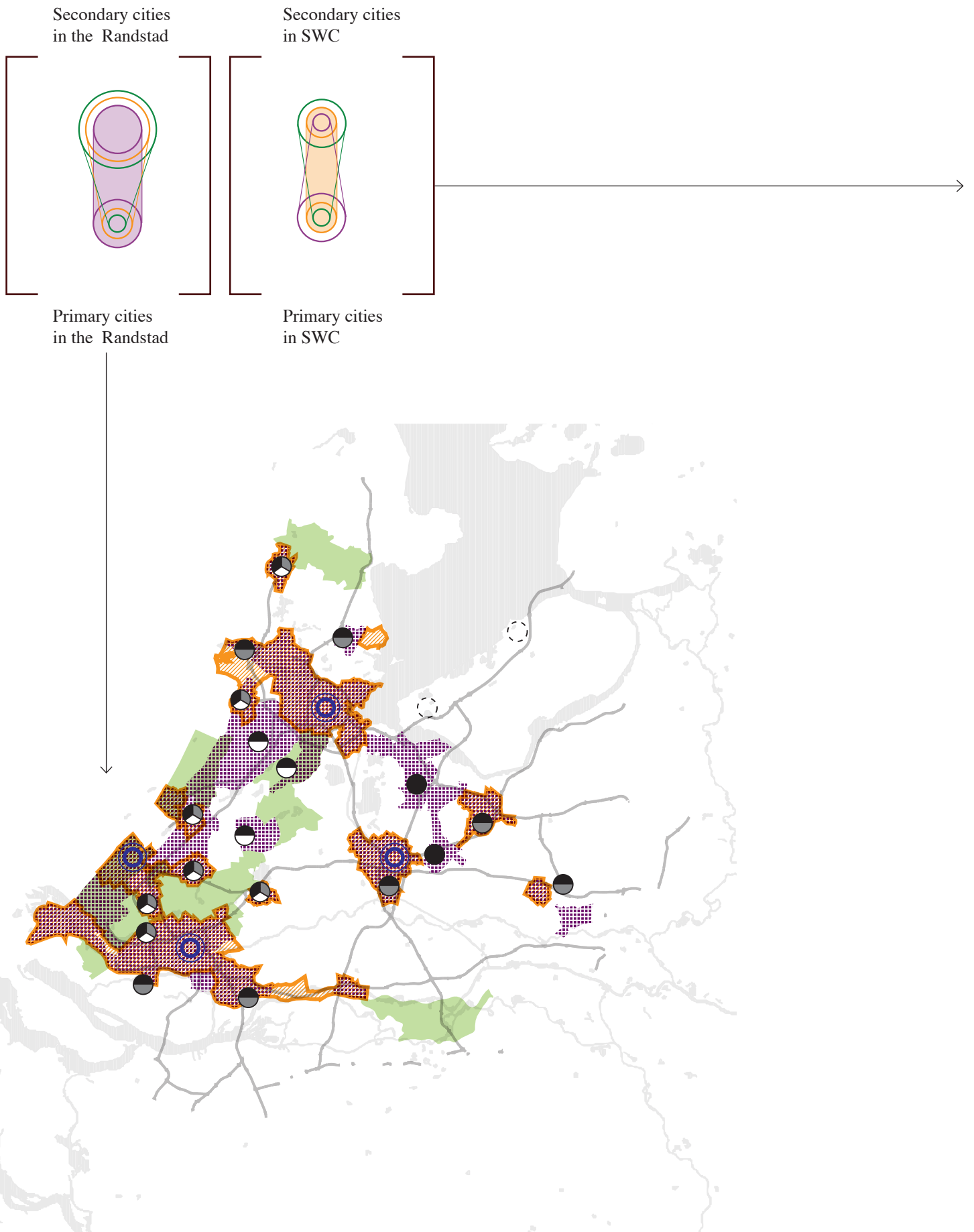

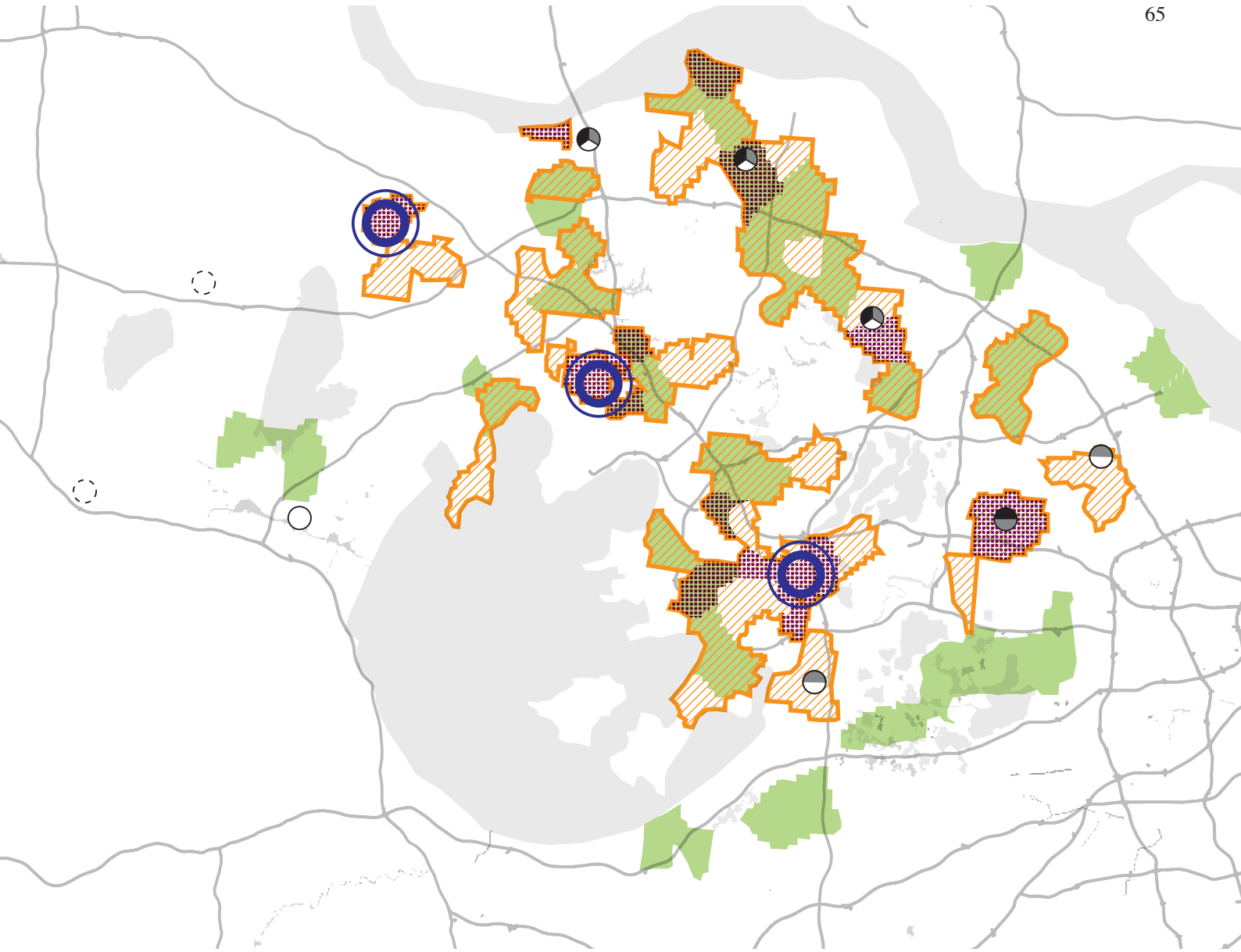





-  Concentrated Activities of Primary Sector
-  Concentrated Activities of Secondary Sector
-  Concentrated Activities of Tertiary Sector
-  Water
-  Highway
-  Regions

3.1.2.c. Conclusion of Distribution of Three Economic Sectors





Map 33: Conclusion Map of Scale Small by Three Economic Sectors

- | | | | |
|---|---|---|--|
|  | Concentrated Activities of Primary Sector |  | Secondary City with All Sectors |
|  | Concentrated Activities of Secondary Sector |  | Secondary City with 2nd or 3rd Sector |
|  | Concentrated Activities of Tertiary Sector |  | Secondary City with 1st and 3rd Sector |
|  | Water |  | Secondary City with 1st and 2nd Sector |
|  | Highway |  | Secondary City with 3rd Sector |
|  | Primary City |  | Secondary City with 1st Sector |
| | |  | Secondary City without Concentrated Activities |

3.2 Diversity - Normative Dimension

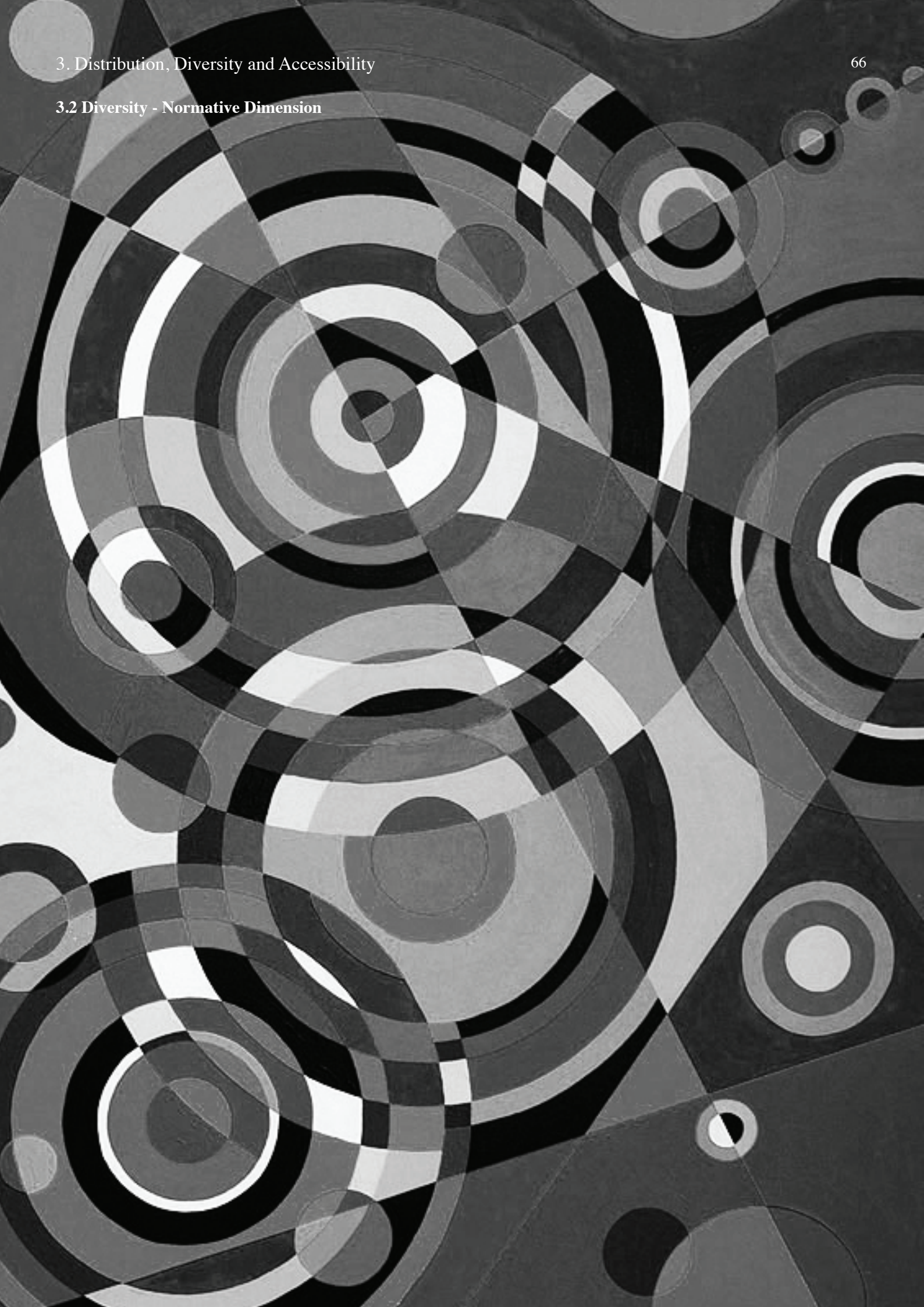

3.2 Diversity - Normative Dimension

Diversity indicator is used to understand how to identify whether and at which scale (spatial level) specialisation of economic activities is taking place. There are a variety of ways to measure specialisation of cities. For instance, there is a research about specialisation of 13 cities in the Randstad according to the business start-up profiles (Kloosterman and Lambregts, 2001). The different position of cities indicates that diversity of the Randstad with specialised cities, such as cities in the Rijmond (Rotterdam, Schiedam and Dordrecht) with transport industry, and The Hague and Delft have relative specialisation of agriculture and food industry. The tendency between 1997 and 1994 can be interpreted as a sort regional specialisation, because the profiles of most cities start to move to the upper right side of the plot (Map 34) including communication and business sector. Thus, “diversity of the region with specialised cities” and “regional specialised” have been discussed and proved in the research according to the business start-up profiles of cities in the Randstad.

However, my research will use a different way to understand specialisation in different scales and contexts. Diversity Index was applied based on the employment in three economic sectors, including Primary sector relating to raw materials, Secondary sector referring to industrial sector and Tertiary sector referring to service sector. Diversity of three sectors shows whether an area is balanced with all three sectors or has emphasis on one of it in the regional scale and the inter-regional scale for two contexts. According to two types of network in PUR, Club Network and Web Network (Figure 35) both could exist to strengthen functional interaction for the region. Club Network, based on the cooperation among centres with similar functions, have some disadvantages or limits, like unhealthy competitions for resources, labour force, infrastructure, etc. However, Web Network is more relevant for PUR, because the complementary relationship among these specialised cities or regions will stimulate functional interaction with one another. Thus, the results of diversity will explain how complementarity contribute to the formulation of a region in different scales and with different contexts.

Map 34: Trajectories of business start-up profiles for 13 cities of the Randstad, 1988-97

(Source: Kloosterman and Lambregts, 2001)

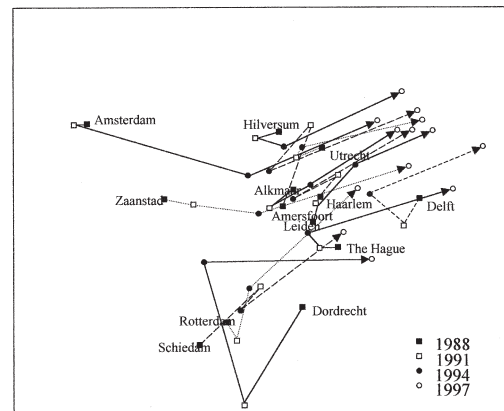
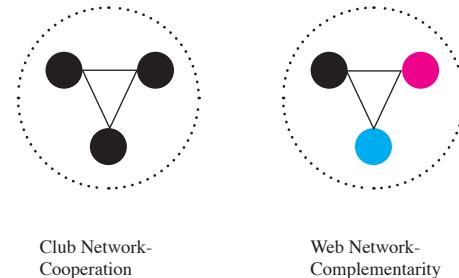

Figure 35: Two Types of Network

based on the Source: Meijers, 2007



3.2.a Mapping Diversity - Three Economic Sectors

Technical Application

Calculation of Employment density of three economic sectors by Diversity Index in Nuts 3 in NWE and in Country level in YRD using Natural Break. Calculation of NWE is based on the source in 2007, while calculation of YRD is based on the source in 2004.

Data Source

Labour Force and Employment data of NWE is from “Atlas ABC” and data of YRD is from the website “Urban and Regional Explorer”.

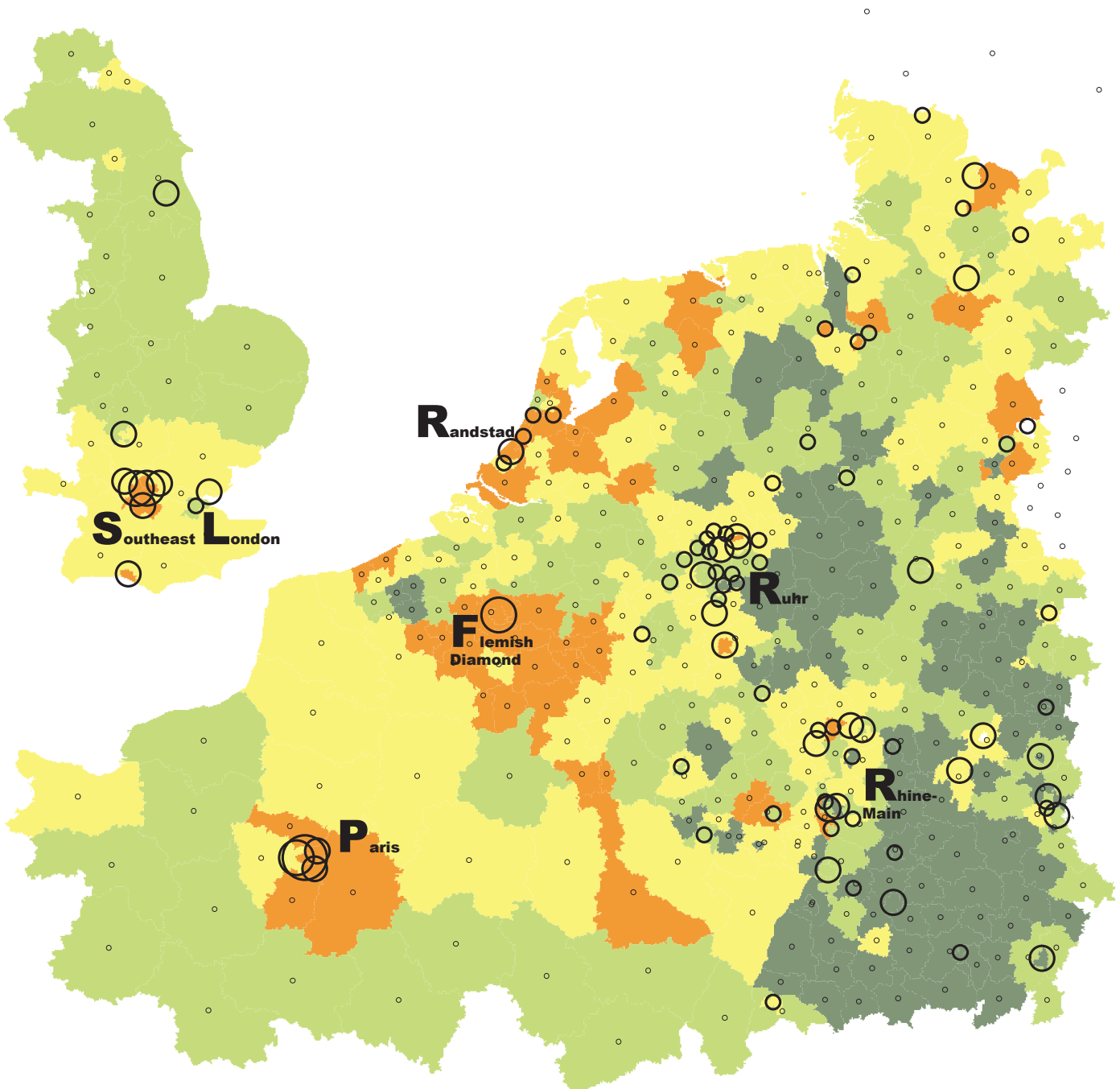

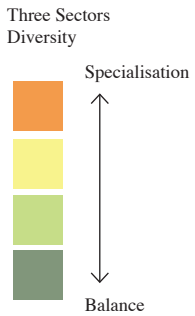
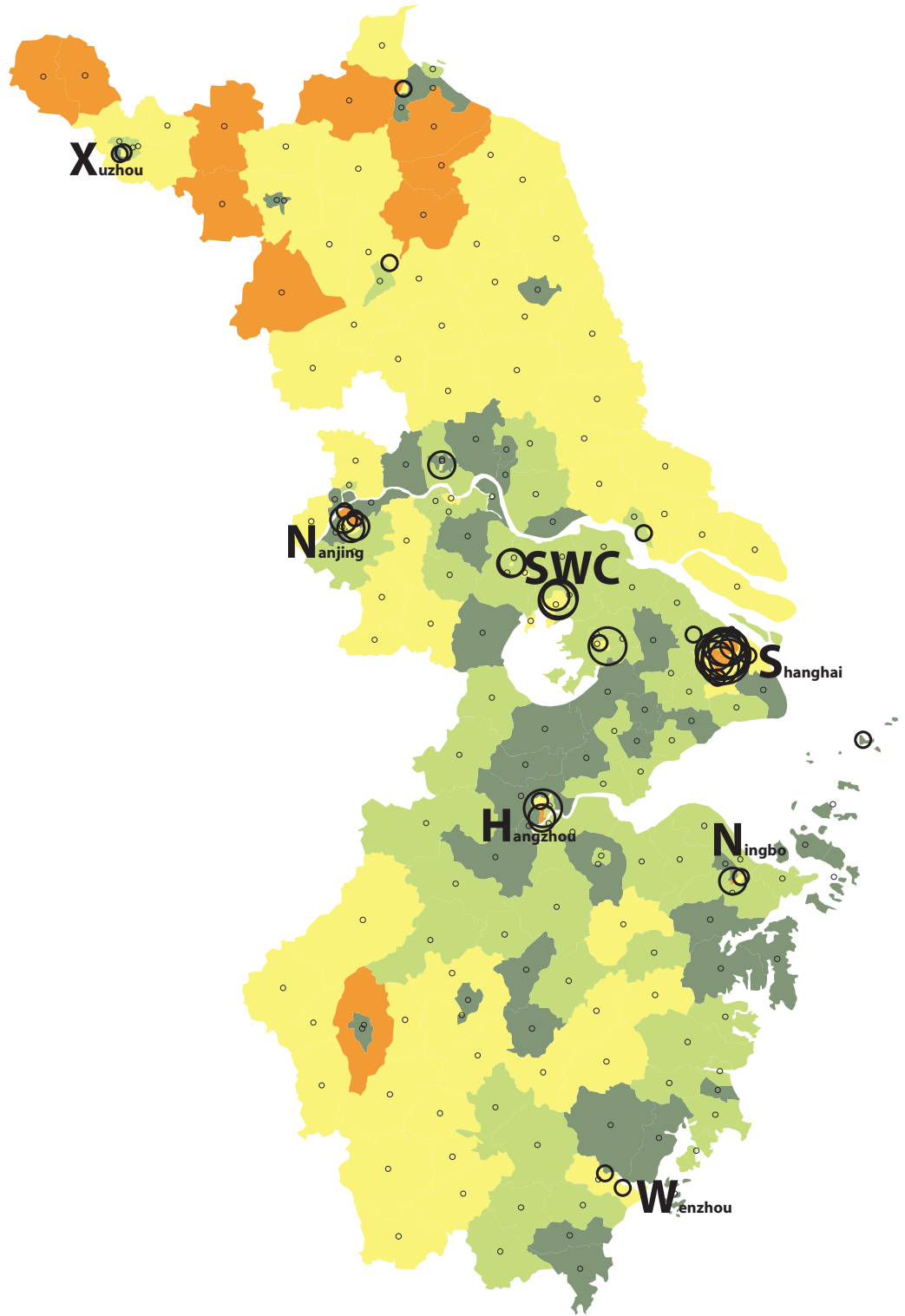

Scale Large-Three Economic Sectors

Orange colour means strong specialisation to one economic sector according to the “diversity Index”. Thus, it is very apparent that the area with specialisation in NWE is located in the urban regions. In other words, most of urban regions have been specialised into its own economic sector comparing with the rest of the land, such as the Randstad, Paris, etc. However, Rhur Area and Rhine-Main in Germany only partly contains the area with specialisation.

However, this correlation between specialisation and urban region doesn’t exist in YRD, except Shanghai Region. Most of clusters with specialisation are on the north of YRD, where agriculture is the main sector.

3.2.1 Mapping Diversity - Three Economic Sectors

Technical Application

Calculation of Employment density of three economic sectors by Diversity Index in Municipality level in the Randstad and in Township level in SWC using Natural Break. Calculation of the Randstad is based on the source in 2005, while calculation of SWC is based on the source in 2004.

Data Source

Labour Force and Employment data of the Randstad is from the website “Centraal Bureau voor de Statistiek” and data of SWC is from the website “Urban and Regional Explorer”.

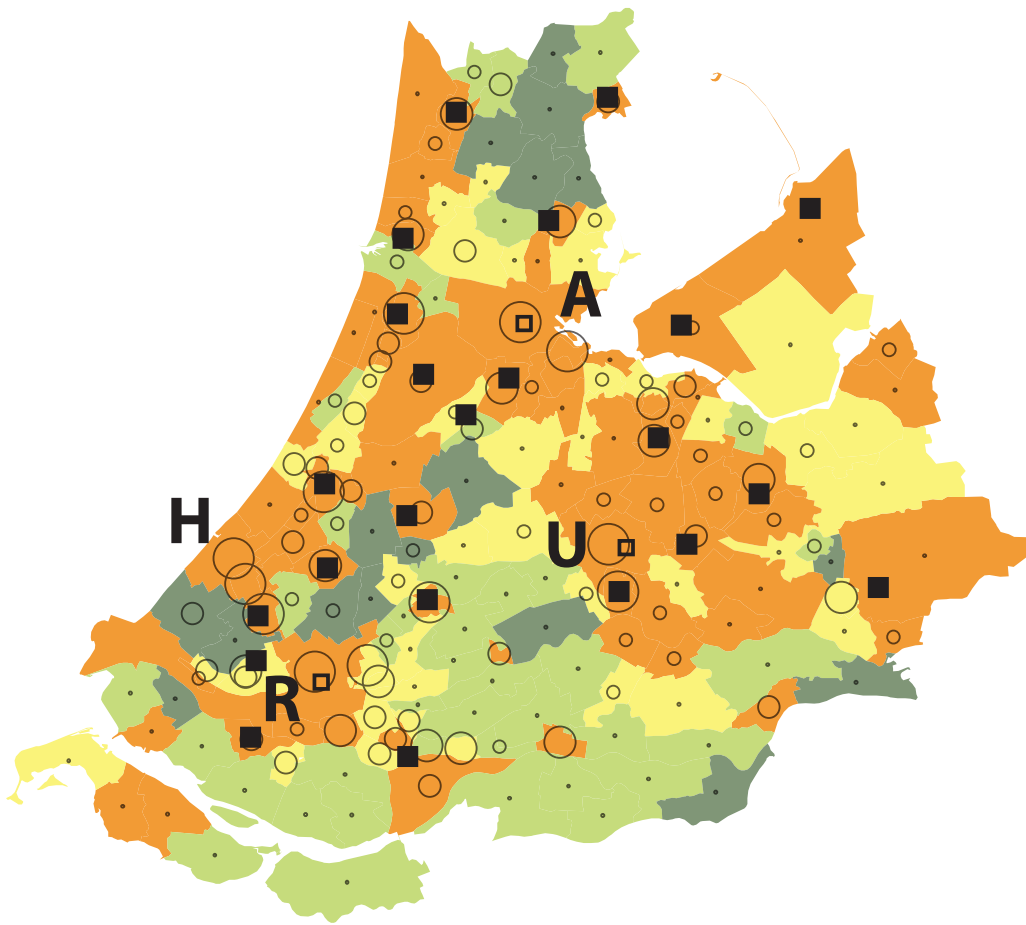

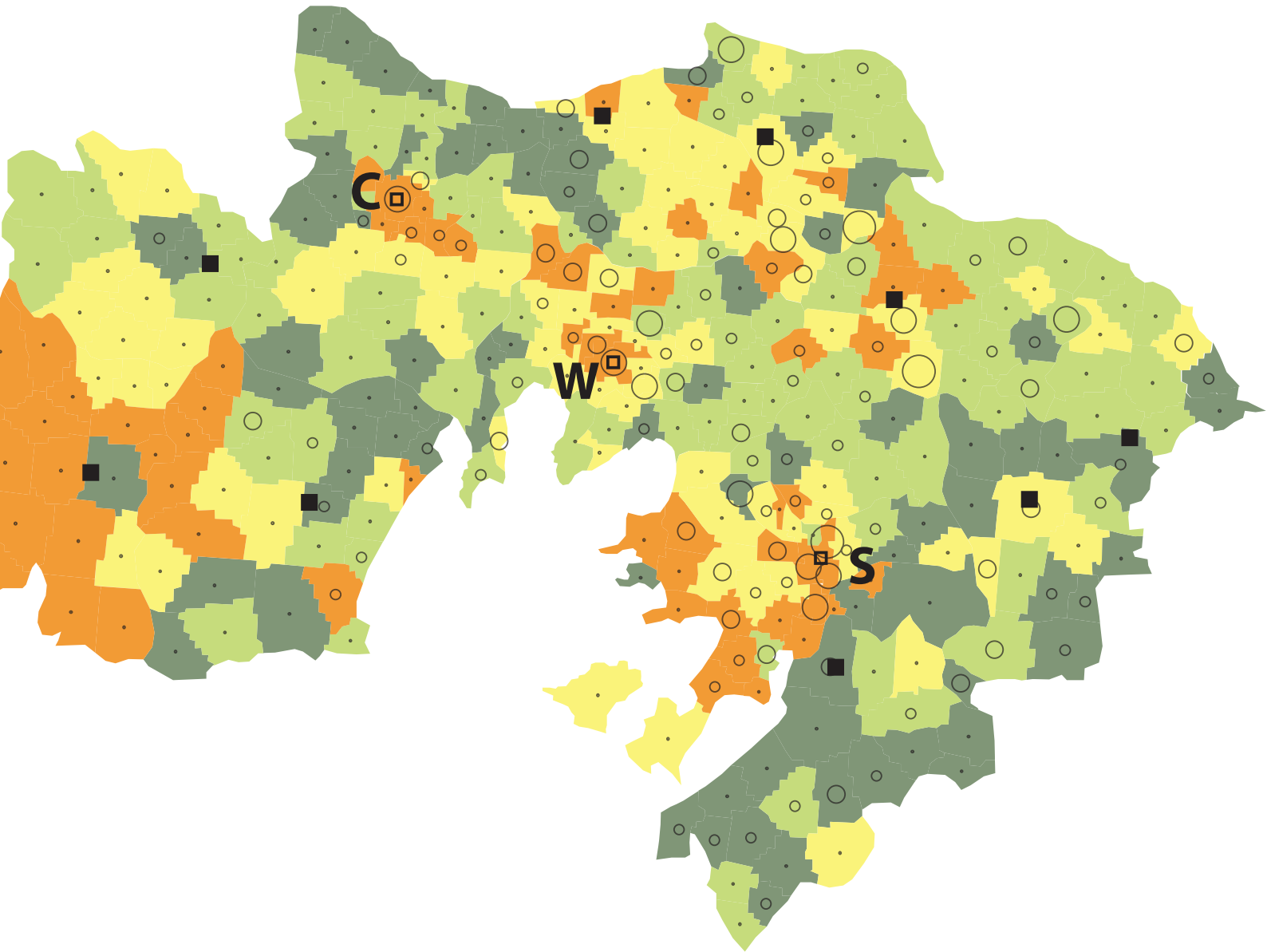

Three Sectors Diversity

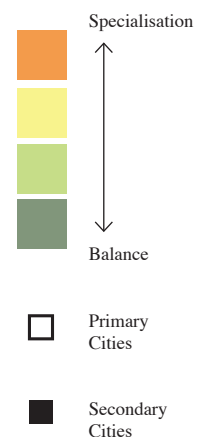

Scale Small-Three Economic Sectors

In the Randstad, It is very interesting to discover that area with specialisation has the ring structure around green heart. Most of cities belong to the category with strongest specialisation. In this sense, the hypothesis, that if a city or a region moving to the direction of the formation of an economic cluster, the supply and the demands more focused towards specific activities (Kloosterman and Lambregts, 2001), could be proved.

However, in SWC specialisation is located on the primary cities, some secondary cities and open area with farm land. The structure of specialisation is not that clear in SWC. There are several reasons for this dispersed structure of specialisation. One reason is the development of the area between cities. In the Randstad, there are many “Transport Oriented Development” along the highway. This area between cities has developed either industry or office park, which results in clusters of ring structure. But in SWC enterprises still prefer the area close to the city centres of primary cities and secondary cities. Definitely the size is another reason for the development. Besides, secondary cities in SWC need to figure out their own specialisations in the region, which could help the establishment of complementarity among cities to stimulate functional interactions in the region.

3.2.b Measuring Diversity

Comparing Polycentric Urban Region

“Polycentricity Matrix” can easily show the differences between two regions, in terms of diversity of three economic sectors. At the same time, the spatial structure of diversity could unpack complementarity or specialisation in different scales.

NWE has more dispersed polycentric structure, which means the areas with specialisation and the areas with balanced three sectors are always mixed together. In other words, there is a large diversity in the scale of NWE, which is crucial for web network in PUR. In the contrast, YRD has a totally different structure: clustered monocentric. where Shanghai is the centre. Clustering structure indicates neighbouring regions have similar economic structure, which means probably more club network is existing in YRD.

However, zooming into Scale Small, clustered or dispersed structure has different explanations. Clusters of specialisation in the Randstad indicates almost all the cities have specialised towards Service sector, which can strengthen the regional specialisation (regional identity). This result is the same as the research of business start-up profiles of 13 cities in the Randstad (Kloosterman & Lambregts, 2001). But within service sector, the cities in the Randstad are trying to identify themselves with a specific economy in order to play complementary roles in the region, like “media city” Hilversum, “Airport City” Hoofddorp. Therefore, there is no conflict between city specialisation and regional specialisation at the same time. In SWC, specialised area is dispersed into the entire region, which means many cities don’t have specialisation at this moment. The lack of city specialisation will become a barrier for the development of regional specialisation.

Figure 36: Comparing Diversity in Scale Large and Scale Small

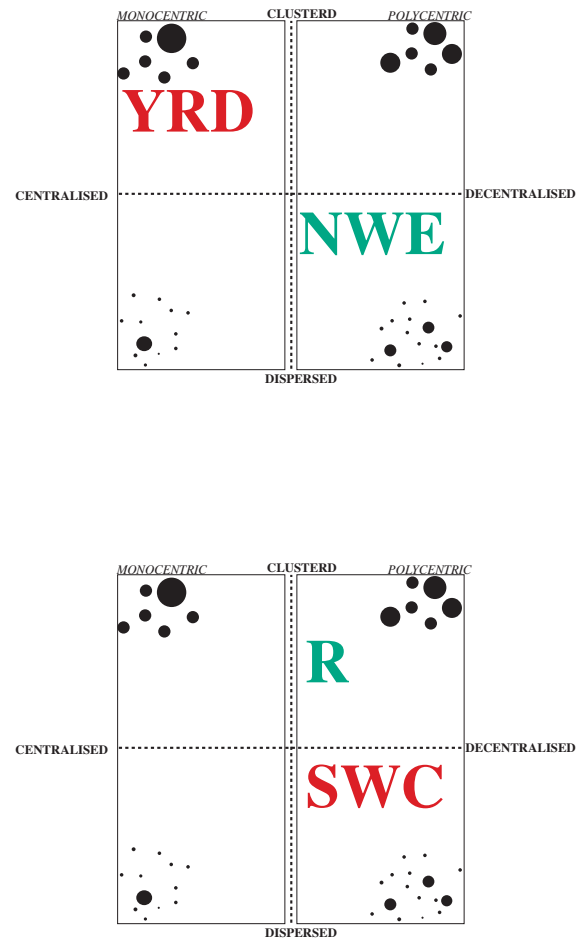

3.2.b Measuring Diversity

Comparing Polycentricity by Scale

This part aims to understand how diversity varies by different scales by using Moran's I (Figure 37). As it was concluded, NWE has high diversity in the inter-regional scale with regional specialisation, while YRD has low diversity in the inter-regional scale and less apparent regional specialisation. Moran's I have proved this differences between two regions with more precise calculation. Moreover, Moran's I discovered how diversity reacts on the spatial scale. It is very interesting to see that diversity in NWE keeps more or less the same by different scales, which means all the scales have high diversity in terms of economic sectors, either regional scale or inter-regional scale. However, YRD has different situation for diversity. 100 km (travel by 1 hour) is the scale with the lowest diversity, and with the scale increasing, the diversity becomes higher. Diversity of YRD indicates the regional diversity within Urban Daily System is not so high that a complementary relationship of the high Polycentricity in the region. And diversity increasing afterwards is caused by the unbalanced distributed economic activities. Therefore, high diversity in all scales in NWE indicates a balanced structure of economic sectors, while balance is an essential value for PUR.

For the Scale Small, Moran's I have proved once more that the Randstad has higher diversity than SWC. Besides, diversity of the Randstad and SWC tend to be higher by the increasing scales. 25 km (travel within half hour) is the scale with the lowest diversity, which could be explained and interpreted differently in the Randstad and SWC. 25 km is the size for the city-region scale, such as Amsterdam City-region. Within city-region in the Randstad, the close relationship between primary cities and secondary cities leads to low diversity for this scale. At the same time, complementary among four primary cities (Amsterdam as financial centre, Utrecht as logistic centre, Rotterdam as Industry centre and the Hague as Administration centre) makes the higher diversity with larger scales. In SWC, 25 km is the size for the primary cities with lowest diversity. Even diversity increases afterwards, the diversity of all the scales in SWC is much lower comparing with the Randstad. Low diversity in SWC has been also mentioned in SWC Regional Plan 2001 by the similarity of manufacture among three primary cities (Figure 38).

Figure 37: Moran's I of Scale Large and Scale Small

YRD:
1 hour is the scale with lowest Diversity

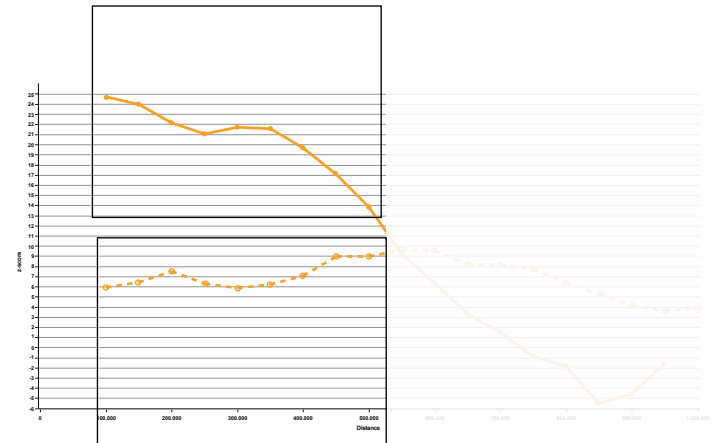

NWE:
Diversity doesn't change with scale and always random

SWC:
Going Down indicate Diversity Increases.
SWC has less Diversity than Randstad

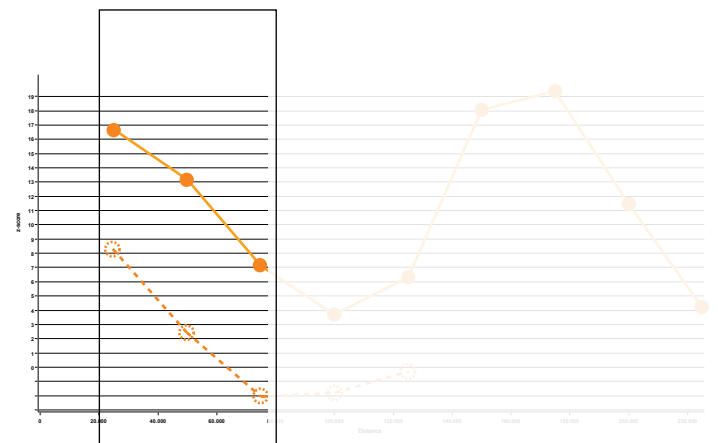

Randstad:
Going Down indicate Diversity Increases.

Figure 38: Similarity of Manufacture of three Primary Cities in SWC (1999)

Source: SWC Regional Plan 2001-2020, 2002

	Suzhou & Wu Xi	Changzhou & Wu Xi	Changzhou & Suzhou
Similarity Index	0.9292	0.9526	0.8661

3.2.b Measuring Diversity Comparing Role of Secondary Cities

The difference between primary cities and secondary cities in the Randstad, in terms of diversity of three economic sectors, is very limited. That's why there is a symmetric triangle for the Randstad (Figure 39). Secondary cities are not satellite cities any more, even though some secondary cities were set up as living area of primary cities. They are trying to find out their specialisations to distinguish from primary cities and other secondary cities.

However, in SWC, most of secondary cities have not been so specialised as the primary cities, which is indicated by an asymmetric triangle. Secondary cities in SWC were considered purely as the area for industry to pursue high GDP. At the same time, most of secondary cities just follow the development trend of primary cities to become a complete city with a large size. What has been neglected is how to make a secondary city special in the region to contribute the interrelationship within the region, so that attention will be a secondary city in the region instead of a single city.

Thus, the balance between primary cities and secondary cities in the Randstad in terms of diversity, indicates that specialisation is taking place in the secondary cities. However, the specialisation of secondary cities in SWC needs to be strengthened and orientated, in order to stimulate the functional interactions within the region.

Figure 39: Comparing Role of Secondary cities

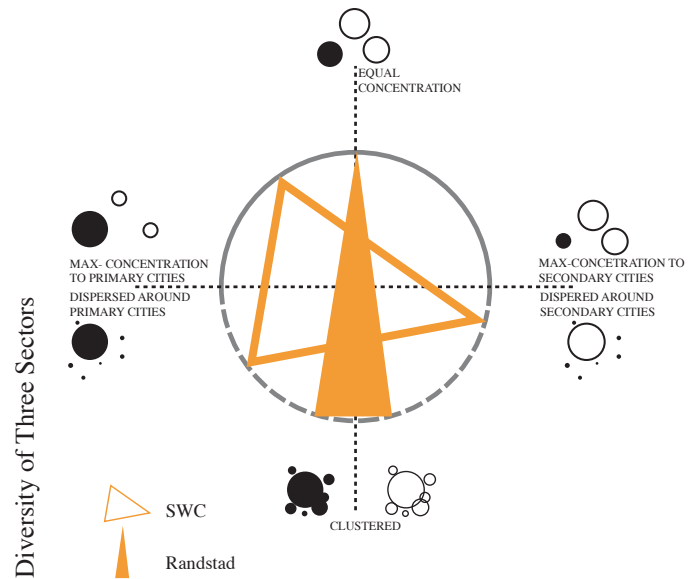

3.2.c Conclusion of Diversity

Scale Large (Map 41)

Regional specialisation is a crucial norm for the development of a region, which can be concluded from the conclusion map of NWE. All the areas with specialisation are located on the functional regions, such as Paris Region, the Randstad. On the other way, not all the regions in NWE have most specialisation, such as Ruhr Area and Rhine-Main. This means regional specialisation is a good norm for the region, especially for the advanced economy era. In YRD, regional specialisation does not exist yet, while only a part of Shanghai Metropolitan Region starts to have some specialisation. Therefore, by learning from NWE, strengthen regional specialisation in YRD will be helpful for the formulation of a functional region rather than a region on the paper.

Another important discover is that NWE always has high diversity, no matter in which scale. No changes of diversity in NWE indicates a sort balanced structure of diversity of economic sectors. Due to this balance in all scales, there is always a high diversity in the regional scale or in the inter-regional scale. Combining with the analysis about distribution, diversity in multi-scales is an important norm for PUR, which could give opportunities to develop region in a complementary way. Thus, for YRD, clustered structure of diversity will indicate web network relationship, which is less relevant for PUR to pursuing a balanced region.

By the comparisons between NWE and YRD, unbalanced structure of YRD has been represented in terms of diversity of three economic sectors. All the regions in YRD are necessary to think about the its own regional specialisation, which can not only stimulate functional interaction in the inter-regional scale (complementarity), but also give a framework for the orientation of all the cities in the region.

Figure 40: Relative Growth of Flow among sub-areas of the Randstad (2011)

Source: OV Bureau Randstad, 2011

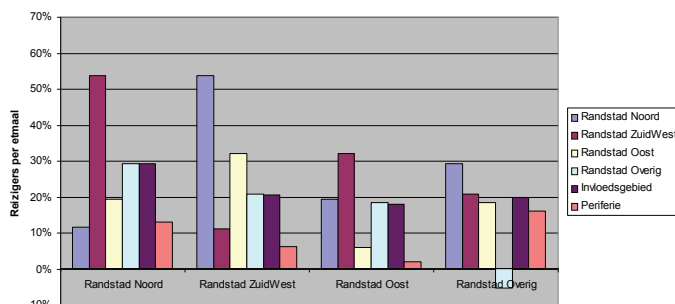

Scale Small (Map 42)

In the Randstad, diversity increased from city-region scale to regional scale, which means club network (cooperation) exists in the city-region scale and web network (complementarity) exists in the regional scale. Referring to most of growth of flows in the Randstad taking place among city-regions (figure 40), complementarity plays a more and more important role, especially for the regional scale or Daily Urban System. In SWC, diversity increased as well by the scale, but diversity is much lower than the Randstad. Thus, SWC needs to pay attention about diversity, especially for the regional scale to create a web network by complementarity among cities.

Referring to city specialisation, all the secondary cities in the Randstad belongs to the category with most specialisation: service economy occupied the most percentages. All the cities are making efforts to concentrate on the service economy and at the same time to specialised themselves within the region, like Bio-science Centre in Leiden, Media City Hilversum, etc. However, in SWC, the area with high specialisation doesn't happen in the secondary cities, which already leads lots of unhealthy competition for infrastructure and institution aspects. How to tackle the city specialisation of secondary cities in SWC will be a highly valuable question.

In the end, regional diversity is always combined with city specialisation, so that a web network by complementary will strengthen functional interaction in the regional scale. Regional specialisation is as the same important as regional diversity, which both could exist in the reality. Regional specialisation aims for diversity in the inter-regional scale to stimulate complementary relationship among regions. Therefore, diversity and specialisation are not two conflict words, conversely, two of them are always combined together, depending on the scale (Figure 41).

Figure 41: Diversity/Specialisation by Scales

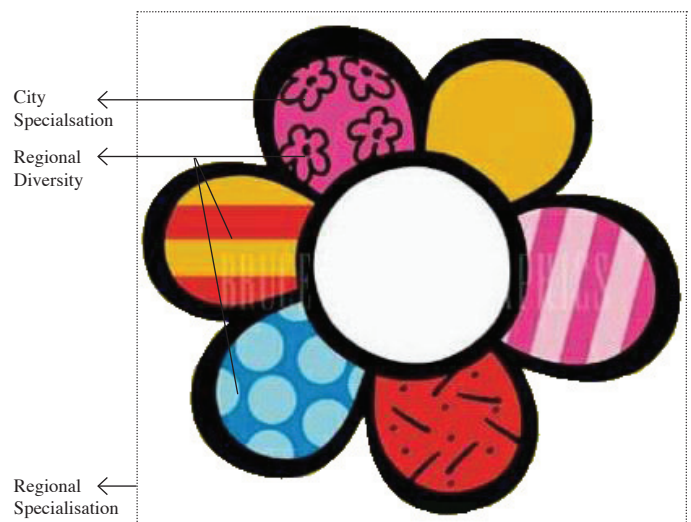

3.2.c Conclusion of Diversity

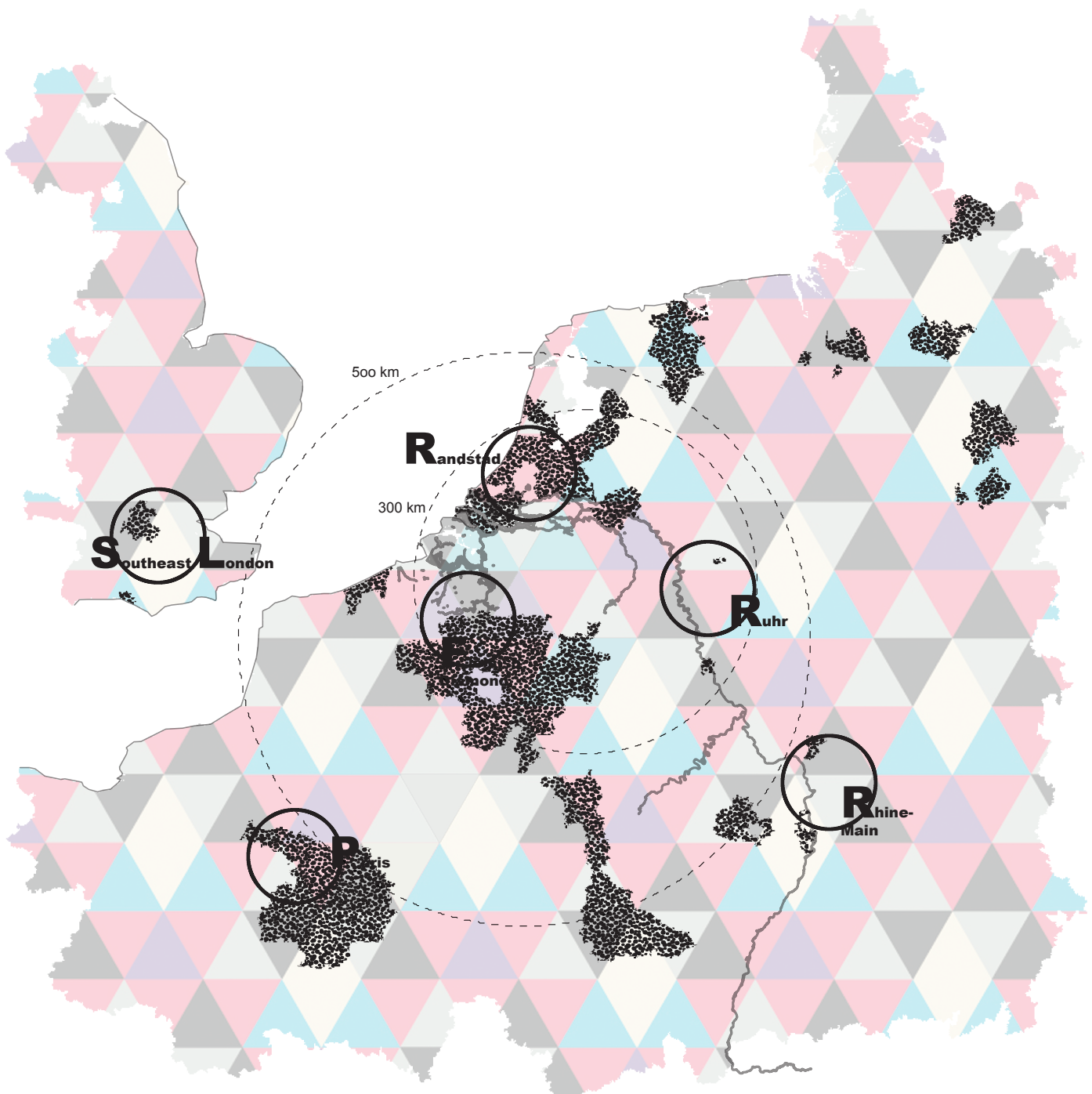

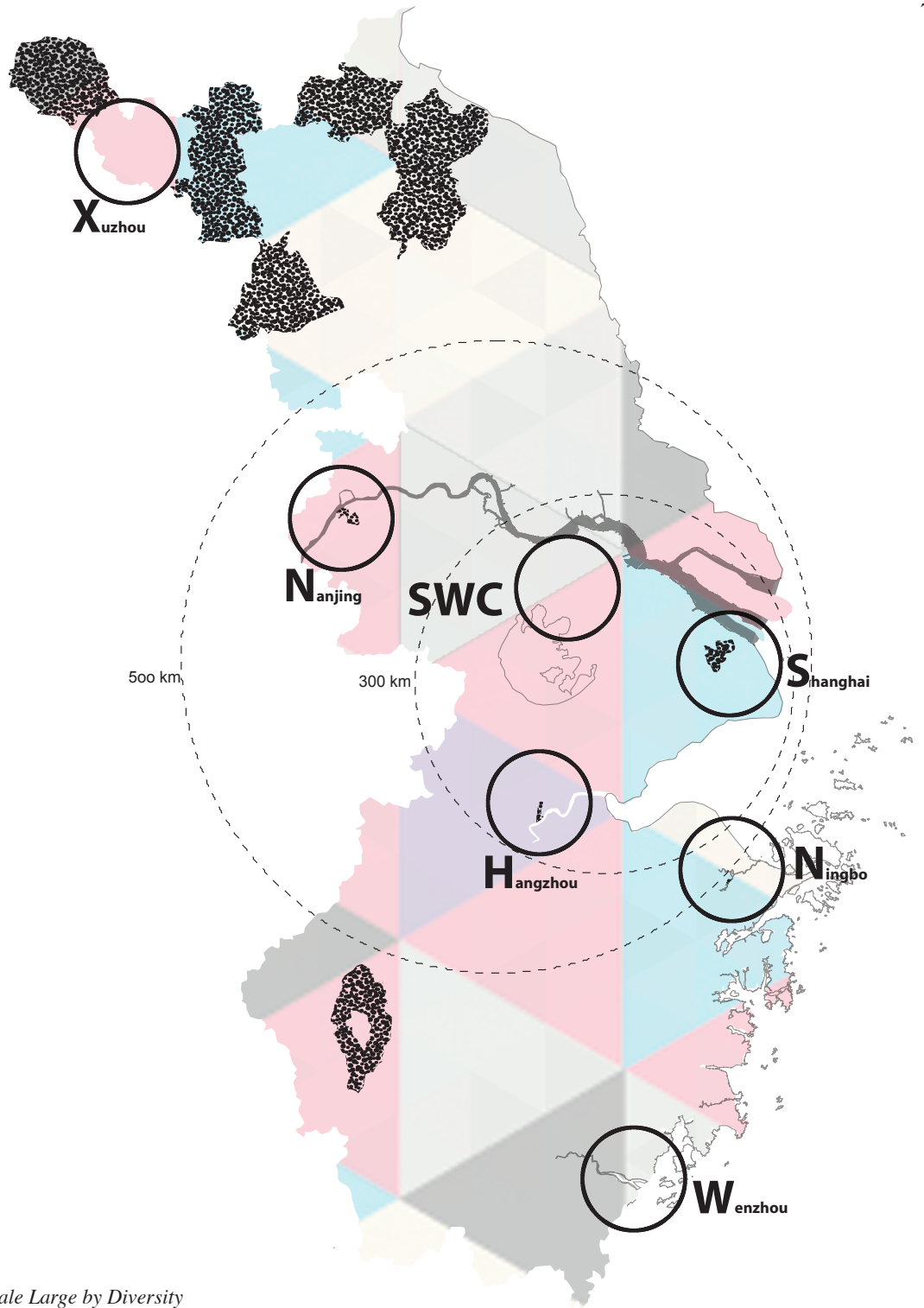

Map 42: Conclusion Map of Scale Large by Diversity

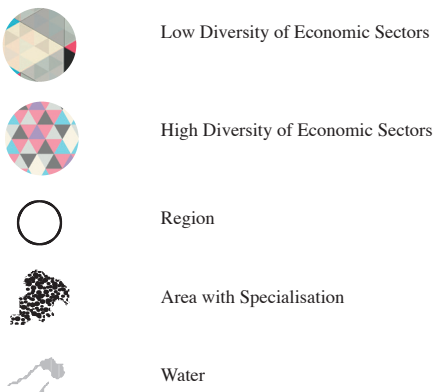



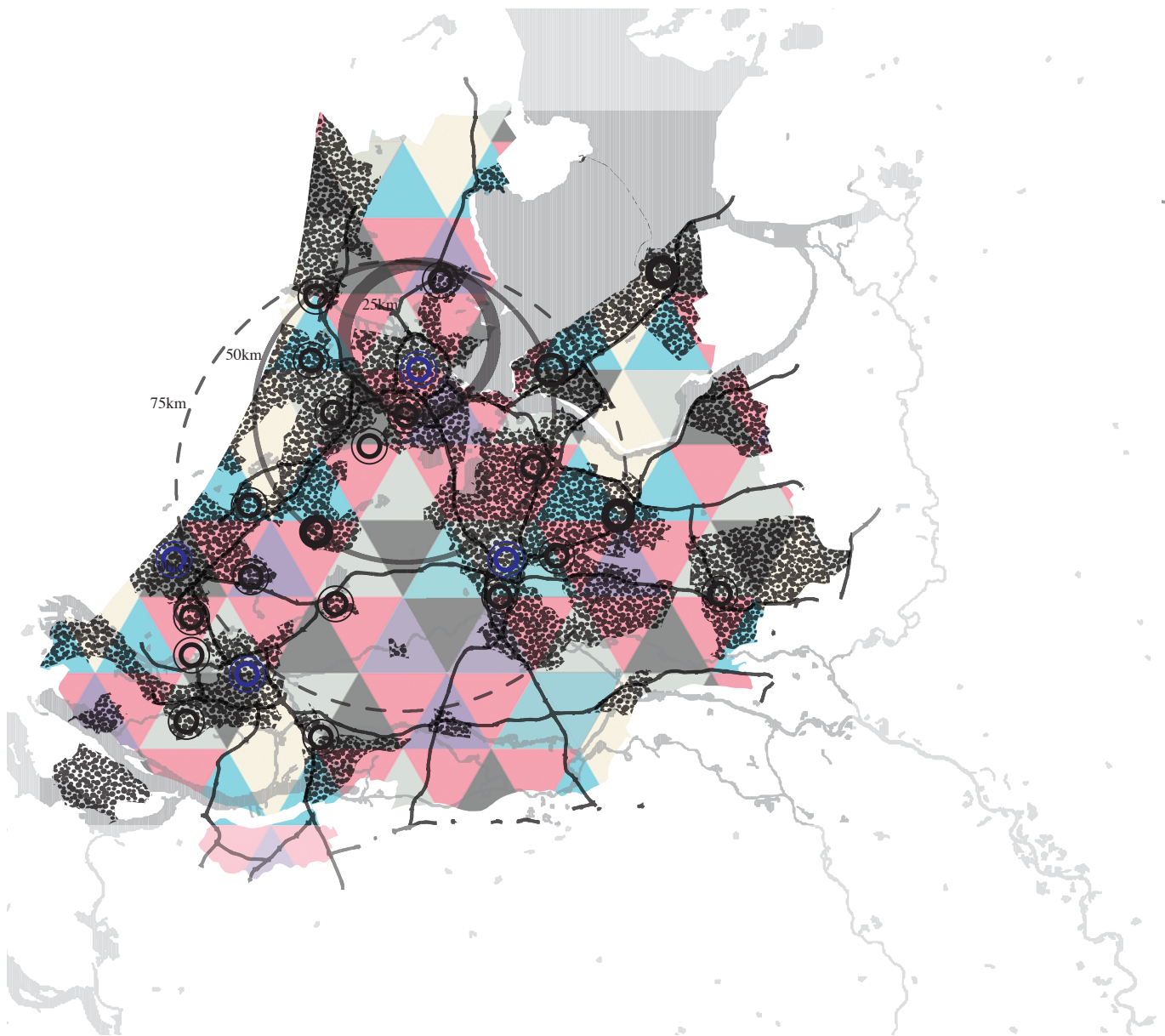

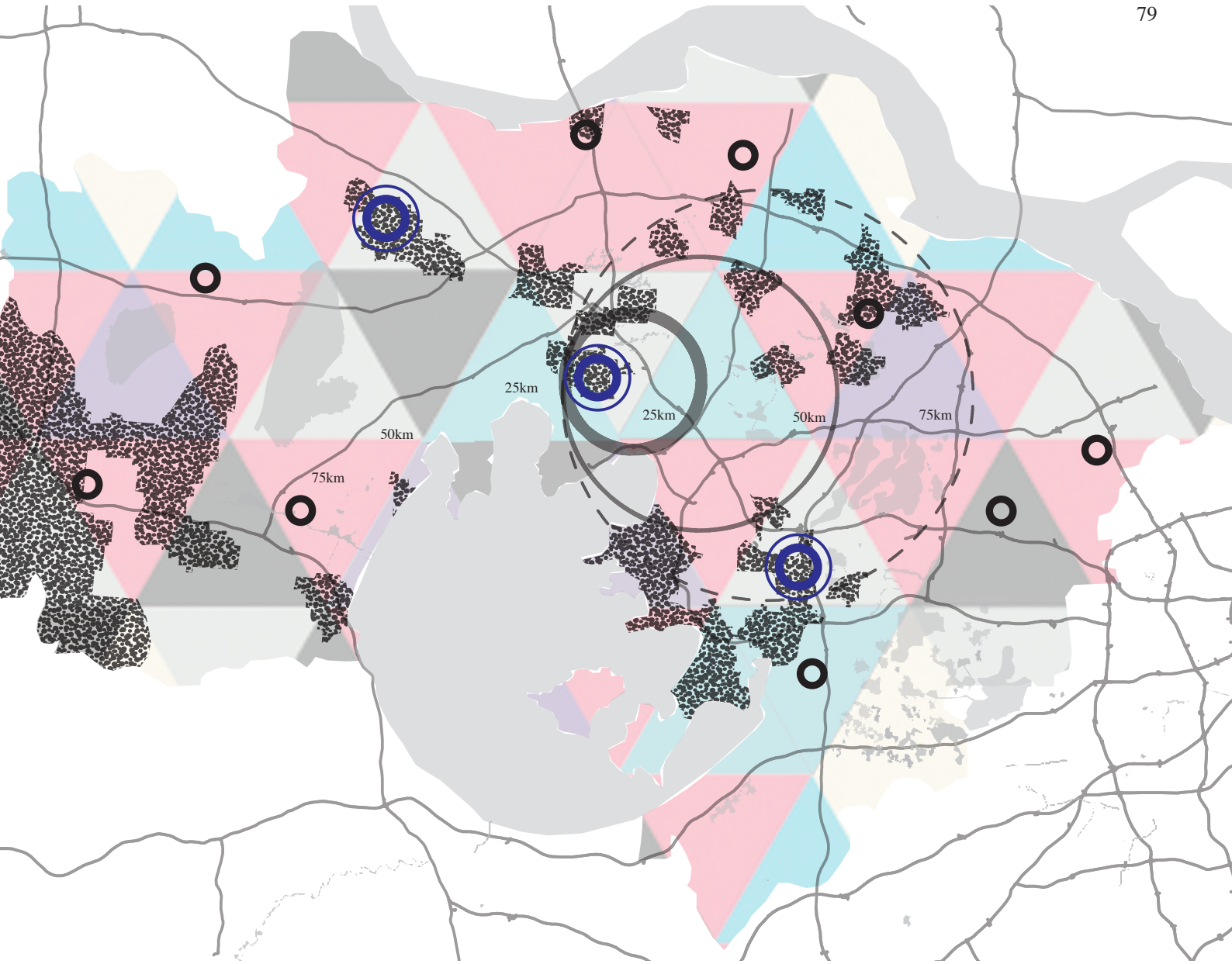
3.2.c Conclusion of Diversity





Map 43: Conclusion Map of Scale Small by Diversity

-  Low Diversity of Economic Sectors
-  High Diversity of Economic Sectors
-  Region
-  Area with Specialisation
-  Water
-  Highway

3.3 Accessibility - Normative Dimension



3.3 Accessibility - Normative Dimension

Accessibility is a key word for the concept of Polycentric Urban Region, because transportation accessibility could form the network among the cities for people, goods and information, particularly after industry revolution. Besides, accessibility underpins the process of decentralisation to achieve a balanced distributed urban structure for PUR. At the same time, bad accessibility correlated with congestion will decrease the attractiveness of the region for investors, businessmen, visitors and local consumers (Romein,2004). Therefore, accessibility is a relevant and important norm to strengthen functional interactions for PUR, which is also a scale depending indicator.

Generally speaking, accessibility indicates the convenience of access of a certain group of actors to the opportunities of activities. Accessibility equation (has been explained in Chapter 2) explains that this indicator needs to be clarified by travel demands (e.g. travel for shopping, or for jobs) and travel cost (e.g. travel within half hour). For example, Map 44 shows totally different images of accessibility to employment by different travel cost. For this analysis, considering the scale issue of accessibility, analysis of accessibility will be accessibility to labour forces within one hour travel by road network for Scale Large (NWE & YRD), accessibility to labour forces and to employment within half hour by road network for Scale Small (the Randstad & SWC).

In summary, accessibility is depending not only on the transportation network but also distribution of different activities. This part aims to evaluate whether accessibility could function as a crucial norm for PUR to tackle functional interactions among regions or cities, especially secondary cities.

Figure 44: Accessibility to Jobs by 30 minutes and 45 minutes (1997)

Source: Ham et al, 2010

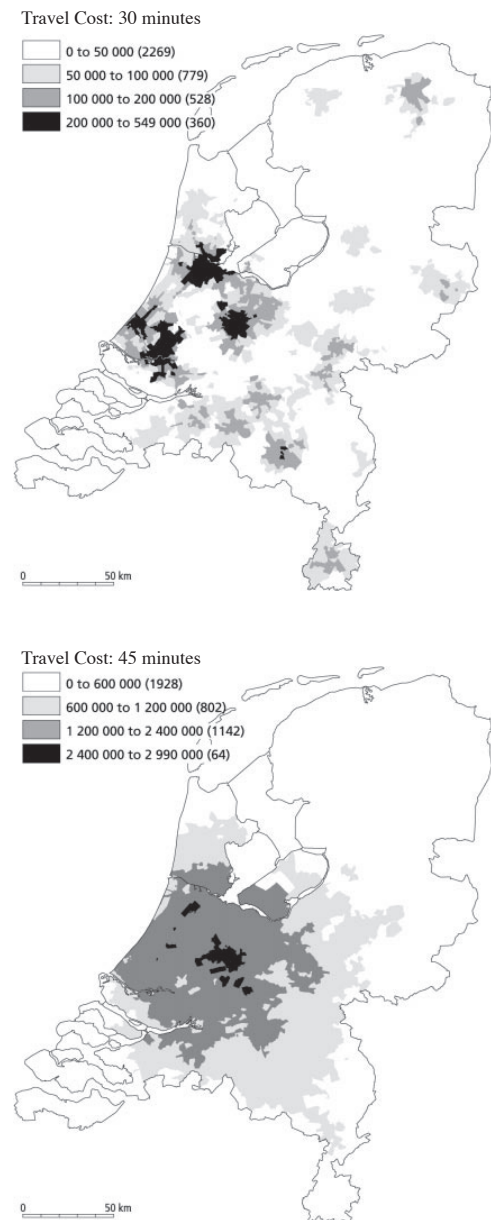

3.3.a Mapping Accessibility

Technical Application

Calculation of labour force density by Accessibility Index within one hour by car in Nuts 3 for NWE and in Country level for YRD using Natural Break. Calculation of NWE is based on the source in 2007, while calculation of YRD is based on the source in 2000.

Data Source

Labour Force and Employment data of NWE is from “Atlas ABC” and data of YRD is from the website “Urban and Regional Explorer”.

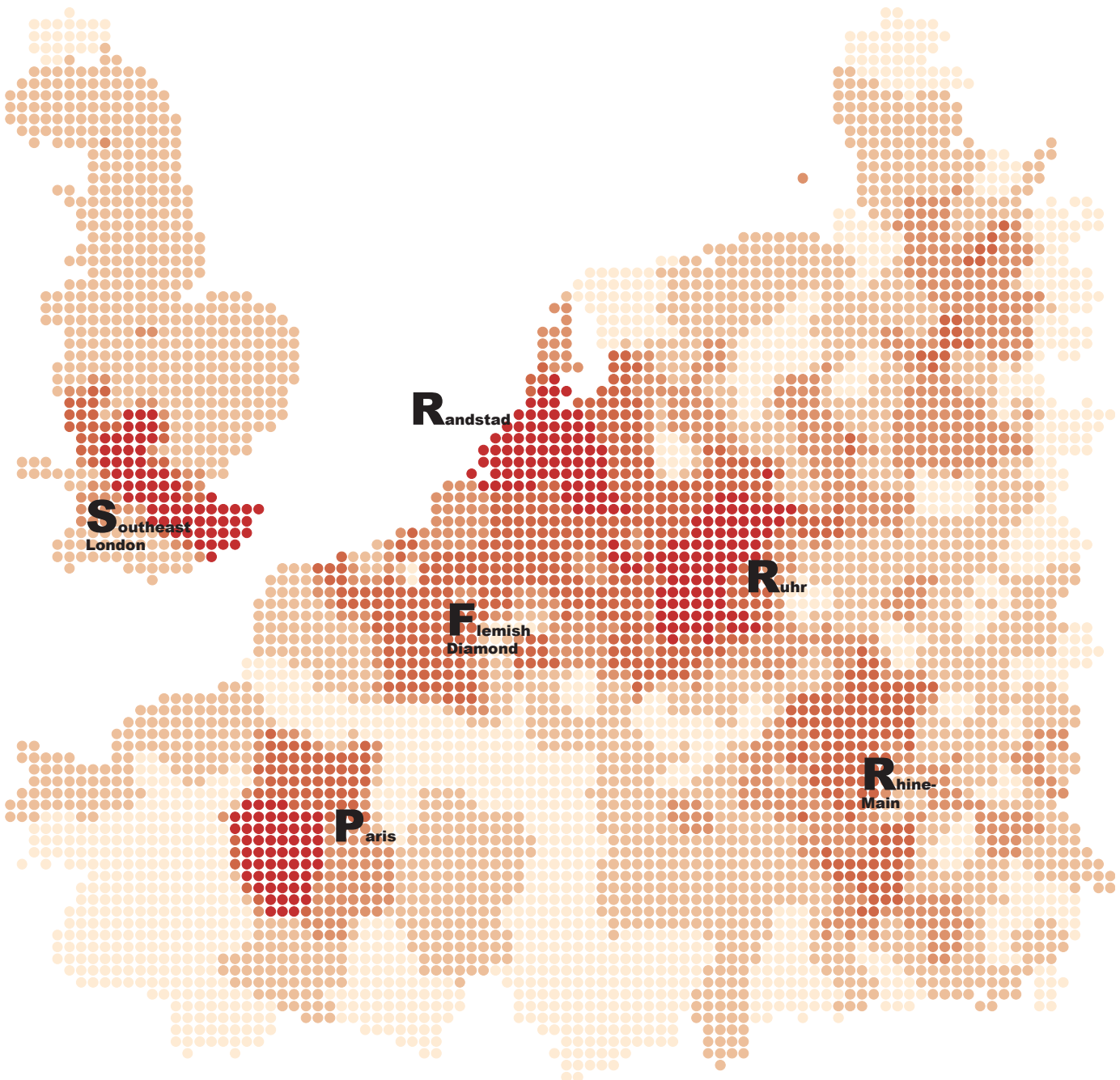

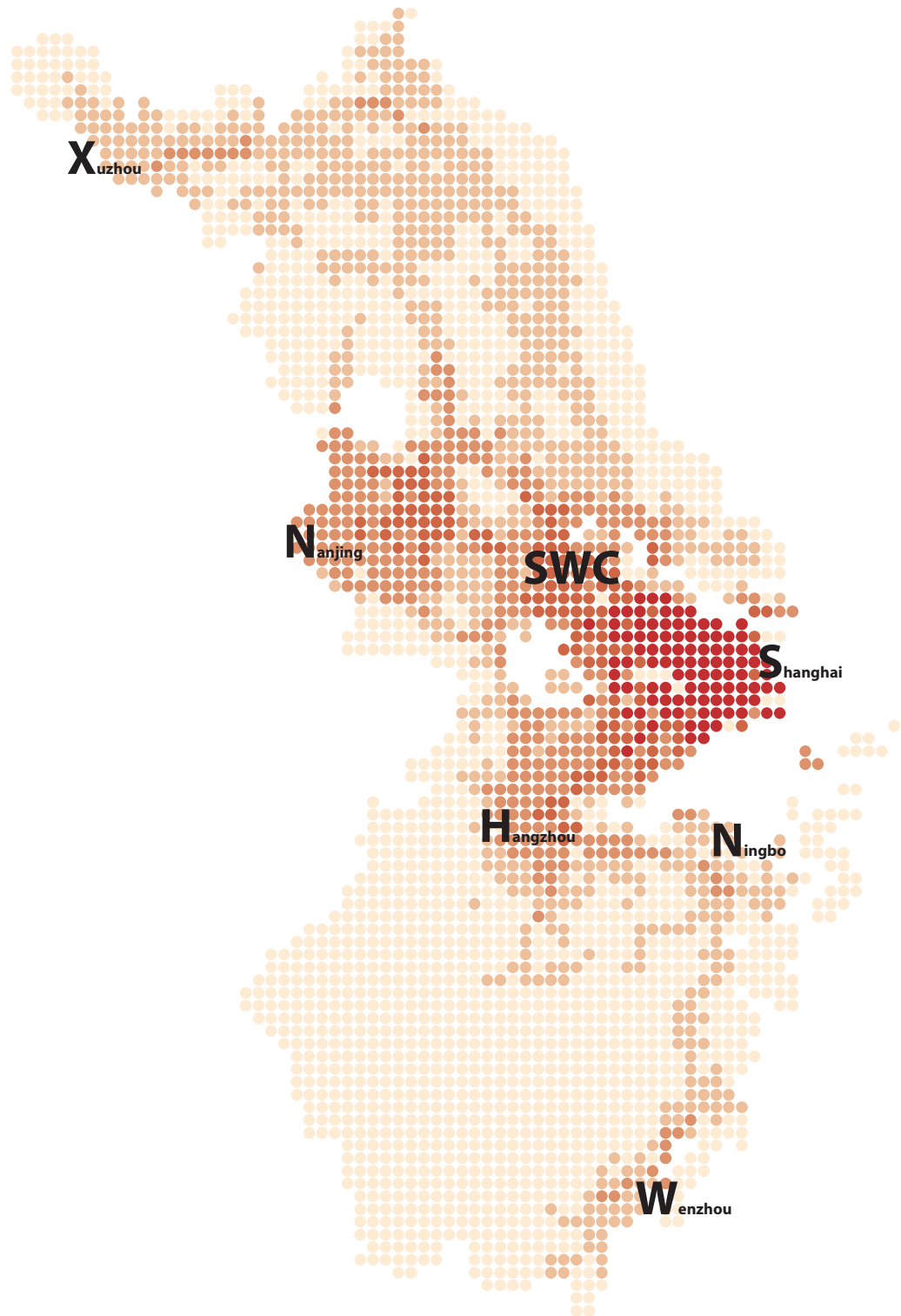

Accessibility to
Labour Force

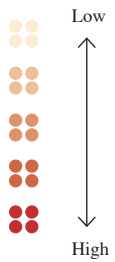

Scale Large- to Labour Force by 1 hour

It is very interesting that accessibility to labour force within one hour by car in Scale Large can indicate emerging Regions clearly: NWE has Polycentric structure with several regions, while YRD has more Monocentric structure with Shanghai Metropolitan Region as the centre.

Besides, accessibility represents the hierarchy of different urban regions for NWE and YRD. In NWE, the Randstad, Ruhr Area, Southeast London and Paris belong to the first level of accessibility to labour force, while Flemish Diamond and Rhine-Main belongs to the second level. In YRD, Shanghai Metropolitan Region has the highest accessibility, whilst SWC, Nanjing Region, Hangzhou Region belongs to second level of accessibility in the middle of YRD.

3.3.a Mapping Accessibility

Technical Application

Calculation of labour force density by Accessibility Index within the half hour by car in Municipality level for the Randstad and in Township level for SWC using Natural Break. Calculation of the Randstad is based on the source in 2005, while calculation of SWC is based on the source in 2004.

Data Source

Labour Force and Employment data of the Randstad is from the website “Centraal Bureau voor de Statistiek” and data of SWC is from the website “Urban and Regional Explorer”.

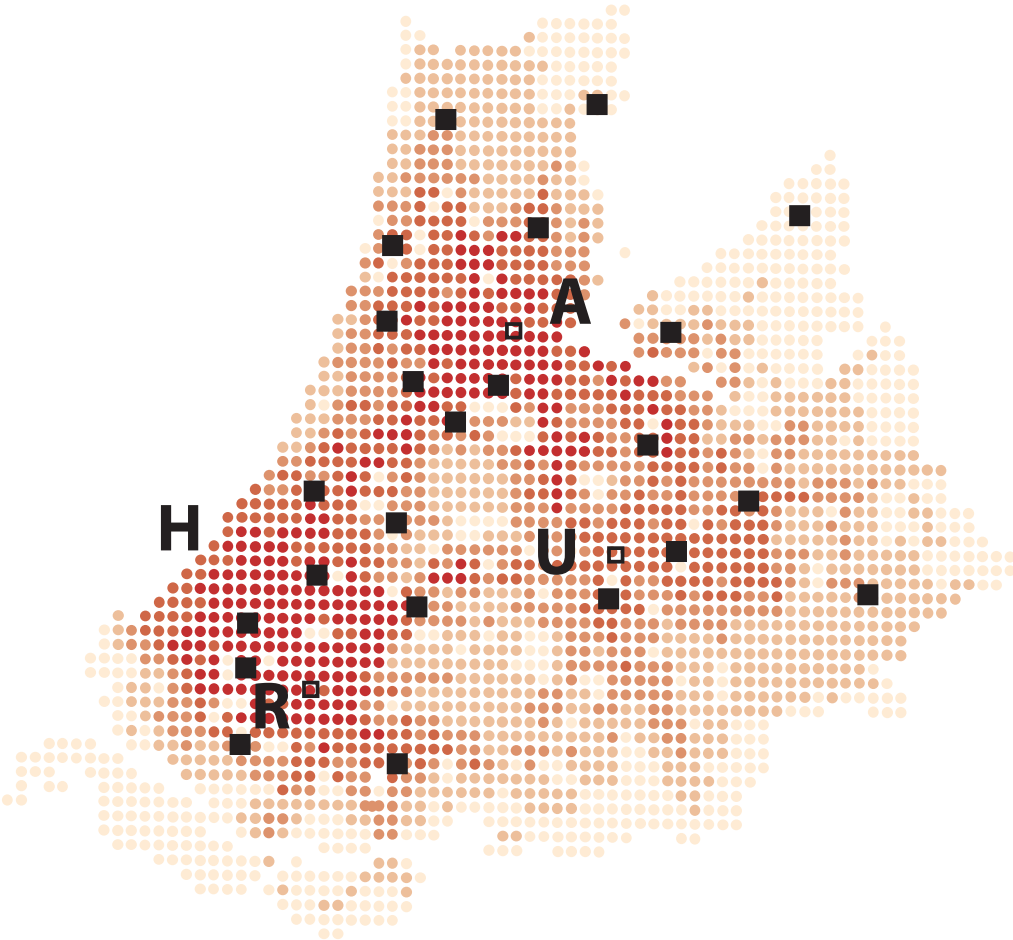

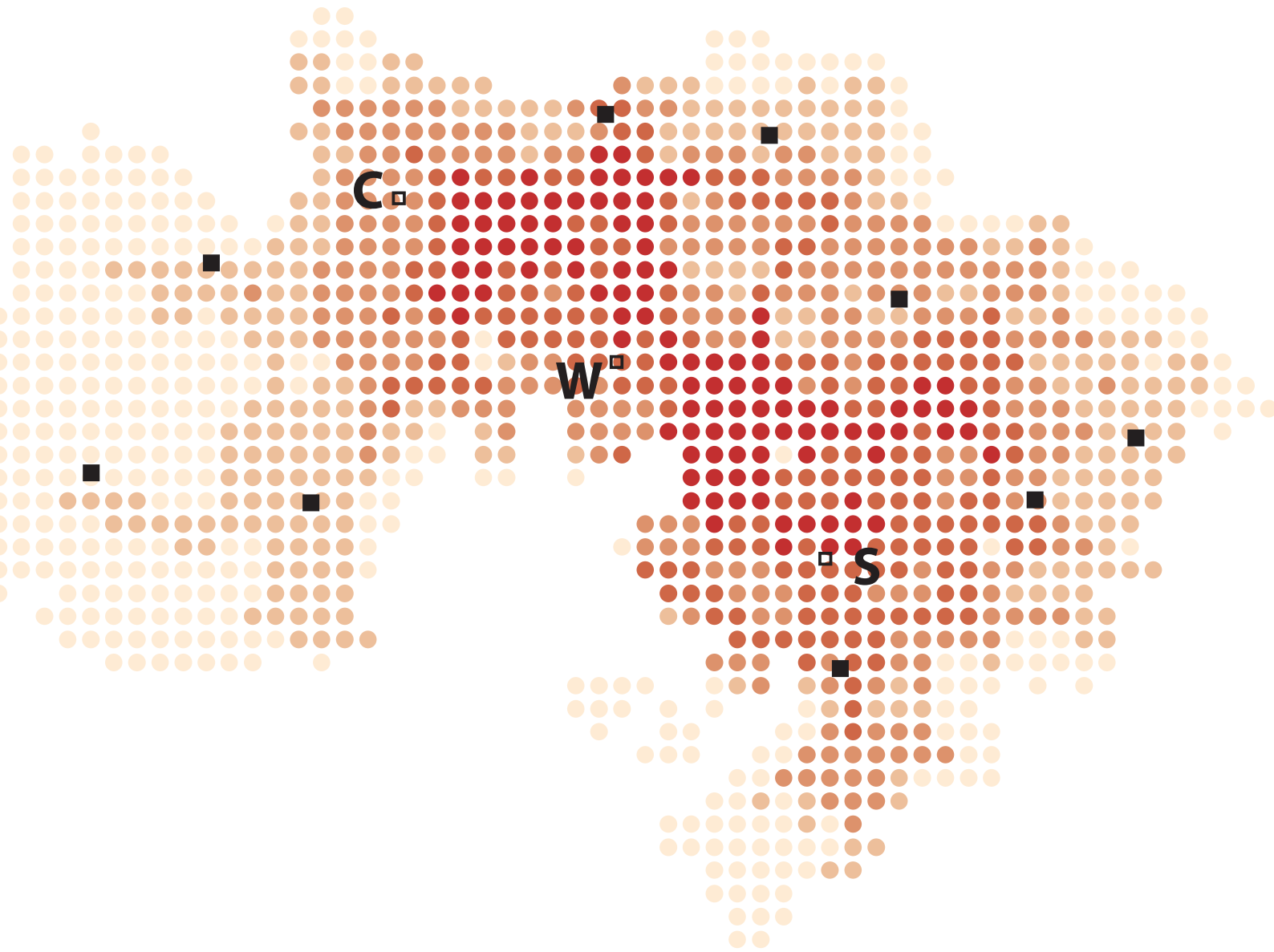

Accessibility to
Labour Force

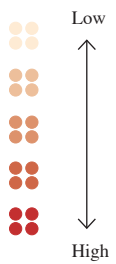

□ Primary
Cities

■ Secondary
Cities

Scale Small - to Labour Force by half hour

Accessibility to labour force by half hour has indicated the main infrastructures for the Randstad and SWC. The Randstad has ring structure, while SWC has a lineal structure from west to east.

Referring to secondary cities, all the secondary cities have high accessibility which are the same as primary cities. However, only three primary cities and secondary cities along Yangtze River or next to Shanghai has high accessibility. This unbalanced accessibility in SWC is caused by all the infrastructure concentrated on the linkage to Shanghai and the relatively high attractiveness of primary cities.

3.3.a Mapping Accessibility

Technical Application

Calculation of employment density by Accessibility Index within the half hour by car in Municipality level for the Randstad and in Township level for SWC using Natural Break. Calculation of the Randstad is based on the source in 2005, while calculation of SWC is based on the source in 2004.

Data Source

Labour Force and Employment data of the Randstad is from the website “Centraal Bureau voor de Statistiek” and data of SWC is from the website “Urban and Regional Explorer”.

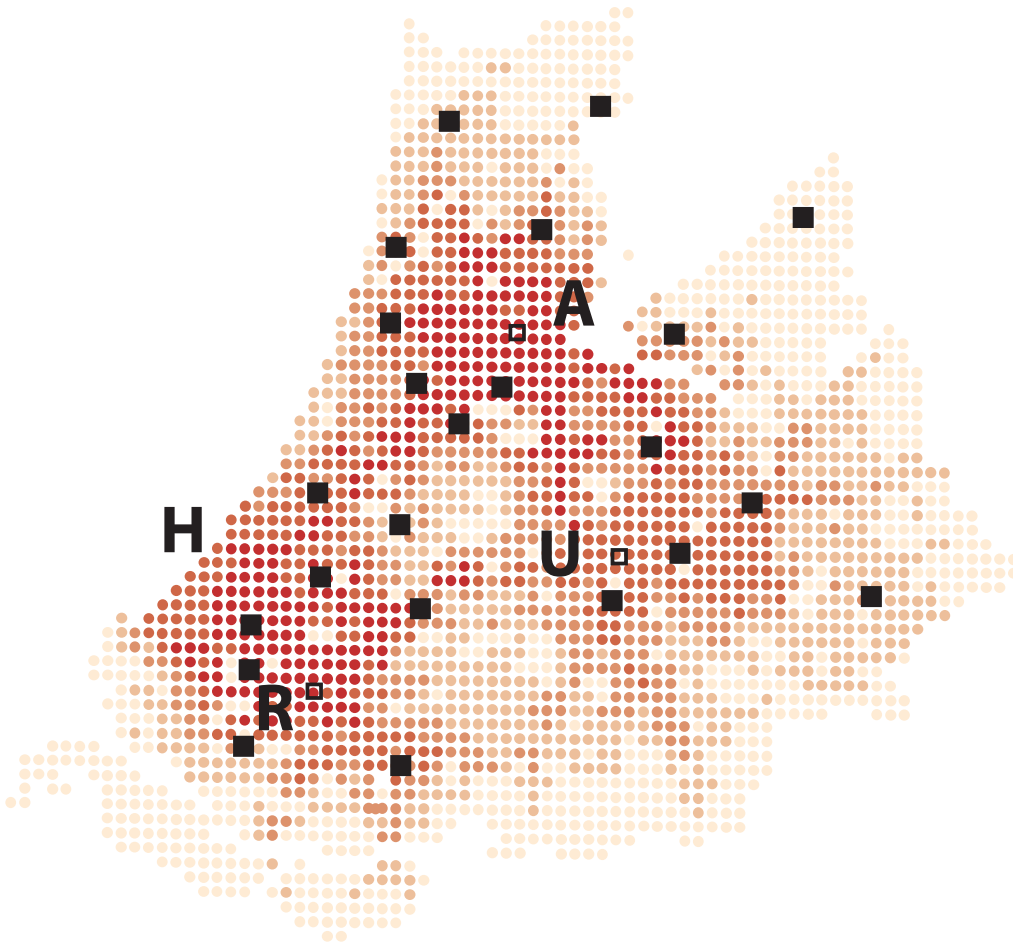

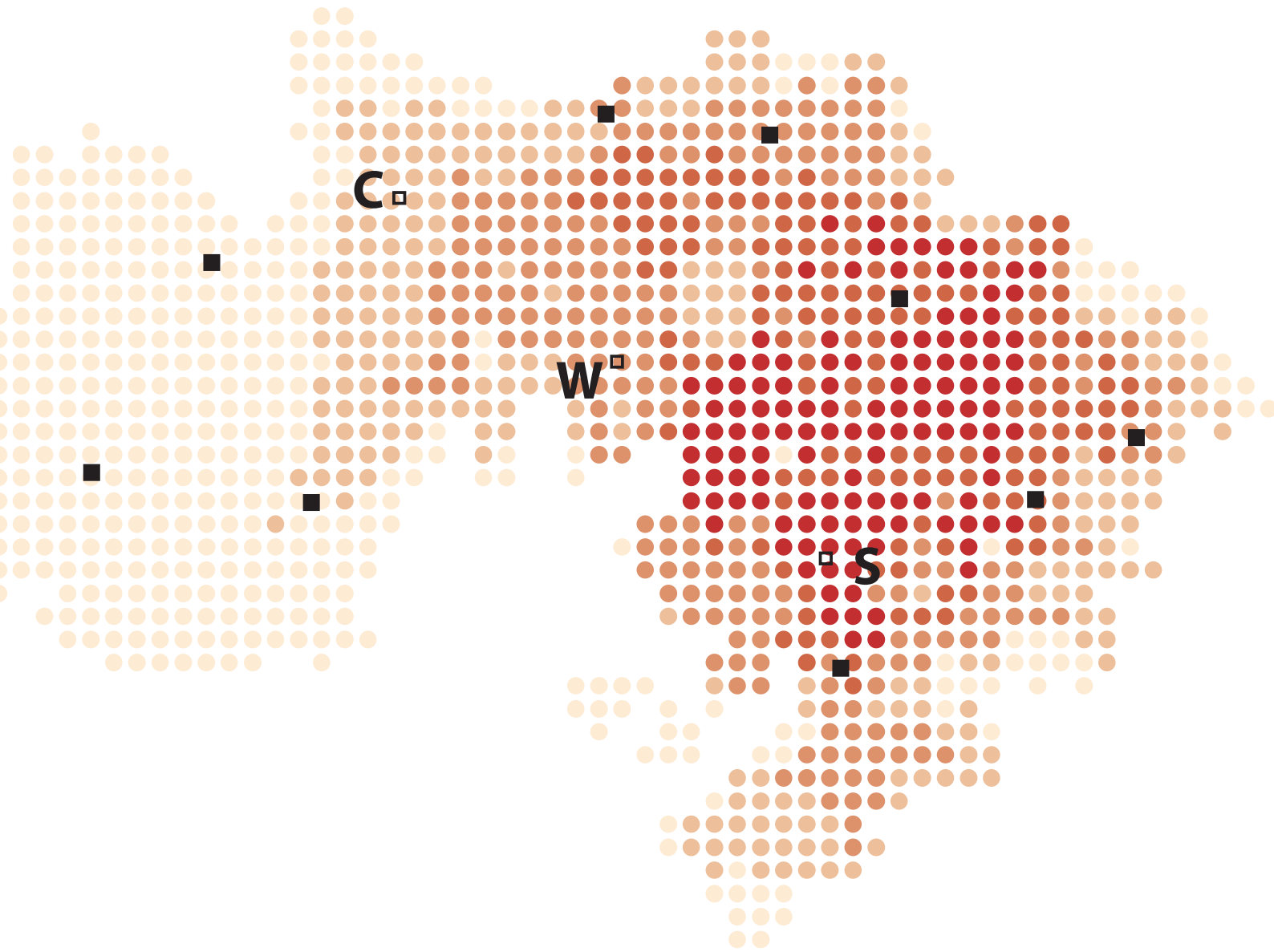

Accessibility to
Employment

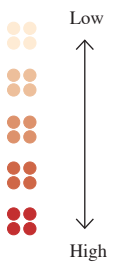

□ Primary
Cities

■ Secondary
Cities

Scale Small - to Employment by half hour

Accessibility to employment in the Randstad is very comparable with accessibility to labour by half hour. Most accessible cities are three primary cities (excluded Utrecht) and secondary cities around them. Thus, secondary cities in the Randstad are ideal living cities with respect to accessibility to jobs.

SWC has different accessibility to employment from to labour force by half hour. The area close to Shanghai has most accessibility to employment within half hour. This area has potential to develop dwellings for people, instead only attracting enterprises. The west part of SWC has barrier to attract people to settle down, due to bad accessibility to jobs. However, these secondary cities could develop their own economy, and pay attention on the connection to other cities with the development of infrastructure..

3.3.b Testing by Travel Pattern

The commuting patterns of the Randstad (Map 45) shows that the most of flows (70% flows are within the city-region: Coffeng, 2011) are taking place in the city-region scale, which means half hour is a preferred travel time for journey to work. Besides, most of flows are happening from secondary cities to primary cities, which means secondary cities are preferred to live for a large amount of people. Interaction between secondary cities is still very weak now. The only flows among secondary cities are one link between Haarlem and Hoofddorp (Airport), as well as the other link between Haarlem to Zaandam (Harbour). Hoofddorp and Zaandam are two important transport nodes, which provide a large number of jobs, especially for the Netherlands as a trading country. Haarlem is well-known as a living city, mainly for Amsterdam. As the Map 45 showed, Haarlem could be an elective city for people who work in Hoofddorp and Zaandam as well. Therefore, if a secondary city would like to be a new node in the region rather than attachment of primary city, he needs to have strong position for accessibility.

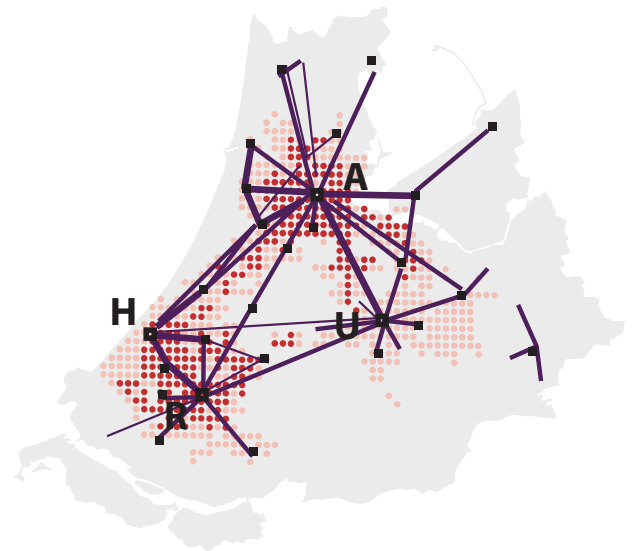

Map 45: Travel Pattern and Accessibility

Amsterdam is the biggest magnet among four primary cities, so more flows are taking place with Amsterdam. It is very exciting that flows between city-regions are steadily growing recently. According to the research about traveller by public transport in the Randstad, there is 55% growth of flows between Randstad North and Southwest, and 30% growth between Randstad Southwest and East from 2008 to 2028 (Coffeng, 2011). which has been mentioned in the Diversity Part. The growth of interaction among city-regions tells that the travel pattern could be expanded by the improved accessibility of the region.

Based on the travel pattern, there is an analysis (Werff et al, 2005) about self-containment of all the cities in the Randstad, which represents how much percentages of people stay at the same city to live and how many percentages of people travels to another city for work (Map 46). What we could observe that all the primary cities and a few secondary cities are self-containment cities with more people working and living at the same city. It means people travelling every day in secondary cities are much more than people to stay. In other words, secondary cities are much more depending on the network of the region. Thus, secondary cities will definitely benefit from the increased accessibility of the region, even more than primary cities.

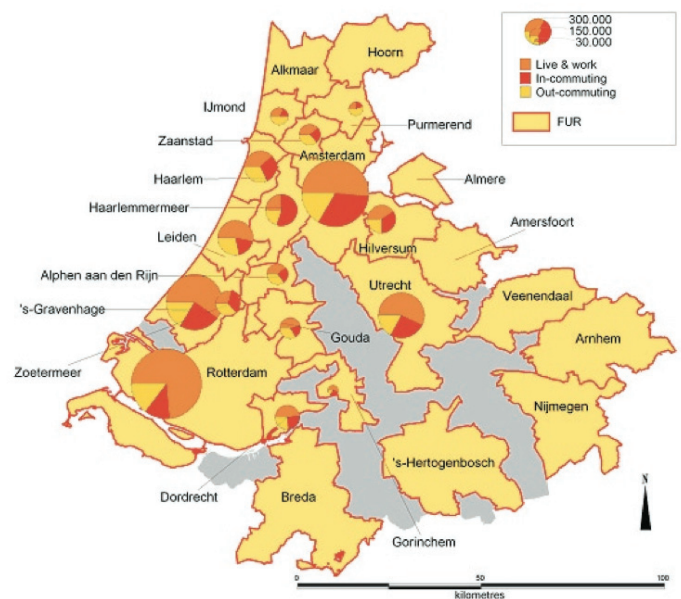

Map 46: Self-Containment by Journey to Work
Source: Werff et al, 2005

3.3.c Conclusion of Accessibility

Scale Large (Map 47)

Mapping Accessibility is an efficient tool to represent regional structure for Scale Large. It is very clear that NWE is a polycentric urban region comparing with YRD which has a monocentric spatial structure. Hierarchy of accessibility among regions (e.g. Paris Region, the Randstad, etc) in NWE is very limited, while the regions in YRD (e.g. SWC, Shanghai Region) have big differences for accessibility. Thus, accessibility is used as an analytical tool to understand existing or emerging PUR.

The analytical dimension of accessibility is caused by the correlation between accessibility and distribution. In other words, the area with distributed activities have high accessibility. Besides, all the regions in NWE are connected with the fast-speed train and the international airport, which results in a balanced accessibility in the inter-regional scale. But in YRD, only three regions in the middle, connected with fast-speed train and international airport, have high accessibility. Waterway connection is still important for NWE and YRD. Regions along Yangtze River in YRD have good accessibility, which means water transport still plays a very important role. However, water transport in NWE is not that as important as YRD, because advanced train network and air network replace the water transport already. From accessibility comparison together with infrastructure, it can be concluded that improving accessibility will reduce the hierarchy among centres to achieve a more balanced spatial structure. Thus, accessibility can be considered as an important norm to improve Polycentricity for the region.

Scale Small (Map 48)

Accessibility to labour force and employment in the Randstad represents the same images, with ring structure that is same as the distribution of activities for live and work. The balanced accessibility in the Randstad proves that the Randstad is emerging as a integral region functionally. However, accessibility to labour force is different from accessibility to employment in SWC. Accessibility to labour force represents more lineal structure facing to Shanghai, and the areas with high accessibility to employment are proximate to Shanghai. These differences between accessibility to labour force and to employment in SWC is caused by the different distribution of labour force and employment. This difference also shows that SWC is a not integral unit yet for the labour market as well as for the residences.





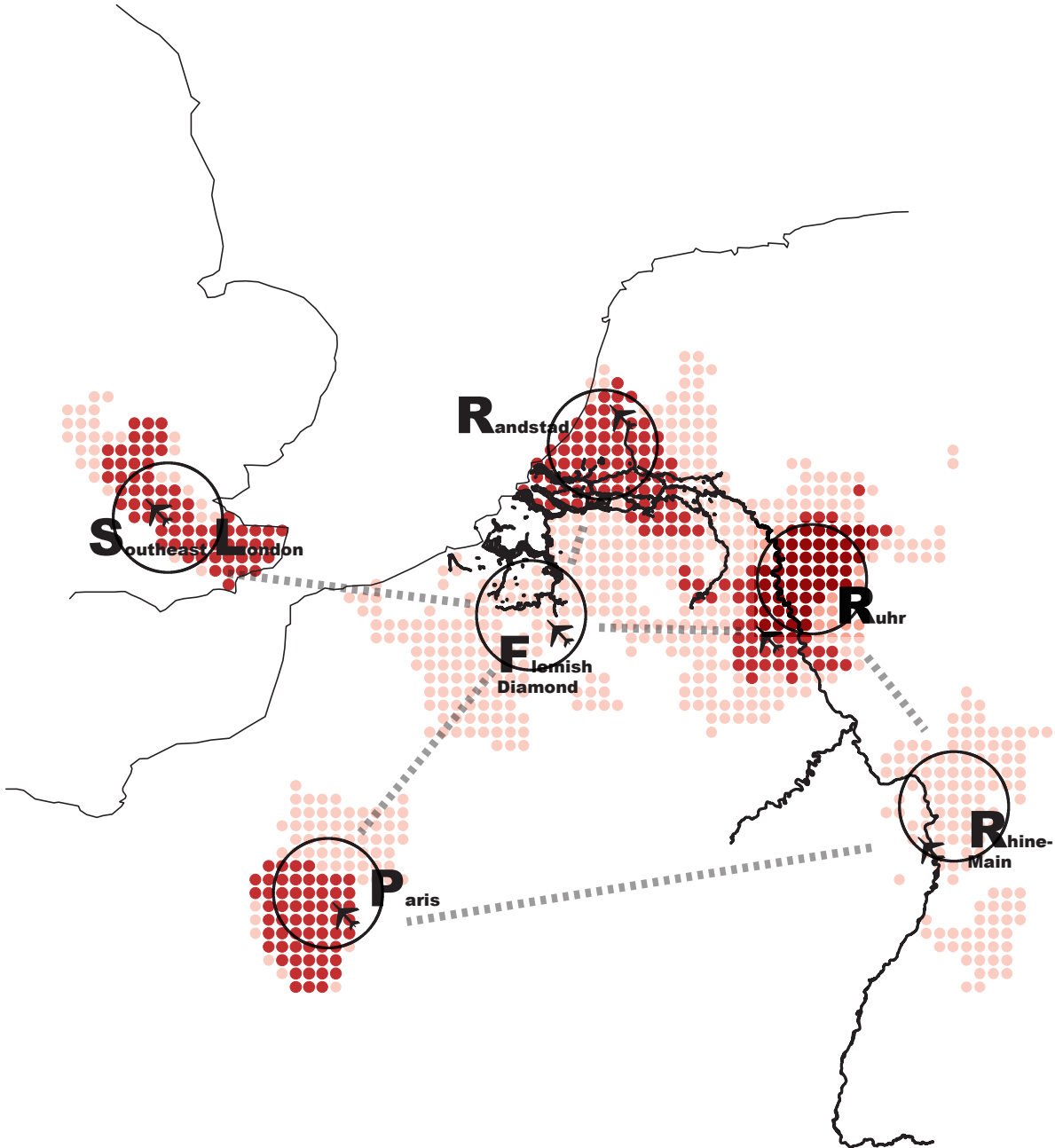

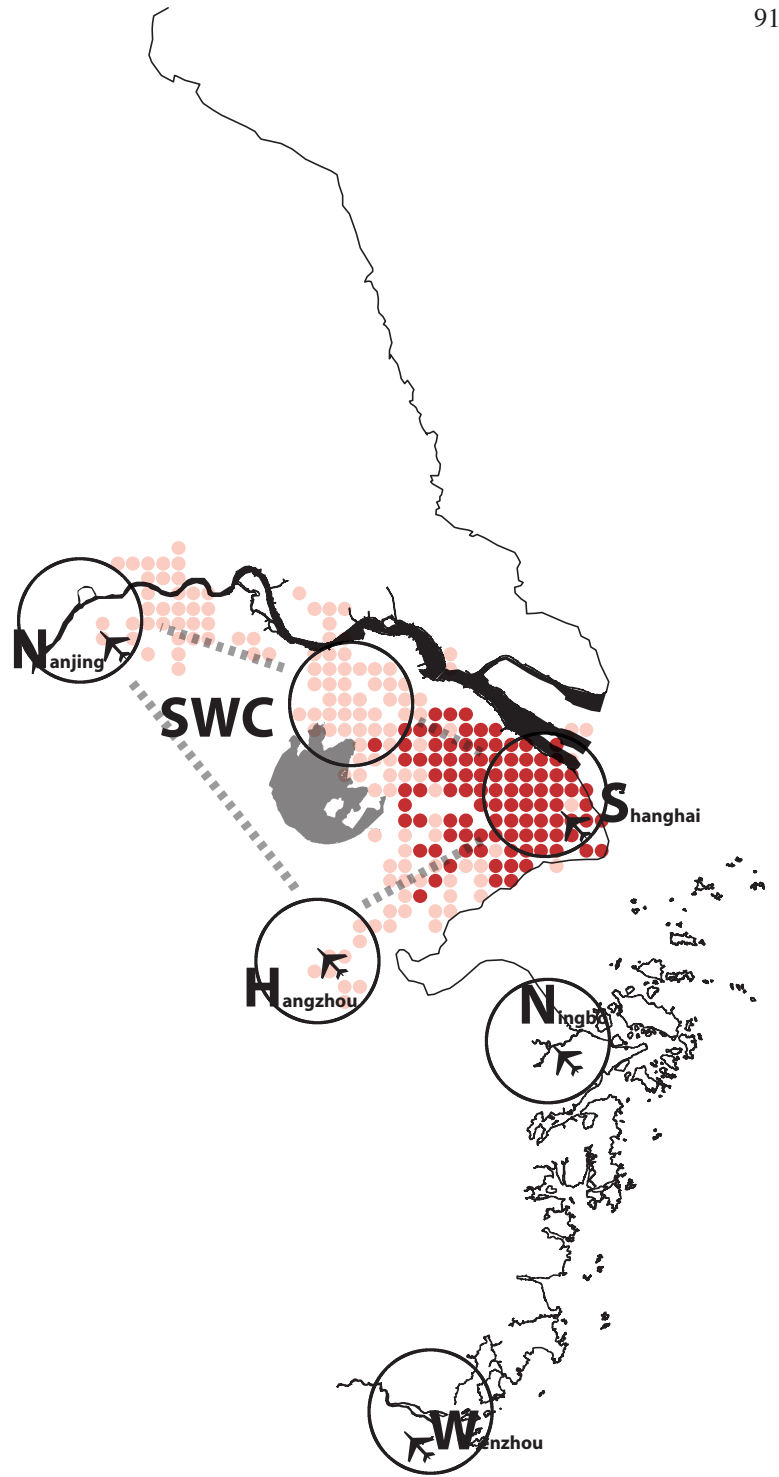

In principle, the area with high accessibility to labour force will be the potential location for the companies, especially the economic sectors requiring a large amount of workers. And the area with high accessibility to employment will attract people to live, because of more opportunities to achieve working places. Thus, accessibility analysis could highlight the potential areas for people as well as companies. According to the accessibility in SWC, the areas with high accessibility could be addressed for the future proposal of SWC.

Secondary cities in the Randstad have good accessibility to labour force and to employment. However, secondary cities on the west part of SWC have bad accessibility, so that they need to improve their accessibility in order to participate in the regional network. In addition, even secondary cities on the east part of SWC have better accessibility, there is a big disparity between accessibility to labour force and to employment. Therefore, by intensifying employment and residences, this kind of disparity will become less and less, in order to achieve a balanced accessibility either to labour force or to employment for the whole region.





Map 47: Conclusion Map of Scale Large by Accessibility to Labour Force

-  Region
-  First Level of Accessibility
-  Second Level of Accessibility
-  River
-  Coast Line
-  Tai Lake
-  Fast-Speed Railway
-  International Airport

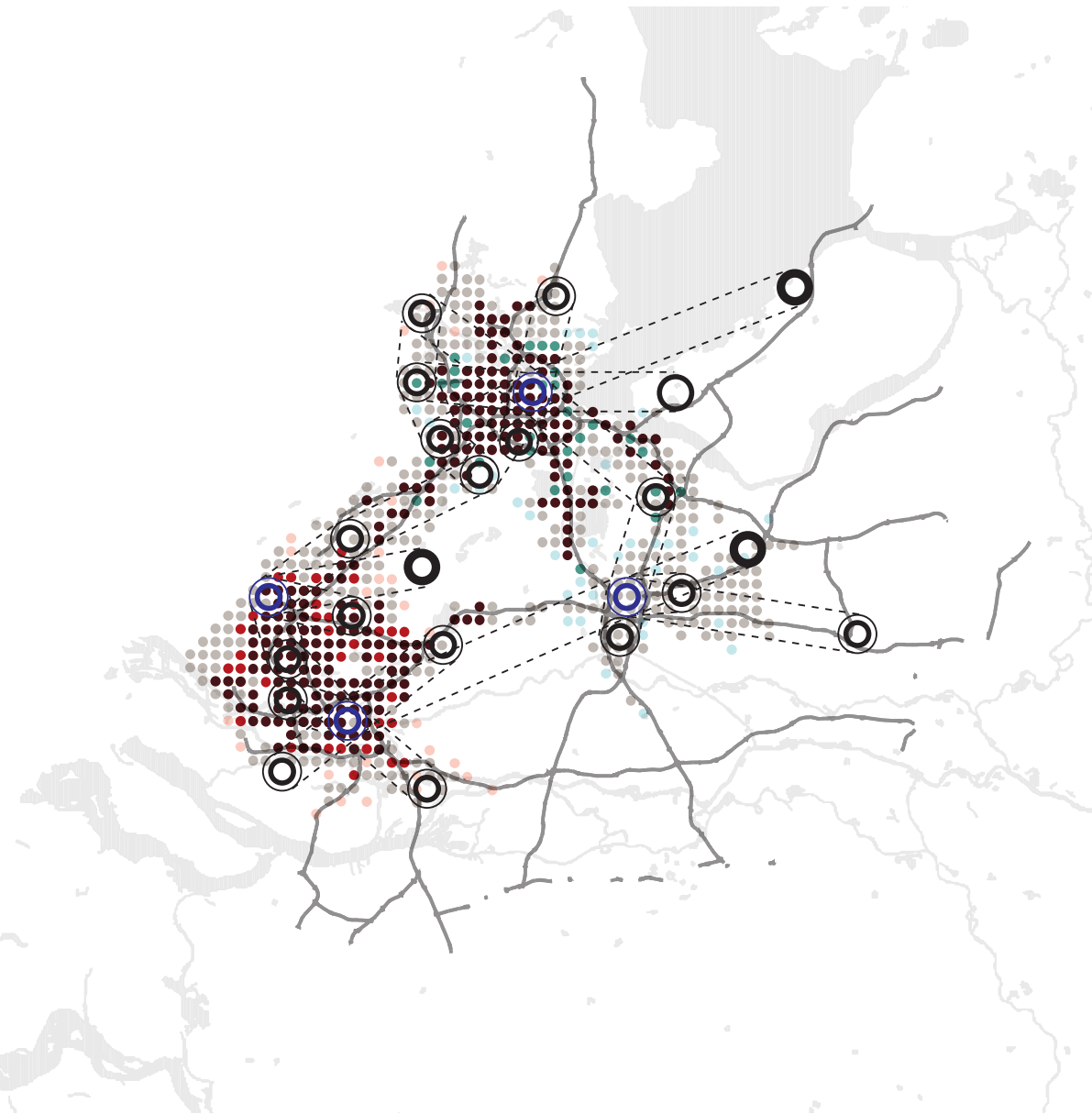

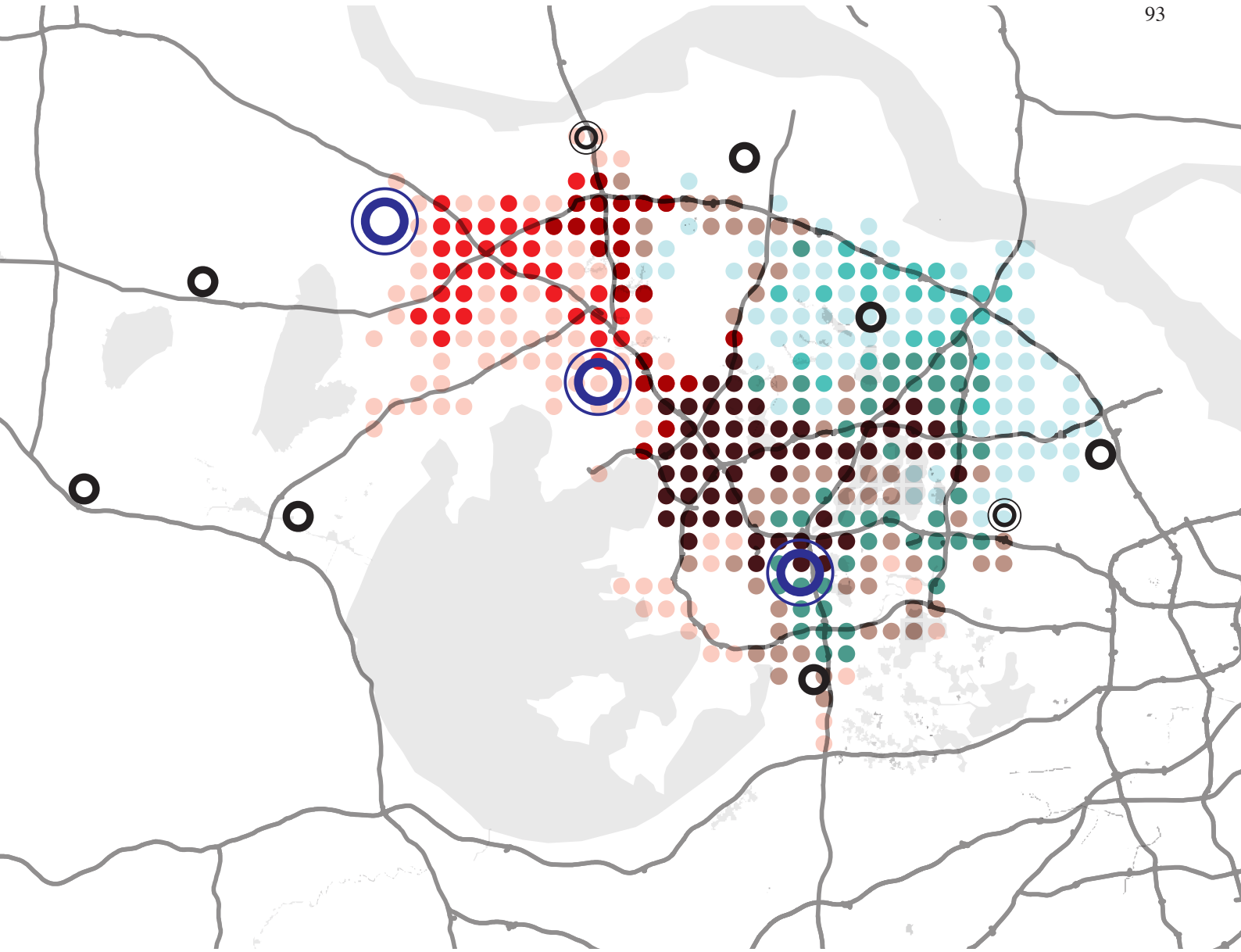

Map 48: Conclusion Map of Scale Small by Accessibility to Labour Force and Employment

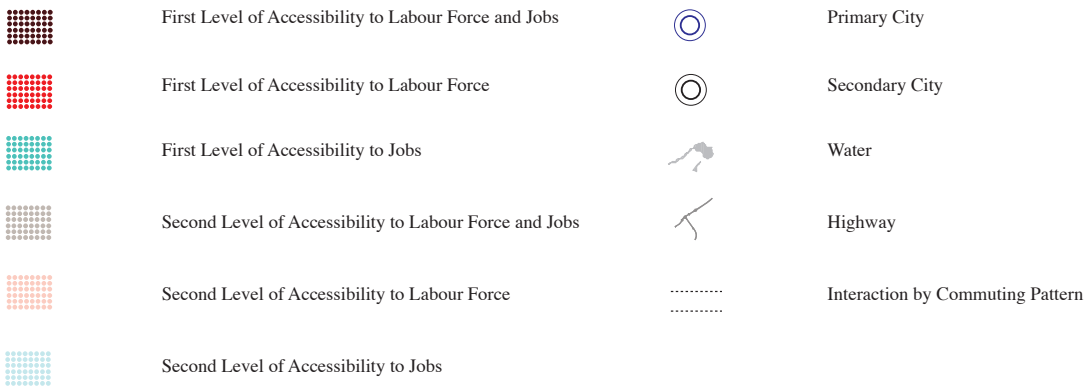



4. From Indicators to Polycentricity

4.1 *Synergy of Three Indicators*

4.2 *Conclusion*

4.1 Synergy of Three Indicators

As three crucial indicators, “Distribution”, “Diversity” and “Accessibility” have been analysed separately by two scales and two contexts. What more important is how to combine all conclusions derived from each indicators. Therefore, Figure 49 briefly explains the relationship between these indicators, with respect to analytical and normative dimension. Generally speaking, “distribution” is used to describe the morphology of regions with different level of polycentricity, which belongs to analytical dimension. The other two indicators “diversity” and “accessibility” are important norms to create possibility for functional interactions in the region. However, there is no absolute distinguish between analytical and normative dimension, because all these three indicators are used to explain the existing PUR as well as strategies for the future regional development. Therefore, final conclusion will describe Polycentricity of YRD and SWC by comparing with NWE and the Randstad, and meanwhile explain what kind of norms are relevant for the PUR for SWC in two scales. Afterwards, the final conclusions for SWC region including secondary cities will be applied to evaluate existing regional plan by an alternative proposals.

Figure 49: Inter-relation among Three Indicators

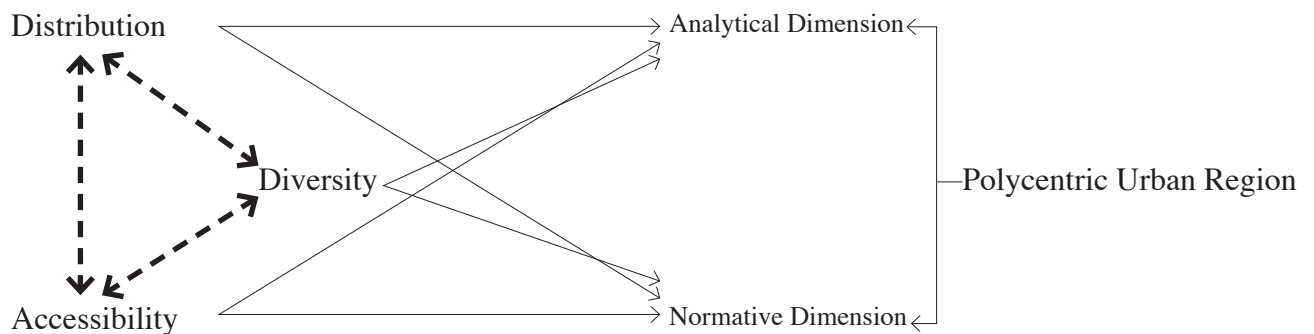

4.2 Final Conclusions

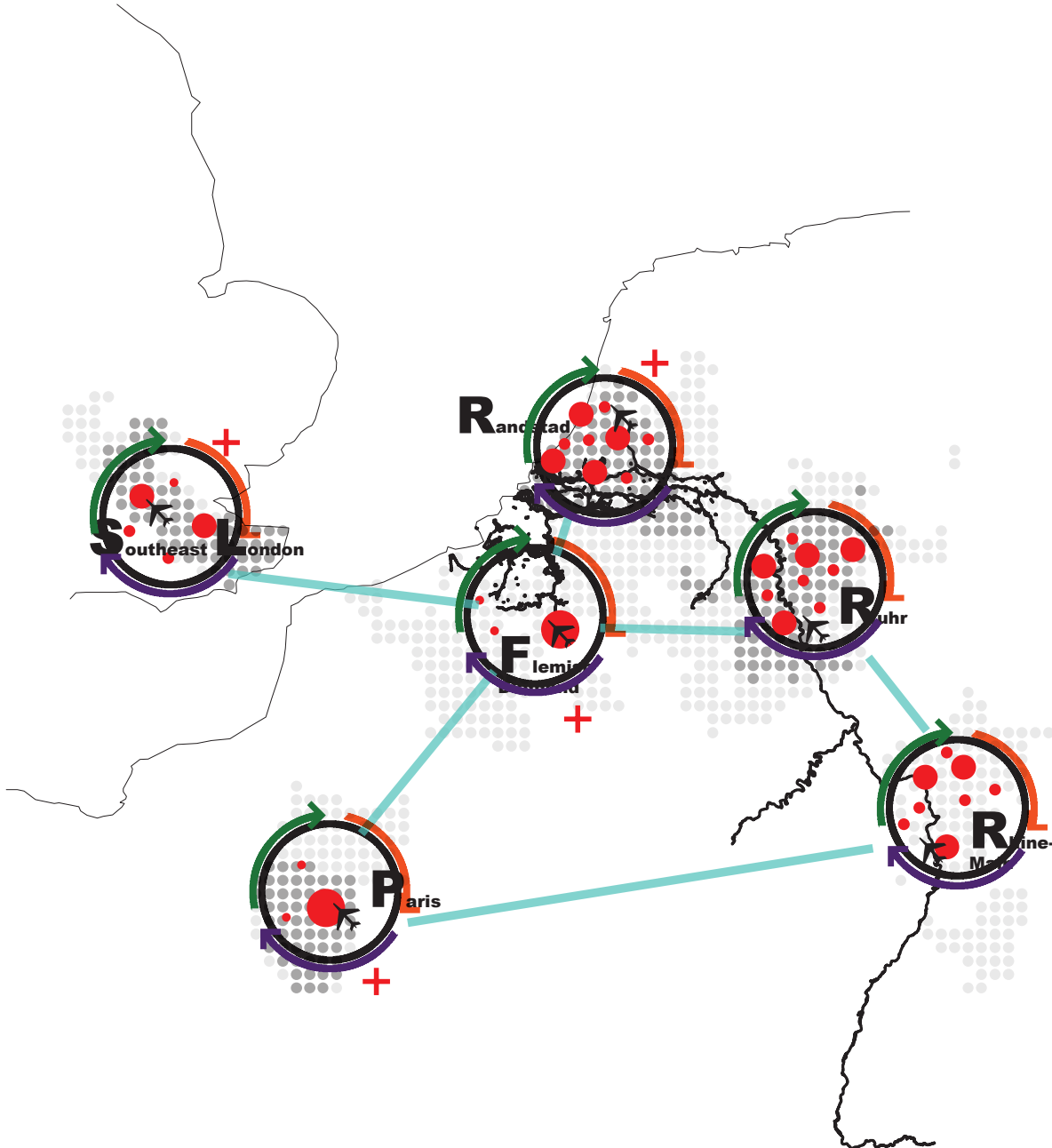

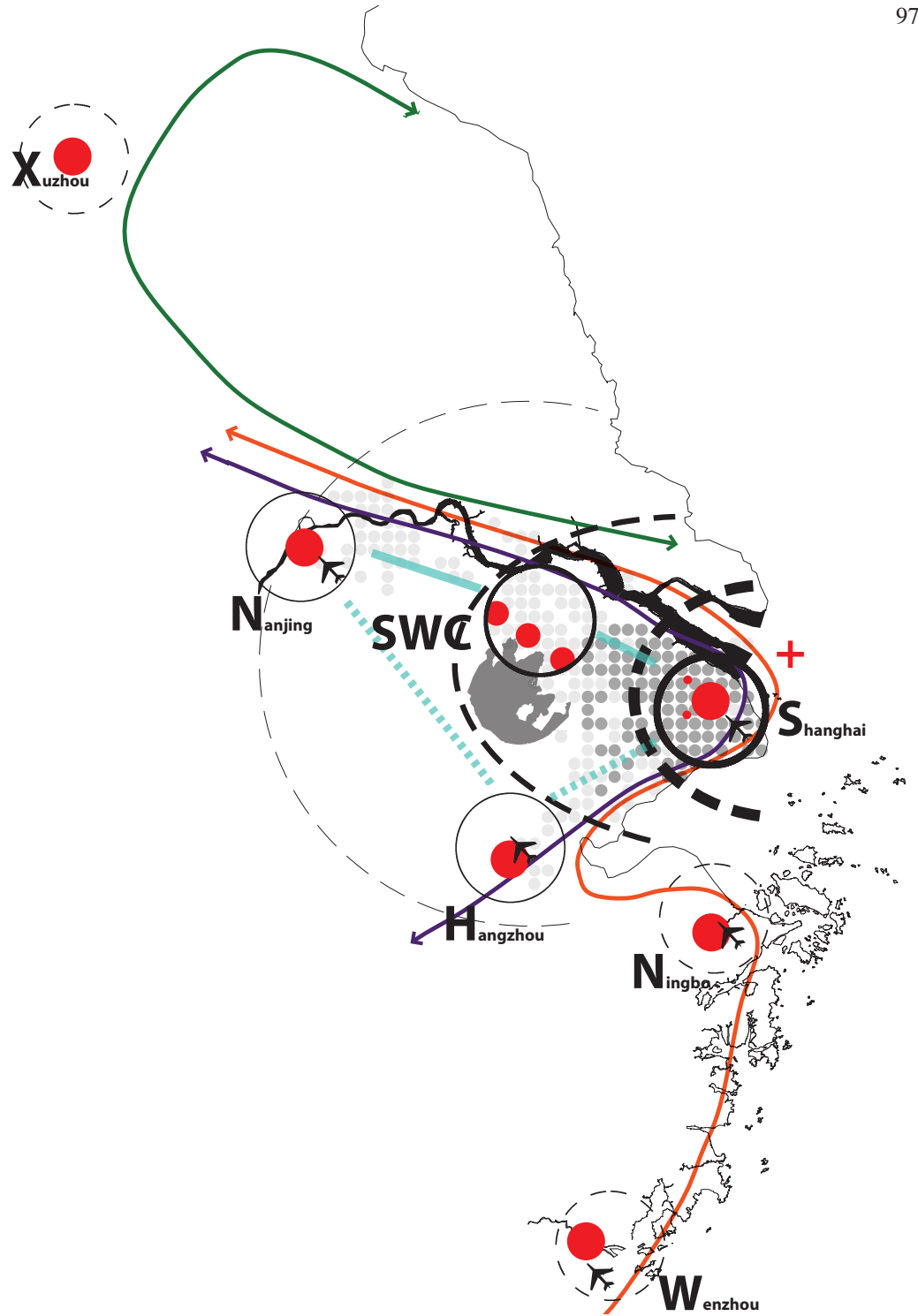

Map 50: Conclusion Map of Three Indicators of Scale Large

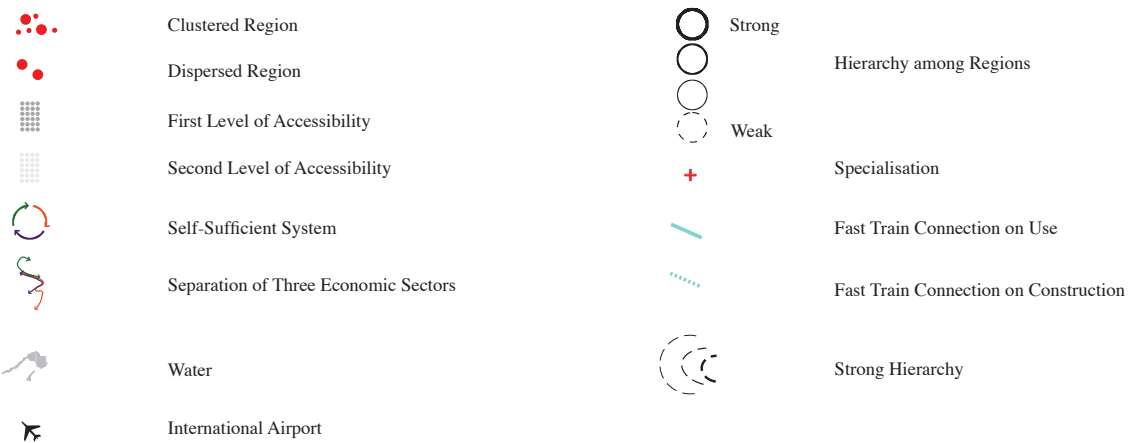

4.2 Final Conclusions



Leiden-
Bio-Science

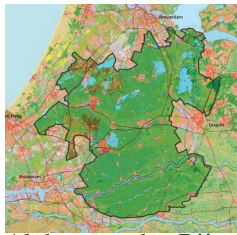

Alphen aan den Rijn-
Living in "Green Heart"



Aalsmeer-
Flower Industry and
Auction



Hilversum-
Media City

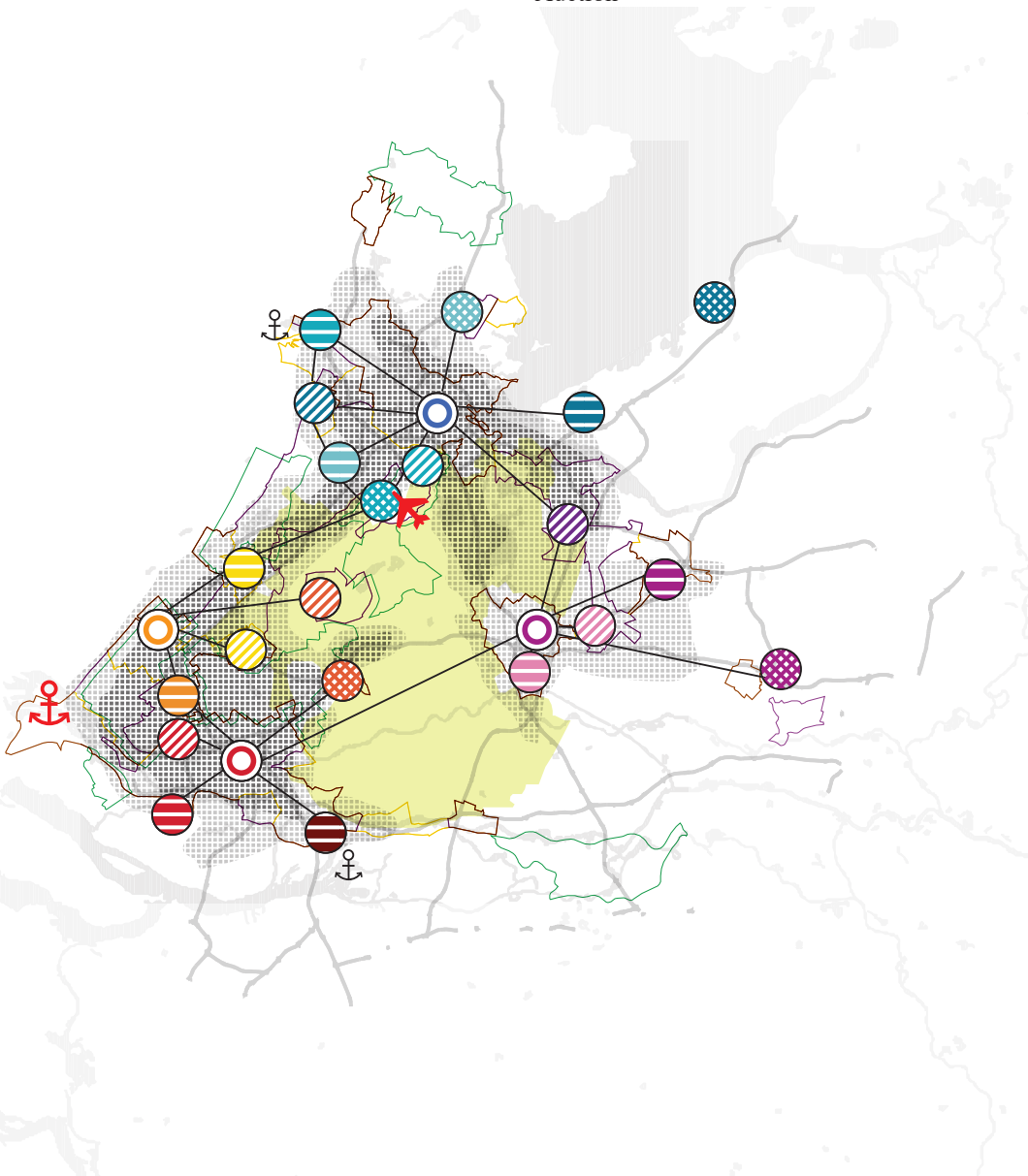

4.2 Final Conclusions

As one of the most important region in China, Yangtze River Delta(YRD) attracted lots of attention either by academic research or government consideration. In 2010, “Regional Plan for Yangtze River Delta 2009-2020” has been legalised by central government of China, which is the first regional plan legalised nationally in China. Definitely YRD is facing a new challenge for the regionalisation now. Meanwhile, within the guideline of “Regional Plan for Yangtze River Delta 2009-2020”, there are several city region plans on the agenda of provincial government, including Suzhou-Wuxi-Changzhou Region (SWC) as a particular region with multi-centres. Therefore, it is very meaningful to understand regions in China by the exemplary study of YRD and SWC.

Polycentricity is the concept to be tested on YRD and SWC, in order to identify YRD and SWC and explore the role of secondary cities in SWC. Thus, the flowing part will make use of polycentricity to unpack the characteristics of YRD and SWC by means of comparisons with Northwest Europe and the Randstad in the western context.

Identifying YRD and SWC by PUR

YRD can be concluded as a monocentric urban region, where Shanghai is the dominating centre as well as a global city. Due to the radiation of Shanghai, SWC belongs to the second level of concentration of activities, while Nanjing Region and Hangzhou Region belong to the third level. Although there are seven city region planed by the government, most of these city regions in reality are not functional regions yet on the scale of YRD. On the contrary, all the regions in NWE including the Randstad are apparent centres. Therefore, comparing with YRD, NWE can be seen as a polycentric urban region. There is a hierarchy in NWE, where the Randstad, Ruhr Area, Southeast London and Paris belong to highest level of concentrations, but the differences by three indicators between regions are very small.

Zooming into the regions in YRD and NWE, all the regions in YRD have a much more dispersed structure than the regions in NWE. Take the Randstad as the example, not only the four primary cities play crucial roles with concentration of a variety of activities, but also other cities as sub-centres are contributing to the region positively. Secondary cities in the Randstad have comparable density of activities with primary cities. That’s why the ring structure in the Randstad is very outstanding, in consist of primary cities and secondary cities. Conversely, the clusters of activities in SWC deviate to primary cities rather than secondary cities, except industry spreads over both primary cities and secondary cities. Comparing with the Randstad, SWC have much more dispersed structure in Scale Large and Scale Small. To some extent, clustered structure of a region is helpful for the interrelationship among different cities to formulate a region as a whole as well as to reduce urban sprawl. To sum up, the total image of YRD will be an emerging monocentric region with Shanghai as the strong centre radiating its power to the rest of regions, while all the regions in YRD including SWC have dispersed structure with little participation of sub-centres.

It is very interesting to conclude that all the regions in NWE belong to self-sufficient system with concentration of three economic sectors (Agriculture, Industry and Service). In other words, clusters of all three economic sectors represent the same images as the distribution of live and work. Self-sufficient system is one reason that all regions in NWE can become centres with concentration of living and working activities. However, in YRD, all three sectors are spread over, without strong clusters. Moreover, three sectors are concentrated separately; for instance, agriculture on the north part of YRD, industry on the south part and service in the middle. The separation and the sprawl of the activities in three economic sectors becomes the barrier for the regional development in YRD, so that the disparity between regions is even tend to be bigger. From this point of view, self-sufficient system is an important norm to formulate a real region, which can be applied for the future development of YRD as well as SWC.

Besides self-sufficient system, specialisation on two scales is another crucial norm that has been tested in this research. Different from Self-sufficient system referring concentration of all three economic sectors, specialisation indicates the proportion of these three sectors. Most of regions in NWE has its own specialisation, which points out service occupying the most percentages of total activities. In other words, the area with specialisation could distinguish itself from other area to become a region with diverse activities. In YRD, only a part of Shanghai Metropolitan Region has specialisation. Thus, it can be concluded that specialisation could help formulate a functional region. Zooming into the Randstad and SWC, all cities in the Randstad mostly concentrate on the service economy, however, each city has its own specialisation of service economy. For example, Amsterdam is the financial centre, Rotterdam is a harbour city, Hilversum is a media city and so on. Specialisation of each city could create a certain diversity by different scales in order to provide potential for the complementary relationship. In the Randstad, the diversity on the city-region scale (25km distance) is lower than regional scale (100km distance), which means secondary cities within the city region scale (like Amsterdam City-region) have more similarity than secondary cities belong to different city-region. This is caused by the dependency on the primary cities, which has been indicated by the real travel pattern of journey to work. In SWC, only city centres and industry area have specialisation spreading all over SWC. All secondary cities have many similarities for the industry. The lack of diversity results in the unhealthy competitions among all cities in SWC. Therefore, specialisation of each city (primary city and secondary city) is necessary for the process of regionalisation with cooperation, at the same time, the level of diversity relating to the scale needs to be well considered for SWC. The scalar diversity refers to city specialisation, regional diversity and regional specialisation. Therefore, diversity in different scales will tackle most of existing problems of SWC and clarify the future development of each cities as well as the entire region.

Accessibility is another crucial norm to understand polycentricity in YRD and SWC. The area with high accessibility in YRD is round Shanghai Metropolitan Region, while all the regions in

NWE have good accessibility by one hour. In order to become a functional region, good accessibility is a necessary condition. Recently, a lot of infrastructures are on the construction in the YRD, particularly on the central area of YRD including SWC. Two fast-speed railways has been finished recently: one is to connect Nanjing Region and Hangzhou Region, and the other to link Shanghai and Hangzhou (Map 50). The railway linking Nanjing Region and Hangzhou Region will provide opportunities for the cities on the west of SWC. An existing airport between Suzhou and Wuxi is upgrading into an international airport, aiming to connect the region to the international network. For the water transport, SWC have four comparable scale of harbours, which is different from the Randstad with an international harbour and several local harbours. Therefore, accessibility of diverse scales of SWC needs to be promoted, and the area with high accessibility could be intervention location at this moment.

To conclude “Identify YRD and SWC by PUR”, all the existing characteristics and important norms need to be combined to achieve a functional region either for YRD or for SWC (Figure 52).

Role of Secondary Cities in SWC

During the explanation of “Identify YRD and SWC”, the role of secondary cities is already very clear. Firstly, instead of “industry city” with enormous pollutions, secondary cities in SWC have ability to develop its own specialisation, as well as complementarity in the region. In this way, unhealthy competition by similarity of different cities can be reduced, and the secondary cities on the west will grow stronger to participate the regional development. Secondly, secondary cities is

not extension of primary cities and Shanghai Metropolitan Region, instead, they could have comparable concentration of diverse activities as primary cities. Thirdly, from the analysis of accessibility and commuting pattern in the Randstad, secondary cities benefits more from the functional interactions in the region. In the Randstad, interdependency of secondary cities and its own primary city is very strong. Conversely, the secondary cities of SWC are mainly depending on Shanghai at this moment (Map 51), which interrupts the formulation of SWC as a whole. Meanwhile, the interactions among three primary cities are strongest in the region now(SWC Regional Plan 2001-2020, 2002). Therefore, the condition of SWC will be different from the Randstad. The interdependency of secondary cities needs to be clarified, according to the situation of SWC. Fourthly, secondary cities need accessibility in diverse scales of the network: international, national and regional. For instance, secondary cities will have advantages if they are well-connected to the international airport, fast-speed railway or important harbour. Finally, spatial structure of different activities is necessary to become more clustered structure, so that urban sprawl will be partly solved and different functions in the region could work more efficiently. Secondary cities play a more and more important role in the region, because their participation directly adds a value to the functional region.

Figure 52: Table of Final Conclusions

		Analytical Dimension	Normative Dimension
Identify PUR	YRD	-Monocentric -Dispersed -Hierarchy -Emerging	-Self-Sufficient System -Participation of Sub-Centres -Regional Specialisation -Accessibility
	SWC	-Polycentric -Dispersed -Unbalanced	-City Specialisation -Regional Diversity / Complementarity -Agriculture Clusters -Accessibility -International Scale
Role of Secondary Cities	SWC	-Industry City / Monofunction -Serving for Primary Cities and Shanghai -Underestimation of Secondary Cities -Neglect of Secondary Cities on the West	-“Interdependency” -Specialisation of Secondary Cities -Complementarity -Intensification of live and work Activities -Clustering Structure of economic activities -Accessibility in Diverse Scales



5. Testing by Design

5.1 Current Vision of SWC Region

5.2 Evaluation of Current Vision of SWC Region

5.3 Proposals

5.1 Current Vision of SWC Region

SWC Regional Plan 2001-2020 was proposed in 2002 by Jiangsu Provincial government, although a new version is on the process which is not public yet. Thus, the old version will be discussed and evaluated in the chapter.

External Relation of SWC

SWC Region definitely has imitate relation with Shanghai Metropolitan Region. Shanghai Metropolitan Region have two scales: 100 km and 200 km. SWC will be the part of Shanghai Metropolitan Region of 200 km, which confirms the power and the influence of Shanghai to SWC. However, they proposed a “two direction development” to tackle the relation between Shanghai and SWC, which is different from before as an area to serve and support Shanghai (Map 53). SWC is trying to seek a complementary way to stand on its own feet instead of only an attachment of Shanghai.

SWC Region plays a leading role in Jiangsu Province. As a region with the highest GDP, advanced governance and upgraded technology, SWC will be connected with other parts of the province by several axes (Map 53). All these axes will create a better network through the whole province, especially to accelerate the development of north part of Jiangsu Province.

In the globe Scale, SWC aims to be an international region based on advanced manufacture, high-tech industry and tourism, which SWC already has good base for. Thus, the transformation of industry and the development of service economy will be a main task for SWC.

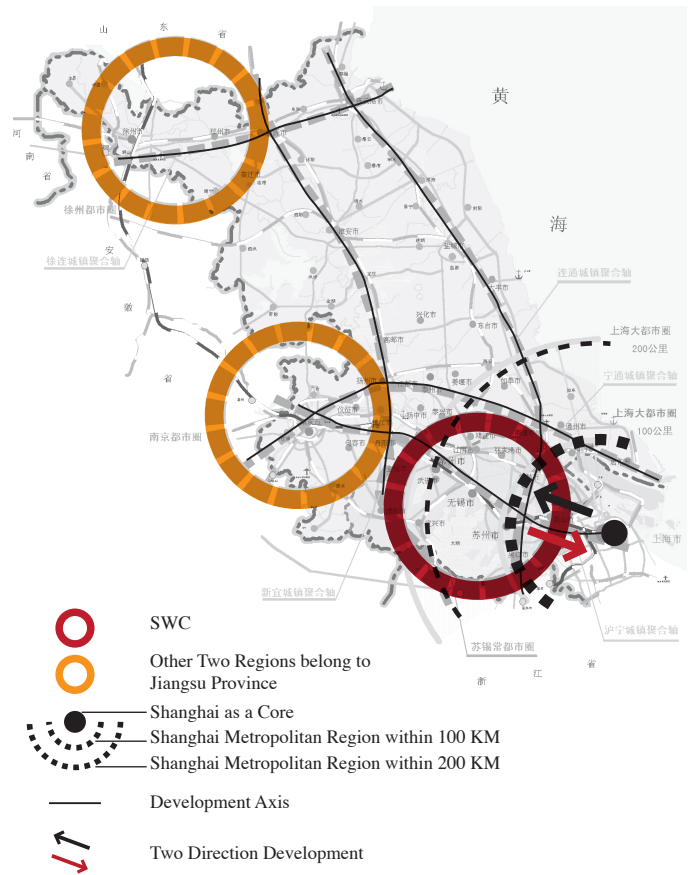

Map 53: External Relation of SWC
Source based on SWC Regional Plan 2001-2020, 2002

relating to two main cities and two small cities. Tai Lake Zone not only contains beautiful nature landscape, but also culture heritage. It has a lot of potential to develop as a national tourism destination. At the same time, tourism and ecology development can reduce the pollution problem nowadays. Thus, Tai Lake Zone will combine the nature landscape, towns and tourism together by an organized transport system.

c. Yangtze River Zone: This area with four small cities has good base of industry, and it is also the important area to link the north part of Jiangsu Province. The main task of this zone will be the regeneration of waterfront and combination of harbour industry and living, so that all these small cities will have characteristic cityscape influenced by Yangtze River.

d. Shanghai Border Zone: This area, direct connected with Shanghai, refers to three small cities. This zone will still be a service area of Shanghai, but it is very helpful to develop complementary economy with Shanghai.

e. Yixing-Suyang Mountainous Area: This area is a relatively less developed place, due the nature mountainous complexity and limitation of infrastructure. The aim of this mountainous area is to develop specialised agriculture, tourism and ecological protection. Three small cities will benefit from the development of this area and become towns as ecology nodes.

After the division of these five zones, SWC Regional Plan presents a variety of proposals from different issues, such as transport issue, development areas with priority, infrastructure, environment protection, integration of nature and culture, management, etc. For instance, two fast-speed railways have been planed in the regional plan (Map 54), and now the one through three main cities is already upgraded and used, and the other one is going to be finished soon (Map 54 & Map 55). Moreover, an intercity railway along the Yangtze River and another railway on the north-south direction to link Jiangyin, Wuxi and Yixin have been planed in the SWC Regional Plan 2001-2020 (Map 54). However, the latest intercity railway plan adds another two railways on the north-south direction (Map 54 & Map 55). Besides intercity railway, upgrading Shuofang airport to international airport is another crucial strategy which can promote this region into global scale, although it will take a long time to achieve this goal.

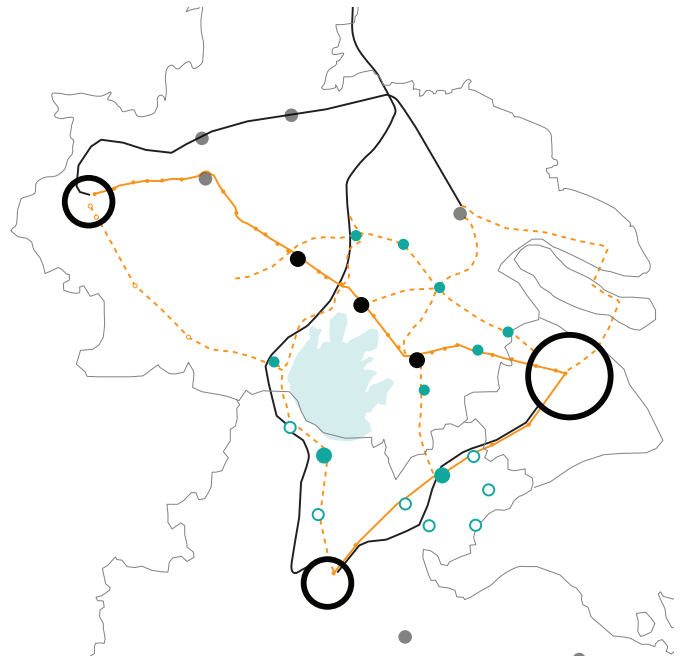

Map 55: Intercity Railway Plan

5.2 Evaluation of Current Vision of SWC Region

This part will evaluate current vision by discussing whether this vision could reduce or solve the main problems (Figure 56) which have been described in the instruction part: rapid urban sprawl, disparity between east and west, lack of identity and difficulties of inter-city cooperation, so that SWC could be a functional region with three primary cities.

Firstly, the relation between SWC and Shanghai has been redefined according to SWC Regional Plan 2001-2020. They proposed a kind of dependency and independency of SWC related to Shanghai by finding out a complementary direction for the future development. This point of view is very relevant for a clear position and role of SWC in the YRD. Later one, Regional Plan supposes to develop advanced manufacture, high-tech industry and tourism to enhance the regional competence, which is comparable with the specialisation of a region in the analysis of Scale Large. However, Regional Plan didn't mention the integration of three sectors for the region. Actually it is an effective strategy to strengthen a functional region and reduce urban sprawl as well.

Secondly, using several development axis with SWC to stimulate the development of north part of Jiangsu Province is very doubtful. From the analysis, the north part is like "void space" between regions. It is not needed to develop that area. Conversely, to leave it open or maybe to stimulate only one or two important city regions could be a better choice.

Thirdly, the two concepts of combining "compact city" with "open space" and "Regional Network" are useful tools to partly stop urban sprawl, identify the cities and strengthen the regional integration. Actually, combination of "compact city" and "open space" is very comparable with norm about "clustered structure" derived from this research. "Regional Network" is addressed in regional plan, with the purpose to stimulate cooperation and

interaction among cities within SWC, instead of single city connecting with Shanghai. This strategy could help the inter-city cooperation definitely, but it is very difficult to see how regional network works from their vision image. For instance, most of new infrastructure connections and planned zonings have east-west orientation, which actually already have relation on this direction. What they only added connection from north to south is to connect two secondary cities which belong to their primary city legally. Thus, the "Regional Network" is not concrete yet from current vision.

Afterwards, based on these two concepts, five zones have been proposed with specific visions. By defining the characteristics of different zones, the role of each city has been described at the same time. It is a very smart way to solve a lot of problems, like urban sprawl, identity and interaction among cities. However, the methodology of zoning can also lead to similarities among cities, which becomes the barrier for the inter-city cooperation. For instance, there are four secondary cities belonging to Yangtze River Zone, so that these cities will regenerate harbour and add dwellings. What is missed here is how to distinguish these secondary cities relating to harbours, which could give new identity to the city.

Finally, the problem about disparity between east and west is not highlighted in this Regional Plan, even they proposed agriculture, tourism and ecology for the west part of SWC, as well as some railway connections. For example, the planned infrastructure development is still emphasised on the east part.

In conclusion, there are many positive points as well as negative points about this current vision. Thus, the next step will make use of this comparative research to give addition from a specific view.

Map 56: Table of Evaluation of Current Vision

Evaluation

Relation with Problems

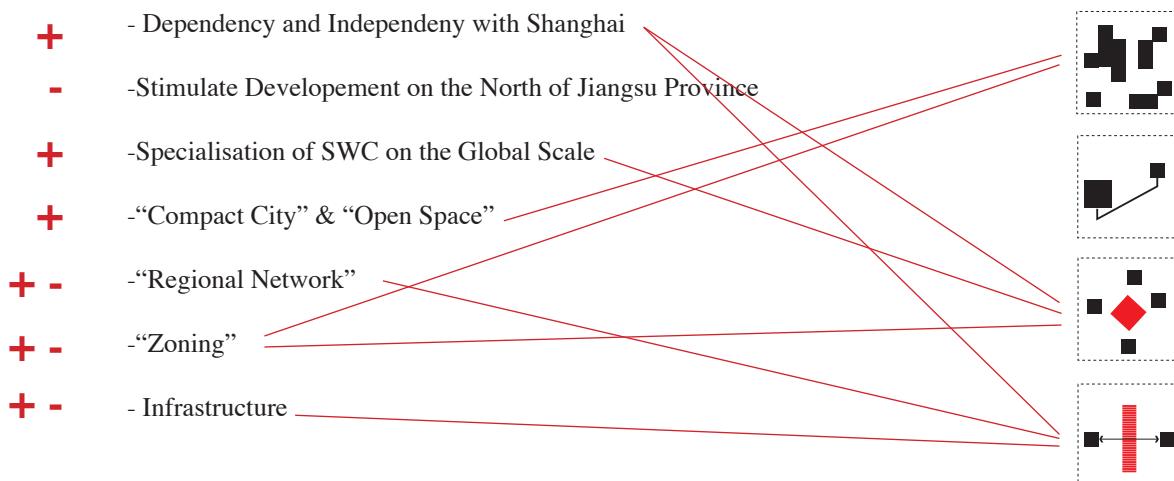

5.3 Proposals

SWC in YRD (Map 57)

In the context of YRD, SWC plays an important role, because it has extremely close relationship with Shanghai, as well as a transition from Shanghai to Nanjing which goes further to Beijing in the national scale. However, with the transformation of industry in SWC, this region is facing a new challenge to reconsider the function and role of SWC in the context of YRD.

Firstly, the dependency on Shanghai will be reduced, so that SWC could stand on its own feet with a specialisation. Shanghai already has specialisation in the scale of YRD, with high percentage of Service economy. Shanghai is the financial centre and international port as well. In order to distinguish with Shanghai, SWC will still focus on Industry, not only production, but also technology research and design. Besides industry, nature and culture heritage can be another advantage for SWC comparing with Shanghai.

Secondly, due to the central position of SWC, a lot of flows by SWC are pass-by flows. Especially with the construction of other two fast-speed railway through SWC, SWC will benefit from this fast network. However, the danger is whether SWC could become one destination instead of a terminal. For example, one fast-speed railway on the west of SWC is going to connect Nanjing Region and Hangzhou Region. SWC could make use of this connection to attract people to come to SWC as a destination. Moreover, the upgraded airport in SWC is a key to locate SWC on national or even international scale, so that SWC as destination will be strengthened.

Thirdly, self-sufficient system is useful for SWC. SWC could consider the development of agriculture and service economy to adjust the existing Industry, aiming for a self-sufficient system. Because self-sufficient system can slow down or stop the urban sprawl, particularly on the east part of SWC close to Shanghai. Meanwhile, this system could strengthen internal relation in SWC and provided more diversity as well.

The last is about the participation of sub-centres. As the analysis explains, the involvement of sub-centres will indicate the level of Polycentricity. Thus, it is very crucial to stimulate the participation of secondary cities in the region by a variety of means. In other words, Regional vision needs pay attention on these secondary cities rather than only primary cities.

To sum up, there are four key words for SWC in the context of YRD: Independency, Destination, Self-sufficient System and Participation of Sub-centres. The following part will explain more detailed vision in the scale of SWC, which reflects on the large scale at the same time.

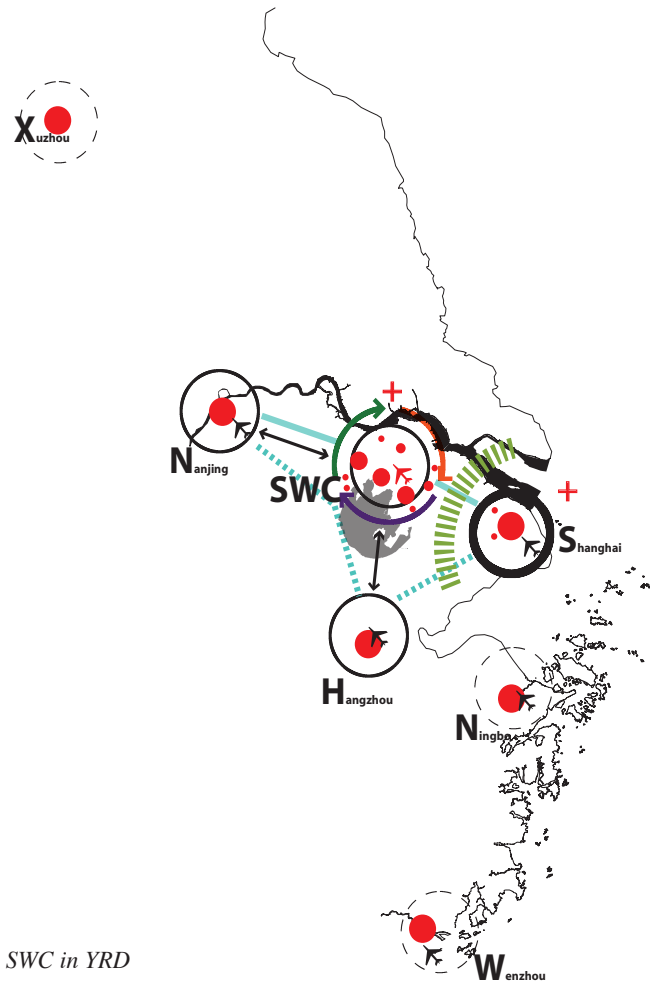

Map 57: SWC in YRD

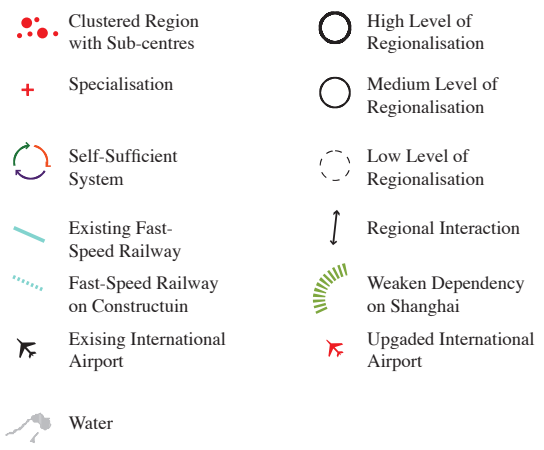

5.3 Proposals

Alternative Proposal of SWC (Map 59)

Based on the conclusions of this research and current SWC Regional Plan, there are six main concepts (Figure 58) which can be added to the existing vision. By explaining these concepts, the final alternative proposals for SWC (Map 59) becomes concrete with the existing context of the region.

First of all, self-sufficient system is used for the small scale as well. Self-sufficient system could prevent urban sprawl outside of the region, and increase functional integration within the region. Derived from the analysis of SWC, there are two belts with concentration of industry activities: one is connecting three primary cities, the other is linking secondary cities along the Yangtze River. Based on this structure of industry as main economic activity, service and agriculture economy will be intensified. Combining with the regional specialisation, high-tech industry, tourism and intensive agriculture are relevant for SWC. Thus, SWC will be a self-sufficient system with diversity of three economic sectors.

Second concept is to increase interdependency between secondary cities and primary cities. As the conclusion map of SWC shows, most of secondary cities in SWC are trying to link to Shanghai, even the distance with three primary cities is shorter. With the transforming of primary cities and good accessibility to primary cities, secondary cities in SWC could change their orientation of interdependency to three primary cities. Particular for the Daily Urban System, not only these secondary cities will benefit from the connection with primary cities, while these connections will strengthen the centrality of primary cities at the same time. Therefore, there will be more linkages on the North-South direction for SWC, instead of the existing strong connection from west to east. New network structure will underpin functional interactions of the region.

Interdependency can not only change the spatial and functional structure of the region, but also can facilitate for city specialisation and regional diversity. First of all, three primary cities need to specialise themselves in order to play complementary roles in SWC. According to YRD Regional Plan, Suzhou is pursuing for international city, focusing on high-tech research, tourism and historical value. Wuxi will emphasis on logistics, professional education, creative design and leisure. Changzhou aims for the centre of new material, garment and new energy. The specialisation of primary cities could be used to tackle the specialisation of the secondary cities. That's why the secondary cities in Map 59 start to have diverse colours. In addition, intensification of secondary cities becomes feasible by the increased connection with primary cities.

Thirdly, intensive agriculture is an important spatial strategy. In the history, SWC is well-known as "an flourish area with rice and fishes". But since 1970s, agriculture has been replaced by the fast growth of the factories. Nowadays, the precious land requires more specific agriculture with high productivity. Two areas with green arrows (Map 59) have potentials for intensive agriculture. The reasons to choose these two areas are: different types of agriculture in two areas can be addressed: fishery production and mountainous agriculture; infrastructure

Figure 58: Concepts

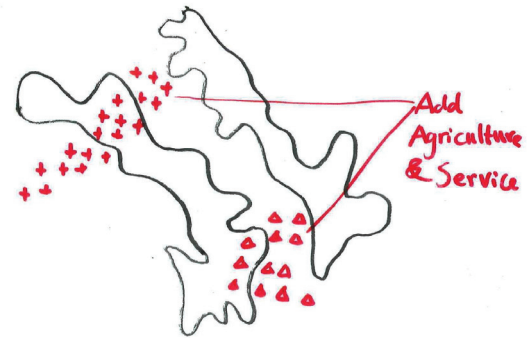

Self-sufficient
by strengthen service and agriculture

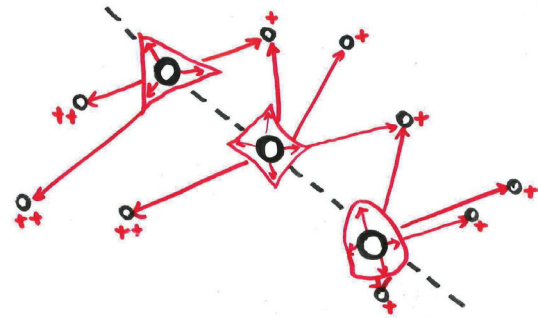

Interdependency
between Secondary Cities and Primary Cities

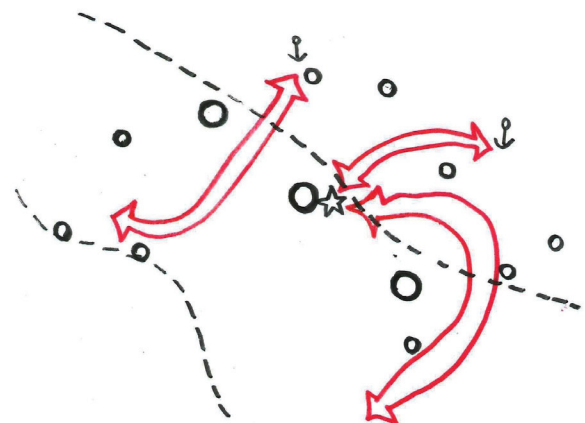

Intensive Agriculture

connection: good connected to the harbour, airport and railway network; and the clustered agriculture will strengthen functional interaction on the north-south direction. Thus, it is valuable to promote agriculture with high productivity by clustering existing fragmented agriculture for SWC.

Fourthly, nowadays more and more cities in SWC pay attention to the transformation from pure industry to high-tech industry that is combined with knowledge, research and innovation. That's why lots of high-tech parks are founded in SWC: two national parks in Suzhou and Wuxi, and some parks in primary cities and one secondary city. There is no doubt about the idea of high-tech industry, but what's more important is to have good planning to control the development of high-tech parks, in order to prevent a variety of problems, such as competition for the same market, insufficiency of some of these high-tech parks, etc. So it is necessary to consider all these high-tech parks as a whole to play complementary roles. Complementarity could be different economic sectors or the hierarchy among High-tech Industry parks, such as two High-tech Industry parks next to international airport has national or international function.

SWC region has a plenty of culture heritage during the long history. Culture heritage could become a special attraction to develop the tourism, so that service sector of SWC will be strengthen. SWC aims to become a recreation centre with tourism, leisure and events for diverse scales. In reality, this function has been developed recently. There is a yearly event for cycling around the Tai Lake, with lots of participators. Besides, one cycling road is already on the construction, which links all the places of interests around the lake. Making use of tourism, there could be more tourism zones planned in SWC, so that the culture heritage and landscape quality of secondary cities (yellow triangles in Map 59) can be improved by connecting on the network. Tourism zone will bring a new structure with functions, resulting in a new layer of functional interactions.

The last concept is to define two entrances (two grey dotted circles in Map 59) as the potential areas with high accessibility. With the development of infrastructure, especially high-speed train through two secondary cities on the east and inter-city train connecting secondary cities on the network, new two entrances will be highlighted, replacing primary cities. Particularly the entrance on the west will reduce disparity between east and west part of the region, so that more flows by this entrance will bring opportunities for the secondary cities on the west.

In conclusion, SWC will be a self-sufficient system with clustered activities of three economical sectors. Not only primary cities need specialisation, secondary cities will specialise themselves by overlapping different concepts, such as interdependency with primary cities, intensive agriculture, high-tech parks, tourism zone, etc. The different hatch of a secondary city indicates what kind characters it has (Map 59). Secondary cities will be intensified with more activities to achieve a balanced distribution in the region, at the same time city specialisation could improve diversity of the region and increase the functional interactions by complementarity, with the support of good accessibility.



High-tech Industry

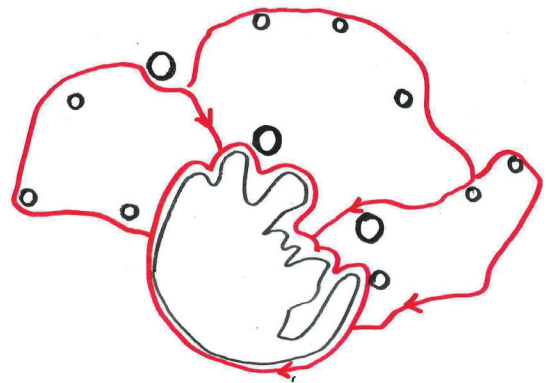

Tourism Zone

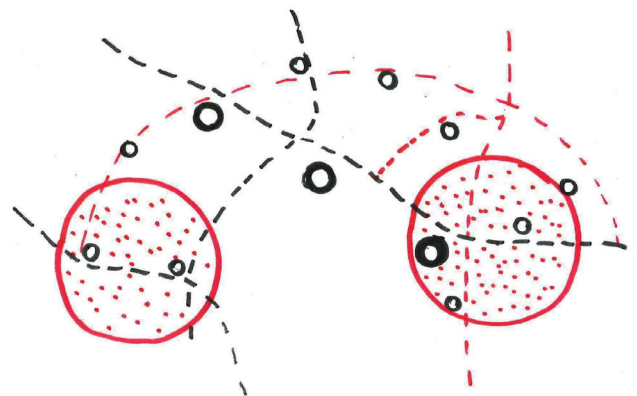

Two Entrances

5.3 Proposals

Map 59: Alternative Proposals

- Primary cities with Specialisations
- Diversity of Secondary Cities with Specialisations
- Interdependency
- Fast-Speed Train Recently
- Existing Railway
- Future Inter-City Railway
- Water
- Existing Industry Clusters
- Intensive Agriculture Clusters
- Valuable Places for Tourism
- Tourism Zones
- High-Tech Park with Specialisation
- High-Tech Park Clusters with Specialisation
- Regional Entrances
- Intensifying Live and Work Density
- International Airport
- Regional Airport
- Hierarchy of Harbours

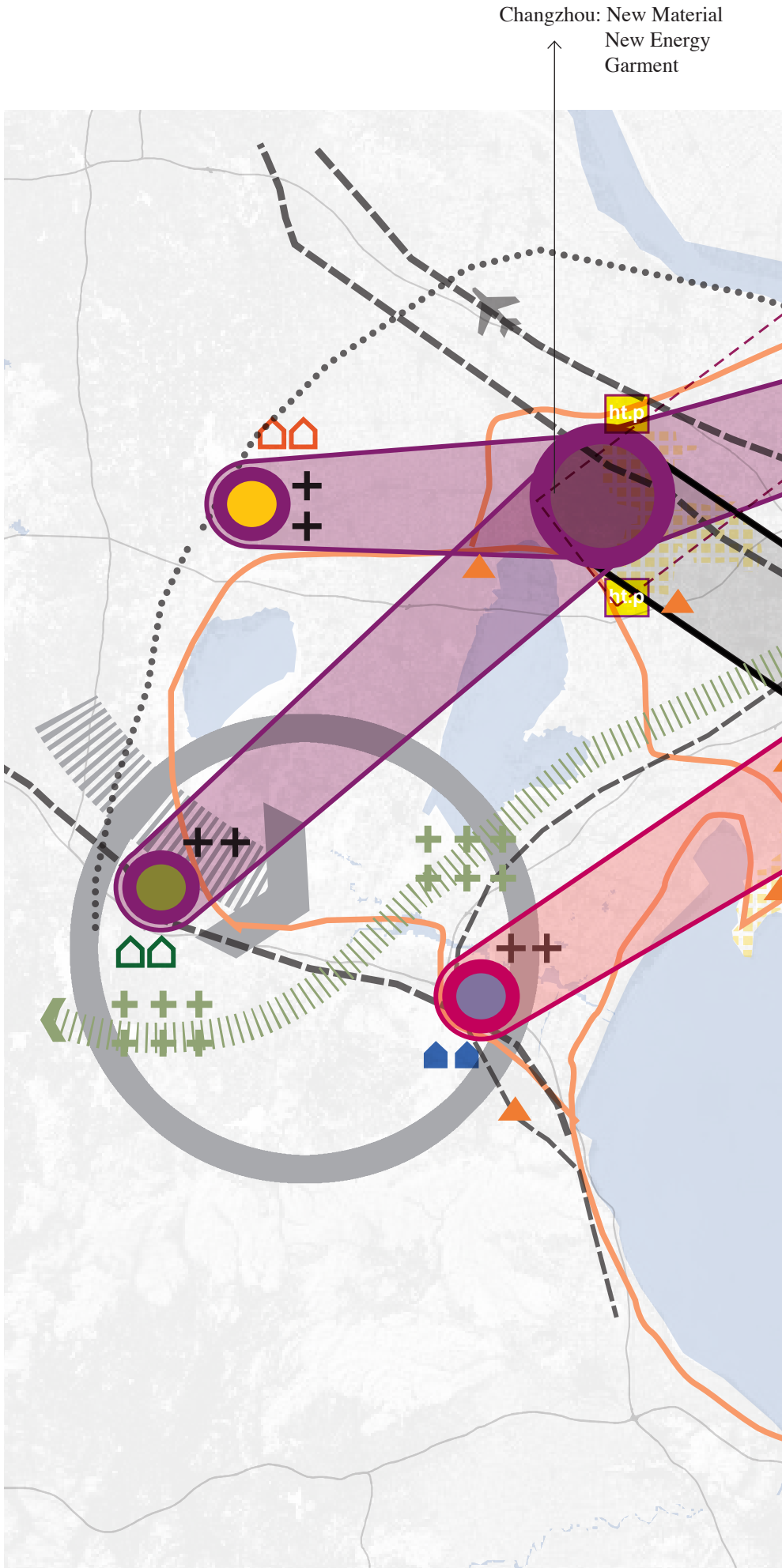

Wuxi: Logistics
Professional Education
Design Centre
Leisure

Suzhou: High-Tech Centre
International Tourism
Historical City

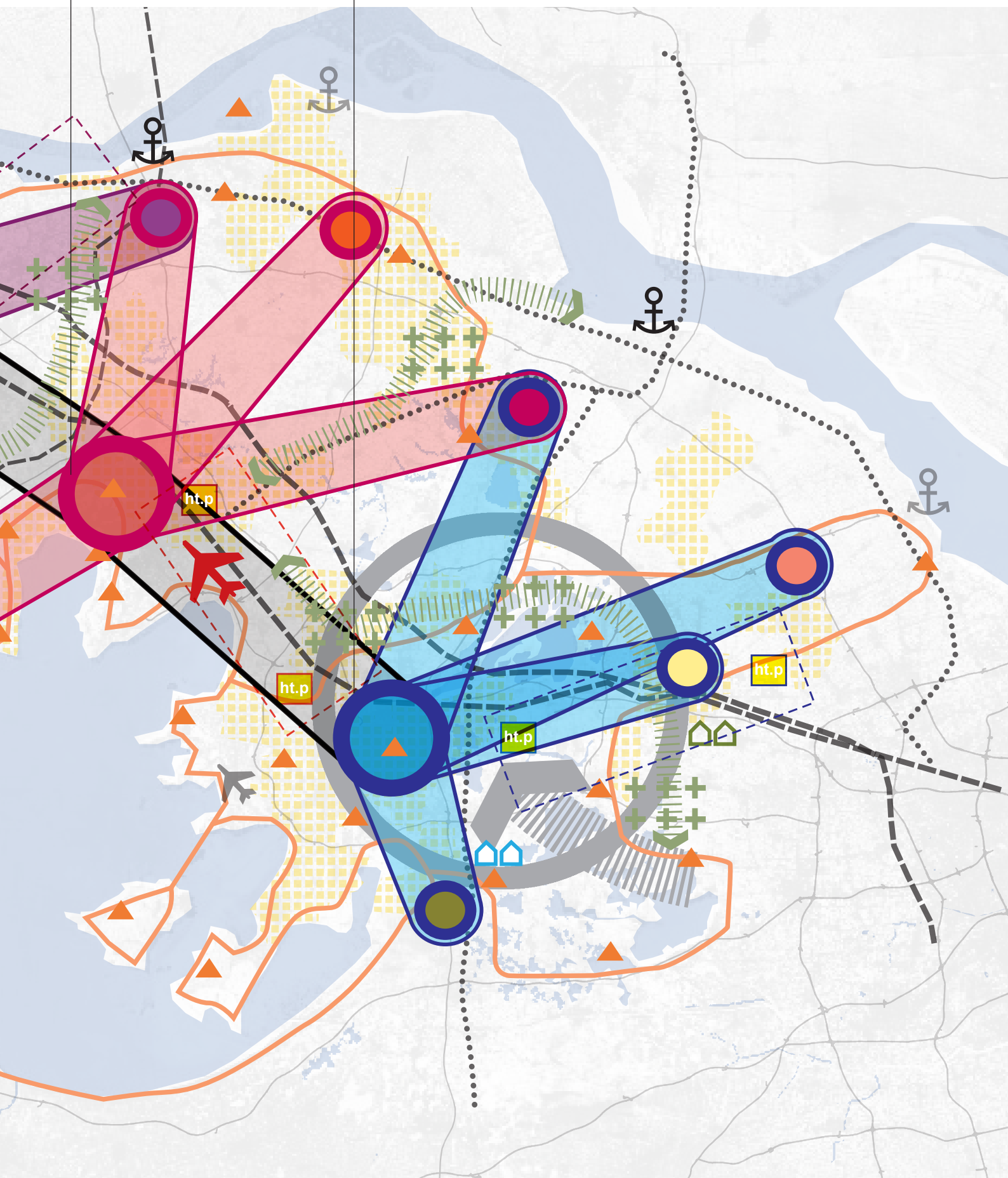

5.3 Proposals

This image aims to visualise a variety of ingredients mentioned in the six concepts. These ingredients are : Agriculture, High-tech Park, Tourism, Events, Infrastructure, etc. The combination of all ingredients represents the concepts of the vision of SWC including secondary cities: self-sufficient system, diversity, concentration, open space, accessibility.





Theoretical Framework

The concept “Polycentric Urban Region” has a variety of explanations by many authors, like Kloosterman, Musterd, Davoudi and etc. It is very crucial to conclude relevant theory for my project. That’s why analytical dimension and normative dimension are very important to understand the existing role and admirable role of secondary cities in the region. This theoretical framework clarify the focus of my project, and give a solid foundation for the research process as well.

Comparative Research

Derived from the theoretical framework, it is important to understand different regiona with different contexts and different scales. Therefore, two context with two scales were chosen: Randstad in Northwest Europe and SWC Region in Yangtze River Delta.

Besides, the choice of indicators are mainly based on theoretical framework. Simin Davoudi (2003) observed that “without the economic underpinning a PUR will simply represent a group of neighbouring cities of more or less similar size and economic weight, rather than a functionally integrated region”. Therefore, all indicators are selected in order to discover the economic activities in the regional scale.

The result of comparative study finally indeed represents similarities and differences of different regions in different scale. Based on these similarities and differences, the existing spatial structures of YRD and SWC have been described, while several norms have been concluded which are applied to the design proposals. Thus, comparative research is a very efficient and useful method for this research project.

Test by Design

Through this process, a variety of issues relating to the real context of SWC have been observed. It is very helpful to understand and evaluate the existing regional plan. By giving proposals, norms have been tested in the real context.

Evaluation of the Process

Reflecting on the whole process of this research, the main research questions are answered from a specific point of view. The main aim has been achieved in the end. Definitely there are still some issues could be improved more. For example, the data of YRD and SWC is five or six years behind the data of NWE and the Randstad, which could influence a bit for the comparison. But considering PUR has different phases to emerge, the data from different years can be partly neglect. To sum up, this research adds and proves some concepts of Polycentric Urban Region, especially with the Chinese context. At the same, this research helps to understand regionalisation in YRD and SWC by the comparison with NWE and the Randstad.

- Albrechts, L. (2011). Strategic Cooperation and Planning Practices: Lessons from European City-regions. Paper presented at the Better Policies for Better Lives-OECD.
- ANAS, A., ARNOTT, R. and SMALL, K. (1998) Urban spatial structure, *Journal of Economic Literature*, 36, pp. 1426–1464
- Anderson, N. B., & Bogart, W. T. (2001). Identifying and Characterizing Employment Centers in Polycentric Metropolitan Areas. *American Journal of Economics and Sociology*, 60(1).
- Atlas ABC. (2011). In D. o. U. TU Delft, Chair of Regional and Metropolitan design and Chair of Spatial Planning (Ed.).
- Centraal Bureau voor de Statistiek. from <http://www.cbs.nl/nl-NL/menu/home/default.htm>
- Coffeng, G. (2011). Ruimte en OV in de Randstad.
- Davoudi, S. (2003). EUROPEAN BRIEFING: Polycentricity in European spatial planning: from an analytical tool to a normative agenda. *European Planning Studies*.
- ESPON (2006): Polycentric Urban Development and Rural-Urban Partnership - Thematic Study of INTERREG and ESPON activities.
- ESPON. (2010). SGPTD - Secondary Growth Poles and Territorial Development in Europe. From http://www.espon.eu/main/Menu_Projects/Menu_Applied_Research/SGPTD.html
- European Commission. (1999). European Spatial Development Perspective, Towards Balanced and sustainable Development of the Territory of the EU. Luxemburg: CEC.
- Ham, M. v., Hooimeijer, P., & Mulder, C. H. (2000). Urban Form and Job Access: Disparate Realities in the Randstad.
- Handy, S.L., & Niemeier, D.A., (1997). Measuring accessibility: an exploration of issues and alternatives. *Environment and planning A*, 29, 1175-1194.
- Hardoy, J. E. and D. Satterthwaite (1988), "Small and intermediate urban centres in the Third World: what role for government?," *Third World Planning Review* Vol.10, No.1.
- Hall, P. (1966). *The world cities*. London: Weidenfeld & Nicolson.
- Hall, P. (2003). In a Lather about Polycentricity Town and Country Planning, 72.
- Hall, P., & Pain, K. (2006). *The Polycentric Metropolis: learning from mega-city region in Europe*. Londaon: Earthscan.
- Kloosterman, R. C., & Lambregts, B. (2001). Clustering of Economic Activities in Polycentric Urban Regions: The Case of the Randstad. *Urban Studies*, 38(4), 717-732.
- Kloosterman, R. C., & Musterd, S. (2001). The polycentric urban region: towards a research agenda. *Urban Studies*.
- Luo, X., & Shen, J. (2008). Why city-region planning does not work well in China: The case of Suzhou– Wuxi–Changzhou. *CITIES*, 25, 207-217.
- Luo, X., & Shen, J. (2009). A study on inter-city cooperation in the Yangtze river delta region, China. *Habitat International*, 33, 52-62.
- Masterplan Zoetermeer 2025 (2002). Zoetermeer.
- Meijers, E. (2007a). *Synergy in Polycentric Urban Region: Complementarity, organising capacity and critical mass*. Amsterdam: IOS Press.
- Meijers, E. (2007b). Clones or Complements? The Division of Labour between the Main Cities of the Randstad, the Flemish Diamond and the RheinRuhr Area. *Regional Studies*, 41(7), 889-900.
- MLIT (Ministry of Land, I., Transport and Tourism, JAPAN). An Overview of Spatial Policy in Asian and European Countries. Retrieved 31th, August, 2012, from http://www.mlit.go.jp/kokudokeikaku/international/spw/general/netherlands/index_e.html
- Parr, J. (2010). The Polycentric Urban Region: A Closer Inspection. *Regional Studies*(38), 231-240.
- Randstad, O. B. (2011). Ruimte en OV in de Randstad, Resultaten Vervoermarktanalyse. In G. Coffeng (Ed.).
- Rck, J. R. v., Oort, F. v., Raspe, O., Daalhuizen, F., & Brussel, J. v. (2006). *Veel Steden Maken Nog Geen Randstad*. Rotterdam : NAI Uitgevers.
- Regional Plan for Yangtze River Delta 2009-2020 (长江三角洲地区区域规划) . (2010). Shanghai, Jiangsu Province and Zhejiang Province.
- Randstad 2040: Samenvatting Structuurvisie. (2008). In M. v. VORM (Ed.).
- Romein, A. (2004). Spatial planning in competitive polycentric urban regions: some practical lessons from Northwest Europe, *City Futures Conference*. Chicago.
- Rondinelli, D.A. (1983). "Implementing Decentralization Programs in Asia: A Comparative Analysis". *Public Administration and Development*, 3(3), 181–207.
- Spatial Vision for North West Europe. (2000). from http://3b.nweurope.eu/upload/documents/spatial_vision/1069.Spatial_Vision_eng.pdf

Stead, D., & Marshall, S. (2001). The Relationships between Urban Form and Travel Patterns. An International Review and Evaluation. *European Journal of Transport and Infrastructure Research*, 1(2), 113-14

SWC Regional Plan 2001-2020(苏锡常都市圈规划) . (2002). In J. I. o. U. P. a. Design (Ed.). Nanjing.

Terlouw, K. (2009). Rescaling Regional Identities: communicating thick and thin regional identities. *Studies in Ethnicity and Nationalism*, 9(3), 452-464.

Urban and Regional Explorer. from <http://chinadataonline.org/cge2/>

Y. H. Dennis Wei, Yuqi Lu & Wen Chen (2009): Globalizing Regional Development in Sunan, China: Does Suzhou Industrial Park Fit a Neo-Marshallian District Model?, *Regional Studies*, 43:3, 409-427

Werff, M. v. d., Lambregts, B., Kapoen, L., & Kloosterman, R. (2005). The Randstad, Commuting & the Definition of Functional Urban Regions. In I. o. C. S. T. Y. F. P. Partners (Ed.).

wiki. Diversity Index. from http://en.wikipedia.org/wiki/Diversity_index

Wu, F. (2008). Urban transition in China: the emergence of city-region governance. Paper presented at the Conference of Regional Economies in a Globalising World: Enhancing Intellectual Capacity and Innovation, Cardiff, Wales, UK.

Xu, W. (2003). Integrated Planning of “City Circle around Taihu Lake”. *Jiangnan Forum*, 9.

Yadav, C. S. (1968). *Comparative Urban Research*. New Delhi: Concept Publishing Company,.

Yeh, A. G.-o., & Wu, F. (1999). The transformation of the urban planning system in China from a centrally-planned to transitional economy. *Progress in Planning*, 51(3), 167-252.

YUAN, F., & SONG, Z. (2012). Spatial distribution of industrial firms in Taihu Basin since China's Reform and Opening-up (改革开放以来太湖流域工业企业布局演变) *Journal of Lake Sciences*, 24, 27-33.

The Role of Secondary Cities in Polycentric Urban Region

From Analytical to Normative Dimension

Liang Wei

1226169_lwei@tudelft.nl
Delft University of Technology, Department of Urbanism
9th Graduation Lab Urbanism Conference

February 2nd 2012

Abstract – Randstad Region represents a very particular polycentric urban region (PUR) in the world. (Kloosterman and Musterd, 2001). Highly frequent movement within Randstad Region stands for close relationship between all the cities or towns. Randstad Region contains four primary cities (Amsterdam, the Hague, Rotterdam, Utrecht) which play complementary roles for the Randstad. Beside these four cores, there are a number of secondary cities around each core city. Due to the decentralization of economic activities, increasing mobility, fragmented spatial distribution of activities and changes of household structure (Davoudi, 2003), some of secondary cities are not periphery cities of their core cities any more, but start to participate the network of the region.

This paper will focus on the role of secondary cities in the Polycentric Urban Region in order to rethink about the future development of secondary cities. In general, A polycentric urban region is a function urban region consists of ‘a number of smaller, specialised, closely-related centres’ (Hall, 1966), which is distinguished from a monocentric urban system with one dominate city in one functional urban region. However, a diversity of theories about Polycentric Urban Region has been addressed beyond the conceptual level of PUR. Davoudi (2010) argued that there are two important dimensions of the concept of PUR: one is analytical dimension to explain an existing or emerging polycentric urban system; the other is normative dimension to use PUR as a planning strategy referring to active encouragement of polycentric development as a policy objective. Thus, there are two main sub-questions. In terms of analytical dimension, how can the existing role of secondary cities in PUR be described and measured? What in terms of normative dimension, what are the values and norms of PUR development as a spatial planning strategy for secondary cities?

This review paper sets up a theoretical framework about the role of secondary cities in PUR from analytical and normative dimension, so that the criteria of this review paper are going to be applied in my graduation project to search for the future development of secondary cities of Yangtze River Delta in China by comparative study of the Randstad in the Netherlands.

Key words – Polycentric Urban Region, Polycentricity, Secondary Cities, Analytical Dimension, Normative Dimension, Regional Planning

1 Introduction

The notion of Polycentricity, usually with regard to a regional system, is a highly popular term by urban planners and policy makers. There are a diversity of explanation about what is Polycentric Urban Region (PUR) by different authors. They tried to conclude

the concept of Polycentricity in regional scale from empirical examples, such as the Randstad in the Netherlands, Rhine-Ruhr region in Germany, area of Padua–Treviso–Venice in northern Italy, the southern Californian urban region in the US and the Kansai area in Japan (Kloosterman and Musterd, 2001).

Based on existing or emerging PUR, Polycentricity was firstly used as an analytical tool. Hall and Pain (2006) defined Polycentric Urban Region development as “a process is often associated with the outward diffusion of functions from major cities to smaller cities with in a regional setting”(Hall and Pain, 2006, p. 4). They mentioned that besides primary cities, smaller cities including secondary cities are contributing to the PUR. In addition, Polycentricity is not only the morphological issue, but also functional relationship (e.g. economic, social-cultural relations) which is even more crucial.

Nowadays more and more research are shifting to normative dimension of PUR. For example, European Spatial development Perspective (European Commission, 1999) concerned to use Polycentricity “to reconcile the social and economic claims for spatial development with the area’s ecological and cultural functions and hence contribute to a sustainable, and balanced territorial development”. Secondary cities in PUR have been paid attention in the European level. For instance, there is a project of ESPD from 2010 called SGPTD - Secondary Growth Poles and Territorial Development in Europe; Performance, Policies and Prospects. (ESPD,2010).

Therefore, the aim of this review paper is to address how to describe and measure the existing role of secondary cities in PUR, which is related to analytical dimension; and to discover the potential role of secondary cities within PUR as a spatial planning strategy which is about normative dimension.

Firstly there is a briefly explanation about the general concept of Polycentric Urban Region and the changes from an analytical tool to a normative agenda. Afterwards in analytical dimension the role of secondary cities will be described and as well as be measured, particularly from morphology and function aspects. Furthermore, in normative dimension PUR development related to secondary cities will be examined from two aspects: the value and the norms. The value will be argued by different issues, such as economic competitiveness, disparity, social cohesion and regional identity. The norms will be emphasised by complementary and cooperation. After understanding two dimensions of PUR related to secondary cities, potentials of secondary cities will be observed. The conclusion part is trying to set up a concrete theoretical framework to unpack the existing role and a desirable role of secondary cities in PUR.

2 General Concept of PUR and Secondary Cities

2.1 Definition of PUR

Definition of PUR can be addressed in a variety of ways. For instance, Kloosterman and Musterd (2001) concluded that PUR contains a small number of large cities and a large number of small cities instead of one leading city. The difference between large and small cities are related to settlement size and economic importance. Some of these cities are historical cities. And all these cities are proximately located but spatially and politically distinct. Parr (2010) supposed that PUR is consist of a cluster of similarly sized centres which are separated by open land (agriculture or simply vacant) with highly intensive interaction (especially economic interaction) and economic specialisation. All these definitions are intent to explain PUR in morphological aspects, like distribution of large cities and small cities or open space between cities. At same time, they also mentioned the interaction and economic specialisations which refer to functional aspect. Particularly due to the function rank rather than size of the cities in PUR, secondary cities as an inevitable part of PUR are distinguished from the primary cities.

2.2 Polycentricity in Scales

Scale is a very crucial issue for PUR, because “polycentricity can occur at multiple levels or spatial scales, and what is monocentric at one level can be polycentric at another-and vice versa” (Hall, 2003).

As Champion (2001) concludes three scales of PUR: Micro Scale, Meso Scale and Macro Scale (illustration 1). Micro scale refers to individual metropolitan area including primary city and suburbans or secondary cities. Meso Scale means intra region scale, in which a region contains more than one primary cities, and mostly these primary cities are metropolitan cities with suburbans and smaller cities around it. The typical of example of Meso scale is the Randstad in the Netherlands. Even there is a third scale of Inter-Region scale named as Macro Scale, which can be illustrated by an example that “the Rhine–Ruhr Metropolitan Region, the Randstad, the Flemish Diamond will develop into one polynucleated urban field at the macro level?”(Dieleman and Faludi, 1998; Champion, 2001) Therefore, the clarifying which scale of analysis area is a prerequisite of understand a PUR.

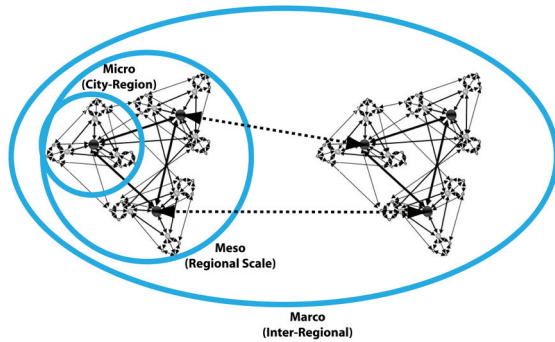

Illustration 1: Micro, Meso and Marco Scale (based on the source: Goei et al,2010)

3 Analytical Dimension

3.1 Morphology of PUR and Secondary cities

3.1.1 PUR, Monocentric Urban Region(MUR) and Decentralised Urban Sprawl (DUS)

In general, Polycentricity is seen as the opposite to monocentricity and urban sprawl (ESPON,2006). PUR contains more than one centre in the region, which is more spread and decentralised than MUR. However, PUR is not same as Decentralised Urban Sprawl, because all the centres in PUR are well-organized in the system, which can be considered as “concentrated decentralisation” in opposite with apparently unorganised urban sprawl (Davoudi, 2003). In addition, the open land between cities (spatially distinct) makes PUR different from Decentralised Urban Sprawl.

3.1.2 Secondary Cities in Alternative Development of PUR

In order to understand the role of secondary cities in PUR from morphological perspective, it is very useful to figure out the “variety of (morphological) origins out of which polycentric urban configurations can emerge”(Lambrechts, 2006).

Champion (2001) concluded three possible ways that PUR can emerge (Illustration 2): centrifugal mode, incorporation mode and fusion mode. The centrifugal model is originally form a monocentric city, “where the continuing growth of the city imposes such severe strains (for example, escalating land rents in the CBD and growing problems of access to the central area from the ever more distant outer residential areas)”. “The most affected production and service activities are squeezed out to alternative centres” which “come to rival the original centre in size” (Champion, 2001). If one secondary city on the track of centrifugal model, it can have opportunities to develop as a new centre or to adjust its function in order to integrate into new configuration of the region. The incorporation

model is that the growth of a large centre incorporated with smaller centres which are self-sufficient in the sense of employment and service. Fusion mode is based on the existing independent cities with similar size which has grown both by size and lateral extent and they began to fuse with each other together with secondary cities in between, “particularly because of the improvement of transport” (Champion, 2001).

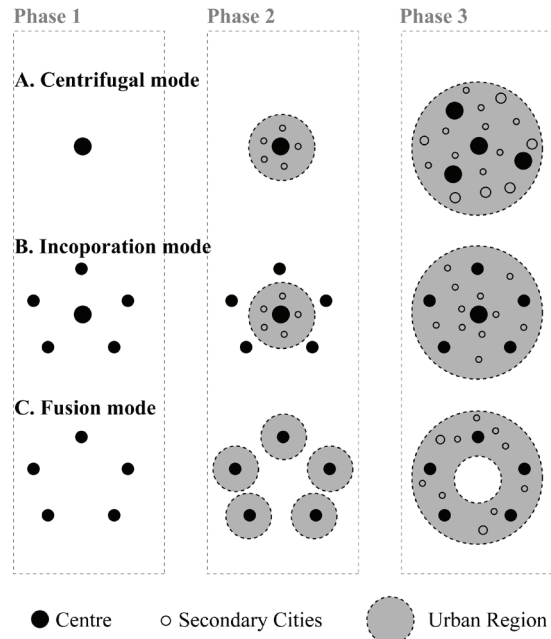

Illustration 2: Alternative Development of PUR (based on the source: Lambrechts,2006)

In conclusion, the original urban configuration substantially influences the morphology development of urban configuration of PUR. Which role is a secondary city play needs to figure out which mode this secondary city belongs to and as well as which phase this secondary city is being. For example, the Randstad and RhineRuhr could be located between phase 2 and phase 3 of fusion mode(Lambrechts,2006). In addition, scale is very important to understand the process of PUR development. Take the Randstad as one example, the fusion mode exists in the scale of the whole region, however centrifugal mode and incorporation mode are simultaneously taking place on the city-region scale, such as Amsterdam or Rotterdam Metropolitan Region.

3.1.3 Rank-Size Distribution of Cities

Rank-Size distribution is a crucial tool to measure the morphological polycentricity in the urban region, so that primary cities and secondary cities can be clearly distinguished. Population rank is one indicator of the rank-size distribution of the city. Besides population, Anderson and Bogart (2001) observed employment follows the rank rule so that it

can be used to represent the rank-size distribution as well.

Thus, by analysing the morphological aspect of PUR by comparison with MUR and DUS or by the origins of PUR or rank-size distribution, it is very helpful to describe and measure the role of secondary cities in PUR. However, morphological polycentricity is not enough to analyse a PUR. A comparison research (Meijers, 2008) between ESPON 1.1.1 and ESPON 1.4.3 revealed that combining with functional aspect will course a very different result by only measuring morphological polycentricity. Therefore, there are more and more research about the function relationship within PUR, either economic activities or social activities.

3.2 Functional PUR and Secondary cities

The term “functional polycentricity” means the proximity is more referring to functional relationship rather than physical distance. In addition, the rank of cities is not according to the size of the city any more, but based on the importance of functions (Cattan, 2007). Thus, this part will discuss about in general what the criteria of functional PUR and especially how to measure the interactions, in order to give a methodological framework for analysing the role of secondary cities in PUR.

3.2.1 Economic Activities

Simin Davoudi (2003) observed that “without the economic underpinning a PUR will simply represent a group of neighbouring cities of more or less similar size and economic weight, rather than a functionally integrated region”. Besides Simin Davoudi, there are a large amount of literature have discussed about economic network in the PUR theoretically and empirically.

Due to the globalisation, economic decentralisation, the improvement of transport and communication etc, the formerly self-supporting cities are able to trade with other cities. Then cities were “stimulated to specialise and build on their specific strengths of natural endowments or economies of scale in particular activities” (Kloosterman and Lambregts, 2001). Meanwhile, the functional economic interaction between cities is intensified. Take the Randstad as an example, the daily travel distance related to labour sector was increased by 40 percentage from 1985 to 1998.

As a secondary city in PUR, the sustainable development will be the focus on the specific economy or localised economy. The ESPON 1.1.1 (NORDREGIO, 2004) reports concluded that the policy of PUR can focus on function specialisation in secondary cities. For example, a secondary city “can host a major university, research facility or

industrial plant” (Cattan, 2007). Particularly in the era of knowledge economy, these secondary cities with universities and research institutions are developing specific industry to strength its own economy or complementing to the primary cities.

3.2.2 Measuring Interaction- “Three S-dimensions” method

Functional interaction not only takes place between primary cities, but “in a polycentric urban system the small and medium-sized towns and their inter-dependencies form important hubs and links” (European Commission, 1999). However, how to measure the functional interaction, including economic and social activities?

There is a “Three S-dimensions” method has been developed, which namely means the strength of interaction, the level of symmetry and the structure of the system (Limtanakool et al. 2007). They proposed indexes to describe and measure the entire urban system (like a region), each node (e.g. a city in a region) and the links between the nodes. **Illustration 3** provides an overview about “Strength, Symmetry and Structure” of spatial interactions referring to urban system or node or link.

Strength: This dimension represents the intensity of interaction between different nodes in the urban system. It means the rank of attraction of a node (or a city) can be figured out. In this way, the role of secondary cities can be measured by the strength of interaction. The dominance index (DIT_i and DII_i) “indicates the degree of involvement of a node in the network” referring to each node. If the direction of flow is taken into account, DII_i will be applied.

$$DII_i = \frac{I_i}{\left(\sum_{j=1}^J I_{j/J}\right)}$$

I_i is the sum of all the trips inwards to node i from other locations. $(\sum_{j=1}^J I_{j/J})$ indicates the average attractiveness of the whole region. Thus, DII_i ranges from 0 to ∞ . The higher DII_i is, the more attractive and more dominant this node is. If DII_i is 1 for every city, it means there is a maximum of polycentricity so that every city are equal with one another. DIT_i ignores the direction of the flows, which is a sum of all the flows inwards and outwards to one city. With the respect to the link rather than the node, RSI_{ij} is used to measure the proportion of interaction on a given link between two nodes relative to the total interaction in the network.

Symmetry: Node Symmetry(NSI_i) “measures the difference between the incoming and outgoing interactions for every node i ” (Limtanakool et al. 2007). -1 and 1 means fully asymmetrical flow of one node and 0 means symmetry between inwards

and outwards flow. If NSI_i of all cities are 0, this urban system will be a maximum of PUR. Similar to Strength, Symmetry can be applied to the level of link by Link Symmetry (LSI_{ij}).

Structure: At the network level, Entropy (EI) is used to “measure the extent to which the total interaction is distributed evenly across all links in the network”(Limtanakool et al, 2007). The EI can therefore be considered as a synthetic indicator at the structure dimension, “with the value of one indicating a fully polycentric network”(Limtanakool et al, 2007).

In conclusion, functional interaction and involvement of secondary cities in PUR is very crucial to address in order to observe the exact role of secondary cities. Economic activity is a basic issue to measure the functional relationship between cities in PUR. Meanwhile, because of the growing flows by leisure and social activities, other kinds of interactions needs to be taken into account instead of only economic issue. In addition, “Three S-dimension” method provides a very precise and practical tool to measure the PUR by node, link and the whole system. In other words, all the cities including secondary cities, all the relationship

	System	Node	Link	Node	Link
	Entropy (EI)	Dominance (DIT _i and DII _i)	Relative strength (RSI _{ij})	Node symmetry (NSI _i)	Link symmetry (LSI _{ij})
Equation	$EI = - \sum_{i=1}^L \frac{(z_i) \ln(z_i)}{\ln(L)}$ <p>for $z = 0$ holds that $(z) \ln(z) = 0$</p>	$DIT_i = \frac{T_i}{\left(\sum_{j=1}^L T_{i/j}\right)}$ $DII_i = \frac{I_i}{\left(\sum_{j=1}^L I_{j/i}\right)}$	$RSI_{ij} = \frac{t_{ij}}{\sum_{i=1}^L \sum_{j=1}^L t_{ij}}$	$NSI_i = \frac{\sum I_i - \sum O_i}{\sum I_i + \sum O_i}$	$LSI_{ij} = - \left[\frac{(f_{ij}) \ln(f_{ij}) + (f_{ji}) \ln(f_{ji})}{\ln(2)} \right]$ $= \left[\frac{f_{ij} - f_{ji}}{f_{ij} + f_{ji}} \right]$
Minimum/maximum value	$0 \leq EI \leq 1$	$0 \leq DII_i$ and $DIT_i < \infty$	$0 \leq RSI_{ij} \leq 1$	$2 \leq NSI_i \leq 1$	$0 \leq LSI_{ij} \leq 1$
Strength	-	0: a node is not involved in the network → ∞: a node dominating the network as every interaction in the network is associated with this node	0: a link does not exist 1: highest strength of a link	-	-
Symmetry	-	-	-	-1: a node is asymmetrical by having a maximum deficit of net flow 0: a node is fully symmetrical in terms of its net flow 1: a node is asymmetrical by having a maximum surplus of net flow	0: a link is fully asymmetrical: an interaction only exists in one direction 1: a link is fully symmetrical: there is two-way interaction and flows in each direction are equally large
Structure	0: all interaction is concentrated on one link in the network 1: no hierarchical structure (when every link in the network has equal intensity of flow)	A network does not have a hierarchical structure when every node in the network is associated with equally large flows	A network does not have a hierarchical structure when every link in the network is equally strong	A network does not have a hierarchical structure when every node in the network has NSI _i = 0	A network does not have a hierarchical structure when every link has LSI _{ij} = 1

Key:

- L Link in the network ($L = 1, 2, 3, \dots, L$).
- Z_i Proportion of journeys on link i in relation to the total number of journeys in the network.
- I_i, I_j The number of inward journeys to nodes i and j .
- T_i, T_j The total number of journeys associated with nodes i and j .
- t_{ij} The number of journeys from node i to j .
- O_i The number of outward journeys from node i .
- f_{ij} The proportion of journeys on the link from node i to node j in relation to the total number of journeys between nodes i and j .
- f_{ji} The proportion of journeys on the link from node j to node i in relation to the total number of journeys between nodes i and j .
- i, j $i = 1, 2, 3, \dots, I; j = 1, 2, 3, \dots, J; \text{ for } i = j$.

Illustration 3: Spatial interaction indices (based on the source: Limtanakool et al, 2007)

between cities and the entire PUR can be quantitatively defined.

4 Normative Dimension

Besides analytical dimension of PUR, normative dimension has attracted more and more attention. There are a large amount of discussion about PUR as a strategical spatial planning tool. For instance, the concept of PUR has become a key component of spatial planning strategy promoted by the European Spatial Development Perspective (ESDP) with the aim of a balanced territorial development at the level of EU. This section will discuss the normative dimension of PUR related to secondary cities by the two aspects of the value and the norms.

4.1 Value of Polycentricity for Secondary cities

If PUR is applied as a spatial planning for a region, what could secondary cities benefit from and at the same time what could secondary cities contribute to the synergy of a PUR?

4.1.1 Regional Competitiveness

Nowadays, region becomes “the most competitive the most important spatial level of international territorial competition” (Meijers, 2007). It is often hypothesised that the PUR is a more effective scale for the global competition than the individual cities: “internal co-operation for external competition” (Romain, 2004). Secondary cities as very important components of the PUR, could benefit from cooperation with other cities through sharing of facilities, infrastructure, labour, knowledge and etc. Meanwhile, secondary cities have lots of complementary advantages, such as relatively cheap and large space for enterprises, qualified and educated labour, ecological value and green living. By making use of these potentials under the PUR planning strategy, secondary cities could develop on an appropriate direction to participate in the entire region rather than an isolated city. To sum up, PUR could guide the development of secondary cities from the view of the entire system, so that the regional competitiveness can be enhanced by the involvement of secondary cities aiming for the synergy of a PUR.

4.1.2 Identity and Vitality of the city

In the PUR, every city including secondary cities are trying to figure out a proper position for the city itself by developing its specialisation, which can be qualitative living environment, or tourist attraction, or densely located international enterprises. This will result in a diversity of different cities with their own identity.

Besides, interaction between cities will bring a large amount of different flows (people, goods and information), which will promote the vitality of the cities in PUR. Particularly for secondary cities that

can be closely connected to core cities, interaction will bring secondary cities also to the global scale. A mixture of local and global scale is beneficial for the vitality of the cities in the PUR.

4.1.3 Balanced Regional Development

Development disparity is taking place at all levels of scale, mostly explicitly on the EU scale and intra-regional scale. For instance, ESDP takes the normative approach of PUR which is used as a preferred spatial structure and a guiding principle in order to achieve a balanced regional development in the Europe.

PURs in general are performing more efficient and balanced than the regions with other spatial structure, because PUR “provides smaller cities and towns with a better chance to compete more effectively in the world market” (Davoudi, 2003). Thus, secondary cities under the normative approach of PUR can have more opportunities to develop themselves and strengthen their positions on the region.

4.2 Norms of Polycentricity for Secondary Cities

The future development of secondary cities not just follows the regional planning, but also can add different scale of spatial planning for the whole region. Particularly on this municipal level, decision making becomes more decentralised and involves more local actors of public and private. Thus, Polycentricity is a multi-scalar and multi-actor spatial planning (Romain, 2004), providing a platform for different scales and various actors to guide the development of secondary cities. The following four issues are main discussion topics by different experts.

4.2.1 Co-operation & Complementarity

What kind of relationship can be existing between cities of a PUR in a synergistic way? Evert Meijers (2007) proposed two possibilities: Co-operation - horizontal synergy, and Complementarity - vertical synergy. Co-operation and complementarity leads to different types of PUR: “club” type and “web” type. In the club type, cities “share a common objective, activity or service, while also having parallel interests and transaction chains” (Meijers, 2007), especially with similar economic sectors, like port cities or tourist cities. Web type is characterised by specialised activities of different cities. For instance, a city with a specific production needs to work with an international city with airport or harbour, and it also needs the support from a knowledge city with universities or research institutions. Thus, these two types of synergy can be existing at the same time (Meijers, 2007).

In the club type of PUR, cooperative cities will face similar problems, like internal competition, a weak

economic base, the same need for public transportation. Distinguished from club type, PUR with web type network means “the individual cities perform different economic roles and host complementary urban facilities, activities, residential and working environments” (Meijers, 2007). Although co-operation and complementarity both can be applied in the PUR, the latter one – complementarity is more relevant of PUR.

Complementarity between two cities can be in different levels. One level is that these two cities emphasise very different functions, for instance one provides transportation and logistic service while the other more about financial service. The other levels is that, even two cities have similar function, such as university cities, they also could play complementary role by providing different specialisations of the education.

As secondary cities in the PUR, it is important to discover what kind of relationship (dominance of co-operation or complementarity) with what sort of other cities. Afterwards, in order to contribute to the synergy of PUR, a sort of development aim of one secondary city can be formulated by enhancing or diminishing the relationship with other cities.

4.2.2 Regional Organization Capacity

In a PUR, many spatial issues ask for coordination among multi-scalar public, semi-public and private stakeholders in addition to government (Romein, 2004). Therefore, regional organization capacity, which means “an institutionalised framework of co-operation, debate, negotiation and decision making in pursuit of regional interests in which a multitude of public and private stakeholders participate” (Meijers, 2007).

There are several examples in the practice. For example, in order to enhance the competitiveness of the Randstad, the Fifth Memorandum for Spatial Planning (VORM, 2001) considered more actors, especially private actors, to participate the regional development. Besides, from the failure of application for the Olympic Games of 2012, the state government of North Rhine-Westphalia noticed that local municipality did not make use their capacity for cooperation. Instead they reinforced this top-down approach of regional planning. That's why regional organization capacity is necessary to be improved to stimulate different actors at various scales aiming for the feasibility of regional spatial planning.

The institutional capacity of secondary cities need to involve actively in the regional planning system as well, especially they are linking higher scale of government with local private actors. It means secondary cities needs to appropriately cooperate

with other cities as a whole and what more difficult is to cooperate with multi-scalar actors.

4.2.3 Intra-Regional Accessibility

Due to the growing flows and interactions between cities in the PUR, urban congestion is taking place. Congestion downgrades the accessibility to many cities in the PUR, particularly to the core cities and transportation nodes, and therefore decreases the attractiveness of the regions for investors, businessmen, visitors and local consumers (Romein, 2004).

In both theoretical can empirical research, several policy have been proposed to solve urban congestion and decreased accessibility of urban centres. The most general policy is to shift private car transport to the public transport. There are already several projects going on, such as “stedenbaan” project in the south wing of the Randstad, MetroRapid in RheinRuhr and Regional Express Networks in the Flemish Diamond.

Besides public transport system as a strategy, multi-scalar approach of transport planning is very crucial to achieve namely a integrated transport system in a PUR. This includes multi-model and multi-scalar transfer nodes (Romain, 2004), strategic transport link according the functional position of cities, multi-layered stakeholders.

Thus, intra-regional accessibility for PUR is the vascular system for the human body. In order to improve this circulatory system of PUR, the development of secondary cities should be adjusted to strengthen the whole transport system.

4.2.4 Spatial Diversity and Quality of Open Space

In the recent half century, most of population growth in PUR were happening in the smaller cities and towns, rather than core cities. The growth of population and decentralised economic activities lead to spatial fragmentation, decreased diversity and quality of open space between cities.

In practice, “Contour Policy” is widely used by different polycentric urban region. In the Netherlands “red and green contours” distinguish where the urban expansion can be implemented and where ecological or cultural landscape must be protected. In Flemish Diamond, the “green contour” is replaced by “blue and green network”.

Therefore, the issues have been discussed above, is only one part of possible values and norms of PUR related to secondary cities. With the widely application of PUR in different context, this normative dimension will be developed more concrete and precise.

5 Conclusion

Based on diversity of theory from Europe and the United State about PUR, this review paper focuses on the role of secondary cities in PUR from analytical and normative dimensions (illustration 4).

Analytical dimension is applied to observing existing spatial structure of PUR including morphology and functional interaction, so that the current role of secondary cities can be figured out. Not only the criteria of secondary cities in PUR are providing, what more crucial is the accurate research method - “Three S-dimension” which can measure the functional interaction depending which issue is addressed.

Normative dimension, concludes the value of PUR as strategy for secondary cites and the whole region. At the same time, norms of PUR provide guideline for the future development of secondary cities, such as co-operation or complementarity within the region, participating to enhance regional organization capacity, accessibility, spatial diversity, quality of open space.

In relation to my project, this review paper gives a theoretical framework for my graduation project. Part of criteria of this review will be used to analyse the current condition of secondary cities in the Randstad and Yangtze River Delta. For instance, in the analytical dimension, “Three S-dimension” method is very useful to measure the interaction between cities. Norms of PUR shows possible future development strategies, which can be tested in secondary cities of the Randstad and applied properly into Yangtze River Delta.

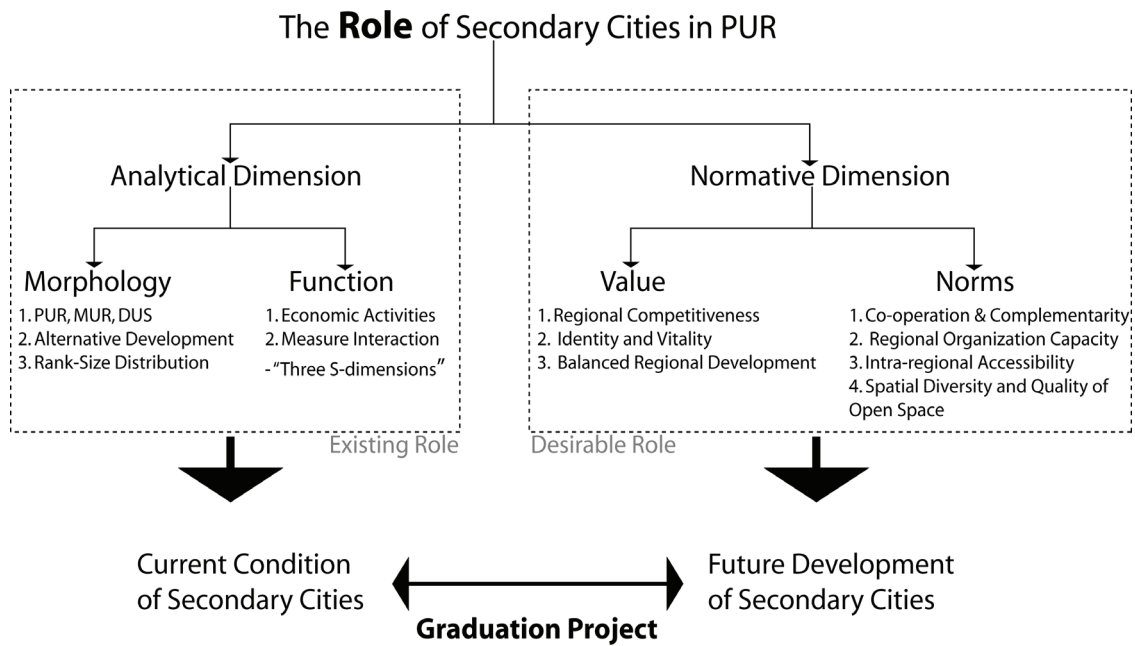

Illustration 4: structure of theory and relation to graduation project

Bibliography

- Anderson, N. B., & Bogart, W. T. (2001). Identifying and Characterizing Employment Centers in Polycentric Metropolitan Areas. *American Journal of Economics and Sociology*, 60(1).
- Camagni, R. (1993) From city hierarchy to city networks: reflections about an emerging paradigm, in: T.R. Lakshmanan and P. Nijkamp (Eds) Structure and change in the Space Economy: Festschrift in honour of Martin Beckmann, pp. 66-87. Berlin: Springer Verlag.
- Cattan, N. (2007). *Cities and networks in Europe. A critical approach of polycentrism*: John Libbey Eurotext Ltd.
- Champion, A. G. (2001). A Changing Demographic Regime and Evolving Polycentric Urban Regions: Consequences for the Size, Composition and Distribution of City Populations. *Urban Studies*.
- Davoudi, S. (2003). EUROPEAN BRIEFING: Polycentricity in European spatial planning: from an analytical tool to a normative agenda. *European Planning Studies*.
- Dieleman, F. M., & Faludi, A. (1998). Polynucleated metropolitan regions in Northwest Europe: Theme of the special issue. *European Planning Studies*, 6, 365-377.
- Eck, J. R. v., & Snellen, D. (2006). Is the Randstad a City Network? Evidence from Commuting Patterns. *European Transport Conference 2006*.
- European Commission. (1999). *European Spatial Development Perspective, Towards Balanced and sustainable Development of the Territory of the EU*. Luxemburg: CEC.
- ESPON. (2006). *Polycentric Urban Development and Rural-Urban Partnership - Thematic Study of INTERREG and ESPON activities*.
- ESPON. (2010). SGPTD - Secondary Growth Poles and Territorial Development in Europe. From http://www.espon.eu/main/Menu_Projects/Menu_Applied_Research/SGPTD.html.
- Goei, B. d., Burger, M. J., Oort, F. G. v., & Kitson, M. (2010). Functional Polycentrism and Urban Network Development in the Greater South East UK: Evidence from Commuting Patterns, 1981-2001. *Regional Studies*, 44, 1149-1170.
- Hall, P. (1966). *The world cities*. London: Weidenfeld & Nicolson.
- Hall, P. (2003). In a Lather about Polycentricity. *Town and Country Planning*, 72.
- Hall, P., & Pain, K. (2006). *The Polycentric Metropolis: learning from mega-city region in Europe*. London: Earthscan.
- Kloosterman, R. C., & Lambregts, B. (2001). Clustering of Economic Activities in Polycentric Urban Regions: The Case of the Randstad. *Urban Studies*, 38(4), 717-732.
- Kloosterman, R. C., & Musterd, S. (2001). The polycentric urban region: towards a research agenda. *Urban Studies*.
- Lambregts, B. (2006). Polycentrism: Boon or Barrier to Metropolitan Competitiveness? The Case of the Randstad Holland. *Build Environment*, 32, 114-123.
- Limtanakool, N., Dijst, M., & Schwanen, T. (2007). A Theoretical Framework and Methodology for Characterising National Urban Systems on the Basis of Flows of People: Empirical Evidence for France and Germany. *Urban Studies*, 44(11), 2123-2145.
- Meijers, E. (2007). *Synergy in Polycentric Urban Region: Complementarity, organising capacity and critical mass*. Amsterdam: IOS Press.
- Meijers, E. (2008). Measuring Polycentricity and its Promises. *European Planning Studies*, 16(9).
- NORDREGIO. (2004). *ESPON 1.1.1: Potentials for polycentric development in Europe*. Stockholm/Luxembourg: Nordregio/ESPON Monitoring Committee.
- Parr, J. (2010). The Polycentric Urban Region: A Closer Inspection. *Regional Studies*(38), 231-240.
- Romein, A. (2004). Spatial planning in competitive polycentric urban regions: some practical lessons from Northwest Europe, *City Futures Conference*. Chicago.
- VROM. (2001). Vijfde Nota over de Ruimtelijke Ordening 'Ruimte Maken, Ruimte Delen' (Fifth Memorandum on Spatial Planning: 'Making Space, sharing space'). In M. v. VROM (Ed.). The Hague.